



Service Manual

**HP DesignJet
Z2100/Z3100/Z3100ps/Z3200/
Z3200ps
GP Photo Printer Series**



**Version 13.0
October 3rd, 2013**

For HP Internal Use Only Warranty

©Copyright Hewlett-Packard Company 2013

This document contains proprietary information that is protected by copyright. All rights are reserved. The information contained herein is subject to change without notice. No part of this document may be photocopied, reproduced, or translated to another language without the prior written consent of Hewlett-Packard Company.

Version 13.0, October 3rd, 2013

The information contained in this document is subject to change without notice.

Hewlett-Packard makes no warranty of any kind with regard to this material, including, but not limited to, the implied warranties of merchantability and fitness for a particular purpose.

Hewlett-Packard shall not be liable for errors contained herein or for incidental or consequential damages in connection with the furnishing, performance, or use of this material.

WARNING

The procedures described in this manual are to be performed by HP-qualified service personnel only.

Electrical Shock Hazard

Serious shock hazard leading to death or injury may result if you do not take the following precautions:

- Ensure that the ac power outlet (mains) has a protective earth (ground) terminal.
- Disconnect the Printer from the power source prior to performing any maintenance.
- Prevent water or any other liquids from running onto electrical components or circuits, or through openings in the enclosure.

Electrostatic Discharge

Refer to the beginning of Chapter 4 of this manual, for precautions you should take to prevent damage to the Printer circuits from electrostatic discharge.

Safety Symbols

General definitions of safety symbols are given immediately after the table of contents.

WARNING

The Warning symbol calls attention to a procedure, practice, or the like, which, if not correctly performed or adhered to, could result in personal injury. Do not proceed beyond a Warning symbol until the indicated conditions are fully understood and met.

CAUTION

The Caution symbol calls attention to an operating procedure, practice, or the like, which, if not correctly performed or adhered to, could result in damage to or destruction of part or all of the product. Do not proceed beyond a Caution symbol until the indicated conditions are fully understood and met.

Content Management Department,
Barcelona Division,
Hewlett-Packard Espanola, S.A.
Avda. Graells, 501
08190 Sant Cugat del Valles
Spain

Table of Contents

- 1 Troubleshooting
- 2 System Error Codes
- 3 Service Tests and Utilities
- 4 Service Calibrations
- 5 Parts and Diagrams
- 6 Removal and Installation
- 7 Preventive Maintenance

For information about Using this Manual, please refer to the next page.

Using this Manual

Purpose

This Service Manual contains information necessary to test, calibrate and service:

- HP Designjet Z2100 Photo Printer 24 inch (Model Q6675A)
- HP Designjet Z2100 Photo Printer 44 inch (Model Q6677A)
- HP Designjet Z2100 Photo Printer Revision C 24 inch (Model Q6675C)
- HP Designjet Z2100 Photo Printer Revision C 44 inch (Model Q6677C)
- HP Designjet Z3100 Photo Printer 24 inch (Model Q5669A)
- HP Designjet Z3100 Photo Printer 44 inch (Model Q6659A)
- HP Designjet Z3100ps Photo Printer 24 inch (Model Q5670A)
- HP Designjet Z3100ps Photo Printer 44 inch (Model Q6660A)
- HP Designjet Z3200 Photo Printer 24 inch (Model Q6718A)
- HP Designjet Z3200 Photo Printer 44 inch (Model Q6719A)
- HP Designjet Z3200ps Photo Printer 24 inch (Model Q6720A)
- HP Designjet Z3200ps Photo Printer 44 inch (Model Q6721A)
- HP Designjet Z2100 Rev.D Photo Printer 24 inch (Model Q6675D)
- HP Designjet Z2100 Rev.D Photo Printer 44 inch (Model Q6677D)
- HP Designjet Z3200 Rev.B Photo Printer 24 inch (Model Q6718B)
- HP Designjet Z3200 Rev.B Photo Printer 44 inch (Model Q6719B)
- HP Designjet Z3200ps Rev.B Photo Printer 24 inch (Model Q6720B)
- HP Designjet Z3200ps Rev.B Photo Printer 44 inch (Model Q6721B)

For information about using these printers, refer to the corresponding User and Quick Reference Guides.

Readership

The procedures described in this Service Manual are to be performed by HP Certified service personnel only.

Part Numbers

Part Numbers for Printer options, accessories and service parts are located in Chapter 5, Parts and Diagrams.

Conventions

A small arrow ⇒ indicates a link to other parts of the Service Manual where you can find information related to the topic you are consulting.

Troubleshooting

1

- Using the Front Panel 1-3
 - Introduction 1-4
 - Using the Front Panel 1-3
 - Troubleshooting System Error Codes 1-4
 - Performing a Service Test on a failed Assembly 1-4
 - Performing the Necessary Service Calibrations 1-5
 - The Printer does not Power ON 1-5
 - What to do if the Front Panel is blank or system error 08:YZ is displayed 1-5
 - The Printer Continuously Rejects Printheads 1-6
 - Cover Sensors are not Working 1-7
 - The Line Sensor has Problems Detecting Media 1-7
 - Banding at variable extreme environmental conditions 1-8
 - Worm marks on HP Coated media with light area fills 1-8
 - Solving Media-Handling Problems 1-9
- Software Troubleshooting 1-10
 - General advice: 1-10
 - Problems with Image Clipping 1-10
 - Output Only Contains a Partial Print 1-11
 - Some objects are missing from the printed image 1-12
 - If the spool file size is bigger than 1GB, part of the image will be clipped 1-12
 - Adobe Photoshop 1-13
 - Adobe Acrobat 1-16
 - Microsoft Powerpoint 1-17
 - Adobe Photoshop CS for Mac 1-17
 - Adobe Illustrator/InDesign for Mac 1-19
- Print Quality Troubleshooting 1-20
 - Print Quality Troubleshooting Actions 1-20
 - The Service Image Quality Diagnostic Print 1-21
 - What is the Service Image Quality Diagnostic Print? 1-21
 - Considerations for Printing the Diagnostic Print 1-22
 - Printing the Diagnostic Print 1-22
 - Reading the Diagnostic Print Results 1-24
 - Diagnostic Part 1: Printhead Reliability 1-24
 - Diagnostic Part 2: Printhead Alignment 1-25
 - Diagnostic Part 3: Printheads & Paper Advance 1-26
 - No Printing Defects Found in the Diagnostic Print 1-28
 - The Advanced Diagnostic Prints 1-29
 - What are the Advanced Diagnostic Prints? 1-29
 - Printing the Advanced Diagnostics Print 1-29
 - Reading the Advanced Diagnostic Print Results 1-31
 - Paper Advance 1-31
 - Visual Alignment Diagnostic 1-34
 - Nozzle Health 1-36
 - Force Drop Detection 1-37
 - Troubleshooting Print Quality Problems 1-38
 - Print Quality General Advice 1-38

- Horizontal Lines Across the Image (Banding) 1-38
- Lines are Missing, Too Thin, or Too Thick 1-39
- Problems with Stepped Lines 1-40
- Lines are Printed Double or in Wrong Colors 1-41
- Lines are discontinuous 1-41
- Lines are Blurred (Ink Bleeds from Lines) 1-42
- Problems with Graininess 1-42
- Paper is not Flat 1-43
- Print Scuffing or Scratching when Touched 1-45
- Marks on the Media 1-45
- Problems with the Edges of objects 1-51
- Bronzing 1-51
- Black and white prints do not look neutral 1-52
- Horizontal lines at the end of a cut sheet print 1-52
- Vertical lines of different colors 1-52
- White spots on the print 1-53
- Problems with Color Accuracy 1-53
- Ink Supplies Troubleshooting 1-55
- Introduction to Ink Supplies 1-55
- What are Ink Supplies? 1-55
- Ink Cartridges 1-55
- Available Ink Cartridges 1-57
- Printheads 1-57
- Available Printheads 1-58
- General Information About the Ink Supplies 1-58
- General Precautions When Handling Ink Supplies 1-59
- When Should You Replace the Ink Supplies? 1-59
- Ink Cartridge Levels, Information, and Replacement 1-59
- Ink Cartridge Levels 1-59
- “View Ink Levels” Direct Access Key 1-59
- “View Ink Levels” from the ink menu 1-60
- Obtaining Ink Cartridge Information 1-60
- Changing an Ink Cartridge 1-61
- Printhead Information, Replacement and Alignment 1-63
- Obtaining Printhead Information 1-63
- Changing a Printhead 1-64
- Aligning Printheads 1-66
- Reinsert Printheads Procedure 1-66
- Image Quality Maintenance Procedure 1-66
- Scanning errors during alignment 1-67
- Ink Cartridge and Printhead Status Messages 1-68
- Ink Cartridge Status Messages 1-68
- Printhead status messages 1-68
- Printhead Error Codes 1-69
- Solving Ink Supplies Problems 1-70
- You Cannot Insert the Ink Cartridge Into the Printer 1-70
- You Cannot Insert the Printhead Into the Printer 1-71
- The front panel says to reset or replace a printhead 1-71
- Maintaining and Cleaning the Printheads 1-72
- Clean the printheads 1-72
- Flex Contacts Cleaning Tool 1-72

Using the Front Panel

Below is a diagram of the front panel.

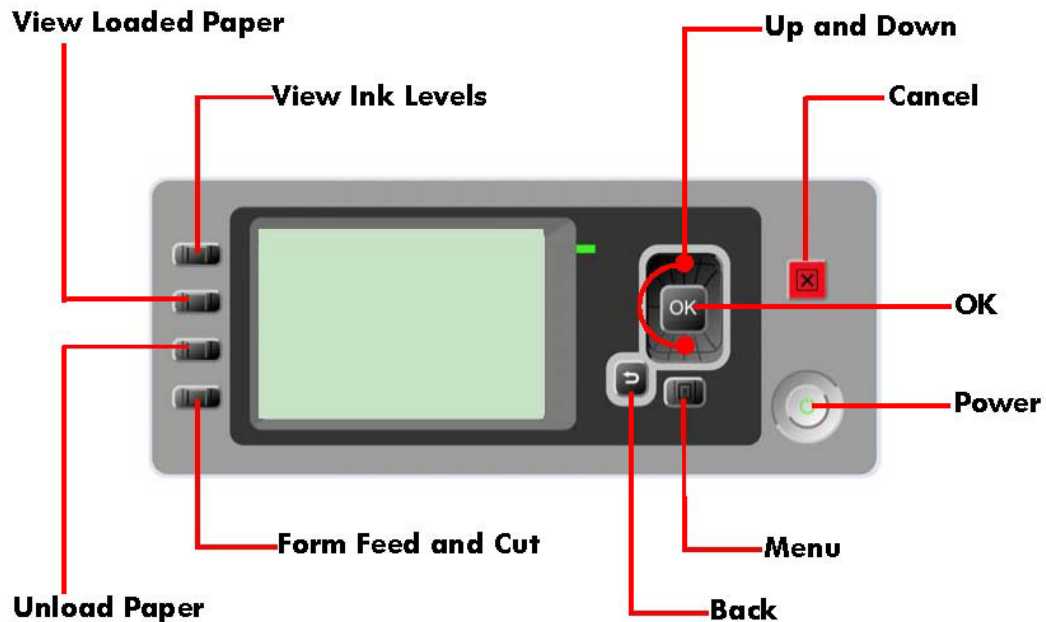

Key Function

- **Arrow Keys**
Use the Arrow keys to scroll through a menu or toggle between YES or NO when prompted.
- **Cancel**
Use the Cancel key to abort or stop a procedure or reject test results.
- **OK**
Use the OK key to select a menu option.
- **Power**
Use the Power key to turn the printer ON and OFF.
- **Menu**
Use the Menu key to enter the main menu.
- **Back**
Use the Back key to go back to the previous menu or reject test results.

Service Key Combinations

- **Diagnostic mode**
With the printer OFF, press and hold the UP and OK keys. While holding the Up and OK keys down, press and hold the Power key to turn on the printer. Hold all three keys until the Power key stops flashing, usually about 20 seconds.
- **Service Menu (Service Engineers Only)**
From the main menu, press and hold the Up and Cancel keys.
- **Service Menu (For users)**
From the main menu, press and hold the Down and Cancel keys.

General Troubleshooting

Introduction

This chapter will guide you through the relevant steps to take when troubleshooting the printer.

Troubleshooting System Error Codes

Chapter 2, *System Error Codes* contains a list of system error codes and their respective descriptions and recommended corrective actions. Only try one recommended action at a time and check if the error code has disappeared.

If you have an error code which is not documented in this Service Manual or you have an error which you cannot resolve, then report the error to the HP Response Center or the nearest HP Support Office. When reporting the error, have the following information ready:

- Model and Serial Number of the printer.
- Which firmware revision the printer is using (See Note below). Check firmware in *Utilities / Statistics / Code rev.*
- The complete error number (See Note below).
- The Service Configuration Print.
- The Current configuration sheet.
- Which software application the customer is using (name, version, etc.).

When reporting the System Error Code, make sure that you supply the full Error Code and the firmware version. Without this information, HP Support Personnel cannot help you.

Performing a Service Test on a failed Assembly

If possible, always perform a Service Test on the component/assembly that you are about to replace, just to make sure that is the component/assembly that has failed.

If the test on that component/assembly passes, you should NOT replace it.

For information on the Service Tests and how to use them see Chapter 3, *Service Tests and Utilities*.

Performing the Necessary Service Calibrations

Is the printer calibrated correctly after replacing a component? For information on the Service Calibrations and how to use them, see *Service Calibration Guide to Removal and Installation*, Page 6-8 and Chapter 4, *Service Calibrations*.

Remember that certain Calibrations are required even if an Assembly has been disassembled to gain access to another Assembly or Component.

The Printer does not Power ON

- 1 Check that the power cord is connected correctly to the Printer and to the Power Socket.
- 2 Check that the Power Switch on the BACK of the Printer is in the ON position.
- 3 Check to see the LED on the Front Panel Power Switch are On.
- 4 Check that the Front-Panel Cable is correctly connected to the Electronics Module. Also make sure that the Front-Panel cable is not damaged.
- 5 Replace the Power Supply Unit ⇒ Page 6-168.

What to do if the Front Panel is blank or system error 08:YZ is displayed

The LEDs of the formatter (only present on Z2100 RevD and Z3200 RevB are visible through the cover) and the power supply can help you troubleshoot a problem when the Front Panel is blank.

- 1 The following image shows the Power Supply LED, looking through the cover.



- 2** The following image shows the Formatter LEDs, which are marked I, II and III.



Use the following table to interpret the LEDs and find the source of the problem. Remember that you should read these LEDs when you push the Power button. Some combinations may require the replacement of two or more components. In this case, always replace one component at a time.

Test the printer to see if the problem has disappeared (check the LEDs again). If the same LED sequence continues, replace the next component indicated in the table.

Power Supply LED	Formatter LED1	Formatter LED2	Formatter LED3	Front Panel Status	Solution (part replacement)
Off	Off	Off	Off	Off	Power issue, replace PSU ⇒Page 6-165.
On	Off	Off	Off	Off	Main PCA ⇒Page 6-165.
On	On	Off	N/A	N/A	Formatter ⇒Page 6-161.
On	On (flashing)	Off	Off	N/A	Hard Disk ⇒Page 6-161.
On	On	On (flashing)	Off	N/A	Hard Disk ⇒Page 6-161.
On	On	On	Off	N/A	1. Formatter⇒Page 6-161. 2. Main PCA⇒Page 6-165.
On	On	On	Off	N/A	1. Main PCA⇒Page 6-165.
On	On	On	On	Off	1. Front Panel ⇒Page 6-48. 2. Formatter⇒Page 6-161. 3. Main PCA⇒Page 6-165. 4. Front Panel Cable ⇒Page 6-48.
On	On	On	On	Off	Front Panel ⇒Page 6-48.

The Printer Continuously Rejects Printheads

- 1** Clean the flex contacts on the Printhead and in the Carriage Assembly using the Carriage Interconnect Wiper (Refer to Page 1-72) and try again.
- 2** If ALL the Printheads are rejected (the status message on the Front Panel does NOT show "OK" for ALL the Printheads) then perform the Electronic Module Test ⇒ Page 3-22.

Cover Sensors are not Working

- 1 Perform the Sensors Test ⇒ Page 3-33.
- 2 Check if the cable for the faulty sensor is not damaged and is connected correctly.
- 3 Replace the faulty Sensor.

The Line Sensor has Problems Detecting Media

- 1 Check the type of media that is being used since the Line sensor may have problems detecting transparent media or some types of Non-HP media. Try loading white HP media in to the Printer and check if the Line sensor detects it.
- 2 Sometimes the line sensor has problems detecting media when sheet media is loaded without a skew check. If the media type allows, always use the automatic skew check feature. If the media type does not allow automatic skew check, manually check that the media is correctly positioned.
- 3 The Line Sensor is not calibrated correctly. Perform the Line Sensor Calibration ⇒ Page 4-15.
- 4 The Line Sensor is damaged or faulty. Replace the Line Sensor ⇒ Page 6-130.

Problems with Color Accuracy

- 1 The Color Sensor ESP (spectrophotometer) is a powerful tool unique to the Z series printers to maintain color accuracy. If you notice any problems with colors, perform the Color Sensor ESP (spectrophotometer) calibration. Refer to Page 4-18.

Troubleshooting Media Jams/Printhead Crashes

The failure modes "media jam" and "head crash" are grouped together because in many cases a media jam causes the media to lift up into the Carriage path and cause a Printhead crash, thus causing many media jam failures to be reported as head crashes.

- 1 Did the media jam occur when loading media?
 - If the client has had media jams, it is common for pieces of media to get stuck in the media path. Clear the media path.

When clearing a media jam, sometimes media is stuck in the paper path. To clear this, you must lift the Media Lever and insert thicker media into the paper path to push out the media that is still stuck there.

- 2 Is the customer using non-HP media?
 - The use of non-HP media can easily be the cause of media jams and head crashes (especially head crashes because HP media is specially formulated to avoid cockle, one of the primary causes of head crashes). If the media is not HP approved, advise the customer to use HP media and check to see if the problem is now solved.

- 3** Has media been loaded without skew check?
- Loading media without skew check can cause printhead crashes both during loading and while printing. Whenever automatic skew check is available for a media type, it should be used. If automatic skew check is not allowed for the media type, manually check that the media is correctly positioned.
 - Standard/Normal Cut Sheets, depending on the degree of skew, cause printhead crashes when the corners are not evenly controlled (they are not pinched at the same time). This makes it more likely that the paper will be bent or damaged. Frequently, the paper curls upward when the paper expands due to ink absorption.
 - Commercial FA Arts Sheets have the same problem as the Standard/Normal Cut Sheets described above. The difference is that the Commercial FA Arts Sheets have a weak, irregular edge that often makes the problem worse.
 - Hand-cut Rollsheets or Leftovers are not supported by the printers because errors are frequently made by the operator that cause printhead crashes.

The printer has problems ejecting sheet media

The printer has problems ejecting sheet media, either continuing to eject the paper long after it has been ejected or stopping the ejecting process before the paper is completely ejected from the printer. To solve the problem, try the following:

- Load media using the skew check feature whenever it is possible. When sheet media is loaded without the skew check feature, the printer estimates the length of the paper to be 4 times the width. If this estimate is either too short or too long, the printer will not properly eject the media.

Banding at variable extreme environmental conditions

Since the Accuracy Calibration has been done at normal environmental conditions, printing in extreme environmental conditions will cause banding because the advance of the Media Advance Roller does not correspond to the conditions present when the calibration was performed. To solve the problem, try the following:

- Perform the Accuracy Calibration in the new environmental conditions (Refer to the User's Guide).

Worm marks on HP Coated media with light area fills

Light bands (S-shaped) in Paper axis direction where light area fills are printed, causing unacceptable Image Quality defect.

- Print the Service Configuration Print and check if the level of Humidity is very low (below 30%). Increasing humidity may help in reducing the

severity of the problem.

The media is causing the problem and NOT the Printer. Do not attempt to try and replace Printer parts to solve this problem.

Solving Media-Handling Problems

The Front Panel indicates that media is misaligned or incorrectly positioned

Roll media

- The roll may be loaded the wrong way. The paper should load over the roll toward you.
- Check that the paper is correctly loaded onto the spindle.
- The paper may be loaded at an angle. The right-hand edge must be aligned with the blue line on the Print Platen.

Ensure that the paper is wrapped tightly on the roll. This is a very important step to remember because if this is not done, the media may be loaded at an angle, causing the media to be rejected.

- Make sure you choose the correct loading option on the Front Panel.

Sheet media

- Always load sheet media using the Rear Input Tray. Do NOT load the media as you would load roll media, unless you are getting marks on the media with thick cut sheet media.
- It must be loaded with the right-hand edge against the blue line on the Print Platen.
- Load the sheet media without skew check.
- The media may be crumpled or warped or may have irregular edges.
- If hand-cut media is used, the edges may not form a right-angle or they may be rough. If possible, hand-cut media should not be used. Only purchased sheet media should be used in the Printer.
- If you have problems with paper jams, check that the Overdrive is not obstructed by bits of paper or using the Turn Drive Roller Service Utility ⇒ Page 3-61.
- Make sure you choose the correct loading option on the Front Panel.

Software Troubleshooting

General advice:

Check that you have the latest driver release. Driver releases are available at www.hp.com/go/graphicarts

Installation

If the driver is available in a share drive, copy the installer or zip file locally into the hard disk before executing it.

The drivers are published in different formats in the web

- Installer for Windows (.exe file that can be executed to start the installation)
- Compressed package including all files that are needed to install the driver through the Add a Printer Wizard in Windows (.exe file that can be automatically extracted)
- Image file for Mac (.dmg file)

Usually the Windows installer includes other components apart from the driver, like the HP Standard TCP/IP Port. This is the recommended port type when you need to install the printer on the network, so make sure that you have installed the driver with the installer at least once to have this port type available.

If you want to upgrade the driver in the future, although it is recommended to continue using the installer, you can use the manual wizard if you are concerned about file download size. When you install the driver from the original CD/DVD, you are using the Installer so the necessary components will be installed also.

Installation logs are located at:

- C:\windows\hpdj\xxxx.log (different for each printer name)
- C:\windows\sounder.his
- C:\windows\hpntwksetup.ini

They might be useful in case of escalating an installation error to the Lfp Helpdesk

Problems with Image Clipping

This normally indicates a discrepancy between the actual printable area on the loaded paper and the printable area as understood by the software. This kind of problem can often be identified before printing by previewing the print.

- Check the actual printable area for the paper size that is loaded.
printable area = paper size – margins
- Check what the software understands to be the printable area (which it may call “printing area” or “imageable area”). For example, some software applications assume standard printable areas that are larger than those used in this Printer.
- If a custom page size with very narrow margins has been defined, the

printer may impose its own minimal margins, clipping the image slightly. Consider using a larger paper size, or border less printing.

- If the image contains its own margins, it may be possible to print it successfully by using the Clip Contents by Margins option.
- If a very long image needs to be printed on a roll, check that the software is capable of printing an image of that size.
- The page may have been rotated from portrait to landscape on a paper size that is not wide enough.
- If the paper was loaded without the skew check feature, the preview function may not function correctly because the printer must estimate the paper length. Whenever possible, load media using the skew check feature.
- If necessary, change the printable area in the software.
- If necessary, reduce the size of the image or document in your software application, so it fits between the margins

Another Possible Explanation

Some applications, such as Adobe Photoshop, Adobe Illustrator, and CorelDRAW, use an internal 16-bit coordinate system which means that they cannot handle an image of more than 32,768 pixels. If you try to print an image larger than this from these applications, the bottom of the image will be clipped. In this case, the only way to print the whole image is to reduce the resolution so that the whole image requires fewer than 32,768 pixels. An image 32,768 pixels long would print at a length of 54.61 in or 1.39 m if you select Best or Quality in the driver, 109.23 in or 2.78 m if you select Fast, Normal or Speed in the driver.

To print the whole image, try these suggestions:

- When printing into a PS printer, Try using the PostScript printer driver to print your job, if you have not already tried it
- The Windows PCL3 driver dialog includes an option called Max. application resolution, which enables you to print successfully in this situation. For the Z3200 it is set to Auto. For older products, or if you want to make sure that the resolution is lowered, you might need to change the setting manually to 300. You can find the option in the Advanced tab, under **Document Options > Printer Features**.
- Save the file in another format, such as TIFF or EPS, and open it with another application.
- Use a RIP to print the file.

Output Only Contains a Partial Print

If the output that was expected only contains a partial image, then try the following to resolve the problem:

- 1 Was the **Cancel** key pressed before all the data was received by the Printer? If so, send the file again and make sure that the **Cancel** key is not pressed.
- 2 The **I/O Timeout** setting may be too short. Increase the I/O timeout setting (Setup Menu/I/O Setup/IO Timeout) and then send the file again.

- 3 There might be a communications problem between the Printer and Computer. Check the USB or network cable between the computer and the Printer to make sure it is not damaged and is connected correctly.
- 4 Make sure that the software settings are correct for the current page size (e.g. long-axis prints).
- 5 If network software is being used, make sure it has not timed out.

Some objects are missing from the printed image

Large quantities of data may be necessary to print a high-quality large-format print job, and in some specific workflow there may be issues that can lead to some objects missing from the output.

Corrective Action

- In the Advanced tab, select Document options, Printer features, and set Send job as bitmap to Enabled (HP-GL/2 driver only).
- In the Advanced tab, select Document options, Printer features, and set 16-bit App. Compatibility to Enabled.
- Select a smaller page size and scale to the desired final page size in the driver or in the front panel.
- Save the file in another format, such as TIFF or EPS, and open it with another application.
- Use a RIP to print the file.
- Reduce the resolution of bitmap images in your application software.
- Select a lower print quality in order to reduce the resolution of the printed image.

The above settings are mentioned for troubleshooting purposes and may adversely affect the final output quality or the time necessary to generate the print job. Therefore, they should be restored to their default values if they do not help to solve the problem.

When working under Mac OS, the above settings are not available. Instead, try reducing the resolution of bitmap images in the application software being used.

If the spool file size is bigger than 1GB, part of the image will be clipped

Versions affected: Any application in Windows XP

Drivers affected: Drivers that use EMF spooling

Description:

Some drivers generate spool files in EMF format. The OS has a limitation in the size of this EMF file. Currently the drivers that use EMF are:

- Z2100/Z3100 PCL3GUI driver
- Z2100/Z3100 HP-GL/2 driver if the preview or back to front printing settings are used

Corrective Action

- Reduce the resolution.

- Reduce resolution in driver by selecting a lower printmode (Best or normal instead of Max Detail).
- In the Advanced tab of the driver, select Max application resolution = 300 to reduce the driver resolution while keeping the rest of the printmode characteristics (number of passes for example).
- Disable the Print Processor module in the PCL3GUI driver, which is responsible for generating EMF. You can do this by going to the Advanced tab of the driver and disabling the Advanced Printing Features. The trade-off is that you cannot use the following features in the PCL3GUI driver: Preview, rotation, scaling, Office features, Back to front printing.
- In the HP-GL/2 driver, do not use preview or back to front printing to avoid generating EMF files.
- Use a RIP or a PS model

Limit for Windows 2000 spool file size is smaller (200MB).

Observation: Customer might report that when choosing preview, the job is not printed but it is printed when he does not select the preview setting. The cause of the problem might be related to the fact that the HP-GL/2 driver will use EMF if you do a preview so this limitation applies in this case.

When the image needs to be rotated, parts of the image might be clipped or disappear

Versions affected: Any application in Windows

Drivers affected: Drivers that use EMF spooling, like the PCL3Gui driver for the Z Series

Description:

When the image is rotated, sometimes part of the image is clipped. We have seen this in several applications like Photoshop or Acrobat. In other cases, instead of clipping the end of the image, the symptom is that some objects inside the image disappear, we have seen the effect in Acrobat.

Corrective Action

- If possible, rotate inside the application instead of in the driver
- Reduce resolution in driver by selecting a lower printmode (Best or normal instead of Max Detail)

Remember that if the image is wider than the paper loaded, the image will be automatically rotated. If possible rotate the image inside the application instead of letting the driver rotate it automatically when it does not fit.

Driver version available in Fall'08 will improve the performance when printing big files or rotating images.

Adobe Photoshop

It is not possible to open images that have more than 300,000

pixels in any direction (width or length)

Versions affected: All

Drivers affected: All

Corrective Action

Not available

It is not possible to print images that have more than 30,000 pixels in any direction (Print menu gets grayed out)

Versions affected: CS and previous

Drivers affected: All

Corrective Action

- Reduce image resolution in Photoshop (Image → Image Size)
- Use a RIP to print the file

Image will be clipped if it is longer than 32768 pixels

Versions affected: All except CS2

Drivers affected: PCL3GUI and HP-GL/2 drivers

Description:

If the page size to be printed is bigger than 32768 pixels in any direction (215 pixels), the image will not be completely printed. The number of pixels depends on the driver resolution:

- At 1200dpi you can print 27.31" (69cm). This is equivalent to Max Detail in the Z2100/Z3100 driver
- At 600 dpi you can print 54.61" (1.39m). This is equivalent to Best in the Z2100/Z3100 driver
- At 300 dpi you can print 109.23" (2.78m). This is equivalent to Fast or Normal in the Z2100/Z3100 driver

Corrective Action

- Reduce resolution in driver by selecting a lower printmode (Best or normal instead of Max Detail)
- In the Advanced tab of the driver, select Max application resolution = 300 to reduce the driver resolution while keeping the rest of the printmode characteristics (number of passes for example)
- Convert the image to PDF and print from Acrobat, or use a RIP
- Print from CS2. CS2 allows printing 231 pixels, which results in lengths of kilometers.
- Reduce the image size so that it is inside the limits that can be printed and then scale from the driver to the desired size
- Use a RIP or a PS model

Carriage stops between swaths leaving some horizontal marks in the middle of the plot

Versions affected: All but seen more often in CS3

Drivers affected: PCL3GUI drivers

Description:

When printing some long or high resolution images, even if being inside the limits of the number of pixels that can be printed, sometimes the carriage stops between different swaths. When the carriage stops, an horizontal line in a different color might be seen due to the ink that has dried between the different passes of the carriage over the same swath

Corrective Action

- Reduce resolution in driver by selecting a lower printmode (Best or normal instead of Max Detail)
- In the Advanced tab of the driver, select Max application resolution = 300 to reduce the driver resolution while keeping the rest of the printmode characteristics (number of passes for example)
- Disable the Memory manager setting in the Advanced tab of the driver

Driver version available in Fall'08 will improve the performance when printing big files or rotating images.

Image does not get correctly centered

<http://www.adobe.com/go/kb402021>

Versions affected: CS3

Drivers affected: All

Description:

Even after selecting the Center option in the Print Menu, the image is not centered

Corrective Action

- Install the Photoshop 10.0.1 update or later

Portrait or landscape orientation is not taken into account

<http://www.adobe.com/go/kb403012>

Versions affected: CS3

Drivers affected: All

Description:

Print options such as landscape orientation, print preview, scale fit to media, roll paper-panorama printing, user-defined paper sizes, and printing the full image, don't work as expected when you print from Photoshop CS3. This can occur when you choose a custom page size in Photoshop CS3.

Corrective Action

- Get the latest CS3 patch
- Select the page size settings inside the File –Print menu instead of the File – Page Setup menu
- Ultimately use CS or CS2 to print the image

Image is printed in letter size

Versions affected: CS3

Drivers affected: All

Description:

When creating a custom page size, the image is printed in letter size. The difference between this limitation and the pixels limitation is that in this case you have a reduction of size both in length and in width. In the case of the pixel limitation you only have the reduction in length, but the width is usually printed correctly.

Corrective Action

- Get the latest CS3 patch
- Create custom page sizes with bigger lengths than widths and then select the landscape option if needed.

Latest drivers do not allow creating page sizes with bigger widths than lengths.

- Select the page size settings inside the File –Print menu instead of the File – Page Setup menu
- In Windows Vista, open the print preferences dialog again after clicking on the Print button of the Photoshop Print dialog, and select again the custom page size. It will be kept in this way.
- Ultimately use CS or CS2 to print the image

Adobe Acrobat**Image is printed in letter size**

Versions affected: All

Drivers affected: All

Description:

When creating a custom page size, it might not be available to be selected from the application until you close Acrobat and open it again. The result is that Acrobat will go back to the default selection for page size, which is Letter. If the customer does not realize that the page size changed again after closing the driver dialog, it will look like part of the image is clipped.

Corrective Action

- Close Acrobat and open it again.

Clipped images when printing long files

Versions affected: All

Drivers affected: Drivers that use EMF spooling

- Z2100/Z3100 PCL3GUI driver
- Z2100/Z3100 HP-GL/2 driver if the following settings are selected:
preview, back to front printing

Description:

The image is not completely printed. We have seen this more often in files that are longer than 54" (printing at 600dpi) or 108" (printing at 300dpi). There is a limitation in the way that Acrobat handles EMF files, sometimes depending on the complexity of the EMF file, part of the image is lost. It could be that the end of the image is not printed, or some objects might disappear.

Corrective Action

- Update to latest Acrobat version. Old Acrobat releases had limitations in the length of images that could be printed
- Create custom page sizes with bigger lengths than widths and then select the landscape option if needed.

Latest drivers do not allow creating page sizes with bigger widths than lengths.

- If you need to rotate the image, rotate it inside the application (with Acrobat Professional). Please be aware that when you rotate in Acrobat Reader you are just rotating the view but the file is not rotated.
- Reduce resolution in driver by selecting a lower printmode (Best or normal instead of Max Detail)
- In the Advanced tab of the driver, select Max application resolution = 300 to reduce the driver resolution while keeping the rest of the printmode characteristics (number of passes for example)
- Disable the Print Processor module in the PCL3GUI driver, which is responsible for generating EMF. You can do this by going to the Advanced tab of the driver and disabling the Advanced Printing Features. The trade-off is that you cannot use the following features in the PCL3GUI driver: Preview, rotation, scaling, Office features, Back to front printing.
- In the HP-GL/2 driver, do not use preview or back to front printing to avoid generating EMF files.
- Use a RIP or a PS model

Microsoft Powerpoint

Part of the image is lost when printing big slides in landscape orientation

Versions affected: All

Drivers affected: Z2100/Z3100 PCL3GUI driver

Description:

When printing a slide in landscape format which will need to be rotated in order to fit in the currently loaded roll, the result is that parts of the image might disappear (objects, background), or the image might be clipped.

Corrective Action

- Upgrade the unit to HP-GL/2 and use the HP-GL/2 driver
- Save in a different format and print from another application
- Print on rolls that are wider than the slides that need to be printed

Driver version available in Fall'08 will improve the performance when printing big files or rotating images.

Adobe Photoshop CS for Mac

It is not possible to open images that have more than 300.000

pixels in any direction (width or length)

Versions affected: All

Drivers affected: All

Corrective Action

Not available

It is not possible to print images that have more than 30.000 pixels in any direction (Print menu gets grayed out)

Versions affected: CS and previous

Drivers affected: All

Corrective Action

- Reduce image resolution in Photoshop (Image → Image Size)
- Use a RIP to print the file

Image will be clipped if it is longer than 32768 pixels

Versions affected: All except CS2. Illustrator or Indesign have similar limitations.

Drivers affected: PCL3GUI drivers

Description:

If the page size to be printed is bigger than 32768 pixels in any direction (215 pixels), the image will not be completely printed. The number of pixels depends on the driver resolution:

- At 1200dpi you can print 27.31" (69cm). This is equivalent to Max Detail in the Z2100/Z3100 driver
- At 600 dpi you can print 54.61" (1.39m). This is equivalent to Best in the Z2100/Z3100 driver
- At 300 dpi you can print 109.23" (2.78m). This is equivalent to Fast or Normal in the Z2100/Z3100 driver

Corrective Action

- Reduce resolution in driver by selecting a lower printmode (Best or normal instead of Max Detail)
- Convert the image to PDF and print from Acrobat, or use a RIP
- Print from CS2. CS2 allows printing 231 pixels, which results in lengths of kilometers.
- Reduce the image size so that it is inside the limits that can be printed and then scale from the driver to the desired size

It is not possible to print longer than 455inches

Versions affected: All

Drivers affected: PCL3GUI drivers

Description:

Photoshop uses an internal resolution of 75dpi, so even if you have reduced the resolution of the image to print longer files and overcome the 30.000 pixels limitation, you will not be able to print longer than 455inches.

Corrective Action

- Use a RIP

Adobe Illustrator/InDesign for Mac

It is not possible to create long documents

Versions affected: All

Drivers affected: All

Description:

When creating a new document, its size is limited to 227.5416 inches for Illustrator and 106inches for InDesign.

Corrective Action

Not Available

It is not possible to print longer than 109inches

Versions affected: All

Drivers affected: PCL3GUI drivers

Description:

Files longer than 109inches will be clipped. The reason is:

- Illustrator does not take into account the raster resolution from the application when printing on raster devices, and it always takes 300dpi, which is the driver resolution, to create the spool file. Therefore it limits the maximum printable document size to 109inches (32.700pixels/300dpi)
- InDesign has different settings to handle resolution (full resolution, optimized resolution or screen resolution). For all cases, the spool file includes 300dpi data so the maximum length is also 109inches

Corrective Action

- Use a different application
- Use a RIP or a PS printer

Print Quality Troubleshooting

Print Quality Troubleshooting Actions

For some Print Quality problems, a Call Agent can try and troubleshoot the Printer by requesting the Customer to perform certain actions. Using this process, most problems can be resolved without the need of an on-site visit.

When faced with a Print Quality problem, perform the following actions in order to resolve the problem:

- 1 Printer Configuration:
 - Check that the paper type loaded corresponds to the paper type selected in the front panel and in the software. You can verify the paper type selected through the Front Panel (Main Menu/Paper menu/View loaded paper).
- If you load a sheet without using the skew check feature, the printer automatically estimates the paper length to be 4 times the width. If skew check is not used, the View Loaded Paper option will only reflect the estimation made by the printer, and not the real length.**
- Make sure that the correct Print Quality settings are used for different types of print content.
 - Dry time should be set to "Optimal".
 - 2 Perform Printhead recovery (Main Menu/Image Quality Maintenance/Clean Printheads).
 - 3 Media:
 - Make sure that HP or HP-approved media is being used.
 - When loading the media, make sure to use the skew check feature whenever possible (skew check is not available for some types of media).
 - 4 Perform the Printhead Alignment (Main Menu/Image Quality Maintenance/Align Printheads), using the same paper type with which you were experiencing unacceptable image quality, if feasible (some paper types are not suitable for Printhead Alignment).
 - 5 Check if the latest version of the firmware is installed. If not, install the latest firmware revision.

The Service Image Quality Diagnostic Print

What is the Service Image Quality Diagnostic Print?

The Printer contains an internal Image Quality Test which helps you to diagnose the possible source of any image quality defects. The Service IQ Diagnostic Print is available in the following options:

- 1 *Image Quality Service Best Plot*. This plot helps you to diagnose in more detail the possible source of any image quality defects. It is accessible through the Service Utility Menu.

The *Image Quality Service Best Plot* uses the Best Print Mode and is divided in to three parts as follows:

- Diagnostic Part 1: Printhead Reliability Test. The purpose of this test is to identify which Printhead is faulty.
 - Diagnostic Part 2: Printhead Alignment Test. This test is designed to check any color-to-color and bi-directional misalignment the printer may have.
 - Diagnostic Part 3: Printheads and Paper Advance test. This test is designed to check whether the Printheads and the Media Advance Mechanism are working correctly.
- 2 *Image Quality Service Normal Plot*. This plot is the same as the *Image Quality Service Best Plot* but uses the Normal Print Mode.
 - 3 *Advanced Diagnostic Plot*. These tests provide more information of the IQ defects that we could find in the *Image Quality Service* plot. For more information, refer to page 1-29, *The Advanced Diagnostic Prints*.

Considerations for Printing the Diagnostic Print

- 1 The IQ Diagnostic Print prints in A3 and B sizes so you must have media loaded (roll or sheet) that is this size or larger.
- 2 Use the same type of media that the customer was using when they found the image quality problem.
- 3 If the customer is using non-HP media and after the Image Quality Test you still have the same image quality problems, change to genuine HP media and repeat the Image Quality Test.
- 4 If you do not see any problems with the Image Quality Test, the problem may not be with the printer itself. The problem may be with the RIP or the driver.

If you do see problems with the Image Quality Test, continue with the Advanced Diagnostic procedures which will help you diagnose the problem.

Printing the Diagnostic Print

- 1 In the Service Utilities submenu, scroll to "Diagnostic Print" and press **OK**.

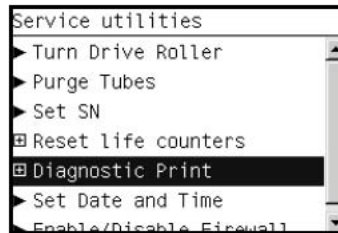

- 2 You will be given three options. Use the **Arrow** keys to make the selection and press the **OK** key to start printing the required Diagnostic Print or to enter the Advanced Diagnostics menu.



- 3 If you selected the Advanced Diagnostics Prints in the previous step, use the **Arrow** keys to make the required selection Paper Advance, Visual Alignment Diagnostic, Nozzle Health, Force Drop Detection or Print Banding Plot, and press the **Enter** key to start printing.

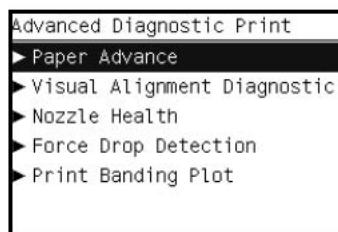

- 4 Make sure media is loaded, the Media Lever is lowered and that the Ink System is correctly installed. Press the **OK** key to print the Diagnostic Print or press **Back/Cancel** to exit without printing the Diagnostic Print.

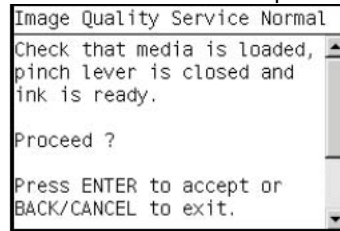

- 5 The selected Diagnostic Print will now be printed.

Reading the Diagnostic Print Results

Diagnostic Part 1: Printhead Reliability

The Nozzle Print Test test is designed to check if the Printhead nozzles print correctly.

The nozzles check (bottom of the plot) is printed in a one-pass full swath mode. The diagnostics test prints out every single nozzle of each Printhead without applying an error hiding or alignment algorithm.

For each Printhead, you can see both the adjacent and the consecutive nozzles.

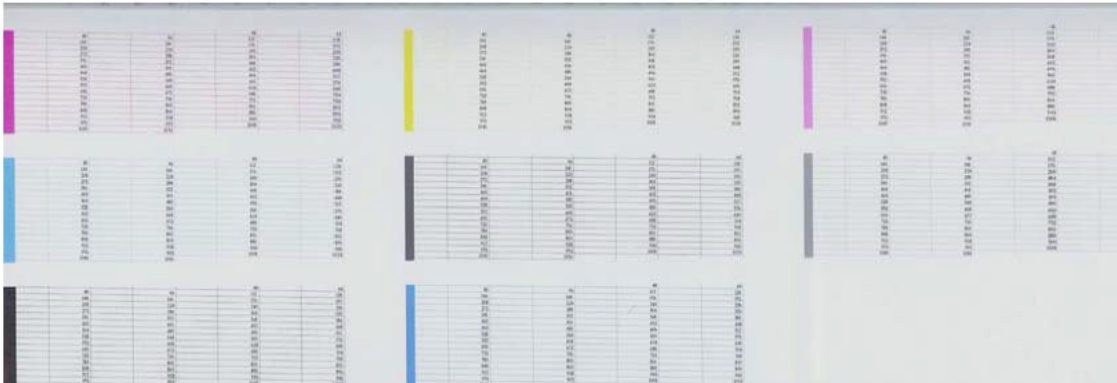

If any nozzles are not printing correctly they will be shown on the right of each Printhead Nozzle test. There is a series of numbered stepped diagonal lines. If one or more of the nozzles are clogged, malfunctioning or mispositioned, you will see that the stepped lines are broken or misdirected in one or more places.

Below, the stepped lines highlighted in yellow are broken. When the line is completely broken, this means the nozzle is out.

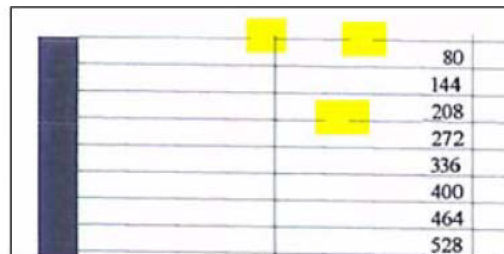

Below, the stepped lines highlighted in yellow are misdirected. When the line is misdirected, this means the nozzle is malfunctioning or out of position.

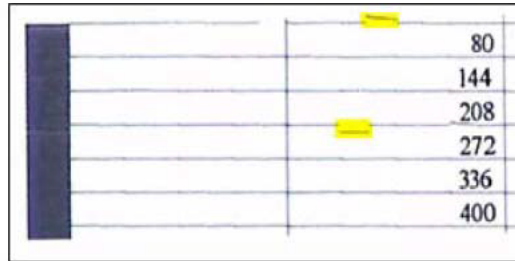

On the left of each Printhead Nozzle test, there is a series of horizontal straight lines. If one or more nozzles are misdirected there will be unequal spaces between the corresponding lines.

Corrective Action

If the printer has nozzle defects, you can still get perfect print quality results. The printer can automatically compensate for nozzle defects, so there is no need to replace the Printhead.

The method of improving Nozzle Defects is to:

- 1 Recover the Printheads, using the Front Panel Main Menu/Image Quality Maintenance/Clean Printheads option.
- 2 Reprint the Printhead Nozzles Test Plot to verify that the defective nozzles have been corrected.
- 3 If the problem continues, replace the defective Printhead.

Diagnostic Part 2: Printhead Alignment

This test is designed to check any color-to-color and bi-directional misalignment the printer may have.

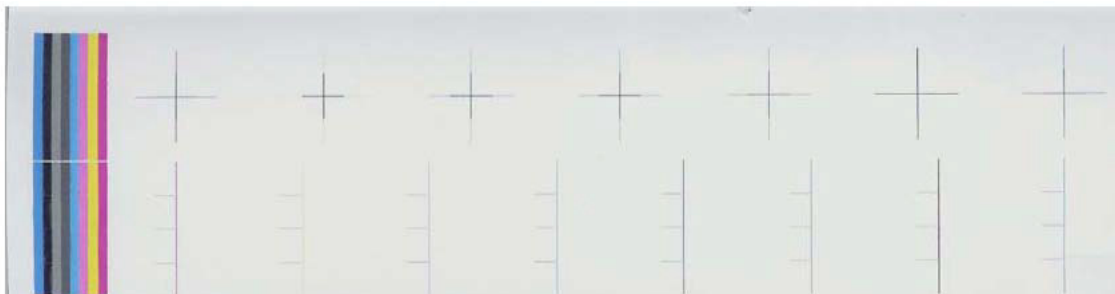

- 1 If the Printer is experiencing **horizontal** misalignment problems, the

Alignment Test will show something like this:

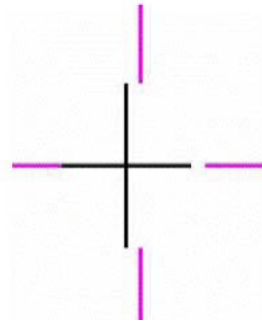

- 2** If the Printer is experiencing **vertical** misalignment problems, the Alignment Test will show something like this:

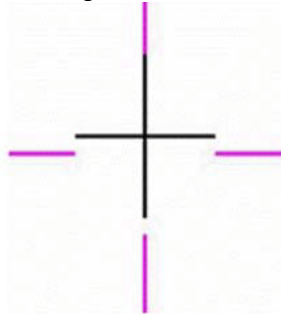

- 3** If the Printer is experiencing **bi-directional** misalignment problems, the Alignment Test will show something like this:

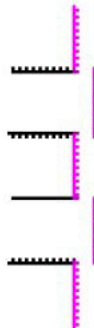

Corrective Action

Perform the Printhead Alignment (Main Menu/Image Quality Maintenance/Align Printheads), using the same paper type with which you were experiencing unacceptable image quality, if feasible (some paper types are not suitable for Printhead Alignment).

Diagnostic Part 3: Printheads & Paper Advance

This test is designed to check whether the Printheads and the Paper Advance Mechanism are working correctly. This part of the Image Quality Test should **NOT** be used to check for color consistency or accuracy.

Banding

If the Printer is experiencing a banding problem, you will see repetitive horizontal bands within the printed image.

- Darker horizontal bands or lines repeated along the vertical band (from top to bottom at the same distance).
- Whiter horizontal bands or lines along the vertical band (from top to bottom at the same distance).

The plot is printed in Best or Normal mode (according to the menu option selected) with Error Hiding ON. The top band has 100% ink density patches while the bottom band has 50% ink density patches.



Troubleshooting Banding Problems

If banding **does NOT** occur in ALL the colors, then it is more than likely a Printhead problem. In this case, try the following:

- 1 Check that the appropriate print quality settings are being used (refer to the User's Guide for more information).
- 2 Recover the printheads using the option through the Front Panel (Main Menu/Image Quality Maintenance/Clean Printheads). Reprint the Diagnostic Print or the print file and if the problem persists, replace the faulty Printhead.

If banding **does** occur in ALL the colors, then it is more than likely a Paper Advance problem:

- If the bands are light, it means that the paper has advanced too much.

- If the bands are dark, it means that the paper hasn't advanced enough.
- In high quality modes, graininess in ALL colors can indicate problems either with alignment or Paper Advance.

Corrective Action

In order to solve problems that result in banding, try the following:

- 1** Check that the appropriate print quality settings are being used (refer to the User's Guide for more information).
- 2** Check that the loaded media is the same type as selected in the printer. You can verify the media type selected through the Front Panel (Main Menu/Paper menu/View loaded paper).
- 3** If the customer is using low quality paper, try recommending better quality paper (preferably HP paper). Printer performance can only be guaranteed by using recommended papers.
- 4** Perform the Paper Advance Calibration using the same type of paper that will be used for the final print (Main Menu/Image Quality Maintenance/Paper Advance Calibration/Calibrate Paper Advance).

If there is white point banding in only one color band and the problem cannot be fixed using the Printhead recoveries, in some cases using the force a drop detection option can fix this issue. see *Force Drop Detection*, Page 1-37

No Printing Defects Found in the Diagnostic Print

If all the test patterns from the Diagnostic Print are correct and you still experience Image Quality problems, you can use the following procedures to resolve the problem.

- Reading the Advanced Diagnostic Print Results
- Visual Alignment Diagnostic
- Nozzle Health
- Force Drop Detection

If you still see Image Quality problems after performing these tests and the Diagnostic Print still looks correct, then it might be a problem with the image itself, or a software/application problem.

The Advanced Diagnostic Prints

What are the Advanced Diagnostic Prints?

Advanced Diagnostic Plot. These tests provide more information of the IQ defects found in the *Image Quality Service* plot.

The *Advanced Diagnostic Plot* is divided into the following parts:

- Visual Media Advanced Diagnostic. Used to check advance reliability.
- Visual Alignment Diagnostic. Used to check pen alignment reliability.
- Visual Nozzle health Diagnostic. Used to check nozzle health reliability.
- Force Drop Detection. Used to reset the nozzle health historic data base and force new drop detection.

Printing the Advanced Diagnostics Print

- 1 In the Service Utilities submenu, scroll to “Diagnostic Print” and press **OK**.

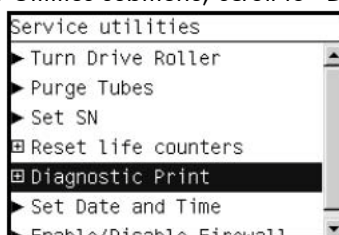

- 2 You will be given three options. Use the **Arrow** keys to select the Advanced Diagnostics menu.

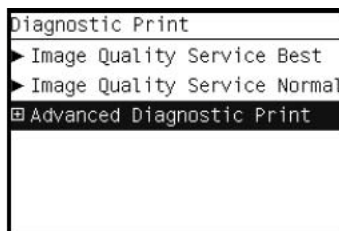

- 3 From the displayed options, use the **Arrow** keys to make the required selection Paper Advance, Visual Alignment Diagnostic, Nozzle Health, Force Drop Detection or Print Banding Plot, and press the **OK** key to start printing.

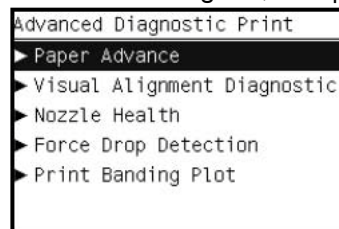

- 4 Make sure media is loaded, the Media Lever is lowered and that the Ink System is correctly installed. Press the **OK** key to print the Diagnostic Print or press **Back/Cancel** to exit without printing the Diagnostic Print.

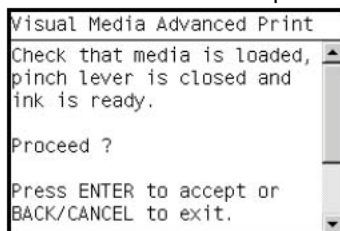

- 5 The selected Advanced Diagnostic Print will now be printed.

Reading the Advanced Diagnostic Print Results

Paper Advance

This plot helps you to visually check any alignment problems of the printer. You use it to precisely measure the media advance error with a one dot row accuracy, and to verify the stability of the media advance.

The whitest vertical line should be positioned in the 0 offset column with minor variations between +2 and -2 columns. If the offset is not positioned on the 0 column or between +2 and -2 columns and the whitest vertical varies greatly, the printer requires Paper Advance Calibration (Main Menu/Image Quality Maintenance/Paper Advance Calibration/Calibrate Paper Advance).

It is very important to verify that the loaded media is the same media type as selected in the front panel. You can verify the media type selected through the Front Panel (Main Menu/Paper menu/View loaded paper). The wrong type of paper selected will produce an offset error in the Paper Advance.

The following plot shows correct media advance, there is a straight white line positioned close to the 0 column for the majority of the points.

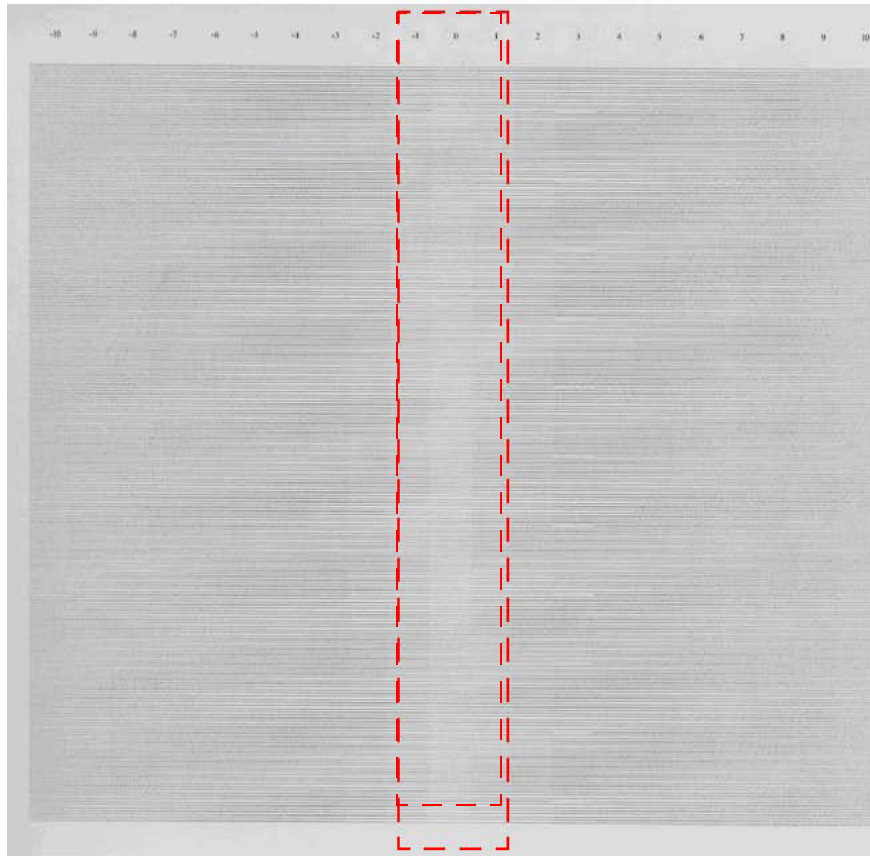

The following plot shows a bad media advance, there is a straight white line positioned close to the -6 column, instead of the 0 column for the majority of the points.



Corrective Action

To fix Paper Advance problems, try the following:

- 1 Check the Paper Advance Calibration Status. This can be done by going to Main Menu/Paper/View Loaded Paper. At the bottom, the Front Panel displays the Paper Advance Calibration status. There are three status messages:
 - **DEFAULT.** The paper loaded is recognized as HP paper, which is already optimized and calibrated for the printer. Do Not calibrate the Paper Advance for this paper.
 - **RECOMMENDED.** The paper loaded is NOT recognized as HP paper, and Paper Advance values have NOT been customized for this paper type. In this case, calibrate the Paper Advance from the user menu.
 - **OK.** This indicates that the paper loaded has been calibrated before. If the printer continues to have banding and graininess problems, calibrate the Paper Advance from the user menu.

Whenever the printer's firmware is upgraded, the paper advance calibration values will be reset to factory default.

- 2 To calibrate the Paper Advance from the user menu, go to Main Menu/Image Quality Maintenance/Paper Advance Calibration/**Calibrate Paper Advance**.

It is very important to verify that the loaded media is the same media type as selected in the front panel. You can verify the media type selected through the Front Panel (Main Menu/Paper menu/View loaded paper). The wrong type of paper selected will produce an offset error in the Paper Advance.

Some paper types are not suitable for Paper Advance Calibration. Do NOT use colored papers or transparent materials such as translucent bond, clear film, matte film, tracing paper, or vellum.

Paper Advance calibration from the user menu will only calibrate the Paper Advance for the paper type loaded in the printer at that moment.

- 3 If Calibrate Paper Advance has mostly solved the problem, try Adjust Paper Advance to fine tune the Paper Advance (Main Menu/Image Quality Maintenance/Paper Advance Calibration/**Adjust Paper Advance**).

Select the percentage of change from -100% to 100%. To correct light banding, decrease the percentage. To correct dark banding, increase the percentage.

- 4 The Paper Advance calibration from the service menu will calibrate the Paper Advance for ALL paper types. This action is recommended when:
 - The Paper Advance calibration from the user menu does NOT solve the problem.
 - The Paper Advance problems affect ALL paper types.

The procedure for Paper Advance Calibration from the service menu is documented in Chapter 5, Service Calibrations. see *Paper Advance Calibration*, Page 4-6.

Visual Alignment Diagnostic

This plot helps you to visually check any alignment problems of the printer. You use it to precisely measure the alignment error with a one dot row accuracy. For the printer to be considered correctly aligned, the results must be within ± 1 dot row.

The illustration shows the complete Printhead Alignment that identifies each of the specific alignment test results covered.

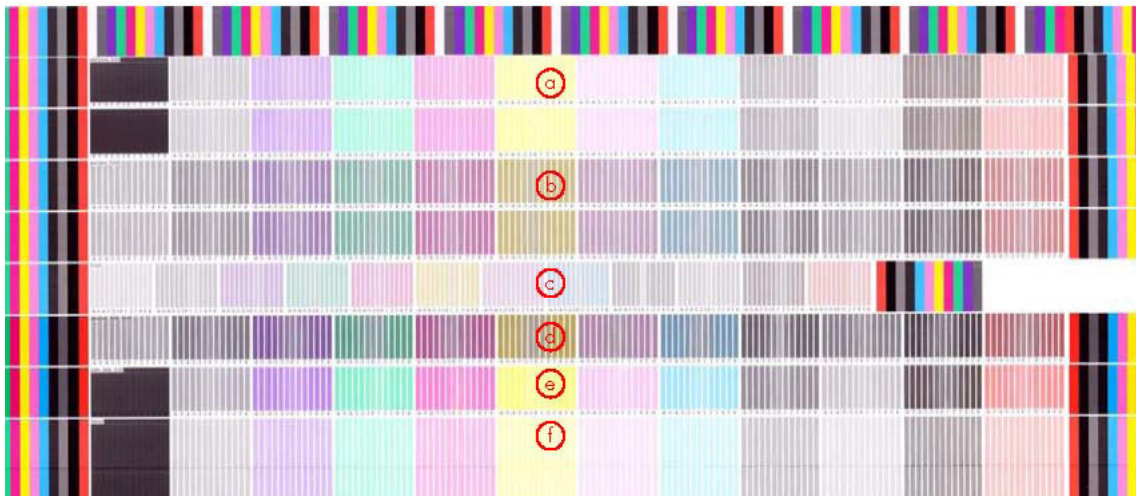

The Visual Alignment Diagnostic print shows the following diagnostic test results:

- a** odd2even_SAD: Horizontal direction in forward and reverse.
- b** pen2pen_SAD: Horizontal direction.
- c** PAD
- d** pen2pen_bidir_SAD: Horizontal bi-direction.
- e** color_bidir_SAD: Horizontal bi-direction.
- f** thetaZ and VLS: only contour part (dark bands).

Reading the Printhead Alignment Diagnostic Print

The following plot shows correct visual alignment. The lightest band is positioned on the 0 column.

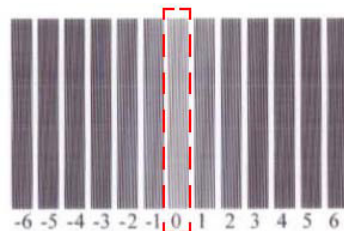

Corrective Action

For the thetaZ and VLS diagnostics the dark band of the print is the area to check. In the following example print the lightest segment of the dark band is positioned on the -1 column.

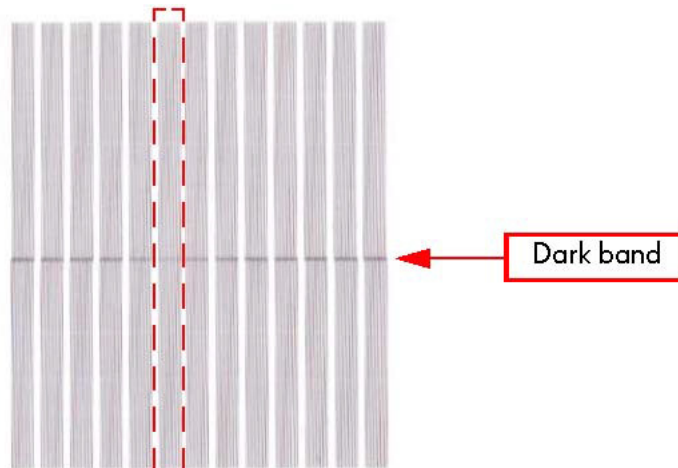

- If any of the printheads are misaligned beyond the ± 1 dot row range, perform a Printhead Alignment. see *Aligning Printheads*, Page 1-66
- If a Printhead Alignment does not correct the problem, replace the bad printhead.

If the customer is using non-HP media and after the Image Quality Test you still have the same image quality problems, change to genuine HP media and repeat the Image Quality Test. The best alignment calibration is obtained using HP Photo Paper.

Nozzle Health

The print contains three separate parts.

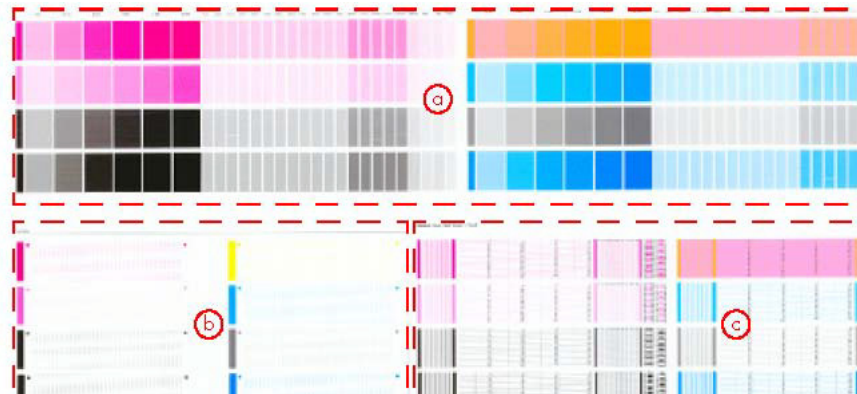

- a** The Variable Frequency Nozzle health plot with odd/even nozzles separation. This is used to detect misdirected or weak nozzles, nozzles not working correctly at all frequencies, or even Gloss Enhancer (GE) color problems.
This plot might show defects with the printheads that are not visible in the Service Image Quality Diagnostic Print. Look at the color bars and lines

to check if you see any missing parts of the plot, banding or white streak in them.

b Inspector measuring tool test plot.

Test b should NOT be used by Service Engineers.

c Nozzle Print Test which is also part of the Image Quality Service Plot. This test is designed to check that the Printhead nozzles print correctly. The test prints out every single nozzle of each Printhead. No error hiding or Printhead Alignment algorithm is applied. For each Printhead, you can see both the adjacent and the consecutive nozzles.

This is what you would see in the **Nozzle Print Test** part if there are nozzles not printing correctly:

- 1** On the right of each Printhead Nozzle test, there is a series of numbered stepped diagonal lines. If one or more of the nozzles are malfunctioning or mis-positioned, you will see that the stepped lines are broken or misdirected in one or more places.
- 2** On the left of each Printhead Nozzle test, there is a series of horizontal straight lines. If one or more nozzles are misdirected there will be unequal spaces between the corresponding lines.

Corrective Action for Nozzle Defects

If the printer has nozzle defects, it does not mean that you will not get perfect print quality results. The printer has automatic procedures to hide many nozzle defects.

- 1** Recover the Printheads using the option through the Front Panel (Main menu/Image quality maintenance/clean printheads).
- 2** Reprint the Nozzle Print test to check that the defective nozzles have been corrected.
- 3** If the problem continues, replace the defective Printhead.

Force Drop Detection

If the **Nozzle Print Test** plot has persistent white point banding in only one color that cannot be fixed with a printhead recovery, you can use this option to resolve the problem by resetting the nozzle health data base so that all nozzles are assumed to be correct.

Once the nozzle health data base has been reset drop detection is forced.

The normal cause of this white point banding in a single color is the incorrect detection of failed nozzles by the drop detector.

Troubleshooting Print Quality Problems

Print Quality General Advice

- 1 To achieve the best performance from the printer, only genuine HP accessories and supplies should be used.
- 2 Make sure that the **paper type** selected in the Front Panel is the same as the paper type loaded into the printer and selected in your software.
- 3 Make sure to use the most appropriate print quality settings for your purposes. A lower print quality is likely to be seen if the print quality slider has been moved to the **Speed** end of the scale, or the custom quality level set to **Fast**.
- 4 Check that the environmental conditions (temperature, humidity) are within the temperature/humidity range as specified for the Printer and customer substrate (refer to the User's Guide for more information).
- 5 Check that the ink cartridges and printheads have not exceeded their expiration dates.
- 6 Avoid touching the paper while printing is in progress.

Horizontal Lines Across the Image (Banding)

Description of problem

When you look at the image you have printed, there are horizontal lines across the image. Shown below is an example of what you might see if you have this problem:



Corrective Action

- 1 Check that the paper type loaded corresponds to the paper type selected in the front panel and in the software. You can verify the paper type selected through the Front Panel (Main Menu/Paper menu/View loaded paper).

- 2 Check that the appropriate print quality settings are being used (refer to the User's Guide for more information) and reprint the image. In some cases print quality problems can be resolved by selecting a higher print quality level.
- 3 In case of banding at Best print quality, try the More Passes option in the driver.
- 4 Print the Service Image Diagnostics Print, and clean any printheads that need cleaning. Reprint the job in case the problem has been solved.
- 5 Check the paper advance calibration status. If the status is PENDING, perform the Paper Advance Calibration (Main Menu/Image Quality Maintenance/Paper Advance Calibration/Calibrate Paper Advance).
- 6 After calibration reprint the job.

Lines are Missing, Too Thin, or Too Thick

Description of problem

Shown below is an example of what you might see if you have this problem:

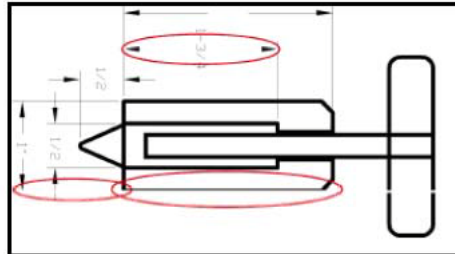

Corrective Action

- 1 Check that the paper type loaded corresponds to the paper type selected in the front panel and in the software. You can verify the paper type selected through the Front Panel (Main Menu/Paper menu/View loaded paper).
- 2 Check that the appropriate print quality settings are being used (refer to the User's Guide for more information). Select the custom print quality options in the Print dialog, try turning on the Maximum detail option. Reprint the job in case the problem has been solved.
- 3 If the resolution of the image is greater than the printing resolution, a loss of line quality may be seen. You can find the Max. Application Resolution option in the Windows driver dialog's Advanced tab, under Document Options > Printer Features. Set the Max Application Resolution to 600. Reprint the job in case the problem has been solved.
- 4 Check the Printhead alignment status. If the status is PENDING, perform the Printhead Alignment (Main Menu/Image Quality Maintenance/Align Printheads). After alignment reprint the job.
- 5 Check the paper advance calibration status. If the status is PENDING, perform the paper advance calibration (Main Menu/Image Quality Maintenance/Paper Advance Calibration/Calibrate Paper Advance). After calibration reprint the job.
- 6 Use Part 3 of the Image Quality Diagnostic Print, check if there are a significant amount of nozzles out in the color that is **actually causing** the

problem (if see you a problem with the Black color in the customer print, then only check the Black printhead in the Image Quality Diagnostic Print). If there is a significant amount of nozzles out then replace the defective Printhead.

Problems with Stepped Lines

Description of problem

When you look at the image you have printed there are **'stepped lines'** in the borders of arrows and diagonal lines. The lines should be straight with no stepping.

Shown below is an example of what you might see if you have problems with Stepped Lines:



Corrective Action

- 1** The problems may be inherent in the image that you are trying to print. Try to improve the image with the application that generated the file.
- 2** Check that the appropriate print quality settings are being used (refer to the User's Guide for more information).
- 3** Turn On the **Maximum Detail** option in the Driver. Printing speed will be reduced, and the maximum detail option sometimes causes problems like missing objects or clipped images. For most print jobs, the default resolution is highly recommended.
- 4** Change the image rendering resolution to 300 dpi or 600 dpi depending on the printing needs. You can find the Max. Application Resolution option in the Windows driver dialog's Advanced tab, under Document Options > Printer Features.

Lines are Printed Double or in Wrong Colors

Description of problem

This problem can have various visible symptoms, as shown below:

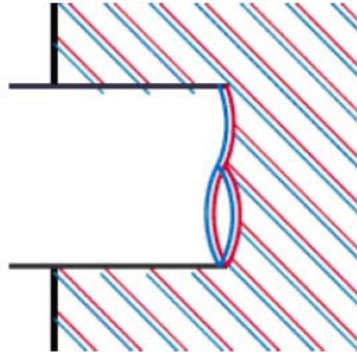

Colored lines are printed double, in different colors

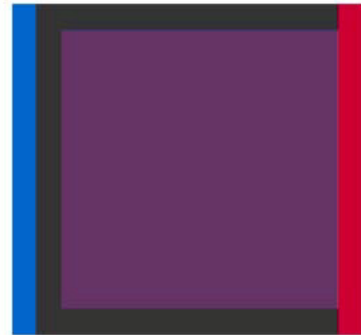

Borders of colored blocks are wrongly colored

Corrective Action

- 1 Reseat the Printheads by removing them and then reinserting them.

As you reseal the printheads, the printer will automatically align the printheads. It is important that the alignment is completed properly, see *Aligning Printheads*, Page 1-66

Lines are discontinuous

If the lines are broken in the following way:



- 1 Check that the appropriate print quality settings are being used (refer to the User's Guide for more information).
- 2 Reseat the Printheads by removing them and then reinserting them.

As you reseal the printheads, the printer will automatically align the printheads. It is important that the alignment is completed properly, see *Aligning Printheads*, Page 1-66

Lines are Blurred (Ink Bleeds from Lines)

Description of problem

This problem is often caused by the ink soaking into the paper, making the lines blurred and fuzzy. This could be because of the humidity in the air.



Corrective Action

- 1 Check that the environmental conditions (temperature, humidity) are suitable for high-quality printing.
- 2 Make sure that the **paper type** selected in the Front Panel is the same as the paper type loaded into the printer and selected in your software.
- 3 Try using a heavier paper type. When printing dense colors, it is recommended to use HP Heavyweight Coated Paper HP Super, Heavyweight Coated Paper or thicker Digital Fine Art papers.
- 4 If glossy paper is being used, try changing to a different type of glossy paper.
- 5 Select the custom print quality options in the Print dialog, and turn on the **More passes** option
- 6 Allow the prints time to dry separately; do NOT cover or stack them.
- 7 Align the printheads. see *Image Quality Maintenance Procedure*, Page 1-66.

Problems with Graininess

Description of problem

Shown below is an example of what you might see if you have problems with graininess:



Corrective Action

- 1 Check that the paper type loaded corresponds to the paper type selected in the front panel and in the software. You can verify the paper type selected through the Front Panel (Main Menu/Paper menu/View loaded paper).
- 2 Check that printing is on the correct side of the paper.
- 3 Check that the appropriate print quality settings are being used (refer to the User's Guide for more information). Select the custom print quality options in the Print dialog, and try turning on the **More passes** option. Reprint the job in case the problem has been solved.
- 4 If you are using a Z3200 series printer, you can reduce grain by turning off or reducing the amount of gloss enhancer. You can do this through the Printer Utility, see the *Users Guide* for more details.
- 5 Check the Printhead alignment status. If the status is PENDING, perform the Printhead Alignment (Main Menu/Image Quality Maintenance/Align Printheads). After alignment reprint the job.
- 6 Check the paper advance calibration status. If the status is PENDING, perform the paper advance calibration (Main Menu/Image Quality Maintenance/Paper Advance Calibration/Calibrate Paper Advance).
- 7 After Paper Advance Calibration, reprint the job.

Paper is not Flat

Description of problem

If the paper does not lie flat when it comes out of the Printer, but has shallow waves in it, you are likely to see visible defects in the printed image, such as vertical stripes. This can happen when you use thin paper that becomes saturated with ink.

Shown below is an example of what you might see if you have problems with the paper not being flat:



Corrective Action

- 1** Check that the paper type loaded corresponds to the paper type selected in the front panel and in the software. You can verify the paper type selected through the Front Panel (Main Menu/Paper menu/View loaded paper).
- 2** Try using a heavier paper type. When printing dense colors, it is recommended to use HP Heavyweight Coated Paper HP Super, Heavyweight Coated Paper or thicker Digital Fine Art papers.
- 3** Check that the environmental conditions (temperature, humidity) are within the temperature/humidity range as specified for the Printer (refer to the User's Guide for further information).
- 4** Select a paper type that is slightly thinner than the paper you have loaded; this will persuade the printer to use less ink. Here are some example paper types in ascending order of thickness:
 - Plain Paper
 - Coated Paper
 - Heavyweight Coated Paper
 - Fine Art Paper
 - Super Heavyweight Plus Matte Paper
 - Thick Fine Art Paper (>250 g/m²).

If your paper type has different versions in the front panel with more and less ink, select the one with less ink.

Print Scuffing or Scratching when Touched

Description of problem

The black ink pigment can smudge when touched by a finger, a pen, or some other object. This is particularly noticeable on coated paper, matte proofing paper, and fine art material.

Glossy paper may be extremely sensitive to damage from the basket or to anything else that it contacts soon after printing, depending on the amount of ink used and the environmental conditions at the time of printing.

Corrective Action

- 1 Handle prints carefully.
- 2 Avoid stacking prints on top of each other.
- 3 Disable the automatic cutter before printing, so that the print will not fall into the basket. Alternatively, leave a sheet of paper in the basket so that freshly printed sheets do not make direct contact with the basket.

Marks on the Media

Marks on the paper can come in a variety of forms, including horizontal smears, pinchwheel marks, starwheel marks, and ink marks on the back of the paper.

Ink marks on the back of the paper

This can happen after a lot of border less printing, especially with non-standard paper sizes. Also, loading media without skew check frequently leads to printing on the platen. Ink residues on the platen are likely to mark the back of the paper.

Corrective Action

- Clean the platen with a soft cloth. Clean each rib separately without touching the foam between the ribs.
- You can also load and unload a sheet of paper 3 times or until clean.

Horizontal Smears on the Paper

Horizontal smears on the paper occur when the printheads touch the paper and smear the image. In extreme conditions the customers print can look like the image below where the printheads have actually come into contact with the media and scraped off the ink. This problem can happen for different reasons, and will mostly depend on the following factors:

- The type of paper used
- The printmode selected

- The environmental printing conditions



Corrective Action

- 1** Whenever you notice this problem, cancel the printing job immediately. Press the **Cancel** key and also cancel the job from your computer application. Soaked paper can damage the printheads.
- 2** Check that the paper type loaded corresponds to the paper type selected in the front panel and in the software. You can verify the paper type selected through the Front Panel (Main Menu/Paper menu/View loaded paper).
- 3** Use a recommended paper type and the correct print settings.
- 4** If using sheet paper, try rotating the sheet 90 degrees. The orientation of the paper fibers may affect performance.
- 5** If you are using sheet media, load the media with skew check enabled if it is possible (skew check might not be suitable for some papers due to the way they are manufactured or cut).
- 6** If a lot of ink is used on plain or coated paper, the paper absorbs the ink quickly and expands. As the printheads move over the paper, the printheads may touch the paper and smear the image. Try using a heavier paper type, like HP Heavyweight Coated Paper, HP Super Heavyweight Coated Paper or thicker Digital Fine Art papers that can absorb ink without expanding.
- 7** Select a paper type that is slightly thinner than the paper you have loaded; this will persuade the printer to use less ink. Here are some example paper types in ascending order of thickness:
 - Plain Paper
 - Coated Paper
 - Heavyweight Coated Paper
 - Fine Art Paper
 - Super Heavyweight Plus Matte Paper
 - Thick Fine Art Paper (>250 g/m²).

If your paper type has different versions in the front panel with more and less ink, select the one with less ink.

- 8 Try to increase the margins by relocating the image to the center of the page with the software application being used.
- 9 If horizontal smearing occurs when you are using Photo Gloss or Semi-Gloss papers, try setting the carriage position to HIGH. To set the carriage position to HIGH, create a custom paper type according to the following procedure:
 - a From the HP Easy Printer Care (Windows) or HP Printer Utility (Mac OS), create a custom paper type based on the paper type that resulted in horizontal smears (for Photo Gloss or Semi-Gloss papers ONLY). For more information on creating custom paper types, see the User's Guide.

When you name the paper type, it is a good idea to use the paper's commercial name and something indicating the high carriage setting.

- b Go to **Change Printing Properties** and select the paper that you just created.
 - c Change the paper thickness to the highest setting.
 - d Select the custom paper type from the Front Panel and align the printheads (see *Aligning Printheads*, Page 1-66)
 - e Check that the custom paper type is selected from the Front Panel and perform a Color Calibration.
 - f If the customer prints with ICC profiles, create a new ICC profile.
 - g Try printing the project again using the new custom paper with the carriage position set to HIGH.
- 10 If the horizontal smearing occurs when you are using Digital Fine Art paper, the cause of the problem may be the environmental conditions. Check that the humidity and temperature are within specifications for both the printer and the paper.
 - 11 If the humidity and temperature are OK, install the Extra High PRS Wedge. The Extra High PRS Wedge increases the distance between the printhead and the paper and can help eliminate horizontal image smearing problems.

The new Extra High PRS Wedge can be ordered using Part Number Q5669-67055. For the relevant removal and installation procedures, see page 6-111.

Pinchwheel Marks

Pinchwheel marks are caused by the pressure of the Pinch Roller on the paper before printing the image. These are vertical marks that go through the entire plot and are more or less visible depending on the contents of the plot.

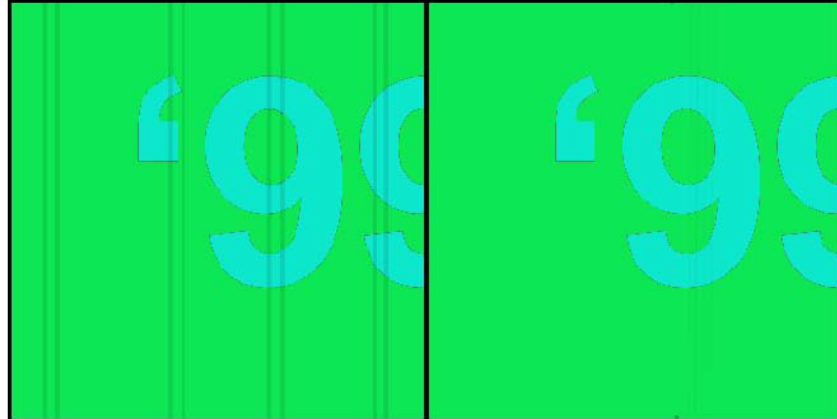

Corrective Action

- 1 The cause of the Pinchwheel marks may be the environmental conditions. Check that the humidity and temperature are within specifications for both the printer and the paper.
- 2 If the printer is a Z2100/Z3100/Z3100ps, install the new Rubber Pinchwheel Kit. The new Pinchwheels are made of rubber material, greatly improving printer performance and eliminating Pinchwheel marks.

The new Rubber Pinchwheel Kit (for the Z2100/Z3100/Z3100ps printers) can be ordered using Part Number Q5669-67060. For the relevant removal and installation procedures, see page 6-203.

The Z3200 series already uses rubber pinchwheels, so this solution does not apply to the Z3200 series.

Rear Tray Marks

Rear Tray Marks are vertical marks that appear when using thick sheet media and loading it with the rear tray path. Although they appear similar to pinchwheel marks, they are not the same and can be diagnosed:

- Rear tray marks are 3 cm wide. Pinchwheel marks are 1.5 cm wide.
- Rear tray marks are 4-10 cm apart. Pinchwheel marks only 1 cm apart.
- The texture of a rear tray mark is very irregular, whereas pinchwheel marks are more consistent.
- For a 24 inch plot, you will see 1-5 rear tray marks. For a 44 inch plot, you will see 1-9 rear tray marks. If you see more marks than that, it is likely that they are pinchwheel marks.

Corrective Action

- 1 Load the media using the roll path instead of the rear tray path. Use the black hub of the spindle to align the sheet. Even if you use the roll path, you

should specify that you are loading a sheet to avoid print quality problems.

Starwheel Marks

Starwheel marks are caused by the pressure of the starwheels on the paper just after the plot is printed. These are vertical, non-continuous marks that are more visible in dark areas of the plot..



Corrective Action

- 1 If the printer is a Z2100/Z3100/Z3100ps, install the new Starwheel Assembly (with Actuator). The new Starwheel Kit tilts the Starwheel Rail, increasing the distance between the active starwheels and the paper and reducing Starwheel marks.

The **active** Starwheels are located over the Starwheel Roller, and the **passive** Starwheels are located inside the print path. The new Starwheel Assembly (with Actuator) reduces active Starwheel marks, but does NOT reduce passive Starwheel marks.

The new Starwheel Assembly (with Actuator) (for the Z2100/Z3100/Z3100ps printers) can be ordered using part numbers Q5669-67061 (24 inch) or Q6659-67016 (44 inch). For the relevant removal and installation procedures, refer to page 6-168.

The Z3200 and Z2100 Revision C series have an automatic starwheel that can be controlled through the printer utility (Z3200) or the front panel (Z2100 Revision C).

- 2 If the printer is a Z3200/Z3200ps or Z2100 Revision C, you can raise the starwheels to the UP position semi-automatically. See the User's Guide.

- 3 For the Z2100 (revision a or b)/Z3100/Z3100ps printers, activate the UP position of the new Starwheel Assembly (with Actuator) on the left side. Slide the left actuator away from the Starwheel Assembly (the UP position).



- 4 Activate the UP position of the new Starwheel Assembly (with Actuator) on the right side. Slide the right actuator away from the Starwheel Assembly (the UP position).

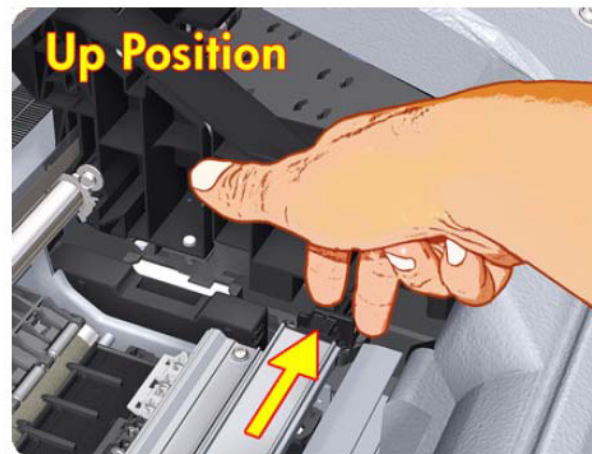

Dark Ink Marks on the Media due to cockle

They appear when the media advance is not properly controlled and so the carriage interferes with it (cockle). These marks can appear at the edges of the media (in the beginning of the plot) or at any other position in the plot.

Corrective Action

- 1 If the starwheel position has been set to HIGH with the printer utility, set the starwheel position to DOWN again (use the actuators for the Z2100/Z3100/Z3100ps, the Printer Utility for the Z3200, or the front panel for Z2100 Revision C). Although starwheel marks will be more visible, it should fix the “dark ink marks on the media” problem.
- 2 If using a roll that is close to its end, it could be that there is too much curling and it is not being well controlled by the Starwheels. A recommendation in this case would be setting the starwheel position to the DOWN position (use the actuators for the Z2100/Z3100/Z3100ps, the Printer Utility for the Z3200, or the front panel for Z2100 Revision C) and trying to remove curling

by, for example, leaving the media loaded on the machine during the night to "straighten" it.

- 3 If the problem continues after you have set the starwheel position to DOWN, the problem could be the Carriage Assembly, the Starwheel Rail, or the Starwheel End Support. Check to see if they are damaged or need to be replaced.

Problems with the Edges of objects

Stepped or not sharp

The edges of objects or lines appear to be poorly defined or lighter in density than expected.



Corrective Action

- Make sure that the Print Quality slider is set to Quality, and that More passes and Max detail are set to OFF.

Darker than expected

The edges of objects seem darker than expected.



Corrective Action

- Make sure that the Print Quality slider is set to Quality, and that More passes and Max detail are set to OFF.

Bronzing

When printing on photo paper with gray and black ink only a gloss differential problem can be encountered when light is directly reflected from the print, producing 'bronzed' reflections where ink has been laid.

Corrective Action

If the printer is a Z2100:

- Use the full set of inks option when printing greyscale images.

If the printer is Z3100/Z3200:

- If using standard print quality options, ensure that the slider is set to Quality.
- If using custom print quality options, ensure that the Gloss enhancer option is set to Whole page. You can also try Economode.
- Make sure that the correct paper type is selected in the front panel and the driver or software of the customer.

If the printer is a Z3200 only:

- -Increase the amount of gloss enhancer used.

As general advice for all models, and as last resource, display the print vertically or behind a glass.

Black and white prints do not look neutral

Consider printing in grayscale (color options submenu inside the printing preference menu). See the User's Guide for more information.

- For all printers, check that the Advanced color options for grayscale printing in the driver are not being used to modify the neutrality of the grayscale prints.
- If the customer is already printing in greyscale, and the printer is a Z2100, select "Print with Black and Grey Inks Only."

Horizontal lines at the end of a cut sheet print

There is a type of defect that only affects the end of a print, within approximately 30 mm of the trailing edge of the paper. Some very thin horizontal lines may be seen across the print.

Corrective Action

- 1 Print the Service Image Diagnostics Print, and clean any printheads that need cleaning. Reprint the job in case the problem has been solved.
- 2 Try printing with roll paper.
- 3 Try using larger margins around the image.

Vertical lines of different colors

The print has vertical bands of different colors along it.

Corrective Action

- 1 Try using a heavier paper type. When printing dense colors, it is recommended to use HP Heavyweight Coated Paper HP Super, Heavyweight Coated Paper or thicker Digital Fine Art papers.
- 2 Use higher print quality settings (refer to the User's Guide for more information).
- 3 If you have already set it to Quality, try selecting **Custom Options** and then **More Passes**.

White spots on the print

White spots are seen on the print. This is probably due to paper fibers, dust, or loose coating material.

Corrective Action

- 1 Clean the paper manually with a brush before printing, to remove any loose fibers or particles.
- 2 Always keep the cover of the printer closed.
- 3 Protect paper rolls and sheets by storing them in bags or boxes.

Problems with Color Accuracy



Corrective Action

- 1 Ensure that the paper type being used has been color calibrated, which will give color consistency from print to print, and from Printer to Printer. Check that the paper type you have loaded corresponds to the paper type selected in the front panel and in your software.
- 2 Check that printing is on the correct side of the paper.
- 3 Check that the appropriate print quality settings are being used (refer to the User's Guide for more information). Reprint the job in case the problem has been solved.
- 4 If the problem consists of color differences between your print and your monitor, please follow the instructions in the "How to calibrate your monitor" section of the HP Color Center. At this point, you may wish to reprint your job in case the problem has been solved.
- 5 If you are using application-managed colors, check that the color profile you are using corresponds to the selected paper type. If you are working with non-HP papers, you might need to create an ICC Profile. If you have doubts about which color settings to use, or you want to create an ICC profile, see the users guide.

- 6 If you select application-managed colors in your application and printer-managed colors in the printer driver, your results will be wrong. You should manage colors in the application or in the printer, but not in both.
- 7 Print the Service Image Diagnostics Print, and clean any printheads that need cleaning. Reprint the job in case the problem has been solved.

Color accuracy using EPS or PDF images in page layout applications

Page layout applications such as Adobe InDesign and QuarkXPress do not support color management of EPS, PDF, or grayscale files.

If these types of files have to be used, try to ensure that the EPS, PDF, or grayscale images are already in the same color space that is intended to be used later on in Adobe InDesign or QuarkXPress. For instance, if the final objective is to print the job in a press that follows the SWOP standard, at the time of creating the EPS, PDF or grayscale the image should be converted into SWOP.

Ink Supplies Troubleshooting

Introduction to Ink Supplies

What are Ink Supplies?

For each of the ink colors used in the printer, there are two components, the Printhead and Ink Cartridge. These components are called Ink Supplies.

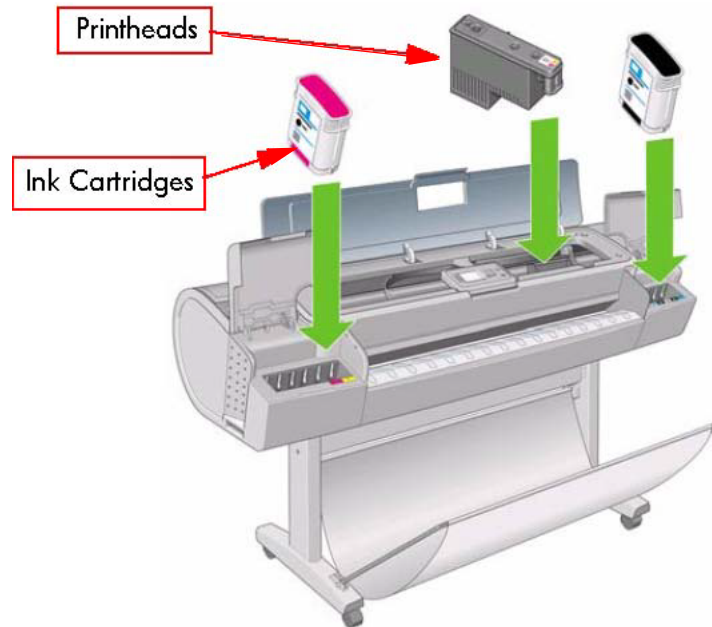

Ink Cartridges

The printer's Ink Cartridges provide ink to the Printheads. The color Ink Cartridges supplied with the printer have a capacity of 69ml but optional 130 ml cartridges are also available.

All these Ink cartridges are physically the same size. Only the internal capacity varies.



The Ink Cartridges for the Z2100/Z3100 Photo Printer series require no maintenance or cleaning. As long as each Ink Cartridge is inserted correctly into its slot, the ink will flow to the Printheads. Because the Printheads control the amount of ink transferred to the page, you will continue to see high-quality printing results even when the ink levels are getting low.

The front panel displays the status of the Ink Cartridge. Using the front panel, detailed information can be viewed regarding the Ink Cartridges.

The following tables include all the ink cartridges available for the Z2100/ Z3100 Photo Printer series.

Available Ink Cartridges

Standard		Z2100	Z3100	Z3200	Part number
HP 70	Matte Black	x	x	x	C9448A
	Photo Black	x	x	x	C9449A
	Gray		x	x	C9450A
	Light Gray	x	x	x	C9451A
	Cyan	x			C9452A
	Magenta	x	x	x	C9453A
	Yellow	x	x	x	C9454A
	Light Magenta	x	x	x	C9455A
	Red		x		C9456A
	Green		x	x	C9457A
	Blue		x	x	C9458A
	Gloss Enhancer		x	x	C9459A
	Light Cyan	x	x	x	C9390A
HP 73	Red			x	CD951A
Twin Pack		Z2100	Z3100	Z3200	Part number
HP 70	Matte Black	x	x	x	CB339A
	Photo Black	x	x	x	CB340A
	Gray		x	x	CB341A
	Light Gray	x	x	x	CB342A
	Cyan	x			C9452A
	Magenta	x	x	x	CB344A
	Yellow	x	x	x	CB345A
	Light Magenta	x	x	x	CB346A
	Red		x		CB347A
	Green		x	x	CB348A
	Blue		x	x	CB349A
	Gloss Enhancer		x	x	CB350A
	Light Cyan	x	x	x	CB351A
HP73	Red			x	CD952A

Printheads

The Printheads are extremely durable and do not need to be replaced every time an Ink Cartridge is replaced. They are independent of the Ink Cartridges and will continue giving excellent image quality results even if the

Ink Cartridges are low on ink.

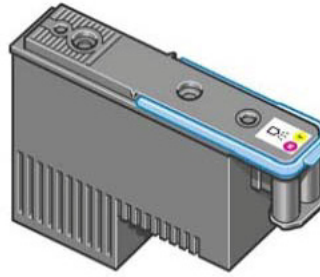

If you notice a decline in print quality such as lines or dots missing from text/graphics, go to Page 1-20, *Print Quality Troubleshooting*.

Available Printheads

Standard		Z2100	Z3100	Z3200	Part number
HP 70	Matte Black/ Cyan	x			C9448A
	Light Magenta/ Light Cyan	x	x	x	C9449A
	Magenta/ Yellow	x	x	x	C9450A
	Photo Black/ Light Gray	x	x	x	C9451A
	Blue/Green		x	x	C9452A
	Matte Black/ Red		x		C9453A
	Gloss Enhancer/Gray		x	x	C9454A
HP 73	Matte Black/ Red			x	CD949A

General Information About the Ink Supplies

For optimum results from the printer and modular ink delivery system always follow these guidelines when handling the ink supplies:

- Always install the Ink Cartridges and Printheads before the expiration date, which is on the packaging.
- Install Ink Cartridges and Printheads in their color-coded slots.
- Follow the instructions on the front panel of the Printer during installation.
- Avoid unnecessary removal of the Ink Cartridges and Printheads.
- When turning off the Printer always use the power Off button on the front panel. The Printheads are then stored correctly which prevents them from drying out.
- The Ink Cartridges should never be removed while the printer is printing. They should only be removed when the printer is ready for you to replace them. The front panel will guide you through the removal and installation

procedure.

General Precautions When Handling Ink Supplies

Use the following precautions when handling Ink Supplies:

Do not touch, wipe or attempt to clean the printhead nozzles. This can damage the printhead.

- Handle the ink supplies with care. In particular the Printhead, which is a high precision device and must be handled carefully.
- Do not touch the Printhead nozzles.
- Do not put the Printhead down on the nozzles.
- Do not be rough when handling the Printheads. Always set them down gently.
- Do not drop the Printheads.
- Proper handling will assure optimum performance throughout the Printhead life.
- Do not touch the end of the Ink Cartridge which is inserted into the printer as there may be a small amount of ink on the connection.
- Avoid storing partially used Ink Cartridges on their ends.

When Should You Replace the Ink Supplies?

When to change the ink supplies is mostly determined by you with guidance from the front panel. In conjunction with the messages displayed in the front panel and the message explanations in this chapter, you will be able to choose for yourself when is the right time to change the ink supplies.

The Printer will also display the ink level and will tell you when the ink supply is low on ink. This means you have constantly updated information about the ink supplies.

Ink Cartridge Levels, Information, and Replacement

Ink Cartridge Levels

Trough out this chapter all the example Front Panel screens are for the Z2100 Photo Printer unless otherwise stated.

The front panel displays Ink Levels shown as level bars. These bars represent how much ink is remaining in the Ink Cartridges: as ink is used up the bars get shorter in length.

There are two methods for checking the ink levels of your Ink Cartridges.

“View Ink Levels” Direct Access Key

- Pressing the “View ink levels” direct access key on the Front Panel will immediately show you the ink levels. For more information about direct

access keys, see *Using the Front Panel*, Page 1-3

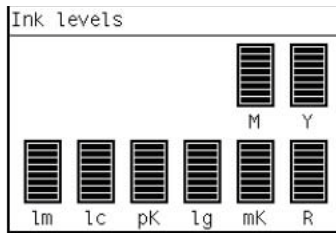

“View Ink Levels” from the ink menu

- Choosing the **View ink levels option** from the Ink menu will immediately show you the ink levels:

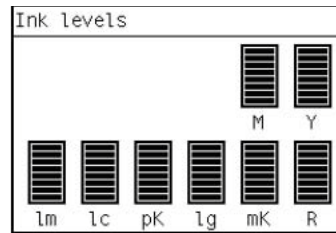

Obtaining Ink Cartridge Information

- 1 Scroll to the Ink Menu icon and press **OK**.



- 2 In the Ink Menu submenu, scroll to **Ink cartridge information** and press **OK**.

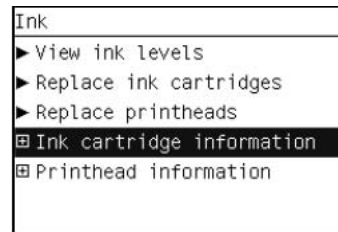

- 3 In the Ink Cartridge Information submenu, scroll to the Ink Cartridge that you want information on and press **OK**.



- 4 The front panel displays information on the selected Ink Cartridge. Use the **Arrow** keys to scroll through the information.

```

R ink cartridge
Color: Red
Product name: HP 70
Product number: C9444A
Serial number: 3488360-10-
10
Status: OK
Ink level: 43 ml
Capacity: 69 ml
    
```

```

R ink cartridge
Status: OK
Ink level: 43 ml
Capacity: 69 ml
Expiration date: Sep 18,
2009
Warranty status: In
warranty
Manufacturer: HP
    
```

The information supplied is:

- The make of the Ink Cartridge (hp no.70/73 is recommended).
- The product number of the Ink Cartridge.
- The serial number of the Ink Cartridge.
- The current status of the Ink Cartridge.
- The current ink level of the ink cartridge in milliliters.
- Original capacity of the ink cartridge in milliliters.
- The manufacturer of the Ink Cartridge (hp is recommended).
- The current warranty status of the Ink Cartridge.

Changing an Ink Cartridge

There are two occasions when you need to remove an ink cartridge:

- The ink cartridge is very low and you want to replace it with a full cartridge for unattended printing (you can use up the remaining ink in the first cartridge at a more convenient time).
- The ink cartridge is empty or faulty, and you must replace it to continue printing.

Do not try to remove an ink cartridge while printing. Remove an ink cartridge only if you are ready to insert another one. Make sure the printer wheels are locked (the brake lever is pressed down) to prevent the printer from moving.

Change an ink cartridge using the following procedure:

- 1 Scroll to the Ink Menu icon and press **OK**.

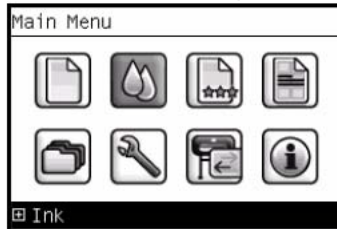

- 2 In the Ink Menu submenu, scroll to **Replace ink cartridges** and press **OK**.

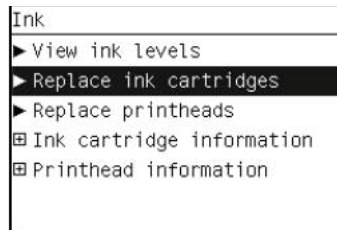

- 3 The front panel displays the status of the Ink Cartridges.

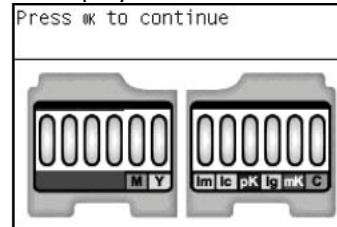

- 4 Press **OK** to continue.
- 5 Open the relevant Ink Cartridge cover for the Ink Cartridge you want to replace.
- 6 Pull the required Ink Cartridge straight up to remove it from the printer.
- 7 The front panel indicates the missing Ink Cartridge.

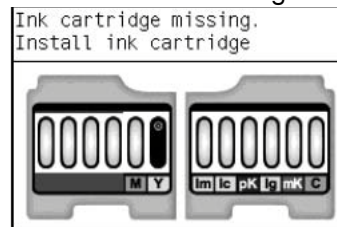

- 8 Before removing the cartridge from its wrapping, shake it vigorously.
- 9 Unwrap the new ink cartridge, find the label identifying the ink color. Check that the letter or letters marking the empty slot, matches the letter or letters on the cartridge label.
- 10 Insert the ink cartridge into its slot.

- 11 Push the cartridge into the slot until it snaps into position. You should hear a beep and see confirmation that the cartridge has been inserted.

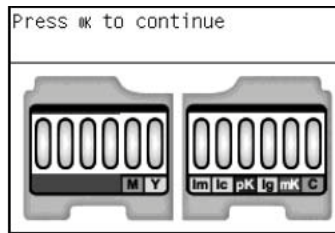

- 12 When all cartridges have been inserted, close the cover.

Printhead Information, Replacement and Alignment

Obtaining Printhead Information

- 1 Scroll to the Ink Menu icon and press **OK**.



- 2 In the Ink Menu submenu, scroll to **Printhead information** and press **OK**.

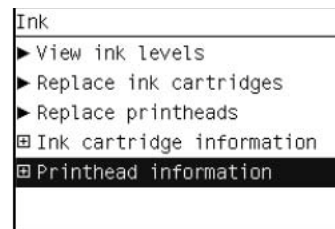

- 3 In the Printhead Information submenu, scroll to the Printhead that you want information on and press **OK**.

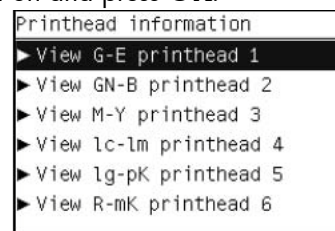

- 4 The front panel displays information on the selected Printhead.

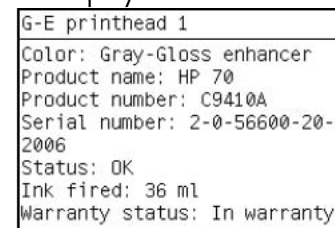

The information supplied is:

- The make of the printhead (hp no.70/73 is recommended).
- The product number of the Printhead.
- The serial number of the Printhead.
- The current status of the printhead.
- How much ink has been fired (consumed) by the printhead. **Note:** It is possible for a printhead to consume more than one Ink Cartridge.
- The current warranty status of the Printhead.

Changing a Printhead

- 1 Scroll to the Ink Menu icon and press **OK**.

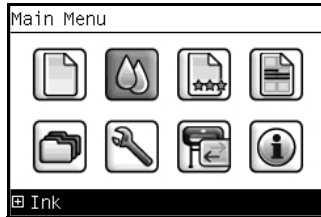

- 2 In the Ink Menu submenu, scroll to **Replace printheads** and press **OK**.

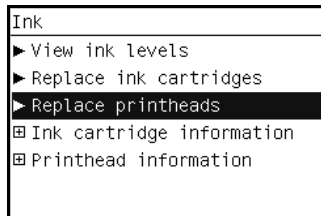

- 3 The printer moves the Carriage to the correct position to replace Printheads.

If the carriage is left in the removal position for more than three minutes without inserting or removing any printheads, it will try to move back to its normal position at the right-hand end.

- 4 When the carriage has stopped moving, the front panel display will prompt you to open the window and lift the carriage cover.

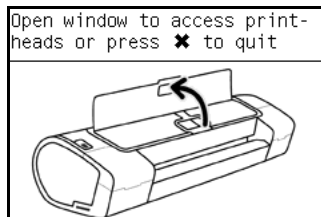

- 5 Open the window.
- 6 Lift the Carriage cover to access the printheads.

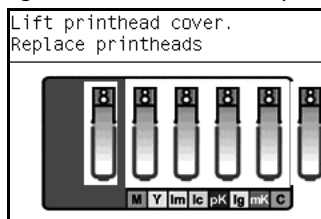

- 7 Lift the blue handle and pull the Printhead straight up out of the Carriage.
- 8 To insert a new printhead first remove the orange protective caps.

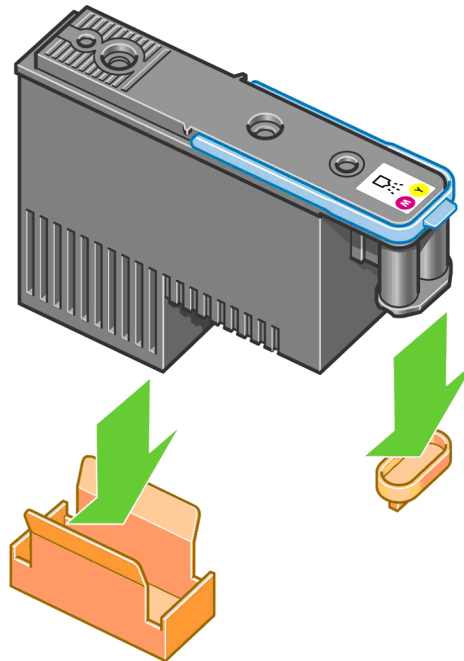

- 9 The printhead is designed to prevent you from accidentally inserting it into the wrong slot. Check that the colored label on the printhead matches the colored label of the carriage slot into which the printhead is to be inserted. Insert the printhead slowly and vertically, straight down. It may be damaged if you insert it too fast, or at an angle, or if you rotate it as you insert it.
- 10 Insert all other printheads that need to be installed, and close the carriage cover.

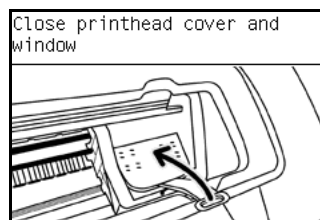

- 11 Close the Window.

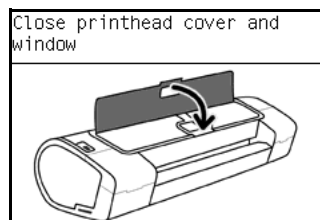

- 12 When all the printheads have been inserted correctly and accepted by the printer, the printer will beep. If the printer does not beep when you insert the printhead and the **Replace** message appears on the front panel display, the printhead may need to be reinserted. The front panel display confirms that all printheads are correctly inserted.

The printer will start checking and preparing the printheads. The default routine process, when all printheads are changed, takes 25 minutes. If the printer finds problems in preparing the printheads, it will take longer, up to 55 minutes. For a single printhead insertion, the times vary between 15 and 35 minutes. After all printheads are checked and prepared, for the printhead realignment.

Aligning Printheads

Precise alignment between printheads is essential for accurate colors, smooth color transitions, and sharp edges in graphical elements. Your printer has an automatic printhead alignment process which runs whenever a printhead has been accessed or replaced.

In cases where the paper has jammed, you have used a custom paper, or are experiencing problems with color accuracy you may need to align the printheads. If the paper has jammed, it is recommended that you reinsert the printheads and initiate the realignment procedure with the Image Quality Maintenance menu.

Do not use transparent and semi-transparent paper to align the printheads. Photo paper is recommended for the best quality, and roll or sheet media loaded with skew check is preferable to loading media without skew check. If possible, always avoid loading media without skew check.

Reinsert Printheads Procedure

- 1 If the realignment process is running and the wrong paper is loaded, press the cancel key on the front panel. Do not print if the realignment process has been canceled. You can restart the alignment with the Image Quality Maintenance menu procedure.
- 2 Load the paper you wish to use,. You can use a roll or cut sheet, however, it must be A3 landscape or larger.
- 3 Remove and re-insert all the printheads, see Remove a printhead and Insert a printhead. This will start the printhead alignment procedure.
- 4 Ensure the transparent window closed, as a strong light source near the printer during printhead realignment can affect alignment.
- 5 The process will take about six minutes. Wait until the front panel display shows the process complete before using the printer.

Image Quality Maintenance Procedure

- 1 Load the paper you wish to use. You can use a roll or cut sheet, however, it must be A3 landscape or larger (420 by 297 mm). Do not use transparent and semi-transparent paper to align the printheads. Photo paper is recommended for the best results; plain, bond and thin coated papers provide acceptable but marginal results.
- 2 Press the Menu key to return to the main menu and select the Image Quality Maintenance menu icon.
- 3 Select Align printheads. The printer will check to see if it has enough paper to run the realignment.

- 4 If the loaded paper is satisfactory, the printer will run the realignment and print a realignment pattern. Ensure the transparent window is closed, as a strong light source near the printer during printhead realignment can affect alignment.

Z3100/Z3100ps/Z3200ps Plot:

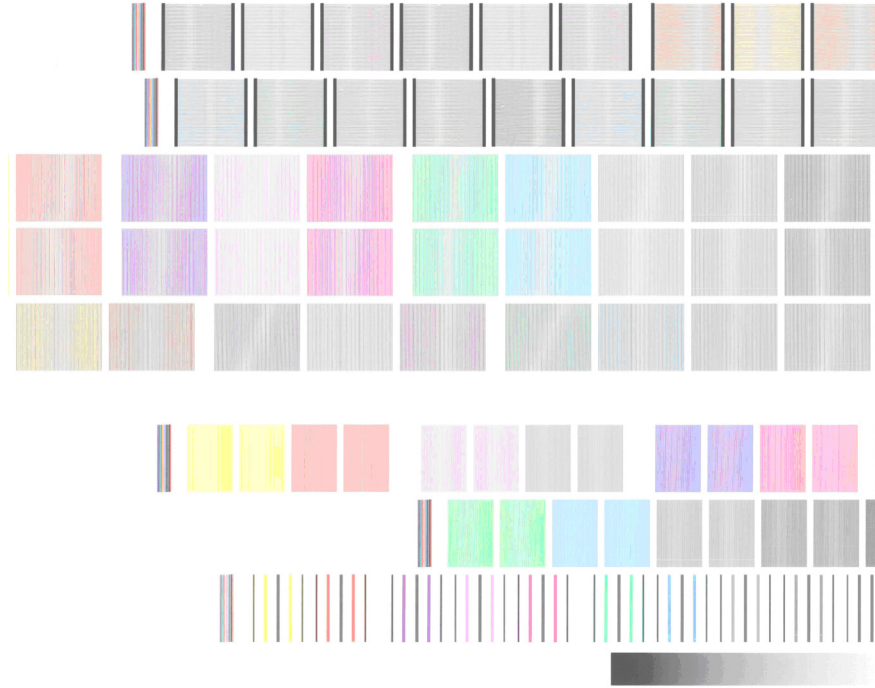

Z2100 Plot:

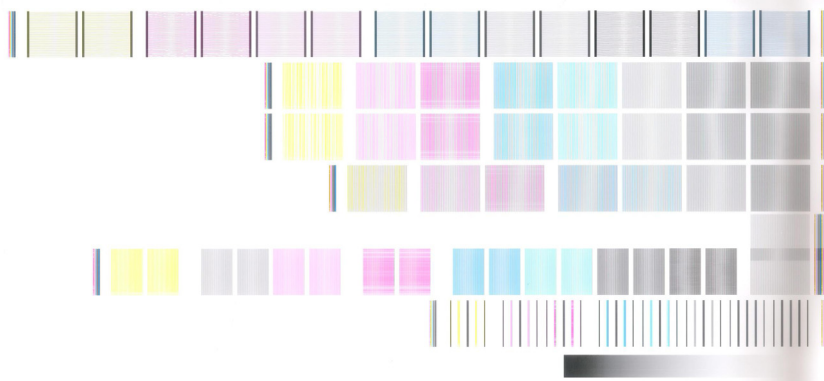

- 5 The process will take about five minutes. Wait until the front panel display shows the process complete before using the printer.

Scanning errors during alignment

If the alignment process FAILs, a scanning problems message appears on the front panel. This means that the alignment has not completed successfully. Therefore the printer is not aligned and the alignment should be repeated before printing with good image quality. The problem may be due to:

- The paper used was not valid, repeat the alignment with valid paper.

- Printhead health problems, clean printheads.
- The alignment was done with the transparent window open, repeat the alignment with the window closed.

If the problem persists after using valid paper, cleaning the printheads, and keeping the window closed, there may be a Failure in the scanning system needing reparation or the printheads, although clean, may not work and need to be replaced.

Ink Cartridge and Printhead Status Messages

Ink Cartridge Status Messages

OK	The Ink Cartridge is operating correctly and no action is required.
Missing	There is no Ink Cartridge present, or it is not properly connected to the printer
Low	The Low message is an early warning sign and it is advisable that new supplies should be obtained of that particular color. The amount of ink remaining in the Ink Cartridge depends on it's capacity, but there is approximately 14% of ink available for the user.
Very Low	When the Very Low message is displayed, overnight printing should not be attempted. Changing the Ink Cartridge is strongly recommended to prevent the printer from stopping halfway through a print. There is approximately 8% of ink available for the user.
Empty	The printer will stop and will not be able to continue printing until a new Ink Cartridge has been installed. If this occurs halfway through printing an image, you should check the quality of this image, as stopping mid-plot can affect the print. It would be recommended to reprint the image once a new Ink Cartridge has been installed.
Reseat	You are recommended to remove the Ink Cartridge and then reinsert it.
Replace	You are recommended to replace the Ink Cartridge with a new Ink Cartridge.
Altered	There is something unexpected about the Ink Cartridge's status.
Expired	The Ink Cartridge has passed the expiration date.

Printhead status messages

OK	The Printhead is operating correctly and no action is required.
Missing	There is no Printhead present, or it is not properly connected to the printer.
Test printhead separately	You are recommended to test the printheads individually to find the failing printhead. Remove all the printheads and insert them alone one by one, Closing the latch and the carriage cover after every insertion. The front panel display will indicate the failing one showing the reseat or replace message.

Reseat You are recommended to start the printhead removal process from the front panel, but instead of removing the printhead, simply press the OK key on the front panel.

Replace You are recommended to remove the printhead and then reinsert it; if that fails, clean the electrical connections; if that fails, replace the printhead with a new printhead.

Replacement incomplete A printhead replacement process has not completed successfully, relaunch the replacement process and let it finish completely (it is not needed to change the printheads).

Remove The printhead is not a suitable type for use in printing (for instance, a setup printhead).

Printhead Error Codes

The following table describes the Printhead Error Codes. Refer to the above descriptions of the status messages for the appropriate action.

Error Code	Status Name	Status Message	Description	Comments
0	Working	OK	The printhead is working properly	
1	Fails Logical V	Replace	The printhead may have a vcc short	
2	Fails Continuity	Reseat		Could be caused by bad insertion. Better to reseat the PEN than to reject it.
4	Shutdown		Not used	
8	Fails Vpp	Replace	Suspected vpp ink short	
16	Temp Extremely High	Replace	Printhead temperature above normal margins	Could be caused by a short in the ink supplies
32	Temp Extremely Low	Reseat	Printhead temperature below normal margins	Could be caused by bad Vpp continuity
64	Temp too High	Replace	Printhead temperature above normal margins	Could be caused by a short in the ink supplies
128	Temp too Low	Reseat	Printhead temperature below normal margins	Could be caused by bad Vpp continuity
256	Bad Acumen Info	Replace	Critical acumen info outside margins	Printhead has a manufacturing problem

Error Code	Status Name	Status Message	Description	Comments
512	No Pen	Missing	There is no printhead	
1024	Bad Accumen Access	Reseat or Test Separately	Accumen cannot be accessed	Bad accumen continuity or a short; Cannot identify problem printhead
2048	Wrong Model	Replace	Wrong printhead inserted	Mechanical lockouts should prevent this. Error is redundant.
4096	Mismatch	Replace	Wrong color inserted	Mechanical lockouts should prevent this
8192	CSdata Not Responding	Reseat	CSdata communication failed	Could be caused by bad insertion
16384	CSdata Transmit Error	Reseat	CSdata communication incorrect	Could be caused by bad contact
32768	Fails Energy Calibration	Reseat	Energy calibration failed	Could be caused by bad contact
65536	Empty Dummy	OK during Purge		Requested during purge, otherwise should be removed
131072	Full Dummy	Remove		Requested during purge
262144	End of Life	Warning	Printhead warranty expired	
524288	Expired	Warning	Printhead has used expired or non-HP ink	

Solving Ink Supplies Problems

Most of the problems that you could encounter when working with the ink supplies are solved with guidance from the front panel. A full list of front panel messages are supplied in the User's Guide.

You Cannot Insert the Ink Cartridge Into the Printer

- 1 Ensure that you have the correct cartridge number for your printer. Z2100/ Z3100 printers use hp no.70 supplies, while the Z3200 uses hp no70 supplies for all colors except red, which is no.73.
- 2 Ensure that the Ink Cartridge is the correct color for that slot.

- 3 Ensure that the Ink Cartridge is the correct orientation, with the color coded label at the top.

Never clean inside the Ink Cartridge slots as this can cause damage to the Printer.

You Cannot Insert the Printhead Into the Printer

- 1 Ensure that you have the correct cartridge number for your printer. Z2100/Z3100 printers use hp no.70 supplies, while the Z3200 uses hp no70 supplies for all colors except red, which is no.73.
- 2 Ensure that the printhead is the correct color for that slot.
- 3 Ensure that the printhead is in the correct orientation.
- 4 Ensure that the protective cap is removed from the Printhead.

The front panel says to reset or replace a printhead

- 1 From the front panel, turn the power off then on.
- 2 Check the front panel display message, if it shows the ready message, the printer is ready to print. If the problem remains continue with the next step.
- 3 Remove the printhead.
- 4 Clean the electrical connections on the backside of the printhead with a lint free cloth. You can carefully use a mild rubbing alcohol if moisture is needed to remove residue. Do not use water. You can use the Flex Contacts Cleaning Tool.

This is a delicate process and may damage the printhead. Do not touch the nozzles on the bottom side of the printhead, especially not with any alcohol.

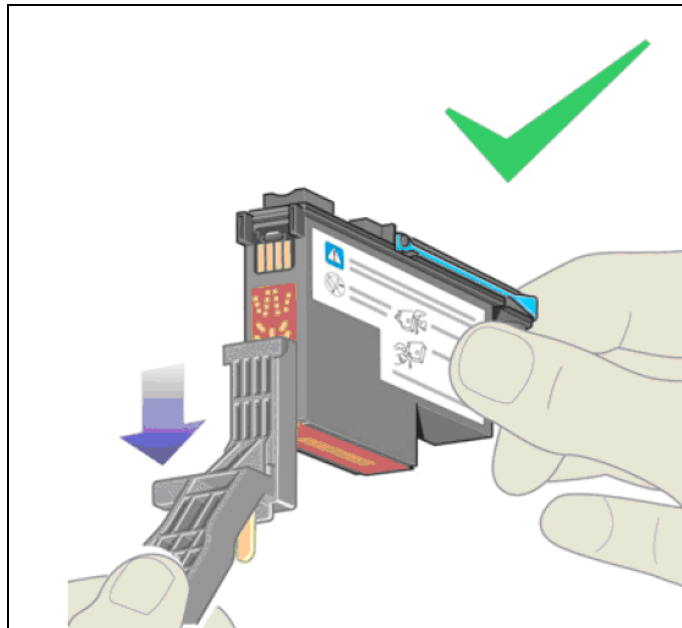

- 5 Reinsert the printhead.
- 6 Check the front panel display message. If the problem remains, try a new printhead.

Maintaining and Cleaning the Printheads

Clean the printheads

As long as the printer is kept turned on, an automatic cleaning is performed periodically. This ensures there is fresh ink in the nozzles and prevents nozzle clogs, which ensures color accuracy.

If you have not already done so, please refer to Horizontal lines across the image (banding) and The Image Diagnostics Print before proceeding.

To clean the printheads, press the Menu key to return to the main menu and select the Image Quality Maintenance menu icon, then Clean Printheads. If you have gone through the Image Quality Diagnostic print process, you know which colors are failing. Select to the pair of printheads which contain the failing colors. If you are not sure which colors to clean, you can also select to clean all printheads.

Cleaning all printheads takes about nine minutes. Cleaning a single pair of printheads takes about six minutes. Cleaning all printheads uses more ink than cleaning a single pair.

If you have cleaned the printheads using the Clean printheads procedure from the front panel and are still experiencing image quality problems, you can try cleaning the printhead nozzles manually using the following procedure.

This is a delicate process and may damage the printhead. Do not touch the electrical connections on the backside of the printhead.

You must remove the printhead (see Remove a printhead) and using a cotton swab and a little de-ionized, distilled water, or Flex Contacts Cleaning Tool clean the bottom of the printhead until the residue is removed.

Flex Contacts Cleaning Tool

The Flex Contacts Cleaning Tool is part of the Maintenance Tool Kit which can be ordered using Part Number Q5669-60690. All the instructions needed to use the Flex Contacts Cleaning Tool will be packaged with the kit.

Whenever you replace the Printhead, check the empty slots to see if they need cleaning. In extreme circumstances, when a Printhead is inserted, it is possible that the Printer will not recognize it due to the build-up of ink on the electrical connection between the Printhead and the Carriage Assembly.

The flex contacts cleaning tool is available as a service part for the Z2100/Z3100 Photo Printer. It contains replacement sponges and an instruction sheet, and should be used for cleaning the electrical interconnects of both the Carriage Assembly and the Printhead.

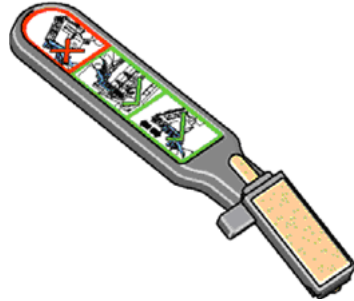

If the front panel displays the message “Reset” or “Replace” next to the offending printhead, try cleaning the flex circuits of the Carriage and the Printheads using the Flex Contacts Cleaning Tool.

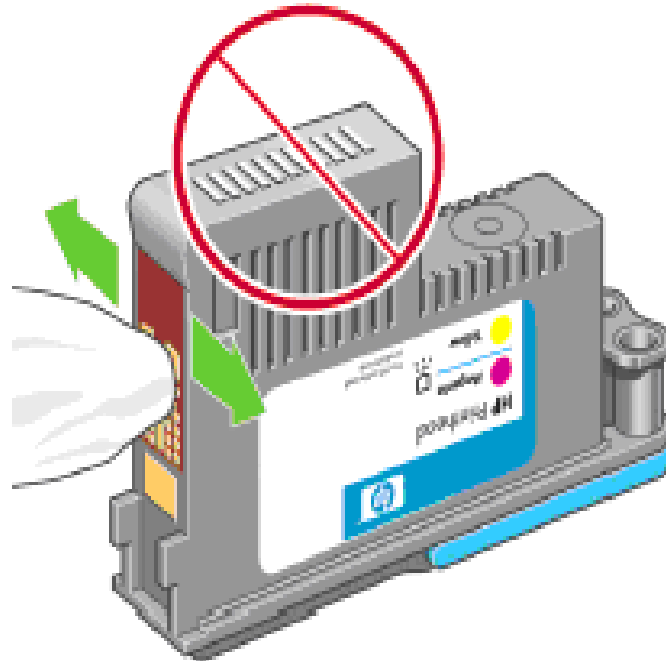

Do not touch, wipe or attempt to clean the printhead nozzles. This can damage the printhead and reduce print quality.

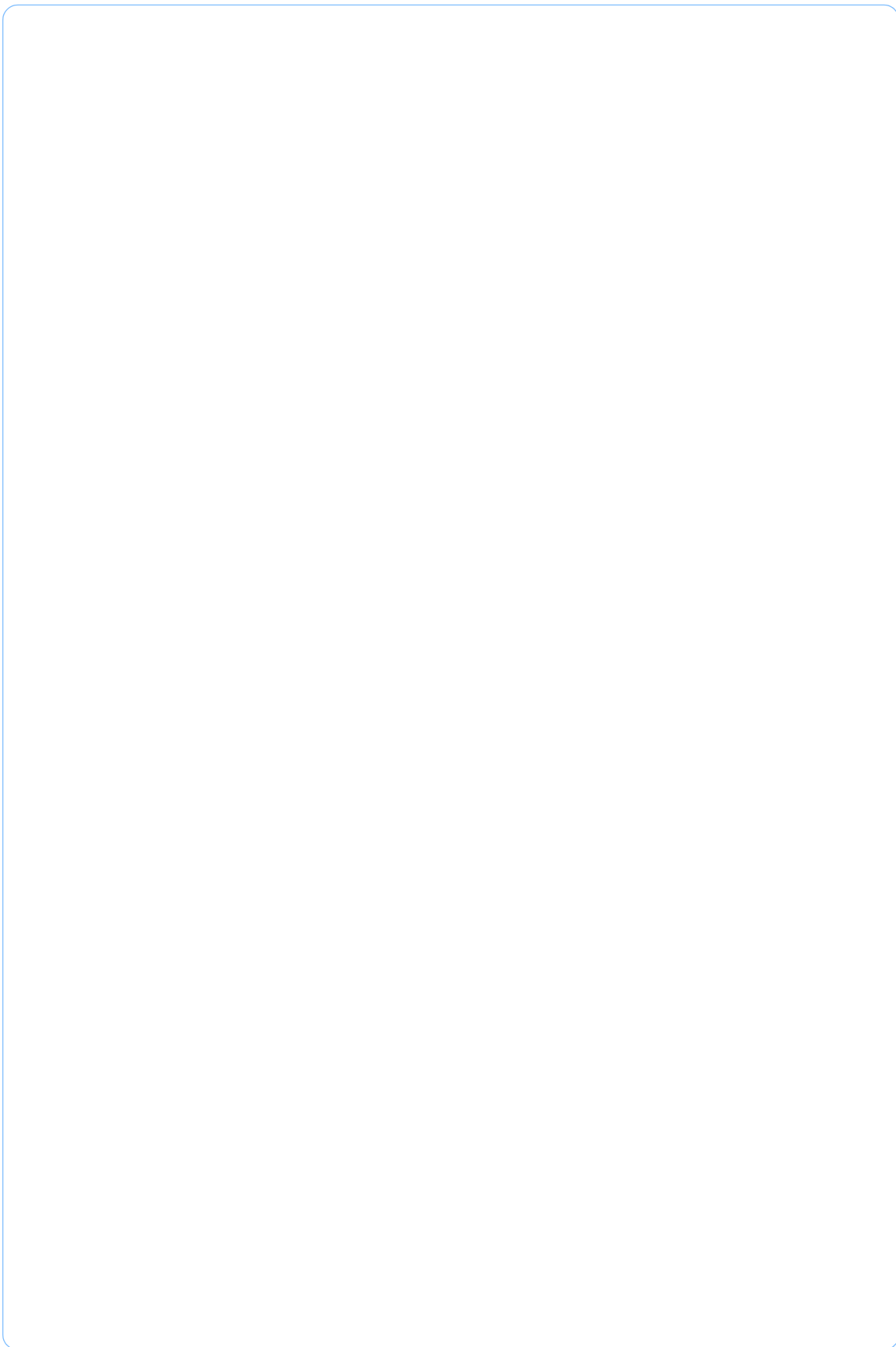



System Error Codes

2

- Introduction 2-2
- Continuable and Non-Continuable Error Codes 2-2
- System Error Code Brief Descriptions 2-3
- System Error Codes - Full Descriptions 2-7

Introduction

System error codes are hexa-decimal based numbers generally caused by internal system errors. The following pages contain a list of system error codes and their respective descriptions and recommended corrective actions. Only try one recommended action at a time and check if the error code has disappeared.

If you have an error code which is not documented in this Service Manual or you have an error which you cannot resolve, then report the error to the HP Response Center or the nearest HP Support Office. When reporting the error, have the following information ready:

- Model and Serial Number of the printer.
- Which firmware revision the printer is using (See Note below). Check firmware in *Setup Menu / Information Menu / Show Printer Information*.
- The complete error number (See Note below).
- The Service Configuration Print.
- The Current configuration sheet.
- Which software application the customer is using (name, version, etc.).

When reporting the System Error Code, make sure that you supply the full Internal Error Code and the firmware version. Without this information, HP Support Personnel cannot help you. To view the Internal Error Code, hold the UP key and press the CANCEL key at the same when the System Error.

Code is displayed on the Front Panel.

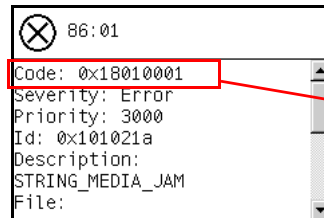

This is the code definition required when escalating a problem

Continuable and Non-Continuable Error Codes

Some of the Error Codes are continuable, which means you can press **OK** on the front-panel and continue working with the Printer. Non-Continuable Error Codes do not allow you to continue working with the Printer, in this case power the Printer OFF and ON again and see if the System Error disappears. If the Error Code reappears, then the Printer requires an on-site visit in order to resolve the problem.

Even though the customer can continue working with a Continuable Error Code, an on-site visit should still be planned to troubleshoot the problem.

System Error Code Brief Descriptions

Reading a System Error Code

System Error Codes explain which component/system is failing and what action should be taken to resolve the problem.

System Error Codes are displayed directly on the front panel (but can also be seen on the Information Page) and have been defined in the format **XX.YZ**, or **XX.n:YZ.m**.

- **XX**: Can be a malfunctioning subsystem or process (2 digits).
- **n**: Subsystem or process Index (if more than one used in the product) - Optional.
 - e.g. Identify the Ink Supply (color and number).
- **Y**: Who should perform the action (1 digit) - (0 for User or 1 for Service Engineer).
- **Z**: Action to perform (1 digit).

System Error Code Table

The following table explains the **XX** part of the System Error Code or Warning:

Code	Component/System
01.0	Main PCA/Electronics module
01.1	Add-on Electronics module (printmech)
01.2	Print Mech PCA
01.3	Right Ink Supply Station
02.1	Carriage PCA
03	Power supply
06	Formatter
08	Formatter, Front panel
11	Trailing cable
21	Service station
21.1	Service station
22.0	Bongo error BPS0 (ISS Left)
22.1	Bongo error BPS1 (ISS Left)
22.2	Bongo error BPS2 (ISS Right)
22.3	Bongo error BPS3 (ISS Right)
24	Tube assembly (IDS)
26.n	Ink Cartridge (color = n)
27	Printhead error
31	Cutter

Code	Component/System
38	Output Tray
41	Paper-axis motor
41.1	Paper-axis motor
42	Scan-axis motor
44	Aerosol fan
47	Star wheel motor
48	PPS mechanism
51	Window Sensor
52	Drop detector
55	Line sensor
56	Drive roller analog encoder sensor
58	Color sensor (ESP)
61	Error job
62	PC Interface
63	Input/output through LAN card
64	Input/output through USB port
65	Input/output (not known what port)
66	Input/output (not known what port)
67	Input/output through FireWire port
68	Loss of engine counters tracking
71	Memory management
71.19	PrintMech PCA/Formatter
72	Firmware error
73	Servo
74	Firmware upgrade
74.1	Media Profile Update
75.1	Preventive Maintenance kit #1
75.2	Preventive Maintenance kit #2
75.3	Preventive Maintenance kit #3
76	Disk Full
77	Web access application
78	Borderless
78.1	Media Settings
79	Assertion (uncontrolled FW error)
79.1	Recoverable Firmware Error
81	Media advance
81.1	Media advance
84	Roll Feed

Code	Component/System
85	Media-axis encoder reading
86	Carriage Movement
87	Scan-axis encoder reading
93	Ink Pumping
94	Color calibration
94.1	Profiler
95	Printhead alignment
97	Paper advance calibration

Corrective Actions Table

The following table explains the **YZ** part of the System Error Code or Warning:

Code	Recovery Action	Response
00	Replace	Possible for customer to perform action
01	Reseat/Reconnect/Clean/Adjust (manually)	
02	Calibrate/Adjust (using Automatic Process)	
03	Power OFF and Restart the Printer	
04	Upgrade System Firmware	
05	Upgrade Driver or Computer Software	
06	Add Accessory	
07	Escalate	
08	Send Plot Again	
09	Wrong Part Installed	

Code	Recovery Action	Response
10	Replace	hp qualified personnel assistance required
11	Reseat/Reconnect/Clean/Adjust (manually)	
12	Calibrate/Adjust (using Automatic Process)	
13	Power OFF	
14	Upgrade System Firmware	
15	Upgrade Driver or Computer Software	
16	Add Accessory	
17	Escalate	
18	Send Plot Again	
19	Wrong Part Installed	

System Error Codes - Full Descriptions

This section describes each of the system error codes and warnings that could be encountered while using the printer and provides the remedial action required to solve the problem detected.

Only replace one component at a time and check if the error has gone before replacing another component. Using this procedure you will be able to determine exactly which component failed.

System Error: 01.0:YZ

Problem Description:

Communication with Main PCA failed.

Corrective Action: Try the following:

- Switch the Power OFF from the back of the Printer and disconnect the Power cord. Reconnect the power cord and power On the Printer.
- Remove the formatter and reinsert it again. Ensure that it connects properly in the Main PCA connector.
- If the System Error continues, replace the Main PCA ⇒ Page 6-165.
- If the System Error continues, replace the Formatter ⇒ Page 6-161.

System Error: 01.1:YZ

Problem Description:

Error in the Print Mech PCA.

Corrective Action: Try the following:

- Switch the Power OFF from the back of the Printer and disconnect the Power cord. Reconnect the power cord and power On the Printer.
- If the System Error continues, replace the Page 6-71 ⇒ Page 6-165.
- If the System Error continues, replace the Formatter ⇒ Page 6-161.

System Error: 01.2:YZ

Problem Description:

Failure reading acumen chip of an Ink Supply Station.

Corrective Action: Try the following:

- Switch the Power OFF from the back of the Printer and disconnect the Power cord. Reconnect the power cord and power On the Printer.
- Check that there are not two cartridges of the same color installed.
- Perform the Ink Delivery System diagnostic test ⇒ Page 3-39.
 - If the test finds that the ink supply is defective, replace it.
 - If the test does not find any errors, remove all the ink supplies from the ISS and reboot the printer.
- Install the ink cartridges with the printer booted in normal mode. Use the replacement option available from the Front Panel and install the cartridges one by one. If an error appears after installing a supply, the

last supply you installed is defective. Replace it.

- If the System Error continues, replace the Main PCA ⇒ Page 6-165.
- If the System Error continues, replace the Left Ink Supply Station ⇒ Page 6-149.
- If the System Error continues, replace the Right Ink Supply Station ⇒ Page 6-145.

System Error: 01.3:YZ

Problem Description: Device I2C acumen Right Ink Supply Station failure.

Corrective Action: Try the following:

- Switch the Power OFF from the back of the Printer and disconnect the Power cord. Reconnect the power cord and power On the Printer.
- Check that the cables between the Right Ink Supply Station and PrintMech PCA are not damaged and are correctly connected.
- Perform the Ink Delivery System diagnostic test to troubleshoot the problem further ⇒ Page 3-38.
- If the System Error continues, replace the Right Ink Supply Station Page 6-145.

System Error: 02.1:YZ

Problem Description: Problem with the Carriage PCA.

Corrective Action: Try the following:

- Switch the Power OFF from the back of the Printer and disconnect the Power cord. Reconnect the power cord and power On the Printer.
- Check that the Trailing Cable is not damaged.
- Check that the Trailing Cable is correctly connected between the Main PCA and Carriage PCA.
- If the System Error continues, replace the Trailing Cable and Carriage PCA Cover. ⇒ Page 6-92.
- If the System Error continues, replace the Carriage PCA ⇒ Page 6-140.
- If the System Error continues, replace the Main PCA. ⇒ Page 6-165.
- Replace the Carriage Assembly ⇒ Page 6-100.

System Error: 03:YZ

Problem Description: Problem with Power Supply Unit.

Corrective Action: Try the following:

- Switch the Power OFF from the back of the Printer and disconnect the Power cord. Reconnect the power cord and power On the Printer.
- Perform the Electronics Module Test Diagnostic to troubleshoot the problem further ⇒ Page 3-22.
- If the System Error continues, replace the Power Supply Unit (PSU) ⇒ Page 6-165.

System Error: 03.0:10

Problem Description: Battery of Real Time Clock ran down.

Corrective Action: Replace the battery:

- 1 Turn the printer off and unplug the cable. Unplug any network or USB cables.
- 2 Loosen the screws that attach the formatter to the printer with your fingers, or with the help of a flat screwdriver, and remove the formatter.
- 3 Locate the round, flat battery in the formatter.
- 4 Push the battery slightly to one side and then pull it up. A little force may be required.
- 5 Insert the new battery by pressing it down.
- 6 Insert the formatter into the printer by pressing it down, and tighten the screws.
- 7 Reconnect the cables and turn the printer on.

System Error: 06:YZ

Problem Description: Failure reading/writing NVM in Hard disk.

Corrective Action: Try the following:

- Switch the Power OFF from the back of the Printer and disconnect the Power cord. Reconnect the power cord and power On the Printer.
- If the System Error continues, replace the Formatter ⇒ Page 6-161.

System Error: 08:YZ (or Front Panel is blank)

Problem Description: No communication between the Front Panel and the Main PCA.

Corrective Action: Try the following:

- Switch the Power OFF from the back of the Printer and disconnect the Power cord. Reconnect the power cord and power On the Printer.
- Check that the Front Panel interface cable is not damaged and is correctly connected between the Main PCA and the Front Panel.
- Check that the connections between the Formatter and the Main PCA are not damaged and are correctly connected.
- If the System Error continues, see page 1-5.
- If the System Error continues, replace the Formatter ⇒ Page 6-161.
- If the System Error continues, replace the Main PCA ⇒ Page 6-165.
- If the System Error continues, replace the Front Panel ⇒ Page 6-48.

System Error: 11:YZ

Problem Description: Trailing Cable does not seem to be detected.

Corrective Action: Try the following:

- Switch the Power OFF from the back of the Printer and disconnect the Power cord. Reconnect the power cord and power On the Printer.
- Check that the Trailing Cable is not damaged.
- Check that the Trailing Cable is correctly connected between the Main PCA and Carriage PCA and make sure that the connectors in these boards are not damaged.
- If the System Error continues, replace the Trailing Cable ⇒ Page 6-92.
- If the System Error continues, replace the Main PCA ⇒ Page 6-165.
- If the System Error continues, replace the Carriage PCA ⇒ Page 6-140.

System Error:**21:YZ****Problem Description:**

Fail moving Service Station.

Corrective Action: Try the following:

-
- Remove the Right Cover and make sure the cables from the Printmech PCA to the Service Station are connected and are not damaged.
- Make sure that the Service Station path is clear. Remove any visible obstacles (e.g. screws, plastic parts, etc...) restricting the movement of the Service Station.
- Perform the Service Station diagnostic test to troubleshoot the problem further ⇒ Page 3-45.
- If the System Error continues, replace the Service Station ⇒ Page 6-60.
- If the System Error continues, replace the PrintMech PCA ⇒ Page 6-71.

System Error:**21.1:YZ****Problem Description:**

Fail moving the Primer Motor of the Service Station.

Corrective Action: Try the following:

- Remove the Right Cover and make sure the cables from the Printmech PCA to the Service Station are connected and are not damaged.
- Perform the Service Station diagnostic test to troubleshoot the problem further ⇒ Page 3-45.
- If the System Error continues, replace the Service Station ⇒ Page 6-60.
- If the System Error continues, replace the PrintMech PCA ⇒ Page 6-71.

Warning:
2x.n:10
Problem Description:

Ink supply error found during IDS diagnostic test. The n represents the ink supply that is failing. The ink supply furthest to the left is always 0, and then they count up from left to right. The following graphic illustrates this for the Z3100/Z3200.

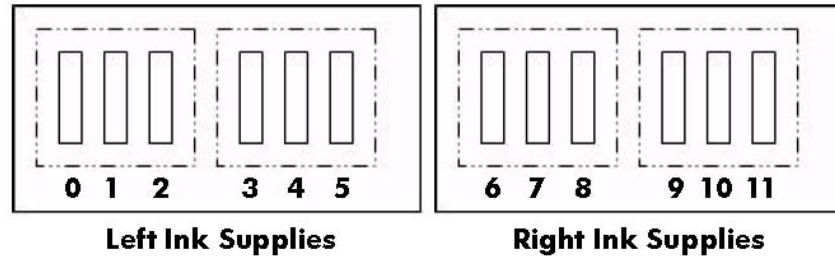

Corrective Action: Try the following:

- Replace the left or right Ink Supply Station, depending on which supply failed ⇒ Page 6-145 and Page 6-149.

System Error: 22.0:YZ
Problem Description:

Left Ink Supply Station error.

Corrective Action: Try the following:

- Switch the Power OFF from the back of the Printer and disconnect the Power cord. Reconnect the power cord and power On the Printer.
- Check that the cables between the Left Ink Supply Station and Main PCA the are not damaged and are correctly connected.
- Perform the Ink Delivery System diagnostic test to troubleshoot the problem further ⇒ Page 3-38.
- If the System Error continues, replace the Left Ink Supply Station ⇒ Page 6-149.
- If the System Error continues, replace the Main PCA ⇒ Page 6-165.

System Error: 22.1:YZ
Problem Description:

Left Ink Supply Station error.

Corrective Action: Try the following:

- Switch the Power OFF from the back of the Printer and disconnect the Power cord. Reconnect the power cord and power On the Printer.
- Check that the cables between the Left Ink Supply Station and Main PCA the are not damaged and are correctly connected.
- Perform the Ink Delivery System diagnostic test to troubleshoot the problem further ⇒ Page 3-38.
- If the System Error continues, replace the Left Ink Supply Station ⇒ Page 6-149.
- If the System Error continues, replace the Main PCA ⇒ Page 6-165.

System Error: 22.2:YZ

Problem Description: Right Ink Supply Station error.

- Corrective Action:** Try the following:
- Switch the Power OFF from the back of the Printer and disconnect the Power cord. Reconnect the power cord and power On the Printer.
 - Check that the cables between the Right Ink Supply Station and PrintMech PCA the are not damaged and are correctly connected.
 - Perform the Ink Delivery System diagnostic test to troubleshoot the problem further ⇒ Page 3-38.
 - If the System Error continues, replace the Right Ink Supply Station ⇒ Page 6-149.
 - If the System Error continues, replace the Main PCA ⇒ Page 6-165.

System Error: 22.3:YZ

Problem Description: Right Ink Supply Station error.

- Corrective Action:** Try the following:
- Switch the Power OFF from the back of the Printer and disconnect the Power cord. Reconnect the power cord and power On the Printer.
 - Check that the cables between the Right Ink Supply Station and PrintMech PCA the are not damaged and are correctly connected.
 - Perform the Ink Delivery System diagnostic test to troubleshoot the problem further ⇒ Page 3-38.
 - If the System Error continues, replace the Right Ink Supply Station ⇒ Page 6-149.
 - If the System Error continues, replace the Main PCA ⇒ Page 6-165.

System Error: 24:YZ

Problem Description: Ink Setup failure (you must bring purgers).

- Corrective Action:** Try the following:
- Switch the Power OFF from the back of the Printer and disconnect the Power cord. Insert the new purgers, reconnect the power cord and power On the Printer.
 - Perform the Ink Delivery System diagnostic test in order to check that the bongos (pushers) go up and down to pressurize ink in the tubes and the Out of Ink sensors work properly ⇒ Page 3-39.
 - Try purging the Ink Supply Tubes again once the Printer has been restarted.
 - If the diagnostic test does not find any problem, install new cartridges in the printer and try purging the Ink Supply Tubes again. It could be that one of the cartridges is defective.
 - If the problem persists, replace the Ink Supply Tubes ⇒ Page 6-153.
 - Replace the Formatter ⇒ Page 6-161.

System Error: 31:01

Problem Description: An error has been detected with the cutter.

Corrective Action: Try the following:

- Switch the Power OFF from the back of the Printer and disconnect the Power cord. Reconnect the power cord and power On the Printer.
- Check the Cutter Assembly for blockage or any other obvious problems.
- Replace the Cutter Assembly ⇒ Page 6-43.

System Error: 31:02

Problem Description: An error has been detected with the cutter.

Corrective Action: Try the following:

- Switch the Power OFF from the back of the Printer and disconnect the Power cord. Reconnect the power cord and power On the Printer.
- Check the Cutter Assembly for blockage or any other obvious problems.
- Replace the Cutter Assembly ⇒ Page 6-43.

System Error: 31:03

Problem Description: Paper is loaded. While testing the cutter, paper should not be loaded.

Corrective Action: Try the following:

- Switch the Power OFF from the back of the Printer and disconnect the Power cord.
- Unload the media.
- Reconnect the power cord and power On the Printer.
-

System Error: 41:03

Problem Description: Media-Axis Motor failure (likely due to friction or obstacles in the media path).

Corrective Action: Try the following:

- Same as 41:YZ but after testing the issue is repeatable.

System Error: 41:YZ

Problem Description: Media-Axis Motor failure (likely due to friction or obstacles in the media path).

Corrective Action: Try the following:

- Switch the Power OFF from the back of the Printer and disconnect the Power cord. Reconnect the power cord and power On the Printer.
- Open the Window and check for any visible obstacles restricting the movement of the Media Advance Roller. If there is a wrinkled mass of media inside the paper path, lift the Pinch wheels (using Media Lever) and clear the obstruction.

- Perform the Paper Drive diagnostic test to troubleshoot the problem further ⇒ Page 3-18.
- If the problem persists check that the Media Advance Drive cable is not damaged and is correctly connected to the Main PCA.
- Replace the Media Advance Drive ⇒ Page 6-183.
- If the System Error continues, replace the Main PCA ⇒ Page 6-165.

System Error: 42:03

Problem Description: Scan-Axis Motor failure (likely due to obstacles in the scan axis or electrical fault).

Corrective Action: Try the following:

- Same as 42:YZ but after testing the issue is repeatable.

System Error: 42:YZ

Problem Description: Scan-Axis Motor failure (likely due to friction or obstacles in the media path).

Corrective Action: Try the following:

- Switch the Power OFF from the back of the Printer and disconnect the Power cord. Reconnect the power cord and power On the Printer.
- Open the Window and check for any visible obstacles restricting the movement of the Media Advance Roller. If there is a wrinkled mass of media inside the paper path, lift the Pinch wheels (using Media Lever) and clear the obstruction.
- Perform the Scan Axis diagnostic test to troubleshoot the problem further ⇒ Page 3-6.
- Check that there is no obstacle preventing the Service Station from working.
- Perform the Service Station diagnostic test to troubleshoot the problem further ⇒ Page 3-45.
- Check that the Scan-Axis Motor cable is not damaged and is correctly connected to the PrintMech PCA.
- Replace the Scan-Axis Motor ⇒ Page 6-118.
- If the System Error continues, replace the PrintMech PCA ⇒ Page 6-71.

System Error: 44:YZ

Problem Description: Fan Electrical fault, or not connected..

Corrective Action: Try the following:

- Switch the Power OFF from the back of the Printer and disconnect the Power cord. Reconnect the power cord and power On the Printer.
- Check that the Aerosol Fan cable is not damaged and is correctly connected to the PrintMech PCA
- Replace the Aerosol Fan Assembly ⇒ Page 6-65.
- If the System Error continues, replace the PrintMech PCA ⇒ Page 6-71.

System Error: 47:03

Problem Description: Star wheels motor error.

Corrective Action: Try the following:

- Same as 47:YZ. The error is continuable, but only if it happens from time to time.

System Error: 47:YZ

Problem Description: Star wheels motor error..

Corrective Action: Try the following:

- Switch the Power OFF from the back of the Printer and disconnect the Power cord. Reconnect the power cord and power On the Printer.
- Check that the Starwheel Assembly cable is not damaged and is correctly connected to Main PCA.
- Open the Window and check for any visible obstacles restricting the movement of the Starwheel Assembly, then clear the obstruction.
- Perform the Scan Axis Starwheel diagnostic test to troubleshoot the problem further ⇒ Page 3-7.
- Replace the Starwheel Motor ⇒ Page 6-214.
- Replace the Starwheel Lifter⇒ Page 6-203 and Page 6-210.
- If the System Error continues, replace the Main PCA ⇒ Page 6-165.

System Error: 48:YZ

Problem Description: PPS system failure.

Corrective Action: Try the following:

- Switch the Power OFF from the back of the Printer and disconnect the Power cord. Reconnect the power cord and power On the Printer.
- Check that the Pen to Paper Space (PPS) Solenoid cable is not damaged and is correctly connected to the PrintMech PCA.
- Perform the Scan Axis PSS diagnostic test to troubleshoot the problem further ⇒ Page 3-9.
- Make sure the Service Station is correctly installed. Sometimes, if the Service Station is not correctly installed, the front of the Service Station falls down (causing the Service Station to be tilted), and the L-Bracket support does not fit properly. The front of the Service Station should be "UP," and the L-Bracket should fit well with the Service Station.
- Replace the Pen to Paper Space (PPS) Solenoid ⇒ Page 6-73.
- If the System Error continues, replace the PrintMech PCA ⇒ Page 6-71.

System Error: 51:YZ

Problem Description: Window Sensor failure.

Corrective Action: Try the following:

- Check that the Window Position Sensor cable is not damaged and is correctly connected to the PrintMech PCA.
- Perform the Sensors Test to troubleshoot the problem further ⇒ Page 3-33.
- Replace the Window Position Sensor ⇒ Page 6-54.

System Error: 52:10

Problem Description: The printer has detected fibers in the Drop Detector.

- Corrective Action:** Try the following:
- Switch the Power OFF from the back of the Printer and disconnect the Power cord. Reconnect the power cord and power On the Printer.
 - Check that the Drop Detector cable is not damaged and is correctly connected to the PrintMech PCA.
 - Clean the drop detector.
 - Check that the Service Station cable is not damaged and is correctly connected to the PrintMech PCA.
 - Replace the Drop Detector ⇒ Page 6-64.
 - Reset the Calibration Flag of the Drop Detector ⇒ Page 4-12.
 - If the System Error continues, replace the PrintMech PCA ⇒ Page 6-71.

System Error: 55:YZ

Problem Description: Problem with the Line Sensor (Tetris). The printer has detected a failure to access Line Sensor EEPROM).

- Corrective Action:** Try the following:
- Switch the Power OFF from the back of the Printer and disconnect the Power cord. Reconnect the power cord and power On the Printer.
 - Perform the Carriage Test to troubleshoot the problem further ⇒ Page 3-27
 - Check the Line Sensor connections to the Carriage PCA.
 - Replace the Line Sensor ⇒ Page 6-130.
 - If the System Error continues, replace the Carriage PCA ⇒ Page 6-140.

System Error: 56:YZ

Problem Description: Drive roller analog encoder sensor fail or calibration failed.

- Corrective Action:** Try the following:
- Switch the Power OFF from the back of the Printer and disconnect the Power cord. Reconnect the power cord and power On the Printer.
 - Perform the Media Path Test to troubleshoot the problem further ⇒ Page 3-18.
 - Replace the Encoder Disk and Encoder Sensor ⇒ Page 6-180.
 - If the System Error continues, replace the Main PCA ⇒ Page 6-165.

System Error: 58:YZ

Problem Description: The Color Sensor ESP (spectrophotometer) of the printer is not working well. It could be any of the following problems:

- Problem with the Color Sensor ESP (spectrophotometer).
- Communication problem between the Color Sensor ESP (spectrophotometer) and Carriage PCA.
- The color sensor shutter does not open properly.

Corrective Action: Try the following:

- Switch the Power OFF from the back of the Printer and disconnect the Power cord. Reconnect the power cord and power On the Printer.
- Replace the Color Sensor ESP (spectrophotometer) ⇒ Page 6-124.
- If the problem persists check the internal code error (Press UP and CANCEL while the error is displayed). If the internal error code is **0x0606002** replace the Service Station ⇒ Page 6-60. If the internal error code is **0x06060003** change the Carriage PCA ⇒ Page 6-140.

System Error: 59.1:09

Problem Description: Two electrical parts have been replaced at the same time causing a compatibility issue.

Corrective Action: Try the following:

- Switch the Power OFF from the back of the Printer and disconnect the Power cord. Replace one part at a time, and restart the product before replacing another.

System Error: 59.2:00

Problem Description: An unsupported part or a part that has already been used has been installed.

Corrective Action: Try the following:

- Only install new parts recommended by HP for this product.

System Error: 59.3:09

Problem Description: A combination of the Product number and/or the firmware release and/or Formatter Hardware are not compatible.

Corrective Action: Try the following:

- The Formatter or Hard Disk or Firmware is incompatible with this product. Install the correct parts or the correct firmware that corresponds to the product.

System Error: 61:YZ

Problem Description: The file format is incorrect and the Printer cannot process the job.

Corrective Action: Try the following:

- Switch the Power OFF from the back of the Printer and disconnect the Power cord. Reconnect the power cord and power On the Printer.

- Check that the driver installed in the customer computer is the one that will work with that printer (i.e if the customer has a Z3100 without an HP-GL/2 upgrade kit, check that the driver installed is the PCL3GUI as other drivers will not work).
- Check the graphic language setting of the Printer (Refer to the User's Guide).
- Resend the file to the printer.
- Check that the Printer has the latest Firmware version. If not, update the Firmware to the latest version.
- The PostScript™ fonts are missing. Upgrading the Firmware will re-install the fonts.
- The file cannot be printed because it is password protected. Resend the file without password protection.

System Error: 63:YZ

Problem Description: Input/Output problem through the network interface of the Formatter.

- Corrective Action:** Try the following:
- Switch the Power OFF from the back of the Printer and disconnect the Power cord. Reconnect the power cord and power On the Printer.
 - Check that the Network cable is correctly connected to the Formatter.
 - Check that the Printer has the latest Firmware version. If not, update the Firmware to the latest version.
 - If the System Error continues, replace the Formatter ⇒ Page 6-161.

System Error: 64:YZ

Problem Description: Input/Output problem through the USB Port.

- Corrective Action:** Try the following:
- Switch the Power OFF from the back of the Printer and disconnect the Power cord. Reconnect the power cord and power On the Printer.
 - Check that the USB cable is correctly connected to the Printer.
 - Check that the Printer has the latest Firmware version. If not, update the Firmware to the latest version.
 - If the System Error continues, replace the Formatter ⇒ Page 6-161.

System Error: 65:YZ

Problem Description: Memory Driver Internal I/O error, I/O Socket Manager Internal I/O error.

- Corrective Action:** Try the following:
- Switch the Power OFF from the back of the Printer and disconnect the Power cord. Reconnect the power cord and power On the Printer.
 - Check that the unknown port cable is correctly connected to the Printer.
 - Check that the Printer has the latest Firmware version. If not, update the Firmware to the latest version.

- If the System Error continues, replace the Formatter ⇒ Page 6-161.

System Error: 68:YZ

Problem Description: Loss of engine counters tracking.

Corrective Action: Try the following:

- Reboot the printer. The printer will continue to function correctly, but the life counters will not continue counting until you restart the printer.

System Error: 71:YZ

Problem Description: Out of memory failure.

Corrective Action: Try the following:

- It is recommended that you remove any unnecessary files from the Hard Disk Drive of the Formatter using the Web Server.
- If there seems to be a problem with the HP-GL/2 driver, try the **Send Job as bitmap** option in the driver
- Reduce the resolution of your image or the print quality in your driver.

System Error: 71:19

Problem Description: Default Serial Number found in the main and backup NVM. It seems that both the Print Mech PCA and Hard Disk Drive have been replaced together.

Corrective Action: Try the following:

- Perform the "Error 71:19 Recovery" Service Utility ⇒ Page 3-55.

You MUST NEVER replace both the Formatter and the PrintMech PCA at the same time. If both parts need to be replaced, you MUST first replace one part and then power ON the Printer until it completely initializes. Then you can power OFF the Printer and replace the other part.

System Error: 72:YZ

Problem Description: A service calibration must be performed. Check the internal error code to see which calibration must be performed. To check the internal error code, press UP and CANCEL together while the error code is displayed.

Corrective Action: Check the internal error code:

- 0x07090001 (gain). Perform the Line Sensor Calibration ⇒ Page 4-15.
- 0x07090002 (LS2K). Perform the Line Sensor Calibration ⇒ Page 4-15.
- 0x07090003 (DD). Perform the Drop Detector Calibration ⇒ Page 4-12.
- 0x07090004 (Adv). Perform the Paper Advance Calibration ⇒ Page 4-6.
- 0x07090005 (Alig). Perform the Printhead Alignment Calibration ⇒ Page 1-66.
- 0x07090007 (CLC). Perform the Color Sensor Calibration ⇒ Page 4-18.
- 0x07090008 (Analog Encoder). Perform the Paper Advance Calibration

⇒ Page 4-6.

System Error: 74:YZ

Problem Description: Error uploading firmware update file.

Corrective Action: Try the following:

- Switch the Power OFF from the back of the Printer and disconnect the Power cord. Reconnect the power cord and power On the Printer.
- Make sure the connection between the computer and the printer is functioning properly.
- Try to update the Firmware again.
- If available, try another connection method to do the upgrade or a different computer/operating system.

System Error: 74.1:YZ

Problem Description: Error uploading media profile update file.

Corrective Action: Try the following:

- Switch the Power OFF from the back of the Printer and disconnect the Power cord. Reconnect the power cord and power On the Printer.
- Make sure the connection between the computer and the printer is functioning properly.
- Try to upload the media profile update file again.
- If available, try another connection method to do the upgrade or a different computer/operating system.

System Error: 75.21:YZ

Problem Description: The spittoons (Left Spittoon, Service Station) have reached 80% capacity.

Corrective Action: Try the following:

- Use Preventive Maintenance Kit #2 to replace the Left Spitton and Service Station.

System Error: 75.22:YZ

Problem Description: The spittoons (Left Spittoon, Service Station) are full.

Corrective Action: Try the following:

- Use Preventive Maintenance Kit #2 to replace the Left Spitton and Service Station.

System Error: 76:YZ

Problem Description: Hard disk drive is full.

Corrective Action: Try the following:

- Remove any unnecessary files from the hard disk using the web server.

System Error: 77:YZ

Problem Description: Web access application. The web server is not functioning correctly.

Corrective Action: Try the following:

- Switch the Power OFF from the back of the Printer and disconnect the Power cord. Reconnect the power cord and power On the Printer.
- Check that the Printer has the latest Firmware version. If not, update the Firmware to the latest version.

System Error: 78:08

Problem Description: The job received can not be printed without borders on this paper.

Corrective Action: Try the following:

- Use a paper that supports borderless printing.
- This system error code does NOT require service help. It should be resolved by the customer.

System Error: 78.1:YZ

Problem Description: Media settings area missing in media settings file.

Corrective Action: Try the following:

- Switch the Power OFF from the back of the Printer and disconnect the Power cord. Reconnect the power cord and power On the Printer.
- Check that the Printer has the latest Firmware version. If not, update the Firmware to the latest version.
- Update the OMES of the paper type that is failing.

System Error: 79:YZ

Problem Description: Generic Firmware error.

Corrective Action: Try the following:

- Switch the Power OFF from the back of the Printer and disconnect the Power cord. Reconnect the power cord and power On the Printer.
- Check that the Printer has the latest Firmware version. If not, update the Firmware to the latest version.

System Error: 79.1:YZ

Problem Description: Recoverable firmware error that does not stop the printing process.

Corrective Action: Try the following:

- Switch the Power OFF from the back of the Printer and disconnect the Power cord. Reconnect the power cord and power On the Printer.

- Check that the Printer has the latest Firmware version. If not, update the Firmware to the latest version.

System Error:**81:YZ****Initial checks:**

This error can occur because the printer has been dropped during transportation, causing structural damage. Before continuing with the 81:YZ troubleshooting, first look for structural damage.

To identify the structural damage, look for the following three things:

- Consistent 81:YZ error codes.
- Platen fingers rubbing on the roller surface, leaving black marks on the roller.

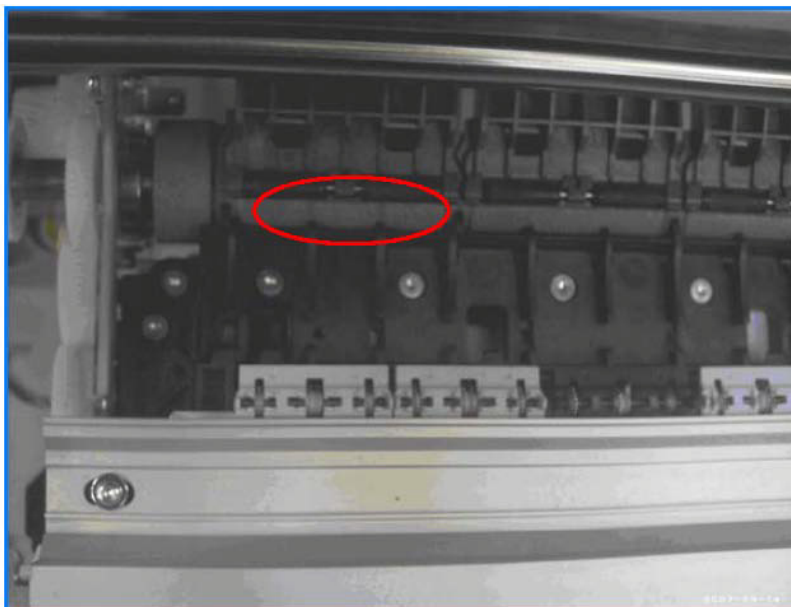

- A gap on the platen beam. If there's any gap in Z (vertical direction) between the plastic feature of the platen and the metal side plate, then the chassis is damaged and the unit cannot be repaired.

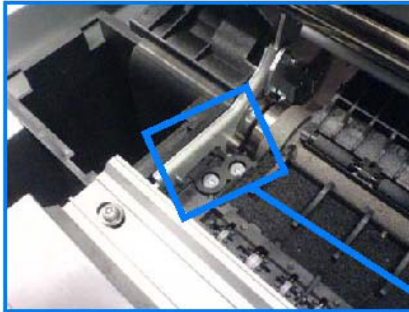

Problem Description:

Problem with paper advance. This source of error could come from an error in any of the following systems: paper motor, disk encoder, cables or main electronics.

Corrective Action: Try the following:

- Open the Window and check for any visible obstacles restricting the movement of the Drive Roller. If there is a wrinkled mass of media inside the paper path, lift the Pinchwheels (using the Media Lever) and clear the obstruction.
- Perform the Media Drive diagnostic test to troubleshoot the problem further ⇒ Page 3-18.
- Check the connections on the Main PCA; the Media Advance Drive is connected to the connector labeled Paper Motor.
- Adjust the encoder disc and motor mount configuration ⇒ See the installation instructions on Page 6-183.
- If the System Error continues, replace the Media Advance Transmission ⇒ Page 6-183.

System Error: 85:YZ

Problem Description:

Problem finding the Drive Roller zero.

Corrective Action: Try the following:

- Check that the Media Advance Drive is connected properly to the Main PCA and is not damaged. The cable is labeled "Paper Motor."
- Perform the Media Drive diagnostic test to troubleshoot the problem further ⇒ Page 3-18.
- If the System Error continues, replace the Encoder Disk and Encoder

Sensor ⇒ Page 6-180.

- If the System Error continues, replace the Main PCA ⇒ Page 6-165.

System Error: 86:01

Problem Description: Problem moving the carriage, most likely due to a paper jam.

Corrective Action: Try the following:

- Switch the Power OFF from the back of the Printer and disconnect the Power cord. Reconnect the power cord and power On the Printer.
- Open the Window and check for any visible obstacles restricting the movement of the carriage. If there is a wrinkled mass of media inside the paper path, lift the Pinch wheels (using the Media Lever) and clear the obstruction.
- If there is no paper jam or obstacle blocking the carriage movement perform the following:
 - Clean the encoder strip.
 - Check the belt assembly.
 - All cables and connections between the Carriag PCA, Scan Axis Motor, and Main PCA.
 - Oil the carriage rails.
- Perform the Scan Axis Diagnostic Test ⇒ Page 3-6.
- If the diagnostic test does not find any specific error, replace the Carriage Assembly ⇒ Page 6-100.
- Replace the Belt Assembly ⇒ Page 6-117.
- Replace the Scan Axis Motor ⇒ Page 6-118.
- Replace the Main PCA ⇒ Page 6-165.

System Error: 87:YZ

Problem Description: Problem finding the Scan-axis encoder reading.

Corrective Action: Try the following:

- Upgrade the firmware.
- Clean the Encoder Strip.
- Replace the Encoder Strip ⇒ Page 6-91.
- Replace the Carriage PCA ⇒ Page 6-140.
- Replace the Trailing Cables ⇒ Page 6-92.

System Error: 93:YZ

Problem Description: Unable to pressurize the Ink Delivery System. The ISS Motor does not move as expected.

Corrective Action: Try the following:

- Switch the Power OFF from the back of the Printer and disconnect the Power cord. Reconnect the power cord and power On the Printer.
- Perform the Ink Delivery System diagnostic test to further troubleshoot the

problem. ⇒ Page 3-38.

- Replace the Left or Right Ink Supply Stations, depending on the results of the diagnostic test ⇒ Page 6-145 and Page 6-149.
- If the problems persist after replacing the appropriate ink supply station (right or left), replace the Main PCA if you have problems with the left side. Replace the Printmech PCA if you have problems with the right side.

System Error: 94:YZ

Problem Description: Color calibration Error.

Corrective Action: Try the following:

- Perform the Color Sensor ESP (spectrophotometer) calibration. You must use glossy paper for this calibration.
- If the System Error continues, replace the Color Sensor ESP (spectrophotometer) ⇒ Page 6-124.
- If the System Error continues, replace the Carriage PCA ⇒ Page 6-140.
- If the System Error continues, replace the Formatter ⇒ Page 6-161.

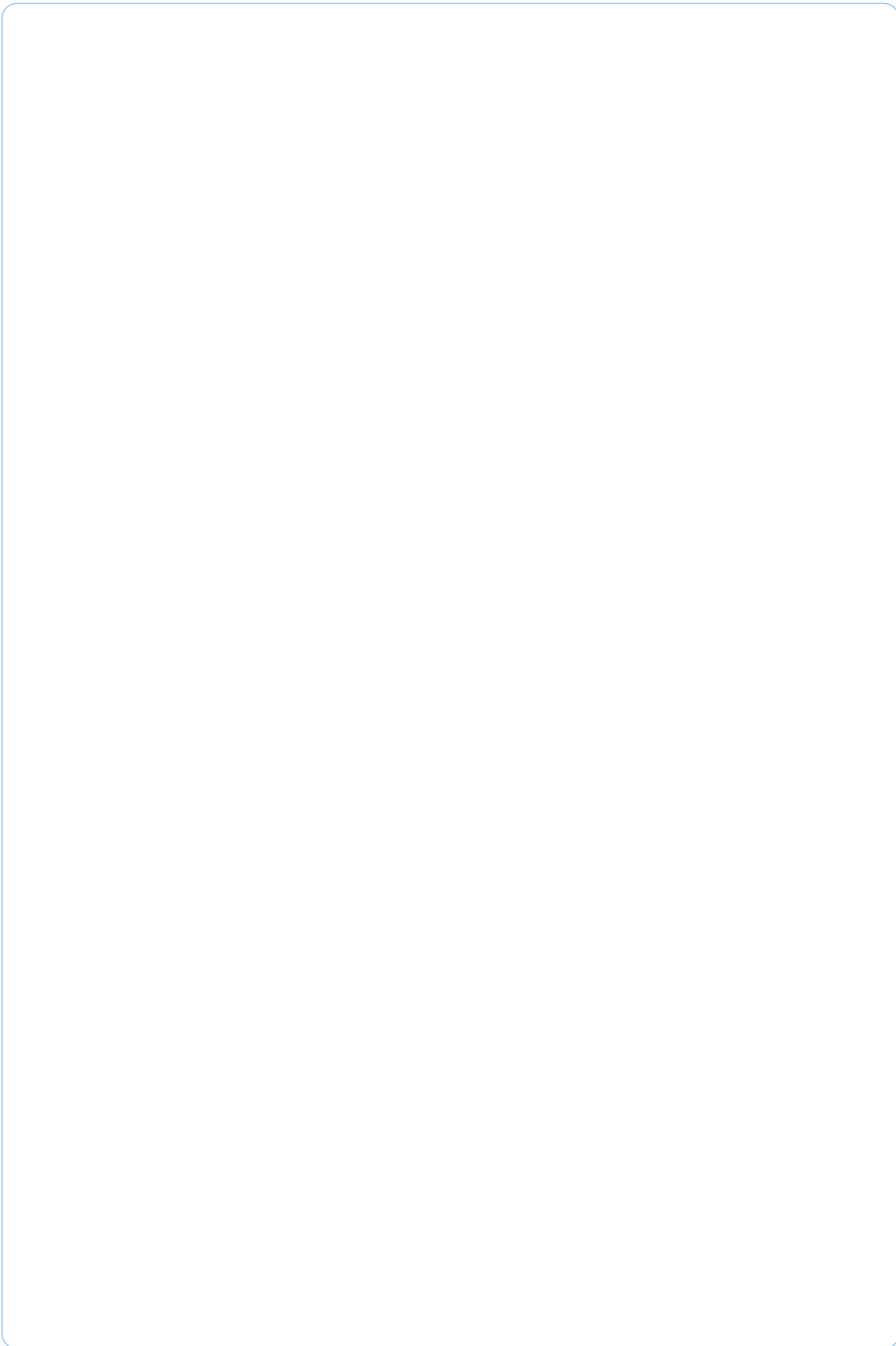

Service Tests and Utilities

3

- Introduction 3-2
 - Diagnostics - Self Test 3-2
- Service Tests (Diagnostics) 3-3
 - Using the Front Panel 3-5
 - Entering the Diagnostic Tests Menu 3-6
 - 1. Scan Axis 3-6
 - 2. Paper Drive 3-18
 - 3. Electronics Module 3-22
 - 4. Carriage Assembly 3-27
 - 5. Sensors 3-33
 - 6. Color Sensor ESP (spectrophotometer) 3-36
 - 7. Ink Delivery System (IDS) 3-38
 - 8. Service Station 3-45
 - 9. I/O Information 3-51
 - 10. Unit Information 3-52
 - 11. EEROM Reset 3-53
 - 12. Set Unit Configuration 3-55
 - 13. Error 71:19 Recovery 3-55
 - 14. Others 3-58
- Service Utilities 3-59
 - Entering the Service Utilities Menu 3-59
 - 1. Turn Drive Roller 3-61
 - 2. Purge Tubes 3-62
 - 3. Set SN 3-65
 - 4. Reset Life Counters 3-66
 - 5. Diagnostic Print 3-67
 - 6. Set Date and Time 3-68
 - 7. Enable/Disable Firewall 3-69

Introduction

This chapter explains how to use the built-in Service Tests and Service Utilities and what to do if any of the Service Tests FAIL.

If possible, always perform a Service Test on the component that you are about to replace, just to make sure that is the component that has FAILED. If the test on that component passes, there is no need to replace it.

Diagnostics - Self Test

Initialization Sequences

Whenever the Printer is switched ON, it automatically performs a series of internal self tests and mechanical initialization sequences. If any of the parts FAIL, a system error will appear and you should consult 2, *System Error Codes*.

Phone Support

In certain circumstances, a Call Agent can try and troubleshoot the Printer by requesting the Customer to perform a Service Test via the phone. Using this process, it can be determined whether the Printer requires any on-site maintenance.

Remember that the Key combination for the Customer to Enter the Service Tests and Utilities is different from the one that the Customer Engineer will use.

Service Tests (Diagnostics)

The following is a list of all internal Service Tests available in the Printer. Instructions for entering the Service Tests menu are given on Page 3-6.

1 Scan Axis Test ⇒ Page 3-6

The purpose of this test is to verify the operation of components related to the Scan Axis. The tests verify the operation of the:

- PRS
- Scan Axis
- Star Wheel Lifter
- Cutter

2 Paper Drive Test ⇒ Page 3-18

The purpose of this test is to verify the operation of components related to the Media Axis.

3 Electronics Module ⇒ Page 3-22

The purpose of this test is to verify the operation of the:

- Main PCA (Formatter).
- Printer Configuration.
- Power Supply Unit.
- PrintMech.
- Carriage Communication.

4 Carriage Assembly Test ⇒ Page 3-27

The purpose of this test is to verify the operation of the Carriage Assembly.

5 Sensors Test ⇒ Page 3-33

The purpose of this test is to verify the operation of the following Sensors:

- Window Sensor.
- Media Lever Sensor.
- Media Sensor.

6 Color Sensor Test ⇒ Page 3-36

The purpose of this test is to verify the operation of the Color Sensor ESP (spectrophotometer).

7 Ink Delivery Test ⇒ Page 3-38

The purpose of this test is to verify the operation of the Ink Delivery System.

8 Service Station Test ⇒ Page 3-45

The purpose of this test is to verify the operation of the Service Station.

9 I/O Information ⇒ Page 3-51

The purpose of this test is to verify the TCP/IP configuration.

10 Unit Information ⇒ Page 3-52

This option allows you to view the Firmware Version, Part Number, and Serial Number of the Printer.

- 11** EEROM Reset ⇒ Page 3-53
The purpose of this test is to reset the EEROM values.
- 12** Set Unit Configuration ⇒ Page 3-55
Not implemented.
- 13** Error 71:19 Recovery ⇒ Page 3-55
The purpose of this utility is to set the Serial Number and Part Number in case both the Formatter and the PrintMech PCA are replaced at the same time or select the correct Serial Number and Part Number if only one of the components has been replaced.
- 14** I/O Tests ⇒ Page 3-58
Not implemented.

Using the Front Panel

Below is a diagram of the front panel.

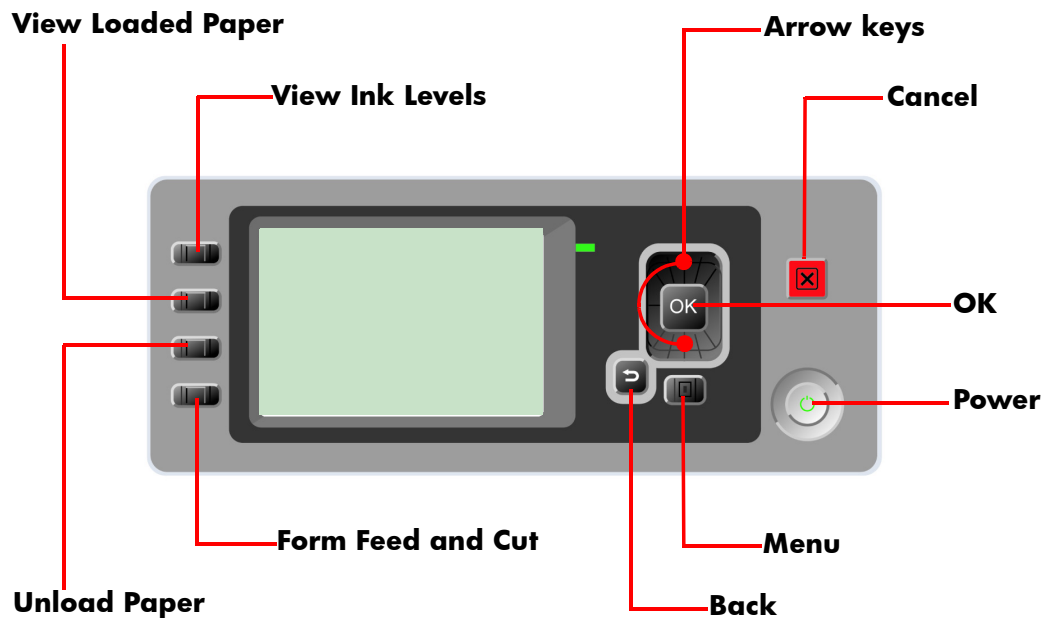

Key Function

- **Arrow Keys**
Use the Arrow keys to scroll through a menu or toggle between YES or NO when prompted.
- **Cancel**
Use the Cancel key to abort or stop a procedure or reject test results.
- **OK**
Use the OK key to select a menu option.
- **Power**
Use the Power key to turn the printer ON and OFF.
- **Menu**
Use the Menu key to enter the main menu.
- **Back**
Use the Back key to go back to the previous menu or reject test results.

Service Key Combinations

- **Diagnostic mode**
With the printer OFF, press and hold the UP and OK keys. While holding the Up and OK keys down, press and hold the Power key to turn on the printer. Hold all three keys until the Power key stops flashing, usually about 20 seconds.
- **Service Menu (Service Engineers Only)**
From the main menu, press and hold the Up and Cancel keys.
- **Service Menu (For users)**
From the main menu, press and hold the Down and Cancel keys.

Entering the Diagnostic Tests Menu

In order to enter the Diagnostic Tests Menu, please refer to the instructions on Page 3-59.

- 1** Make sure the printer is switched OFF from the power switch on the front of the printer and **NOT** from the power switch on the back of the printer.
- 2** For On-Site Engineers, hold the **Up** arrow key and the **OK** key down and switch the printer **ON** using the front power switch. Wait until the LED of the power switch stops flashing (usually after 20 seconds) before releasing ALL three keys.
- 3** Once inside the Service Tests Menu use the **Arrow** keys to scroll through the “diagnostic test” selections. Press the **OK** key to begin a specific test when the required diagnostic test is highlighted.

PHONE SUPPORT
ON-SITE SUPPORT

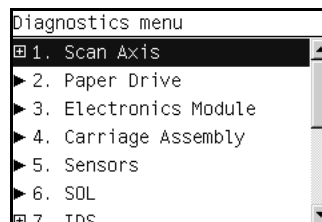

The diagnostic tests work in a special Mode which does NOT require the full Initialization of the Printer. Therefore it is important that once you have finished with the diagnostic tests, you MUST power OFF the Printer and Power ON again before trying to print or before executing another Service Test.

In some cases a quick press of a button may not be recognized by the Printer. When pressing a button, be sure to press it deliberately and all the way to the bottom of its travel.

If the Printer hangs up during a test, switch the Printer OFF and restart from step 1.

1. Scan Axis

The complete Scan Axis test consists of individual tests for the different components related to the Scan Axis. The subsystem that are included in this assembly are:

- Star Wheel Lifter
- Automatic PPS Adjustment.
- Scan Axis Servosystem
- Cutter

You must perform the Scan-Axis Test after:

- System Error Code 87:XZ.
- System Error Code 42:XZ.
- System Error Code 47:XZ.
- System Error Code 73:XZ.
- System Error Codes related to Scan-Axis shutdown or Carriage jam.

Diagnostic tests also need to be performed after removing or replacing certain printer components. If you have removed or replaced printer components, check the Service Calibration Guide to Removal and Installation to see which tests and calibrations you need to perform. Refer to Page 6-8.

ALL THE COVER SENSORS ARE DISABLED WHEN IN THE SERVICE TESTS MENU. IF THE CARRIAGE IS MOVING IT WILL NOT STOP IF THE WINDOW IS OPENED, SO BE VERY CAREFUL NOT TO PUT YOUR HANDS INSIDE.

IF POSSIBLE, ALWAYS PERFORM THIS TEST BEFORE REPLACING ANY COMPONENT OF THE SCAN-AXIS.

Star Wheel Lifter test

The Star Wheel Lifter subassembly is designed to move the Start Wheel support to the up and down positions. This is used to load roll or sheet media and avoid damage to the Star Wheel caused by paper jams etc.

Perform the Scan Axis - Starwheel lifter test as follows:

Perform this test with the Printheads and the Tubes System installed in order to get values that can be compared correctly.

- 1 In the Diagnostics menu, scroll to **1. Scan Axis** and press **OK**.

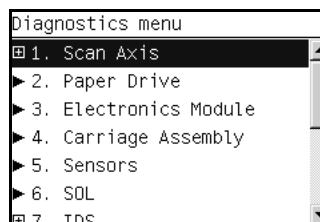

- 2 The Front Panel will show the **1. Scan Axis** submenu.



- 3 In the **Scan Axis** submenu, scroll to **Star Wheel Lifter** and press **OK** to start the test.

If there is a Failure at any point during the tests, the Front Panel will display the relevant **System Error Code**. To trouble shoot any displayed error codes, refer to page 1-7, *System Error Codes - Full Descriptions*.

- 4 The printer then starts the Star wheel lifter PWM control test to verify the subsystem. As the test executes the Front Panel displays the following messages:
 - Starting Horsburgh & Mips.
 - Starting nvm
 - Starting Tests PWM.
 - Starting Tests GPIO.
 - Booting up the Carriage.
 - Starting SVS Motor
 - Starting Carriage Motor.
 - Starting Service Station.
 - Starting Scan Axis.
 - Moving SVS out of Scan Axis.
 - Homing Scan Axis.
 - Move Carriage out of SVS path.
 - Homing Service Station
 - Starting Servicing Services.
 - Capping Service Station.
 - Uncapping Service Station.
 - Starting Star Wheels Motor.
 - Doing Dummy Cycles
 - Getting SWL path length.
 - Checking SWL length.
- 5 The printer displays the test results and prompts you to continue.

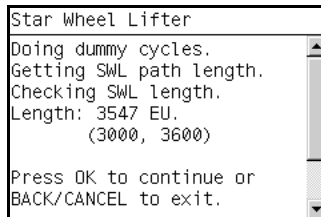

```

Star Wheel Lifter
Doing dummy cycles.
Getting SWL path length.
Checking SWL length.
Length: 3547 EU.
      (3000, 3600)

Press OK to continue or
BACK/CANCEL to exit.
  
```

- 6 Press **OK** to continue. Once you continue the test, the Front Panel displays the following messages:
 - Checking SWL PWM Forward.
 - Moving & Getting traces.
 - Moving SWL Motor
 - Dumping motor traces.
 - Analyzing motor traces.
 - Checking PWM results.
 - Checking SWL PWM Backward.
 - Moving & Getting traces.
 - Moving SWL Motor

- Dumping motor traces.
- Analyzing motor traces.
- Checking PWM results.

If there is a Failure at any point during the test, the Front Panel will display the relevant **System Error Code**. To trouble shoot any displayed error codes, refer to page 1-7, *System Error Codes - Full Descriptions*.

- 7 Once the test has been completed the Front Panel displays the test results.

```
Star Wheel Lifter
PWM Results (FW/BW):
Average: 3597.150/2972.840
Minimum: 1024/512
Maximum: 8064/6656
Max Pos: 108/101 EU/Int
Length: 3666 EU
Press any key to finish.
```

- 8 Press any key to finish.
- 9 The Front Panel shows the test complete display for a few seconds.

```
Star Wheel Lifter
      00  K  K
     0 0  K  K
     0 0  KK
     0 0  KK
     0 0  K  K
     00  K  K
```

- 10 The Front Panel prompts you to shutdown the printer to complete the test.

```
Star Wheel Lifter
Press any key to shutdown
the system.
```

- 11 Press any key to shutdown the printer.

PRS Test

The PRS subsystem is designed to move the carriage assembly between two predetermined vertical positions with respect to print platen plane. This allows different media of different thicknesses to be used without losing print quality.

Perform the Scan Axis - PRS test as follows:

Perform this test with the Printheads and the Tubes System installed in order to get values that can be compared correctly.

- 1 In the Diagnostics menu, scroll to **1. Scan Axis** and press **OK**.

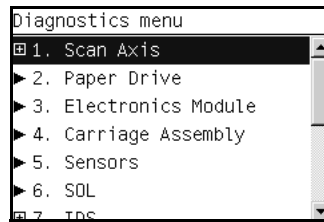

- 2 The Front Panel will show the **1. Scan Axis** submenu.

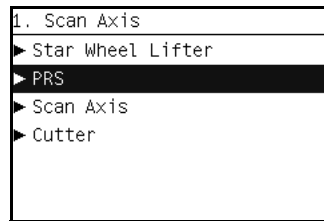

- 3 In the **Scan Axis** submenu, scroll to **PRS** and press **OK** to start the test.

The Printer will start the Scan Axis subsystem Common Initialization and PRS test initialization. If there is a Failure at any point during the tests, the Front Panel will display the relevant **System Error Code**. To trouble shoot any displayed error codes, refer to page 1-7, *System Error Codes - Full Descriptions*.

- 4 The printer then starts the PRS test to verify the subsystem. As the test executes the Front Panel displays the following messages:

- Starting Horsburgh and Mips.
- Starting Nvm.
- Starting Tests PWM.
- Starting Tests GPIO.
- Booting up the Carriage.
- Starting SVS Motor.
- Starting Carriage Motor.
- Starting PpsMotor.
- Starting Service Station.
- Starting Scan Axis.
- Moving SVS out of Scan.
- Homing Scan Axis.
- Move Carriage out of SVS.
- Homing Service Station.
- Starting Servicing Services.
- Reading PRS Position.
- Moving PRS position to HIGH.
- Moving PRS position to LOW.
- Moving PRS position to HIGH.
- Moving PRS position to HIGH.
- Moving PRS position to LOW.

- Moving PRS position to LOW.
 - Moving PRS position to HIGH.
- 5 Once the test has completed, the Front Panel prompts you to confirm that the PRS moved.

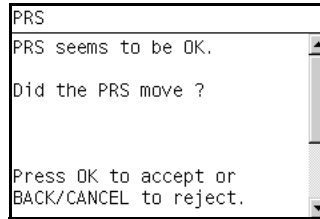

- 6 If the PRS moved, press OK to accept the results. If the PRS did not move, press Back or Cancel to reject the results and exit the test.
- 7 The Front Panel shows the test complete display for a few seconds.

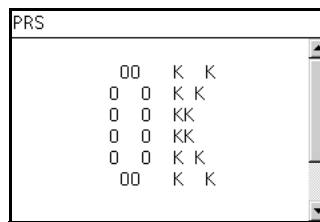

- 8 The Front Panel prompts you to shutdown the printer to complete the test.

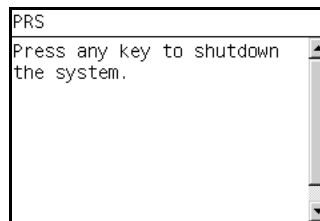

- 9 Press any key to shutdown the printer.

Scan Axis Test

The Scan Axis subsystem is designed to move the carriage assembly between two predetermined horizontal positions with respect to the print platen plane. This allows media of different widths to be used without losing print quality.

Perform the Scan Axis - Scan Axis test as follows:

Perform this test with the Printheads and the Tubes System installed in order to get values that can be compared correctly.

- 1 In the Diagnostics menu, scroll to **1. Scan Axis** and press **OK**.

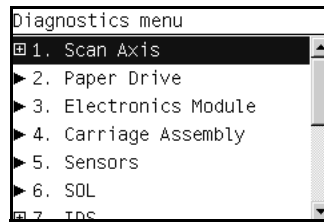

- 2 The Front Panel will show the **1. Scan Axis** submenu.

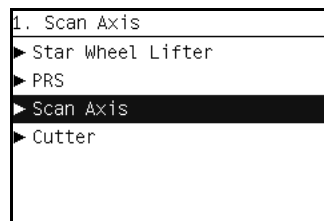

- 3 In the **Scan Axis** submenu, scroll to **Scan Axis** and press **OK** to start the test.

The Printer will start the Scan Axis subsystem Common Initialization. If there is a Failure at any point during the tests, the Front Panel will display the relevant **System Error Code**. To trouble shoot any displayed error codes, refer to page 1-7, *System Error Codes - Full Descriptions*.

- 4 The printer then starts the Scan Axis test initialization. As the test executes the Front Panel displays the following messages:

- Starting Horsburgh and Mips.
- Starting Nvm.
- Starting PWMManagerDelSol.
- Starting Tests PWM.
- Starting Tests GPIO.
- Moving StarWheelLifter to lower bump.

- 5 The Front Panel then asks if the Starwheel Lifter moved to the lower position.

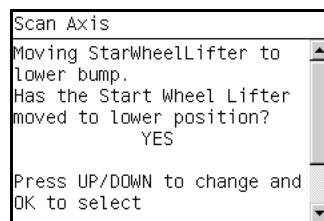

- 6 If the starwheel lifter is moved to the **LOW** position, press **OK** to accept the result. If the result is not correct use the **Arrow** keys to select **NO** and press **OK**.

If there is a Failure at any point during the test, the Front Panel will display the relevant **System Error Code**. To trouble shoot any displayed error codes, refer to page 1-7, *System Error Codes - Full Descriptions*.

- 7 The printer then starts the PSU check. As the test executes the Front Panel displays the following messages:

- Clear GPIO psu_sleep.
- Clear GPIO psu_Carr.
- Clear GPIO psu_Fan.
- Checking Voltage.
- Set GPIO psu_sleep.
- Set GPIO psu_Carr.
- Checking Voltage.

- 8 The Front Panel prompts you to confirm that the carriage supply LED is switched on.

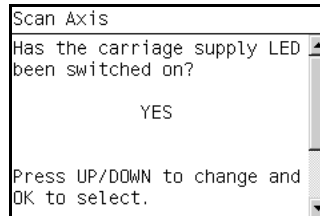

- 9 Open the Window and verify that the LED is on. The LED can be seen through the slots in the carriage cover.
- 10 Press **OK** if the LED is on. If the LED is not on or use the **Arrow** keys to select NO and press **OK**.
- 11 The printer then continues the Scan Axis test. As the test executes the Front Panel displays the following messages:
- Booting Up Carriage.
 - Starting SVS Motor.
 - Getting Part Number.
 - Getting Scan Axis Size
 - Preparing SVS.
 - Prog slow PWM scan.
 - Moving Carriage middle.

- 12 The Front Panel prompts you to confirm that the Carriage has moved.

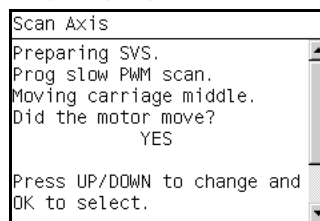

- 13 If the motor moved, press **OK** to accept the result. If the motor did not move, use the **Arrow** keys to select NO and press **OK**.
- 14 Press **OK** to continue.

- 15** The Front Panel prompts you to confirm that the Carriage has moved to the middle position.

```

Scan Axis
Preparing SVS.
Prog slow PWM scan.
Moving carriage middle.
Did the motor move?
Is carriage at middle?
      YES
Press UP/DOWN to change and
OK to select.
  
```

- 16** Use the **Arrow** keys to select whether or not the carriage has moved to the middle.
- 17** Press **OK** to continue.
- 18** The printer then continues the Scan Axis test. As the test executes the Front Panel displays the following messages:
- Starting Carriage Encoder.
 - Checking encoder readings.
- 19** The Front Panel prompts you to move the carriage to check the encoder readings.

```

Scan Axis
Checking encoder readings.
Please keep out from platen
zone and press
UP(left)/DOWN(right) to
move the carriage.

Remaining movements: 10
Last movement: 0 eu
  
```

- 20** Use the **Arrow** keys to move the Carriage left or right as prompted to by the Front Panel.
- 21** Repeat step 20 to complete the ten Carriage movements used to check the encoder.
- 22** The Front Panel displays the encoder check results.

```

Scan Axis
Max,Min mov: 528,464 eu
Avg mov: 493 eu
There is encoder feedback.

Encoder seems to be OK.

Press any key to continue.
  
```

- 23** Press any key to continue.
- 24** The printer then continues the Scan Axis test. As the test executes the Front Panel displays the following messages:
- Starting Carriage Motor.
 - On/Off Carriage Motor.
 - Doing a right side bump.
 - Doing a left side bump.
 - Exit bump position.
 - Checking scan axis length.

- 25** The Printer checks the complete length of the Scan-Axis and displays the result on the Front Panel.

```

Scan Axis
Checking scan axis length.
Total length: 1075008.
Press any key to continue.
  
```

- 26** Press any key to continue.
- 27** The printer then continues with the PWM test. As the test executes the Front Panel displays the following messages:
- Starting PpsMotor.
 - Starting Scan Axis.
 - Doing PWM test.
- 28** The Front Panel displays the PWM check results and prompts you to confirm or reject the test results.
- The PWM Average should be **between 0 and 18750**.
 - The PWM min diff limit should be **greater than or equal to 40**.

```

Scan Axis
PWM Average got (Fw/Bw):
10828.332 / 10772.450
PWM min diff limit: 40
PWM min diff got (Fw/Bw):
12208.00 / 11461.00
Press OK to confirm or
BACK/CANCEL to reject.
  
```

- 29** If the results are correct, press **OK** to accept the results. If the results are not correct, press **Back/Cancel** to reject the results and FAIL the test.
- 30** The printer then continues the Scan Axis test. As the test executes the Front Panel displays the following messages:
- Moving PRS to High.
- 31** The Front Panel displays the PRS position check results.

```

Scan Axis
PRS Position : HIGH.
Press any key to finish.
  
```

- 32** Press any key finish.

- 33** The Front Panel shows the test complete display for a few seconds.

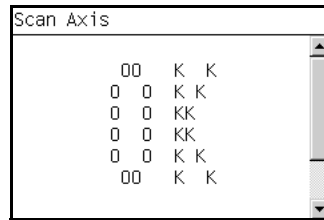

- 34** The Front Panel prompts you to shutdown the printer to complete the test.

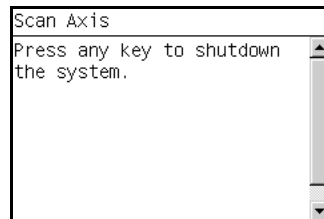

- 35** Press any key to shutdown the printer.

Cutter test

The Cutter is designed to cut roll media after printing for the size of sheet defined. Before executing this test you should run the Scan Axis, Media Drive and Carriage tests to ensure that each of these subsystems is operating correctly.

Perform the Scan Axis - Cutter test as follows:

- 1** In the Diagnostics menu, scroll to **1. Scan Axis** and press **OK**.

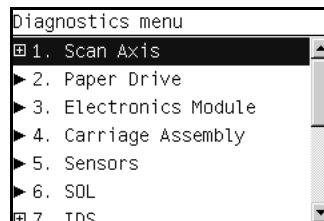

- 2** The Front Panel will show the **1. Scan Axis** submenu.

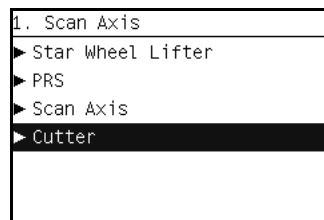

- 3** In the **Scan Axis** submenu, scroll to **Cutter** and press **OK** to start the test.

The Printer will start the Scan Axis subsystem Common Initialization and Cutter test initialization. If there is a Failure at any point during the tests, the Front Panel will display the relevant **System Error Code**. To trouble shoot any displayed error codes, refer to page 1-7, *System Error Codes - Full Descriptions*.

- 4** The printer then starts the Cutter test to verify the subsystem. As the test executes the Front Panel displays the following messages:

- Starting Horsburgh and Mips.
 - Starting Nvm.
 - Starting TestsGPIO.
 - Starting Nvm Motor
 - Getting Part Number.
 - Starting SvsMotor.
 - Starting CarriageMotor.
 - Starting ServiceStation.
 - Moving SVS to rear bump.
 - Homing Scan Axis.
 - Move Carriage out of SVS path.
 - Homing Service Station.
 - Starting ServicingServices.
 - Capping Service Station.
 - Uncapping Service Station.
 - Starting Cutter.
 - Starting PaperMotor.
 - Starting Media Sensor.
 - Reading Media Presence.
- 5** If paper is already loaded, the printer detects the paper and continues the test. If paper is NOT loaded, the Front Panel prompts you to load roll media.

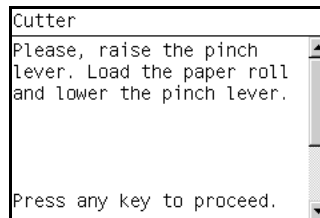

- 6** Raise the Media Lever, load roll media, lower the Media Lever, and press any key to continue.
- 7** The printer then starts an actual test cut of the media. As the test executes the Front Panel displays the following messages:
- Advance paper.
 - Engaging cutter.
 - Cutting paper.
 - Disengaging cutter.
- 8** Once the test has completed the Front Panel displays the test result and prompts you to confirm that the cutter worked.

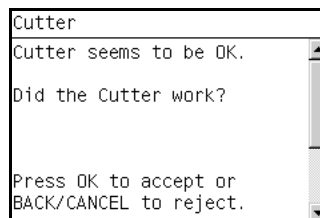

- 9 Press OK if the cutter worked or BACK/CANCEL if the cutter did NOT work.
- 10 The Front Panel shows the test complete display for a few seconds.

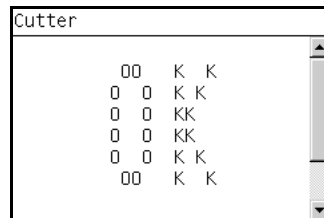

- 11 The Front Panel prompts you to shutdown the printer to complete the test.

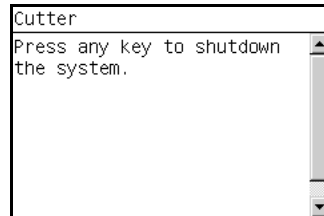

- 12 Press any key to shutdown the printer.

2. Paper Drive

The Paper Drive test diagnoses Failures of components of the Media-Axis.

You must perform the Paper Drive Test after:

- System Error Code 81:XZ.
- System Error Code 41:XZ.
- System Error Code 73:XZ.

Diagnostic tests also need to be performed after removing or replacing certain printer components. If you have removed or replaced printer components, check the Service Calibration Guide to Removal and Installation to see which tests and calibrations you need to perform. Refer to Page 6-8.

ALL THE COVER SENSORS ARE DISABLED WHEN IN THE SERVICE TESTS MENU. IF THE CARRIAGE IS MOVING IT WILL NOT STOP IF THE WINDOW IS OPENED, SO BE VERY CAREFUL NOT TO PUT YOUR HANDS INSIDE.

IF POSSIBLE ALWAYS PERFORM THIS TEST BEFORE REPLACING ANY COMPONENT OF THE MEDIA-AXIS.

Perform the Paper Drive test as follows:

Perform this test with the Printheads and the Tubes System installed in order to get values that can be compared correctly.

- 1** In the Diagnostics menu, scroll to **2. Paper Drive** and press **OK**.

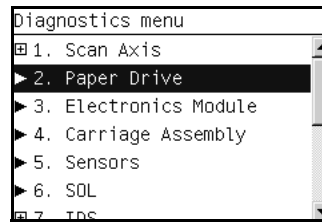

- 2** The printer starts the Paper Drive test to verify the subsystem. As the test executes the Front Panel displays the following messages:

- Starting Horsburgh and Mips.
- Starting Nvm
- Starting Tests PWM.
- Starting Tests GPIO.
- Booting up the Carriage.
- Starting DelSol1.
- Starting Carriage.
- Starting AnalogEncoder.
- Getting Part Number.
- Part Number
- Getting PCA revision.

- 3** The Front Panel then displays the Main PCA Revision and prompts you to press any key to continue.

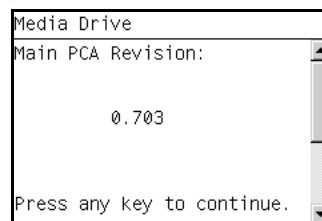

- 4** Press any key to continue.
- 5** The Front Panel displays the following messages:
- Prog slow PWM paper.
- 6** The Front Panel then prompts you to remove the media.

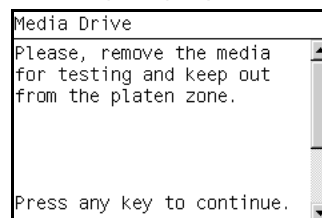

- 7** Remove the media.
- 8** Press any key to continue.

- 9 The Front Panel then displays the Open Loop ROLL test result.

```
Media Drive
Checking Open Loop ROLL.
Movement done: 417095 eu.
Press any key to continue.
```

- 10 Press any key to continue.

- 11 The Front Panel then displays the Open Loop UNROLL test result.

```
Media Drive
Checking Open Loop UNROLL.
Movement done: 558859 eu.
Press any key to continue.
```

- 12 Press any key to continue.

- 13 The Front Panel then displays:

- Starting Paper Motor.
- Starting Paper Axis.
- Calib. Analog Decoder.

- 14 The Front Panel then displays the Analog Decoder calibration results.

```
Media Drive
Analog Encoder results:
CHANNEL  GAIN  OFFSET
A         2.0   10.0
B         2.0   11.0
Press OK to confirm or
BACK/CANCEL to reject.
```

- The GAIN for channel A must be **between 0 and 3.5**.
- The GAIN for channel B must be **between 0 and 4.5**.
- The OFFSET for channel A must be **between -63.5 and 63.5**.
- The OFFSET for channel B must be **between 63.5 and 63.5**.

- 15 If the results are correct, press **OK** to accept the results. If the results are not correct, press **Back/Cancel** to reject the results and FAIL the test.

- 16 If you accept the results, the Front Panel then displays:

- Starting Media Path.
- Homing and repeatability test.

- 17 The Front Panel then prompts you to remove the media.

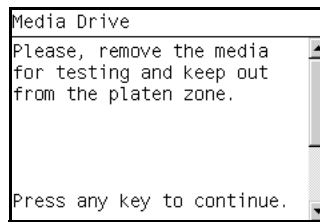

- 18 Remove the media.
- 19 Press any key to continue.
- 20 The Front Panel then displays:
- PWM test without paper.
- 21 The Front Panel then displays the test results.
- The PWM avg results must be **between 16000 and 14000**.
 - The Speed error results must be **less than 50**.
 - The PWM StDev results must be **between 0 and 500**.
 - The PWM max results must be **between 15000 and 20000**.

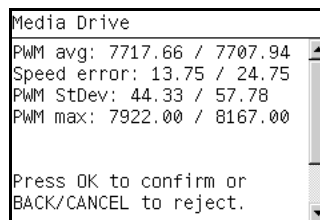

- 22 If the results are correct, press **OK** to accept the results. If the results are not correct, press **Back/Cancel** to reject the results and FAIL the test.
- 23 If you accept the results, the Front Panel shows the test complete display for a few seconds:

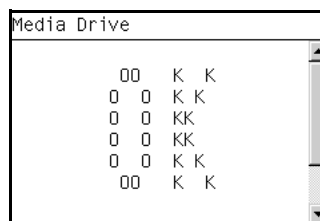

- 24 The Front Panel prompts you to shutdown the printer to complete the test.

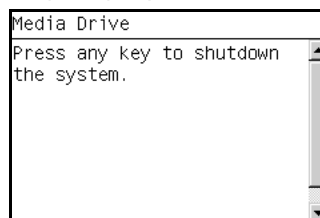

- 25 Press any key to shutdown the printer.

3. Electronics Module

The Electronics Module test diagnoses Failures of the following components:

- Main PCA components
- Electronics Module to Carriage interfacing.
- Print Mech PCA components.
- Power Supply Unit voltages.

Diagnostic tests also need to be performed after removing or replacing certain printer components. If you have removed or replaced printer components, check the Service Calibration Guide to Removal and Installation to see which tests and calibrations you need to perform. Refer to Page 6-8.

Perform the Electronics Module test as follows:

- 1 In the Diagnostics menu, scroll to **2. Electronics Module** and press **OK**.

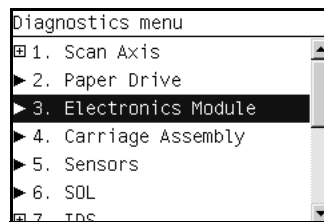

- 2 The printer starts the Electronics Module test and displays the following messages:

- Starting Horsburgh and Mips.
- Starting Nvm.
- Accessing Nvm.

- 3 The printer starts the Electronics Module test to verify the subsystem and prompts you to test the Power Supply:

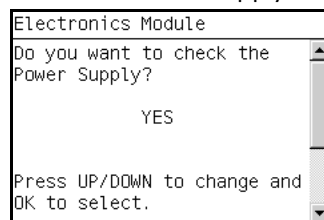

- 4 Press **OK** to test the Power Supply. If you do not wish to test the power supply use the **Arrow** keys to select NO and press **OK**.
- 5 The Power supply test starts and the Front Panel displays the following messages:
 - Starting DelSol7.
 - Starting Carriage.
 - Getting PSU voltages.

- 6 The Front Panel then displays the Power Supply test results.

```

Electronics Module
Power supply voltages:
Volt. (45/32/5):
43.70/31.58/5.03
Volt (3.3/3.3_F/2.5):
3.313/3.313/2.436
Volt (1.25A/1.25_B):
1.199/1.225
Press any key to continue.
  
```

- 7 Press any key to continue.
- 8 The Fan Speed test starts and the Front Panel displays:
- Getting PSU Fan Rotation
- 9 The Front Panel then displays the Fan Speed test result and prompts you to press any key to continue.

```

Electronics Module
PSU Fan Speed: OK
Press any key to continue.
  
```

- 10 Press any key to continue.
- 11 The Front Panel then prompts you to test the Formatter.

```

Electronics Module
Do you want to check the
Formatter?

YES

Press UP/DOWN to change and
OK to select.
  
```

- 12 Press **OK** to test the Formatter. If you do not wish to test the Formatter use the **Arrow** keys to select **NO** and press **OK**.
- 13 The Formatter voltage test starts and the Front Panel displays the following messages:
- Starting DelSol1.
 - Getting PCA revision.
- 14 The Front Panel then displays PCA Rev. Voltage test result and prompts you to press any key to continue.

```

Electronics Module
PCA Rev. Voltage: 0.77
Press any key to continue.
  
```

- 15 Press any key to continue.
- 16 The Formatter memory size test starts and the Front Panel displays the following messages:

- Starting DelSol1.
- Getting PCA Revision.
- Checking Memory Size.
- Getting Memory Size.

17 The Front Panel then displays Formatter Memory Size and prompts you to press any key to continue.

```

Electronics Module
Formatter Memory Size:
114MB (128 MB)
Press any key to continue.

```

18 Press any key to continue.

19 The Formatter hard disk test starts and the Front Panel displays the following messages:

- Starting DelSol1.
- Getting PCA Revision.
- Checking Memory Size.
- Getting HDA info.

20 The Front Panel then displays Formatter Hard Disk information test results and prompts you to press any key to continue.

```

Electronics Module
Device Boot Id Blocks
HDA1 * 83 136048+
HDA2 83 1050840
HDA3 83 3152520
HDA6 83 11536528+
HDA7 83 9442408+
HDA8 83 10599088+
Press any key to continue.

```

21 Press any key to continue.

22 The Formatter hard disk file information test starts and the Front Panel displays the following messages:

- Starting DelSol1.
- Getting PCA Revision.
- Checking Memory Size.
- Getting HDA Info.
- Getting File System Info.

23 The Front Panel then displays Formatter Hard Disk File information test results and prompts you to press any key to continue.

```

Electronics Module
Device 1k-Blocks %Used
HDA1 132207 12%
HDA6 11352976 1%
HDA7 9288792 11%
HDA8 10444292 4%
Press any key to continue.

```

- 24** Press any key to continue.
- 25** The MainBoard Revision Voltage test starts and the Front Panel displays the following messages:
- Starting DelSol1.
 - Getting PCA Revision.
 - Checking Memory Size.
 - Getting HDA Info.
 - Getting File System Info.
 - Getting MainBoard Rev.
- 26** The Front Panel then displays MainBoard Voltage test results and prompts you to press any key to continue.

```

Electronics Module
MainBoard Revision voltage:
                                0.696
Press any key to continue.
  
```

- 27** Press any key to continue.
- 28** The Main Memory Size test starts and the Front Panel displays the following messages:
- Starting DelSol1.
 - Getting PCA Revision.
 - Checking Memory Size.
 - Getting HDA Info.
 - Getting File System Info.
 - Getting MainBoard Rev.
 - Getting Main Memory Size.
- 29** The Front Panel then displays Main Memory size test results and prompts you to press any key to continue.

```

Electronics Module
Main memory size: 128MB
Press any key to continue.
  
```

- 30** Press any key to continue.
- 31** The Front Panel then prompts you to test the Formatter Communications.

```

Electronics Module
Do you want to check the
Formatter communications?
                                YES
Press UP/DOWN to change and
ENTER to select.
  
```

- 32** Press **OK** to test the Formatter. If you do not wish to test the Formatter use the **Arrow** keys to select **NO** and press **OK**.
- 33** The Formatter Communications test starts and the front Panel displays the following messages:
- Starting Micci2Bus.
 - Starting Micci2BusProxy.
 - Checking Communications.
- 34** The Front Panel then displays Formatter Communications test results and prompts you to press any key to continue.

```

Electronics Module
ID      Device name
1       DelSol1
5       DelSol15
7       DelSol17
2       Luna2
Press any key to continue.

```

- 35** Press any key to continue.
- 36** The Front Panel then prompts you to check the Plotter Information.

```

Electronics Module
Do you want to check the
Plotter information?

        YES

Press UP/DOWN to change and
OK to select.

```

- 37** Press **OK** to check the Plotter Information. If you do not wish to test the Plotter Information use the **Arrow** keys to select **NO** and press **OK**.
- 38** The Plotter information test starts and the Front Panel displays the following messages:
- Starting Nvm
 - Accessing Nvm.
 - Getting Plotter info.
- 39** The Front Panel then displays the Plotter Information results and prompts you to press any key to finish.

```

Electronics Module
Proto-Name:    LP1
Proto-Product: TROYA-8
Scan Axis size: 24
Press any key to finish.

```

- 40** Press any key to finish.

- 41** The Front Panel shows the test complete display for a few seconds.

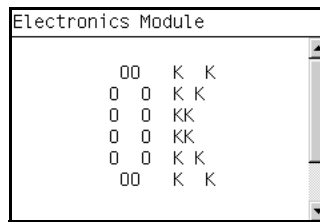

- 42** The Front Panel prompts you to shutdown the printer to complete the test.

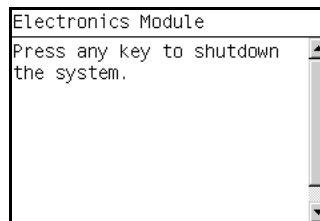

- 43** Press any key to shutdown the printer.

4. Carriage Assembly

The Carriage assembly test diagnoses Failures of any components of the Carriage. Always run this test before replacing the Carriage Assembly.

Diagnostic tests also need to be performed after removing or replacing certain printer components. If you have removed or replaced printer components, check the Service Calibration Guide to Removal and Installation to see which tests and calibrations you need to perform. Refer to Page 6-8.

- 1** In the Diagnostics menu, scroll to **4. Carriage Assembly** and press **OK**.

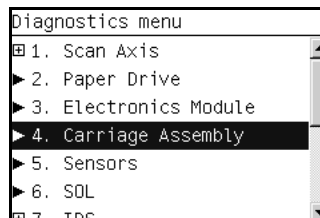

- 2** The Power supply test starts and the Front Panel displays the following messages:

- Starting Horsburgh.
- Starting Nvm.
- Accessing Nvm.
- Starting AdcManagerHorus.
- Starting Carriage.
- Getting Carriage PCA Rev.

- 3** The Front Panel prompts you to verify the Carriage Assembly PCA revision. The PCA Rev must be **between 0.823 and 1.005**.

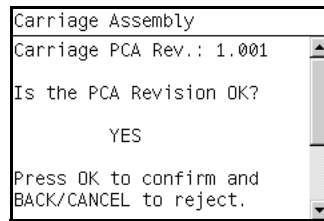

- 4** If the results are correct, press **OK** to accept the results. If the results are not correct, press **Back/Cancel** to reject the results and FAIL the test.
- 5** The Carriage Assembly test starts and the Front Panel displays the following messages followed by their results:
- Getting Num of pens.
 - Getting Scan Access size.
 - Getting Vs Carriage Voltage.
- 6** The Front Panel then displays the Carriage Voltage (+Vs) test results. The +vs Voltage should be **between 43.6 and 46.3**.

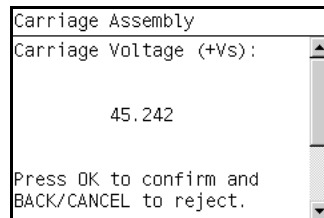

- 7** If the results are correct, press **OK** to accept the results. If the results are not correct, press **Back/Cancel** to reject the results and FAIL the test.
- 8** The Carriage Assembly Vaux test starts and the Front Panel displays:
- Getting Vaux Carriage Volt.
- 9** The Front Panel then displays the Carriage Voltage (+Vaux) test results.

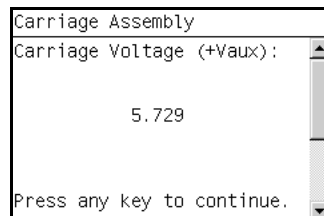

- 10** Press any key to continue.
- 11** The Carriage Assembly UVC flag test starts and the Front Panel displays:
- Clearing UVC flag.
 - Reading UVC flag.
 - Checking UVC flag.

- 12** The Front Panel then displays the UVC flag test results.

```

Carriage Assembly
Clearing UVC flag.
Reading UVC flag.
Checking UVC flag.
UVC Flag is OK

Press any key to continue.
    
```

- 13** Press any key to continue.
- 14** The Carriage Assembly Pens Voltage test starts and the Front Panel displays:
- Reading Vpp.
- 15** The Front Panel then displays the Pens Voltage test results. The result must be **between 26.5 and 33 Volts**.

```

Carriage Assembly
Pens Voltage (Vpp):

                29.861

Press OK to confirm and
BACK/CANCEL to reject.
    
```

- 16** If the results are correct, press **OK** to accept the results. If the results are not correct, press **Back/Cancel** to reject the results and FAIL the test.
- 17** The Carriage Assembly test continues and the Front Panel displays:
- Starting Line Sensor Leds.
 - Starting Light Sensor.
 - Starting SVS Motor.
 - Starting Carriage Motor.
 - Moving SVS out of Sax.
 - Moving Carriage middle.
 - Initializing LineSensor.
- 18** The Front Panel then prompts you to load roll media.

```

Carriage Assembly
Please, raise the pinch
lever.
Load Roll paper and lower
the pinch lever.

Press any key to proceed..
    
```

- 19** Load roll media.

For the LED test to work properly, the paper must be loaded completely through the carriage path.

- 20** Press any key to continue.
- 21** The Carriage Assembly test continues and the Front Panel displays the result of each phase of the test:

- Setting LS low intensity.
For each color LED: Blue, Green, Red, and Amber
- Setting LS max intensity.
For each color LED: Blue, Green, Red, and Amber
- Checking Tolerance.
- Deactivating LS.
- Starting NvmLineSensor.
- Initializing NvmLineSensor.
- Getting LS Serial Number.
- Reading LS Nvm.
- Writing new LS Nvm.
- Checking LS Serial Number.
- Restoring LS Serial Number.
- Starting Service Station.
- Starting Scan Axis.
- Moving SVS out of sax.
- Homing Scan Axis.
- Moving Carriage out of SVS.
- Homing Service Station.
- Starting Servicing Services.
- Capping Service Station.
- Uncapping Service.
- Moving to Pen position.
- Reading Pen presence.
- Starting ColorSensing.
- Reading esp status.

- 22** The Front Panel then prompts you to enable the Color Sensor ESP (spectrophotometer).

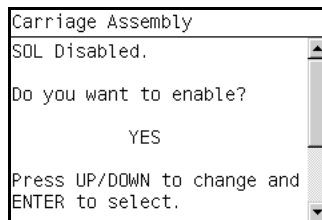

- 23** Press **OK** to enable the Color Sensor ESP (spectrophotometer). If you do not wish to enable the Color Sensor ESP (spectrophotometer) use the **Arrow** keys to select NO and press **OK**.
- 24** The Color Sensor ESP (spectrophotometer) enable test starts and the front Panel displays the following messages:
- Starting ColorSensor.
 - Starting ColorSensing.
 - Reading Color Sensor ESP (spectrophotometer) status.
 - Enabling Color Sensor ESP (spectrophotometer).

- 25** The Front Panel then displays Color Sensor ESP (spectrophotometer) enable test result and prompts you to press any key to continue.

```

Carriage Assembly
Starting ColorSensor.
Starting ColorSensing.
Reading SOL status.
Enabling SOL.
SOL enable/disable OK

Press any key to continue.
    
```

- 26** Press any key to continue.
- 27** The Front Panel then prompts you to confirm the information.

```

Carriage Assembly
FW Revision: V4.080D
Sensor Type: PP2
Serial Number: 169857308
Mfg date: 0622

YES.
Press ENTER to confirm and
BACK/CANCEL to reject.
    
```

- 28** Press **OK** to confirm the information. If you want to reject the information use the **Arrow** keys to select NO and press **OK**.
- 29** The Carriage Assembly calibration test starts and the front Panel displays the following messages:
- Starting ColorSensor.
 - Starting ColorSensing.
 - Reading Color Sensor ESP (spectrophotometer) status.
 - Reading registers.
 - Performing calibration.
- 30** The Front Panel then displays DeltaE test result and prompts you to press any key to continue.

```

Carriage Assembly
Maximum DeltaE: 2.560

Press any key to continue.
    
```

- 31** Press any key to continue.
- 32** The Carriage checks that the printheads are currently inserted, moves into the print path and the front Panel then prompts you to remove all the printheads.

```

Carriage Assembly
Please, remove all pens...

Press any key to continue.
    
```

- 33** Open the Window.
- 34** Open the Carriage cover.
- 35** Remove all the Printheads from the Carriage.
- 36** Press any key to continue.
- 37** The Carriage Assembly pens test verifies that the printheads are not inserted.
- 38** The Front Panel then prompts you to insert all the Printheads.

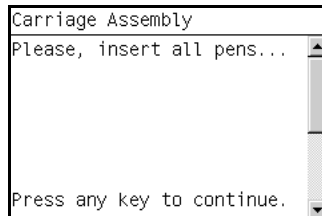

- 39** Replace all the Printheads.
- 40** Close the Carriage Cover.
- 41** Close the Window.
- 42** Press any key to continue.
- 43** The Carriage Assembly pens test verifies that the printheads are inserted.
- 44** The Front Panel then displays the test result.

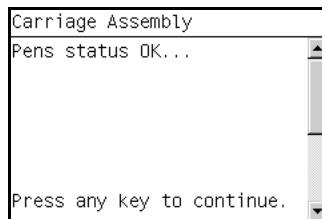

- 45** Press any key to continue.
- 46** The printer continues the test, and the Front Panel displays:
 - Preparing Pen initialization.
 - Checking Pen status
- 47** The Front Panel then displays the test result.

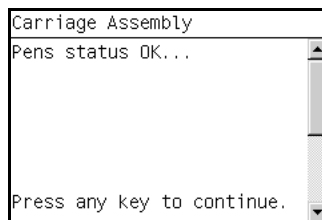

- 48** The Encoder Manager test starts and the Front Panel displays:
 - Starting EncoderManager.
 - Moving Carriage center.
 - Setting Encoder.
 - Reading Encoder position.
 - Moving Carriage to left.

- Reading Encoder position.
- Checking Encoder readings.
- Moving Carriage rightwards
- Reading Encoder positions
- Checking Encoder readings

49 The Front Panel then displays Encoder Difference (Left/Right) test result and prompts you to press any key to finish.

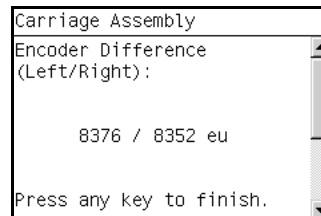

50 Press any key to finish.

51 The Front Panel shows the test complete display for a few seconds.

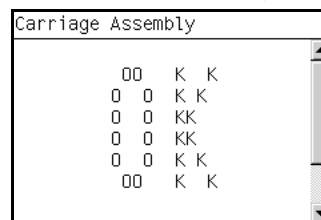

52 The Front Panel prompts you to shutdown the printer to complete the test.

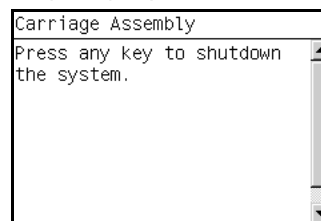

53 Press any key to shutdown the printer.

5. Sensors

The Sensors test diagnoses Failures of any sensors of the printer. Always run this test before replacing any of the following sensors:

- Window sensor.
- Media Lever position sensor.
- Media sensor

Diagnostic tests also need to be performed after removing or replacing certain printer components. If you have removed or replaced printer components, check the Service Calibration Guide to Removal and Installation to see which tests and calibrations you need to perform. Refer to Page 6-8.

- 1 In the Diagnostics menu, scroll to **5. Sensors** and press **OK**.

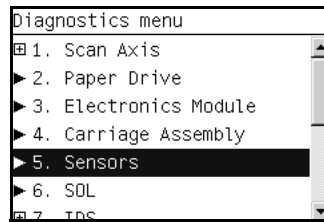

- 2 The Sensors test starts and the Front Panel then displays the following messages:

- Starting Horsburgh and Mips
- Starting Nvm
- Starting Tests GPIO
- Getting part number

- 3 The Sensors test starts and the Front Panel prompts you to verify default sensor positions:

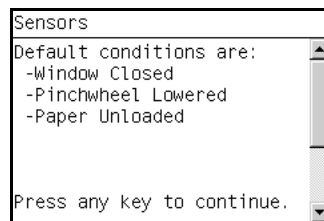

- 4 Verify that the sensors are in the default positions and any key to continue.
- 5 The Window sensor test starts and the Front Panel prompts you to open the Window:

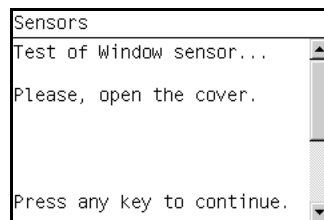

- 6 Open the Window.
- 7 Press any key to continue.
- 8 The Window sensor test continues and the Front Panel prompts you to close the Window:

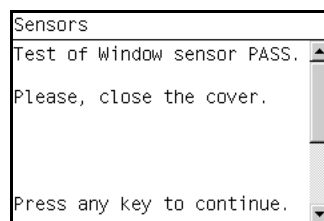

- 9 Close the Window.
- 10 Press any key to continue.

- 11** The Media Lever sensor test starts and the Front Panel prompts you to raise the Media Lever:

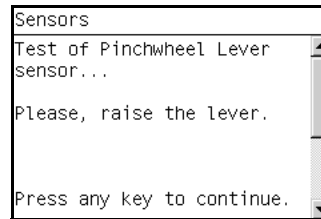

- 12** Raise the Media Lever.
13 Press any key to continue.
14 The Media Lever sensor test continues and the Front Panel prompts you to lower the Media Lever:

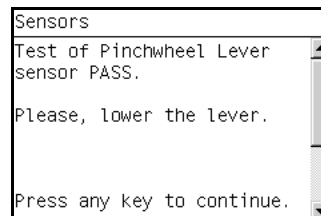

- 15** Lower the Media Lever.
16 Press any key to continue.
17 The Media sensor test starts and the Front Panel prompts you load media:

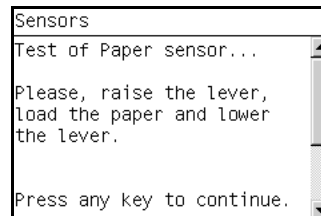

- 18** Raise the Media Lever.
19 Load media.
20 Lower the Media Lever.
21 Press any key to continue.
22 The Media sensor test continues and the Front Panel prompts to remove media:

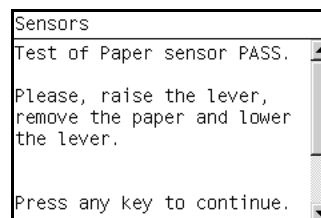

- 23** Raise the Media Lever.
24 Unload the media.
25 Lower the Media Lever.

- 26** Press any key to continue.
- 27** The Front Panel shows the test complete display for a few seconds.

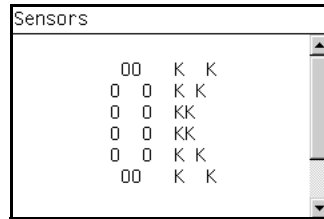

- 28** The Front Panel prompts you to shutdown the printer to complete the test.

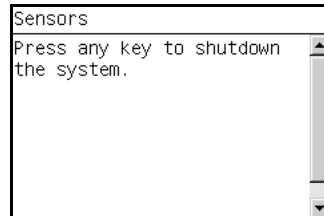

- 29** Press any key to shutdown the printer.

6. Color Sensor ESP (spectrophotometer)

The Color Sensor ESP (spectrophotometer) test diagnoses Failures of the Color Sensor located on the carriage. Always run this test before replacing the Color sensor.

Diagnostic tests also need to be performed after removing or replacing certain printer components. If you have removed or replaced printer components, check the Service Calibration Guide to Removal and Installation to see which tests and calibrations you need to perform. Refer to Page 6-8.

- 1** In the Diagnostics menu, scroll to **6. Color Sensor ESP (spectrophotometer)** and press **OK**.

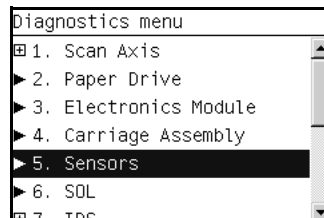

- 2** The Color Sensor ESP (spectrophotometer) test starts and the front Panel displays the following messages:
- Starting Horburgh.
 - Starting Carriage.
 - Starting Nvm.
 - Getting Part Number.
 - Getting Scan Axis size.
 - Starting Service Station.
 - Starting Scan Axis.
 - Moving SVS out of Sax.

- Homing Scan Axis.
 - Moving Carriage out of SVS.
 - Homing Service Station.
 - Starting Servicing Services.
 - Capping Service Station.
 - Starting ColorSensor.
- 3 The Front Panel then prompts you to enable the Color Sensor ESP (spectrophotometer).

```

SQL
SQL Disabled.

Do you want to enable?

        YES

Press UP/DOWN to change and
ENTER to select.
  
```

- 4 Press **OK** to enable the Color Sensor ESP (spectrophotometer). If you do not wish to enable the Color Sensor ESP (spectrophotometer) use the **Arrow** keys to select NO and press **OK**.
- 5 The Color Sensor ESP (spectrophotometer) enable test starts and the front Panel displays the following messages:
- Starting ColorSensor.
 - Starting ColorSensing.
 - Reading Color Sensor ESP (spectrophotometer) status.
 - Enabling Color Sensor ESP (spectrophotometer).
- 6 The Front Panel then displays Color Sensor ESP (spectrophotometer) enable test result and prompts you to press any key to continue.

```

SQL
Starting ColorSensor.
Starting ColorSensing.
Reading SQL status.
Enabling SQL.
SQL enable/disable OK

Press any key to continue.
  
```

- 7 Press any key to continue.
- 8 The Front Panel then displays the Color Sensor ESP (spectrophotometer) details and prompts you to press any key to continue.

```

SQL
FW Revision:  V4.080D
Sensor Type:  PP2
Serial Number: 169857228
Mfg date:    0622

        YES.
Press ENTER to confirm and
BACK/CANCEL to reject.
  
```

- 9 The Front Panel then prompts you load media:

```
SOL
Please, raise the pinch
lever.
Load Roll paper and lower
the pinch lever.

Press any key to proceed.
```

- 10 Raise the Media Lever.
 11 Load media.
 12 Lower the Media Lever.
 13 Press any key to continue.
 14 The Front Panel then displays the DeltaE test result and prompts you to press any key to continue.

```
SOL
Maximum DeltaE: 2.735

Press any key to continue.
```

- 15 Press any key to continue.
 16 The Front Panel shows the test complete display for a few seconds.

```
SOL

  00  K  K
  0 0  K K
  0 0  KK
  0 0  KK
  0 0  K K
  00  K  K
```

- 17 The Front Panel prompts you to shutdown the printer to complete the test.

```
SOL
Press any key to shutdown
the system.
```

- 18 Press any key to shutdown the printer.

7. Ink Delivery System (IDS)

The complete Ink Delivery System test consists of individual tests for the different components related to this subsystem. These tests are:

- Ink Delivery System
- Check Ink Supplies
- Check Leakage

Diagnostic tests also need to be performed after removing or replacing certain printer components. If you have removed or replaced printer components, check the Service Calibration Guide to Removal and Installation to see which tests and calibrations you need to perform. Refer to Page 6-8.

Ink Delivery System

If you get a system error code 22.n:10 during this test, please refer to the system error code description on Page 2-77 for more information.

- 1 In the Diagnostics menu, scroll to **7. IDS** and press **OK**.

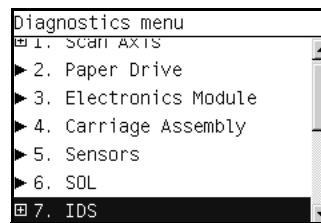

- 2 The Front Panel will show the **7. IDS** submenu.

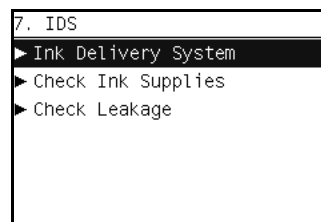

- 3 In the **IDS** submenu, scroll to **Ink Delivery System** and press **OK** to start the test.
- 4 The Ink Delivery System test starts and the front Panel prompts you to remove all the Ink Supplies.

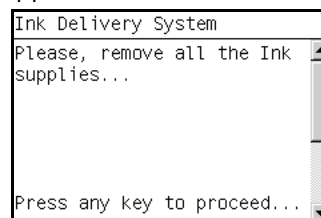

- 5 Remove all the Ink Cartridges.
- 6 Press **OK** to continue.
- 7 The test continues and the front Panel displays the following messages:
 - Starting Horsburgh.
 - Starting Mips.
 - Starting Nvm.
 - Getting Part Number.
 - Starting ISS Motors.
 - Moving Bongos down.

- Reading Bongos down.
- Moving Bongos up.
- Reading Bongos up.
- Starting OutOfInk sensors.
- Reading OutOfInk.

8 The Front Panel then prompts you push down Bongo0.

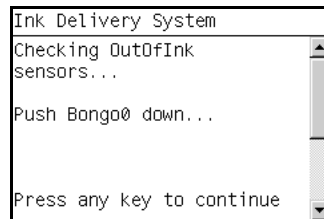

9 Press and hold down Bongo0 which is located at the furthest left Ink Cartridge position.

10 Press any key.

11 Release Bongo0.

12 Press any key.

13 The Front Panel then displays the Bongo0 test results.

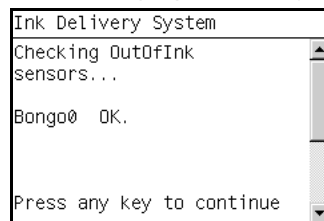

14 Press any key to continue.

15 Repeat steps 8 through 14 for the remaining Out of Ink sensors for each of the Ink Cartridges.

16 The front Panel prompts you to insert all the Ink Supplies.

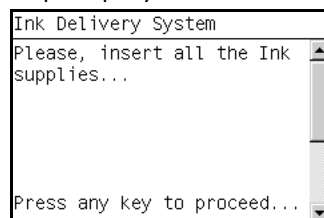

17 Install all the Ink Cartridges.

18 Press **OK** to continue.

19 The Acumen Supplies test and the front Panel displays the following messages:

- Starting AcumenSupplies.
- Reading AcumenSupplies.

- 20** The Front Panel then displays Acumen Supplies test results.

```

Ink Delivery System
Starting AcumenSupplies.
Reading Acumen Supplies.

Acumen Supplies OK.

Press any key to finish.
  
```

- 21** The Front Panel shows the test complete display for a few seconds.

```

Ink Delivery System

      00  K  K
      0 0  K K
      0 0  KK
      0 0  KK
      0 0  K K
      00  K  K
  
```

- 22** The Front Panel prompts you to shutdown the printer to complete the test.

```

Ink Delivery System
Press any key to shutdown
the system.
  
```

- 23** Press any key to shutdown the printer.

Check Ink Supplies

- 1** In the Diagnostics menu, scroll to **7. IDS** and press **OK**.

```

Diagnostics menu
└─ 1. Scan Axis
  └─ 2. Paper Drive
    └─ 3. Electronics Module
      └─ 4. Carriage Assembly
        └─ 5. Sensors
          └─ 6. SQL
            └─ 7. IDS
  
```

- 2** The Front Panel will show the **7. IDS** submenu.

```

7. IDS
└─ Ink Delivery System
  └─ Check Ink Supplies
  
```

- 3** In the **IDS** submenu, scroll to **Check Ink Supplies** and press **OK** to start the test.
- 4** The Check Ink Supplies test starts and the front Panel displays the following messages:
- Starting Horburgh & Mips.
 - Starting Nvm.

- Getting Part Number.
 - Starting Supplies.
 - Starting AcumenSupplies.
 - Reading Ink Supplies.
- 5 The Front Panel then displays Check Ink Supplies test results. Use the **Arrow** keys to view the second results screen.

```

Check Ink Supplies
      F  N  V  G
OK purge:  YES YES YES YES
Ink (%):   090 096 097 097
Ink (CC):  120 128 130 129

Press UP/DOWN to show next
window and OK to exit.

```

```

Check Ink Supplies
      M  Y  m  lc
OK purge:  YES YES YES YES
Ink (%):   097 091 098 098
Ink (CC):  129 122 131 130

Press UP/DOWN to show next
window and OK to exit.

```

```

Check Ink Supplies
      k  n  K  R
OK purge:  YES YES YES YES
Ink (%):   097 092 098 094
Ink (CC):  129 122 130 125

Press UP/DOWN to show next
window and OK to exit.

```

- 6 Press **OK** to exit.
- 7 The Front Panel shows the test complete display for a few seconds.

```

Check Ink Supplies
      00  K  K
      0 0  K K
      0 0  KK
      0 0  KK
      0 0  K K
      00  K  K

```

- 8 The Front Panel prompts you to shutdown the printer to complete the test.

```

Check Ink Supplies
Press any key to shutdown
the system.

```

- 9 Press any key to shutdown the printer.

Check Leakage

- 1 In the Diagnostics menu, scroll to **7. IDS** and press **OK**.

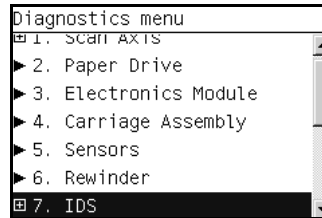

- 2 The Front Panel will show the **7. IDS** submenu.

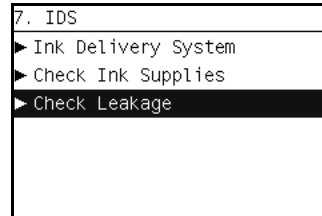

- 3 In the **IDS** submenu, scroll to **Check Leakage** and press **OK** to start the test.
- 4 The Ink Delivery System test starts and the front Panel prompts you to remove all the Ink Supplies.

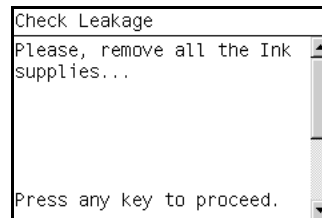

- 5 The Check Leakage test starts and the Front Panel displays the following messages:
 - Starting Horsburgh and Mips
 - Starting Nvm
 - Starting Tubes
 - Reading Tubes status
 - Getting Part Number
 - Starting ISS Motors
 - Starting OOI Sensors
 - Moving Bongos down
- 6 While the printer moves the Bongos down, the Front Panel displays the following message:

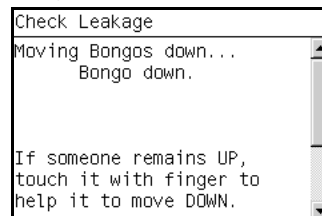

- 7** If a Bongo remains in the UP position, use your finger to help push it down. The test continues and displays the following messages:
- Reading OOI Sensors
 - Moving Bongos up
 - Reading OOI Sensors
 - Moving Bongos down

- 8** The front Panel prompts you to insert all the Ink Supplies.

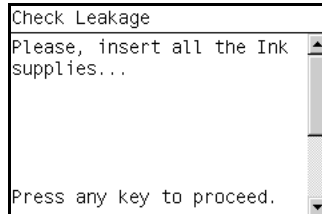

- 9** Install all the Ink Cartridges.
- 10** Press **OK** to continue.
- 11** The test continues and displays the following messages:
- Moving Bongos up
 - Checking OOI condition
- 12** The Front Panel then displays Check Leakage test results.

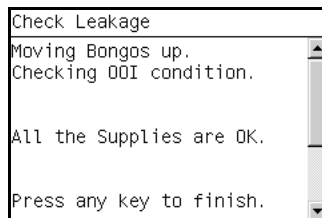

- 13** The Front Panel shows the test complete display for a few seconds.

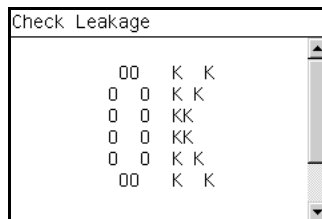

- 14** The Front Panel prompts you to shutdown the printer to complete the test.

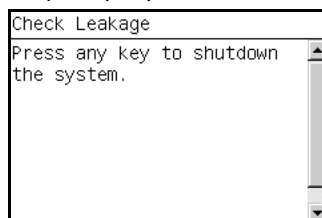

- 15** Press any key to shutdown the printer.

8. Service Station

The complete Service Station test consists of individual tests for the different components related to this subsystem.

These tests are:

- Service Station
- Primer Motor
- Aerosol Fan

Diagnostic tests also need to be performed after removing or replacing certain printer components. If you have removed or replaced printer components, check the Service Calibration Guide to Removal and Installation to see which tests and calibrations you need to perform. Refer to Page 6-8.

Service Station

- 1 In the Diagnostics menu, scroll to **8. Service Station** and press **OK**.

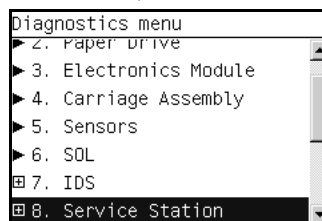

- 2 The Front Panel will show the **8. Service Station** submenu.

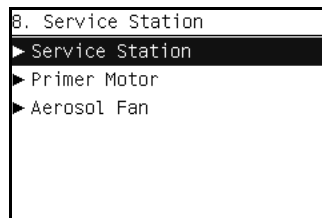

- 3 In the **8. Service Station** submenu, scroll to **Service Station** and press **OK** to start the test.
- 4 The Service Station test starts and the front Panel displays the following messages:
 - Starting Horsburgh and Mips
 - Starting Nvm
 - Booting up Carriage.
 - Starting SVS Motor.
 - Starting Carriage Motor
 - Getting Part Number.
 - Starting Service Station.
 - Starting Scan Axis.
 - Moving SVS out of Sax.
 - Homing Scan Axis.
 - Moving Carriage out of SVS.
 - Homing Service Station.

- Moving to Spit Rear pos.
- Moving to Spit Front pos.
- Moving to Wipe forward pos.
- Moving to Wipe reverse pos.
- Moving to Cleaner pos.
- Moving to ESP pos.
- Moving to PEG pos.
- Moving to Color Sensor ESP (spectrophotometer) pos.
- Homing Scan Axis.
- Starting ServicingServices.
- Capping Service Station.
- Uncapping Service Station.
- Starting Mechanical Init.

5 The Front Panel then prompts you to check the status of the printer.

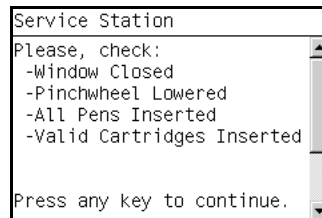

6 Check that:

- The Window is closed.
- The Media Lever is lowered.
- All Printheads are inserted.
- Valid Cartridges are inserted.

7 Press **OK** to continue.

8 The test continues and the Front Panel displays the following messages:

- Moving SVS to Wiping bider position.
- Moving SVS to Scrape position.
- Moving SVS to Snout Wipe position.

9 The Front Panel then asks if you want to cap the Service Station.

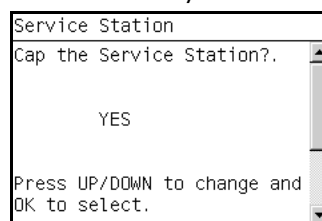

10 Select YES to cap the Service Station or NO to skip this test.

11 The test continues and displays the following messages:

- Capping Service Station.

- 12** The Front Panel displays the Service Station test results.

```

Service Station
Moving SVS to Wiping bidir.
Moving SVS to Scrape.
Moving SVS to Snout Wipe.
Capping Service Station.
Service Station OK.

Press any key to finish.
    
```

- 13** Press any key to finish the test.

- 14** The Front Panel shows the test complete display for a few seconds.

```

Service Station

      00  K  K
     0 0  K K
    0 0  KK
   0 0  KK
  0 0  K K
 00  K  K
    
```

- 15** The Front Panel prompts you to shutdown the printer to complete the test.

```

Service Station
Press any key to shutdown
the system.
    
```

- 16** Press any key to shutdown the printer.

Primer Motor

- 1** In the Diagnostics menu, scroll to **8. Service Station** and press **OK**.

```

Diagnostics menu
▶ 2. Paper Drive
▶ 3. Electronics Module
▶ 4. Carriage Assembly
▶ 5. Sensors
▶ 6. SOL
▶ 7. IDS
▶ 8. Service Station
    
```

- 2** The Front Panel will show the **8. Service Station** submenu.

```

8. Service Station
▶ Service Station
▶ Primer Motor
▶ Aerosol Fan
    
```

- 3** In the **8. Service Station** submenu, scroll to **Primer Motor** and press **OK** to start the test.

- 4** The Primer Motor test starts and the front Panel displays the following messages:

- Starting Horsburgh and Mips.
- Starting Nvm.
- Starting TestsGpio.
- Getting Part Number.
- Starting Service Station.
- Starting Scan Axis.
- Moving SVS out of Sax.
- Homing Scan Axis.
- Moving Carriage out of SVS.
- Homing Service Station.
- Starting ServicingServices.
- Capping Service Station.
- Uncapping Service Station.
- Starting Primer Motor
- Starting AcumenSupplies
- Starting FluidManager
- Starting Primer
- Preparing SVS
- Reading Homing Sensor
- Zero Sensor initial value: 0.
- Step 1: current zeroSensor value: 0.
- OK: It has been detected a change in zero sensor.
- Homing Primer Motor
- Starting Mechanical Init.

5 The Front Panel then prompts you to check the status of the printer.

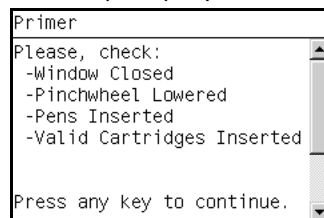

6 Check that:

- The Window is closed.
- The Media Lever is lowered.
- All Printheads are inserted.
- Valid Cartridges are inserted.

7 Press **OK** to continue.

- 8 The Primer Motor test continues and the Front Panel shows the progress of the test.

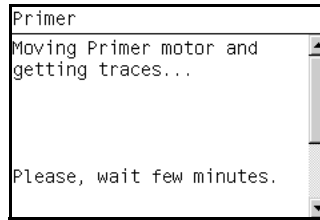

- 9 The Front Panel shows the test complete display for a few seconds.

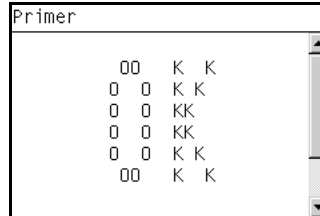

- 10 The Front Panel prompts you to shutdown the printer to complete the test.

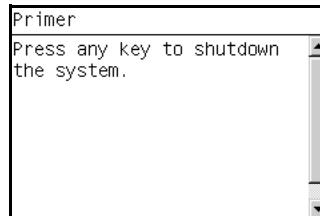

- 11 Press any key to shutdown the printer.

Aerosol Fan

Some printers function without an aerosol fan. Before performing the aerosol fan diagnostic test, remove the Right Cover to verify that the printer has an aerosol fan installed (Refer to page 6-27). If the printer does not have an aerosol fan installed, do not perform this test.

- 1 In the Diagnostics menu, scroll to **8. Service Station** and press **OK**.

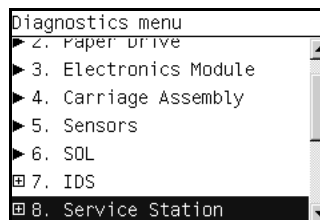

- 2 The Front Panel will show the **8. Service Station** submenu.

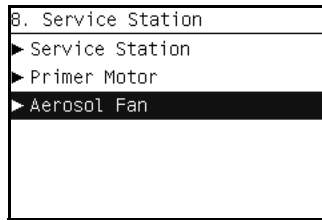

- 3 In the **8. Service Station** submenu, scroll to **Aerosol Fan** and press **OK** to start the test.

- 4 The Aerosol Fan test starts and the front Panel displays the following messages:

- Starting Horsburgh and Mips.
- Starting Nvm.
- Starting TestsGpio.
- Getting Part number.
- Reading Aerosol Fan.

- 5 The front Panel then prompts you switch on the Aerosol Fan.

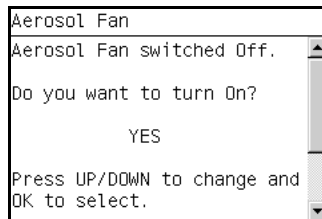

- 6 Press **OK** to switch on the Aerosol Fan. If you do not wish to switch on the Aerosol Fan use the **Arrow** keys to select **NO** and press **OK**.

- 7 The test continues and the Front Panel displays the results.

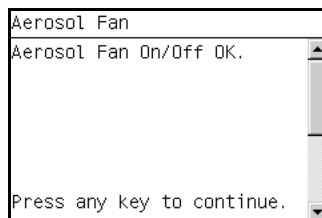

- 8 Press any key to continue.

- 9 The front panel prompts you to check if the Aerosol Fan is operating.

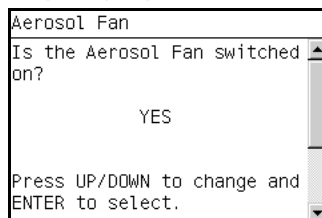

- 10 Listen carefully to check if the Aerosol Fan is operating.

- 11 If it is operating, use the **Arrow** keys to select **YES** and press **OK**. If it is **NOT** operating, select **NO** and press **OK**.

- 12** The Front Panel shows the test result.

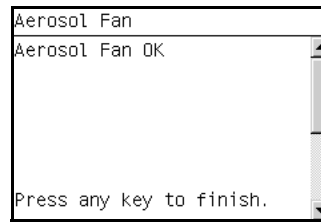

- 13** Press any key to finish.

- 14** The Front Panel shows the test complete display for a few seconds.

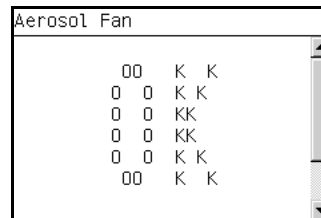

- 15** The Front Panel prompts you to shutdown the printer to complete the test.

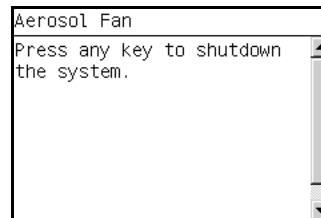

- 16** Press any key to shutdown the printer.

9. I/O Information

The I/O Information test retrieves the TC/IP Network configuration parameters from the printer.

- 1** In the Diagnostics menu, scroll to **9. I/O Information** and press **OK**.

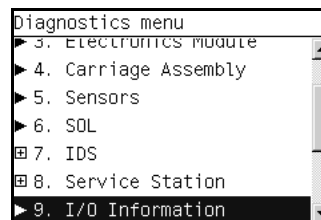

- 2** The I/O Information test starts and the front Panel displays the following message:

- Getting IO interface.
- Getting Interface info.

- 3 The Front Panel displays the I/O Information.

```

I/O Information
IP:          16.23.114.71
Gateway:    16.23.112.1
Net Mask:   255.255.248.0

Press any key to finish.

```

- 4 Press any key to finish.

- 5 The Front Panel shows the test complete display for a few seconds.

```

I/O Information

      00  K  K
     0 0  K K
    0 0  KK
   0 0  KK
  0 0  K K
 00  K  K

```

- 6 The Front Panel prompts you to shutdown the printer to complete the test.

```

I/O Information
Press any key to shutdown
the system.

```

- 7 Press any key to shutdown the printer.

10. Unit Information

- 1 The Unit Info test recovers the Firmware Version, Serial Number and Part Number of the printer.
- 2 In the Diagnostics menu, scroll to **10. Unit Information** and press **OK**.

```

Diagnostics menu
▶ 4. Carriage Assembly
▶ 5. Sensors
▶ 6. SQL
▣ 7. IDS
▣ 8. Service Station
▶ 9. I/O Information
▶ 10. Unit Information

```

- 3 The Unit Information test starts and the front Panel displays the following message:

- Starting Horsburgh and Mips.
- Starting Nvm.
- Getting FW version.
- Getting Serial Number
- Getting Part Number.

- 4 The Front Panel shows the result of the test.

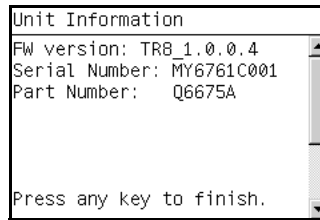

- 5 Press any key to continue.
6 The Front Panel shows the test complete display for a few seconds.

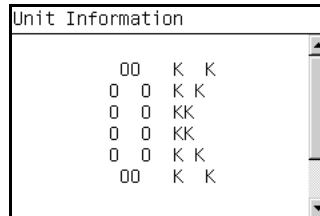

- 7 The Front Panel prompts you to shutdown the printer to complete the test.

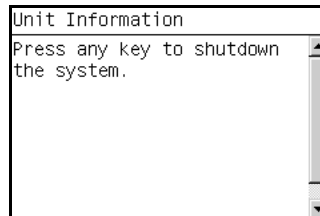

- 8 Press any key to shutdown the printer.

11. EEROM Reset

The EEROM Reset removes all contents and print jobs from the queue and all accounting information is reset. After an EEROM Reset, the printhead alignment and color calibrations become obsolete.

Custom paper types, ICC profiles, and usage information, such as the life counters for printer components or Preventive Maintenance Kits, are kept after an EEROM Reset (they will not be deleted).

After an EEROM Reset, the printer will automatically purge the tubes and perform a printhead alignment. This process can take some time. Make sure to plan ahead.

- 1 In the Diagnostics menu, scroll to **11. EEROM** and press **OK**.

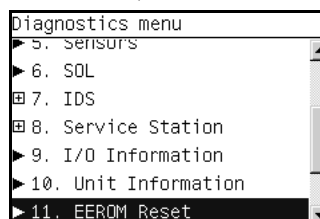

- 2 The EEROM Reset test starts and the front Panel prompts you to request if you want to continue.

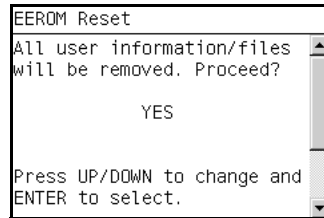

- 3 If you do want to continue the test, use the **Arrow** keys to select YES and press **OK**. If you do NOT want to continue, select NO and press **OK**.

- 4 The EEROM Reset test continues and the front Panel displays the following message:

- Starting Horsburgh.
- Starting Nvm.
- Getting Part Number.
- Setting default config.

- 5 The Front Panel finishes the test and prompts you to Recover the Printheads after completing the test and rebooting the printer.

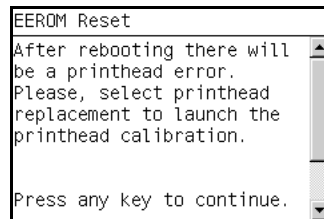

- 6 The Front Panel shows the test complete display for a few seconds.

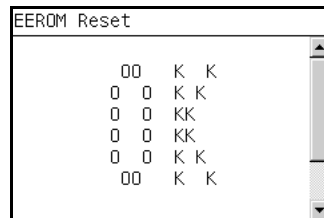

- 7 The Front Panel prompts you to shutdown the printer to complete the test.

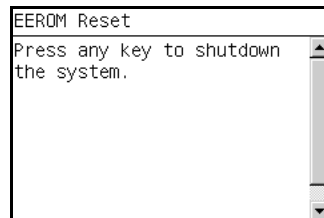

- 8 Press any key to shutdown the printer.

- 9 When the printer restarts, it will purge tubes and perform a printhead alignment.

12. Set Unit Configuration

This diagnostic test is not available for Z2100/Z3100/Z3100ps/Z3200/Z3200ps printers.

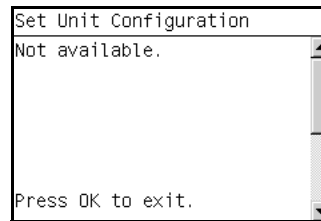

13. Error 71:19 Recovery

This test might not exist for the latest printers with the latest firmware release.

This diagnostic test utility is used to set the Serial Number and Part Number if either the Formatter or the Printmech PCA or both have been replaced.

The complete Error 71:19 Recovery utility consists of individual utilities to handle different serial and part number setting requirements. These tests are:

- Set Serial Number
- Select Right S/N

Set Serial Number

The purpose of this utility is to set the Serial Number and Part Number in case both the Formatter and the Printmech PCA are replaced at the same time.

Set the Serial Number as follows:

- 1 In the Diagnostics menu, scroll to **13. Error 71:19 Recovery** and press **OK**.

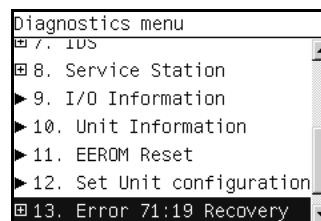

- 2 The Front Panel will show the **13. Error 71:19 Recovery** submenu.

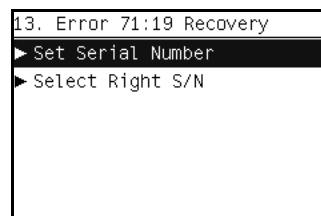

- 3 In the **13. Error 71:19 Recovery** submenu, scroll to **Set Serial Number** and press **OK** to start the test.

- 4 The Set Serial Number test starts and the front Panel displays the following messages:
 - Checking SE Log.
 - Starting Horsburgh & Mips.
 - Starting NvmBackup.
 - Starting NvmMain
 - Getting Serial Number
 - Checking Serial Number.
 - Starting Nvm.
 - Getting Part Number.
 - Setting default config.

- 5 The Front Panel prompts you to enter the Serial Number.

```
SE 71:19 Recovery
Current Serial Number:
SG00000000
New Serial Number:
_00000000
Use UP/DOWN to scroll, BACK
to move cursor or ENTER to
confirm.
```

- 6 Use the UP, DOWN and BACK keys to select each character of the Serial Number and use the OK to confirm.

- 7 The Front Panel shows the test complete display for a few seconds.

```
SE 71:19 Recovery
      00  K  K
    0 0  K  K
    0 0  KK
    0 0  KK
    0 0  K  K
      00  K  K
```

- 8 The Front Panel prompts you to shutdown the printer to complete the test.

```
SE 71:19 Recovery
Press any key to shutdown
the system.
```

- 9 Press any key to shutdown the printer.

Select Right S/N

The purpose of this utility is to set the correct Serial Number and Part Number in case either the Formatter or the Printmech PCA have been replaced.

Set the correct Serial Number as follows:

- 1 In the Diagnostics menu, scroll to **13. Error 71:19 Recovery** and press

OK.

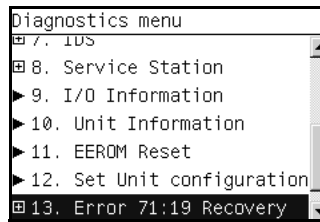

- 2 The Front Panel will show the **13. Error 71:19 Recovery** submenu.
- 3 In the **13. Error 71:19 Recovery** submenu, scroll to **Select Right S/N** and press **OK** to start the test.

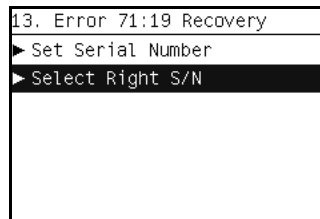

- 4 The Select Right S/N test starts and the front Panel displays the following message:
 - Checking SE Log.
 - Starting Horsburgh.
 - Starting NvmMain
 - Starting NvmBackup.
 - Getting Serial Number.
- 5 The Front Panel prompts choose the correct Serial Number and Part Number.

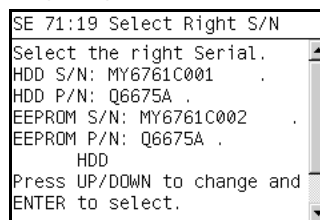

- 6 Use the ARROW keys to select the location containing the correct Serial and Part Number, HDD for the Formatter or EEPROM for the PrintMech PCA.
- 7 Press OK to confirm your choice.
- 8 The Select Right S/N test continues and the front Panel displays the following messages as the correct Serial Number and Part Number are copied from the selected location to the other memory location:
 - Starting NvmMain
 - Starting NvmBackup.
 - Getting Serial Number.
 - Checking Serial Number.
 - Getting Part Number.
 - Writing the right S/N.

- 9 The Front Panel shows the test complete display for a few seconds.

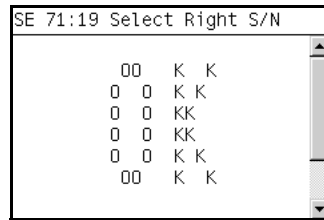

- 10 The Front Panel prompts you to shutdown the printer to complete the test.

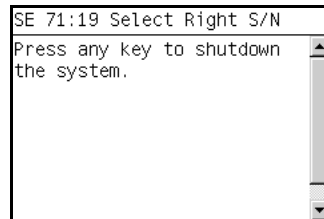

- 11 Press any key to shutdown the printer.

14. Others

This test is not implemented for the current version of the printer.

Service Utilities

The following is a list of all internal Service Utilities available in the Printers. Instructions for entering the Service Utilities menu are given on Page 3-59.

1 Turn Drive Roller ⇒ Page 3-61

The purpose of this Service Utility is to rotate the Drive Roller and the Overdrive in order to clean them.

2 Prime Tubes ⇒ Page 3-62

The purpose of this Service Utility is to Prime the Tubes when the Ink Tubes are NOT new and they need to be re-primed or automatic priming was not completed correctly.

3 Set SN ⇒ Page 3-65

The purpose of this Service Utility is to set the Serial Number of the Printer.

4 Reset Life Counters ⇒ Page 3-66

The purpose of this Service Utility is to reset the internal life counters. There are two submenus that allow you to:

- Reset ALL the counters related to a Preventive Maintenance Kit (PMK).
- Reset only the counters related to a specific replaced part.

5 Diagnostic Print ⇒ Page 3-67

The purpose of this Service Utility is to print the Diagnostic Print in order to identify image quality problems.

6 Set Time and Date ⇒ Page 3-68

The purpose of this Service Utility is to set the Real Time Clock (RTC) of the Printer.

7 Enable/Disable Firewall ⇒ Page 3-69

The purpose of this Service Utility is to enable or disable the built-in system firewall.

Entering the Service Utilities Menu

- 1** Once the message “Ready” or “Ready for paper” is displayed on the front-panel, press the **Menu** key. For information regarding the front panel buttons, see *Using the Front Panel*, Page 3-5

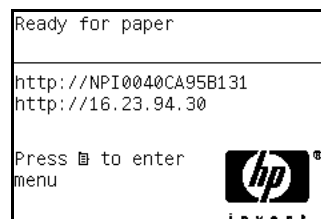

- 2 To have the user to perform certain Service Utilities, once inside the “Main Menu”, press the **Down** arrow key and the **Cancel** key together. You are now in the **Service Tools** Menu.

PHONE SUPPORT



- 3 For On-Site Engineers, once inside the “Main Menu”, press the **Up** arrow key and the **Cancel** key together. You are now in the **Service Menu** Menu.

ON-SITE REPAIR



- 4 Use the **Arrow** keys to scroll to the “Service Utilities” menu option and press the **OK** key.

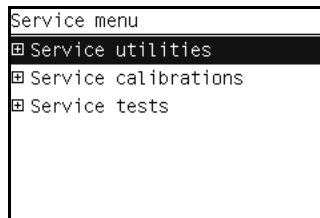

- 5 Use the **Arrow** keys to scroll through the “Service Utilities” selections and press the **OK** key to begin a specific operation when the required Service Utility is highlighted.

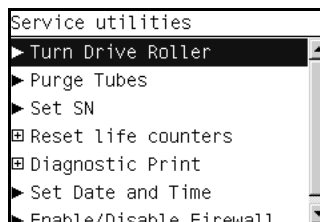

If the printer is not used for 135 seconds, the printer exits out of the Service Utilities Menu and you must repeat the above steps to enter Service Utilities again.

In some cases a quick press of a button may not be recognized by the Printer. When pressing a button, be sure to press it deliberately and all the way to the bottom of its travel.

1. Turn Drive Roller

The purpose of this Service Utility is to rotate the Drive Roller and the Overdrive in order to clean them.

REMOVE THE MEDIA BEFORE PERFORMING THIS OPERATION.

OPEN THE WINDOW OF THE PRINTER AND ACTIVATE THE WINDOW SENSOR (USE A PIECE OF PAPER TO COVER THE SENSOR) BEFORE PERFORMING THIS SERVICE UTILITY.

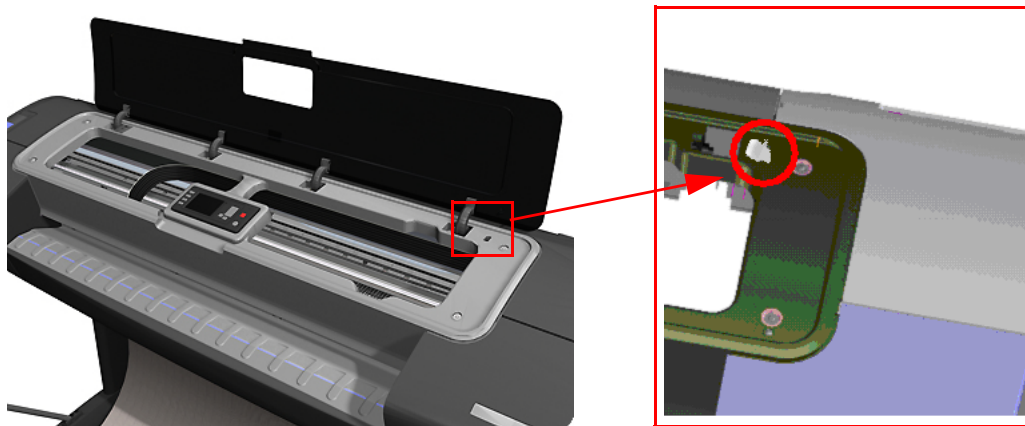

Perform the Turn Drive Roller utility as follows:

- 1 In the Service Utilities submenu, scroll to **Turn Drive Roller** and press **OK**.

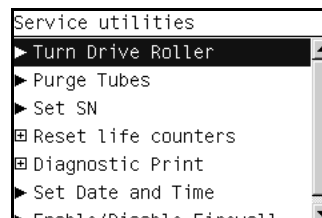

- 2 The test begins and the Front Panel displays the following message:
 - Checking Media Presence Sensor
- 3 If media is loaded, the service utility will be cancelled. In this case, unload the media and start again from **step 1**. If no media is loaded, the test will continue.
- 4 The Drive Roller begins to turn slowly and the following message is displayed on the Front Panel:

```
Turn Drive Roller
Rotation started.
Please, clean the
DRIVE_ROLLER.

Turn(s): 2.0
Timeout: 567

Press CANCEL key to finish.
```

- 5 Refer to the Cleaning Instructions on Page 7-3.
- 6 Once you have finished cleaning the Drive Roller and the Overdrive, press the **Cancel** key to finish the utility.
- 7 If the utility exits correctly, OK will be displayed on the Front Panel.

```
Turn Drive Roller

      00  K  K
     0 0  K K
    0 0  KK
   0 0  KK
  0 0  K K
 00  K  K
```

REMEMBER TO REMOVE THE PIECE OF PAPER FROM THE WINDOW SENSOR BEFORE CLOSING THE WINDOW AS THIS COULD DAMAGE THE WINDOW AND THE SENSOR.

2. Purge Tubes

The purpose of this Service Utility is to Prime the Tubes when the Ink Tubes need to be re-primed or automatic priming was not completed correctly.

Make sure that NEW Ink Cartridges are installed or that the ink volume remaining in the Ink cartridges is above 88% before starting to prime the tubes. If you do not comply, you will get a warning message and cannot finish the test.

- 1 In the Service Utilities submenu, scroll to Purge Tubes and press **OK**.

```
Service utilities
▶ Turn Drive Roller
▶ Purge Tubes
▶ Set SN
☑ Reset life counters
☑ Diagnostic Print
▶ Set Date and Time
▶ Enable/Disable Firewall
```

- 2 When the front panel prompts you to reboot the system, you must select whether you would like to continue with the procedure by pressing the **Enter** key, in which case the Printer will reboot. Press **Back** or **Cancel** to exit the procedure at this point.
- 3 The Front Panel displays a message to say the Printer is going to reboot.

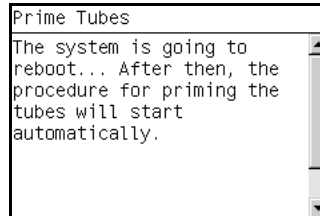

- 4 Once the Printer has rebooted, the Front Panel will instruct you to open the Window and remove ALL the Printheads installed in the Carriage.

Lift printhead cover.
Replace printheads

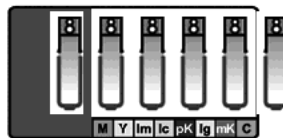

- 5 Once ALL the Printheads have been removed, the Front Panel will instruct you to install the Setup Printheads into the Carriage.
- 6 Install the Setup Printheads in the carriage.

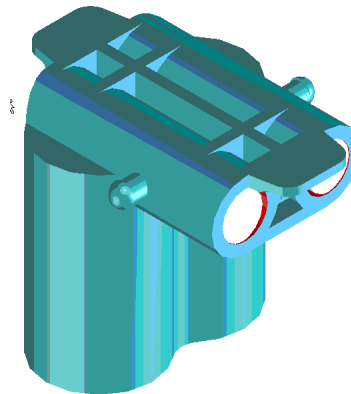

- 7 Once all the Setup Printheads are installed, the following message will appear on the front panel. Close the carriage cover and close the window.

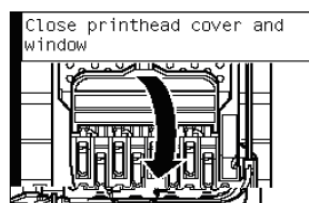

- 8 The printer will begin to purge the tubes system.

- 9 Once the tubes system has been purged, the following message will instruct you to open the Window and the carriage to access the printheads:

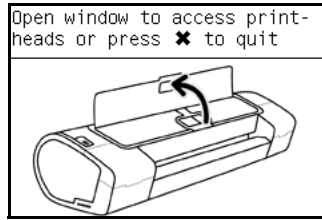

- 10 Once you have opened the carriage cover, the Front Panel prompts you to verify that the Setup Printheads contain ink. If the Ink Supply Tubes have been primed correctly, the windows will contain ink. If the windows on top of each Setup Printhead do **NOT** contain ink, then you may need to repeat the Prime Tubes process from the beginning.

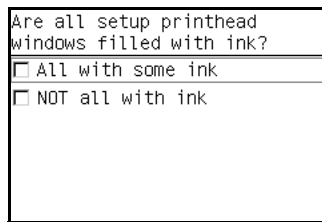

- 11 If all the Setup Printheads contain ink, select **All with some ink**. If one or more of the Setup Printheads do **NOT** contain ink, select **Not all with ink**.
- 12 Remove ALL the Setup Printheads from the Carriage and install the previously removed Printheads.
- 13 Once ALL the Printheads are installed, the Front Panel will instruct you to close the Carriage cover and close the Window.

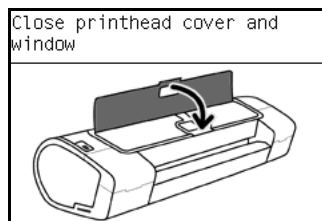

- 14 The Printer will now perform the Printhead Alignment and Front Panel will prompt you to continue with the Printhead Alignment, select **Align now** and press the **OK** key.

- 15** Once the Printhead Alignment is completed, the following message will be displayed on the Front Panel. Press the **OK** key to continue.

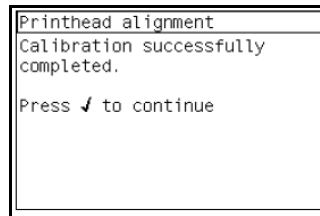

3. Set SN

The purpose of this Service Utility is to set the Serial Number of the Printer. Perform the Set SN utility as follows:

- 1** In the Service Utilities submenu, scroll to **Set SN** and press **OK**.

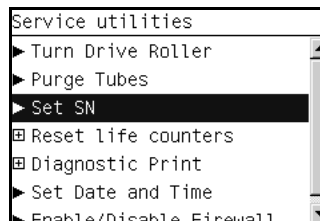

- 2** The Printer will display the current Serial Number and the new Serial Number of the Printer. Use the **Up** and **Down** keys to go through the digits and press the **OK** key to go to the next digit. You can press the **Cancel** key at any time to exit the utility without making any changes.

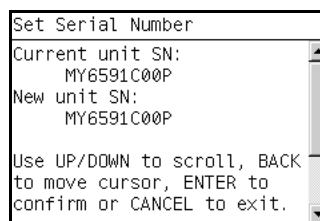

If the Serial Number or the Part Number cannot be read, the Front Panel will display the relevant System Error code. see *System Error Codes - Full Descriptions*, Page 2-7

- 3** Once the new Serial Number has been entered, the Front Panel will display the Serial Number and Model Number of the Printer. Press the **OK** to confirm the Serial Number or the **Cancel** key to exit the utility without making any changes or the **Back** key to modify again.
- 4** If the utility exits correctly, OK will be displayed on the Front Panel.
- 5** When the printer is restarted after a serial number change an NVM setting sequence is initiated to synchronize the serial number stored in the backup memory.

4. Reset Life Counters

The purpose of this Service Utility is to reset the internal life counters.

There are two submenus that allow you to:

- Reset ALL the counters related to Preventive Maintenance Kits 1 and 2.
- Reset only the counters related to a specific replaced part.

Always reset the life counter of a corresponding part after replacing it.

Perform the Reset Life Counters utility as follows:

- 1 In the Service Utilities submenu, scroll to **Reset Life Counters** and press **OK**.

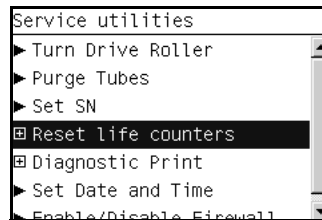

- 2 Select **Reset Maintenance Kit usage** to reset the Life Counter for ALL parts included in a Preventative Maintenance Kit (PMK).

Select **Reset usage counters** to reset the Life Counter of a single part.

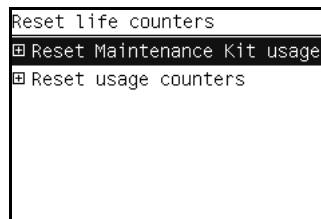

- a If you select Reset Maintenance usage, which will reset the Life Counter for ALL parts included in a Preventive Maintenance Kit (PMK), you can choose from the following Preventive Maintenance Kits:
 - Preventive Maintenance Kit 1 (PMK1). see *Preventive Maintenance Kit #1*, Page 7-5
 - Preventive Maintenance Kit 2 (PMK2). see *Preventive Maintenance Kit #2*, Page 7-6

The counters included in the preventive maintenance kits can be found on page 7-3.

It is also advisable to check the status of the Life Counters related to the other Preventive Maintenance Kits to avoid multiple trips to the customer.

- b If you select to Reset usage counters, which will reset the Life Counter of a single part, you can choose from the following parts:
 - Tubes and Trailing Cable
 - Scan-Axis Belt

- Scan Motor
- Left Spittoon
- Right Spittoon
- Full Bleed Foams
- Aerosol Fans
- Carriage
- Service Station

- 3** Once you have selected a Life Counter to reset, the following message will be displayed on the Front Panel. Press the **OK** key to reset the selected Life Counter or press **Back/Cancel** to exit without resetting the Life Counter.

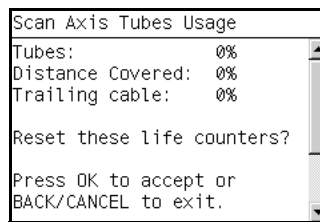

If the Usage Counter information cannot be read, the Front Panel will display “Unable to get usage counter”. This could be a possible Firmware error. In this case, make sure you have the latest version of the Firmware.

- 4** If the utility exits correctly, OK will be displayed on the Front Panel.

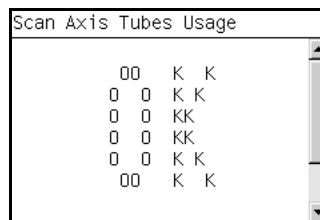

5. Diagnostic Print

The purpose of this Service Utility is to print the Diagnostic Print in order to identify Print Quality problems. Information regarding the Diagnostic Print is located in Chapter 1, Troubleshooting. Specifically:

The procedure to make a Diagnostic Print can be found at 1-22, *Printing the Diagnostic Print*.

The procedure to make an Advanced Diagnostic Print can be found at 1-29, *Printing the Advanced Diagnostics Print*.

Additional print quality information such as troubleshooting and corrective measures can be found at 1-20, *Print Quality Troubleshooting*.

6. Set Date and Time

The purpose of this Service Utility is to set the internal clock of the Printer.

Perform the Set Date and Time utility as follows:

- 1 In the Service Utilities submenu, scroll to **Set Date and Time** and press **OK**.

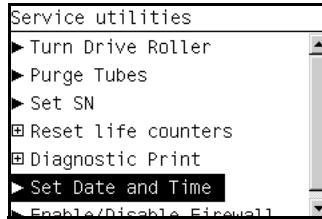

- 2 The Printer will display the current time and the new time. Use the **Up** and **Down** keys to go through the digits and press the **OK** key to go to the next digit. You can press the **Cancel** key at any time to exit the utility without making any changes.

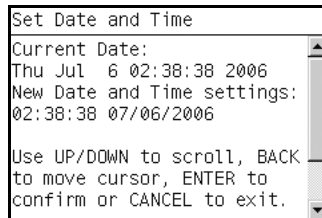

- 3 Once the new time has been entered, the Front Panel prompts you to confirm the new date and time.

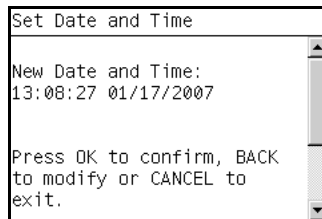

- 4 Press **OK** to confirm the new date and time. Press **BACK** to modify the new date and time. Press **CANCEL** to exit without changing the date and time.
- 5 Once the new time has been entered, the Front Panel will prompt you to shut down the printer.

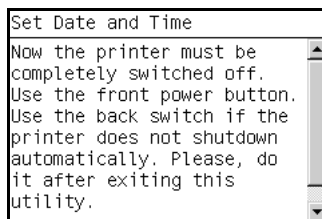

If the current RTC Clock cannot be set, it could be a possible Firmware error. Make sure you have the latest version of the Firmware.

- 6 Restart the printer.

7. Enable/Disable Firewall

The purpose of this Service Utility is to enable or disable the system firewall.

Perform the Enable/Disable Firewall utility as follows:

- 1 In the Service Utilities submenu, scroll to **Enable/Disable Firewall** and press **OK**.

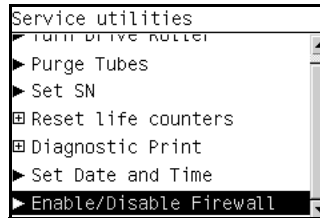

- 2 The utility checks to see if the firewall is enabled or disabled and the Front panel displays the following message:
 - Getting Information of Firewall.
- 3 When the following message appears on the front panel, you must select whether you would like to enable or disable the firewall. Use the **Up** and **Down** keys to make your selection and press the **OK** key.

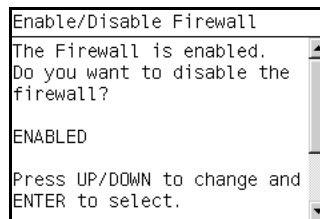

- 4 The system upgrades the internal memory to reflect the chosen selection.

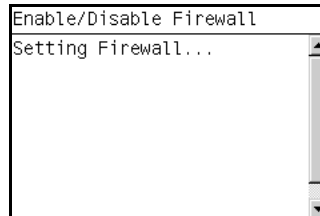

- 5 The Front Panel shows the test complete display for a few seconds.

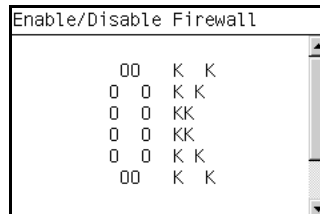

Service Calibrations

4

- Service Calibrations 4-2
 - Using the Front Panel 4-3
 - Entering the Service Calibrations Menu 4-4
 - Scan Axis Calibration 4-4
 - Service Station Calibration 4-5
 - Paper Advance Calibration 4-6
 - Drop Detector Calibration 4-12
 - Line Sensor Calibration 4-15
 - Carriage PCA 4-18
 - Color Sensor ESP (spectrophotometer) Calibration 4-18

Service Calibrations

The Printer has several calibration procedures that must be performed under certain conditions.

REMEMBER THAT CERTAIN CALIBRATIONS ARE REQUIRED EVEN IF AN ASSEMBLY HAS BEEN DISASSEMBLED TO GAIN ACCESS TO ANOTHER ASSEMBLY OR COMPONENT.

The following is a list of all internal service calibrations available in the Printers. Instructions for entering the service calibrations menu are given on Page 4-4.

- 1** Scan Axis Calibration ⇒ Page 4-4
The purpose of this Service Calibration is to carry out a PWM check, and calibrate the intensity of the Line Sensor.
- 2** Service Station Calibration ⇒ Page 4-5
The purpose of this Service Calibration is to calibrate the Drop Detector (located in the Service Station) in relation to the Carriage Assembly.
- 3** Paper Advance Calibration ⇒ Page 4-6
The purpose of this Service Calibration is to calibrate the nominal advance of the media. This calibration is necessary to control the exact movement of the media in order to avoid print quality problems like banding.
- 4** Drop Detector Calibration ⇒ Page 4-12
The purpose of this Service Calibration is to calibrate the Drop Detector (located in the Service Station) in relation to the Carriage Assembly.
- 5** Line Sensor Calibration ⇒ Page 4-15
The purpose of this Service Calibration is to calibrate the intensity of the Line Sensor. An incorrect calibration can result in edge-detection failures during media loading and incorrect reading of prints that are used for alignment or calibration.
- 6** Carriage Setup ⇒ Page 4-18
The purpose of this Service Calibration is to reset the ink short thresholds after replacing the Carriage PCA.
- 7** Color Sensor ⇒ Page 4-18
The purpose of this Service Calibration is to calibrate the Color Sensor.

If ALL the Calibrations need to be performed (for example, when both the Formatter and the Print Mech PCA have been replaced), you must perform them in the following order:

- Drop Detector/Service Station Calibration.
- Line Sensor/Scan Axis Calibration.
- Paper Advance Calibration.

Using the Front Panel

Below is a diagram of the front panel.

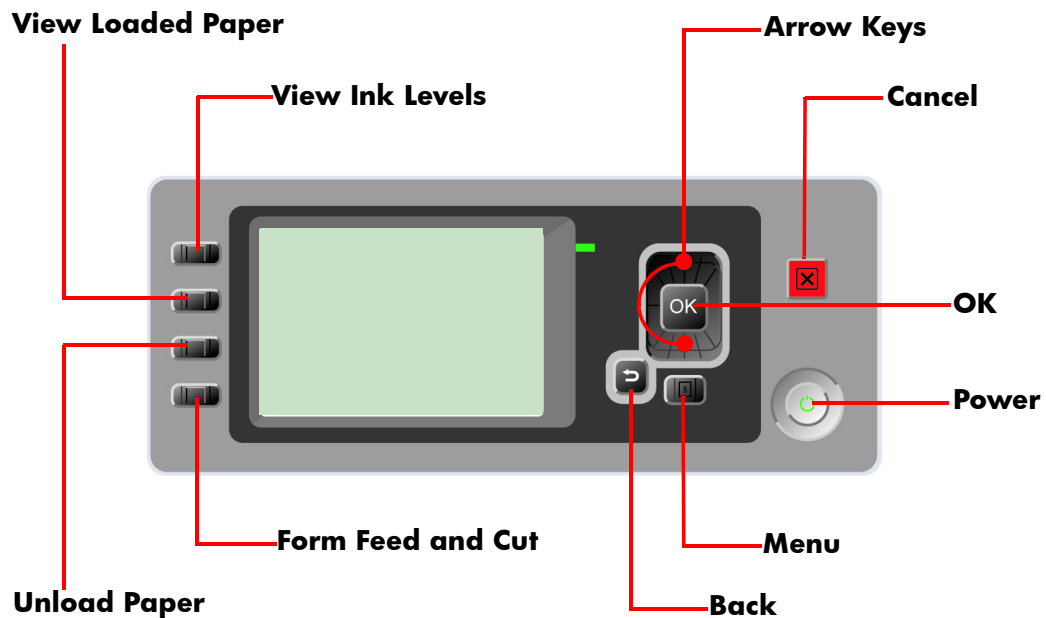

Key Function

- **Arrow Keys**
Use the Arrow keys to scroll through a menu or toggle between YES or NO when prompted.
- **Cancel**
Use the Cancel key to abort or stop a procedure or reject test results.
- **OK**
Use the OK key to select a menu option.
- **Power**
Use the Power key to turn the printer ON and OFF.
- **Menu**
Use the Menu key to enter the main menu.
- **Back**
Use the Back key to go back to the previous menu or reject test results.

Service Key Combinations

- **Diagnostic mode**
With the printer OFF, press and hold the UP and OK keys. While holding the Up and OK keys down, press and hold the Power key to turn on the printer. Hold all three keys until the Power key stops flashing, usually about 20 seconds.
- **Service Menu (Service Engineers Only)**
From the main menu, press and hold the Up and Cancel keys.
- **Service Menu (For users)**
From the main menu, press and hold the Down and Cancel keys.

Entering the Service Calibrations Menu

- 1 Once the message “Ready” or “Ready for paper” is displayed on the front-panel, press the **Menu** key.

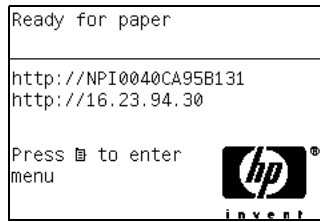

- 2 To have the user to perform certain Service Utilities, once inside the “Main Menu”, press the **Down** arrow key and the **Cancel** key together. You are now in the **Service Tools** Menu.



PHONE SUPPORT

- 3 For On-Site Engineers, once inside the “Main Menu”, press the **Up** arrow key and the **Cancel** key together. You are now in the **Service Menu** Menu.



ON-SITE REPAIR

If the printer is not used for 135 seconds, the printer exits out of the Service Utilities Menu and you must repeat the above steps to enter Service Calibrations again.

In some cases a quick press of a button may not be recognized by the Printer. When pressing a button, be sure to press it deliberately and all the way to the bottom of its travel.

Scan Axis Calibration

The purpose of this Service Calibration is to carry out a PWM check, calibrate the intensity of the Line Sensor and calibrate the Line Sensor

position to the Black Printhead. This calibration is integrated into the Scan Axis diagnostic test. see *1. Scan Axis*, Page 3-6

Perform the Scan Axis Calibration as follows:

Make sure you load one of the following media into the Printer before performing this calibration:

- HP Bond Paper.
- HP Glossy Media.
- HP Coated Paper.
- HP Productivity Photo Gloss.
- HP Heavyweight Coated Paper.
- HP Super Heavyweight Coated Paper.
- HP Bright White Inkjet Paper.

- 1 In the Service Calibrations submenu, scroll to **Scan Axis Calibration** and press **Enter**.

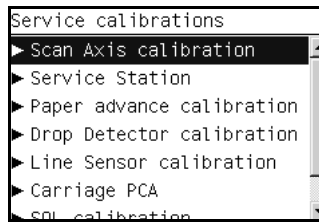

- 2 To calibrate the Scan Axis, run the Scan Axis diagnostic test. see *1. Scan Axis*, Page 3-6

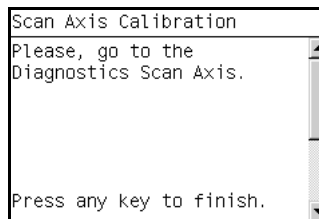

Service Station Calibration

The purpose of this Service Calibration is to calibrate the Service Station in relation to the Carriage Assembly. This calibration is integrated into the Scan Axis diagnostic test. see *8. Service Station*, Page 3-45

- 1 In the Service Calibrations submenu, scroll to **Service Station** and press **Enter**.

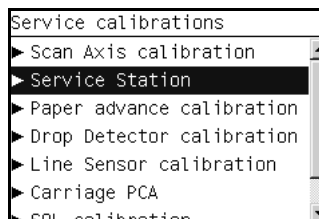

- 2 To calibrate the Service Station, run the Service Station diagnostic test. see 8. *Service Station*, Page 3-45

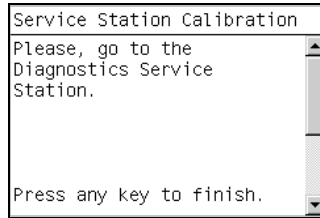

Paper Advance Calibration

The purpose of this Service Calibration is to calibrate the nominal advance of the media. This calibration is necessary to control the exact movement of the media in order to avoid print quality problems like banding.

If you need to perform a Paper Advance Calibration to solve a print quality problem, it is recommended that you first try the Paper Advance Calibration from the user's menu, which will calibrate the printer to a specific paper type.

In order to perform the Paper Advance Calibration, you must order the Z2100/Z3100/Z3100ps Paper Advance Calibration Kit, which contains two sheets of HP Universal Instant-Dry Photo Gloss paper.
24 inch Q6675-60103
44 inch Q6677-60030

When you load the HP Universal Instant-Dry Photo Gloss sheet, make sure you load it with the skew check.

Perform the Service Accuracy Calibration whenever:

- Banding is detected in prints.

Service calibrations also need to be performed after removing or replacing certain printer components. If you have removed or replaced printer components, check the Service Calibration Guide to Removal and Installation to see which tests and calibrations you need to perform. Refer to Page 6-8.

The Paper Advance Calibration is split into two parts and should **always** be done in this order:

- 1 Print Calibration Pattern - The Printer first calibrates the Analog Encoder and then prints the Paper Advance Calibration pattern.
- 2 Scan Calibration Pattern - The Printer scans the Paper Advance Calibration pattern in order to calibrate the nominal advance of the media.

Only scan the Calibration Pattern in the Printer that was used to print it. Using the Calibration in a different Printer could cause it to experience media advance problems. After scanning the Calibration Pattern, it should be discarded.

Perform the Paper Advance Calibration as follows:

Make sure that you unload media from the Printer before performing the Paper Advance Calibration.

- 1 In the Service Calibrations submenu, scroll to “Paper Advance Calibration” and press **OK**.

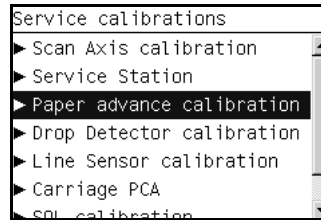

- 2 In the Paper Advance Calibration submenu, scroll to **Print Calibration Pattern** and press **OK**.

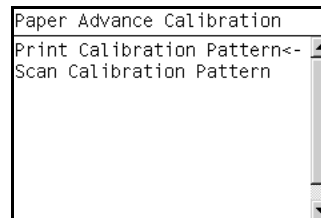

- 3 When the following message appears on the front panel, you must select whether you would like to continue with the calibration by pressing the **OK** key. Press **Back** or **Cancel** to exit the calibration.

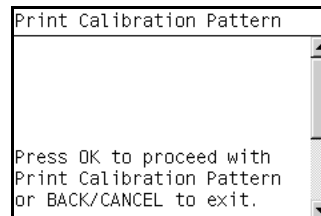

- 4 If paper is detected, the printer will prompt you to remove the media. If paper is NOT detected, the calibration will continue.
- 5 The Printer will start to calibrate the Analog Encoder and the following message will be displayed on the Front Panel.

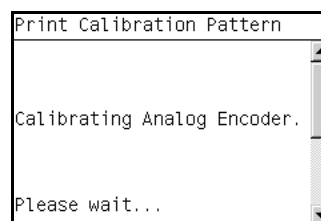

If the Calibration is not done or if the values are out of the limits, a warning message will appear on the Front Panel. In this case, try the following:

- Check that the Printer has the latest Firmware version. If not, update the Firmware to the latest version.

- Retry the Paper Advance Calibration.

Once the Analog Encoder has been calibrated correctly, the Front Panel prompts you to select the type of media you will use. Use the **Arrow** keys to choose ROLL or SHEET media. Make sure to load the media included in the Paper Advance Calibration Kit (**24 inch** Q6675-60103, **44 inch** Q6677-60030)

- 6 Press the **OK** key to start the media load process.

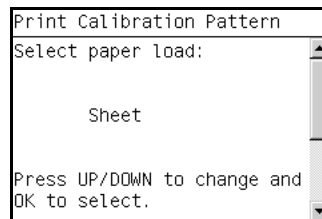

- 7 The Front Panel prompts you to select the paper category you will use for the calibration. Use the **Arrow** keys to scroll to your paper category and press the **OK** key to continue the media load process.

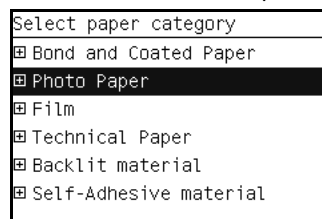

- 8 The Front Panel prompts you to select the specific type of paper you will use for the calibration. Use the **Arrow** keys to scroll through the menu and the **OK** key to select your paper type.

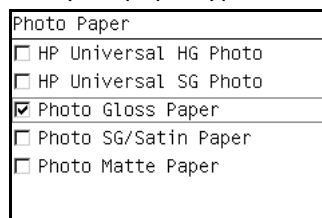

- 9 The Front Panel prompts you to load the paper. Make sure you load the paper that corresponds to your paper type selection.

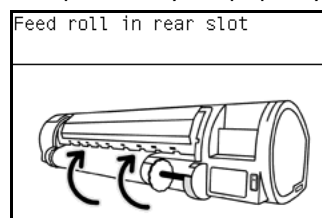

- 10 Once the media is loaded into the Printer, the following message will appear on the Front Panel. If roll media has been used instead of cut sheet media, you will need to unroll a minimum of 1 meter of media in order to

prevent any back tension which could cause any media advance problems. Press the **OK** key to continue.

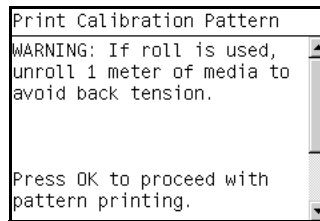

- 11 The Printer advances about a meter of paper. The Front Panel displays the following messages:
 - Advancing Paper
 - Printing Pattern
- 12 The Printer will start to print the Paper Advance Calibration Pattern. This could take several minutes during which the following message will be displayed on the Front Panel.

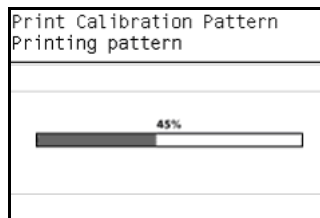

- 13 Once the Accuracy Calibration Pattern has been printed successfully, the Front panel will prompt you to continue.

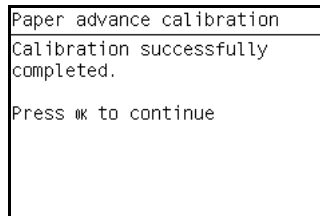

- 14 Press the **Enter** key to continue.
- 15 If you used roll media to print the Paper Advance Calibration, the Printer detects that media is loaded, and prompts you to lift the Media Lever.

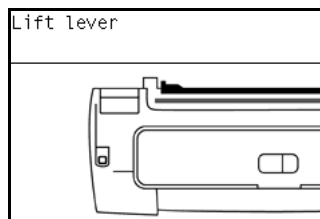

- 16 Raise the media lever.

- 17** The Printer prompts you to remove the media.

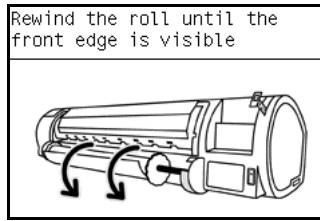

- 18** The Printer prompts you to lower the media lever.

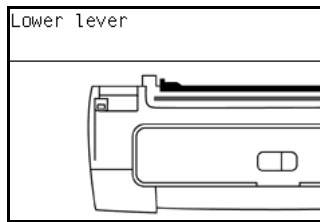

If the Paper Advance Calibration fails for any reason, a warning message will appear on the Front Panel. In this case, try the following:

- Retry the Paper Advance Calibration.
- If necessary, perform a Printhead Recovery through the Front Panel and retry the calibration.

Remove the pattern from the printer and leave it to dry for a few minutes before continuing with the Calibration.

MAKE SURE NO MEDIA IS LOADED INTO THE PRINTER BEFORE STARTING TO SCAN THE CALIBRATION PATTERN.

- 19** You will need to re-enter the Paper Advance Calibration submenu and scroll to Scan Calibration Pattern and press **OK**.

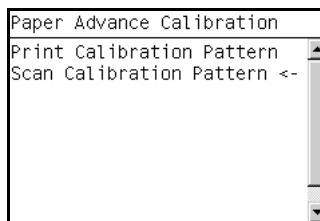

- 20** When the following message appears on the front panel, you must select whether you would like to continue with the calibration by pressing the **OK** key. Press **Back** or **Cancel** to exit the calibration.

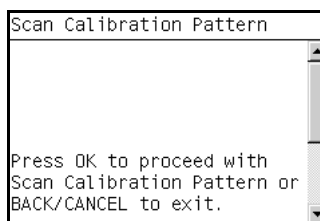

- 21** A message will appear advising you that you will need to load the Calibration Pattern in to the Printer. Make sure that you rotate the printed

pattern 90° clockwise and reload it printed-side down, so that the black arrows go into the printer first. Press the **OK** key to continue.

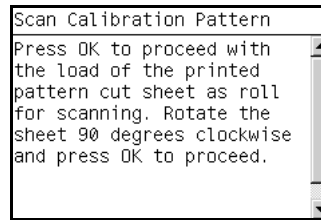

Only scan the Calibration Pattern in the Printer that was used to actually print it. Using the Calibration in a different Printer could cause it to experience media advance problems.

After scanning the Calibration Pattern, it should be discarded. When loading the Calibration Pattern, use the Cutter blade on the Print Platen to align the edge of the sheet. If you follow this advice, you will prevent the cutter from cutting a section of the Calibration Pattern, which could cause the Calibration to FAIL.

- 22** The Front Panel prompts you to select the paper category you used for the calibration. Select the same paper that you used to perform the Paper Advance Calibration print. Use the **Arrow** keys to scroll to your paper category and press the **OK** key to continue the media load process.

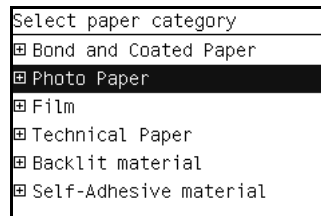

- 23** The Front Panel prompts you to select the specific type of paper you used for the calibration. Use the **Arrow** keys to scroll through the menu and the **OK** key to select your paper type.

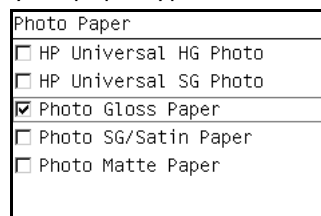

- 24** Load the Calibration Pattern following the instructions on the Front Panel. Once the Calibration Pattern is loaded correctly, the following message will be displayed on the Front Panel. Press the **OK** key to continue.

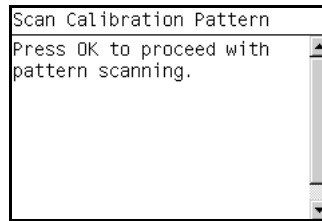

- 25** The Printer will scan the Calibration Pattern which could take several minutes. Once the calibration is completed successfully, the following message will be displayed on the Front Panel. Press the **OK** key to continue.

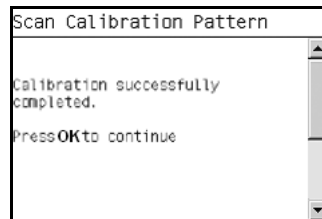

If the Paper Advance Calibration fails for any reason, a warning message will appear on the Front Panel. In this case, try the following:

- Check that the Calibration Pattern was not incorrectly cut (trimming the actual pattern) during the media load process. If this is the case, perform the Paper Advance Calibration again from **step 1**.
- Perform a Line Sensor Calibration (⇒ Page 4-15) and then rescan the Calibration pattern.
- Replace the Line Sensor ⇒ Page 6-130.
- If the problem continues, replace the Media Advance Driver ⇒ Page 6-183.

Drop Detector Calibration

The purpose of this Service Calibration is to calibrate the Drop Detector (located in the Service Station) in relation to the Carriage Assembly. There are two menu options to calibrate the Drop Detector:

- Reset Calibration Flag
- Calibrate Drop Detector

Always perform the Reset Calibration Flag calibration BEFORE calibrating the drop detector.

Service calibrations also need to be performed after removing or replacing certain printer components. If you have removed or replaced printer components, check the Service Calibration Guide to Removal and Installation to see which tests and calibrations you need to perform. Refer to Page 6-8.

Reset Calibration Flag

- 1** In the Service Calibrations submenu, scroll to **Drop Detector Calibration**

and press **OK**.

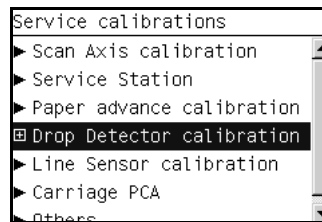

- 2** In the Drop Detector Calibration menu, scroll to **Reset Calibration Flag** and press **OK**.

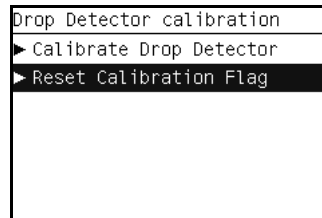

- 3** When the following message appears on the front panel, you must select whether you would like to continue with the calibration by pressing the **OK** key. Press **Back** or **Cancel** to exit the calibration.

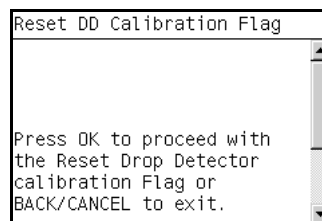

- 4** The printer will start to reset the calibration flag.

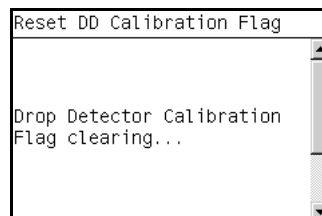

- 5** Once the calibration is completed, the Front Panel will return to the menu.
6 Restart the printer, and the printer will automatically calibrate the drop detector.

Calibrate Drop Detector

If you still need to perform the Drop Detector Calibration, use the following procedure:

- 1** In the Service Calibrations submenu, scroll to **Drop Detector Calibration**

and press **OK**.

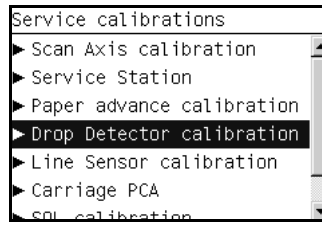

- 2** In the Drop Detector Calibration submenu, scroll to **Calibrate Drop Detector** and press **OK**.

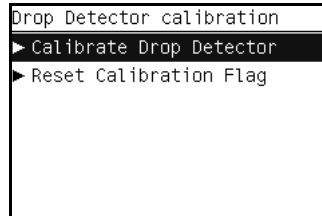

- 3** When the following message appears on the front panel, you must select whether you would like to continue with the calibration by pressing the **OK** key. Press **Back** or **Cancel** to exit the calibration.

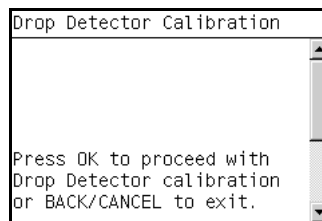

- 4** The Printer will start to calibrate the Drop Detector.

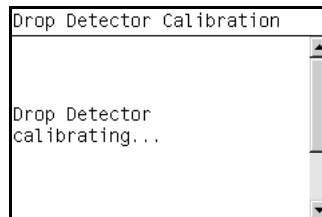

- 5** Once the Drop Detector has been calibrated, the results will be displayed on the Front Panel. Press **OK** to finish the calibration.

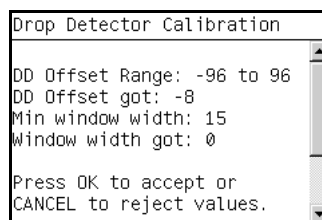

- Once the calibration is completed, OK will be displayed on the Front Panel.

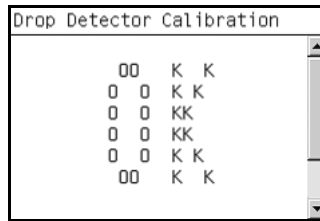

Line Sensor Calibration

The purpose of this Service Calibration is to calibrate the intensity of the line sensor in the Carriage PCA. An incorrect calibration can result in edge-detection failures during media loading and incorrect reading of prints that are used for alignment or calibration.

Perform the Line Sensor Calibration whenever:

- Edge detect procedure fails during media loading.
- Carriage is disassembled or replaced.
- Line Sensor is disassembled or replaced.
- Banding is detected in prints.
- Misalignment between colors is detected.

Service calibrations also need to be performed after removing or replacing certain printer components. If you have removed or replaced printer components, check the Service Calibration Guide to Removal and Installation to see which tests and calibrations you need to perform. Refer to Page 6-8.

Perform the Line Sensor Calibration as follows:

Make sure you load one of the following media into the Printer before performing this calibration:

- HP Glossy Media.

- In the Service Calibrations submenu, scroll to Line Sensor Calibration and press **OK**.

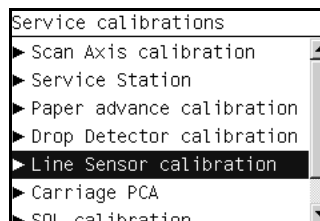

- 2** When the following message appears on the front panel, you must select whether you would like to continue with the calibration by pressing the **OK** key. Press **Back** or **Cancel** to exit the calibration.

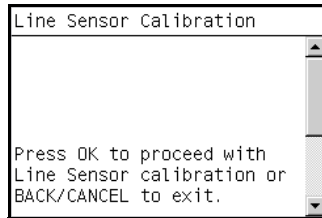

- 3** If media is not loaded, the following message appears on the front panel. Load media in to the Printer and start again from **step 1**.

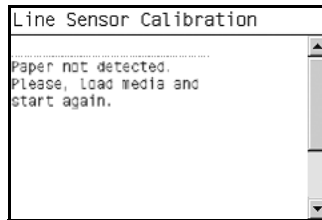

Before continuing, the Printer will check the following:

- The Media Lever is in the lowered position.
- The correct paper type is loaded (check list on previous page).
- The correct paper size (minimum paper size 24 inches).

If these conditions are **not** met, a warning will be displayed on the Front Panel and you will need to restart the Calibration from **step 1**.

Make sure you keep your hands away from the Print Platen as the Carriage will be moving at high speed and you could injure yourself or damage the Carriage Assembly.

- 4** The printer will start to calibrate the Line Sensor. Once the Line Sensor has been calibrated, the results will be displayed on the Front Panel. Press **OK** to continue or press **Back** or **Cancel** to exit the calibration.

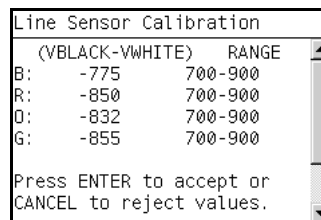

If the values are not within the range specified, an error will appear on the Front Panel. In this case, try the following:

- Try the Scan-Axis Calibration again.
- Replace the Line Sensor

- 5 The Printer will start to calibrate the Line Sensor position to the Black Printhead. The printer will print a line of black dots and then scan them:



- 6 Once the Line Sensor has been calibrated, the results will be displayed on the Front Panel. Press **OK** to finish the calibration or press **Back** or **Cancel** to exit the calibration.

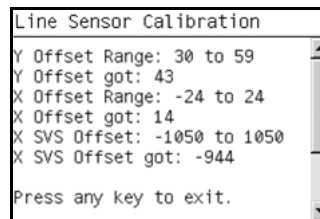

- 7 The Printer will now perform the Printhead Alignment. When the following message appears on the front panel, you must select whether you would like to continue with the calibration by pressing the **OK** key. Press **Back** or **Cancel** to exit the calibration.

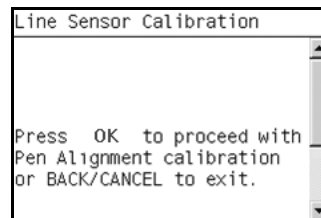

- 8 Once the Printhead Alignment is completed, the following message will be displayed on the Front Panel. Press the **OK** key to continue.

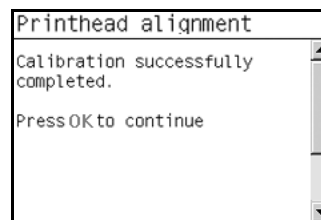

If the Printhead Alignment fails for any reason, a warning message will appear on the Front Panel. In this case, try the following:

- Enter the Front Panel menu and retry the Printhead Alignment. If the Alignment completes successfully, then perform the Color Calibration.
- If the Alignment fails again, check the Alignment pattern to see if any of the Printheads are printing incorrectly. If necessary, perform a Printhead

Recovery through the Front Panel and retry the Printhead Alignment.

- 9 Once the complete Line Sensor calibration is completed successfully, OK will be displayed on the Front Panel.

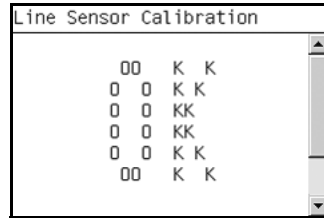

Carriage PCA

The purpose of this Service Calibration is to reset the ink short thresholds after replacing the Carriage PCA. This calibration is integrated into the Scan Axis diagnostic test. see 4. *Carriage Assembly*, Page 3-27

Perform the Carriage Setup as follows:

- 1 In the Service Calibrations submenu, scroll to Carriage PCA and press **OK**.

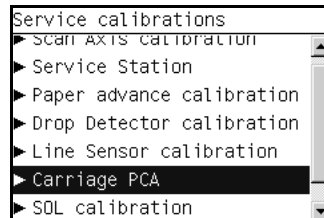

- 2 To calibrate the Carriage PCA, run the Carriage Assembly diagnostic test. see 4. *Carriage Assembly*, Page 3-27

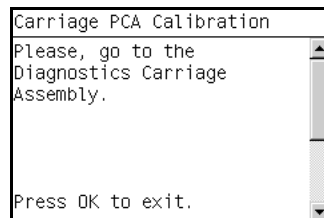

Color Sensor ESP (spectrophotometer) Calibration

The purpose of this Service Calibration is to calibrate the Color Sensor (Color Sensor ESP (spectrophotometer)).

Service calibrations also need to be performed after removing or replacing certain printer components. If you have removed or replaced printer components, check the Service Calibration Guide to Removal and Installation to see which tests and calibrations you need to perform. Refer to Page 6-8.

Perform the Color Sensor ESP (spectrophotometer) Calibration as follows:

- 1 In the Service Calibrations submenu, scroll to Color Sensor ESP

(spectrophotometer) **Calibration** and press **OK**.

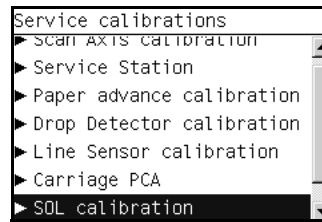

- When the following message appears on the front panel, you must select whether you would like to continue with the Carriage Setup by pressing **OK**. Press **Back** or **Cancel** to exit the utility.

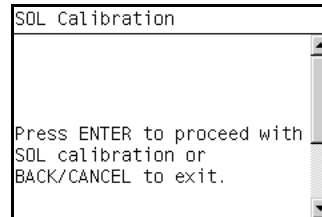

- The printer will start to calibrate the Color Sensor:

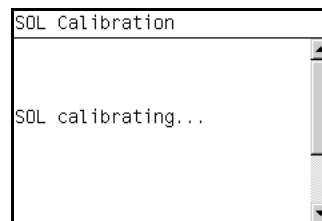

- Once the Color Sensor calibration has completed successfully, OK will be displayed on the Front Panel.

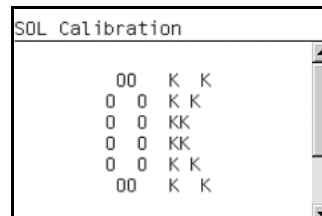

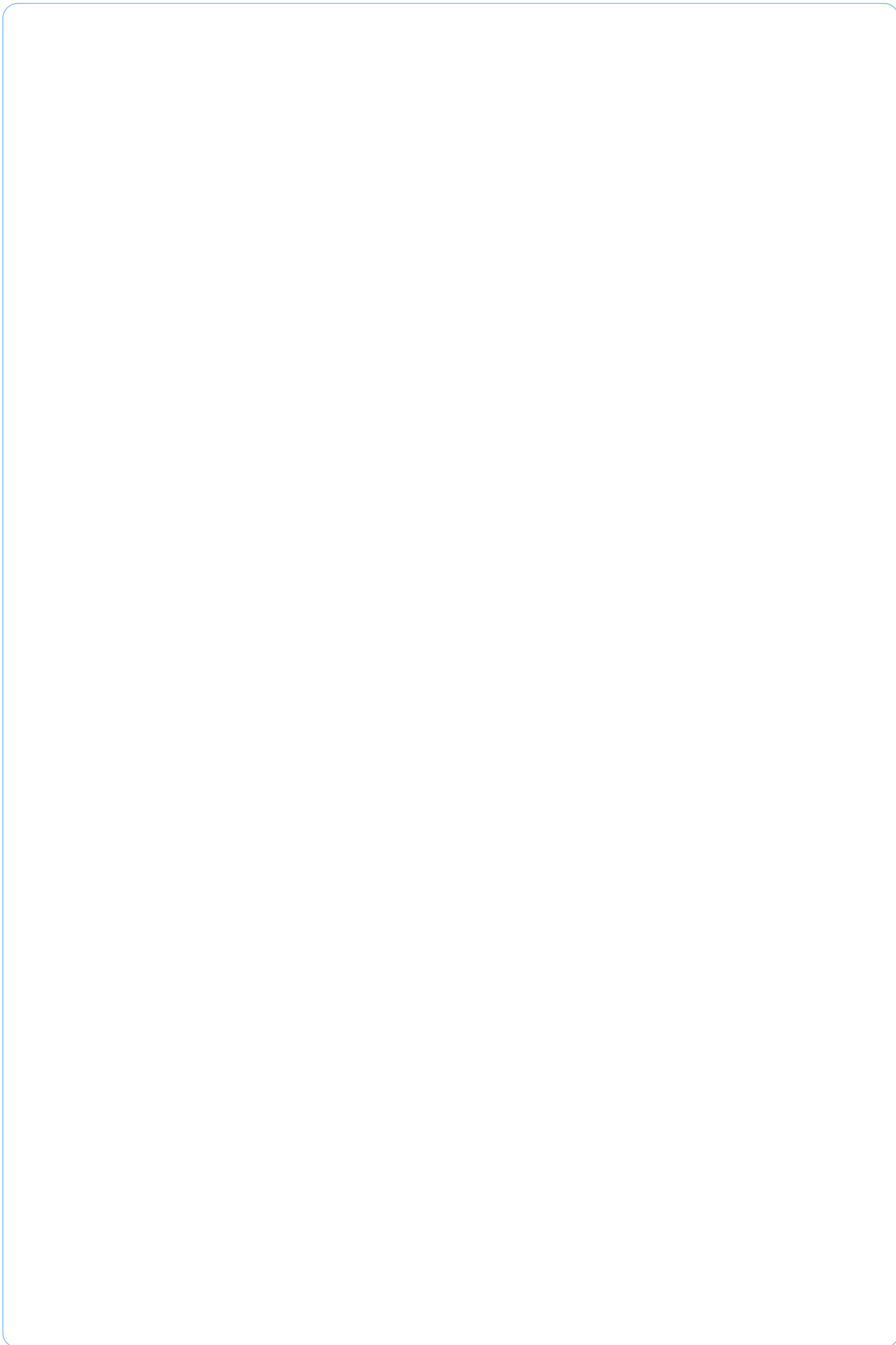

Parts and Diagrams

5

Introduction 5-2
Center Covers (Front) 5-5
Center Covers (Rear) 5-7
Right Cover 5-9
Left Cover 5-11
Right Hand Assemblies 5-13
Left Hand Assemblies 5-15
Carriage Assembly 5-17
Scan-Axis Assemblies 5-19
Paper Path Assemblies (Front) 5-21
Paper Path Assemblies (Rear) 5-23
Tool Kits 5-25
Miscellaneous Parts 5-27

Introduction

This chapter shows views of the service parts and the service part numbers and descriptions. When the part is described with a specific revision (Rev A, B, C or D), this indicates it is only compatible with the revision shown. If there is no revision shown, this indicates it is compatible with all revisions of the printer.

Before ordering a new component, always make sure that you have performed the relevant service test from Chapter 4. If the test passes you will not need to replace the component.

Printer Support

Reference on Figure	HP Part Number	Part Description	Printer Model	Size	Page ^a
1	Q5669-60718	Leg Cover	All	All	N/A
2	Q5669-60716	Legs Assembly	All	All	N/A
3	Q5669-60715	Foot Assembly (includes 1 foot and 1 support tube)	All	All	N/A
4	Q5669-60719	Bin Assembly (Includes the Bin Support)	All	24 inch	N/A
	Q6659-60237			44 inch	N/A
5	Q5669-60717	X-Brace Assembly	All	24 inch	N/A
	Q6659-60236			44 inch	N/A
-	Q5669-60730	Hardware Kit (Includes screws for Legs Assembly)	All	All	N/A
-	Q5669-67063	Basket Tubes and Adaptors	All	All	N/A

a Refers to the page in the Removal and Installation Chapter



Figure 5-1: Introduction

Center Covers (Front)

Reference on Figure	HP Part Number	Part Description	Printer Model	Size	Page ^a
1	Q5669-60662	Window	All	24 inch	6-13
	Q6659-60172			44 inch	
2	Q5669-60656	Top Cover	All	24 inch	
	Q6659-60168			44 inch	
3	Q5669-60675	Window Position Sensor	All	All	6-54
4	Q5669-60155	Media Output Assembly	All	24 inch	6-18
	Q6659-60089			44 inch	
5	Q5669-60651	Front Cover	Z2100	24 inch	6-17
	Q6659-60165			44 inch	
	Q5669-67001		Z3100/ Z3100ps /Z3200/ Z3200ps	24 inch	
	Q6659-67001			44 inch	
6	Q6675-60060	Front Panel	Z2100	All	6-48
	Q5669-60714		Z3100/ Z3100ps		
	Q6718-67010		Z3200/ Z3200ps		

^a Refers to the page in the Removal and Installation Chapter

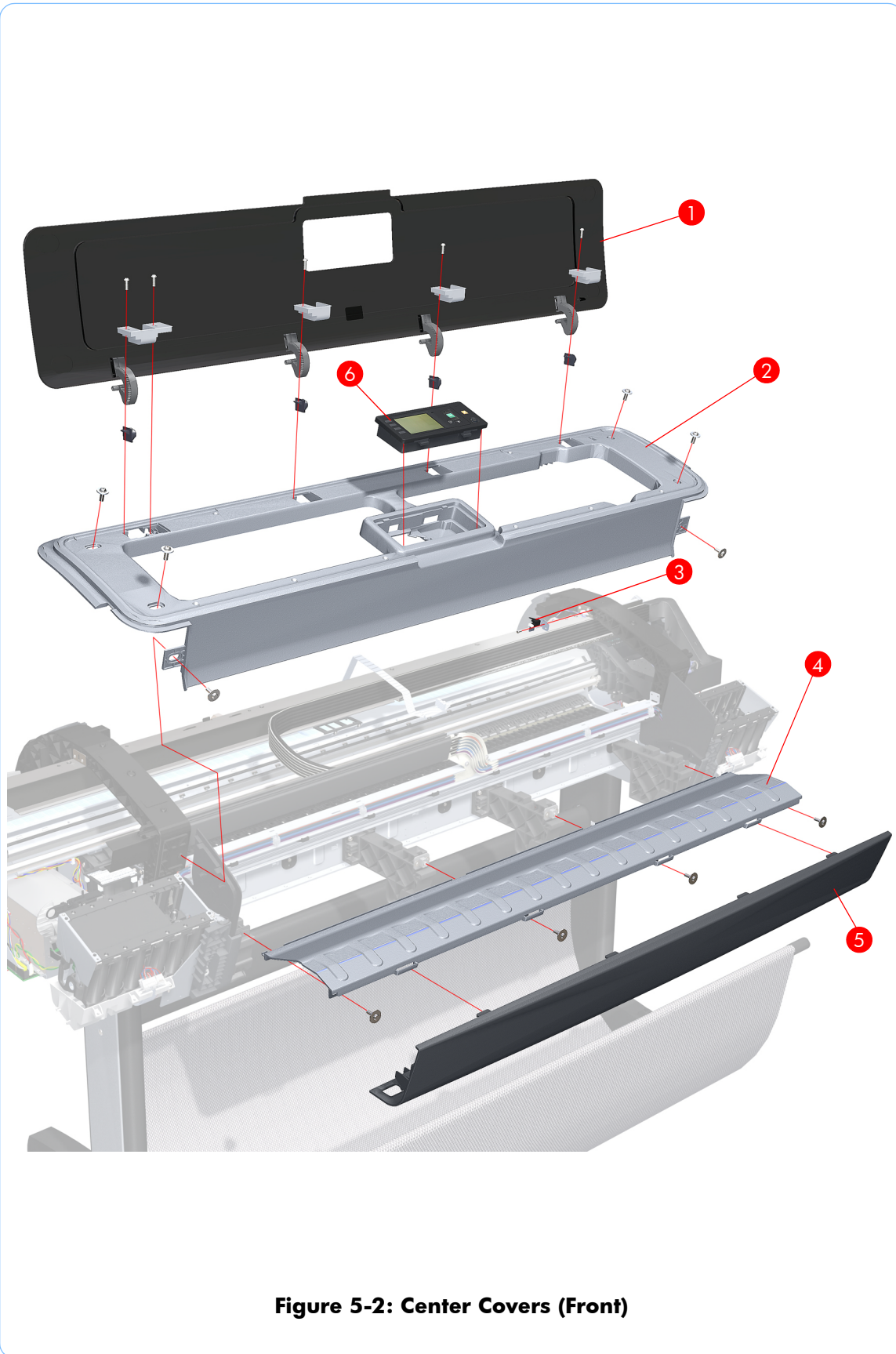

Figure 5-2: Center Covers (Front)

Center Covers (Rear)

Reference on Figure	HP Part Number	Part Description	Printer Model	Size	Page ^a
1	Q5669-60660	Rear Tray Supports	Z2100/ Z3100/ Z3100ps	All	6-44
	Q6683-60207		Z3200/ Z3200ps		
2	Q6683-67802	Clean Out Assembly	All	24 inch	6-78
	Q6687-67801			44 inch	
3	Q5669-60676	Out Of Paper Sensor	All	All	6-79
4	Q5669-60659	Rear Tray (For the Z2100/Z3100/ Z3100ps printers, there are two valid Rear Tray types. One type has an extension tray, and the other type does not. All Rear Trays ordered as service parts have the extension.)	Z2100/ Z3100/ Z3100ps	24 inch	6-36
	Q6659-60170			44 inch	
	Q6683-60194		Z3200/ Z3200ps	24 inch	
	Q6687-60058			44 inch	
5	Q5669-60650	Rear Cover	All	24 inch	6-37
	Q6659-60164			44 inch	

^a Refers to the page in the Removal and Installation Chapter

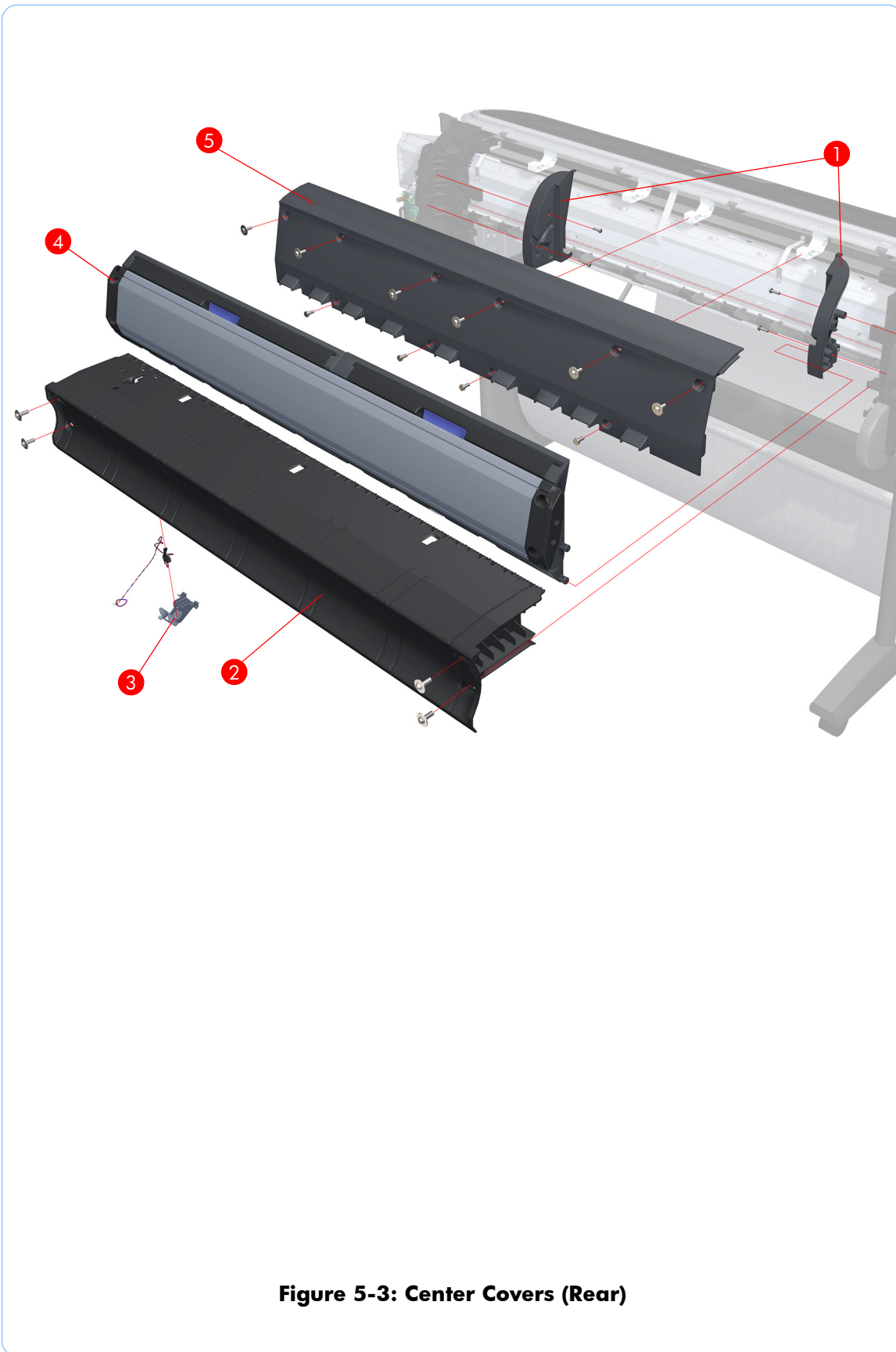

Figure 5-3: Center Covers (Rear)

Right Cover

Reference on Figure	HP Part Number	Part Description	Printer Model	Size	Page ^a
1	Q6675-60015	Right Cover (without Right Ink Cartridge Door)	Z2100	All	6-27
	Q5669-60653		Z3100/ Z3100ps		
	Q6718-67019		Z3200/ Z3200ps		
2	Q5669-60657	Left Front Trim/Right Front Trim (Left not shown. There are two valid Left/Right Trim types. One type is integrated with the Output Support, and the other type is separate from the Output Support. All Left/Right Trim ordered as service parts are integrated.)	All	All	6-19
3	Q6675-60017	Right Ink Cartridge Door	Z2100	All	6-23
	Q5669-60655		Z3100/ Z3100ps		
	Q6675-60089		All		
	Q6718-67016		Z3200/ Z3200ps		

^a Refers to the page in the Removal and Installation Chapter

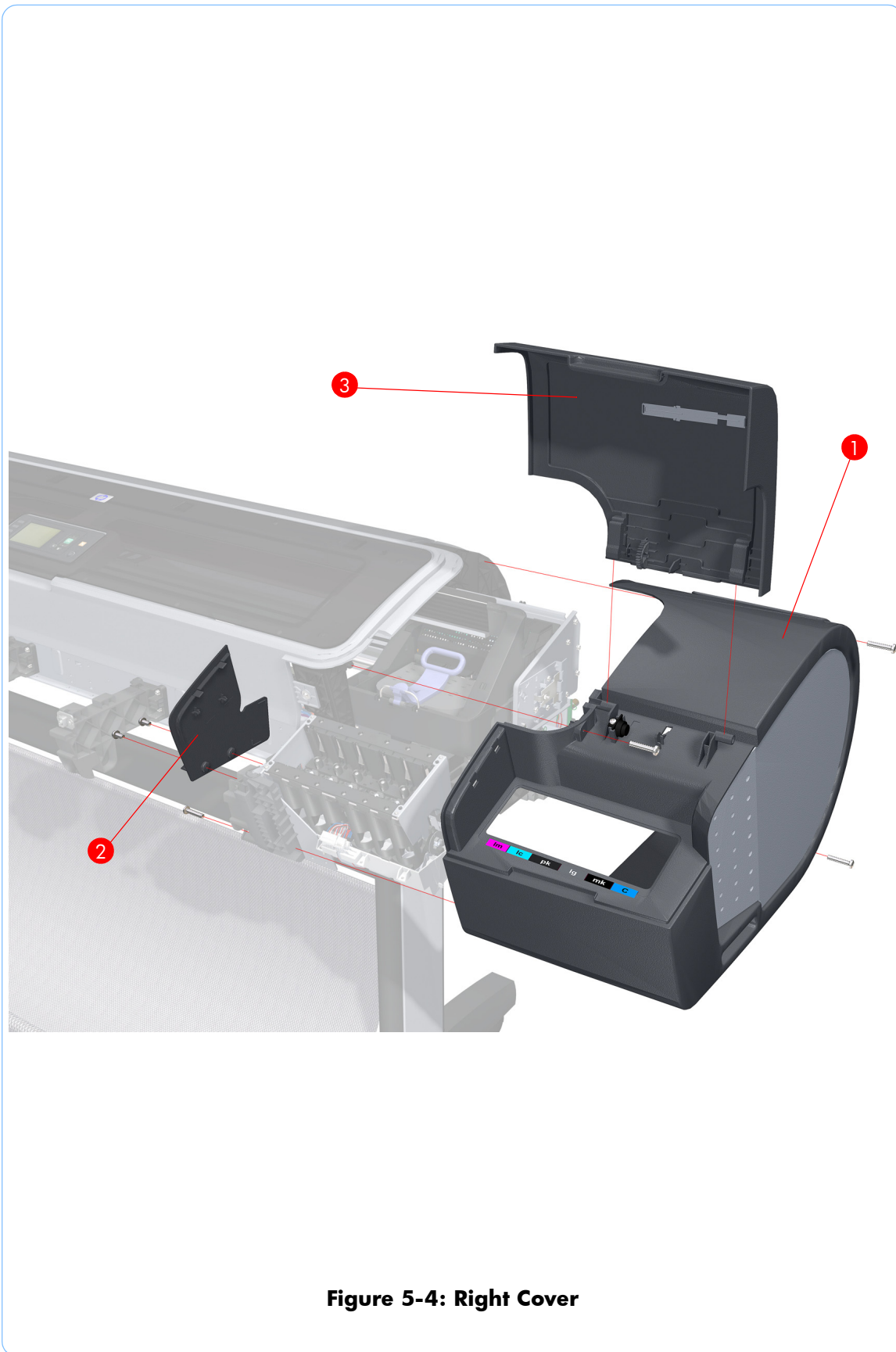

Figure 5-4: Right Cover

Left Cover

Reference on Figure	HP Part Number	Part Description	Printer Model	Size	Page ^a
1	Q6675-60016	Left Ink Cartridge Door	Z2100/ Z3100	All	6-25
	Q6675-60088		All		
2	Q5669-60657	Left Front Trim/Right Front Trim (Right not shown. There are two valid Left/Right Trim types. One type is integrated with the Output Support, and the other type is separate from the Output Support. All Left/Right Trim ordered as service parts are integrated.)	All	All	6-21
3	Q6675-67003	Left Side Panel	All	All	6-30
4	Q6675-60014	Left Cover (without Left Ink Cartridge Door)	Z2100	All	6-30
	Q5669-60652		Z3100/ Z3100ps		
	Q6675-67021	Ink Trim Assembly	Z2100	All	

a Refers to the page in the Removal and Installation Chapter



Figure 5-5: Left Cover

Right Hand Assemblies

Reference on Figure	HP Part Number	Part Description	Printer Model	Size	Page ^a
1	Q6675-60043	Carriage Rail Oiler	All	All	6-122
2	Q5669-67807	Pen to Paper Space (PPS) Solenoid	All	All	6-73
3	Q5669-60674	Scan-Axis Motor	All	All	6-118
4	Q6675-67801	PrintMech PCA	All	All	6-71
5	Q5669-60667	Service Station Spittoon	All	All	6-60
6	Q5669-60664	Aerosol Fan Assembly	All	All	6-65
7	Q6718-67025	Service Station	All	All	6-60
8	Q5669-60666	Drop Detector	All	All	6-64
9	Q6675-60020	Right Ink Supply Station	Z2100	All	6-145
	Q5669-60670		Z3100/ Z3100ps		
	Q6718-67001		Z3200/ Z3200ps		

^a Refers to the page in the Removal and Installation Chapter

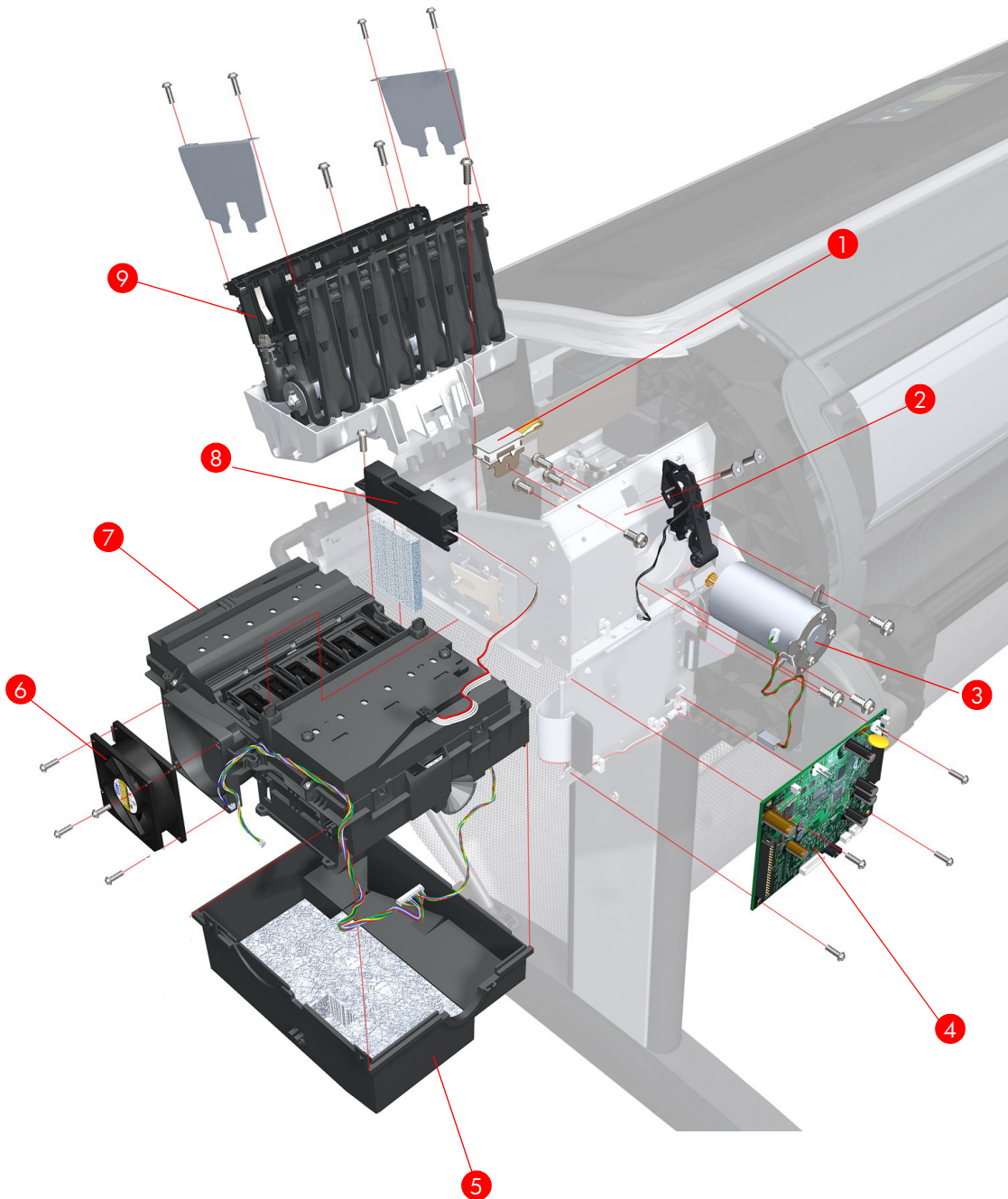

Figure 5-6: Right Hand Assemblies

Left Hand Assemblies

Ref	HP Part Number	Part Description	Printer Model	Size	Page
1	Q6675-60019	Left Ink Supply Station	Z2100	All	6-149
	Q5669-60669		Z3100/Z3100ps /Z3200/ Z3200ps		
2	Q6708-67017	Starwheel Motor	All	All	6-214
3	Q5669-60703	Encoder Sensor	All	All	6-180
4	Q5669-60702	Encoder Disk	All	All	6-180
5	Q5669-60700	Media Advance Transmission	All	All	6-183
6	Q5669-67049	Left Spittoon	All	All	6-177
7	Q5669-60693	Power Supply Unit (PSU) Assembly	Z2100Z3100/ Z3100ps	All	6-165
	Q6718-67005		Z3200/ Z3200ps		
8	Q6677-67007	Main PCA with Power Supply Unit (PSU) Assembly	Z2100 Rev C Z3100, Z3100ps	All	6-165
	Q6718-67029		Z3200 Rev. A Z3200ps Rev. A	All	
	Q677-67008		Z2100 Rev. D	All	
	Q6719-67009		Z3200 Rev. B Z3200ps Rev. B	All	
9	Q6675-67029	Formatter with HDD	Z2100 Rev. C	All	6-161
	Q5669-60175		Z3100		
	Q5670-67001		Z3100ps		
	Q6718-60047		Z3200 Rev. A Z3200ps Rev. A		
9a	CK837-67026	Formatter without HDD	Z2100 Rev. D Z3200 Rev. B Z3200ps Rev. B	All	
9b	Q6677-67009	Hard Disk Drive	Z2100 Rev. D	All	
	Q6719-67010		Z3200 Rev. B Z3200ps Rev. B	All	
10	Q5669-60705	Media Lever	All	All	6-38
11	Q5669-60706	Media Lever Position Sensor	All	All	6-41

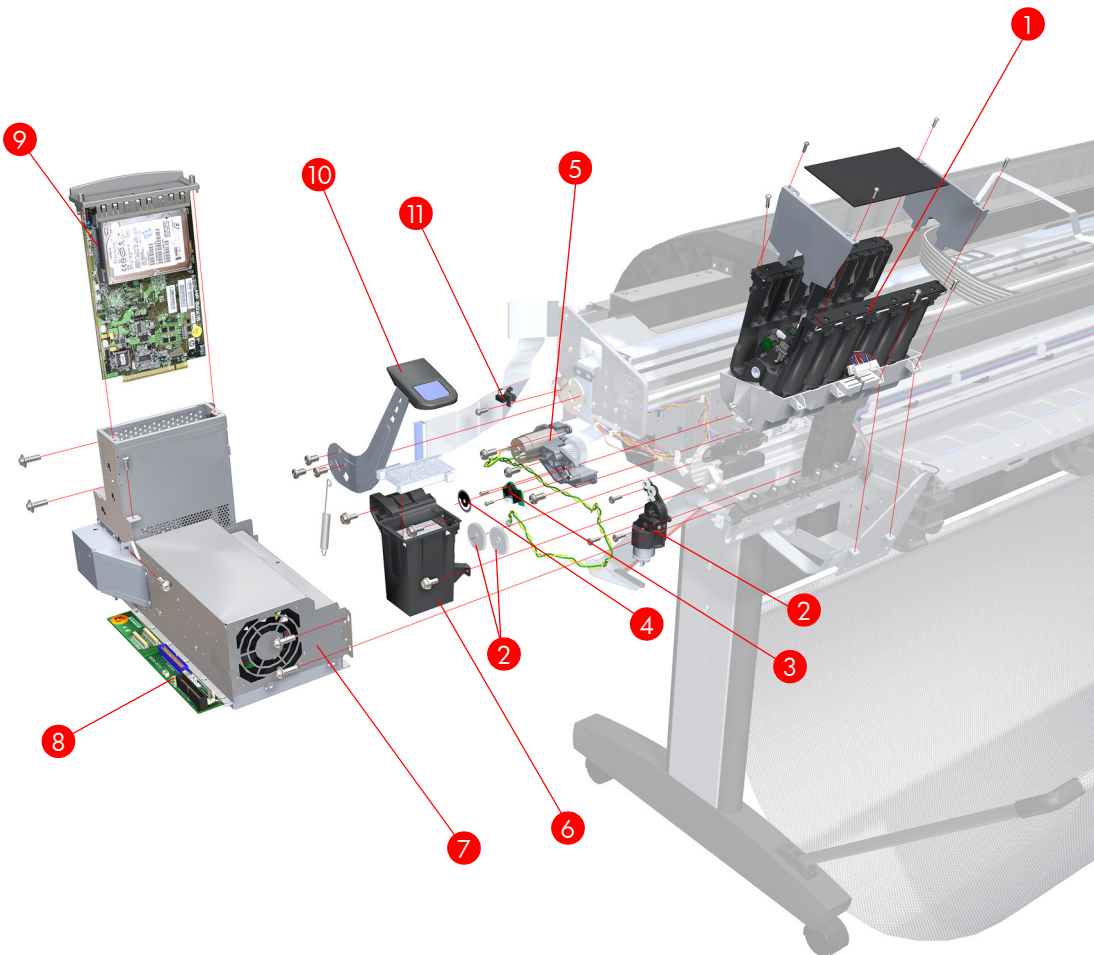

Figure 5-7: Left Hand Assemblies

Carriage Assembly

Reference on Figure	HP Part Number	Part Description	Printer Model	Size	Page ^a
1	Q5669-60689	Carriage PCA Cover	All	All	6-140
2	Q5669-60685	Carriage Latch	All	All	6-135
3	Q5669-60686	Carriage Cover (includes Carriage Latch)	All	All	6-135
4	Q5669-60682	Carriage PCA	Z2100/ Z3100/ Z3100ps	All	6-140
	Q6718-67003		Z3200/ Z3200ps	44 inch	
5	Q5669-60687	Carriage Rear Bushing	All	All	6-115
6	Q6683-67004	Line Sensor	All	All	6-130
7	Q5669-60684	Color Sensor ESP (spectrophotometer)	All	All	6-124
8	Q5669-67052	Trailing Cable	All	24 inch	6-92
	Q6659-67015			44 inch	
1 - 8	Q6675-67020	Carriage Assembly (includes: Line Sensor, Carriage Cover, Carriage Latch, Carriage PCA, Carriage Rear Bushing, Trailing Cable, and Color Sensor (ESP))	Z2100	24 inch	6-100
	Q6677-67004		Z2100	44 inch	
	Q5669-67051		Z3100/ Z3100ps	24 inch	
	Q6659-67014		Z3100/ Z3100ps	44 inch	
	Q6718-67012		Z3200/ Z3200ps	24 inch	
	Q6719-67003		Z3200/ Z3200ps	44 inch	
	Q5669-67055	Extra High PRS Wedge	All	All	6-111

^a Refers to the page in the Removal and Installation Chapter

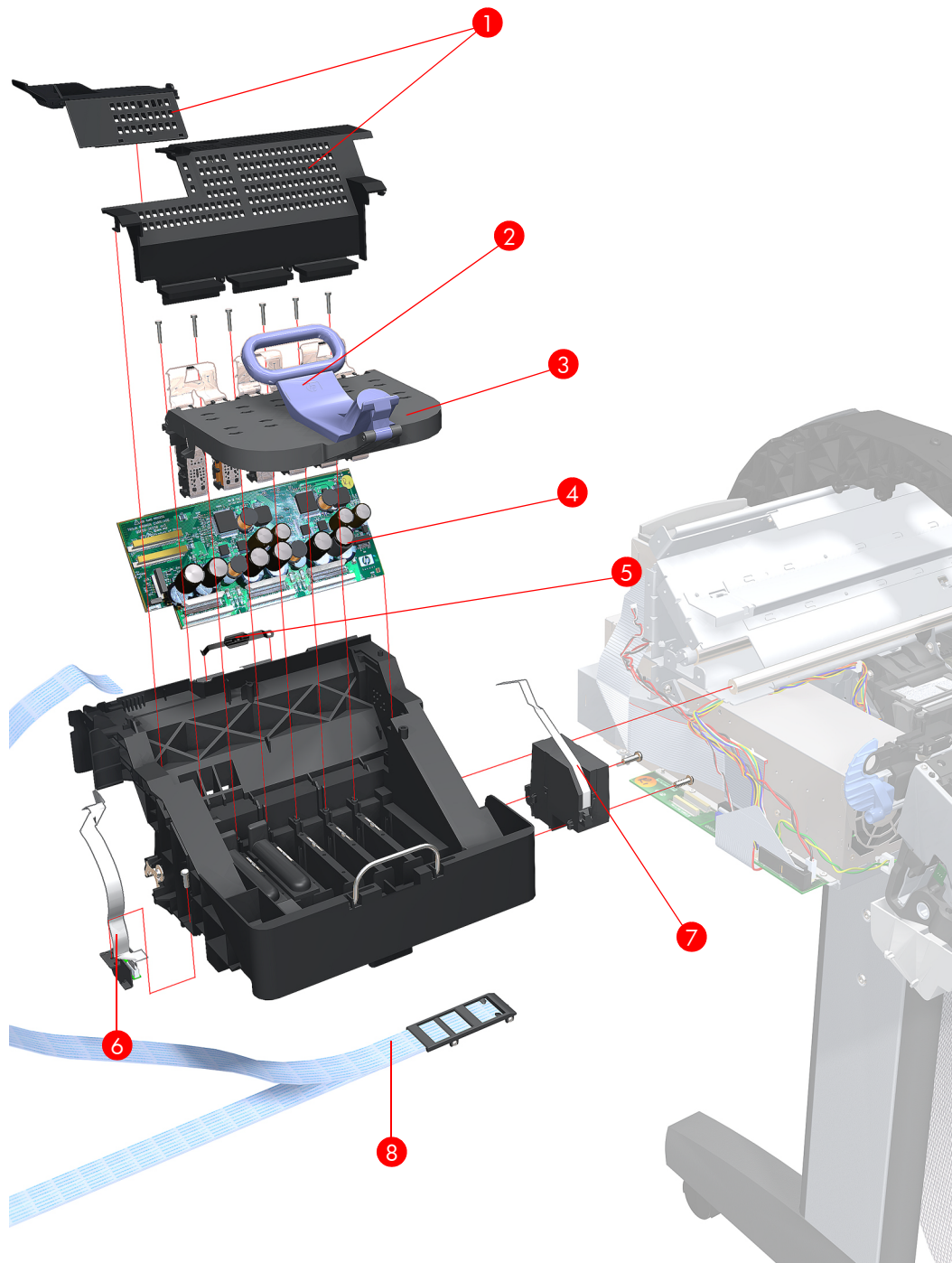

Figure 5-8: Carriage Assembly

Scan-Axis Assemblies

Reference on Figure	HP Part Number	Part Description	Printer Model	Size	Page ^a
1	Q6675-60021	Ink Supply Tubes	Z2100	24 inch	6-153
	Q5669-60671		Z3100/ Z3100ps		
	Q6677-60007		Z2100	44 inch	
	Q6659-60174		Z3100/ Z3100ps		
	Q6718-67002		Z3200/ Z3200ps	24 inch	
	Q6719-67001			44 inch	
2	Q6675-60071	Encoder Strip (including Encoder Strip Spring and Nut)	All	24 inch	6-84
	Q6677-60024			44 inch	
3	Q5669-60673	Belt Assembly	All	24 inch	6-117
	Q6659-60175			44 inch	
4	Q5669-60672	Belt Tensioner	All	All	6-117
5	Q5669-67052	Trailing Cable (with Carriage PCA Cover)	All	24 inch	6-92
	Q6659-67015			44 inch	
-	Q5669-60679	Encoder Strip (including Encoder Strip Spring and Nut) - 50 units	All	24 inch	6-84
	Q6659-60176			44 inch	

^a Refers to the page in the Removal and Installation Chapter

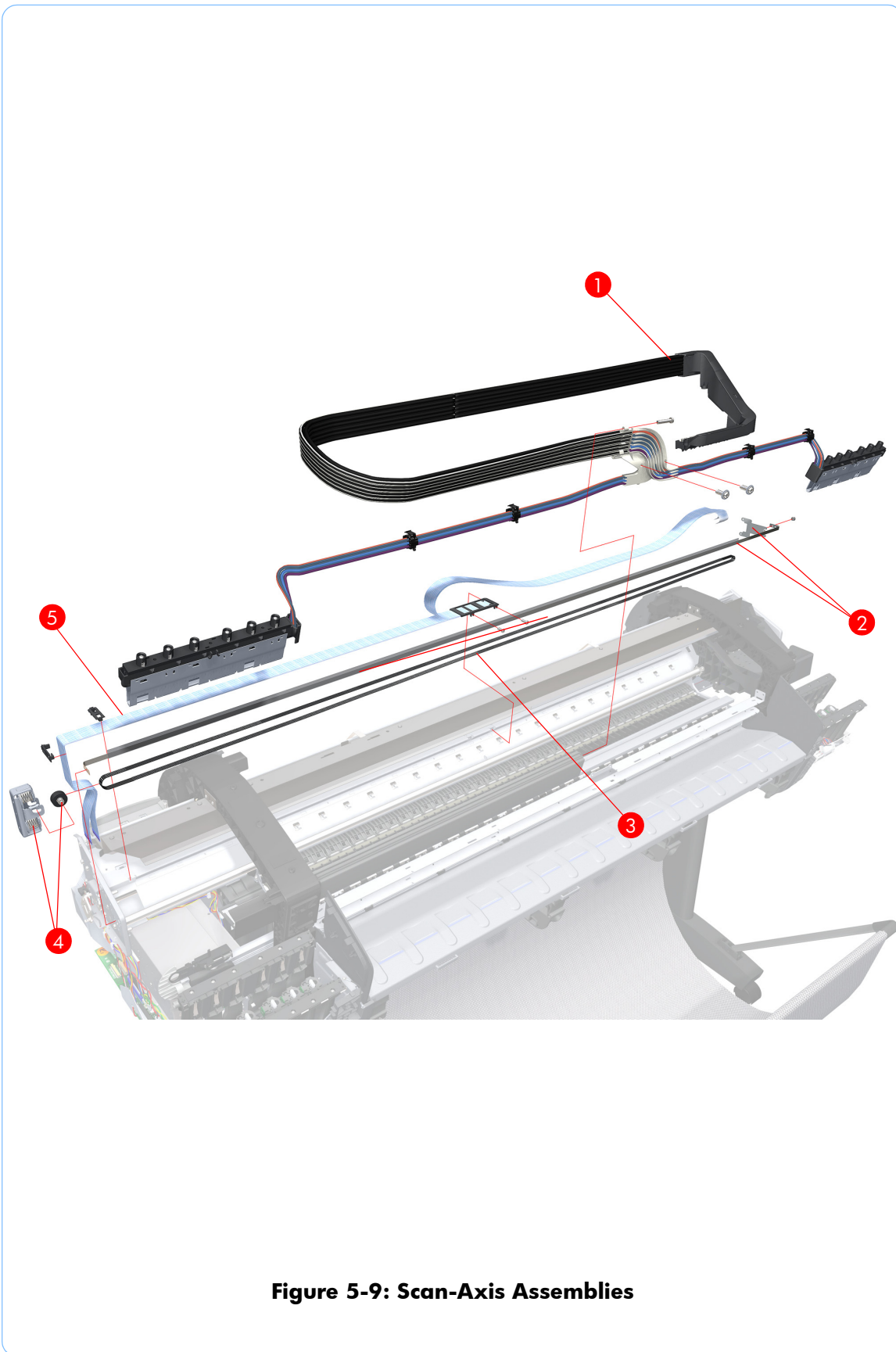

Figure 5-9: Scan-Axis Assemblies

Paper Path Assemblies (Front)

Reference on Figure	HP Part Number	Part Description	Printer Model	Size	Page ^a
1	Q6718-67014	Starwheel Assembly (without Actuator)	All	24 inch	6-168
	Q6719-67004		All	44 inch	
1	Q5669-67061	Starwheel Assembly (with Actuator)	Z2100/ Z3100/ Z3100ps	24 inch	6-168
	Q6659-67016			44 inch	
2	Q6675-60042	Print Zone Overdrive	All	24 inch	6-173
	Q6677-60018			44 inch	
3	Q5669-67054	Starwheel Lifter	Z2100/ Z3100/ Z3100ps Z3200/ Z3200ps	All	6-207
	Q6718-67013				
4	Q5669-60713	Cutter Assembly	All	All	6-43
5	Q5669-60701	Full Bleed Foam Kit	All	24 inch	6-216
	Q6659-60182			44 inch	

a Refers to the page in the Removal and Installation Chapter

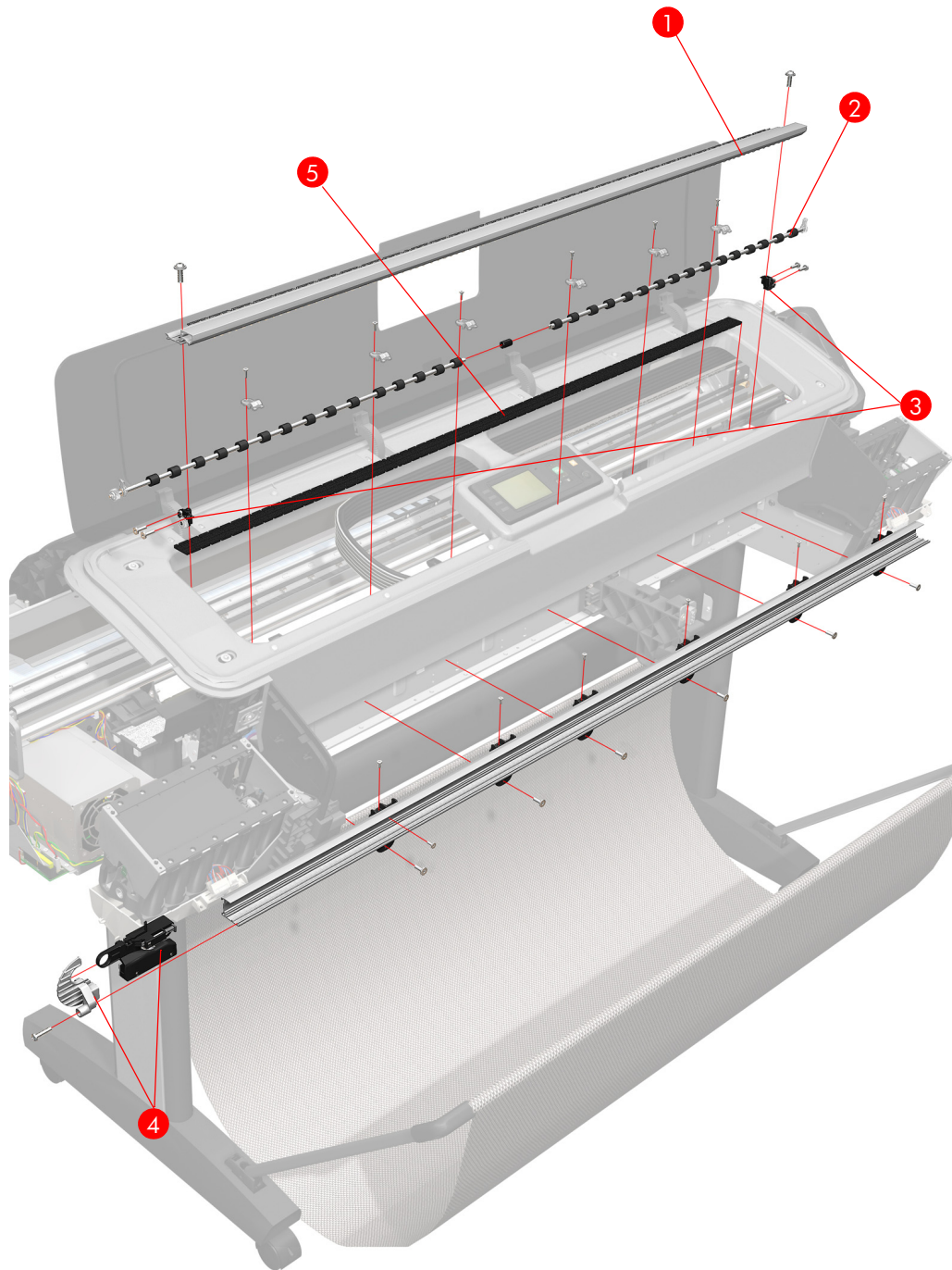

Figure 5-10: Paper Path Assemblies (Front)

Paper Path Assemblies (Rear)

Reference on Figure	HP Part Number	Part Description	Printer Model	Size	Page ^a
1	Q5669-60708	Pinch Roller (plastic pinchwheels)	All	All	6-202
2	Q5669-60707	Pinchwheel Assembly	All	All	6-194
-	Q5669-67060	Rubber Pinchwheel Kit	Z2100/ Z3100/ Z3100ps	All	6-203
3	Q6677-60019	Left Roll Guide	All	44 inch	6-82
4	Q5669-60711	Left Spindle Holder	Z2100/ Z3100/ Z3100ps	All	6-76
	Q6718-67008		Z3200/ Z3200ps		
5	Q5669-60710	Spindle (There are two valid spindle types for the 24 inch printers. The difference is the diameter of the spindle. All spindles ordered as service parts have the thicker diameter).	All	24 inch	6-75
	Q6659-60183			44 inch	
5	Q6677-60028	Tech 44 Spindle (for increased back tension)	All	44 inch	6-75
6	Q5669-60712	Right Spindle Holder	Z2100/ Z3100/ Z3100ps	All	6-77
	Q6718-67009		Z3200/ Z3200ps		
7	Q6675-60044	Right Roll Guide	All	All	6-83
-	Q6675-60103	Media Advance Kit	All	24 inch	
	Q6677-60030			44 inch	
-	Q6675-60093	3 inch Spindle Adaptor Kit	All	All	N/A

^a Refers to the page in the Removal and Installation Chapter

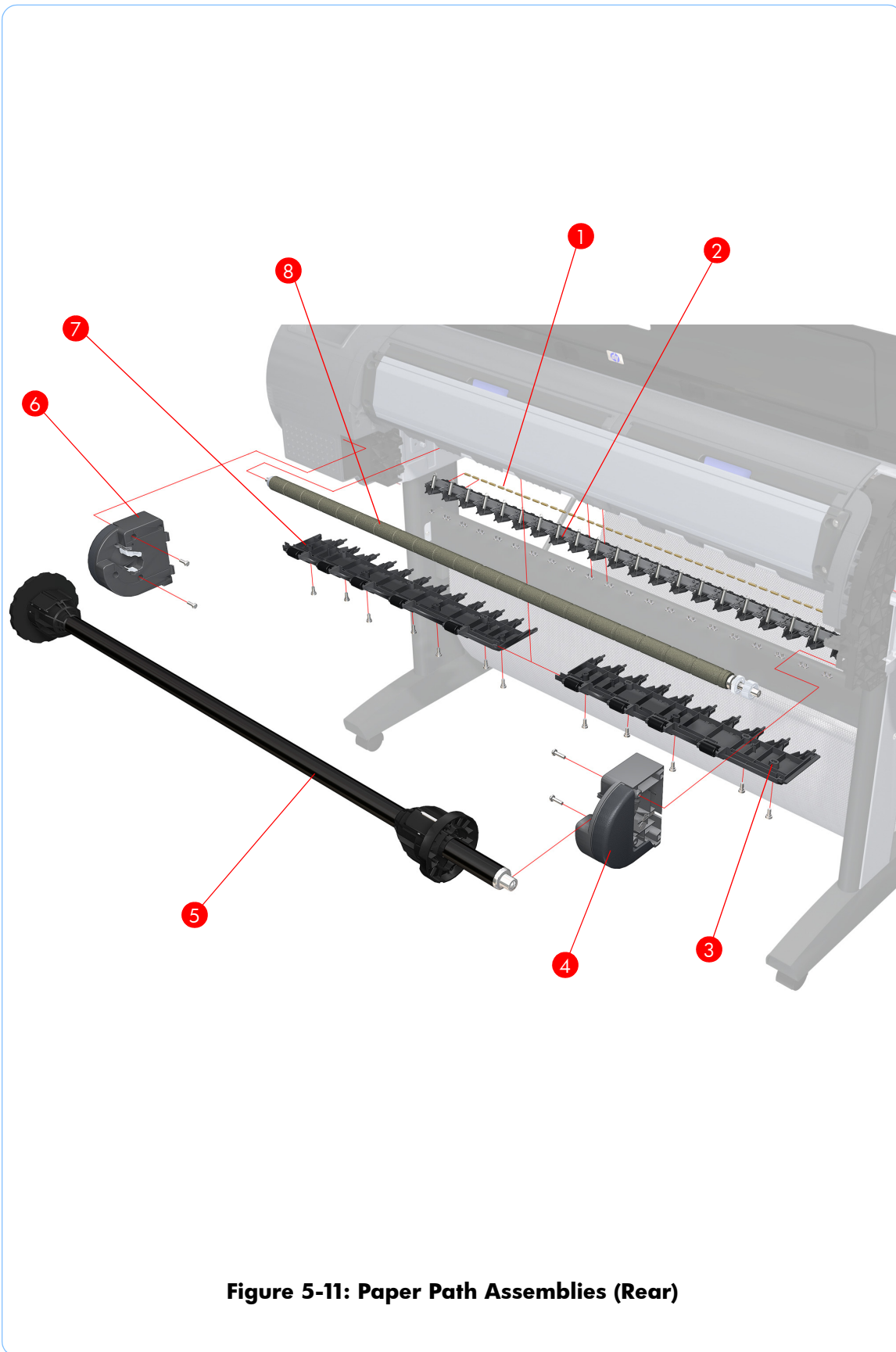

Figure 5-11: Paper Path Assemblies (Rear)

Took Kits

Reference on Figure	HP Part Number	Part Description	Printer Model	Size
2	Q5669-60690	Flex Contacts Cleaning Tool	All	All
1	Q6675-67018	Media Driver Tool Kit (includes the Handle for Media Driver Tool Support and the Media Driver Adjustment Tool)	All	All
3-4	Q6687-60084	Pinchwheel Insertion Tool	All	All
5	Q6675-67017	Spanner Tool	All	All
6	Q6683-67001	Tool Kit (includes pinwheel alignment tool, media driver tool, spanner # 13, oil dispenser, insert spring tool, tweezers, T15 screwdriver, 100cc Isopropyl Alcohol, lubricant oil, plastic gloves, flex contacts cleaning tool and cleaning kit)	All	All
7	Q5669-60692	Lubrication Kit	All	All

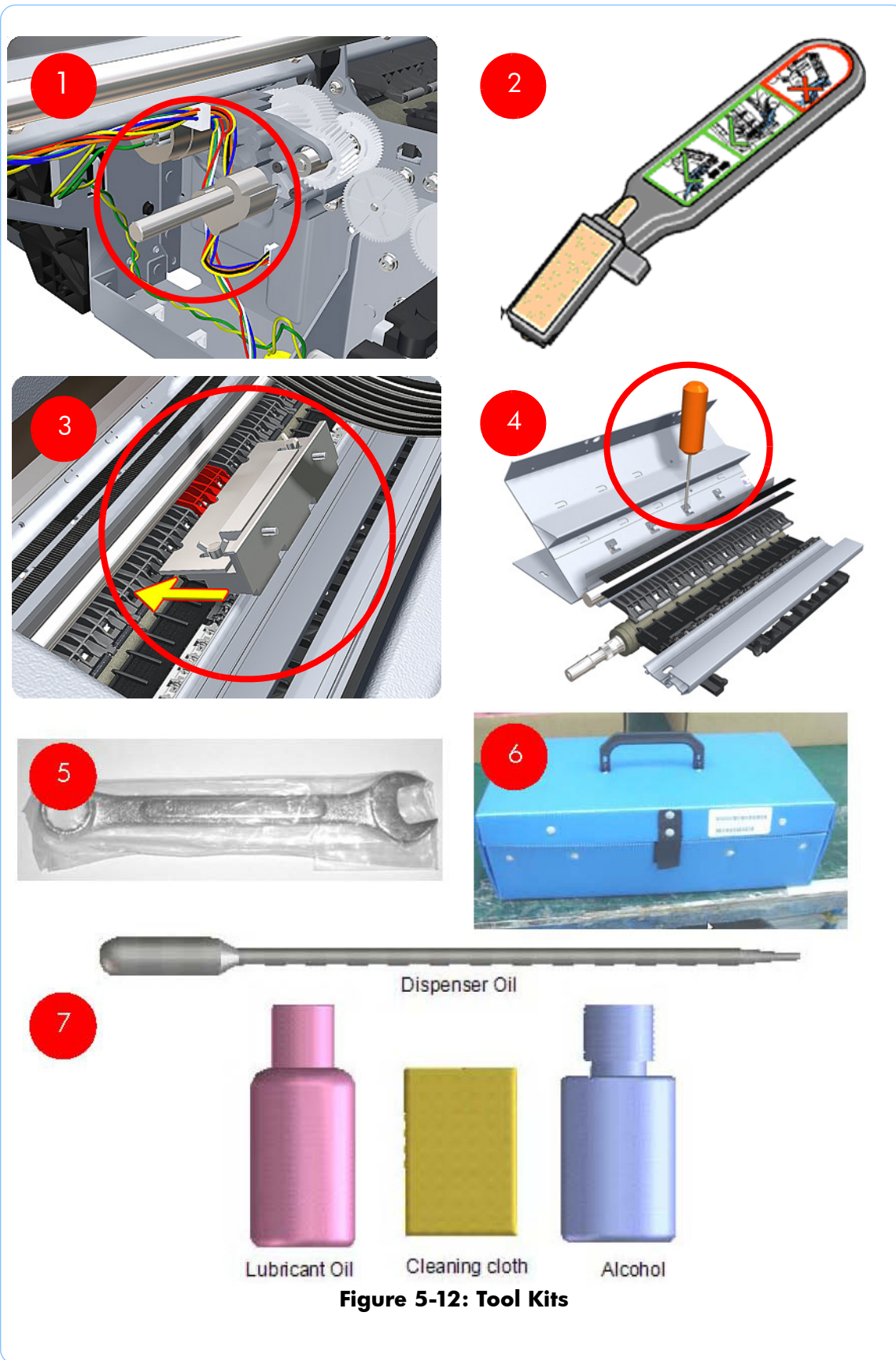
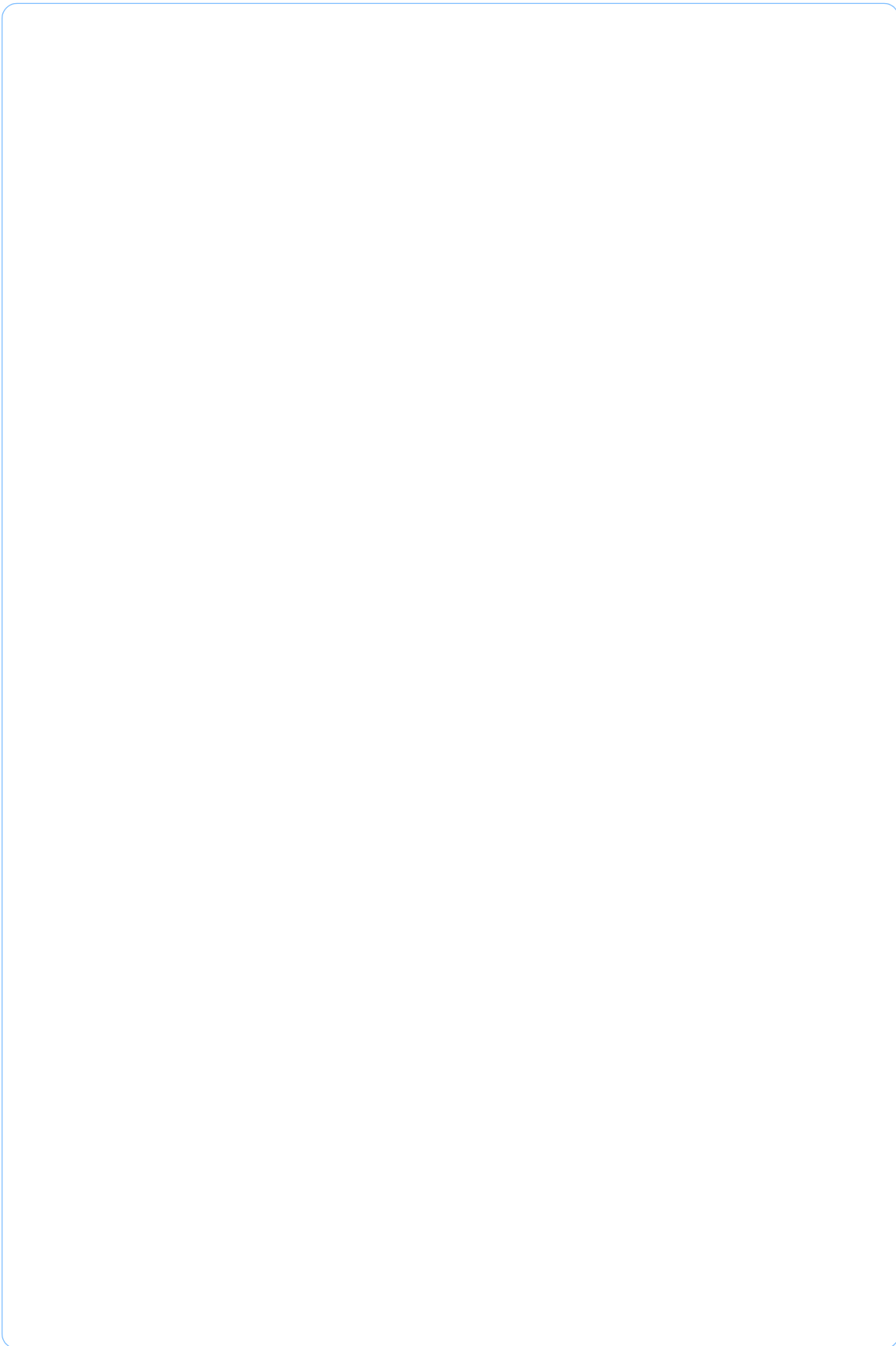

Figure 5-12: Tool Kits

Miscellaneous Parts

HP Part Number	Part Description	Printer Model	Size
Q6675-67019	Preventive Maintenance Kit #1	Z2100	24 inch
Q5669-67050		Z3100/ Z3100ps	
Q6677-67003		Z2100	44 inch
Q6659-67013		Z3100/ Z3100ps	
Q6718-67011		Z3200/ Z3200ps	24 inch
Q6719-67002			44 inch
Q6718-67026	Preventive Maintenance Kit #2	All	All
Q5669-60722	Preventive Maintenance Kit #3	All	All
Q6675-60103	Paper Advance Calibration Kit	All	24 inch
Q6677-60030			44 inch
Q6675-60092	Harness Cables (includes Left ISS, Right ISS, Printmech PCA 24 inch and 44 inch)	All	All
Q6675-60068	Serial Number Label	All	All
Q6675-67004	Ink System Purgers (6 Units)	All	All
Q6675-67005	Ink System Purgers (100 Units)	All	All
Q6675-67006	Double Sided Adhesive Pad	All	All



Removal and Installation

6

Introduction 6-2
Service Calibration Guide to Removal and Installation 6-8
Window 6-13
Covers and Trims 5-17
Rear Tray 6-36
Rear Cover 6-37
Media Lever 6-38
Media Lever Position Sensor 6-41
Cutter Assembly 6-43
Left Rear Tray Support 6-46
Front Panel 6-48
Top Cover 6-51
Window Position Sensor 6-54
Ink Supply Tubes Support Rail 6-56
Service Station 6-60
Drop Detector 6-64
Aerosol Fan Assembly 6-65
Primer Assembly 6-67
PrintMech PCA 6-71
Pen to Paper Space (PPS) Solenoid 6-73
Spindle 6-75
Left Spindle Holder 6-76
Right Spindle Holder 6-77
Clean Out Assembly 6-78
Out Of Paper Sensor 6-79
Left Roll Guide 6-82
Right Roll Guide 6-83
Encoder Strip (with spring and attachment nut) 6-84
Clean Encoder Strip Procedure 6-86
Trailing Cable (with Carriage PCA Cover) 6-92
Carriage Assembly and Trailing Cable 6-100
Extra High PRS Wedge 6-111
Carriage Rear Bushing 6-115
Belt Assembly 6-117
Scan-Axis Motor 6-118
Carriage Rail Oiler 6-122
Color Sensor ESP (spectrophotometer) 6-124
Line Sensor 6-130
Carriage Cover (includes Carriage Latch) 6-135
Carriage PCA 6-140
Right Ink Supply Station 6-145
Left Ink Supply Station 6-149
Ink Supply Tubes 6-153
Formatter 6-161
Hard Disk Drive 6-163
Electronics Module (Main PCA and PSU) 6-165
Starwheel Assembly 6-168
Print Zone Overdrive 6-173
Left Spittoon 6-177
Encoder Disk and Encoder Sensor 6-180
Media Advance Drive 6-183
Media Advance Roller 6-188
Pinchwheel Assembly 6-194
Pinch Roller 6-202
Rubber Pinchwheel Kit 6-203
Left Starwheel Lifter 6-207
Right Starwheel Lifter 6-210
Starwheel Motor 6-214
Full Bleed Foam 6-216

Introduction

This chapter is a step-by-step guide to the removal and installation of the key components of the printer. You may find it useful to check off the steps as they are performed. Use the illustrations for each procedure to identify the parts referred to in the text.

The procedures appear in order of removal. The whole machine can be stripped down by starting at the beginning of this chapter and working through the subsequent procedures.

Before using this chapter to remove and install a new component, always make sure that you have performed the relevant service test from Chapter 4. If the test passes you will not need to replace the component.

Safety Precautions

Review the instructions identified by WARNING and CAUTION symbols before you service the printer. Follow these warnings and cautions for your protection and to avoid damaging the printer.

Serious shock hazard leading to death or injury may result if you do not take the following precautions:

- **Ensure that the ac power outlet (mains) has a protective earth (ground) terminal.**
- **Switch the plotter off, and disconnect it from the power source prior to performing any maintenance.**
- **Prevent water or other liquids from running onto electrical components or circuits, or through openings in the module.**

Electrostatic Discharge (ESD) Precautions

To prevent damage to the Printer circuits from high-voltage electrostatic discharge (ESD):

1. Do not wear clothing that is subject to static build-up.
2. Do not handle integrated circuits (ICs) in carpeted areas.
3. Do not remove an IC or a printed circuit assembly (PCA) from its conductive foam pad or conductive packaging until you are ready to install it.
4. Ground (earth) your body while disassembling and working on the Printer.
5. After removing a cover from the Printer, attach an earthing (ground) lead between the PCA common and earth ground. Touch all tools to earth ground to remove static charges before using them on the Printer.
6. After removing any PCA from the Printer, place it on a conductive foam pad or into its conductive packaging to prevent ESD damage to any ICs on the PCA.

Required Tools

All the special tools and equipment required to disassemble, service and repair the Printer are provided in the Toolkit P/N . Some tools can be ordered separately from the toolkit. Refer to Page 5-25.

The Toolkit contains the following tools:

Toolkit P/N	
Description/Comments	HP Part Number
Spanner 13 mm	Q6675-67011
Alcohol	Q6675-60070
Allen Key #2	Q6675-60041
Cleaning Cloth	9300-2531
Cleaning Sponge/Bag Assembly	C6071-60218
Flex Contacts Cleaning Support	Q1271-60754
Lubricant Oil	Q6675-60061
Isopropyl Alcohol	Q6675-60091
Media Driver Adjustment Tool	Q6675-67009
Handle for Media Driver Tool Support	Q6675-67010
Oil Dispenser	Q6675-60062
Pinchwheel Alignment Tool	Q5669-20595
Pinchwheel Insertion Tool	Q5669-20594
Protective Plastic Gloves	Q6675-60035
T-15 Screwdriver	8710-2456
Tweezers	Q6675-60037

You will also need the following standard hand tools:

Standard Tool Requirements	
Description/Comments	Size
Long Torx Screwdriver	1/4 inch drive
Torx Bit (75 mm)	8
	10
	15
	20
Philips Screwdriver	1
Pliers	N/A
Snips	N/A
Pipe Spanner	5.5 mm
Flat Bladed Screwdriver	N/A

System Diagrams

Primer components

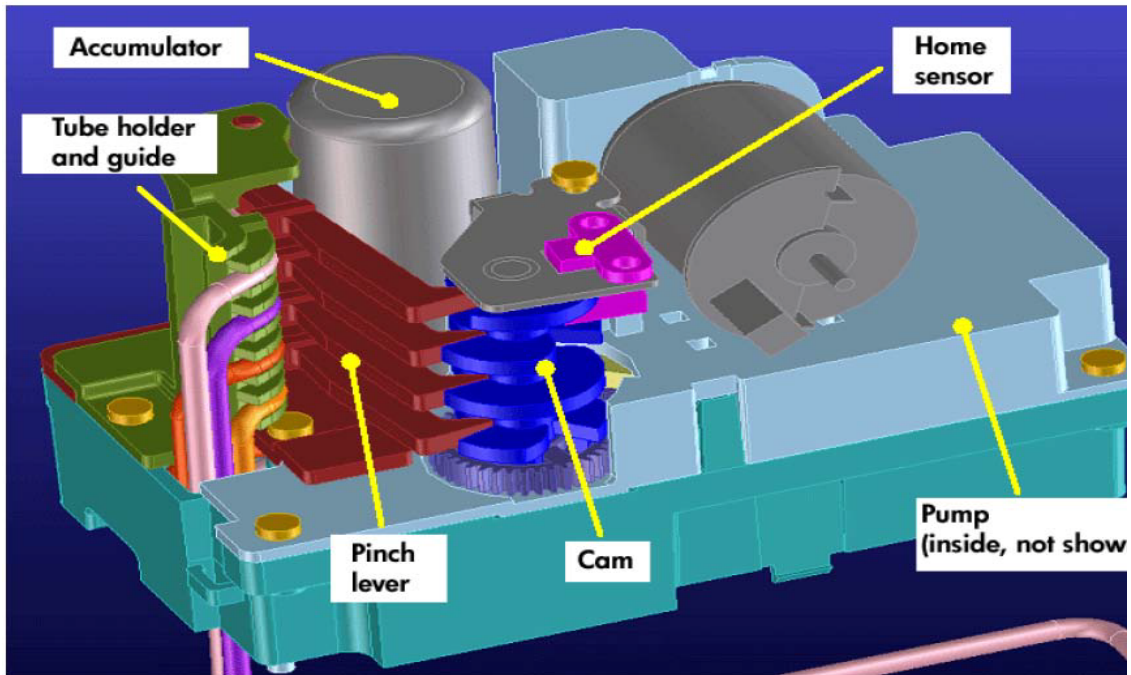

Primer schematic

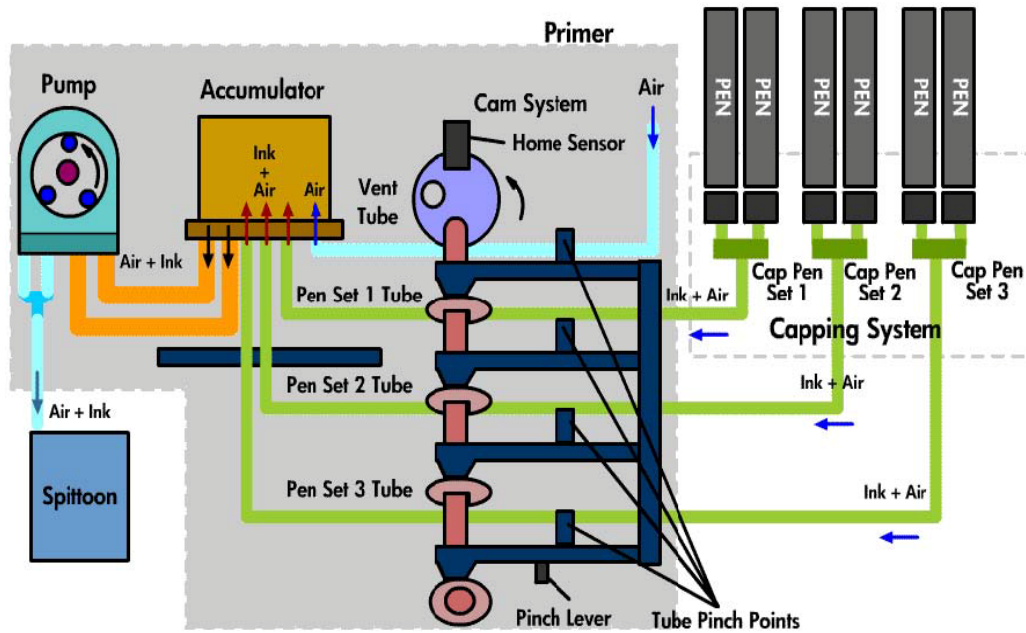

Electronic layout

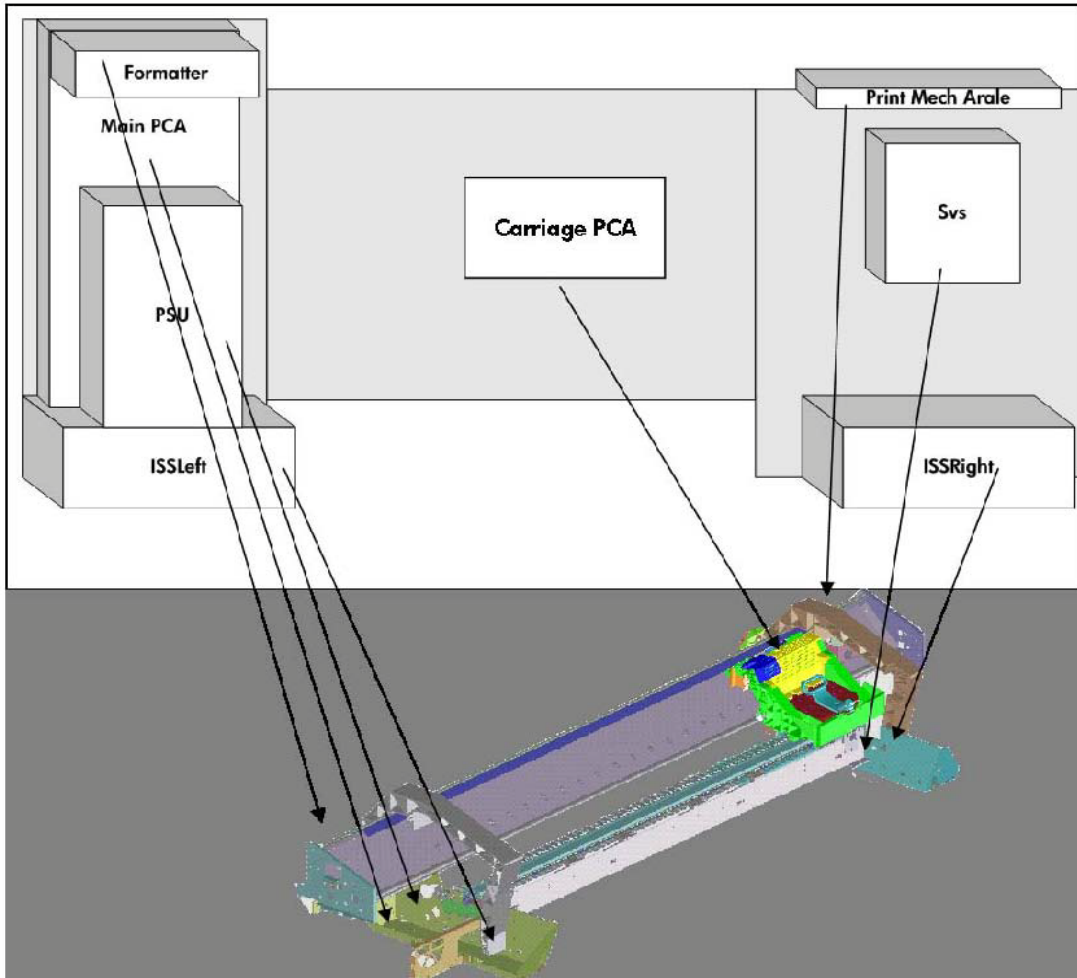

Main electronics and cabling

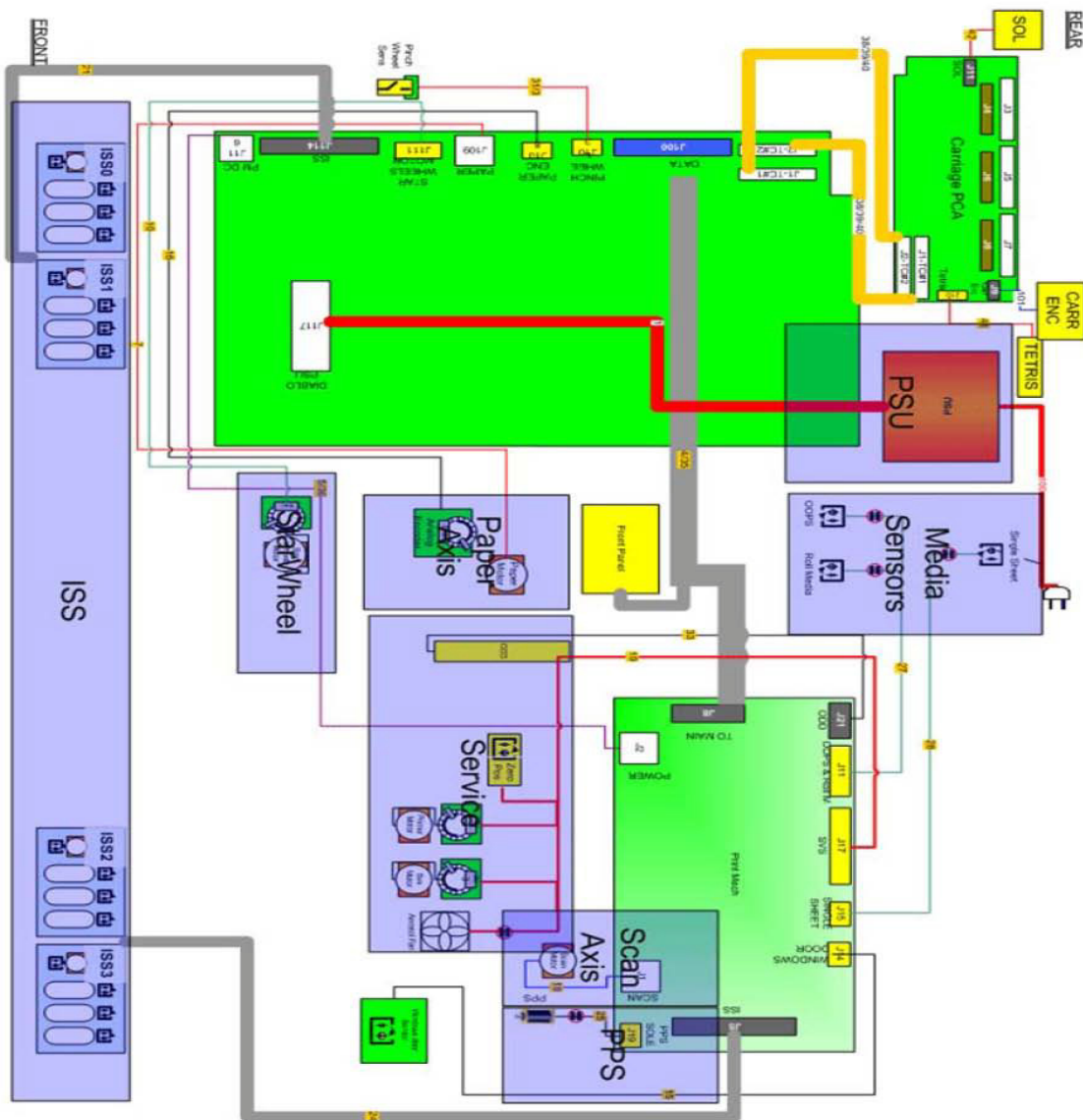

Ink supply station schematic

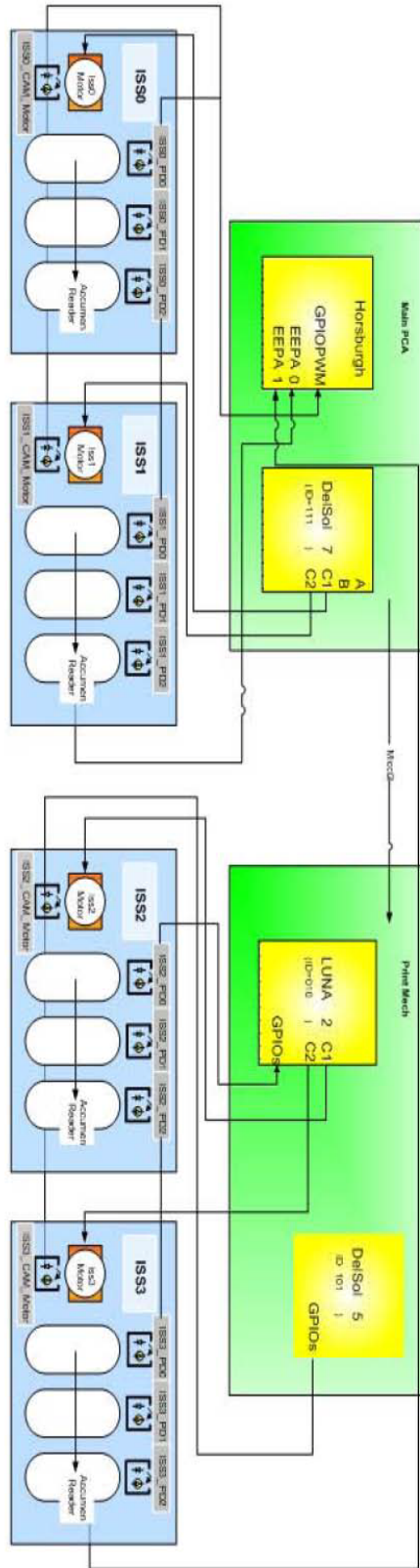

Service Calibration Guide to Removal and Installation

Using the Service Calibration Guide

When you remove most printer components, you will need to perform a particular set of Service Calibrations and Diagnostic tests to ensure proper printer performance.

The Service Calibration Matrix explains which service calibrations and diagnostic tests (top row) need to be performed whenever you remove and install particular printer components (left most column).

A number in the body of the table indicates that the service calibration of the same column must be performed whenever you remove the corresponding component. The calibrations must be performed in the order they are numbered.

Start by locating the component you have removed and installed in the left most column.

Even if you do not replace the removed component with a new component, you still need to perform all the calibrations indicated by the matrix EXCEPT reset life counters, which only needs to be done when a new component is installed to replace a failing component.

The Service Calibration Matrix

	PRS Test	Scan Axis Test	Cutter test	Star Wheel Lifter test	2. Paper Drive	3. Electronics Module	4. Carriage Assembly	5. Sensors	Color Sensor ESP (spectrophotometer) Calibration	7. Ink Delivery System (IDS)	8. Service Station	Paper Advance Calibration	Drop Detector Calibration	Line Sensor Calibration	4. Reset Life Counters (after replacement only)
Service Station											1		2		3
Aerosol Fan Assembly											1		2		3
Drop Detector											1		2		

	PRS Test	Scan Axis Test	Cutter test	Star Wheel Lifter test	2. Paper Drive	3. Electronics Module	4. Carriage Assembly	5. Sensors	Color Sensor ESP (spectrophotometer) Calibration	7. Ink Delivery System (IDS)	8. Service Station	Paper Advance Calibration	Drop Detector Calibration	Line Sensor Calibration	4. Reset Life Counters (after replacement only)
Service Station Spittoon											1		2		
Primer Assembly											1		2		
Left Ink Supply Station										1					
Right Ink Supply Station										1					
Carriage Cover						3	1								2
Carriage Latch						3	1								2
Carriage PCA						3	1								2
PrintMech PCA						1									
Front Panel						1									
Power Supply Unit (PSU)						1									
Main PCA						1									
Ink Supply Tubes		1				2									3
Media Advance Drive					1	3						2			
Encoder Disk					1	3						2			
Encoder Sensor					1	3						2			
Media Advance Roller					1	3		4				2			
Carriage Assembly		2	5				1	4						3	6

	PRS Test	Scan Axis Test	Cutter test	Star Wheel Lifter test	2. Paper Drive	3. Electronics Module	4. Carriage Assembly	5. Sensors	Color Sensor ESP (spectrophotometer) Calibration	7. Ink Delivery System (IDS)	8. Service Station	Paper Advance Calibration	Drop Detector Calibration	Line Sensor Calibration	4. Reset Life Counters (after replacement only)
Belt Tensioner		2					1	4						3	
Belt Assembly		2					1	4						3	5
Scan-Axis Motor		2					1	4						3	5
Trailing Cable		2					1	4						3	5
Carriage Rear Bushing		2	5				1	4						3	
Line Sensor						3		2						1	
Window Position Sensor						2		1							
Out of Paper Sensor								1							
Right Roll Guide								1							
Left Roll Guide								1							
Clean Out Assembly								1							
Pen to Paper Space (PPS) Solenoid	1														
Encoder Strip		1													
Starwheel Assembly				1											
Starwheel Motor				1	2										
Left Starwheel Lifter				1	2										
Right Starwheel Lifter															

	PRS Test	Scan Axis Test	Cutter test	Star Wheel Lifter test	2. Paper Drive	3. Electronics Module	4. Carriage Assembly	5. Sensors	Color Sensor ESP (spectrophotometer) Calibration	7. Ink Delivery System (IDS)	8. Service Station	Paper Advance Calibration	Drop Detector Calibration	Line Sensor Calibration	4. Reset Life Counters (after replacement only)
Print Zone Overdrive				1											
Media Lever Position Sensor								1							
Pinchwheel Assembly					1			2							
Pinch Roller * If you replace more than half of the rollers, perform 3, Paper Advance Calibration					1			2				3			
Preventive Maintenance Kit #1		2					1	4						3	5
Preventive Maintenance Kit #2											1		2		3
Preventive Maintenance Kit #3			1												2
Cutter Assembly			1												
Color Sensor ESP (spectrophotometer)						3		2	1						
Top Cover						1									
Ink Supply Tubes Support Rail						1		2							

Performing the Service Calibrations and Diagnostic Tests

When you are ready to perform the service calibrations and diagnostic tests that correspond to the component you have installed or replaced, consult the following page numbers for procedures:

- PRS Test - Refer to Page 3-9.
- Scan Axis Test - Refer to Page 3-11.
- Cutter test - Refer to Page 3-16.
- Star Wheel Lifter test - Refer to Page 3-7.
- 2. Paper Drive - Refer to Page 3-18.
- 3. Electronics Module - Refer to Page 3-22.
- 4. Carriage Assembly - Refer to Page 3-27.
- 5. Sensors - Refer to Page 3-33.
- 6. Color Sensor ESP (spectrophotometer) - Refer to Page 3-36.
- 7. Ink Delivery System (IDS) - Refer to Page 3-38.
- 8. Service Station - Refer to Page 3-45.
- Paper Advance Calibration - Refer to Page 4-6.
- Drop Detector Calibration - Refer to Page 4-12.
- Line Sensor Calibration - Refer to Page 4-15.
- 4. Reset Life Counters - Refer to Page 3-66. (after replacement only)

Window

Removal

Switch off the printer and remove the power cable.

The Window can also be removed with the Top Cover to avoid scratching the Window. To remove the Window with the Top Cover, Refer to Page 6-51.

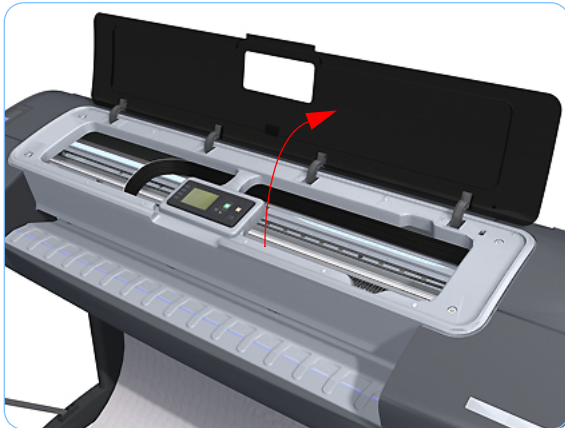

1. Open the Window.

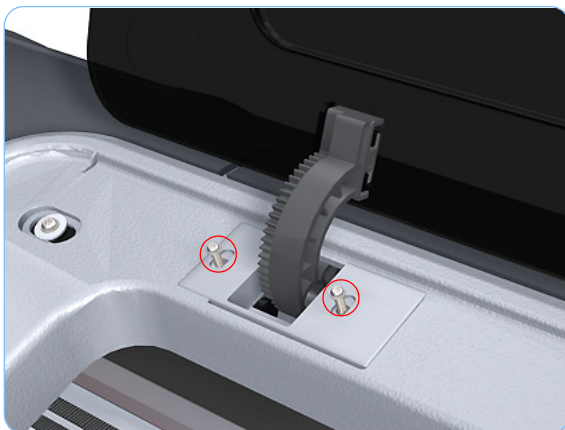

2. Remove the two T-15 screws that secure the left Window hinge locking plate to the Top Cover.

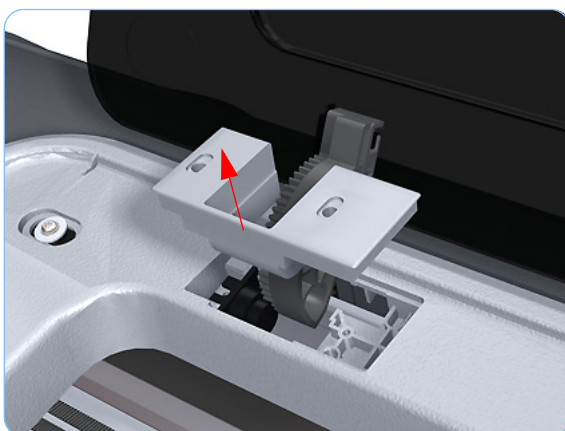

3. Remove the left Window hinge locking plate from the Top Cover.

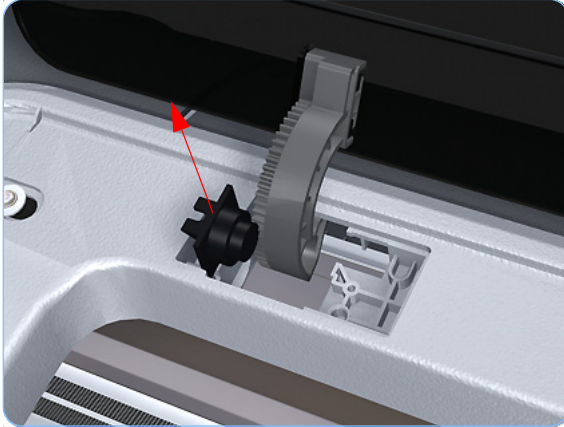

- 4.** Remove the Damper Rotary from the Top Cover.

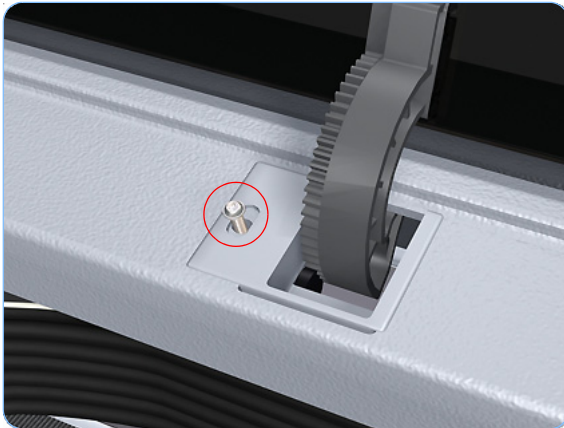

- 5.** Remove the T-15 screws that secure each of the remaining three Window hinge locking plates to the Top Cover.

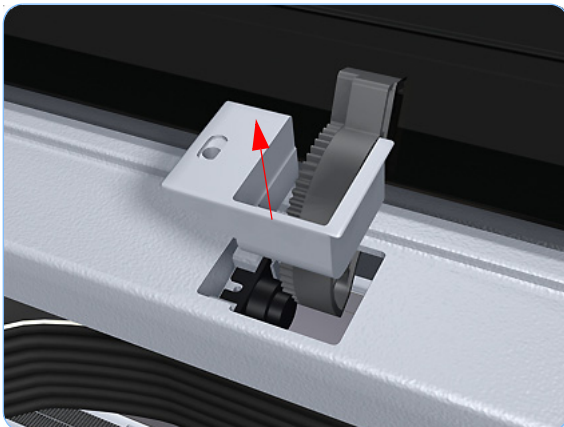

- 6.** Remove the remaining three Window hinge locking plates from the Top Cover.

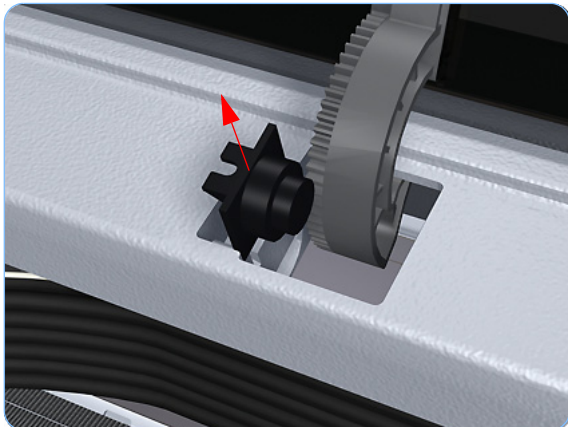

7. Remove the remaining three Damper Rotary pieces from the Top Cover.



8. Grip the Window at the left and right edges and move it horizontally towards the right as far as it will go.



9. Pull the Window towards the front to disengage the hinges.



10. Lift the Window vertically out of the printer.

Front Cover

Removal

Switch off the printer and remove the power cable.

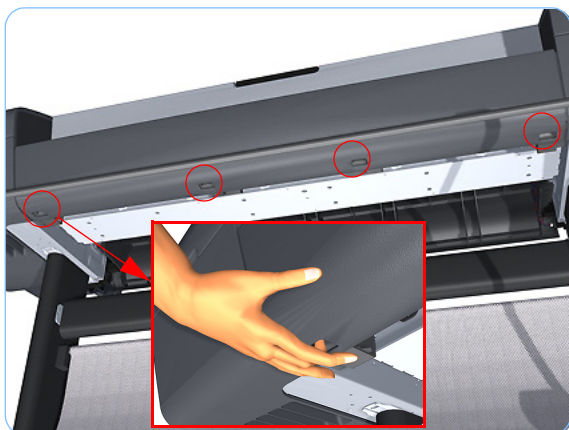

1. Squeeze each of the four attachment clips under the Front Cover, to release the cover from the printer.



2. Carefully pull the bottom of the Front Cover forwards until you can release it from its attachments.

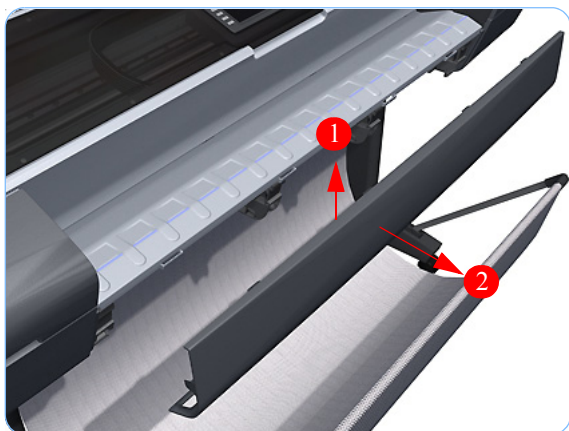

3. Unhook the Front Cover from the four attachments and remove it from the printer.

Media Output Assembly

Removal

Switch off the printer and remove the power cable.

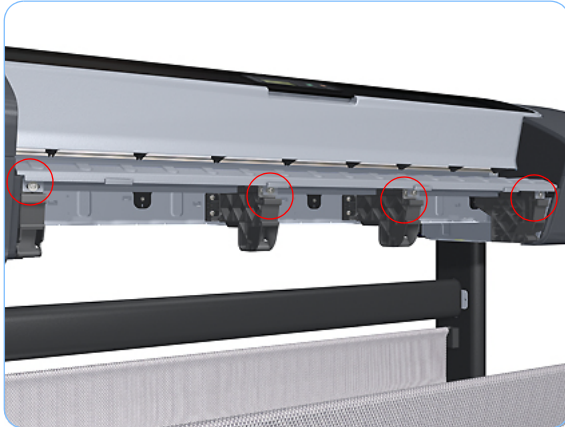

1. Remove the Front Cover (refer to page 6-17).
2. Remove four T-15 screws that secure the Media Output Assembly to the printer.

On some printers, the Left and Right Front Trim is integrated with the Output Support. On some 24 inch printers, the center Output Support is replaced by a small cylinder (that is not attached to the Media Output Assembly). Otherwise, the procedure remains the same, but the printer may appear differently than shown.

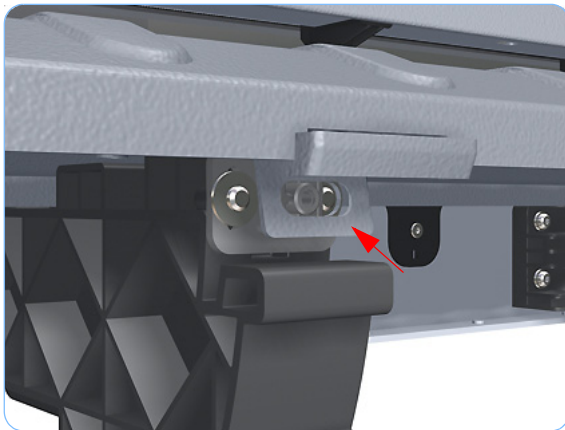

3. Release the four attachment clips.

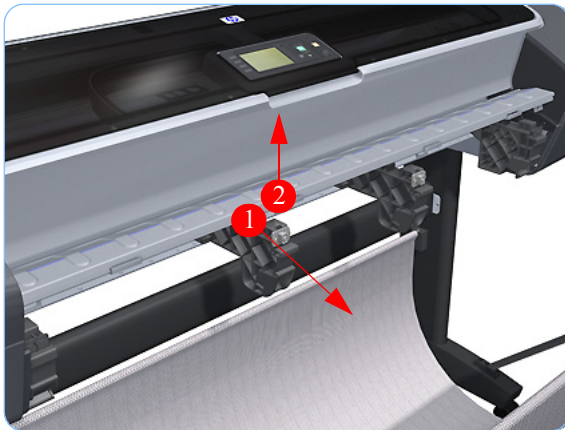

4. Unclip the Media Output Assembly from the clips and remove it from the printer.

Right Front Trim

Removal

Switch off the printer and remove the power cable.

1. Remove the Front Cover (refer to page 6-17).
2. Remove the Media Output Assembly (refer to page 6-18).
3. Remove two T-15 screws that secure the Right Front Trim to the printer.

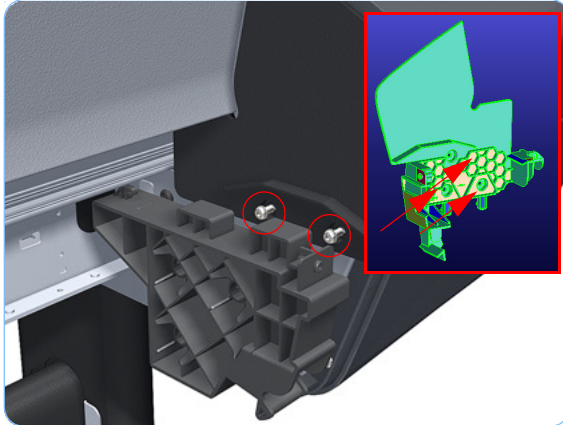

On some printers, the Right Front Trim is integrated with the Output Support. In this case, you need to remove three screws that secure the Right Front Trim to the printer (shown in the small graphic on the left). Once you have removed the three screws, you are free to remove the Right Front Trim from the printer.

4. Open the Right Ink Cartridge Door.

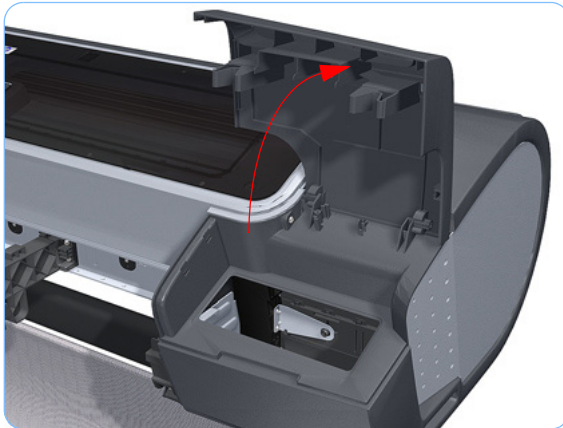

5. Unclip the Right Front Trim.

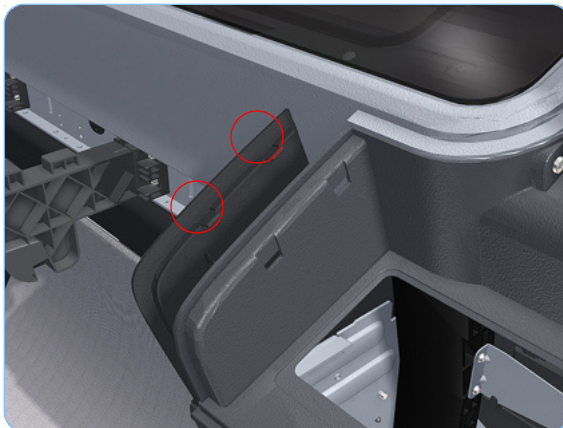

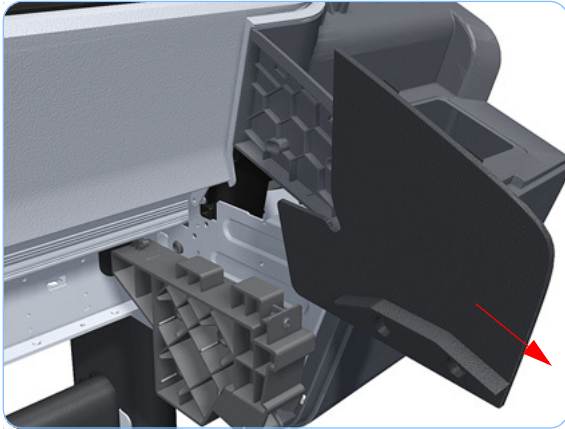

6. Remove Right Front Trim from the printer.

Left Front Trim

Removal

Switch off the printer and remove the power cable.

1. Remove the Front Cover (refer to page 6-17).
2. Remove the Media Output Assembly (refer to page 6-18).
3. Remove two T-15 screws that secure the Left Front Trim to the printer.

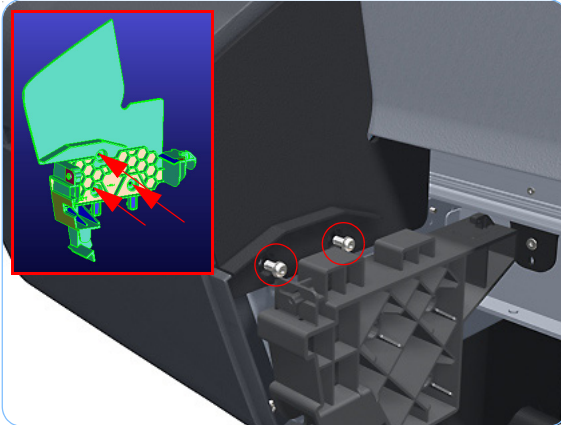

On some printers, the Left Front Trim is integrated with the Output Support. In this case, you need to remove three screws that secure the Left Front Trim to the printer (shown in the small graphic on the left). Once you have removed the three screws, you are free to remove the Left Front Trim from the printer.

4. Open the Left Ink Cartridge Door.



5. Unclip the Left Front Trim.



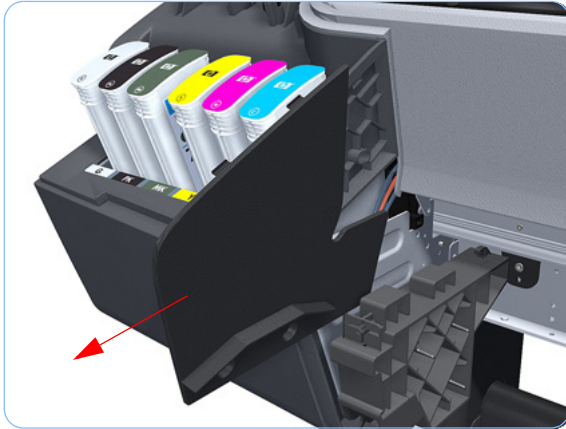

6. Remove Left Front Trim from the printer.

Right Ink Cartridge Door

Removal

Switch off the printer and remove the power cable.

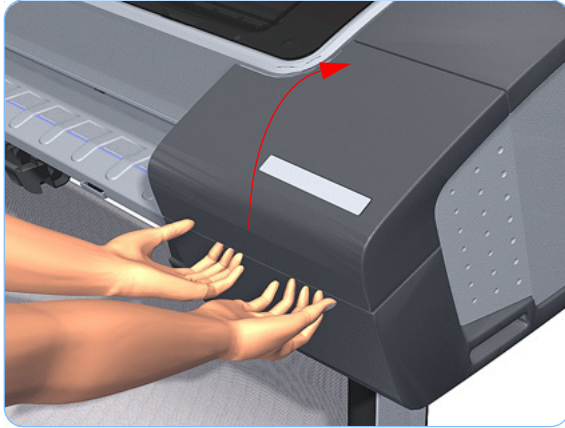

1. Open the Right Ink Cartridge Door.



2. Unclip the right side of the Right Ink Cartridge Door.

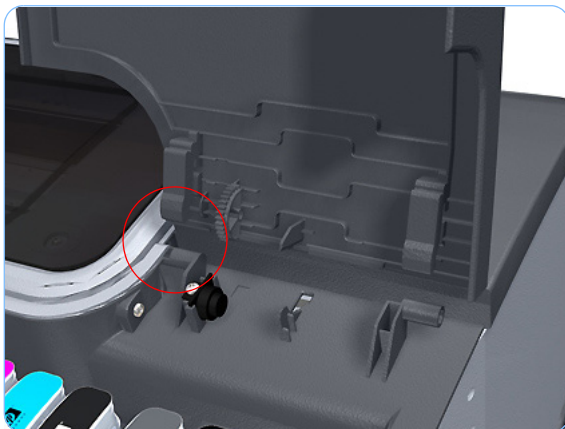

3. Unclip the left side of the Right Ink Cartridge Door.



4. Remove the Right Ink Cartridge Door.

Left Ink Cartridge Door

Removal

Switch off the printer and remove the power cable.



1. Open the Left Ink Cartridge Door.



2. Unclip the left side of the Left Ink Cartridge Door.

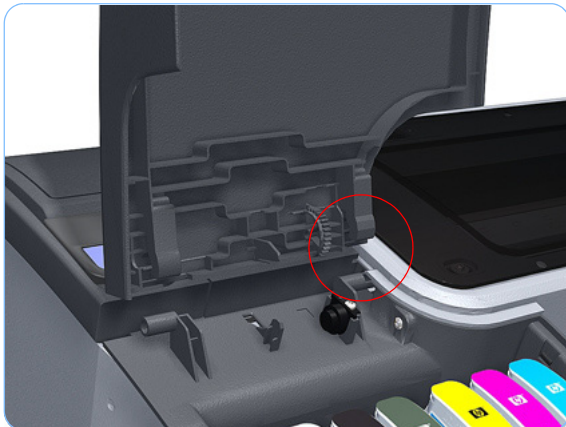

3. Unclip the right side of the Left Ink Cartridge Door.



4. Remove the Left Ink Cartridge Door.

Right Cover

Removal

Switch off the printer and remove the power cable.

1. Remove the Front Cover (refer to page 6-17).
2. Open the Right Ink Cartridge Door.

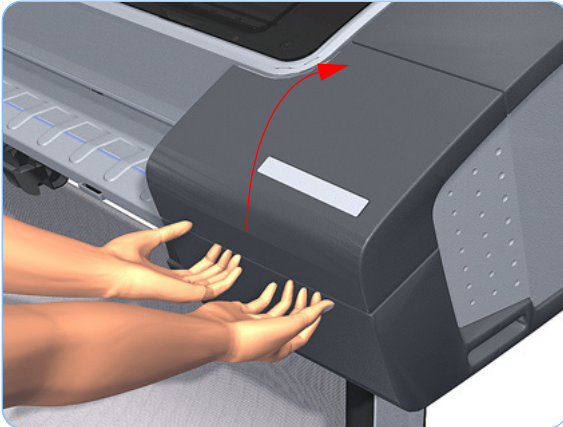

3. Remove the Ink Cartridges from the printer.



4. Remove one T-15 screw that secures the Right Cover to the printer (at the rear of the Printer).

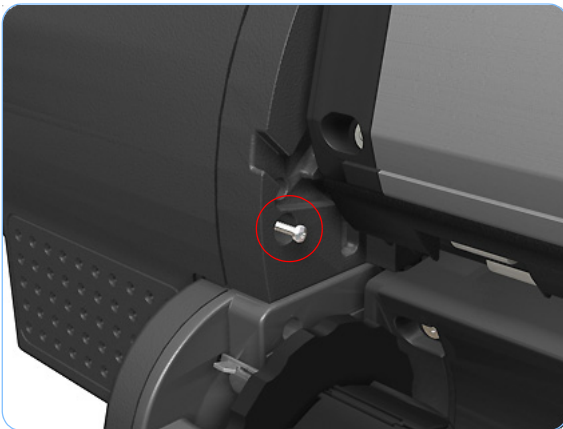

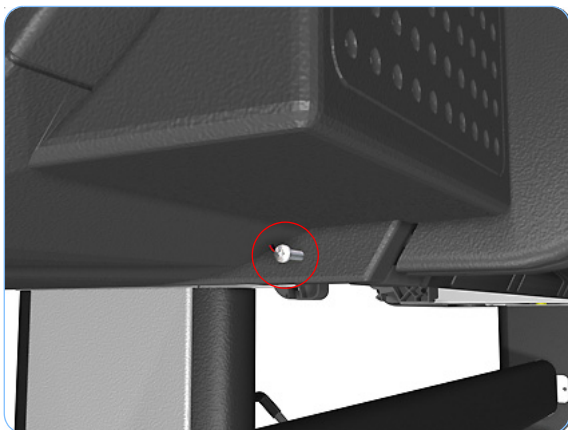

5. Remove one T-15 screw that secures the Right Cover to the printer (at the rear of the Printer).



6. Remove one T-15 screw that secures the Right Cover to the printer (at the rear of the printer).

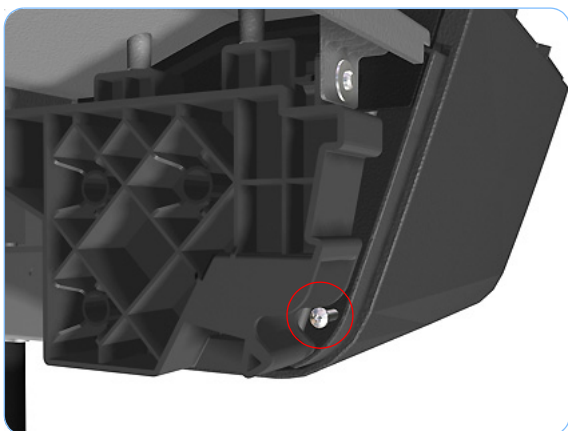

7. Remove one T-15 screw that secures the Right Cover to the printer (accessible under the Front Cover).

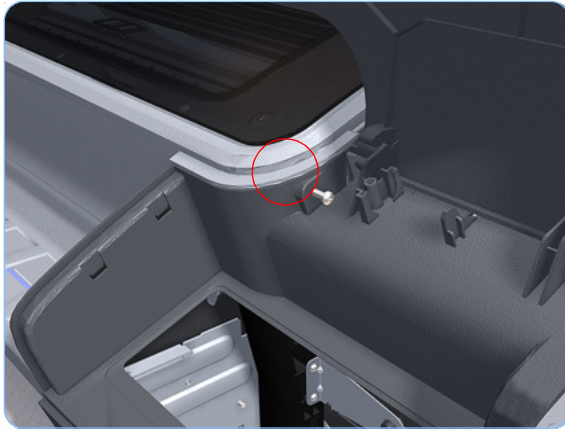

8. Remove one T-15 screw that secures the Right Cover to the printer (accessible from within the cartridge bay).

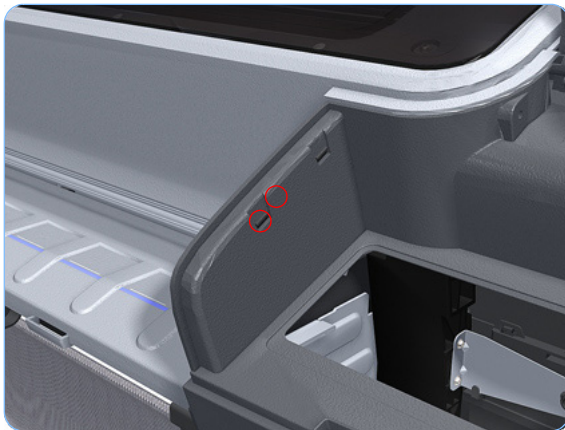

9. Unclip the Right Trim.

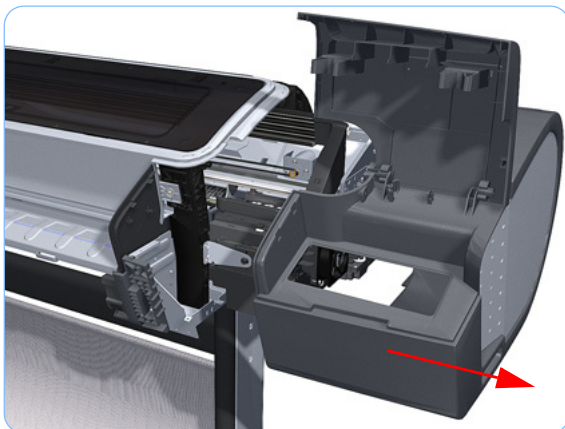

10. Remove the Right Cover from the printer.

Left Cover

Removal

Switch off the printer and remove the power cable.

1. Remove the Front Cover (refer to page 6-17)
2. Open the Left Ink Cartridge Door.

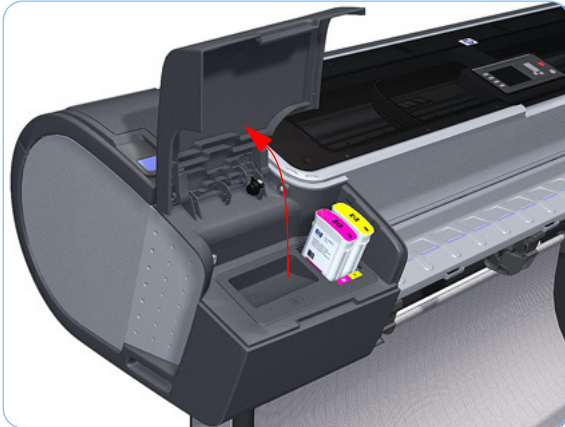

3. Press the clip to release the Left Cover Finishing Panel.

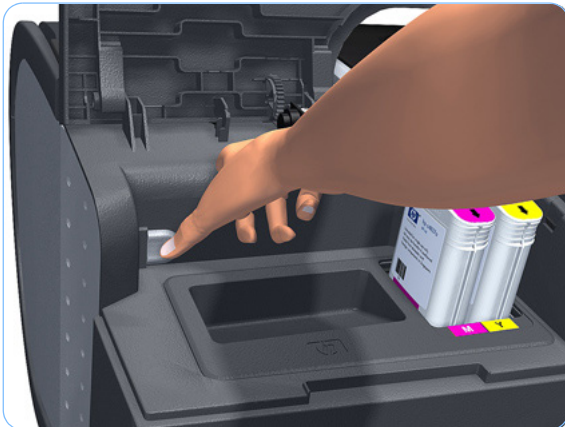

4. Remove the Left Cover Finishing Panel.

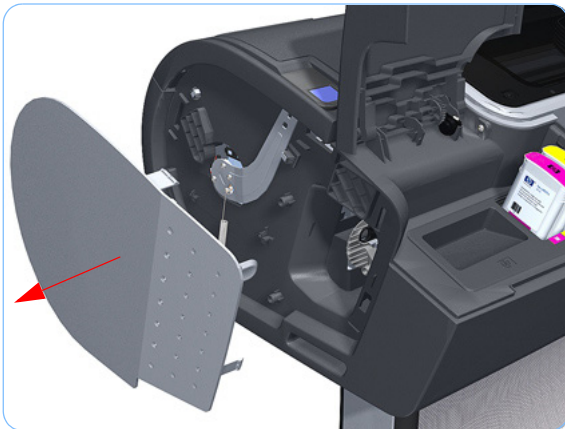

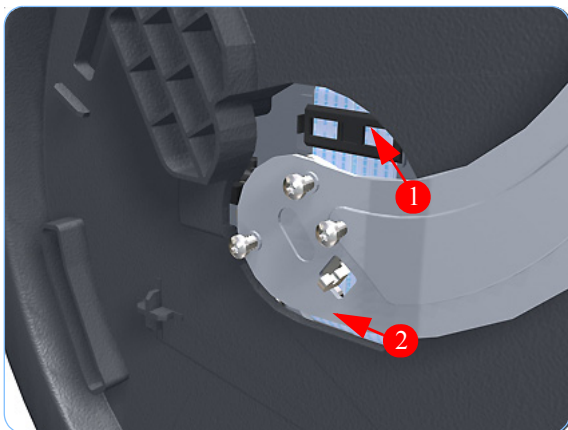

5. Unclip the spring from the attachment points on the Media Lever and Left Cover.

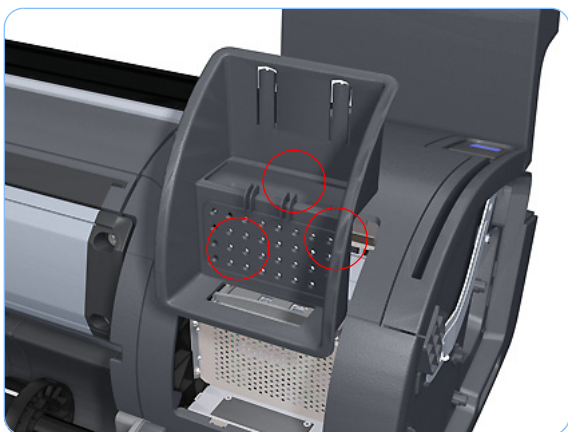

6. Remove three T-15 screws that secure the Media Lever.

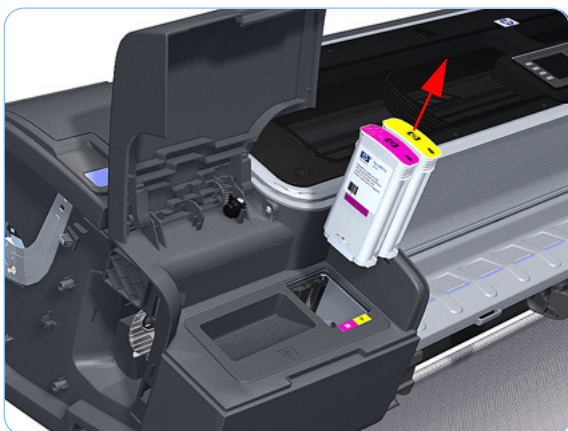

7. Remove the Ink Cartridges from the Printer. The illustration shows the Z2100 which has only two Ink Cartridges, for the Z3100 there are six Ink Cartridges.

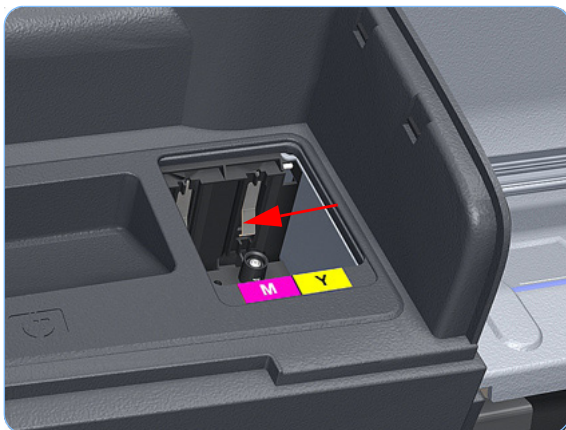

8. For the Z2100, carefully push the edge of the Ink Trim Assembly to the left. For the Z3100, continue from step 11 of this procedure.

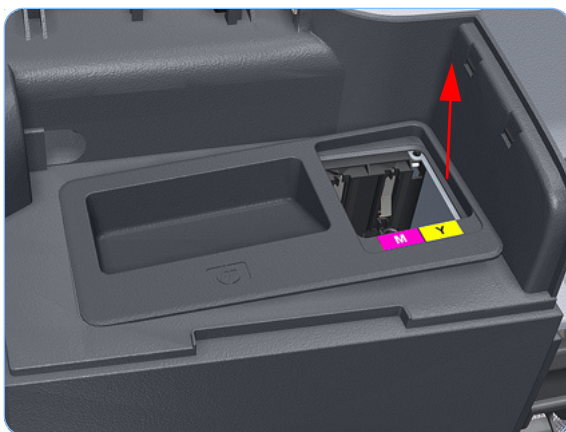

9. Lift the right edge of the Ink Trim Assembly.

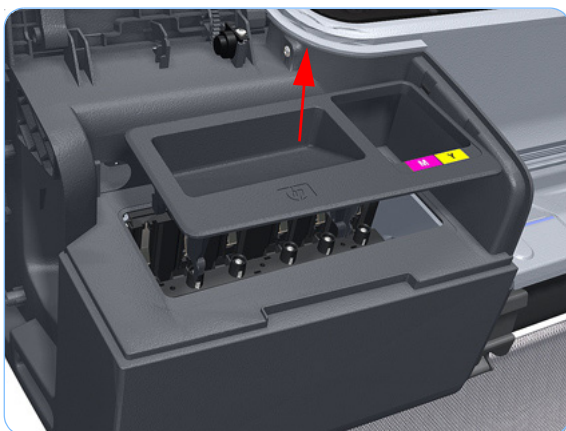

10. Remove the Ink Trim Assembly from the Printer.

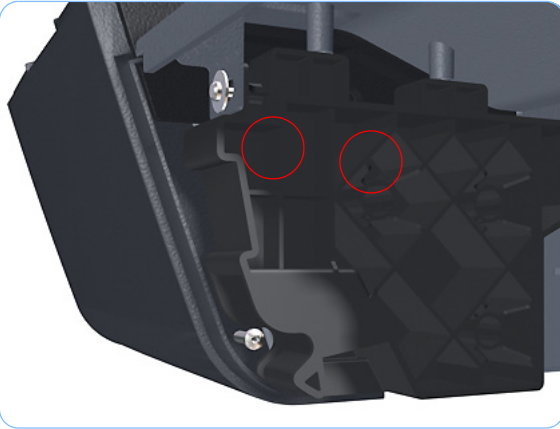

11. Use a flat bladed screwdriver to unclip the two attachment clips of the Formatter Housing.

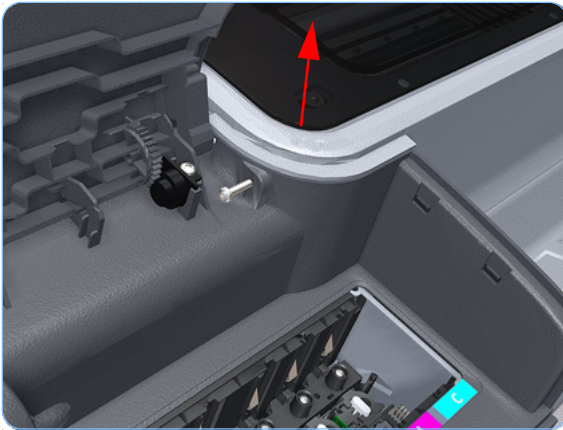

12. Lift the Formatter Housing out of the printer.

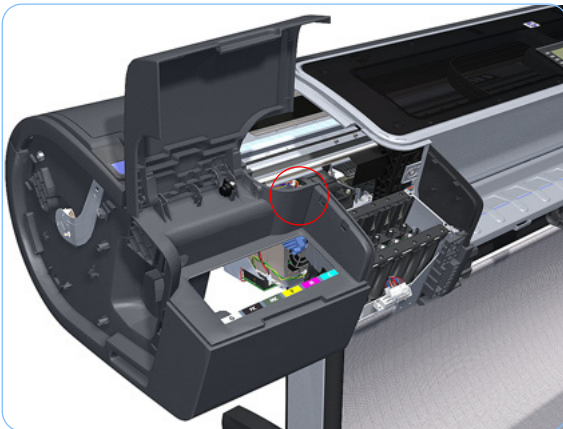

13. Remove one T-15 screw that secures the Left Cover (top rear, accessible under the Formatter Housing).

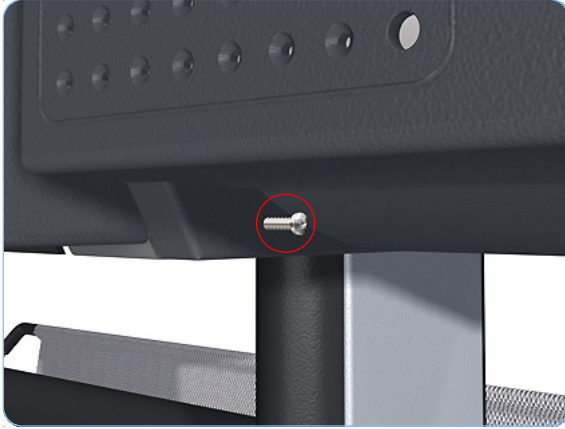

14. Remove one T-15 screw that secures the Left Cover (bottom rear).

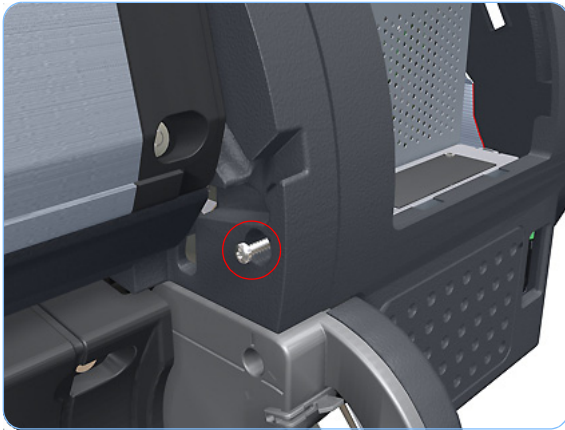

15. Remove one T-15 screw that secures the Left Cover (bottom rear).

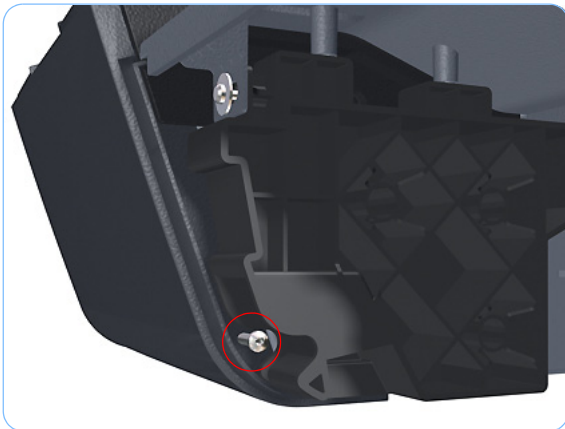

16. Remove one T-15 screw that secures the Left Cover (bottom front, accessible under Front Cover).

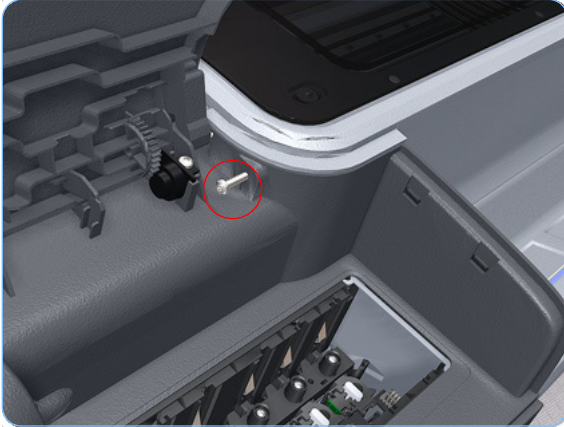

17. Remove one T-15 screw that secures the Left Cover (top front, accessible Ink Cartridge Door).

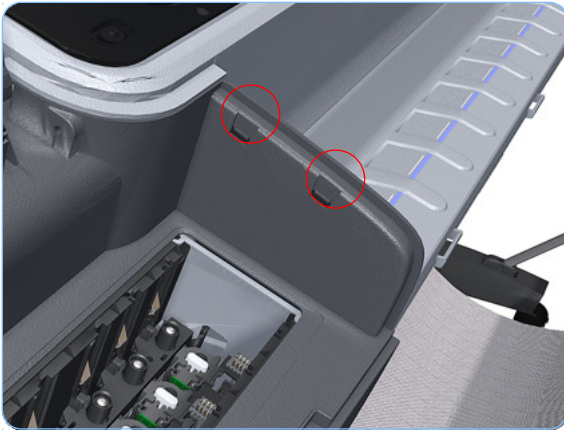

18. Unclip the Left Trim.

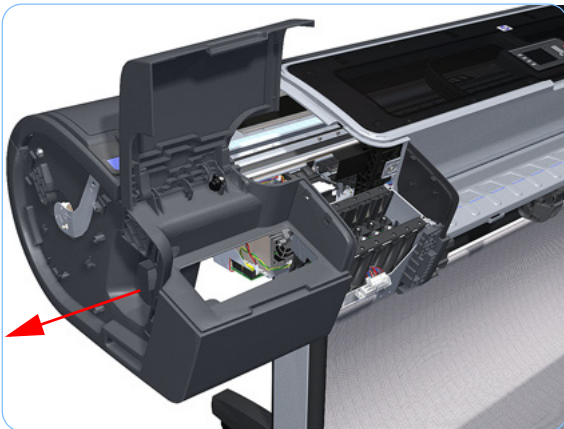

19. Remove the Left Cover from the Printer.

Rear Tray

Removal

Switch off the printer and remove the power cable.

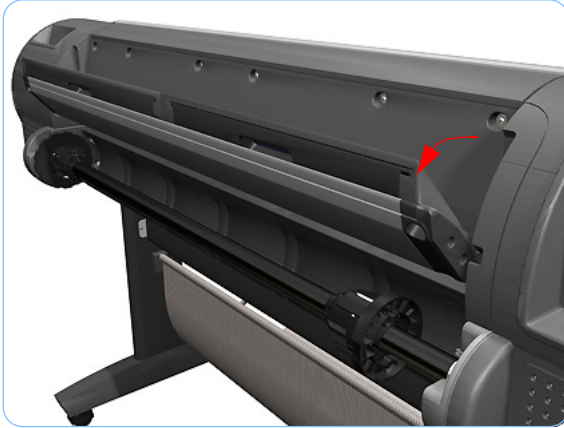

1. Open the Rear Tray to approximately 10 degrees less than the fully open position.

Some printers have Rear Trays with tray extensions and some printers do not have extension trays.



2. Lift the Rear Tray vertically enough (approximately 20 mm) to allow the rear attachment lugs to be out of the locked position.

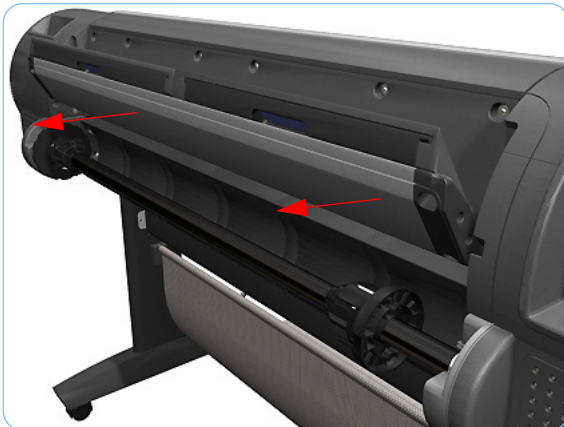

3. Carefully slide the Rear Tray out of the printer.

Rear Cover

Removal

Switch off the printer and remove the power cable.

1. Remove the Rear Tray (refer to page 6-36).
2. Remove the Right Cover (refer to page 6-27).
3. Remove the Left Cover (refer to page 6-30).
4. Remove ten T-15 screws that secure the Rear Cover to the printer.



5. Remove the Rear Cover from the printer.

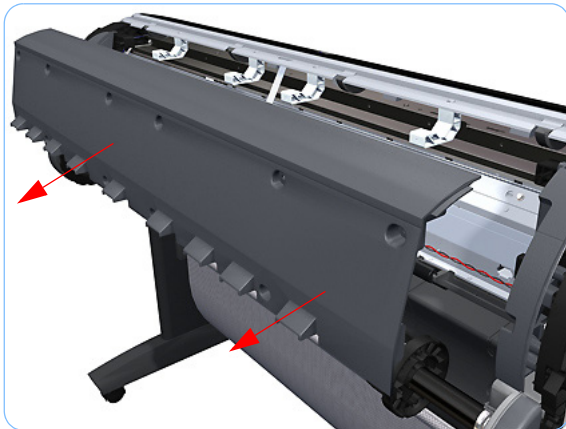

Media Lever

Removal

Switch off the printer and remove the power cable.



1. Open the Ink Cartridge Door.



2. Press the clip to release the Left Cover Finishing Panel.

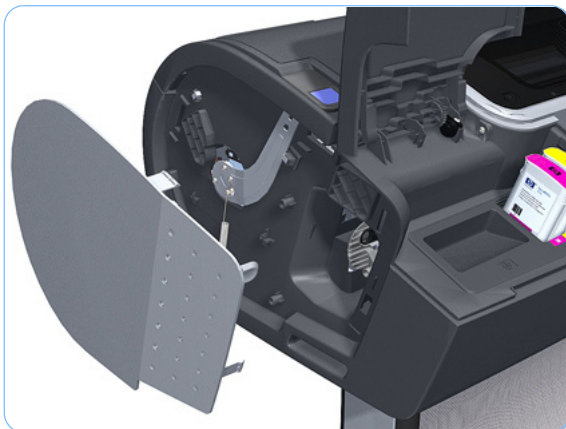

3. Remove the Left Cover Finishing Panel.

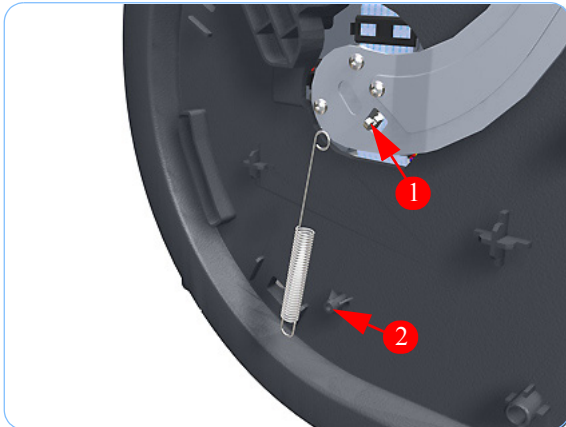

4. Unclip the spring from the attachment points on the Media Lever and Left Cover.

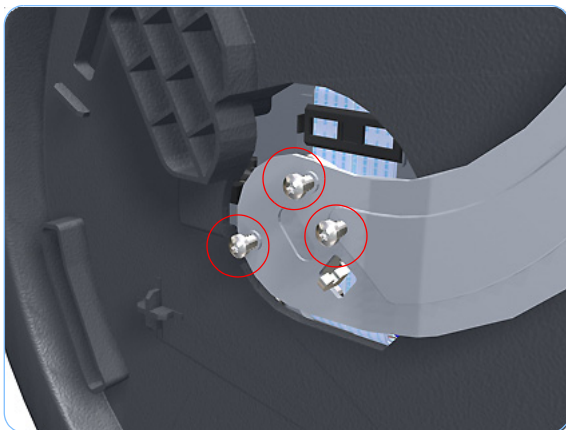

5. Remove three T-15 screws that secure the Media Lever.

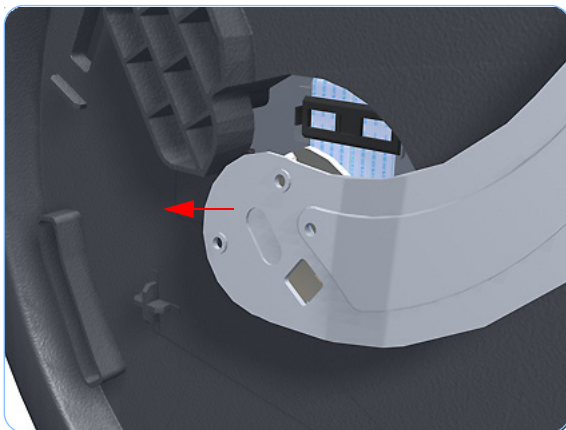

6. Lift the Media Lever of the mounting.

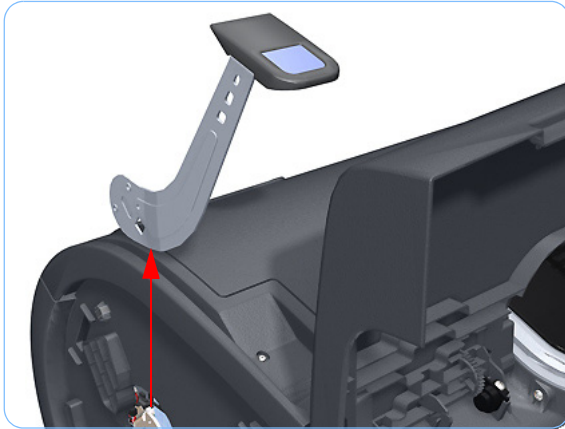

7. Remove the Media Lever from the printer.

Media Lever Position Sensor

Removal

Switch off the printer and remove the power cable.

1. Raise the Media Lever.
2. Remove the Left Cover (refer to page 6-30).
3. Disconnect the Media Lever Position Sensor.

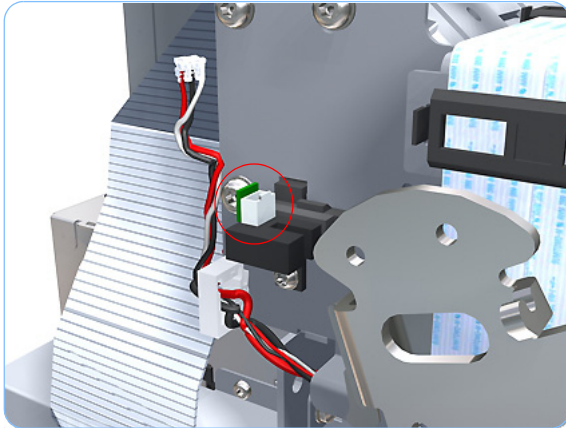

4. Remove one T-15 screw that secures the Media Lever Position Sensor to the Scan Side Panel.

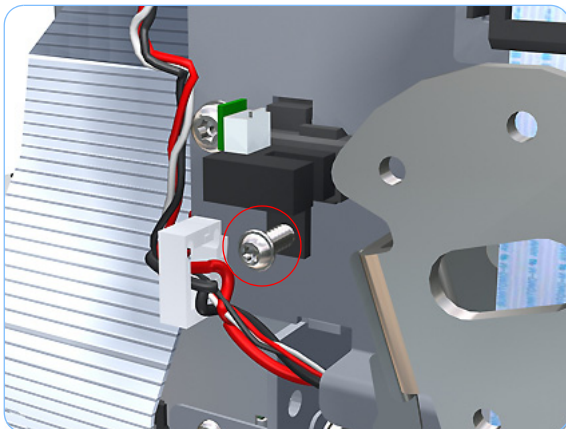

5. Rotate the Media Lever Position Sensor vertically to disengage the attachment lug from the Scan Side Panel.

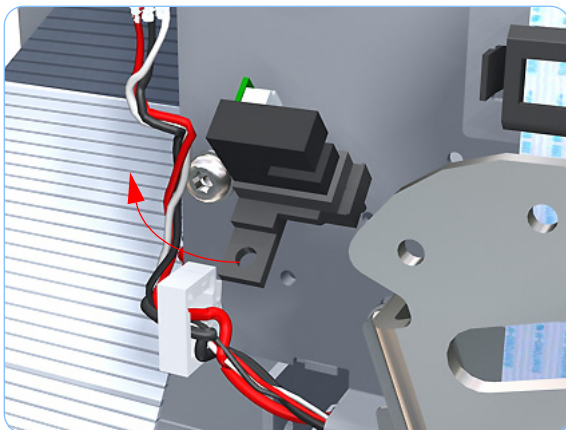

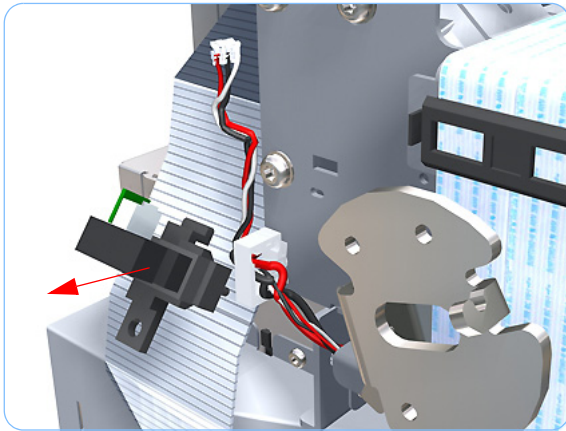

6. Remove the Media Lever Position Sensor.

When you finish installing or replacing this component, you must perform the necessary Service Calibrations. To find which calibrations you must perform, Refer to page 6-8, *Service Calibration Guide to Removal and Installation*.

Cutter Assembly

Removal

Switch off the printer and remove the power cable.

1. Remove the Left Cover Finishing Panel (refer to step 3 of the Left Cover removal procedure on page 5-30).
2. Fully loosen the cutter rail end cap attachment screw.

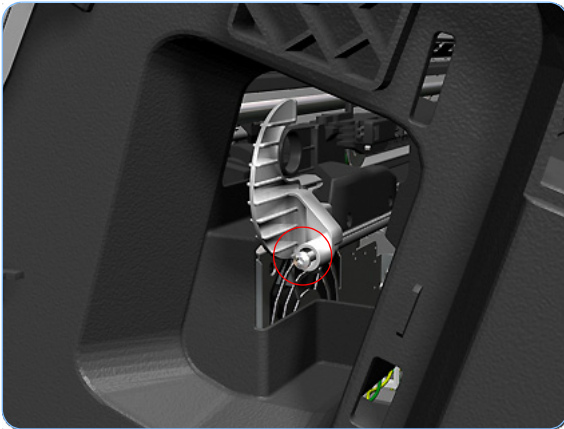

3. Remove the cutter rail end cap.

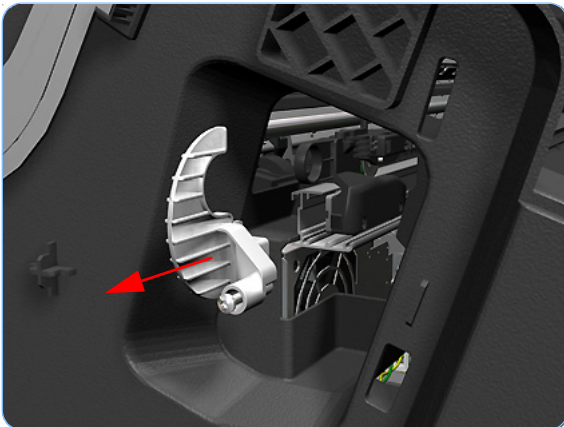

4. Slide the Cutter Assembly out of the printer.

When you install the new Cutter Assembly, follow the installation instructions provided with the new Cutter Assembly.

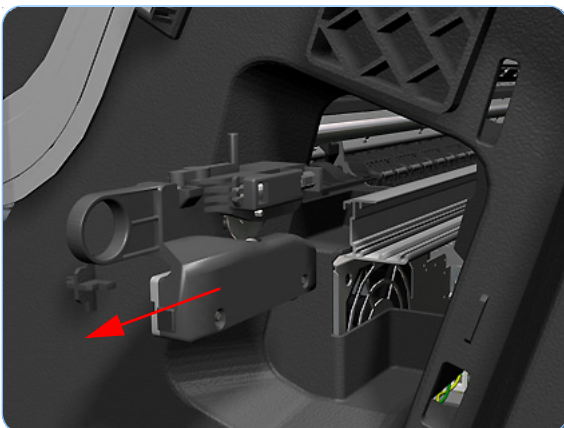

Right Rear Tray Support

Removal

Switch off the printer and remove the power cable.

1. Remove the Rear Tray (refer to page 6-36).
2. Remove the Right Cover (refer to page 6-27).
3. Remove the Left Cover (refer to page 6-30).
4. Remove the Rear Cover (refer to page 6-37).
5. Remove two T-15 screws that secure the Right Rear Tray Support to the printer.

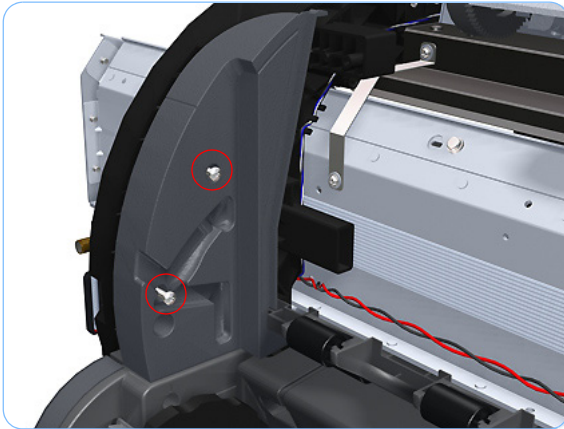

6. Rotate the Right Rear Tray Support counterclockwise approximately 30 degrees.

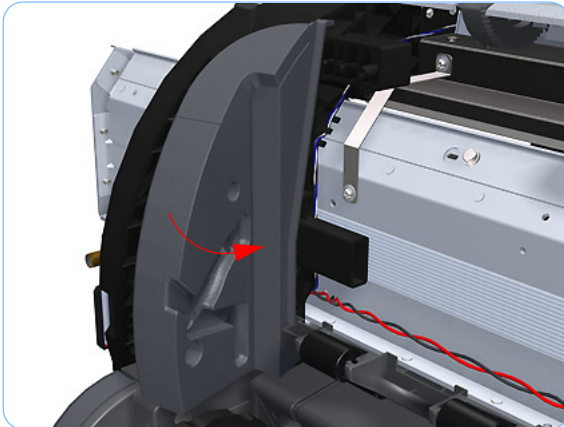

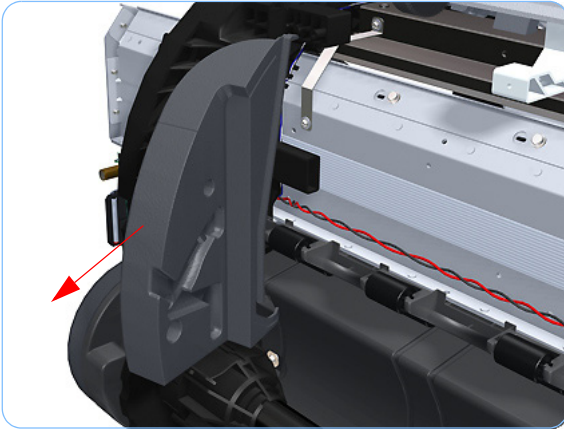

7. Remove the Right Rear Tray Support from the printer.

Left Rear Tray Support

Removal

Switch off the printer and remove the power cable.

1. Remove the Rear Tray (refer to page 6-36).
2. Remove the Right Cover (refer to page 6-27).
3. Remove the Left Cover (refer to page 6-30).
4. Remove the Rear Cover (refer to page 6-37).
5. Remove two T-15 screws that secure the Left Rear Tray Support to the printer.

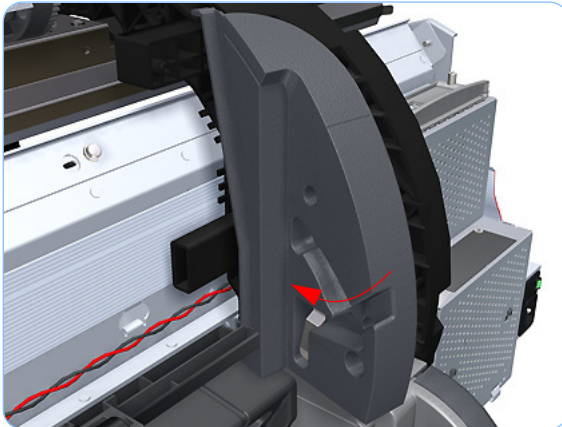
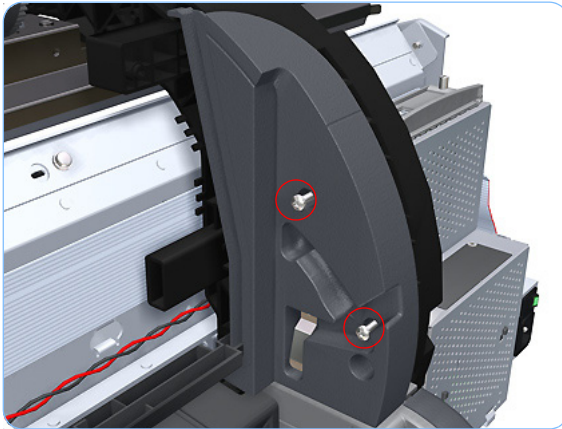

6. Rotate the Left Rear Tray Support clockwise approximately 30 degrees.

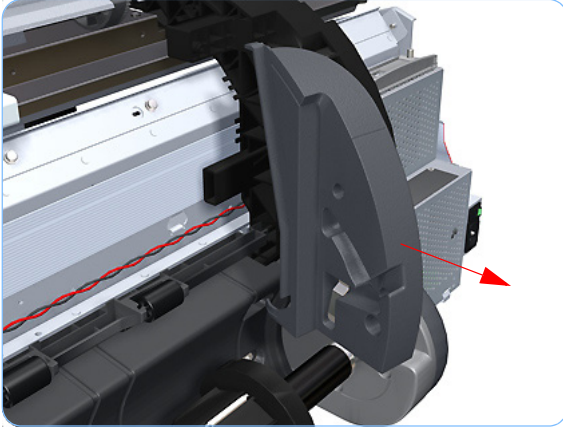

7. Remove the Left Rear Tray Support from the printer.

Front Panel

Removal

Switch off the printer and remove the power cable.

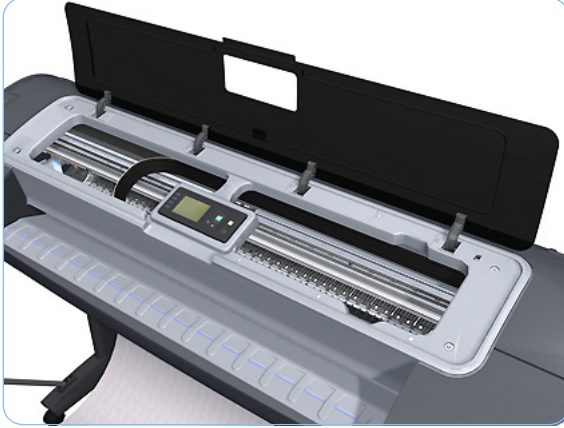

1. Open the Window.



2. With strong pressure, squeeze the top edge of the front panel enough to release the attachment clips, and begin rotating the Front Panel vertically in the next step.



3. Rotate the front panel vertically.

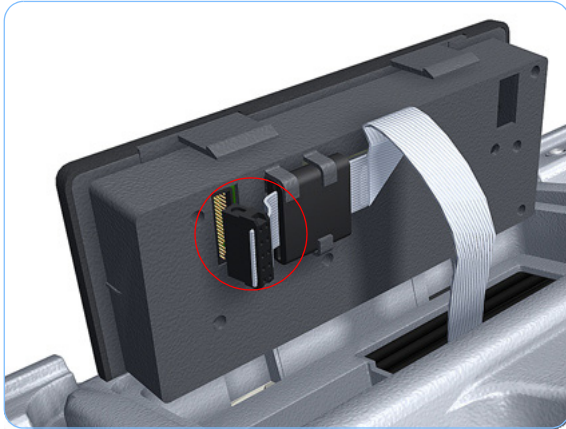

4. Disconnect the interface cable from the Front Panel.

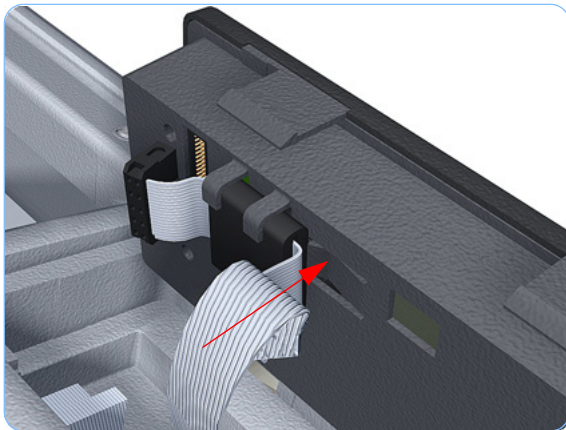

5. Push in the clip that prevents the Ferrite Core from being removed.

Some printers do not have a Ferrite Core. If the printer does not have a Ferrite Core, carefully remove the interface cable from the Front Panel. If the printer does have a Ferrite Core, continue with the service manual procedure.

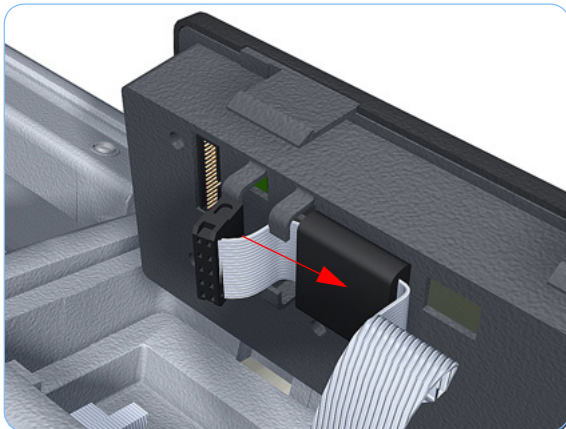

6. Slide the Ferrite Core out of the brackets.

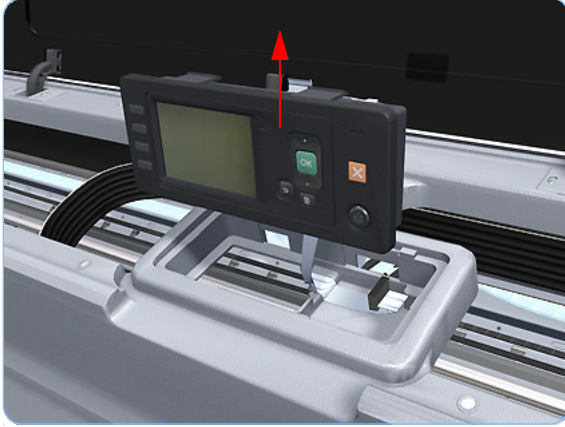

7. Remove the Front Panel.

When you reinstall the Front Panel, you must make sure that the Ferrite Core is correctly positioned. The Ferrite Core is necessary to avoid electrostatic interference being generated.

When you finish installing or replacing this component, you must perform the necessary Service Calibrations. To find which calibrations you must perform, Refer to page 6-8, *Service Calibration Guide to Removal and Installation*.

Top Cover

Removal

Switch off the printer and remove the power cable.

1. Remove the Window (refer to page 6-13).
2. Remove the Right Cover (refer to page 6-27).
3. Remove the Left Cover (refer to page 6-30).
4. Remove the Rear Tray (refer to page 6-36).
5. Remove the Rear Cover (refer to page 6-37).
6. Remove the Front Panel (refer to page 6-48).
7. Remove the four T-15 top screws that secure the Top Cover to the printer.

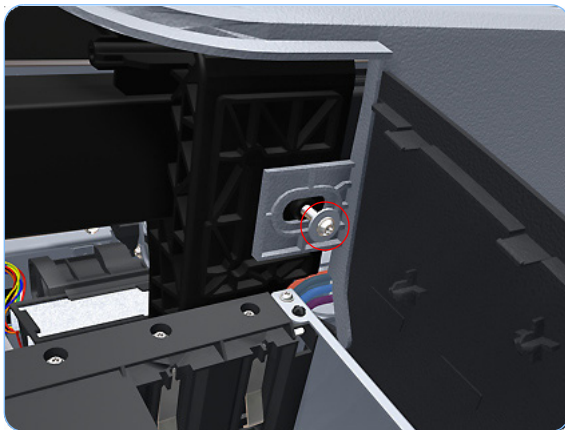

8. Remove the front T-15 screw that secures the front left side of the Top Cover to the printer.

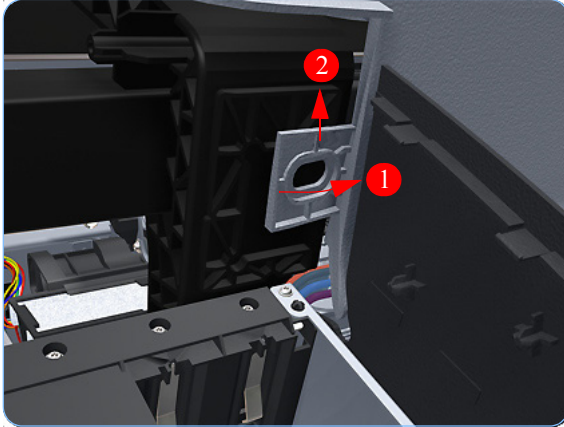

- 9.** Carefully pull the attachment clip forward until you can lift the bottom left corner of the Top Cover approximately 10 mm.

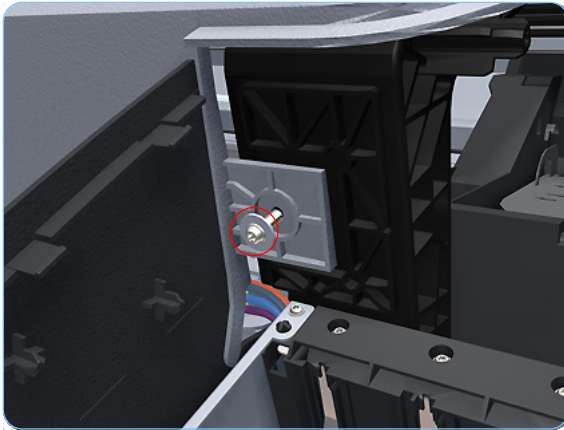

- 10.** Remove the front T-15 screw that secures the front left side of the Top Cover to the printer.

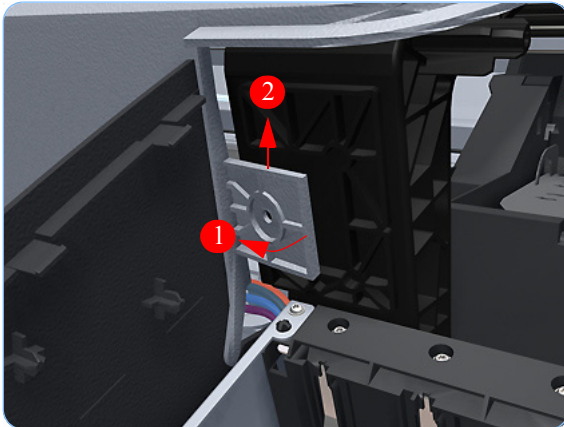

- 11.** Carefully pull the attachment clip forward until you can lift the bottom left corner of the Top Cover approximately 10 mm.

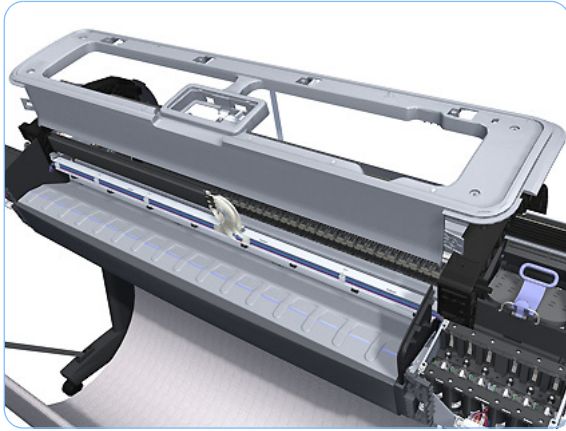

12. Lift the Top Cover of the printer sufficiently to gain access to the Front Panel ribbon cable.

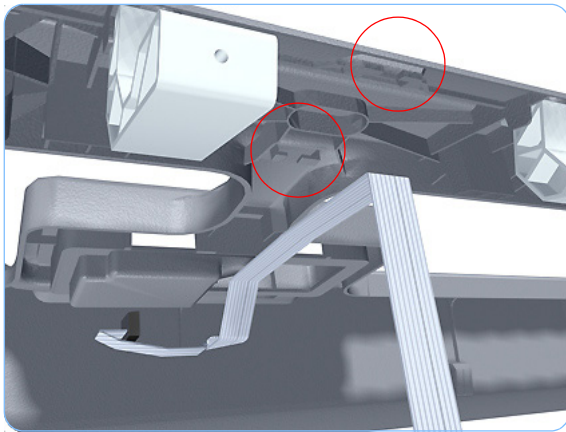

13. Unroute the Front Panel ribbon cable from the two cable clamps on the bottom surface of the Top Cover.

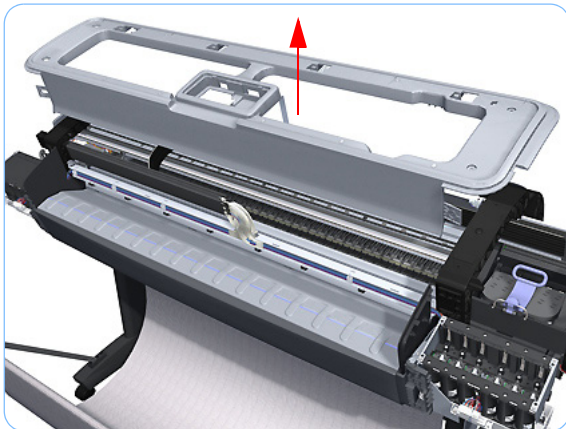

14. Lift the Top Cover off the printer.

When you finish installing or replacing this component, you must perform the necessary Service Calibrations. To find which calibrations you must perform, Refer to page 6-8, *Service Calibration Guide to Removal and Installation*.

Window Position Sensor

Removal

Switch off the printer and remove the power cable.

1. Remove the Right Cover (refer to page 6-27).
2. Remove the Left Cover (refer to page 6-30).
3. Remove the Front Panel (refer to page 6-48).
4. Remove the Top Cover (refer to page 6-51).
5. Disconnect the Window Position Sensor.

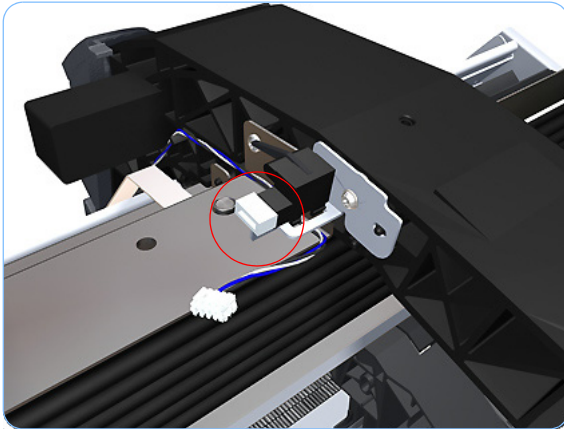

6. Remove one T-15 screw that secures the Window Position Sensor to the printer.

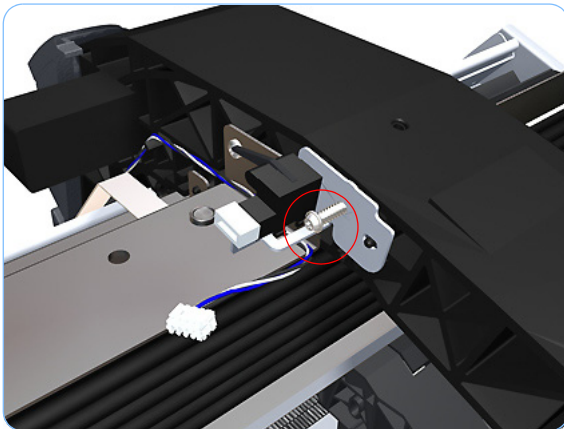

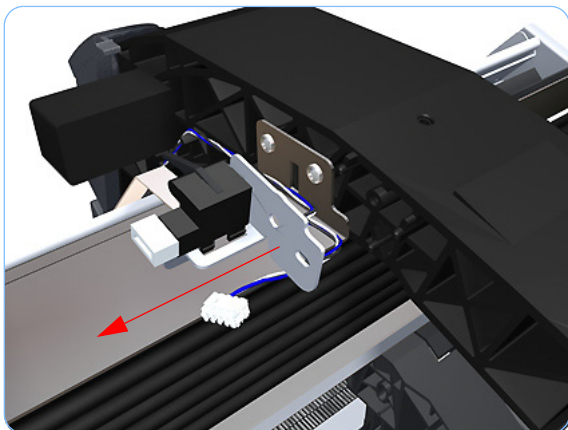

7. Remove the Window Position Sensor to the printer.

When you finish installing or replacing this component, you must perform the necessary Service Calibrations. To find which calibrations you must perform, Refer to page 6-8, *Service Calibration Guide to Removal and Installation*.

Ink Supply Tubes Support Rail

Removal

Switch off the printer and remove the power cable.

1. Remove the Right Cover (refer to page 6-27).
2. Remove the Left Cover (refer to page 6-30).
3. Remove the Front Panel (refer to page 6-48).
4. Remove the Top Cover (refer to page 6-51).
5. Remove the Window Position Sensor (refer to page 6-54).
6. Remove the Ink Supply Tubes from the Ink Supply Tubes Support Rail.

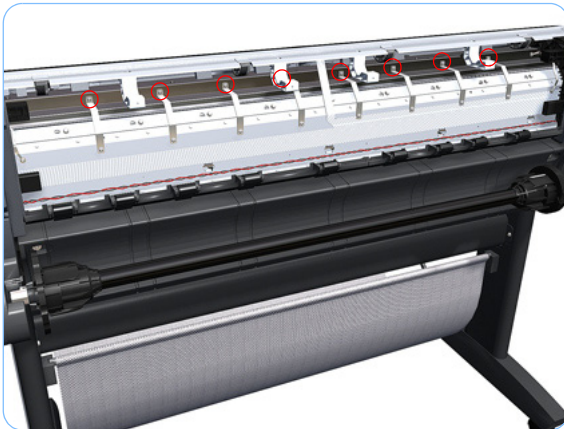
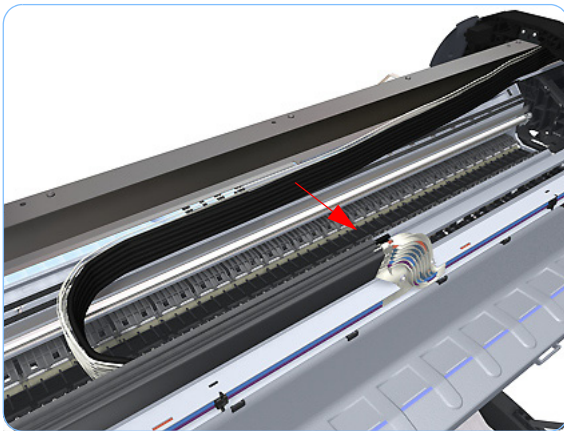

7. Remove the T-15 screws that secure the rear attachment brackets to the Ink Supply Tubes Support Rail.

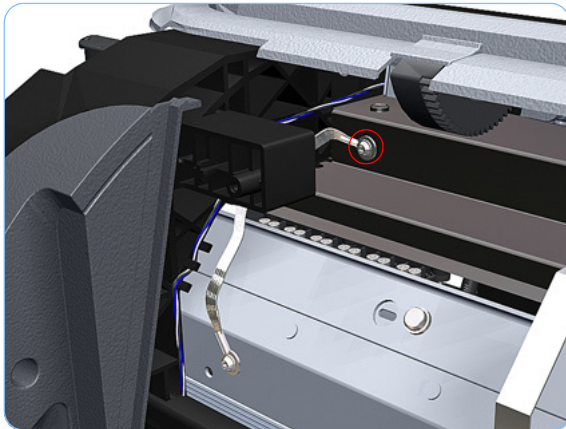

8. Remove the T-15 screw that attaches the right bonding cable.

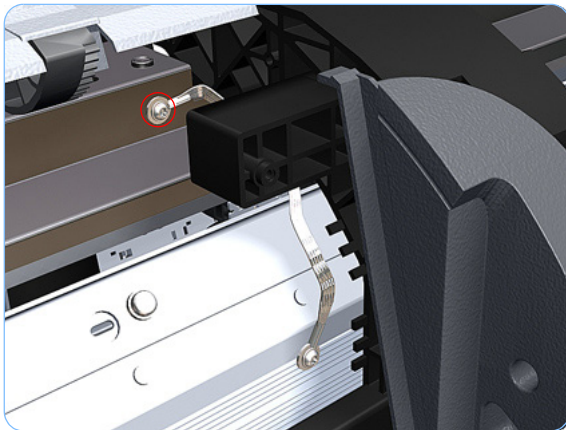

9. Remove the T-15 screw that attaches the left bonding cable.

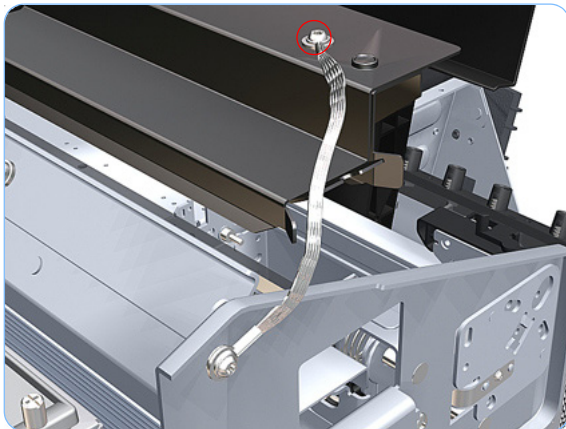

10. Remove the T-15 screw that attaches the left bonding cable.

If you are working with a newer printer, the screw location may be different.

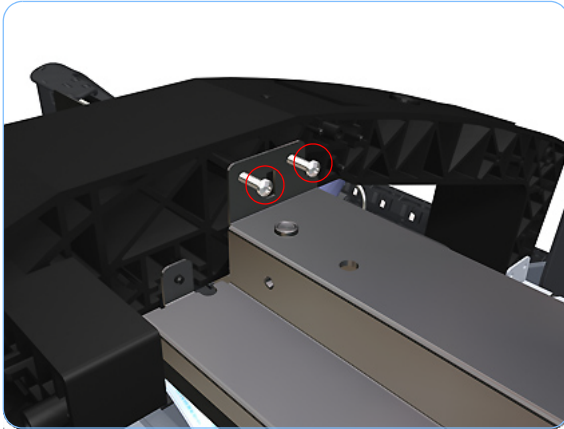

11. Remove two T-15 screws that secure the Ink Supply Tubes Support Rail to the right Top Cover Support.

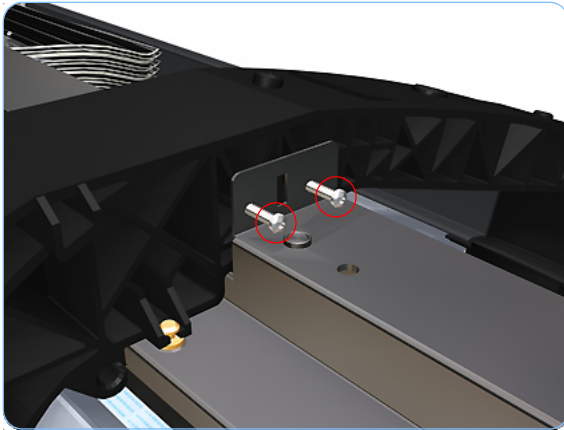

12. Remove two T-15 screws that secure the Ink Supply Tubes Support Rail to the left Top Cover Support.

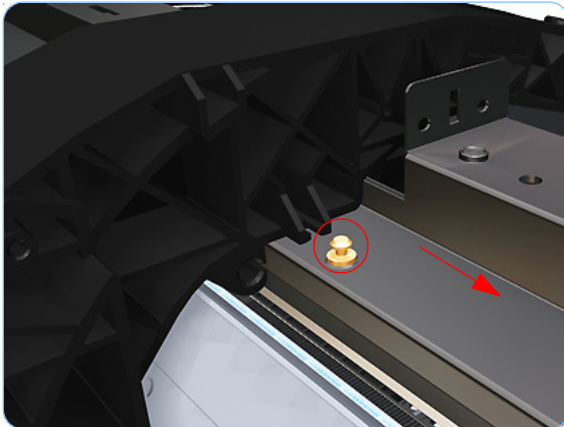

13. Slide the rail to the enough to disengage it from the attachment lug.

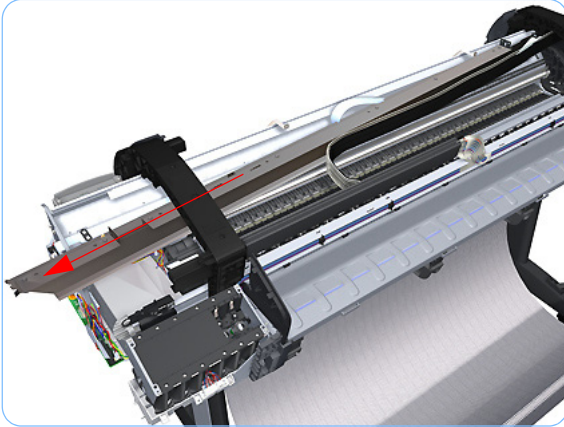

- 14.** Carefully slide the Ink Supply Tubes Support Rail to the left until the right end is clear of the right Top Cover Support.



- 15.** Remove the Ink Supply Tubes Support Rail from the printer.

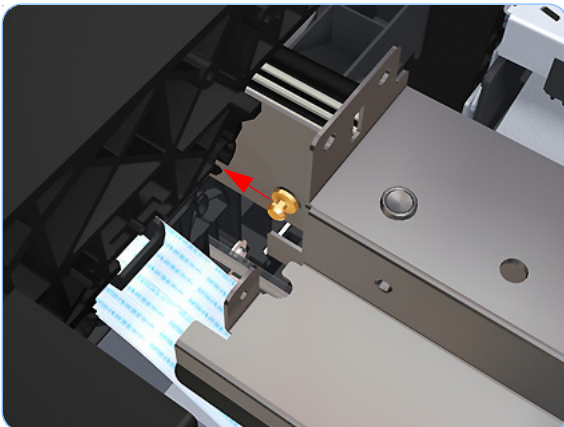

When you reinstall the Ink Supply Tubes Support Rail make sure that the attachment lug is correctly engaged with the right Top Cover Support.

When you reinstall the Ink Supply Tubes Support Rail make sure all the attachment brackets and bonding leads are correctly connected. These are important to avoid electrostatic interference being generated.

When you finish installing or replacing this component, you must perform the necessary Service Calibrations. To find which calibrations you must perform, Refer to page 6-8, *Service Calibration Guide to Removal and Installation*.

Service Station

Removal

Switch off the printer and remove the power cable.

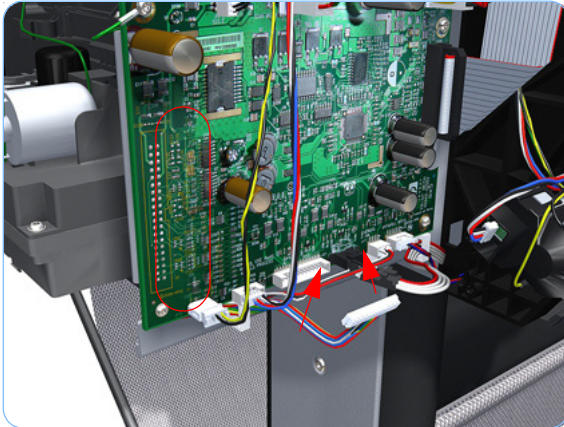

1. Remove the Right Cover (refer to page 6-27).
2. Disconnect the Ink Supply Station ribbon connector and two lower connectors from the PrintMech PCA.

The Ink Supply Station ribbon connector has to be disconnected so the other cables can be unrouted

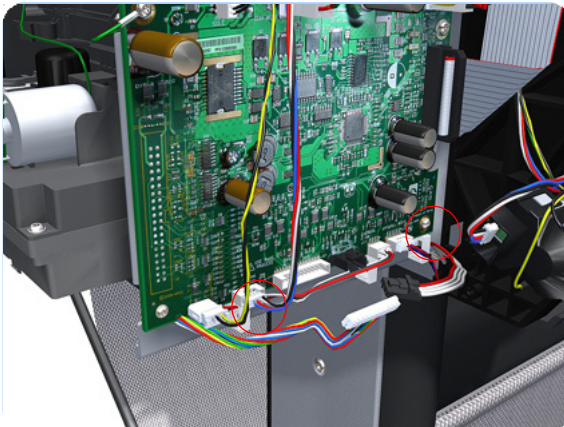

3. Unroute the two cables disconnected in step 2 from the two cable clamps below the PrintMech PCA.

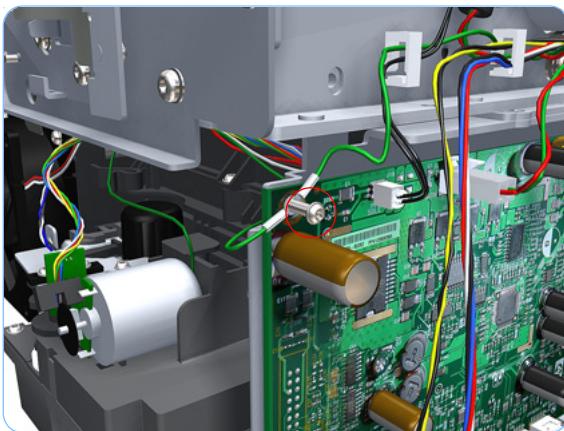

4. Remove the grounding cable attachment screw from the PrintMech PCA.

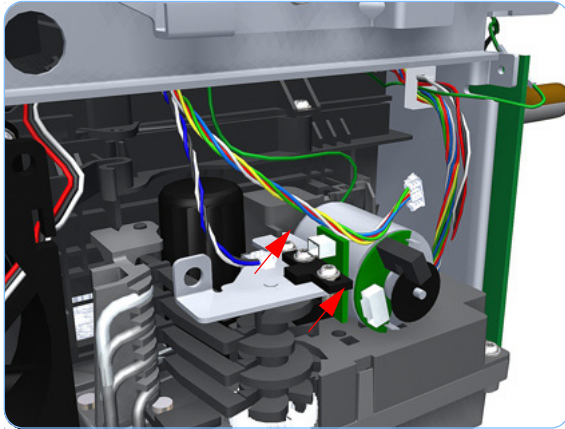

5. Disconnect connector from the Drop Detector Motor and Drop Detector Sensor.

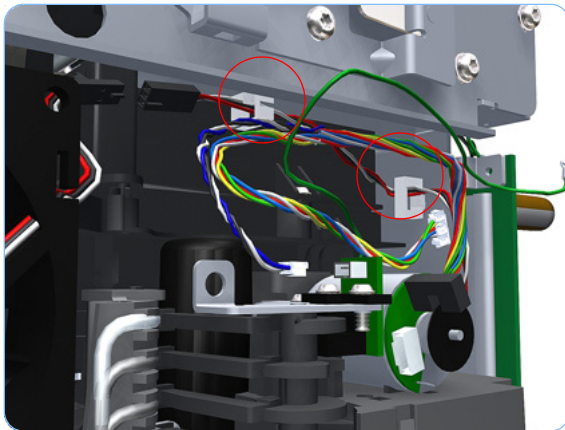

6. Unroute the cables disconnected in steps 4 and 5 from the two cable clamps.

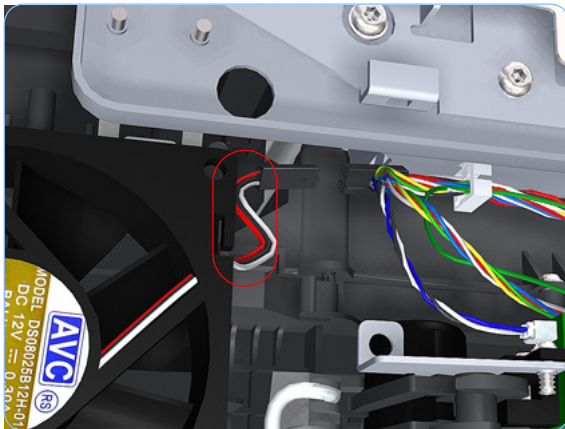

7. Disconnect the Aerosol Fan Assembly inline connector.

Some printers function without an aerosol fan. If the printer does not have an aerosol fan, make the inline connection during installation even though there is no fan.

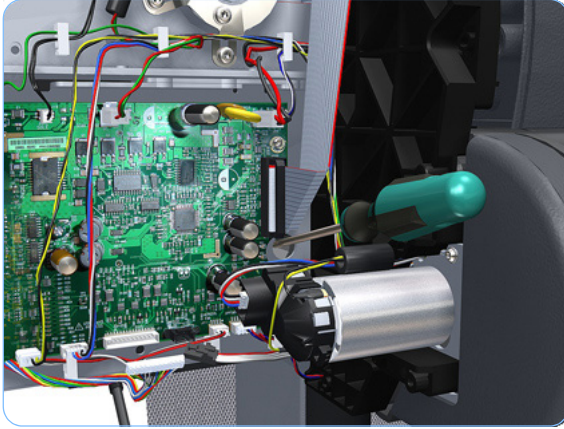

8. Loosen the T-10 uncapping screw sufficiently so you can manually move the Carriage Assembly in step 9.

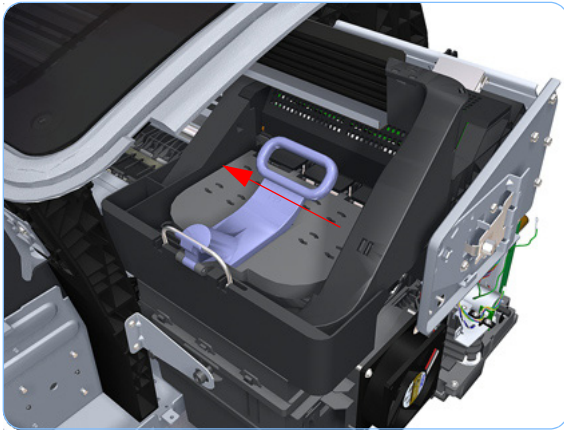

9. Push the Carriage Assembly into the print path to gain access to two T-15 screws that secure the Service Station to the Carriage Rail.

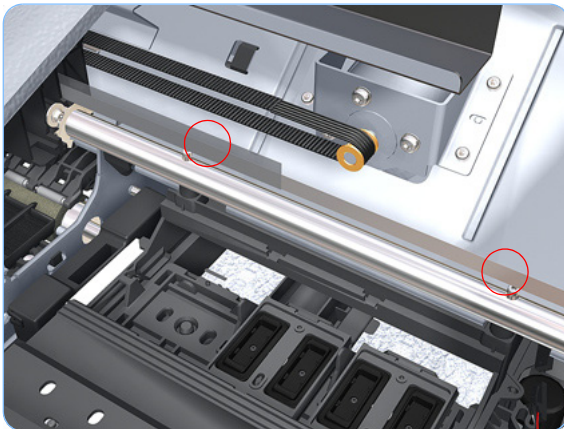

10. Use an allen key provided in the tool kit to remove two allen screws that secure the Service Station to the Carriage Rod.

Support the Service Station so it does not fall when you remove the attachment screws.

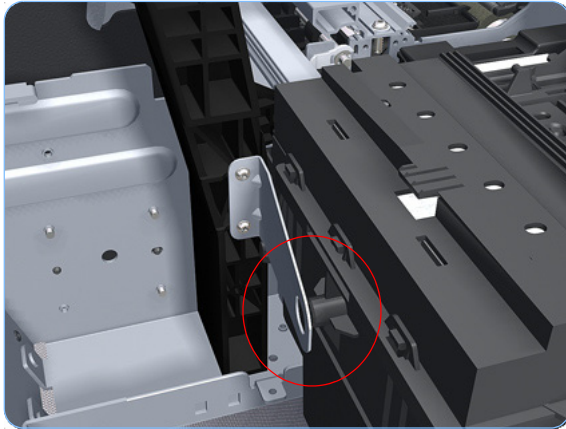

11. Unclip the clip to release the Service Station from the printer.

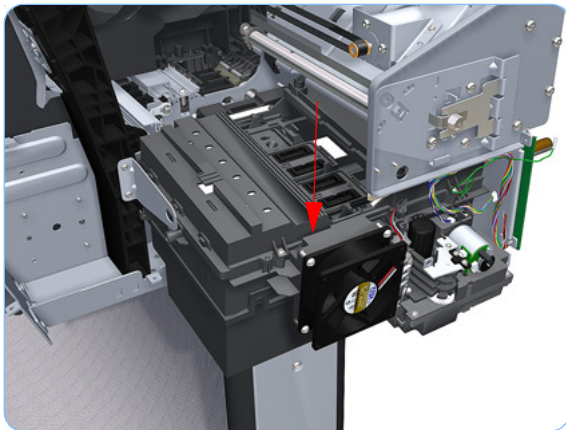

12. Lower the Service Station from the printer.

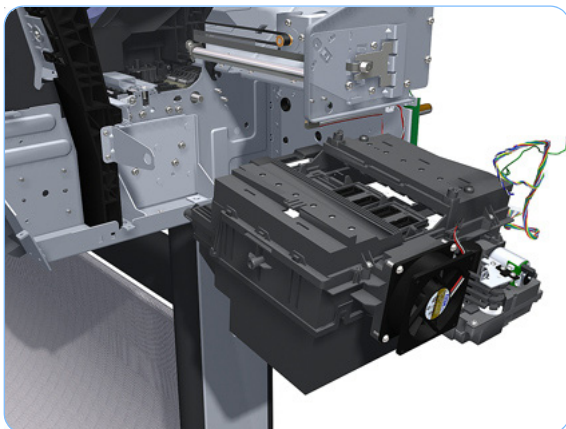

13. Lower the right of the Service Station enough to allow you to slide it carefully out of the printer.

When you finish installing or replacing this component, you must perform the necessary Service Calibrations. To find which calibrations you must perform, Refer to page 6-8, *Service Calibration Guide to Removal and Installation*.

Drop Detector

Removal

Switch off the printer and remove the power cable.

1. Remove the Right Cover (refer to page 6-27).
2. Remove the Service Station (refer to page 6-60).
3. Unroute the Drop Detector ribbon cable from the Service Station cable clamps.

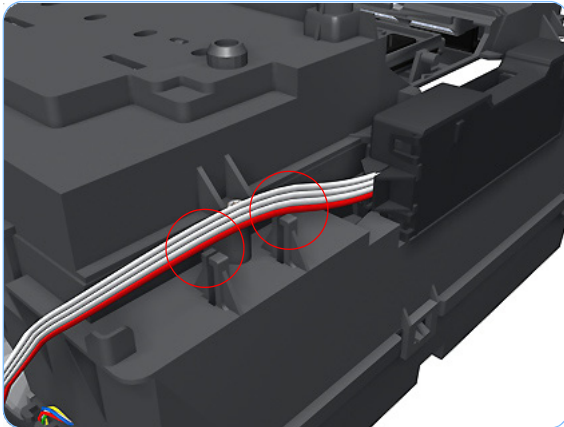

4. Remove the T-15 screw that secures the Drop Detector to the Service Station.

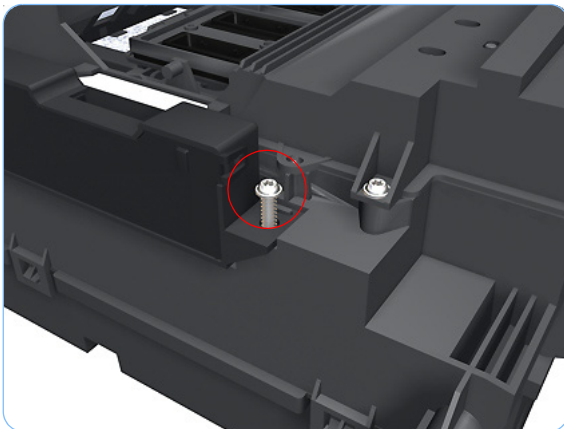

5. Lift the Drop Detector off the Service Station.

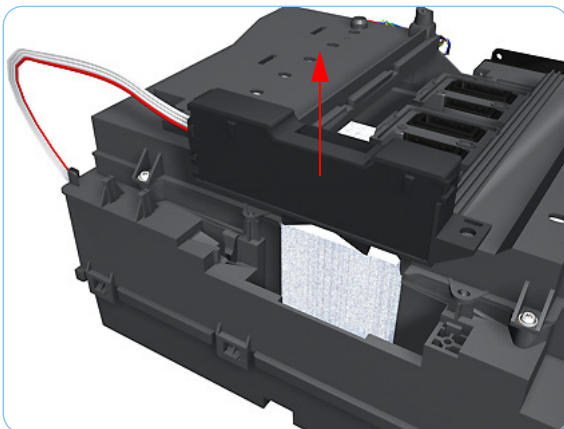

When you finish installing or replacing this component, you must perform the necessary Service Calibrations. To find which calibrations you must perform, Refer to page 6-8, *Service Calibration Guide to Removal and Installation*.

Aerosol Fan Assembly

Removal

Switch off the printer and remove the power cable.

1. Remove the Right Cover (refer to page 6-27).
2. Disconnect the Aerosol Fan Assembly in-line connector.

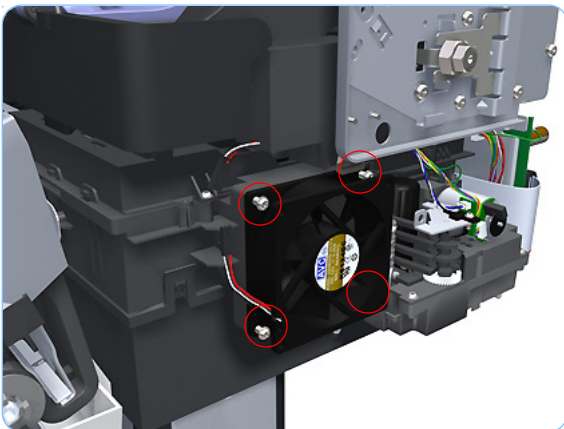
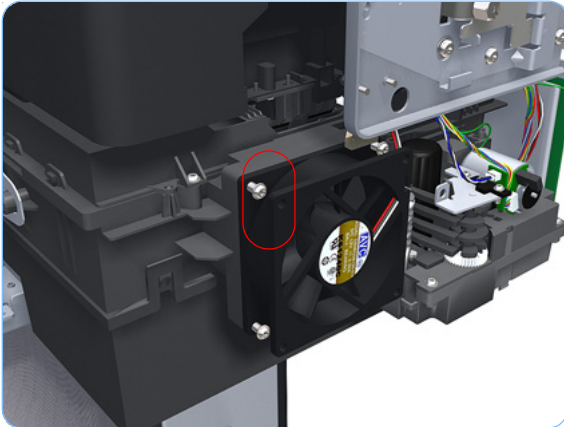

3. Remove the four T-15 screws that secure the Aerosol Fan Assembly to the Service Station.

The four access holes in the Aerosol Fan Assembly housing are the same size as the attachment screw diameter so you will need a normal Torx Screwdriver, not a multi-tool, to remove the screws.

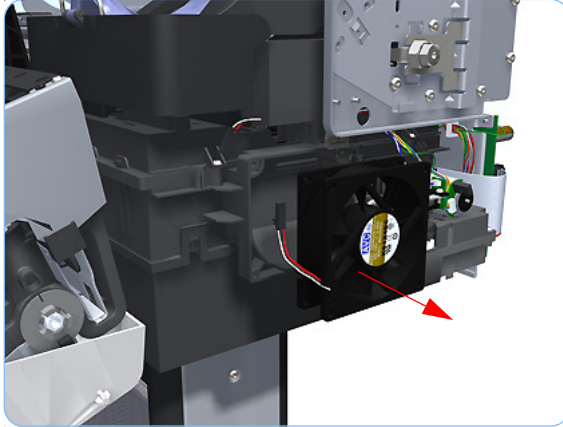

4. Remove the Aerosol Fan Assembly from the Service Station.

When you reinstall the Aerosol Fan Assembly make sure you position it so that the power cable is on the outside exiting to the right.

When you finish installing or replacing this component, you must perform the necessary Service Calibrations. To find which calibrations you must perform, Refer to page 6-8, *Service Calibration Guide to Removal and Installation*.

Primer Assembly

Removal

Switch off the printer and remove the power cable.

1. Remove the Right Cover (refer to page 6-27).
2. Remove the Service Station (refer to page 6-60).
3. Pull out the spitting tube from the Service Station Spittoon and unroute it from the attachment clip.

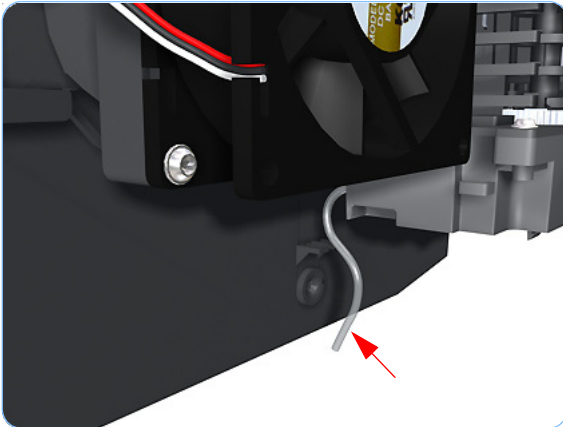

4. Unroute the cable assembly from attachment clip on the Service Station Spittoon.

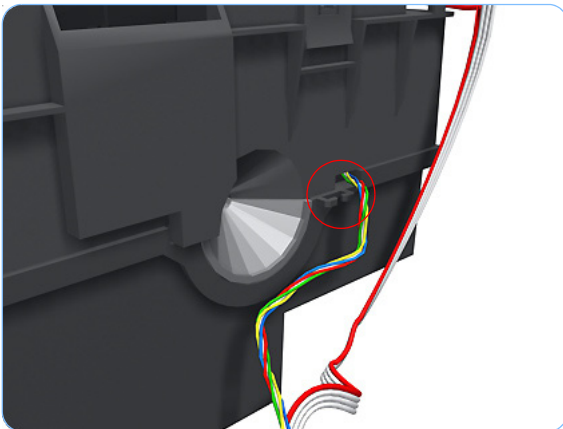

5. Unclip the front left clip that secures the Service Station to the Service Station Spittoon.

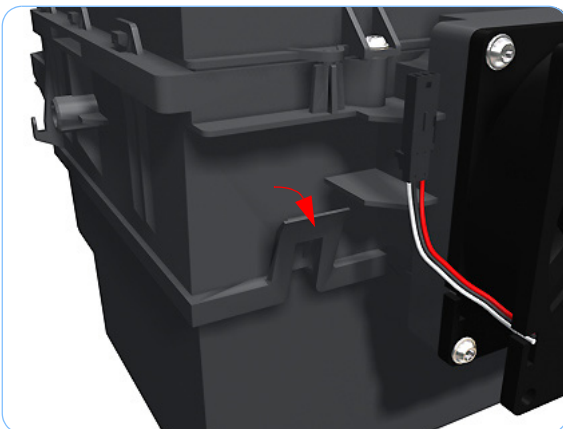

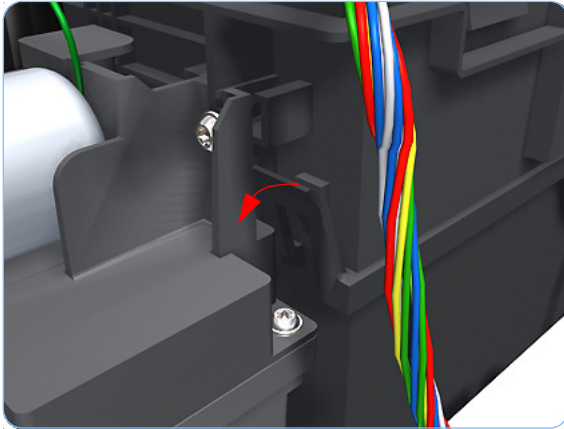

6. Unclip the front left clip that secures the Service Station to the Service Station Spittoon.

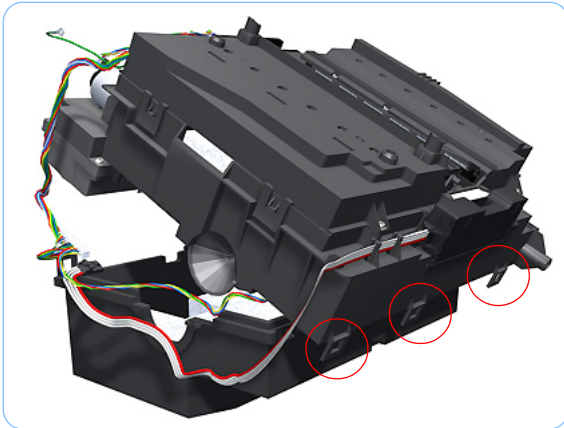

7. Carefully raise the Service Station vertically from the clip side (by approximately 30 degrees) until you can disengage it from the three attachments on the opposite side to remove it from the Left Spittoon.

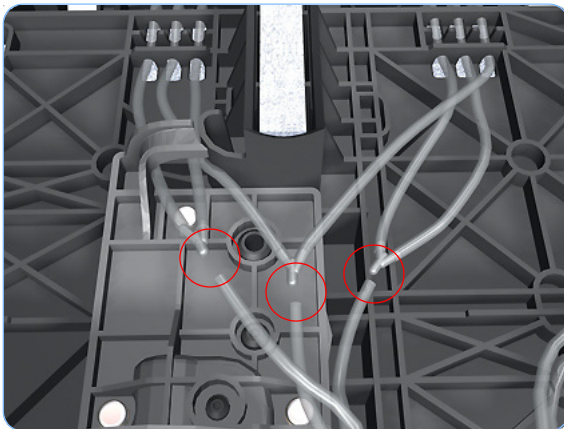

8. Disconnect the three Primer Assembly tubes.

It is recommended that you use protective gloves when handling the Primer Assembly

Use a suitable method to identify each Primer Assembly tube for correct re-connection during assembly components.

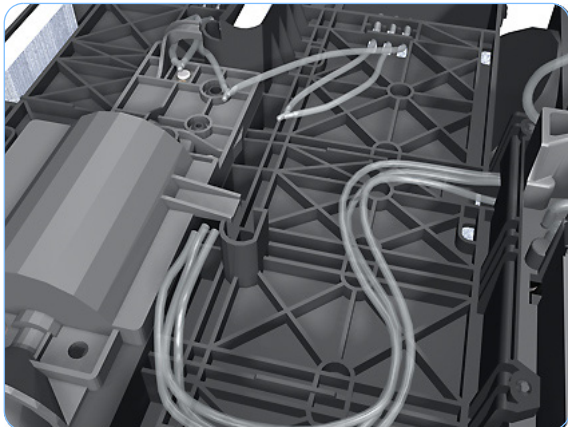

9. Unroute the three Primer Assembly tubes.

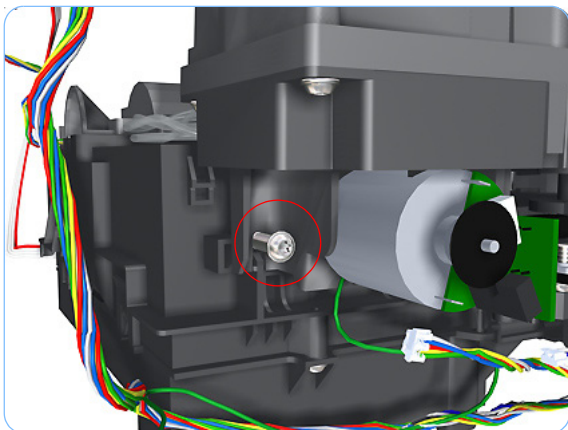

10. Remove the T-15 screw that secure the Primer Assembly to the Service Station.

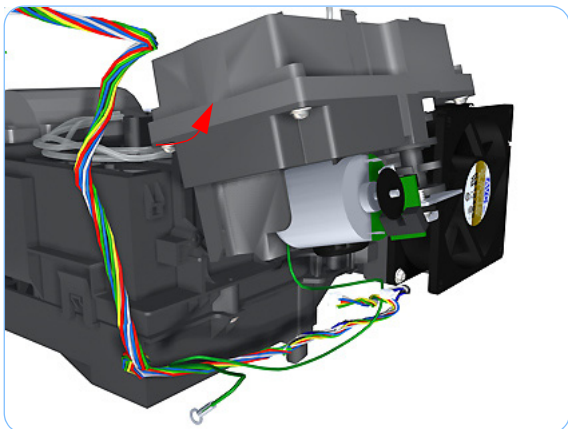

11. Tilt the Primer Assembly to disengage the lower edge.

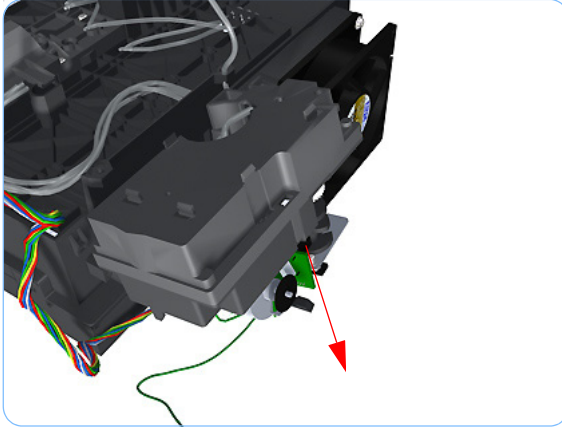

12. Lower the Primer Assembly to disengage the top attachment lugs.

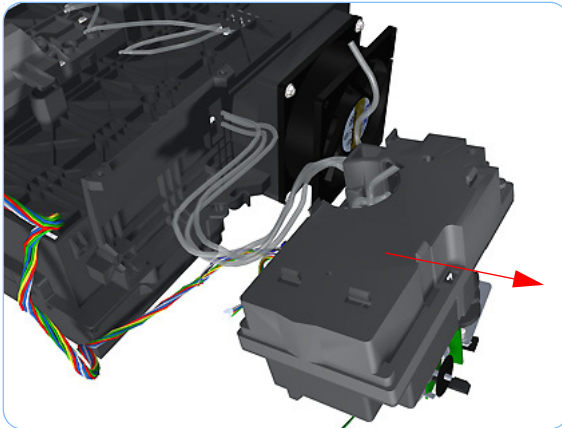

13. Remove the Primer Assembly from the Service Station.

When you install the Primer Assembly make sure you connect the three primer tubes in accordance with their identification markings.

When you finish installing or replacing this component, you must perform the necessary Service Calibrations. To find which calibrations you must perform, Refer to page 6-8, *Service Calibration Guide to Removal and Installation*.

PrintMech PCA

Removal

Do NOT remove and install both the PrintMech PCA and the Formatter at the same time.

If you have previously removed and installed the Formatter, make sure that you complete the procedure and the instructions provided on the flyer that accompanies the Formatter. Refer to Page 6-161 before installing the PrintMech PCA.

Switch off the printer and remove the power cable.

1. Remove the Right Cover (refer to page 6-27).
2. Disconnect all the electrical connectors from the PrintMech PCA.

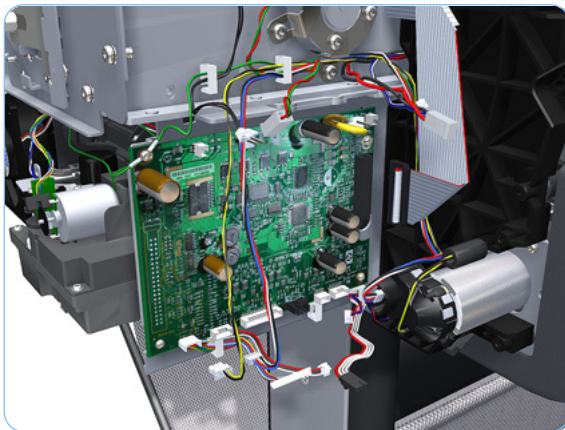

3. Remove the grounding cable attachment screw from the PrintMech PCA.

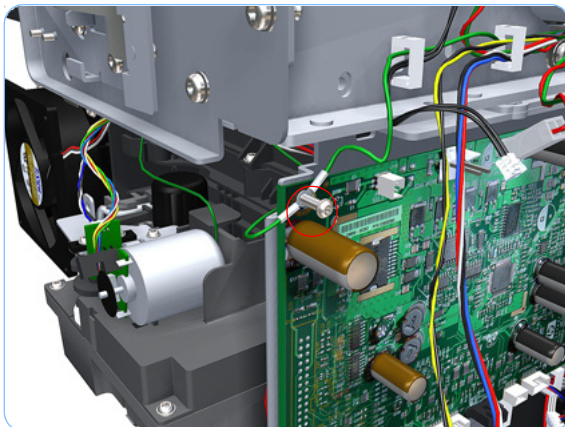

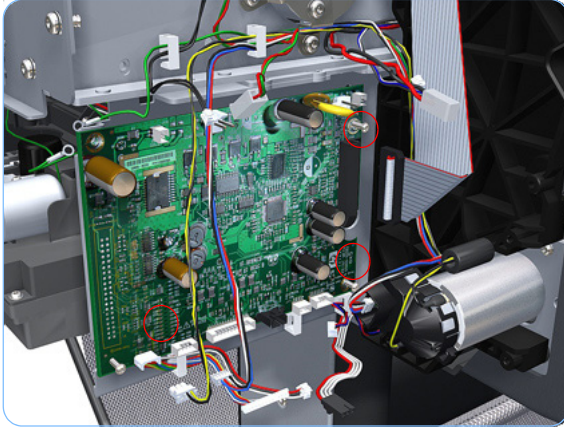

4. Remove the three T-15 screws that secure the PrintMech PCA to the Service Station.

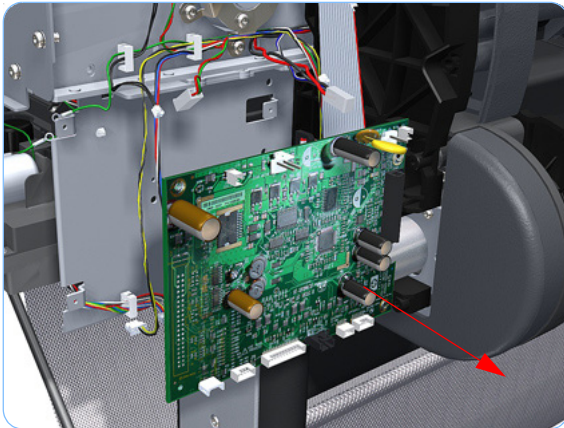

5. Remove the PrintMech PCA from the printer.

When you finish installing or replacing this component, you must perform the necessary Service Calibrations. To find which calibrations you must perform, Refer to page 6-8, *Service Calibration Guide to Removal and Installation*.

Pen to Paper Space (PPS) Solenoid

Removal

Switch off the printer and remove the power cable.

1. Remove the Right Cover (refer to page 6-27).
2. Unroute the Pen to Paper Space (PPS) Solenoid cable from the cable clamp.

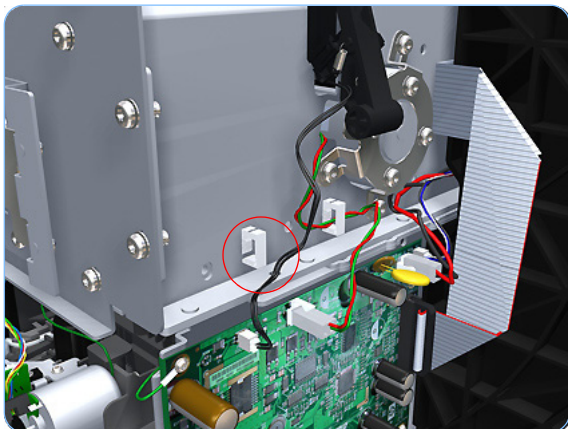

3. Disconnect the Pen to Paper Space (PPS) Solenoid connector from the PrintMech PCA.

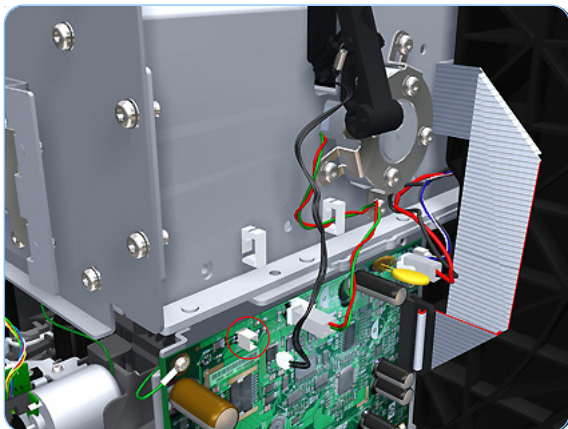

4. Remove two T-15 screws that secure the Pen to Paper Space (PPS) Solenoid to the printer.

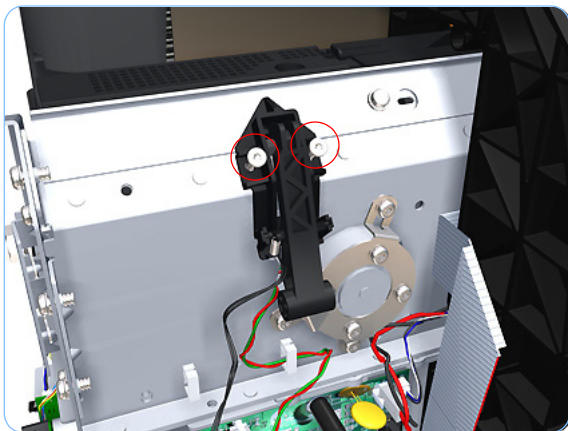

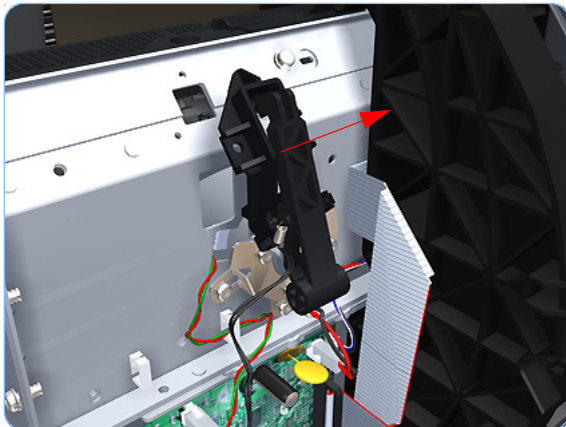

5. Remove the Pen to Paper Space (PPS) Solenoid from the printer.

When you finish installing or replacing this component, you must perform the necessary Service Calibrations. To find which calibrations you must perform, Refer to page 6-8, *Service Calibration Guide to Removal and Installation*.

Spindle

Removal

Switch off the printer and remove the power cable.



1. Pull the left end of the Spindle (viewed from the front of the printer) out of the Left Spindle Holder.

It is normal to encounter Spindles of different diameters and weights.



2. Lift the Spindle out of the printer towards the left (viewed from the front of the printer).

Left Spindle Holder

Removal

Switch off the printer and remove the power cable.



1. Remove the Spindle (refer to page 6-75).
2. Remove two T-15 screws that secure the Left Spindle Holder to the printer.



3. Rotate the Left Spindle Holder towards the left.



4. Remove the Left Spindle Holder from the printer.

Right Spindle Holder

Removal

Switch off the printer and remove the power cable.

1. Remove the Spindle (refer to page 6-75).
2. Remove two T-15 screws that secure the Right Spindle Holder to the printer.

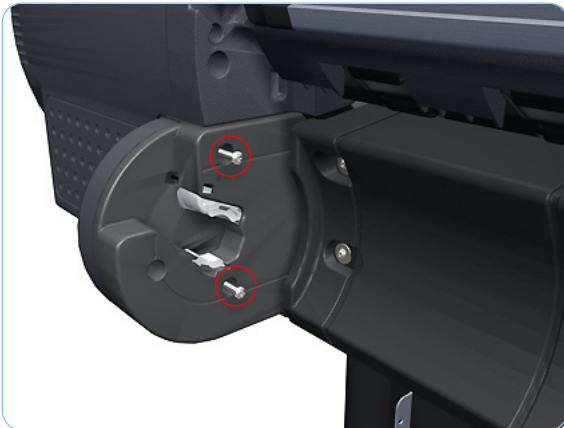

3. Rotate the Right Spindle Holder towards the right.

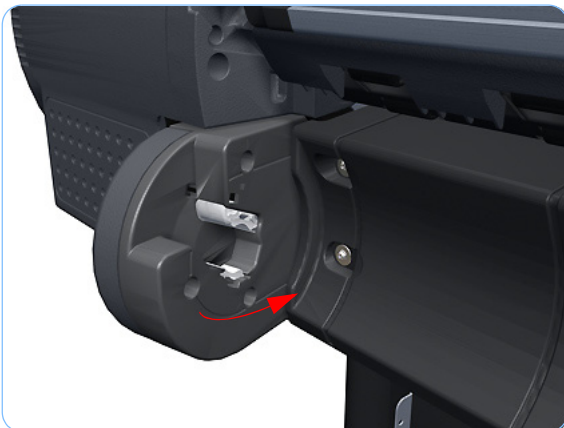

4. Remove the Right Spindle Holder from the printer.

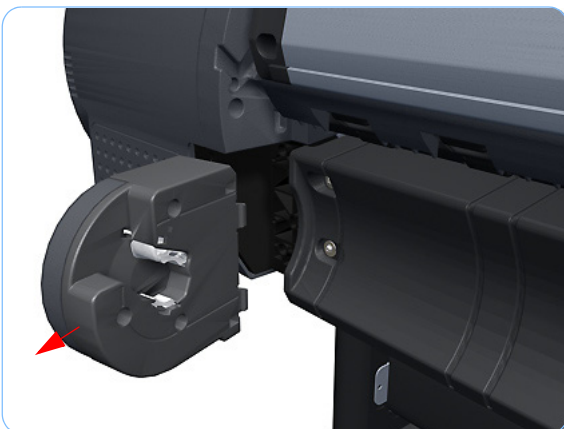

Clean Out Assembly

Removal

Switch off the printer and remove the power cable.

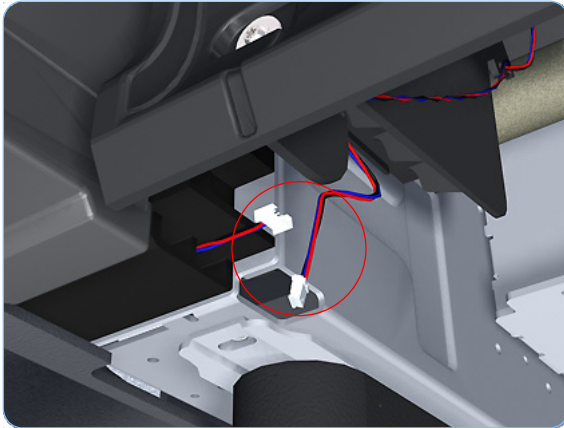

1. Remove the Spindle (refer to page 6-75).
2. Disconnect the Out Of Paper Sensor in-line connector and unrout the its cable.

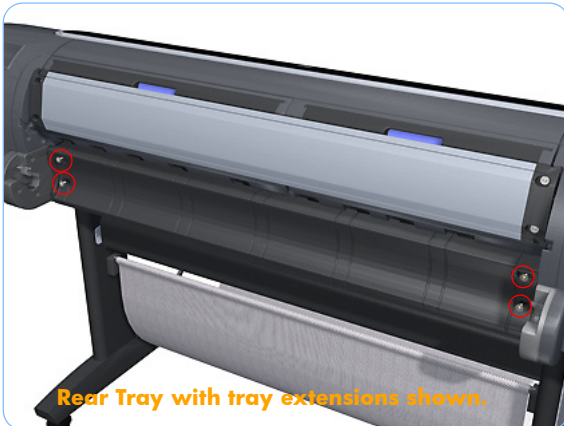

Rear Tray with tray extensions shown.

3. Remove the four T-15 screws that secure Clean Out Assembly to the printer.



Rear Tray with tray extensions shown.

4. Beginning with the **left** side, slide the Clean Out Assembly out of the printer. Double check that you haven't broken the Out Of Paper Sensor on the left side of the Clean Out Assembly.

When you finish installing or replacing this component, you must perform the necessary Service Calibrations. To find which calibrations you must perform, Refer to page 6-8, *Service Calibration Guide to Removal and Installation.*

Out Of Paper Sensor

Removal

Switch off the printer and remove the power cable.

1. Remove the Spindle (refer to page 6-75).
2. Remove the Clean Out Assembly (refer to page 6-78).
3. Unroute the Out Of Paper Sensor electrical cables from the Clean Out Assembly.

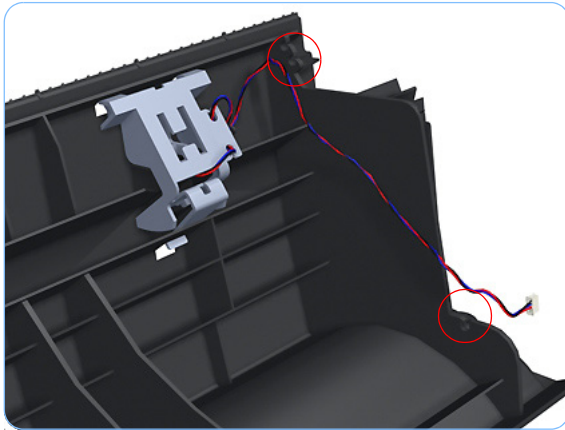

4. Unroute (unwind) the Out Of Paper Sensor electrical cables from the Out Of Paper Sensor cover.

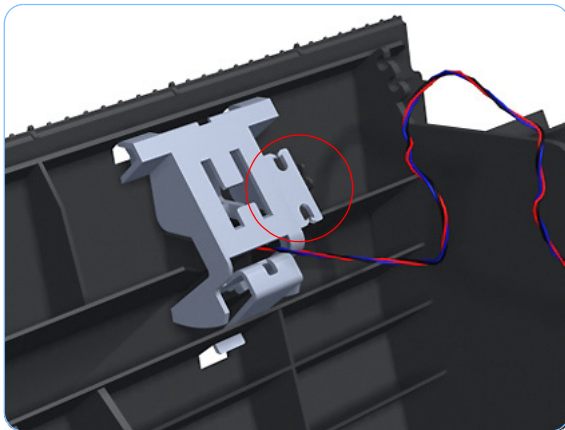

5. Press the clip to remove the Out Of Paper Sensor cover from the Clean Out Assembly.

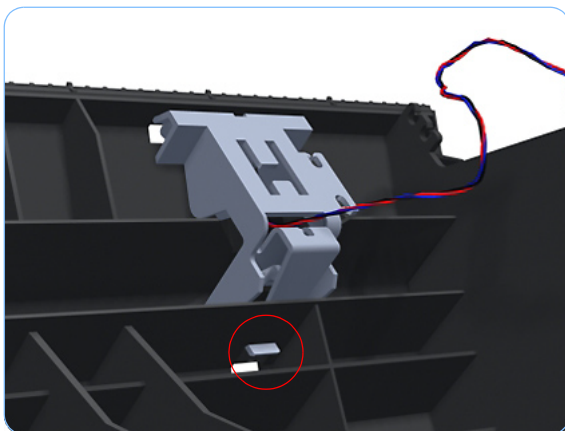

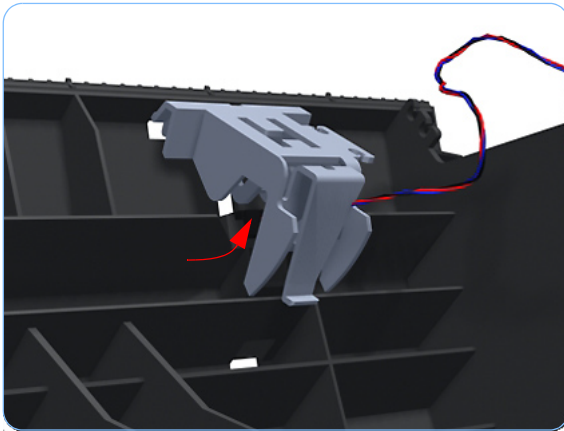

6. Rotate the Out Of Paper Sensor cover approximately 45 degrees.

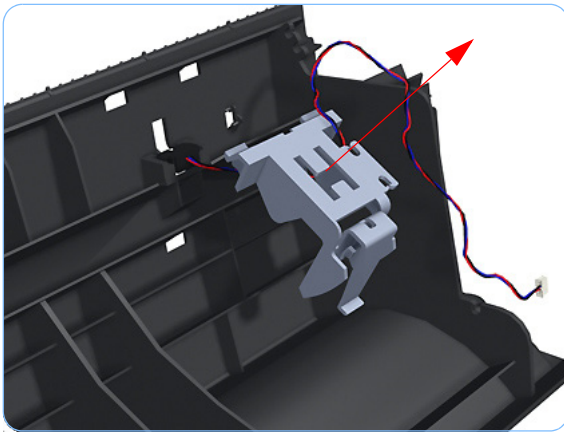

7. Remove the Out Of Paper Sensor cover from the Clean Out Assembly

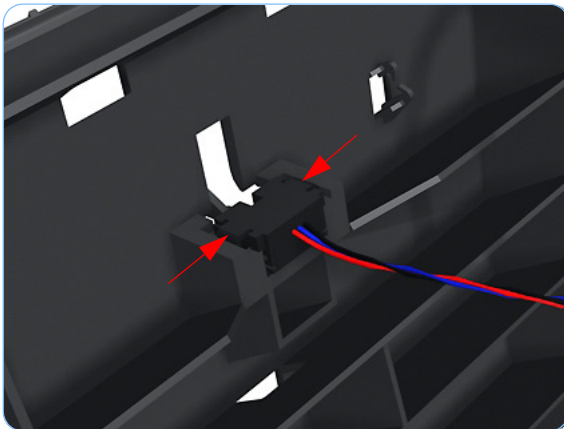

8. Squeeze the Out Of Paper Sensor attachment clips to remove it from the Clean Out Assembly.

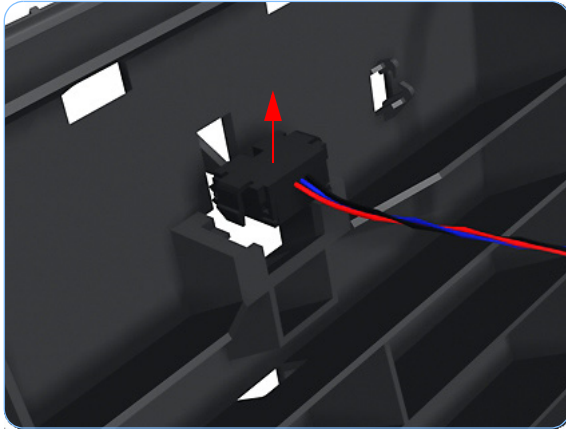

9. Lift the Out Of Paper Sensor out of the Clean Out Assembly.

When you finish installing or replacing this component, you must perform the necessary Service Calibrations. To find which calibrations you must perform, Refer to page 6-8, *Service Calibration Guide to Removal and Installation*.

Left Roll Guide

Removal

Switch off the printer and remove the power cable.

1. Remove the Spindle (refer to page 6-75).
2. Remove the Clean Out Assembly (refer to page 6-78).
3. Remove five T-15 screws that secure Left Roll Guide to the printer.

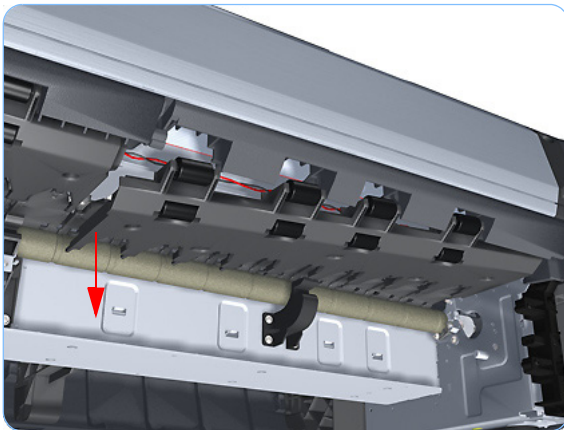
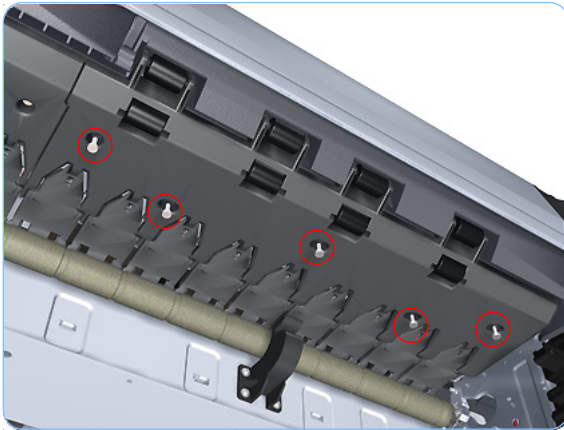

4. Lower the left end and remove the Left Roll Guide from the printer.

When you finish installing or replacing this component, you must perform the necessary Service Calibrations. To find which calibrations you must perform, Refer to page 6-8, *Service Calibration Guide to Removal and Installation*.

Right Roll Guide

Removal

Switch off the printer and remove the power cable.

1. Remove the Spindle (refer to page 6-75).
2. Remove the Clean Out Assembly (refer to page 6-78).
3. Remove the Left Roll Guide (refer to page 6-82).
4. Remove seven T-15 screws that secure Right Roll Guide to the printer.

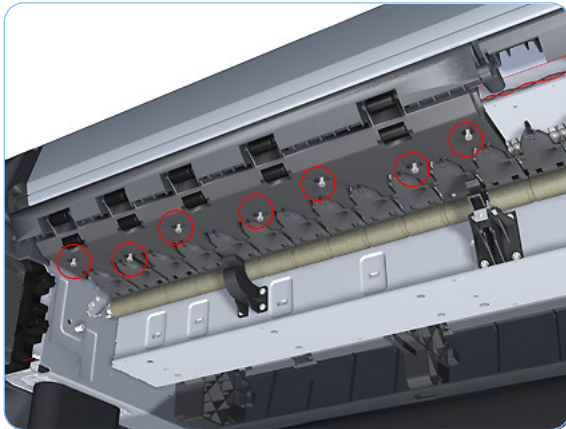

5. Lower the right end and remove the Right Roll Guide from the printer.

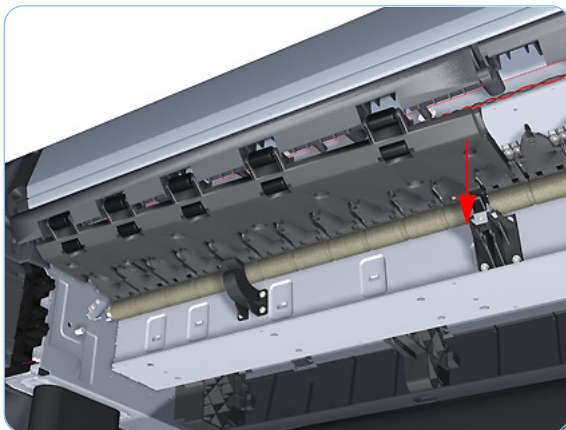

When you finish installing or replacing this component, you must perform the necessary Service Calibrations. To find which calibrations you must perform, Refer to page 6-8, *Service Calibration Guide to Removal and Installation*.

Encoder Strip (with spring and attachment nut)

Removal

Switch off the printer and remove the power cable.

1. Remove the Right Cover (refer to page 6-27).
2. Remove the Left Cover (refer to page 6-30).
3. Remove the T-15 screw that secures Encoder Strip to the printer.

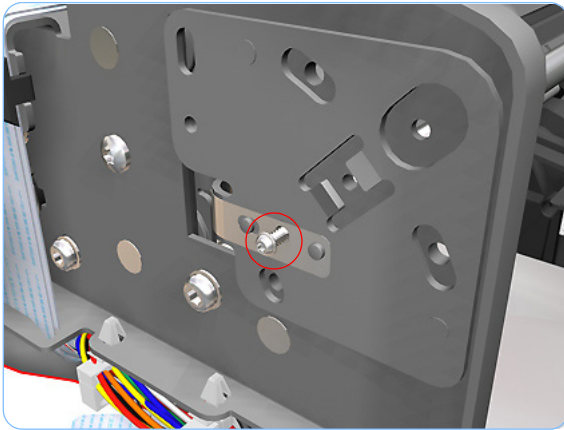

4. Grip the Encoder Strip and move it towards the left to take off the tension until you have completed the next step.

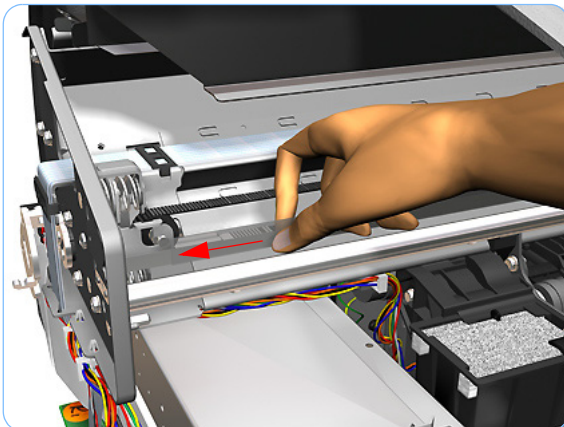

5. Unclip the Encoder Strip from its attachment lugs.

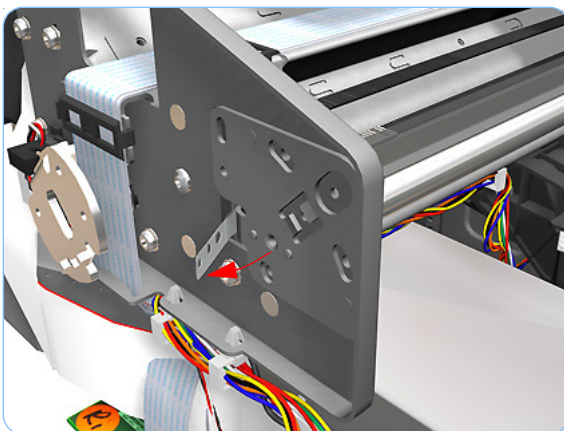

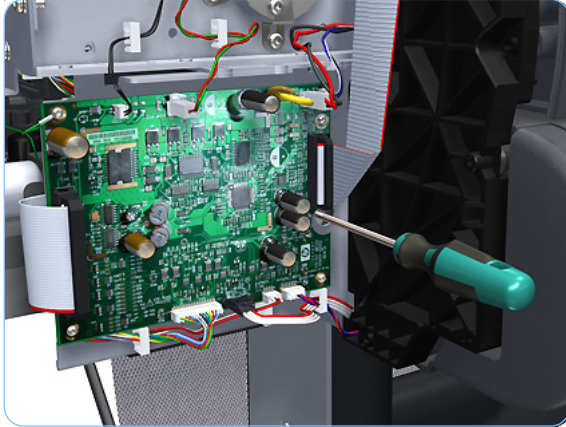

6. Loosen the T-10 uncapping screw sufficiently so you can manually move the Carriage Assembly in step 7.

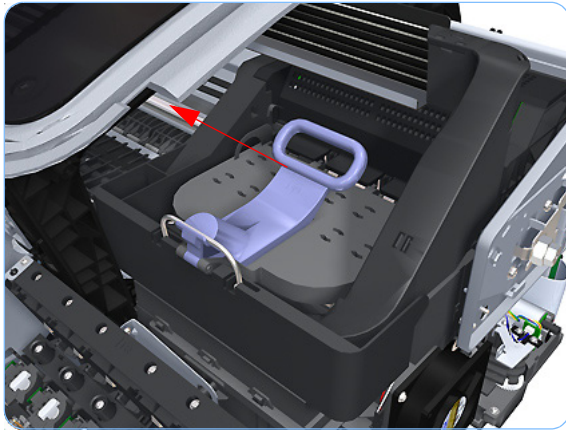

7. Push the Carriage Assembly into the print path.

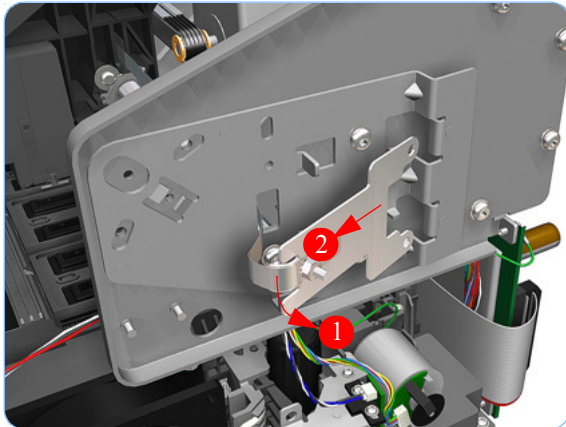

8. Unclip the Encoder Strip tensioner from the right hand end.

There are two sizes of nuts on the Encoder Strip tensioner. If you are working with a newer printer, the nut will be smaller.

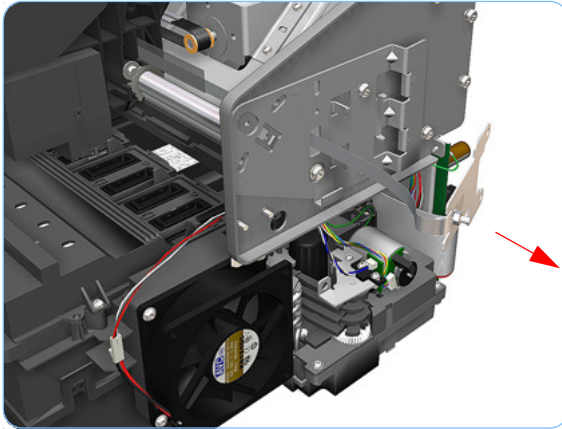

- Carefully pull the Encoder Strip out of the printer from the right hand end.

When you finish installing or replacing this component, you must perform the necessary Service Calibrations. To find which calibrations you must perform, Refer to page 6-8, *Service Calibration Guide to Removal and Installation*.

Clean Encoder Strip Procedure

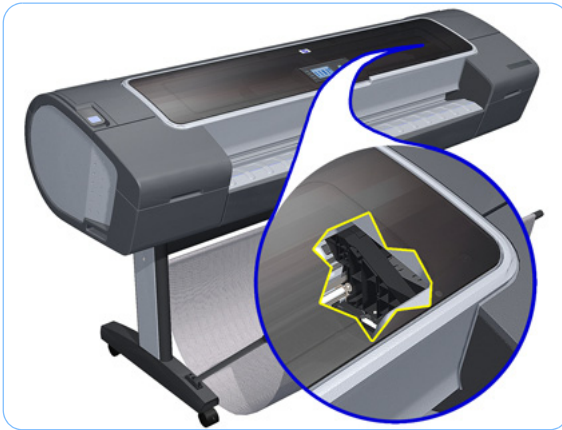

- Make sure that the printer is OFF and that the carriage assembly is located at the service station on the far right side of the printer.

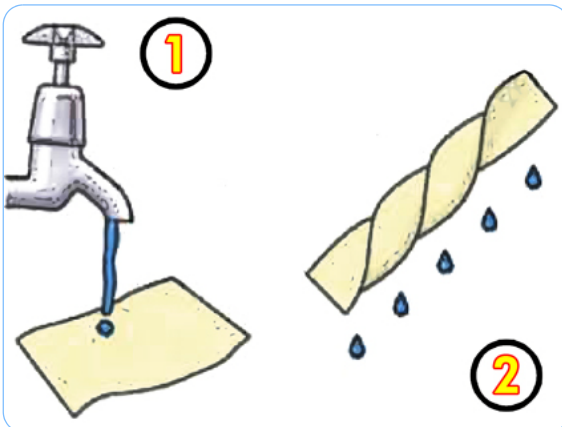

- Use tap water and a small cloth that will not leave fibers in the printer to clean the encoder strip. Dampen the cloth and remove any excess water so that the cloth is damp but not wet.

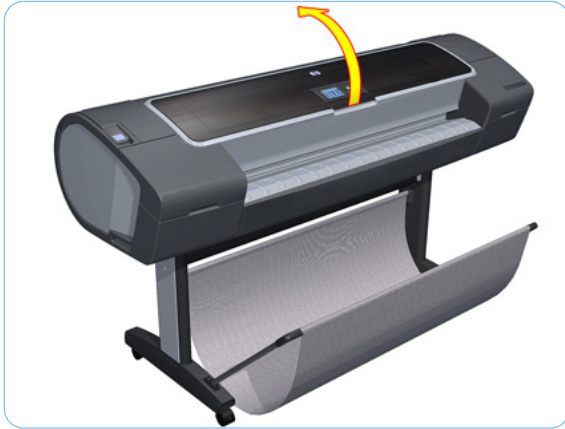

3. Open the window.

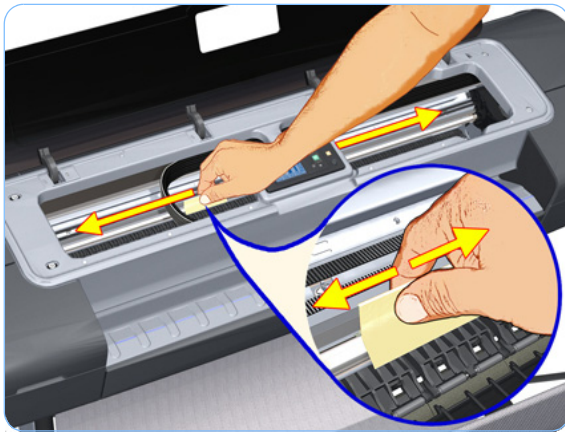

4. Hold the cloth in an inverted "U" shape around the encoder strip and carefully wipe until no ink residue appears on the cloth. Be very careful not to scratch the encoder strip with your fingernail or any other object.



5. Do not hold the cloth as shown.

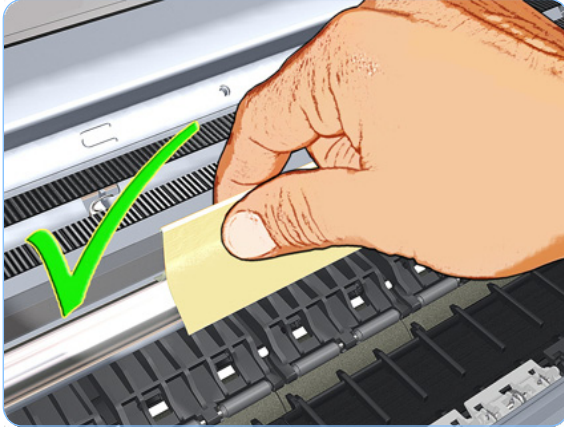

6. Hold the cloth as shown, in the appropriate "U" shape.

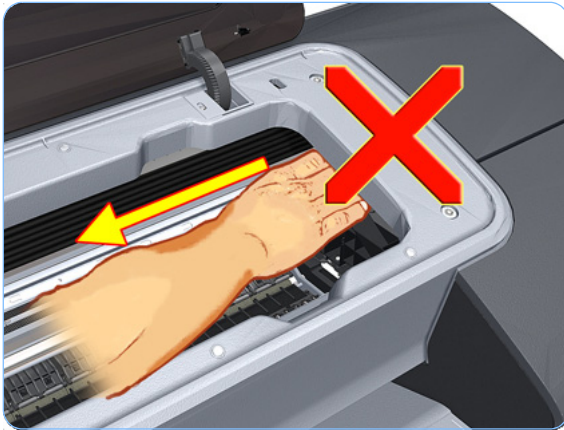

7. Do not move the carriage assembly away from the service station.



8. Close the window.

Ink

- ▶ View ink levels
- ▶ Replace ink cartridges
- ▶ Replace printheads
- ⊕ Ink cartridge information
- ⊕ Printhead information

- 9.** On the front panel, select the ink icon, and then select Replace Printheads. The carriage assembly moves to the left and stops in the correct position to remove the printheads.

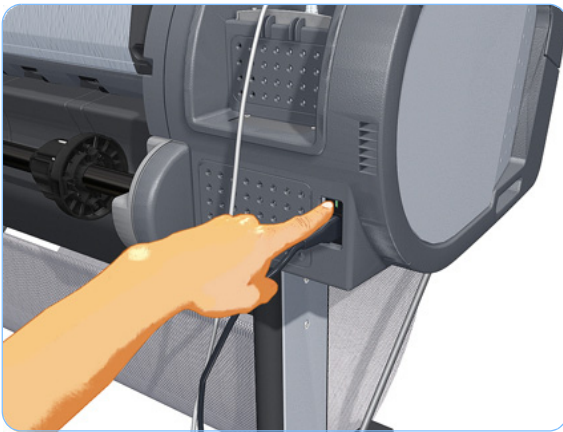

- 10.** Turn off the printer the power switch on the back of the printer.

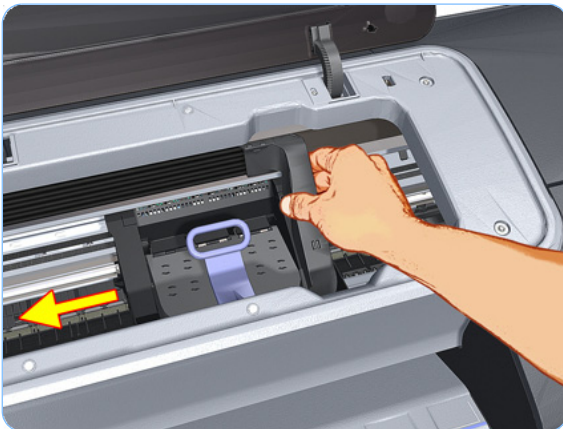

- 11.** Open the window and move the carriage assembly further to the left, allowing you to access the service station.

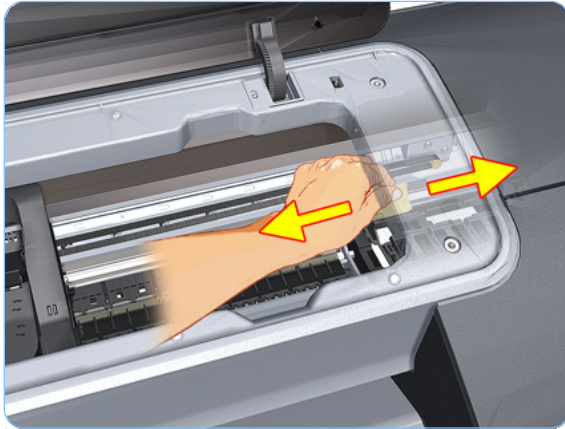

12. Clean the part of the encoder strip next to the service station by repeating steps 2 to 6.



13. Close the window. When you are done, make sure to turn the printer back on.

Encoder Strip

Removal

Switch off the printer and remove the power cable.

1. Remove the Right Cover (refer to page 6-27).
2. Remove the Left Cover (refer to page 6-30).
3. Remove the Encoder Strip (with spring and attachment nut) (refer to page 6-84).
4. Use the spanner provided in the tool kit to remove the 13 mm locking nut that secures the Encoder Strip to the Encoder Strip Spring.

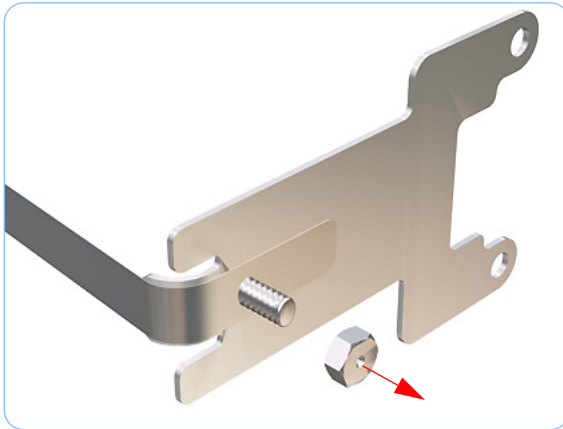

There are two sizes of nuts. If you are working with a newer printer, the nuts will be smaller.

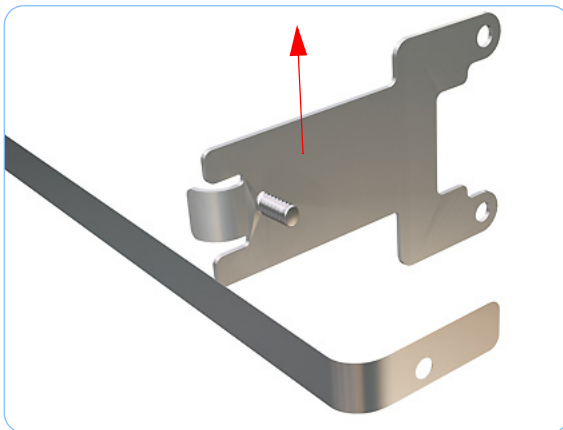

5. Remove the Encoder Strip Spring.

When you finish installing or replacing this component, you must perform the necessary Service Calibrations. To find which calibrations you must perform, Refer to page 6-8, *Service Calibration Guide to Removal and Installation*.

Trailing Cable (with Carriage PCA Cover)

Removal

Switch off the printer and remove the power cable.

1. Remove the Left Cover (refer to page 6-30).
2. Remove the Right Cover (refer to page 6-27).
3. Remove the Front Panel (refer to page 6-48).
4. Remove the Top Cover (refer to page 6-51).
5. Remove the Window Position Sensor (refer to page 6-54).
6. Remove the Ink Supply Tubes Support Rail (refer to page 6-56).
7. Loosen the T-10 uncapping screw sufficiently so you can manually move the Carriage Assembly in step 8.

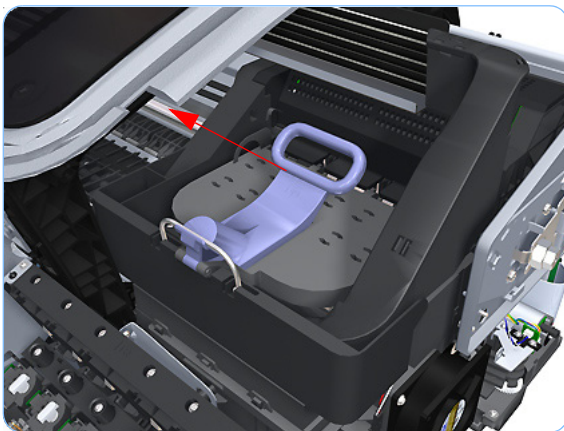
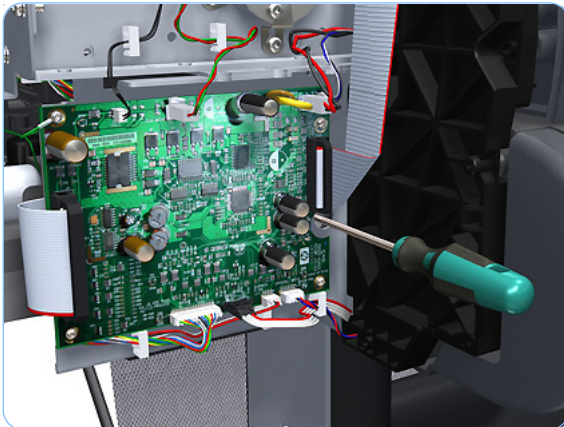

8. Push the Carriage Assembly into the print path.



9. Unclip the small cover of the Carriage PCA.

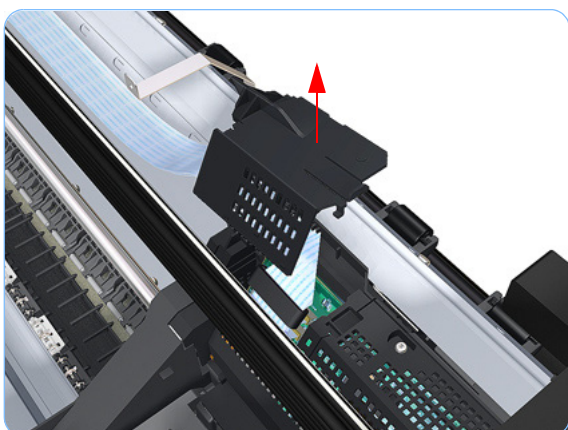

10. Remove the small cover of the Carriage PCA.

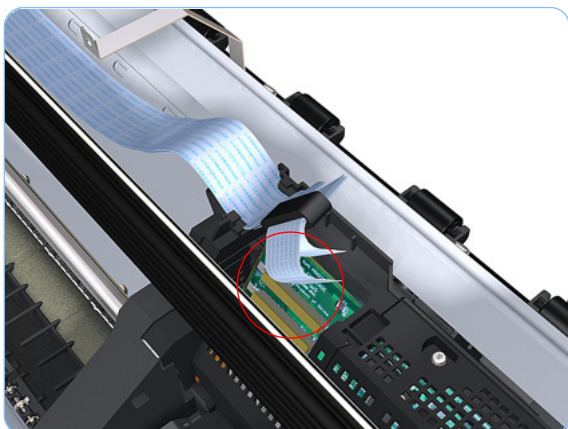

11. Disconnect the two ribbon cables of the Trailing Cables from the Carriage PCA.

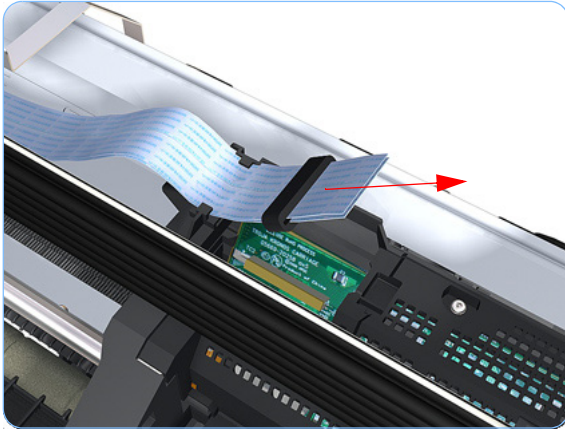

12. Straighten the two ribbon cables of the Trailing Cables and remove the Ferrite Core.

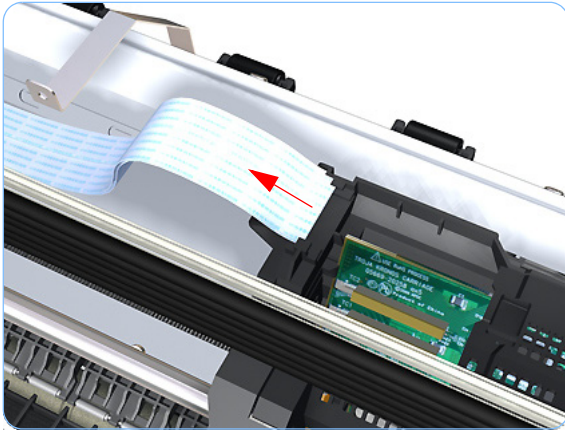

13. Slide the Trailing Cables out of the attachment clips of the Carriage Assembly.

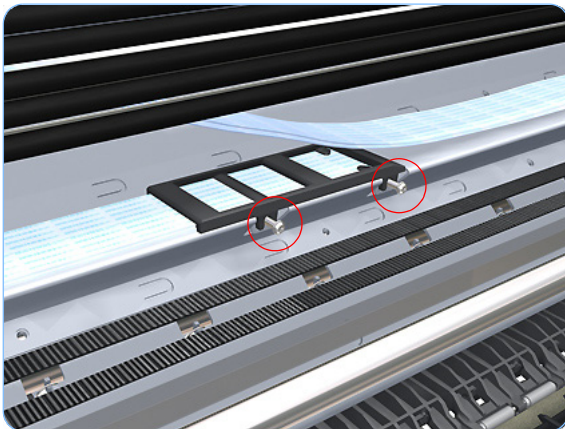

14. Use a short torx screwdriver to remove the two T-10 screws that secure the center attachment of the Trailing Cables.

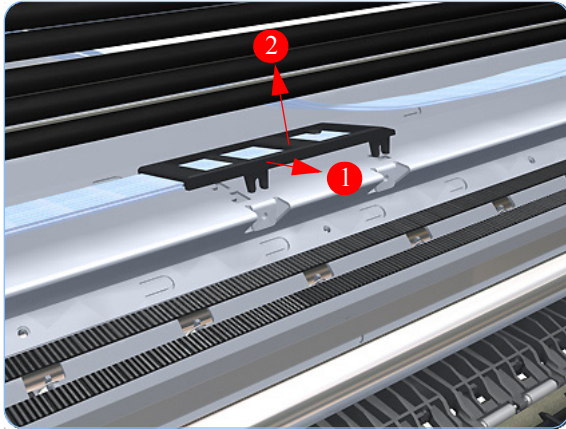

15. Unclip the center attachment of the Trailing Cables.

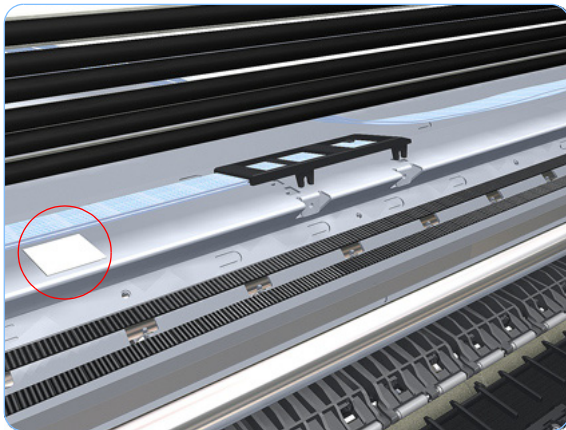

16. Remove the Trailing Cables from the double sided adhesive pad that attaches it to the printer.

Some printers have clips instead of adhesive pads that attach the Trailing Cables to the printer. In this case, unclip the Trailing Cables from the printer.

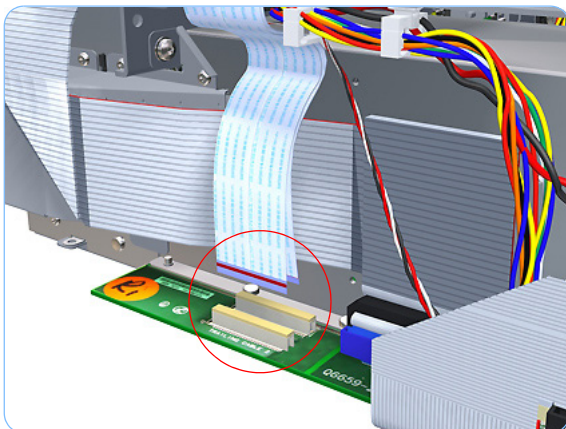

17. Disconnect the two ribbon cables of the Trailing Cables from the Electronics Module.

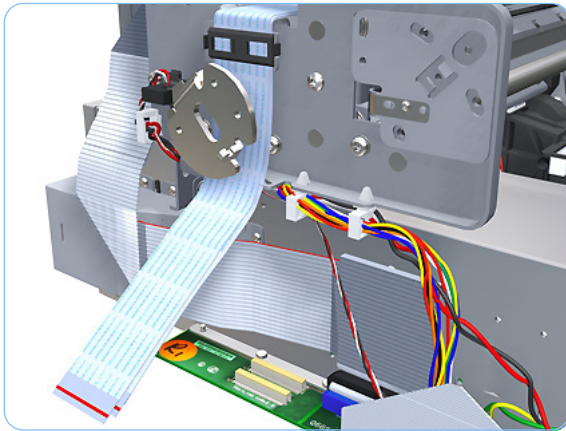

18. Unroute the Trailing Cables.

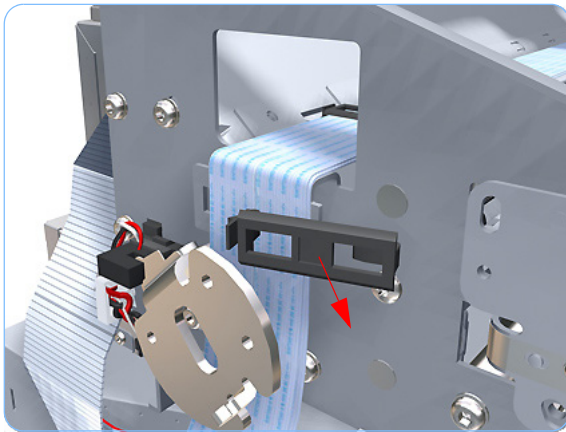

19. Unclip and remove the cable clamp of the Trailing Cables.

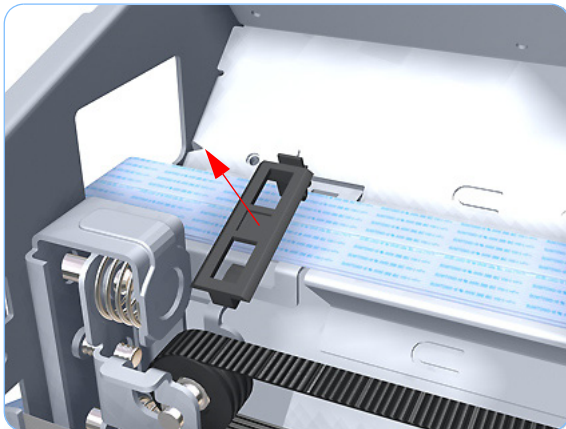

20. Unclip and remove the cable clamp of the Trailing Cables.

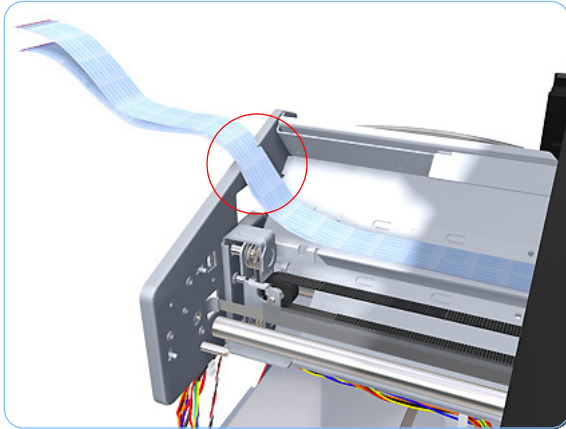

21. Unroute the Trailing Cables.

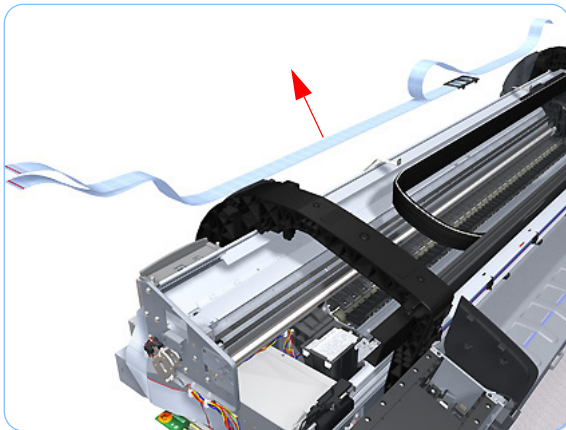

22. Remove the Trailing Cables from the printer.

Installation

Make sure to install the new Carriage PCA Cover when you reinstall the Trailing Cable.

Some printers have clips instead of adhesive pads that attach the Trailing Cables to the printer. Use the adhesive pads or clips that are included in the Trailing Cable service kit, replacing the clips or adhesive pads as necessary.

When you finish installing or replacing this component, you must perform the necessary Service Calibrations. To find which calibrations you must perform, Refer to page 6-8, *Service Calibration Guide to Removal and Installation*.

Make sure you carry out the following actions during the installation of the Trailing Cable

1. Use an alcohol (from the Lubrification Kit or Tool Kit) dampened cloth to remove all traces of residual adhesive (remaining from the double sided pads removed in step 16) from the printer before applying new pads in the same positions as the original pads.

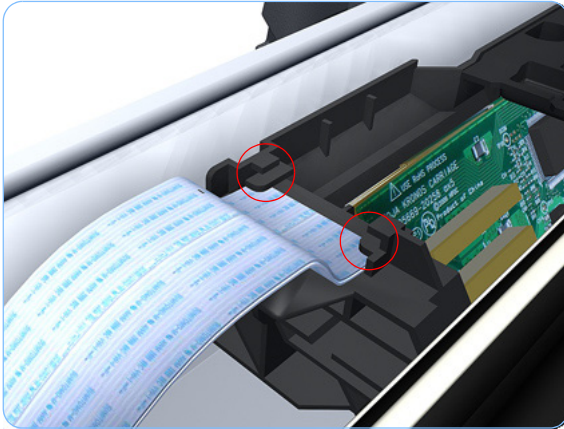

2. Make sure both ribbon cables of the Trailing Cable are routed below the lower attachment clips of the Carriage Assembly.

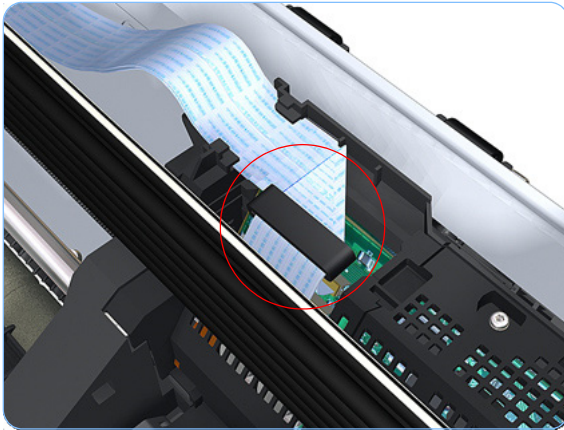

3. Make sure that the Ferrite Core is correctly positioned so that the small cover of the Carriage PCA closes correctly to avoid possible friction damage to the Trailing Cable during operation of the printer.

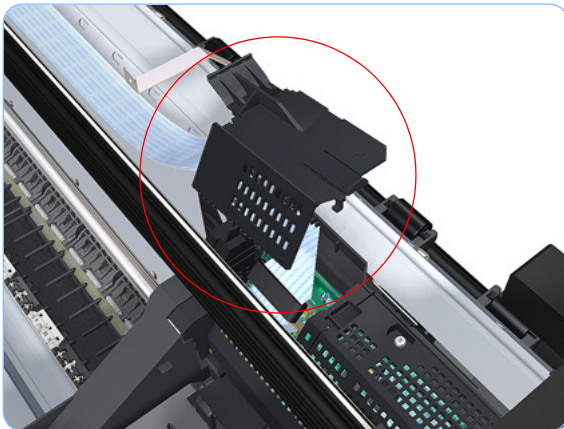

4. When you replace the Carriage PCA Cover, use the new part included in the Carriage PCA service kit.



5. Make sure that the Carriage PCA Cover is closed correctly to avoid damage to the Trailing Cable.

Carriage Assembly and Trailing Cable

Removal

Switch off the printer and remove the power cable.

1. Remove the Front Cover (refer to page 6-17).
2. Remove the Right Cover (refer to page 6-27).
3. Remove the Left Cover (refer to page 6-30).
4. Remove the Cutter Assembly (refer to page 6-43).
5. Remove the Front Panel (refer to page 6-48).
6. Remove the Top Cover (refer to page 6-51).
7. Remove the Window Position Sensor (refer to page 6-54).
8. Remove the Ink Supply Tubes Support Rail (refer to page 6-56).
9. Loosen the T-10 uncapping screw to manually uncap the Service Station before removing the Encoder Strip (with spring and attachment nut) (refer to page 6-84).
10. Remove the Encoder Strip (with spring and attachment nut) (refer to page 6-84).
11. If necessary manually move the Carriage Assembly fully right into the docking station.
12. Use a short torx screwdriver to remove the two T-10 screws that secure the center attachment of the Trailing Cables.

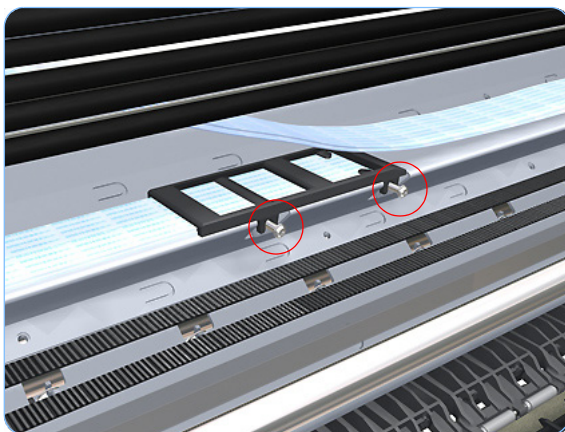
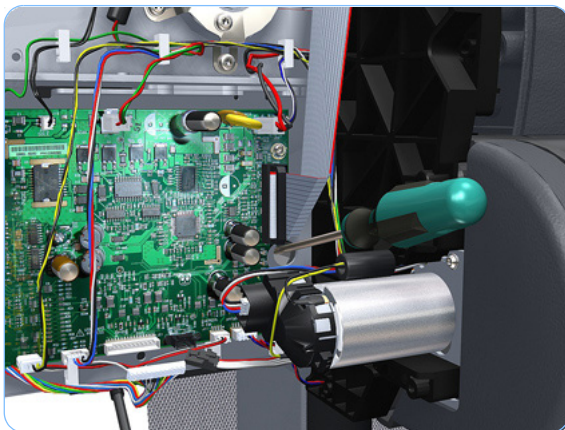

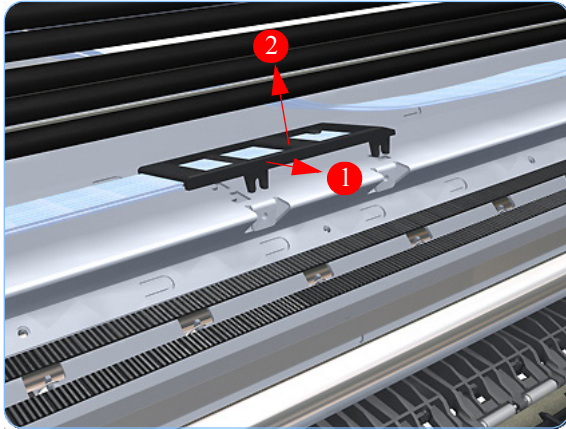

13. Unclip the center attachment of the Trailing Cables.

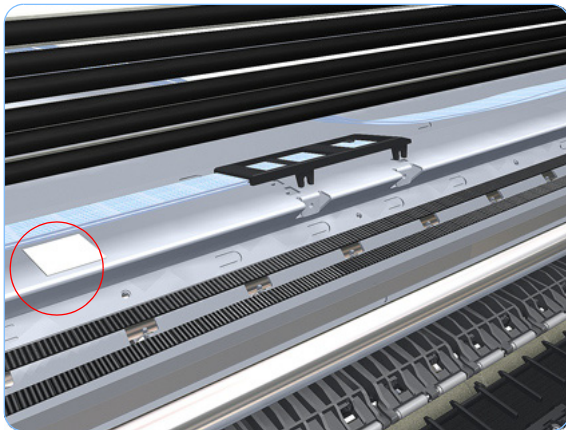

14. Remove the Trailing Cables from the two double sided adhesive pads that attach it to the printer.

Some printers have clips instead of adhesive pads that attach the Trailing Cables to the printer. In this case, unclip the Trailing Cables from the printer.

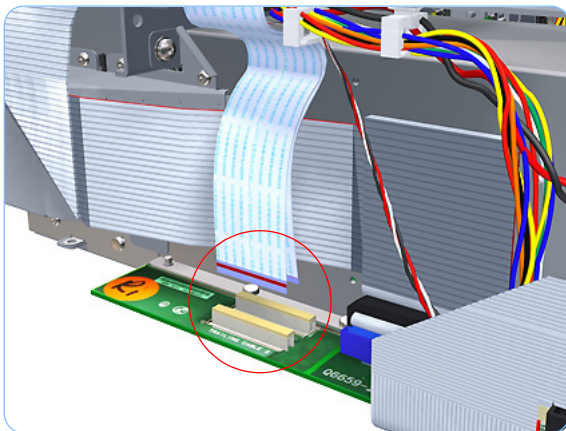

15. Disconnect the two ribbon cables of the Trailing Cables from the Electronics Module.

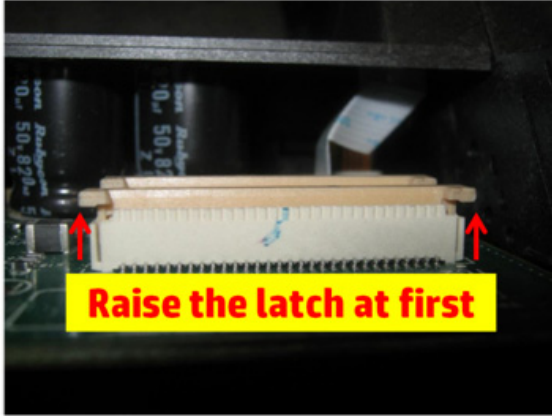

- 16.** Release the two latches securing the two ribbon cables before you pull the cables out from the connector.

The plastic colored part shown here is the latch of the connector. Whenever these ribbons are removed or installed these latches must be released/closed.

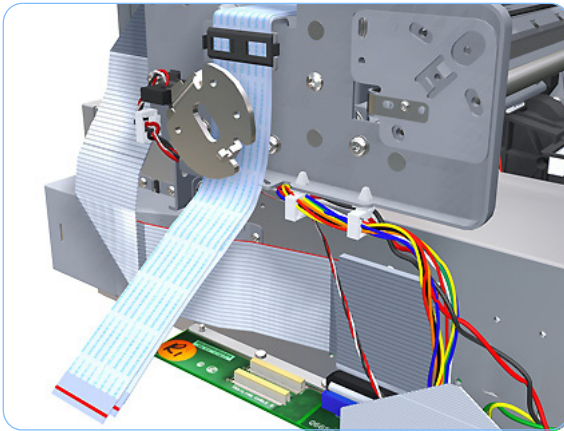

- 17.** Unroute the Trailing Cables.

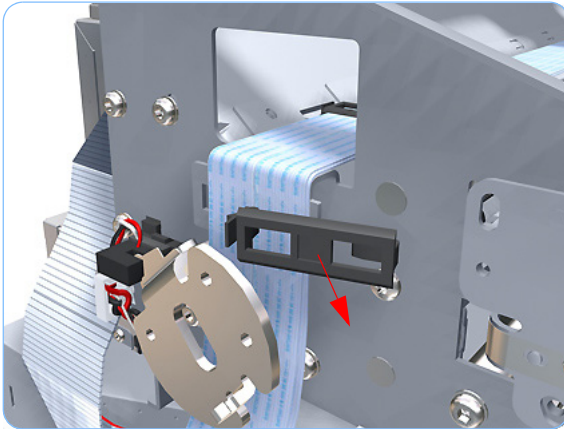

- 18.** Unclip and remove the cable clamp of the Trailing Cables.

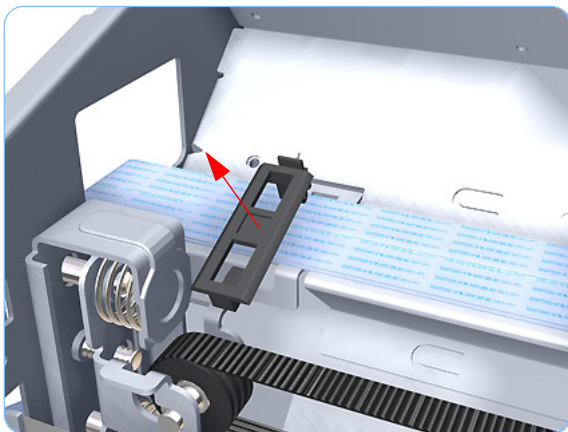

19. Unclip and remove the cable clamp of the Trailing Cables.

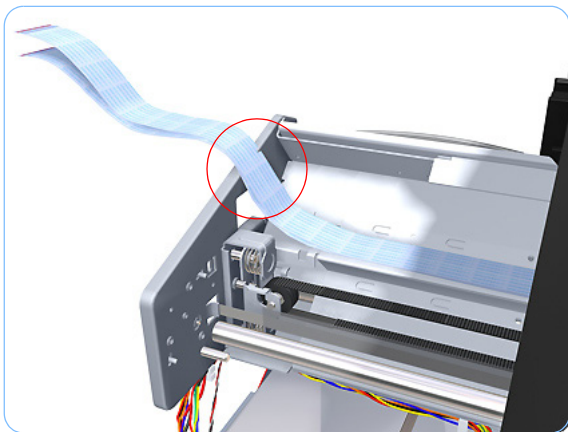

20. Unroute the Trailing Cables.

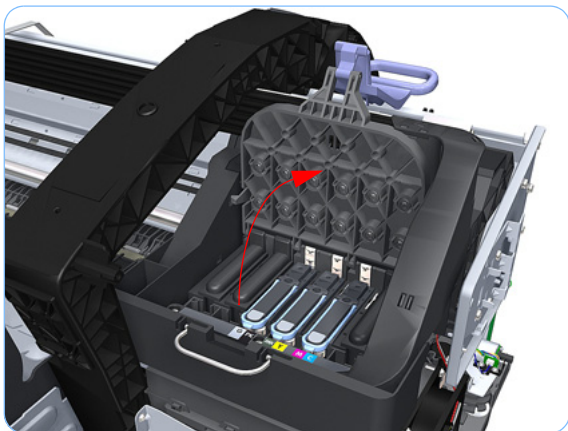

21. Open the Carriage Cover. The illustration shows the Z2100 which has four Printheads. For the Z3100, there are six Printheads.

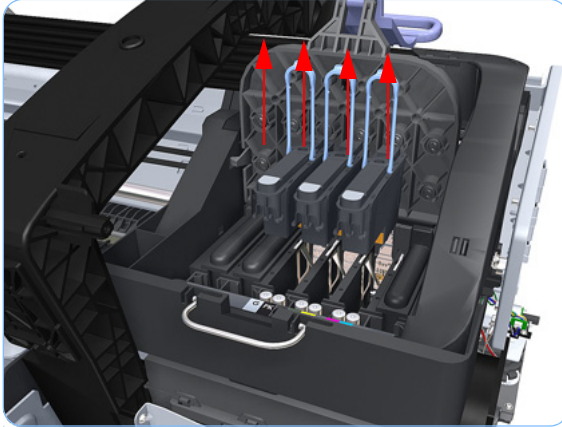

22. Remove all the Printheads.

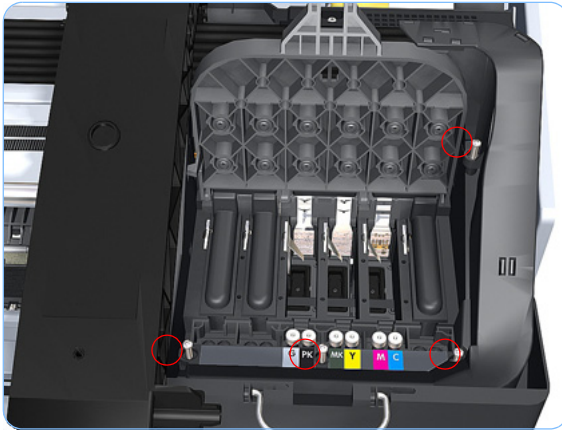

23. Remove the four T-15 screws that secure the Ink Supply Tubes to the Carriage Assembly.

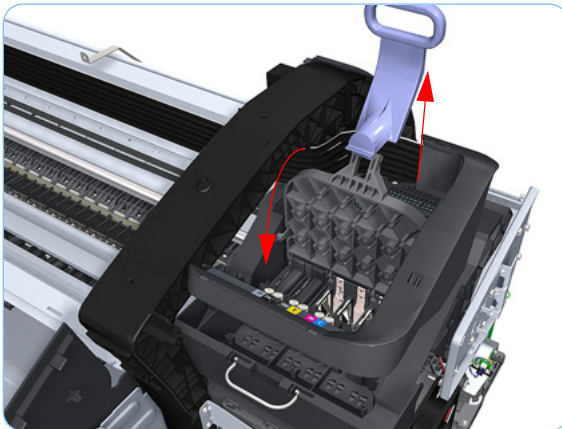

24. Carefully lift out the Ink Supply Tubes and close the carriage cover at the same time.

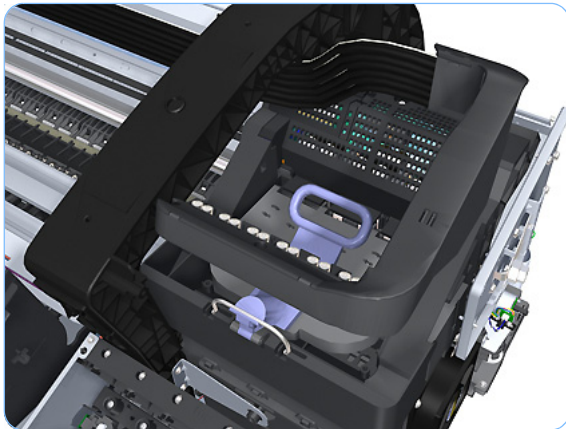

25. Close and lock the Carriage Cover.

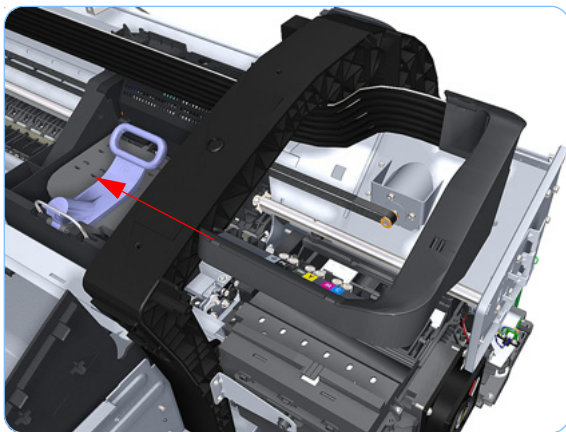

26. Push the Carriage Assembly into the print path.

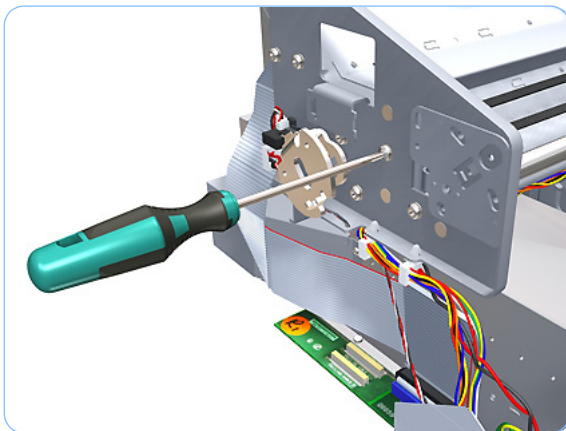

27. Loosen the T-15 screw Belt Tensioner to the printer to remove the tension from the belt.

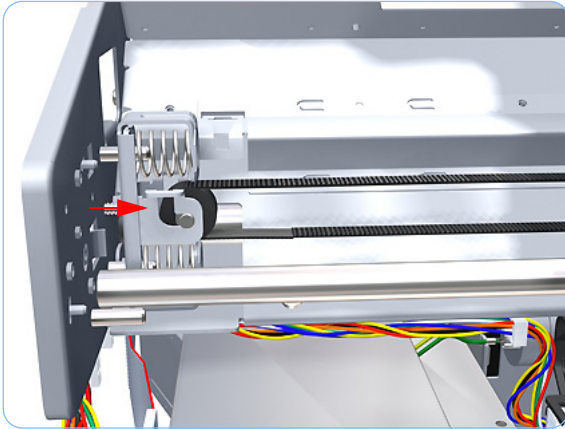

28. Leave the Belt Tensioner in place with all the tension removed.

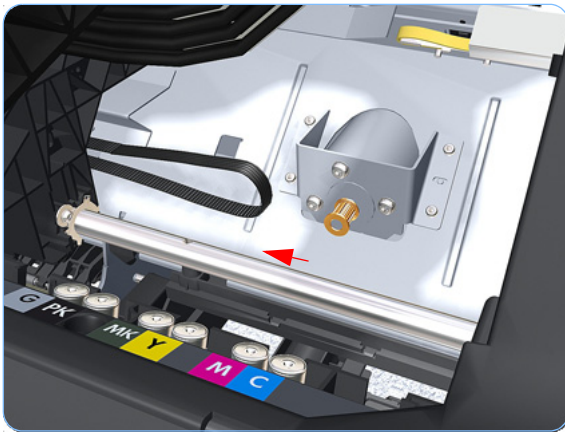

29. Remove the Belt Assembly from the Scan-Axis Motor drive wheel.

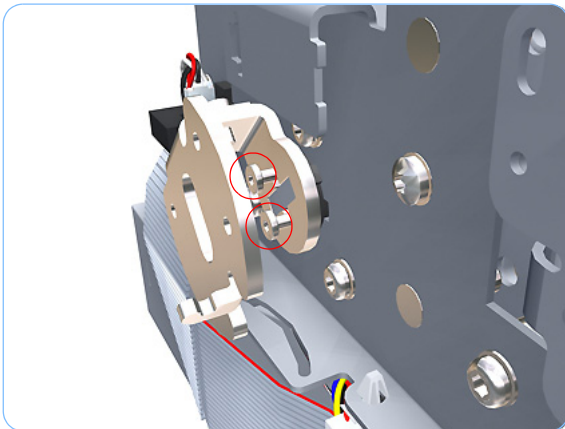

30. Remove the two T-15 screw that secure the Media Lever attachment plate.

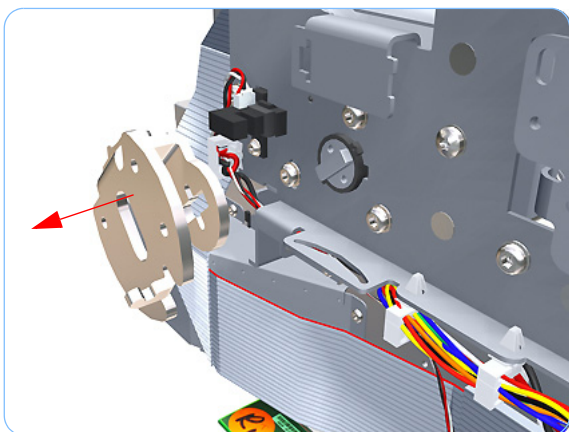

31. Remove the Media Lever attachment plate.

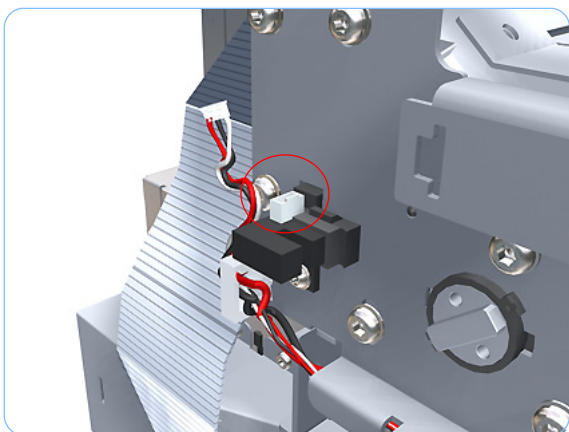

32. Disconnect the Pinchwheel Lifter Sensor.

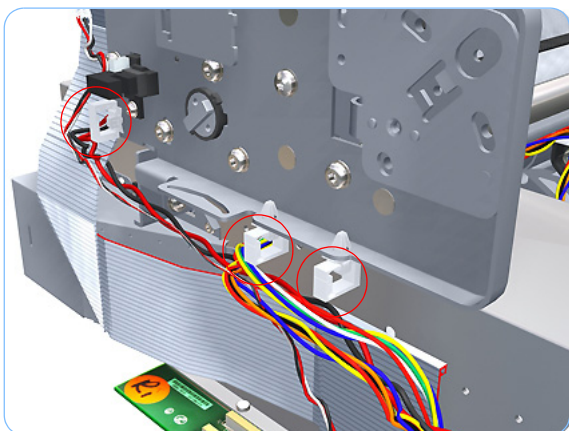

33. Unroute the cables from the cable clamps on the Scan Side Panel.

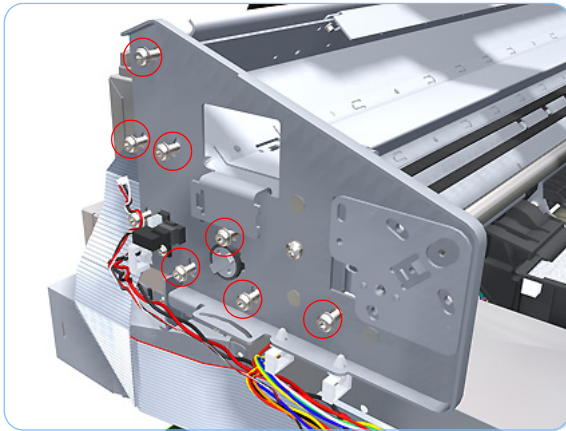

34. Remove the seven T-15 screw that secure the Scan Side Panel to the printer.

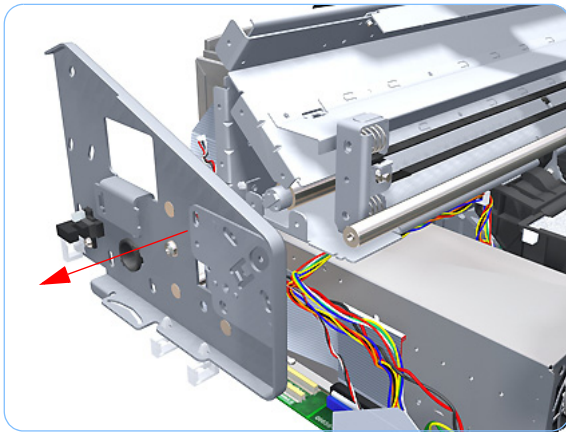

35. Remove the Scan Side Panel.

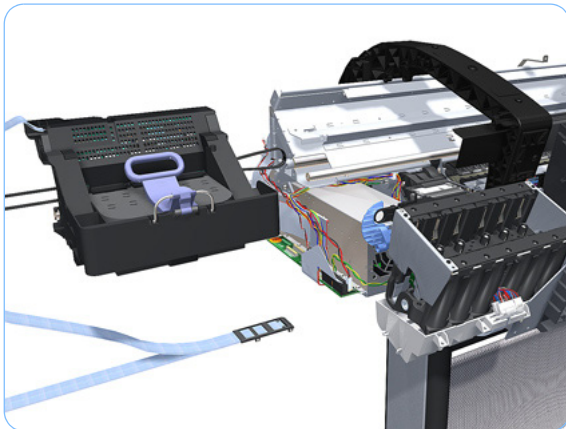

36. Carefully slide the Carriage Assembly, Belt Assembly and Trailing Cable out of the printer.

Installation

Before you reinstall the Carriage Assembly use an alcohol dampened cloth to remove all traces of residual adhesive (remaining from the double sided pads removed in step 14) from the printer before applying new pads or clips in the same positions as the original pads.

When reinstalling the Carriage Assembly, take caution not to damage the PRS Slider.

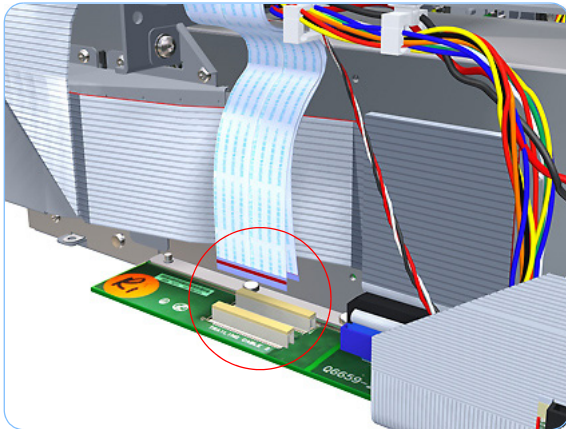

1. When reinstalling the ribbon cables of the trailing cable, please raise up the connector latch first, then reinsert the cable and lower the latch down.

2. Make sure that the cable is completely inserted by checking that the verification line is flat.

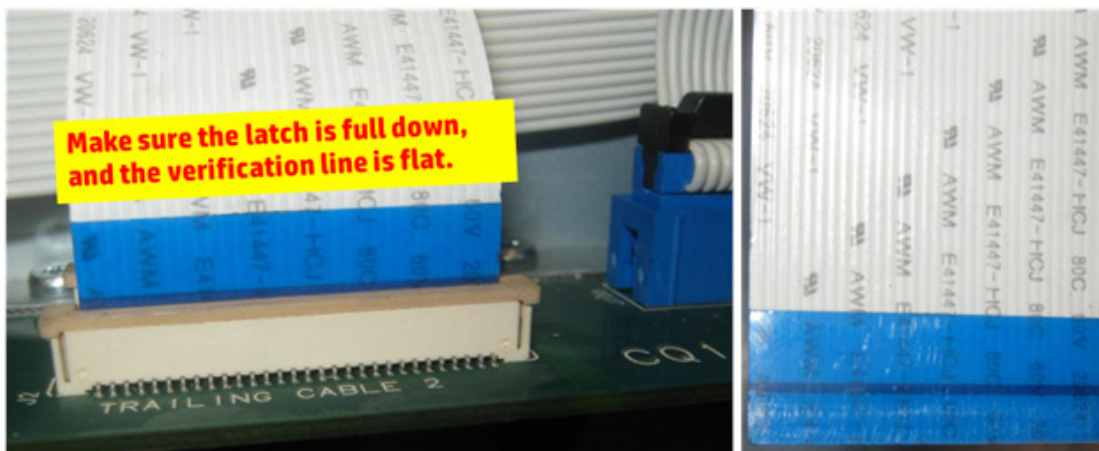

3. When reinstalling the Scan side panel, make sure that there is no gap between the carriage rod and the side panel.

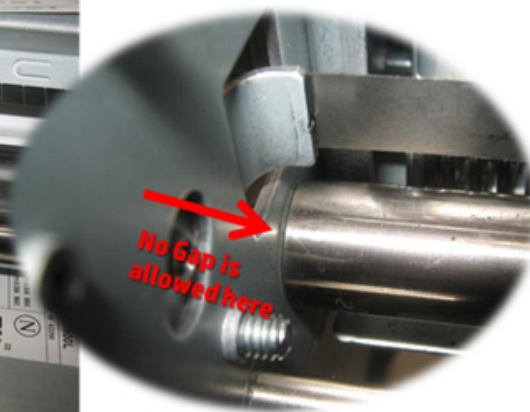
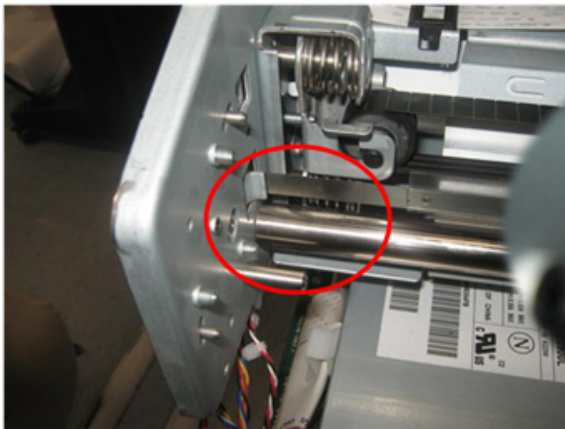
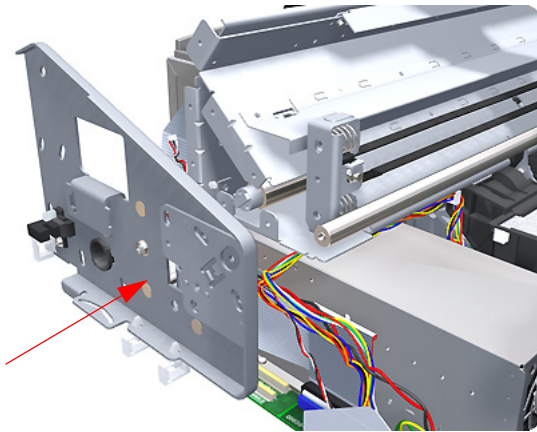

4. After reinstalling the carriage, check if the belt is correctly attached to the motor and correctly routed through the carriage bottom clip.

When you have finished replacing this component, you must perform the necessary Service Calibrations. To find which calibrations you must perform, Refer to page 6-8, *Service Calibration Guide to Removal and Installation*.

Extra High PRS Wedge

Replacement

Switch off the printer and remove the power cable.

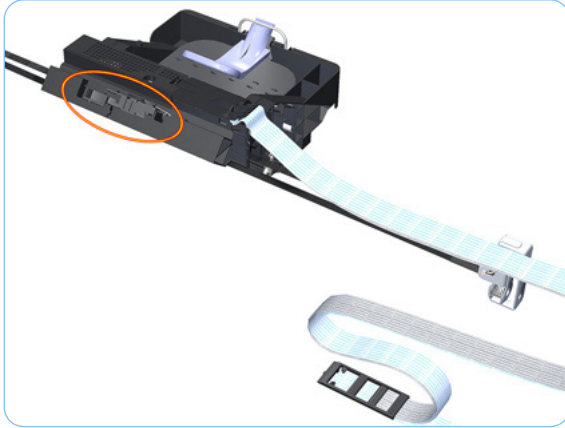

1. Remove the Carriage Assembly and Trailing Cable from the unit using the procedures documented (Refer to page 5-100).

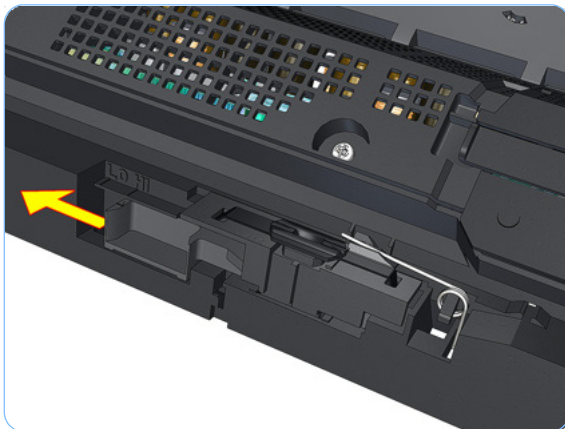

2. Slide the 2 Levels Wedge to the left position.

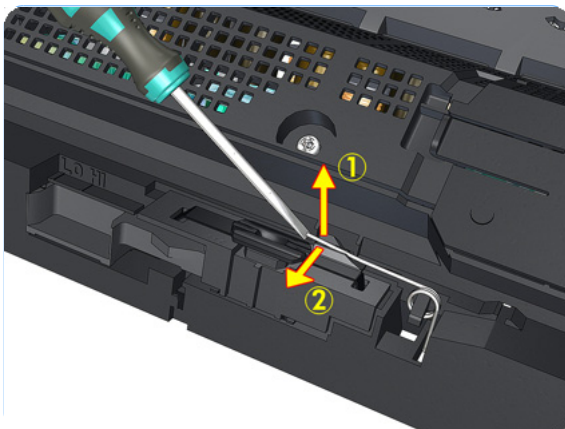

3. Lift the top of the PRS Tension Spring and pull it away from the Carriage to release the tension.

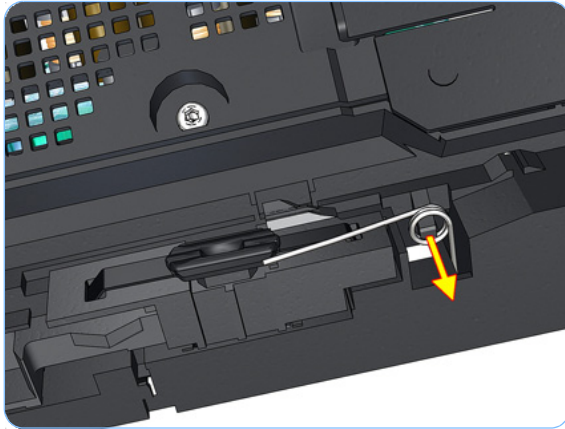

4. Slide the center of the PRS Tension Spring from the post.

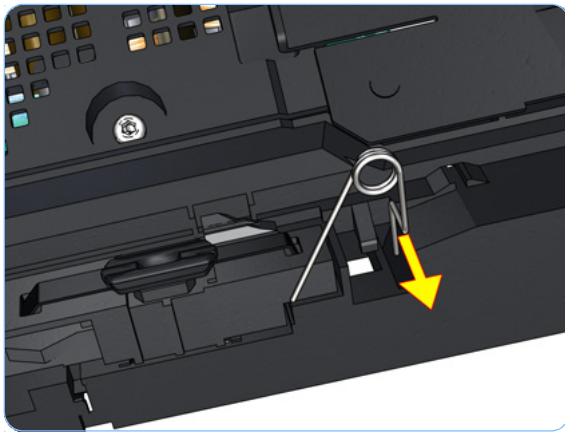

5. Remove the PRS Tension Spring from the Carriage.

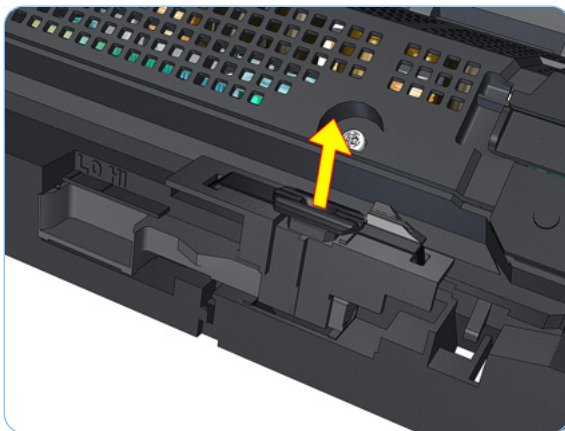

6. Remove the Slider Bushing Guide from the Carriage.

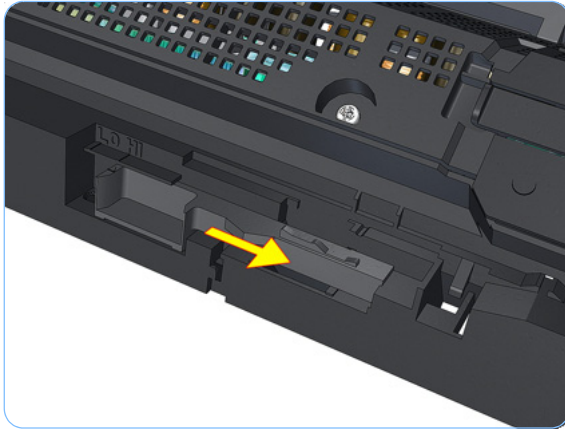

7. Slide the 2 Levels Wedge to the right position.

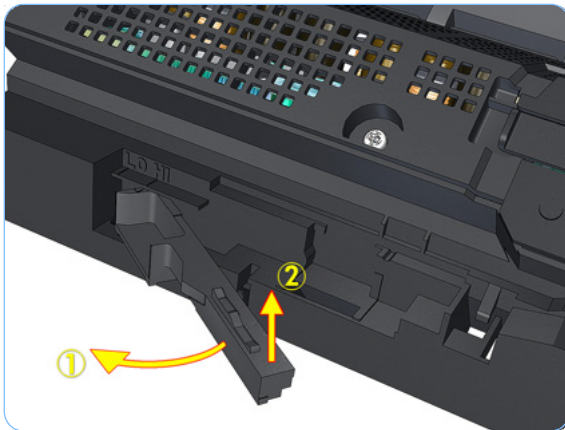

8. Rotate the 2 Levels Wedge and remove it from the carriage.

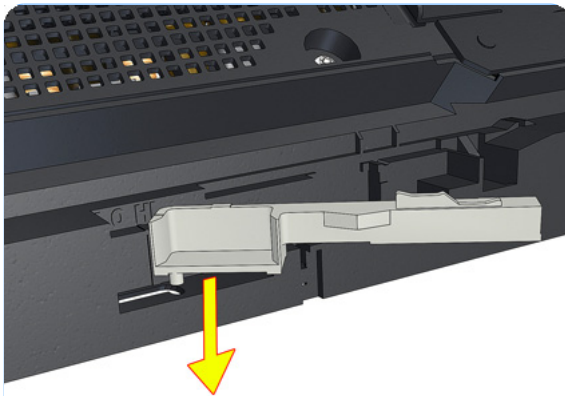

9. Install the new 2 Levels Wedge, taking care to fit it properly to the carriage.

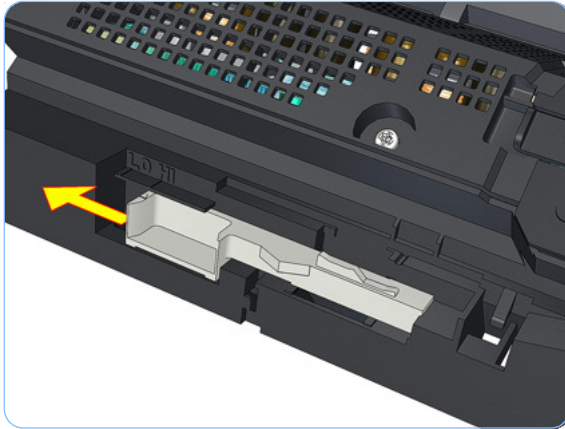

10. Slide the new 2 Levels Wedge to the left position.

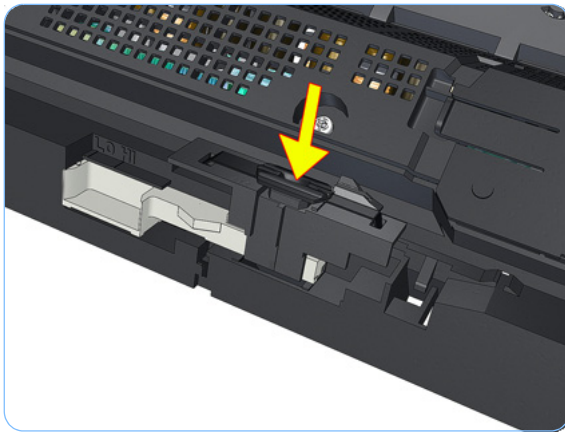

11. Reinstall the outside Slider Bushing Guide.



12. Replace the PRS Torsion Spring, taking care that it holds the Slider Bushing Guide properly.

13. Reinstall the Carriage Assembly and Trailing Cable, (Refer to page 5-100).

When you finish installing or replacing this component, you must perform the necessary Service Calibrations for the Carriage Assembly. To find which calibrations you must perform, Refer to page 6-8, *Service Calibration Guide to Removal and Installation*.

The Extra High PRS Wedge service part includes extra PRS Torsion Springs (Q5669-00269), Slider Bushing Guides (Q5669-40502) and 2 Level Wedges (C7769-40065) in case these parts are damaged during installation.

Carriage Rear Bushing

Removal

Switch off the printer and remove the power cable.

1. Remove the Front Cover (refer to page 6-17).
2. Remove the Right Cover (refer to page 6-27).
3. Remove the Left Cover (refer to page 6-30).
4. Remove the Cutter Assembly (refer to page 6-43).
5. Remove the Front Panel (refer to page 6-48).
6. Remove the Top Cover (refer to page 6-51).
7. Remove the Window Position Sensor (refer to page 6-54).
8. Remove the Ink Supply Tubes Support Rail (refer to page 6-56).
9. Remove the Encoder Strip (with spring and attachment nut) (refer to page 6-84).
10. Remove the Carriage Assembly and Trailing Cable (refer to page 6-100).
11. Squeeze the left hand clip of the Carriage Rear Bushing sufficiently to be able to release it from the Carriage Assembly.

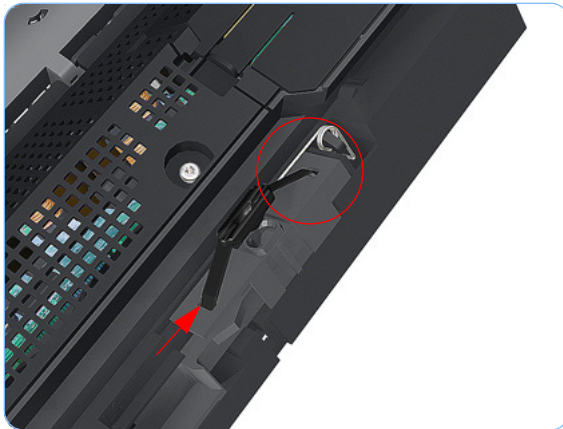

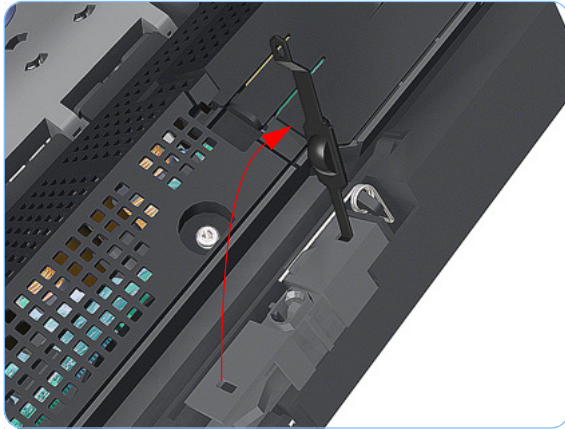

12. Rotate the Carriage Rear Bushing vertically and remove it from the Carriage Assembly.



When you reinstall the Carriage Rear Bushing, use the Oil and Oil Dispenser from the Lubrification Kit to add 2-3 drops of oil to the small depression in it.

When you finish installing or replacing this component, you must perform the necessary Service Calibrations. To find which calibrations you must perform, Refer to page 6-8, *Service Calibration Guide to Removal and Installation*.

Belt Assembly

Removal

Switch off the printer and remove the power cable.

1. Remove the Carriage Assembly and Trailing Cable (refer to page 6-100).
2. Slide the Belt Assembly out of the attachment on the Carriage Assembly.

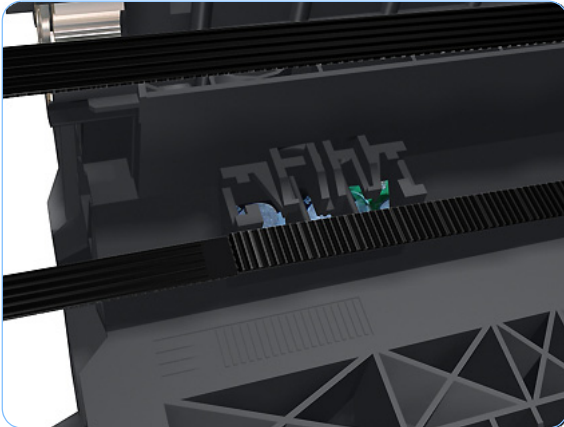

3. Remove the pulley to release the Belt Assembly from the Belt Tensioner.

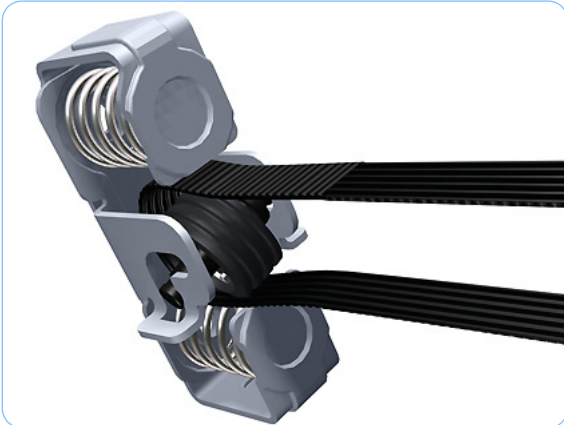

When you finish installing or replacing this component, you must perform the necessary Service Calibrations. To find which calibrations you must perform, Refer to page 6-8, *Service Calibration Guide to Removal and Installation*.

Scan-Axis Motor

Removal

Switch off the printer and remove the power cable.

1. Remove the Right Cover (refer to page 6-27).
2. Remove the Left Cover (refer to page 6-30).
3. Loosen the T-10 uncapping screw sufficiently so you can manually move the Carriage Assembly in step 4.

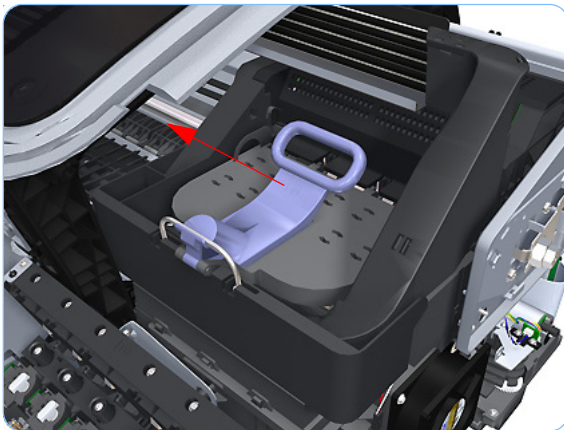
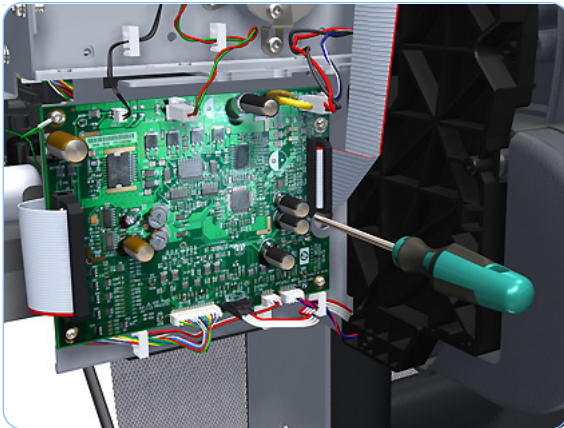

4. Push the Carriage Assembly into the print path.

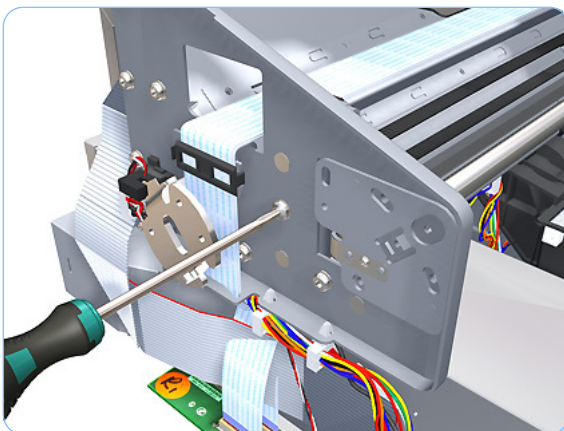

5. Loosen the T-15 screw Belt Tensioner to the printer to remove the tension from the belt.

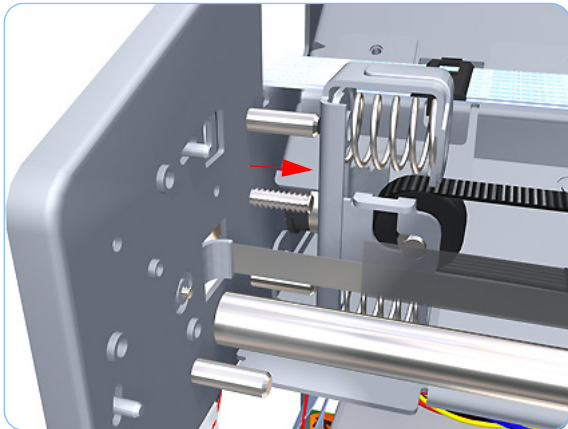

6. Leave the Belt Tensioner in place.

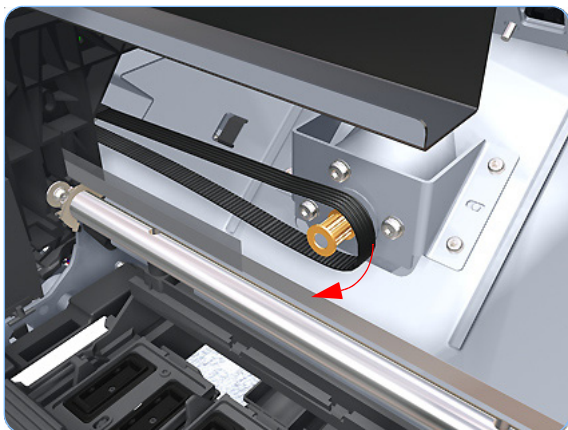

7. Remove the Belt Assembly from the drive wheel of the Scan-Axis Motor.



8. Remove three T-15 screws that secure the Scan-Axis Motor to the printer.

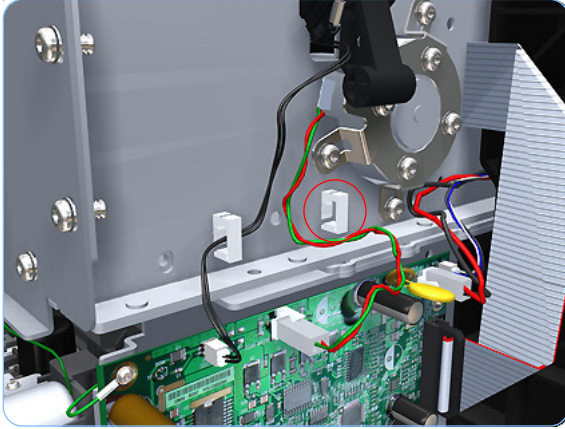

- 9.** Unroute the Scan-Axis Motor supply cable from the cable clamp.

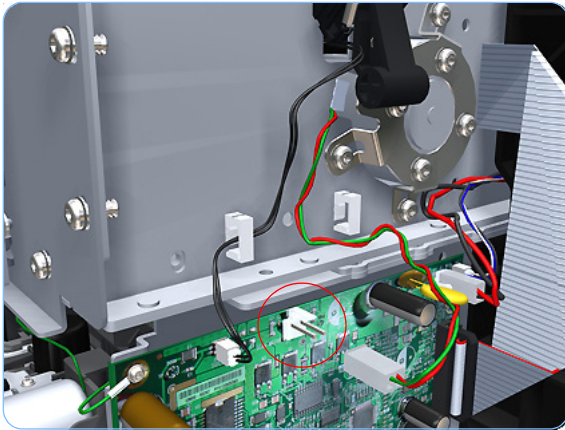

- 10.** Disconnect the Scan-Axis Motor supply connector from PrintMech PCA.

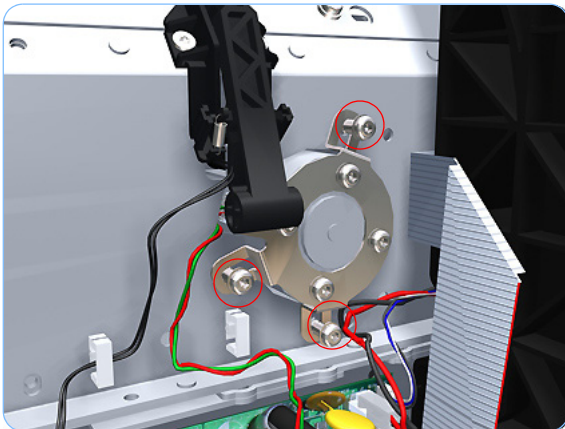

- 11.** Remove three T-15 screws that secure the Scan-Axis Motor to the printer.

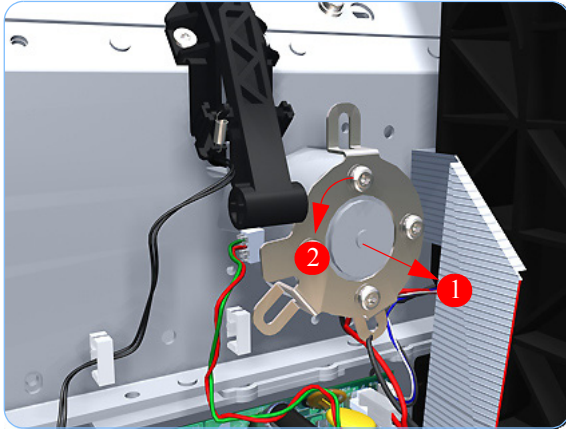

12. Carefully pull the Scan-Axis Motor out of the printer (10 mm) until you can rotate it approximately 30 degrees counterclockwise.

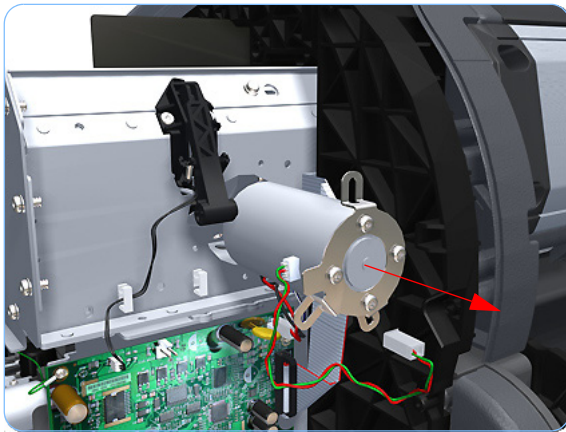

13. Remove the Scan-Axis Motor from the printer.

When you finish installing or replacing this component, you must perform the necessary Service Calibrations. To find which calibrations you must perform, Refer to page 6-8, *Service Calibration Guide to Removal and Installation*.

Carriage Rail Oiler

Removal

Switch off the printer and remove the power cable.

1. Remove the Right Cover (refer to page 6-27).
2. Remove the T-15 Carriage Rail Oiler attachment screw.

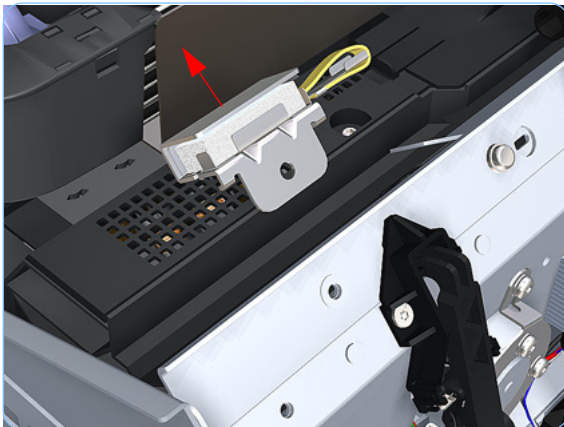

3. Remove the Carriage Rail Oiler from the printer.

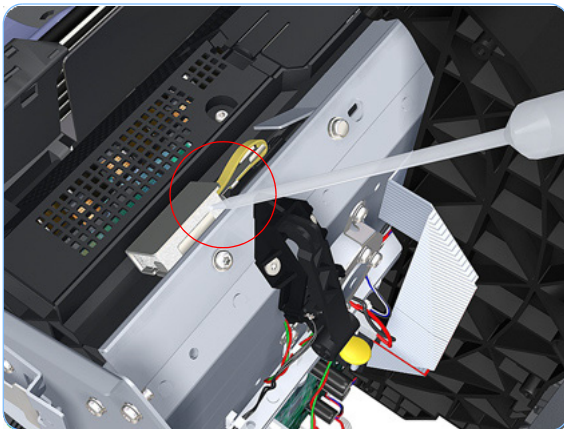

When you reinstall the Carriage Rail Oiler, use the Oil and Oil Dispenser from the Lubrication Kit to add 2-3 drops of oil to the foam of the Carriage Rail Oiler and in the small depression of the Carriage Rear Bushing.

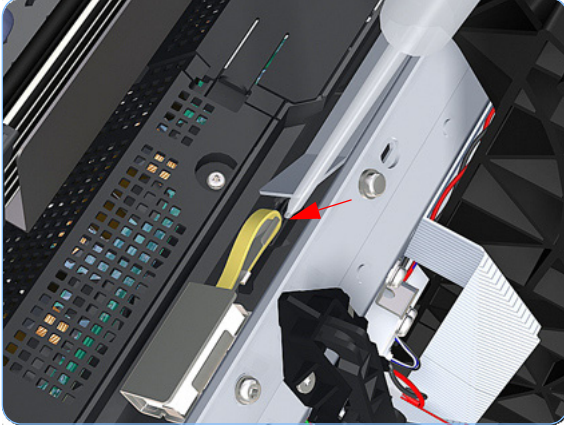

4. Add 2 or 3 drops of oil in the depression where the Slider fits.

Color Sensor ESP (spectrophotometer)

Removal

Switch off the printer and remove the power cable.

1. Remove the Right Cover (refer to page 6-27).
2. Remove the Left Cover (refer to page 6-30).
3. Remove the Front Panel (refer to page 6-48).
4. Remove the Top Cover (refer to page 6-51).
5. Remove the Window Position Sensor (refer to page 6-54).
6. Remove the Ink Supply Tubes Support Rail (refer to page 6-56).
7. Open the Carriage Cover.
The illustration shows the Z2100 which only has four Printheads, for the Z3100 there are six Printheads.

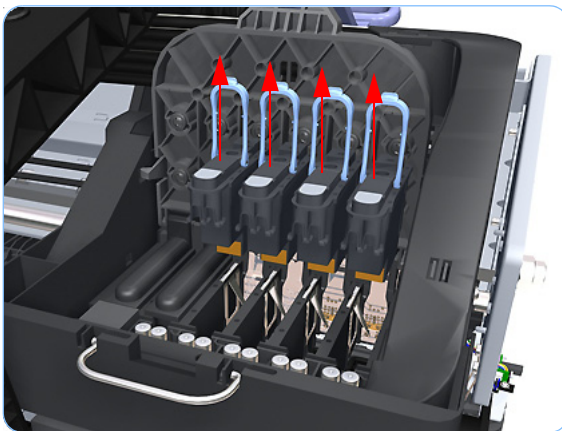
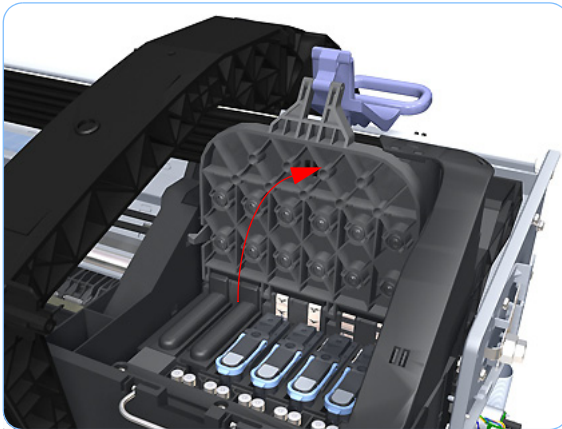

8. Remove all the Printheads.



9. Remove the four T-15 screws that secure the Ink Supply Tubes to the Carriage Assembly.

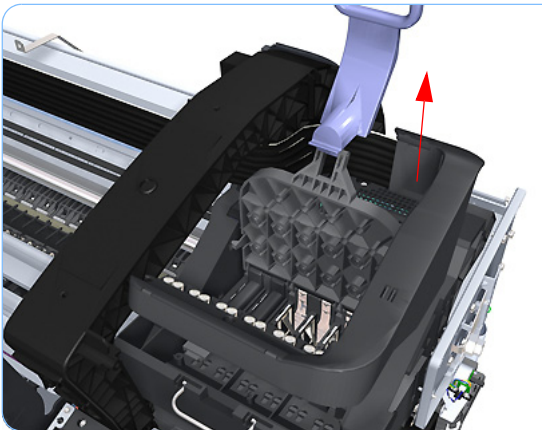

10. Carefully lift out the Ink Supply Tubes and close the carriage cover at the same time.

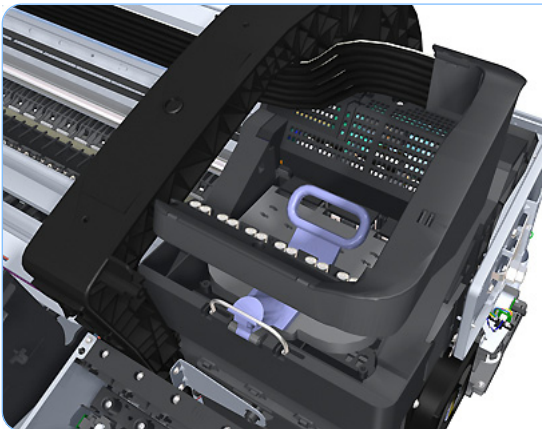

11. Close and lock the Carriage Cover.

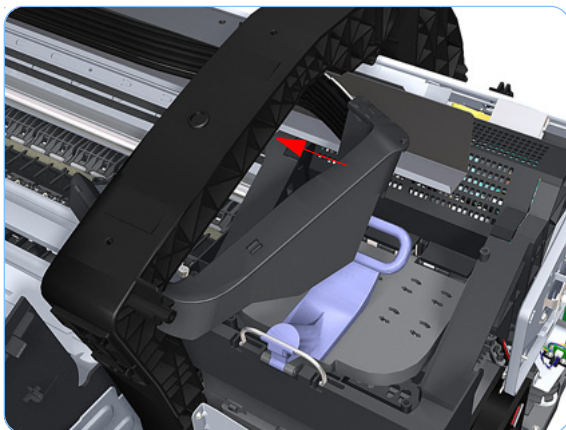

12. Carefully move the Ink Supply Tubes into the print path.



13. Unclip and slide off the small cover of the Carriage Assembly Carriage PCA.



14. Remove one T-15 screws that secures the large cover of the Carriage PCA.

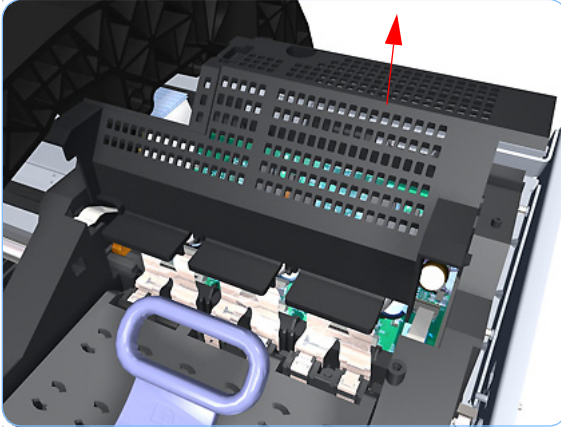

15. Remove the large cover of the Carriage PCA.

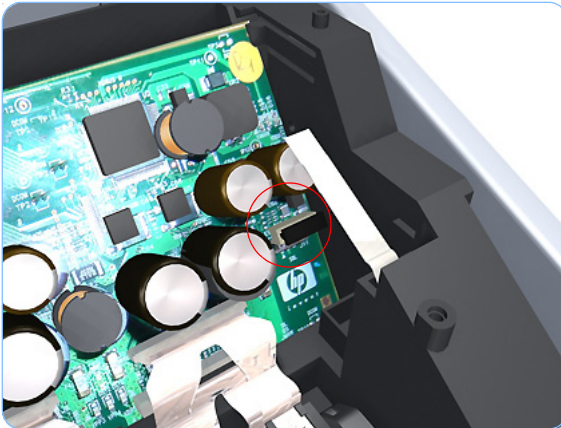

16. Disconnect the Color Sensor ESP (spectrophotometer) electrical connection from the Carriage PCA.

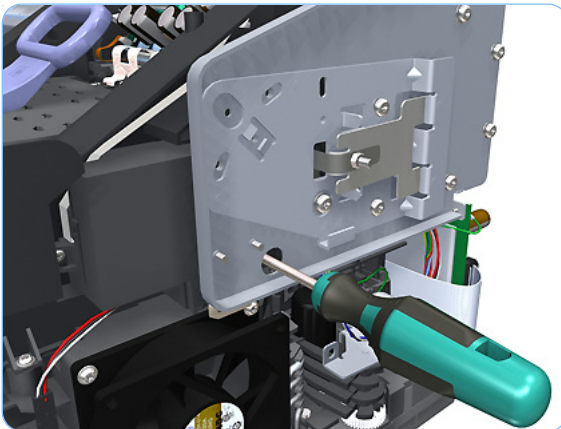

17. Remove one T-10 screw that secures the Color Sensor ESP (spectrophotometer) to the Carriage Assembly.

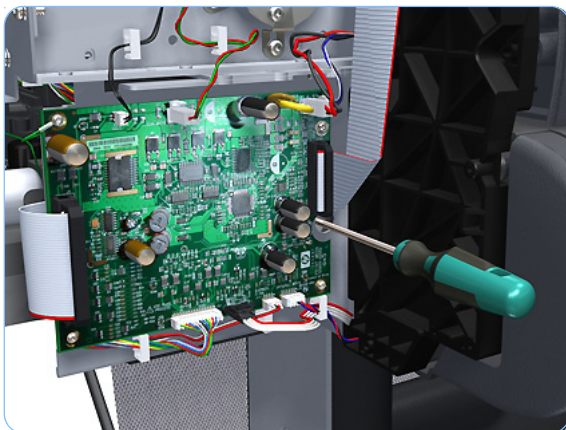

- 18.** Loosen the T-10 uncapping screw sufficiently so you can manually move the Carriage Assembly in step 26.

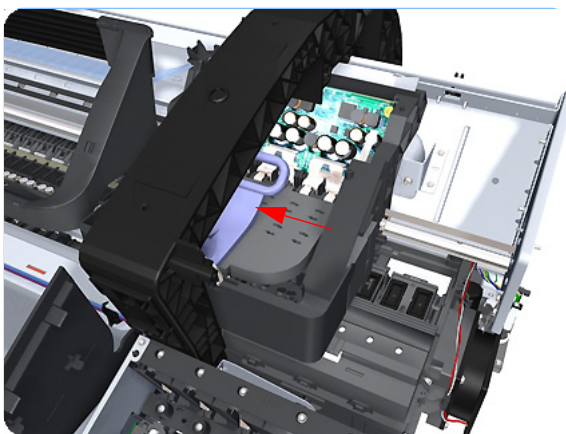

- 19.** Push the Carriage Assembly into the print path enough to allow access to the Color Sensor ESP (spectrophotometer).

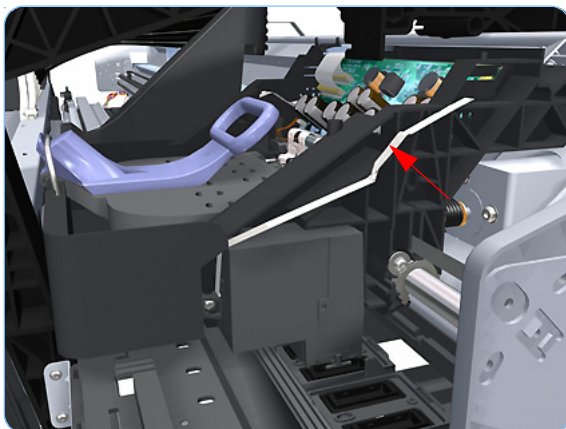

- 20.** Carefully unroute the Color Sensor ESP (spectrophotometer) cable from the Carriage Assembly.

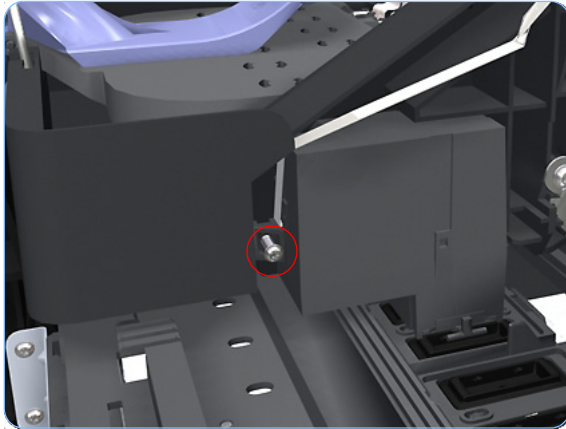

- 21.** Remove one T-10 screw that secures the Color Sensor ESP (spectrophotometer) to the Carriage Assembly.

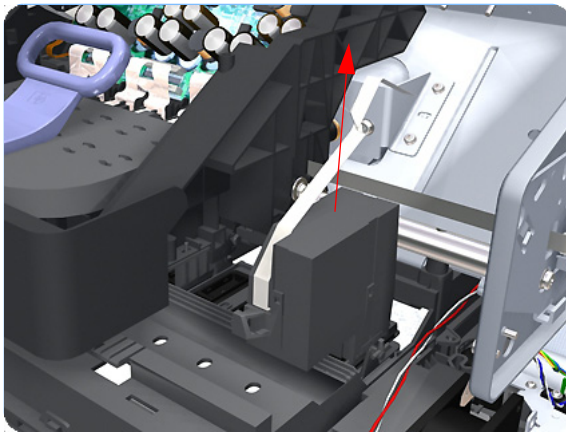

- 22.** Remove the Color Sensor ESP (spectrophotometer) from Carriage Assembly.

When you reinstall the Color Sensor ESP (spectrophotometer), be very careful not to overtighten the attachment screw because this can cause irreparable damage to it.

Take care when you route the Color Sensor ESP (spectrophotometer) cable so it lays flat and is not twisted. This ensures that when you reconnect it to the connector in the Carriage Assembly it is connected correctly. If the cable has been twisted during

Line Sensor

Removal

Switch off the printer and remove the power cable.

1. Remove the Right Cover (refer to page 6-27).
2. Remove the Left Cover (refer to page 6-30).
3. Remove the Front Panel (refer to page 6-48).
4. Remove the Top Cover (refer to page 6-51).
5. Remove the Window Position Sensor (refer to page 6-54).
6. Remove the Ink Supply Tubes Support Rail (refer to page 6-56).
7. Open the Carriage Cover.
The illustration shows the Z2100 which only has four Printheads, for the Z3100 there are six Printheads.

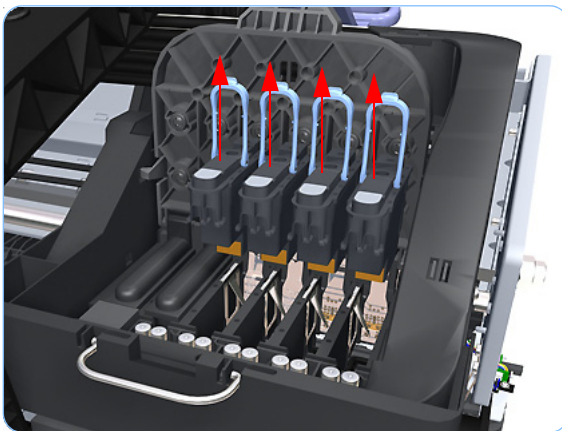
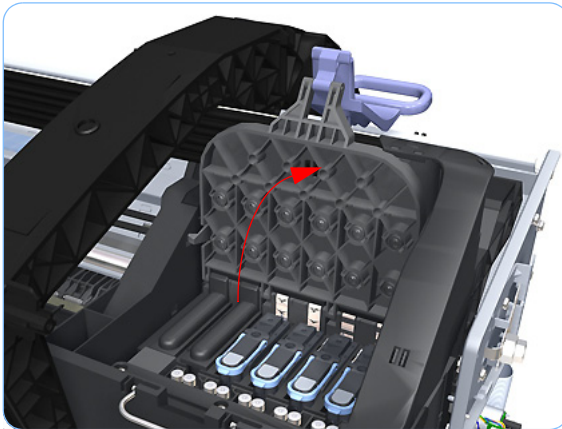

8. Remove all the Printheads.



9. Remove the four T-15 screws that secure the Ink Supply Tubes to the Carriage Assembly.

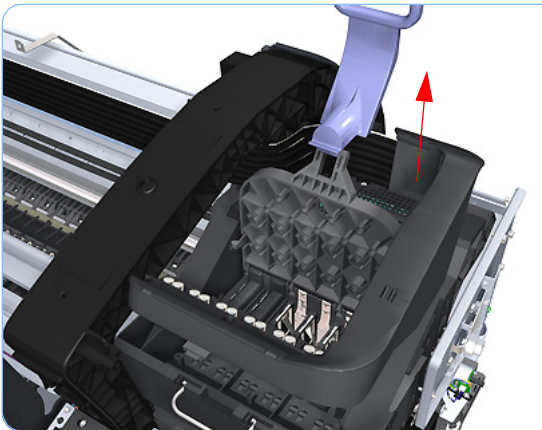

10. Carefully lift out the Ink Supply Tubes and close the carriage cover at the same time.

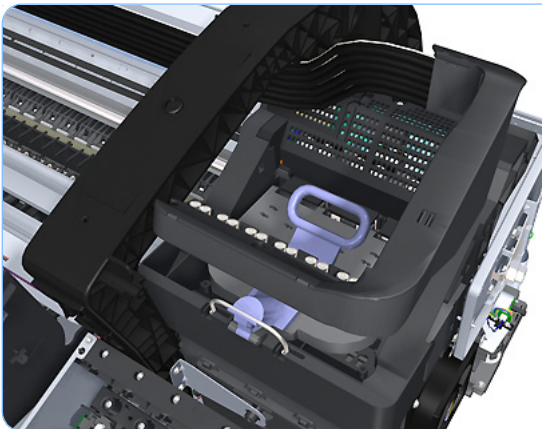

11. Close and lock the Carriage Cover.

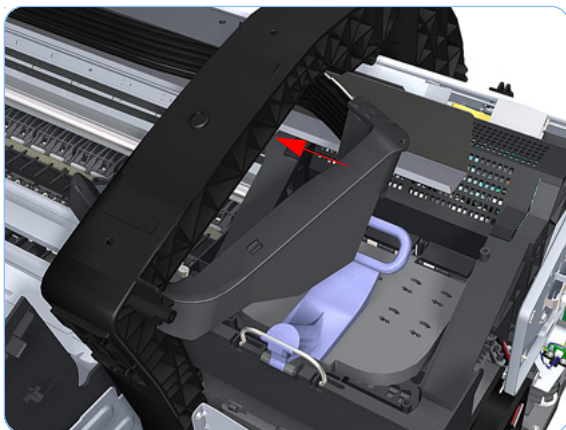

12. Carefully move the Ink Supply Tubes into the print path.

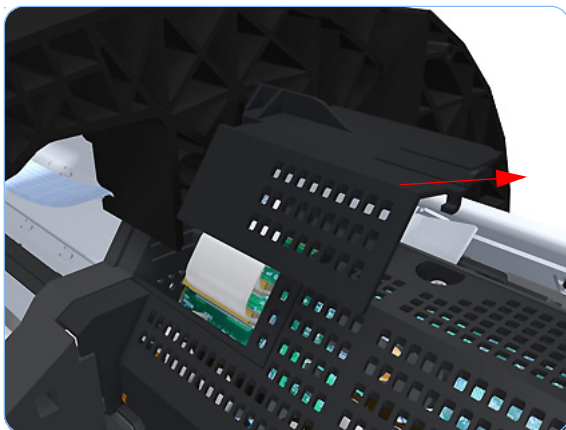

13. Unclip and slide off the small cover of the Carriage Assembly Carriage PCA.

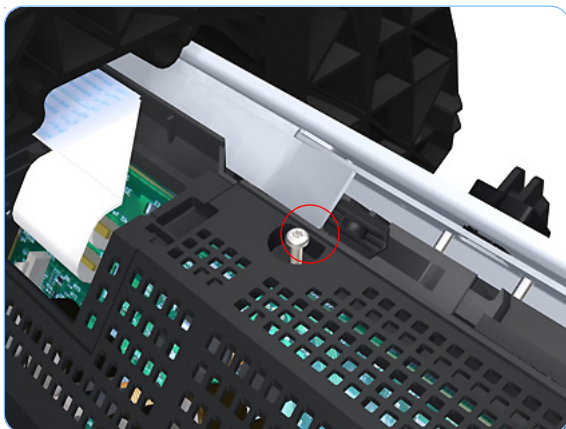

14. Remove one T-15 screws that secures the large cover of the Carriage PCA.

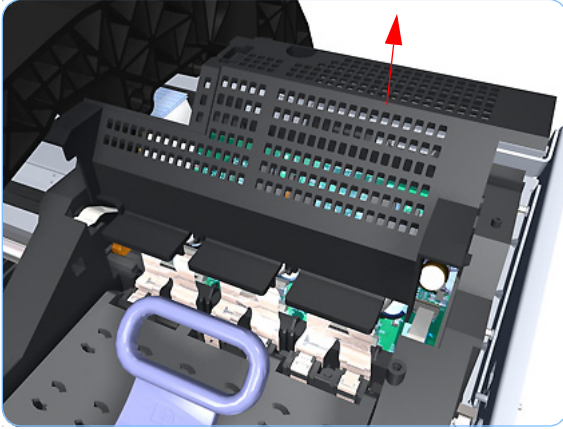

15. Remove the large cover of the Carriage PCA.

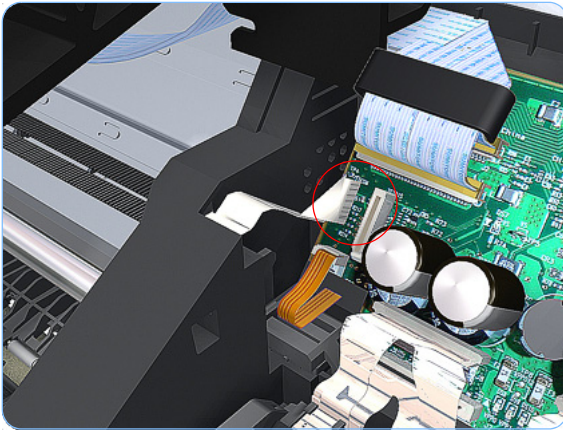

16. Disconnect the Line Sensor electrical connection from the Carriage PCA.

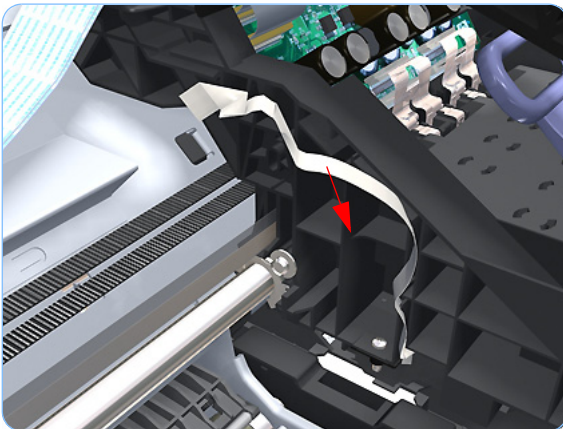

17. Carefully unrout the Line Sensor cable from the Carriage Assembly.

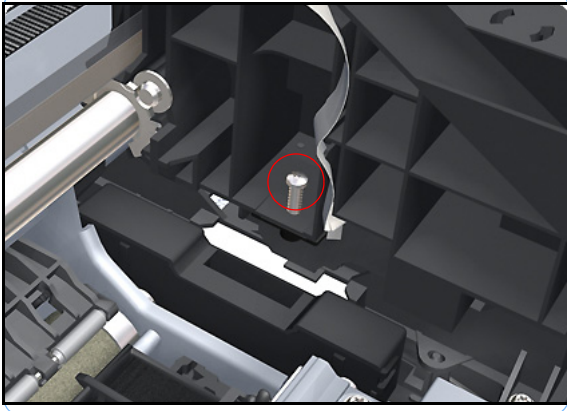

18. Remove one T-10 screw that secures the Line Sensor to the Carriage Assembly.

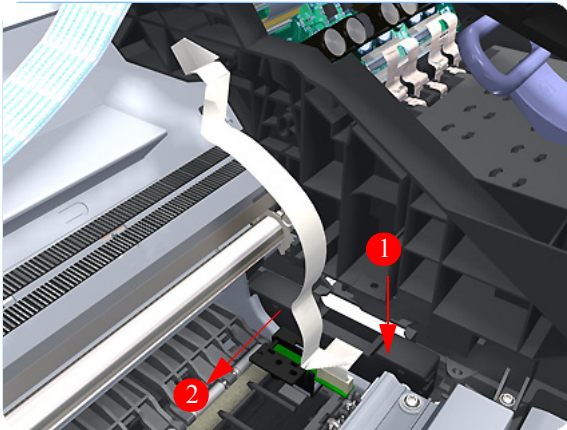

19. Remove the Line Sensor from Carriage Assembly.

When you finish installing or replacing this component, you must perform the necessary Service Calibrations. To find which calibrations you must perform, Refer to page 6-8, *Service Calibration Guide to Removal and Installation*.

Carriage Cover (includes Carriage Latch)

Removal

Switch off the printer and remove the power cable.

1. Remove the Right Cover (refer to page 6-27).
2. Remove the Left Cover (refer to page 6-30).
3. Remove the Front Panel (refer to page 6-48).
4. Remove the Top Cover (refer to page 6-51).
5. Remove the Window Position Sensor (refer to page 6-54).
6. Remove the Ink Supply Tubes Support Rail (refer to page 6-56).
7. Open the Carriage Cover.
The illustration shows the Z2100 which only has four Printheads, for the Z3100 there are six Printheads.

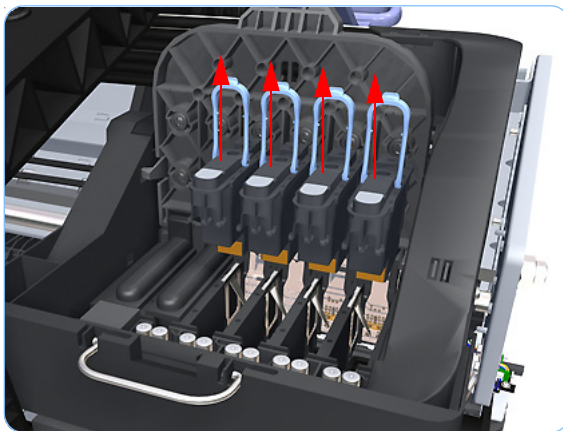
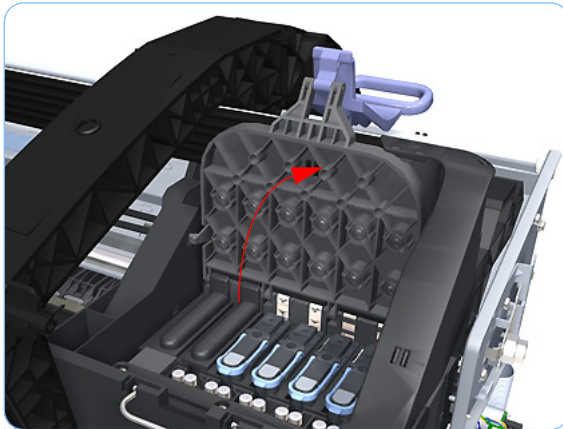

8. Remove all the Printheads.

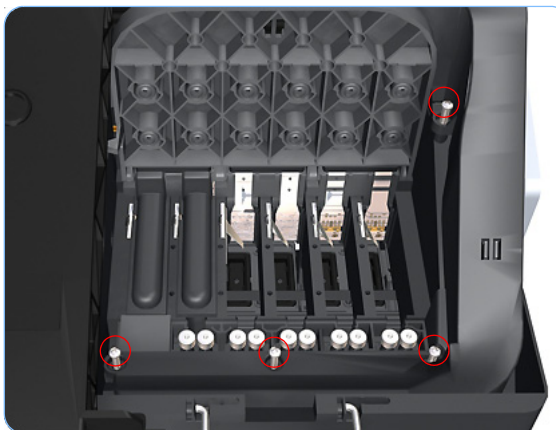

- 9.** Remove the four T-15 screws that secure the Ink Supply Tubes to the Carriage Assembly.

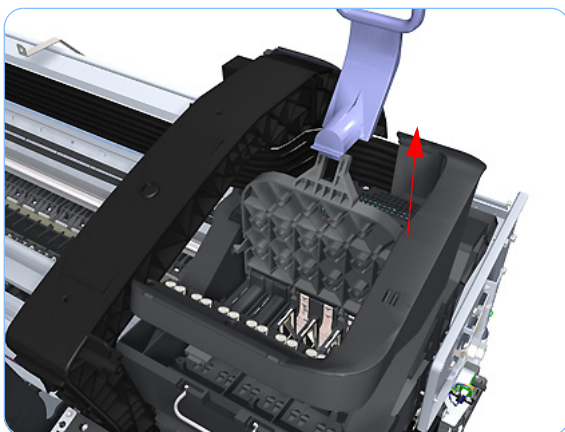

- 10.** Carefully lift out the Ink Supply Tubes and close the carriage cover at the same time.



- 11.** Close and lock the Carriage Cover.

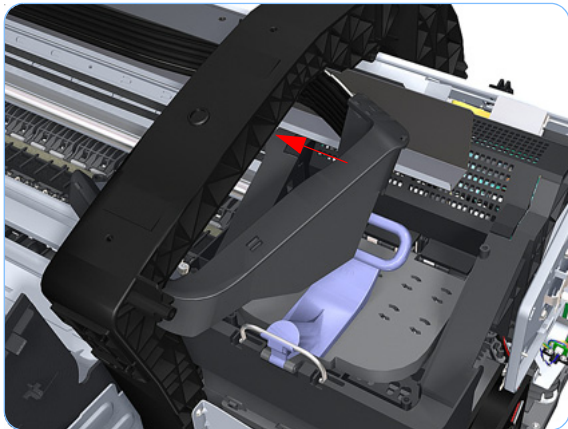

12. Carefully move the Ink Supply Tubes into the print path.

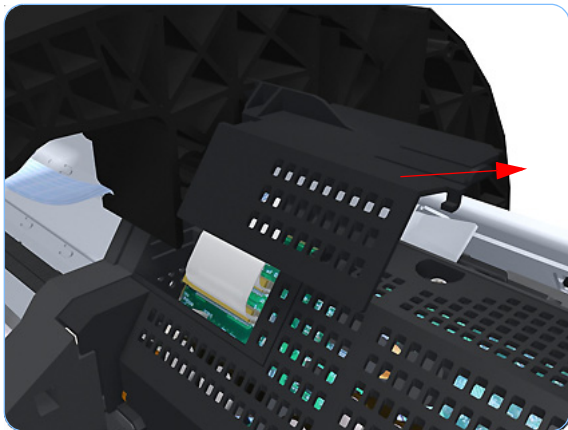

13. Unclip and slide off the small cover of the Carriage Assembly Carriage PCA.

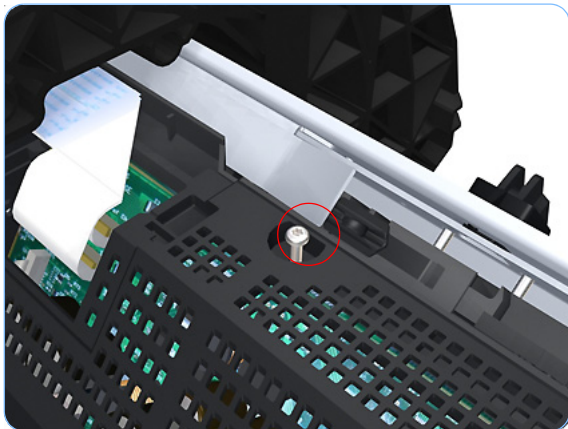

14. Remove one T-15 screws that secures the large cover of the Carriage PCA.

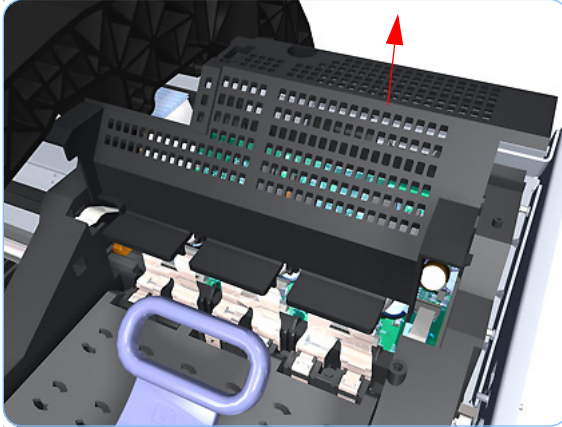

15. Remove the large cover of the Carriage PCA.

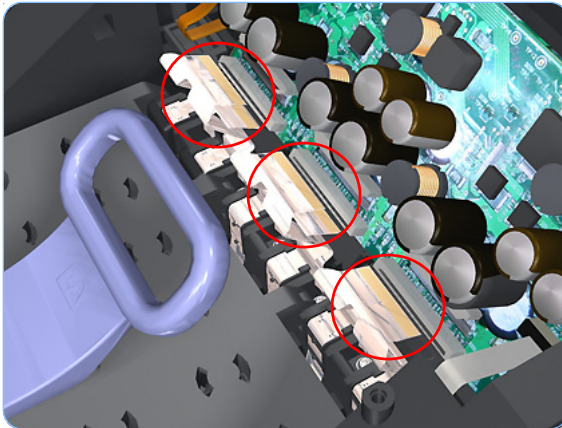

16. Disconnect the six ribbon cables of Carriage Cover from the Carriage Assembly PCB.

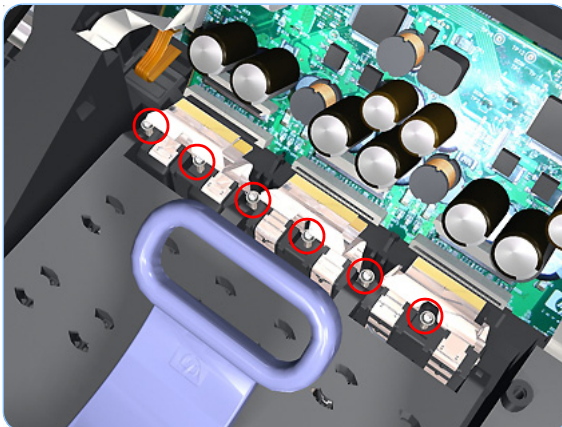

17. Remove six T-10 screws that secure the Carriage Assembly Cover hinge.

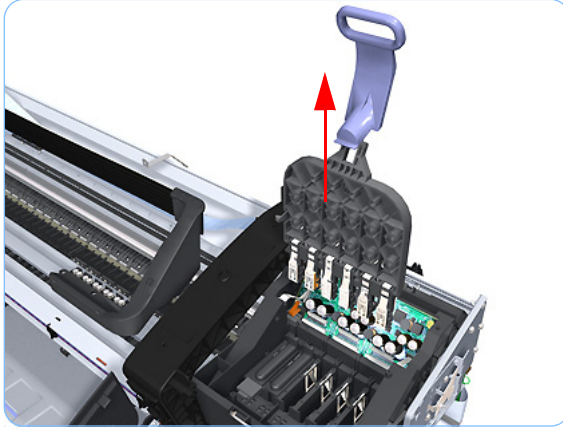

18. Carefully lift the Carriage Cover in the vertical position to remove it from the Carriage Assembly.

When you finish installing or replacing this component, you must perform the necessary Service Calibrations. To find which calibrations you must perform, Refer to page 6-8, *Service Calibration Guide to Removal and Installation*.

Carriage PCA

Removal

Switch off the printer and remove the power cable.

1. Remove the Right Cover (refer to page 6-27).
2. Remove the Left Cover (refer to page 6-30).
3. Remove the Front Panel (refer to page 6-48)
4. Remove the Top Cover (refer to page 6-51).
5. Remove the Window Position Sensor (refer to page 6-54).
6. Remove the Ink Supply Tubes Support Rail (refer to page 6-56).
7. Open the Carriage Cover.
The illustration shows the Z2100 which only has four Printheads, for the Z3100 there are six Printheads.

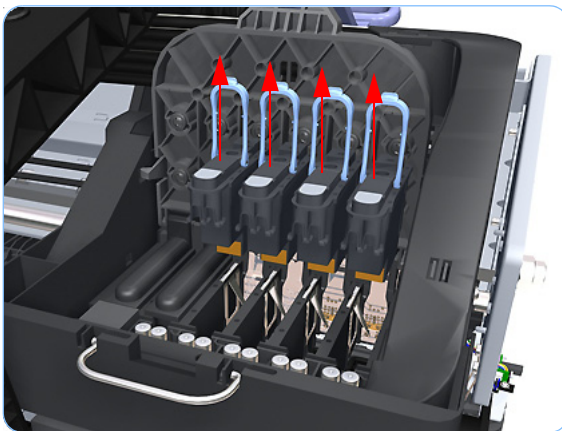
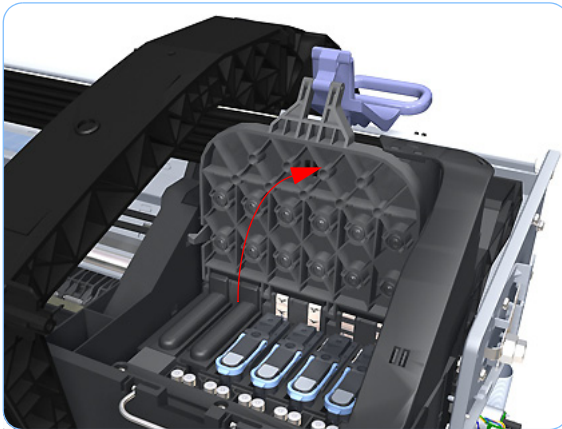

8. Remove all the Printheads.



9. Remove the four T-15 screws that secure the Ink Supply Tubes to the Carriage Assembly.

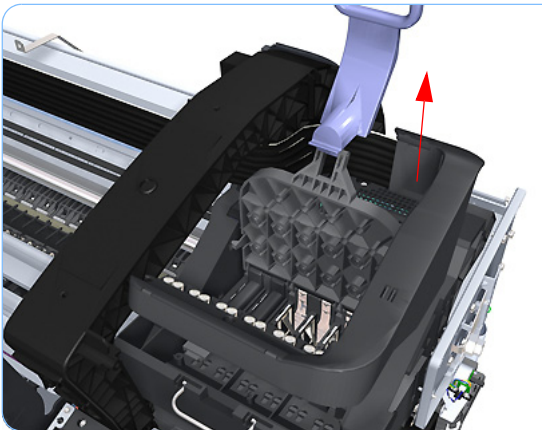

10. Carefully lift out the Ink Supply Tubes and close the carriage cover at the same time.

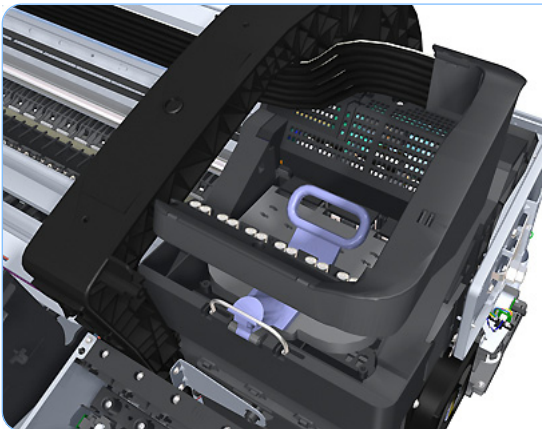

11. Close and lock the Carriage Cover.

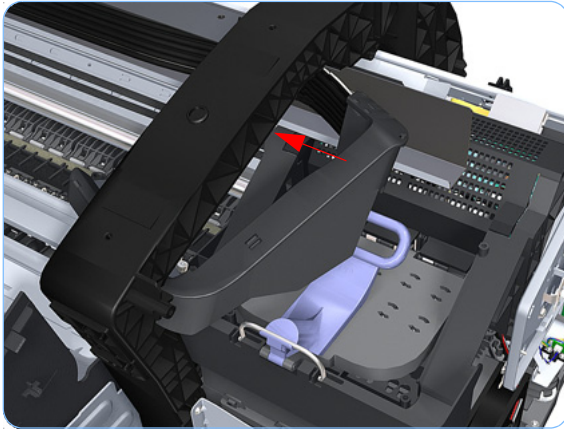

12. Carefully move the Ink Supply Tubes into the print path.

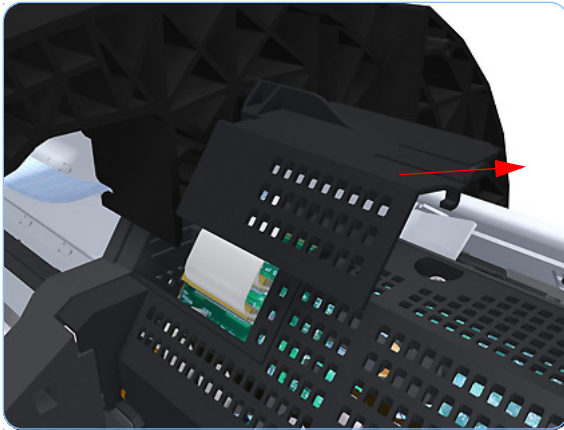

13. Unclip and slide off the small cover of the Carriage Assembly Carriage PCA.

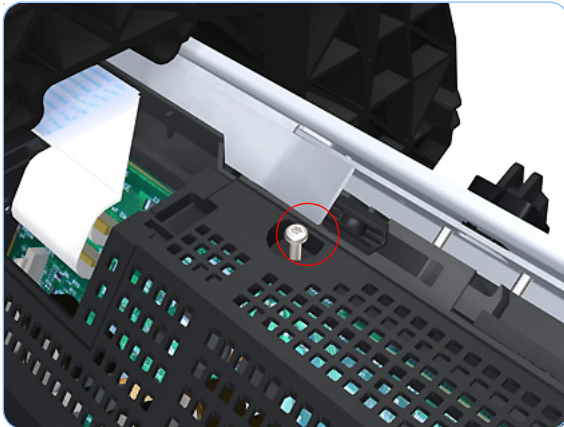

14. Remove one T-15 screws that secures the large cover of the Carriage PCA.

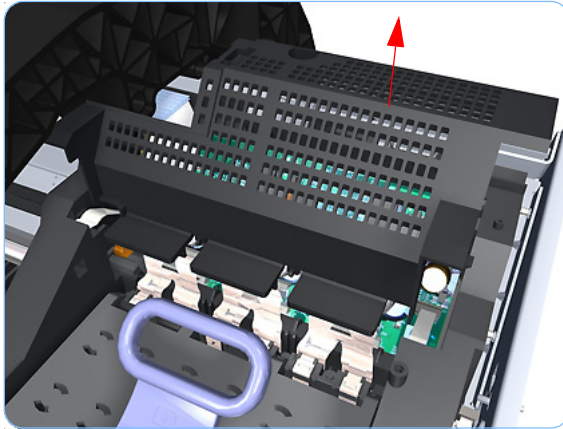

15. Remove the large cover of the Carriage PCA.

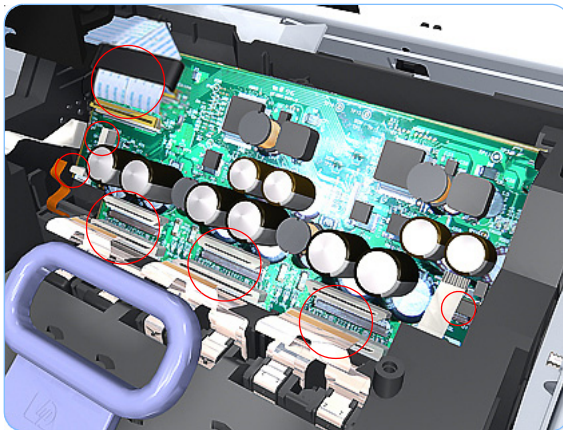

16. Disconnect the ten ribbon cables from the Carriage Assembly PCB.

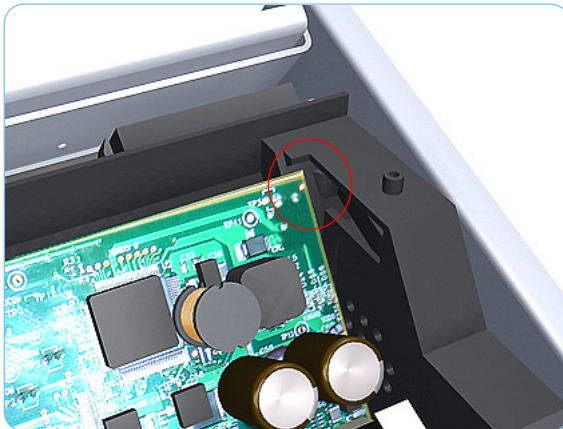

17. Press the locking clip to release the Carriage Assembly PCB from the carriage.

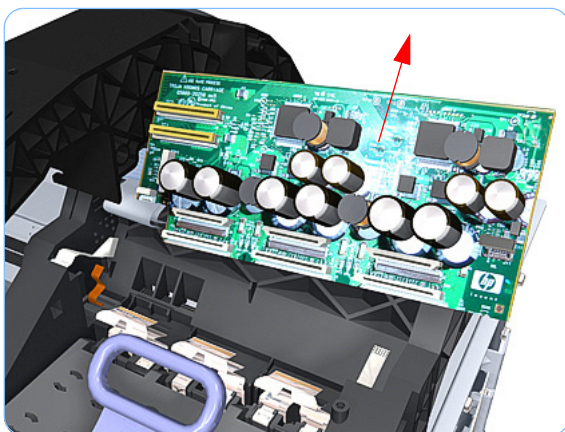

18. Remove the Carriage PCA from the carriage.

When you finish installing or replacing this component, you must perform the necessary Service Calibrations. To find which calibrations you must perform, Refer to page 6-8, *Service Calibration Guide to Removal and Installation*.

Right Ink Supply Station

Removal

Switch off the printer and remove the power cable.

1. Remove the Right Cover (refer to page 6-27).
2. Remove two T-10 screws that secure the Right Side Plate of the Ink Supply Station.

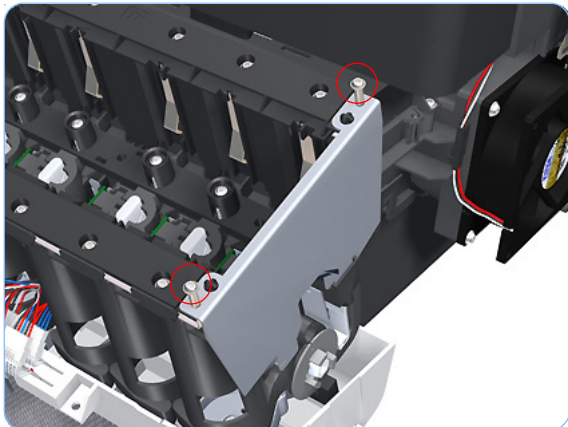

3. Remove the Right Side Plate of the Right Ink Supply Station.

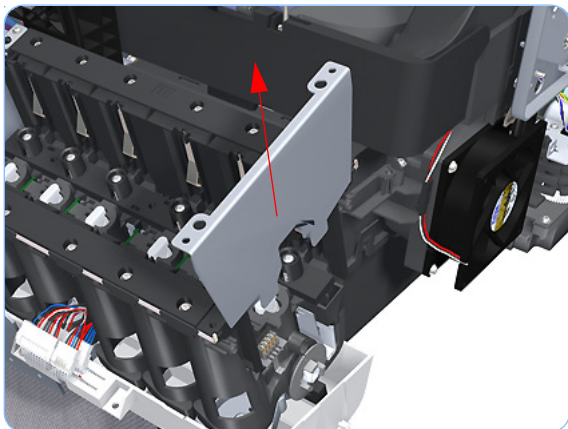

4. Remove two T-10 screws that secure the Left Side Plate of the Right Ink Supply Station.

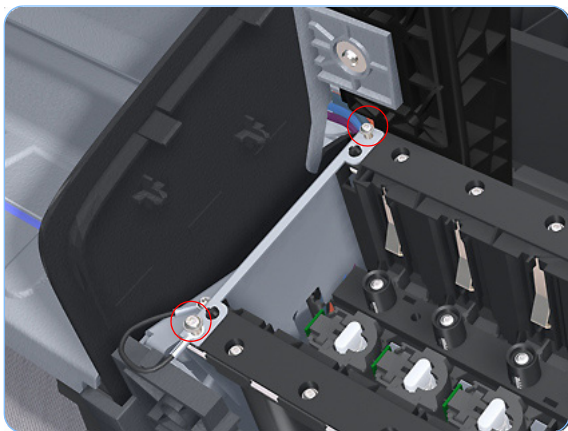

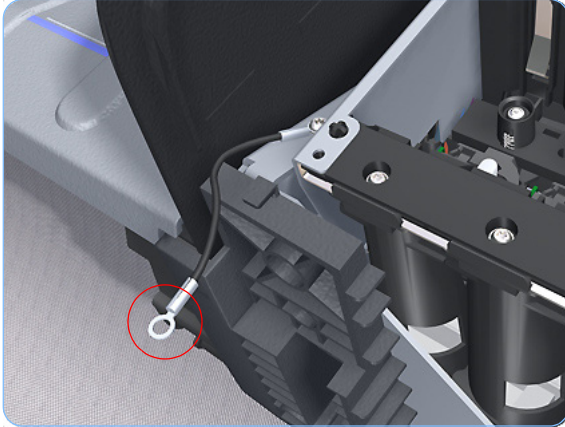

5. Remove the Right Ink Supply Station bonding cable.

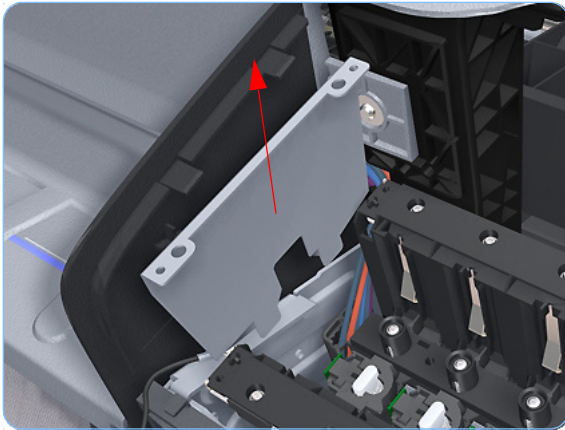

6. Remove the Right Side Plate of the Right Ink Supply Station.

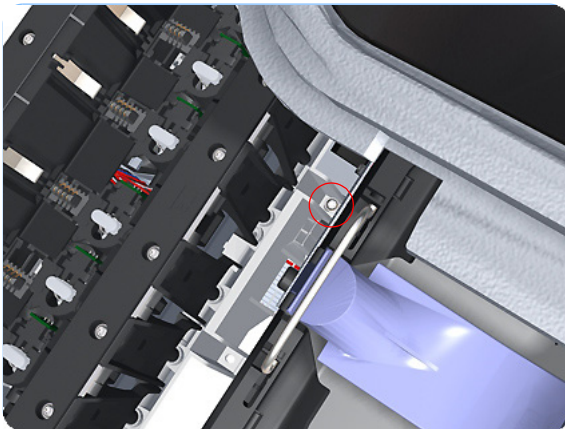

7. Remove the T-15 screw that secures the Right Ink Supply Station to the printer.

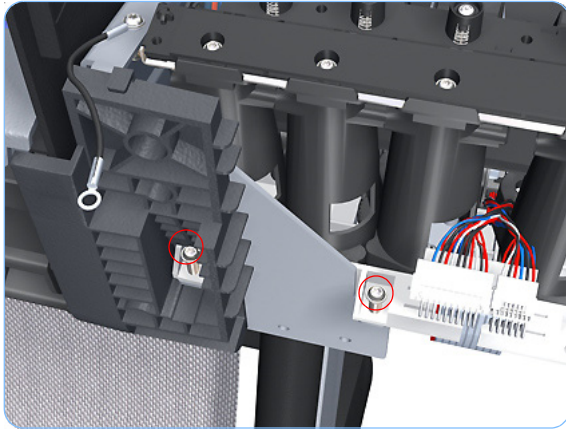

8. Remove the two T-15 screws that secure the Right Ink Supply Station to the printer.

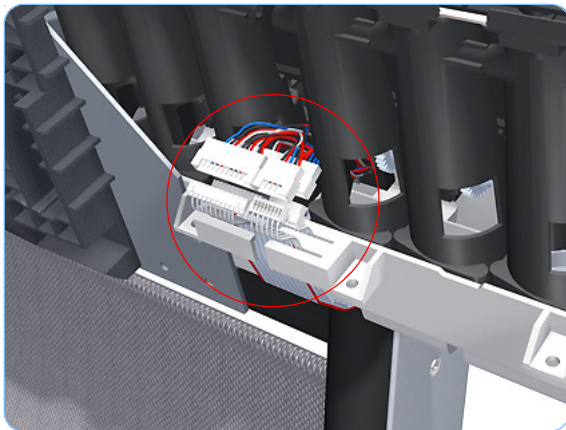

9. Disconnect the three connectors from the Right Ink Supply Station.

If you need to change the ISS Harness Cable, make sure you keep the previously used plastic connector. The new cable will arrive with a female end, which you will replace with the existing male end.

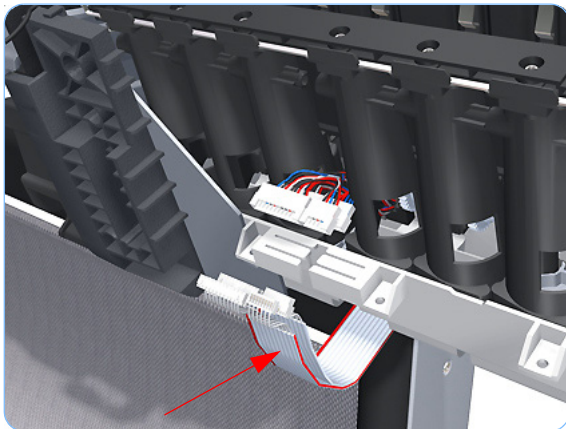

10. Unroute the three cables from the Right Ink Supply Station.

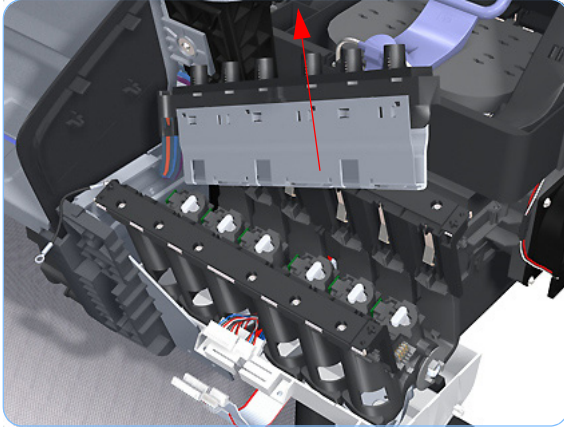

11. Carefully lift the Cartridge Tubes Connector out of the Right Ink Supply Station.

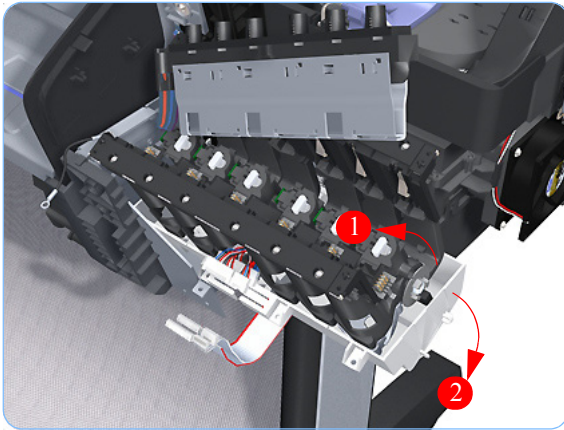

12. Carefully lift the Right Ink Supply Station enough so that you can rotate it clockwise to release the front attachment from the printer.

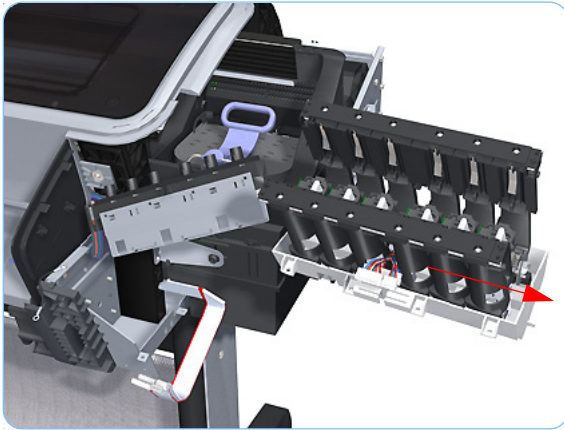

13. Carefully lift the Right Ink Supply Station completely out of the printer.

When you finish installing or replacing this component, you must perform the necessary Service Calibrations. To find which calibrations you must perform, Refer to page 6-8, *Service Calibration Guide to Removal and Installation*.

Left Ink Supply Station

Removal

Switch off the printer and remove the power cable.

1. Remove the Left Cover (refer to page 6-30).
2. Remove two T-10 screws that secure the Left Side Plate of the Left Ink Supply Station.

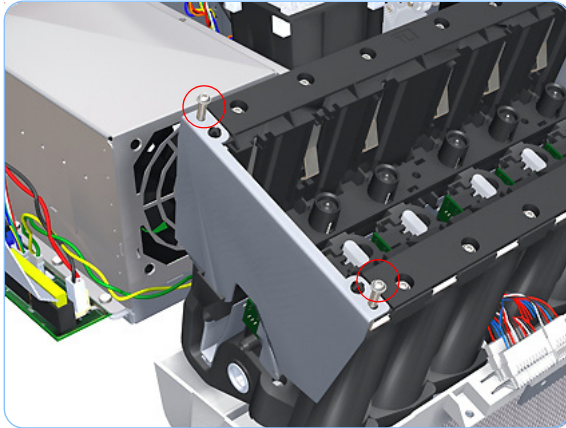

3. Remove the Left Side Plates of the Left Ink Supply Station.

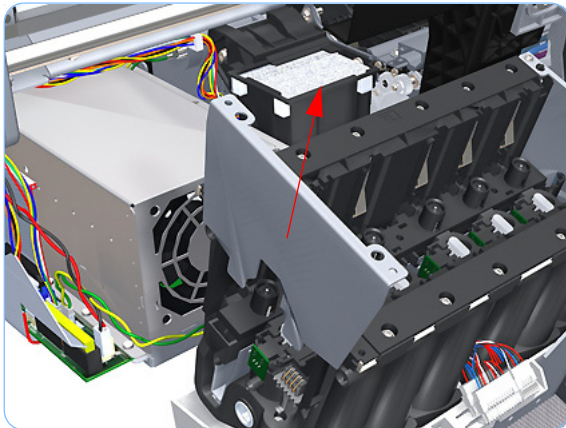

4. Remove two T-10 screws that secure the Right Side Plate of the Left Ink Supply Station.

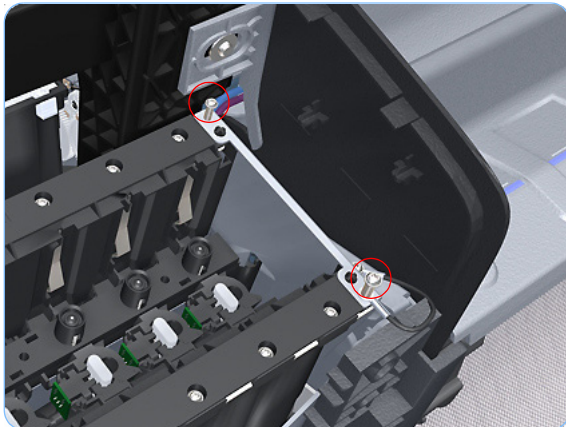

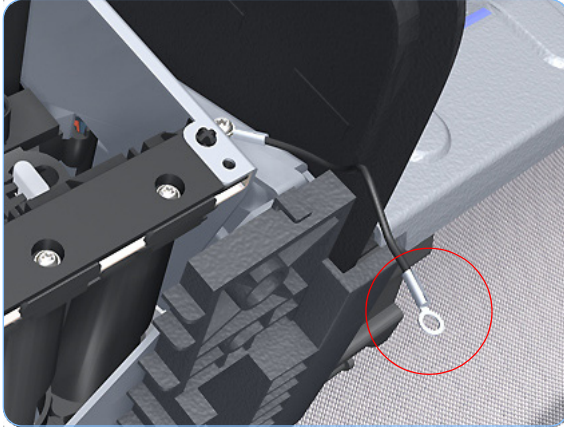

5. Remove the Left Ink Supply Station bonding cable.

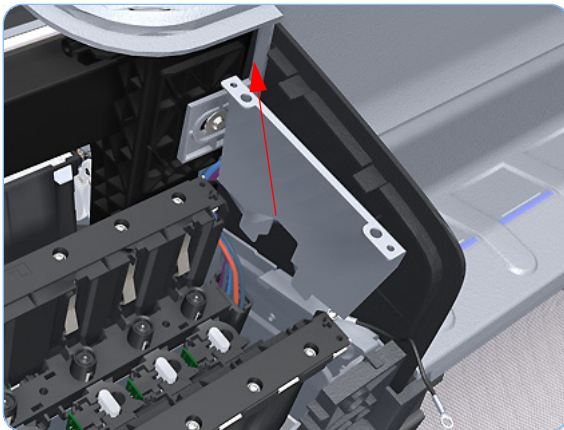

6. Remove the Right Side Plate of the Left Ink Supply Station.

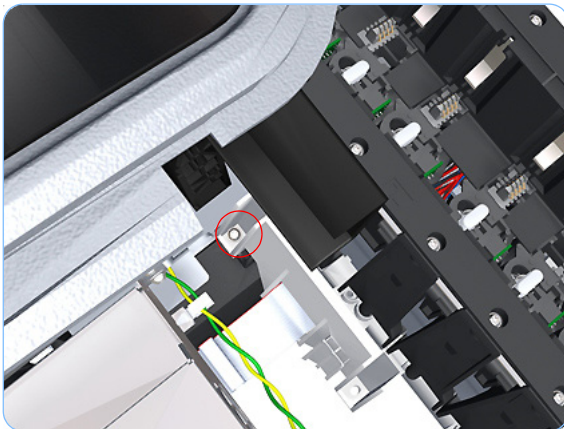

7. Remove the T-15 screw that secures the Left Ink Supply Station to the printer.

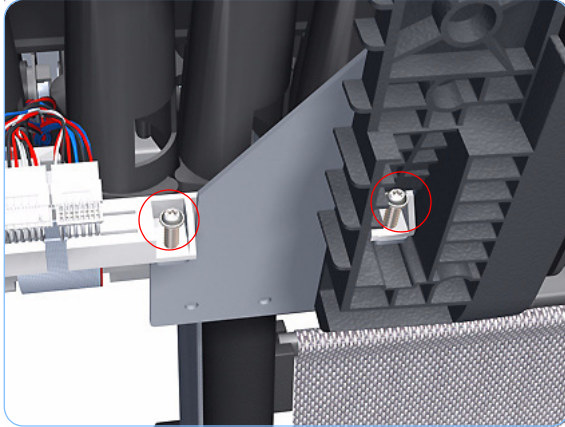

8. Remove the two T-15 screws that secure the Left Ink Supply Station to the printer.

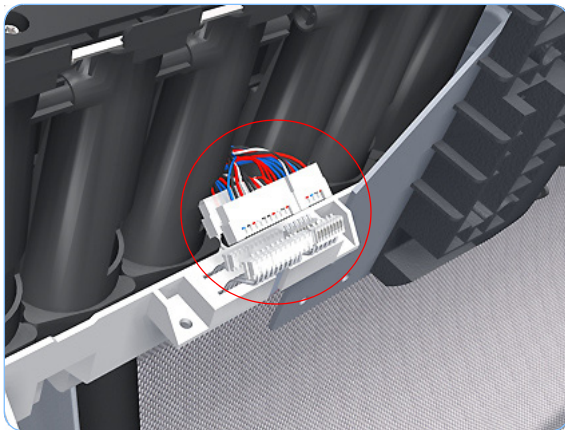

9. Disconnect the three connectors from the Left Ink Supply Station.

If you need to change the ISS Harness Cable, make sure you keep the previously used plastic connector. The new cable will arrive with a female end, which you will replace with the existing male end.

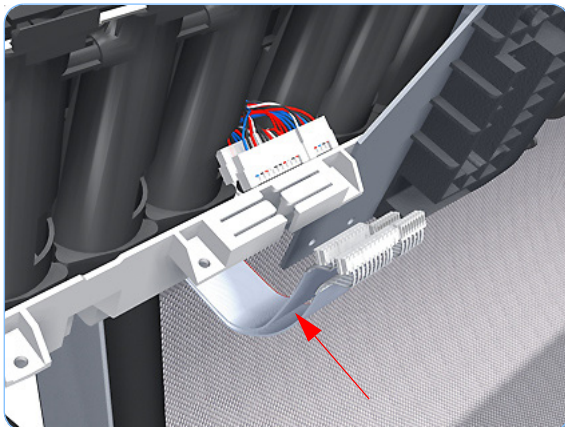

10. Unroute the three cables from the Left Ink Supply Station.

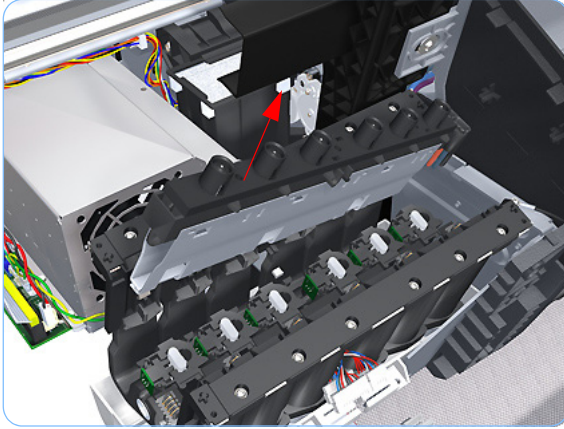

11. Carefully lift the Cartridge Tubes Connector out of the Left Ink Supply Station.

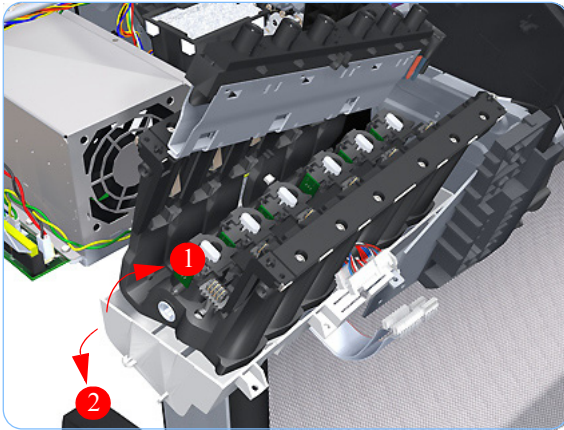

12. Carefully lift the Left Ink Supply Station enough so that you can rotate it counterclockwise to release the front attachment from the printer.

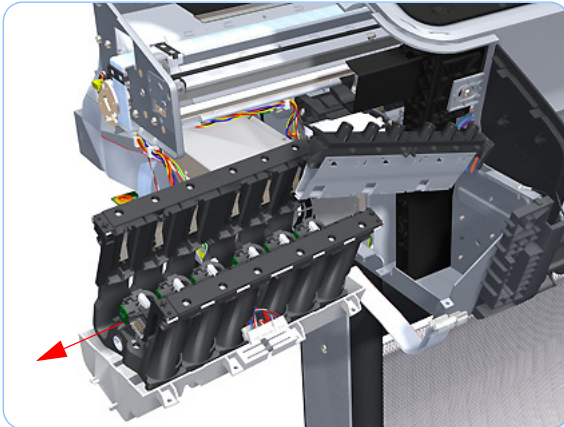

13. Carefully lift the Left Ink Supply Station completely out of the printer.

When you finish installing or replacing this component, you must perform the necessary Service Calibrations. To find which calibrations you must perform, Refer to page 6-8, *Service Calibration Guide to Removal and Installation*.

Ink Supply Tubes

Removal

Switch off the printer and remove the power cable.

1. Remove the Right Cover (refer to page 6-27).
2. Remove the Left Cover (refer to page 6-30).
3. Remove the Front Panel (refer to page 6-48).
4. Remove the Top Cover (refer to page 6-51).
5. Open the Carriage Cover.
The illustration shows the Z2100 which only has four Printheads, for the Z3100 there are six Printheads.

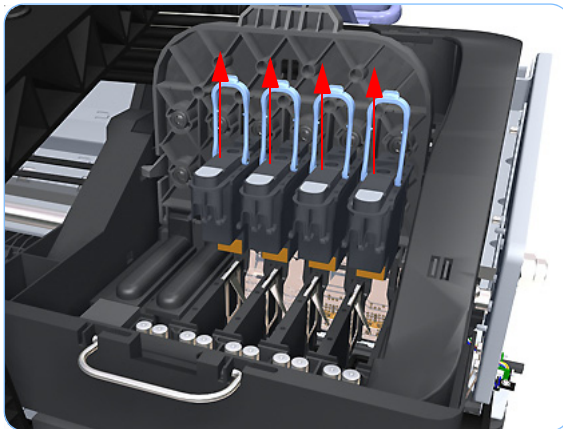
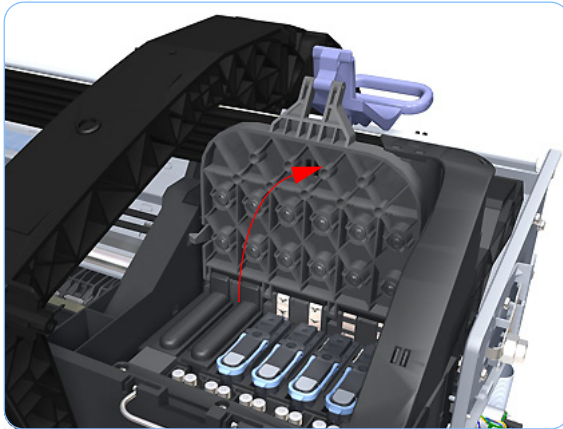

6. Remove all the Printheads.



7. Remove the four T-15 screws that secure the Ink Supply Tubes to the Carriage Assembly.

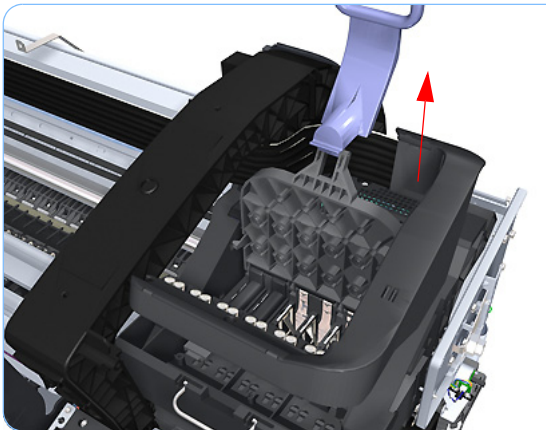

8. Carefully lift out the Ink Supply Tubes and close the carriage cover at the same time.

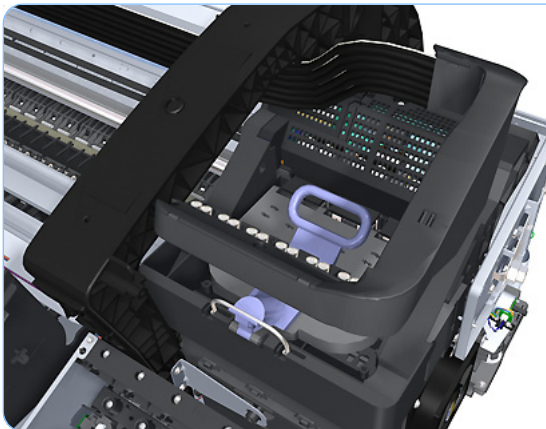

9. Close and lock the Carriage Assembly cover.

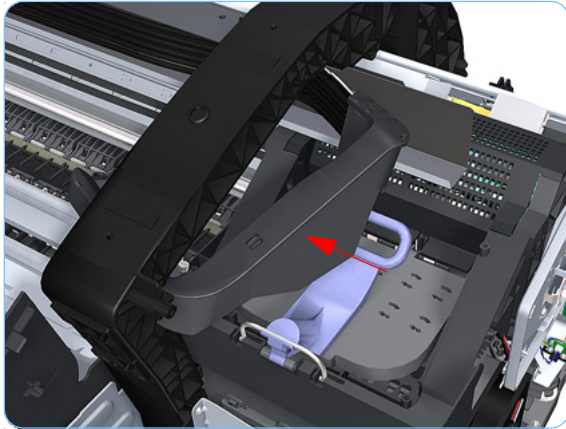

10. Carefully feed the Ink Supply Tubes into the print path area.

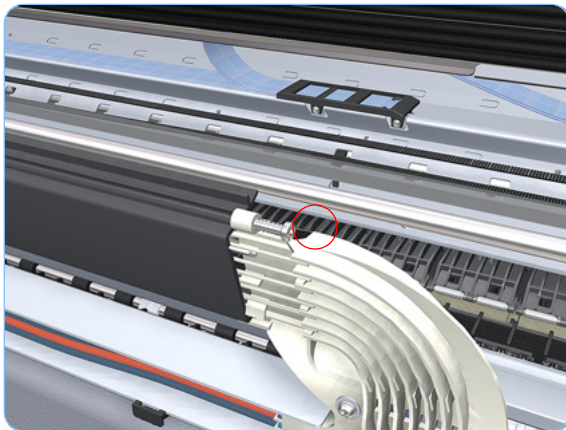

11. Remove the top T-15 screw that secures Ink Supply Tubes guide to the printer.

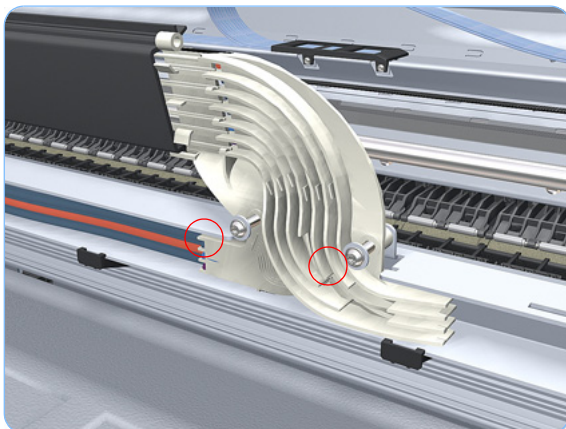

12. Remove the two front T-15 screws that secure Ink Supply Tubes guide to the printer.

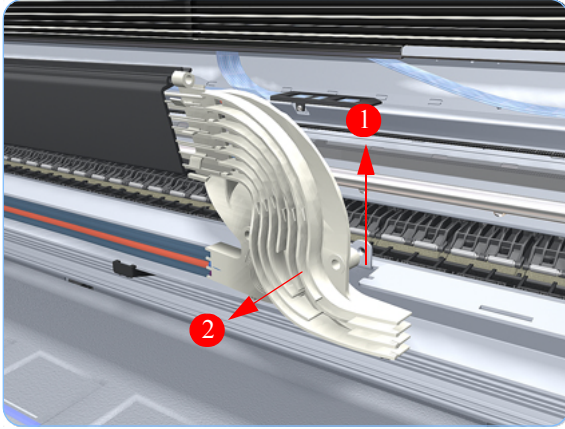

13. Carefully lift the Ink Supply Tubes guide enough until you can slide it forwards out of the printer.

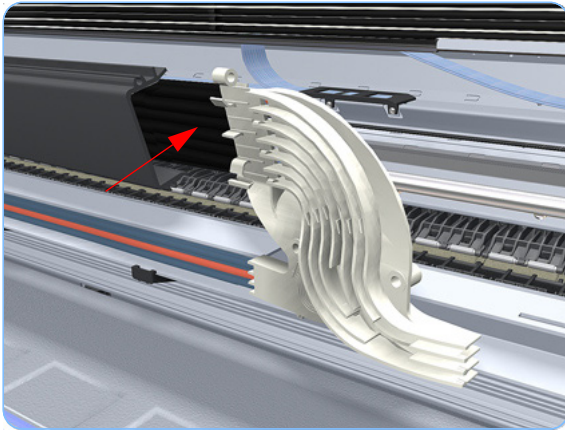

14. Gently move the Ink Supply Tubes from the printer.



15. Use a flat bladed screwdriver to release all the Ink Supply Tubes clamps from the printer.

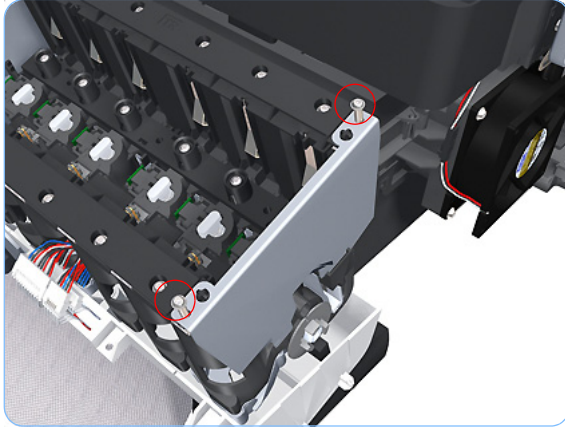

16. Remove two T-10 screws that secure the right Side Plate of the Right Ink Supply Station.

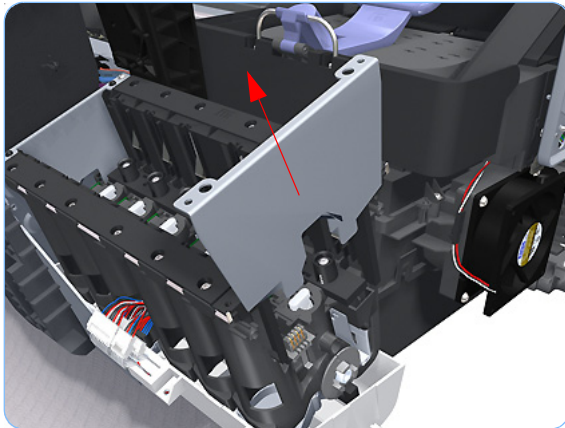

17. Remove the Right Side Plate of the Right Ink Supply Station.

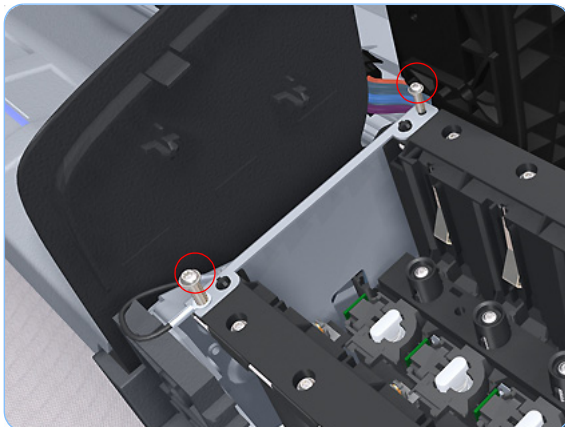

18. Remove two T-10 screws that secure the left Side Plate of the Right Ink Supply Station.

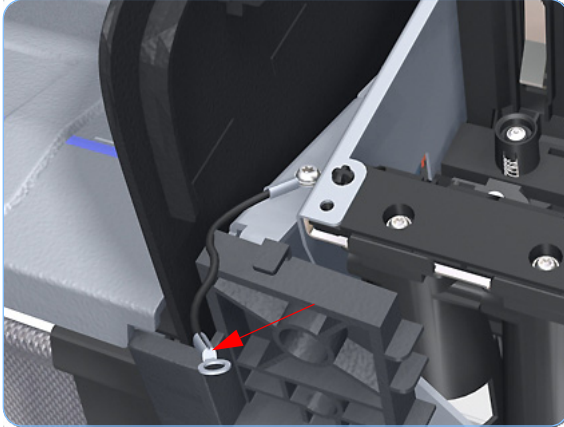

19. Remove the Right Ink Supply Station bonding cable.

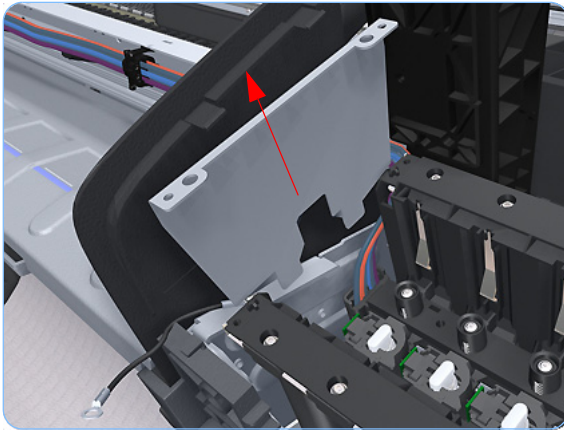

20. Remove the left Side Plate of the Right Ink Supply Station.

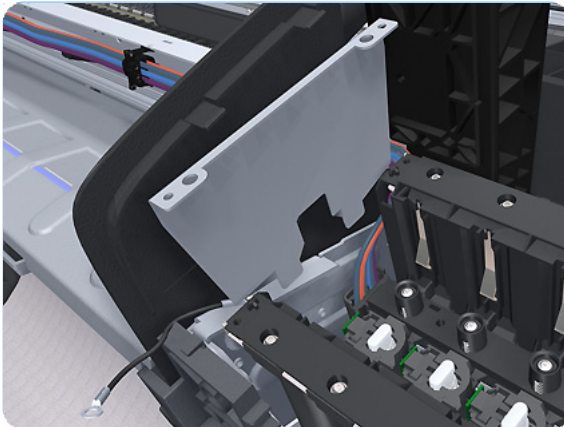

21. Carefully lift the Cartridge Tubes Connector out of the Right Ink Supply Station.

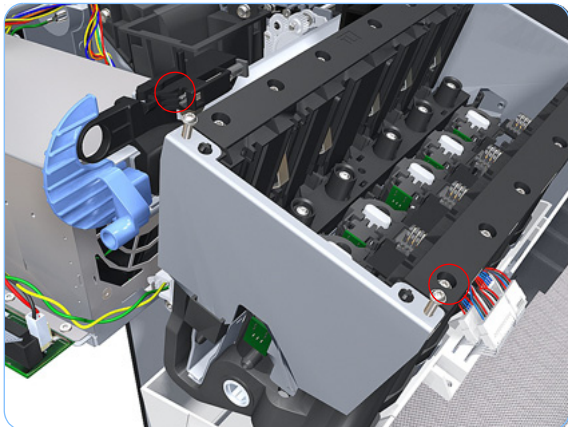

22. Remove two T-10 screws that secure the left Side Plate of the Left Ink Supply Station.

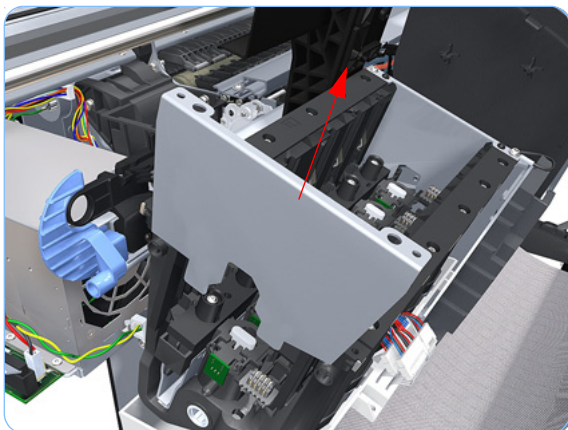

23. Remove the left Side Plate of the Left Ink Supply Station.

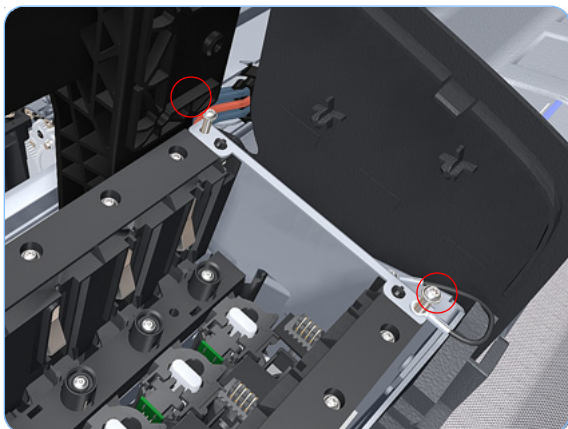

24. Remove two T-10 screws that secure the right Side Plate of the Left Ink Supply Station.

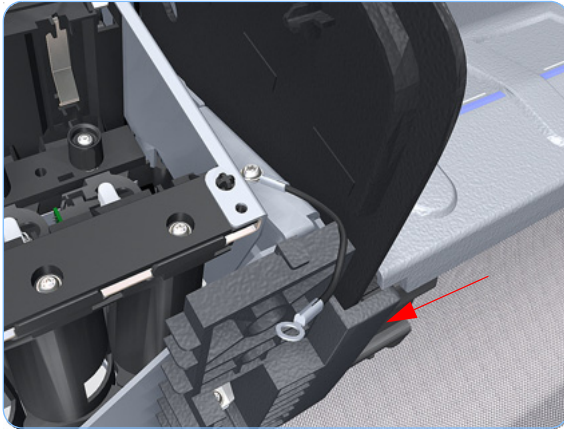

25. Remove the Left Ink Supply Station bonding cable.

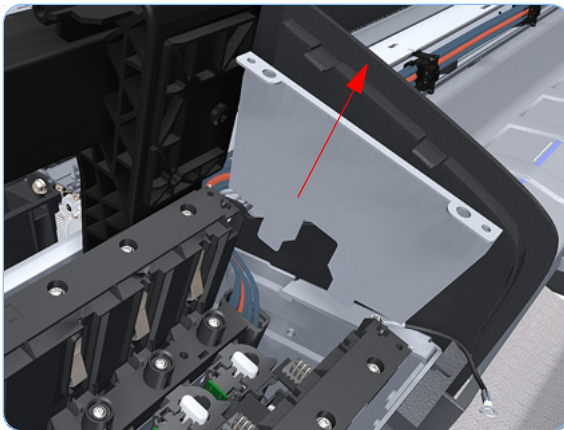

26. Remove the right Side Plate of the Left Ink Supply Station.

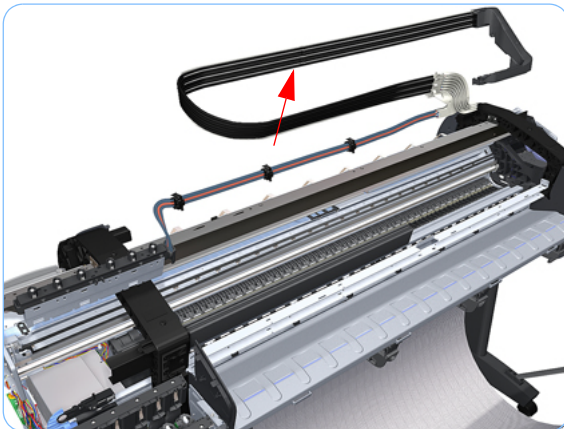

27. Carefully lift the Ink Supply Tubes out of the printer.

After you reinstall the Ink Supply Tubes, run the Purge Tubes Service Utility before performing the necessary service calibrations. Refer to Page 3-62.

When you finish installing or replacing this component, you must perform the necessary Service Calibrations. To find which calibrations you must perform, Refer to page 6-8, *Service Calibration Guide to Removal and Installation*.

Formatter

Removal

Do NOT remove and install both the PrintMech PCA and the Formatter at the same time.

If you have previously removed and installed the PrintMech PCA, make sure that you complete the procedure and perform the necessary Service Calibrations. Refer to Page 6-71 to make sure you have completed the procedure, and Refer to Page 6-8, *Service Calibration Guide to Removal and Installation*, to check what Service Calibrations you should perform.

Switch off the printer and remove the power cable.

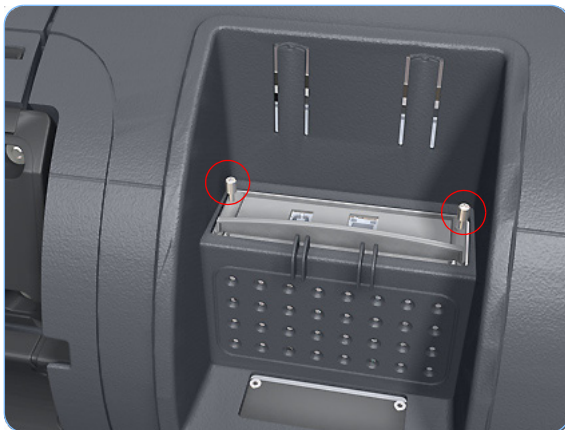

1. Fully loosen the two locking thumbscrews that secure the Formatter in the printer.

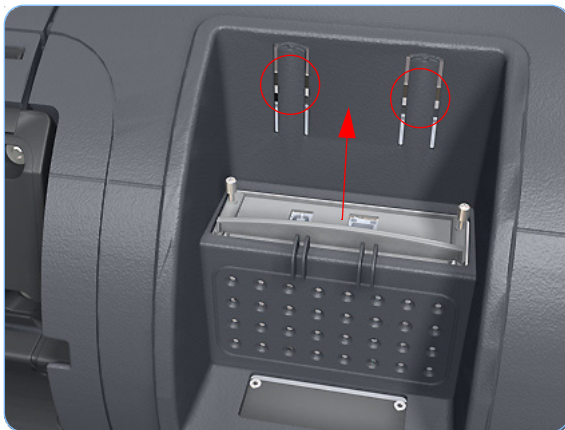

1. Begin lifting the Formatter from the printer. Push the clips and provide upward force at the same time.

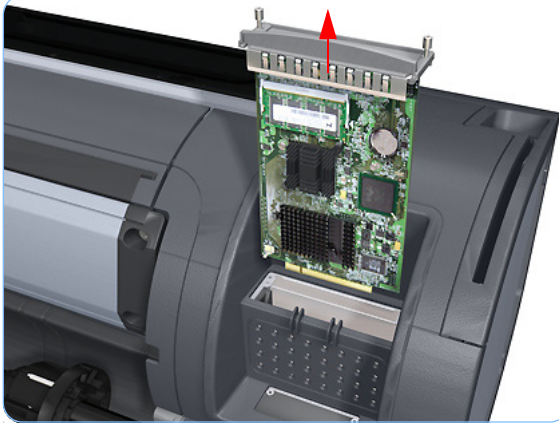

2. Lift the Formatter out of the printer.

When you install a new formatter follow the instructions provided on the Flyer that accompanies it to set up the printer.

Hard Disk Drive

Removal

Switch off the printer and remove the power cable.

1. Remove the Formatter (refer to page 6-161).
2. Unscrew four screws in the formatter.

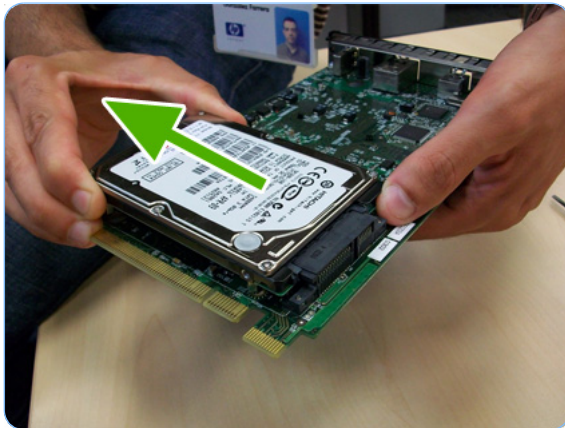
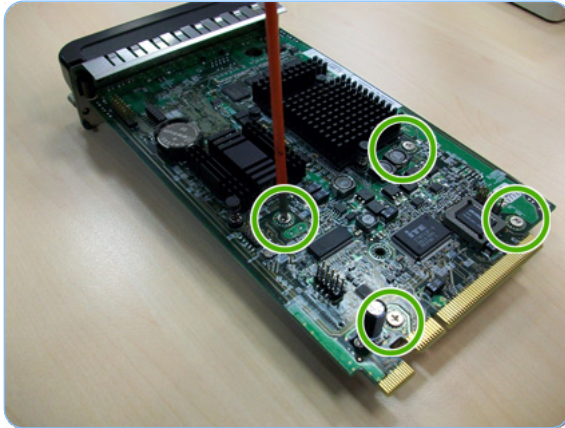

3. Remove the Hard Disk Drive from the Formatter by sliding it in the direction shown.

Installation

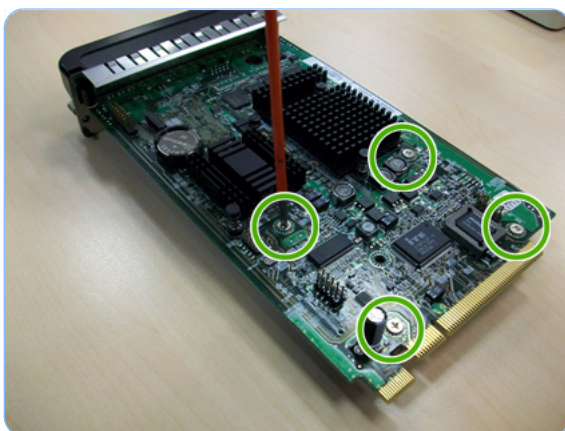

4. Insert a new Hard Disk Drive.

If you try to insert a previously used Hard Disk Drive, the printer will display a 59.2:00 System Error.



5. Replace all the screws removed previously.

Electronics Module (Main PCA and PSU)

Removal

Switch off the printer and remove the power cable.

1. Remove the Left Cover (refer to page 6-30).
2. Disconnect all the connectors on the Electronics Module.

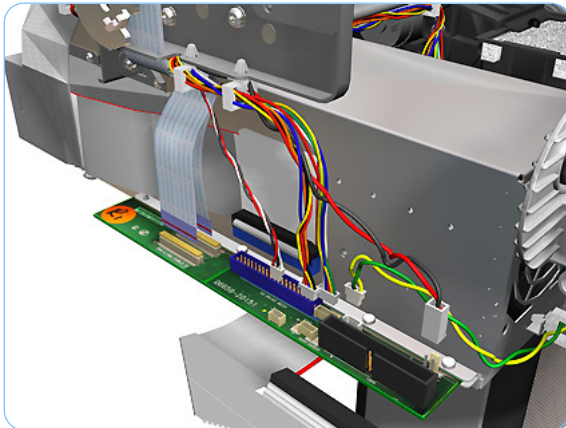

3. Unroute all the cables disconnected in the previous step.

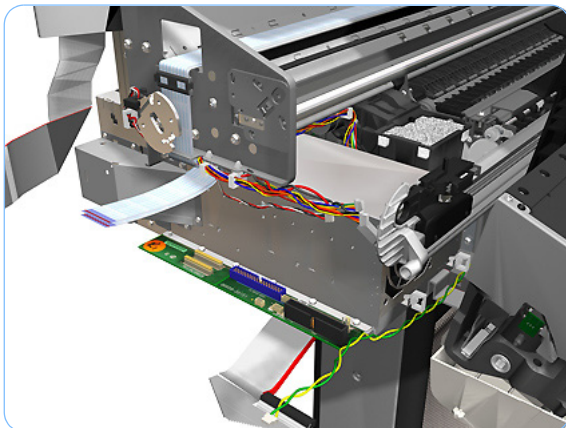

4. Remove two T-15 screws that secure the Electronics Module to the Printer.

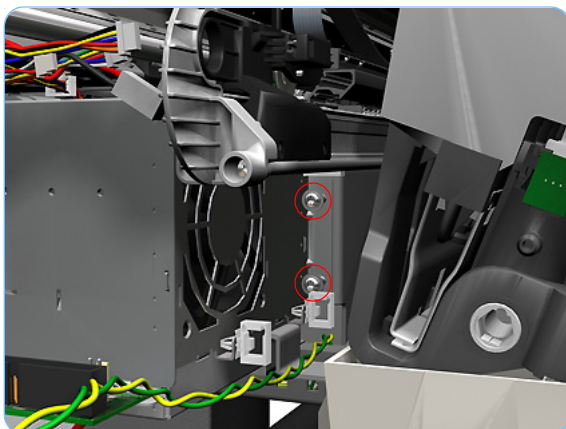

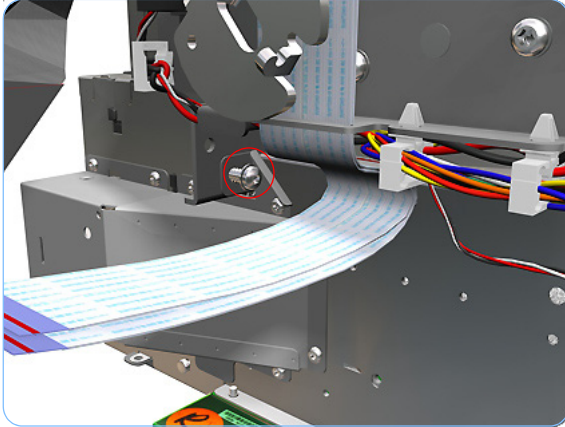

5. Remove one T-15 screw that secures the Electronics Module to the Printer.

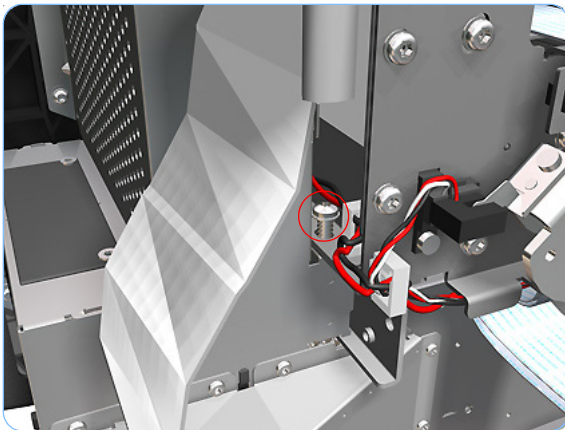

6. Remove one T-15 screw that secures the Electronics Module to the Printer.

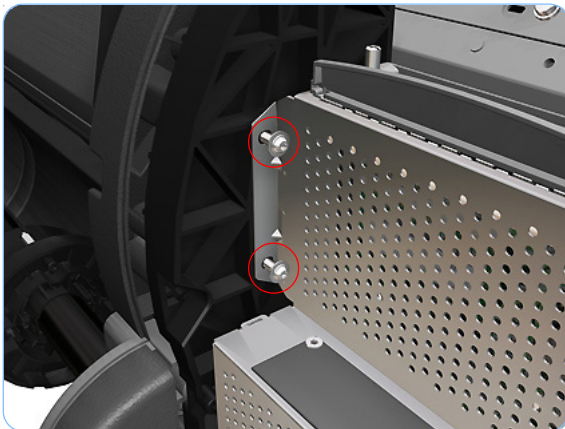

7. Remove two T-15 screws that secure the Electronics Module to the Printer.

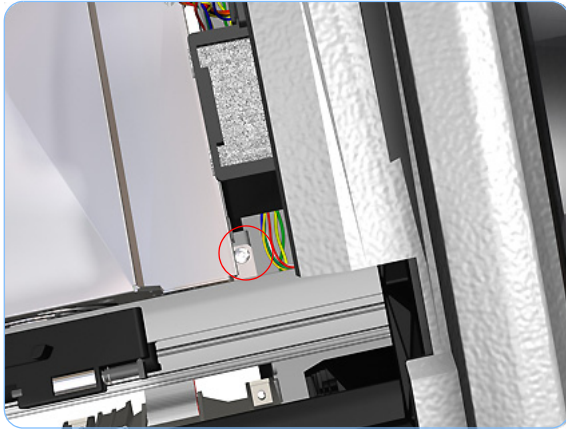

8. Remove one T-15 screw that secures the Electronics Module to the printer.

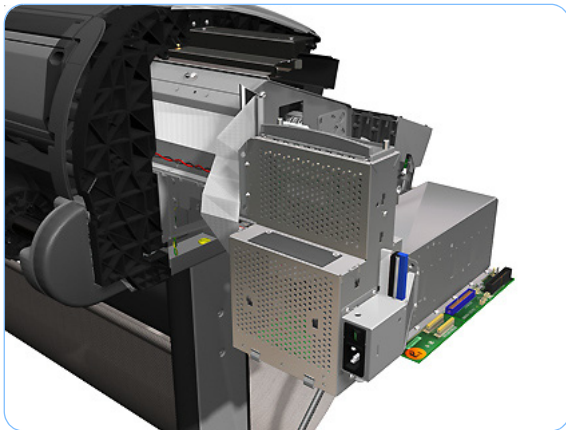

9. Carefully lift the Electronics Module out of the printer.

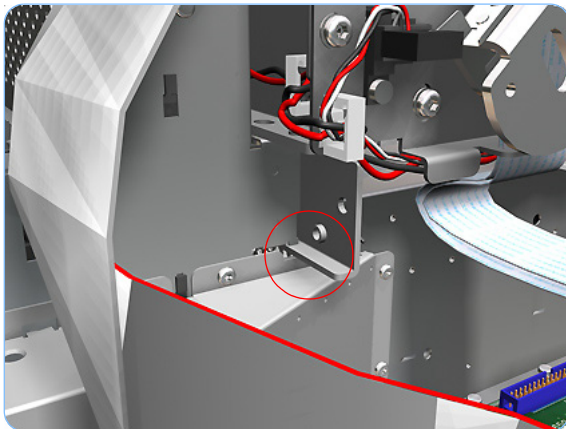

When you install the Electronics Module make sure it is correctly aligned with the mounting rail.

When you finish installing or replacing this component, you must perform the necessary Service Calibrations. To find which calibrations you must perform, Refer to page 6-8, *Service Calibration Guide to Removal and Installation*.

Starwheel Assembly

Removal

For Print Quality issues regarding starwheel marks on the media, refer to page 1-49.

Switch off the printer and remove the power cable.

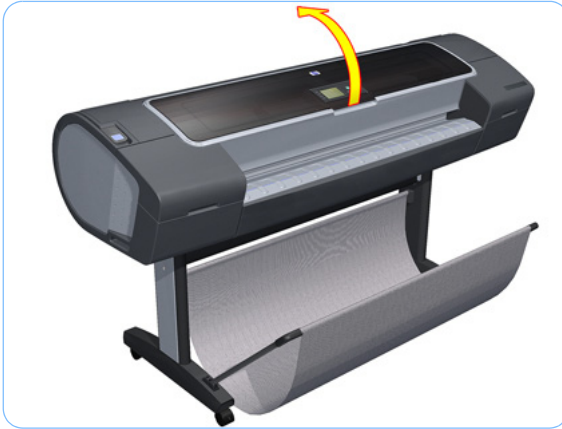

1. Open the Window.

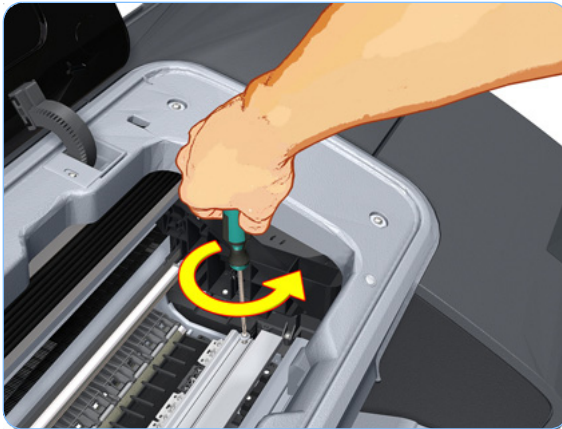

2. Remove one T-15 screw that secures the Starwheel Assembly to the Printer.

The screw is installed with two washers. Be careful that the washers do not fall into the printer.

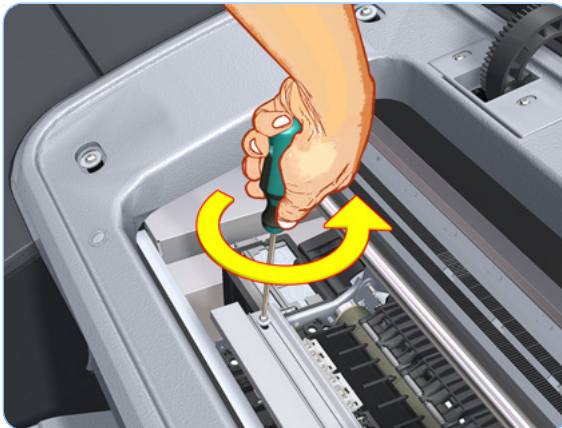

3. Remove one T-15 screw that secures the Starwheel Assembly to the Printer.

The screw is installed with two washers. Be careful that the washers do not fall into the printer.

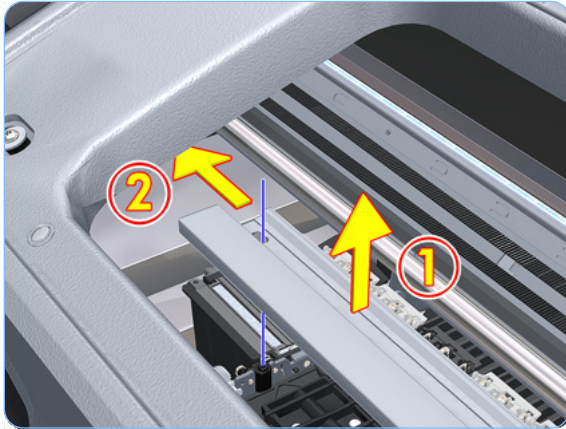

- Carefully lift the Starwheel Assembly and move it into the space to the left so you can remove it from the printer in the next step.

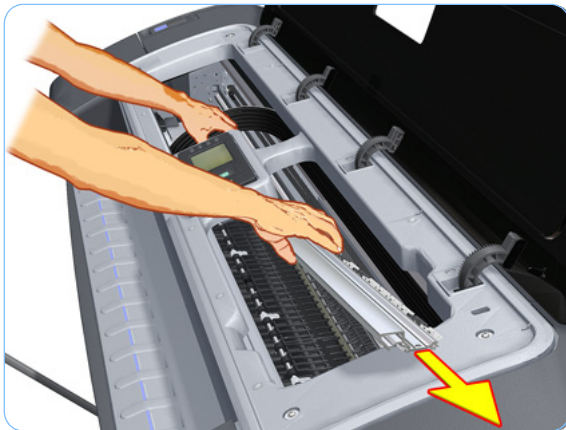

- Carefully remove the Starwheel Assembly from the printer to the right.

When you finish installing or replacing this component, you must perform the necessary Service Calibrations. To find which calibrations you must perform, Refer to page 6-8, *Service Calibration Guide to Removal and Installation*.

Installation

The Starwheel Assembly with Actuator is only used for Z2100/Z3100 printers (except Z2100 Revision C).

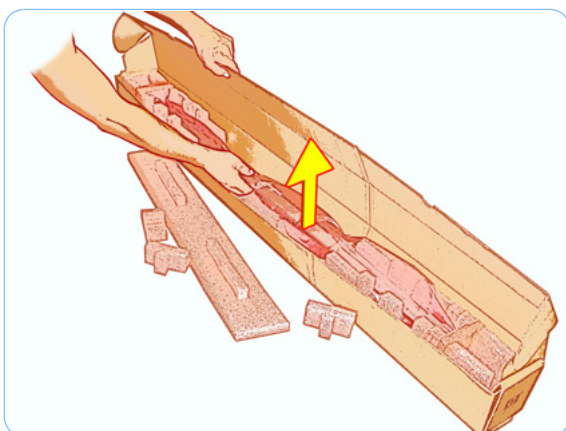

- Carefully remove the Starwheel Assembly from the packaging.

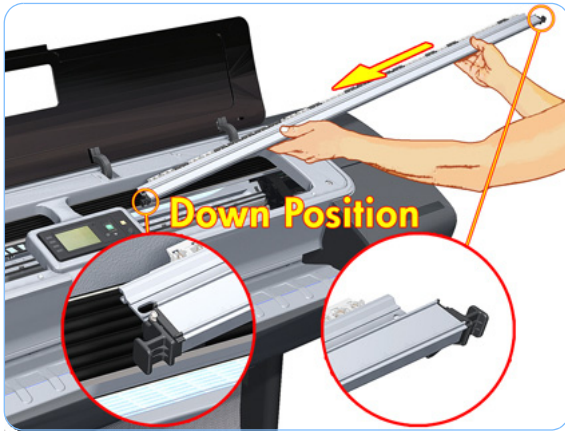

2. With the Starwheel Assembly in the DOWN position, carefully put the Starwheel Assembly in the printer.

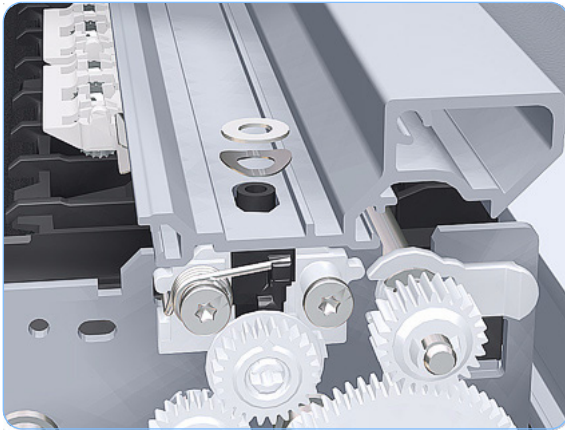

3. On Z3200 series printers, make sure that you install the washers in the proper order, with the black washer on the bottom. The curvature of the washers should be as shown in the graphic.

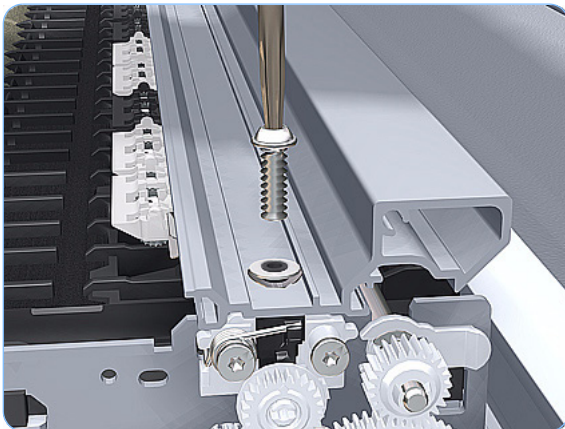

4. Replace the screw when you are certain the washers are correctly placed.

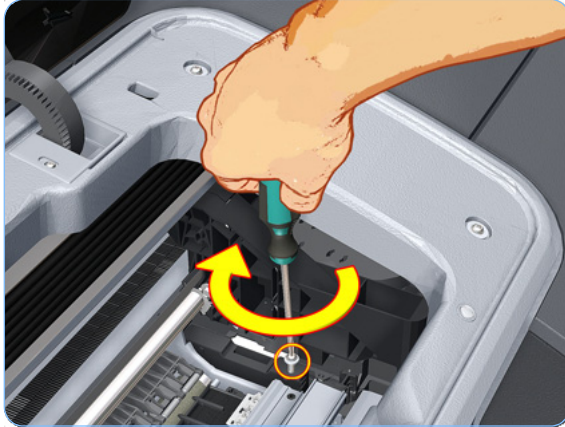

5. Align the Starwheel Assembly and tighten the T15 screw that secures it to the printer.

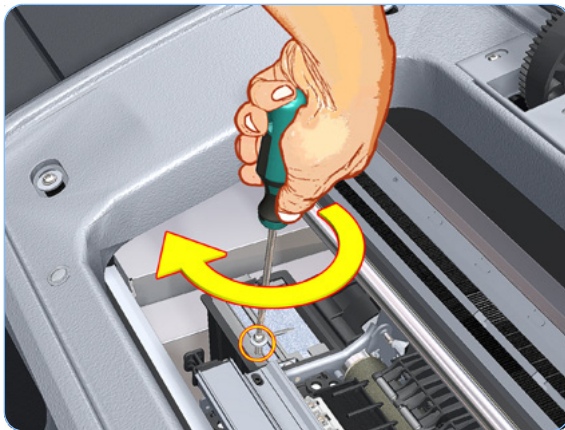

6. Align the Starwheel Assembly and tighten the T15 screw that secures it to the printer.

Set the Starwheel Assembly to the DOWN Position (Z2100/Z3100/Z3100ps only)

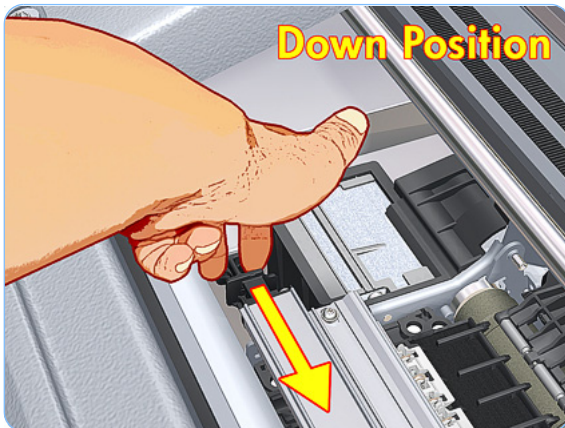

1. Slide the left actuator toward the Starwheel Assembly (the DOWN position).

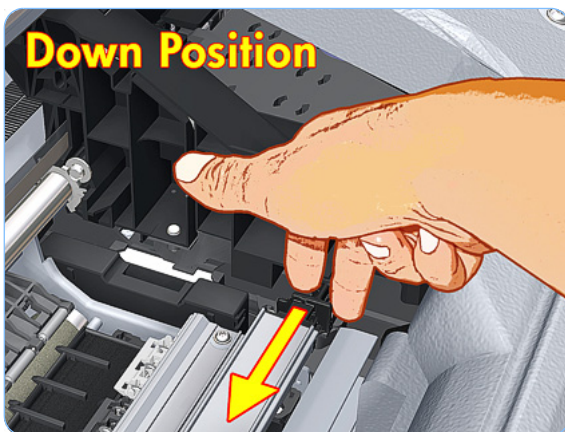

2. Slide the right actuator toward the Starwheel Assembly (the DOWN position).

If you are installing a Starwheel Assembly (with Actuator) because of problems with Marks on the Media, refer to page 1-49.

Print Zone Overdrive

Removal

Switch off the printer and remove the power cable.

1. Remove the Starwheel Assembly (refer to page 6-168).

The Print Zone Overdrive is in two sections (left and right). This procedure describes the removal of both of the sections. If you only want to remove one of the sections skip the steps for the other section.

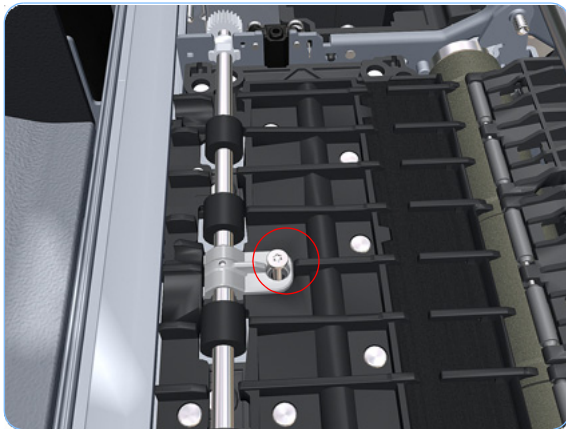

2. Remove one T-15 screw that secures the left clamp of the Print Zone Overdrive to the Platen.

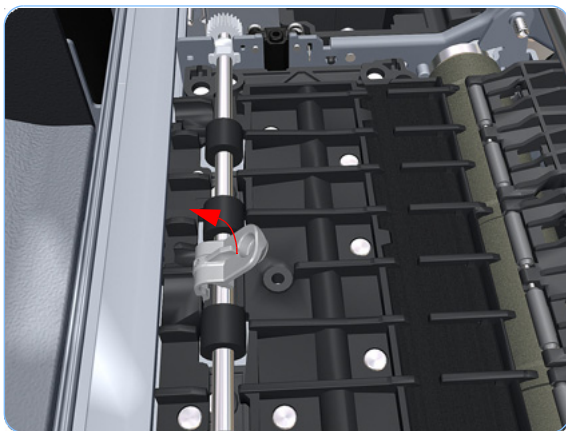

3. Lift attachment clamp vertically to release it from the Platen.

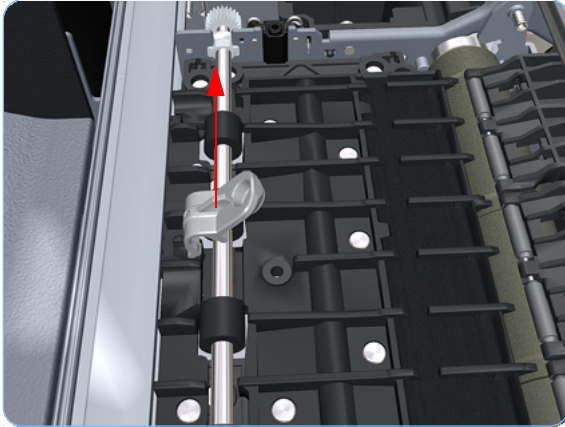

4. Remove the clamp.



5. Repeat steps 2 to 4 to remove the remaining five attachment clamps.

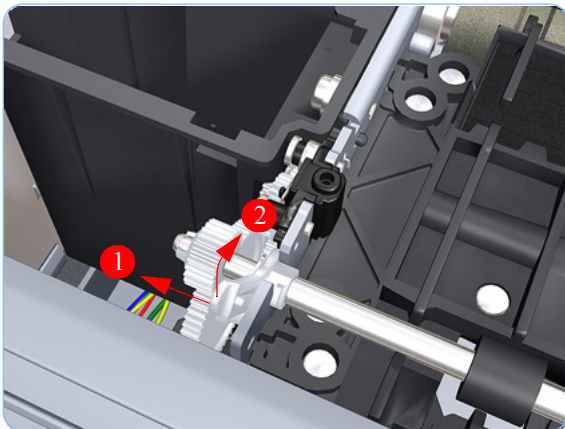

6. Use a flat bladed screwdriver to unclip the left Print Zone Overdrive retaining clip and rotate the clip vertically.

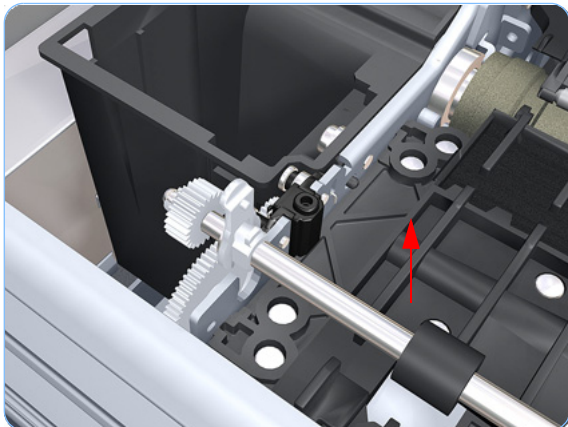

7. Carefully lift the left Print Zone Overdrive enough (10 mm) so you can slide it to the left.

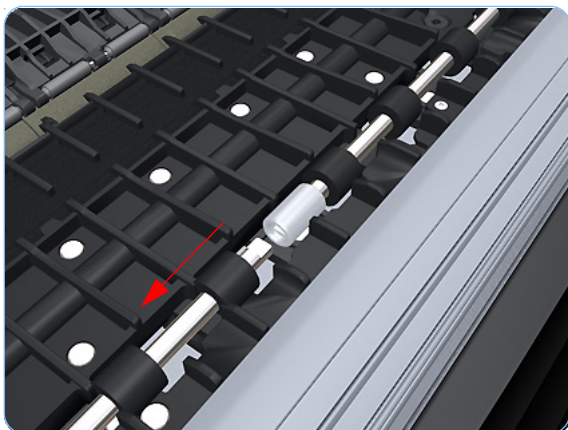

8. Slide the left Print Zone Overdrive to the left disengage the center coupling.

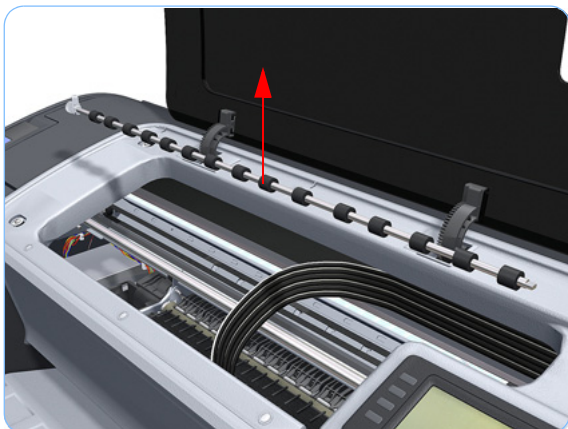

9. Carefully lift the left Print Zone Overdrive out of the printer.

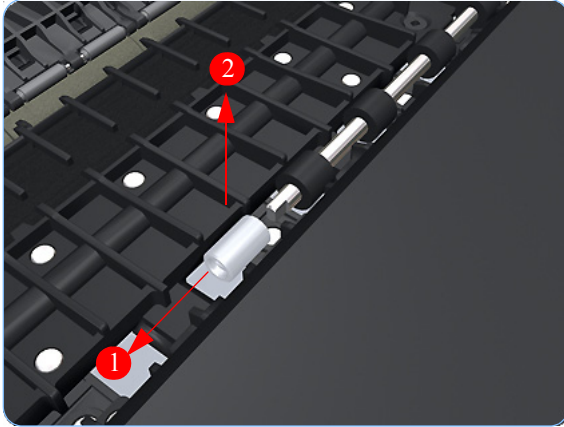

10. Remove the center coupling.

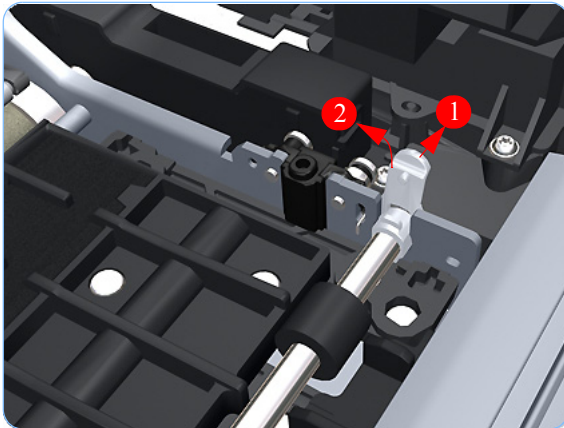

11. Use a flat bladed screwdriver to unclip the left Print Zone Overdrive retaining clip and rotate the clip vertically.

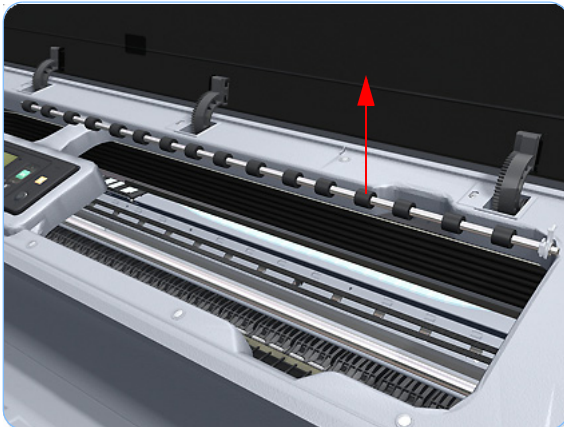

12. Carefully lift the right Print Zone Overdrive out of the printer.

When you finish installing or replacing this component, you must perform the necessary Service Calibrations. To find which calibrations you must perform, Refer to page 6-8, *Service Calibration Guide to Removal and Installation*.

Left Spittoon

Removal

This procedure describes how to remove the complete Left Spittoon which is necessary to gain access to other components. If you only need to replace the Foams of the Left Spittoon, use the protective gloves and the tweezers (provided in the Tool Kit) to remove them with it in place.

Switch off the printer and remove the power cable.

1. Remove the Left Cover (refer to page 6-30).
2. Remove the Electronics Module (Main PCA and PSU) (refer to page 6-165).
3. Unclip the Left Spittoon Retainer from the Left Spittoon.

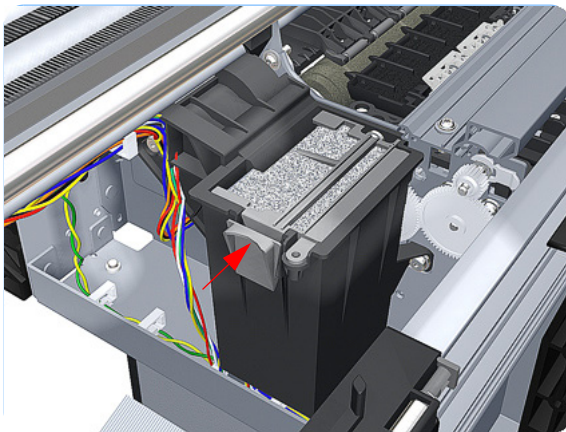

4. Lift the side of the Left Spittoon Retainer with the clip.

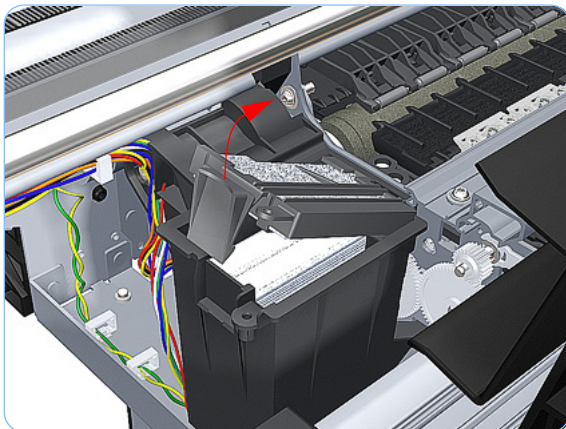

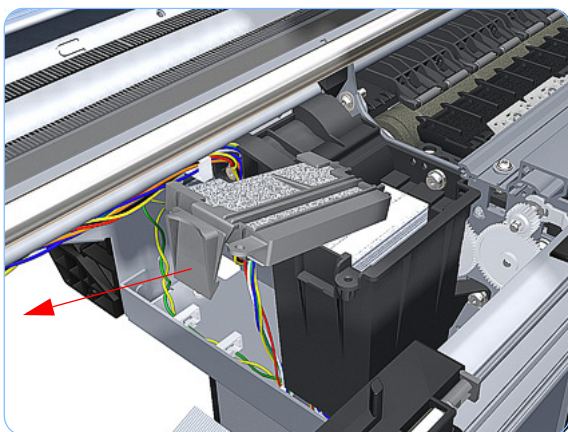

- 5.** Remove the Left Spittoon Retainer from the Left Spittoon.

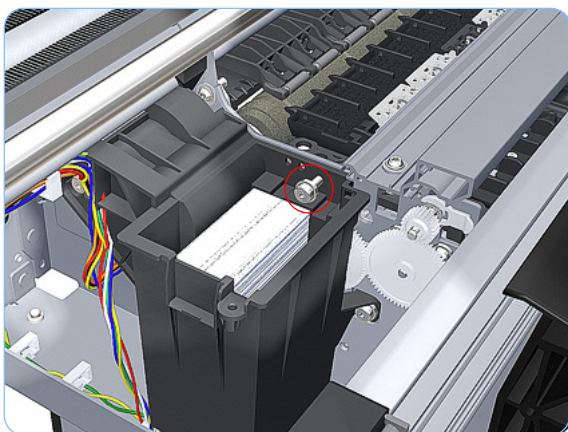

- 6.** Remove one T-8 screw that secures the Left Spittoon to the printer.

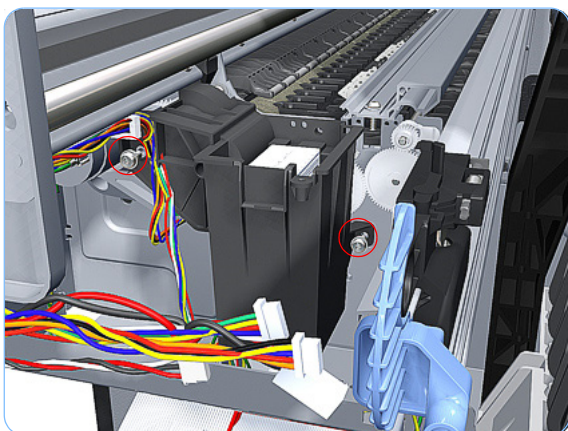

- 7.** Remove two T-8 screws that secure the Left Spittoon to the printer.

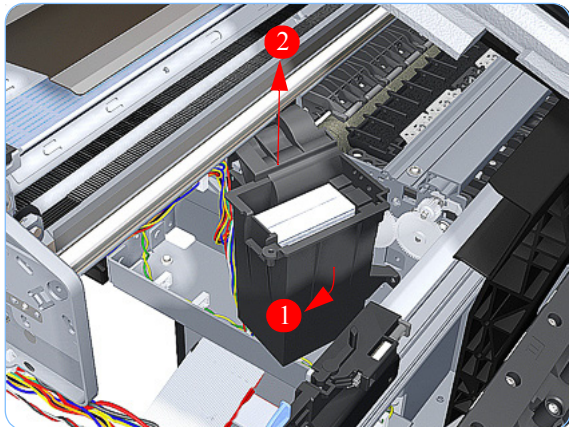

8. Rotate the Left Spittoon clockwise approximately 45 degrees and carefully lift it out of the printer.

Encoder Disk and Encoder Sensor

Removal

Switch off the printer and remove the power cable.

1. Remove the Left Cover (refer to page 6-30).
2. Remove the Electronics Module (Main PCA and PSU) (refer to page 6-165).
3. Remove the Left Spittoon (refer to page 6-177).
4. Remove the Encoder Disk straight off Media Advance Roller spindle, lift it straight out of the printer.

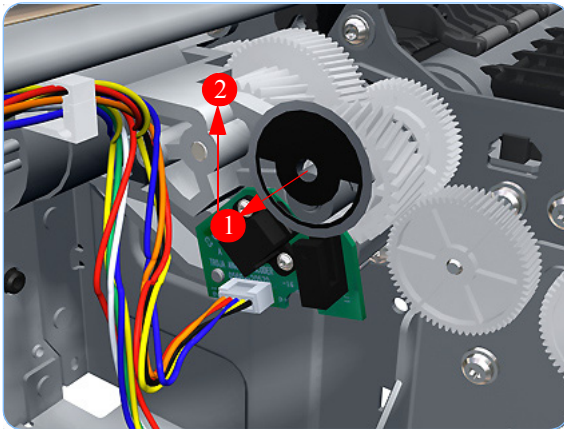

The Media Advance Roller spindle is delicate. Remove the Encoder Disk gently.

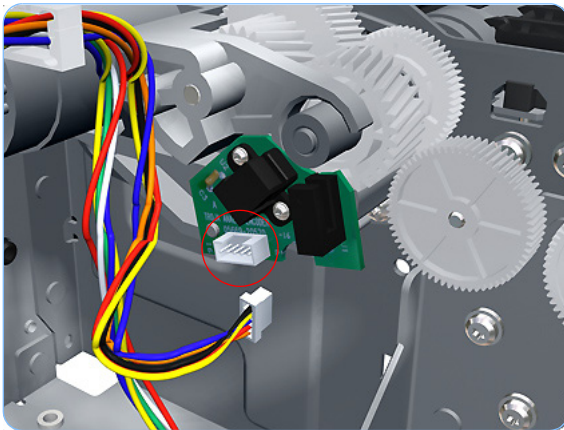

5. Disconnect the Encoder Sensor connector.

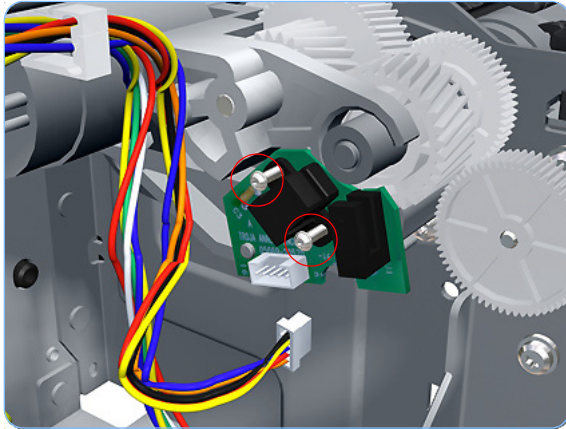

6. Remove two T-6 screws that secure the Encoder Sensor to the Media Advance Drive.

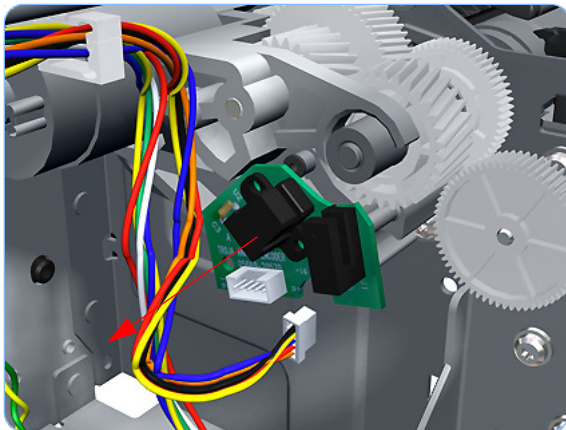

7. Remove the Encoder Sensor PCA from the printer.

Installation

When you finish installing or replacing this component, you must perform the necessary Service Calibrations. To find which calibrations you must perform, Refer to page 6-8, *Service Calibration Guide to Removal and Installation*.

When you replace the Encoder Disk, clean it with the alcohol included in the toolkit.

If you are installing the Encoder Sensor after replacing the Media Advance Drive with a new unit, you will need to adjust the Encoder Sensor position on the Media Advance Drive. To do this you will need Media Advance Drive Adjustment Tool available from the following:

- When you order a new media advance transmission kit and
- From the from the HP Designjet Z2100/Z3100 Printer Tool Kit (Q6683-67001).

1. If you are in installing the Encoder Sensor after replacing the Media Advance Drive with a new unit, first fully loosen the Encoder Sensor position adjustment screw. Ignore this step if you are replacing the previously removed Media Advance Drive.

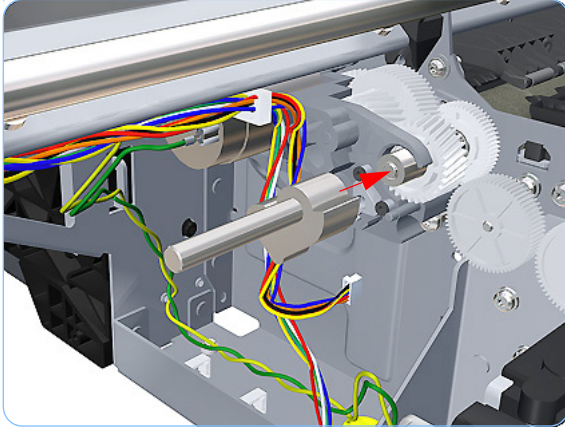

2. Position the Media Advance Drive Adjustment Tool on the end Media Advance Roller shaft, push it firmly onto the shaft and maintain a constant pressure to ensure it is flush to the Media Advance Drive.

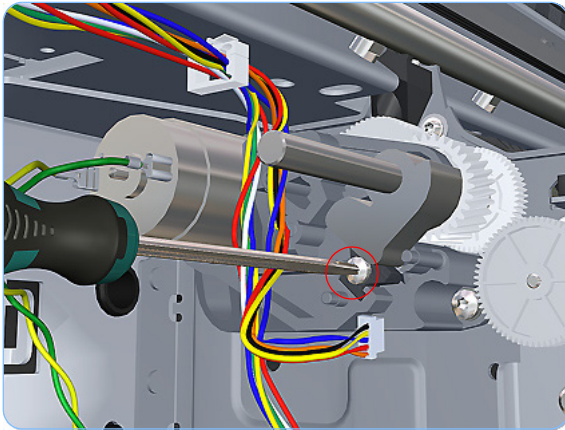

3. While still maintaining pressure on the Media Advance Drive Adjustment Tool, fully tighten the Encoder Sensor position adjustment screw.

This step is important. If not done correctly, the printer may not function correctly.

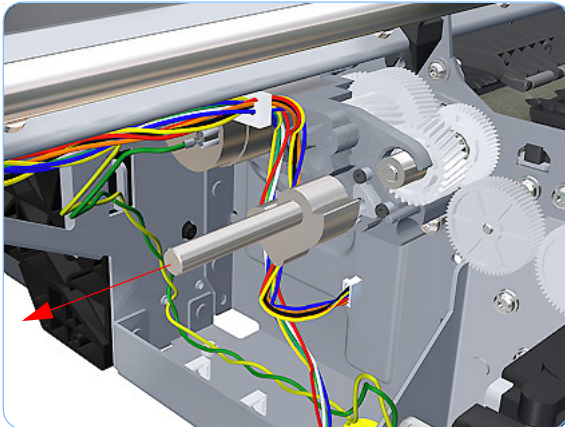

4. Remove the Media Advance Drive Adjustment Tool.
5. Complete the installation of the Encoder Sensor and a new Encoder Disk.

Media Advance Drive

Removal

Switch off the printer and remove the power cable.

1. Remove the Left Cover (refer to page 6-30).
2. Remove the Electronics Module (Main PCA and PSU) (refer to page 6-165).
3. Remove the Left Spittoon (refer to page 6-177).
4. Remove the Encoder Disk and Encoder Sensor (refer to page 6-180).
5. Unroute the Media Advance Drive power cable.

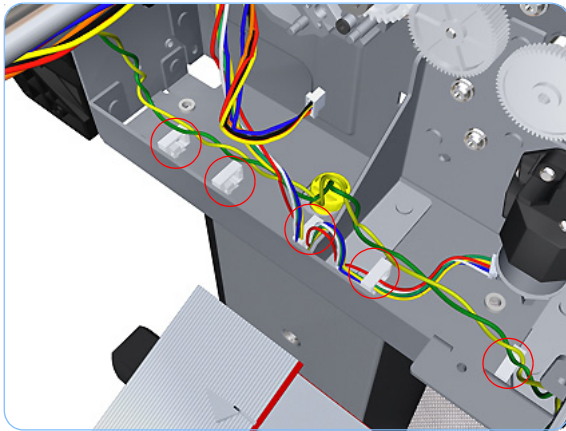

6. Remove three T-15 screws that secure the Media Advance Drive to the printer.

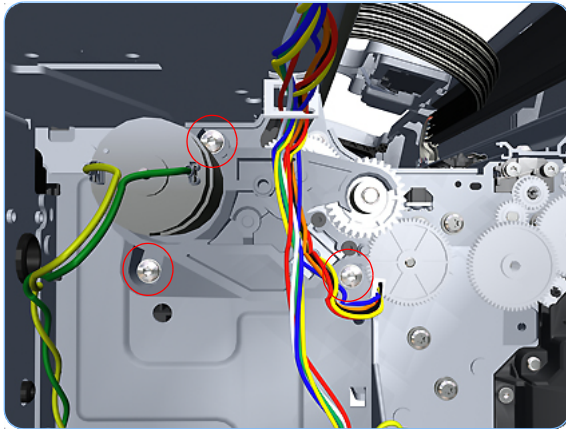

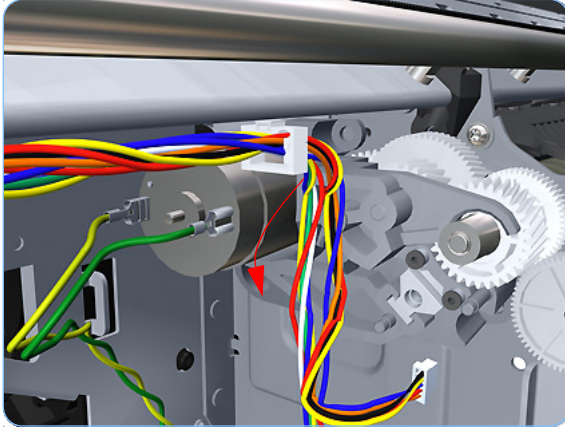

- 7.** Grip the motor housing of the Media Advance Drive and gently pull it towards you sufficiently to allow you disengage the Media Advance Drive from printer.

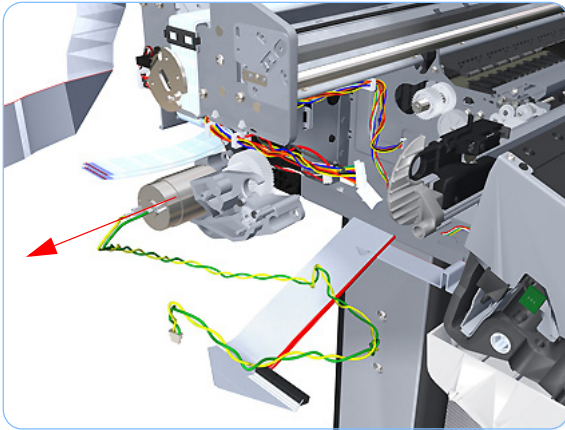

- 8.** Carefully lift the Media Advance Drive out of the printer.

Installation

When you finish installing or replacing this component, you must perform the necessary Service Calibrations. To find which calibrations you must perform, Refer to page 6-8, *Service Calibration Guide to Removal and Installation*.

Use the following procedure to install and correctly adjust a new Media Advance Drive. You will need Media Advance Drive Adjustment Tool from the HP Designjet Z2100/Z3100 Printer Tool Kit (Q6683-67001). If you are installing the Encoder Sensor after replacing the Media Advance Drive with a new unit, you will need to adjust the Encoder Sensor position on the Media Advance Drive (refer to page 6-183).

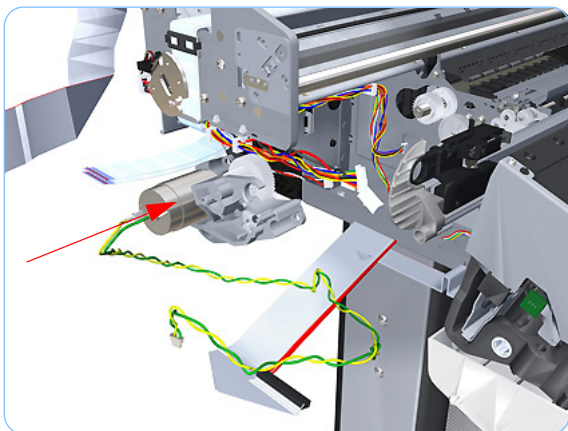

1. Carefully position the Media Advance Drive in the printer.



2. These parts should be loose during disassembly. They will be tightened in the following steps.

Follow these instructions exactly. If you do not follow these instructions, the printer may not function properly.

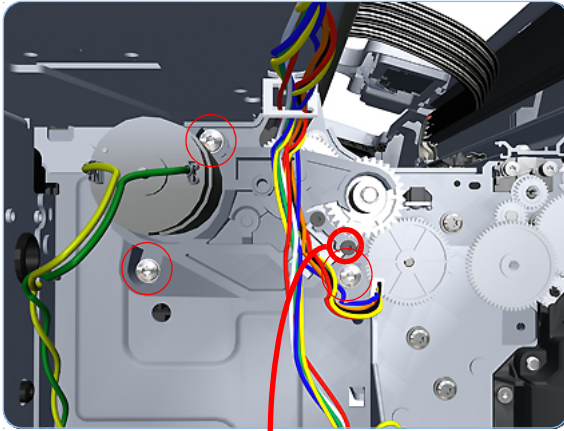

Encoder sensor position adjustment screw

3. Insert the three T-15 attachment screws and the encoder sensor position adjustment screw, but do NOT fully tighten them.

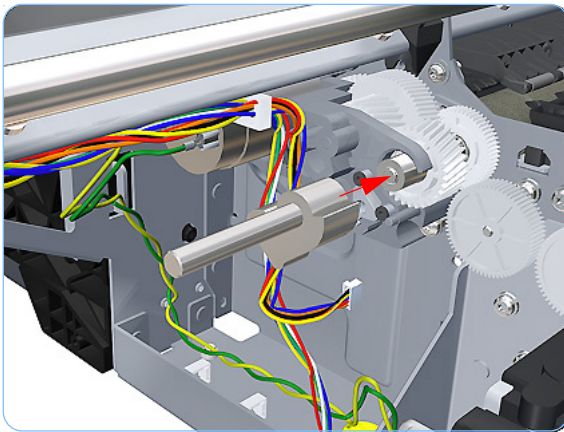

4. Position the Media Advance Drive Adjustment Tool on the end Media Advance Roller shaft, push it firmly onto the shaft and maintain a constant pressure to ensure it is flush to the Media Advance Drive.

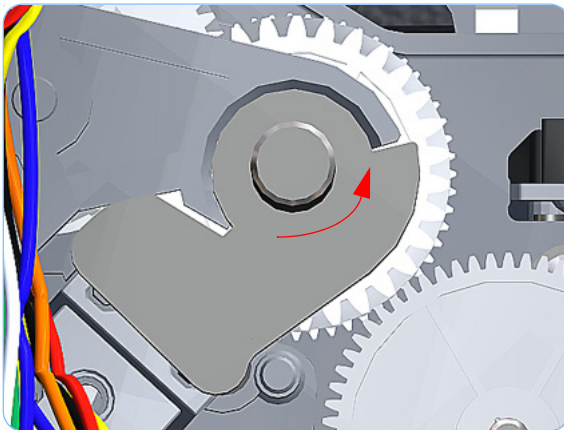

5. Rotate the Media Advance Drive Adjustment Tool fully counter-clockwise to ensure its flat surface of the tool is firmly against the flat surface of the Media Advance Drive mounting.

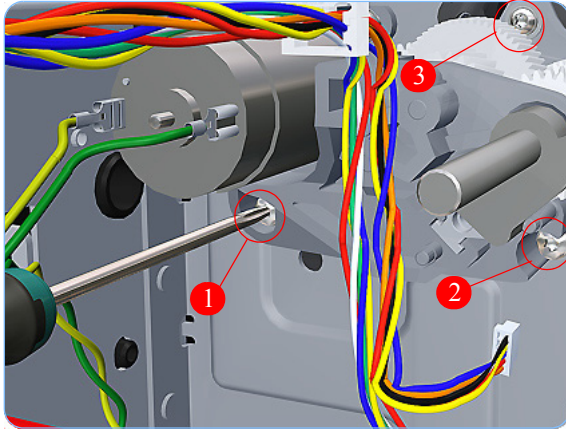

6. While maintaining pressure on the Media Advance Drive Adjustment Tool, fully tighten the three T-15 attachment screws in the order shown.

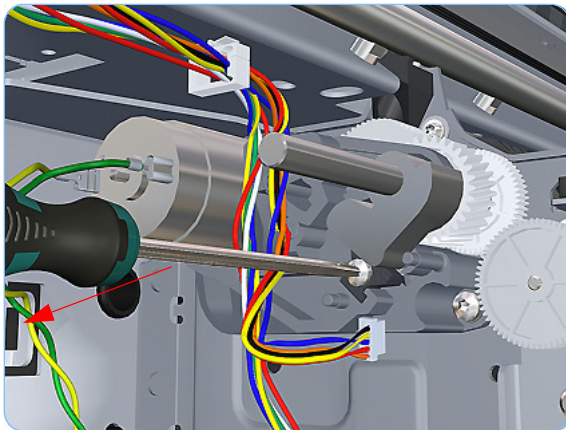

7. While still maintaining pressure on the Media Advance Drive Adjustment Tool, fully tighten the Encoder Sensor position adjustment screw.

This step is important. If not done correctly, the printer may not function correctly.

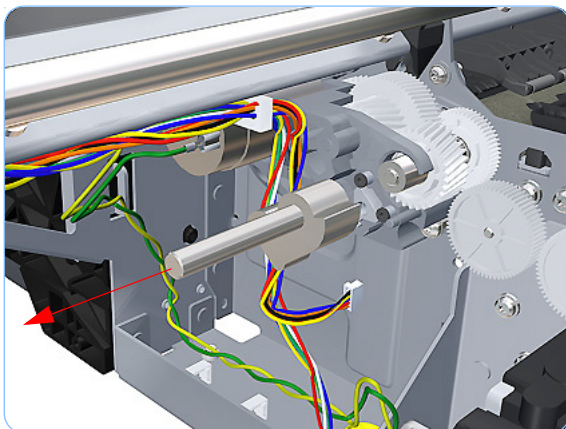

8. Remove the Media Advance Drive Adjustment Tool.

Media Advance Roller

Removal

Switch off the printer and remove the power cable.

1. Remove the Left Cover (refer to page 6-30).
2. Remove the Clean Out Assembly (refer to page 6-78).
3. Remove the Electronics Module (Main PCA and PSU) (refer to page 6-165).
4. Remove the Left Spittoon (refer to page 6-177).
5. Remove the Media Advance Drive (refer to page 6-183).
6. Remove the Media Advance Roller drive gear wheel to gain access the locking plate attachment screw.

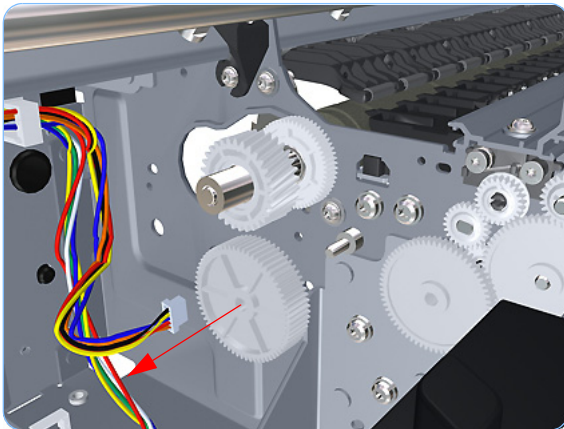

The Media Advance Roller drive gear is delicate, and should be removed straight off the spindle.

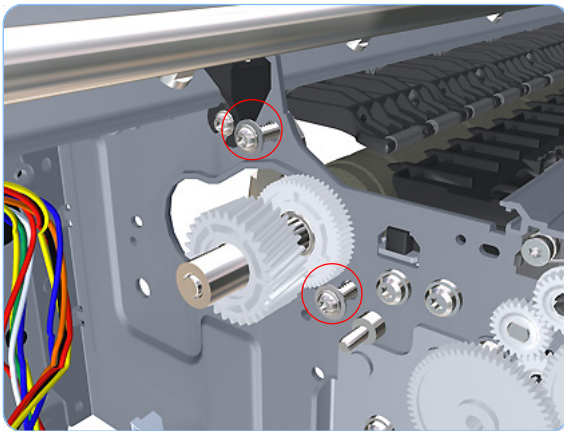

7. Remove two T-15 screws that secure the Media Advance Roller locking plate to the printer.

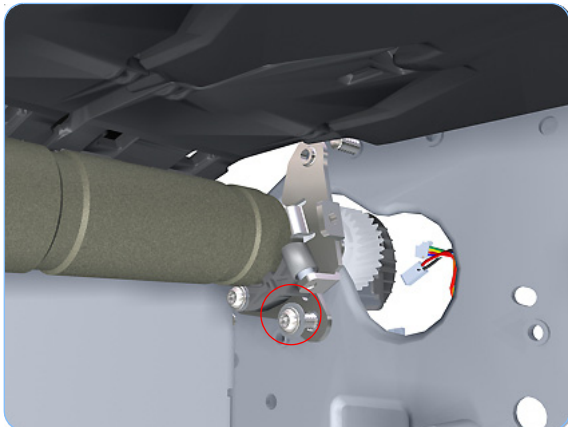

8. Remove one T-15 screw that secures the Media Advance Roller locking plate to the printer.

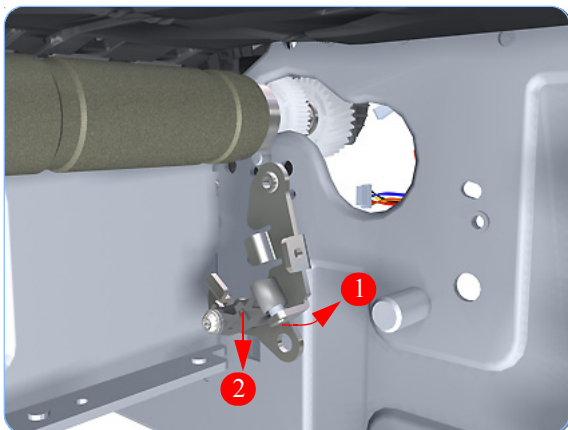

9. Rotate the Media Advance Roller locking plate counterclockwise approximately 10 degrees and remove it from the printer (viewed from the rear of the printer).

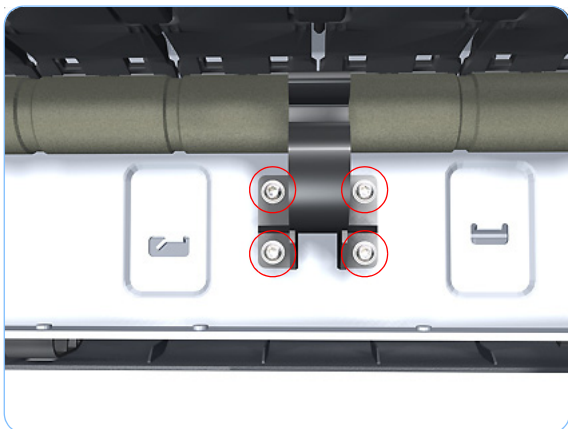

10. Remove four T-15 screws that secure the Media Advance Roller right support to the printer.

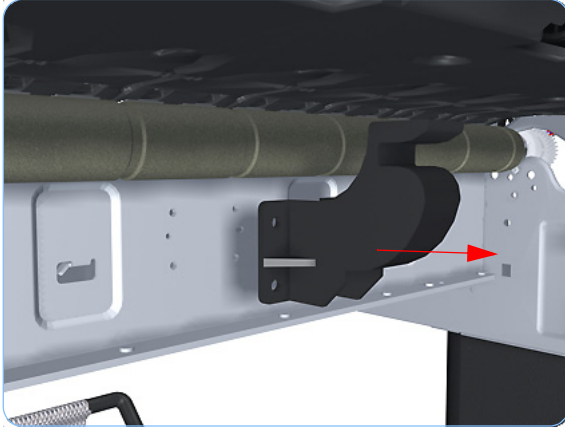

- 11.** Remove the Media Advance Roller right support from the printer.
- 12.** Repeat steps 12 and 13 for the Media Advance Roller left support.



- 13.** Remove two T-15 screws that secure the Media Advance Roller left locking plate (viewed from the rear of the printer).



- 14.** Remove the Media Advance Roller left locking plate (viewed from the rear of the printer).

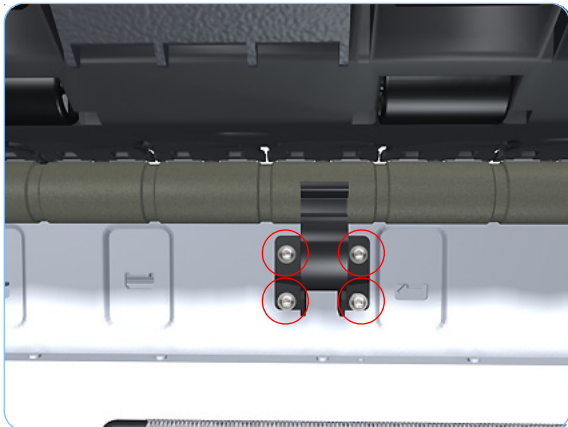

15. Remove four T-15 screws that secure the Media Advance Roller left support to the printer.

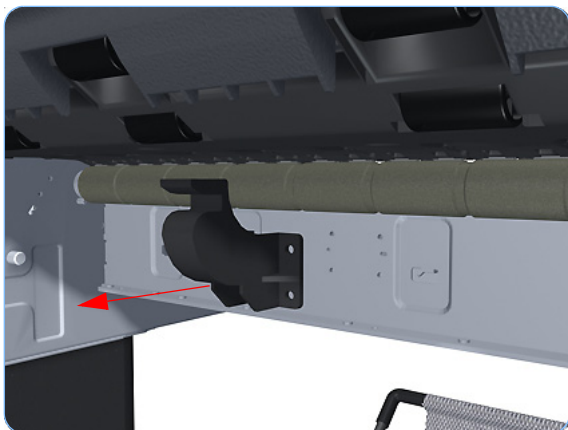

16. Remove the Media Advance Roller left support from the printer.

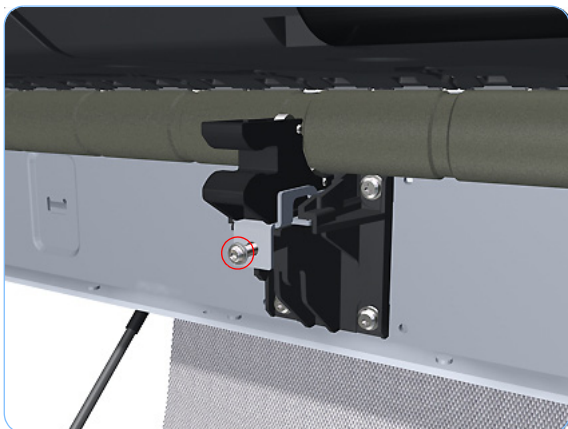

17. Remove one T-15 screw that secures the Media Advance Roller center support locking plate.

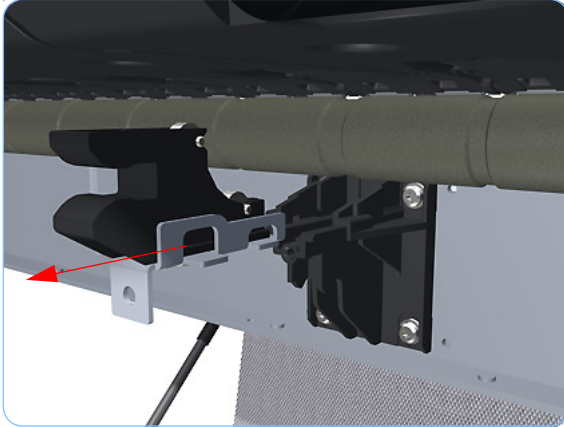

- 18.** With firm pressure, remove the Media Advance Roller center support locking plate.

You will need to use extra force to remove the center support locking plate.

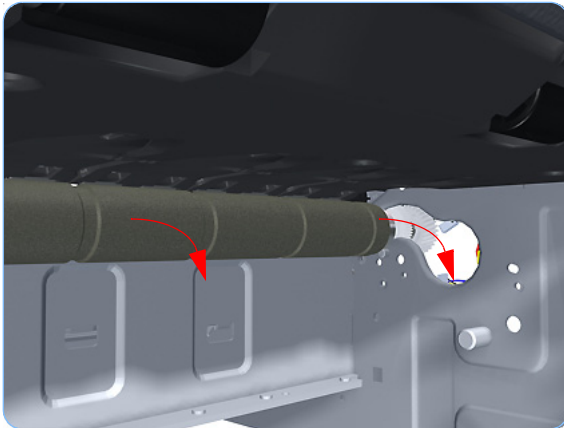

- 19.** Slide the Media Advance Roller into removal position.



- 20.** Slide the Media Advance Roller towards the right (viewed from the rear of the printer) until you can disengage the left end (viewed from the rear of the printer).

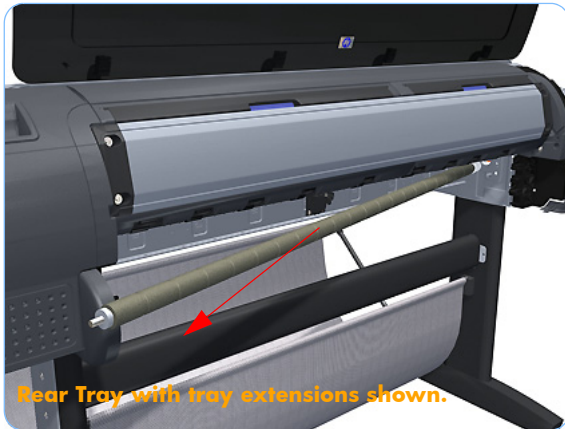

21. Slide the Media Advance Roller towards the left to disengage the left end and remove the Media Advance Roller from the printer.

Do not let the Media Advance Roller touch any surfaces, particularly metallic surfaces.

When you finish installing or replacing this component, you must perform the necessary Service Calibrations. To find which calibrations you must perform, Refer to page 6-8, *Service Calibration Guide to Removal and Installation*.

Pinchwheel Assembly

Removal

Switch off the printer and remove the power cable.

Never remove and replace all the Pinchwheel Assemblies at the same time. In order to align a Pinchwheel Assembly, you need a minimum one Pinchwheel Assembly correctly aligned by the manufacturer.

1. Remove the Window (refer to page 6-13).
2. Remove the Spindle (refer to page 6-75).
3. Remove the Left Roll Guide (refer to page 6-82).
4. Remove the Right Roll Guide (refer to page 6-83).
5. Raise the Media Lever.

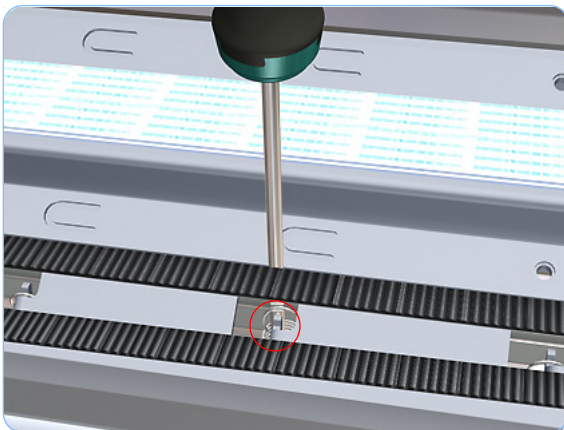
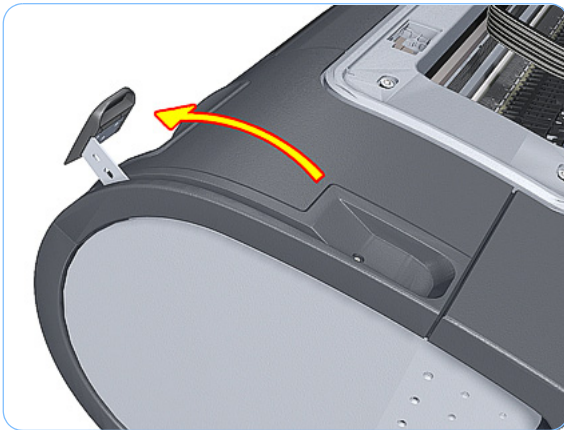

6. Use the Pinchwheel Insertion Tool to remove the spring from the attachment on the printer.

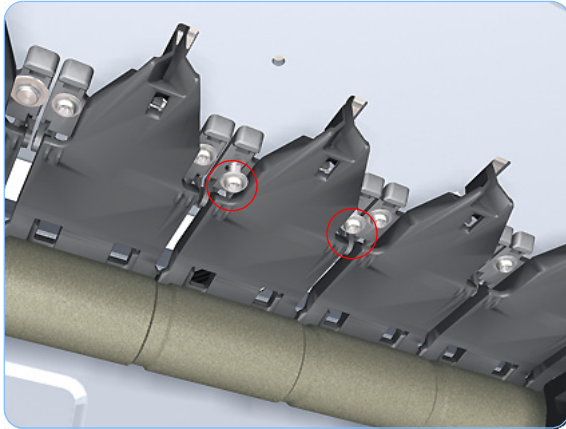

7. Remove two T-15 screws that secure the Pinchwheel Assembly to the printer.

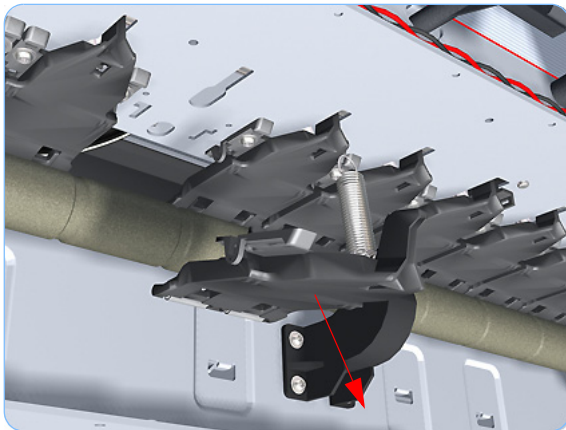

8. Remove the Pinchwheel Assembly from the printer.

Installation

Use the following procedure to align the Pinchwheel Assembly using the Pinchwheel Alignment Tool during reassembly

Never remove and replace all the Pinchwheel Assemblies at the same time. In order to align a Pinchwheel Assembly, you need a minimum one Pinchwheel Assembly correctly aligned by the manufacturer.

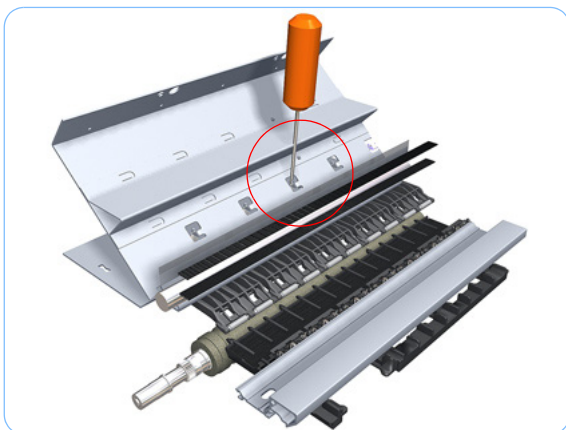

1. Insert the Pinchwheel Insertion Tool through the appropriate access hole for the Pinchwheel Assembly you are installing.

Be very careful not to damage the Encoder Strip or the Belt Assembly with the Pinchwheel Insertion Tool.

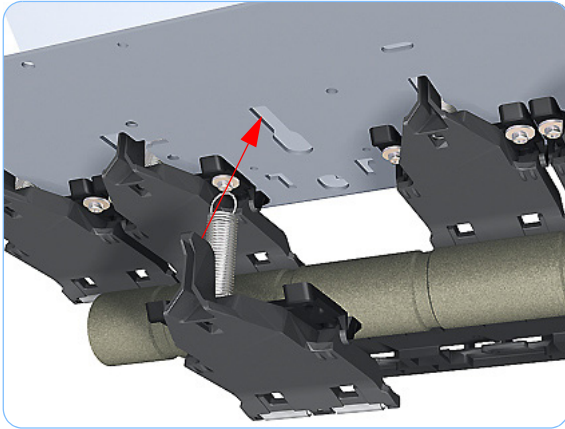

2. Position the new Pinchwheel Assembly correctly on its hanger.

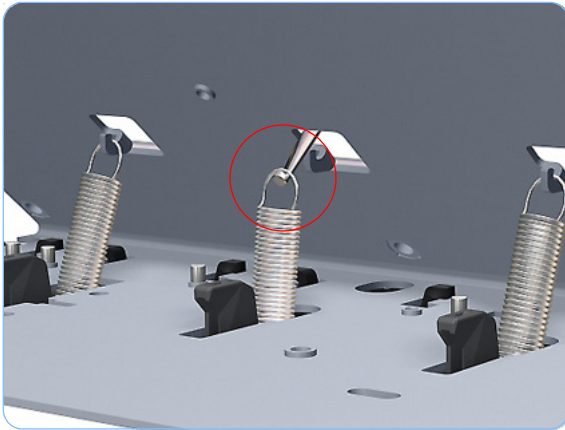

3. Hook the spring of the Pinchwheel Assembly you are installing with the Pinchwheel Insertion Tool.

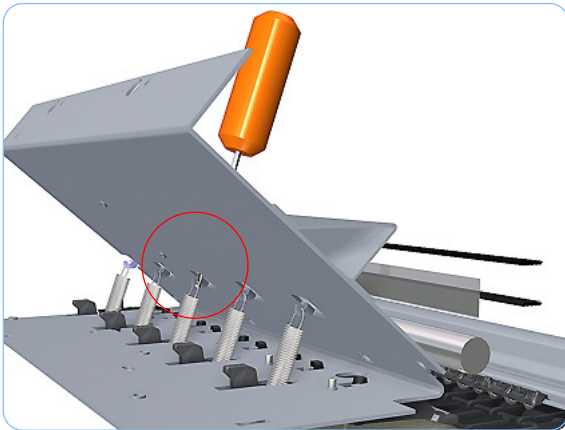

4. Attach the spring to its attachment point on the hanger and remove the Pinchwheel Insertion Tool.

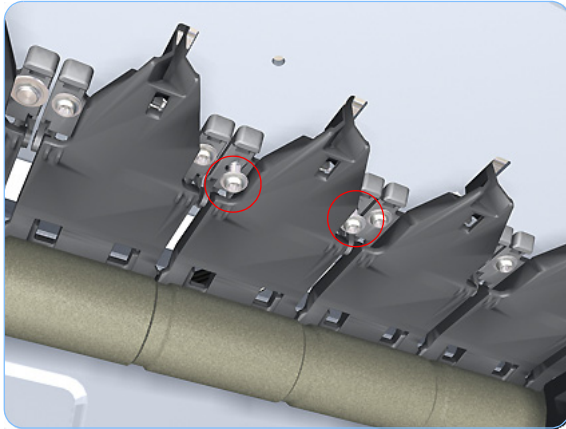

5. Attach the new Pinchwheel Assembly with the two T-15 screws that secure to the printer but do fully NOT tighten the screws.



6. Lower the Media Lever.

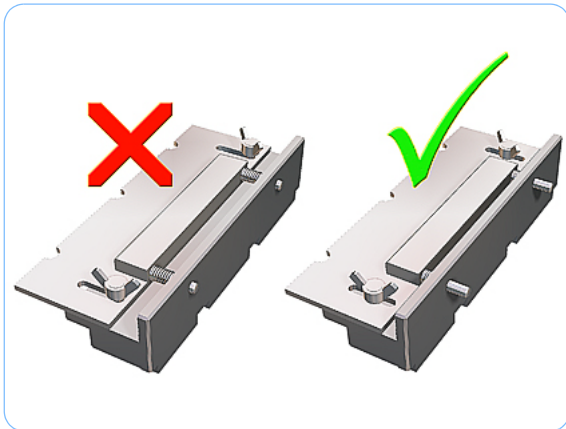

7. Make sure the Pinchwheel Alignment Tool is in the collapsed position.

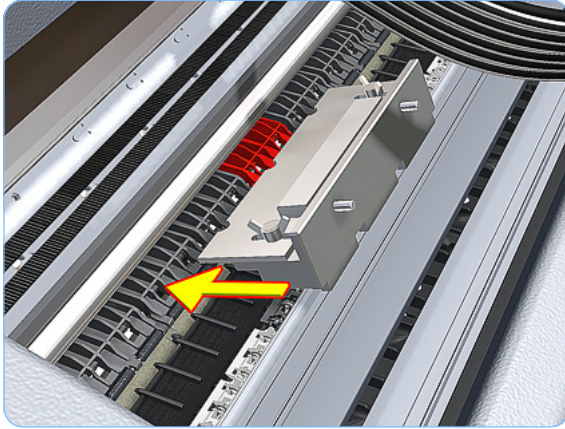

8. Fit the end of the Pinchwheel Alignment Tool to the Pinchwheel Assembly you need to align.

Alternate view, Step 8

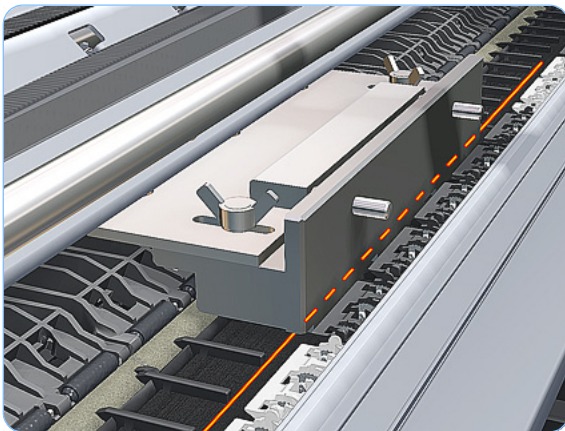
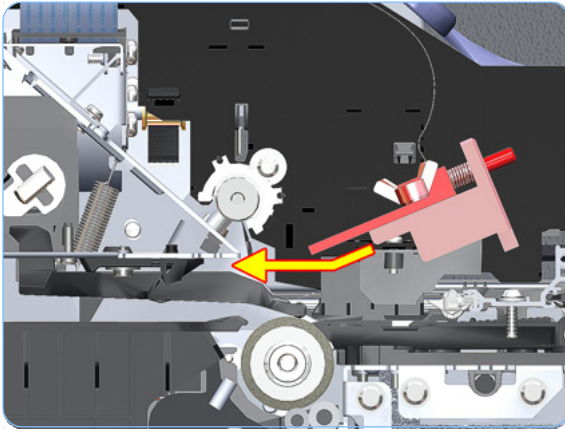

9. Set the Pinchwheel Alignment Tool on the print platen. The tool should fit like it does in the graphics shown.

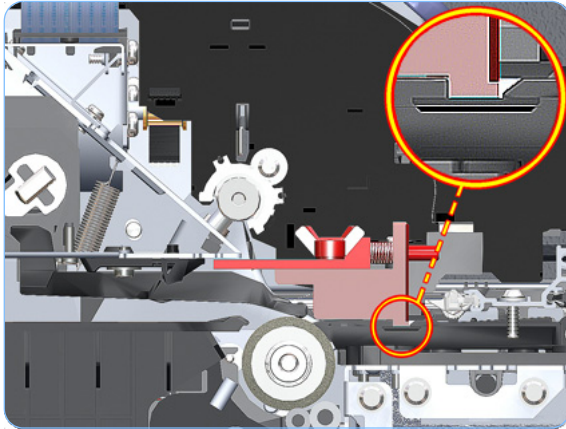

Alternate view, Step 9

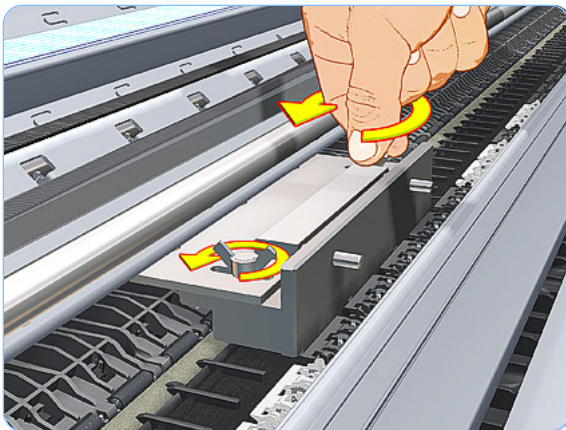

- 10.** Loosen the wing nuts on the Pinchwheel Alignment Tool.

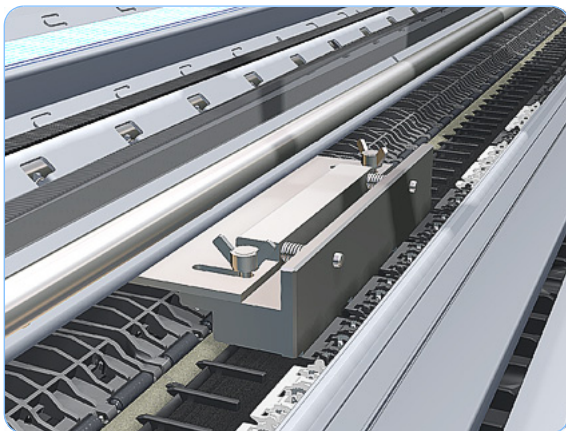

- 11.** Allow the Pinchwheel Alignment Tool to expand. Make sure that the tool is fully expanded.

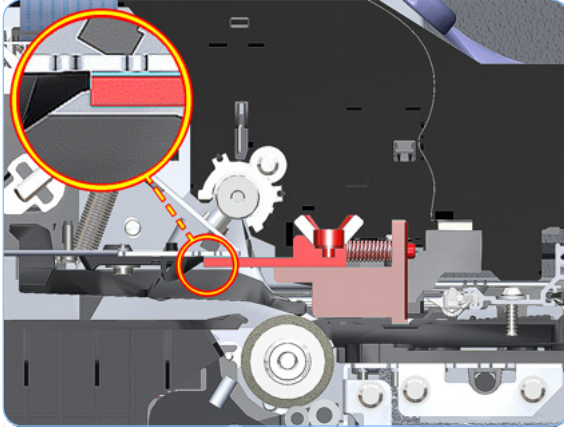

Alternate view, Step 11

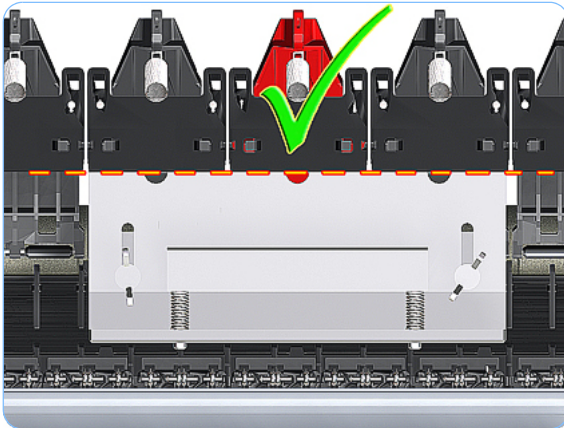

- 12.** When the Pinchwheel Alignment Tool is fully expanded, the Pinchwheel Assembly is properly aligned.

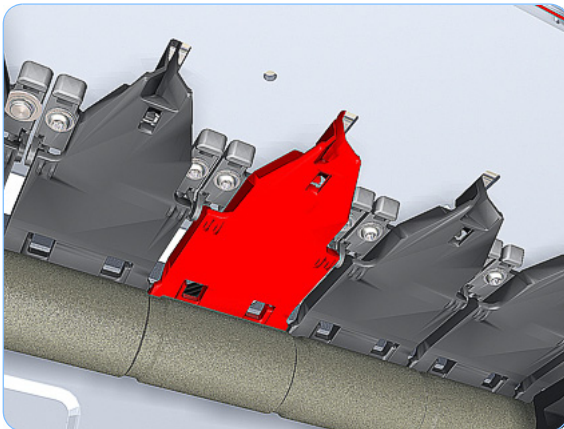

- 13.** Fully tighten the two T-15 attachment screws that secure the Pinchwheel Assembly to the printer.

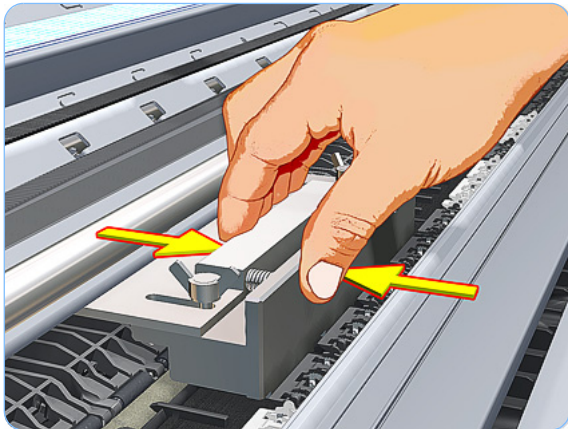

14. Collapse the Pinchwheel Alignment Tool to remove it.

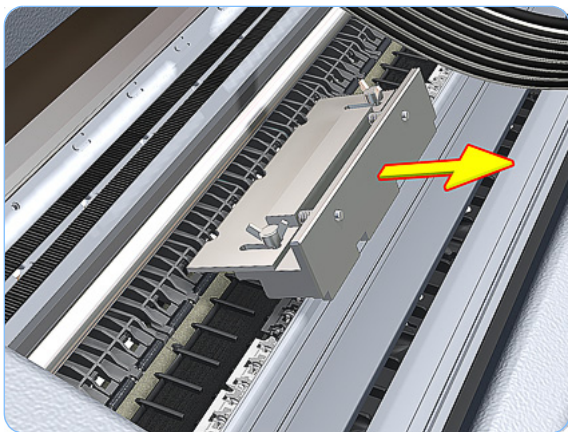

15. Remove the Pinchwheel Alignment Tool from the printer.

When you finish installing or replacing this component, you must perform the necessary Service Calibrations. To find which calibrations you must perform, Refer to page 6-8, *Service Calibration Guide to Removal and Installation*.

Pinch Roller

Removal

Switch off the printer and remove the power cable.

1. Open the Window.
2. Raise the Media Lever.

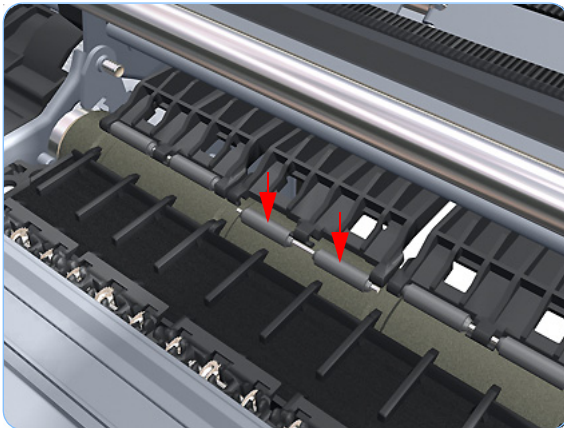
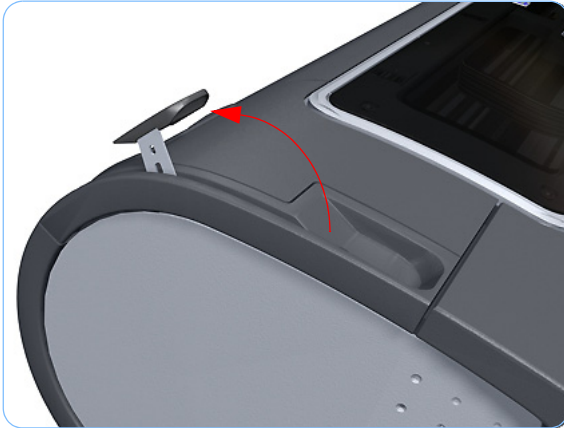

3. Apply enough downward pressure to the Pinch Roller to release it from the Pinchwheel Assembly.

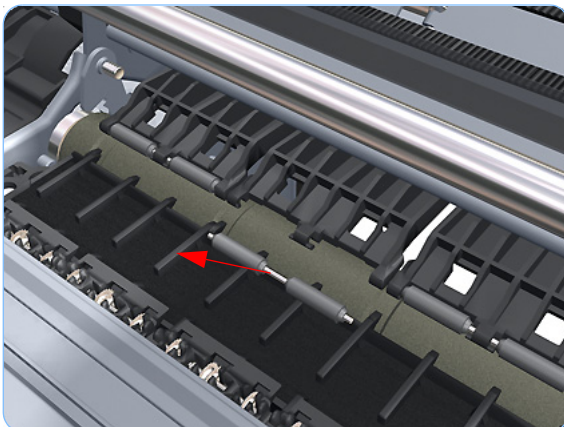

4. Remove the Pinch Roller.

When you finish installing or replacing this component, you must perform the necessary Service Calibrations. To find which calibrations you must perform, Refer to page 6-8, *Service Calibration Guide to Removal and Installation*.

Rubber Pinchwheel Kit

Replacement

Switch off the printer and remove the power cable.

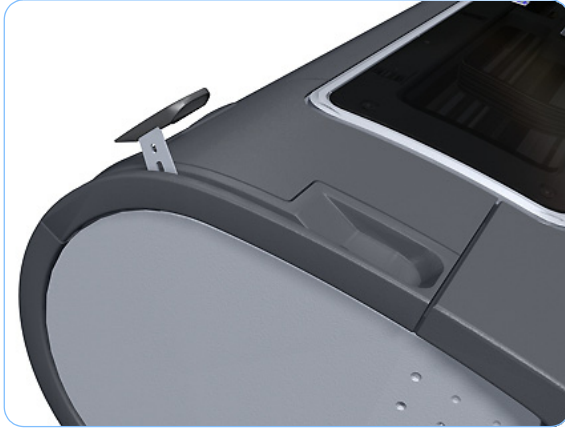

1. Raise the Media Lever.

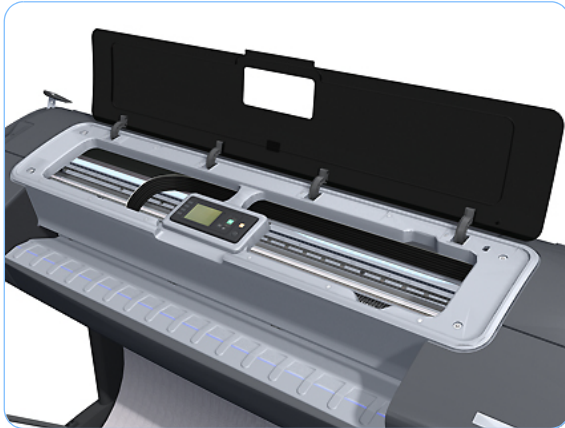

2. Open the Window.

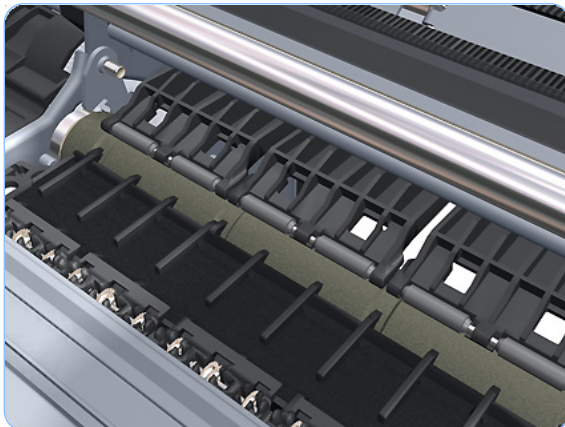

3. Lift the Pinchwheel Assembly from the center of the Pinch Roller using the Plastic Tie included in the Rubber Pinchwheel Kit.

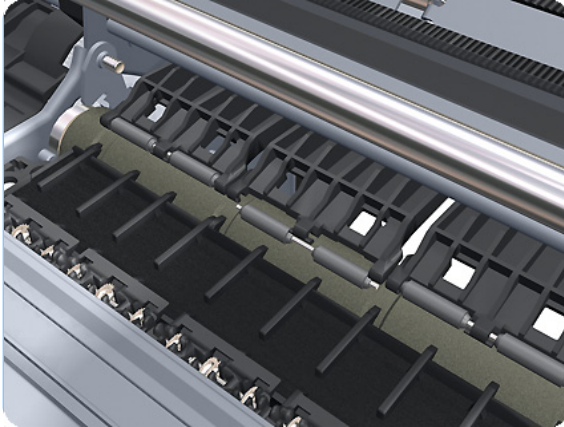

4. With the Plastic Tie in place, apply downward pressure on the Pinch Roller (do not apply pressure to the Pinchwheel Assembly) with two fingers until you hear a "click." Apply pressure close to the center of the Pinch Roller to avoid bending the metal shaft.

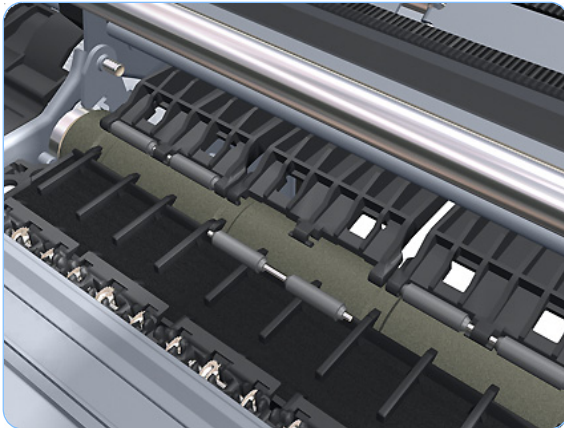

5. When the Pinch Roller is fully released, remove it from the printer.

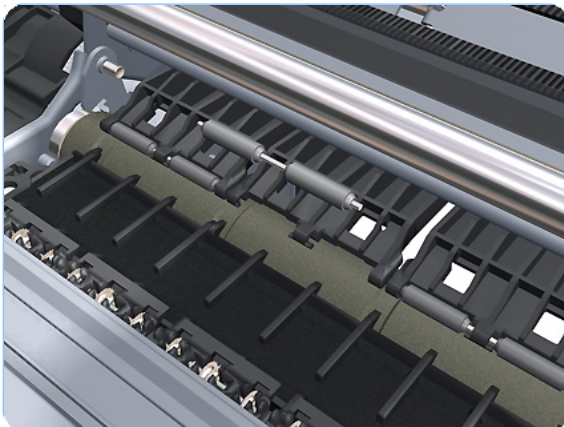

6. Take two new pinch rollers and fit them onto a Pinch Roller metal shaft.

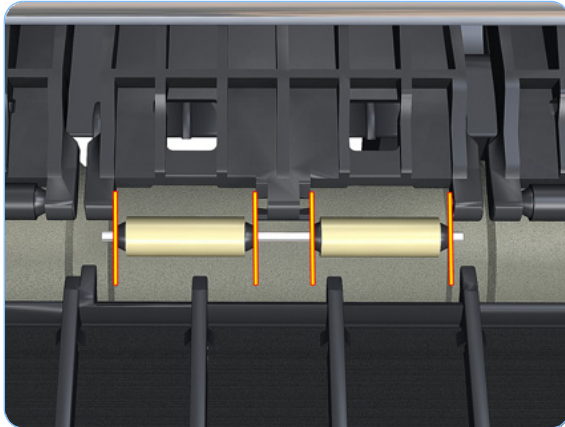

7. Place the new Pinch Roller (assembled in the last step) on the platen, as close as possible to the Grit Roller. Take care that the Pinch Roller is positioned properly, according to the graphic.

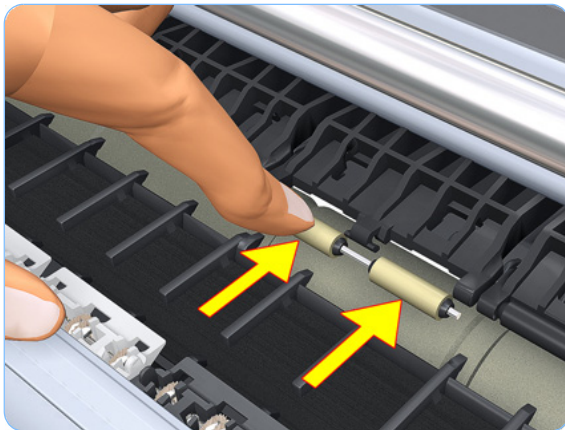

8. Make sure the Media Lever is still up. Roll the new Pinch Roller into position below the Pinchwheel Assembly.

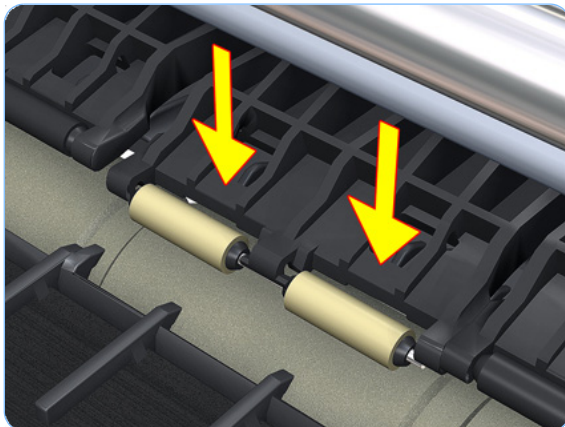

9. Carefully apply even, downward pressure on the Pinchwheel Assembly, and make sure that the Pinch Roller is directly below the corresponding clip.

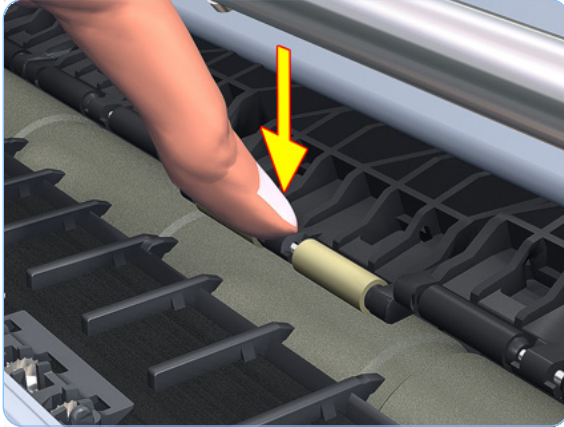

10. SNAP IT INTO PLACE: Finally, press down on the center to snap the Pinch Roller metal shaft into place. When the Pinch Roller metal shaft is correctly snapped into place, you will hear a "click".

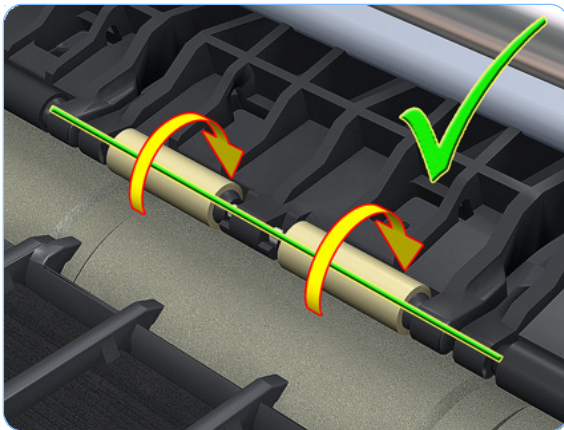

11. When the assembly operation is finished, the Pinch Rollers should be aligned with the Pinchwheel Assembly as shown. The rollers should also turn freely, without friction.

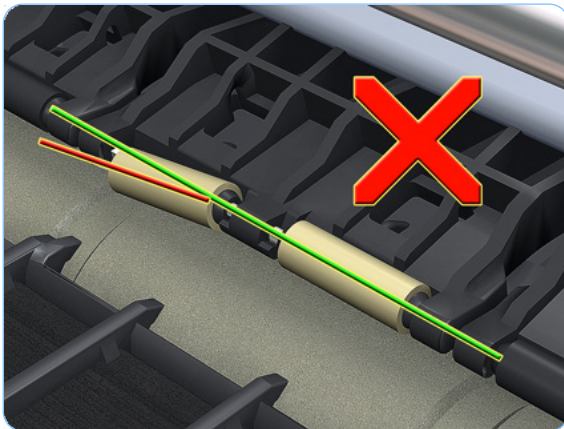

12. If the rollers are NOT correctly aligned or do NOT turn freely, remove the new Pinch Roller and go back to step 7. Make sure the new Pinch Roller was not damaged in any way.

The Rubber Pinchwheel Kit includes 4 Pinchwheel Assemblies in case these parts are damaged during installation. When you finish installing or replacing this component, you must perform the necessary Service Calibrations. To find which calibrations you must perform, Refer to page 6-8, *Service Calibration Guide to Removal and Installation*.

Left Starwheel Lifter

Removal

Switch off the printer and remove the power cable.

For Z3200 series: To be able to remove this assembly, the starwheels rail must be at the HIGH position. To reach this position, restart the printer. During the initialization (near the beginning), the printer will raise the starwheels rail to the HIGH position. Turn off the printer when the starwheels rail is at the highest point using the rear button.

1. If you are working on a Z3200 series printer, set the starwheels rail to the HIGH position using the procedure outlined in the note above.
2. Remove the Front Cover (refer to page 6-17).
3. Remove the Left Cover (refer to page 6-30).
4. Remove the Electronics Module (Main PCA and PSU) (refer to page 6-165).
5. Remove the Left Spittoon (refer to page 6-177).
6. Remove the Starwheel Assembly (refer to page 6-168).
7. Remove two T-8 screws that secure the Left Starwheel Lifter to the printer.

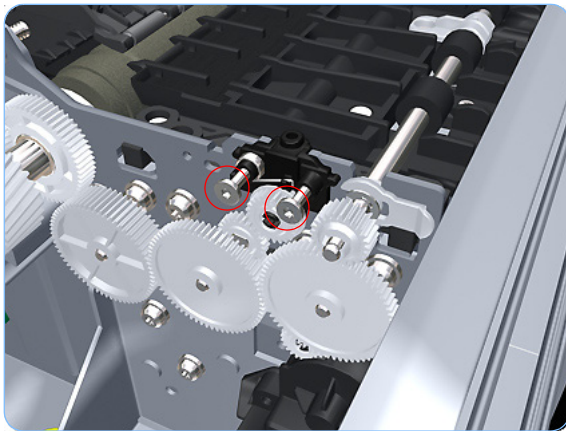

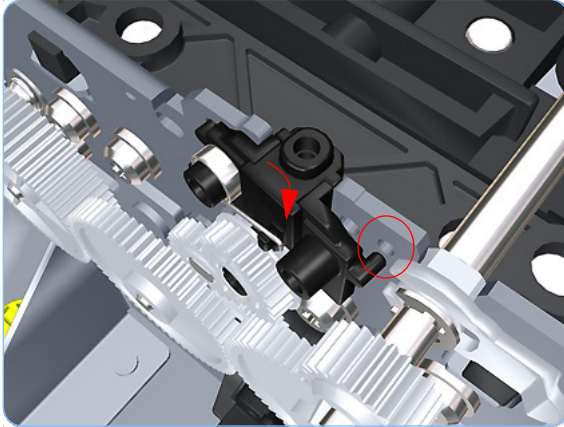

8. Rotate the Left Starwheel Lifter sufficiently to disengage the right attachment lug.

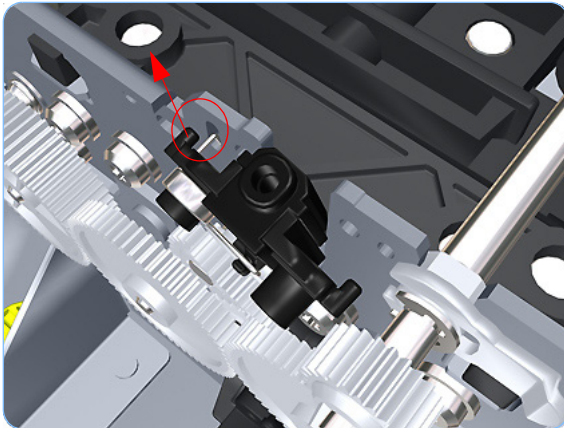

9. Tilt the Left Starwheel Lifter sufficiently to disengage the left attachment lug.

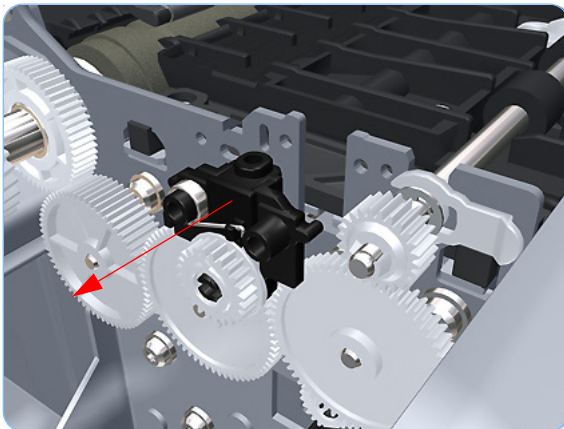

10. Remove the Left Starwheel Lifter from the printer.

When you finish installing or replacing this component, you must perform the necessary Service Calibrations. To find which calibrations you must perform, Refer to page 6-8, *Service Calibration Guide to Removal and Installation*.

Installation

The following installation procedure is used only for Z3200 printers (Q6675C) and Z2100 Revision C printers (Q6677C).

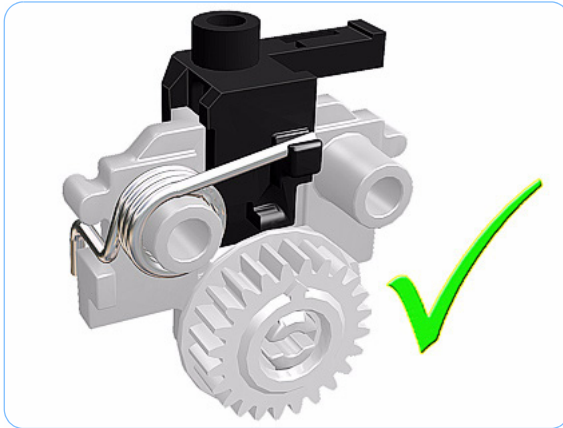

1. For Z3200/Z2100 Revision C series printers, turn the cam gear on the left end support until the support is in the highest position.

Take care that the spring does not jump out of the left end support.

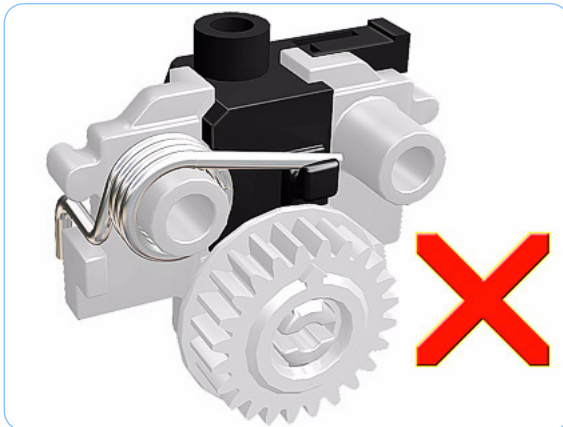

2. Do not leave it in the low position.

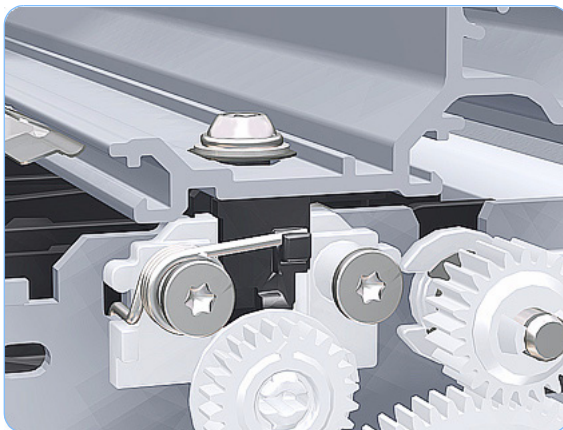

3. When mounted, it should appear as it does in this illustration.

Right Starwheel Lifter

Removal

Switch off the printer and remove the power cable.

For Z3200 series: To be able to remove this assembly, the starwheels rail must be at the HIGH position. To reach this position, restart the printer. During the initialization (near the beginning), the printer will raise the starwheels rail to the HIGH position. Turn off the printer when the starwheels rail is at the highest point using the rear button.

1. If you are working on a Z3200 series printer, set the starwheels rail to the HIGH position using the procedure outlined in the note above.
2. Remove the Front Cover (refer to page 6-17).
3. Remove the Right Cover (refer to page 6-27).
4. Remove the Starwheel Assembly (refer to page 6-168).
5. Loosen the T-10 uncapping screw sufficiently so you can manually move the Carriage Assembly in step 6.

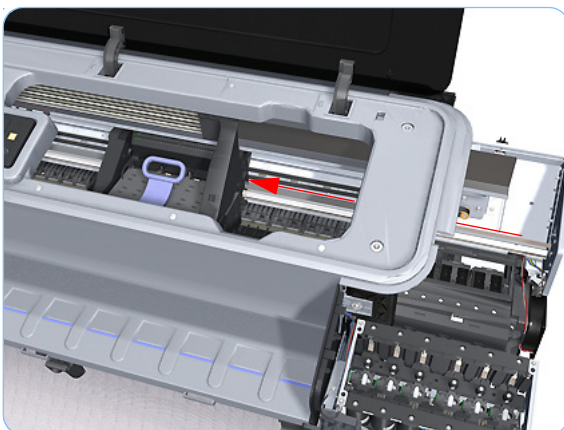
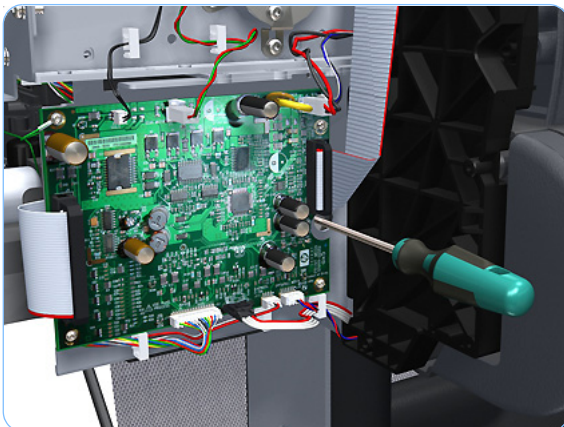

6. Push the Carriage Assembly into the print path.

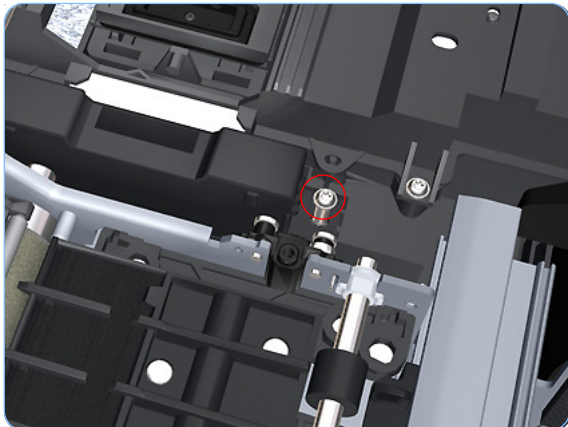

7. Remove one T-15 screw that secures the Drop Detector to the Service Station.

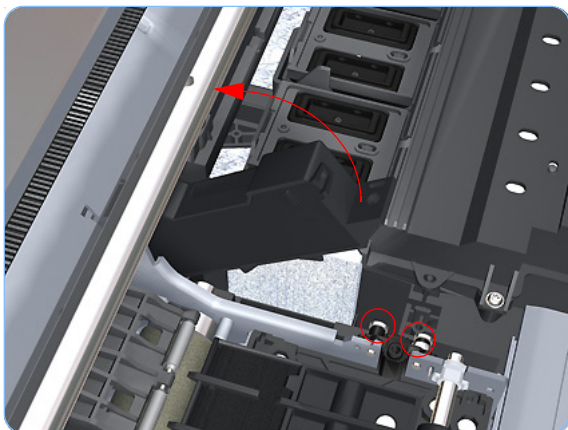

8. Rotate the Drop Detector vertically to gain access to the two screws that secure the Right Starwheel Lifter.

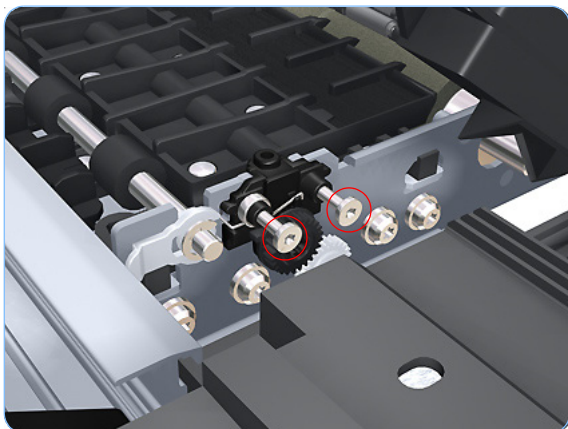

9. Remove two T-8 screws that secure the Right Starwheel Lifter to the printer.

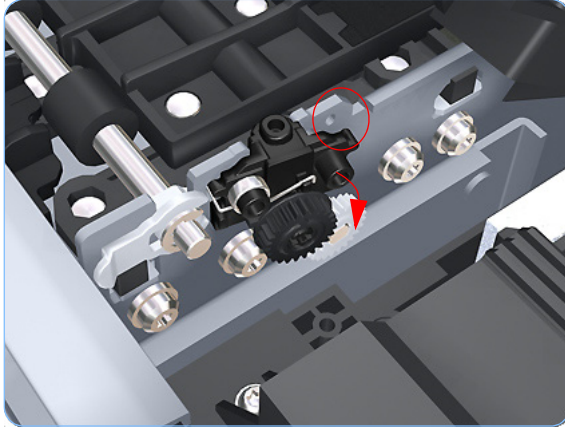

10. Rotate the Right Starwheel Lifter sufficiently to disengage the right attachment lug.

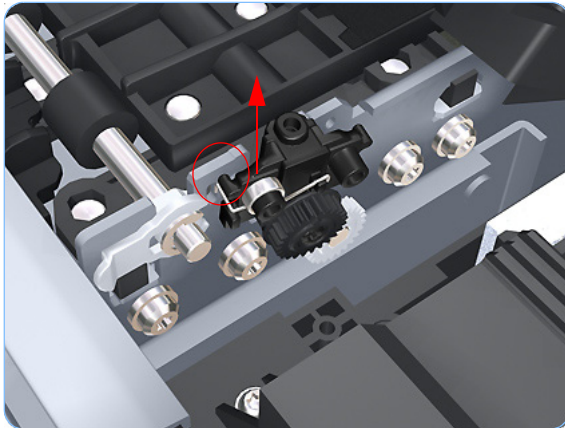

11. Tilt the Right Starwheel Lifter sufficiently to disengage the left attachment lug.

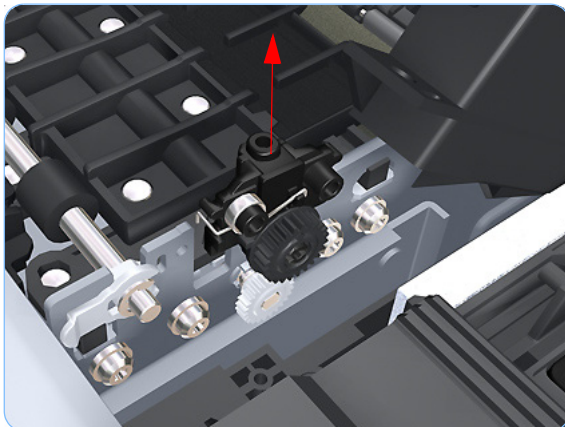

12. Remove the Right Starwheel Lifter from the printer.

When you finish installing or replacing this component, you must perform the necessary Service Calibrations. To find which calibrations you must perform, Refer to page 6-8, *Service Calibration Guide to Removal and Installation*.

Installation

The following installation procedure is used only for Z3200 printers (Q6675C) and Z2100 Revision C printers (Q6677C).

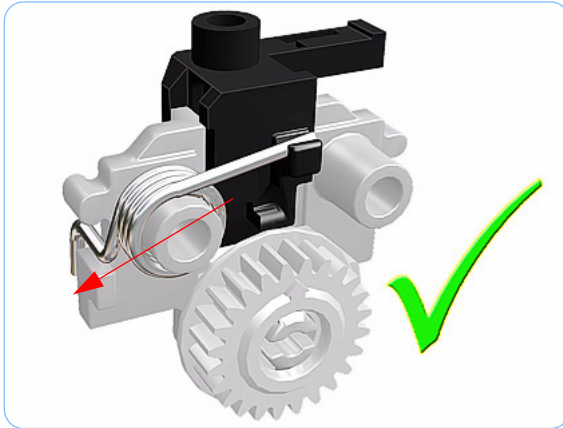

1. For Z3200/Z2100 Revision C series printers, turn the cam gear on the left end support until the support is in the highest position.

Take care that the spring does not jump out of the left end support.

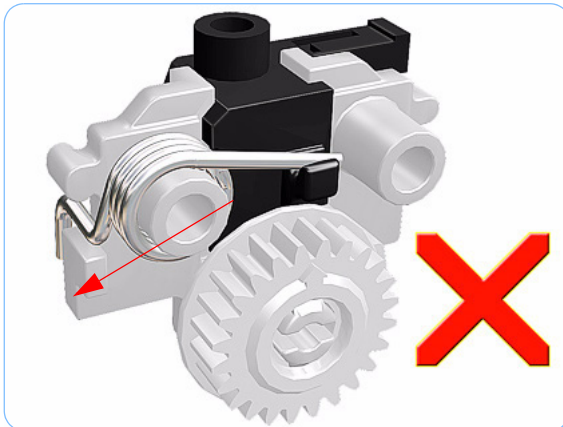

Starwheel Motor

Removal

Switch off the printer and remove the power cable.

1. Remove the Front Cover (refer to page 6-17).
2. Remove the Left Cover (refer to page 6-30).
3. Remove the Electronics Module (Main PCA and PSU) (refer to page 6-165).
4. Remove the Left Spittoon (refer to page 6-177).
5. Disconnect the Starwheel Motor electrical connector.

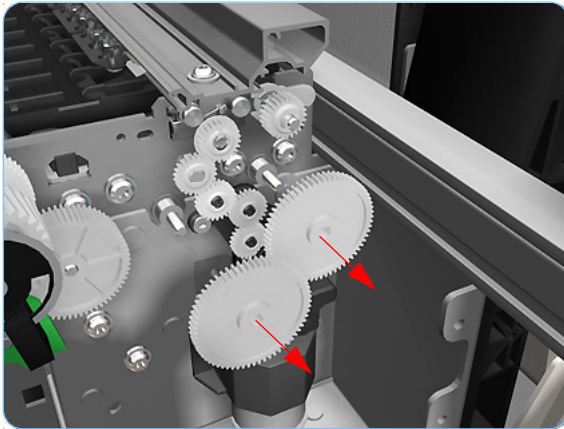
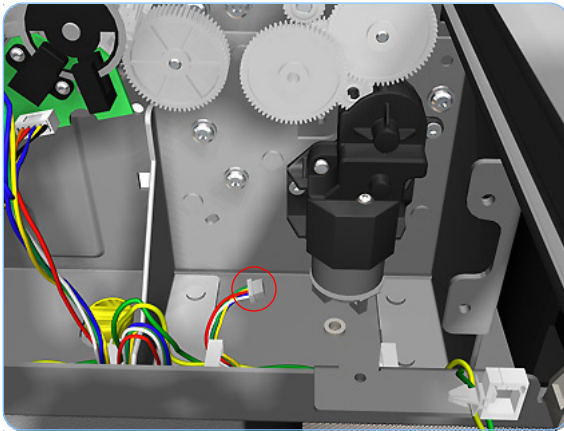

6. Carefully pull the two gear wheels off their shafts to gain access to the Starwheel Motor attachment screws.

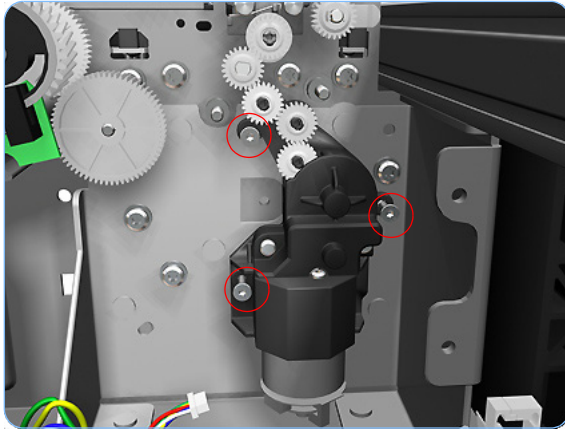

7. Remove three T-15 screws that secure the Starwheel Motor to the printer.

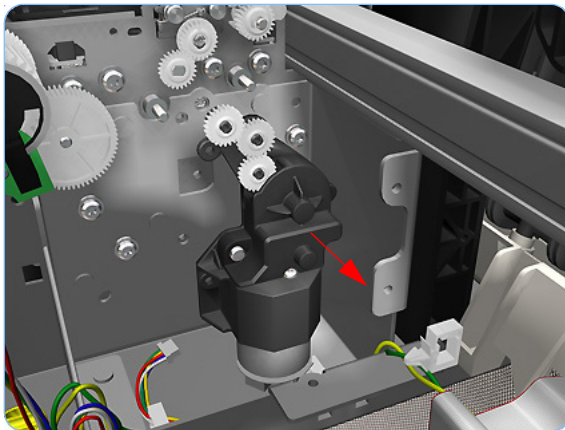

8. Lift the Starwheel Motor out of the printer.

When you finish installing or replacing this component, you must perform the necessary Service Calibrations. To find which calibrations you must perform, Refer to page 6-8, *Service Calibration Guide to Removal and Installation*.

Full Bleed Foam

Removal

Switch off the printer and remove the power cable.

The complete Full Bleed Foam is constructed of three separate sections, left, center and right. This procedure only describes how to remove the left section. Removal of the other two sections is identical.

1. Open the Window.
2. Remove the Left Full Bleed Foam from the left platen.
3. Remove the Platten Middle Foams that are exposed once the Full Bleed Foam has been removed.



When you reinstall the full bleed foams, take care to correctly seat them to avoid possible damage to the Carriage Assembly

Preventive Maintenance



Preventive Maintenance 7-2
Moisture on the Printer 7-2
Noisy Carriage Bushing 7-2
Belt Swelling 7-2
Cleaning the Printer 7-2
General Cleaning 7-3
Cleaning the Drive Roller and Overdrive 7-3
Level of Printer Usage 7-3
Preventive Maintenance Kits 7-5
Preventive Maintenance Kit #1 7-5
Preventive Maintenance Kit #2 7-6
Preventive Maintenance Kit #3 7-6

Preventive Maintenance

Moisture on the Printer

Users should use the Printer in an environment between 20% and 80% relative humidity. To recover from moisture condensation, turn the Printer Off, and, using the main roller as a reference, wait until the Printer is completely dry before using it again.

Noisy Carriage Bushing

To prevent noisy movement of the carriage, remove aluminum or dust particles from the bushing at the back of the carriage, and from the slider path along which the bushing moves. Lubricate the slider path using the Lubrification Kit (Q5669-60692).

Belt Swelling

To prevent new belts from swelling incorrectly, keep them in their bags with desiccant until you need to install them.

Cleaning the Printer

To maintain the Printer in good operating condition, keep it free of dust accumulation, ink, and other contamination. Cleaning intervals are determined by the Printer environment and by the types of Printer supplies used.

Carriage Assembly Lubrication

To ensure correct operation of the printer you must lubricate the Carriage Assembly whenever any of the following are encountered if:

- The Front Panel displays "Maintenance #1 required".
- There is excessive noise when moving the Carriage Assembly.
- A shut down of the carriage PWM error message appears.
- There are IQ (vertical banding problems).

You should also lubricate the Carriage Assembly whenever you change any of the following service parts:

- The Carriage Rear Bushing.
- The Carriage Assembly.
- The Carriage Rail Oiler.

To lubricate the Carriage Assembly you will require the Lubrification Kit (Q5669-60692). Use the following procedure to lubricate the Carriage Assembly:

- 1 Use the IPA alcohol (Q6675-60070) and the cleaning cloth to clean the Carriage Rail and the Carriage Slider Rod.

- 2 Use an Oil Dispenser (Q6675-60062) to lubricate the Carriage Rail and the Carriage Slider Rod.
- 3 Replace the Carriage Rail Oiler (refer to page 5-122) with the new one contained in the kit and add 2-3 drops of oil to the foam of the Carriage Rail Oiler.
- 4 Use an Oil Dispenser (Q6675-60062) to lubricate the Carriage Rear Bushing.

General Cleaning

Proper general cleaning should include the following:

To prevent an electric shock, make sure that the Printer is switched OFF and unplugged before any cleaning is performed. Do NOT let any water get inside the Printer.

- 1 Blow away dust accumulation with compressed air if available.
- 2 Clean the outer surface of the Printer with a damp sponge or cloth. Use a mild soap and water solution if necessary. Do not use abrasive cleaners.
- 3 Wipe the Printer dry with a soft lint-free cloth.

Cleaning the Drive Roller and Overdrive

**If ink is spilled on the Overdrive, remove the ink immediately. Due to the ink's reflectance, ink on the Overdrive can disrupt the Printer's edge-sensing function. To remove any ink from the Overdrive, perform the following procedure:
Prevent water or other liquids from running onto electrical components or circuits, or through openings in the Electronics Module.**

- 1 Perform the Turn Drive Roller Utility (Refer to Page 3-61).
- 2 Open the window and apply any common household cleaning solution (water based only) to a soft, lint-free rag and apply it to the Drive Roller and Overdrive surface while it is rotating. Make sure that you thoroughly clean the Drive Roller and Overdrive surface.
- 3 Press **Enter** when you have completed the cleaning procedure.
- 4 Allow the Drive Roller to dry before loading media in to the Printer.

Level of Printer Usage

Normal printer use means 6,000,000 Carriage Cycles (which corresponds to approximately 100,000 A0 prints on average). Under normal usage conditions, it will be approximately 5 years before the printer needs maintenance. If the printer is used more than the normal usage conditions, then it will need maintenance service much more frequently.

One of the EEROM counters is assigned to counting the number of carriage cycles.

Service Part	LIFE_VALUE	Maintenance Advice
Belt Cycles	6000000	PMKIT1
Bushings Life	3000000	PMKIT1
Trailing Cable Cycles	3000000	PMKIT1
Scan Axis Cycles	6000000	PMKIT1
Scan Axis Distance Covered	4500000	PMKIT1
Tubes Cycles	6500000	PMKIT1
Service Station Life	450000000	PMKIT2
Left Spittoon Volume	51000000	PMKIT2
Cutter Life	25000	PMKIT3

When these components of the Printer exceed this amount, the front panel displays the following message:

"Maintenance #1 required"

"Maintenance #2 required"

"Maintenance #3 required"

Once one of the maintenance advised messages is displayed, the relevant preventive maintenance kit must be used to replace the most worn parts of the printer. Use the Removal and Installation Chapter of this Service Manual as a guide to replace the necessary parts.

Preventive Maintenance Kits

Preventive Maintenance Kit #1

The Preventive Maintenance Kit #1 is available in the following different versions:

Z2100 (24 inch) P/N Q6675-67019

Part Number	Description
Q6675-67020	Carriage Assy SV (with Trailing Cable)
Q6675-60021	Ink Supply Tubes 24 SV
Q5669-60673	Belt 24 SV
Q5669-60674	Scan Axis Motor SV
Q5669-60692	Lubrication Kit SV

Z2100 (44 inch) P/N Q6677-67003:

Part Number	Description
Q6677-67004	Carriage Assy SV (with Trailing Cable)
Q6677-60007	Ink Supply Tubes 44 SV
Q6659-60175	Belt 44 SV
Q5669-60674	Scan Axis Motor SV
Q5669-60692	Lubrication Kit SV

Z3100/Z3100ps (24 inch) P/N Q5669-67050:

Part Number	Description
Q5669-67051	Carriage Assy SV (with Trailing Cable)
Q5669-60671	Ink Supply Tubes 24 SV
Q5669-60673	Belt 24 SV
Q5669-60674	Scan Axis Motor SV
Q5669-60692	Lubrication Kit SV

Z3100/Z3100ps (44 inch) P/N Q6659-67013:

Part Number	Description
Q6659-67014	Carriage Assy SV (with Trailing Cable)
Q6659-60174	Ink Supply Tubes 44 SV
Q6659-60175	Belt 44 SV
Q5669-60674	Scan Axis Motor SV
Q5669-60692	Lubrication Kit SV

Z3200/Z3200ps (24 inch) P/N Q6718-67011:

Part Number	Description
Q6718-67012	Carriage Assy 24 inch
Q5669-60681	Trailing Cable
Q6718-67002	Ink Supply Tubes 24 inch
Q5669-60673	Belt 24 SV
Q5669-60674	Scan Axis Motor SV
Q5669-60692	Lubrication Kit SV

Z3200/Z3200ps (44 inch) P/N Q6719-67002:

Part Number	Description
Q6719-67003	Carriage Assy 44 inch
Q6659-60177	Trailing Cable
Q6719-67001	Ink Supply Tubes 44 inch
Q6659-60175	Belt 44 SV
Q5669-60674	Scan Axis Motor SV
Q5669-60692	Lubrication Kit SV

After replacing a preventive maintenance kit, make sure to reset the relevant life counter. For the Reset Life Counters procedure, refer to page 3-66.

Preventive Maintenance Kit #2

The Preventive Maintenance Kit #2 is available in the following different versions:

All versions (24 inch/44 inch) P/N Q6718-67026

Part Number	Description
Q6718-67025	Service Station
Q5669-67049	Left spittoon

After replacing a preventive maintenance kit, make sure to reset the relevant life counter. For the Reset Life Counters procedure, refer to page 3-66.

Preventive Maintenance Kit #3

The Preventive Maintenance Kit #3 is available in the following different versions:

All versions (24 inch/44 inch) P/N Q5669-60722

Part Number	Description
Q5669-60713	Cutter Assembly SV

After replacing a preventive maintenance kit, make sure to reset the relevant life counter. For the Reset Life Counters procedure, refer to page 3-66.

