



DesignJet T7100 and T7100 Monochrome Printer Series

Service Manual

© 2012, 2018 HP Development Company, L.P.

4th edition, August 2018

Legal notices

This document contains proprietary information that is protected by copyright. All rights are reserved. No part of this document may be photocopied, reproduced, or translated to another language without the prior written consent of HP Company.

Notices

<p>Warranty</p> <p>The information contained in this document is subject to change without notice.</p> <p>HP makes no warranty of any kind with regard to this material, including, but not limited to, the implied warranties of merchantability and fitness for a particular purpose.</p> <p>HP shall not be liable for errors contained herein or for incidental or consequential damages in connection with the furnishing, performance, or use of this material.</p>	<p>WARNING</p> <p>The procedures described in this manual are to be performed by HP-qualified service personnel only.</p> <p>Electrical shock hazard</p> <p>Serious shock hazard leading to death or injury may result if you do not take the following precautions:</p> <ul style="list-style-type: none"> • Ensure that the AC power outlet (mains) has a protective earth (ground) terminal. • Disconnect the printer from the power source prior to performing any maintenance. • Prevent water or any other liquids from running onto electrical components or circuits, or through openings in the enclosure. <p>Electrostatic discharge</p> <p>Refer to the beginning of Service tests and utilities on page 85 in this manual for precautions you should take to prevent damage to the printer circuits from electrostatic discharge.</p> <p>Safety symbols</p> <p>General definitions of safety symbols are given immediately after the table of contents.</p>	<p>WARNING</p> <p>The Warning symbol calls attention to a procedure, practice, or the like, which, if not correctly performed or adhered to, could result in personal injury. Do not proceed beyond a Warning symbol until the indicated conditions are fully understood and met.</p> <p>CAUTION</p> <p>The Caution symbol calls attention to an operating procedure, practice, or the like, which, if not correctly performed or adhered to, could result in damage to or destruction of part or all of the product. Do not proceed beyond a Caution symbol until the indicated conditions are fully understood and met.</p>
<p>Customer Assurance</p> <p>Customer Experience Section</p> <p>Large Format Printing Division</p> <p>HP Española, S.L.</p> <p>Cami de Can Graells, 1-21</p> <p>08174 Sant Cugat del Vallès</p> <p>Spain</p>		

Using this manual

Purpose

This service manual contains information necessary to test, calibrate, and service:

- HP DesignJet T7100 printer (Models CQ105A, CQ105B, CQ106A)
- HP DesignJet T7100 Monochrome printer (Models CQ101A, CQ102A)

For information about using these printers, refer to the *Using your printer* manual.

Readership

The procedures described in this service manual are to be performed by HP-certified service personnel only.

Part Numbers

Part numbers for printer options, accessories, and service parts are located in [Parts and diagrams on page 185](#).

Table of contents

1 Printing tips and tricks	1
Paper loading	2
Paper-advance calibration	2
Printhead alignment	2
Use of multiple rolls	3
2 Troubleshooting	5
Printer education and training	7
Firmware update	7
Print-quality troubleshooting	8
Troubleshooting system error codes	8
Performing a service test on a failed assembly	8
Performing the necessary service calibrations	8
The printer does not power on	8
The printer hangs during printing and displays 'processing'	9
The printer continuously rejects printheads	9
A new maintenance cartridge is incorrectly detected as 'used'	10
Cover sensors are not working	10
The Line Sensor has problems detecting paper	10
How to remove the Left Hub when the actuator is broken	10
Troubleshooting paper jams and printhead crashes	11
Troubleshooting shutdowns	12
Vacuum suction much lower at high altitudes	13
Banding at variable extreme environmental conditions	13
Printhead crashes/smears on high-density prints using coated paper	13
Banding due to ink cartridge replacement while printing	14
34" Rice Paper not supported	14
Worm marks on HP Coated Paper with light area fills	14
Solving paper-handling problems	14
Difficult to load paper: "Too much skew"	15
How to read the power switch LEDs	15
How to read the Formatter LEDs	15

If the front panel turns on and then stops	17
How to interpret the Service Information Pages	18
When the main window is open and the printer is printing (safety compliance)	26
How to troubleshoot the 79:04 system error	27
3 System error codes	39
What to do if the front panel is blank	40
System error codes	40
Explanation of system error codes and warnings	40
Continuable and non-continuable error codes	43
4 Ink supplies	73
What are ink supplies?	74
General information about the ink supplies	76
General precautions when handling ink supplies	76
Priming the ink system	77
When should you replace the ink supplies?	77
Obtaining Ink Cartridge information	77
Obtaining Printhead information	78
Summary of solving ink supplies problems	82
Troubleshooting Printhead error codes	82
Carriage Interconnect Wiper	83
Warranty information for ink supplies	84
5 Service tests and utilities	85
Introduction	86
Diagnostics—self test	86
Phone support	86
Service tests (diagnostics)	86
Entering the Service Tests menu	87
Service utilities	103
6 Service calibrations	119
Service calibrations	120
Entering the Service Calibrations menu	121
7 Print quality	143
Initial print-quality troubleshooting actions	144
Troubleshooting tools	146
How to use the Image Quality Service Diagnostic Print	149

Print-quality issues by symptom	167
Working with other commercially available papers	179
8 Parts and diagrams	185
Printer	186
Stacker	207
9 Printer part removal and installation	217
Service part order	218
Disassembly order	221
10 Stacker part removal and installation	425
Right Cover	426
Left Cover	428
Top Cover	429
Lower Front Cover	432
Pinchwheels	437
Drive Motor	439
Front Cover Sensor	441
Safety Temperature Sensor	442
Temperature Sensor PCA	444
Media Sensor	447
Extension Tray	449
Receiving Tray	450
Printer Interlocks	452
Paper Infeed Platen	454
Electronics PCA	455
Power Supply Unit	457
Heating Lamp	462
Heat Roller	466
Transport Belt	468
11 Preventive maintenance	475
Moisture on the printer	476
Noisy Carriage Bushing	476
Belt swelling	476
General cleaning	476
Clean the Drive Roller and Overdrive	476
Clean the Platen	477
Clean the Encoder Strip	478

Clean the Paper-advance Sensor window	480
Apply oil to the Overdrive	480
Lubricate the Carriage Assembly	481
Scheduled maintenance	482
Preventive Maintenance Kits	482

1 Printing tips and tricks

- [Paper loading](#)
- [Paper-advance calibration](#)
- [Printhead alignment](#)
- [Use of multiple rolls](#)

Paper loading

Rolls with 3-inch cores cause fewer ink smears and paper jams, and the finished prints stack better, in the bin or the HP stacker.

To avoid selecting the wrong paper name when loading, we recommend hiding paper types that you never use, which can be done from the HP Utility.

Paper-advance calibration

The printer will automatically start paper-advance calibration in the following situations.

- A new type of plain or coated paper is loaded for the first time. Each type is calibrated separately: for instance, there is one calibration for plain paper and another for HP Universal Inkjet Paper.
- A new matte-black printhead is installed.
- The firmware is updated.

Calibration adjusts the paper advance to reduce banding and line continuity issues for each paper type (including all different roll sizes). It is important to use a different front-panel name for each paper type. For example, if a third-party plain paper A is loaded as “plain” in the front panel, and a third-party paper B is also loaded as “plain”, the printer may not be optimized for paper B. We recommend in this case using a different name for B, for instance “HP Universal Inkjet Paper”.

Factory paper-advance calibration	OMAS calibration	Automatic paper-advance calibration	Manual paper-advance calibration
Paper-advance settings specific to each paper category. This is a baseline for the printer, to which the other calibrations add a correction.	This is a dynamic correction applied to every advance depending on the OMAS readings. It is applied to the specific paper loaded.	This is an offset applied to the paper advance that takes into account the printheads and the specific paper loaded.	This is an offset applied to the other paper-advance calibrations.
Hard-coded in printer		Automatically triggered by printer or by user	Triggered by user only
Used with paper types, such as films, with which OMAS cannot be used.	Used with paper types that are compatible with OMAS.	Mandatory for fiber-based papers printing with relatively few passes. Does not work with natural tracing paper. Optional for other papers, such as heavyweight or glossy.	May be used by customers to fine-tune the paper advance. Also useful for natural tracing paper, with which automatic calibration does not work.

The paper advance is normally managed by a combination of automatic paper-advance calibration and OMAS tracking of the paper movement.

Printhead alignment

For printhead alignment to work best with all kinds of plain paper, it is recommended to perform the alignment using HP Coated or HP Bright White papers. Vertical line straightness with other plain papers (such as non-HP plain papers and recycled papers) will improve.

The printheads must be aligned whenever a new printhead is installed, and should be aligned after any paper jam that may have moved the printhead slightly.

Use of multiple rolls

There are various ways to set up the printer for multi-roll printing, using the roll-switch and paper-mismatch policies. Here are some examples.

1. Same paper type and different sizes loaded: this is typical when printing line drawings in standard sizes. For instance, two rolls with A0 size plain paper and one roll with A1 size plain paper. Driver settings: paper type to **Any** and roll to **Any**.
 - Roll switching policy:
 - **Minimize paper waste:** Recommended setting for this workflow. With this setting, roll switch takes precedence over autorotate. This setting minimizes the paper wasted. For instance, if an A2 portrait is sent, the printer autorotates the A2 to fit it onto the A1 roll in landscape. But, if a A1 portrait is sent and the active roll is A0, the printer switches to an A1 roll to save paper.
 - **Minimize roll changes:** Not recommended except for very specific situations, when the customer wants to consume a roll faster. Autorotate takes precedence over roll switch, which reduces overall printing speed.
 - **Use roll with less paper:** Not recommended in this workflow. This setting ensures that the roll with least paper is used up before changing to another.
 - Paper mismatch policy:
 - **Print anyway:** In this case, for instance, if a A0 page is sent and no A0 roll is available, the printer uses an A1 roll and clips the image. Recommended for a workgroup environment in which users share one printer.
 - **Put job on hold:** The printer saves the A0 page on hold in the queue and prints the next pages in the queue that can be printed. To reprint the A0 page, the customer needs to access the queue from the front panel or the Embedded Web Server. This setting is confusing in a workgroup environment because distributed customers may not know how to access the queue, but it can be useful in a centralized print environment to avoid clipping.
 - **Pause printer to load paper:** The printer stops printing completely. This could be useful for a centralized printing environment where project print order must be maintained—for instance, when a project is a mix of A0, A1 and A2 in a given order. For a workgroup environment this would not be recommended. Can be useful in a centralized print environment to will avoid clipping and preserve the printing order.
2. The same setup as example 1. This time, the customer does not want to waste paper, but he does not want the printer to stop if the document size does not match the paper size.
 - Roll switching policy: **Match exact size**
 - Paper mismatch policy: **Put job on hold**
3. Three rolls loaded, two with plain and one with glossy paper: this is typical when printing line drawings of standard sizes and where some high-density printing is requested. Roll 1 with A0 plain, Roll 2 with A1 plain and Roll 3 with glossy. Driver settings: paper type to **Any** and roll to **Any**. To print on glossy paper, set paper type to **Glossy paper** or roll to **Roll 3**.

- Roll switching policy: **Minimize paper waste**
 - Paper mismatch policy: **Print anyway** for workgroups and **Put job on hold** or **Pause printer to load paper** for centralized printing
 - Protect roll 3, to avoid printing with glossy paper unless the roll or paper type has been explicitly selected.
4. The same setup as example 3. This time, the customer does not want to waste paper, but he does not want the printer to stop if the document size does not match the paper size.
- Roll switching policy: **Match exact size**
 - Paper mismatch policy: **Put job on hold**
5. The same setup as example 3. This time, the customer is not concerned about wasting paper, and he does not want the printer to stop.
- Roll switching policy: **Minimize paper waste**
 - Paper mismatch policy: **Print anyway**
6. Working with HP IP Pro. This is a solution specifically designed for centralized environments managed by an operator. With HP IP, the jobs to be printed are selected one by one, previewed and assigned to a specific roll to print. So no automatic roll selection is used in this case. When a roll is out of paper, the queue stops, waiting for the operator to load paper, to ensure correct page order.

Roll switching policy	Paper mismatch policy	Result
Match exact size	Print anyway	Prints always. If the loaded paper is narrower than the document to be printed, the document is clipped.
	Put job on hold	Puts the job on hold if the document width does not match any of the loaded rolls.
	Pause printer to load paper	Stops printing if the document width does not match any of the loaded rolls.
Minimize paper waste	Print anyway	Prints always. If the loaded paper is narrower than the document to be printed, the document is clipped.
	Put job on hold	Puts the job on hold if the document is wider than any of the loaded rolls.
	Pause printer to load paper	Stops printing if the document is wider than any of the loaded rolls.

2 Troubleshooting

- [Printer education and training](#)
- [Firmware update](#)
- [Print-quality troubleshooting](#)
- [Troubleshooting system error codes](#)
- [Performing a service test on a failed assembly](#)
- [Performing the necessary service calibrations](#)
- [The printer does not power on](#)
- [The printer hangs during printing and displays 'processing'](#)
- [The printer continuously rejects printheads](#)
- [A new maintenance cartridge is incorrectly detected as 'used'](#)
- [Cover sensors are not working](#)
- [The Line Sensor has problems detecting paper](#)
- [How to remove the Left Hub when the actuator is broken](#)
- [Troubleshooting paper jams and printhead crashes](#)
- [Troubleshooting shutdowns](#)
- [Vacuum suction much lower at high altitudes](#)
- [Banding at variable extreme environmental conditions](#)
- [Printhead crashes/smears on high-density prints using coated paper](#)
- [Banding due to ink cartridge replacement while printing](#)
- [34" Rice Paper not supported](#)
- [Worm marks on HP Coated Paper with light area fills](#)
- [Solving paper-handling problems](#)
- [Difficult to load paper: "Too much skew"](#)
- [How to read the power switch LEDs](#)

- [How to read the Formatter LEDs](#)
- [If the front panel turns on and then stops](#)
- [How to interpret the Service Information Pages](#)
- [When the main window is open and the printer is printing \(safety compliance\)](#)
- [How to troubleshoot the 79:04 system error](#)

Printer education and training

Before any attempt is made to troubleshoot the printer, you must have the relevant training on the HP DesignJet T7100 printer series. If you are not trained on this printer, please contact HP Education or HP Training to enquire about becoming 'HP Service Qualified' for this printer.

Firmware update

The first step to take when trying to clear an error with the printer is to check that the firmware installed in the printer is the latest available. Firmware updates often include fixes for common problems, and simply updating the firmware can often resolve the problem. New firmware can be downloaded here: <http://www.hp.com/go/designjet/downloads>

USB firmware update

If it is not possible to perform a firmware update using the Embedded Web Server (for instance, if the printer has a System Error and the Embedded Web Server is inaccessible), it is still possible to do it using a USB flash drive.

1. Turn off the printer.
2. Ensure that your USB flash drive contains a valid FMW firmware file and no other files.
3. Connect the USB flash drive to the USB host port on the Formatter.
4. Turn on the printer and follow the instructions on the front panel.

Forced firmware update

When the printer is started for the first time, it may automatically request a firmware update in order to fix some known issues. You can respond in one of the following ways.

- Use the USB flash drive provided in the box with the printer.

When a firmware update is requested, you should find a USB flash drive in the box, containing the new FMW firmware file. Follow the instructions in the flier accompanying the USB flash drive.

 **NOTE:** The USB flash drive is provided only to update the printer's firmware. No other uses of the USB flash drive are supported.

 **NOTE:** If the USB flash drive is not in the printer box, or fails to work properly, then download the firmware instead.

- Download the FWM firmware file from the HP Web site.

Store the file in a standard USB flash drive with no other files. Connect the flash drive to the formatter's USB host port to perform the firmware update, following the instructions on the front panel.

- Skip the firmware update.

If you cannot find the USB flash drive and you have no Internet connection, you can skip the forced firmware update temporarily by pressing the **OK** key on the front panel three times, and the printer will continue with the initialization sequence. Make sure that the firmware update is performed later. The printer will request the firmware update every time that it starts, until the update is performed.

Print-quality troubleshooting

Whenever a print-quality problem appears, it is advisable to print the Diagnostic Print to help diagnose the problem. The Diagnostic Print will help you differentiate between possible printhead errors and other problems such as incorrect front-panel selection, driver or RIP configuration or mechanical problems. For more information on solving print-quality problems, see [Print quality on page 143](#).

Troubleshooting system error codes

[System error codes on page 39](#) contains a list of system error codes and their respective descriptions and recommended corrective actions. Try only one recommended action at a time and check whether the error code has disappeared.

If you have an error code which is not documented in this Service Manual or you have an error which you cannot resolve, then report the error to the HP Response Center or the nearest HP Support Office. When reporting the error, have the following information ready:

- Model and serial number of the printer.
- Which firmware revision the printer is using (see Note below). Check firmware in Utilities / Statistics / Code rev.
- The complete error number.



NOTE: When reporting the system error code, make sure that you supply the full error code and the firmware version. Without this information, HP support personnel cannot help you.

- The service configuration print.
- The current configuration sheet.
- Which software application the customer is using (name, version, and so on).

Performing a service test on a failed assembly

If possible, always perform a Service Test on the component/assembly that you are about to replace, just to make sure that is the component/assembly that has failed.



NOTE: If the test on that component/assembly passes, you should NOT replace it.

For information on the Service Tests and how to use them, see [Service tests and utilities on page 85](#).

Performing the necessary service calibrations

Is the printer calibrated correctly after replacing a component? For information on the Service Calibrations and how to use them see [Service calibrations on page 119](#).



NOTE: Remember that certain Calibrations are required even if an Assembly has been disassembled to gain access to another Assembly or Component.

The printer does not power on

To resolve printer power up problems, do the following.

1. Check that the power cord is connected correctly to the printer and to the power socket.
2. Check that the power switch at the rear of the printer is in the on position.
3. Check that the front-panel cable is correctly connected to the Electronics Module. Also make sure that the front-panel cable is not damaged.
4. Check to see if any of the LEDs on the power switch are on. If any of the LEDs are on, then see [How to read the power switch LEDs on page 15](#) for more information.

The printer hangs during printing and displays ‘processing’

It has been seen under certain circumstances that the printer hangs whilst printing, this may happen immediately after printing, or only a partial print. In some cases when this occurs if the machine is restarted a system error 79:04 is displayed, although restarting again appears to clear this error. After this point, although the printer displays that it is in the “Ready” state, attempting to print anymore plots will once again hang the printer, including internal demo plots.

79:04

Cause	Solution
The reason for this error is that a large spooled file (11 GB for example) has been sent to the printer and has been placed in the disk partition which is related to the print queue. The file completely fills up all the disk space, because of this it will never successfully print, and so the file remains in the disk partition. Even after restarting the printer the file remains, subsequent print requests also fail as there is not sufficient space available in the partition to process anything else.	<p>Perform the following few steps to clear the error:</p> <ol style="list-style-type: none"> 1. Check that the firmware is the latest available 2. Turn Off and ON the printer. 3. Set Queue to OFF. 4. Set ‘When Start Printing’ to ‘Immediately’. <p>Please guide the customer through the front panel of the printer to set up the “Queue” to “OFF” and “When Start Printing” to “Immediately”.</p> <p>Wipe disk solution</p> <p>If the above procedure does not clear the error, use the wipe the hard disk procedure (Unsecure mode) ➡ See Disk Wipe DoD 5330.22'M on page 112. This will delete all previous jobs, ICC profiles and paper presets that were present on the hard disk. This procedure has an advantage for the customer in that it solves the issue without the need to wait for an onsite engineer to come to their premises and remove and replace the HDD (which would also have the same affect of deleting all the previous jobs, ICC profiles and paper presets). The whole procedure should not take more than 30-35 minutes.</p> <p>Important step is that you need to select the Unsecure mode.</p>

The printer continuously rejects printheads

To resolve printhead rejection problems, do the following.

1. Clean the flex contacts on the Printhead and in the Carriage Assembly using the Carriage Interconnect Wiper (see [Carriage Interconnect Wiper on page 83](#)) and try again.
2. If all the Printheads are rejected (for each Printhead, the status message on the Front Panel does not show 'OK') then perform the Carriage Assembly Test ⇒ [Carriage Assembly test on page 91](#)..

A new maintenance cartridge is incorrectly detected as 'used'

This can occur if the printer has detected the previous Maintenance Cartridge was nearly full, and when a new Maintenance Cartridge is installed the Front Panel displays an error that the cartridge is 'used'. To resolve the problem, manually reset the counter of the Maintenance Cartridge ⇒ [Reset Life Counters on page 108](#).

Cover sensors are not working

To resolve cover sensor problems, do the following.

1. Check that the cable for the faulty sensor is not damaged and is connected correctly.
2. Replace the faulty sensor.

The Line Sensor has problems detecting paper

To resolve Line Sensor paper detection problems, do the following.

1. Check the type of paper that is being used: the Line sensor may have problems detecting transparent paper or some types of Non-HP paper. Try loading white HP paper into the printer and check whether the Line Sensor detects it.
2. Excessive ink deposits on the Platen surface can fool the sensor by reflecting the light. Clean the Center Platen.
3. Clean the Encoder Strip ⇒ See [Clean the Encoder Strip on page 478](#).
4. The Line Sensor is not calibrated correctly. Perform the Line Sensor Calibration ⇒ See [Line Sensor calibration on page 126](#).
5. The Line Sensor is damaged or faulty. Replace the Line Sensor ⇒ See [Line Sensor Assembly on page 302](#).

How to remove the Left Hub when the actuator is broken

You need a standard 90° Torx/Allen key (Torx T10 or Allen 2.5).



1. Insert the key about 20 mm between the sheet-metal and plastic parts.
2. Pull the key to the left to release the brake.

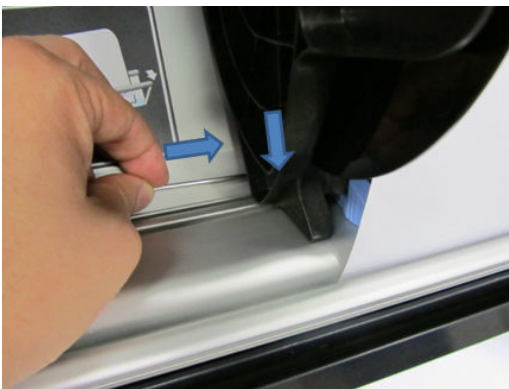

Troubleshooting paper jams and printhead crashes

 **NOTE:** If you were using HP Coated Paper when the problem occurred, see also [Printhead crashes/smears on high-density prints using coated paper on page 13](#).

Paper jams and printhead crashes are grouped together because in many cases a paper jam causes the paper to lift up into the Carriage path and cause a printhead crash, which means that many paper jams are reported as printhead crashes.

Question	Answer
Did the paper jam occur when loading paper?	If paper jams have occurred previously, some pieces of paper may still be stuck in the paper path. Clear the paper path. NOTE: Customers often store used rolls without protecting them from office environmental conditions; when exposed to high humidity, the paper edges tend to curl. This curling can cause paper jams when paper is loaded by feeding paper in.
Is the customer using non-HP paper?	The use of non-HP paper can easily be the cause of paper jams and printhead crashes—especially printhead crashes, because HP paper is specially formulated to avoid cockle, one of the primary causes of head crashes. If the paper is not HP-approved, advise the customer to use HP paper and check to see if the problem is now solved.

 **TIP:** When clearing a paper jam, sometimes paper is stuck in the paper path. To clear this, you must open the Rear Door and insert thicker paper into the paper path to push out the paper that is still stuck there.

Troubleshooting shutdowns

If a shutdown occurs, you will get the message “Switch Power Off” followed by one of these messages:

- Check Maintenance Cartridge Path
- Check Paper Path
- Check Printhead Path

 **NOTE:** A shutdown in each path will require different steps to resolve the problem as explained below. In each case, make sure that you power off the printer before trying to resolve the problem.

Also check that the Rewinder Motor moves easily (without friction) with the printer turned off.

Maintenance cartridge path

Open the right door of the printer and check for any visible obstacles restricting the movement of the Service Station. Manually move the Service Station, checking for smooth and free movement.

Paper path

To resolve paper path problems, do the following.

1. Open the Window and check for any visible obstacles restricting the movement of the Drive Roller. Make sure that the mylar is not damaged. If there is a wrinkled mass of paper inside the paper path, lift the Pinchwheels (opening the Rear Door) and clear the obstruction.
2. If this shutdown happens at the end of a Roll of Paper, it could be because the paper is stuck firmly to the Roll. Lift the Pinchwheels (opening the Rear Door) and pull the paper clear.
3. Replace the spindle if broken.
4. Perform the Paper Drive Test to obtain further information on the problem ⇒ [Paper Drive test on page 88](#).

Printhead path

When a shutdown occurs in the Printhead path, you will get the message “Switch Power Off / Check Printhead Path (*). The (*) will be a number, which will give an indication on where the failure occurred.

PWM shutdown

To resolve a PWM shutdown, do the following.

1. Clean Slider Rods and Apply Oil along the complete axis of the Slider Rods. After applying the Oil, perform the Scan-Axis Test ⇒ See [Scan Axis test on page 88](#) and check that the values are within the given limits.
2. Clean the Encoder Strip ⇒ See [Clean the Encoder Strip on page 478](#).
3. Perform the Scan-Axis Test to obtain further information on the problem ⇒ [Scan Axis test on page 88](#).

Velocity shutdown

To resolve a velocity shutdown, do the following.

1. Open the Window and check for any visible obstacles restricting the movement of the Carriage Assembly. Try and move the Carriage Assembly manually, checking for smooth and free movement.
2. Check that the Encoder Strip is clean. If necessary, clean Encoder Strip using a damp cloth.

Energy shutdown

To resolve an energy shutdown, do the following.

1. Clean Slider Rods and Apply Oil along the complete axis of the Slide Rods. After applying the Oil, perform the Scan-Axis Test ⇒ See [Scan Axis test on page 88](#) and check that the values are within the given limits.
2. Clean the Encoder Strip ⇒ See [Clean the Encoder Strip on page 478](#).
3. Perform the Scan-Axis Test to obtain further information on the problem ⇒ [Scan Axis test on page 88](#).

Vacuum suction much lower at high altitudes

At altitudes above 3,000 meters, the vacuum force holding down the paper will be lower, therefore the paper will not be held in place properly causing:

- Ink Smearing on the Paper.
- Printhead crashes against the Paper.
- Roll Paper loading problems (low probability).

Banding at variable extreme environmental conditions

 **NOTE:** This problem is only applicable if the OMAS is disabled.

Since the Accuracy Calibration has been done at normal environmental conditions, printing in extreme environmental conditions will cause banding because the advance of the Drive Roller does not correspond to the same conditions that the calibration was done in. To solve the problem, perform the Accuracy Calibration in the new environmental conditions (see *Using your printer*).

Printhead crashes/smears on high-density prints using coated paper

High density prints can cause cockle mainly on HP Coated Paper. This causes two main problems:

1. Cockling in the borders - Because the printer places too much ink on the Coated Paper, the borders of the print become raised, causing the Printhead to crash against the paper. To solve the problem, try the following.
 - Change the paper margins to 15mm, either in the Front Panel or in the Driver. If the customer is printing PostScript images, send them a PPD file containing the extended margins of 15mm.
2. Cockling within the print - If the printer places too much ink within the print, the paper starts to ripple, causing the Printhead to smear against the paper. To solve the problem, try the following.

- Check in the Front Panel if **Ink Limiting** is ON or OFF. If Ink Limiting is OFF, turn it ON.
- Never use HP Coated Paper for High Density prints. As a substitute use HP Heavy Coated Paper.

Banding due to ink cartridge replacement while printing

A user has removed the Ink Cartridge while the printer was printing, which has caused the printer to stop. If the user does not replace the Ink Cartridge immediately, when the printer starts to print again, a band will appear in the position where the printing restarted. This is because the wet ink interacts with the dried ink on the paper causing the band to appear. To solve the problem, try the following.

- Do NOT remove the Ink Cartridge while the printer is Printing. Only replace/remove Ink Cartridges in between Prints.
- If the Ink Cartridge was replaced due to the “Empty” status on the Front Panel, then advise the customer to replace the Ink Cartridge when the “Very Low” status is showing on the Front Panel.
- Reprint the file (without remove the Ink Cartridge).

34" Rice Paper not supported

Roll width is 34" (non-standard), and the pinch wheels can't control the edge of the paper, causing ink smears and printhead crashes.

Worm marks on HP Coated Paper with light area fills

Light bands (S-shaped) in the direction of the media axis when light area fills are printed, causing an unacceptable print-quality defect.

- Print the Service Configuration Print and check whether the ambient humidity is very low (below 30%). Increasing humidity may help to reduce the severity of the problem.



NOTE: The paper is causing the problem and not the printer. Do not attempt to replace printer parts to solve this problem.

Solving paper-handling problems

The front panel keeps indicating that paper is misaligned or incorrectly positioned.

- The roll may be loaded the wrong way. The paper should load over the roll toward you.
- Check that the paper is correctly loaded onto the spindle.
- The paper may be loaded at an angle. The right-hand edge must be aligned with the blue line on the Print Platen.



NOTE: Ensure that the paper is wrapped tightly on the roll. This is a very important step to remember because if this is not done, the paper may be loaded at an angle, causing the paper to be rejected.

- The Line Sensor may be malfunctioning. See [The Line Sensor has problems detecting paper on page 10](#).

Difficult to load paper: “Too much skew”

If you encounter a high failure rate when loading paper and the front panel reports “Too much skew” it is likely that:

- The encoder strip must be cleaned (this can be carried out by the customer using the User Maintenance Kit).
- The Line Sensor must be cleaned.
- The Blue Line calibration must be performed. See [Platen blue line calibration on page 135](#).

How to read the power switch LEDs

In certain circumstances, the LEDs located on top of the power switch (located at the rear of the printer) indicate the status of power supply to the printer.

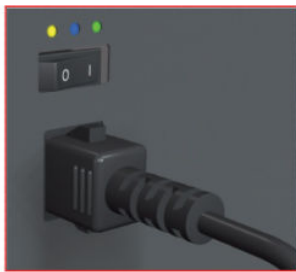

Amber is on the Left
Blue is in the center
Green is on the Right

Make sure you look directly at the LEDs and not at an angle.

1. When only the **Amber LED** is On:
 - The printer has been switched Off from the Front Panel (after having pressed the On/Off button).
 - The Power Supply Unit only delivers a 5 V “Standby”; power that is needed to restart the printer after the Front Panel On/Off button is pressed (the Formatter will start the printer).
2. When the **Blue LED** is On: Deliver standard “ATX” power for the Electronics Module PCAs (+12V, +5V, -5V, -12V and so on). All the functions of the Electronics Module are fully operational (Embedded Web Server and so on).
3. When the **Green LED** is On: Deliver “analog” 24V and 36V to enable printing.

If you turn on the printer at the front panel, and the Blue LED does not come on, there is a problem. Turn off the printer using the switch at the rear, then turn it on again using the same switch. If the Blue LED still does not come on, replace the Power Supply Unit.

If the Blue LED comes on this time, you will probably see an error reported on the front panel as the printer starts up. If no error is reported, but you continue to have problems when turning on the printer from the front panel, see [How to read the Formatter LEDs on page 15](#).

How to read the Formatter LEDs

The LEDs located on the Formatter can help to troubleshoot the printer. The LEDs can either be on or off; different combinations can indicate different problems.

The following image shows the three Formatter LEDs, which are numbered from the top down: number I at the top, number II in the middle, number III at the bottom.



Use the following table to interpret the LEDs and find the source of the problem. Remember that you should read these LEDs when you push the **Power** button.

Some combinations may require you to replace two or more components. In this case, always replace one component at a time. Test the printer to see if the problem has disappeared (check the LEDs again). If the same LED sequence continues, replace the next component indicated in the table.

Power amber LED	Power blue LED	Power green LED	Formatter I LED	Formatter II LED	Formatter III LED	Front panel status	Problem and recommendations
Off	Off	Off	Off	Off	Off	Off	The printer is not receiving electrical power. <ol style="list-style-type: none"> 1. Ensure that the printer is connected to the power outlet. 2. Ensure that the outlet delivers the expected power. 3. Replace the Power Supply Unit.
On	Off	Off	Off	Off	Off	Off	The Power key fails to turn on the printer. <ol style="list-style-type: none"> 1. Turn the printer off using the switch at the rear, and disconnect the power cord. Reconnect the power cord and turn on the printer using the switch at the rear. 2. If the problem persists, replace the Front Panel.

Power amber LED	Power blue LED	Power green LED	Formatter I LED	Formatter II LED	Formatter III LED	Front panel status	Problem and recommendations
Off	On	Off	Off	Off	Off	Off	There is a power failure in the Formatter. <ol style="list-style-type: none"> 1. Reseat the power connector in the Formatter. 2. Replace the Main PCA. 3. If the problem persists, replace the Formatter. 4. If the problem persists, replace the Power Supply Unit.
Off	On	Off	On	Off	Off	Off	The Formatter BIOS is unable to start. If an external Memory Module is installed: <ol style="list-style-type: none"> 1. Reseat the Memory Module. 2. Remove the Memory Module and restart the printer. 3. If the printer is able to start normally, replace the Memory Module. If not, replace the Formatter. If an external Memory Module is not installed, replace the Formatter.
Off	On	Off	Flashing	Off	Off	Off	The Formatter BIOS cannot detect the Hard Disk Drive. <ol style="list-style-type: none"> 1. Reseat the Hard Disk Drive connectors. 2. Replace the Hard Disk Drive.
Off	On	Off	On	Flashing	Off	Off	The operating system has experienced a fatal error. Replace the Hard Disk Drive.
Off	On	Off	On	On	Off	Off	There is a communication failure with the Main PCA. <ol style="list-style-type: none"> 1. Reseat the Main PCA. 2. Replace the Main PCA.
Off	On	Off	On	On	Flashing	Off	There is an initialization failure in the Formatter. Replace the Formatter.
Off	On	Off	On	On	On	Off	There is an initialization failure in the Front Panel. <ol style="list-style-type: none"> 1. Reseat the Front Panel cable. 2. Replace the Front Panel.

If the front panel turns on and then stops

If the power-up process stops while the front panel is displaying a number, respond as follows.

1. If the printer's Power-Up process stops when the front panel is displaying the number **17**, this indicates that there is a problem with the file system on the printer's Hard Disk Drive, so the printer is checking the whole file system and making any necessary corrections. This problem can arise when there has been a power cut while the printer was switched On, or if there is a physical problem with the Hard Disk Drive.

Checking the whole file system normally takes about half an hour (but could take much longer). There is nothing that can be done to speed up the file checking process. If you turn Off the printer during the checking process, the file system check will restart whenever you turn it On again

If you experience this problem repeatedly when there has been no power cut, then this could mean that the Hard Disk Drive is faulty. In this case, replace the Hard Disk Drive ⇒ See [Hard Disk Drive \(HDD\) on page 383](#).

2. If the printer's start-up process stops when the front panel is displaying any other number between **1** and **30**, then try the following.
 - Turn the power off at the rear of the printer and disconnect the power cord. Reconnect the power cord and turn on the printer.
 - If the printer continues to stop during the power-up process, replace the Hard Disk Drive ⇒ See [Hard Disk Drive \(HDD\) on page 383](#).

How to interpret the Service Information Pages

The Service Information Pages contain the following information:

- Current Configuration
- Current Information
- Usage Information
- Event Logs
- Calibration Status
- Connectivity Configuration
- All Pages

It is possible to print the Service Information Pages either through the Front Panel or through the Embedded Web Server:

- Front Panel:  icon > **Service information prints**.
- Embedded Web Server: **Support** tab > **Service support** > **Printer information**.

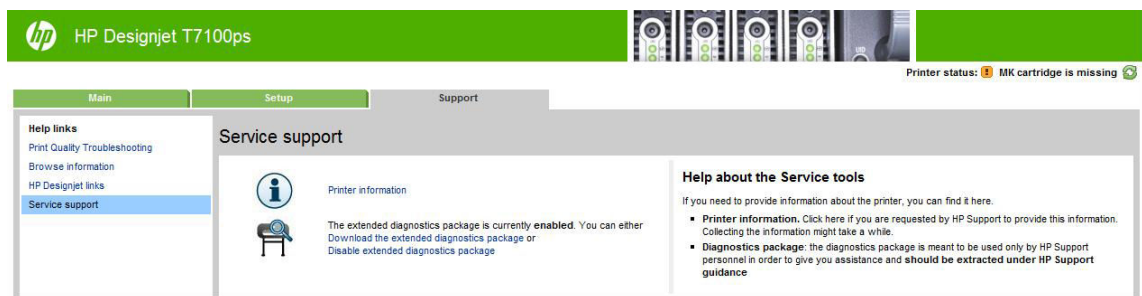

Even if the printer cannot print, the Information Pages are still accessible through the Embedded Web Server.

Main characteristics

- Only available in English (except the current information page).
- From the Front Panel, you can choose to print all pages or just select the specific pages that are needed. If all pages are printed:
 - Nesting is turned on automatically (and turned off once all the pages have been printed).
 - Nesting cannot be mixed with other jobs in the queue.
- Each page can be printed from the Web browser when using the Embedded Web Server.
- Each page can be sent by e-mail from the Web Browser when using the Embedded Web Server (File ⇒ Send ⇒ Page by E-mail).
- You can see the same information through the Front Panel or the Embedded Web Server.

Current configuration

This page contains full details of the current configuration of the printer.

HP Designjet T7100ps (CQ105A)
Current configuration

Date: 26-Sep-10
 Serial number: MY9B309003DC42
 FW version: dragon-
 Virtual Memory: 32.0 GB
 Physical Memory: 768 MB RAM
 Disk capacity: 160.0 GB
 Paper Type: Plain Paper
 Paper Source: Roll 2

Connectivity -> Gigabit Ethernet - General Configuration
 Link state: Up
 Host name: NP002655130461.emea.hpqcorp.net
 mDNS service name: HP Designjet T7100ps [130461]
 MAC address: 002655130461
 - IPv4 Configuration
 IP address: 16.23.114.203
 Config. by: DHCP
 Subnet mask: 255.255.248.0
 Default gateway: 16.23.112.1
 - IPv6 Configuration
 Link-Local: fe80::226:55ff:fe13:461
 See Connectivity Configuration internal print

Setup -> Front panel options
 Language: English
 Display contrast: 50 %
 Buzzer: On

Setup -> Print retrieval
 Print retrieval: On
 Drying time: On

Setup -> Printing preferences -> Color options
 Color/Grayscale: Print in color
 RGB input profile: sRGB IEC61966-2.1
 Printer emulation: Off
 CMYK input profile: US Web Coated (SWOP) v2
 Rendering intent: Perceptual
 Black point compensation: On
 HP PANTONE® emulation: On

Setup -> Job management options
 Queue: On
 When to start printing: Optimized
 Max. number of printed jobs: 32 jobs
 Job recovery mode: Put on hold

Setup -> Printing preferences -> Paper options
 Paper size: Automatic
 Remove top/bottom blanks: Off
 Resize: 100 %
 Rotate: 0 °

Setup -> Printing preferences -> Margins
 Encoding: Automatic

Setup -> Job management options -> Nest options
 Nesting: Off
 Wait time: 1 min

Connectivity -> Advanced
 I/O timeout: 30 sec
 Allow EWS: On
 Allow SNMP: On

Connectivity -> Advanced -> Web Services
 Printer utility software: Enabled
 Color and paper management: Enabled

Setup -> Printing preferences -> Print quality
 Quality level: Fast
 Maximum detail: Off

Setup -> Printing preferences -> HP-GL/2 options
 Palette: Software
 Merge: Off

Setup -> Printing preferences -> HP-GL/2 options -> Define palette

Factory				Palette A				Palette B			
Pen no.	Width	Color	Pen no.	Width	Color	Pen no.	Width	Color	Pen no.	Width	Color
0	0.13 mm	0	0	0.13 mm	0	0	0.13 mm	0	0	0.13 mm	0
1	0.18 mm	1	1	0.18 mm	1	1	0.18 mm	1	1	0.18 mm	1
2	0.25 mm	2	2	0.25 mm	2	2	0.25 mm	2	2	0.25 mm	2
3	0.35 mm	3	3	0.35 mm	3	3	0.35 mm	3	3	0.35 mm	3
4	0.50 mm	4	4	0.50 mm	4	4	0.50 mm	4	4	0.50 mm	4
5	0.65 mm	5	5	0.65 mm	5	5	0.65 mm	5	5	0.65 mm	5
6	0.70 mm	6	6	0.70 mm	6	6	0.70 mm	6	6	0.70 mm	6
7	0.80 mm	7	7	0.80 mm	7	7	0.80 mm	7	7	0.80 mm	7
8	0.90 mm	8	8	0.90 mm	8	8	0.90 mm	8	8	0.90 mm	8
9	1.00 mm	12	9	1.00 mm	12	9	1.00 mm	12	9	1.00 mm	12
10	1.40 mm	19	10	1.40 mm	19	10	1.40 mm	19	10	1.40 mm	19
11	2.00 mm	27	11	2.00 mm	27	11	2.00 mm	27	11	2.00 mm	27
12	3.00 mm	35	12	3.00 mm	35	12	3.00 mm	35	12	3.00 mm	35
13	5.00 mm	68	13	5.00 mm	68	13	5.00 mm	68	13	5.00 mm	68
14	8.00 mm	100	14	8.00 mm	100	14	8.00 mm	100	14	8.00 mm	100
15	12.00 mm	110	15	12.00 mm	110	15	12.00 mm	110	15	12.00 mm	110

Current media, printhead and ink information

This page contains the following information:

- Current Printer Configuration.
- Paper Loaded Information.
- Current Printhead Kit Information.
- Current Ink cartridge Information I and II.

Current configuration | Current information | Usage information | Event logs | Calibration status | Connectivity configuration | All pages

Current Media, Printhead and Ink Information (1 of 2)

Date: 26-Sep-10 Product: HP DesignJet T7100ps Serial Number: MY9830903DC42
 Firmware: dragon- Product number: CQ105A Service ID: 2091
 Printer status: MK cartridge is missing

Current Printer Configuration

Language:	English	Virtual Memory:	32.0 GB
Disk capacity:	160.0 GB	Physical Memory:	768 MB RAM
Current Temperature:	27.5°C ±2°C		

Paper Loaded Information

Paper Path:	Roll 1	Paper Loaded Status:	65 Out of paper
Paper Path:	Roll 2	Paper Loaded Status:	9 Standby
Media Type:	Plain Paper		
Media Width:	610 mm / 24.0 inches	Media Length:	not available
Paper Path:	Roll 3	Paper Loaded Status:	65 Out of paper

Current Printhead Kit Info (I)

	Warranty status	Status	Error ID Code	Product Number
1 - Yellow	See warranty note	OK	0	CH645A
2 - Yellow	See warranty note	OK	0	CH645A
3 - Cyan-Magenta	See warranty note	OK	0	CH646A
4 - Cyan-Magenta	See warranty note	OK	0	CH646A
5 - Matte black	See warranty note	OK	0	CH648A
6 - Matte black	See warranty note	OK	0	CH648A
7 - Dark Gray-Gray	See warranty note	OK	0	CH647A
8 - Dark Gray-Gray	See warranty note	OK	0	CH647A

Current Printhead Kit Info (II)

	Product Name	Serial Number	Warranty Date
1 - Yellow	HP 761	4-1-5778130-31-2009	20110605
2 - Yellow	HP 761	4-1-5778127-31-2009	20110605
3 - Cyan-Magenta	HP 761	4-1-5223728-27-2009	20110708
4 - Cyan-Magenta	HP 761	4-1-5223718-27-2009	20110708
5 - Matte black	HP 761	4-1-5434078-28-2009	20110715
6 - Matte black	HP 761	4-1-5434043-28-2009	20110715
7 - Dark Gray-Gray	HP 761	4-1-5718117-31-2009	20110805
8 - Dark Gray-Gray	HP 761	4-1-5718105-31-2009	20110805

Current Printhead Kit Info (III)

	Used non-HP ink	Used expired ink	Ink Used	Warranty Spent
1 - Yellow	false	true	315 ml	26%
2 - Yellow	false	true	316 ml	26%
3 - Cyan-Magenta	false	true	234 ml	19%
4 - Cyan-Magenta	false	true	235 ml	19%
5 - Matte black	false	true	380 ml	31%
6 - Matte black	false	true	388 ml	32%
7 - Dark Gray-Gray	false	true	320 ml	26%
8 - Dark Gray-Gray	false	true	324 ml	27%

Current Printhead Kit Info (IV)

	Usage Time	Max. Recovery Level	Scan Axis Shutdown
1 - Yellow	0 h	0	0
2 - Yellow	0 h	0	0
3 - Cyan-Magenta	0 h	0	0
4 - Cyan-Magenta	0 h	0	0
5 - Matte black	0 h	0	0
6 - Matte black	0 h	0	0
7 - Dark Gray-Gray	0 h	0	0
8 - Dark Gray-Gray	0 h	0	0

Current Media, Printhead and Ink Information (2 of 2)

Date: 26-Sep-10 Product: HP DesignJet T7100ps Serial Number: MY9830903DC42
 Firmware: dragon- Product number: CQ105A Service ID: 2091
 Printer status: MK cartridge is missing

Current Ink Cartridge Info (I)

	Status	Product Name	Product Number	Serial Number	Install Date
Yellow	OK	HP 761	CM992A	284688-5-4	20100331
Cyan	OK	HP 761	CM994A	241960-5-4	20100710
Matte black	missing	HP 761	CM996A	1185440-24-4	20100711
Dark Gray	OK	HP 761	CM993A	2808908-15-4	20100516
Magenta	OK	HP 761	CM995A	2268-14-4	20100430
Gray	OK	HP 761			

Current Ink Cartridge Info (II)

	Expiration Date	Manufacturer	Capacity	Level	Used non-HP ink
Yellow	20120810	HP	400 ml	44 %	false
Cyan	20120805	HP	400 ml	90 %	false
Matte black			ml	%	
Dark Gray	20121220	HP	400 ml	88 %	false
Magenta	20121021	HP	400 ml	74 %	false
Gray	20121009	HP	400 ml	58 %	false

The first two lines are available at the beginning of each Service Information Page and contains standard information (like Service ID, firmware version).

Printer usage information

This page contains the following information:

- Printer Usage
- Usage per Printhead Slot
- Usage per Cartridge Slot
- Media Usage per Paper Type
- Component Usage
- Spittoon Usage

- Preventive Maintenance Usage

Current configuration	Current information	Usage information	Event logs	Calibration status	Connectivity configuration	All pages	
Printer Usage Information							
Date:	26-Sep-10	Product:	HP DesignJet T7100ps	Serial Number:	MY9B309003DC42		
Firmware:	dragon	Product number:	CO105A	Service ID:	2091		
Printer status:						MK cartridge is missing	
Printer Usage							
Total printed media:	500.72 m ² / 5,389.65 ft ²				Total number of prints:	771	
Usage per Printhead Slot							
Slot	Color	Product Number	Printheads Used	Total Insertions			
Slot 1	Yellow-Unknown	CH645A	0	3			
Slot 2	Yellow-Unknown	CH645A	0	3			
Slot 3	Cyan-Magenta	CH646A	1	4			
Slot 4	Cyan-Magenta	CH646A	1	5			
Slot 5	Matte black-Matte black	CH648A	1	5			
Slot 6	Matte black-Matte black	CH648A	1	3			
Slot 7	Dark Gray-Gray	CH647A	0	3			
Slot 8	Dark Gray-Gray	CH647A	0	4			
Usage per Cartridge Slot							
Cartridge	Product Number	Usage					
1 - Yellow	CM992A	1 Cartridges / 235.0 cc					
1 - Yellow	CM986S	2 Cartridges / 89.0 cc					
2 - Cyan	CM994A	1 Cartridges / 44.0 cc					
2 - Cyan	CM988S	2 Cartridges / 140.0 cc					
3 - Matte black	CM997A	1 Cartridges / 8.0 cc					
3 - Matte black	CM991A	5 Cartridges / 616.0 cc					
3 - Matte black	CM985S	0 Cartridges / 0.0 cc					
4 - Dark Gray	CM996A	2 Cartridges / 88.0 cc					
4 - Dark Gray	CM990S	3 Cartridges / 169.0 cc					
5 - Magenta	CM993A	1 Cartridges / 123.0 cc					
5 - Magenta	CM987S	2 Cartridges / 104.0 cc					
6 - Gray	CM995A	2 Cartridges / 188.0 cc					
6 - Gray	CM989S	2 Cartridges / 119.0 cc					
Media Usage per Media Type							
Coated Paper						46.41 m ² / 499.53 ft ²	
Heavyweight Coated Paper						4.09 m ² / 44.06 ft ²	
HP Coated Paper						41.87 m ² / 450.71 ft ²	
Plain Paper						304.08 m ² / 3,273.13 ft ²	
HP Universal Bond Paper						83.10 m ² / 894.49 ft ²	
Photo Glass Paper						16.82 m ² / 181.04 ft ²	
Recycled Bond Paper						2.00 m ² / 21.51 ft ²	
Adhesive Polyprop. Satin						2.00 m ² / 21.55 ft ²	
HP Uni Hg Photo Paper						0.11 m ² / 1.15 ft ²	
Component Usage							
Belt usage (# cycles):	15427	Motor usage (# cycles):	15427	Cutter usage (# cycles):	401		
Trailing cable usage (# cycles):	15427	Tube ISS usage (# cycles):	15427	Tube Primer (cc):	0		
Motor usage (Working time in hours):	0	Bushings life (# cycles):	15400	Color Sensor Aerosol Exposure (# cycles):	0		
Color sensor life (hours):	0	Drop detector working time (hours):	0	Power Off Cycles:	149		
Power On Cycles:	452	Service Station Cycles:	2700	Pen On/Off Cycles:	890		
Plug Time (hours):	2958	Correct profiles:	0	Total Profiles:	0		
Scan Axis run distance (meters):	23209037	Line Sensor Life (hours):	0	Working time (hours):	2		
Number of OMAS Navigation fails:	19	Number of OMAS Navigation OK:	390	OMAS Paper length (meters):	322		
SDL Ink Used (cc):	1652	Encoder Strip Ink Used (cc):	1652	Total CLCs:	2		
Correct CLCs:	0						
Spittoon Usage							
Left Spittoon:	98418	Maintenance Cartridge:	102640	Drop Detector Spittoon Ink Volume:	8447661	Aerosol FAN:	3
Preventative maintenance Usage							
Preventive maintenance kit #1						0%	
Preventive maintenance kit #2						0%	
Job Accounting							
Date	Job name	Optimized for	Image quality	Max detail			
2010-09-25 22:51:06	(502)_bike.TIF	Images	Fast	Off			
2010-09-21 20:13:11	ducky_rotate_croplines.gI2	Images	Fast	Off			
2010-09-21 20:12:37	ducky_rotate.gI2	Images	Fast	Off			
2010-09-21 19:03:41	Adobe_RGB_(1996).jpg	Images	Fast	Off			
2010-09-21 19:00:41	(502)_bike.TIF	Images	Fast	Off			

Media used sections

- Total media used in the printer.
- Media used for each media type.

It is possible that the sum of the media used for each media type is lower than the total amount of media used in the printer. This is because only the total media used in the printer is saved in the backup EEROM which is located in the ISS PCA. When the Hard Disk Drive is replaced, the total media used per media type is reset to zero (0), but the total media used is recovered from the backup EEROM.

Printhead section

The Printheads section displays the Printhead usage per slot.

- **Total Insertions:** This is linked with the crane of the Ink Supply Tubes. When the Ink Supply Tubes are replaced, the total insertions amount will be reset to zero (0).

Cartridge section

The Ink Cartridges section displays the ink usage per cartridge.

Preventive maintenance section

Once the value reaches 100%, the corresponding Preventive Maintenance Kit should be used. For further details, see [Preventive maintenance on page 475](#).

Component usage

One cycle is counted when the Carriage makes one movement to the left of the printer and then returns to the right.

To find the total of Monochrome ink consumed in cc use the the formula $\wedge 0.61$. Example: For a value marked as 11504, use the formula $\wedge 0.61$ to convert it to cc=300cc ($11504^{0.61}=300$).

Spittoon section

This section contains information on the different Spittoons located in the printer.

Event logs

This page contains the following information:

- Last 20 System Error Codes (which prevented the printer from booting).
- Last 20 System Warnings (which did not prevent the printer from booting, but which required the user to acknowledge the problem).

- Printhead Error log.

Current configuration	Current information	Usage information	Event logs	Calibration status	Connectivity configuration	All pages	
Event Logs							
Date:	26-Sep-10	Product:	HP DesignJet T7100ps	Serial Number:	MY9B309003DC42		
Firmware:	dragon-	Product number:	CO105A	Service ID:	2091		
Printer status:						MK cartridge is missing	
System Errors							
Event #	Severity	Error Code	Internal Code	FW Version	Media Usage	Line	Date
1	severe	23:10	273686534	DRAGON_01_00_07.1	496.637695	PumpAndes.cpp:1277	20100918
2	severe	79:04	-1161889074	DRAGON_01_00_07.1	496.637695	AnalogSensorCommon.cpp:254	20100914
3	severe	21:13	278925314	DRAGON_01_00_07.1	496.637695	ServiceStationCommon.cpp:1112	20100914
4	severe	21:13	278925314	DRAGON_01_00_07.1	496.637695	ServoMotorServiceStation.cpp:72	20100914
5	severe	79:04	-1161889074	LATEST	496.637695	MemoryAsicCommonMsg.cpp:93	20100906
6	severe	21:13	278925314	LATEST	496.637695	ServoMotorServiceStation.cpp:72	20100906
7	severe	79:04	-1161889074	LATEST	493.797058	MemoryAsicCommonMsg.cpp:93	20100905
8	severe	79:04	-1161889074	LATEST	493.797058	VppRegulatorHorus.cpp:631	20100905
9	severe	79:04	-1161889074	LATEST	493.797058	MemoryAsicCommonMsg.cpp:93	20100905
10	severe	79:04	-1161889074	LATEST	493.797058	VppRegulatorHorus.cpp:631	20100905
11	severe	21:13	278925314	LATEST	493.797058	ServoMotorServiceStation.cpp:72	20100903
12	severe	79:04	-1161889074	LATEST	493.235779	MemoryAsicCommonMsg.cpp:93	20100831
13	severe	21:13	278925314	LATEST	493.235779	ServoMotorServiceStation.cpp:72	20100831
14	severe	79:04	-1161889074	LATEST	492.969971	MemoryAsicCommonMsg.cpp:93	20100831
15	emergency	79:04	1074794497	LATEST	492.969971	EngineWatchdogBase.cpp:594	20100831
16	severe	23:10	273686534	LATEST	492.969971	PumpAndes.cpp:1277	20100831
17	severe	79:04	-1161889074	LATEST	491.104797	vpmRotationStorage.cpp:589	20100828
18	severe	79:04	-1161889074	LATEST	489.291260	MemoryAsicCommonMsg.cpp:93	20100827
19	severe	21:13	278925314	LATEST	489.291260	ServoMotorServiceStation.cpp:72	20100827
20	severe	79:04	-1161889074	LATEST	489.025452	MemoryAsicCommonMsg.cpp:93	20100824
System Warnings							
Event #	Severity	Error Code	Internal Code	FW Version	Media Usage	Line	Date
1	advisory	79:03	271585281	DRAGON_01_00_07.1	496.637695	SpaceRpcElektra.cpp:1464	20100914
2	advisory	79:03	271585281	LATEST	496.637695	SpaceRpcElektra.cpp:1422	20100906
3	advisory	79:03	271585281	LATEST	496.637695	SpaceRpcElektra.cpp:1422	20100906
4	advisory	79:03	271585281	LATEST	496.637695	SpaceRpcElektra.cpp:1422	20100906
5	advisory	79:03	271585281	LATEST	493.797058	SpaceRpcElektra.cpp:1422	20100905
6	advisory	79:03	271585281	LATEST	493.797058	SpaceRpcElektra.cpp:1422	20100905
7	advisory	79:03	271585281	LATEST	493.797058	SpaceRpcElektra.cpp:1422	20100905
8	advisory	79:03	271585281	LATEST	493.797058	SpaceRpcElektra.cpp:1422	20100905
9	advisory	79:03	271585281	LATEST	493.797058	SpaceRpcElektra.cpp:1422	20100903
10	advisory	79:03	271585281	LATEST	493.235779	SpaceRpcElektra.cpp:1422	20100831
11	advisory	79:03	271585281	LATEST	493.235779	SpaceRpcElektra.cpp:1422	20100831
12	advisory	79:03	271585281	LATEST	493.235779	SpaceRpcElektra.cpp:1422	20100831
13	advisory	39.1.01.3	277880833	LATEST	491.847382	DragonRollStateMachine.cpp:1190	20100830
14	advisory	39.1.01.3	277880833	LATEST	489.822876	DragonRollStateMachine.cpp:1190	20100828
15	advisory	79:03	271585281	LATEST	489.025452	SpaceRpcElektra.cpp:1422	20100824
16	advisory	79:03	271585281	LATEST	489.025452	SpaceRpcElektra.cpp:1422	20100824
17	advisory	79:03	271585281	LATEST	489.025452	SpaceRpcElektra.cpp:1422	20100824
18	advisory	79:03	271585281	LATEST	489.025452	SpaceRpcElektra.cpp:1422	20100824
19	advisory	79:03	271585281	LATEST	489.025452	SpaceRpcElektra.cpp:1422	20100824
20	advisory	79:03	271585281	LATEST	489.025452	SpaceRpcElektra.cpp:1422	20100824
Printhead Error Log							
Printheads name	Serial Number	Status	Usage time	% Ink Used	Max Recovery Level	Error Code	
1 - Yellow-Unknown	4-1-5778130-31-2009	0	0 h	26	0	524288	
2 - Yellow-Unknown	4-1-5778127-31-2009	0	0 h	26	0	524288	
3 - Cyan-Magenta	4-1-5223728-27-2009	0	0 h	19	0	524288	
4 - Cyan-Magenta	4-1-5223718-27-2009	0	0 h	19	0	524288	
5 - Matte black-Matte black	4-1-5434078-28-2009	0	0 h	31	0	524288	
6 - Matte black-Matte black	4-1-5434043-28-2009	0	0 h	32	0	524288	
7 - Dark Gray-Gray	4-1-5718117-31-2009	0	0 h	26	0	524288	
8 - Dark Gray-Gray	4-1-5718105-31-2009	0	0 h	26	0	524288	

System/Warning error

- The **Line** and **Internal Code** do not provide much information, but are useful in the case of escalating a problem to the division (different internal error codes can point to the same error code (e.g. 01.10:10)).
- **Media Usage** (in square meters) and **Date** (from the printer's Internal Clock (RTC)) help you to understand if the printer has been used (media usage) and how much time has passed since the last error.

Printhead error log

- Printheads ago: History of the last three Printheads used ('0' represents the current Printhead used).
- **Status:** '0' = Working, '1' = No Printhead Detected, '2' = Replace, '4' = Reseat, '8' = Remove.
- **% Ink Used:** Percentage of the warranty life (1200 ml).
- **Error Code:** Specific error code generated by the printer when the Printhead has been replaced.
- **Max Recovery:**

- 0: No manual Printhead recovery has been performed on the Printhead.
- 1 or higher: At least one Printhead recovery has been performed.

Calibration status

This page contains the following information:

- General Calibrations (performed by Service Engineers).
- Media Specific Calibrations (performed by the User).

Current configuration	Current information	Usage information	Event logs	Calibration status	Connectivity configuration	All pages
Calibration Status						
Date:	26-Sep-10	Product:	HP DesignJet T7100ps	Serial Number:	MY9B309003DC42	
Firmware:	dragon-	Product number:	CQ105A	Service ID:	2091	
Printer status:						MK cartridge is missing
General Calibrations						
Printhead alignment	done	Drop Detector calibration	done	Line Sensor calibration	not done	
Media-specific Calibrations						
Media Name	Color	Date	Paper Advance	Date		
Backlit Material	N/A	-	Default	-		
Plain Paper	N/A	-	OK	Sep 21, 2010		
Recycled Bond Paper	N/A	-	Recommended	-		
HP Bright White Inkjet Paper	N/A	-	Recommended	-		
Heavyweight Coated Paper	Recommended	-	Default	-		
Transparent/Clear Film	N/A	-	Default	-		
Photo Gloss Paper	Recommended	-	Default	-		
Bright White Bond Paper	N/A	-	Recommended	-		
Matte Film	N/A	-	Default	-		
Photo Semi-Gloss/Satin Paper	Recommended	-	Default	-		
Natural Tracing Paper	N/A	-	Default	-		
Photo Matte Paper	Recommended	-	Default	-		
Translucent Bond	N/A	-	Default	-		
Vellum paper	N/A	-	Default	-		
Adhesive Paper	N/A	-	Default	-		
Adhesive Polypropylene Satin	N/A	-	Default	-		
HP Coated Paper	Recommended	-	Recommended	-		
HP Universal High-gloss Photo Paper	Recommended	-	Default	-		
HP Recycled Bond Paper	N/A	-	Recommended	-		
HP Universal Bond Paper	N/A	-	Recommended	-		
Coated Paper	Recommended	-	Recommended	-		
Printer Status Codes						
Nozzle Health	X4X4444444444444	Printhead Alignment	X1X11111111111111			
Media Advance Calibration	11111111	Closed Loop Color Calibration	X0X0000000000000			

General calibrations

- **Printhead Alignment** relates to the Printhead Alignment which changes to 'pending' when a Printhead is replaced and the Printhead Alignment has not been performed.



NOTE: When a component is replaced, the corresponding calibration is NOT automatically set to 'NOT DONE'. This is because the printer does not know that there is a new part installed.

- **Drop Detector** relates to the Drop Detector or Service Station calibration.
- **Line Sensor** relates to the Line Sensor Calibration.

Media-specific calibrations

This section shows the following for each type of media:

- Media Name
- Color
- Paper Advance

Connectivity configuration

This page contains full details of the current configuration of the printer.

The screenshot displays the HP printer's web interface, specifically the 'Connectivity Configuration' page. The top navigation bar includes tabs for 'Current configuration', 'Current information', 'Usage information', 'Event logs', 'Calibration status', 'Connectivity configuration', and 'All pages'. The main content area is divided into two sections, both titled 'Connectivity Configuration'.

The first section shows a summary of the printer's configuration:

- Date: 26-Sep-10
- Firmware: dragon-
- Printer status: MK cartridge is missing
- Product: HP Designjet T7100ps
- Product number: CQ105A
- Serial Number: MY9B309003DC42
- Service ID: 2091

The second section provides a detailed view of the Gigabit Ethernet configuration:

- General Information:** Status: I/O Card Ready; Model Number: CQ105A; Hardware Address: 00265130461; Firmware Version: dragon-; Port Config: AUTO; Auto Negotiation: On.
- IP Addressing:** IP Address: 16.23.114.203; Subnet Mask: 255.255.248.0; Default Gateway: 16.23.112.1; Config By: DHCP; DHCP Server: 16.228.51.250.
- Security Settings:** IPsec: Disabled; Secure Web: HTTPS Optional; Cert Expires: 2015-07-11 22:00 UTC; SNMP Versions: 1,2; SNMP Set Cmty Name: Not Specified/Default; SNMP Get Cmty Name: Not Specified/Default.
- Network Statistics:** Total Packets Received: 243827; Unicast Packets Received: 2170857; Bad Packets Received: 0; Framing Errors Received: 0; Total Packets Transmitted: 59257; Undeliverable Packets: 0; Transmit Collisions: 0; Transmit Late Collisions: 0.
- TCP/IP Settings:** IPv4: Enabled; IPv6: Enabled; Host Name: NPI00265130461; IPv4 Domain Name: emea.hpqcorp.net; IPv6 Domain Name: Not Specified; Primary DNS Server: 16.110.135.52; Secondary DNS Server: 16.110.135.51; DNS (IPv6): Not Specified; WINS Server: 16.228.51.247; Idle Timeout: 280 sec.

When the main window is open and the printer is printing (safety compliance)

We describe the details of the behavior of the printer when the window is opened while the carriage is moving.

If the main window is opened while the printer is doing something, be it a swath of a print job or a system task, the printer will:

1. Before the carriage stops, it will finish whatever it was doing when the window was opened. It will not finish an image it was printing, but it will finish the current swath, so as to avoid any impact on image quality. If it was performing a system task it will finish it before stopping.
2. If the carriage finishes on the left side of the printer, the carriage will always slowly move to the right side of the printer.
3. The printheads will be placed in their 'capping' positions.

Here are some different scenarios of what happens when the window is opened:

- If the printer is printing an image when the window is opened: The carriage will not stop immediately, the printer will finish the swath and then stop. If the cover is then closed, the printer will start to print from the position it was stopped.
- If the printer is cutting the media: The carriage finishes the cutting procedure.
- If the printer is checking the SKEW while loading the media: During the skew check, the printer does small movements of the carriage on the right side of the printer, and also moves the media when needed. This procedure checks that the edge of the media is moving laterally or not. If the window is opened while the printer is checking the media SKEW, the printer will complete the skew procedure (and it will continue well after the window has been opened). This is the only case when the printer will not stop the carriage at the end of a lateral movement (as a swath).

The safety system in place is designed to detect an object in the path of the carriage as it moves across the printer, any object encountered will cause the system to shut down the driver motor in the carriage. This method of ensuring safety is considered sufficient by the regulatory agencies that inspect and assess the product prior to its placement in the market. The window and its switch are considered a 'supplementary' safety feature, and as such the behavior of the switch has been adjusted as a trade off between the level of safety provided and the printer's functionality.

How to troubleshoot the 79:04 system error

- [Introduction](#)
- [Possible causes](#)
- [Troubleshooting based on symptoms](#)

Introduction

The System error 79:04 is a generic firmware error (equivalent to a blue screen in Windows). It's the System Error that the printer will display when an unknown exception occurs that cannot be pointed to by any specific subsystem of the printer.

Since this is a generic error, there can be multiple causes behind it. This document will cover the most probable causes behind a system error 79:04 and will recommend the most efficient troubleshooting steps to resolve customer issues.

One important point to mention is that, although 79:04 system errors can be caused by a hardware malfunction, the vast majority of 79:04 system errors are pure software or firmware issues. In these cases the issue can only be solved by determining the root cause and implementing a solution. The solution can usually be applied by either correctly configuring a selection, updating the printer's firmware/software that is being used or by fixing an error in the code).

Possible causes

Since the 79:04 system error is a generic error, the number of possible causes behind it is large. The majority can be grouped, however, into the following groups.

Job-related SE 79:04

A specific print job that is not correctly formatted for the printer or that is not correctly processed by it can trigger a 79:04 system error.

The incorrect format or processing can come from two sources:

- Incorrect commands in the job itself: for example, a PS job with some commands that do not have the correct PS format
- Issues applying to the settings in the job

Cause

A system error 79:04 caused by a print job always has the same symptoms:

1. The job is received by the printer and starts to process.
2. In the middle of the processing, the printer stops and displays 79:04.
3. The printer displays the 79:04 system error again immediately after restart. This is because the printer tries to reprint the job, which is pending in the queue, after restart.
4. After the second restart, the printer will start normally.
5. If the same job is sent again, it always produces a 79:04 system error.

These types of 79:04 system errors are normally caused by jobs that have been generated by third-party applications (RIPs, third-party drivers, files exported by an application to PS, PDF, HP-GL/2, RTL, or any other format supported by the printer). Jobs generated by HP drivers will not normally generate 79:04 system errors, since the output that our drivers generate is under control and has been designed taking into consideration the characteristics of our printer's language interpreters.

As an exception to this general rule, there are certain applications that can generate their own PS code, such as Adobe PhotoShop, Adobe Illustrator, Adobe Acrobat, Corel Draw, Freehand and QuarkXpress. When used with a PS driver, these applications generate the output PS themselves, instead of using the driver's rendering capabilities. This is known as PostScript pass-through. So, when using an HP PostScript driver together with an application that has PS passthrough capabilities, the PS code that comes into the printer has not been rendered by the HP driver, and, should the source file contain any PS commands that are not correctly processed by the printer, a 79:04 system error could occur even though an HP driver is being used.

Solution

When a job consistently generates a 79:04 system error, it is either because of a issue in the printer's firmware or because of a defect in the job itself (when it has been generated by third-party software). In order to identify the cause and find out a solution, these issues should always be immediately escalated to the GBU through the GCC.

However, there are some workarounds and short-term solutions that can be tried in order to get the customer up and running in the shortest possible time.

1. Send the job using a variety of different settings. The issue is often caused by a combination of the job contents combined with some specific setting(s).
2. If the customer is sending the file directly to the printer, try using the HP driver instead.
3. If the issue occurs when printing through the HP PostScript driver from an application with PS passthrough, try changing the options in the application so that it prints PS as raster (the option is typically located in the **Advanced** options of the application's printing dialog).

Data-related SE 79:04

The printer has a hard disk and non-volatile memory that contain databases and files that can be modified by the customer. Some examples include:

- The printer's queue
- The hard-disk partitions that contain the customer's jobs
- The database that stores printer settings
- The database that stores accounting information

Some of these data are accessed by the printer at start-up time, and some others are accessed as needed.

If any of these fields contain corrupt data or data with characters or values that cannot be correctly processed by the printer, a 79:04 system error may occur.

Cause

There are two different types of symptoms for data-related 79:04 system errors.

1. When the corrupt data are accessed during start up:
 - a. The printer will display a 79:04 during the start-up process
 - b. Switching the printer off and on again will not solve the issue. The printer will continue displaying the 79:04 system error until the corrupt data have been cleared through a service procedure.
2. When the corrupt data are accessed during normal printer operation:
 - a. The printer will start up normally.
 - b. When the data are accessed (for example while printing, while navigating the queue or when changing some settings), the printer displays a 79:04 system error.
 - c. The printer can restart normally.
 - d. When the data are accessed again (typically, under the same conditions as in step b), the 79:04 system error is displayed again.

Solution

Data-related 79:04 errors are often resolved by means of hardware intervention. Since data are stored in physical components (RAM, EEROM and hard disk), replacing these components with new ones that are empty usually solves the problem. However, there are quicker and more effective solutions to these types of errors.

1. Clear all information that has been introduced by the customer using the standard tools available in the printer.

- a. Delete all jobs from the queue (from the front panel or the Embedded Web Server).
 - b. Reset to factory defaults to clear the customer's configurations and calibrations.
 - c. Delete any non-standard paper presets in the printer (both the ones that have been created by the user and the ones that have been installed as OMES profiles through the Embedded Web Server or the HP Utility).
2. If step 1 did not resolve the issue, you can use Service Tools to clear additional information that could be causing the issue.
- a. Start the printer in Diagnostics Boot Mode.
 - b. Perform an EEROM reset.
3. If step 2 did not resolve the issue, it is possible to clear all the information on the hard disk and the different EEROMs, leaving them as they were when the printer was new.
- a. Access the Service Utilities Menu.
 - b. In the Secure Disk Wipe menu, set the Sanitize level to **Insecure mode**.
 - c. Execute the disk wipe. This will clear all partitions on the hard disk that contain customer data, including the partition in which the operating system is installed. After the disk wipe has completed, a backup firmware version will automatically be installed from a backup partition to allow the printer to start up. This backup firmware is a very old version.
 - d. The firmware in the printer should be updated to the latest official version as soon as the printer has restarted.

After step "c", any 79:04 which is caused by corrupt data in the printer will be solved.

 **NOTE:** It is possible that the corrupt data came to be in the printer as a consequence of some activity in the customer's workflow. In this case, it is possible that the issue will happen again. In these cases, it is very important to understand the sequence of events in the customer's workflow that led to the error occurring. Once the error can be traced in the customer's workflow, escalate the issue to the GBU (through the GCC). This is done to implement any changes in the printer's firmware that can prevent these issues occurring again.

Network-related SE 79:04

The printer has built-in networking capabilities. Network settings can be set manually, but in most cases they are obtained automatically from the printer. These settings include many different fields, such as IP address and subnet mask, available gateways, host and domain names and so on.

In some cases, there can be issues in the firmware that can cause a certain value in one of these fields to be interpreted incorrectly, and this can lead to a 79:04 system error.

Cause

There is no single set of symptoms that can absolutely pinpoint a network-related 79:04 system error. However, the following guidelines can be applied.

- It can happen at start-up time or when accessing the Network Configuration section of the front panel.
- In both cases, repeating the action with the LAN cable disconnected does not cause the 79:04 to occur.

Solution

In the majority of cases, these issues will be due to an issue in the printer's firmware. As soon as the conditions in which the issue happens can be understood, it should be escalated to the GBU through the GCC.

At the same time, the following short-term solutions and workarounds can help the customer to get up and running in the shortest possible time.

1. Disconnect the network cable to be able to start the printer and change network settings.
2. In the Network configuration menu in the Front Panel, disable any protocols that you are not using, including IPv6, SNMP and WebServices.
3. If step 2 does not work, try configuring the printer manually.
 - a. Enter the correct subnet mask and an IP address in the valid range.
 - b. In the Gateway field, set the same value as in the IP address field.
 - c. Do not set a host name or a domain name.
4. If step 3 does not work and the customer is using the network card built into the printer, try using an accessory Jetdirect card instead.

User-interaction-related SE 79:04

In some cases the printer may not react as expected when a certain set of conditions coincide. In these cases, if the printer doesn't know how to react, it may simply display a 79:04 system error and force a restart. Here are some examples (not real) that may help to illustrate this.

- An error occurs when a job is cancelled when it is at the "Finishing print" state and when the queue is disabled.
- An error occurs if the Window is opened while the printer is checking the printheads.

These errors will probably happen only in very specific corner cases that have not been identified during the development or the qualification of the printer. Therefore they do not normally impact the customer severely, as they do not affect their usual workflows.

Cause

The symptoms here are as numerous as the number of possible interactions between the user and the printer. In any case, it's possible to identify the steps that caused the error to occur and avoid them as the steps will always be the same with no variance.

Solution

First identify the state the printer was in at the time the error was displayed. For example, an action taken when the printer is drying can produce an error, whereas the same action when the printer is doing something else (or is idle) may not produce any error.

When you have identified the steps that caused the error, proceed as follows.

1. Escalate the issue to the GBU through the GCC in order to have it corrected in the firmware.
2. Recommend to customers that they try to avoid the same steps to avoid the error.
3. If the conditions that cause the error are in the customer's regular workflow, try to identify a different way of achieving the same result.

Random SE 79:04 (memory leaks and concurrence issues)

Some 79:04 errors can happen randomly when the printer is heavily used. However, it's impossible to find a single set of conditions that reproduce the problem. It just happens from time to time, without a defined pattern.

These random 79:04 errors can have two different types of root causes.

- **Memory leaks:** Before a program is executed, it allocates the memory it will need. After the execution is complete, the allocated memory is freed to be used by other programs. If the allocation or the release of the memory are not properly programmed, every time the program is executed some memory will be incorrectly labelled (either as used or as free). This is known as a memory leak. When a program with a memory leak is executed a lot, the memory becomes progressively full (since it is not properly freed). When the leak becomes too big, the printer is left 'out of memory' to execute new processes and a 79:04 is triggered.
- **Concurrence issues:** There are certain resources that can be accessed by multiple programs or by multiple executions of the same program (what is known as multiple threads). Access to these resources must be correctly controlled to prevent unexpected behavior. Issues caused by incorrect control of these resources are concurrence issues.

For example, imagine that there is a counter that controls the communication between the Jetdirect card and the printer's firmware. Whenever a new packet of information is sent by the Jetdirect card to the printer, the counter increases. When the printer receives the packet and processes it correctly, the counter decreases. Another process checks the counter from time to time to see its value and draw conclusions from it. If the counter is near 0, it means that the printer is processing correctly, and if it grows too large, it may mean that there is a bottleneck somewhere and maybe the Jetdirect card throughput is decreased to control its speed to the printer. However, if the access to this counter is not properly controlled, undesirable effects may happen: in a real environment, a Jetdirect card processes thousands of information packets per second, so this counter is updated frequently, both by the Jetdirect and the printer. If at a certain point the Jetdirect card and the printer try to access the counter at the same time and the code is not prepared to handle this, it may happen that the Jetdirect cannot increase the counter because the printer is writing to it, and what's worse, it does not realize this fact. If this happens a few times each second, it may happen that the counter is decreasing faster than it's increasing and that at a certain point it has a negative value. And then, what will the process that is checking this counter do? Most likely, the process will not be prepared to react to a negative value and will launch an exception that will trigger a 79:04 system error.

Cause

This type of 79:04 error always occurs in heavy load conditions, so the symptoms will normally follow this pattern.

- A printer that is heavily used (printing a project or in a reprographics environment) produces 79:04 errors randomly, forcing the user to restart.
- After restarting, the printer can be used without any issues for an extended period of time, but if the workload is consistently high a random error will occur again.
- The error can never be associated with a specific file. The file that was being printed when the error last occurred can be printed without issues after restart. And a file that has been printed without issues several times can trigger the error in the future.
- This error is very dependent on the customer's workflow. The most common user workflows have been extensively tested both by HP and by our beta sites, so random 79:04 issues are most unlikely to occur in these cases. These random issues tend to occur in very specific corner cases, and cannot be reproduced unless the exact conditions of the workflow are replicated. They normally happen when sending files generated by external applications (RIPs, third-party drivers, and so on).

Solution

Random 79:04 errors are, by far, the most complex ones to diagnose and to fix. The only solutions available in these cases are as follows.

1. Identify the root cause (either in the files or in the firmware) and fix it in the code, which requires the intervention of the GBU.
2. Test any options available to modify the customer's workflow and see if any combination of them solves the issue.

In both cases, a profound understanding of the customer's workflow is necessary. The following information should be obtained.

- The front-panel settings
- The application, and the RIP or driver that are being used
- The application/RIP/driver settings
- The type of output files that this application, RIP or driver is generating
- Some sample files that are representative of what the customer is using
- The operating system
- The method of connection to the printer
- A description of the normal flow when the issue occurs and the typical frequency of occurrence (for instance, once every hour when sending several files non-stop, each of them with multiple copies)

With this information, the environment can be replicated in order to try to find workarounds. This is also the information that will be needed at the GBU to investigate and fix the root cause of this issue once it is escalated.

Hardware-related SE 79:04

Hardware is, by far, the least likely cause of a 79:04 system error. Replacing hardware components does not normally fix the issue and increases the total turnaround time in finding a workable solution.

In some cases, a failure in a component in the printer's electronics may cause a 79:04 system error, since the printer's electronics are involved in the execution of the firmware and the processing of jobs. However, hardware failures in the electronics tend to produce specific system errors that point directly to the component that is failing.

Some hardware causes that could be behind a 79:04 error are as follows.

- Defective clusters on the hard disk. If these clusters are used to execute the firmware or to process a job, they may produce a 79:04 error. However, most 79:04 errors that are solved by a hard disk replacement are in fact, data-related 79:04 errors that could have been solved more efficiently and quickly by following the recommendations for such an error.
- Defective memory segments. If the RAM memory has some defective segments, a 79:04 error may occur when these segments are used.
- Intermittent defects in the electronic components that are involved in the processing of a job: Carriage PCA, Trailing Cable, Formatter and PrintMech PCA. This is a highly unlikely cause, since defects in these components will produce subsystem-specific errors.

Cause

There's no single set of symptoms behind hardware-related 79:04 system errors. However, there are two relatively common causes.

- 79:04 during start-up. Restarting the printer may or may not solve the problem.
- 79:04 while processing or printing a job. Restarting the printer and printing the same job does not always produce the error.

Solution

In the following procedure, perform each step as it appears in the list and move on to the next step only when you are sure the 79:04 error has not been cleared.

1. Restart the printer in Diagnostics Boot mode and execute the service tests to check the functionality of all the electronics components.
2. Check for data-related system errors: see [Data-related SE 79:04 on page 29](#).
3. Replace the memory.
4. Replace the hard disk drive.
5. Escalate the issue before replacing any additional parts.

Troubleshooting based on symptoms

This section will describe which troubleshooting steps to perform for a 79:04 system error based on the symptoms of the issue. Perform each step as it appears in the list and only move on to the next step once you are sure the 79:04 error has not been cleared.

Front panel displays 79:04 at start-up

1. Restart the printer twice. If the system error has been caused by a job in an incorrect format, restarting twice clears the error (the first time after restart, the printer tries to print the job again, which causes the error to re-appear). If restarting the printer twice solves the issue, then it is an issue related to the job: see [Job-related SE 79:04 on page 28](#).
2. Update the printer's firmware. Even if the currently installed firmware version is the latest, reinstall it. Since the printer cannot start normally, you must update the firmware while starting the printer in Diagnostics Boot Mode.
3. Disconnect the network cable and restart the printer. If this solves the problem, then it is a network-related 79:04 error and you should follow the guidelines for this type of 79:04 error, see [Network-related SE 79:04 on page 30](#).
4. Remove all cartridges, printheads and the maintenance cartridge. Unload the paper. Restart the printer. If the printer can start normally, insert the consumables one by one until you isolate the one that is causing the error. Do not insert any of the replaced consumables in another printer.
5. Restart the printer in Diagnostics Boot Mode and perform the "Electronics test". If an electronic component is identified as faulty, replace it.
6. Restart the printer in Diagnostics Boot Mode and Reset the EEROM. If the issue is solved by this, this is a data-related 79:04 system error and you should follow the guidelines, see [Data-related SE 79:04 on page 29](#).

7. If the unit has been used for some time and suddenly has started to show this behavior, replace the Hard Disk Drive (it may be included with the Formatter in some models).
8. If the issue is new and the issue happens since the first boot, do not replace the Hard Disk Drive.
9. If none of the previous steps solved the issue, escalate the issue with the following information:
 - Unit information: S/N, P/N, accessories
 - Conditions where the problem occurs and conditions prior to the first occurrence of the problem
 - The results of the previous steps
 - The System Error detailed information (this can be obtained by pressing CANCEL + Down)
 - The printer logs

Front panel displays 79:04 during printer operation – not while sending jobs

1. Restart the printer.
2. Update the printer's firmware. Even if the currently installed firmware version is the latest one, reinstall it.
3. Reset the printer to factory defaults.
4. In order to narrow the scope of the issue, try the following.
 - a. Disable the queue
 - b. Disable any unused network protocols
 - c. Disable SNMP and WebServices (if they are available in the printer)
 - d. Disable "Sleep mode" from the Service Utilities menu
 - e. Delete any Paper Presets that you may have uploaded or created using the printer Spectrophotometer.
5. Restart the printer in Diagnostics Boot Mode and perform the "Electronics test". If an electronic component is identified as faulty, replace it.
6. Restart the printer in Diagnostics Boot Mode and Reset the EEROM. If the issue is solved by this, this is a data-related 79:04 system error and you should follow the guidelines for this type of error, see [Data-related SE 79:04 on page 29](#).
7. Format the Hard Disk. To do so, you will need to start the printer normally, enter the Service Utilities menu and then the Secure Disk Erase option. Set the Erase method to "Fast Erase" and then perform the disk erase process. This will take 45-75 minutes and will erase all user information from the disk, resolving any issue caused by corrupt data. After the erase process, a firmware update will be required. If this solves the issue, this is a data-related 79:04 system error and you should follow the guidelines for this type of 79:04, see [Data-related SE 79:04 on page 29](#).
8. Try to identify the combination of settings or actions that led to the system error and try to reach the same result with a different combination. Escalate the issue to fix the original problem.
9. If none of the previous steps could solve the issue, escalate it with the following information:
 - Unit information: S/N, P/N, accessories
 - Conditions where the problem occurs and conditions prior to the first occurrence of the problem

- The result of the previous steps
- The printer information pages (either printed and faxed or obtained through the Embedded Web Server)
- The System Error detailed information (it can be obtained by pressing CANCEL + Down)
- The printer logs

Front panel displays 79:04 while printing

- [A. While printing a single job](#)
- [B. Random 79:04 during continuous printing](#)

A. While printing a single job

The error happens after a single job is sent. It's easy to identify which job that has produced the error, since every time that this same job is sent, the error is replicated.

1. Restart the printer twice (after the first restart, the printer will show the 79:04 system error again, since the printer will attempt to reprint the last job in the queue, which is the one that caused the issue)
2. If you are using an HP driver, update the driver to the latest version
3. Update the printer's firmware. Even if the currently installed firmware version is the latest one, reinstall it. Send the job using different print settings. The following ones can be helpful:
 - a. Try sending the job without selecting a paper preset in the driver
 - b. Try changing the Image Quality settings
 - c. If you are using the HP-GL/2 driver, try the option "Send job as bitmap"
 - d. If you are using the PS driver, try using the HP-GL/2 driver instead
 - e. If you are using the PS driver from an Adobe application (or any other application that can handle PS), try changing the application's print settings so that the PS is generated as Raster.
4. Try the following Front Panel settings:
 - a. Change the Print Language option in the Front Panel from "Automatic" (which is the default setting) to the language that is being printed (PS, HP-GL/2, ...)
 - b. Queue = OFF
 - c. Start Printing = After processing
 - d. For PS SKUs, try changing the encoding setting ("Automatic" by default) to Binary or ASCII
5. If you are using a third-party application that does not print through the HP driver, try modifying the printing workflow by:
 - a. Using an HP driver
 - b. Changing the settings in the application's printing dialog
6. If you are using an accessory Jetdirect card, try using the internal network connector or USB (if available).
7. Escalate the issue, providing the following information.

- Unit information: S/N, P/N, accessories
- Conditions where the problem occurs and conditions prior to the first occurrence of the problem
- The results of the previous steps
- The printer information pages (either printed and faxed or obtained through the Embedded Web Server)
- The System Error detailed information (it can be obtained by pressing **CANCEL + Down**)
- Information on the workflow:
 - Operating System
 - Application
 - Driver
 - Settings in the driver and the application
 - Settings in the printer
 - Connection method and settings:
 - The original file along with the information on how to reproduce the issue
 - A print to file that can reproduce the issue
- The printer logs

B. Random 79:04 during continuous printing

The error does not happen with a single job. It happens randomly during continuous printing, normally while the printer is managing a heavy load (printing a project or in a reprographics environment).

This type of error is caused either by memory leaks or by concurrence issues in the printer's firmware. They normally happen in unusual environments where these memory leaks or concurrence issues that have not been detected during qualification have occurred. These issues cause the printer to crash at a completely random moment during printing, and are not associated to a specific job.

Because of this, troubleshooting these issues is normally quite complex.

1. Restart the printer twice (after the first restart, the printer will show the 79:04 system error again, since the printer will attempt to reprint the last job in the queue. If the issue continues occurring randomly, continue troubleshooting).
2. If you are using an HP driver, update the driver to the latest version.
3. Update the printer's firmware. Even if the currently installed firmware version is the latest one, reinstall it.
4. Try the following changes in the workflow:
 - a. Change the Print Language option in the Front Panel from "Automatic" (which is the default setting) to the language that is being printed (PS, HP-GL/2, ...)
 - b. Queue = OFF
 - c. Start Printing = After processing

- d. For PS SKUs, try changing the encoding setting (“Automatic” by default) to Binary or ASCII
 - e. If you are using the HP-GL/2 driver, try sending the job as a bitmap
5. If you are using a third-party application that does not print through the HP driver, try modifying the printing workflow by:
 - a. Using an HP driver
 - b. Changing the settings in the application’s printing dialog
6. Escalate the issue with the following information:
 - Unit information: S/N, P/N, accessories
 - The printer information pages (either printed and faxed or obtained through the Embedded Web Server)
 - The System Error detailed information (it can be obtained by pressing **CANCEL** + **Down**)
 - Information on the workflow:
 - Operating System
 - Application
 - Driver
 - Settings in the driver and the application
 - Settings in the printer
 - Connection method and settings
 - Exact information on how to replicate the environment that reproduces the issue, including some example files that can be sent to the printer to replicate a heavy load environment. These files will need to be:
 - Original application files, if the issue happens printing from an application through our driver
 - Print to files if the issue happens when printing from a third-party application

3 System error codes

- [What to do if the front panel is blank](#)
- [System error codes](#)
- [Explanation of system error codes and warnings](#)
- [Continuable and non-continuable error codes](#)

What to do if the front panel is blank

No system error message can be displayed when the front panel is blank. In these cases the front panel has not necessarily failed—any other electronic component can be the root cause. The Power Switch and Formatter LEDs can help you to troubleshoot a problem in this situation; see [How to read the power switch LEDs on page 15](#) and [How to read the Formatter LEDs on page 15](#).

System error codes

System error codes are hexadecimal numbers generally caused by internal system errors. The following pages contain a list of system error codes and their respective descriptions and recommended corrective actions. Try one recommended action at a time and check whether the error code has disappeared.

If you have an error code which is not documented in this Service Manual or you have an error which you cannot resolve, then report the error to the HP Response Center or the nearest HP Support Office. When reporting the error, have the following information ready:

- Model and Serial Number of the printer.
- Which firmware revision the printer is using (see Note below). Check firmware in *Setup Menu / Information Menu / Show Printer Information*.
- The complete error number (see Note below).
- The complete error number (see Note below).
- The Service Configuration Print.
- The Current configuration sheet.
- Which software application the customer is using (name, version and so on).

 **NOTE:** When reporting the System Error Code, make sure that you supply the full Internal Error Code and the firmware version. Without this information, HP Support Personnel cannot help you. To view the Internal Error Code, hold the **DOWN** key and press the **CANCEL** key at the same time when the System Error Code is displayed on the Front Panel.

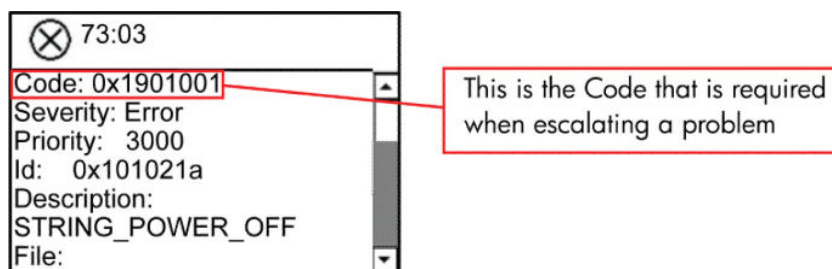

Explanation of system error codes and warnings

System Error Codes explain which component/system is failing and what action should be taken to resolve the problem.

System Error Codes are displayed directly on the front panel (but can also be seen on the Information Page) and have been defined in the format **XX.YZ**, or **XX.n:YZ.m**.

- **XX:** Service Part (2 digits).
- **n:** Service Part Index (if more than one used in the product) - Optional.
 - e.g. Identify the Ink Supply (color and number).
- **Y:** Who should perform the action (1 digit) - (User or Service Engineer).
- **Z:** Action to perform (1 digit).
- **m:** additional actions/information to consider (1 digit) - Optional.
 - e.g. Non-authorized ink was detected, PM was triggered or Printhead in/out of Warranty.

The following table explains the **XX** part of the System Error Code or Warning:

Code	Component/System
01.0	Main PCA
01.1	Printmech PCA
01.2	ISS Top PCA
01.3	ISS Bottom PCA
02.1	Carriage PCA
03	Power Supply Unit
05	Formatter
05.1	Formatter Fan
06	Hard Disk Drive
08	Front Panel
11	Trailing Cable
17	Other cables
21	Service Station
23	Air Pressure System (APS)
24	Ink Supply Tubes
26.n	Ink Cartridge (color n)
27.n, 28.n	Printhead (color n)
29	Maintenance Cartridge
41	Media-Axis Motor
42	Scan-Axis Motor
43	Vacuum Fan
44	Aerosol Fan
45	Rewinder
46	Primer
50	OMAS

Code	Component/System
51	Window Position Sensor
51.1	Maintenance Cartridge Door Sensor
52	Drop Detector
53	Media Sensor
55	Line Sensor
56	Paper Encoder Sensor
59	Incompatible parts
60	Initialization
61	Language Interpreting
64	Input/Output through USB Port
71	Memory Management
74	Firmware Update
75	Ink consumption
76	Hard Disk Full
77	Embedded Web Server
78	Media Settings
79	Assertion (Uncontrollable Firmware Error)
81	Paper Advance
85	Media-Axis Encoder Reading
86	Carriage Movement
87	Scan-axis encoder reading
94	Color Calibration

The following table explains the **YZ** part of the System Error Code or Warning:

Code	Recovery action	Response
00	Replace	
01	Reseat/Reconnect/Clean/Adjust (manually)	
02	Calibrate/Adjust (using Automatic Process)	
03	Power OFF and Restart the printer	Possible for customer to perform action
04	Update System Firmware	
05	Upgrade Driver or Computer Software	
06	Add Accessory	
07	Escalate	

Code	Recovery action	Response
08	Send Plot Again	
09	Wrong Part Installed	
10	Replace	
11	Reseat/Reconnect/Clean/Adjust (manually)	
12	Calibrate/Adjust (using Automatic Process)	
13	Power OFF	
14	Update System Firmware	HP qualified personnel assistance required
15	Upgrade Driver or Computer Software	
16	Add Accessory	
17	Escalate	
18	Send Plot Again	
19	Wrong Part Installed	

Continuable and non-continuable error codes

Some of the Error Codes are continuable, which means you can press **OK** on the front-panel and continue working with the printer. Non-Continuable Error Codes do not allow you to continue working with the printer, in this case power the printer **OFF** and **ON** again and see if the System Error disappears. If the Error Code reappears, then the printer requires an on-site visit in order to resolve the problem.



NOTE: If the solution calls for a replacement part, replace one component at a time and check if the error has been cleared before replacing another component. Using this procedure you will be able to determine exactly which component has failed.

SE 01.0:10

Cause: Main PCA hardware failure

Solution: Try the following.

- Turn the power off at the rear of the printer and disconnect the power cord. Reconnect the power cord and turn on the printer.
- Replace the Main PCA ⇒ [Main PCA on page 377](#).

SE 01.1:10

Cause: PrintMech PCA hardware failure

Solution: Try the following.

- Turn the power off at the rear of the printer and disconnect the power cord. Reconnect the power cord and turn on the printer.
- Remove the Ink Cartridges.

- Replace the Power Supply Unit [Power Supply Unit \(PSU\) on page 387](#).
- Replace the PrintMech PCA [PrintMech PCA on page 391](#).

SE 01.2:10

Cause: ISS Top PCA communication failure

Solution: Try the following.

- Turn the power off at the rear of the printer and disconnect the power cord. Reconnect the power cord and turn on the printer.
- Replace the Ink Supply Tubes and Trailing Cable.



NOTE: If the Ink Supply Tubes are to be replaced, the Ink Cartridges need to be checked beforehand to see if they are capable of purging the new tubes. If they are not, new Ink Cartridges must also be sent with the parts to be replaced. To check the Ink Cartridges, see [Check ink supplies on page 94](#).

SE 01.3:10

Cause: ISS Bottom PCA communication failure

Solution: Try the following.

- Turn the power off at the rear of the printer and disconnect the power cord. Reconnect the power cord and turn on the printer.
- Replace the Ink Supply Tubes and Trailing Cable.



NOTE: If the Ink Supply Tubes are to be replaced, the Ink Cartridges need to be checked beforehand to see if they are capable of purging the new tubes. If they are not, new Ink Cartridges must also be sent with the parts to be replaced. To check the Ink Cartridges, see [Check ink supplies on page 94](#).

SE 02.1:10

Cause: Carriage PCA communication failure

Solution: Try the following.

- Turn the power off at the rear of the printer and disconnect the power cord. Reconnect the power cord and turn on the printer.
- Check that the Trailing Cable is not damaged.
- Check that the Trailing Cable is correctly connected to the Carriage PCA, Interconnect PCA and Main PCA.
- Replace the Carriage PCA ⇒ [Carriage PCA on page 293](#).

SE 03:10

Cause: Power distribution failure

Solution: Try the following.

- Turn the power off at the rear of the printer and disconnect the power cord. Reconnect the power cord and turn on the printer.
- If the Power Supply Unit's blue LED is on, replace the PrintMech PCA ⇒ [PrintMech PCA on page 391](#). If not, replace the Power Supply Unit ⇒ [Power Supply Unit \(PSU\) on page 387](#).

SE 05:10

Cause: Formatter communication failure with ISS

Solution: Try the following.

- Turn the power off at the rear of the printer and disconnect the power cord. Reconnect the power cord and turn on the printer.
- Check that the Formatter to PrintMech PCA cable is correctly connected.
- If the printer is a Rev A, replace the Formatter ⇒ [Formatter on page 380](#).
- If the printer is a Rev B, replace the Formatter and the Hard Disk Drive ⇒ [Hard Disk Drive \(HDD\) on page 383](#).

SE 05.1:10

Cause: Formatter CPU fan stopped or burnt

Solution: Try the following.

- Turn the power off at the rear of the printer and disconnect the power cord. Reconnect the power cord and turn on the printer.
- If the printer is a Rev A, replace the Formatter ⇒ [Formatter on page 380](#).
- If the printer is a Rev B, replace the Formatter and the Hard Disk Drive ⇒ [Hard Disk Drive \(HDD\) on page 383](#).

SE 06:03

Cause: Main NVM communication failure

Solution: Try the following.

- Turn the power off at the rear of the printer and disconnect the power cord. Reconnect the power cord and turn on the printer.
- If the printer is a Rev A, replace the Hard Disk Drive ⇒ [Hard Disk Drive \(HDD\) on page 383](#).
- If the printer is a Rev B, replace the Hard Disk Drive and the Formatter ⇒ [Formatter on page 380](#).

SE 06:10

Cause: Main NVM communication failure

Solution: Try the following.

- Turn the power off at the rear of the printer and disconnect the power cord. Reconnect the power cord and turn on the printer.
- If the printer is a Rev A, replace the Hard Disk Drive ⇒ [Hard Disk Drive \(HDD\) on page 383](#).
- If the printer is a Rev B, replace the Hard Disk Drive and the Formatter ⇒ [Formatter on page 380](#).

SE 08:11

Cause: Front Panel communication failure

Solution: Try the following.

- Turn the power off at the rear of the printer and disconnect the power cord. Reconnect the power cord and turn on the printer.
- See [What to do if the front panel is blank on page 40](#).

SE 11:10

Cause: Trailing Cable does not seem to be connected

Solution: Try the following.

- Check that the Trailing Cable is not damaged.
- Check that the Trailing Cable is correctly connected to the Carriage PCA, Interconnect PCA and Main PCA.
- Replace the Ink Supply Tubes and Trailing Cable.



NOTE: If the Ink Supply Tubes are to be replaced, the Ink Cartridges need to be checked beforehand to see if they are capable of purging the new tubes. If they are not, new Ink Cartridges must also be sent with the parts to be replaced. To check the Ink Cartridges, see [Check ink supplies on page 94](#).

SE 17.0:11

Cause: PrintMech to Interconnect Power cable does not seem to be connected

Solution: Try the following.

- Check that the PrintMech to Interconnect Power cable is not damaged.
- Check that the PrintMech to Interconnect Power cable is correctly connected to the PrintMech PCA and the Interconnect PCA.
- Replace the PrintMech to Interconnect Power cable (which is included in the Electronics Module Cable Kit).

SE 17.1:11

Cause: PrintMech to Interconnect Data 1 cable does not seem to be connected

Solution: Try the following.

- Check that the PrintMech to Interconnect Data 1 cable is not damaged.
- Check that the PrintMech to Interconnect Data 1 cable is correctly connected to the PrintMech PCA and the Interconnect PCA.
- Replace the PrintMech to Interconnect Data 1 cable (which is included in the Electronics Module Cable Kit).

SE 17.2:11

Cause: PrintMech to Interconnect Data 2 cable does not seem to be connected

Solution: Try the following.

- Check that the PrintMech to Interconnect Data 2 cable is not damaged.
- Check that the PrintMech to Interconnect Data 2 cable is correctly connected to the PrintMech PCA and the Interconnect PCA.
- Replace the PrintMech to Interconnect Data cable 2 (which is included in the Electronics Module Cable Kit).

SE 17.3:11

Cause: Main PCA to PrintMech Black 1 cable does not seem to be connected

Solution: Try the following.

- Check that the Main PCA to PrintMech Black 1 cable is not damaged.
- Check that the Main PCA to PrintMech Black 1 cable is correctly connected to the Main PCA and the PrintMech PCA.
- Replace the Main PCA to PrintMech Black 1 cable (which is included in the Electronics Module Cable Kit).

SE 17.4:11

Cause: Main PCA to PrintMech Blue 2 cable does not seem to be connected

Solution: Try the following.

- Check that the Main PCA to PrintMech Blue 2 cable is not damaged.
- Check that the Main PCA to PrintMech Blue 2 cable is correctly connected to the Main PCA and the PrintMech PCA.
- Replace the Main PCA to PrintMech Blue 2 cable (which is included in the Electronics Module Cable Kit).

SE 21:03

Cause: Service Station electrical current limit

Solution: Try the following.

- Turn the power off at the rear of the printer and disconnect the power cord. Reconnect the power cord and turn on the printer.
- Make sure that the Service Station path is clear. Remove any visible obstacles (such as foam from the printer's packaging, screws and plastic parts) restricting the movement of the Service Station.
- If the System Error continues, replace the Service Station ⇒ [Service Station on page 246](#).

SE 21:13

Cause: Service Station jam

Solution: Try the following.

- Turn the power off at the rear of the printer and disconnect the power cord. Reconnect the power cord and turn on the printer.
- Make sure that the Service Station path is clear. Remove any visible obstacles (such as foam from the printer's packaging, screws and plastic parts) restricting the movement of the Service Station.
- If the System Error continues, replace the Service Station ⇒ [Service Station on page 246](#).

SE 23:10

Cause: Air Pressurization System failure; unable to pressurize or depressurize tubes

Solution: Try the following.

- Turn the power off at the rear of the printer and disconnect the power cord. Reconnect the power cord and turn on the printer.
- Check that the APS cable is not damaged and is correctly connected to the PrintMech PCA.
- Check that the air tubes are properly connected and are not kinked or pinched.
- Replace the APS Assembly ⇒ [APS Assembly on page 320](#).

SE 24:03

Cause: Ink Supply Tubes purge failure

Solution: Try the following.

- Turn the power off at the rear of the printer and disconnect the power cord. Reconnect the power cord and turn on the printer.
- Ensure that the dummy printheads are correctly installed and purge the Ink Supply Tubes again.
- If the problem persists, replace the Setup Printhead Kit.

SE 24:10

Cause: A broken bag has been detected in one of the Ink Cartridges

Solution: Try the following.

- Press **Down** + **Cancel** to see which cartridges have a broken bag. Remove the affected cartridges, shake each one three times within 2 seconds through a distance of about 40 cm, and check whether the cartridge

air tower is contaminated with ink. If at least one cartridge is contaminated, replace the Ink Supply Tubes and Trailing Cable ⇒ [Ink Supply Tubes and Trailing Cable on page 303](#).

 **NOTE:** If the Ink Supply Tubes are to be replaced, the Ink Cartridges need to be checked beforehand to see if they are capable of purging the new tubes. If they are not, new Ink Cartridges must also be sent with the parts to be replaced. To check the Ink Cartridges, see [Check ink supplies on page 94](#).

- If no cartridge seems contaminated, follow the broken bag recovery procedure for more information ⇒ [Recover broken bag on page 97](#).

SE 24:11

Cause: PrintMech to ISS Top cable does not seem to be connected

Solution: Try the following.

- Check that the PrintMech to ISS Top cable cable is not damaged.
- Check that the PrintMech to ISS Top cable is correctly connected to the PrintMech PCA and ISS Top PCA.
- Replace the PrintMech to ISS Top cable (which is included in the Electronics Module Cable Kit).

SE 24.1:11

Cause: ISS Top to ISS Bottom cable does not seem to be connected

Solution: Try the following.

- Check that the ISS Top to ISS Bottom cable cable is not damaged.
- Check that the ISS Top to ISS Bottom cable is correctly connected to the ISS Top PCA and ISS Bottom PCA.
- Replace the ISS Top to ISS Bottom cable (which is included in the Electronics Module Cable Kit).

SE 26.0:01

Cause: Bad contact detected in ISS slot 0 floater

Solution: Try the following operations on the Yellow Ink Cartridge (T7100) or the Matte Black Ink Cartridge (T7100 Monochrome).

- Remove the Ink Cartridge and reinstall it into the printer.
- Replace the Ink Cartridge.
- Check that the ISS to Cartridge cable is not damaged and is correctly connected to the Ink Supply Tubes PCA.
- Replace the ISS to Cartridge cable ⇒ [ISS to Cartridge Cables on page 312](#).

SE 26.1:01

Cause: Bad contact detected in ISS slot 1 floater

Solution: Try the following operations on the Cyan Cartridge (T7100) or the Dark Gray Cartridge (T7100 Monochrome).

- Remove the Ink Cartridge and reinstall it into the printer.
- Replace the Ink Cartridge.
- Check that the ISS to Cartridge cable is not damaged and is correctly connected to the Ink Supply Tubes PCA.
- Replace the ISS to Cartridge cable ⇒ [ISS to Cartridge Cables on page 312](#).

SE 26.2:01

Cause: Bad contact detected in ISS slot 2 floater

Solution: Try the following operations on the Matte Black Cartridge (T7100); the T7100 Monochrome should not experience this error.

- Remove the Ink Cartridge and reinstall it into the printer.
- Replace the Ink Cartridge.
- Check that the ISS to Cartridge cable is not damaged and is correctly connected to the Ink Supply Tubes PCA.
- Replace the ISS to Cartridge cable ⇒ [ISS to Cartridge Cables on page 312](#).

SE 26.3:01

Cause: Bad contact detected in ISS slot 3 floater

Solution: Try the following operations on the Dark Gray Cartridge (T7100); the T7100 Monochrome should not experience this error.

- Remove the Ink Cartridge and reinstall it into the printer.
- Replace the Ink Cartridge.
- Check that the ISS to Cartridge cable is not damaged and is correctly connected to the Ink Supply Tubes PCA.
- Replace the ISS to Cartridge cable ⇒ [ISS to Cartridge Cables on page 312](#).

SE 26.4:01

Cause: Bad contact detected in ISS slot 4 floater

Solution: Try the following operations on the Magenta Cartridge (T7100); the T7100 Monochrome should not experience this error.

- Remove the Ink Cartridge and reinstall it into the printer.
- Replace the Ink Cartridge.
- Check that the ISS to Cartridge cable is not damaged and is correctly connected to the Ink Supply Tubes PCA.
- Replace the ISS to Cartridge cable ⇒ [ISS to Cartridge Cables on page 312](#).

SE 26.5:01

Cause: Bad contact detected in ISS slot 5 floater

Solution: Try the following operations on the Gray Cartridge (T7100); the T7100 Monochrome should not experience this error.

- Remove the Ink Cartridge and reinstall it into the printer.
- Replace the Ink Cartridge.
- Check that the ISS to Cartridge cable is not damaged and is correctly connected to the Ink Supply Tubes PCA.
- Replace the ISS to Cartridge cable ⇒ [ISS to Cartridge Cables on page 312](#).

SE 27.1:01

Cause: Calibration failed to due to poor performance of the Yellow Printhead (T7100) or Matte Black Printhead (T7100 Monochrome) in slot 1

Solution: This may impact your print quality. If it becomes unacceptable in the future, clean all printheads and check their status.

SE 27.2:01

Cause: Calibration failed to due to poor performance of the Yellow Printhead (T7100) or Matte Black Printhead (T7100 Monochrome) in slot 2

Solution: This may impact your print quality. If it becomes unacceptable in the future, clean all printheads and check their status.

SE 27.3:01

Cause: Calibration failed to due to poor performance of the Magenta/Cyan Printhead (T7100) or Dark Gray Printhead (T7100 Monochrome) in slot 3

Solution: This may impact your print quality. If it becomes unacceptable in the future, clean all printheads and check their status.

SE 27.4:01

Cause: Calibration failed to due to poor performance of the Magenta/Cyan Printhead (T7100) or Dark Gray Printhead (T7100 Monochrome) in slot 4

Solution: This may impact your print quality. If it becomes unacceptable in the future, clean all printheads and check their status.

SE 27.5:01

Cause: Calibration failed to due to poor performance of the Matte Black Printhead (T7100) in slot 5; the T7100 Monochrome should not experience this error

Solution: This may impact your print quality. If it becomes unacceptable in the future, clean all printheads and check their status.

SE 27.6:01

Cause: Calibration failed to due to poor performance of the Matte Black Printhead (T7100) in slot 6; the T7100 Monochrome should not experience this error

Solution: This may impact your print quality. If it becomes unacceptable in the future, clean all printheads and check their status.

SE 27.7:01

Cause: Calibration failed to due to poor performance of the Gray/Dark Gray Printhead (T7100) in slot 7; the T7100 Monochrome should not experience this error

Solution: This may impact your print quality. If it becomes unacceptable in the future, clean all printheads and check their status.

SE 27.8:01

Cause: Calibration failed to due to poor performance of the Gray/Dark Gray Printhead (T7100) in slot 8; the T7100 Monochrome should not experience this error

Solution: This may impact your print quality. If it becomes unacceptable in the future, clean all printheads and check their status.

SE 28.1:01

Cause: The Yellow Printhead (T7100) or Matte Black Printhead (T7100 Monochrome) in slot 1 is deteriorating

Solution: This may impact your print quality. If it becomes unacceptable in the future, replace that printhead with a new one.



NOTE: This system error appears only after the printhead is out of warranty.

SE 28.2:01

Cause: The Yellow Printhead (T7100) or Matte Black Printhead (T7100 Monochrome) in slot 2 is deteriorating

Solution: This may impact your print quality. If it becomes unacceptable in the future, replace that printhead with a new one.



NOTE: This system error appears only after the printhead is out of warranty.

SE 28.3:01

Cause: The Magenta/Cyan Printhead (T7100) or Dark Gray Printhead (T7100 Monochrome) in slot 3 is deteriorating

Solution: This may impact your print quality. If it becomes unacceptable in the future, replace that printhead with a new one.



NOTE: This system error appears only after the printhead is out of warranty.

SE 28.4:01

Cause: The Magenta/Cyan Printhead (T7100) or Dark Gray Printhead (T7100 Monochrome) in slot 4 is deteriorating

Solution: This may impact your print quality. If it becomes unacceptable in the future, replace that printhead with a new one.

 **NOTE:** This system error appears only after the printhead is out of warranty.

SE 28.5:01

Cause: The Matte Black Printhead (T7100) in slot 5 is deteriorating; the T7100 Monochrome should not experience this error

Solution: This may impact your print quality. If it becomes unacceptable in the future, replace that printhead with a new one.

 **NOTE:** This system error appears only after the printhead is out of warranty.

SE 28.6:01

Cause: The Matte Black Printhead (T7100) in slot 6 is deteriorating; the T7100 Monochrome should not experience this error

Solution: This may impact your print quality. If it becomes unacceptable in the future, replace that printhead with a new one.

 **NOTE:** This system error appears only after the printhead is out of warranty.

SE 28.7:01

Cause: The Gray/Dark Gray Printhead (T7100) in slot 7 is deteriorating; the T7100 Monochrome should not experience this error

Solution: This may impact your print quality. If it becomes unacceptable in the future, replace that printhead with a new one.

 **NOTE:** This system error appears only after the printhead is out of warranty.

SE 28.8:01

Cause: The Gray/Dark Gray Printhead (T7100) in slot 8 is deteriorating; the T7100 Monochrome should not experience this error

Solution: This may impact your print quality. If it becomes unacceptable in the future, replace that printhead with a new one.

 **NOTE:** This system error appears only after the printhead is out of warranty.

SE 28.1:02

Cause: The Yellow Printhead (T7100) or Matte Black Printhead (T7100 Monochrome) in slot 1 is nearing the end of its useful life

Solution: This printhead may have reached a degradation level that prevents the printer from producing acceptable prints consistently. If it becomes unacceptable in the future, run the Clean (Recover) Printhead procedure.

 **NOTE:** This system error appears only after the printhead is out of warranty.

SE 28.2:02

Cause: The Yellow Printhead (T7100) or Matte Black Printhead (T7100 Monochrome) in slot 2 is nearing the end of its useful life

Solution: This printhead may have reached a degradation level that prevents the printer from producing acceptable prints consistently. If it becomes unacceptable in the future, run the Clean (Recover) Printhead procedure.

 **NOTE:** This system error appears only after the printhead is out of warranty.

SE 28.3:02

Cause: The Magenta/Cyan Printhead (T7100) or Dark Gray Printhead (T7100 Monochrome) in slot 3 is nearing the end of its useful life

Solution: This printhead may have reached a degradation level that prevents the printer from producing acceptable prints consistently. If it becomes unacceptable in the future, run the Clean (Recover) Printhead procedure.

 **NOTE:** This system error appears only after the printhead is out of warranty.

SE 28.4:02

Cause: The Magenta/Cyan Printhead (T7100) or Dark Gray Printhead (T7100 Monochrome) in slot 4 is nearing the end of its useful life

Solution: This printhead may have reached a degradation level that prevents the printer from producing acceptable prints consistently. If it becomes unacceptable in the future, run the Clean (Recover) Printhead procedure.

 **NOTE:** This system error appears only after the printhead is out of warranty.

SE 28.5:02

Cause: The Matte Black Printhead (T7100) in slot 5 is nearing the end of its useful life; the T7100 Monochrome should not experience this error

Solution: This printhead may have reached a degradation level that prevents the printer from producing acceptable prints consistently. If it becomes unacceptable in the future, run the Clean (Recover) Printhead procedure.

 **NOTE:** This system error appears only after the printhead is out of warranty.

SE 28.6:02

Cause: The Matte Black Printhead (T7100) in slot 6 is nearing the end of its useful life; the T7100 Monochrome should not experience this error

Solution: This printhead may have reached a degradation level that prevents the printer from producing acceptable prints consistently. If it becomes unacceptable in the future, run the Clean (Recover) Printhead procedure.

 **NOTE:** This system error appears only after the printhead is out of warranty.

SE 28.7:02

Cause: The Gray/Dark Gray Printhead (T7100) in slot 7 is nearing the end of its useful life; the T7100 Monochrome should not experience this error

Solution: This printhead may have reached a degradation level that prevents the printer from producing acceptable prints consistently. If it becomes unacceptable in the future, run the Clean (Recover) Printhead procedure.

 **NOTE:** This system error appears only after the printhead is out of warranty.

SE 28.8:02

Cause: The Gray/Dark Gray Printhead (T7100) in slot 8 is nearing the end of its useful life; the T7100 Monochrome should not experience this error

Solution: This printhead may have reached a degradation level that prevents the printer from producing acceptable prints consistently. If it becomes unacceptable in the future, run the Clean (Recover) Printhead procedure.

 **NOTE:** This system error appears only after the printhead is out of warranty.

SE 29:00

Cause: Maintenance Cartridge almost full

Solution: Replace the Maintenance Cartridge.

SE 29:01

Cause: Maintenance Cartridge not inserted correctly

Solution: Try the following.

- Open the Maintenance Cartridge door on the right-hand side of the printer, make sure that the maintenance cartridge is correctly seated, then close the door.
- If the problem persists, replace the Maintenance Cartridge.

SE 29:02

Cause: Ink Absorber almost full

Solution: Replace the Ink Absorber.

SE 35:10

Cause: Rear Door sensor error detected

Solution: Try the following:

- Check that the Left and Right Rear Door Sensor cables are not damaged and are connected correctly to the Interconnect PCA.
- Replace the Rear Door ⇒ [Rear Door on page 352](#).

SE 37:03

Cause: ARSS motor shutdown

Solution: Try the following:

- Turn the power off at the rear of the printer and disconnect the power cord. Reconnect the power cord and turn on the printer.
- Replace the Rear Door ⇒ [Rear Door on page 352](#).

SE 38:03

Cause: Stacker communication protocol error

Solution: Try the following:

- Restart the printer.
- Check that the cable between the stacker and the printer is undamaged and correctly connected.
- Update the stacker firmware.
- Replace the Stacker Electronics PCA ⇒ [Electronics PCA on page 455](#).

SE 38.0:01

Cause: Paper jam detected in stacker; buffer sensor activated

Solution: Try the following:

- Remove any paper jammed in the printer or stacker, and restart the printer.
- Perform the Paper Drive test ⇒ [Paper Drive test on page 88](#).

SE 38.0:10

Cause: Paper jam detected in stacker; buffer sensor not activated

Solution: Try the following:

- Remove any paper jammed in the printer or stacker, and restart the printer.
- Perform the Paper Drive test ⇒ [Paper Drive test on page 88](#).

SE 38.1:01

Cause: Stacker communication error

Solution: Try the following:

- Restart the printer.
- Check that the cable between the stacker and the printer is undamaged and correctly connected.
- Update the stacker firmware.
- Replace the Stacker Electronics PCA ⇒ [Electronics PCA on page 455](#).

SE 38.1:03

Cause: Stacker multiple firmware upgrades

Solution: Try the following:

- Turn the power off from the rear of the printer and disconnect the power cord. Reconnect the power cord and turn on the printer.
- Check that the printer has the latest firmware version. If not, update the firmware to the latest version.
- Replace the Stacker Electronics PCA ⇒ [Electronics PCA on page 455](#).

SE 38.1:04

Cause: Stacker unable to update firmware

Solution: Try the following:

- Check that the printer has the latest firmware version. If not, update the firmware to the latest version.

SE 38.1:10

Cause: Stacker initialization error

Solution: Try the following:

- Turn the power off from the rear of the printer and disconnect the power cord. Reconnect the power cord and turn on the printer.
- Check that the printer has the latest firmware version. If not, update the firmware to the latest version.
- Check that all the connections to the Main Stacker PCA are correct.
- Replace the Stacker Electronics PCA ⇒ [Electronics PCA on page 455](#).

SE 38.2:03

Cause: Stacker unable to reach target temperature

Solution: Try the following:

- Turn the power off from the rear of the printer and disconnect the power cord. Reconnect the power cord and turn on the printer.
- After turning on the stacker, check whether the Roller is getting hot. If not, check the Heating Lamp.
- Check the Safety Temperature Sensor.

SE 38.2:10

Cause: Stacker temperature too high

Solution: Try the following:

- Check that the Safety Temperature Sensor is correctly installed.
- Replace the Safety Temperature Sensor ⇒ [Safety Temperature Sensor on page 442](#).

SE 38.2:11

Cause: Stacker temperature too low

Solution: Try the following:

- Check that the Safety Temperature Sensor is correctly installed.
- Replace the Safety Temperature Sensor ⇒ [Safety Temperature Sensor on page 442](#).

SE 38.3:11

Cause: Stacker heating element overhead switch off

Solution: Try the following:

- Turn off the stacker and leave it to cool down for 10 minutes.
- Check the distance of the Safety Temperature Sensor from the Heater Roller.
- Check the temperature of the Heater Roller.

SE 38.4:10

Cause: Stacker heating element failure

Solution: Try the following:

- Turn the power off from the rear of the printer and disconnect the power cord. Reconnect the power cord and turn on the printer.
- Check that the Heating Lamp is correctly installed.
- Replace the Heating Lamp ⇒ [Heating Lamp on page 462](#).

SE 38.5:01

Cause: Stacker motor overload

Solution: Try the following:

- Check that the Drive Motor is not blocked by turning the stacker off and on.
- Check that the Stacker Transport Belt can turn freely.
- Check for any debris in the paper path.

- Check that all the connections to the Drive Motor are correct.
- Replace the Drive Motor ⇒ [Drive Motor on page 439](#).

SE 38.5:10

Cause: Stacker abnormal motor condition

Solution: Try the following:

- Check that all the connections to the Drive Motor are correct.
- Replace the Drive Motor ⇒ [Drive Motor on page 439](#).

SE 38.5:11

Cause: Stacker motor encoder failure

Solution: Try the following:

- Check that all the connections to the Drive Motor are correct, especially the connection to the encoder.
- Replace the Drive Motor ⇒ [Drive Motor on page 439](#).

SE 38.6:11

Cause: Stacker power supply failure

Solution: Try the following:

- Replace the Stacker Power Supply Unit ⇒ [Power Supply Unit on page 457](#).

SE 38.8:01

Cause: Paper jam detected in stacker; paper jam sensor activated

Solution: Try the following:

- Remove any paper inside the stacker.
- Check for paper jams in the paper path.
- Check that the Media Sensor is not damaged.
- Replace the Stacker Media Sensor ⇒ [Media Sensor on page 447](#).

SE 38.8:10

Cause: Paper jam detected in stacker; paper jam sensor not activated

Solution: Try the following:

- Remove any paper inside the stacker.
- Check for paper jams in the paper path.

- Check that the Media Sensor is not damaged.
- Replace the Stacker Media Sensor ⇒ [Media Sensor on page 447](#).

SE 39.1:01.2

Cause: Unable to load roll 1 from standby/parking position; roll mispositioned

Solution: Roll 1 has been unloaded. Reload it and check that the paper is correctly aligned with the hubs.

SE 39.2:01.2

Cause: Unable to load roll 2 from standby/parking position; roll mispositioned

Solution: Roll 2 has been unloaded. Reload it and check that the paper is correctly aligned with the hubs.

SE 39.2:01.2

Cause: Unable to load roll 3 from standby/parking position; roll mispositioned

Solution: Roll 3 has been unloaded. Reload it and check that the paper is correctly aligned with the hubs.

SE 39.1:01.3

Cause: Unable to load roll 1 from standby/parking position; paper edges were not found

Solution: Roll 1 has been unloaded. Reload it.

SE 39.2:01.3

Cause: Unable to load roll 2 from standby/parking position; paper edges were not found

Solution: Roll 2 has been unloaded. Reload it.

SE 39.2:01.3

Cause: Unable to load roll 3 from standby/parking position; paper edges were not found

Solution: Roll 3 has been unloaded. Reload it.

SE 40:03

Cause: Smart Roll-loading System Motor shutdown

Solution: Try the following:

- Turn the power off at the rear of the printer and disconnect the power cord. Reconnect the power cord and turn on the printer.
- Open the Smart Roll-loading System and check for any visible obstacles restricting its movement.
- Replace the Smart Roll-loading System Gear and Motor ⇒ [Smart Roll-loading System Gear on page 266](#) and [Smart Roll-loading System Motor on page 264](#).

SE 41:03

Cause: Paper motor electrical current limit

Solution: Try the following.

- Turn the power off at the rear of the printer and disconnect the power cord. Reconnect the power cord and turn on the printer.
- Open the Window and check for any visible obstacles restricting the movement of the Drive Roller. If there is a wrinkled mass of paper inside the paper path, lift the Pinchwheels (opening the Rear Door) and clear the obstruction.
- Replace the Media-Axis Motor ⇒ [Media-Axis Motor on page 330](#).

SE 42:03

Cause: Scan-Axis motor electrical current limit

Solution: Try the following.

- Turn the power off at the rear of the printer and disconnect the power cord. Reconnect the power cord and turn on the printer.
- Open the Window and check for any visible obstacles restricting the movement of the Carriage Assembly. If there is a wrinkled mass of paper blocking the Carriage Assembly, then clear the obstruction.
- Clean the Encoder Strip ⇒ [Clean the Encoder Strip on page 478](#).
- Replace the Scan-Axis Motor ⇒ [Scan-Axis Motor on page 326](#).

SE 43:01

Cause: Vacuum Fan spinning at wrong speed

Solution: Try the following.

- Turn the power off at the rear of the printer and disconnect the power cord. Reconnect the power cord and turn on the printer.
- If the system error persists, replace the Vacuum Fan ⇒ [Vacuum Fan on page 250](#).

SE 43:10

Cause: Vacuum Fan failure

Solution: Try the following.

- Turn the power off at the rear of the printer and disconnect the power cord. Reconnect the power cord and turn on the printer.
- Check that the Vacuum Fan cable is not damaged and is correctly connected to the Vacuum Driver PCA and to both Vacuum Motors.
- Check that the Interconnect to Vacuum Driver cable is not damaged and correctly connected to Vacuum Driver PCA and to the Interconnect PCA.
- Replace the Vacuum Fan ⇒ [Vacuum Fan on page 250](#).

SE 43.1:10

Cause: Vacuum Driver PCA communication or hardware failure

Solution: Try the following.

- Turn the power off at the rear of the printer and disconnect the power cord. Reconnect the power cord and turn on the printer.
- If the system error persists, replace the Vacuum Fan ⇒ [Vacuum Fan on page 250](#).

SE 43:11

Cause: Vacuum Fan PCA cable does not seem to be connected

Solution: Try the following.

- Check that the Interconnect PCA to Vacuum Fan cable is not damaged.
- Check that the Interconnect PCA to Vacuum Fan cable is correctly connected to the Interconnect PCA and the Vacuum Fan PCA.
- If the problem persists, replace the Interconnect PCA to Vacuum Fan cable ⇒ [Vacuum Fan Cable on page 253](#).

SE 44.2:10

Cause: Right Aerosol Fan stopped or spinning at lower speed

Solution: Try the following.

- Turn the power off at the rear of the printer and disconnect the power cord. Reconnect the power cord and turn on the printer.
- Check that the Right Aerosol Fan cable is not damaged and is correctly connected to the PrintMech PCA.
- Check that there is no obstacle blocking the fan.
- Replace the Right Aerosol Fan ⇒ [Aerosol Fan and Filter on page 255](#).

SE 44.4:10

Cause: Right Aerosol Fan Filter blocked

Solution: Try the following.

- Turn the power off at the rear of the printer and disconnect the power cord. Reconnect the power cord and turn on the printer.
- Check that the Right Aerosol Fan cable is not damaged and is correctly connected to the PrintMech PCA.
- If the system error persists, replace the Aerosol Filter ⇒ [Aerosol Fan and Filter on page 255](#).

SE 45:03

Cause: Rewinder servo shutdown

Solution: Try the following.

- Turn the power off at the rear of the printer and disconnect the power cord. Reconnect the power cord and turn on the printer.
- Open the Window and check for any visible obstacles restricting the movement of the Rewinder. If there is a wrinkled mass of paper inside the paper path, open the Rear Door and clear the obstruction.
- Replace the Rewinder Motor ⇒ [Rewinder Gear and Motor on page 274](#).

SE 46:03

Cause: Primer servo shutdown

Solution: Try the following.

- Check that the Primer Arm is not damaged and there are no obstacles in its way.
- Turn the power off at the rear of the printer and disconnect the power cord. Reconnect the power cord and turn on the printer.
- Replace the Primer Assembly ⇒ [Primer Assembly on page 241](#).

SE 46:13

Cause: Primer test distance failed

Solution: Try the following.

- Check that the Primer Arm is not damaged and there are no obstacles in its way.
- Turn the power off at the rear of the printer and disconnect the power cord. Reconnect the power cord and turn on the printer.
- Replace the Primer Assembly ⇒ [Primer Assembly on page 241](#).

SE 50:03

Cause: OMAS fatal error or disconnected

Solution: Try the following.

- Turn the power off at the rear of the printer and disconnect the power cord. Reconnect the power cord and turn on the printer.
- Check that the Power Supply to OMAS Controller cable is not damaged and is correctly connected to the PSU and the OMAS Controller Card.
- Replace the OMAS Controller Card ⇒ [OMAS Controller Card on page 368](#)

SE 50.1:10

Cause: OMAS Module communication failure

Solution: Try the following.

- Turn the power off at the rear of the printer and disconnect the power cord. Reconnect the power cord and turn on the printer.
- Check that the printer has the latest firmware version. If not, update the firmware to the latest version.

- Check that the OMAS Controller to OMAS Sensor cable is not damaged and is correctly connected to the OMAS Controller Card and the OMAS Module.
- Replace the OMAS Module ⇒ [Optical Media Advance Sensor \(OMAS\) on page 359](#).

SE 50:14

Cause: Firmware version mismatch between the OMAS Controller Card and Hard Disk Drive

Solution: Try the following.

- Turn the power off at the rear of the printer and disconnect the power cord. Reconnect the power cord and turn on the printer.
- Check that the printer has the latest firmware version. If not, update the firmware to the latest version.
- Replace the OMAS Controller Card ⇒ [OMAS Controller Card on page 368](#).

SE 50.2:10

Cause: OMAS Controller Card communication failure

Solution: Try the following.

- Turn the power off at the rear of the printer and disconnect the power cord. Reconnect the power cord and turn on the printer.
- Check that the printer has the latest firmware version. If not, update the firmware to the latest version.
- Replace the OMAS Controller Card ⇒ [OMAS Controller Card on page 368](#).

SE 50.3:11

Cause: Main PCA to OMAS Controller cable does not seem to be connected

Solution: Try the following.

- Check that the Main PCA to OMAS Controller cable is not damaged.
- Check that the Main PCA to OMAS Controller cable is correctly connected to the Main PCA and the OMAS Controller Card.

SE 51:10

Cause: Error detected in the Window Position Sensor

Solution: Try the following.

- Check that the Window Position Sensor cable is not damaged and is correctly connected to the Interconnect PCA.
- Replace the Window Position Sensor ⇒ [Window Position Sensor on page 346](#).

SE 51.1:10

Cause: Error detected in the Maintenance Cartridge Door Sensor (Service Station Door Sensor)

Solution: Try the following.

- Check that the Maintenance Cartridge Door Sensor cable is not damaged and is correctly connected to the Interconnect PCA.
- Replace the Service Station Cable, which includes the Maintenance Cartridge Door Sensor. ⇒ [Maintenance Cartridge Door Sensor on page 334](#).

SE 51.9:10

Cause: Smart Roll-loading System Door Sensor error detected

Solution: Try the following:

- Check that the Left and Right Smart Roll-loading System Door Sensor cables are not damaged and are connected correctly to the Interconnect PCA.
- Replace the Smart Roll-loading System Door Switch ⇒ [Smart Roll-loading System Door Switch on page 280](#).

SE 52:10

Cause: Drop Detector switch On/Off failure

Solution: Try the following.

- Turn the power off at the rear of the printer and disconnect the power cord. Reconnect the power cord and turn on the printer.
- Check that the Drop Detector cable is not damaged and is correctly connected to the Service Station cable.
- Check that the Service Station cable is not damaged and is correctly connected to the Interconnect PCA.
- Replace the Drop Detector ⇒ [Drop Detector on page 257](#).

SE 53:10

Cause: Media Sensor error

Solution: Try the following.

- Check that the Media Sensor cable is not damaged and is connected correctly to the Interconnect PCA.
- Replace the Media Sensor ⇒ [Media Sensor on page 342](#).

SE 53.1:11

Cause: Media Sensor cable does not seem to be connected

Solution: Try the following.

- Check that the Media Sensor cable is not damaged.
- Check that the Media Sensor cable is correctly connected to the Interconnect PCA.

SE 55:10

Cause: Line Sensor communication failure

Solution: Try the following.

- Turn the power off at the rear of the printer and disconnect the power cord. Reconnect the power cord and turn on the printer.
- Replace the Line Sensor ⇒ [Line Sensor Assembly on page 302](#).

SE 56:01

Cause: Incorrect readings from paper encoder

Solution: Try the following.

- Turn the power off at the rear of the printer and disconnect the power cord. Reconnect the power cord and turn on the printer.
- Perform Paper Drive diagnostics.
- Replace the Encoder Disc and Sensor ⇒ [Encoder Disc and Sensor on page 408](#).

SE 56:10

Cause: Paper Encoder calibration failed

Solution: Try the following.

- Turn the power off at the rear of the printer and disconnect the power cord. Reconnect the power cord and turn on the printer.
- Perform Paper Drive diagnostics.
- Replace the Encoder Disc and Sensor ⇒ [Encoder Disc and Sensor on page 408](#).

SE 59.1:09

Cause: Two electrical parts have been replaced at the same time

Solution: Replace one part at a time, and restart the printer before replacing another.

SE 59.2:00

Cause: An unsupported or reused part has been installed

Solution: Install only new parts recommended by HP for this printer.

SE 60.1:11

Cause: Initialization error

Solution: Try the following.

- Turn the power off at the rear of the printer and disconnect the power cord.
- Check that the printer is properly connected in all other respects. In particular, check that the tag cable is well connected to the ISS Top PCA, and the ISS Top PCA is well connected to the PrintMech PCA.
- Reconnect the power cord and turn on the printer.
- If the error persists, contact HP.

SE 60.2:17

Cause: Initialization error

Solution: Contact HP.

SE 61:01

Cause: The file format is incorrect and the printer cannot process the job

Solution: Try the following.

- Turn off the printer using the switch at the rear, and disconnect the power cord. Reconnect the power cord and turn on the printer.
- Check the graphic language setting of the printer (see the *User's Guide*).

SE 61:04.1

Cause: The PostScript fonts are missing

Solution: Perform a full firmware update.

SE 61:04.2

Cause: PostScript unknown Paper ID

Solution: Perform a full firmware update.

SE 61:08

Cause: The paper type specified in the file is incorrect and the printer cannot process the job

Solution: Try the following.

- Turn off the printer using the switch at the rear, and disconnect the power cord. Reconnect the power cord and turn on the printer.
- Change the paper type and resend the file to the printer.

SE 61:08.1

Cause: The file cannot be printed because it is password-protected

Solution: Resend the file without password protection.

SE 61:08.2

Cause: The file contains format errors or incorrect settings and the printer cannot process the job

Solution: Try the following.

- Ensure that the file format sent is supported by the printer.
- Turn off the printer using the switch at the rear, and disconnect the power cord. Reconnect the power cord and turn on the printer.
- Resend the file to the printer using the Embedded Web Server.

SE 61:10

Cause: A slow computer processing complex files can pause for longer than the default printer timeout, which can be interpreted by the printer as an End Of Job, in which case some elements of the job may be lost

Solution: Try the following:

- Increase the I/O timeout using the printer's front panel (see 'Configure network settings' in *Using your printer*).
- Send the job from a faster computer.
- Send the job from the Embedded Web Server.

SE 64.1:01

Cause: The printer does not recognize the USB Hard Disk Drive accessory

Solution: Try the following.

- Turn off the printer using the switch at the rear.
- Connect the Hard Disk Drive accessory, check that the USB cable is properly connected and turn the printer on. If the Hard Disk Drive accessory is not available (has been lost or broken), proceed to the next step.
- If the problem persists, turn off the printer using the switch at the rear. Turn the printer on again while pressing **Menu**, **OK** and **Cancel** simultaneously until the front panel asks **Printer configured to use External Hard Disk. Do you want to revert the printer to Internal Hard Disk?**. Confirm by pressing **OK** (twice). Remove the Hard Disk Drive accessory (if connected). The printer restarts.
- After the printer reaches the Ready state, try connecting any other USB device (known to work properly) to the printer port where the Hard Disk Drive accessory should be connected. If a message appears on the front panel reacting to the USB device just connected (such as **Please remove USB device** or **Press OK to...**), press **Cancel** and remove the USB Device. This means the Hard Disk Drive accessory is faulty and should be replaced. See Formatter.
- If nothing appears on the front panel reacting to the USB device just connected, the Formatter is faulty and should be replaced. See Formatter.

SE 71:03

Cause: Out of memory failure

Solution: Try the following.

- Turn off the printer using the switch at the rear, and disconnect the power cord. Reconnect the power cord and turn on the printer.
- If the problem persists, resend the job with one or more of the following options:
 - Decrease resolution to 300 dpi.
 - Select **Economode** print mode.
 - Select **Send Job As Bitmap**, to have the main processing of the print job done by the computer rather than the printer.

SE 71:08

Cause: Insufficient display list

Solution: Resend the job with one or more of the following options: decrease resolution to 300 dpi, select Economode print mode, select **Send Job As Bitmap** to have the main processing of the print job done by the computer rather than the printer.

SE 74:01

Cause: Error uploading firmware update file

Solution: Try the following.

- Turn the power off at the rear of the printer and disconnect the power cord. Reconnect the power cord and turn on the printer.
- Resend the firmware update file to the printer.

SE 75.21:10

Cause: Total printer ink consumption reached upper limit

Solution: This is a continuable system error. The customer may continue to print normally but may encounter print-quality issues or ink buildups in the Service Station. To avoid these problems, it's best to apply Preventive Maintenance Kit #2.

SE 76:03

Cause: Hard Disk Drive out of space

Solution: Try the following.

- Turn the power off at the rear of the printer and disconnect the power cord. Reconnect the power cord and turn on the printer.
- Resend the file to the printer.
- Remove any unnecessary files from the Hard Disk Drive using the Web Server.
- If the problem persists, perform Hard Disk Recovery (see [Hard Disk recovery on page 116](#)).

SE 77:04

Cause: Embedded Web Server internal software error

Solution: Try the following.

- Turn the power off at the rear of the printer and disconnect the power cord. Reconnect the power cord and turn on the printer.
- Check that the printer has the latest firmware version. If not, update the firmware to the latest version.

SE 78.1:04

Cause: Media Settings area missing in media settings file

Solution: Resend the file.

SE 79:03

Cause: Generic firmware error

Solution: Try the following.

- Turn the power off at the rear of the printer and disconnect the power cord. Reconnect the power cord and turn on the printer.
- Check that the printer has the latest firmware version. If not, update the firmware to the latest version.
- If the problem persists, perform Hard Disk Recovery (see [Hard Disk recovery on page 116](#)).

SE 79:04

Cause: Generic firmware error

Solution: Try the following.

- Turn the power off at the rear of the printer and disconnect the power cord. Reconnect the power cord and turn on the printer.
- Check that the printer has the latest firmware version. If not, update the firmware to the latest version.
- Try to reprint the image using different selections in the driver.
- Disable nesting and the queue.
- If the problem persists, perform Hard Disk Recovery (see [Hard Disk recovery on page 116](#)).
- For more detailed information, see [How to troubleshoot the 79:04 system error on page 27](#).

SE 79.2:04

Cause: Operating-system signal error

Solution: Try the following.

- Turn the power off at the rear of the printer and disconnect the power cord. Reconnect the power cord and turn on the printer.
- Check that the printer has the latest firmware version. If not, update the firmware to the latest version.
- Try to reprint the image using different selections in the driver.
- Disable nesting and the queue.
- If the problem persists, perform Hard Disk Recovery (see [Hard Disk recovery on page 116](#)).

SE 81:01

Cause: Paper servo shutdown; possible paper jam

Solution: Try the following.

- Open the Window and check for any visible obstacles restricting the movement of the Drive Roller. If there is a wrinkled mass of paper inside the paper path, lift the Pinchwheels (opening the Rear Door) and clear the obstruction.
- Check that the OMAS Controller Card to PrintMech PCA cable is not damaged.
- Check that the OMAS Controller Card to PrintMech PCA cable is correctly connected to the OMAS Controller Card and the PrintMech PCA.
- Perform the Media Drive Diagnostic (⇒ [Paper Drive test on page 88](#)) to further troubleshoot the error code.

SE 85:03

Cause: Problem finding the Drive Roller zero

Solution: Perform the Media Drive Diagnostic (⇒ [Paper Drive test on page 88](#)) to further troubleshoot the error code.

SE 86:01

Cause: Carriage servo shutdown; possible paper jam

Solution: Try the following.

- Open the Window and check for any visible obstacles restricting the movement of the Carriage Assembly. If there is a wrinkled mass of paper inside the paper path, lift the Pinchwheels (opening the Rear Door) and clear the obstruction.
- Perform the Scan-Axis Diagnostic (⇒ [Scan Axis test on page 88](#)) to obtain further information on the problem.

SE 86:11

Cause: Scan-Axis length requires too much force or energy

Solution: Try the following.

- Check that cutter disengages correctly.
- Lubricate Scan Axis.
- Apply Preventive Maintenance Kit 1.

SE 87:01

Cause: Problem with the Scan Axis encoder sensor readings

Solution: Try the following.

- Check whether the Encoder Strip is dirty. If necessary, clean it. Pay special attention to the area near the Service Station. Follow the instructions on the front panel after selecting the Ink menu and then **Clean Encoder Strip**.
- Check whether the Encoder Strip is broken or damaged. If necessary, replace it.
- If the system error persists, clean the Encoder Sensor.

- If the system error persists, replace the Encoder Sensor.
- Perform the Scan Axis diagnostic test to troubleshoot the problem further.

SE 87:10

Cause: Problem with the Carriage Encoder Sensor readings

Solution: Try the following.

- Check that the Encoder Sensor is correctly connected to the Carriage PCA.
- Check whether the Encoder Strip is broken or damaged. If necessary, replace it.
- Check whether the Encoder Strip is dirty. If necessary, clean it. Pay special attention to the area near the Service Station. Follow the instructions on the front panel after selecting the Ink menu and then **Clean Encoder Strip**.
- If the system error persists, clean the Encoder Sensor.
- If the system error persists, replace the Encoder Sensor.

SE 88:10

Cause: Smart Roll-loading System Position Sensor error detected

Solution: Try the following:

- Check that the Left and Right Smart Roll-loading System Index Sensor and Actuator cables are not damaged and are connected correctly to the Interconnect PCA.
- Replace the Indexer and Right Slider ⇒ [Indexer and Right Slider on page 278](#).

4 Ink supplies

- [What are ink supplies?](#)
- [General information about the ink supplies](#)
- [General precautions when handling ink supplies](#)
- [Priming the ink system](#)
- [When should you replace the ink supplies?](#)
- [Obtaining Ink Cartridge information](#)
- [Obtaining Printhead information](#)
- [Summary of solving ink supplies problems](#)
- [Troubleshooting Printhead error codes](#)
- [Carriage Interconnect Wiper](#)
- [Warranty information for ink supplies](#)

What are ink supplies?

Three different components are classed as ink supplies: the Ink Cartridges, the Printheads and the Maintenance Cartridge.

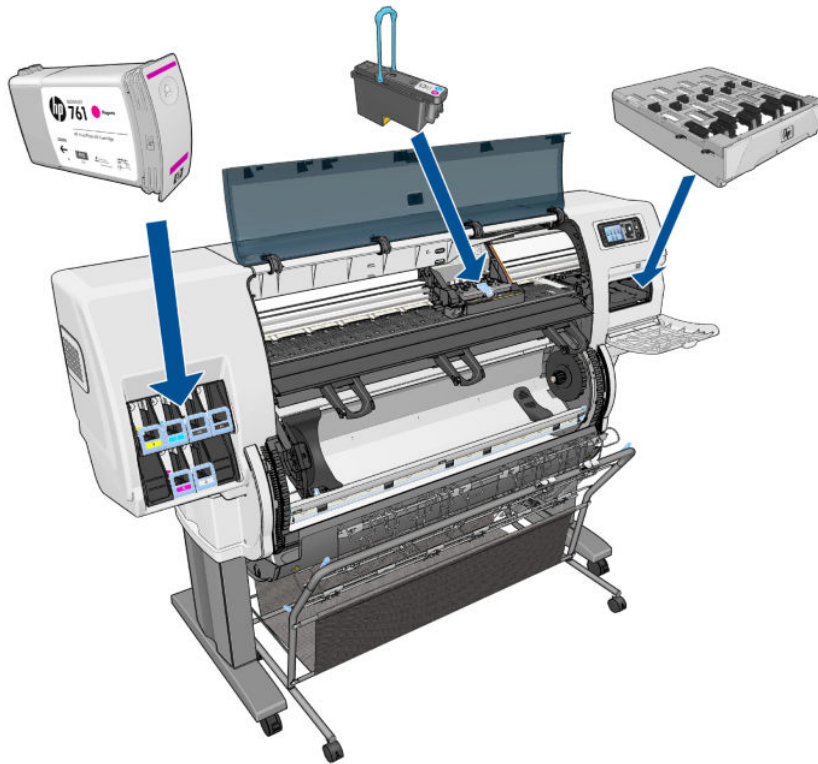

Ink Cartridges

The color printer's six Ink Cartridges provide matte black, dark gray, gray, magenta, cyan and yellow ink to the Printheads. The Introductory Ink Cartridges supplied with the printer have 160 ml of ink, which is an average lifespan of one month beyond the ink used to set up and install the printer. The 'Host' Ink Cartridges which are purchased to replace the Introductory Ink Cartridges hold approximately 400 ml, and there is also a larger Matte Black Ink Cartridge that holds approximately 775 ml.

The monochrome printer's two Ink Cartridges provide matte black and dark gray ink to the Printheads. It uses the same matte black and dark gray Ink Cartridges as the color printer.



The Ink Cartridges require no maintenance or cleaning. As long as each Ink Cartridge is inserted correctly into its slot, the ink will flow to the Printheads. Because the Printheads control the amount of ink transferred to the page, you will continue to see high-quality printing results even when the ink levels are getting low.

The front panel displays the status of the Ink Cartridge. Using the front panel, detailed information can be checked on the Ink Cartridges.

The following table lists the Ink Cartridges for the HP DesignJet T7100 printer series.

Description	Part number
HP 761 Matte Black 400 ml Ink Cartridge	CM991A
HP 761 Yellow 400 ml Ink Cartridge	CM992A
HP 761 Magenta 400 ml Ink Cartridge	CM993A
HP 761 Cyan 400 ml Ink Cartridge	CM994A
HP 761 Gray 400 ml Ink Cartridge	CM995A
HP 761 Dark Gray 400 ml Ink Cartridge	CM996A
HP 761 Matte Black 775 ml Ink Cartridge	CM997A

Printheads

The printheads are connected to the ink cartridges. They use jet action to put ink on the paper. Each printhead has two ink cartridge connection points and two jet nozzles, which means that each printhead accommodates two ink cartridges. For example, the following printhead image indicates a printhead that draws and jets ink from the magenta and yellow cartridges.

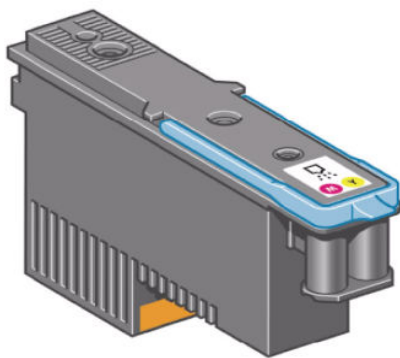

The Printheads are extremely durable and do not need to be replaced every time an Ink Cartridge is replaced. They are independent of the Ink Cartridges and will continue giving excellent image quality results even if the Ink Cartridges are low on ink.

If you notice a decline in print quality such as lines or dots missing from text/graphics, go to [Initial print-quality troubleshooting actions on page 144](#).

The following table lists the Printheads for the HP DesignJet T7100 printer series. The Matte Black & Matte Black Printhead is used in both the color and the monochrome printers. The Dark Gray Printhead is used in the monochrome printer only.

Description	Part number
HP 761 Yellow Printhead	CH645A

HP 761 Magenta & Cyan Printhead	CH646A
HP 761 Matte Black & Matte Black Printhead	CH648A
HP 761 Gray & Dark Gray Printhead	CH647A
HP 762 Dark Gray Printhead	CN074A

Maintenance Cartridge

Use the Maintenance Cartridge to clean and maintain the Printheads, ensure the best possible print quality, and seal the Printheads when they are not in use to prevent them from drying out.

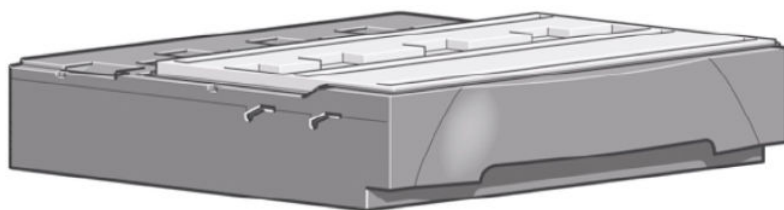



The Maintenance Cartridge for the color printer is the HP 761 Maintenance Cartridge, part number CH649A; the monochrome printer uses the HP 762 Maintenance Cartridge, part number CM998A.

General information about the ink supplies

For optimum results from the printer and modular ink delivery system always follow these guidelines when handling the ink supplies:

- Allow the printer and the Maintenance Cartridge to automatically clean the Printheads.
- Follow the instructions on the front panel of the printer during installation.
- Avoid unnecessary removal of the Ink Cartridges and Printheads.
- When turning off the printer always use the power Off button on the front panel. The Printheads are then stored correctly which prevents them from drying out.
- The Ink Cartridges should never be removed while the printer is printing. They should only be removed when the printer is ready for you to replace them. The front panel will guide you through the removal and installation procedure.

 **NOTE:** The expiration date for the Ink Cartridges, Printheads and Maintenance Cartridge is printed on the packaging.

 **NOTE:** When reporting a system error code, make sure that you supply the full error code and the firmware version. Without this information, HP support personnel cannot help you.

General precautions when handling ink supplies

 **CAUTION:** Do not touch, wipe or attempt to clean the printhead nozzles. This can damage the printhead.

- Handle the ink supplies with care. In particular the Printhead, which is a high precision device and must be handled carefully.
- Do not touch the Printhead nozzles.

- Do not put the Printhead down on the nozzles.
- Do not be rough when handling the Printheads. Always set them down gently.
- Do not drop the Printheads.
- Proper handling will assure optimum performance throughout the Printhead life.
- The Maintenance Cartridge should always be handled and stored upright to avoid a potential spillage of ink.
- Do not touch the end of the Ink Cartridge which is inserted into the printer as there may be a small amount of ink on the connection.
- Avoid storing partially used Ink Cartridges on their ends.

Priming the ink system

When the customer first receives the printer, it is supplied with a set of four Setup Printheads pre-installed in the Carriage Assembly. These Setup Printheads are used for the priming of the tubes in the modular ink delivery system. The customer must not remove the Setup Printheads from the Carriage without following the procedures in the *Assembly Instructions*.

When the printer is powered on for the first time, the printer will automatically perform the priming process. Without the priming process, the customer will not be able to use the printer.

Why does the printer require priming:

- The Tubes System is empty when the customer receives the printer.
- The Tubes System has to be pressurized and filled with ink, ejecting any air bubbles.

⚠ CAUTION: If the Printing Printheads are installed in the carriage during the priming process, they will be rejected and the front panel will show a warning message.

When should you replace the ink supplies?

When to change the ink supplies is mostly determined by you with guidance from the front panel. In conjunction with the messages displayed in the front panel and the message explanations in this chapter, you will be able to choose for yourself when is the right time to change the ink supplies.

The printer will also display the ink level and will tell you when the ink supply is low on ink. This means you have constantly updated information about the ink supplies.

Printhead life is anticipated to be 1200 ml or twelve months in the printer, whichever occurs first, provided that the printhead is used under normal operating conditions (using HP Ink Cartridges only) and its “install before date” has not lapsed. However results vary depending on the print quality setting being used.

Obtaining Ink Cartridge information

Use the following procedure to obtain Ink Cartridge information:

1. At the front panel, select the  icon, then **Ink cartridge information**.
2. In the Ink Cartridge Information submenu, scroll to the **Ink Cartridge** on which you want information and press **OK**.

3. The front panel displays information on the selected Ink Cartridge. You can use the UP and DOWN keys to scroll through the information.

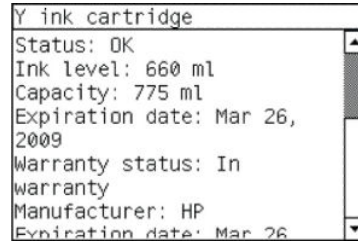
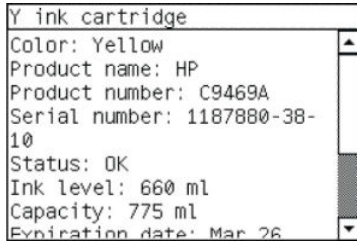

The information supplied is:

- The color of the Ink Cartridge
- The product name
- The product number of the Ink Cartridge
- The serial number of the Ink Cartridge
- The current status of the Ink Cartridge
- The current ink level of the ink cartridge in milliliters
- Original capacity of the ink cartridge in milliliters
- The warranty status of the Ink Cartridge
- The manufacturer of the Ink Cartridge (HP is recommended)
- The expiration date of the Ink Cartridge

Obtaining Printhead information

1. At the front panel, select the  icon, then **Printhead information**.
2. In the Printhead Information submenu, scroll to the Printhead on which you want information and press **OK**.
3. The front panel displays information on the selected printhead.

```
Y printhead 2
Color: Yellow
Product name: HP 761
Product number: CH645A
Serial number: 4-2-9858086-15-
2010
Status: OK
Ink fired: 58 ml
Warranty status: In warranty
```

The information supplied is:

- The make of the printhead
- The product number of the Printhead

- The serial number of the Printhead
- The current status of the printhead
- How much ink has been fired (consumed) by the printhead



NOTE: It is possible for a printhead to consume more than one Ink Cartridge.

- The current warranty status of the Printhead
- The current status of the Maintenance Cartridge

Ink Cartridge status messages

Status Bars

The front panel displays four horizontal bars. These bars represent how much ink is remaining in the Ink Cartridges: as ink is used up the bars get shorter in length. To see how much ink is remaining, go to the **Ink Cartridge Information** submenu. See [Obtaining Ink Cartridge information on page 77](#).

Ink Cartridge status while printing

OK

The Ink Cartridge is operating correctly and no action is required.

Low

The **Low** message is an early warning sign and it is advisable that new supplies should be obtained of that particular color. The amount of ink remaining in the Ink Cartridge depends on its capacity, but there is approximately 14% of ink available for the user.

Very Low

When the **Very Low** message is displayed, overnight printing should not be attempted. Changing the Ink Cartridge is strongly recommended to prevent the printer from stopping halfway through a print. There is approximately 8% of ink available for the user.

Empty

The printer will stop and will not be able to continue printing until a new Ink Cartridge has been installed. If this occurs halfway through printing an image, you should check the quality of this image, as stopping mid-plot can affect the print. It is recommended to reprint the image once a new Ink Cartridge has been installed.

Faulty

The Ink Cartridge is unable to operate correctly. The printer will stop and will not be able to continue printing until a new Ink Cartridge has been installed. If this occurs halfway through printing an image, you should check the quality of this image, as stopping mid-plot can affect the print. It is recommended to reprint the image once a new Ink Cartridge has been installed.

Ink Cartridge status while replacing

The printer can report the following status messages while the Ink Cartridge is being replaced:

Missing

The Ink Cartridge has not been installed or is installed incorrectly. The printer will not print until all Ink Cartridges have been installed correctly.

Reseat

The Ink Cartridge is having continuity problems. Try removing the Ink Cartridge from the printer and inserting it in again.

Replace

The Ink Cartridge is faulty and needs to be replaced before the printer can continue printing.

Unknown

The Ink Cartridge installed is not approved **but** the user has confirmed that he is using refilled or non-HP Ink Cartridges. Refer to the User's Guide for further information regarding using refilled or non-HP approved Ink Cartridges.

The main actions for all four status messages is as follows:

1. Reseat the Ink Cartridge.
2. If reseating does not resolve the status message, replace the Ink Cartridge.
3. If the Status messages continue to appear, even after replacing the Ink Cartridge, replace the Ink Supply Tubes and Trailing Cable ⇒ [Ink Supply Tubes and Trailing Cable on page 303](#).

Printhead status messages while printing

Detailed below are the printhead status messages that may be displayed while printing.

OK

The printhead is operating correctly and will provide an acceptable level of print quality. To find more information on the printheads, refer to [Obtaining Printhead information on page 78](#).

Replace

The Printhead is faulty and needs to be replaced before the printer can continue printing.

If this message continues to appear (for example after installing new Printheads), try the following.

1. Reseat the Printheads and check if the message disappears.
2. Remove the Drop Detector and make sure that there are no obstacles inside which are blocking the sensor.
3. Print the Diagnostic Print ⇒ [Printing the Image Quality Service Print on page 150](#) to check that the Printhead nozzles are firing correctly.
4. Perform the Service Station test ⇒ [Service Station test on page 98](#).
5. Replace all the Printheads.

Printhead status messages while replacing

The following are the Printhead status messages that may be displayed while replacing the Printheads.

Reseat

In this situation, select the Printhead replacement option through the Front Panel but do NOT remove the Printheads. If this status message continues to appear then remove the Printheads and install them again.

Remove

The Printhead is not a suitable type for use in printing (for example, a Setup Printhead).

Missing

No Printhead has been detected in that Carriage stall. If a Printhead is installed in the Carriage stall when this status message is shown:

1. Reseat the Printhead, making sure it is installed correctly.
2. Clean the Carriage and Printhead flex circuits using the Carriage Interconnect Wiper ⇒ [Carriage Interconnect Wiper on page 83](#).
3. Replace the Printhead.
4. Perform the Electronic Systems Test ⇒ [Electronics Module test on page 90](#).



NOTE: If all the Printheads are installed but have the Status message “Missing”, it is possible that the Carriage Assembly is faulty.

Maintenance Cartridge status messages while printing

Detailed below are the Maintenance Cartridge status messages that may be displayed while printing.

OK

The Maintenance Cartridge is operating correctly and no action is required.

End of Life

The Maintenance Cartridge has reached the end of its life and should be replaced.

Maintenance Cartridge status messages while replacing

The following are the Maintenance Cartridge status messages that may be displayed while replacing the Printheads.

Reset Cleaner

In this situation, remove the Maintenance Cartridge and install it again.

Missing

The Maintenance Cartridge has not been installed or is installed incorrectly. The printer will not print until the Maintenance Cartridge has been installed correctly.

Not replaced with Printhead

A new Printhead has been installed without installing a new Maintenance Cartridge that came with it. Make sure a new Maintenance Cartridge is installed every time you replace a Printhead.

If a Maintenance Cartridge needs to be removed or reseated, you must first start the Printhead Replacement process. Open the Window when prompted to do so by the front panel. If the front panel shows the Printheads with **no** Printhead blinking, you do not need to touch the Printheads. Just close the window again, and the printer will proceed to Maintenance Cartridge replacement.

Summary of solving ink supplies problems

Most of the problems that you could encounter when working with the ink supplies are solved with guidance from the front panel. A full list of front panel messages are supplied in the User's Guide.

Problems reseating the printhead

If you have inserted the printhead into the printhead carriage assembly and the printer does not "BEEP" try the following steps.

⚠ CAUTION: Check that during the priming process, the Setup Printheads are installed in the Carriage. If the printing Printheads are installed in the carriage during the priming process, they will be rejected and the front panel will show a warning message.

- Check that the protective tape has been removed from the printhead.
- Insert the Printhead into the Carriage Assembly but this time correctly close the cover using the latch.
- Clean the electrical contacts on both the printheads and the printhead Carriage Assembly using the carriage interconnect wiper → [Carriage Interconnect Wiper on page 83](#).
- Replace the Printhead with a new one.

You cannot insert the Ink Cartridge into the printer

1. Ensure that you have the correct HP 761 Ink Cartridge.
2. Ensure that the Ink Cartridge is the correct color for that slot.
3. Ensure that the Ink Cartridge is the correct orientation, with the color coded label at the top.

⚠ CAUTION: Never clean inside the Ink Cartridge slots as this can cause damage to the printer.

You cannot insert the Printhead into the printer

1. Ensure that you have the correct HP 761 Printhead.
2. Ensure that the printhead is the correct color for that slot.
3. Ensure that the printhead is in the correct orientation.
4. Ensure that the protective cap is removed from the Printhead.

You cannot insert the Maintenance Cartridge into the printer

1. Ensure that you have the correct HP 761 Maintenance Cartridge.
2. Ensure that the Maintenance Cartridge is in the correct orientation.

Troubleshooting Printhead error codes

The Printhead Error Codes can be found on the Service Information Print (Setup Menu/Information Menu/Internal Prints/Print Service Information/Current Information). The actual error code is a decimal number and it has to be converted to a binary number before it can be used.

Current Printhead Kit Info (I)				
	Warranty status	Status	Error ID Code	Product Number
1 - Yellow	See warranty note	OK	0	CH645A
2 - Yellow	See warranty note	OK	0	CH645A
3 - Cyan-Magenta	See warranty note	OK	0	CH646A
4 - Cyan-Magenta	See warranty note	OK	0	CH646A
5 - Matte black	See warranty note	OK	0	CH648A
6 - Matte black	See warranty note	OK	0	CH648A
7 - Dark Gray-Gray	See warranty note	OK	0	CH647A
8 - Dark Gray-Gray	See warranty note	OK	0	CH647A

In order to convert the decimal error code to a binary error code, you can use a calculator. For example, if you had the error code 4099, you would enter 4099 as a decimal number and then select the binary option which would give you a binary number of 1000000000011.

The following table explains the meaning of the different bits (0 or 1). When the value of the error code is reported as 0, it means that the Printhead is working correctly:

Bit	Meaning	Bit	Meaning
1 st	FAILS_LOGICAL_V	11 th	BAD_ACUMEN_ACCESS
2 nd	FAILS_CONTINUITY	12 th	WRONG_MODEL
3 rd	SHUTDOWN	13 th	MISMATCH
4 th	FAILS_VPP	14 th	CSDATA_NOT_RESPONDING
5 th	TEMP_EXTREMELY_HIGH	15 th	CSDATA_TRANSMIT_ERROR
6 th	TEMP_EXTREMELY_LOW	16 th	FAILS_ENERGY_CALIBRATION
7 th	TEMP_TOO_HIGH	17 th	EMPTY_DUMMY
8 th	TEMP_TOO_LOW	18 th	FULL_DUMMY
9 th	BAD_ACUMEN_INFO	19 th	END_OF_LIFE
10 th	NO_PEN	20 th	OUT_OF_WARRANTY

The binary number needs to be read from right to left so that the 1st bit corresponds to the right one of the binary number. For example, the error code 4099 is converted to binary number 1000000000011. So using the table above, the error code means “FAILS_LOGICAL_V”, “FAILS_CONTINUITY” and “MISMATCH”.

Carriage Interconnect Wiper

Whenever you replace the Printhead, check the empty slots to see if they need cleaning. In extreme circumstances, when a Printhead is inserted, it is possible that the printer will not recognize it due to the build-up of ink on the electrical connection between the Printhead and the Carriage Assembly.

The Carriage Interconnect Wiper is available as an accessory in a separate package. The package also contains replacement sponges and an instruction sheet. This tool should be used for cleaning the electrical interconnects of both the Carriage Assembly and the Printhead.

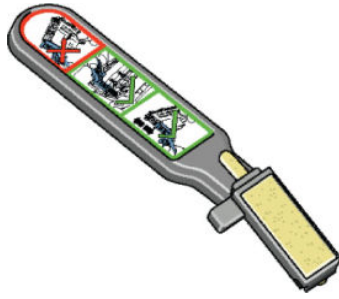

If the front panel displays the message **Reseat** or **Replace** next to the offending printhead, try cleaning the flex circuits of the Carriage and the Printheads.

⚠ CAUTION: Do not touch, wipe or attempt to clean the printhead nozzles. This can damage the printhead and reduce print quality.

Warranty information for ink supplies

- [Ink Cartridge](#)
- [Printheads](#)

Ink Cartridge

The warranty for an Ink Cartridge ends when one of the following occurs:

- 30 months have passed since the date of manufacture.
- or
- The Ink Cartridge has supplied all the ink that it is advertised as containing.
- or
- The customer confirms that non-HP ink has been used in empty override mode.

The actual end of warranty date is printed on the supply label.

Printheads

The warranty for the Printheads will end when one of the following occurs:

- 24 months have passed since the date of manufacture that is printed on the Printhead.
- or
- 1200 ml/42 oz of HP original ink has been consumed by the Printhead.
- or
- The customer confirms that non-HP ink has been used in empty override mode.

5 Service tests and utilities

- [Introduction](#)
- [Diagnostics—self test](#)
- [Phone support](#)
- [Service tests \(diagnostics\)](#)
- [Entering the Service Tests menu](#)
- [Service utilities](#)

Introduction

This chapter explains how to use the built-in Service Tests and Service Utilities and what to do if any of the Service Tests fail.

 **NOTE:** If possible, always perform a Service Test on the component that you are about to replace, just to make sure that is the component that has failed. If the test on that component passes, there is no need to replace it.

Diagnostics—self test

Whenever the printer is switched ON, it automatically performs a series of internal self tests and mechanical initialization sequences. If any of the parts fail, a system error will appear; see [System error codes on page 39](#).

Phone support

In certain circumstances, a Call Agent can try and troubleshoot the printer by requesting the Customer to perform a Service Test via the phone. Using this process, it can be determined whether the printer requires any on-site maintenance.

Remember that the key combination for the customer to enter the Service Tests and Utilities is different from the one that the engineer will use.

Service tests (diagnostics)

The following is a list of all internal Service Tests available in the printer. To access these tests, see [Entering the Service Tests menu on page 87](#).

1. Scan Axis Test ⇒ [Scan Axis test on page 88](#).

The purpose of this test is to check the operation of components related to the Scan Axis.

2. Paper Drive Test ⇒ [Paper Drive test on page 88](#).

The purpose of this test is to check the operation of components related to the Media Axis.

3. Electronics Module Test ⇒ [Electronics Module test on page 90](#).

The purpose of this test is to check the operation of the Formatter.

4. Carriage Assembly Test ⇒ [Carriage Assembly test on page 91](#).

The purpose of this test is to check the operation of the Carriage Assembly.

5. IDS Tests ⇒ [IDS tests on page 94](#).

The purpose of these tests is to check the operation of the Ink Delivery System.

6. Service Station Test ⇒ [Service Station test on page 98](#).

The purpose of this test is to check the operation of the Service Station.

7. Primer Test ⇒ [Primer test on page 99](#).

The purpose of this test is to check the operation of the Primer.

8. Aerosol Test ⇒ [Aerosol test on page 100](#).

The purpose of this test is to check the operation of the Aerosol Fans.

9. I/O Information ⇒ [I/O Information on page 101](#).

The purpose of this test is to view information about input/output.

10. Unit Information ⇒ [Unit information on page 101](#).

The purpose of this test is to view the firmware version, part number, serial number and PostScript configuration.

11. EEROM Reset ⇒ [EEROM Reset on page 102](#).

The purpose of this test is to reset the EEROM.

12. Hard Disk Recovery ⇒ [Hard Disk recovery on page 103](#).

The purpose of this service utility is to clean user data on the Hard Disk, to try to recover the printer from an unstable state.

13. File System Check ⇒ [File system check on page 103](#).

The purpose of this service utility is to check the consistency of the file system on the Hard Disk. If the utility detects a problem, it will try to fix it automatically.

14. OMAS Module Test ⇒ [OMAS Module test on page 103](#).

The purpose of this test is to check the operation of the OMAS system.

Entering the Service Tests menu

 **NOTE:** To enter the Service Utilities Menu, see [Entering the Service Utilities menu on page 105](#).

1. Make sure the printer is switched off with the **Power** key on the front of the printer and **not** with the power switch on the back of the printer.
2. For Call Agents who will request the user to perform certain troubleshooting actions, hold the **Down** and **OK** keys down and turn the printer on using the **Power** key. Wait until you hear one beep (usually after 5 seconds) before releasing all three keys.
3. For On-Site Engineers, hold the **Up** and **OK** keys down and turn the printer on using the **Power** key. Wait until you hear one beep (usually after 5 seconds) before releasing all three keys.
4. Once inside the Service Tests Menu, use the arrow keys to scroll through the **Service Tests** selections. Press the **OK** key to begin a specific test when the required Service Test is highlighted.

 **NOTE:** The Service Tests work in a special mode that does not require full initialization of the printer. Therefore, once you have finished with the Service Tests, you must power off the printer and power on again before trying to print.

In some cases a quick press of a button may not be recognized by the printer. When pressing a button, be sure to press it deliberately and all the way to the bottom of its travel.

If the printer hangs up during a test, switch the printer off and restart from step 1.

Scan Axis test

The purpose of this test is to diagnose a failure in the operation of components related to the Scan Axis.

Perform the Scan Axis test as follows:

1. In the Diagnostics submenu, select **Scan Axis** and press **OK**.

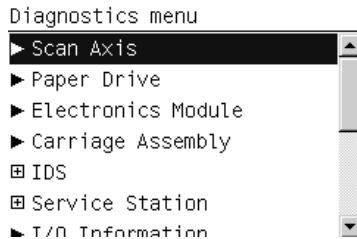

The diagnostic starts checking the Scan Axis motor; the front panel announces the current activity.

 **NOTE:** The Carriage may move repeatedly during the tests.

2. Depending on the results of the tests, you may be asked to open the Window, close the Window, or move the Carriage manually. Follow the instructions on the front panel.

 **CAUTION:** The Carriage should move easily, without resistance. If you feel resistance, do not try to force it: you may damage something.

3. When the tests are successfully completed, the following message is displayed.

```
Scan Axis
-----
Diagnostic result: OK
```

```
Press OK to continue
```

4. Press **OK** to return to the menu.

Paper Drive test

The purpose of this test is to diagnose a failure in the operation of components related to the Paper Axis.

You must perform the Paper Drive Test after:

- System Error Code 81:YX
- System Error Code 41:YX
- System Error Code 73:YX

 **NOTE:** If possible always perform this test before replacing any component of the media-axis.

1. In the Diagnostics submenu, scroll to **Paper Drive** and press **OK**.

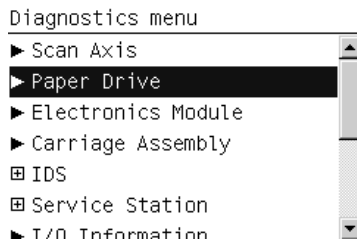

2. The front panel asks you to unload the paper. If there is a roll loaded, unload it manually. Press **OK** when done.

```
Paper Drive
-----
Please unload the paper
Press OK to continue
```

3. The printer performs some movement tests. The drive roller may move repeatedly during the tests. At the end the following message will be shown if the tests succeeded:

```
Paper Drive
-----
Checking movement
Test passed
Press OK to continue
```

4. Depending on the results of the tests, the front panel may display one of the following messages.

- The printer was unable to make the test movements correctly.

```
Paper Drive
-----
Checking movement
Failed to perform movement
Press OK to continue
```

- You are asked to load paper manually, and press **OK**.

```
Paper Drive
-----
Please raise the lever
Please load the paper
Please lower the lever
Press OK to continue
```



NOTE: Please ignore references to the lever. You may need to open and close the rear door.

- The printer tries the movements again.

```
Paper Drive
-----
Is paper moving?
Press ▲ and ▼ to change the
value
Yes
Press OK to confirm selection
```

5. The printer calibrates the analog encoder.

```
Paper Drive
-----
Calibrating analog encoder
```

6. The calibration results are displayed.

```
Paper Drive
-----
Diagnostic result:
  A      2.0    2.0
  B      2.0    1.0
```

Press **OK** to continue
Press **X** to reject

Acceptable values are:

- Gain: between 0 and 5
- DGain: between 0 and 15
- Offset: between -80 and 80

If the results are acceptable, press **OK**. If the results are unacceptable, then press **Cancel**.

7. The printer performs the encoder homing test.

```
Paper Drive
-----
Analog encoder homing test
```

8. The front panel asks you to remove the paper. If you loaded a roll earlier, unload it manually. Press **OK** when done.
9. Some further tests are performed, and the results displayed.

```
Paper Drive
-----
PWM avg: 20820.46
Speed error: 21.00
PWM StDev: 100.89
PWM max: 20975.00
```

Press **OK** to continue

10. When the whole test has been completed successfully, the following message is displayed. Press **OK** to restart the printer.

```
Paper Drive
-----
Diagnostic result: OK
```

Press **OK** to restart

Electronics Module test

The purpose of this test is to diagnose a failure in the operation of the Formatter.

1. In the Service Tests submenu, scroll to **Electronics Module Test** and press **OK**.
2. A message appears on the Front Panel asking whether you would like to check the Formatter. Press **OK** to continue with the test, or **Cancel** to exit.

```
Electronics Module
-----
Check the formatter?
```

Press **OK** to confirm or
X to exit

- The front panel displays the amount of memory installed. “Real memory size” is the real size detected, and “Total memory size” shows the rounded memory size. Press **OK** to continue.

```

Electronics Module
-----
Real memory size: 501 MB
Total memory size: 512 MB

```

Press **OK** to continue

- The front panel displays the name, type and size of all the partitions on the Hard Disk. Press **OK** to continue.

```

Electronics Module
-----
12000554+
SDA7      83
35985599+
SDA8      83
51006374+
SDA9      83
43046167
Press OK to continue

```

- The front panel displays the name, size and percentage used of the data and boot partitions on the Hard Disk. Press **OK** to continue.

```

Electronics Module
-----
Device 1k-Blocks %Used
SDA1    245076     10%
SDA6    11812056  11%
SDA7    35420004   1%
SDA8    50205832   1%
SDA9    42369548   1%

```

Press **OK** to continue

- When the test is complete, **OK** is displayed on the front panel. Press **OK** to restart the printer.

Carriage Assembly test

The purpose of this test is to check the operation of the Carriage Assembly.

 **NOTE:** If possible, always perform this test before replacing the Carriage Assembly. If this test passes, do not replace the Carriage Assembly.

Perform the Carriage Assembly test as follows:

- In the Diagnostics submenu, select **Carriage Assembly** and press **OK**.

```

Diagnostics menu
-----
▶ Scan Axis
▶ Paper Drive
▶ Electronics Module
▶ Carriage Assembly
⊞ IDS
⊞ Service Station
▶ T/O Information

```

While the diagnostic is testing the Carriage Assembly, it displays announcements of its current activity such as **Initializing**, **Getting information** and **Checking voltages**.

- When the tests are done, the values of some parameters (mostly voltages) are displayed, together with their allowed or valid range. Press **OK** after each one to continue.

```
Carriage Assembly
Carriage Voltage (Vs):
31.697 V
Valid range is: 30.0 - 34.0
Press OK to continue
```

- When prompted by the front panel, open the Window, open the Carriage Cover and remove all printheads from the Carriage. Then close the Carriage Cover and the Window and press **OK**.

```
Carriage Assembly
Please remove all pens
Press OK to continue
```

If a printhead remains in the carriage after you press **OK**, you are reminded to remove it.

```
Carriage Assembly
Pen 0 detected
Please remove all pens
Press OK to continue or X to
exit
```

If you are sure that all printheads were removed before this message appeared, press **Cancel**; the test ends and a system error message is displayed.

- When the printheads have been removed, some additional parameters are checked, and their values and/or ranges are displayed.

```
Carriage Assembly
Carriage Voltage (Vpp0):
Valid range is: 28.696 -
29.696
Press OK to continue
```

5. The front panel prompts you to put a sheet of blank paper under the Carriage, which is already in the middle of the platen, to perform the LED and sensor checks. The paper should be large enough to cover the whole Carriage area. Press **OK** to continue.

```
Carriage Assembly
Put a piece of blank paper
under the carriage

Press OK when done
```

6. The diagnostic checks the Carriage LEDs and sensors, which can take a few minutes. When the checks are done, the front panel prompts you to remove the paper from under the Carriage.

```
Carriage Assembly
Remove paper

Press OK when done
```

7. When you see the message below, open the Window, open the Carriage Cover and re-insert all the printheads. Then close the Carriage Cover and the Window, and press **OK**.

```
Carriage Assembly
Please insert all pens

Press OK to continue
```

If a printhead has not been correctly inserted, the front panel reminds you to insert it.

```
Carriage Assembly
Pen 1 not detected

Please insert all pens
Press OK to continue or X to
exit
```

If you are sure that all printheads were correctly inserted before this message was displayed, press **Cancel**; the test ends and a system error message is displayed.

- When the printheads have been inserted, some further checks are made. When the tests are completed, the following message is displayed.

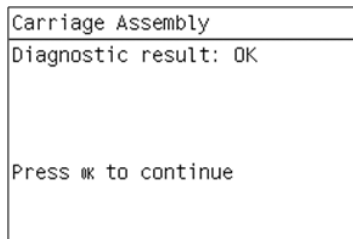

- Press **OK** to return to the menu.

IDS tests

The purpose of these tests is to check the operation of the Ink Delivery System.

To start the Ink Delivery System tests, scroll to **IDS** and press **OK**.

The test consists of a series of subtests as described below.

Air pressure system

The purpose of this test is to check the operation of the Air Pressurization System (APS). You should perform this test before replacing the APS; if it passes the test, you do not need to replace it.

- Select **Air pressure system** from the Ink Delivery System Test menu.
- The front panel asks for confirmation.
- The front panel asks you to insert the Ink Cartridges. Press **OK** after inserting all of them.
- The printer initializes various electrical subsystems, pressurizes the APS, holds the pressure for while, then depressurizes it. The current pressure is displayed on the front panel at each stage.
- If the test finishes successfully, the front panel displays **OK**.

Check ink supplies

The purpose of this test is to check which Ink Cartridges are valid for the purge process, and their current available ink levels. The status of some Ink Cartridges may not be accessible if they have previously suffered a failure (faulty, broken bag and so on).

- Select **Check ink supplies** from the Ink Delivery System Test menu.
- After a brief delay, the front panel displays information on the status of the ink supplies, or an error message if any problem is found.
- If the test finishes successfully, the front panel displays **OK**.

Clean air tubes

The purpose of this procedure is to remove ink that may have got into the air tubes after a bag has broken in an Ink Cartridge. This is this first stage in recovering from a broken bag. It should be performed if there is any ink visible in the air tubes of the APS.

1. Remove the Left Cover and check that the tubes from the APS to the ISS are clean. If the tubes are clean of ink this procedure does not need to be performed. However, if there are sections of tube that have ink in them, such as the examples indicated below with the red arrows, then you should proceed with the following steps.

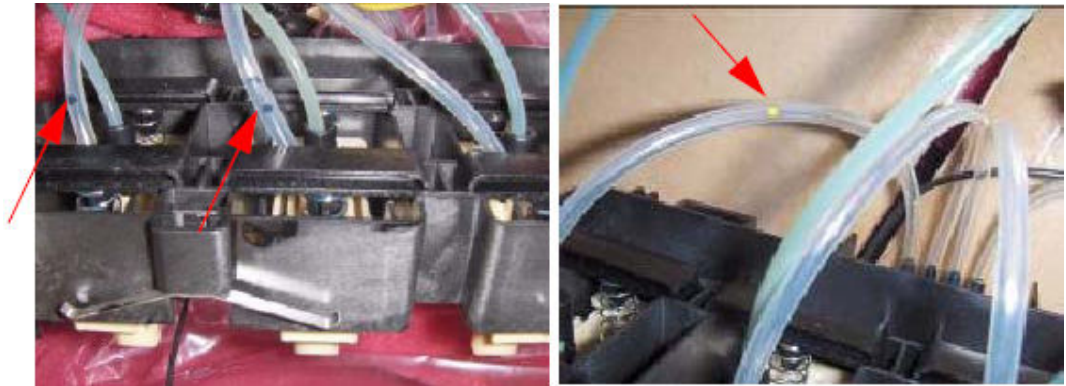

2. Remove all the Ink Cartridges and install the dummy Ink Cartridges from the Broken Bag Fixing Tools kit (part number CH955-67076).
3. One of the dummy Ink Cartridges has two holes at the top. This dummy Ink Cartridge must be inserted into the slot with the Broken Bag error.

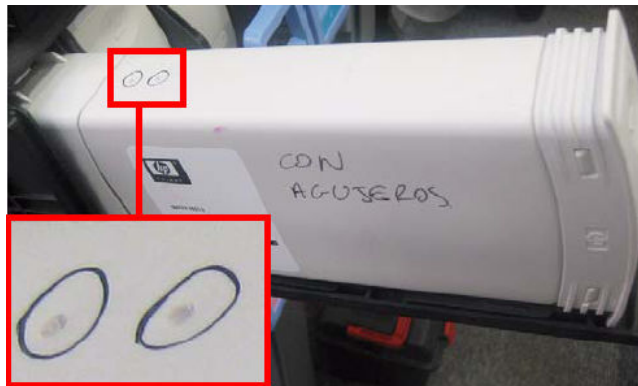

4. Select **Clean air tubes** from the Ink Delivery System Test menu.
5. The front panel asks for confirmation.
6. The front panel asks you to confirm that the dummy Ink Cartridges are installed.
7. The printer pumps air through the air tubes, pushing any ink into the dummy Ink Cartridge with the two holes at the top.
8. The front panel asks whether you want to repeat the process with a different cartridge. If you choose to do so, move the dummy Ink Cartridge with the two holes to a different slot. If not, the printer will shut down.

Refill ink tubes

A broken bag in an Ink Cartridge is likely to cause air bubbles in the ink tubes. It is important to remove the air bubbles because they can damage the Printheads.

The purpose of this procedure is to refill the ink tubes, removing any air bubbles, after an Ink Cartridge with a broken bag has been replaced. This is the third and final stage in recovering from a broken bag, and it should be performed only in that context. See [Recover broken bag on page 97](#).

1. Remove all the dummy Ink Cartridges and replace them with normal Ink Cartridges.

 **NOTE:** Be careful not to reinstall the Ink Cartridge with the broken bag; it should be replaced with a new Ink Cartridge.

2. Select **Refill ink tubes** from the Ink Delivery System Test menu.
3. The printer initializes various electrical subsystems.
4. When the front panel displays a screen similar to the following, use the **Up** and **Down** keys to select the ink color that had the broken bag, and press **OK**.

```
Refill Ink Tubes...
Slot1: Y <-
Slot2: C
Slot3: MK
Slot4: DG
Slot5: M
Slot6: G
```

5. The front panel asks whether there is air in the ink tubes. If not, the situation is correct and there is no need to continue. If there is air, press **OK** to continue the procedure.
6. The front panel asks you to confirm that the new Ink Cartridges are installed.
7. The front panel asks you to open the Window and the Carriage Cover.
8. The front panel asks you to remove the two printheads of the color you already selected (which had the broken bag). Remove the printheads and press **OK** to continue.
9. The front panel asks you to introduce the needle of the syringe into one of the FI towers of the selected color. Use the syringe from the Broken Bag Fixing Tools kit. Use the FI tower that is closer to the rear of the Carriage, as shown. Press **OK** to continue.



10. The front panel displays a status message.

```
Refill Ink Tubes...
Pumping air 2 minutes.
Time      : 13 sec.
Pressure  : 5755 milipsi.
```

Ink is now pumping through the ink tube, pushing any air bubbles from the ink tube into the syringe. The amount of ink pumped through the ink tube into the syringe is 33 ml + air.



11. After two minutes, the front panel asks you to confirm that there is now 35 ml of ink + air in the syringe.
12. The front panel explains that the printer is accounting for the ink used.
13. The front panel displays **OK**, then asks if you want to repeat the procedure. If you want to repeat (because there is still some air in the ink tube, or because more than one bag was broken), press **OK**. Otherwise press **Cancel** and continue with the remaining steps.

 **NOTE:** If you cannot clear the bubbles from the ink tube, replace the complete SRK Tubes Assembly.

14. The front panel asks you to remove the syringe from the FI tower.
15. The front panel asks you to reinstall the printheads that you removed earlier.
16. The front panel asks you to close the Carriage Cover and the Window.

Recover broken bag

The purpose of this procedure is to return the printer to normal ready status after a broken bag has been detected in one of the Ink Cartridges.

A badly broken bag will stop the printer from functioning and will need to be fixed and cleared of the error before the printer can continue printing normally. If ink leaks from the broken bag and leaves the confines of the ink cartridge, it could damage various parts of the printer.

1. Clean any ink out of the air tubes: see [Clean air tubes on page 94](#).
2. Replace the Ink Cartridge that has the broken bag with a new Ink Cartridge.
3. Select **Recover broken bag** from the Ink Delivery System Test menu.
4. The front panel asks you to confirm that the air tubes are clean (contain no ink).

5. The front panel asks whether you want to remove the broken bag condition.
6. If you confirm, the printer checks all the Ink Cartridges for a broken bag and displays a message if any are found.
7. When the procedure is complete, the printer shuts down.
8. Refill the ink tubes: see [Refill ink tubes on page 95](#).

Service Station test

The purpose of this test is to check the operation of the Service Station.

1. In the Diagnostics menu, scroll to **Service Station** and press **OK**.

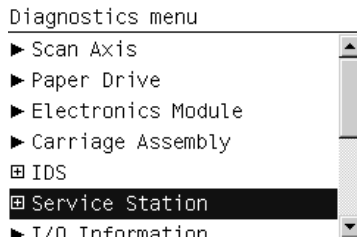

2. Within the Service Station submenu, select the **Service Station** test.

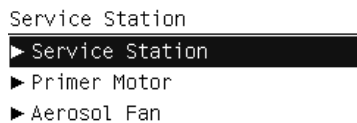

3. The front panel then prompts you to check the status of the printer.

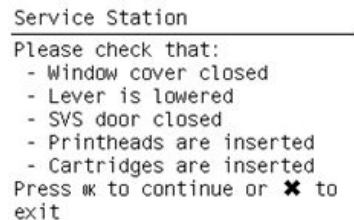

4. Check that:
 - The window is closed.
 - The service station door is closed.
 - The rear door is closed.
 - All printheads are inserted.
 - All cartridges are inserted.
5. Press **OK** to continue.

- The printer performs a series of movements numbered from 1 to 10. It takes about 2 minutes to perform all the movements.

```
Service Station
-----
Performing movements

Step 1 of 10
```

- The front panel asks if you want to cap the printheads. Press **OK** to cap the service station or **Cancel** to leave the printheads uncapped.

```
Service Station
-----
Do you want to leave the
service station in the
default position (capping
the printheads)?

Press OK for yes or X for no
```

- The front panel announces the result of the test. Press **OK** to turn off the printer.

```
Service Station
-----
Diagnostic result: OK

Press OK to shut down
```

 **TIP:** If a system error message appears during the above procedure, see [System error codes on page 39](#).

Primer test

The purpose of this test is to prime a specified printhead.

 **NOTE:** If possible always perform this test before replacing the primer. If this test passes, do not replace the primer.

Perform the Primer test as follows:

- Start the printer in Diagnostic mode (**Up** and **OK** keys pressed at switch-on time, until the HP logo appears). Go to the Service Station submenu.

```
Diagnostics menu
-----
▶ Scan Axis
▶ Paper Drive
▶ Electronics Module
▶ Carriage Assembly
▣ IDS
▣ Service Station
▶ T/O Information
```

- Within the Service Station submenu, select the Primer test.

```
Service Station
-----
▶ Service Station
▶ Primer
▶ Aerosol Fan
```

3. The printer will ask you to check that the printer covers and doors are closed, and the printheads and cartridges correctly inserted. After checking those things, press **OK**.

```
Primer
-----
Please check that:
- Window cover closed
- Lever is lowered
- SVS door closed
- Printheads are inserted
- Cartridges are inserted
Press OK to continue or X to
exit
```

4. The printer will initialize some subsystems and move the carriage out of the service station. After that it will ask you to select the printhead to prime. Use the **Up/Down** keys to change the printhead number, and press **OK** to select.

```
Primer
-----
Select the printhead you want
to prime:

Printhead 1

Use UP/DOWN to scroll,
ENTER to confirm or
CANCEL to exit.
```

While the printhead is being primed, a message saying **Priming printhead** will appear in the front panel, indicating the number of the selected printhead. If any error occurs, a system error will identify the part that has failed.

5. Once the printhead has been primed correctly, the message below appears. Press **OK** to turn off the printer.

```
Primer
-----
Diagnostic result: OK

Press OK to shut down
```

Aerosol test

The purpose of this test is to check the operation of the Aerosol Fan(s).

Perform the Aerosol test as follows:

1. Start the printer in Diagnostic mode (**Up** and **OK** keys pressed at switch-on time, until the HP logo appears). Go to the Service Station submenu.

```
Diagnostics menu
┆ Scan Axis
┆ Paper Drive
┆ Electronics Module
┆ Carriage Assembly
┆ IDS
┆ Service Station
┆ T/O Information
```

2. Within the Service Station submenu, select the Aerosol test.

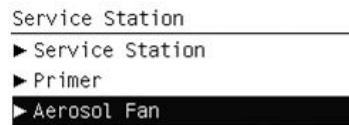

3. The test is automatic and needs no user intervention. After the test, the printer will show that the diagnostic result is OK, and ask you to press **OK** to continue. If there is any failure, an error message will identify the part that failed.

I/O Information

This option allows you to view information about input/output.

1. In the Service Tests submenu, scroll to **I/O Information** and press **OK**.
2. The printer will start to initialize and the Front Panel will display the following messages:
 - Getting IO Interface
 - Getting Interface info

If there is a failure at this point, the Front Panel will display an error.

If no active interface is found, the Front Panel will display **No active interface found. Press any key to finish.**

3. Once the IO information is obtained, it is displayed on the Front Panel. Press any key to exit.

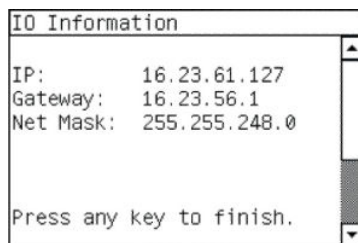

4. Once the process is completed, **OK** will be displayed on the Front Panel.

Unit information

This option allows you to view the following printer information:

- Firmware version
- Serial number
- Part number
- PostScript language (if applicable)

View the Unit Information as follows:

1. In the Service Tests submenu, scroll to **Unit Information** and press **OK**.

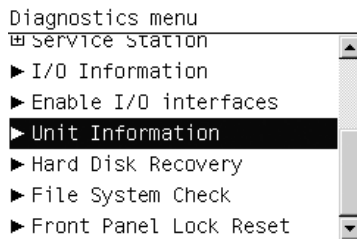

2. The printer starts to initialize and the front panel displays the following messages:

- Starting Nvm
- Getting FW version
- Getting Serial Number
- Getting Part Number

If there is a failure at this point, the Front Panel will display **System Error Code 79:03**. For more information on troubleshooting this error code, see [SE 79:03 on page 70](#).

- Getting PS Language (if the PostScript accessory is installed)

If there is a failure at this point, the front panel will display an error.

3. Once the unit information is obtained, it is displayed on the front panel. Press **OK** to exit.

```
Unit Information
-----
Firmware: KHN_01_00_06.1
Serial number: MY99F0902HK042
Part number: CQ109A
PS type: Roman

Press OK to continue
```

4. Once the process is completed, **OK** is displayed on the front panel.

```
Electronics Module
-----
Diagnostic result: OK
```

Press **OK** to restart

EEROM Reset

The purpose of this diagnostic is to reset the EEROM values.

 **NOTE:** Once the EEROM has been reset, the printer will act as if it is being started for the first time, except that the Ink Supply Tubes have already been primed.

Perform an EEROM Reset as follows:

1. In the Service Tests submenu, scroll to **EEROM Reset** and press **OK**.

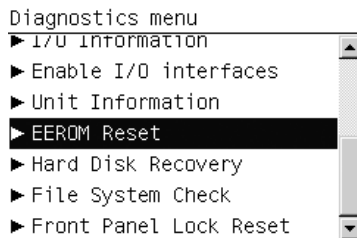

2. The front panel advises you that all user information/files will be removed. Press **OK** to reset the EEROM or **Cancel** to exit.

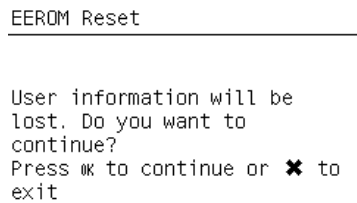

3. While the EEROM is being reset, the front panel displays the following message.

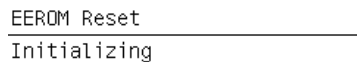

4. When the EEROM has been reset, the front panel displays the following message. Press **OK** to shut down the printer.

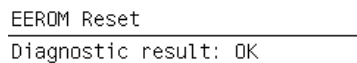

Press **OK** to shut down

Hard Disk recovery

This option is a utility that is also available from the Service Utilities menu. See [Hard Disk recovery on page 116](#).

File system check

This option is a utility that is also available from the Service Utilities menu. See [File system check on page 116](#).

OMAS Module test

The purpose of this test is to check the operation of the Optical Paper Advance Sensor (OMAS) system.

In the Service Tests submenu, scroll to **OMAS Test** and press **OK**.

Service utilities

The following is a list of all internal Service Utilities available in the printers. Instructions for entering the Service Utilities menu are given on [Entering the Service Utilities menu on page 105](#).

1. Turn Drive Roller ⇒ [Turn Drive Roller on page 105](#).

The purpose of this Service Utility is to rotate the Drive Roller and the Overdrive in order to clean them.

2. Prime Tubes ⇒ [Prime Tubes on page 107](#).

The purpose of this Service Utility is to Prime the Tubes when the Ink Tubes are NOT new and they need to be re-primed or automatic priming was not completed correctly.

3. Reset Life Counters ⇒ [Reset Life Counters on page 108](#).

The purpose of this Service Utility is to reset the internal life counters. There are two submenus that allow you to:

- Reset ALL the counters related to a Preventive Maintenance Kit (PMK).
- Reset only the counters related to a specific replaced part.

4. Diagnostic Print ⇒ [Diagnostic Print on page 110](#).

The purpose of this Service Utility is to print the Diagnostic Print in order to identify image quality problems.

5. Replace Cutter ⇒ [Replace Cutter on page 111](#).

The purpose of this Service Utility is to move the Carriage to a position where the Cutter can be replaced easily.

6. Enable/Disable Firewall ⇒ [Enable/Disable Firewall on page 111](#).

The purpose of this Service Utility is to enable or disable the printer's firewall.

7. Disk Wipe DoD 5330.22'M ⇒ [Disk Wipe DoD 5330.22'M on page 112](#).

The purpose of this Service Utility is to securely erase data on the Hard Disk.

8. Show/Hide Front Panel Info.

This Service Utility enables you to show or hide the IP address of the printer on the front panel.

9. Paper Sensor Replacement ⇒ [Paper Sensor replacement on page 114](#).

The purpose of this Service Utility is to unload the paper and leave the Smart Roll-loading System in a position in which the Media Sensor can be replaced easily.

10. Soft Printhead Servicing ⇒ [Soft Printhead servicing on page 114](#).

The purpose of this Service Utility is to enable or disable the soft printhead servicing mode, which may be enabled when spitting is visible on the print and the print quality is poor.

11. Test Cutter ⇒ [Test Cutter on page 115](#).

The purpose of this service utility is to check that the Cutter works properly.

12. Hard Disk Recovery ⇒ [Hard Disk recovery on page 116](#).

The purpose of this service utility is to clean user data on the Hard Disk, to try to recover the printer from an unstable state.

13. File System Check ⇒ [File system check on page 116](#).

The purpose of this service utility is to check the consistency of the file system on the Hard Disk. If the utility detects a problem, it will try to fix it automatically.

Entering the Service Utilities menu

1. Once the **Ready** message is displayed on the front panel, select the  icon.
2. For Call Agents who will request the user to perform certain Service Utilities, once inside the Setup menu, press the **Down** arrow key and the **Cancel** key together. You are now in the Service Tools menu.
3. For On-Site Engineers, once inside the Setup menu, press the **Up** arrow key and the **Cancel** key together. You are now in the Service Tools menu.
4. Use the **arrow** keys to scroll to the Service Utilities menu and press the **OK** key.

```
Service menu
▣ Service utilities
▣ Service calibrations
```

5. Use the arrow keys to scroll through the Service Utilities selections and press the **OK** key to begin a specific operation when the required service utility is highlighted.

```
Service utilities
▶ Turn Drive Roller
▶ Prime Tubes
▣ Reset life counters
▣ Diagnostic Print
▶ Replace cutter
▶ Enable/Disable Firewall
▣ Disk Wipe Done 5:22 AM 7/20/08
```

 **NOTE:** If the printer is not used for 135 seconds, the printer exits from the Service Utilities menu and you must repeat the above steps to enter Service Utilities again.

In some cases a quick press of a button may not be recognized by the printer. When pressing a button, be sure to press it deliberately and all the way to the bottom of its travel.

Turn Drive Roller

The purpose of this Service Utility is to rotate the Drive Roller and the Overdrive in order to clean them.

 **NOTE:** Unload the paper before performing this operation.

Open the Window and activate the Window Sensor (using a piece of paper) before performing this service utility.

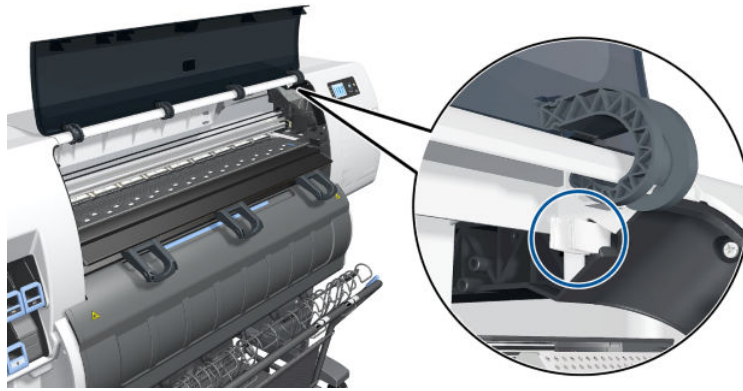

Perform the Turn Drive Roller utility as follows:

1. In the Service Utilities submenu, scroll to **Turn Drive Roller** and press **OK**.

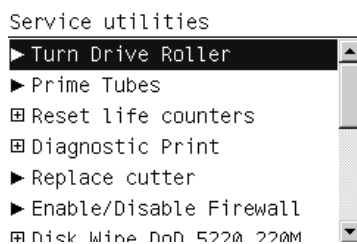

2. The printer checks to see if paper is loaded. If paper is loaded, the front panel displays the following message. Unload the paper and start again from the beginning.

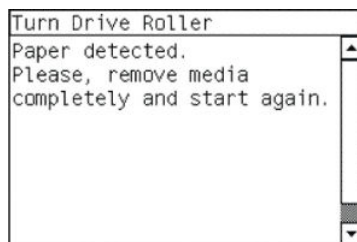

3. The Drive Roller begins to turn slowly and the following message is displayed on the front panel.

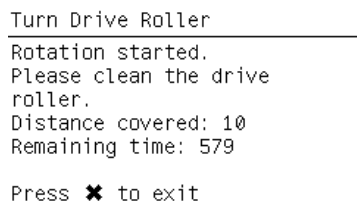

4. Refer to the Cleaning Instructions ⇒ [Clean the Drive Roller and Overdrive on page 476](#).
5. Once you have finished cleaning the Drive Roller and the Overdrive, press the **Cancel** key to finish the utility.
6. If the utility exits correctly, **OK** will be displayed on the front panel.

 **NOTE:** Please remember to remove the piece of paper from the Window Sensor before closing the Window, as it could damage the Window and the Sensor.

Prime Tubes

The purpose of this Service Utility is to prime the Tubes when the Ink Tubes are not new and they need to be re-primed or automatic priming was not completed correctly.

 **NOTE:** Make sure that new Ink Cartridges are installed or that the ink volume remaining in the Ink Cartridges is below 88% before starting to prime the tubes. Otherwise, you will see a warning message.

1. In the Service Utilities submenu, scroll to **Prime Tubes** and press **OK**.

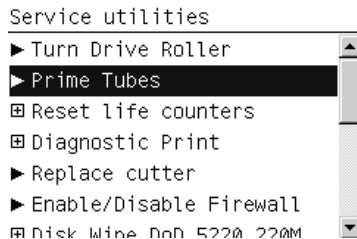

2. If the Ink Cartridges are not suitable for priming, the following message will appear on the front panel. Replace the installed Ink Cartridges with Ink Cartridges that are new or contain less than 88% of ink. Press any key to exit.

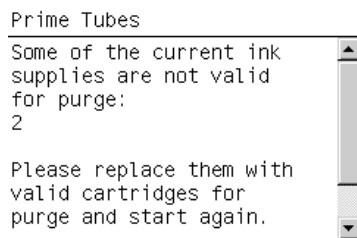

3. When the following message appears on the front panel, press **OK** to continue or **Cancel** to exit.

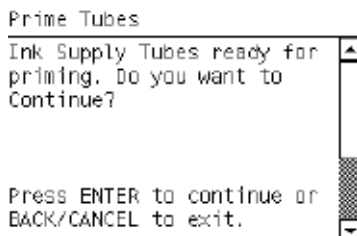

4. The front panel displays the following message, then restarts the purge process.

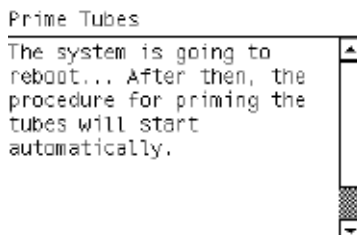

- When the printer has restarted, the front panel asks you to open the Window and remove all the Printheads.

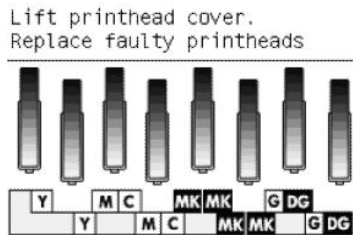

- When you have removed all the Printheads, the front panel asks you to install the Setup Printheads.
- When you have installed the Setup Printheads, the front panel displays the following message.

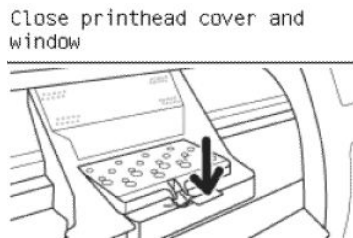

- When you have closed the Printhead Cover and the Windows, the printer begins to purge the tubes.
- When the tubes have been purged, the front panel asks you to open the Window.
- Check that all the Setup Printheads have some ink.

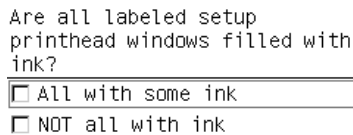

- The front panel asks you to change the ink funnel and waste bottle, but you should ignore this request. Continue the purge procedure, pressing OK to advance through the procedure, but without changing any parts.
- At the end of the procedure, the printer aligns the Printheads.

Reset Life Counters

The purpose of this Service Utility is to reset the internal life counters. There are two submenus that allow you to:

- Reset all the counters related to a Preventive Maintenance Kit (PMK).
- Reset only the counters related to a specific replaced part.

 **NOTE:** Always reset the life counter of a corresponding part only after replacing it.

Perform the Reset Life Counters utility as follows:

- In the Service Utilities submenu, scroll to **Reset life counters** and press **OK**.

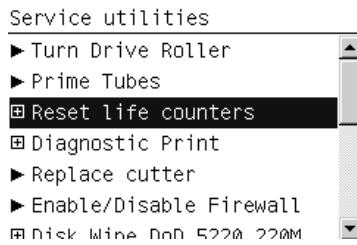

2. You will be given an option either to reset the life counter for all the parts related to a Preventive Maintenance Kit (PMK) or to reset the life counter for a particular part only.

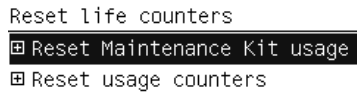

- a. If you select to reset the life counter for all the parts related to a Preventive Maintenance Kit (PMK), you will be given an option to reset the life counter of:
- Preventive Maintenance Kit 1 (PMK1)
 - Preventive Maintenance Kit 2 (PMK2)
- b. If you select to reset the life counter for a particular part, you will be given an option to reset the life counter of the:
- Carriage ME
 - Tubes and Trailing Cable
 - Scan Motor
 - Left Spittoon
 - Drop Detector
 - Line Sensor
 - APS Pump
 - Maintenance Cartridge Spittoon
 - Paper Motor
 - OMAS Module
 - Primer Mech
 - SVS

- Once you have selected a life counter to reset, a message similar to the following will be displayed on the front panel. Press **OK** to reset the selected life counter or press **Cancel** to exit without resetting the life counter.

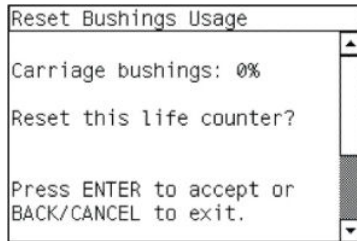

If the life counter information cannot be read, the front panel will display **Unable to get usage counter**. This could point to a possible firmware error.

- If the utility exits correctly, **OK** will be displayed on the front panel.

Diagnostic Print

The purpose of this Service Utility is to print the Diagnostic Print in order to identify image quality problems.

Print the Diagnostic Print as follows:

- In the Service Utilities submenu, scroll to **Diagnostic Print** and press **OK**.

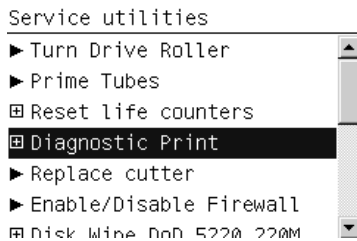

- The front panel offers a selection of prints. Use the arrow keys to make the selection and press the **OK** key to start printing the required Diagnostic Print.

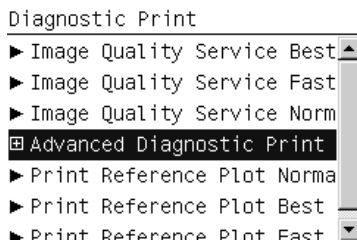

If you select **Advanced Diagnostic Print**, a submenu appears.

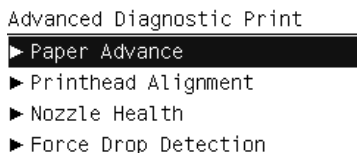

If the OMAS sensor is enabled the printer will display a message: **Do you want to disable the OMAS sensor?** Select **Yes** or **No**.

3. Make sure that paper is loaded and that the Ink System is correctly installed. Press the **OK** key to print the Diagnostic Print or press **Cancel** to exit without printing the Diagnostic Print.

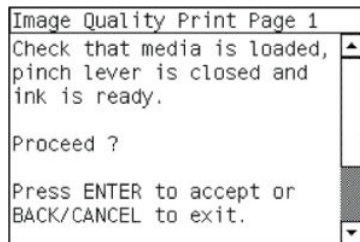

4. The selected Diagnostic Print is now printed. For further information on how to use troubleshoot print-quality problems, see [How to use the Image Quality Service Diagnostic Print on page 149](#).

Replace Cutter

The purpose of this Service Utility is to move the Carriage to a position where the Cutter can be replaced easily.

Perform the Replace Cutter utility as follows:

1. In the Service Utilities submenu, scroll to **Replace cutter** and press **OK**.

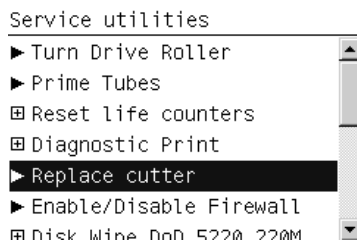

2. When the following message appears on the front panel, press **OK** to continue with the Cutter replacement, or **Cancel** to exit.

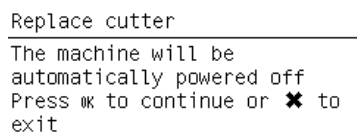

3. The Carriage moves to the Cutter replacement position and the following message is displayed on the front panel. After a few seconds the printer will begin to shut down.

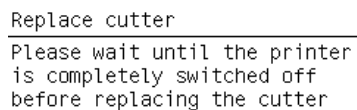

4. Before replacing the Cutter, make sure that you turn the printer off at the rear switch.

Enable/Disable Firewall

The purpose of this Service Utility is to enable or disable the firewall of the printer.

Perform the Enable/Disable Firewall utility as follows:

1. In the Service Utilities submenu, scroll to **Enable/Disable Firewall** and press **OK**.

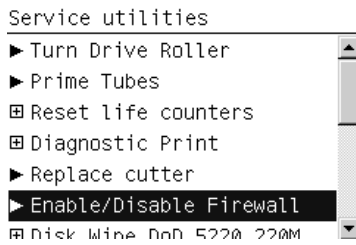

2. The printer checks whether the firewall is enabled or disabled.
3. When the following message appears on the front panel, you must select whether you would like to enable or disable the firewall. Use the **Up** and **Down** keys to make your selection and press the **OK** key.

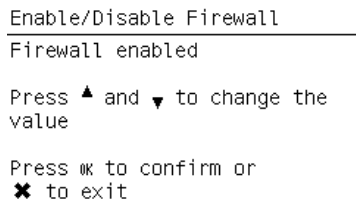

4. The system upgrades the internal memory to reflect the chosen selection.
5. If the utility exits correctly, **OK** will be displayed on the Front Panel.

Disk Wipe DoD 5330.22'M

The purpose of this Service Utility is to securely erase data on the Hard Disk according to the directive DoD 5220.22-M.

The printer's hard disk is used as a temporary storage area for print jobs. The Secure Disk Erase facility can completely erase your information from the hard disk to protect it from unauthorized access.

Secure Disk Erase provides three different levels of security:

- **Insecure Mode:** All pointers to the information are erased. The information itself remains on the hard disk until the disk space it occupies is needed for other purposes, and it is then overwritten. While it remains on the disk, it is difficult for most people to access, but may be accessed using software designed for the purpose. This is the normal method in which files are erased on most computer systems; it is the fastest method but the least secure. This is the default security level when using Secure Disk Erase.
- **1-Pass Mode:** All pointers to the information are erased, and the information itself is also overwritten with a fixed character pattern. This method is slower than Insecure Mode, but more secure. It may still be possible to access fragments of the erased information by using special tools to detect residual magnetic traces.
- **5-Pass Mode:** All pointers to the information are erased, and the information itself is repetitively overwritten using an algorithm designed to eliminate any residual traces. This is the slowest method, but the most secure. 5-Pass Mode meets the US Department of Defense 5220-22.m requirements for clearing and sanitization of disk media.

Use the Disk Wipe DoD 5330.22-M utility as follows:

1. In the Service Utilities submenu, scroll to **Disk Wipe DoD 5330.22-M** and press **OK**.

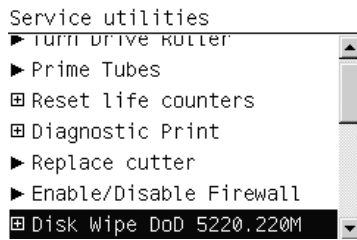

2. In the Disk Wipe DoD 5330.22-M submenu, scroll to **Sanity Level** and press **OK**.

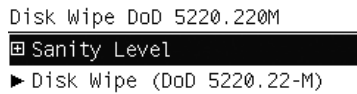

3. In the Sanity Level submenu, scroll to the required Sanity Level and press **OK**.

 **NOTE:** Erasing the Hard Disk drive using anything but Insecure Mode is a very slow process: 6 hours for the 1-Pass Mode and 40 hours for the 5-Pass Mode.

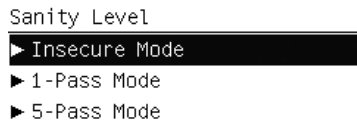

4. Press **Back** to return to the Disk Wipe DoD 5330.22-M submenu.
5. In the Disk Wipe DoD 5330.22-M submenu, scroll to **Disk Wipe DoD 5330.22-M** and press **OK**.
6. When the following message appears on the front panel, press **OK** to perform a complete erase of the Hard Disk Drive using the previously selected erase mode, or press **Cancel** to exit.

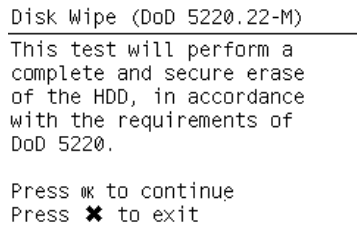

7. When the following message appears on the Front Panel, press **OK** to continue and completely erase the Hard Disk Drive, or press **Cancel** to exit.

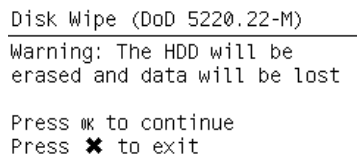

8. The erase process starts and the front panel shows the total time required to erase the Hard Disk Drive using the selected Sanity Level along with a progress bar.

DoD 5220.22-M

invent
Total Time: 6 Hours

1-Pass Mode

DoD 5220.22-M

invent
Total Time: 40 Hours

5-Pass Mode

Paper Sensor replacement

The purpose of this Service Utility is to unload the paper and leave the Smart Roll-loading System in a position in which the Media Sensor can be replaced easily, before powering off the printer to proceed with the replacement.

1. In the Service Utilities submenu, scroll to **Paper Sensor Replacement** and press **OK**.

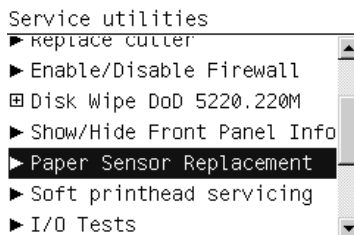

2. Check that there is no print remaining in the printer. If so, open the Window and cut the print with a cutter or scissors, leaving the leading edge of the paper in the platen near the pinchwheels. Press **OK** when done.

Paper Sensor Replacement
Please first cut any hanging
plot then start the process
Press **OK** to continue or **X** to
exit

3. The printer begins to unload all rolls from the printer. Follow the instructions to remove all the rolls from the printer.

 **NOTE:**  All rolls must be removed to prevent the Smart Roll-loading System from moving while the printer is powered off and the Sensor is being changed.

Paper Sensor Replacement
Processing, please wait.

4. After removing the rolls, press **OK** to shut down the printer. Once the printer has powered off, the Paper Sensor can be replaced after opening the Roll Cover.

Paper Sensor Replacement
Press **OK** to shut down

Soft Printhead servicing

The purpose of this Service Utility is to enable or disable the soft printhead servicing mode, which is disabled by default, but may be enabled when spitting is visible on the print and the print quality is poor.

1. In the Service Utilities submenu, scroll to **Soft printhead servicing** and press **OK**.

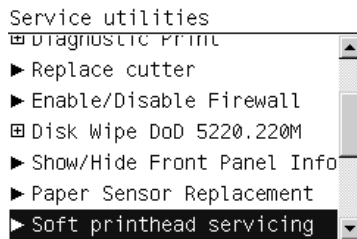

2. Press **OK** to enable soft printhead servicing, or **Cancel** to disable it.

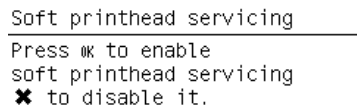

3. The front panel confirms your selection.

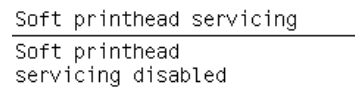
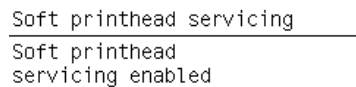

If you change your mind, you can just enable or disable it again.

Test Cutter

The purpose of this service utility is to check that the Cutter works properly.

1. In the Service Utilities submenu, scroll to **Test Cutter** and press **OK**.

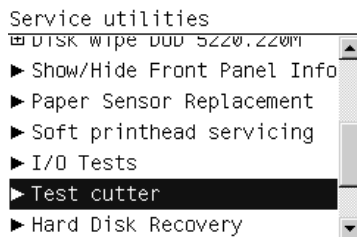

2. Make sure that paper is loaded, then press **OK** to proceed with the test.



3. The printer advances the paper, prepares the Cutter, and tries to cut the paper.
4. When it has finished cutting, the printer disengages the Cutter.

5. The front panel asks you to confirm that the Cutter has cut the paper.

```
Cutter
-----
Cutter seems to be OK.
Was the paper cut?

Press OK for yes,
Cancel for no.
```

Hard Disk recovery

The purpose of this service utility is to clean user data on the Hard Disk, to try to recover the printer from an unstable state.

1. In the Service Utilities submenu, scroll to **Hard Disk Recovery** and press **OK**.

```
Service utilities
DISK wipe 000 5220.220M
▶ Show/Hide Front Panel Info
▶ Paper Sensor Replacement
▶ Soft printhead servicing
▶ I/O Tests
▶ Test cutter
▶ Hard Disk Recovery
```

2. When the following message appears on the front panel, press **OK** to perform a Hard Disk recovery, or **Cancel** to exit.

```
Hard Disk Recovery
-----
Please unload the paper

Press OK to continue
Press X to exit
```

3. When the following message appears on the front panel, again press **OK** to perform a Hard Disk recovery, or **Cancel** to exit.

```
Hard Disk Recovery
-----
This test will clean some
folders on the hard disk

Press OK to continue
Press X to exit
```

File system check

The purpose of this service utility is to check the consistency of the file system on the Hard Disk. If the utility detects a problem, it will try to fix it automatically.

1. In the Service Utilities submenu, scroll to **File System Check** and press **OK**.

```
Service utilities
▶ Paper sensor replacement
▶ Soft printhead servicing
▶ I/O Tests
▶ Test cutter
▶ Hard Disk Recovery
▶ File System Check
▶ Enabled/Disable Port280
```

2. When the following message appears on the front panel, press **OK** to perform a file system check, or **Cancel** to exit.

File System Check

Do you want to launch
the file system check?

This will restart the printer
and will take several minutes
to complete.
Press **OK** to continue or **X** to
exit

6 Service calibrations

- [Service calibrations](#)
- [Entering the Service Calibrations menu](#)

Service calibrations

The printer has several calibration procedures that must be performed under certain conditions.

The following is a list of all internal service calibrations available in the printer. See [Entering the Service Calibrations menu on page 121](#).



NOTE: Remember that certain calibrations are required even if an assembly has been disassembled to gain access to another assembly or component.

1. Paper Advance Calibration ⇒ See [Paper-advance calibration on page 121](#)

The purpose of this Service Calibration is to calibrate the nominal advance of the paper. This calibration is necessary to control the exact movement of the paper in order to avoid print-quality problems like banding.

2. Drop Detector Calibration ⇒ See [Drop Detector calibration on page 124](#)

The purpose of this Service Calibration is to calibrate the Drop Detector (located in the Service Station) in relation to the Carriage Assembly.

3. Line Sensor Calibration ⇒ See [Line Sensor calibration on page 126](#)

The purpose of this Service Calibration is to calibrate the intensity of the Line Sensor. An incorrect calibration can result in edge-detection failures during paper loading and incorrect reading of prints that are used for alignment or calibration.

4. Calibrate Rewinder ⇒ See [Calibrate Rewinder on page 129](#)

The purpose of this Service Calibration is to calibrate the Rewinder Motor.

5. Primer Calibration ⇒ See [Primer calibration on page 130](#)

The purpose of this Service Calibration is to calibrate the Primer.

6. Reset Vacuum Calibration ⇒ See [Reset vacuum calibration on page 134](#)

The purpose of this Service Calibration is to reset the nominal values of the Vacuum Calibration. Should be used only if the vacuum fans are working, but the vacuum pressure is incorrect and there are carriage crashes.

7. Platen Blue Line Calibration ⇒ See [Platen blue line calibration on page 135](#)

The purpose of this Service Calibration is to calibrate the blue line which is marked on the Print Platen.

8. OMAS Calibration ⇒ See [OMAS Calibration on page 137](#)

The purpose of this Service Calibration is to calibrate the OMAS Module.

If all the calibrations need to be performed (for example, when both the HDD and the ISS PCA have been replaced), you should perform them in the following order:

- Vacuum Calibration
- Drop Detector/Service Station Calibration
- Line Sensor Calibration
- Paper Advance Calibration

- Platen Blue Line Calibration
- Calibrate Rewinder

Entering the Service Calibrations menu

1. Once the message **Ready** is displayed on the front panel, press the **Menu** key.
2. Once inside the Printer menu, press the **Down** key first, and hold it down while pressing the **Cancel** key. You are now in the Service menu.
3. Select **Service calibrations** and press the **OK** key.

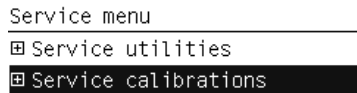

4. Scroll through the various service calibrations and press the **OK** key to begin the highlighted calibration.

 **NOTE:** If the printer is not used for 135 seconds, the printer leaves the Service Calibrations menu and you must repeat the above steps to return to it.

Paper-advance calibration

The purpose of this Service Calibration is to calibrate the nominal advance of the paper to compensate for any irregularities in the drive roller, which is not a perfect cylinder. Calibration is necessary to control the precise movement of the paper in order to avoid print-quality problems such as banding.

1. In the Service Calibrations submenu, select **Paper Advance Calibration** and press **OK**.

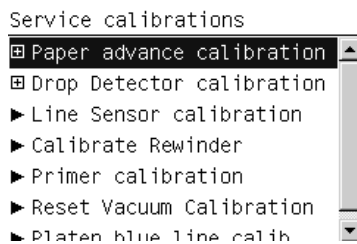

2. The Paper Advance Calibration submenu offers four options.
 - **Check calibration status** tests whether the current calibration values are valid.
 - **Perform new calibration** performs a calibration in order to obtain a new set of calibration values. The calibration values are automatically set to zero when a calibration process is launched.
 - **Reset current calibration** sets all the calibration values to zero.
 - **Show current calibration values** displays the current calibration values.

Check calibration status

This option tests whether the current calibration values are valid. The process is very similar to the calibration process. The printer makes a series of paper advances, and the OMAS sensor registers the distance covered in each advance.



NOTE: Before starting the process, make sure that HP Coated Paper is loaded and ready to print.

At the end of the process, the printer checks whether the current calibration values are valid, using the data obtained during the paper advances. If the values are considered valid, then the following message will be shown.

```
Check Current Parameters
```

```
_____
The current calibration
values are valid
Press OK to continue
```

If they are not valid, the front panel displays the reason (for example, the AMP1 parameter value is greater than the maximum allowed).

```
Check Current Parameters
```

```
_____
The obtained calibration
values are not valid
AMP1 (23) > 20
Press OK to continue
```

Press **OK** to return to the main screen.

Perform new calibration

This option performs a calibration in order to obtain a new set of calibration values. The printer makes a series of paper advances, and the OMAS sensor registers the distance covered in each advance. When all the paper advances have been performed, the calibration values are calculated based on the data obtained.



NOTE: Before starting the process, make sure that HP Coated Paper is loaded and ready to print.

1. The printer checks that there is paper ready to print. If there is no paper ready, the following message is displayed. After a few seconds, the front panel automatically returns to the Paper Advance Calibration submenu.

```
Perform Calibration Process
```

```
_____
Paper not ready
```

2. If there is paper ready, the printer performs the zero search for the Paper Motor. During this phase, the following message is displayed.

```
Perform Calibration Process
```

```
_____
Performing paper advance
calibration...
```

3. When the Paper Motor has been initialized, the printer starts to perform the series of paper advances. During this process, the front panel displays the current iteration number and the total number of iterations.

```
Perform Calibration Process
```

```
_____
Performing paper advance
calibration...
Iteration 32 of 90
Press X to exit
```

You can cancel the calibration process at any time by pressing **Cancel**. In this case, the previous calibration values are restored and the cancelled process has no effect on the printer.

4. If the calibration process finishes without errors, the new calibration values are checked. If the values are considered valid, they are displayed and saved for use in future. Press **OK** to return to the main screen.

```
Perform Calibration Process
SLOPE: 0.001672
AMP1: 13.000000
PH1: 3.359320
FREQ1: 1.000000
AMP2: 0.000000
PH2: 0.000000
FREQ2: 2.000000
AMP3: 0.000000
```

 **NOTE:** Both the Automatic and the Manual Paper Advance Calibration (which can be launched from the user menu), if they exist, are automatically set to zero for each kind of paper.

5. If the calibration values are not valid, the front panel displays the reason (for example, the percentage of good navigations is less than 90%). In this case the calibration process has no effect on the printer. Press **OK** to return to the main screen.

```
Perform Calibration Process
The obtained calibration
values are not valid
GOOD NAVS (17.8) < 90%
Press OK to continue
```

Reset current calibration

This option sets all the calibration values to zero.

1. The front panel asks for confirmation before proceeding with the reset operation. Press **Cancel** to exit or **OK** to continue with the reset operation.

```
Reset Calibration Parameters
WARNING: The current paper
advance calibration will be
deleted
Press OK to continue or X to
exit.
```

2. If you press **OK**, the printer resets the calibration values, after which the following message is displayed. Press **OK** to return to the main screen.

```
Reset Calibration Parameters
The paper advance calibration
values have been deleted
Press OK to continue
```

Show current calibration values

This option displays the current calibration values. There are ten calibration parameters in total: SLOPE, AMP1, PH1, FREQ1, AMP2, PH2, FREQ2, AMP3, PH3, and FREQ3. Press **OK** to return to the main screen.

```
Show Calibration Parameters
SLOPE: 0.001672
AMP1: 13.000000
PH1: 3.359320
FREQ1: 1.000000
AMP2: 0.000000
PH2: 0.000000
FREQ2: 2.000000
AMP3: 0.000000
```

Drop Detector calibration

The purpose of this Service Calibration is to calibrate the Drop Detector (located in the Service Station) in relation to the Carriage Assembly. Perform Drop Detector calibration whenever the Drop Detector is disassembled or replaced.

There are two menu options to calibrate the Drop Detector:

- Reset Calibration Flag
- Calibrate Drop Detector

Reset Calibration Flag

Always reset the calibration flag before replacing the Drop Detector, so that the printer will not try to perform drop detection until the new Drop Detector has been calibrated.

1. In the Service Calibrations submenu, select **Drop Detector calibration** and press **OK**.

```
Service calibrations
▣ Paper advance calibration
▣ Drop Detector calibration
▶ Line Sensor calibration
▶ Calibrate Rewinder
▶ Primer calibration
▶ Reset Vacuum Calibration
▶ Platen blue line calib
```

2. In the Drop Detector Calibration menu, select **Reset Calibration Flag** and press **OK**.

```
Drop Detector calibration
▶ Calibrate Drop Detector
▶ Reset Calibration Flag
```

3. When the following message appears on the front panel, press **OK** to continue with the calibration; press **Cancel** to exit.

```
Reset Calibration Flag
Current value: 1

Clear drop detector
calibration flag?
Press OK to continue or X to
exit
```

4. The printer resets the calibration flag. Press **OK** to return to the menu.

```
Reset Calibration Flag
-----
Diagnostic result: OK
```

Press **OK** to continue

5. Turn off the printer and replace the Drop Detector.
6. Turn on the printer and calibrate the Drop Detector.

Drop Detector calibration

1. In the Service Calibrations submenu, select **Drop Detector calibration** and press **OK**.

```
Service calibrations
├─ Paper advance calibration
├─ Drop Detector calibration
├─ Line Sensor calibration
├─ Calibrate Rewinder
├─ Primer calibration
├─ Reset Vacuum Calibration
└─ Platen blue line calib
```

2. In the Drop Detector Calibration submenu, select **Calibrate Drop Detector** and press **OK**.

```
Drop Detector calibration
├─ Calibrate Drop Detector
└─ Reset Calibration Flag
```

3. When the following message appears on the front panel, press **OK** to continue with the calibration, or press **Cancel** to exit.

```
Calibrate Drop Detector
-----
Do you want to perform the
drop detection calibration?
```

Press **OK** for yes or **X** for no

4. The printer will start to calibrate the Drop Detector, which takes about 1 minute.

```
Calibrate Drop Detector
-----
Calibrating...
```

Step 1 of 18

5. Once the Drop Detector has been calibrated, the results are displayed on the front panel.

```
Calibrate Drop Detector
```

```
Offset: 18  
(valid range -70..70)  
Window width: 12  
(minimum 5)
```

```
Press OK to accept or ✘ to  
reject values
```

The offset is the displacement from the nominal Carriage position for drop detection. The window width refers to values captured by the drop detector sensor. The offset should be within the valid range, and the window width should be at least the minimum shown. If the values are correct, press **OK** to accept them. If not, the Drop Detector is not correctly installed, either because the Service Station has not been correctly installed in the Scan Axis or because the Drop Detector is not correctly installed or not working properly. Press **Cancel** to reject the values.

 **CAUTION:** Do not accept these values if they are not within the right range, as the printer will not work properly.

6. Press **OK** to end the calibration.

```
Calibrate Drop Detector
```

```
Diagnostic result: OK
```

```
Press OK to continue
```

Line Sensor calibration

The purpose of this Service Calibration is to calibrate the intensity of the Line Sensor in the Carriage PCA. An incorrect calibration can result in edge-detection failures during paper loading and incorrect reading of prints that are used for alignment or calibration.

Perform Line Sensor Calibration whenever:

- The edge-detect procedure fails during paper loading.
- The Carriage is disassembled or replaced.
- The Line Sensor is disassembled or replaced.
- Banding is detected in prints.
- Misalignment between colors is detected.

Perform the Line Sensor Calibration as follows:

1. Load the printer with glossy paper at least 36 inches wide, if feasible. If you have difficulty in loading the paper (which can happen if the Line Sensor is miscalibrated), continue with no paper loaded.

2. In the Service Calibrations submenu, select **Line Sensor calibration** and press **OK**.

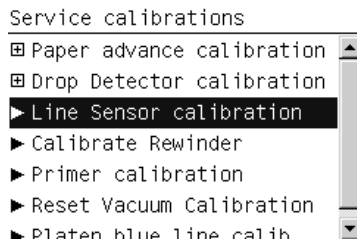

3. When the following message appears on the front panel, press **OK** to continue the calibration, or press **Cancel** to exit.

```
Line Sensor calibration
-----
Open back door

Please feed paper
to cover right side
of print platen

Close back door
Press OK to continue
```

4. If no paper is loaded, the following message is displayed.

```
Line Sensor calibration
-----
Paper needed for this
calibration. Press OK to
load paper manually.
Press Cancel to exit and
load paper normally.
Press OK to continue or X to
exit
```

If the wrong type of paper is loaded, the following message is displayed.

```
Line Sensor calibration
-----
Invalid paper type (HP, 1101)
Please use any glossy paper
Please change paper
Press OK to exit
```

If you choose to load the paper manually, follow the instructions on the front panel.

```
Line Sensor calibration
-----
Please raise the lever

Please feed paper
to cover right side
of print platen

Please lower the lever
Press OK to continue
```

5. The printer starts to calibrate the Line Sensor. When the Line Sensor has been calibrated, the results are displayed on the front panel. Press **OK** to continue or **Cancel** to exit.

Line Sensor calibration

	(WHITE-BLACK)	RANGE
B:	833	700-900
R:	841	700-900
O:	851	700-900
G:	835	700-900

Press **OK** to confirm or
X to exit

If the values are not within the range specified, an error will appear on the front panel. In this case, try the following.

- Repeat the calibration.
 - Replace the Line Sensor ⇒ See [Line Sensor Assembly on page 302](#).
6. If you loaded the paper manually, you must now unload it and then reload it in the normal way, before the calibration can continue. In this case, the following message is displayed.

Line Sensor calibration

Please raise the lever

Please unload the paper

Please lower the lever
Press **OK** to continue

When you have unloaded the paper, the front panel prompts you to load it in the normal way.

Line Sensor calibration

Diagnostic result: OK
Please load paper and start
again.

Press **OK** to continue

Load the paper, then press **OK**.

7. The printer starts to calibrate the Line Sensor position to the black printhead. It prints a line of black dots and then scans them:



8. When the Line Sensor has been calibrated, the results are displayed on the front panel. Press **OK** to finish the calibration or **Cancel** to exit.

Line Sensor calibration

Y offset range: 30 to 59
Y offset got: 45
X offset range: -20 to 20
X offset got: 4

Press **OK** to confirm or
X to exit

- The printer now aligns the printheads. When the following message appears, press **OK** to continue or **Cancel** to exit.

```
Line Sensor calibration
-----
Printhead Alignment
Calibration
Press OK to continue or X to
exit
```

- When the printhead alignment is completed, the following message is displayed. Press **OK** to continue.

```
Printhead alignment
-----
Printhead alignment
successfully completed.

Press OK to continue
```

If the printhead alignment fails for any reason, a warning message will appear on the front panel. In this case, try the following.

- Enter the front panel menu and retry the printhead alignment.
 - If the printhead alignment fails again, check the alignment pattern to see whether any of the printheads are printing incorrectly. If necessary, perform a printhead recovery through the front panel and retry the printhead alignment.
- When the whole Line Sensor calibration is completed successfully, the following message is displayed.

```
Line Sensor calibration
-----
Diagnostic result: OK

Press OK to continue
```

Calibrate Rewinder

The purpose of this Service Calibration is to calibrate the printer's Rewinder Motor parameters.

To perform this test, first load an empty paper core on the printer, then the printer will start a set of movements to characterize and calibrate the motor

- Select **Calibrate Rewinder** from the Calibrations menu.

```
Service calibrations
┌─ Paper advance calibration
├─ Drop Detector calibration
├─ Line Sensor calibration
├─ Calibrate Rewinder
├─ Primer calibration
├─ Reset Vacuum Calibration
└─ Platen blue line calib
```

- The front panel prompts you start the calibration.

```
Calibrate Rewinder
-----
Press OK to continue
Press X to exit
```

3. The front panel displays a message while performing rewinder calibration.

```
Calibrate Rewinder
-----
Please wait...
```

4. If the calibration completes successfully, the front panel shows the result and prompts you to press **OK** to save values; or **Cancel** if you prefer not to save values.

```
Calibrate Rewinder
-----
Store Values: -251 -304
Press OK to continue
Press X to exit
```

5. If the calibration fails, the front panel displays the reason.

Primer calibration

The purpose of this Service Calibration is to compute the optimum position of the Primer Assembly with respect to the Carriage.

The calibration is a visual procedure, so you will have to remove the Right Cover before starting.

Perform the Primer Assembly as follows:

1. Remove the Right Cover ⇒ See [Cover, Right on page 225](#).
2. Block the Maintenance Cartridge door switch in the closed position.
3. In the Service Calibrations submenu, scroll to **Primer Calibration** and press **OK**.

```
Service calibrations
┌─ Paper advance calibration
┌─ Drop Detector calibration
└─ Line Sensor calibration
└─ Calibrate Rewinder
└─ Primer calibration
└─ Reset Vacuum Calibration
└─ Platen blue line calib
```

4. When the following message appears on the front panel, you must press **OK** to continue, or **Cancel** to exit the calibration.

```
Primer Calibration
-----
Remove the service station
cover carefully.
Hold the service station door
sensor pressed
Beware of moving parts.
Press OK to continue or X to
exit
```

5. The calibration process starts, and the front panel shows the following message:

```
Primer Calibration
-----
Initializing
```

- When the printer is ready, the front panel prompts you to use the **Up/Down** keys to move the carriage until the right-hand edge of the left alignment mark on the Carriage Cover is correctly aligned with the Primer Positioning Indicator. When the carriage is correctly aligned, press **OK**.

Primer Calibration

Use the up/down buttons to move the carriage until the primer's long piece of plastic falls from the plastic piece of the carriage latch. Press **OK** when done.

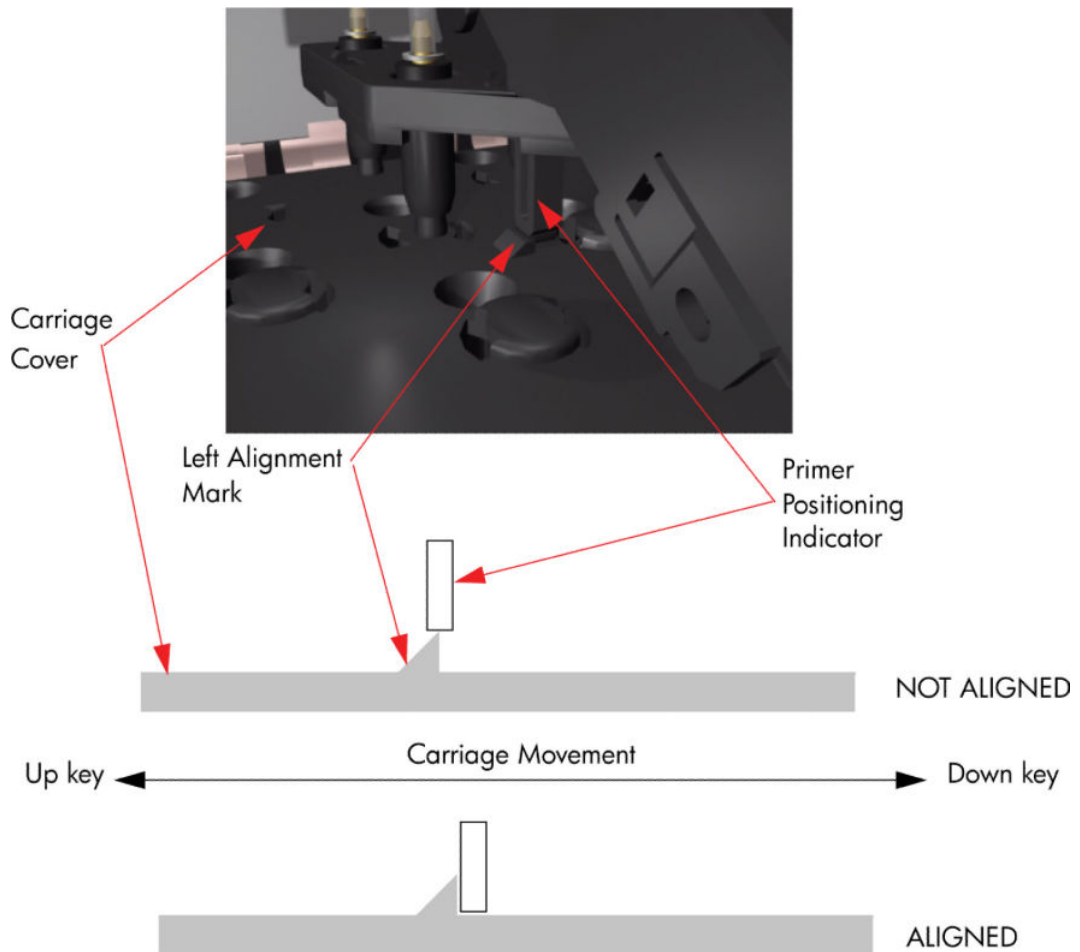

TIP: To see the exact position while aligning the Carriage to the Primer, it is a good idea to press down lightly on the Primer while you are moving the Carriage.

While the Carriage is moving, the front panel shows the actual position and the direction of movement and prompts you to press **OK** when done.

Primer Calibration

Moving left...
Current position 25888
Press **OK** when done.

7. The front panel shows the actual left offset value and then the left alignment position.

Primer Calibration

The left offset between
nominal and real value was
374

Primer Calibration

The left alignment between
Carriage and Primer was found
at the position 25984

- When the printer is ready, the front panel prompts you to use the **Up/Down** keys to move the carriage until the right-hand edge of the left alignment mark on the Carriage Cover is correctly aligned with the Primer Positioning Indicator. When the carriage is correctly aligned, press **OK**.

Primer Calibration

Use the up/down buttons to move the carriage until the primer's long piece of plastic falls from the plastic piece of the carriage latch. Press **OK** when done.

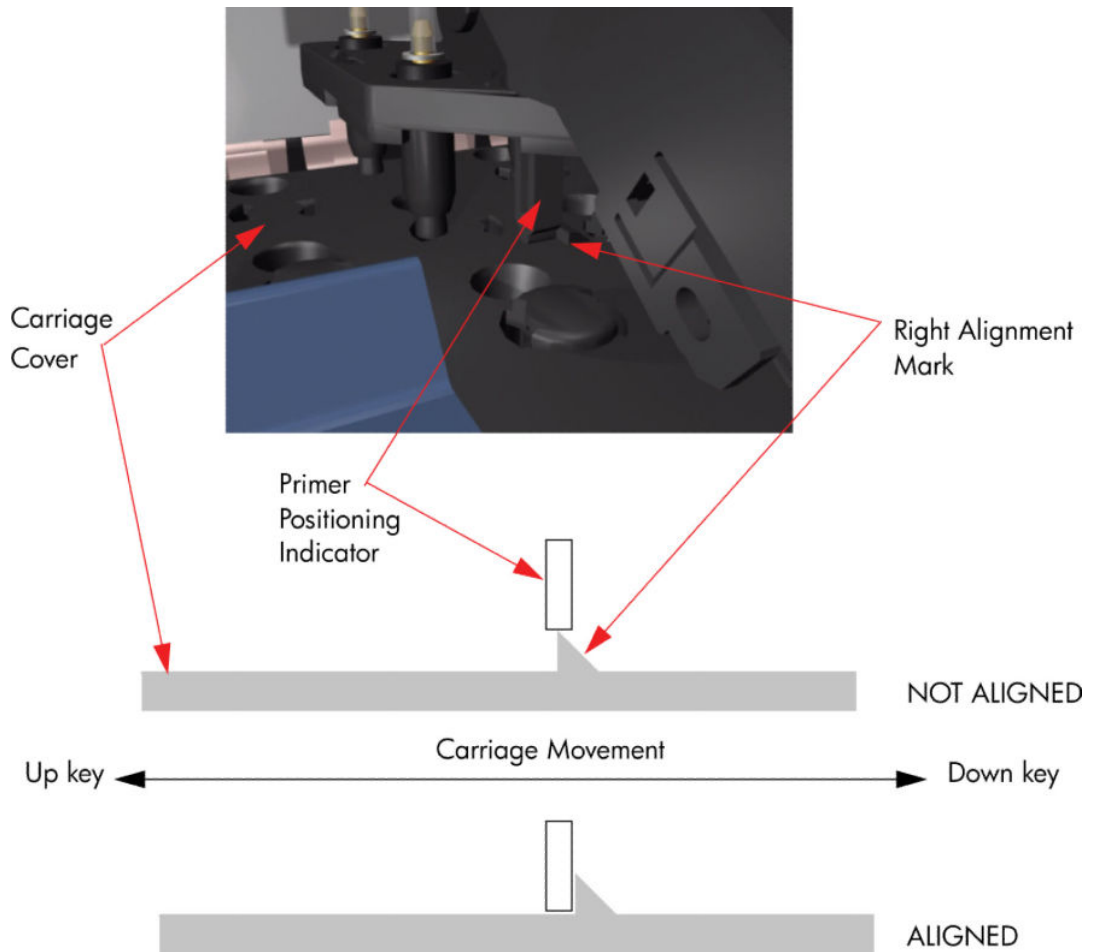

TIP: To see the exact position while aligning the Carriage to the Primer, it is a good idea to press down lightly on the Primer while you are moving the Carriage.

While the Carriage is moving, the front panel shows the actual position and the direction of movement and prompts you to press **OK** when done.

Primer Calibration

Moving right...
Current position 95808
Press **OK** when done

9. The front panel shows the actual right offset value and then the right alignment position.

```
Primer Calibration
-----
The right offset between
nominal and real value was
527
```

```
Primer Calibration
-----
The right alignment between
Carriage and Primer was found
at the position 95680
```

10. The calibration process continues, and the front panel shows the new nominal offset value. Press **OK** to continue.

```
Primer Calibration
-----
Nominal offset is 4800...
New nominal offset is 5298...
Press OK to continue
```

11. When the calibration is complete, the result is displayed on the front panel. Press **OK** to leave the calibration process.

```
Primer Calibration
-----
Diagnostic result: OK
```

Press **OK** to continue

12. Replace the Right Cover ⇒ See [Cover, Right on page 225](#).

Reset vacuum calibration

The purpose of this Service Calibration is to reset the nominal values of the Vacuum Calibration.

 **NOTE:** Reset the vacuum calibration only if the vacuum fans are working (the printer can turn them on without system errors), but the vacuum pressure is incorrect and there are carriage crashes. The existing calibration will be lost.

Reset the vacuum calibration as follows:

1. In the Service Calibrations submenu, select **Vacuum Calibration** and press **OK**.

```
Service calibrations
├─ Paper advance calibration
├─ Drop Detector calibration
├─ Line Sensor calibration
├─ Calibrate Rewinder
├─ Primer calibration
├─ Reset Vacuum Calibration
└─ Platen blue line calib
```

- When the following message appears on the front panel, press **OK** to continue, or press **Cancel** to exit.

```
Reset Vacuum Calibration
-----
The original calibration
will be lost. Reset this
calibration only if the
printer is having
vacuum problems.
Press OK to continue or X to
exit
```

- The front panel asks for confirmation. If you are sure that you want to reset the calibration, press **OK** to continue, or press **Cancel** to exit.

```
Reset Vacuum Calibration
-----
The original calibration will
be lost. Are you sure that
you want to reset the
calibration?
Press OK to continue or X to
exit
```

- The printer resets the nominal values of the Vacuum Calibration. If all goes well, an acknowledgement is displayed.

```
Reset Vacuum Calibration
-----
Vacuum calibration
reset successfully.
```

- Press **OK** to return to the menu.

Platen blue line calibration

The purpose of this Service Calibration is to calibrate the blue line that is marked on the Print Platen.

You should calibrate the blue line whenever the Center Platen is disassembled or replaced.

- If paper is loaded in the printer, unload it.
- In the Service Calibrations submenu, scroll to “**Platen blue line calib.**” and press **OK**.

```
Service calibrations
▣ Paper advance calibration
▣ Drop Detector calibration
▶ Line Sensor calibration
▶ Calibrate Rewinder
▶ Primer calibration
▶ Reset Vacuum Calibration
▶ Platen blue line calib.
```

- When the following message appears on the front panel, you can press **OK** to continue with the calibration, or **Cancel** to exit.

```
Platen blue line calib.
-----
Press OK to continue or X to
exit
```

4. Follow the instructions on the front panel, using a sheet of white paper. Then press **OK** to continue with the calibration, or **Cancel** to exit.

```
Platen blue line calib.  
-----  
1) Open window and bk door.  
2) Align sheet with platen  
blue line.  
3) Close bk door and window.  
Press OK to continue or X to  
exit
```

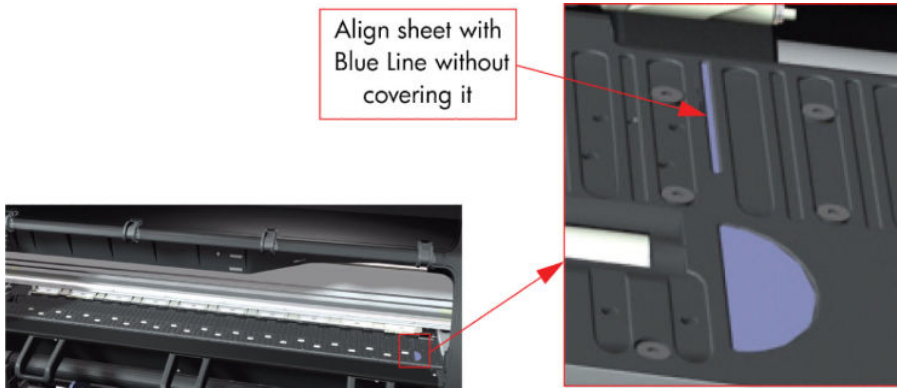

5. The printer starts to calibrate the blue line.

```
Platen blue line calib.  
-----  
Calibrating blue line...
```

6. The results of the calibration are displayed on the front panel. Press **OK** to continue.

```
Platen blue line calib.  
-----  
Calibrating blue line...  
Tolerances: 8707 +/- 47 .  
Measured value: 8675  
Blue line correctly  
calibrated  
Press OK to continue
```

7. Follow the instructions on the front panel. Then press **OK** to continue.

```
Platen blue line calib.  
-----  
1) Open window and lift  
pinch lever.  
2) Remove paper.  
3) Lower pinch lever and  
close window.  
Press OK to continue
```

8. The front panel announces the success of the calibration. Press **OK** to return to the menu.

```
Platen blue line calib.  
-----  
Diagnostic result: OK
```

Press **OK** to continue

OMAS Calibration

The purpose of this Service Calibration is to calibrate the OMAS Module. The calibration process consists of printing a special calibration plot and then scanning it with the printer. The resulting scanned values are compared with the actual printed values to obtain a PASS/FAIL result.

 **NOTE:** In order to perform this calibration, you should order the Paper Advance Calibration Kit (part number CQ109-67042), which contains a 150-ft roll of HP Coated Paper, 36 inches wide (part number C6020B).

Print OMAS Calibration Pattern

1. Load the roll of HP Coated Paper from the Paper Advance Calibration Kit into the printer.
2. In the Service Calibrations menu, scroll to **OMAS Calibration** and press **OK**.

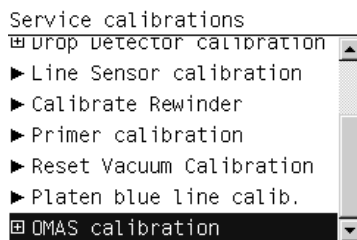

3. In the OMAS Calibration submenu, scroll to **Print Calibration Pattern** and press **OK**.

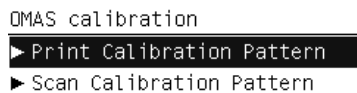

4. When the following message appears on the front panel, press **OK** to continue with the calibration, or press **Cancel** to exit.

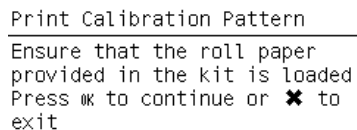

5. The printer starts to print the OMAS Calibration Pattern. This could take several minutes, during which the following message is displayed on the front panel.

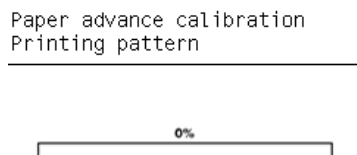

- Once the OMAS Calibration Pattern has been printed successfully, the following message is displayed on the front panel. Press **OK** to continue.

```
Paper advance calibration
-----
Calibration successfully
completed.
```

Press **⏏** to continue

If the OMAS Calibration Pattern fails to print for any reason, an error message is displayed with instructions to follow. Try the process again, making sure to select HP Coated when loading the 36-inch roll that is provided. If the Calibration Pattern still fails to print, unload all rolls, restart the printer and try again.

 **NOTE:** Remove the Calibration Pattern from the printer and leave it to dry for a few minutes before continuing with the calibration.

Scan OMAS Calibration Pattern

- Re-enter the OMAS Calibration submenu, scroll to **Scan Calibration Pattern** and press **OK**.

```
OMAS calibration
-----
▶ Print Calibration Pattern
▶ Scan Calibration Pattern
```

- When the following message appears on the front panel, press **OK** to continue with the calibration, or press **Cancel** to exit.

```
Scan Calibration Pattern
-----
Press ⏏ to continue or ✖ to
exit
```

-  You must remove all rolls of paper from the printer. Follow the instructions on the front panel to remove the rolls.
- The front panel advises you to prepare the OMAS Calibration Pattern for loading into the printer. Rotate the printed pattern 90° clockwise, with the printed side down. Press the **OK** key when you are ready to load.

```
Scan Calibration Pattern
-----
Press OK to proceed with the
load of the printed pattern
cut sheet for scanning.
Rotate the sheet 90 degrees
(arrows on top)
Press ⏏ to continue or ✖ to
exit
```

- The front panel prompts you to load the OMAS Calibration Pattern into the printer.

```
Scan Calibration Pattern
-----
Load sheet
Refer to Service Manual
Press ⏏ to continue or ✖ to
exit
```

6. Open the printer's rear door.



7. Insert the bottom of the OMAS Calibration Pattern sheet into the printer as shown.



8. Insert the top of the sheet between the roller and the metal guide, until it reaches the platen.



9.  Align the sheet with the blue line and the cutter guide, to avoid skew.



10. Close the window.
11. Check that the paper is unwrinkled.
12. Close the rear door.
13. Press **OK** at the front panel to continue the process.
14. The printer checks the paper edges.

```
Scan Calibration Pattern
-----
Checking paper.
```

15. Press **OK** at the front panel to proceed with the scan.

```
Scan Calibration Pattern
-----
Preparing to scan
Press OK to continue or X to
exit
```

16. The printer scans the OMAS Calibration Pattern, which could take several minutes.

```
Scan Calibration Pattern
-----
Scanning pattern
```

17. When the calibration has finished, the front panel displays the results. In the example below, each value passes the test. Press **OK** to continue.

```
Scan Calibration Pattern
-----
Test passed
Test Results:
Correlation: 0.8 > 0.7
StdDev Error: 6.4 < 8.0
Mean angle: 111.1 < 2400.0
Press OK to continue
```

18. The front panel confirms the success or failure of the calibration. Press **OK** to continue.

```
Scan Calibration Pattern
-----
Diagnostic result: OK
```

Press **OK** to continue

If the calibration fails for any reason, try the following suggestions in order. If one suggestion solves the problem, there is no need to continue to the next.

1. Repeat the OMAS Calibration process from the beginning.
2. Replace the OMAS Sensor and repeat the calibration ⇒ See [Optical Media Advance Sensor \(OMAS\) on page 359](#).
3. Replace the OMAS Controller Card and repeat the calibration ⇒ See [OMAS Controller Card on page 368](#).
4. Replace the Media-Axis Motor and repeat the calibration ⇒ See [Media-Axis Motor on page 330](#).

7 Print quality

- [Initial print-quality troubleshooting actions](#)
- [Troubleshooting tools](#)
- [How to use the Image Quality Service Diagnostic Print](#)
- [Print-quality issues by symptom](#)
- [Working with other commercially available papers](#)

Initial print-quality troubleshooting actions

For the majority of print-quality problems, a Call Agent can try to troubleshoot the printer by requesting that the customer performs the following troubleshooting actions. Using this process, most problems can be resolved without the need of an on-site visit.

Perform the following actions in the order described:

1. Printer Configuration:

- Make sure that the **paper type** selected in the Front Panel is the same as the paper type loaded into the printer. To check this, use the [View paper information](#) key on the front panel. At the same time, check that the paper type has been calibrated. Also make sure that the paper type selected in your software is the same as the paper type loaded into the printer.
- Check that the customer is printing on the correct side of the paper.
- Check that the customer is using the most appropriate print-quality settings. If **Fast** or **Normal** has been selected, the customer may not achieve the most accurate colors. Set the print-quality setting to **Best**. See also “Select print quality” in *Using your printer*.



NOTE: If the customer has set the print quality with the printer driver or with the Embedded Web Server, this will override a print-quality setting from the front panel.



NOTE: You cannot change the print quality of pages that the printer is already receiving or has already received (even if they have not started to print yet).

- Dry time should be set to “Optimal”.

2. Check if the latest version of the firmware is installed. If not, install the latest firmware revision.

3. Check that your ink cartridges and printheads have not passed their expiration dates.

4. Perform Printhead recovery: icon, then **Clean printheads**.

5. Perform Printhead alignment: icon, then **Align printheads**.

6. If a new paper type has been created from the Color Center, check that the correct parent paper type has been used. This is because there are some ‘high ink’ and ‘low ink’ paper types for some categories of paper used, such as the photo category.

7. Perform color calibration: icon, then **Calibrate color**.

8. Perform paper advance calibration: icon, then **Calibrate paper advance**.

9. If you are using Application Color Management check the following.

- Ensure that within the color tab of the driver, **Application manage colors** has been selected.
- That the color profile you are using in the application corresponds to the paper type and print quality settings.
- In addition for PostScript printers check the following.

- If you have doubts about the installed 'output' ICC profiles on the computer, perform the following from the Color Center: **Manage papers** > **Update profiles**.
 - If you need to create a color profile, go through the Color Center: **Create and Install ICC profile**.
 - If you have any doubt about the created ICC profile, recreate it, or re-install the default one (from the Color Center: **Create and Install ICC profile** or **Manage paper** > **Restore factory ICC profile**).
10. If the issue is the color difference between the printer and the monitor, ensure that the monitor has been calibrated, refer the customer to the HP LFP Knowledge Center for details on how to perform this: http://www.hp.com/go/knowledge_center/djT7100/.
 11. Check that your environmental conditions (temperature, humidity) are in the recommended range. Avoid touching the paper while printing is in progress.
 12. If PANTONE colors are inaccurate, refer to the Color Management chapter within *Using your printer*. The section is called 'HP Professional PANTONE Emulation'.
 13. Color accuracy using EPS or PDF images in page layout applications such as Adobe InDesign and QuarkXPress do not support color management of EPS, PDF or Grayscale files.

If these types of files have to be used, try to ensure that the EPS, PDF or grayscale images are already in the same color space that is to be used later on in Adobe InDesign or QuarkXPress. For example, if the final objective is to print the job in a press that follows the SWOP standard, at the time of creating the EPS, PDF or grayscale the image should be converted into SWOP.
 14. Check the procedures described in [Colors are inaccurate on page 173](#).



NOTE: The HP LFP Knowledge Center is an excellent source of color accuracy information, the database includes step-by-step procedures on achieving the best color image quality when using various applications. Go to http://www.hp.com/go/knowledge_center/djT7100/.

Troubleshooting tools

To access the troubleshooting tools in the Embedded Web Server, select the **Support** tab. The first two tools can also be accessed from the front panel's Image quality maintenance menu.

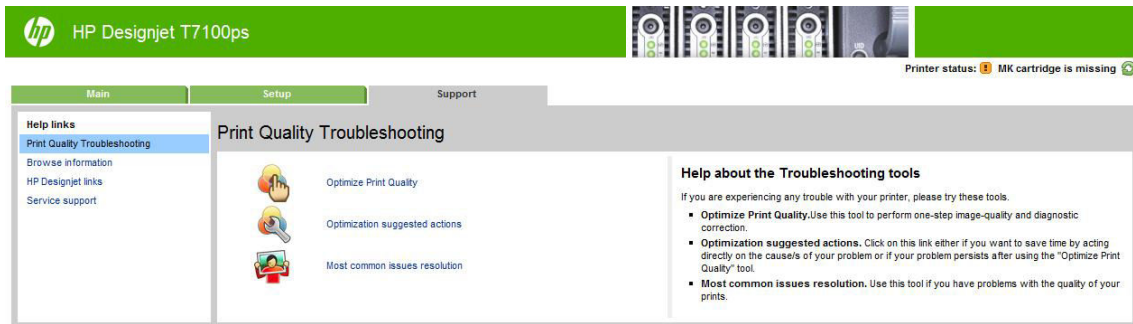

Optimize print quality

This option ensures that printer and supplies are adjusted to deliver optimum print quality. Click **Next** to execute all calibration and recovery procedures automatically. The following procedures are included:

- Printhead cleaning
- Media advance calibration
- Printhead alignment
- Color calibration

The whole process consumes 80 cm (31.5 in) of paper and may take up to 20 minutes.



NOTE: This option can also be selected from the front panel. From the main menu, select , then **Optimize print quality**.

Optimization suggested actions

This option suggests a series of recommended actions to improve print quality, based on the results of internal checks. These actions may include reseating a printhead, changing paper to run a specific calibration, cleaning some printer component and so on. Execute them in the proposed order.



TIP: Use this option if you want to save time by acting directly on the causes of your problem, or if your problem persists after the automatic **Optimize print quality** process.



NOTE: This option can also be selected from the front panel. From the main menu, select , then **Optimization suggested actions**.

Most-common issues resolution

This option is designed to help you resolve some of the most common print-quality issues that users encounter in large-format printing:

- Dark or light horizontal lines across the image (banding)
- Graininess

- Poor line quality
- Inaccurate colors

In the first window, select the print-quality issue that you are experiencing and click **Next**.

A list of suggestions for corrective action appears along with help to guide you through each action.

Status codes

After running any of the print-quality troubleshooting tools, the Embedded Web Server updates and displays status codes that may be helpful if any further troubleshooting is required. To see the status codes, select the **Support** tab, then **Service Support** > **Printer Information** > **Calibration Status**. Look for the Printer Status Codes section at the end of the page.

 **NOTE:** If no problem has been reported, the status codes are irrelevant and should be ignored.

 **TIP:** When troubleshooting a print-quality problem, you are recommended to execute **Optimize print quality** to ensure that the status codes are up to date.

Nozzle health

The T7100 status code consists of 16 digits, one for each group of nozzles, in the following order: empty, yellow 1, empty, yellow 2, magenta 1, cyan 1, magenta 2, cyan 2, matte black 1, matte black 1, matte black 2, matte black 2, light gray 1, dark gray 1, light gray 2, dark gray 2.

The T7100 Monochrome status code consists of 8 digits, one for each group of nozzles, in the following order: matte black 1, matte black 1, matte black 2, matte black 2, empty, dark gray 1, empty, dark gray 2.

Each digit can take one of the following values:

- 0 : no data, or error
- 1 : nozzle health OK, printhead in warranty
- 2 : nozzle health at risk (level 1), printhead in warranty
- 3 : nozzle health at risk (level 2), printhead in warranty
- 4 : nozzle health OK, printhead out of warranty
- 5 : nozzle health at risk (level 1), printhead out of warranty
- 6 : nozzle health at risk (level 2), printhead out of warranty

If nozzle health is at risk, you are recommended to check the maintenance cartridge, and replace the printhead if necessary.

If all digits are 0 or more than 50% of printheads are at risk, check the Drop Detector (cleaning it to verify there are no fibers blocking it), perform a Drop Detector calibration, and replace it if the problem persists.

Media advance calibration

The status code consists of 8 digits, each of which can take one of the following values:

- 0 : no data, or error
- 1 : parameter OK

- 2 : parameter at risk (level 1)
- 3 : parameter at risk (level 2)
- 8 : non-navigable paper type
- 9 : OMAS disconnected

If all digits are 0, media advance calibration has not been performed on that paper type. In this case, perform media advance calibration.

If the 4th or 7th digits are not 1, there is some mismatch between OMAS and the printer calibration. Clean the Media Advance Sensor, and replace it if the problem does not disappear.

If you see a 9 anywhere, the OMAS sensor has been disconnected. Clean the Media Advance Sensor, and replace it if the problem does not disappear.

If you see a 2 or 3 anywhere, the calibration has not worked well. Check that the paper is correctly loaded and that the calibration is correctly printed (otherwise clean the printheads), and try the calibration again.

Printhead alignment

The T7100 status code consists of 16 digits, one for each group of nozzles, in the following order: empty, yellow 1, empty, yellow 2, magenta 1, cyan 1, magenta 2, cyan 2, matte black 1, matte black 1, matte black 2, matte black 2, light grey 1, dark grey 1, light grey 2, dark grey 2.

The T7100 Monochrome status code consists of 8 digits, one for each group of nozzles, in the following order: matte black 1, matte black 1, matte black 2, matte black 2, empty, dark grey 1, empty, dark grey 2.

Each digit can take one of the following values:

- 0 : no data, or error
- 1 : scans and corrections OK
- 2 : corrections at risk (level 1)
- 3 : scans at risk (level 1)
- 4 : scans and corrections at risk (level 2)
- 5 : corrections at risk (level 2)
- 6 : scans at risk (level 2)
- 7 : scans and corrections at risk (level 2)

If all digits are 0, printhead alignment is pending. In this case, perform printhead alignment.

If you see 3, 4, 6 or 7 anywhere, the results of the pattern scan are worse than expected. Try loading photo paper to ensure that the problem is not the paper. If the problem persists, calibrate the Line Sensor; if the problem still persists, replace the Line Sensor.

If you see 2 or 5 anywhere, the pattern scan is OK, but the corrections are out of the expected range. Try reseating the affected printhead(s) and then perform the alignment again. If the problem persists, replace the affected printhead(s).

Closed-loop color calibration

The T7100 status code consists of 16 digits, one for each group of nozzles, in the following order: empty, yellow 1, empty, yellow 2, magenta 1, cyan 1, magenta 2, cyan 2, matte black 1, matte black 1, matte black 2, matte black 2, light grey 1, dark grey 1, light grey 2, dark grey 2.

The T7100 Monochrome status code should be ignored: closed-loop color calibration is not available for this printer.

Each digit can take one of the following values:

- 0 : no data, or error
- 1 : corrections OK
- 2 : corrections at risk (level 1)
- 3 : corrections at risk (level 2)

If all digits are 0, color calibration is pending for this paper type. In this case, perform color calibration.

If you see 3 anywhere, the corrections are out of the expected range. Try repeating the color calibration. If the problem persists, replace the affected printhead(s).

How to use the Image Quality Service Diagnostic Print

- [What is the Image Quality Service Diagnostic Print?](#)
- [Considerations for printing the Diagnostic Print](#)
- [Printing the Image Quality Service Print](#)
- [Diagnostic Part 1: Printhead Problems](#)
- [Diagnostic Part 2: Alignment test](#)
- [Diagnostic Part 3: Printheads and paper advance test](#)
- [No printing defects found in the diagnostic print](#)
- [Force drop detection](#)
- [Disable Paper Advance Sensor](#)
- [Fix paper advance issues](#)
- [Clean the paper advance sensor window](#)
- [The user advance calibration](#)
- [Visual paper advance plot](#)
- [Interpreting plot results](#)

What is the Image Quality Service Diagnostic Print?

The printer contains a series of internal image-quality tests that help you to diagnose image-quality defects. These tests are available from the Service Utility menu and are come in several categories:

- Printhead reliability tests: To identify which Printhead is faulty.
- Printhead alignment tests: To check any color-to-color and bi-directional misalignment the printer may have.
- Printheads and paper advance tests: To check whether the Printheads and the paper advance mechanism are working correctly.

The following diagnostic prints are available:

1. **Image Quality Service Best:** This plot helps you to diagnose in more detail the possible source of any image-quality defects.
2. **Image Quality Service Normal:** This plot is the same as the Image Quality Service Best Plot but uses the Normal print mode and does not contain the Printhead Alignment test. This plot can be used to find banding that would be hidden if the Best plot was used.
3. **Image Quality Service Fast:** This plot is the same as the Image Quality Service Best Plot but uses the Fast print mode and does not contain the Printhead Alignment test. This plot can be used to find banding that would be hidden if the Best plot was used.
4. **Advanced diagnostic prints.** These tests provide more information than the Image Quality plots:
 - Visual Alignment Print, to check printhead alignment.
 - Visual Media Advance, to check paper advance.
 - Force Drop Detection, to reset the nozzle health historic data base and force new drop detection.
 - Paper Advance Sensor, which allows the Paper Advance Sensor to be disabled and forces the advance control to use the analog encoder system. The Paper Advance sensor will operate again after the printer has been restarted.
5. **Print Reference Plot Best**
6. **Print Reference Plot Normal**
7. **Print Reference Plot Fast**

Considerations for printing the Diagnostic Print

1. You must have paper loaded.
2. Use the same type of paper on which the image-quality problem occurred.
3. If the customer is using non-HP paper and after the Image Quality Test you still have the same image-quality problem, change to genuine HP paper and repeat the Image Quality Test.
4. If you do not see any problems with the Image Quality Test, then the problem may not be with the printer itself. The problem may be with the RIP or the driver, for example.

However, if you do see problems with the Image Quality Test, then continue with the Advanced Diagnostic procedures, which will help you to diagnose the problem.

Printing the Image Quality Service Print

1. In the Service Utilities submenu, scroll to **Diagnostic Print** and press **OK**.

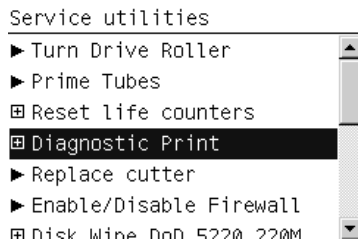

2. The front panel offers a selection of prints. Use the arrow keys to make the selection and press the **OK** key to start printing the required Diagnostic Print.

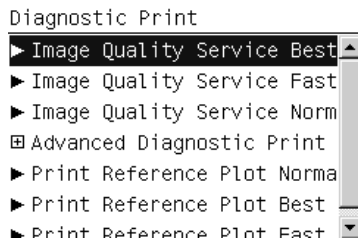

3. Make sure paper is loaded and that the Ink System is correctly installed. Press the **OK** key to print the Diagnostic Print or press **Cancel** to exit without printing the Diagnostic Print.

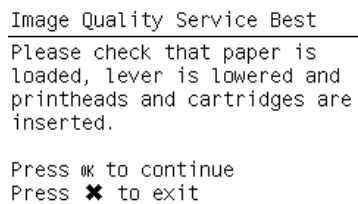

4. The selected Diagnostic Print is printed.

Diagnostic Part 1: Printhead Problems

The Nozzle print test is designed to check if the Printhead nozzles print correctly. The Image Quality Service Best should always be used to print this plot.

The nozzles check (bottom of the plot) is printed in a one-pass full swath mode. The diagnostics test prints out every single nozzle of each Printhead without applying an error hiding or alignment algorithm.

For each Printhead, you can see both the adjacent and the consecutive nozzles. For every Printhead there is a different horizontal band that can be identified with the help of the template marked with the colors of the Printhead used at the right of every band.



There are a series of numbered stepped diagonal lines. If one or more of the nozzles are malfunctioning or mispositioned, you will see that the stepped lines are broken or misdirected in one or more places.

This is an example of nozzles outs. You can see the broken or the skewed line, in this case marked in yellow to help you to understand the issue. In the service plot there are no yellow marks.

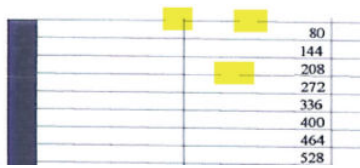

This is an example of nozzles mis-positioned or malfunctioning. You can see the broken or the skewed line, in this case marked in yellow to help you to understand the issue. In the service plot there are no yellow marks.



Corrective Action

If the printer has nozzle defects, it does not mean that you will not get perfect print quality results because the printer can automatically compensate for this so there is no need to replace the Printhead.

The method of improving Nozzle Defects is to:

1. To clean the printheads, go to the printer's front panel and select the ink, then Image quality maintenance > Clean printheads. Then select which printheads you would like cleaned. You can clean all of the printheads or only some of them. Your choices are:
 - Clean all
 - Clean Y
 - Clean M-C
 - Clean MK-MK
 - Clean D-DG

Cleaning all of the printheads takes about five minutes. Cleaning any two printheads takes about three minutes. Purging the ink takes about six minutes.

2. Reprint the Printhead Nozzles Test Plot to check that the defective nozzles have been corrected.
3. If the problem continuous, replace the defective Printhead.

Diagnostic Part 2: Alignment test

This test is designed to check any color-to-color and bi-directional misalignment the printer may have. The Image Quality Service Best should always be used to print this plot.

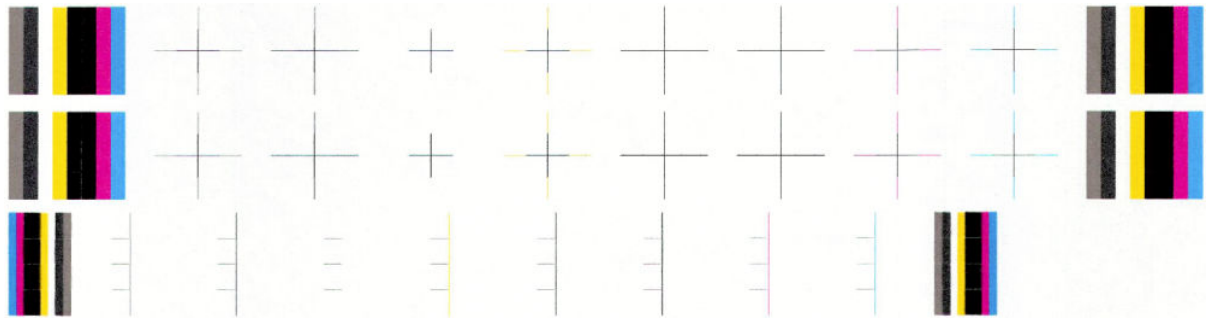

1. If the printer is experiencing horizontal misalignment problems, the Alignment Test will show something like this:

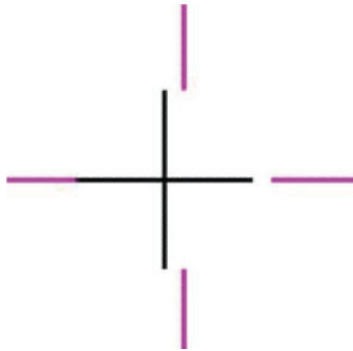

2. If the printer is experiencing vertical misalignment problems, the Alignment Test will show something like this:

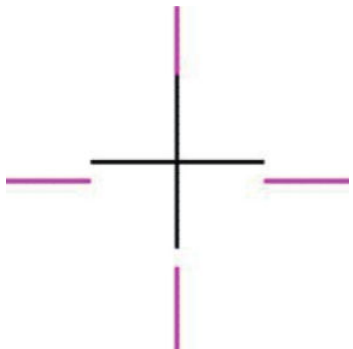

3. If the printer is experiencing **bi-directional** misalignment problems, the Alignment Test will show something like this:



Corrective Action

- ▲ Perform a Printhead Alignment, using the same paper type with which you were experiencing unacceptable image quality, if feasible (some paper types are not suitable for Printhead Alignment).

Diagnostic Part 3: Printheads and paper advance test

This test is designed to check whether the Printheads and the Paper Advance Mechanism are working correctly. This part of the Image Quality Test should not be used to check for color consistency or accuracy.

Banding

If the printer is experiencing a banding problem, you will see repetitive horizontal bands within the printed image.

- Dark line banding repeated along the band (from top to bottom at the same distance).
- White line banding repeated along the band (from top to bottom at the same distance).

The plot is printed in Best or Normal mode (according to the menu option selected) with Error Hiding on. The first top band has 100% ink density patches while the bottom band has 50% ink density.

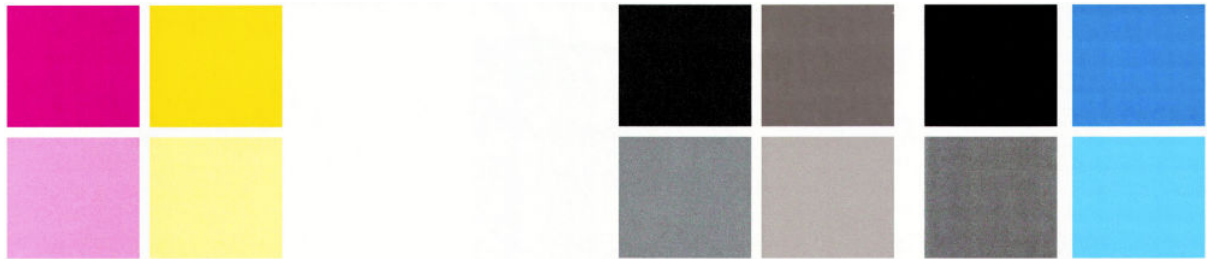

Troubleshooting Banding Problems

If banding **does not** occur in all the colors, then it is more than likely a Printhead problem. In this case, try the following.

1. Check that the appropriate print quality settings are being used.
2. Recover the printheads using the option through the Front Panel (**Image quality maintenance > Clean printheads**). Reprint the Diagnostic Print or the print file and if the problem persists, replace the faulty Printhead.

If banding does occur in all the colors, then it is more than likely a Paper Advance problem:

- If the bands are light, it means that the paper has advanced too much.
- If the bands are dark, it means that the paper hasn't advanced enough.
- In high quality modes, graininess in all colors can indicate problems either with alignment or Paper Advance.

In order to solve any of these problems, try the following.

1. Check that the appropriate print quality settings are being used.
2. Check that the loaded paper is the same type as selected in the printer. Check this through the front panel (at the front panel, select the  icon, then **View loaded paper > View paper details**).

3. If the customer is using low-quality paper, try recommending better quality paper (preferably HP paper). Printer performance can only be guaranteed by using recommended papers.
4. Check the advance with the help of the Visual Paper Advanced Diagnostic.

 **NOTE:** If there is white point banding in only one color band and the problem cannot be fixed using the Printhead recoveries, in some cases using the force a drop detection option can fix this issue (see Others Diagnostics: Force Drop Detection).

No printing defects found in the diagnostic print

If all the test patterns from the Diagnostic Print are correct and you still experience Image Quality problems, you can use the following advanced procedures to resolve the problem.

- Visual Alignment Diagnostics
- Visual Paper Advanced Diagnostic
- Force Drop Detection
- Disable Paper Advance Sensor

Visual Alignment Diagnostic Print

This print helps you to check any alignment problems of the printer.

You can use it to measure the alignment error with an accuracy of one dot row.

The print is split into three areas. The first two are the same print, printed at different speeds: 40 and 60 ips to check most of the printhead alignment. The print modes associated with these speeds are shown in the following table:

PM by Paper Category		ips
Paper Type Category	Quality Setting	
Plain or Technical: Bond, Recycled, Matte Film, Natural Tracing Paper, Translucent Bond and so on	Econofast	60
	Fast	
	Normal	30
	Best	
	Best, Extra passes	
Coated Paper	Econofast	60
	Fast	
	Normal	40
	Best	
	Best, Extra passes	
Heavyweight Coated Paper, Glossy Paper, Backlit, Polypropylene	All	40

The third part is to check the same color staggered printhead overlap.

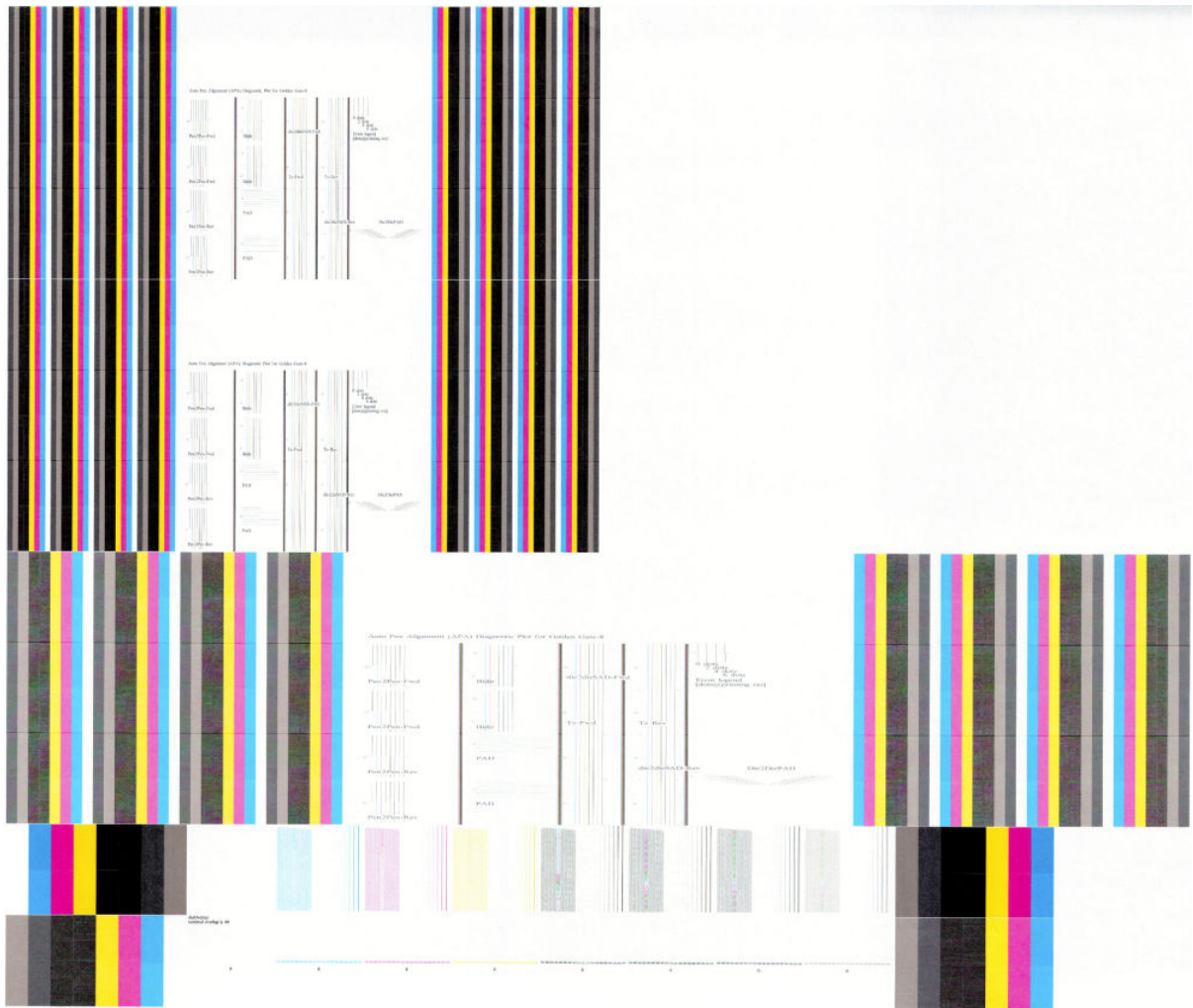

What to see in the Auto Printhead Alignment Diagnostics:

1. At the left we have four checks for the printhead to printhead alignment in scan axis direction (Pen2Pen-Fwd or Pen2Pen-Rev). It is forward and reverse.
 - The top pattern is related to the front printhead (nearest to the user when doing the printhead replacement).
 - The bottom pattern is related to the rear printhead (more far to the user when doing the printhead replacement)

The area to check is the junction (marked with a “-”) of the black with the rest of colors.

2. The bidirectional check is at the top, marked as number 2 (Bidir)
 - The top pattern is related to the front printhead (nearest to the user when doing the printhead replacement).
 - The bottom pattern is related to the rear printhead (more far to the user when doing the printhead replacement)

Check that the lines are continuous without a gap. The junction is marked with a “-”

3. The printhead to printhead alignment in paper advance direction (PAD) is marked as number 3.

- The top pattern is related to the front printhead (nearest to the user when doing the printhead replacement).
- The bottom pattern is related to the rear printhead (more far to the user when doing the printhead replacement)

The area to check is the junction (marked with a "-") of the black with the rest of colors.

4. The alignment in scan axis direction between both printhead of the same color is marked as 4a (in forward direction die2dieSAD-Fwd) and 4b (in reverser direction die2dieSAD-Rev).

The area to check is the junction (marked with a "-"). The lines have to be continuous.

5. The ThetaZ of the printhead are checked in the area marked as 5. It checks in forward (Tz-Fwd) and reverse directions (Tz-Rev).

The area to check is the junction (marked with a "-"). The lines have to be continuous.

6. The area marked as number 6 is a reference legend that shows junction misalignments of 2, 4 and 6 dots. The junction to check has to be below 4 in all cases. If the error is above 4 dots, then realign the printheads.

In the next example, the Bidir is above this 4 dots and the unit should be realigned. The rest of the pattern shows a right alignment.

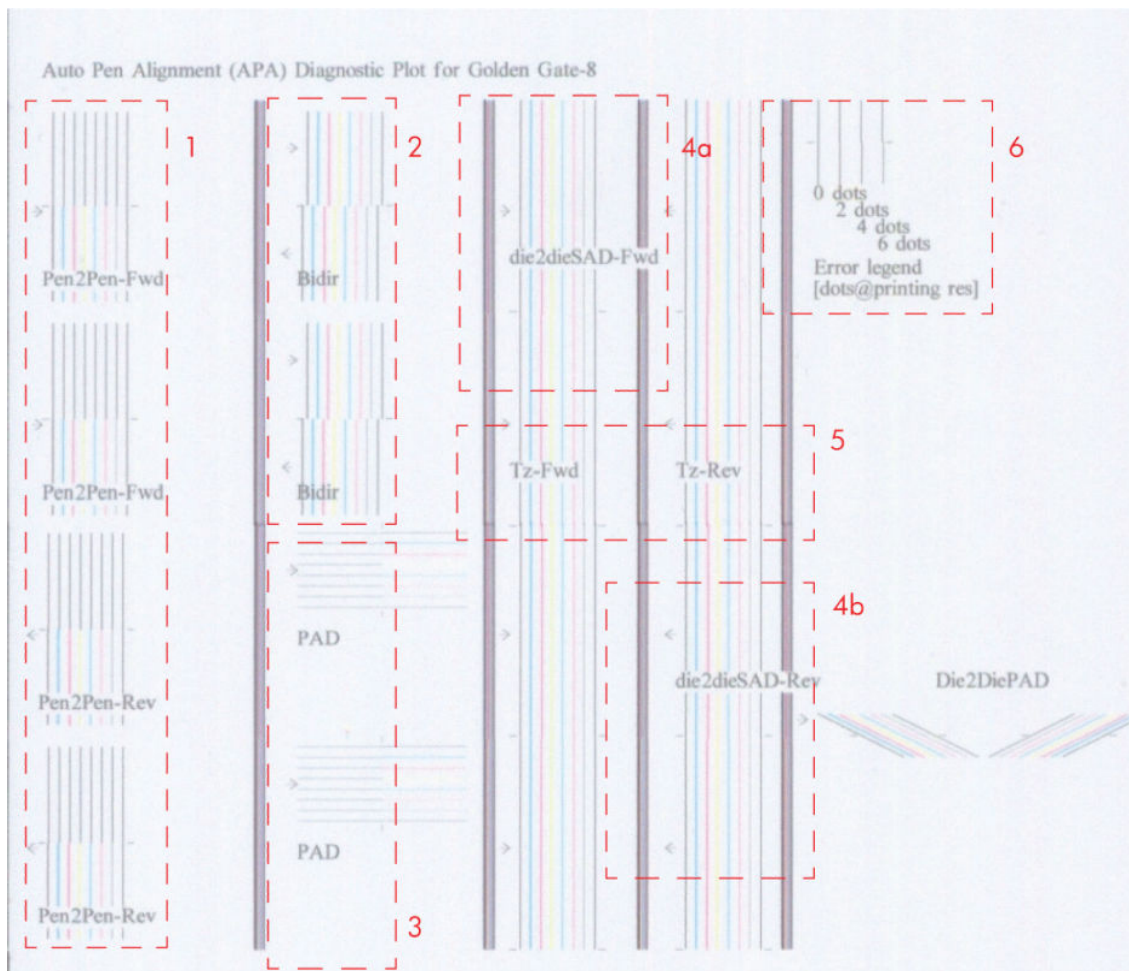

What to see in the Dye Overlap Alignment.

The area to check is only the bottom junction pattern for all the colors. The clearest band has to be around the 0 (± 3 dots). Every band is equal to 1 dot error.



In order to solve any problem in the alignment, try the following.

- Repeat the printhead alignment. You are recommended to use glossy paper, which gives the most accurate printhead alignment. There are some paper types that are not suitable for Printhead Alignment (transparent, translucent, ...)
- If the alignment process shows the message **Printhead alignment may use up to 3m of paper** in the front panel, it is because the OMAS is not working. This is normal for a few paper types that cannot be controlled by OMAS. To check whether your paper is OMAS or non-OMAS, go to the Service Menu, then select **Diagnostic print > Others > Visual Media Diagnostic**.
- If the issue cannot be fixed after repeating the printhead alignment, then try to clean the printheads. To clean the printheads, go to the front panel and select the  icon, then **Clean printheads**.
- If the issue cannot be fixed, then replace the printhead color that is failing in the align check pattern.
- If there is an issue in the ThetaZ and it cannot be fixed, check whether the paper works with OMAS. If so, the issue could be that the OMAS subsystem is malfunctioning. Go to the advance troubleshooting and apply the OMAS process.

Force drop detection

If the Nozzle Print Test plot has persistent white-point banding in only one color that cannot be fixed with a printhead recovery, you can use this option to resolve the problem by resetting the nozzle health database so that all nozzles are assumed to be correct. Once the nozzle health database has been reset, drop detection is forced.

The normal cause of this white-point banding in a single color is the incorrect detection of failed nozzles by the drop detector.

Perform the test as follows.

1. Go to the Service utilities menu and select **Diagnostic Print**.

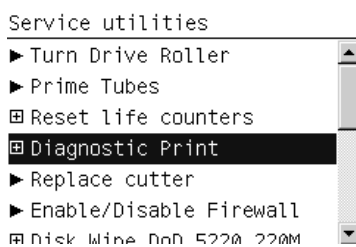

2. Select **Advanced Diagnostic Print**.

```
Diagnostic Print
├── Image Quality Service Best
├── Image Quality Service Fast
├── Image Quality Service Normal
└── Advanced Diagnostic Print
    ├── Print Reference Plot Normal
    └── Print Reference Plot Fast
```

3. Select **Force Drop Detection**.

```
Advanced Diagnostic Print
├── Paper Advance
├── Printhead Alignment
├── Nozzle Health
└── Force Drop Detection
```

4. Make sure that the ink system is ready and the covers and doors are closed, then press **OK**.

```
Force Drop Detection
Please check that:
- Ink system is ready
- Covers and doors are closed
Press OK to continue or X to
exit
```

5. The printer performs drop detection.

```
Force Drop Detection
Running drop detection
process
```

6. When the process has ended, press **OK** to return to the menu.

Disable Paper Advance Sensor

This option allows the disabling of the Paper Advance Sensor and forces the advance control to use the analog encoder system. The Paper Advance sensor will return to the default status after the unit is restarted. The Paper Advance Sensor is also known as the Optimal Media Advance Sensor or OMAS.

Fix paper advance issues

T7100 printers have a Paper Advance Sensor system that corrects the advance error automatically. This system avoids the use of the traditional advance calibration system.

However, there are some types of paper where this system cannot operate correctly because the type of material used for the paper. To work with these types of paper the traditional advance system based on an Analog Encoder Sensor is provided in the printer. This analog encoder calibration requires the Advance Calibration (carried out at the factory or in service through the service menu) to work properly.

Some of the papers type that will not work with the new Paper Advance Sensor are: Clear Film, Backlit, Some types of Matte film, Some types of Polypropylene.

To check if your paper can use the Paper Advance Sensor go to the *Service Menu > Diagnostic print > Others > Visual Paper Advance Diagnostic*. The test will allow you to check if advance control is used. The reference paper to use for the Paper Advance Calibration is HP Universal Photo Gloss. If the customer does not have this media,

order support part: Q1272-60296 (Inst. dry photo glossy Calibration Sheets). The flow to fix and advance issues is as follows:

^a List of types of media which are NOT used (non navigable) by the OMAS media sensor:

HP or HP Approved Clear Film

HP or HP Approved Backlit

HP or HP Approved types of Matt film

HP or HP Approved types of Polypropylene

A non HP or HP Approved Media

^b In order to perform this Calibration, you should order the Paper Advance Calibration Kit (Part Number Q1273-60296) which contains two cut sheets of HP Universal Instant-dry Gloss Photo media (36-inches wide by 42-inches long).

^c 'OMAS Blinking' means that the red LED in the OMAS lens blinks ON/OFF during paper advance when OMAS is operating.

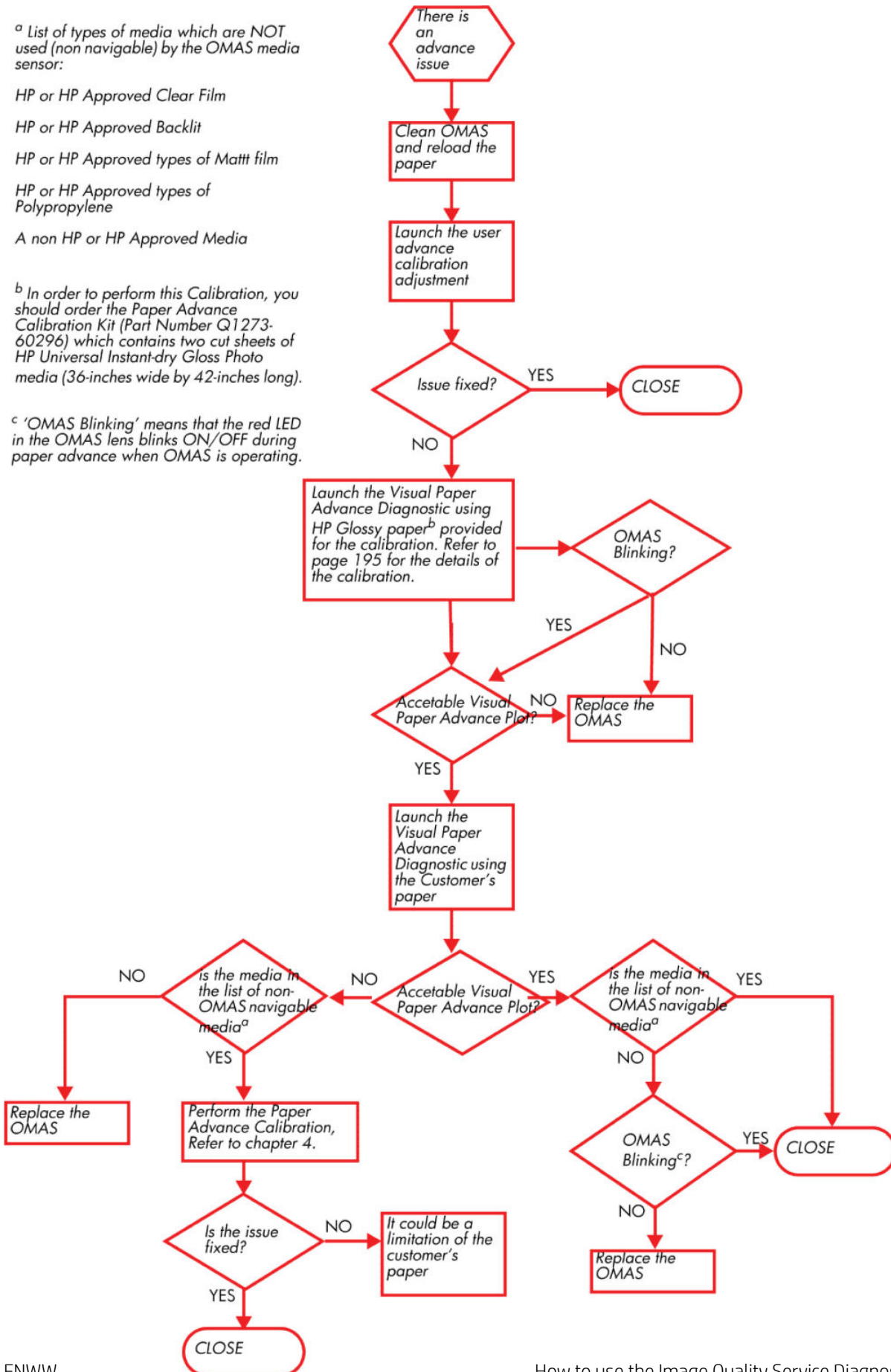

Clean the paper advance sensor window

The paper advance sensor is the very small rectangular window (less than 1 square centimeter in size and shown in the graphic below) found near the sixth platen roller from the right.

Very gently wipe off any dust and loosened ink deposits from the sensor window, using a clean, absorbent, lint-free cloth, slightly dampened with isopropyl alcohol.

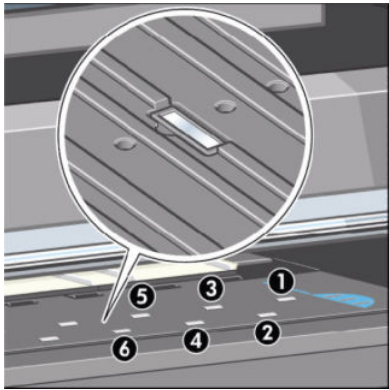

The user advance calibration

If the paper does not advanced the correct distance between passes of the printheads in the Carriage Assembly, light and dark bands appear in the print job and the image may look grainy.

The printer is calibrated to advance correctly with all the papers in the front panel. When you select the type of loaded paper, the printer adjusts the rate at which to advance the paper while printing. However, if you are using custom paper or are not satisfied with the default calibration of your paper, you may need to calibrate the rate at which the paper advances.

You can check the paper advance calibration status of the currently loaded paper at any time. Select the  icon > View loaded paper > View paper details. There are three types of status:

- **DEFAULT:** This status is displayed when loading an HP paper. HP papers in the front panel have been optimized by default and unless you experience image quality problems in your printed image such as banding or graininess it is not recommended to calibrate the paper advance.
- **RECOMMENDED:** This status appears when a new paper is created. The paper advance values for this paper are inherited from the family type. In cases such as these it is recommended that you perform a paper advance calibration to optimize the values.
- **OK:** This status indicates that the loaded paper has been calibrated before. However you may need to repeat the calibration if you experience image quality problems such as banding or graininess in your printed image.

 **NOTE:** Whenever you update the printer's firmware, the paper advance calibration values will be reset to factory default.

 **NOTE:** Colored papers and transparent materials such as translucent bond, clear film, matte film, tracing paper, and vellum are not suitable for paper advance calibration.

 **NOTE:** User advance calibration works in both advance control systems: paper advance sensor and analog encoder system.

The Paper Advance Calibration procedure

If your paper is not suitable for paper advance calibration, override steps 1 and 2 (Calibrate Paper Advance) and go directly to step 3 (Adjust Paper Advance).

1. At the front panel, select the  icon, then **Paper advance calibration > Calibrate paper advance**. The printer automatically calibrates the paper advance and prints a paper advance calibration image.
2. Wait until the front panel displays the status screen and re-print your print.

 **NOTE:** The calibration procedure takes approximately three minutes. Do not worry about the paper advance calibration image. The front-panel display shows any errors in the process.

- If you are satisfied with the image quality of the print after performing the calibration you can stop here.
 - If you can detect an improvement in the image quality of the print but want to fine tune the settings further, continue to step 3.
 - If you are dissatisfied with the calibration, you can return to the default calibration, refer to the next procedure 'Return to default calibration' seen below.
3. If you would like to fine-tune the calibration, select the  icon, then **Paper advance calibration > Adjust paper advance**.
 4. Select the percentage of change from -100% to 100%. To correct light banding, decrease the percentage. To correct dark banding, increase the percentage.
 5. Press the **OK** key on the front panel, to save the value.
 6. Wait until the front panel displays the status screen and re-print your print.

Return to default calibration

Returning to the default calibration sets all the corrections made by the paper advance calibration to zero. To return to the default paper advance calibration value, you must reset the calibration.

1. At the front panel, select the  icon, then **Paper advance calibration > Reset paper advance**.
2. Wait until the front panel displays the operation has completed successfully before pressing the **Back** key to return to the main menu.

Visual paper advance plot

The Visual Paper Advance Diagnostic prints a test plot to check that the paper advance is operating correctly. The plot is accessible from Service Utilities submenu > Diagnostic Print > Others > Visual Paper Advance Diagnostic menu option. It consists of three plots printed at the left, center, and right of the paper. These three plots are the same and contain seven numbered columns. The following illustrations shows an example of the Visual Paper Advance Diagnostic plot.

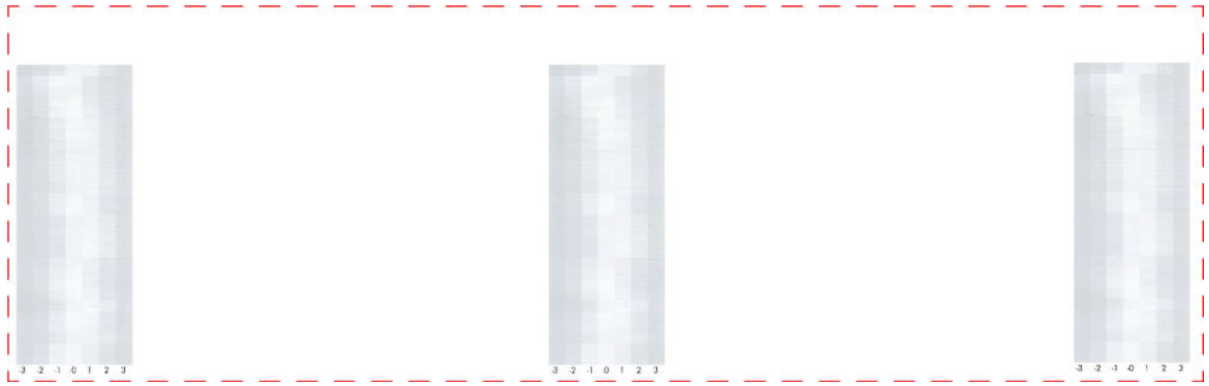

Interpreting plot results

The three plots are all printed using Photo Black ink in 6-pass print mode (even on Gloss paper) and should each be similar. The white/lightest band of must be within the center ± 1 area for a PASS result. This should be true for all three plots or the printer will have differential banding (a difference of advance between the left and right). There is a 3-inch white band before the plots to ensure there is no platen noise causing advance errors while the media is covering the platen.

Example acceptable plot

The following illustration shows an example of a PASS plot.

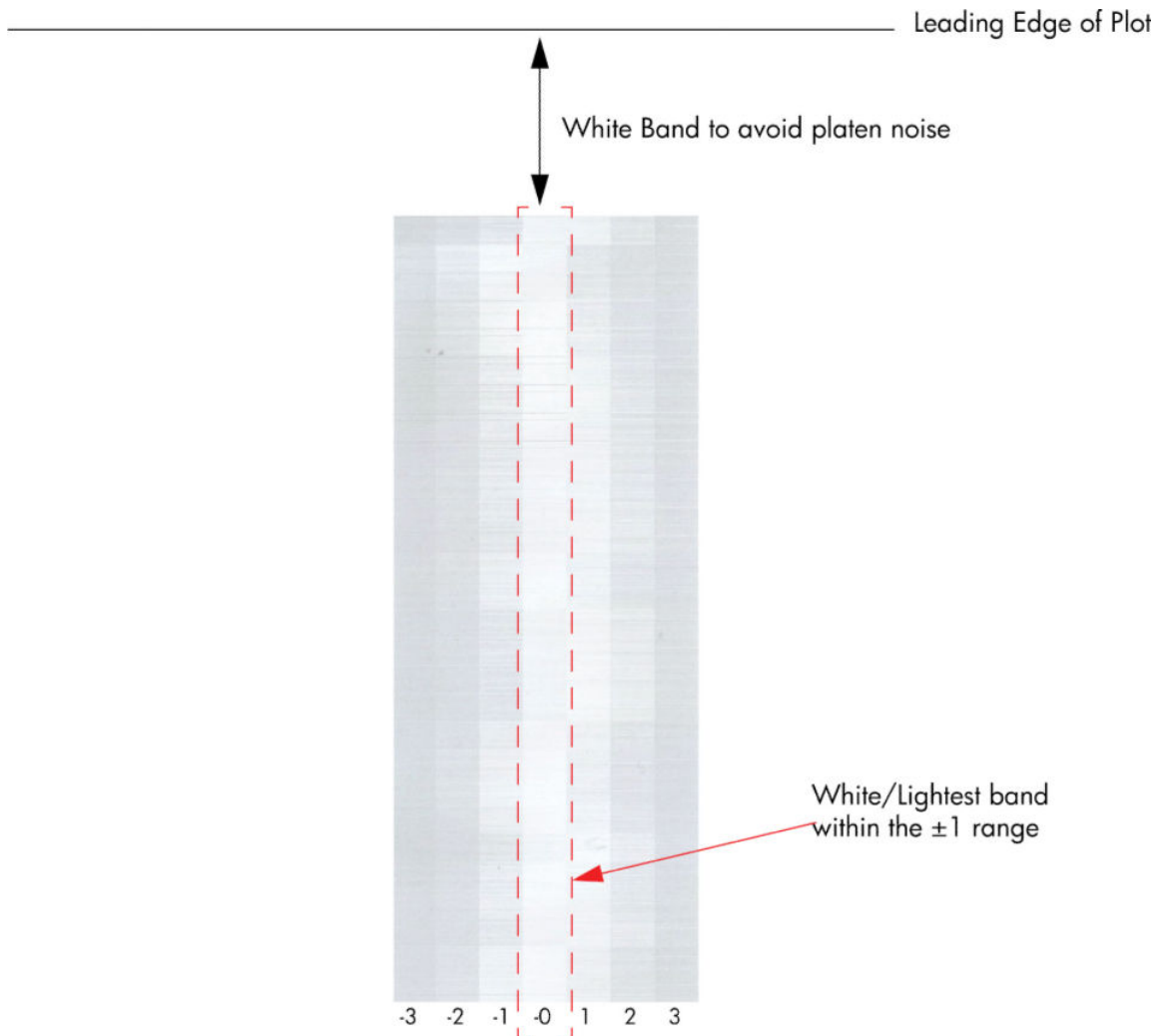

Example defective advance plot

This defect has the follow possible causes:

- OMAS is not clean or is defective so you should repeat the plot with OMAS disabled. This will allow you to establish if this is an OMAS related fault. If the same fault is detected the problem cannot be attributed to OMAS.
- The Drive roller is not clean so it slips against the media.
- Any other component affecting the media advance:
 - Spindle/Back Tension
 - Input roller
 - Pinchwheels

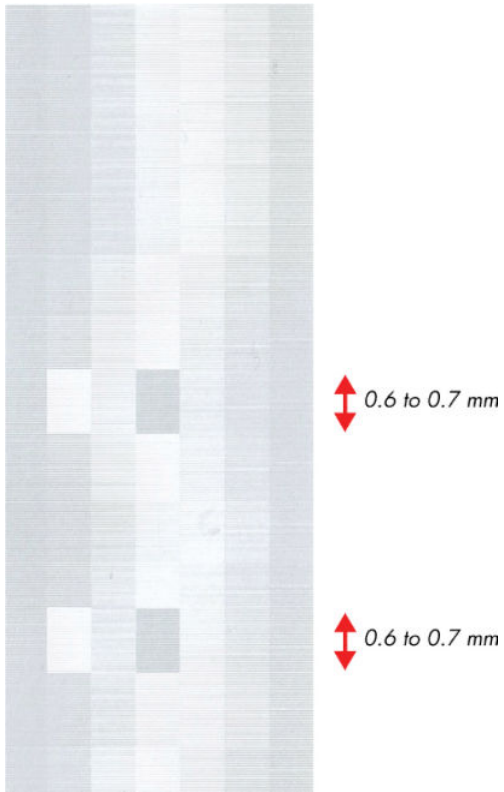

Example defective nozzle plot

This example is caused by a defective nozzle so there is no issue with the paper advance.

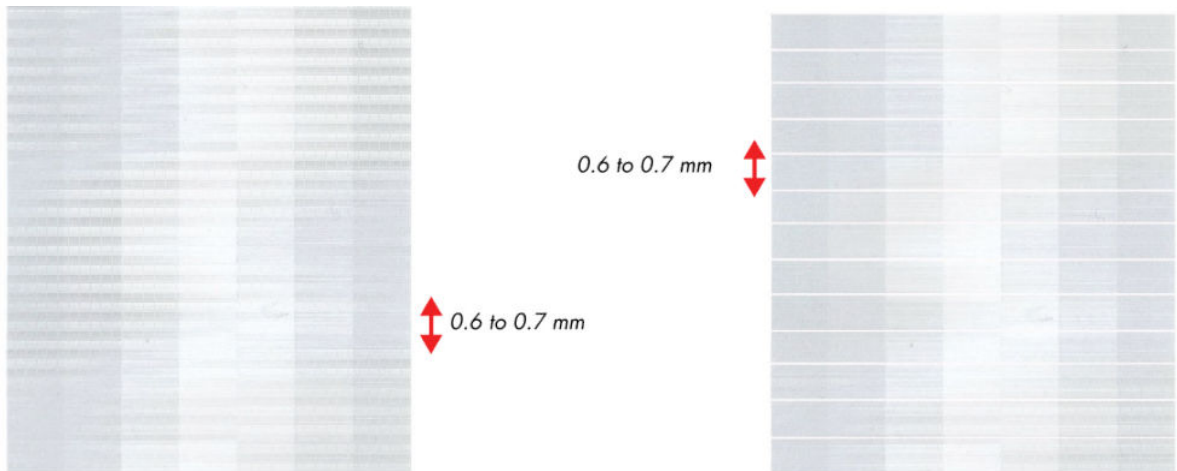

Print-quality issues by symptom

This section describes the common symptoms seen, and how to solve the issues.

There is banding in the image

If banding **does not** occur in ALL the colors, then it is probably a printhead problem. In this case, try the following.

1. Check that the appropriate print quality settings are being used.
2. Recover the printheads using the option through the Front Panel (📄 icon, then **Clean printheads**).
Reprint the Diagnostic Print or the print file and if the problem persists, replace the faulty Printhead.

If banding **does** occur in ALL the colors, then it is probably a paper advance problem:

- If the bands are light, it means that the paper has advanced too much.
- If the bands are dark, it means that the paper hasn't advanced enough.
- In high quality modes, graininess in ALL colors can indicate problems either with alignment or paper advance.



In order to solve any of these problems, try the following.

1. Check that the appropriate print quality settings are being used.
2. Check that the loaded paper is the same type as selected in the printer. Check this through the front panel (at the front panel, select the 📄 icon, then **View loaded paper > View paper details**).
3. If the customer is using low-quality paper, try recommending better-quality paper (preferably HP paper). Printer performance can only be guaranteed by using recommended papers.
4. Check the advance with the help of the Visual Paper Advanced Diagnostic, refer to [Visual paper advance plot on page 163](#).

 **NOTE:** If there is white point banding in only one color band and the problem cannot be fixed using Printhead recovery, in some cases using the Force Drop Detection option can fix this issue (see Others Diagnostics: Force Drop Detection).

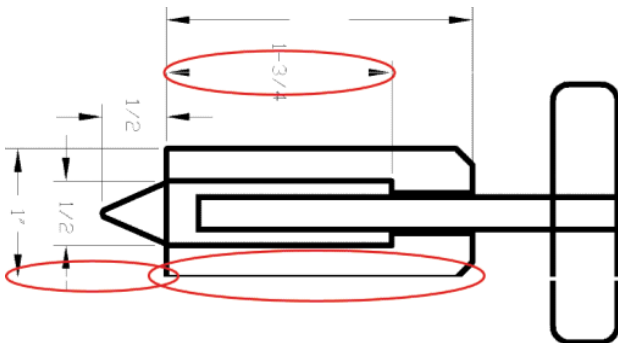
Lines are too thick, too thin or missing



1. Check that the paper type you have loaded corresponds to the paper type selected in the front panel and in your software. To check on the front panel, use the [View information](#) key .
2. Check that you are using appropriate print-quality settings for your purposes. Select the custom print-quality options in the driver dialog, and try turning on the **Maximum detail** option (if available). You may wish to reprint your job at this point in case the problem has been solved.
3. If the resolution of your image is greater than the printing resolution, you may notice a loss of line quality. If you are using the HP-GL/2 and HP RTL driver for Windows, you can find the **Max. Application Resolution** option in the driver dialog's **Advanced** tab, under **Document Options > Printer Features**. If you change this option, you may wish to reprint your job at this point in case the problem has been solved.
4. If lines are too thin or missing, print the Image Diagnostics Print.
5. If the problem remains, go to the front panel and select the Ink menu icon , then **Printhead information** to see the printhead alignment status. If the status is PENDING, you should align the printheads. After alignment, you may wish to reprint your job in case the problem has been solved.
6. Go to the front panel and press the [View information](#) key  to see the paper advance calibration status. If the status is DEFAULT or RECOMMENDED, you should perform paper advance calibration.

Lines appear stepped or jagged

If lines in your image appear stepped or jagged when printed:

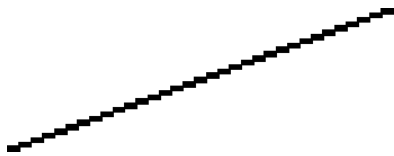

1. The problem may be inherent in the image. Try to improve the image with the application you are using to edit it.
2. Check that you are using appropriate print-quality settings.
3. Select the custom print-quality options in the driver dialog, and turn on the **Maximum detail** option (if available).

Lines print double or in the wrong colors

This problem can have various visible symptoms:

- Colored lines are printed double, in different colors.

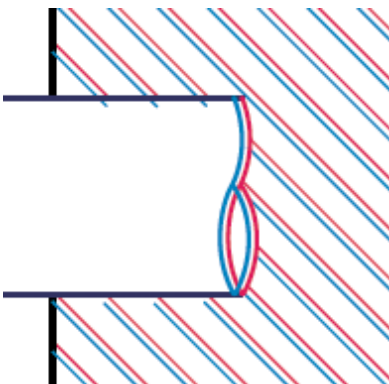

- The borders of colored blocks are wrongly colored.



To correct this kind of problem:

1. Reseat the printheads by removing them and then reinserting them.
2. Align the printheads.

Lines are discontinuous

If your lines are broken in the following way:



1. Check that you are using appropriate print-quality settings.
2. Reseat the printheads by removing them and then reinserting them.
3. Align the printheads.

Lines are blurred



Humidity can cause ink to soak into the paper, making the lines blurred and fuzzy. Try the following.

1. Check that your environmental conditions (temperature, humidity) are suitable for high-quality printing.
2. Check that the paper type selected in the front panel is the same as the paper type you are using. To check on the front panel, use the [View information](#) key .
3. Try changing to a heavier paper type, such as HP Heavyweight Coated Paper or HP Super Heavyweight Plus Matte Paper.
4. Select a paper type that is slightly thinner than the paper you have loaded; this will persuade the printer to use less ink. Here are some example paper types in ascending order of thickness: Plain Paper, Coated Paper, Heavyweight Coated Paper, Super Heavyweight Plus Matte Paper.
5. If you are using glossy paper, try changing to a different type of glossy paper.
6. Align the printheads.

Line lengths are inaccurate



If you have measured your printed lines and find that the lengths are not sufficiently accurate for your purposes, you can try to improve line length accuracy in the following ways.

1. Print on HP Matte Film, for which your printer's line length accuracy is specified.

Polyester film is about ten times more dimensionally stable than paper. However, using film that is thinner or thicker than HP Matte Film will reduce line length accuracy.
2. Set the Print Quality slider to **Quality**.
3. Maintain the room at a steady temperature between 10 and 30°C (50 and 86°F).
4. Load the roll of film and let it rest for five minutes before printing.
5. If you are still not satisfied, try recalibrating the paper advance.

The whole image is blurry or grainy



1. Check that the paper type you have loaded corresponds to the paper type selected in the front panel and in your software. To check on the front panel, use the [View information](#) key .
2. Check that you are printing on the correct side of the paper.
3. Check that you are using appropriate print-quality settings. In some cases, you can overcome a print-quality problem merely by selecting a higher print-quality level. For instance, if you have set the Print Quality slider to **Speed**, try setting it to **Quality**. If you change the print-quality settings, you may wish to reprint your job at this point in case the problem has been solved.
4. Go to the front panel and select the Ink menu icon , then **Printhead information** to see the printhead alignment status. If the status is PENDING, you should align the printheads. After alignment, you may wish to reprint your job in case the problem has been solved.
5. Go to the front panel and press the [View information](#) key  to see the paper advance calibration status. If the status is DEFAULT or RECOMMENDED, you should perform paper advance calibration.

The paper is not flat

If the paper does not lie flat when it comes out of the printer, but has shallow waves in it, you are likely to see defects in the printed image, such as vertical stripes. This can happen when you use thin paper that becomes saturated with ink.



1. Check that the paper type you have loaded corresponds to the paper type selected in the front panel and in your software. To check on the front panel, use the [View information](#) key .
2. Try changing to a thicker paper type, such as HP Heavyweight Coated Paper or HP Super Heavyweight Plus Matte Paper.
3. Select a paper type that is slightly thinner than the paper you have loaded; this will persuade the printer to use less ink. Here are some example paper types in ascending order of thickness: Plain Paper, Coated Paper, Heavyweight Coated Paper, Super Heavyweight Plus Matte Paper.

The print is scuffed or scratched

The black ink pigment can be scuffed or scratched when touched by a finger, a pen or some other object. This is particularly noticeable on coated paper.

Glossy paper may be extremely sensitive to the basket or to anything else that it contacts soon after printing, depending on the amount of ink used and the environmental conditions at the time of printing.

To reduce the risk of scuffs and scratches:

- Handle prints carefully.
- Avoid stacking prints on top of each other.
- Catch your prints as they are cut from the roll and do not let them fall into the basket. Alternatively, leave a sheet of paper in the basket so that freshly printed sheets do not make direct contact with the basket.

Ink marks on the paper

If a lot of ink is used on plain or coated paper, the paper absorbs the ink quickly and expands. As the printheads move over the paper, the printheads may come into contact with the paper and smear the printed image. This problem is normally seen only on cut sheets of paper (not on roll paper).

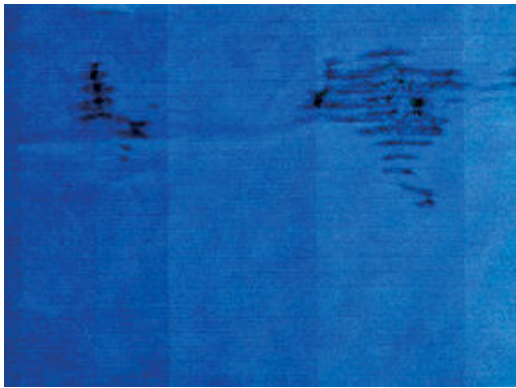

Whenever you notice this problem, cancel the printing job immediately. Press the [Cancel](#) key and also cancel the job from your computer application. Soaked paper can damage the printheads.

Try the following suggestions to avoid this problem:

1. Check that the paper type you have loaded corresponds to the paper type selected in the front panel and in your software. To check on the front panel, use the [View information](#) key .
2. Use a recommended paper type and the correct print settings.
3. Try changing to a thicker paper type, such as HP Heavyweight Coated Paper and HP Super Heavyweight Plus Matte Paper.
4. Select a paper type that is slightly thinner than the paper you have loaded; this will persuade the printer to use less ink. Here are some example paper types in ascending order of thickness: Plain Paper, Coated Paper, Heavyweight Coated Paper, Super Heavyweight Plus Matte Paper.
5. Try to increase the margins by relocating the image to the center of the page using your software application.

Black ink comes off when you touch the print

This problem may be caused by printing with matte black ink on glossy paper. The printer will not use matte black ink if it knows that the paper will not retain it. To be sure of avoiding matte black ink, you can select Photo Glossy Paper as the paper type (in the Photo Paper category).

Vertical lines of different colors

If your print has vertical bands of different colors along it:

1. Try using thicker paper, choosing from the recommended paper types such as HP Heavyweight Coated Paper and HP Super Heavyweight Paper.
2. Try using higher print-quality settings. For instance, if you have set the Print Quality slider to **Speed**, try setting it to **Quality**.

White spots on the print

You may notice white spots on the print. This is probably due to paper fibers, dust or loose coating material. To avoid this problem:

1. Try cleaning the paper manually with a brush before printing, to remove any loose fibers or particles.
2. Always keep the cover of your printer closed.
3. Protect your paper rolls by storing them in bags or boxes.

Colors are inaccurate

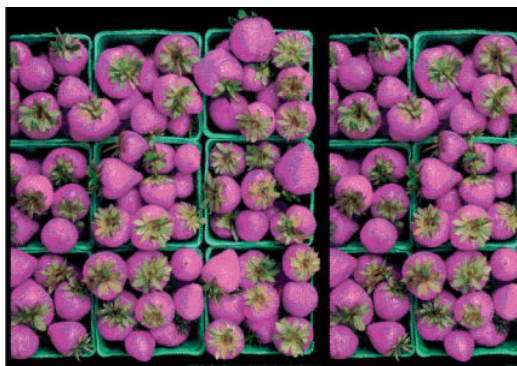

If the colors of your print do not match your expectations, try the following remedies:

1. Check that the paper type you have loaded corresponds to the paper type that you selected on the front panel and in your software. At the same time, check the color-calibration status. If the status is **RECOMMENDED** or **OBSOLETE**, you should perform color calibration. If you have made any changes, reprint your job if the problem has been solved.
2. Check that you are printing on the correct side of the paper.
3. Make sure that you are using the appropriate print-quality settings. If you have selected the **EconoMode** or **Speed** options, you might not get accurate colors. If you change the print-quality settings, reprint your job if the problem has been solved.
4. If you are using Application Color Management, make sure that the color profile that you are using corresponds to the selected paper type and print-quality settings.
5. If the problem consists of color differences between your print and your monitor, follow the instructions in the “How to calibrate your monitor” section of the HP Color Center. Reprint your job if the problem has been solved.
6. Print the Image Diagnostics Print.

PANTONE* colors are inaccurate

See 'HP Professional PANTONE Emulation' in the *User's Guide*.

Colors between different HP DesignJets do not match

If you print an image on two different printer models (for instance, on an HP DesignJet T7100 printer series and an HP DesignJet 4500 printer series), the colors of the two prints might not match well.

Matching two printing devices that use different ink chemistry, paper chemistry, and printheads is unlikely to be completely successful. Use the information provided here to attempt to make one printer match another.

Print with PostScript drivers

The situation describes printing with the PostScript driver installed for that printer. In this example, we are using an HP DesignJet T7100 printer series and an HP DesignJet 4500 printer series.

1. Check that both printers have the most recent firmware version.
2. Check that you have the most recent printer driver for both printers. You can download the latest versions for any HP printer from <http://www.hp.com/go/designjet>.
3. Make sure that color calibration is turned on. On the front panel of the HP DesignJet T7100, select the  icon, then **Enable color calibration**.
4. Load the printers with the same type of paper.
5. Check that the Paper Type setting on the front panel corresponds to the paper that you have loaded.
6. Use your normal settings to print your image on the HP DesignJet 4500.
7. Now prepare to print the same image on the HP DesignJet T7100.

In your software, set the color space of the image to emulate the HP DesignJet 4500 and the specific paper type that you used in that printer. The data sent to the driver must be already converted to this emulation color space, which is a CMYK color space. See the online help for the software program to find information about how to do this. In this way, the T7100 will emulate the colors that the 4500 can produce when printing on that paper type.

8. In the PostScript driver for the HP DesignJet T7100, go to the Color Management section and set the CMYK input profile to the same HP DesignJet 4500 color space that you selected in the software (the emulation color space).
9. Print the image on the HP DesignJet T7100.

Print with HP-GL/2 drivers



The situation describes printing with the HP-GL/2 driver installed for that printer.

1. Check that both printers have the most recent firmware version.
2. Check that you have the most recent printer drivers for both printers. You can download the latest versions for any HP printer from <http://www.hp.com/go/designjet>.
3. Make sure that color calibration is turned on. On the front panel of the HP DesignJet T7100 printer series, select the  icon, then **Enable color calibration**.

4. Load the printers with the same type of paper.
5. Check that the Paper Type setting on the front panel corresponds to the paper you have loaded.
6. In the HP-GL/2 driver for the HP DesignJet T7100, click the **Color** tab, and select **Printer Emulation** from the list of color management options. Then select the HP DesignJet 4500 from the list of emulated printers.
7. In the HP-GL/2 driver for the HP DesignJet 4500, click the **Options** tab, and then select **Manual Color > Color Control > Match Screen**. Also click the **Paper Size** tab, and then select **Paper Type**.

Print the same HP-GL/2 file

The situation describes how to produce an HP-GL/2 file (also known as a PLT file) with the HP-GL/2 driver installed for one printer that you intend to send to another printer.

1. Check that both printers have the most recent firmware version.
2. Make sure that Color Calibration is turned on. At the front panel of the HP DesignJet T7100, select the  icon, then **Enable color calibration**.
3. Load the printers with the same type of paper.
4. Check that the Paper Type setting on the front panel corresponds to the paper you have loaded.
5. If you have an HP-GL/2 file for an HP DesignJet 4500 and you want to print it on an HP DesignJet T7100, use the Embedded Web Server or the front panel.
 - Through the Embedded Web Server: leave the color options set to **Default**.
 - On the front panel: select the  icon, and then select **Setup > Printing preferences > Color options > Emulate printer > HP DesignJet 4500 Series**.

For other HP DesignJet printers, set both printers to match the screen colors (sRGB, if that is available), as when printing with separate HP-GL/2 drivers.

The output is completely blank

If the front-panel graphic language setting is **Automatic** (the default), try the other settings: **PostScript** for a PostScript file, **HP-GL/2** for an HP-GL/2 file, and so on. Then send the file again.

When you have finished this particular print, remember to reset the graphic language to **Automatic**.

The output contains only a partial print

- If you pressed **Cancel** before the printer received all the data, you ended the data transmission and will have to print the page again.
- The **I/O timeout** setting might be too short. This setting determines how long the printer waits for the computer to send more data, before deciding that the job is finished. On the front panel, increase the **I/O timeout** setting to a longer period and then send the print again by selecting the  icon, then **Advanced > Select I/O timeout**.
- A communications problem between your computer and the printer might exist. Check your USB or network cable.

- Check that your software settings are correct for your current page size (for example, long-axis prints).
- If you are using network software, make sure that it has not timed out.

The image is clipped

Clipping normally indicates a discrepancy between the actual printable area on the loaded paper and the printable area as described by your software. You can often identify this kind of problem before printing by previewing your print.

- Check the actual printable area for the paper size that you have loaded.
printable area = paper size – margins
- Check what your software understands to be the printable area (which it might cite as "printing area" or "imageable area"). For example, some software programs assume standard printable areas that are larger than those used in this printer.
- If you have defined a custom page size that has very narrow margins, the printer might impose its own minimal margins and clip your image slightly. You might want to use a larger paper size.
- If your image contains its own margins, you might be able to print it successfully by using the **Clip contents by margins** option.
- If you are trying to print a very long image on a roll, make sure that your software can print an image of that size.
- You might have asked to rotate the page to landscape orientation on a paper size that is not sufficiently wide.
- If necessary, reduce the size of the image or document in your software, so that it fits between the margins

Other explanations exist for a clipped images. Some programs, such as Adobe Photoshop, Adobe Illustrator, and CorelDRAW, use an internal 16-bit coordinate system which means that they cannot handle an image of more than 32,768 pixels. If you try to print a larger image, the bottom of the image will be clipped. To print the entire image, try these suggestions:

- If you are using an HP-GL/2 driver, you can reduce the resolution so that the whole image requires fewer than 32,768 pixels. The Windows driver includes an option called **16-bit App. Compatibility**, which reduces the resolution automatically. The option is on the **Advanced** tab, under **Document Options > Printer Features**.
- Save the file in another format, such as TIFF or EPS, and open it in another program.
- Use a RIP to print the file.

The image is in one portion of the printing area

- In the software, have you selected a page size that is too small?
- Does your software read the image as being in one portion of the page?

The image is unexpectedly rotated

On the front panel, select the  icon, and then select **Printing preferences > Paper options > Rotate**. Check that the setting is what you wanted.

For non-PostScript files: if **Nesting** is **On**, pages are sometimes automatically rotated to save paper.

The print is a mirror image of the original

On the front panel, select the  icon, and then select **Printing preferences > Paper options > Enable mirror image**. Check that the setting is what you wanted.



The print is distorted or unintelligible

- The interface cable that is connecting your printer to your network (or to your computer) might be faulty. Try another cable.
- On the front panel, select the  icon, and then select **Printing preferences > Select graphics language**. If the language setting is **Automatic** (the default), try the other settings: **PostScript** for a PostScript file, **HP-GL/2** for an HP-GL/2 file, on so on. Then send the file again.
- Depending on the software, drivers, and RIPs that you are using with your printer, different ways to solve this problem exist. Refer to the vendor's user documentation for details.

One image overlays another on the same print

The **I/O timeout** setting might be too long. On the front panel, decrease the setting and print again. Select the  icon, then **Advanced > Select I/O timeout**.

Pen settings seem to have no effect

- You have changed the settings on the front panel by selecting the  icon followed by **Printing preferences > HP-GL/2 > Define palette**, but did not select that palette in **Printing preferences > HP-GL/2 > Select palette**.
- To enable the software-driven pen settings, go to the front panel and select the  icon followed by **Printing preferences > HP-GL/2 > Select palette > Software**.

The image has a wood-grain appearance (aeroworms)



Aeroworms are wavy, horizontal bands produced by air-induced dot placement error (DPE). In extreme cases, aeroworms give the image a wood-grain appearance. The problem occurs most commonly on print jobs that are set for low-quality and high-speed. It does not occur when the custom print-quality setting is set to “best.”

To eliminate aeroworms, select a higher IQ print setting.

CAD Lines look misaligned, images are blurred

This issue can be seen even after the customer has performed the Printhead Alignment procedure. The misalignment is most highlighted in CAD drawings, there are double-lines and images are 'ghosted'. See the two examples below.

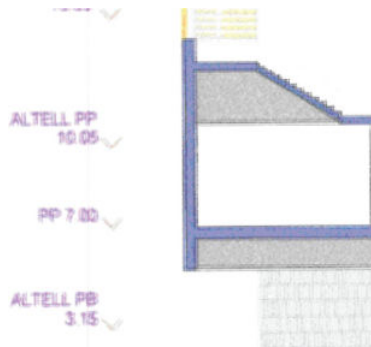

Here the CAD drawing has the issue, the CAD lines are misaligned and the image looks blurred/grainy

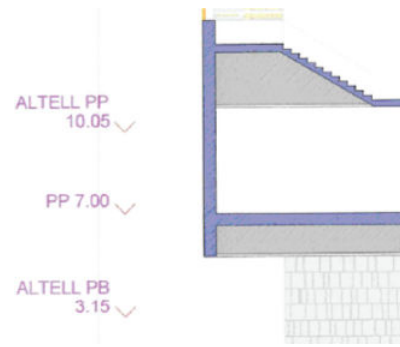

Here the CAD drawing does not have the issue and the drawing looks ok.

This issue can be solved by updating the firmware to the latest version.

Some paper types may deform when printing high area fill

This issue is known as PEPA: Paper Expansion Paper Advance. The quality of some images might be reduced if you use a paper type that is unsuitable for your image. This is especially important to consider when printing on fiber-based papers such as HP Universal Coated Paper, HP Coated Paper, HP Heavyweight Coated Paper and HP Universal Heavyweight Coated Paper. Printing images that contain high-saturation area fills on fiber-based papers can create unwanted wavy patterns as a result of paper expansion. This can ultimately contribute to more severe problems. Consider using Super Heavyweight Coated Paper and other cockle-free papers when printing high-saturation area fills.

Finally, as this paper expansion is increasing when a high quantity of ink is placed at once, the HP DesignJet T7100 might exhibit this paper expansion more than when compared to the DJ5x00 or DJ10x0 series.

Printheads fail repeatedly

If you encounter intermittent quality issues that are not solved after replacing Printheads or repeated replacement of the same Printheads there might be a capping problem. This could be caused damage to the Maintenance Cartridge or even the actual Carriage Assembly which is preventing the Printheads from being correctly capped.

The Maintenance Cartridge provides the capping for all of the Printheads and contains integrated Printhead caps, wipers, cleaners and waste ink disposal.

The following illustration shows a the components that make up the Maintenance Cartridge.

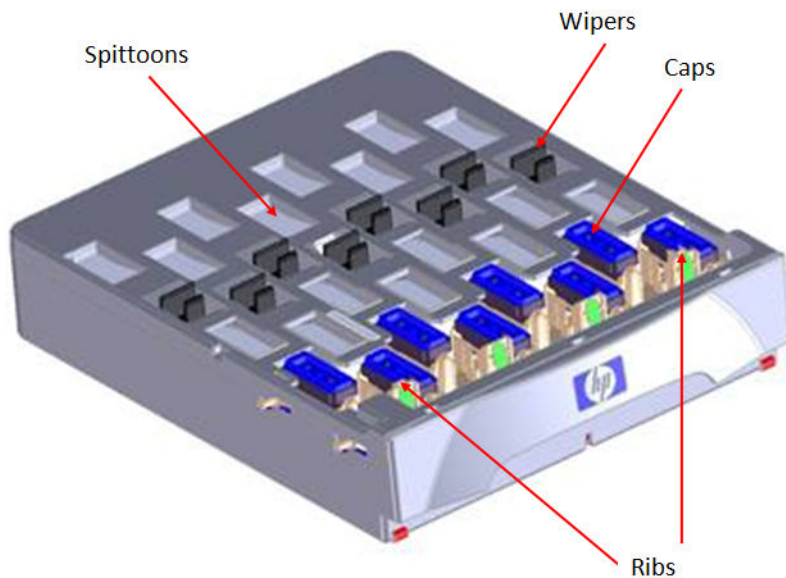

To cap the Printheads:

- The Carriage Assembly is first positioned over the Service Station.
- The Maintenance Cartridge moves towards the back of the printer which allows Pin #1 and Pin #2 on the Carriage Assembly to push against Rib #1 and Rib #2 to lift the caps into contact with the Printheads.

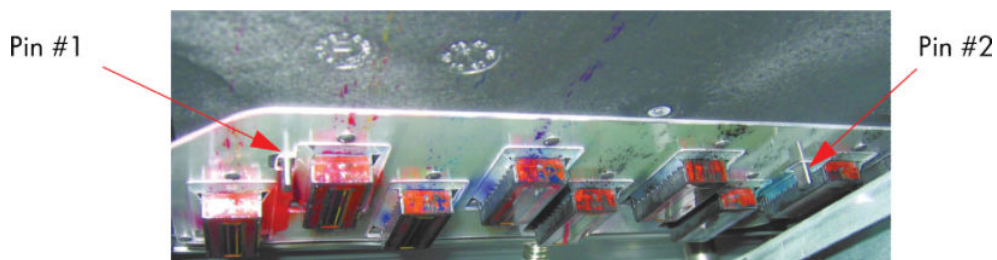

Improper capping of printheads will occur when any of the following elements break:

- Rib #1 or Rib #2 of the Maintenance Cartridge,
- Pin #1 or Pin #2 of the Carriage Assembly

You should also check all the other elements of the Maintenance Cartridge (plastic of each cap, and so on) and make sure the vacuum ports are clear. If they are blocked, you can clear them with a T-8 Torx bit but you should also check to make sure the Aerosol Fan is operating correctly.

Working with other commercially available papers

This section provides a quick reference guide to selecting the correct settings in the printer so that the printer achieves the best possible image quality when using a paper type that does not come from HP.

For papers available in the market from sources other than HP, please refer to the information in Tables 1, 2 and 3 in order to choose the correct category.

Table 1 defines the print characteristics used in Tables 2 and 3.

For optimum results, first load the paper with the recommended settings, then calibrate and profile the paper. To create an ICC profile, there are two different options:

- Profile the paper using the HP Color Center
- Use an alternative profile (often available from the paper’s manufacturer).

Selecting the correct paper presets

Table 1 defines the print characteristics used in Table 2: Other Commercially-available Paper Print Characteristics and Table 3: Original HP Printing Material Print Characteristics.

Table 1: Definition of Print Characteristics		
Paper Type	The name displayed in the driver and the front panel (the English version)	
Printing Black	Photo Black (P) / Matte Black (M) / Light Gray (lg): This setting indicates which inks are used when printing black: <ul style="list-style-type: none"> • All black inks (All) • P and lg only (P lg) 	
Ink Limit		
Print Mode “Best Quality” or slider in the right position	Rendering Resolution (RR)	Resolution at which the image is rasterized/ processed in the host (in pixels per printed inch, or pppi)
	Printing Resolution (PR)	Resolution at which the image is printed (in dots per inch, or dpi)
	# passes Other info (O)Bidirectional	Typically, the higher the number of passes, the better the image quality, but at a lower speeds. Also, papers such as glossy paper need a longer drying time that will generally require a higher number of passes. Whether printing when the carriage is traveling in a single direction only (Unidirectional) or in both directions (Bidirectional). Unidirectional modes typically provide better image quality – depending on the number of passes – but at lower speeds.
Automatic Cutter	Yes (Y) / No (N): Indicates whether cutting will be performed. Even if “Yes” is selected, cutting can be disabled later through the driver. However, if “No” is selected here, cutting cannot be re-enabled through the driver.	

Notes:

- Make sure the most similar paper is chosen to create your own paper presets, taking into account type and finishing (Matt or Gloss) but also weight and thickness. For example, use “HP Universal Instant-dry Gloss” (190 g/m², 7.4mil/188 microns) if you are loading a similar 190 g/m² gloss-like paper. Good examples of these are “dtec Photobase Universal 190 gsm” or “Océ Smart Dry Photo Paper Gloss” (190 g/m², 188 microns). In this case, do **not** use the “HP Premium Instant-Dry Gloss”, which is much heavier and thicker (260 g/m², 10.3 mil/260 microns).
- Selecting the wrong basic paper type to create a paper preset can result in printing issues such as poor color performance or the paper not being advanced accurately.
- Do not use the cutter on Fine Art papers.

For paper settings that can be downloaded from the HP Knowledge Center, refer to Downloading Paper Presets. After downloading and installing a paper preset, the new paper will display inside the 'Custom' category, both in the driver and in the front panel.

Paper type		Printing black	Ink limiting	Print mode (Best)			Auto Cutter
				RR	PR	OI	
Bond and Coated Paper	Plain Paper	All	24	600	1200×1200	4p bidi	Yes
	Bright White Bond Paper	All	24			4p bidi	
	Coated Paper	All	24			8p bidi	
	Heavyweight Coated Paper	All	30			10p bidi	
	Super Heavyweight Coated Paper	All	60			10p bidi	
Photo Paper	Photo Matte Paper	All	30	600	600×1200	10p bidi	Yes
	Photo Gloss/Semi-Gloss/Satin Paper	P Lg	37			12p bidi	
	Photo Gloss/Semi-Gloss/Satin Paper (more ink)	P Lg	45			12p bidi	
	Photo Gloss/Semi-Gloss/Satin Paper (less ink)	P Lg	32			12p bidi	
Proofing Paper	Proofing Gloss Paper	P Lg	45	600	600×1200	12p bidi	Yes
	Proofing Semi-gloss Satin Paper	P Lg	45			12p bidi	
	Proofing Matte Paper	All	30		1200×1200	10p bidi	
Technical Paper	Natural Tracing Paper	All	24	600	1200×1200	4p bidi	Yes
	Translucent Bond	All	24				
	Vellum	All	24				
Film	Transparent Clear Film	All	24	600	1200×1200	10p bidi	Yes
	Matte Film	All	24				
Backlit	Backlit Material	P Lg	57	600	1200×1200	16p bidi	Yes
	Backlit Material (more ink)	P Lg	72				
Fine Art Paper	Canvas	All	44	600	1200×1200	16p bidi	No
	Canvas (more ink)	All	60			10p bidi	
	Fine Art Paper	All	44				
	Fine Art Paper (more ink)	All	60				
Banner & Sign Material	Indoor Banner	P Lg	45	600	1200×1200	16p bidi	Yes
	Scrim Banner	All	60			10p bidi	
Self Adhesive	Adhesive Vinyl	All	60	600	1200×1200	16p bidi	Yes
	Adhesive Polypropylene	All	60			10p bidi	

Table 3: Original HP paper types

Paper type		Printing black	Ink limiting	Print mode (Best)			Auto Cutter
				RR	PR	OI	
Bond and Coated Paper	HP Bright White Inkjet Bond Paper	All	24	600	1200×1200	6p bidi	Yes
	HP Universal Bond Paper	All	24			4p bidi	
	HP Coated Paper	All	24			8p bidi	
	HP Universal Coated Paper	All	24			8p bidi	
	HP Heavyweight Coated Paper	All	30			10p bidi	
	HP Universal Heavyweight Coated Paper	All	30				
	HP Super Heavyweight Coated Plus Matte Paper	All	60				
	HP Recycled Bond Paper	All	24			4p bidi	
Photo Paper	HP Premium Instant-dry Photo Gloss	P Lg	45	600	600×1200	12p bidi	Yes
	HP Universal Instant-dry Photo Gloss	P Lg	37				
	HP Everyday Pigment Ink Gloss Photo Paper	P Lg	37				
	HP Premium Instant-dry Photo Satin	P Lg	45				
	HP Professional Satin Photo Paper	P Lg	45				
	HP Universal Instant-dry Photo Semi-gloss	P Lg	37				
	HP Everyday Pigment Ink Satin Photo Paper	P Lg	37				
	HP Premium Matte Photo Paper	All	60		1200×1200	10p bidi	
Technical Paper	HP Natural Tracing Paper	All	24	600	1200×1200	4p bidi	Yes
	HP Translucent Bond Paper	All	24				
	HP Vellum	All	24				
Film	HP Clear Film	All	24	600	1200×1200	10p bidi	Yes
	HP Matte Film	All	24				
Backlit	HP Premium Vivid Color Backlit Film	P Lg	72	600	1200×1200	16p bidi	Yes
Fine Art Paper	HP Professional Matte Canvas	All	44	600	1200×1200	16p bidi	No
	HP Collector Satin Canvas	All	44			14p bidi	
	HP Artist Matte Canvas	All	44			14p bidi	
	HP Universal Matte Canvas	All	44			14p bidi	
	HP Matte Litho-realistic Paper	All	44			10p bidi	

Banner & Sign Material	HP Durable Banner with Dupont Tyvek	All	60	600	1200×1200	10p bidi	Yes
	HP Opaque Scrim	All	60				
Self Adhesive	HP Everyday Adhesive Matte Polypropylene	All	60	600	1200×1200	16p bidi	Yes
	HP Colorfast Adhesive Vinyl	All	60			10p bidi	

Downloading paper presets

A 'paper preset' is a file that contains the set of instructions that enables the printer to print on a specific type of paper. It resides in the printer's firmware or it can be downloaded from a Web page to update the printer's firmware for a new paper type.

To download a paper preset from the HP Knowledge Center, use the following link: http://www.hp.com/go/knowledge_center/djT7100/.

8 Parts and diagrams

- [Printer](#)
- [Stacker](#)

Printer

- [Printer support](#)
- [Center Covers](#)
- [Electronics Module](#)
- [Right Cover](#)
- [Left Cover](#)
- [Right-hand Assemblies](#)
- [Left-hand Assemblies](#)
- [Carriage Assembly](#)
- [Scan-axis Assemblies](#)
- [Drive Roller and Media-axis Motor](#)
- [Paper Path Assemblies](#)
- [Pinchwheel Assembly](#)
- [Smart Roll-loading System A](#)
- [Smart Roll-loading System B](#)
- [Rear Door](#)
- [Entry Platen](#)
- [Miscellaneous parts](#)

Printer support

Number in figure	HP part number	Description	Cross-reference
1	CQ105-67058	Leg Covers (right and left)	N/A
2	CQ105-67055	Stand and Leg Covers (right and left)	N/A
3	CQ105-67060	Bin	N/A
–	CQ105-67059	Hardware Kit	N/A



Center Covers

Number in figure	HP part number	Description	Cross-reference
1	CQ105-67025	PW Cover	
2	CQ105-67022	Left Connector Cover	Connector Cover, Left on page 238
3	CQ105-67021	Right Connector Cover	Connector Cover, Right on page 237
4	CQ105-67024	Window Position Sensor	N/A
5	CQ109-67041	Window	Window on page 229
6	CQ105-67046	Top Cover	Cover, Top on page 232

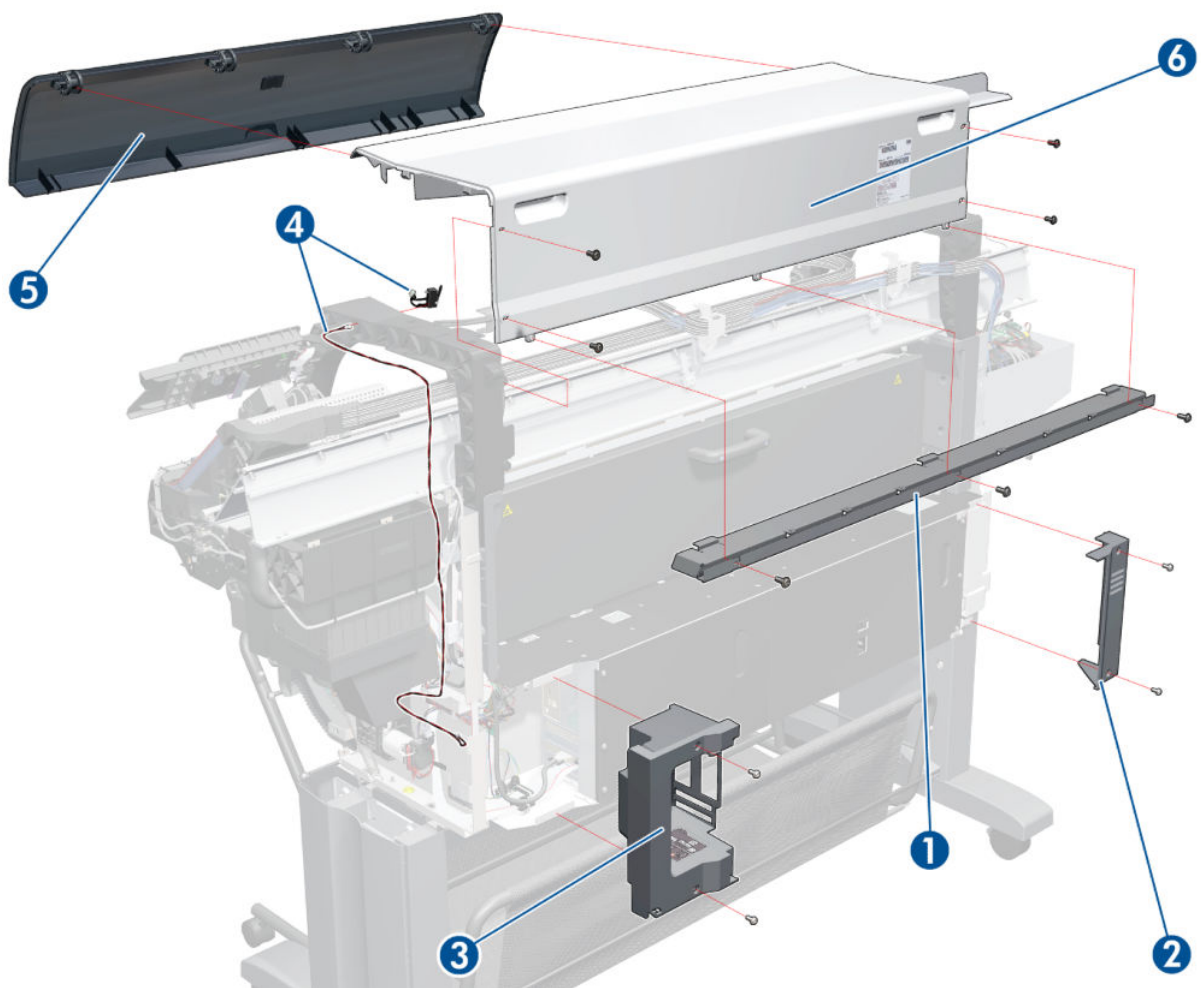

Electronics Module

Number in figure	HP part number	Description	Cross-reference
1	CQ109-67014	OMAS Controller Card	OMAS Controller Card on page 368
2	CQ109-67028	Main PCA	Main PCA on page 377
3	CQ109-67020	Formatter (includes Processor, Heat Sink, Fan) (Rev A printers only)	Formatter on page 380
3 & 7	CQ105-67063	Formatter and Encrypted Hard Disk (Rev B printers only)	Formatter on page 380 and Hard Disk Drive (HDD) on page 383
4	CQ109-67012	Interconnect PCA	Interconnect PCA on page 364
5	CQ109-67006	Power Supply Unit (PSU)	Power Supply Unit (PSU) on page 387
6	CQ105-67056	PrintMech PCA	PrintMech PCA on page 391
7	CQ105-67039	Hard Disk Drive for T7100 (includes holder and screws) (Rev A printers only)	Hard Disk Drive (HDD) on page 383
7	CQ101-67004	Hard Disk Drive for T7100 Monochrome (includes holder and screws) (Rev A printers only)	Hard Disk Drive (HDD) on page 383
8	CQ105-67049	EE Box Cover	
9	CQ105-67051	EE Box Cable Kit	
10	CQ109-67030	EE Box Base 42 (includes EE Box Cover and EIO Cover)	
11	Q1273-60237	EIO to PCI Interface	
12	CQ105-67017	EE Box Top Cover	

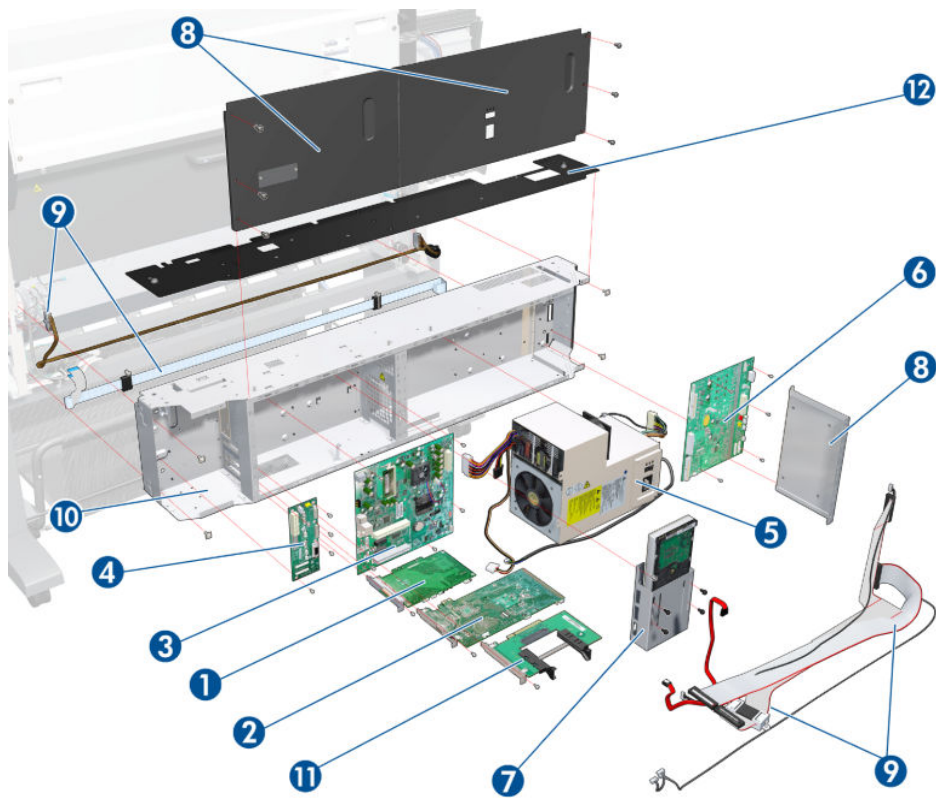

Right Cover

Number in figure	HP part number	Description	Cross-reference
1	CQ105-67048	Right Cover	Cover, Right on page 225
2	CQ105-67052	Right Service Station Door for T7100	Maintenance Cartridge Door on page 333
2	CQ101-67009	Right Service Station Door for T7100 Monochrome	Maintenance Cartridge Door on page 333
3	CQ105-67037	Right Trim	Trim, Right on page 340
4	CQ105-67005	Front Panel and cable	Front Panel on page 239
5	CQ105-67018	Right and Left Smart Roll-loading System Cover	

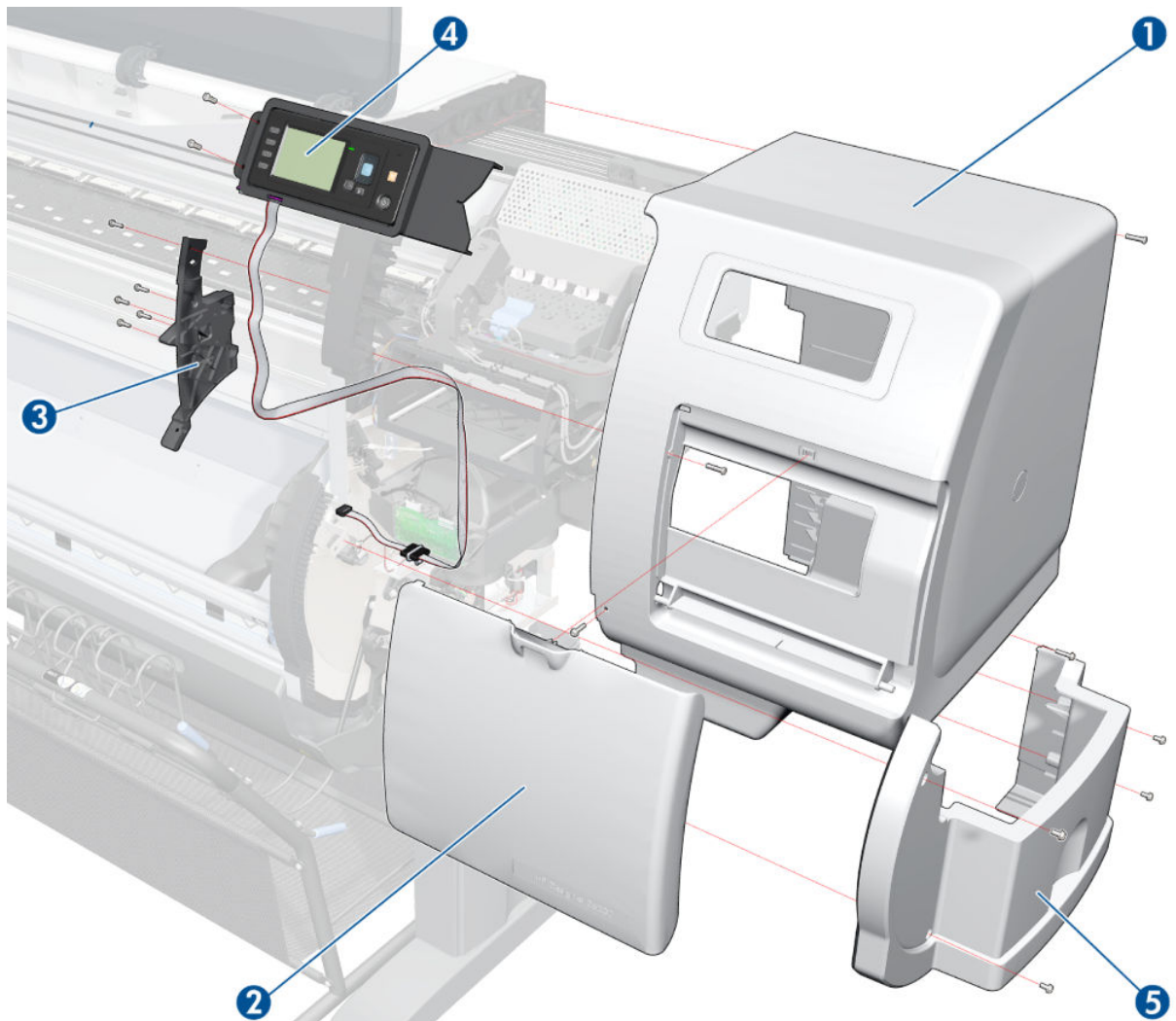

Left Cover

Number in figure	HP part number	Description	Cross-reference
1	CQ105-67036	Left Trim	Trim, Left on page 341
2	CQ105-67026	Left Cover	Cover, Left on page 228
3	CQ105-67018	Right and Left Smart Roll-loading System Cover	

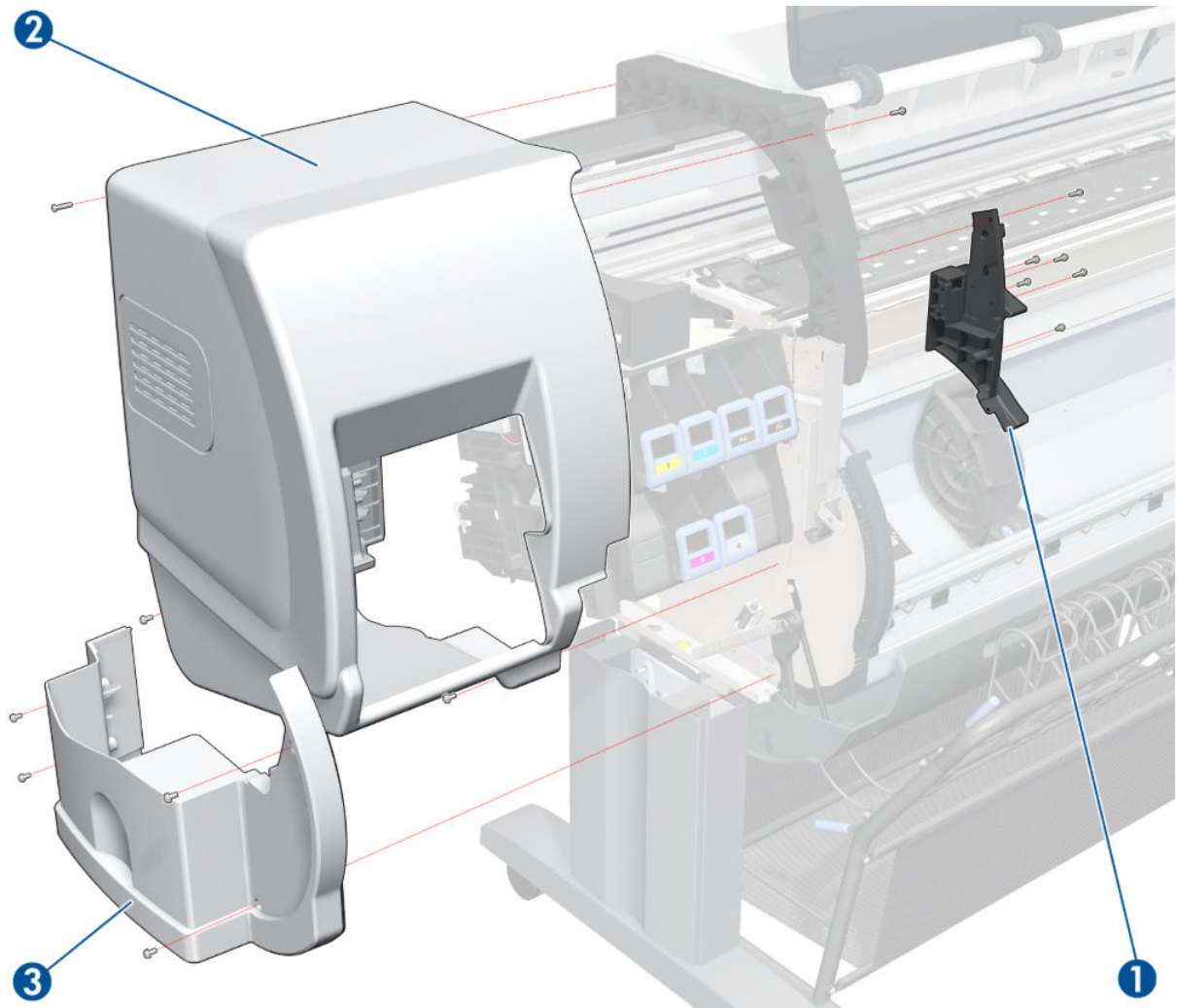

Right-hand Assemblies

Number in figure	HP part number	Description	Cross-reference
1	Q1273-60086	Right Scan-Axis Bracket	-
2	CQ105-67042	Service Station Assembly and cable for T7100	Service Station on page 246
2	CQ101-67005	Service Station Assembly and cable for T7100 Monochrome	Service Station on page 246
3	CQ109-67017	Primer Valves and Primer Tubes Assembly	Primer Valves on page 243
4	Q1273-60084	Aerosol Filter	Aerosol Fan and Filter on page 255
5	CQ109-67003	Aerosol Fan Assembly	Aerosol Fan and Filter on page 255
6	CQ105-67015	Service Station Cable for T7100 (includes Maintenance Cartridge Door Sensor)	Service Station on page 246
6	CQ101-67001	Service Station Cable for T7100 Monochrome (includes Maintenance Cartridge Door Sensor)	Service Station on page 246
7	CQ109-67022	Vacuum Fan Assembly	Vacuum Fan on page 250
8	Q1273-60236	Drop Detector	Drop Detector on page 257
9	CQ109-67016	Primer Assembly	Primer Assembly on page 241
10	CQ105-67061	Vacuum Fan Controller PCA	

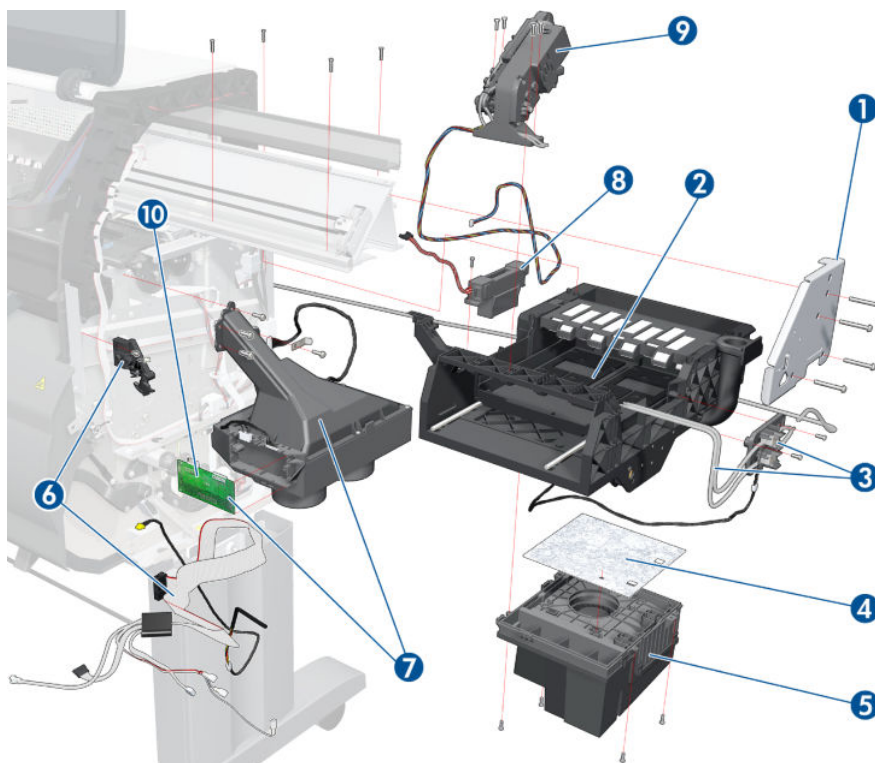

Left-hand Assemblies

Number in figure	HP part number	Description	Cross-reference
1	CQ105-67054	Cartridge Trays for T7100	Cartridge Tray on page 318
1	CQ101-67010	Cartridge Trays for T7100 Monochrome	Cartridge Tray on page 318
2	CQ105-67044	Lower Ink Supply Station (without APS Assembly but including Cartridge Tray)	Ink Supply Station (ISS) on page 314
3	CQ105-67043	Upper Ink Supply Station for T7100 (without APS Assembly but including Cartridge Tray)	Ink Supply Station (ISS) on page 314
3	CQ101-67006	Upper Ink Supply Station for T7100 Monochrome (without APS Assembly but including Cartridge Tray)	Ink Supply Station (ISS) on page 314
4	Q1273-60245	ISS to Cartridge Cable	N/A
5	CQ105-67050	APS Assembly for T7100 (includes Pump, Holder and Relief Valve)	APS Assembly on page 320
5	CQ101-67008	APS Assembly for T7100 Monochrome (includes Pump, Holder and Relief Valve)	APS Assembly on page 320
6	Q6651-60326	Internal Secondary Spittoon	
–	Q6651-60315	Left Scan-axis Bracket	

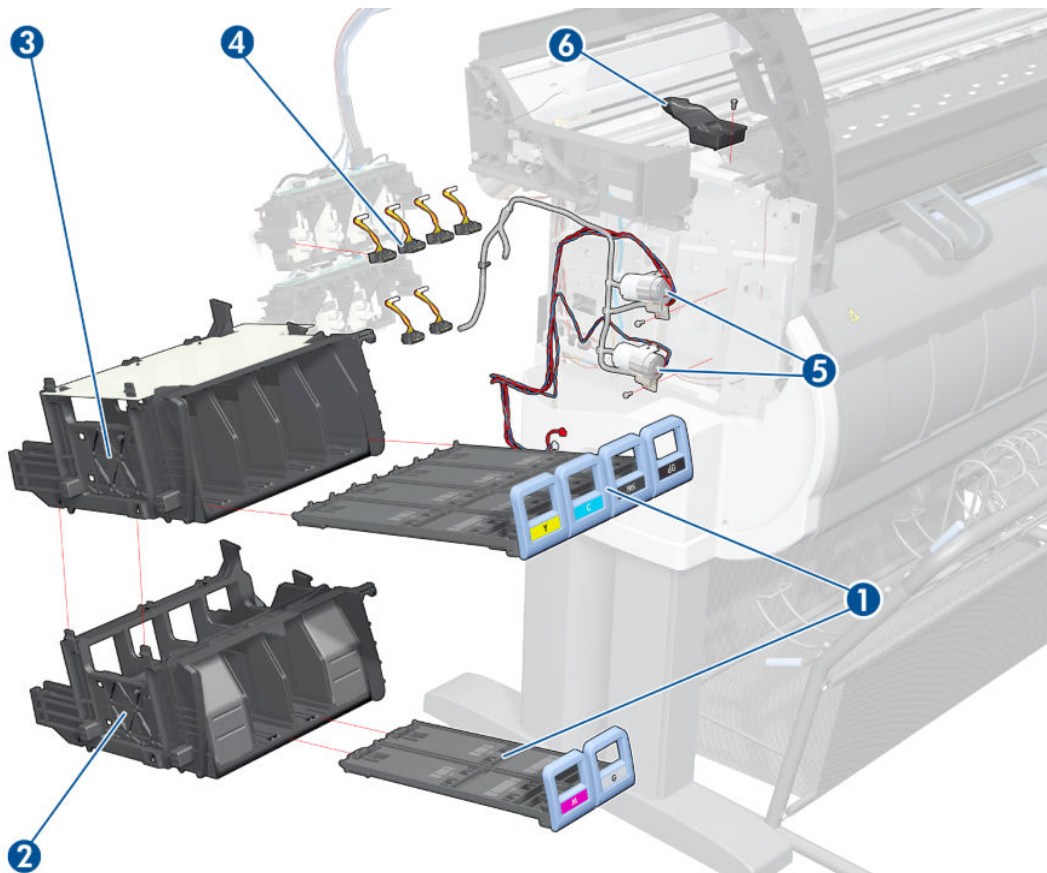

Carriage Assembly

Number in figure	HP part number	Description	Cross-reference
1	CQ105-60130	Line Sensor Assembly ^a	Line Sensor Assembly on page 302
2	Q6651-60051	Encoder Sensor (includes Encoder Strip)	Encoder Strip and Encoder Sensor on page 298
3	CQ109-67011	Carriage Assembly ^b	Carriage on page 286
4	CH955-67007	Cutter Assembly	Cutter Assembly on page 348
5	Q6651-60341	Carriage Stopper (includes Carriage Stopper Screw and Media-Axis Motor Bracket)	Carriage on page 286
6	Q6651-60337	Carriage Flex Cables	Carriage Flex Cables on page 296
7	CQ109-67034	Carriage PCA for T7100	Carriage PCA on page 293
7	CQ101-67011	Carriage PCA for T7100 Monochrome	Carriage PCA on page 293
8	Q6651-60335	Setup Printhead Kit	

a. Includes Line Sensor Holder and Cable

b. Does not include Carriage PCA or Encoder Sensor

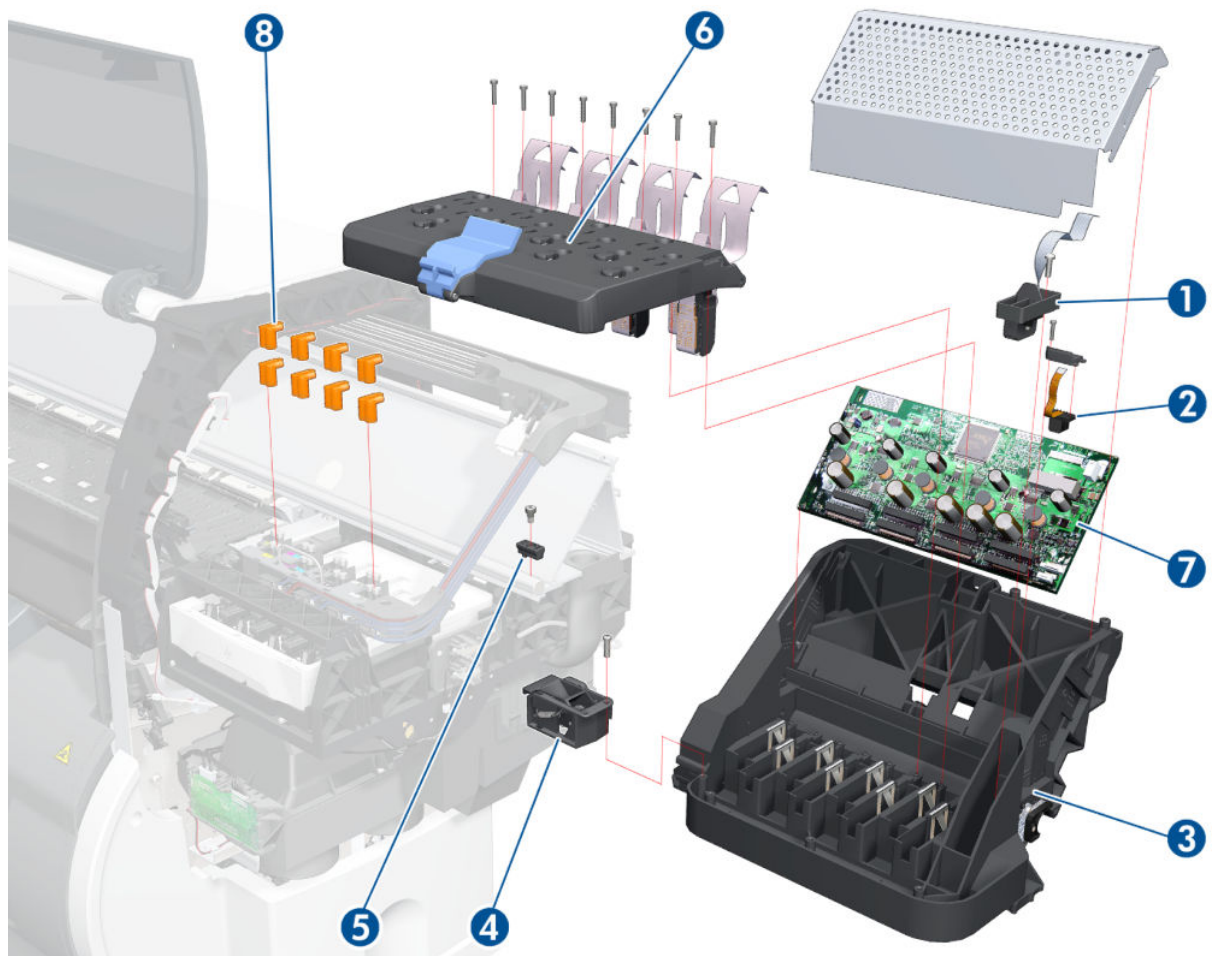

Scan-axis Assemblies

Number in figure	HP part number	Description	Cross-reference
1	Q6651-60051	Encoder Strip and Encoder Sensor Kit	Encoder Strip and Encoder Sensor on page 298
2	CQ109-67001	Scan-Axis Motor	Scan-Axis Motor on page 326
3	CQ105-67045	Ink Supply Tubes and Trailing Cable for T7100	Ink Supply Tubes and Trailing Cable on page 303
3	CQ101-67007	Ink Supply Tubes and Trailing Cable for T7100 Monochrome	Ink Supply Tubes and Trailing Cable on page 303
4	Q6651-60334	Ink Supply Tubes Clips	Ink Supply Tubes and Trailing Cable on page 303
5	Q6651-60336	Rear Tube Shelf and Brackets	Ink Supply Tubes and Trailing Cable on page 303
6	CQ109-67004	Belt and Tensioner Assembly	Cutter Assembly on page 348

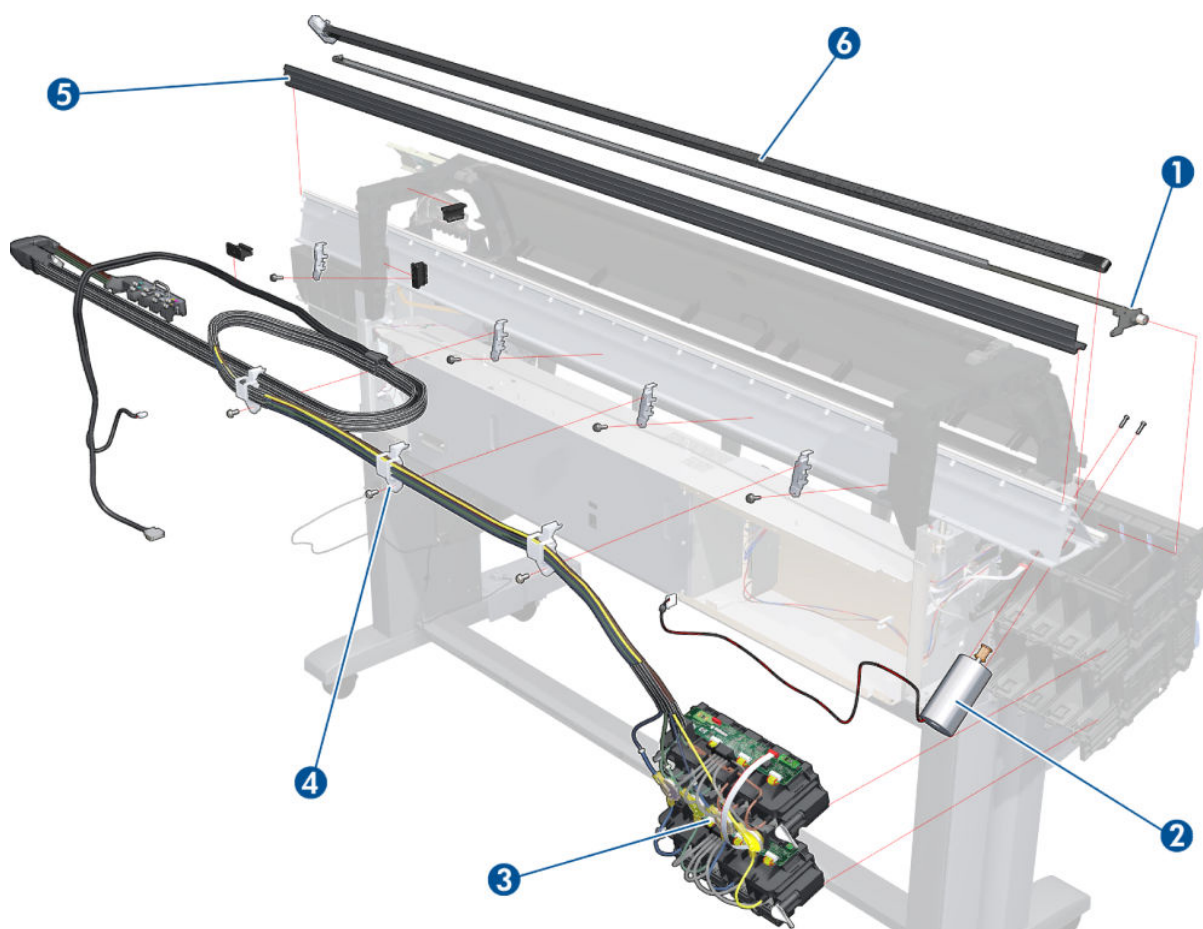

Drive Roller and Media-axis Motor

Number in figure	HP part number	Description	Cross-reference
1	CQ105-67053	Drive Roller Encoder Kit	Scan-Axis Motor on page 326
2	Q1273-60242	Drive Roller Gears and Drive Roller Brake Kit	Drive Roller on page 416
3	Q1273-60039	Drive Roller	Drive Roller on page 416
4	CQ105-67012	Media-Axis Motor	

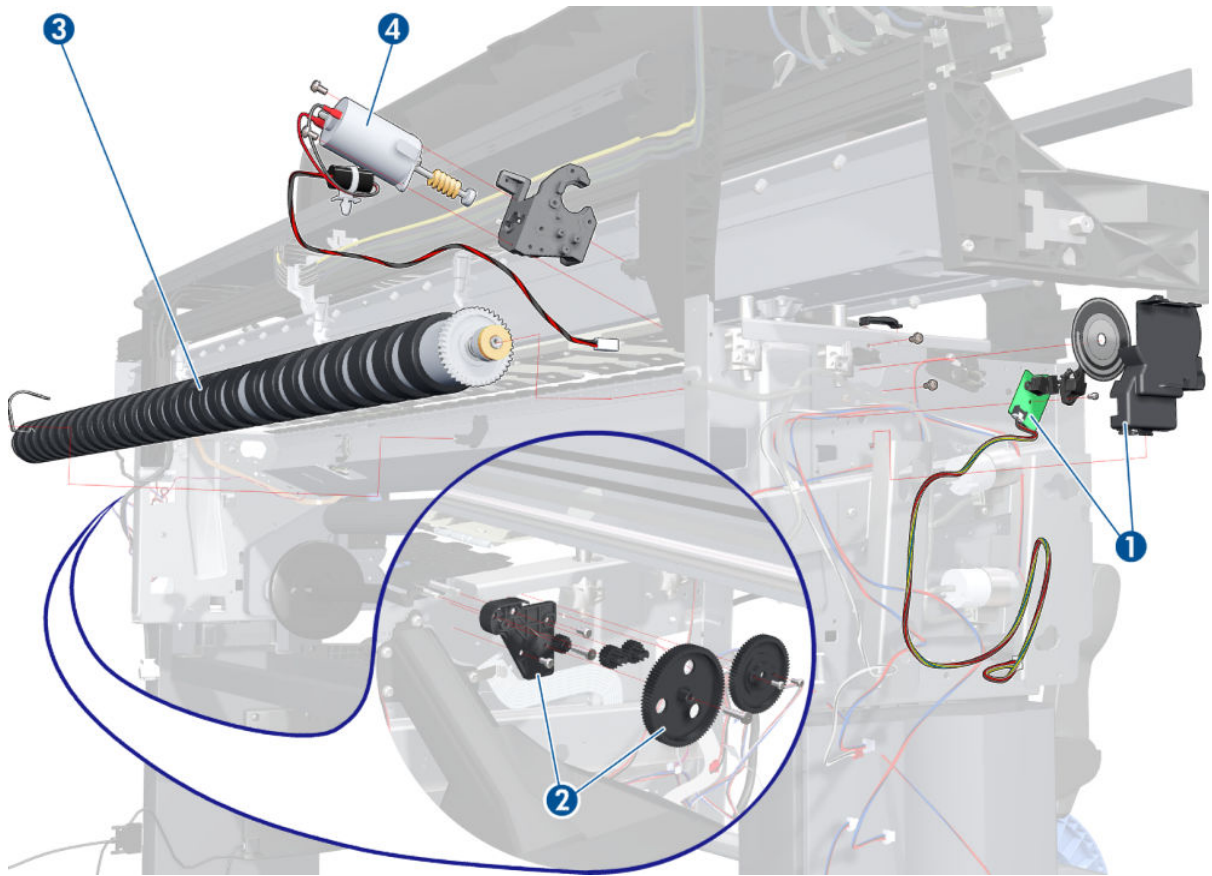

Paper Path Assemblies

Number in figure	HP part number	Description	Cross-reference
1	Q6651-60281	Center Platen ^a	Center Platen on page 398
2	CQ105-67002	Media Deflector (1)	Media Deflector on page 335
3	Q6651-60270	OMAS Module	Optical Media Advance Sensor (OMAS) on page 359
4	CQ105-67040	OMAS Cable	OMAS Cable on page 371
5	CQ105-67038	Output Platen (includes 3 Media Deflectors)	
6	CQ105-67004	Deflector and Stacker	
–	CQ109-67042	HP Coated roll	

a. Includes the Attachment Screw Retainer

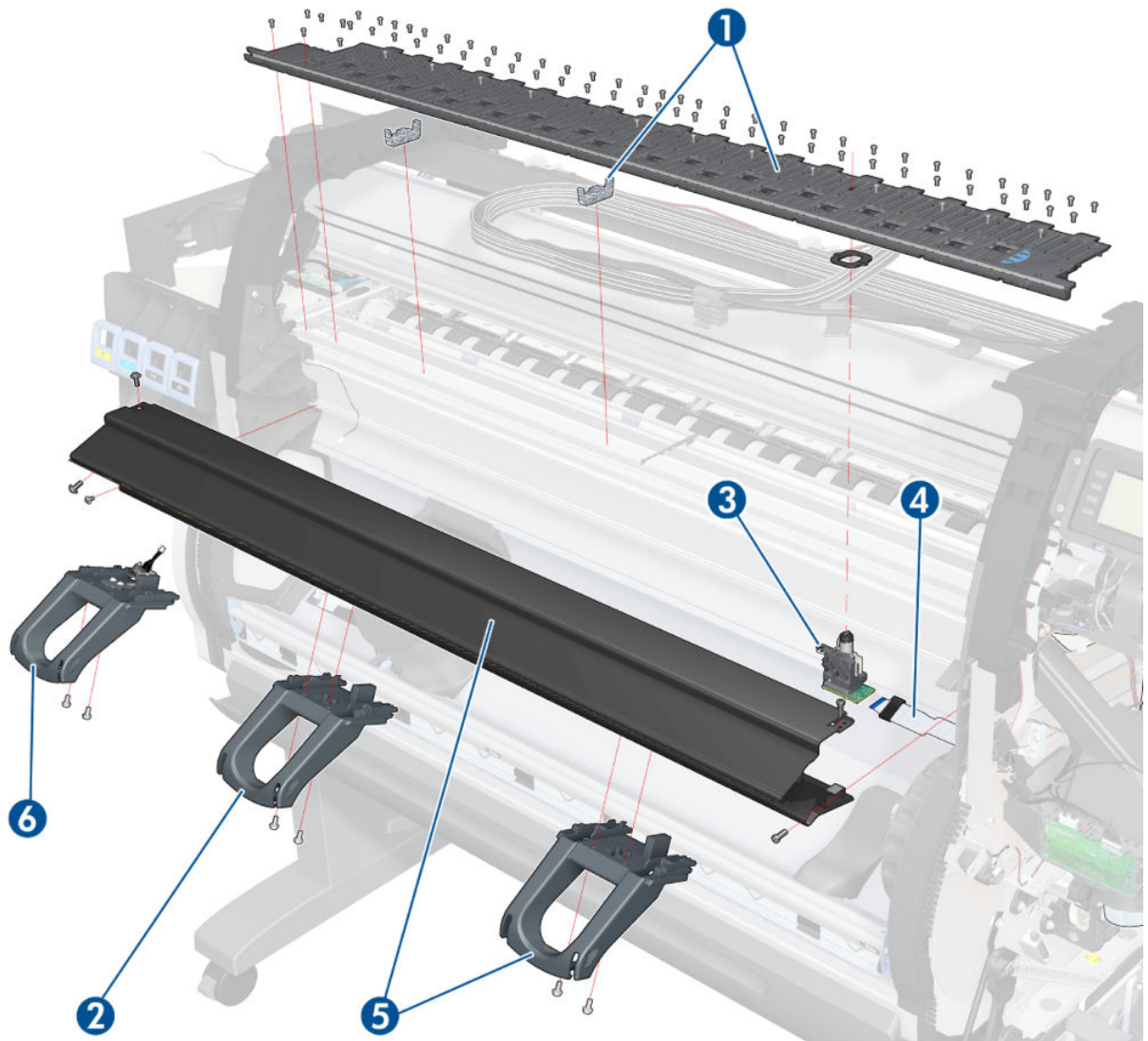

Pinchwheel Assembly

Number in figure	HP part number	Description	Cross-reference
1	CQ105-67035	Complete Pinchwheel Assembly	Pinchwheel Assembly on page 412
2	Q1271-60185	Pinchwheel Lever	
3	Q1271-60185	Pinchwheels Kit	Pinchwheel Assembly on page 412

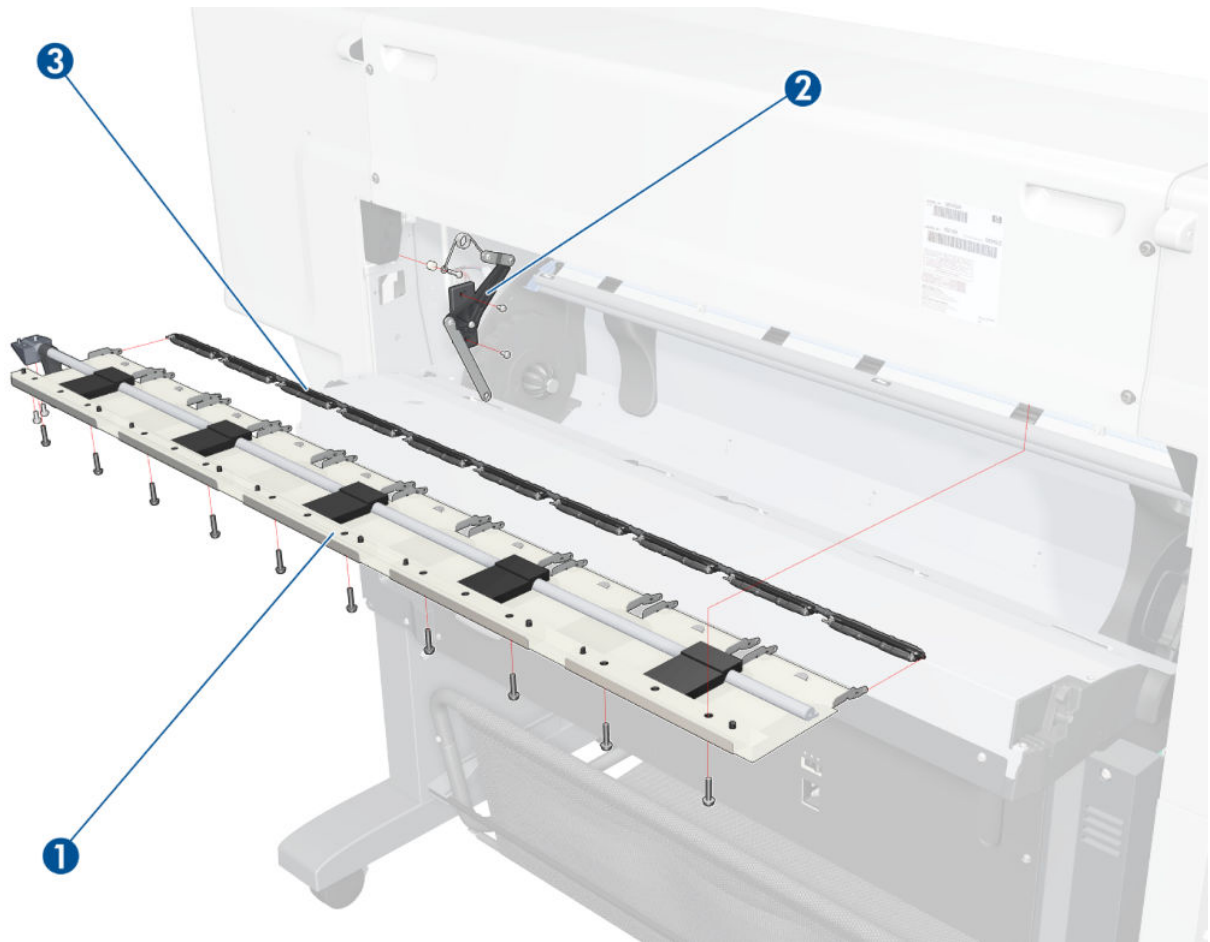

Smart Roll-loading System A

Number in figure	HP part number	Description	Cross-reference
1	CQ105-67010	Multi-roll Gear and Motor	
2	CQ105-67027	Multi-roll Door Arms	
3	CQ105-67011	Indexer and Right Slider	
4	CQ105-67029	Multi-roll Door Springs	
5	CQ105-67028	Dampers	
6	CQ105-67001	Rewinder Gear and Motor	
7	CQ105-67007	Door Switches	

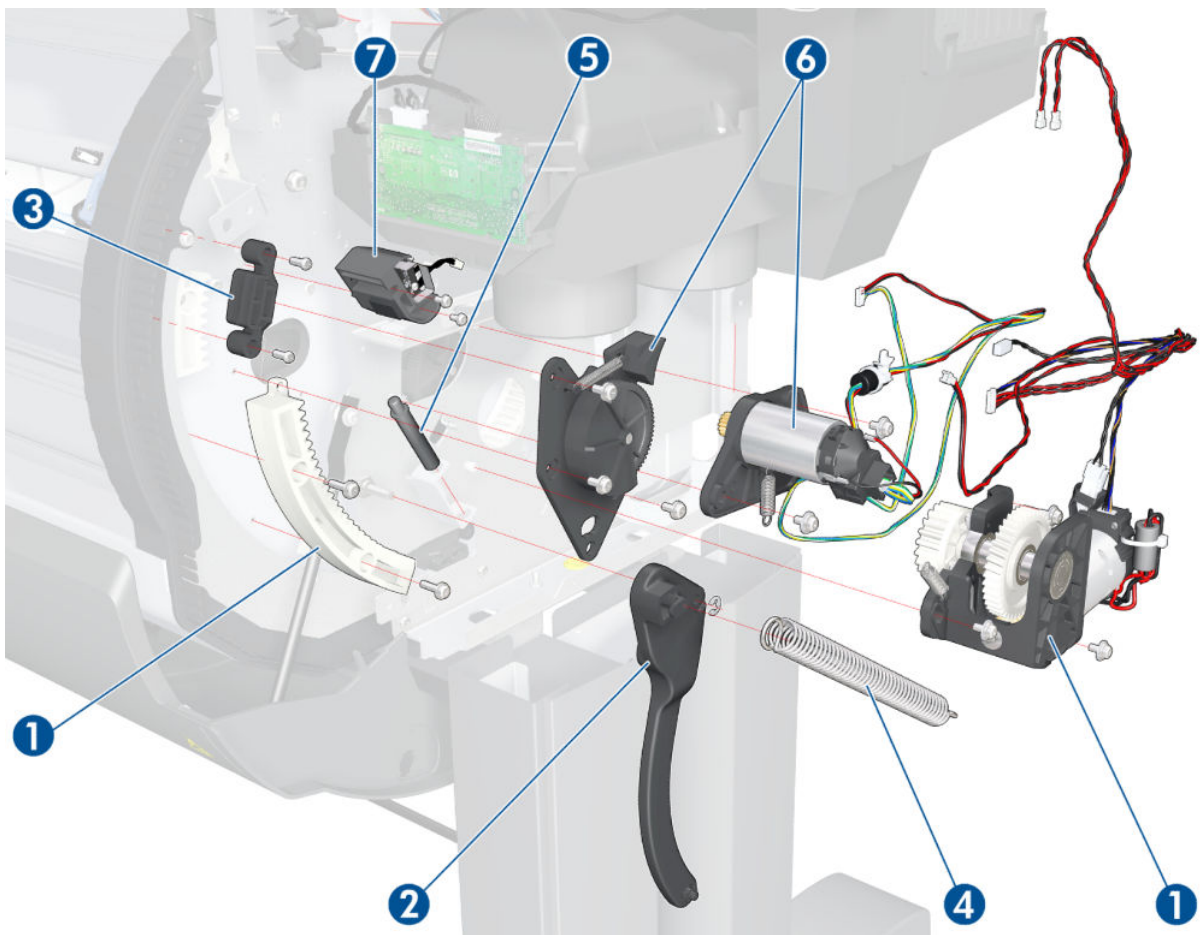

Smart Roll-loading System B

Number in figure	HP part number	Description	Cross-reference
8	CQ105-67003	Hub Support and Adaptors	
9	CQ105-67020	Door	
10	CQ105-67057	3-inch Adaptor Kit	
11	CQ105-67014	Cosmetic Sheet Metal and Sep Mnt	
12	CQ105-67009	Threading Roller	
13	CQ105-67006	Paper Feed Brake	

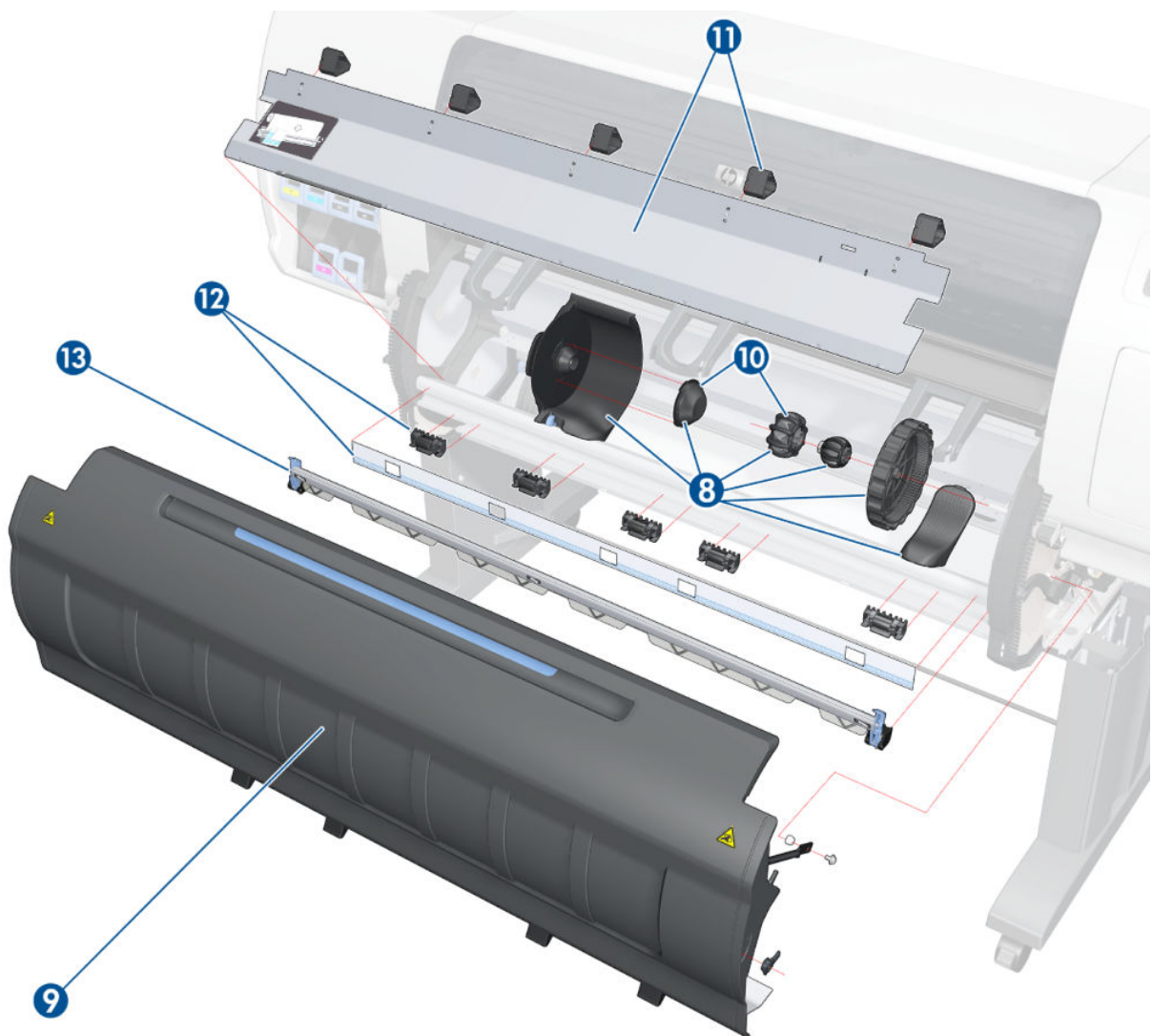

Rear Door

Number in figure	HP part number	Description	Cross-reference
1	CQ105-67030	Rear Door	Rear Door on page 352
2	CQ105-67031	Rear Door Right Flange	
3	CQ105-67023	Rear Trim Left and Right	

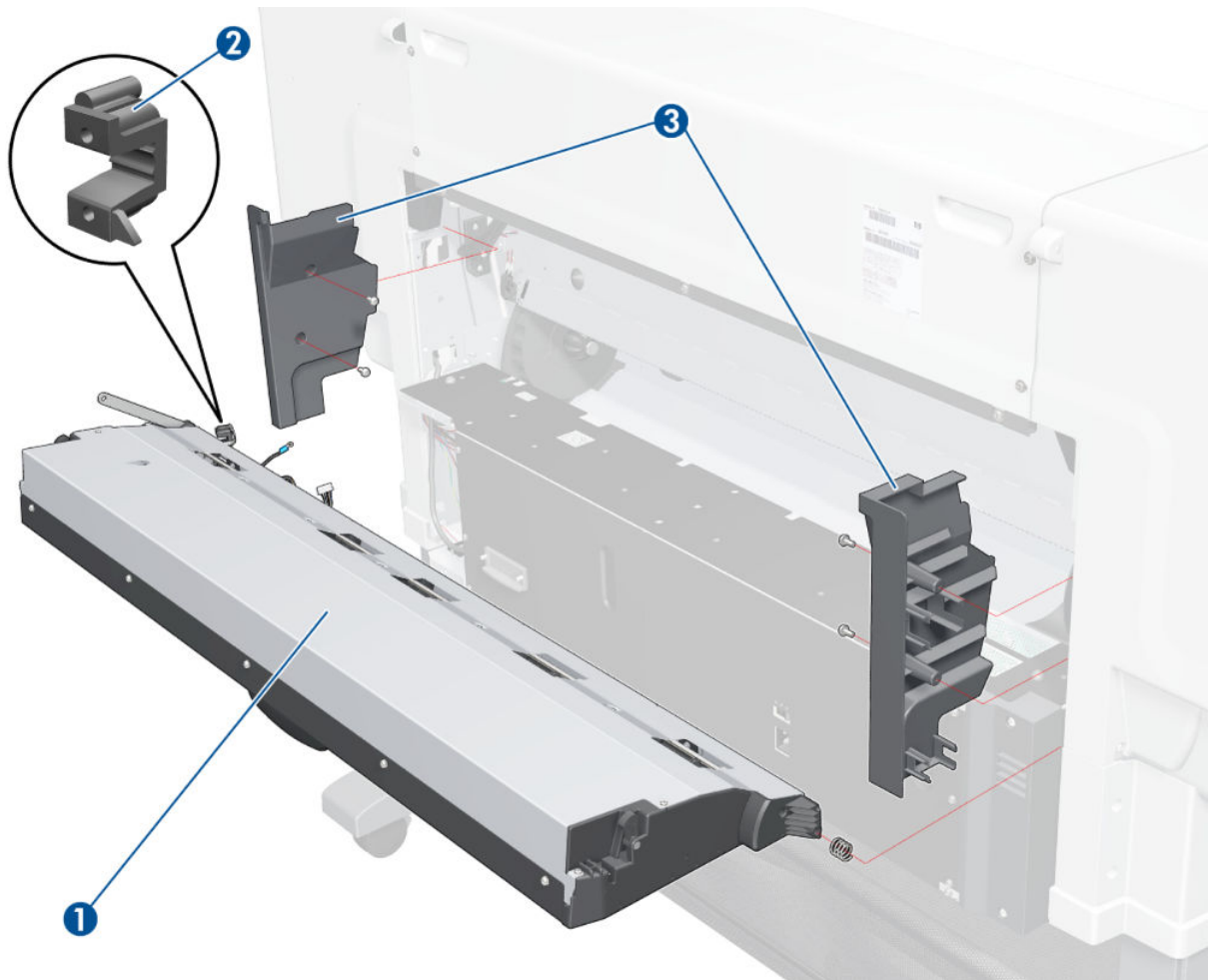

Entry Platen

Number in figure	HP part number	Description	Cross-reference
1	CQ105-67032	Entry Platen (includes kit 2,3,5 and Right Slider)	
2	CQ105-67033	Roller Guide with Maylar	
3	CQ105-67034	Left Slider	
4	CQ105-67011	Indexer and Right Slider	
5	CQ105-67008	Media Sensor	Media Sensor on page 342

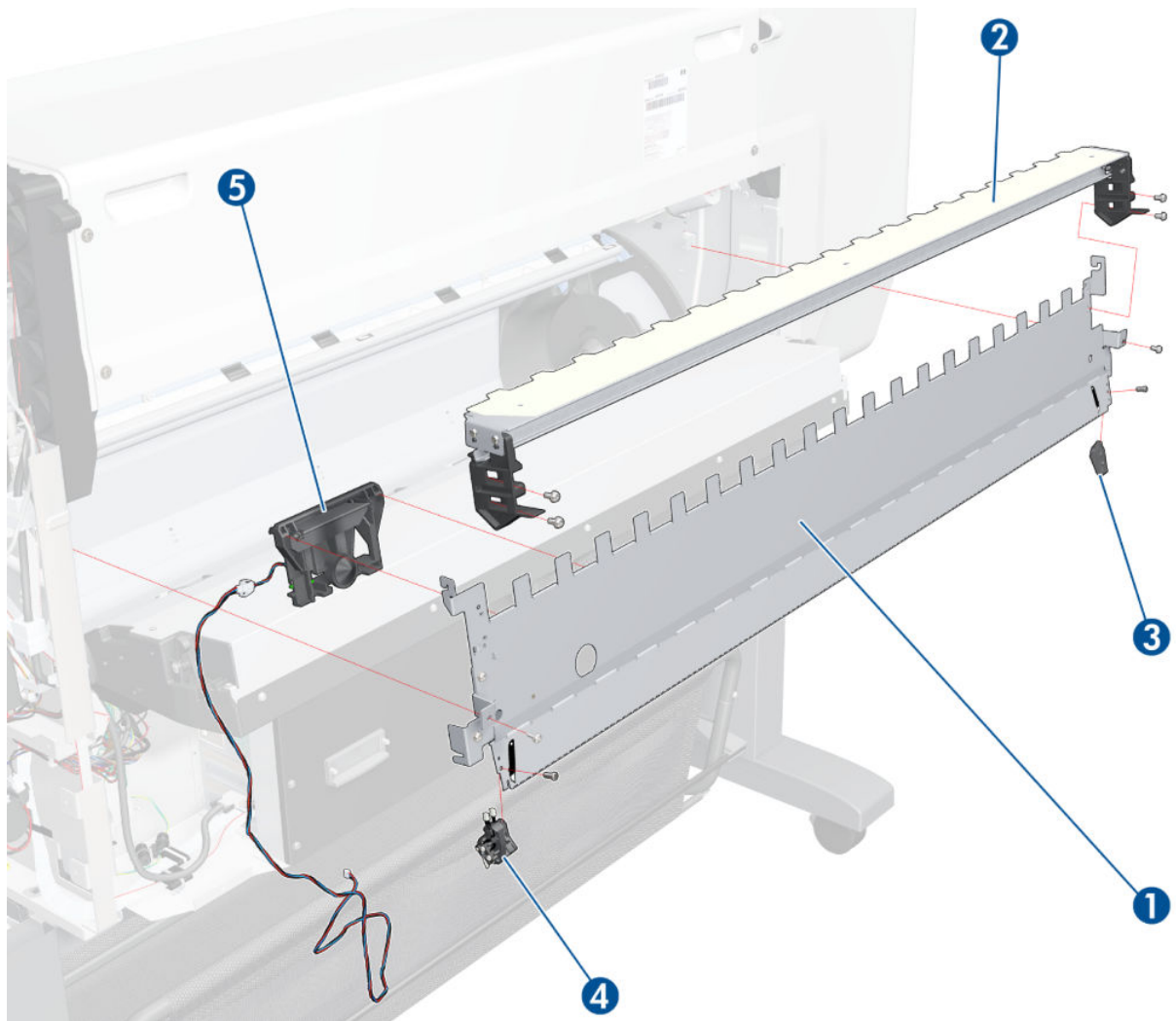

Miscellaneous parts

HP part number	Description
Q1273-60097	Right Arc
Q1273-60098	Left Arc
Q6715A	User's Maintenance/Cleaning Kit
	Preventive Maintenance Kit # 1 for T7100:
	<ul style="list-style-type: none"> • Scan-Axis Motor (see Scan-axis Assemblies on page 197)
CQ105-67019	<ul style="list-style-type: none"> • Encoder Strip (see Scan-axis Assemblies on page 197) • Belt Assembly (see Scan-axis Assemblies on page 197) • Carriage Assembly without PCA and Cutter
	Preventive Maintenance Kit # 1 for T7100 Monochrome:
	<ul style="list-style-type: none"> • Scan-Axis Motor (see Scan-axis Assemblies on page 197)
CQ101-67003	<ul style="list-style-type: none"> • Encoder Strip (see Scan-axis Assemblies on page 197) • Belt Assembly (see Scan-axis Assemblies on page 197) • Carriage Assembly without PCA and Cutter
	Preventive Maintenance Kit # 2:
	<ul style="list-style-type: none"> • Aerosol Filter (see Service Station on page 246)
CQ105-67041	<ul style="list-style-type: none"> • Service Station Aerosol Assembly (see Service Station on page 246) • Ink Absorber (see User's Guide) • Line Sensor (see Line Sensor Assembly on page 302) • Encoder Strip (see Scan-axis Assemblies on page 197)
	Preventive Maintenance Kit #3:
	<ul style="list-style-type: none"> • Rewinder Gear and Motor, CQ105-67001
	<ul style="list-style-type: none"> • Hub Support and Adaptor, CQ105-67003
	<ul style="list-style-type: none"> • Paper Feed Brake, CQ105-67006
	<ul style="list-style-type: none"> • Media Sensor, CQ105-67008
	<ul style="list-style-type: none"> • Media Axis Motor
	<ul style="list-style-type: none"> • Drive Roller Encoder Kit, CQ105-67053
	<ul style="list-style-type: none"> • Drive Roller Gears and Driver Roller Brake Kit, Q1273-60242
CQ533-60001	Power Cord Kit for Europe (EU, Switzerland, Middle East, South Africa)
CQ533-60002	Power Cord Kit for America (USA, Canada, Mexico, Argentina, Brazil, Chile)
CQ533-60003	Power Cord Kit for Asia (Singapore, Hong Kong, India, Thailand, Philippines, Vietnam, Cambodia, Korea, Indonesia, Japan, China, Taiwan, Australia, New Zealand)

HP part number	Description
	CPU Fan
	Jumper Cord for Chile, Uruguay, Argentina

Stacker

- [Stand](#)
- [Covers and Sensors](#)
- [Paper Trays](#)
- [Rollers and Transport Belt](#)
- [Roller Bushings](#)
- [Drive Motor](#)
- [Electronics Module](#)
- [Input Trays](#)
- [Miscellaneous](#)

Stand

Number in figure	HP part number	Description	Cross-reference
1	Q5677-60024	Complete Stand (including Right and Left Leg, Leg Extension, Crossbeam)	
2	Q5677-60025	Wheels and Foot Extension Kit	



Covers and Sensors

Number in figure	HP part number	Description	Cross-reference
1	Q5677-60022	Left Cover	
2	Q5677-60023	Right Cover	
3	Q5677-60011	Top Cover (including Front Cover)	
4	Q5677-60004	Lower Front Cover	
5	Q5677-60002	Tray Full and Media Sensor	
6	Q5677-60001	Front Cover Sensor	
7	Q5677-60019	Safety Temperature Sensor	
8	Q5677-60018	Temperature Sensor	
9	Q5677-60017	Pinchwheels (5)	

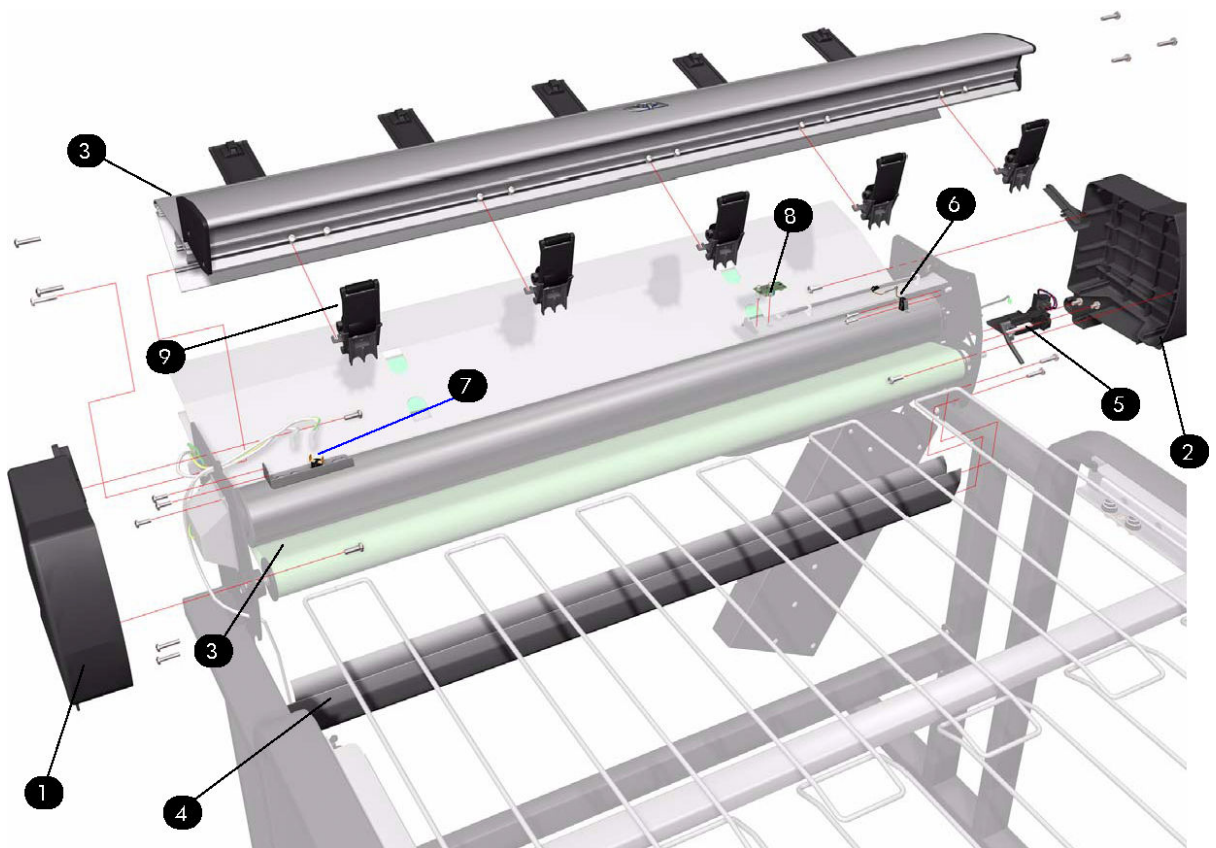

Paper Trays

Number in figure	HP part number	Description	Cross-reference
1	Q5677-60026	Receiving Paper Tray	
2	Q5677-60027	Tray Extension	

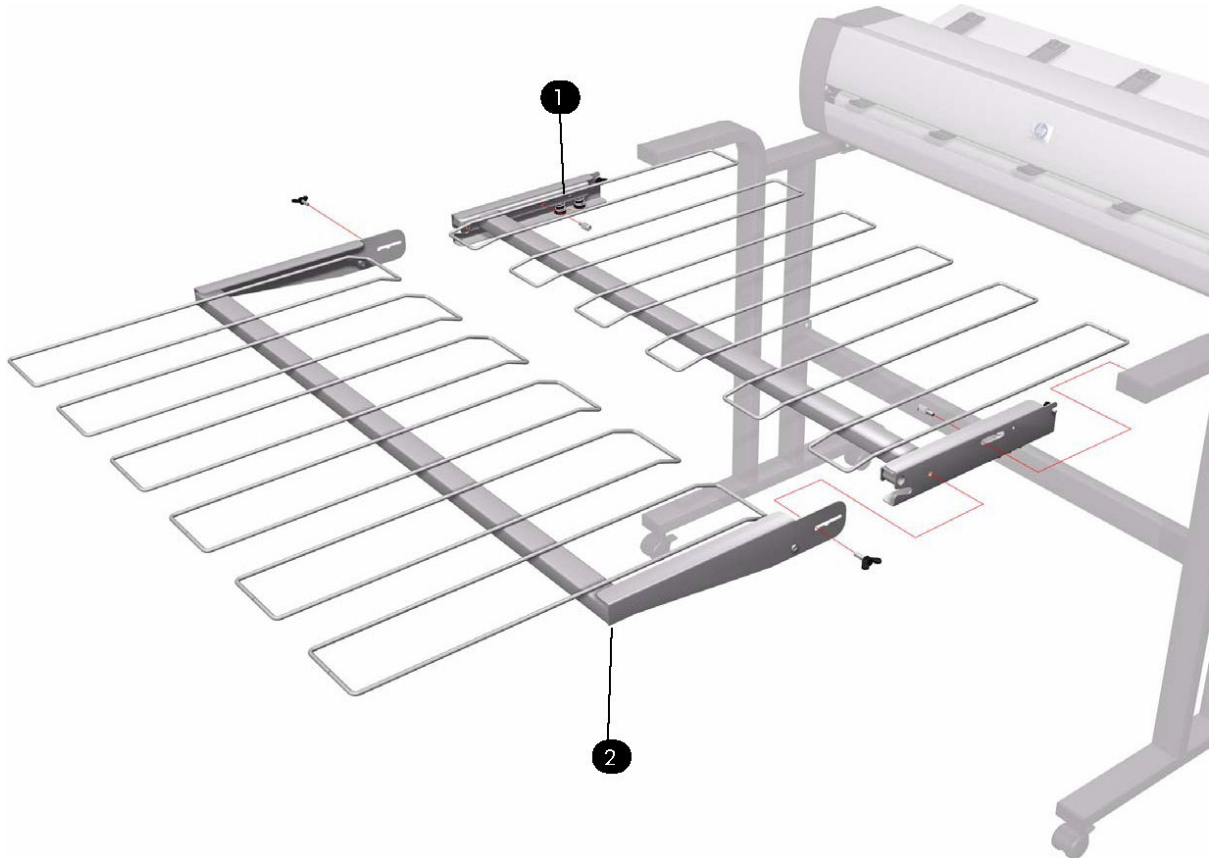

Rollers and Transport Belt

Number in figure	HP part number	Description	Cross-reference
1	Q5677-60020	Heat Roller	
2	Q5677-60040	Heating Lamp (including 6 Springs) (110 V)	
	Q5677-60021	Heating Lamp (including 6 Springs) (220 V)	
3	Q5677-60013	Output Roller	
4	Q5677-60014	Input Roller	
5	Q5677-60015	Transport Belt	

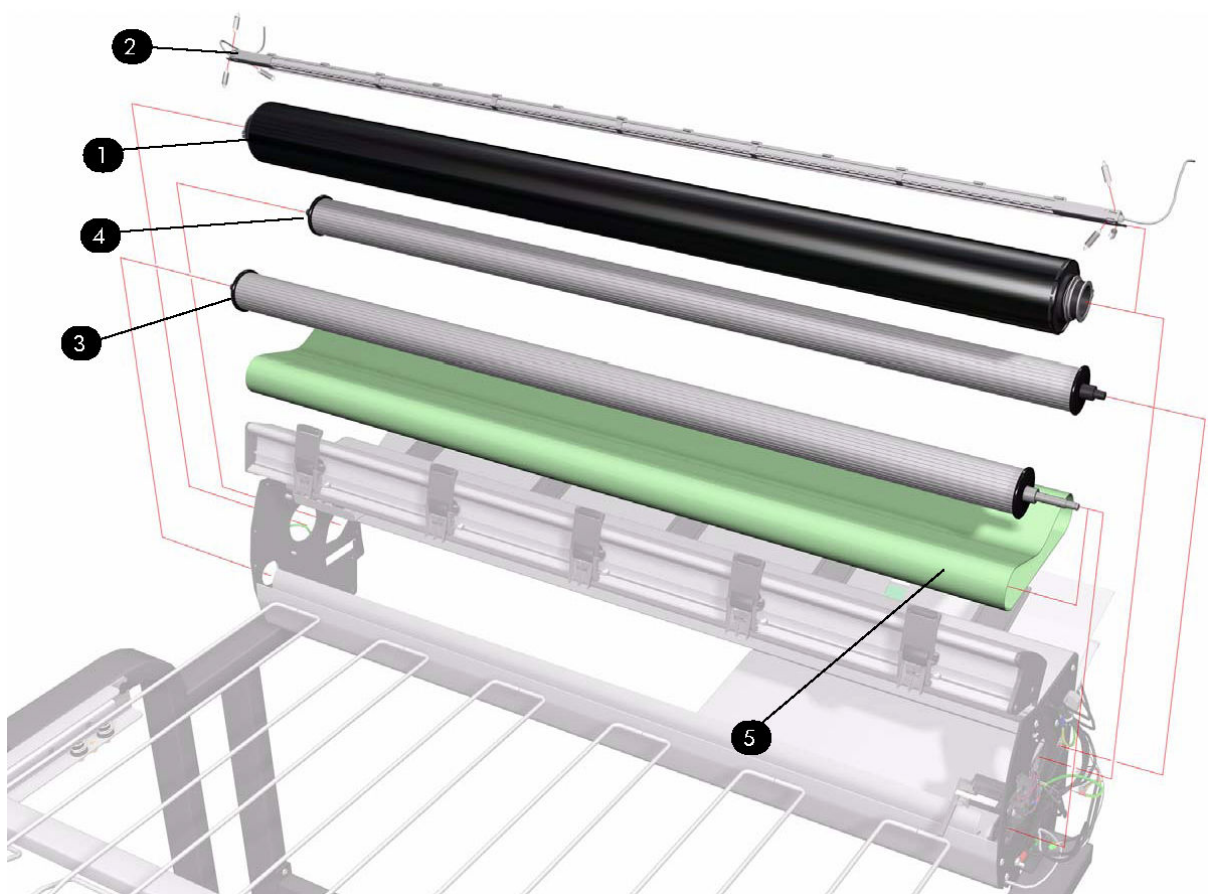

Roller Bushings

Number in figure	HP part number	Description	Cross-reference
1	Q5677-60031	Roller Bushing Kit (including Left Output Roller Bearing, Left Input Roller Bearing, Right Input Roller Bearing, 2 Springs, Circlip)	

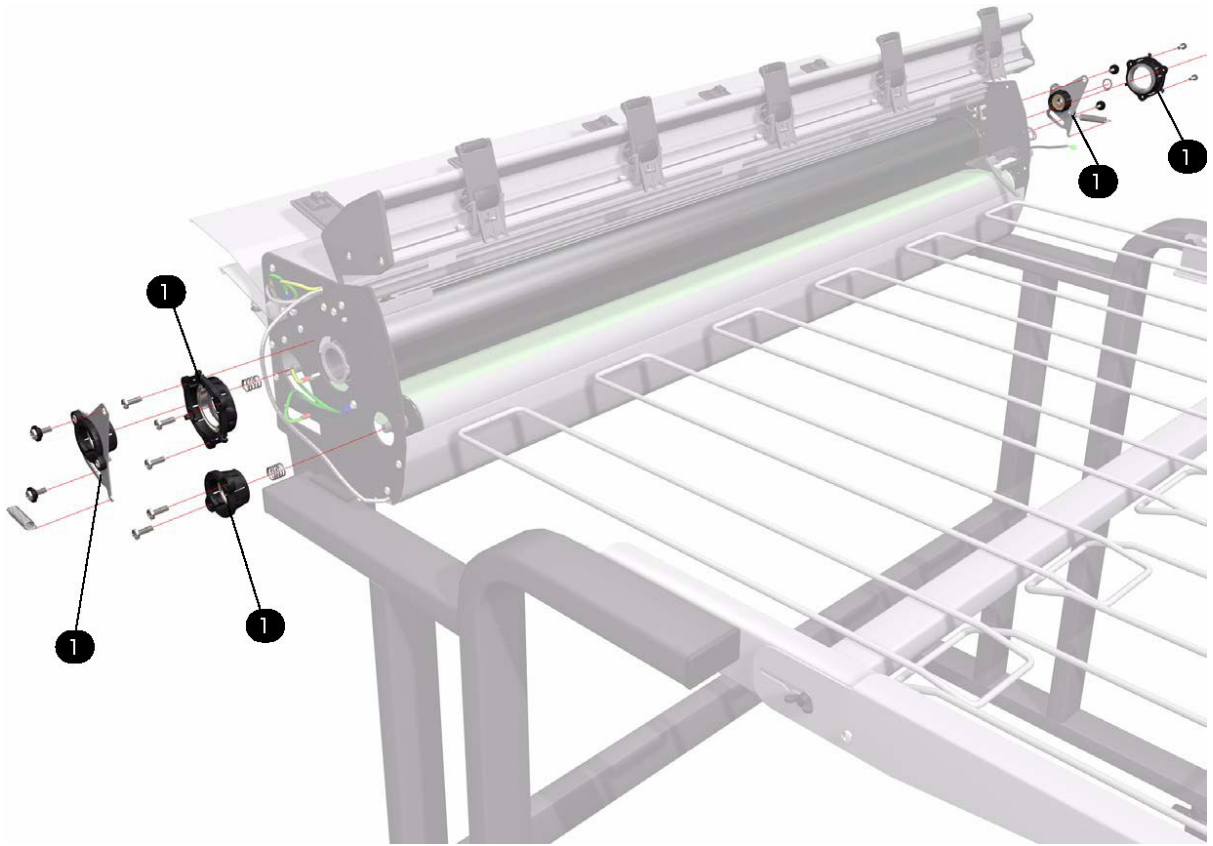

Drive Motor

Number in figure	HP part number	Description	Cross-reference
1	Q5677-60016	Drive Motor Assembly (including Gear and O-ring)	

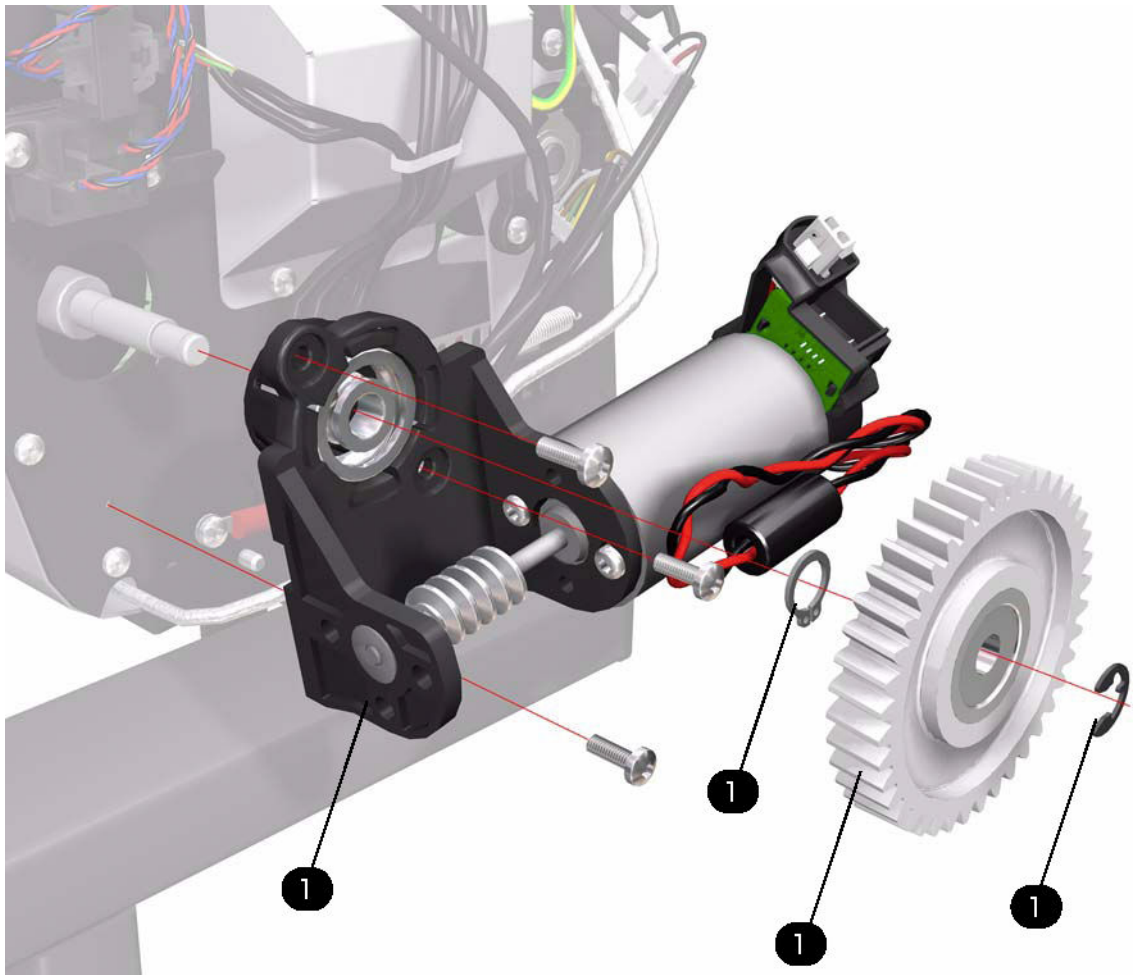

Electronics Module

Number in figure	HP part number	Description	Cross-reference
1	Q5677-60012	Electronics Module Assembly (220 V) (not including Main PCA or Power Supply Unit)	
	Q5677-60039	Electronics Module Assembly (110 V) (not including Main PCA or Power Supply)	
2	Q5677-60033	Main PCA	
3	Q5677-60032	Power Supply	
4	Q5677-60035	Fuse (220 V)	
	Q5677-60038	Fuse (110 V)	
5	CQ742-67003	Data Cable	
6	Q5677-60029	Cables Assembly	

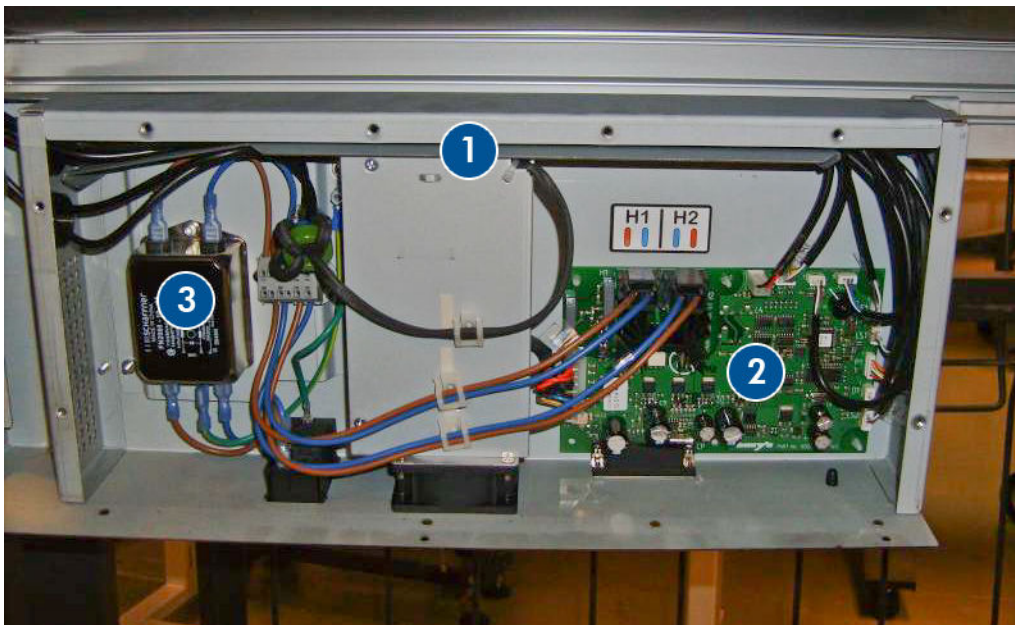

Input Trays

Number in figure	HP part number	Description	Cross-reference
1	Q5677-60009	Input Platen	
2	Q5677-60005	Lower Input Platen	
3	Q5677-60006	Right Printer Interlock	
4	Q5677-60007	Left Printer Interlock	
5	Q5677-60010	Deflectors	
6	Q5677-60008	Buffer Sensor	

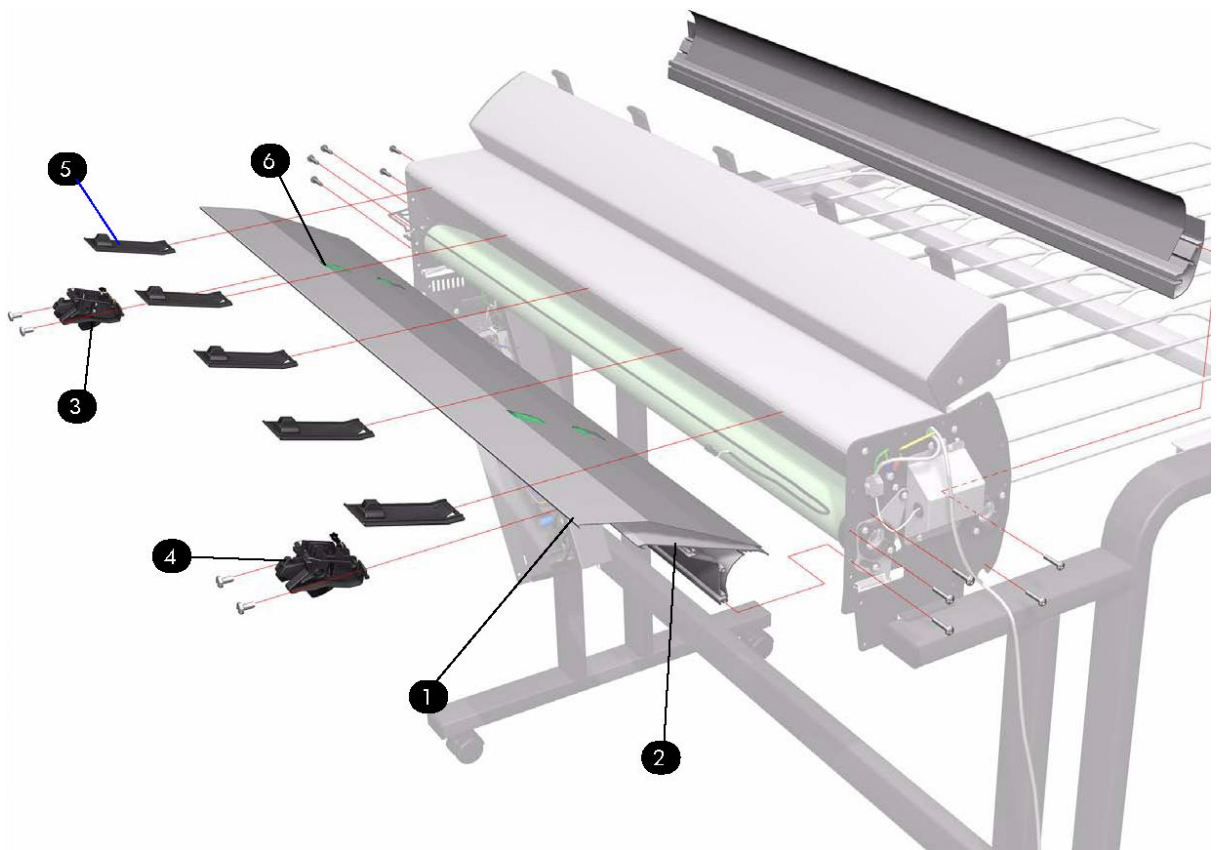

Miscellaneous

Number in figure	HP part number	Description	Cross-reference
1	Q5677-60030	Packaging	
2	Q5677-60034	Setup Screws	
3	Q5677-60041	Heating Tube Covers	

Heating Tube Cover

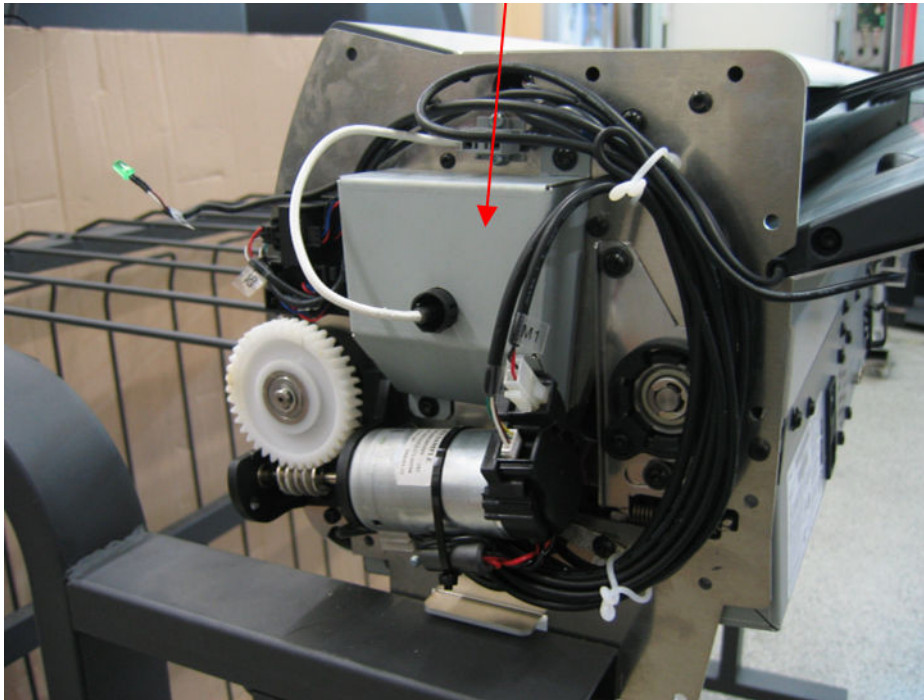

9 Printer part removal and installation

Two contents lists are provided for this chapter to help you to quickly find the service part you want to replace. The first list is provided in Service Part Order and the second in Disassembly Order.

- [Service part order](#)
- [Disassembly order](#)

Service part order

- [Introduction on page 223](#)
- [Screw types on page 224](#)
- [Aerosol Fan and Filter on page 255](#)
- [APS Assembly on page 320](#)
- [Belt Assembly on page 345](#)
- [Carriage on page 286](#)
- [Carriage Flex Cables on page 296](#)
- [Carriage PCA on page 293](#)
- [Cartridge Tray on page 318](#)
- [Center Platen on page 398](#)
- [Connector Cover, Left on page 238](#)
- [Connector Cover, Right on page 237](#)
- [Cover, Left on page 228](#)
- [Cover, Right on page 225](#)
- [Cover, Top on page 232](#)
- [Cutter Assembly on page 348](#)
- [Deflector and Stacker Switch on page 339](#)
- [Drive Roller on page 416](#)
- [Drop Detector on page 257](#)
- [EIO to PCA Interface Card on page 366](#)
- [Electronics Module on page 395](#)
- [Encoder Disc and Sensor on page 408](#)
- [Encoder Strip and Encoder Sensor on page 298](#)
- [Entry Platen on page 356](#)
- [Formatter on page 380](#)
- [Formatter Battery on page 394](#)
- [Front Panel on page 239](#)
- [Hard Disk Drive \(HDD\) on page 383](#)
- [Hub, Left, and Roll Support on page 282](#)
- [Indexer and Right Slider on page 278](#)

- [Ink Supply Station \(ISS\) on page 314](#)
- [Ink Supply Tubes and Trailing Cable on page 303](#)
- [Interconnect Cables on page 410](#)
- [Interconnect PCA on page 364](#)
- [ISS to Cartridge Cables on page 312](#)
- [Line Sensor Assembly on page 302](#)
- [Main PCA on page 377](#)
- [Maintenance Cartridge Door on page 333](#)
- [Maintenance Cartridge Door Sensor on page 334](#)
- [Media-Axis Motor on page 330](#)
- [Media Deflector on page 335](#)
- [Media Sensor on page 342](#)
- [OMAS Cable on page 371](#)
- [OMAS Controller Card on page 368](#)
- [Optical Media Advance Sensor \(OMAS\) on page 359](#)
- [Output Platen on page 336](#)
- [Paper Feed Brake on page 262](#)
- [Pinchwheel Assembly on page 412](#)
- [Pinchwheel Lever on page 355](#)
- [Power Supply Unit \(PSU\) on page 387](#)
- [Primer Assembly on page 241](#)
- [Primer Valve Cable on page 244](#)
- [Primer Valves on page 243](#)
- [PrintMech PCA on page 391](#)
- [PW Cover on page 349](#)
- [Rear Door on page 352](#)
- [Rear Trim, Left on page 350](#)
- [Rear Trim, Right on page 351](#)
- [Rewinder Gear and Motor on page 274](#)
- [Roller Guide with Mylar on page 358](#)
- [Scan-Axis Motor on page 326](#)

- [Service Station on page 246](#)
- [Smart Roll-loading System Cosmetic Sheet Metal and Separator on page 344](#)
- [Smart Roll-loading System Cover, Left on page 261](#)
- [Smart Roll-loading System Cover, Right on page 260](#)
- [Smart Roll-loading System Damper on page 280](#)
- [Smart Roll-loading System Door on page 284](#)
- [Smart Roll-loading System Door Arms on page 272](#)
- [Smart Roll-loading System Door Spring on page 271](#)
- [Smart Roll-loading System Door Switch on page 280](#)
- [Smart Roll-loading System Gear on page 266](#)
- [Smart Roll-loading System Motor on page 264](#)
- [Threading Roller on page 263](#)
- [Trim, Left on page 341](#)
- [Trim, Right on page 340](#)
- [Vacuum Fan on page 250](#)
- [Vacuum Fan Cable on page 253](#)
- [Window on page 229](#)
- [Window Position Sensor on page 346](#)

Disassembly order

- [Introduction](#)
- [Screw types](#)
- [Cover, Right](#)
- [Cover, Left](#)
- [Window](#)
- [Cover, Top](#)
- [Connector Cover, Right](#)
- [Connector Cover, Left](#)
- [Front Panel](#)
- [Primer Assembly](#)
- [Primer Valves](#)
- [Primer Valve Cable](#)
- [Service Station](#)
- [Vacuum Fan](#)
- [Vacuum Fan Cable](#)
- [Aerosol Fan and Filter](#)
- [Drop Detector](#)
- [Smart Roll-loading System Cover, Right](#)
- [Smart Roll-loading System Cover, Left](#)
- [Paper Feed Brake](#)
- [Threading Roller](#)
- [Smart Roll-loading System Motor](#)
- [Smart Roll-loading System Gear](#)
- [Smart Roll-loading System Door Spring](#)
- [Smart Roll-loading System Door Arms](#)
- [Rewinder Gear and Motor](#)
- [Indexer and Right Slider](#)
- [Smart Roll-loading System Damper](#)
- [Smart Roll-loading System Door Switch](#)
- [Hub, Left, and Roll Support](#)

- [Smart Roll-loading System Door](#)
- [Carriage](#)
- [Carriage PCA](#)
- [Carriage Flex Cables](#)
- [Encoder Strip and Encoder Sensor](#)
- [Line Sensor Assembly](#)
- [Ink Supply Tubes and Trailing Cable](#)
- [ISS to Cartridge Cables](#)
- [Ink Supply Station \(ISS\)](#)
- [Cartridge Tray](#)
- [APS Assembly](#)
- [Scan-Axis Motor](#)
- [Media-Axis Motor](#)
- [Maintenance Cartridge Door](#)
- [Maintenance Cartridge Door Sensor](#)
- [Media Deflector](#)
- [Output Platen](#)
- [Deflector and Stacker Switch](#)
- [Trim, Right](#)
- [Trim, Left](#)
- [Media Sensor](#)
- [Smart Roll-loading System Cosmetic Sheet Metal and Separator](#)
- [Belt Assembly](#)
- [Window Position Sensor](#)
- [Cutter Assembly](#)
- [PW Cover](#)
- [Rear Trim, Left](#)
- [Rear Trim, Right](#)
- [Rear Door](#)
- [Pinchwheel Lever](#)
- [Entry Platen](#)

- [Roller Guide with Mylar](#)
- [Optical Media Advance Sensor \(OMAS\)](#)
- [Interconnect PCA](#)
- [EIO to PCA Interface Card](#)
- [OMAS Controller Card](#)
- [OMAS Cable](#)
- [Main PCA](#)
- [Formatter](#)
- [Hard Disk Drive \(HDD\)](#)
- [Power Supply Unit \(PSU\)](#)
- [PrintMech PCA](#)
- [Formatter Battery](#)
- [Electronics Module](#)
- [Center Platen](#)
- [Encoder Disc and Sensor](#)
- [Interconnect Cables](#)
- [Pinchwheel Assembly](#)
- [Drive Roller](#)

Introduction

This chapter is a step-by-step guide to the removal and installation of the key components of the printer. You may find it useful to tick off the steps as they are performed. Use the illustrations for each procedure to identify the parts referred to in the text.

The procedures appear in order of removal. So the whole machine can be stripped down by starting at the beginning of this chapter and working through the subsequent procedures.



NOTE: Before using this chapter to remove and install a new component, always make sure that you have performed the relevant service test (see [Service tests and utilities on page 85](#)). If the test passes, you do not need to replace the component.

Safety Precautions

Review the instructions identified by WARNING and CAUTION symbols before you service the printer. Follow these warnings and cautions for your protection and to avoid damaging the printer.

⚠ WARNING! Serious shock hazard leading to death or injury may result if you do not take the following precautions:

- Ensure that the AC power outlet (mains) has a protective earth (ground) terminal.
- Switch the plotter **off**, and disconnect it from the power source prior to performing any maintenance.
- Prevent water or other liquids from running onto electrical components or circuits, or through openings in the module.

Electrostatic Discharge (ESD) Precautions

To prevent damage to the printer circuits from high-voltage electrostatic discharge (ESD):

1. Do not wear clothing that is subject to static build-up.
2. Do not handle integrated circuits (ICs) in carpeted areas.
3. Do not remove an IC or a printed circuit assembly (PCA) from its conductive foam pad or conductive packaging until you are ready to install it.
4. Ground (earth) your body while disassembling and working on the printer.
5. After removing a cover from the printer, attach an earthing (ground) lead between the PCA common and earth ground. Touch all tools to earth ground to remove static charges before using them on the printer.
6. After removing any PCA from the printer, place it on a conductive foam pad or into its conductive packaging to prevent ESD damage to any ICs on the PCA.

Required Tools

The following tools are required to disassemble and repair the printer.

- A long Torx Screwdriver with the following attachments: T8, T10, T15, T20, and T25.
- A long thin-bladed T-10 Torx Screwdriver to remove the Primer. The blade must be longer than 12 cm with a maximum diameter of 10 mm.
- A long thin-bladed T-20 Torx Screwdriver to remove the OMAS Sensor. The blade must be longer than 11 cm with a maximum diameter of 4 mm.
- A T8 Torx Screwdriver to remove the left cover. The blade must be longer than 5 cm with a maximum diameter of 9 mm.

Screw types

Type	Torx	Length (mm)	Head Type	Thread Type	Part Number
A	T-20	17	Pan	Taptite	0515-1743
B	T-20	10	Pan	Taptite	0515-2282
C	T-10	7.0	Pan	Machined	0515-4613
D	T-8	5.5	Pan	Taptite	0515-2850
E	T-15	-	Pan	-	C3180-20001
F	T-15	9.5	Pan	Plastite	0515-2981
G	T-15	12.7	Pan	Taptite	0624-0769

H	T-15	12.7	Pan	Taptite	0515-4706
I	T-10	8.0	Pan	Taptite	0515-2200
J	T-15	20	Pan	Plastite	0624-0771
K	T-8	9.5	Pan	Taptite	0624-0680
L	T-8	12.7	Pan	Taptite	0624-0768
M	T-20	-	Pan	-	0515-2521
N	T-20	35	Pan	Sheet Metal	C6071-20025
O	T-20	12.7	Pan	-	0624-1062
P	T-15	11.6	Pan	Machined	C2847-20018
Q	T-20	-	Pan	Taptite	0515-2916
R	T-15	-	Pan	Taptite	0515-1916
S	T-15	18.4	Pan	Machined	Q6651-20179

Cover, Right

Removal

1. Open the Window.

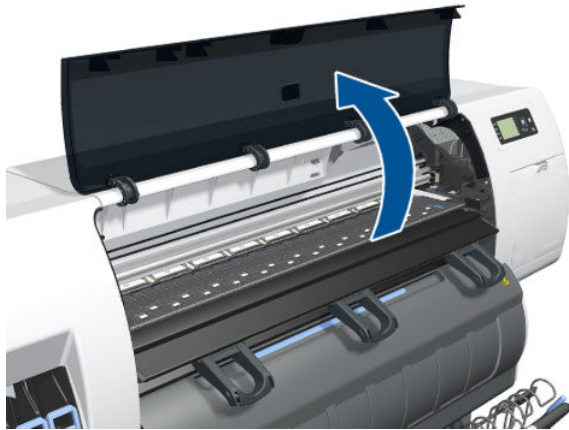

2. Remove one T-15 screw inside the printer.



3. Open the Maintenance Cartridge Door.



4. Remove one T-15 screw.



5. Remove one T-20 and one T-15 screw from the rear of the printer.

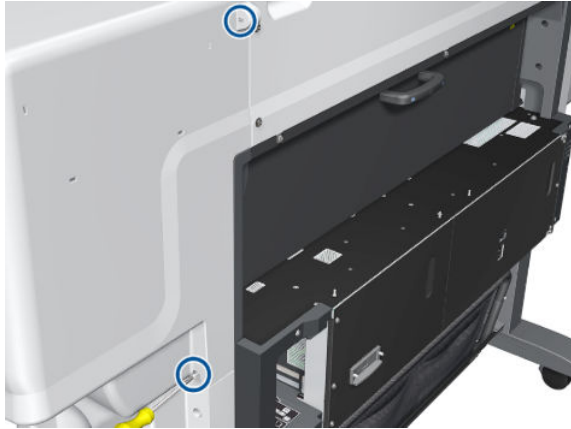

6. Open the Smart Roll-loading System Door.

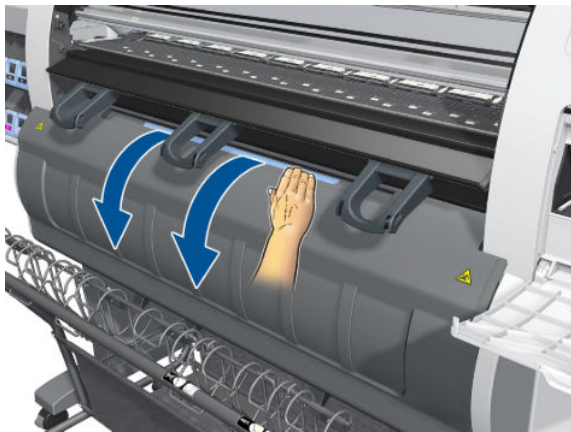

7. Remove the last T-20 screw that secures the Right Cover.

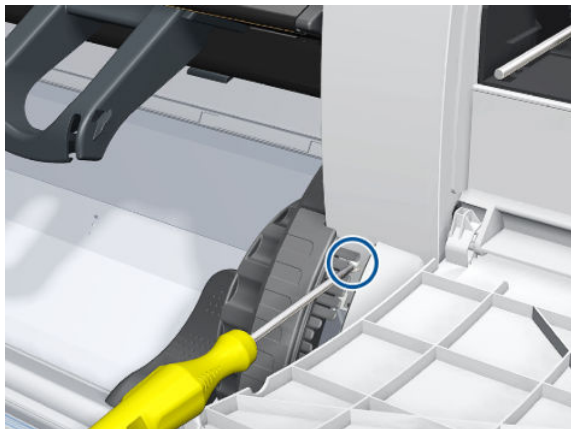

8. Remove the Right Cover from the printer.

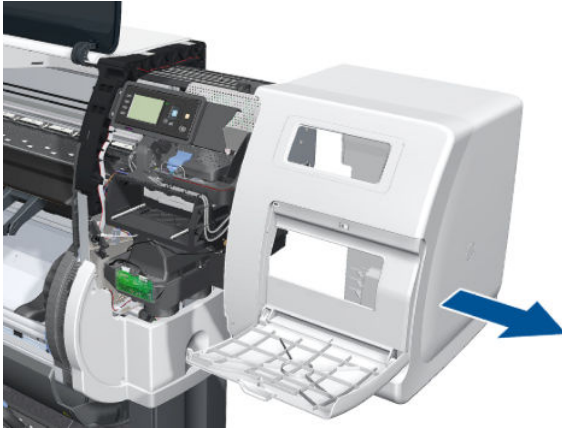

Cover, Left

Removal

1. Open the Window.

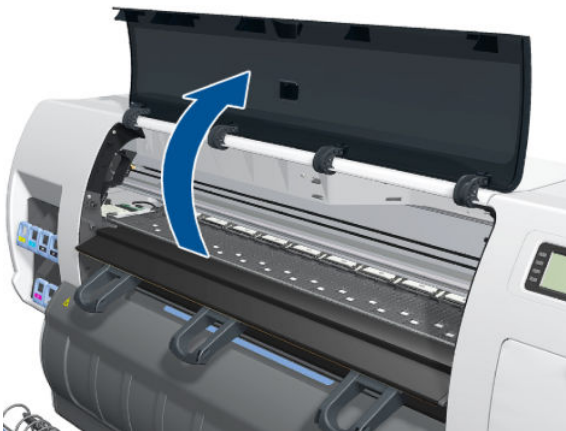

2. Remove one T-15 screw inside the printer.



3. Remove one T-20 and one T-15 screw from the rear of the printer.



4. Remove one T-20 screw from the front.

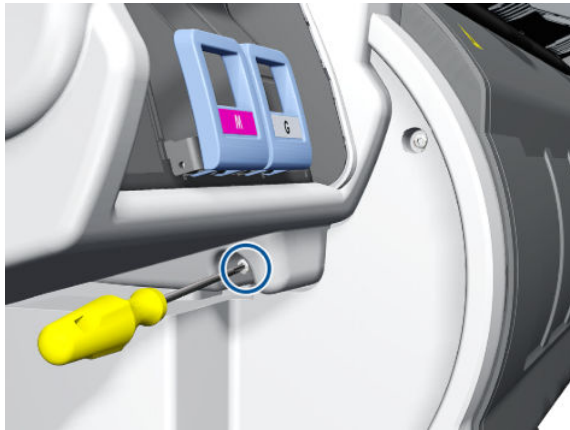

5. Remove the Left Cover from the printer.



Window

Removal

 **WARNING!** Switch **off** the printer and remove the power cable.

 **NOTE:** Throughout this section the graphics actually show the HP DesignJet 4000 printer series but the steps of the procedure are identical for the HP DesignJet Z6000 printer series.

1. Open the Window.

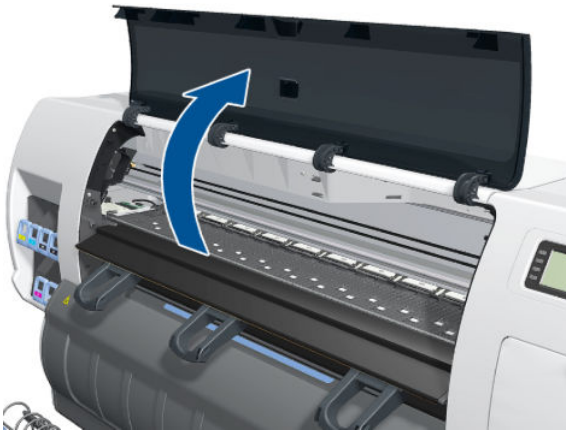

2. Unclip the Window hinges from the Top Cover.

 **NOTE:** Since the hinges are very hard to unclip, it is recommended that you use a screwdriver or other tool to forcefully unclip the Window hinges from the Top Cover.

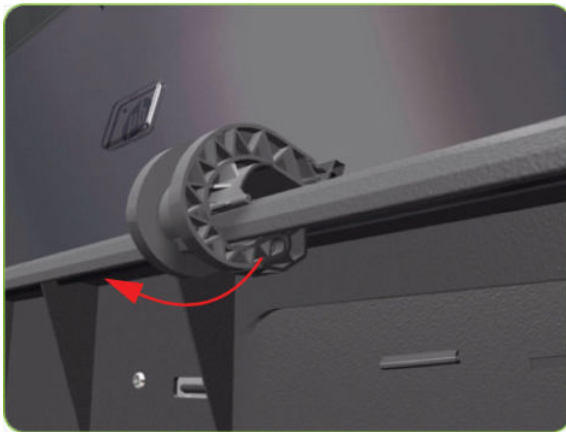

3. Remove the Window from the printer.

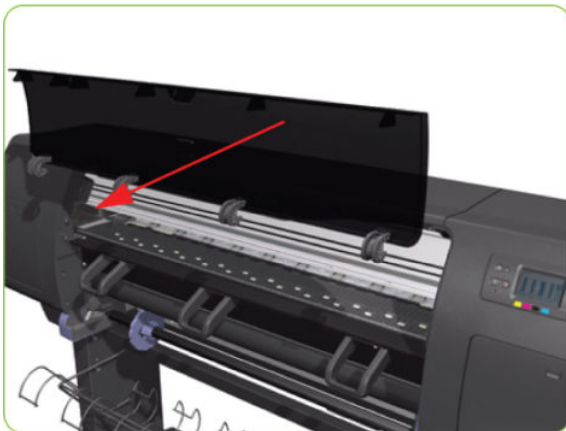

Installation of New Window

1. Identify the two ends of the Window hinge (four in total) - one end is clipped to the Window and the other to the Top Cover.

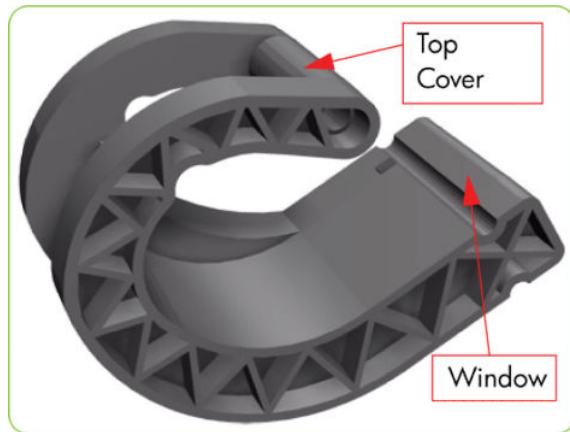

2. Slide the Window hinges on to the Window.

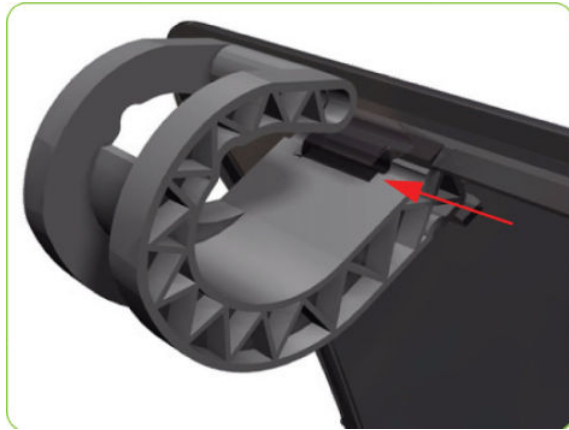

3. Clip the Window Hinges to the Top Cover.

 **NOTE:** Since the hinges are very hard to clip, you will need to forcefully clip the Window hinges to the Top Cover.

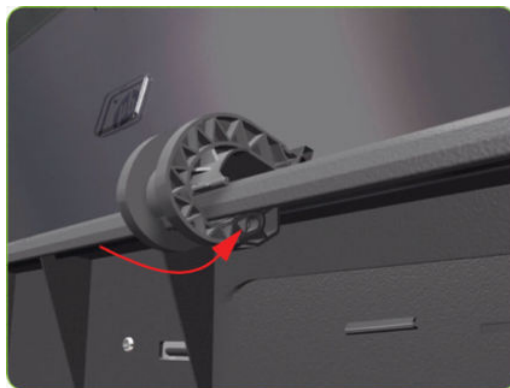

Cover, Top

Removal

⚠ WARNING! Switch *off* the printer and remove the power cable.

1. Remove the Right Cover ⇒ See [Cover, Right on page 225](#).
2. Remove the Left Cover ⇒ See [Cover, Left on page 228](#).
3. Release the three clips securing the Ink Supply Tubes and the Trailing Cable to the Top Cover.



4. Release the Ink Supply Tubes and Trailing Cable from the clip underneath the Top Cover.

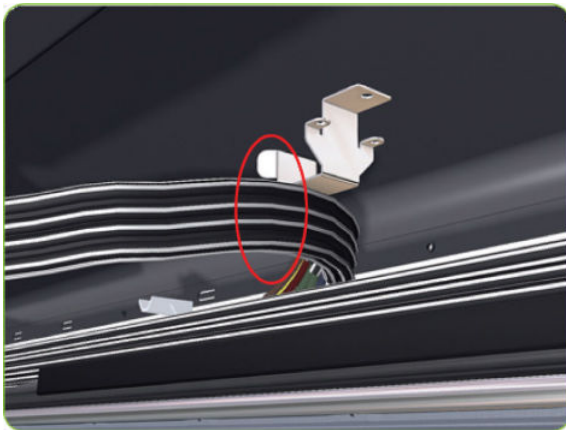

5. Remove the Ink Supply Tubes and Trailing Cable from within the Top Cover and lay them on the Print Platen.

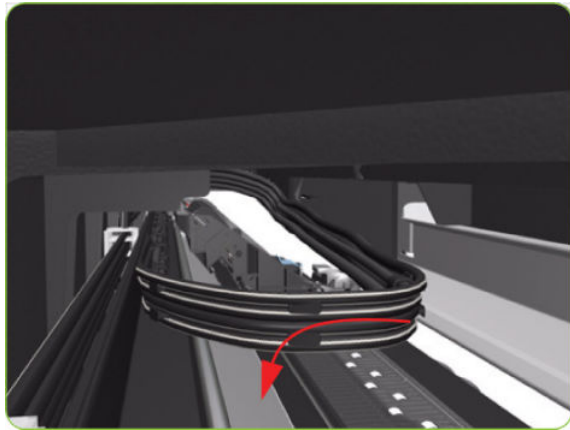

6. Remove one T-10 (Type I) screw that secures the ESD Strip to the Top Cover (on the left-hand side of the printer).

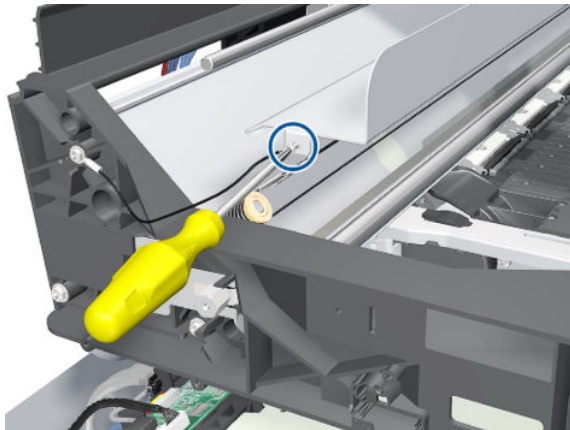

7. Disconnect the ESD Strip from the Top Cover.

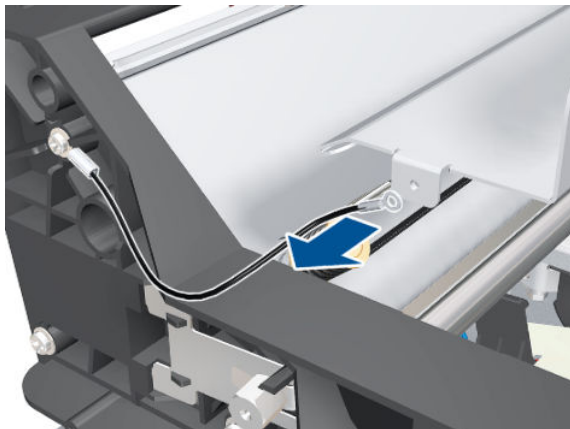

8. Remove the three T-15 screws that secure the PW Cover.

 **NOTE:** Each screw includes a washer (part number 3050-1267).

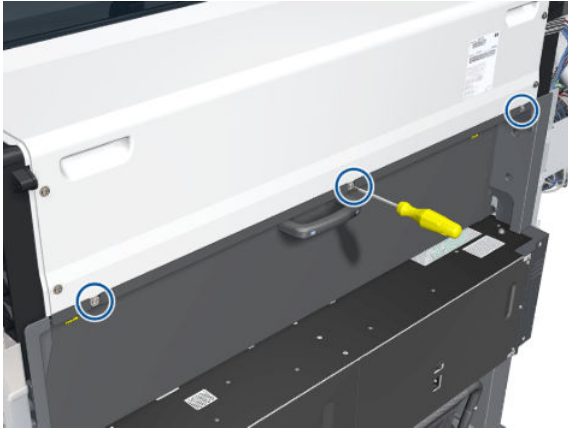

9. Remove the PW Cover.



10. Remove four T-15 screws (Type H) that secure the Top Cover from the rear of the printer.

 **NOTE:** Each screw includes a washer (part number 3050-1267).



11. Release the Top Cover from the rear of the printer.

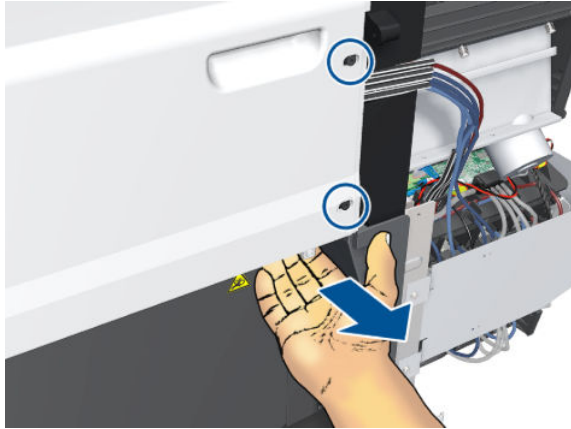

12. Using a flat-head screwdriver, release the Top Cover from the right-hand side of the printer.

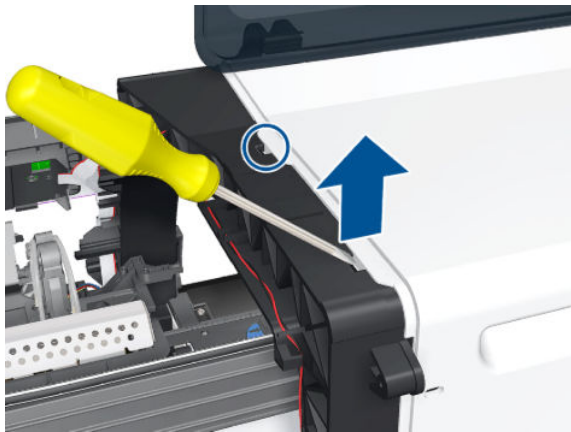

13. Raise the right-hand side of the Top Cover and pull out to the right.

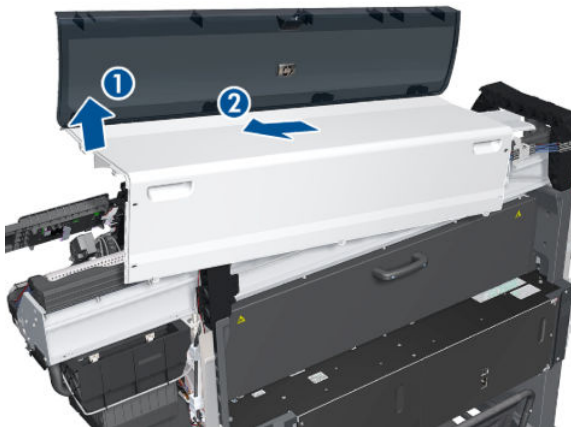

Installation

Before installing a new Top Cover, take note of the following instructions.

1. Position the Metallic Support on to the Top Cover.

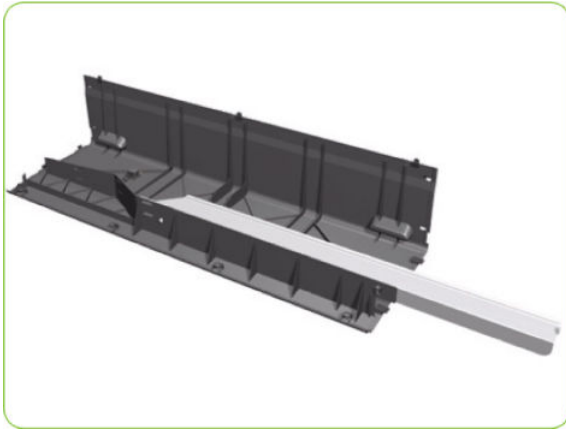

2. Lock the Metallic Support on to the Top Cover.

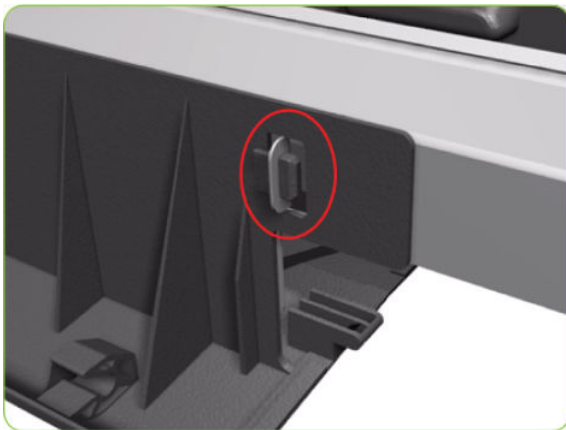

3. Install the T-20 screw that secures the Metallic Support to the Top Cover.

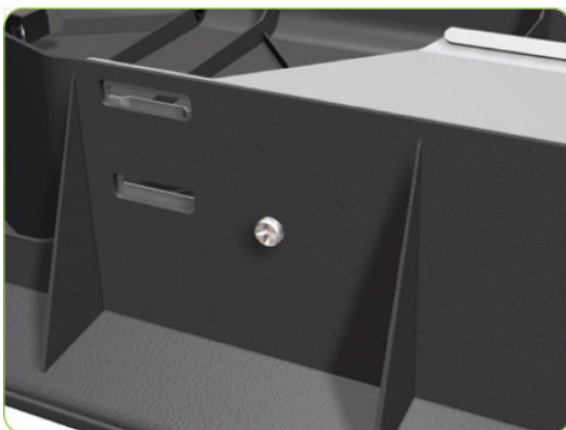

4. Remove the Window (⇒ See [Window on page 229](#)) from the old Top Cover and install it on the new Top Cover.



NOTE: When installing the Ink Supply Tubes and Trailing Cable on to the Top Cover, take note of the of the two red marks on the Ink Supply Tubes. These two red marks should be aligned with the first slot in the Top Cover as this will help with the rest of the installation.

Connector Cover, Right

Removal

1. Remove two T-20 screws from the Right Connector Cover.

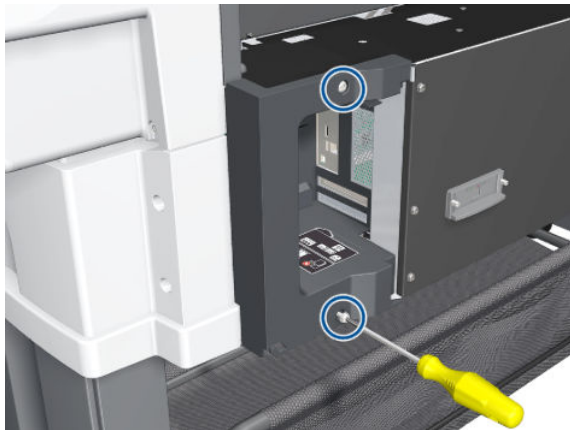

2. Rotate the Right Connector Cover a few degrees counter-clockwise so that it can be removed from the printer.

3. Remove the Right Connector Cover.

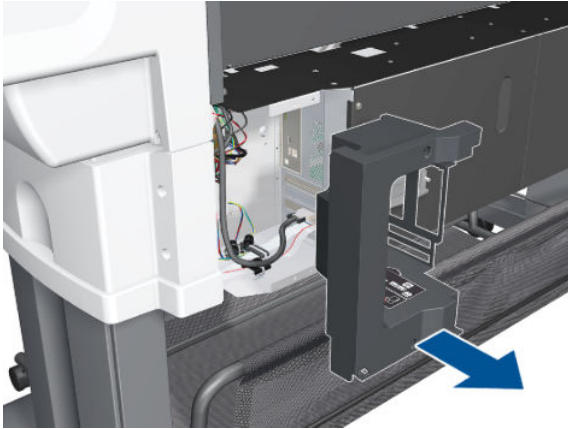

Connector Cover, Left

Removal

1. Remove two T-20 screws from the Left Connector Cover.

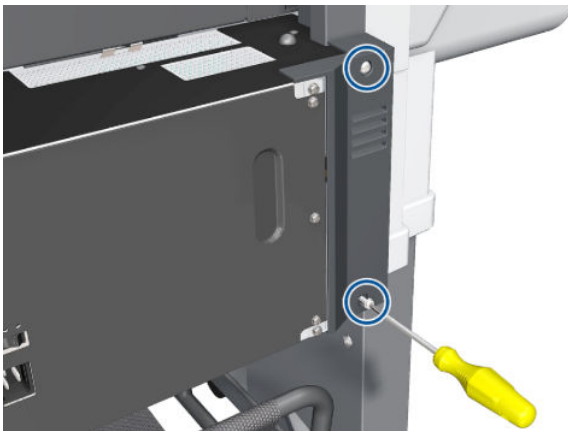

2. Remove the Left Connector Cover.

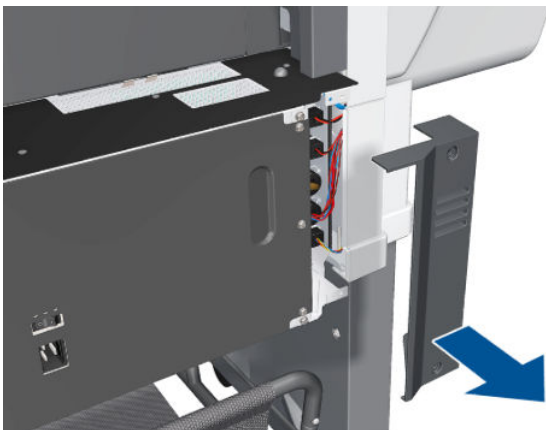

Front Panel

Removal

⚠ WARNING! Switch **off** the printer and remove the power cable.

1. Remove the Right Connector Cover ⇒ See [Connector Cover, Right on page 237](#).
2. Remove the Right Smart Roll-loading System Cover ⇒ See [Smart Roll-loading System Cover, Right on page 260](#).
3. Disconnect the Front Panel cable.



4. Disconnect the ferrite clip.

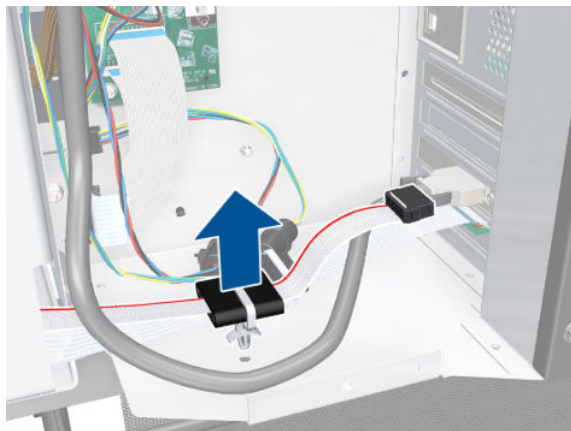

5. Unroute the cable.

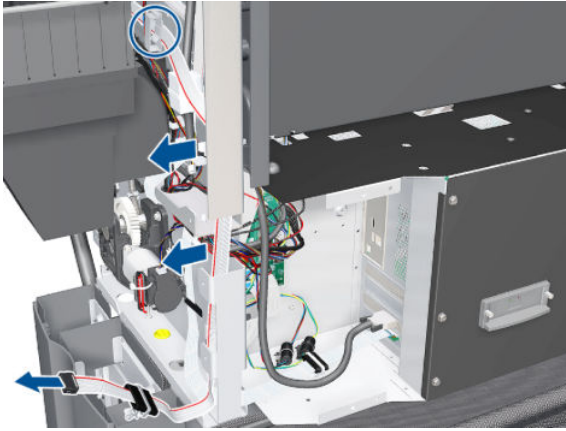

6. Release the cable from the Right Arc.

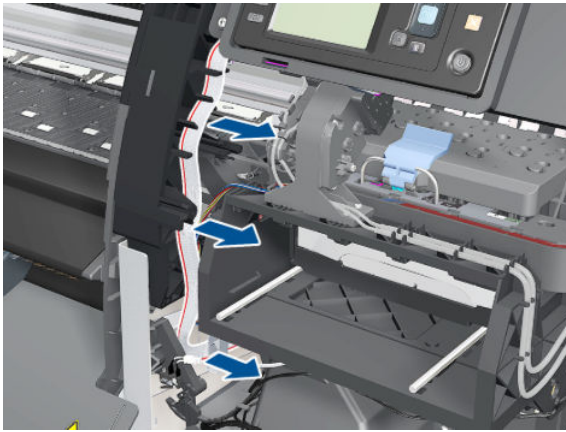

7. Remove two T-15 screws from the Front Panel.



8. Remove the Front Panel.

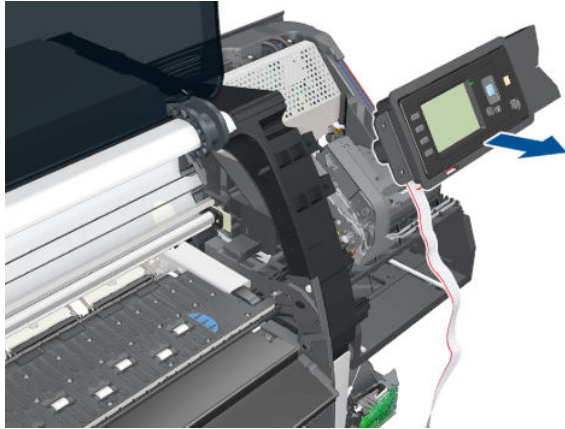

Primer Assembly

Removal

⚠ WARNING! Switch off the printer and remove the power cable.

1. Remove the Right Cover ⇒ See [Cover, Right on page 225](#).
2. Remove the Right Connector Cover ⇒ See [Connector Cover, Right on page 237](#).
3. Remove the Front Panel ⇒ See [Front Panel on page 239](#).
4. Disconnect the Primer Assembly cable from the Interconnect PCA.

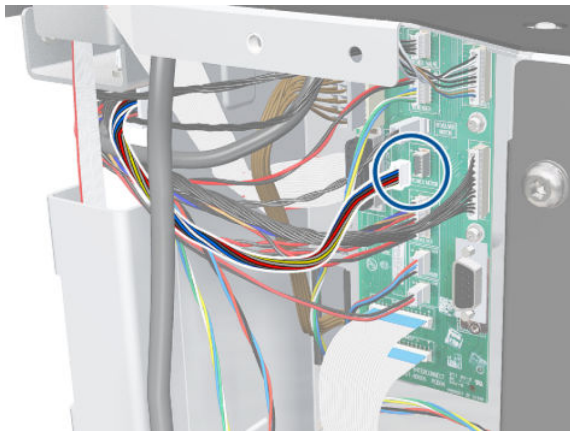

5. Unroute the Primer Assembly cable from the cable clamps.

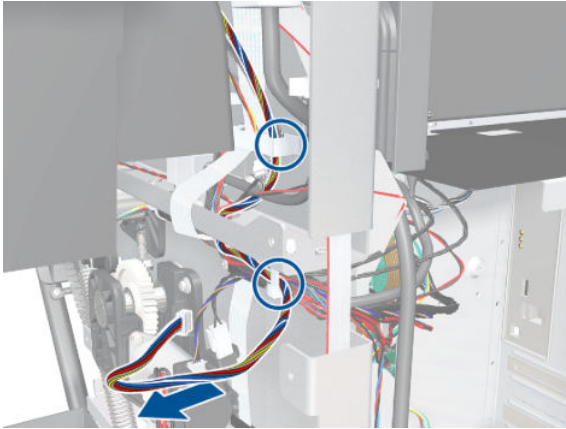

6. Disconnect the two Primer Assembly tubes.

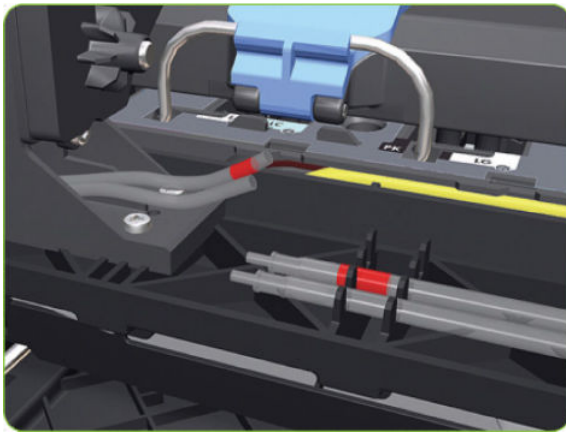

7. Remove four T-10 screws that secure the Primer Assembly to the Service Station.

 **NOTE:** Use a short screw driver, less than 10 cm in length.

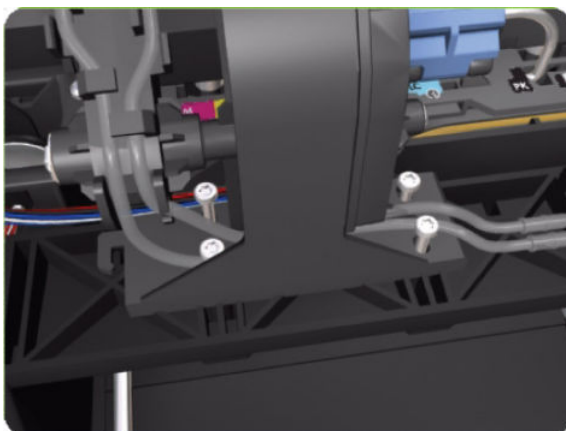

8. Remove the Primer Assembly from the Service Station.

 **NOTE:** When installing the Primer Assembly, use the identification marks on the Primer Assembly Tubes to ensure they are correctly connected.

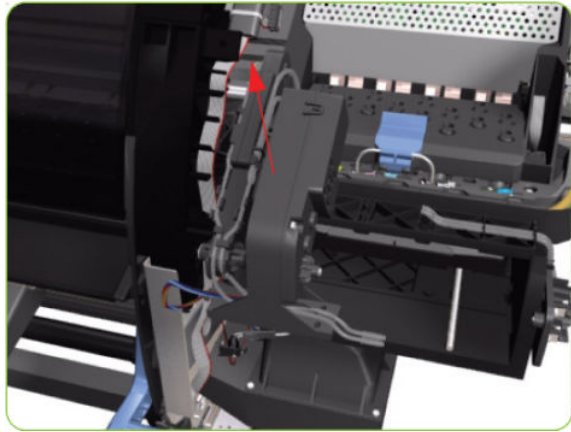

Primer Valves

Removal

 **WARNING!** Switch **off** the printer and remove the power cable.

1. Remove the Right Cover ⇒ See [Cover, Right on page 225](#).
2. Disconnect the Primer Valve Cables.

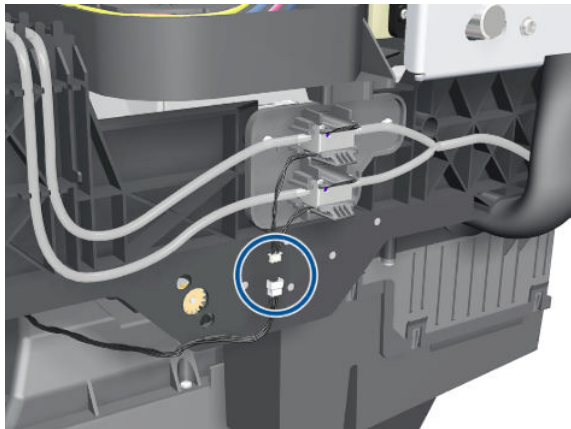

3. Disconnect the Primer Valve tubes.

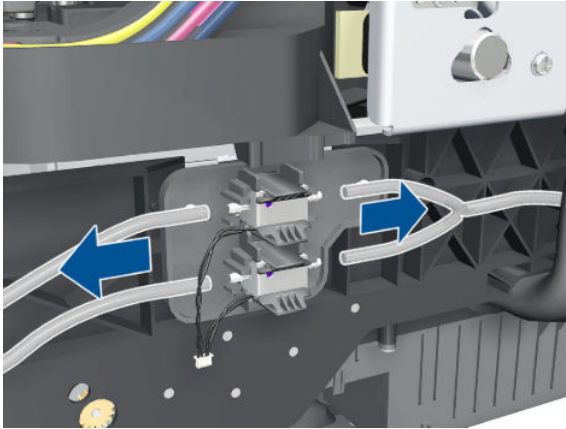

4. Remove two T-15 screws.

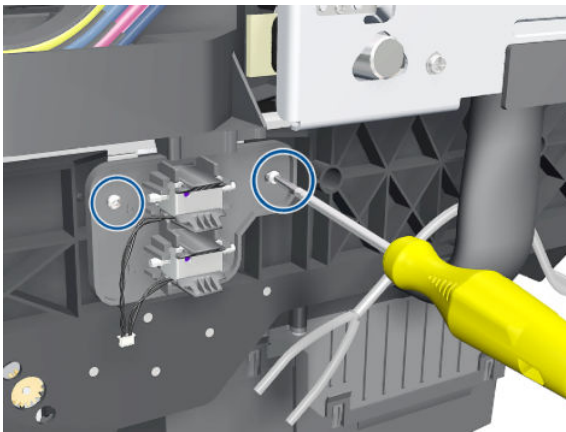

5. Remove the Primer Valves.

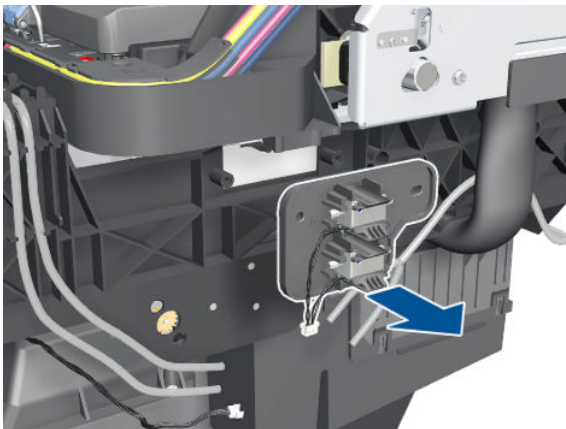

Primer Valve Cable

Removal

 **WARNING!** Switch **off** the printer and remove the power cable.

1. Remove the Right Cover ⇒ See [Cover, Right on page 225](#).
2. Remove the Right Connector Cover ⇒ See [Connector Cover, Right on page 237](#).
3. Remove the Right Smart Roll-loading System Cover ⇒ See [Smart Roll-loading System Cover, Right on page 260](#).
4. Disconnect both Primer Valves from the Interconnect PCA.

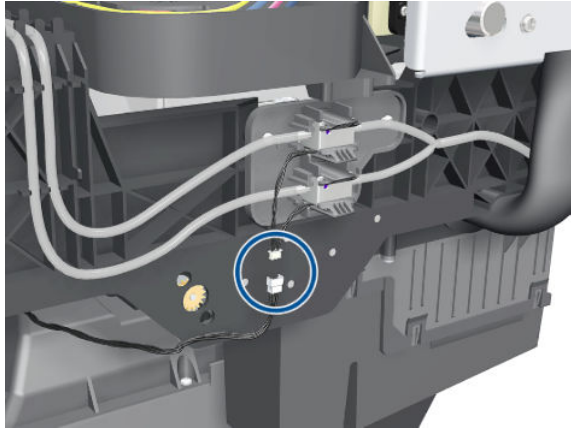

5. Unplug the Primer Valve Cable.

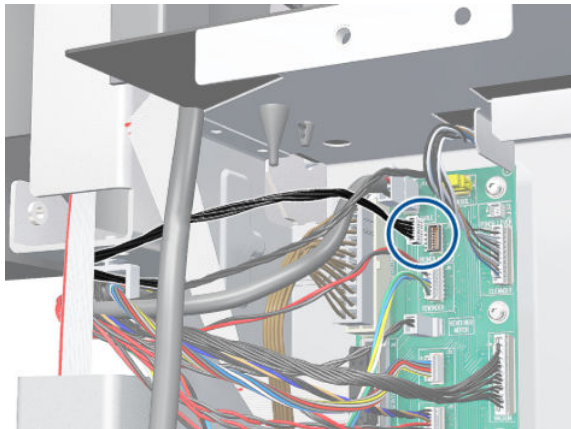

6. Unroute the Primer Valve cable from the cable clamp.

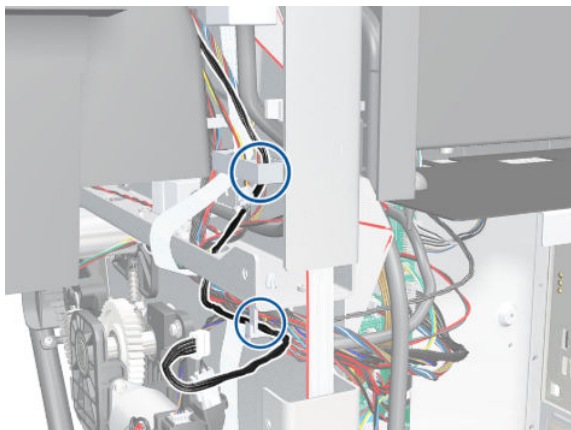

7. Completely unroute the Primer Valve cable from the Service Station.

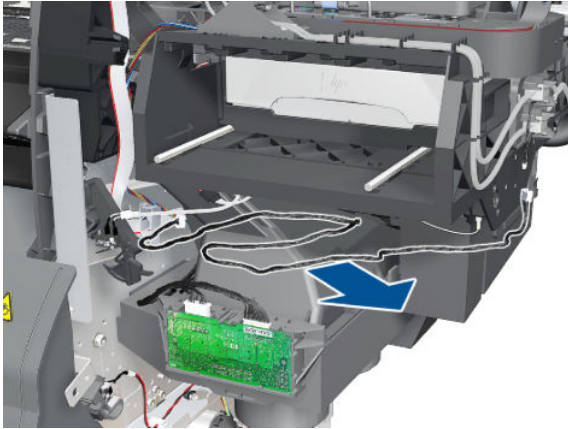

Service Station

Removal

⚠ WARNING! Switch **off** the printer and remove the power cable.

1. Remove the Right Cover ⇒ See [Cover, Right on page 225](#).
2. Remove the Primer Assembly ⇒ See [Primer Assembly on page 241](#).
3. Remove the Primer Valves ⇒ See [Primer Valves on page 243](#).
4. Remove the Drop Detector ⇒ See [Drop Detector on page 257](#).
5. Remove the Right Connector Cover ⇒ See [Connector Cover, Right on page 237](#).
6. Remove the Maintenance Cartridge ⇒ See the User's Guide.
7. Remove the Right Rear Trim ⇒ See [Rear Trim, Right on page 351](#).
8. Disconnect the cable from the Maintenance Cartridge Door Switch.



9. Disconnect the Service Station cable (labelled “SS and DD”) from the Interconnect PCA.

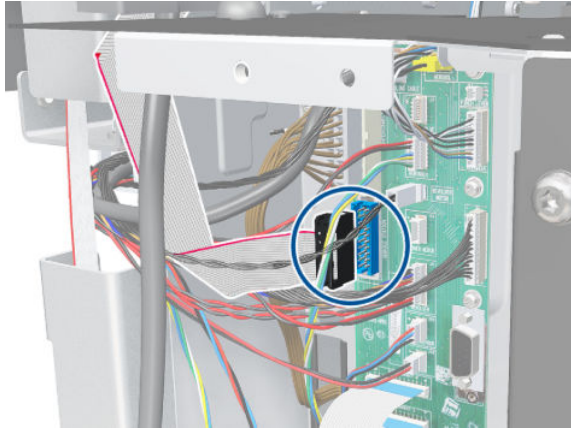

10. Unroute the Service Station cable.

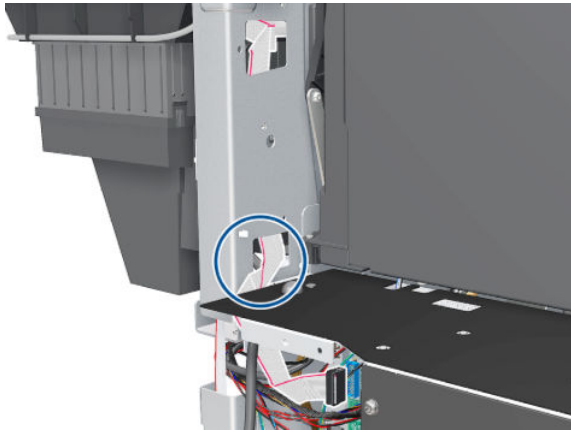

11. Disconnect the Aerosol Fan cable.

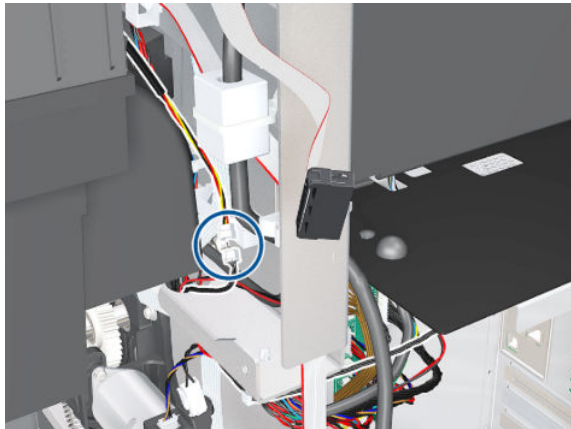

12. Unroute the Primer Assembly Valves tube from the Service Station.

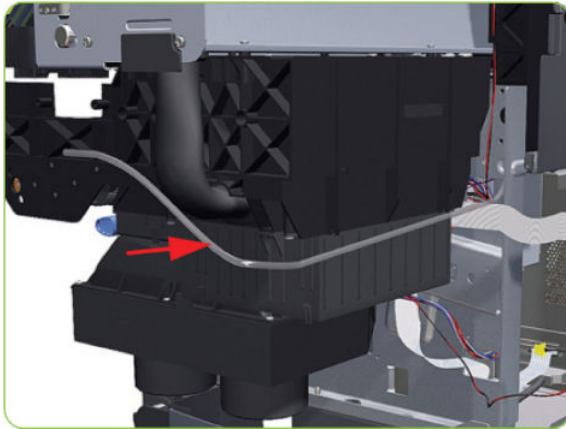

13. Remove two T-15 screws (Type J) that secure the rear of the Service Station to the Chassis.

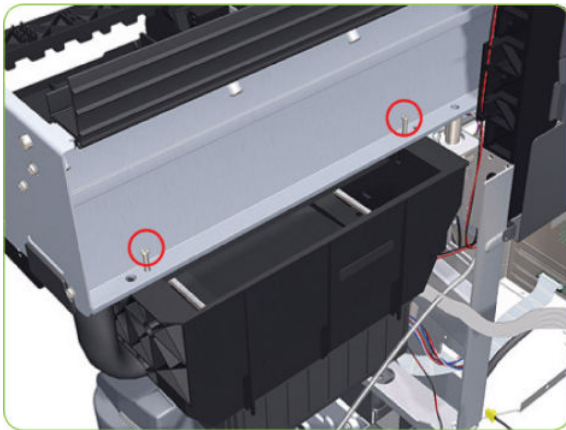

14. Remove two T-15 screws (Type J) that secure the Service Station to the Chassis.

⚠ CAUTION: When removing the screws, be careful not to damage the Encoder Strip.

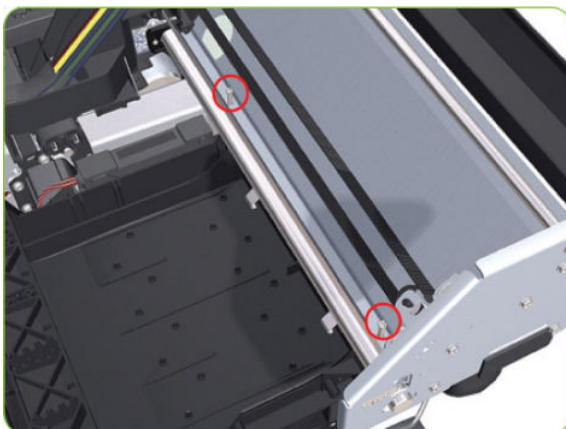

15. Disconnect the Aerosol Fan Tube from the Chassis.

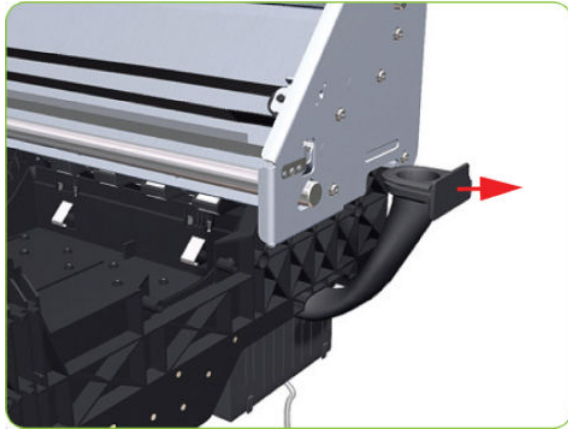

16. Lower the right side of the Service Station.

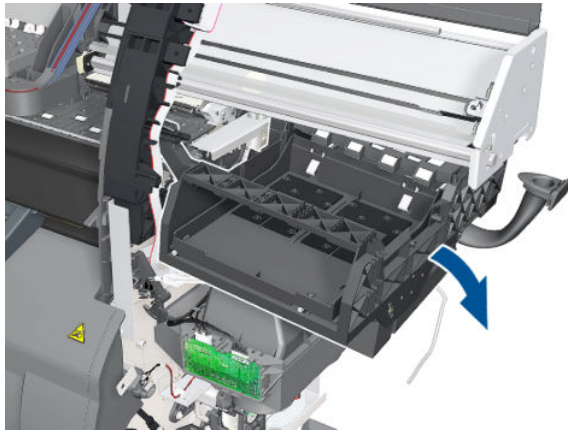

17. Remove the Service Station from the printer.

 **NOTE:** After installing the new Service Station, make sure you perform the following Service Utility:

- Reset Counter PHC spittoon ⇒ [Reset Life Counters on page 108.](#)

 **NOTE:** After installing the new Service Station, make sure you perform the following Service Calibration:

- Drop Detector Calibration ⇒ [Drop Detector calibration on page 124.](#)

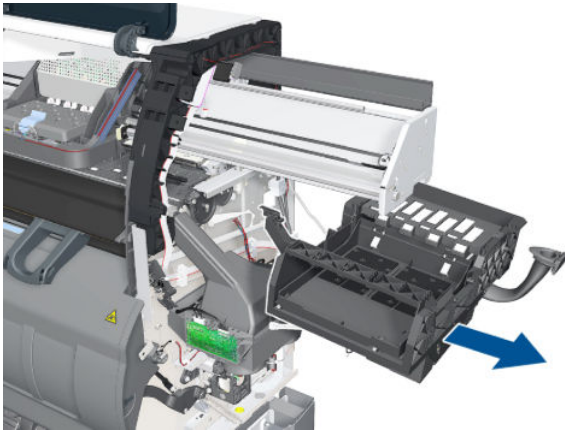

Removal of the Service Station Scraper

1. Release the clip securing the Scraper to the Service Station.

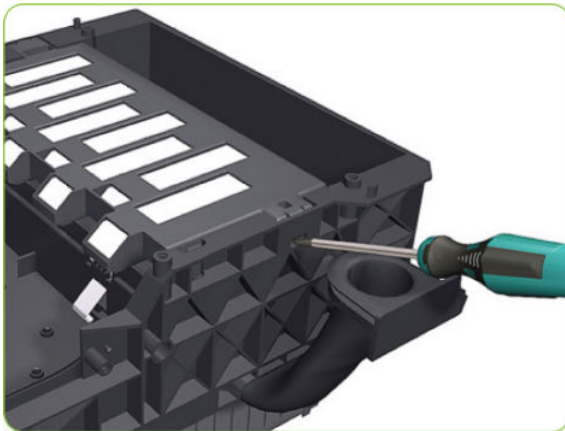

2. Remove the Scraper from the Service Station.

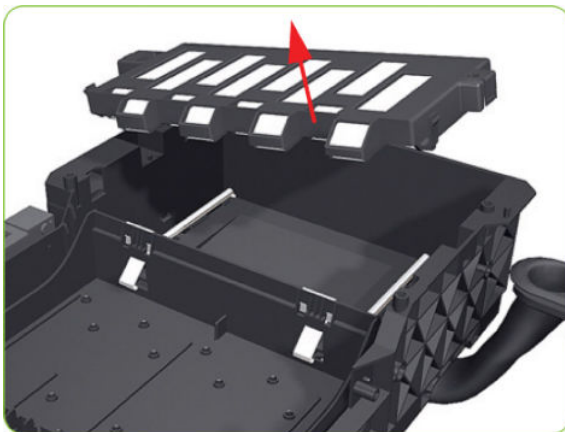

Vacuum Fan

Removal

 **WARNING!** Switch off the printer and remove the power cable.

1. Remove the Right Cover ⇒ See [Cover, Right on page 225](#).
2. Remove the Primer Assembly ⇒ See [Primer Assembly on page 241](#).
3. Remove the Primer Valves ⇒ See [Primer Valves on page 243](#).
4. Remove the Maintenance Cartridge ⇒ See the User's Guide.
5. Remove the Service Station ⇒ See [Service Station on page 246](#).
6. Disconnect the cable labelled on the Vacuum Fan PCA as "Interconnect Cable".

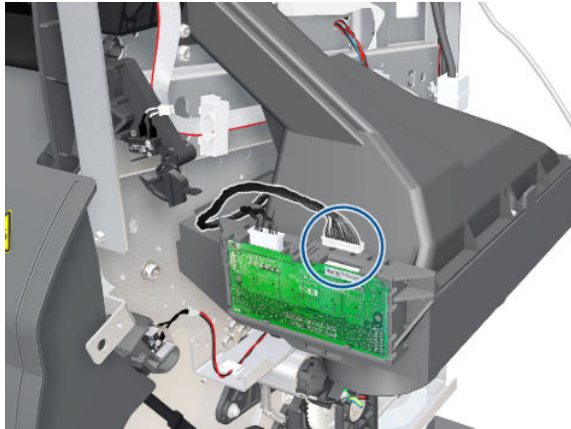

7. Unroute the Interconnect Cable.

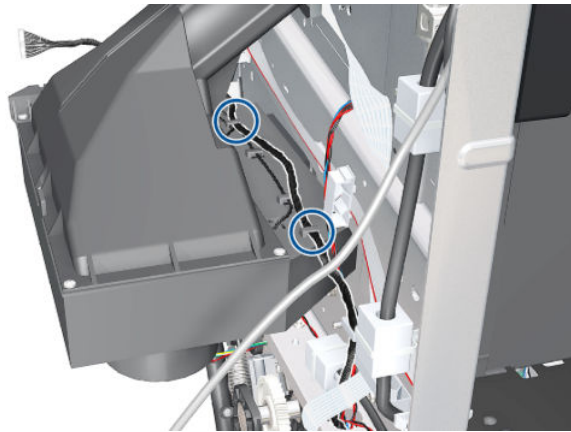

8. Remove four T-20 screws (Type B) that secure the Vacuum Fan to the printer.

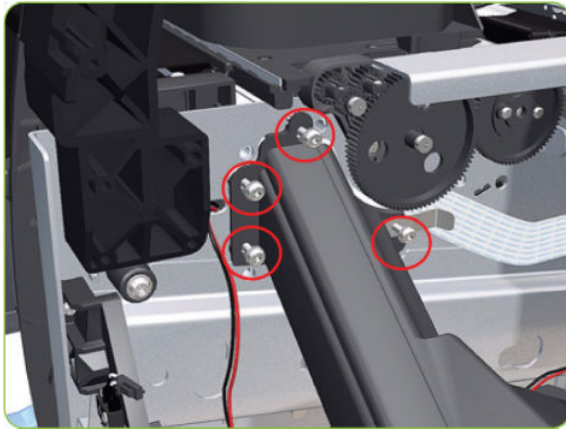

9. Remove the OMAS cable clamp from the printer.

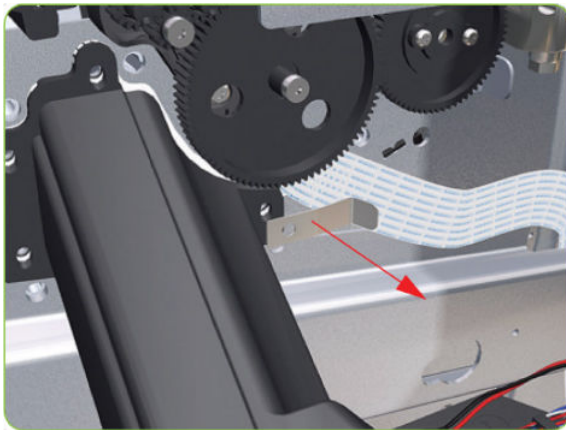

10. Lower then lift the Vacuum Fan out of its attachment.

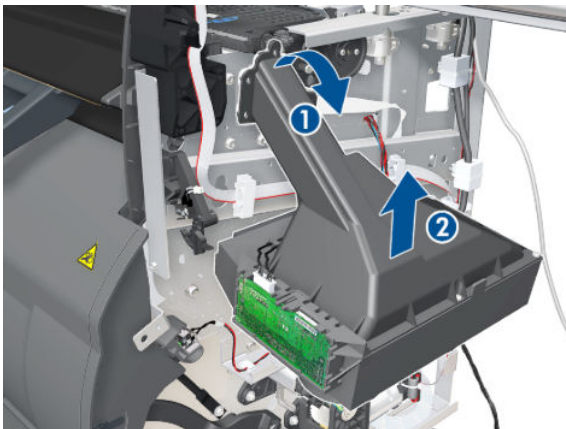

11. Remove the Vacuum Fan from the printer.

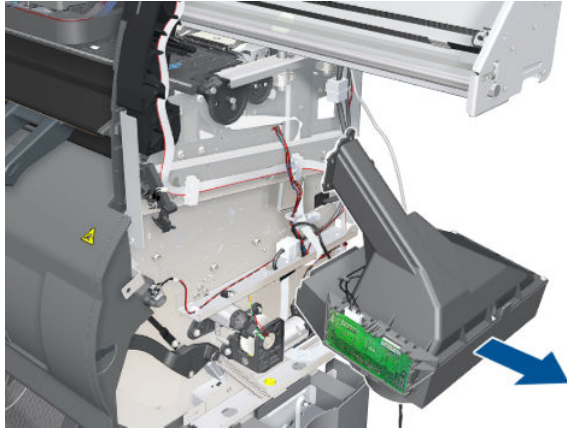

Installation

When connecting the Vacuum Fan cables to the Interconnect PCA, make sure you connect the cable with the label marked Vacuum Fan 1 to connector 1 and the cable with the label marked Vacuum Fan 2 to connector 2. You can check if both cables are labelled correctly by the actual markings on the Vacuum Fan.

Make sure that the OMAS ribbon cable is free of slack when you install the cable clamp.

After installing the new Vacuum Fan, make sure you perform Paper-advance Calibration ⇒ [Paper-advance calibration on page 121](#).

Vacuum Fan Cable

Removal

⚠ WARNING! Switch off the printer and remove the power cable.

1. Remove the Right Cover ⇒ See [Cover, Right on page 225](#).
2. Remove the Right Connector Cover ⇒ See [Connector Cover, Right on page 237](#).
3. Remove the Right Smart Roll-loading System Cover ⇒ See [Smart Roll-loading System Cover, Right on page 260](#).
4. Disconnect the cable labelled on the Vacuum Fan PCA as “Interconnect Cable”.

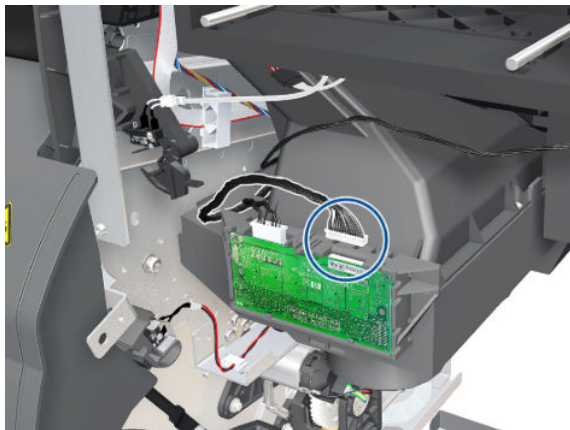

5. Unroute the Interconnect Cable.

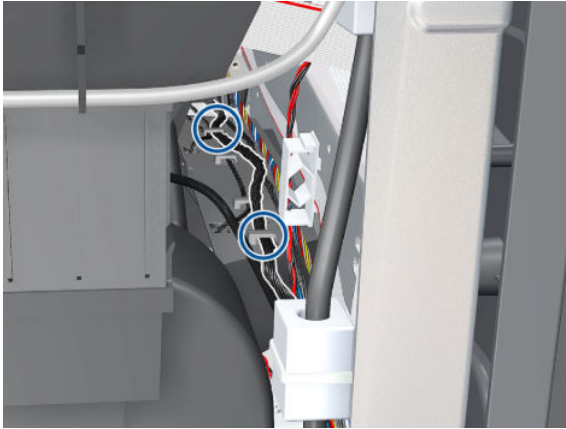

6. Disconnect the Vacuum Fan Cable from the Interconnect PCA.

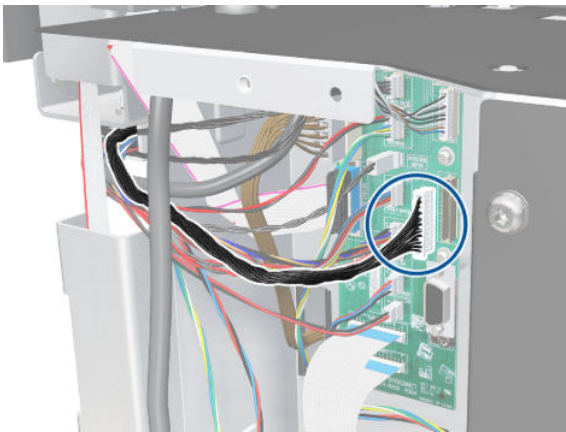

7. Unclip the cables from the cable clamps.

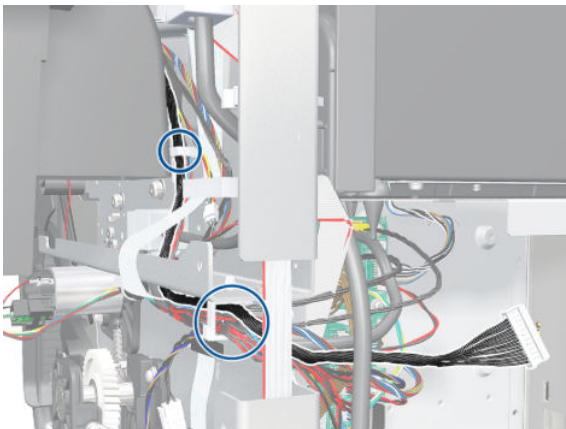

8. Unroute the Vacuum Fan Cable from the Interconnect PCA.

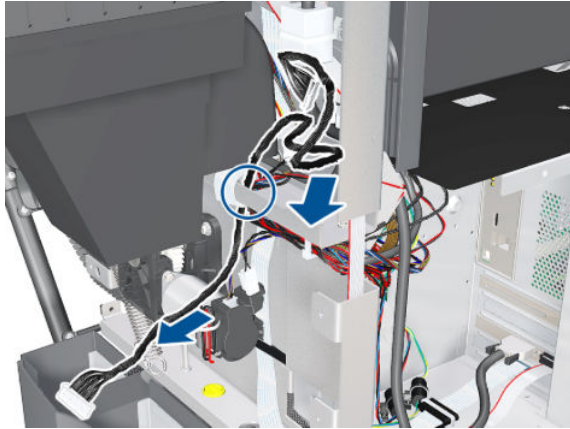

Installation

Make sure that the OMAS ribbon cable is free of slack when you install the cable clamp.

After installing the new Vacuum Fan, make sure you perform Paper-advance Calibration ⇒ [Paper-advance calibration on page 121](#).

Aerosol Fan and Filter

Removal

⚠ WARNING! Switch off the printer and remove the power cable.

1. Remove the Right Cover ⇒ See [Cover, Right on page 225](#).
2. Remove the PW Cover ⇒ See [PW Cover on page 349](#).
3. Remove the Right Connector Cover ⇒ See [Connector Cover, Right on page 237](#).
4. Remove the Service Station ⇒ See [Service Station on page 246](#).
5. Remove four T-15 screws (**Type G**) that secure the Aerosol Fan to the Service Station.

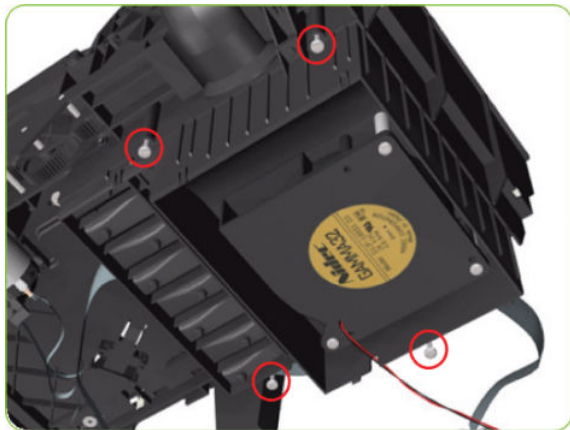

6. Remove the Aerosol Fan from the Service Station.

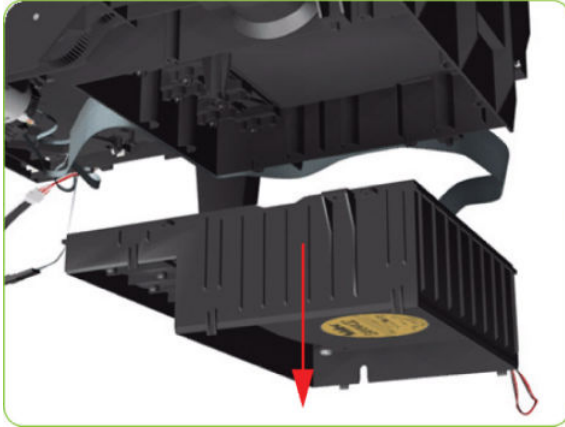

7. If necessary, remove the Aerosol Fan Filter from the Aerosol Fan.

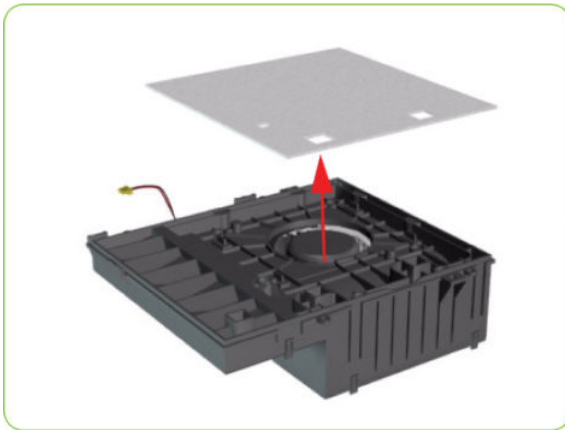

Installing

When the new aerosol Fan and Filter have been installed, it is important to check that the fan is functioning correctly, otherwise the printer will suffer from Aerosol spray. To check that the fan is working correctly, make sure the printer is printing and check for airflow in the area of the rear of the Service Station.

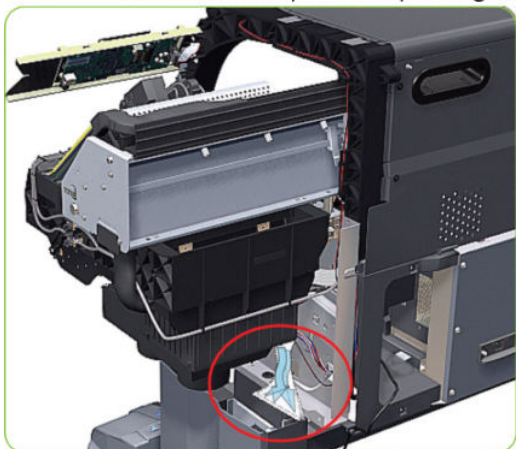

Drop Detector

Removal

 **WARNING!** Switch off the printer and remove the power cable.

1. Remove the Right Cover ⇒ See [Cover, Right on page 225](#).
2. Disconnect the Drop Detector Cable from the Service Station Cable.

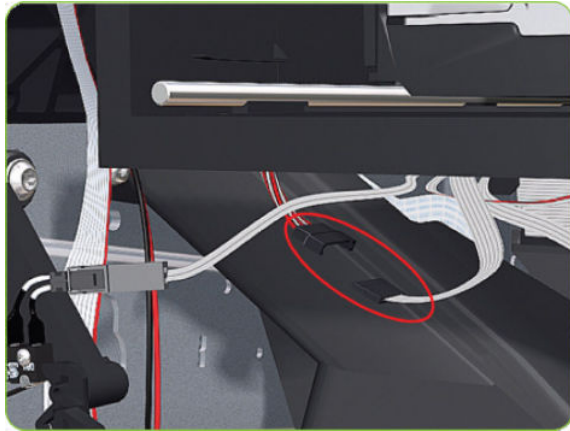

3. Release the Drop Detector Cable from the Service Station.

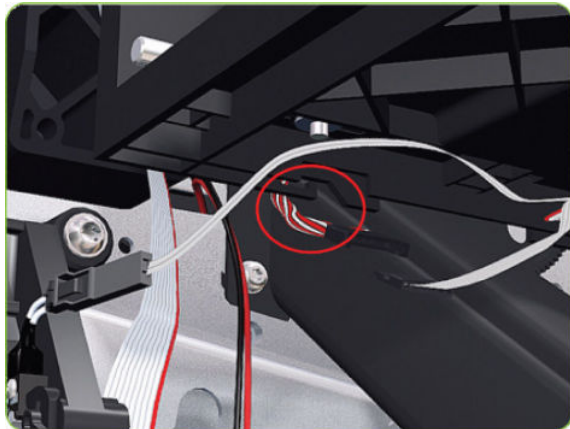

4. Pull out the Maintenance Cartridge fully from the Service Station to release the Carriage Assembly.



5. Lift the Primer and hold it as high as possible to avoid damaging it when you move the Carriage Assembly in the next step.

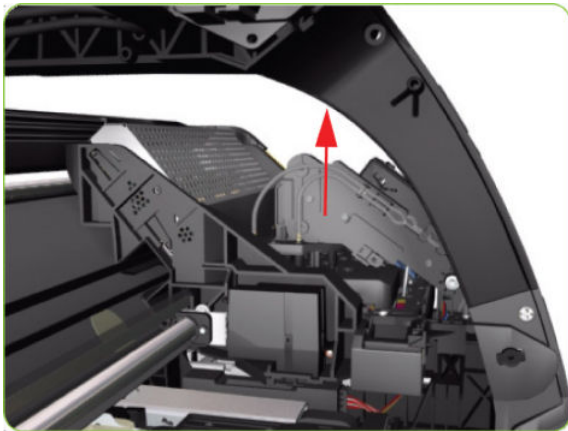

6. Slide the Carriage Assembly leftwards into the print path so that you can reach the Drop Detector.

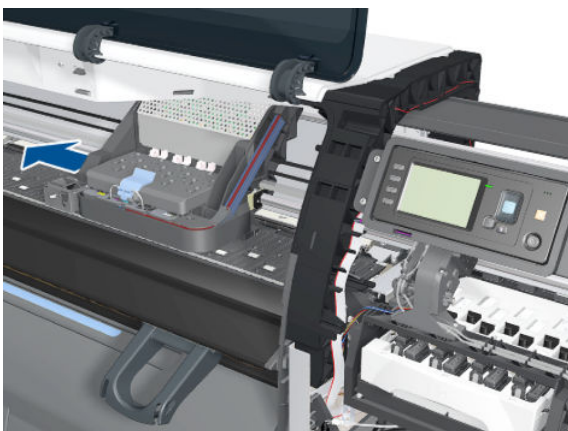

7. Remove one T-8 screw (**Type K**) that secures the Drop Detector to the Service Station.

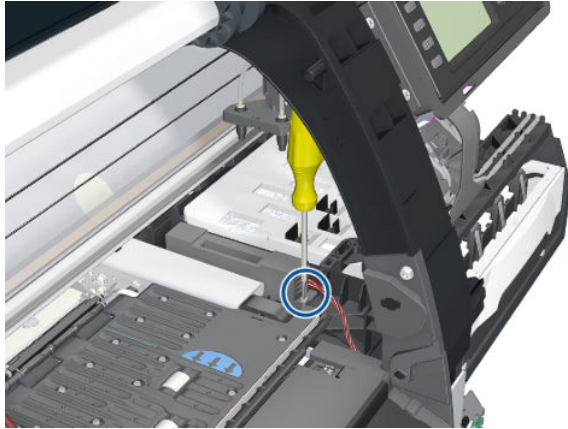

8. Slide the Drop Detector forward so you can release it from the Service Station.



9. Remove the Drop Detector from the printer.

 **NOTE:** After installing the new Drop Detector, make sure you perform the following Service Calibration:

- Drop Detector Calibration ⇒ [Drop Detector calibration on page 124.](#)

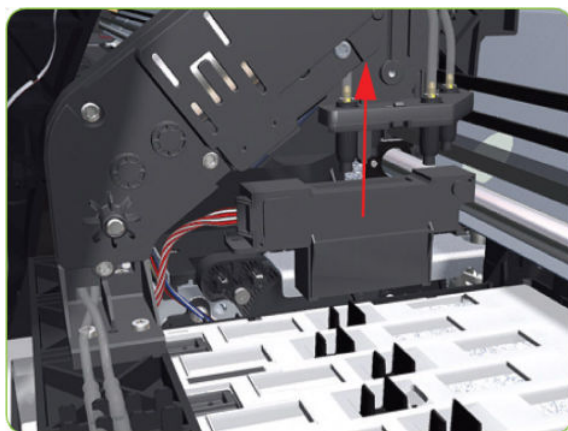

Smart Roll-loading System Cover, Right

Removal

1. Remove two T-20 screws from the Right Smart Roll-loading System Cover.

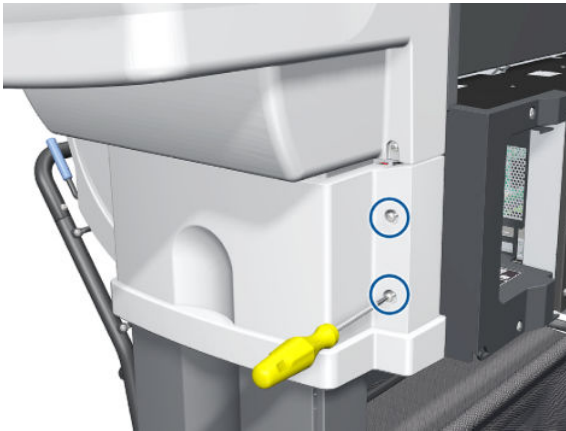

2. Remove two more T-20 screws from the Right Smart Roll-loading System Cover.

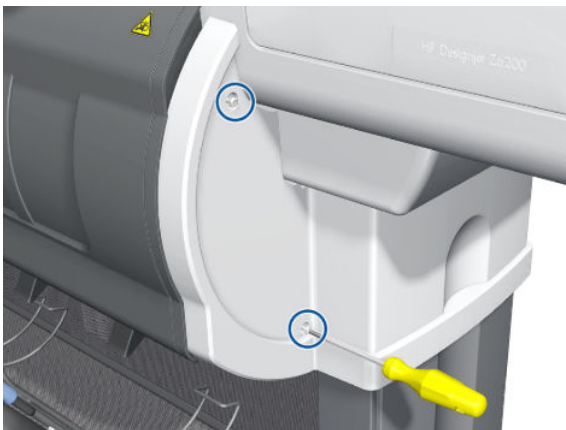

3. Remove the Right Smart Roll-loading System Cover.

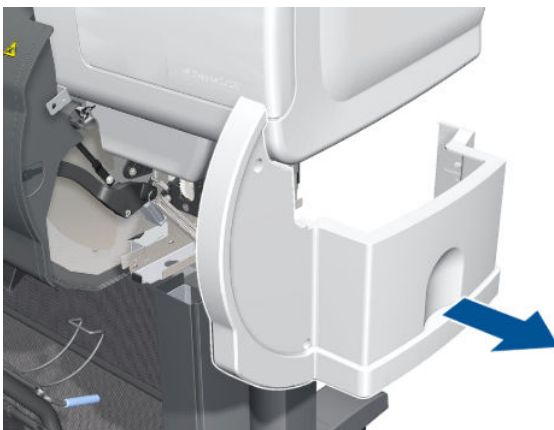

Smart Roll-loading System Cover, Left

Removal

1. Remove two T-20 screws from the Left Smart Roll-loading System Cover.



2. Remove two more T-20 screws from the Left Smart Roll-loading System Cover.

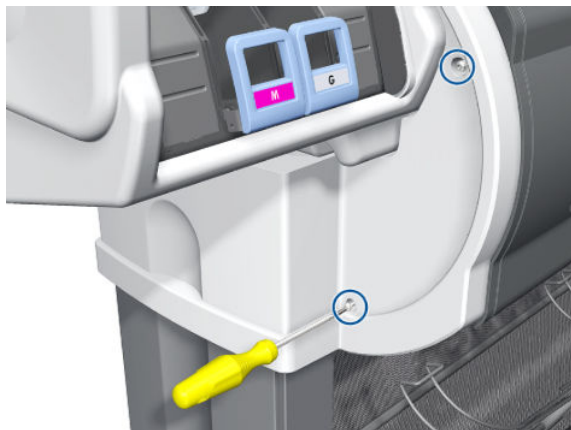

3. Remove the Left Smart Roll-loading System Cover.

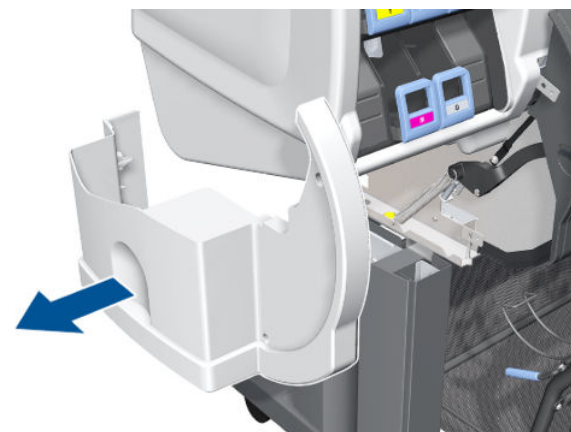

Paper Feed Brake

Removal

1. Open the Smart Roll-loading System Door.



2. Release the catch at the bottom of the blue lever on the right.



3. Release the right end of the Paper Feed Brake.

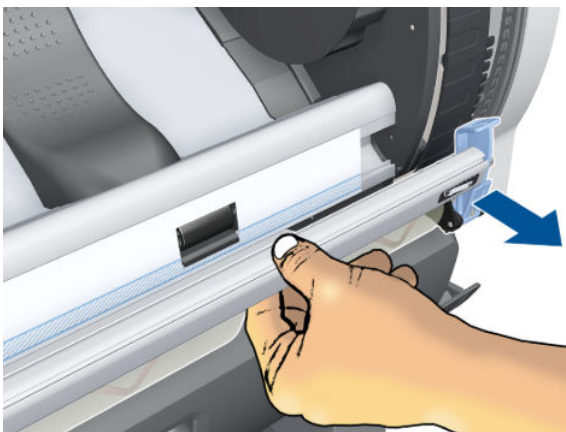

4. Release the catch at the bottom of the blue lever on the right.



5. Remove the Paper Feed Brake.



Threading Roller

Removal

1. Remove the Paper Feed Brake ⇒ See [Paper Feed Brake on page 262](#).
2. Remove the Threading Roller Cover.

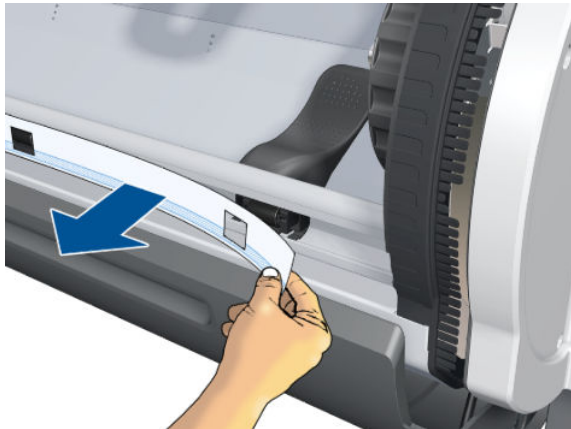

 **NOTE:** Before attaching a new Threading Roller Cover, you must clean off the glue from the previous one.

3. Pull up the clips.

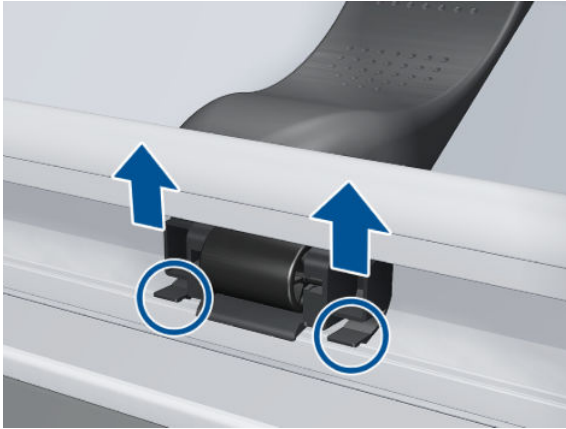

4. Remove the Threading Roller.

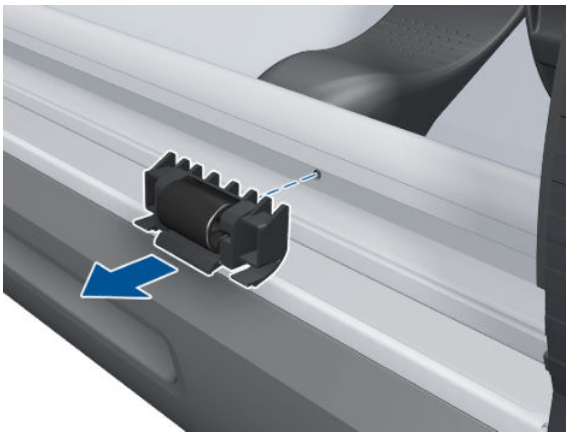

Smart Roll-loading System Motor

Removal

1.  Remove all paper rolls from the printer.
2. Remove the Right Smart Roll-loading System Cover \Rightarrow See [Smart Roll-loading System Cover, Right on page 260](#).

3. Disconnect the cables from the Smart Roll-loading System Motor.

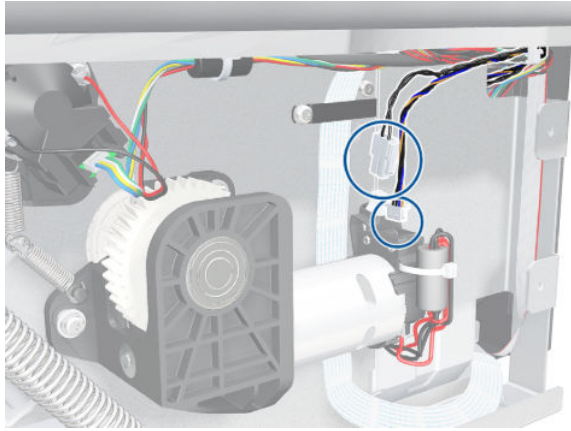

4. Remove the spring from the Smart Roll-loading System Motor.

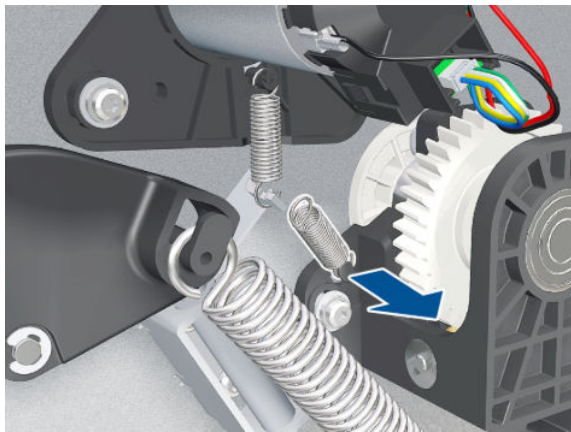

5. Remove three T-20 screws.

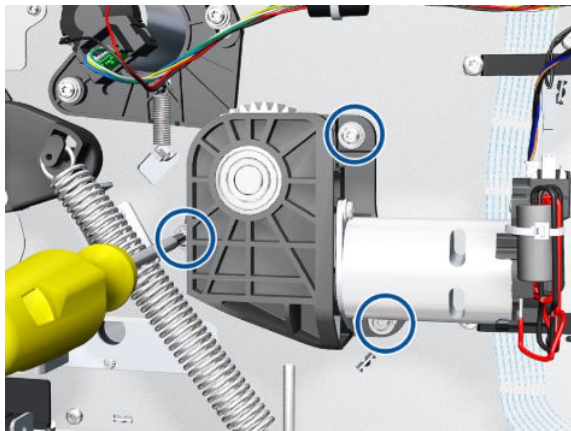

6. Remove the Smart Roll-loading System Motor.

⚠ WARNING! The Smart Roll-loading System could rotate unexpectedly when you remove the Motor.

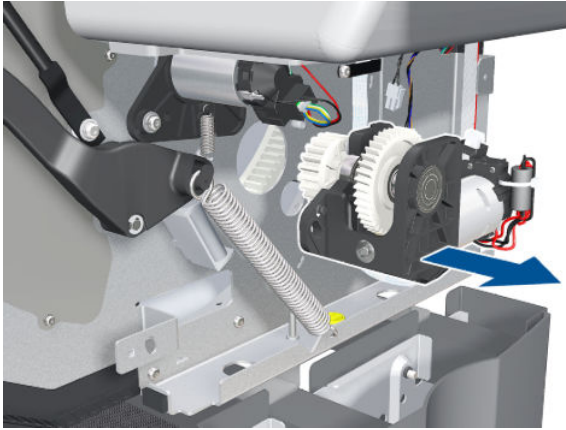

Smart Roll-loading System Gear

Removal

1. Open the Smart Roll-loading System Door.
2. **⚠** Remove all paper rolls from the printer.
3. Remove three T-10 screws from the Roller Cover.

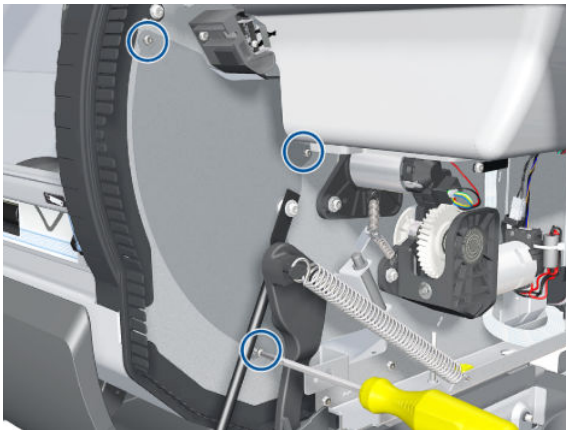

4. Remove the Roller Cover.

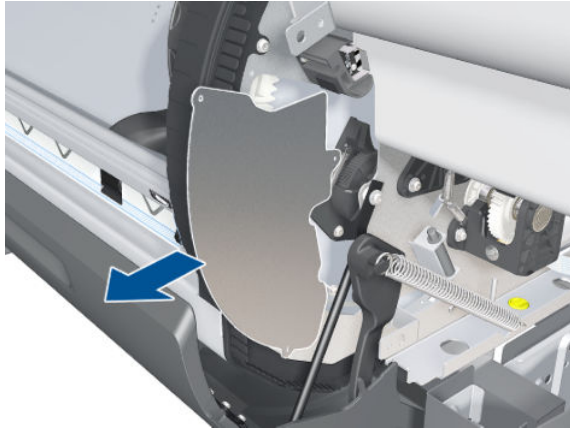

5. Rotate 1 so that you can see the faulty segment in zone 2.

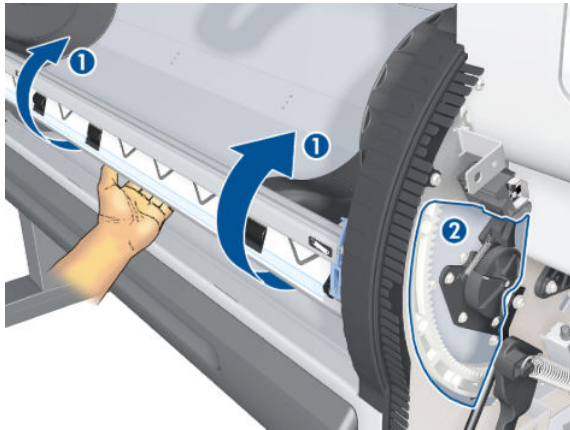

6. Locate the damaged segment (shown in red) to be removed.

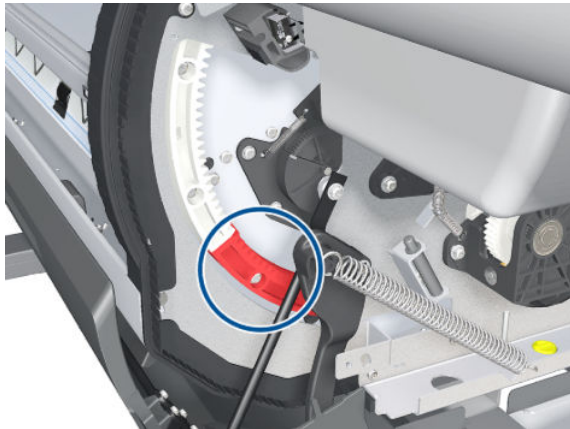

7. Remove three T-20 screws as indicated below.

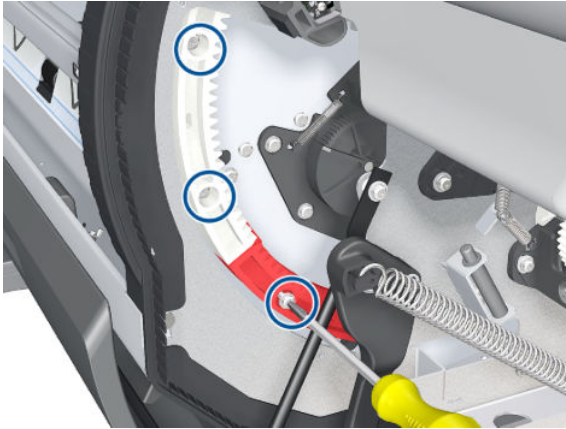

8. Rotate the gear to access the second screw of the faulty segment.

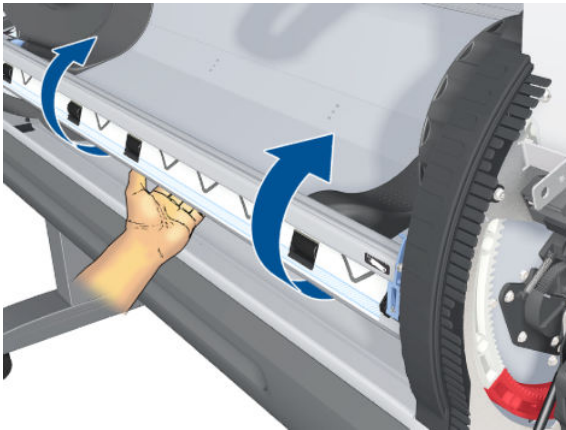

9. Remove the second T-20 screw.

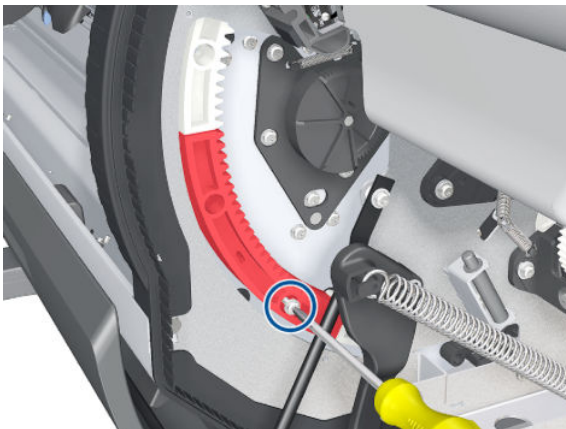

10. Disconnect the two segments.

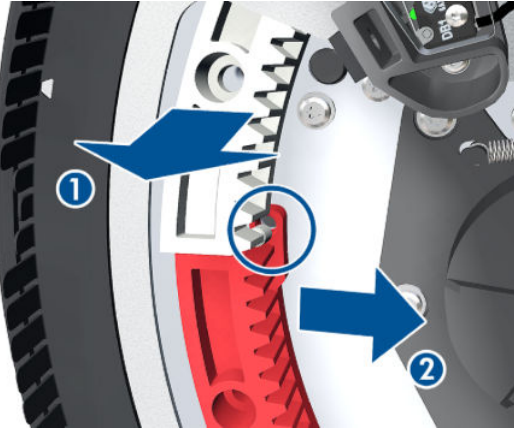

11. Pull out faulty segment.

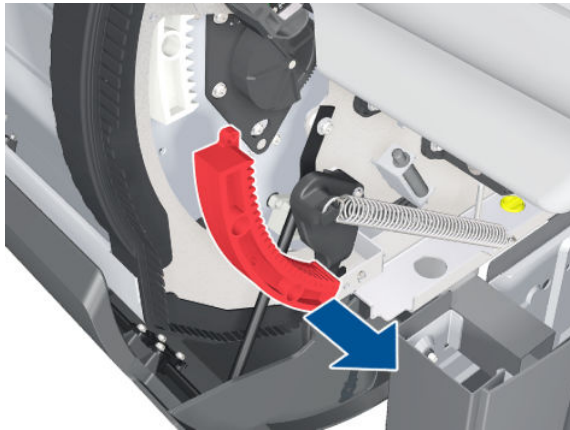

Installation

1. Put the new segment in place.

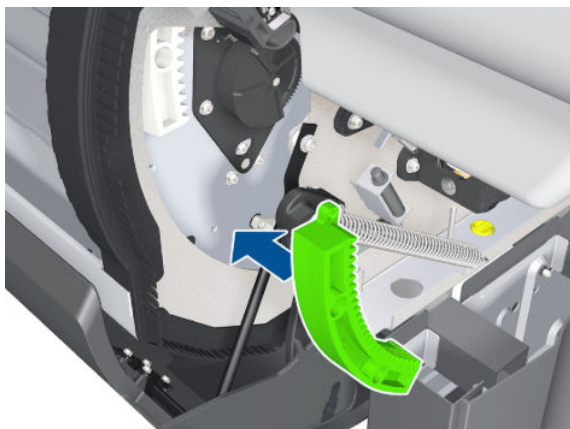

2. Insert the pin at the bottom end of the segment.

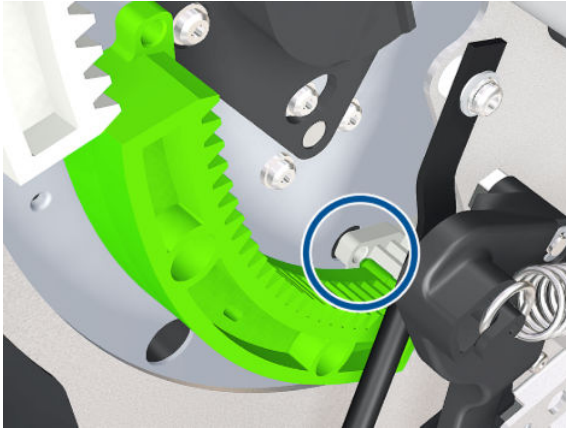

3. Move aside the upper segment temporarily before engaging it with the new segment.

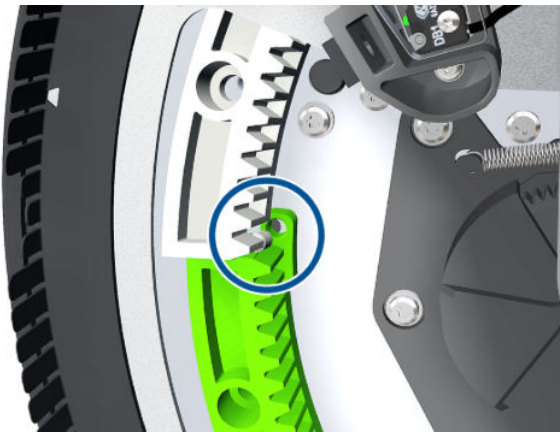

4. Insert two T-20 screws into the new segment and another into the upper segment.

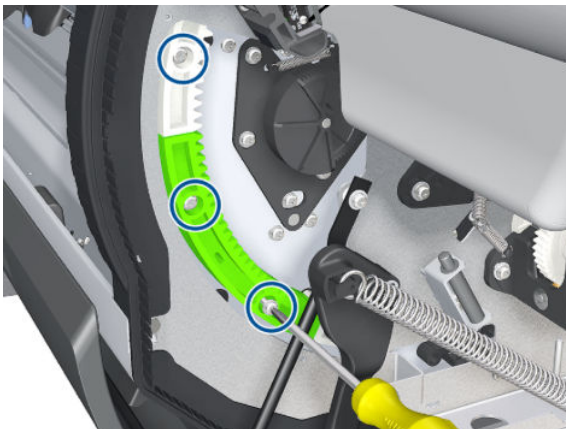

5. Rotate the gear.



6. Insert the remaining screw in the upper segment.

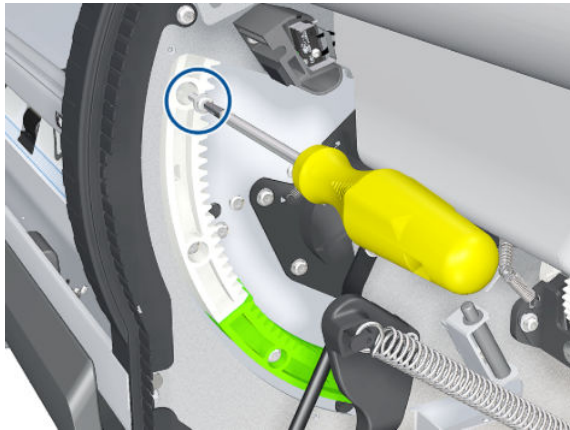

Smart Roll-loading System Door Spring

Removal

1. Close the Smart Roll-loading System Door.
2. Remove the Left Smart Roll-loading System Cover ⇒ See [Smart Roll-loading System Cover, Left on page 261](#).
3. Remove the Right Smart Roll-loading System Cover ⇒ See [Smart Roll-loading System Cover, Right on page 260](#).

4. Put on a glove to disengage and remove the Smart Roll-loading System Door Spring on each side.

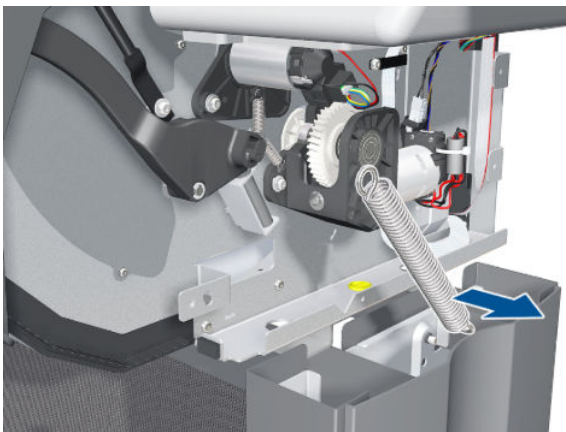
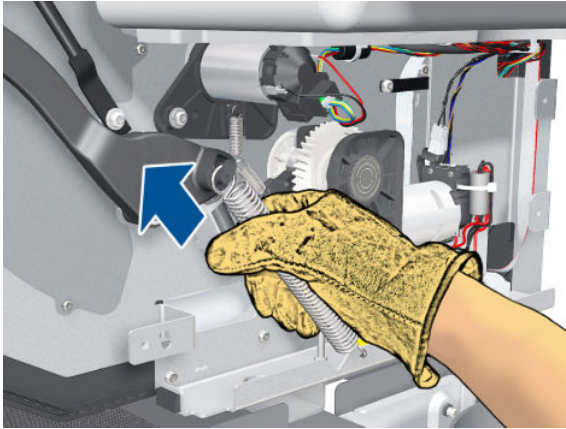

Smart Roll-loading System Door Arms

Removal

1. Turn down the lever on each side of the Smart Roll-loading System Door.



2. Open the Smart Roll-loading System Door.

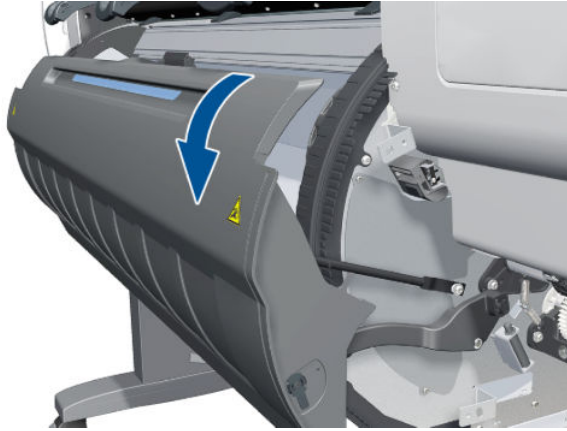

3. Remove the lever from each side.

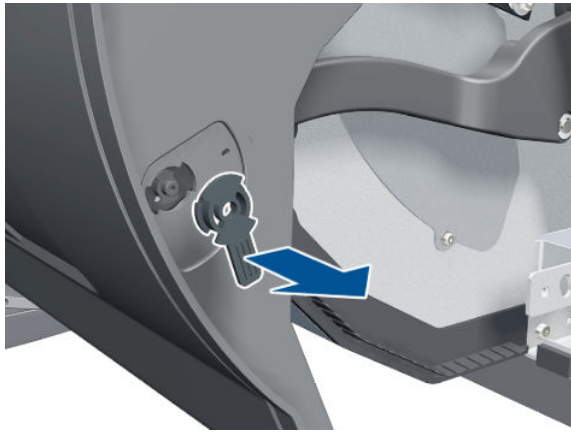

4. Move each Smart Roll-loading System Door Arm inwards to disengage it from the door.

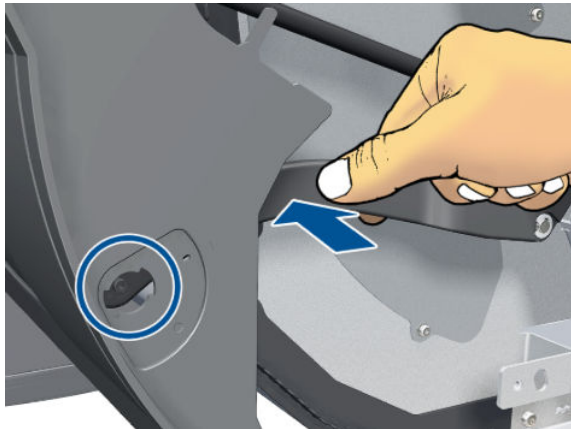

5. Move each Smart Roll-loading System Door Arm downwards, away from the door.

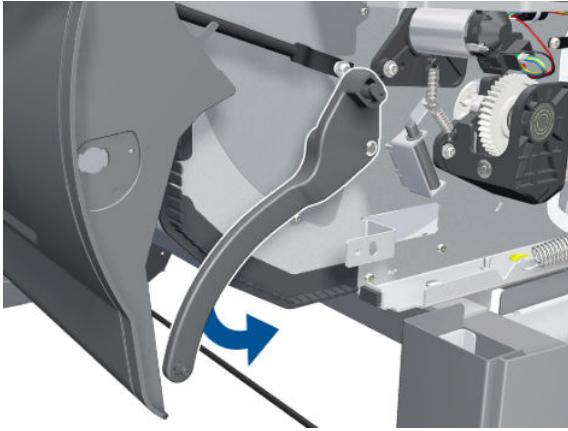

6. Remove the circlip, using pliers if necessary.

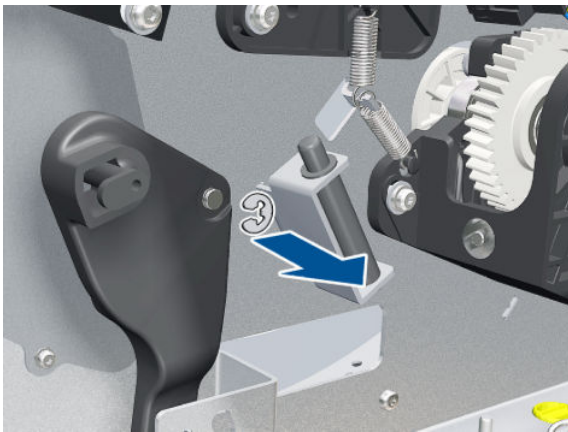

7. Remove the Smart Roll-loading System Door Arm.

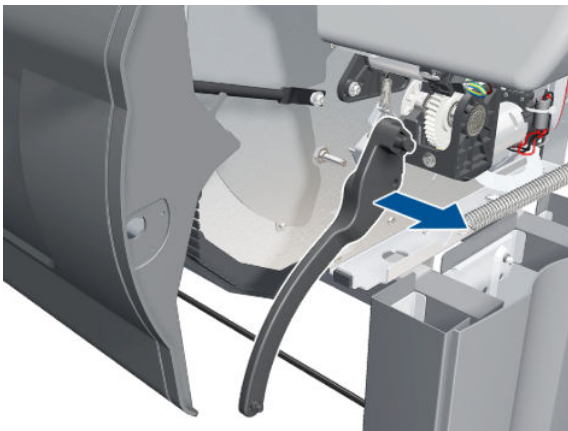

Rewinder Gear and Motor

Removal

1. Unload the paper.
2. Remove the Right Cover ⇒ See [Cover, Right on page 225](#).
3. Remove the Right Connector Cover ⇒ See [Connector Cover, Right on page 237](#).
4. Remove the Right Smart Roll-loading System Cover ⇒ See [Smart Roll-loading System Cover, Right on page 260](#).
5. Open the Smart Roll-loading System Door.
6. Remove three T-10 screws.

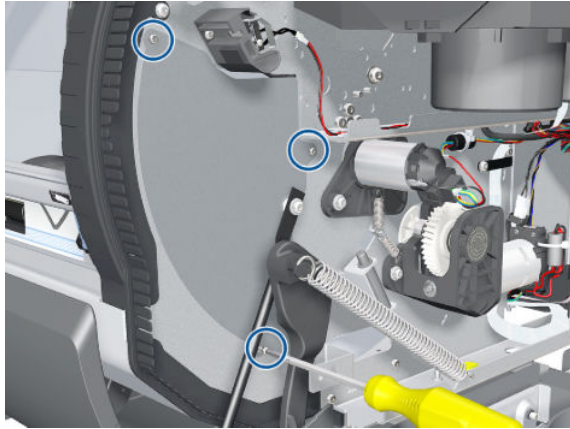

7. Remove the Roller Cover.

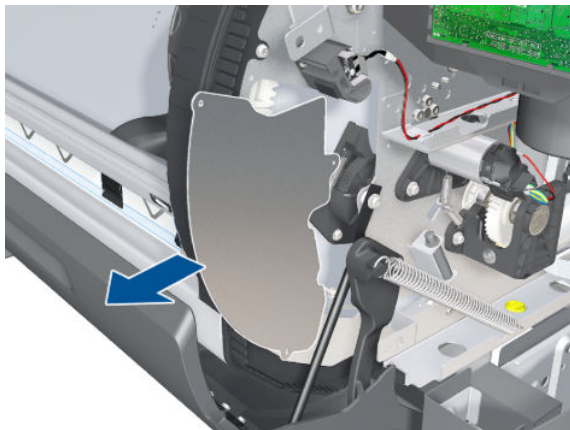

8. Rotate the Smart Roll-loading System manually (1) until the gear to be replaced can be seen through the hole in the side plate (2).

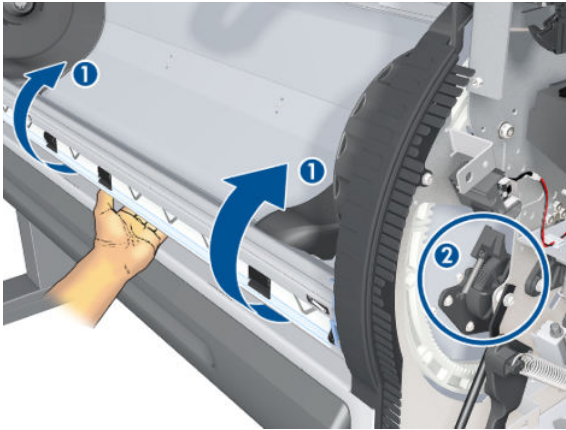

9. Remove three T-20 screws.

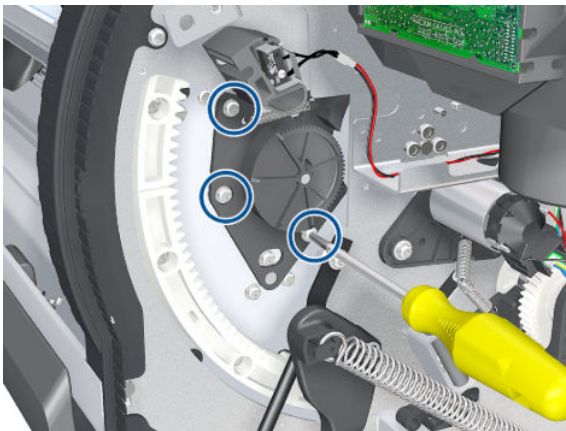

10. Remove the Rewinder Gear.

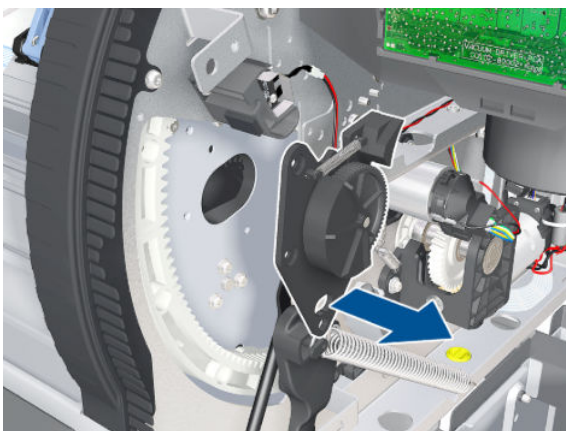

11. Disconnect the power and data cables from the Rewinder to the Interconnect PCA.

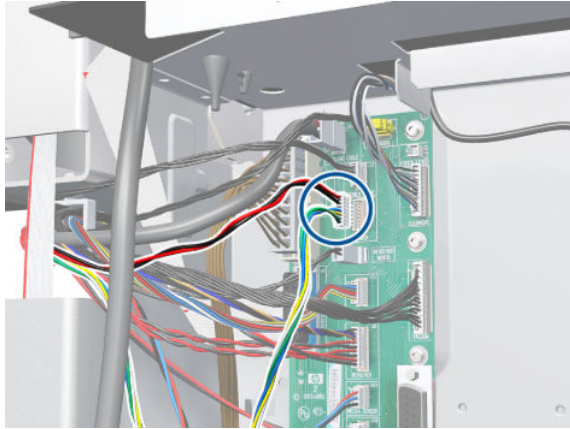

12. Unclip the cable and disconnect the ferrite.

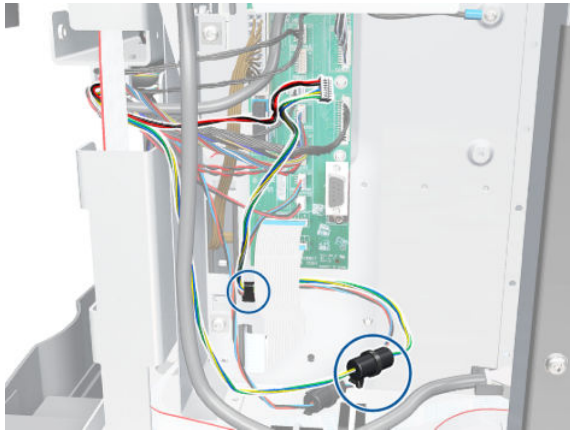

13. Unroute the cable and disconnect the ferrite.

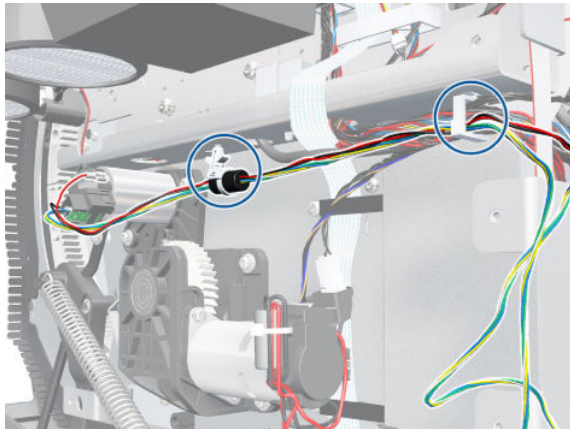

14. Remove the spring that holds the Rewinder Drive and Smart Roll-loading System Drive Motor. Be careful not to lose the spring.

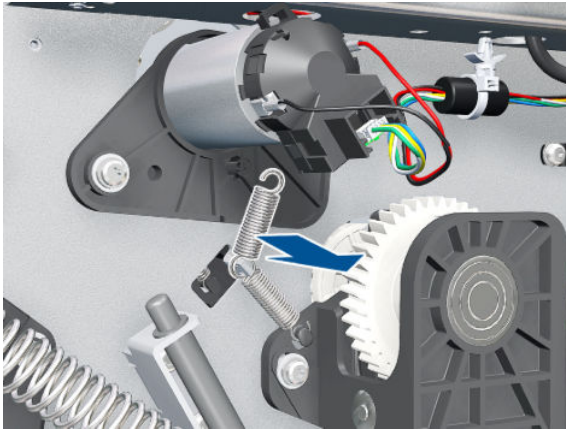

15. Remove two T-20 screws and washers.

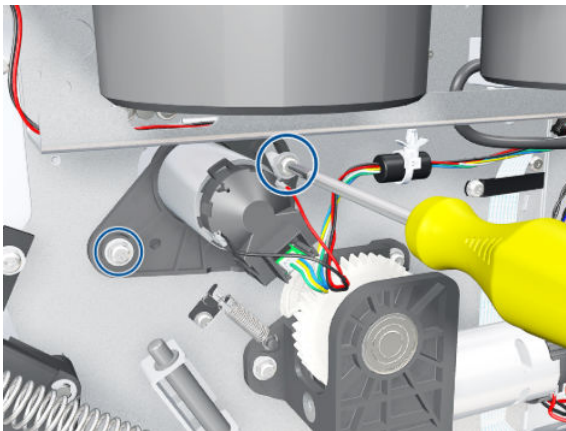

16. Remove the Rewinder Drive from the printer.

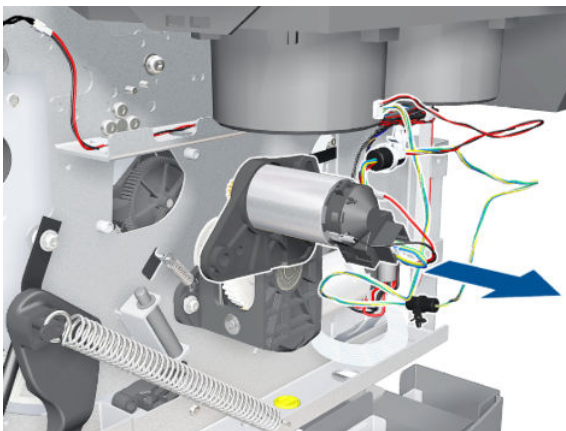

Indexer and Right Slider

Removal

1. Remove the Right Smart Roll-loading System Cover ⇒ See [Smart Roll-loading System Cover, Right on page 260](#).
2. Remove the rubber protector.

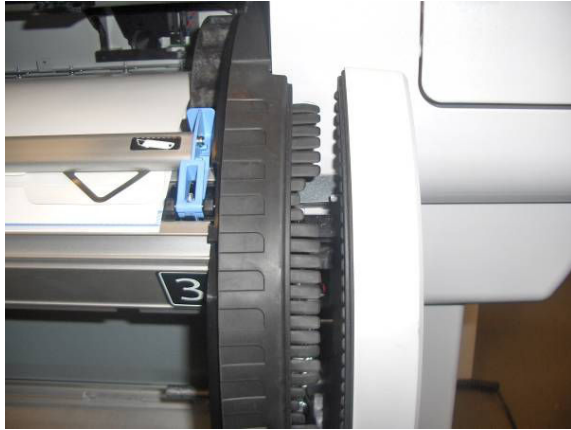

3. Remove two T-15 screws.

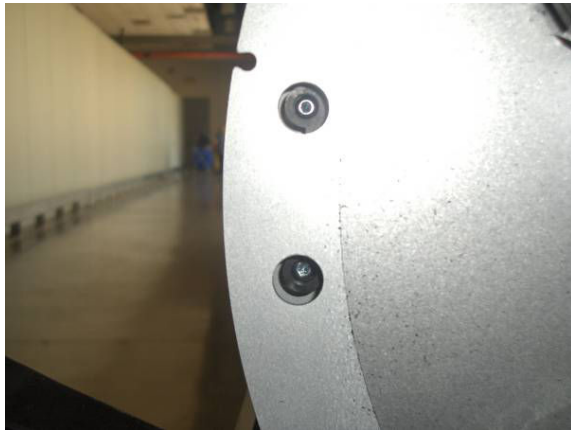

4. Remove the Indexer.



5. Remove the Entry Platen ⇒ See [Entry Platen on page 356](#).

6. Remove two T-8 screws that connect the Right Slider and the Smart Roll-loading System Sensor to the Entry Platen.

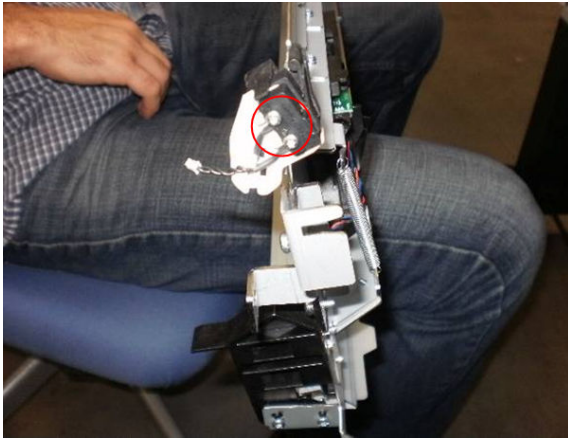

7. Remove the Right Slider.

Smart Roll-loading System Damper

Removal

1. Remove the Left Smart Roll-loading System Cover ⇒ See [Smart Roll-loading System Cover, Left on page 261](#).
2. Remove the Right Smart Roll-loading System Cover ⇒ See [Smart Roll-loading System Cover, Right on page 260](#).
3. Open the Smart Roll-loading System Door.
4. Remove the Smart Roll-loading System Damper from both sides.

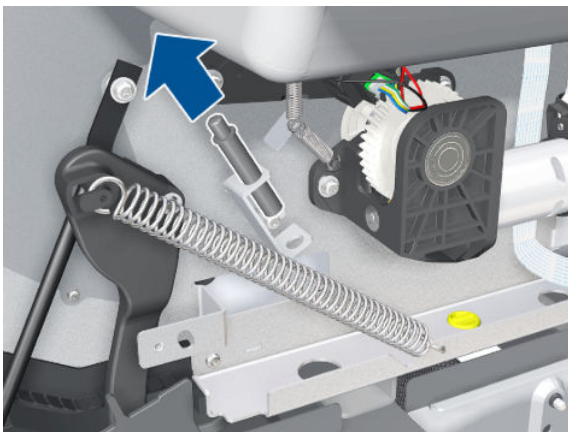

Smart Roll-loading System Door Switch

Removal

1. Remove the Left Smart Roll-loading System Cover ⇒ See [Smart Roll-loading System Cover, Left on page 261](#).
2. Remove the Right Smart Roll-loading System Cover ⇒ See [Smart Roll-loading System Cover, Right on page 260](#).
3. Open the Smart Roll-loading System Door.
4. Disconnect the Smart Roll-loading System Door Switch cable.

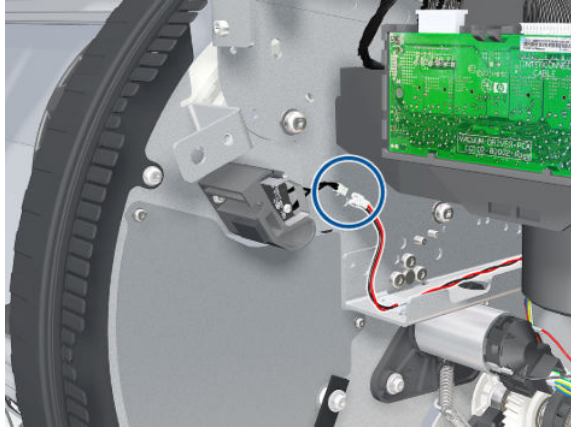

5. Remove two T-10 screws.

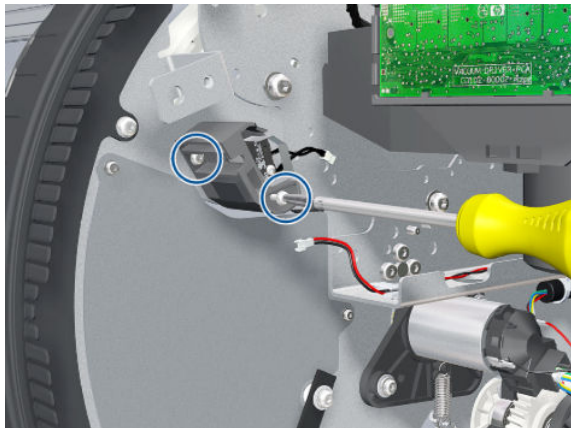

6. Remove the Smart Roll-loading System Door Switch.

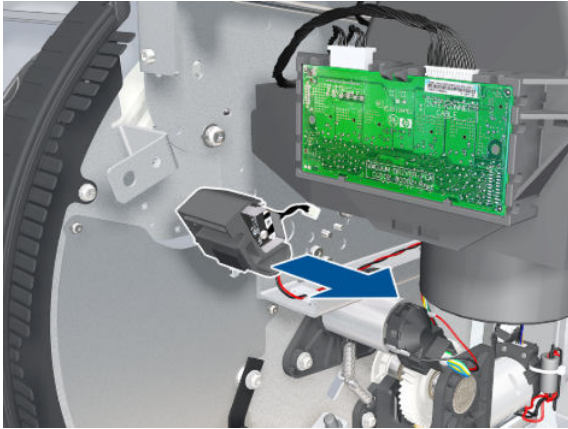

Installation

Before installing the Smart Roll-loading System Door Switch, you must insert the screws into the switch.

Hub, Left, and Roll Support

Removal

1. Open the Smart Roll-loading System Door.
2. Unload the paper.
3. Remove one screw from the ball.

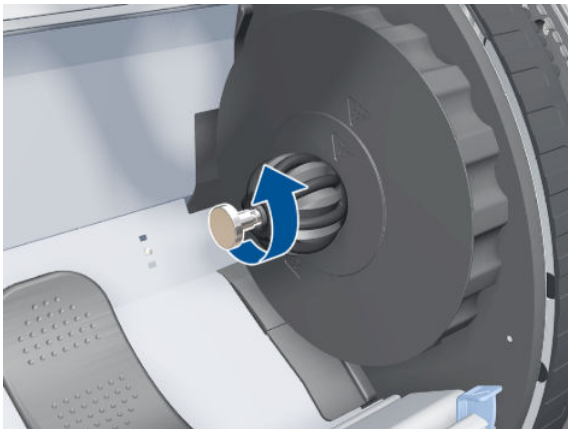

4. Remove the ball from the Left Hub.

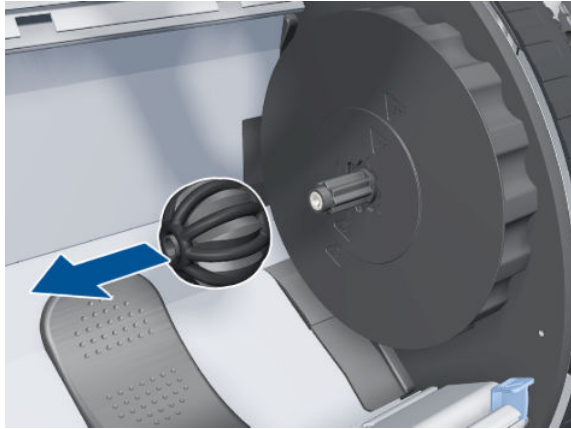

5. Remove the Roll Support from the base.

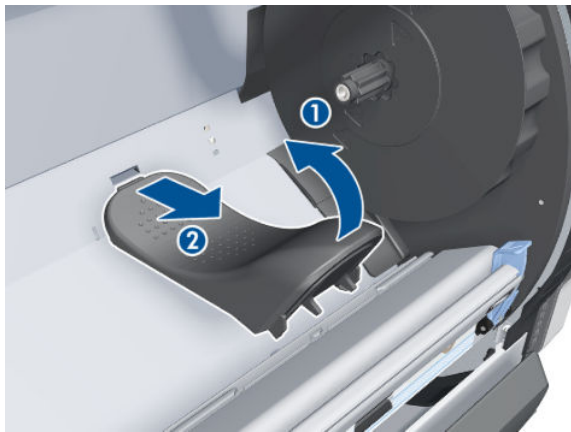

6. Slide the Left Hub to the right.



7. Continue sliding the Left Hub to the right until it reaches the slots.

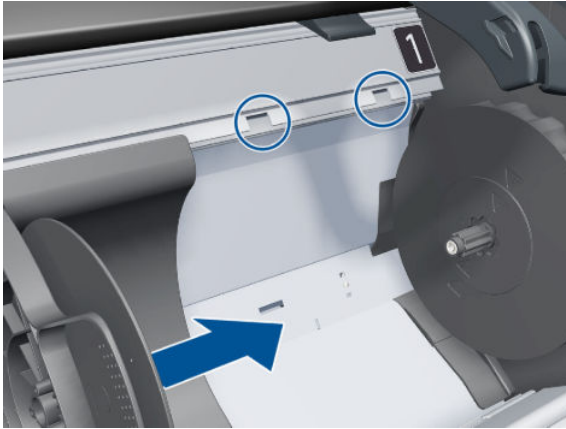

8. Disengage the Left Hub from the slots.

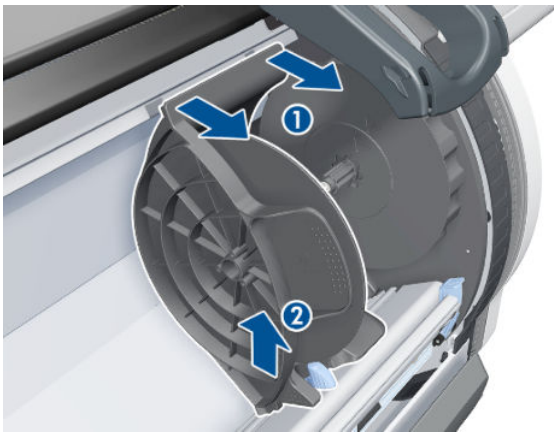

9. Remove the Left Hub.



Smart Roll-loading System Door

Removal

1. Remove the Right Smart Roll-loading System Cover ⇒ See [Smart Roll-loading System Cover, Right on page 260](#).
2. Remove the Left Smart Roll-loading System Cover ⇒ See [Smart Roll-loading System Cover, Left on page 261](#).
3. Put the tube bushing in this position on each side.



4. Remove the tube bushing by pushing it from behind.

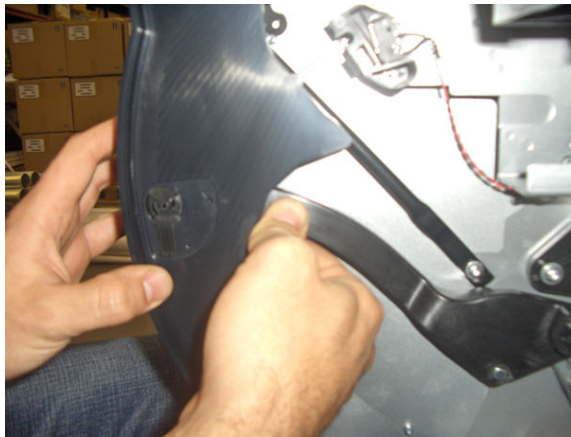

5. Remove one T-15 screw from the left-hand lever.



6. Remove one T-15 screw from the right-hand lever.



7. Remove the Smart Roll-loading System Door.

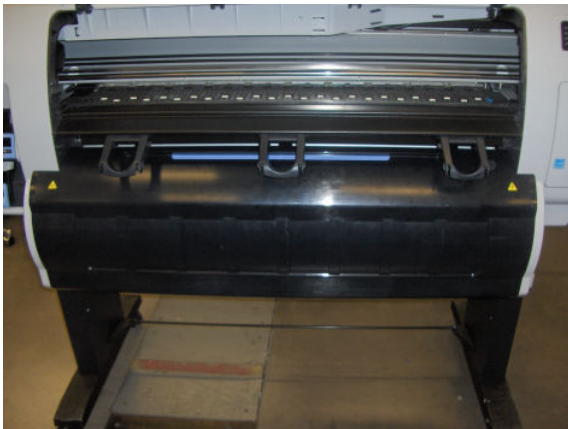

Carriage

Removal

⚠ WARNING! Switch off the printer and remove the power cable.

1. Remove the Right Cover ⇒ See [Cover, Right on page 225](#).
2. Remove the Front Panel ⇒ See [Front Panel on page 239](#).
3. Remove the Primer Assembly ⇒ See [Primer Assembly on page 241](#).
4. Remove the Left Cover ⇒ See [Cover, Left on page 228](#).
5. Remove the Encoder Strip ⇒ See [Encoder Strip and Encoder Sensor on page 298](#).
6. Pull out the Printhead Maintenance Cartridge tray.

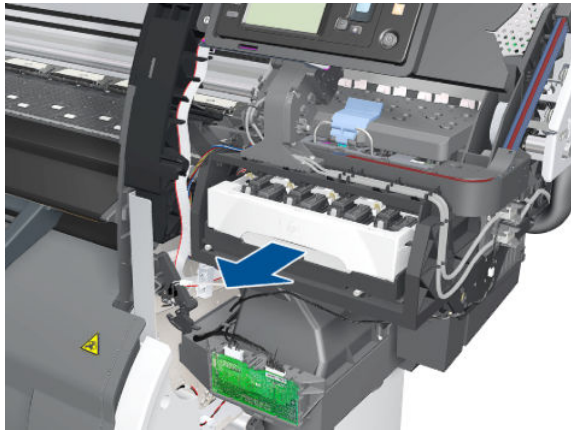

7. Lift the Primer and hold the Primer to its maximum position to avoid damaging it when you move the Carriage in the next step.

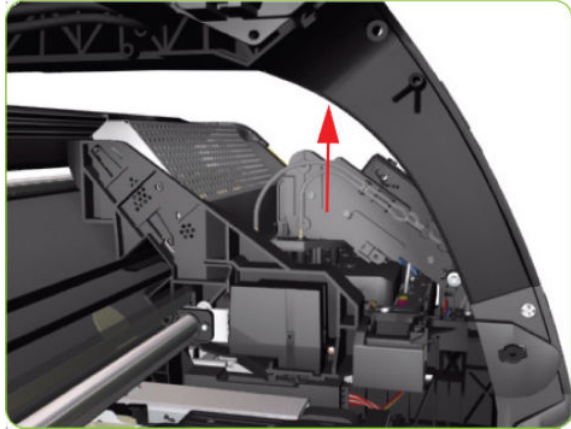

8. Move the Carriage to the extreme right of the printer.

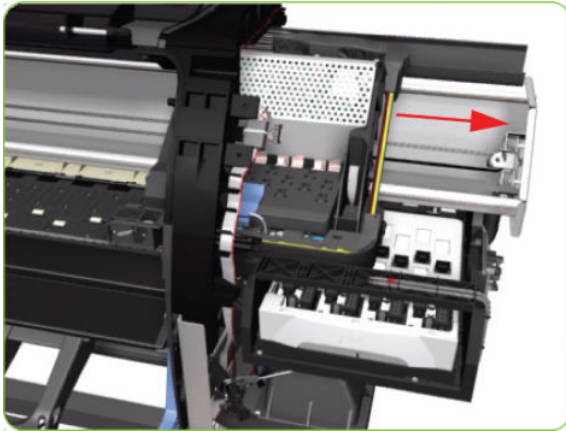

9. Press the two sides of the Carriage PCA Cover and unclip from the Carriage.

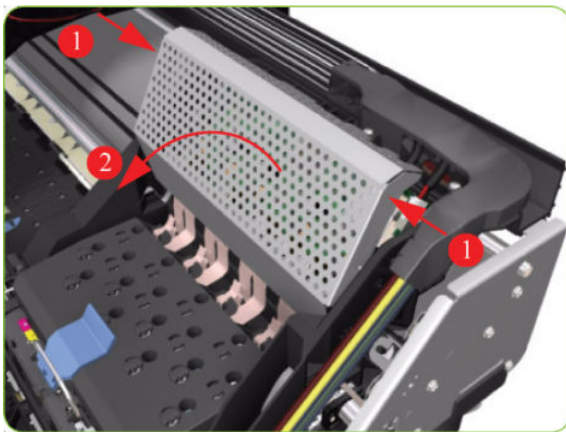

10. Disconnect the Trailing Cable from the Carriage PCA.

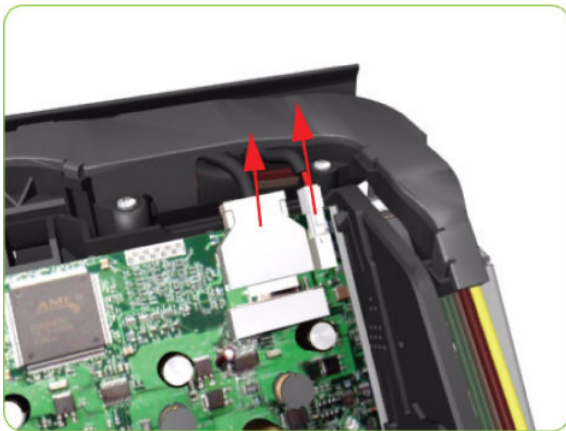

11. Open the Carriage Cover and remove ALL the Printheads from the Carriage.

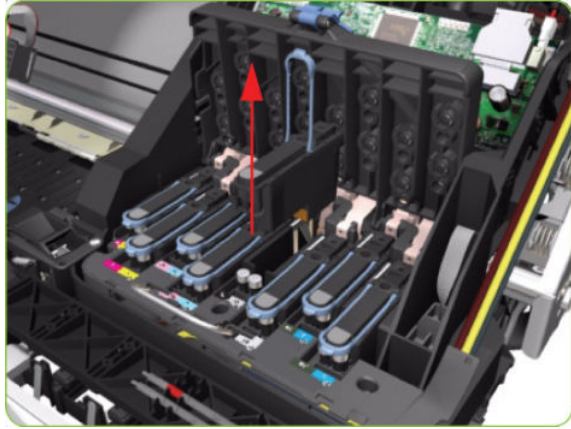

12. Remove five T-15 screws (Type G) that secure the Ink Supply Tubes to the Carriage.

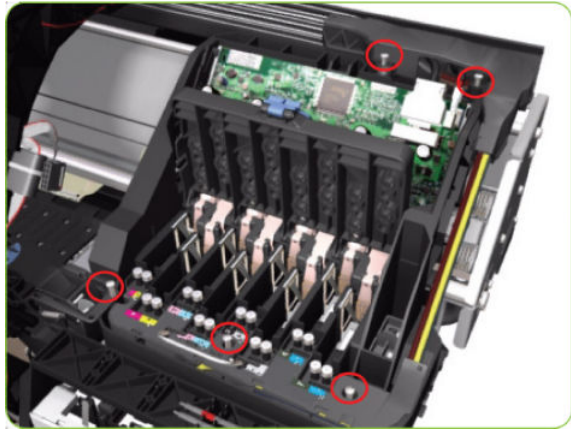

13. Remove the Ink Supply Tubes from the Carriage and safely place to one side of the printer.

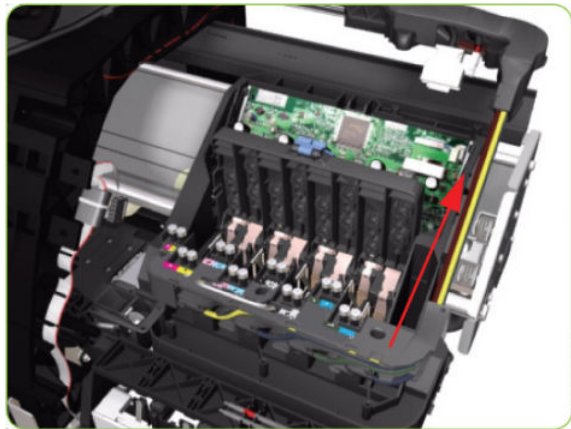

14. Disconnect the Aerosol Fan Tube from the Chassis.

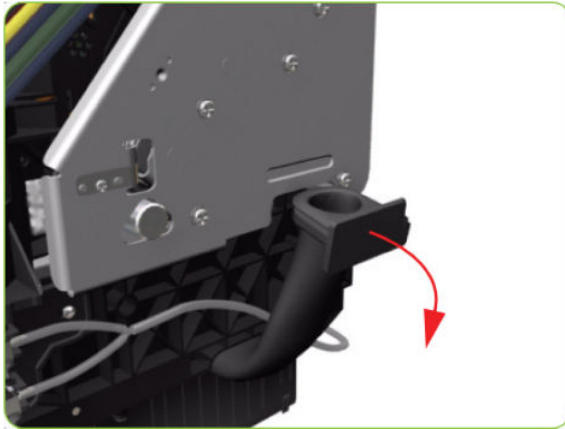

15. Remove one T-20 screw (Type A) that secures the Belt Tensioner to the Chassis.



16. Lift the Primer and hold the Primer to its maximum position to avoid damaging it when you move the Carriage in the next step.

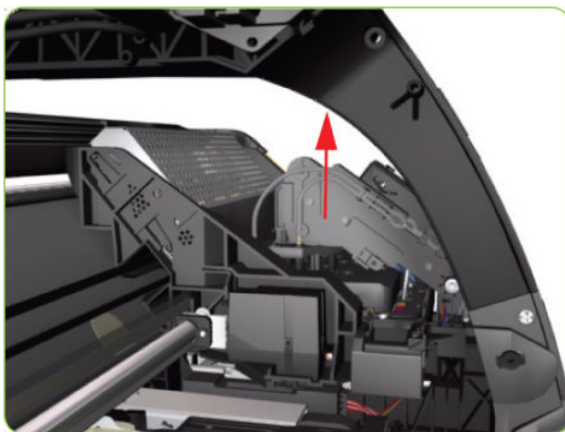

17. Move the Carriage slightly away from the right Scan-Axis Bracket.

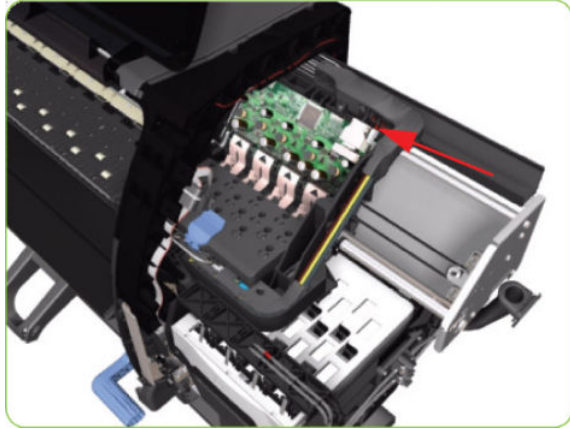

18. Release the Carriage Belt from the Scan-Axis Motor on the left-hand side of the printer.

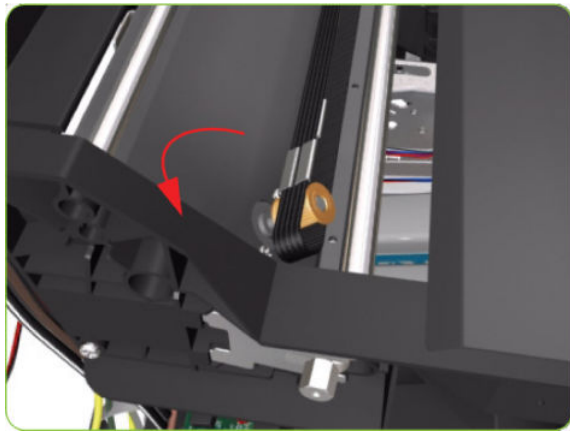

19. Remove one T-10 screw (Type C) that secure the Encoder Strip.



20. Remove four T-20 screws (**Type N**) that secure the right Scan-Axis Bracket.

 **NOTE:** Note that these are Chassis screws and in normal circumstances should NEVER be removed, but in this case we need to remove them in order to remove the Carriage.



21. Remove the right Scan-Axis Bracket from the printer.

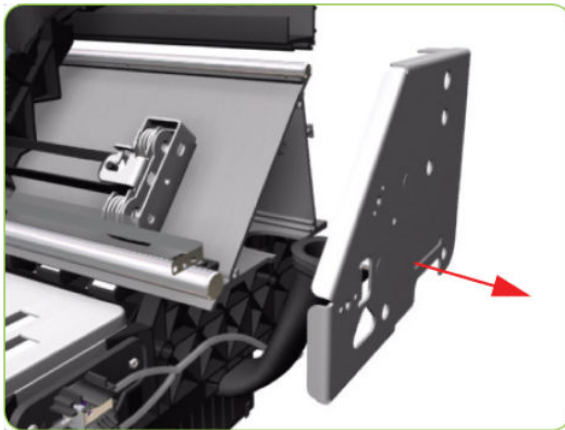

22. Remove the Carriage Stopper Screw (T-20) from the Chassis.

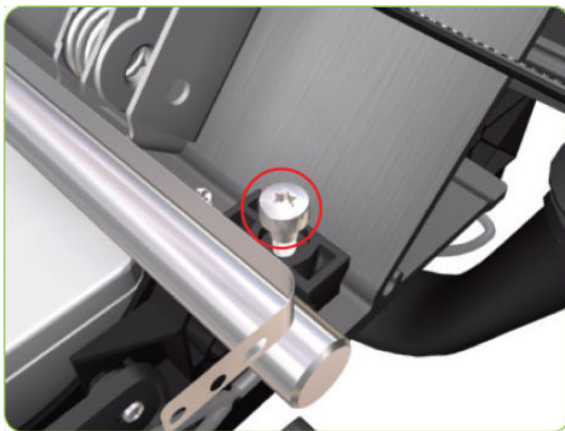

23. Remove the Carriage Stopper from the printer.

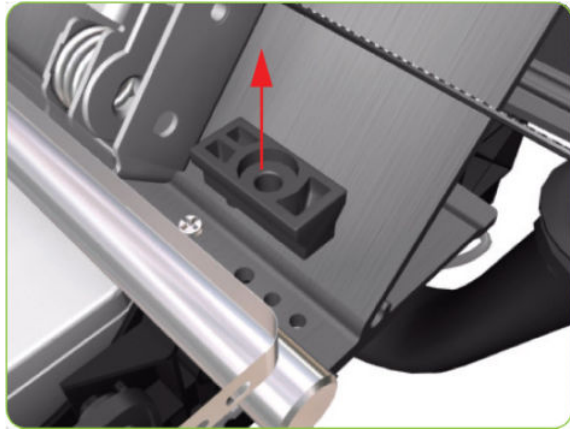

24. Slide the Carriage (including the belt) to the right and out of the printer.
25. If the Carriage is to be replaced, make sure that you remove the Belt, the Carriage PCA, Encoder and Line Sensors and the Cutter (in order to install them on the new Carriage).

 **NOTE:** After installing the new Carriage, make sure you perform the following Service Utility and Calibrations:

- Reset life counter Carriage ME ⇒ [Reset Life Counters on page 108](#).
- Drop Detector Calibration ⇒ [Drop Detector calibration on page 124](#).
- Line Sensor Calibration ⇒ [Line Sensor calibration on page 126](#).



Carriage PCA

Removal

 **WARNING!** Switch off the printer and remove the power cable.

1. Remove the Right Cover ⇒ See [Cover, Right on page 225](#).

2. Press the two side of the Carriage PCA Cover and unclip from the FPCA.

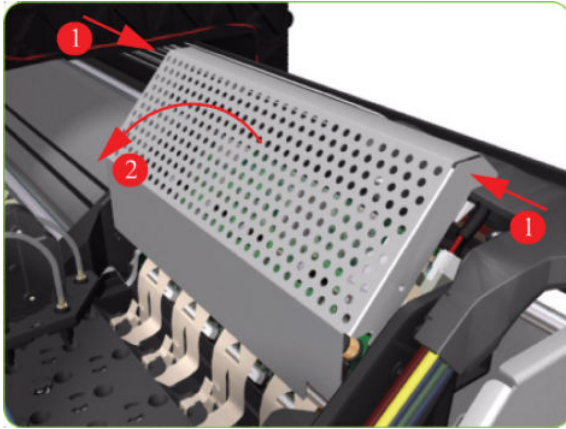

3. Disconnect the Trailing Cable from the Carriage PCA.

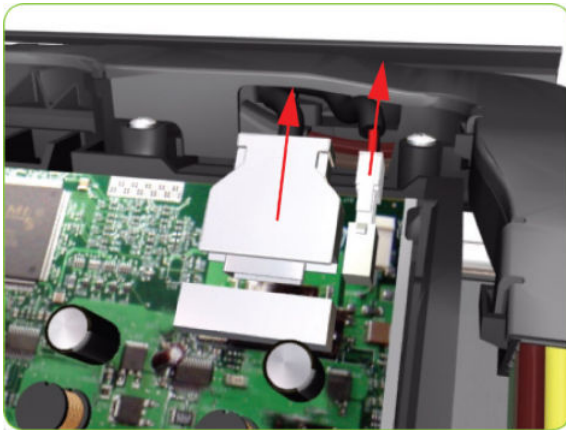

4. Use a flat-bladed screwdriver to release the ALL the clips, securing the Carriage Flex Cables to the Carriage Assembly, by pulling upwards.

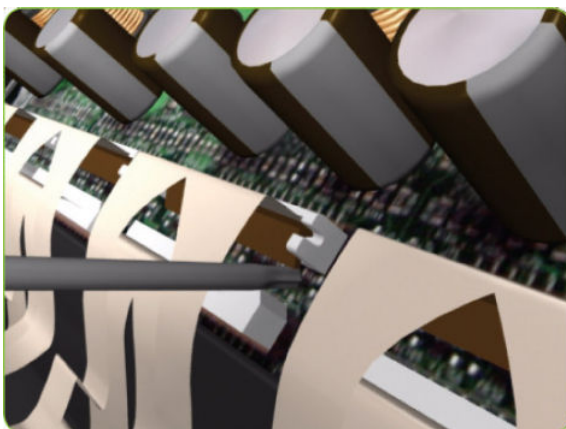

5. Disconnect the Flex Cables from the Carriage PCA.



6. Disconnect the Line Sensor Cable and the Encoder Sensor Cable from the Carriage PCA.

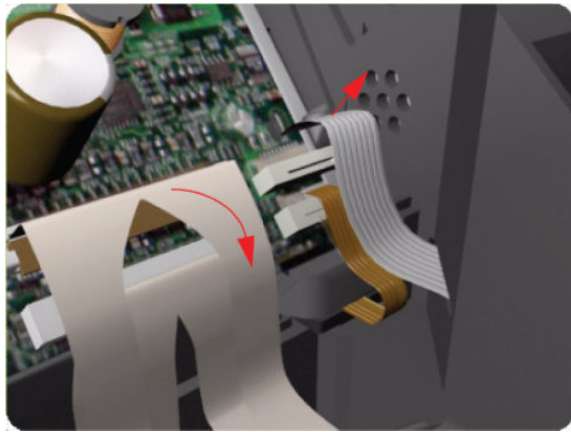

7. Push inwards the four clips that secure the Carriage PCA.



8. Remove the Carriage PCA from the printer.

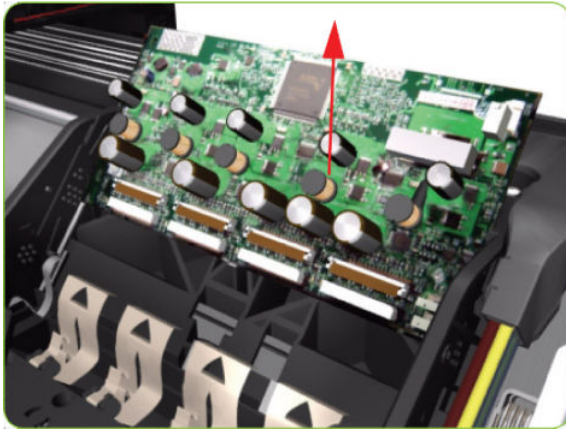

 **NOTE:** Once you have installed a new Carriage PCA, you must perform the following steps to ensure that the printer will function correctly:

1. Turn on the printer.
2. Install the Printheads.
3. Reset life counter Carriage PCA ⇒ [Reset Life Counters on page 108](#).

Carriage Flex Cables

Removal

 **WARNING!** Switch off the printer and remove the power cable.

1. Remove the Right Cover ⇒ See [Cover, Right on page 225](#).
2. Remove the Front Panel ⇒ See [Front Panel on page 239](#).
3. Disconnect the Trailing Cable from the Carriage PCA.
4. Press the two side of the Carriage PCA Cover and unclip from the Carriage Assembly.

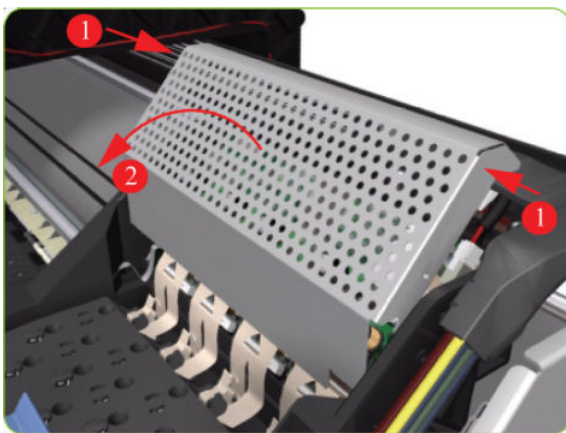

5. Use a flat bladed screwdriver to release the all the clips, securing the Carriage Flex Cables to the Carriage Assembly, by pulling upwards.



6. Remove eight T-8 screws (Type L) that secure the Carriage Flex Cables to the Carriage Assembly.

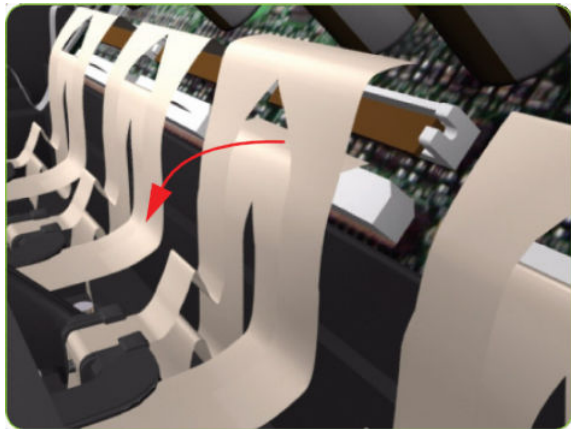

7. Open the Carriage Cover and remove all the Printheads from the Carriage Assembly.

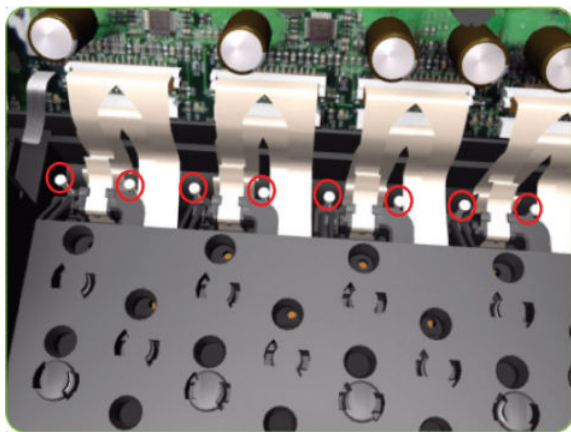

8. Open the Carriage Cover and remove all the Printheads from the Carriage Assembly.

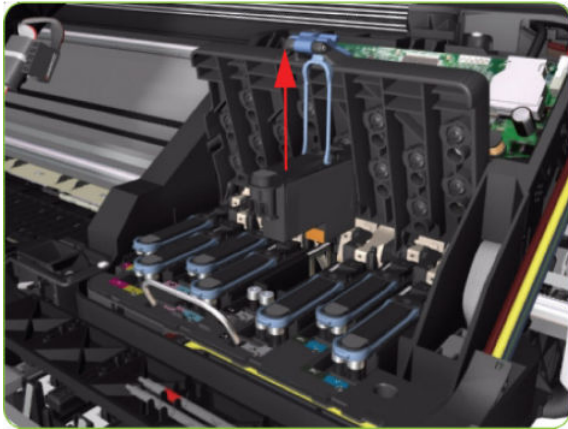

9. Remove the Carriage Flex Cable from the printer.

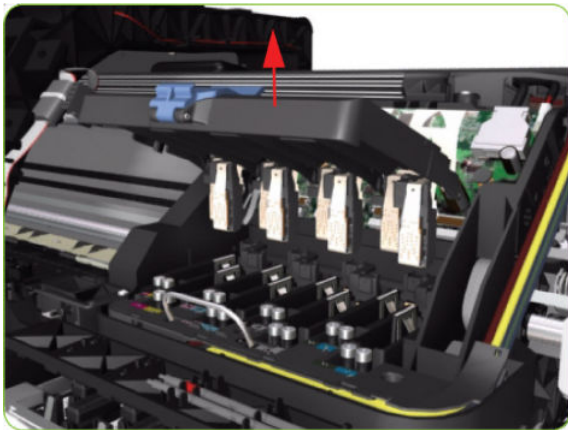

Encoder Strip and Encoder Sensor

Removal

⚠ WARNING! Switch off the printer and remove the power cable.

1. Remove the Right Cover ⇒ See [Cover, Right on page 225](#).
2. Remove the Left Cover ⇒ See [Cover, Left on page 228](#).

3. Uncap the Carriage Assembly by manually pulling out the Printhead Maintenance Cartridge tray.



4. Lift the Primer and hold the Primer to its maximum position to avoid damaging it when you move the Carriage Assembly in the next step.

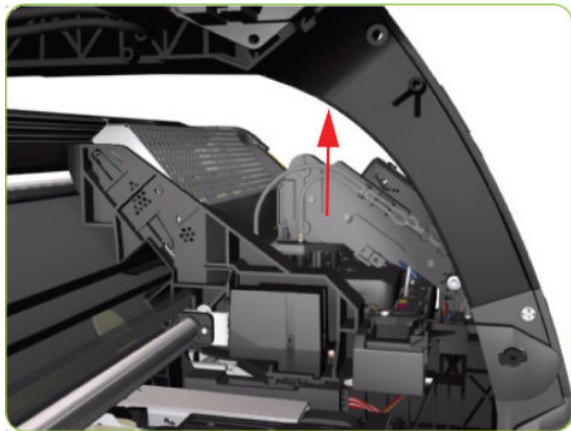

5. Move the Carriage Assembly out of the Service Station.

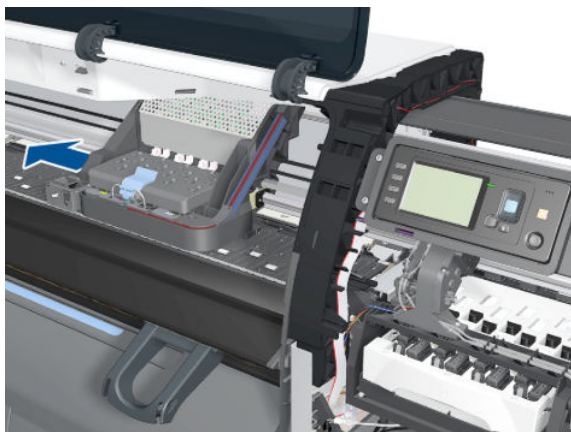

6. Remove one T-10 screw (**Type I**) that secures the Encoder Strip on the right-hand side of the printer.



7. Release the Encoder Strip from the locating pins on the right-hand side of the printer.



8. Release the Spring Clip from the Bracket on the left-hand side of the printer.

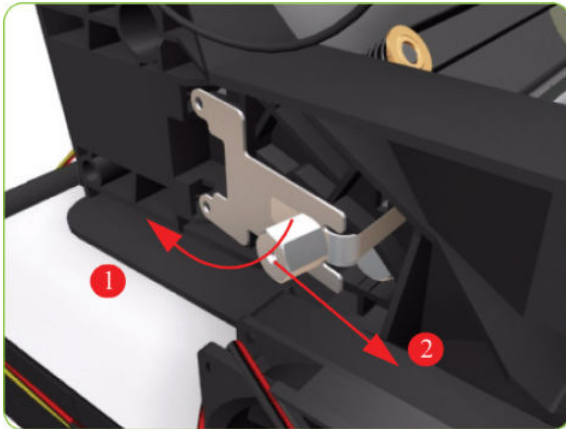

9. Carefully pull the Encoder Strip out of the left-hand side of the printer.

10. Remove the Carriage PCA ⇒ See [Carriage PCA on page 293](#).

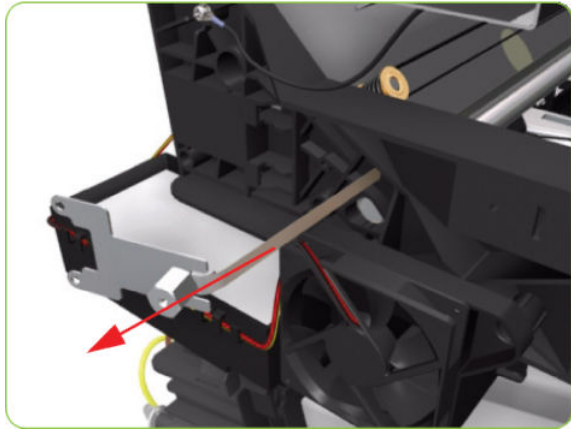

11. Remove one T-8 (Type L) screw that secures the Encoder Sensor to the Carriage Assembly.

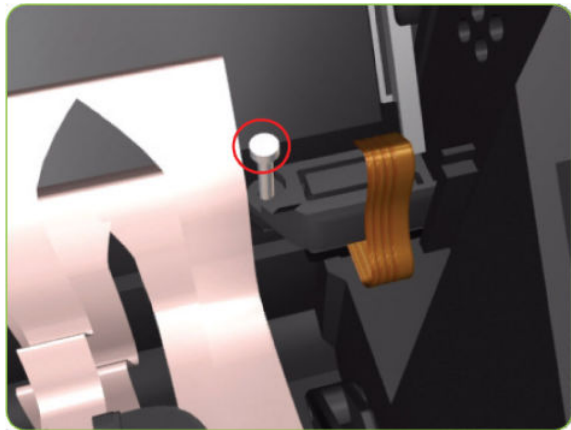

12. Remove the plastic cover from the Encoder Sensor.

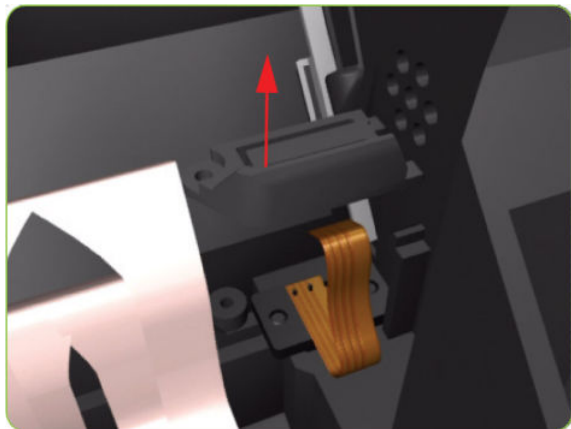

13. Remove the Encoder Sensor from the printer.

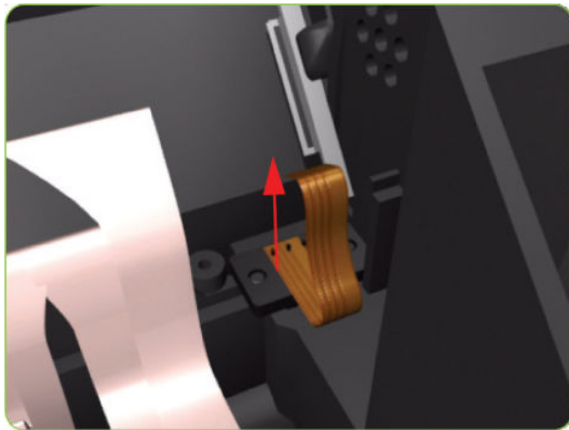

Line Sensor Assembly

Removal

⚠ WARNING! Switch off the printer and remove the power cable.

1. Remove the Right Cover ➔ See [Cover, Right on page 225](#).
2. Press the two side of the Carriage PCA Cover and unclip from the Carriage Assembly.

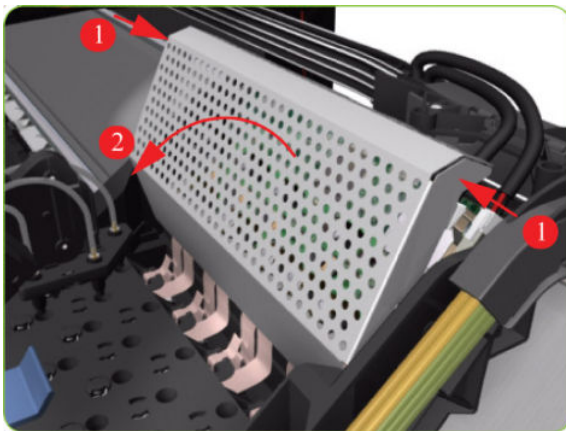

3. Release the clip and disconnect the Line Sensor cable from the Carriage PCA.

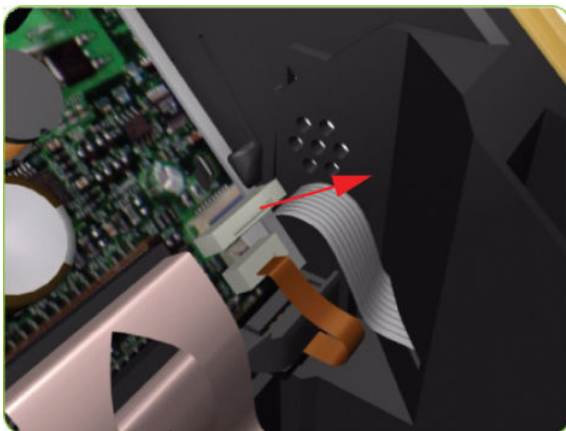

4. Remove the Line Sensor from the Carriage Assembly.

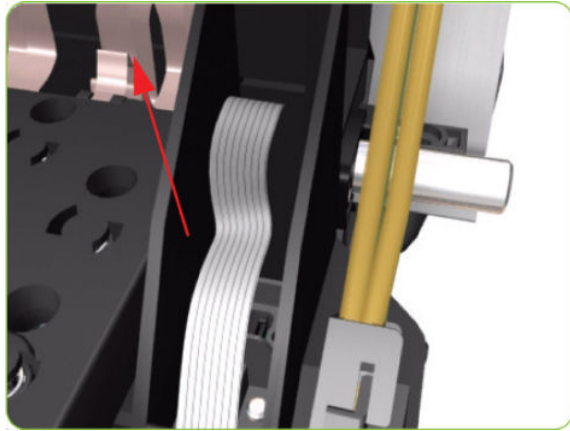

5. Remove the protective foam from around the sensor.

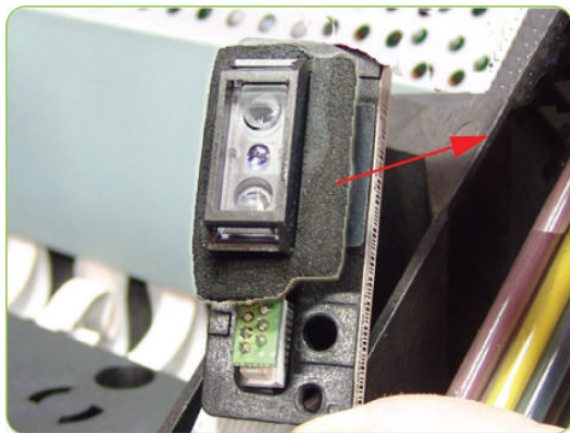

 **NOTE:** After installing the new Line Sensor, make sure you perform the following Service Calibrations:

- Line Sensor Calibration ⇒ [Line Sensor calibration on page 126](#).



Ink Supply Tubes and Trailing Cable

Removal

-  **WARNING!** Switch off the printer and remove the power cable.
-  **CAUTION:** You MUST NEVER replace both the Hard Disk Drive and the Ink Supply Tubes and Trailing Cable at the same time. If both parts need to be replaced, you MUST first replace one part and then power **ON** the printer until it completely initializes. Then you can power **OFF** the printer and replace the other part.

1. Remove the Right Cover ⇒ See [Cover, Right on page 225](#).
2. Remove the Left Cover ⇒ See [Cover, Left on page 228](#).
3. Remove the Top Cover ⇒ See [Cover, Top on page 232](#).
4. Remove the Right Connector Cover ⇒ See [Connector Cover, Right on page 237](#).
5. Remove the Right Rear Trim ⇒ See [Rear Trim, Right on page 351](#).

6. Remove the Right Smart Roll-loading System Cover ⇒ See [Smart Roll-loading System Cover, Right on page 260](#).
7. Disconnect the Trailing Cable from the Interconnect PCA and the Main PCA.

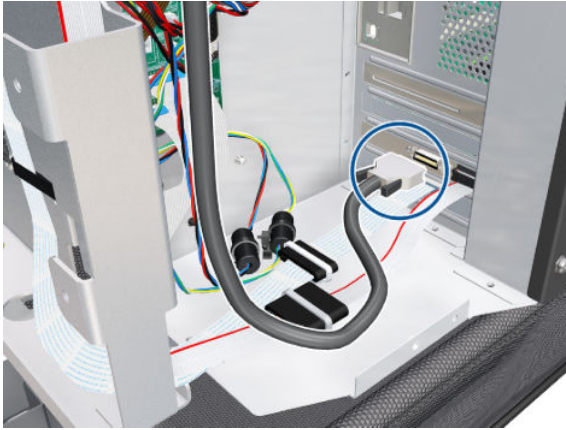

8. Unclip the Trailing Cable ferrites from the left side of the Electronic Module, and pass the cable through the sideplate.

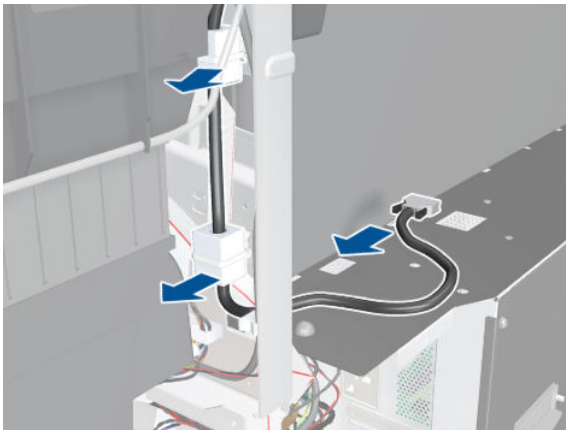

9. Pass the cable through the arc.

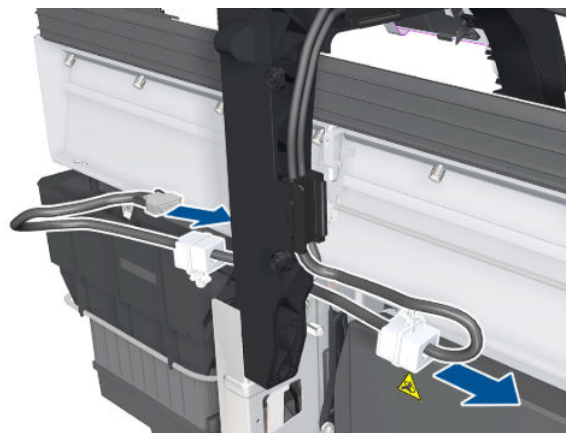

10. Disconnect the Trailing Cable from the Interconnect PCA.

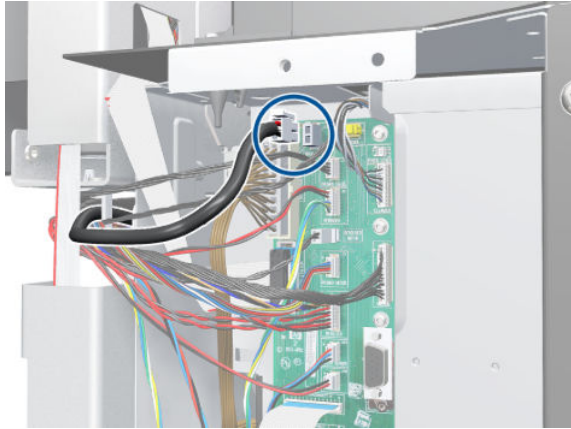

11. Unclip the Trailing Cable from the cable clamps and unrout it.

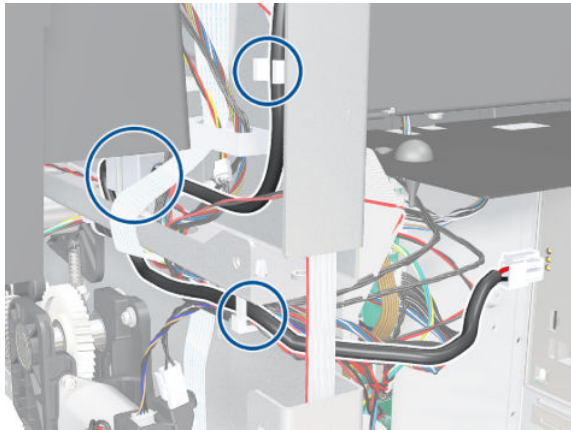

12. Pass the Trailing Cable through the arc.

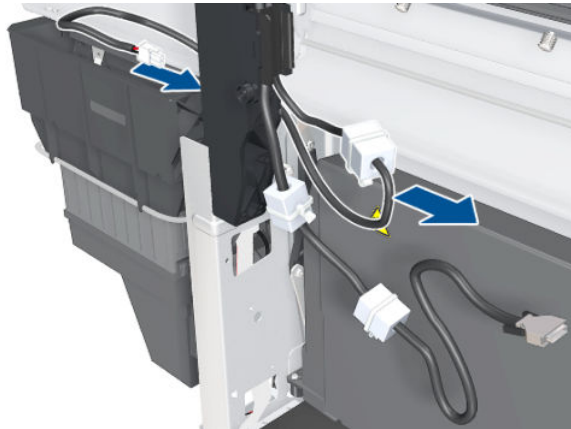

13. Slide out the Maintenance Cartridge.

14. Disconnect the Trailing Cable from the Carriage PCA.

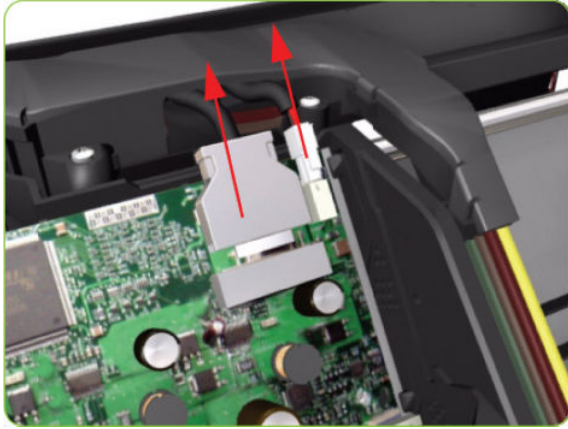

15. Move the Carriage to the center of the Platen.

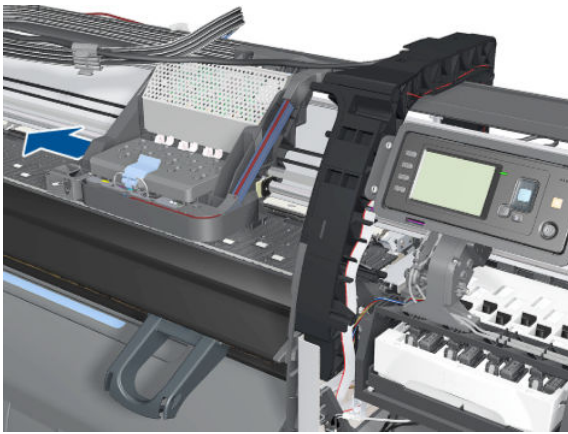

16. Press the two side of the Carriage PCA Cover and unclip from the Carriage Assembly.

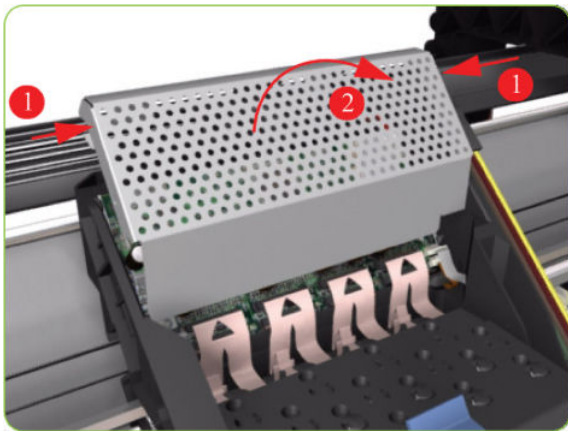

17. Disconnect the Trailing Cable from the Carriage PCA.

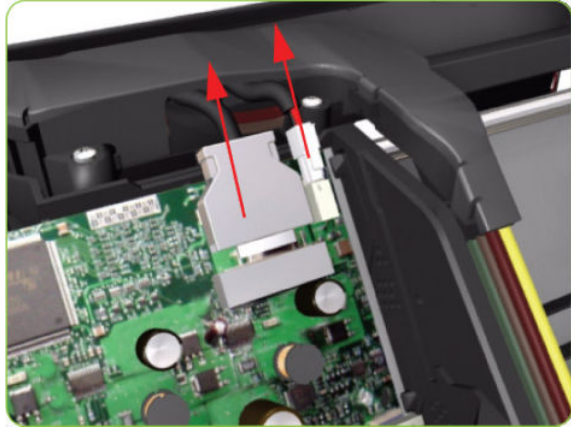

18. Open the Carriage Cover and remove all the Printheads from the Carriage Assembly.

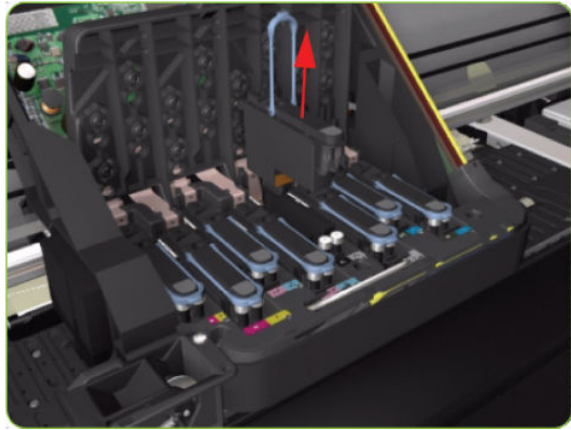

19. Remove five T-15 screws (Type G) that secure the Ink Supply Tubes to the Carriage Assembly.

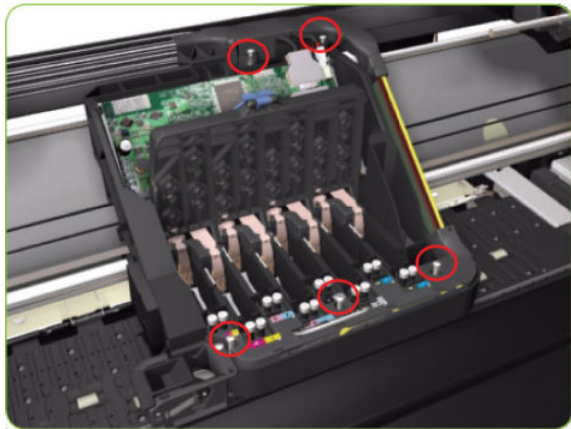

20. Remove the Ink Supply Tubes from the Carriage Assembly and safely place to one side of the printer.

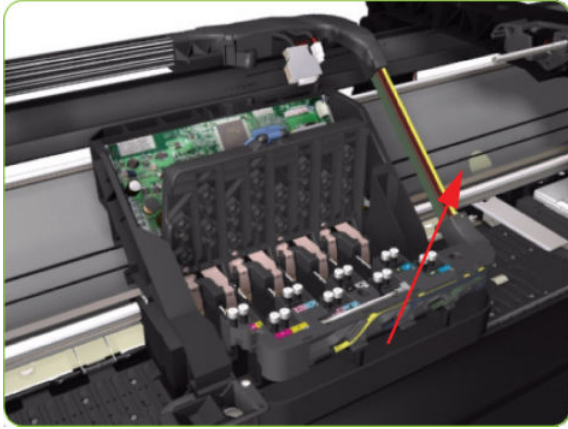

21. Remove two T-20 screws that attach the bonding cable to the printer chassis.

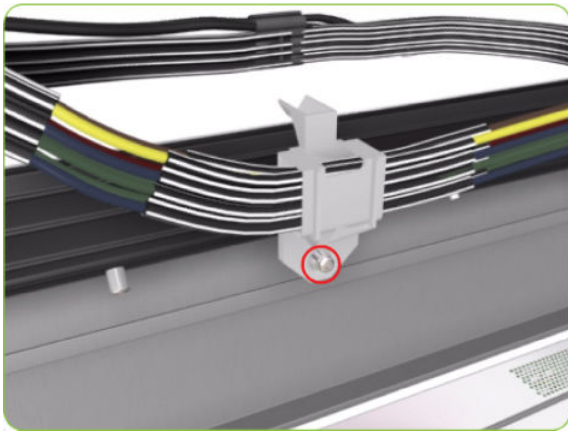

22. Remove two T-20 screws from the ISS Shielding.

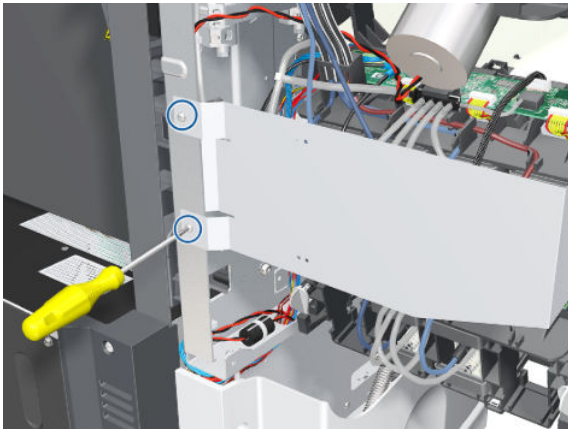

23. Remove the ISS Shielding.

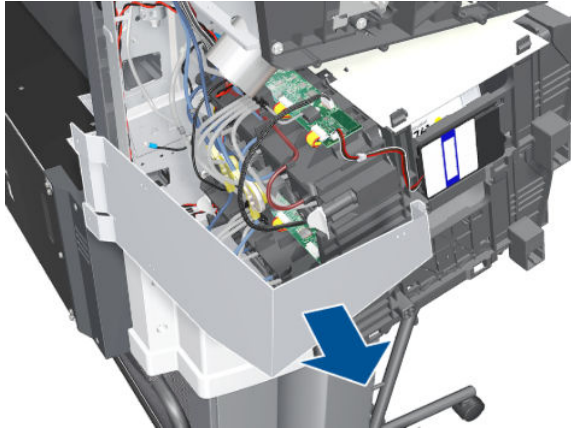

24. Unroute the RFDI cable from the bridge.

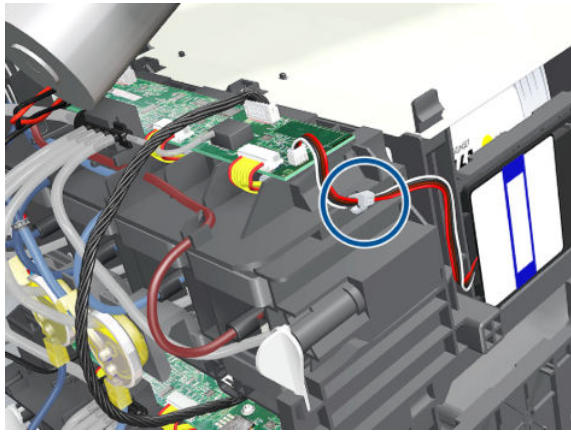

25. Disconnect the RFDI cable.

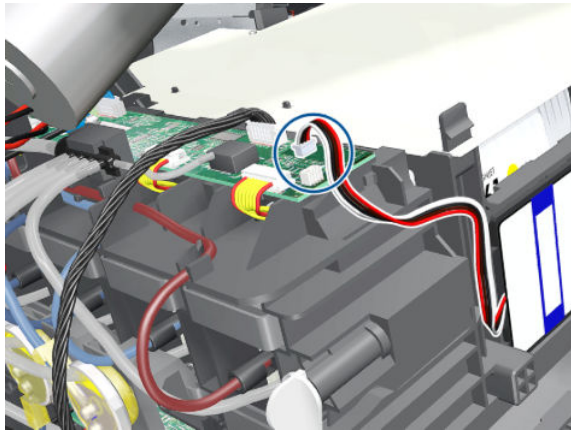

26. Disconnect the cable.

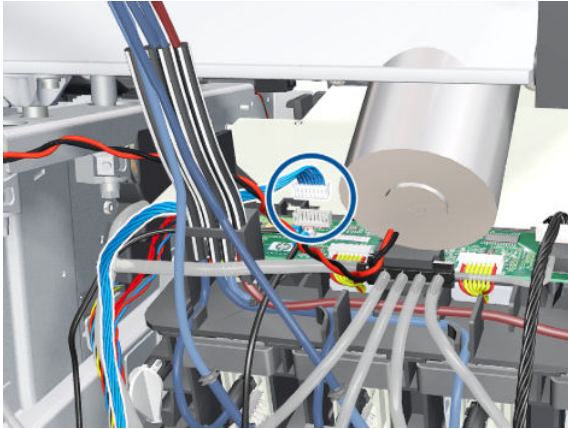

27. Remove the grounding screw.

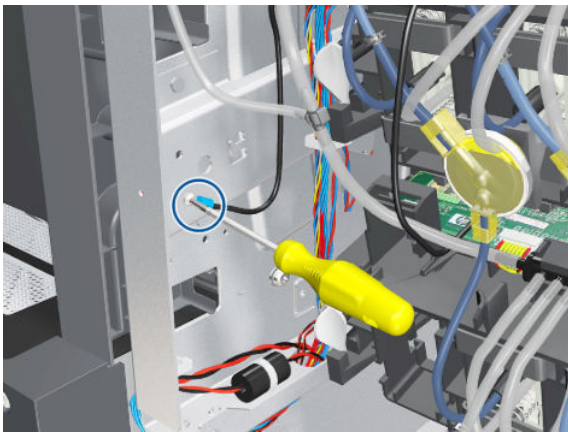

28. Slide out the Ink Cartridges.

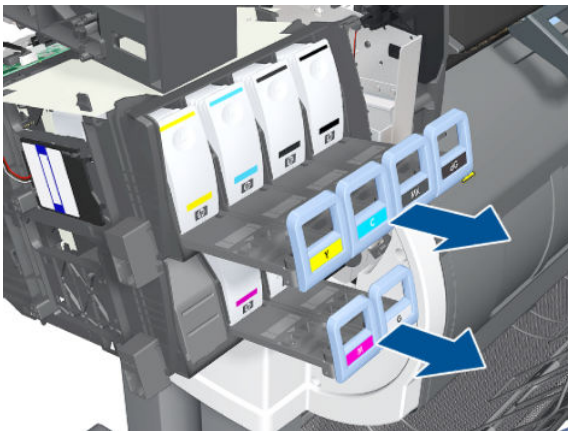

29. Disconnect the Air Tubes from the Ink Cartridge Tube Connector.

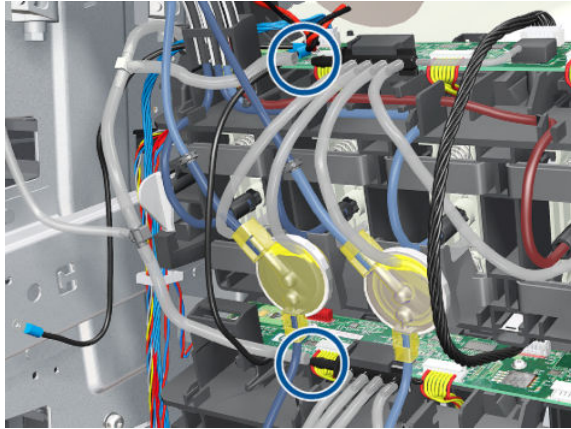

30. Twist the four latches at the rear of the Ink Cartridge Tube Connector and release the complete assembly.

 **NOTE:** Be careful not to damage the interconnecting cable.

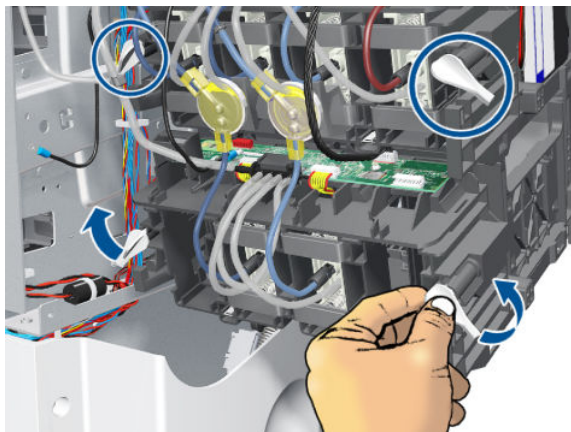

31. Carefully slide the Ink Cartridge Tube Connector off the Ink Supply Station.

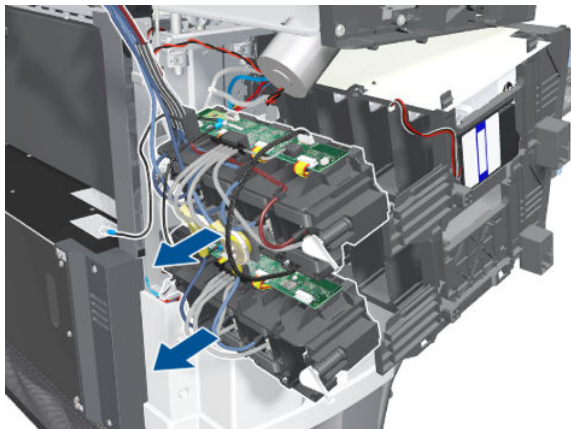

32. Remove the Ink Supply Tubes and Trailing Cable from the printer.

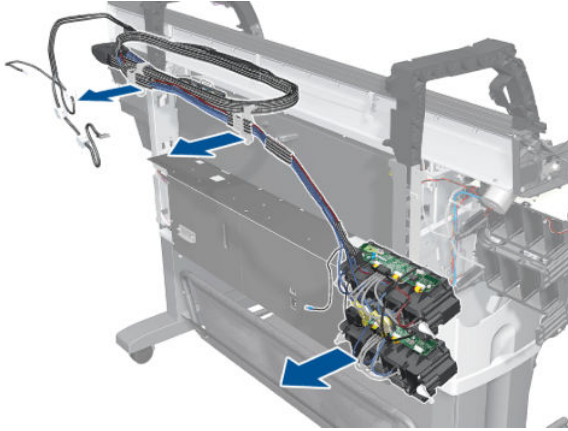

Installation of the Ink Supply Tubes and Trailing Cable

 **NOTE:** After installing the new Ink Supply Tubes and Trailing Cable, make sure you perform the following Service Utility:

- Reset life counter scan cycles tubes/cable ⇒ [Reset Life Counters on page 108](#).

ISS to Cartridge Cables

Removal

 **WARNING!** Switch off the printer and remove the power cable.

1. Remove the Left Cover ⇒ See [Cover, Left on page 228](#).
2. Remove two T-20 screws from the ISS shielding.

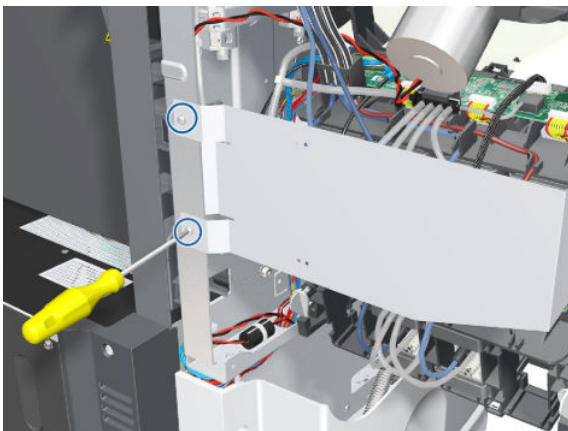

3. Remove the ISS Shielding.

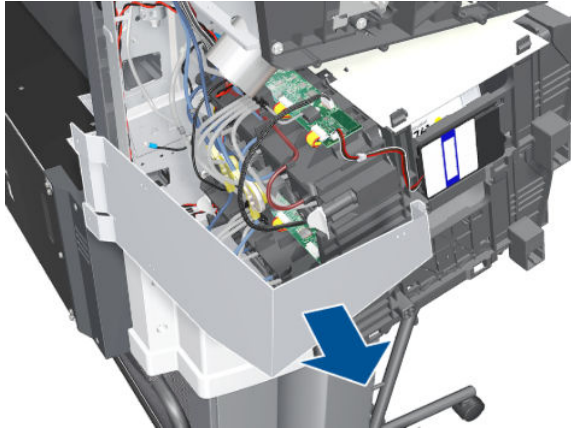

4. Disconnect the ISS to Cartridge Cable from the ISS PCA.

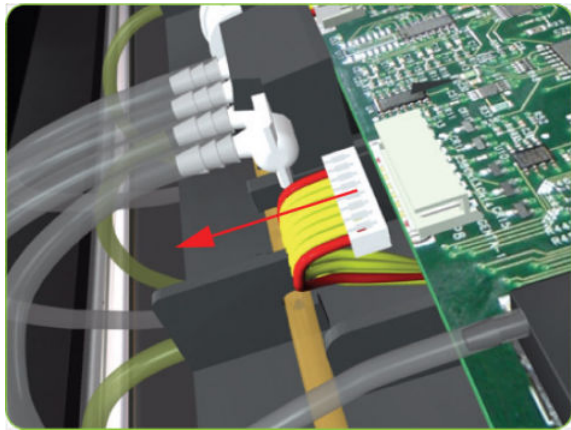

5. Release the clips securing the ISS to Cartridge Cable.

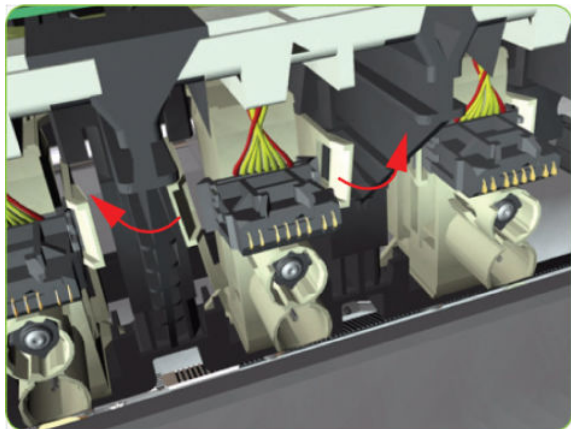

6. Remove the ISS to Cartridge Cable from the printer.

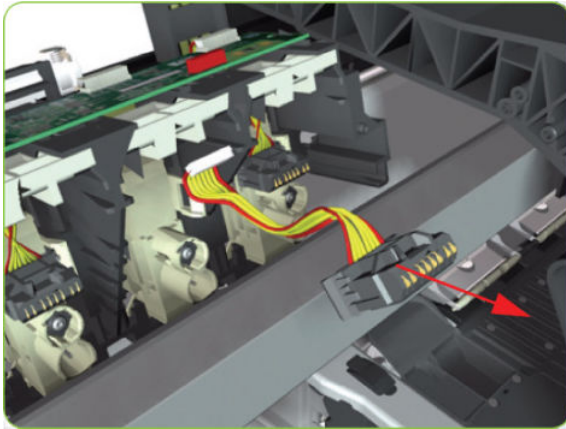

Ink Supply Station (ISS)

Removal

⚠ WARNING! Switch off the printer and remove the power cable.

1. Remove the Scan-Axis Motor ⇒ See [Scan-Axis Motor on page 326](#).
2. Pull out the top row of Cartridge Trays and remove the Ink Cartridges.

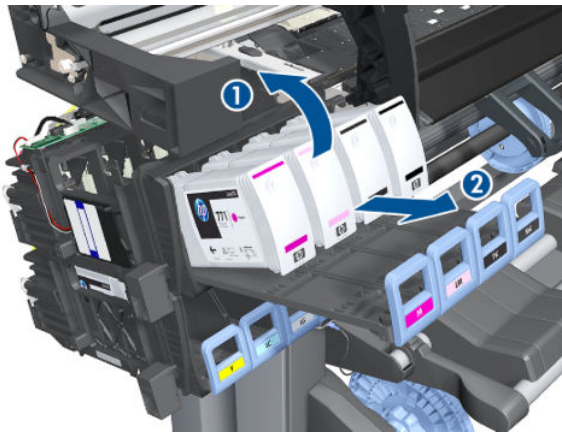

3. Close the top row of Cartridge Trays and pull out the bottom row.

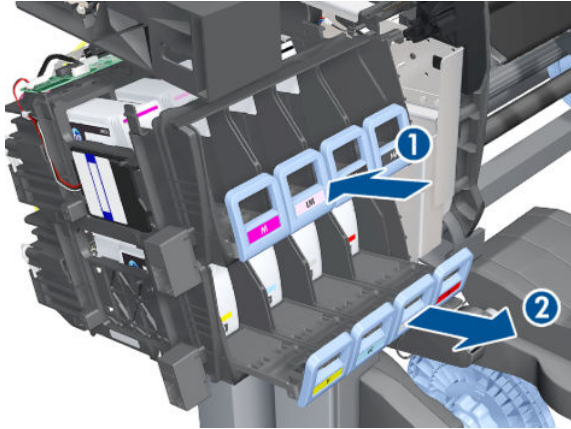

4. Pull out the bottom row of Cartridge Trays and remove the Ink Cartridges.

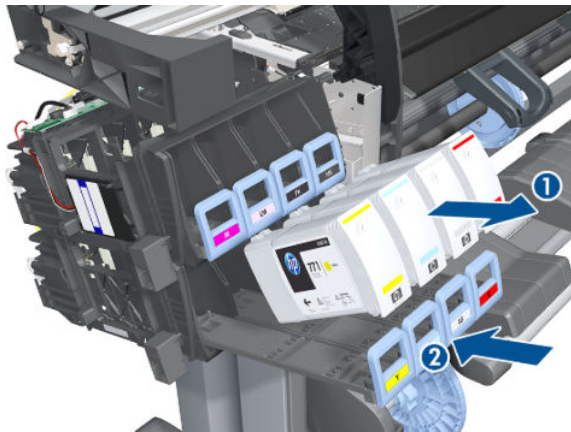

5. Unroute the RFDI cable from the bridge.

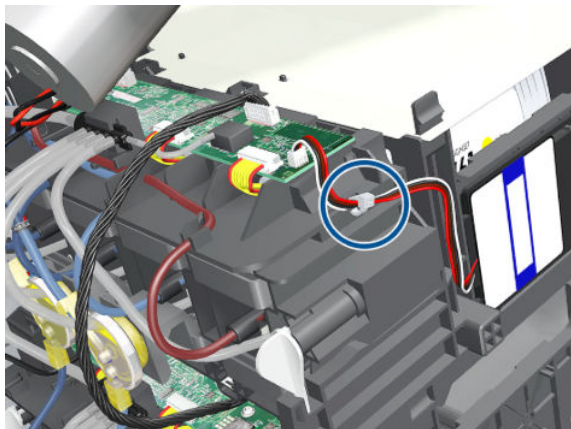

6. Disconnect the RFDI cable.

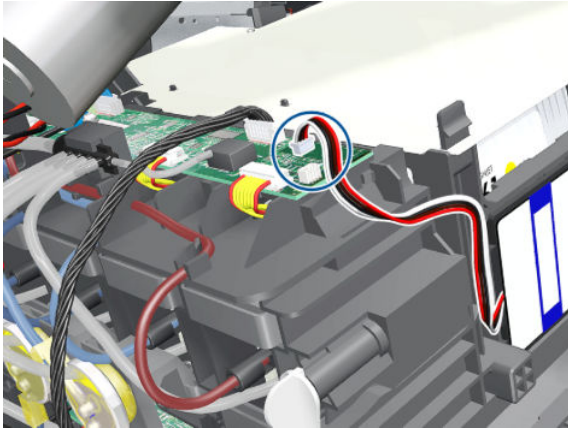

7. Disconnect the cable.

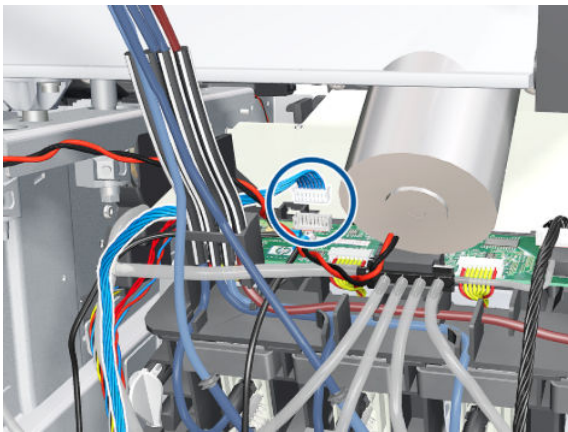

8. Remove the grounding screw.

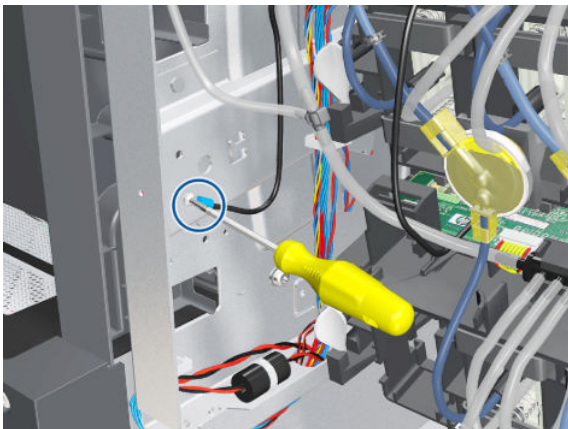

9. Disconnect the Air Tubes from the Ink Cartridge Tube Connector.

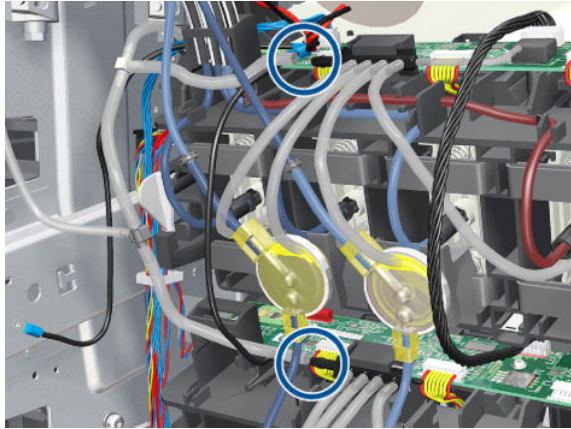

10. Twist the four latches at the rear of the Ink Cartridge Tube Connector and release the complete assembly.

 **NOTE:** Be careful not to damage the interconnecting cable.

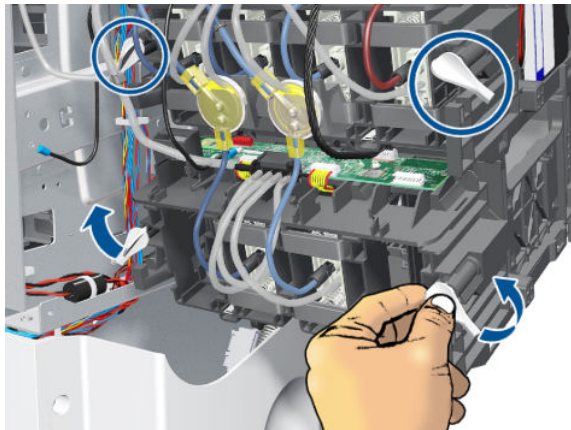

11. Carefully slide the Ink Cartridge Tube Connector off the Ink Supply Station.

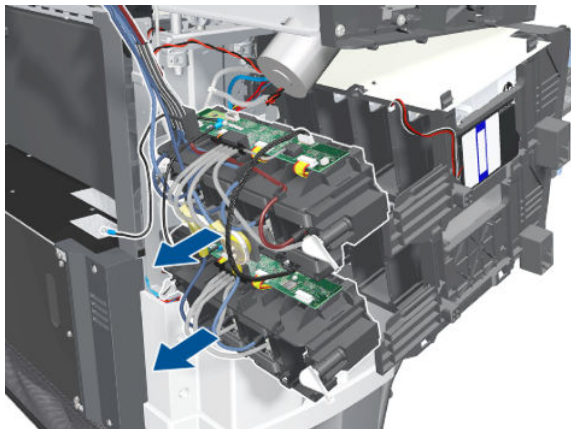

12. Remove the Cartridge Tube Connector from the Ink Supply Station.

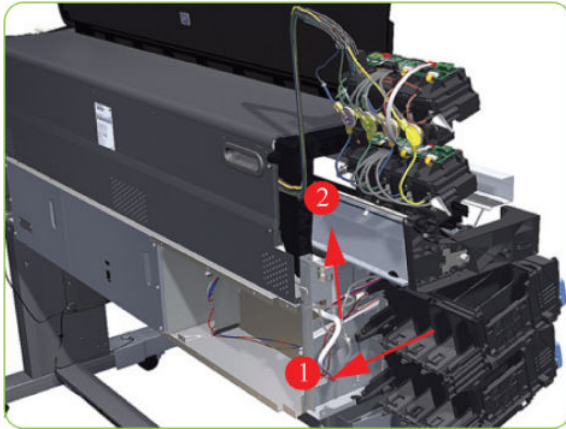

13. Unhook Ink Supply Station cables from the printer.

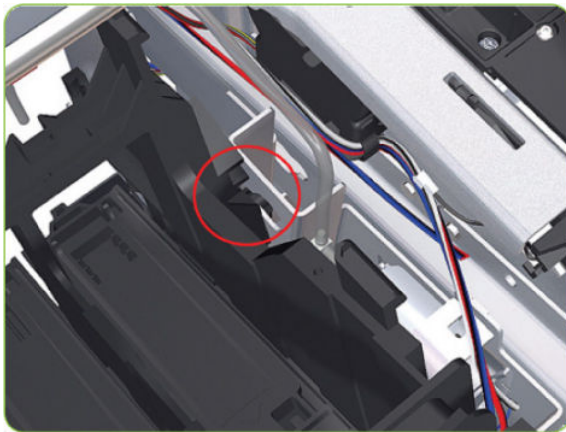

14. Remove the complete Ink Supply Station (upper and lower assemblies) from the printer.

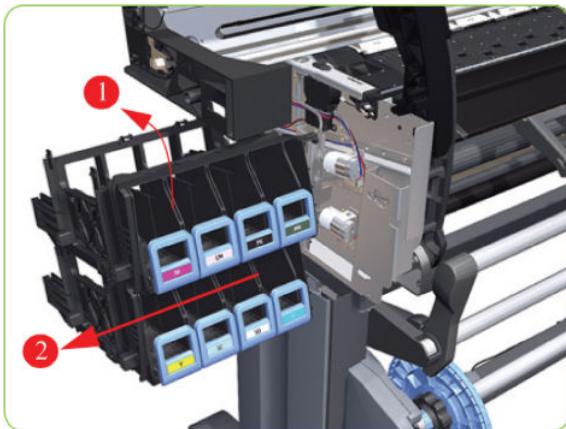

Cartridge Tray

Removal

1. Release the Tray Lever of the required color and pull out the Tray.

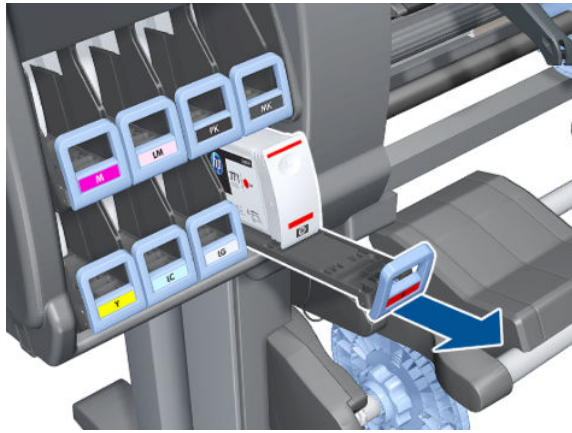

2. Remove the Ink Cartridge if installed.

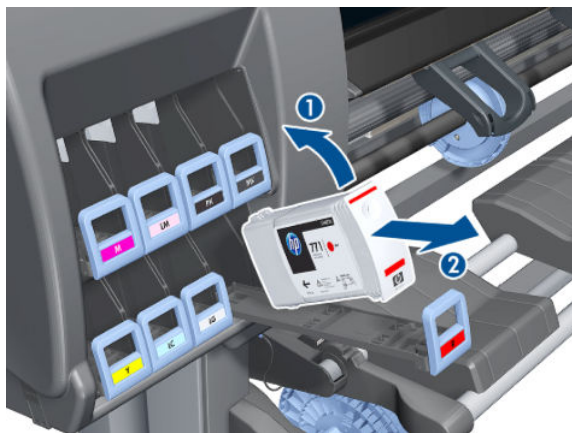

3. Press down on the Tray clip.

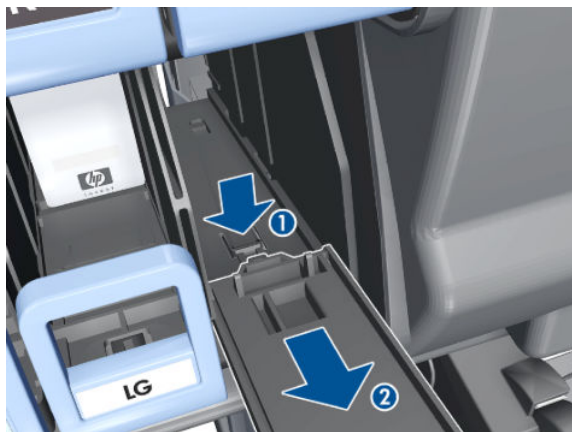

4. Pull the Tray completely out of the printer.

 **NOTE:** Note that each Cartridge Tray is different even though they look very similar. When selecting the Cartridge Tray from the Support Part, choose the Tray that exactly matches the one that you have just removed.



APS Assembly

Removal

 **WARNING!** Switch off the printer and remove the power cable.

1. Remove the Left Cover ⇒ See [Cover, Left on page 228](#).
2. Remove the Left Connector Cover ⇒ See [Connector Cover, Left on page 238](#).
3. Remove the Scan-Axis Motor ⇒ See [Scan-Axis Motor on page 326](#).
4. Remove the ISS ⇒ See [Ink Supply Station \(ISS\) on page 314](#).

5. Disconnect the APS 1 (top unit) valve electrical connectors from the PrintMech PCA, and remove the cable from the ferrite on the right-hand side of the Electronic Module.

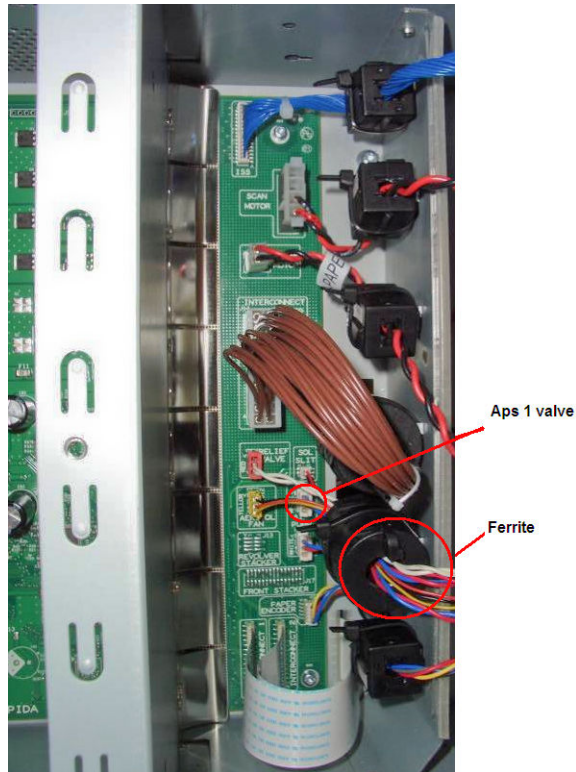

6. Unclip the APS 1 electrical cables from the cable clamps in the left connector panel

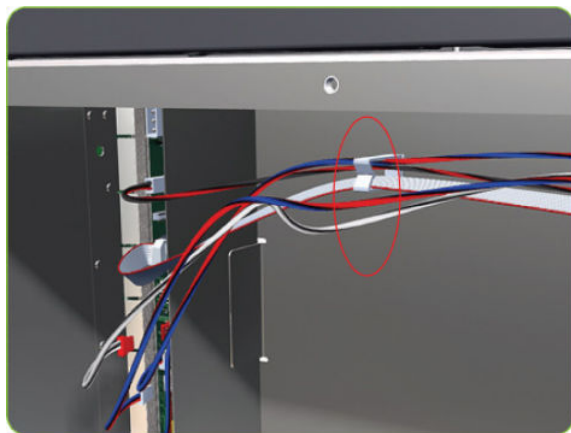

7. Unroute the APS 1 electrical connections from the left connector panel.

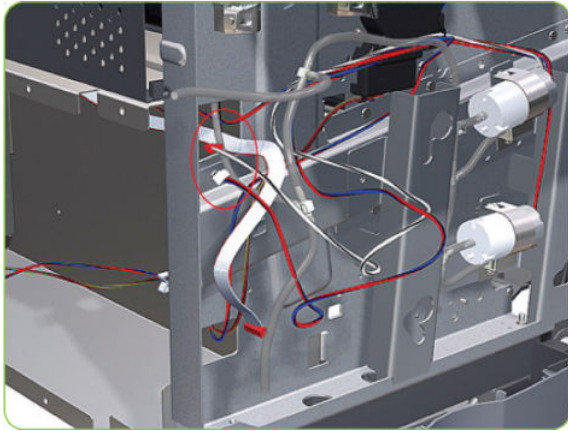

8. Unroute the electrical connections from the printer.

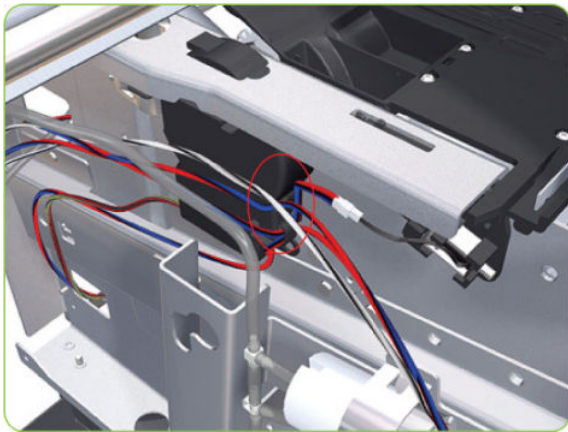

9. Disconnect both air tubes from APS 1.

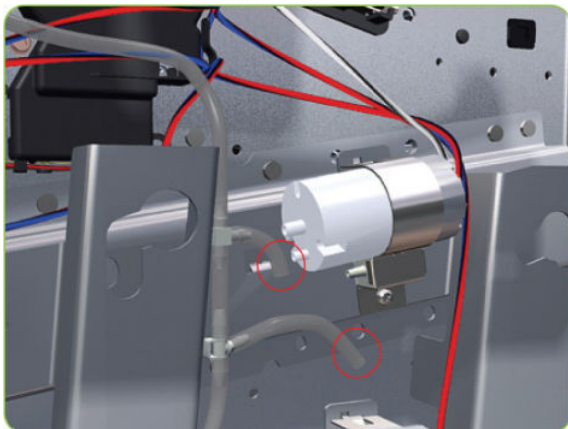

10. Remove one T-20 attachment screw from APS 1 (Top unit).

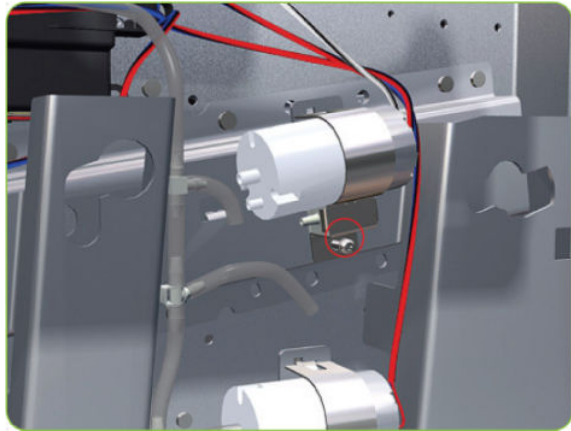

11. Remove APS 1 (Top unit) from the printer.

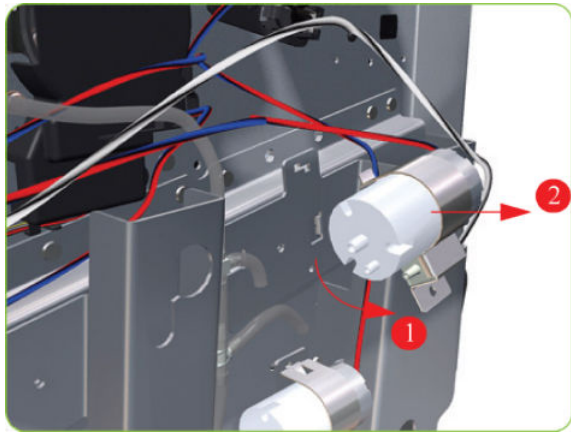

12. Remove the ISS ⇒ See [Ink Supply Station \(ISS\) on page 314](#).

13. Disconnect the APS 2 (top unit) valve electrical connectors from the PrintMech PCA, and remove the cable from the ferrite on the right-hand side of the Electronic Module.

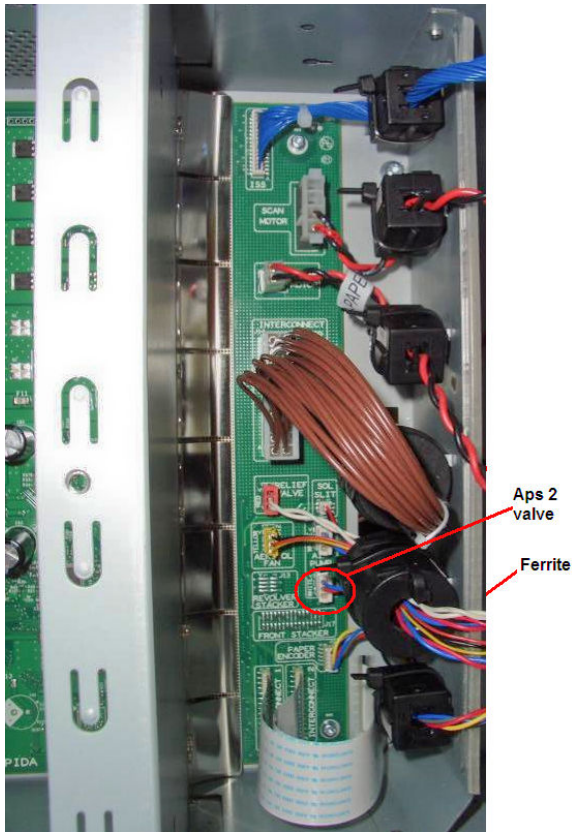

14. Unclip the APS 2 electrical cable from the cable clamps in the left connector panel

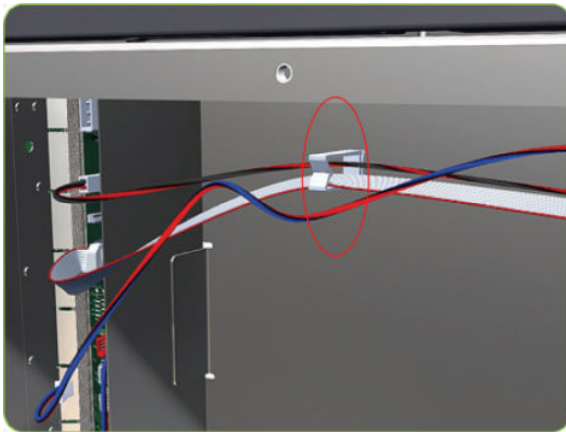

15. Unroute the APS 2 electrical connection from the Media Path Cover Encoder.

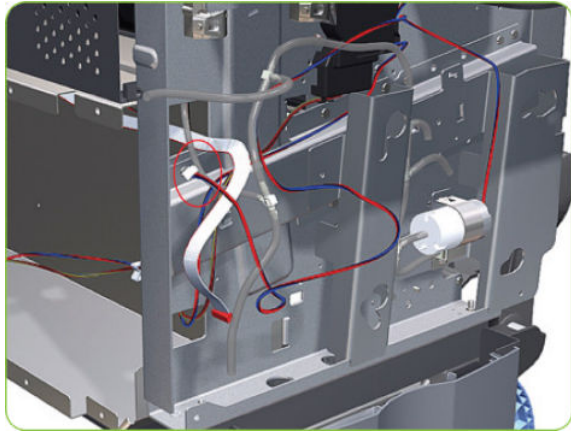

16. Unroute the APS 2 electrical connection from the printer.

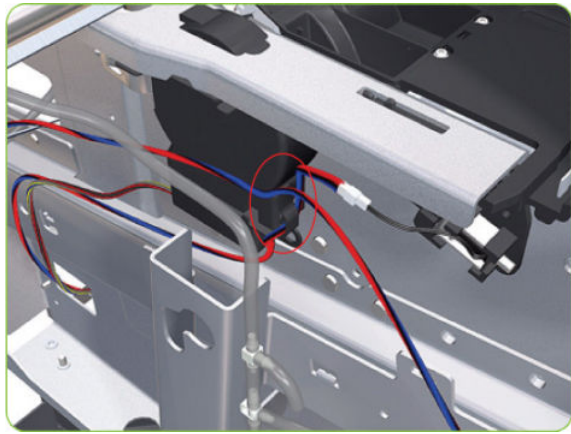

17. Disconnect both air tubes from APS 2.

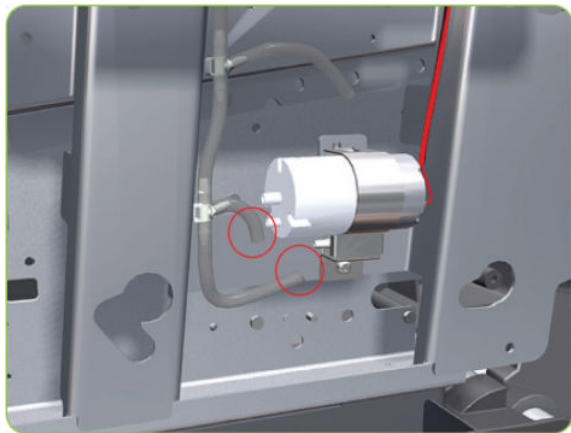

18. Remove one T-20 attachment screw from APS 1 (Top unit).

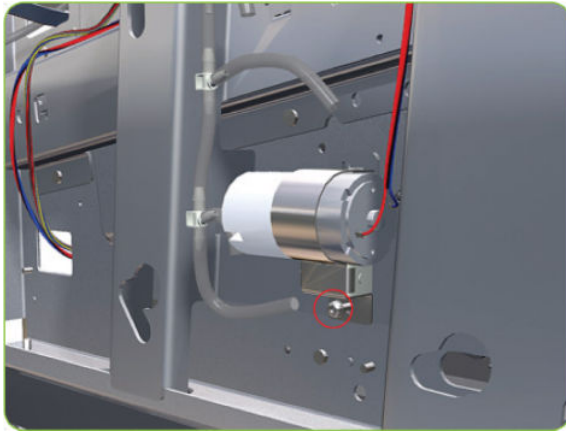

19. Remove APS 2 (Bottom unit) from the printer.

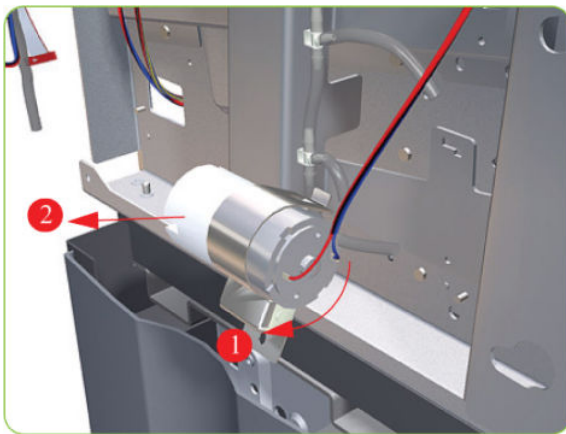

Scan-Axis Motor

Removal

⚠ WARNING! Switch off the printer and remove the power cable.

1. Remove the Right Cover ⇒ See [Cover, Right on page 225](#).
2. Remove the Left Cover ⇒ See [Cover, Left on page 228](#).
3. Remove the Left Connector Cover ⇒ See [Connector Cover, Left on page 238](#).

4. Uncap the Carriage Assembly by manually pulling out the Printhead Maintenance Cartridge tray.



5. Lift the Primer and hold the Primer to its maximum position to avoid damaging it when you move the Carriage Assembly in the next step.

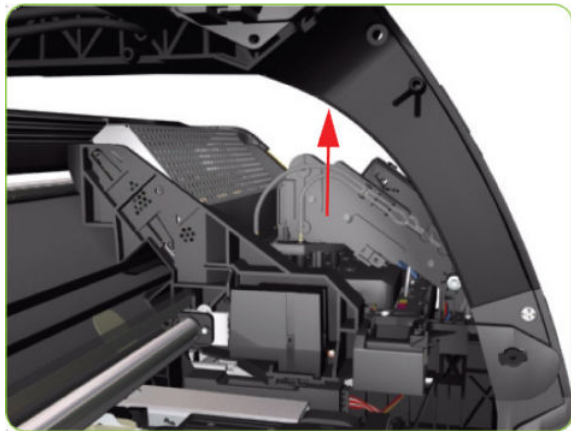

6. Move the Carriage Assembly slightly away from the right Scan-Axis Bracket.

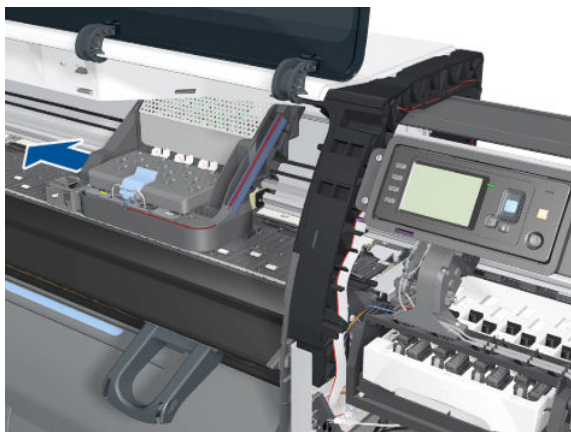

7. Remove one T-20 screw that secures the Belt Tensioner to the Chassis.



8. Release the Carriage Belt from the Scan-Axis Motor on the left-hand side of the printer.

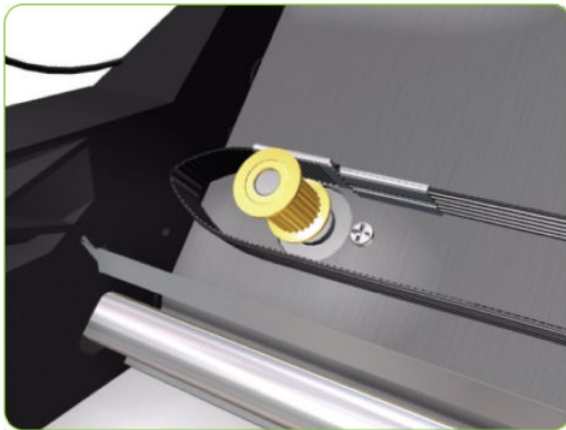

9. Disconnect the Scan-Axis Motor cable from the PrintMech PCA and its ferrite.



10. Unroute the Scan-Axis Motor cable from the chassis.

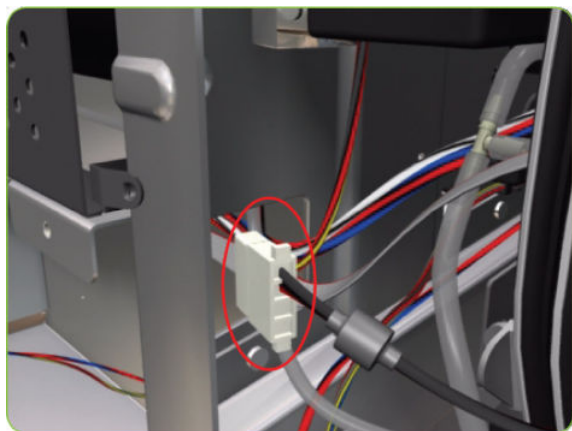

11. Remove two T-20 screws (**Type A**) that secure the Scan-Axis Motor.

 **NOTE:** Make sure you hold the Scan-Axis Motor securely when removing the screws.

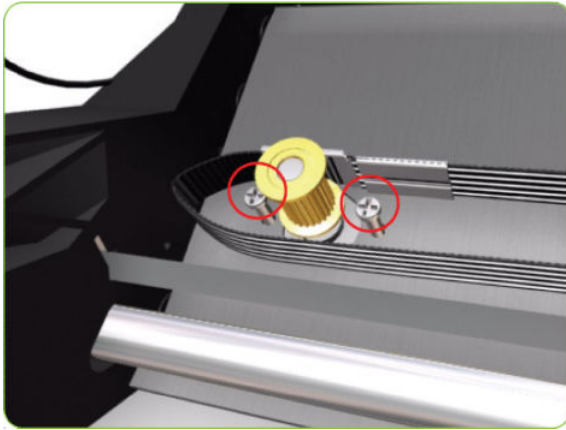

12. Remove the Scan-Axis Motor from the printer.

NOTE: After installing the new Scan-Axis Motor, make sure you perform the following Service Utility:

- Reset scan motor life counter ⇒ [Reset Life Counters on page 108](#).

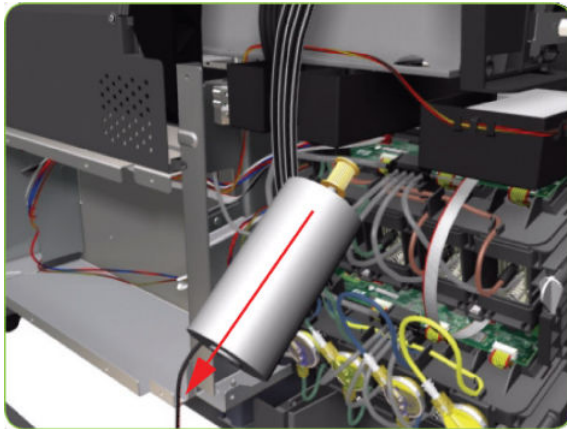

Media-Axis Motor

Removal

 **WARNING!** Switch off the printer and remove the power cable.

1. Remove the Left Cover ⇒ See [Cover, Left on page 228](#).
2. Remove the PW Cover ⇒ See [PW Cover on page 349](#).
3. Remove the Left Connector Cover ⇒ See [Connector Cover, Left on page 238](#).

4. Disconnect the Media-Axis Motor cable from the PrintMech PCA and its ferrite.



5. Detach the clamp of the ferrite core of the Media-Axis Motor cable from the printer chassis.

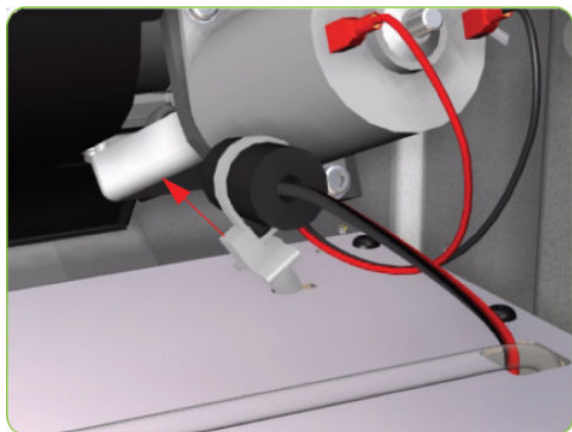

6. Remove the T-15 screws (**Type R**) identified (A) and loosen the T-15 screws (**Type R**) identified (B) that secure the Media-Axis Motor.

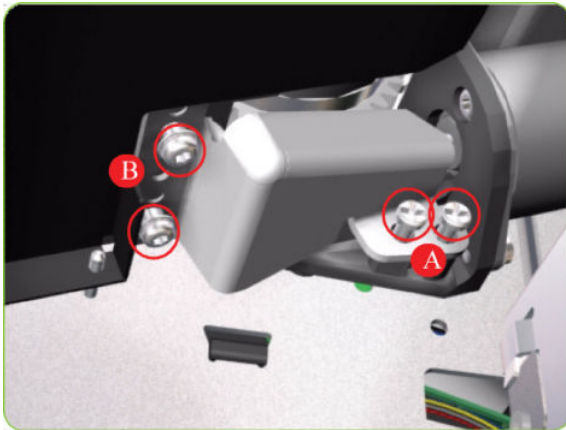

7. Remove the Media-Axis Motor Bracket.

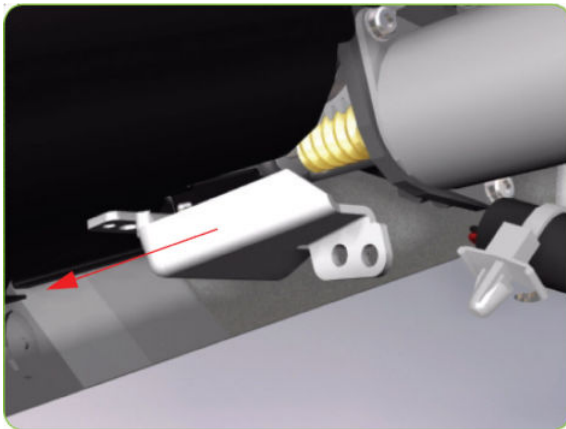

8. Remove two T-20 screws (**Type B**) that secure the Media-Axis Motor Bracket.

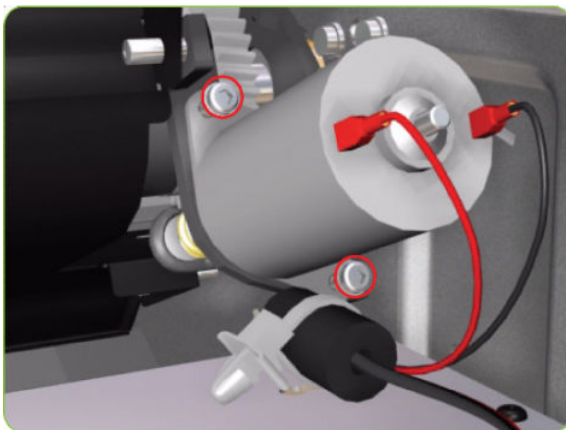

9. Remove the Media-Axis Motor from the printer.

 **NOTE:** When reinstalling the parts, make sure you apply the grease (included with the support part) to the gears.

 **NOTE:** After installing the new Media-Axis Motor, make sure you perform the following Service Calibration:

- Paper-advance Calibration ⇒ [Paper-advance calibration on page 121](#).

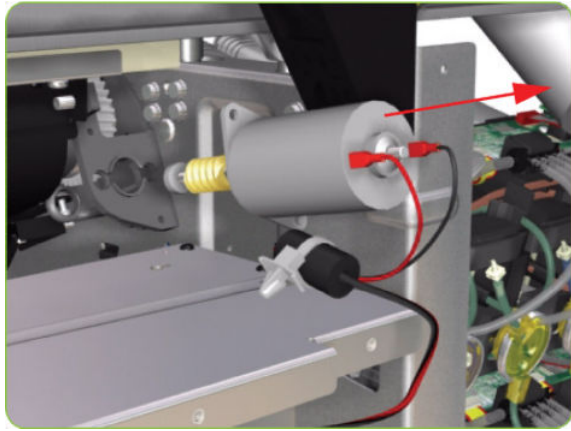

Maintenance Cartridge Door

Removal

 **WARNING!** Switch off the printer and remove the power cable.

1. Open the Maintenance Cartridge Door.



2. Unclip and remove the Maintenance Cartridge Door from Right Cover.



Maintenance Cartridge Door Sensor

Removal

⚠ WARNING! Switch off the printer and remove the power cable.

1. Remove the Right Cover ⇒ See [Cover, Right on page 225](#).
2. Disconnect the Maintenance Cartridge Door Sensor cable.

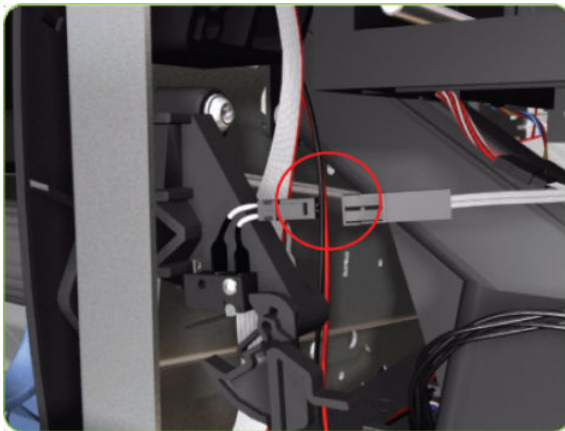

3. Release one T-10 screw that attaches the Maintenance Cartridge Door Sensor assembly to the printer.

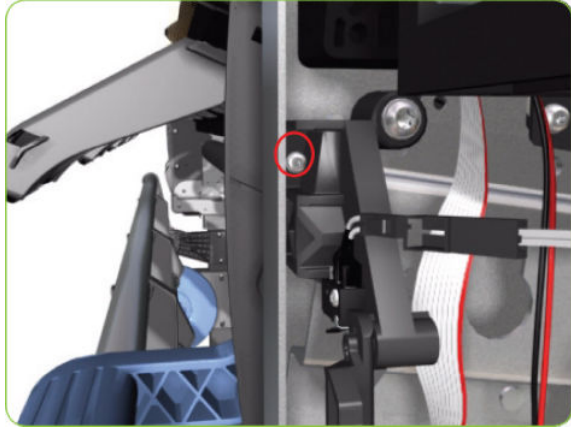

4. Remove the Maintenance Cartridge Door Sensor assembly from the printer.

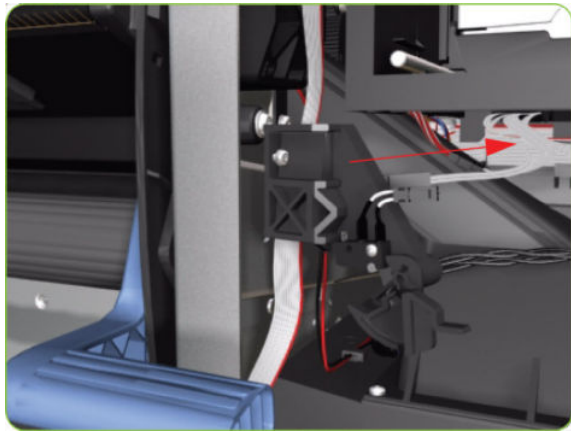

Media Deflector

Removal

 **WARNING!** Switch off the printer and remove the power cable.

1. Remove two T-20 screw (**Type B**) that secures the Media Deflector that needs to be replaced.



2. Remove the Media Deflector (slide upwards first) from the printer.

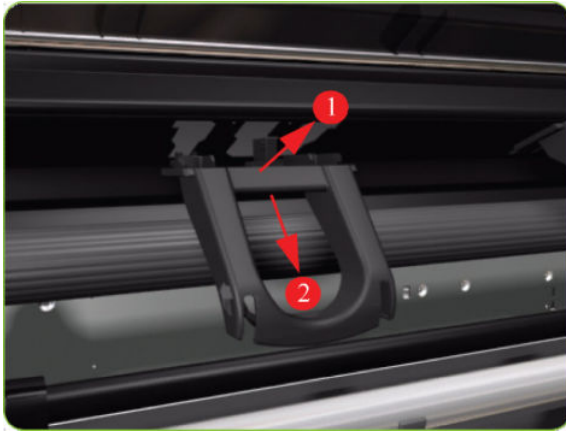

Output Platen

Removal

⚠ WARNING! Switch off the printer and remove the power cable.

1. Open the Window.

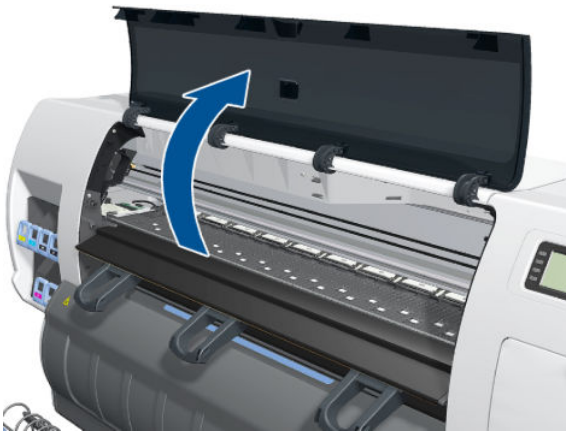

2. Open the Smart Roll-loading System Door.

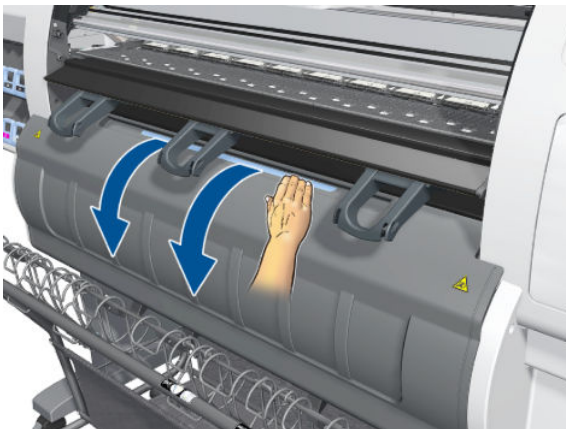

3. Unscrew two T-20 screws from the left-hand deflector.



4. Remove the left-hand deflector.



5. Disconnect the sensor cable.



6. Remove a T-15 screw from the right of the Output Platen.

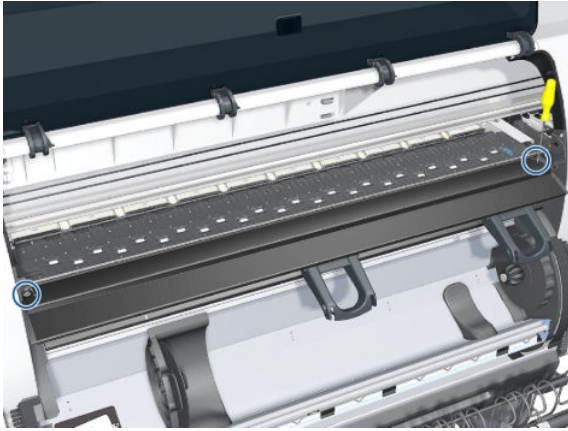

7. Remove a T-15 screw (with washer) from the right of the Output Platen.



8. Remove a T-10 and a T-15 screw (with washer) from the left of the Output Platen.



9. Release the clips on the left- and right-hand sides of the Front Platen.

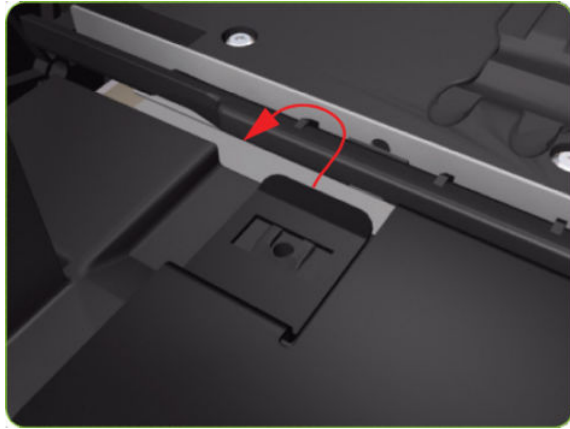

10. Pull out the left side of the Output Platen.



11. Remove the Output Platen.



Deflector and Stacker Switch

Removal

1. Remove the Output Platen ⇒ See [Output Platen on page 336](#).

2. Inside the Output Platen, remove one T-8 screw, then remove the Switch Sensor.



Trim, Right

Removal

⚠ WARNING! Switch **off** the printer and remove the power cable.

1. Remove the Output Platen ⇒ See [Output Platen on page 336](#).
2. Remove five T-15 screws that secure the Right Trim.



3. Disengage the rubber strip from the hole in the Right Trim.

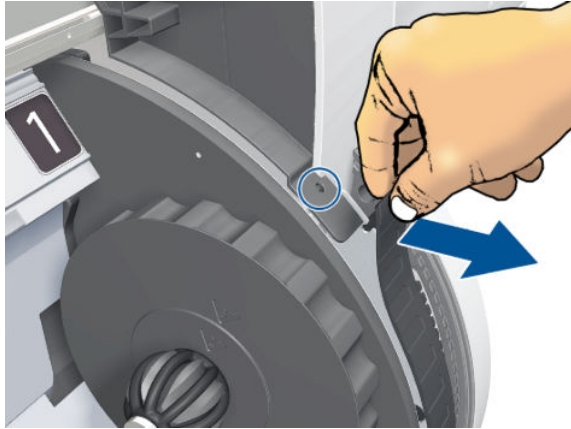

4. Remove the Right Trim from the printer.



Trim, Left

Removal

⚠ WARNING! Switch **off** the printer and remove the power cable.

1. Remove the Output Platen ➡ See [Output Platen on page 336](#).

2. Remove three T-15 and three T-20 screws that secure the Left Trim.

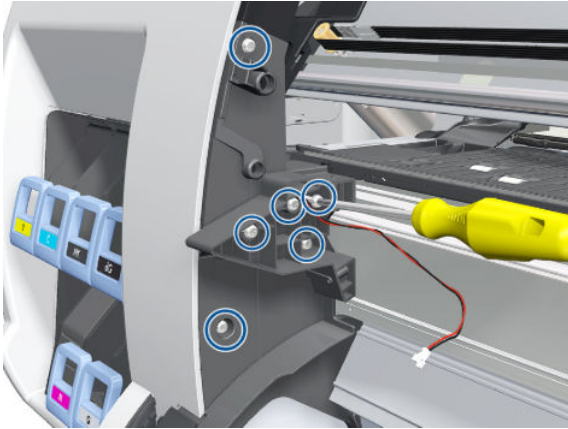

3. Disengage the rubber strip from the hole in the Left Trim.



4. Carefully remove the Left Trim from the printer.

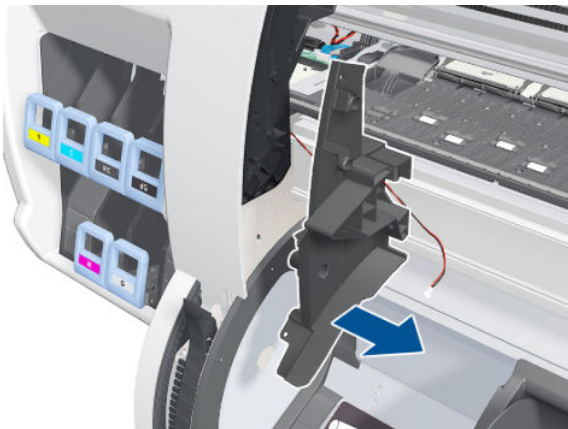

Media Sensor

Removal

1. Open the Smart Roll-loading System Door and put the Smart Roll-loading System into the following position.



2. Disconnect the Media Sensor cable.

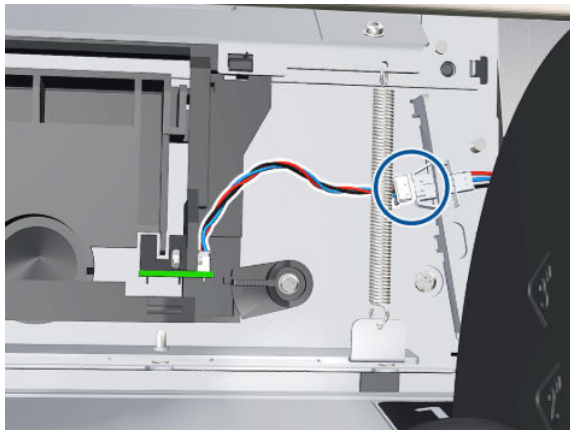

3. Rotate the clamp.

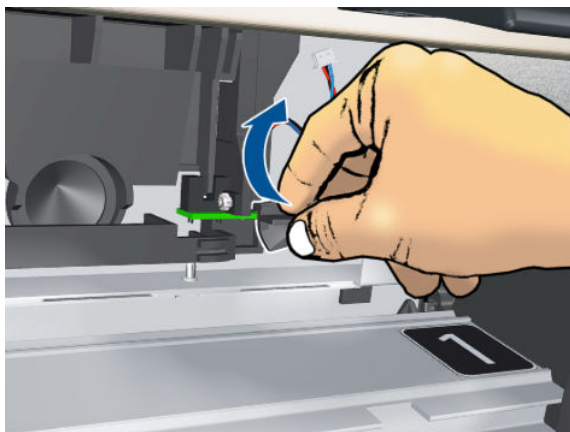

4. Pull the bottom of the Media Sensor out a little.

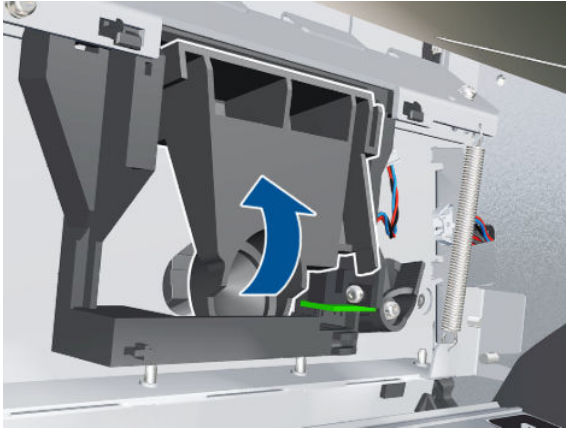

5. Rotate the Media Sensor to detach it from the Entry Platen.

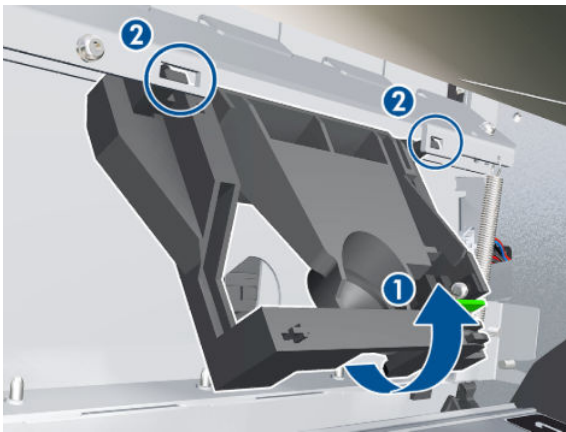

6. Remove the Media Sensor.

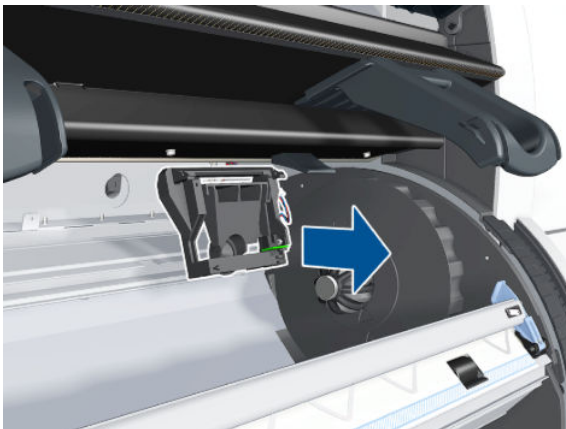

Smart Roll-loading System Cosmetic Sheet Metal and Separator

Removal

1. Remove the Left Hub and Roll Support ⇒ See [Hub, Left, and Roll Support on page 282](#).
2. Remove five T-8 screws.
3. Remove the Cosmetic Sheet Metal and Separator.

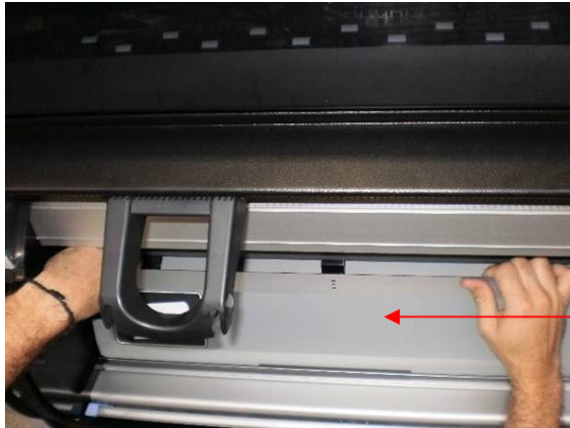

Belt Assembly

Removal

⚠ WARNING! Switch off the printer and remove the power cable.

1. Remove the Right Cover ⇒ See [Cover, Right on page 225](#).
2. Remove the Left Cover ⇒ See [Cover, Left on page 228](#).
3. Remove the Top Cover ⇒ See [Cover, Top on page 232](#).
4. Remove the Encoder Strip ⇒ See [Encoder Strip and Encoder Sensor on page 298](#).
5. Remove the Carriage Assembly ⇒ See [Carriage on page 286](#).
6. Release the Belt from the bottom of the Carriage Assembly.

📝 NOTE: After installing the new Belt Assembly, make sure you perform the following Service Utility:

- Reset life counter scan cycles belt ⇒ [Reset Life Counters on page 108](#).

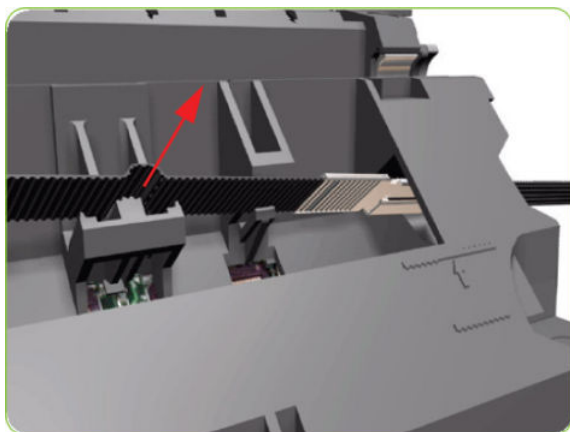

Window Position Sensor

Removal

⚠ WARNING! Switch **off** the printer and remove the power cable.

1. Remove the Right Cover ⇒ See [Cover, Right on page 225](#).
2. Remove the Left Cover ⇒ See [Cover, Left on page 228](#).
3. Remove a T-8 screw from the Window Position Sensor.

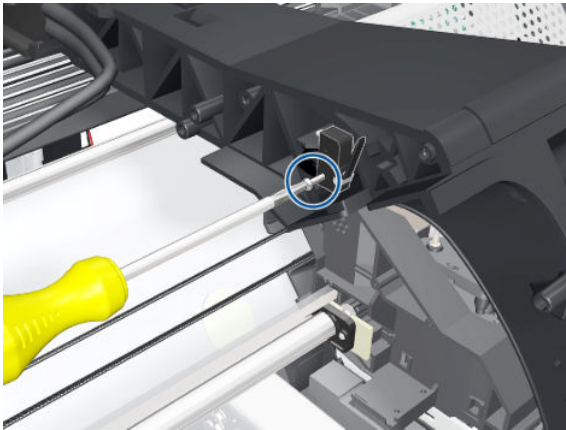

4. Disconnect and remove the Window Position Sensor.

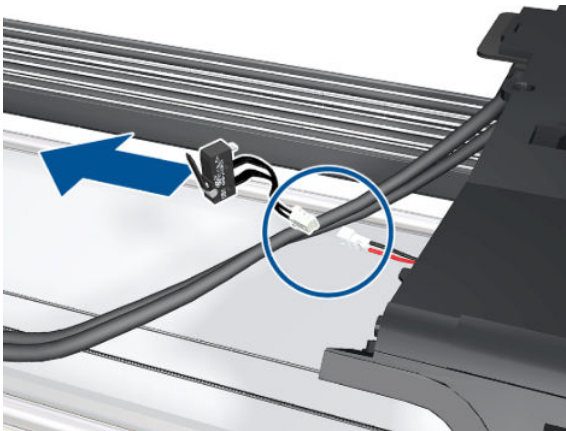

5. Remove the Right Smart Roll-loading System Cover ⇒ See [Smart Roll-loading System Cover, Right on page 260](#).
6. Remove the Right Connector Cover ⇒ See [Connector Cover, Right on page 237](#).

7. Pull the cable through the hole.

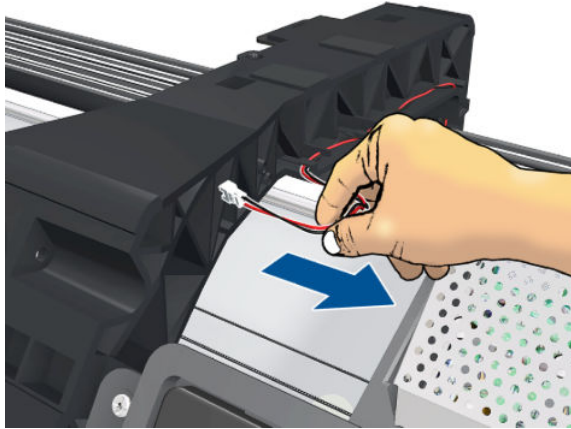

8. Unroute the cable from the right arc.

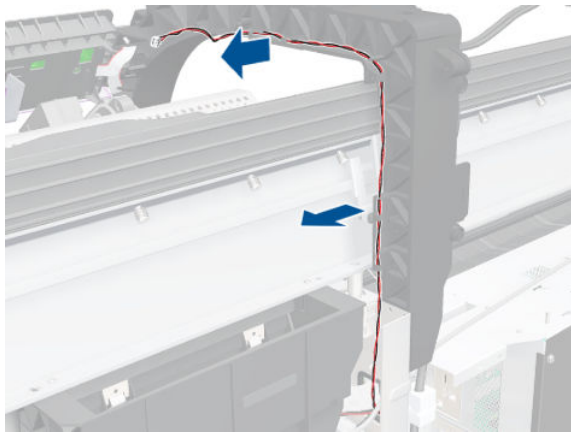

9. Continue unrouting the cable.

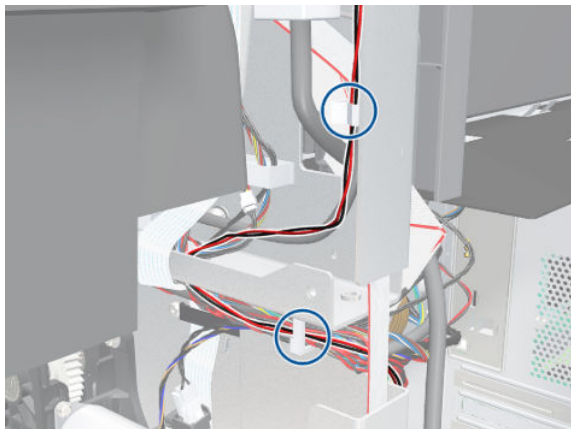

10. Disconnect the far end of the cable from the Main PCA, and remove the cable.

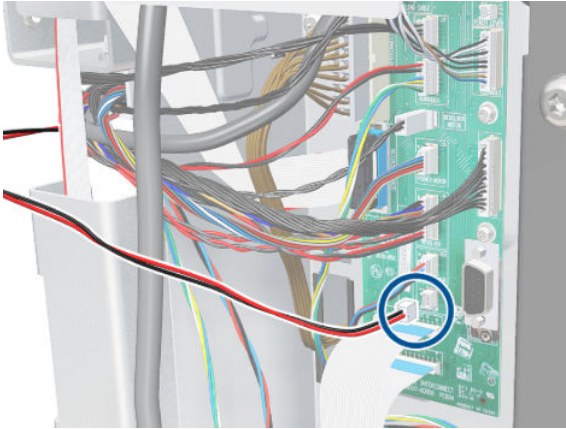

Cutter Assembly

Removal

1. Select **Replace cutter** from the Service Menu (see [Replace Cutter on page 111](#)) and follow the instructions on the Front Panel.
2. Open the Window.

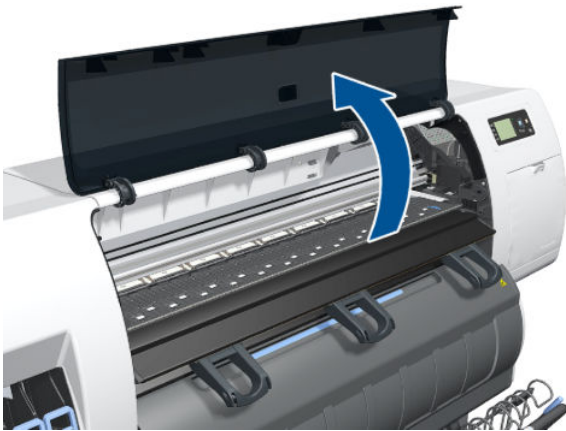

3. Open the Carriage Cover.



4. Remove one T-15 screw (**Type G**) that secures the Cutter Assembly to the Carriage Assembly.

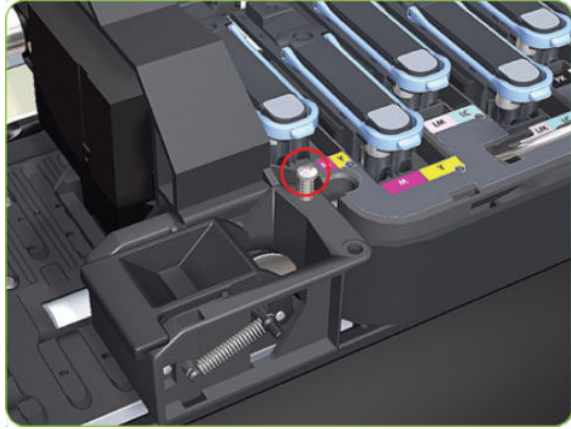

5. Slide the Cutter Assembly to the left and remove from the printer.

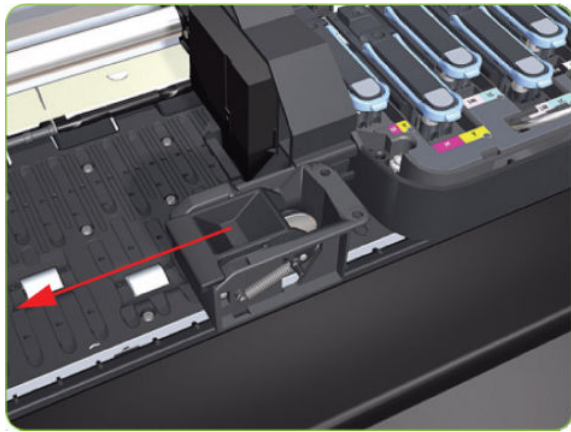

PW Cover

Removal

1. Remove three T-15 screws from the PW Cover.

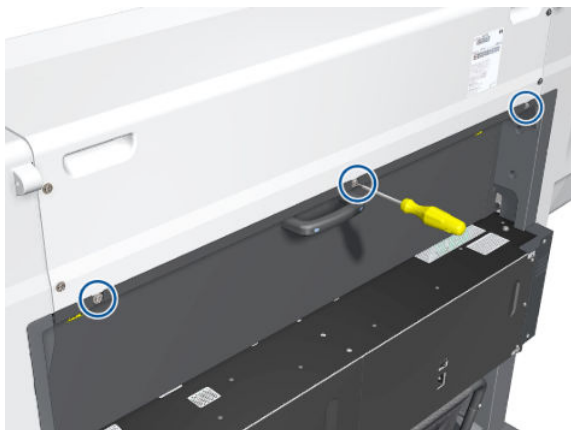

2. Remove the PW Cover, pulling it out of the printer.



Rear Trim, Left

Removal

1. Remove two T-20 screws from the Left Rear Trim.

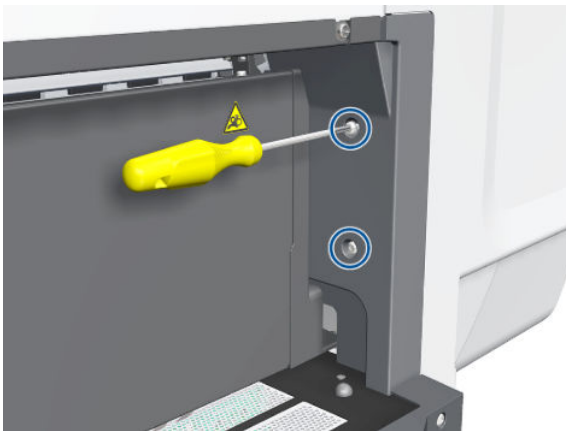

2. Remove the Left Rear Trim.



Rear Trim, Right

Removal

1. Loosen two screws in the Right Cover.



2. Detach the Right Cover slightly, leaving a small gap.

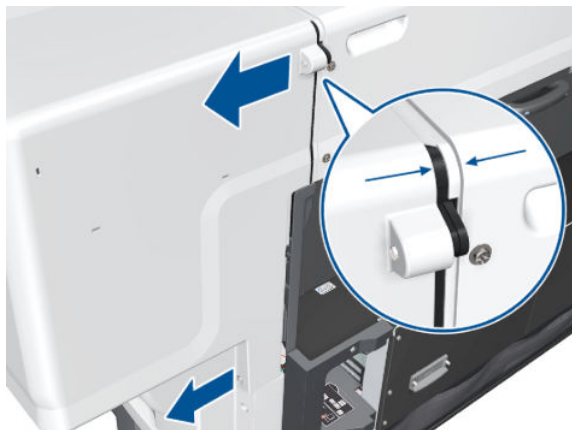

3. Remove two T-20 screws from the Right Rear Trim.



4. Remove the Right Rear Trim.

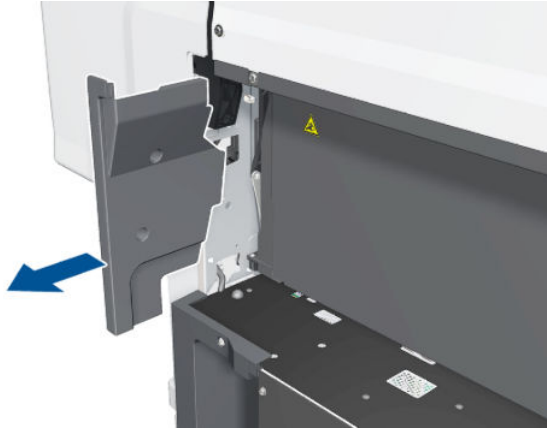

Rear Door

Removal

1. Remove the Right Connector Cover ⇒ See [Connector Cover, Right on page 237](#).
2. Remove the Left Connector Cover ⇒ See [Connector Cover, Left on page 238](#).
3. Disconnect the Rear Door cable from the Interconnect PCA.

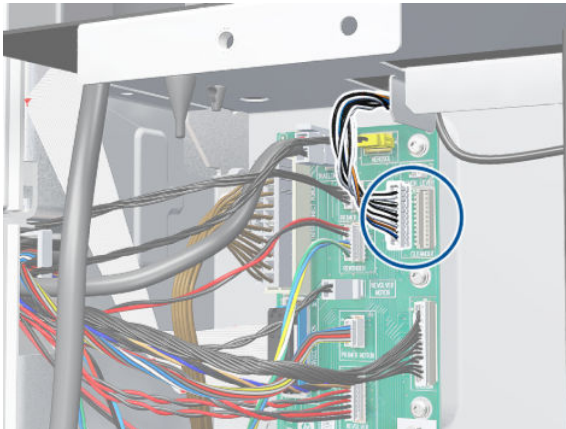

4. Unscrew another cable beside the Interconnect PCA.

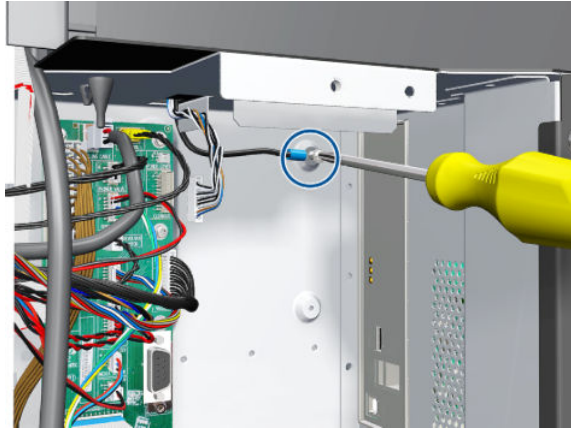

5. Open the Rear Door.



6. Use a long screwdriver to remove two T-15 screws from the Right Plate Flange of the Rear Door.

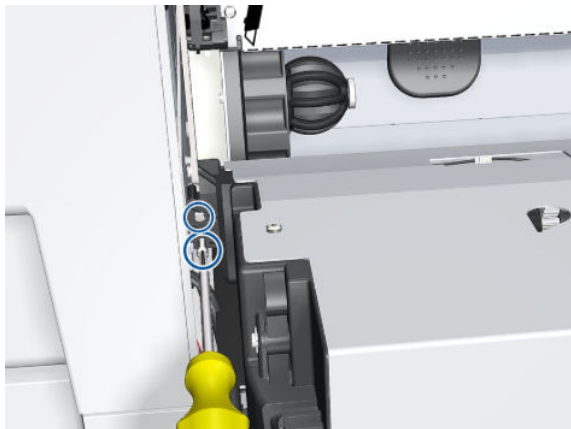

7. Remove the Rear Door Right Flange.

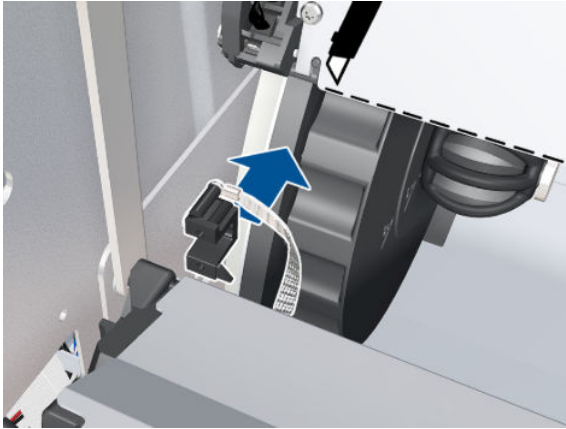

8. Remove one T-15 screw from the PW Connecting Rod on the left of the Rear Door.

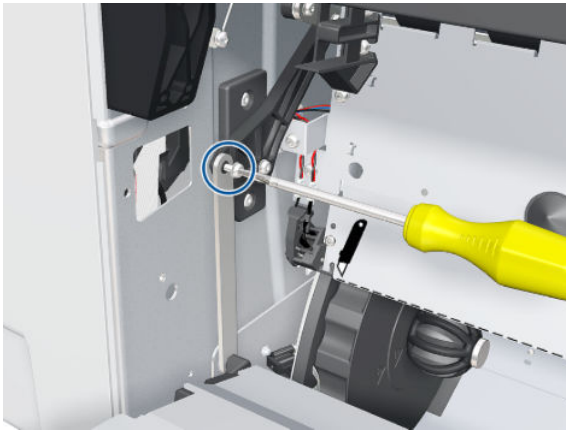

9. Detach the PW Connecting Rod.



10. Pull the Rear Door cables up through the hole.

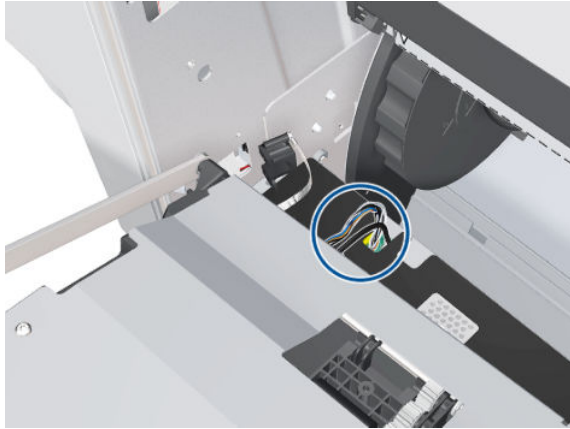

11. Remove the Rear Door.

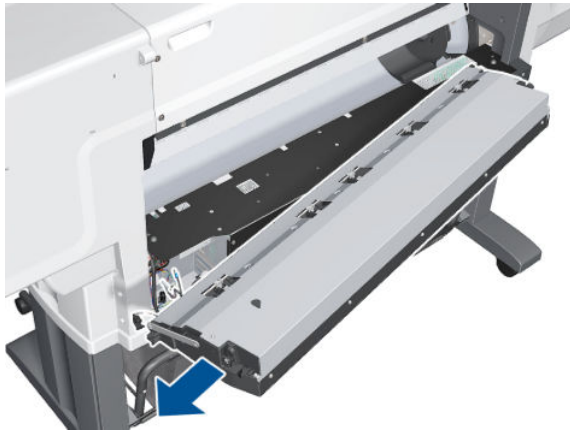

 **NOTE:** Be careful not to lose the spring.



Pinchwheel Lever

Removal

1. Remove the Right Cover ⇒ See [Cover, Right on page 225](#).
2. Remove the Left Rear Trim ⇒ See [Rear Trim, Left on page 350](#).

3. Remove two T-15 screws from the Pinchwheel Double Lever, then remove the Pinchwheel Double Lever.

Remove two T-15 screws from the Pinchwheel Double Lever support, then remove the Pinchwheel Double Lever support.

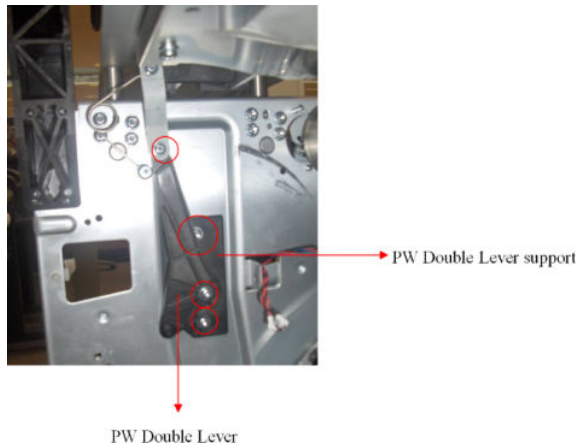

Entry Platen

Removal

1. Remove the Left Rear Trim ⇒ See [Rear Trim, Left on page 350](#).
2. Remove the Right Rear Trim ⇒ See [Rear Trim, Right on page 351](#).
3. Remove the PW Cover ⇒ See [PW Cover on page 349](#).
4. Disconnect two cables from the Entry Platen to the Interconnect PCA, remove a T-15 screw from the Pinchwheel Double Lever and remove a T-15 screw from the PW Connecting Rod.

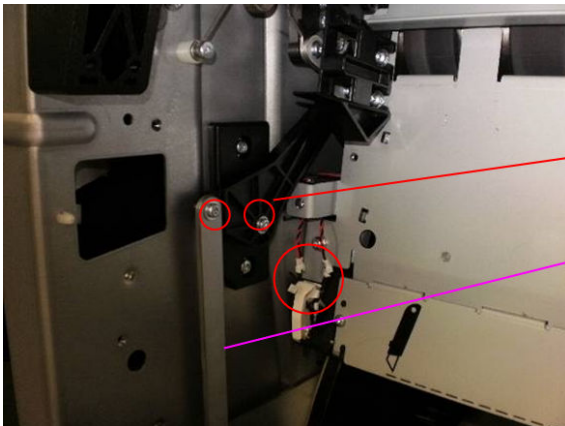

5. Disconnect the Media Sensor cable from the Entry Platen to the Interconnect PCA.

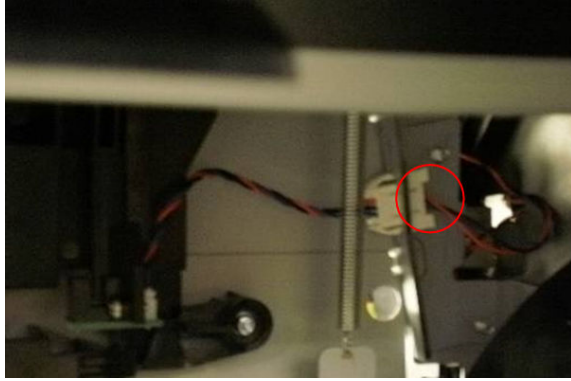

6. Remove one T-20 screw on the right.

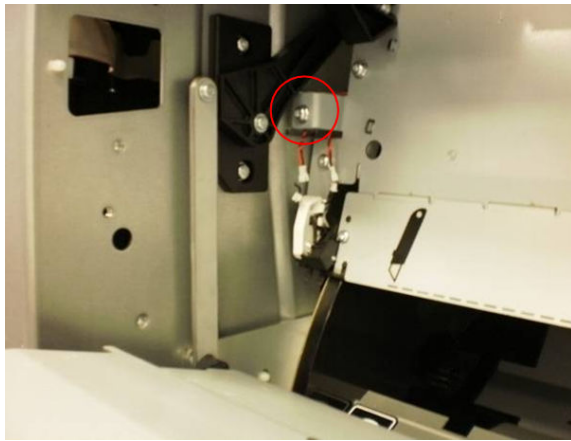

7. Put the PW Connecting Rod in this position in order to remove the Entry Platen more easily.

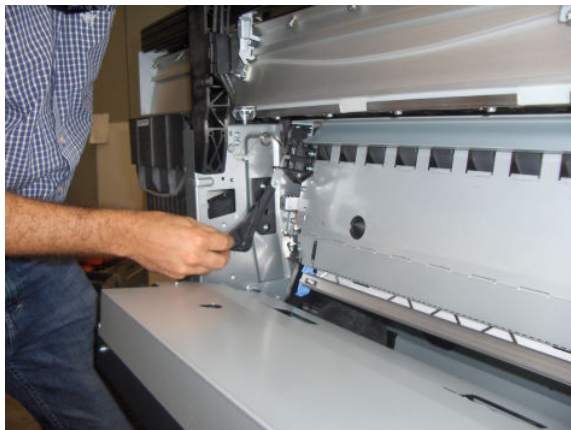

8. Remove one T-20 screw on the left.

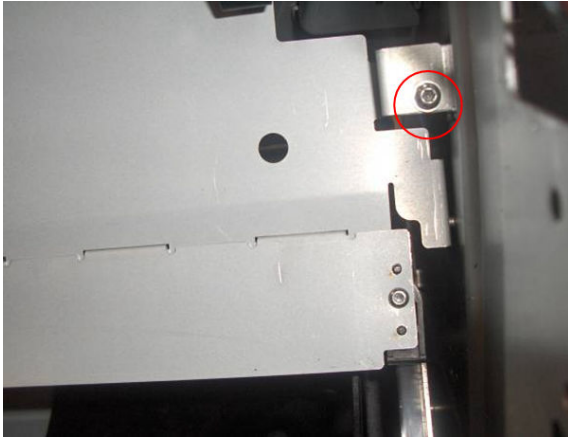

9. Remove the Entry Platen.



Roller Guide with Mylar

Removal

1. Remove the Entry Platen ⇒ See [Entry Platen on page 356](#).
2. Remove two T-20 screws from the left side.

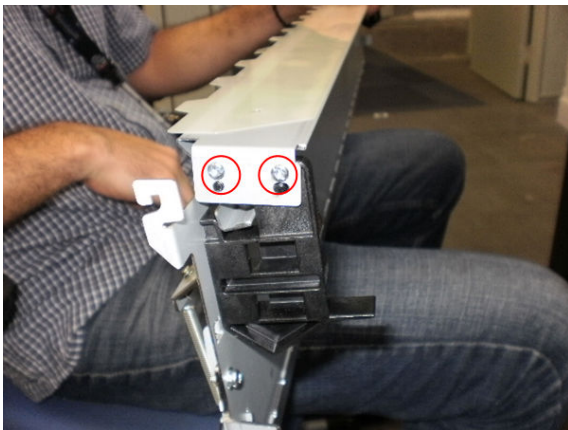

3. Remove two T-20 screws from the right side.



4. Remove the Roller Guide with Mylar from the Entry Platen.

Optical Media Advance Sensor (OMAS)

Removal

⚠ WARNING! Switch off the printer and remove the power cable.

1. Open the Rear Door.
2. Remove paper if loaded.
3. Remove the Entry Platen ➡ See [Entry Platen on page 356](#).
4. Insert the T-20 thin bladed torx screwdriver (supplied with the replacement OMAS) into the access hole at the rear of the printer.

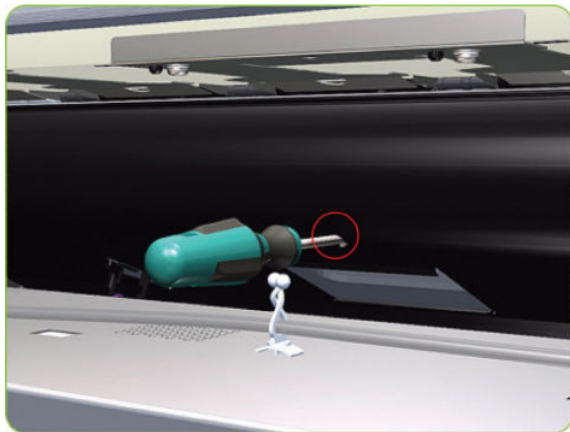

5. Remove and discard one T-20 screw which secures the OMAS horizontally to the printer.



6. From the bottom of the printer, remove and discard one T-20 screw which secures the OMAS vertically to the printer.



7. Carefully lower the OMAS from the printer as far as you can with the large ribbon cable still connected.

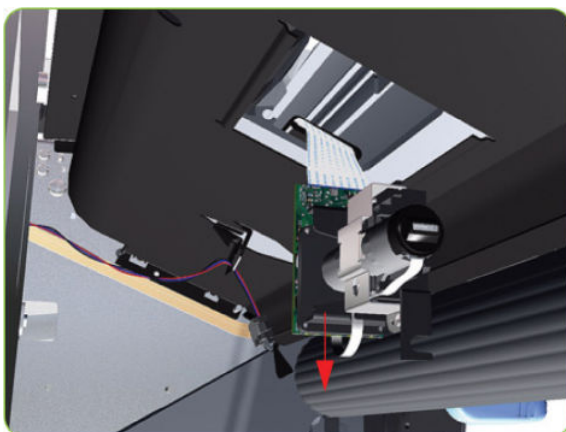

8. Release the two locking clips of the large ribbon cable connector.

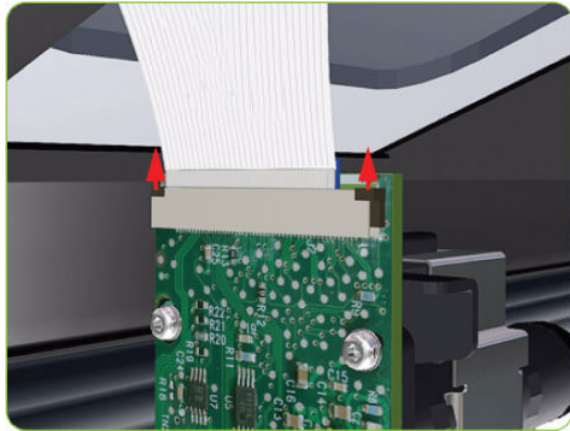

9. Disconnect the large ribbon cable from the OMAS.

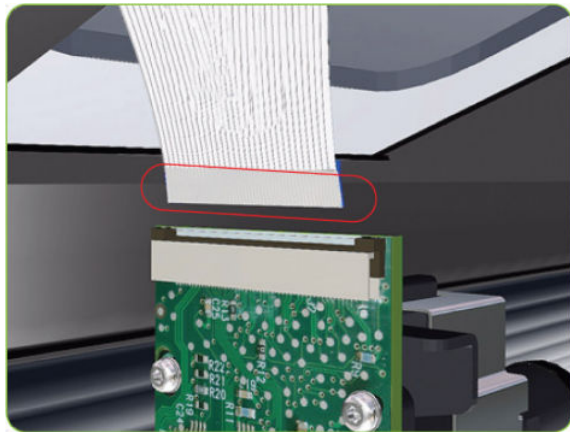

10. Remove the OMAS Sensor from the printer.

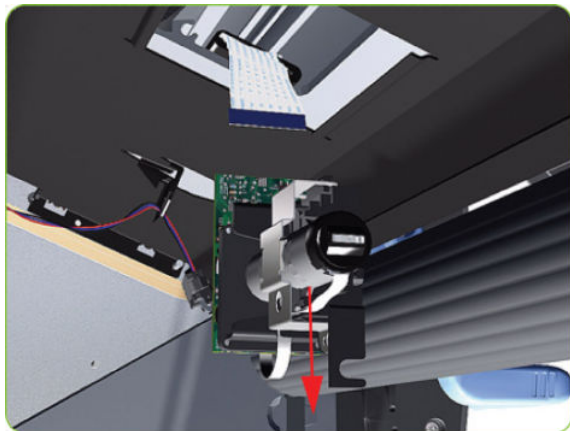

Installation

 **NOTE:** To simplify the installation of the OMAS an Attachment Screw Retainer has been added to hold the two T-20 attachment screws. This part is delivered attached to the replacement OMAS unit with the two attachment screws. It is also delivered as a separate part with the Center Platen in case the OMAS is completely removed during its replacement.

1. Check that the two T-20 attachment screws are correctly positioned in the Attachment Screw Retainer.



2. Position the OMAS under the printer and connect the large ribbon.

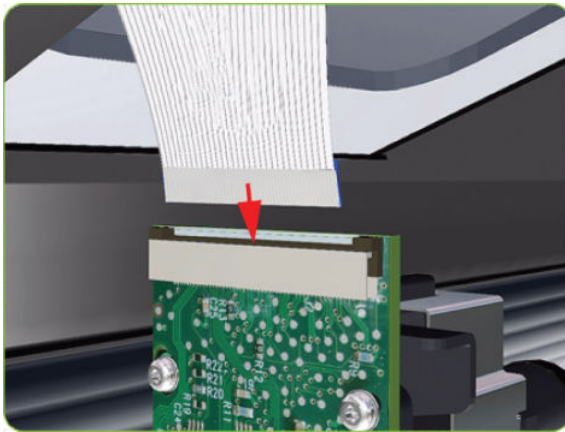

3. Lock the clips of the large ribbon cable connector.

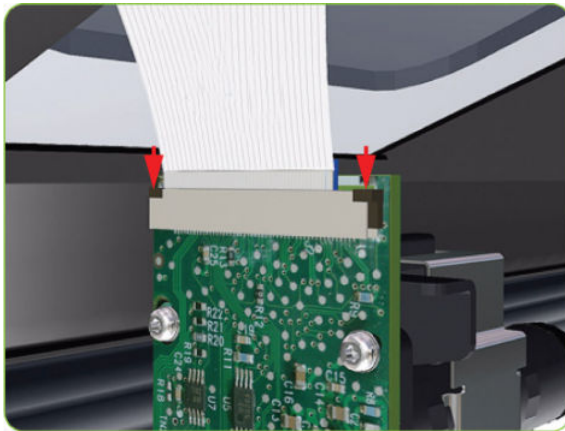

- Carefully push the OMAS fully up into its mounting so that the OMAS window protrudes slightly **ABOVE** the Center Platen (approximately 0-2 mm). To ensure the OMAS is correctly positioned, slide a sheet of paper over the Platen Ribs until it is stopped by the OMAS. This ensures the OMAS is protruding slightly above the platen.

⚠ CAUTION: Make sure the OMAS is pushed completely up into its mounting or you will encounter an error during the OMAS calibration because it will not be able to focus on the paper.



- Slide a sheet of paper over the OMAS window, if the paper is not stopped by the OMAS, repeat step 4 to ensure the OMAS is pushed fully up into its the mounting.



- FULLY** tighten the T-20 vertical attachment screw.



7. Insert the T-20 thin bladed torx screwdriver into the access hole at the rear of the printer.



8. Fully tighten the T-20 horizontal attachment screw which secures the OMAS to the printer.

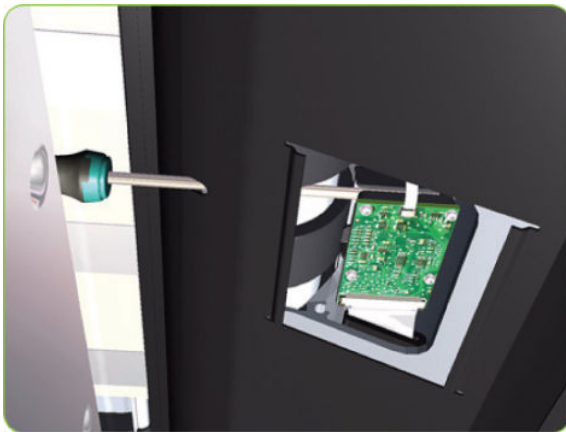

9. Clip the OMAS access cover back into place by sliding one edge of the cover into the slot and then applying enough pressure to it so you can clip it into the other slot.

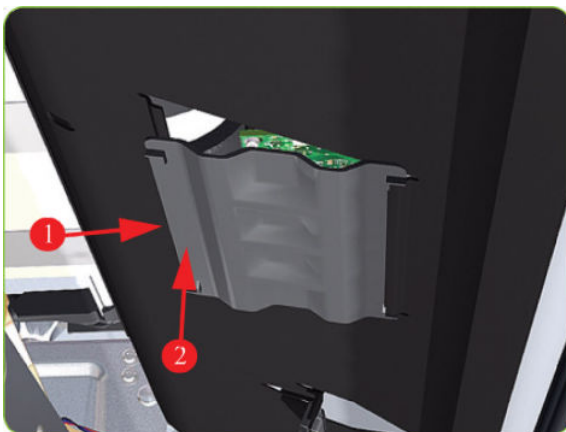

10. Calibrate the OMAS ⇒ See [OMAS Calibration on page 137](#).

Interconnect PCA

Removal

⚠ WARNING! Switch off the printer and remove the power cable.

1. Remove the Right Connector Cover ⇒ See [Connector Cover, Right on page 237](#).
2. Disconnect all cables from the Interconnect PCA.

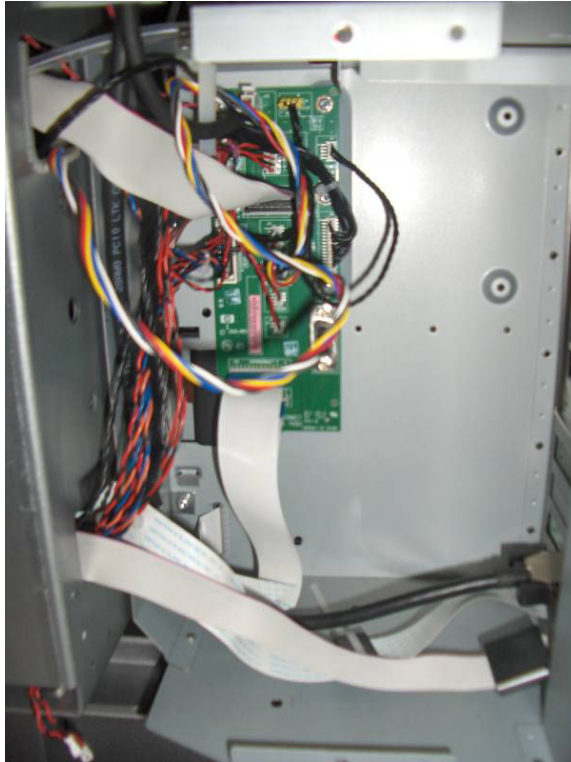

3. Remove five T-10 screws that secure the Interconnect PCA.

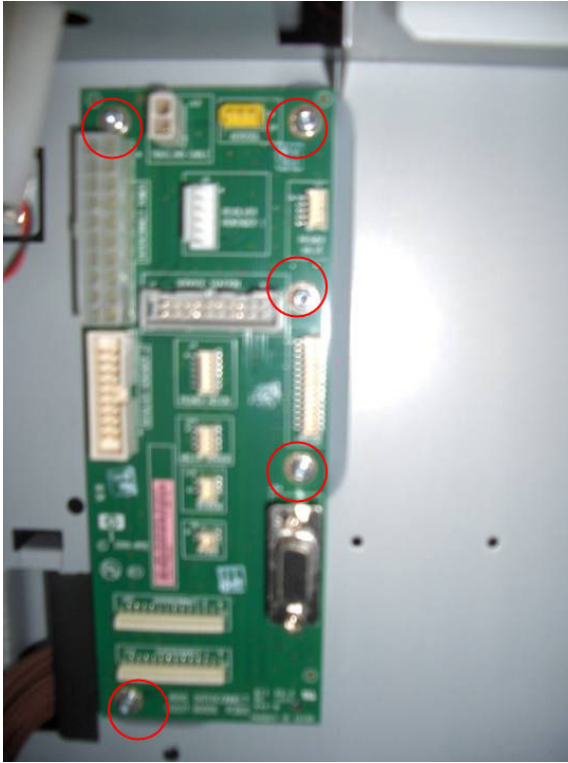

4. Remove the Interconnect PCA.

EIO to PCA Interface Card

Removal

⚠ WARNING! Switch off the printer and remove the power cable.

1. Remove the Jetdirect Card (if installed).

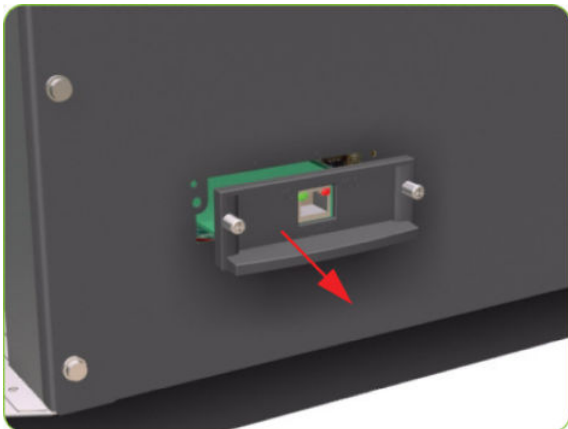

2. Remove three T-20 screws that secure the Formatter cover.

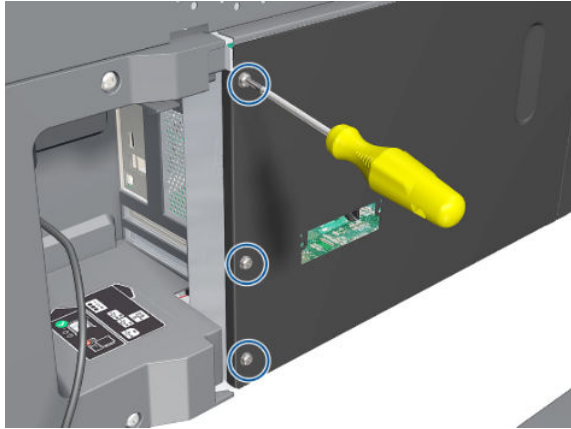

3. Remove the Formatter Cover from the printer.

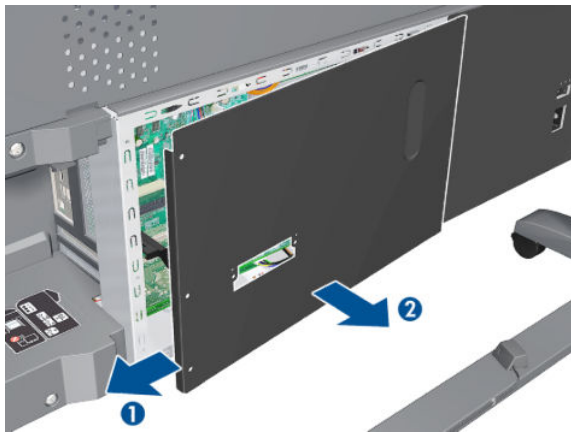

4. Remove one T-10 screw (Type I) that secures the Interface Card.



5. Disconnect the Interface Card from the Formatter and remove from the printer.



OMAS Controller Card

Removal

⚠ WARNING! Switch off the printer and remove the power cable.

1. Remove the Right Connector Cover ⇒ See [Connector Cover, Right on page 237](#).
2. Remove the Jetdirect Card (if installed).

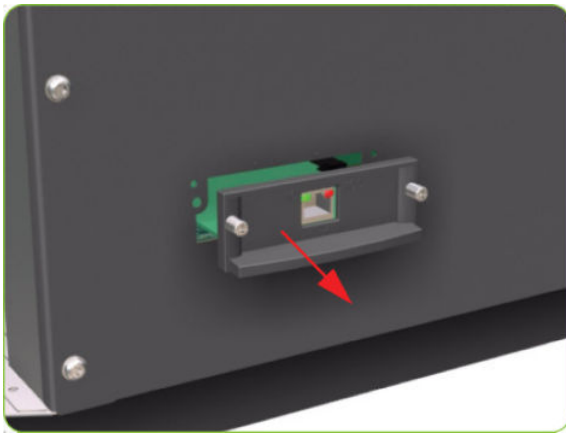

3. Remove three T-20 screws that secure the Ebox Cover Left.

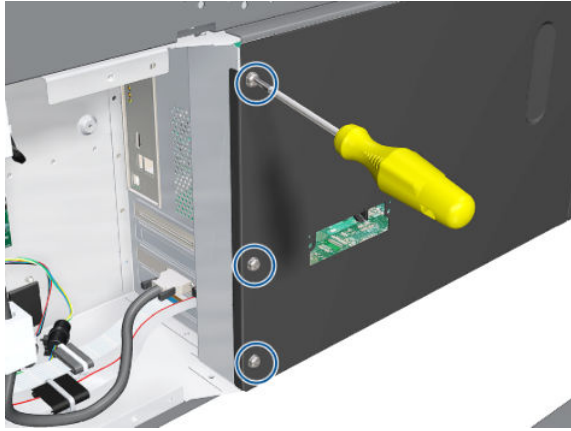

4. Remove the Ebox Cover Left from the printer.

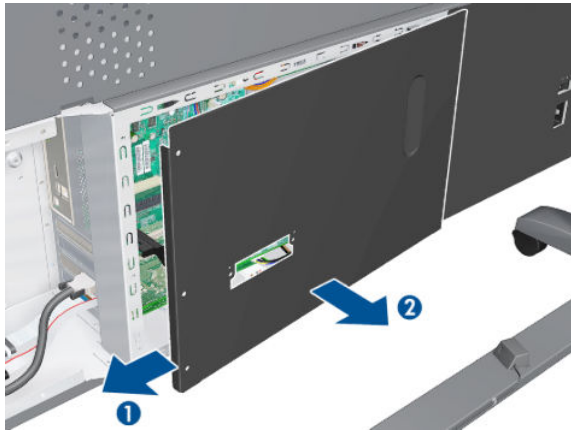

5. Disconnect the Trailing Cable to make the next step easier.

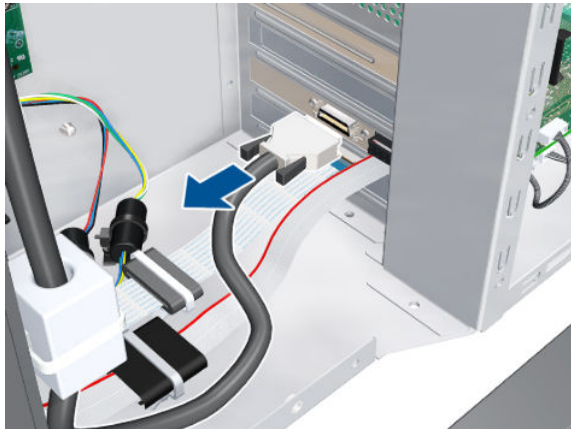

6. Unclip the connector, then disconnect the OMAS Controller Card.

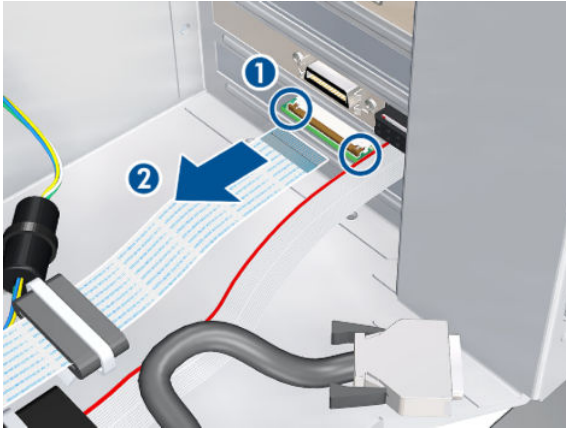

7. Disconnect three cables.

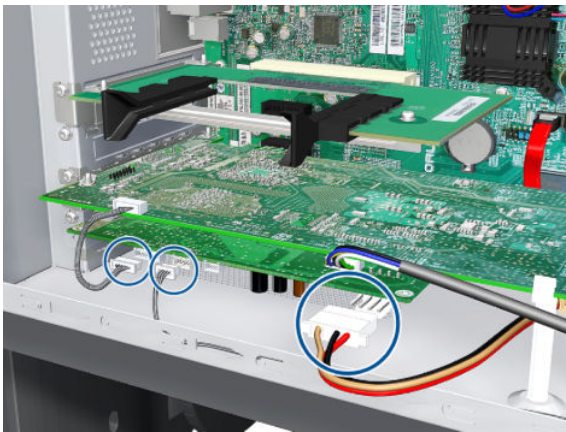

8. Remove one T-10 screw (**Type I**) that secures the OMAS Controller Card.



9. Disconnect the OMAS Controller Card from the Formatter and remove it from the printer.

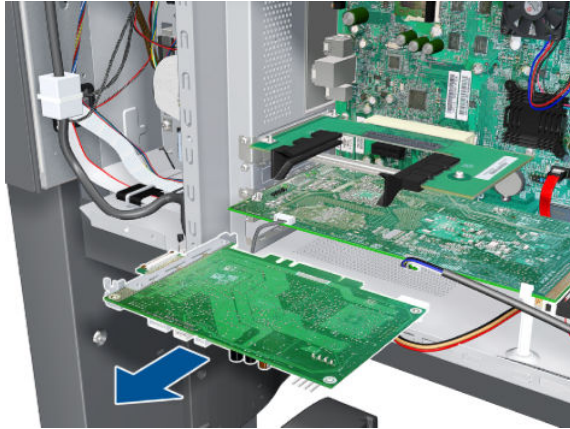

OMAS Cable

Removal

⚠ WARNING! Switch off the printer and remove the power cable.

1. Remove the Right Cover ⇒ See [Cover, Right on page 225](#).
2. Remove the Right Connector Cover ⇒ See [Connector Cover, Right on page 237](#).
3. Remove the Right Smart Roll-loading System Cover ⇒ See [Smart Roll-loading System Cover, Right on page 260](#).
4. Remove the Service Station ⇒ See [Service Station on page 246](#).
5. Remove the OMAS ⇒ See [Optical Media Advance Sensor \(OMAS\) on page 359](#).
6. Remove one T-15 screw that secures the OMAS Cable clamp from the printer.



7. Remove the OMAS Cable clamp from the printer.

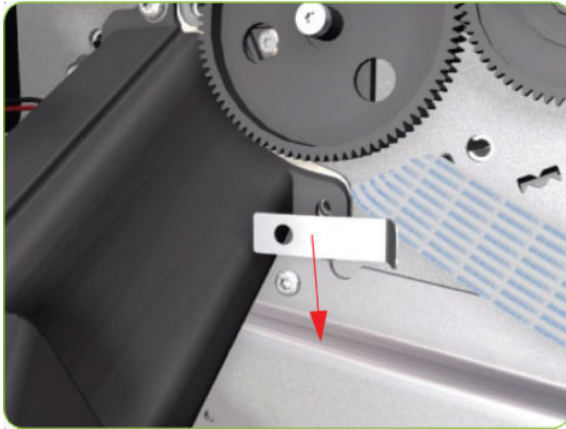

8. Carefully Pull the OMAS Cable out of the Vacuum Beam.

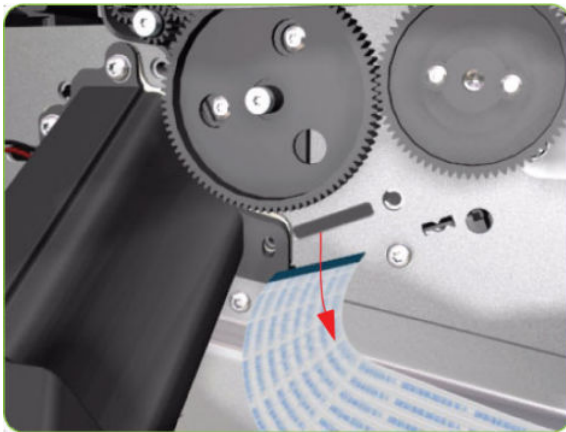

9. Disconnect the OMAS Cable from the OMAS Controller Card.

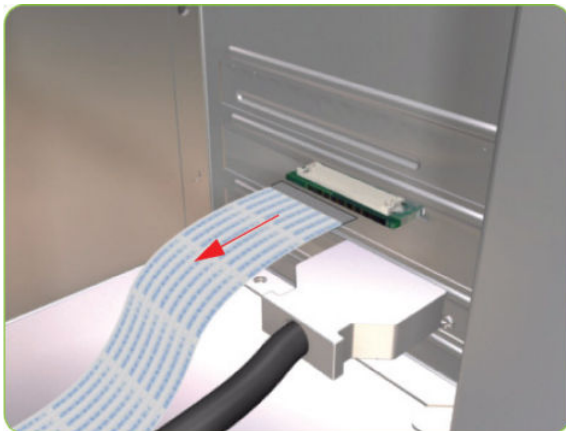

10. Unroute the OMAS Cable from the Ferrite Core.

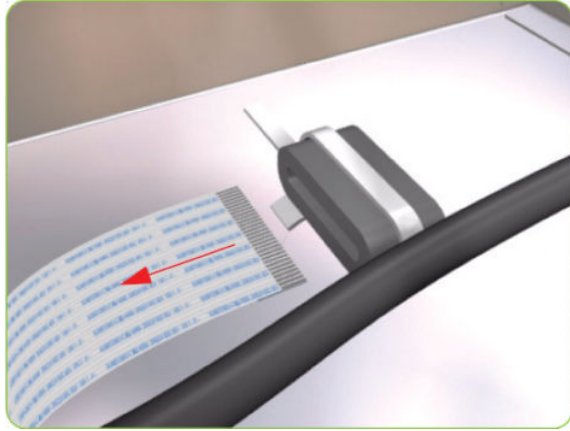

11. Unroute and remove the OMAS Cable from the printer.

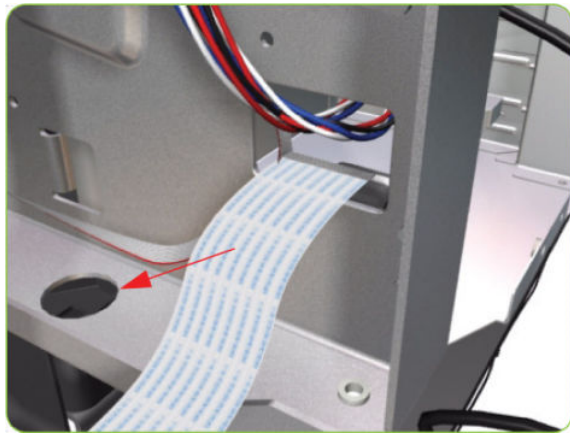

Installation

⚠ CAUTION: It is critical that the OMAS Cable is correctly positioned in the Vacuum Beam so that it does not cause physical interference to the Media Sensor.

The following illustration shows a cross-section of the Vacuum Beam with the OMAS Cable correctly routed to avoid interference to the Media Sensor.

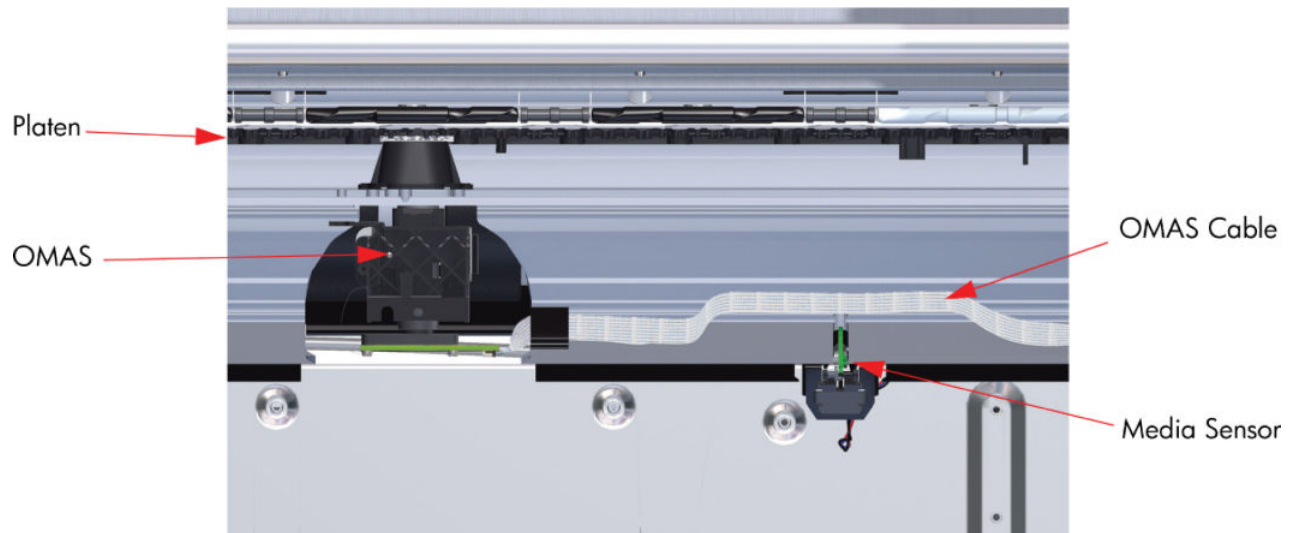

- ▲ Before you can start to install the OMAS Cable you must first identify which end connects to which component. The end of the cable that has the most perpendicular and diagonal folds is the end that connects to the OMAS with the blue reinforcing on the top. The other end must be connected to the OMAS Controller Card with the blue reinforcing on the bottom.

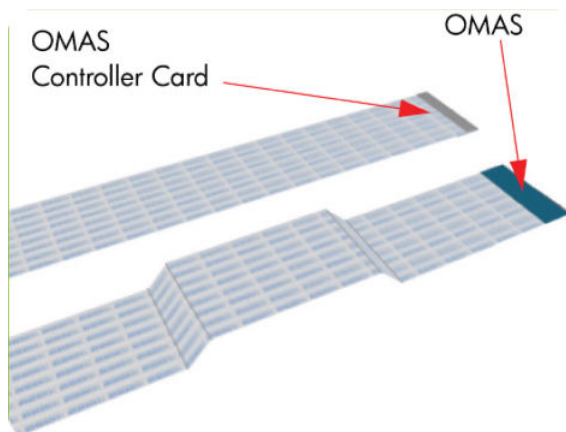

1. Carefully slide the Ferrite Core and its associated attachment plate out of the vacuum beam.

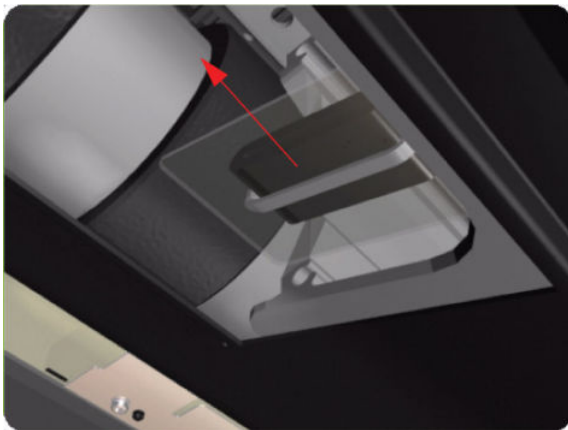

2. Position the OMAS Cable in the Vacuum Beam slot so that the blue reinforcement enters first.

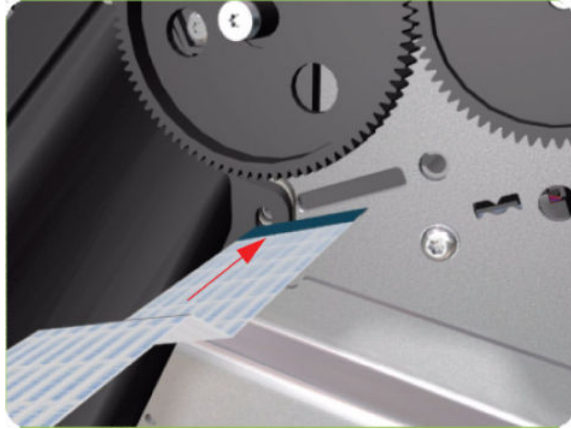

3. Carefully feed the OMAS cable through the Vacuum Beam sufficiently to have approximately 20 cm hanging from the OMAS installation position.

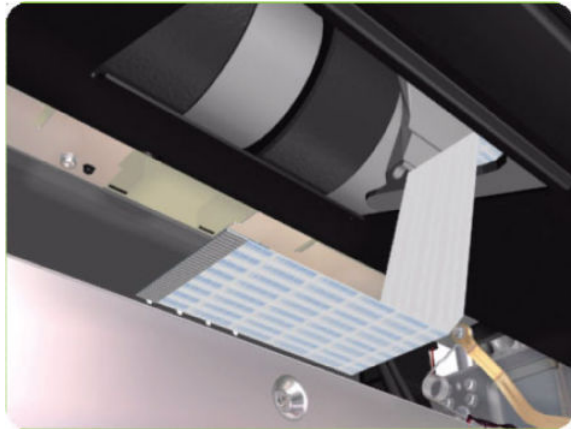

4. Slide the Ferrite Core and its associated Attachment Plate (on the top) onto the OMAS Cable.

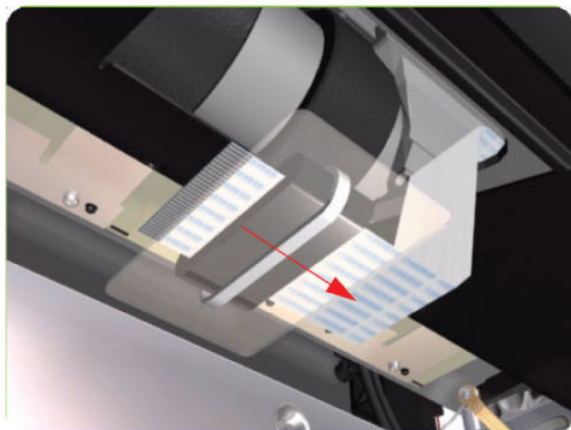

5. Push the Attachment Plate into its slot in the Vacuum beam until it is level with the edge of OMAS installation position.

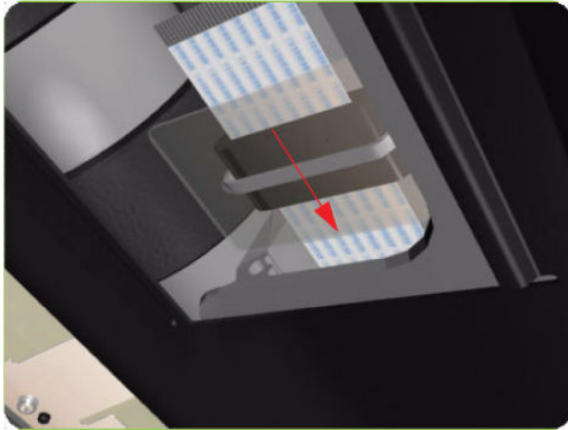

6. Carefully pull the OMAS Cable back into the Vacuum Beam (from the Service Station end) until the straight fold immediately before the first diagonal fold (from the OMAS sensor end) is aligned with the slot, fold the OMAS Cable across the diagonal fold, and install the cable clamp to lock the OMAS Cable in the correct position.

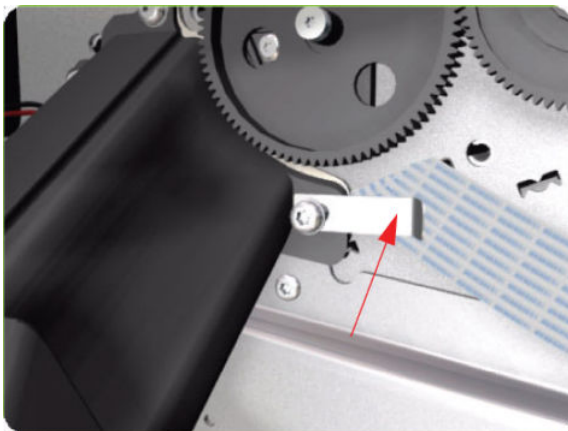

7. Route the OMAS Cable to the Ferrite Core in the Right Interconnect panel.

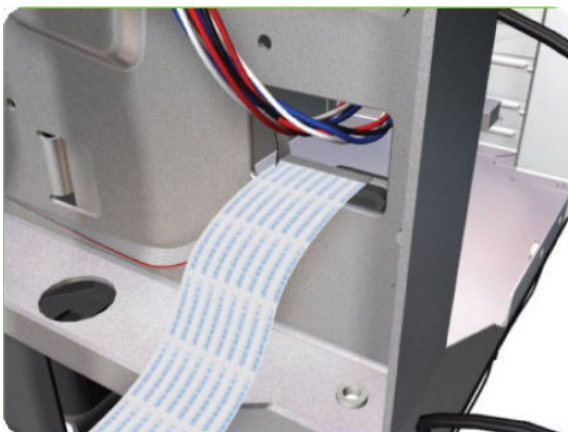

8. Feed the OMAS Cable through Ferrite Core.

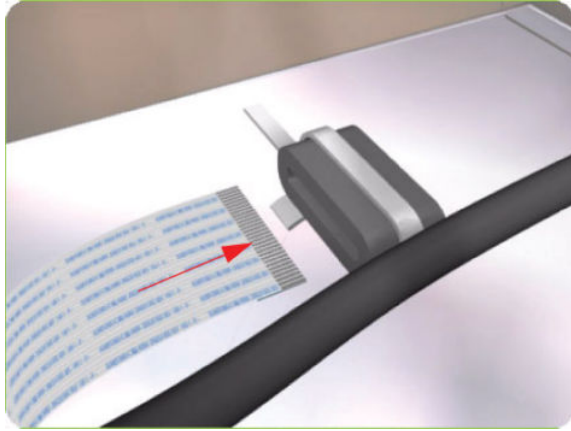

9. Connect the OMAS Cable to the OMAS Controller Card with the connections on the top.

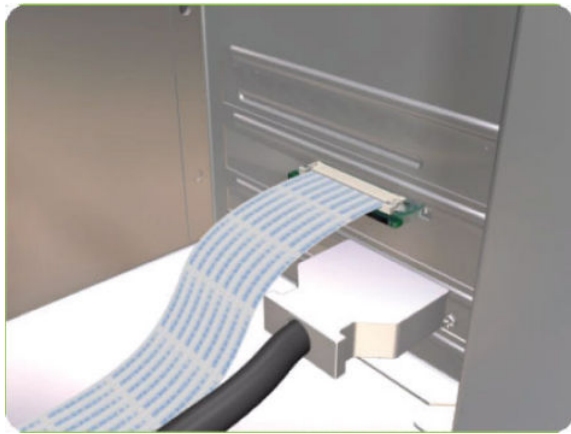

Main PCA

Removal

⚠ WARNING! Switch off the printer and remove the power cable.

1. Remove the Right Connector Cover ⇒ See [Connector Cover, Right on page 237](#).

2. Remove the Jetdirect Card (if installed).

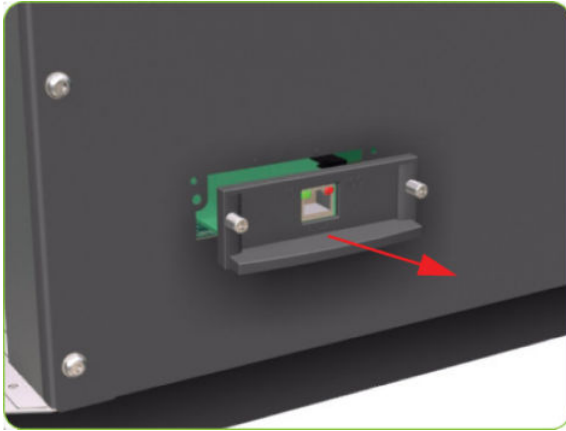

3. Remove three T-20 screws that secure the Ebox Cover Left.

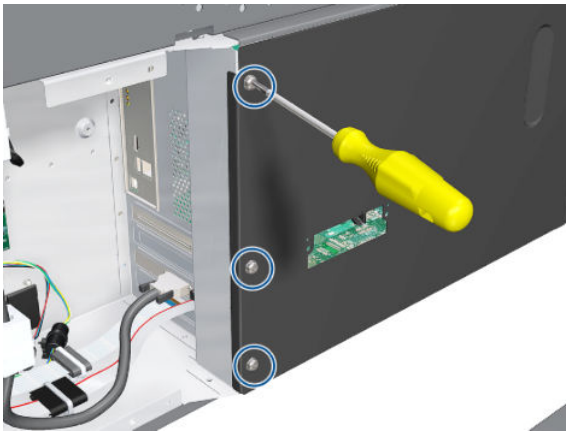

4. Remove the Ebox Cover Left from the printer.

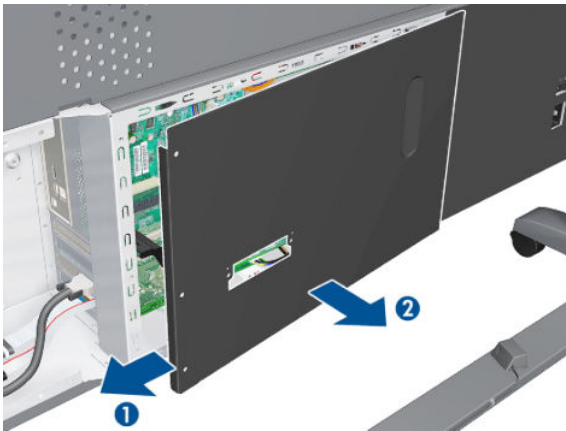

5. Disconnect the Trailing Cable and the Front Panel cable from the Main PCA.

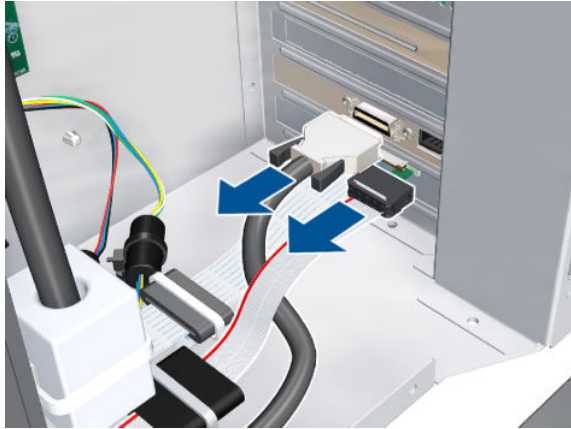

6. Disconnect two ribbon cables.

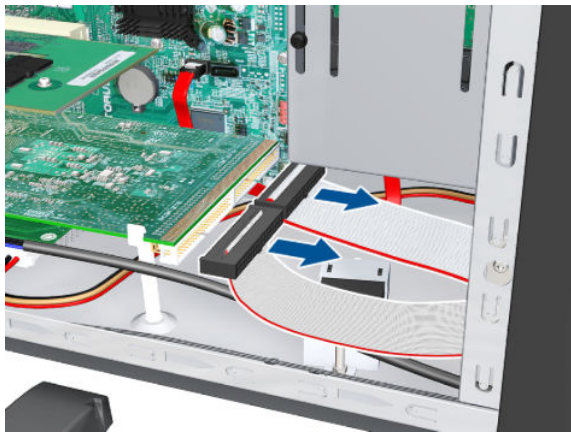

7. Disconnect two cables.

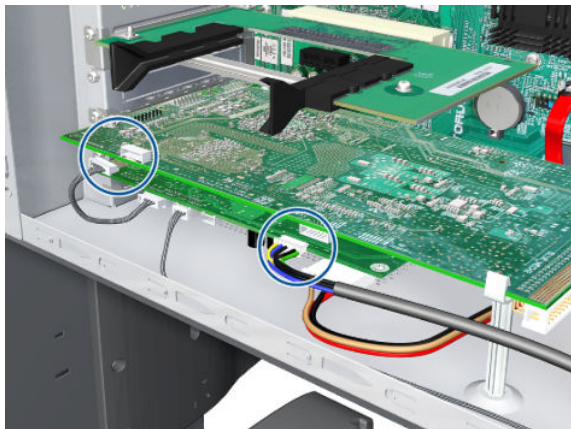

8. Remove one T-10 screw (**Type I**) that secures the Main PCA.

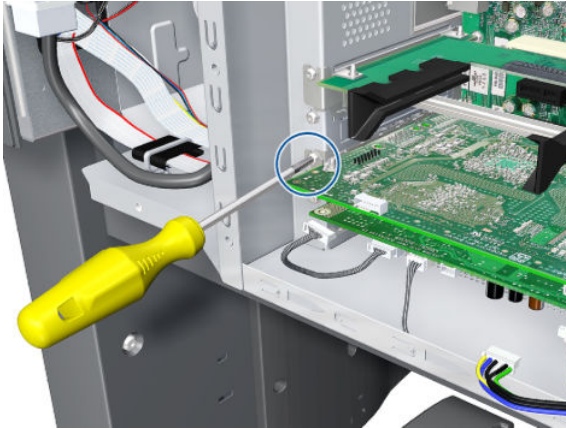

9. Unclip the Main PCA.

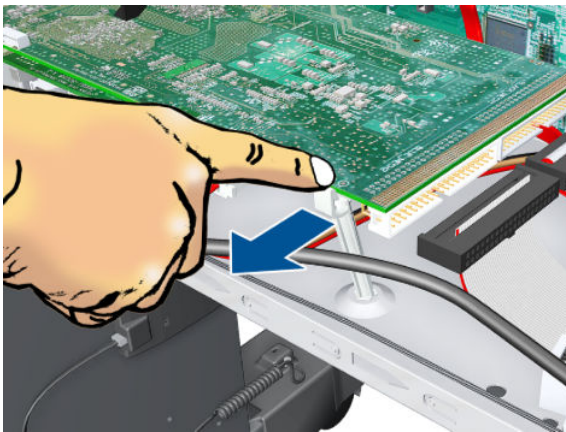

10. Remove the Main PCA.

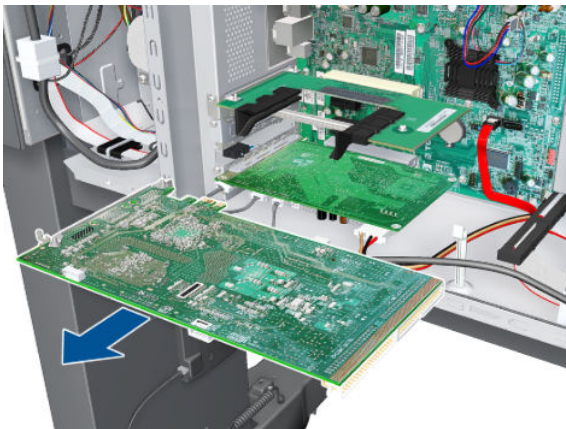

Formatter

Removal

 **WARNING!** Switch off the printer and remove the power cable.

⚠ CAUTION: Do not remove the Fan or the Processor (located under the Fan) from the Formatter. The Fan and the Processor are part of the Formatter support part and should be replaced as one assembly.

1. Remove the EIO to PCI Interface Card ⇒ See [EIO to PCA Interface Card on page 366](#).
2. Remove the Main PCA ⇒ See [Main PCA on page 377](#).
3. Remove the OMAS Controller Card ⇒ See [OMAS Controller Card on page 368](#).
4. Disconnect all cables connected to the Formatter.

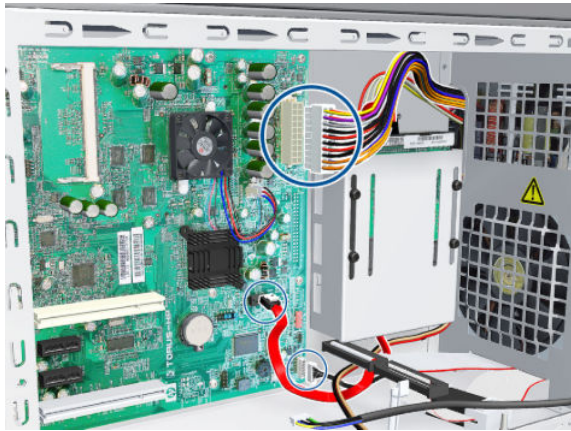

5. Remove eight T-10 screws (**Type I**) that secure the Formatter.



6. Release the plastic locating pin that secures the Formatter.

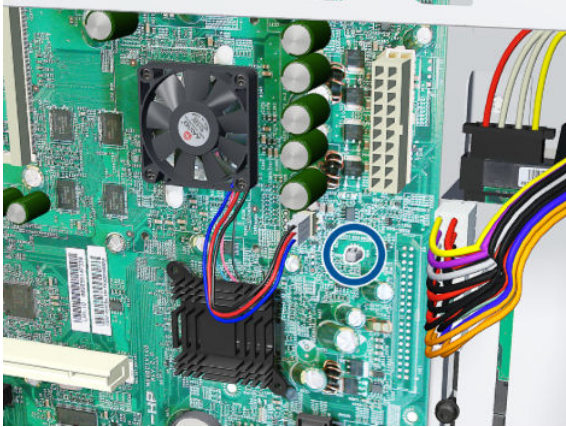

7. Remove the Formatter from the printer.

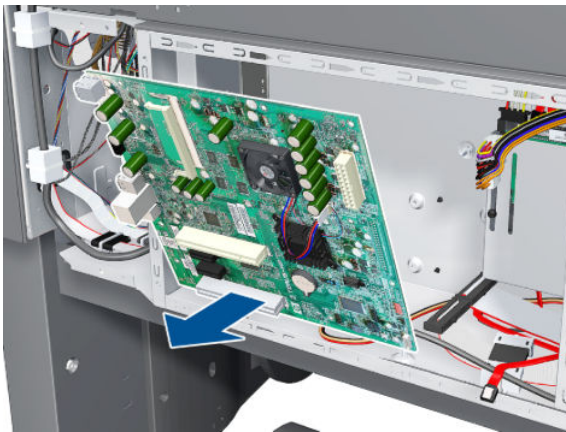

Installation (Rev B printers only)

1. Locate the Formatter on the plastic locating pin, then install the screws.
2. Move the jumper from the default connection to the password reset connection.

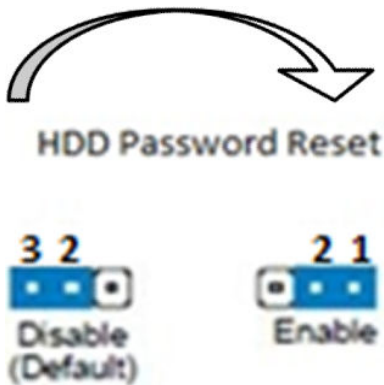

3. Cover the EBox temporarily, with a couple of screws to hold the cover in place.
4. Turn on the printer, wait until it has completely started up, then turn it off again.

5. When the printer is completely turned off, remove the power cable.
6. Remove the cover from the EBox.
7. Move the jumper from the password reset connection to the default connection.

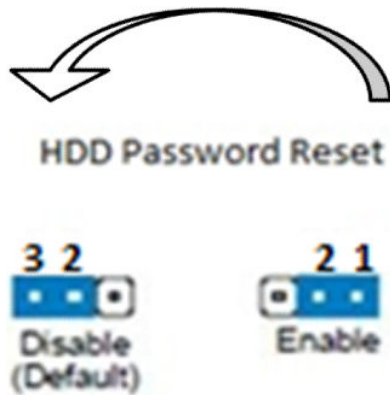

8. Cover the EBox again.

TIP: When you first start a printer with a new Hard Disk Drive, encrypted or not, it may display an error message (79:04). Turn off the printer and restart. The printer should start normally.

CAUTION: Turning off the printer during the start-up procedure with a new Formatter and Hard Disk Drive may corrupt the BIOS password, leaving the system useless with no ability to restart.

TIP: After installing a new Formatter board in a Rev B printer, reset the password.

Hard Disk Drive (HDD)

Removal

WARNING! Switch off the printer and remove the power cable.

NOTE: You must never replace both the Hard Disk Drive and the Ink Supply Tubes and Trailing Cable at the same time. If both parts need to be replaced, you must first replace one part and then power on the printer until it initializes completely. Then you can power off the printer and replace the other part.

1. Remove the Jetdirect Card (if installed).

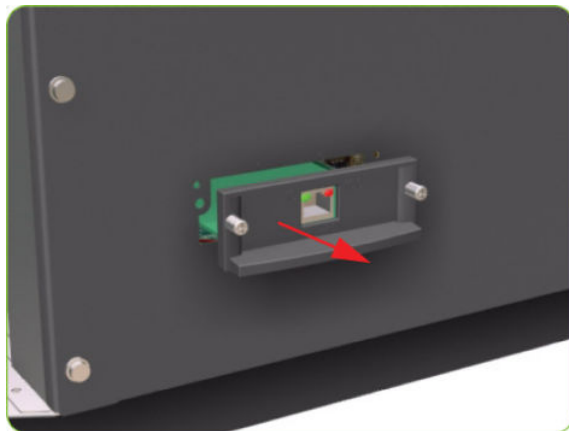

2. Remove three T-20 screws that secure the Formatter cover.

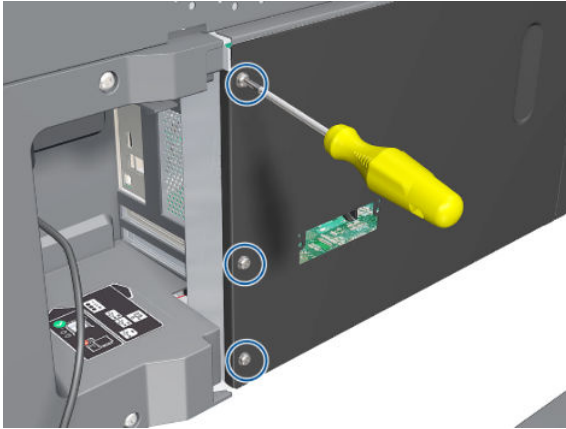

3. Remove the Formatter Cover from the printer.

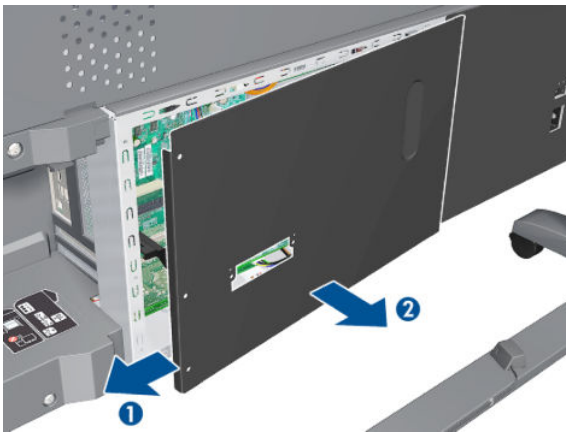

4. Disconnect the power and data cables connected to the Hard Disk Drive.

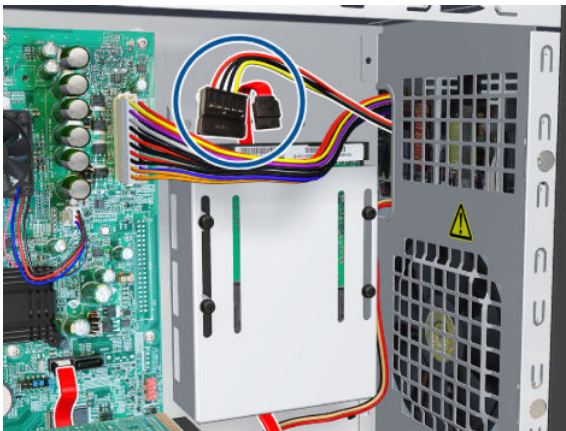

5. Remove one T-10 screw (**Type I**) from the HDD Holder.

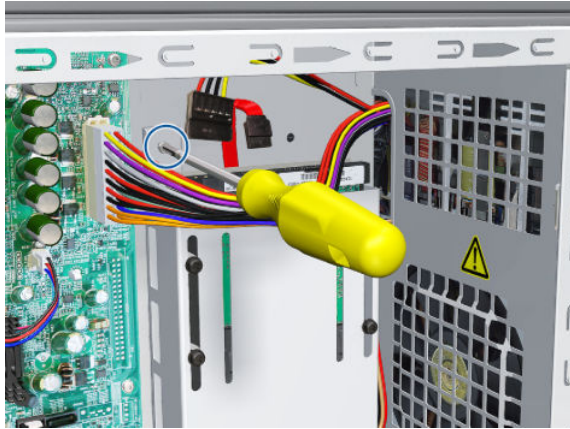

6. Slide the Hard Disk Drive upwards and remove from the printer.

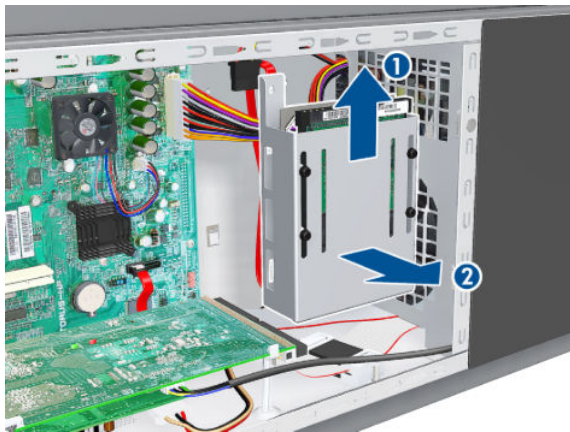

 **NOTE:** It is not necessary to remove the screws securing the HDD inside the metal casing.

Installation (Rev A printers)

After installing a new HDD, make sure you perform the following user calibrations:

- Printhead Alignment
- Paper Advance Calibration
- Color Calibration

Installation (Rev B printers)

1. Install the new HDD assembly and T-10 screw.
2. Connect the SATA cable to the Formatter SATA connector and the other end to the HDD SATA connector.
3. Connect the SATA power cable to the HDD power cable from the PSU to the SATA power connector.

4. Identify the HDD Protect Jumper.

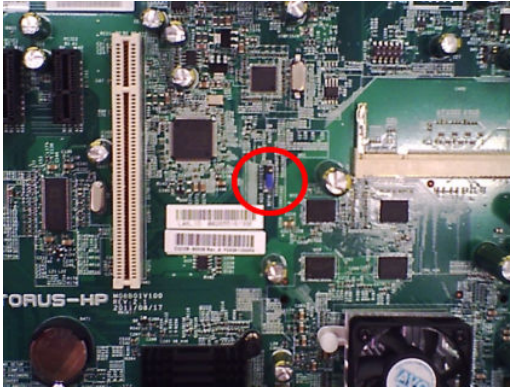

5. Move the jumper from the default connection to the password reset connection.

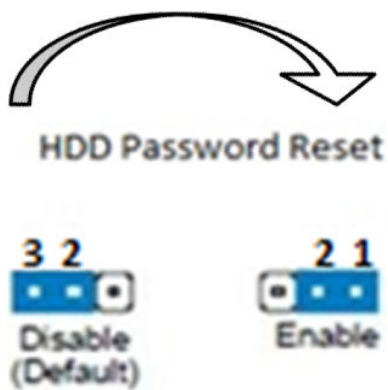

6. Replace the cover on the EBox provisionally with a couple of screws to hold the cover in place.
7. Power up the printer and turn it on (wait until it starts up).
8. Shut down the printer and power off. Remove the power cable.
9. Remove the cover from the EBox.
10. Move the jumper from the password reset connection to the default position.

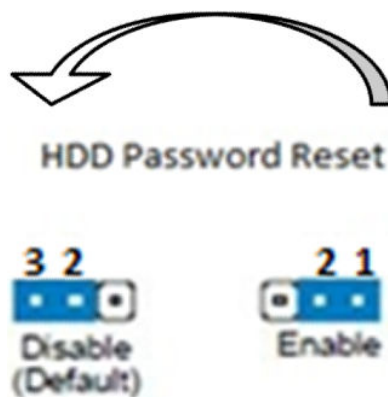

11. Cover the EBox.

 **NOTE:** When you first start the printer with a new HDD, encrypted or not, you may see a 79:04 system error. Switch off and restart; the printer should start normally.

 **CAUTION:** Powering off the printer while starting it with a new Formatter and HDD may corrupt the BIOS password, leaving the printer useless because it will be unable to start.

After installing a new HDD, make sure you perform the following user calibrations:

- Printhead Alignment
- Paper Advance Calibration
- Color Calibration

Power Supply Unit (PSU)

Removal

 **WARNING!** Switch off the printer and remove the power cable.

1. Remove the Left Connector Cover ➡ See [Connector Cover, Left on page 238](#).
2. Remove the Jetdirect Card (if installed).

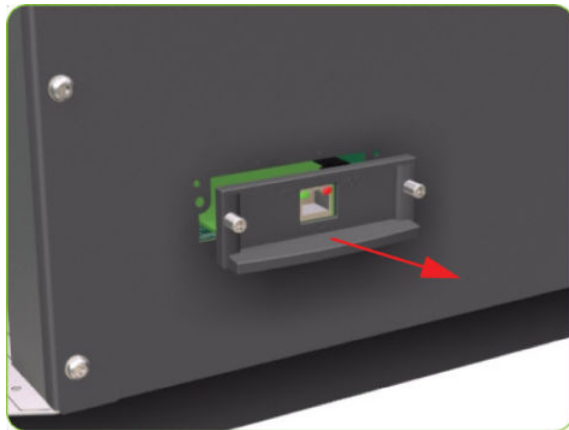

3. Remove three T-20 screws that secure the Formatter cover.

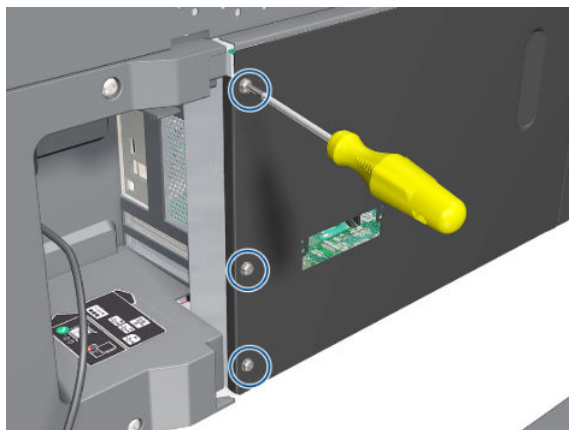

4. Remove the Formatter Cover from the printer.

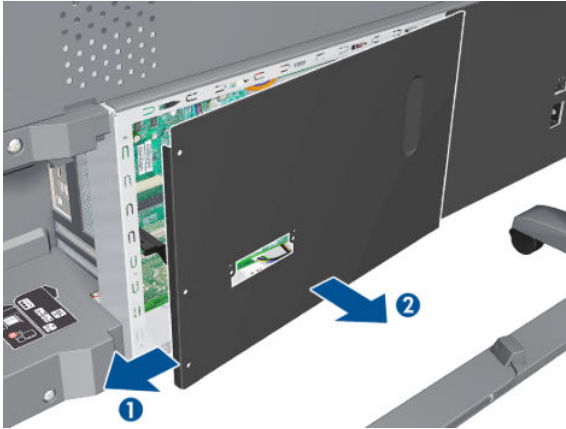

5. Remove three T-20 screws that secure the PSU cover.

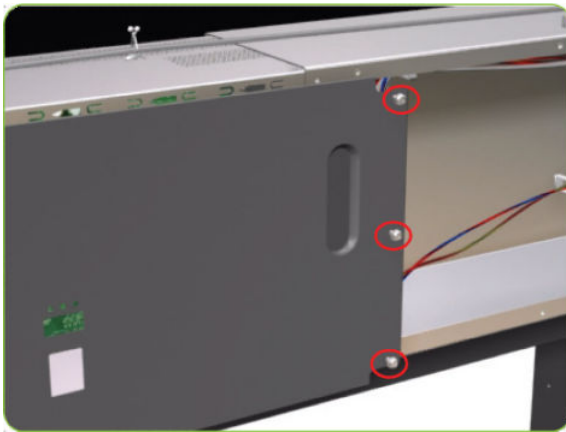

6. Remove the PSU Cover from the printer.

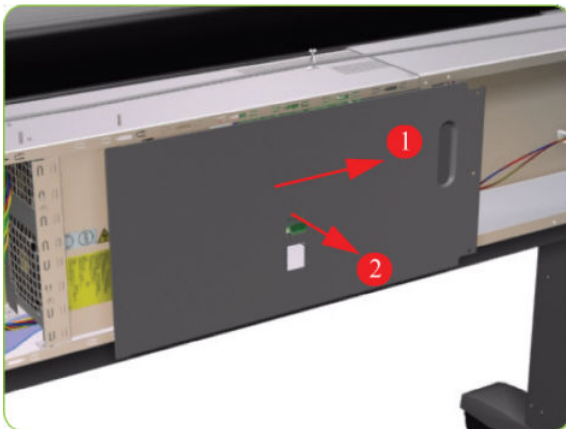

7. Disconnect the Power Supply from the PrintMech PCA.

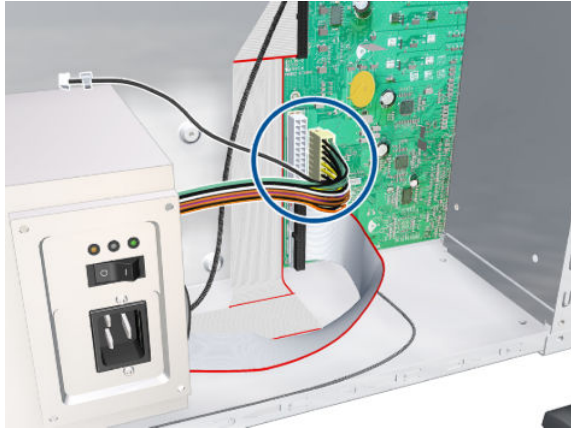

8. Disconnect the power supply cable from the Formatter.

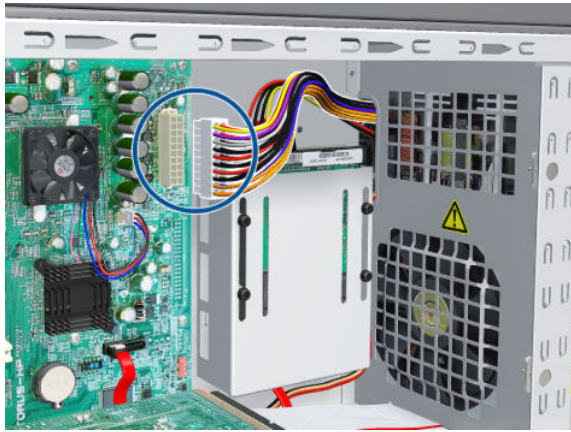

9. Disconnect one cable from the Hard Disk Drive.

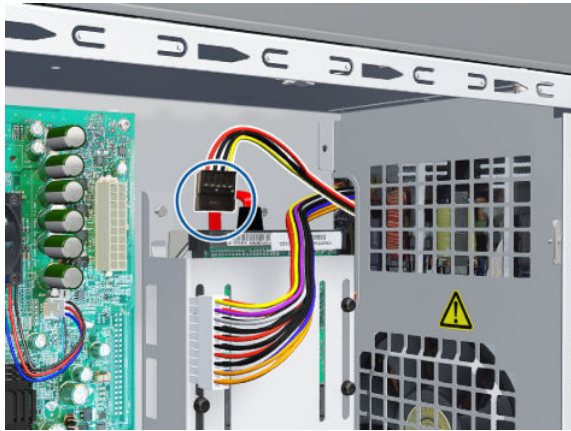

10. Disconnect the cable as shown.

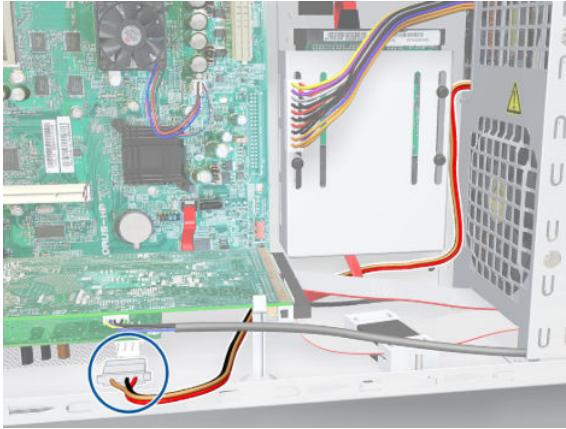

11. Disconnect the cable and pass it through the hole.

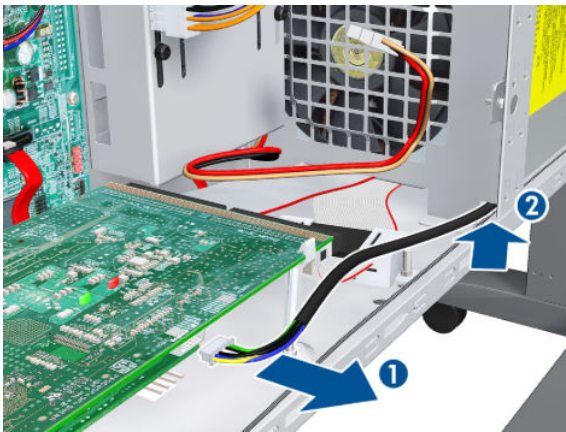

12. Remove four T-10 screws (Type I) that secure the Power Supply Unit.



13. Route the cables through the hole in the Electronics Module.



14. Remove the Power Supply Unit from the printer.

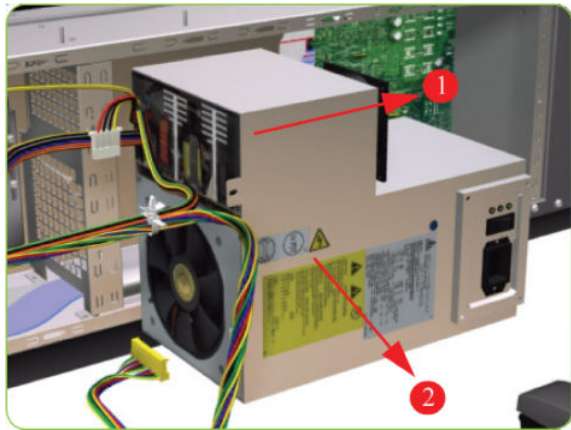

PrintMech PCA

Removal

⚠ WARNING! Switch off the printer and remove the power cable.

1. Remove the Left Connector Cover ➡ See [Connector Cover, Left on page 238](#).

2. Remove three T-20 screws that secure the PSU Cover.

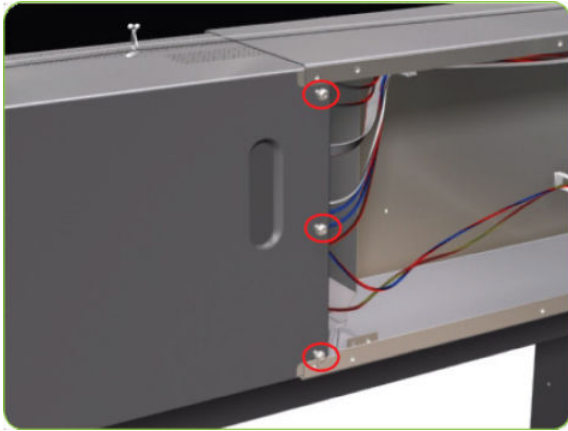

3. Remove the PSU Cover from the printer.

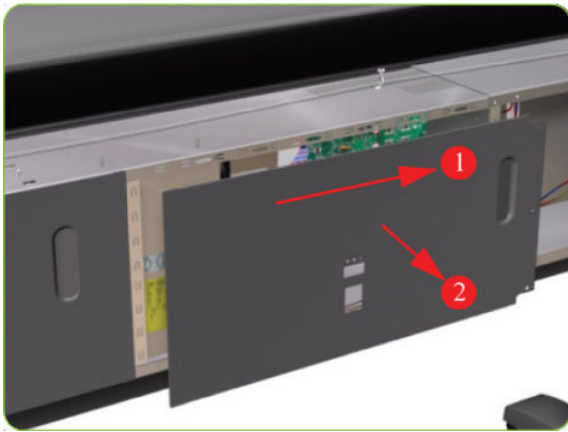

4. Remove two T-20 screws from the PrintMech Cover.

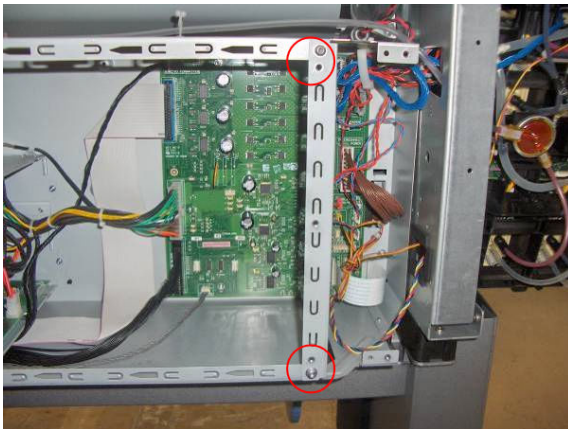

5. Slide the PrintMech Cover out of the printer.

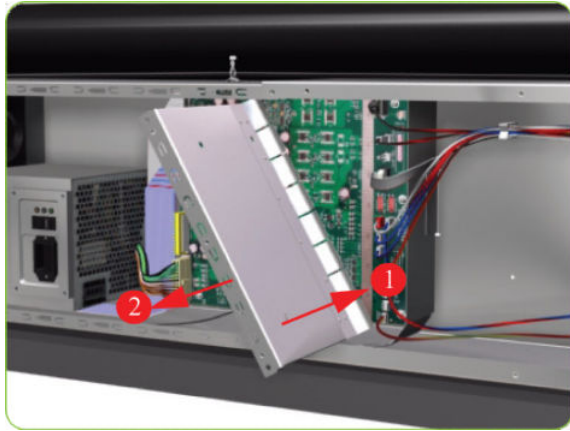

6. Disconnect all cables from the PrintMech PCA.



7. Remove five T-10 screws (**Type I**) that secure the PrintMech PCA.



8. Remove the PrintMech PCA from the printer.



Formatter Battery

Removal

⚠ WARNING! Switch off the printer and remove the power cable.

1. Remove the Jetdirect Card (if installed).

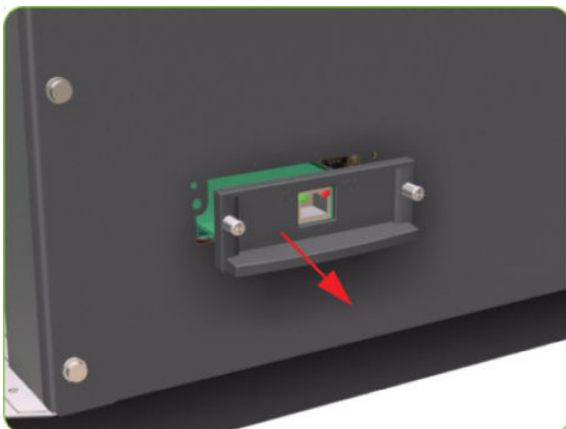

2. Remove three T-20 screws that secure the Formatter cover.

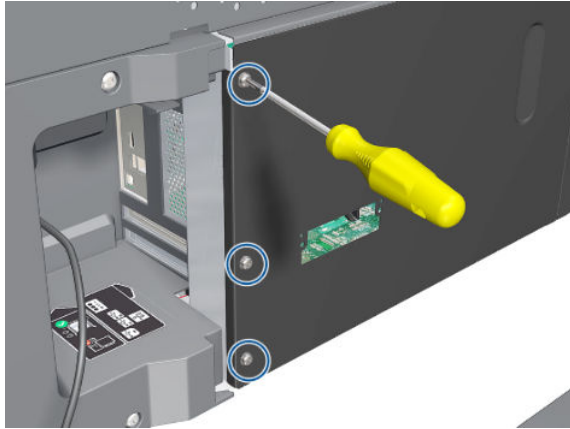

3. Remove the Formatter Cover from the printer.

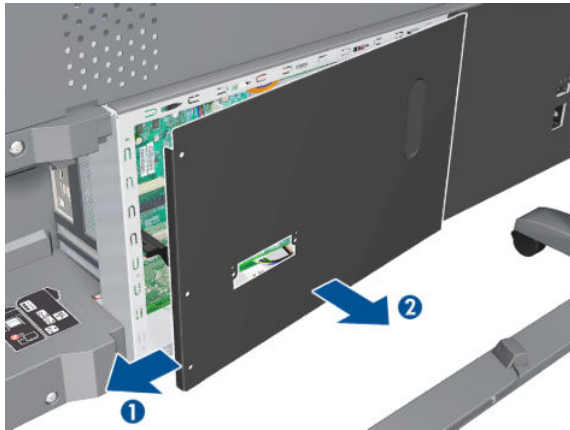

4. Remove the EIO to PCA Interface Card ⇒ See [EIO to PCA Interface Card on page 366](#).

5. Push the clip down and release the battery from the Formatter.

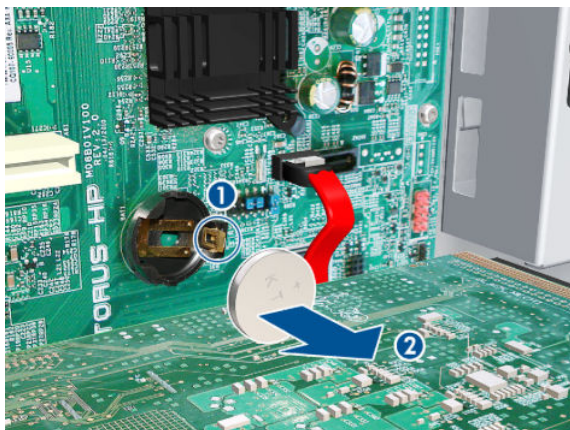

Electronics Module

Removal

⚠ WARNING! Switch off the printer and remove the power cable.

1. Remove the Right Connector Cover ⇒ See [Connector Cover, Right on page 237](#).
2. Remove the Left Connector Cover ⇒ See [Connector Cover, Left on page 238](#).
3. Disconnect all the cables connected to the right Interconnect PCA and the Main PCA.

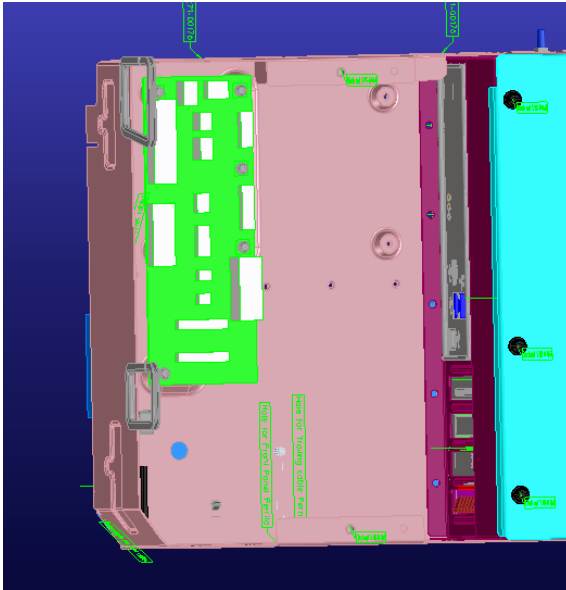

4. Unroute all the disconnected cables so they are clear of the Electronics Module.

5. Remove two T-20 screws (**Type B**) that secure the right side Electronics Module.

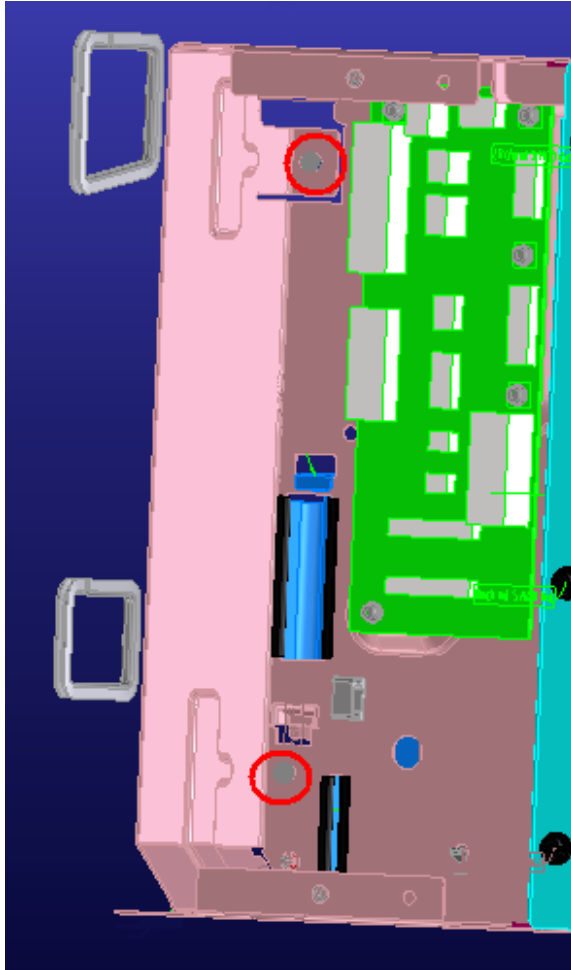

6. Remove two T-20 screws (**Type B**) that secure the left side Electronics Module.

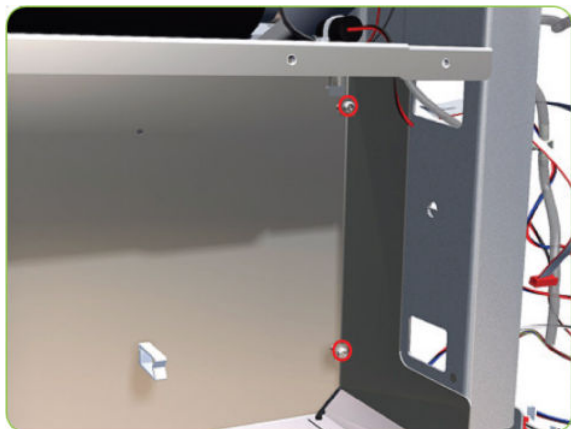

7. Lift the Electronics Module sufficiently (approximately 2 cm) to release it from the attachments.

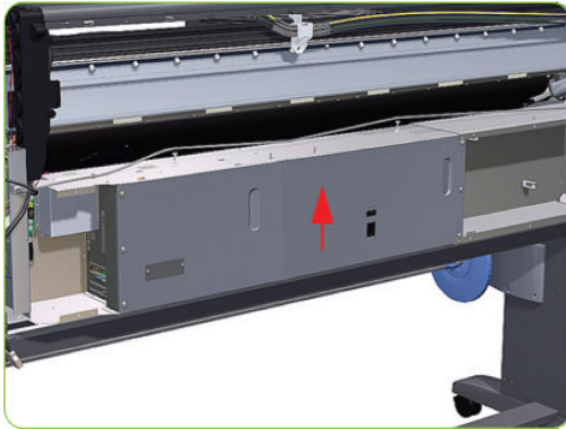

8. Remove the Electronics Module from the printer.



Center Platen

Removal

⚠ WARNING! Switch off the printer and remove the power cable.

1. Remove the Right Cover ⇒ See [Cover, Right on page 225](#).
2. Remove the Left Cover ⇒ See [Cover, Left on page 228](#).
3. Remove the Top Cover ⇒ See [Cover, Top on page 232](#).
4. Remove the Service Station ⇒ See [Service Station on page 246](#).
5. Remove the Rear Door ⇒ See [Rear Door on page 352](#).
6. Remove the Entry Platen ⇒ See [Entry Platen on page 356](#).

7. Insert the T-20 thin bladed torx screwdriver (supplied with the replacement OMAS) into the access hole at the rear of the printer.

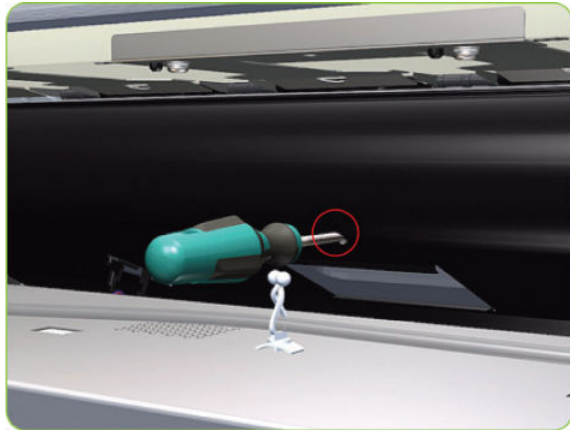

8. Loosen approximately two turns the T-20 screw which secures the OMAS horizontally to the printer.



9. From the bottom of the printer, loosen approximately two turns the T-20 screw which secures the OMAS vertically to the printer.



10. Remove one T-15 screw (Type P) that secures the Center Platen Gear.

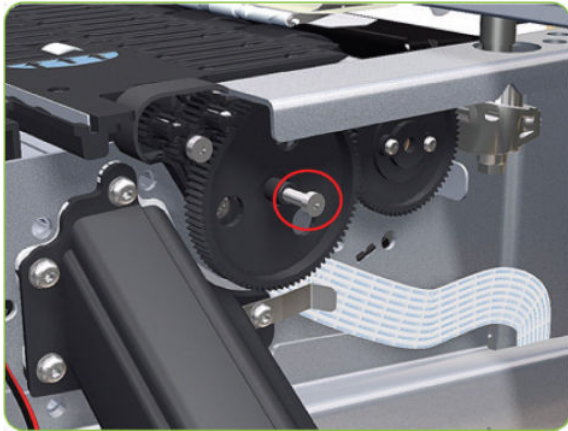

11. Remove the Center Platen Gear from the printer.

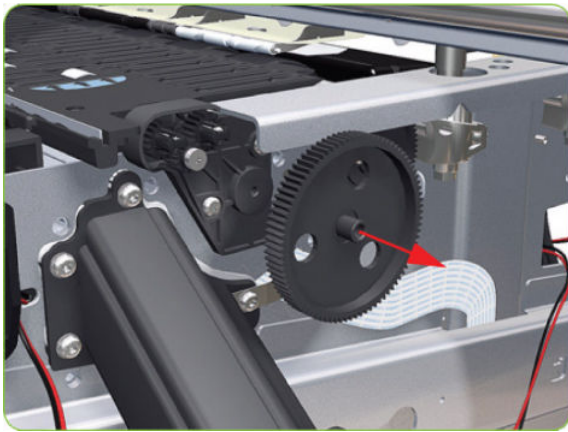

12. Remove one T-15 screw that secures the small Gear.

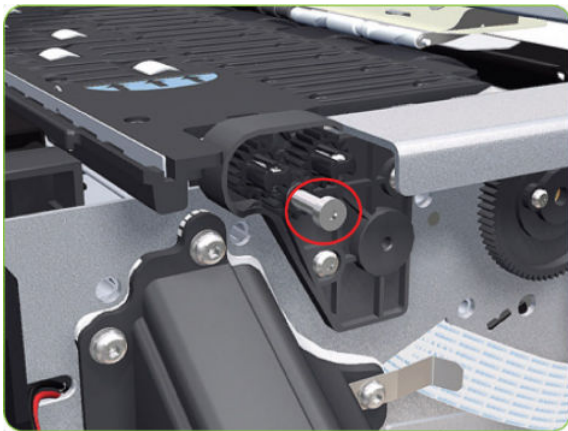

13. Remove the small Gear from the printer.



14. Remove the two small Platen Gears by releasing the clips.



15. Remove two T-20 screws (Type Q) that secure the Gear Bracket.

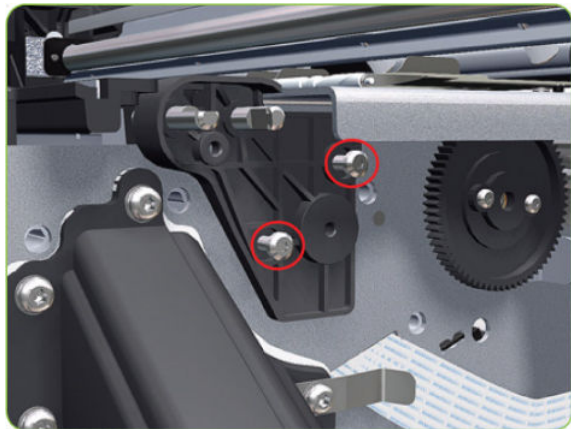

16. Remove the Gear Bracket from the printer.

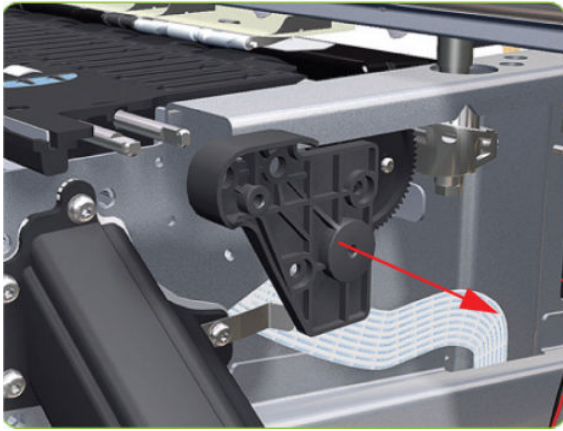

17. Move the Carriage Assembly fully to the right.



18. Remove the 80 T-10 screws (Type C) that secure the Center Platen.

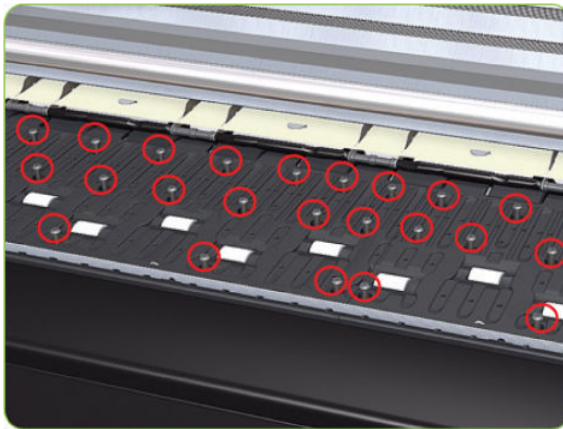

19. Remove the Secondary Spittoon Blank.



20. Remove the Center Platen from the printer.

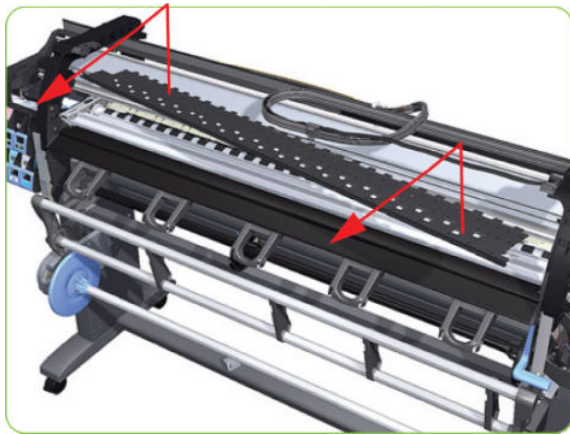

Installation of the Foams

Before installing the Center Platen, make sure you check the foams that are stuck on the Vacuum Beam. These foams should ONLY be changed if they are damaged. In the circumstance where they do need to be changed, use the following illustrations to guide you:

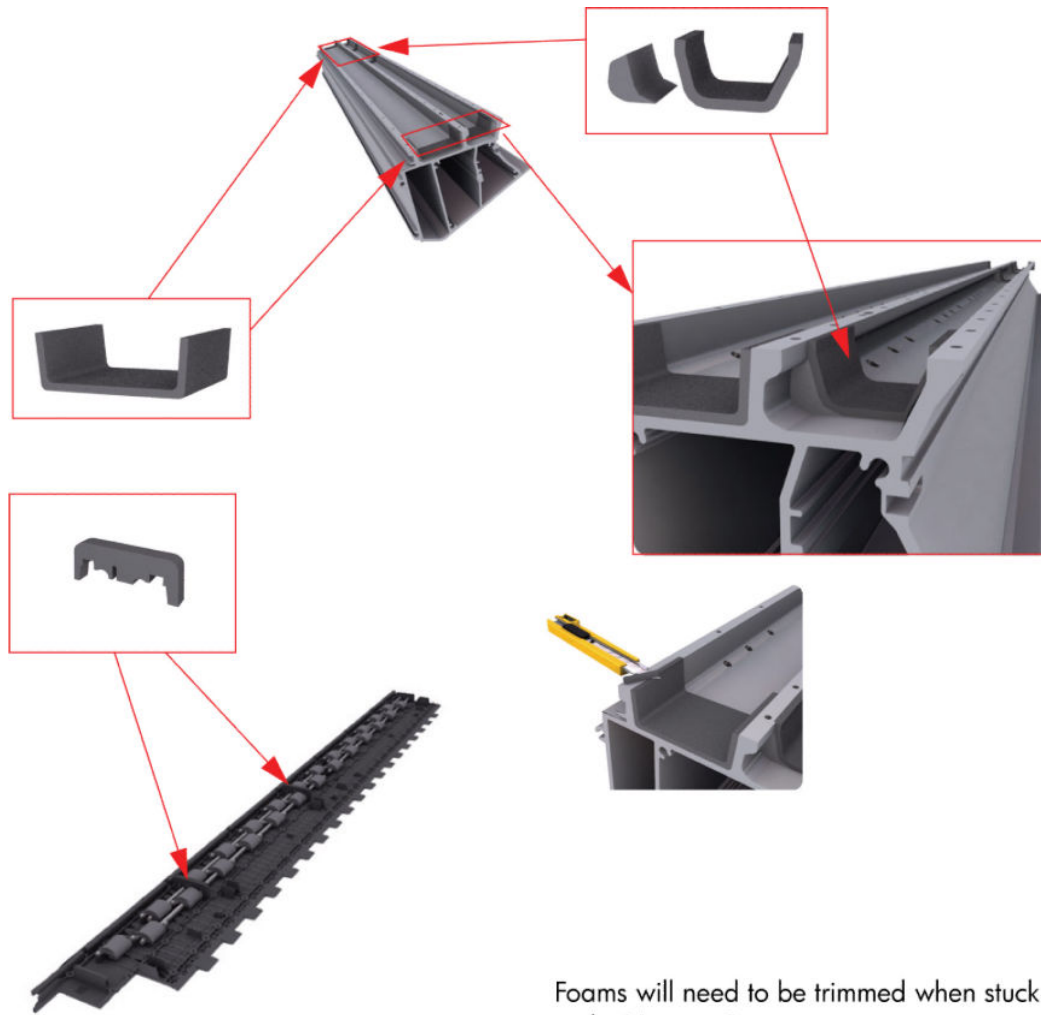

Foams will need to be trimmed when stuck to the Vacuum Beam

 **NOTE:** Make sure you take note of the positions of the Foams located underneath the center Platen.

 **NOTE:** When reinstalling the parts, make sure you apply the grease (included with the support part) to the gears.

 **NOTE:** After installing the new Center Platen, make sure you perform the following Service Calibration:

- Paper-advance Calibration ⇒ [Paper-advance calibration on page 121](#).

 **NOTE:** To simplify the installation of the OMAS an Attachment Screw Retainer has been added to hold the two T-20 attachment screws. This part is delivered with the Center Platen in case either of the OMAS attachment screws are completely removed during the removal of the Center Platen.

OMAS Attachment Screws Completely Removed during Center Platen Removal

1. Completely remove OMAS from the printer ⇒ See [Optical Media Advance Sensor \(OMAS\) on page 359](#).
2. Install the Center Platen.

 **NOTE:** When reinstalling the parts, make sure you apply the grease (included with the support part) to the gears.

3. Position the Attachment Screw Retainer on the OMAS and secure it with the T-8 attachment screw provided with Center Platen.



4. Check that the two T-20 attachment screws are correctly positioned in the Attachment Screw Retainer.



5. Position the OMAS under the printer and connect the large ribbon.

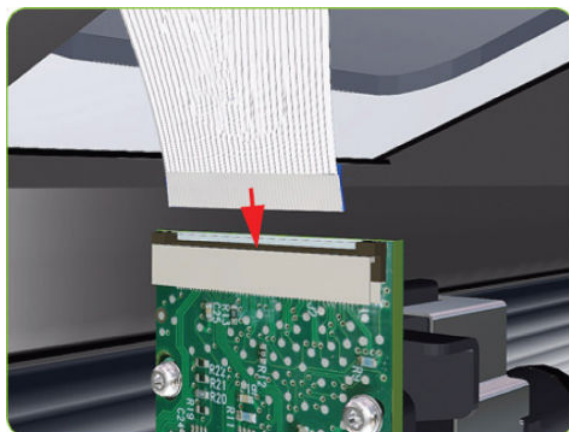

6. Lock the clips of the large ribbon cable connector.

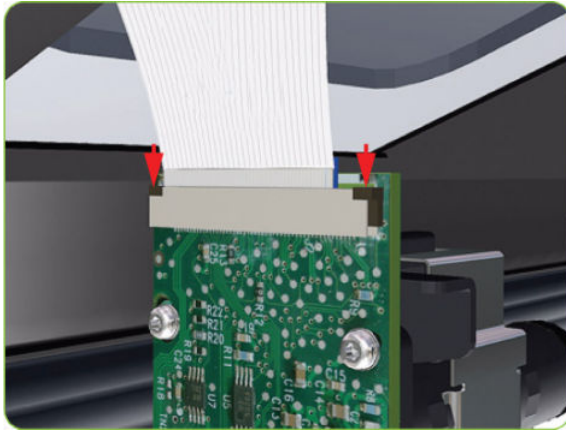

7. Carefully push the OMAS fully up into its mounting so it protrudes slightly (approximately 0.1 mm) above the Center Platen. To ensure the OMAS is correctly positioned, slide a sheet of paper over the Platen Ribs until it is stopped by the OMAS. This ensures the OMAS is protruding slightly above the platen.

⚠ CAUTION: Make sure the OMAS is pushed completely up into its mounting or you will encounter an error during the OMAS calibration because it will not be able to focus on the paper.



8. If the paper is not stopped by the OMAS, repeat step 4 to ensure the OMAS is pushed fully up into its mounting.



9. Fully tighten the T-20 vertical attachment screw.



10. Insert the T-20 thin bladed torx screwdriver into the access hole at the rear of the printer.



11. Fully tighten the T-20 horizontal attachment screw which secures the OMAS to the printer.

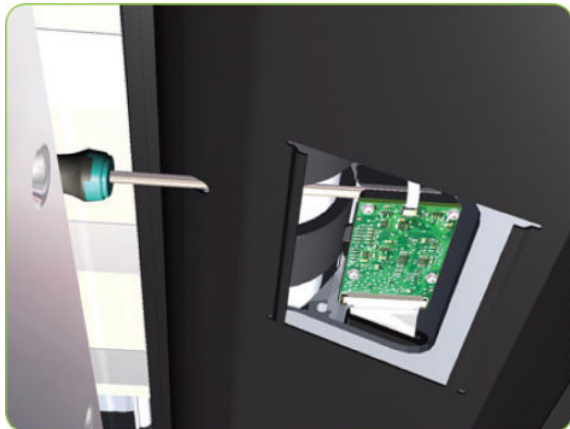

- Clip the OMAS access cover back into place by sliding one edge of the cover into the slot and then applying enough pressure to it so you can clip it into the other slot.

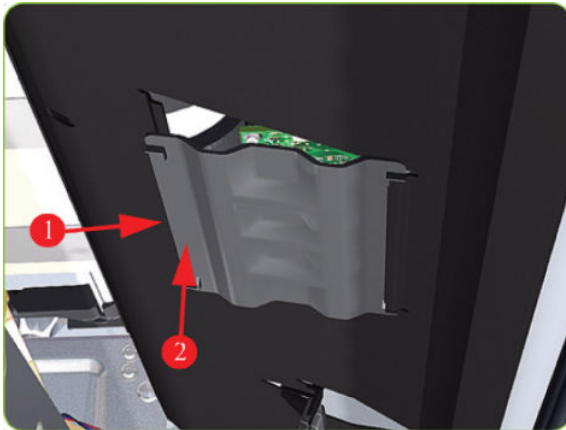

- Perform the following calibrations.
 - OMAS Calibration ⇒ See [OMAS Calibration on page 137](#).
 - Paper-advance Calibration ⇒ See [Paper-advance calibration on page 121](#).

Encoder Disc and Sensor

Removal

⚠ WARNING! Switch off the printer and remove the power cable.

⚠ CAUTION! Please handle the Encoder Disc very carefully since any finger prints, scratches or stains could cause the printer to malfunction.

- Remove the Left Cover ⇒ See [Cover, Left on page 228](#).
- Remove the Left Connector Cover ⇒ See [Connector Cover, Left on page 238](#).
- Remove the Ink Supply Station ⇒ See [Ink Supply Station \(ISS\) on page 314](#).
- Disconnect the Encoder Sensor cable from the PrintMech PCA.

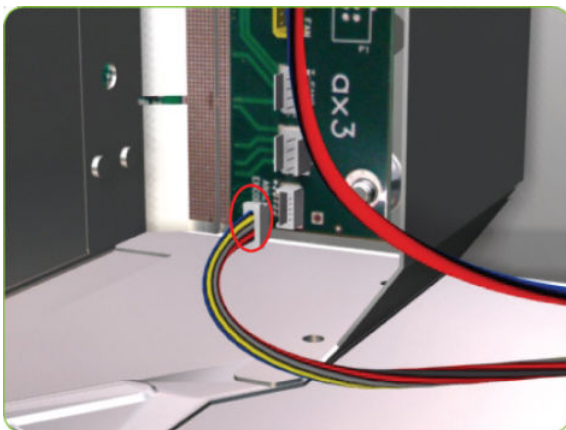

5. Release the Encoder Sensor cable from the clip located on the Electronics Module.

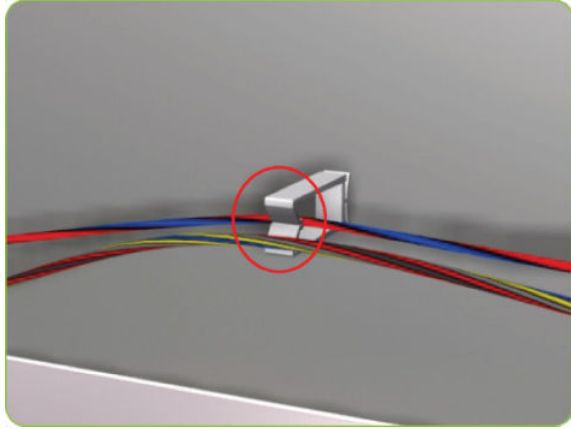

6. Release the Encoder Sensor cable from the clip located on the Encoder Disc Cover.

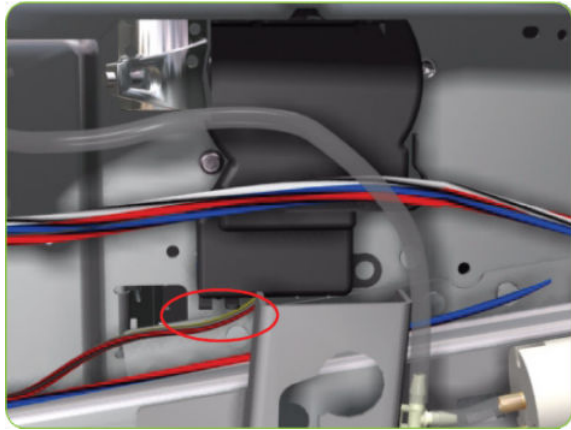

7. Unclip the Encoder Disc Cover and remove from the printer.

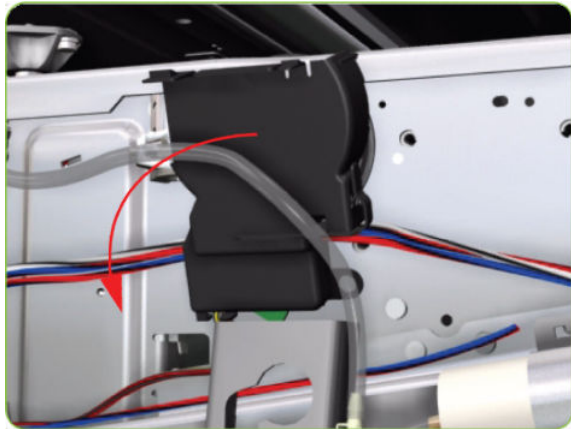

8. Remove one T-8 screw (**Type D**) that secures the Encoder Sensor to the Chassis.

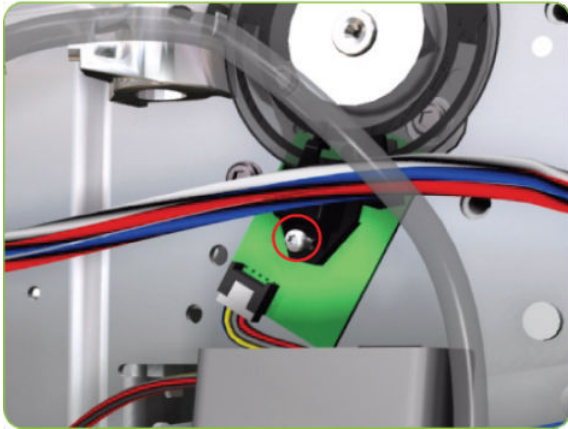

9. Remove the Encoder Sensor from the printer.

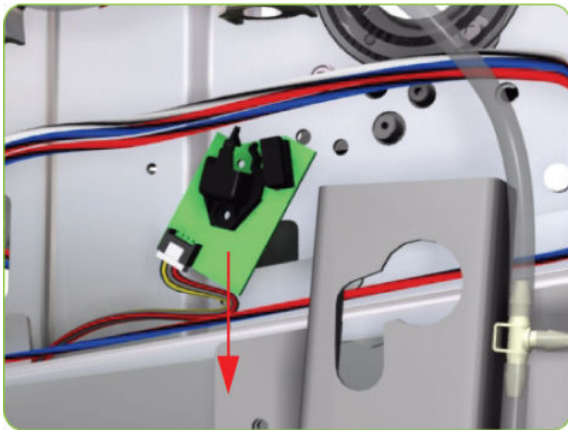

10. Carefully peel the Encoder Disc from the Drive Roller.

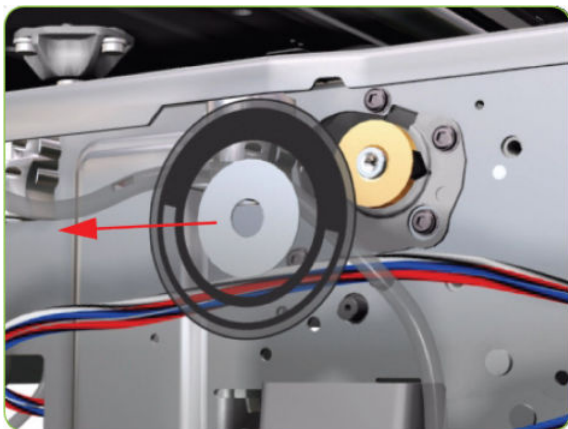

Interconnect Cables

Removal

1. Disconnect the Interconnect Cable from the Interconnect PCA.

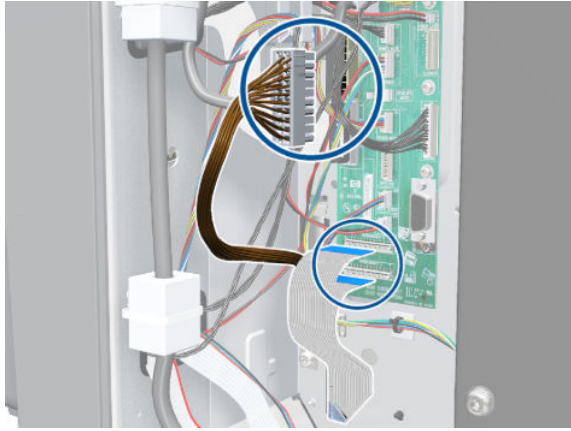

2. Disconnect the Interconnect Cable and the Interconnect Power Cable from the PrintMech PCA.

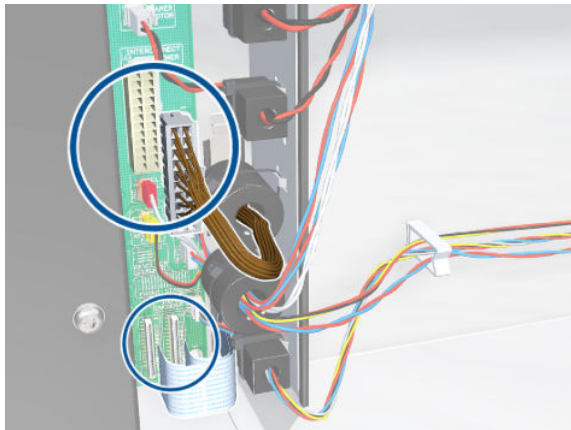

3. Unclip the seven cable holders.

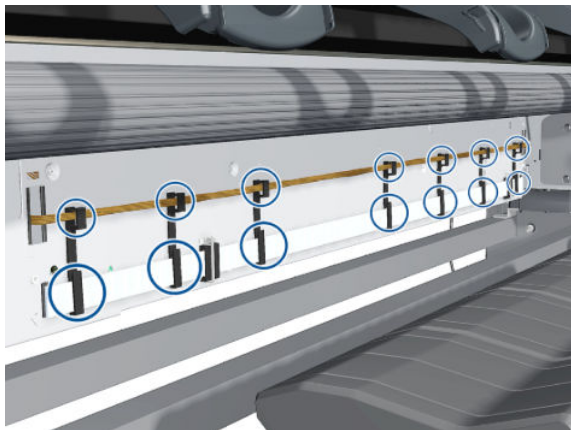

4. Remove the Interconnect Cable and the Interconnect Power Cable.

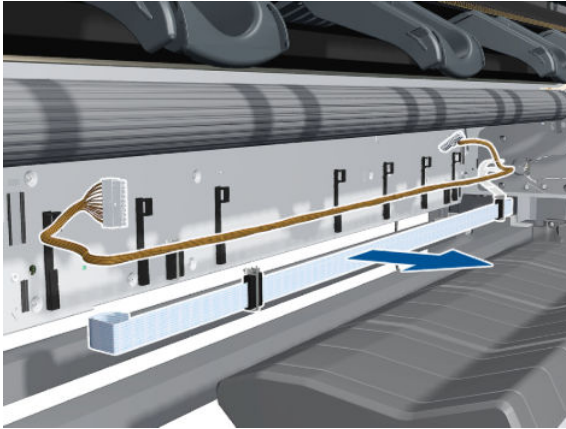

Pinchwheel Assembly

Removal

⚠ WARNING! Switch off the printer and remove the power cable.

1. Remove the Right Cover ⇒ See [Cover, Right on page 225](#).
2. Open the Rear Door.
3. Remove one T-20 screw that secures the Linkage to the Spring.

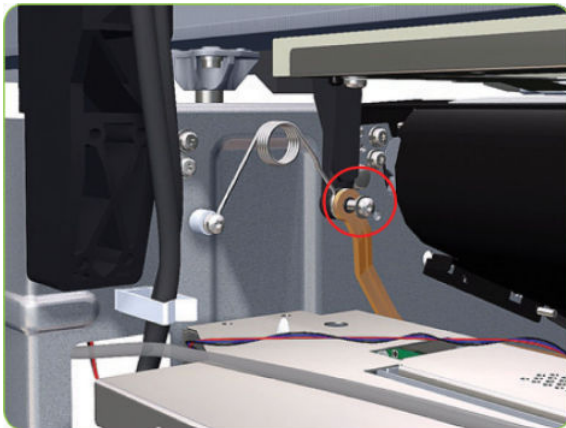

4. Disconnect the linkage from the Pinch Wheel cam-arm.

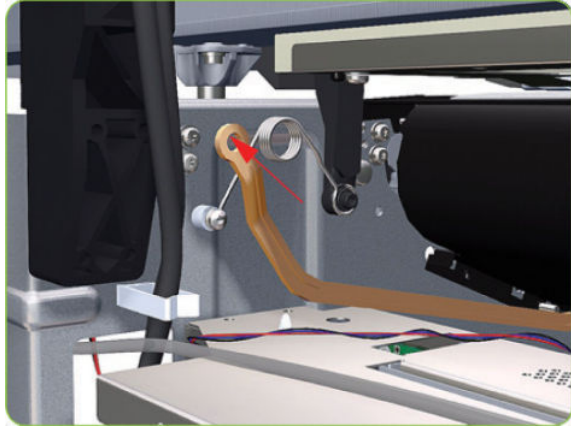

5. Disconnect the spring from the Pinch Wheel cam-arm.

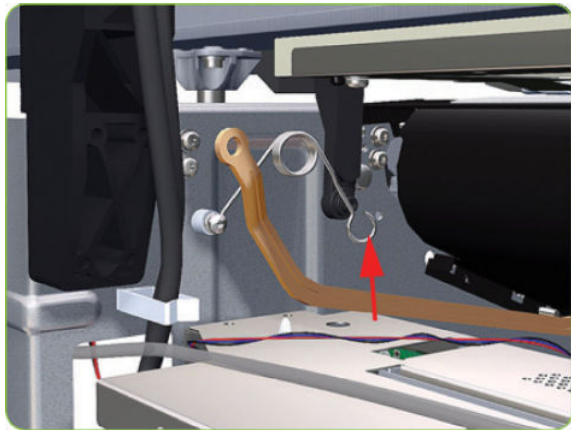

6. Remove one T-20 screw that secures the Cam to the Cam Lever.

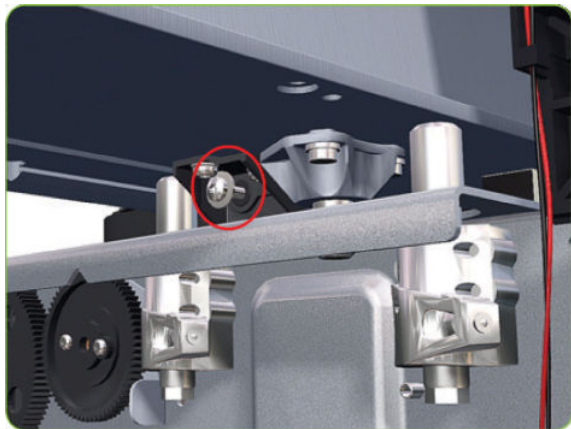

7. Insert a plastic stud into each Pinchwheel Subassembly (the Plastic Studs can be found in the replacement Pinchwheel Assembly kit).



8. Remove two T-20 screws (**Type M**) from each Pinchwheel Subassembly (a 90° screwdriver is included with the replacement Pinchwheel Assembly).

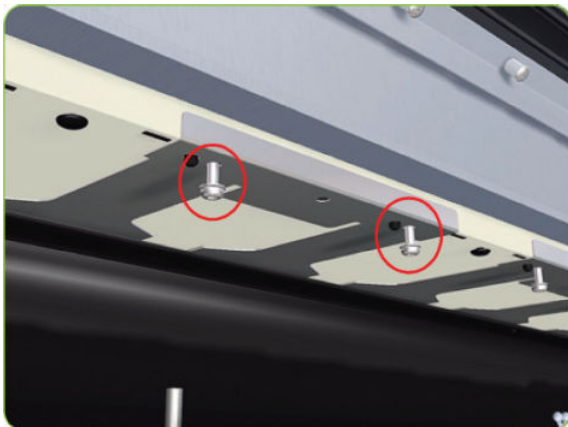

9. Remove the complete Pinchwheel Assembly (including the Cam and Cam Lever) from the printer.

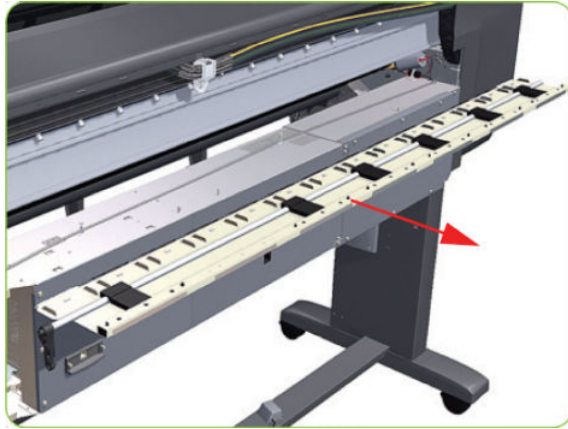

 **NOTE:** Before installing the new Pinchwheel Assembly, insert the plastic studs into each Pinchwheel subassembly. This will make it easier to install the complete Pinchwheel Assembly.

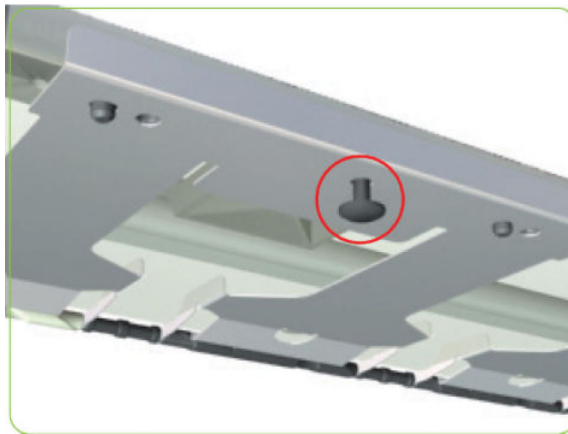

Removing individual Pinchwheel Rollers

- ▲ To remove an individual Pinchwheel roller, push apart the metal part that secures the Pinchwheel roller and then pull out the individual Pinchwheel roller.



Important Information on Installation of Pinchwheels

The Pinchwheel Assembly contains 3 white Pinchwheels and several black Pinchwheels. The black Pinchwheels are symmetrical so can be installed without any problems, BUT the white Pinchwheels are NOT symmetrical so it is VERY IMPORTANT to install them correctly using the following illustration:

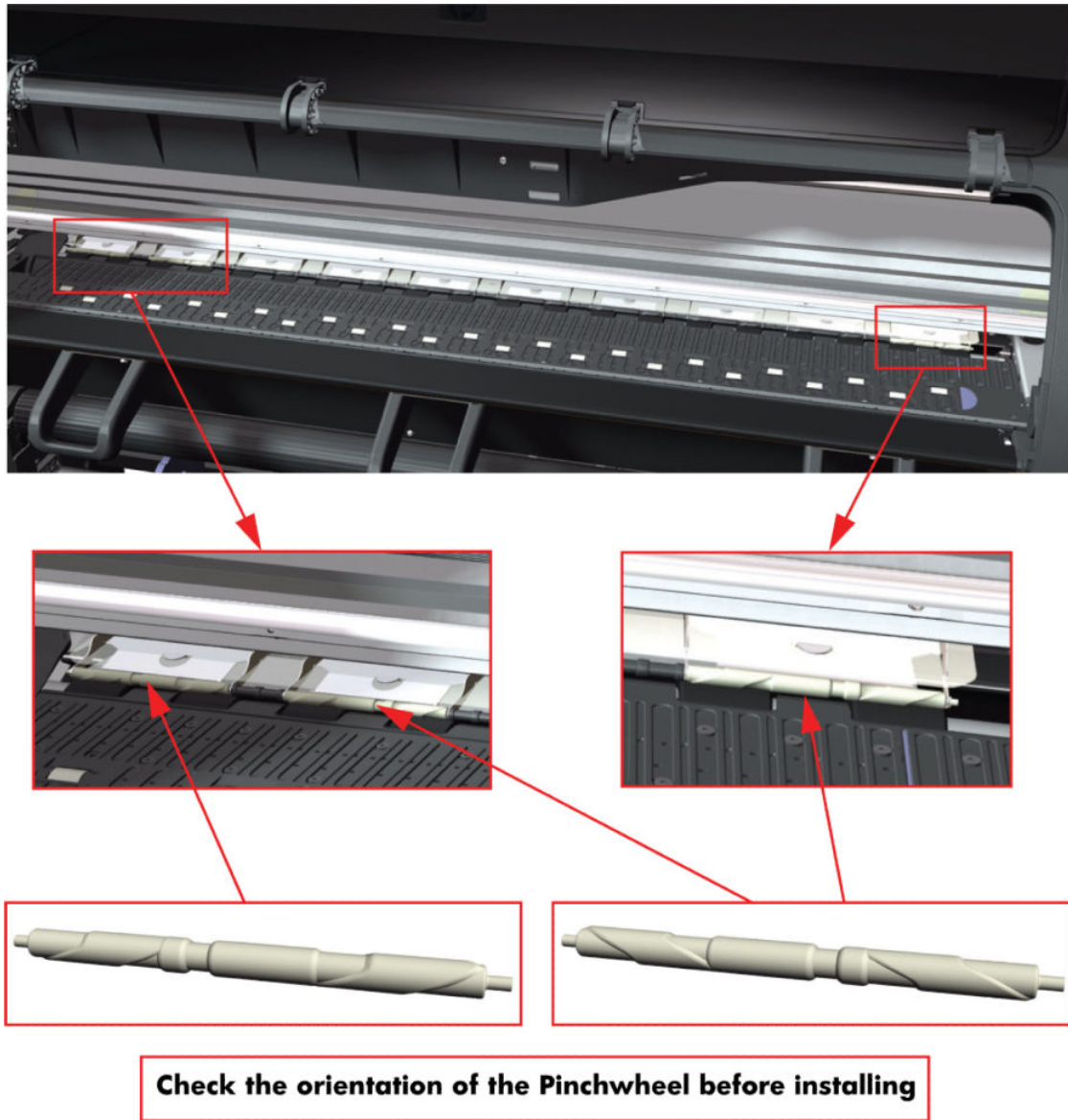

Drive Roller

Removal

⚠ WARNING! Switch off the printer and remove the power cable.

1. Remove the Right Cover ⇒ See [Cover, Right on page 225](#).
2. Remove the Left Cover ⇒ See [Cover, Left on page 228](#).
3. Remove the Right Connector Cover ⇒ See [Connector Cover, Right on page 237](#).
4. Remove the Left Connector Cover ⇒ See [Connector Cover, Left on page 238](#).

5. Remove the Service Station ⇒ See [Service Station on page 246](#).
6. Remove the Ink Supply Station ⇒ See [Ink Supply Station \(ISS\) on page 314](#).
7. Remove the Media-Axis Motor ⇒ See [Media-Axis Motor on page 330](#).
8. Remove the Encoder Disc and Sensor ⇒ See [Encoder Disc and Sensor on page 408](#).
9. Remove two T-10 screws that secure the Drive Roller Gear.

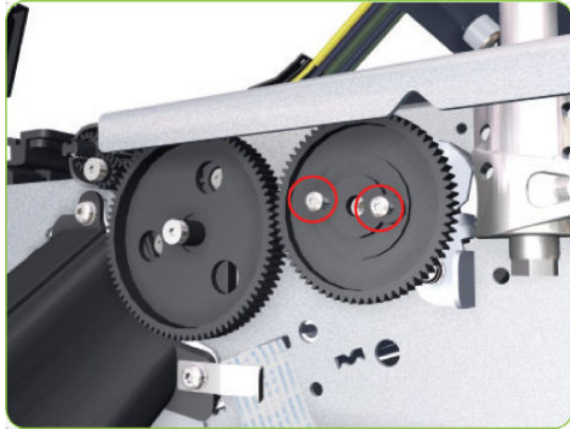

10. Remove the Drive Roller Gear from the printer.

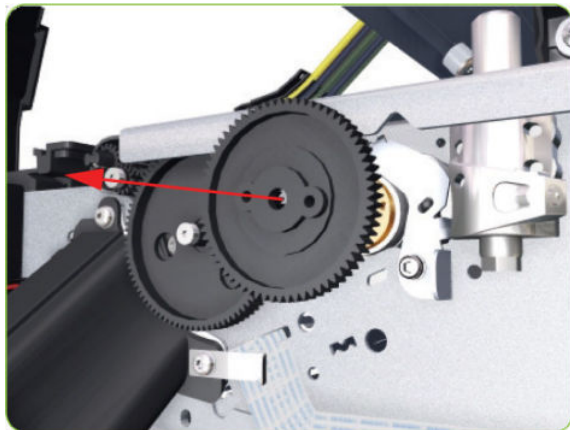

11. Remove one T-20 screw (**Type B**) that secures the cover on the right-hand side of the printer.



12. Remove the Cover.

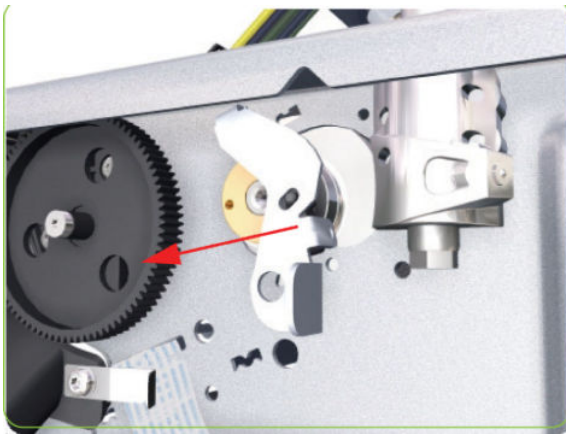

13. Remove three T-20 screws that secure the cover on the left-hand side of the printer.

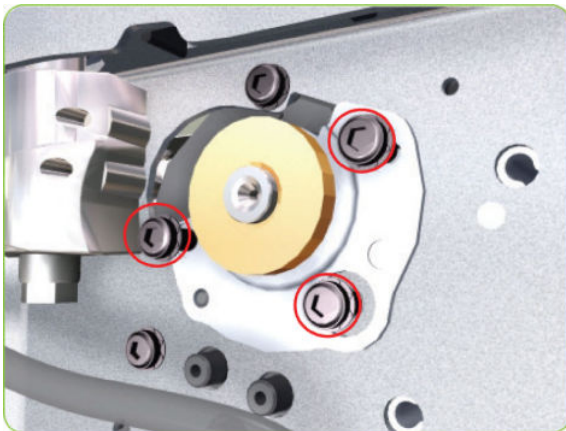

14. Remove the Cover.

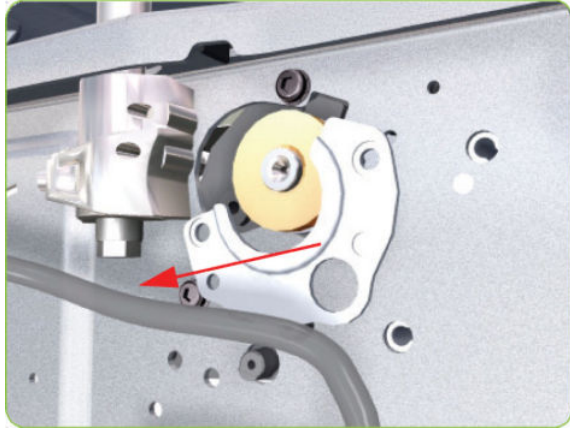

15. Remove T-20 screws that secure the Media-Axis Motor Bracket to the side-plate.

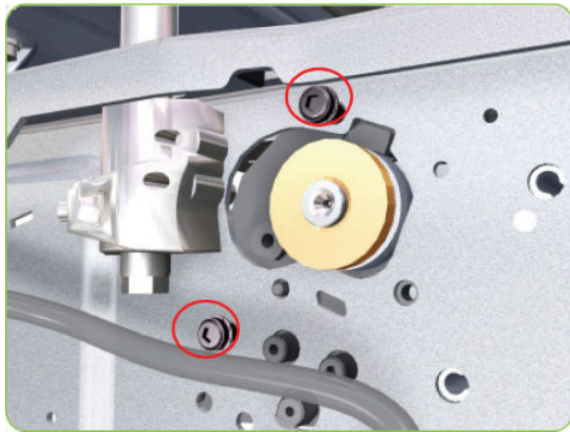

16. Remove two T-20 screws (Type A) that secure the Media-Axis Motor Bracket to the Chassis.

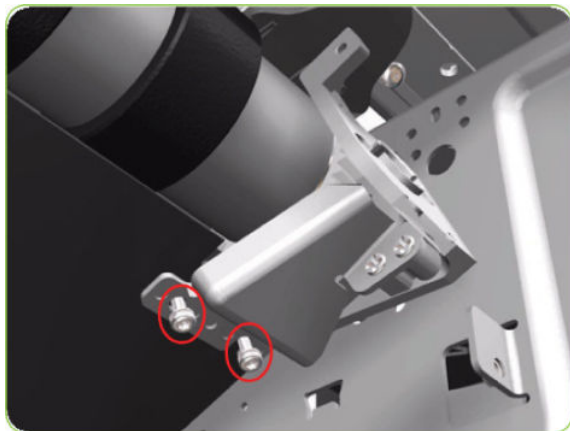

17. Remove the Media-Axis Motor Bracket from the printer.

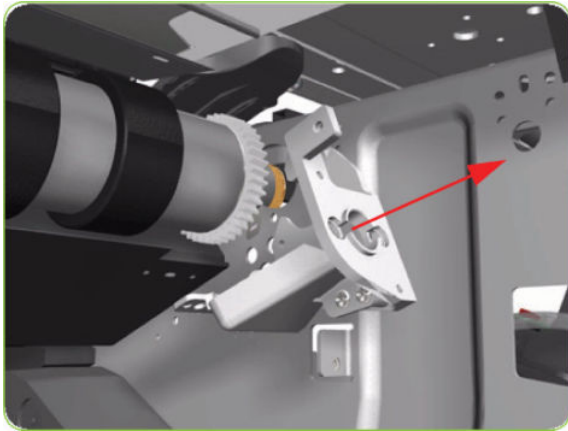

18. Remove the Drive Roller by sliding it to the right, then downwards and then out of the printer.

 **NOTE:** When reinstalling the parts, make sure you apply the grease (included with the support part) to the gears.

 **NOTE:** After installing the new Drive Roller, make sure you perform the following Service Calibration.

- Paper-advance Calibration ⇒ [Paper-advance calibration on page 121](#).

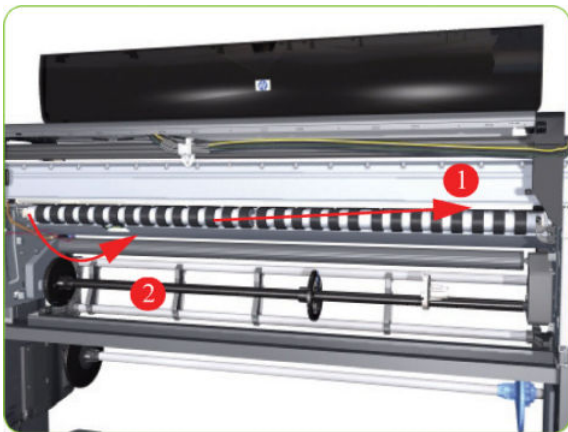

Installation of the Drive Roller

When installing the Drive Roller, several different datums have to be met in order to ensure that the Drive Roller has no axial play. Use the following illustrations to ensure that ALL the datums are met:

Figure 9-1 Left-Hand Side of the printer

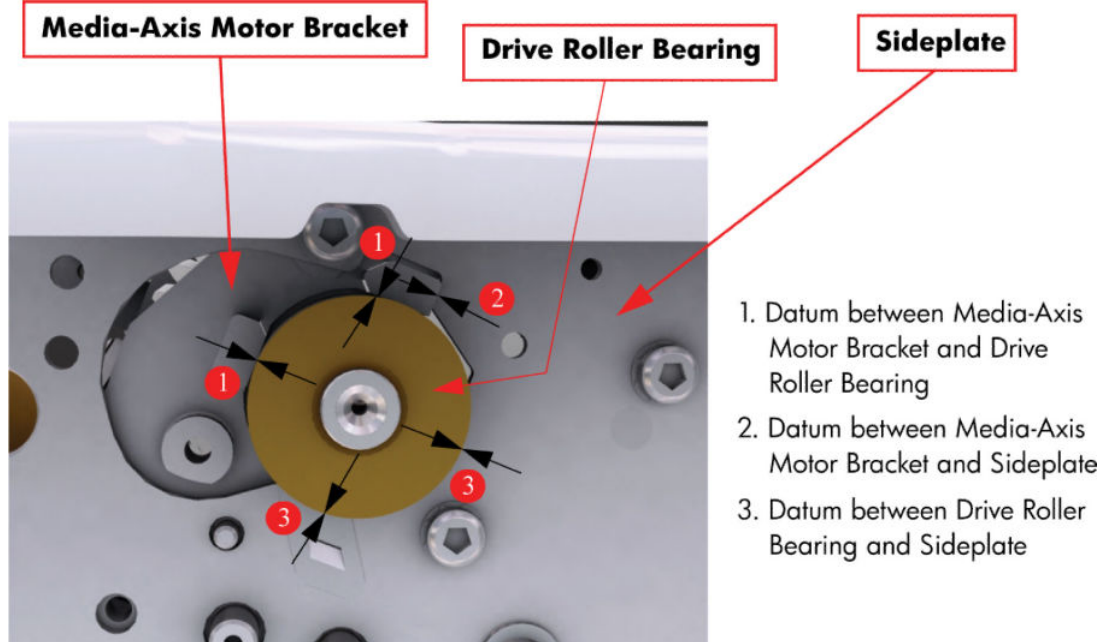
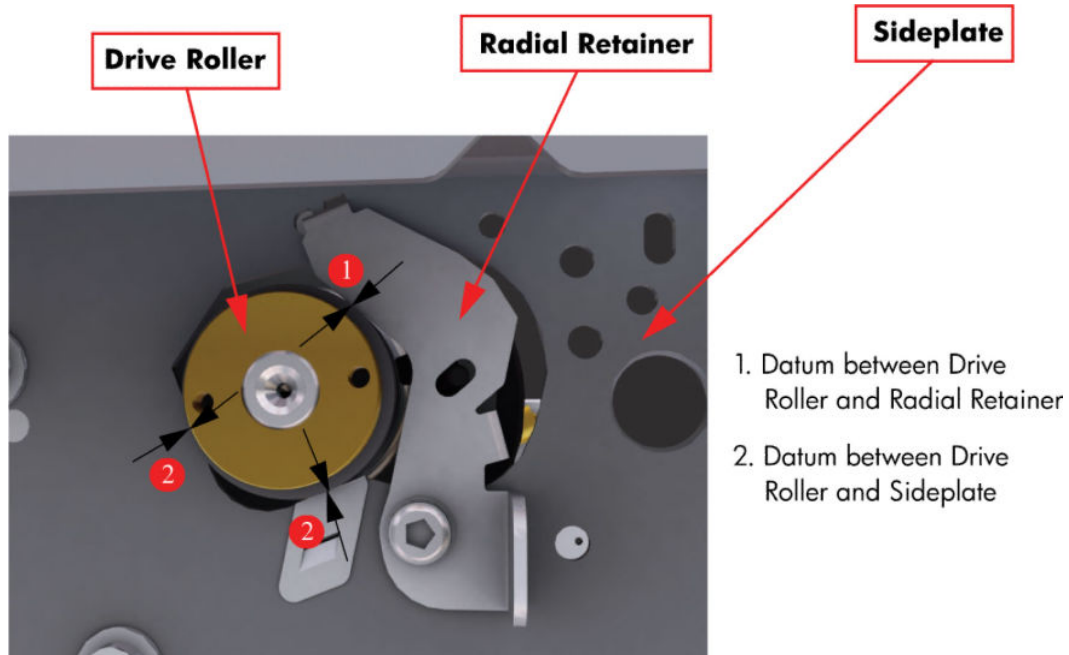
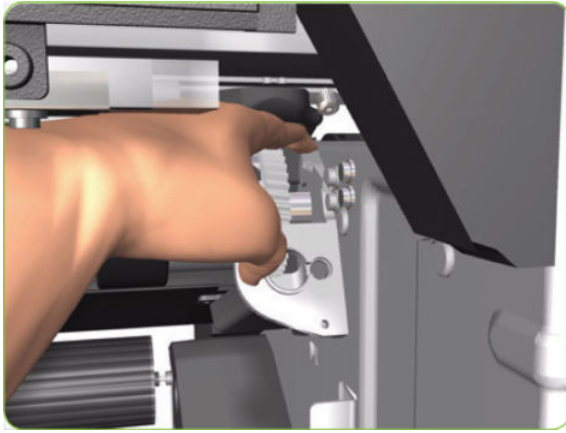

Figure 9-2 Right-Hand Side of the printer



To make sure that ALL the datums are met when installing the Media-Axis Motor Bracket, make sure you follow these

1. Place the Media-Axis Motor Bracket in the correct position on the printer. Make sure you keep it pushed down (as shown in the illustration) until the first screw has been installed and fully tightened.



2. Install the first screw (T-15) in the position shown. Make sure you tighten the screw fully so that the Media-Axis Motor Bracket cannot be moved.



3. Check that there is no play (movement) between the Media-Axis Motor Bracket and the Drive Roller. If there is play, then check that the screw installed in the previous step is fully tightened.

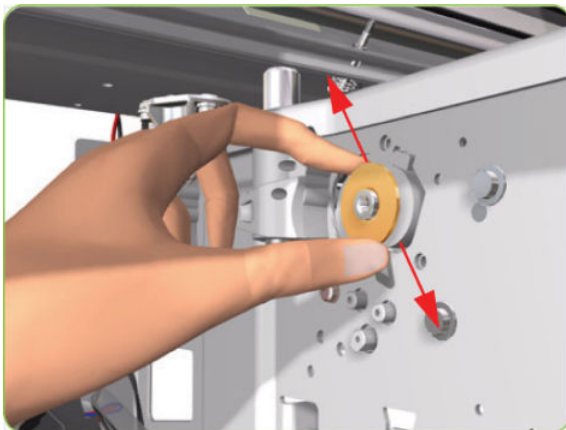

4. Install the remaining two screws (T-15) that secure the Media-Axis Motor Bracket.

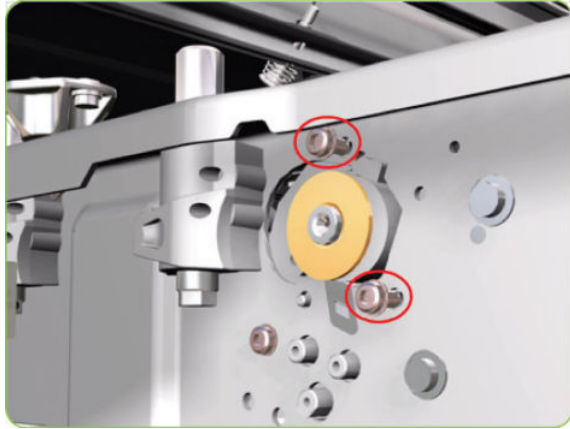

10 Stacker part removal and installation

This chapter is a step-by-step guide to the removal and installation of the key components in the stacker.

- [Right Cover](#)
- [Left Cover](#)
- [Top Cover](#)
- [Lower Front Cover](#)
- [Pinchwheels](#)
- [Drive Motor](#)
- [Front Cover Sensor](#)
- [Safety Temperature Sensor](#)
- [Temperature Sensor PCA](#)
- [Media Sensor](#)
- [Extension Tray](#)
- [Receiving Tray](#)
- [Printer Interlocks](#)
- [Paper Infeed Platen](#)
- [Electronics PCA](#)
- [Power Supply Unit](#)
- [Heating Lamp](#)
- [Heat Roller](#)
- [Transport Belt](#)

Right Cover

Removal

1. Switch off the stacker and remove the power cable.
2. Open the Front Cover.



3. Remove one screw that secures the Right Cover.



4. Remove one screw that secures the Right Cover from the rear of the printer.



5. Remove one screw that secures the Right Cover from underneath at the rear.



6. Remove the LED from inside the Right Cover.

 **TIP:** Use a flat-ended screwdriver to prise off the plastic holder securing the LED to the inside of the Right Cover.



7. Remove the Right Cover.

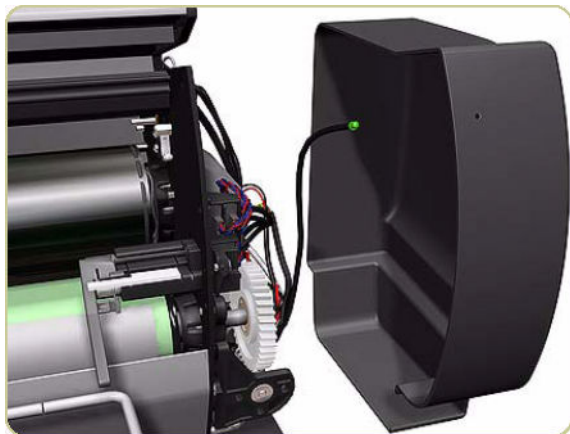

Left Cover

Removal

1. Switch off the stacker and remove the power cable.
2. Open the Front Cover.



3. Remove one screw that secures the Left Cover.



4. Remove one screw that secures the Left Cover from the rear.



5. Remove one screw that secures the Left Cover from underneath at the rear.

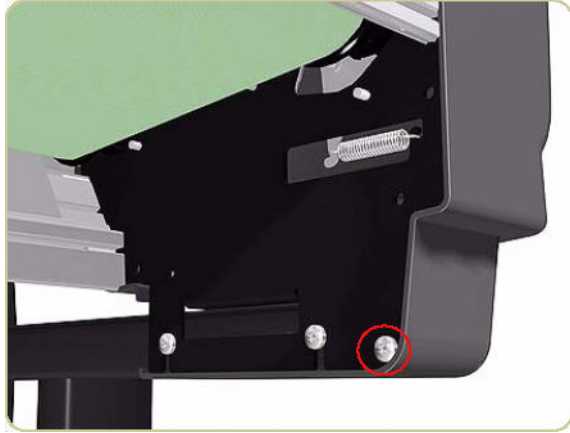

6. Remove the Left Cover.

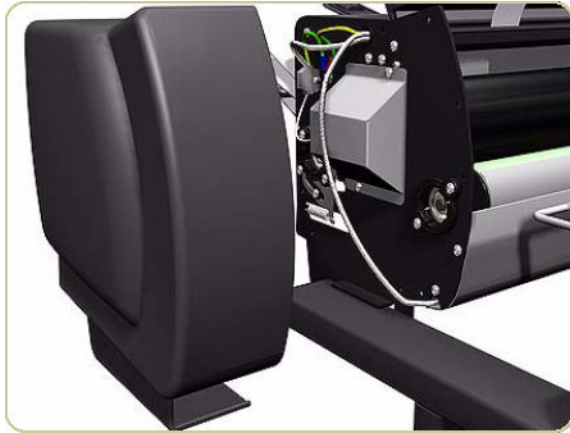

Top Cover

Removal

1. Remove the Right Cover ⇒ [Right Cover on page 426](#).
2. Remove the Left Cover ⇒ [Left Cover on page 428](#).

3. Remove two screws that secure the Temperature Sensor Plate.

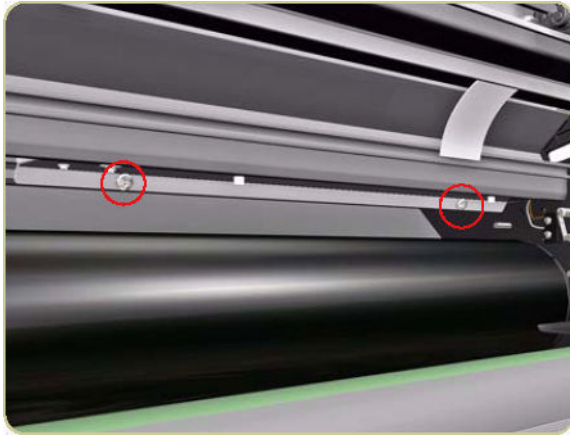

4. Pull down the Temperature Sensor Plate.



5. Remove two screws that secure the Safety Temperature Sensor Bracket from the left side of the chassis.

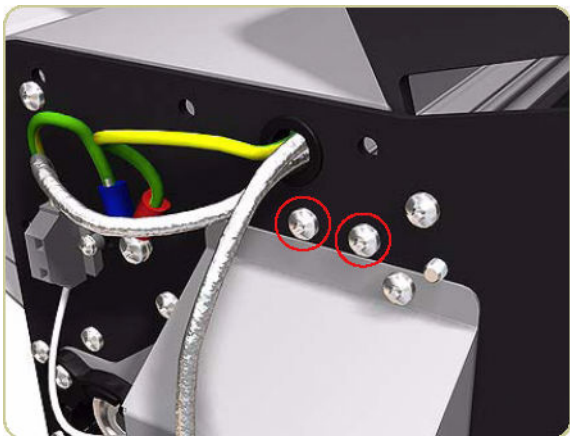

6. Loosen one screw that secures the top of the Left Heating Lamp Cover.

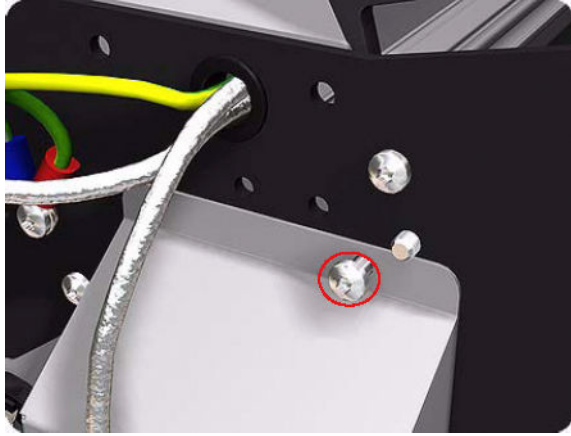

7. Slide down the Safety Temperature Sensor Bracket.

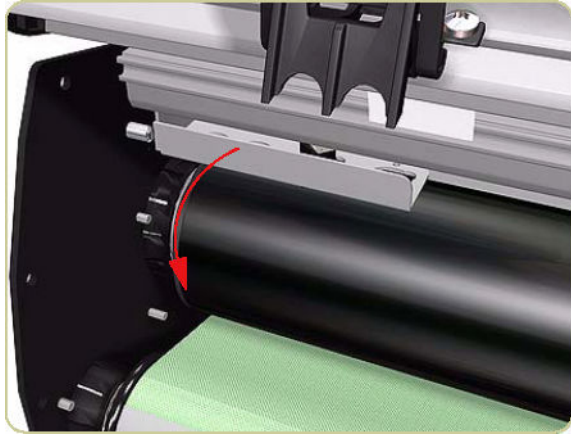

8. Remove three screws that secure the Top Cover from the right side.

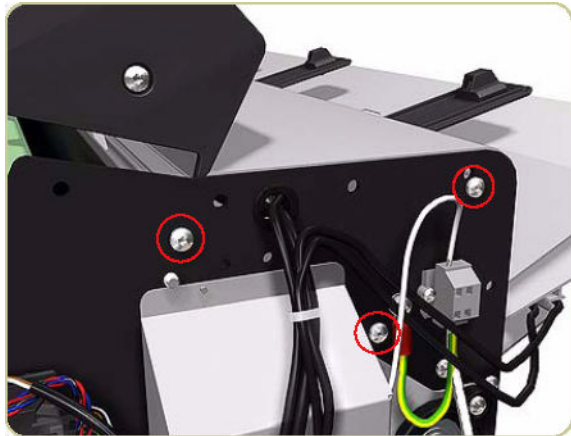

9. Remove three screws that secure the Top Cover from the left side.

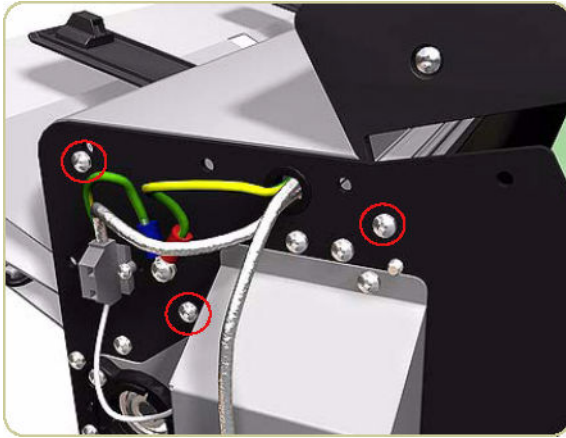

10. Remove the Top Cover with the Front Cover.



Lower Front Cover

Removal

1. Remove the Right Cover ⇒ [Right Cover on page 426](#).
2. Remove the Left Cover ⇒ [Left Cover on page 428](#).
3. Remove the Drive Motor ⇒ [Drive Motor on page 439](#).

4. Remove six screws that secure the top of the Electronics Module to the chassis.



5. Pull the Electronics Module down.



6. Remove two screws that secure the Electronics Module Cover.



7. Remove the Electronics Module Cover.

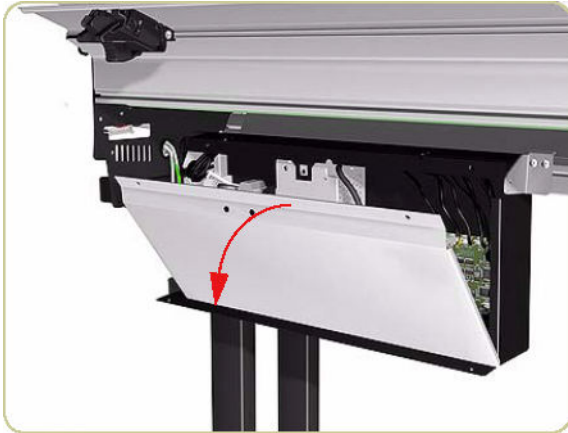

8. Disconnect the cable on the left of the Power Supply Unit by pushing down with an Allen key and releasing the cable.

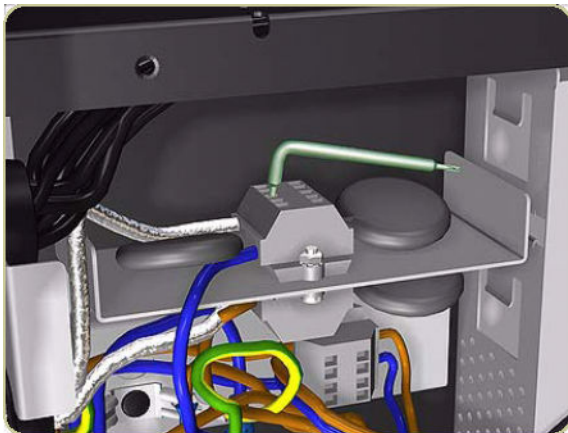

9. Remove the cable from the Electronics Module.

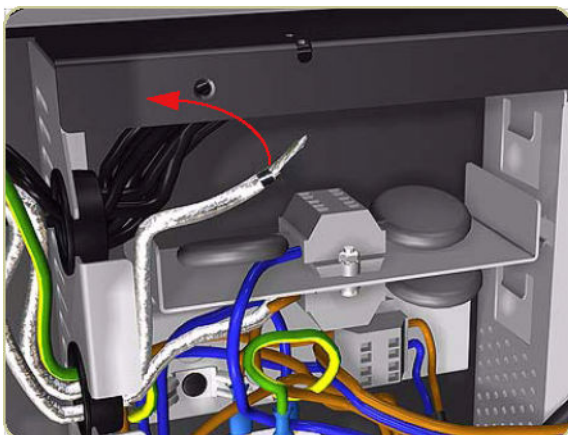

10. Push the cable back inside the Lower Front Cover.

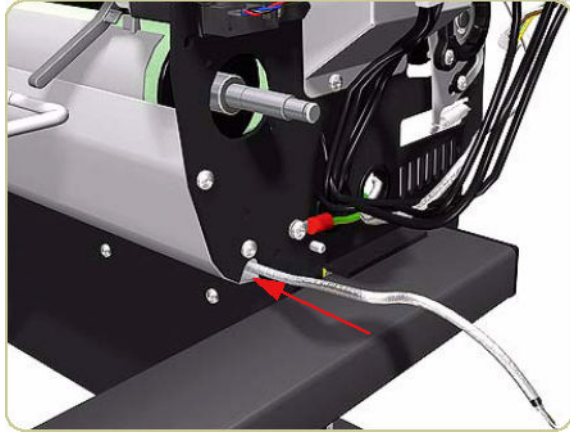

11. Pull the cable from the Lower Front Cover on the left side of the stacker.

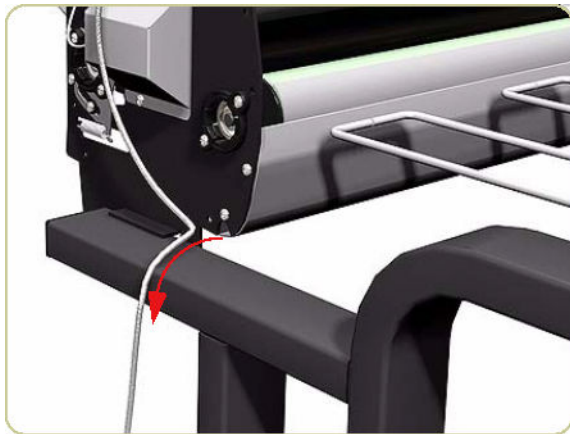

12. Remove two screws that secure the Right Hinge of the Electronics Module.

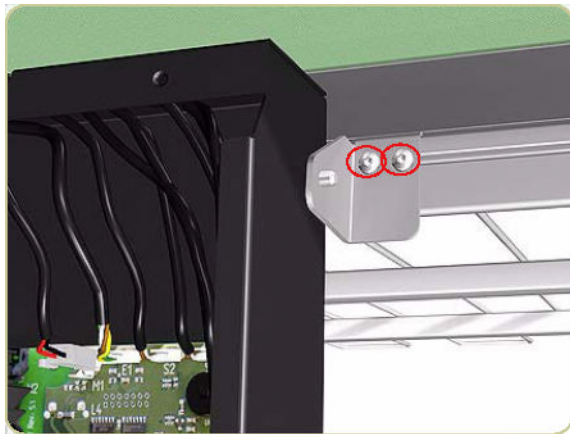

13. Remove the Right Hinge.

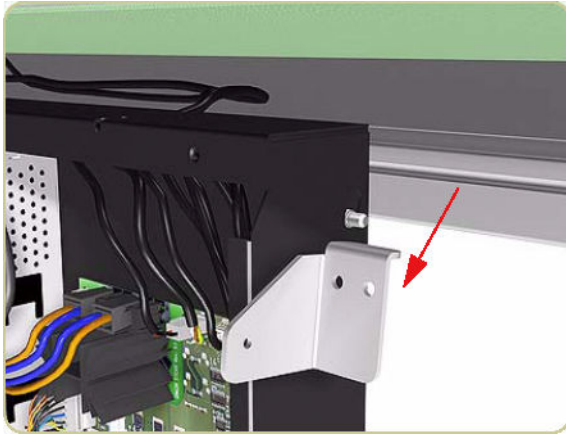

14. Slide down the right side of the Electronics Module.

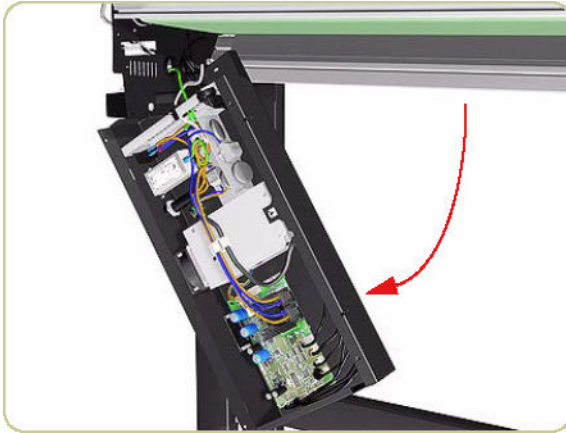

15. Remove two screws that secure the Lower Front Cover from the right side of the stacker.



16. Remove two screws that secure the Lower Front Cover from the left side of the stacker.

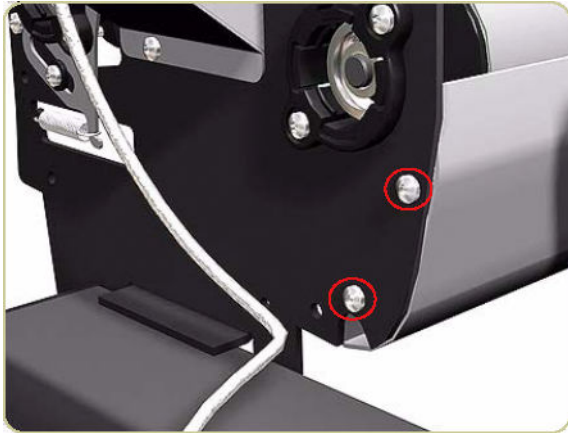

17. Remove the Lower Front Cover.

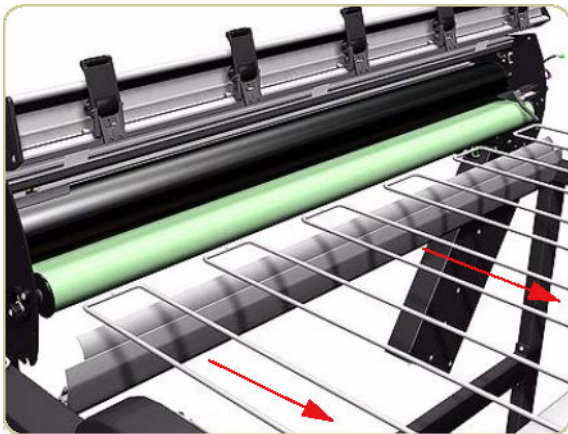

Pinchwheels

Removal

1. Switch off the stacker and remove the power cable.
2. Open the Front Cover.



3. Loosen one screw on the left side of the Pinchwheel.



4. Loosen one screw on the right side of the Pinchwheel.



5. Rotate the bottom of the Pinchwheel slightly.

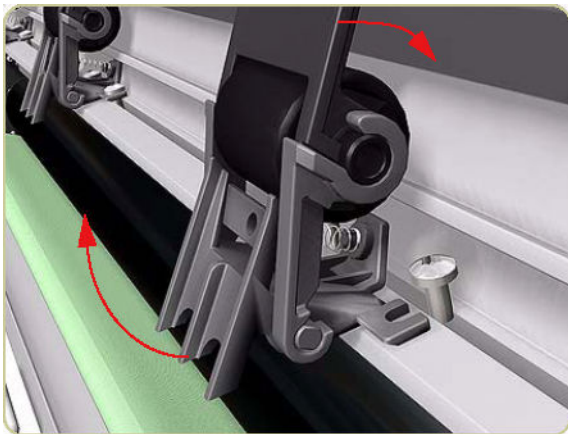

6. Remove the Pinchwheel.

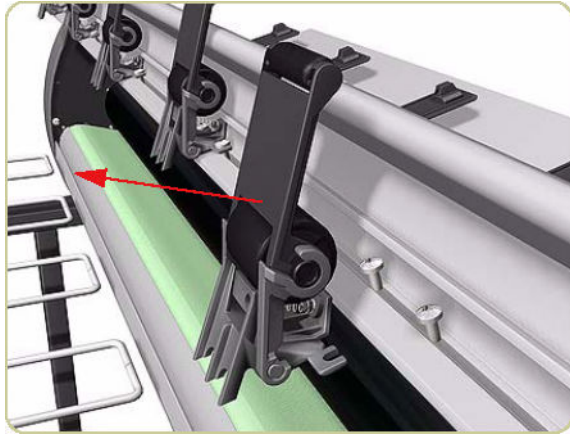

Drive Motor

Removal

1. Remove the Right Cover ⇒ [Right Cover on page 426](#).
2. Disconnect two cables from the Drive Motor.

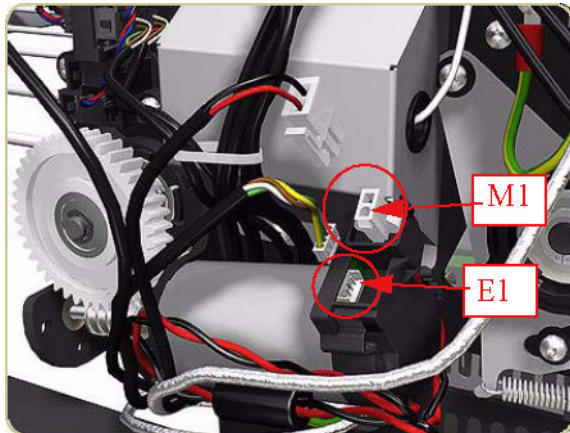

3. Remove an E-clip from the Drive Gear.

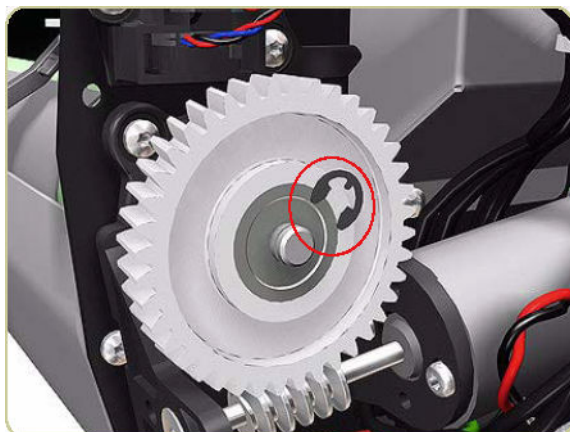

4. Remove the Drive Gear.

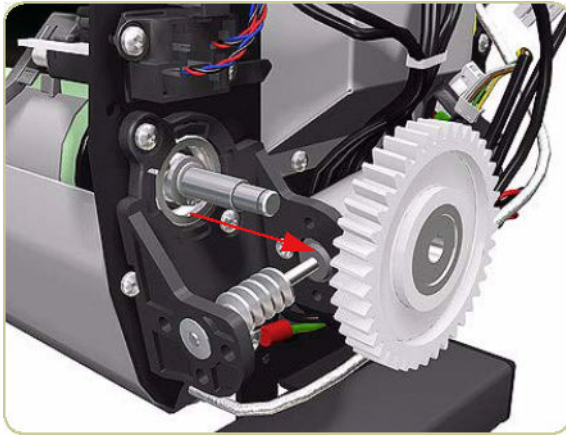

5. Remove four screws that secure the Driver Motor Assembly.

 **NOTE:** One screw is hidden below the Drive Motor behind cables; this screw also secures an ESD clip to the stacker.

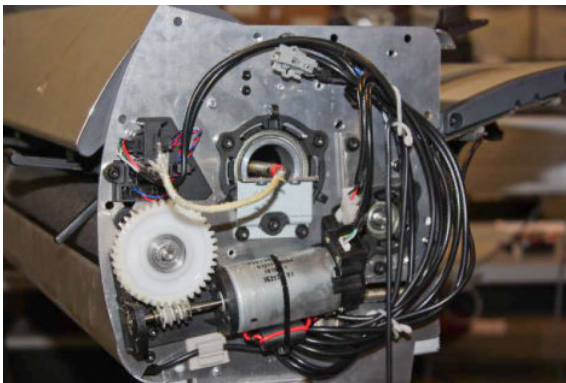

6. Remove the Drive Motor.

 **TIP:** Use a flat-ended screwdriver to prise the Drive Motor away from the right end of the stacker.

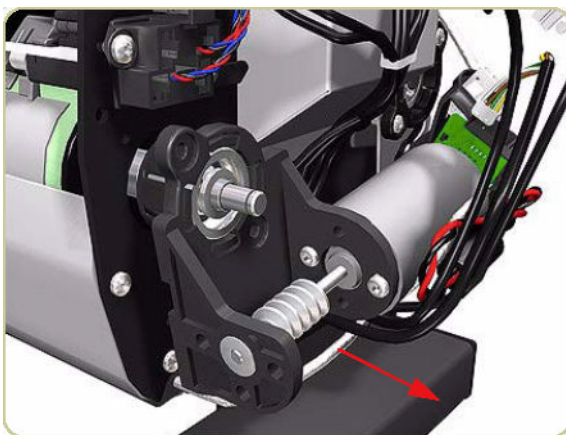

Front Cover Sensor

Removal

1. Switch off the stacker and remove the power cable.
2. Open the Front Cover.



3. Remove two screws that secure the Temperature Sensor Plate.

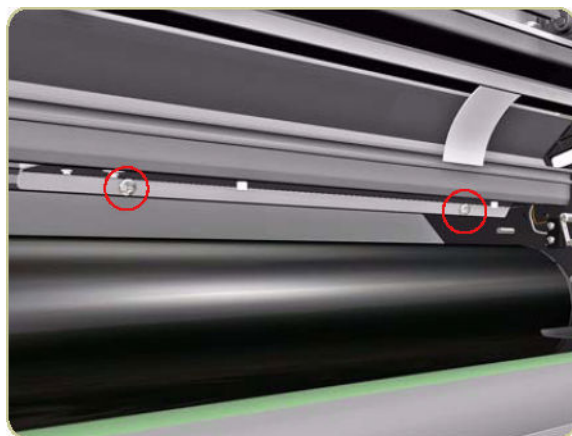

4. Slide down the Temperature Sensor Plate.



5. Disconnect the cable from the Front Cover Sensor.

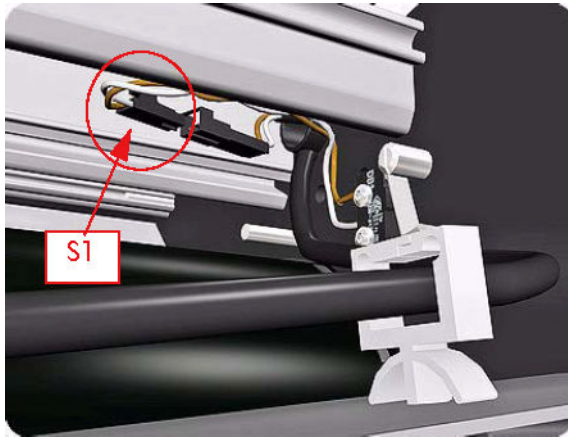

6. Remove two screws that secure the Front Cover Sensor.

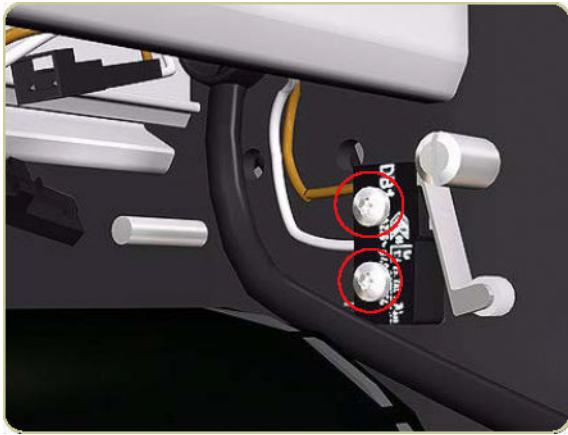

7. Remove the Front Cover Sensor.

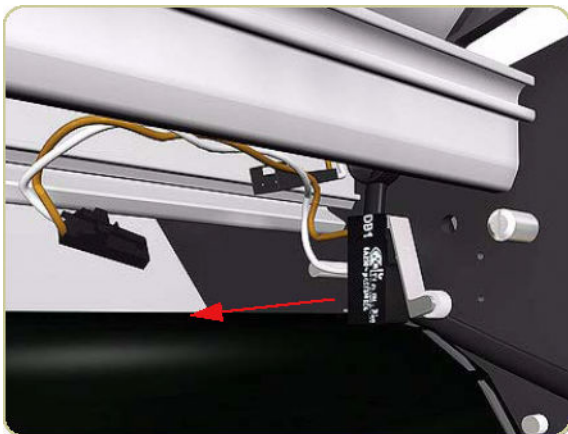

Safety Temperature Sensor

Removal

1. Remove the Left Cover ⇒ [Left Cover on page 428](#).

2. Remove two screws that secure the Safety Temperature Sensor Bracket from the left side of the chassis.

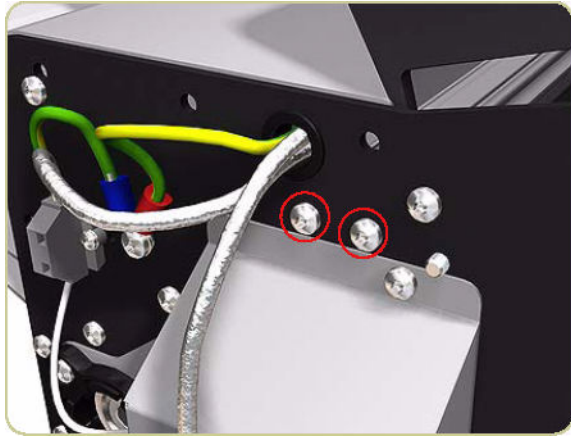

3. Loosen one screw that secures the top of the Left Heating Lamp Cover.

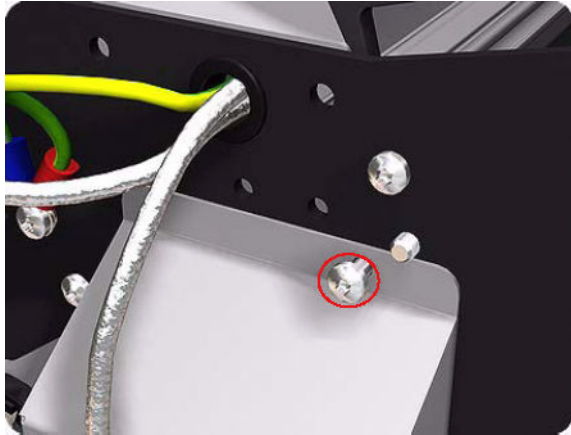

4. Slide down the Safety Temperature Sensor Bracket.

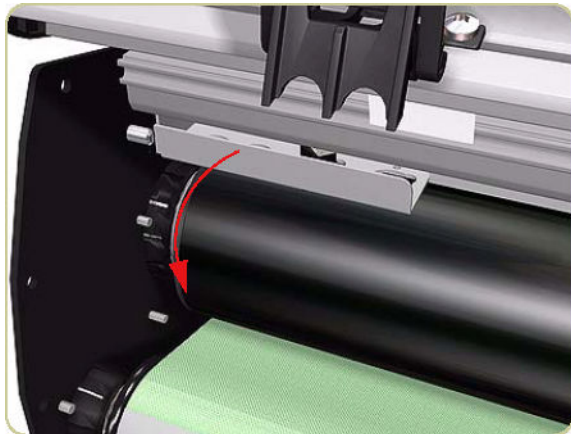

5. Disconnect the cables from the Safety Temperature Sensor.

 **NOTE:** When removing or installing the Safety Temperature Sensor, take care not to damage the surface of the Heat Roller.

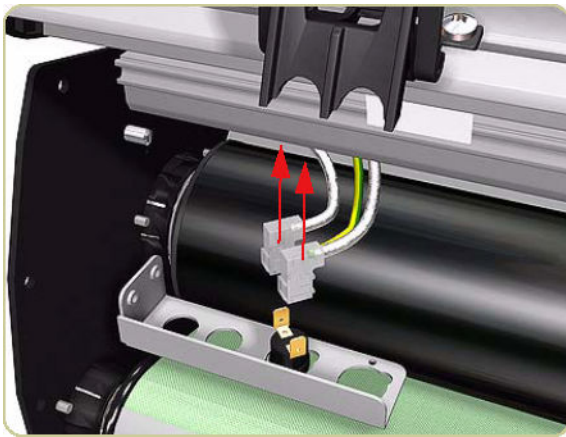

Temperature Sensor PCA

Removal

1. Switch off the stacker and remove the power cable.
2. Open the Front Cover.

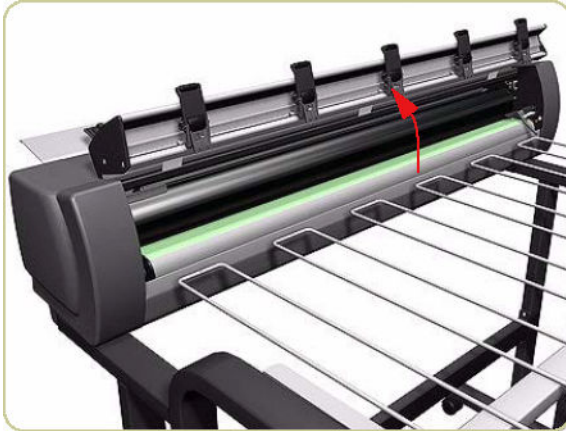

3. Remove two screws that secure the Temperature Sensor Plate.

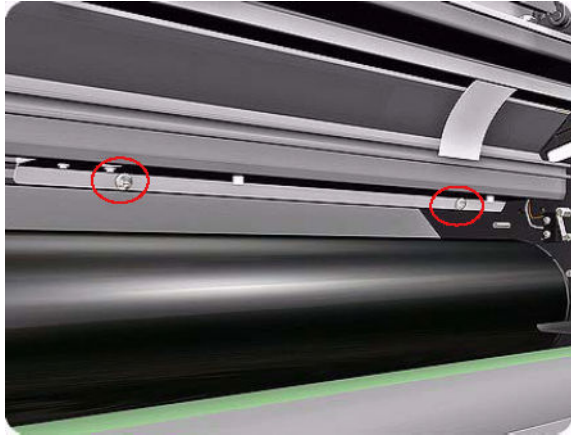

4. Slide the Temperature Sensor Plate down.

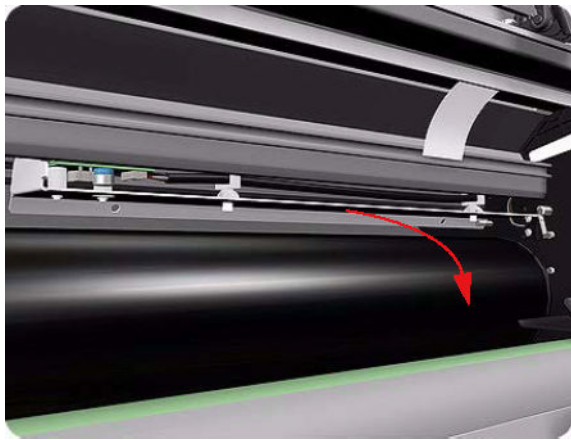

5. Turn the Temperature Sensor Plate over.

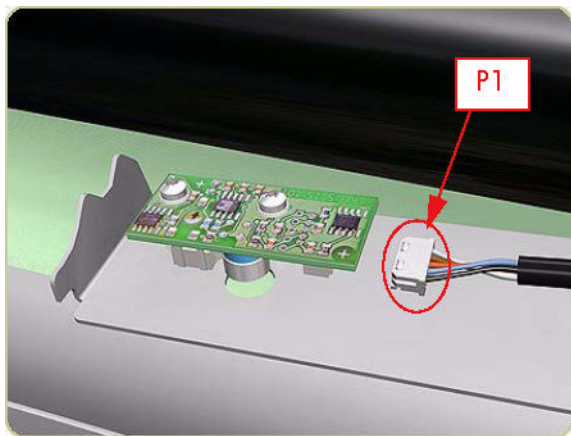

6. Disconnect the cable from the Temperature Sensor PCA.

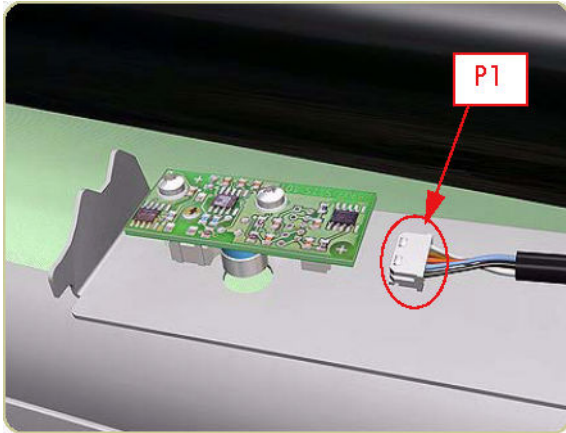

7. Loosen two screws that secure the Temperature Sensor PCA.

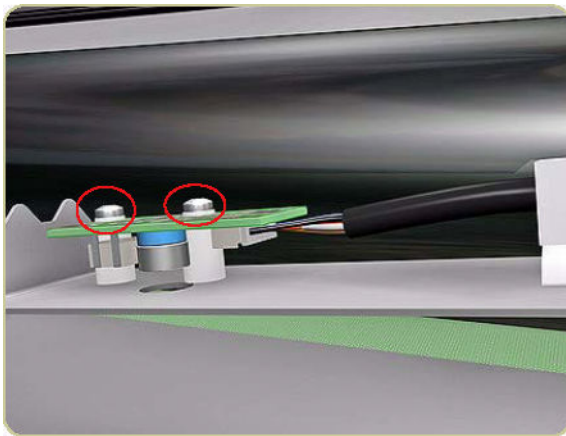

8. Remove the Temperature Sensor PCA.

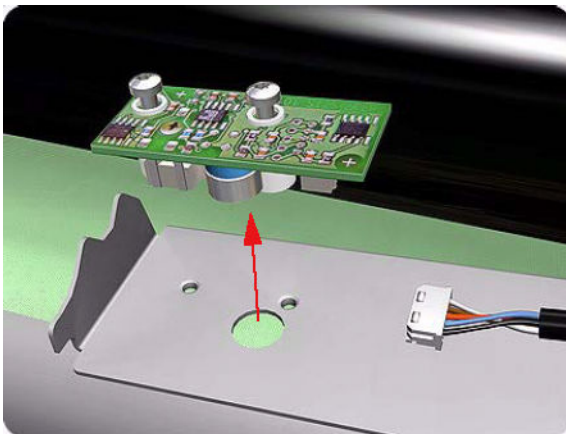

Media Sensor

Removal

1. Remove the Right Cover ⇒ [Right Cover on page 426](#).
2. Disconnect the cables from the Media Sensor on the right side of the stacker.

 **NOTE:** When you reinstall the Media Sensor, it is important to connect the cables correctly. The cable marked LS2 is closest to you, the cable marked LS1 is closest to the stacker.

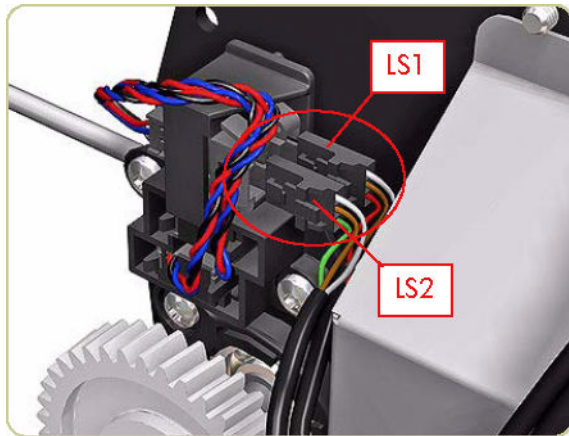

3. Remove two screws that secure the Media Sensor.

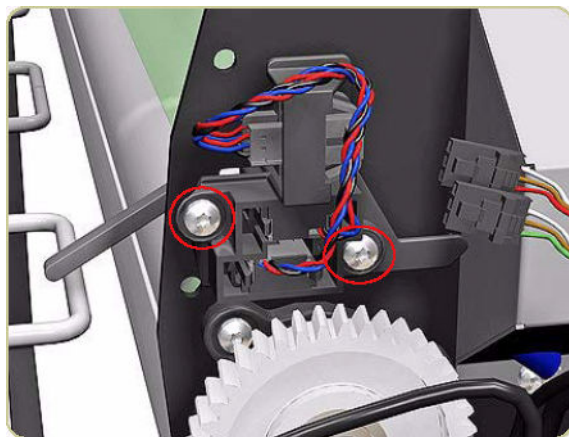

4. Slide the Media Sensor to the right.

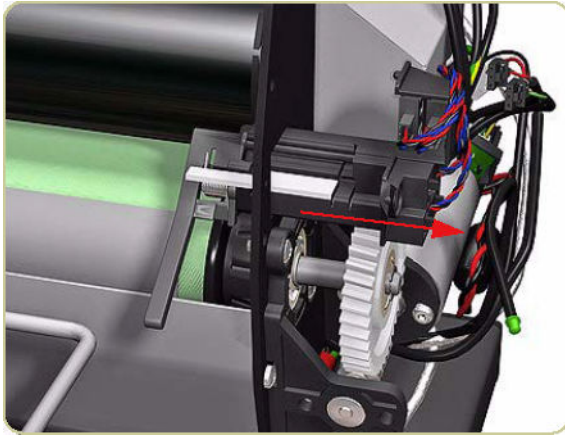

5. To enable you to pass the Media Sensor through the hole in the chassis, you have to push up the Media Jam Lever (shown in green).

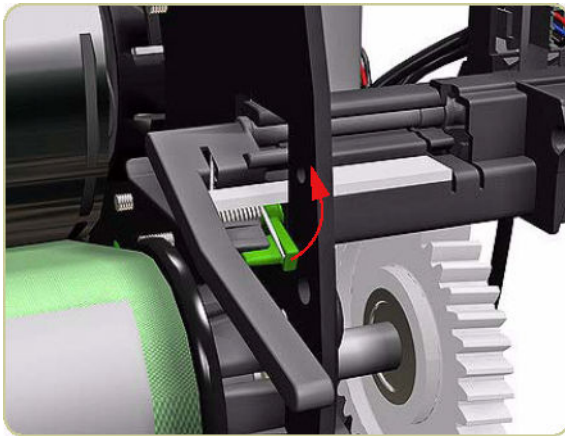

6. Carefully pass the Media Sensor out through the hole by slightly turning the sensor horizontally.

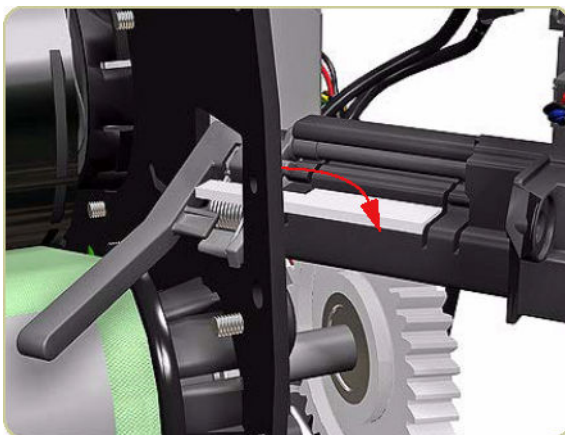

7. Remove the Media Sensor.



Extension Tray

Removal

1. Switch off the stacker and remove the power cable.
2. Make sure the Extension Tray is in the Up position.



3. Remove one wing screw from each side of the Extension Tray.



4. Pull out the Extension Tray.

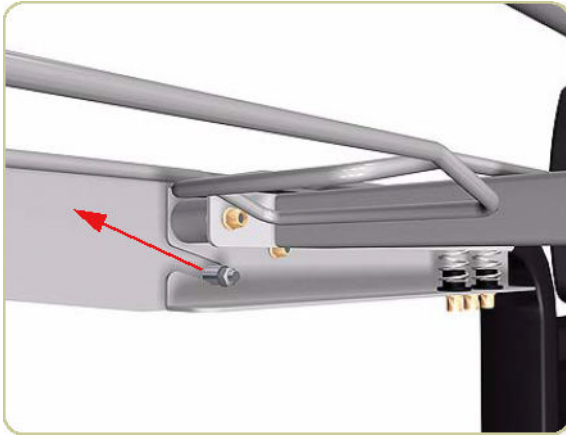

5. Remove the Extension Tray.



Receiving Tray

Removal

1. Remove the Extension Tray ⇒ [Extension Tray on page 449](#).

2. Remove two screws and a bearing from each side of the stacker

 **NOTE:** The stacker has only one spring here, and not two as shown in these illustrations.



3. Loosen two wing screws each side of the stacker.



4. Pull out each side of the Receiving Tray.



5. Remove the Receiving Tray.

 **NOTE:** When removing and installing the Receiving Tray, make sure you do not damage the Media Sensor.

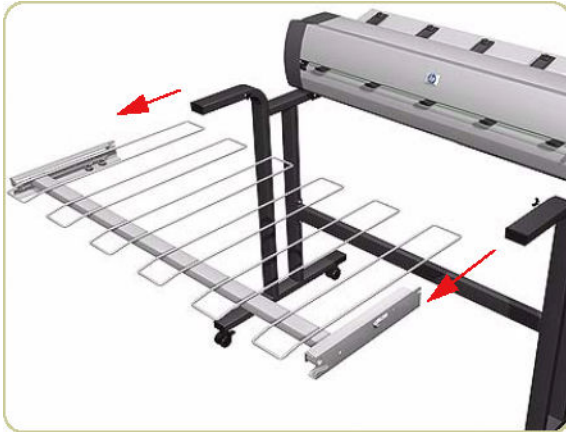

Printer Interlocks

Removal

1. Remove the Right Cover ⇒ [Right Cover on page 426](#).
2. Remove the Left Cover ⇒ [Left Cover on page 428](#).
3. Remove two screws that secure each side of the two Printer Interlocks.

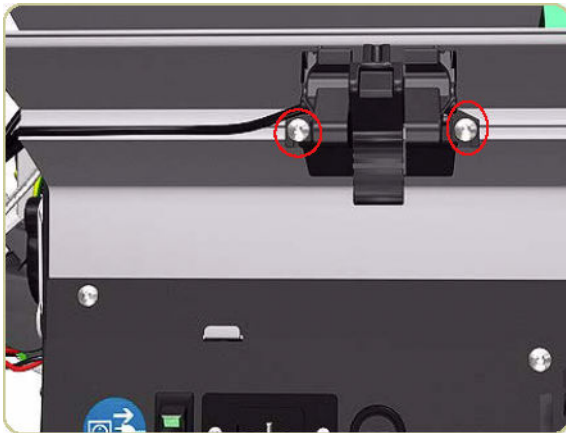

4. Remove the two Printer Interlocks.



5. Remove the Printer Interlock Sensor from the Right Printer Interlock.

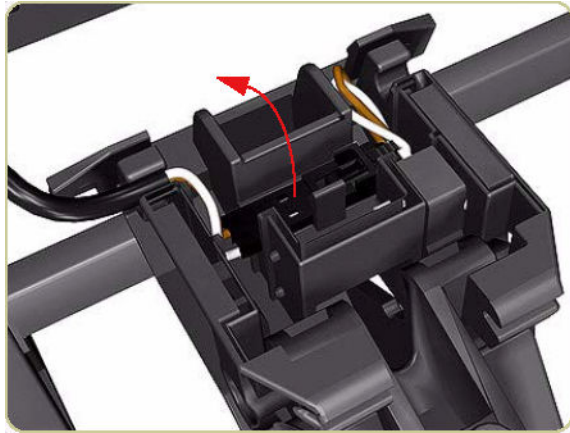

6. Disconnect the cable from the Right Printer Interlock.

 **NOTE:** Only the Right Printer Interlock contains a sensor and cable. When reinstalling the Printer Interlocks, make sure they are installed in the same position as when they were removed.

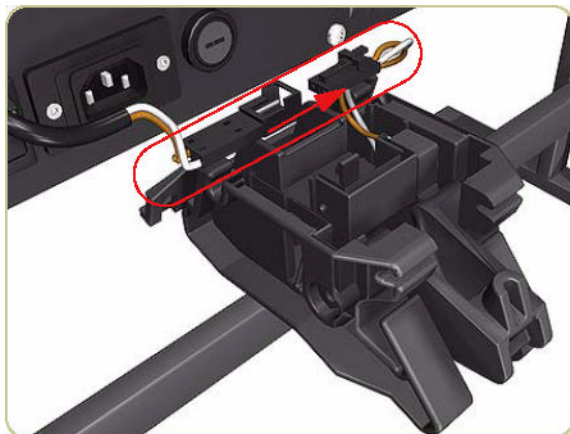

Paper Infeed Platen

Removal

1. Remove the Printer Interlocks ⇒ [Printer Interlocks on page 452](#).
2. Remove three screws that secure the right side of the Paper Infeed Platen.

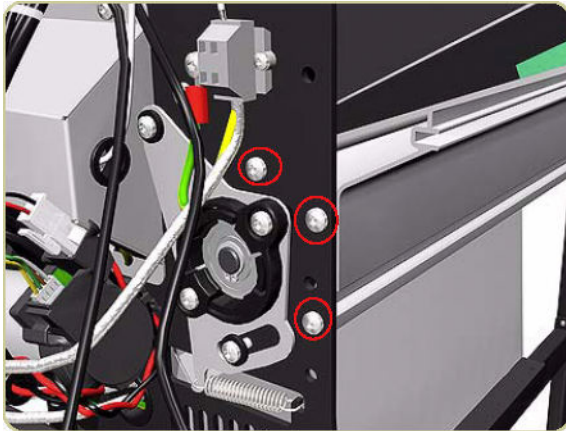

3. Remove three screws that secure the left side of the Paper Infeed Platen.



4. Remove the Paper Infeed Platen.



Electronics PCA

Removal

1. Switch off the stacker and remove the power cable.
2. Remove six screws that secure the top of the Electronics Module to the chassis.



3. Pull the Electronics Module down.



4. Remove eight screws that secure the Electronics Module Cover.



5. Remove the Electronics Module Cover.

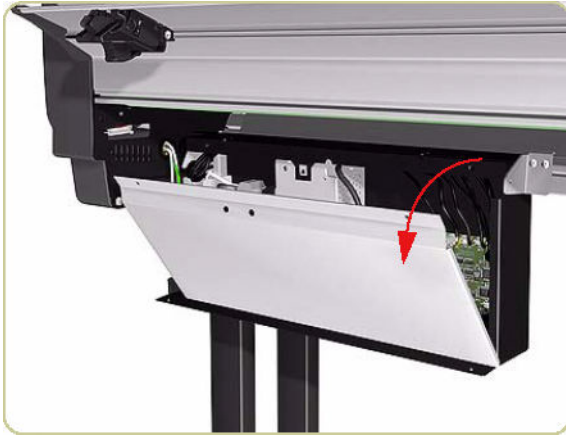

6. Disconnect all cables from the Electronics PCA.



7. Remove two screws that secure the Electronics Module Power Connector.

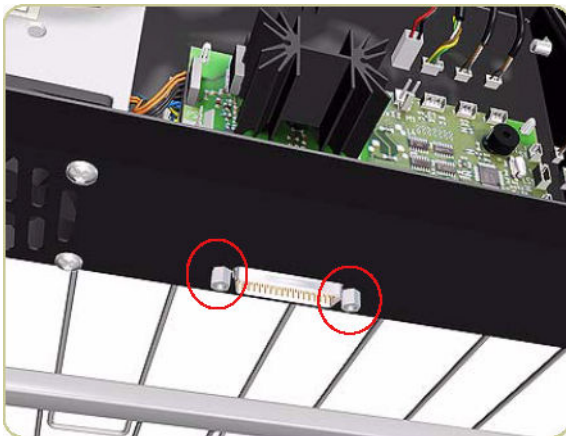

8. Release the Electronics PCA from four plastic locating pins.

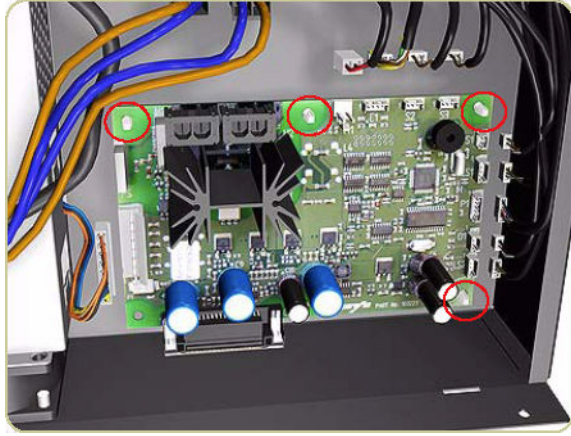

9. Remove the Electronics PCA.



Power Supply Unit

Removal

1. Switch off the stacker and remove the power cable.

2. Remove six screws that secure the top of the Electronics Module to the chassis.



3. Pull the Electronics Module down.



4. Remove eight screws that secure the Electronics Module Cover



5. Remove the Electronics Module Cover.

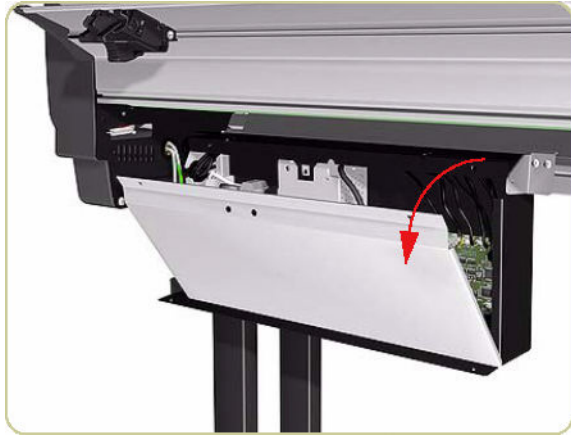

6. Disconnect brown and blue cables (H1 and H2) from the Electronics PCA.

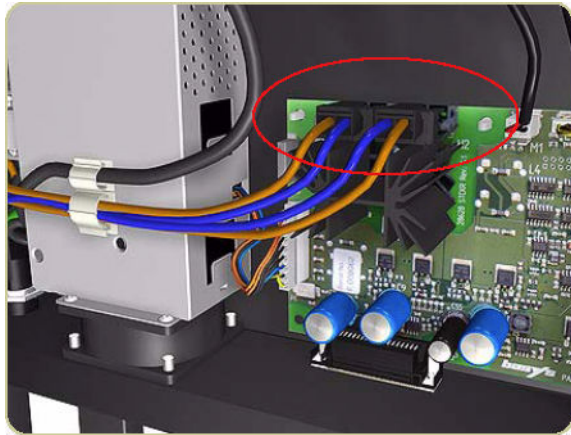

7. Disconnect the cable connecting the Power Supply Unit to the Electronics PCA.

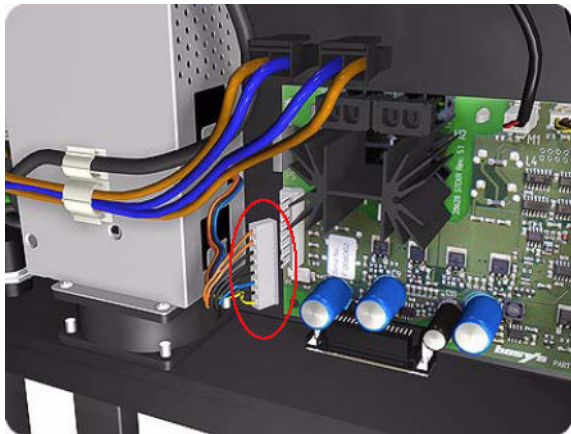

8. Remove the blue and brown cables from the cable clamp on the Power Supply Unit.

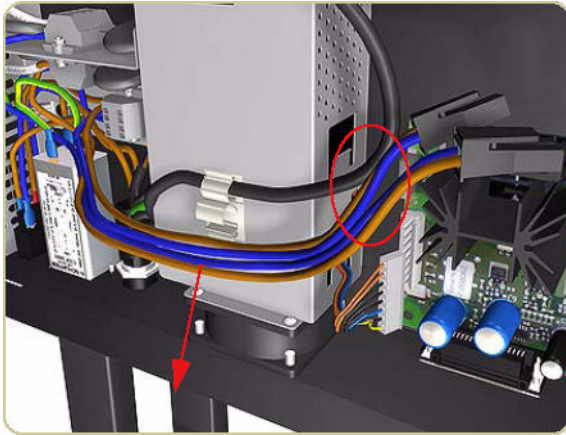

9. Disconnect two cables on the left of the Power Supply Unit by pushing in with a screw driver.

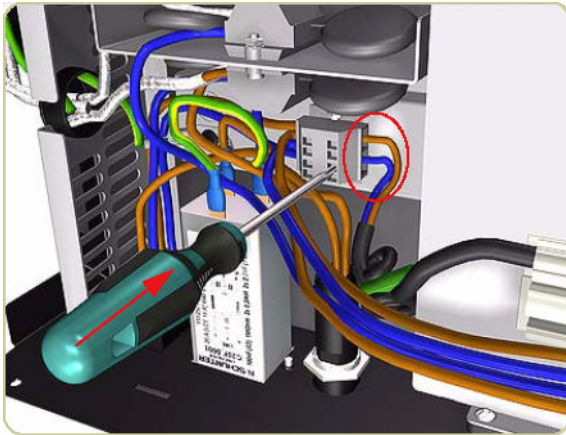

10. Remove the two cables.

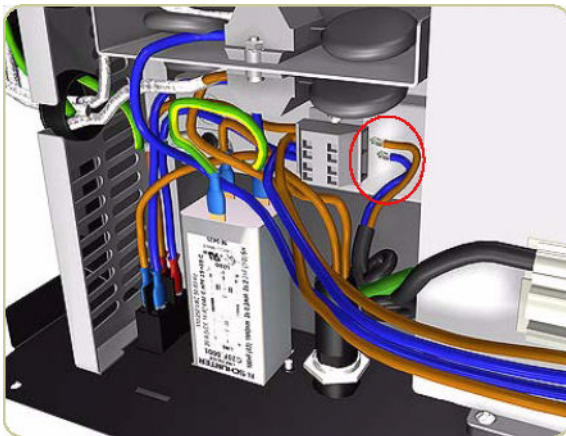

11. Remove four screws that secure the Power Supply Unit to the Electronics Module.

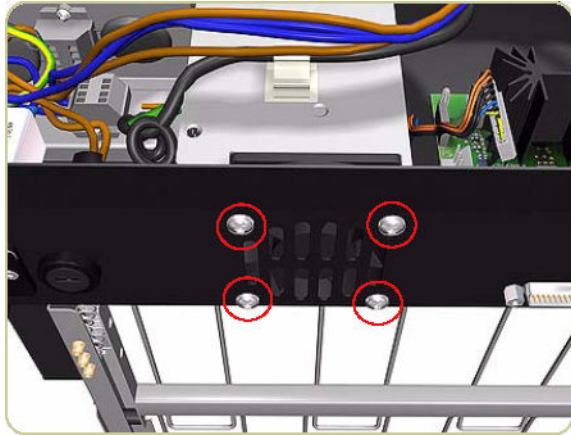

12. Lift up the Power Supply Unit.

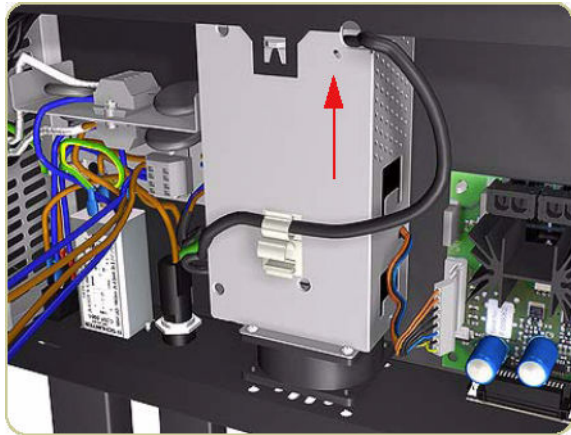

13. Remove the bottom part of the Power Supply Unit.

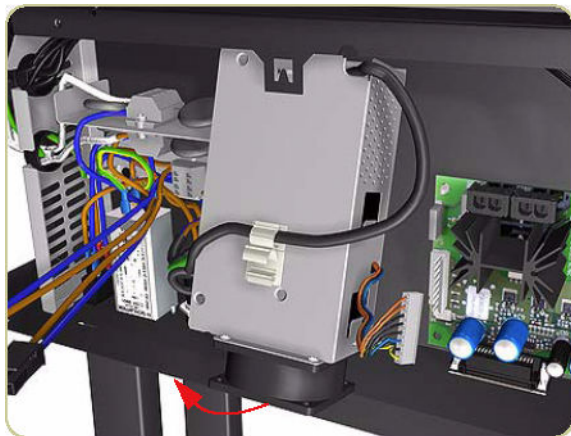

14. Remove the Power Supply Unit.

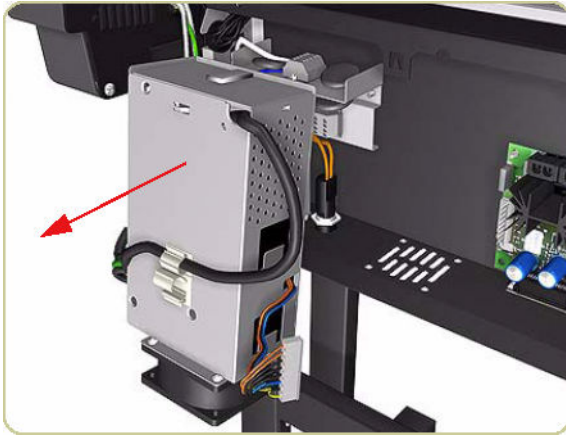

Heating Lamp

Removal

1. Remove the Right Cover ⇒ [Right Cover on page 426](#).
2. Remove the Left Cover ⇒ [Left Cover on page 428](#).
3. Disconnect the Heating Lamp Cable on the left of the chassis, push in the retaining clip with a screwdriver and release the cable.

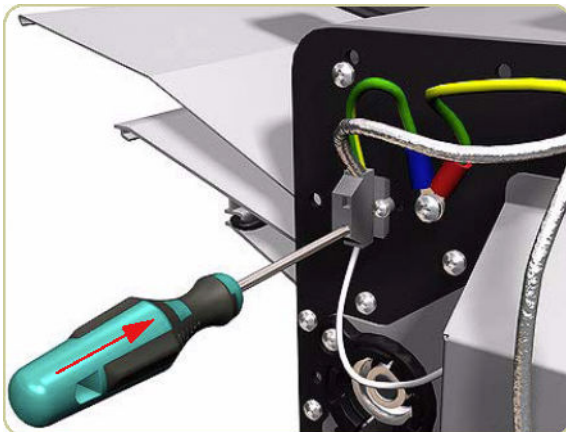

4. Remove the Heating Lamp Cable.

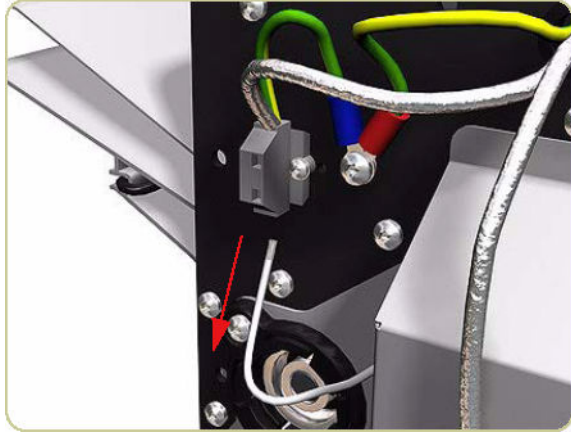

5. Remove two screws that secure the Left Heating Lamp Cover.

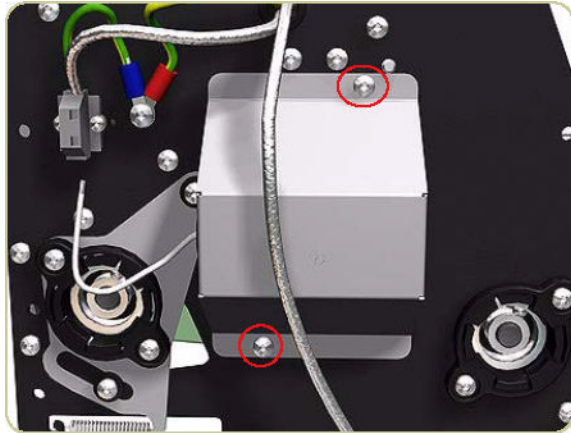

6. Remove the Left Heating Lamp Cover.

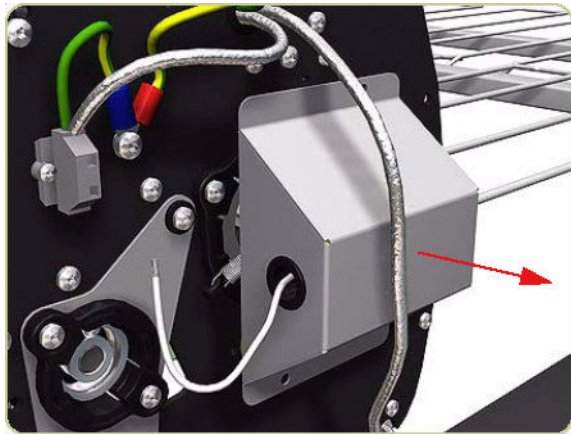

7. Disconnect the Earthing Cable from the left end of the Heating Lamp.

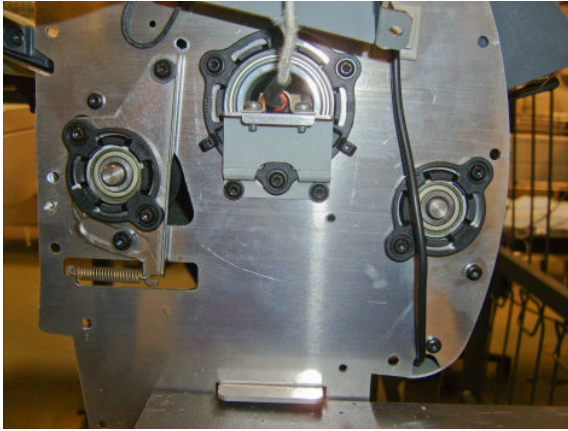

8. Remove three springs from the left end of the Heating Lamp.

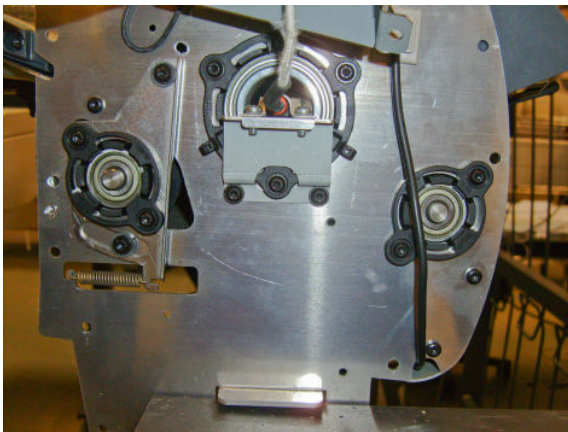

9. Disconnect the Heating Lamp Cable on the right of the chassis, push in the retaining clip with a screw driver and release the cable.

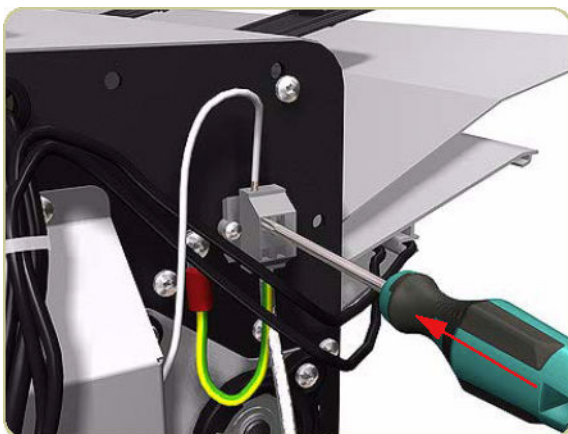

10. Remove the Heating Lamp Cable.

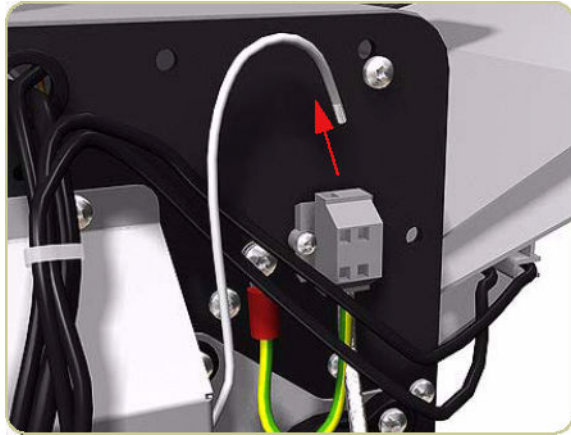

11. Remove two screws that secure the Right Heating Lamp Cover.

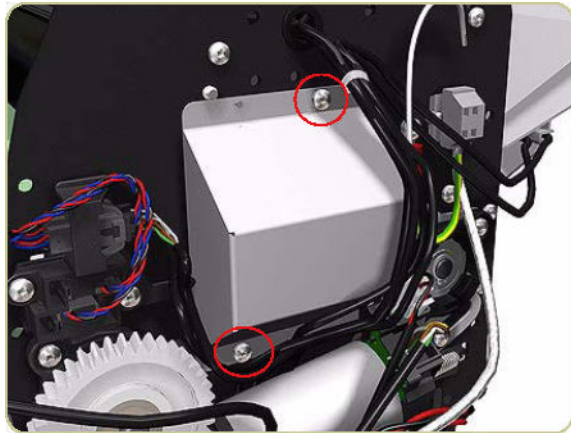

12. Remove the Right Heating Lamp Cover.

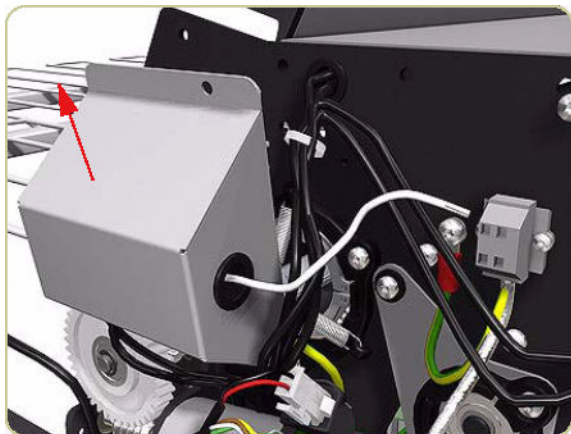

13. Remove the Heating Lamp.

 **NOTE:** When removing and installing the heating lamp, make sure you do not damage the heating element inside.

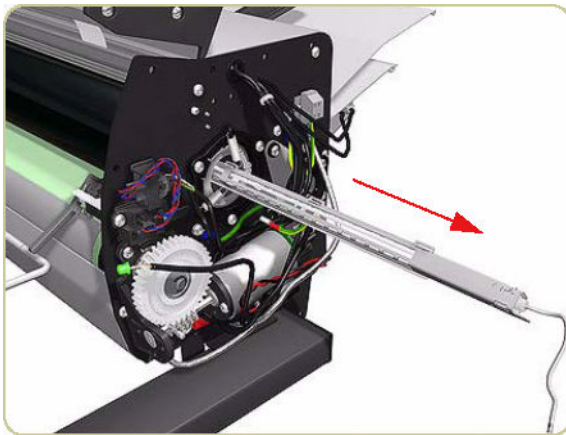

Heat Roller

Removal

1. Remove the Heating Lamp ⇒ [Heating Lamp on page 462](#).
2. Remove three screws that secure the Right Heat Roller Bearing.

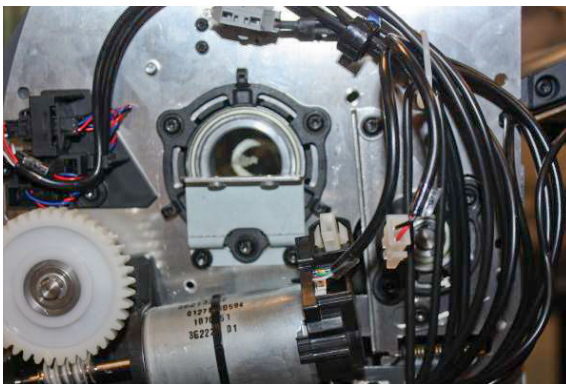

3. Remove the Right Heat Roller Bearing.

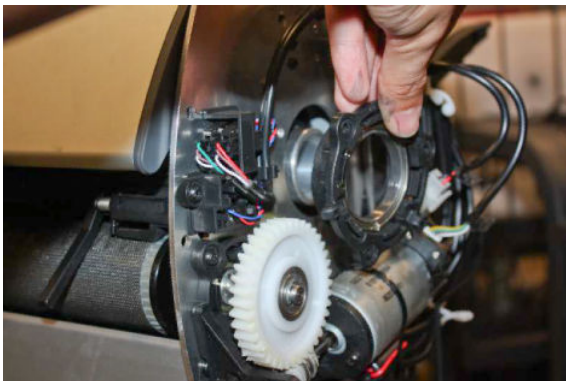

4. Remove three screws that secure the Left Heat Roller Bearing.

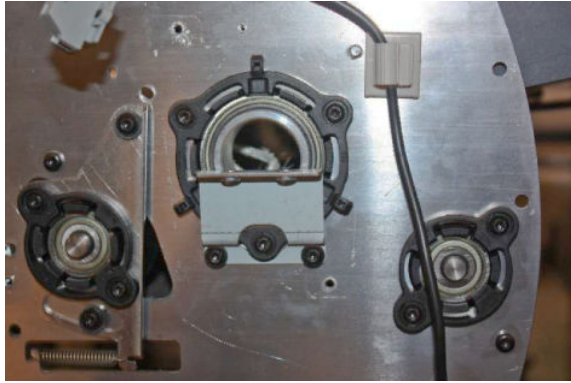

5. Remove the Left Heat Roller Bearing.

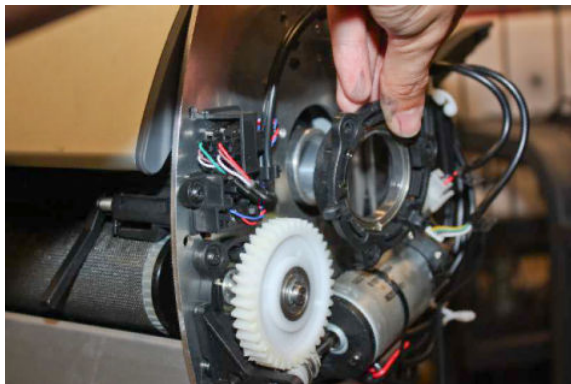

6. Slide the Heat Roller to the right.



7. Remove the Heat Roller.

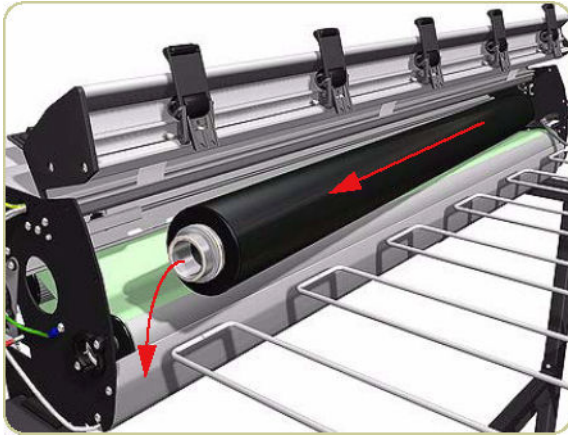

 **NOTE:** When installing the Heat Roller, make sure that the two bevel washers are on the right side of the Heat Roller.

Transport Belt

Removal

1. Remove the Drive Motor ⇒ [Drive Motor on page 439](#).
2. Remove the Heat Roller ⇒ [Heat Roller on page 466](#).
3. Remove two screws that secure the Left Output Roller Bearing.

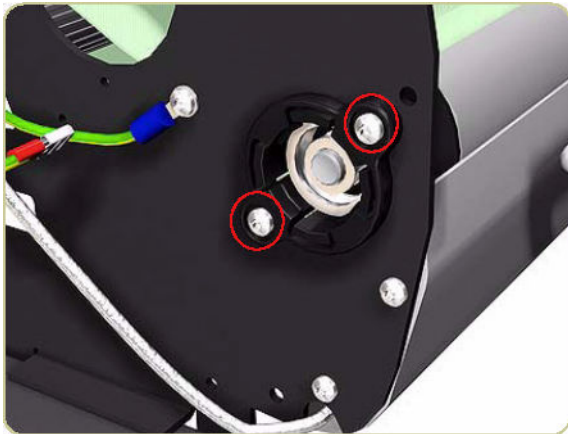

4. Remove the Left Output Roller Bearing.

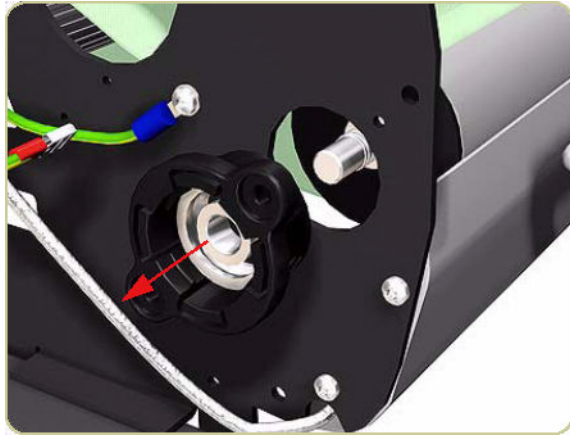

5. Remove the spring from the end of the shaft.

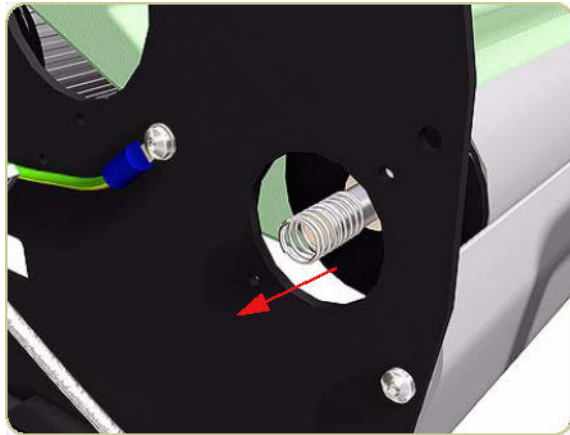

6. Slide the left end of the Output Roller back towards the hole left empty when the Heat Roller was removed.

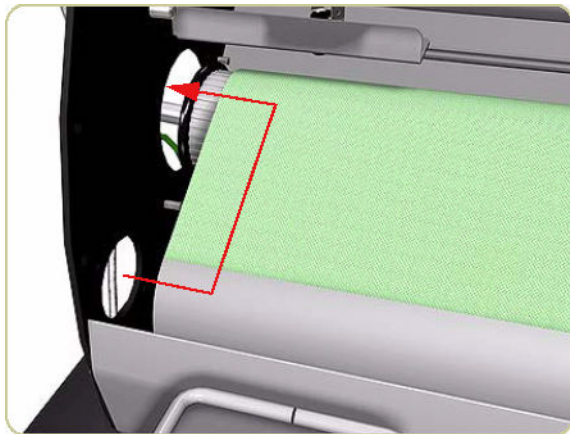

7. Pass the Output Roller through the hole.

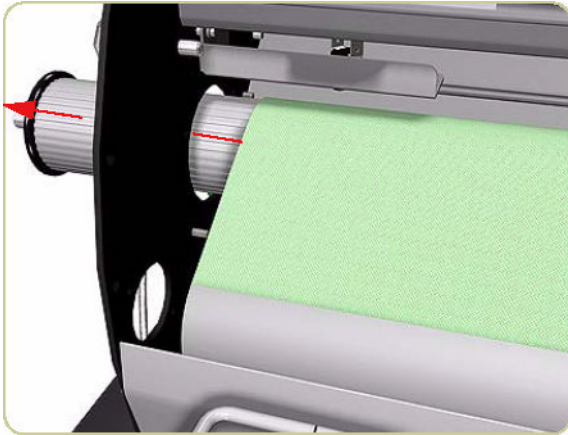

8. Remove the Output Roller.

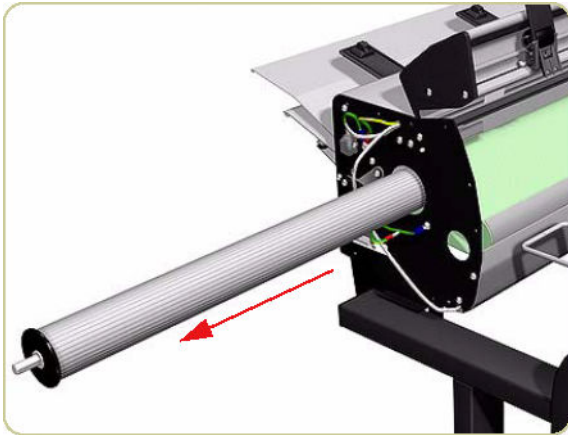

9. Remove the spring from the left side of the stacker.

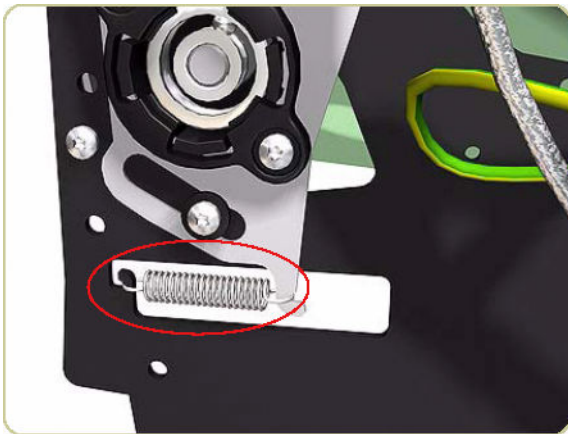

10. Remove two screws and washers that secure the Left Input Roller Bearing.

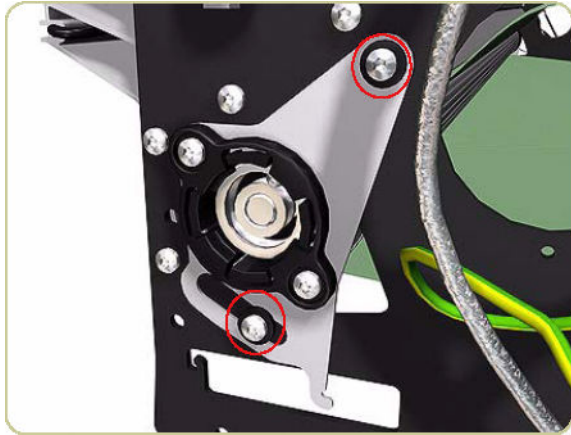

11. Remove the Left Input Roller Bearing.

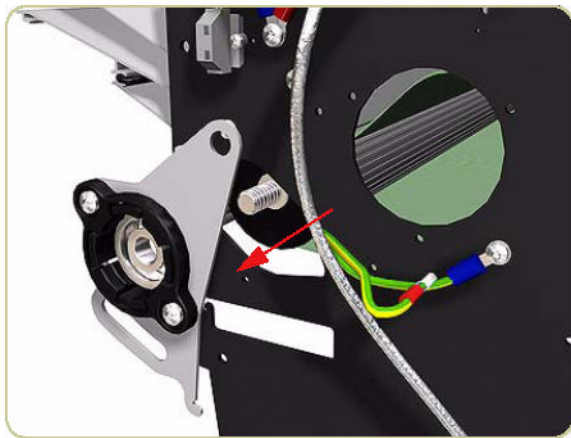

12. Remove the spring from the left end of the shaft.

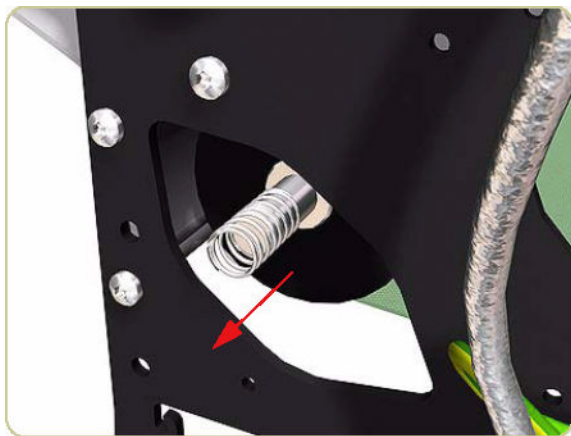

13. Remove the spring from the right side of the stacker.

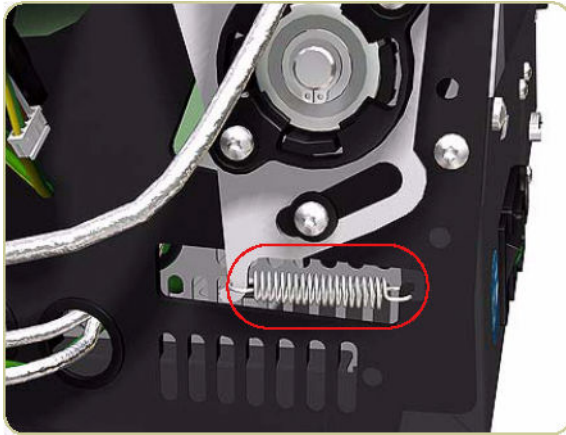

14. Remove the circlip.



15. Remove two screws and washers that secure the Right Input Roller Bearing.



16. Remove the Right Input Roller Bearing.

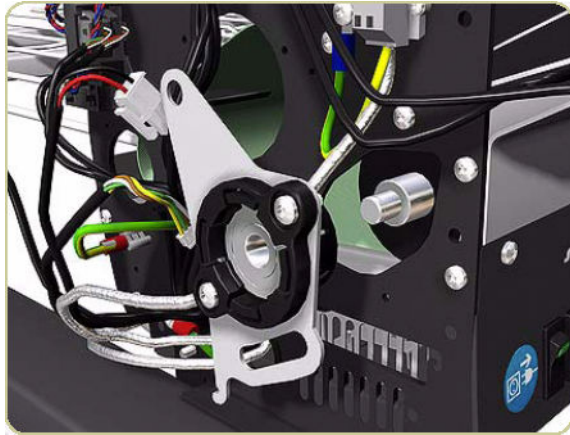

17. Slide the left end of the Input Roller towards the hole left empty when you removed the Heat Roller.

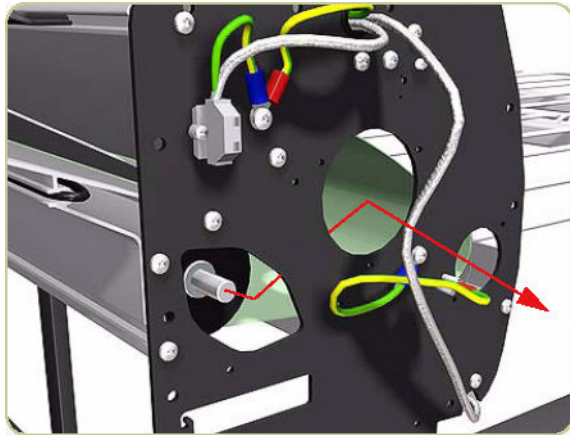

18. Pass the Input Roller through the hole.

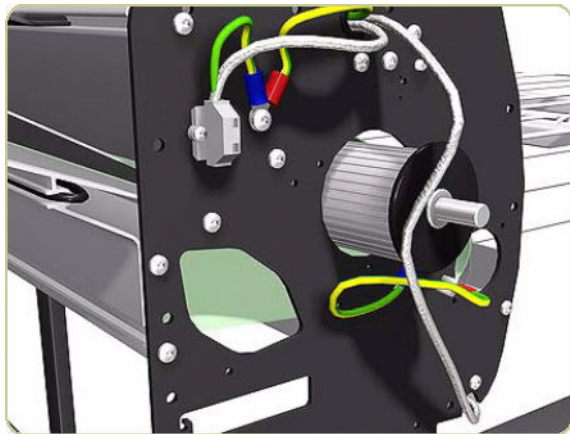

19. Remove the Input Roller.

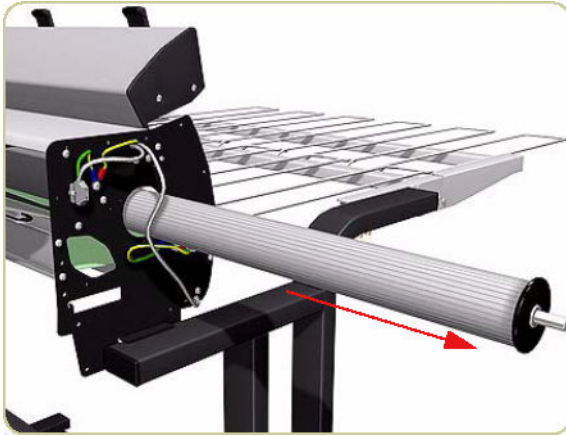

20. Remove the Transport Belt from underneath the stacker.

 **NOTE:** When reinstalling the Output Roller, the side with the longer shaft is installed on the right side of the stacker.



11 Preventive maintenance

- [Moisture on the printer](#)
- [Noisy Carriage Bushing](#)
- [Belt swelling](#)
- [General cleaning](#)
- [Clean the Drive Roller and Overdrive](#)
- [Clean the Platen](#)
- [Clean the Encoder Strip](#)
- [Clean the Paper-advance Sensor window](#)
- [Apply oil to the Overdrive](#)
- [Lubricate the Carriage Assembly](#)
- [Scheduled maintenance](#)
- [Preventive Maintenance Kits](#)

Moisture on the printer

Users should use the printer in an environment between 20% and 80% relative humidity. To recover from moisture condensation, turn the printer **Off**, and, using the main roller as a reference, wait until the printer is completely dry before using it again.

Noisy Carriage Bushing

To prevent noisy movement of the carriage, remove aluminum or dust particles from the bushing at the back of the carriage, and from the slider path along which the bushing moves.

Belt swelling

To prevent new belts from swelling incorrectly, keep them in their bags with desiccant until you need to install them.

General cleaning

To maintain the printer in good operating condition, keep it free of dust accumulation, ink, and other contamination. Cleaning intervals are determined by the printer environment and by the types of printer supplies used.

Proper general cleaning should include the following.

⚠ WARNING! To prevent an electric shock, make sure that the printer is switched **off** and unplugged before any cleaning is performed. Do not let any water get inside the printer.

1. Clean the outer surface of the printer with a damp sponge or cloth. Use a mild soap and water solution if necessary. Do not use abrasive cleaners.
2. Wipe the printer dry with a soft lint-free cloth.

Clean the Drive Roller and Overdrive

⚠ CAUTION: If ink is spilled on the Overdrive, remove the ink immediately. Due to the ink's reflectance, ink on the Overdrive can disrupt the printer's edge-sensing function. To remove any ink from the Overdrive, perform the following procedure.

CAUTION: Prevent water or other liquids from running onto electrical components or circuits, or through openings in the Electronics Module.

1. Perform the Turn Drive Roller Utility (see [Turn Drive Roller on page 105](#)).
2. Open the Window and apply any common household cleaning solution (water based only) to a soft, lint-free rag and apply it to the Drive Roller and Overdrive surface while it is rotating. Make sure that you thoroughly clean the Drive Roller and Overdrive surface.
3. Press **OK** when you have completed the cleaning procedure.
4. Allow the Drive Roller to dry before loading media into the printer.

Clean the Platen

CAUTION: If wide paper is used to print after narrower paper is used for some time, you may find that the left-hand side of the Center Platen has become dirty and will leave marks on the back of the paper if not cleaned.

It is recommended to clean the Center Platen on a regular basis (at least every few months or when required) as follows:

1. Unload any paper from the printer.
2. Open the Window and with a dry brush remove ink deposits from the Cutter Groove and the Center Platen surface.

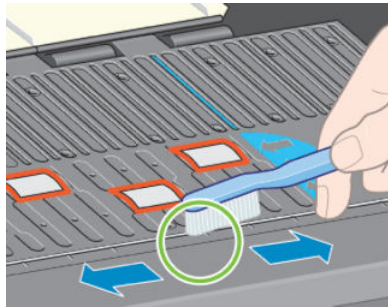

Cutter Groove

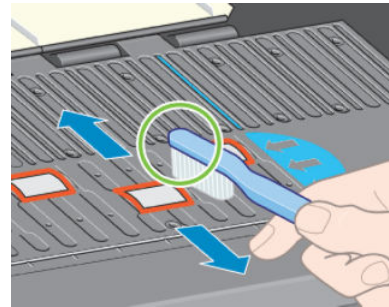

Center Platen Surface

3. Use a clean, absorbent lint-free cloth, dampened with isopropyl alcohol, to wipe loosened ink deposits from the Center Platen.

CAUTION: Do not:

- Use commercial cleaners or abrasive cleaners.
- Wet the Center Platen directly because you will leave too much moisture behind.
- Wet the rubber wheels at all (not even with the cloth).

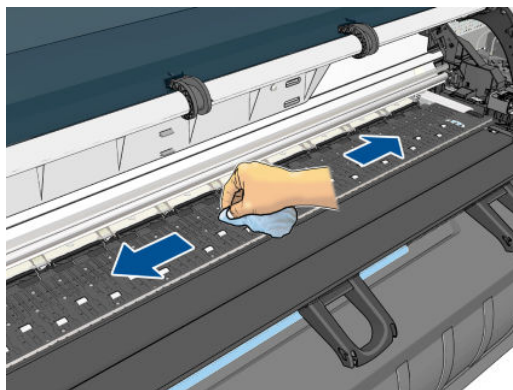

4. Clean the Cutter ramp with the damp cloth.

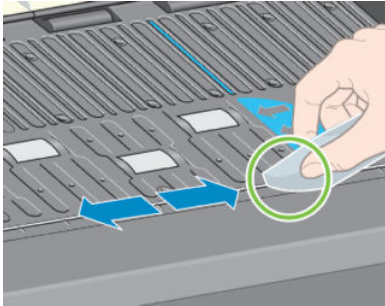

5. Clean the exposed part of the wheels with a dry cloth. Ideally, clean the whole circumference of these wheels (see [Turn Drive Roller on page 105](#)).

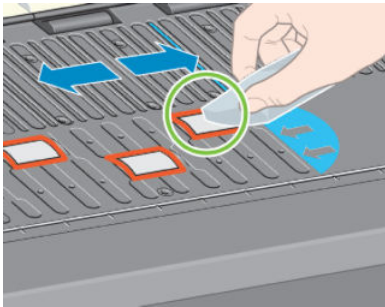

Clean the Encoder Strip

Cleaning the Encoder Strip is a vital part of the printer's maintenance and can clear a variety of system errors:

- 86:01 or 87:01 system errors and related mispositioning of the Carriage Assembly errors, such as the carriage bumping into the side of the printer.
- 42:10 system error, related to failures starting and homing the carriage on the scan axis.
- 29:01 and 29:02 system errors which cannot be cleared even after installing new Maintenance Cartridges.
- There are occasions when an Encoder Strip that needs cleaning can cause paper loading issues, as the Carriage cannot correctly detect the position of the paper.

With the type of pigmented ink that is used in the printer, the Encoder Strip cleaning must be performed at regular intervals. Cleaning must be performed after every 10 liters of ink used. The front panel will display a message when cleaning is required:

"For optimal printer performance
follow the
Clean the encoder strip
process as described in the User
Maintenance Kit"

This message is displayed after every 5th job until the cleaning is performed, and the counter has been reset. This procedure is normally performed by the customer. Instructions and materials are provided within the User Maintenance kit. The kit can be ordered using part number Q6715A (HP DesignJet T7100 User Maintenance Kit).

 **NOTE:** When the message is displayed on the front panel, a 'silent' warning message is added within the system error log '8:01'. This helps when reviewing the error log history, to see if the message has been displayed.

Cleaning procedure

1. At the front panel, select **Clean Encoder Strip** from the Ink menu.

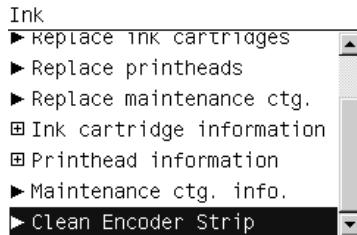

2. The front panel explains what you need to clean the Encoder Strip. Press **OK** to continue or **Cancel** to exit.

Clean Encoder Strip
Get a cloth from the cleaning kit and wet it 'ONLY' with water.
Press **OK** to continue or **X** to cancel.

3. Open the Window.

Open window

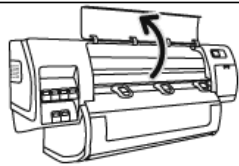

4. Clean the Encoder Strip as shown in the front panel, and press **OK** when finished.

Clean encoder strip on both sides with cloth, press **OK**

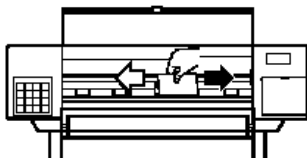

5. Close the Window. The Carriage moves to the left-hand side of the printer.

Close window to continue

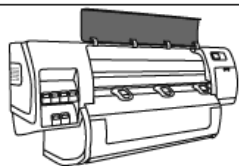

6. The front panel prompts you to reopen the Window and clean the right-hand side of the encoder strip (inside the Service Station). Press **OK** when finished.

Clean encoder strip inside service station, then Press **OK**

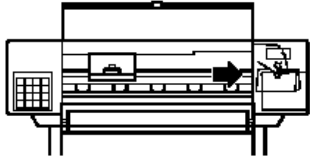

7. Close the Window. The Carriage returns to its ready position in the Service Station.

Close window to continue

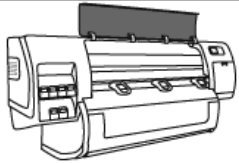

Clean the Paper-advance Sensor window

The paper advance sensor is the very small rectangular window (less than 1 square centimeter in size and shown in the following graphic) near the sixth platen roller from the right.

Use a clean, absorbent, lint-free cloth that you have slightly dampened with isopropyl alcohol to very gently wipe any dust and loosened ink deposits from the sensor window.

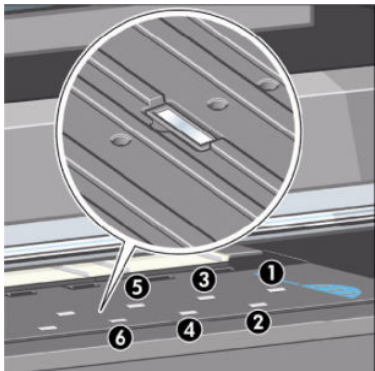

Apply oil to the Overdrive

Occasionally, it may be necessary to oil the Overdrive in order to stop the rollers from squeaking:

1. Open the Window.
2. There are small holes in the Center Platen beside some of the rollers.

3. A bottle of oil is supplied with the Maintenance Kit. Insert the pointed end of the bottle into each hole in turn, and put three drops into each.



4. Be very careful not to spill any oil onto the Center Platen.

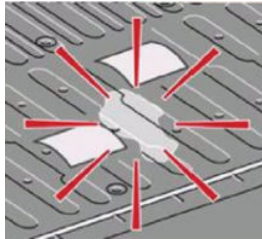

5. If there is oil on the Center Platen, wipe it away with the cloth supplied with the Maintenance Kit.

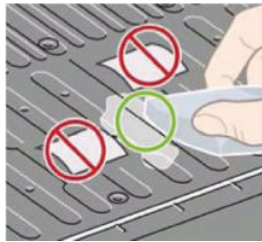

6. Close the Window.

Lubricate the Carriage Assembly

The Carriage Assembly needs to be lubricated occasionally so that it can slide easily along the Slider Rod.

1. Using the Front Panel, in the Printheads menu, select "Replace printheads now". The Carriage Assembly will move to the center of the printer.
2. Open the Window and apply a few drops of oil (bottle of oil can be found in the Maintenance Kit) to the pads on either side of the Carriage Assembly.
3. Apply a few drops of oil directly to the Slider Rod on either side of the Carriage Assembly.

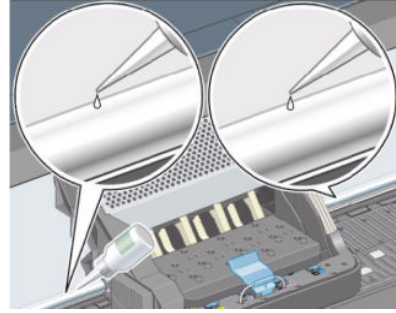
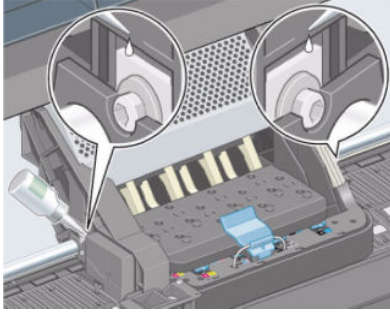

Scheduled maintenance

In some segments of the printer market, the customer tends to print more than the maximum number of prints that the throughput allows, exceeding by far the limit of the design. When this happens the customer runs into print quality problems and continuous printer failures.

The purpose of scheduled preventive maintenance is to avoid these failures - ensuring a good performance during all the product life.

Preventive Maintenance Kits

Normal printer use means 6,000,000 Carriage Cycles (which corresponds to approximately 100,000 A0 prints on average). Under normal usage conditions, it will be approximately 5 years before the printer needs maintenance. If the printer is used more heavily than normal, then it will need maintenance service much more frequently.

One of the EEROM counters is assigned to counting the number of carriage cycles. When certain components of the printer exceed this amount, the front panel displays the following message:

“Maintenance #1 required”

The following message is triggered depending on the total quantity of ink spitted in each Spittoon.

“Maintenance #2 required”

Once one of the maintenance advised messages is displayed, the preventive maintenance kit must be used to replace the most worn parts of the printer. See [Printer part removal and installation on page 217](#).

Preventive Maintenance Kit #1 (F2L46-67001)

This Preventive Maintenance Kit #1 contains the following components:

- Encoder Strip ⇒ [Encoder Strip and Encoder Sensor on page 298](#)
- Encoder spring+Nut ⇒ [Encoder Strip and Encoder Sensor on page 298](#), step 8
- Carriage PCA Cover ⇒ [Carriage PCA on page 293](#)
- Belt Tensioner Assembly ⇒ [Scan-Axis Motor on page 326](#), step 7
- Cutter Assembly ⇒ [Cutter Assembly on page 348](#)
- Redial Retainer Assembly ⇒ [Installation of the Drive Roller on page 420](#)
- Line Sensor Cable ⇒ [Line Sensor Assembly on page 302](#)

- Air Purges (Setup Printheads)
- Aerosol foam protector ⇒ [Line Sensor Assembly on page 302](#), step 6
- Carriage Assembly (with Encoder sensor) ⇒ [Carriage on page 286](#) (does not include PCA nor Cutter)
- Ink Supply Tubes and Trailing Cable ⇒ [Ink Supply Tubes and Trailing Cable on page 303](#)
- Tubes retaining clip ⇒ [Cover, Top on page 232](#), step 7
- Scraper Assembly and Absorber Foams ⇒ [Removal of the Service Station Scraper on page 250](#)
- Scan-Axis Motor ⇒ [Scan-Axis Motor on page 326](#)
- Belt Assembly ⇒ [Belt Assembly on page 345](#)

You must also clean the holes in the Service Station which are located under the Maintenance Cartridge and check that the Aerosol Fan is functioning correctly.

Preventive Maintenance Kit #2 (CQ105-67041)

This Preventive Maintenance Kit #2 contains the following components:

- Aerosol Filter ⇒ [Service Station on page 246](#)
- SVS Aerosol Fan assembly ROHS ⇒ [Service Station on page 246](#)
- Ink Absorber ⇒ See User's Guide
- Line Sensor ⇒ [Line Sensor Assembly on page 302](#)
- Encoder Strip ⇒ [Encoder Strip and Encoder Sensor on page 298](#)

You must also clean the holes in the Service Station which are located under the Maintenance Cartridge and check that the Aerosol Fan is functioning correctly.

Preventive Maintenance Kit #3 (CQ105-67064)

This Preventive Maintenance Kit #3 contains the following components:

- Rewinder Gear and Motor ⇒ CQ105-67001
- Hub Support and Adaptor ⇒ CQ105-67003
- Paper Feed Bake ⇒ CQ105-67006
- Media Sensor ⇒ CQ105-67008
- Media Axis Motor ⇒ CQ105-67012
- Drive Roller Encoder Kit ⇒ CQ105-67053
- Drive Roller Gears and Driver Roller Brake Kit ⇒ Q1273-60242

You must also clean the holes in the Service Station which are located under the Maintenance Cartridge and check that the Aerosol Fan is functioning correctly.

