



service manual

**hp designjet
multi-roll feeder
(for 1000 series)**



For HP Internal Use Only Warranty

©Copyright Hewlett-Packard Company 2001

This document contains proprietary information that is protected by copyright. All rights are reserved. No part of this document may be photocopied, reproduced, or translated to another language without the prior written consent of Hewlett-Packard Company.

First Edition, August 2001

The information contained in this document is subject to change without notice.

Hewlett-Packard makes no warranty of any kind with regard to this material, including, but not limited to, the implied warranties of merchantability and fitness for a particular purpose.

Hewlett-Packard shall not be liable for errors contained herein or for incidental or consequential damages in connection with the furnishing, performance, or use of this material.

WARNING

The procedures described in this manual are to be performed by HP-qualified service personnel only.

Electrical Shock Hazard

Serious shock hazard leading to death or injury may result if you do not take the following precautions:

- Ensure that the ac power outlet (mains) has a protective earth (ground) terminal.
- Disconnect the Printer from the power source prior to performing any maintenance.
- Prevent water or any other liquids from running onto electrical components or circuits, or through openings in the enclosure.

Electrostatic Discharge

Refer to the beginning of Chapter 4 of this manual, for precautions you should take to prevent damage to the Printer circuits from electrostatic discharge.

Safety Symbols

General definitions of safety symbols are given immediately after the table of contents.

WARNING

The Warning symbol calls attention to a procedure, practice, or the like, which, if not correctly performed or adhered to, could result in personal injury. Do not proceed beyond a Warning symbol until the indicated conditions are fully understood and met.

CAUTION

The Caution symbol calls attention to an operating procedure, practice, or the like, which, if not correctly performed or adhered to, could result in damage to or destruction of part or all of the product. Do not proceed beyond a Caution symbol until the indicated conditions are fully understood and met.

Content Management Department,
Barcelona Division,
Hewlett-Packard Espanola, S.A.
Avda. Graells, 501
08190 Sant Cugat del Valles
Spain



service manual

**hp designjet
multi-roll feeder
(for 1000 series)**

Using this Manual

Purpose

This Service Manual contains information necessary to troubleshoot and service:

- **hp** designjet multi-roll feeder for 1000 plus series - Model C2394A
- **hp** designjet multi-roll feeder for 1050c printer - Model C2394B
- **hp** designjet multi-roll feeder for 1050cm printer - Model C2394C

For information about using these products, refer to the corresponding User and Quick Reference Guides.

Readership

The procedures described in this Service Manual are to be performed by HP Certified service personnel only.

Part Numbers

Part Numbers for service parts are located in Chapter 3.

Conventions

A small arrow \Rightarrow is used to indicate other parts of the Service Manual where you can find information related to the topic you are consulting.

Table of Contents

Troubleshooting 1-1

System Error Codes 2-1

Parts and Diagrams 3-1

Removal and Installation 4-1

Index



--	--

Troubleshooting

7

Is the Problem with the Printer or Multi-Roll Feeder	1-2
Troubleshooting System Error Codes	1-2
The Media Does Not Feed In	1-2
Media Does Not Advance Correctly	1-2
Media Jam in the Infeed Channel of the Multi-Roll	1-3
The Multi-Roll Feeder does not Power ON	1-3
The Media Does Not Unload Correctly	1-4
Communication Problem Between the Printer and the Multi-Roll Feeder	1-4
Media Jam in the Printer	1-5
Marks on Glossy Media	1-5
Problem with the Media Loading Procedure	1-6
How to Prevent Media Jams	1-8
The Printer Doesn't Print or the Prints are Partially Printed	1-9
Selecting Media Width Which is Not 24" or 36"	1-9
Multi-Roll Feeder Information Utility	1-10
Service Print	1-11
Media Basket Capacity Limitations	1-12
Media Basket features	1-12
Media Basket - Climatic Conditions	1-13
Multi-Roll Feeder Capacity Limitations	1-13
Warranty Information	1-14
Logging a Call Related to the Multi-Roll Feeder	1-14
Check Warranty Status	1-14
Multi-Roll Feeder Calibration	1-15
Multi-Roll Usage (Counters) Utility	1-17
Multi-Roll Reset (Counters) Utility	1-18
Limitations of the Printer with the Multi-Roll Feeder	1-19

Guide to Troubleshooting the Multi-Roll Feeder

Is the Problem with the Printer or Multi-Roll Feeder

If you encounter the following symptoms, the problem could be related to the multi-roll feeder:

- System Error ⇒ **only** 0D00XX error codes.
- Multi-Roll Feeder red LED ON **or** blinking.

If you encounter the following symptoms, disable the multi-roll feeder and check the printer:

- **Only** Image Quality problems related to banding/paper advance and scratches on Glossy Media.
- Media load problems (misalignment, media jams).
- Paper Jams.

Troubleshooting System Error Codes

Chapter 2 - *System Error Codes* contains a list of system error codes and their respective descriptions and recommended corrective actions. Only try one recommended action at a time and check if the error code has disappeared.

The Media Does Not Feed In

If the media does not feed into the infeed slot in the media cabinet, try the following:

- 1 Make sure **both** Roller Levers are lowered to open the infeed slot.
- 2 Trim the leading edge of the media so it does not get caught in the slot.
- 3 Insert the media evenly to avoid angles - do not insert one corner and then the other.

If you hear a 'beep' this means that the printer has detected the media in the infeed slot.

Media Does Not Advance Correctly

If the media does not advance far enough into the infeed channel in the media cabinet, the problem could be that the media is slipping and the rollers are not "gripping" the media correctly. In this case, try the following:

- 1 Maybe the pre-tension was not applied correctly - pre-tension always needs to be applied by turning the star screw on the left hand side of the Spindle. Tension should **never** be applied by turning the media roll or the spindle disks.
- 2 Clean the rollers using the cleaning procedure.
- 3 Maybe the media spindle was installed incorrectly - make sure the removable media disks are on the left hand side of the spindle.

Media Jam in the Infeed Channel of the Multi-Roll

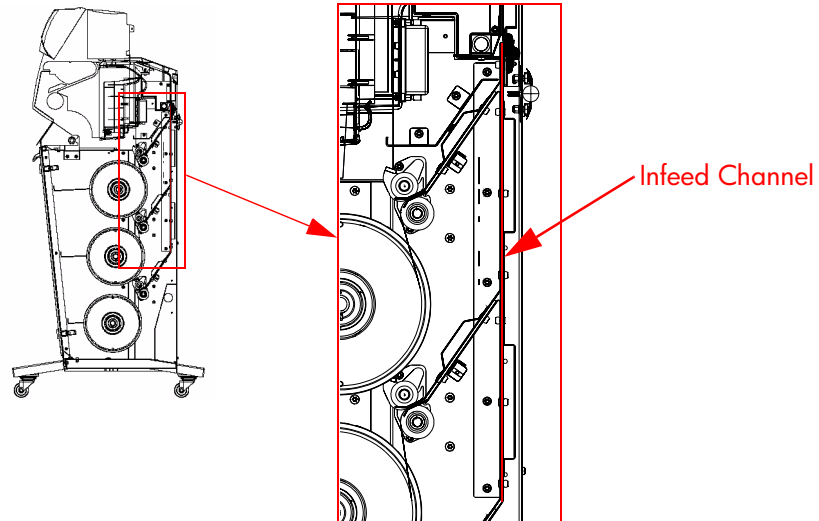

If there is a media jam in the infeed channel, try the following:

- 1** Turn OFF the multi-roll feeder from the power isolator switch on the connector panel at the back.
- 2** Open the media cabinet doors and lower the roller lever on both sides.
- 3** Turn the spindle away from you to pull the media out of the infeed channel and to collect it back on to the media roll.
- 4** If the media is blocked, you can place the spindle in the park position for better access to the infeed channel, and then pull the media edges in a downwards direction on both sides.
- 5** If you cannot reach the media because the roll has finished and it has not been ejected from the front of the printer, open the Rear Top-Cover and try to remove the media from the Motion Control Unit.

Do not insert media with crumpled or damaged edges - trim it first.

The Multi-Roll Feeder does not Power ON

- 1** Check that the power cord is connected correctly to the multi-roll feeder and to the Power Socket.
- 2** Check that the Power Switch on the BACK of the multi-roll is in the ON position.
- 3** Check if either the green or red LED on the rear side, near the multi-roll serial and parallel connectors, is ON. If one or both of them are ON, replace the Main PCA ⇒ Page 4-15.
- 4** If both the red and green LEDs are OFF then:
 - Replace the Power Supply Unit ⇒ Page 4-13.
 - If the problem still continues, replace the Main PCA ⇒ Page 4-15.

The Media Does Not Unload Correctly

If the media does not fully unload from the infeed channel in the media cabinet, try the following:

- 1 Maybe the pre-tension was not applied correctly - pre-tension always needs to be applied by turning the star screw on the left hand side of the spindle three or four times, or more if the spindle is on a low retainer bracket - tension should **never** be applied by turning the media roll or the spindle disks.
- 2 The spring applying pressure on the retainer bracket is loose and the spindle is slipping in the retainer bracket. Power off the multi-roll feeder and turn the retainer bracket screw 1 turn in a clockwise direction.

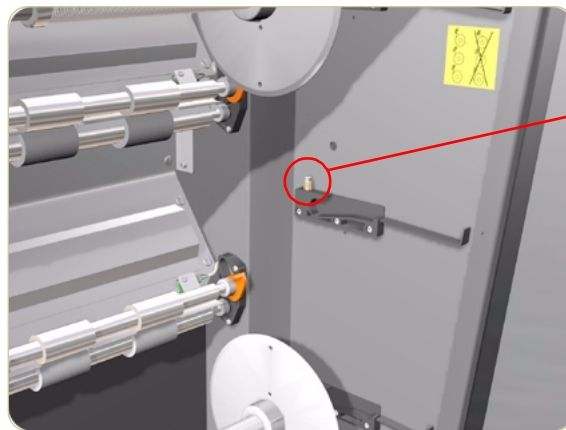

Turn screw clockwise

Communication Problem Between the Printer and the Multi-Roll Feeder

Communication Failure
Power off printer
and Multi-roll
Check multi-roll
Check connections

Needs Rebooting

Communication Failure
Check multi-roll
Check connections
Try again ----->
Uninstall Multi-roll ----->

Continuable Message

If the front panel displays either of the above messages, try the following:

- 1 For the message that can appear during normal operation, follow the instructions in the message.
- 2 If the message appears during multi-roll feeder installation or while powering ON, try the following:
 - Check that the multi-roll feeder power isolator switch at the rear is ON.
 - Open the media cabinet doors and check that the parallel cable (and serial cable for certain models) is correctly connected to the rear of the printer.

Media Jam in the Printer

Switch Power off
 Check printhead path
 (xxxxxx shut down)

Switch Power off
 Check paper path
 (xxxxxx shut down)

If the front panel displays either of the above messages, try the following:

- 1 Turn the printer OFF at the front panel, and open the printer window.
- 2 Turn OFF the multi-roll feeder from the power isolator switch on the connector panel at the back.
- 3 Carefully move the printhead carriage out of the way - if possible, all the way to the enclosed area on the left or the right. Which way you are able to move it depends on where the media is jammed.

When moving the printhead carriage, touch only the black plastic parts.

- 4 Carefully remove any of the jammed media which you can easily lift up and out from the top of the printer.
- 5 Open the media cabinet doors and lower the roller lever on both sides.
- 6 Carefully pull the media down and out of the infeed channel. If this is not possible:
 - Go to the back of the multi-roll feeder and open the rear cover.
 - From the back, carefully pull the media out of the infeed assembly.
 - Now pull the media down and out of the infeed channel in the media cabinet.
- 7 Lower the window and switch on the printer and the multi-roll feeder. Press the Form Feed and Cut key to eject any pieces of media that are still in the media path.
- 8 Reload the media as normal.

Marks on Glossy Media

When using Glossy Media, it is possible that the media could be marked while passing through the infeed channel on its way to the Printer. It is recommended to:

- 1 Use Roll 1 (top roll) for Glossy Media.
- 2 Prevent anything from blocking the infeed channel.

Problem with the Media Loading Procedure

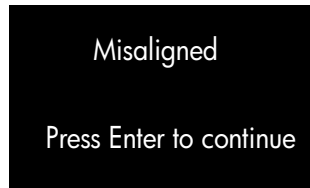

When this message is displayed, the printer unloads the media. Press Enter to continue and the printer will display the **Ready for paper** status message. Do the following:

- 1 Check for even tension across the width of the media. If there is less tension on one side than the other then the media is not straight in the infeed slot.
- 2 Lower the roller levers on both sides and adjust the media so that tension is even across the whole width. You can turn the spindle disk quickly two or three times away from you and then two or three times in the opposite direction. This will help to create an even tension.
- 3 Lift the roller levers on both sides and try to load the media again.

If this does not solve the problem, remove the media from the infeed slot and repeat the loading procedure.

- Make sure the roll is fully against the right hand spindle disk (fully inside the roll core) and do the same for the left hand spindle disk. The printer verifies correct alignment using the blue line on the right hand side of the printing area as a reference.
- 4 When loading different media widths (as shown below), make sure that you **always** load the shortest width on the top roll (roll 1), the medium width on middle roll (roll 2) and longest width on the bottom (roll 3). If one of the media loaded is glossy, make sure that you **always** load it on the top roll (roll 1) even if it is not the shortest width.
 - 5 When loading media, make sure you align the media against the hole on the right hand side (as shown below).

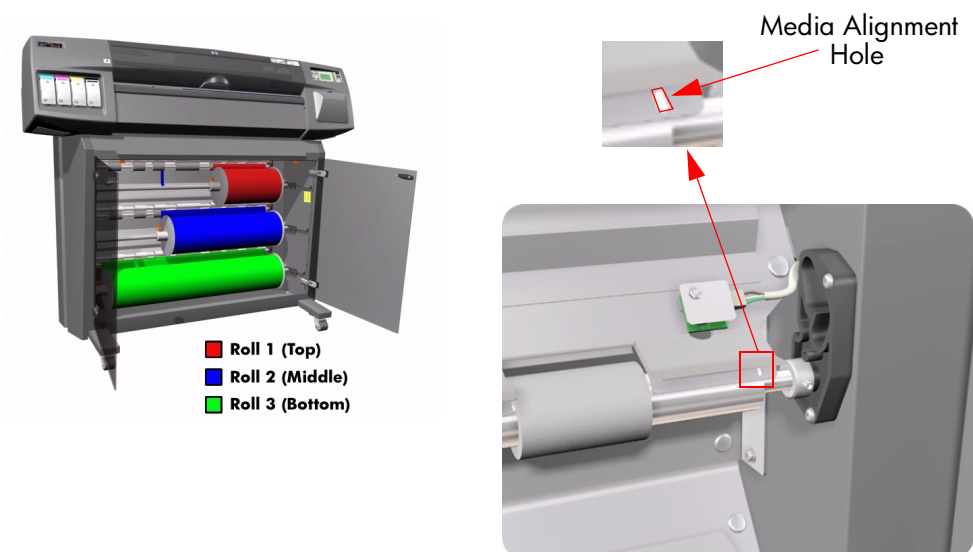

- 6** If the media loading procedure fails frequently, it is advisable to clean the the corresponding roll.
- 7** Make sure that there is no skew between the infeed unit and the printer paper entry. Check that the complete length of the infeed unit is pushed up against the printer.

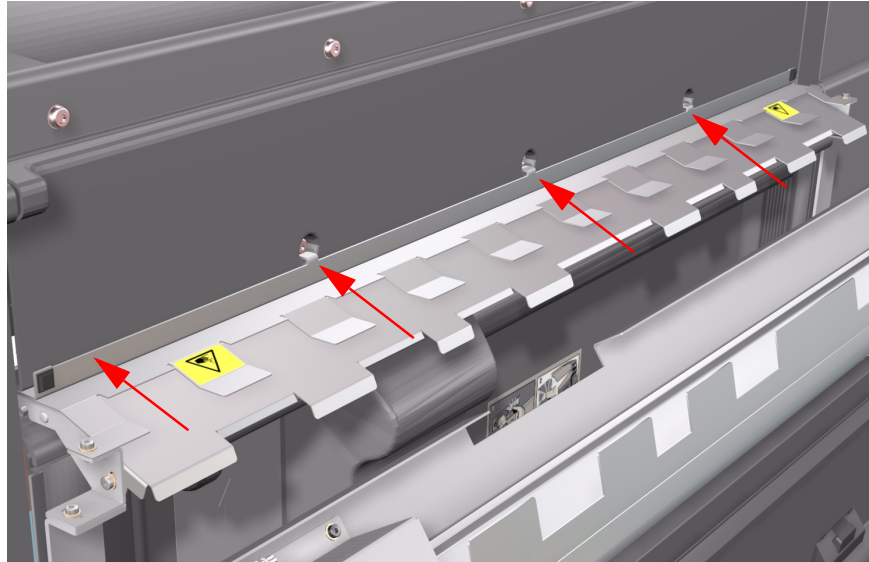

Make sure the Infeed Unit is firmly pushed up against the Printer

How to Prevent Media Jams

There are a few simple steps to prevent media jamming in the multi-roll feeder. When loading media:

- 1 Make sure the Rear Top-Cover of the multi-roll feeder is fully closed.
- 2 Use rolls of media that are not glued to the core.
- 3 Make sure the leading edge of the media is trimmed straight.
- 4 Make sure there is even tension across the width of the media.
- 5 Make sure media is aligned - the same amount of media is fed across the width.
- 6 Pre-tension the media after loading.

When you intend to use your printer unattended for a long period of time, it is a good idea to load and unload each roll using the Load/Unload commands from the front panel (if you did not complete the media loading procedure when prompted by the printer). This will ensure that each roll of media loaded is correctly aligned and that the printer is capable of loading/unloading each roll when requested by the print jobs in the queue.

- 7 The multi-roll feeder has some limitations on the widths that it can handle, so always try and use media widths that will allow the edges of the media to be gripped well between the rubber grips on the Transport Roller and the Riding Roller (see below).

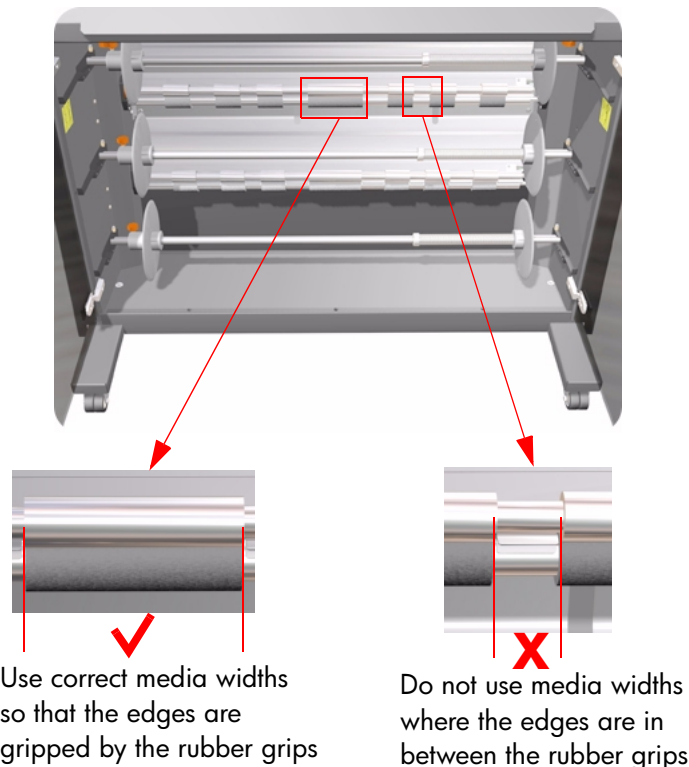

The Printer Doesn't Print or the Prints are Partially Printed

If the printer doesn't print or the prints are clipped or cropped, try the following:

- 1** Check the multi-roll configuration in your printer driver: Check that the **Has multi-roll feeder** check box is ticked.
- 2** Check default roll configuration: Check that a roll is installed for the roll configured as default. If you do not select a roll from the printer driver, the printer will try to print to the default roll and if no identical roll is available, it will not print the job.
- 3** Check Productivity mode settings: If the mode is set to off/not optimized and the requested roll has finished, the job cannot be printed.
- 4** Check cable connections: Check that the printer and any network cables are securely connected to the printer. Make sure the parallel cable (and serial cable for certain models) is connected between the multi-roll feeder and the printer and ensure that it is also firmly connected between the computer and the multi-roll feeder.
- 5** Check media configuration: Make sure the media rolls are configured correctly.
- 6** Check document file: If you are printing files generated with versions of printer drivers for printers without multi-roll feeders, the header section of some file formats already contain information on the media: in these files, roll information corresponds to roll 1 and sheet information corresponds to the default roll in the multi-roll feeder. It is advisable to use the top roll, that is roll 1, as the default.
- 7** Also note that the header section may also include print mode information, so if different media is used the quality of your prints may be affected. It is recommended that the print file is regenerated from the original document to avoid unexpected results.

Selecting Media Width Which is Not 24" or 36"

If the width of the media that is being loaded is not 24" or 36", you must still select the width as 24" or 36" through the front panel. The way to decide whether to choose 24" or 36" is by measuring the width of the media and if it's 24" or smaller, then select 24" through the front panel and if it's bigger than 24", then select 36". The reason for only having these 2 options is so that when media finishes on one roll, the printer can automatically load a new roll of media which is of a similar size (when optimized mode is selected in the productivity mode settings).

The printer will actually measure the width of the media loaded and will never print on the print platen by mistake.

Multi-Roll Feeder Information Utility

The purpose of the multi-roll feeder information utility is to:

- Report basic parameters for call qualification.
- Provide information integrated within the printer user interface.

Check the multi-roll feeder information as follows:

- 1 In the Utilities submenu, scroll to "Statistics" and press **Enter**.

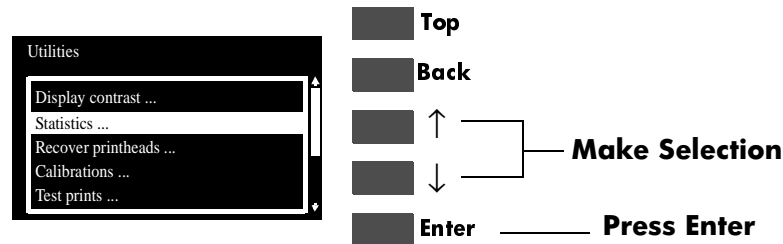

- 2 In the Statistics submenu, scroll to "Multi-roll info" and press **Enter**.

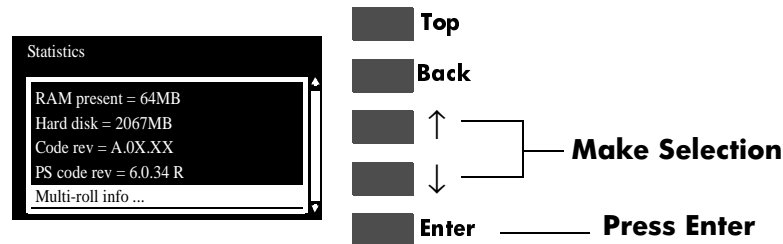

If the multi-roll feeder is NOT installed, you will not be able to view the multi-roll information utility.

- 3 The Printer will display the following information on the front panel. You will need to use the arrow keys to scroll through the complete list because the front panel only allows 6 lines to be displayed at one time.

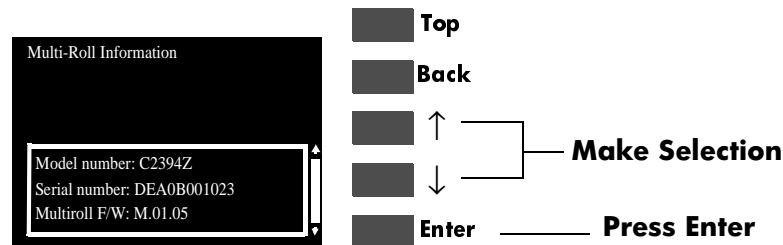

If no serial number is available, the front panel will show "Serial number: None"

Each parameter of the multi-roll information utility is explained as follows:

- **Model Number** - This identifies the model type of the multi-roll feeder and should be the same number as printed on the Product Label (located at the back of the multi-roll feeder).
- **Serial Number** - The Serial Number should be the same number as printed on the Product Label (located at the back of the multi-roll feeder).
- **Multi-roll F/W** - The current version of the Firmware being used by the multi-roll feeder.

If for some reason the multi-roll information is NOT displayed even though the multi-roll feeder IS installed, try the following:

- 1 Check cable connections: Check that the printer and any network cables are securely connected to the printer. Make sure the parallel cable is connected between the multi-roll feeder and the printer and ensure that it is also firmly connected between the computer and the multi-roll feeder.
- 2 The multi-roll feeder is not enabled in the Device Setup menu. In order to enable the multi-roll feeder, go to Device setup ⇒ Multiroll ⇒ YES, NO).

Service Print

When the Multi-Roll feeder is enabled, the Service Print will be modified and will include additional information on the Multi-Roll Feeder. A few details to remember about the Service Print when the Multi-Roll Feeder is enabled:

- The information for the Service Print will be printed on 2 pages.
- If Nesting is turned ON, the Service Print will be printed side by side (in order to save paper).
- If Nesting is turned OFF, the Service Print will be printed on 2 pages.

Valid Product/Model Numbers

	C2394A	C2394B	C2394C	C2394Z
Includes	multi-roll feeder	multi-roll feeder and printer with RTL firmware	multi-roll feeder and printer with PS firmware	multi-roll feeder from the Factory
For Which Printer	hp designjet 1000 plus series and in all of Latin America Region	hp designjet 1000 series without PS upgrade	hp designjet 1000 series with PS	ALL printers
Shown On	Label on product box and proof of purchase	Label on product box and proof of purchase	Label on product box and proof of purchase	Printer's front panel, service config print and product label (at the back of the multi-roll feeder)

Media Basket Capacity Limitations



The media basket is the output solution that can be used with the multi-roll feeder. The capacity limitations of the media basket are as follows:

- **Plain Paper** - the media basket can handle up to **30 m** of rolled prints. If the prints are folded and flattened (if this is acceptable) the capacity of the media basket is increased to **90 m**.
- **Coated Paper** - the media basket can handle up to **30 m** of rolled prints. If the prints are folded and flattened (if this is acceptable) the capacity of the media basket is increased to **90 ms**.
- **Heavy Coated Paper** - the media basket can handle up to **35 m** of rolled prints.
- **Glossy Paper** - the media basket can handle up to **35 m** of rolled prints.

It is possible that the black ink could transfer from one print to another in certain circumstances.

Media Basket features

	Drawings & low ink content images	High ink content images	COMMENTS
Plain, Coated, Translucent Bond and Vellum paper	A0/A1/A2/A3 ●	A0/A1/A2/A3 ●	When there are lots of plots, the bottom ones are flattened. High ink content plots are not rolled.
Heavy coated paper	A0/A1/A2/A3 ●	A0/A1/A2/A3 ●	Capacity of 30 m, with plots being rolled.
Glossy paper	A0/A1/A2/A3 ●	A0/A1/A2/A3 ●	Plots well rolled and stocked in Basket. Black ink transfers from 1 plot to another.

Media Basket - Climatic Conditions

	15C, 20%	35C, 80%
Plain Paper	OK. Behavior similar to normal conditions.	All plots are folded, some in a very bad way.
Coated Paper	OK. Behavior similar to normal conditions. Electrostatic behavior of some plots which are stuck to the front of the Multi-Roll Feeder, but this does not create any problems.	All plots are folded, some in a very bad way.
Heavy Coated	High ink content plots are not rolled as in normal conditions. Other plots are rolled normally.	All plots are folded, some in a very bad way.
Glossy Paper	High ink content plots are not rolled as in normal conditions. Other plots are rolled normally. Problem with the transfer of black ink from plot to plot.	All plots are folded, some in a very bad way. Some plots are stuck together, and inks are transferred from plot to plot.

Multi-Roll Feeder Capacity Limitations

The **maximum width** that the multi-roll feeder can handle is 914 mm (36").

The **minimum width** that the multi-roll feeder can handle is 610 mm (24") for hp supported media and 297 mm (11.7") for non-hp media.

The **maximum length** that the multi-roll feeder can handle is 91 m (300 feet) for hp supported media and 250 m (824 feet) for non-hp media (90g/m²).

The **minimum length** that the multi-roll feeder can handle is 297 mm (11.7").

The multi-roll feeder DOES NOT support hp canvas or hp vinyl media types.

Warranty Information

The multi-roll feeder comes with a one year warranty which is independent from the warranty status of the printer. The following information is stated in the warranty for the multi-roll feeder:

- Cleaning and preventive maintenance is excluded.
- Some parts are customer replaceable at the discretion of hp.
- The warranty is global.

Refer to the Warranty Statement in the Legal Information Document for the official Information.

Logging a Call Related to the Multi-Roll Feeder

The multi-roll feeder has it's own product number and warranty so if a customer calls with a problem related to the multi-roll feeder, the case should be logged against the multi-roll feeder and NOT the printer that the customer is using.

Check Warranty Status

The serial number of the multi-roll feeder uses the hp format which codifies the manufacturing date.

serial number format

Barcelona
CCRYMXXXXX

where:
 CC = country code, e.g. "ES"
 R = revision (A-Z)
 Y = year of the decade, e.g. '4' for 1994
 M = nth month (1-C)
 X = digit (0-9)

i.e. ESA0600001

Singapore
CCYMDVLXXX

where:
 CC = country code, e.g. "US", "SG"
 Y = year of the decade, e.g. '4' for 1994
 M = nth month, base 36 (alphanumeric)
 D = nth day, base 36
 V = version number of the model, base 30
 L = top-level line number, base 30
 X = base 30 character

Note:
 1. The XXX number will be reset to 001 only at midnight.
 The number will not be reset during changing of models.
 2. Base 36 includes alphanumeric (0-9) and (A-Z).
 3. Base 30 is the same as base 36, but excluding A, E, I, O, U and L.

The Serial Number can be found in the following locations:

- On the Product Label located at the back of the multi-roll feeder.
- On the 2nd page of the Service Configuration Print (Printer Setup Option ⇒ Utilities ⇒ Test Prints ⇒ Service Config).
- Through the printer's front panel (Printer Setup Option ⇒ Utilities ⇒ Statistics ⇒ multiroll info).

The model number of the multi-roll feeder will always be reported or marked as C2394Z

Multi-Roll Feeder Calibration

To control the load and paper movement, an analog sensor is mounted in the motion control unit of the multi-roll feeder. The voltages to be measured when this analog sensor is in: maximum position, reference position and idle position, are stored in the Non-Volatile Memory of the main electronics in the manufacturing line and then, used during normal operation. These values are dependent on the specific analog sensor mounted in the multi-roll feeder and they have to be measured and stored under controlled conditions.

To increase capacity in the manufacturing process and due to the variability in the output between different analog sensors, a potentiometer is mounted on the Main PCA that allows adjusting the gain for that specific sensor and then, linearize its output range.

ALWAYS PERFORM THIS CALIBRATION AFTER REPLACING THE MAIN PCA, MOTION CONTROL UNIT OR THE MOTION CONTROL SENSOR.

Perform the multi-roll feeder calibration as follows:

Make sure that you unload the media from the Printer before performing this calibration.

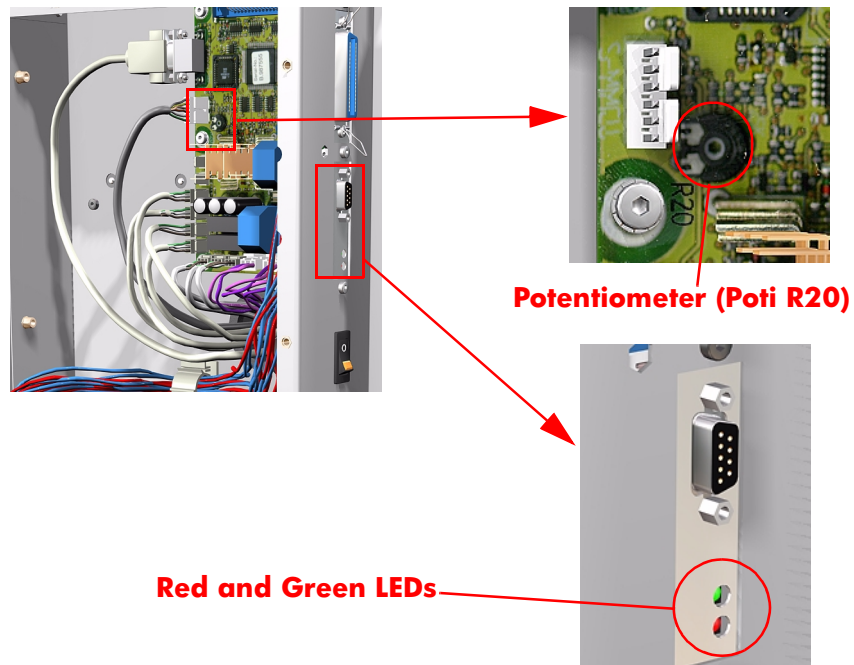

- 1** Switch on the printer and the multi-roll feeder. Make sure the multi-roll feeder is enabled and detected by the printer (Device Setup ⇒ Multi-roll ⇒ YES).
- 2** Load bright white paper, coated media or other media available which is not too thick (between 80 and 120g/m²) onto roll 1, but **do not** load it into the printer (printer may ask to load it when detected as new roll).

- 3 Through the front panel, launch the multi-roll calibration (Service Menu ⇒ Service Utilities ⇒ Multi-roll Calib). The multi-roll feeder automatically loads roll 1 into the printer, so that the idle level and the reference level are measured, then the media is pulled out of the printer so that the maximum position level is measured. The multi-roll feeder checks these 3 measured values and reports to the printer whether the calibration was performed correctly or not. If the printer reports the calibration has failed, a potentiometer placed in the main electronics, Poti R20, has to be adjusted.
- 4 Check if the green LED on the rear side, near the multi-roll serial and parallel connectors, is ON. If the calibration in **step 3** was successful and the green LED is ON, then the calibration was performed correctly and you must go directly to **step 17**.
- 5 If the red LED is ON or both the red and the green are flashing, the Poti R20 must be adjusted. In this case, it is very likely that **step 3** failed with a calibration error, but this does not matter.
- 6 Power OFF both the printer and the multi-roll feeder.
- 7 Unload the media from the printer as follows:
 - Remove the front top-cover of the multi-roll feeder
 - Raise the printer handles.
 - Turn roll 1 away from you to collect part of the media back onto the roll.
 - Lower the printer handles.
- 8 Remove the electronics access cover (⇒ Page 4-12), turn it over and re-install it so that it covers **only** the power supply unit. You must do this in order to protect yourself from any accidental electrical shock.
- 9 Power ON both the printer and the multi-roll feeder. Through the front panel, relaunch the multi-roll calibration (Service Menu ⇒ Service Utilities ⇒ Multi-roll Calib). The multi-roll feeder automatically loads roll 1 and performs the calibration (do not worry if it fails).



Make sure you take the necessary precautions in order to avoid electrical shock and ESD damages.

- 10 The Poti R20 in the main electronics has to be adjusted. Use a 2mm flat screwdriver and touch the metal casing of the main electronics before starting.
- 11 Slowly adjust the Poti R20 until the green LED is ON **and** the red LED is OFF. Be very careful when doing this because there is a very small window when the green LED is ON **and** the red LED is OFF.
- 12 Switch OFF the printer and the multi-roll feeder and wait 5 seconds.
- 13 Unload the media from the printer as follows:
 - Raise the printer handles.
 - Turn roll 1 away from you to collect part of the media back onto the roll.
 - Lower the printer handles.
- 14 Switch ON the printer and the multi-roll feeder and wait until initialization has finished; if the printer requests to configure a new roll **do not** load any roll.

- 15 Through the front panel, relaunch the multi-roll calibration (Service Menu ⇒ Service Utilities ⇒ Multi-roll Calib). The multi-roll feeder automatically loads roll 1 into the printer, so that the idle level and the reference level are measured again, now with the correct Poti adjustment. The media is then pulled out of the printer so that the maximum position level is measured. The multi-roll feeder checks these 3 measured values and reports to the printer whether the calibration was performed correctly or not.
- 16 Now the calibration result must be OK; if not, power OFF and repeat the process. Even though the calibration may pass after the second attempt, it is still possible that the red LED is ON (if it is, don't worry about it).
- 17 Power OFF both the printer and the multi-roll feeder and wait 5 seconds. If necessary, install the front top-cover.
- 18 Switch ON the printer and the multi-roll feeder and wait until initialization has finished; if the printer requests to configure a new roll **do not** load any roll.
- 19 Unload the roll through the printer's front panel.
- 20 Print a test print in order to check if loading and operation works (if the calibration was not successful, the loading will fail with an error).

Multi-Roll Usage (Counters) Utility

The purpose of the multi-roll usage utility is to view:

- **Load counters** - How many media loads have been performed during the life of the multi-roller feeder.
- **Total length cnt** - How much media has passed through the printer during the life of the multi-roll feeder (measured in inches).
- **Partial length cnt** - How much media has passed through the printer since the counters were last reset (measured in inches). This counter can be reset using the Reset Counter Utility.

Perform the multi-roll usage utility as follows:

- 1 Enter the Service Tools menu (Printer Setup Options ⇒ Utilities ⇒ Up and Enter keys together).
- 2 In the Service Utilities submenu, scroll to "11. Multi-roll Usage" and press **Enter**.

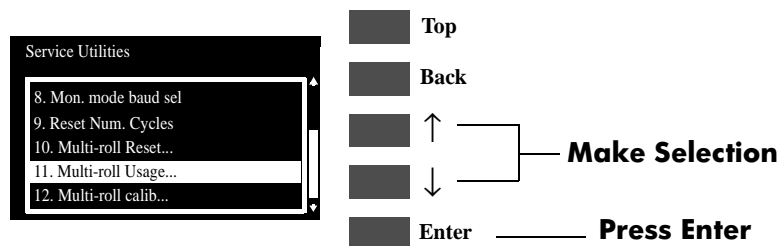

- 3 When the following message appears on the front panel, you must select whether you would like to view the mount of media loads, total length of

media loaded or partial media loaded. Press **ENTER** once you have made your selection.

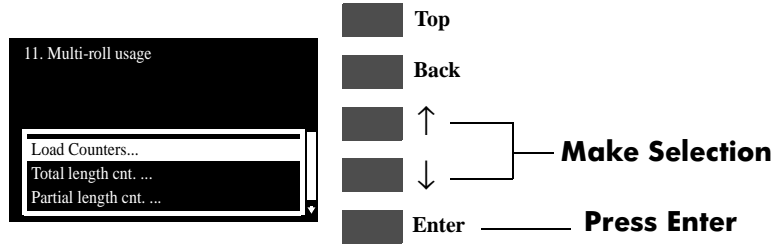

4 Depending on which option you select, you will see the following screen:

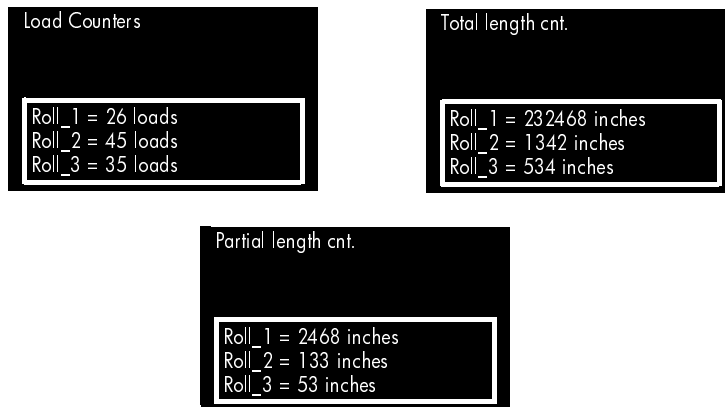

The above information is also available in the Service Print.

Multi-Roll Reset (Counters) Utility

The purpose of the multi-roll reset utility is to reset the partial length counter after one of the following parts are replaced:

- Transport Roller.
- Drive Clutches.
- Drive Motor.

For example, If you replace the Transport Roller for Roll 1, you would use this utility to reset the partial length counter for Roll 1 to 0 (zero).

- 1 Enter the Service Tools menu (Printer Setup Options ⇒ Utilities ⇒ Up and Enter keys together).
- 2 In the Service Utilities submenu, scroll to "10. Multi-roll Reset" and press **Enter**.

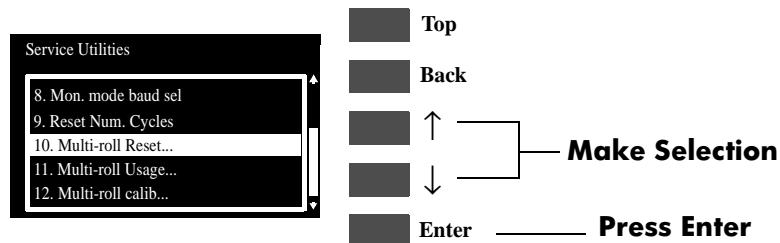

- 3** When the following message appears on the front panel, you must select which roll counter you want to reset. Press **ENTER** once you have made your selection.

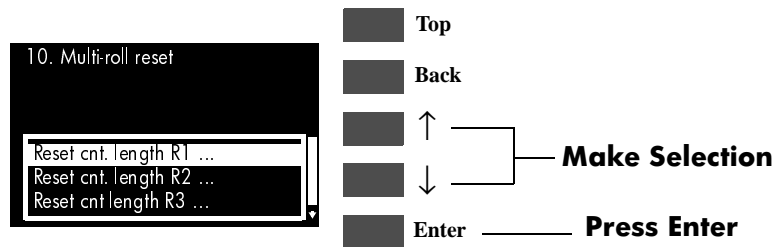

- 4** The following message will appear asking you to confirm the selection. Select **ACCEPT** if you want to continue, or select **CANCEL** if you want to cancel the test. Press **Enter** once the selection has been made.

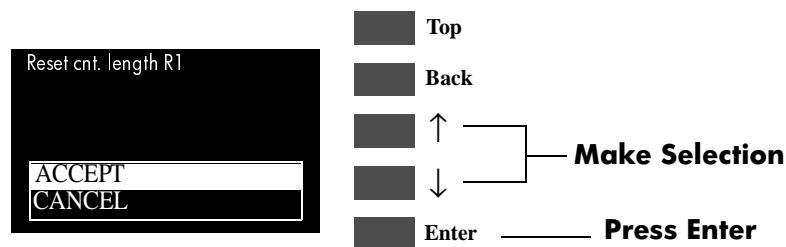

Limitations of the Printer with the Multi-Roll Feeder

There are some limitations of the printer when the multi-roll feeder is installed (or enabled) and these are explained as follows:

- 1** Even though some files can be printed with the printer (without the multi-roll feeder), it will report an 'Out of Memory' message if the printer has the multi-roll feeder option enabled. This is because the memory size available for the display list is ~2MB, and the memory needed for the firmware to control the multi-roll feeder is ~100KB, so when the multi-roll feeder is enabled, the available memory is reduced by 5%. **Solution** - If possible, upgrade the size of the memory available.
- 2** When loading a roll for the first time, if an ink cartridge is removed at the same time that the multi-roll feeder is loading the media, an error code will appear on the front panel (070100 XXXXXXX). **Solution** - Advise the customer not to remove the ink cartridges while the media is being loaded.
- 3** When nesting is turned ON and the printer is waiting for the next print in the nest, if the customer unloads a roll, removes it from the multi-roll feeder and installs a new, an error code will appear on the front panel (070100 XXXXXXX). **Solution** - Advise the customer not to unload a roll while the printer is waiting for the next print in the nest.



System Error Codes

2

System Error Codes for the Multi-Roll Feeder Only 2-2

0D0000 (Non-Continuable)	2-3
0D0001 (Non-Continuable)	2-3
0D0002 (Non-Continuable)	2-3
0D0003 (Non-Continuable)	2-3
0D0004 (Non-Continuable)	2-4
0D0005 (Non-Continuable)	2-4
0D0006 (Non-Continuable)	2-5
0D0007 (Non-Continuable)	2-6
0D0009 (Continuable)	2-7
0D000A (Continuable)	2-7
0D000B (Continuable)	2-8
0D000C (Non-Continuable)	2-8
0D000D (Non-Continuable)	2-8
0D000E (Non-Continuable)	2-9
0D000F (Non-Continuable)	2-9
0D0010 (Non-Continuable)	2-9
0D0011 (Non-Continuable)	2-9
0D0012 (Continuable)	2-10
0D0013 (Continuable)	2-10
0D0014 (Continuable)	2-11
0D0015 (Non-Continuable)	2-11
0D0016 (Non-Continuable)	2-12
0D0017 (Continuable)	2-12
0D0018 (Continuable)	2-12
0D001A (Continuable)	2-13
0D001B (Continuable)	2-13
0D001D (Non-Continuable)	2-13
0D001F (Non-Continuable)	2-13
0D0020	2-14
0D0021	2-14
0D0022 (Continuable)	2-14
0D0023 (Continuable)	2-14
0D0024 (Non-Continuable)	2-15
0D0025 (Non-Continuable)	2-15
0D0026 (Non-Continuable)	2-15
0D0027 (Non-Continuable)	2-15

System Error Codes for the Multi-Roll Feeder Only

Introduction

System error codes are hexa-decimal based numbers generally caused by internal system errors. The following pages contain a list of system error codes and their respective descriptions and recommended corrective actions. Only try one recommended action at a time and check if the error code has disappeared.

If you have an error code which is not documented in this Service Manual or you have an error which you cannot resolve, then report the error to the HP Response Center or the nearest HP Support Office. When reporting the error, have the following information ready:

- Model and Serial Number of the printer and the Multi-Roll Feeder.
- Which firmware revision the printer is using. Check firmware in *Utilities / Statistics / Code rev.*
- The complete error number.
- The Service Configuration Print.
- The Current configuration sheet.
- Which software application the customer is using (name, version, etc.).

Continuable Error Codes

Some of the Error Codes are continuable, which means the user can press **Enter** on the front-panel and he will be shown a second message explaining what to do in order to solve the problem.

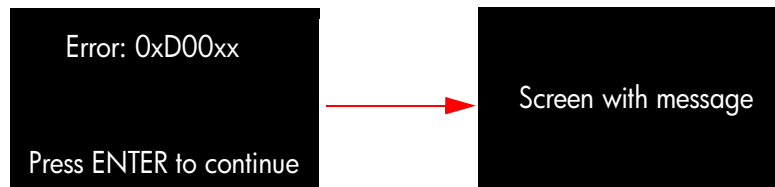

Even though the customer can continue working with a Continuable Error Code, an on-site visit should still be planned to troubleshoot the problem if it occurs frequently.

Non-Continuable Error Codes

Non-Continuable Error Codes do not allow you to continue working with the Printer and the Multi-Roll Feeder, in this case switch the Printer and the Multi-Roll Feeder OFF and ON again and see if the System Error disappears. If the Error Code reappears, then the Printer or the Multi-Roll Feeder may require an on-site visit in order to resolve the problem.

System Error:	OD0000 (Non-Continuable)
Problem Description:	Error in Channel Sensor 1 .
Front Panel Message	Switch power off/printer and multi-roll
Corrective Action:	Try the following: <ul style="list-style-type: none">■ Check that Channel Sensor 1 is correctly connected and positioned.■ Replace Channel Sensor 1 ⇒ Page 4-35.■ Replace the Main PCA ⇒ Page 4-15.
System Error:	OD0001 (Non-Continuable)
Problem Description:	Error in Channel Sensor 2 .
Front Panel Message	Switch power off/printer and multi-roll
Corrective Action:	Try the following: <ul style="list-style-type: none">■ Check that Channel Sensor 2 is correctly connected and positioned.■ Replace Channel Sensor 2 ⇒ Page 4-35.■ Replace the Main PCA ⇒ Page 4-15.
System Error:	OD0002 (Non-Continuable)
Problem Description:	Error in Channel Sensor 3 .
Front Panel Message	Switch power off/printer and multi-roll
Corrective Action:	Try the following: <ul style="list-style-type: none">■ Check that Channel Sensor 3 is correctly connected and positioned.■ Replace Channel Sensor 3 ⇒ Page 4-35.■ Replace the Main PCA ⇒ Page 4-15.
System Error:	OD0003 (Non-Continuable)
Problem Description:	Error in the Reference Sensor (the channel sensor directly below the motion control unit).
Front Panel Message	Switch power off/printer and multi-roll
Corrective Action:	Try the following: <ul style="list-style-type: none">■ Check that the Reference Sensor (Channel Sensor) is correctly connected and positioned.■ Replace the Reference Sensor (Channel Sensor) ⇒ Page 4-35.■ Replace the Main PCA ⇒ Page 4-15.

System Error: OD0004 (**Non-Continuable**)

Problem Description: Unexpected stop in Spindle Drive Motor **1** - can be due to motor overloaded, motor short-circuited, motor not connected, over-temperature, excessive driving length due to sensor errors, media jam or media related problem.

Front Panel Message: Switch power off/printer and multi-roll

- Corrective Action:** Try the following:
- Check that the orange levers are released.
 - Check that there is no media jam inside the Multi-Roll Feeder - Some media rolls are manufactured with the trailing edge bent, so that when the roll ends it causes higher friction than expected and then an overload is reported.
 - Clean the rollers to prevent paper dust from accumulating.
 - Make sure that the media currently being used is supported since high friction media could generate overloads.
 - Unload media from roll **1**. Press down the orange levers to open the slot between the rollers. Check that the riding roller has a horizontal play of 0.5 - 1.00 mm, otherwise the pressure is too low in order to move the media, causing it to slip.
 - With no media loaded in roll **1** and the orange levers down, check that the transport roller has a horizontal play of 0.5 - 1.00 mm.
 - Check that the transport roller is clutched correctly to the spindle drive motor. Try to turn the transport roller to get a back-force from the motor (the clutch must be fixed on the motor side and the transport roller side).
 - Check that ALL cables are connected correctly to the Spindle Drive Motor and that the cables are connected correctly to the Main PCA.
 - Replace the Spindle Drive Motor **1** ⇒ Page 4-18.

System Error: OD0005 (**Non-Continuable**)

Problem Description: Unexpected stop in Spindle Drive Motor **2** - can be due to motor overloaded, motor short-circuited, motor not connected, over-temperature, excessive driving length due to sensor errors, media jam or media related problem.

Front Panel Message: Switch power off/printer and multi-roll

- Corrective Action:** Try the following:
- Check that the orange levers are released.
 - Check that there is no media jam inside the Multi-Roll Feeder - Some media rolls are manufactured with the trailing edge bent, so that when the roll ends it causes higher friction than expected and then an overload is reported.
 - Clean the rollers to prevent paper dust from accumulating.
 - Make sure that the media currently being used is supported since high friction media could generate overloads.
 - Check that the riding roller has a horizontal play of 0.5 - 1.00 mm, otherwise the pressure is too low in order to move the media, causing it to slip.
 - Try using roll 1 and see if the problem also occurs there. If the problem

does not appear in roll 1, then use roll 1 for the type of media being used, and move media with less friction to roll 2.

- Unload media from roll **2**. Press down the orange levers to open the slot between the rollers. Check that the riding roller has a horizontal play of 0.5 - 1.00 mm, otherwise the pressure is too low in order to move the media, causing it to slip.
- With no media loaded in roll **2** and the orange levers down, check that the transport roller has a horizontal play of 0.5 - 1.00 mm.
- Check that the transport roller is clutched correctly to the spindle drive motor. Try to turn the transport roller to get a back-force from the motor (the clutch must be fixed on the motor side and the transport roller side).
- Check that ALL cables are connected correctly to the Spindle Drive Motor and that the cables are connected correctly to the Main PCA.
- Replace the Spindle Drive Motor **2** ⇒ Page 4-18.

System Error: OD0006 (**Non-Continuable**)

Problem Description: Unexpected stop in Spindle Drive Motor **3** - can be due to motor overloaded, motor short-circuited, motor not connected, over-temperature, excessive driving length due to sensor errors, media jam or media related problem.

Front Panel Message: Switch power off/printer and multi-roll

- Corrective Action:** Try the following:
- Check that the orange levers are released.
 - Check that there is no media jam inside the Multi-Roll Feeder - Some media rolls are manufactured with the trailing edge bent, so that when the roll ends it causes higher friction than expected and then an overload is reported.
 - Clean the rollers to prevent paper dust from accumulating.
 - Make sure that the media currently being used is supported since high friction media could generate overloads.
 - Check that the riding roller has a horizontal play of 0.5 - 1.00 mm, otherwise the pressure is too low in order to move the media, causing it to slip.
 - Try using roll 1 and see if the problem also occurs there. If the problem does not appear in roll 1, then use roll 1 for the type of media being used, and move media with less friction to roll 3.
 - Unload media from roll **3**. Press down the orange levers to open the slot between the rollers. Check that the riding roller has a horizontal play of 0.5 - 1.00 mm, otherwise the pressure is too low in order to move the media, causing it to slip.
 - With no media loaded in roll **3** and the orange levers down, check that the transport roller has a horizontal play of 0.5 - 1.00 mm.
 - Check that the transport roller is clutched correctly to the spindle drive motor. Try to turn the transport roller to get a back-force from the motor (the clutch must be fixed on the motor side and the transport roller side).
 - Check that ALL cables are connected correctly to the Spindle Drive Motor and that the cables are connected correctly to the Main PCA.
 - Replace the Spindle Drive Motor **3** ⇒ Page 4-18.

System Error: OD0007 (**Non-Continuable**)**Problem Description:**

The digital sensor (which is part of the Motion Control Sensor) is active on start of load but there must be NO media loaded. This System Error could also appear if the Multi-Roll Feeder received a shock during transportation that could have deformed the metal sheet holding the Motion Control Sensor and moved the digital sensor.

Front Panel Message

Switch power off/printer and multi-roll

Corrective Action: Try the following:

- If the Motion Control Sensor, Motion Control Unit or the Main PCA has been replaced, the Multi-Roll Feeder must be calibrated first ⇒ Page 1-15.
- This System Error Code could also appear if the Multi-Roll Feeder received a shock during transportation that could have deformed the metal sheet holding the Motion Control Sensor - Check if the Rear Top-Cover is damaged.
- Check that the Motion Control Sensor is correctly connected and positioned - when the motion control unit is in the idle position (no paper loaded in the printer), the digital sensor must be clear out of the slot of the screen-photocell. The distance between the digital-sensor component and the slot of the screen-photocell must be between 1.0-1.5 mm (see illustration on the left).
- If the digital sensor is misplaced due to damage during transportation, replace the Motion Control Unit ⇒ Page 4-30 (and then recalibrate).
- If the digital sensor is still correctly positioned but doesn't work, replace the Motion Control Sensor ⇒ Page 4-33 (and then recalibrate).
- Recalibrate the Multi-Roll Feeder ⇒ Page 1-15.

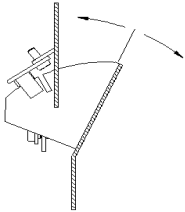
**System Error:** OD0008 (**Non-Continuable**)**Problem Description:**

Error in the analog sensor of the Motion Control Unit.

Front Panel Message

Switch power off/printer and multi-roll

Corrective Action: Try the following:

- Check that the Motion Control Sensor is correctly connected and positioned centrally to the hole of the sensor bracket.
- Replace the Motion Control Sensor ⇒ Page 4-33 (and then recalibrate).
- Recalibrate the Multi-Roll Feeder ⇒ Page 1-15.

System Error:

 OD0009 (**Continuable**)

Problem Description:

 Material jam detected on Roll **1** - During initialization it is possible that the system is not able to determine what roll generated the media jam.

Front Panel Message

Possibly a paper jam ⇒ 1. Power off printer and multi roll/2. Clear paper path/3. Switch power on/4. Align printheads

Corrective Action:

Try the following:

- Check that there is no media remaining in the media channel.
- Check that there is no media blocking the Motion Control Sensor.
- Clean rollers to remove any paper dust.
- Check that the Motion Control Sensor (Analog and Digital) is correctly connected and positioned.
 - the analog sensor positioned centrally to the hole of the sensor bracket.
 - when the motion control unit is in the idle position (no paper loaded in the printer), the digital sensor must be clear out of the slot of the screen-photocell. The distance between the digital-sensor component and the slot of the screen-photocell must be between 1.0-1.5 mm (see illustration on the left).
- Check that the top channel sensor (reference sensor) is positioned centrally to the hole of the sensor bracket.
- Replace the Motion Control Sensor ⇒ Page 4-33 (and then recalibrate).
- Recalibrate the Multi-Roll Feeder ⇒ Page 1-15.

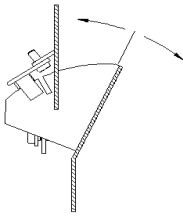
System Error:

 OD000A (**Continuable**)

Problem Description:

 Material jam on Roll **2**.

Front Panel Message

Possibly a paper jam ⇒ 1. Power off printer and multi roll/2. Clear paper path/3. Switch power on/4. Align printheads

Corrective Action:

Try the following:

- Check that there is no media remaining in the media channel.
- Check that there is no media blocking the Motion Control Sensor.
- Clean rollers to remove any paper dust.
- Check that the Motion Control Sensor (Analog and Digital) is correctly connected and positioned.
 - the analog sensor positioned centrally to the hole of the sensor bracket.
 - when the motion control unit is in the idle position (no paper loaded in the printer), the digital sensor must be clear out of the slot of the screen-photocell. The distance between the digital-sensor component and the slot of the screen-photocell must be between 1.0-1.5 mm (see illustration on the left).
- Check that the top channel sensor (reference sensor) is positioned centrally to the hole of the sensor bracket.
- Replace the Motion Control Sensor ⇒ Page 4-33 (and then recalibrate).
- Recalibrate the Multi-Roll Feeder ⇒ Page 1-15.

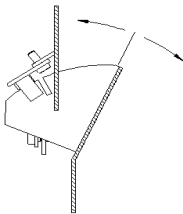

System Error: 0D000B (**Continuable**)**Problem Description:**

Material jam on Roll 3.

Front Panel Message

Possibly a paper jam ⇒ 1. Power off printer and multi roll/2. Clear paper path/3. Switch power on/4. Align printheads

Corrective Action:

Try the following:

- Check that there is no media remaining in the media channel.
- Check that there is no media blocking the Motion Control Sensor.
- Clean rollers to remove any paper dust.
- Check that the Motion Control Sensor (Analog and Digital) is correctly connected and positioned.
 - the analog sensor positioned centrally to the hole of the sensor bracket.
 - when the motion control unit is in the idle position (no paper loaded in the printer), the digital sensor must be clear out of the slot of the screen-photocell. The distance between the digital-sensor component and the slot of the screen-photocell must be between 1.0-1.5 mm (see illustration on the left).
- Check that the top channel sensor (reference sensor) is positioned centrally to the hole of the sensor bracket.
- Replace the Motion Control Sensor ⇒ Page 4-33 (and then recalibrate).
- Recalibrate the Multi-Roll Feeder ⇒ Page 1-15.

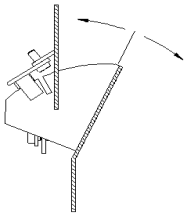
**System Error:** 0D000C (**Non-Continuable**)**Problem Description:**

Undervoltage +12v.

Front Panel Message

Switch power off/printer and multi-roll

Corrective Action:

Try the following:

- Check the cable connection between the Main PCA and the Power Supply Unit.
- Replace the Power Supply Unit ⇒ Page 4-13
- Replace the Main PCA ⇒ Page 4-15.

System Error: 0D000D (**Non-Continuable**)**Problem Description:**

Excess voltage +12v.

Front Panel Message

Switch power off/printer and multi-roll

Corrective Action:

Try the following:

- Check the cable connection between the Main PCA and the Power Supply Unit.
- Replace the Power Supply Unit ⇒ Page 4-13
- Replace the Main PCA ⇒ Page 4-15.

System Error:	OD000E (Non-Continuable)
Problem Description:	Undervoltage -12v.
Front Panel Message	Switch power off/printer and multi-roll
Corrective Action:	Try the following: <ul style="list-style-type: none">■ Check the cable connection between the Main PCA and the Power Supply Unit.■ Replace the Power Supply Unit ⇒ Page 4-13■ Replace the Main PCA ⇒ Page 4-15.
System Error:	OD000F (Non-Continuable)
Problem Description:	Excess voltage -12v.
Front Panel Message	Switch power off/printer and multi-roll
Corrective Action:	Try the following: <ul style="list-style-type: none">■ Check the cable connection between the Main PCA and the Power Supply Unit.■ Replace the Power Supply Unit ⇒ Page 4-13■ Replace the Main PCA ⇒ Page 4-15.
System Error:	OD0010 (Non-Continuable)
Problem Description:	Undervoltage +24v.
Front Panel Message	Switch power off/printer and multi-roll
Corrective Action:	Try the following: <ul style="list-style-type: none">■ Check the cable connection between the Main PCA and the Power Supply Unit.■ Replace the Power Supply Unit ⇒ Page 4-13■ Replace the Main PCA ⇒ Page 4-15.
System Error:	OD0011 (Non-Continuable)
Problem Description:	Excess voltage +24v.
Front Panel Message	Switch power off/printer and multi-roll
Corrective Action:	Try the following: <ul style="list-style-type: none">■ Check the cable connection between the Main PCA and the Power Supply Unit.■ Replace the Power Supply Unit ⇒ Page 4-13■ Replace the Main PCA ⇒ Page 4-15.

System Error: OD0012 (**Continuable**)**Problem Description:** An overload is detected in Spindle Drive Motor **1**.**Front Panel Message:** High Roller friction ⇒ 1. Power off printer and multi roll/2. Clear paper path/
3. Power on, perform cleaning on roll 1**Corrective Action:** Try the following:

- This error could occur while cleaning the Transport Roller as a protection for the user. If this is the case, try cleaning the Transport Roller using lighter force.
- Check that there is no media jam.
- Check that there is no media or object blocking the movement of the Transport Roller.
- Clean the Transport Roller.
- Unload media from roll **1**. Press down the orange levers to open the slot between the rollers. Check that the transport roller has a horizontal play of 0.5 - 1.00 mm.
- Check that the transport roller is clutched correctly to the spindle drive motor. Try to turn the transport roller to get a back-force from the motor (the clutch must be fixed on the motor side and the transport roller side).

System Error: OD0013 (**Continuable**)**Problem Description:** An overload is detected in Spindle Drive Motor **2**.**Front Panel Message:** High Roller friction ⇒ 1. Power off printer and multi roll/2. Clear paper path/
3. Power on, perform cleaning on roll 1**Corrective Action:** Try the following:

- This error could occur while cleaning the Transport Roller as a protection for the user. If this is the case, try cleaning the Transport Roller using lighter force.
- Check that there is no media jam.
- Check that there is no media or object blocking the movement of the Transport Roller.
- Clean the Transport Roller.
- Unload media from roll **2**. Press down the orange levers to open the slot between the rollers. Check that the transport roller has a horizontal play of 0.5 - 1.00 mm.
- Check that the transport roller is clutched correctly to the spindle drive motor. Try to turn the transport roller to get a back-force from the motor (the clutch must be fixed on the motor side and the transport roller side).

System Error: OD0014 (**Continuable**)

Problem Description: An overload is detected in Spindle Drive Motor **3**.

Front Panel Message: High Roller friction ⇒ 1. Power off printer and multi roll/2. Clear paper path/3. Power on, perform cleaning on roll 1

Corrective Action: Try the following:

- This error could occur while cleaning the Transport Roller as a protection for the user. If this is the case, try cleaning the Transport Roller using lighter force.
- Check that there is no media jam.
- Check that there is no media or object blocking the movement of the Transport Roller.
- Clean the Transport Roller.
- Unload media from roll **3**. Press down the orange levers to open the slot between the rollers. Check that the transport roller has a horizontal play of 0.5 - 1.00 mm.
- Check that the transport roller is clutched correctly to the spindle drive motor. Try to turn the transport roller to get a back-force from the motor (the clutch must be fixed on the motor side and the transport roller side).

System Error: OD0015 (**Non-Continuable**)

Problem Description: High temperature measured on the Main PCA for the Multi-Roll Feeder near the bridge transistors for the motor drives.

Front Panel Message: Switch power off/printer and multi-roll

Corrective Action: Try the following:

- Power OFF both the printer and the Multi-Roll Feeder and wait a few minutes. Power ON both the printer and the Multi-Roll Feeder and check if the problem reappears.
- Check that the room temperature is within the environmental specifications.
- Clean the Transport Rollers.
- If the problem continues, replace the Main PCA ⇒ Page 4-15.

System Error: ODO016 (**Non-Continuable**)**Problem Description:**

Loading Error (Reference Sensor not reached) - When loading media, the leading edge of the media takes too long to reach the reference sensor (the channel sensor directly below the motion control unit) from the corresponding channel sensor.

Front Panel Message

Switch power off/printer and multi-roll

Corrective Action:

Try the following:

- Check that there is no media jam inside the Multi-Roll Feeder and that there is media loaded.
- Check that the Reference Sensor (Channel Sensor) is correctly connected and positioned.
- Clean rollers to remove any paper dust.
- Replace the Reference Sensor (Channel Sensor) ⇒ Page 4-35.

System Error: ODO017 (**Continuable**)**Problem Description:**

Loading error (printer transport system) - The printer is not picking up the leading edge of the roll provided by the Multi-Roll Feeder.

Front Panel Message

Unable to load paper ⇒ 1. Power off printer and multi roll/2. Clear paper path/3. Check rear cover is completely closed

Corrective Action:

Try the following:

- Check that the printer handles (used to load sheet paper) are fully closed.
- Check that the Rear Top-Cover is fully closed.
- Check that there is no media jam in the Printer.
- Clean rollers to remove any paper dust.
- Check the media sensor in the Printer.

System Error: ODO018 (**Continuable**)**Problem Description:**

Loading error (overcount of motor-steps) - A roll is being loaded and, when moving the media from the channel sensor to the reference sensor, the reference sensor is not reached because of the excessive driving length.

Front Panel Message

Possibly out of paper or paper slips ⇒ 1. Power off printer and multi roll/2. If paper slips, perform cleaning

Corrective Action:

Try the following:

- Check that there is no media jam inside the Multi-Roll Feeder and that there is media loaded.
- Check that the orange levers are released.
- Check that the transport roller is clutched correctly to the spindle drive motor. Try to turn the transport roller to get a back-force from the motor (the clutch must be fixed on the motor side and the transport roller side).
- Check that the Reference Sensor (Channel Sensor) is correctly connected and positioned.
- Replace the Reference Sensor (Channel Sensor) ⇒ Page 4-35.

System Error:	OD001A (Continuable)
Problem Description:	Unable to unload rest of paper web - After several attempts, the Multi-Roll Feeder failed to unload the media because the media is still detected by the reference sensor.
Front Panel Message	Unable to unload paper ⇒ 1. Power off printer and multi roll/2. Clean paper path
Corrective Action:	Try the following: <ul style="list-style-type: none">■ Check that the Cutter is installed in the Printer. If the Cutter is removed, it could cause an excessive amount of media to be in front of the Printer.■ Check that there is no media blocking the Reference Sensor (the channel sensor directly below the motion control unit).■ Check that the Reference Sensor (Channel Sensor) is correctly connected and positioned.■ Replace the Reference Sensor (Channel Sensor) ⇒ Page 4-35.
System Error:	OD001B (Continuable)
Problem Description:	Communication error (during load or unload).
Front Panel Message	Communication fail ⇒ 1. Power off printer and multi roll/2. Check multi-roll/3. Check connections
Corrective Action:	Try the following: <ul style="list-style-type: none">■ Make sure that the Printer is ON and working.■ Check the connections between the Printer and the Multi-Roll Feeder (Parallel port connected and serial port for printers models C6074A and C6075A).
System Error:	OD001D (Non-Continuable)
Problem Description:	Error while reading from the EEPROM in the Main PCA of the Multi-Roll Feeder.
Front Panel Message	Switch power off/printer and multi-roll
Corrective Action:	Try the following: <ul style="list-style-type: none">■ Check that the Multi-Roll Feeder is On and working.■ If the problem continues, replace the Main PCA ⇒ Page 4-15.
System Error:	OD001F (Non-Continuable)
Problem Description:	Multi-Roll Feeder busy - Multi-Roll Feeder takes too long to process a command so a Printer timeout has occurred.
Front Panel Message	Switch power off/printer and multi-roll
Corrective Action:	Try the following: <ul style="list-style-type: none">■ Reboot the Printer and the Multi-Roll Feeder.■ If the problem continues, check for a new Printer firmware version.

System Error:	OD0020
Problem Description:	Multi-Roll Feeder unknown - Communication has been lost.
Front Panel Message	Switch power off/printer and multi-roll
Corrective Action:	<p>Try the following:</p> <ul style="list-style-type: none"> ■ Reboot the Printer and the Multi-Roll Feeder. ■ Check the connections between the Printer and the Multi-Roll Feeder (Parallel port connected and serial port for printers models C6074A and C6075A). ■ Replace the cable connection between the Printer and the Multi-Roll Feeder (parallel cable for printers models C6074B and C6075B and serial cable for printers models C6074A and C6075A). ■ If the problem continues, check for a new Printer firmware version.
System Error:	OD0021
Problem Description:	Multi-Roll Feeder error - Communication has been lost when processing a command.
Front Panel Message	Switch power off/printer and multi-roll
Corrective Action:	<p>Try the following:</p> <ul style="list-style-type: none"> ■ Reboot the Printer and the Multi-Roll Feeder. ■ If the problem continues, check for a new Printer firmware version.
System Error:	OD0022 (Continuable)
Problem Description:	No ACK received from the Multi-Roll Feeder - Communication has been lost when processing a command.
Front Panel Message	Communication fail ⇒ 1. Power off printer and multi roll/2. Check multi-roll/3. Check connections
Corrective Action:	<p>Try the following:</p> <ul style="list-style-type: none"> ■ Reboot the Printer and the Multi-Roll Feeder. ■ If the problem continues, check for a new Printer firmware version.
System Error:	OD0023 (Continuable)
Problem Description:	No RET received from the Multi-Roll Feeder - Communication has been lost when processing a command.
Front Panel Message	Communication fail ⇒ 1. Power off printer and multi roll/2. Check multi-roll/3. Check connections
Corrective Action:	<p>Try the following:</p> <ul style="list-style-type: none"> ■ Reboot the Printer and the Multi-Roll Feeder. ■ If the problem continues, check for a new Printer firmware version.

- System Error:** OD0024 (**Non-Continuable**)
- Problem Description:** Multi-Roll Feeder WAIT command received - Communication has been lost when processing a command.
- Front Panel Message:** Switch power off/printer and multi-roll
- Corrective Action:** Try the following:
- Reboot the Printer and the Multi-Roll Feeder.
 - If the problem continues, check for a new Printer firmware version.
- System Error:** OD0025 (**Non-Continuable**)
- Problem Description:** Multi-Roll Feeder initialization not finished - Multi-Roll Feeder takes too long to initialize so a Printer timeout has occurred.
- Front Panel Message:** Switch power off/printer and multi-roll
- Corrective Action:** Try the following:
- Make sure that the Multi-Roll Feeder is ON and working.
 - Check for a new Printer firmware version.
- System Error:** OD0026 (**Non-Continuable**)
- Problem Description:** Multi-Roll Feeder error - While printing, the communication is lost and the Multi-Roll Feeder does not reply.
- Front Panel Message:** Switch power off/printer and multi-roll
- Corrective Action:** Try the following:
- Make sure that the Multi-Roll Feeder is ON and working.
 - Power OFF both the printer and the Multi-Roll Feeder.
 - Check the connections between the Printer and the Multi-Roll Feeder.
- System Error:** OD0027 (**Non-Continuable**)
- Problem Description:** Error while writing to the EEPROM in the Main PCA of the Multi-Roll Feeder.
- Front Panel Message:** Switch power off/printer and multi-roll
- Corrective Action:** Try the following:
- Replace the Main PCA ⇒ Page 4-15.



--

Parts and Diagrams

3

Front Assemblies 3-2
Right Assemblies 3-4
Left Assemblies 3-6
Rear Assemblies 3-8
Internal Assemblies 3-10
Miscellaneous Items 3-12

Front Assemblies

Front Assemblies			
Reference on Drawing	HP Part Number	Quantity	Description/Comments
1	C2394-60010	1	Right Door
2	C2394-60011	1	Left Door
3	C2394-60009	2	Foot Assembly
4	C2394-60003	1	Front Bottom Cover
5	C2394-60007	1	Front Top Cover

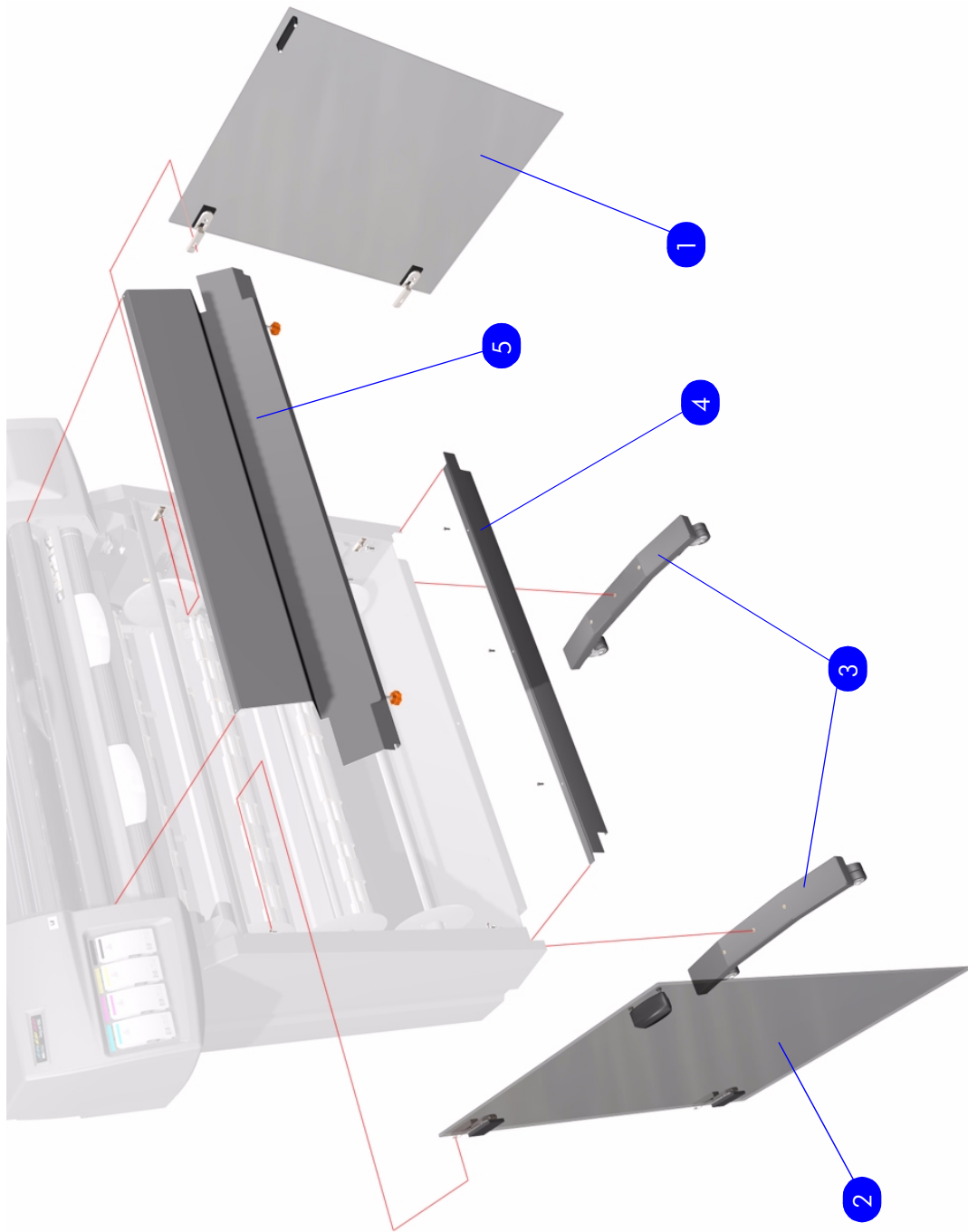

Figure 1: Front Assemblies

Right Assemblies

Right Assemblies			
Reference on Drawing	HP Part Number	Quantity	Description/Comments
1	C2394-60005	1	Right Side Cover
2	C2394-60025	1	Electronics Module Chassis
3	C2394-60002	1	Main PCA
4	C2394-60001	1	Power Supply Unit

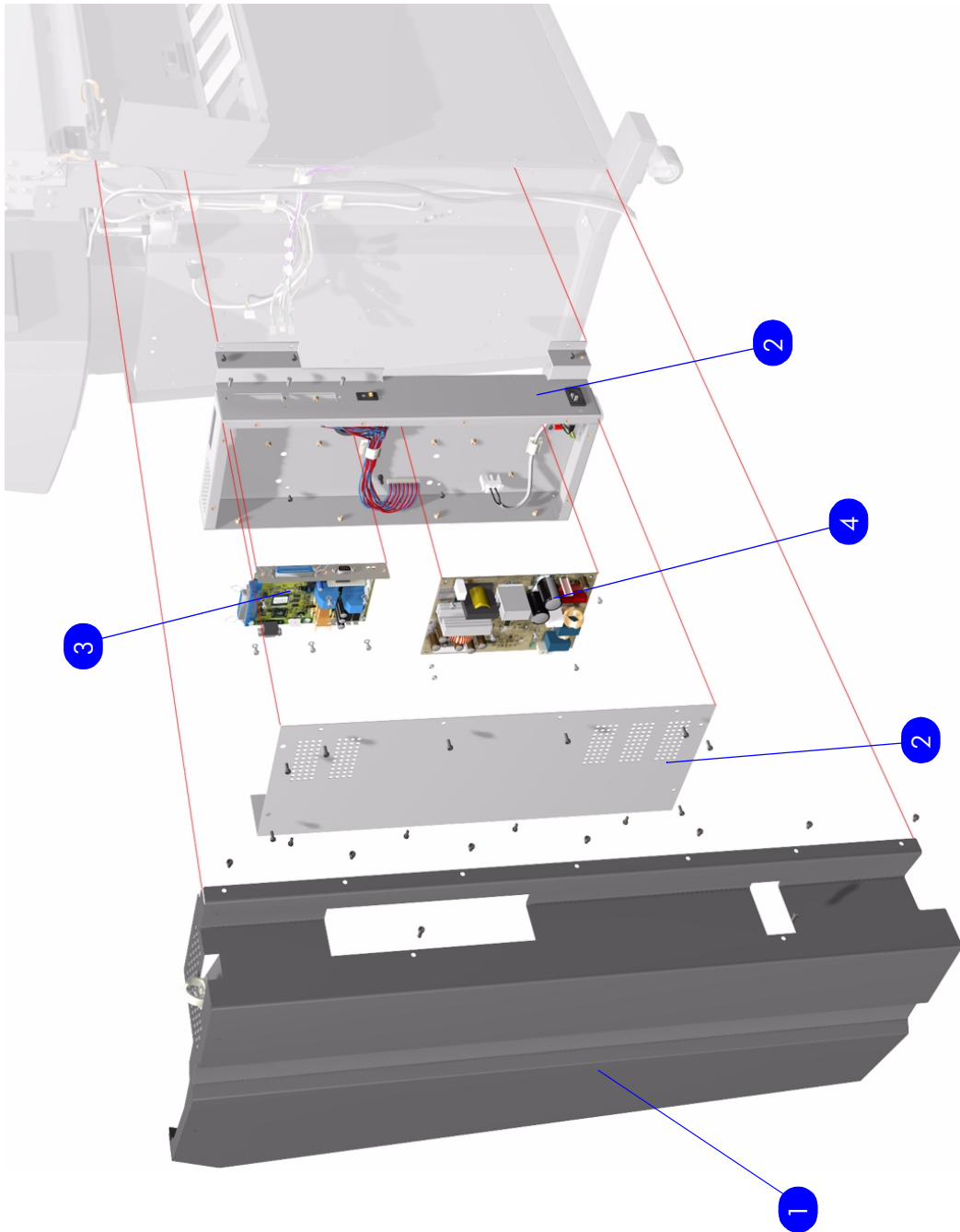

Figure 2: Right Assemblies

Left Assemblies

Left Assemblies			
Reference on Drawing	HP Part Number	Quantity	Description/Comments
1	C2394-60004	1	Left Side Cover
2	C2394-60022	3	Spindle Drive Motor
3	C2394-60023	3	Drive Clutches

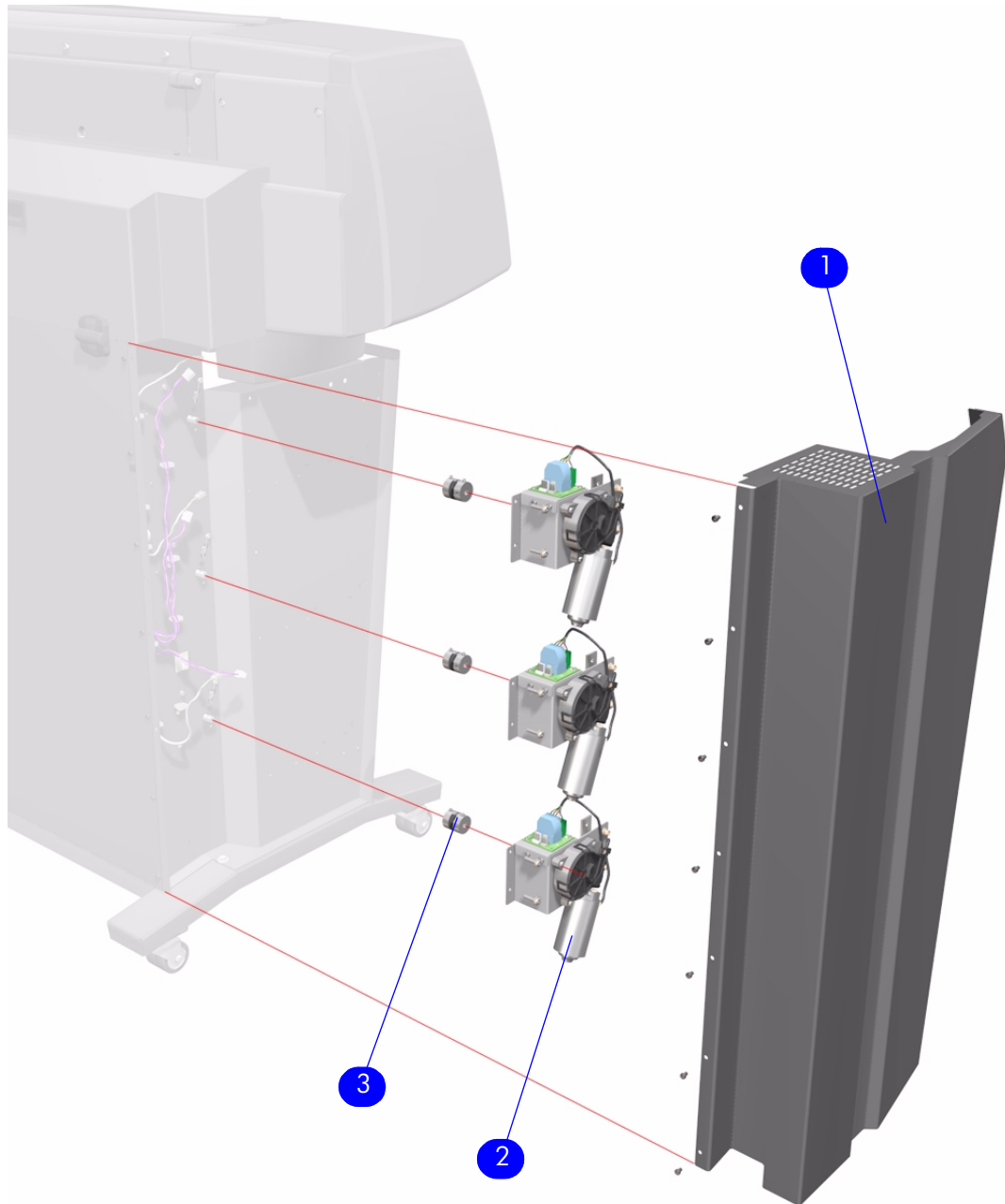

Figure 3: Left Assemblies

Rear Assemblies

Rear Assemblies			
Reference on Drawing	HP Part Number	Quantity	Description/Comments
1	C2394-60008	1	Rear Top Cover
2	C2394-60006	1	Rear Bottom Cover
3	C2394-60012	1	Infeed Unit
4	C2394-60020	1	Motion Control Unit (also includes the motion control sensor)
5	C2394-60019	1	Motion Control Sensor
6	C2394-60018	1	Wiring Harness

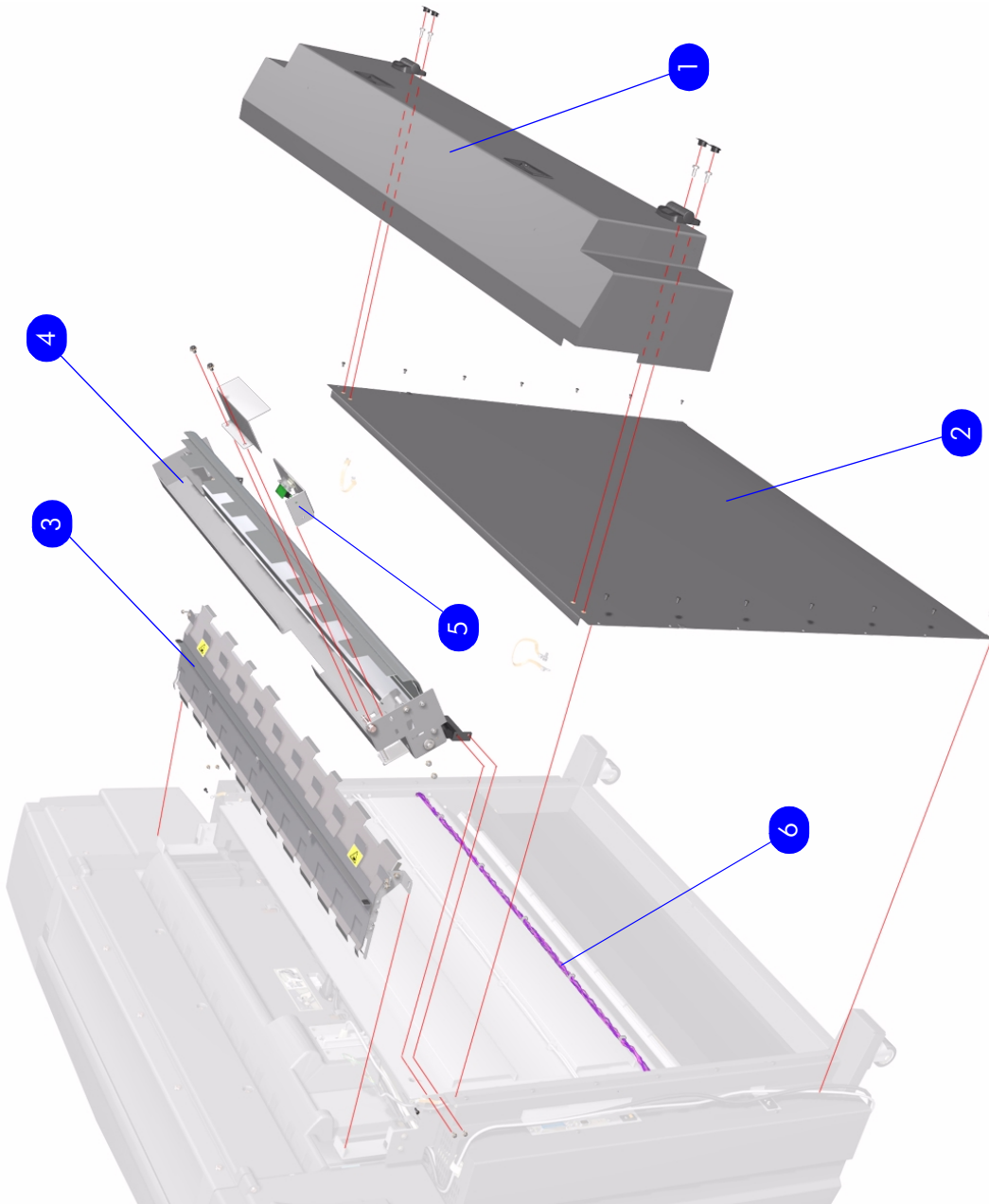

Figure 4: Rear Assemblies

Internal Assemblies

Internal Assemblies			
Reference on Drawing	HP Part Number	Quantity	Description/Comments
1	C2394-60016	3	Spindle
2	C2394-60017	3	Left and Right Spindle Retainers
3	C2394-60013	3	Riding Roller
4	C2394-60024	3	Left and Right Roller Levers
5	C2394-60014	1	Transport Roller
6	C2394-60015	3	Roller bearing
7	C2394-60021	4	Channel Sensor

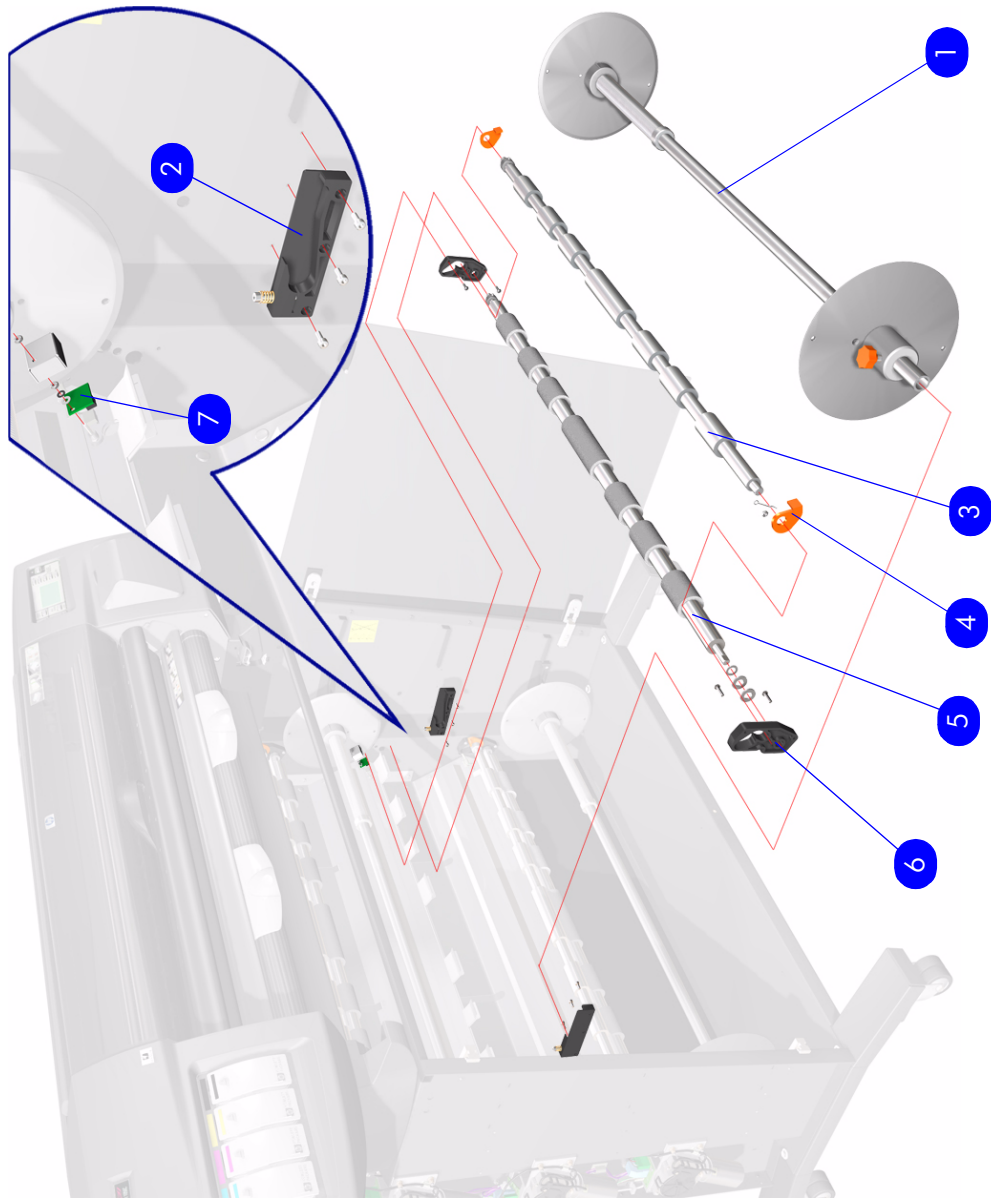

Figure 5: Internal Assemblies

Miscellaneous Items

Miscellaneous Assemblies			
Reference on Drawing	HP Part Number	Quantity	Description/Comments
-	C2394-60026	1	Hardware Kit (Includes Screw Drivers)
-	C2394-60027	1	Media Basket
-	C6074-60304	1	Printer Firmware - RTL Version (1000 series)
-	C6075-60249	1	Printer Firmware - PostScript Version (1000 series)
-	C6074-60294	1	Printer Firmware - RTL Version (1000 plus series)
-	C6074-60295	1	Printer Firmware - PostScript Version (1000 plus series)

Removal and Installation

4

Introduction	4-2
Left Door (P/N C2394-60011) - User Replaceable	4-4
Right Door (P/N C2394-60010) - User Replaceable	4-5
Front Bottom-Cover (P/N C2394-60003) - User Replaceable	4-6
Front Top-Cover (P/N C2394-60007) - User Replaceable	4-7
Right Side Cover (P/N C2394-60005) - User Replaceable	4-8
Left Side Cover (P/N C2394-60004) - User Replaceable	4-10
Electronics Access Cover (P/N C2394-60025)	4-12
Power Supply Unit (P/N C2394-60001)	4-13
Main PCA (P/N C2394-60002)	4-15
Bottom Electronics Cover (P/N C2394-60025)	4-17
Spindle Drive Motors 1, 2 and 3 (P/N C2394-60022)	4-18
Drive Clutches (P/N C2394-60023)	4-20
Left and Right Spindle Retainers (P/N C2394-60017)	4-21
Riding Roller (P/N C2394-60013)	4-22
Roller Levers (P/N C2394-60024)	4-24
Transport Roller (P/N C2394-60014)	4-25
Rear Top-Cover (P/N C2394-60008)	4-28
Motion Control Unit (P/N C2394-60020)	4-30
Motion Control Sensor (P/N C2394-60019)	4-33
Channel Sensor (P/N C2394-60021)	4-35
Rear Bottom-Cover (P/N C2394-60006) - User Replaceable	4-37
Infeed Unit (P/N C2394-60012) - User Replaceable	4-38

Introduction

This chapter is a step by step guide to the removal and installation of the key components in the product. You may find it useful to tick off the steps as they are performed. Use the illustration at each procedure to identify the parts referred to in the text.

The procedures appear in order of removal. So the whole product can be stripped down by starting at the beginning of this chapter and working through the subsequent procedures.

Safety Precautions

Review WARNING and CAUTION symbols and instructions before you service the printer. Follow these warnings and cautions for your protection and to avoid damaging the printer.

Serious shock hazard leading to death or injury may result if you do not take the following precautions:

Ensure that the ac power outlet (mains) has a protective earth (ground) terminal.

Switch both the printer and the multi-roll feeder OFF, and disconnect them from the power source prior to performing any maintenance.

Prevent water or other liquids from running onto electrical components or circuits, or through openings in the module.

Electrostatic Discharge (ESD) Precautions

To prevent damage to the Product circuits from high-voltage electrostatic discharge (ESD):

1. Do not wear clothing that is subject to static build-up.
2. Do not handle integrated circuits (ICs) in carpeted areas.
3. Do not remove an IC or a printed circuit assembly (PCA) from its conductive foam pad or conductive packaging until you are ready to install it.
4. Ground (earth) your body while disassembling and working on the multi-roll feeder. This can be done by touching any metallic part of the multi-roll feeder.
5. After removing a cover from the multi-roll feeder, attach an earthing (ground) lead between the PCA common and earth ground. Touch all tools to earth ground to remove static charges before using them on the multi-roll feeder.
6. After removing any PCA from the multi-roll feeder, place it on a conductive foam pad or into its conductive packaging to prevent ESD damage to any ICs on the PCA.

Required Tools

The following tools are required to disassemble and repair the multi-roll feeder.

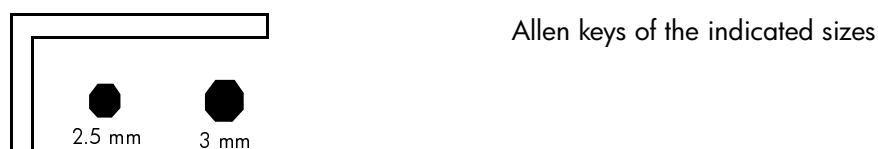
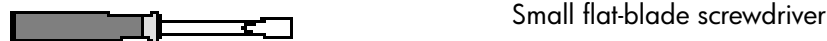
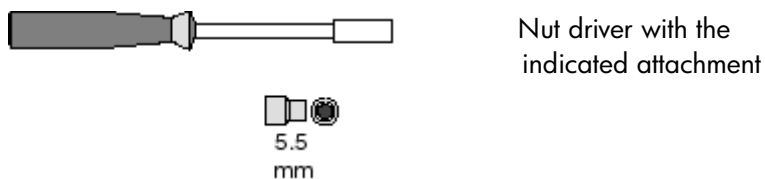
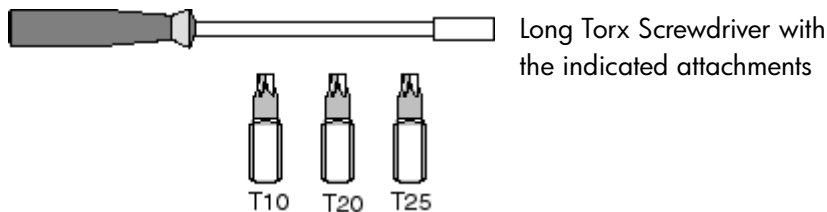

Left Door (P/N C2394-60011) - User Replaceable

Removal

Switch both the printer and the multi-roll feeder OFF, and disconnect them from the power source prior to performing any maintenance.



1. Open the Left Door.

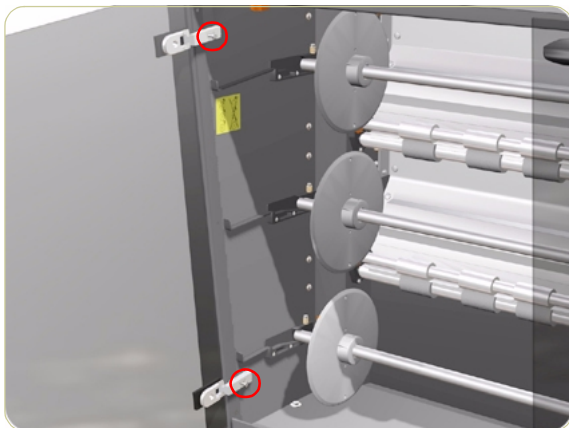

2. Loosen 2 screws that secure the Left Door to the Multi-Roll Feeder.

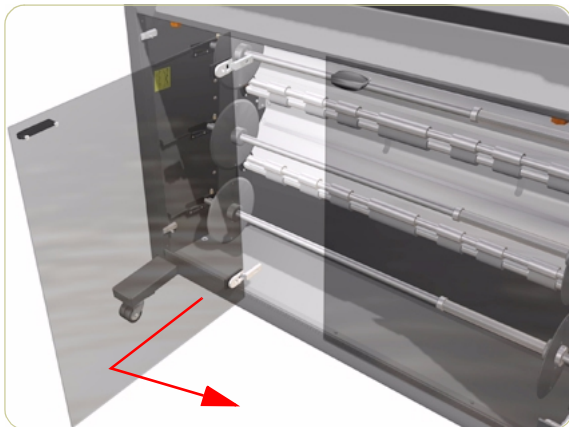

3. Remove the Left Door.

Be careful not to break the Door when removing it.

Right Door (P/N C2394-60010) - User Replaceable

Removal

Switch both the printer and the multi-roll feeder OFF, and disconnect them from the power source prior to performing any maintenance.



1. Open the Right Door.

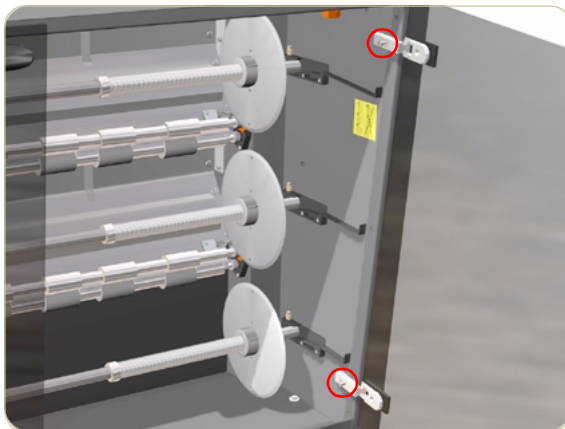

2. Loosen 2 screws that secure the Right Door to the Multi-Roll Feeder.

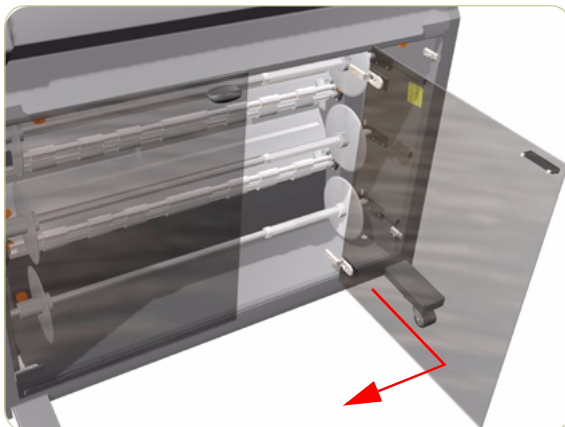

3. Remove the Right Door.

Be careful not to break the Door when removing it.

Front Bottom-Cover (P/N C2394-60003) - User Replaceable

Removal

Switch both the printer and the multi-roll feeder OFF, and disconnect them from the power source prior to performing any maintenance.

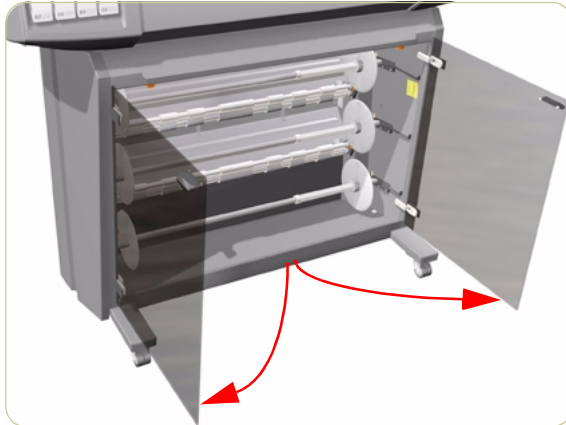

1. Open both the Left and Right Doors.

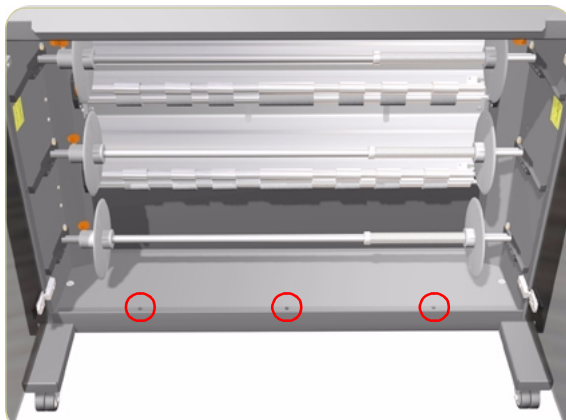

2. Remove 3 T-20 screws that secure the Front Bottom Cover to the Multi-Roll Feeder.

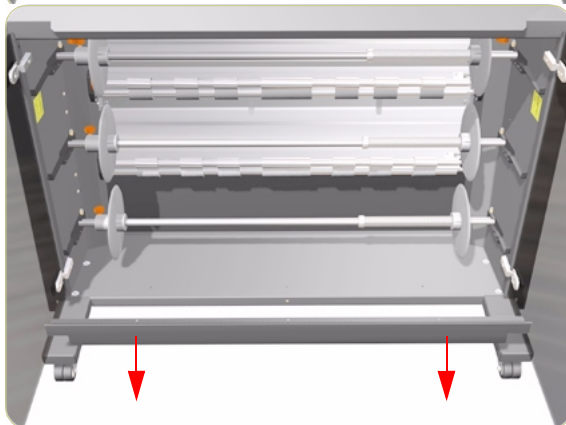

3. Remove the Front Bottom Cover.

Front Top-Cover (P/N C2394-60007) - User Replaceable

Removal

Switch both the printer and the multi-roll feeder OFF, and disconnect them from the power source prior to performing any maintenance.

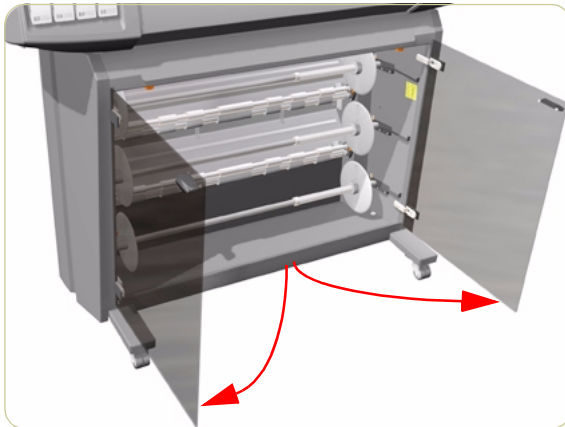

1. Open both the Left and Right Doors.

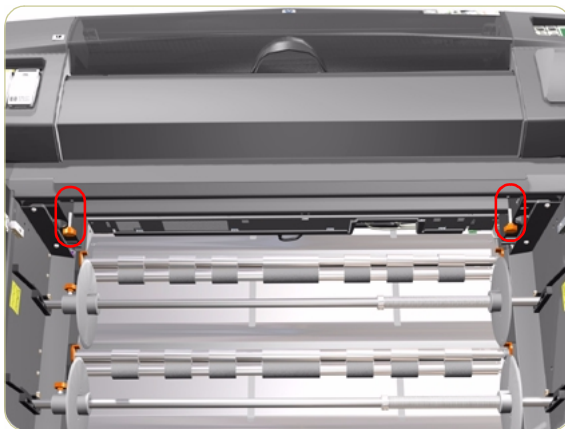

2. Remove 2 star screws (**Orange**) that secure the Front Top-Cover to the Multi-Roll Feeder.



3. Remove the Front top-Cover.

Right Side Cover (P/N C2394-60005) - User Replaceable

Removal

Switch both the printer and the multi-roll feeder OFF, and disconnect them from the power source prior to performing any maintenance.

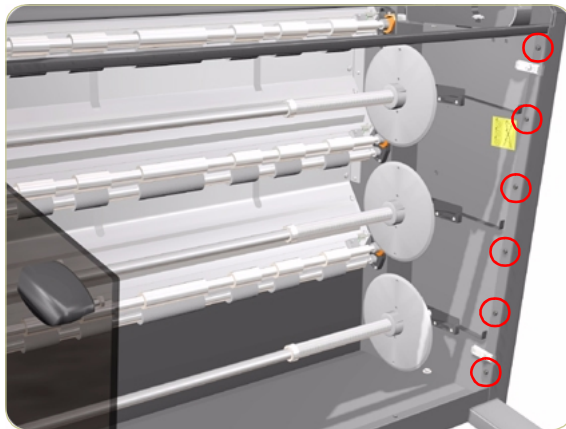

1. Remove the Right Door ⇒ Page 4-5.
2. Remove the Front Top-Cover ⇒ Page 4-7.
3. Remove 6 T-20 screws that secure the Right Side Cover to the Multi-Roll Feeder from the front.

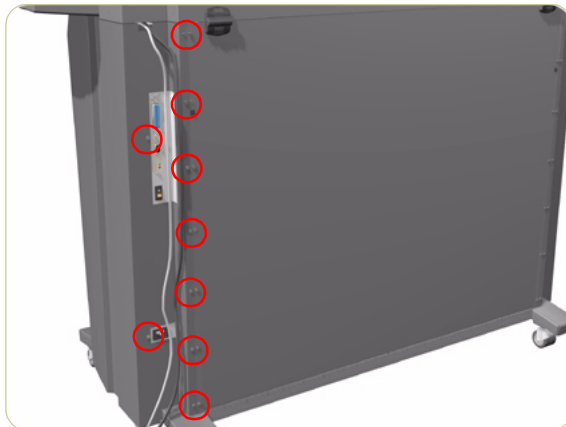

4. Remove 9 T-20 screws that secure the Right Side Cover to the Multi-Roll Feeder from the rear.

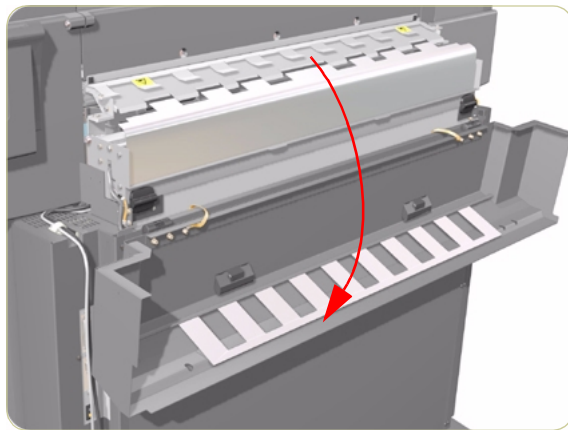

5. Open the Rear Top-Cover.

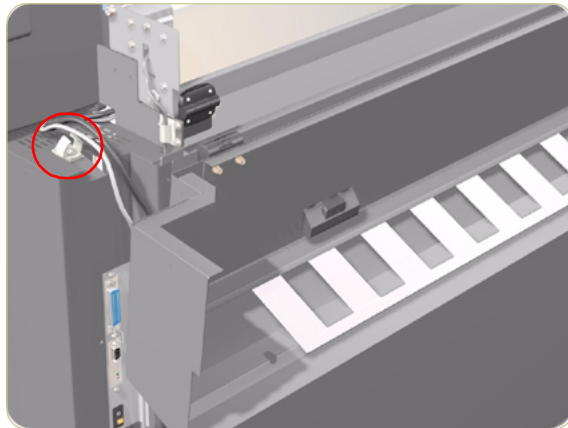

6. Release the Cable that is attached to the top of the Right Side Cover.

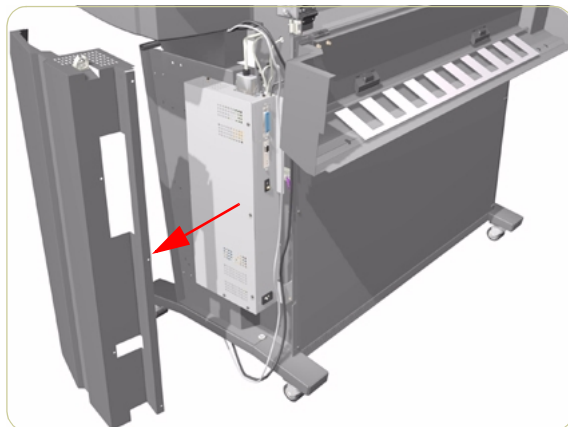

7. Remove the Right Side Cover.

Left Side Cover (P/N C2394-60004) - User Replaceable

Removal

Switch both the printer and the multi-roll feeder OFF, and disconnect them from the power source prior to performing any maintenance.



1. Remove the Left Door ⇒ Page 4-4.
2. Remove the Front Top-Cover ⇒ Page 4-7.
3. Remove 7 T-20 screws that secure the Left Side Cover to the Multi-Roll Feeder from the rear.

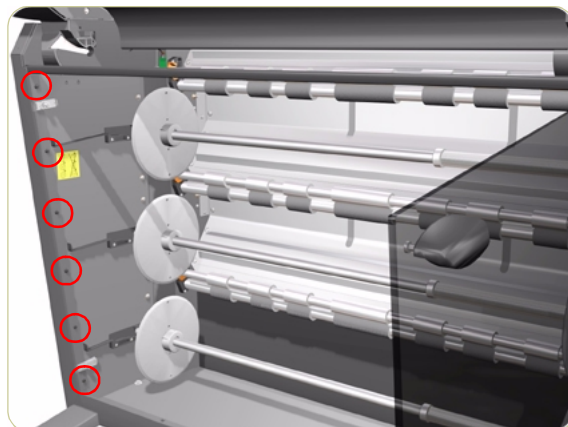

4. Remove 6 T-20 screws that secure the Left Side Cover to the Multi-Roll Feeder from the front.

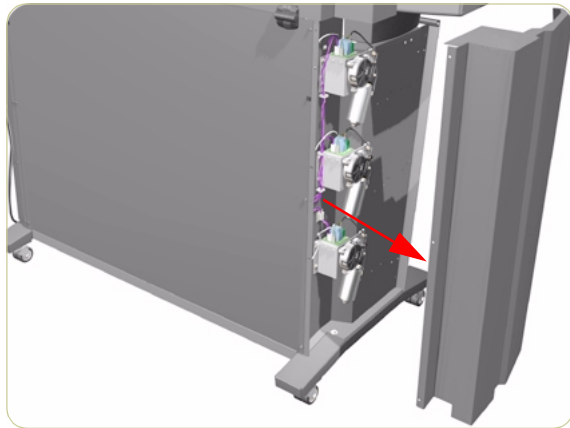

5. Remove the Left Side Cover.

Electronics Access Cover (P/N C2394-60025)

P/N C2394-60025 is for the complete Electronics Module Chassis which includes both the Electronics Access Cover and the Bottom Electronics Cover.

Removal

Switch both the printer and the multi-roll feeder OFF, and disconnect them from the power source prior to performing any maintenance.

1. Remove the Right Door ⇒ Page 4-5.
2. Remove the Front Top-Cover ⇒ Page 4-7.
3. Remove the Right Side Cover ⇒ Page 4-8.
4. Remove 12 T-20 screws that secure the Electronics Access Cover.

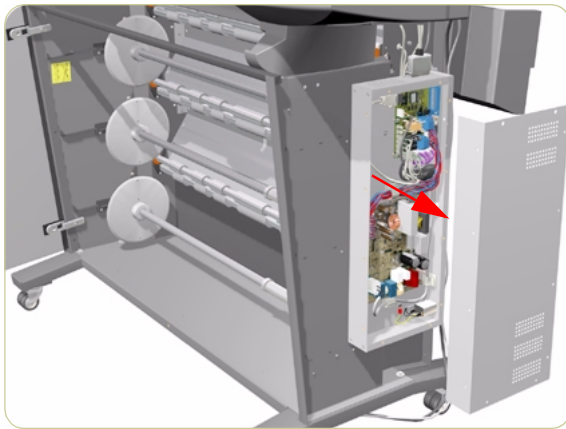
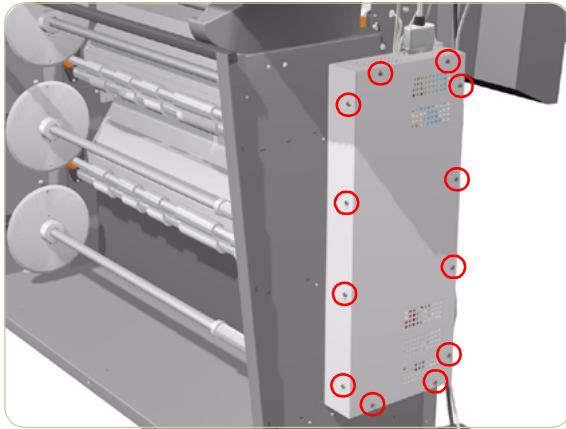

5. Remove the Electronics Access Cover.

Power Supply Unit (P/N C2394-60001)

Removal

Switch both the printer and the multi-roll feeder OFF, and disconnect them from the power source prior to performing any maintenance.

1. Remove the Right Door ⇒ Page 4-5.
2. Remove the Front Top-Cover ⇒ Page 4-7.
3. Remove the Right Side Cover ⇒ Page 4-8.
4. Remove the Electronics Access Cover ⇒ Page 4-12.
5. Disconnect 2 Cables that are attached to the Power Supply Unit.

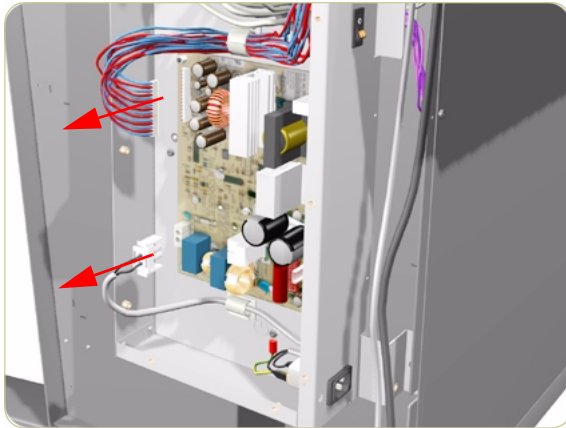

6. Remove 5 T-20 screws and 2 Nuts (5.5 mm) that secure the Power Supply Unit.

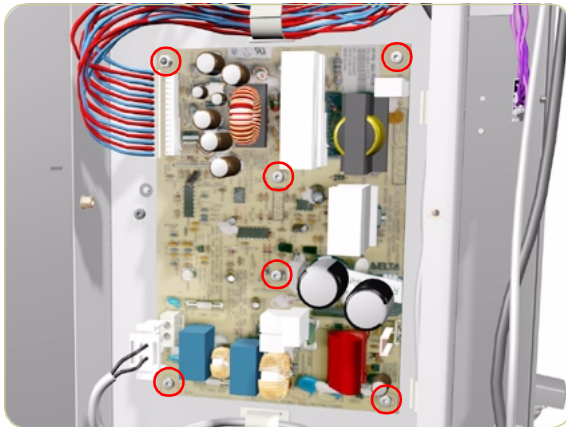

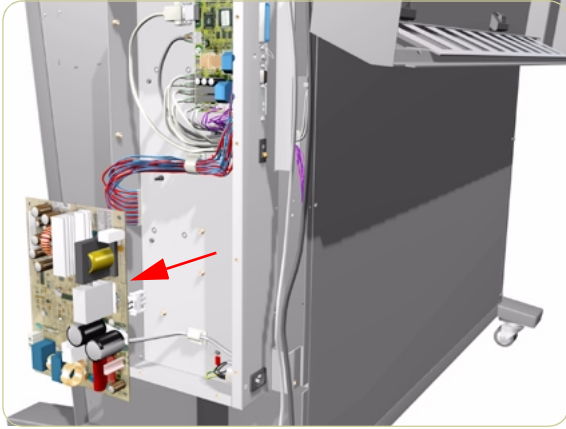

7. Remove the Power Supply Unit.

Main PCA (P/N C2394-60002)

Removal

Switch both the printer and the multi-roll feeder OFF, and disconnect them from the power source prior to performing any maintenance.

1. Remove the Right Door ⇒ Page 4-5.
2. Remove the Front Top-Cover ⇒ Page 4-7.
3. Remove the Right Side Cover ⇒ Page 4-8.
4. Remove the Electronics Access Cover ⇒ Page 4-12.
5. Disconnect ALL the Cables connected to the Main PCA.

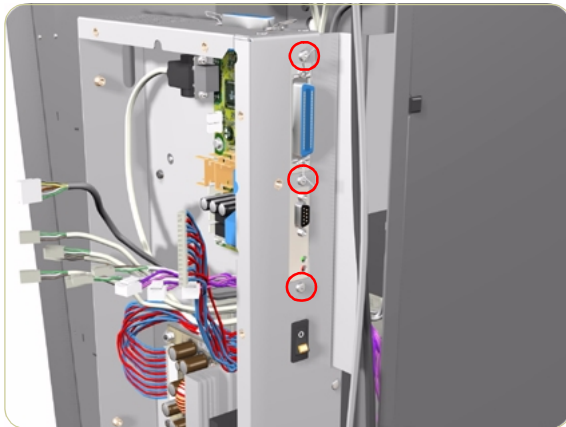
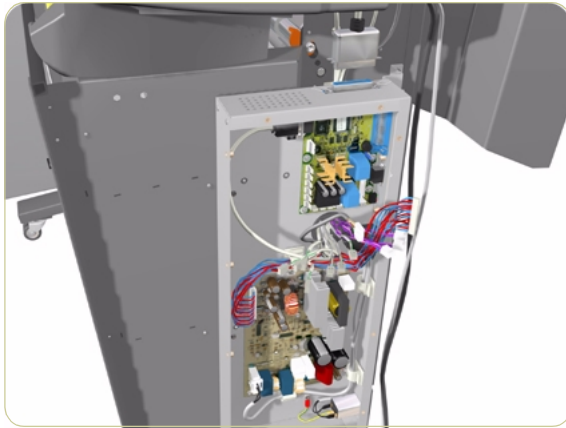

6. Remove 3 T-20 screws that secure the Main PCA from the outside.

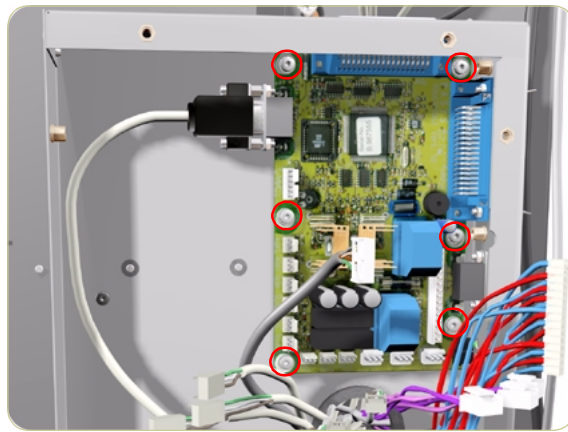

7. Remove 6 T-20 screws that secure the Main PCA from the inside.

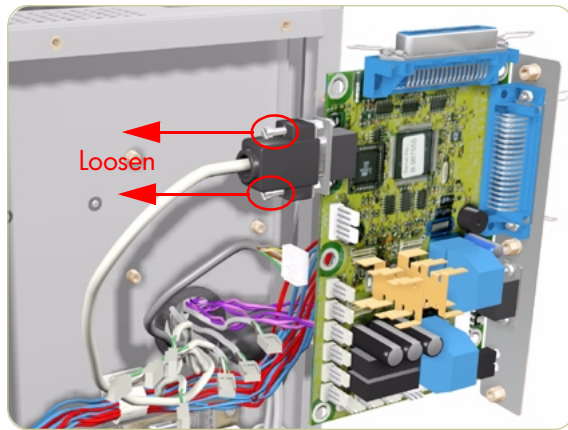

8. Remove the Main PCA from the base and loosen 2 screws from the serial cable.

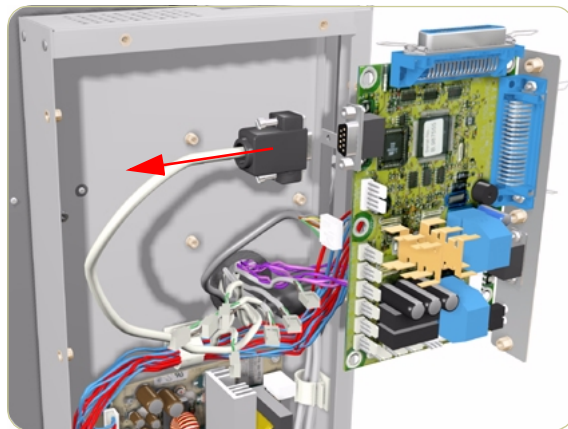

9. Disconnect the serial cable from the Main PCA.

After replacing the Main PCA, make sure you perform the Multi-Roll Feeder Calibration. To perform the calibration ⇒ Page 1-14.

Bottom Electronics Cover (P/N C2394-60025)

P/N C2394-60025 is for the complete Electronics Module Chassis which includes both the Electronics Access Cover and the Bottom Electronics Cover.

Removal

Switch both the printer and the multi-roll feeder OFF, and disconnect them from the power source prior to performing any maintenance.

1. Remove the Right Door ⇒ Page 4-5.
2. Remove the Front Top-Cover ⇒ Page 4-7.
3. Remove the Right Side Cover ⇒ Page 4-8.
4. Remove the Electronics Access Cover ⇒ Page 4-12.
5. Remove the Power Supply Unit ⇒ Page 4-13.
6. Remove the Main PCA ⇒ Page 4-15.
7. Remove 5 T-20 screws that secure the Bottom Electronics Cover.

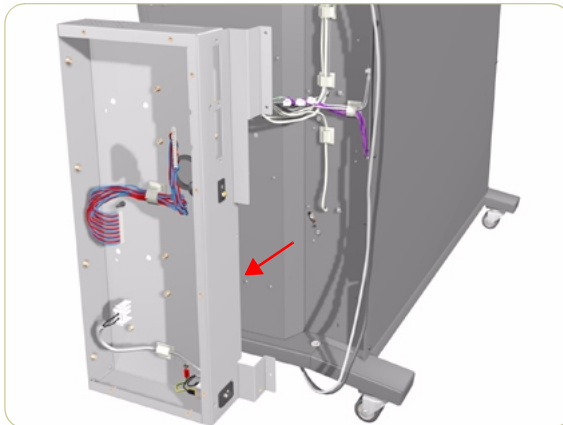
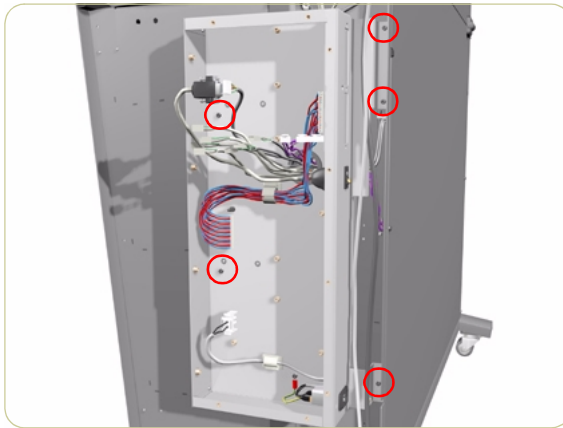

8. Remove the Bottom Electronics Cover.

Spindle Drive Motors 1, 2 and 3 (P/N C2394-60022)

Removal

Switch both the printer and the multi-roll feeder OFF, and disconnect them from the power source prior to performing any maintenance.

1. Remove the Left Door ⇒ Page 4-4.
2. Remove the Front Top-Cover ⇒ Page 4-7.
3. Remove the Left Side Cover ⇒ Page 4-10.
4. Loosen 1 screw (Allen key 2.5 mm) that secures the outer Drive Clutch on the Spindle Drive Motor.

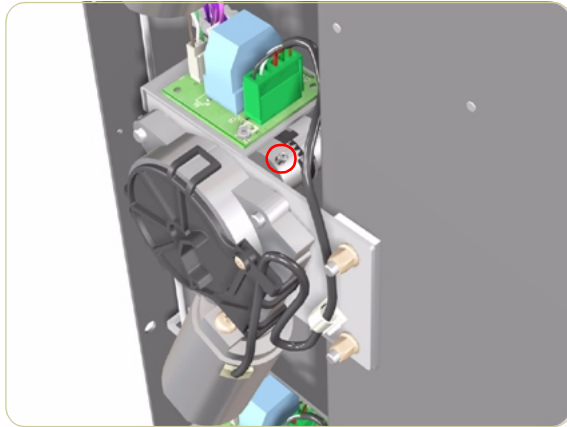

If necessary, turn the Transport Roller manually until you can access the screw in the Drive Clutch.

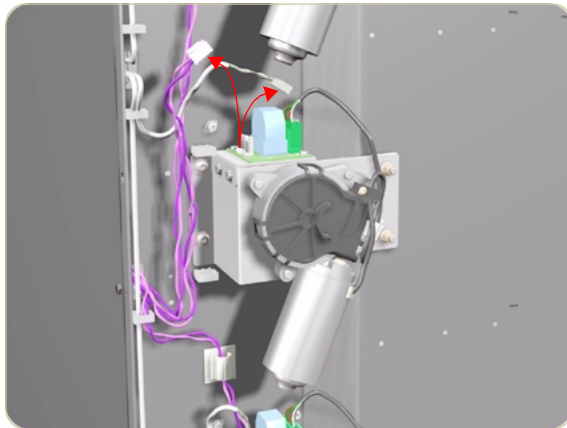

5. Disconnect the Cables connected to the Spindle Drive Motor.

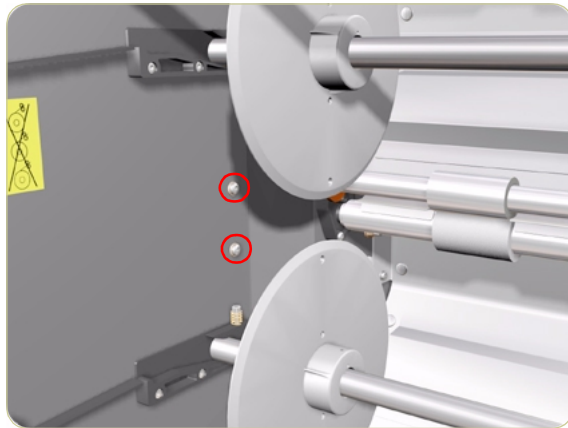

6. Remove 2 T-20 screws that secure the Spindle Drive Motor from the inside.

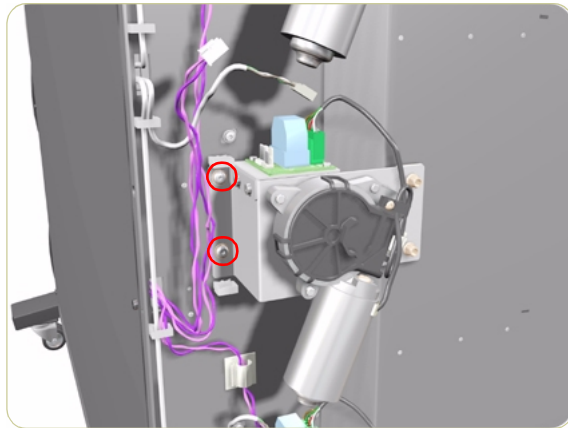

7. Remove 2 T-20 screws that secure the Spindle Drive Motor from the outside.

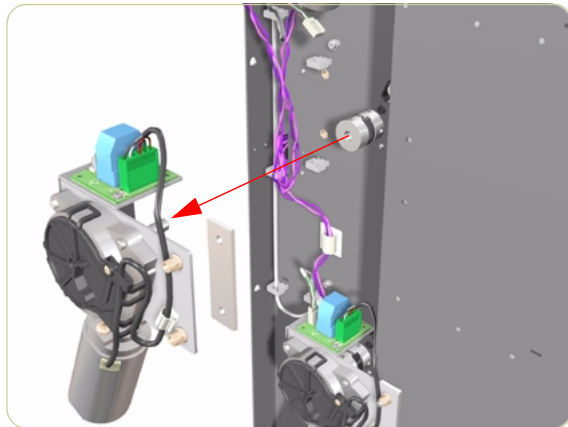

8. Remove the Spindle Drive Motor.

After replacing the Drive Clutches, make sure you reset the counter length for the corresponding roll (e.g. if you replaced the Drive Clutches for Roll 1, reset the partial length counter for Roll 1 to zero). To reset the counter ⇒ Page 1-17.

When installing the Spindle Drive Motors, make sure you first push the Transport Roller to the extreme right, and then secure the Drive Clutches (from the outside). This will ensure that there is a horizontal play in the Transport Roller of 0.5 - 1.00 mm.

Drive Clutches (P/N C2394-60023)

Removal

Switch both the printer and the multi-roll feeder OFF, and disconnect them from the power source prior to performing any maintenance.

1. Remove the Left Door ⇒ Page 4-4.
2. Remove the Front Top-Cover ⇒ Page 4-7.
3. Remove the Left Side Cover ⇒ Page 4-10.
4. Remove the relevant Spindle Drive Motor ⇒ Page 4-18.
5. Loosen 1 screw (Allen key 2.5 mm) that secures the inner Drive Clutch on the Transport Roller.

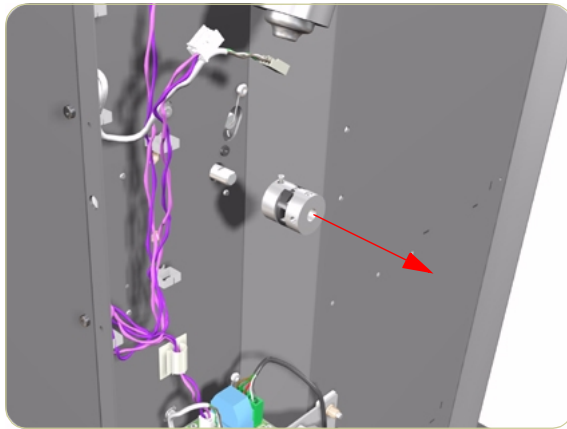
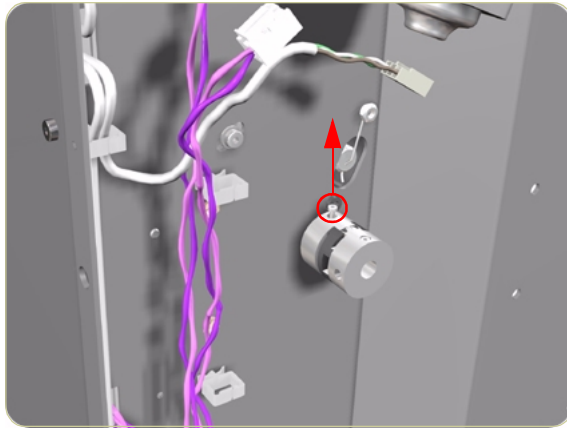

6. Remove the inner and outer Drive Clutches and the Transmission Washer together.

After replacing the Drive Clutches, make sure you reset the counter length for the corresponding roll (e.g. if you replaced the Drive Clutches for Roll 1, reset the partial length counter for Roll 1 to zero). To reset the counter ⇒ Page 1-17.

When installing the Drive Clutches, make sure you first push the Transport Roller to the extreme right, and then secure the Drive Clutches (from the outside). This will ensure that there is a horizontal play in the Transport Roller of 0.5 - 1.00 mm.

Left and Right Spindle Retainers (P/N C2394-60017)

Removal

Switch both the printer and the multi-roll feeder OFF, and disconnect them from the power source prior to performing any maintenance.

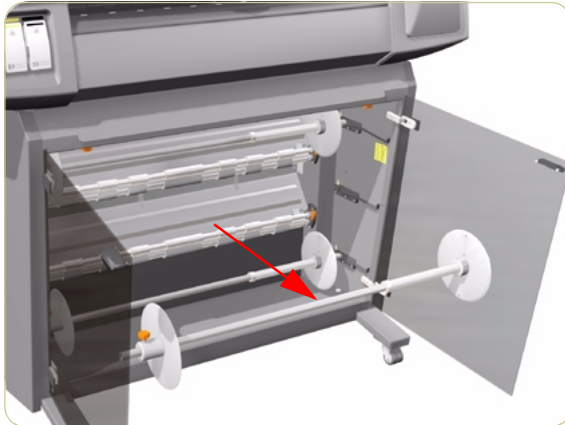

1. Open both the Left and Right Doors and remove Spindle from the relevant Spindle Retainer.

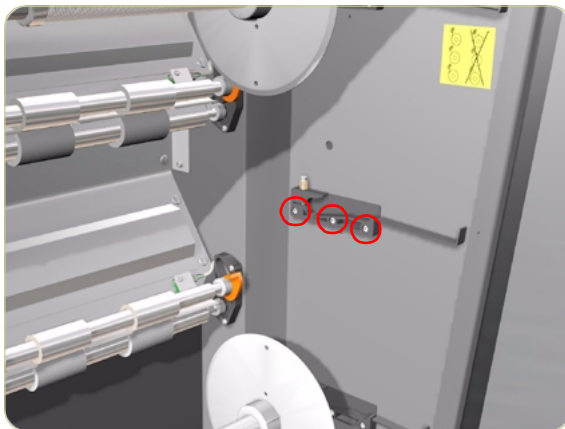

2. Remove 3 T-20 screws that secure the Spindle Retainer.

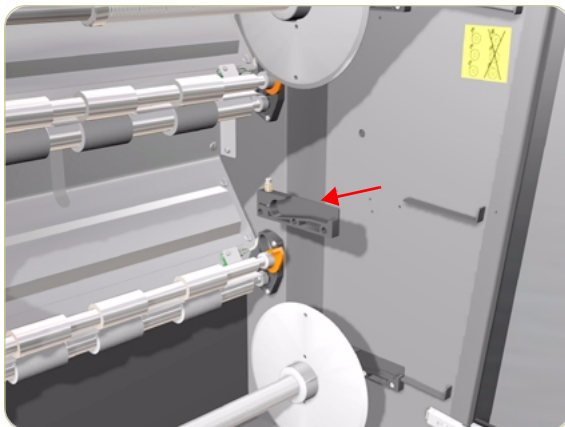

3. Remove the Spindle Retainer.

Riding Roller (P/N C2394-60013)

Removal

Switch both the printer and the multi-roll feeder OFF, and disconnect them from the power source prior to performing any maintenance.

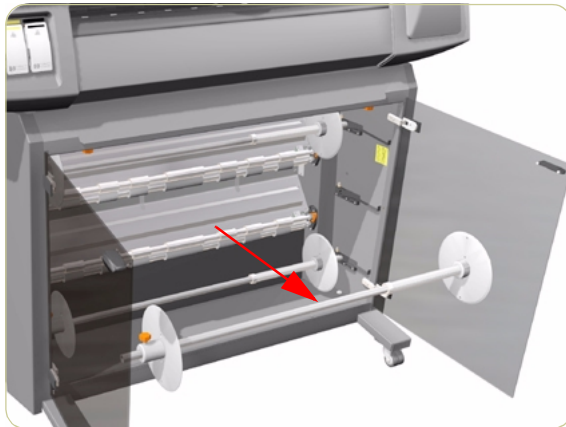

1. Open both the Left and Right Doors and remove Spindle from the relevant Spindle Retainer.

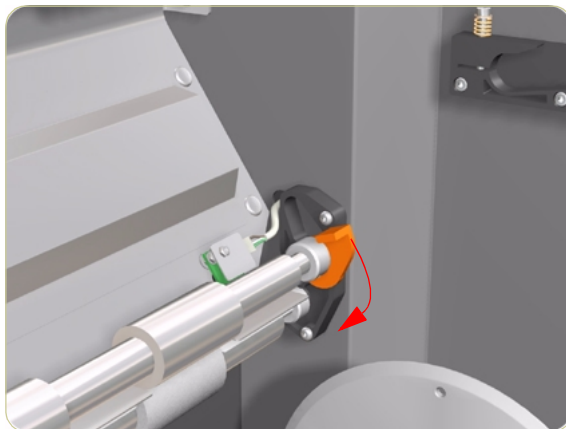

2. Lower the Roller Levers on both sides of the Riding Roller.

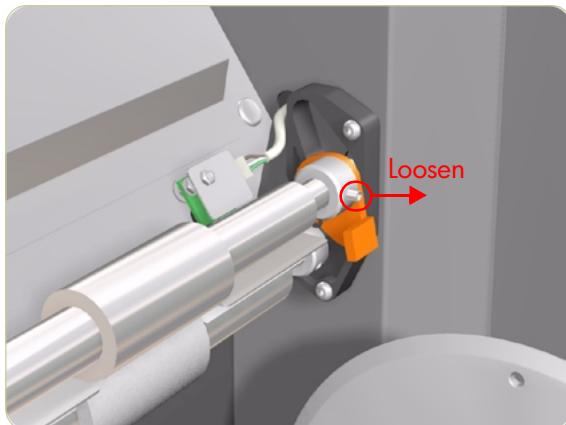

3. Loosen 1 screw (Allen key 3 mm) that secures the bushing to the Riding Roller.

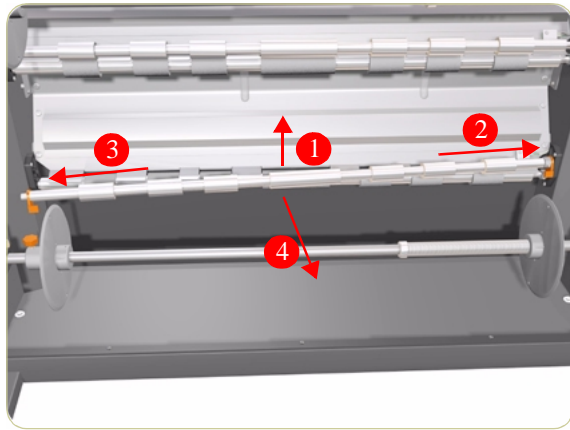

4. Raise the Riding Roller first, and then slide it to the right and then remove from the Multi-Roll Feeder.

When installing the Riding Roller, make sure you first push the Riding Roller to the extreme right, and then secure the bushing (on the left hand side of the Riding Roller). This will ensure that there is a horizontal play in the Riding Roller of 0.5 - 1.00 mm.

Roller Levers (P/N C2394-60024)

Removal

Switch both the printer and the multi-roll feeder OFF, and disconnect them from the power source prior to performing any maintenance.

1. Remove the relevant Riding Roller ⇒ Page 4-22.
2. Remove the Roller Levers from either side of the Riding Roller.

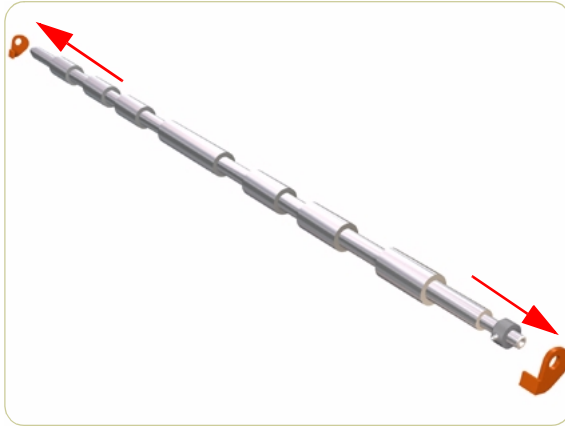

When installing the Riding Roller, make sure you first push the Riding Roller to the extreme right, and then secure the bushing (on the left hand side of the Riding Roller). This will ensure that there is a horizontal play in the Riding Roller of 0.5 - 1.00 mm.

Transport Roller (P/N C2394-60014)

Removal

Switch both the printer and the multi-roll feeder OFF, and disconnect them from the power source prior to performing any maintenance.

1. Remove the Left Door ⇒ Page 4-4.
2. Remove the Front Top-Cover ⇒ Page 4-7.
3. Remove the Left Side Cover ⇒ Page 4-10.
4. Remove the relevant Riding Roller ⇒ Page 4-22.
5. Remove 1 T-20 screw and loosen the other T-20 screw from the Drive Motor PCA and slide the PCA to one side.

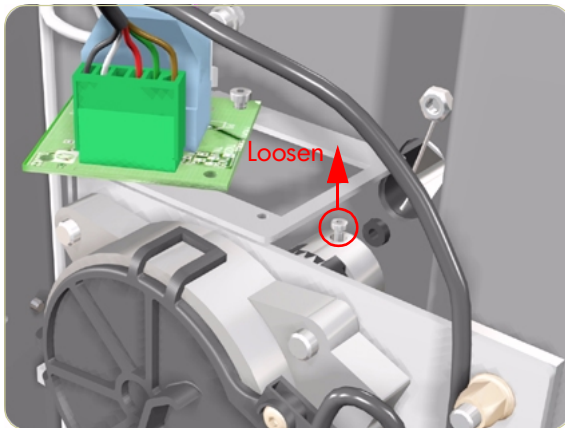
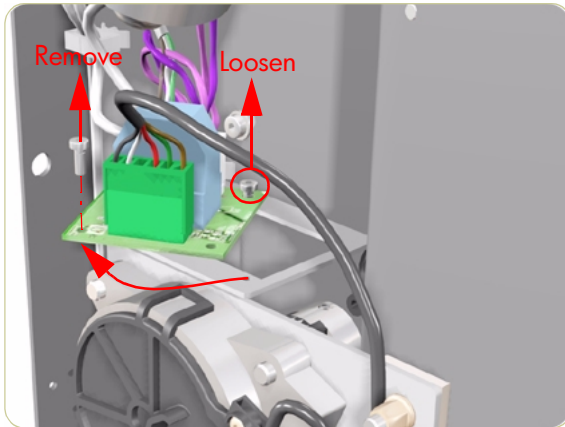

6. Loosen 1 screw (Allen key 2.5 mm) that secures the inner Drive Clutch on the Transport Roller (outside).

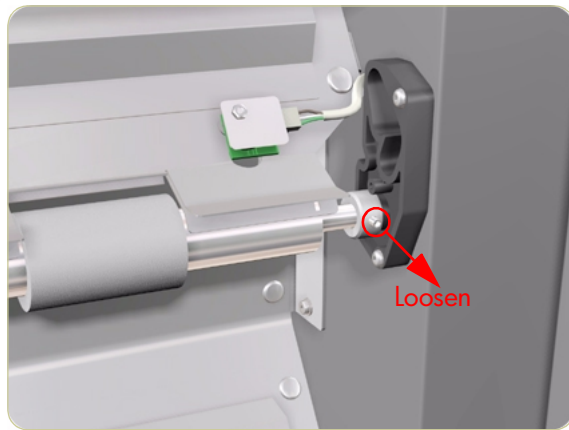

7. Loosen 1 screw (Allen key 2.5 mm) that secures the bushing to the Transport Roller on the right hand side (inside).

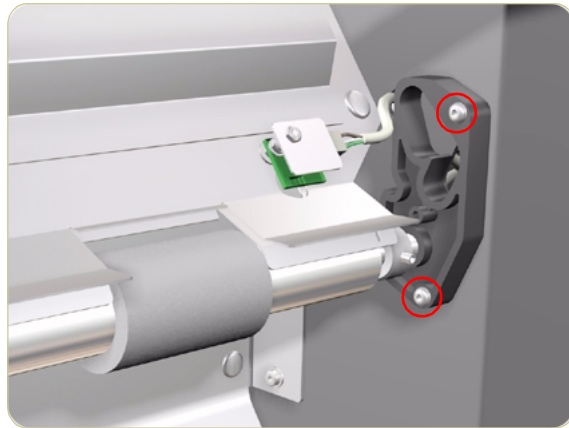

8. Remove 2 T-20 screws that secure the right Roller Bearing.

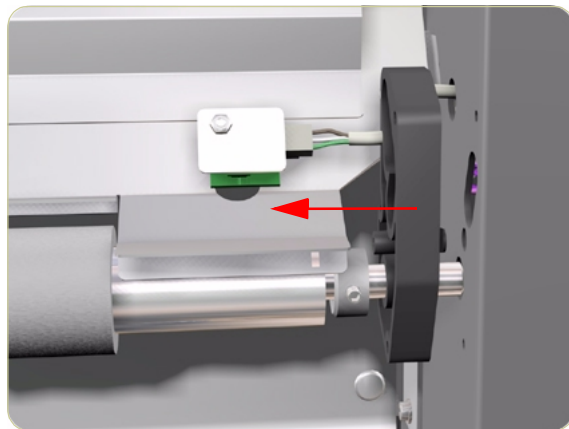

9. Slide the right Roller Bearing to the left.

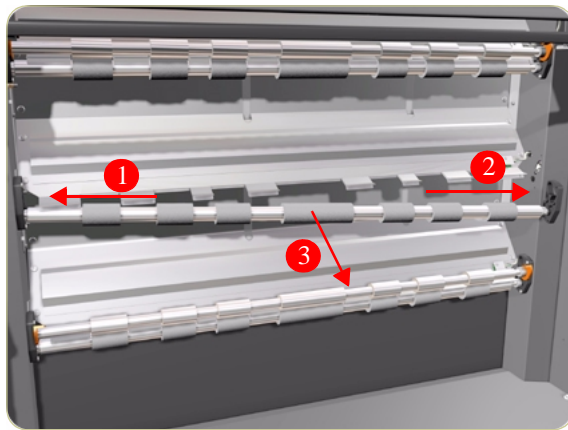

- 10.** Slide the Transport Roller first to the left and then remove from the Multi-Roll Feeder.

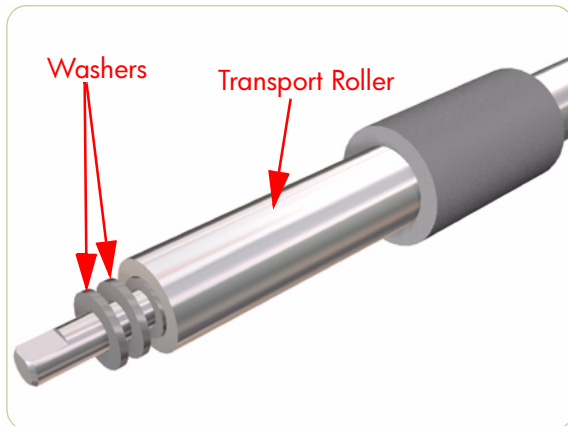

When installing the Transport Roller, make sure you reinstall the same number of washers that you removed from the left hand side of the Transport Roller.

After replacing the Transport Roller, make sure you reset the counter length for the corresponding roll (e.g. if you replaced the Transport Roller for Roll 1, reset the partial length counter for Roll 1 to zero). To reset the counter ⇒ Page 1-17.

When installing the Transport Roller, make sure you first push the Transport Roller to the extreme right, and then secure the Drive Clutches (from the outside). This will ensure that there is a horizontal play in the Transport Roller of 0.5 - 1.00 mm.

Rear Top-Cover (P/N C2394-60008)

Removal

Switch both the printer and the multi-roll feeder OFF, and disconnect them from the power source prior to performing any maintenance.

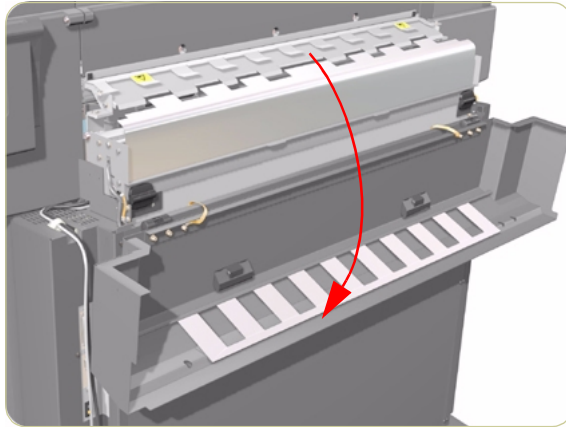

1. Open the Rear Top-Cover.



2. Remove the Nut and 2 washers that secure the grounding strip to the Rear Top-Cover.

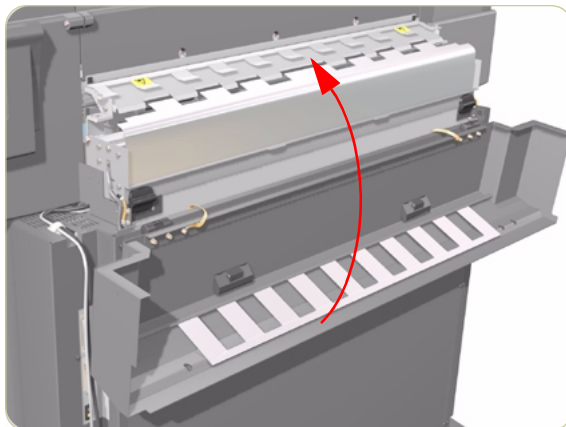

3. Close the Rear Top-Cover.

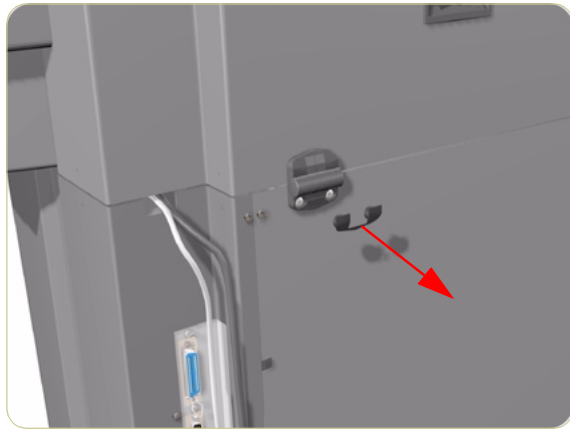

4. Remove the screw covers from both sides.

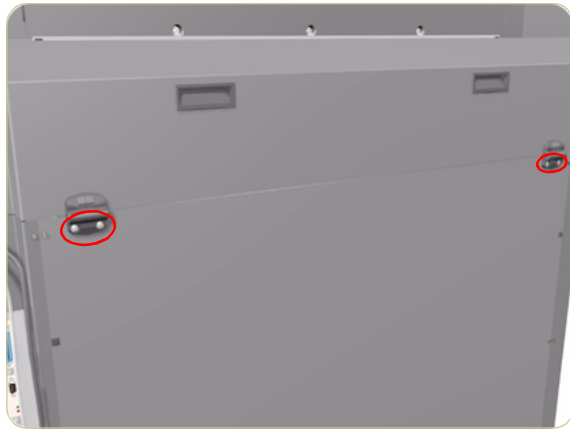

5. Remove 4 T-20 screws that secure the Rear Top-Cover.

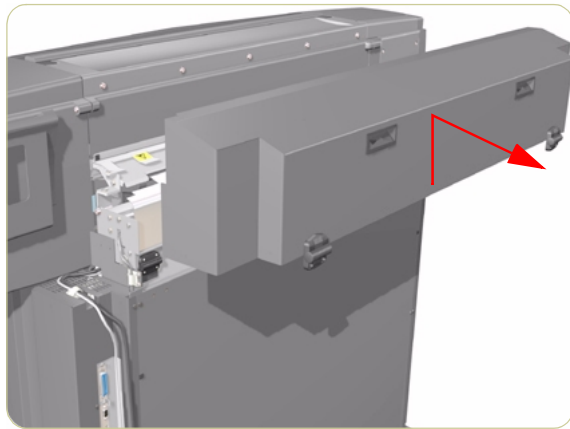

6. Remove the Rear Top-Cover.

Becareful when removing the Rear Top-Cover because it is very heavy and could accidently fall.

Motion Control Unit (P/N C2394-60020)

Removal

Switch both the printer and the multi-roll feeder OFF, and disconnect them from the power source prior to performing any maintenance.

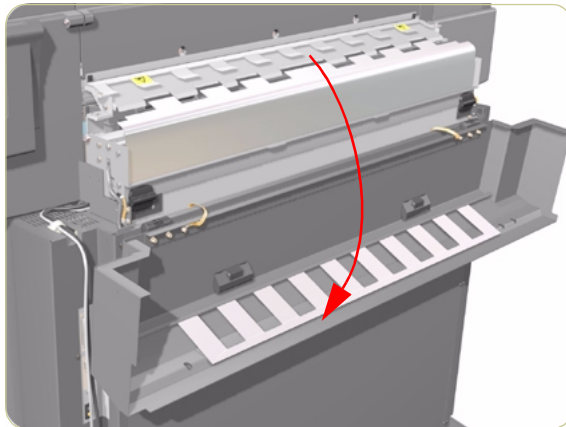

1. Open the Rear Top-Cover.

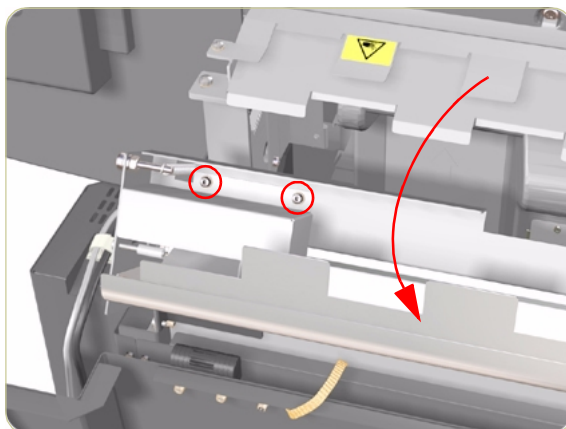

2. Open the Motion Control Unit and remove 2 screws from the Sensor Cover.

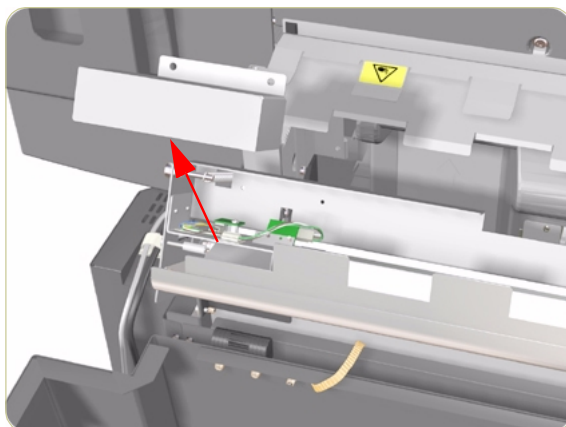

3. Remove the Motion Control Unit Sensor Cover.

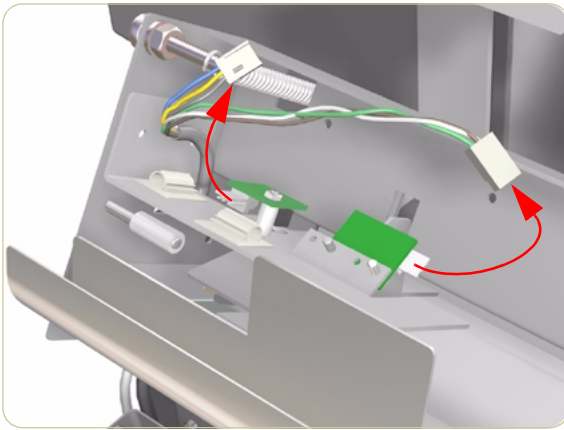

4. Disconnect 2 cables from the Motion Control Sensor and release them from the securing clips

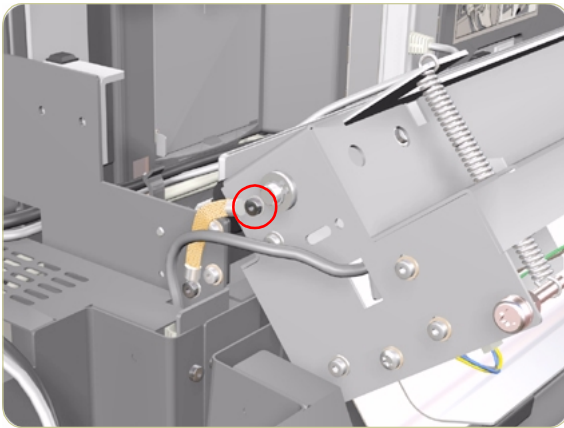

5. Remove 1 T-20 screw from the grounding strip on **both** sides of the Motion Control Unit.

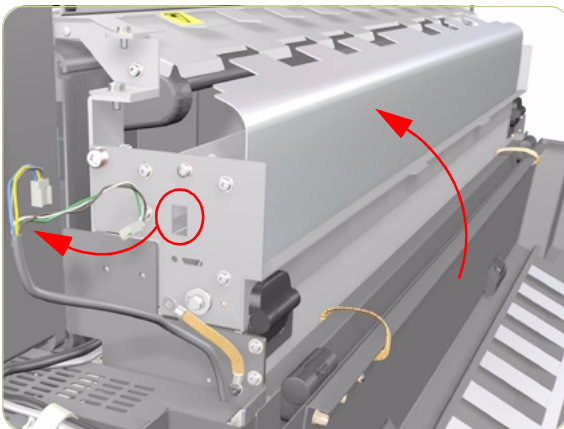

6. Close the Motion Control Unit and then pull the 2 motion control sensor cables through the hole in the motion control unit.

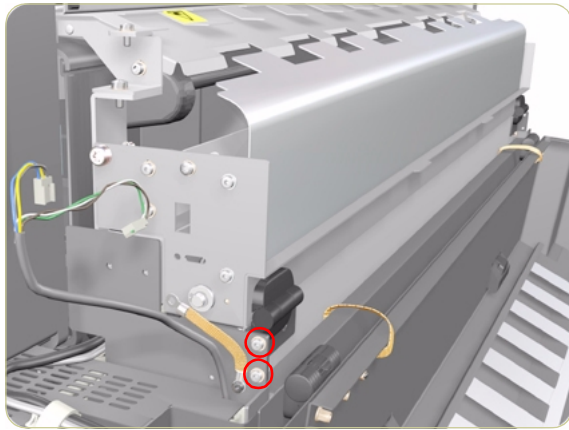

7. Remove 2 T-20 screws that secure the Motion Control Unit on **both** sides.

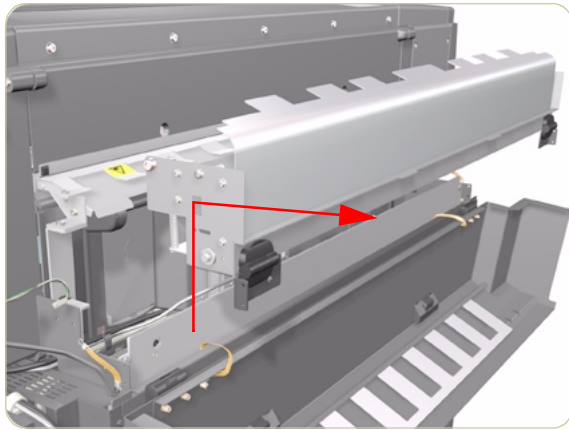

8. Remove the Motion Control Unit by lifting it upwards and then towards you.

After replacing the Motion Control Unit, make sure you perform the Multi-Roll Feeder Calibration. To perform the calibration ⇒ Page 1-14.

Motion Control Sensor (P/N C2394-60019)

Removal

Switch both the printer and the multi-roll feeder OFF, and disconnect them from the power source prior to performing any maintenance.

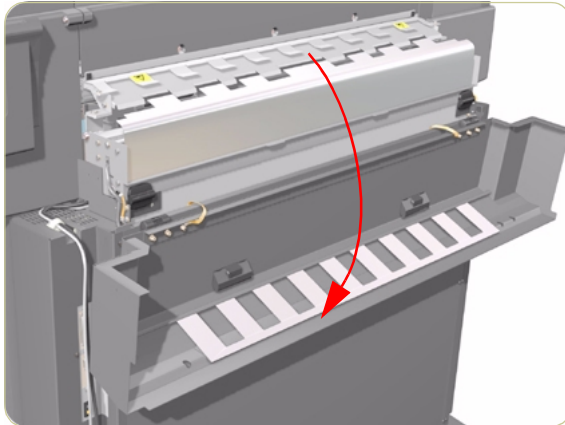

1. Open the Rear Top-Cover.

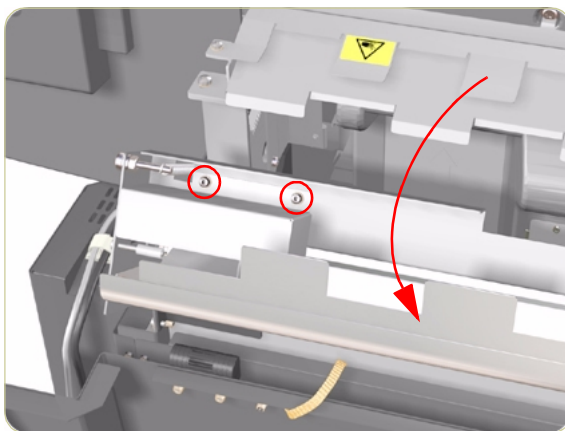

2. Open the Motion Control Unit and remove 2 screws from the Sensor Cover.

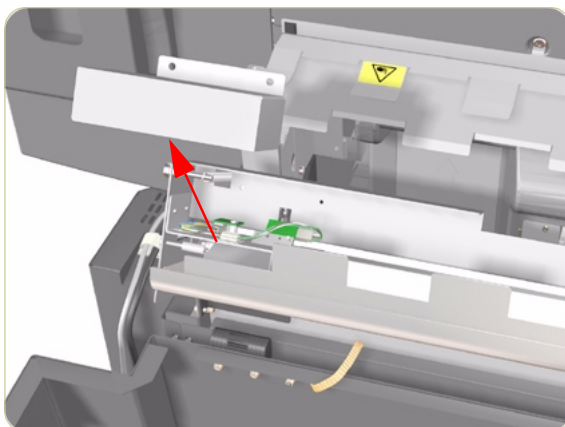

3. Remove the Motion Control Unit Sensor Cover.

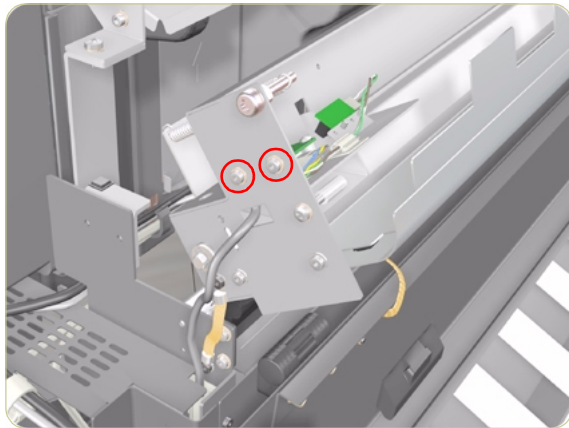

4. Remove 2 T-20 screws that secure the Motion Control Sensor.

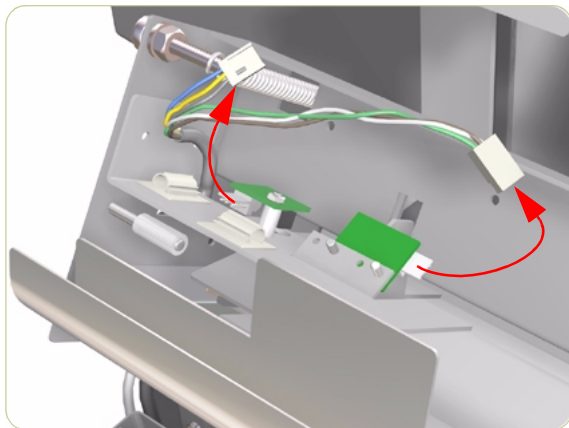

5. Disconnect 2 cables from the Motion Control Sensor and release them from the securing clips.

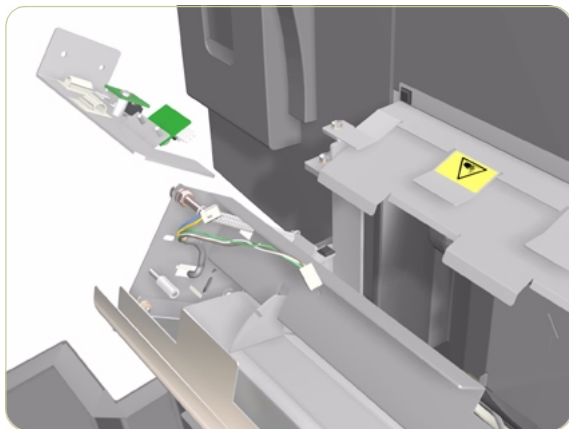

6. Remove the Motion Control Sensor.

When installing the Motion Control Sensor, make sure that the digital sensor is centered correctly.

After replacing the Motion Control Sensor, make sure you perform the Multi-Roll Feeder Calibration. To perform the calibration ⇒ Page 1-14.

Channel Sensor (P/N C2394-60021)

Removal

Switch both the printer and the multi-roll feeder OFF, and disconnect them from the power source prior to performing any maintenance.

1. Locate the relevant Channel Sensor to be removed:
 - 1 behind the Motion Control Unit.
 - 1 behind each Transport Roller.
2. Remove these items that secure the Channel Sensor (in this order):
 - 1 Nut (5 mm).
 - 1 Sensor Cover.
 - 1 Nut (5 mm).
 - 2 Washers.

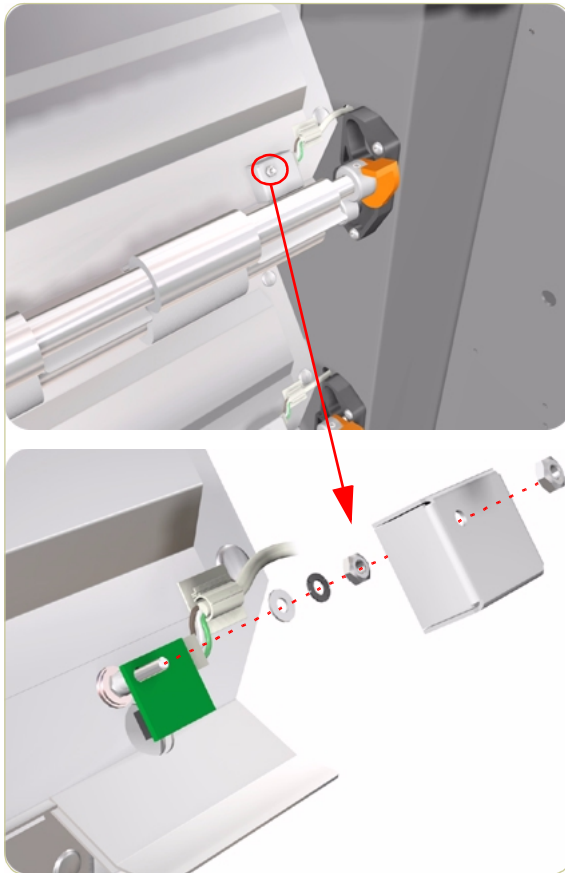

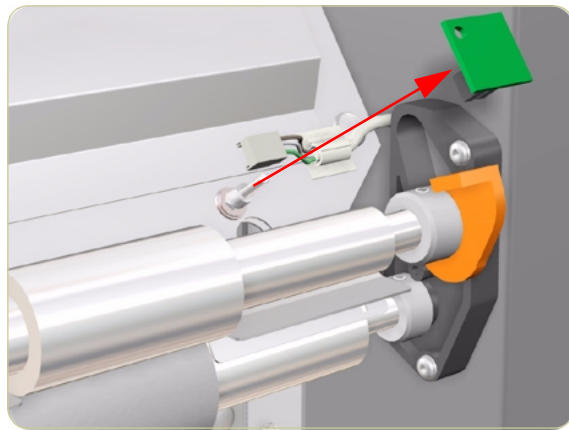

3. Disconnect the Cable from the Channel Sensor and remove.

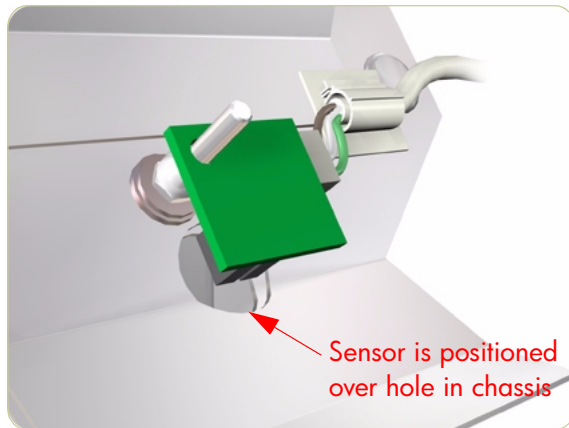

When installing the Motion Control Sensor, make sure you position it as shown in this drawing.

Rear Bottom-Cover (P/N C2394-60006) - User Replaceable

Removal

Switch both the printer and the multi-roll feeder OFF, and disconnect them from the power source prior to performing any maintenance.

1. Remove the Rear Top-Cover ⇒ Page 4-28.
2. Remove 14 T-20 screws that secure the Rear Bottom-Cover.

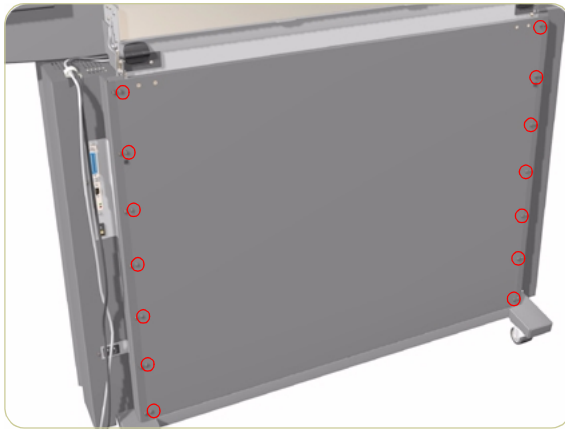

3. Remove the Rear Bottom-Cover.

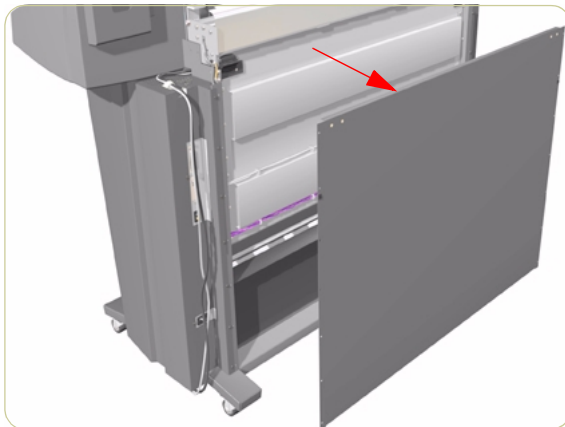

If you are installing a NEW Rear Bottom-Cover, it will come with a product label where you will need to write down the serial number of the multi-roll feeder (the serial number can be found on the OLD Rear Bottom-Cover).

Infeed Unit (P/N C2394-60012) - User Replaceable

Removal

Switch both the printer and the multi-roll feeder **OFF**, and disconnect them from the power source prior to performing any maintenance.

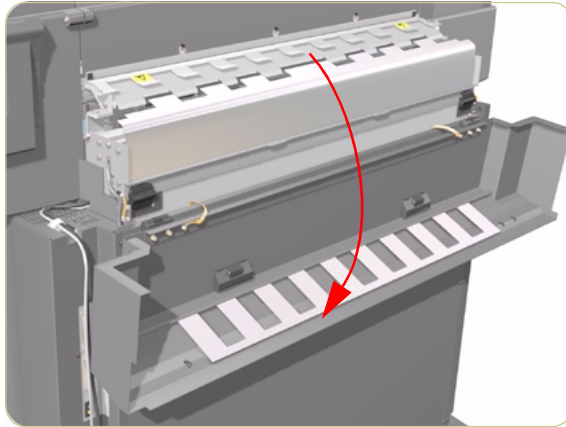

1. Open the Rear Top-Cover.

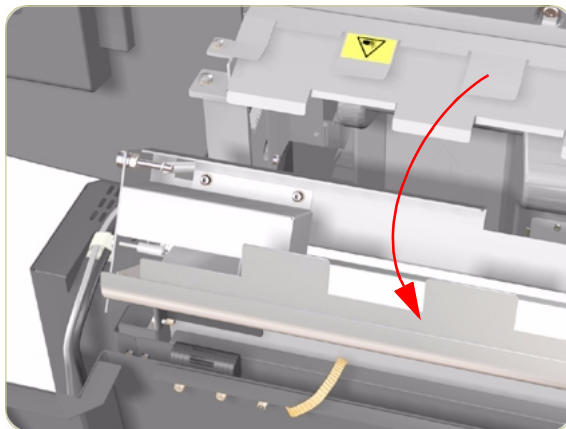

2. Open the Motion Control Unit.

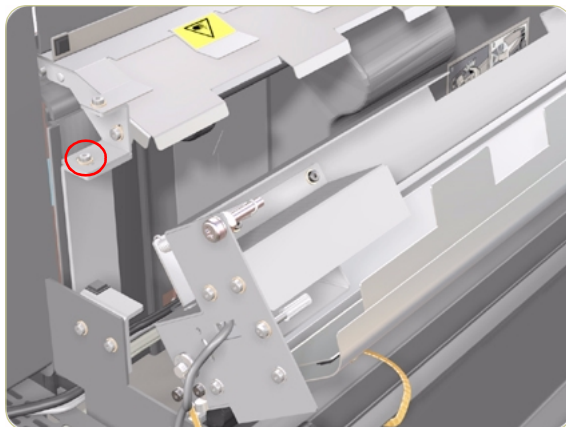

3. Remove 2 T-20 screws (one on **each** side of the Motion Control Unit) that secure the Infeed Unit.

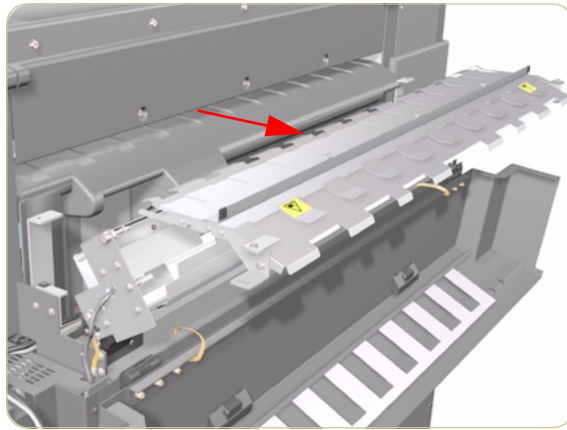

4. Remove the Infeed Unit.



About this Edition

This is the 1st edition of this Service Manual

1st edition, titled

hp designjet multi-roll feeder (for 1000 series) service manual (models C2394A/
C2394B/C2394CB) - August 2001

What's in this Service Manual

This manual contains information necessary to test, calibrate and service:

- **hp** designjet multi-roll feeder for 1000 plus series - Model C2394A
- **hp** designjet multi-roll feeder for 1050c printer - Model C2394B
- **hp** designjet multi-roll feeder for 1050cm printer - Model C2394C

For information about using these printers, refer to the corresponding User and Quick Reference Guides.

The procedures described in this manual are to be performed by HP-qualified Service Personnel only.