



# HP HD Pro 42-in Scanner

Service manual

©2015 HP Development Company, L.P.

For HP Internal Use Only

1st edition

**Legal notices**

This document contains proprietary information that is protected by copyright. All rights are reserved. No part of this document may be photocopied, reproduced, or translated to another language without the prior written consent of Hewlett-Packard Company.

## Notices

---

### Warranty

The information contained in this document is subject to change without notice.

**Hewlett-Packard makes no warranty of any kind with regard to this material, including, but not limited to, the implied warranties of merchantability and fitness for a particular purpose.**

Hewlett-Packard shall not be liable for errors contained herein or for incidental or consequential damages in connection with the furnishing, performance, or use of this material.

**WARNING!** The procedures described in this manual are to be performed by HP-qualified service personnel only.

### Electrical Shock Hazard

Serious shock hazard leading to death or injury may result if you do not take the following precautions:

- Ensure that the AC power outlet (mains) has a protective earth (ground) terminal.
- Disconnect the product from the power source prior to performing any maintenance.
- Prevent water or any other liquids from running onto electrical components or circuits, or through openings in the enclosure.

### Electrostatic Discharge

See [Electrostatic Discharge \(ESD\) Precautions on page 55](#) for precautions you should take to prevent damage to the printer circuits from electrostatic discharge.

### Safety Symbols

General definitions of safety symbols are given immediately after the table of contents.

**WARNING!** The Warning symbol calls attention to a procedure, practice, or the like, which, if not correctly performed or adhered to, could result in personal injury. Do not proceed beyond a Warning symbol until the indicated conditions are fully understood and met.

**CAUTION:** The Caution symbol calls attention to an operating procedure, practice, or the like, which, if not correctly performed or adhered to, could result in damage to or destruction of part or all of the product. Do not proceed beyond a Caution symbol until the indicated conditions are fully understood and met.

---

Content Management Department, Large Format Printing

Barcelona Division,

Hewlett-Packard Espanola, S.A.

Camí de Can Graells, 1-21

08174 Sant Cugat del Vallès

Spain

---



## Using this Manual

### **Purpose**

This Service Manual contains information necessary to troubleshoot and service:

- HP HD Pro 42-in Scanner

For information about using the product, see the corresponding user guide.

This Service Manual is about the Scanner and the integration with the printer as a copier. In order to troubleshoot the printer, see the corresponding Service Manual for the printer.

### **Readership**

The procedures described in this Service Manual are to be performed by HP Certified service personnel only.

### **Part Numbers**

Part Numbers for service parts can be found in [Parts and Diagrams on page 48](#).



---

# Table of contents

<b>1 Troubleshooting</b> .....	<b>1</b>
Troubleshooting tips .....	2
Is the problem with the Printer or the Scanner? .....	2
Image-quality problems .....	2
Output problems .....	2
Troubleshooting System Error Codes .....	3
Using the Service Tools from the Touchscreen .....	3
Troubleshooting Issues .....	8
Troubleshooting print-quality and copy issues .....	8
Troubleshooting general scanner issues .....	12
Troubleshooting Specific Scanner Issues .....	18
Cleaning the Scanning Area .....	20
Troubleshooting Specific Panel PC Problems .....	23
Touch screen fails .....	26
Preventive Maintenance Kit for HP HD Pro Scanners .....	26
<b>2 System Error Codes</b> .....	<b>28</b>
System Error Codes for the Scanner Only .....	29
Software Related Errors .....	30
Scanner related errors .....	33
Error Codes for the JetImage Software RIP .....	40
Error Messages for the Touch Screen .....	45
<b>3 Parts and Diagrams</b> .....	<b>48</b>
Exterior .....	49
Interior .....	50
Panel PC .....	52
<b>4 Removal and Installation</b> .....	<b>53</b>
Introduction .....	55
Safety Precautions .....	55

Electrostatic Discharge (ESD) Precautions .....	55
Required Tools .....	55
Scanner main board .....	56
Lamp and motor controller board .....	58
Power Supply .....	59
Cooling Fan Filters .....	61
Cooling Fans .....	61
Size Detection Sensors .....	62
Paper Sensors (Load & Entry) .....	62
ATAC Closed Sensors .....	63
Camera Module .....	64
Stepper Motor Assembly .....	65
Drive Belt .....	67
RFI Filter .....	68
Power Inlet .....	68
Gas Spring for Guide plate .....	69
Tacho Sensor .....	70
Elevation motor driver board .....	70
ATAC Roller Pressure Sensor .....	72
ATAC Top Position Sensor .....	73
ATAC Down Position Sensor .....	73
Elevation motor .....	74
Original guide plate (ATAC) without top profile .....	75
Paper Sensors (Exit) .....	76
Right side cover assembly including operators panel .....	77
White Background Plate .....	78
Lamp Cartridge .....	79
Glass Plate .....	80
PanelPC .....	80

## **5 Scanner Adjustments and Calibrations ..... 94**

Introduction .....	95
Tools Required .....	95
Terminology .....	95
Camera Design Overview .....	95
Scanner Maintenance .....	108
ATAC Position Sensors check .....	109
Original Guide Sensor Test .....	112
Calibrate ATAC (Automatic Thickness Adjustment Control) .....	117
Lamp and motor controller board Communication Test .....	118
Upgrade Scanner Software .....	119



---

# 1 Troubleshooting

- [Troubleshooting tips](#)
- [Is the problem with the Printer or the Scanner?](#)
- [Image-quality problems](#)
- [Output problems](#)
- [Troubleshooting System Error Codes](#)
- [Using the Service Tools from the Touchscreen](#)
- [Troubleshooting Issues](#)
- [Troubleshooting print-quality and copy issues](#)
- [Troubleshooting general scanner issues](#)
- [Troubleshooting Specific Scanner Issues](#)
- [Cleaning the Scanning Area](#)
- [Troubleshooting Specific Panel PC Problems](#)
- [Touch screen fails](#)
- [Preventive Maintenance Kit for HP HD Pro Scanners](#)

## Troubleshooting tips

1. First record whether the problem is with the Printer, the Scanner, or the Touch Screen.
2. Make sure that the scanning area is completely clean.
3. Test 20: Noise Test can help you find where the scanning area is dirty.
4. The SCAN dump files can help you to understand the light profile of the affected scanner.
5. Remember, in order to cancel when copying, press the **Cancel** button on the Touch Screen and the [Cancel](#) button on the printer.

## Is the problem with the Printer or the Scanner?

If you experience the following symptoms, the problem could be related to the scanner:

- System Error on the Touch Screen.
- LED's flashing on the Scanner Operator Panel.
- WIDEsystem error message.
- Vertical lines (either color or black) in the scanned image.

If you experience the following symptoms, then perform an Image Preview and send a Test Print:

- Image Quality Problems.
- No Output
- Output is not as expected.

If the Image preview fails, this points to a problem with the Scanner. If the Test Print fails, this points to a problem with the Printer.

## Image-quality problems

If you have Image Quality problems in any prints, try the following:

1. Print out a file already stored or print out a demo file.
  2. Once the print is finished, insert it into the Scanner.
  3. Once scanned, print out the scanned image.
- If the scanned image already shows the problem, then the problem is associated with the scanner.
  - If the scanned image looks fine but then the print looks incorrect, then the problem may probably be associated with the printer.

## Output problems

If the output is not as you expected it to be, try the following:

- Check all the settings in the Software: Color Settings and Margins.
- Check media settings: Media profile (in software) and media loaded in the printer (front panel selection) should be the same.
- Perform Color Calibration (both Scanner and printer).
- Check the Preview Image.

If there is no output at all, then try the following:

- Check the connection between the Printer and the scanner.
- Check the selected settings: List, Collate, Scan to file...

## Troubleshooting System Error Codes

Chapter 2, [System Error Codes on page 28](#), contains a list of system error codes and their respective descriptions and recommended corrective actions. Only try one recommended action at a time and check if the error code has disappeared.

## Using the Service Tools from the Touchscreen

Here we briefly describe the various tests found in the software Service Tools menu (called SCANTest 6 in previous systems), for more detail of some of the Adjustments shown below see Chapter 5, [Scanner Adjustments and Calibrations on page 94](#).

The purpose of the Service Tools is to support the troubleshooting and adjustment of the Scanner.

To access the software you must go to the **Setup** tab and to: **Options, System, Service** (this part is password protected, the password is 'support.')

When Service Tools has been started, the Scanner is switched ON in Test Mode, and the Diagnostic LED on the Operator Panel is turned ON.

### Service Tools Menu

- Test 1: Scanner Information
- Test 2: LED Test
- Test 5: Lamp Test
- Test 6: Motor Test
- Test 9: Oscilloscope view cameras
- Test 11: Stitching and Vertical Alignment
- Test 12: Adjust Y-Axis Scaling
- Test 20: Noise Test
- Test 28: Original Guide Sensor Test
- Test 30: Calibrate ATAC
- Test 31: Driver Board Communication Test

- Test 42: Backup Calibration and statistics
- Test 43: Restore Calibration and statistics
- Test 45: Operator Panel Key Test
- Test 46: Paper Sensor Test

If Service Tools is started when the scanner is in Error Mode, the Error Code Number and a short description of the error will be displayed on the screen.

### Test 1: Scanner Information

This test displays general information regarding the scanner. When executed, the test displays the following:

- Scanner Model:
- Firmware Release:
- Firmware Build:
- Scanner ID:
- Mac Address:
- Serial Number:
- Lamp Light On: (Number of hours that the lamps have been on):

The tool allows also to reset the lamp counter when a new lamp is installed.

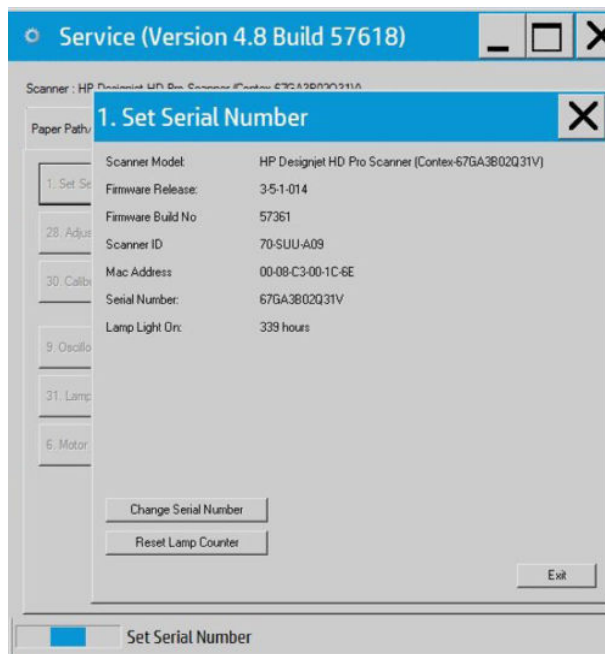

### Test 2: LED Test

This test checks the functionality of the LED Indicators on the Operator Panel. When the test is executed, all the LEDs are sequentially switched ON/OFF until Test 2 is terminated. If any of the LEDs fail, you will NOT get an error message, instead the LED will NOT switch ON or OFF. If the LED test fails, replace the Operators Panel Interconnect Board, or the Operators panel which is included in the Right Side cover.

### **Test 5: Lamp Test**

This test checks the functionality of the Lamp and associated electronics.

When the test is executed, a message on the screen will indicate whether the **Lamp** is turned ON or OFF (**Lamp power is turned ON/OFF**) and whether the **Light** is ON/OFF (**Light is detected or not**). The Lamp is delayed for approximately 2 seconds when switched ON.

### **Test 6: Motor Test**

This test checks the functionality of the Stepper Motor and any associated electronics.

When the test is executed, a menu appears that allows you to select the motor speed and the motor direction.

If the Stepper Motor or the Driver Board fails to run when the test is executed, then the Stepper Motor should be replaced.

### **Test 9: Oscilloscope View**

This test contains a Software Oscilloscope that allows you to check and adjust the CCD-Cameras. The following functions can be selected from the Test Program Menu.

- Uncorrected or Corrected Light Profile.
- Red, Green, or Blue Color Channel.
- Special Detail Views for Light Profile, Scan Width, and Vertical Positioning.
- Forward / Reverse controls for the Camera Motor.
- Save screen images.
- Print screen images.

The content of the Detail Views is marked on the upper overview window by red vertical lines. The continuous lines refer to the left Detail View and the dashed lines to the right Detail View.

### **Test 11: Stitching and Vertical Alignment**

This test is also included in the Scanner Maintenance Software.

This test performs Automatic Vertical Alignment and Horizontal Stitching.

Once the test has been started:

- Insert Calibration Sheet.
- Select Vertical Alignment to align the cameras.
- Select Horizontal Stitching to stitch the cameras.

The screen image can be saved or printed.

This test allows manual setting of the Stitch Values. The Stitch Values are stored in the Flash Memory on the Scanner Main Board.

The Vertical Alignment may be adjusted manually by controlling the Camera Motor from the control field '**<< dddd >>**'. The two buttons marked '**<< respectively >>**' are used to start the motor and to determine the direction of rotation. When started, the motor runs for dddd mili-seconds as entered into the control field.

### **Test 12: Adjustment of Y-Axis Scaling**

This test allows you to adjust the Y-Axis Scaling.

The scaling (dpi) in the mechanical scan direction (Y-Axis) depends on the speed of the stepper motor relative to the scanline Exposure Time. The default motor speed can be changed  $\pm 1\%$ , either from Test 12 or by using the '**Scanner Setup/Correction factor ...**' option of SW copying. The correction factor is stored in the Flash Memory on the Scanner Main Board.

### **Test 20: Noise Test**

The purpose of this test is to detect and locate the possible cause (dust, dirt, scratches,...) of vertical lines running from top to bottom of the scanned image.

When the test is executed, it scans the White Calibration Area of the Calibration Sheet and displays, for each color channel, the graytone values of each separate pixel averaged over the scanned band.

The displayed image of the Calibration Sheet will be superimposed by low level noise caused by the CCD chip, and larger spikes most likely caused by dust, dirt, scratches, or similar defects on the Glass Plate. In rare cases, larger spikes may be caused by dust, dirt, or pixel faults on the CCD chip.

The positions of larger spikes are shown by the numbers (cm or inch units) opposite to the spikes. The numbers refer to the Sideload-ruler on the scanner. Larger spikes going downwards are often caused by dust, dirt, scratches, or similar defects on the Glass Plate and may be removed by cleaning the Glass Plate. Downward spikes often show up as darker vertical lines in the scanned image.

Larger spikes going upwards are often caused by dust or dirt present on the Glass Plate during the last calibration with Scanner Maintenance. These defects are memorized by the Light Profiles stored in the Flash Memory and can only be removed by cleaning of the Glass Plate followed by running Scanner Maintenance again. Upward spikes show up as very bright vertical lines in the scanned image.

White vertical lines in the scanned image may be found even if Noise Test shows a perfectly 'clean' scanner. In this case, the cause may be white dust or particles on the backside of the Glass Plate having the same color as the white background. In this case, the Light Profiles of Service Tools, Test 9 may show upwards going spikes when a dark original is placed in the scan area.

### **Test 28: Original Guide Sensor Test**

This is to test the Guide Plate Sensors which are located under the Guide Plate. See Original Guide Sensor Test.

### **Test 30: Calibrate ATAC (Automatic Thickness Adjustment Control)**

This test sets the current level at which the ATAC will stop if something is preventing it from moving down. See Calibrate ATAC (Automatic Thickness Adjustment Control).

### **Test 31: Driver Board Communication Test**

This test checks the communication between the Scanner and the Driver Board. See Driver Board Communication Test.

### **Test 42: Backup Calibration and statistics**

Use this option to backup the calibrations and the scanner accounting values onto a USB drive.

### **Test 43: Restore Calibration and Statistics**

Use this option to restore the calibrations and accounting values previously backed up onto a USB drive.

### **Test 45: Operator Panel Key Test**

This test checks the functionality of the Keys on the Operator Panel. When pressing each of the keys, the test will show that the key has been activated, and will show if the result is correct or not.

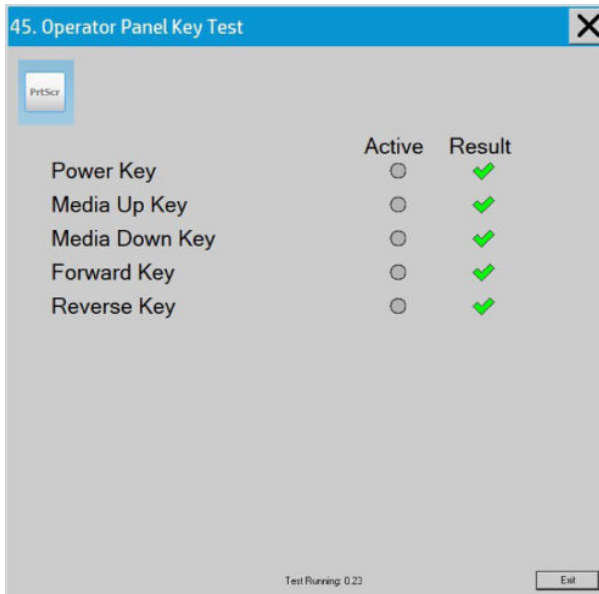

If the Key test fails, replace the Operators Panel Interconnect Board, or the Operators Panel which is included in the Right Side Cover.

#### **Test 46: Paper Sensor Test**

This test checks the functionality of the Media Sensors.

To test the Media Sensors, use a sheet of media to activate the different sensors one by one. When activated, the test will show that the sensor has been activated and will show if the result is correct or not.

For testing the ATAC Closed sensors; open and close the scanner cover.

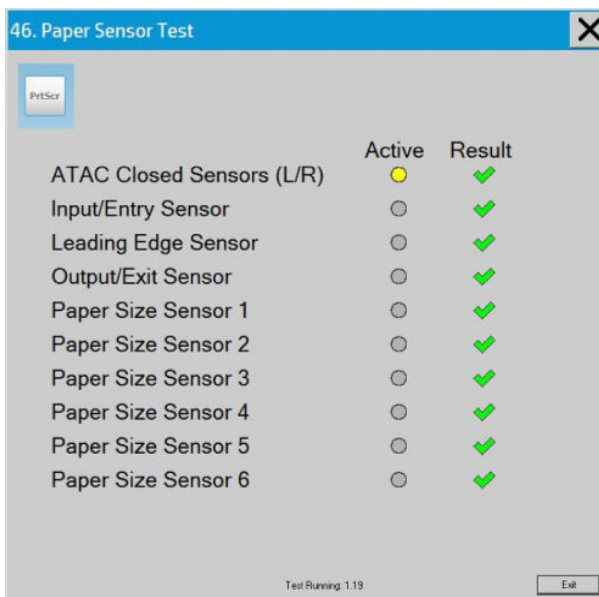

If the test fails, then the problem will be related to corresponding Sensor.

## Troubleshooting Issues

The following guide will help you to find a solution to some typical problems that some customers may experience. The problems (**P#**) that can be solved remotely through on-phone support and customer intervention are marked **C**. The problems that require on-site intervention performed by a Support Technician are marked **T**.



**NOTE:** Before sending a Support Technician to the customer, identify whether the problem is related to the scanner or the Panel PC (PPC).

If the problem is scanner-related, erase the parameter block and run the scanner maintenance. Then perform the system recover using the most recent version of the software.

If the problem is PPC-related, perform the system recovery using the most recent version of the software.

If the problem persists, try the solutions listed in the tables below.

## Troubleshooting print-quality and copy issues

P#	Category	Problem	Q#	Question	Yes/No	C/T	Solution
1	Copy problem	The colors on one side of the copy do not correspond to the colors on the other side of the copy	1	Have you cleaned and calibrated your scanner recently?	No	C	Camera differences - The scanner needs to be cleaned and calibrated (see P25 and P25).
					Yes		See Q2
			2	Have you upgraded the system software to the latest version?	No	C	Upgrade system software
					Yes	T	Cameras need adjusting or the Camera Board replacing

P#	Category	Problem	Q#	Question	Yes/No	C/T	Solution
2	Copy problem	I get thin lines of wrong colors in my copy	1	Are the lines vertical and also present in your preview?	Yes	C	Erase the parameter block and run the scanner maintenance. Then clean and calibrate the scanner (see P25 and P25).
					No		See Q2
			2	Are the lines horizontal and equally spaced?	Yes	C	Check printheads by starting printhead test on Printer
					No		See Q3
			3	Are the lines horizontal, but irregular (maybe only 1 line)?	Yes	C	The lines could be caused by a data error. Upgrade system software



P#	Category	Problem	Q#	Question	Yes/No	C/T	Solution
					No		See Q4
			4	Do you have a great number of regular spaced lines very close to each other and restricted to one side (1 camera) only?	Yes	T	You have a camera error. Replace Camera Board

P#	Category	Problem	Q#	Question	Yes/No	C/T	Solution
3	Copy problem	I get thick lines of slightly wrong colors in my copy	1	Are the lines vertical and also present in your preview?	Yes	C	The scanner needs to be cleaned and calibrated (see P25 and P25).
					No		See Q2
			2	Are the lines horizontal and equally spaced?	Yes	C	Check printheads by starting printhead test on Printer
					No		See P2.

P#	Category	Problem	Q#	Question	Yes/No	C/T	Solution
4	Copy problem	Some colors are not the same when I compare the master print with the copy	1	Is the scanner clean and calibrated?	No	C	See P1. Clean and calibrate the scanner (see P25 and P25).
					Yes		See Q2
			2	Do you use the correct media profile for the actual media?	No	C	If you are using e.g. Glossy Media for this copy, the media profile selected should also be for Glossy Media.
					Yes		See Q3
			3	Is the media profile valid?	No	C	Create a new media profile (see P26)
					Yes		See Q4
			4	Is the option 'Ink Printer Original' set in accordance with your original?	No	C	If original was printed using an Inkjet Printer, set this option (see P27)
					Yes		See Q5
			5	Is the media you are printing on the same type as the original?	No	C	e.g. Use Glossy Media to reproduce a Glossy original
					Yes	C	Create a new media profile (see P26)

P#	Category	Problem	Q#	Question	Yes/No	C/T	Solution
5	Copy problem	Only a part of the master print is being copied	1	Are you scanning a thick original?	Yes	C	Uncheck extended media handling box in scanner settings (using extended media will load the original between both entry and exit rollers before scanning - this means that you will not have the start of the thick original scanned. Also the scan speed will be slower, and no "back - ups"/reversing is allowed while scanning)
					No		See Q2
			2	Have you selected 'Auto size'?	Yes	C	The scanner needs to be cleaned (see P24)
					No		See Q3
			3	Is the length too short and the width OK?	Yes	C	The problem may be with the Printer (not able to print close to the edges) or Panel PC (Hard Disk is full).
					No	C	Check that the margins that are set are not too big. Also check Scanner Media Offsets

P#	Category	Problem	Q#	Question	Yes/No	C/T	Solution
6	Copy problem	Which setting will give me the best result when copying?	-	-	-	C	See section about media profile (P4). Use copy quality best. Choose the correct Type of original ("Map" for maps, "Photo" for photos, etc). Eventually go to Original Setup to fine adjust colors and sharpening. (See also online help for more details - button with "?" symbol)

P#	Category	Problem	Q#	Question	Yes/No	C/T	Solution
7	Copy Problem	Nesting feature is not working	1	Is the correct printer selected?	No	C	Select the correct Printer
					Yes		See Q2
			2	Is the Hard Disk close to being full?	Yes	C	Free up some space, or try to run a nesting job with only 2 or 3 small pictures. If that works, see P27.
					No	C	Make sure that Nesting is set: Select: <b>Output Layout Nesting optimized</b>

P#	Category	Problem	Q#	Question	Yes/No	C/T	Solution
8	Copy problem	The Collate Copy function does not work	1	Is your Hard Disk close to full?	Yes	C	Free up some space, or try to run a collate job with a smaller picture.
					No	C	Follow the step by step instructions in the online help under <b>Collate Copy</b> .

P#	Category	Problem	Q#	Question	Yes/No	C/T	Solution
9	Copy problem	The lines are not accurate	1	Are the lines wavy and irregular?	Yes	C/T	<b>C:</b> The original could be curled or crumpled. Try to flatten the original (in case of very irregular waves there could be a mechanical problem with the scanner). <b>T:</b> check motor and belt drive tension.
					No		See Q2
			2	Are the lines not sharp?	Yes	C/T	<b>C:</b> Are you using the correct copy method? Try sharpening. If sharpness is different between Cameras, you may have a Focus Problem. <b>T:</b> Check focus of cameras (see <a href="#">5. Adjust camera tilt on page 104</a> ).
					No		See Q3
			3	Are the lines broken and the errors situated in a vertical column between 2 columns?	Yes	C	You might have a visible stitching error (see P28).
					No	C	Check the dpi. In the case of too low resolution, jagged diagonal lines will appear.

P#	Category	Problem	Q#	Question	Yes/No	C/T	Solution
10	Copy Problem	One side of the preview is black	1	Have you upgraded the system software to the latest version?	No	C	Upgrade system software.
					Yes	T	Most likely a Camera Error. Perform the Manual Camera Adjustment (Test 9). Replace the Camera Board if necessary.

## Troubleshooting general scanner issues

P#	Category	Problem	Q#	Question	Yes/No	C/T	Solution
11	Copy problem	Only a part of the master print is being copied	1	Are you scanning a thick original?	Yes	C	Uncheck extended media handling box in scanner settings (using extended media will load the original between both entry and exit rollers before scanning - this means that you will not have the start of the thick original scanned. Also the scan speed will be slower, and no "back - ups"/ reversing is allowed while scanning).
					No		See Q2
			2	Have you selected 'Auto size'?	Yes	C	The scanner needs to be cleaned (see P24).
					No		See Q3
			3	Is the length too short and the width OK?	Yes	C	The problem may be with the Printer (not able to print close to the edges) or Panel PC (Hard Disk is full).
					No	C	Check that the margins that are set are not too big. Also check Scanner Media Offsets.

P#	Category	Problem	Q#	Question	Yes/No	C/T	Solution
12	System Error	What should I do when the program hangs?	1	Are you running a copy job?	Yes	C	Making a copy takes a lot of resources according to the settings. Wait till the copy is done before performing another action.
					No		Restart the system. If the problem comes back, reinstall the system.

P#	Category	Problem	Q#	Question	Yes/No	C/T	Solution
13	File problem	When I scan to file, the file is very big	1	Are you scanning in color?	Yes	C	Scanning large drawings will generate very big files. An A0 color drawing scanned at 300 dpi will generate a file size of approx. three Gigabytes when scanned in an uncompressed format. In order to reduce file size, select TIFF - pack bits as format. You can reduce size even more by selecting JPEG format, but this format will reduce picture quality.
					No		See Q2

P#	Category	Problem	Q#	Question	Yes/No	C/T	Solution
			2	Are you scanning in gray tones?	Yes	C	Scanning large drawings will generate big files. An A0 gray tone drawing scanned at 300 dpi will generate a file size of approx. 300 Mbytes when scanned in an uncompressed format. In order to reduce file size, select TIFF - pack bits as format. You can reduce size even more by selecting JPEG format, but this format will reduce picture quality.
					No		In order to reduce file size on scanned B/W drawings, select TIFF group 4 compression.

P#	Category	Problem	Q#	Question	Yes/No	C/T	Solution
14	File problem	When I scan to file my application cannot read the file	1	Did you get an error message when creating the file?	Yes	C	Check that you have enough disk space and scan to file again, choosing TIFF uncompressed as format
					No	C	We only recommend to use the built-in viewer for file viewing. Large format drawing files may not load correctly in other viewers due to file size. Try to scan a smaller original (A4).

P#	Category	Problem	Q#	Question	Yes/No	C/T	Solution
15	Network Problem	I cannot access the system from the network	1	Is the PC connected to the network?	Yes	C	Do basic network troubleshooting.
					No	C	Connect the PC to the Network.

P#	Category	Problem	Q#	Question	Yes/No	C/T	Solution
16	Scan to network	I cannot access network drivers	1	With the Panel PC connected to the LAN, can you access the Panel PC from another computer on the network?	Yes	C	Go to Q2
					No	C	Check the network performance and connection to the scanner Panel PC.
			2	Is the folder of the server you are trying to map already mapped by another user in the Panel PC?	Yes	C	Windows does not allow the same server to be mapped by two different users on one computer. Use the access connection previously mapped or delete the connection and map a new access connection.
					No	C	Go to Q3

P#	Category	Problem	Q#	Question	Yes/No	C/T	Solution
			3	Do you have permission to access and write to the network folder you are trying to map?	Yes	C	Go to Q4
					No	C	You cannot access this network folder. Select a network folder for which you have read and write permissions.
			4	Are you using the correct user name and password?	Yes	C	Try to map the network file from another computer by selecting <b>Windows Explorer, Tools, Map network drive</b> . If you are able to map the drive in this manner, you should also be able to map through the Panel PC.
					No	C	Use the correct user name and password.

P#	Category	Problem	Q#	Question	Yes/No	C/T	Solution
18	Scanner Calibration Problem	Scanner Maintenance did not succeed	1	Did any error occur when performing the Scanner Maintenance?	Yes	C	See Q2
					No	C	Clean the scanner and then run Scanner Maintenance again (see P24 and P 25). If that does not help, see Q5.
			2	Error: <b>Basic calibration was performed. but failed to stitch scanner or Could not find horizontal line or Could not read bar lines or Could not recognize the scanned IT8 picture.</b>	Yes	C	Clean the scanner and then run Scanner Maintenance again (see P24 and P 25). If that does not help, see Q5.
					No		See Q3.
			3	Error: <b>Sheet not recognized.</b>	Yes	C	Reinsert calibration sheet correctly and run Scanner Maintenance again. If that does not help, see Q5.
					No		See Q4.
			4	Error: <b>No movement in camera position has been detected during vertical camera alignment.</b>	Yes	T	Check the camera.
					No		See Q5.
			5	Have you upgraded the system software to the latest version?	No	C	Upgrade system software. Clean the scanner and then run Scanner Maintenance again (see P24 and P 25).
					Yes	T	Check the camera.

P#	Category	Problem	Q#	Question	Yes/No	C/T	Solution
19	System error	I cannot install my application on the system.	-	-	-	C	The copy system is only meant to handle the factory installed software and applications.

P#	Category	Problem	Q#	Question	Yes/No	C/T	Solution
20	Updating	How do I update the system?	-	-	-	C	Download the new system file from the the HP Support web site and copy into a USB drive. Go to System Options > Advanced > Update software, and follow the instructions.

P#	Category	Problem	Q#	Question	Yes/No	C/T	Solution
21	Start-up Problem	The system does not power up	1	Is the system dead (no LEDs are lit, the Panel PC screen is black, and no fan-noise can be heard)?	Yes	C	<ol style="list-style-type: none"> <li>1. Check that all power switches on the equipment are ON.</li> <li>2. Check if there is power at the wall outlet.</li> <li>3. Check power cables between wall outlet and the individual units.</li> </ol>
					No		See Q2.
			2	Does Panel PC start with the normal initial screen?	Yes	C	See Q5.
					No		See Q3.
			3	Does Panel PC start normally, but the software does not work?	Yes	C	Reinstall system software
					No		See Q4
			4	Is the Panel PC dead (no fan noise can be heard and no screen image appears)?	Yes	T	Troubleshoot the Panel PC.
					No		See Q5.
			5	Is the Scanner dead (no fan noise can be heard and no LEDs are lit)?	No		See Q6.
					Yes	T	Check, and if necessary replace: <ol style="list-style-type: none"> <li>1. Power Supply Unit</li> <li>2. Lamp and motor controller board</li> </ol>

P#	Category	Problem	Q#	Question	Yes/No	C/T	Solution
			6	Does the scanner hangup with all LEDs lit?	Yes	T	Try the following: <ol style="list-style-type: none"> <li>1. Erase parameter block</li> <li>2. Update the system software</li> <li>3. Replace the Scanner Main Board</li> </ol>
					No		See P23.

P#	Category	Problem	Q#	Question	Yes/No	C/T	Solution
22	Mechanical Problem	I cannot load the original	1	Please try to load a new piece of A4 paper at the center of the scanner. Does this paper load?	Yes	C	You have a problem with your original. Please check that paper edges are not bent or curled in any way.
					No		See Q2.
			2	Can paper be loaded by pressing the "Forward" key?	Yes	C	See Q3.
					No	T	Try replacing the following: <ol style="list-style-type: none"> <li>1. Lamp and motor controller board</li> <li>2. Power Supply Unit</li> <li>3. Feed motor (Stepper motor)</li> <li>4. Scanner Main Board</li> </ol>
			3	Does the Ready LED turn ON when activating Original Sensor (insert paper)?	No	T	Check, and if necessary replace: <ol style="list-style-type: none"> <li>1. Paper/lid sensors</li> <li>2. Scanner Main Board</li> </ol>
					Yes	C	Check the settings in the software for media loading.

P#	Category	Problem	Q#	Question	Yes/No	C/T	Solution
23	Error code	I get an Error Code, what do I do?	-	-	-	-	Re-power the system, and check if the error code reappears. If it does, see Q1.
			1	Have you upgraded the system software to the latest version?	No	C	Upgrade the system software. Check if Error Codes reappears. If it does, see P23a.



P#	Category	Problem	Q#	Question	Yes/No	C/T	Solution
23a	Error Code	I still get an error code, what do I do?		Does the Diagnostic LED (and, in some cases also other LEDs) blink?	Yes	C	Lower Guide Plate to Normal position, start Preview Scan to obtain an Error Code or check if WIDSystem gives an Error Code.  See <a href="#">System Error Codes on page 28</a> for the meaning of the error code.
		"No scanner found"	1	Does the scanner start normally?	No	C	See P23.
					Yes	C	See Q2.
			2	Are the interface cables (Ethernet) properly connected to the scanner and the Panel PC?	Yes	C	See Q3.
			3	Have you upgraded your system software?	Yes	T	<ol style="list-style-type: none"> <li>1. Replace network cable</li> <li>2. Replace Scanner Main Board</li> </ol>

P#	Category	Problem	Q#	Question	Yes/No	C/T	Solution
24	Cleaning	How do I clean the scanner?	-	-	-	C	Clean the Glass Plate on both sides with mild detergent, and wipe thoroughly with a lint-free cloth until dry. Check for scratches. Deep scratches on the glass plate or background platen means replacement of the part.

P#	Category	Problem	Q#	Question	Yes/No	C/T	Solution
25	Color Calibration	How do I color calibrate the scanner?	1	Do you have the correct and "as new" scanner maintenance sheet for the scanner?	Yes	C	Clean scanner (see P24). Insert the scanner maintenance sheet. Start scanner maintenance. The process is automatic and will also include stitching.
					No	C	Get Correct/New Scanner Maintenance Sheet.

P#	Category	Problem	Q#	Question	Yes/No	C/T	Solution
26	Media Validation	What is media validation? How do I validate?	—	—	-	C	If the validate feature is chosen, a new color patch sheet is printed and can be scanned for validation. In this way it can be determined whether the produced color map has passed.

P#	Category	Problem	Q#	Question	Yes/No	C/T	Solution
27	Ink Printer Original	What is Ink Printer Original?	-	—	-	C	When the original has been printed on an Inkjet printer this option should be enabled.

P#	Category	Problem	Q#	Question	Yes/No	C/T	Solution
28	Visible stitching Errors	What is a visible stitching error?	-	-	-	C	A visible stitching error appears typically as a column of broken lines between 2 cameras. Normally it can be solved by running Scanner Maintenance, which will perform an automatic stitching adjustment. With some curled or creased/crumpled originals it is necessary to straighten out the original to prevent it from lifting from the glass plate. With thick originals it can be necessary to adjust the stitching (stitching used for thick originals only, set this in scanner setup). A visible stitching error should not be confused with the error message <b>Error 32 - Could not stitch Camera A and B</b> .

## Troubleshooting Specific Scanner Issues

P#	Category	Problem	Q#	Question	Yes/No	C/T	Solution
29	Vertical lines (possible dust problem)	The image has a vertical, white or black line, which could be caused by dust. To verify that the line is caused by dust, preview the image and inspect the preview using the viewing section buttons.	-	-	-	C	Perform Scanner Maintenance: Cleaning and Camera Alignment. Using Test 20 from Service Tools may help to identify dusty/ dirty areas.

P#	Category	Problem	Q#	Question	Yes/No	C/T	Solution
30	Firmware	You are receiving firmware-related errors.	-	-	-	C	Try upgrading the System Software.

P#	Category	Problem	Q#	Question	Yes/No	C/T	Solution
31	Stepper Motor	The Stepper Motor does not work.	-	-	-	C	<p>Try the following:</p> <ol style="list-style-type: none"> <li>1. Use <b>Test 6: Motor Test</b> to check the functionality of the Stepper Motor.</li> <li>2. Replace the lamp and Motor Controller Board.</li> <li>3. Replace the Stepper Motor.</li> </ol>

P#	Category	Problem	Q#	Question	Yes/No	C/T	Solution
32	Lamp	The lamp does not work.	-	-	-	C	<p>Try the following:</p> <ol style="list-style-type: none"> <li>1. Reseat the lamp cartridge.</li> <li>2. Ensure that the Lamp and Motor Controller Board is connected to the power supply unit.</li> <li>3. Ensure that the lamp sensor and the Lamp and Motor Controller Board are functioning correctly.</li> </ol>

P#	Category	Problem	Q#	Question	Yes/No	C/T	Solution
33	Skewing	There is a skewing problem	-	-	-	C	<p>Try the following:</p> <ol style="list-style-type: none"> <li>1. Ensure that the Guide Plate is closed and latched.</li> <li>2. Replace the Guide Plate.</li> <li>3. Clean the rollers with isopropyl alcohol.</li> <li>4. Replace the rollers.</li> </ol>

P#	Category	Problem	Q#	Question	Yes/No	C/T	Solution
34	Media Loading	The media cannot be loaded or there are other media loading problems.	-	-	-	C	<p>Try the following:</p> <ol style="list-style-type: none"> <li>1. Check the Original Sensor (green LED when loading media), or use <b>Test 46: Paper Sensor Test</b> to check the functionality of the sensor.</li> <li>2. Use <b>Test 6: Motor Test</b> to check the functionality of the Stepper Motor.</li> </ol>

P#	Category	Problem	Q#	Question	Yes/No	C/T	Solution
35	Fan	The fan is not working	-	-	-	C	<p>Try the following:</p> <ol style="list-style-type: none"> <li>1. Ensure that the fan is correctly connected.</li> <li>2. If the fan is connected and still doesn't work, replace the Lamp, Motor Controller Board or the fan.</li> </ol>

P#	Category	Problem	Q#	Question	Yes/No	C/T	Solution
36	Software	You are experiencing problems with the software	-	-	-	C	<p>Try the following:</p> <ol style="list-style-type: none"> <li>1. Reload the software.</li> <li>2. After reloading the software, set-up the system on the network again (if necessary).</li> <li>3. If the problems persist, reinstall the software, and delete the user's files (press F12).</li> </ol>

P#	Category	Problem	Q#	Question	Yes/No	C/T	Solution
37	Firmware	<p>All of the LEDs in the scanner's front panel are flashing when you turn on the scanner (as shown in the image below), indicating that printer firmware needs to be upgraded.</p> <p><b>NOTE:</b> This describes a different situation than when the scanner is turned on in special boot mode, in which the LEDs also flash.</p>	-	-	-		<p>The most probable reason for this situation is that the last system software upgrade attempt was not successful. To remedy this situation, upgrade the system software.</p>

## Cleaning the Scanning Area

The following parts must be cleaned using a soft lint-free cloth and a mild, streak-free, cleaning detergent. Alternatively, the parts may be cleaned without the use of cleaning detergents by using a damp micro-fibre cleaning cloth (soak the cloth with water and wring until damp):

- Main scanner cover. Clean the main scanner cover to ensure that no dust is introduced into the scanning area when you scan an original.
- White Background Plate on the Guide Plate
- The Glass Plate. If you clean both sides, be very careful not to touch the Stitching Wire (located under the Glass Plate) out of position. Do not use solvents, as this may dissolve the paint used for the black masks on the Glass Plate. Do not recommend that customers clean the underside of the glass plate; it should only be cleaned by an HP support technician.
- The Mirrors. It is necessary to remove the Mirror Chassis to get access to the Mirrors for cleaning. The Camera Adjustment must be checked and if necessary readjusted after the replacement of the Mirror Chassis.



**NOTE:** The mirrors are normally "Out of Focus", therefore small dust particles on the mirrors will not deteriorate the scanning result.

- The Feed Rollers. These may be cleaned with a damp micro-fibre cleaning cloth.

Once all these procedures have been completed, the scanner will be ready to work correctly.

### The Cleaning Procedure

When cleaning any part of the scanning area **DO NOT** use abrasives, acetone, benzene or fluids that contain these chemicals. Do not spray liquids directly onto the scanner glass plate or anywhere else in the scanner.

1. Turn the scanner power off.
2. Disconnect the scanner power cable.
3. Open the Guide Plate by pushing up the left and right locking levers and flipping upwards to expose the scan area.



4. Gently wipe the Glass Plate. Clean the glass with a lint-free cloth and a mild, streak-free, glass cleaner.

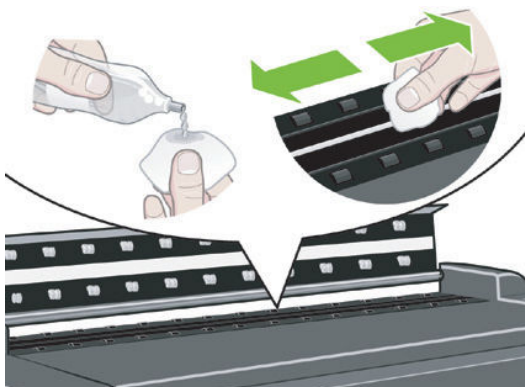

5. Dry the glass completely using a separate clean, dry lint-free cloth like the one provided with the maintenance kit.

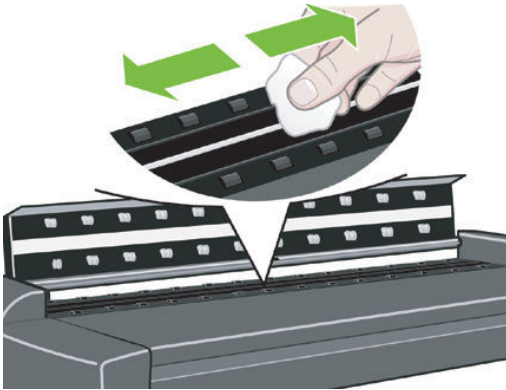

6. Clean the white background assembly. Wipe the white metal area with a lint-free cloth and a mild, streak-free, glass cleaner.

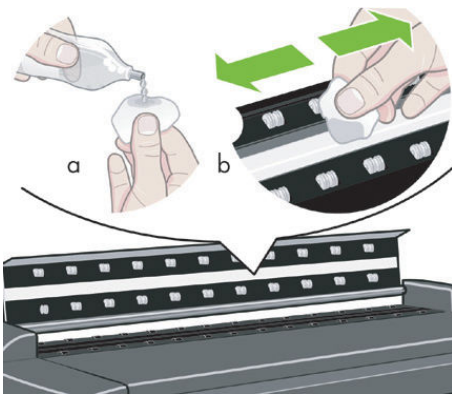

7. Clean the platen rollers. Wipe the rollers with a lint-free cloth and a mild, streak-free, glass cleaner.

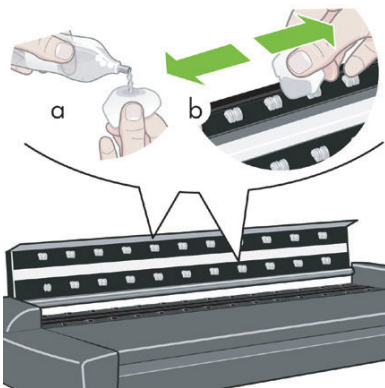

8. Dry the platen and rollers completely using a separate clean, dry lint-free cloth.



9. Close the Guide Plate.

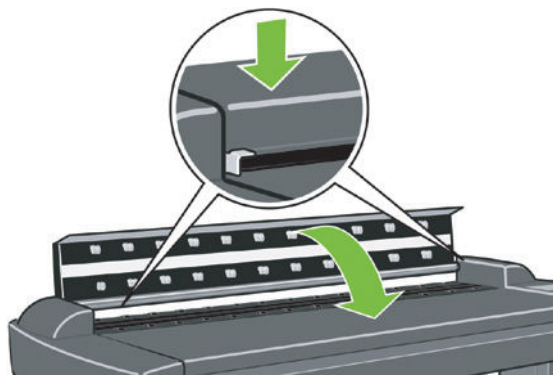

10. Use the dust sheet to protect the Scanner when not in use.



**CAUTION:** Ensure that the scanner is turned off before covering it with the dust sheet. The scanner will overheat if covered while turned on.

## Troubleshooting Specific Panel PC Problems

- [Power failure](#)
- [Boot up fails](#)
- [LCD fails](#)
- [No backlight and no display](#)
- [With backlight but no display](#)
- [The HDD fails](#)
- [DDR DRAM fails](#)

The following section is related to the PanelPC and it's related components.

## Power failure

If the power has been turned on, and there is no message on the screen, try the following:

- Make sure the power cord is correctly connected.
- Plug the power cord to another power outlet.
- The system fan should start up if there is power in the PanelPC. If not, replace the External Power Supply.

## Boot up fails

The PanelPC issues a series of beeps which can be used to identify which part is failing.

- One short beep: No error during POST (Power on Self-Test).
- One long beep followed by two short beeps: Video initial error.
- One long beep followed by nine short beeps: BIOS Bootblock error.
- Single long beep repeatedly: DRAM error.

## LCD fails

The failure of the LCD display can be divided into two issues, the PanelPC has no backlight and no display, or the PanelPC has the backlight but there is no display. Use the two troubleshooting flow charts to solve the problem:

### No backlight and no display

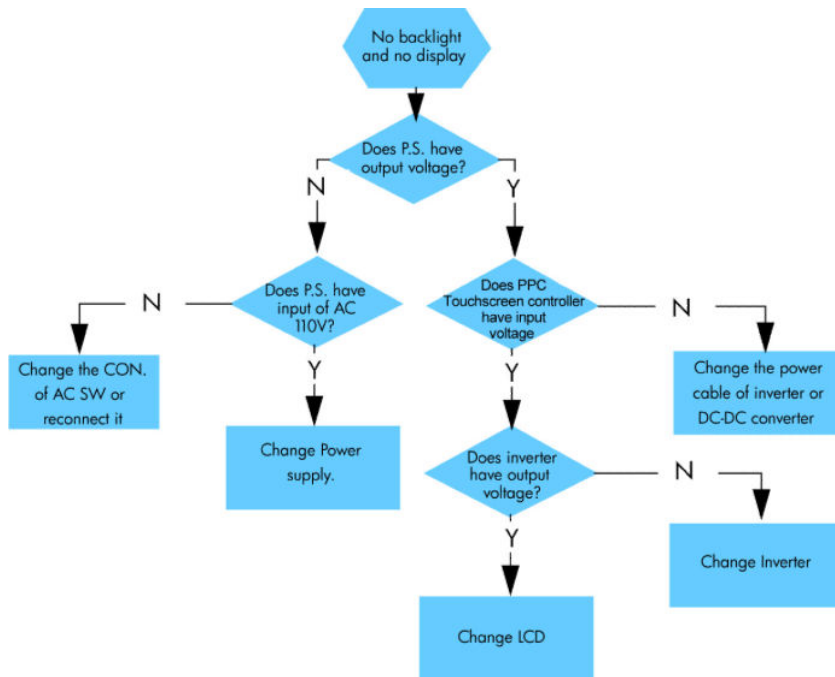



## With backlight but no display

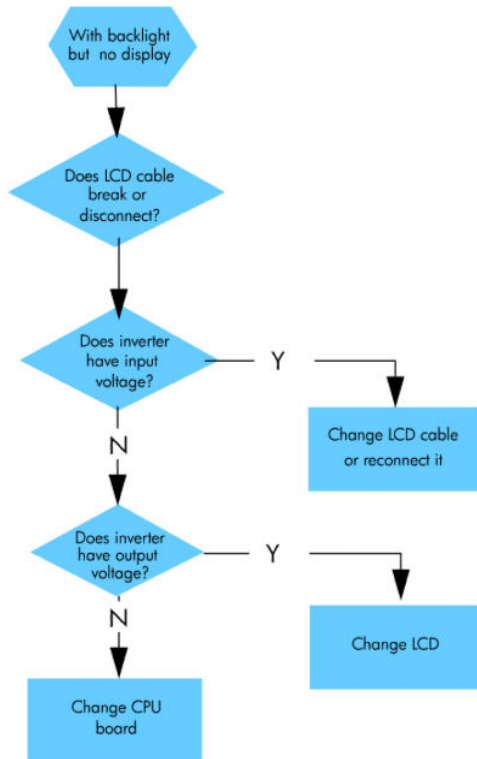

## The HDD fails

The HDD is running, and the system configuration has identified the HDD's ID while booting up. Try the following:

- Set the type of hard disk to AUTO in STANDARD CMOS SETUP.
- Reconnect the cable between HDD and main board.
- Change the HDD. See [HDD on page 82](#).

The HDD is not running, and the system configuration can not identify the HDD's ID while booting up. Try the following:

- Reconnect the cable between HDD and main board.
- Change the cable between HDD and main board.
- Change the HDD. See [HDD on page 82](#).

## DDR DRAM fails

If the computer repeatedly makes a long beep, and the display is blank when you power on, this indicates a DDR DRAM error, replace the DDR DRAM.

## Touch screen fails

Follow the steps in the flowchart below to quickly check if the touch screen fails:

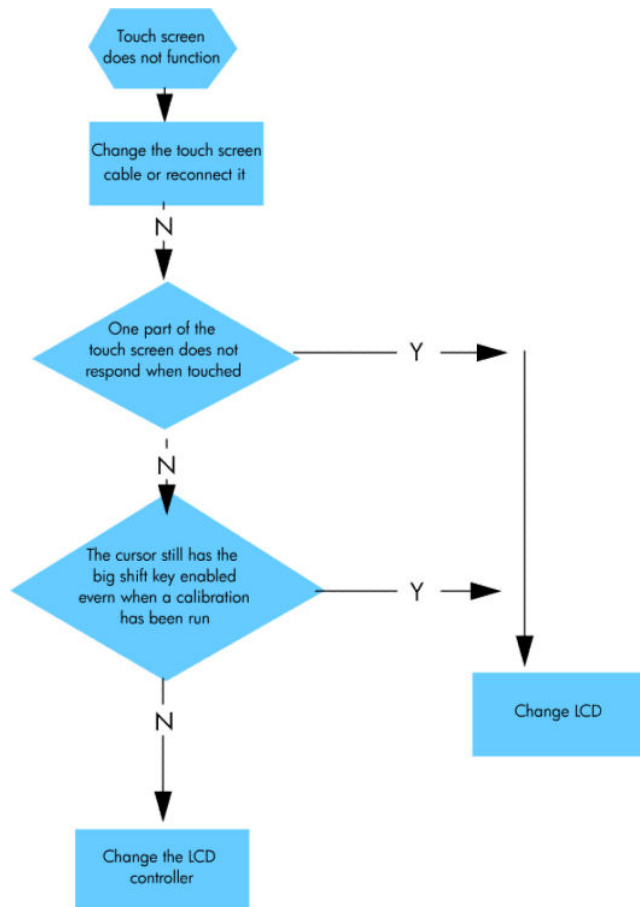

### Touch screen is working but can't control the cursor

Try the following:

- Run the calibration program.
- Check that the cable between the LCD controller and the LCD is connected in the correct position.
- Replace the LCD controller.
- Replace the LCD.

## Preventive Maintenance Kit for HP HD Pro Scanners

The following scanner messages are shown on the touch screen. They are all shown in the "scanner messages" window that pops up automatically if a message should be notified to the user, and the window can also be recalled manually by pressing the progress bar area of JETimage.

User warnings:

- **Scanner Maintenance has not been run for 30 days.**
- **Lamp quality fails.**

The lamp quality is electrically monitored and the warning appears when the light quality starts to degrade, which typically happens after at least 4000 hours of usage. The scanner maintenance warning appears when scanner maintenance has not been performed for 30 days. However, the frequency with which scanner maintenance should be performed depends on scanner usage.

---

## 2 System Error Codes

- [System Error Codes for the Scanner Only on page 29](#)
- [Error Codes for the JetImage Software RIP on page 40](#)
- [Error Messages for the Touch Screen on page 45](#)

# System Error Codes for the Scanner Only

## Introduction

The following pages contain a list of system error codes and their respective descriptions and recommended corrective actions. Only try one recommended action at a time and check if the error code has disappeared.

If you have an error code which is not documented in this Service Manual or you have an error which you cannot resolve, then report the error to the HP Response Center or the nearest HP Support Office. When reporting the error, have the following information ready:

- Model and Serial Number of the scanner.
- Which firmware revision the printer and the scanner is using.
- SW version.
- The complete error number.
- ScanDump of Light Profiles.

## Error Codes displayed on the Keypad

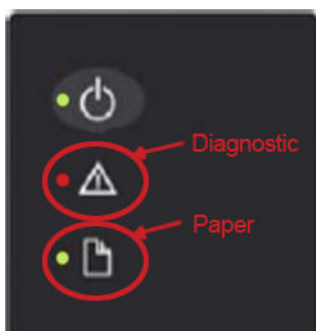

An error condition is indicated by a flashing Diagnostic Indicator. The error may be identified by an Error Code Number being displayed on the screen and/or by the following combinations of flashing (F) indicators on the Operator Panel: See [The Software Modules on page 30](#) for an overview, and the lists of individual error codes that follow after for details.

Error Description	Diagnostic	Paper
Boot Error	F	F
General Error: see error code on Panel PC for details	F	OFF
Scanner main board error	F	F
Camera board error	F	2 X F
Elevation motor driver board error	F	4 X F

1 X F, 2 X F, means that the Paper Indicator flashes 1, 2, times every time the Diagnostic Indicator is turned on. F, F, means that both indicators are flashing simultaneously.

## The Software Modules

The first set of numbers in the error code refer to a part of the Scanner software or the Scanner.

Software Modules	Comments/Notes
51 - Scanner API	Low level scanner control library. All scanner communication goes through this API.
52 - Image Format Library	Printer and file formatting. All printing and file read/write is formatted/ decoded by this library.
53 - Copy Engine	The central processing engine in the (JETimage) software.
54 - Closed Loop Calibration	Color Management math library that calculates the media profiles.
55 - Test Software	Scanner Maintenance / SCANTest.
56 - Jetimage container	All user interface and business logic except for Scanner Maintenance / SCANTest and WIDEsystem.
57 - WIDEsystem (WS)	Scanner surveillance utility
100 - Scanner	Mechanical part of the Scanner.

## Software Related Errors

### System Error: 55-101

**Description:**

No scanner found.

**Corrective Action:**

1. Check that the scanner is properly connected and turned on.
2. Reboot the system.

### System Error: 55-121

**Description:**

Unknown error.

**Corrective Action:**

- ▲ Restart the system.

### System Error: 55-302

**Description:**

Failed to initialize Basic Calibration.

**Corrective Action:**

1. Check sheet , white background and glass plate.
2. Clean if needed.

## System Error: 55-319

**Description:**

The calibration sheet was not recognized as the right sheet.

**Corrective Action:**

1. Please check that the correct sheet is being used.
2. Inspect the sheet for scratches or wear, and replace it if the problem continues.

## System Error: 55-351

**Description:**

Alignment and Stitching Failed.

**Corrective Action:**

- ▲ Please check sheet.

## System Error: 55-503

**Description:**

Color calibration failed.

**Corrective Action:**

1. Please clean scanner.
2. Please run application again.
3. Inspect the sheet for scratches or wear, and replace it if the problem continues.

## System Error: 55-509

**Description:**

IT8 file is not accessible.

**Corrective Action:**

1. If you have received a new Calibration Sheet, please allow application to find reference file over the internet.
2. If problem persists reinstall the software to correct the issue.
3. If software does not find the new reference file on the internet, please get the IT8 file from the DVD included with the scanner and copy it onto a USB stick. Insert the USB in the Panel PC and try to recalibrate.

## System Error: 55-513

**Description:**

The IT8 reference file could not be found on the internet.

**Corrective Action:**

- ▲ Get the IT8 file from the DVD included with the scanner and copy it onto a USB stick. Insert the USB in the Panel PC and try to recalibrate.

## System Error: 55-523

**Description:**

Sheet not recognized.

**Corrective Action:**

1. Please clean scanner.
2. Please run application again.
3. Inspect the sheet for scratches or wear, and replace it if the problem continues.

## System Error: 55-530

**Description:**

When checking new calibration the result was not within the limits.

**Corrective Action:**

- ▲ Inspect the sheet for scratches or wear, and replace it if the problem continues.

## System Error: 55-611

**Description:**

Unknown Scanner Status Error.

**Corrective Action:**

- ▲ Reboot system.

## System Error: 55-613

**Description:**

No paper was detected in the scanner.

**Corrective Action:**

- ▲ Place the correct sheet in the scanner.

## System Error: 55-1025

**Description:**



Stitch and Alignment Failed. Could not recognize sheet. Line distance varies.

**Corrective Action:**

- ▲ Please clean glass plate and inspect sheet, then redo calibration.

## System Error: 55-1038

**Description:**

Alignment failed.

**Corrective Action:**

- ▲ Please clean glass plate and inspect sheet, then redo calibration.

## System Error: 56-62

**Description:**

An error occurred while applying network settings.

**Corrective Action:**

- ▲ Please check that the entered settings are valid for the network.

## System Error: 56-70

**Description:**

Invalid network folder.

**Corrective Action:**

- ▲ Please check that your entered network folder settings are valid.

## System Error: 262-51

**Description:**

Error closing file, corrupted image.

**Corrective Action:**

- ▲ Image size and resolution exceeds file format limitations. Reduce resolution or image size.

## Scanner related errors

### Error code: 100-40035

**Keypad error code:** ERR\_CB

**Level:** Support Correctable

**Description:** CBx, Camera A not found

**Corrective Action:**

1. Camera board.
2. Scanner main board.
3. Related cabling.

**Error code: 100-40036**

**Keypad error code:** ERR\_CB

**Level:** Support Correctable

**Description:** CBx, Camera B not found

**Corrective Action:**

1. Camera board.
2. Scanner main board.
3. Related cabling.

**Error code: 100-40037**

**Keypad error code:** ERR\_CB

**Level:** Support Correctable

**Description:** CBx, Camera C not found

**Corrective Action:**

1. Camera board.
2. Scanner main board.
3. Related cabling.

**Error code: 100-40038**

**Keypad error code:** ERR\_CB

**Level:** Support Correctable

**Description:** CBx, Camera D not found

**Corrective Action:**

1. Camera board.
2. Scanner main board.
3. Related cabling.

**Error code: 100-40076**

**Keypad error code:** ERR\_CB

**Level:** Support Correctable

**Description:** CBx, Camera board error

**Corrective Action:**

1. Camera board.
2. Scanner main board.
3. Related cabling.

## Error code: 100-20086

**Keypad error code:** ERR\_MDA

**Level:** Support Correctable

**Description:** Unable to communicate with MDx board

**Corrective Action:**

1. Elevation motor driver board.
2. Scanner main board.
3. Related cabling.

## Error code: 100-20087

**Keypad error code:** ERR\_MDA

**Level:** User Correctable

**Description:** Unable to perform paper guide movement (ATAC). Please turn scanner off and on

**Corrective Action:**

1. Try turning the scanner off and back on again.
2. Elevation motor driver board.
3. Scanner main board.

## Error code: 100-08208

**Keypad error code:** NONE

**Level:** Support Correctable

**Description:** Operator's panel failed

**Corrective Action:**

1. Related cabling.
2. Operator Panel Interconnect Board.
3. Scanner main board.

## Error code: 100-08220

**Keypad error code:** ERR\_GENERAL

**Level:** User Correctable

**Description:** The Scanner Lamp-Unit is detached. Please check that it is intact and correctly inserted

**Corrective Action:**

- ▲ Check that the scanner lamp is properly inserted.

## Error code: 100-30222

**Keypad error code:** ERR\_GENERAL

**Level:** User Correctable

**Description:** The Scanner Lamp-Unit needs to be replaced

**Corrective Action:**

- ▲ Replace the scanner lamp.

## Error code: 100-50272

**Keypad error code:** ERR\_GENERAL

**Level:** User Correctable

**Description:** The Scanner Lamp-Unit doesn't turn on. The Scanner Lamp-Unit needs to be replaced

**Corrective Action:**

- ▲ Replace the scanner lamp.

## Error code: 100-50231

**Keypad error code:** BOOT

**Level:** RD Correctable

**Description:** Firmware download is in progress

**Corrective Action:**

- ▲ Wait for firmware to finish downloading.

## Error code: 100-50234

**Keypad error code:** NONE

**Level:** User Correctable

**Description:** Scanner is in safe-mode. Please reboot scanner or download new firmware

**Corrective Action:**

1. Restart the scanner.
2. Perform a system upgrade or reinstallation.
3. Replace the Scanner main board.

## **Error code: 100-50262**

**Keypad error code:** ERR\_GENERAL

**Level:** Support Correctable

**Description:** LMx, Unable to communicate with LMx board

**Corrective Action:**

1. Lamp and Motor driver board.
2. Scanner main board.
3. Related cabling.

## **Error code: 100-20088**

**Keypad error code:** ERR\_GENERAL

**Level:** Support Correctable

**Description:** Motor system error; motor movement not detected

**Corrective Action:**

1. Belt & Stepper Motor.
2. Scanner main board.

## **Error code: 100-20237**

**Keypad error code:** ERR\_GENERAL

**Level:** Support Correctable

**Description:** Fan 1 error

**Corrective Action:**

1. Check and replace left fan.
2. Lamp and Motor driver board.

## **Error code: 100-20238**

**Keypad error code:** ERR\_GENERAL

**Level:** Support Correctable

**Description:** Fan 2 error

**Corrective Action:**

1. Check and replace right fan.
2. Lamp and Motor driver board.

## **Error code: 100-40251**

**Keypad error code:** ERR\_CB

**Level:** Support Correctable

**Description:** CBx, Camera E not found

**Corrective Action:**

1. Camera board.
2. Scanner main board.
3. Related cabling.

## **Error code: 100-50600**

**Keypad error code:** ERR\_SU

**Level:** Support Correctable

**Description:** SUx, Mainboard hardware error

**Corrective Action:**

1. Scanner main board.
2. Switch Mode Power Supply.

## **Error code: 100-50602**

**Keypad error code:** ERR\_GENERAL

**Level:** User Correctable

**Description:** Firmware error. Please download latest firmware.

**Corrective Action:**

1. Upgrade or reinstall system software.
2. Scanner main board.

## **Error code: 100-50603**

**Keypad error code:** ERR\_GENERAL

**Level:** User Correctable

**Description:** Unrecoverable scanner state. Please reboot the scanner. Download of the latest firmware and PC application/driver may be required.

**Corrective Action:**

1. Reboot scanner.
2. Upgrade/reinstall system software.

**Error code: 100-50268**

**Keypad error code:** ERR\_SU

**Level:** Support Correctable

**Description:** SUx, Ethernet loopback error

**Corrective Action:**

- ▲ Scanner main board.

**Error code: 100-50271**

**Keypad error code:** ERR\_SU

**Level:** Support Correctable

**Description:** SUx, Scanner has no MAC address

**Corrective Action:**

- ▲ Scanner main board.

# Error Codes for the JetImage Software RIP

**-19 When combining thick media handling (paper guide in extended position) with auto size detection, the size detection must be done separately by running a preview scan before the final copy or scan operation.**

Cause	Solution
When combining thick media handling (paper guide in extended position) with auto size detection, the size detection must be done separately by running a preview scan before the final copy or scan operation.	Try the following: <ul style="list-style-type: none"><li>• Run a preview scan before the final copy or scan operation.</li><li>• Perform the copy or scan to file instead.</li></ul>

**-13 Unable to rename the folder.**

Cause	Solution
Unable to rename the folder.	Occurs during file browsing operations, usually due to a share issue.

**-12 Unable to delete the folder.**

Cause	Solution
Unable to delete the folder (occurs during file browsing operations, typically if a folder is shared).	Close all the applications and try again.

**-11 The folder must be empty.**

Cause	Solution
The folder must be empty (occurs during file browsing operations).	Check that the folder is empty before deleting it.

**-2 No media profile selected for current printer.**

Cause	Solution
No media profile selected for current printer.	Prepare a Media Profile before performing the operation.

**-1 No printer selected.**

Cause	Solution
No printer selected.	Select a printer. A printer must be configured in the application before trying to print.



---

**02 Invalid scan coordinates. The paper frame was placed fully outside the scan image.**

---

<b>Cause</b>	<b>Solution</b>
Invalid scan coordinates. The paper frame was placed fully outside the scan image.	Try repositioning the paper frame so that it covers some of the scannable area.

---

---

**06 Not enough disk space for spool file.**

---

<b>Cause</b>	<b>Solution</b>
Not enough disk space for spool file.	Make sure that the environment TEMP (or secondary TMP) points to a folder with plenty of space.

---

---

**08 The scanner is currently on standby. Please press the soft power button on the scanner to activate it.**

---

<b>Cause</b>	<b>Solution</b>
The scanner is currently on standby.	Press the soft <b>Power</b> button on the scanner to activate it.

---

---

**00003 Scanning invalid size of area requested for scanning.**

---

<b>Cause</b>	<b>Solution</b>
Negative scan-width specified.	Reselect the scan area and try again.

---

---

**01003 Error printing colorsheet.**

---

<b>Cause</b>	<b>Solution</b>
Error printing colorsheet.	Try the following: <ul style="list-style-type: none"><li>• Check the printer to make sure it is switched ON and connected to the scanner.</li><li>• Try printing a test print to make sure that the printer is working.</li></ul>

---

---

**01013 Error detecting index-mark.**

---

<b>Cause</b>	<b>Solution</b>
Skew: Error detecting the index mark.	Try the following: <ul style="list-style-type: none"><li>• Try restarting the system.</li><li>• If the problem persists, view the scandump.tif file for further diagnosis.</li></ul>

---

**01014 Sheet bad aligned.**

<b>Cause</b>	<b>Solution</b>
Sheet badly aligned.	Try the following: <ul style="list-style-type: none"><li>• Reinsert the sheet, making sure that it is straight and at the right position.</li><li>• If the problem persists, view the scandump.tif file for further diagnosis.</li></ul>

**01015 Error detecting left margin.**

<b>Cause</b>	<b>Solution</b>
Error detecting the left margin of the sheet.	Try the following: <ul style="list-style-type: none"><li>• Try reinserting the sheet.</li><li>• If the problem persists, view the scandump.tif file for further diagnosis.</li></ul>

**01016 Error detecting right margin.**

<b>Cause</b>	<b>Solution</b>
Error detecting the right margin of the sheet.	Try the following: <ul style="list-style-type: none"><li>• Try reinserting the sheet.</li><li>• If the problem persists, view the scandump.tif file for further diagnosis.</li></ul>

**01017 Error reading colorsheet.**

<b>Cause</b>	<b>Solution</b>
Error reading the colorsheet. The end of the sheet is reached before expected.	Check that the correct colorsheet is being used.

**01018 CLC aborted.**

<b>Cause</b>	<b>Solution</b>
The Close Loop Calibration (CLC) has been aborted.	The user has cancelled the color map operation.

**01019 Wrong insert position.**

<b>Cause</b>	<b>Solution</b>
The sheet has been inserted in the wrong position.	Try the following: <ul style="list-style-type: none"><li>• Reinsert the sheet, making sure that it is at the right position.</li><li>• If the problem persists, view the scandump.tif file for further diagnosis.</li></ul>

**01020 Can't find top of sheet.**

<b>Cause</b>	<b>Solution</b>
The top of the sheet couldn't be found.	Reinsert the sheet, making sure that it is at the right position.

**01021 Can't find bottom of sheet.**

<b>Cause</b>	<b>Solution</b>
The bottom of the sheet couldn't be found.	Reinsert the sheet, making sure that it is at the right position.

**02004 Unable to open device for reading.**

<b>Cause</b>	<b>Solution</b>
Unable to open the device for reading.	Check that the device (file) is available.

**02005 Unable to open device for writing.**

<b>Cause</b>	<b>Solution</b>
Unable to open the device for writing.	Check that the device (file or printer) is available.

**02006 Unable to read from device.**

<b>Cause</b>	<b>Solution</b>
Unable to read from the device.	Try the operation again.

**02007 Unable to write to device.**

<b>Cause</b>	<b>Solution</b>
Unable to write to the device.	Try the operation again.

**02013 Destination already exists.**

Cause	Solution
Destination already exists.	Try the operation again with a different file name.

**03008 Device not available.**

Cause	Solution
Scanner not found.	Try the following: <ul style="list-style-type: none"><li>• Check that the scanner is turned ON.</li><li>• Check the connection to the scanner.</li></ul>

**13496 The scanner is initializing or warming up.**

Cause	Solution
The scanner is initializing.	This happens if you try to scan too quickly after powering ON the scanner. Wait a short while and then try scanning again.

**17977 Media is present in scanner, but command was aborted by user.**

Cause	Solution
User interfered with the scanner.	Try the operation again.

**17980 Paper jam.**

Cause	Solution
Paper jam.	Check rollers and mechanical paper detectors for any paper jam. Once paper jam is cleared, try the operation again.

# Error Messages for the Touch Screen

## BIOS ROM checksum error - system halted.

Cause	Solution
Error during initialization.	Reboot the system and enter the BIOS setting. Load <b>Setup Default</b> and save the BIOS setting.

## CMOS battery failed.

Cause	Solution
The battery life is approximately three years before it requires replacement.	Replace the CMOS Battery.

## CMOS checksum error - defaults loaded.

Cause	Solution
Error detected in the CMOS.	Reboot the system and enter the BIOS setting. Load <b>Setup Default</b> and save the BIOS setting.

## Display switch is set incorrectly

Cause	Solution
Problem found with the Touch Screen.	Connect the Touch Screen to a CRT Monitor and check the resolution setting for the display. If the CRT Monitor is working well then it seems there is an LCD problem.

## Hard Disk install failure.

Cause	Solution
No Hard Disk detected, error related to Hard Disk Drive.	Try the following: <ul style="list-style-type: none"><li>• In the BIOS setup select <b>Standard CMOS Features</b> and check if the IDE/SATA detection method is set to AUTO (password to access the BIOS is bigcoco)?<ul style="list-style-type: none"><li>◦ If Yes: In Advanced BIOS features, set HDD to first boot device.</li><li>◦ If No: Choose auto for all IDE/SATA detection.</li></ul></li><li>• Check if HDD can be detected in the boot-up system configuration table:<ul style="list-style-type: none"><li>◦ If Yes: check the boot up files in HDD, recover it if necessary.</li><li>◦ If No: replace HDD.</li></ul></li></ul>

### Primary master hard disk fail.

Cause	Solution
No Hard Disk detected, error related to Hard Disk Drive.	<p>Try the following:</p> <ul style="list-style-type: none"><li>• In the BIOS setup select <b>Standard CMOS Features</b> and check if the IDE/SATA detection method is set to AUTO (password to access the BIOS is bigcoco)?<ul style="list-style-type: none"><li>◦ If Yes: In Advanced BIOS features, set HDD to first boot device.</li><li>◦ If No: Choose auto for all IDE/SATA detection.</li></ul></li><li>• Check if HDD can be detected in the boot-up system configuration table:<ul style="list-style-type: none"><li>◦ If Yes: check the boot up files in HDD, recover it if necessary.</li><li>◦ If No: replace HDD.</li></ul></li></ul>

### Secondary master hard disk fail.

Cause	Solution
No Hard Disk detected, error related to Hard Disk Drive.	<p>Try the following:</p> <ul style="list-style-type: none"><li>• In the BIOS setup select <b>Standard CMOS Features</b> and check if the IDE/SATA detection method is set to AUTO (password to access the BIOS is bigcoco)?<ul style="list-style-type: none"><li>◦ If Yes: In Advanced BIOS features, set HDD to first boot device.</li><li>◦ If No: Choose auto for all IDE/SATA detection.</li></ul></li><li>• Check if HDD can be detected in the boot-up system configuration table:<ul style="list-style-type: none"><li>◦ If Yes: check the boot up files in HDD, recover it if necessary.</li><li>◦ If No: replace HDD.</li></ul></li></ul>

### Primary slave hard disk fail.

Cause	Solution
No Hard Disk detected, error related to Hard Disk Drive.	<p>Try the following:</p> <ul style="list-style-type: none"><li>• In the BIOS setup select <b>Standard CMOS Features</b> and check if the IDE/SATA detection method is set to AUTO (password to access the BIOS is bigcoco)?</li></ul>

### Primary slave hard disk fail.

Cause	Solution
	<ul style="list-style-type: none"><li>◦ If Yes: In Advanced BIOS features, set HDD to first boot device.</li><li>◦ If No: Choose auto for all IDE/SATA detection.</li><li>• Check if HDD can be detected in the boot-up system configuration table:<ul style="list-style-type: none"><li>◦ If Yes: check the boot up files in HDD, recover it if necessary.</li><li>◦ If No: replace HDD.</li></ul></li></ul>

### Secondary slave hard disk fail.

Cause	Solution
No Hard Disk detected, error related to Hard Disk Drive.	<p>Try the following:</p> <ul style="list-style-type: none"><li>• In the BIOS setup select <b>Standard CMOS Features</b> and check if the IDE/SATA detection method is set to AUTO (password to access the BIOS is bigcoco)?<ul style="list-style-type: none"><li>◦ If Yes: In Advanced BIOS features, set HDD to first boot device.</li><li>◦ If No: Choose auto for all IDE/SATA detection.</li></ul></li><li>• Check if HDD can be detected in the boot-up system configuration table:<ul style="list-style-type: none"><li>◦ If Yes: check the boot up files in HDD, recover it if necessary.</li><li>◦ If No: replace HDD.</li></ul></li></ul>

### Memory test fail.

Cause	Solution
Memory test has failed.	<p>Try the following:</p> <ul style="list-style-type: none"><li>• Re-install the SDRAM and check if the problem is solved:<ul style="list-style-type: none"><li>◦ If Yes: There was a poor connection between the Main Board and the SDRAM Memory Module.</li><li>◦ If No: Replace the SDRAM Memory Module.</li></ul></li></ul>

---

## 3 Parts and Diagrams

- [Exterior on page 49](#)
- [Interior on page 50](#)
- [Panel PC on page 52](#)



# Exterior

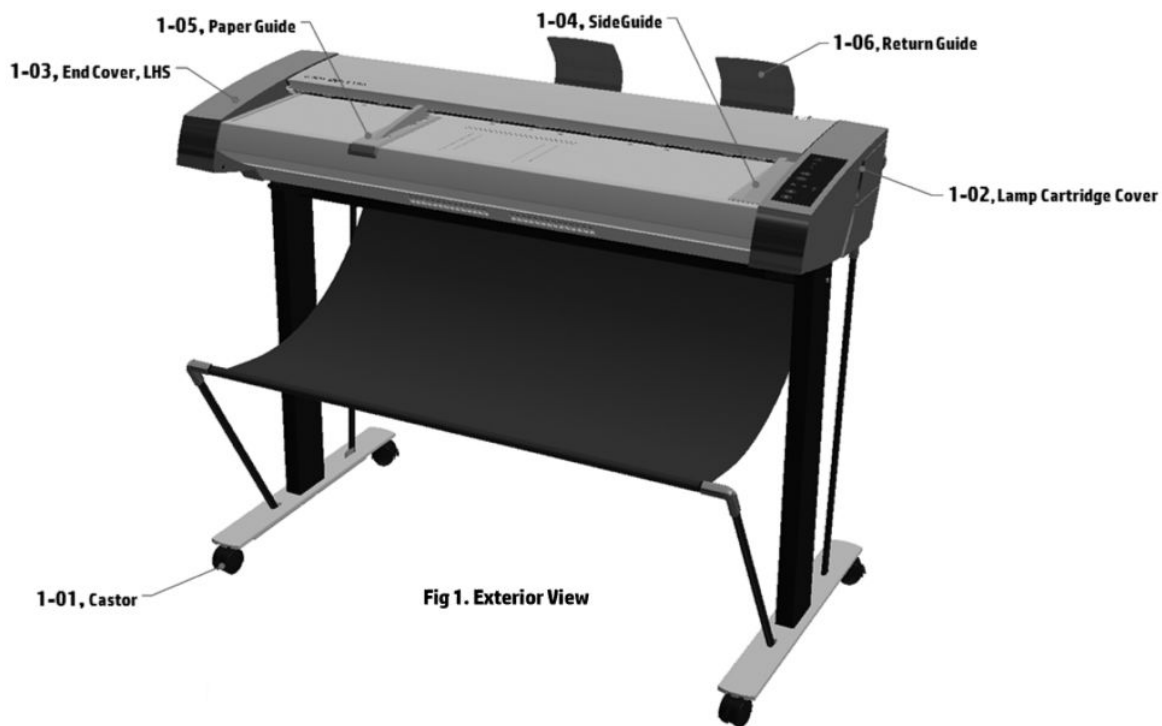
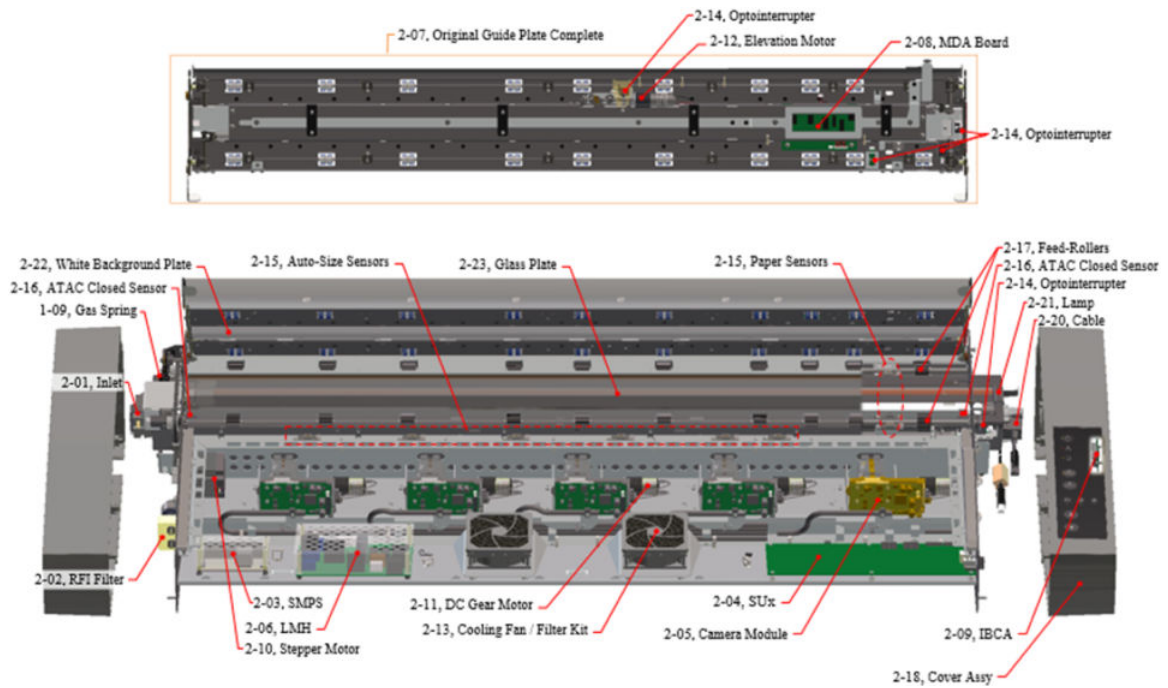

Fig 1. Exterior View

Number in photo	Description	HP Part Number
Fig. 1-01	Castors	G6H51-67026
Fig. 1-02	Lamp Cartridge Cover	G6H51-67027
Fig. 1-03	Left-Side End Cover	G6H51-67028
Fig. 1-04	Side Guide, Right	G6H51-67029
Fig. 1-05	Paper Guide	G6H51-67030
Fig. 1-06	Return Guide	G6H51-67031
N/A	Optical Adjustment pattern 5 cam	G6H51-67032
N/A	Adjustment tools for Top position sensor	Q1277-60084
N/A	Europe Power Cord SV KIT	CQ533-60001
N/A	America Power Cord SV KIT	CQ533-60002
N/A	Asia Power Cord SV KIT	CQ533-60003
N/A	Calibration Sheet	1

# Interior



Number in photo	Description	HP Part Number
Fig. 2-01	Inlet	CM719-60011
Fig. 2-02	RFI-Filter	G6H51-67002
Fig. 2-03	Scanner Power supply	G6H51-67003
Fig. 2-04	Scanner Main Board	G6H51-67004
Fig. 2-05	Camera Module (includes Board)	G6H51-67005
Fig. 2-06	Lamp and motor Controller Board	G6H51-67006
Fig. 2-07	Original Guide Plate (ATAC) without Top Profile	G6H51-67007
Fig. 2-08	Elevation Motor driver board	G6H51-67008
Fig. 2-09	Operators Panel Interconnect Board	G6H51-67050
Fig. 2-10	Stepper motor	G6H51-67010
Fig. 2-11	DC Gear Motor	G6H51-67011
Fig. 2-12	Elevation Motor	G6H51-67012
Fig. 2-13	Cooling Fan	G6H51-67013
Fig. 2-13	Cooling Fan Filter kit	G6H51-67014
Fig. 2-14	Optointerrupter (Tacho sensor, ATAC sensors)	G6H51-67015
Fig. 2-15	Paper/Lid Sensor	G6H51-67016
Fig. 2-16	ATAC Closed Sensors	G6H51-67017
Fig. 2-17	Shaft with Feed Rollers	G6H51-67018
Fig. 2-18	Right Side Cover Assy including operators panel	G6H51-67019

Fig. 2-19	Gas Spring	G6H51-67020
Fig. 2-20	Cable Interface	G6H51-67021
Fig. 2-21	Lamp Cartridge	G6H51-67022
Fig. 2-22	White Background	G6H51-67023
Fig. 2-23	Glass Plate	Q1277-60014
N/A	Calibration Sheet	G6H51-67025

## Panel PC

HP Part Number	Description
G6H51-67044	PPC Touch Screen Controller
G6H51-67049	PPC LED light board
G6H51-67052	PPC Panel Module
G6H51-67054	PPC-7151W Main Board
G6H51-67055	PPC-7151W External PSU
G6H51-67056	PPC-7151W SDRAM
G6H51-67057	PPC-7151W CPU
G6H51-67058	PPC-7151W Cooler
G6H51-67059	PPC-7151W Rear Cover
G6H51-67061	PPC-7151W Cable Harness
G6H51-67062	PPC-7151W HDD
G6H51-67063	PPC-7151W Panel Module
G6H51-67064	PPC-7151W Front Bezel Module
G6H51-67065	PPC-7151W Side USB Module

---

# 4 Removal and Installation

- [Introduction on page 55](#)
- [Safety Precautions on page 55](#)
- [Electrostatic Discharge \(ESD\) Precautions on page 55](#)
- [Required Tools on page 55](#)
- [Scanner main board on page 56](#)
- [Lamp and motor controller board on page 58](#)
- [Power Supply on page 59](#)
- [Cooling Fan Filters on page 61](#)
- [Cooling Fans on page 61](#)
- [Size Detection Sensors on page 62](#)
- [Paper Sensors \(Load & Entry\) on page 62](#)
- [ATAC Closed Sensors on page 63](#)
- [Camera Module on page 64](#)
- [Stepper Motor Assembly on page 65](#)
- [Drive Belt on page 67](#)
- [RFI Filter on page 68](#)
- [Power Inlet on page 68](#)
- [Gas Spring for Guide plate on page 69](#)
- [Tacho Sensor on page 70](#)
- [Elevation motor driver board on page 70](#)
- [ATAC Roller Pressure Sensor on page 72](#)
- [ATAC Top Position Sensor on page 73](#)
- [ATAC Down Position Sensor on page 73](#)
- [Elevation motor on page 74](#)

- [Original guide plate \(ATAC\) without top profile on page 75](#)
- [Paper Sensors \(Exit\) on page 76](#)
- [Right side cover assembly including operators panel on page 77](#)
- [White Background Plate on page 78](#)
- [Lamp Cartridge on page 79](#)
- [Glass Plate on page 80](#)

## Introduction

This chapter is a step-by-step guide to the removal and installation of the key components in the product. You may find it useful to tick off the steps as they are performed. Use the illustration at each procedure to identify the parts referred to in the text.

The procedures appear in order of removal. So the whole product can be stripped down by starting at the beginning of this chapter and working through the subsequent procedures.

## Safety Precautions

Review **WARNING** and **CAUTION** instructions before you service the product. Follow these warnings and cautions for your protection and to avoid damaging the product.

---

 **NOTE:** Serious shock hazard leading to death or injury may result if you do not take the following precautions:

Ensure that the AC power outlet (mains) has a protective earth (ground) terminal.

Switch off the printer, the scanner, and the PC, and then disconnect them from the power source prior to performing any maintenance.

Prevent water or other liquids from running onto electrical components or circuits, or through openings in the module.

---

## Electrostatic Discharge (ESD) Precautions

To prevent damage to the product circuits from high-voltage electrostatic discharge (ESD):

1. Do not wear clothing that is subject to static build-up.
2. Do not handle integrated circuits (ICs) in carpeted areas.
3. Do not remove an IC or a printed circuit assembly (PCA) from its conductive foam pad or conductive packaging until you are ready to install it.
4. Ground (earth) your body while disassembling and working on the Scanner. This can be done by touching any metallic part of the Scanner.
5. After removing a cover from the Scanner, attach an earthing (ground) lead between the PCA common and earth ground. Touch all tools to earth ground to remove static charges before using them on the Scanner.
6. After removing any PCA from the Scanner, place it on a conductive foam pad or into its conductive packaging to prevent ESD damage to any ICs on the PCA.

## Required Tools

The following Special Service Tools are required to disassemble and repair the Scanner:

- Optical Adjustment Pattern
- Adj. Tool Top position Sensor (ATAC)
- Adj. Tool Roller Pressure Sensor (ATAC)

The following Common Hand Tools are required to disassemble and repair the Scanner:

- Torx 6 Straight
- Torx 9 Straight
- Torx 10 Straight & Angled
- Torx 15 Straight & Angled
- Torx 20 Straight & Angled
- Torx 25 Straight
- Torx 30 Straight
- Wrench 5.5 mm
- Wrench 7.0 mm
- Slotted 0.6 x 10 x 75 mm

 **NOTE:** Before replacing any electrical parts such as SUx (Scanner Control Unit) or cameras, try calibrating the scanner in order to get the scanner to recreate the content of the parameter block. This will solve the problem in most cases.

## Scanner main board

 **NOTE:** If possible, please back up the values of the scanner main board in a USB stick before replacing the scanner main board. Restore the values again after installing the new main board. See tests 42 and 43 in [Using the Service Tools from the Touchscreen on page 3](#)

### Removal

1. Release the latches, tilt open the guide plate (A), and remove the paper guides (B).

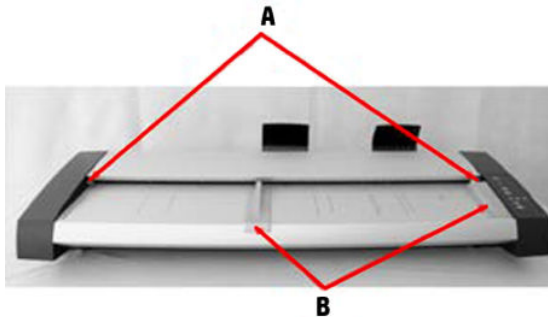



2. Remove the screws in the top cover side list (A), and remove the top cover side lists (B).

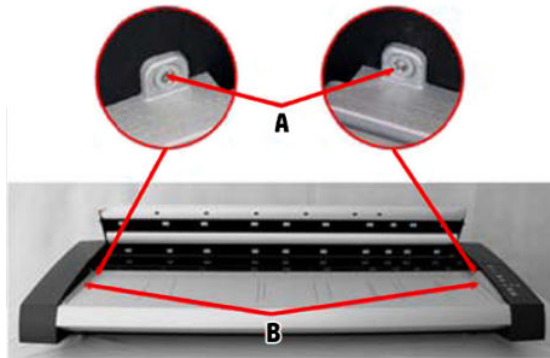

3. Remove the screws in the front profile (A), and remove the front profile by pulling to the front (B).

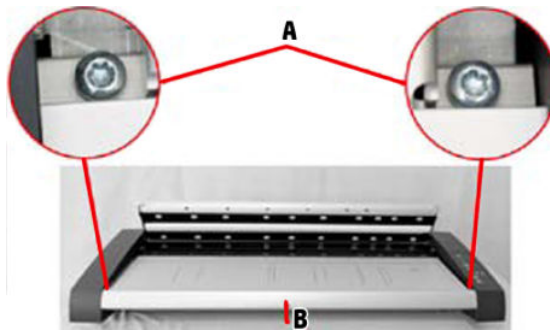

4. Remove the top cover by sliding it towards the front (A).

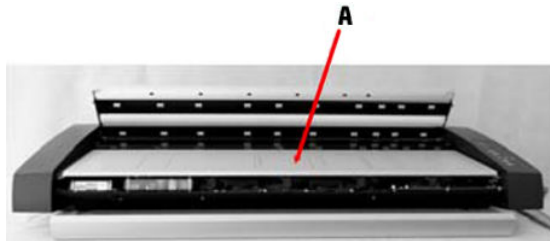

5. Disconnect the 11 cables (A), and remove the screws (B).

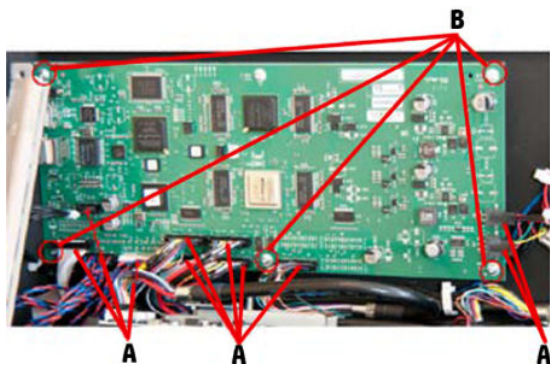

6. Slide the board to the side (A), disconnect the cables (B), and remove the board (C).

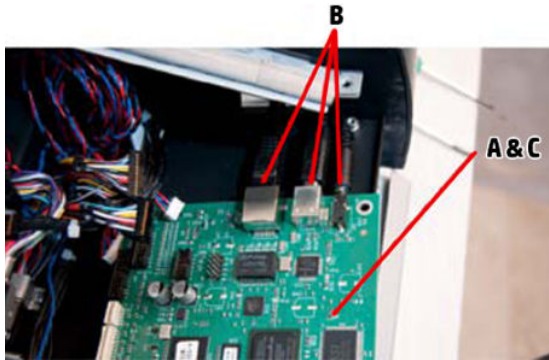

### Replacement

- ▲ To install the new SUU board reverse the removal steps. Power on the scanner WIDeSystem and it will automatically prompt you to type in the Serial no. It can also be set to WIDeSystem/Service, Test 1. Update the firmware, Clean the Glass plate, and run Full Scanner Calibration.

## Lamp and motor controller board

### Removal

1. Tilt the guide plate open, remove the front profile and top cover. See [Scanner main board on page 56](#) steps 1–4.
2. Remove the screws (A, Torx 10) and remove the protection cover (B).

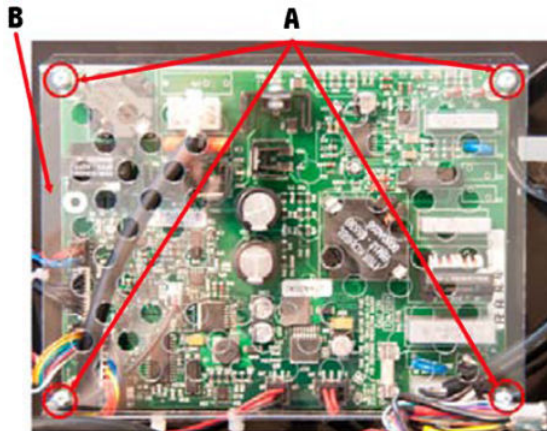

3. Disconnect the 9 cables (A).

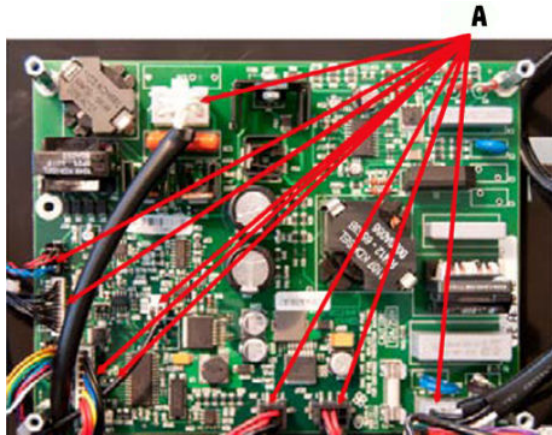

4. Remove the threaded riser (A, 6mm wrench) and remove the board (B).

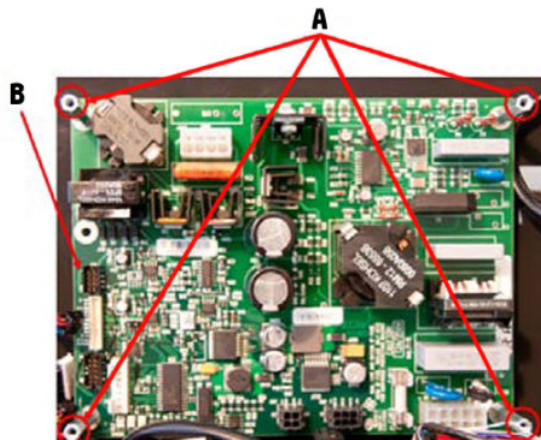

### Replacement

- ▲ Replace the Lamp Driver Board and reverse the removal steps.

## Power Supply

### Removal

1. Tilt the guide plate open, remove the front profile and top cover. See [Scanner main board on page 56](#) steps 1–4.

2. Remove the screws (A, Torx 10) 2 and remove the protection cover (B).

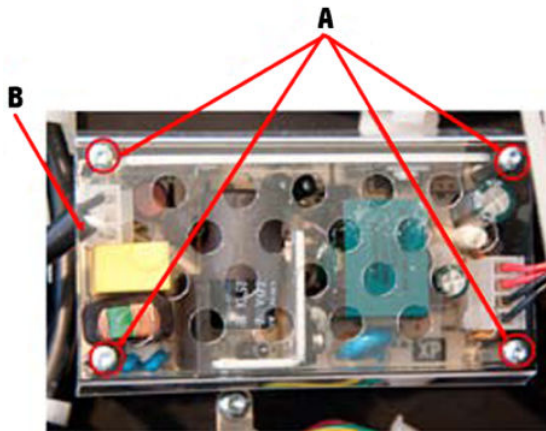

3. Disconnect the 2 cables (A).

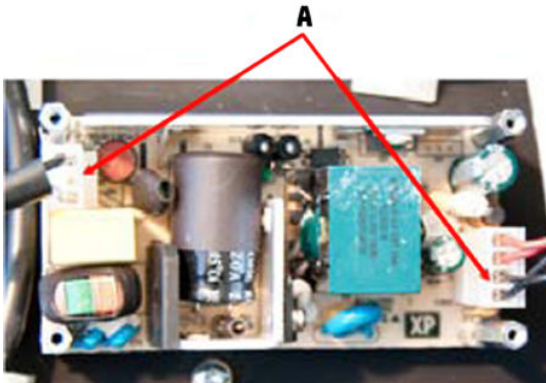

4. Remove the threaded riser (A, 6mm wrench) and remove the board (B).

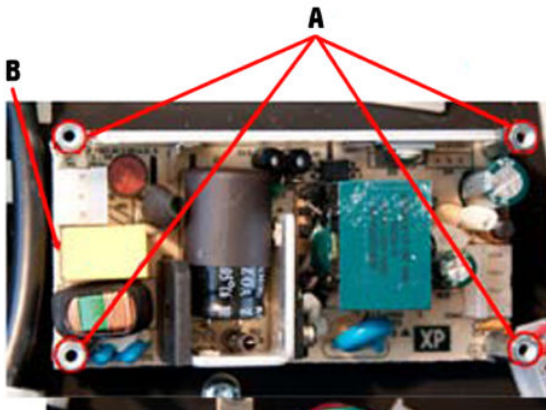

### Replacement

- ▲ Replace the Power Supply Board and reverse the removal steps.

# Cooling Fan Filters

## Removal

1. Tilt the guide plate open, remove the front profile and top cover. See [Scanner main board on page 56](#) steps 1–4.
2. Pull off and remove the filter (no tool required).

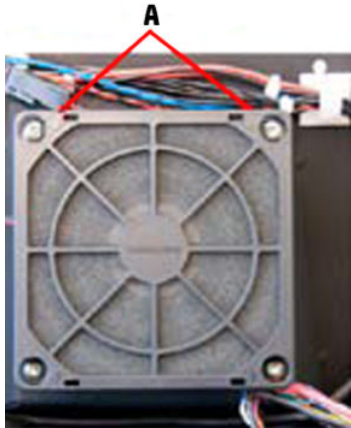

## Replacement

- ▲ Replace the Fan Filter and reverse the removal steps.

# Cooling Fans

## Removal

1. Tilt the guide plate open, remove the front profile and top cover. See [Scanner main board on page 56](#) steps 1–4.
2. Remove the [Cooling Fan Filters on page 61](#).
3. Disconnect the cables (A).

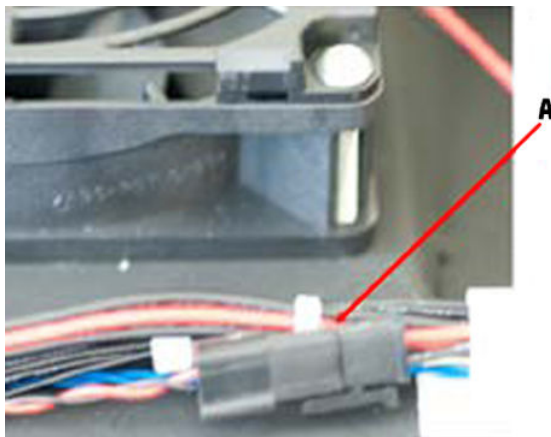



4. Remove the screws and remove the Cooling Fan (A).

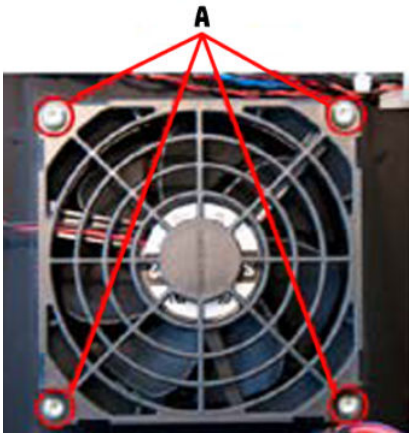

#### Replacement

- ▲ Replace the Cooling Fan and reverse the removal steps.

## Size Detection Sensors

#### Removal

1. Tilt the guide plate open, remove the front profile and top cover. See [Scanner main board on page 56](#) steps 1–4.
2. Disconnect the sensor (A), and remove the screw (B).

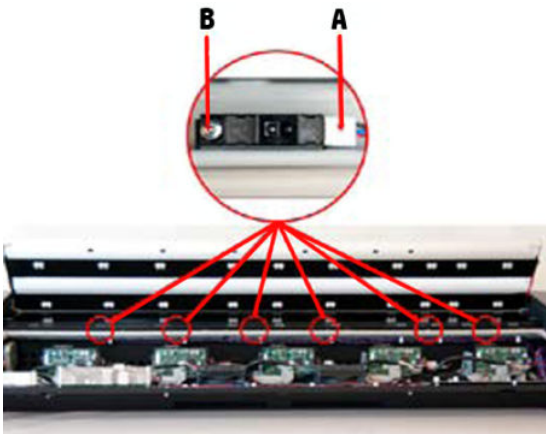

#### Replacement

- ▲ Replace the sensor and reverse the removal steps.

## Paper Sensors (Load & Entry)

#### Removal

1. Tilt the guide plate open, remove the front profile and top cover. See [Scanner main board on page 56](#) steps 1–4.

2. Loosen the screws along the Front Roller cover (A), and gently lift the cover up (B).

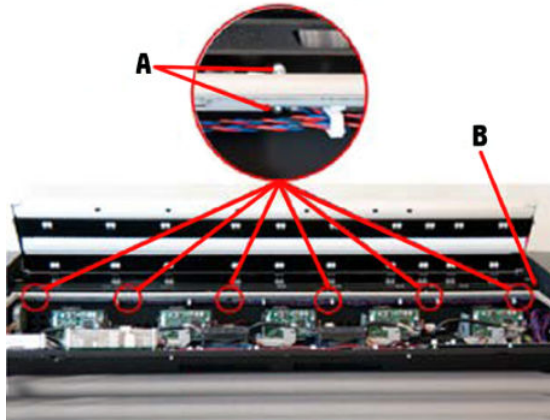

3. Disconnect the Sensor (A), and remove the screw (B).

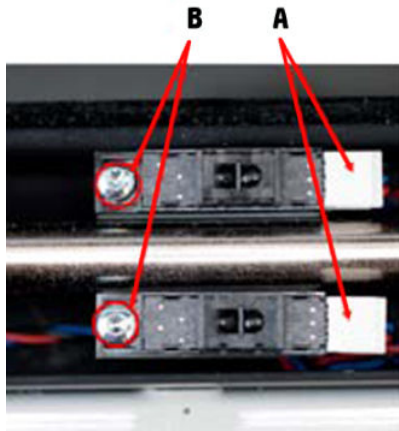

### Replacement

- ▲ Replace the sensor and reverse the removal steps.

## ATAC Closed Sensors

### Removal

1. Tilt the guide plate open, remove the front profile and top cover. See [Scanner main board on page 56](#) steps 1–4.
2. Remove the Front Roller Cover. See [Paper Sensors \(Load & Entry\) on page 62](#) step 1.

3. Disconnect the Sensor (A). Carefully lift the sensor (B, wiggle it loose and out).

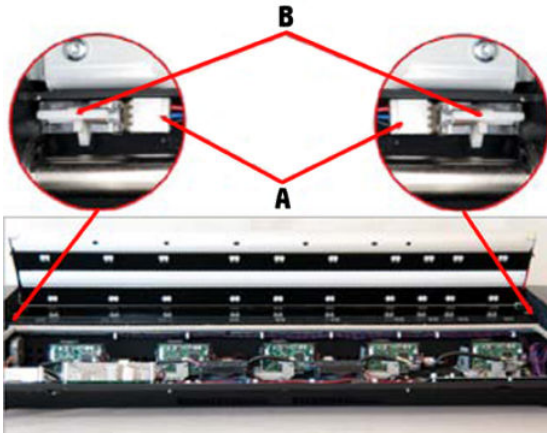

### Replacement

- ▲ Replace the sensor and reverse the removal steps.

## Camera Module

### Removal

1. Tilt the guide plate open, remove the front profile and top cover. See [Scanner main board on page 56](#) steps 1–4.
2. Remove the bracket screw (A), and unplug the cables (B).

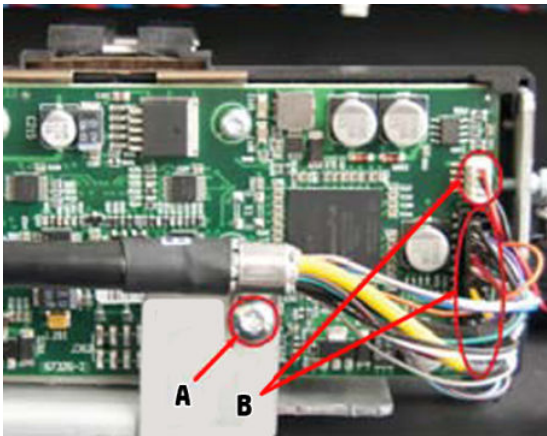



3. Remove the screw from the back of the camera module (A), and loosen the camera screws (B).

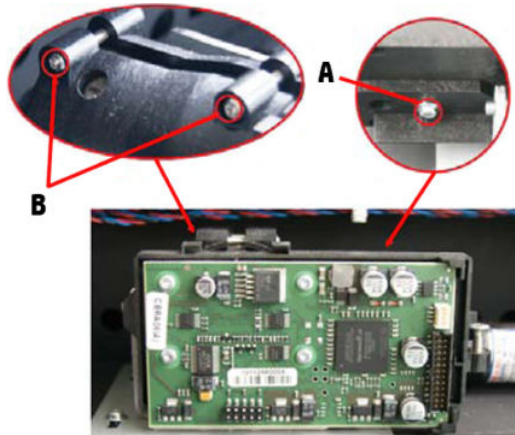

4. Carefully wiggle the Camera Module out while pulling backwards (A), taking care not to hit the tilt screw (B).

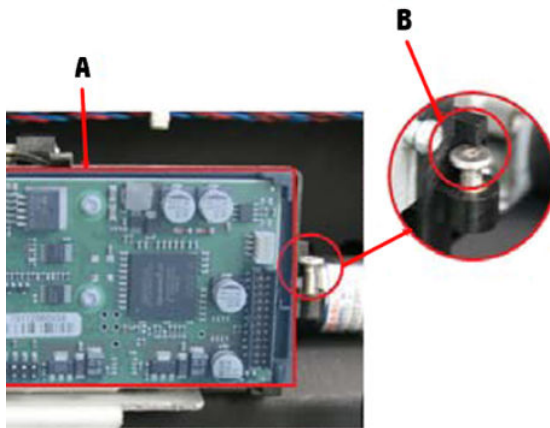

### Replacement

- ▲ Replace the Camera Module and reverse the removal steps. Complete with the Camera Adjustment.

## Stepper Motor Assembly

### Removal

1. Tilt the guide plate open, and remove the front profile and top cover. See [Scanner main board on page 56](#) steps 1–4.

2. Remove the screws (A, Torx 20). Remove the screws, and pull off the side cover (B).

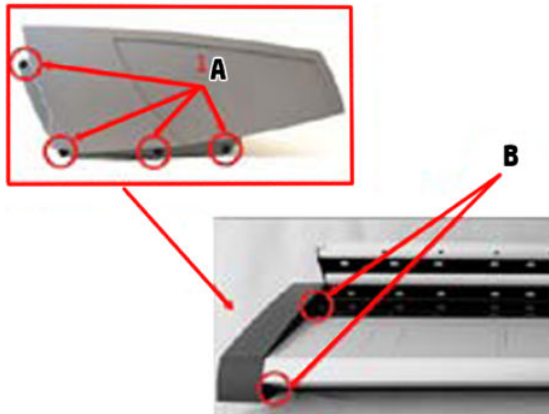

3. Loosen the screw (A), rotate the belt tension to its most clockwise position (B), and tighten the screw (C).

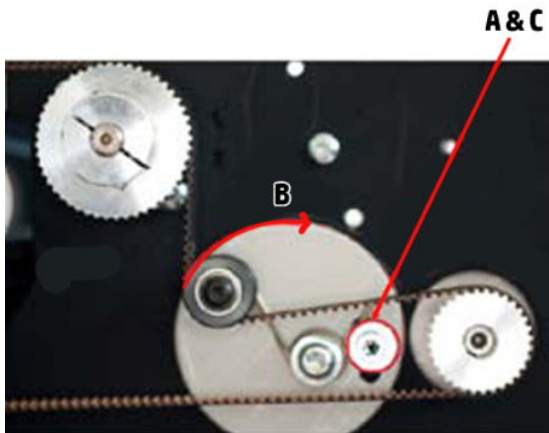

4. Disconnect the Motor cable (A), remove the screws (B), and gently pull the Motor out (C).

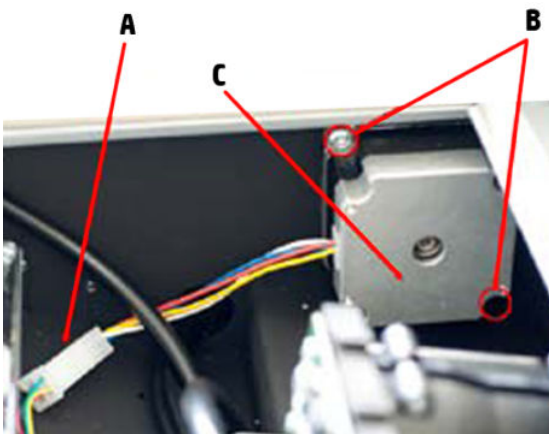

### Replacement

- ▲ Replace the Motor and reverse the removal steps. Adjust the belt tension.

# Drive Belt

## Removal

1. Tilt the guide plate open, and remove the front profile and top cover. See [Scanner main board on page 56](#) steps 1–4.
2. Remove the LHS cover. See [Stepper Motor Assembly on page 65](#) steps 4.
3. Remove the Lamp Cartridge. See [Lamp Cartridge on page 79](#) steps 4.
4. Remove the Connector by pressing lock flaps (A), and pulling out (B).

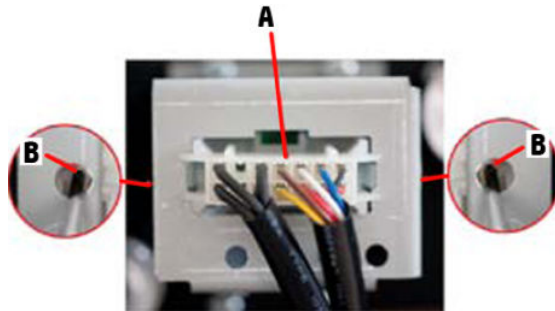

5. Loosen the screw (A). Rotate the belt tension to most its most clockwise position. Tighten the screw (A).

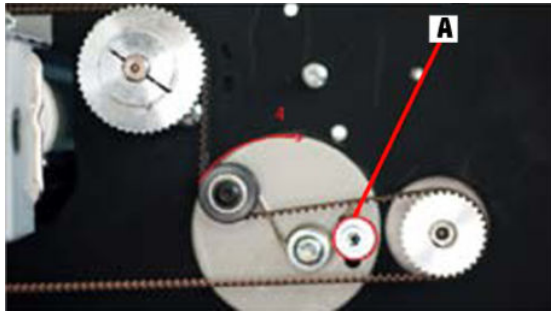

6. Take note to remember the belt “route”, then remove the belt.



## Replacement

- ▲ Replace the Belt and reverse the removal steps. Adjust the belt tension.

## RFI Filter

### Removal

1. Tilt the guide plate open. See [Scanner main board on page 56](#).
2. Remove the LHS cover. See [Stepper Motor Assembly on page 65](#) steps 4.
3. Disconnect the cables (A), remove the screws, and remove the filter (B).

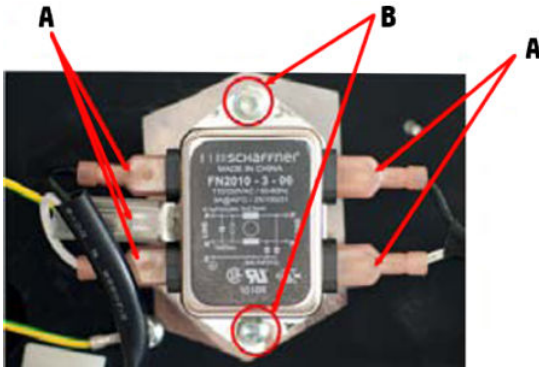

### Replacement

- ▲ Replace the EMI filter and reverse the removal steps.

## Power Inlet

### Removal

1. Tilt the guide plate open, remove the front profile and top cover. See [Scanner main board on page 56](#) steps 1–4.
2. Remove the LHS cover. See [Stepper Motor Assembly on page 65](#) steps 4.
3. Remove the cables (A), press in the lock flaps, and push the inlet out through the back (B).

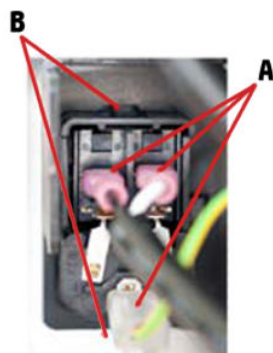

### Replacement

- ▲ Replace the Gas Power Inlet and reverse the removal steps.

# Gas Spring for Guide plate

## Removal

1. Tilt the guide plate open, remove the front profile and top cover. See [Scanner main board on page 56](#) steps 1–4.
2. Remove the LHS cover. See [Stepper Motor Assembly on page 65](#) steps 4.
3. Loosen the screw (A). Remove the screws while supporting the guide plate (B).

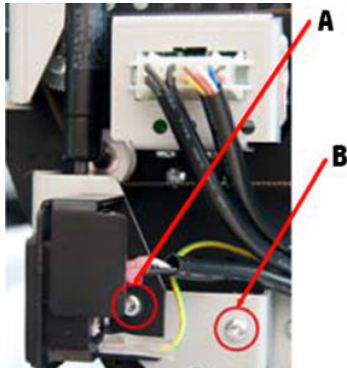

4. While supporting the guide plate; remove the screw and brush bushing (A).

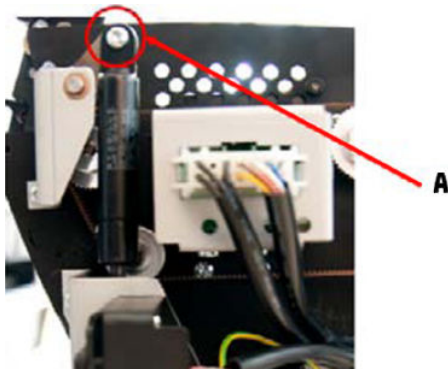

5. Remove screw and brush bushing (A). Remove Gas Spring.

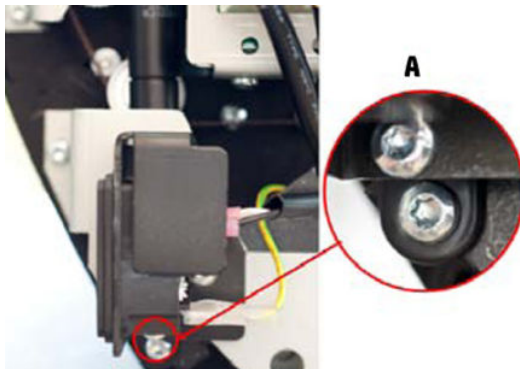

## Replacement

- ▲ Replace the Gas Spring and reverse the removal steps.

# Tacho Sensor

## Removal

1. Tilt the guide plate open. See [Scanner main board on page 56](#).
2. Remove the screws (A, Torx 20), and pull off the side cover (B, be careful not to damage the Ribbon Cable going to the Keypad).

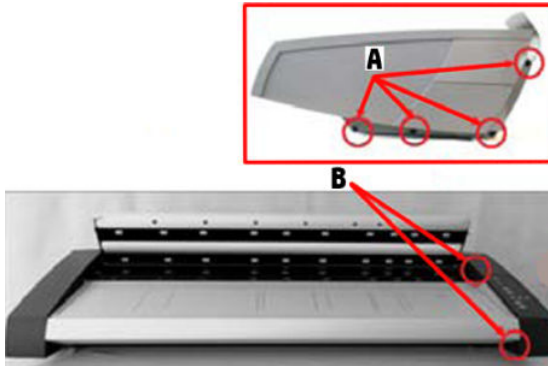

3. Loosen the screws (A), and remove the tacho wheel (B). Disconnect the cable (C), squeeze the lock flaps, and remove the sensor.

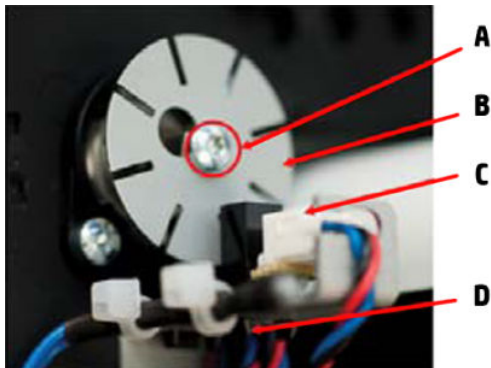

## Replacement

- ▲ Replace the Tacho Sensor and reverse the removal steps.

# Elevation motor driver board

## Removal

1. Release the latches and tilt open the guide plate (A), and remove the paper guides (B).

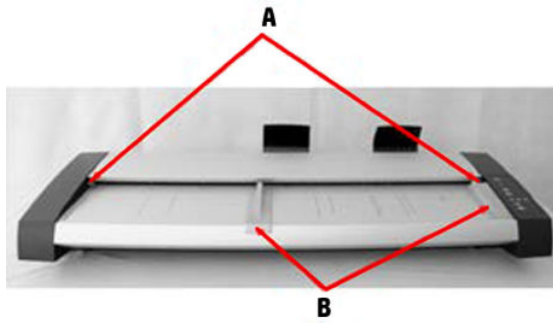

2. Loosen the screws completely (A, they will not come out), and tilt open the cover by pulling forward slightly (B).

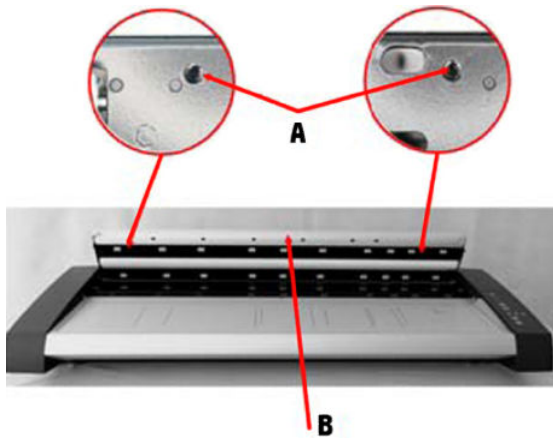

3. Lift the cover off the hinges (A).

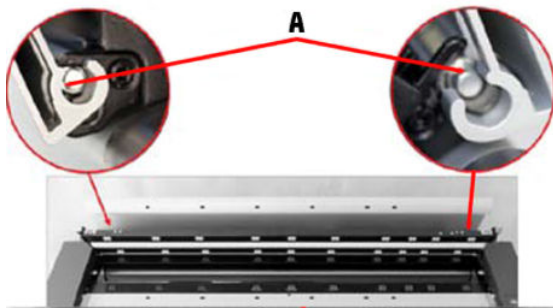



4. Disconnect the 3 cables (A), remove the screws (B), and remove the MDA Board.

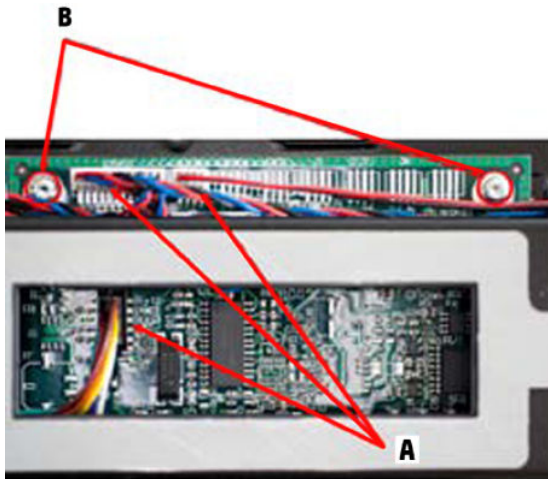

### Replacement

- ▲ Replace the Board and reverse the removal steps.

## ATAC Roller Pressure Sensor

### Removal

1. Remove the top cover for the guide plate. See [Elevation motor driver board on page 70](#) steps 1–3.
2. Disconnect the sensor (A), remove the screws (B), and remove the sensor.

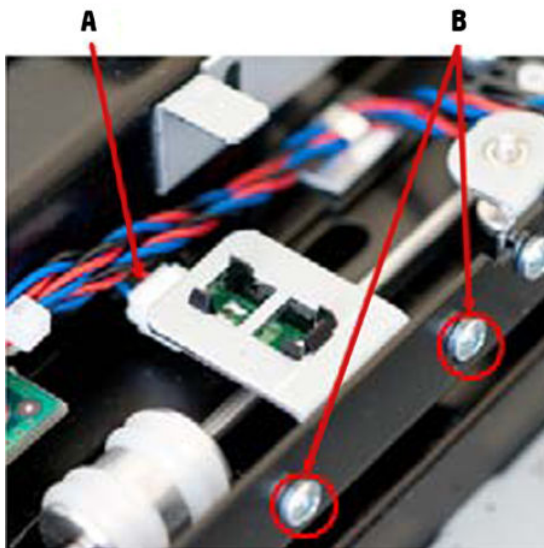

### Replacement

- ▲ Replace the Board and reverse the steps. Adjust the roller pressure.



## ATAC Top Position Sensor

### Removal

1. Remove the top cover for the guide plate. See [Elevation motor driver board on page 70](#) steps 1–3.
2. Loosen the screws (A), press down to move sensor into top position (B), tighten the screws (C), and disconnect the sensor (D). Remove the sensor from the bracket by releasing the locks (E).

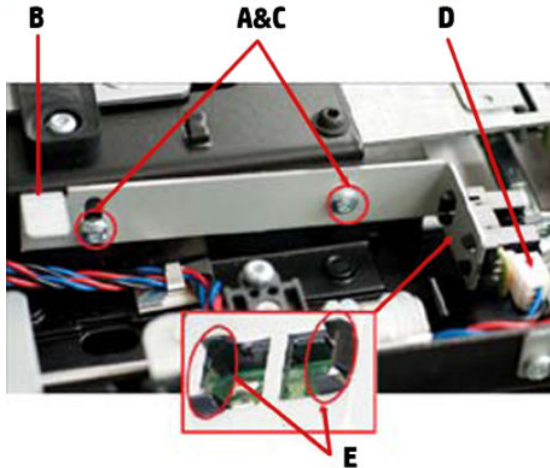

### Replacement

- ▲ Replace the Sensor and reverse the steps. Adjust the top position.

## ATAC Down Position Sensor

### Removal

1. Remove the top cover for the guide plate. See [Elevation motor driver board on page 70](#) steps 1–3.
2. Unplug the cables (A), remove the screws from the bracket (B), and remove the sensor from the bracket by releasing the locks (C).

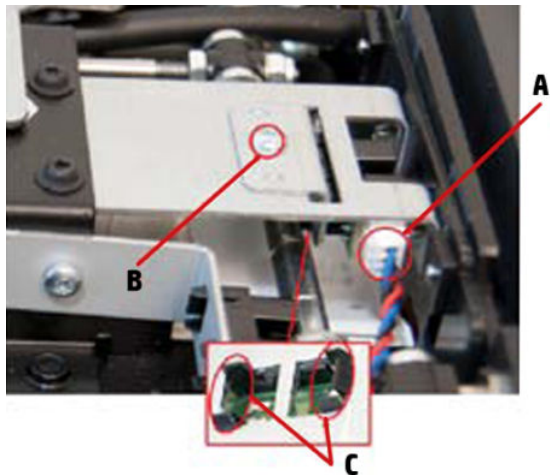

### Replacement

- ▲ Replace the Sensor and reverse the steps. No adjustment required.

## Elevation motor

### Removal

1. Remove the top cover for the guide plate. See [Elevation motor driver board on page 70](#) steps 1–3.
2. Unplug the cables (A), and remove the cable from the cable holder (B).

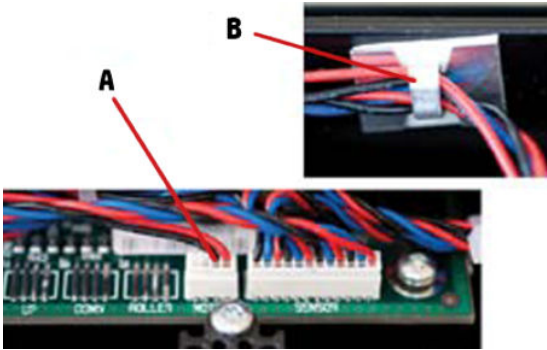

3. Disconnect the sensor (A), remove the screw (B), and remove the bracket (C).

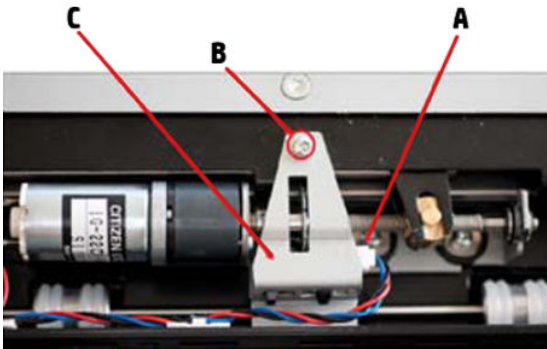

4. Loosen the screw (A), and remove the screws from bracket (B).

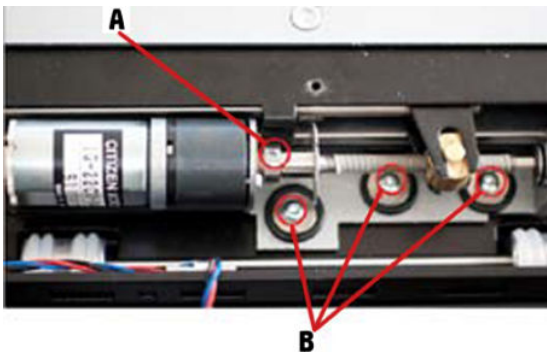

5. Remove the spacer rings (A).

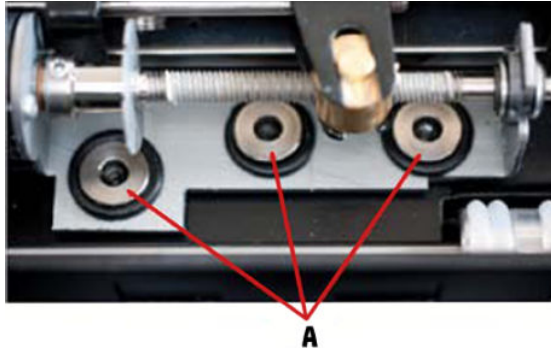

6. Gently remove the motor and bracket (A).

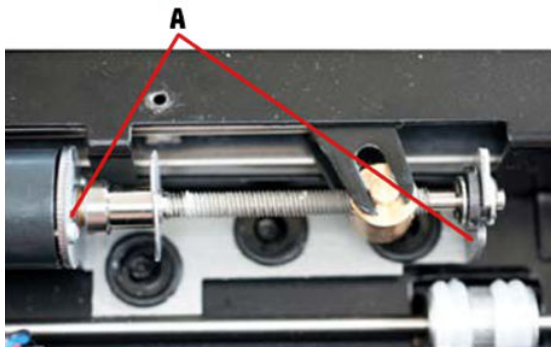

7. Loosen the screw (A) and remove the screws and motor (B).

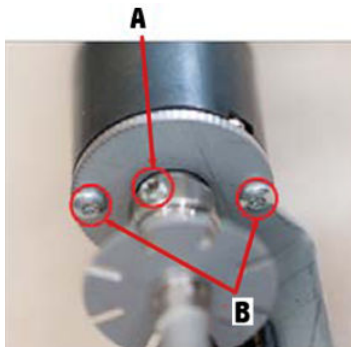

### Replacement

- ▲ Replace the ATAC Motor and reverse the steps. Calibrate the ATAC system.

## Original guide plate (ATAC) without top profile

### Removal

1. Move the Guide Plate into the top position (with the power on). Remove the top cover for the guide plate. See [Elevation motor driver board on page 70](#) steps 1–3.

2. Disconnect the cable (A), remove the screws from the bracket, and remove (B).

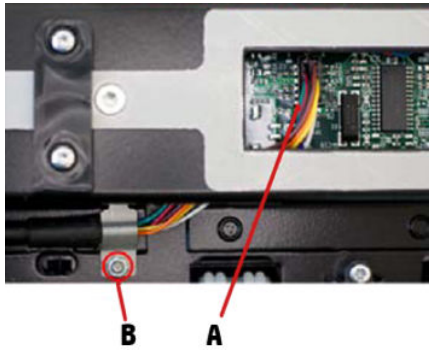

3. Remove screws while supporting Guide Plate (A).

 **NOTE:** Take note of the bracket position (!).

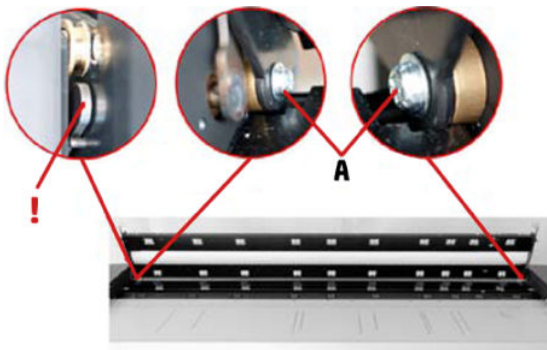

4. Guide the cable through the holder before removing the guide plate from the scanner (A).

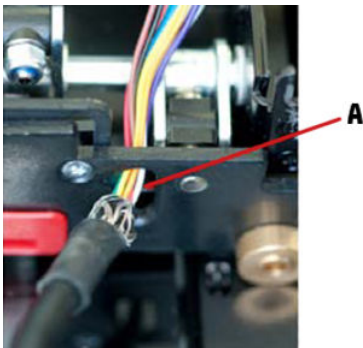

### Replacement

- ▲ Replace the ATAC Guide Plate. Calibrate the Roller Pressure & Top position Sensor. Calibrate the ATAC system.

## Paper Sensors (Exit)

### Removal

1. Remove the top cover for the guide plate. See [Elevation motor driver board on page 70](#) steps 1–3.  
Remove the ATAC Guide plate. See [Original guide plate \(ATAC\) without top profile on page 75](#).

2. Remove the screws from the Rear Cover (A). Remove the Rear Cover by sliding it slightly upwards first (B).

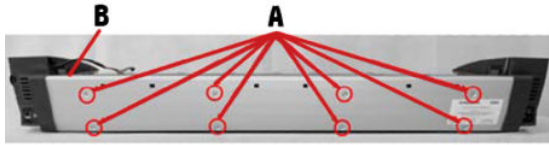

3. Loosen the screws (A), but do not remove them. Carefully lift the Roller Cover Sheet out (B).

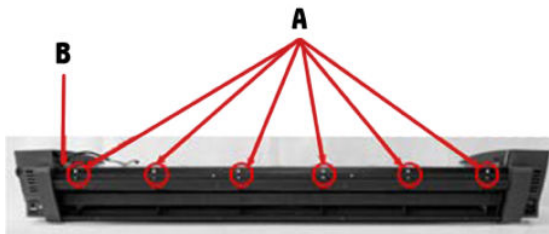

4. Disconnect the Sensor (A), and remove the screw (B).

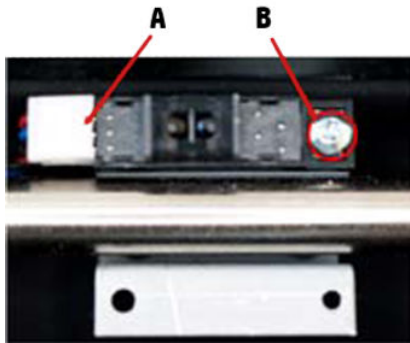

#### Replacement

- ▲ Replace the Exit Sensor and reverse the removal steps.

## Right side cover assembly including operators panel

#### Removal

1. Tilt the guide plate open. See [Scanner main board on page 56](#).

2. Remove screws (A, Torx 20), and pull off the side cover (B, be careful not to damage the Ribbon Cable going to the Keypad).

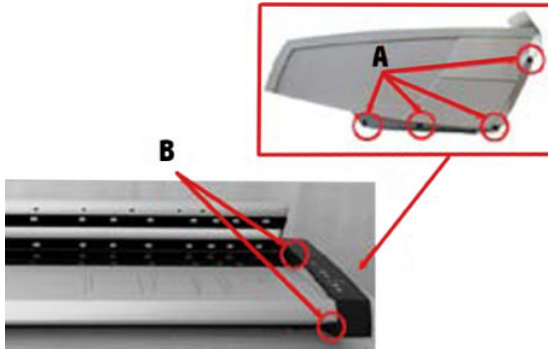

3. Disconnect the cables (A), remove the screws (B), and remove the Interconnection Board.



### Replacement

- ▲ Replace the RHS cover and reverse the removal steps.

## White Background Plate

### Removal

1. Tilt the guide plate open. See [Scanner main board on page 56](#).
2. Remove the White background lock strip (A).

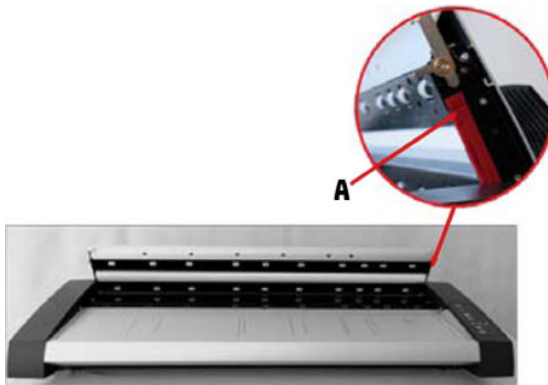

3. Pull out the White Background Plate (A).

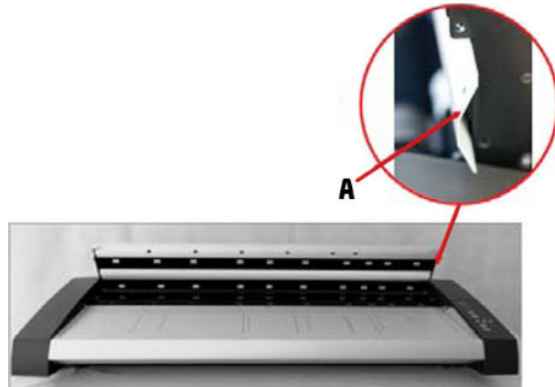

### Replacement

- ▲ Replace the White Background Plate and reverse the removal steps.

## Lamp Cartridge

### Removal

1. Turn off the scanner.
2. Remove the Lamp Cartridge cover.

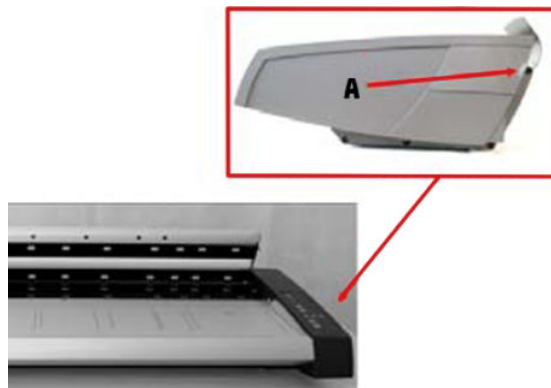

3. Pull out the Lamp Cartridge.

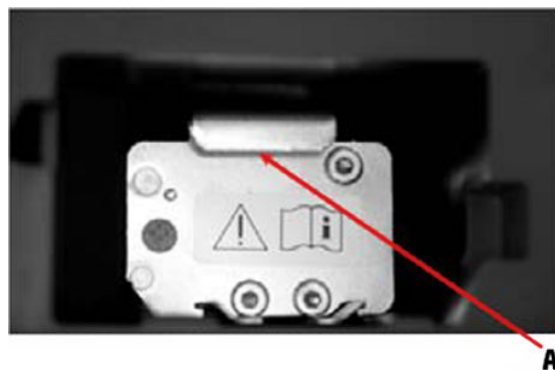



## Replacement

- ▲ Replace the Lamp Cartridge, make a full Calibration, and reverse the removal steps.

## Glass Plate

### Removal

1. Tilt the guide plate open. See [Scanner main board on page 56](#).
2. Flip the Glass Plate into the upright position by using the knobs (A).

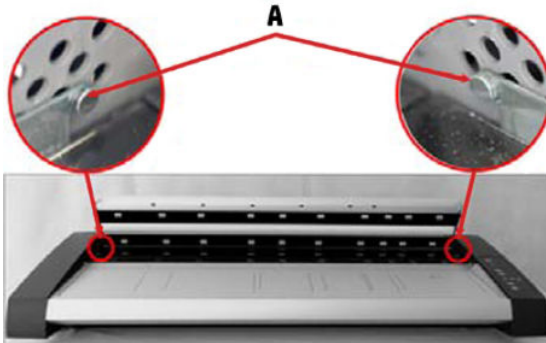

3. Lift Glass plate out of the hinges (A).

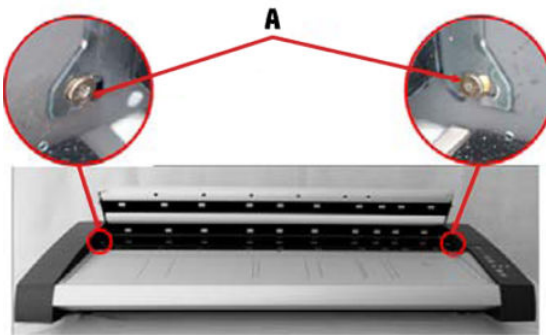

### Replacement

- ▲ Replace the Glass Plate and reverse the removal steps. If necessary run a full Scanner Calibration.

## PanelPC

This chapter is a step by step guide to the removal and installation of the key components in the PanelPC.

### Rear Cover, Power Switch Cable, Adapter Cable Fix Rail and Ring

#### Removal and replacement

1. Remove the 10 screws on the rear cover first.



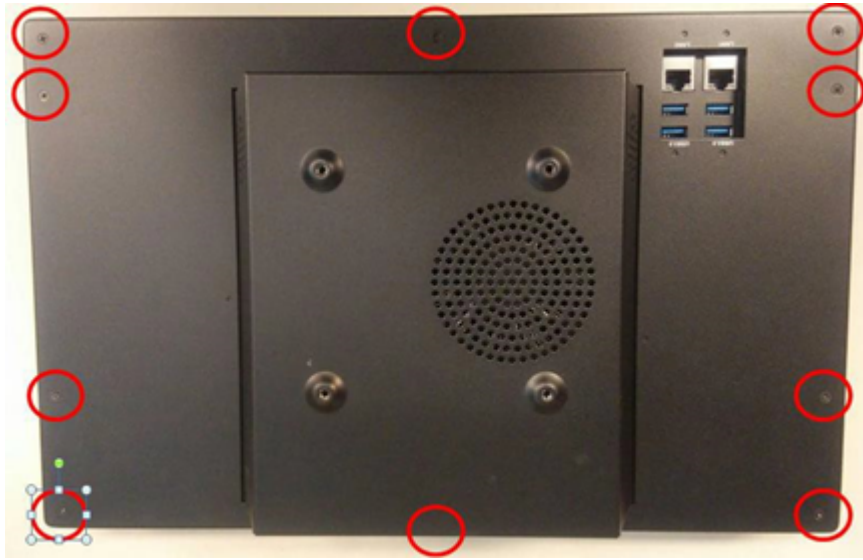

2. Remove the Rear Cover, then remove the power switch cable and power button cable.

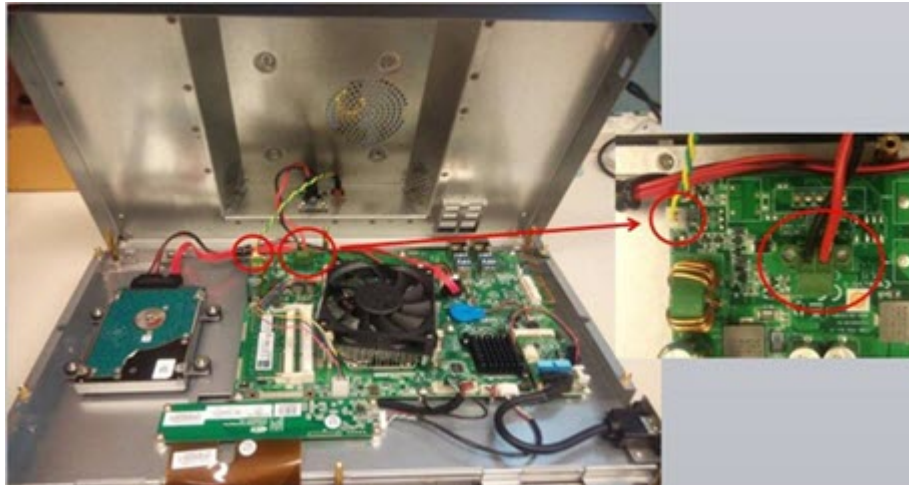

3. Use a screw driver to push down the iron plate marked in red below, then push out the switch outside the Rear Cover, and you can take out the cable and replace it (1700002294). Meanwhile, the Rear Cover (1960071408N001) can be replaced.

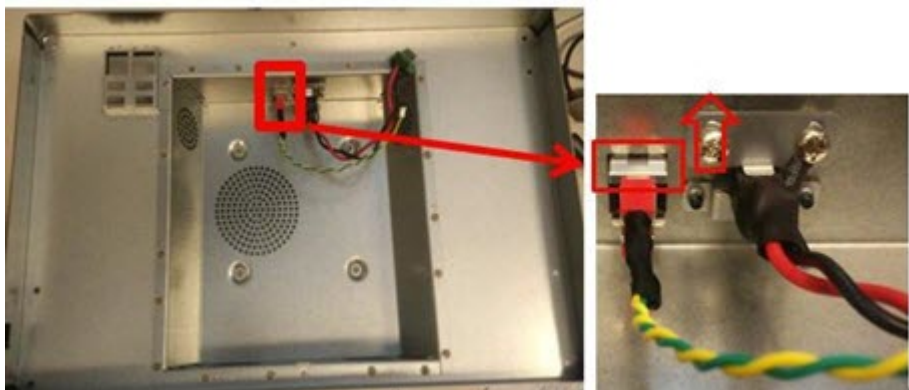

4. Squeeze the plastic hook in the direction of the arrow, then push out the adapter cable fix rail and ring (1960071406N000 and 1960071407N000). Replace with a new one.

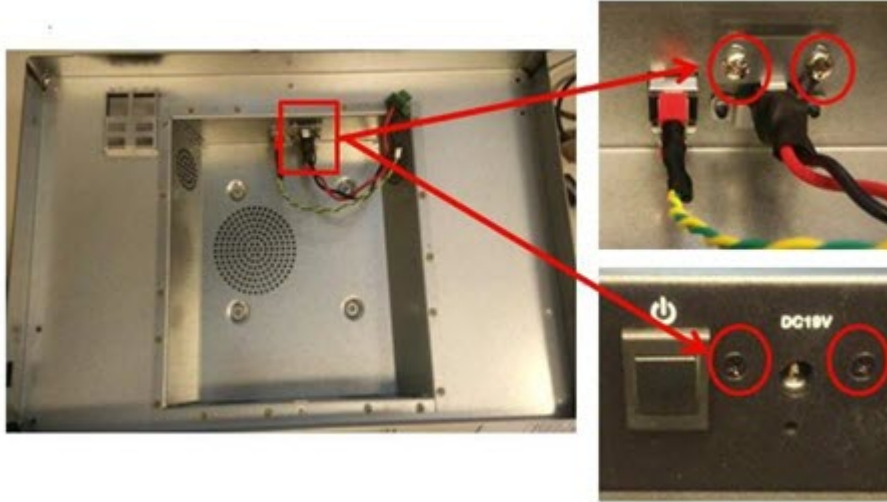

## HDD

### Removal

1. First, follow steps 1 and 2 in [Rear Cover, Power Switch Cable, Adapter Cable Fix Rail and Ring on page 80](#). Then remove the HDD cable and 4 screws..



2. Remove the 4 screws on the bracket, and take out the HDD to be replaced (96ND500G-ST-SG5K4). The HDD rubber (1990015239T000) is marked below with green circles.



### Replacement

- ▲ Replace the HDD (G6H51-67062) and reverse the removal steps.

## Rear cover and T/S Control Board

### Removal and replacement

1. First, follow steps 1 and 2 in [Rear Cover, Power Switch Cable, Adapter Cable Fix Rail and Ring on page 80](#). Then remove the 6 screws on the Rear Cover, then replace the Rear Cover (1960071408N001).

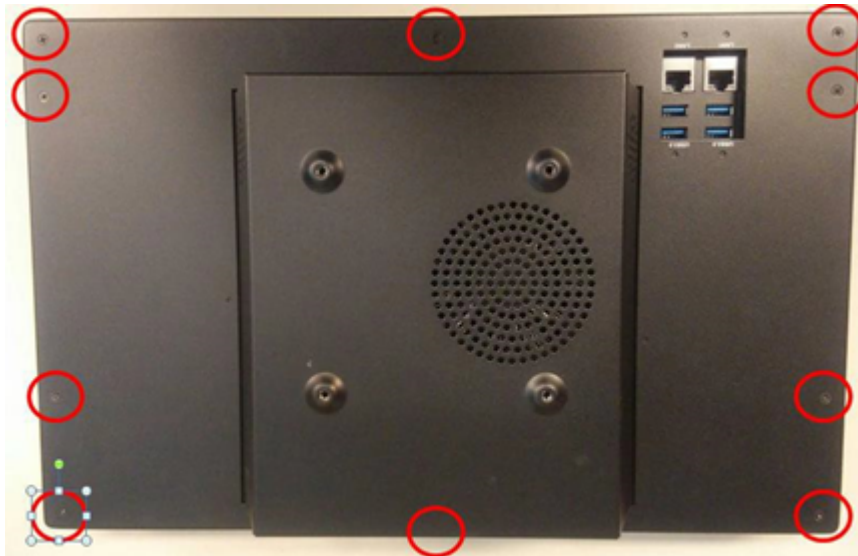



2. Find the T/S control board and remove the USB touch cables and 4 screws.



3. On the other side; unlock the 2 clips on the connector, remove the FPC cable, then remove the control board.

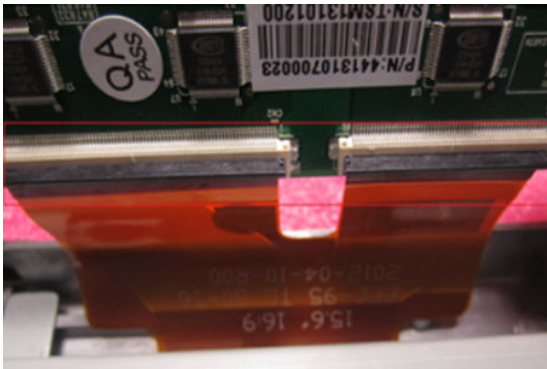

4. Take a new control board (98RK715101E), unlock the clip on the connector, then insert the FPC cable to the end and lock the clip.

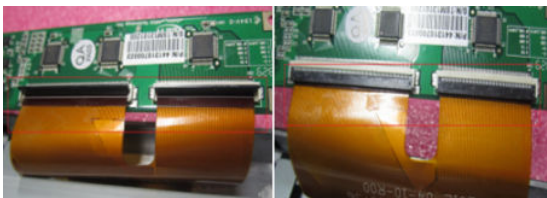

## Mother Board

### Removal

1. First, follow steps 1 and 2 in [Rear Cover, Power Switch Cable, Adapter Cable Fix Rail and Ring on page 80](#). Remove the SATA cable connector (A), remove front LED cable connector (B), remove the USB cable connector (C), remove the Backlight cable, LVDS cable and touch-sensor cable (D).

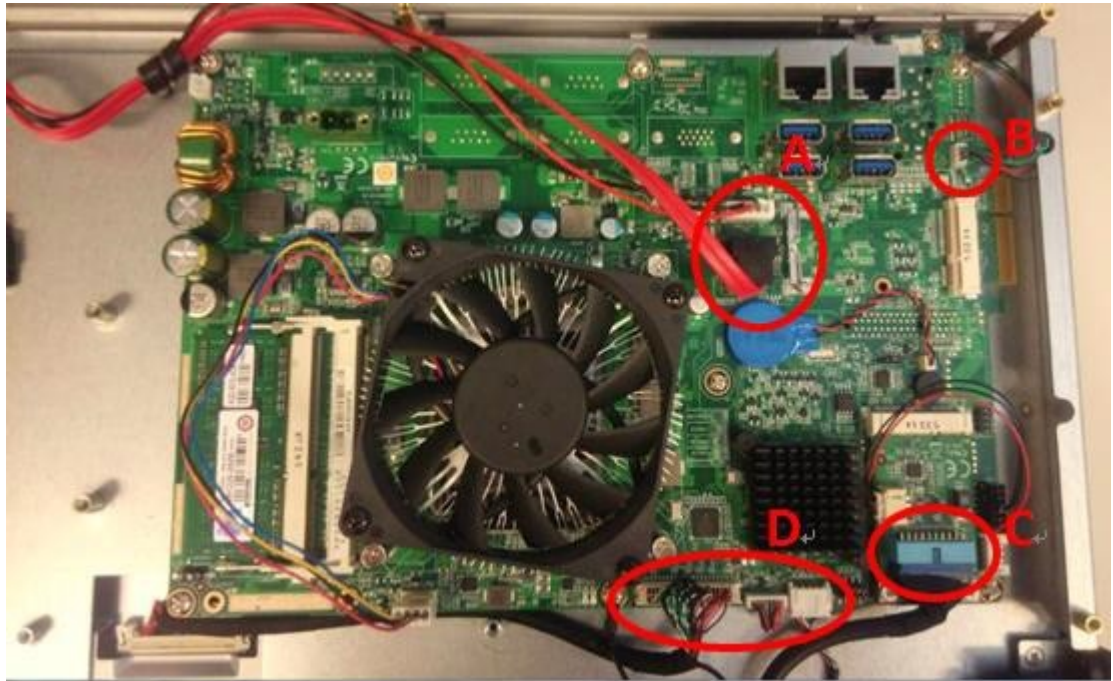

2. Loosen the cable clip, and remove the SATA cable.
3. Remove the 7 screws from the below-specified positions.

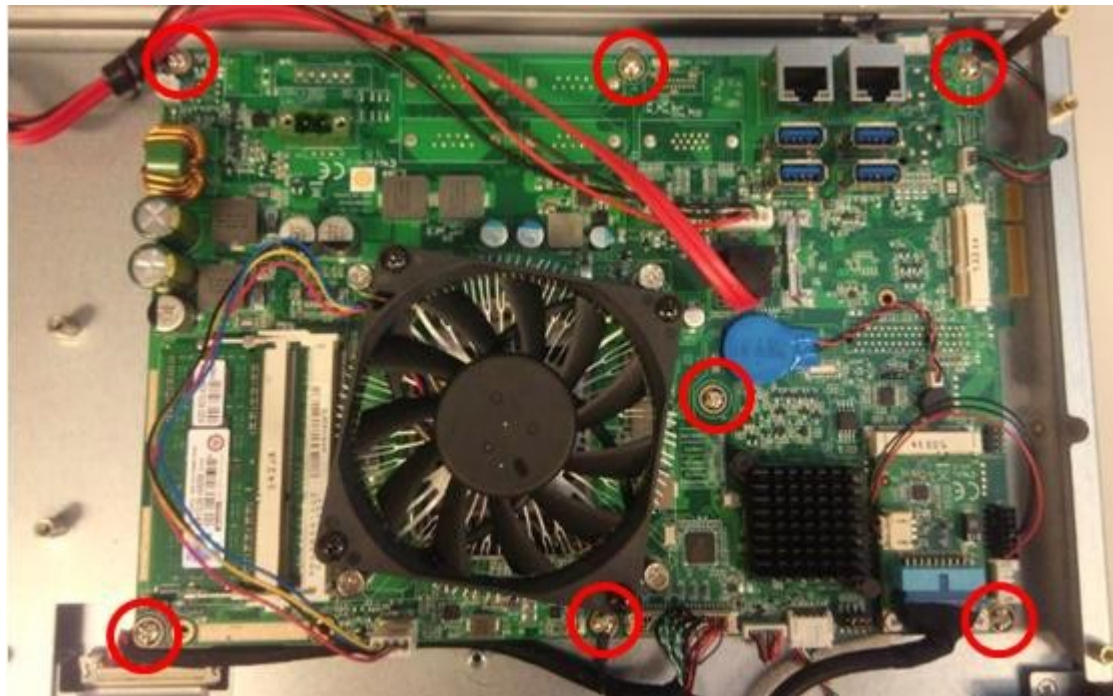



4. Remove the Cooler cable and 4 screws.

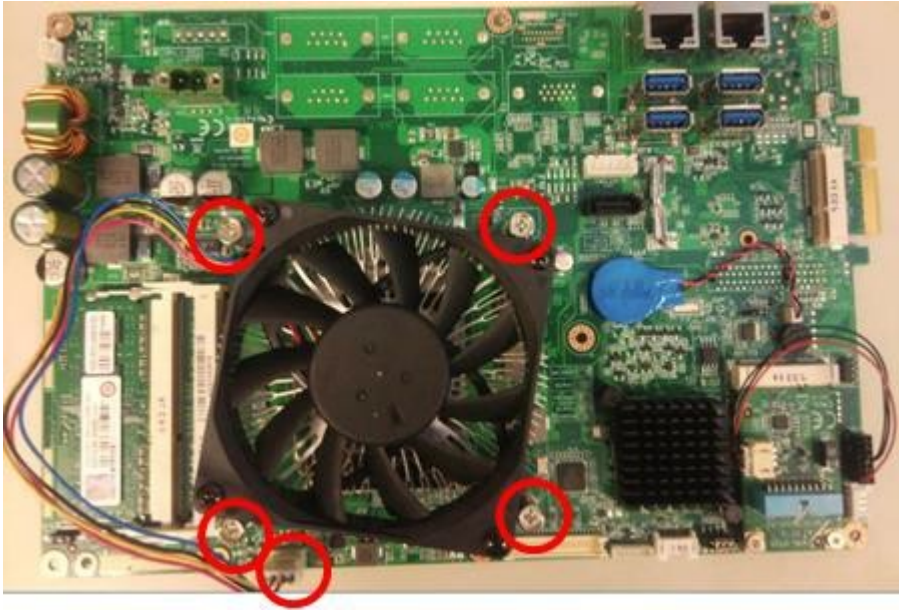

5. Move the cooler out, then you can replace the Memory (A; AQD-SD3L4GN16-SG), Mother Board (9893B90100E) or CPU (B; 96MPI7-3.2-8M10T).

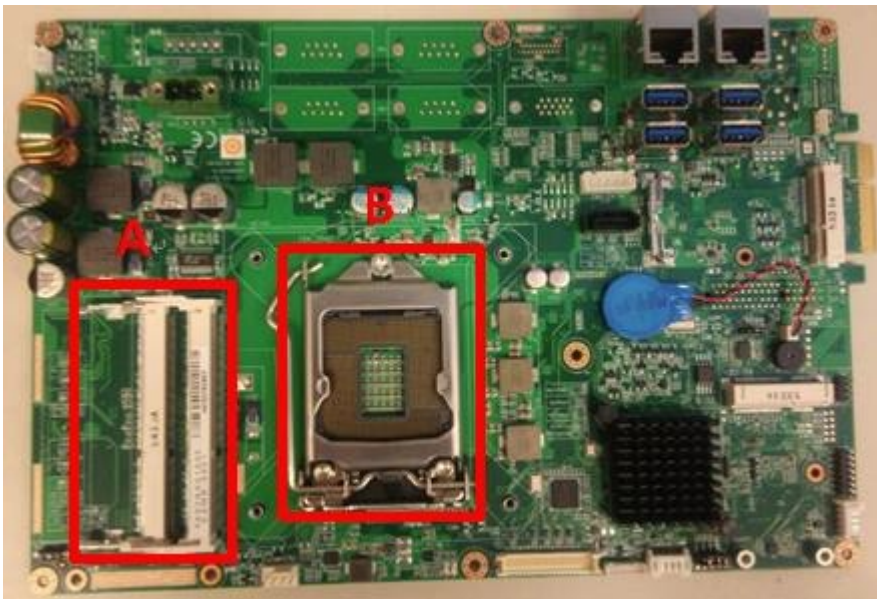

### Replacement

- ▲ Replace the Cooler (98RK715004E), Mother Board (98RK715003E) or Memory (96SD3-2G1600NN-AP) and reverse the removal steps.

## Front LED Board and Power LED cable

### Removal and replacement

- ▲ First, follow steps 1 and 2 from [Rear Cover, Power Switch Cable, Adapter Cable Fix Rail and Ring on page 80](#). Then, find the front LED light board (9893PH2410E), loosen the screw, and remove the cable or replace it (1700022218-01).



## USB cable for right-hand side USB

### Removal and replacement

- ▲ First, follow steps 1 and 2 from [Rear Cover, Power Switch Cable, Adapter Cable Fix Rail and Ring on page 80](#). Then remove 2 screws near the USB connector, then remove the USB cable from the connector on M/B, then you can replace this USB cable for the right-hand side USB (1700024318-11).

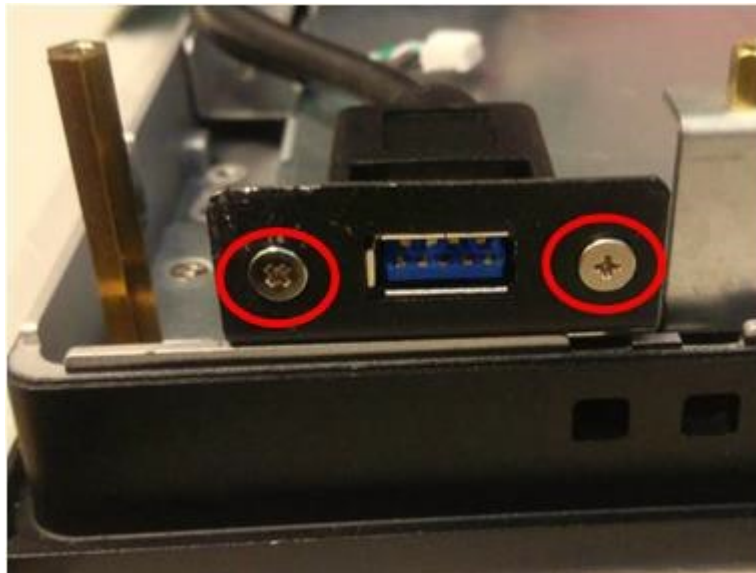

## LED Panel module and Front bezel module

### Removal and replacement

1. Remove the Mother Board Cover. See [Rear Cover, Power Switch Cable, Adapter Cable Fix Rail and Ring on page 80](#).
2. Remove the HDD. See [HDD on page 82](#).
3. Remove the Touch Screen Control Board. See [Rear cover and T/S Control Board on page 83](#).
4. Remove the Mother board. See [Mother Board on page 84](#).
5. Find the LVDS cable connector on the Panel, and push the metal clip on the connector inward, then pull out the LVDS cable.

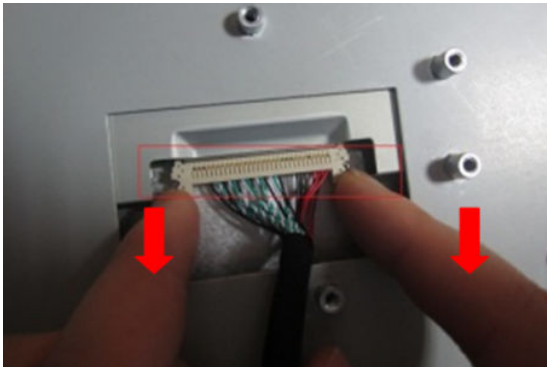

6. Remove the 2 screws from the positions specified below.

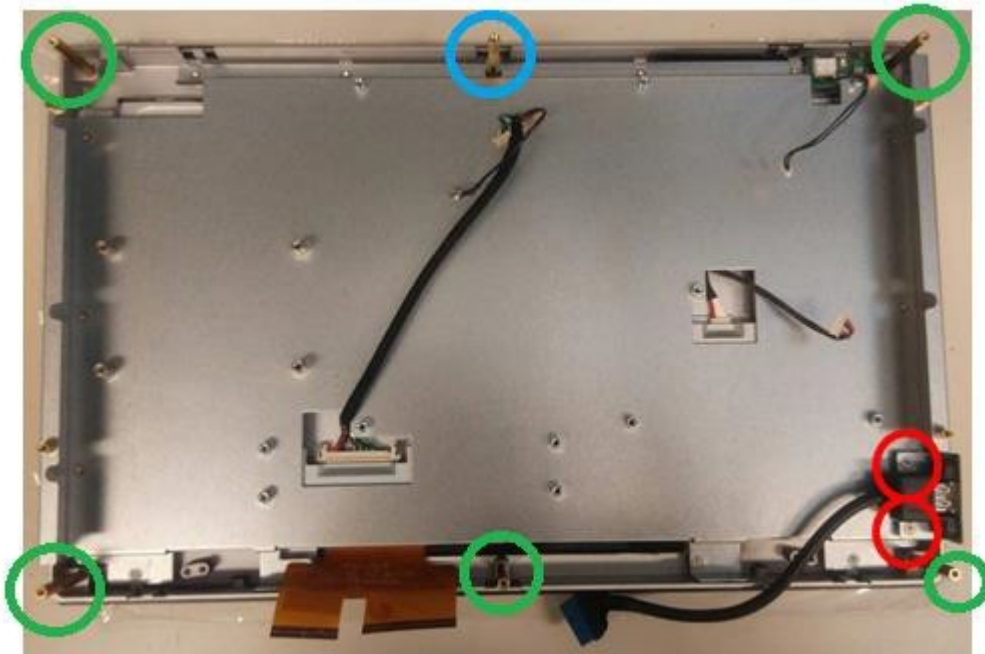



7. Remove the 14 screws from the specified positions, then replace the Panel backlight light cable before removing the screws (marked by the red circles below).

You also can see POST (34mm) 4 pcs placed around the middle bracket (marked as green circle above)  
And POST (38mm) 1 pcs (marked as blue circle above).

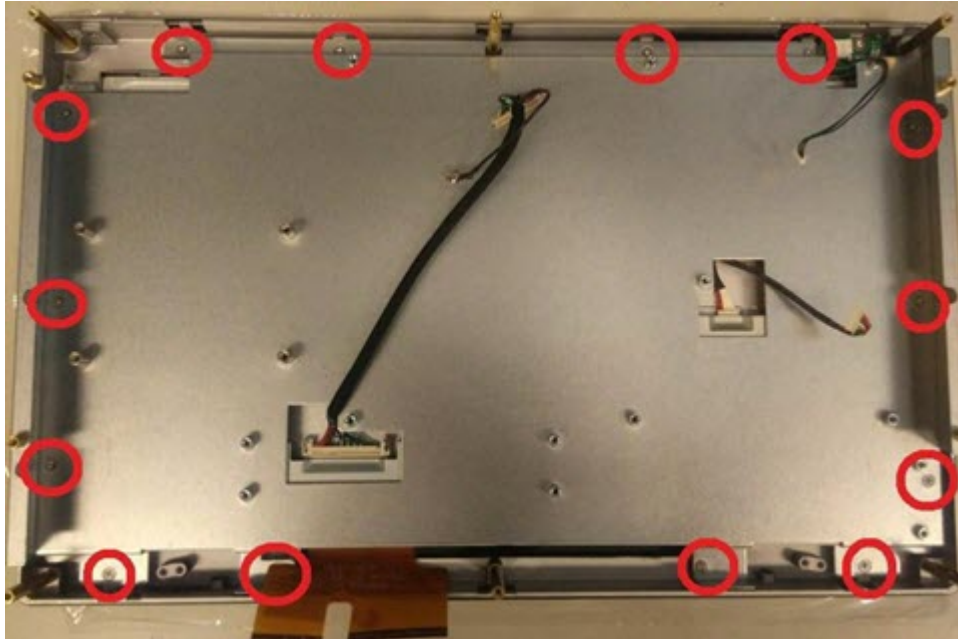

8. Take out the LED panel module (98RK715102E) and replace it. The only thing left is the touch screen module (front bezel + touch screen 98RK715103E); this can also be replaced now if required.



9. Remove the 4 screws (marked as red circles below) to separate the LED Panel and left/right Bracket.

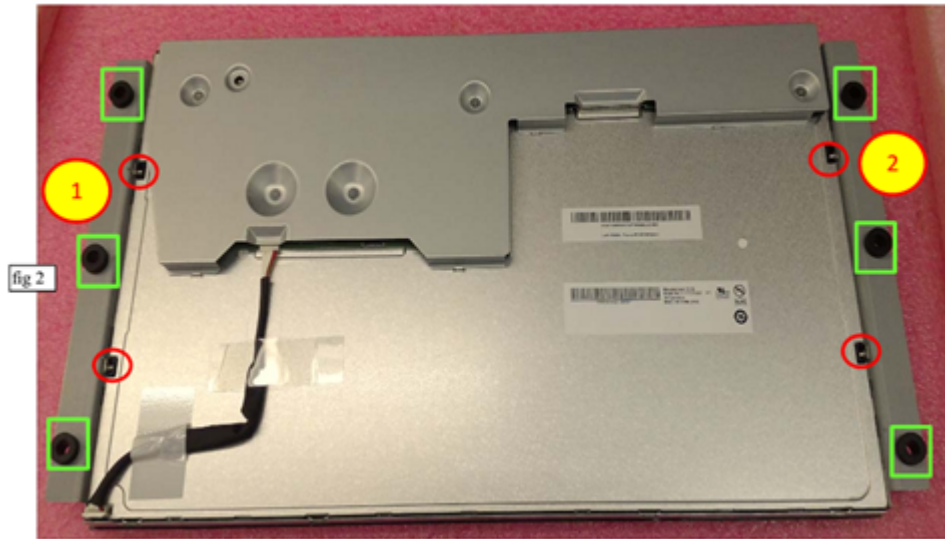

## LVDS Cable

### Removal

- ▲ Please follow [LED Panel module and Front bezel module on page 87](#), as it explains how to extract the LVDS cable.

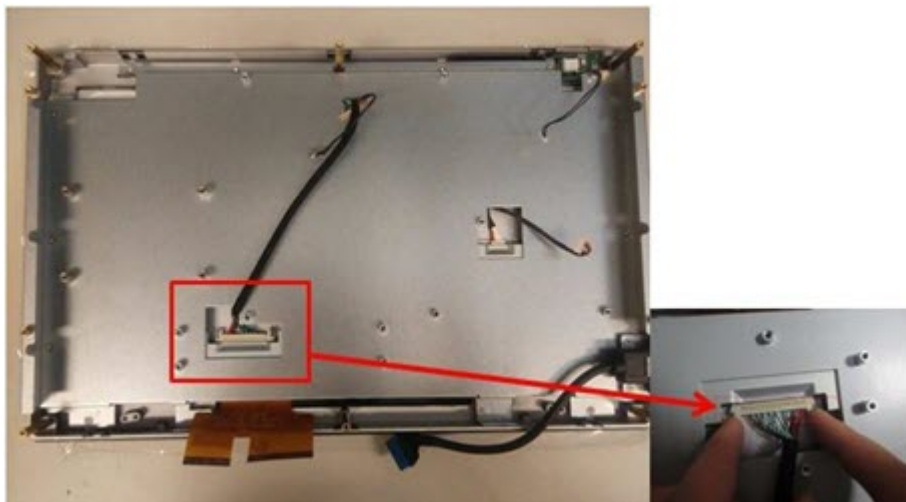

### Replacement

- ▲ Reverse the removal steps.

## SATA Cable

### Removal

- ▲ First, follow steps 1 and 2 in [Rear Cover, Power Switch Cable, Adapter Cable Fix Rail and Ring on page 80](#). Remove the SATA cable (marked in red below) from the HDD.



## Replacement

- ▲ Replace the SATA cable (1700024634-01) and reverse the removal steps.



## USB board

### Removal

1. Remove USB 3.0 cable (1700024318-11).



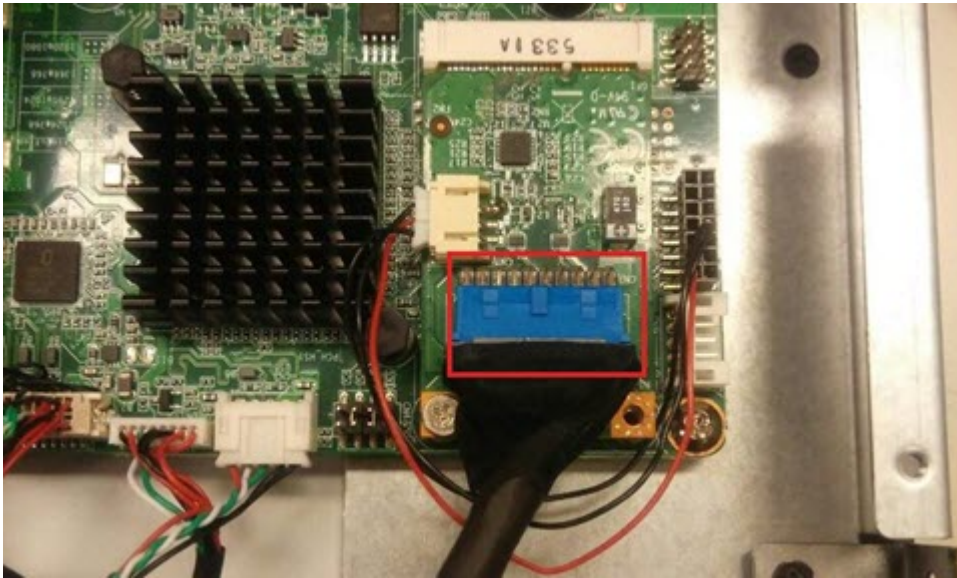

2. Remove 2 screws (circled in red below) and USB board +5V cable (1700024308-01), then replace the USB board.



### Replacement

- ▲ Replace the USB cable, right hand side USB (1700022128-01), and reverse the removal steps.

---

# 5 Scanner Adjustments and Calibrations

- [Introduction](#)
- [Tools Required](#)
- [Terminology](#)
- [Camera Design Overview](#)
- [Scanner Maintenance](#)
- [ATAC Position Sensors check](#)
- [Original Guide Sensor Test](#)
- [Calibrate ATAC \(Automatic Thickness Adjustment Control\)](#)
- [Lamp and motor controller board Communication Test](#)
- [Upgrade Scanner Software](#)

# Introduction

This chapter explains how to adjust the scanner for optimal scanning quality. It describes the adjusting procedures in detail and provides additional information regarding acceptance criteria.

A general concept when adjusting the scanner is to loosen screws just slightly. If you loosen the screws too much, you will have difficulties controlling the adjustments, because of too much play in the adjustment levers and other adjustment points. Unless this chapter states otherwise, always loosen screws and nuts only slightly. They should be snug; there should be no play when you try to wiggle them. When tightening a set of screws, tighten all of them little by little, rather than fully tightening one, and then another, and so on.

## Tools Required

To perform the Camera Adjustment you will need:

- Optical Adjustment Pattern for 5 cameras
- Torx 15 and 20 for camera access
- Torx 6 and 10 (preferably both straight and angled) for camera adjustment

To perform the Sensor Adjustments you will need:

- Adjustment Tools for ATAC Sensors
- Torx 10

## Terminology

Throughout this chapter a number of visual elements are used to guide you through the adjustment process.

---

 **WARNING!** The exclamation mark is used to point out possible sources of errors. If something can go wrong when performing a specific action, this visual item describes it.

---

Thumps up symbol is used with hints, tips and tricks that make a specific action easier to complete.

A hand in an illustration means that this particular adjustment does not require a tool. It can be adjusted with your fingers.

A screwdriver in an illustration means that this particular adjustment requires a tool. It cannot be adjusted with your fingers alone.

Text in **bold** describes a mechanical part, an item, or a program button, which can be located in one of the illustrations.

## Camera Design Overview

### Introduction

HP HD Pro scanners use five cameras. Each camera scans its own part of the image.

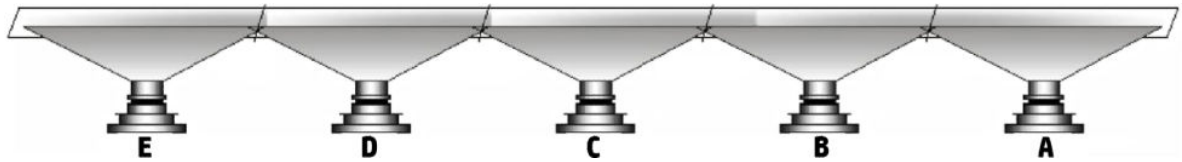

The cameras are named A, B, C, D and E, from right to left. The scan area of each camera overlaps slightly, to ensure that the scanner scans the complete image.

Most of the scanner adjustments are focused on getting the correct scan width. The adjustment ensures that a camera scans the right amount of image data so that the basic DPI resolution of the camera is precise. This fine-tunes the accuracy of the scanner. A metal vertical plate (which acts as a stitching wire in older scanners) in the overlapping area helps the scanner to adjust the cameras electronically.

The following drawing shows what the camera looks like.

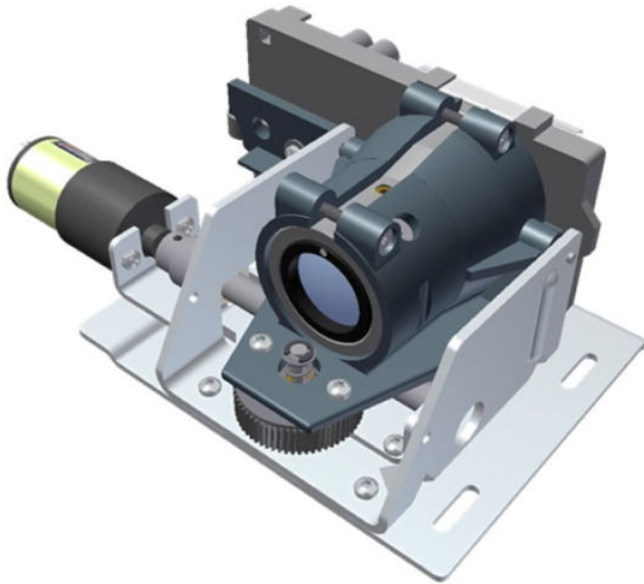

## The CCD Element

The central component of the Camera is the Sony CCD (Charge Coupled Device) element, which is responsible for capturing the colors reflected from the original image.



The CCD is formed as a chip, and is inserted into a standard dual in-line socket just like a normal chip. The chip has 4 rows each containing 7500 pixels.

The four rows each scan a different color. Combined, the three rows provide 24 bit color. The last row is for panchromatic scanning. Each CCD pixel is formed as a square with a side length of 5  $\mu\text{m}$ . There is 40  $\mu\text{m}$  between the adjacent lines.



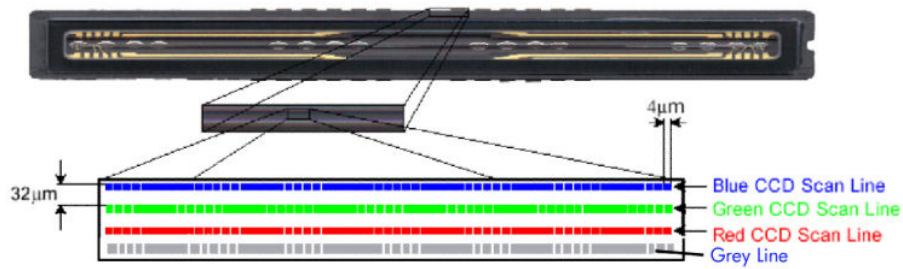

## Camera Board Adjustments

### Camera Overview

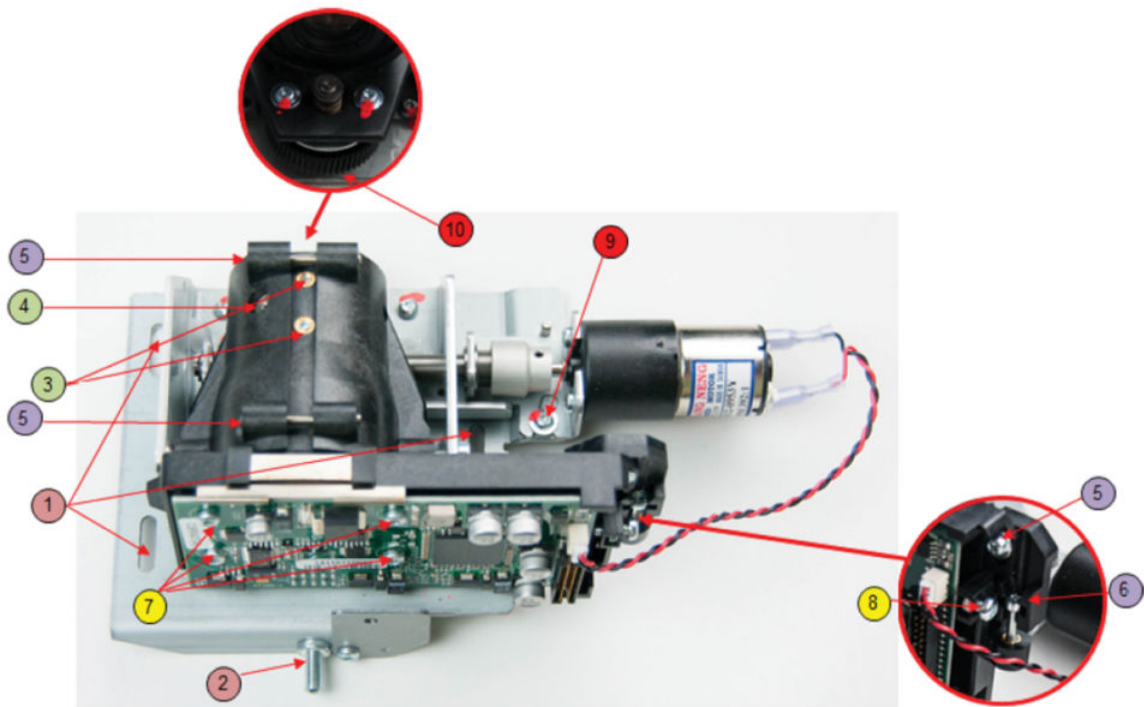

Number	Description
1	Camera Base Fixing Screws. Loosen when adjusting Scan Width
2	ScanWidth Adjustment Screw
3	Focus Lock Screws. Loosen when adjusting Focus
4	Focus Adjustment Screw
5	Camera Unit Fixing Screws. Loosen when adjusting Tilt
6	Tilt Adjustment Screw
7	Camera Board/Centring Fixing Screws
8	CCD Centring Screw (One way adjustment, manual opposite direction)
9	Motor Fixing Screw
10	Vertical Position Adjustment Wheel

## 1. Tilt the guide plate open, remove the front profile and top cover

▲ (see [Scanner main board on page 56](#), steps 1–4).

## 2. Adjust, Light Profile Height

For all cameras:

1. Select RGB.



2. Loosen the Motor Fixing Screw (9).

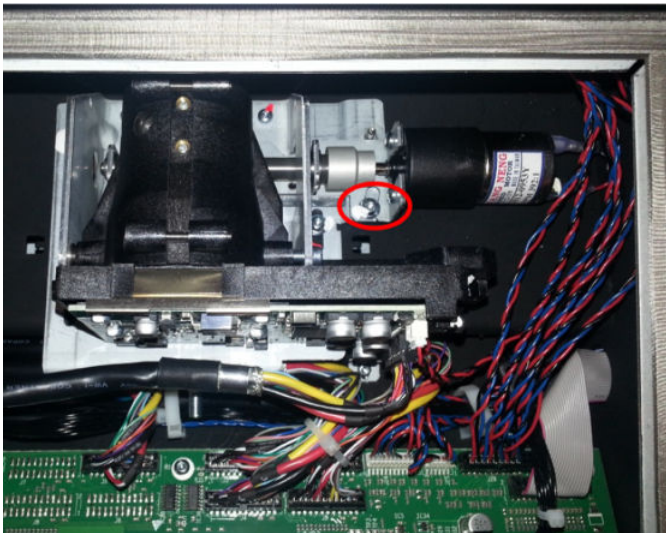

3. Turn the Vertical position adjustment wheel (10), located under the camera, until the cameras show undisturbed light profiles. In order to release the camera and be able to change its vertical position, slide the motor towards the front and hold it while using the Vertical position adjustment wheel.

4. Select Camera Adj., this will adjust gain and offset. Wait until the light profiles have “settled.”

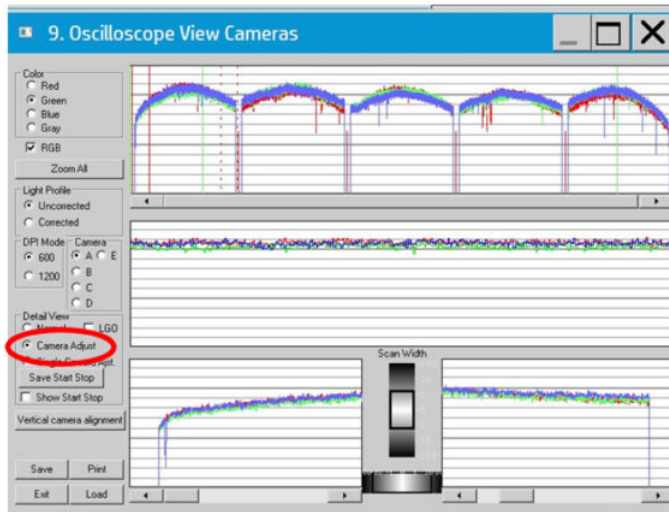

5. If no light profile is visible; validate that camera is working by shining light into the camera lens. Adjust vertical position using the wheel until the light profile is visible.
6. After all cameras have been adjusted, tighten the Motor fixing screw (9).

### 3. Adjust Camera Focus

For all cameras:

1. Open the Original Guide and place the Original Adjustment Pattern (OAP) in the scan area. Make sure to position the pattern by pushing it fully forwards and to the right.

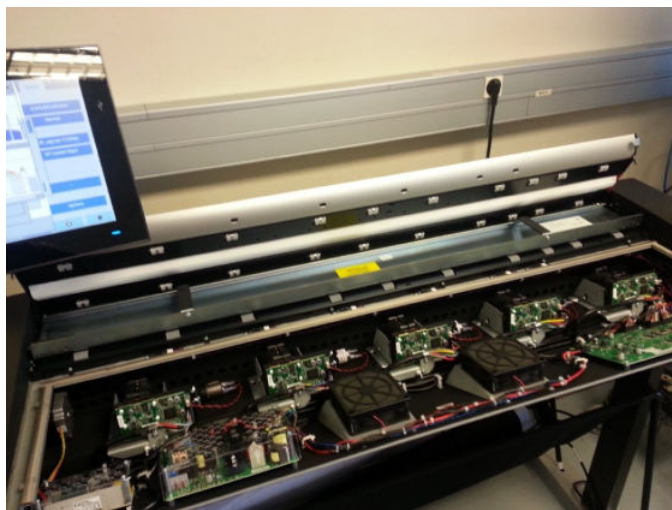

2. Deselect RGB.

3. Select Normal.

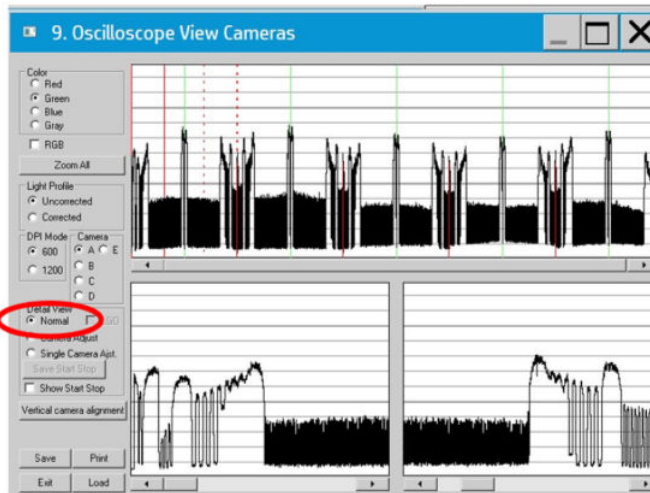

4. Loosen the Focus Lock Screws (3).

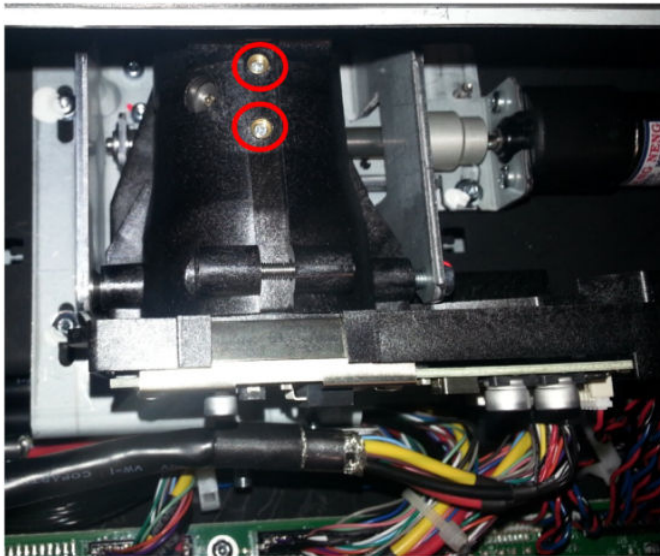

- Adjust the focus by turning the Focus Adjustment Screw (4) until focus is as good as possible. In order to optimize focus, make sure that the signal height is as broad as possible, and all camera signals have a similar broadness.

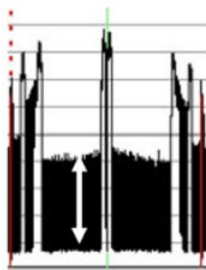
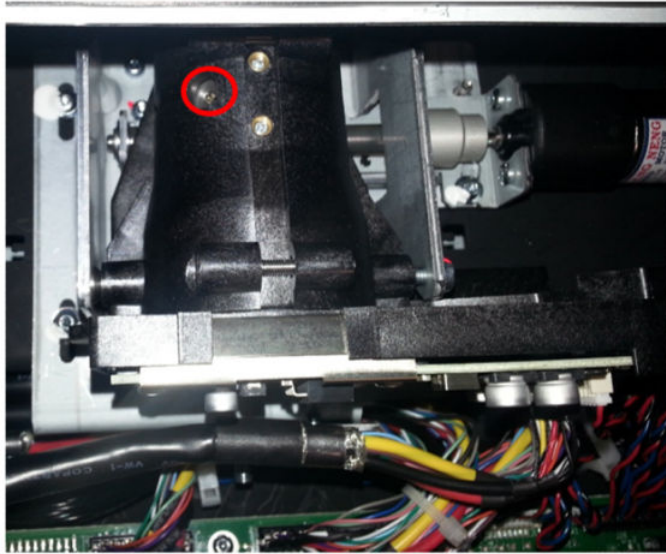

- After focus in all cameras has been adjusted, tighten the Focus lock screws.

#### 4. Adjust camera scan width

- Select Camera Adj.

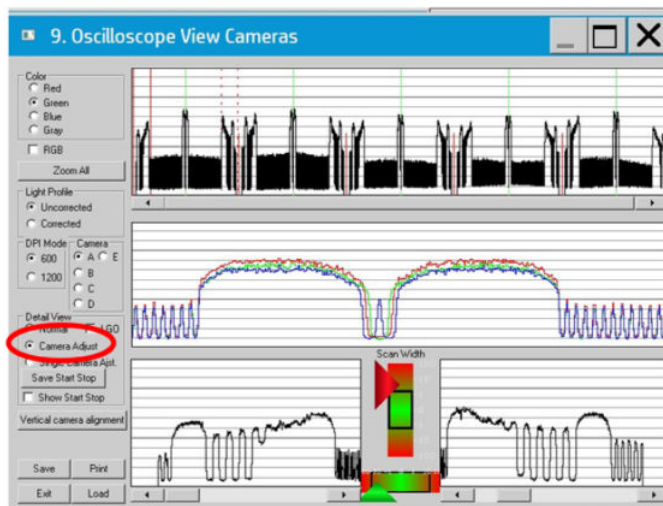



2. Lightly loosen the Camera Base Fixing Screws (1).

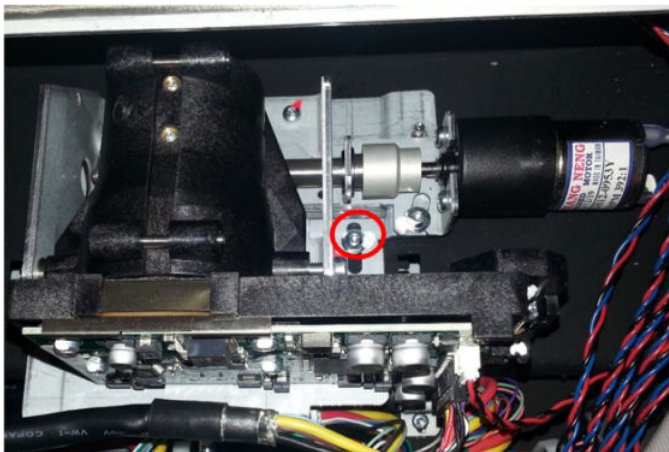
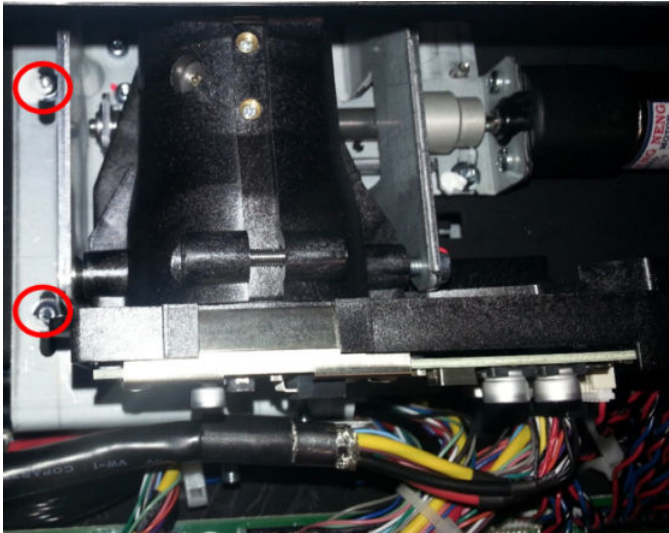

3. Select camera A.

4. Adjust the Scan Width Adjustment Screw (2) until the arrow in the Scan Width box is within the black box and the arrow turns green.

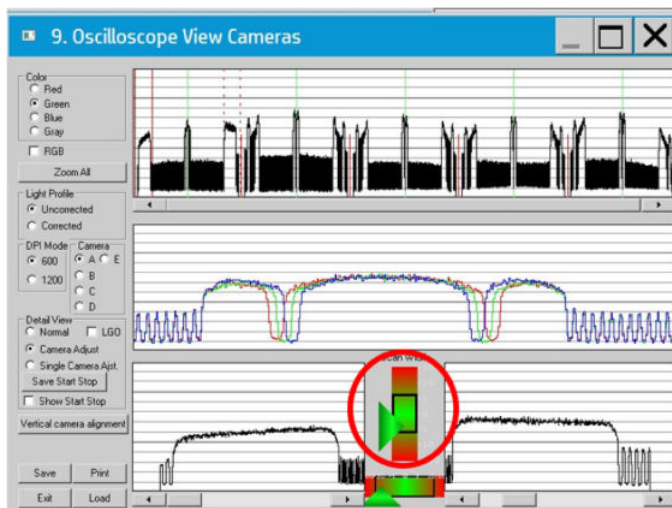
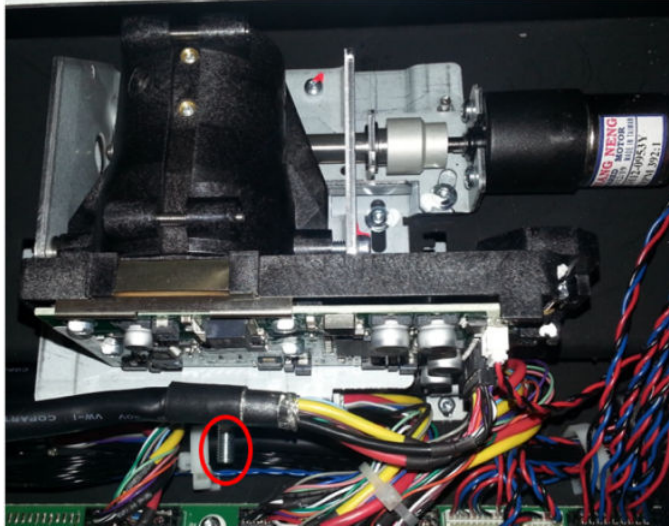

5. Repeat for other cameras (select B, C, D, E in turn).
6. Tighten the Camera Base Plate Fixing Screws (1).

### 5. Adjust camera tilt

1. Loosen the Camera Unit Fixing screws (5).

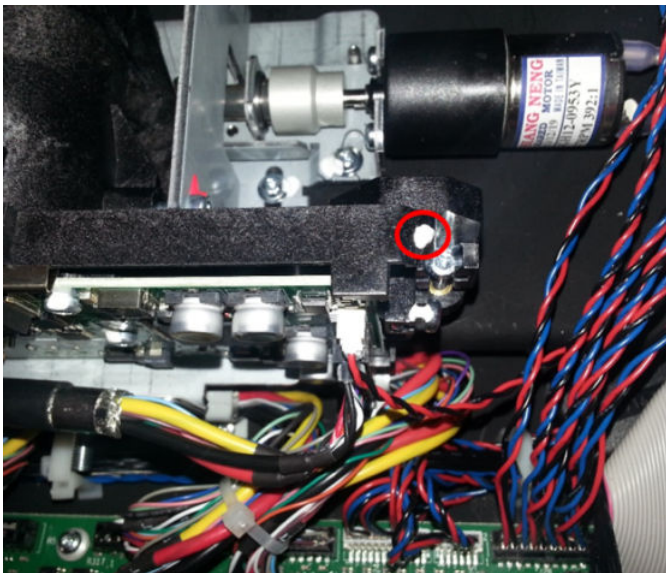
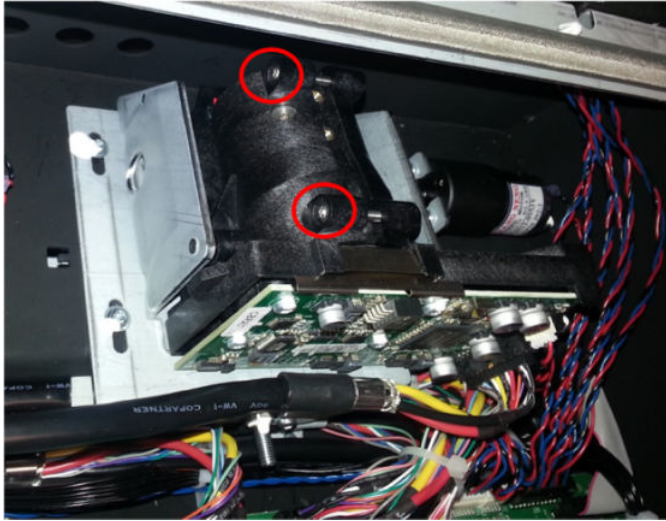



2. Adjust the Tilt Adjustment Screw (6) until start and end have the same number of lines. If necessary also use Vertical Position Adjustment Wheel (10), remember to loosen the motor fixing screw first (9).

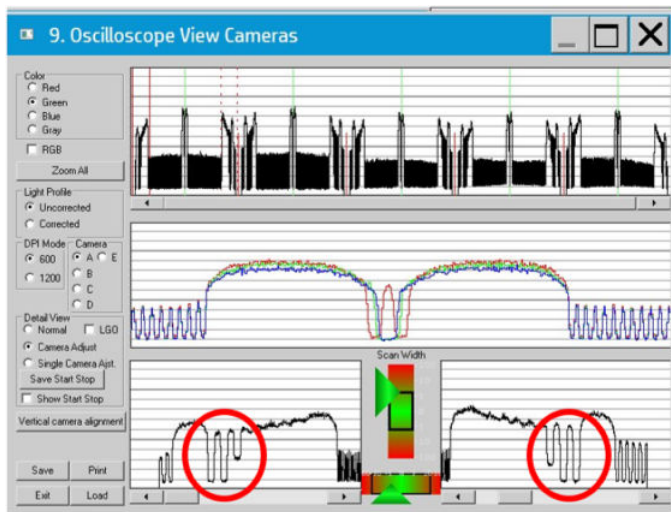
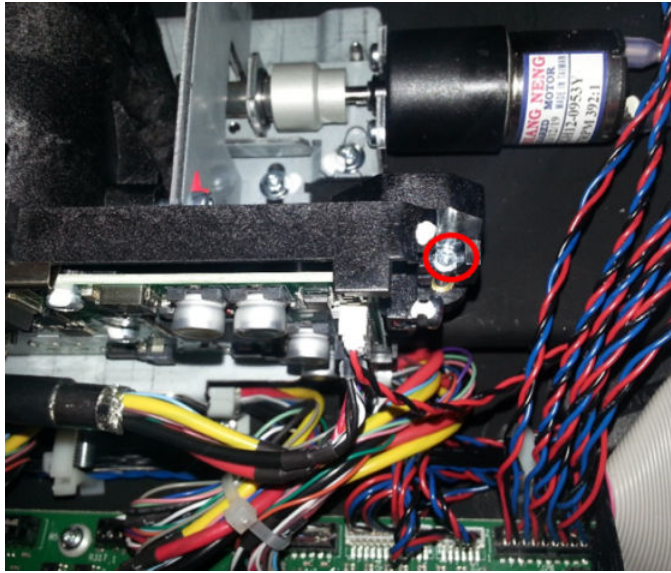

3. Tighten the Camera Unit Fixing Screws (5).
4. Repeat for other cameras.

## 6. Adjust vertical camera alignment

1. Loosen the Camera board fixing Screws (7).

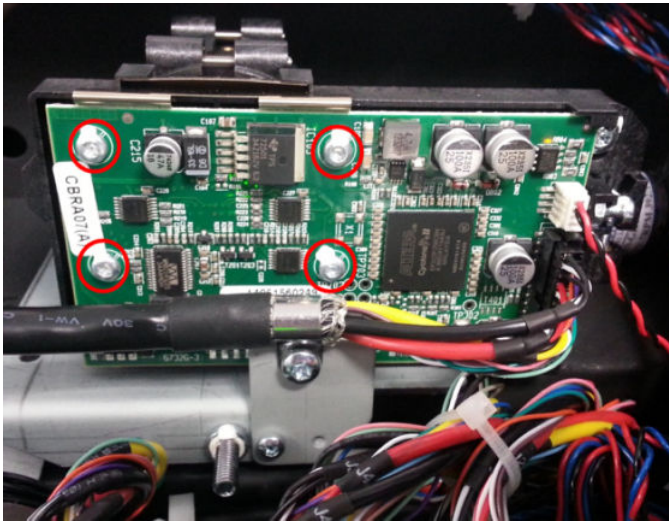

2. Adjust the centering Screw (8) until the arrow in the bottom horizontal bar is in the center and turned green. The adjustment screw allows adjustment of the board in one way, if needed manually push the board in the other direction after releasing the centering screw.

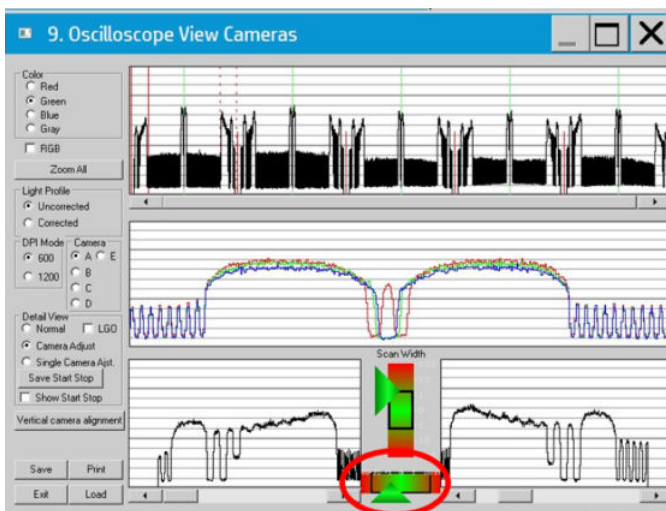
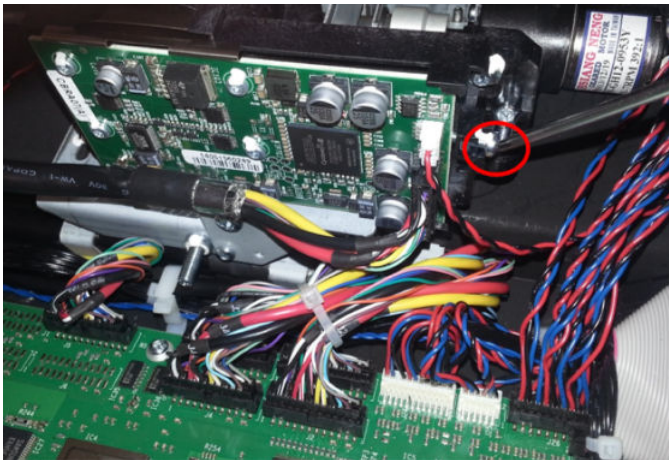

3. Tighten the Camera Board Fixing Screws (7).
4. Repeat for the other cameras (select B, C, D, E in turn).

## 7. Adjust camera centering

1. Select Vertical Camera Alignment.



2. Select "Center all cameras." This will center the cameras to the center of the glass plate.

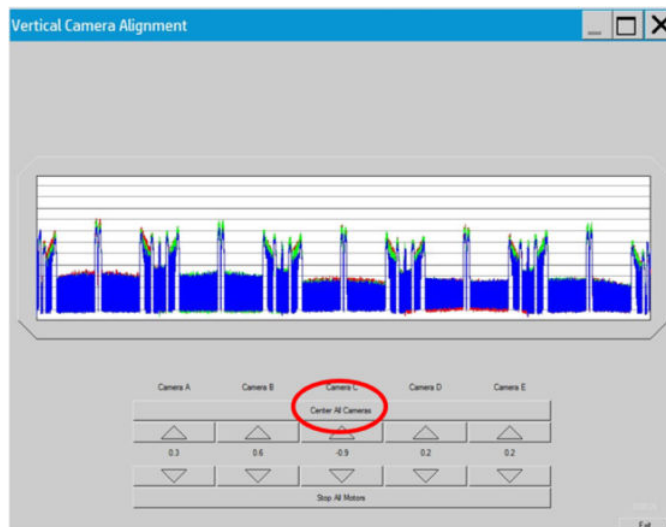

3. Exit and return to the Oscilloscope view.

4. Before exiting camera adjustment and removing the OAP, save Start Stop values.

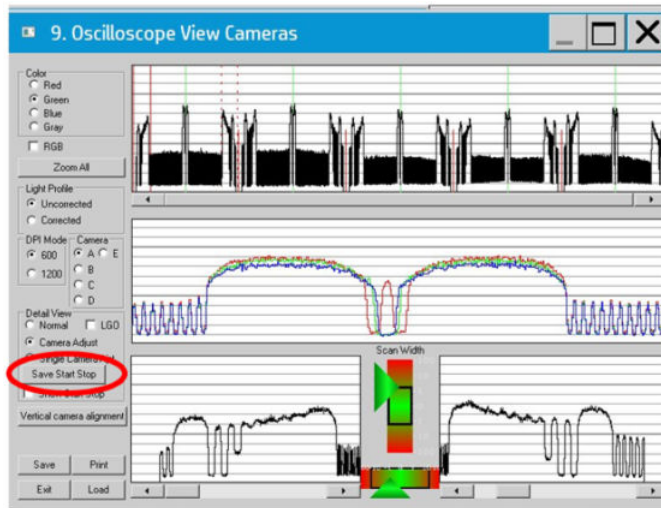

## 8. Reinstall the cover and clean the unit

- ▲ See [Cleaning the Scanning Area on page 20](#).

## 9. Calibrate the scanner

- ▲ See [Scanner Adjustments and Calibrations on page 94](#).

# Scanner Maintenance

Once the cameras are adjusted, you will need to adjust the whole scanner to fine-tune it by performing the Scanner Maintenance. Scanner Maintenance does the following three things **automatically**:

1. Runs Vertical Alignment, which adjusts the vertical position of the Cameras.
2. Adjusts the Stitching, which controls the overlap between the Cameras.
3. Color Calibrates the Scanner to get optimal colors and gray tones.

## Performing Scanner Maintenance

For this part of the adjustments you will need the following item:

- Scanner Maintenance Calibration Sheet 42”
1. Start by removing the **Optical Adjustment Pattern**, cleaning the scanning area, and then closing the Guide Plate.
  2. Exit the Camera Adjustment Wizard and exit SCANTest 6.

3. Wait for the Scanner to reboot and then start Scanner Maintenance when only the green lamp is lit up on the scanner keyboard.



4. Select either:
  - **Camera Alignment:** Will align horizontal capture for correct image stitching.
  - **Full Calibration:** Will perform Camera Alignment, Black & White Calibration, and Color calibration in the same session.
5. Insert the Scanner Maintenance Calibration sheet and press **Next** two times.
6. Wait for Scanner Maintenance to finish. It takes about 30 minutes.
7. Remember to put the calibration sheets back into the original packing, so that they last longer.

## ATAC Position Sensors check

This procedure is to check the sensors in the Original Guide come on when the media sensors are activated.

1. Make sure the guide is in the lower position.

2. Start the Service Tools and select **Test 28, Adjust ATAC sensors**. The attention LED turns red, the paper LED turns green and the Guide Up arrow LED turns orange.

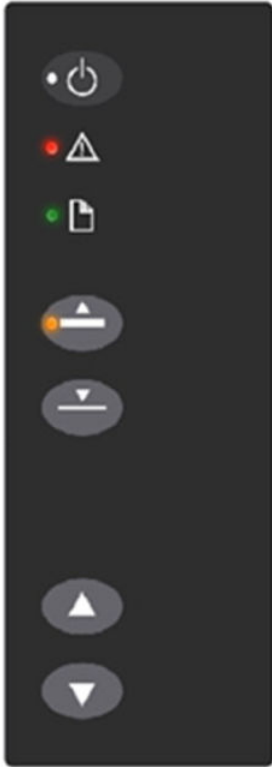

3. Press the **UP** Key on the scanner front panel to move the Guide Plate to the Top Position and observe that:
  - Paper LED is OFF
  - Guide Up arrow LED is OFF
  - The Power LED turns green (Top Position Sensor activated)

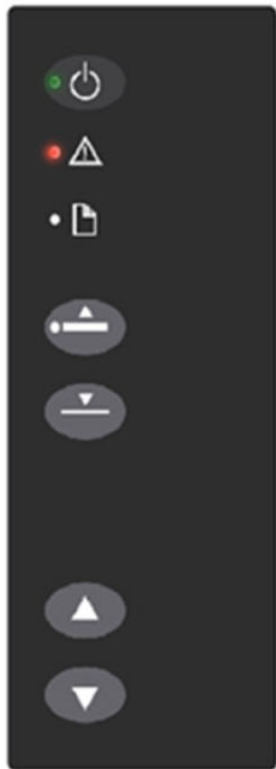

4. Move the Guide Plate down by pressing the **Down** Key on the scanner front panel and observe the LEDs:

- Power LED turns OFF
- Up arrow LED turns yellow (Down Position Sensor activated)



---

**NOTE:** The Down Position Sensor cannot be adjusted.

- Paper LED turns green (Roller sensor activated)

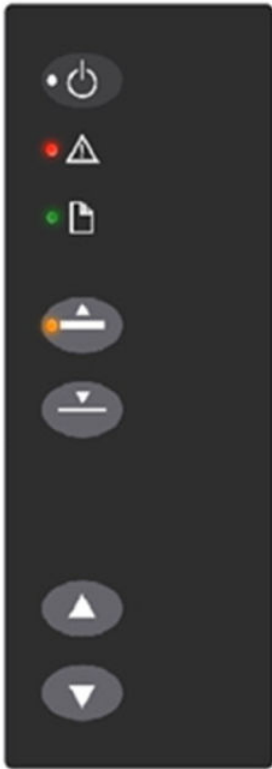

## Original Guide Sensor Test

This is to test the sensors which are located inside the Guide Plate.

## Adjustment of the Roller Sensor

To perform this adjustment you will need the two Roller Sensor Adjustment tools.

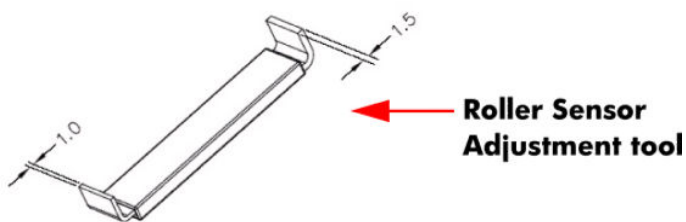

1. Perform the following:
  - Remove ruler from the front of the Guide Plate.
  - Open the Top Profile on the Guide Plate See [Scanner main board on page 56](#).



2. Start the Service Tools and select **Test 28. Adjust ATAC sensors**.

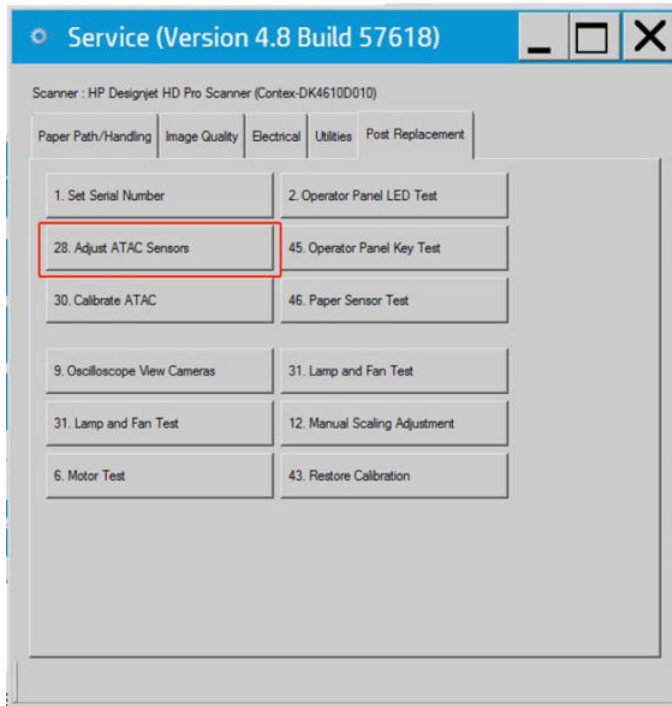

3. Press the **UP** Key on the front panel of the Scanner to move the Guide Plate up until the Power LED turns green.

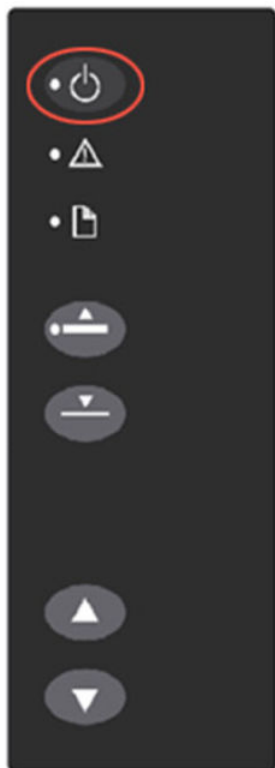

4. Loosen the two screws that secure the Roller Sensor.

- Using the 1.5 mm end of each of the two Adjustment Tools, insert them on both sides of the Roller Sensor under the roller shaft. Notice the roller sensor is located at the right side of the guide plate.

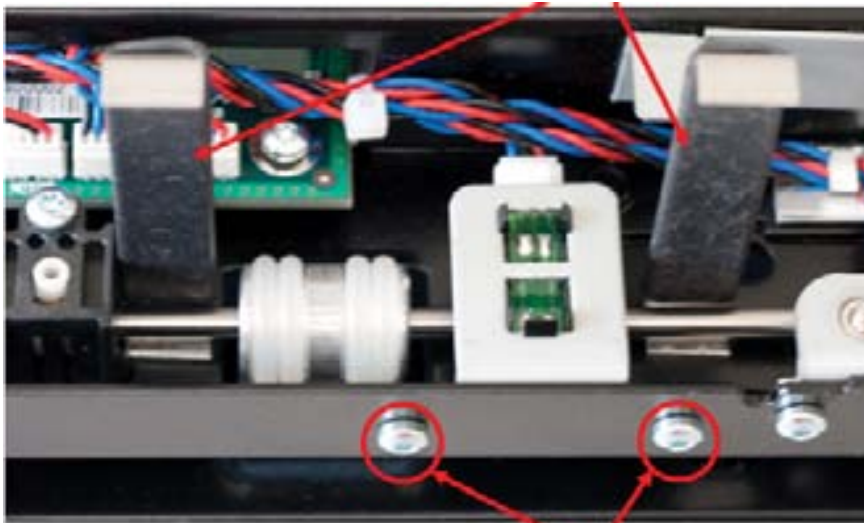

Fixing screws for Roller Sensor

- Adjust the position of the Roller Sensor so that the green Paper LED just about turns ON.

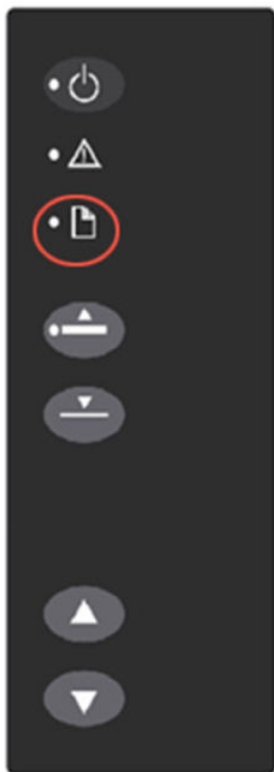

- Using the 1 mm end of each of the two Adjustment Tools, insert them on both sides of the Roller Sensor under the roller shaft. Notice the roller sensor is located at the right side of the guide plate.

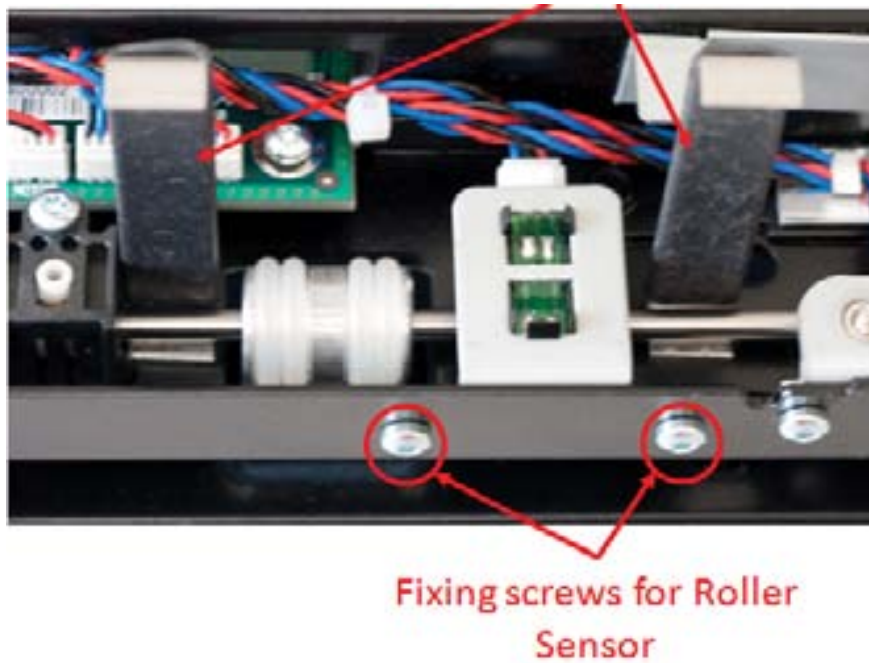

- Check that the green Paper LED is OFF.
- Tighten the two screws that secure the Roller Sensor.

## Adjustment of Top Position Sensor

To perform this adjustment you will need the adjustment tool for the Top Position Sensor:

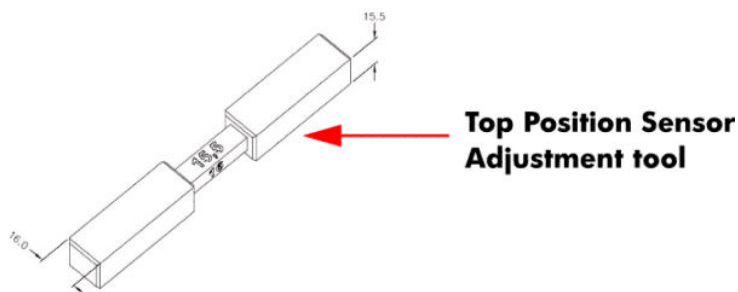

- Perform the following:
  - Remove the ruler from the front of the Guide Plate.
  - Open the Top Profile on the Guide Plate.
- Close and lock the Guide Plate.
- Start the Service Tools and select **Test 28. Adjust ATAC sensors.**

4. Loosen the two screws that secure the sensor bracket, move the sensor to its uppermost position and tighten the four screws.

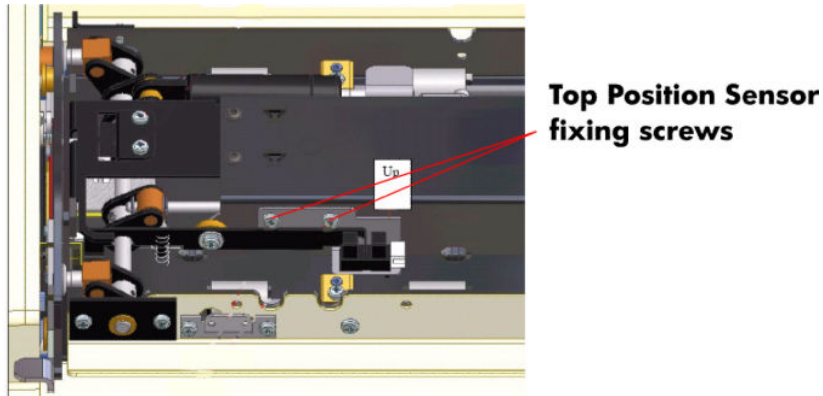

5. Press the **UP** Key to move the Guide Plate to the highest position.
6. Open the Guide Plate.
7. Orientate the two adjustment guides for 16 mm spacing and insert the guides under the Guide Plate at both ends of the scan area.
8. Place the two adjustment guides so that the surface marked “**16**” is facing the White Background. To avoid possible damage to the White Background, place the cut-out centered over the light aperture of the glass plate.
9. Close the Guide Plate and make sure that both Release Handles are locked.
10. Press the **Down** key to move the Guide Plate down until it automatically stops against the adjustment guides.  

If the **Down** key is pressed after the Guide Plate has stopped, the MDA Board turns OFF and you need to power the scanner ON again.
11. Loosen two screws that secure the Top Position sensor.
12. Adjust the Top Position sensor so that the green Power LED just about turns ON.
13. Tighten the two screws that secure the Top Position sensor.
14. Open the Guide Plate.
15. Orientate the two adjustment guides for 15.5 mm spacing and insert the guides under the Guide Plate at both ends of the scan area.
16. Place the two adjustment guides so that the surface marked “**15.5**” is facing the White Background. To avoid possible damage to the White Background, place the cut-out centered over the light aperture of the glass plate.
17. Close the Guide Plate and make sure that both Release Handles are locked.
18. Press the **Down** key on the Scanner front panel to move the Guide Plate down until it automatically stops against the adjustment guides.
19. Check that the Power LED is OFF.

# Calibrate ATAC (Automatic Thickness Adjustment Control)

To run this test start the Service Tools and select: **30. Calibrate ATAC**.

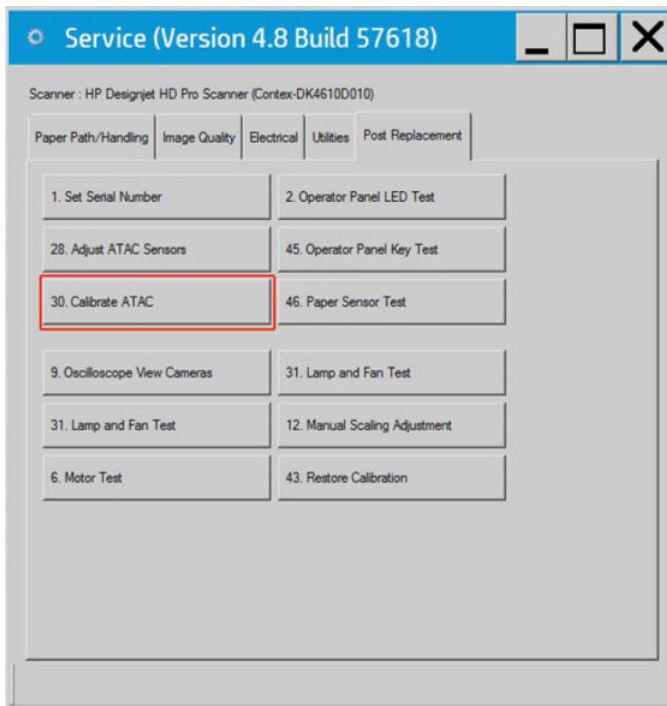

This test sets the current level at which the ATAC will stop if something is preventing it from moving. It is a safety measure designed to prevent fingers from being inadvertently pinched in the guide plate.

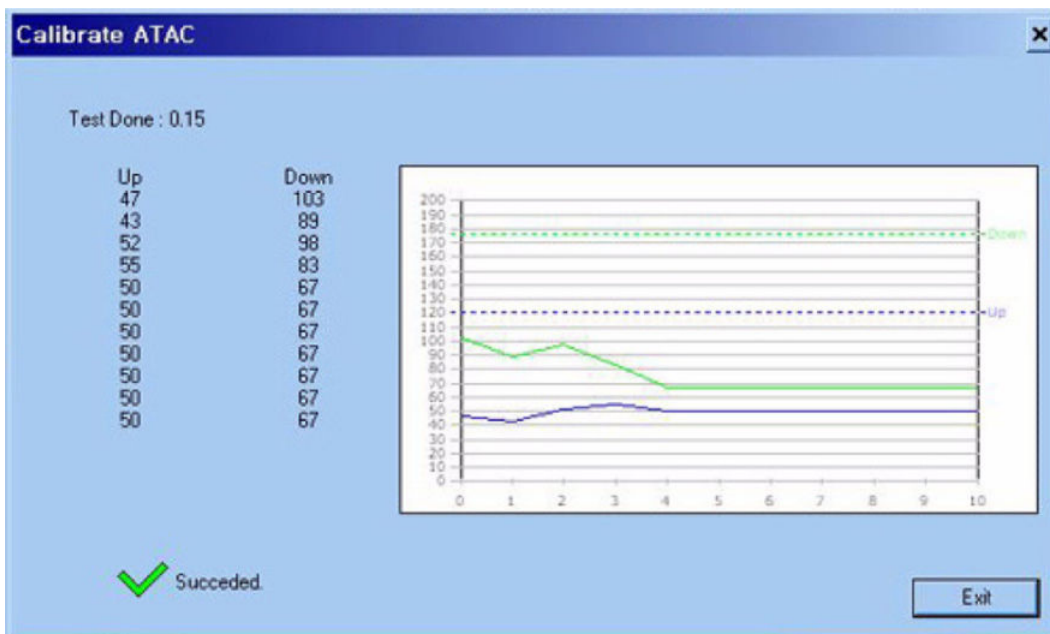

# Lamp and motor controller board Communication Test

To run this test start the Service Tools and select: **31. LMx Communication Test.**

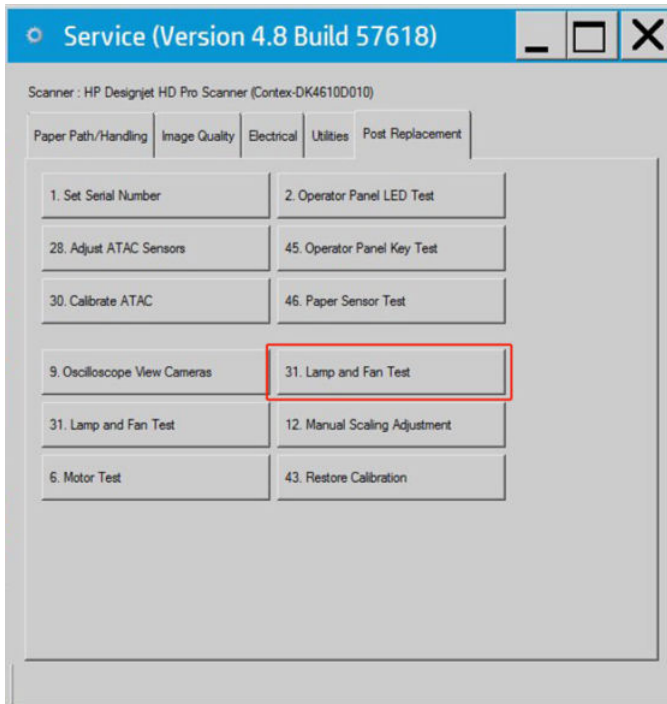

This tests the communication between the Lamp and motor controller board and the Scanner. When the test is run it will check the:

- Lamp
- The Light levels
- The two fans



# Upgrade Scanner Software

## Upgrade the HD Pro Scanner system software

1. Download a new system file from [hp.com/go/hdproscanner/support/software/](http://hp.com/go/hdproscanner/support/software/) and copy it to a USB flash drive. System software on the Web is divided into 5 packages to facilitate downloading.
  1. Download all 5 files—part 1 through part 5. Save all of them to the same folder on your computer.
  2. Extract part 1. Note that all of the parts will be extracted one after the other to the folder that you have chosen.
  3. After that, you will find the full System SW located in the previously selected folder. File size should be 4.46 GB and the extension “.sif.”
  4. Copy the System SW to a standard NTFS–formatted USB flash drive, and insert it in the USB jack of the Panel PC.
2. Insert the USB drive into the PPC USB port.
3. Select the **Update Software** option on the Panel PC (**Setup** menu > **System Options** > **Advanced** > **Update Software**) as shown below.

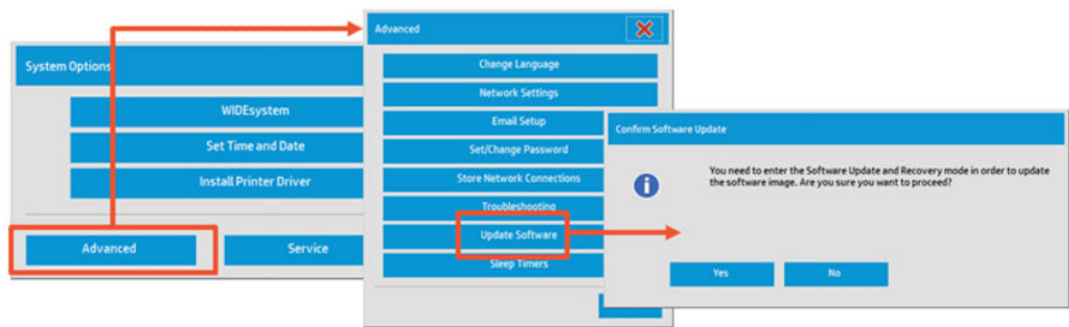

4. The system will ask permission to restart the scanner in System Upgrade mode. Follow the instructions on the screen.