



Dell 3130cn **Service Manual**

21 Aug 2009

**Information in this document is subject to change without notice.
2010 Dell Inc. All rights reserved.**

Reproduction in any manner whatsoever without the written permission of Dell Inc. is strictly forbidden.
Trademarks used in this text: Dell and the DELL logo are trademarks of Dell Inc.

Other trademarks and trade names may be used in this document to refer to the entities claiming the marks and names of their products. Dell Inc. disclaims any proprietary interest in trademarks and trade names other than its own.

		□.1 □□□ □□□□□□
□.1□	□□□□□□□2□□□	□.1□ □□□□□□ □□□□□ □□□□□□ 1□□P . □□□□□25-1□□□ □□□□□□ □□□ □□□□□□. (□□□□□□ □□ □□□□□□□□□ (□1□-3□□).)
□.2□	□□□□□□□12□2□□□	□.2□ □□□□□□ □□□□□ □□□□□□ 1□□P . □□□□□25□□P1.25□ □□□ □□□ □□□□1□-317 □□□ □1□-3□□ □□□ □□□□□□□□□ □□□□□31□□P1.31□ □□□ □□-□□□□□□□ □□□□□ □□□ □□□ □□□□□□.
□.3□	□□□□□□□21□2□□□	□.3□ □□□□□□ □□□□□ □□□□□□ 1□□P . □□□□□25□□P1.25□ □□□ □□□□□□□ □□□□□□□□□□ □□□ □□ □□ □□□□□□□ □ □□□ □□□ □□□□□□□ (□ □□□ □1□-317) □□□□□25-1□□□□ □□□ □□□□□□□ □□□□□□□□ □□ □□ □□ □□□□□□□ □ □□□ □□□□□□□ □□□□□□□ (□1□-3□□) □□□□□31□□P1.31□ □□□ □□□□□□□ □□□□□□□ □□□ □□ □□ □□□□□□□ □ □□□ □□□ □□□□□□□ (□1□-37□)

Cautions

Operation contents of this document may be subject to modification without notice.

Ö^||Á&È will not assume responsibility for accidental or incidental damages, or editorial errors or omissions in this manual, the issue of this manual, or the use of this manual.

This document is protected by copyright. Do not photocopy or duplicate any part of this document in any form without written permission from Ö^||Á&È

1. About this manual

This manual is a standard service manual of Q&E containing information and maintenance of this laser printer (standard specifications).

2. Marks giving caution

Maintenance operations requiring special cautions or additional information regarding descriptions in this manual are presented as "Warning," "Caution," or "Note," depending on their nature.



If instructions are not observed, death or serious injury may result.



If instructions are not observed, injuries to workers or physical damage to assets (including this laser printer) may result.

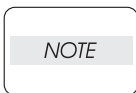

Essentials for procedures, steps, rules, and others.

Reference *Incidental information to descriptions.*

3. Related documents

- Instruction manuals (standard manuals)

Describe the operation and handling of this laser printer.

- Performance specifications

Describe in detail various specifications of this laser printer.

(In the event of a discrepancy between this manual and the performance specifications, the performance specifications take precedence.)

- Spare parts list

Information on maintenance parts (spare parts) for this laser printer.

4. Safety

To prevent possible accidents during maintenance operation, you should observe strictly the "Warning" and "Caution" information in this manual.

Avoid dangerous operations and operations out of the scope of this manual.

Various processes not covered by this manual may be required in actual operations, and should be performed carefully, always giving attention to safety.

4.1 Power source

Keep the power plug disconnected during the maintenance operation to prevent electric shock, burns and other damages.

If the power supply should be kept connected to measure voltage or for other similar reasons, take sufficient care to prevent electric shock, by following the procedures in this manual.



While the printer is on, never touch live parts if not required.



Power is supplied to the power switch / inlet even while the printer is off. Never touch its live components.



Do not touch live parts unless otherwise specified.

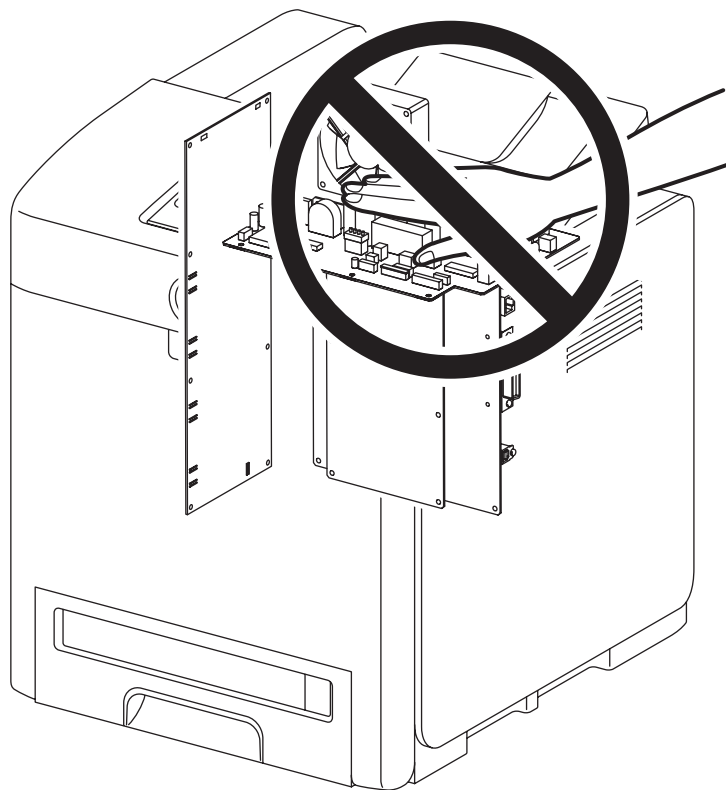

Zna00002KA

4.2 Driving units

When servicing gears or other driving units, be sure to turn off the power switch and unplug the power cord. Drive them manually when required.



Do not do the print work removing the cover of the printer to confirm the operation of driving part.

4.3 High-temperature units

When servicing high-temperature units (securing unit, etc.), be sure to turn them off to prevent burns, injuries and other troubles. Remove the power plug and start service processes after they have cooled down sufficiently.



Because high-temperature units are still hot after they complete an operation, wait at least 40 minutes before starting maintenance service.

4.4 Laser beams



- *If your eyes are exposed to laser beams, you may lose your eyesight.*
- *Never open the cover if the warning label for laser beams is attached there.*
- *Before disassembling and reassembling this laser printer, be sure to turn it OFF.*
- *When servicing this laser printer while it is running, be sure to follow the procedures specified in this manual.*
- *You should be well aware that the laser beams are capable of injuring you and other people near the printer.*

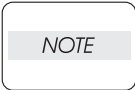

Laser beams have features as follows:

- Frequencies are smaller in width than other beams (sun and electric bulbs) and phases are uniform so that high monochromatic and convergence performance can be obtained and thin beams of light can reach places at a long distance.
- Being highly converged, the laser beams exert a heating action that may be harmful to human body.

Reference: *The laser beams of this laser printer are invisible rays.*

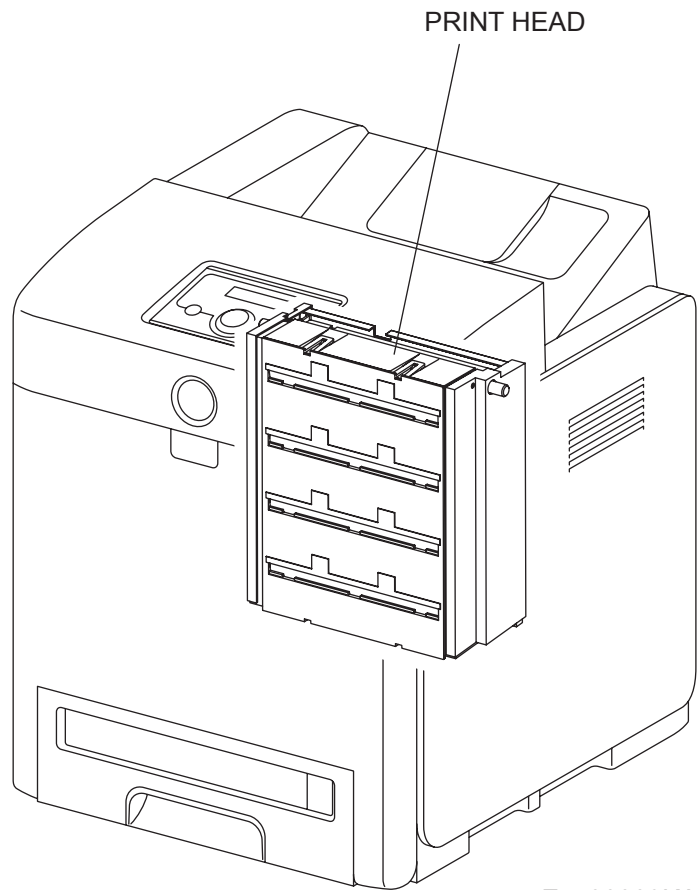

4.5 Warning/caution labels

Warning labels and caution labels are attached to this laser printer to prevent accidents. Check those labels for their peeling or stains when servicing the printer.

4.5.1 Caution label for high-temperature units

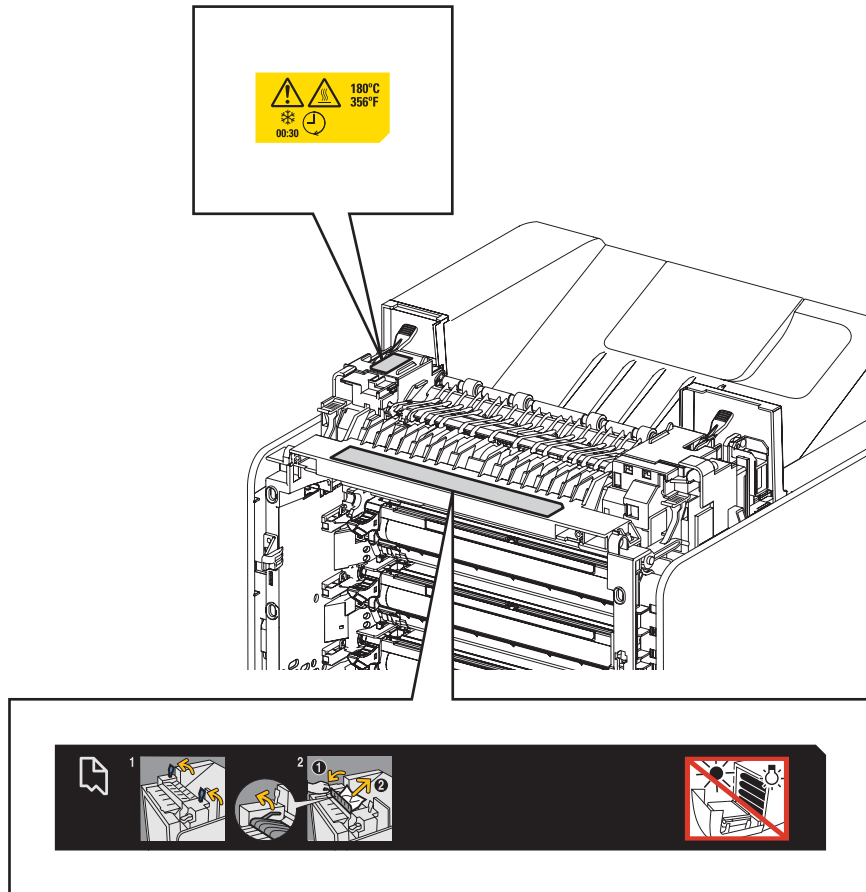

Zna00004KB

4.5.2 Caution label for toner cartridges

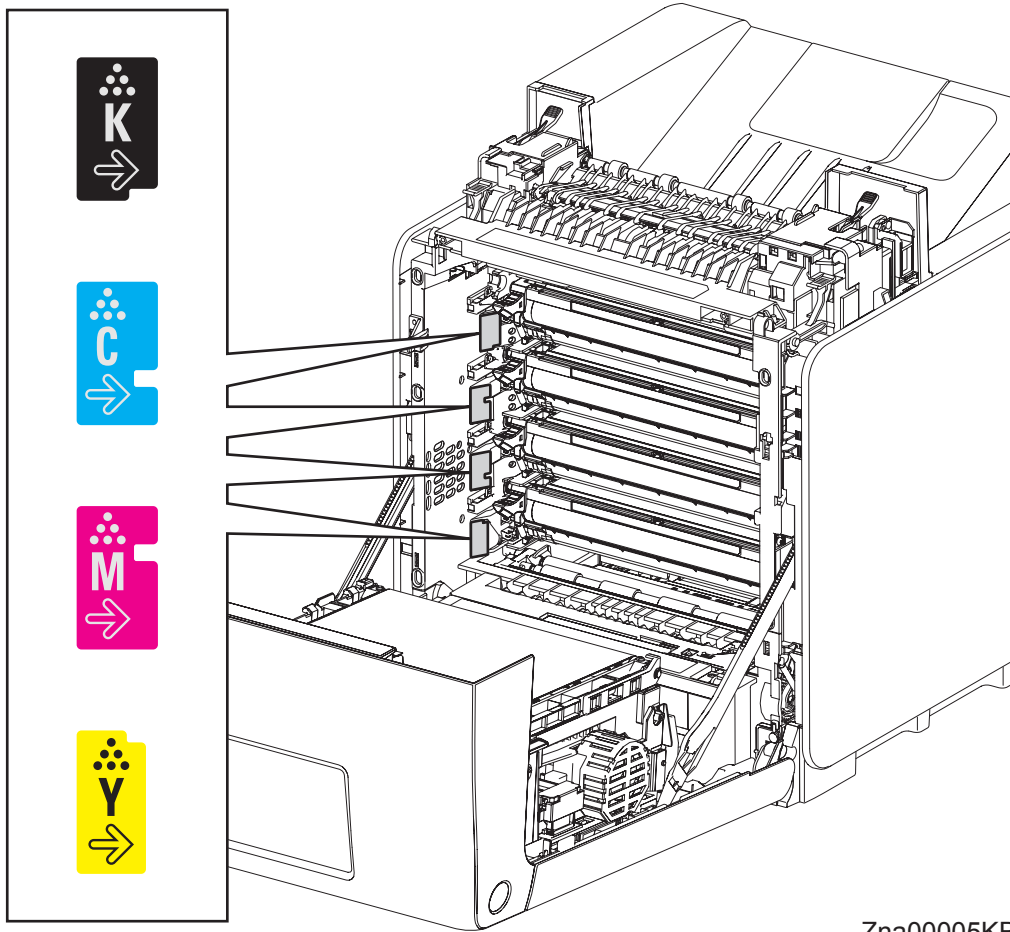

Zna00005KB

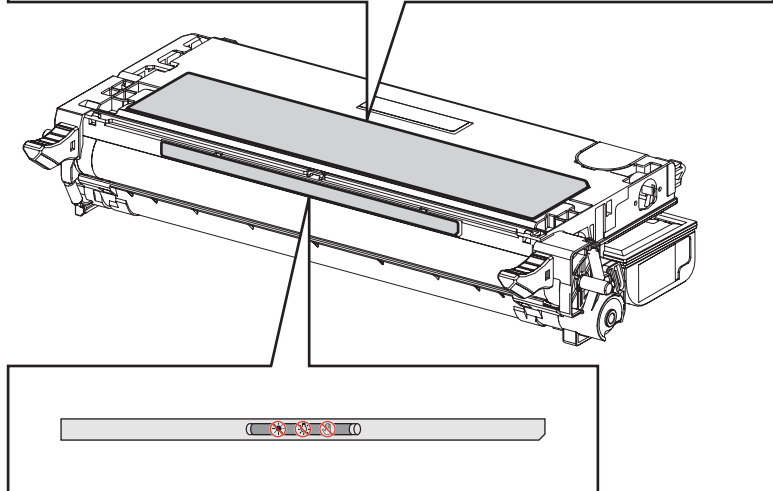
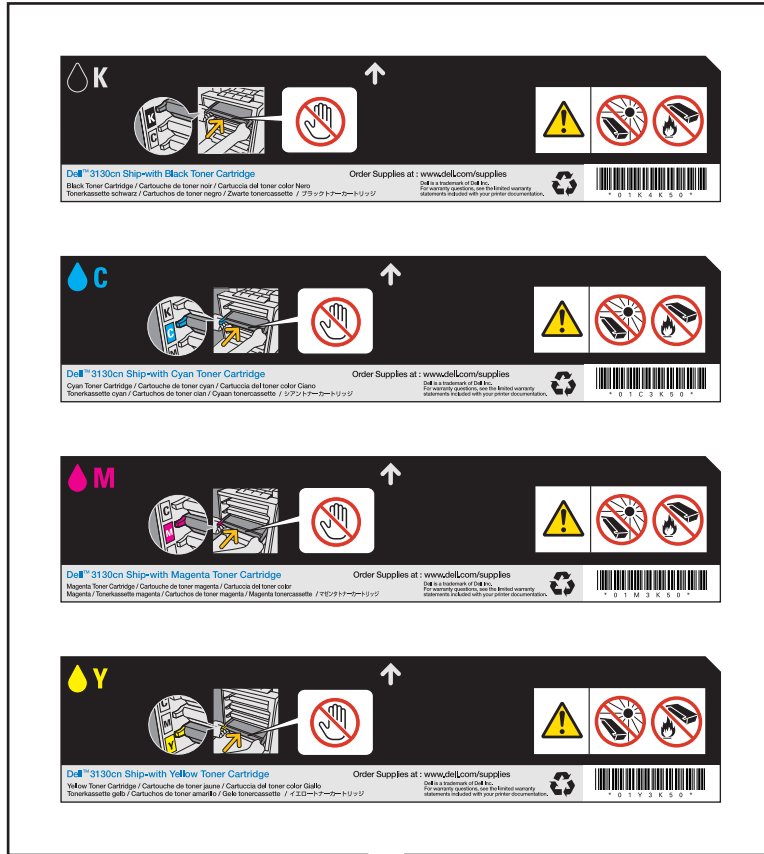

Zna00006KB

4.5.3 Caution label for MPF

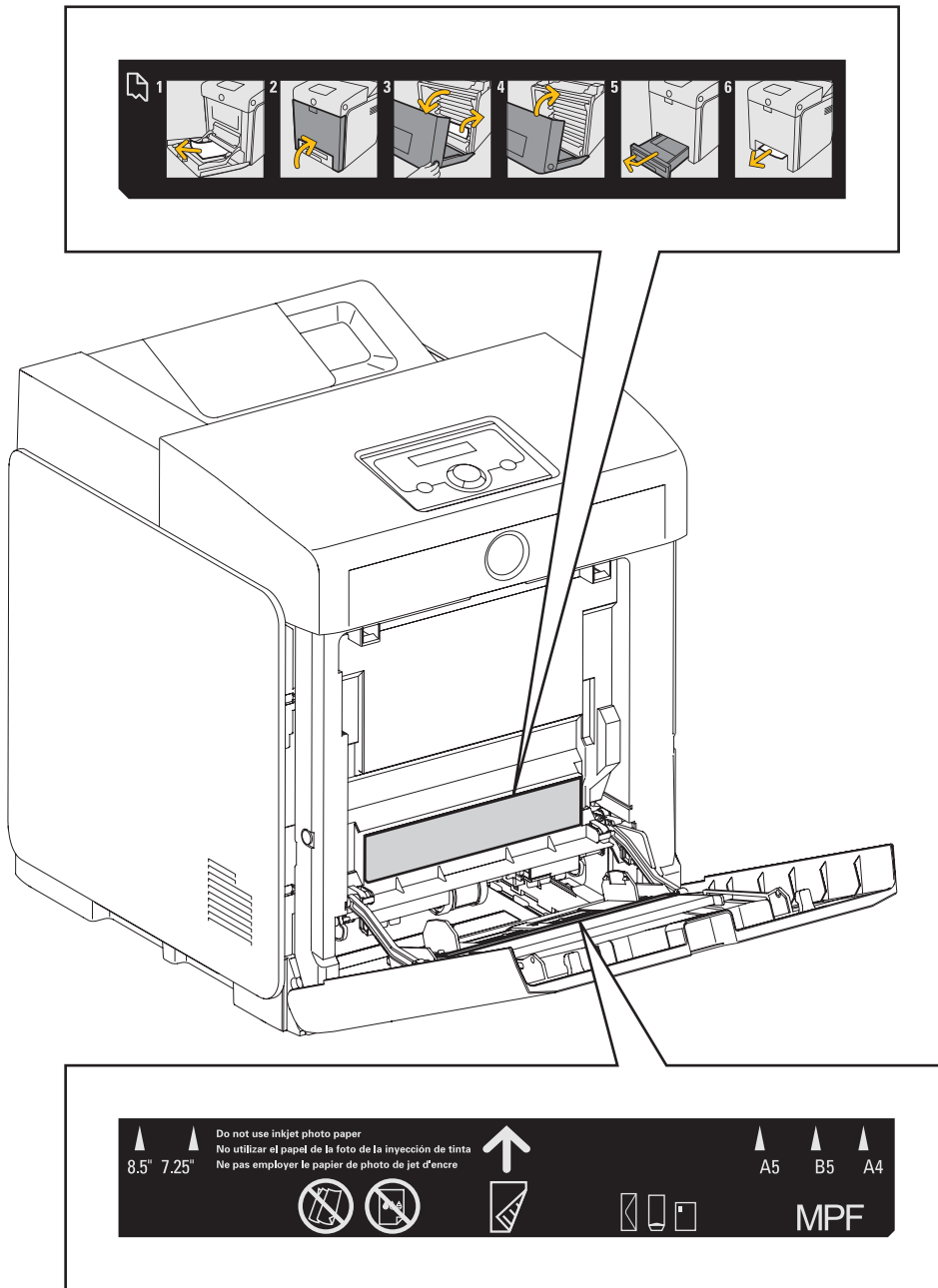

Zna00008KB

4.5.4 Caution label for print head

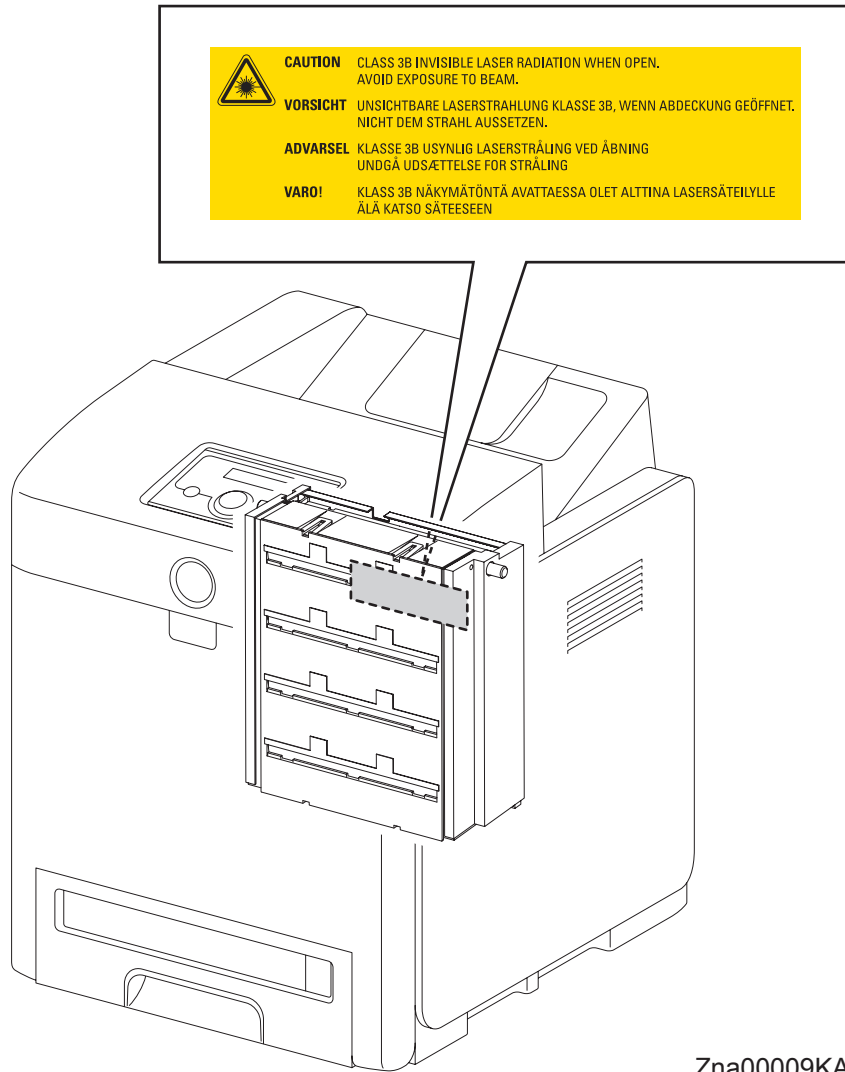

4.5.5 Caution label for transfer belt

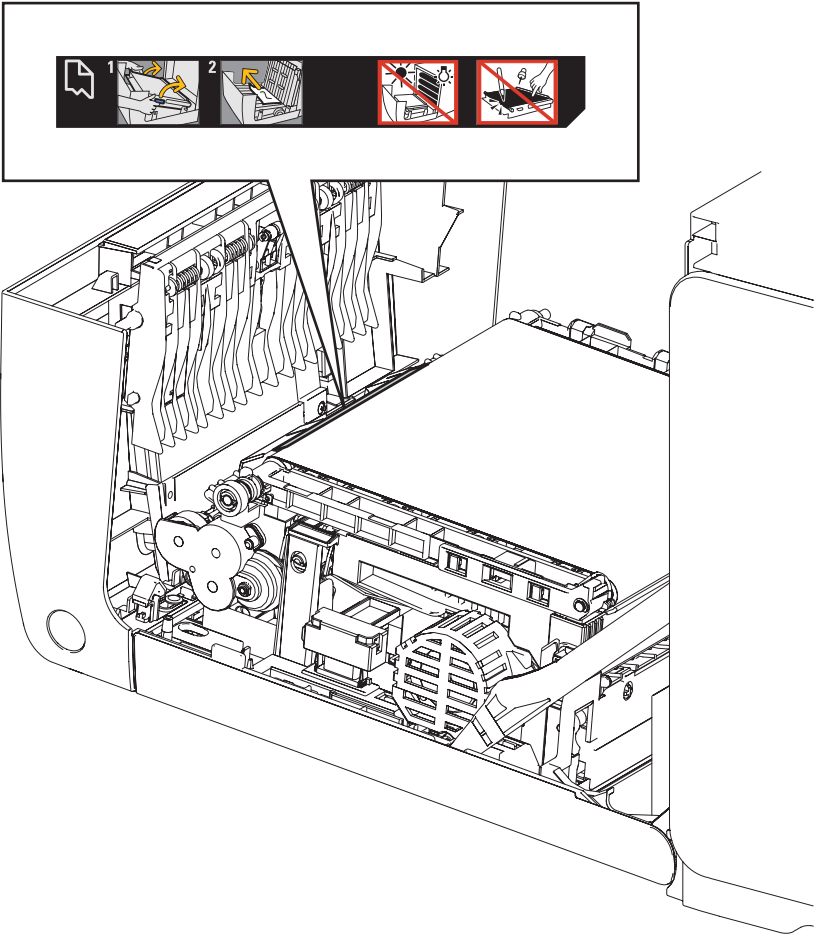

Zna00007KA

4.5.6 Caution label for duplex

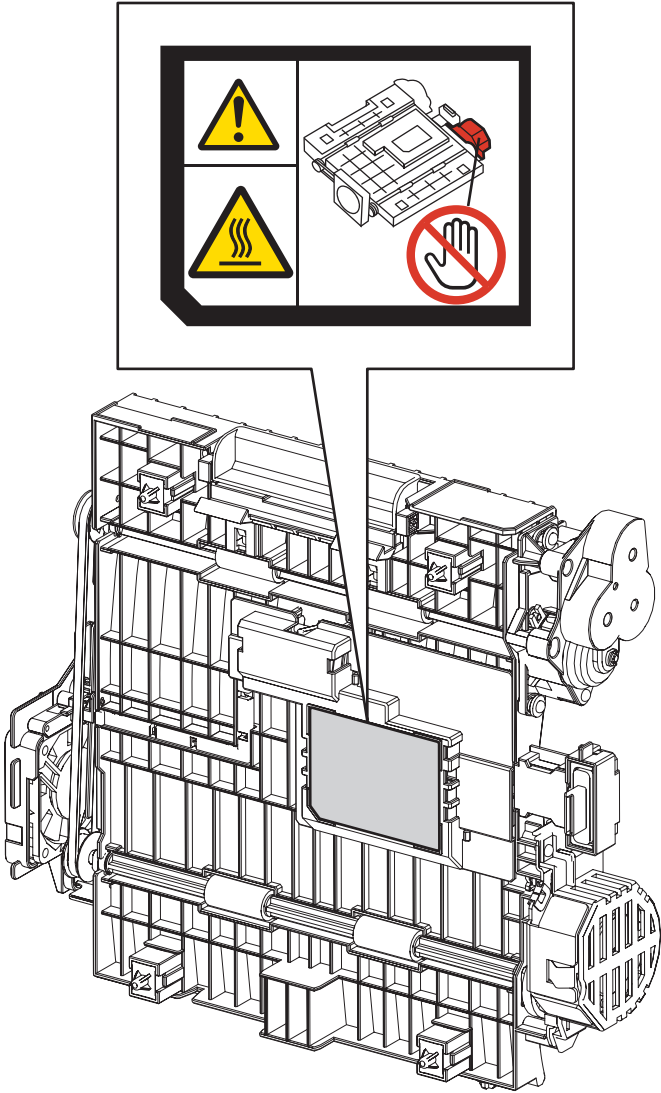

Zna00011KA

Unpacking the Printer



The printer must be carried horizontally with two or more persons.



Take extreme care to avoid personal injuries.

Check visually the printer for evidence of any damages.

Peel all tapes off the printer.

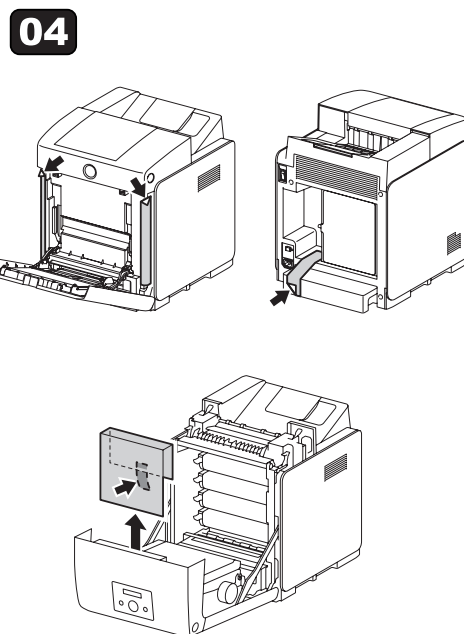
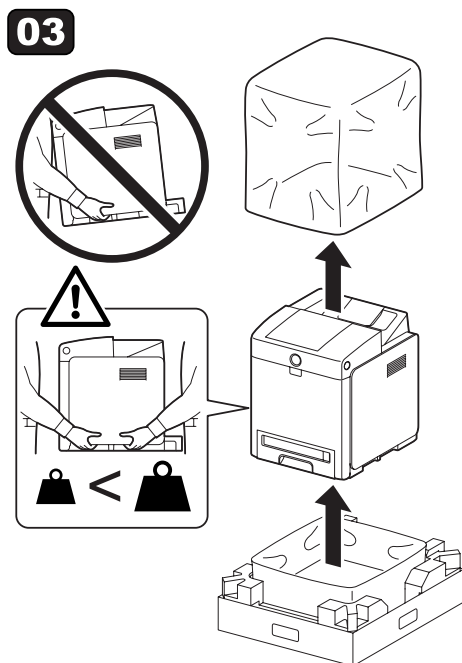
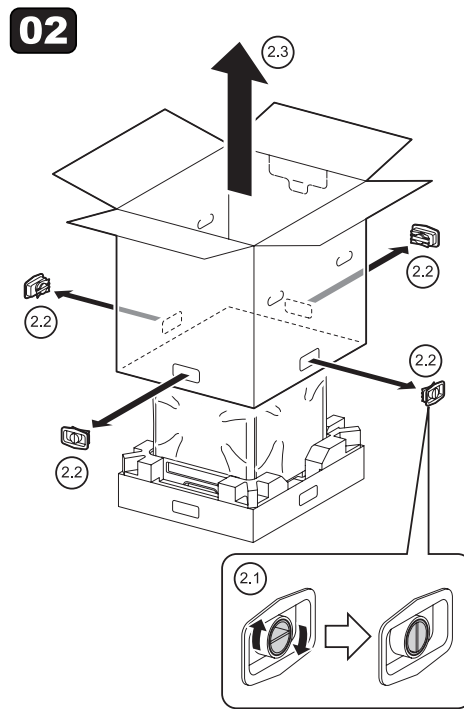
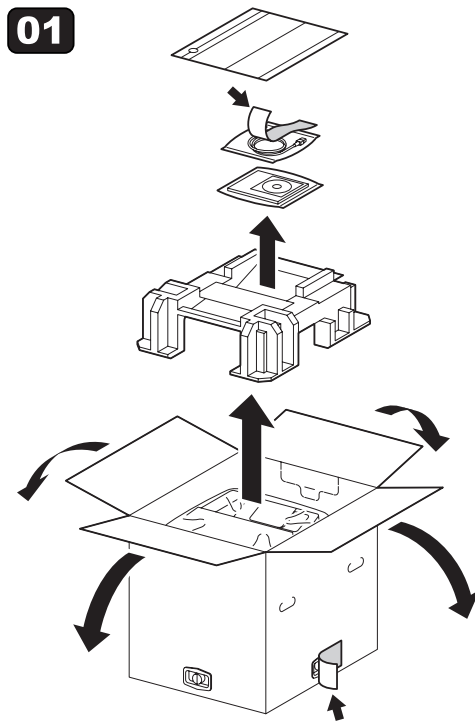

Zna00012KB

Blank Page

TABLE OF CONTENTS

1. About this manual.....	ii
2. Marks giving caution.....	ii
3. Related documents.....	ii
4. Safety	iii
4.1 Power source	iii
4.2 Driving units	iv
4.3 High-temperature units	iv
4.4 Laser beams	v
4.5 Warning/caution labels.....	vi
4.5.1 Caution label for high-temperature units.....	vi
4.5.2 Caution label for toner cartridges.....	vii
4.5.3 Caution label for MPF	ix
4.5.4 Caution label for print head.....	x
4.5.5 Caution label for transfer belt.....	xi
4.5.6 Caution label for duplex	xii
Unpacking the Printer.....	xiii
Chapter 1 Troubleshooting.....	1 - 1
Chapter 2 Operation of Diagnostic	2 - 1
Chapter 3 Removal and Replacement Procedures	3 - 1
Chapter 4 Plug/Jack(P/J) Connector Locations.....	4 - 1
Chapter 5 Parts List.....	5 - 1
Chapter 6 Principles of Operation	6 - 1
Chapter 7 Wiring Diagrams and Signal Information	7 - 1
Chapter 8 Printer Specifications	8 - 1

Chapter 1 Troubleshooting CONTENTS

1. Troubleshooting Overview	1 - 1
1.1 Flow of Troubleshooting.....	1 - 1
1.2 Check Installation Status	1 - 2
1.3 Cautions on Service Operations	1 - 3
1.4 Cautions on Using FIP	1 - 4
1.5 Items To Be Confirmed Before Going To FIP Troubleshooting	1 - 6
2. FIP	1 - 12
2.1 FIP	1 - 12
2.2 Flow of FIP	1 - 12
2.3 Status Code List.....	1 - 13
3. Error Code FIP	1 - 36
3.1 Troubleshooting for the call center.....	1 - 36
Flows 1 001-360-01 Restart Printer	1 - 36
Flows 2 001-360-02 Restart Printer	1 - 37
Flows 3 003-340-01/003-340-02/003-340-03/003-340-04/003-340-05/003-340-07/003-340-08/ 003-340-0A/003-340-0B/003-340-14 Restart Printer	1 - 38
Flows 4 003-340-09 Restart Printer	1 - 39
Flows 5 003-356 Restart Printer	1 - 40
Flows 6 004-310 Restart Printer	1 - 41
Flows 7 004-311 Restart Printer	1 - 42
Flows 8 006-370 Restart Printer	1 - 43
Flows 9 007-340-00 Restart Printer	1 - 44
Flows 10 007-340-01 Restart Printer	1 - 45
Flows 12 007-340-03 Restart Printer	1 - 46
Flows 13 007-340-04 Restart Printer	1 - 47
Flows 14 007-371 Restart Printer	1 - 48
Flows 15 009-360 Restart Printer	1 - 49
Flows 16 009-361 Restart Printer	1 - 50
Flows 17 009-362 Restart Printer	1 - 51
Flows 18 009-363 Restart Printer	1 - 52
Flows 19 009-654-01 Restart Printer	1 - 53
Flows 20 009-654-02 Restart Printer	1 - 55
Flows 21 010-317 Restart Printer	1 - 57
Flows 22 010-351 Restart Printer	1 - 58
Flows 23 010-354 Restart Printer	1 - 59
Flows 24 010-377 Restart Printer	1 - 60
Flows 25 016-300/016-301/016-302/016-310/016-313/016-315/016-317/016-323/016-327/016-344/ 016-345/016-346/016-347 Restart / Erase Flash Err. 016-392 / Write Flash Err. 016-393 / Verify Error 016-394.....	1 - 61
Flows 25-1 016-340 Restart Printer	1 - 62
Flows 26 016-312/016-361 Restart Printer	1 - 64
Flows 27 016-316/016-318 Restart Printer	1 - 65
Flows 28 016-338 Restart Printer	1 - 66
Flows 29 016-350 Restart Printer	1 - 67
Flows 30 016-365 Restart Printer	1 - 68
Flows 31 016-370 Restart Printer	1 - 69
Flows 32 093-964 Restart Printer	1 - 71
Flows 33 Paper Jam 071-100	1 - 72
Flows 34 Paper Jam 072-100	1 - 74
Flows 35 Paper Jam 075-100	1 - 77
Flows 36 Paper Jam 077-100/077-101	1 - 79
Flows 37 Paper Jam 077-102/077-103	1 - 80
Flows 38 Paper Jam 077-104/077-107	1 - 81

Chapter 1 Troubleshooting CONTENTS

Flows 39 Paper Jam 077-105/077-106	1 - 83
Flows 40 Paper Jam 077-900/077-901	1 - 85
Flows 41 Paper Jam 077-903	1 - 89
Flows 42 Paper Jam 077-907	1 - 90
Flows 43 Load Tray N or MPF 024-910/024-911/024-914	1 - 93
Flows 44 Load Tray N or MPF 024-965/024-966/024-969	1 - 95
Flows 45 CRUM ID 009-367/009-368/009-369/009-370	1 - 98
Flows 46 Error Y Cart 093-919	1 - 99
Flows 47 Error M Cart 093-920	1 - 100
Flows 48 Error C Cart 093-921	1 - 101
Flows 49 Error K Cart 093-922	1 - 102
Flows 50 093-950 Yellow Toner / 093-951 Magenta Toner / 093-952 Cyan Toner / 093-953 Black Toner	1 - 103
Flows 51 Replace Cart 093-930/093-931/093-932/093-933	1 - 104
Flows 52 Ready to Print 093-423/093-424/093-425/093-426	1 - 105
Flows 53 Insert Print Cart 093-970	1 - 106
Flows 54 Insert Print Cart 093-971	1 - 107
Flows 55 Insert Print Cart 093-972	1 - 108
Flows 56 Insert Print Cart 093-973	1 - 109
Flows 57 CRUM ID 009-371	1 - 110
Flows 58 Ready to Print 094-422	1 - 111
Flows 59 Insert Belt Unit 094-910	1 - 112
Flows 60 Belt Unit 094-911	1 - 113
Flows 61 010-359 Restart Printer	1 - 114
Flows 62 Ready to Print 010-421	1 - 115
Flows 63 Tray Detached 024-946/007-912	1 - 116
Flows 64 Load Tray 024-947	1 - 117
Flows 65 Close Front Cover 077-300	1 - 118
Flows 66 Invalid ID 016-383 / Range Chk Error 016-384 / Header Error 016-385 / Check Sum Error 016-386 / Format Error 016-387	1 - 119
Flows 67 Out of Memory 016-700	1 - 120
Flows 68 Disc Full 016-980	1 - 121
Flows 69 Collate Full 016-981	1 - 122
Flows 70 016-720 PDL Error	1 - 124
Flows 71 Invalid User 016-757	1 - 125
Flows 72 Disabled Func 016-758	1 - 126
Flows 73 Reached Limits 016-759	1 - 127
Flows 74 Invalid Job 016-799	1 - 128
Flows 75 Ready to Print 193-700	1 - 129
Flows 76 Over Heat 042-700 / Ready to Print 142-700	1 - 130
Flows 77 Electrical Noise	1 - 131
Flows 78 Faint print (Low contrast)	1 - 132
Flows 79 Blank print (No print)	1 - 134
Flows 80 Solid black	1 - 135
Flows 81 Vertical blank lines (White stripes in paper transport direction)	1 - 136
Flows 82 Horizontal band cross out (White stripes in the horizontal direction)	1 - 138
Flows 83 Vertical stripes	1 - 140
Flows 84 Horizontal stripes	1 - 142
Flows 85 Partial Deletion	1 - 144
Flows 86 Spots	1 - 147
Flows 87 Afterimage (Ghost)	1 - 149
Flows 88 Grey Background	1 - 151
Flows 89 Skew	1 - 153
Flows 90 Paper damage	1 - 156
Flows 91 Unfusing	1 - 160
Flows 92 Color Registration (Color Shift)	1 - 161
Flows 93 Noise: When Power is Turned On	1 - 165

Chapter 1 Troubleshooting CONTENTS

Flows 94 Noise: During Standby.....	1 - 167
Flows 95 Noise: During Printing.....	1 - 168
Flows 96 AC.....	1 - 172
Flows 97 DC.....	1 - 173
Flows 98 Multiple feed.....	1 - 174
Flows 99 Control Panel Freezes.....	1 - 175
3.2 Troubleshooting for the repair center.....	1 - 177
FIP1.1 001-360-01 Restart Printer.....	1 - 177
FIP1.2 001-360-02 Restart Printer.....	1 - 178
FIP1.3 003-340-01/003-340-02/003-340-03/003-340-04/003-340-05/003-340-07/003-340-08/003-340-0A/ 003-340-0B/003-340-0C/003-340-0D/003-340-0E/003-340-0F/003-340-10/003-340-11/ 003-340-12/003-340-13/003-340-14 Restart Printer.....	1 - 179
FIP1.4 003-340-09 Restart Printer.....	1 - 180
FIP1.5 003-356 Restart Printer.....	1 - 181
FIP1.6 004-310 Restart Printer.....	1 - 182
FIP1.7 004-311 Restart Printer.....	1 - 183
FIP1.8 006-370 Restart Printer.....	1 - 184
FIP1.9 007-340-00 Restart Printer.....	1 - 185
FIP1.10 007-340-01 Restart Printer.....	1 - 187
FIP1.12 007-340-03 Restart Printer.....	1 - 188
FIP1.13 007-340-04 Restart Printer.....	1 - 189
FIP1.14 007-371 Restart Printer.....	1 - 191
FIP1.15 009-360 Restart Printer.....	1 - 193
FIP1.16 009-361 Restart Printer.....	1 - 194
FIP1.17 009-362 Restart Printer.....	1 - 195
FIP1.18 009-363 Restart Printer.....	1 - 196
FIP1.19 009-654-01 Restart Printer.....	1 - 197
FIP1.20 009-654-02 Restart Printer.....	1 - 199
FIP1.21 010-317 Restart Printer.....	1 - 201
FIP1.22 010-351 Restart Printer.....	1 - 202
FIP1.23 010-354 Restart Printer.....	1 - 203
FIP1.24 010-377 Restart Printer.....	1 - 204
FIP1.25 016-300/016-301/016-302/016-310/016-313/016-315/016-317/016-323/016-327/016-340/ 016-344/016-345/016-346/016-347 Restart / Erase Flash Err. 016-392 / Write Flash Err. 016-393 / Verify Error 016-394.....	1 - 205
FIP1.26 016-312/016-361 Restart Printer.....	1 - 206
FIP1.27 016-316/016-318 Restart Printer.....	1 - 207
FIP1.28 016-338 Restart Printer.....	1 - 208
FIP1.29 016-350 Restart Printer.....	1 - 209
FIP1.30 016-365 Restart Printer.....	1 - 210
FIP1.31 016-370 Restart Printer.....	1 - 211
FIP1.32 093-964 Restart Printer.....	1 - 212
FIP1.33 Paper Jam 071-100.....	1 - 213
FIP1.34 Paper Jam 072-100.....	1 - 215
FIP1.35 Paper Jam 075-100.....	1 - 219
FIP1.36 Paper Jam 077-100/077-101.....	1 - 222
FIP1.37 Paper Jam 077-102/077-103.....	1 - 223

Chapter 1 Troubleshooting CONTENTS

FIP1.38 Paper Jam 077-104/077-107.....	1 - 224
FIP1.39 Paper Jam 077-105/077-106.....	1 - 228
FIP1.40 Paper Jam 077-900/077-901.....	1 - 231
FIP1.41 Paper Jam 077-903.....	1 - 235
FIP1.42 Paper Jam 077-907.....	1 - 236
FIP1.43 Load Tray N or MPF 024-910/024-911/024-914.....	1 - 239
FIP1.44 Load Tray N or MPF 024-965/024-966/024-969.....	1 - 241
FIP1.45 CRUM ID 009-367/009-368/009-369/009-370.....	1 - 245
FIP1.46 Error Y Cart 093-919.....	1 - 246
FIP1.47 Error M Cart 093-920.....	1 - 247
FIP1.48 Error C Cart 093-921.....	1 - 248
FIP1.49 Error K Cart 093-922.....	1 - 249
FIP1.50 093-950 Yellow Toner/093-951 Magenta Toner/093-952 Cyan Toner/093-953 Black Toner	1 - 250
FIP1.51 Replace Cart 093-930/093-931/093-932/093-933.....	1 - 251
FIP1.52 Ready to Print 093-423/093-424/093-425/093-426.....	1 - 252
FIP1.53 Insert Print Cart 093-970.....	1 - 253
FIP1.54 Insert Print Cart 093-971.....	1 - 254
FIP1.55 Insert Print Cart 093-972.....	1 - 255
FIP1.56 Insert Print Cart 093-973.....	1 - 256
FIP1.57 CRUM ID 009-371.....	1 - 257
FIP1.58 Ready to Print 094-422.....	1 - 258
FIP1.59 Insert Belt Unit 094-910.....	1 - 259
FIP1.60 Belt Unit 094-911.....	1 - 260
FIP1.61 010-359 Restart Printer.....	1 - 261
FIP1.62 Ready to Print 010-421.....	1 - 262
FIP1.63 Tray Detached 024-946/007-912.....	1 - 263
FIP1.64 Load Tray 024-947.....	1 - 264
FIP1.65 Close Front Cover 077-300.....	1 - 265
FIP1.66 Invalid ID 016-383 / Range Chk Error 016-384 / Header Error 016-385 / Check Sum Error 016-386 / Format Error 016-387.....	1 - 266
FIP1.67 Out of Memory 016-700 / Disc Full 016-980 / Collate Full 016-981.....	1 - 267
FIP1.68 016-720 PDL Error.....	1 - 268
FIP1.69 Invalid User 016-757 / Disabled Func 016-758 / Reached Limits 016-759.....	1 - 269
FIP1.70 Invalid Job 016-799.....	1 - 270
FIP1.71 Ready to Print 193-700.....	1 - 271
FIP1.72 Over Heat 042-700/Ready to Print 142-700.....	1 - 272
FIP1.73 Electrical Noise.....	1 - 273
4. Image Quality Trouble.....	1 - 274
4.1 Entry Chart for Image Quality Troubleshooting.....	1 - 274
4.2 Diagnosis Test Chart.....	1 - 278
4.3 Items to be Confirmed Before Image Quality Troubleshooting.....	1 - 283
4.4 Print Image Quality Specification.....	1 - 285
4.5 Image Quality FIP.....	1 - 288
FIP-1.P1 Faint print (Low contrast).....	1 - 2□□
FIP-1.P2 Blank print (No print).....	1 - 2□□

Chapter 1 Troubleshooting CONTENTS

FIP-1.P3 Solid black	1 - 2□2
FIP-1.P4 Vertical blank lines (White stripes in paper transport direction)	1 - 2□□
FIP-1.P5 Horizontal band cross out (White stripes in the horizontal direction)	1 - 2□□
FIP-1.P6 Vertical stripes.....	1 - 2□□
FIP-1.P7 Horizontal stripes.....	1 - 3□□
FIP-1.P8 Partial Deletion.....	1 - 3□2
FIP-1.P9 Spots.....	1 - 3□□
FIP-1.P10 Afterimage (Ghost).....	1 - 3□□
FIP-1.P11 Grey Background	1 - 3□□
FIP-1.P12 Skew	1 - 3□□
FIP-1.P13 Paper damage.....	1 - 311
FIP-1.P14 Unfusing.....	1 - 313
FIP-1.P15 Color Registration (Color Shift).....	1 - 31□
5. Abnormal Noise Trouble.....	1 - 317
5.1 Entry Chart for Abnormal Noise Troubleshooting	1 - 317
5.2 Operation Mode Table	1 - 318
FIP-1.N1 When Power is Turned On.....	1 - 31□
FIP-1.N2 During Standby.....	1 - 32□
FIP-1.N3 During Printing.....	1 - 321
6. Other FIP	1 - 323
FIP-AC.....	1 - 323
FIP-DC.....	1 - 32□
FIP-Multiple fee□.....	1 - 325
FIP-Control Panel Freezes.....	1 - 32□

Chapter 1 Troubleshooting CONTENTS

Blank Page

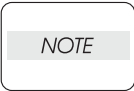

The troubleshooting procedures described herein assume the use of the Diag Tool. However, the procedures can be performed without the Diag Tool as long as they are carefully followed.

1. Troubleshooting Overview

To increase the efficiency of troubleshooting, ensure that preliminary checks should be made to confirm the trouble status before proceeding to the Fault Isolation Procedure (FIP), Operation of Diagnostic (Chapter 2), Wiring Diagrams (Chapter 7), and Principles of Operation (Chapter 6).

1.1 Flow of Troubleshooting

Flow of the troubleshooting is as follows:

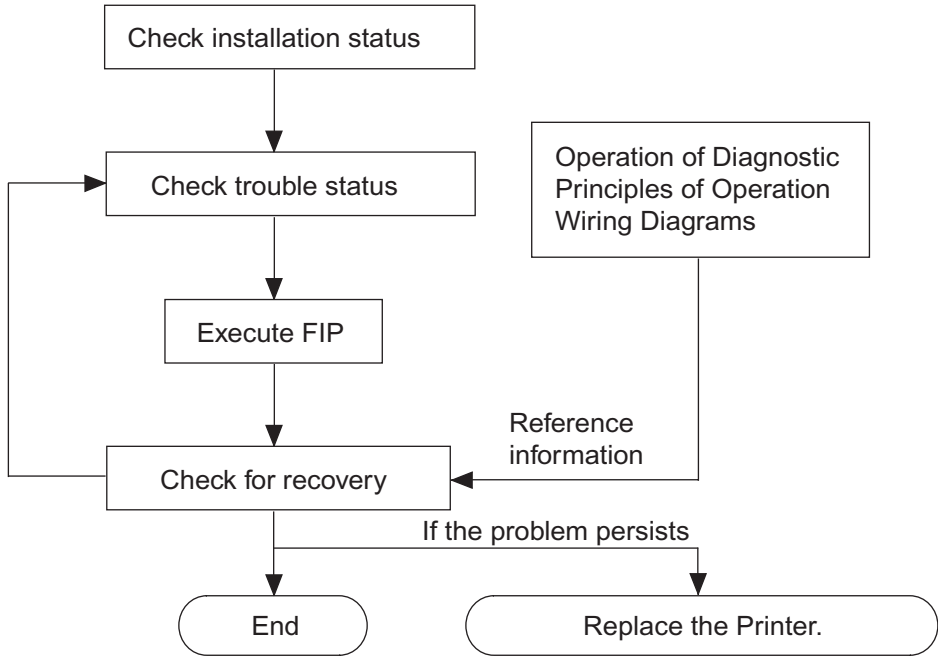

1.2 Check Installation Status

Be sure to check the following items before starting the troubleshooting procedures

- 1) The power supply voltage is within the specifications (measure the voltage at the wall outlet).
- 2) The power cord is free from breakage, short-circuit, open wire, or internal miswiring.
- 3) The printer is properly grounded.
- 4) The printer is not installed at a place subjected to high/low temperature, humidity, and sudden temperature changes.
- 5) The printer is not installed at or near water facilities, humidifier, heating appliance, fire, dust, or in airflow from air conditioner.
- 6) The printer is not installed in a place subjected to volatile or inflammable gas.
- 7) The printer is not installed under direct sunlight.
- 8) The printer is installed in a well-ventilated place.
- 9) The printer is installed on a firm and stable surface.
- 10) The paper meets the specifications (standard paper is recommended).
- 11) The printer is handled properly.
- 12) The high frequency service items are replaced at the recommended print count intervals.

1.3 Cautions on Service Operations

- 1) Be sure to remove the power cord unless otherwise required.



While the printer is powered ON, never touch the conductive parts unless otherwise required.

Never touch the conductive parts of the power switch and inlet of the LVPS, because they are live even while the printer is powered off.

- 2) When checking some parts with covers removed and with the interlock, safety, and power switches ON, remove the connector (P/J151) on the ROS ASSY unless otherwise required.



When checking some parts with covers removed and with the interlock, safety, and switches ON, laser beams may be irradiated from the ROS ASSY. For your safety, be sure to remove the connector (P/J151) unless otherwise required.

- 3) When checking some parts with the Front Cover removed and the printer powered ON, be sure to remove the connector (P/J16) on the PWBA MCU unless otherwise required.



When checking some parts with the Front Cover removed and the printer powered ON, be sure to remove the connector (P/J16) on the MCU. Otherwise, a high voltage may be output from the HVPS.

When connecting the connector (P/J16) on the MCU according to the instructions in the FIP, never touch the HVPS and high voltage parts.

- 4) When outputting a high voltage using the Diag Tool, etc., keep all the covers on unless otherwise required.



When outputting a high voltage using the Diag Tool, etc., ensure that:

- The high voltage carrying parts must never be touched.***
- The instructions in this manual must be followed.***

- 5) When operating the drive unit using the Diag Tool, etc., keep all the covers on unless otherwise required.



When operating the drive unit using the Diag Tool, etc., ensure that:

- The drive unit must never be touched.***
- The instructions in this manual must be followed.***

- 6) When touching hot parts, be careful not to get burnt.

- 7) While working, be sure to wear a wrist band or the like to dissipate static charges from your body.

1.4 Cautions on Using FIP

- 1) When troubleshooting according to the FIP, have on hand a normal MCU, LVPS, HVPS, FUSER ASSY, BELT ASSY, etc., for possible fault isolation.
- 2) In the initial check according to the FIP, check only items which can be simply checked.
- 3) In the initial check according to the FIP, check the constitutive parts of the major check parts and related parts, as well as major check parts.
- 4) When working with the printer, be sure to remove the power cord unless otherwise required. Never touch live parts if not required, while the power cord is connected.
- 5) Connector condition is denoted as follows:
 - [P/J12] → Connector (P/J12) is connected.
 - [P12] → Plug side with the connector (P/J12) removed (except when attached directly to the board).
 - [J12] → Jack side with the connector (P/J12) removed (except when attached directly to the board).
- 6) [P/J1-2PIN <=> P/J3-4PIN] in the FIP means measurement with the positive side of the measuring instrument connected to [2PIN] of [P/J1] and the negative side to [4PIN] of [P/J3].
- 7) [P/J1<=> P/J2] in the FIP means measurement for all terminals corresponding between [P/J1] and [P/J2] based on "Wiring Diagrams".
- 8) In [P/J1-2PIN <=> P/J3-4PIN] in the FIP where voltage is measured, [P/J3-4PIN] on the rear negative side is always at the AG (analog ground), SG (signal ground), or RTN (return). Therefore, after checking of proper conductivity between AGs, SGs, or RTNs respectively, the rear negative side can be connected to the PIN of AG, SG or RTN instead of [P/J3-4PIN]. However, care should be taken not to confuse [AG], [SG], and [RTN] because they are not on the same level.
- 9) When measuring the voltage at small connectors, use the dedicated tool. Handle the tool with care because its business end is pointed.
- 10) When measuring the voltage, set the BELT ASSY, print cartridge and paper cassette, close the COVERs and power ON unless otherwise required.
- 11) Numerical values in the FIP are only for guideline. Approximate values are acceptable.
- 12) In each step of the FIP, parts removal and other procedures implicitly required for the step are omitted.
- 13) In the FIP, "Replacement" means the replacement of the parts that are considered to be the cause of the trouble. Replacement of those parts means the replacement of the assembly part (HIGH ASSY) that contain them.

- 14) In the FIP, the paper cassette immediately below the printer main body is called "Tray 1", and the cassette below it is called "Tray 2".
- 15) Some of the instructions in the FIP are branched off depending on the specifications. Follow the applicable instruction.
- 16) For some optional components, you may have to refer to the manual of the relevant component for troubleshooting. Have the relevant manual at hand as needed.

1.5 Items To Be Confirmed Before Going To FIP Troubleshooting

Basic Printer Problems

Some printer problems can be easy to resolve. If a problem occurs with your printer, check each the following:

- 1) If a message is displayed on the LCD of operator panel, see "2.3 Status Code List".
- 2) The printer power cable is plugged into the printer and a properly grounded electrical outlet.
- 3) The printer power is powered ON.
- 4) The electrical outlet is not turned off by any switch or breaker.
- 5) Other electrical equipment plugged into the outlet is working.
- 6) All options are properly installed.
- 7) If you have checked all of the above and still have a problem, turn off the printer, wait for 10 seconds, and then turn on the printer. This often solves the problem.

Display Problems

- 1) If the operator panel displays only diamonds or is blank, check and try the action below. If the problem persists even after checking and executing the items below, execute Flow 96, Flow 97, or "FIP-AC" and "FIP-DC" in "6. Other FIP".
 - a) Turn off the printer, wait for 10 seconds, and turn on the printer.
 - b) Self Test Message appears on the operator panel. When the test is completed, "Ready to Print" is displayed.
- 2) If menu settings changed from the operator panel have no effect, check and try the actions below.

Settings in the software program, the printer driver, or the printer utilities are overriding the settings made on the operator panel.

 - a) Change the menu settings from the printer driver, the printer utilities, or the software program instead of the operator panel.
 - b) Disable the settings in the printer driver, the printer utilities, or the software program so you can change settings on the operator panel.

Printing Problems

- 1) If a job did not print correct or incorrect characters were printed, check and try the actions below.
 - a) Make sure "Ready to Print" appears on the operator panel before sending a job to print. Press **Menu** to return to "Ready to Print".
 - b) Make sure print media is loaded in the printer. Press **Menu** to return to "Ready to Print".
 - c) Verify that you are using the correct printer driver.
 - d) Make sure you are using the correct Ethernet or USB cables and it securely connected at the back of the printer.
 - e) Verify that the correct print media size is selected.
 - f) If using a print spooler, verify that the spooler has not stalled.
 - g) Check the printer interface from the "Configure" menu. Determine the host interface you are using. Print a Panel Setting page to verify that the current interfaces settings are correct.
 - h) Output fonts will not print correctly using the PCL driver in its default mode. To correct this problem, use PostScript driver when using the PCL driver.

- 2) If secure print is not available or not printing, refer to the requirements below.
 - a) Minimum 256 MB is required.
 - b) RAM Disk must be enabled using the operation panel.
 - c) The number of secure print jobs your printer can store is dependent on the job size including number of pages, graphics, color attributes, and the amount of memory installed. To increase this number, add additional memory.
- 3) If print media misfeeds or multiple feeds occur, check and try the actions below.
 - a) Make sure the print media you are using meets the specifications for your printer. Refer to **Print Media Guidelines** of this section.
 - b) Flex print media before loading it in any of the sources.
 - c) Make sure the print media is loaded correctly.
 - d) Make sure the width and length guides on the print media sources are adjusted correctly.
 - e) If the print media are overfilled in sources, reduce the amount of media.
 - f) Load the recommended print side correctly for the type of print media you are using.
 - g) Turn the print media over or around and try printing again to see if feeding improves.
 - h) Check the print media type loaded in the source, and refill only one type of print media, if print media types are mixed.
 - i) Refill a new ream of print media, if some reams are mixed.
 - j) Remove the top and bottom sheets of a ream before loading the print media.
 - k) Do not reload print media until the print media source is empty.
- 4) If envelope misfeeds or multiple feeds occur, check and try the action below.
 - a) Remove the stack of envelopes from the multiple purpose feeder (MPF).
- 5) If page breaks in unexpected places, check and try the action below.
 - a) Check the "Job Timeout" in the Basic Settings menu and increase the value.
- 6) If a job prints from the wrong source or on the wrong print media, check and try the action below.
 - a) Check the "Paper Size" and "Paper Type" in the Tray Settings menu on the printer operator panel and in the printer driver.
- 7) If print media does not stack neatly in the output tray, check and try the action below.
 - a) Turn the print media stack over in the tray or multipurpose feeder.

Print Media Guidelines

Print media is paper, transparencies, labels, envelopes, coated paper among others. Your printer provides high-quality printing on a variety of print media. Selecting the appropriate print media for your printer helps avoid printing troubles. This section describes how to select print media, how to care for print media, and how to load the print media in the optional 250-sheet tray module or 550-sheet tray module.

Paper

For the best print quality in color, use 75 g/m² (20 lb.) xerographic, grain long paper. For the best print quality in black and white, use 90 g/m² (24 lb.) xerographic, grain long paper. Before buying large quantities of any print media, Dell recommends trying a sample first.

When loading paper, identify the recommended print side on the paper package, and load the paper accordingly. See "Loading Print Media in Optional Trays" and "Loading the Multipurpose Feeder" for detailed loading instructions.

Paper Characteristics

The following paper characteristics affect print quality and reliability. Dell recommends that you follow these guidelines when evaluating new paper stock.

Weight

The tray automatically feeds paper weights from 60 to 216 g/m² (16 to 57.6 lb. bond) grain long. The multipurpose feeder automatically feeds paper weights from 60 to 216 g/m² (16 to 56 lb. bond) grain long. Paper lighter than 60 g/m² (16 lb.) might not be stiff enough to feed properly, and could cause paper jams. For best performance, use 75 g/m² (20 lb. bond) grain long paper.

Curl

Curl is the tendency of print media to curve at its edges. Excessive curl can cause paper feeding problems. Curl usually occurs after the paper passes through the printer, where it is exposed to high temperatures. Storing paper unwrapped in humid conditions, even in the paper tray, can contribute to paper curling prior to printing and cause feeding problems.

Smoothness

The degree of paper smoothness directly affects print quality. If the paper is too rough, the toner does not fuse to the paper properly, resulting in poor print quality. If the paper is too smooth, it can cause paper feeding problems. Smoothness between 150 and 250 Sheffield points produces the best print quality.

Moisture Content

The amount of moisture in the paper affects both print quality and the ability of the printer to feed the paper properly. Leave the paper in its original packaging until you are ready to use it. This limits the exposure of the paper to moisture changes that can degrade its performance.

Grain Direction

Grain refers to the alignment of the paper fibers in a sheet of paper. Grain is either grain long, running the length of the paper, or grain short, running the width of the paper. For 60 to 135 g/m² (16 to 36 lb. bond) paper, grain long fibers are recommended. For papers heavier than 135 g/m² (36 lb. bond), grain short is preferred.

Fiber Content

Most high-quality xerographic paper is made from 100% chemically pulped wood. Paper containing fibers such as cotton possess characteristics that can result in degraded paper handling.

Recommended Paper

To ensure the best print quality and feed reliability, use 75 g/m² (20 lb.) xerographic paper. Business papers designed for general business use also provide acceptable print quality.

Always print several samples before buying large quantities of any type of print media. When choosing any print media, you should consider the weight, fiber content, and color.

The laser printing process heats paper to high temperatures of 225°C (437°F) for Magnetic Ink Character Recognition (MICR) applications, and 205°C (401°F) for non-MICR applications. Only use paper able to withstand these temperatures without discoloring, bleeding, or releasing hazardous emissions. Check with the manufacturer or vendor to determine whether the paper you have chosen is acceptable for laser printers.

Unacceptable Paper

The following paper types are not recommended for use with the printer:

- 1) Chemically treated papers used to make copies without carbon paper, also known as carbonless papers, carbonless copy paper (CCP), or no carbon required (NCR) paper
- 2) Preprinted papers with chemicals that may contaminate the printer
- 3) Preprinted papers that can be affected by the temperature in the printer fuser

- 4) Preprinted papers that require a registration (the precise print location on the page) greater than ± 0.09 in., such as optical character recognition (OCR) forms
In some cases, you can adjust registration with your software program to successfully print on these forms.
- 5) Coated papers (erasable bond), synthetic papers, thermal papers
- 6) Rough-edged, rough or heavily textured surface papers or curled papers
- 7) Recycled papers containing more than 25% post-consumer waste that do not meet DIN 19 309
- 8) Multiple-part forms or documents
- 9) Label paper with Cut

Selecting Paper

Proper paper selection helps prevent jams and ensures trouble-free printing.

To help avoid jams or poor print quality:

1. Always use new, undamaged paper.
2. Before loading the paper, identify the recommended print side of the paper. This information is usually indicated on the paper package.
3. Do not use paper that you have cut or trimmed yourself.
4. Do not mix print media sizes, weights, or types in the same source. This may result in a paper jam.
5. Do not remove trays while a job is printing or Printing is displayed on the operator panel.
6. Make sure the Paper Type and Paper Size settings are correct.
7. Make sure the paper is properly loaded in the tray.
8. Flex paper back and forth, and then fan them. Straighten the edges of the stack on a level surface.
9. When curl is excessive, with plain paper, turn it over and reset it.

Identifying Print Media Sources and Specifications

The following tables provide information on standard and optional print media sources.

Print Media Sizes and Support Y: Yes N: No

	Multipurpose Feeder	250-sheet Tray	Optional 550-sheet Tray
A4	Y	Y	Y
A5	Y	Y	Y
B5	Y	Y	Y
Letter	Y	Y	Y
Folio (8.5 x 13 in.)	Y	Y	Y
Legal (8.5 x 14 in.)	Y	Y	Y
Executive	Y	Y	Y
COM-10 envelope	Y	N	N
Monarch	Y	N	N
C5	Y	N	N
DL	Y	N	N
User-specified print media	Y	N	N
Yokei size 2	Y	N	N
Yokei size 3	Y	N	N
Yokei size 4	Y	N	N
Yochokei size 3	Y	N	N
Chokey size 3	Y	N	N

	Multipurpose Feeder	250-sheet Tray	Optional 550-sheet Tray
Japanese Post Card	Y	N	N

Print Media Supported

Y: Yes N: No

	Multipurpose Feeder	250-sheet Tray	Optional 550-sheet Tray
Plain Paper Light (60-76gsm)	Y	Y	Y
Plain Paper Normal (80gms)	Y	Y	Y
Plain Paper Thick (82-98gms)	Y	Y	Y
Covers Normal (106-163gms)	Y	Y	Y
Covers Thick (164-216gms)	Y	Y	Y
Transparency	Y	N	N
Labels	Y	Y	Y
Coated Normal (106-163gms)	Y	Y	Y
Coated Thick (164-216gms)	Y	Y	Y
Envelope	Y	N	N
Recycled Paper	Y	Y	Y
Japanese Coated Paper	Y	Y	Y
Japanese Post Card	Y	N	N

About indication of near life and Life over for consumables life

The table below gives details on how the near life (Near Empty) and Life over for consumables life are to be indicated.

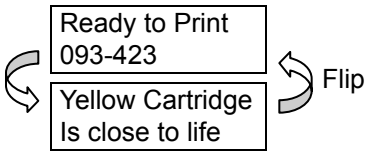
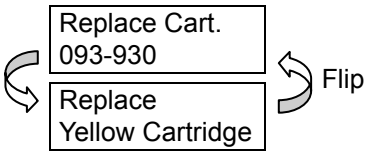
Consumables	Near Life Indication	Life over Indication
Print Cartridge (Y/M/C/K)	<p>When the remaining life of the Print Cartridge reaches approximately 25%, the following messages are displayed.</p> <p>Example) Print Cartridge for Yellow</p> <p><Panel></p>  <p><Status Window> The Yellow Cartridge needs to be replaced soon.</p> <p>093-423</p> <p>NOTE: The message displayed varies depending on the color of the Print Cartridge.</p>	<p>When the Print Cartridge reaches its end of life, the following messages are displayed.</p> <p>Example) Print Cartridge for Yellow</p> <p><Panel></p>  <p><Status Window> The XXX Cartridge need to be replaced now. Open the Front Cover. Then remove the used Yellow Cartridge and install a new one. Please click the Show Me How Button for details.</p> <p>093-930</p> <p>NOTE: The message displayed varies depending on the color of the Print Cartridge.</p>

Consumables	Near Life Indication	Life over Indication
FUSER	<p>When the remaining life of the FUSER reaches approximately 20%, the following messages are displayed.</p> <p><Panel></p> <div style="border: 1px solid black; padding: 5px; width: fit-content; margin: 0 auto;"> <p>Ready to Print 010-421</p> <p>Replace Fuser Contact Support</p> </div> <p style="text-align: center;">Flip</p> <p><Status Window> Contact customer support if this failure is repeated.</p> <p>010-421</p>	<p>When the FUSER reaches its end of life, the following messages are displayed.</p> <p><Panel></p> <div style="border: 1px solid black; padding: 5px; width: fit-content; margin: 0 auto;"> <p>Replace FUSER 010-351</p> <p>Replace FUSER</p> </div> <p style="text-align: center;">Flip</p> <p><Status Window> The Fuser needs to be replaced now. Remove the used Fuser and install a new one. Please click the Show Me How Button for details.</p> <p>010-351</p>
Belt Unit	<p>When the remaining life of the Belt Unit reaches approximately 20%, the following messages are displayed.</p> <p><Panel></p> <div style="border: 1px solid black; padding: 5px; width: fit-content; margin: 0 auto;"> <p>Ready to Print 094-422</p> <p>Replace Belt Contact Support</p> </div> <p style="text-align: center;">Flip</p> <p><Status Window> Contact customer support if this failure is repeated.</p> <p>094-422</p>	<p>When the Belt Unit reaches its end of life, the following messages are displayed.</p> <p><Panel></p> <div style="border: 1px solid black; padding: 5px; width: fit-content; margin: 0 auto;"> <p>Belt Unit 094-911</p> <p>Replace Belt Contact Support</p> </div> <p style="text-align: center;">Flip</p> <p><Status Window> The Belt Unit needs to be replaced now. Remove the used Belt Unit and install a new one. Please click the Show Me How Button for details.</p> <p>094-911</p>

NOTE

The remaining amounts given in this table are for reference only.

2. FIP

2.1 FIP

The FIP is the first step for trouble diagnosis. The FIP isolates the presence of various troubles including error codes, and guides the troubleshooting procedure.

2.2 Flow of FIP

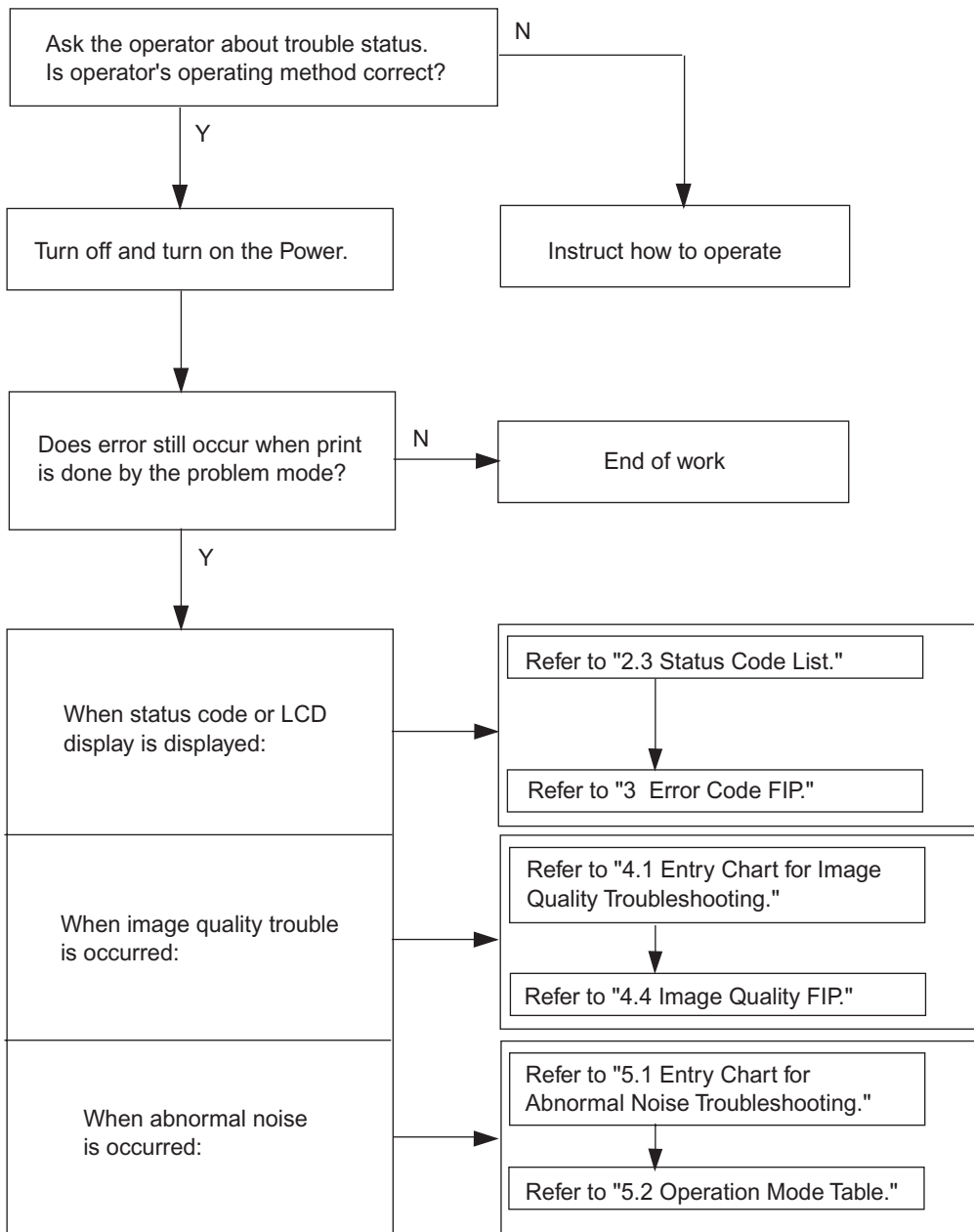

2.3 Status Code List

Error Message		Error Contents	FIP to be referred
LCD	Status Window		
001-360 Restart Printer ↕ Flip Contact Support IfMessageReturns	Printer error. Turn off the printer, and turn it on again. Contact customer support if this failure is repeated. 001-360-01(or 02)*1	<IOT Fan Motor Failure> MCU detects an error upon receiving error signal from the Rear Fan or Duplexer Fan. Pressing three keys (<↓> + <↑> + <✓>) shows detail error code. Line1 001-360 Line2 Code:01(or 02)*	Flows 1: Rear Fan Flows 2: Duplexer Fan FIP1.1: Rear Fan FIP1.2: Duplexer Fan
	*1: The error code number varies depending on the error contents. 01: "Rear Fan Motor error" 02: "Duplex Fan Motor error"		
003-340 Restart Printer ↕ Flip Contact Support IfMessageReturns	Printer error. Turn off the printer, and turn it on again. Contact customer support if this failure is repeated. 003-340-01(or 02 to 14)*1	<IOT Firmware Error> MCU firmware error occurs. Pressing three keys (<↓> + <↑> + <✓>) shows detail error code. Line1 003-340 Line2 Code:01(or 02 to 14)*1	Flows 3: Other than Code 09 Flows 4: Code 09 FIP1.3: Other than Code 09 FIP1.4: Code 09
	*1: The error code number varies depending on the error contents. 01-02,04-05,0B-14: "Unexpected firmware trap error" 03: "I2C retry error" 07: "Master fail 1 error" 08: "Master fail 2 error" 09: "NVM illegal data error" 0A: "Over dispense error"		
003-356 Restart Printer ↕ Flip Contact Support IfMessageReturns	Printer error. Turn off the printer, and turn it on again. Contact customer support if this failure is repeated. 003-356-0000XXXX	<IOT NVRAM Error> The error is detected by MCU NVRAM check. Pressing three keys (<↓> + <↑> + <✓>) shows detail error code. Line1 003-356 Line2 Code:1000-1FFF (or 3100-3CFF)*1	Flows 5 FIP1.5
	*1: The error code number varies depending on the error contents. 1000-1FFF: EEPROM of PWBA MCU 3100-31FF: HVPS 3800-38FF: PWBA EEPROM XPRO 3A00-3AFF: Belt CRUM 3C00-3CFF: Fuser CRUM		
004-310 Restart Printer ↕ Flip Reseat Feeder Contact Support	Printer error. Turn off the printer. Confirm Feeder is correctly installed. Turn on the printer. Contact customer support if this failure is repeated. 004-310	<IOT Option Feeder Failure> The error is detected by Option Feeder communication check.	Flows 6 FIP1.6

Error Message		Error Contents	FIP to be referred
LCD	Status Window		
004-311 Restart Printer ↕ Flip Reseat Duplexer Contact Support	Printer error. Turn off the printer. Confirm Duplex is correctly installed. Turn on the printer. Contact customer support if this failure is repeated. 004-311	<IOT Option Duplexer Failure> The error is detected by Option Duplexer check.	Flows 7 FIP1.7
006-370 Restart Printer ↕ Flip Contact Support IfMessageReturns	Printer error. Turn off the printer, and turn it on again. Contact customer support if this failure is repeated. 006-370-01(or 02 to 0F)*1	<IOT ROS Failure> The rotational error is detected by ROS Motor check. Pressing three keys (<↓> + <↑> + <✓>) shows detail error code. Line1 006-370 Line2 Code:01(or 02 to 0F)*1	Flows 8 FIP1.8
*1: The error code number varies depending on the error contents. 01 to 0F: "IOT ROS Failure error"			
007-340 Restart Printer ↕ Flip Contact Support IfMessageReturns	Printer error. Turn off the printer, and turn it on again. Contact customer support if this failure is repeated. 007-340-01(or 02 to 04)*1	<IOT Motor Failure> Motor failure is detected. Pressing three keys (<↓> + <↑> + <✓>) shows detail error code. Line1 007-340 Line2 Code:01(or 02 to 04)*1	Flows 9: Main Motor Flows 10: Sub Motor Flows 12: PH Motor Flows 13: Option Feeder Motor FIP1.9: Main Motor FIP1.10: Sub Motor FIP1.12: PH Motor FIP1.13: Option Feeder Motor
*1: The error code number varies depending on the error contents. 00: "Main Motor error" 01: "Sub Motor error" 02: Not Used 03: "PH Motor error" 04: "Option Feeder Motor error"			
007-371 Restart Printer ↕ Flip Contact Support IfMessageReturns	Printer error. Turn off the printer, and turn it on again. Contact customer support if this failure is repeated. 007-371	<IOT K Mode Solenoid Error> K Mode Solenoid (Color Mode Switching Solenoid) error is detected.	Flows 14 FIP1.14
009-360 Restart Printer ↕ Flip Reseat Y Cart. Contact Support	Printer error. Turn off the printer. Confirm toner is correctly installed. Turn on the printer. Contact customer support if this failure is repeated. 009-360	<IOT (Y) Toner CRUM Error> Yellow Toner CRUM communication error is detected.	Flows 15 FIP1.15

Error Message		Error Contents	FIP to be referred
LCD	Status Window		
009-361 Restart Printer ↕ Flip Reseat M Cart. Contact Support	Printer error. Turn off the printer. Confirm toner is correctly installed. Turn on the printer. Contact customer support if this failure is repeated. 009-361	<IOT (M) Toner CRUM Error> Magenta Toner CRUM communication error is detected.	Flows 16 FIP1.16
009-362 Restart Printer ↕ Flip Reseat C Cart. Contact Support	Printer error. Turn off the printer. Confirm toner is correctly installed. Turn on the printer. Contact customer support if this failure is repeated. 009-362	<IOT (C) Toner CRUM Error> Cyan Toner CRUM communication error is detected.	Flows 17 FIP1.17
009-363 Restart Printer ↕ Flip Reseat K Cart. Contact Support	Printer error. Turn off the printer. Confirm toner is correctly installed. Turn on the printer. Contact customer support if this failure is repeated. 009-363	<IOT (K) Toner CRUM Error> Black Toner CRUM communication error is detected.	Flows 18 FIP1.18
009-654 Restart Printer ↕ Flip Contact Support IfMessageReturns	Printer error. Turn off the printer, and turn it on again. Contact customer support if this failure is repeated. 009-654-01(or 02)*1	<IOT ADC Sensor Error> ADC sensor sensed the high density or low density. Pressing three keys (<↓> + <↑> + <✓>) shows detail error code. Line1 009-654 Line2 Code:01(or 02)*1	Flows 19: ADC fail 1 (high) Flows 20: ADC fail 2 (low) FIP1.19: ADC fail 1 (high) FIP1.20: ADC fail 2 (low)
010-317 Restart Printer ↕ Flip Reseat Fuser Contact Support	Printer error. Turn off the printer, and turn it on again. Contact customer support if this failure is repeated. 010-317	<IOT Fuser Detached> Fuser detached is detected.	Flows 21 FIP1.21
010-351 Replace Fuser ↕ Flip Replace Fuser	Printer error. Turn off the printer, and turn it on again. Contact customer support if this failure is repeated. 010-351	<IOT Fuser Life Over> The value of Fuser counter has reached the replacement time.	Flows 22 FIP1.22

Error Message		Error Contents	FIP to be referred
LCD	Status Window		
010-354 Restart Printer ↕ Flip Contact Support IfMessageReturns	Printer error. Turn off the printer, and turn it on again. Contact customer support if this failure is repeated. 010-354	<IOT environment Sensor Error> Temperature Sensor Error is detected.	Flows 23 FIP1.23
010-377 Restart Printer ↕ Flip Reseat Fuser Contact Support	Printer error. Turn off the printer. Confirm Fuser is correctly installed. Turn on the printer. Contact customer support if this failure is repeated. 010-377-01(or 02 to 13)*1	<IOT Fuser Failure> The NC sensor circuit is defective in the MCU. NC: No Contact Pressing three keys (<↓> + <↑> + <✓>) shows detail error code. Line1 010-377 Line2 Code:01(or 02 to 13)*1	Flows 24 FIP1.24
	*1: The error code number varies depending on the error contents. 01: "NC circuit fail error" 02: "NCD snap out error" 03: "NCD fail error" 04: "NCC snap out error" 05: "NC comp fail error" 06: "NC-STs temp over error" 07: "STs-NC temp over error" 08: "NC comp fail error" 09: "NC overheat error" 0A: "STs snap out error" 0B: "STs overheat error" 0C: "Low temp1 error" 0D: "Low temp2 error" 0E: "Timeout 1 error" 0F: "Timeout 2 error" 10: "Timeout 3 error" 11: "Relay cutoff 1 error" 12: "Relay cutoff 2 error" 13: "Relay cutoff 3 error"		
016-300 Restart Printer ↕ Flip Contact Support IfMessageReturns	Printer error. Turn off the printer, and turn it on again. Contact customer support if this failure is repeated. 016-300	<ESS Data Cache Error> CPU data cache error.	Flows 25 FIP1.25
016-301 Restart Printer ↕ Flip Contact Support IfMessageReturns	Printer error. Turn off the printer, and turn it on again. Contact customer support if this failure is repeated. 016-301	<ESS Instruction Cache Error> CPU instruction cache error.	Flows 25 FIP1.25

Error Message		Error Contents	FIP to be referred
LCD	Status Window		
016-302 Restart Printer ↕ Flip Contact Support IfMessageReturns	Printer error. Turn off the printer, and turn it on again. Contact customer support if this failure is repeated. 016-302	<ESS Illegal Exception> CPU illegal exception.	Flows 25 FIP1.25
016-310 Restart Printer ↕ Flip Contact Support IfMessageReturns	Printer error. Turn off the printer, and turn it on again. Contact customer support if this failure is repeated. 016-310	<ESS FontROM Error (Main)> Checksum error in the built-in font ROM.	Flows 25 FIP1.25
016-312 Restart Printer ↕ Flip Contact Support IfMessageReturns	Printer error. Turn off the printer, and turn it on again. Contact customer support if this failure is repeated. 016-312	<ESS HDD Fail> HDD error is detected.	Flows 26 FIP1.26
016-313 Restart Printer ↕ Flip Contact Support IfMessageReturns	Printer error. Turn off the printer, and turn it on again. Contact customer support if this failure is repeated. 016-313	<ESS ASIC Fail> The error is detected by ASIC error.	Flows 25 FIP1.25
016-315 Restart Printer ↕ Flip Contact Support IfMessageReturns	Printer error. Turn off the printer, and turn it on again. Contact customer support if this failure is repeated. 016-315	<ESS On Board RAM R/W Check Fail> The error is detected by on board RAM R/W check during initialization.	Flows 25 FIP1.25
016-316 Restart Printer ↕ Flip Reseat Memory Contact Support	Printer error. Turn off the printer. Confirm Memory is correctly installed. Turn on the printer. Contact customer support if this failure is repeated. 016-316	<ESS DIMM Slot RAM R/W Check Fail> The error is detected by DIMM slot RAM R/W check during initialization.	Flows 27 FIP1.27
016-317 Restart Printer ↕ Flip Contact Support IfMessageReturns	Printer error. Turn off the printer, and turn it on again. Contact customer support if this failure is repeated. 016-317	<ESS ROM Check (Main) Fail> Checksum error in the main program ROM.	Flows 25 FIP1.25

Error Message		Error Contents	FIP to be referred
LCD	Status Window		
016-318 Restart Printer ↕ Flip Reseat Memory Contact Support	Printer error. Turn off the printer, and turn it on again. Contact customer support if this failure is repeated. 016-318	<ESS DIMM Slot RAM Error> Power-on initialization detected that unsupported DIMM was installed.	Flows 27 FIP1.27
016-323 Restart Printer ↕ Flip Contact Support IfMessageReturns	Printer error. Turn off the printer, and turn it on again. Contact customer support if this failure is repeated. 016-323	<ESS NVRAM 1 R/W Check Fail> The fail is detected by NVRAM 1 R/W check during initialization.	Flows 25 FIP1.25
016-327 Restart Printer ↕ Flip Contact Support IfMessageReturns	Printer error. Turn off the printer, and turn it on again. Contact customer support if this failure is repeated. 016-327	<ESS NVRAM 1 SIZE And ID Check Fail> The error is detected by consistency check between the NVRAM size required by the system and its actual size, and by consistency check of the ID recorded when turning ON the power.	Flows 25 FIP1.25
016-338 Restart Printer ↕ Flip Reseat Wireless Contact Support	Printer error. Turn off the printer, and turn it on again. Contact customer support if this failure is repeated. 016-338	<Wireless Option Error> The error is detected by Wireless option check.	Flows 28 FIP1.28
016-340 Restart Printer ↕ Flip Contact Support IfMessageReturns	Printer error. Turn off the printer, and turn it on again. Contact customer support if this failure is repeated. 016-340	<ESS Network Communication Fail> Communication error between CPU network and ESS F/W.	Flows 25-1 FIP1.25
016-344 Restart Printer ↕ Flip Contact Support IfMessageReturns	Printer error. Turn off the printer, and turn it on again. Contact customer support if this failure is repeated. 016-344	<ESS Network MAC Address Checksum Error> Checksum error in the Network MAC address.	Flows 25 FIP1.25
016-345 Restart Printer ↕ Flip Contact Support IfMessageReturns	Printer error. Turn off the printer, and turn it on again. Contact customer support if this failure is repeated. 016-345	<ESS Network Ethernet BIST parity/ RAM R/W Error> The error is detected by network Ethernet parity RAM R/W check.	Flows 25 FIP1.25

Error Message		Error Contents	FIP to be referred
LCD	Status Window		
016-346 Restart Printer ↕ Flip Contact Support IfMessageReturns	Printer error. Turn off the printer, and turn it on again. Contact customer support if this failure is repeated. 016-346	<ESS Network Internal Loopback Error> The error is detected by on board Network Internal Loopback check.	Flows 25 FIP1.25
016-347 Restart Printer ↕ Flip Contact Support IfMessageReturns	Printer error. Turn off the printer, and turn it on again. Contact customer support if this failure is repeated. 016-347	<ESS Network Fatal Error> The fatal error is detected by On Board Network check.	Flows 25 FIP1.25
016-350 Restart Printer ↕ Flip Reseat Parallel Contact Support	Printer error. Turn off the printer, and turn it on again. Contact customer support if this failure is repeated. 016-350	<IEEE1284 Data Error> The error is detected by IEEE1284 controller of ESS.	Flows 29 FIP1.29
016-361 Restart Printer ↕ Flip Reseat HDD Contact Support	Printer error. Turn off the printer, and turn it on again. Contact customer support if this failure is repeated. 016-361	<ESS PCI Option #0 Fail> Detection error of PCI option 0.	Flows 26 FIP1.26
016-365 Restart Printer ↕ Flip Reseat NPA Contact Support	Printer error. Turn off the printer, and turn it on again. Contact customer support if this failure is repeated. 016-365	<HW Key Option Fatal Error> Network Adapter error is detected when it is connected to the printer.	Flows 30 FIP1.30
016-370 Restart Printer ↕ Flip Contact Support IfMessageReturns	Printer error. Turn off the printer, and turn it on again. Contact customer support if this failure is repeated. 016-370	<MCU-ESS Communication Fail> Communication fail between MCU and ESS.	Flows 31 FIP1.31
093-964 Restart Printer ↕ Flip Reseat Fuser Contact Support	Printer error. Turn off the printer, and turn it on again. Contact customer support if this failure is repeated. 093-964	<IOT Fuser CRUM ID Error> Fuser CRUM communication error is detected.	Flows 32 FIP1.32

Problem	Error Message		Error Contents	FIP to be referred
	LCD	Status Window		
Paper Jam	Paper Jam 071-100 ⇕ Flip Open Tray1 Remove Paper ⇕ Flip Open & close Front Cover	Paper Jam has occurred at the Tray 1. Clear the paper path. Please click the Show Me How Button for details. 071-100	<IOT 250 Feeder Misfeed JAM> The Regi sensor is not turned ON within the specified time.	Flows 33 FIP1.33
	Paper Jam 072-100 ⇕ Flip Open Tray2 Remove Paper ⇕ Flip Open & close Front Cover	Paper Jam has occurred at the Tray 2. Clear the paper path. Please click the Show Me How Button for details. 072-100	<IOT Option Feeder Misfeed JAM> The Regi sensor is not turned ON within the specified time.	Flows 34 FIP1.34
	Paper Jam 075-100 ⇕ Flip Check MPF Remove Paper ⇕ Flip Open & close Front Cover	Paper Jam has occurred at the MPF. Clear the paper path. Please click the Show Me How Button for details. 075-100	<IOT MPF Misfeed JAM> The Regi sensor is not turned ON within the specified time.	Flows 35 FIP1.35
	Paper Jam 077-100 ⇕ Flip Open Front Cover Remove Paper	Paper Jam has occurred at the Print Cartridge. Push the Side Button to open the Front Cover and remove the jammed paper. 077-100	<IOT Reg1 JAM> Fuser Exit Senor does not turn ON after a paper is detected by Registra- tion Sensor.	Flows 36 FIP1.36
	Paper Jam 077-101 ⇕ Flip Open Front Cover Remove Paper	Paper Jam has occurred at the Print Cartridge. Push the Side Button to open the Front Cover and remove the jammed paper. 077-101	<IOT Reg2 JAM> Registration Senor does not turn OFF after a paper is detected by Registra- tion Sensor.	Flows 36 FIP1.36
	Paper Jam 077-102 ⇕ Flip Open Front Cover Remove Paper	Paper Jam has occurred at the Print Cartridge. Push the Side Button to open the Front Cover and remove the jammed paper. 077-102	<IOT Exit1 JAM> Fuser Exit Senor does not turn OFF after a paper is detected by Fuser Exit Sensor.	Flows 37 FIP1.37

Problem	Error Message		Error Contents	FIP to be referred
	LCD	Status Window		
Paper Jam	Paper Jam 077-103 ↕ Flip Open Front Cover Remove Paper	Paper Jam has occurred at the Print Cartridge. Push the Side Button to open the Front Cover and remove the jammed paper. 077-103	<IOT Exit2 JAM> Fuser Exit Senor detect turn OFF too early after a paper is detected by Fuser Exit Sensor.	Flows 37 FIP1.37
	Paper Jam 077-104 ↕ Flip Open Front Cover & Belt Unit Remove Paper	Paper Jam has occurred at the Duplexer. Push the Side Button to open the Front Cover and the Belt Unit. Then remove the jammed paper. 077-104	<IOT Duplexer1 JAM> Registration Senor detects turn ON too early after a paper is detected by Duplexer JAM Sensor.	Flows 38 FIP1.38
	Paper Jam 077-105 ↕ Flip Open Front Cover & Belt Unit Remove Paper	Paper Jam has occurred at the Duplexer. Push the Side Button to open the Front Cover and the Belt Unit. Then remove the jammed paper. 077-105	<IOT Duplexer2 JAM> Duplexer Senor does not turn ON after switching back a paper.	Flows 39 FIP1.39
	Paper Jam 077-106 ↕ Flip Open Front Cover & Belt Unit Remove Paper	Paper Jam has occurred at the Duplexer. Push the Side Button to open the Front Cover and the Belt Unit. Then remove the jammed paper. 077-106	<IOT Duplexer3 JAM> Duplexer Senor does not turn OFF after a paper is detected by Duplexer JAM Sensor.	Flows 39 FIP1.39
	Paper Jam 077-107 ↕ Flip Open Front Cover & Belt Unit Remove Paper	Paper Jam has occurred at the Duplexer. Push the Side Button to open the Front Cover and the Belt Unit. Then remove the jammed paper. 077-107	<IOT Duplexer4 JAM> Registration Senor does not turn ON after a paper is detected by Duplexer JAM Sensor.	Flows 38 FIP1.38

Problem	Error Message		Error Contents	FIP to be referred
	LCD	Status Window		
Paper Jam	Paper Jam 077-900 ↕ Flip Open Front Cover Remove Paper	Paper Jam has occurred at the Print Cartridge. Push the Side Button to open the Front Cover and remove the jammed paper. 077-900	<IOT Remain Paper JAM> -The remain paper at the Exit Sensor. -The paper does not reach the Exit Sensor within the specified time. -The paper passed Exit Sensor earlier than the specified times.	Flows 40 FIP1.40
	Paper Jam 077-901 ↕ Flip Open Front Cover Remove Paper	Paper Jam has occurred at the Print Cartridge. Push the Side Button to open the Front Cover and remove the jammed paper. 077-901	<IOT Remain Paper JAM> -The remain paper at the Regi Sensor. -The paper does not reach the Exit Sensor within the specified time after the Regi Sensor is ON. -The paper does not pass through the Regi Sensor within the specified time.	Flows 40 FIP1.40
	Paper Jam 077-903 ↕ Flip Open Tray1 Remove Paper ↕ Flip Open & close Front Cover	Paper Jam has occurred at the Tray 1. Clear the paper path. Please click the Show Me How Button for details. 077-903	<IOT Feed JAM> The arrival time of the regi sensor is early than the specified time.	Flows 41 FIP1.41
	Paper Jam 077-907 ↕ Flip Open Front Cover & Belt Unit ↕ Flip Remove Paper	Paper Jam has occurred at the Duplexer. Push the Side Button to open the Front Cover and the Belt Unit. Then remove the jammed paper. 077-907	<IOT Duplexer Remain Paper JAM> -The remain paper at the Dup Jam Sensor. -The paper reached Dup Jam Sensor earlier than the specified time. -The paper passed Dup Jam Sensor earlier than the specified time. -The paper does not pass through the Dup Jam Sensor within the specified time. -The paper does not reach the Regi Sensor within the specified time, after the Dup Jam Sensor is ON.	Flows 42 FIP1.42

Problem	Error Message		Error Contents	FIP to be referred
	LCD	Status Window		
Paper Setting	Load Tray 1 024-910 ↕ Flip Load Tray 1 A4(Paper Size) ↕ Flip Load Tray 1 Plain(Paper Type)	Actual paper size in tray and specified paper size are different. Load the specified paper in Tray 1. Paper Size: A4 Paper Type: Plain 024-910	<IOT Paper Size Mismatch> The paper size mismatch is detected	Flows 43 FIP1.43
	Load Tray 2 024-911 ↕ Flip Load Tray 2 A4(Paper Size) ↕ Flip Load Tray 2 Plain(Paper Type)	Actual paper size in tray and specified paper size are different. Load the specified paper in Tray 2. Paper Size: A4 Paper Type: Plain 024-911		
	Load Tray MPF 024-914 ↕ Flip Load MPF A4(Paper Size) ↕ Flip Load MPF Plain(Paper Type)	Actual paper size in tray and specified paper size are different. Load the specified paper in MPF. Paper Size: A4 Paper Type: Plain 024-914		
	Load Tray 1 024-965 ↕ Flip Load Tray 1 A4(Paper Size) ↕ Flip Load Tray 1 Plain(Paper Type)	No paper detected. Load the specified paper in Tray 1. Paper Size: A4 Paper Type: Plain 024-965	<IOT No Suitable Paper> The specified tray is paper empty, size mismatch or type mismatch.	Flows 44 FIP1.44
	Load Tray 2 024-966 ↕ Flip Load Tray 2 A4(Paper Size) ↕ Flip Load Tray 2 Plain(Paper Type)	No paper detected. Load the specified paper in Tray 2. Paper Size: A4 Paper Type: Plain 024-966		
	Load Tray MPF 024-969 ↕ Flip Load MPF A4(Paper Size) ↕ Flip Load MPF Plain(Paper Type)	No paper detected. Load the specified paper in MPF. Paper Size: A4 Paper Type: Plain 024-969		

Problem	Error Message		Error Contents	FIP to be referred
	LCD	Status Window		
Toner	CRUM ID 009-367 ⇕ Flip Reseat Cyan Cartridge	An unsupported Cyan Cartridge is installed. Open the Front Cover. Remove the unsupported Cyan Cartridge and install a supported one. Please click the Show Me How Button for details. 009-367	<IOT Print Cartridge ID Error> The toner CRUM ID error is detected.	Flows 45 FIP1.45
	CRUM ID 009-368 ⇕ Flip Reseat Magenta Cartridge	An unsupported Magenta Cartridge is installed. Open the Front Cover. Remove the unsupported Magenta Cartridge and install a supported one. Please click the Show Me How Button for details. 009-368		
	CRUM ID 009-369 ⇕ Flip Reseat Yellow Cartridge	An unsupported Yellow Cartridge is installed. Open the Front Cover. Remove the unsupported Yellow Cartridge and install a supported one. Please click the Show Me How Button for details. 009-369		
	CRUM ID 009-370 ⇕ Flip Reseat Black Cartridge	An unsupported Black Cartridge is installed. Open the Front Cover. Remove the unsupported Black Cartridge and install a supported one. Please click the Show Me How Button for details. 009-370		

Problem	Error Message		Error Contents	FIP to be referred
	LCD	Status Window		
Toner	Error Yellow Cart 093-919 ⇕ Flip Remove Tape from Yellow Cart	The sealing tape is still on the Yellow Cartridge. Open the Front Cover. Pull the toner seal straight up to remove it. Please click the Show Me How Button for details. 093-919	<IOT Toner Seal Staying : on the default Print Cartridge> The toner seal staying is detected. When a new print cartridge is installed, the ADC sensor checks that the density of the toner patch on the transfer belt does not reach the spec- ified value.	Flows 46 Y Flows 47 M Flows 48 C Flows 49 K FIP1.46 Y FIP1.47 M FIP1.48 C FIP1.49 K
	Error Magenta Cart 093-920 ⇕ Flip Remove Tape from Magenta Cart	The sealing tape is still on the Magenta Car- tridge. Open the Front Cover. Pull the toner seal straight up to remove it. Please click the Show Me How Button for details. 093-920		
	Error Cyan Cart 093-921 ⇕ Flip Remove Tape from Cyan Cart	The sealing tape is still on the Cyan Cartridge. Open the Front Cover. Pull the toner seal straight up to remove it. Please click the Show Me How Button for details. 093-921		
	Error Black Cart 093-922 ⇕ Flip Remove Tape from Black Cart	The sealing tape is still on the Black Cartridge. Open the Front Cover. Pull the toner seal straight up to remove it. Please click the Show Me How Button for details. 093-922		

Problem	Error Message		Error Contents	FIP to be referred
	LCD	Status Window		
Toner	Error Yellow Cart 093-950 ⇕ Flip Remove Sheet from Yellow Cart	The protection cover is still on the Yellow Cartridge. Open the Front Cover. Remove the protection cover. Please click the Show Me How Button for details. 093-950	<IOT CRU Cover Staying : on the reordered Print Cartridge> The CRU Cover staying is detected. When a new print cartridge is installed, the ADC sensor checks that the density of the toner patch on the transfer belt does not reach the specified value.	Flows 50 FIP1.50
	Error Magenta Cart 093-951 ⇕ Flip Remove Sheet from Magenta Cart	The protection cover is still on the Magenta Cartridge. Open the Front Cover. Remove the protection cover. Please click the Show Me How Button for details. 093-951		
	Error Cyan Cart 093-952 ⇕ Flip Remove Sheet from Cyan Cart	The protection cover is still on the Cyan Cartridge. Open the Front Cover. Remove the protection cover. Please click the Show Me How Button for details. 093-952		
	Error Black Cart 093-953 ⇕ Flip Remove Sheet from Black Cart	The protection cover is still on the Black Cartridge. Open the Front Cover. Remove the protection cover. Please click the Show Me How Button for details. 093-953		

Problem	Error Message		Error Contents	FIP to be referred
	LCD	Status Window		
Toner	Replace Cart. 093-930 ⇕ Flip Reseat Yellow Cartridge	The Yellow Cartridge need to be replaced now. Open the Front Cover. Then remove the used Yellow Cartridge and install a new one. Please click the Show Me How Button for details. 093-930	<IOT Print Cartridge Life Over> The value of print cartridge counter has reached the replacement time. When all print cartridges have reached their replacement timing at the same time, a warning is indicated on the LCD panel in the following order: 1)Black → 2)Cyan → 3)Magenta → 4)Yellow	Flows 51 FIP1.51
	Replace Cart. 093-931 ⇕ Flip Reseat Magenta Cartridge	The Magenta Cartridge need to be replaced now. Open the Front Cover. Then remove the used Magenta Cartridge and install a new one. Please click the Show Me How Button for details. 093-931		
	Replace Cart. 093-932 ⇕ Flip Reseat Cyan Cartridge	The Cyan Cartridge need to be replaced now. Open the Front Cover. Then remove the used Cyan Cartridge and install a new one. Please click the Show Me How Button for details. 093-932		
	Replace Cart. 093-933 ⇕ Flip Reseat Black Cartridge	The Black Cartridge need to be replaced now. Open the Front Cover. Then remove the used Black Cartridge and install a new one. Please click the Show Me How Button for details. 093-933		

Problem	Error Message		Error Contents	FIP to be referred
	LCD	Status Window		
Toner	Ready to Print 093-423 ↕ Flip Yellow Cartridge Is close to Life	The Yellow Cartridge need to be replaced soon. 093-423	<IOT Print Cartridge Near Empty> The value of print cartridge counter is going to reach the replacement time. When all print cartridges are near their replacement timing at the same time, a warning is indicated on the LCD panel in the following order: 1)Black → 2)Cyan → 3)Magenta → 4)Yellow	Flows 52 FIP1.52
	Ready to Print 093-424 ↕ Flip Magenta Cartridge Is close to Life	The Magenta Cartridge need to be replaced soon. 093-424		
	Ready to Print 093-425 ↕ Flip Cyan Cartridge Is close to Life	The Cyan Cartridge need to be replaced soon. 093-425		
	Ready to Print 093-426 ↕ Flip Black Cartridge Is close to Life	The Black Cartridge need to be replaced soon. 093-426		

Problem	Error Message		Error Contents	FIP to be referred
	LCD	Status Window		
Toner	Insert PrintCart 093-970 ⇕ Flip Insert Yellow Cartridge	The Yellow Cartridge is either missing or not fully inserted into the printer. Open the Front Cover and make sure that the Yellow Cartridge have been fully installed. Please click the Show Me How Button for details. 093-970	<IOT Print Cartridge Detached> The yellow, magenta, cyan or black Print Cartridge detached is detected. The print cartridge sensor detected the cartridge detached. When no print cartridges are installed, a warning is indicated on the LCD panel in the following order: 1)Black → 2)Cyan → 3)Magenta → 4)Yellow	Flows 53 Y Flows 54 M Flows 55 C Flows 56 K FIP1.53 Y FIP1.54 M FIP1.55 C FIP1.56 K
	Insert PrintCart 093-971 ⇕ Flip Insert Magenta Cartridge	The Magenta Cartridge is either missing or not fully inserted into the printer. Open the Front Cover and make sure that the Magenta Cartridge have been fully installed. Please click the Show Me How Button for details. 093-971		
	Insert PrintCart 093-972 ⇕ Flip Insert Cyan Cartridge	The Cyan Cartridge is either missing or not fully inserted into the printer. Open the Front Cover and make sure that the Cyan Cartridge have been fully installed. Please click the Show Me How Button for details. 093-972		
	Insert PrintCart 093-973 ⇕ Flip Insert Black Cartridge	The Black Cartridge is either missing or not fully inserted into the printer. Open the Front Cover and make sure that the Black Cartridge have been fully installed. Please click the Show Me How Button for details. 093-973		

Problem	Error Message		Error Contents	FIP to be referred
	LCD	Status Window		
Belt	CRUM ID 009-371 ↕ Flip Reseat Belt Unit	An unsupported Belt Unit is installed. Open the Front Cover. Remove the unsupported Belt Unit and install a supported one. Please click the Show Me How Button for details. 009-371	<IOT Belt Unit CRUM ID Error> The Belt Unit CRUM ID error is detected. The Belt Unit CRUM ID read by the sensor is different from the one that was recorded.	Flows 57 FIP1.57
	Ready to Print 094-422 ↕ Flip Replace Belt Contact Support	Contact customer support if this failure is repeated. 094-422	<IOT Belt Unit Life Warning> The Belt Unit Counter is going to reach the replacement time.	Flows 58 FIP1.58
	Insert Belt Unit 094-910 ↕ Flip Insert Belt Unit	The Belt Unit is either missing or not fully inserted into the printer. Open the Front Cover and make sure that the Belt Unit have been fully installed. Please click the Show Me How Button for details. 094-910	<IOT Belt Unit Detached> The Belt Unit Detached is detected.	Flows 59 FIP1.59
	Belt Unit 094-911 ↕ Flip Replace Belt Contact Support	The Belt Unit needs to be replaced now. Remove the used Belt Unit and install a new one. Please click the Show Me How Button for details. 094-911	<IOT Belt Unit Life Over> The Belt Unit Counter has reached the replacement time.	Flows 60 FIP1.60

Problem	Error Message		Error Contents	FIP to be referred
	LCD	Status Window		
Fuser	010-351 Restart Printer ↕ Flip Reseat Fuser Contact Support	The Fuser needs to be replaced now. Remove the used Fuser and install a new one. Please click the Show Me How Button for details. 010-351	<IOT Fuser Life Over> The Fuser Counter has reached the replacement time.	Flows 22 FIP1.22
	010-359 Restart Printer ↕ Flip Reseat Fuser Contact Support	An unsupported Fuser is installed. Open the Front Cover. Remove the unsupported Fuser and install a supported one. Please click the Show Me How Button for details. 010-359	<IOT Fuser CRUM ID Error> The Fuser CRUM ID error is detected. The Fuser CRUM ID read by the sensor is different from the one that was recorded.	Flows 61 FIP1.61
	Ready to Print 010-421 ↕ Flip Replace Fuser Contact Support	Contact customer support if this failure is repeated. 010-421	<IOT Fuser Life Warning> The Fuser Counter is going to reach the replacement time.	Flows 62 FIP1.62
Tray	Tray Detached 024-946 ↕ Flip Push In Tray 1	No Message.	<IOT Tray Detached> The paper cassette(Tray1) is detached. The Tray Size Switch detected the no tray.	Flows 63 FIP1.63
	Tray Detached 024-947 ↕ Flip Push In Tray 2	No Message.	<IOT Tray Detached> The paper cassette(Tray2) is detached. The Tray Size Switch detected the no tray.	Flows 64 FIP1.64
	Load Tray 1 077-912 ↕ Flip Push In Tray 1	Insert Tray 1. Tray cannot be detected. 077-912	<Upper Cassette Detached> The Tray 1 paper cassette is detached when the tray 2 is selected. The Tray Size Switch detected the no tray.	Flows 63 FIP1.63
Cover Open	Close FrontCover 077-300 ↕ Flip Front Cover Is Open	The Front Cover is open. Close the Front Cover. 077-300	<IOT Cover Front Open> The Front Cover is open.	Flows 65 FIP1.65

Problem	Error Message		Error Contents	FIP to be referred
	LCD	Status Window		
Other	Invalid ID 016-383 ↕ Flip Data Violation Press ✓	Firmware download ID error has occurred. Press the Set Button. Contact customer support if this failure is repeated. 016-383	<Download Error> An error occurred because an invalid firmware is installed.	Flows 66 FIP1.66
	Range Chk Error 016-384 ↕ Flip Data Violation Press ✓	Firmware download range error has occurred. Press the Set Button. Contact customer support if this failure is repeated. 016-384	<Download Error> The address of the write destination is invalid.	Flows 66 FIP1.66
	Header Error 016-385 ↕ Flip Data Violation Press ✓	Firmware download header checksum error has occurred. Press the Set Button. Contact customer support if this failure is repeated. 016-385	<Download Error> The header information is invalid.	Flows 66 FIP1.66
	Check Sum Error 016-386 ↕ Flip Data Violation Press ✓	Firmware download checksum error has occurred. Press the Set Button. Contact customer support if this failure is repeated. 016-386	<Download Error> The checksum is invalid.	Flows 66 FIP1.66
	Format Error 016-387 ↕ Flip Data Violation Press ✓	Firmware download format error has occurred. Press the Set Button. Contact customer support if this failure is repeated. 016-387	<Download Error> The format is invalid.	Flows 66 FIP1.66

Problem	Error Message		Error Contents	FIP to be referred
	LCD	Status Window		
Other	Erase Flash Err. 016-392 ↕ Flip Contact Support IfMessageReturns	Firmware download delete error has occurred. Contact customer support if this failure is repeated. 016-392	<Download Error> An error occurred erasing the Flash.	Flows 25 FIP1.25
	Write Flash Err. 016-393 ↕ Flip Contact Support IfMessageReturns	Firmware download write error has occurred. Contact customer support if this failure is repeated. 016-393	<Download Error> An error occurred writing the Flash.	Flows 25 FIP1.25
	Verify Error 016-394 ↕ Flip Contact Support IfMessageReturns	Firmware download verify error has occurred. Contact customer support if this failure is repeated. 016-394	<Download Error> An error occurred verifying the Flash.	Flows 25 FIP1.25
	Out of Memory 016-700 ↕ Flip Job too Large Press ✓	The printer memory is full and cannot continue processing the current print job. Press Set Button to clear the message, cancel the current print job. Please click the Show Me How Button for details. 016-700	<Memory Over flow> The printer memory is full and cannot continue processing the current print job.	Flows 67 FIP1.67
	Disk Full 016-980 ↕ Flip Job too Large Press ✓	Disk space is insufficient and cannot continue processing the current print job. Press Set Button to clear the message, cancel the current print job. Please click the Show Me How Button for details. 016-980	<Memory Over flow> RAM disk memory or hard disk is full and cannot continue processing the current print job.	Flows 68 FIP1.67

Problem	Error Message		Error Contents	FIP to be referred
	LCD	Status Window		
Other	Collate Full 016-981 ↕ Flip Job too Large Press ✓	Disk space is insufficient and cannot continue processing the current print job. Press Set Button to clear the message, cancel the current print job. Please click the Show Me How Button for details. 016-981	<Memory Over flow> Exceeds the memory capacity.	Flows 69 FIP1.67
	PDL Error 016-720 ↕ Flip Data Violation Press ✓	Error relating to PDL emulation problems occurs. Press Set Button to clear the message, cancel the current print job. Please click the Show Me How Button for details. 016-720	<PDL Error> PDL error occurs. The print data cannot be processed by PDL.	Flows 70 FIP1.68
	Invalid User 016-757 ↕ Flip Account Denied Press ✓	Authentication error has occurred. The account is not registered. Please inquire of the system administrator. 016-757	<Auditron Error> An error occurred because the user's account settings did not match those of the Administrator.	Flows 71 FIP1.69
	Disabled Func 016-758 ↕ Flip Denied Col print Press ✓	Function unavailable. It is a function that cannot be used. Please inquire of the system administrator. 016-758	<Auditron Error> An error occurred because a user authorized only for B&W print attempted to execute color printing.	Flows 72 FIP1.69
	Reached Limits 016-759 ↕ Flip Over your limits Press ✓	Printable page limit reached. Printable page limit reached, cannot print. Please inquire of the system administrator. 016-759	<Auditron Error> An attempt was made to print more copies than the print count limit.	Flows 73 FIP1.69

Problem	Error Message		Error Contents	FIP to be referred
	LCD	Status Window		
Other	Invalid Job 016-799 ↕ Flip Data Violation Press ✓	The configuration of the printer on the printer driver does not conform to the printer. Press the Cancel button to cancel the print job. Make sure that the configuration of the printer on the printer driver conforms to the printer. 016-799	<Job Environment Violation> Detects violation data for the print condition. The print data specifies paper type/size not available for the printer.	Flows 74 FIP1.70
	Ready to Print 193-700 ↕ Flip non-DELL Toner Installed	No Message.	<Custom Toner Mode> The printer is in custom toner mode.	Flows 75 FIP1.71
	Over Heat 042-700 ↕ Flip cooling down Please Wait...	An internal temperature of the printer became a high temperature. Please wait for a while until falling in temperature. 042-700	<IOT Over Heat Stop> The temp. sensor sensed high temperature.	Flows 76 FIP1.72
	Ready to Print 142-700 ↕ Flip Over Heat Turned Halfmode	No Message.	<IOT Over Heat Warning> The printing mode becomes half speed mode, by the high temperature. The temp. sensor sensed high temperature.	Flows 76 FIP1.72

3. Error Code FIP

3.1 Troubleshooting for the call center

Flows 1 001-360-01 Restart Printer

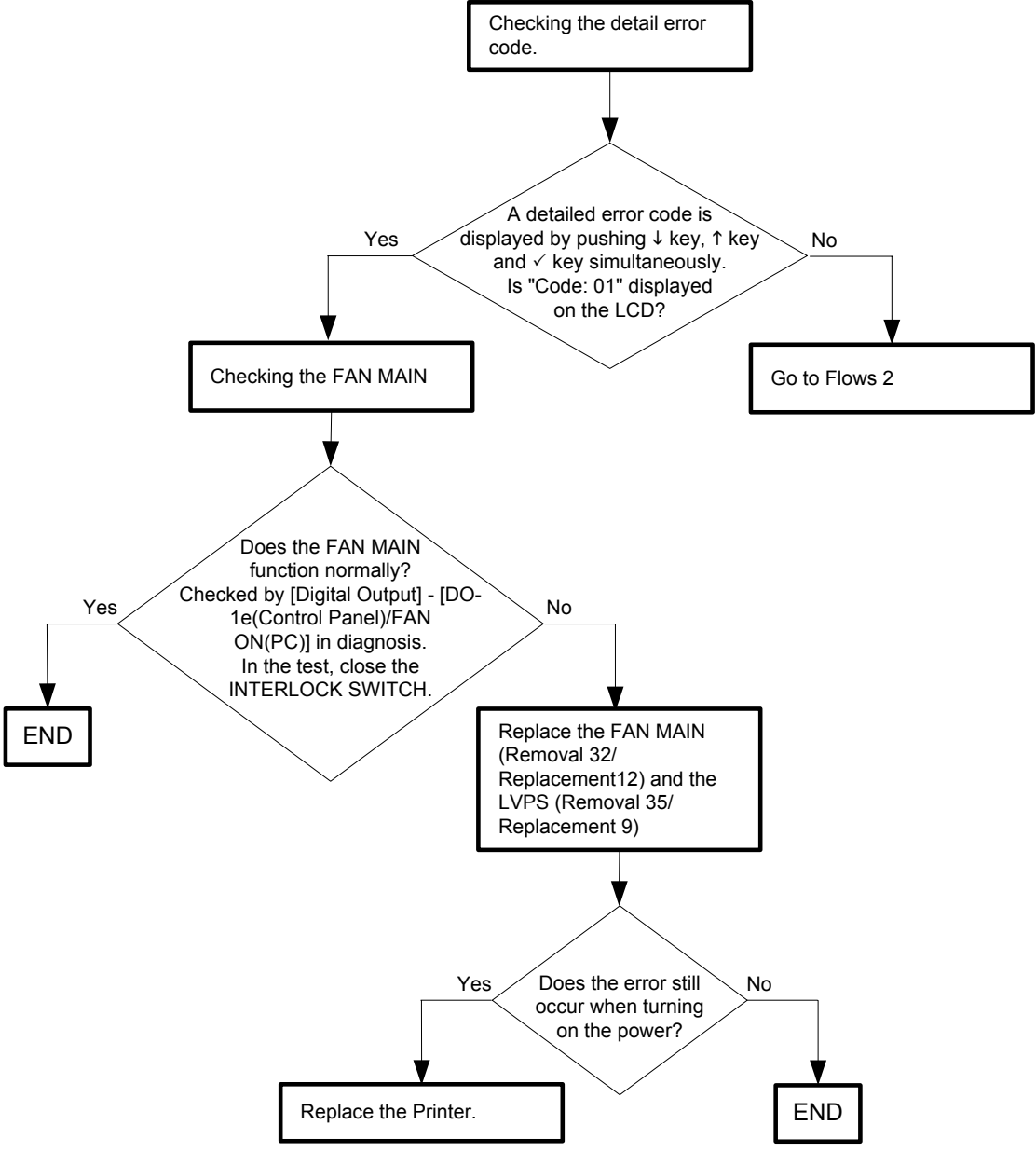

Flows 2 001-360-02 Restart Printer

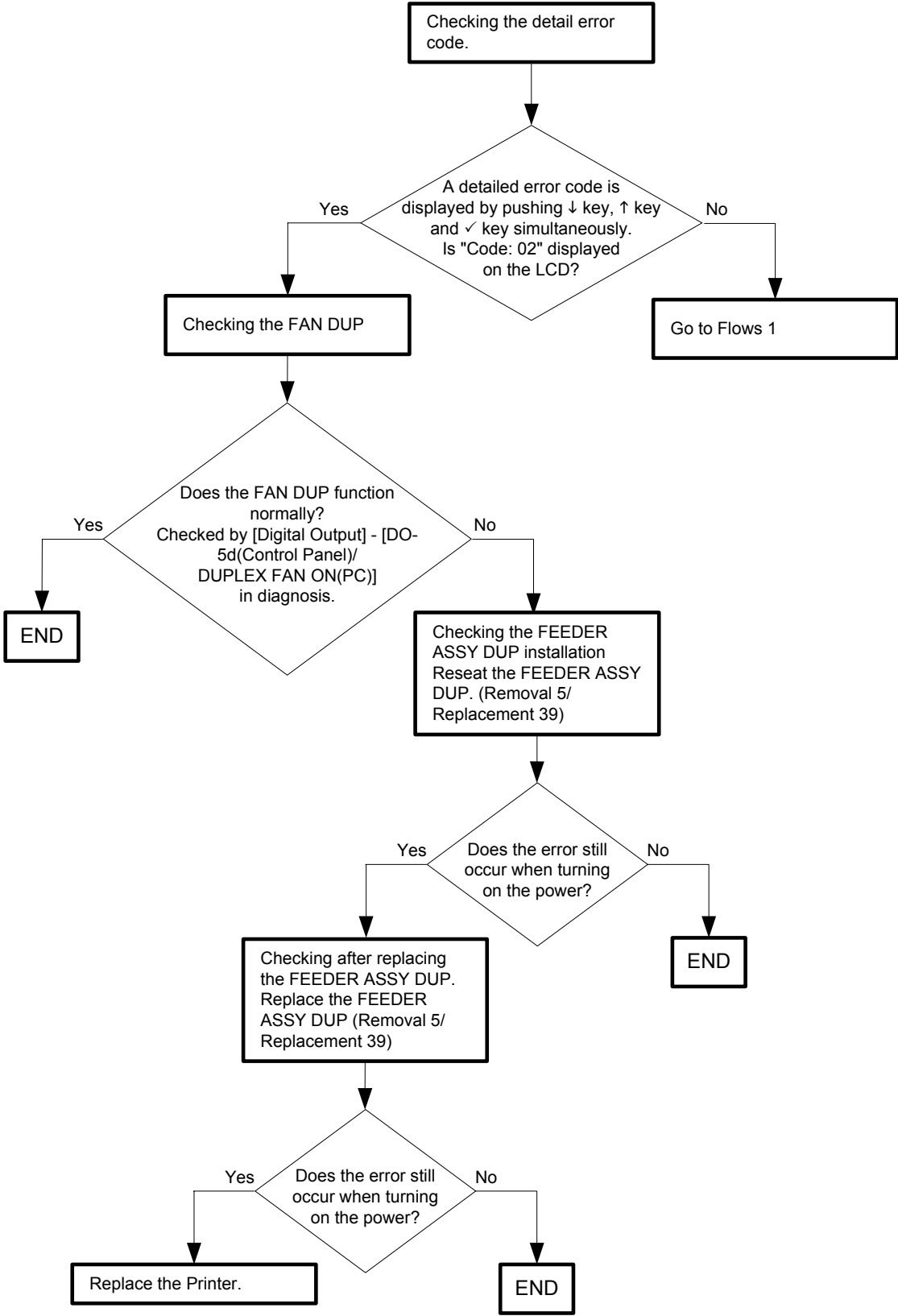

Flows 3 003-340-01/003-340-02/003-340-03/003-340-04/003-340-05/003-340-07/003-340-08/003-340-0A/003-340-0B/003-340-14 Restart Printer

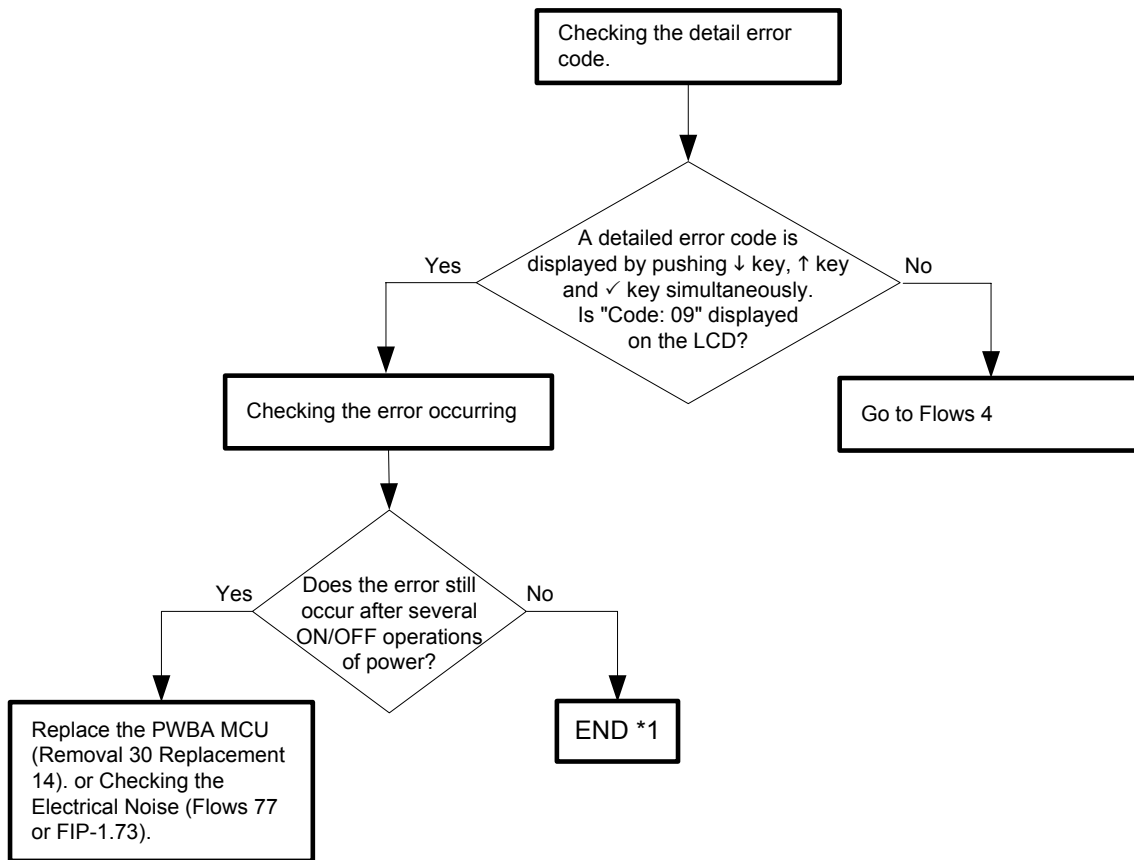

*1: Though some kind of external noise would be possible cause, go to [FIP1.73 Electrical Noise] and check, to make sure.

Flows 4 003-340-09 Restart Printer

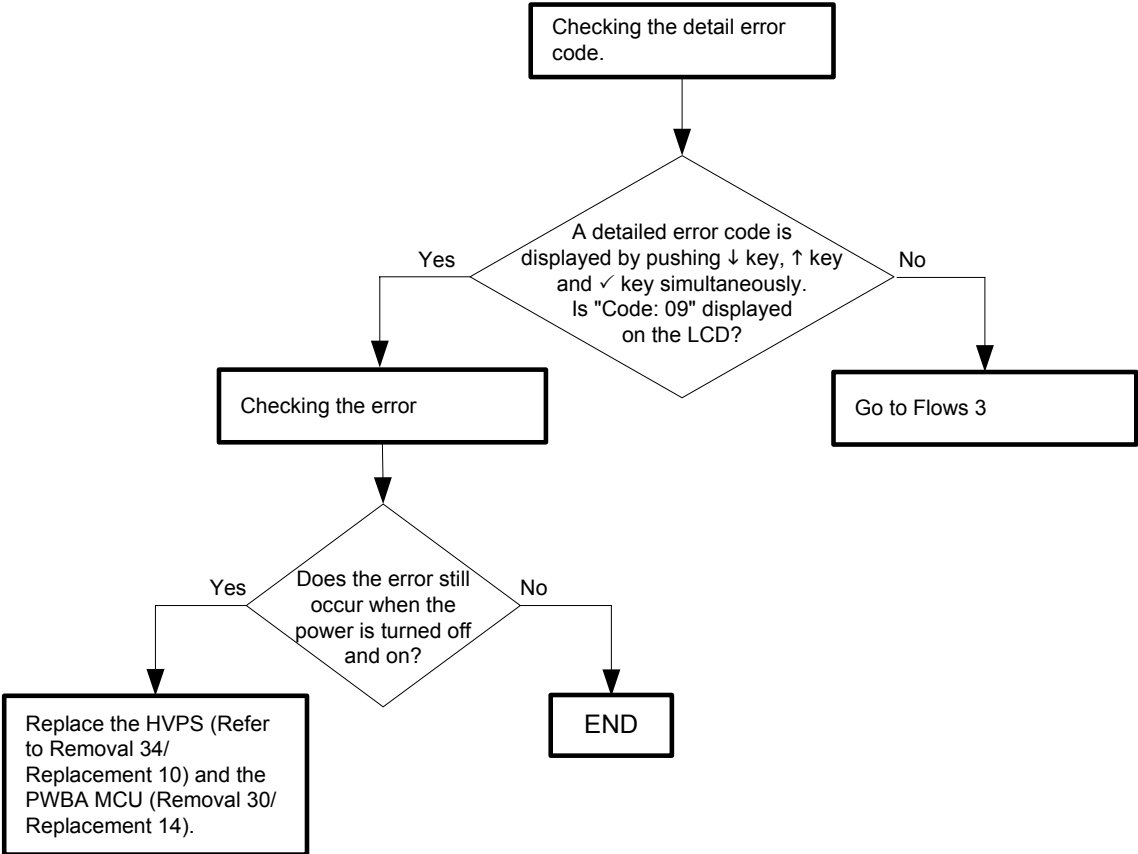

Flows 5 003-356 Restart Printer

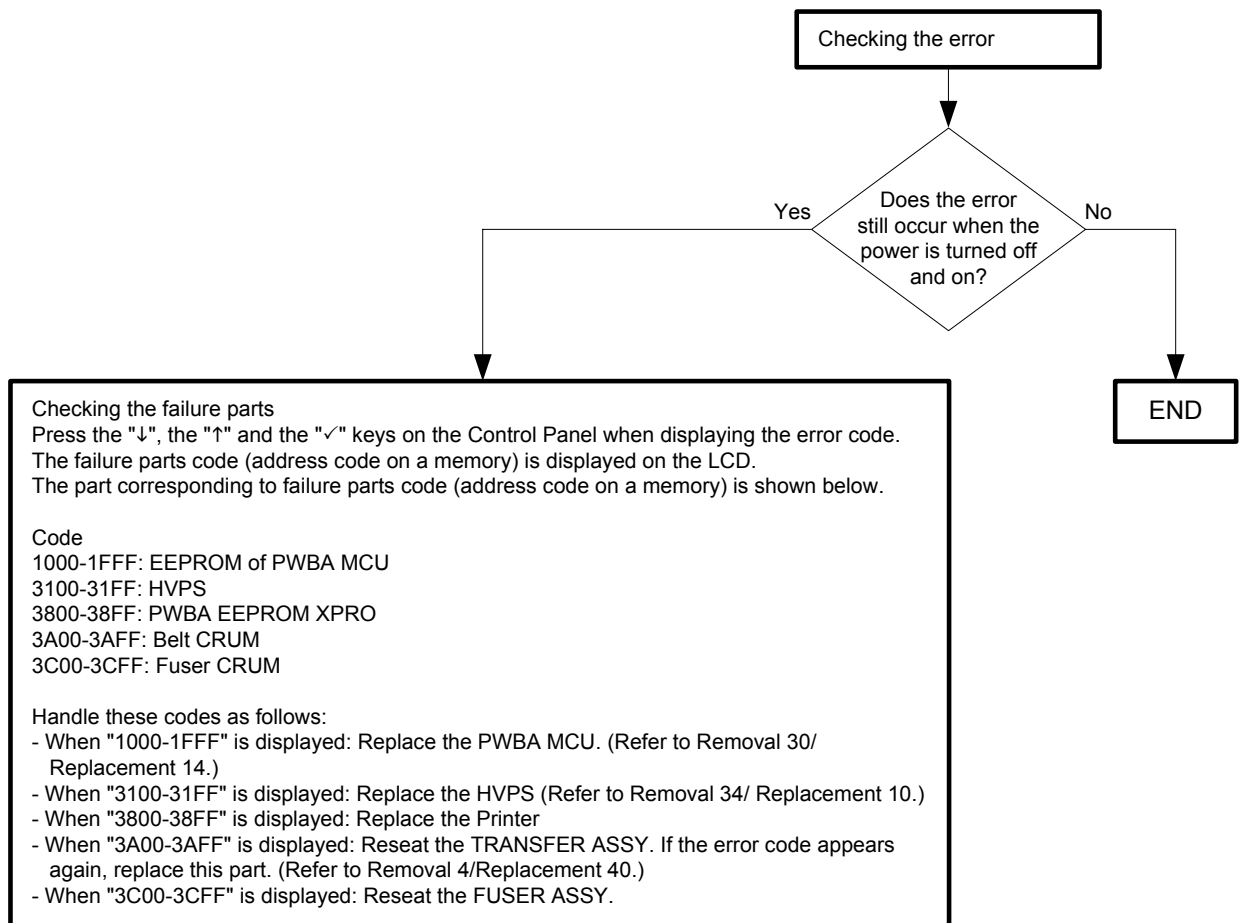

Flows 6 004-310 Restart Printer

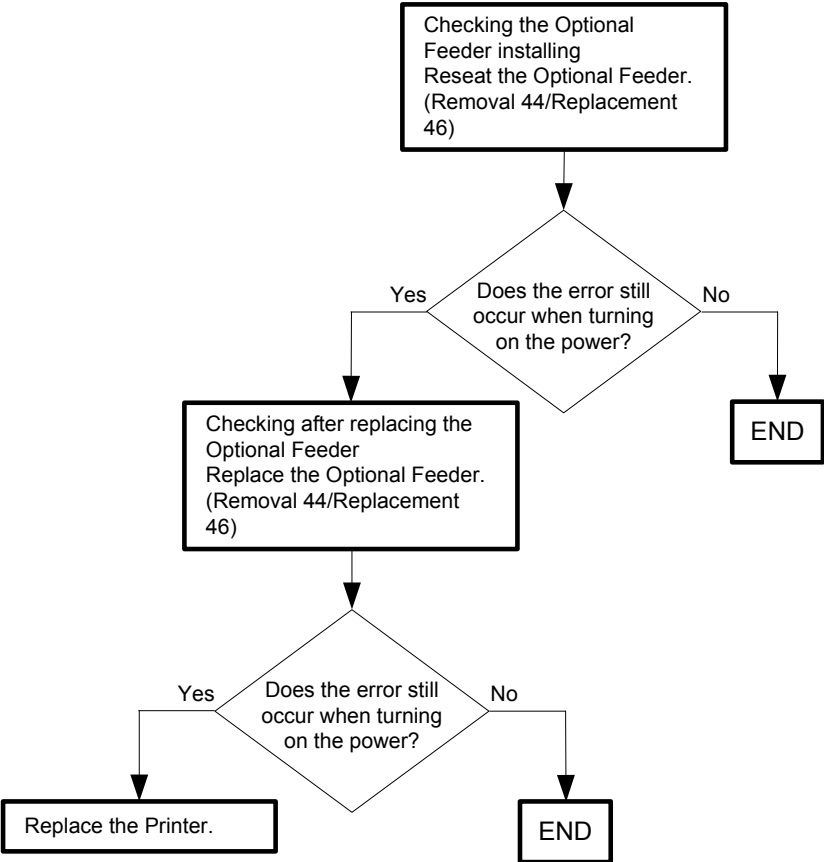

Flows 7 004-311 Restart Printer

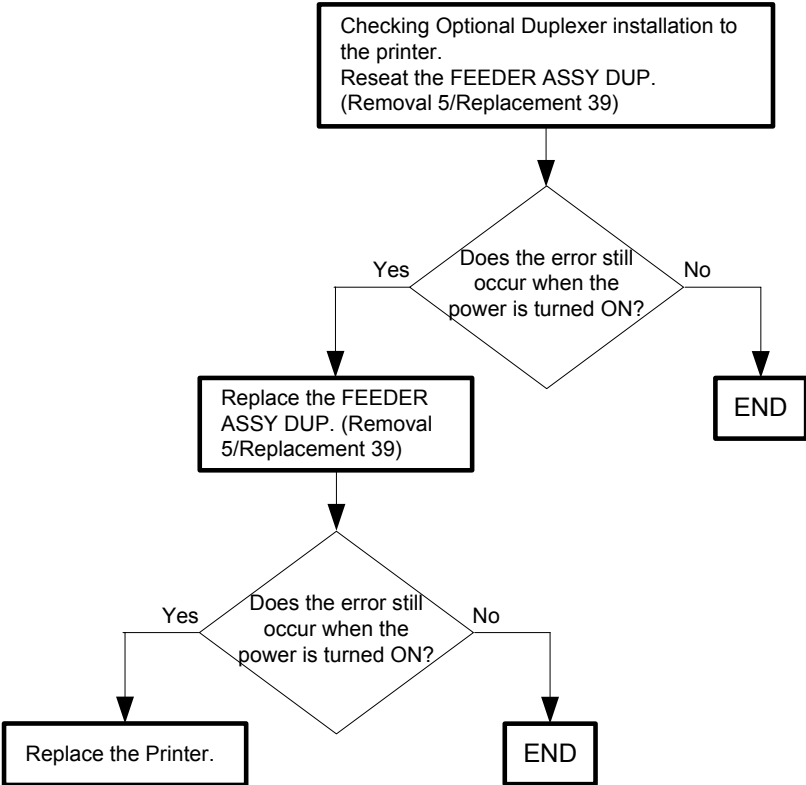

Flows 8 006-370 Restart Printer

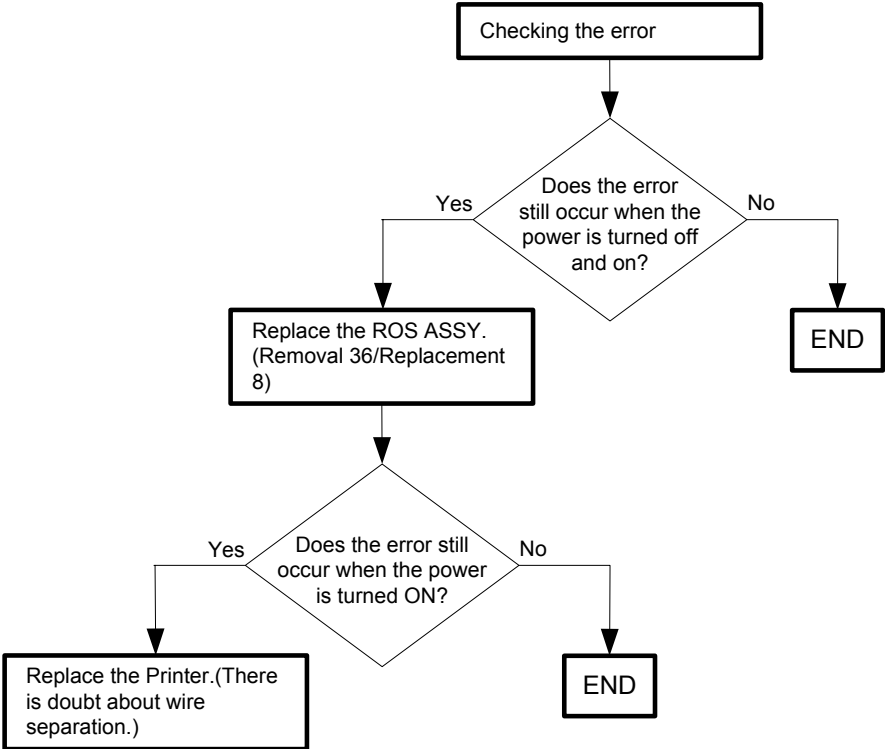

Flows 9 007-340-00 Restart Printer

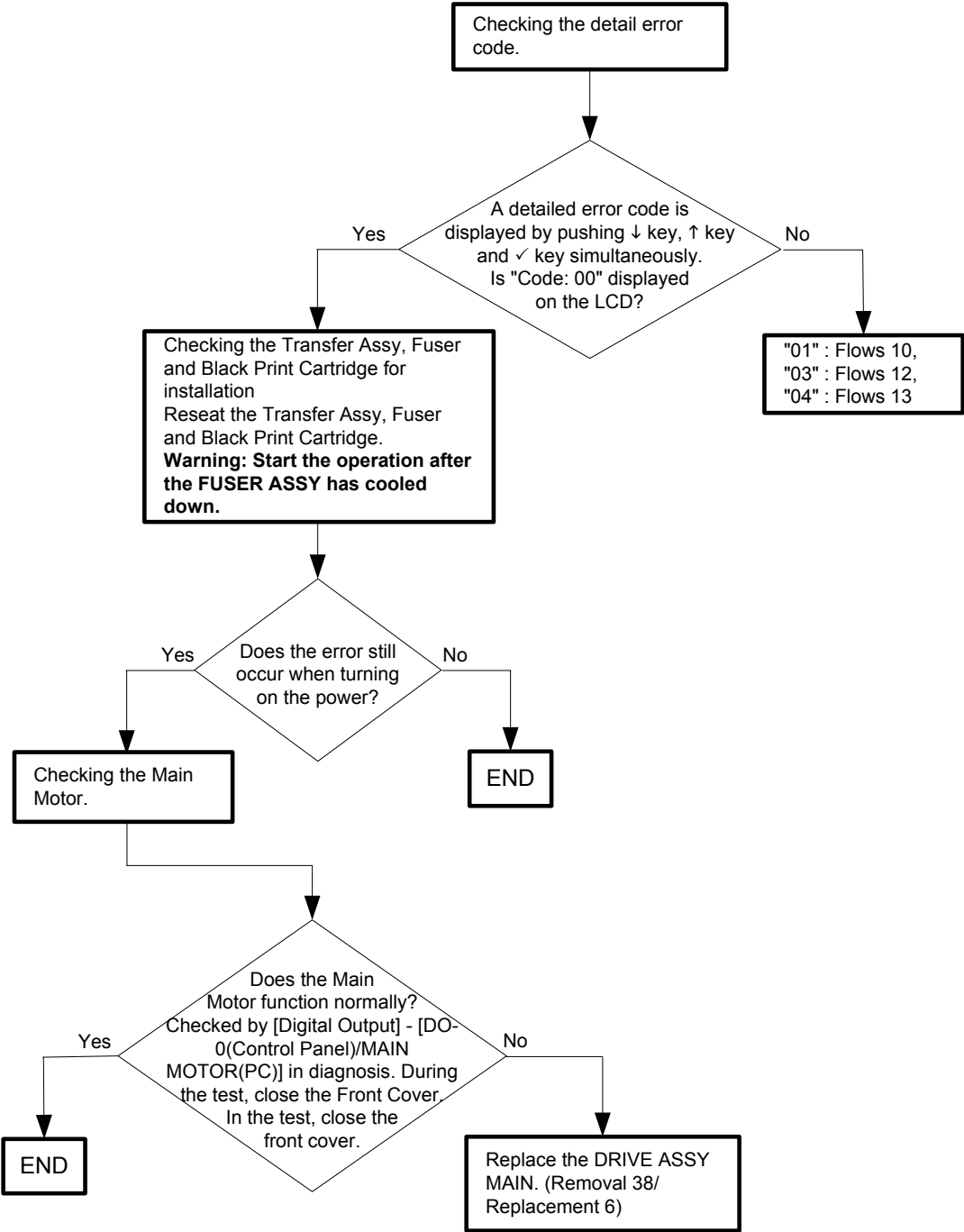

Flows 10 007-340-01 Restart Printer

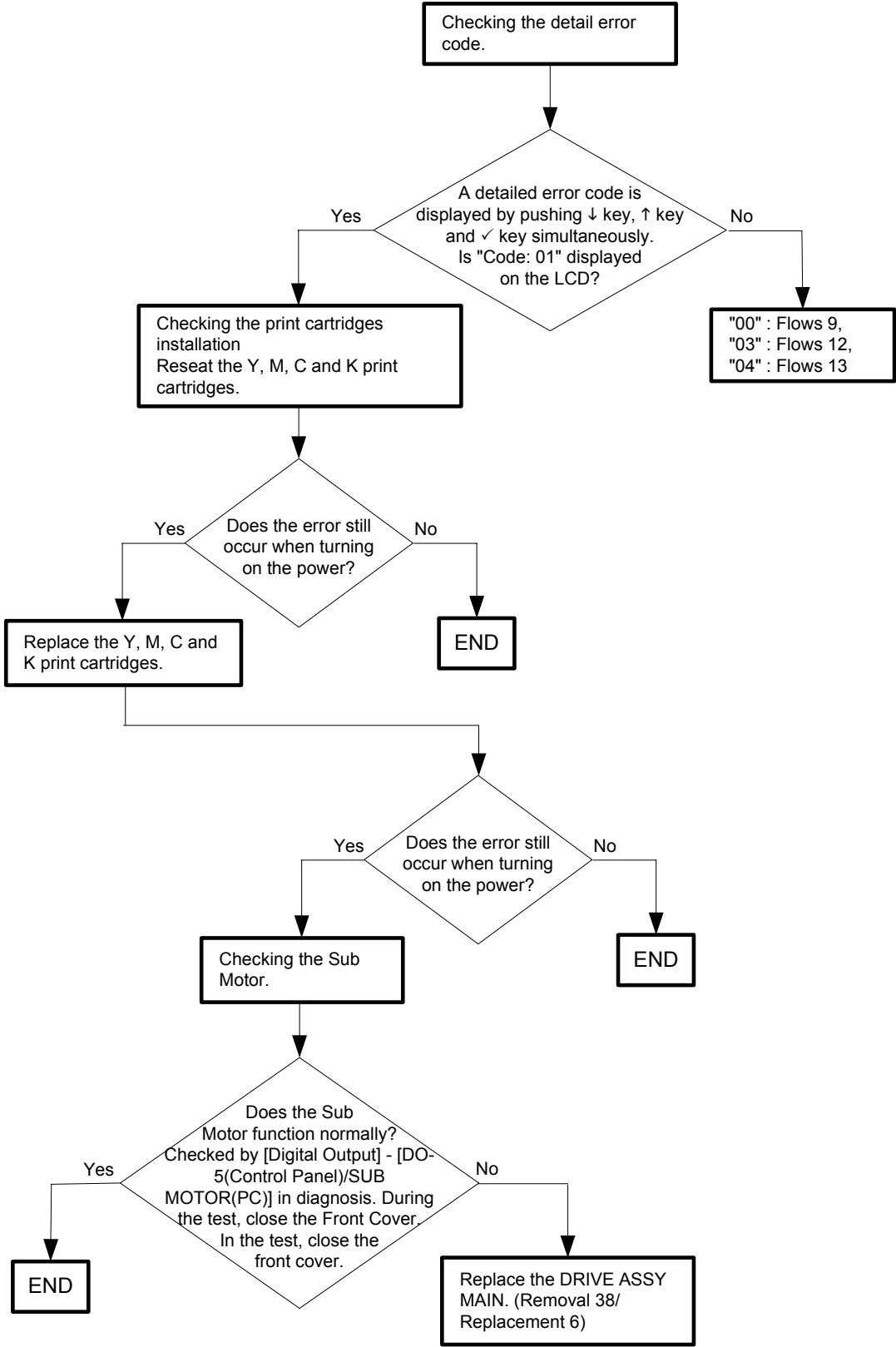

Flows 12 007-340-03 Restart Printer

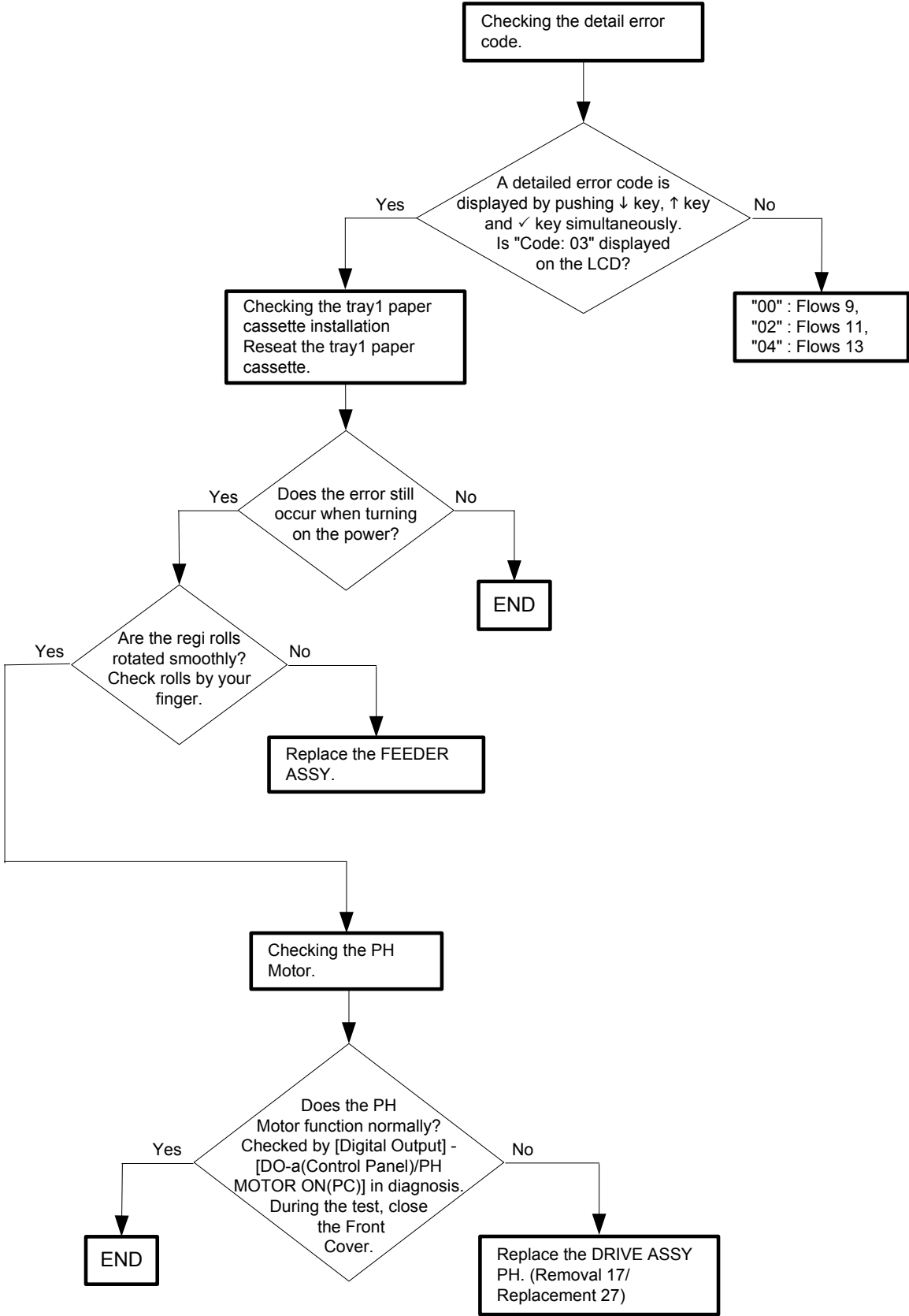

Flows 13 007-340-04 Restart Printer

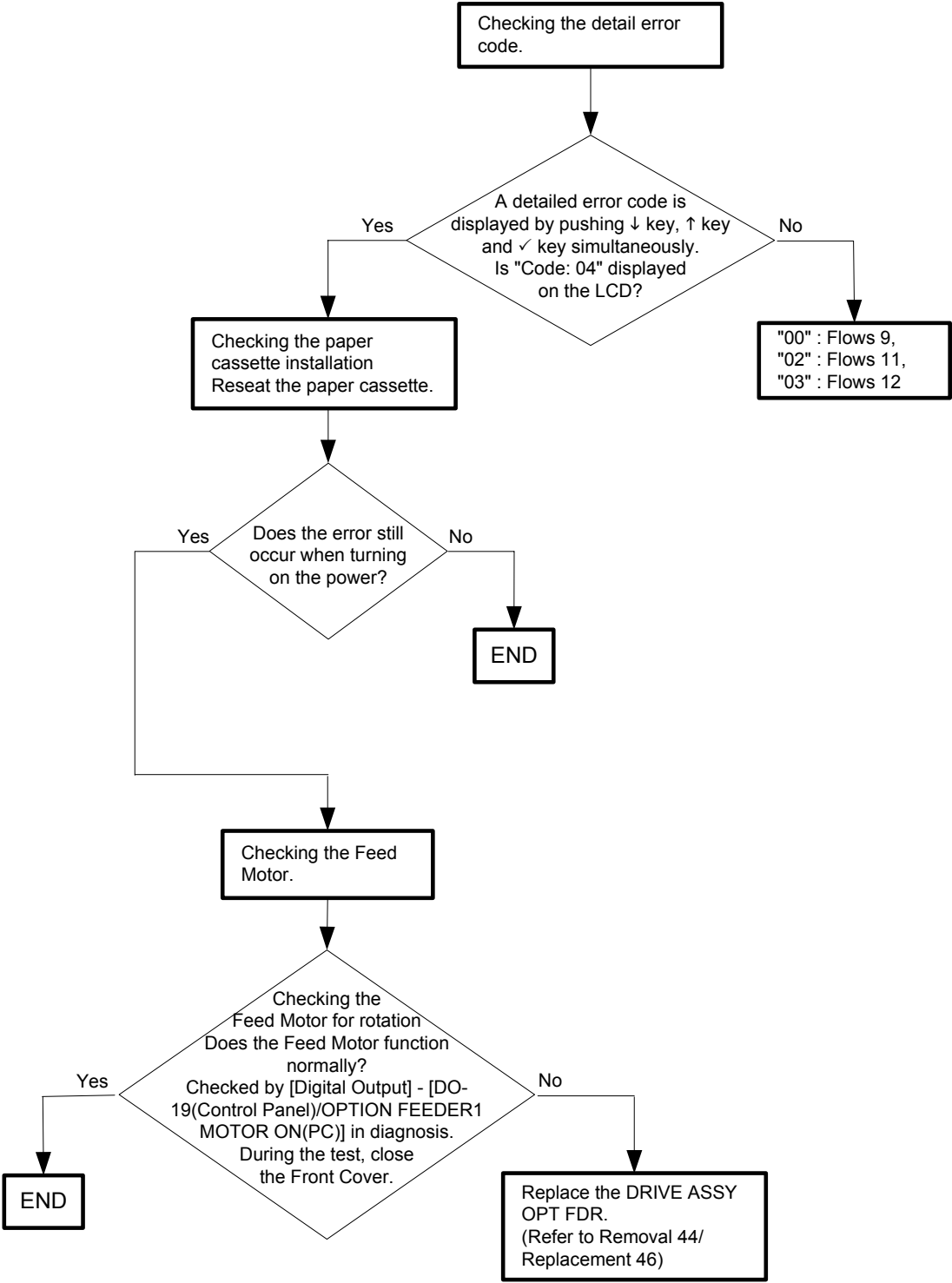

Flows 14 007-371 Restart Printer

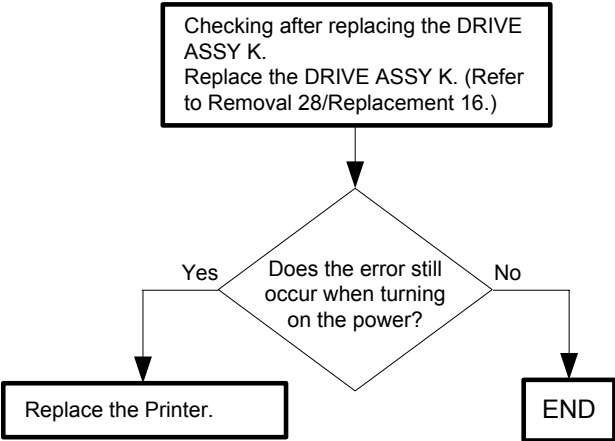

Flows 15 009-360 Restart Printer

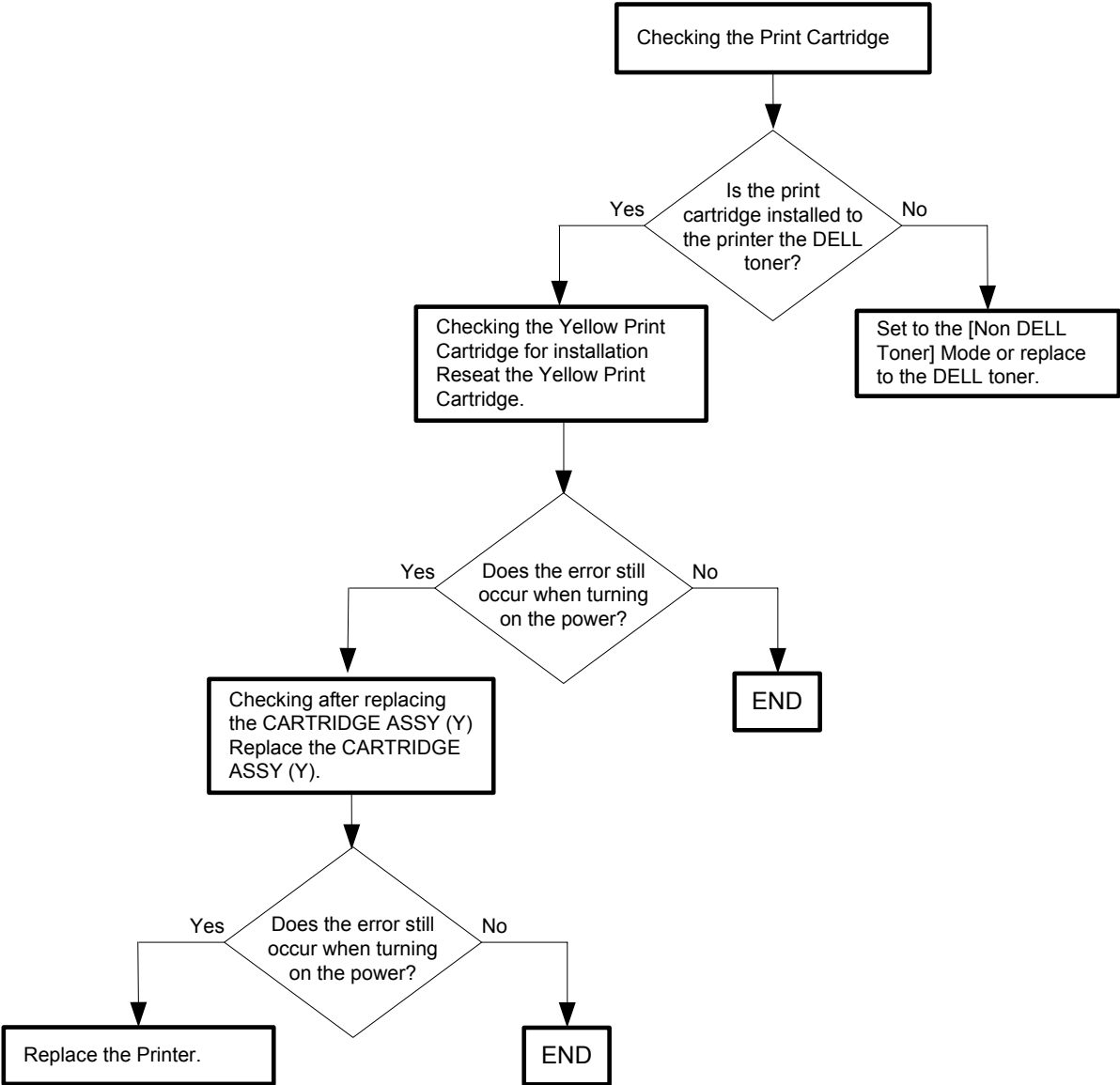

Flows 16 009-361 Restart Printer

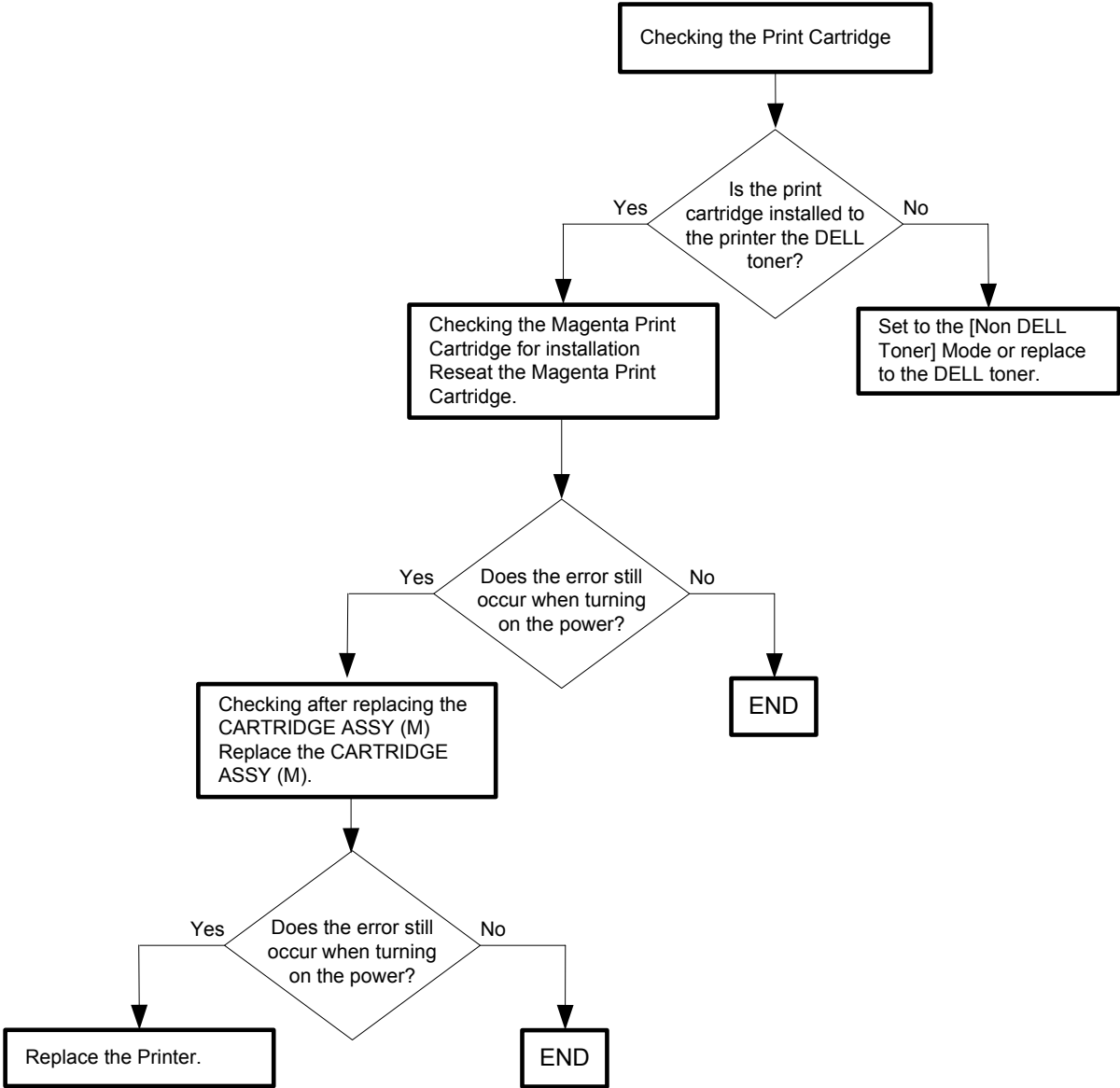

Flows 17 009-362 Restart Printer

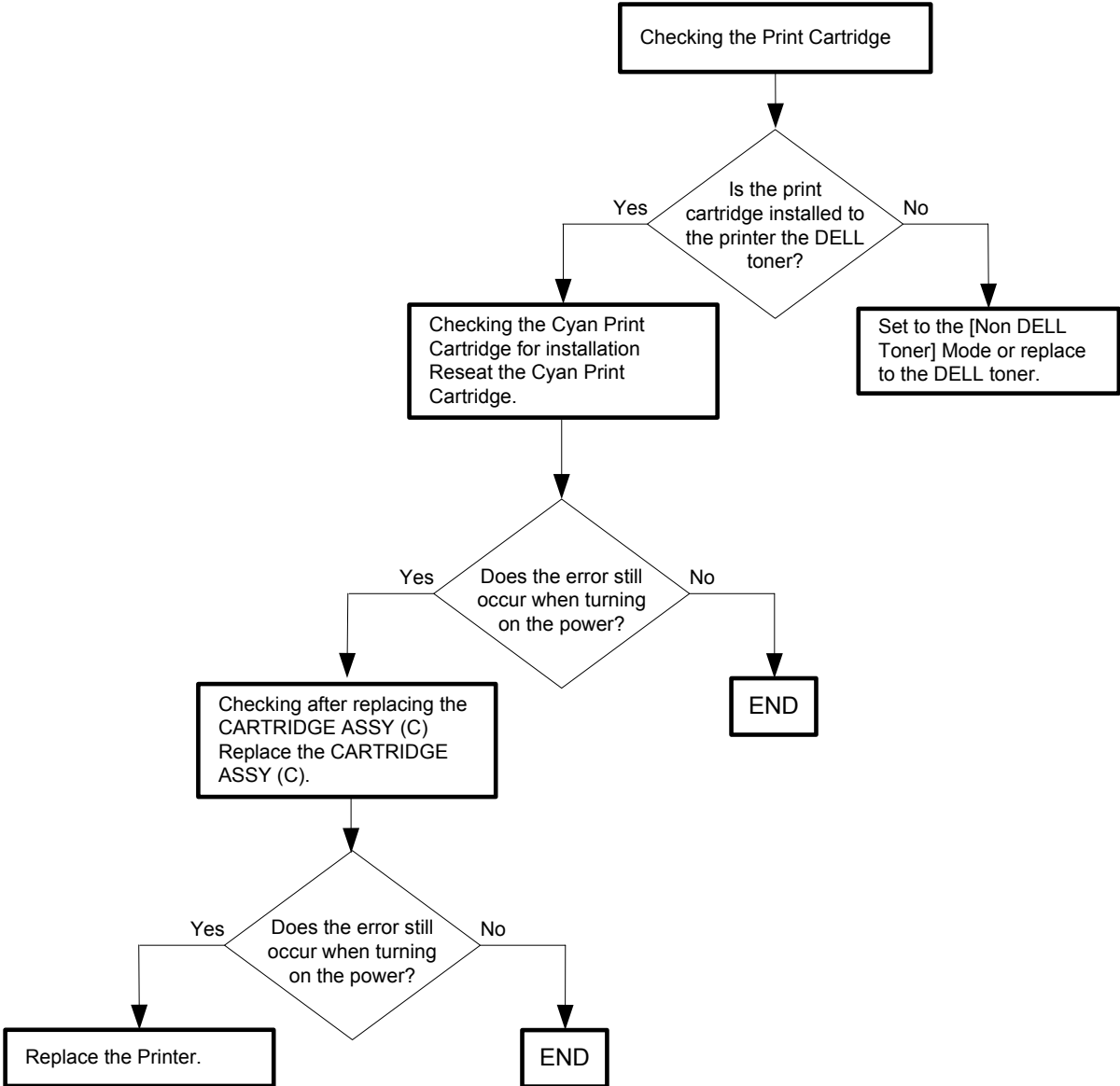

Flows 18 009-363 Restart Printer

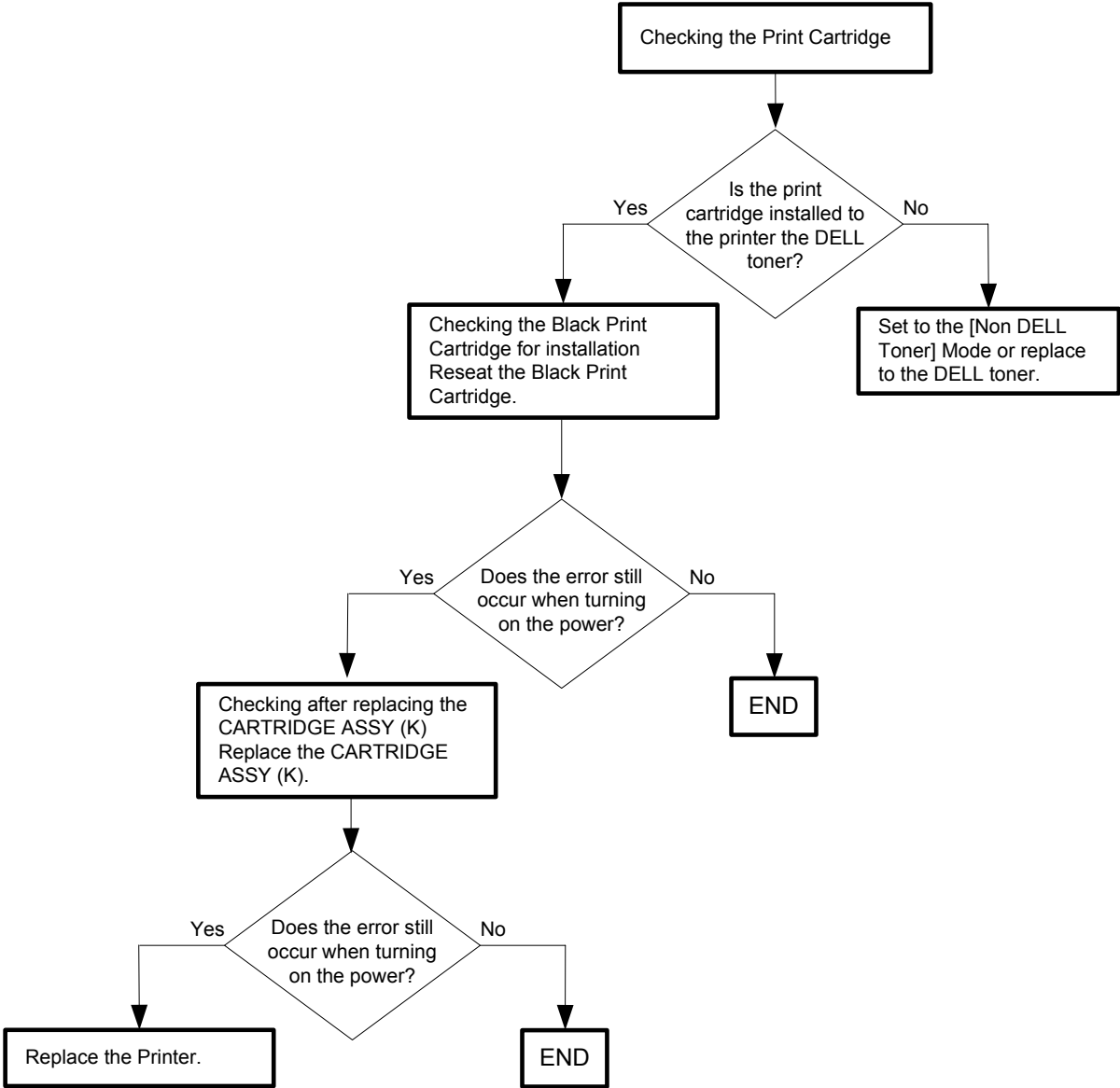

Flows 19 009-654-01 Restart Printer

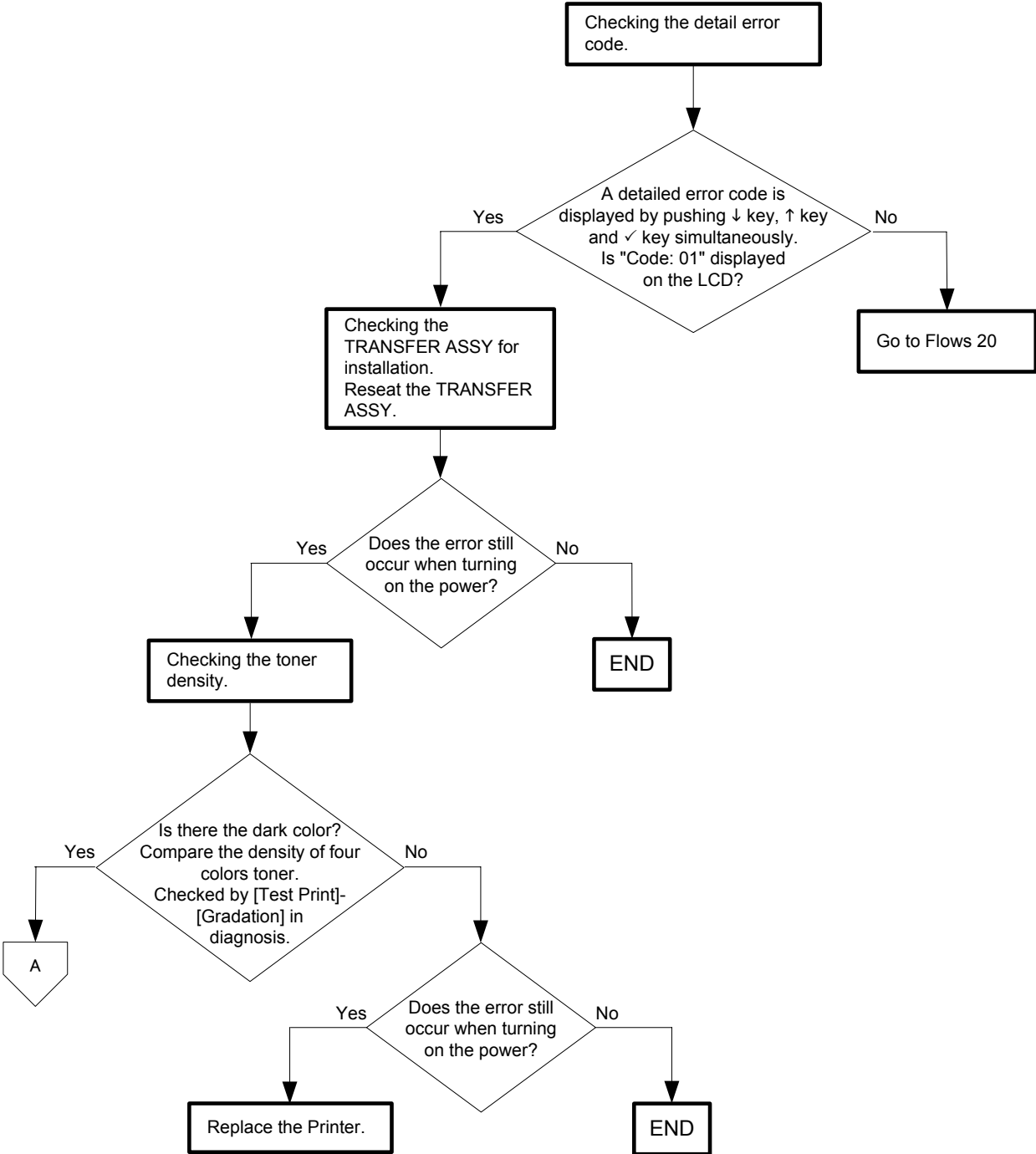

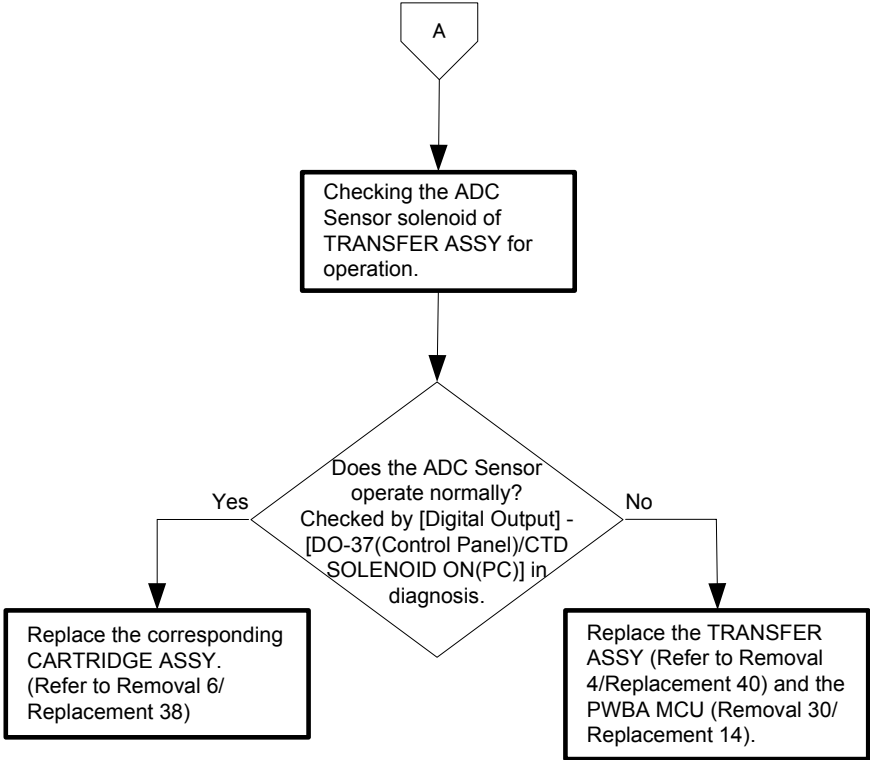

Flows 20 009-654-02 Restart Printer

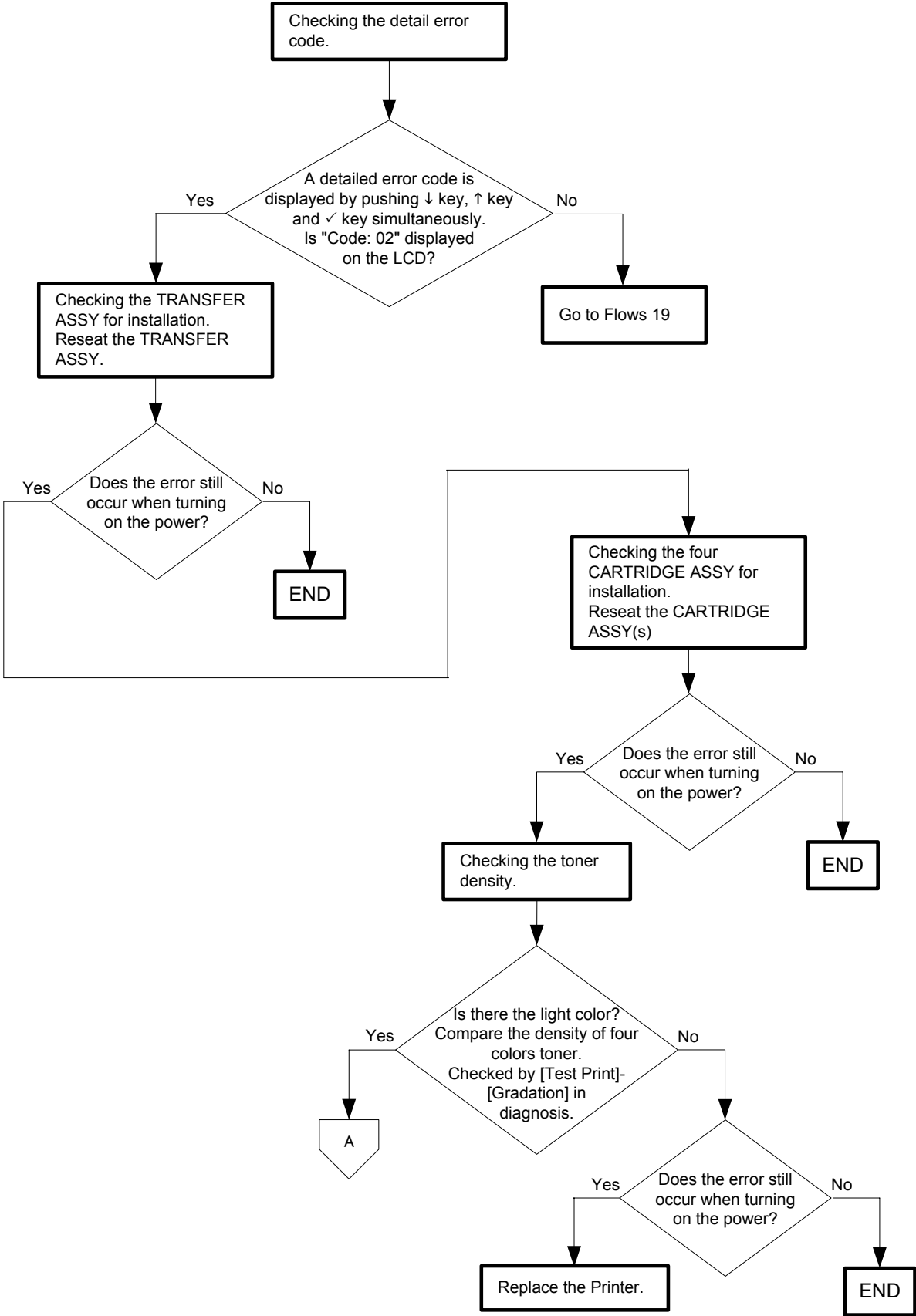

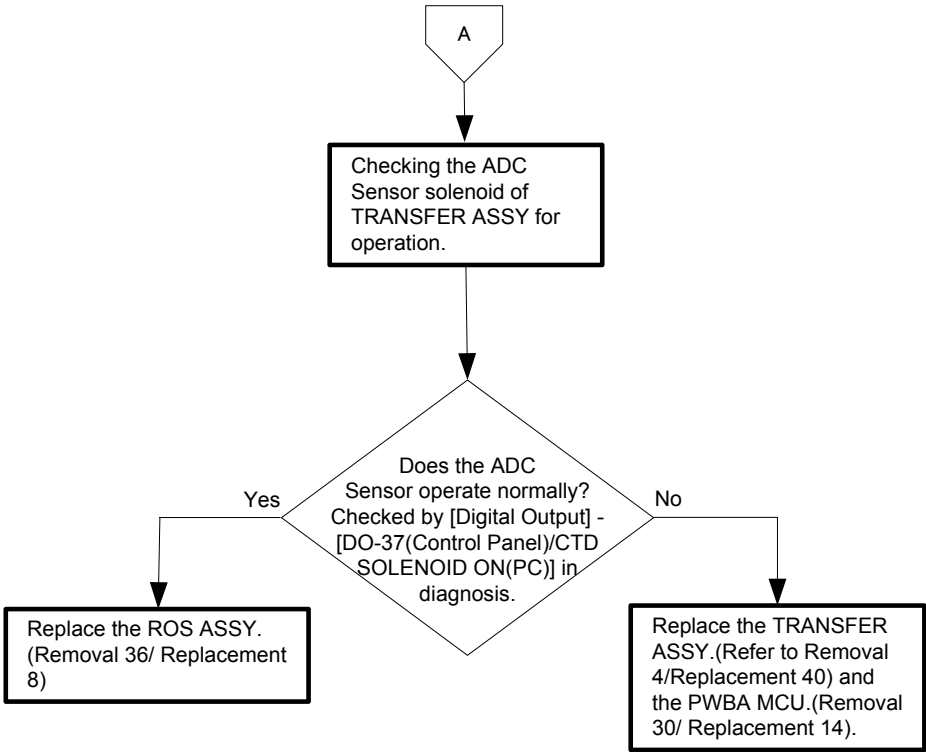

Flows 21 010-317 Restart Printer

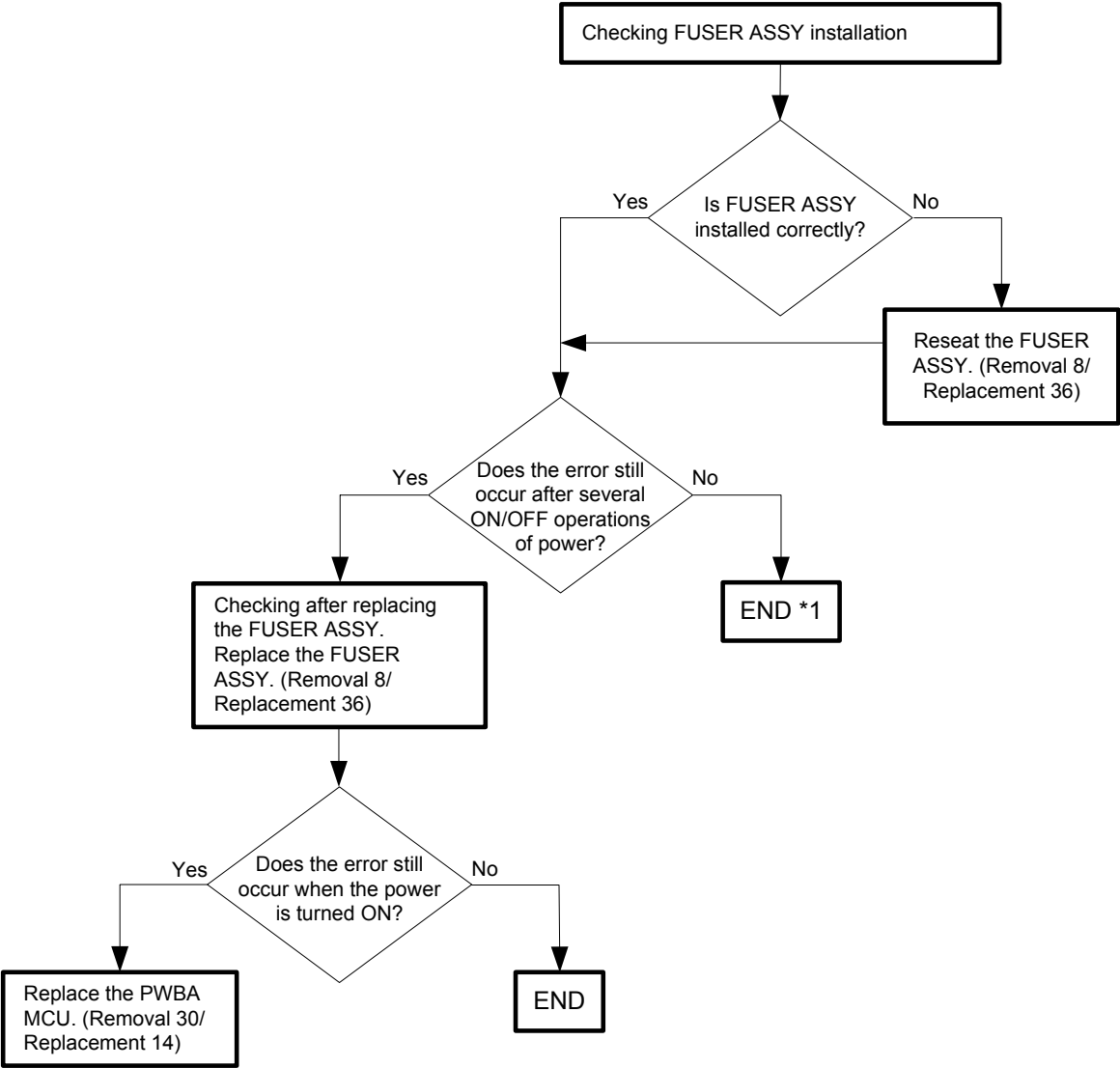

*1: Though some kind of external noise would be possible cause, go to [FIP1.73 Electrical Noise] and check, to make sure.

Flows 22 010-351 Restart Printer

NOTE

This error code is displayed when the Fuser ASSY has reached its end of life and needs replacing.

Immediately replace the Fuser ASSY with a new one.

If this error code is displayed although the Fuser ASSY has been replaced only recently, follow the following flow.

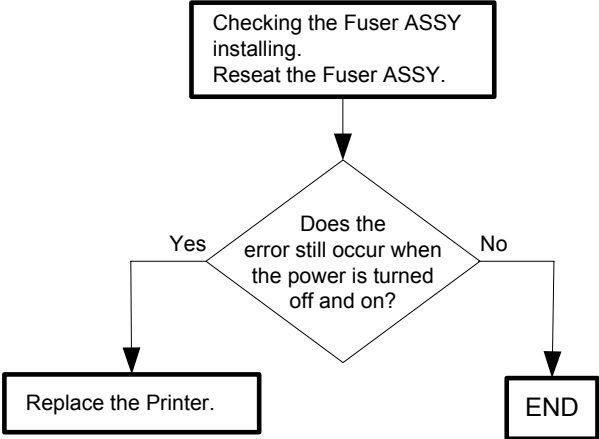

Flows 23 010-354 Restart Printer

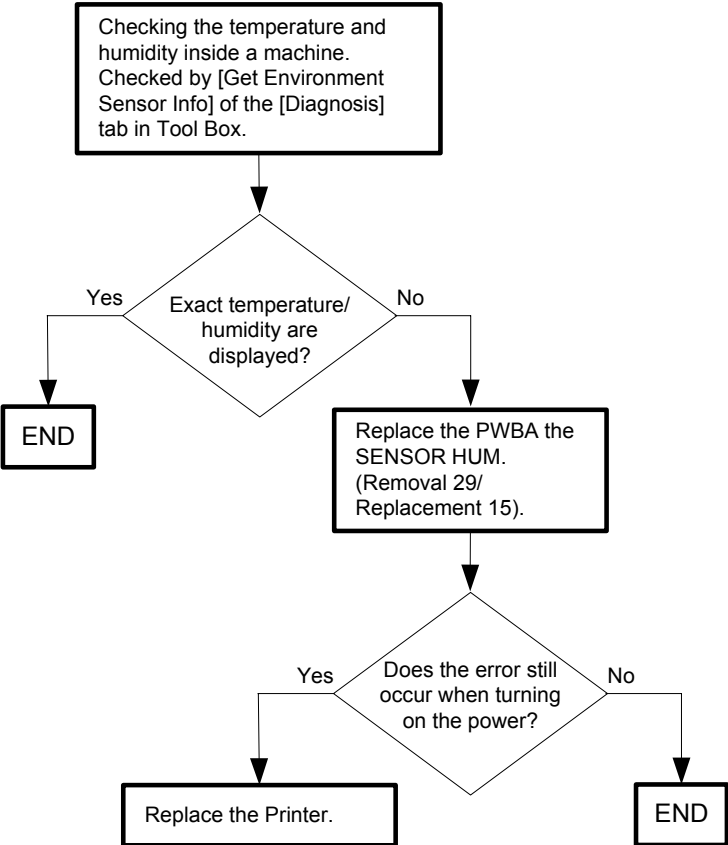

Flows 24 010-377 Restart Printer

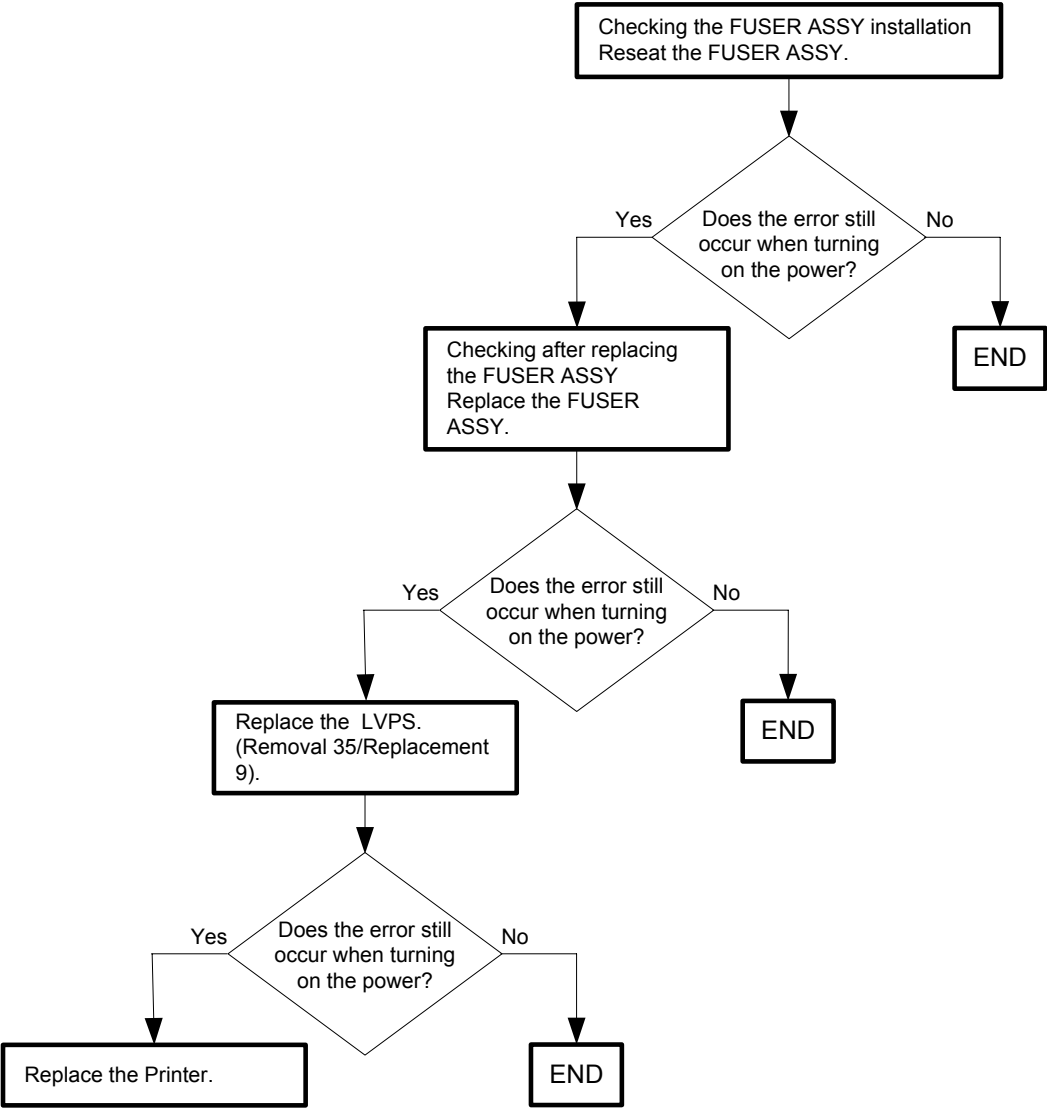

Flows 25 016-300/016-301/016-302/016-310/016-313/016-315/016-317/016-323/016-327/016-344/016-345/016-346/016-347 Restart / Erase Flash Err. 016-392 / Write Flash Err. 016-393 / Verify Error 016-394

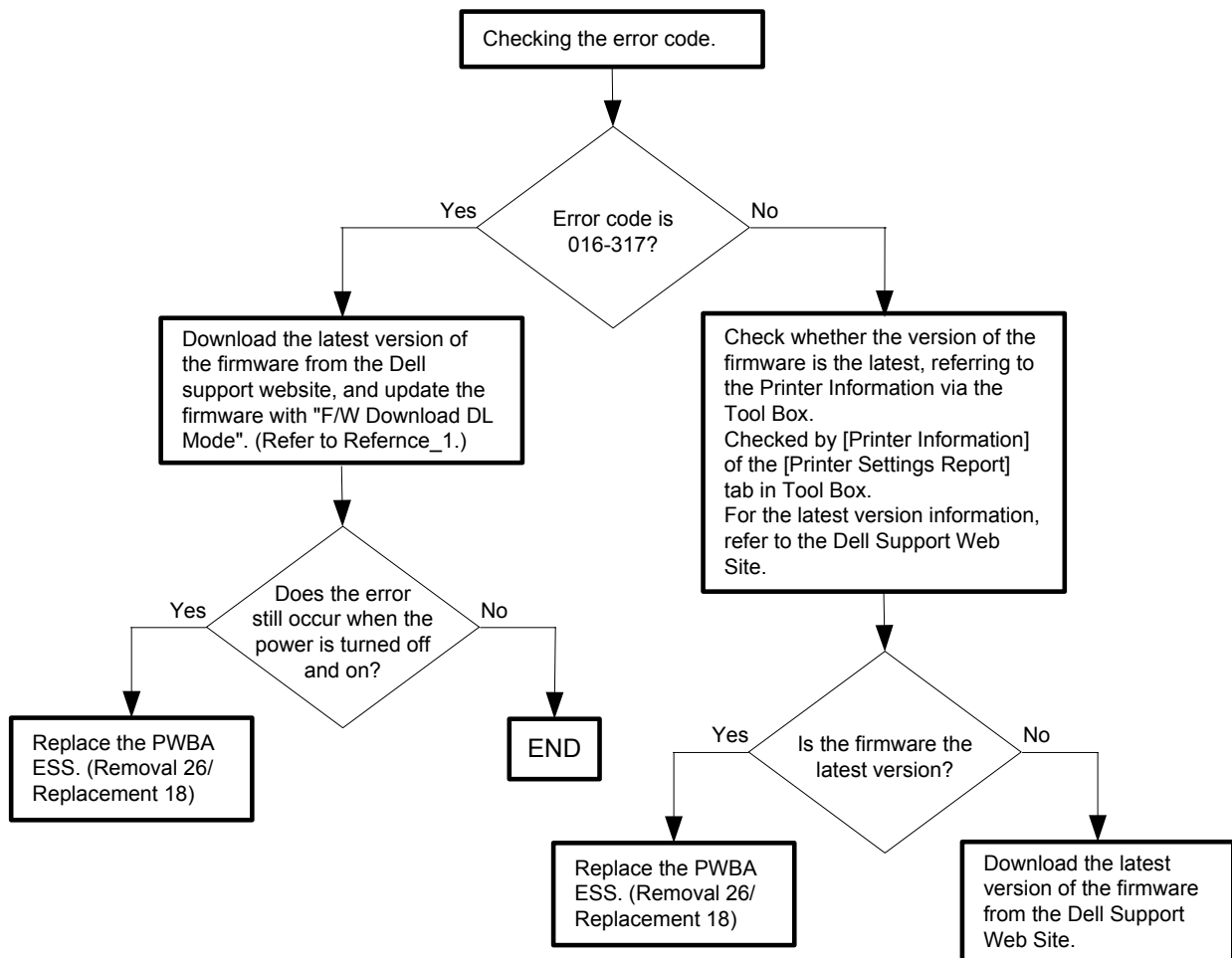

Reference_1:

1. Make sure that the printer is connected to the computer via USB port or Parallel port (remove the network cable). Then, try downloading as follows:
 - 1) Power on the printer while pressing the <X Cancel> and <✓> buttons.
 - 2) Press <▼> button to select "F/W Download DL Mode Parallel" or "F/W Download DL Mode USB", and then press <✓> button.
 - 3) The printer goes into the Download Mode with a message "Download Mode Ready. Then, activate firmware update tool and follow the instruction displayed.

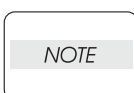

While the firmware download is being executed, the printer displays a message "Writing..... F/W", and the computer displays a progress bar and may be restarted during the downloading process. Never power off the printer or the computer until the downloading process completes, and never interrupt the downloading process.

Flows 25-1 016-340 Restart Printer

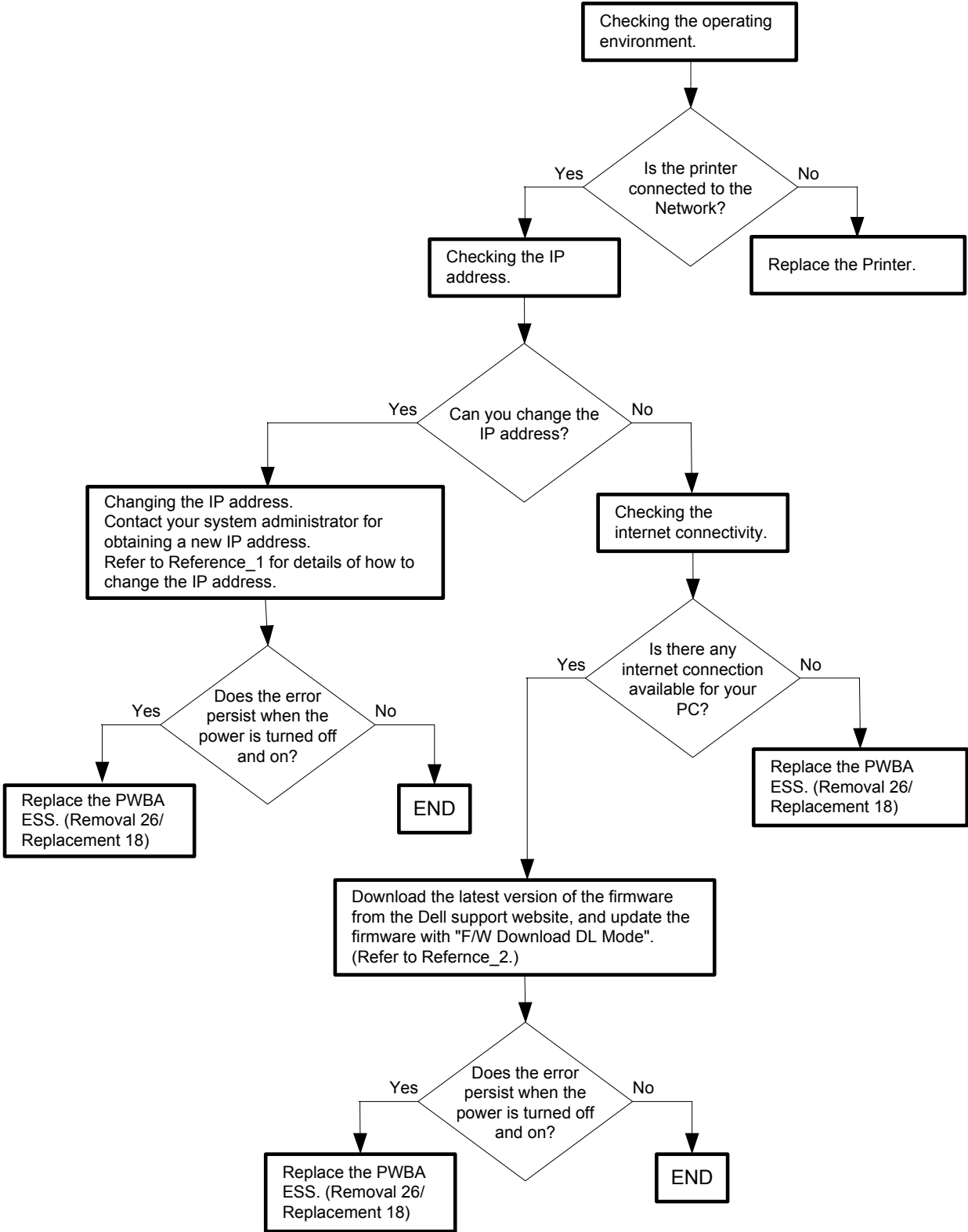

Reference_1: Changing the IP address

- 1) Remove the network cable, and power off the printer and then on
- 2) Change the IP address on the Control Panel.
- 3) Plug the network cable back into the printer, and then turn the power on.
- 4) On the Control Panel, open [Admin] > [Network] > [TCP/IP], and confirm that the IP address has been changed.

Reference_2:

1. Make sure that the printer is connected to the computer via USB port or Parallel port (remove the network cable). Then, try downloading as follows:
 - 1) Power on the printer while pressing the <X Cancel> and <✓> buttons.
 - 2) Press <▼> button to select "F/W Download DL Mode Parallel" or "F/W Download DL Mode USB", and then press <✓> button.
 - 3) The printer goes into the Download Mode with a message "Download Mode Ready". Then, activate firmware update tool and follow the instruction displayed.

NOTE

While the firmware download is being executed, the printer displays a message "Writing..... F/W", and the computer displays a progress bar and may be restarted during the downloading process. Never power off the printer or the computer until the downloading process completes, and never interrupt the downloading process.

Flows 26 016-312/016-361 Restart Printer

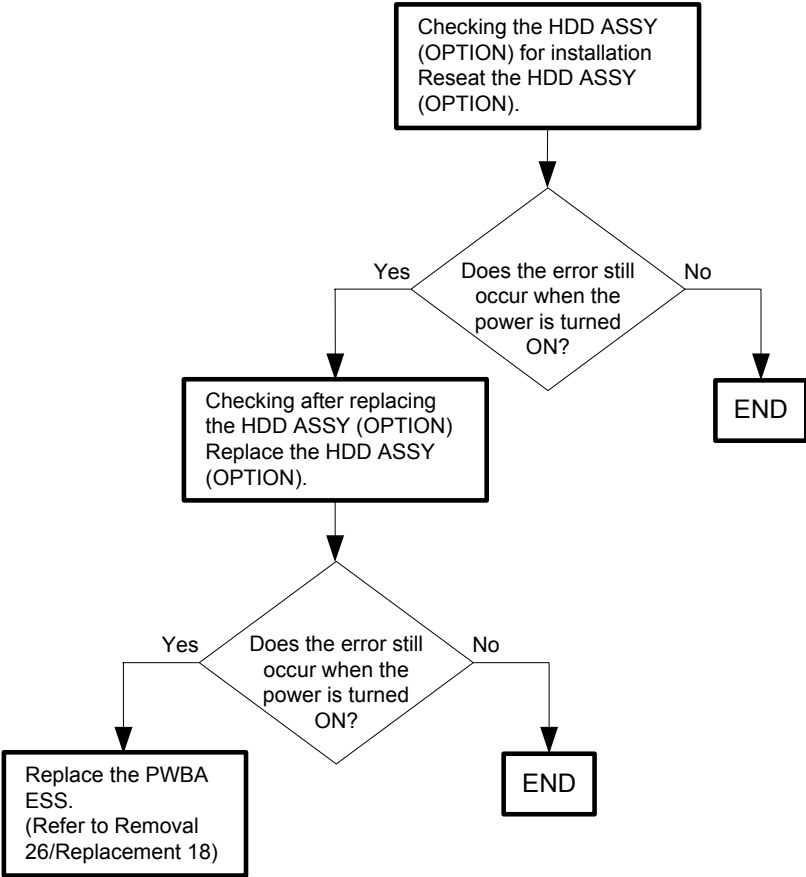

Flows 27 016-316/016-318 Restart Printer

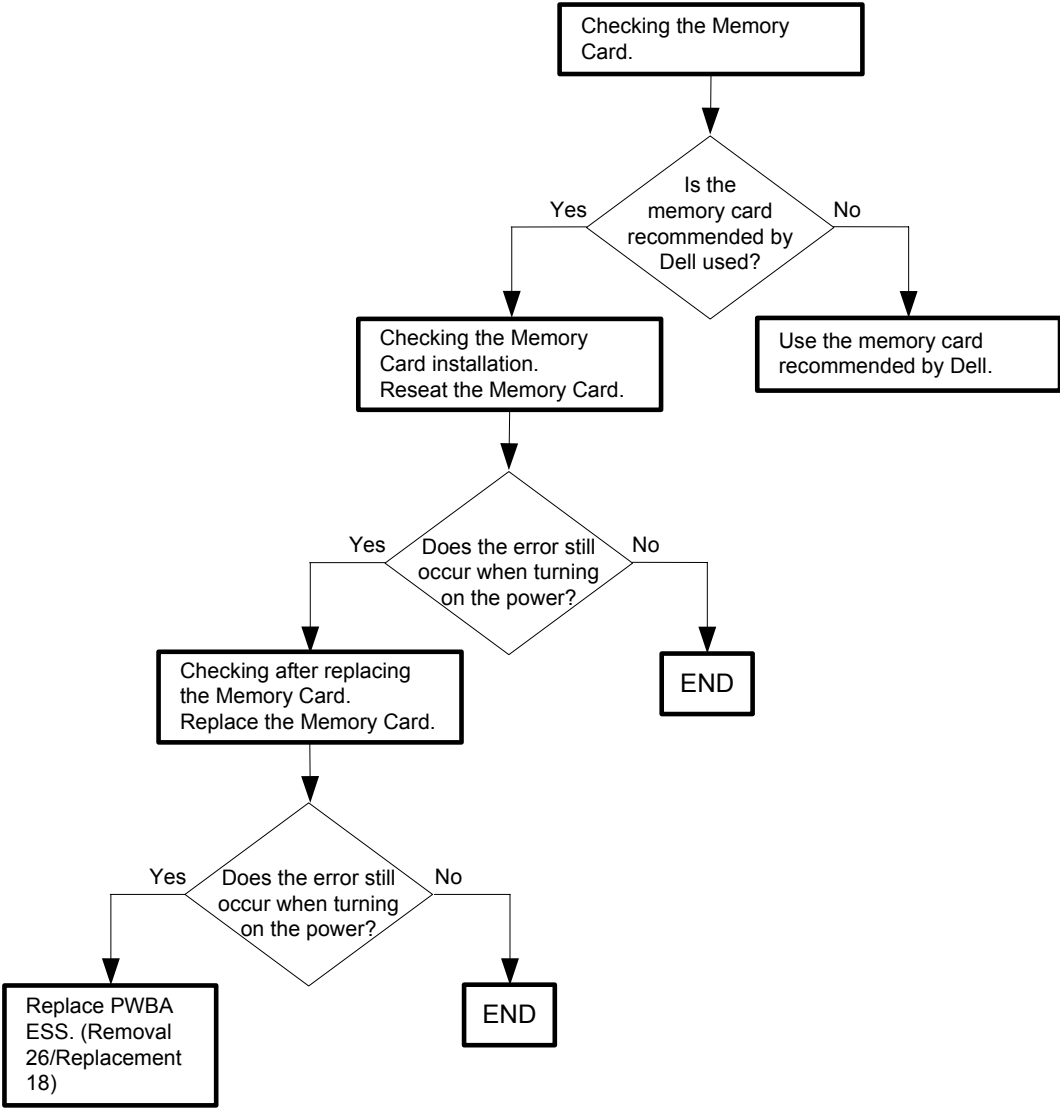

Flows 28 016-338 Restart Printer

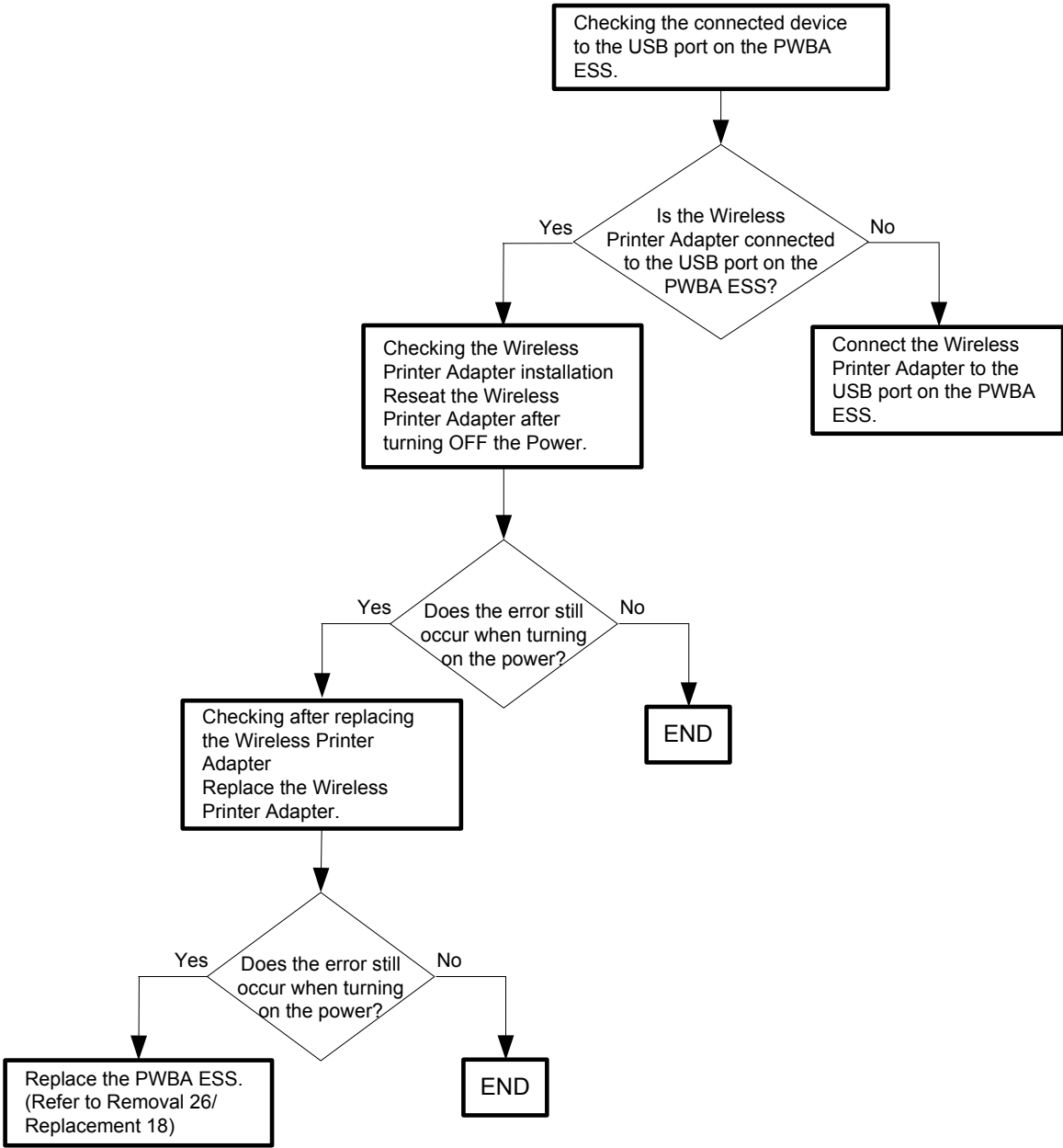

Flows 29 016-350 Restart Printer

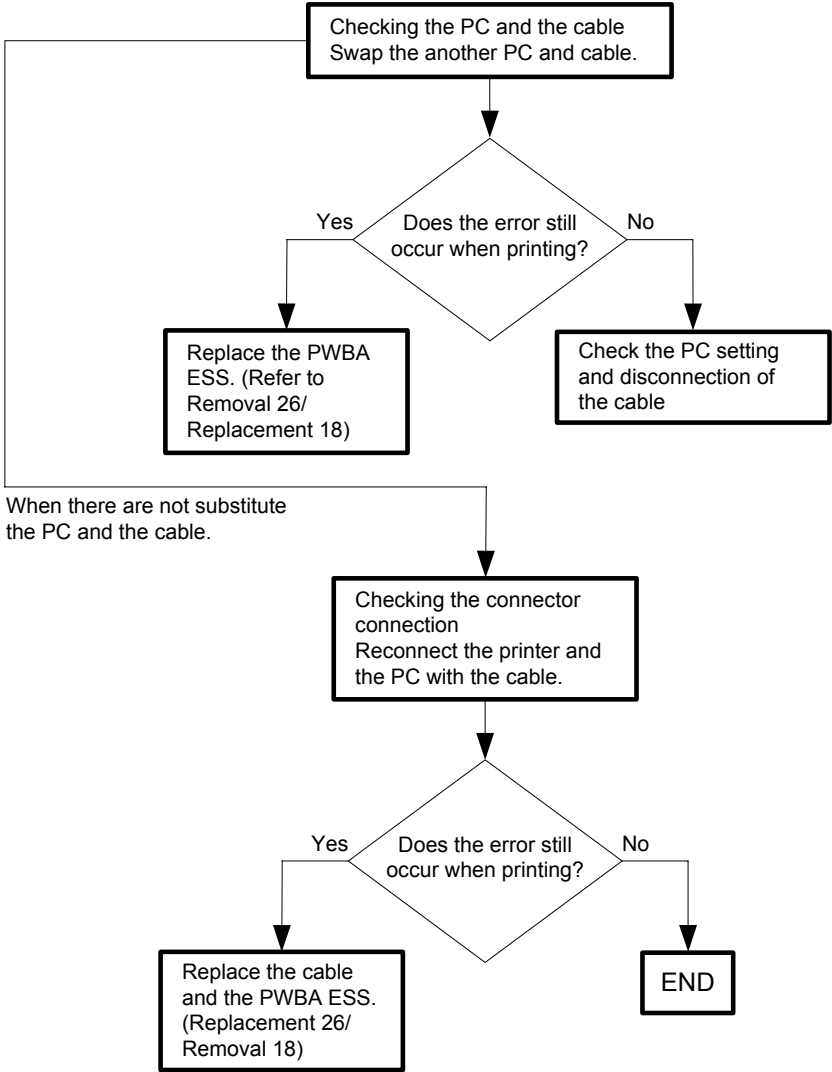

Flows 30 016-365 Restart Printer

NOTE

If Network Adapter is missing you cannot print to the protocols it supports over the network (wired or wireless).

To use the printer without the Network Adapter, you need to clear the Wireless LAN settings. Refer to the User Guide for how to clear the Wireless LAN settings.

To keep the printer connected to your wireless network, replace the Network Adapter with a new one.

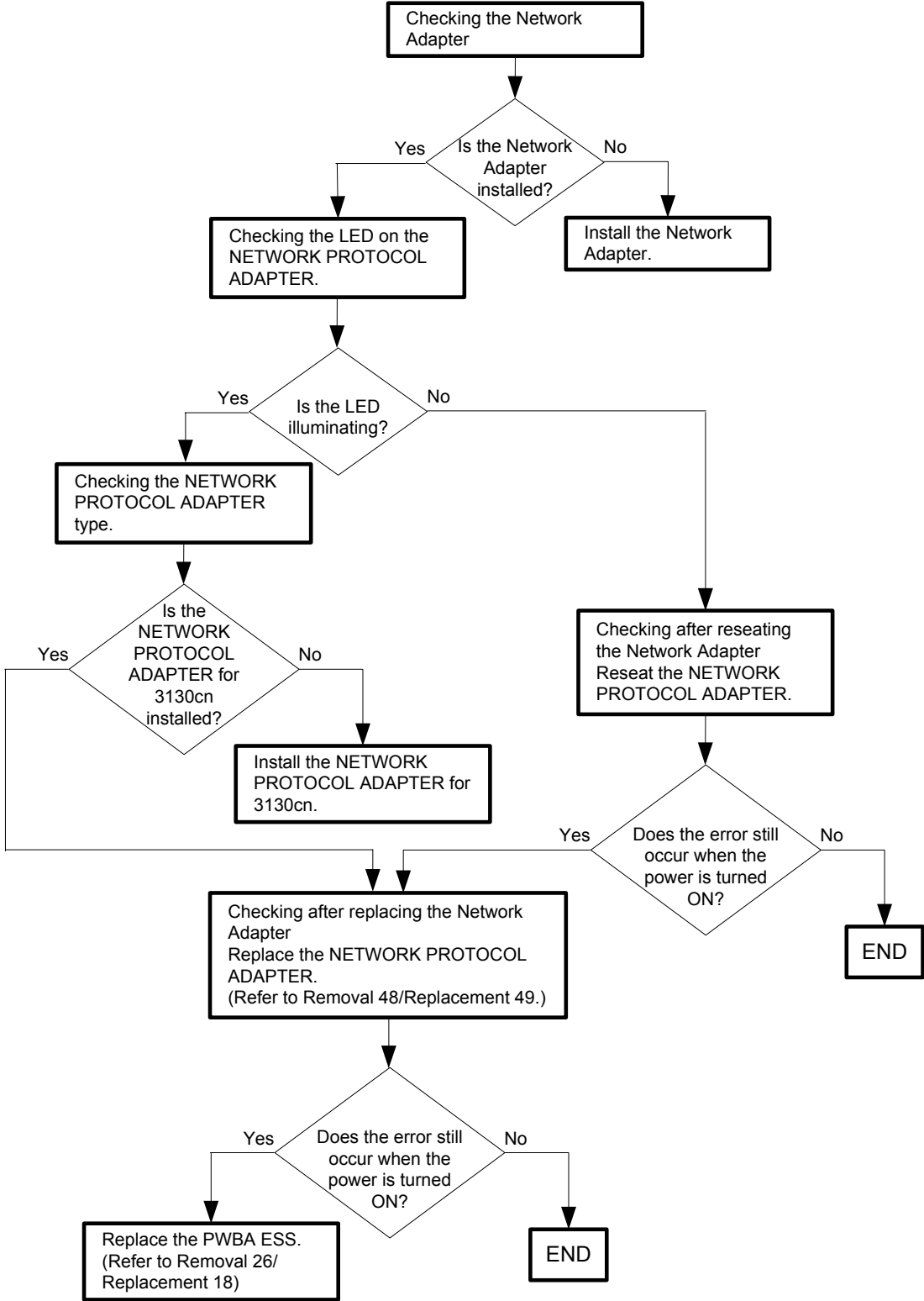

Flows 31 016-370 Restart Printer

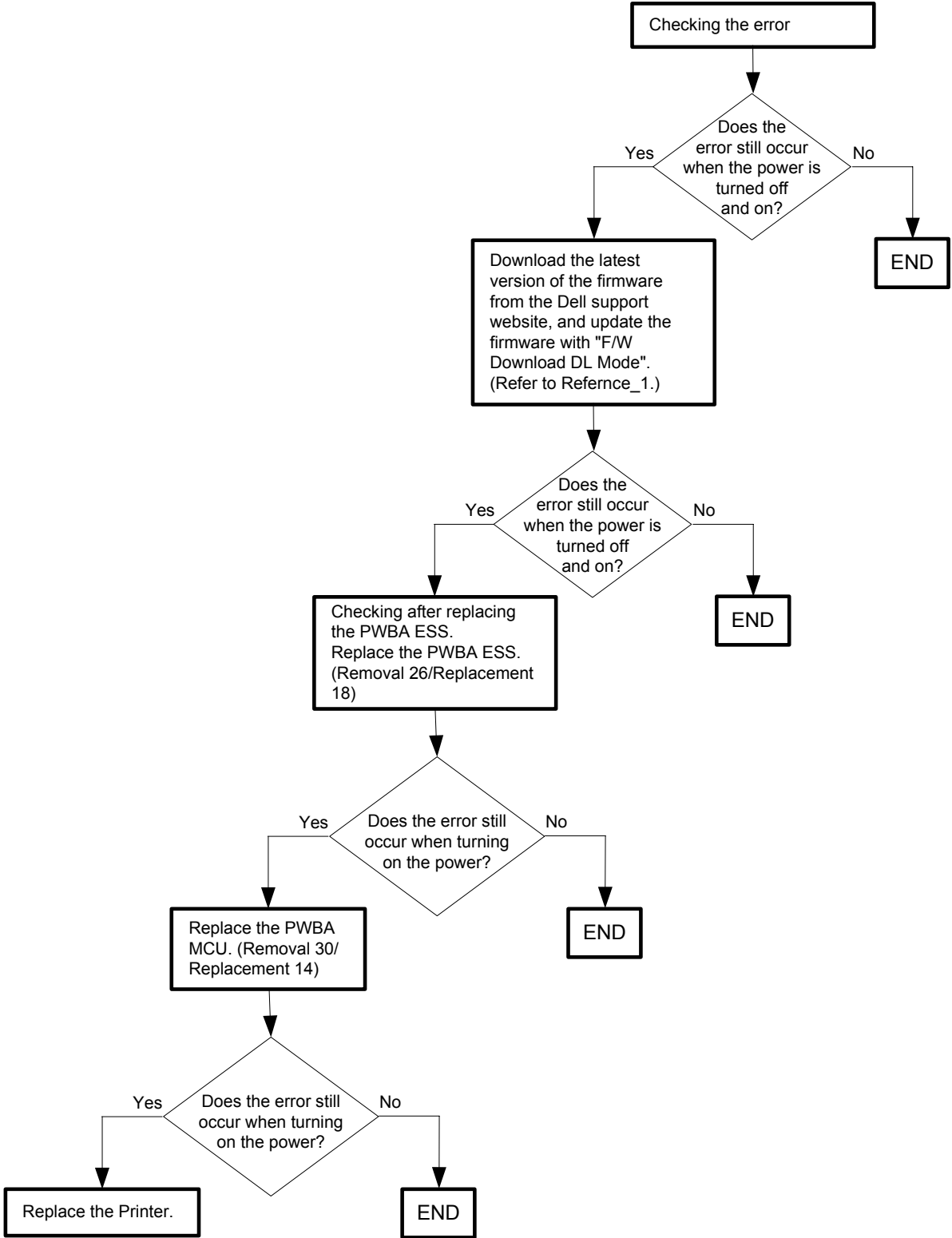

Reference_1:

1. Make sure that the printer is connected to the computer via USB port or Parallel port (remove the network cable). Then, try downloading as follows:
 - 1) Power on the printer while pressing the <X Cancel> and <✓> buttons.
 - 2) Press <▼> button to select "F/W Download DL Mode Parallel" or "F/W Download DL Mode USB", and then press <✓> button.
 - 3) The printer goes into the Download Mode with a message "Download Mode Ready. Then, activate firmware update tool and follow the instruction displayed.

NOTE

While the firmware download is being executed, the printer displays a message "Writing..... F/W", and the computer displays a progress bar and may be restarted during the downloading process. Never power off the printer or the computer until the downloading process completes, and never interrupt the downloading process.

Flows 32 093-964 Restart Printer

NOTE

For the PPID, refer to the label on the FUSER.

Example) FUSER for 100V
XX-0M507D-XXXXX-XXX-XXXX

↑
PPID No.

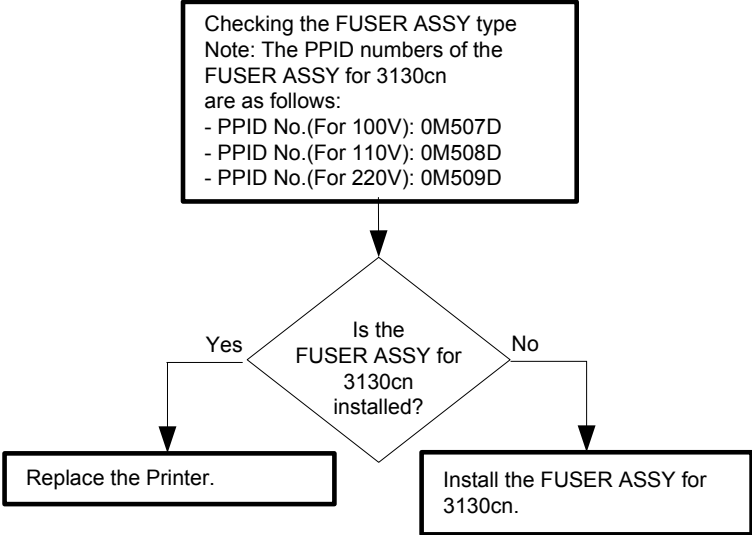

Flows 33 Paper Jam 071-100

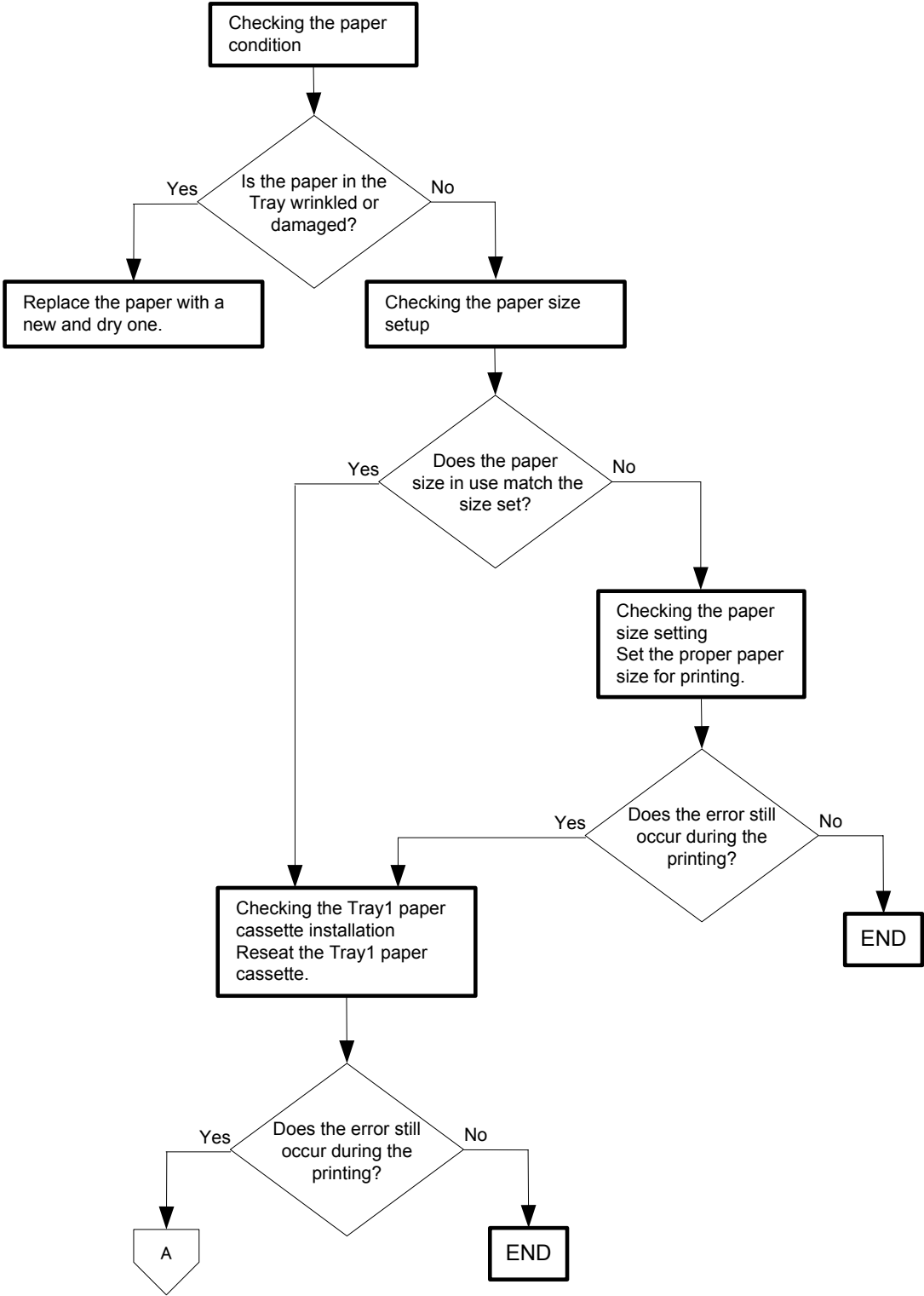

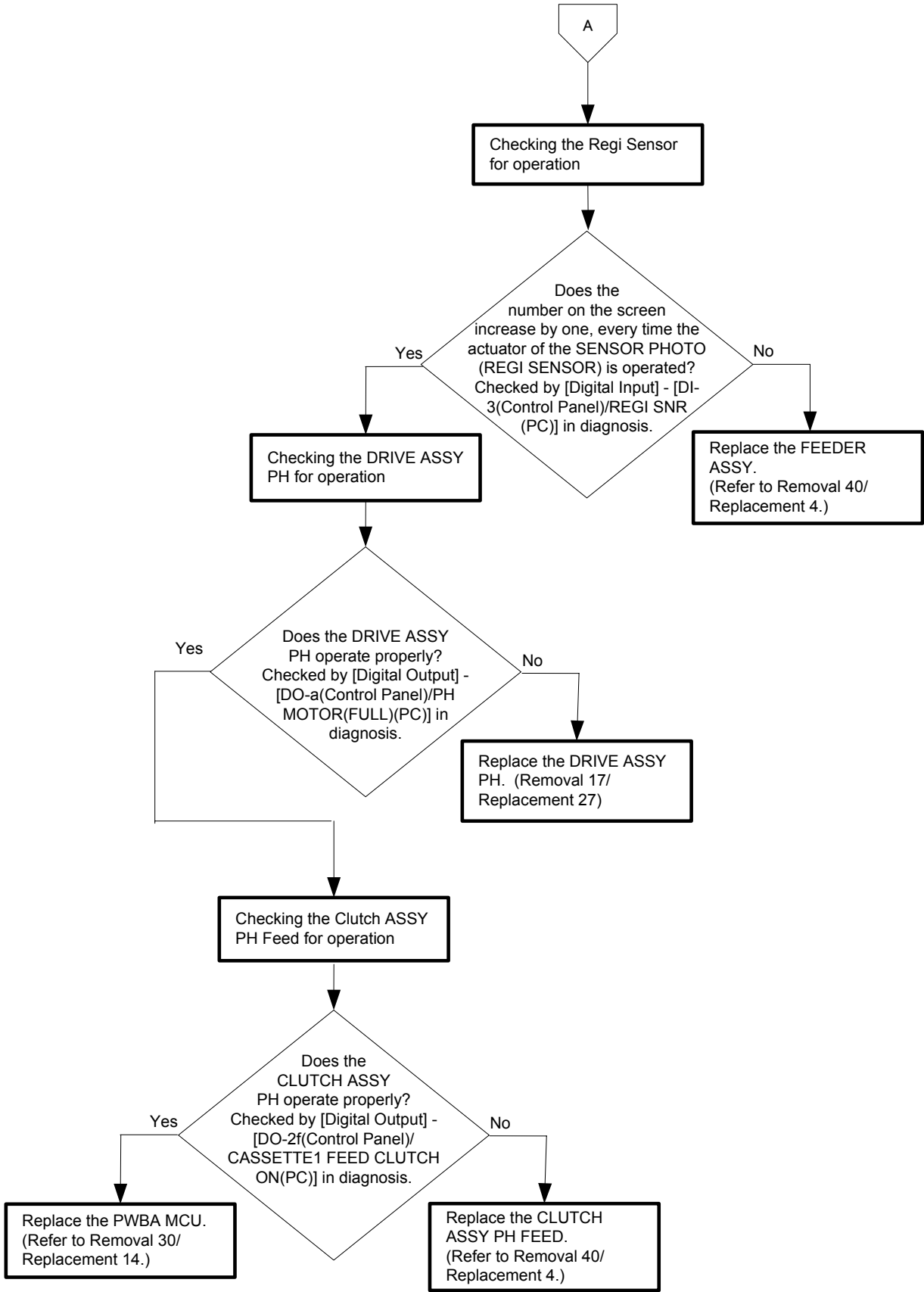

Flows 34 Paper Jam 072-100

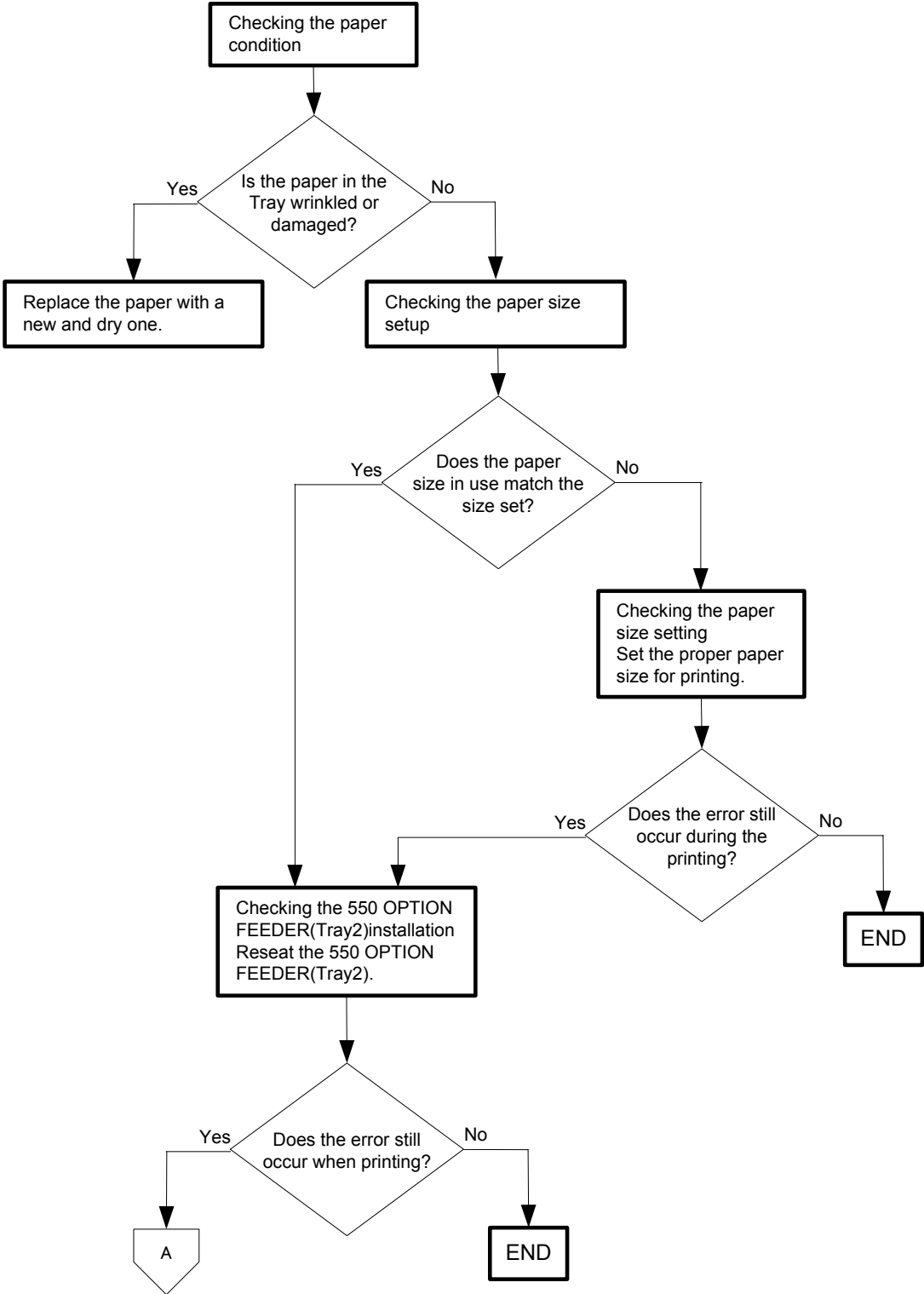

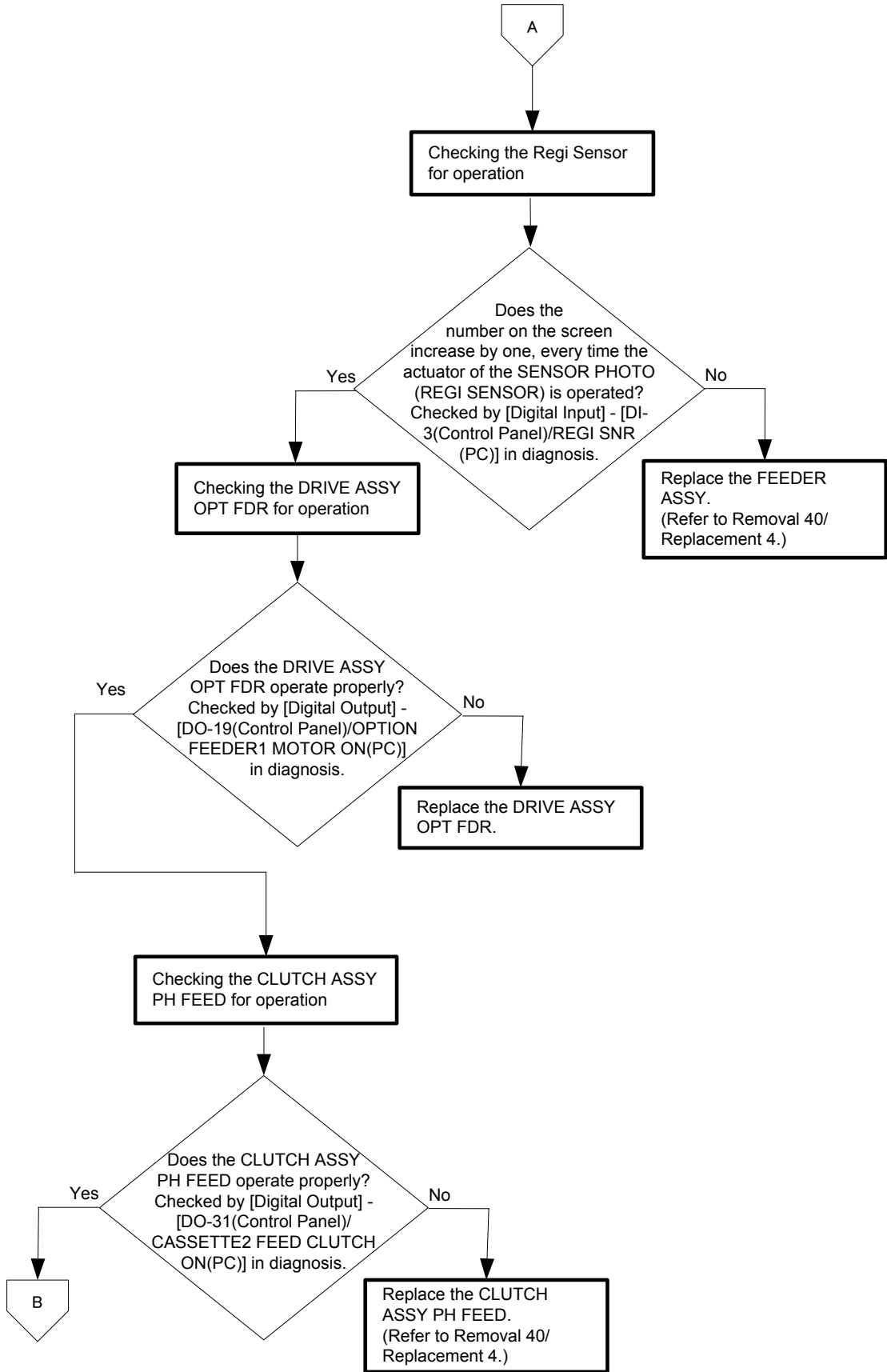

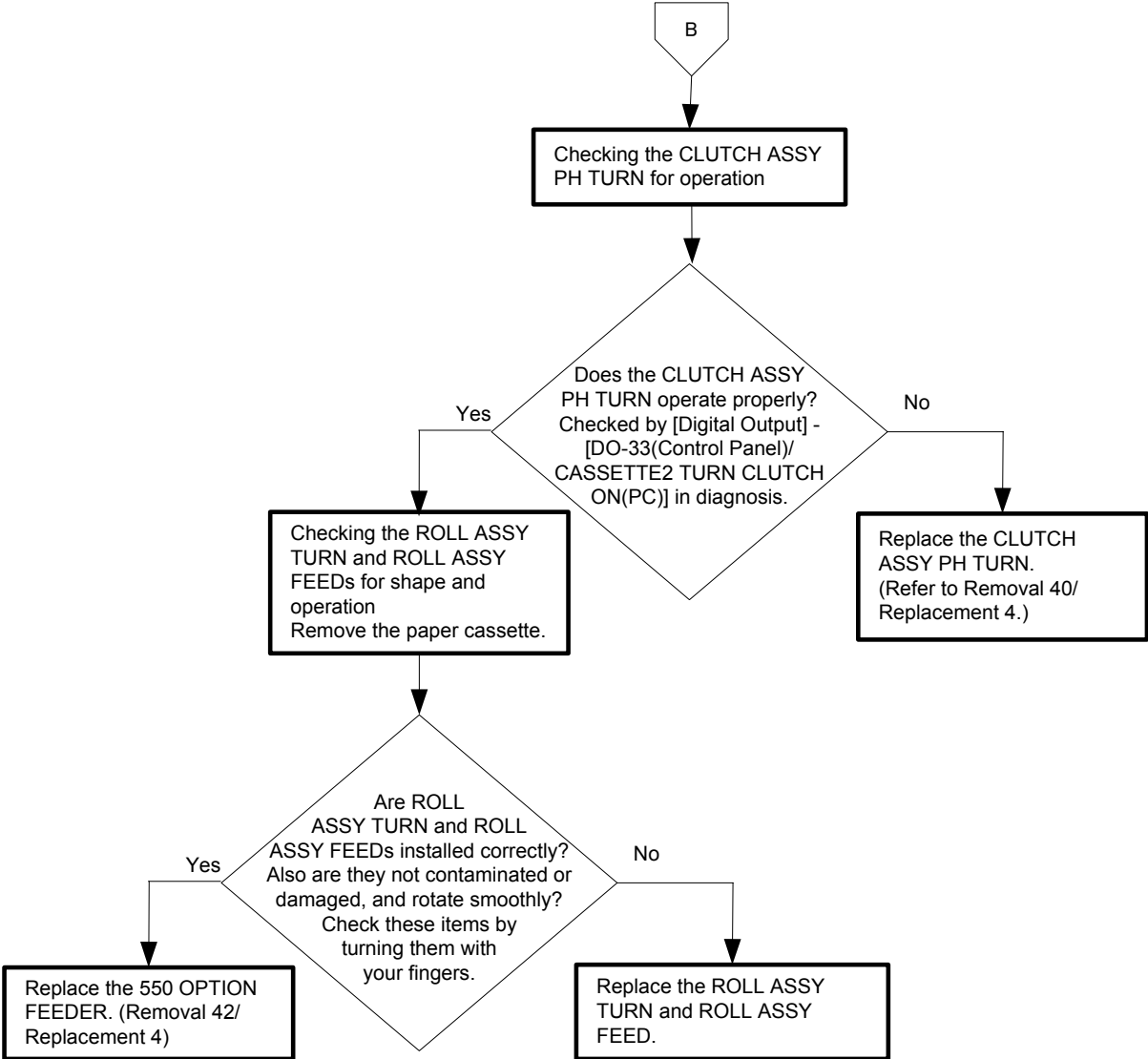

Flows 35 Paper Jam 075-100

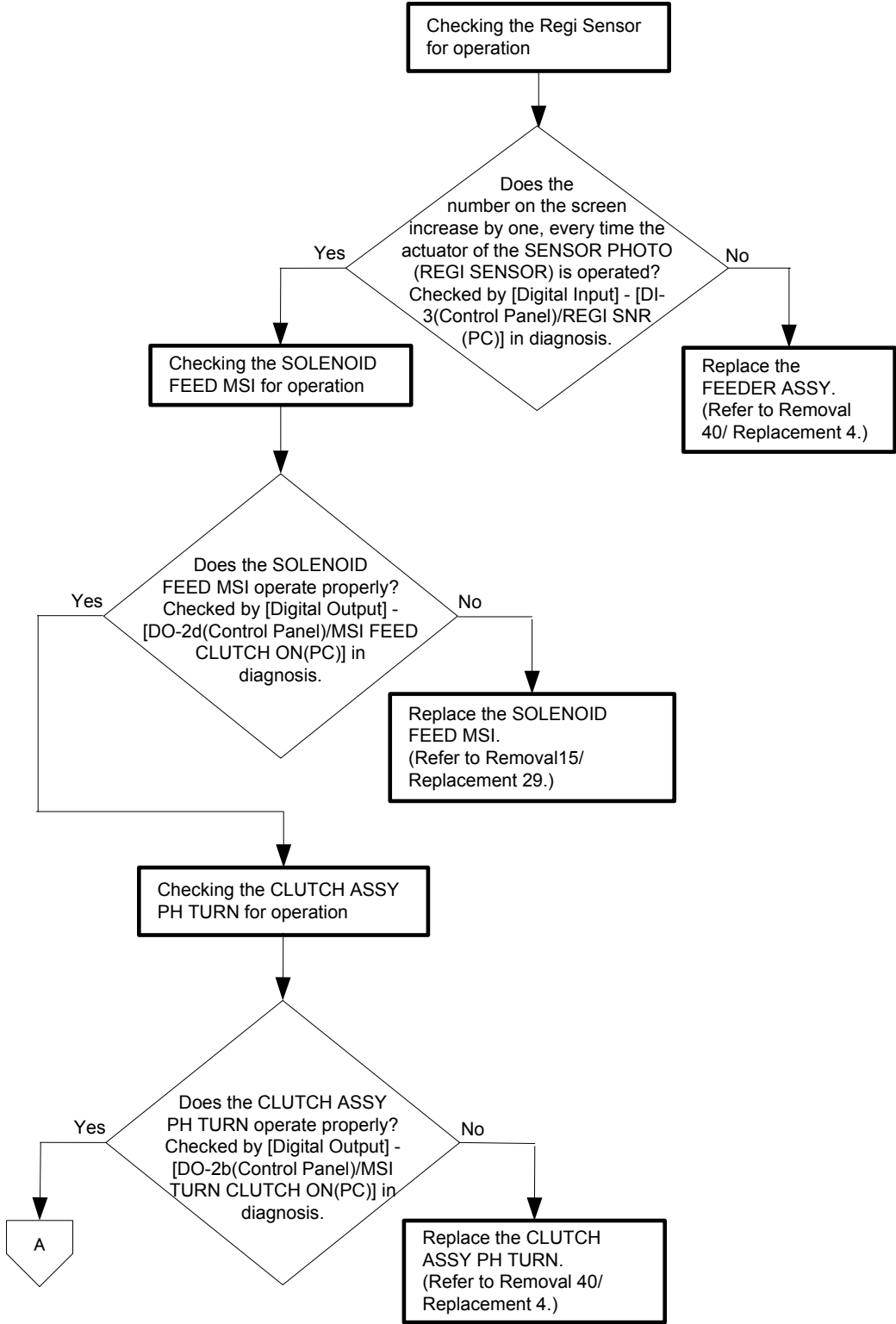

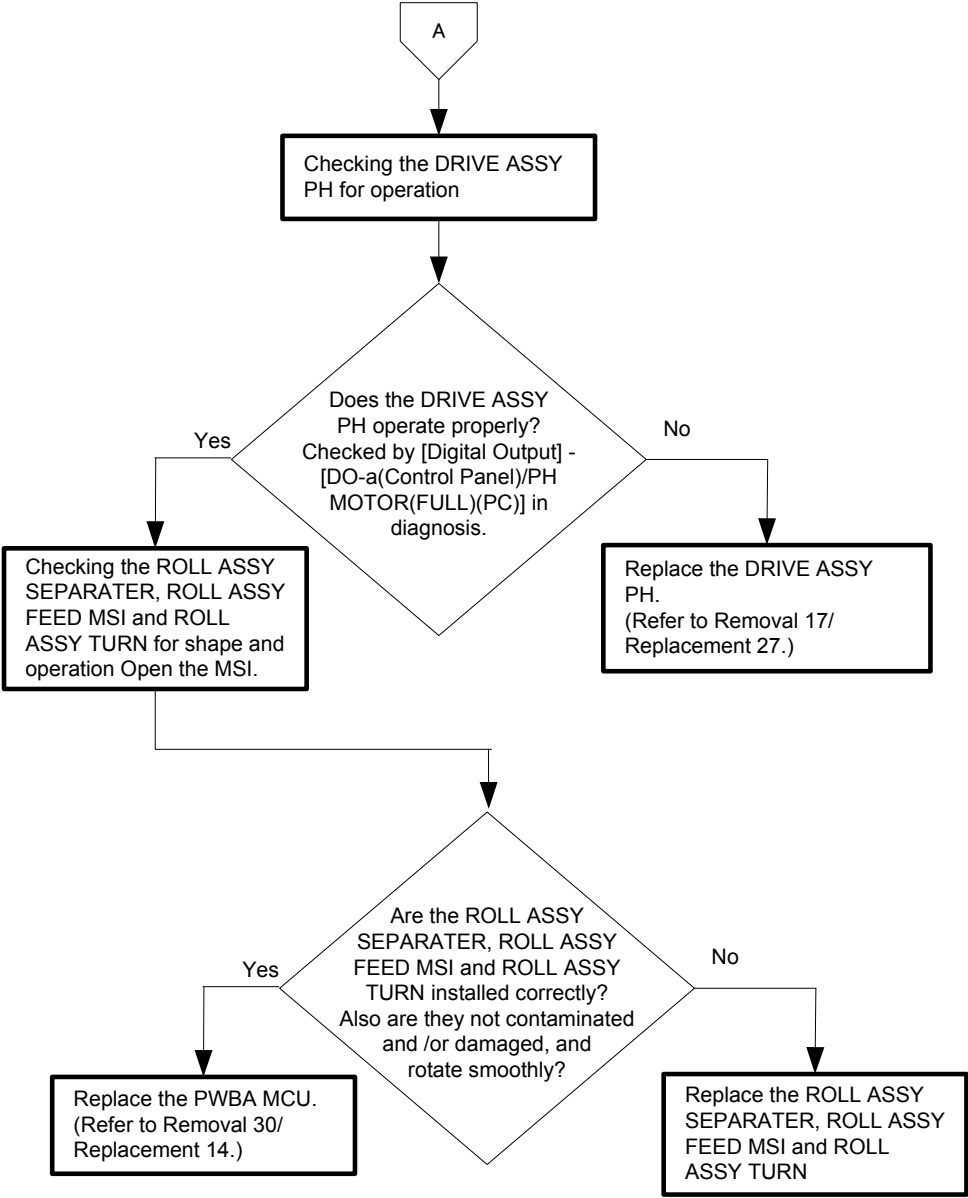

Flows 36 Paper Jam 077-100/077-101

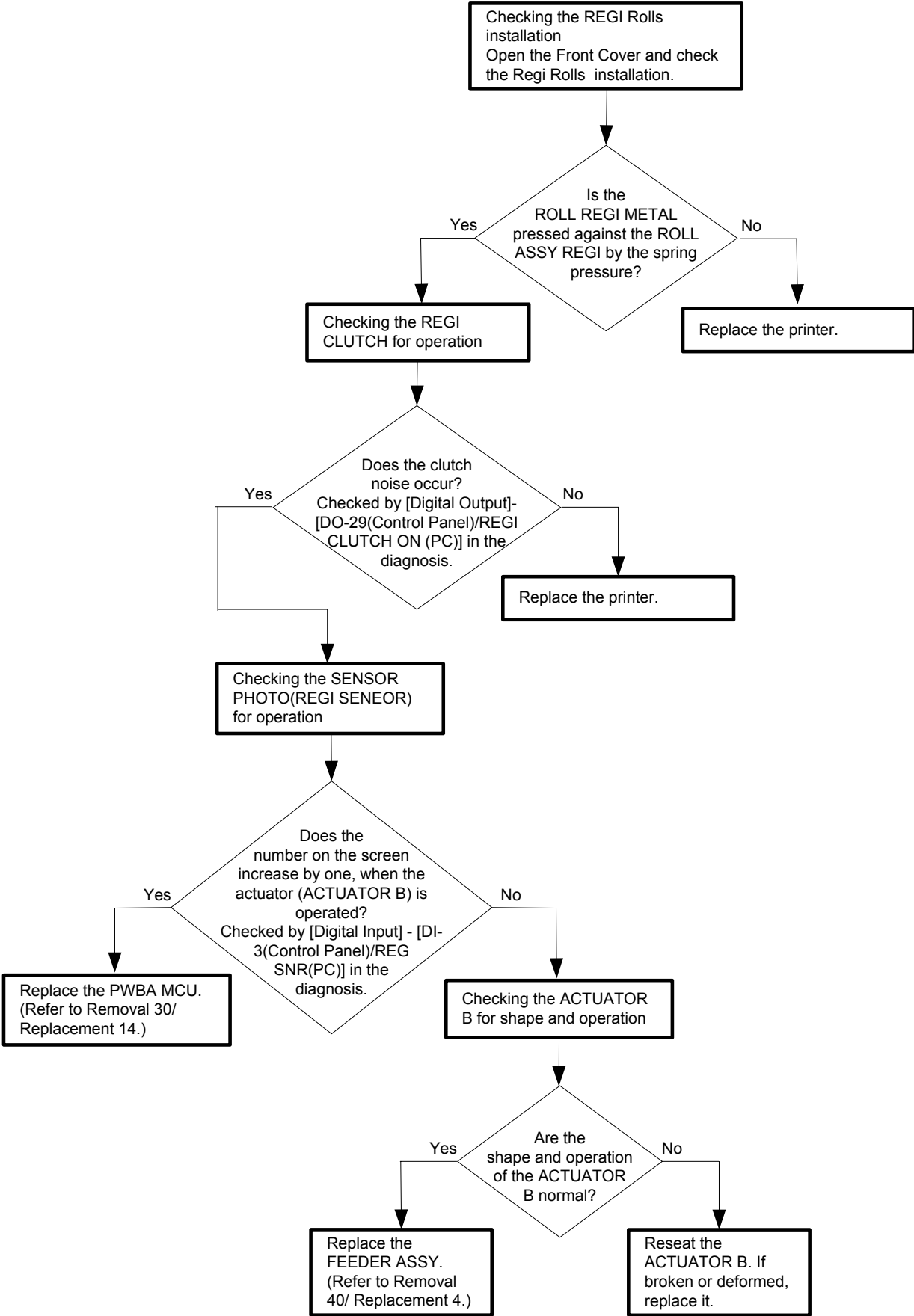

Flows 37 Paper Jam 077-102/077-103

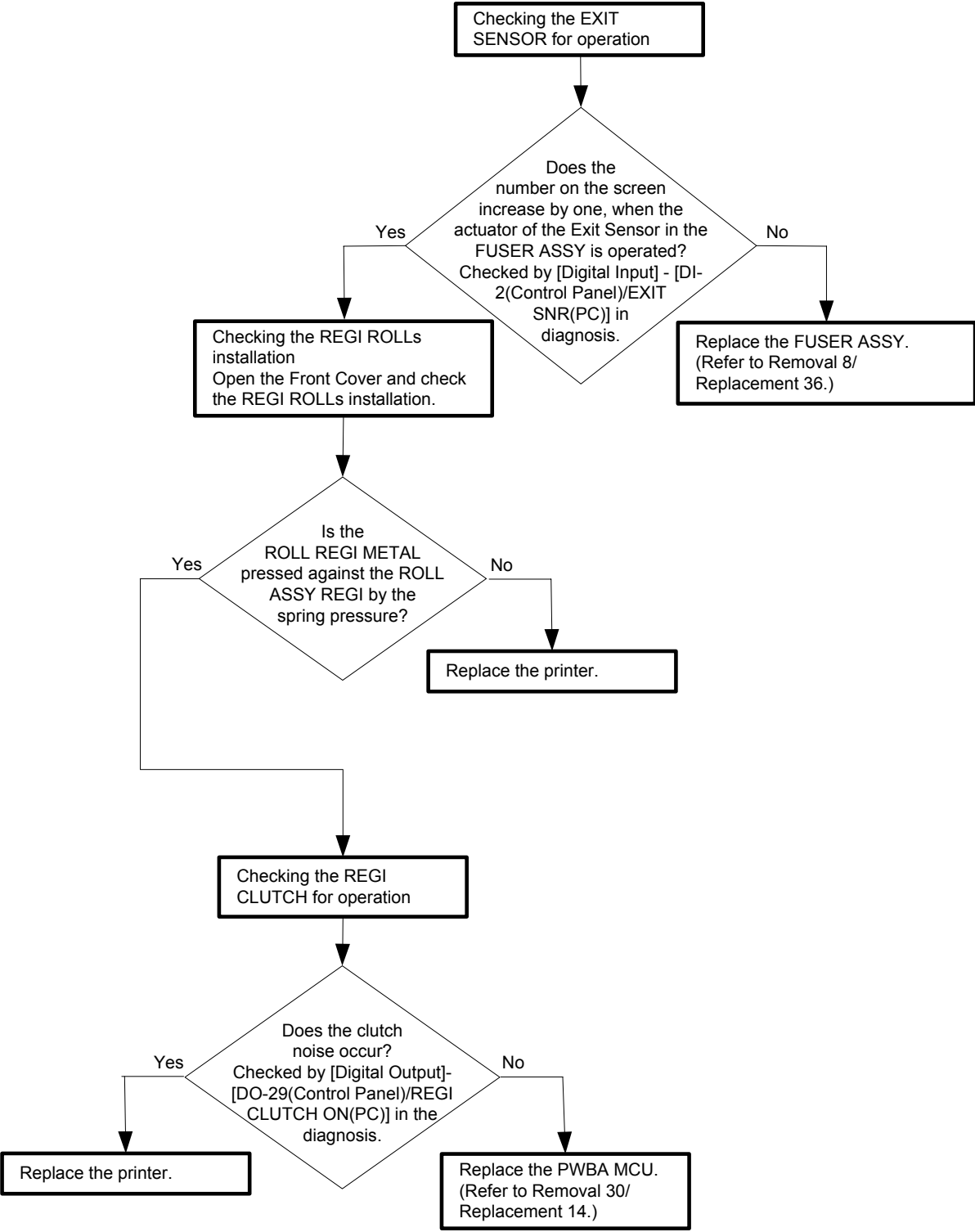

Flows 38 Paper Jam 077-104/077-107

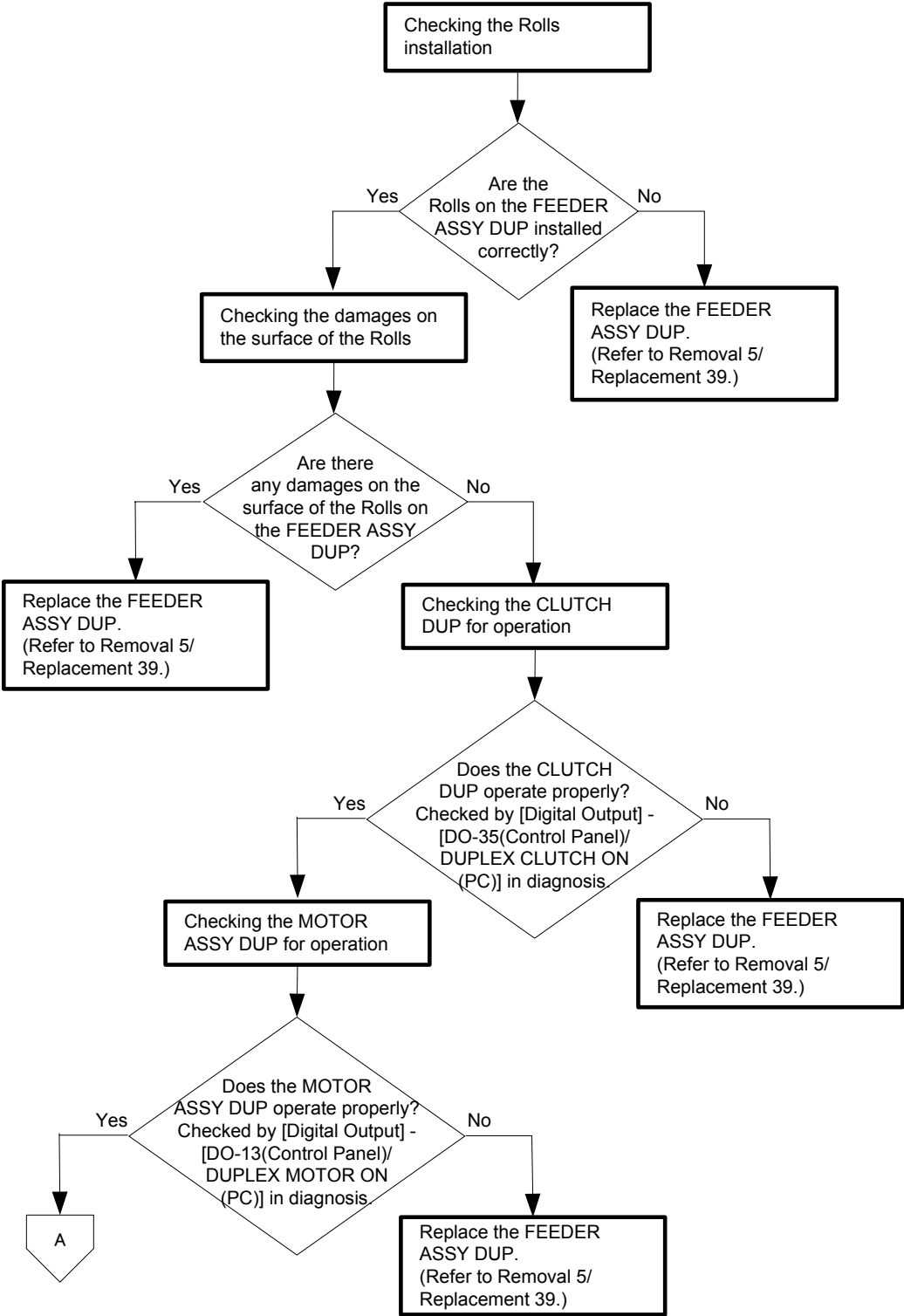

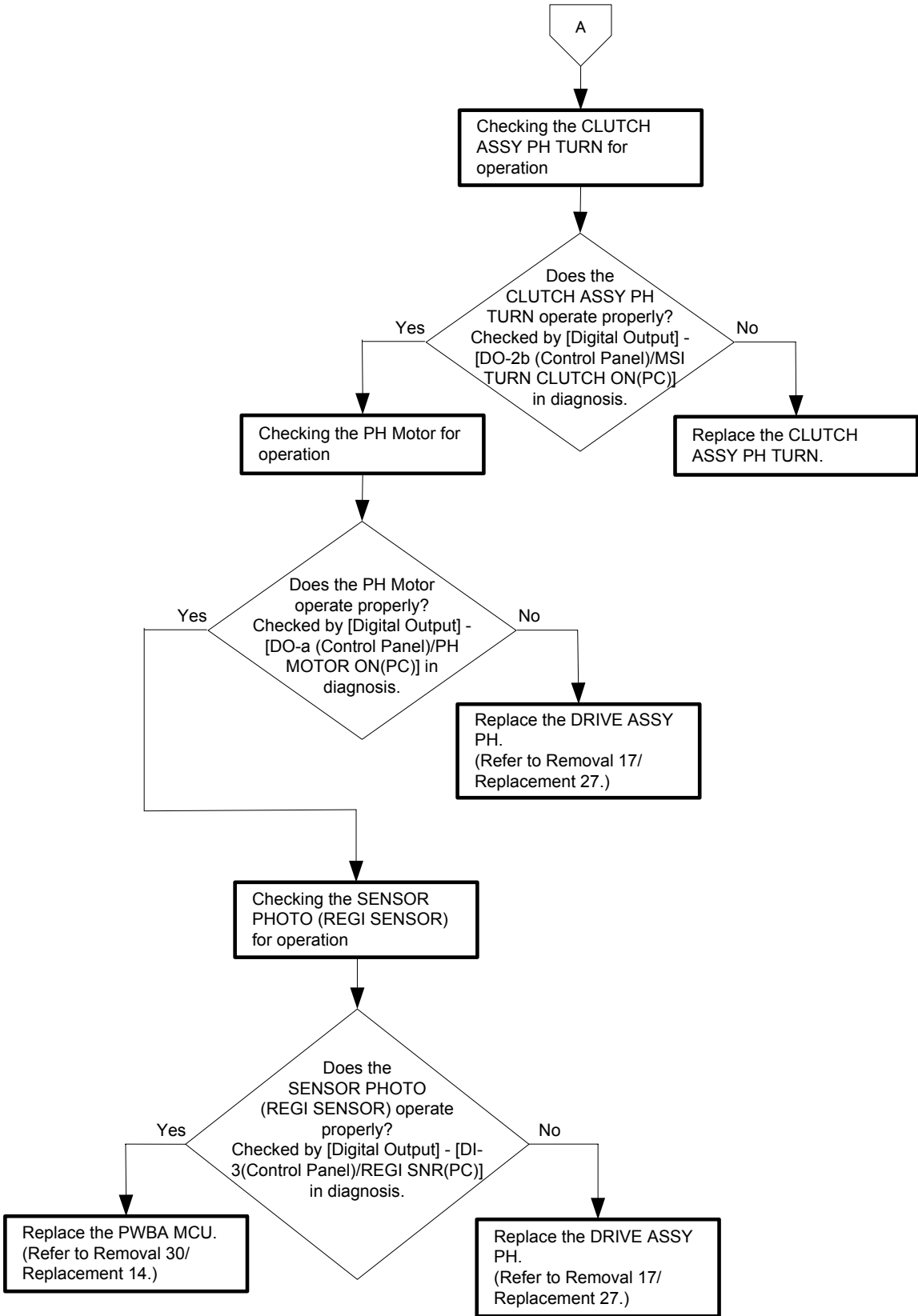

Flows 39 Paper Jam 077-105/077-106

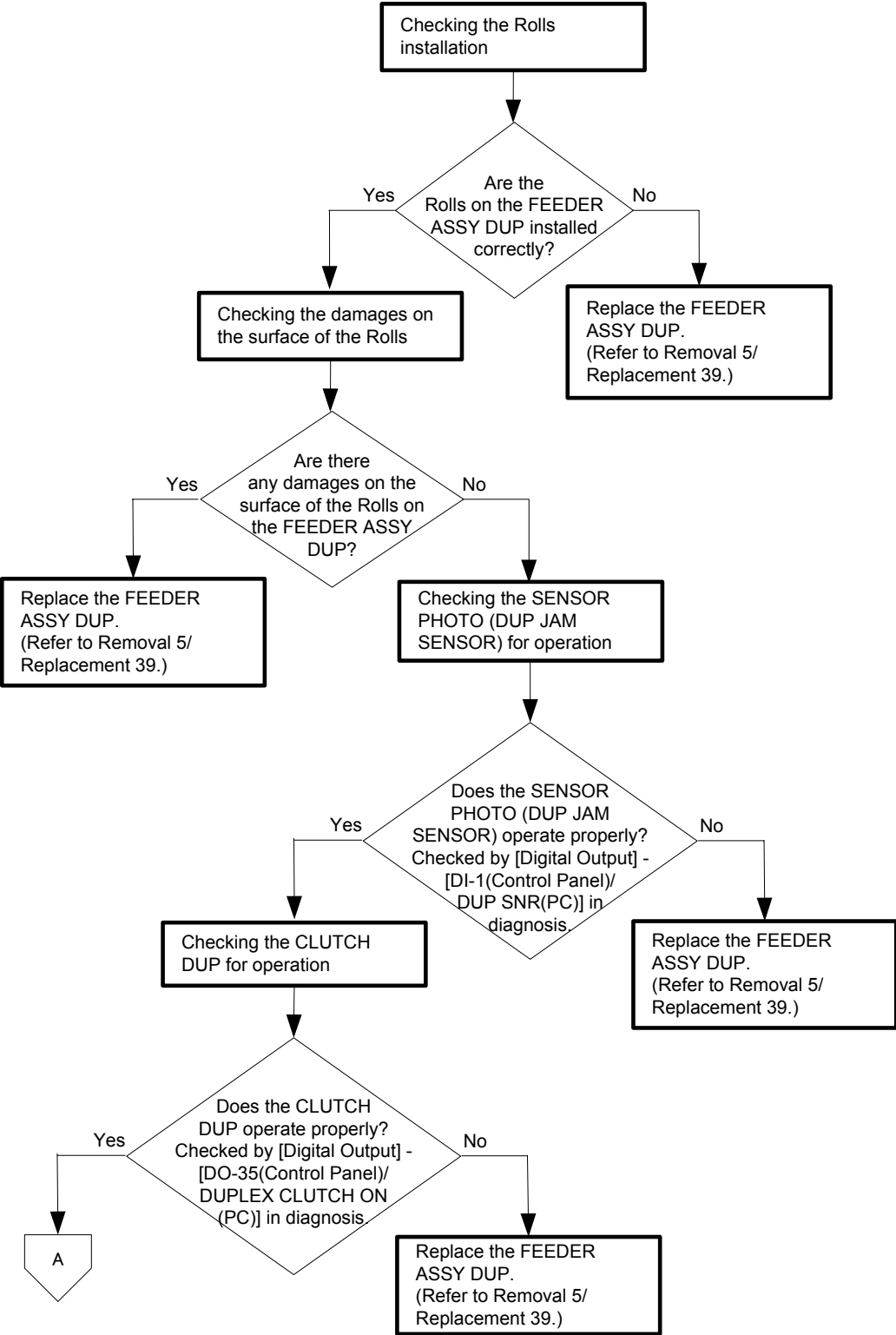

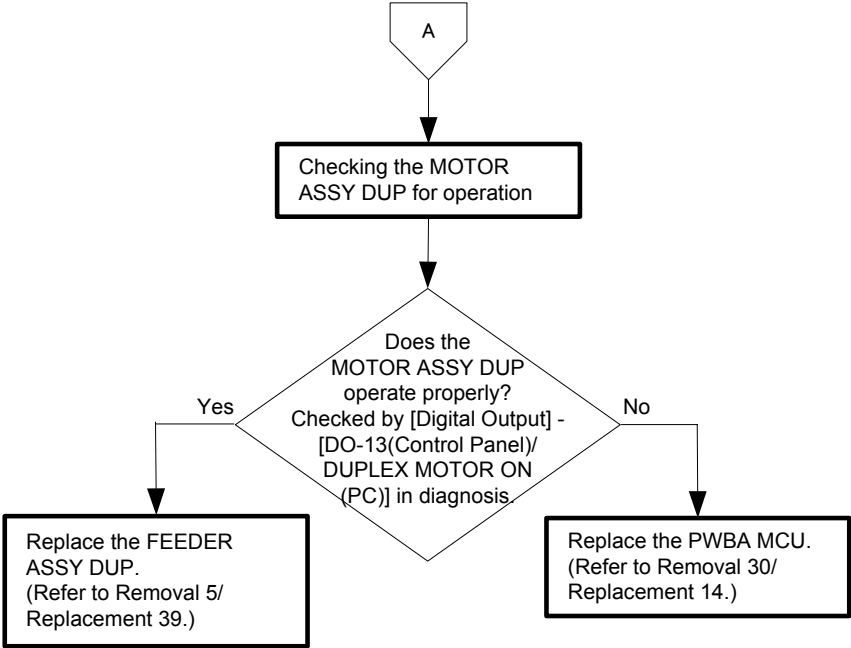

Flows 40 Paper Jam 077-900/077-901

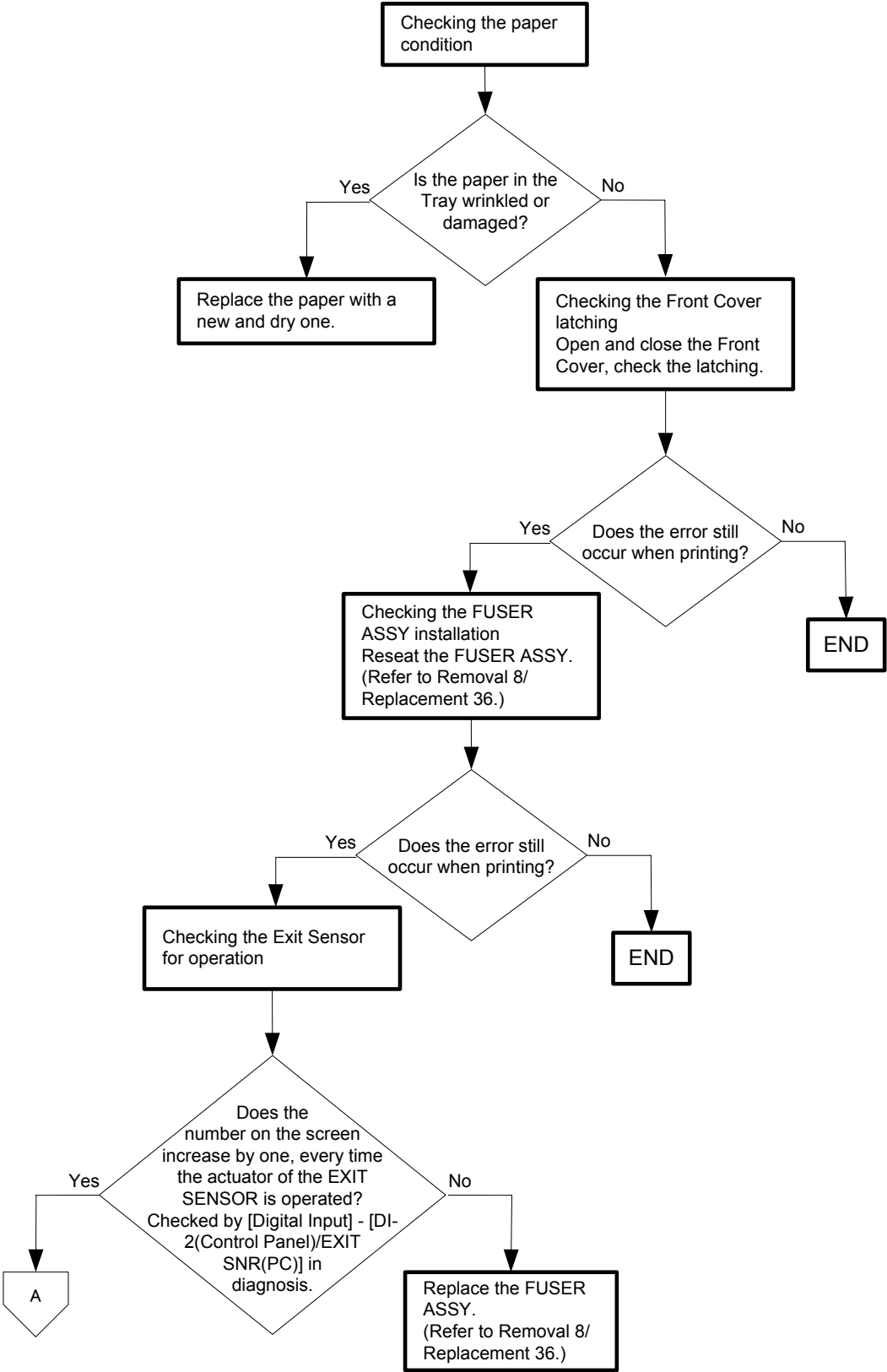

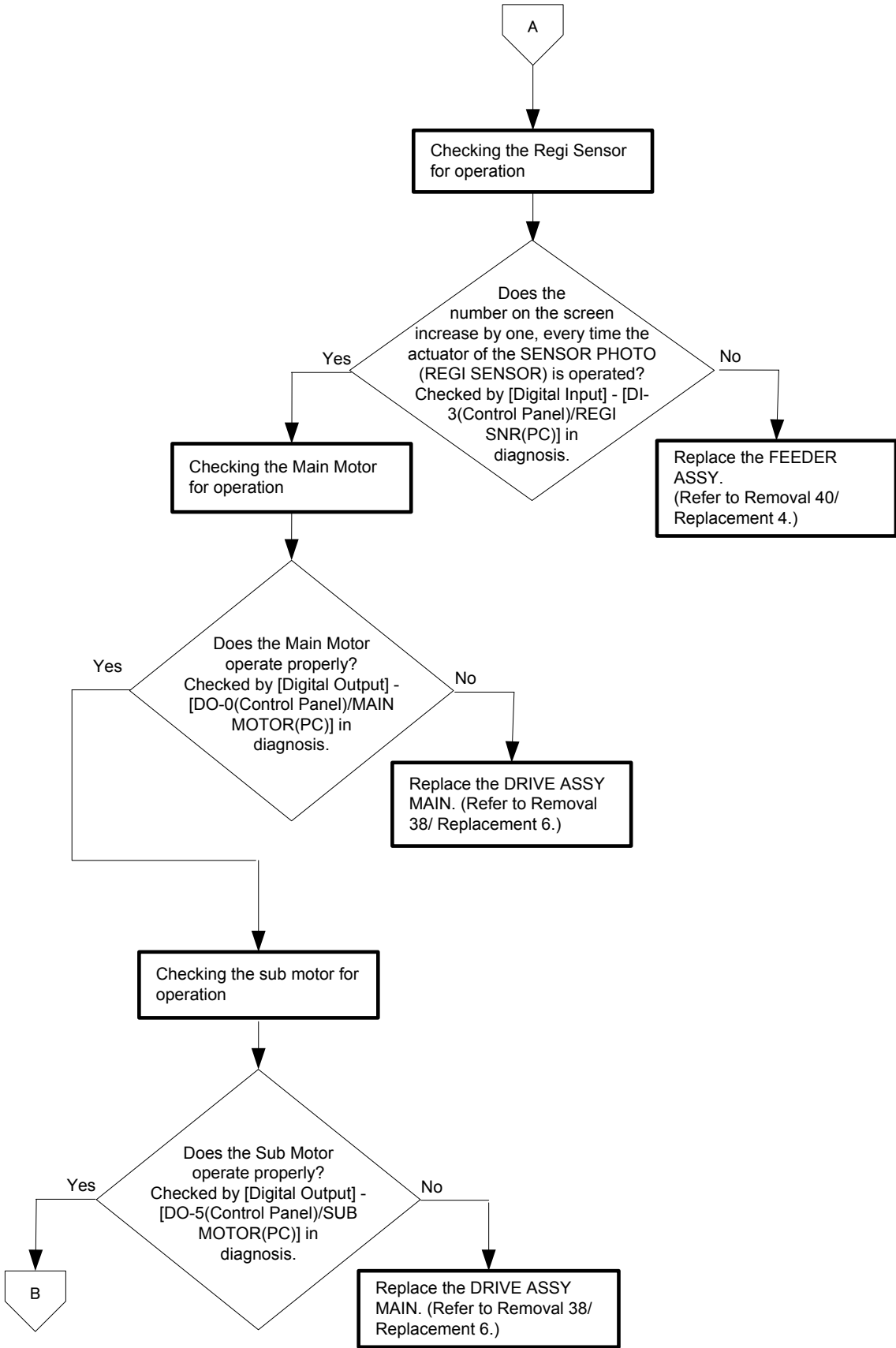

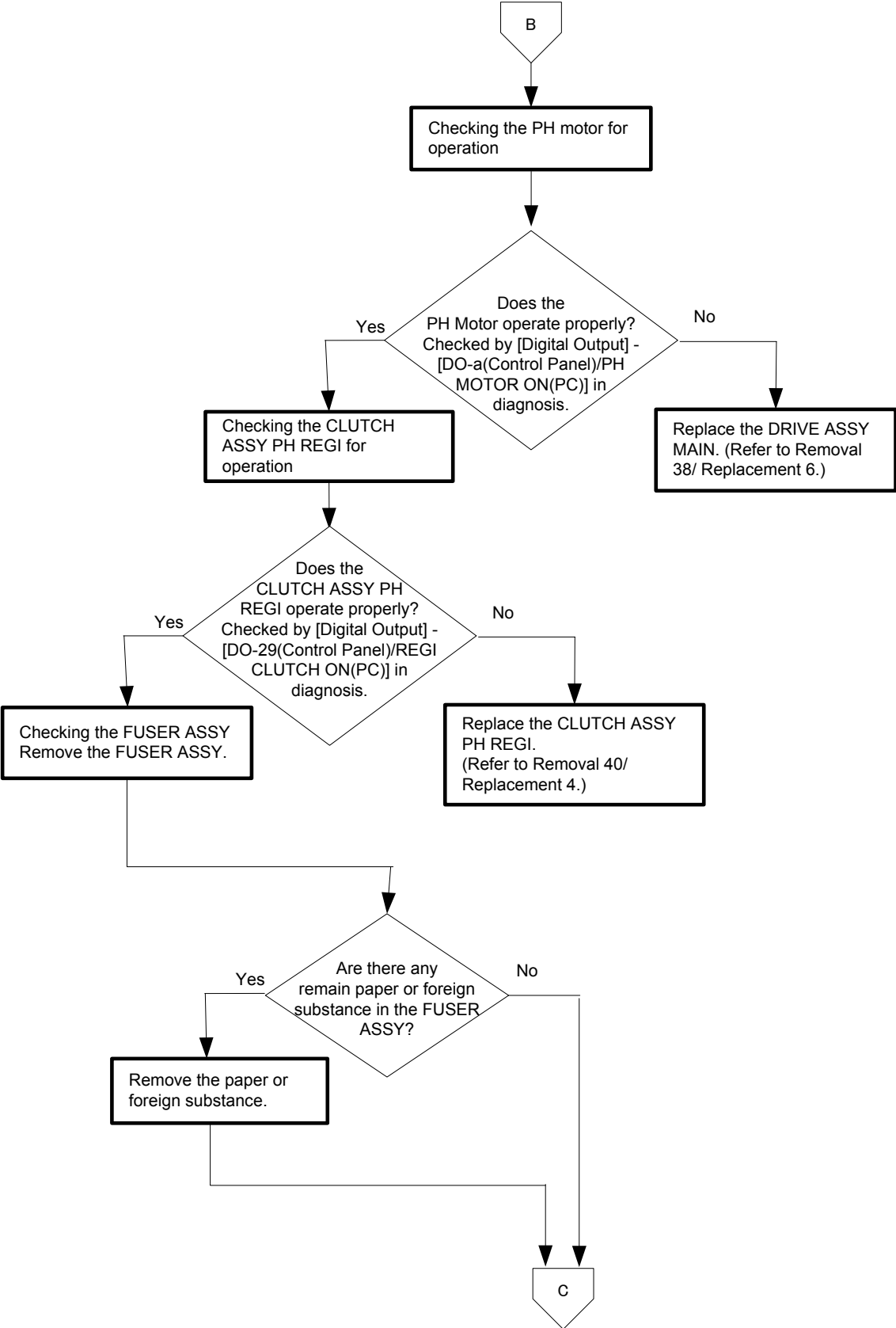

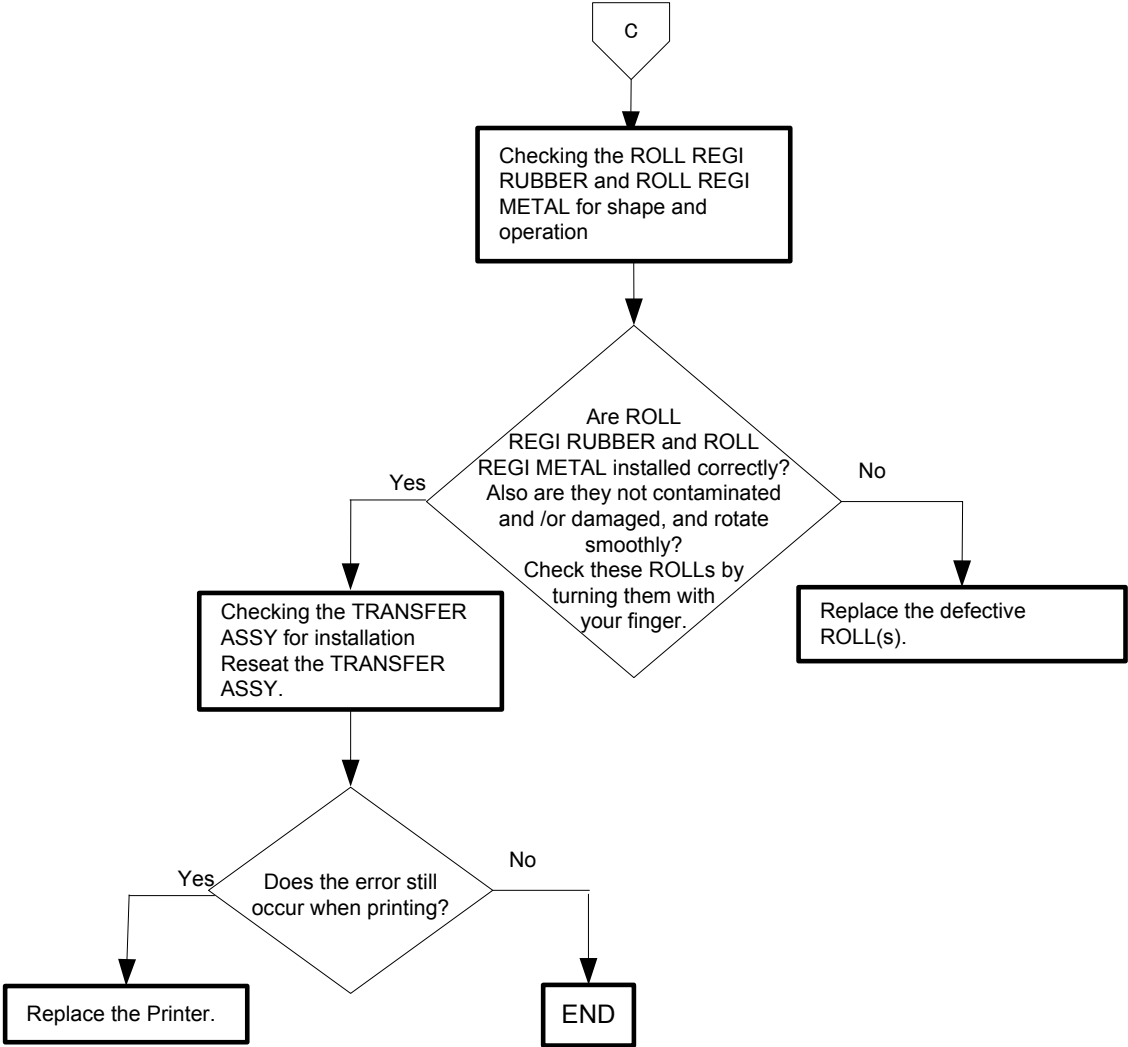

Flows 41 Paper Jam 077-903

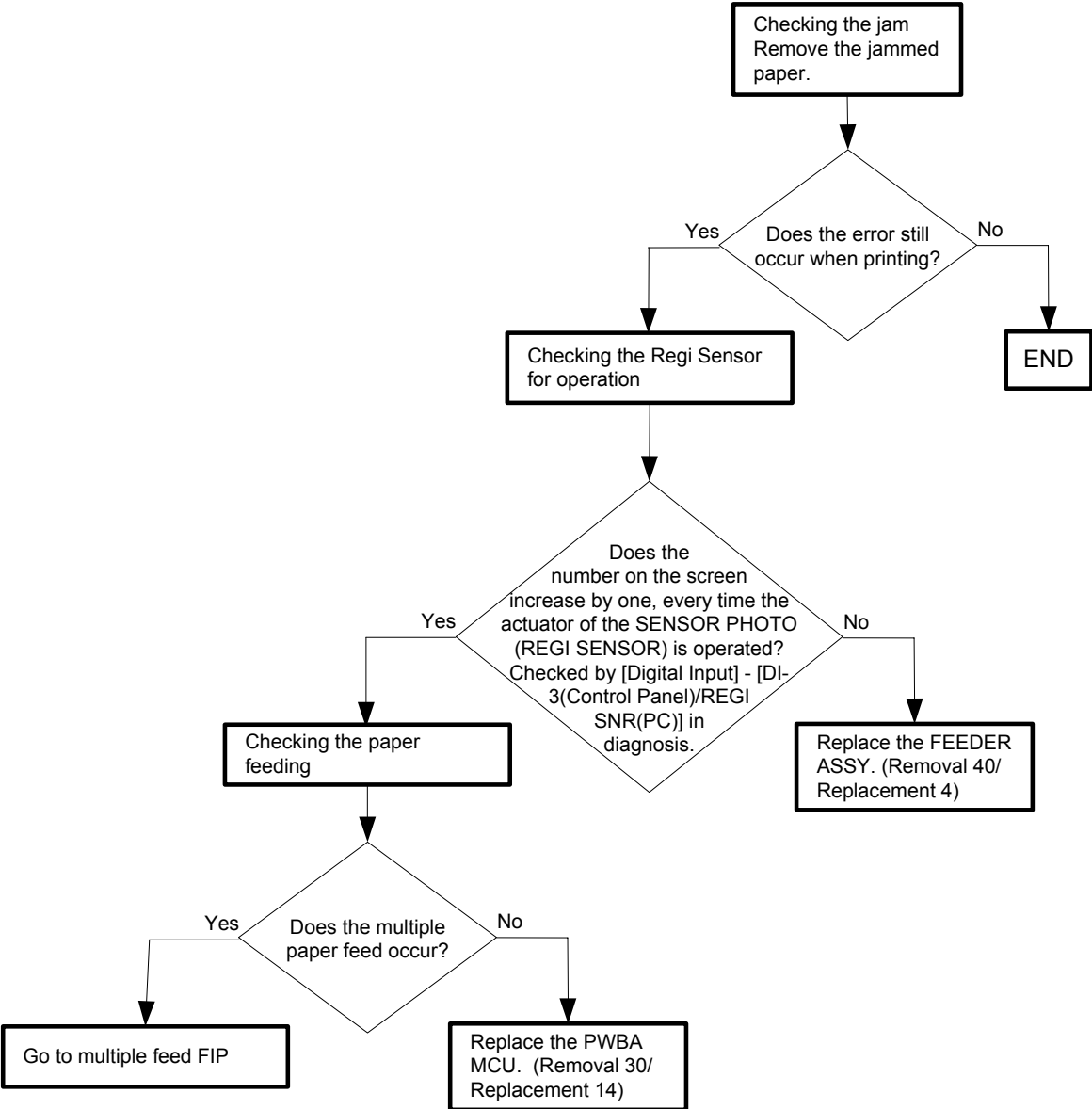

Flows 42 Paper Jam 077-907

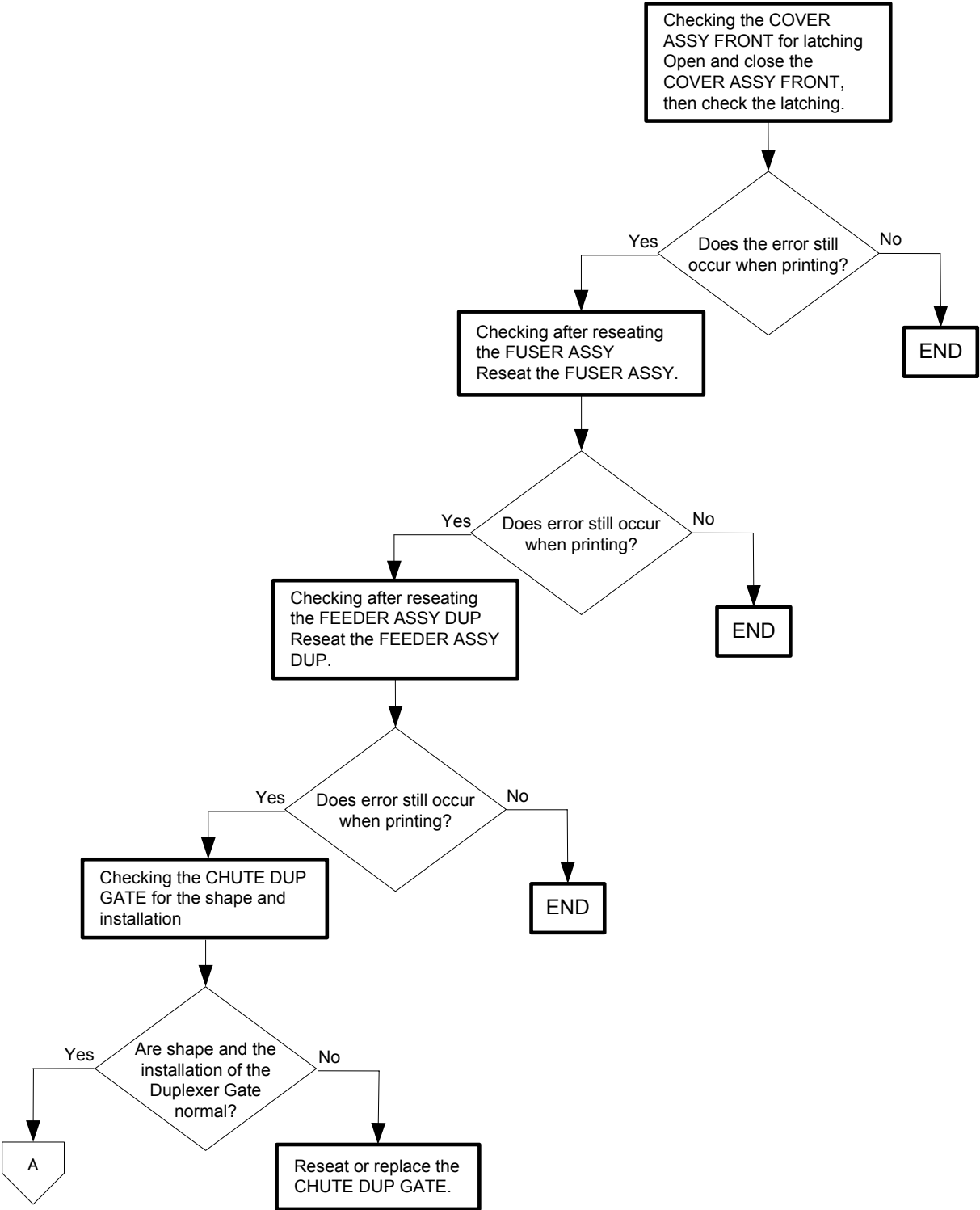

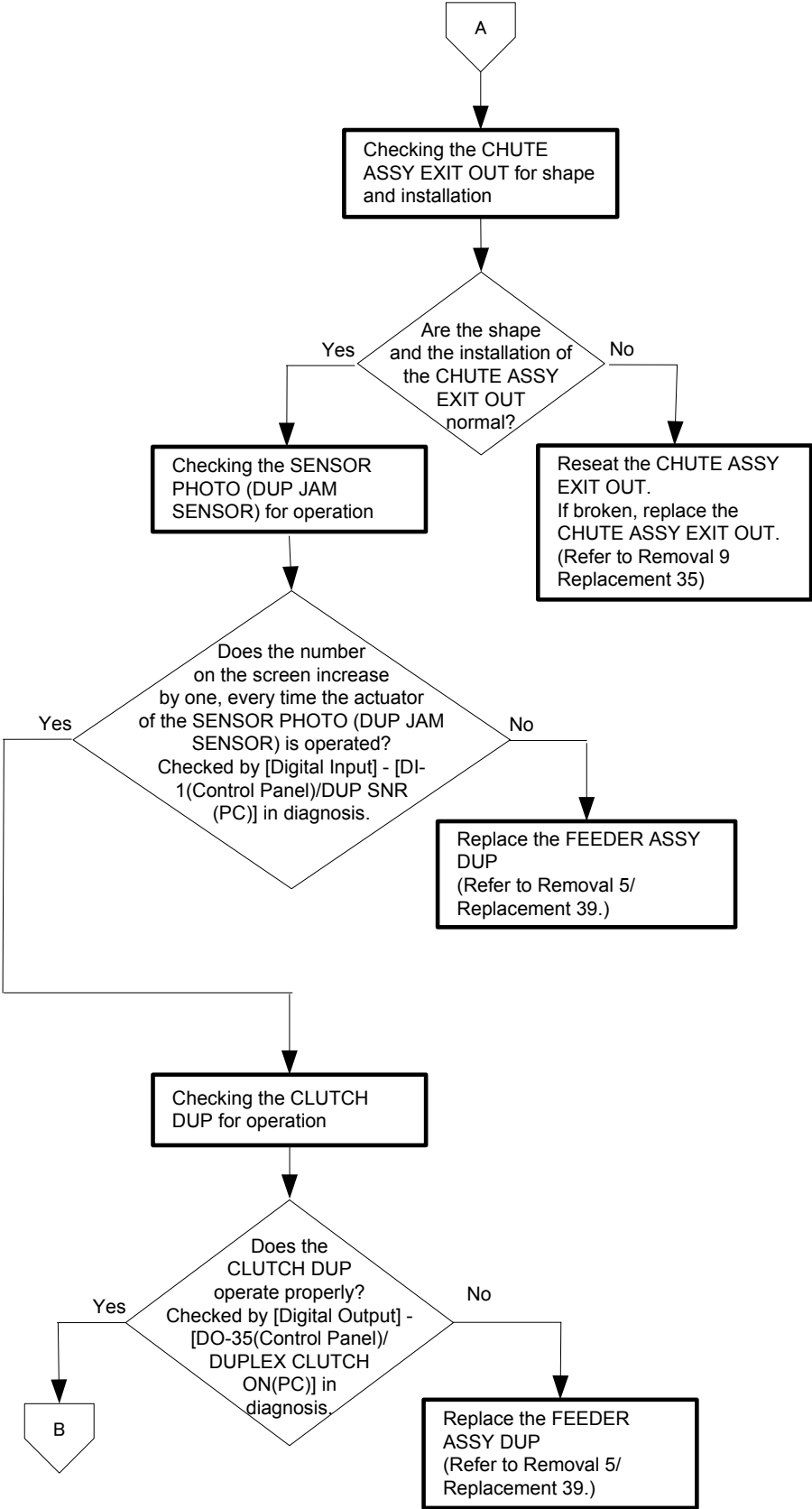

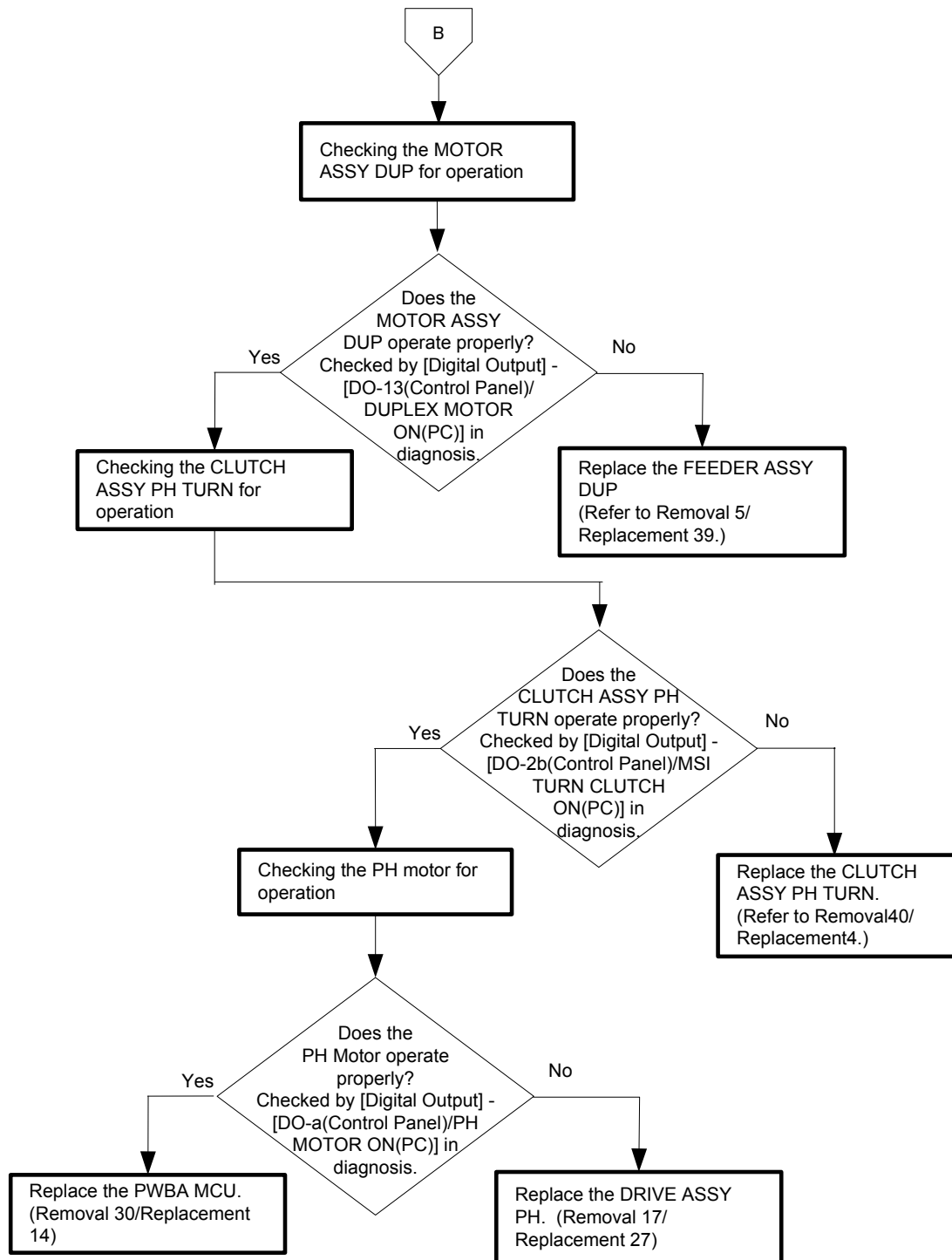

Flows 43 Load Tray N or MPF 024-910/024-911/024-914

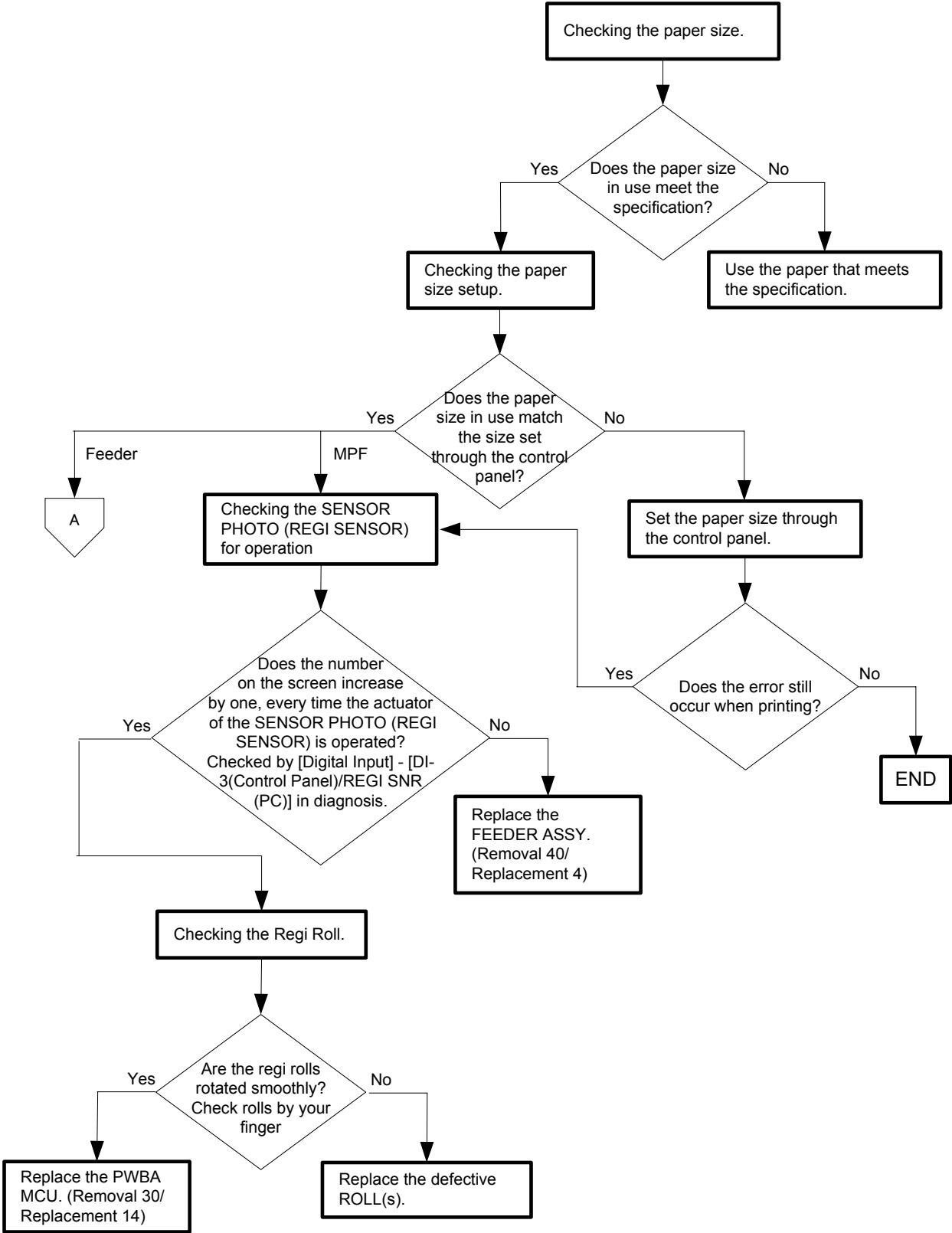

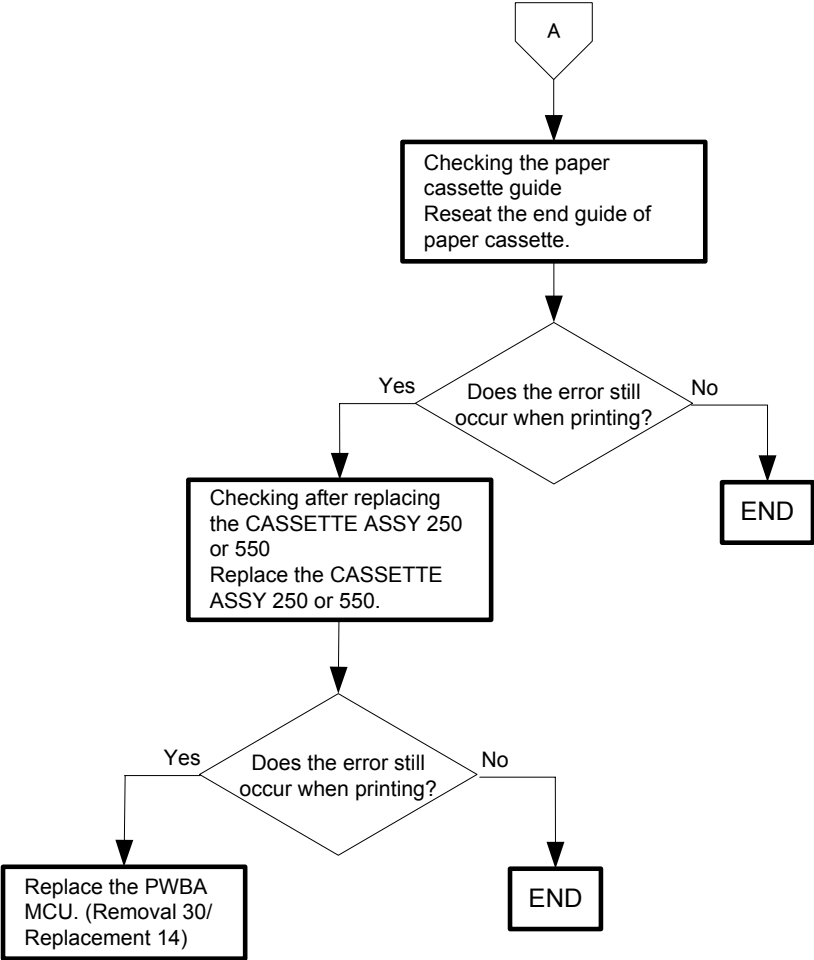

Flows 44 Load Tray N or MPF 024-965/024-966/024-969

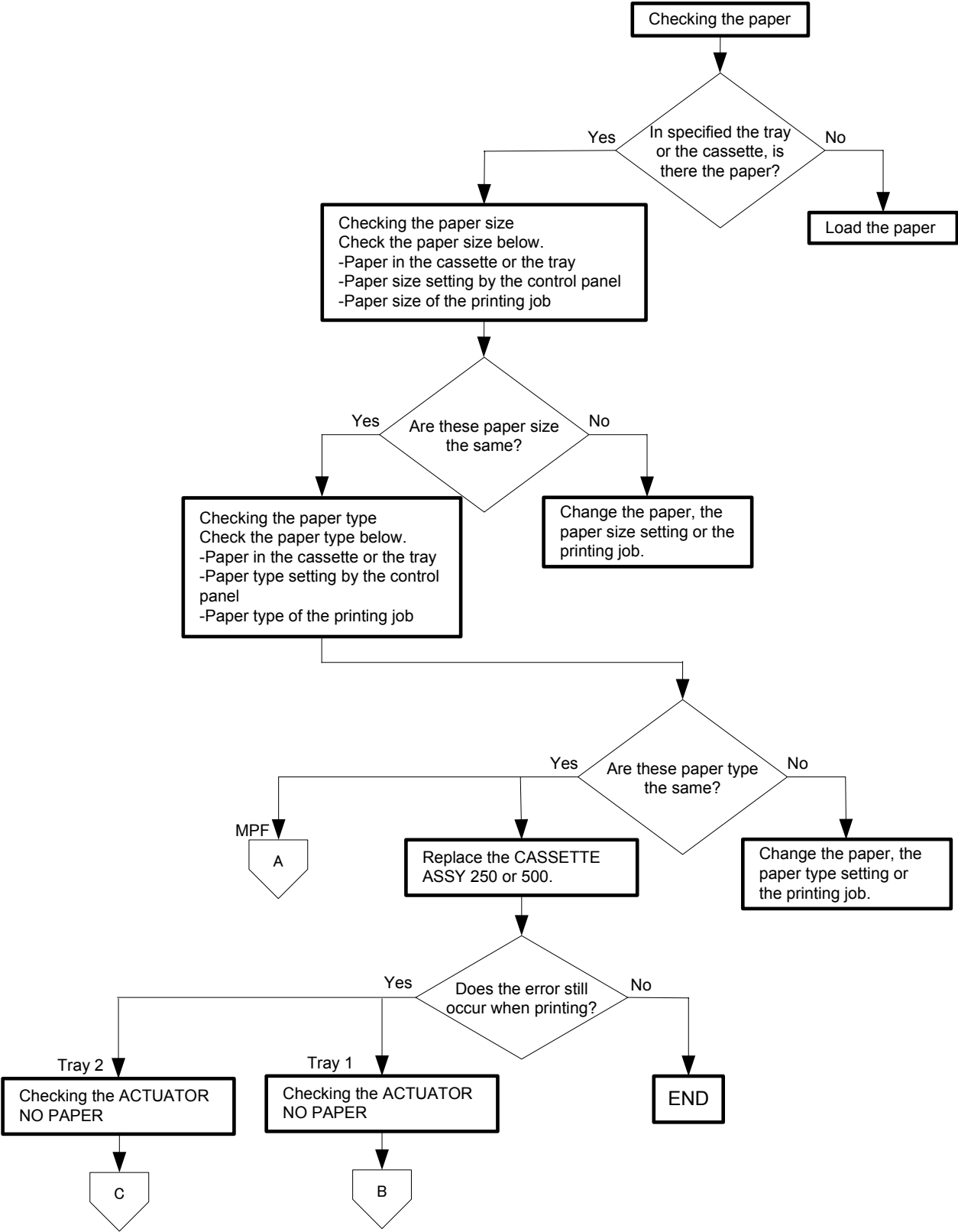

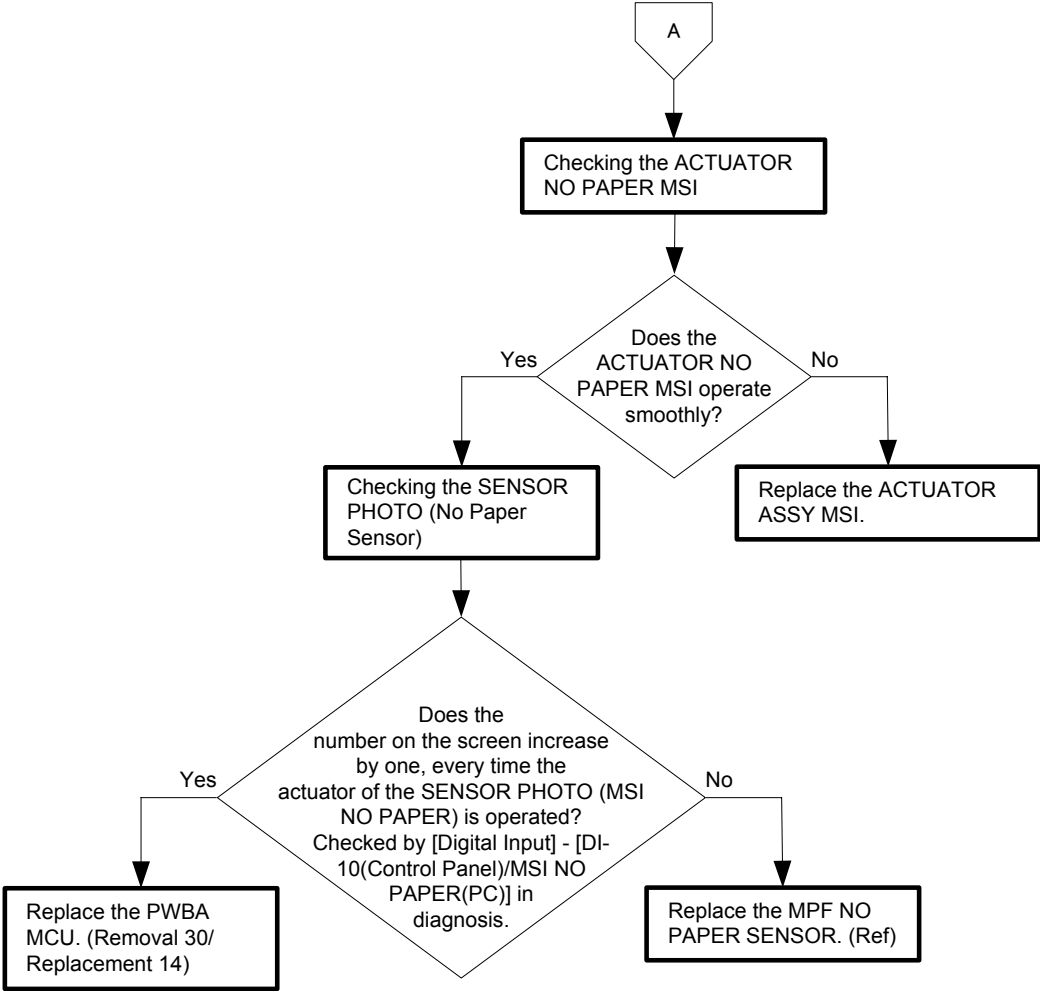

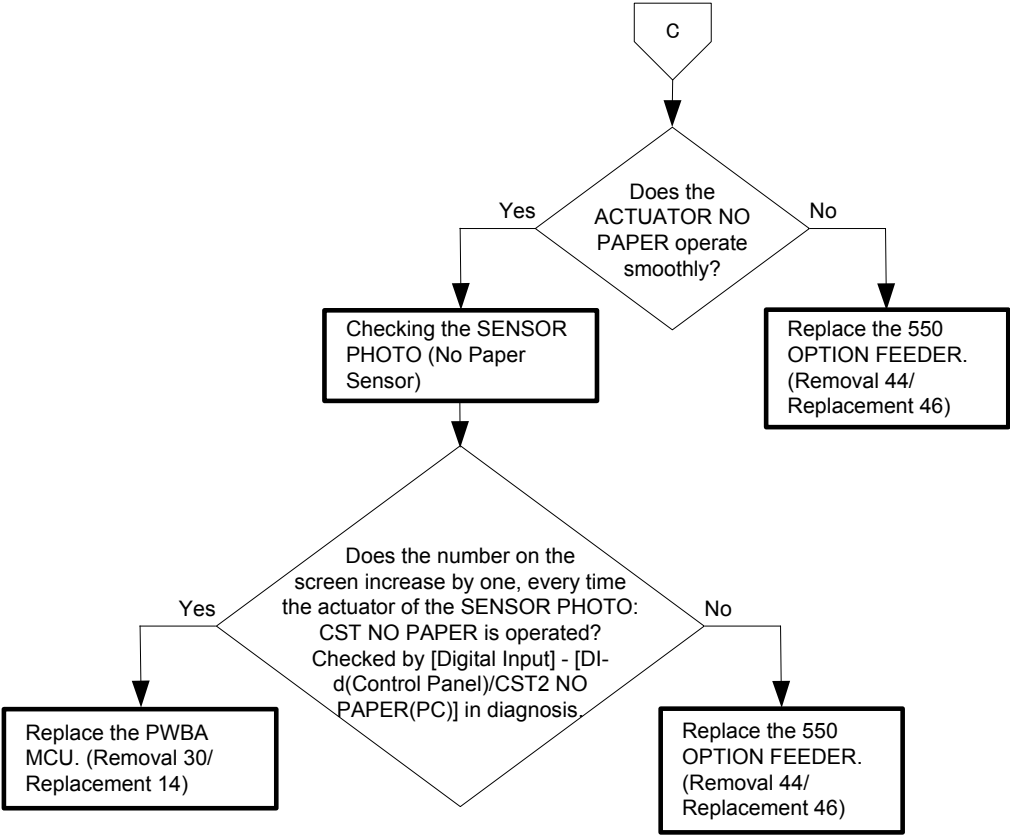
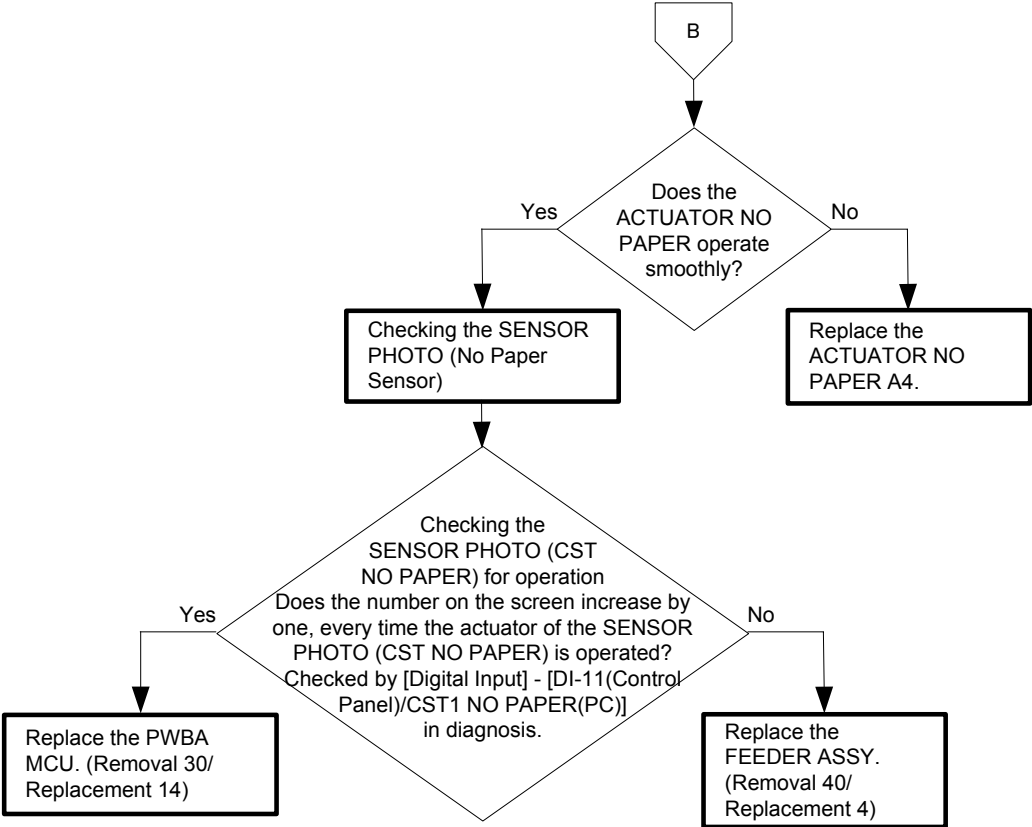

Flows 45 CRUM ID 009-367/009-368/009-369/009-370

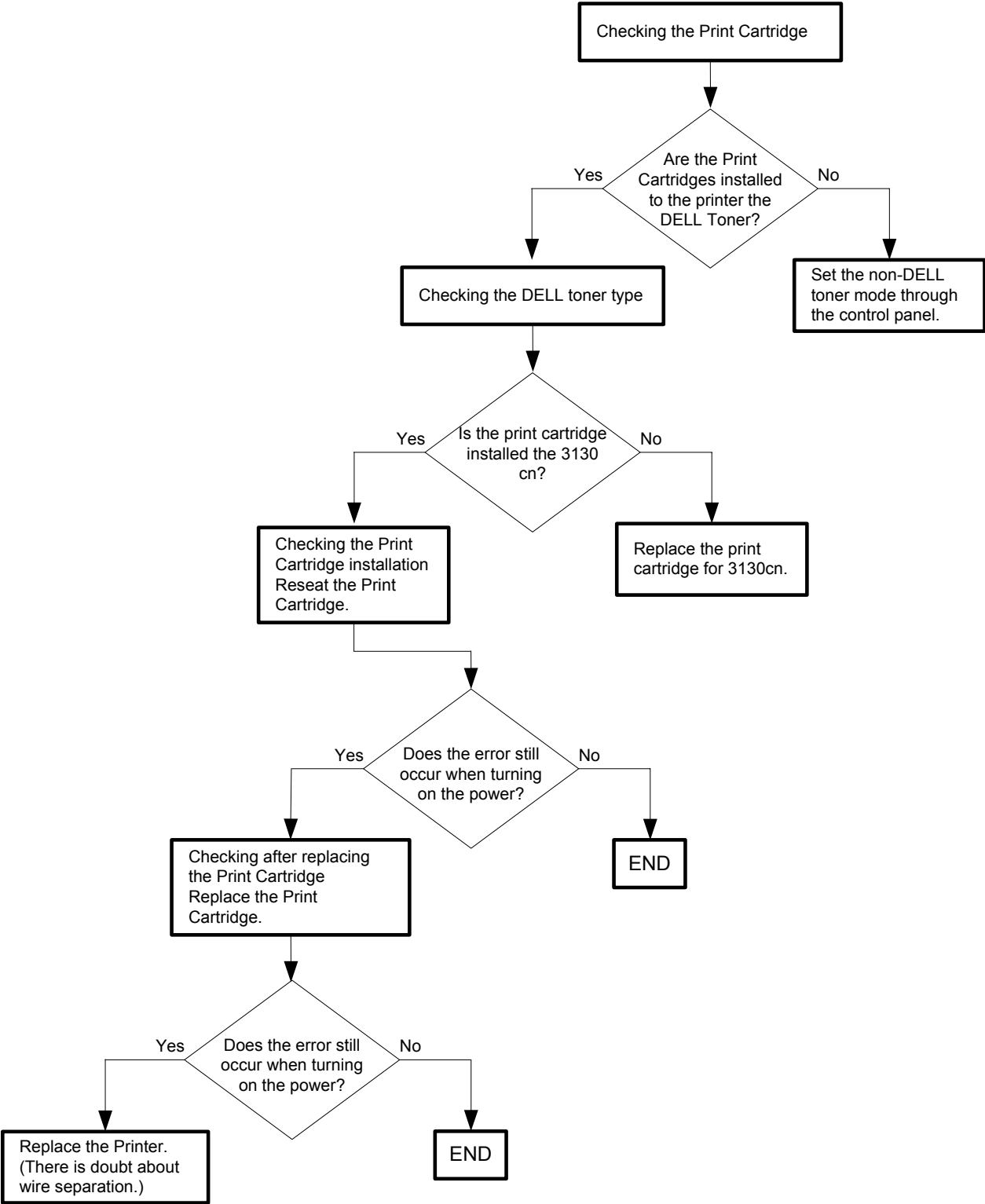

Flows 46 Error Y Cart 093-919

NOTE

Every unused Print Cartridge originally installed in the printer is covered with a Toner Tape that protects the drum from intense light. This error is displayed when the printer is operated without removing the Toner Tape.

Open the Front Cover to check if the Toner Tape is affixed on the Print Cartridge (Y).

Remove the Toner Tape if present.

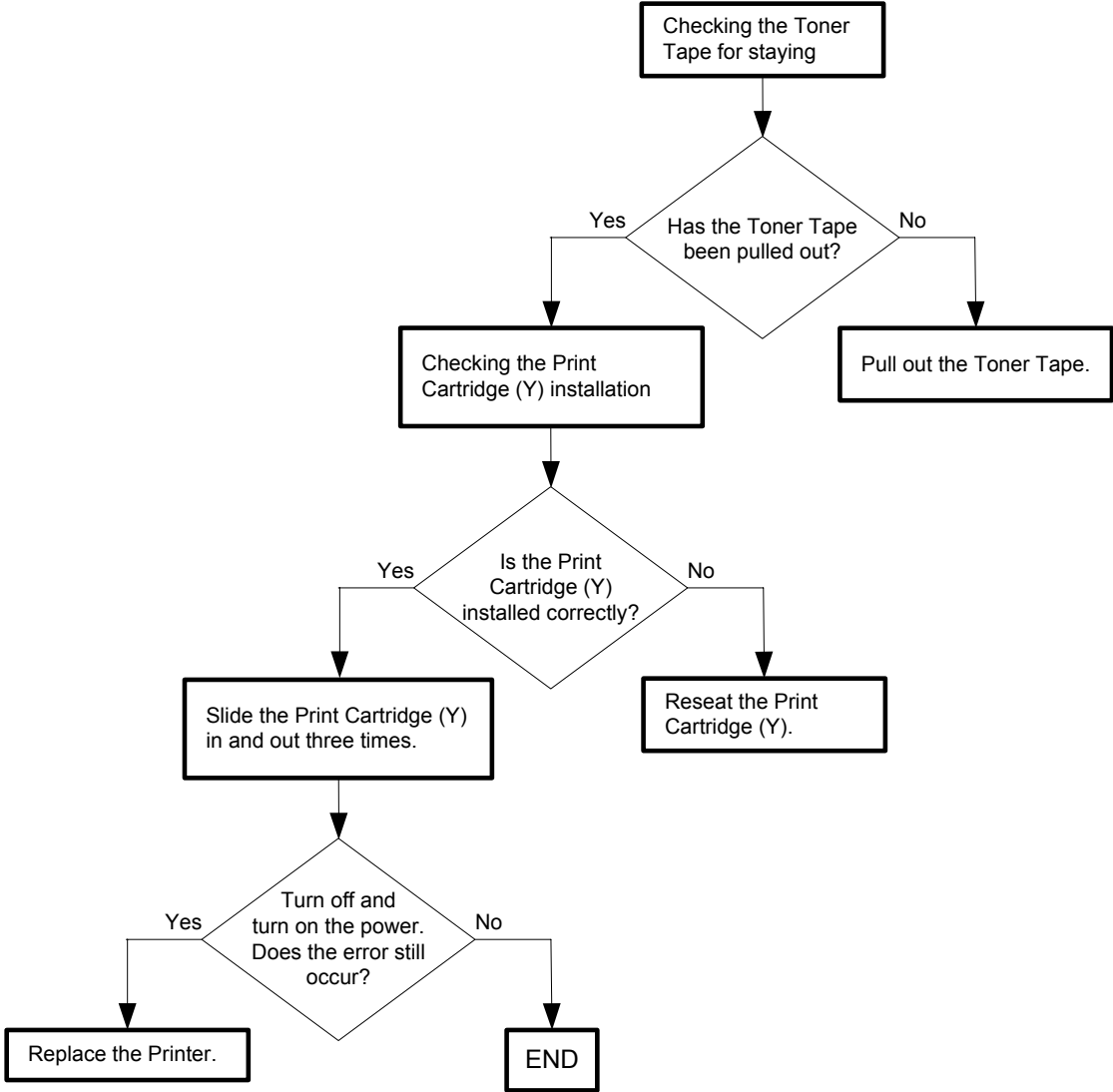

Flows 47 Error M Cart 093-920

NOTE

Every unused Print Cartridge originally installed in the printer is covered with a Toner Tape that protects the drum from intense light. This error is displayed when the printer is operated without removing the Toner Tape.

Open the Front Cover to check if the Toner Tape is affixed on the Print Cartridge (M).

Remove the Toner Tape if present.

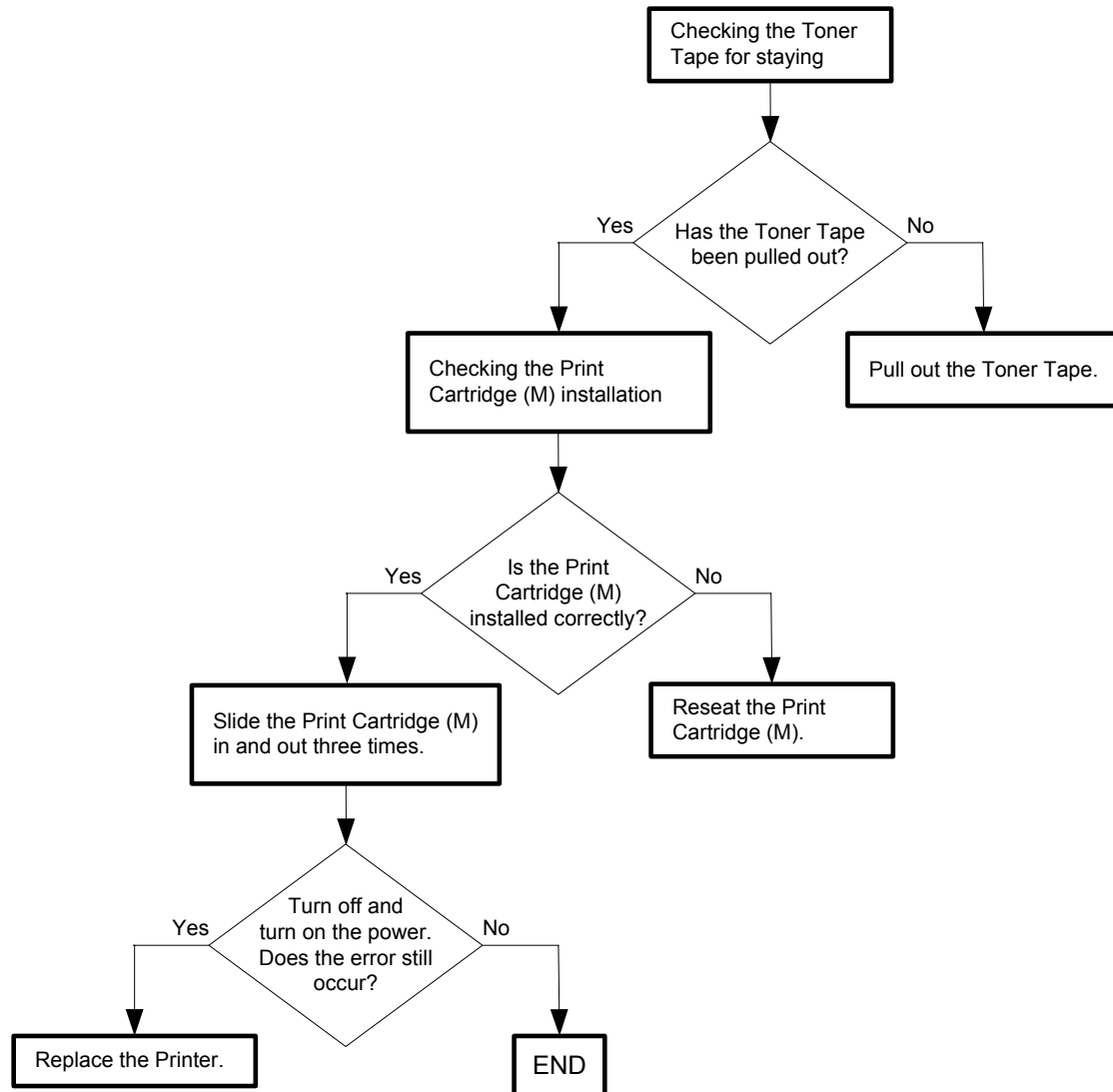

Flows 48 Error C Cart 093-921

NOTE

Every unused Print Cartridge originally installed in the printer is covered with a Toner Tape that protects the drum from intense light. This error is displayed when the printer is operated without removing the Toner Tape.

Open the Front Cover to check if the Toner Tape is affixed on the Print Cartridge (C).

Remove the Toner Tape if present.

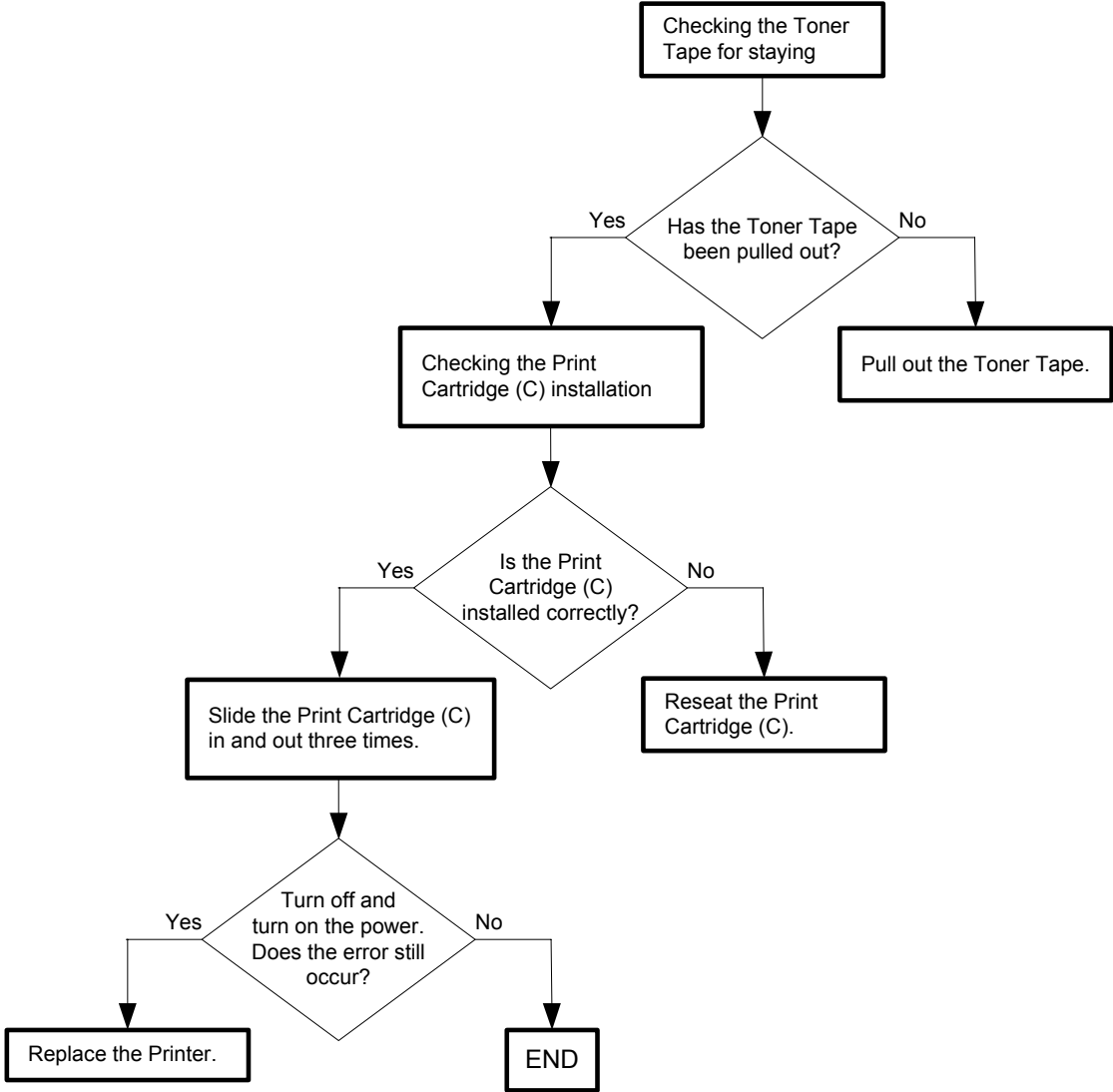

Flows 49 Error K Cart 093-922

NOTE

Every unused Print Cartridge originally installed in the printer is covered with a Toner Tape that protects the drum from intense light. This error is displayed when the printer is operated without removing the Toner Tape.

Open the Front Cover to check if the Toner Tape is affixed on the Print Cartridge (K).

Remove the Toner Tape if present.

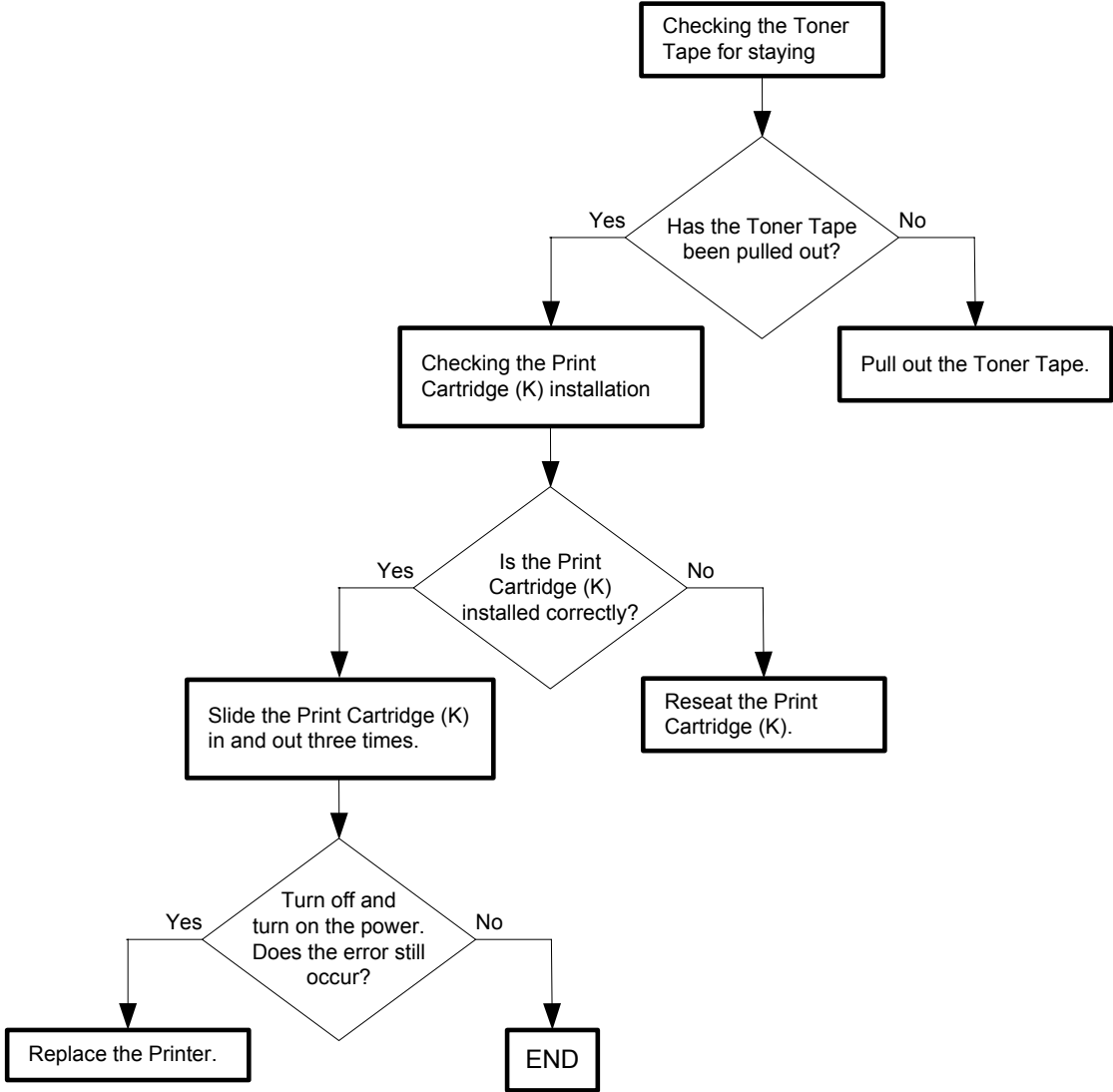

Flows 50 093-950 Yellow Toner / 093-951 Magenta Toner / 093-952 Cyan Toner / 093-953 Black Toner

NOTE

Every reorder Print Cartridge is covered with an orange Protect Cover (At the time of printer purchase, it is Protect Paper.)that protects the drum from intense light. This error is displayed when the printer is operated without removing the Protect Cover(or Protect Paper).

Open the Front Cover and check if the Protect Cover(or Protect Paper) is affixed on the Print Cartridges (Y, M, C, or K).

Remove the Protect Cover(or Protect Paper) if present.

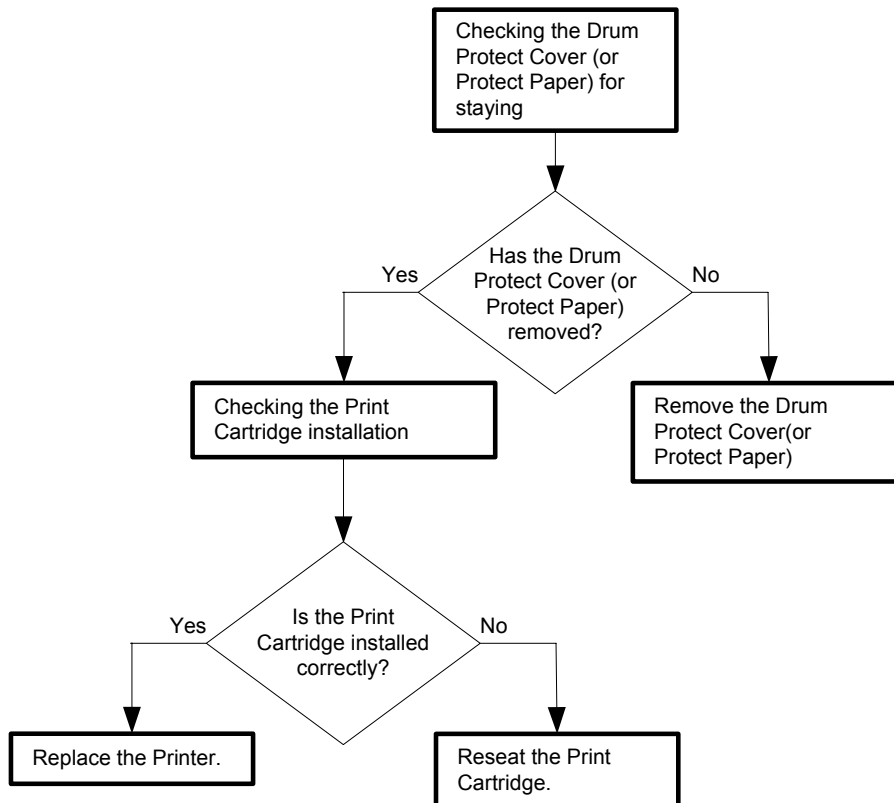

Flows 51 Replace Cart 093-930/093-931/093-932/093-933

NOTE

This error code is displayed when the Print Cartridge (Y, M, C, or K) has reached its end of life and needs replacing.

Immediately replace the Print Cartridge (Y, M, C, or K) with a new one.

If this error code is displayed although the Print Cartridge (Y, M, C, or K) has been replaced only recently, follow the following flow.

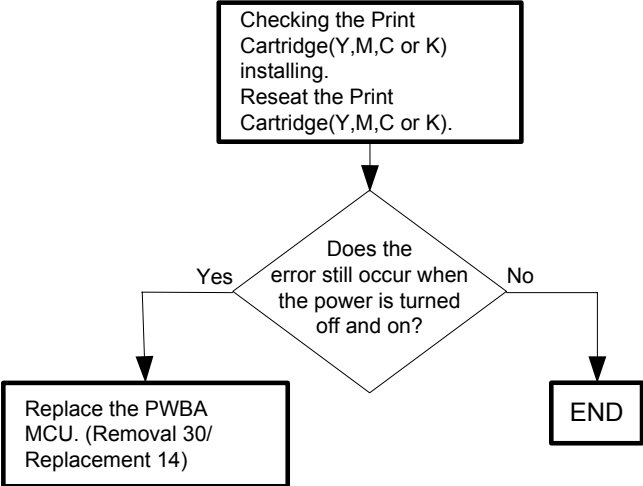

Flows 52 Ready to Print 093-423/093-424/093-425/093-426

NOTE

This error code is not a fault warning and only denotes that the Print Cartridge (Y, M, C, or K) is approaching but has not reached its end of life. Immediately prepare a new Print Cartridge (Y, M, C, or K). If this error code is displayed although the Print Cartridge (Y, M, C, or K) has been replaced only recently, follow the following flow.

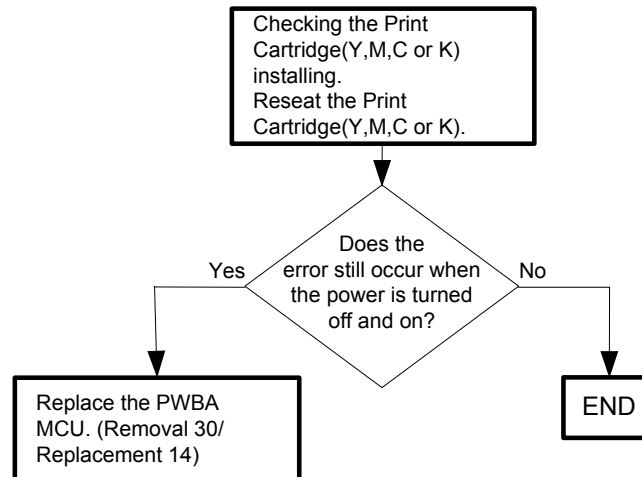

Flows 53 Insert Print Cart 093-970

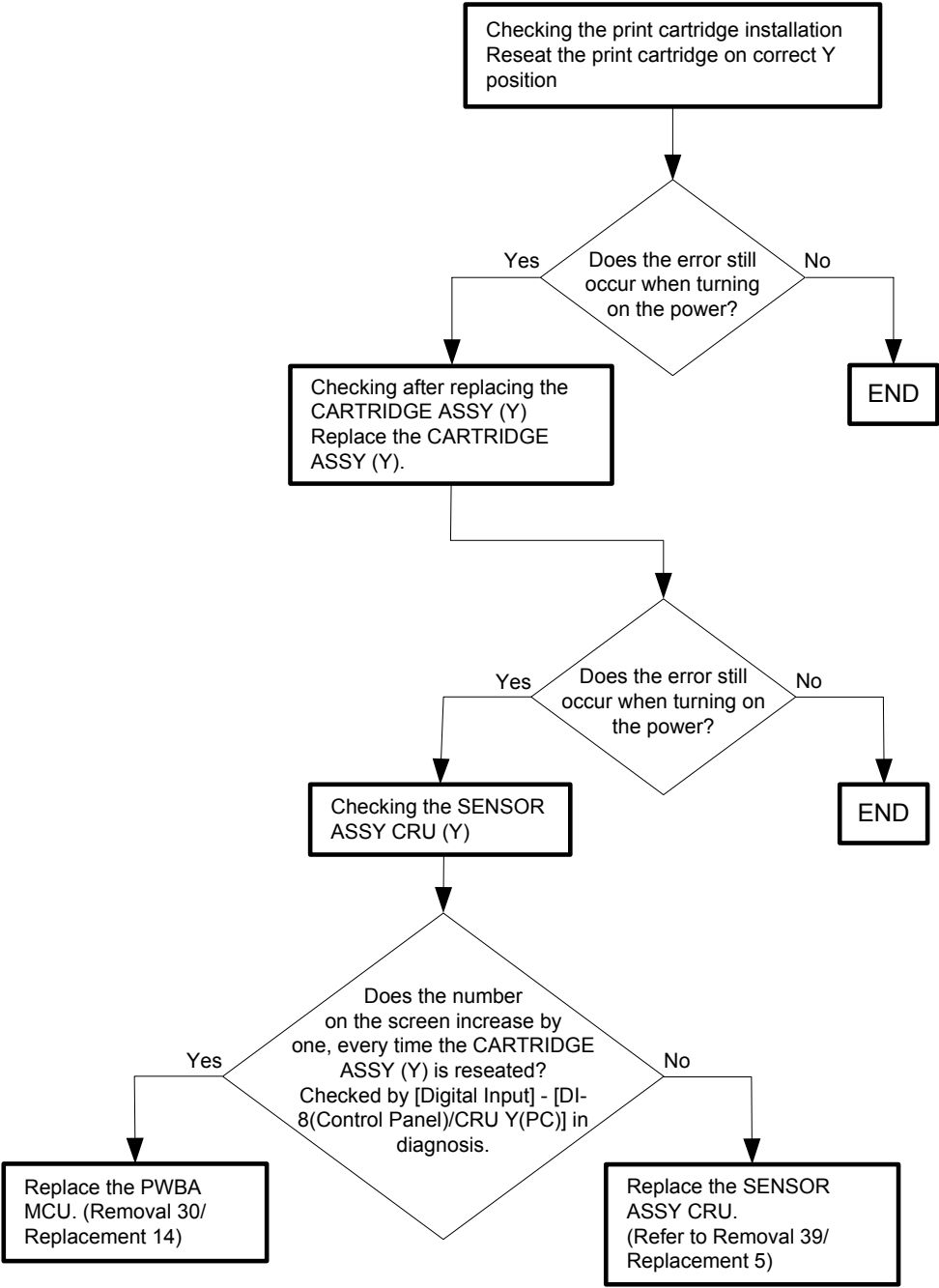

Flows 54 Insert Print Cart 093-971

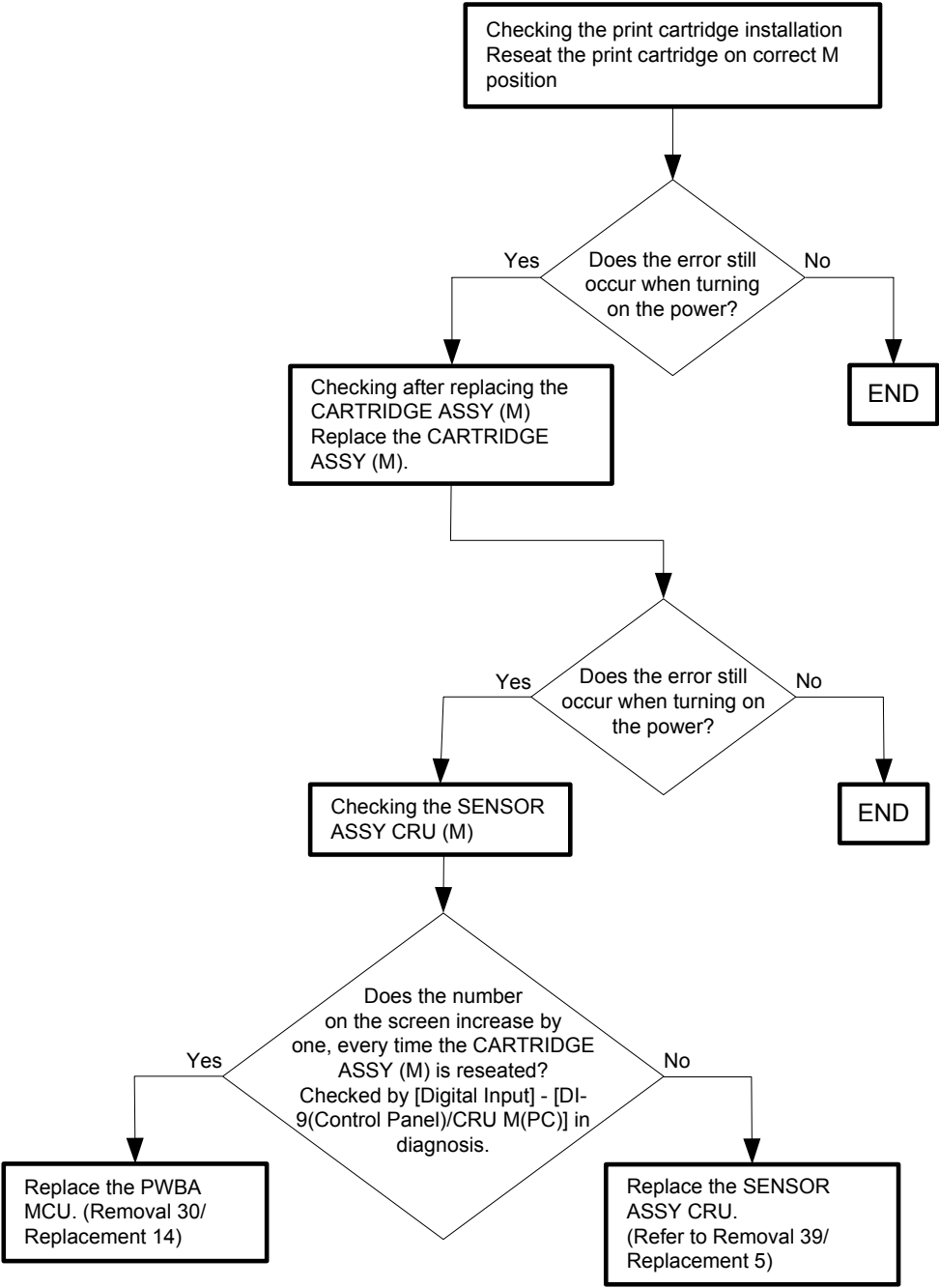

Flows 55 Insert Print Cart 093-972

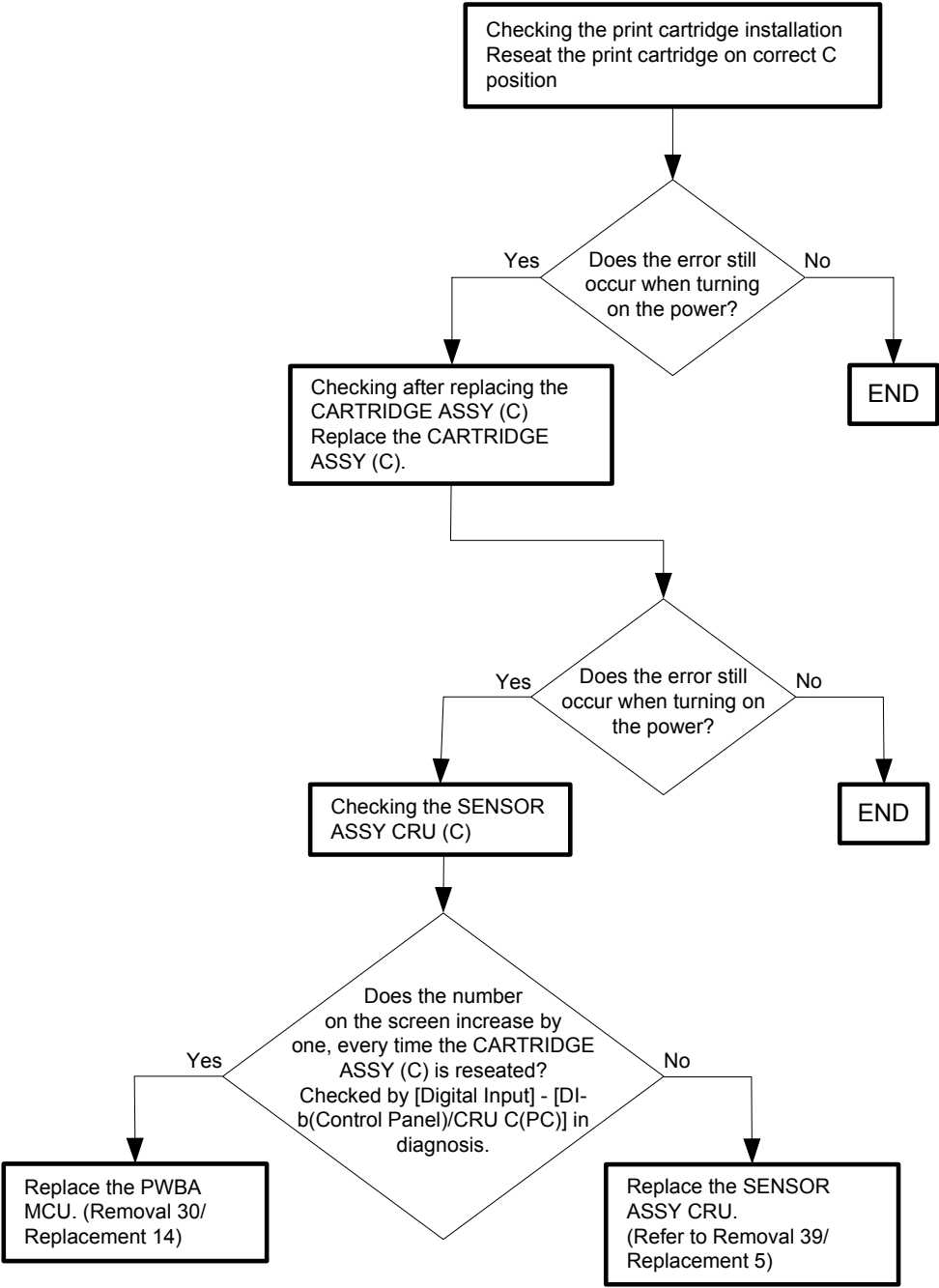

Flows 56 Insert Print Cart 093-973

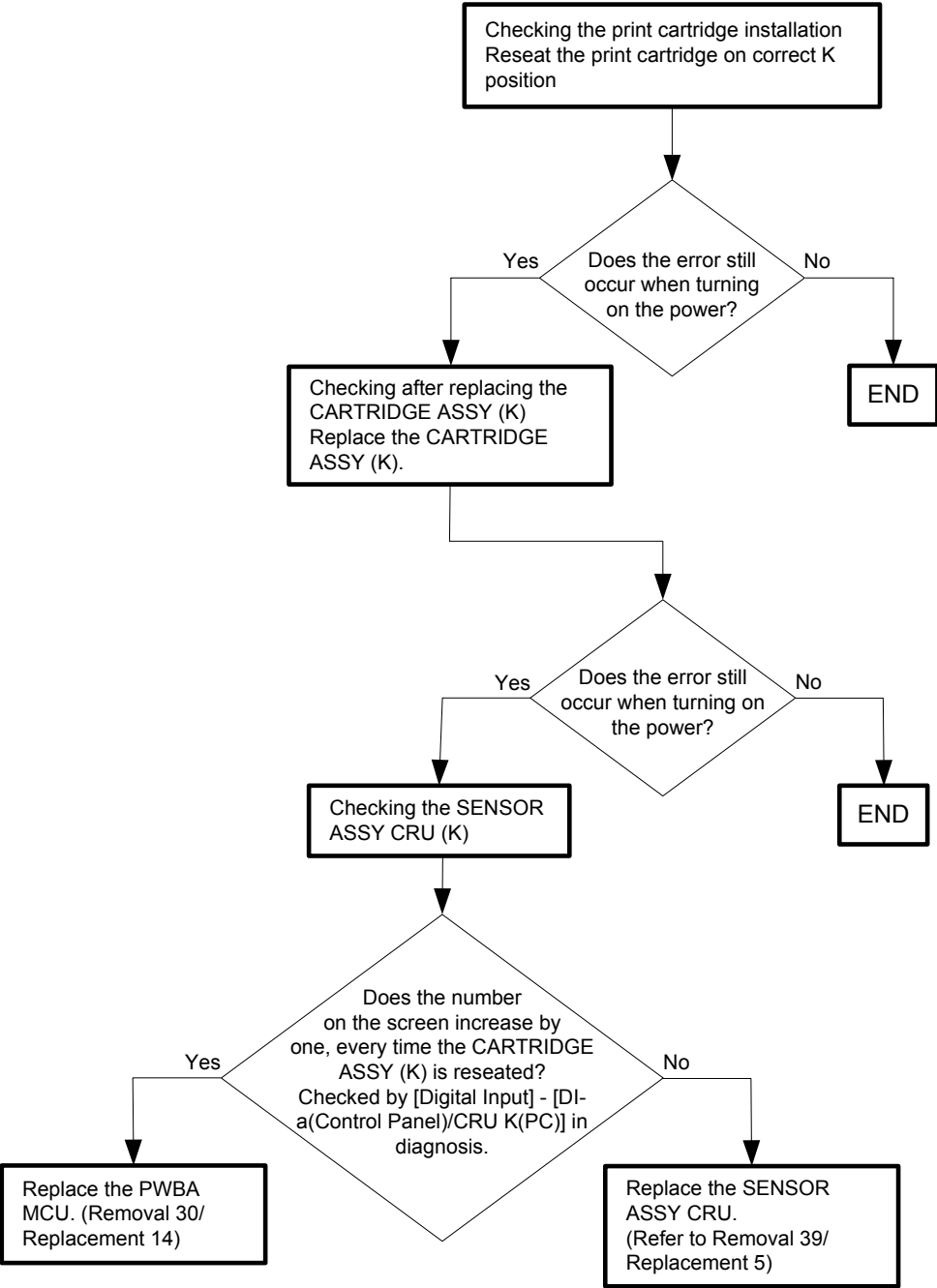

Flows 57 CRUM ID 009-371

NOTE

For the PPID, refer to the label on the TRANSFER ASSY.

XX-0R298D-XXXXX-XXX-XXXX

↑
PPID No.

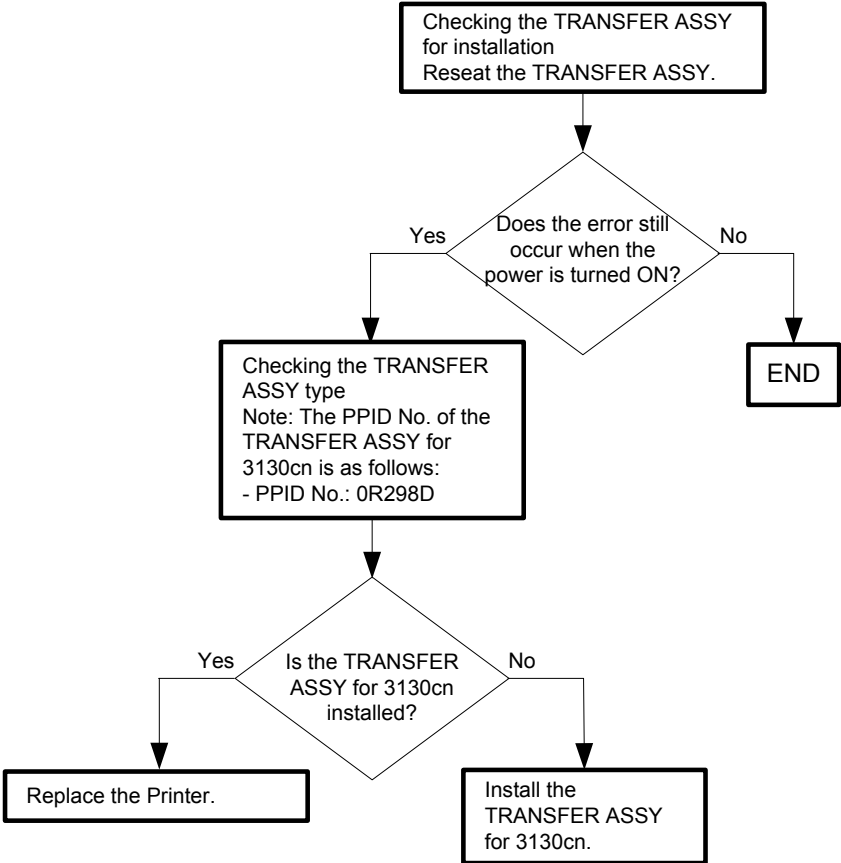

Flows 58 Ready to Print 094-422

NOTE

This error code is not a fault warning and only denotes that the Transfer ASSY (Belt Unit) is approaching but has not reached its end of life. Immediately prepare a new Transfer ASSY (Belt Unit). If this error code is displayed although the Transfer ASSY (Belt Unit) has been replaced only recently, follow the following flow.

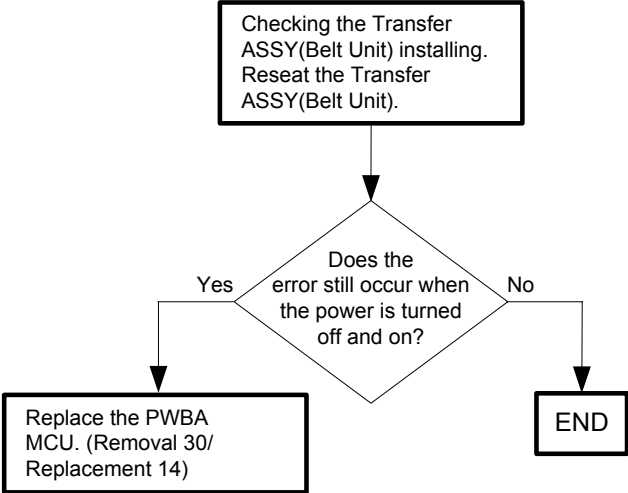

Flows 59 Insert Belt Unit 094-910

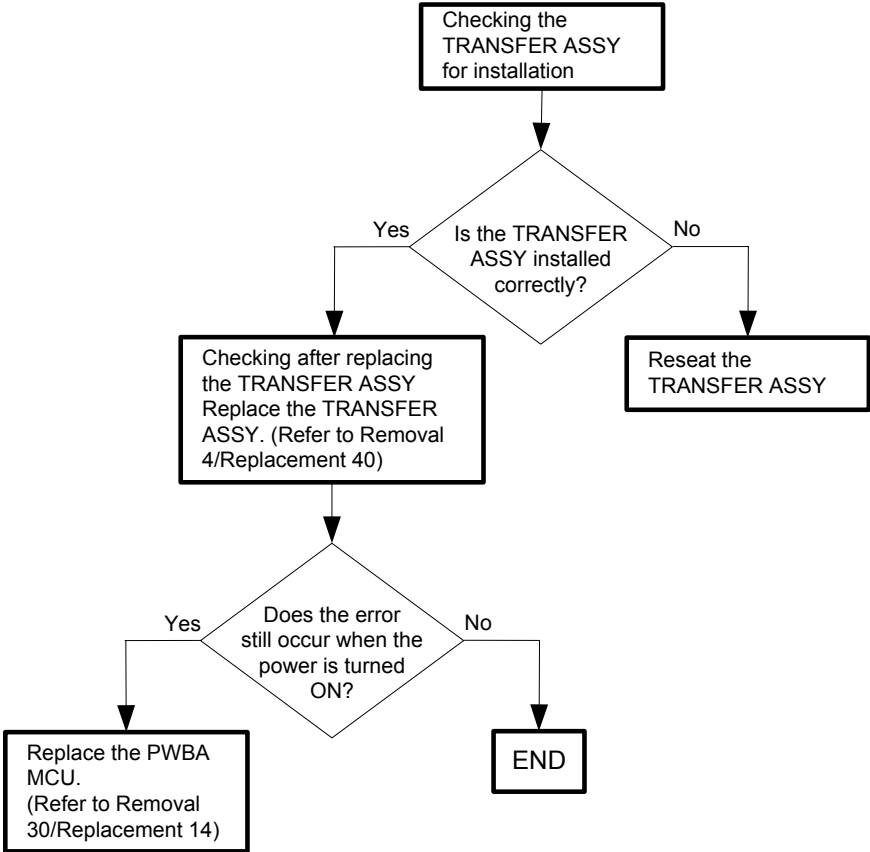

Flows 60 Belt Unit 094-911

NOTE

This error code denotes that the Transfer ASSY (Belt Unit) has reached its end of life and needs replacing.
Immediately replace the Transfer ASSY (Belt Unit) with a new one.
If this error code is displayed although the Transfer ASSY (Belt Unit) has been replaced only recently, follow the following flow.

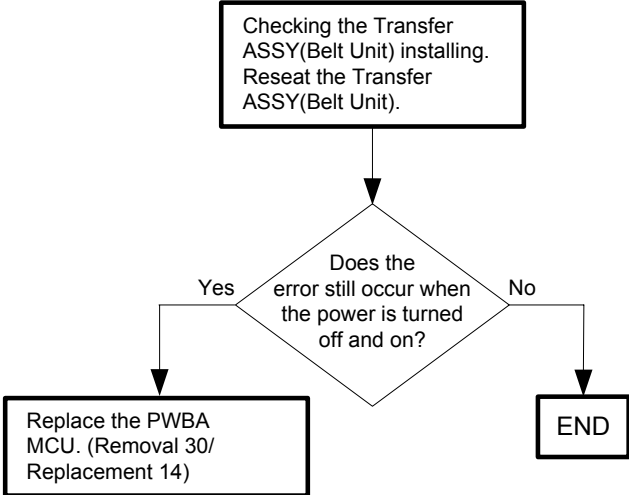

Flows 61 010-359 Restart Printer

NOTE

For the PPID, refer to the label on the FUSER.

Example) FUSER for 100V
XX-0M507D-XXXXX-XXX-XXXX

↑
PPID No.

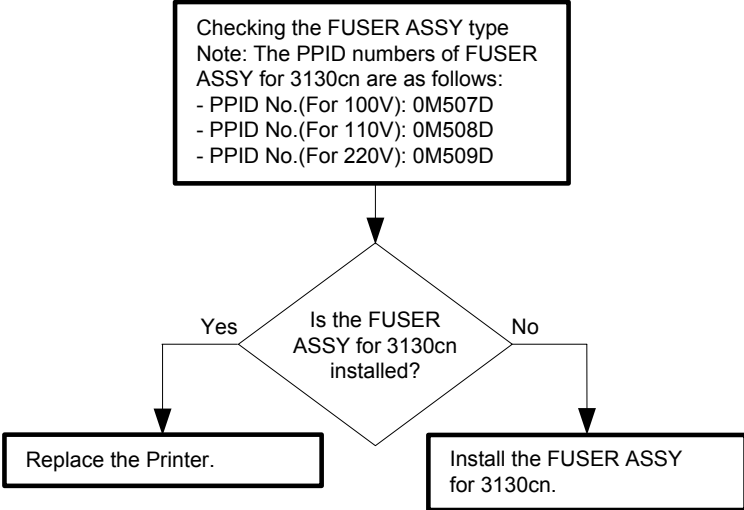

Flows 62 Ready to Print 010-421

NOTE

This error code is not a fault warning and only denotes that the Fuser ASSY is approaching but has not reached its end of life.

Immediately prepare a new Fuser ASSY.

If this error code is displayed although the Fuser ASSY has been replaced only recently, follow the following flow.

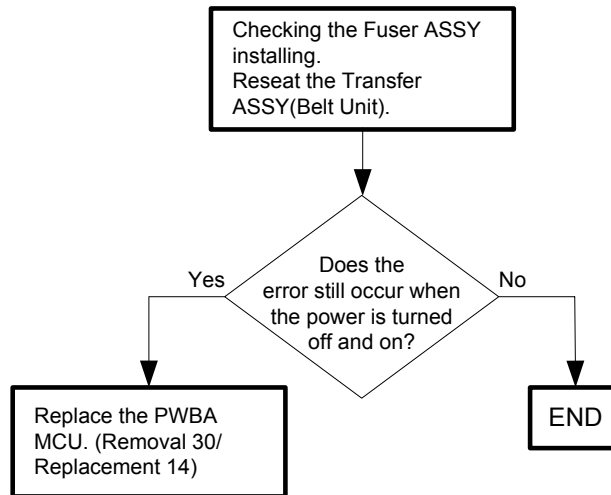

Flows 63 Tray Detached 024-946/007-912

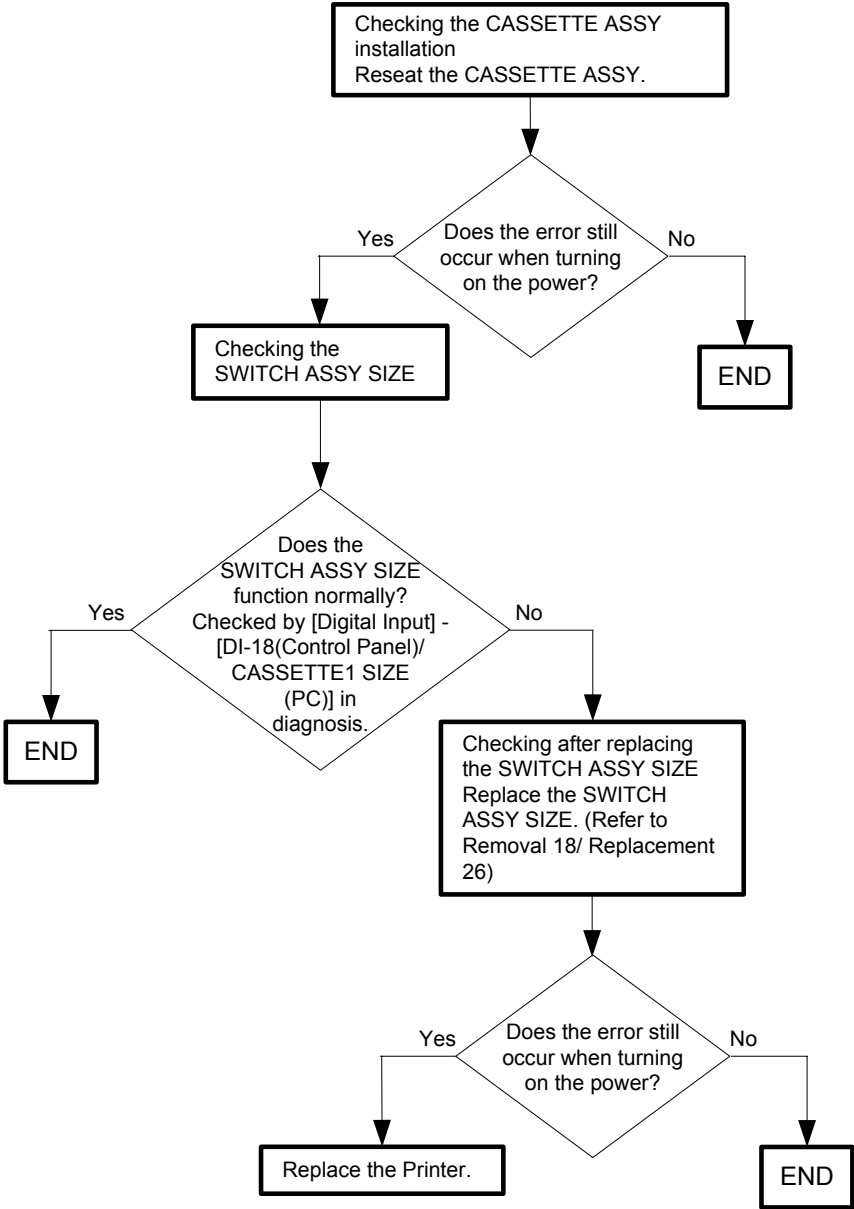

Flows 64 Load Tray 024-947

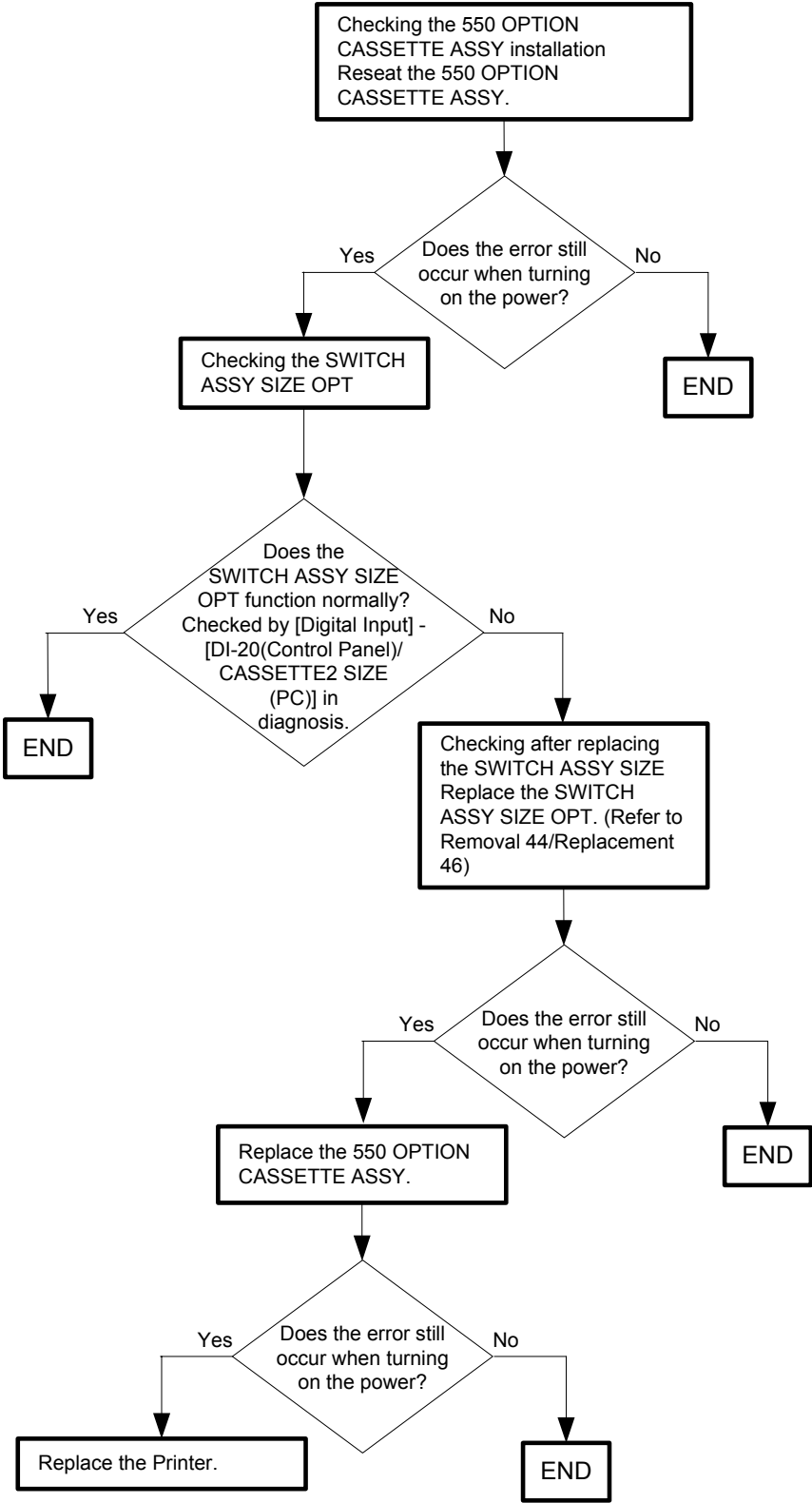

Flows 65 Close Front Cover 077-300

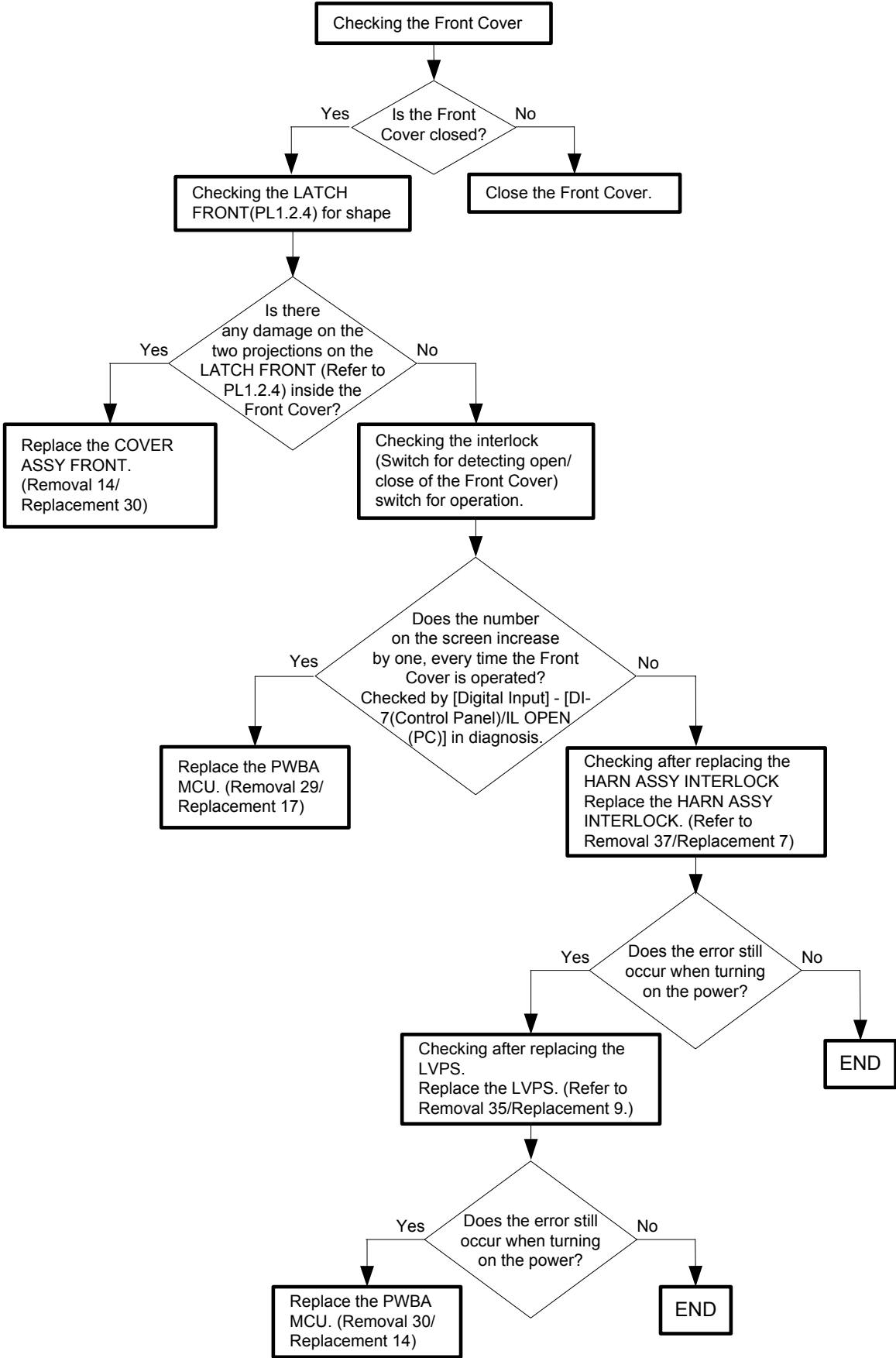

Flows 66 Invalid ID 016-383 / Range Chk Error 016-384 / Header Error 016-385 / Check Sum Error 016-386 / Format Error 016-387

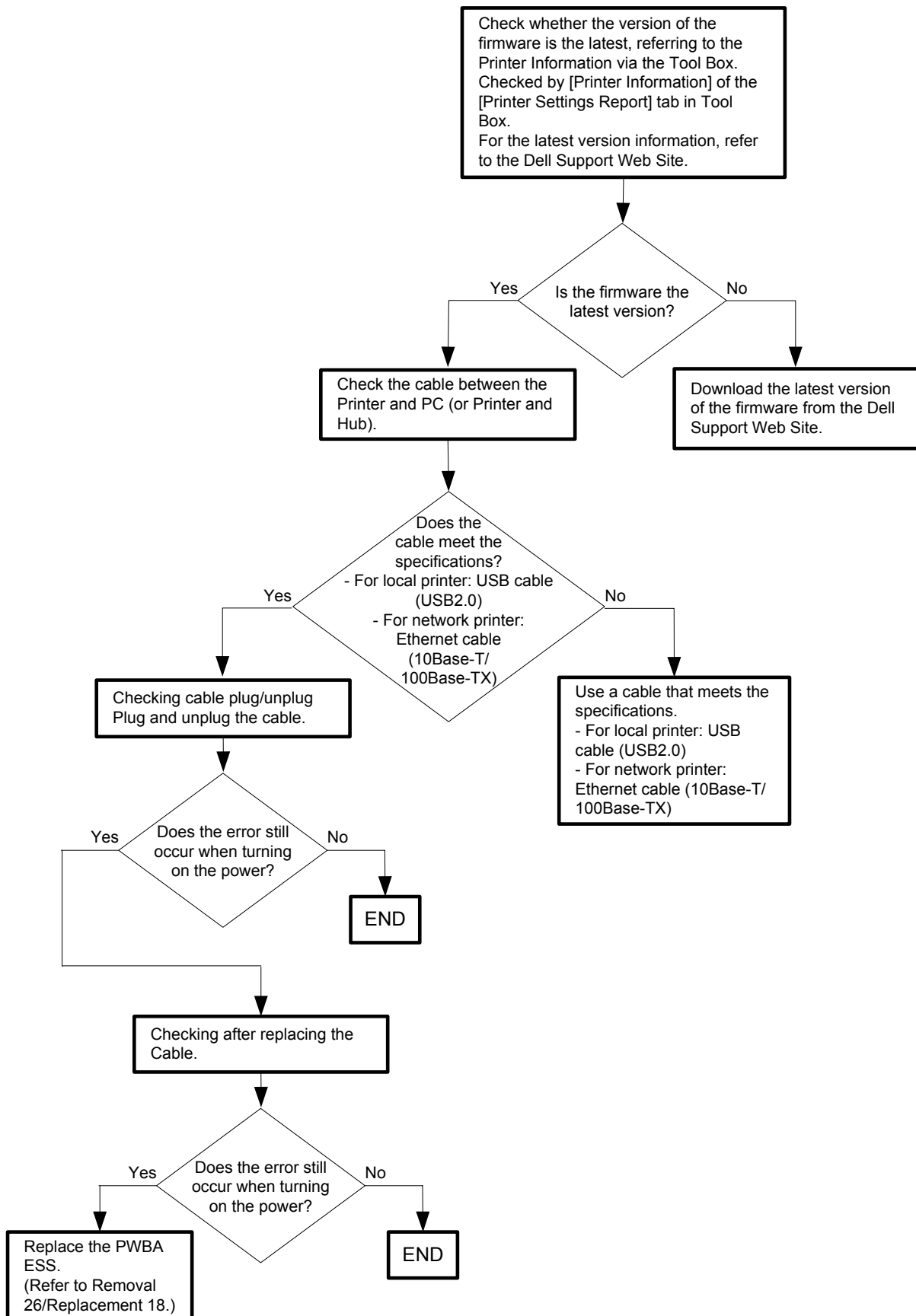

Flows 67 Out of Memory 016-700

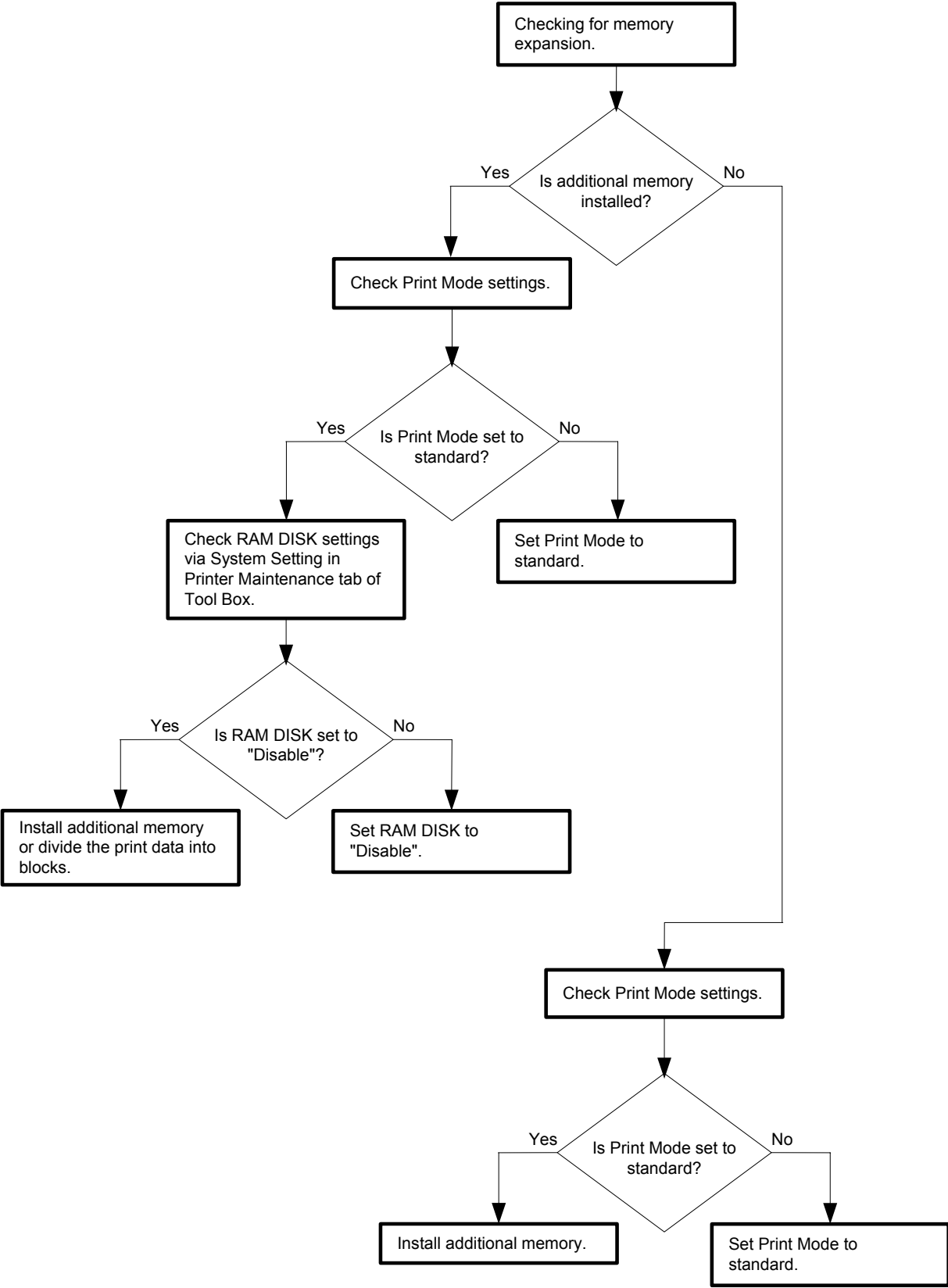

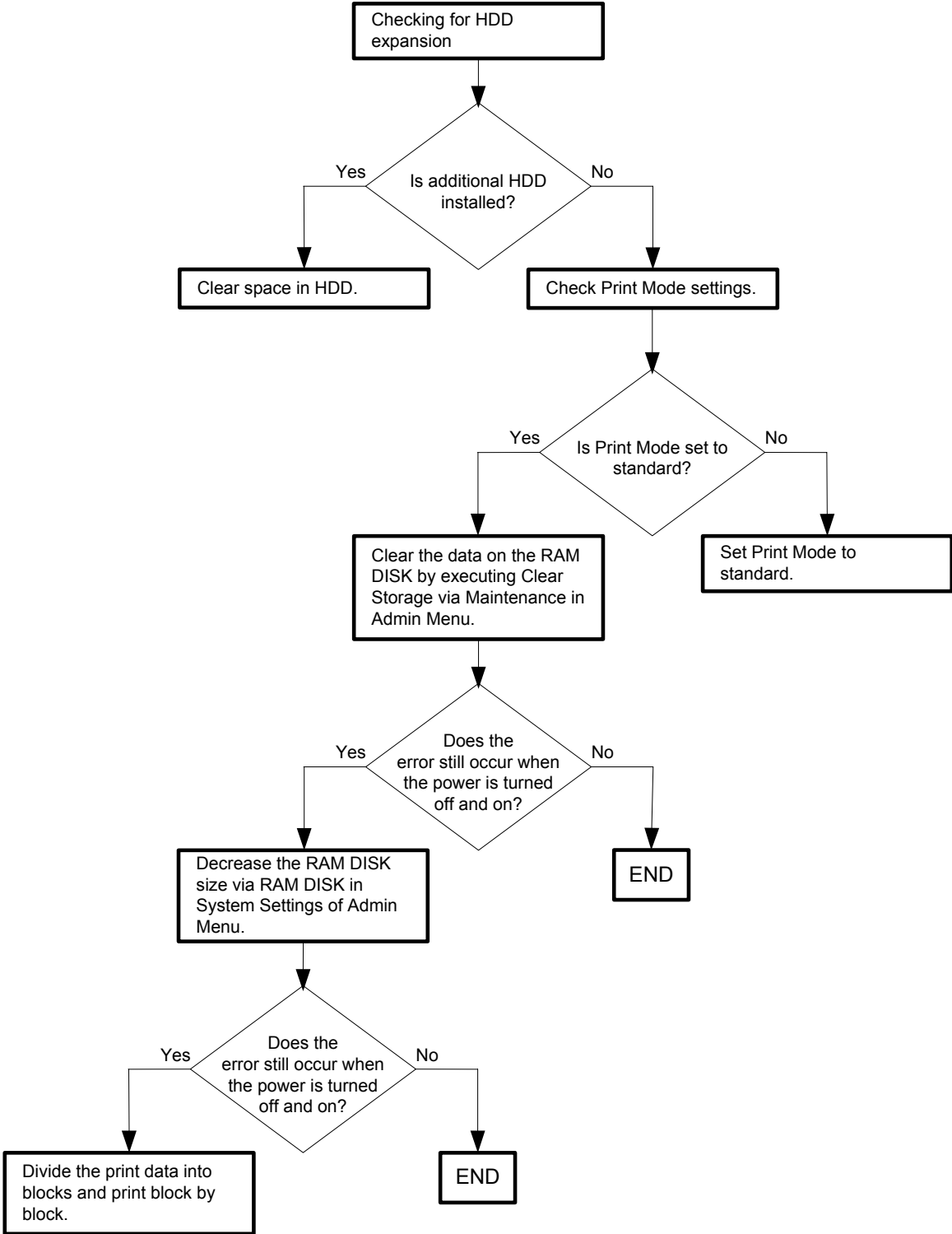

Flows 69 Collate Full 016-981

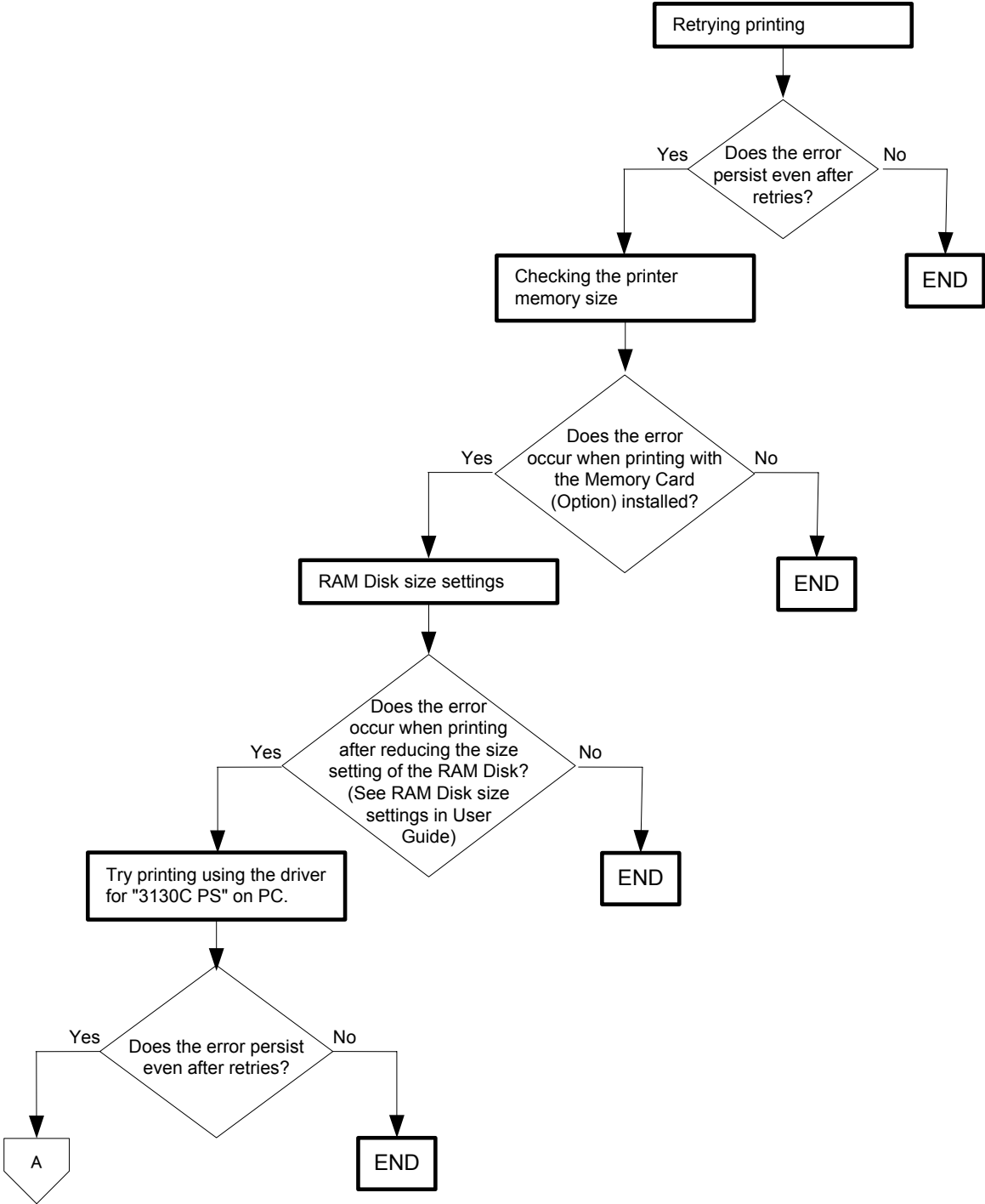

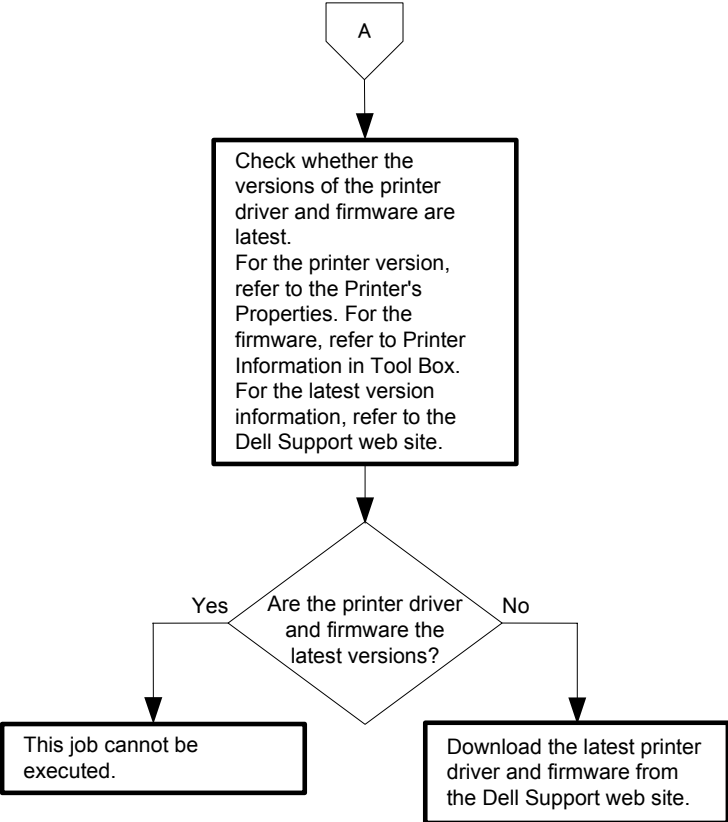

Flows 70 016-720 PDL Error

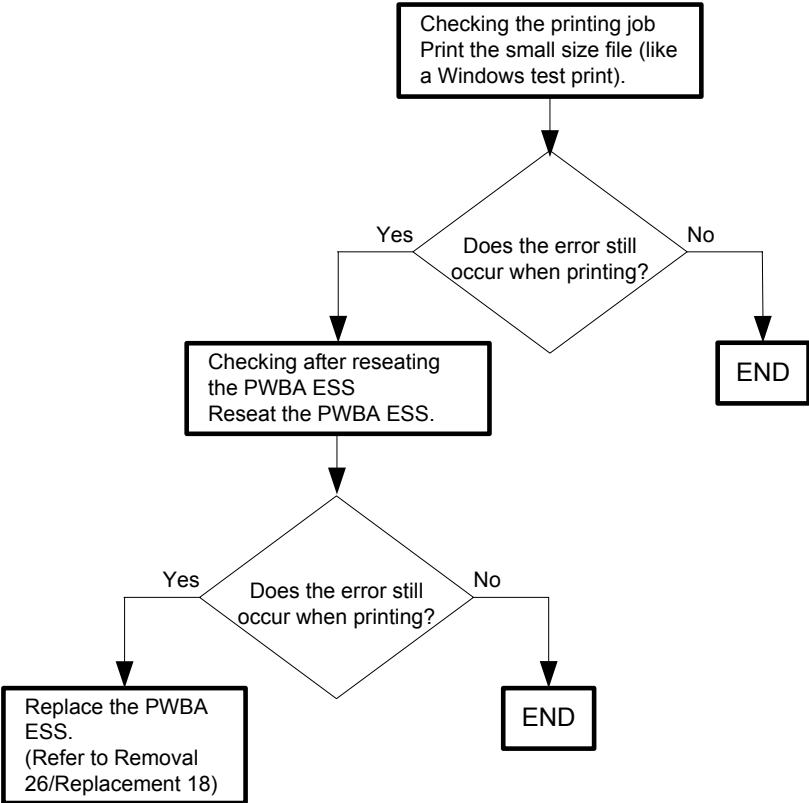

Flows 71 Invalid User 016-757

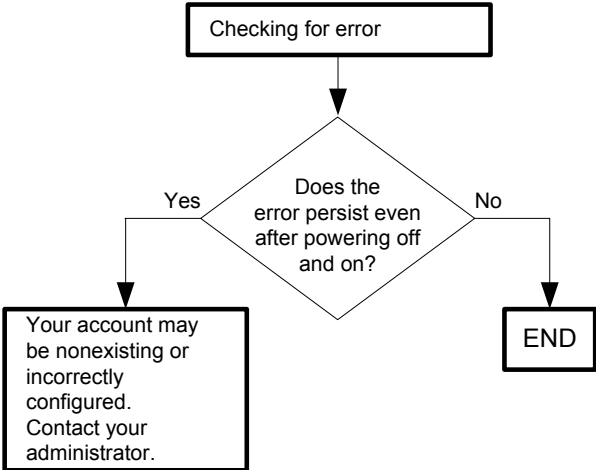

Flows 72 Disabled Func 016-758

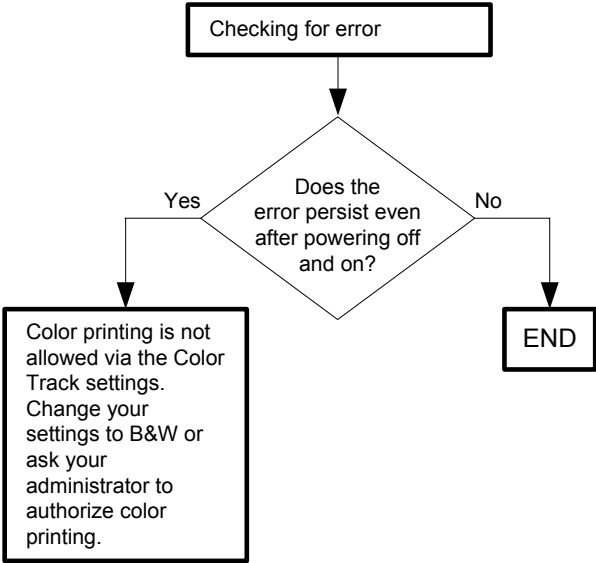

Flows 73 Reached Limits 016-759

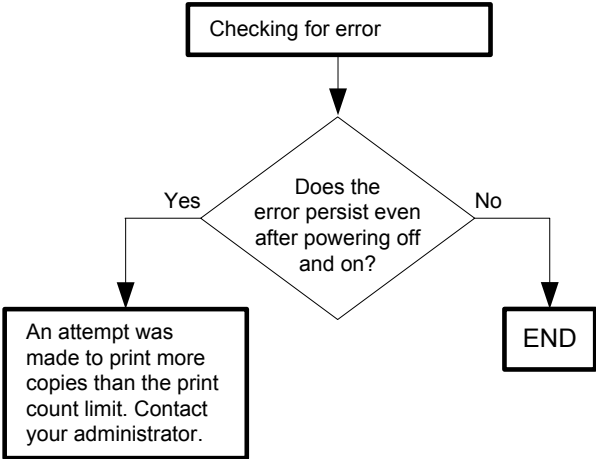

Flows 74 Invalid Job 016-799

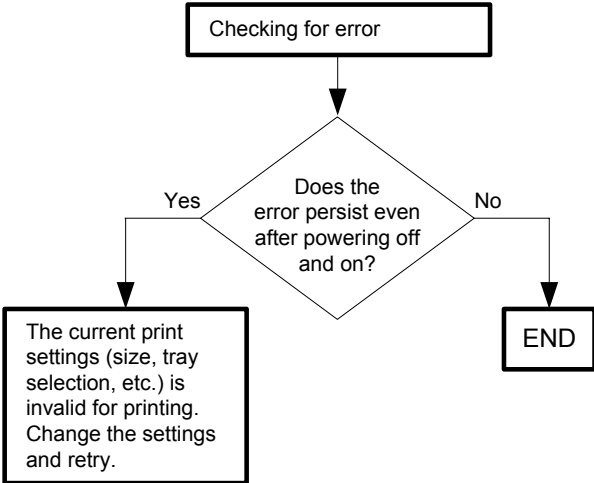

Flows 75 Ready to Print 193-700

NOTE

- This message appears when [Non-Dell Toner] setting of [Maintenance] on [Admin Menu] is turned to [ON] for using non-Dell toner cartridge.

Printing is available while this message is displayed.

Use of a non-Dell print cartridge may result in some of the printer's functions to be unavailable, a reduction in print quality, or deterioration of printer's reliability. Use of a new Dell brand print cartridge is recommended for your printer.

- When you use Dell toner cartridge, you can turn off the message by turning the [Non-DELL Toner] setting to [OFF].

- Use of a non-Dell print cartridge may result in some of the printer's functions to be unavailable, a reduction in print quality, or deterioration of printer's reliability. Use of a new Dell brand print cartridge is recommended for your printer.

The Dell warranty does not cover any problems caused by the use of any accessory, part, or component that is not supplied by Dell.

If this error code is displayed although the [Non-Dell Toner] setting is [OFF], follow the following flow.

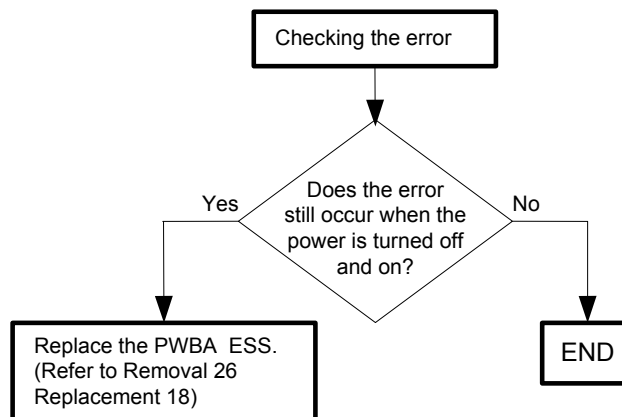

Flows 76 Over Heat 042-700 / Ready to Print 142-700

NOTE

- The error code "042-700" is displayed when the internal temperature of the printer has risen to somewhere near the predetermined value due to a large volume 2-sided printing. Wait a while with the printer on until the error disappears.

When performing a large volume of 2-sided printing, make the printing interval as long as possible.

If this error code is displayed although you have not performed any large volume 2-sided printing, follow the following flow.

- The error code "142-700" is displayed when the internal temperature of the printer has risen due to a large volume printing. Do not start another print job until the warning disappears.

If this error code is displayed although you have not performed any large volume printing, follow the following flow.

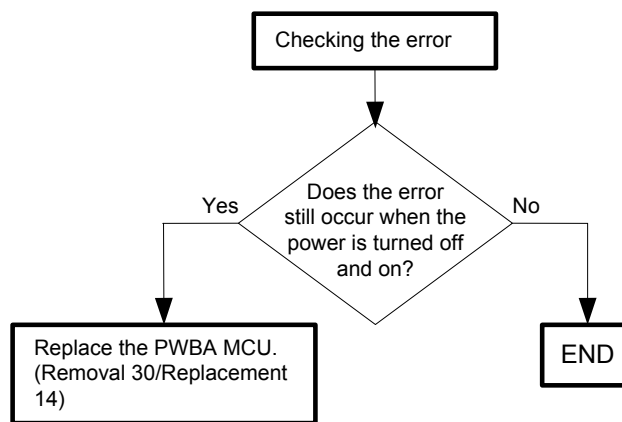

Flows 77 Electrical Noise

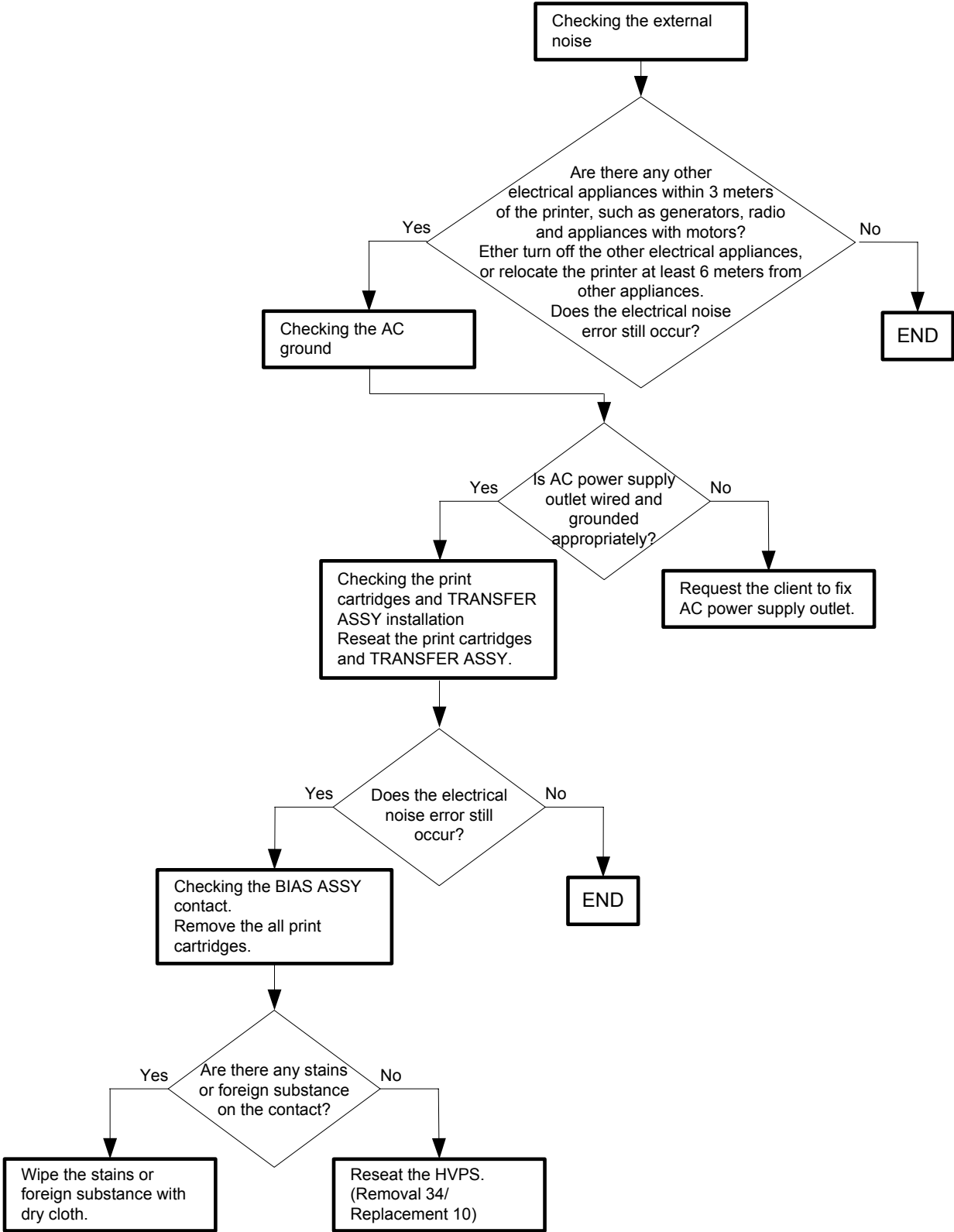

Flows 78 Faint print (Low contrast)

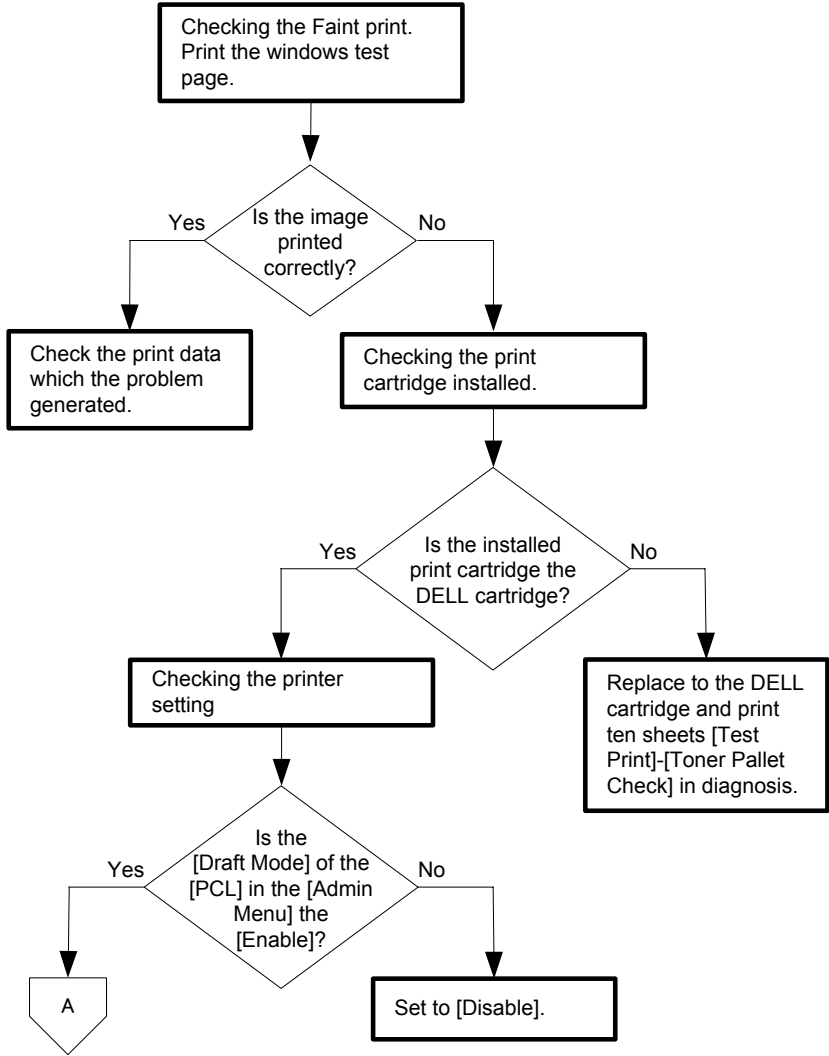
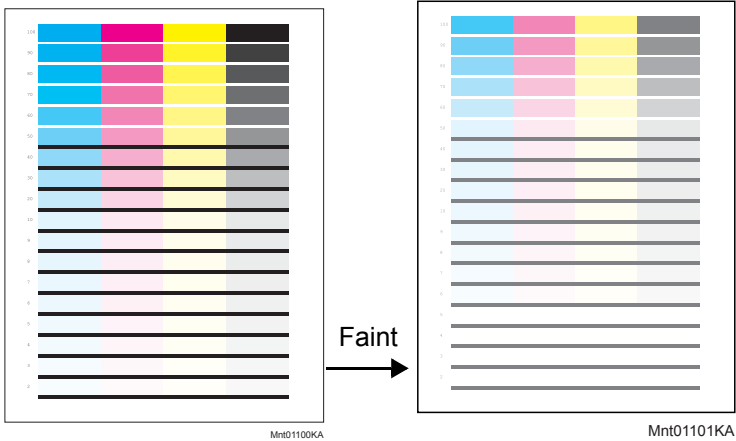

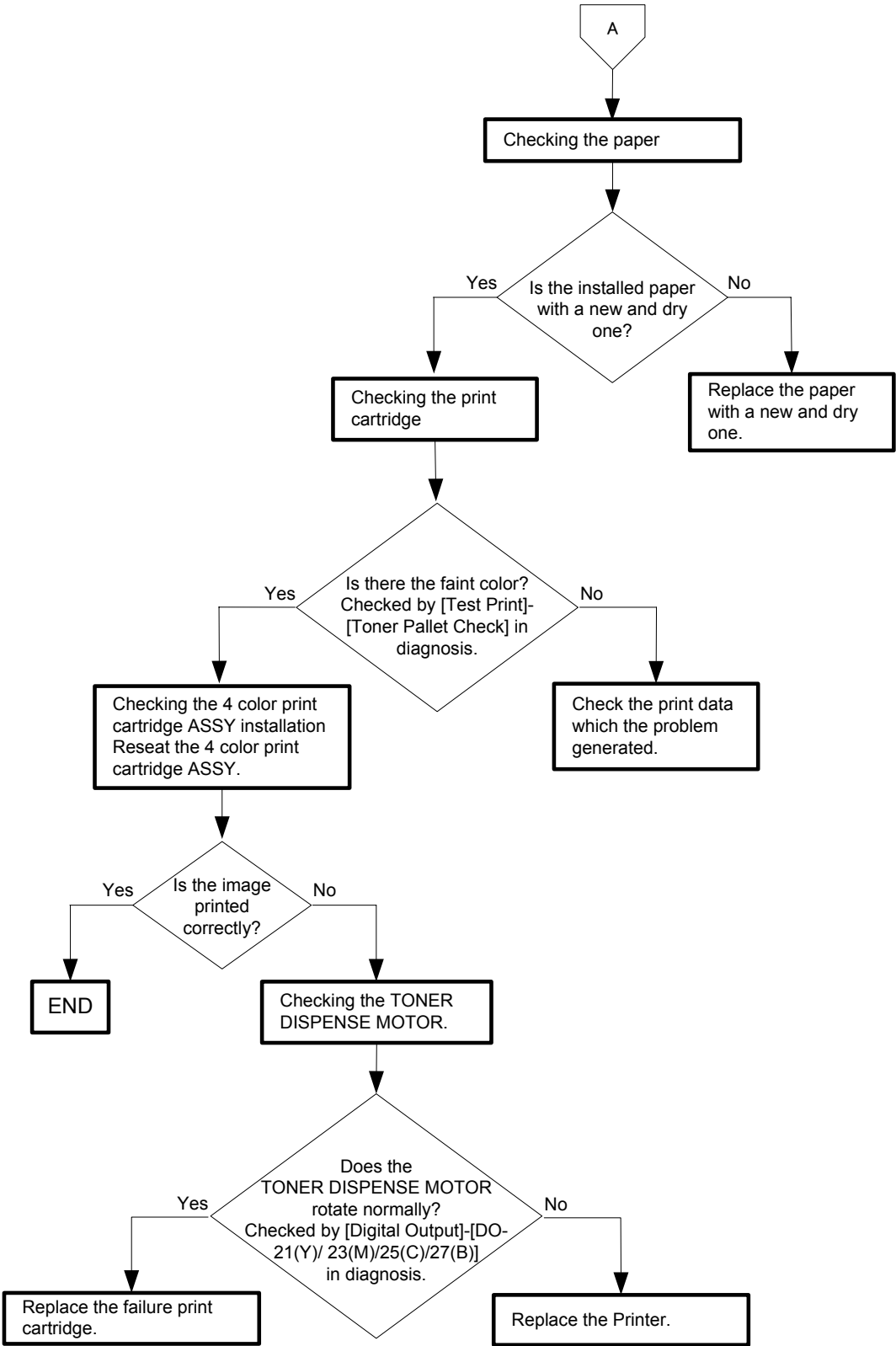

Flows 79 Blank print (No print)

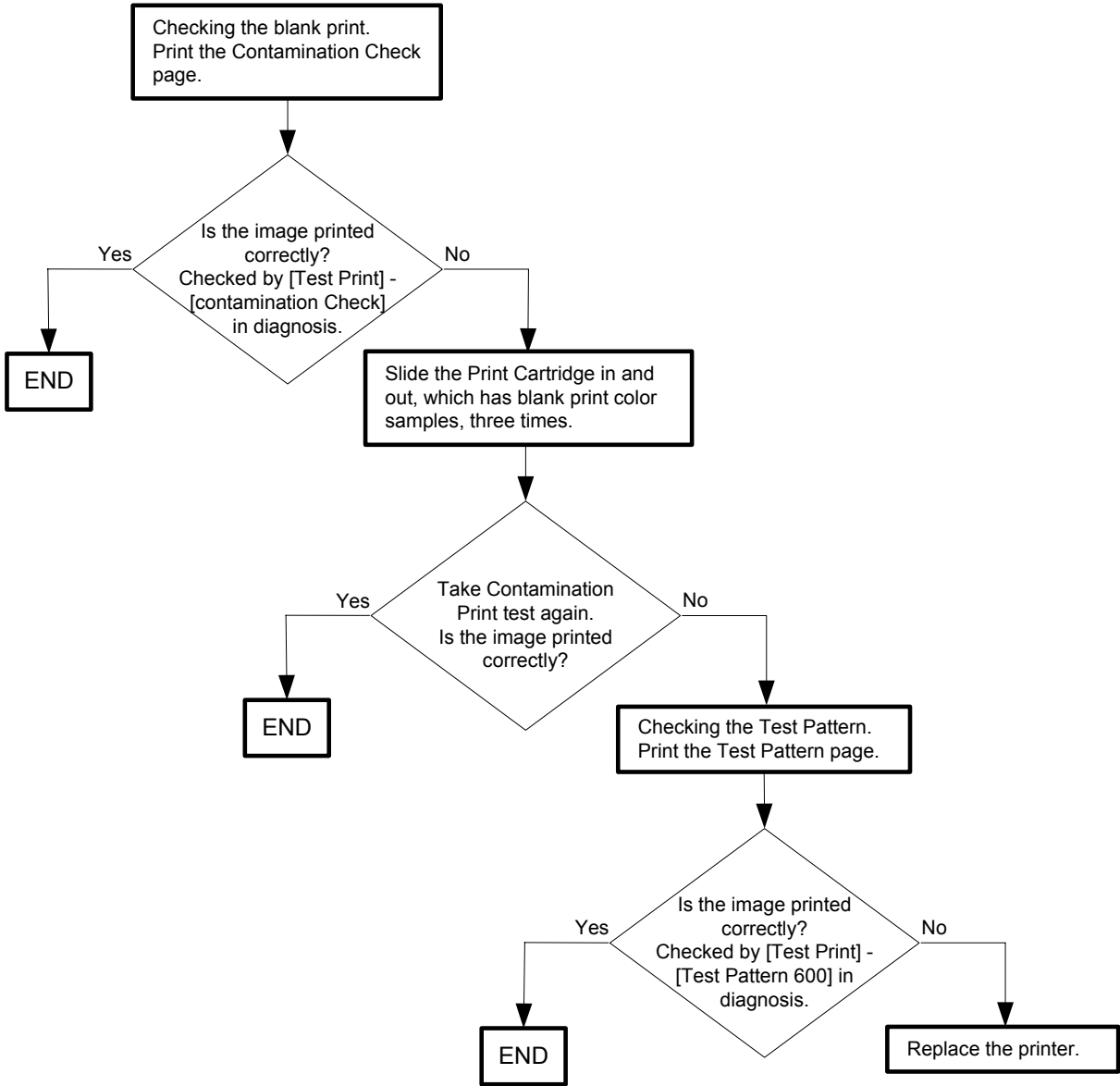
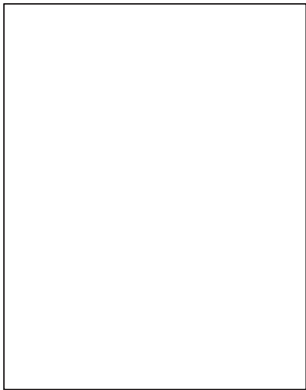

Flows 80 Solid black

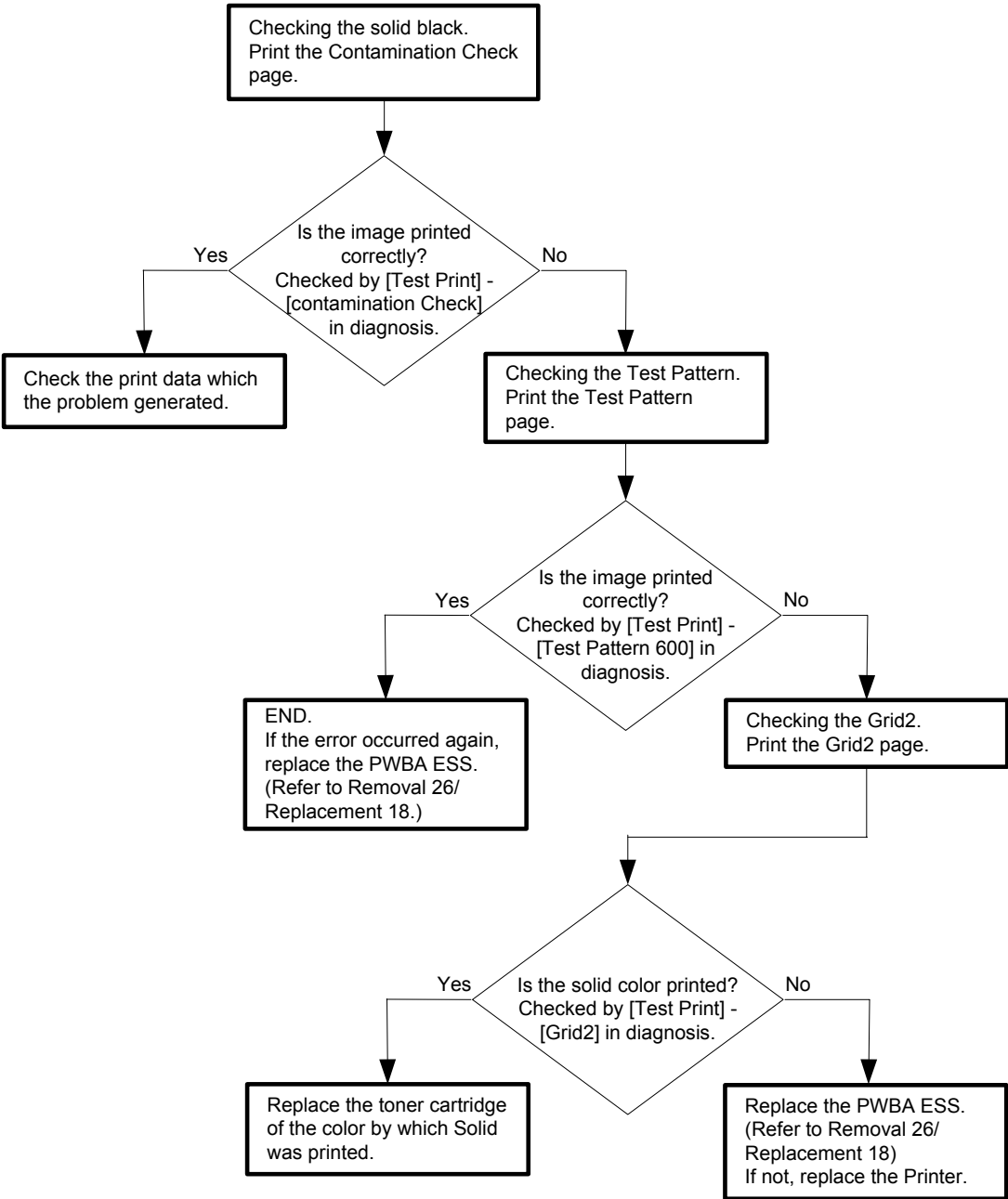
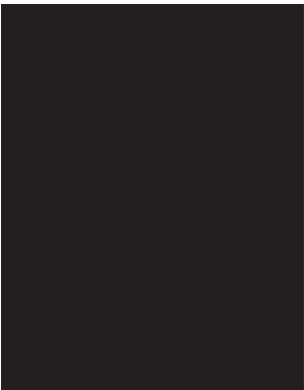

Flows 81 Vertical blank lines (White stripes in paper transport direction)

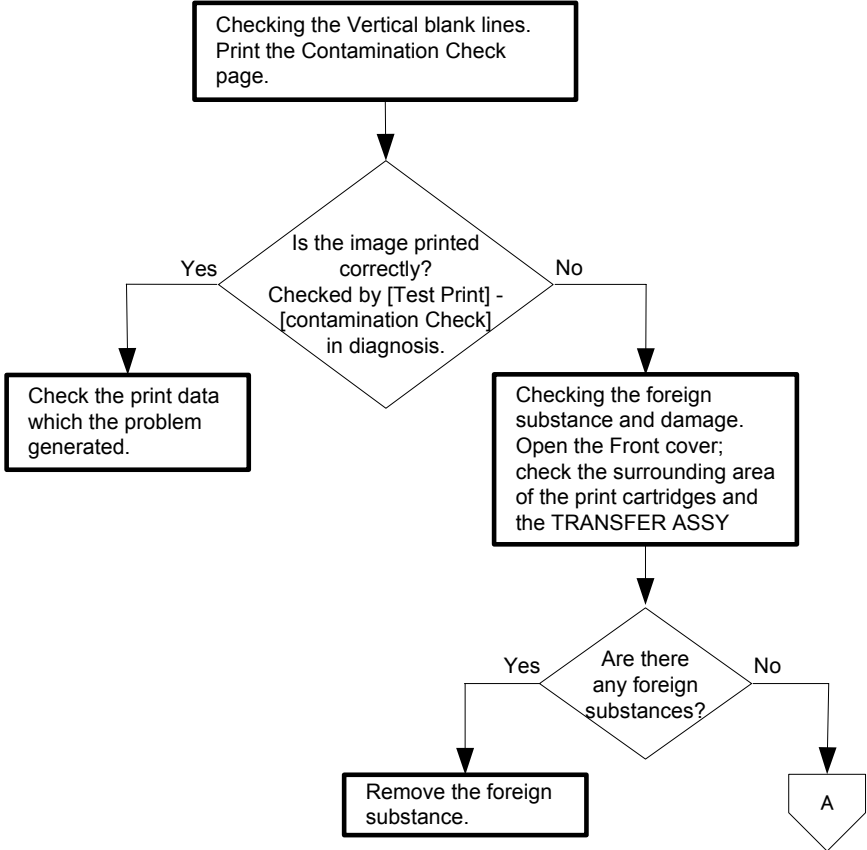
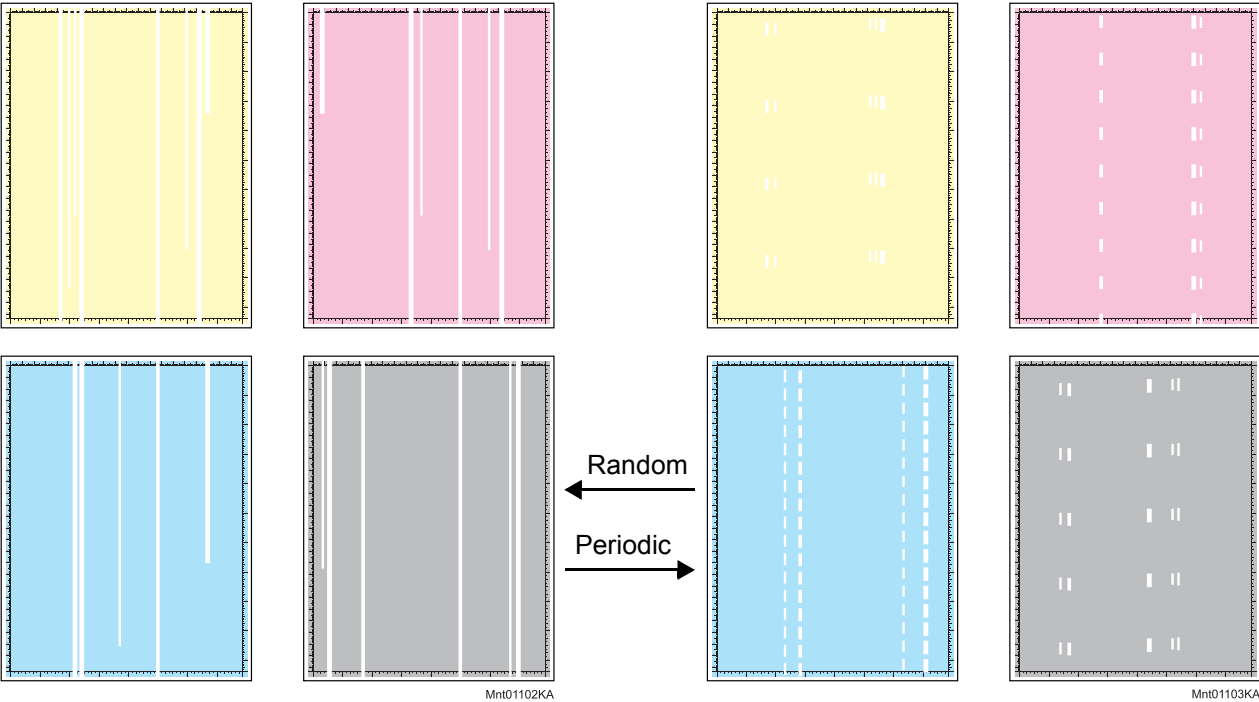

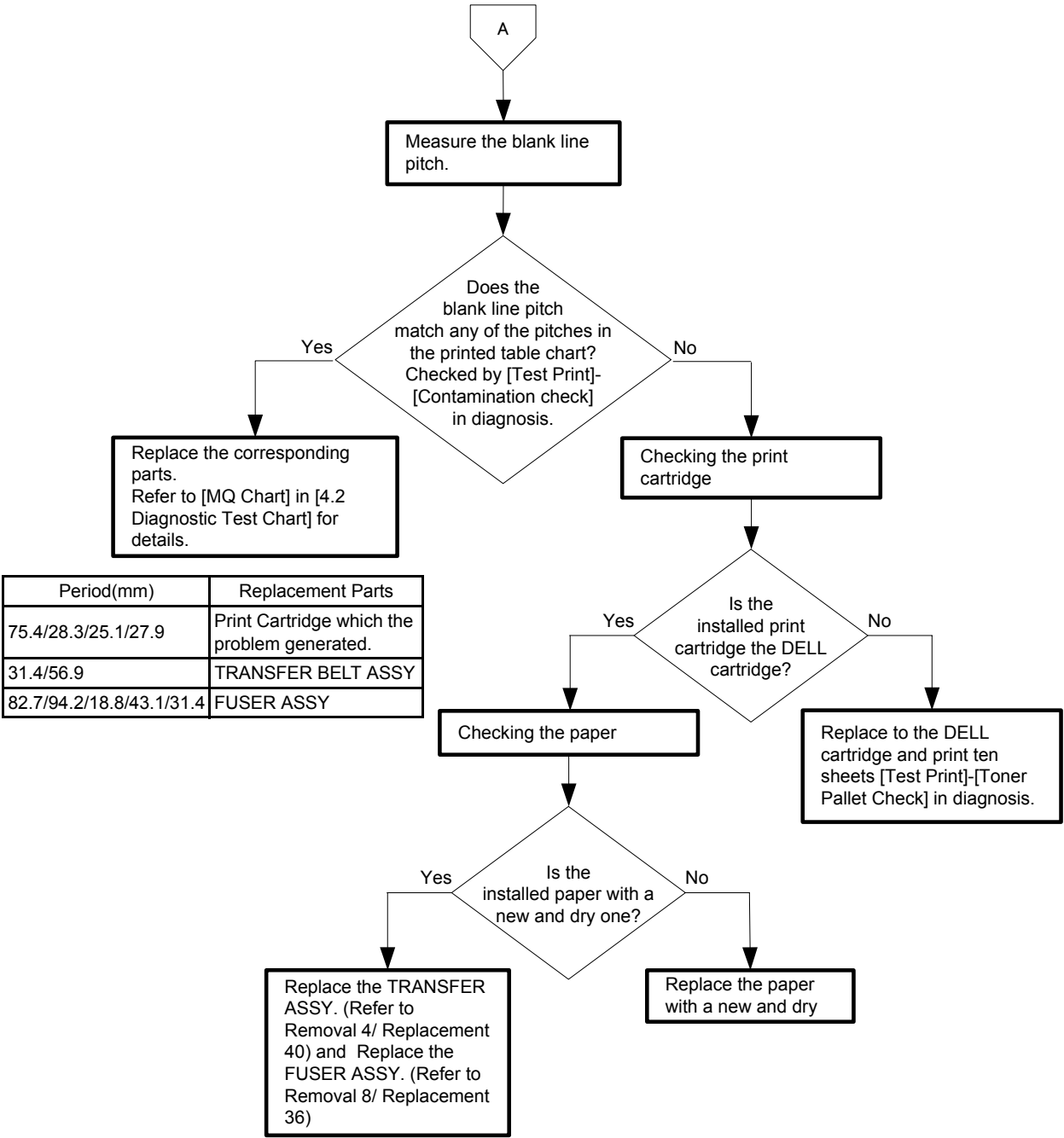

Flows 82 Horizontal band cross out (White stripes in the horizontal direction)

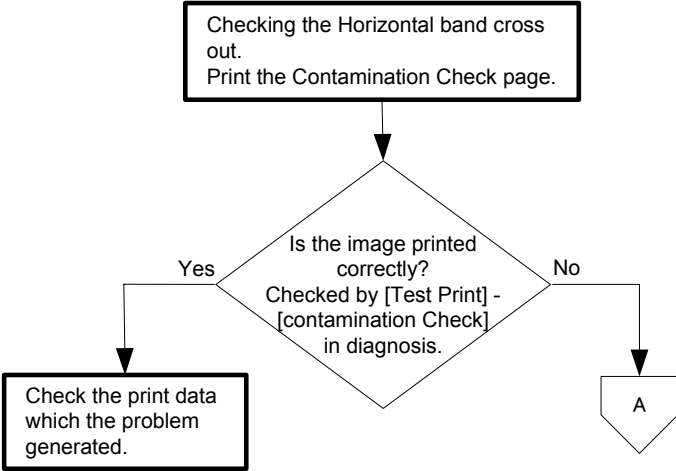
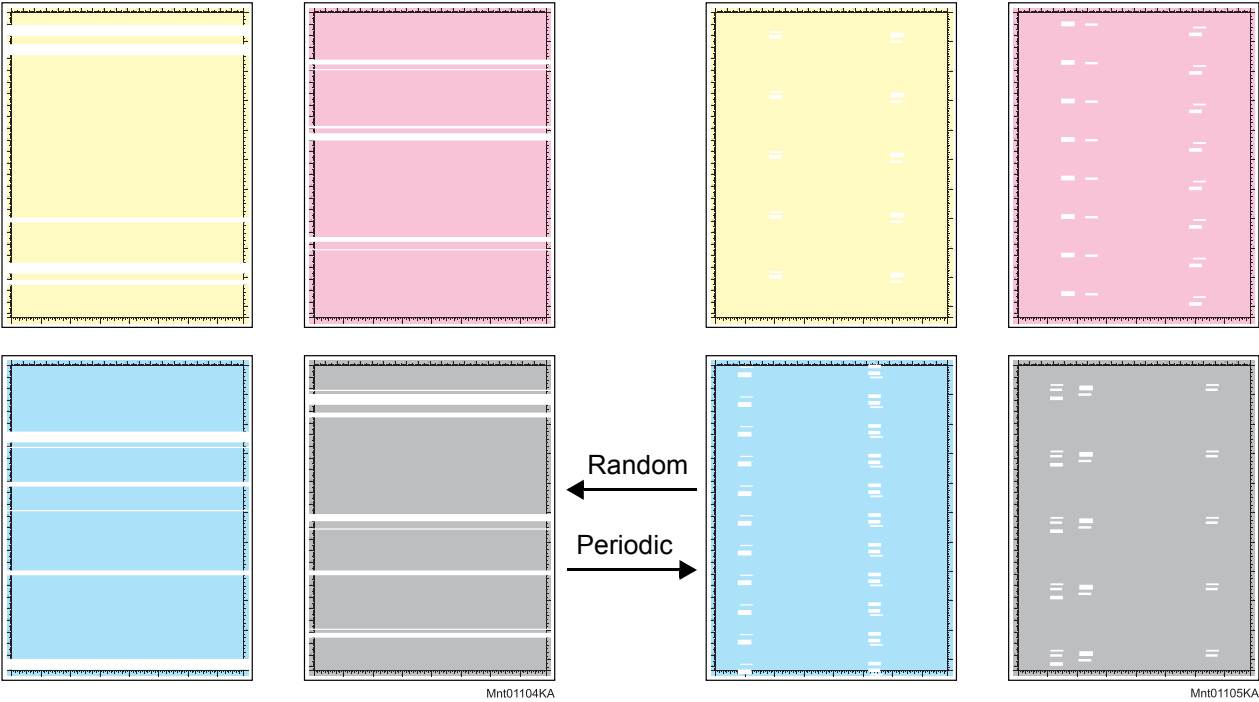

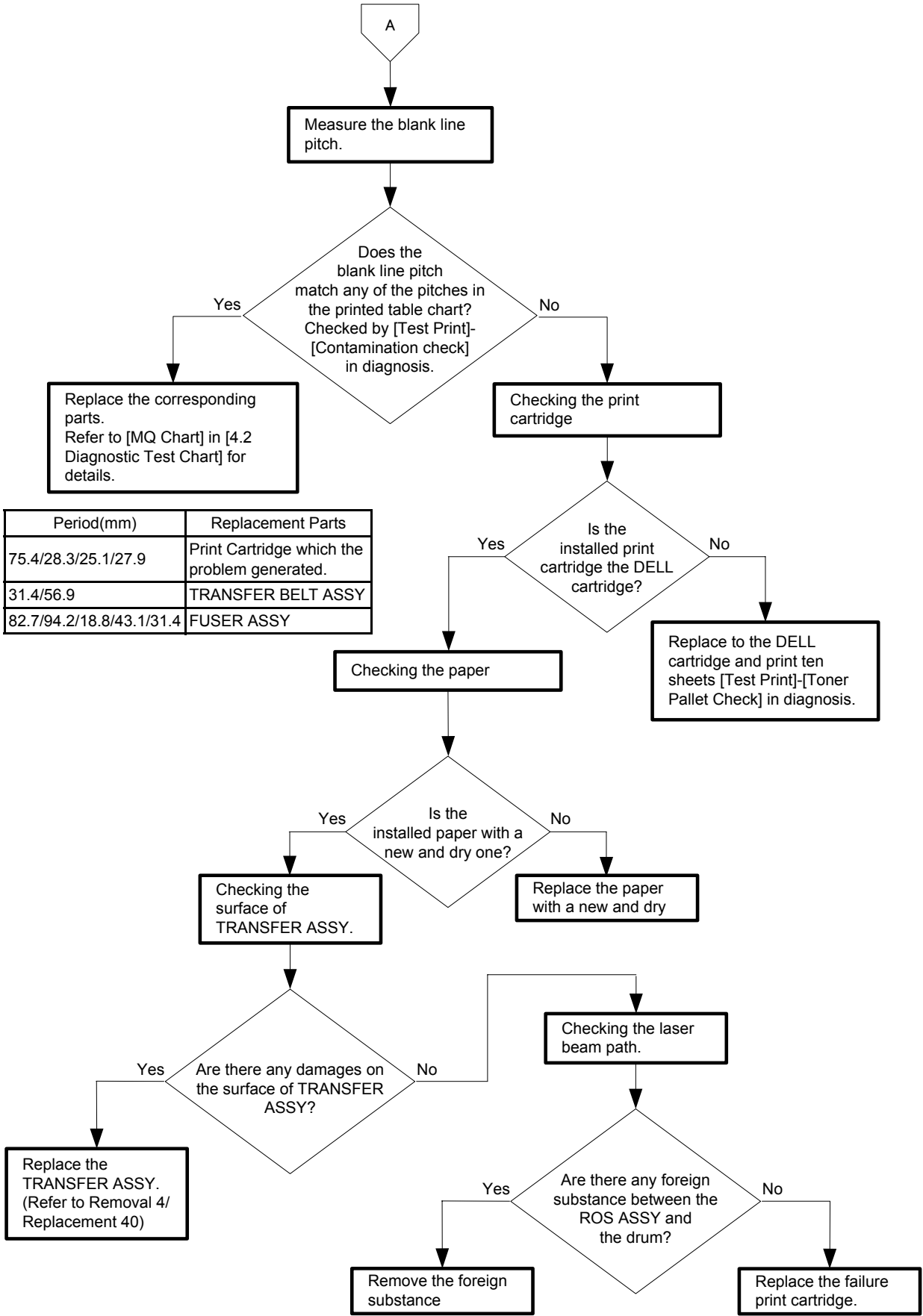

Flows 83 Vertical stripes

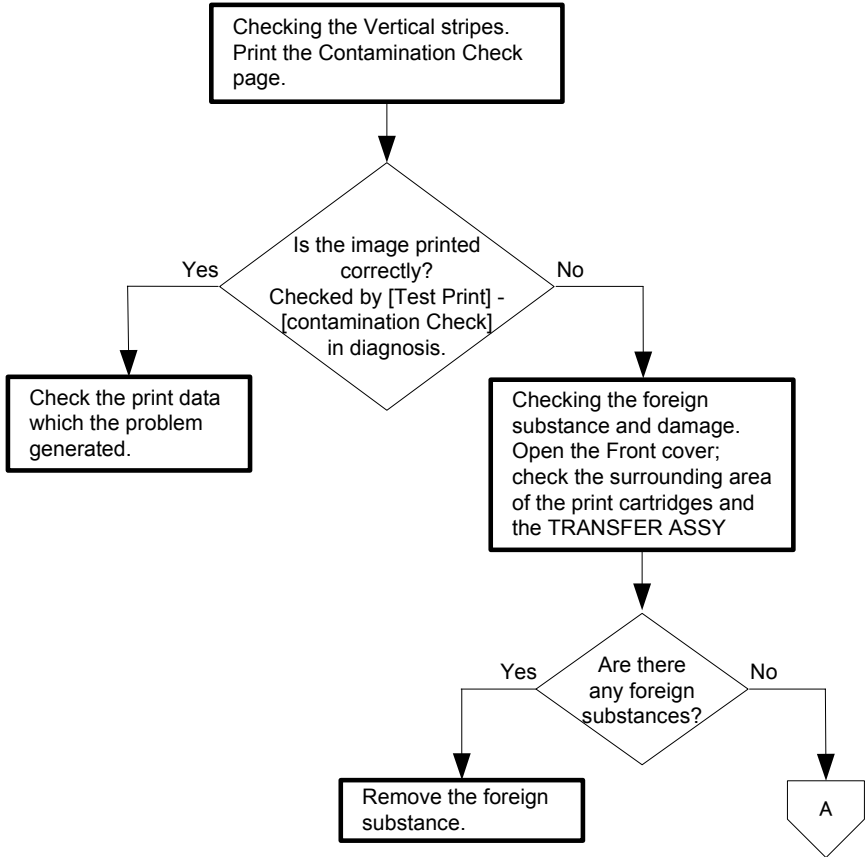
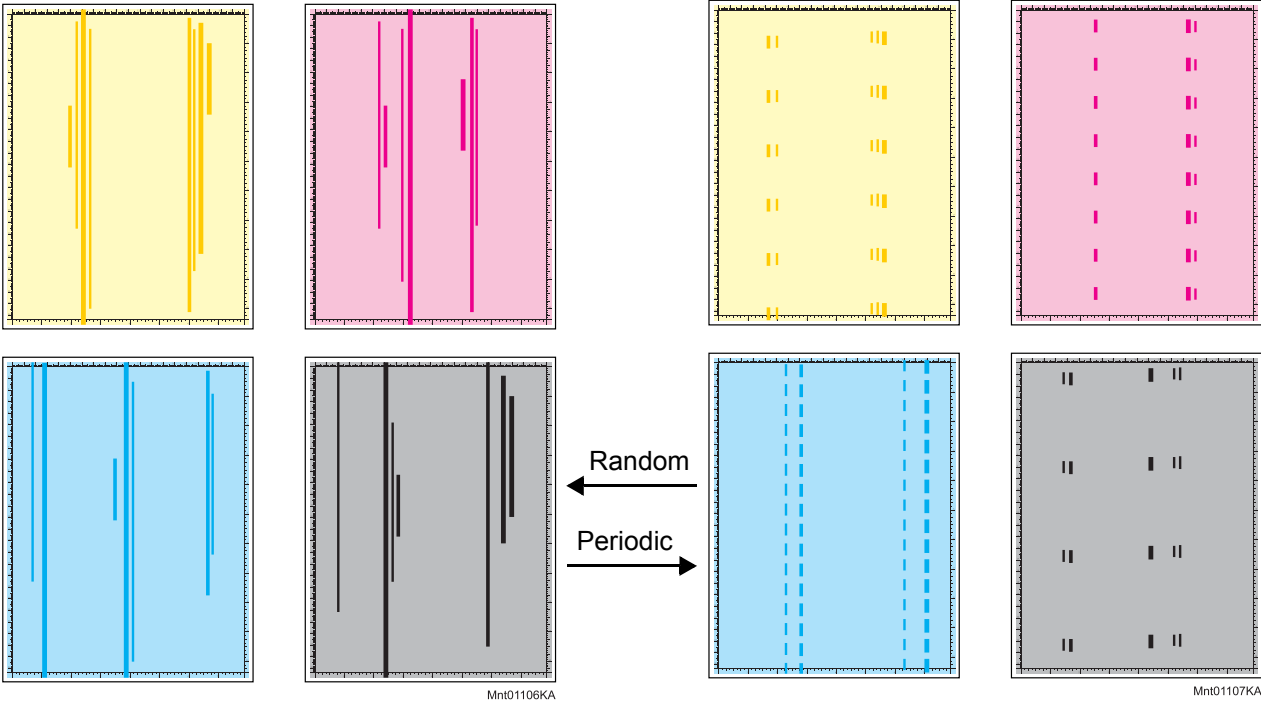

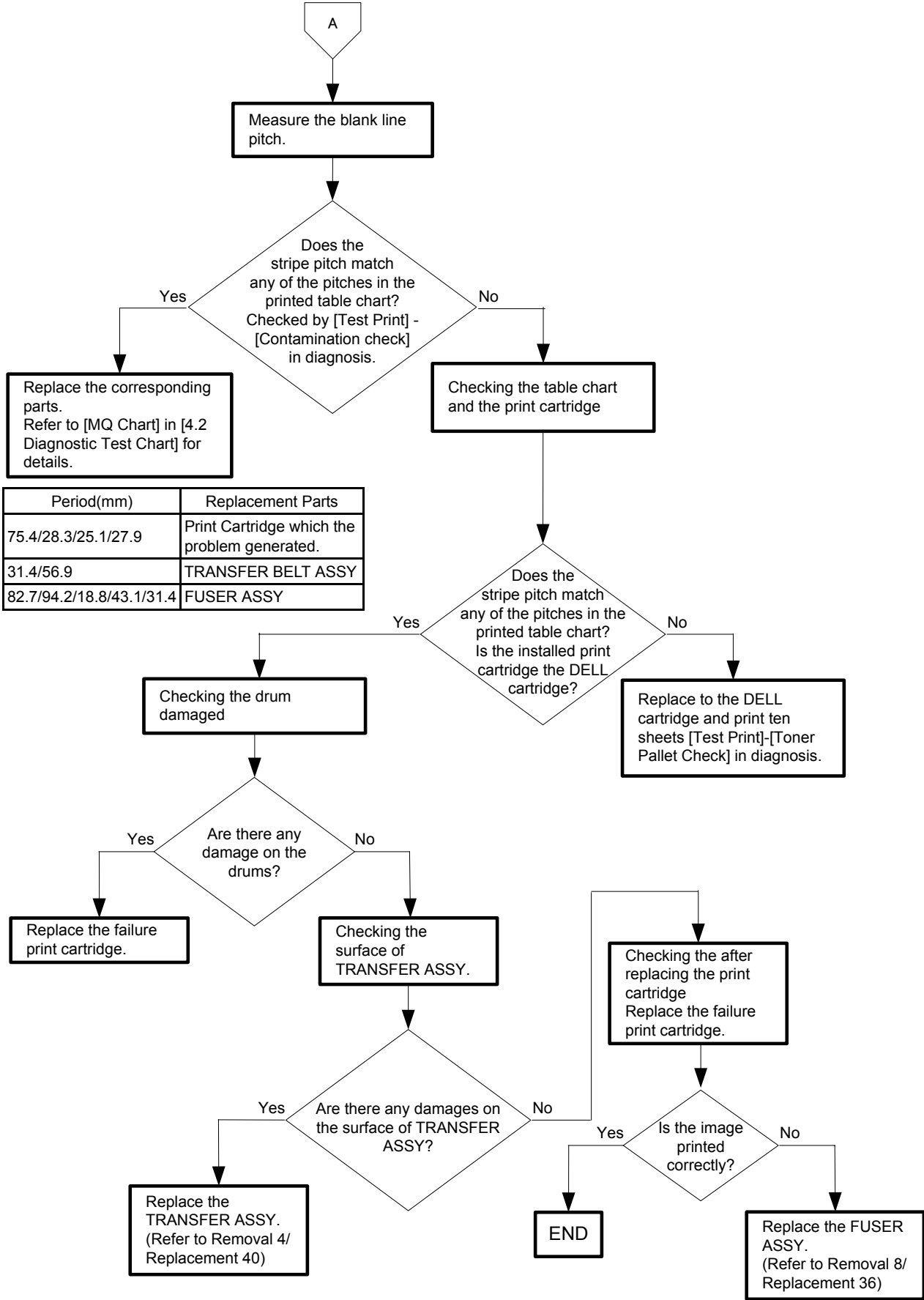

Flows 84 Horizontal stripes

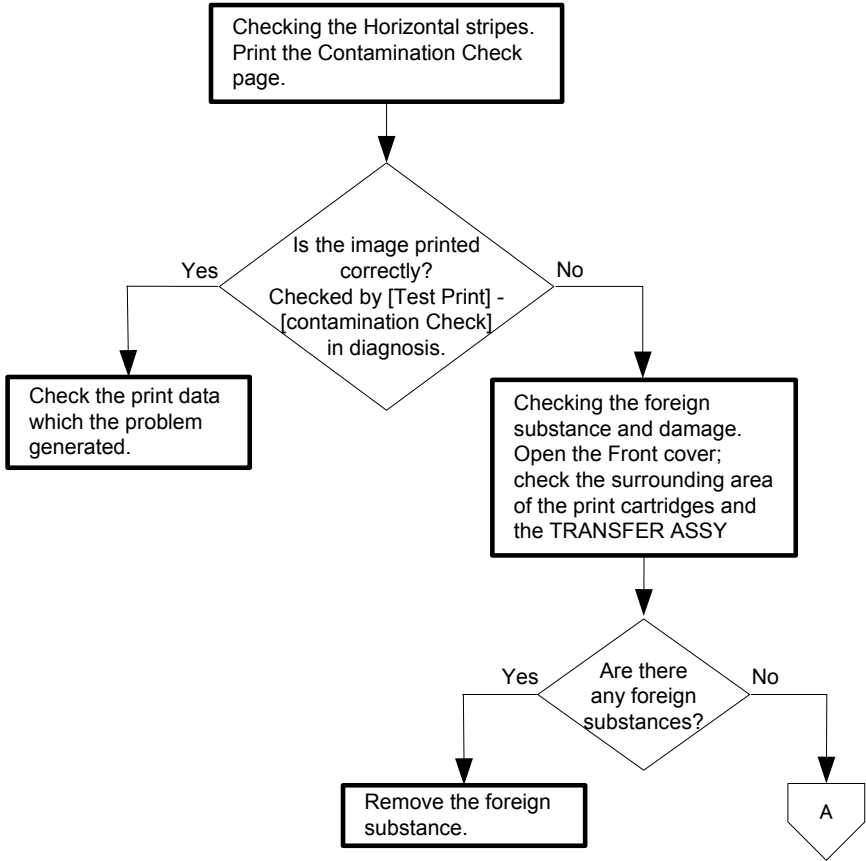
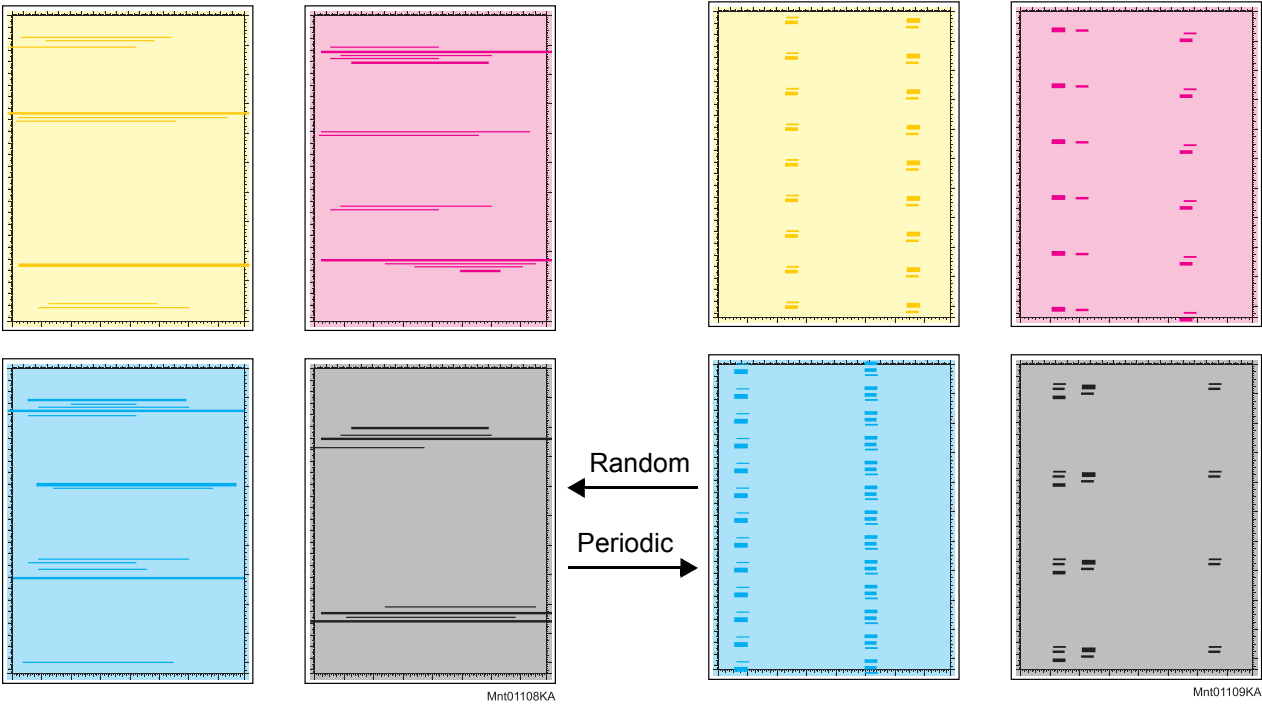

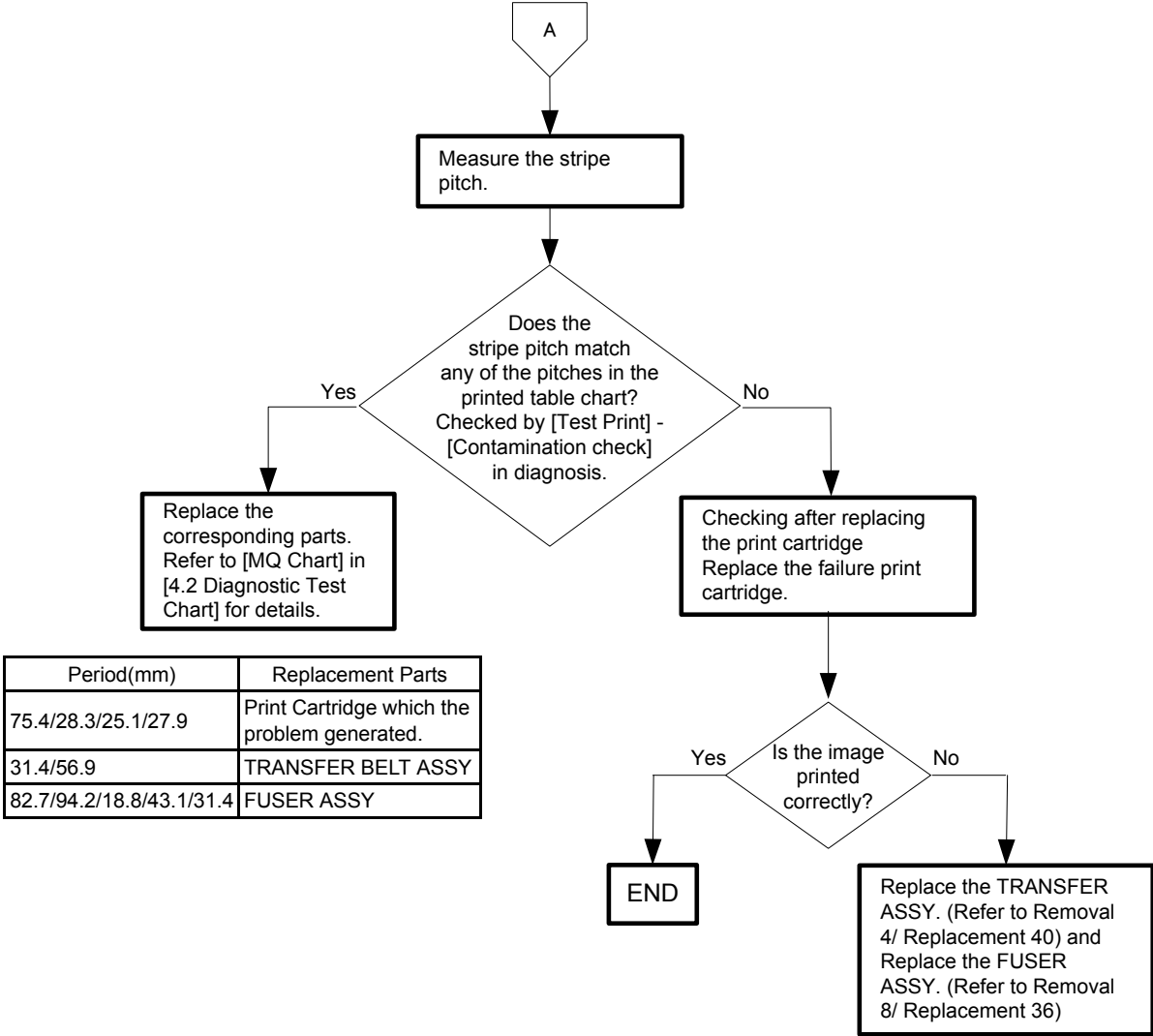

Flows 85 Partial Deletion

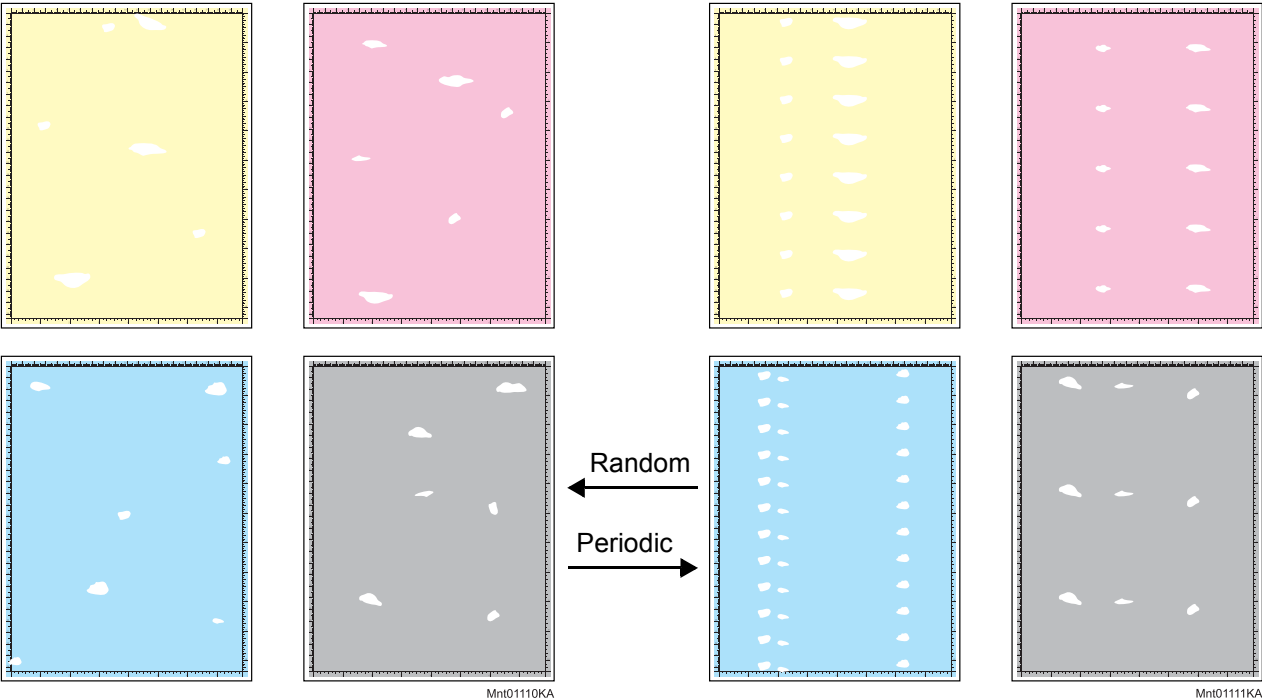

Checking the Partial Deletion.
Print the Contamination Check page.

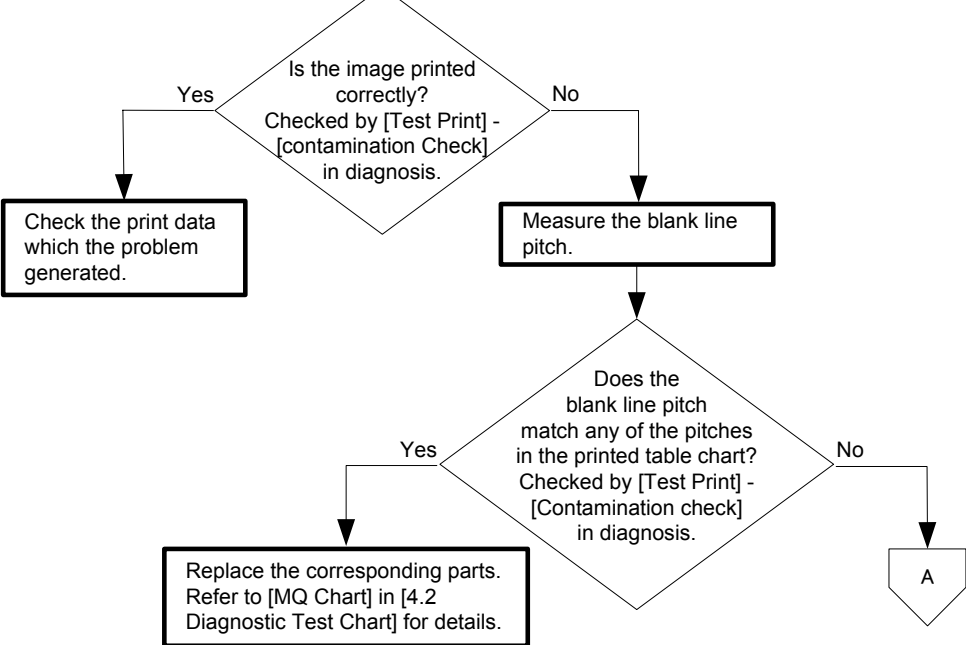

Period(mm)	Replacement Parts
75.4/28.3/25.1/27.9	Print Cartridge which the problem generated.
31.4/56.9	TRANSFER BELT ASSY
82.7/94.2/18.8/43.1/31.4	FUSER ASSY

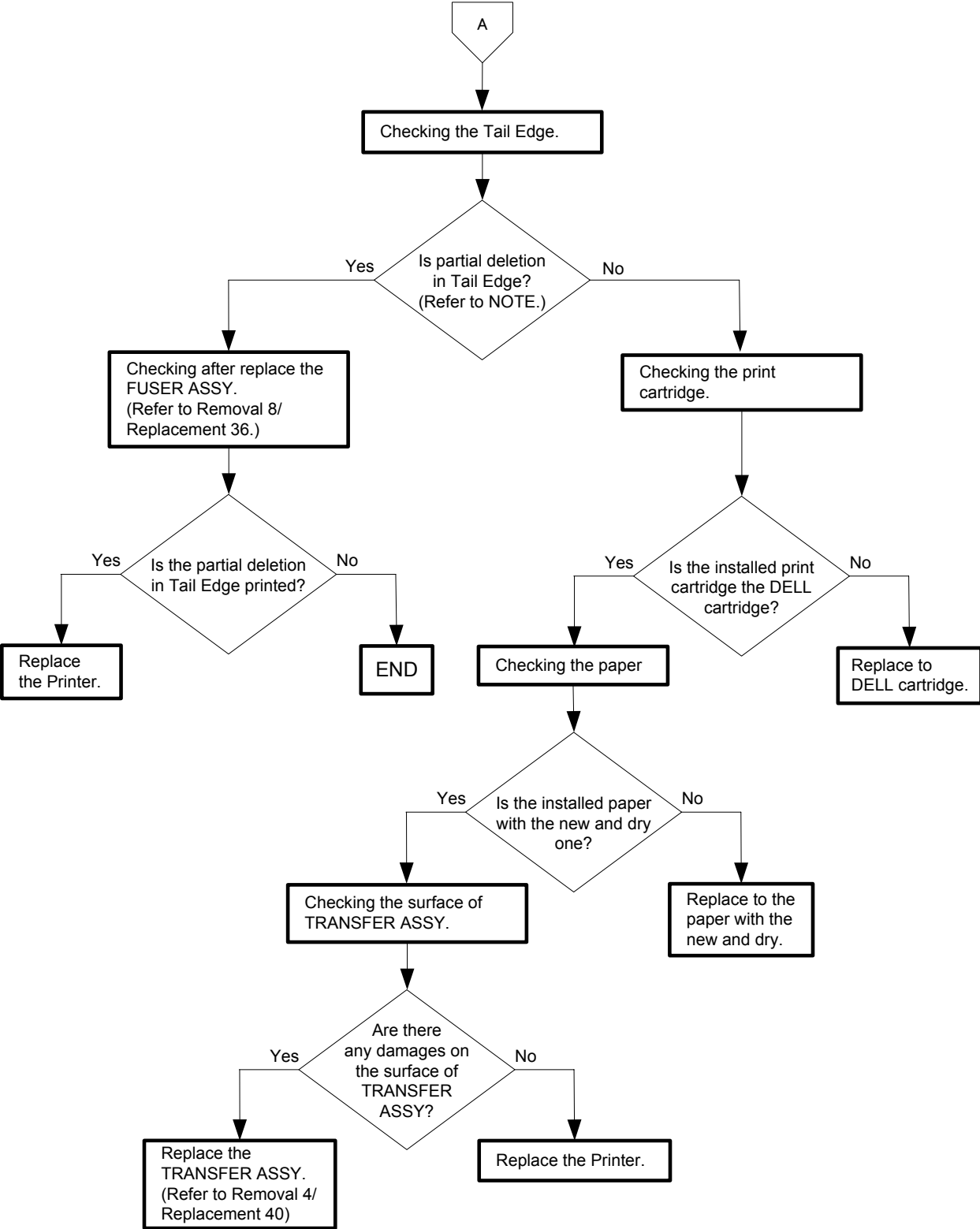

NOTE

This partial deletion is called as "smudge". Can be seen A4 size and half tone print. The partial deletion sample of Tail Edge is shown below.

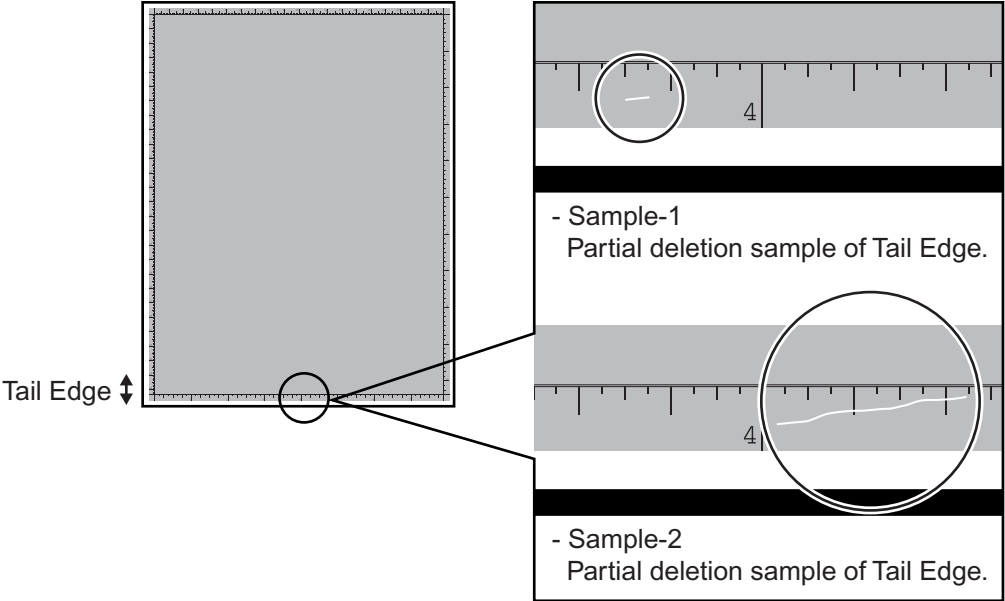

Zna0500KA

Flows 86 Spots

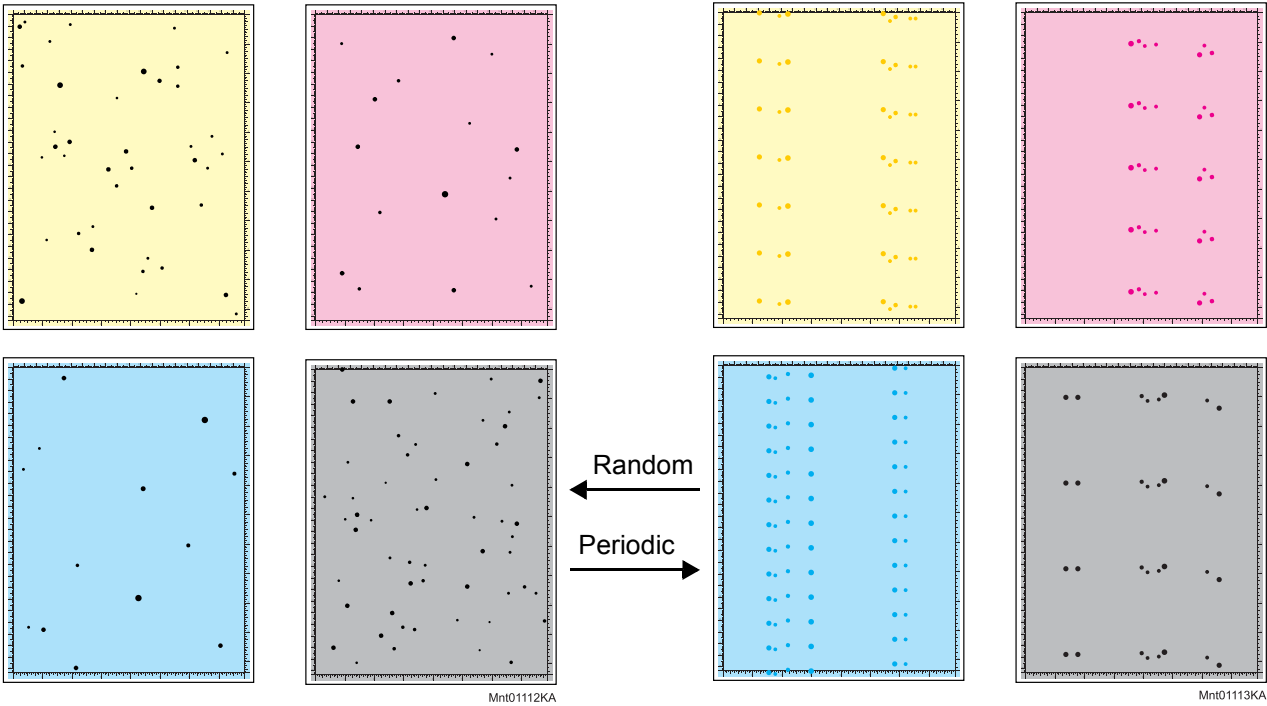

Mnt01112KA

Mnt01113KA

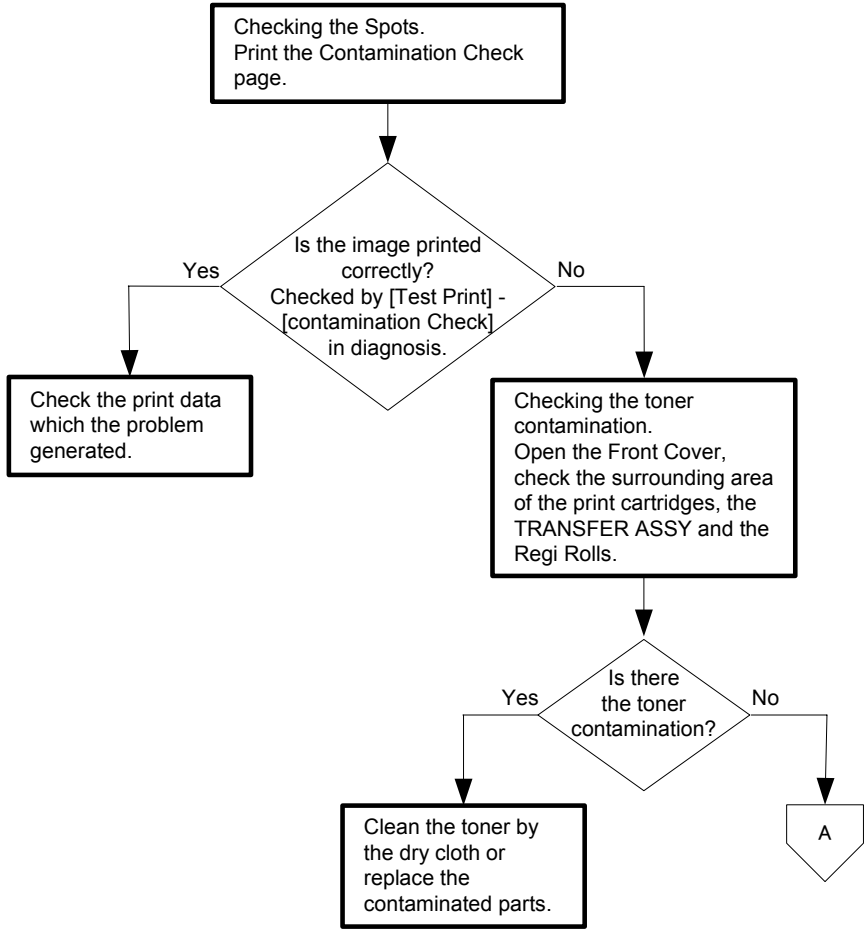

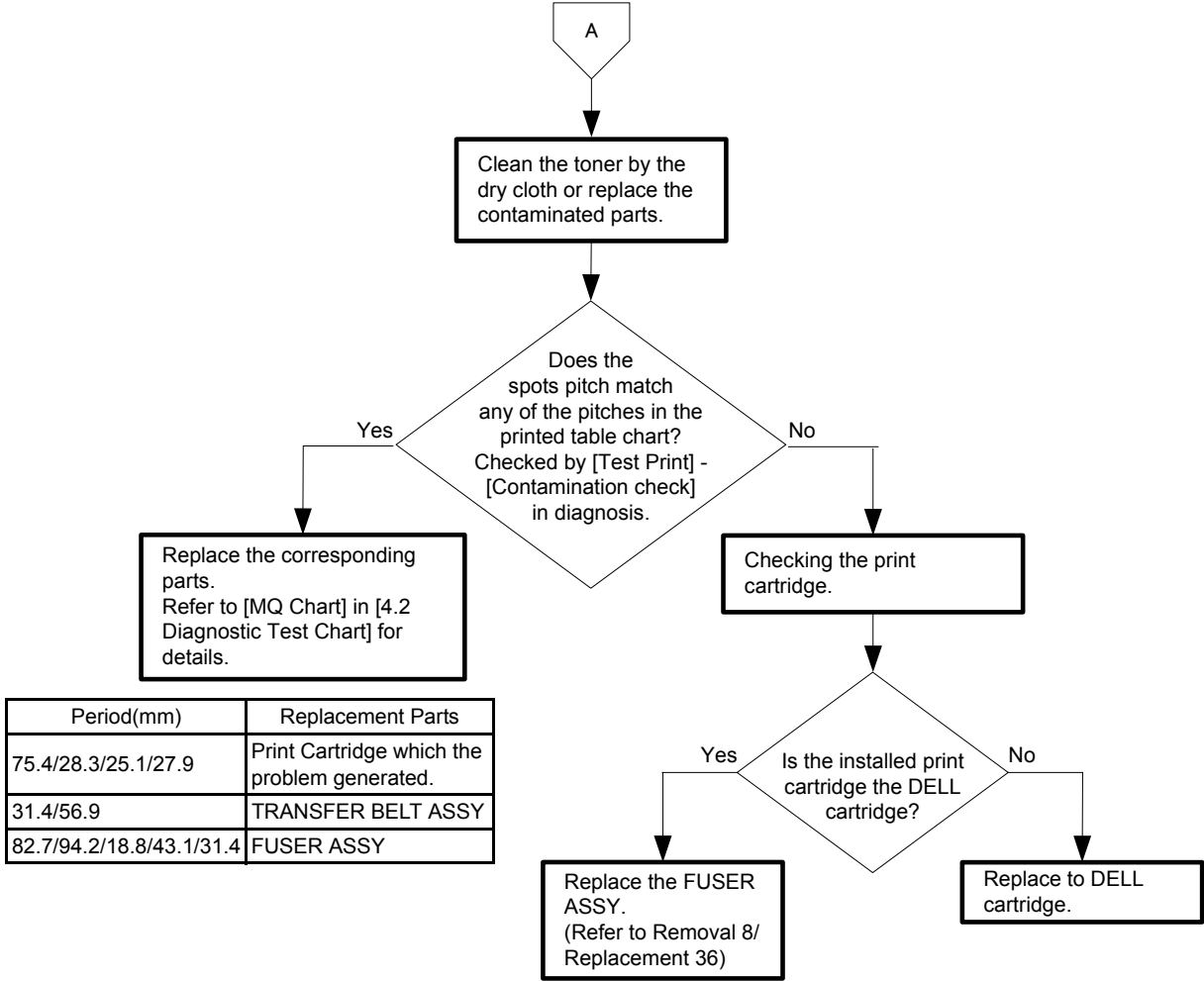

Period(mm)	Replacement Parts
75.4/28.3/25.1/27.9	Print Cartridge which the problem generated.
31.4/56.9	TRANSFER BELT ASSY
82.7/94.2/18.8/43.1/31.4	FUSER ASSY

Flows 87 Afterimage (Ghost)

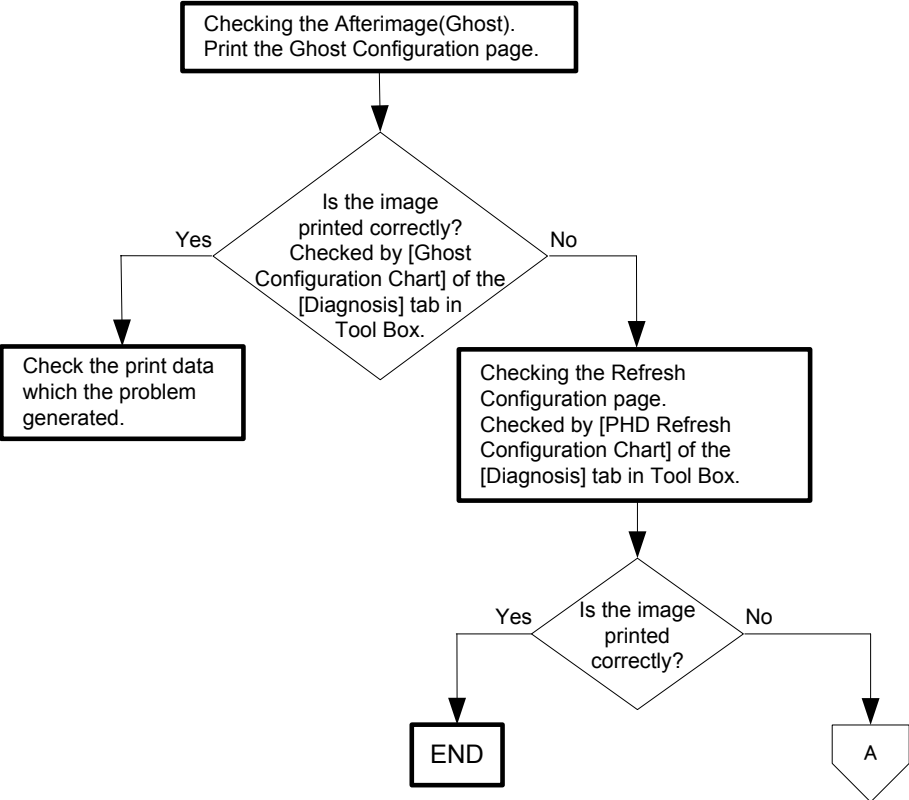
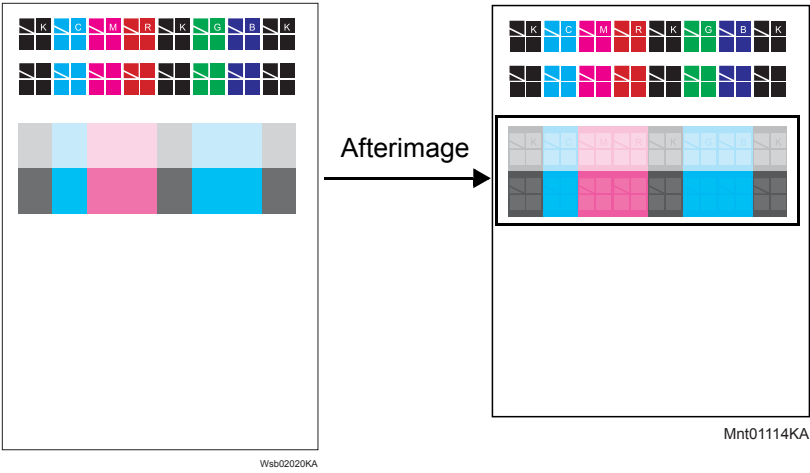

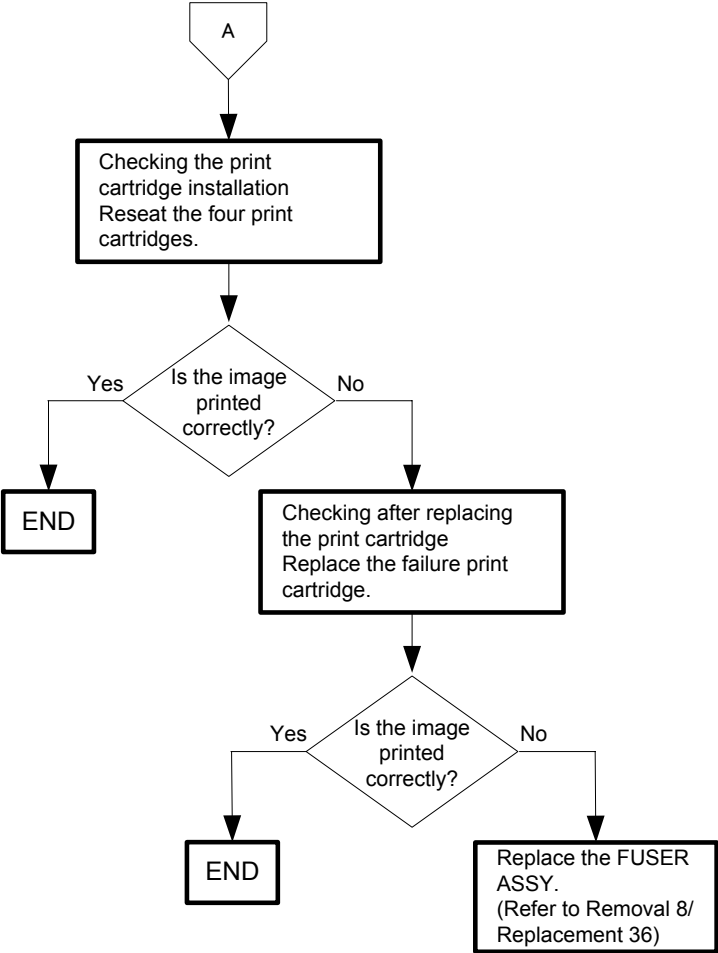

Flows 88 Grey Background

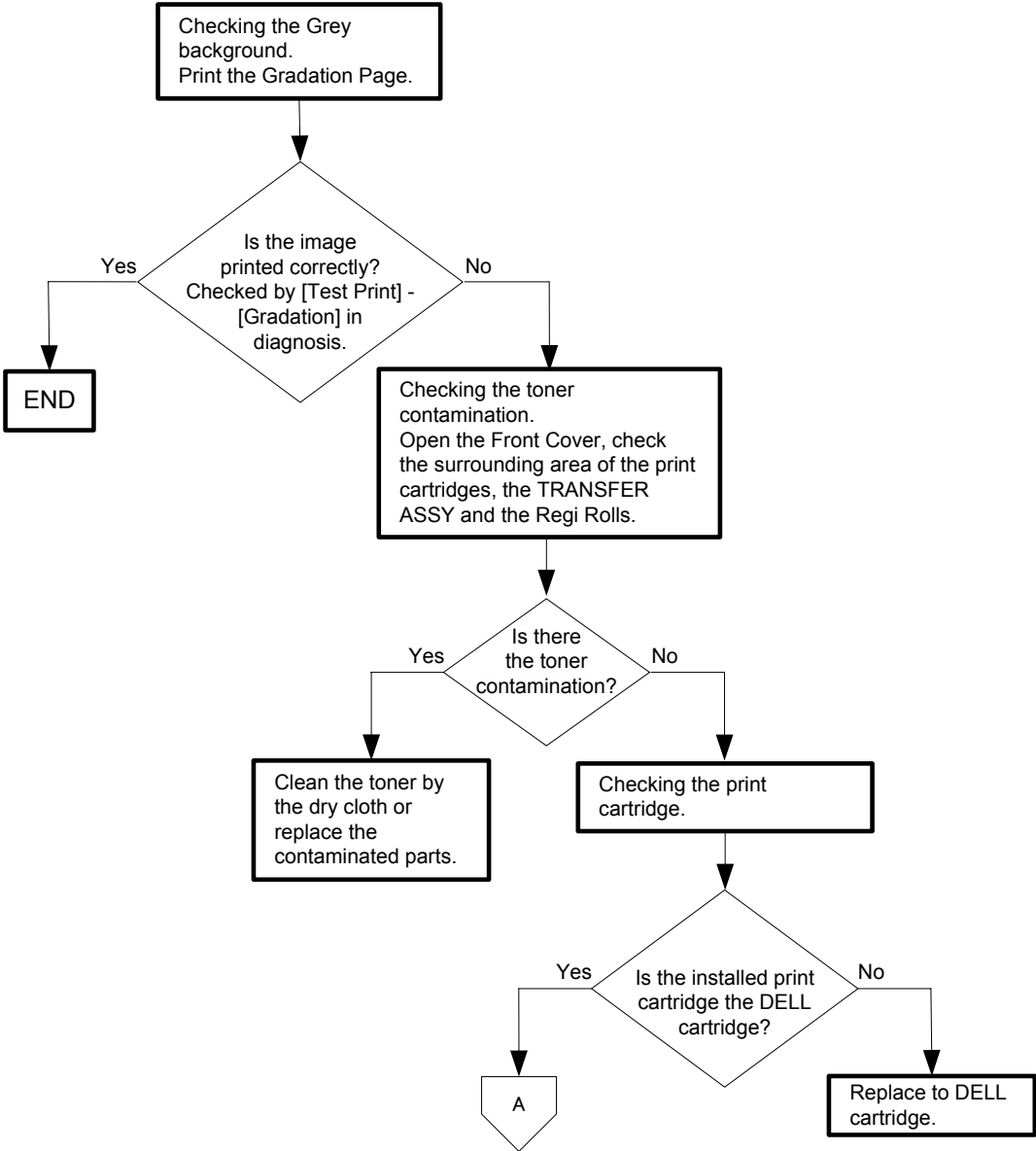
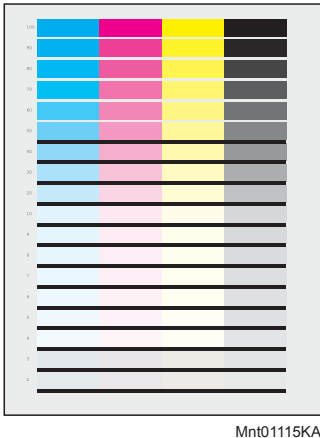

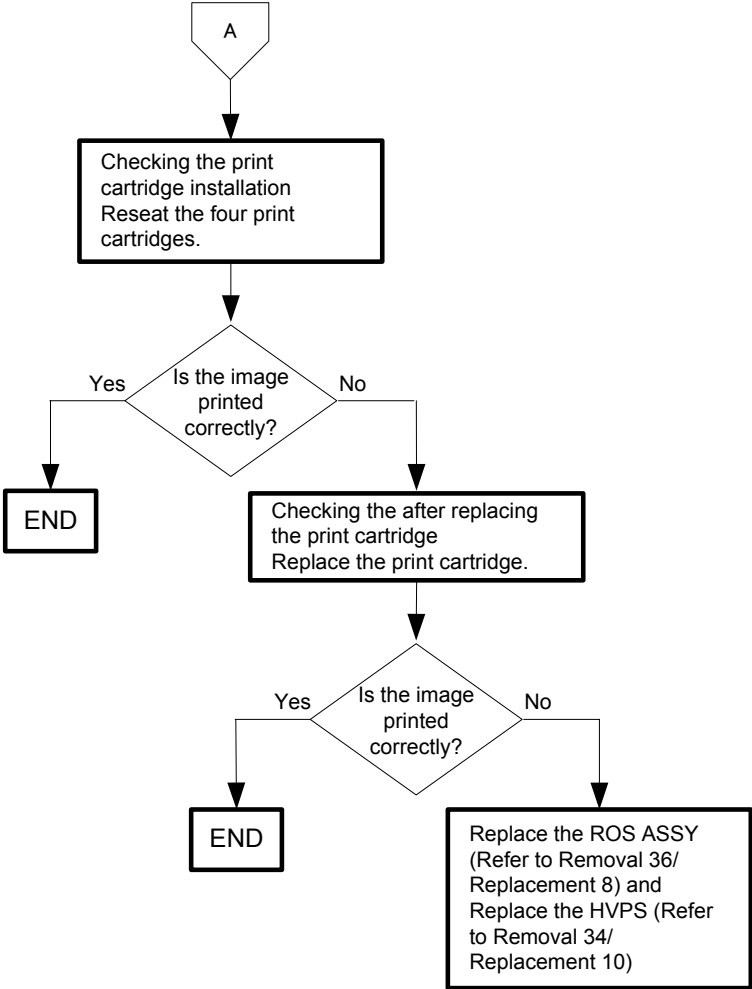

Flows 89 Skew

NOTE

Tray is recommended for paper feeding because sheets fed via SSF is prone to skew depending on how the sheet is placed of SSF.

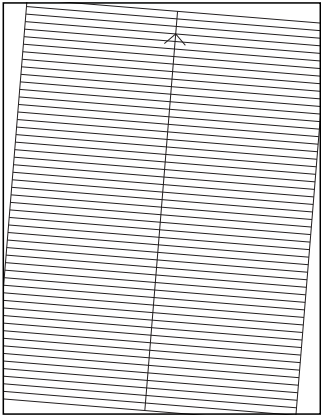

Mnt01116KA

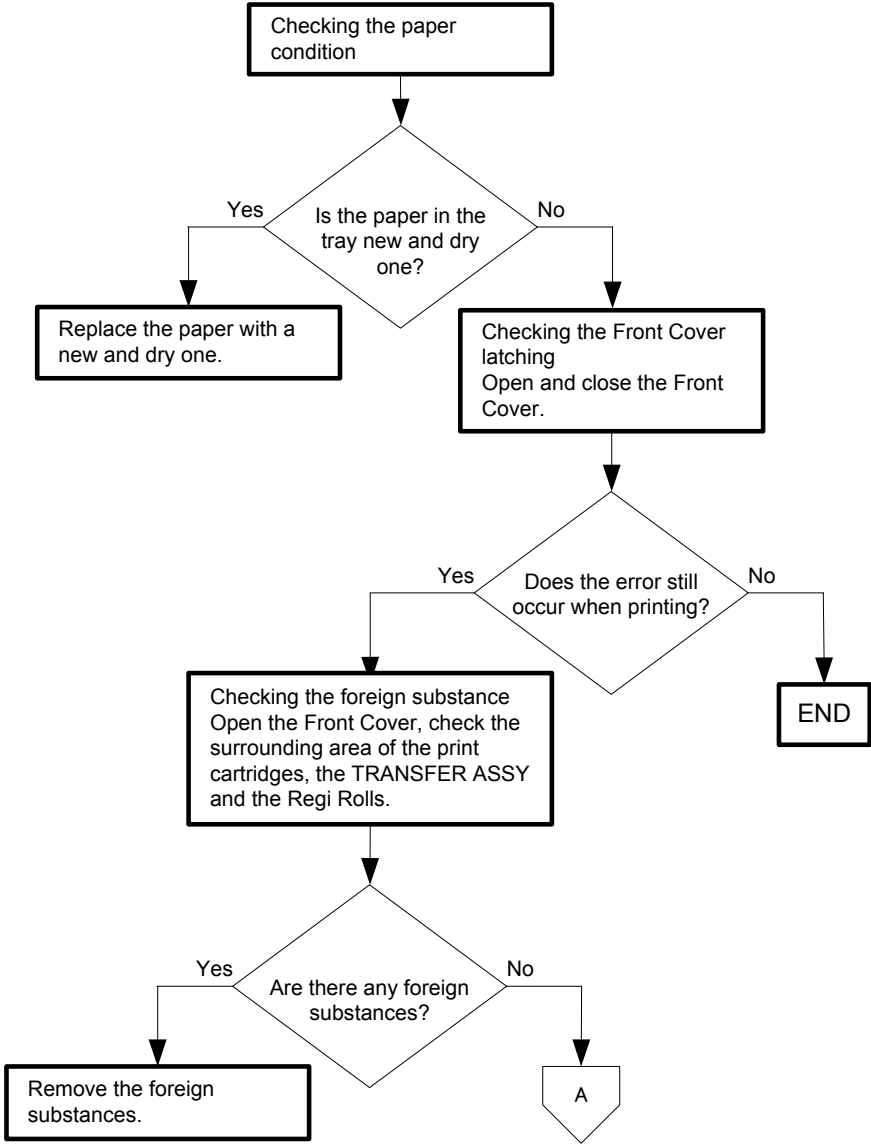

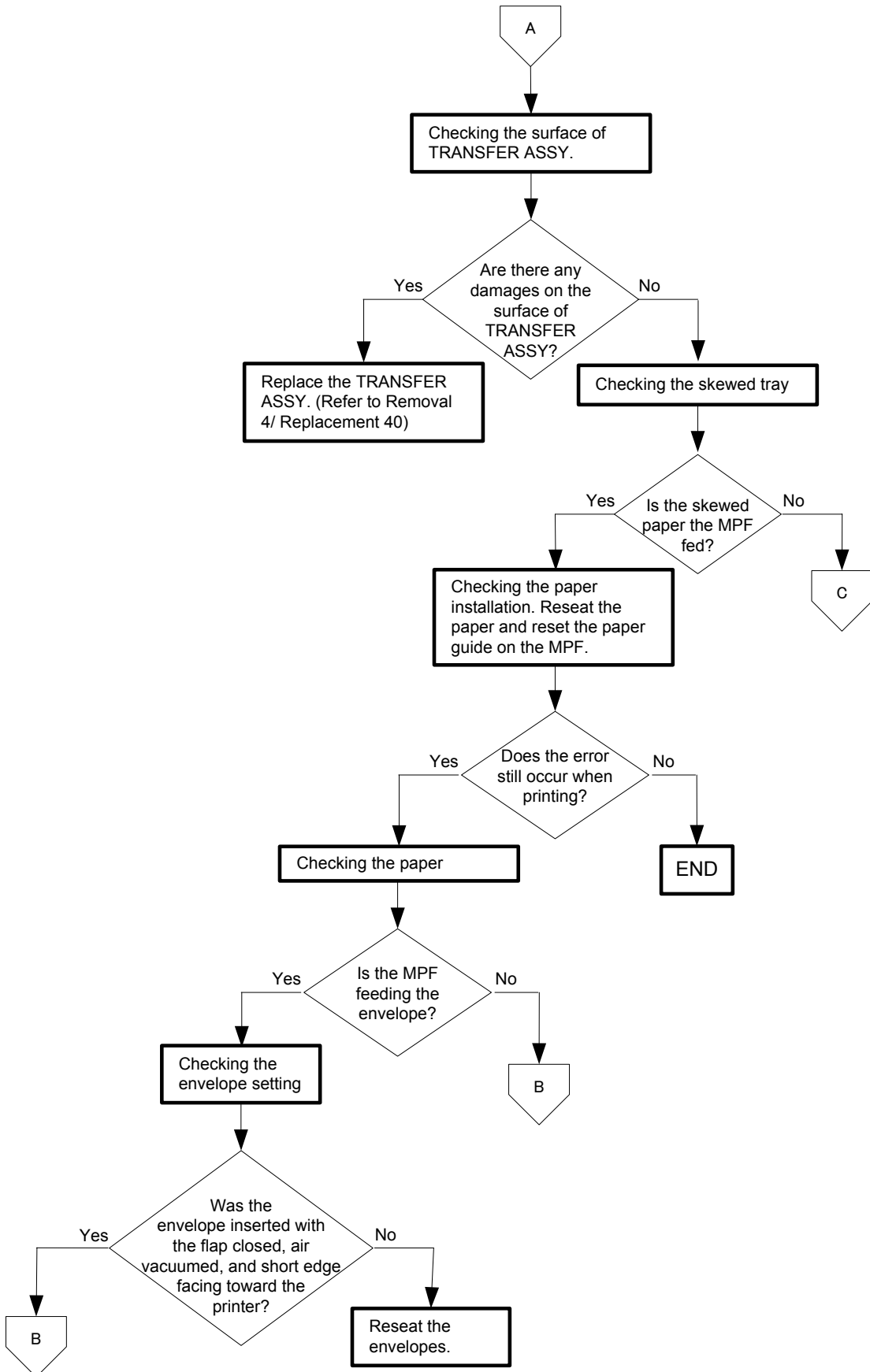

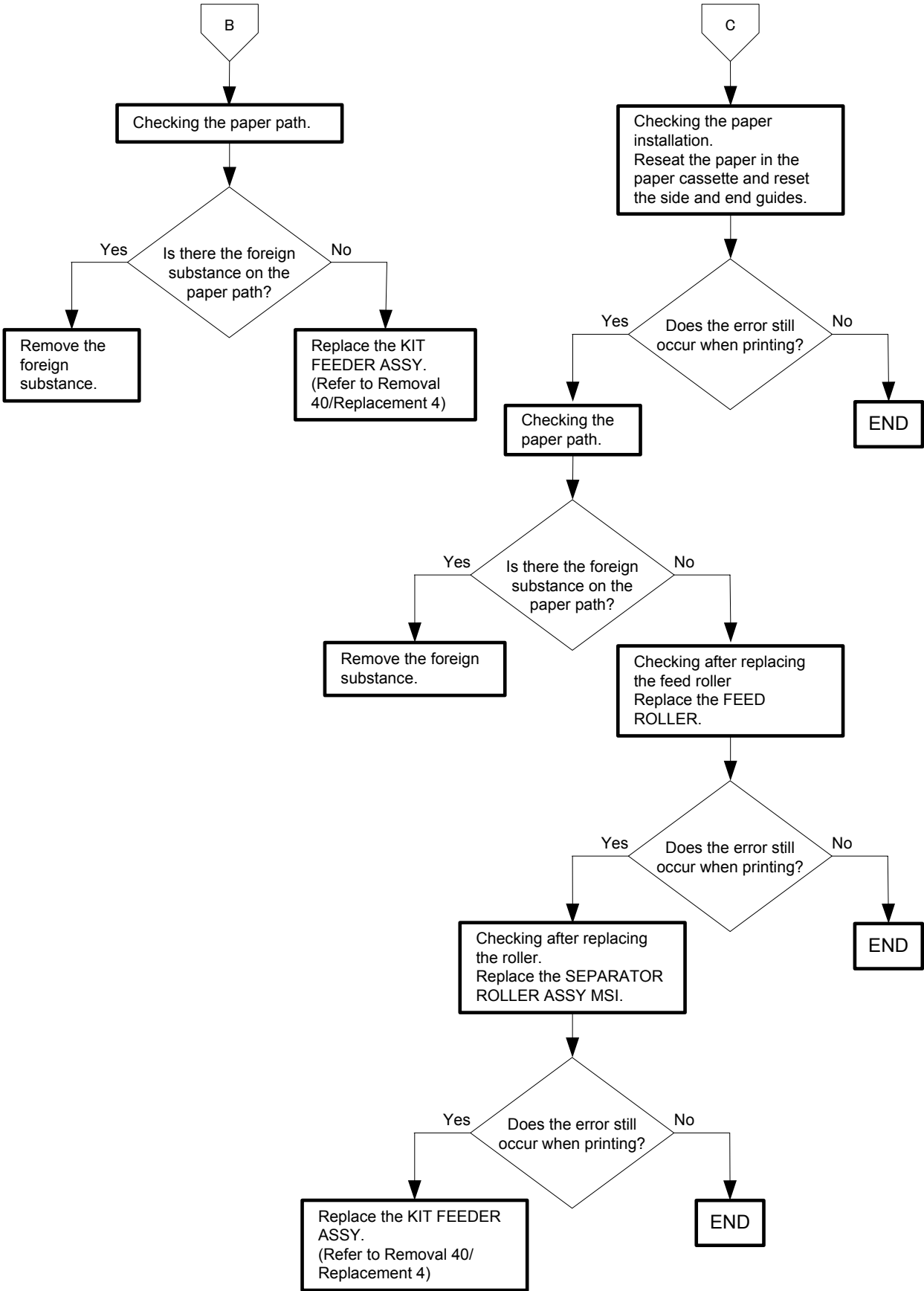

Flows 90 Paper damage

NOTE

Tray is recommended for paper feeding because sheets fed via SSF is prone to skew depending on how the sheet is placed on SSF.

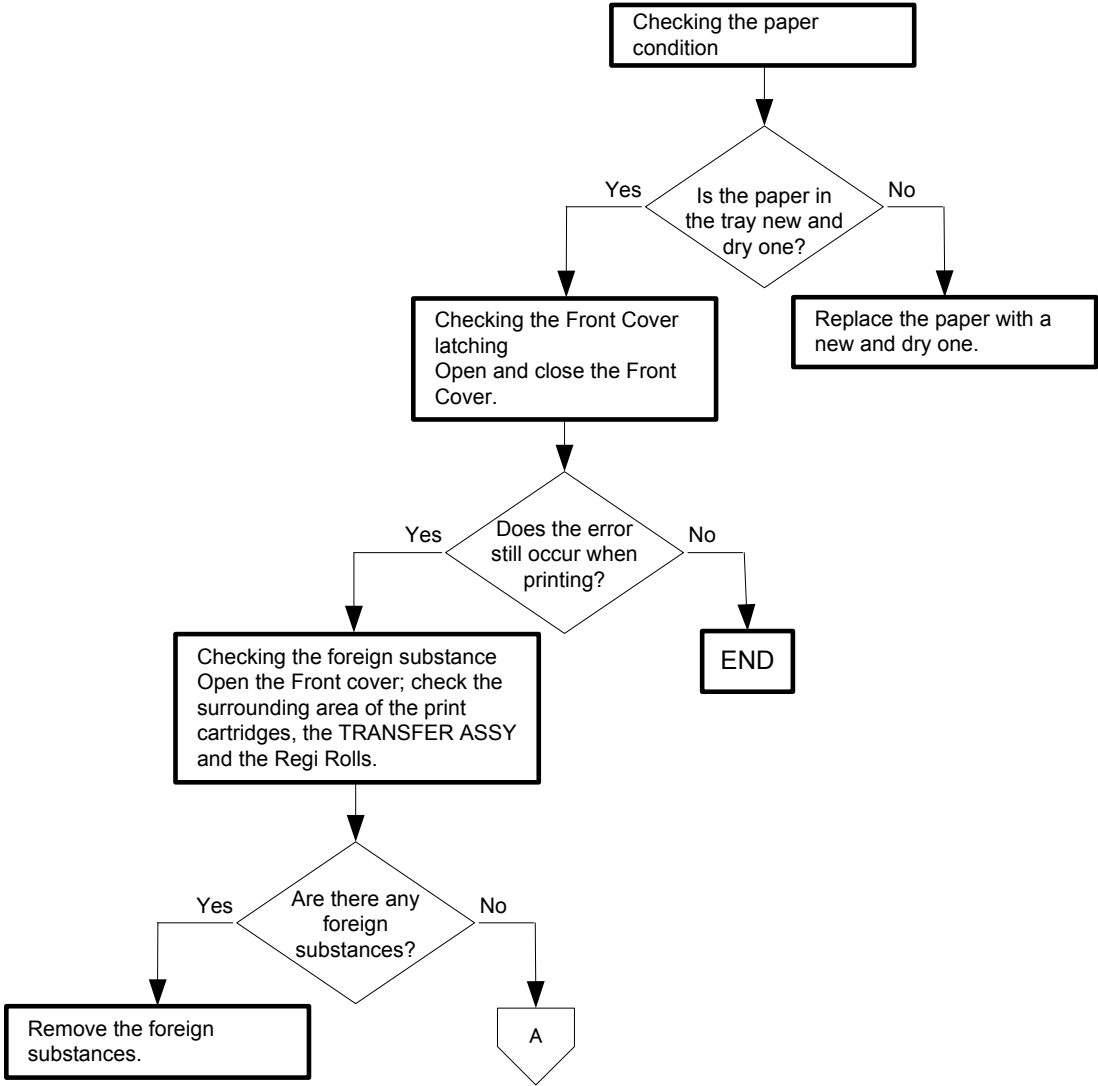
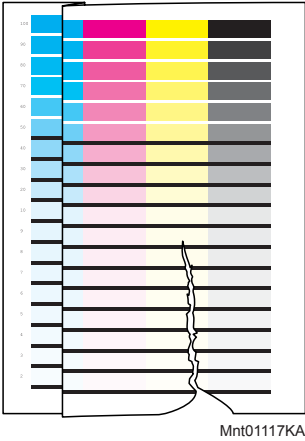

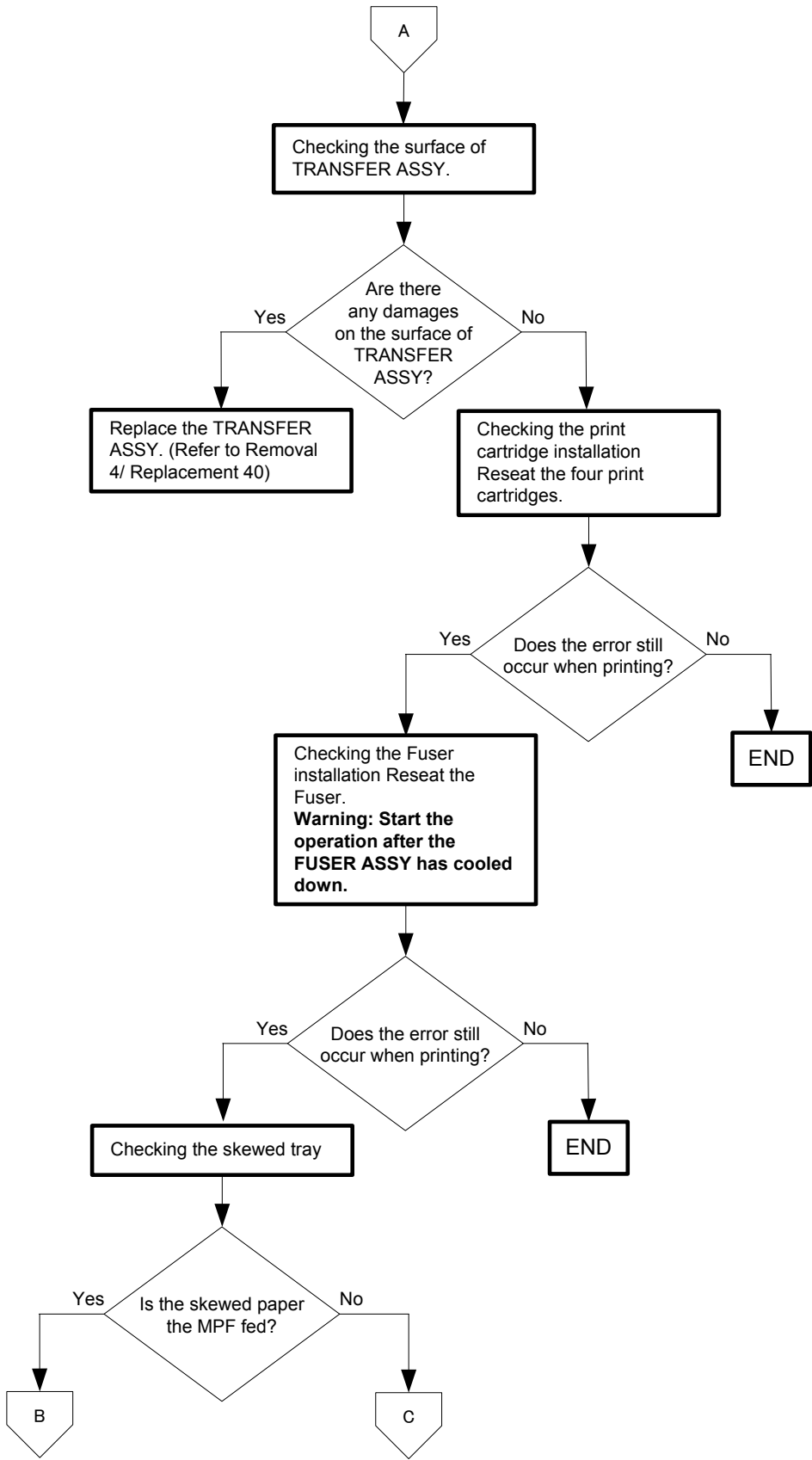

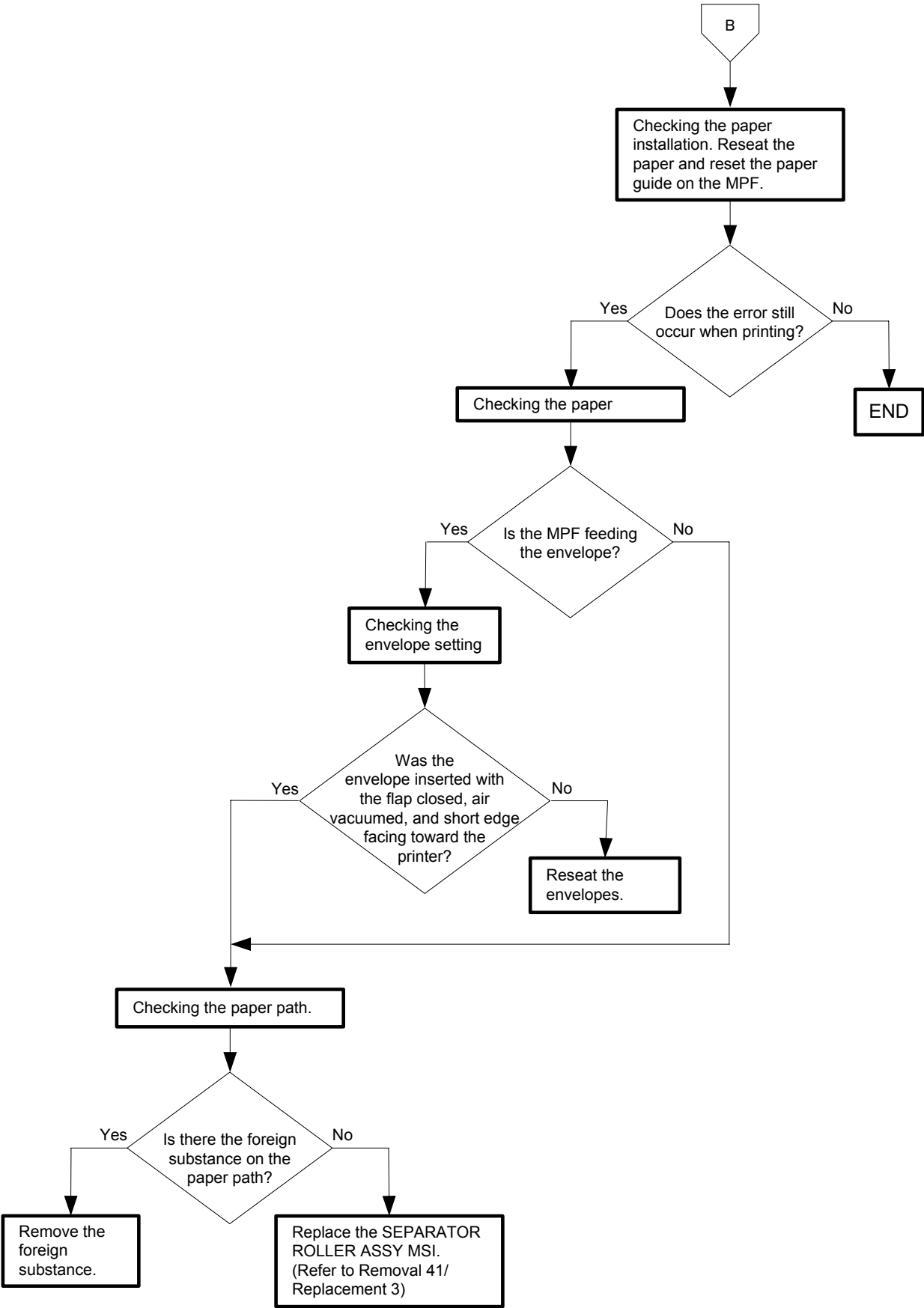

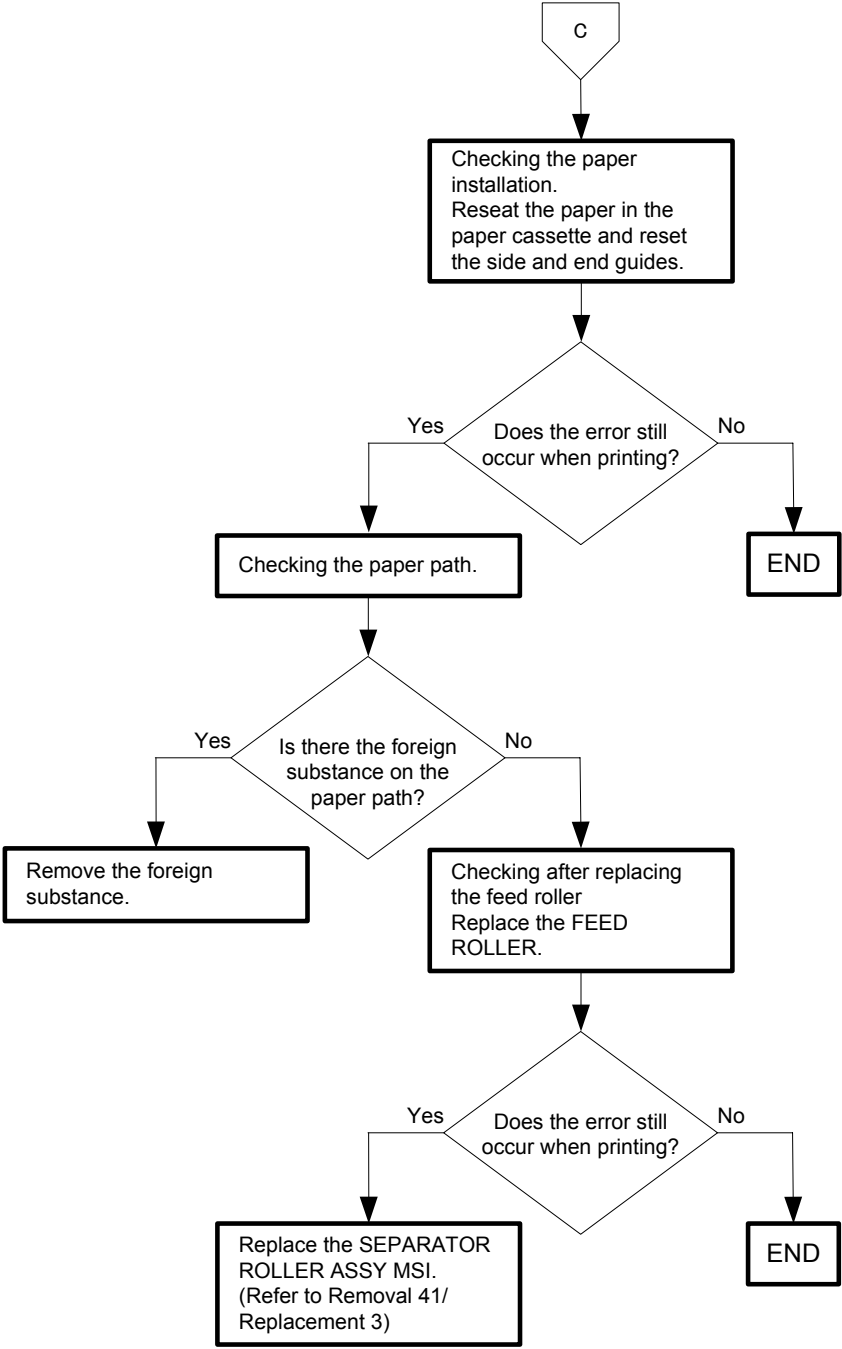

Flows 91 Unfusing

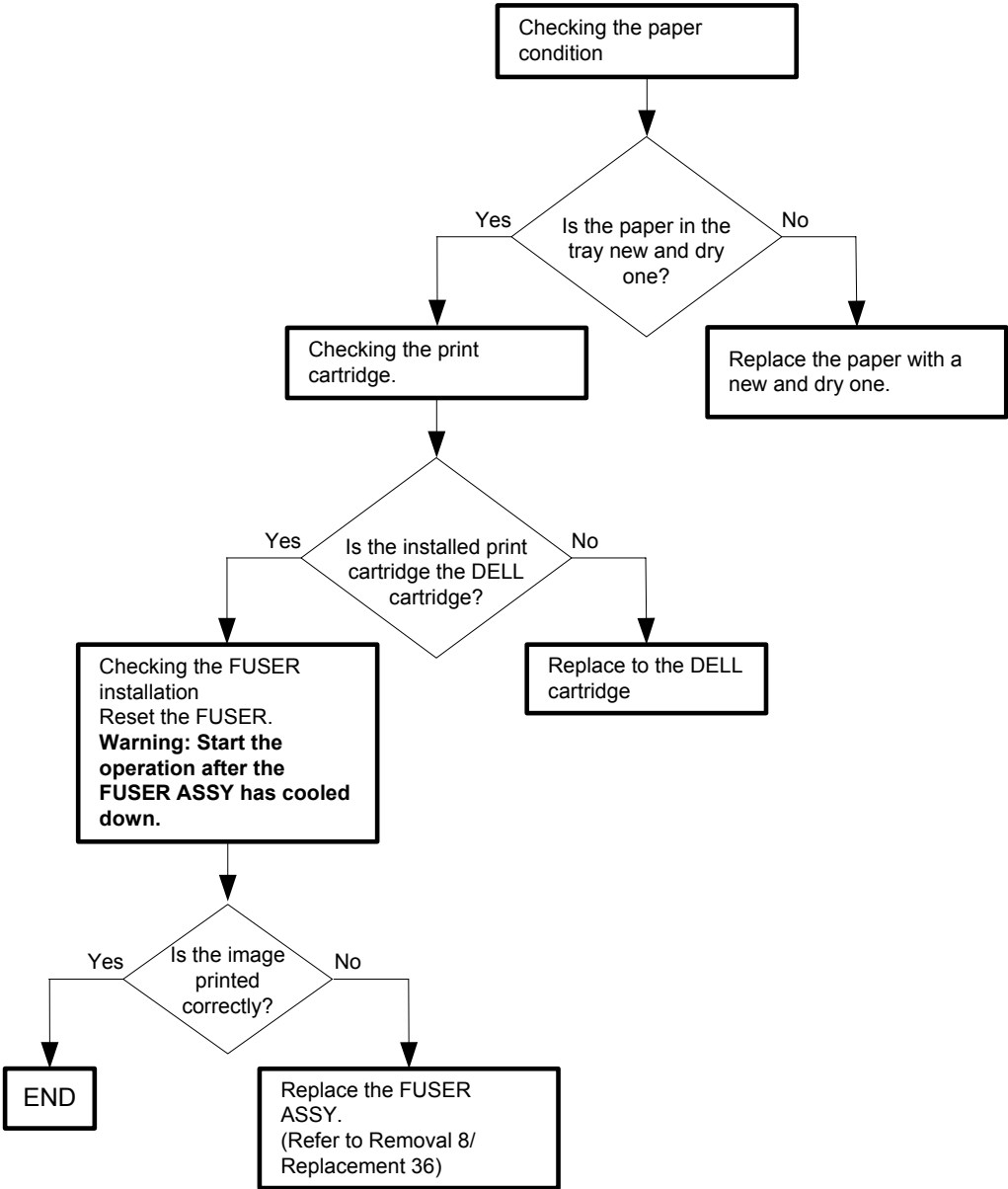
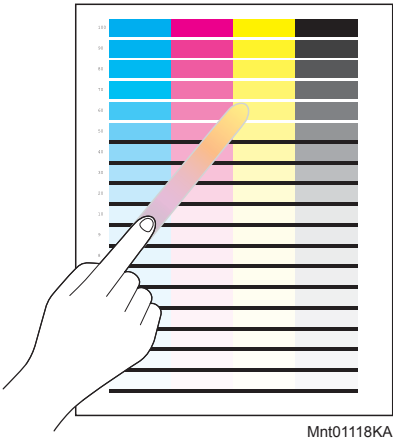

Flows 92 Color Registration (Color Shift)

- Troubleshooting of a control system

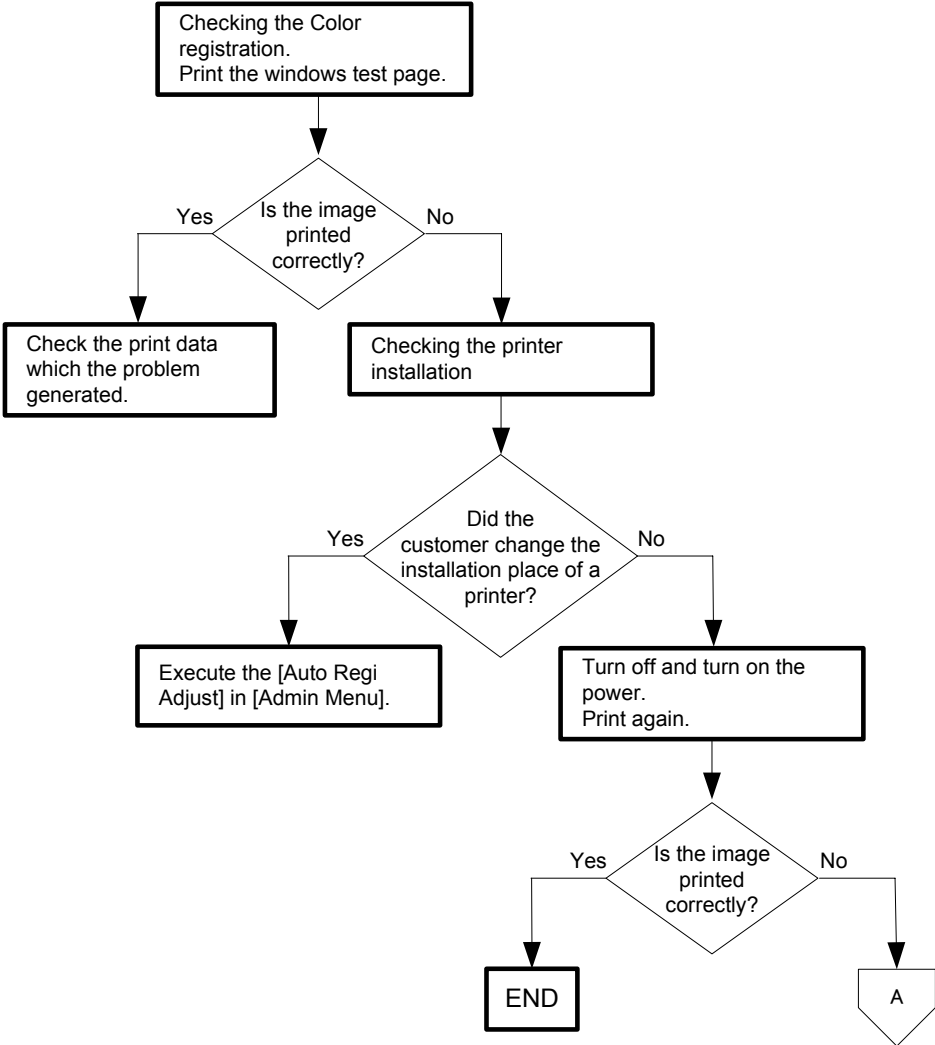

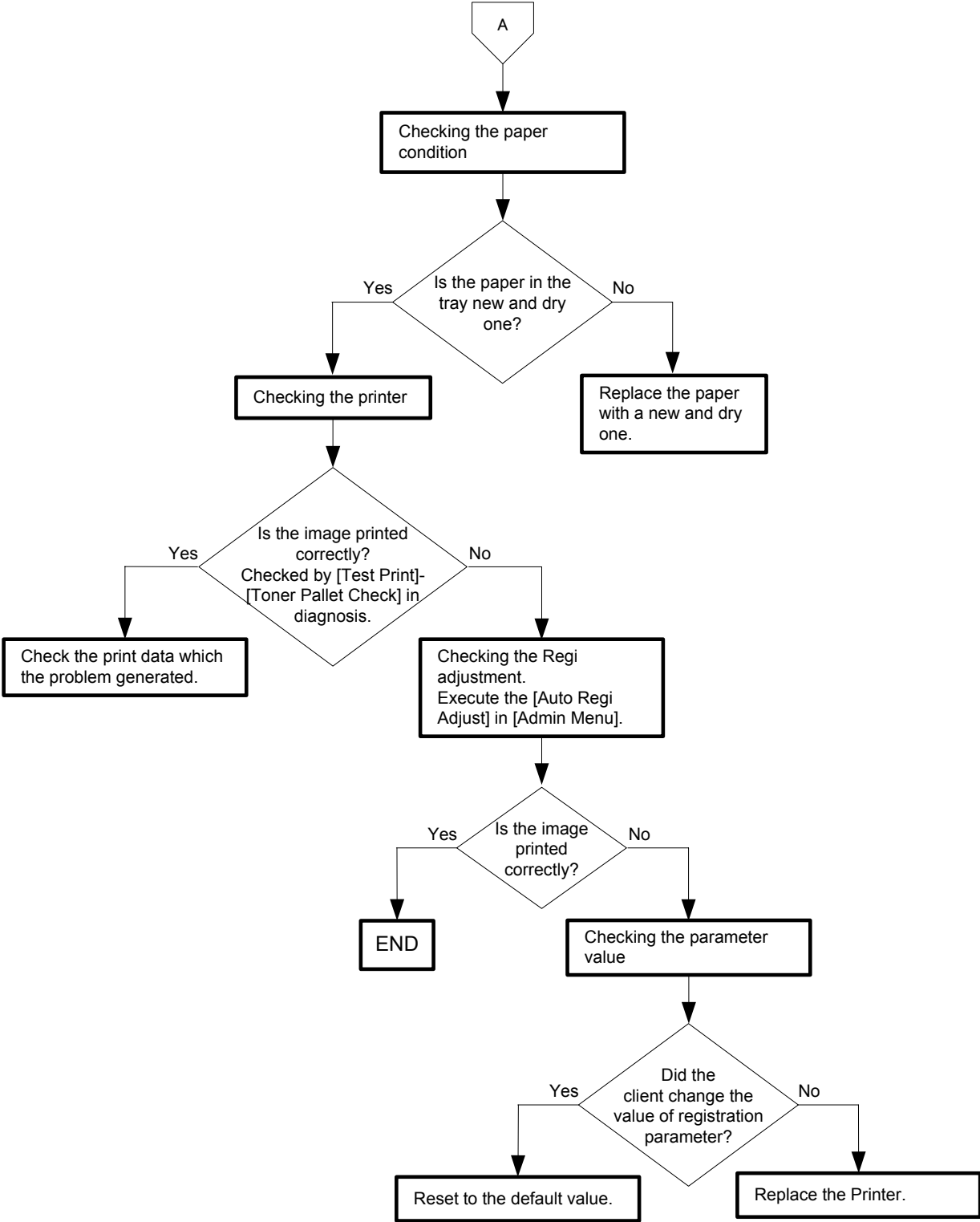

- Troubleshooting of a paper feeding system

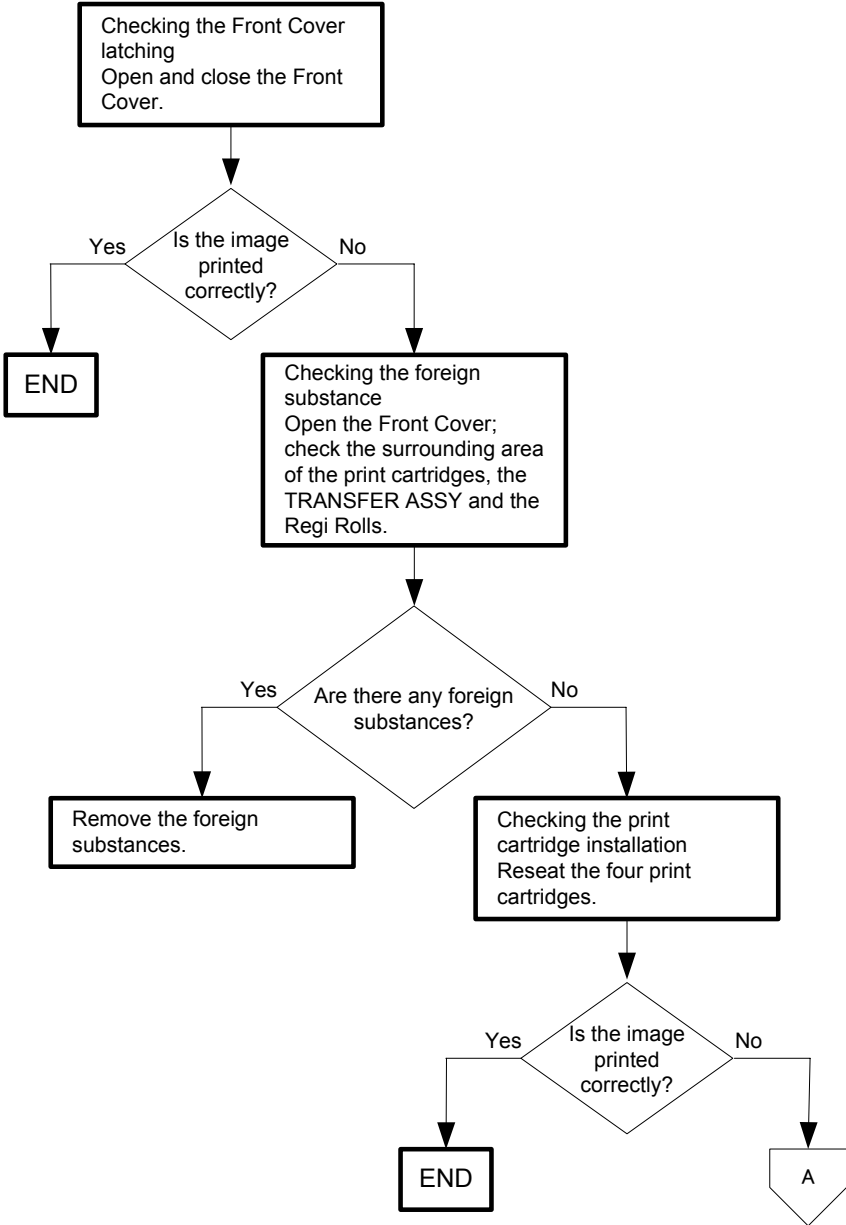
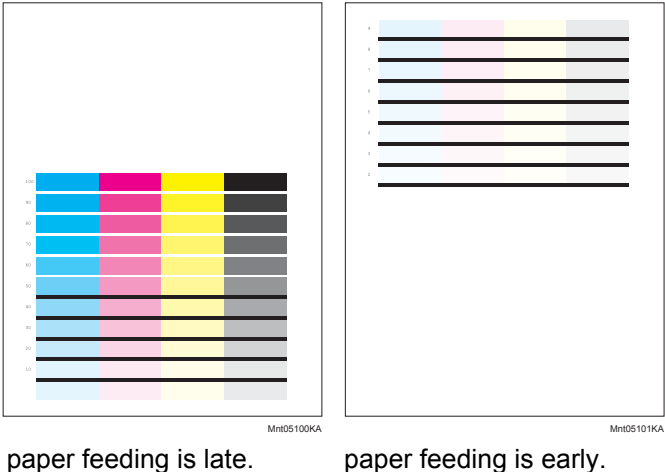

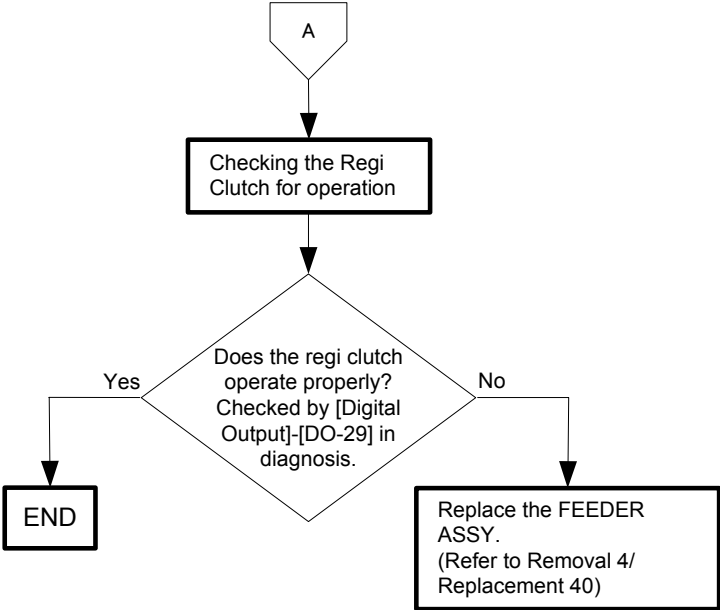

Flows 93 Noise: When Power is Turned On

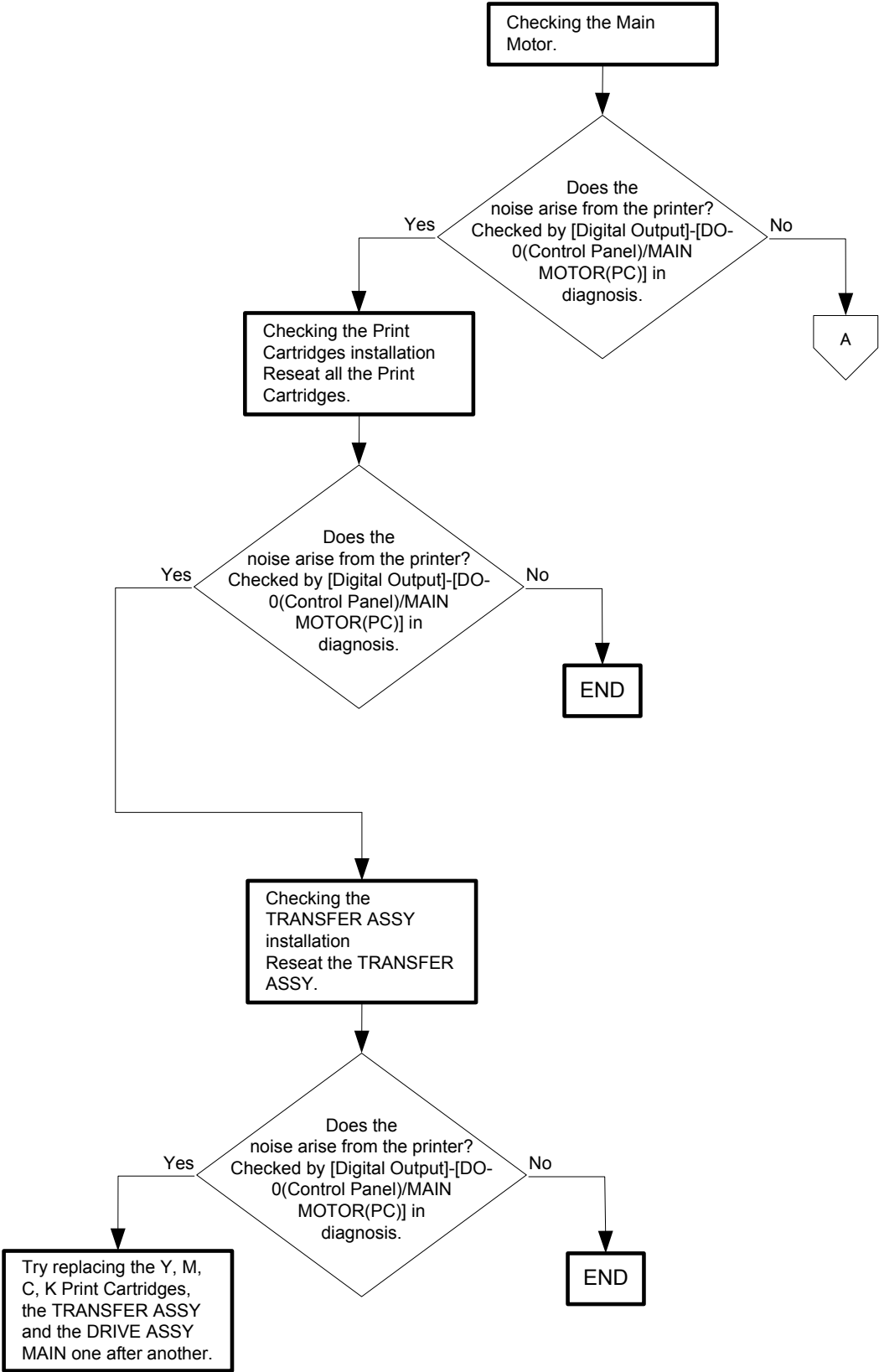

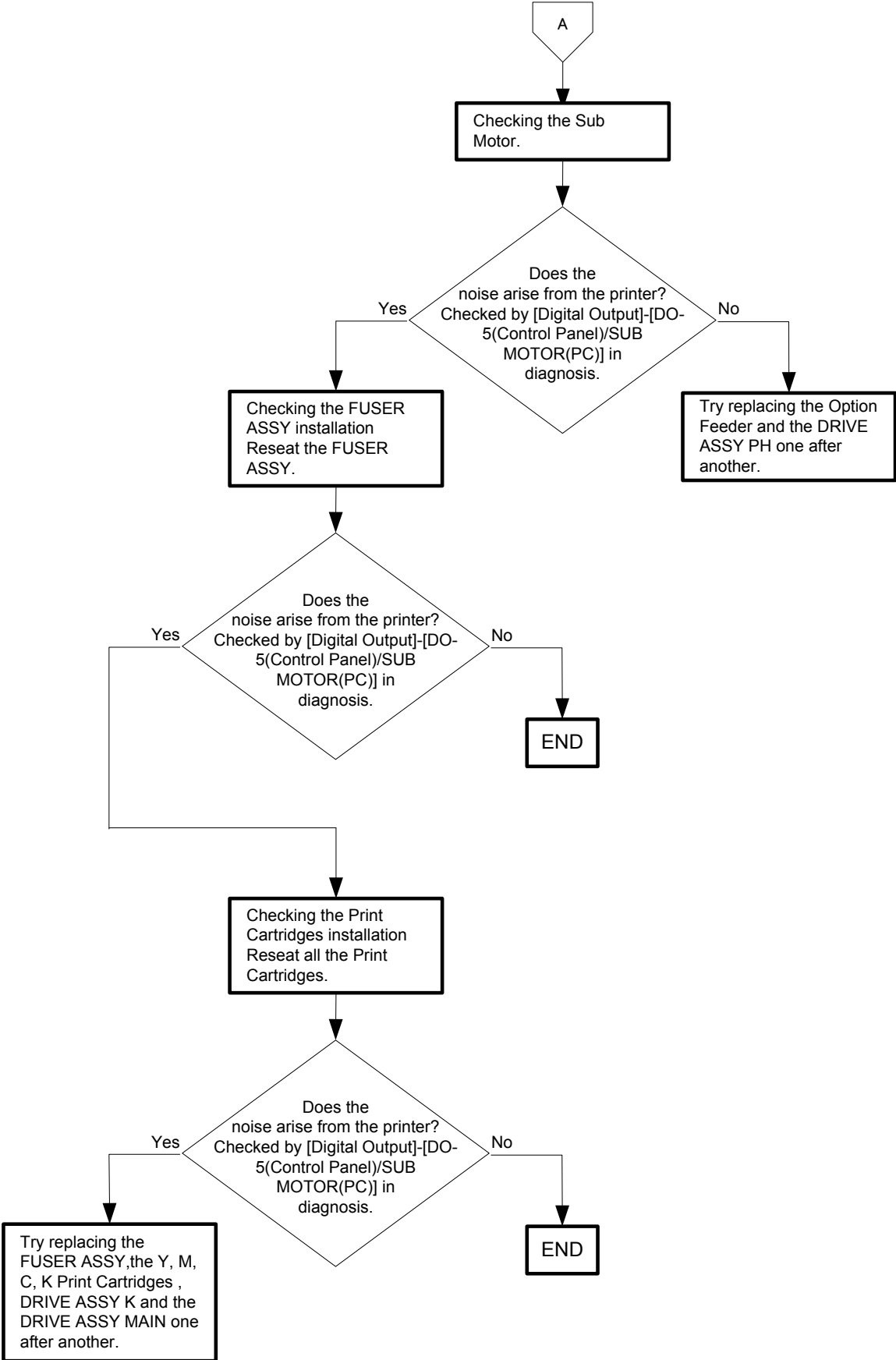

Flows 94 Noise: During Standby

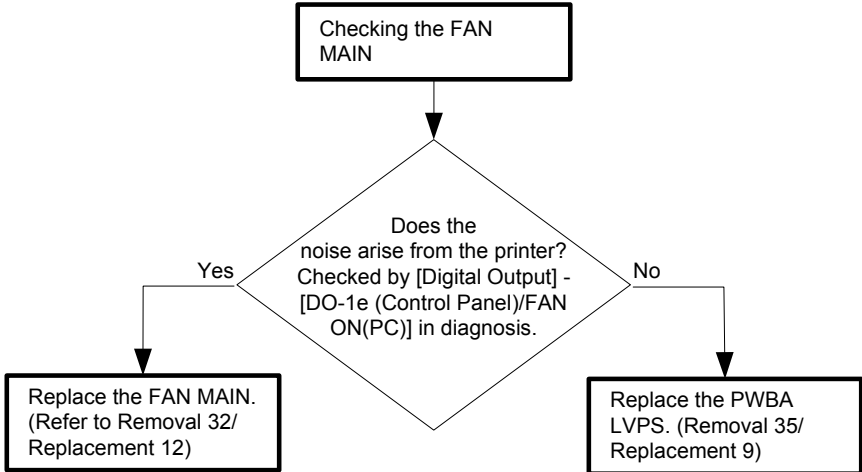

Flows 95 Noise: During Printing

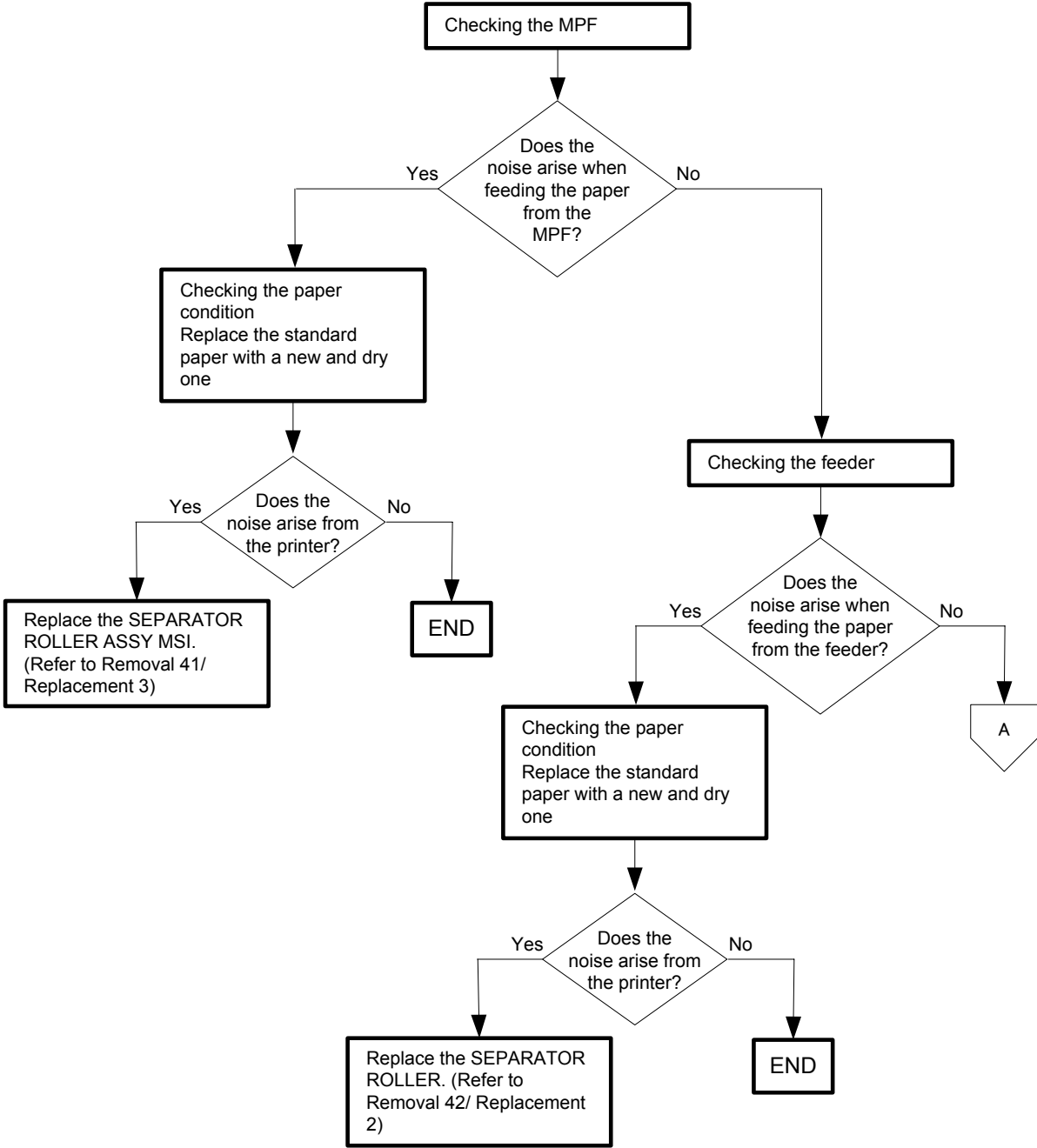

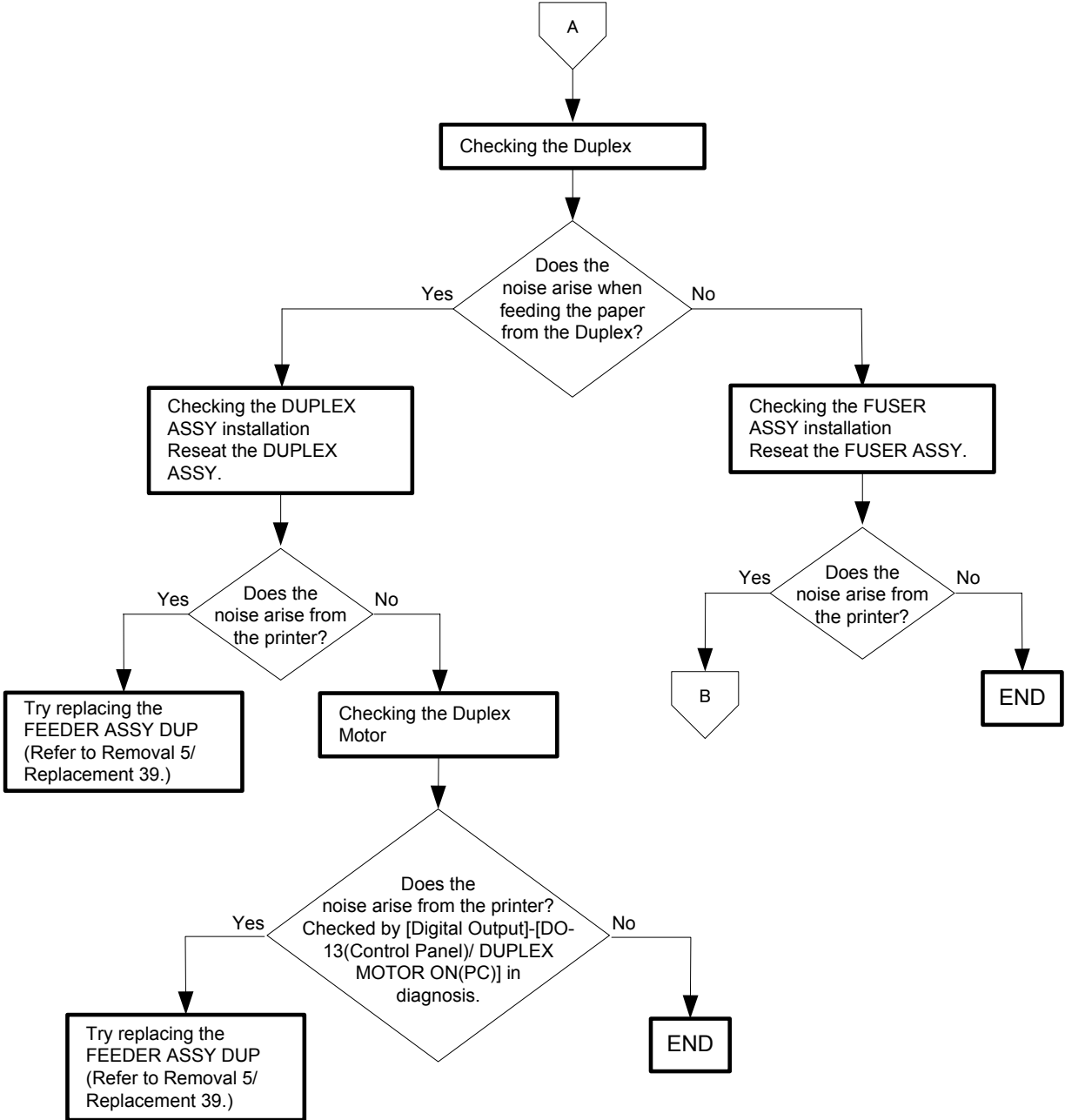

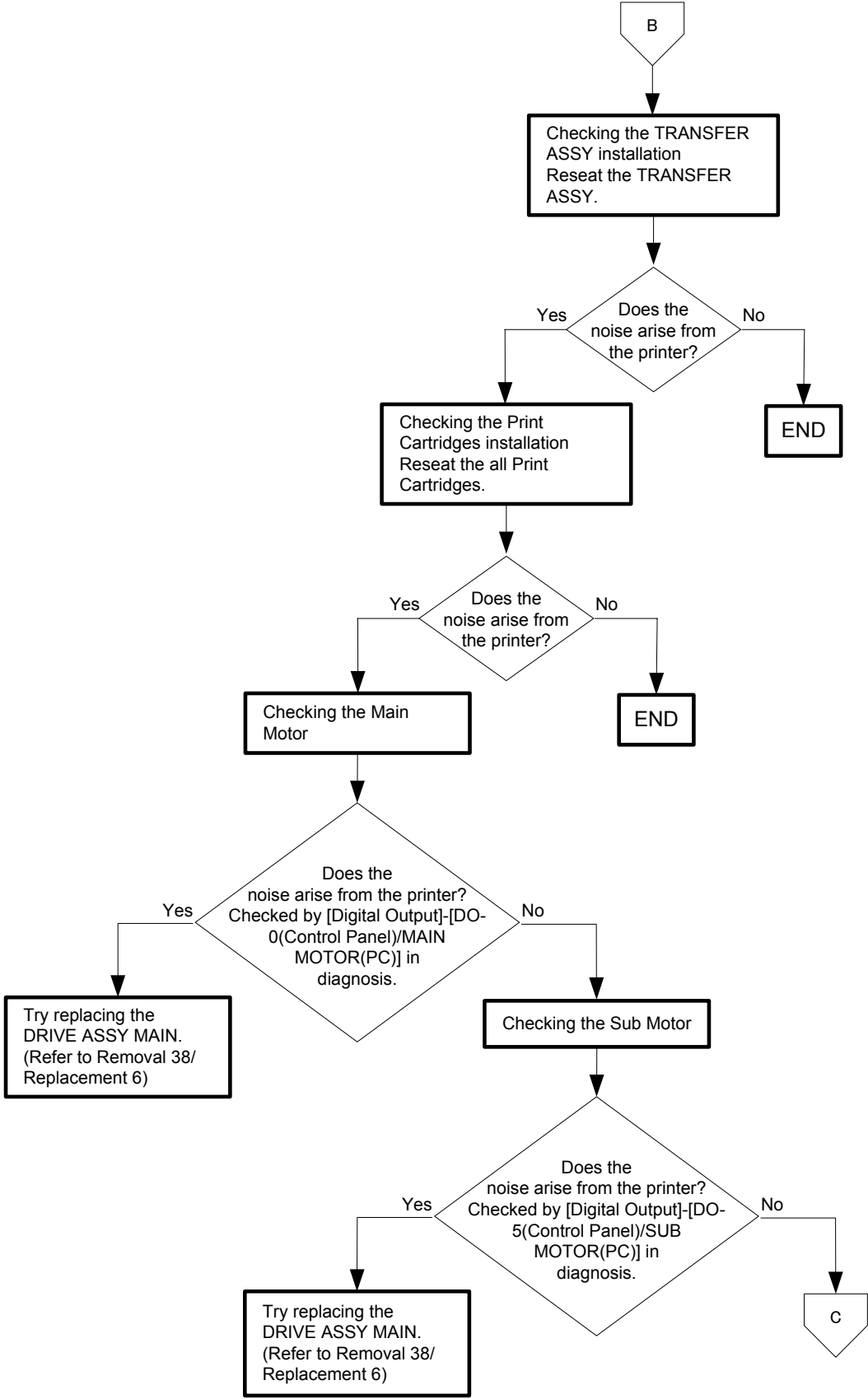

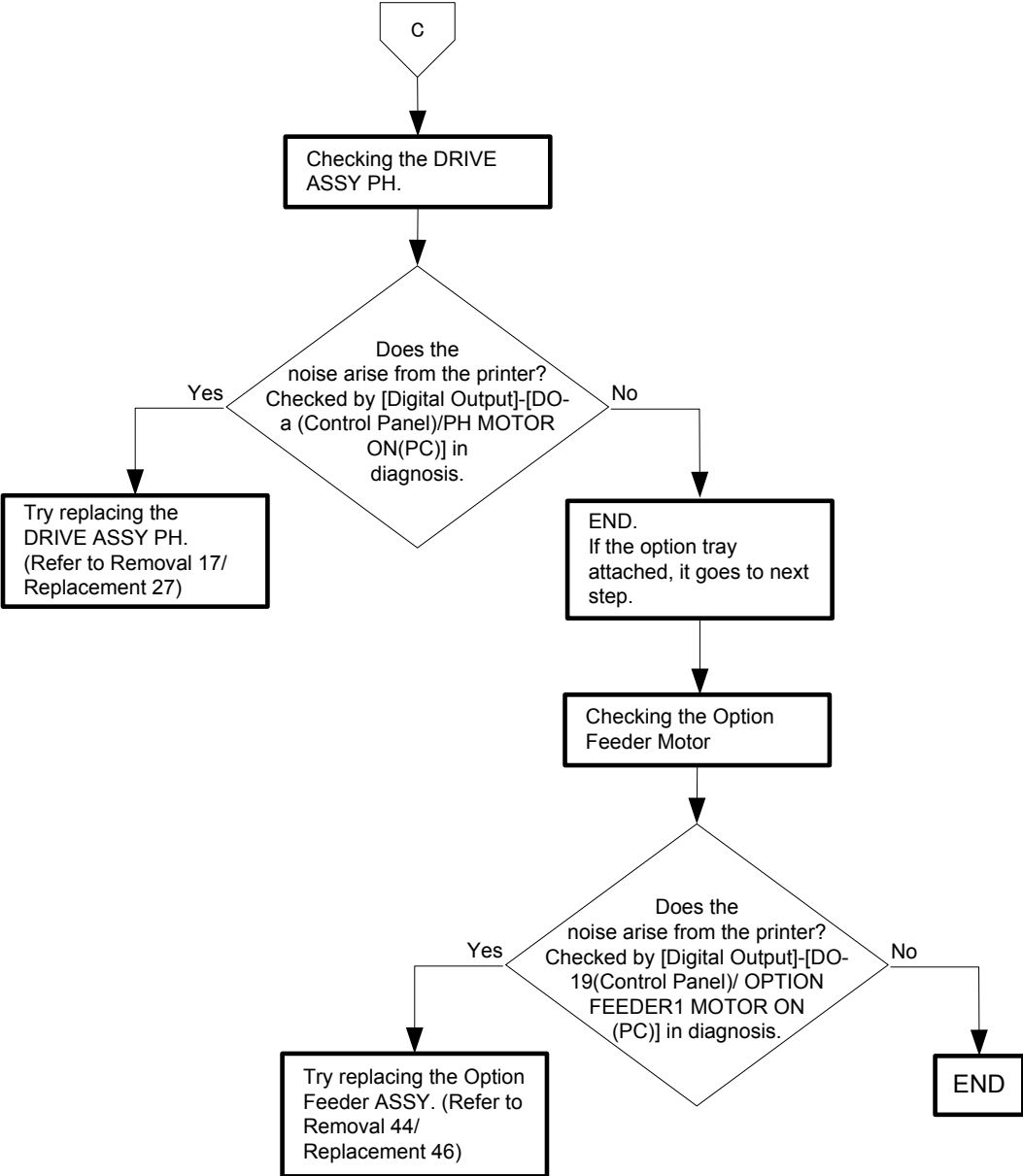

Flows 96 AC

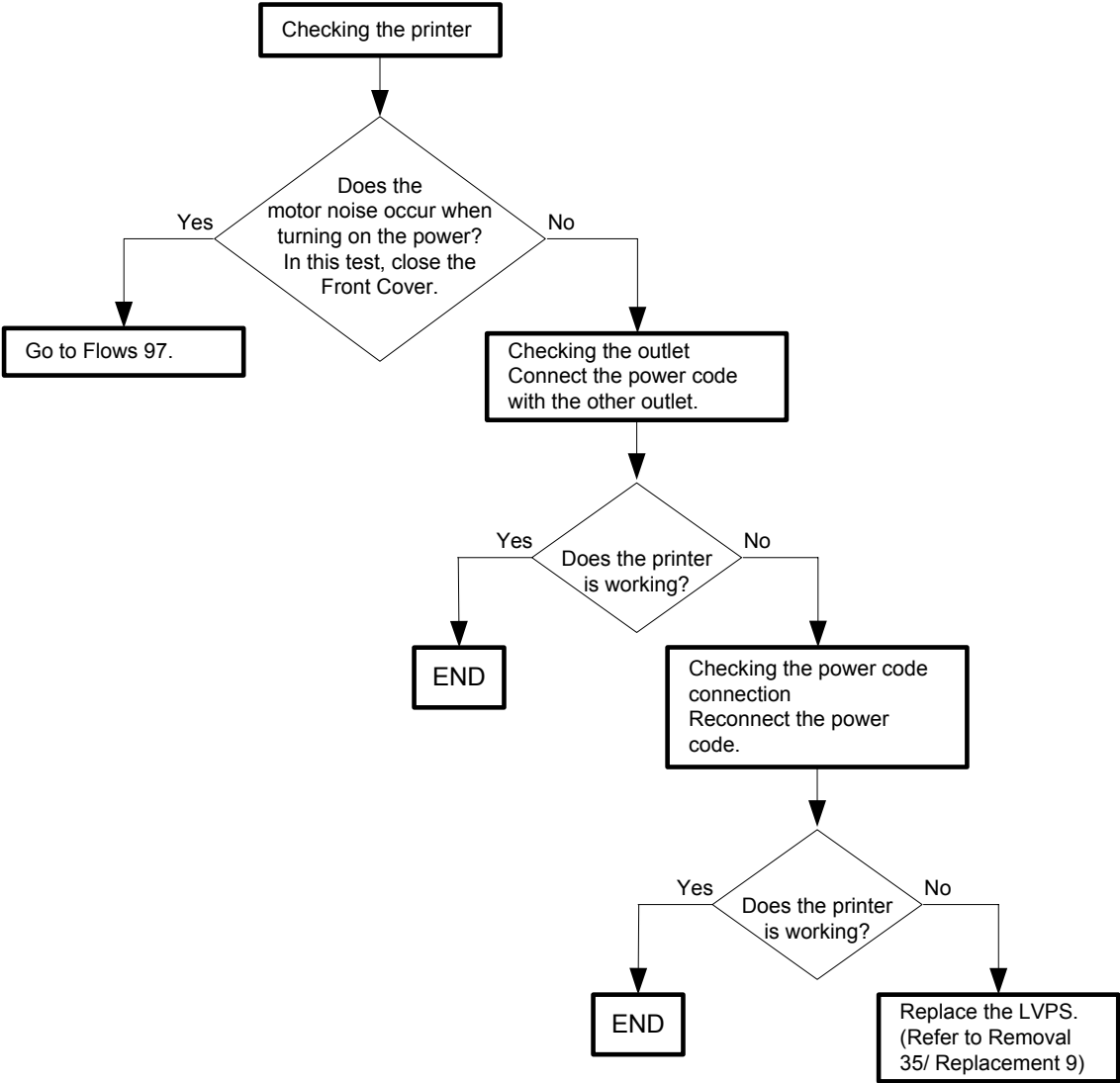

Flows 97 DC

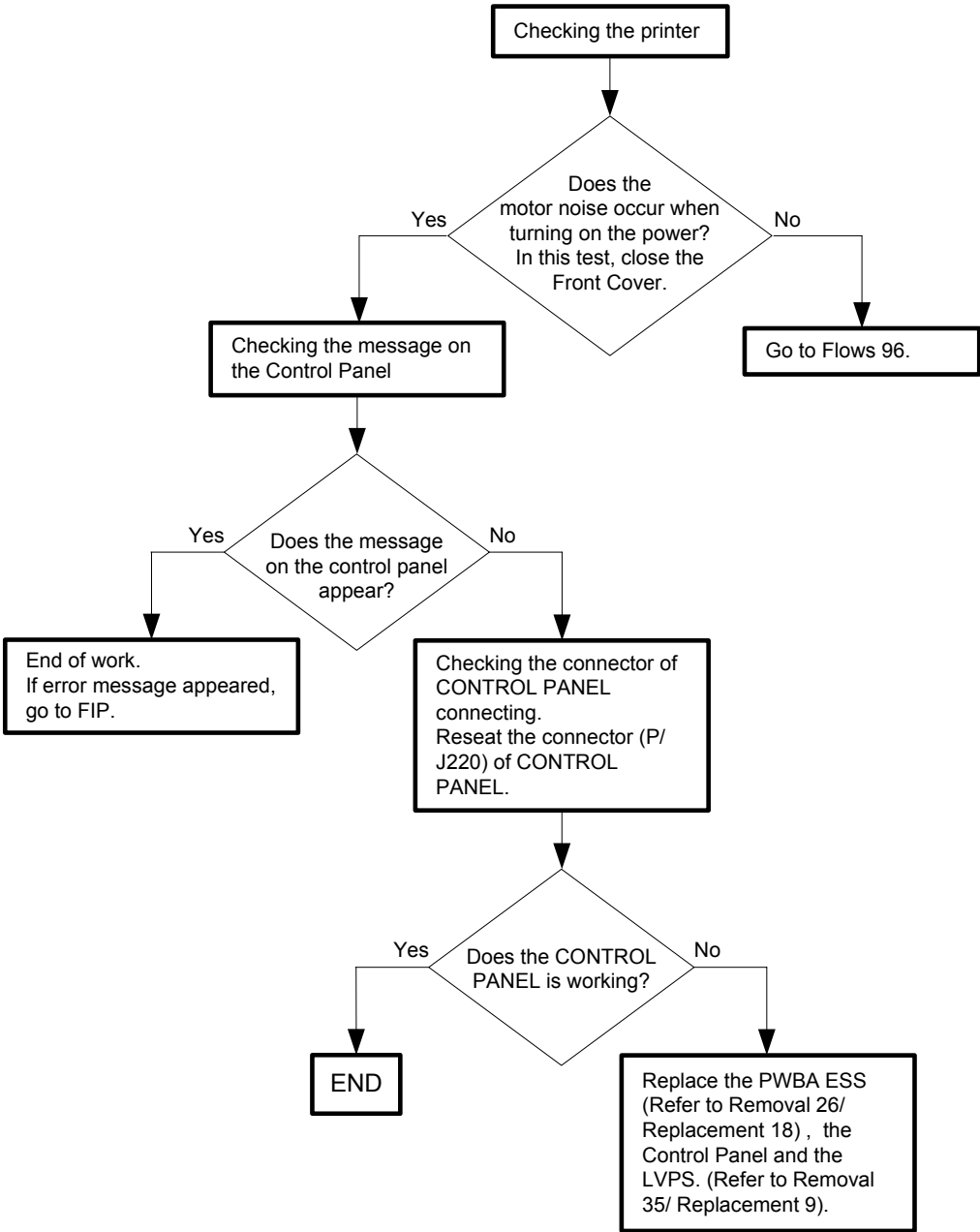

Flows 98 Multiple feed

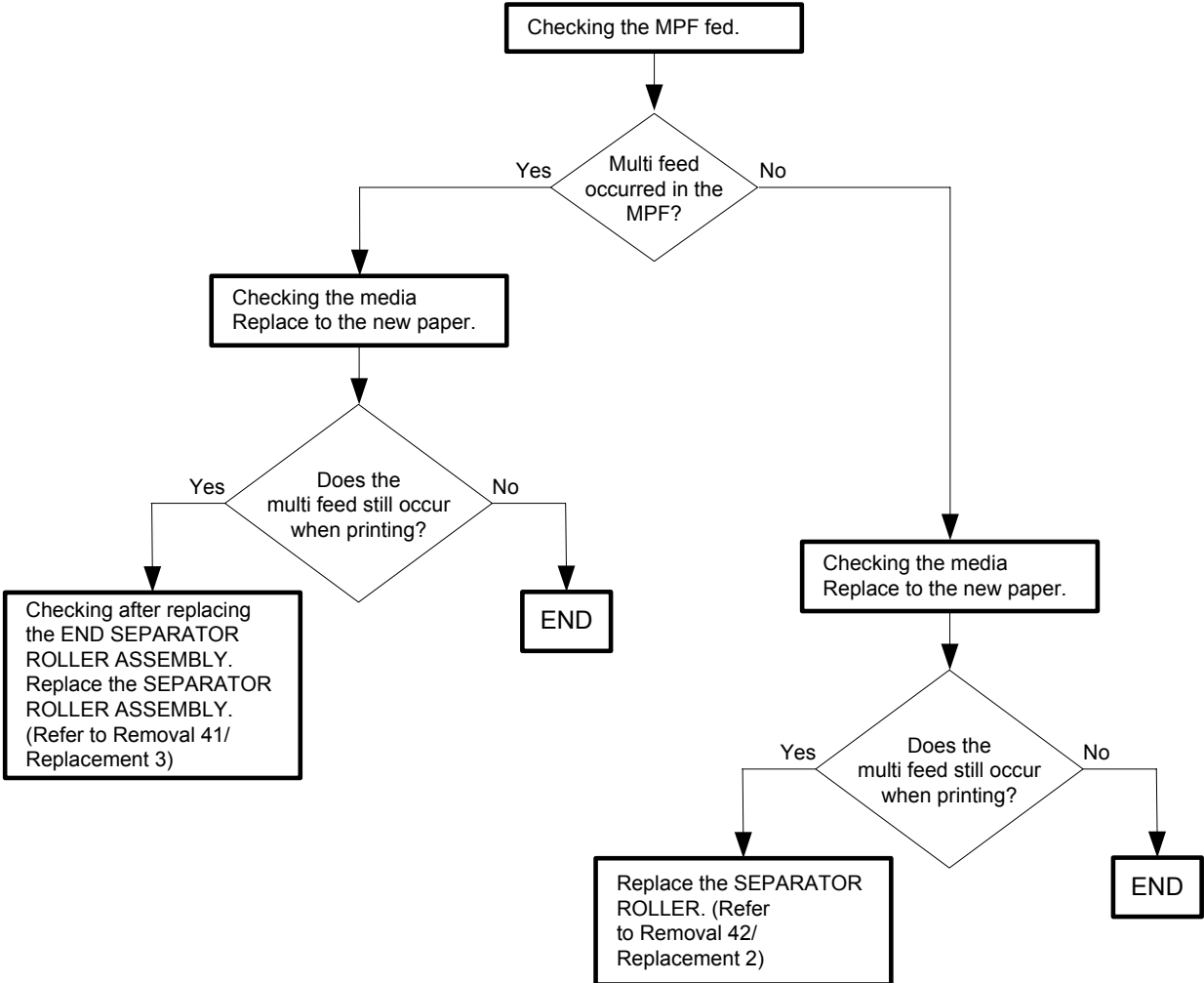

Flows 99 Control Panel Freezes

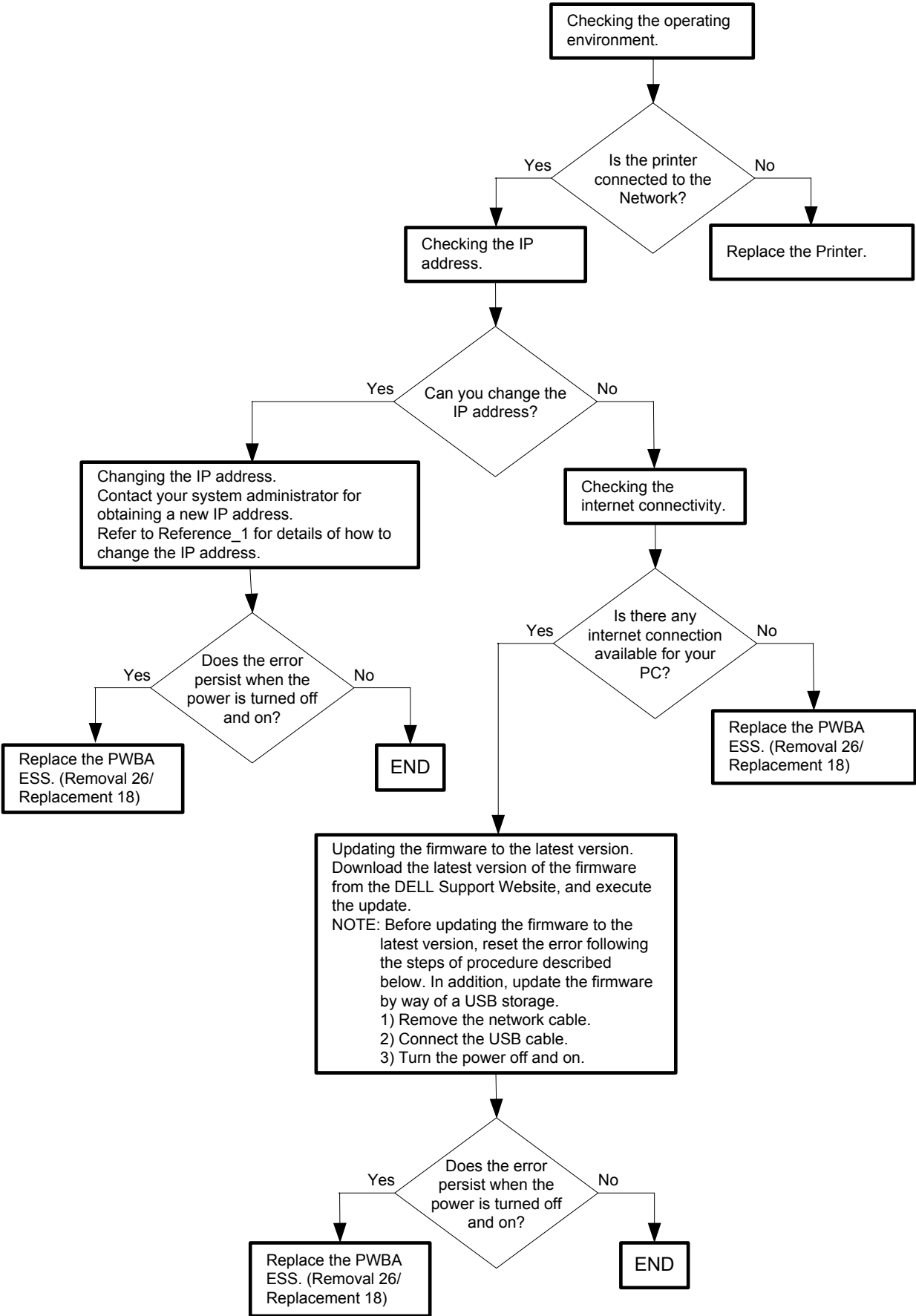

Reference_1: Changing the IP address

- 1) Remove the network cable, and power off the printer and then on
- 2) Change the IP address on the Control Panel.
- 3) Plug the network cable back into the printer, and then turn the power on.
- 4) On the Control Panel, open [Admin] > [Network] > [TCP/IP], and confirm that the IP address has been changed.

3.2 Troubleshooting for the repair center

FIP1.1 001-360-01 Restart Printer

Step	Check	Yes	No
	Possible causative parts: FAN MAIN (PL9.1.10) HARN ASSY LV TOP (PL10.1.16) LVPS (PL9.1.4) PWBA MCU (PL9.1.20)		
1	Checking the detail error code. A detailed error code is displayed by pushing ↓ key, ↑ key and ✓ key simultaneously. Is "Code:01" displayed on the LCD?	Go to step 2.	Go to FIP1.2.
2	Checking the connectors for connection Check the connections between the FAN MAIN and LVPS. Is P/J503 connected surely?	Go to step 3.	Reconnect the connector P/J503 surely, then go to step 3.
3	Does the error still occur when the power is turned ON?	Go to step 4.	End of work
4	Checking the FAN MAIN for rotation Does the FAN MAIN function normally? Checked by [Digital Output] - [DO-1e(Control Panel)/FAN ON(PC)] in diagnosis.	Replace the PWBA MCU. (Refer to Removal 30/Replacement 14)	Go to step 5.
5	Checking the HARN ASSY LV TOP for continuity Disconnect P/J501 from the LVPS. Disconnect P/J13 from the PWBA MCU. Is each cable of P/J501 <=> P/J13 continuous?	Go to step 6.	Replace the HARN ASSY LV TOP.
6	Checking the output power of LVPS Disconnect P/J503 on the LVPS. Is the voltage across ground <=> J503-1pin on the LVPS, about +24 VDC when the interlock switch (HARN ASSY INTERLOCK) is pushed?	Go to step 7.	Replace the LVPS. (Refer to Removal 35/Replacement 9)
7	Checking after replacing FAN MAIN. Replace the FAN MAIN. Does the error still occur when the power is turned ON?	Replace the PWBA MCU. (Refer to Removal 30/Replacement 14)	End of work

FIP1.2 001-360-02 Restart Printer

Step	Check	Yes	No
	Possible causative parts: FAN DUP (PL11.1.25) HARN ASSY DUP UNIT (PL11.1.18) HARNESS ASSY FRONT COVER (PL1.2.11) HARN ASSY R SIDE (PL10.1.15) PWBA MCU (PL9.1.20) PWBA DUP-H (PL11.1.15)		
1	Checking the detail error code. A detailed error code is displayed by pushing ↓ key, ↑ key and ✓ key simultaneously. Is "Code:02" displayed on the LCD?	Go to step 2.	Go to FIP1.1.
2	Checking the connectors for connection Check the connections between the FAN DUP and PWBA DUP. Is P/J427 connected surely?	Go to step 3.	Reconnect the connector P/J427 surely, then go to step 3.
3	Does the error still occur when the power is turned ON?	Go to step 4.	End of work
4	Checking the FAN DUP for rotation Does the FAN DUP function normally? Checked by [Digital Output] - [DO-5d(Control Panel)/DUPLICATE FAN ON(PC)] in diagnosis.	Replace the PWBA MCU. (Refer to Removal 30/Replacement 14).	Go to step 5.
5	Checking the connectors of the PWBA DUP and PWBA MCU for connection Check the connections between the PWBA DUP and PWBA MCU. Are P/J428, P/J2720, P/J272 and P/J27 connected surely?	Go to step 6.	Reconnect the connector(s) P/J428, P/J2720, P/J272 and/or P/J27 surely.
6	Checking the HARN ASSY DUP UNIT for continuity Disconnect P/J428 from the PWBA DUP. Disconnect P/J2720 from the HARNESS ASSY FRONT COVER. Is each cable of P/J428 <=> P/J2720 continuous?	Go to step 7.	Replace the HARN ASSY DUP UNIT.
7	Checking the HARNESS ASSY FRONT COVER for continuity Disconnect P/J2720 from the HARNESS ASSY DUP UNIT. Disconnect P/J272 from the HARN ASSY R SIDE. Is each cable of P/J2720 <=> P/J272 continuous?	Go to step 8.	Replace the HARNESS ASSY FRONT COVER.
8	Checking the HARN ASSY R SIDE for continuity Disconnect P/J272 from the HARNESS ASSY FRONT COVER. Disconnect P/J27 from the PWBA MCU. Is each cable of P/J272 <=> P/J27 continuous?	Go to step 9.	Replace the HARN ASSY R SIDE.
9	Checking the power to the PWBA DUP Disconnect P/J27 on the PWBA MCU. Are the voltages across ground <=> J27-17pin and J27-18pin on the PWBA MCU, about +24 VDC when the interlock switch (HARN ASSY INTERLOCK) is pushed?	Replace the FEEDER ASSY DUP. (Refer to Removal 5/Replacement 39)	Replace the PWBA MCU. (Refer to Removal 30/Replacement 14)

FIP1.3 003-340-01/003-340-02/003-340-03/003-340-04/003-340-05/003-340-07/003-340-08/003-340-0A/003-340-0B/003-340-0C/003-340-0D/003-340-0E/003-340-0F/003-340-10/003-340-11/003-340-12/003-340-13/003-340-14 Restart Printer

Step	Check	Yes	No
	Possible causative parts: PWBA MCU (PL9.1.20)		
1	Checking the detail error code. A detailed error code is displayed by pushing ↓ key, ↑ key and ✓ key simultaneously. Is "Code:09" displayed on the LCD?	Go to FIP1.4.	Go to step 2.
2	Does Error still occur after several ON/OFF procedures of the power?	Go to step 3.	End of work *1
3	Checking the firmware version Does the firmware is the latest version?	Go to step 4.	Upgrade the firm-ware version, then go to step 4.
4	Checking after reseating the PWBA MCU Reseat the PWBA MCU. Does Error still occur when the power is turned ON?	Go to step 5.	End of work *1
5	Checking after replacing the PWBA MCU Replace the PWBA MCU. (Refer to Removal 30/Replacement 14) Does Error still occur when the power is turned ON?	Go to Electrical noise.	End of work

*1: Though some kind of foreign noise would be possible cause, go to FIP1.73 Electrical Noise in Other FIP and check, to make sure.

FIP1.4 003-340-09 Restart Printer

NOTE

If the error occurred after replacing the PWBA MCU, transfer the internal data of the old PWBA to a new PWBA.

Step	Check	Yes	No
	Possible causative parts: PWBA MCU (PL9.1.20) HVPS (PL5.1.17)		
1	Checking the detail error code. A detailed error code is displayed by pushing ↓ key, ↑ key and ✓ key simultaneously. Is "Code:09" displayed on the LCD?	Go to step 2.	Go to FIP1.3.
2	Checking the connectors for connection Are the following connectors connected correctly? - P/J16 and P/J28 on the PWBA MCU - P/J144 on the PWBA EEPROM	Go to step 4.	Reconnect the connector(s) P/J16, P/J28 and/or P/J144 surely, then go to step 3.
3	Does the error still occur when the power is turned ON?	Go to step 4.	End of work
4	Checking after replacing the HVPS Replace the HVPS. (Refer to Removal 34/Replacement 10) Does the error still occur when the power is turned ON?	Replace the PWBA MCU. (Refer to Removal 30/Replacement 14)	End of work

FIP1.5 003-356 Restart Printer

Step	Check	Yes	No
	Possible causative parts: HARN ASSY R SIDE (PL10.1.15) PWBA EEPROM (PL9.1.1) PWBA MCU (PL9.1.20)		
1	Does Error still occur after several ON/OFF procedures of the power?	Go to step 2.	End of work *1
2	Checking the firmware version Does the firmware is the latest version?	Go to step 3.	Upgrade the firm-ware version, then go to step 3.
3	Checking after reseating the PWBA MCU Reseat the PWBA MCU. Does Error still occur when the power is turned ON?	Go to step 4.	End of work *1
4	Checking the connectors for connection Check the connections between the PWBA EEPROM and PWBA MCU. Are P/J28 and P/J144 connected surely?	Go to step 6.	Reconnect the connector(s) P/J28 and/or P/J144 surely, then go to step 5.
5	Does the error still occur when the power is turned ON?	Go to step 6.	End of work
6	Checking the HARN ASSY R SIDE for continuity Disconnect P/J28 form the PWBA MCU. Disconnect P/J144 from the PWBA EEPROM. Is each cable of P/J28 <=> P/J144 continuous?	Go to step 7.	Replace the HARN ASSY R SIDE.
7	Checking the power to PWBA EEPROM Disconnect P/J28 on the PWBA MCU. Is the voltage across ground <=> J28-16pin on the PWBA MCU, about +3.3 VDC?	Replace the PWBA MCU.	Go to step 8.
8	Checking after replacing the PWBA MCU Replace the PWBA MCU. (Refer to Removal 30/Replacement 14) Does Error still occur when the power is turned ON?	Go to Electrical noise.	End of work

*1: Though some kind of foreign noise would be possible cause, go to FIP1.73 Electrical Noise in Other FIP and check, to make sure.

FIP1.6 004-310 Restart Printer

Step	Check	Yes	No
	Possible causative parts: HARN ASSY FDR UNIT (PL12.2.3) HARN ASSY R SIDE (PL10.1.15) PWBA OPT FDR (PL12.2.6) 550 OPTION FEEDER (PL12.1.1) PWBA MCU (PL9.1.20)		
1	Checking the Optional Feeder for installation Is the Optional Feeder installed correctly?	Go to step 3.	Reseat the Optional Feeder, then go to step 2.
2	Does the error still occur when the power is turned ON?	Go to step 3.	End of work
3	Checking the connectors for connection Check the connections between the PWBA OPT FDR and PWBA MCU. Are P/J28, P/J281, and P/J419 connected surely?	Go to step 5.	Reconnect the connector(s) P/J28, P/J281 and/or P/J419 surely, then go to step 4.
4	Does the error still occur when the power is turned ON?	Go to step 5.	End of work
5	Checking the HARN ASSY FDR UNIT for continuity Disconnect P/J419 from the PWBA OPT FDR. Disconnect P/J281 from the HARN ASSY R SIDE. Is each cable of P/J419 <=> P/J281 continuous?	Go to step 6.	Replace the HARN ASSY FDR UNIT.
6	Checking the HARN ASSY R SIDE for continuity Disconnect P/J28 from the PWBA MCU. Disconnect P/J281 from the HARNESS ASSY FDR UNIT. Is each cable of P/J28 <=> P/J281 continuous?	Go to step 7.	Replace the HARN ASSY R SIDE.
7	Checking after replacing the PWBA OPT FDR Replace the PWBA OPT FDR. (Refer to Removal 44/ Replacement 46) Does the error still occur when the power is turned ON?	Go to step 8.	End of work
8	Checking after replacing the 550 OPTION FEEDER Replace the 550 OPTION FEEDER. (Refer to Removal 44/ Replacement 46) Does the error still occur when the power is turned ON?	Replace the PWBA MCU. (Refer to Removal 30/Replacement 14)	End of work

FIP1.7 004-311 Restart Printer

Step	Check	Yes	No
	Possible causative parts: HARNASS ASSY DUP UNIT (PL11.1.18) HARNASS ASSY FRONT COVER (PL1.2.11) HARN ASSY R SIDE (PL10.1.15) PWBA DUP-H (PL11.1.15) PWBA MCU (PL9.1.20)		
1	Checking the Option Duplex for installation Is the Option Duplex installed correctly?	Go to step 3.	Reseat the Option Duplex, then go to step 2.
2	Does the error still occur when the power is turned ON?	Go to step 3.	End of work
3	Checking the connectors for connection Check the connections between the PWBA DUP-H and PWBA MCU. Are P/J27, P/J272, P/J2720 and P/J 428 connected surely?	Go to step 5.	Reconnect the connector(s) P/J27, P/J272, P/J2720 and/or P/J 428 surely, then go to step 4.
4	Does the error still occur when the power is turned ON?	Go to step 5.	End of work
5	Checking the HARN ASSY DUP UNIT for continuity Disconnect P/J428 from the PWBA DUP-H. Disconnect P/J2720 from the HARNASS ASSY FRONT COVER. Is each cable of P/J428 <=> P/J2720 continuous?	Go to step 6.	Replace the HARN ASSY DUP UNIT.
6	Checking the HARNASS ASSY FRONT COVER for continuity Disconnect P/J272 from the HARN ASSY R SIDE. Disconnect P/J 2720 from the HARNASS ASSY DUP UNIT. Is each cable of P/J272 <=> P/J2720 continuous?	Go to step 7.	Replace the HARNASS ASSY FRONT COVER.
7	Checking the HARN ASSY R SIDE for continuity Disconnect P/J272 from the HARNASS ASSY FRONT COVER. Disconnect P/J27 from the PWBA MCU. Is each cable of P/J272 <=> P/J27 continuous?	Go to step 8.	Replace the HARN ASSY R SIDE.
8	Checking after replacing the FEEDER ASSY DUP Replace the FEEDER ASSY DUP. (Refer to Removal 5/ Replacement 39) Does the error still occur when the power is turned ON?	Replace the PWBA MCU. (Refer to Removal 30/Replacement 14)	End of work

FIP1.8 006-370 Restart Printer

Step	Check	Yes	No
	Possible causative parts: ROS ASSY (PL13.3.12) PWBA MCU (PL13.5.13)		
1	Checking the ROS ASSY for installation Is the ROS ASSY installed correctly?	Go to step 3.	Reseat the ROS ASSY, then go to step 2.
2	Does the error still occur when the power is turned ON?	Go to step 3.	End of work
3	Checking the connector for connection Check the connection the PWBA MCU. Are P/J12 and P/J151 connected surely?	Go to step 5.	Reconnect the connector(s) P/J12 and/or P/J151 surely, then go to step 4.
4	Does the error still occur when the power is turned ON?	Go to step 5.	End of work
5	Checking the PWBA MCU for installation Is the PWBA MCU installed correctly?	Go to step 7.	Reseat the PWBA MCU, then go to step 6.
6	Does the error still occur when the power is turned ON?	Go to step 7.	End of work
7	Checking after replacing the ROS ASSY Replace the ROS ASSY. (Refer to Removal 36/Replacement 8) Does the error still occur when the power is turned ON?	Replace the PWBA MCU. (Refer to Removal 30/Replacement 14)	End of work

FIP1.9 007-340-00 Restart Printer

Step	Check	Yes	No
	Possible causative parts: PWBA MCU (PL9.1.20) HARN ASSY R SIDE (PL10.1.15) DRIVE ASSY MAIN (PL8.1.2)		
1	Checking the detail error code. A detailed error code is displayed by pushing ↓ key, ↑ key and ✓ key simultaneously. Is "Code:00" displayed on the LCD?	Go to step 2.	"01":Go to FIP1.10. "03":Go to FIP1.12. "04":Go to FIP1.13.
2	Checking the Transfer Assy, Fuser and Black Print Cartridge for installation Are the Transfer Assy, Fuser and Black Print Cartridge installed correctly?	Go to step 4.	Reseat the Transfer Assy, Fuser and/or Black Print Cartridge, then go to step 3.
3	Does the error still occur when the power is turned ON?	Go to step 4.	End of work
4	Checking the connectors for connection Check the connections between the PWBA MCU and DRIVE ASSY MAIN. Are P/J22 and P/J222 connected surely?	Go to step 6.	Reconnect the connector(s) P/J22 and/or P/J222 surely, then go to step 5.
5	Does the error still occur when the power is turned ON?	Go to step 6.	End of work
6	Checking the Main Motor in the DRIVE ASSY MAIN for rotation Does the Main Motor function normally? Checked by [Digital Output] - [DO-0(Control Panel)/MAIN MOTOR(PC)] in diagnosis. During the test, close the Front Cover.	Replace the PWBA MCU. (Refer to Removal 30/Replacement 14)	Go to step 7.
7	Checking the DRIVE ASSY MAIN for installation Is the DRIVE ASSY MAIN installed correctly?	Go to step 8.	Reseat the DRIVE ASSY MAIN, then go to step 8.
8	Does the error still occur when the power is turned ON?	Go to step 9.	End of work
9	Checking the connectors of the Main Motor on the DRIVE ASSY MAIN for connection Check the connections between the PWBA MCU and DRIVE ASSY MAIN. Are P/J22 and P/J222 connected surely?	Go to step 10.	Reconnect the connector(s) P/J22 and/or P/J222 surely.
10	Checking the HARN ASSY R SIDE for continuity Disconnect P/J22 from the PWBA MCU. Disconnect P/J222 from the DRIVE ASSY MAIN. Is each cable of P/J22 <=> P/J222 continuous?	Go to step 11.	Replace the HARN ASSY R SIDE.

Step	Check	Yes	No
11	Checking the power to DRIVE ASSY MAIN Disconnect the connector of P/J22 on the PWBA MCU. Are the voltages across ground \Leftrightarrow J22-B2pin/J21-B4pin on the PWBA MCU, about +24 VDC when the interlock switch (HARN ASSY INTERLOCK) is pushed?	Replace the DRIVE ASSY MAIN. (Refer to Removal 38/Replacement 6)	Replace the PWBA MCU. (Refer to Removal 30/Replacement 14)

FIP1.10 007-340-01 Restart Printer

Step	Check	Yes	No
	Possible causative parts: PWBA MCU (PL9.1.20) HARN ASSY R SIDE (PL10.1.15) DRIVE ASSY MAIN (PL8.1.2)		
1	Checking the detail error code. A detailed error code is displayed by pushing ↓ key, ↑ key and ✓ key simultaneously. Is "Code:01" displayed on the LCD?	Go to step 2.	"00":Go to FIP1.9. "03":Go to FIP1.12. "04":Go to FIP1.13.
2	Checking the print cartridges for installation Are the Y, M, C and K print cartridges installed correctly?	Go to step 4.	Reseat the print cartridge(s), then go to step 3.
3	Does the error still occur when the power is turned ON?	Go to step 4.	End of work
4	Checking the connectors for connection Check the connections between the PWBA MCU and DRIVE ASSY MAIN. Are P/J22 and P/J221 connected surely?	Go to step 5.	Reconnect the connector(s) P/J22 and/or P/J221 surely, then go to step 5.
5	Checking the Sub Motor in the DRIVE ASSY MAIN for rotation Does the Sub Motor function normally? Checked by [Digital Output] - [DO-5(Control Panel)/SUB MOTOR(PC)] in diagnosis. During the test, close the Front Cover.	Replace the PWBA MCU. (Refer to Removal 30/Replacement 14)	Go to step 6.
6	Checking the DRIVE ASSY MAIN for installation Is the DRIVE ASSY MAIN installed correctly?	Go to step 7.	Reseat the DRIVE ASSY MAIN, then go to step 7.
7	Does the error still occur when the power is turned ON?	Go to step 8.	End of work
8	Checking the connectors of the Sub Motor on the DRIVE ASSY MAIN for connection Check the connections between the PWBA MCU and DRIVE ASSY MAIN. Are P/J22 and P/J221 connected surely?	Go to step 9.	Reconnect the connector(s) P/J22 and/or P/J221 surely.
9	Checking the HARN ASSY R SIDE for continuity Disconnect P/J22 from the PWBA MCU. Disconnect P/J221 from the DRIVE ASSY MAIN. Is each cable of P/J22 <=> P/J221 continuous?	Go to step 10.	Replace the HARN ASSY R SIDE.
10	Checking the power to DRIVE ASSY MAIN Disconnect the connector of P/J22 on the PWBA MCU. Are the voltages across ground <=> J22-A2pin/J22-A4pin on the PWBA MCU, about +24 VDC when the interlock switch (HARN ASSY INTERLOCK) is pushed?	Replace the DRIVE ASSY MAIN. (Refer to Removal 38/Replacement 6)	Replace the PWBA MCU. (Refer to Removal 30/Replacement 14)

FIP1.12 007-340-03 Restart Printer

Step	Check	Yes	No
	Possible causative parts: FEEDER ASSY (PL3.2.1) PWBA MCU (PL9.1.20) HARN ASSY R SIDE (PL10.1.15) DRIVE ASSY PH (PL8.1.7)		
1	Checking the detail error code. A detailed error code is displayed by pushing ↓ key, ↑ key and ✓ key simultaneously. Is "Code:03" displayed on the LCD?	Go to step 2.	"00":Go to FIP1.9. "01":Go to FIP1.10. "04":Go to FIP1.13.
2	Checking the ROLL REGI RUBBER for rotation Does the ROLL REGI RUBBER rotate smoothly? Check the rotation of the ROLL REGI RUBBER with a finger.	Go to step 3.	Replace the FEEDER ASSY.
3	Checking the connectors for connection Check the connections between the PWBA MCU and DRIVE ASSY PH. Are P/J25 and P/J251 connected surely?	Go to step 4.	Reconnect the connector(s) P/J25 and/or P/J251 surely, then go to step 4.
4	Checking the PH Motor for rotation Does the PH Motor function normally? Checked by [Digital Output] - [DO-a(Control Panel)/PH MOTOR ON(PC)] in diagnosis. During the test, close the Front Cover.	Replace the PWBA MCU. (Refer to Removal 30/Replacement 14)	Go to step 5.
5	Checking the DRIVE ASSY PH for installation Is the DRIVE ASSY PH installed correctly?	Go to step 6.	Reseat the DRIVE ASSY PH, then go to step 6.
6	Does the error still occur when the power is turned ON?	Go to step 7.	End of work
7	Checking the connectors of the DRIVE ASSY PH for connection Check the connections between the PWBA MCU and DRIVE ASSY PH. Are P/J25 and P/J251 connected surely?	Go to step 8.	Reconnect the connector(s) P/J25 and/or P/J251 surely.
8	Checking the HARN ASSY R SIDE for continuity Disconnect P/J25 from the PWBA MCU. Disconnect P/J251 from the DRIVE ASSY PH. Is each cable of P/J25 <=> P/J251 continuous?	Go to step 9.	Replace the HARN ASSY R SIDE.
9	Checking the power to DRIVE ASSY PH Disconnect the connector of P/J25 on the PWBA MCU. Are the voltages across ground <=> J25-1pin/J25-2pin on the PWBA MCU, about +24 VDC when the interlock switch (HARN ASSY INTERLOCK) is pushed?	Replace the DRIVE ASSY PH. (Refer to Removal 17/Replacement 27)	Replace the PWBA MCU. (Refer to Removal 30/Replacement 14)

FIP1.13 007-340-04 Restart Printer

Step	Check	Yes	No
	Possible causative parts: SEPARATOR ROLLER (PL12.5.17) ROLL ASSY FEED (PL12.3.29) PWBA MCU (PL9.1.20) DRIVE ASSY OPT FDR (PL12.2.10) HARN ASSY C2 MOT (PL12.2.9) HARN ASSY FDR UNIT (PL12.2.3) HARN ASSY R SIDE (PL10.1.15) PWBA OPT FDR (PL12.2.6)		
1	Checking the detail error code. A detailed error code is displayed by pushing ↓ key, ↑ key and ✓ key simultaneously. Is "Code:04" displayed on the LCD?	Go to step 2.	"00":Go to FIP1.9. "01":Go to FIP1.10. "03":Go to FIP1.12.
2	Checking the paper cassette for installation Is the paper cassette installed correctly?	Go to step 4.	Reseat the paper cassette, then go to step 3.
3	Does the error still occur when the power is turned ON?	Go to step 4.	End of work
4	Checking the ROLL ASSY FEEDS and SEPARATOR ROLLER for rotation Do these ROLLS rotate smoothly? Check the rotation of the ROLLS with a finger.	Go to step 5.	Replace the defective ROLL(s).
5	Checking the connectors for connection Check the connections between the PWBA OPT FDR and DRIVE ASSY OPT FDR. Are P/J422, P/J4221 and P/J4222 connected surely?	Go to step 6.	Reconnect the connector(s) P/J422, P/J 4221 and/or P/J4222 surely, then go to step 6.
6	Checking the Feed Motor for rotation Does the Feed Motor function normally? Checked by [Digital Output] - [DO-19(Control Panel)/OPTION FEEDER1 MOTOR ON(PC)] in diagnosis. During the test, close the Front Cover.	Replace the PWBA MCU. (Refer to Removal 30/Replacement 14)	Go to step 7.
7	Checking the DRIVE ASSY OPT FDR for installation Is the DRIVE ASSY OPT FDR installed correctly?	Go to step 8.	Reseat the DRIVE ASSY OPT FDR, then go to step 8.
8	Does the error still occur when the power is turned ON?	Go to step 9.	End of work
9	Checking the connectors of the DRIVE ASSY OPT FDR for connection Check the connections between the PWBA OPT FDR and DRIVE ASSY OPT FDR. Are P/J422 and P/J4222 connected surely?	Go to step 10.	Reconnect the connector(s) P/J422 and/or P/J4222 surely.

Step	Check	Yes	No
10	Checking the HARN ASSY C2 MOT for continuity Disconnect P/J422 from the PWBA OPT FDR. Disconnect P/J4222 from the DRIVE ASSY OPT FDR. Is each cable of P/J422 <=> P/J4222 continuous?	Go to step 11.	Replace the HARN ASSY C2 MOT.
11	Checking the power to DRIVE ASSY OPT FDR Disconnect the connector of P/J422 on the PWBA OPT FDR. Is the voltage across ground <=> J422-6pin on the PWBA OPT FDR, about +24 VDC when the interlock switch (HARN ASSY INTERLOCK) is pushed?	Replace the DRIVE ASSY OPT FDR. (Refer to Removal 44/Replacement 46)	Go to step 5.
12	Checking the connectors of the PWBA OPT FDR and PWBA MCU for connection Check the connections between the PWBA OPT FDR and PWBA MCU. Are P/J419, P/J281 and P/J28 connected surely?	Go to step 13.	Reconnect the connector(s) P/J419, P/J281 and/or P/J28 surely.
13	Checking the HARN ASSY FDR UNIT for continuity Disconnect P/J419 from the PWBA OPT FDR. Disconnect P/J281 from the HARN ASSY R SIDE. Is each cable of P/J419 <=> P/J281 continuous?	Go to step 14.	Replace the HARN ASSY FDR UNIT.
14	Checking the HARN ASSY R SIDE for continuity Disconnect P/J281 from the HARNESS ASSY FDR UNIT. Disconnect P/J28 from the PWBA MCU. Is each cable of P/J281 <=> P/J28 continuous?	Go to step 15.	Replace the HARN ASSY R SIDE.
15	Checking the power to the PWBA OPT FDR Disconnect the connector of P/J28 on the PWBA MCU. Is the voltage across ground <=> J28-4pin/J28-5pin on the PWBA MCU, about +24 VDC when the interlock switch (HARN ASSY INTERLOCK) is pushed?	Replace the PWBA OPT FDR. (Refer to Removal 44/Replacement 46)	Replace the PWBA MCU. (Refer to Removal 30/Replacement 14)

FIP1.14 007-371 Restart Printer

Step	Check	Yes	No
	Possible causative parts: DRIVE ASSY K (PL8.1.10) PWBA MCU (PL.1.20) DRIVE ASSY K(HARN ASSY KSNR REGCL) (PL8.1.10)		
1	Checking the K Mode Solenoid (Color Mode Switching Solenoid) for operation Does the K Mode Solenoid function normally? Checked by [Digital Output] - [DO-61(Control Panel)/K MODE CLUTCH ON(PC)] in diagnosis. During this check, close the COVER ASSY FRONT. Does the K Mode Solenoid click sound arise from the DRIVE ASSY K, when the K Mode Solenoid check is performed?	Go to step 2.	Go to step 3.
2	Checking after reseating the DRIVE ASSY K Reseat the DRIVE ASSY K. Does the error still occur when the power is turned ON?	Go to step 7.	End of work
3	Checking the connectors for connection Check the connections between the PWBA MCU and K Mode Solenoid. Are P/J24 and P/J241 connected surely?	Go to step 4.	Reconnect the connector(s) P/J24 and/o P/J241 surely, then go to step 4.
4	Does the error still occur when the power is turned ON?	Go to step 5.	End of work
5	Checking the power to the K Mode Solenoid Disconnect J24 from the PWBA MCU. Is the voltage across P24-1pin <=> ground on the PWBA MCU, about +24 VDC when the Interlock Switch (HARN ASSY INTERLOCK) is pushed?	Go to step 6.	Replace the PWBA MCU. (Refer to Removal 30/ Replacement 14.)?
6	Checking the K Mode Solenoid for resistance Disconnect P/J24 from the PWBA MCU. Is the resistance across J24-1 and J24-2 about 80 to 110-ohm?	Replace the PWBA MCU. (Refer to Removal 30/ Replacement 14.)	Replace the DRIVE ASSY K. (Refer to Removal 28/ Replacement 16.)
7	Checking the connectors of the K Mode Sensor in the DRIVE ASSY K for connection Check the connections between the PWBA MCU and K Mode Sensor. Are P/J20 and P/J201 connected correctly?	Go to step 8.	Reconnect the connector(s) P/J20 and/o P/J201 surely, then go to step 8.
8	Does the error still occur when the power is turned ON?	Go to step 9.	End of work
9	Checking the HARN ASSY KSNR REGCL for continuity Disconnect J20 from the PWBA MCU. Disconnect J201 from the K Mode Sensor. Is each cable of J20 <=> J201 continuous?	Go to step 10.	Replace the HARN ASSY KSNR REGCL.
10	Checking the power to the K Mode Sensor Disconnect J20 from the PWBA MCU. Is the voltage across P20-1pin <=> ground on the PWBA MCU, about +3.3 VDC?	Go to step 11.	Replace the PWBA MCU. (Refer to Removal 30/ Replacement 14.)

Step	Check	Yes	No
11	Checking the K Mode Sensor for operation Remove the DRIVE ASSY K from the printer once, but P/J201 and P/J24 should be connected. Enter the [Digital Input] - [DI-0(Control Panel)/K MODE SNR (PC)] in diagnosis. During this check, close the COVER ASSY FRONT. Does the voltage change, when a piece of paper is inserted into the gap of the K Mode Sensor?	Replace the PWBA MCU. (Refer to Removal 30/ Replacement 14.)	Replace the DRIVE ASSY K. (Refer to Removal 28/ Replacement 16.)

FIP1.15 009-360 Restart Printer

Step	Check	Yes	No
	Possible causative parts: CARTRIDGE ASSY (Y) (PL5.1.21) CONNECTOR CRUM (PL5.1.3) HARN ASSY CRUM (PL10.1.13) PWBA MCU (PL9.1.20)		
1	Checking the CARTRIDGE ASSY (Y) for installation Is the CARTRIDGE ASSY (Y) installed correctly?	Go to step 3.	Reseat the CARTRIDGE ASSY (Y), then go to step 2.
2	Does the error still occur when the power is turned ON?	Go to step 3.	End of work
3	Checking the CONNECTOR CRUM for installation Is the CONNECTOR CRUM installed correctly?	Go to step 4.	Reseat the CONNECTOR CRUM, then go to step 4.
4	Checking the connectors for connection Check the connections between the PWBA MCU and CONNECTOR CRUM. Are P/J31 and P/J311 connected surely?	Go to step 5.	Reconnect the connector(s) P/J31 and/or P/J311 surely, then go to step 5.
5	Checking the HARN ASSY CRUM for continuity Disconnect P/J31 from the PWBA MCU. Disconnect P/J311 from the CONNECTOR CRUM. Is each cable of P/J31 <=> P/J311 continuous?	Go to step 6.	Replace the HARN ASSY CRUM.
6	Checking the CONNECTOR CRUM for shape Is there any damage on the CONNECTOR CRUM?	Replace the CONNECTOR CRUM.	Go to step 7.
7	Checking after replacing the CONNECTOR CRUM Replace the CONNECTOR CRUM. Does the error still occur when the power is turned ON?	Go to step 8.	End of work
8	Checking after replacing the CARTRIDGE ASSY (Y) Replace the CARTRIDGE ASSY (Y). Does the error still occur when the power is turned ON?	Replace the PWBA MCU. (Refer to Removal 30/Replacement 14)	End of work

FIP1.16 009-361 Restart Printer

Step	Check	Yes	No
	Possible causative parts: CARTRIDGE ASSY (M) (PL5.1.20) HARN ASSY CRUM (PL10.1.13) CONNECTOR CRUM (PL5.1.3) PWBA MCU (PL9.1.20)		
1	Checking the CARTRIDGE ASSY (M) for installation Is the CARTRIDGE ASSY (M) installed correctly?	Go to step 3.	Reseat the CARTRIDGE ASSY (M), then go to step 2.
2	Does the error still occur when the power is turned ON?	Go to step 3.	End of work
3	Checking the CONNECTOR CRUM for installation Is the CONNECTOR CRUM installed correctly?	Go to step 4.	Reseat the CONNECTOR CRUM, then go to step 4.
4	Checking the connectors for connection Check the connections between the PWBA MCU and CONNECTOR CRUM. Are P/J31 and P/J 312 connected surely?	Go to step 5.	Reconnect the connector(s) P/J31 and/or P/J 312 surely, then go to step 5.
5	Checking the HARN ASSY CRUM for continuity Disconnect P/J31 from the PWBA MCU. Disconnect P/J312 from the CONNECTOR CRUM. Is each cable of P/J31 <=> P/J 312 continuous?	Go to step 6.	Replace the HARN ASSY CRUM.
6	Checking the CONNECTOR CRUM for shape Is there any damage on the CONNECTOR CRUM?	Replace the CONNECTOR CRUM.	Go to step 7.
7	Checking after replacing the CONNECTOR CRUM Replace the CONNECTOR CRUM. Does the error still occur when the power is turned ON?	Go to step 8.	End of work
8	Checking after replacing the CARTRIDGE ASSY (M) Replace the CARTRIDGE ASSY (M). Does the error still occur when the power is turned ON?	Replace the PWBA MCU. (Refer to Removal 30/Replacement 14)	End of work

FIP1.17 009-362 Restart Printer

Step	Check	Yes	No
	Possible causative parts: CARTRIDGE ASSY (C) (PL5.1.19) HARN ASSY CRUM (PL10.1.13) CONNECTOR CRUM (PL5.1.3) PWBA MCU (PL9.1.20)		
1	Checking the CARTRIDGE ASSY (C) for installation Is the CARTRIDGE ASSY (C) installed correctly?	Go to step 3.	Reseat the CARTRIDGE ASSY (C), then go to step 2.
2	Does the error still occur when the power is turned ON?	Go to step 3.	End of work
3	Checking the CONNECTOR CRUM for installation Is the CONNECTOR CRUM installed correctly?	Go to step 4.	Reseat the CONNECTOR CRUM, then go to step 4.
4	Checking the connectors for connection Check the connections between the PWBA MCU and CONNECTOR CRUM. Are P/J31 and P/J 313 connected surely?	Go to step 5.	Reconnect the connector(s) P/J31 and/or P/J 313 surely, then go to step 5.
5	Checking the HARN ASSY CRUM for continuity Disconnect P/J31 from the PWBA MCU. Disconnect P/J313 from the CONNECTOR CRUM. Is each cable of P/J31 <=> P/J313 continuous?	Go to step 6.	Replace the HARN ASSY CRUM.
6	Checking the CONNECTOR CRUM for shape Is there any damage on the CONNECTOR CRUM?	Replace the CONNECTOR CRUM.	Go to step 7.
7	Checking after replacing the CONNECTOR CRUM Replace the CONNECTOR CRUM. Does the error still occur when the power is turned ON?	Go to step 8.	End of work
8	Checking after replacing the CARTRIDGE ASSY (C) Replace the CARTRIDGE ASSY (C). Does the error still occur when the power is turned ON?	Replace the PWBA MCU. (Refer to Removal 30/Replacement 14)	End of work

FIP1.18 009-363 Restart Printer

Step	Check	Yes	No
	Possible causative parts: CARTRIDGE ASSY (K) (PL5.1.18) HARN ASSY CRUM (PL10.1.13) CONNECTOR CRUM (PL5.1.3) PWBA MCU (PL9.1.20)		
1	Checking the CARTRIDGE ASSY (K) for installation Is the CARTRIDGE ASSY (K) installed correctly?	Go to step 3.	Reseat the CARTRIDGE ASSY (K), then go to step 2.
2	Does the error still occur when the power is turned ON?	Go to step 3.	End of work
3	Checking the CONNECTOR CRUM for installation Is the CONNECTOR CRUM installed correctly?	Go to step 4.	Reseat the CONNECTOR CRUM, then go to step 4.
4	Checking the connectors for connection Check the connections between the PWBA MCU and CONNECTOR CRUM. Are P/J31 and P/J314 connected surely?	Go to step 5.	Re-connect the connector(s) P/J31 and/or P/J314 surely, then go to step 5.
5	Checking the HARN ASSY CRUM for continuity Disconnect P/J31 from the PWBA MCU. Disconnect P/J314 from the CONNECTOR CRUM. Is each cable of P/J31 <=> P/J314 continuous?	Go to step 6.	Replace the HARN ASSY CRUM.
6	Checking the CONNECTOR CRUM for shape Is there any damage on the CONNECTOR CRUM?	Replace the CONNECTOR CRUM.	Go to step 7.
7	Checking after replacing the CONNECTOR CRUM Replace the CONNECTOR CRUM. Does the error still occur when the power is turned ON?	Go to step 8.	End of work
8	Checking after replacing the CARTRIDGE ASSY (K) Replace the CARTRIDGE ASSY (K). Does the error still occur when the power is turned ON?	Replace the PWBA MCU. (Refer to Removal 30/Replacement 14)	End of work

FIP1.19 009-654-01 Restart Printer

Step	Check	Yes	No
	Possible causative parts: TRANSFER ASSY (PL4.1.1) CARTRIDGE ASSY (K) (PL5.1.18) CARTRIDGE ASSY (C) (PL5.1.19) CARTRIDGE ASSY (M) (PL5.1.20) CARTRIDGE ASSY (Y) (PL5.1.21) HARNESS ASSY FRONT COVER (PL13.2.1) HARN ASSY R SIDE (PL10.1.15) PWBA MCU (PL9.1.20)		
1	Checking the detail error code. A detailed error code is displayed by pushing ↓ key, ↑ key and ✓ key simultaneously. Is "Code:01" displayed on the LCD?	Go to step 2.	Go to FIP1.20.
2	Checking the TRANSFER ASSY for installation Is the TRANSFER ASSY installed correctly?	Go to step 4.	Reseat the TRANSFER ASSY, then go to step 3.
3	Does the error still occur when the power is turned ON?	Go to step 4.	End of work
4	Checking the toner density Is there the dark color? Compare the density of four colors toner. Checked by [Test Print] - [Gradation] in diagnosis.	Go to step 5.	Replace the PWBA MCU. (Refer to Removal 30/Replacement 14)
5	Checking the solenoid in the TRANSFER ASSY for operation Does the ADC Sensor operate normally? Checked by [Digital Output] - [DO-37(Control Panel)/CTD SOLENOID ON(PC)] in diagnosis.	Replace the corresponding CARTRIDGE ASSY. (Refer to Removal 6/Replacement 38)	Go to step 6.
6	Checking the connectors for connection Check the connections between the PWBA MCU and TRANSFER ASSY. Are P/J27, P/J272 and P/J2721 connected surely?	Go to step 7.	Reconnect the connector(s) P/J27, P/J272 and/or P/J2721 surely, then go to step 7.
7	Checking the HARNESS ASSY FRONT COVER for continuity Disconnect P/J2721 from the TRANSFER ASSY. Disconnect P/J272 from the HARN ASSY R SIDE. Is each cable of P/J2721 <=> P/J272 continuous?	Go to step 8.	Replace the HARNESS ASSY FRONT COVER.
8	Checking the HARN ASSY R SIDE for continuity Disconnect P/J27 from the PWBA MCU. Disconnect P/J272 from the HARNESS ASSY FRONT COVER. Is each cable of P/J27 <=> P/J272 continuous?	Go to step 9.	Replace the HARN ASSY R SIDE.

Step	Check	Yes	No
9	Checking the power to ADC SENSOR Disconnect P/J27 on PWBA MCU. Is the voltage across ground \Leftrightarrow J27-7pin on the PWBA MCU, about +5 VDC?	Replace the TRANSFER ASSY. (Refer to Removal 4/Replacement 40)	Replace the PWBA MCU. (Refer to Removal 30/Replacement 14)

FIP1.20 009-654-02 Restart Printer

Step	Check	Yes	No
	Possible causative parts: TRANSFER ASSY (PL4.1.1) CARTRIDGE ASSY (K) (PL5.1.18) CARTRIDGE ASSY (C) (PL5.1.19) CARTRIDGE ASSY (M) (PL5.1.20) CARTRIDGE ASSY (Y) (PL5.1.21) DRIVE ASSY MAIN (PL8.1.2) ROS ASSY (PL5.1.12) HARNESS ASSY FRONT COVER (PL1.2.11) HARN ASSY R SIDE (PL10.1.15) PWBA MCU (PL9.1.20)		
1	Checking the detail error code. A detailed error code is displayed by pushing ↓ key, ↑ key and ✓ key simultaneously. Is "Code:02" displayed on the LCD?	Go to step 2.	Go to FIP1.19.
2	Checking the TRANSFER ASSY for installation Is the TRANSFER ASSY installed correctly?	Go to step 4.	Reseat the TRANSFER ASSY, then go to step 3.
3	Does the error still occur when the power is turned ON?	Go to step 4.	End of work
4	Checking the four CARTRIDGE ASSY for installation Are the CARTRIDGE ASSYs installed correctly?	Go to step 6.	Reseat the CARTRIDGE ASSY(s), then go to step 5.
5	Does the error still occur when the power is turned ON?	Go to step 6.	End of work
6	Checking the toner density Is there the light color? Compare the density of four colors toner. Checked by [Test Print] - [Gradation] in diagnosis.	Go to step 7.	Replace the PWBA MCU. (Refer to Removal 30/Replacement 14)
7	Checking the solenoid in the TRANSFER ASSY for operation Does the ADC Sensor operate normally? Checked by [Digital Output] - [DO-37(Control Panel)/CTD SOLENOID ON(PC)] in diagnosis.	Go to step 12.	Go to step 8.
8	Checking the connectors for connection Check the connections between the PWBA MCU and TRANSFER ASSY. Are P/J27, P/J272 and P/J2721 connected surely?	Go to step 9.	Reconnect the connector(s) P/J27, P/J272 and/or P/J2721 surely, then go to step 9.
9	Checking the HARNESS ASSY FRONT COVER for continuity Disconnect P/J2721 from the TRANSFER ASSY. Disconnect P/J272 from the HARN ASSY R SIDE. Is each cable of P/J2721 <=> P/J272 continuous?	Go to step 10.	Replace the HARNESS ASSY FRONT COVER.

Step	Check	Yes	No
10	Checking the HARN ASSY R SIDE for continuity Disconnect P/J27 from the PWBA MCU. Disconnect P/J272 from the HARNESS ASSY FRONT COVER. Is each cable of P/J27 <=> P/J272 continuous?	Go to step 11.	Replace the HARN ASSY R SIDE.
11	Checking the power to ADC SENSOR Disconnect the connector of P/J27 on PWBA MCU. Is the voltage across ground <=> J27-7pin on the PWBA MCU, about +5 VDC?	Replace the TRANSFER ASSY. (Refer to Removal 4/ Replacement 40)	Replace the PWBA MCU. (Refer to Removal 30/Replacement 14)
12	Checking after replacing the corresponding CARTRIDGE ASSY Replace the CARTRIDGE ASSY. (Refer to Removal 6/ Replacement 38) Does the error still occur when the power is turned ON?	Replace the ROS ASSY. (Refer to Removal 36/ Replacement 8)	End of work

FIP1.21 010-317 Restart Printer

Step	Check	Yes	No
	Possible causative parts: FUSER ASSY (PL6.1.10) PWBA MCU (PL9.1.20) HARN ASSY FUSER (PL6.1.11) HARN ASSY LV TOP (PL10.1.16)		
1	Checking the FUSER ASSY for installation Is the FUSER ASSY installed correctly?	Go to step 2.	Reseat the FUSER ASSY, then go to step2.
2	Does the error still occur when the power is turned ON?	Go to step 3.	End of work *1
3	Checking the connectors for connection Remove the FUSER ASSY. Check the connections between the PWBA MCU and FUSER ASSY. Warning: Start the operation after the FUSER ASSY has cooled down. Are P/J17, P/J171 connected surely?	Go to step 4.	Reconnect the connector(s) P/J17 and/or P/J171 surely, then go to step 4.
4	Checking the HARN ASSY FUSER for continuity Remove the FUSER ASSY. Warning: Start the operation after the FUSER ASSY has cooled down. Disconnect P/J17 from the PWBA MCU. Disconnect P/J171 from the FUSER ASSY. Is each cable of P/J17 <=> P/J171 continuous?	Go to step 5.	Replace the HARN ASSY FUSER.
5	Checking after replacing the FUSER ASSY Replace the FUSER ASSY. (Refer to Removal 8/ Replacement 36.) Warning: Start the operation after the FUSER ASSY has cooled down. Does the error still occur when the power is turned ON?	Replace the PWBA MCU. (Refer to Removal 30/ Replacement 14.)	End of work

*1: Though some kind of foreign noise would be possible cause, go to FIP1.73 Electrical Noise in Other FIP and check, to make sure.

FIP1.22 010-351 Restart Printer

Step	Check	Yes	No
	Possible causative parts: FUSER ASSY (PL6.1.10) PWBA MCU (PL9.1.20)		
1	Checking the life counter value of the FUSER ASSY. Does the life counter value show the near of the end?	Replace the FUSER ASSY. (Refer to Removal 8/ Replacement 36.) After replacement, be sure to clear the life counter value.	Go to step 2.
2	Checking the FUSER ASSY for installation Is the FUSER ASSY installed correctly? Warning: Start the operation after the FUSER ASSY has cooled down.	Go to step 4.	Reseat the FUSER ASSY, then go to step 3.
3	Does the error still occur when the power is turned ON?	Go to step 4.	End of work
4	Checking after replacing the FUSER ASSY Replace the FUSER ASSY. (Refer to Removal 8/ Replacement 36.) Warning: Start the operation after the FUSER ASSY has cooled down. Does the error still occur when the power is turned ON?	Replace the PWBA MCU. (Refer to Removal 30/ Replacement 14.)	End of work

FIP1.23 010-354 Restart Printer

Step	Check	Yes	No
	Possible causative parts: SENSOR HUM (PL9.1.19) HARN ASSY HUM (PL10.1.4) PWBA MCU (PL9.1.20)		
1	Checking the SENSOR HUM for installation Is the SENSOR HUM installed correctly?	Go to step 2.	Reseat the SENSOR HUM, then go to step 2.
2	Does the error still occur when the power is turned ON?	Go to step 3.	End of work
3	Checking the connectors for connection Check the connections between the PWBA MCU and SENSOR HUM. Are P/J26 and P/J261 connected surely?	Go to step 4.	Reconnect the connector(s) P/J26 and/or P/J261 surely, then go to step 4.
4	Checking the HARN ASSY HUM for continuity Disconnect P/J26 from the PWBA MCU. Disconnect P/J261 from the SENSOR HUM. Is each cable of P/J26 <=> P/J261 continuous?	Go to step 5.	Replace the HARN ASSY HUM.
5	Checking the power to SENSOR HUM Disconnect the connector of P/J26 on PWBA MCU. Is the voltage across ground <=> J26-4pin on the PWBA MCU, about +5 VDC?	Replace the SENSOR HUM. (Refer to Removal 29/Replacement 15)	Replace the PWBA MCU. (Refer to Removal 30/Replacement 14)

FIP1.24 010-377 Restart Printer

Step	Check	Yes	No
	Possible causative parts: FUSER ASSY (PL6.1.10) HARN ASSY FUSER (PL6.1.11) HARN ASSY LV TOP (PL10.1.16) LVPS (PL9.1.4) PWBA MCU (PL9.1.20)		
1	Checking the FUSER ASSY for installation Is the FUSER ASSY installed correctly?	Go to step 2.	Reseat the FUSER ASSY, then go to step 2.
2	Does the error still occur when the power is turned ON?	Go to step 3.	End of work
3	Checking the connectors for connection Remove the FUSER ASSY. Check the connections between the PWBA MCU and FUSER ASSY. Warning: Start the operation after the FUSER ASSY has cooled down. Check the connections between the FUSER ASSY and LVPS. Check the connections between the LVPS and PWBA MCU. Are P/J17, P/J171, P/J47, P/J501 and P/J13 connected surely?	Go to step 4.	Reconnect the connector(s) P/J17, P/J171, P/J47, P/J501 and/or P/J13 surely, then go to step 4.
4	Checking the HARN ASSY FUSER for continuity Remove the FUSER ASSY. Warning: Start the operation after the FUSER ASSY has cooled down. Disconnect P/J17 from the PWBA MCU. Disconnect P/J171 from the FUSER ASSY. Is each cable of P/J17 <=> P/J171 continuous?	Go to step 5.	Replace the HARN ASSY FUSER.
5	Checking the HARN ASSY LV TOP for continuity Disconnect P/J171 from the FUSER ASSY. Disconnect P/J47 and 501 from the LVPS. Disconnect P/J13 from the PWBA MCU. Is each cable of P/J47 <=> P/J171 continuous? Is each cable of P/J501 <=> P/J13 continuous?	Go to step 6.	Replace the HARN ASSY LV TOP.
6	Checking after replacing the FUSER ASSY Replace the FUSER ASSY. (Refer to Removal 8/Replacement 36) Warning: Start the operation after the FUSER ASSY has cooled down. Does the error still occur when the power is turned ON?	Go to step 7	End of work
7	Checking after replacing the LVPS Replace the LVPS. (Refer to Removal 35/Replacement 9) Does the error still occur when the power is turned ON?	Replace the PWBA MCU. (Refer to Removal 30/Replacement 14)	End of work

FIP1.25 016-300/016-301/016-302/016-310/016-313/016-315/016-317/016-323/016-327/
016-340/016-344/016-345/016-346/016-347 Restart / Erase Flash Err. 016-392 /
Write Flash Err. 016-393 / Verify Error 016-394

Step	Check	Yes	No
	Possible causative parts: PWBA ESS (PL9.1.27)		
1	Checking the error code. Error code is 016-317 or 016-340?	Go to step 2.	Go to step 3.
2	Download the latest version of the firmware from the Dell support website, and update the firmware with "F/W Download DL Mode". (Refer to Reference_1.) Does the error still occur when the power is turned off and on?	Replace the PWBA ESS. (Removal 26/ Replacement 18)	End of work
3	Check whether the version of the firmware is the latest, referring to the Printer Information via the Tool Box. Checked by [Printer Information] of the [Printer Settings Report] tab in Tool Box. For the latest version information, refer to the Dell Support Web Site. Is the firmware the latest version?	Replace the PWBA ESS. (Removal 26/ Replacement 18)	Download the latest version of the firmware from the Dell Support Web Site.

Reference_1:

1. Make sure that the printer is connected to the computer via USB port or Parallel port (remove the network cable). Then, try downloading as follows:
 - 1) Power on the printer while pressing the <X Cancel> and <✓> buttons.
 - 2) Press <▼> button to select "F/W Download DL Mode Parallel" or "F/W Download DL Mode USB", and then press <✓> button.
 - 3) The printer goes into the Download Mode with a message "Download Mode Ready. Then, activate firmware update tool and follow the instruction displayed.

NOTE

While the firmware download is being executed, the printer displays a message "Writing..... F/W", and the computer displays a progress bar and may be restarted during the downloading process. Never power off the printer or the computer until the downloading process completes, and never interrupt the downloading process.

FIP1.26 016-312/016-361 Restart Printer

Step	Check	Yes	No
	Possible causative parts: PWBA ESS (PL9.1.27) HDD ASSY (OPTION) (PL9.1.47)		
1	Checking the HDD ASSY (OPTION) for installation Reseat the HDD ASSY (OPTION). Does the error still occur when the power is turned ON?	Go to step 2.	End of work
2	Checking after replacing the HDD ASSY (OPTION) Replace the HDD ASSY (OPTION). Does the error still occur when the power is turned ON?	Replace the PWBA ESS. (Refer to Removal 26/Replacement 18)	End of work

FIP1.27 016-316/016-318 Restart Printer

Step	Check	Yes	No
	Possible causative parts: MEMORY CARD (OPTION) (PL9.1.30) PWBA ESS (PL9.1.27)		
1	Checking the MEMORY CARD for installation Reseat the MEMORY CARD. Does the error still occur when the power is turned ON?	Got to step 2.	End of work
2	Checking after replacing the MEMORY CARD Replace the MEMORY CARD. Does the error still occur when the power is turned ON?	Replace the PWBA ESS. (Refer to Removal 26/Replacement 18)	End of work

FIP1.28 016-338 Restart Printer

Step	Check	Yes	No
	Possible causative parts: PWBA ESS (OPTION) (PL9.1.27) WIRELESS PRINTER ADAPTER (OPTION) (PL9.1.32)		
1	Checking the connected device to the USB port on the PWBA ESS Is the WIRELESS PRINTER ADAPTER connected to the USB port on the PWBA ESS?	Go to step 2.	Connect the WIRELESS PRINTER ADAPTER to the USB port on the PWBA ESS.
2	Checking the WIRELESS PRINTER ADAPTER for installation Reseat the WIRELESS PRINTER ADAPTER. Does the error still occur when the power is turned ON?	Go to step 3.	End of work
3	Checking the PWBA ESS for installation Reseat the PWBA ESS. Does the error still occur when the power is turned ON?	Go to step 4.	End of work
4	Checking after replacing the WIRELESS PRINTER ADAPTER Replace the WIRELESS PRINTER ADAPTER. Does the error still occur when the power is turned ON?	Replace the PWBA ESS. (Refer to Removal 26/Replacement 18)	End of work

FIP1.29 016-350 Restart Printer

Step	Check	Yes	No
	Possible causative parts: IEEE1284 Cable PWBA ESS (PL9.1.27)		
1	Checking the PC and cable for connection Swap another PC and cable. (If there are not substitute PC and cable, go to step 2.) Does the error still occur when printing?	Replace the PWBA ESS. (Refer to Removal 26/Replacement 18)	Check the PC set- ting and discon- nection of the cable, then go to step 2.
2	Checking the connection Reconnect the printer and PC with the cable. Does the error still occur when printing?	Go to step 3.	End of work
3	Checking after replacing the cable Replace the cable. Does the error still occur when printing?	Replace the PWBA ESS. (Refer to Removal 26/Replacement 18)	End of work

FIP1.30 016-365 Restart Printer

Step	Check	Yes	No
	Possible causative parts: PWBA ESS (PL9.1.27) NETWORK PROTOCOL ADAPTER (OPTION) (PL9.1.46)		
1	Checking after reseating the Network Adapter Reseat the NETWORK PROTOCOL ADAPTER. Does the error still occur when the power is turned ON?	Go to step 2.	End of work
2	Checking after replacing the Network Adapter Replace the NETWORK PROTOCOL ADAPTER. (Refer to Removal 48/Replacement 49.) Does the error still occur when the power is turned ON?	Replace the PWBA ESS. (Refer to Removal 26/ Replacement 18.)	End of work

FIP1.31 016-370 Restart Printer

Step	Check	Yes	No
	Possible causative parts: PWBA ESS (PL9.1.27) PWBA MCU (PL9.1.20)		
1	Download the latest version of the firmware from the Dell support website, and update the firmware with "F/W Download DL Mode". (Refer to Reference_1.) Does the error still occur when the power is turned off and on?	Go to step 2.	End of work
2	Checking after replacing the PWBA ESS Replace the PWBA ESS. Does the error still occur when the power is turned off and on?	Go to step 3.	End of work
3	Checking after replacing the PWBA MCU. Replace the PWBA MCU. Does the error still occur when the power is turned off and on?	Replace the Printer.	End of work

Reference_1:

1. Make sure that the printer is connected to the computer via USB port or Parallel port (remove the network cable). Then, try downloading as follows:
 - 1) Power on the printer while pressing the <X Cancel> and <✓> buttons.
 - 2) Press <▼> button to select "F/W Download DL Mode Parallel" or "F/W Download DL Mode USB", and then press <✓> button.
 - 3) The printer goes into the Download Mode with a message "Download Mode Ready. Then, activate firmware update tool and follow the instruction displayed.

NOTE

While the firmware download is being executed, the printer displays a message "Writing..... F/W", and the computer displays a progress bar and may be restarted during the downloading process. Never power off the printer or the computer until the downloading process completes, and never interrupt the downloading process.

FIP1.32 093-964 Restart Printer

Step	Check	Yes	No
	Possible causative parts: FUSER ASSY (PL6.1.10) PWBA MCU (PL9.1.20)		
1	Checking the FUSER ASSY for installation Is the FUSER ASSY installed correctly?	Go to step 2.	Reseat the FUSER ASSY, then go to step 2.
2	Does the error still occur when the power is turned ON?	Go to step 3.	End of work
3	Checking the FUSER ASSY type Remove the FUSER ASSY. Is the FUSER ASSY installed the 3130cn FUSER?	Go to step 4.	End of work
4	Checking after replacing the FUSER ASSY Replace the FUSER ASSY. (Refer to Removal 8/ Replacement 36.) Does the error still occur when the power is turned ON?	Replace the PWBA MCU. (Refer to Removal 30/ Replacement 14.)	End of work

FIP1.33 Paper Jam 071-100

Step	Check	Yes	No
	Possible causative parts: HARN ASSY REGI SNR (PL3.2.37) HARN ASSY R SIDE (PL10.1.15) SENSOR PHOTO (REGI SENSOR) (PL3.2.30) PWBA MCU (PL9.1.20) CLUTCH ASSY PH FEED (PL3.2.24) DRIVE ASSY PH (PL8.1.7)		
1	Checking the paper condition Is the paper in the Tray wrinkled or damaged?	Replace the paper with a new and dry one, then go to step 2.	Go to step 2.
2	Checking the paper size setup Does the paper size in use match the size setup set through the control panel?	Go to step 3.	Correct the paper size through the control panel, then go to step 3.
3	Does the error still occur when printing?	Go to step 4.	End of work
4	Checking after reseating the Paper Cassette Reseat the Paper Cassette. Does the error still occur when printing?	Go to step 5.	End of work
5	Checking the paper transfer path Check if there are any stains or obstacles on the paper transfer path. Are there any obstacles on the paper transfer path?	Remove the obstacles or stains from the paper transfer path.	Go to step 6.
6	Checking the SENSOR PHOTO (REGI SENSOR) for operation Does the number on the screen increase by one, every time the actuator of the SENSOR PHOTO (REGI SENSOR) is operated? Checked by [Digital Input] - [DI-3(Control Panel)/REGI SNR(PC)] in diagnosis.	Go to step 7.	Go to step 9.
7	Checking the DRIVE ASSY PH for operation Does the DRIVE ASSY PH operate properly? Checked by [Digital Output] - [DO-a(Control Panel)/PH MOTOR(FULL)(PC)] in diagnosis.	Go to step 8.	Go to step 14.
8	Checking the CLUTCH ASSY PH FEED for operation Does the CLUTCH ASSY PH operate properly? Checked by [Digital Output] - [DO-2f(Control Panel)/CASSETTE1 FEED CLUTCH ON(PC)] in diagnosis.	Replace the PWBA MCU. (Refer to Removal 30/Replacement 14)	Go to step 17.
9	Checking the connectors of the SENSOR PHOTO (REGI SENSOR) for connection Check the connections between the PWBA MCU and REGI SENSOR. Are P/J29, P/J292 and P/J2922 connected surely?	Go to step 10.	Reconnect the connector(s) P/J29, P/J292 and/or P/J2922 surely.

Step	Check	Yes	No
10	Checking the HARN ASSY REGI SNR for continuity Disconnect P/J2922 from the REGI SENSOR. Disconnect P/J292 from the HARN ASSY R SIDE. Is each cable of P/J2922 <=> P/J292 continuous?	Go to step 11.	Replace the HARN ASSY REGI SNR.
11	Checking the HARN ASSY R SIDE for continuity Disconnect P/J29 from the PWBA MCU. Disconnect P/J292 from the HARNESS ASSY REGI SNR. Is each cable of P/J29 <=> P/J292 continuous?	Go to step 12.	Replace the HARN ASSY R SIDE.
12	Checking the power to REGI SENSOR Disconnect the connector of P/J29 on the PWBA MCU. Is the voltage across ground <=> J29-8pin on the PWBA MCU, about +3.3 VDC?	Go to step 13.	Replace the PWBA MCU. (Refer to Removal 30/ Replacement 14.)
13	Checking the REGI SENSOR for operation Measure the voltage across ground <=> J29-10pin on the PWBA MCU. Does the voltage change, every time the actuator of the REGI SENSOR is operated?	Replace the PWBA MCU. (Refer to Removal 30/ Replacement 14.)	Replace the SENSOR PHOTO (REGI SENSOR).
14	Checking the connectors of the DRIVE ASSY PH for connection Check the connections between the PWBA MCU and DRIVE ASSY PH. Are P/J25 and P/J251 connected surely?	Go to step 15.	Reconnect the connector(s) P/J25 and/or P/J251 surely.
15	Checking the HARN ASSY R SIDE for continuity Disconnect P/J25 from the PWBA MCU. Disconnect P/J251 from the DRIVE ASSY PH. Is each cable of P/J25 <=> P/J251 continuous?	Go to step 16.	Replace the HARN ASSY R SIDE.
16	Checking the power to DRIVE ASSY PH Disconnect the connector of P/J25 on the PWBA MCU. Are the voltages across ground <=> J25-1pin/J25-2pin on the PWBA MCU, about +24 VDC when the interlock switch (HARN ASSY INTERLOCK) is pushed?	Replace the DRIVE ASSY PH. (Refer to Removal 17/ Replacement 27.)	Replace the PWBA MCU. (Refer to Removal 30/ Replacement 14.)
17	Checking the connectors of the CLUTCH ASSY PH FEED for connection Check the connections between the PWBA MCU and CLUTCH ASSY PH FEED. Are P/J23 and P/J233 connected surely?	Go to step 18.	Reconnect the connector(s) P/J23 and/or P/J233 surely.
18	Checking the HARN ASSY R SIDE for continuity Disconnect P/J23 from the PWBA MCU. Disconnect P/J233 from the CLUTCH ASSY PH FEED. Is each cable of P/J23 <=> P/J233 continuous?	Go to step 19.	Replace the HARN ASSY R SIDE.
19	Checking the power to CLUTCH ASSY PH FEED Disconnect the connector of P/J23 on the PWBA MCU. Is the voltage across ground <=> J23-5pin on the PWBA MCU, about +24 VDC when the interlock switch (HARN ASSY INTERLOCK) is pushed?	Replace the CLUTCH ASSY PH FEED. (Refer to Removal 40/ Replacement 4.)	Replace the PWBA MCU. (Refer to Removal 30/ Replacement 14.)

FIP1.34 Paper Jam 072-100

Step	Check	Yes	No
	Possible causative parts: ROLL ASSY TURN (PL12.3.4) ROLL ASSY FFEED (Feed Roll) (PL12.3.29) ROLL ASSY FEED (Nudger Roll) (PL12.3.29) 550 OPTION FEEDER (PL12.1.1) SENSOR PHOTO (REGI SENSOR) (PL3.2.30) CLUTCH ASSY FEED OPT (PL12.1.6) CLUTCH ASSY TURN OPT (PL12.1.5) HARN ASSY REGI SNR (PL3.2.37) HARN ASSY R SIDE (PL10.1.15) HARN ASSY C2 MOT (PL12.2.9) HARN ASSY FDR UNIT (PL12.2.3) HARN ASSY C2 CHUTE(PL12.2.7) HARN ASSY C2 TURN(PL12.2.8) PWBA OPT FDR (PL12.2.6) PWBA MCU (PL9.1.20) DRIVE ASSY OPT FDR(PL12.2.10)		
1	Checking the paper condition Is the paper in the Tray wrinkled or damaged?	Replace the paper with a new and dry one, then go to step 2.	Go to step 2.
2	Checking the paper size setup Does the paper size in use match the size setup set through the control panel?	Go to step 3.	Correct the paper size through the control panel, then go to step 3.
3	Does the error still occur when printing?	Go to step 4.	End of work
4	Checking after reseating the CASSETTE ASSY 550 OPT Reseat the CASSETTE ASSY 550 OPT. Does the error still occur when printing?	Go to step 5.	End of work
5	Checking the SENSOR PHOTO (REGI SENSOR) for operation Does the number on the screen increase by one, every time the actuator of the SENSOR PHOTO (REGI SENSOR) is operated? Checked by [Digital Input] - [DI-3(Control Panel)/REGI SNR(PC)] in diagnosis.	Go to step 6.	Go to step 11.
6	Checking the DRIVE ASSY OPT FDR for operation Does the DRIVE ASSY OPT FDR operate properly? Checked by [Digital Output] - [DO-19(Control Panel)/OPTION FEEDER1 MOTOR ON(PC)] in diagnosis.	Go to step 7.	Go to step 16.
7	Checking the CLUTCH ASSY PH FEED for operation Does the CLUTCH ASSY PH FEED operate properly? Checked by [Digital Output] - [DO-31(Control Panel)/CASSETTE2 FEED CLUTCH ON(PC)] in diagnosis.	Go to step 8.	Go to step 23.
8	Checking the CLUTCH ASSY PH TURN for operation Does the CLUTCH ASSY PH TURN operate properly? Checked by [Digital Output] - [DO-33(Control Panel)/CASSETTE2 TURN CLUTCH ON(PC)] in diagnosis.	Go to step 9.	Go to step 30.

Step	Check	Yes	No
9	Checking the ROLL ASSY TURN and ROLL ASSY FEEDs for shape and operation Remove the paper cassette. Are ROLL ASSY TURN and ROLL ASSY FEEDs installed correctly? Also are they not contaminated and /or damaged, and rotate smoothly? Check these items by turning them with your finger.	Go to step 10.	Replace the defective ROLL(s).
10	Checking after replacing the 550 OPTION FEEDER Replace the 550 OPTION FEEDER. (Refer to Removal 44/ Replacement 46) Does the error still occur when printing?	Replace the PWBA MCU. (Refer to Removal 30/Replacement 14)	End of work
11	Checking the connectors of the SENSOR PHOTO (REGI SENSOR) for connection Check the connections between the PWBA MCU and REGI SENSOR. Are P/J29, P/J292 and P/J2922 connected surely?	Go to step 12.	Reconnect the connector(s) P/J29, P/J292 and/or P/J2922 surely.
12	Checking the HARN ASSY REGI SNR for continuity Dis-connect P/J2922 from the REGI SENSOR. Disconnect P/J292 from the HARN ASSY R SIDE. Is each cable of P/J2922 <=> P/J292 continuous?	Go to step 13.	Replace the HARN ASSY REGI SNR.
13	Checking the HARN ASSY R SIDE for continuity Disconnect P/J29 from the PWBA MCU. Disconnect P/J292 from the HARN ASSY REGI SNR. Is each cable of P/J29 <=> P/J292 continuous?	Go to step 14.	Replace the HARN ASSY R SIDE.
14	Checking the power to REGI SENSOR Disconnect the connector of P/J29 on the PWBA MCU. Is the voltage across ground <=> J29-8pin on the PWBA MCU, about +3.3 VDC?	Go to step 15.	Replace the PWBA MCU. (Refer to Removal 30/ Replacement 14.)
15	Checking the REGI SENSOR for operation Measure the voltage across ground <=> J29-10pin on the PWBA MCU. Does the voltage change, every time the actuator of the REGI SENSOR is operated?	Replace the PWBA MCU. (Refer to Removal 30/ Replacement 14.)	Replace the SENSOR PHOTO (REGI SENSOR).
16	Checking the connectors of the DRIVE ASSY OPT FDR for connection Check the connections between the PWBA OPT FDR and DRIVE ASSY OPT FDR. Are P/J422 and P/J4222 connected surely?	Go to step 17.	Reconnect the connector(s) P/J422 and/or P/J4222 surely.
17	Checking the HARNESS ASSY C2 MOT for continuity Disconnect P/J422 from the PWBA OPT FDR. Disconnect P/J4222 from the DRIVE ASSY OPT FDR. Is each cable of P/J422 <=> P/J4222 continuous?	Go to step 18.	Replace the HARN ASSY C2 MOT.

Step	Check	Yes	No
18	Checking the power to DRIVE ASSY OPT FDR Disconnect the connector of P/J422 on the PWBA OPT FDR. Is the voltage across ground \Leftrightarrow J422-6pin on the PWBA OPT FDR, about +24 VDC when the interlock switch (HARN ASSY INTERLOCK) is pushed?	Replace the DRIVE ASSY OPT FDR.	Go to step 19.
19	Checking the connectors of the PWBA OPT FDR and PWBA MCU for connection Check the connections between the PWBA OPT FDR and PWBA MCU. Are P/J419, P/J281 and P/J28 connected surely?	Go to step 20.	Reconnect the connector(s) P/J419, P/J281 and/or P/J28 surely.
20	Checking the HARN ASSY FDR UNIT for continuity Disconnect P/J419 from the PWBA OPT FDR. Disconnect P/J281 from the HARN ASSY R SIDE. Is each cable of P/J419 \Leftrightarrow P/J281 continuous?	Go to step 21.	Replace the HARN ASSY FDR UNIT.
21	Checking the HARN ASSY R SIDE for continuity Disconnect P/J281 from the HARN ASSY FDR UNIT. Disconnect P/J28 from the PWBA MCU. Is each cable of P/J281 \Leftrightarrow P/J28 continuous?	Go to step 22.	Replace the HARN ASSY R SIDE.
22	Checking the power to the PWBA OPT FDR Disconnect the connector of P/J28 on the PWBA MCU. Is the voltage across ground \Leftrightarrow J28-4pin/J28-5pin on the PWBA MCU, about +24 VDC when the interlock switch (HARN ASSY INTERLOCK) is pushed?	Replace the PWBA OPT FDR.	Replace the PWBA MCU. (Refer to Removal 30/ Replacement 14.)
23	Checking the connectors of the CLUTCH ASSY FEED OPT for connection Check the connections between the PWBA OPT FDR and CLUTCH ASSY FEED OPT. Are P/J421 and P/J4213 connected surely?	Go to step 24.	Reconnect the connector(s) P/J421 and/or P/J4213 surely.
24	Checking the HARN ASSY C2 CHUTE for continuity Disconnect P/J421 from the PWBA OPT FDR. Disconnect P/J4213 from the CLUTCH ASSY PH FEED. Is each cable of P/J421 \Leftrightarrow P/J4213 continuous?	Go to step 25.	Replace the HARN ASSY C2 CHUTE.
25	Checking the power to CLUTCH ASSY FEED OPT Disconnect the connector of P/J421 on the PWBA OPT FDR. Is the voltage across ground \Leftrightarrow J421-1pin on the PWBA OPT FDR, about +24 VDC when the interlock switch (HARN ASSY INTERLOCK) is pushed?	Replace the CLUTCH ASSY PH FEED. (Refer to Removal 40/ Replacement 4.)	Go to step 26.
26	Checking the connectors of the PWBA OPT FDR and PWBA MCU for connection Check the connections between the PWBA OPT FDR and PWBA MCU. Are P/J419, P/J281 and P/J28 connected surely?	Go to step 27.	Reconnect the connector(s) P/J419, P/J281 and/or P/J28 surely.
27	Checking the HARN ASSY FDR UNIT for continuity Disconnect P/J419 from the PWBA OPT FDR. Disconnect P/J281 from the HARN ASSY R SIDE. Is each cable of P/J419 \Leftrightarrow P/J281 continuous?	Go to step 28.	Replace the HARN ASSY FDR UNIT.

Step	Check	Yes	No
28	Checking the HARN ASSY R SIDE for continuity Disconnect P/J281 from the HARN ASSY FDR UNIT. Disconnect P/J28 from the PWBA MCU. Is each cable of P/J281 <=> P/J28 continuous?	Go to step 29.	Replace the HARN ASSY R SIDE.
29	Checking the power to the PWBA OPT FDR Disconnect the connector of P/J28 on the PWBA MCU. Is the voltage across ground <=> J28-4pin/J28-5pin on the PWBA MCU, about +24 VDC when the interlock switch (HARN ASSY INTERLOCK) is pushed?	Replace the PWBA OPT FDR.	Replace the PWBA MCU. (Refer to Removal 30/ Replacement 14.)
30	Checking the connectors of the CLUTCH ASSY TURN OPT for connection Check the connections between the PWBA OPT FDR and CLUTCH ASSY TURN OPT. Are P/J420 and P/J4201 connected surely?	Go to step 31.	Reconnect the connector(s) P/J420 and/or P/J4201 surely.
31	Checking the HARN ASSY C2 TURN for continuity Disconnect P/J420 from the PWBA OPT FDR. Disconnect P/J4201 from the CLUTCH ASSY TURN OPT. Is each cable of P/J420 <=> P/J4201 continuous?	Go to step 32.	Replace the HARN ASSY C2 TURN.
32	Checking the power to CLUTCH ASSY TURN OPT Disconnect the connector of P/J420 on the PWBA OPT FDR. Is the voltage across ground <=> J420-1pin on the PWBA OPT FDR, about +24 VDC when the interlock switch (HARN ASSY INTERLOCK) is pushed?	Replace the CLUTCH ASSY PH TURN. (Refer to Removal 40/ Replacement 4.)	Go to step 33.
33	Checking the connectors of the PWBA OPT FDR and PWBA MCU for connection Check the connections between the PWBA OPT FDR and PWBA MCU. Are P/J419, P/J281 and P/J28 connected surely?	Go to step 34.	Reconnect the connector(s) P/J419, P/J281 and/or P/J28 surely.
34	Checking the HARN ASSY FDR UNIT for continuity Disconnect P/J419 from the PWBA OPT FDR. Disconnect P/J281 from the HARN ASSY R SIDE. Is each cable of P/J419 <=> P/J281 continuous?	Go to step 35.	Replace the HARN ASSY FDR UNIT.
35	Checking the HARN ASSY R SIDE for continuity Disconnect P/J281 from the HARN ASSY FDR UNIT. Disconnect P/J28 from the PWBA MCU. Is each cable of P/J281 <=> P/J28 continuous?	Go to step 36.	Replace the HARN ASSY R SIDE.
36	Checking the power to the PWBA OPT FDR Disconnect the connector of P/J28 on the PWBA MCU. Is the voltage across ground <=> J28-4pin/J28-5pin on the PWBA MCU, about +24 VDC when the interlock switch (HARN ASSY INTERLOCK) is pushed?	Replace the PWBA OPT FDR.	Replace the PWBA MCU. (Refer to Removal 30/ Replacement 14.)

FIP1.35 Paper Jam 075-100

Step	Check	Yes	No
	Possible causative parts: ROLL ASSY FFEED MSI (PL3.1.10) ROLL ASSY TURN (PL3.2.32) SENSOR PHOTO (REGI SENSOR) (PL3.2.30) SOLENOID FEED MSI (PL3.1.3) CLUTCH ASSY PH TURN (PL3.2.25) DRIVE ASSY PH (PL8.1.7) HARN ASSY R SIDE (PL10.1.15) HARN ASSY REGI SNR (PL3.2.37) PWBA MCU (PL9.1.20)		
1	Checking the paper condition Is the paper on the MPT wrinkled or damaged?	Replace the paper with a new and dry one, then go to step 2.	Go to step 2.
2	Checking the paper size setup Does the paper size in use match the size setup set through the control panel?	Go to step 3.	Correct the paper size through the control panel, then go to step 3.
3	Does the error still occur when printing?	Go to step 4.	End of work
4	Checking after reseating the side guides of the MPT Reseat the side guides. Does the error still occur when printing?	Go to step 5.	End of work
5	Checking the SENSOR PHOTO (REGI SENSOR) for operation Does the number on the screen increase by one, every time the actuator of the SENSOR PHOTO (REGI SENSOR) is operated? Checked by [Digital Input] - [DI-3(Control Panel)/REGI SNR(PC)] in diagnosis.	Go to step 6.	Go to step 10.
6	Checking the SOLENOID FEED MSI for operation Does the SOLENOID FEED MSI operate properly? Checked by [Digital Output] - [DO-2d(Control Panel)/MSI FEED CLUTCH ON(PC)] in diagnosis.	Go to step 7.	Go to step 15.
7	Checking the CLUTCH ASSY PH TURN for operation Does the CLUTCH ASSY PH TURN operate properly? Checked by [Digital Output] - [DO-2b(Control Panel)/MSI TURN CLUTCH ON(PC)] in diagnosis.	Go to step 8.	Go to step 18.
8	Checking the DRIVE ASSY PH for operation Does the DRIVE ASSY PH operate properly? Checked by [Digital Output] - [DO-a(Control Panel)/PH MOTOR(FULL)(PC)] in diagnosis.	Go to step 9.	Go to step 21.

Step	Check	Yes	No
9	<p>Checking the ROLL ASSY SEPARATER, ROLL ASSY FEED MSI and ROLL ASSY TURN for shape and operation Open the MSI. Are the ROLL ASSY SEPARATER, ROLL ASSY FEED MSI and ROLL ASSY TURN installed correctly? Also are they not contaminated and /or damaged, and rotate smoothly? Check these ROLLS by turning them with your finger.</p>	<p>Replace the PWBA MCU. (Refer to Removal 30/Replacement 14)</p>	<p>Replace the troubled ROLL(s).</p>
10	<p>Checking the connectors of the SENSOR PHOTO (REGI SENSOR) for connection Check the connections between the PWBA MCU and REGI SENSOR. Are P/J29, P/J292 and P/J2922 connected surely?</p>	<p>Go to step 11.</p>	<p>Reconnect the connector(s) P/J29, P/J292 and/or P/J2922 surely.</p>
11	<p>Checking the HARN ASSY REGI SNR for continuity Disconnect P/J2922 from the REGI SENSOR. Disconnect P/J292 from the HARN ASSY R SIDE. Is each cable of P/J2922 <=> P/J292 continuous?</p>	<p>Go to step 12.</p>	<p>Replace the HARN ASSY REGI SNR.</p>
12	<p>Checking the HARN ASSY R SIDE for continuity Disconnect P/J29 from the PWBA MCU. Disconnect P/J292 from the HARN ASSY REGI SNR. Is each cable of P/J29 <=> P/J292 continuous?</p>	<p>Go to step 13.</p>	<p>Replace the HARN ASSY R SIDE.</p>
13	<p>Checking the power to REGI SENSOR Disconnect the connector of P/J29 on the PWBA MCU. Is the voltage across ground <=> J29-8pin on the PWBA MCU, about +3.3 VDC?</p>	<p>Go to step 14.</p>	<p>Replace the PWBA MCU. (Refer to Removal 30/ Replacement 14.)</p>
14	<p>Checking the REGI SENSOR for operation Measure the voltage across ground <=> J29-10pin on the PWBA MCU. Does the voltage change, every time the actuator of the REGI SENSOR is operated?</p>	<p>Replace the PWBA MCU. (Refer to Removal 30/ Replacement 14.)</p>	<p>Replace the SENSOR PHOTO (REGI SENSOR).</p>
15	<p>Checking the connectors of the SOLENOID FEED MSI for connection Check the connections between the PWBA MCU and SOLENOID FEED MSI. Are P/J29 and P/J234 connected surely?</p>	<p>Go to step 16.</p>	<p>Reconnect the connector(s) P/J29 and/or P/J234 surely.</p>
16	<p>Checking the HARN ASSY R SIDE for continuity Disconnect P/J29 from the PWBA MCU. Disconnect P/J234 from the SOLENOID FEED MSI. Is each cable of P/J29 <=> P/J234 continuous?</p>	<p>Go to step 17.</p>	<p>Replace the HARN ASSY R SIDE.</p>
17	<p>Checking the power to SOLENOID FEED MSI Disconnect the connector of P/J29 on the PWBA MCU. Is the voltage across ground <=> J29-7pin on the PWBA MCU, about +24 VDC when the interlock switch (HARN ASSY INTERLOCK) is pushed?</p>	<p>Replace the SOLENOID FEED MSI. (Refer to Removal 15/ Replacement 29.)</p>	<p>Replace the PWBA MCU. (Refer to Removal 30/ Replacement 14.)</p>

Step	Check	Yes	No
18	Checking the connectors of the CLUTCH ASSY PH TURN for connection Check the connections between the PWBA MCU and CLUTCH ASSY PH TURN. Are P/J23 and P/J232 connected surely?	Go to step 19.	Reconnect the connector(s) P/J23 and/or P/J232 surely.
19	Checking the HARN ASSY R SIDE for continuity Disconnect P/J23 from the PWBA MCU. Disconnect P/J232 from the CLUTCH ASSY PH TURN. Is each cable of P/J23 <=> P/J232 continuous?	Go to step 20.	Replace the HARN ASSY R SIDE.
20	Checking the power to CLUTCH ASSY PH TURN Disconnect the connector of P/J23 on the PWBA MCU. Is the voltage across ground <=> J23-3pin on the PWBA MCU, about +24 VDC when the interlock switch (HARN ASSY INTERLOCK) is pushed?	Replace the CLUTCH ASSY PH TURN. (Refer to Removal 40/ Replacement 4.)	Replace the PWBA MCU. (Refer to Removal 30/ Replacement 14.)
21	Checking the connectors of the DRIVE ASSY PH for connection Check the connections between the PWBA MCU and DRIVE ASSY PH. Are P/J25 and P/J251 connected surely?	Go to step 22.	Reconnect the connector(s) P/J25 and/or P/J251 surely.
22	Checking the HARN ASSY R SIDE for continuity Disconnect P/J25 from the PWBA MCU. Disconnect P/J251 from the DRIVE ASSY PH. Is each cable of P/J25 <=> P/J251 continuous?	Go to step 23.	Replace the HARN ASSY R SIDE.
23	Checking the power to DRIVE ASSY PH Disconnect the connector of P/J25 on the PWBA MCU. Are the voltages across ground <=> J25-1pin/J25-2pin on the PWBA MCU, about +24 VDC when the interlock switch (HARN ASSY INTERLOCK) is pushed?	Replace the DRIVE ASSY PH. (Refer to Removal 17/ Replacement 27.)	Replace the PWBA MCU. (Refer to Removal 30/ Replacement 14.)

FIP1.36 Paper Jam 077-100/077-101

Step	Check	Yes	No
	Possible causative parts: ACTUATOR B (PL3.2.15) SENSOR PHOTO(REGI SENEOR) (PL3.2.30) HARN ASSY R SIDE (PL10.1.15) PWBA MCU(PL9.1.20)		
1	Checking the error Replace to known good paper. Does the error still occur when printing?	Go to step 2.	End of work
2	Checking the REGI Rolls installation Open the Front Cover and check the Regi Rolls installation. Is the ROLL REGI METAL pressed against the ROLL ASSY REGI by the spring pressure?	Go to step 3.	Replace the printer.
3	Checking the REGI CLUTCH for operation Does the clutch noise occur? Checked by [Digital Output]-[DO-29(Control Panel)/REGI CLUTCH ON (PC)] in the diagnosis.	Go to step 4.	Replace the printer.
4	Checking the SENSOR PHOTO(REGI SENEOR) for operation Does the number on the screen increase by one, when the actuator (ACTUATOR B) is operated? Checked by [Digital Input] - [DI-3(Control Panel)/REG SNR(PC)] in the diagnosis.	Replace the PWBA MCU. (Refer to Removal 30/ Replacement 14.)	Go to step 5.
5	Checking the ACTUATOR B for shape and operation Are the shape and operation of the ACTUATOR B normal?	Go to step 6.	Reseat the ACTUATOR B. If broken or deformed, replace it.
6	Checking the connectors of the SENSOR PHOTO (REGI SENEOR)) for connection Check the connections between the PWBA MCU and SENSOR PHOTO (REGI SENEOR)). Are P/J29 and P/J292 connected correctly?	Go to step 7.	Reconnect the connector(s) P/J29 and/or P/J292 correctly.
7	Checking the HARN ASSY R SIDE for continuity Disconnect J29 from the PWBA MCU. Disconnect J292 from the SENSOR PHOTO. Is each cable of J29 <=> J292 continuous?	Go to step 8.	Replace the HARN ASSY R SIDE.
8	Checking the power to the SENSOR PHOTO(REGI SENEOR) Disconnect J29 from the PWBA MCU. Is the voltage across P29-8pin <=> ground on the PWBA MCU, about +3.3 VDC?	Go to step 9.	Replace the PWBA MCU. (Refer to Removal 30/ Replacement 14.)
9	Checking the SENSOR PHOTO(REGI SENEOR) for operation Check the voltage across J29-10pin <=> ground on the PWBA MCU. Does the voltage change, when the actuator (ACTUATOR REGI IN) is operated?	Replace the PWBA MCU. (Refer to Removal 30/ Replacement 14.)	Replace the SENSOR PHOTO (REGI SENEOR).

FIP1.37 Paper Jam 077-102/077-103

Step	Check	Yes	No
	Possible causative parts: FUSER ASSY (PL6.1.10) PWBA MCU (PL9.1.20) HARN ASSY FUSER (PL6.1.11)		
1	Checking the error Replace to known good paper. Does the error still occur when printing?	Go to step 2.	End of work
2	Checking the EXIT SENSOR for operation Does the number on the screen increase by one, when the actuator of the Exit Sensor in the FUSER ASSY is operated? Checked by [Digital Input] - [DI-2(Control Panel)/EXIT SNR(PC)] in diagnosis. Warning: Start the operation after the FUSER ASSY has cooled down.	Go to step 7.	Go to step 3.
3	Checking the connectors of the SENSOR PHOTO(EXIT SENSOR) in the FUSER ASSY for connection Check the connections between the PWBA MCU and FUSER ASSY. Are P/J17 and P/J171 connected correctly?	Go to step 4.	Reconnect the connector(s) P/ J17 and/or P/J171 correctly.
4	Checking the HARN ASSY FUSER for continuity Remove the FUSER ASSY. Disconnect J17 from the PWBA MCU. Is each cable of J17 <=> P171 continuous?	Go to step 5.	Replace the HARN ASSY FUSER.
5	Checking the power to the SENSOR PHOTO(EXIT SENSOR) in the FUSER ASSY Disconnect the connector of J17 on the PWBA MCU. Is the voltage across J17-1pin <=> ground on the PWBA MCU, about +3.3 VDC?	Go to step 6.	Replace the PWBA MCU. (Refer to Removal 30/ Replacement 14.)
6	Checking the SENSOR PHOTO(EXIT SENSOR) for operation Check the voltage across J17-3pin <=> ground on the PWBA MCU. Does the voltage change, when the actuator of the Exit Sensor is operated?	Replace the PWBA MCU. (Refer to Removal 30/ Replacement 14.)	Replace the FUSER ASSY.
7	Checking the REGI ROLLs installation Open the Front Cover and check the REGI ROLLs installation. Is the ROLL REGI METAL pressed against the ROLL ASSY REGI by the spring pressure?	Go to step 8.	Replace the printer.
8	Checking the REGI CLUTCH for operation Does the clutch noise occur? Checked by [Digital Output]-[DO-29(Control Panel)/REGI CLUTCH ON(PC)] in the diagnosis.	Replace the printer.	Replace the PWBA MCU. (Refer to Removal 30/ Replacement 14.)

FIP1.38 Paper Jam 077-104/077-107

Step	Check	Yes	No
	Possible causative parts: CLUTCH DUP (PL11.2.10) MOTOR ASSY DUP (PL11.2.23) ROLL ASSY DUP1 (PL11.2.14) ROLL ASSY DUP2 (PL11.2.15) ROLL ASSY TURN (PL3.2.32) CLUTCH ASSY PH TURN (PL3.2.25) DRIVE ASSY PH (PL8.1.7) REGI SENSOR (PL3.2.30) PWBA DUP-H (PL11.1.15) PWBA MCU (PL9.1.20) HARN ASSY DUP UNIT(PL11.1.18) HARNESS ASSY FRONT COVER(PL1.2.11) HARN ASSY R SIDE(PL10.1.15) HARN ASSY REGI SNR(PL3.2.37)		
1	Checking the paper path Are there any contaminations of the toner on the paper path?	Clean the paper path.	Go to step 2.
2	Checking the Rolls installation Are the Rolls on the FEEDER ASSY DUP installed correctly?	Go to step 3.	Reinstall the Rolls.
3	Are there any damages on the surface of the Rolls on the FEEDER ASSY DUP?	Replace the FEEDER ASSY DUP. (Refer to Removal 5/ Replacement 39.)	Go to step 4.
4	Checking the CLUTCH DUP for operation Does the CLUTCH DUP operate properly? Checked by [Digital Output] - [DO-35(Control Panel)/ DUPLEX CLUTCH ON(PC)] in diagnosis.	Go to step 5.	Go to step 9.
5	Checking the MOTOR ASSY DUP for operation Does the MOTOR ASSY DUP operate properly? Checked by [Digital Output] - [DO-13(Control Panel)/ DUPLEX MOTOR ON(PC)] in diagnosis.	Go to step 6.	Go to step 16.
6	Checking the CLUTCH ASSY PH TURN for operation Does the CLUTCH ASSY PH TURN operate properly? Checked by [Digital Output] - [DO-2b (Control Panel)/MSI TURN CLUTCH ON(PC)] in diagnosis.	Go to step 7.	Go to step 18.
7	Checking the PH Motor for operation Does the PH Motor operate properly? Checked by [Digital Output] - [DO-a (Control Panel)/PH MOTOR ON(PC)] in diagnosis.	Go to step 8.	Go to step 21.
8	Checking the SENSOR PHOTO (REGI SENSOR) for operation Does the SENSOR PHOTO (REGI SENSOR) operate properly? Checked by [Digital Output] - [DI-3(Control Panel)/REGI SNR(PC)] in diagnosis.	Replace the PWBA MCU. (Refer to Removal 30/ Replacement 14.)	Go to step 24.

Step	Check	Yes	No
9	Checking the connectors of the PWBA DUP-H and CLUTCH DUP for connection Check the connections between the PWBA DUP-H and CLUTCH DUP. Are P/J431 connected surely?	Go to step 10.	Reconnect the connector(s) P/J431 surely.
10	Checking the power to the CLUTCH DUP Disconnect the connector of P/J431 on the PWBA DUP. Is the voltage across ground \Leftrightarrow J431-1pin on the PWBA DUP, about +24 VDC?	Replace the FEEDER ASSY DUP (Refer to Removal 5/ Replacement 39.)	Go to step 11.
11	Checking the connectors of the PWBA DUP-H and PWBA MCU for connection Check the connections between the PWBA DUP-H and PWBA MCU. Are P/J428, P/J2720, P/J272 and P/J27 connected surely?	Go to step 12.	Reconnect the connector(s) P/J428, P/J2720, P/J272 and/or P/J27 surely.
12	Checking the HARNESS ASSY DUP UNIT for continuity Disconnect P/J428 from the PWBA DUP-H. Disconnect P/J2720 from the HARN ASSY FRONT COVER. Is each cable of P/J428 \Leftrightarrow P/J2720 continuous?	Go to step 13.	Replace the HARNESS ASSY DUP UNIT.
13	Checking the HARNESS ASSY FRONT COVER for continuity Disconnect P/J2720 from the HARNESS ASSY DUP UNIT. Disconnect P/J272 from the HARN ASSY R SIDE. Is each cable of P/J2720 \Leftrightarrow P/J272 continuous?	Go to step 14.	Replace the HARNESS ASSY FRONT COVER.
14	Checking the HARN ASSY R SIDE for continuity Disconnect P/J272 from the HARNESS ASSY FRONT COVER. Disconnect P/J27 from the PWBA MCU. Is each cable of P/J272 \Leftrightarrow P/J27 continuous?	Go to step 15.	Replace the HARN ASSY R SIDE.
15	Checking the power to the PWBA DUP-H Disconnect the connector of P/J27 on the PWBA MCU. Is the voltage across ground \Leftrightarrow J27-15pin on the PWBA MCU, about +3.3 VDC?	Replace the FEEDER ASSY DUP (Refer to Removal 5/ Replacement 39.)	Replace the PWBA MCU. (Refer to Removal 30/ Replacement 14.)
16	Checking the connectors of the PWBA DUP-H and MOTOR ASSY DUP for connection Check the connections between the PWBA DUP-H and MOTOR ASSY DUP. Are P/J429 connected surely?	Go to step 17.	Reconnect the connector(s) P/J429 surely.
17	Checking the power to the MOTOR ASSY DUP Disconnect the connector of P/J429 on the PWBA DUP. Is the voltage across ground \Leftrightarrow J429-2pin on the PWBA DUP, about +24 VDC?	Replace the FEEDER ASSY DUP (Refer to Removal 5/ Replacement 39.)	Go to step 11.

Step	Check	Yes	No
18	Checking the connectors of the CLUTCH ASSY PH TURN for connection Check the connections between the PWBA MCU and CLUTCH ASSY PH TURN. Are P/J23 and P/J232 connected surely?	Go to step 19.	Reconnect the connector(s) P/J23 and/or P/J232 surely.
19	Checking the HARN ASSY R SIDE for continuity Disconnect P/J23 from the PWBA MCU. Disconnect P/J232 from the CLUTCH ASSY PH TURN. Is each cable of P/J23 <=> P/J232 continuous?	Go to step 20.	Replace the HARN ASSY R SIDE.
20	Checking the power to CLUTCH ASSY PH TURN Disconnect the connector of P/J23 on the PWBA MCU. Is the voltage across ground <=> J23-3pin on the PWBA MCU, about +24 VDC?	Replace the CLUTCH ASSY PH TURN.	Replace the PWBA MCU. (Refer to Removal 30/ Replacement 14.)
21	Checking the connectors of the DRIVE ASSY PH for connection Check the connections between the PWBA MCU and DRIVE ASSY PH. Are P/J25 and P/J251 connected surely?	Go to step 22.	Reconnect the connector(s) P/J25 and/or P/J251 surely.
22	Checking the HARN ASSY R SIDE for continuity Disconnect P/J25 from the PWBA MCU. Disconnect P/J251 from the DRIVE ASSY PH. Is each cable of P/J25 <=> P/J251 continuous?	Go to step 23.	Replace the HARN ASSY R SIDE.
23	Checking the power to DRIVE ASSY PH Disconnect the connector of P/J25 on the PWBA MCU. Are the voltages across ground <=> J25-1pin/J25-2pin on the PWBA MCU, about +24 VDC?	Replace the DRIVE ASSY PH. (Refer to Removal 17/ Replacement 27.)	Replace the PWBA MCU. (Refer to Removal 30/ Replacement 14.)
24	Checking the connectors of the SENSOR PHOTO (REGI SENSOR) for connection Check the connections between the PWBA MCU and REGI SENSOR. Are P/J29, P/J292 and P/J2922 connected surely?	Go to step 25.	Reconnect the connector(s) P/J29, P/J292 and/or P/J2922 surely.
25	Checking the HARNESS ASSY REGI SNR for continuity Disconnect P/J2922 from the REGI SENSOR. Disconnect P/J292 from the HARN ASSY R SIDE. Is each cable of P/J2922 <=> P/J292 continuous?	Go to step 26.	Replace the HARNESS ASSY REGI SNR.
26	Checking the HARN ASSY R SIDE for continuity Disconnect P/J29 from the PWBA MCU. Disconnect P/J292 from the HARN ASSY REGI SNR. Is each cable of P/J29 <=> P/J292 continuous?	Go to step 27.	Replace the HARN ASSY R SIDE.
27	Checking the power to REGI SENSOR Disconnect the connector of P/J29 on the PWBA MCU. Is the voltage across ground <=> J29-8pin on the PWBA MCU, about +3.3 VDC?	Go to step 28.	Replace the PWBA MCU. (Refer to Removal 30/ Replacement 14.)

Step	Check	Yes	No
28	Checking the SENSOR PHOTO (REGI SENSOR) for operation Disconnect the connector of P/J29 on the PWBA MCU. Is the voltage across ground \leq J29-10pin on the PWBA MCU Does the voltage change, every time the actuator of the REGI SENSOR is operated?	Replace the PWBA MCU. (Refer to Removal 30/ Replacement 14.)	Replace the SENSOR PHOTO (REGI SENSOR).

FIP1.39 Paper Jam 077-105/077-106

Step	Check	Yes	No
	Possible causative parts: DUP JAM SENSOR (PL11.1.12) CLUTCH DUP (PL11.2.10) MOTOR ASSY DUP (PL11.2.23) ROLL ASSY DUP1 (PL11.2.14) ROLL ASSY DUP2 (PL11.2.15) PWBA DUP (PL11.1.15) PWBA MCU (PL9.1.20) HARN ASSY DUP UNIT(PL11.1.18) HARNESS ASSY FRONT COVER(PL1.2.11) HARN ASSY R SIDE(PL10.1.15) HARN ASSY DUP SNR(PL11.1.13)		
1	Checking the paper path Are there any contaminations of the toner on the paper path?	Clean the paper path.	Go to step 2.
2	Checking the Rolls installation Are the Rolls on the FEEDER ASSY DUP installed correctly?	Go to step 3.	Reinstall the Rolls.
3	Are there any damages on the surface of the Rolls on the FEEDER ASSY DUP?	Replace the FEEDER ASSY DUP (Refer to Removal 5/ Replacement 39.)	Go to step 4.
4	Checking the SENSOR PHOTO (DUP JAM SENSOR) for operation Does the SENSOR PHOTO (DUP JAM SENSOR) operate properly? Checked by [Digital Output] - [DI-1(Control Panel)/DUP SNR(PC)] in diagnosis.	Go to step 5.	Go to step 7.
5	Checking the CLUTCH DUP for operation Does the CLUTCH DUP operate properly? Checked by [Digital Output] - [DO-35(Control Panel)/DUPLEX CLUTCH ON(PC)] in diagnosis.	Go to step 6.	Go to step 16.
6	Checking the MOTOR ASSY DUP for operation Does the MOTOR ASSY DUP operate properly? Checked by [Digital Output] - [DO-13(Control Panel)/DUPLEX MOTOR ON(PC)] in diagnosis.	Replace the FEEDER ASSY DUP (Refer to Removal 5/ Replacement 39.)	Go to step 23.
7	Checking the connectors of the PWBA DUP-H and SENSOR PHOTO (DUP JAM SENSOR) for connection Check the connections between the PWBA DUP-H and SENSOR PHOTO (DUP JAM SENSOR). Are P/J430 and P/J4301 connected surely?	Go to step 8.	Reconnect the connector(s) P/J430 and/or P/J4301 surely.
8	Checking the HARNESS ASSY DUP SNR for continuity Disconnect P/J4301 from the REGI SENSOR. Disconnect P/J430 from the PWBA DUP-H. Is each cable of P/J430 <=> P/J4301 continuous?	Go to step 9.	Replace the HARNESS ASSY DUP SNR.

Step	Check	Yes	No
9	Checking the power to the DUP JAM SENSOR Disconnect the connector of P/J430 on the PWBA DUP-H. Is the voltage across ground \Leftrightarrow J430-1pin on the PWBA DUP, about +3.3 VDC?	Go to step 10.	Go to step 11.
10	Checking the SENSOR PHOTO (DUP JAM SENSOR) for operation Disconnect the connector of P/J430 on the PWBA DUP-H. Is the voltage across ground \Leftrightarrow J430-3pin on the PWBA MCU Does the voltage change, every time the actuator of the DUP JAM SENSOR is operated?	Go to step 11.	Replace the FEEDER ASSY DUP. (Refer to Removal 5/ Replacement 39.)
11	Checking the connectors of the PWBA DUP-H and PWBA MCU for connection Check the connections between the PWBA DUP-H and PWBA MCU. Are P/J428, P/J2720, P/J272 and P/J27 connected surely?	Go to step 12.	Reconnect the connector(s) P/J428, P/J2720, P/J272 and/or P/J27 surely.
12	Checking the HARNESS ASSY DUP UNIT for continuity Disconnect P/J428 from the PWBA DUP-H. Disconnect P/J2720 from the HARNESS ASSY FRONT COVER. Is each cable of P/J428 \Leftrightarrow P/J2720 continuous?	Go to step 13.	Replace the HARNESS ASSY DUP UNIT.
13	Checking the HARNESS ASSY FRONT COVER for continuity Disconnect P/J2720 from the HARNESS ASSY DUP UNIT. Disconnect P/J272 from the HARN ASSY R SIDE. Is each cable of P/J2720 \Leftrightarrow P/J272 continuous?	Go to step 14.	Replace the HARNESS ASSY FRONT COVER.
14	Checking the HARN ASSY R SIDE for continuity Disconnect P/J272 from the HARNESS ASSY FRONT COVER. Disconnect P/J27 from the PWBA MCU. Is each cable of P/J272 \Leftrightarrow P/J27 continuous?	Go to step 15.	Replace the HARN ASSY R SIDE.
15	Checking the power to the PWBA DUP-H Disconnect the connector of P/J27 on the PWBA MCU. Is the voltage across ground \Leftrightarrow J27-17pin / J27-18pin on the PWBA MCU, about +24 VDC?	Replace the FEEDER ASSY DUP (Refer to Removal 5/ Replacement 39.)	Replace the PWBA MCU. (Refer to Removal 30/ Replacement 14.)
16	Checking the connectors of the PWBA DUP-H and CLUTCH DUP for connection Check the connections between the PWBA DUP-H and CLUTCH DUP. Are P/J431 connected surely?	Go to step 17.	Reconnect the connector(s) P/J431 surely.
17	Checking the power to the CLUTCH DUP Disconnect the connector of P/J431 on the PWBA DUP. Is the voltage across ground \Leftrightarrow J431-1pin on the PWBA DUP, about +24 VDC?	Replace the FEEDER ASSY DUP (Refer to Removal 5/ Replacement 39.)	Go to step 18.

Step	Check	Yes	No
18	Checking the connectors of the PWBA DUP-H and PWBA MCU for connection Check the connections between the PWBA DUP-H and PWBA MCU. Are P/J428, P/J2720, P/J272 and P/J27 connected surely?	Go to step 19.	Reconnect the connector(s) P/J428, P/J2720, P/J272 and/or P/J27 surely.
19	Checking the HARNESS ASSY DUP UNIT for continuity Disconnect P/J428 from the PWBA DUP-H. Disconnect P/J2720 from the HARN ASSY FRONT COVER. Is each cable of P/J428 <=> P/J2720 continuous?	Go to step 20.	Replace the HARNESS ASSY DUP UNIT.
20	Checking the HARNESS ASSY FRONT COVER for continuity Disconnect P/J2720 from the HARNESS ASSY DUP UNIT. Disconnect P/J272 from the HARN ASSY R SIDE. Is each cable of P/J2720 <=> P/J272 continuous?	Go to step 21.	Replace the HARNESS ASSY FRONT COVER.
21	Checking the HARN ASSY R SIDE for continuity Disconnect P/J272 from the HARNESS ASSY FRONT COVER. Disconnect P/J27 from the PWBA MCU. Is each cable of P/J272 <=> P/J27 continuous?	Go to step 22.	Replace the HARN ASSY R SIDE.
22	Checking the power to the PWBA DUP-H Disconnect the connector of P/J27 on the PWBA MCU. Is the voltage across ground <=> J27-15pin on the PWBA MCU, about +3.3 VDC?	Replace the FEEDER ASSY DUP (Refer to Removal 5/ Replacement 39.)	Replace the PWBA MCU. (Refer to Removal 30/ Replacement 14.)
23	Checking the connectors of the PWBA DUP-H and MOTOR ASSY DUP for connection Check the connections between the PWBA DUP-H and MOTOR ASSY DUP. Are P/J429 connected surely?	Go to step 24.	Reconnect the connector(s) P/J429 surely.
24	Checking the power to the MOTOR ASSY DUP Disconnect the connector of P/J429 on the PWBA DUP. Is the voltage across ground <=> J429-2pin on the PWBA DUP, about +24 VDC?	Replace the FEEDER ASSY DUP (Refer to Removal 5/ Replacement 39.)	Go to step 18.

FIP1.40 Paper Jam 077-900/077-901

Step	Check	Yes	No
	Possible causative parts: ROLL REGI RUBBER (PL3.2.7) SENSOR PHOTO (REGI SENSOR) (PL3.2.30) CLUTCH ASSY PH REGI (PL3.2.23) DRIVE ASSY PH (PL8.1.7) DRIVE ASSY MAIN (PL8.1.2) HARN ASSY REGI SNR (PL3.2.37) HARN ASSY FUSER (PL6.1.11) HARN ASSY R SIDE (PL10.1.15) PWBA MCU (PL9.1.20)		
1	Checking the paper condition Is the paper in the Tray wrinkled or damaged?	Replace the paper with a new and dry one, then go to step 2.	Go to step 2.
2	Checking the COVER ASSY FRONT for latching Open and close the COVER ASSY FRONT, then check the latching. Does the error still occur when printing?	Go to step 3.	End of work
3	Checking after reseating the FUSER ASSY Reseat the FUSER ASSY. Warning: Start the operation after the FUSER ASSY has cooled down. Does the error still occur when printing?	Go to step 4.	End of work
4	Checking the EXIT SENSOR for operation Does the number on the screen increase by one, every time the actuator of the EXIT SENSOR is operated? Checked by [Digital Input] - [DI-2(Control Panel)/EXIT SNR(PC)] in diagnosis. Warning: Start the operation after the FUSER ASSY has cooled down.	Go to step 5.	Go to step 13.
5	Checking the SENSOR PHOTO (REGI SENSOR) for operation Does the number on the screen increase by one, every time the actuator of the SENSOR PHOTO (REGI SENSOR) is operated? Checked by [Digital Input] - [DI-3(Control Panel)/REGI SNR(PC)] in diagnosis.	Go to step 6.	Go to step 17.
6	Checking the Main Motor for operation Does the Main Motor operate properly? Checked by [Digital Output] - [DO-0(Control Panel)/MAIN MOTOR(PC)] in diagnosis.	Go to step 7.	Go to step 22.
7	Checking the Sub Motor for operation Does the Sub Motor operate properly? Checked by [Digital Output] - [DO-5(Control Panel)/SUB MOTOR(PC)] in diagnosis.	Go to step 8.	Go to step 25.
8	Checking the PH Motor for operation Does the PH Motor operate properly? Checked by [Digital Output] - [DO-a(Control Panel)/PH MOTOR ON(PC)] in diagnosis.	Go to step 9.	Go to step 28.

Step	Check	Yes	No
9	Checking the CLUTCH ASSY PH REGI for operation Does the CLUTCH ASSY PH REGI operate properly? Checked by [Digital Output] - [DO-29(Control Panel)/REGI CLUTCH ON(PC)] in diagnosis.	Go to step 10.	Go to step 31.
10	Checking the FUSER Are there any remaining paper and/or foreign substance in the FUSER ASSY? Warning: Start the operation after the FUSER ASSY has cooled down.	Remove the paper and/or substance, then go to step 11.	Go to step 11.
11	Checking the ROLL REGI RUBBER and ROLL REGI METAL for shape and operation Are ROLL REGI RUBBER and ROLL REGI METAL installed correctly? Also are they not contaminated and /or damaged, and rotate smoothly? Check these ROLLS by turning them with your finger.	Go to step 12.	Replace the defective ROLL(s).
12	Checking the TRANSFER ASSY for installation Reseat the TRANSFER ASSY. Does the error still occur when printing?	Replace the PWBA MCU. (Refer to Removal 30/Replacement 14)	End of work
13	Checking the connectors of the Exit Sensor on the FUSER ASSY for connection Check the connections between the PWBA MCU and FUSER ASSY. Are P/J17 and P/J171 connected surely?	Go to step 14.	Reconnect the connector(s) P/J17 and/or P/J171 surely.
14	Checking the HARN ASSY FUSER for continuity Disconnect P/J17 from the PWBA MCU. Disconnect P/J171 from the FUSER. Is each cable of P/J17 <=> P/J171 continuous?	Go to step 15.	Replace the HARN ASSY FUSER.
15	Checking the power to Exit Sensor on the FUSER ASSY Disconnect the connector of P/J17 on the PWBA MCU. Is the voltage across ground <=> J17-1pin on the PWBA MCU, about +3.3 VDC?	Go to step 16.	Replace the PWBA MCU. (Refer to Removal 30/Replacement 14.)
16	Checking the Exit Sensor for operation Measure the voltage across ground <=> P/J17-3pin on the PWBA MCU. Does the voltage change, every time the actuator of the Exit Sensor is operated?	Replace the PWBA MCU. (Refer to Removal 30/Replacement 14.)	Replace the FUSER ASSY. (Refer to Removal 8/Replacement 36.)
17	Checking the connectors of the SENSOR PHOTO (REGI SENSOR) for connection Check the connections between the PWBA MCU and REGI SENSOR. Are P/J29, P/J292 and P/J2922 connected surely?	Go to step 18.	Reconnect the connector(s) P/J29, P/J292 and/or P/J2922 surely.
18	Checking the HARN ASSY REGI SNR for continuity Disconnect P/J2922 from the REGI SENSOR. Disconnect P/J292 from the HARN ASSY R SIDE. Is each cable of P/J2922 <=> P/J292 continuous?	Go to step 19.	Replace the HARN ASSY REGI SNR.

Step	Check	Yes	No
19	Checking the HARN ASSY R SIDE for continuity Disconnect P/J29 from the PWBA MCU. Disconnect P/J292 from the HARN ASSY REGI SNR. Is each cable of P/J29 <=> P/J292 continuous?	Go to step 20.	Replace the HARN ASSY R SIDE.
20	Checking the power to REGI SENSOR Disconnect the connector of P/J29 on the PWBA MCU. Is the voltage across ground <=> J29-8pin on the PWBA MCU, about +3.3 VDC?	Go to step 21.	Replace the PWBA MCU. (Refer to Removal 30/Replacement 14.)
21	Checking the REGI SENSOR for operation Measure the voltage across ground <=> J29-10pin on the PWBA MCU. Does the voltage change, every time the actuator of the REGI SENSOR is operated?	Replace the PWBA MCU. (Refer to Removal 30/Replacement 14.)	Replace the SENSOR PHOTO (REGI SENSOR).
22	Checking the connectors of the Main Motor on the DRIVE ASSY MAIN for connection Check the connections between the PWBA MCU and DRIVE ASSY MAIN. Are P/J22 and P/J222 connected surely?	Go to step 23.	Reconnect the connector(s) P/J22 and/or P/J222 surely.
23	Checking the HARN ASSY R SIDE for continuity Disconnect P/J22 from the PWBA MCU. Disconnect P/J222 from the DRIVE ASSY MAIN. Is each cable of P/J22 <=> P/J222 continuous?	Go to step 24.	Replace the HARN ASSY R SIDE.
24	Checking the power to DRIVE ASSY MAIN Disconnect the connector of P/J22 on the PWBA MCU. Are the voltages across ground <=> J22-B2pin/J22-B4pin on the PWBA MCU, about +24 VDC when the interlock switch (HARN ASSY INTERLOCK) is pushed?	Replace the DRIVE ASSY MAIN. (Refer to Removal 38/Replacement 6.)	Replace the PWBA MCU. (Refer to Removal 30/Replacement 14.)
25	Checking the connectors of the Sub Motor on the DRIVE ASSY MAIN for connection Check the connections between the PWBA MCU and DRIVE ASSY MAIN. Are P/J22 and P/J221 connected surely?	Go to step 26.	Reconnect the connector(s) P/J22 and/or P/J221 surely.
26	Checking the HARN ASSY R SIDE for continuity Disconnect P/J22 from the PWBA MCU. Disconnect P/J221 from the DRIVE ASSY MAIN. Is each cable of P/J22 <=> P/J221 continuous?	Go to step 27.	Replace the HARN ASSY R SIDE.
27	Checking the power to DRIVE ASSY MAIN Disconnect the connector of P/J22 on the PWBA MCU. Are the voltages across ground <=> J22-A2pin/J22-A4pin on the PWBA MCU, about +24 VDC when the interlock switch (HARN ASSY INTERLOCK) is pushed?	Replace the DRIVE ASSY MAIN. (Refer to Removal 38/Replacement 6.)	Replace the PWBA MCU. (Refer to Removal 30/Replacement 14.)
28	Checking the connectors of the DRIVE ASSY PH for connection Check the connections between the PWBA MCU and DRIVE ASSY PH. Are P/J25 and P/J251 connected surely?	Go to step 22.	Reconnect the connector(s) P/J25 and/or P/J251 surely.

Step	Check	Yes	No
29	Checking the HARN ASSY R SIDE for continuity Disconnect P/J25 from the PWBA MCU. Disconnect P/J251 from the DRIVE ASSY PH. Is each cable of P/J25 <=> P/J251 continuous?	Go to step 23.	Replace the HARN ASSY R SIDE.
30	Checking the power to DRIVE ASSY PH Disconnect the connector of P/J25 on the PWBA MCU. Are the voltages across ground <=> J25-1pin/J25-2pin on the PWBA MCU, about +24 VDC when the interlock switch (HARN ASSY INTERLOCK) is pushed?	Replace the DRIVE ASSY PH. (Refer to Removal 17/Replacement 27.)	Replace the PWBA MCU. (Refer to Removal 30/Replacement 14.)
31	Checking the connectors of the CLUTCH ASSY PH REGI for connection Check the connections between the PWBA MCU and CLUTCH ASSY PH REGI. Are P/J23 and P/J231 connected surely?	Go to step 32.	Reconnect the connector(s) P/J23 and/or P/J231 surely.
32	Checking the HARN ASSY R SIDE for continuity Disconnect P/J23 from the PWBA MCU. Disconnect P/J231 from the CLUTCH ASSY PH REGI. Is each cable of P/J23 <=> P/J231 continuous?	Go to step 33.	Replace the HARN ASSY R SIDE.
33	Checking the power to CLUTCH ASSY PH REGI Disconnect the connector of P/J23 on the PWBA MCU. Is the voltage across ground <=> J23-1pin on the PWBA MCU, about +24 VDC when the interlock switch (HARN ASSY INTERLOCK) is pushed?	Replace the CLUTCH ASSY PH REGI. (Refer to Removal 40/Replacement 4.)	Replace the PWBA MCU. (Refer to Removal 30/Replacement 14.)

FIP1.41 Paper Jam 077-903

Step	Check	Yes	No
	Possible causative parts: HARN ASSY REGI SNR (PL3.2.37) HARN ASSY R SIDE (PL10.1.15) SENSOR PHOTO (REGI SENSOR) (PL3.2.30) PWBA MCU (PL9.1.20)		
1	Checking the jam Remove the jammed paper. Does the error still occur when printing?	Go to step 2.	End of work
2	Checking the SENSOR PHOTO (REGI SENSOR) for operation Does the number on the screen increase by one, every time the actuator of the SENSOR PHOTO (REGI SENSOR) is operated? Checked by [Digital Input] - [DI-3(Control Panel)/REGI SNR(PC)] in diagnosis.	Go to step 3.	Go to step 4.
3	Checking the paper feed Does the multiple paper feed occur?	Go to Multiple Feed in Other FIP.	Replace the PWBA MCU. (Refer to Removal 30/Replacement 14)
4	Checking the connectors of the SENSOR PHOTO (REGI SENSOR) for connection Check the connections between the PWBA MCU and REGI SENSOR. Are P/J29, P/J292 and P/J2922 connected surely?	Go to step 5.	Reconnect the connector(s) P/J29, P/J292 and/or P/J2922 surely.
5	Checking the HARNESS ASSY REGI SNR for continuity Disconnect P/J2922 from the REGI SENSOR. Disconnect P/J292 from the HARN ASSY R SIDE. Is each cable of P/J2922 <=> P/J292 continuous?	Go to step 6.	Replace the HARN ASSY REGI SNR.
6	Checking the HARN ASSY R SIDE for continuity Disconnect P/J29 from the PWBA MCU. Disconnect P/J292 from the HARN ASSY REGI SNR. Is each cable of P/J29 <=> P/J292 continuous?	Go to step 7.	Replace the HARN ASSY R SIDE.
7	Checking the power to REGI SENSOR Disconnect the connector of P/J29 on the PWBA MCU. Is the voltage across ground <=> J29-8pin on the PWBA MCU, about +3.3 VDC?	Go to step 8.	Replace the PWBA MCU. (Refer to Removal 30/Replacement 14.)
8	Checking the REGI SENSOR for operation Measure the voltage across ground <=> J29-10pin on the PWBA MCU. Does the voltage change, every time the actuator of the REGI SENSOR is operated?	Replace the PWBA MCU. (Refer to Removal 30/Replacement 14.)	Replace the SENSOR PHOTO (REGI SENSOR).

FIP1.42 Paper Jam 077-907

Step	Check	Yes	No
	Possible causative parts: CHUTE ASSY EXIT OUT (PL6.1.1) CHUTE DUP GATE (PL6.1.13) FEEDER ASSY DUP (PL11.1.1) DRIVE ASSY PH (PL8.1.7) CLUTCH ASSY PH TURN (PL3.2.25) HARN ASSY R SIDE (PL10.1.15) HARN ASSY DUP UNIT (PL11.1.18) HARNESS ASSY FRONT COVER (PL1.2.11) PWBA DUP-H (PL11.1.15) PWBA MCU (PL9.1.20)		
1	Checking the COVER ASSY FRONT for latching Open and close the COVER ASSY FRONT, then check the latching. Does the error still occur when printing?	Go to step 2.	End of work
2	Checking after reseating the FUSER ASSY Reseat the FUSER ASSY. Warning: Start the operation after the FUSER ASSY has cooled down. Does the error still occur when printing?	Go to step 3.	End of work
3	Checking after reseating the FEEDER ASSY DUP Reseat the FEEDER ASSY DUP. Does the error still occur when printing?	Go to step 4.	End of work
4	Checking the CHUTE DUP GATE for the shape and installation Are the shape and the installation of the CHUTE DUP GATE normal?	Go to step 5.	Reseat or replace the CHUTE DUP GATE.
5	Checking the CHUTE ASSY EXIT OUT for shape and installation Are the shape and the installation of the CHUTE ASSY EXIT OUT normal?	Go to step 6.	Reseat the CHUTE ASSY EXIT OUT. If broken, replace the CHUTE ASSY EXIT OUT. (Refer to Removal 9/Replacement 35)
6	Checking the SENSOR PHOTO (DUP JAM SENSOR) for operation Does the number on the screen increase by one, every time the actuator of the SENSOR PHOTO (DUP JAM SENSOR) is operated? Checked by [Digital Input] - [DI-1(Control Panel)/DUP SNR(PC)] in diagnosis.	Go to step 7.	Go to step 11.
7	Checking the CLUTCH DUP for operation Does the CLUTCH DUP operate properly? Checked by [Digital Output] - [DO-35(Control Panel)/DUPLEX CLUTCH ON(PC)] in diagnosis.	Go to step 8.	Go to step 11.

Step	Check	Yes	No
8	Checking the MOTOR ASSY DUP for operation Does the MOTOR ASSY DUP operate properly? Checked by [Digital Output] - [DO-13(Control Panel)/DUPLEX MOTOR ON(PC)] in diagnosis.	Go to step 9.	Go to step 11.
9	Checking the CLUTCH ASSY PH TURN for operation Does the CLUTCH ASSY PH TURN operate properly? Checked by [Digital Output] - [DO-2b(Control Panel)/MSI TURN CLUTCH ON(PC)] in diagnosis.	Go to step 10.	Go to step 17.
10	Checking the PH Motor for operation Does the PH Motor operate properly? Checked by [Digital Output] - [DO-a(Control Panel)/PH MOTOR ON(PC)] in diagnosis.	Replace the PWBA MCU. (Refer to Removal 30/Replacement 14)	Go to step 20.
11	Checking the connectors of the PWBA DUP-H and PWBA MCU for connection Check the connections between the PWBA DUP-H and PWBA MCU. Are P/J428, P/J2720, P/J272 and P/J27 connected surely?	Go to step 12.	Reconnect the connector(s) P/J428, P/J2720, P/J272 and/or P/J27 surely.
12	Checking the HARN ASSY DUP UNIT for continuity Disconnect P/J428 from the PWBA DUP. Disconnect P/J2720 from the HARN ASSY FRONT COVER. Is each cable of P/J428 <=> P/J2720 continuous?	Go to step 13.	Replace the HARN ASSY DUP UNIT.
13	Checking the HARNESS ASSY FRONT COVER for continuity Disconnect P/J2720 from the HARNESS ASSY DUP UNIT. Disconnect P/J272 from the HARN ASSY R SIDE. Is each cable of P/J2720 <=> P/J272 continuous?	Go to step 14.	Replace the HARNESS ASSY FRONT COVER.
14	Checking the HARN ASSY R SIDE for continuity Disconnect P/J272 from the HARNESS ASSY FRONT COVER. Disconnect P/J27 from the PWBA MCU. Is each cable of P/J272 <=> P/J27 continuous?	Go to step 15.	Replace the HARN ASSY R SIDE.
15	Checking the power to the PWBA DUP-H <The check of DUP JAM SENSOR> Disconnect the connector of P/J27 on the PWBA MCU. Is the voltage across ground <=> J27-15pin on the PWBA MCU, about +3.3 VDC? <The check of CLUTCH DUP/MOTOR ASSY DUP > Disconnect the connector of P/J27 on the PWBA MCU. Is the voltage across ground <=> J27-17,18pin on the PWBA MCU, about +24 VDC?	Go to step 16.	Replace the PWBA MCU. (Refer to Removal 30/Replacement 14.)
16	Checking after replacing the PWBA DUP-H Replace the PWBA DUP-H. Does the error still occur when the power is turned ON?	End of work	Replace the FEEDER ASSY DUP (Refer to Removal 5/Replacement 39.)

Step	Check	Yes	No
17	Checking the connectors of the CLUTCH ASSY PH TURN for connection Check the connections between the PWBA MCU and CLUTCH ASSY PH TURN. Are P/J23 and P/J232 connected surely?	Go to step 18.	Reconnect the connector(s) P/J23 and/or P/J232 surely.
18	Checking the HARN ASSY R SIDE for continuity Disconnect P/J23 from the PWBA MCU. Disconnect P/J232 from the CLUTCH ASSY PH TURN. Is each cable of P/J23 <=> P/J232 continuous?	Go to step 19.	Replace the HARN ASSY R SIDE.
19	Checking the power to CLUTCH ASSY PH TURN Disconnect the connector of P/J23 on the PWBA MCU. Is the voltage across ground <=> J23-3pin on the PWBA MCU, about +24 VDC when the interlock switch (HARN ASSY INTERLOCK) is pushed?	Replace the CLUTCH ASSY PH TURN. (Refer to Removal 40/Replacement 4.)	Replace the PWBA MCU. (Refer to Removal 30/Replacement 14.)
20	Checking the connectors of the DRIVE ASSY PH for connection Check the connections between the PWBA MCU and DRIVE ASSY PH. Are P/J25 and P/J251 connected surely?	Go to step 21.	Reconnect the connector(s) P/J25 and/or P/J251 surely.
21	Checking the HARN ASSY R SIDE for continuity Disconnect P/J25 from the PWBA MCU. Disconnect P/J251 from the DRIVE ASSY PH. Is each cable of P/J25 <=> P/J251 continuous?	Go to step 22.	Replace the HARN ASSY R SIDE.
22	Checking the power to DRIVE ASSY PH Disconnect the connector of P/J25 on the PWBA MCU. Are the voltages across ground <=> J25-1pin/J25-2pin on the PWBA MCU, about +24 VDC when the interlock switch (HARN ASSY INTERLOCK) is pushed?	Replace the DRIVE ASSY PH. (Refer to Removal 17/Replacement 27.)	Replace the PWBA MCU. (Refer to Removal 30/Replacement 14.)

FIP1.43 Load Tray N or MPF 024-910/024-911/024-914

Step	Check	Yes	No
	Possible causative parts: CASSETTE ASSY 250 (PL2.1.1) CASSETTE ASSY 550 OPT (PL12.4.1) SWITCH ASSY SIZE (PL7.1.18) SWITCH ASSY SIZE OPT (PL12.2.5) HARN ASSY REGI SNR (PL3.2.37) HARN ASSY R SIDE (PL10.1.15) SENSOR PHOTO (REGI SENSOR) (PL3.2.30) PWBA MCU (PL9.1.20)		
1	Checking the paper size Does the paper size in use meet the specification?	Go to step 2.	Use the paper that meets the specification.
2	Checking the paper for size setup Does the paper size in use match the size set through the control panel?	For Tray1 and Tray2: Go to step 4. For MPF: Go to step 6.	Set the paper size through the control panel, then go to step 3.
3	Does the error still occur when printing?	For Tray1 and Tray2: Go to step 4. For MPF: Go to step 6.	End of work
4	Checking after reseating the Paper Cassette Guide Reseat the end guide of the Paper Cassette. Does the error still occur when printing?	Go to step 5.	End of work
5	Checking after replacing the CASSETTE ASSY 250 or 550 Replace the CASSETTE ASSY 250 or 550. Does the error still occur when printing?	Go to step 7.	End of work
6	Checking the SENSOR PHOTO (REGI SENSOR) for operation Does the number on the screen increase by one, every time the actuator of the SENSOR PHOTO (REGI SENSOR) is operated? Checked by [Digital Input] - [DI-3(Control Panel)/REGI SNR(PC)] in diagnosis.	Replace the PWBA MCU. (Refer to Removal 30/Replacement 14).	Go to step 10.
7	Checking the SWITCH ASSY SIZE of Tray 1 for operation Does the SWITCH ASSY SIZE operate properly? Checked by [Digital Input] - [DI-18(Control Panel)/CASSETTE1 SIZE(PC)] in diagnosis.	Go to step 8.	Replace the SWITCH ASSY SIZE. (Refer to Removal 18/Replacement 26)
8	Checking the SWITCH ASSY SIZE of Tray 2 for operation Does the SWITCH ASSY SIZE OPT operate properly? Checked by [Digital Input] - [DI-20(Control Panel)/CASSETTE2 SIZE(PC)] in diagnosis.	Go to step 9.	Replace the SWITCH ASSY SIZE OPT. (Refer to Removal 44/Replacement 46)

Step	Check	Yes	No
9	Checking the ROLLs for rotation Do the ROLLs rotate smoothly? Check the rotation with your finger.	Replace the PWBA MCU. (Refer to Removal 30/Replacement 14)	Replace the defective ROLL(s).
10	Checking the connectors of the SENSOR PHOTO (REGI SENSOR) for connection Check the connections between the PWBA MCU and REGI SENSOR. Are P/J29, P/J292 and P/J2922 connected surely?	Go to step 5.	Reconnect the connector(s) P/J29, P/J292 and/or P/J2922 surely.
11	Checking the HARN ASSY REGI SNR for continuity Disconnect P/J2922 from the REGI SENSOR. Disconnect P/J292 from the HARN ASSY R SIDE. Is each cable of P/J2922 <=> P/J292 continuous?	Go to step 6.	Replace the HARN ASSY REGI SNR.
12	Checking the HARN ASSY R SIDE for continuity Disconnect P/J29 from the PWBA MCU. Disconnect P/J292 from the HARN ASSY REGI SNR. Is each cable of P/J29 <=> P/J292 continuous?	Go to step 7.	Replace the HARN ASSY R SIDE.
13	Checking the power to REGI SENSOR Disconnect the connector of P/J29 on the PWBA MCU. Is the voltage across ground <=> J29-8pin on the PWBA MCU, about +3.3 VDC?	Go to step 8.	Replace the PWBA MCU. (Refer to Removal 30/Replacement 14.)
14	Checking the REGI SENSOR for operation Measure the voltage across ground <=> J29-10pin on the PWBA MCU. Does the voltage change, every time the actuator of the REGI SENSOR is operated?	Replace the PWBA MCU. (Refer to Removal 30/Replacement 14.)	Replace the SENSOR PHOTO (REGI SENSOR).

FIP1.44 Load Tray N or MPF 024-965/024-966/024-969

Step	Check	Yes	No
	Possible causative parts: HARN ASSY R SIDE (PL10.1.15) HARN ASSY REGI SNR (PL3.2.37) HARN ASSY C2 CHUTE (PL12.2.7) HARN ASSY C2 NO PAPER (PL12.3.30) HARN ASSY FDR UNIT (PL12.2.3) HARN ASSY MSI NPP (PL3.1.17) SENSOR PHOTO (CST NO PAPER SENSOR) (PL3.2.30) SENSOR PHOTO (CST NO PAPER SENSOR) (PL12.3.14) SENSOR PHOTO (MSI NO PAPER SENSOR) (PL3.1.15) PWBA OPT FDR (PL12.2.6) PWBA MCU (PL9.1.20)		
1	Checking the paper Is there the paper in the specified tray or the cassette?	Go to step 2.	Load the paper.
2	Checking the paper size Check the paper size below. - Paper in the cassette or the tray - Paper size setting through the control panel - Paper size of the printing job Are these paper sizes the same?	Go to step 3.	Change the paper, paper size setting or printing job.
3	Checking the paper type Check the paper type below. - Paper in the cassette or the tray - Paper type setting through the control panel - Paper type of the printing job Are these paper types the same?	For Tray; Go to step 4. For MPF: Go to step 9.	Change the paper, paper type setting or printing job.
4	Checking after reseating the CASSETTE ASSY 250 or 550 Reseat the CASSETTE ASSY 250 or 550. Does the error still occur when printing?	For Tray 1: Go to step 5. For Tray 2: Go to step 7.	End of work
5	Checking the ACTUATOR NO PAPER A4 for operation Does the ACTUATOR NO PAPER A4 operate smoothly?	Go to step 6.	Replace the ACTUATOR NO PAPER A4.
6	Checking the SENSOR PHOTO (CST NO PAPER) for operation Does the number on the screen increase by one, every time the actuator of the SENSOR PHOTO (CST NO PAPER) is operated? Checked by [Digital Input] - [DI-11(Control Panel)/CST1 NO PAPER(PC)] in diagnosis.	Replace the PWBA MCU. (Refer to Removal 30/Replacement 14)	Go to step 11.
7	Checking the ACTUATOR NO PAPER A4 for operation Does the ACTUATOR NO PAPER A4 operate smoothly?	Go to step 8.	Replace the ACTUATOR NO PAPER A4.

Step	Check	Yes	No
8	Checking the SENSOR PHOTO (CST NO PAPER) for operation Does the number on the screen increase by one, every time the actuator of the SENSOR PHOTO: CST NO PAPER is operated? Checked by [Digital Input] - [DI-d(Control Panel)/CST2 NO PAPER(PC)] in diagnosis.	Replace the PWBA MCU. (Refer to Removal 30/Replacement 14)	Go to step 16.
9	Checking the ACTUATOR ASSY MSI for operation Does the ACTUATOR ASSY MSI operate smoothly?	Go to step 10.	Replace the ACTUATOR ASSY MSI.
10	Checking the SENSOR PHOTO (MPF NO PAPER) for operation Does the number on the screen increase by one, every time the actuator of the SENSOR PHOTO (MSI NO PAPER) is operated? Checked by [Digital Input] - [DI-10(Control Panel)/MSI NO PAPER(PC)] in diagnosis.	Replace the PWBA MCU. (Refer to Removal 30/Replacement 14)	Go to step 26.
11	Checking the connectors of the SENSOR PHOTO (CST NO PAPER SENSOR) for connection Check the connections between the PWBA MCU and SENSOR PHOTO (CST NO PAPER SENSOR). Are P/J29, P/J292 and P/J2921 connected surely?	Go to step 12.	Reconnect the connector(s) P/J29, P/J292 and/or P/J2921 surely.
12	Checking the HARN ASSY R SIDE for continuity Disconnect P/J29 from the PWBA MCU. Disconnect P/J292 from the HARN ASSY REGI SNR. Is each cable of P/J29 <=> P/J292 continuous?	Go to step 13.	Replace the HARN ASSY R SIDE.
13	Checking the HARNESS ASSY REGI SNR for continuity Disconnect P/J292 from the HARN ASSY R SIDE. Disconnect P/J2921 from the SENSOR PHOTO (CST NO PAPER SENSOR). Is each cable of P/J292 <=> P/J2921 continuous?	Go to step 14.	Replace the HARN ASSY REGI SNR.
14	Checking the power to SENSOR PHOTO (CST NO PAPER SENSOR) Disconnect P/J29 on the PWBA MCU. Is the voltage across ground <=> J29-5pin on the PWBA MCU, about +3.3 VDC?	Go to step 15.	Replace the PWBA MCU. (Refer to Removal 30/Replacement 14.)
15	Checking the SENSOR PHOTO (CST NO PAPER SENSOR) for operation Measure the voltage across ground <=> J29-7pin on the PWBA MCU. Does the voltage change, every time the ACTUATOR NO PAPER A4 of the SENSOR PHOTO (CST NO PAPER SENSOR) is operated?	Replace the PWBA MCU. (Refer to Removal 30/Replacement 14.)	Replace the SENSOR PHOTO (CST NO PAPER SENSOR).
16	Checking the connectors of the SENSOR PHOTO (CST NO PAPER SENSOR) for connection Check the connections between the PWBA OPT FDR and SENSOR PHOTO (CST NO PAPER SENSOR). Are P/J421, P/J4212 and P/J42121 connected surely?	Go to step 17.	Reconnect the connector(s) P/J421, P/J4212 and/or P/J42121 surely.

Step	Check	Yes	No
17	Checking the HARNESS ASSY C2 CHUTE for continuity Disconnect P/J421 from the PWBA OPT FDR. Disconnect P/J4212 from the HARN ASSY C2 NO PAPER. Is each cable of P/J421 <=> P/J4212 continuous?	Go to step 18.	Replace the HARN ASSY C2 CHUTE.
18	Checking the HARNESS ASSY C2 NO PAPER for continuity Disconnect P/J4212 from the HARN ASSY C2 CHUTE. Disconnect P/J42121 from the SENSOR PHOTO (CST NO PAPER SENSOR). Is each cable of P/J4212 <=> P/J42121 continuous?	Go to step 19.	Replace the HARN ASSY C2 NO PAPER.
19	Checking the power to the SENSOR PHOTO (CST NO PAPER SENSOR) Disconnect P/J421 on the PWBA OPT FDR. Is the voltage across ground <=> J421-3pin on the PWBA OPT FDR, about +3.3 VDC?	Go to step 20.	Go to step 22.
20	Checking the SENSOR PHOTO (CST NO PAPER SENSOR) for operation Measure the voltage across ground <=> J421-5pin on the PWBA OPT FDR. Does the voltage change, every time the ACTUATOR NO PAPER A4 of the SENSOR PHOTO (CST NO PAPER SENSOR) is operated?	Go to step 21.	Replace the SENSOR PHOTO (CST NO PAPER SENSOR).
21	Checking after replacing the PWBA OPT FDR Replace the PWBA OPT FDR. Does the error still occur when the power is turned ON?	End of work	Replace the PWBA MCU. (Refer to Removal 30/Replacement 14.)
22	Checking the connectors of the PWBA OPT FDR and PWBA MCU for connection Check the connections between the PWBA OPT FDR and PWBA MCU. Are P/J419, P/J281 and P/J28 connected surely?	Go to step 23.	Reconnect the connector(s) P/J419, P/J281 and/or P/J28 surely.
23	Checking the HARNESS ASSY FDR UNIT for continuity Disconnect P/J419 from the PWBA OPT FDR. Disconnect P/J281 from the HARN ASSY R SIDE. Is each cable of P/J419 <=> P/J281 continuous?	Go to step 24.	Replace the HARN ASSY FDR UNIT.
24	Checking the HARN ASSY R SIDE for continuity Disconnect P/J281 from the HARN ASSY FDR UNIT. Disconnect P/J28 from the PWBA MCU. Is each cable of P/J281 <=> P/J28 continuous?	Go to step 25.	Replace the HARN ASSY R SIDE.
25	Checking the power to the PWBA OPT FDR Disconnect P/J28 on the PWBA MCU. Is the voltage across ground <=> J28-7pin on the PWBA MCU, about +3.3 VDC?	Replace the PWBA OPT FDR.	Replace the PWBA MCU. (Refer to Removal 30/Replacement 14.)
26	Checking the connectors of the SENSOR PHOTO (MSI NO PAPER SENSOR) for connection Check the connections between the PWBA MCU and SENSOR PHOTO (MSI NO PAPER SENSOR). Are P/J28, P/J282 and P/J2821 connected surely?	Go to step 27.	Reconnect the connector(s) P/J28, P/J282 and/or P/J2821 surely.

Step	Check	Yes	No
27	Checking the HARN ASSY R SIDE for continuity Disconnect P/J28 from the PWBA MCU. Disconnect P/J282 from the HARN ASSY MSI NPP. Is each cable of P/J28 <=> P/J282 continuous?	Go to step 28.	Replace the HARN ASSY R SIDE.
28	Checking the HARNESS ASSY MSI NPP for continuity Disconnect P/J282 from the HARN ASSY R SIDE. Disconnect P/J2821 from the SENSOR PHOTO (MSI NO PAPER SENSOR). Is each cable of P/J282 <=> P/J2821 continuous?	Go to step 29.	Replace the HARN ASSY MSI NPP.
29	Checking the power to SENSOR PHOTO (MSI NO PAPER SENSOR) Disconnect P/J28 on the PWBA MCU. Is the voltage across ground <=> J28-B11pin on the PWBA MCU, about +3.3 VDC?	Go to step 30.	Replace the PWBA MCU. (Refer to Removal 30/Replacement 14.)
30	Checking the SENSOR PHOTO (MSI NO PAPER SENSOR) for operation Measure the voltage across ground <=> J28-B13pin on the PWBA MCU. Does the voltage change, every time the ACTUATOR NO PAPER MSI of the SENSOR PHOTO (MSI NO PAPER SENSOR) is operated?	Replace the PWBA MCU. (Refer to Removal 30/Replacement 14.)	Replace the SENSOR PHOTO (MSI NO PAPER SENSOR).

FIP1.45 CRUM ID 009-367/009-368/009-369/009-370

Step	Check	Yes	No
	Possible causative parts: CARTRIDGE ASSY (K) (PL5.1.18) CARTRIDGE ASSY (C) (PL5.1.19) CARTRIDGE ASSY (M) (PL5.1.20) CARTRIDGE ASSY (Y) (PL5.1.21) PWBA MCU (PL9.1.20)		
1	Checking the Print Cartridge Are the Print Cartridges installed to the printer the DELL Toner?	Go to step 2.	Set the non-DELL toner mode through the control panel.
2	Checking the DELL toner type Is the print cartridge installed the 3130cn?	Go to step 3.	Replace the print cartridge.
3	Checking the Print Cartridge installation Reseat the Print Cartridge. Does the error still occur when the power is turned ON?	Go to step 4.	End of work
4	Checking after replacing the Print Cartridge Replace the Print Cartridge. Does the error still occur when the power is turned ON?	Replace the PWBA MCU. (Refer to Removal 30/Replacement 14.)	End of work

FIP1.46 Error Y Cart 093-919

Step	Check	Yes	No
	Possible causative parts: CARTRIDGE ASSY (Y) (PL5.1.21) DISPENSER ASSY (PL5.1.12) HARN ASSY LV TOP (PL10.1.16) PWBA MCU (PL9.1.20)		
1	Checking the Toner Tape for staying Has the Toner Tape been pulled out?	Go to step 2.	Pull the Toner Tape out, then go to step 2.
2	Does the error still occur when the power is turned ON?	Go to step 3.	End of work
3	Checking after replacing the CARTRIDGE ASSY (Y) Replace the CARTRIDGE ASSY (Y). Does the error still occur when the power is turned ON?	Go to step 4.	End of work
4	Checking the Dispenser Motor for rotation Does the Dispense Motor function normally? Checked by [Digital Output] - [DO-21(Control Panel)/ TONER MOTOR Y ON(PC)] in diagnosis. During the test, close the interlock switch (HARN ASSY INTERLOCK).	Check the gear of the Auger is not damaged. If the gear is damaged, replace the DISPENSER ASSY (Y). (Refer to Removal 24/Replacement 20) Replace the PWBA MCU. (Refer to Removal 30/Replacement 14)	Go to step 5.
5	Checking the connector for connection Check the connectors between the PWBA MCU and DISPENSER ASSY. Are P/J18 and P/J181 connected surely?	Go to step 6.	Reconnect the connector(s) P/J18 and/or P/J181 surly, then go to step 6.
6	Does the error still occur when the power is turned ON?	Go to step 7.	End of work
7	Checking the HARN ASSY LV TOP for continuity Disconnect P/J18 from the PWBA MCU. Disconnect P/J181 from the DISPENSER ASSY. Is each cable of P/J18 <=> P/J181 continuous?	Go to step 8.	Replace the HARN ASSY LV TOP.
8	Checking the power to DISPENSER ASSY Disconnect P/J18 on the PWBA MCU. Are the voltages across ground <= >J18-A1pin/A2pin on PWBA MCU, about +24 VDC when the interlock switch (HARN ASSY INTERLOCK) is pushed.	Replace the DISPENSER ASSY. (Refer to Removal 24/Replacement 20)	Replace the PWBA MCU. (Refer to Removal 30/Replacement 14)

FIP1.47 Error M Cart 093-920

Step	Check	Yes	No
	Possible causative parts: CARTRIDGE ASSY (M) (PL5.1.20) DISPENSER ASSY (PL5.1.12) HARN ASSY LV TOP (PL10.1.16) PWBA MCU (PL9.1.20)		
1	Checking the Toner Tape for staying Has the Toner Tape been pulled out?	Go to step 2.	Pull the Toner Tape out, then go to step 2.
2	Does the error still occur when the power is turned ON?	Go to step 3.	End of work
3	Checking after replacing the CARTRIDGE ASSY (M) Replace the CARTRIDGE ASSY (M). Does the error still occur when the power is turned ON?	Go to step 4.	End of work
4	Checking the Dispenser Motor for rotation Does the Dispense Motor function normally? Checked by [Digital Output] - [DO-23(Control Panel)/ TONER MOTOR M ON(PC)] in diagnosis. During the test, close the interlock switch (HARN ASSY INTERLOCK).	Check the gear of the Auger is not damaged. If the gear is damaged, replace the DISPENSER ASSY. (Refer to Removal 24/Replacement 20) Replace the PWBA MCU. (Refer to Removal 30/Replacement 14)	Go to step 5.
5	Checking the connector for connection Check the connectors between the PWBA MCU and DISPENSER ASSY. Are P/J18 and P/J182 connected surely?	Go to step 6.	Reconnect the connector(s) P/J18 and/or P/J182 surly, then go to step 6.
6	Does the error still occur when the power is turned ON?	Go to step 7.	End of work
7	Checking the HARN ASSY LV TOP for continuity Disconnect P/J18 from the PWBA MCU. Disconnect P/J182 from the DISPENSER ASSY. Is each cable of P/J18 <=> P/J182 continuous?	Go to step 8.	Replace the HARN ASSY LV TOP.
8	Checking the power to DISPENSER ASSY Disconnect P/J18 on the PWBA MCU. Are the voltages across ground <= >J18-A7pin/A8pin on PWBA MCU, about +24 VDC when the interlock switch (HARN ASSY INTERLOCK) is pushed?	Replace the DISPENSER ASSY. (Refer to Removal 24/Replacement 20)	Replace the PWBA MCU. (Refer to Removal 30/Replacement 14)

FIP1.48 Error C Cart 093-921

Step	Check	Yes	No
	Possible causative parts: CARTRIDGE ASSY (C) (PL5.1.19) DISPENSER ASSY (PL5.1.12) HARN ASSY LV TOP (PL10.1.16) PWBA MCU (PL9.1.20)		
1	Checking the Toner Tape for staying Has the Toner Tape been pulled out?	Go to step 2.	Pull the Toner Tape out, then go to step 2.
2	Does the error still occur when the power is turned ON?	Go to step 3.	End of work
3	Checking after replacing the CARTRIDGE ASSY (C) Replace the CARTRIDGE ASSY (C). Does the error still occur when the power is turned ON?	Go to step 4.	End of work
4	Checking the Dispenser Motor for rotation Does the Dispense Motor function normally? Checked by [Digital Output] - [DO-25(Control Panel)/ TONER MOTOR C ON(PC)] in diagnosis. During the test, close the interlock switch (HARN ASSY INTERLOCK).	Check the gear of the Auger is not damaged. If the gear is damaged, replace the DISPENSER ASSY. (Refer to Removal 24/Replacement 20). Replace the PWBA MCU. (Refer to Removal 30/Replacement 14).	Go to step 5.
5	Checking the connector for connection Check the connectors between the PWBA MCU and DISPENSER ASSY. Are P/J18 and P/J184 connected surely?	Go to step 6.	Reconnect the connector(s) P/J18 and/or P/J184 surly, then go to step 6.
6	Does the error still occur when the power is turned ON?	Go to step 7.	End of work
7	Checking the HARN ASSY LV TOP for continuity Disconnect P/J18 from the PWBA MCU. Disconnect P/J184 from the DISPENSER ASSY. Is each cable of P/J18 <=> P/J184 continuous?	Go to step 8.	Replace the HARN ASSY LV TOP.
8	Checking the power to DISPENSER ASSY Disconnect P/J18 on the PWBA MCU. Are the voltages across ground <=> J18-B7pin/B8pin on PWBA MCU, about +24 VDC when the interlock switch (HARN ASSY INTERLOCK) is pushed?	Replace the DISPENSER ASSY. (Refer to Removal 24/Replacement 20).	Replace the PWBA MCU. (Refer to Removal 30/Replacement 14).

FIP1.49 Error K Cart 093-922

Step	Check	Yes	No
	Possible causative parts: CARTRIDGE ASSY (K) (PL5.1.18) DISPENSER ASSY (PL5.1.12) HARN ASSY LV TOP (PL10.1.16) PWBA MCU (PL9.1.20)		
1	Checking the Toner Tape for staying Has the Toner Tape been pulled out?	Go to step 2.	Pull the Toner Tape out, then go to step 2.
2	Does the error still occur when the power is turned ON?	Go to step 3.	End of work
3	Checking after replacing the CARTRIDGE ASSY (K) Replace the CARTRIDGE ASSY (K). Does the error still occur when the power is turned ON?	Go to step 4.	End of work
4	Checking the Dispenser Motor for rotation Does the Dispense Motor function normally? Checked by [Digital Output] - [DO-27(Control Panel)/ TONER MOTOR K ON(PC)] in diagnosis. During the test, close the interlock switch (HARN ASSY INTERLOCK).	Check the gear of the Auger is not damaged. If the gear is damaged, replace the DISPENSER ASSY. (Refer to Removal 24/Replacement 20). Replace the PWBA MCU. (Refer to Removal 30/Replacement 14).	Go to step 5.
5	Checking the connector for connection Check the connectors between the PWBA MCU and DISPENSER ASSY. Are P/J18 and P/J183 connected surely?	Go to step 6.	Reconnect the connector(s) P/J18 and/or P/J183 surly, then go to step 6.
6	Does the error still occur when the power is turned ON?	Go to step 7.	End of work
7	Checking the HARN ASSY LV TOP for continuity Disconnect P/J18 from the PWBA MCU. Disconnect P/J183 from the DISPENSER ASSY. Is each cable of P/J18 <=> P/J183 continuous?	Go to step 8.	Replace the HARN ASSY LV TOP.
8	Checking the power to DISPENSER ASSY Disconnect P/J18 on the PWBA MCU. Are the voltages across ground <= >J18-B1pin/B2pin on PWBA MCU, about +24 VDC when the interlock switch (HARN ASSY INTERLOCK) is pushed?	Replace the DISPENSER ASSY. (Refer to Removal 24/Replacement 20).	Replace the PWBA MCU. (Refer to Removal 30/Replacement 14)

FIP1.50 093-950 Yellow Toner/093-951 Magenta Toner/093-952 Cyan Toner/093-953
Black Toner

Step	Check	Yes	No
	Possible causative parts: CARTRIDGE ASSY (K) (PL5.1.18) CARTRIDGE ASSY (C) (PL5.1.19) CARTRIDGE ASSY (M) (PL5.1.20) CARTRIDGE ASSY (Y) (PL5.1.21)		
1	Checking the Drum Protect Cover for staying Has the Drum Protect Cover removed?	Go to step 2.	Remove the Drum Protect Cover
2	Checking the Print Cartridge installation Is the Print Cartridge installed correctly?	Go to the FIP below. Yellow :FIP1.53 Magenta:FIP1.54 Cyan :FIP1.55 Black :FIP1.56	Reseat the Print Cartridge.

FIP1.51 Replace Cart 093-930/093-931/093-932/093-933

Step	Check	Yes	No
	Possible causative parts: CARTRIDGE ASSY (K) (PL5.1.18) CARTRIDGE ASSY (C) (PL5.1.19) CARTRIDGE ASSY (M) (PL5.1.20) CARTRIDGE ASSY (Y) (PL5.1.21) PWBA MCU (PL13.5.13)		
1	Checking the CARTRIDGE ASSY for installation Are the CARTRIDGE ASSYs installed correctly?	Go to step 3.	Reseat the CARTRIDGE ASSY, then go step 2.
2	Does the error still occur when the power is turned ON?	Go to step 3.	End of work
3	Checking after replacing the CARTRIDGE ASSY Replace the CARTRIDGE ASSY. (Refer to Removal 6/ Replacement 38) Does the error still occur when the power is turned ON?	Replace the PWBA MCU. (Refer to Removal 30/Replacement 14)	End of work

FIP1.52 Ready to Print 093-423/093-424/093-425/093-426

Step	Check	Yes	No
	Possible causative parts: CARTRIDGE ASSY (K) (PL5.1.18) CARTRIDGE ASSY (C) (PL5.1.19) CARTRIDGE ASSY (M) (PL5.1.20) CARTRIDGE ASSY (Y) (PL5.1.21) PWBA MCU (PL13.5.13)		
1	Checking the CARTRIDGE ASSY for installation Are the CARTRIDGE ASSYs installed correctly?	Go to step 3.	Reseat the CARTRIDGE ASSY, then go step 2.
2	Does the error still occur when the power is turned ON?	Go to step 3.	End of work
3	Checking after replacing the CARTRIDGE ASSY Replace the CARTRIDGE ASSY. (Refer to Removal 6/ Replacement 38) Does the error still occur when the power is turned ON?	Replace the PWBA MCU. (Refer to Removal 30/Replacement 14)	End of work

FIP1.53 Insert Print Cart 093-970

Step	Check	Yes	No
	Possible causative parts: CARTRIDGE ASSY (Y) (PL5.1.21) SENSOR ASSY CRU (PL5.1.4) HARN ASSY CRU SNR (PL10.1.9) PWBA MCU (PL9.1.20)		
1	Checking the CARTRIDGE ASSY (Y) for installation Is the CARTRIDGE ASSY (Y) installed correctly?	Go to step 3.	Reseat the CARTRIDGE ASSY (Y), then go step 2.
2	Does the error still occur when the power is turned ON?	Go to step 3.	End of work
3	Checking after replacing the CARTRIDGE ASSY (Y) Replace the CARTRIDGE ASSY (Y). Does the error still occur when the power is turned ON?	Go to step 4.	End of work
4	Checking the SENSOR ASSY CRU (Y) Does the number on the screen increase by one, every time the CARTRIDGE ASSY (Y) is reseated? Checked by [Digital Input] - [DI-8(Control Panel)/CRU Y(PC)] in diagnosis.	Replace the PWBA MCU. (Refer to Removal 30/Replacement 14)	Go to step 5.
5	Checking the connector for connection Check the connectors between the PWBA MCU and SENSOR ASSY CRU (Y). Are P/J19 and P/J191 connected surely?	Go to step 6.	Reconnect the connector(s) P/J19 and/or P/J191 surly, then go to step 6.
6	Does the error still occur when the power is turned ON?	Go to step 7.	End of work
7	Checking the HARN ASSY CRU SNR for continuity Disconnect P/J19 from the PWBA MCU. Disconnect P/J191 from the SENSOR ASSY CRU. Is each cable of P/J19 <=> P/J191 continuous?	Go to step 8.	Replace the HARN ASSY CRU SNR.
8	Checking the power to SENSOR ASSY CRU Disconnect P/J19 on the PWBA MCU. Are the voltage J19-1pin <=> J19-2pin, about +3.3 VDC?	Go to step 9.	Replace the PWBA MCU. (Refer to Removal 30/Replacement 14)
9	Checking the SENSOR ASSY CRU for operation Measure the voltage across ground <=> P/J19-3pin. Check that the voltage changes when the paper is inserted into the sensor detecting point.	Replace the PWBA MCU. (Refer to Removal 30/Replacement 14)	Replace the SENSOR ASSY CRU. (Refer to Removal 39/Replacement 5)

FIP1.54 Insert Print Cart 093-971

Step	Check	Yes	No
	Possible causative parts: CARTRIDGE ASSY (M) (PL5.1.20) SENSOR ASSY CRU (PL5.1.4) HARN ASSY CRU SNR (PL10.1.9) PWBA MCU (PL9.1.20)		
1	Checking the CARTRIDGE ASSY (M) for installation Is the CARTRIDGE ASSY (M) installed correctly?	Go to step 3.	Reseat the CARTRIDGE ASSY (M), then go step 2.
2	Does the error still occur when the power is turned ON?	Go to step 3.	End of work
3	Checking after replacing the CARTRIDGE ASSY (M) Replace the CARTRIDGE ASSY (M). Does the error still occur when the power is turned ON?	Go to step 4.	End of work
4	Checking the SENSOR ASSY CRU (M) Does the number on the screen increase by one, every time the CARTRIDGE ASSY (M) is reseated? Checked by [Digital Input] - [DI-9(Control Panel)/CRU M(PC)] in diagnosis.	Replace the PWBA MCU. (Refer to Removal 30/Replacement 14)	Go to step 5.
5	Checking the connector for connection Check the connectors between the PWBA MCU and SENSOR ASSY CRU (M). Are P/J19 and P/J192 connected surely?	Go to step 6.	Reconnect the connector(s) P/J19 and/or P/J192 surly, then go to step 6.
6	Does the error still occur when the power is turned ON?	Go to step 7.	End of work
7	Checking the HARN ASSY CRU SNR for continuity Disconnect P/J19 from the PWBA MCU. Disconnect P/J192 from the SENSOR ASSY CRU. Is each cable of P/J19 <=> P/J192 continuous?	Go to step 8.	Replace the HARN ASSY CRU SNR.
8	Checking the power to SENSOR ASSY CRU Disconnect P/J19 on the PWBA MCU. Are the voltage J19-4pin <=> J19-5pin, about +3.3 VDC?	Go to step 9.	Replace the PWBA MCU. (Refer to Removal 30/Replacement 14)
9	Checking the SENSOR ASSY CRU for operation Measure the voltage across ground <=> P/J19-6pin. Check that the voltage changes when the paper is inserted into the sensor detecting point.	Replace the PWBA MCU. (Refer to Removal 30/Replacement 14)	Replace the SENSOR ASSY CRU. (Refer to Removal 39/Replacement 5)

FIP1.55 Insert Print Cart 093-972

Step	Check	Yes	No
	Possible causative parts: CARTRIDGE ASSY (C) (PL5.1.19) SENSOR ASSY CRU (PL5.1.4) HARN ASSY CRU SNR (PL10.1.9) PWBA MCU (PL9.1.20)		
1	Checking the CARTRIDGE ASSY (C) for installation Is the CARTRIDGE ASSY (C) installed correctly?	Go to step 3.	Reseat the CARTRIDGE ASSY (C), then go step 2.
2	Does the error still occur when the power is turned ON?	Go to step 3.	End of work
3	Checking after replacing the CARTRIDGE ASSY (C) Replace the CARTRIDGE ASSY (C). Does the error still occur when the power is turned ON?	Go to step 4.	End of work
4	Checking the SENSOR ASSY CRU (C) Does the number on the screen increase by one, every time the CARTRIDGE ASSY (C) is reseated? Checked by [Digital Input] - [DI-b(Control Panel)/CRU C(PC)] in diagnosis.	Replace the PWBA MCU. (Refer to Removal 30/Replacement 14)	Go to step 5.
5	Checking the connector for connection Check the connectors between the PWBA MCU and SENSOR ASSY CRU (C). Are P/J19 and P/J194 connected surely?	Go to step 6.	Reconnect the connector(s) P/J19 and/or P/J194 surly, then go to step 6.
6	Does the error still occur when the power is turned ON?	Go to step 7.	End of work
7	Checking the HARN ASSY CRU SNR for continuity Disconnect P/J19 from the PWBA MCU. Disconnect P/J194 from the SENSOR ASSY CRU. Is each cable of P/J19 <=> P/J194 continuous?	Go to step 8.	Replace the HARN ASSY CRU SNR.
8	Checking the power to SENSOR ASSY CRU Disconnect P/J19 on the PWBA MCU. Are the voltage J19-10pin <=> J19-11pin, about +3.3 VDC?	Go to step 9.	Replace the PWBA MCU. (Refer to Removal 30/Replacement 14)
9	Checking the SENSOR ASSY CRU for operation Measure the voltage across ground <=> P/J19-12pin. Check that the voltage changes when the paper is inserted into the sensor detecting point.	Replace the PWBA MCU. (Refer to Removal 30/Replacement 14)	Replace the SENSOR ASSY CRU. (Refer to Removal 39/Replacement 5)

FIP1.56 Insert Print Cart 093-973

Step	Check	Yes	No
	Possible causative parts: CARTRIDGE ASSY (K) (PL5.1.18) SENSOR ASSY CRU (PL5.1.4) HARN ASSY CRU SNR (PL10.1.9) PWBA MCU (PL9.1.20)		
1	Checking the CARTRIDGE ASSY (K) for installation Is the CARTRIDGE ASSY (K) installed correctly?	Go to step 3.	Reseat the CARTRIDGE ASSY (K), then go step 2.
2	Does the error still occur when the power is turned ON?	Go to step 3.	End of work
3	Checking after replacing the CARTRIDGE ASSY (K) Replace the CARTRIDGE ASSY (K). Does the error still occur when the power is turned ON?	Go to step 4.	End of work
4	Checking the SENSOR ASSY CRU (K) Does the number on the screen increase by one, every time the CARTRIDGE ASSY (K) is reseated? Checked by [Digital Input] - [DI-a(Control Panel)/CRU K(PC)] in diagnosis.	Replace the PWBA MCU. (Refer to Removal 30/Replacement 14)	Go to step 5.
5	Checking the connector for connection Check the connectors between the PWBA MCU and SENSOR ASSY CRU (K). Are P/J19 and P/J193 connected surely?	Go to step 6.	Reconnect the connector(s) P/J19 and/or P/J193 surly, then go to step 6.
6	Does the error still occur when the power is turned ON?	Go to step 7.	End of work
7	Checking the HARN ASSY CRU SNR for continuity Disconnect P/J19 from the PWBA MCU. Disconnect P/J193 from the SENSOR ASSY CRU. Is each cable of P/J19 <=> P/J193 continuous?	Go to step 8.	Replace the HARN ASSY CRU SNR.
8	Checking the power to SENSOR ASSY CRU Disconnect P/J19 on the PWBA MCU. Are the voltage J19-7pin <=> J19-8pin, about +3.3 VDC?	Go to step 9.	Replace the PWBA MCU. (Refer to Removal 30/Replacement 14)
9	Checking the SENSOR ASSY CRU for operation Measure the voltage across ground <=> P/J19-9pin. Check that the voltage changes when the paper is inserted into the sensor detecting point.	Replace the PWBA MCU. (Refer to Removal 30/Replacement 14)	Replace the SENSOR ASSY CRU. (Refer to Removal 39/Replacement 5)

FIP1.57 CRUM ID 009-371

Step	Check	Yes	No
	Possible causative parts: TRANSFER ASSY (PL4.1.1) PWBA MCU (PL9.1.20)		
1	Checking the TRANSFER ASSY for installation Is the TRANSFER ASSY installed correctly? Does the error still occur when the power is turned ON?	Go to step 2.	End of work
2	Checking the TRANSFER ASSY model Is the TRANSFER ASSY installed the 3130cn?	Go to step 3.	Replace the TRANSFER ASSY.
3	Checking after replacing the TRANSFER ASSY Replace the TRANSFER ASSY. (Refer to Removal 4/ Replacement 40.) Does the error still occur when the power is turned ON?	Replace the PWBA MCU. (Refer to Removal 30/Replacement 14.)	End of work

FIP1.58 Ready to Print 094-422

Step	Check	Yes	No
	Possible causative parts: TRANSFER ASSY (PL4.1.1) PWBA MCU (PL9.1.20)		
1	Checking the life counter value of the TRANSFER ASSY. Does the life counter value show the near of the end?	Replace the TRANSFER ASSY. (Refer to Removal 4/ Replacement 40.) After replacement, be sure to clear the life counter value.	Go to step 2.
2	Checking after replacing the TRANSFER ASSY Replace the TRANSFER ASSY. (Refer to Removal 4/ Replacement 40) Does the error still occur when the power is turned ON?	Replace the PWBA MCU. (Refer to Removal 30/Replacement 14)	End of work

FIP1.59 Insert Belt Unit 094-910

Step	Check	Yes	No
	Possible causative parts: TRANSFER ASSY (PL4.1.1) HARN ASSY R SIDE (PL10.1.15) HARNESS ASSY FRONT COVER (PL1.2.11) PWBA MCU (PL9.1.20)		
1	Checking the TRANSFER ASSY for installation Is the TRANSFER ASSY installed correctly?	Go to step 3.	Reseat the TRANSFER ASSY, then go step 2.
2	Does the error still occur when the power is turned ON?	Go to step 3.	End of work
3	Checking the connector for connection Check the connectors between the PWBA MCU and TRANSFER ASSY. Are P/J27, P/J272 and P/J2721 connected surely?	Go to step 4.	Reconnect the connector(s) P/J27, P/J272 and P/J2721 surly, then go to step 4.
4	Checking the HARN ASSY R SIDE for continuity Disconnect P/J27 from the PWBA MCU. Disconnect P/J272 from the HARNESS ASSY FRONT COVER. Is each cable of P/J27 <=> P/J272 continuous?	Go to step 5.	Replace the HARN ASSY R SIDE.
5	Checking the HARNESS ASSY FRONT COVER for continuity Disconnect P/J272 from the HARN ASSY R SIDE. Disconnect P/J2721 from the TRANSFER ASSY. Is each cable of P/J272 <=> P/J2721 continuous?	Go to step 6.	Replace the HARNESS ASSY FRONT COVER .
6	Checking after replacing the TRANSFER ASSY Replace the TRANSFER ASSY. (Refer to Removal 4/ Replacement 40) Does the error still occur when the power is turned ON?	Replace the PWBA MCU. (Refer to Removal 30/Replacement 14)	End of work

FIP1.60 Belt Unit 094-911

Step	Check	Yes	No
	Possible causative parts: TRANSFER ASSY (PL4.1.1) PWBA MCU (PL9.1.20)		
1	Checking the life counter value of the TRANSFER ASSY. Does the life counter value show the near of the end?	Replace the TRANSFER ASSY. (Refer to Removal 4/ Replacement 40.) After replacement, be sure to clear the life counter value.	Go to step 2.
2	Checking after replacing the TRANSFER ASSY Replace the TRANSFER ASSY. (Refer to Removal 4/ Replacement 40) Does the error still occur when the power is turned ON?	Replace the PWBA MCU. (Refer to Removal 30/Replacement 14)	End of work

FIP1.61 010-359 Restart Printer

Step	Check	Yes	No
	Possible causative parts: FUSER ASSY (PL6.1.10) PWBA MCU (PL9.1.20)		
1	Checking the FUSER ASSY for installation Is the FUSER ASSY installed correctly? Warning: Start the operation after the FUSER ASSY has cooled down. Does the error still occur when the power is turned ON?	Go to step 2.	End of work
2	Checking the FUSER ASSY type Is the FUSER ASSY installed the 3130cn FUSER?	Go to step 3.	Replace the FUSER ASSY.
3	Checking after replacing the FUSER ASSY Replace the FUSER ASSY. (Refer to Removal 8/ Replacement 36.) Warning: Start the operation after the FUSER ASSY has cooled down. Does the error still occur when the power is turned ON?	Replace the PWBA MCU. (Refer to Removal 30/Replacement 14.)	End of work

FIP1.62 Ready to Print 010-421

Step	Check	Yes	No
	Possible causative parts: FUSER ASSY (PL6.1.10) PWBA MCU (PL9.1.20)		
1	Checking the life counter value of the FUSER ASSY. Does the life counter value show the near of the end?	Replace the FUSER ASSY. (Refer to Removal 8/ Replacement 36.) After replacement, be sure to clear the life counter value.	Go to step 2.
2	Checking the FUSER ASSY for installation Is the FUSER ASSY installed correctly? Warning: Start the operation after the FUSER ASSY has cooled down.	Go to step 4.	Reseat the FUSER ASSY, then go step 3.
3	Does the error still occur when the power is turned ON?	Go to step 4.	End of work
4	Checking after replacing the FUSER ASSY Replace the FUSER ASSY. (Refer to Removal 8/Replacement 36) Warning: Start the operation after the FUSER ASSY has cooled down. Does the error still occur when the power is turned ON?	Replace the PWBA MCU. (Refer to Removal 30/Replacement 14)	End of work

FIP1.63 Tray Detached 024-946/007-912

Step	Check	Yes	No
	Possible causative parts: HARN ASSY R SIDE (PL10.1.15) SWITCH ASSY SIZE (PL7.1.18) PWBA MCU (PL9.1.20)		
1	Checking the cassette assy installation Is the cassette assy installed correctly?	Go to step 3.	Reseat the cassette assy, then go to step 2.
2	Does the error still occur when the power is turned ON?	Go to step 3.	End of work
3	Checking the SWITCH ASSY SIZE Does the SWITCH ASSY SIZE function normally? Checked by [Digital Input] - [DI-18(Control Panel)/CASSETTE1 SIZE(PC)] in diagnosis.	End of work	Go to step 4.
4	Checking the HARN ASSY R SIDE for continuity Disconnect P/J29 from the PWBA MCU. Disconnect P/J291 from the SWITCH ASSY SIZE. Is each cable of P/J29 <=> P/J291 continuous?	Go to step 5.	Replace the HARN ASSY R SIDE.
5	Checking after replacing the SWITCH ASSY SIZE Replace the SWITCH ASSY SIZE. (Refer to Removal 18/Replacement 26) Does the error still occur when the power is turned ON?	Replace the PWBA MCU. (Refer to Removal 30/Replacement 14)	End of work

FIP1.64 Load Tray 024-947

Step	Check	Yes	No
	Possible causative parts: HARN ASSY C2 CHUTE (PL12.2.7) SWITCH ASSY SIZE OPT (PL12.2.5) PWBA MCU (PL9.1.20)		
1	Checking the cassette assy installation Is the cassette assy installed correctly?	Go to step 3.	Reseat the cassette assy, then go to step 2.
2	Does the error still occur when the power is turned ON?	Go to step 3.	End of work
3	Checking the SWITCH ASSY SIZE OPT Does the SWITCH ASSY SIZE OPT function normally? Checked by [Digital Input] - [DI-20(Control Panel)/CASSETTE2 SIZE(PC)] in diagnosis.	End of work	Go to step 4.
4	Checking the HARN ASSY C2 CHUTE for continuity Disconnect P/J421 from the PWBA MCU. Disconnect P/J4211 from the SWITCH ASSY SIZE OPT. Is each cable of P/J421 <=> P/J4211 continuous?	Go to step 5.	Replace the HARN ASSY C2 CHUTE.
5	Checking after replacing the SWITCH ASSY SIZE Replace the SWITCH ASSY SIZE OPT. (Refer to Removal 44/Replacement 46) Does the error still occur when the power is turned ON?	Replace the PWBA MCU. (Refer to Removal 30/Replacement 14)	End of work

FIP1.65 Close Front Cover 077-300

Step	Check	Yes	No
	Possible causative parts: COVER ASSY FRONT (PL1.2.98) HARN ASSY INTERLOCK (PL9.1.3) LVPS (PL9.1.4) PWBA MCU (PL9.1.20)		
1	Checking the COVER ASSY FRONT for shape Are there any damages on the COVER ASSY FRONT?	Replace the COVER ASSY FRONT. (Refer to Removal 14/Replacement 30)	Go to step 2.
2	Checking the interlock switch for operation Does the number on the screen increase by one, every time the Front Cover is operated? Checked by [Digital Input] - [DI-7(Control Panel)/IL OPEN(PC)] in diagnosis.	Replace the PWBA MCU. (Refer to Removal 30/Replacement 14)	Go to step 3.
3	Checking after replacing the HARN ASSY INTERLOCK Replace the HARN ASSY INTERLOCK. (Refer to Removal 37/Replacement 7) Does the error still occur when the power is turned ON?	Go to step 4.	End of work
4	Checking after replacing the LVPS. Replace the LVPS. (Refer to Removal 35/Replacement 9.) Does the error still occur when the power is turned ON?	Replace the PWBA MCU. (Refer to Removal 30/Replacement 14.)	End of work

FIP1.66 Invalid ID 016-383 / Range Chk Error 016-384 / Header Error 016-385 / Check Sum Error 016-386 / Format Error 016-387

Step	Check	Yes	No
	Possible causative parts: PWBA ESS (PL9.1.27)		
1	Checking the download firmware Is the download firmware the 3130cn?	Go to step 2.	Redownload the correct firmware.
2	Checking the PWBA ESS for installation Does the error still occur when downloading the firmware?	Replace the PWBA ESS. (Refer to Removal 26/Replacement 18.)	End of work

FIP1.67 Out of Memory 016-700 / Disc Full 016-980 / Collate Full 016-981

Step	Check	Yes	No
	Possible causative parts: PWBA ESS (PL9.1.27) MEMORY CARD (OPTION) (PL9.1.30)		
1	Checking the memory capacity for print Print the small size file (like a Windows test print). Does the error still occur when printing?	Go to step 2.	Add the MEMORY CARD or divide the printing job.
2	Checking after reseating the MEMORY CARD Reseat the MEMORY CARD. Does the error still occur when printing?	Go to step 3.	End of work
3	Checking the memory card capacity Is the memory capacity recognized normally? Checked by [Information Page] - [Configuration] in [Setup].	Go to step 4.	Replace the PWBA ESS. (Refer to Removal 26/Replacement 18)
4	Checking after replacing the MEMORY CARD Replace the MEMORY CARD. Does the error still occur when printing?	Replace the PWBA ESS. (Refer to Removal 26/Replacement 18)	End of work

FIP1.68 016-720 PDL Error

Step	Check	Yes	No
	Possible causative parts: PWBA ESS (PL9.1.27)		
1	Checking the printing job Print the small size file (like a Windows test print). Does the error still occur when printing?	Go to step 2.	End of work
2	Checking after reseating the PWBA ESS Reseat the PWBA ESS. Does the error still occur when printing?	Replace the PWBA ESS. (Refer to Removal 26/Replacement 18)	End of work

FIP1.69 Invalid User 016-757 / Disabled Func 016-758 / Reached Limits 016-759

Step	Check	Yes	No
	Possible causative parts: PWBA ESS (PL9.1.27)		
1	Checking the Color Track setting Is the Color Track setting correctly? Use the Dell Printer Configuration Web Tool.	Replace the PWBA ESS. (Refer to Removal 26/Replacement 18.)	Set the Color Track setting.

FIP1.70 Invalid Job 016-799

Step	Check	Yes	No
	Possible causative parts: PWBA ESS (PL9.1.27)		
1	Checking the paper size Does the paper size in use meet the specification?	Go to step 2.	Use the paper that meets the specification.
2	Checking the paper size setup Does the paper size in use match the size set through the control panel?	Go to step 4.	Go to step 3.
3	Set the paper size through the control panel. Does the error still occur when printing?	Replace the PWBA ESS. (Refer to Removal 26/Replacement 18)	End of work
4	Does the error still occur when printing?	Go to step 5.	End of work
5	Checking the printing job Does the error still occur when printing the windows test print?	Replace the PWBA ESS. (Refer to Removal 26/Replacement 18)	End of work

FIP1.71 Ready to Print 193-700

Step	Check	Yes	No
	Possible causative parts: PWBA ESS (PL9.1.27)		
1	Checking the Print Cartridge. Is the installed print cartridge to the printer the DELL toner?	Go to step 2.	End of work
2	Checking the PWBA ESS. Cancel the non DELL toner mode by the control panel. Does the message on the LCD turn off the non DELL toner?	End of work	Go to step 3.
3	Checking after replacing the print cartridge. Replace the print cartridge. Does the error still occur when printing?	Replace the PWBA ESS. (Refer to Removal 26/Replacement 18.)	End of work

FIP1.72 Over Heat 042-700/Ready to Print 142-700

Step	Check	Yes	No
	Possible causative parts: KIT FEEDER ASSY (PL3.2.99) PWBA MCU (PL9.1.20)		
1	Checking the room temperature Is the room temp. Over 32 degrees C?	Change the room or cool down the room	Go to step 2.
2	Checking the printing Did the client print the large volume of printing?	Go to step 3.	Go to step 4.
3	Checking the printing after cool down of five minutes. Does the error still occur when printing?	Go to step 4.	End of work
4	Checking the PWBA MCU Reseat the PWBA MCU. Does the error still occur when printing?	Go to step 5.	End of work
5	Checking after replacing the PWBA MCU Replace the PWBA Does the error still occur when printing?	Replace the KIT FEEDER ASSY. (Refer to Removal 40/Replacement 4)	End of work

FIP1.73 Electrical Noise

Step	Check	Yes	No
1	Checking the external noise Are there any other electrical appliances within 3 meters of the printer, such as generators, radio and appliances with motors? Either turn off the other electrical appliances, or relocate the printer at least 6 meters from other appliances. Does the electrical noise error still occur?	Go to step 2.	End of work
2	Checking the AC ground Is AC power supply outlet wired and grounded appropriately?	Go to step 3.	Request the client to fix AC power supply outlet.
3	Checking the print cartridges and TRANSFER ASSY installation Reseat the print cartridges and TRANSFER ASSY. Does the electrical noise error still occur?	Go to step 4.	End of work
4	Checking the BIAS ASSY contact. Remove the all print cartridges. Are there any stains or foreign substance on the contact?	Wipe the stains or foreign substance with dry cloth.	Reseat the HVPS. (Refer to Removal 34/Replacement 10)

4. Image Quality Trouble

4.1 Entry Chart for Image Quality Troubleshooting

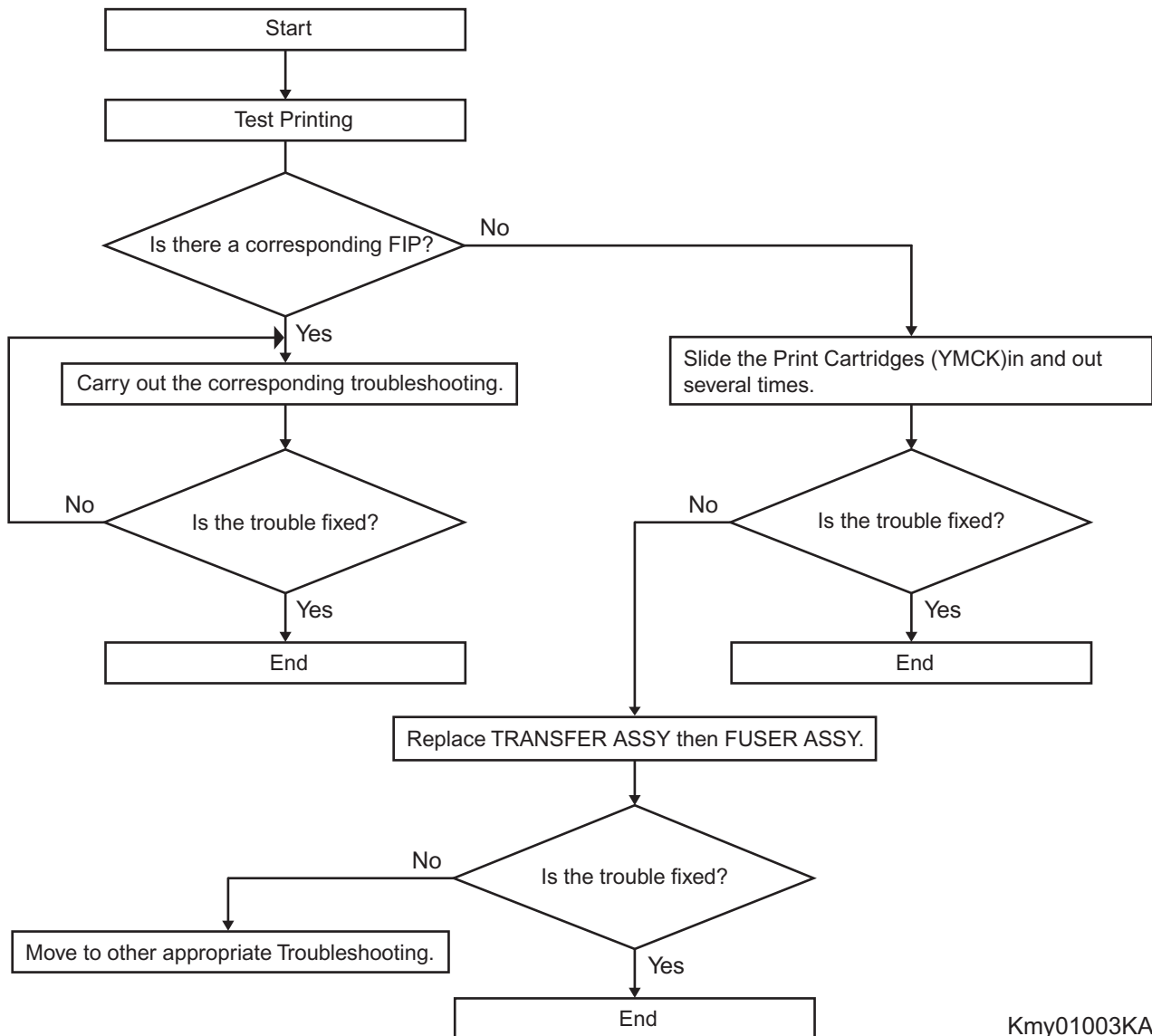

Kmy01003KA

NOTE

By performing a test print with the engine only, you can determine if the failure is Printer Controller-caused or engine-caused, except for phenomena that cannot be determined by test print.

- Test print result with the engine only is normal. ---> Malfunction on Printer Controller side

- Test print result with the engine only is also abnormal. ---> Malfunction on the engine side

When Printer-Controller-caused is more likely, replace with normal

Printer Controller and normal Interface Cable, and then confirm the operation.

When the trouble persists even after replacement, check the host, and then operate Troubleshooting efficiently, using the following image quality FIP for each phenomenon.

When the image quality trouble of print occurs, get a print to judge, understand and treat the trouble substance precisely and appropriately, and then troubleshoot efficiently, using the image quality FIP table according to each phenomenon.

When trouble restoration with image quality FIP is not possible, check again with the image quality FIP, and then replace [ESS and possible causative parts] in order and check, and operate Troubleshooting, using [Chapter 2 Diagnostic].

Image quality FIP states regarding the typical image quality trouble, as follows.

- FIP-1.P1 Faint print (Low contrast)
- FIP-1.P2 Blank print
- FIP-1.P3 Solid black
- FIP-1.P4 Vertical blank lines (White stripes in paper transport direction)
- FIP-1.P5 Horizontal band cross out (White stripes in the horizontal direction)
- FIP-1.P6 Vertical stripes
- FIP-1.P7 Horizontal stripes
- FIP-1.P8 Partial lack
- FIP-1.P9 Spots
- FIP-1.P10 Afterimage
- FIP-1.P11 Background (Fog)
- FIP-1.P12 Skew
- FIP-1.P13 Paper damage
- FIP-1.P14 No fix
- FIP-1.P15 Color Registration (Color Shift)

NOTE

When horizontal lines and/or spot occur periodically, it is possibly caused by the trouble of a particular roll. In this case, measure the trouble interval on the test print, and check the relation to the roll in the table below. The interval does not necessarily match circumference of the roll. The trouble may be solved easily by the check.

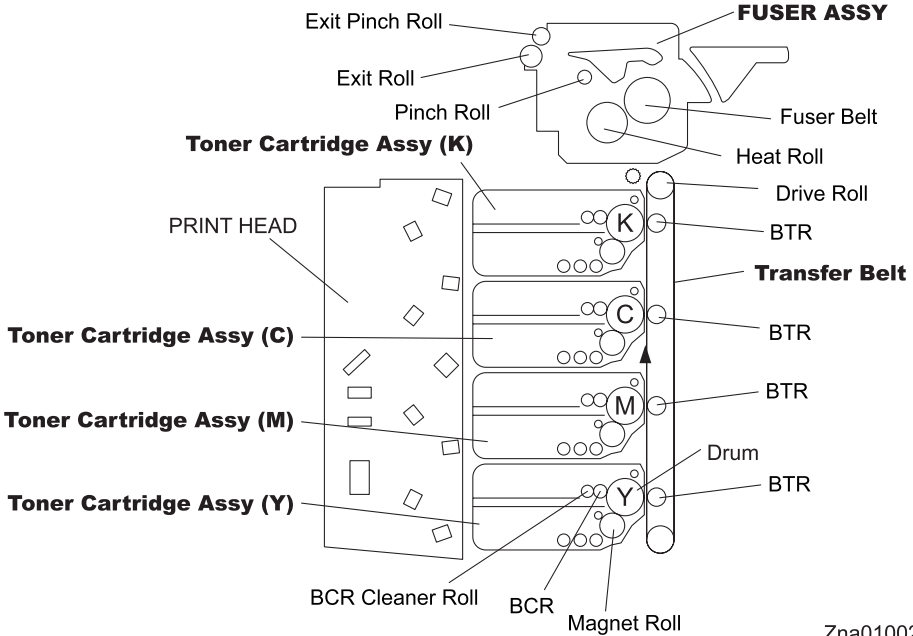

Zna01002KA

-Pitch Chart

The chart is printed [Pitch Configuration Chart] in the [Diagnosis] tab of the [Tool Box].

Page 1

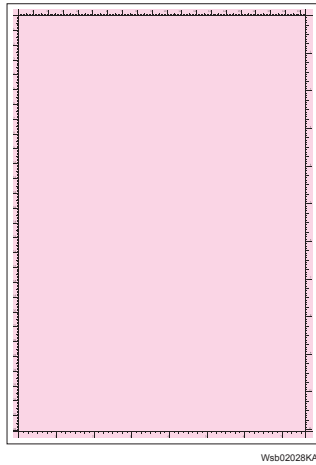

Wsb02028KA

Page 2

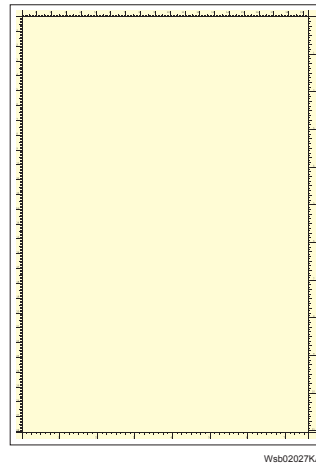

Wsb02027KA

Page 3

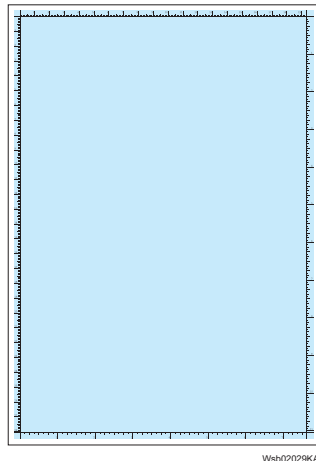

Wsb02029KA

Page 4



Wsb02030KA

Page 5

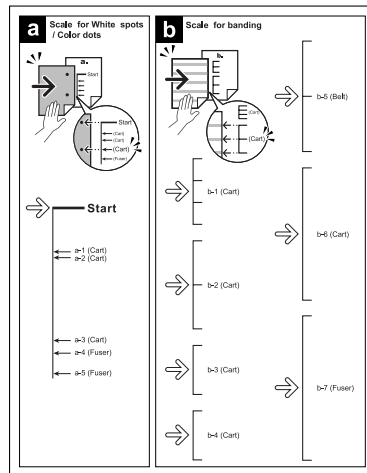

Zna02119KA

4.2 Diagnosis Test Chart

The test charts to improve a defective image quality or to specify the cause of generation when a defective image was generated are in [Diagnosis] tab in [Tool Box].

Use the following test charts properly by the state of a defective image quality.

-Drum Refresh

When the result of [Contamination Check] corresponds to b-6 (Drum) of the pitch chart, performing this test print may improve image quality.

This chart is printed the [Drum Refresh Configuration Chart] of the [Diagnosis] tab in [Tool Box].

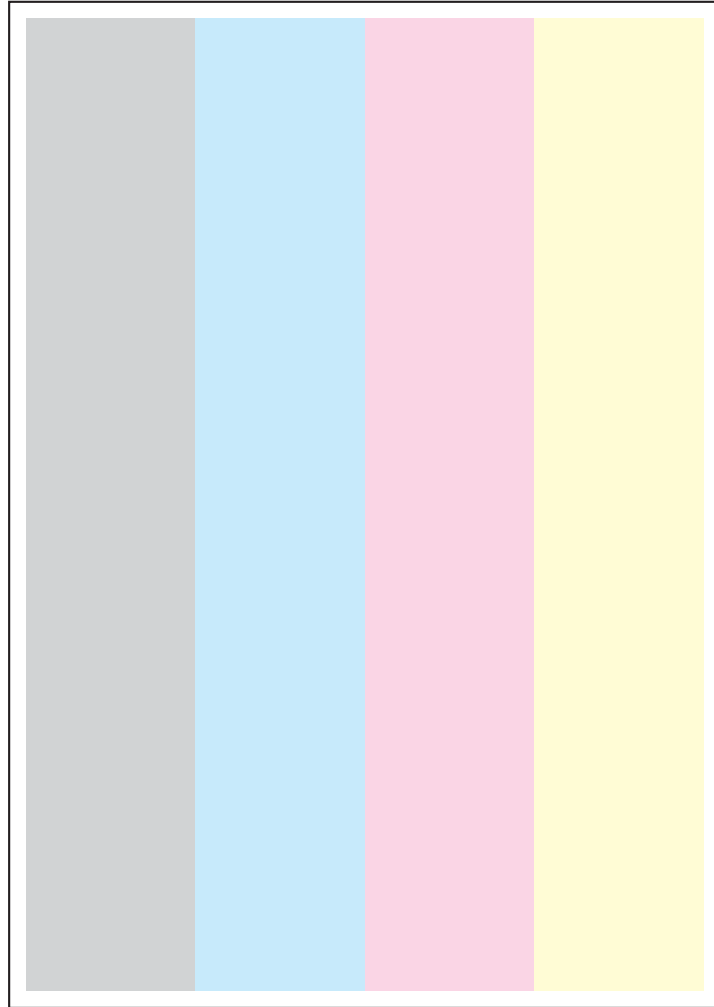

Wsb02021KA

-MQ Chart

This chart allows you to check for a banding if any occurs.

This chart is printed the [MQ Chart] of the [Diagnosis] tab in [Tool Box].

When the image quality is normal, the waves of Y, M, and C are confined within the frame. When the image quality is abnormal, the wave runs out the frame. Compare the pitch of the wave with the pitch chart of second page.

No	Roll Parts	Period (mm)	Replaceable parts
Drum	Toner Cartridge ASSY	75.4	TONER CARTRIDGE ASSY
BCR	Toner Cartridge ASSY	28.3	TONER CARTRIDGE ASSY
BCR Cleaner Roll	Toner Cartridge ASSY	25.1	TONER CARTRIDGE ASSY
Sleeve (K)	Toner Cartridge ASSY	27.9	TONER CARTRIDGE ASSY
Sleeve (Y,M,C)	Toner Cartridge ASSY	27.9	TONER CARTRIDGE ASSY
1stBTR	Transfer Belt	31.4	TRANSFER BELT ASSY
Drive Roll	Transfer Belt	56.9	TRANSFER BELT ASSY
Fuser Roll	FUSER ASSY	82.7	FUSER ASSY
Fuser Belt	FUSER ASSY	94.2	FUSER ASSY
Pinch Roll	FUSER ASSY	18.8	FUSER ASSY
Exit Roll	FUSER ASSY	43.1	FUSER ASSY
Exit Pinch Roll	FUSER ASSY	31.4	FUSER ASSY

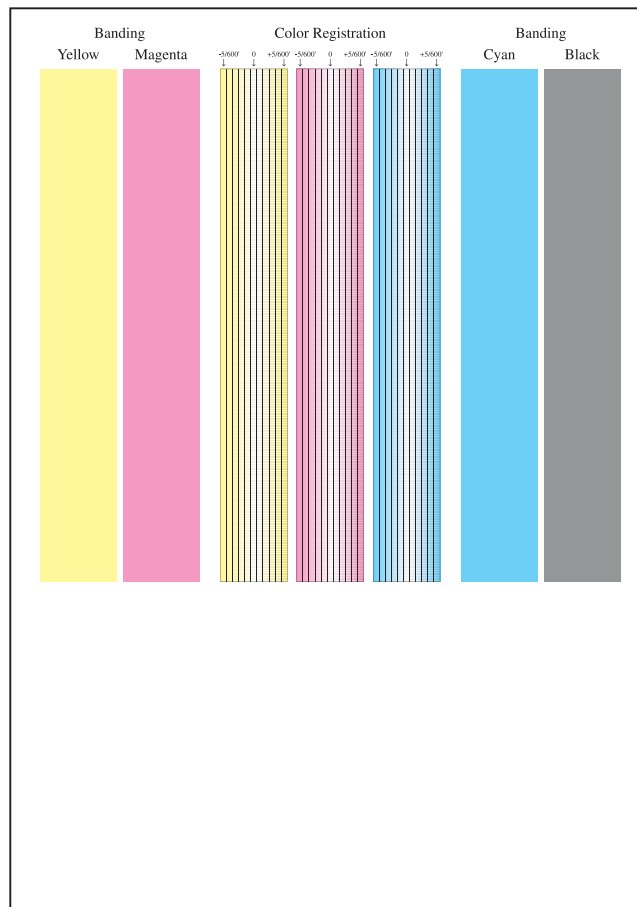

Wsb02024KA

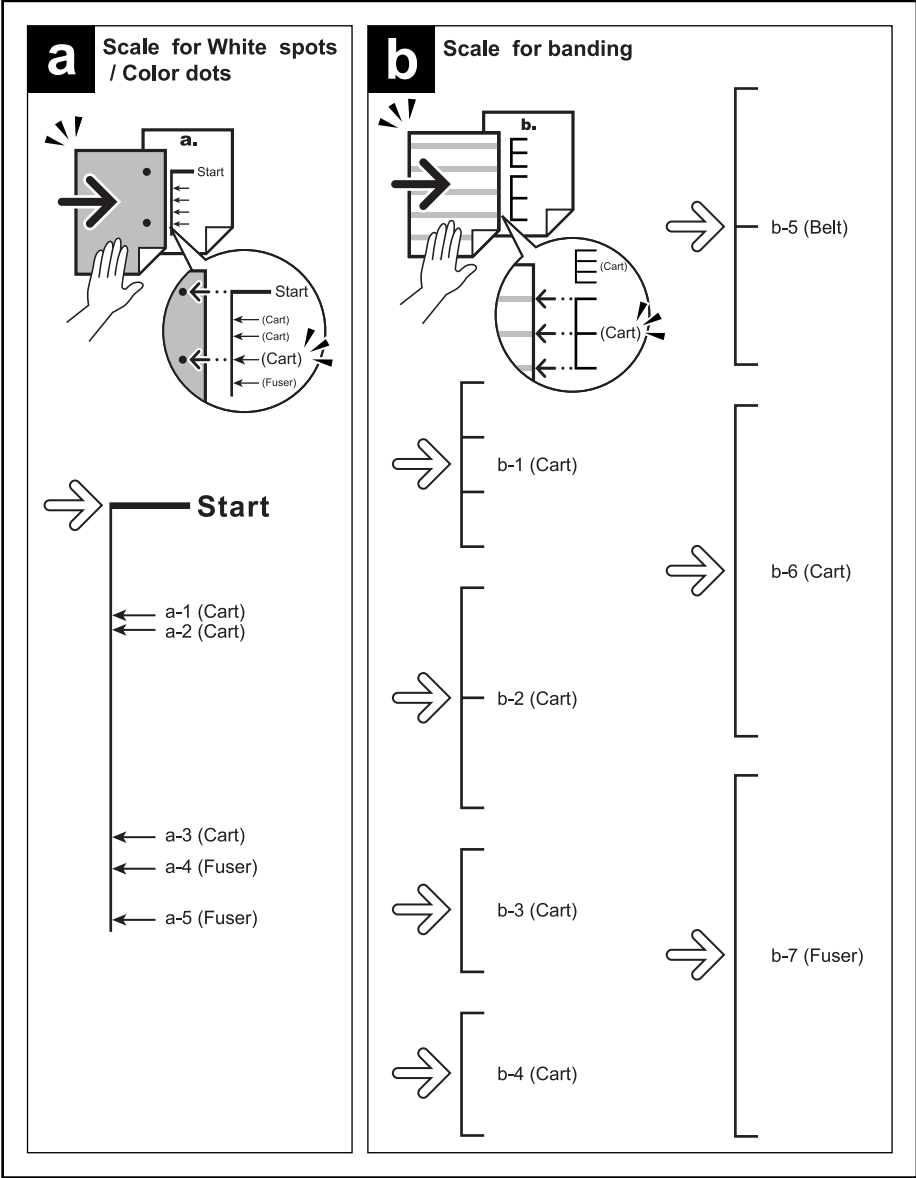

Zna02119KA

-Alignment Chart

This chart allows you to check for the skewed paper if any occurs.
This chart is printed the [Alignment Chart] of the [Diagnosis] tab in [Tool Box].

When the sheet is fed normally, the vertical and horizontal lines are aligned parallel to the edges of the sheet. When there is a problem, this alignment is skewed.

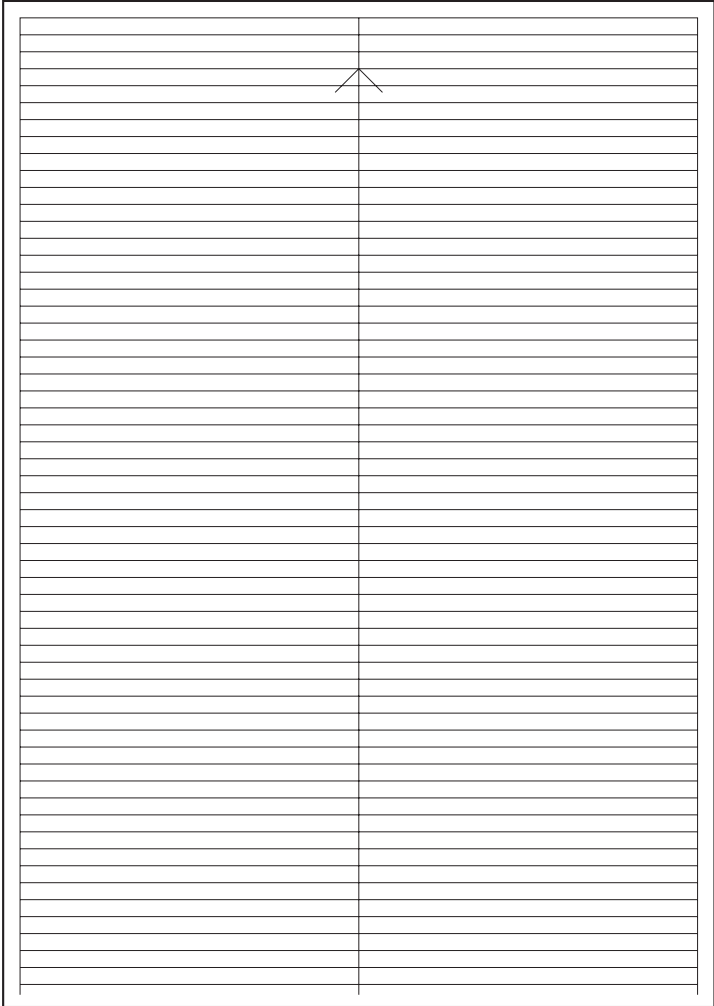

Wsb02022KA

-Ghost Chart

This chart allows you to check for a ghost if any occurs.

This chart is printed the [Ghost Configuration Chart] of the [Diagnosis] tab in [Tool Box].

When a ghost occurs, the patches with open cross and character K/B/G/R/M/C appear on the light-colored patches K/C/M in the lower half of the chart, and the patches with open cross only appears on the dark-colored patches K/C/M below the light-colored patches.

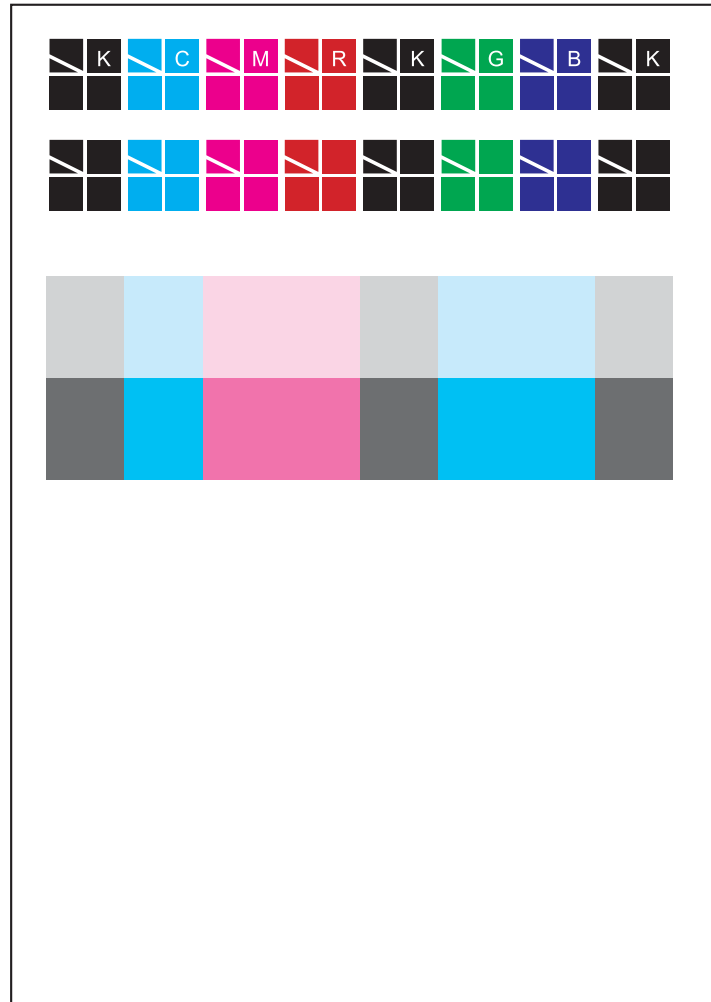

Wsb02020KA

4.3 Items to be Confirmed Before Image Quality Troubleshooting

Print Quality Problems

Customers may need your help determining the cause of print quality issues such as streaking, fading, or dropouts. Here are some questions that may help you determine why your customer's printer is not printing optionally. First, confirm the following items to understand customer's operating condition.

1. Does your customer's print media fall within the Printer Media Guidelines? (Go to 1.5 of this chapter and refer to "**Printer Media Guidelines**").
2. Is there enough toner?
3. Has the printer been cleaned recently?

Checking printer condition

Toner

Low toner can cause print quality problems such as fading, streaking, white lines, or dropouts.

Have your customer print a small document from a different application to replicate the problem and verify the amount of toner available for printing. When your customers print a document, the Laser Printer Status Monitor should display a dialog box that estimates the amount of toner left in the cartridge.

If the toner is low, your customers can something extend the cartridge life by removing the cartridge from the 3130cn, gently shaking it from side-to-side, and replacing it (Rocking the print cartridge from side-to-side loosens toner that may get stuck).

Cleaning

Paper, toner, and dust particles can accumulate inside the 3130cn printer and cause print quality problems, such as smearing or toner specks. Clean inside the 3130cn to prevent these problems.

Prior checks before troubleshooting

Check the following items if any print quality problems occur before going to each troubleshooting. Those actions may solve problems easily and simply.

If the any problems below have occurred, check and take actions described in each item.

- 1) Color is out of alignment:
 - a) Clean inside of the printer.
 - b) If you install a new black print cartridge and a Print Head cleaning has not been done, this problem will happen. Clean inside of the printer.
- 2) Print is too light:
 - a) The toner may be low. Confirm the amount of the toner and change the print cartridges if necessary.
 - b) Set the **Draft Mode** check box to off in the Advanced in the printer driver.
 - c) If you are printing on an uneven print surface, change the Paper Type settings in the Tray Settings menu.
 - d) Verify that the correct print media is being used.
 - e) The print cartridge may need to be replaced. Change the print cartridge.
- 3) Toner smears or print comes off page:
 - a) If you are printing on an uneven print surface, change the Paper Type settings in the Tray Settings menu.
 - b) Verify that the print media is within the printer specifications. (Go to 1.5 of this chapter and refer to "**Printer Media Guidelines**").

- 4) Toner spots appear on the page/printing is blurred:
 - a) Check the print cartridge to make sure it is installed correctly.
 - b) Change the print cartridge.
- 5) Entire page is white:
 - a) Make sure the packaging material is removed from the print cartridge.
 - b) Check the print cartridge to make sure it is installed correctly.
 - c) The toner may be low. Change the print cartridge.
- 6) Streaks appear on the page:
 - a) The toner may be low. Change the print cartridge.
 - b) If you are using preprinted forms, make sure the toner can withstand temperatures of 0°C to 35°C.
- 7) Characters have jagged or uneven edges:
 - a) Change the **Print Mode** in the **Graphics** tab (or **Advanced** dialog box) to **Standard** in the printer driver.
 - b) If you are using downloaded fonts, verify that the fonts are supported by the printer, the host computer, and the software program.
- 8) Part or all of the page prints in black:
 - a) Check the print cartridge to make sure it is installed correctly.
- 9) The job prints, but the top and side margins are incorrect:
 - a) Make sure the Paper Size setting in the Tray Settings is correct.
 - b) Make sure the margins are set correctly in your software program.
- 10) Printing on both ends of the transparencies is faded:
 - a) This occurs when the printer is operating in a location where relative humidity reaches 85% or more. Adjust the humidity or relocate the printer to an appropriate environment.

Parallelism

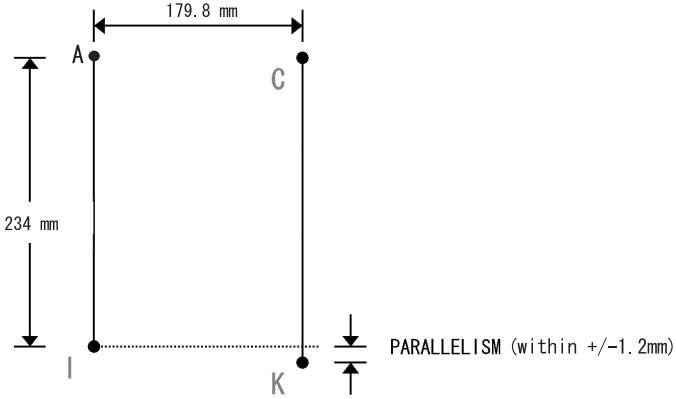

Perpendicularity

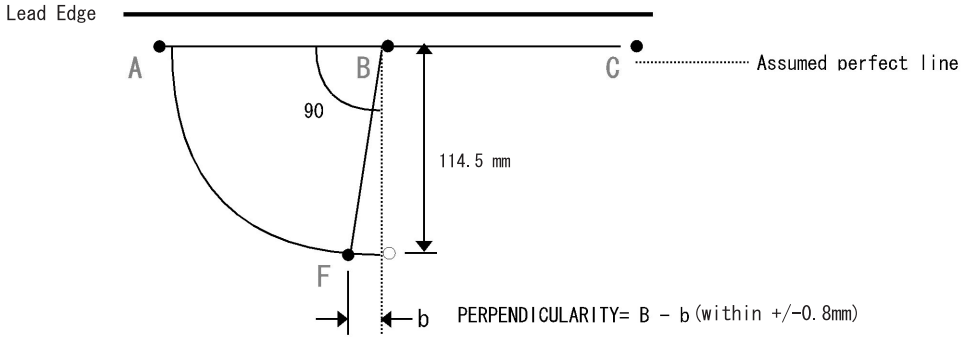

Skew

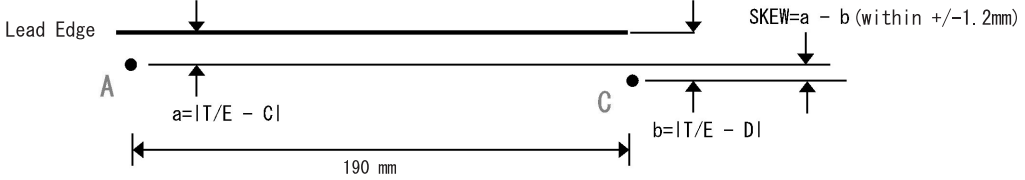

Linearity

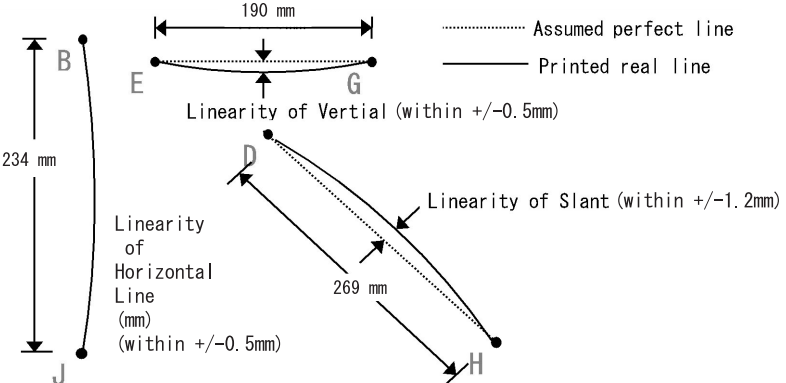

Magnification Error

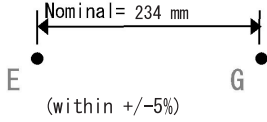
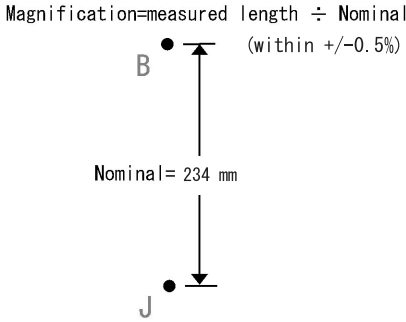

Registration

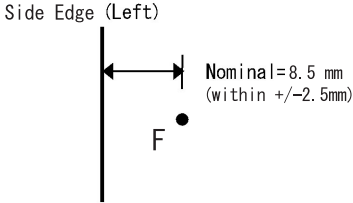
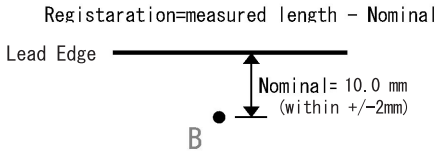

Printed Guaranteed Area

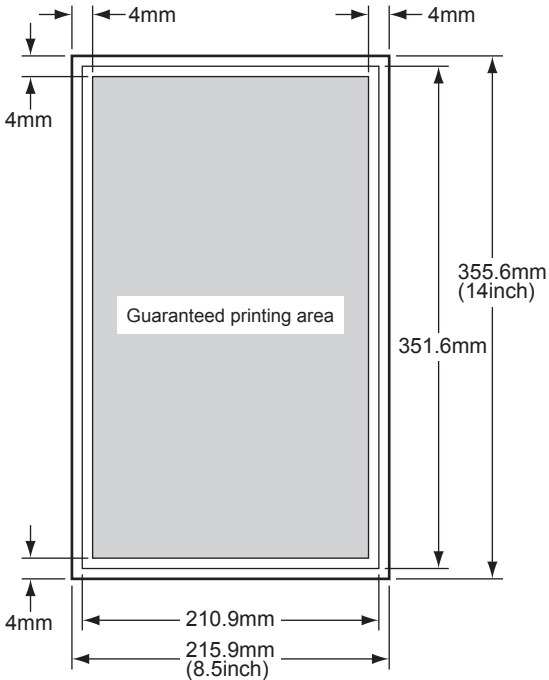

Kmy01001KA

4.5 Image Quality FIP

FIP-1.P1 Faint print (Low contrast)

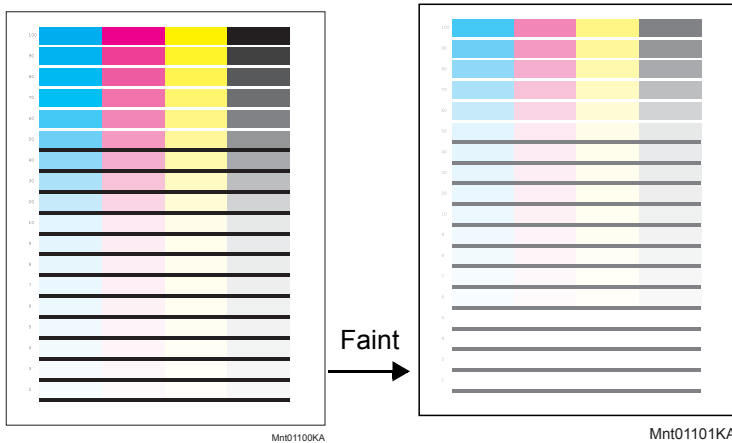

Trouble substance

The density of the image is entirely too faint.

Possible causative parts

- TRANSFER ASSY (PL4.1.1)
- DISPENSER ASSY (PL5.1.12)
- CARTRIDGE ASSY (PL5.1.18(K)/
PL5.1.19 (C)/PL5.1.20 (M)/PL5.1.21 (Y))
- PWBA MCU (PL9.1.20)

Before commencing troubleshooting, check the paper transfer path. Make sure there is no foreign materials on the transfer path, such as staples, paper clips, scraps of paper and so on.

Step	Check	Yes	No
1	Checking the Faint print. Print the windows test page. Is the image printed correctly?	Check the print data which the problem generated.	Go to step 2.
2	Checking the print cartridge installation. Is the installed print cartridge the DELL cartridge?	Go to step 3.	Replace to the DELL cartridge and print ten sheets [Test Print]-[Toner Pallet Check] in diagnosis.
3	Checking the sealing tape staying Remove the print cartridge from the printer. Is there the sealing tape on the right side of the print cartridge? (The drum side is the front.)	Pull the tape out.	Go to step 4.
4	Checking the printer setting Is the [Draft Mode] of the [PCL] in the [Admin Menu] the [Enable]?	Go to step 5.	Set to [Disable].
5	Checking the paper Is the installed paper with a new and dry one?	Go to step 6.	Replace the paper with a new and dry one.
6	Checking the print cartridge Is there the faint toner? Checked by [Test Print]- [Toner Pallet Check] in diagnosis.	Go to step 7.	Check the print data which the problem generated.

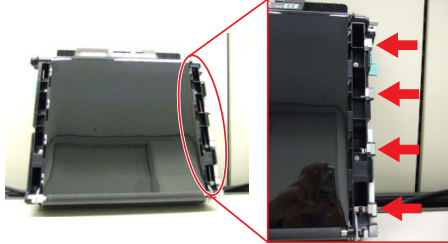
Step	Check	Yes	No
7	Checking the PLATE EARTH CRU(Drum Terminal). Are the PLATE EARTH CRU clean?	Go to step 8.	Clean up the PLATE EARTH CRU.
8	Checking the PLATE EARTH CRU ground Is PLATE EARTH CRU grounded appropriately?	Go to step 9.	Replace the printer.
9	<p>Checking the high voltage terminal of the TRANSFER ASSY. Open the Front Cover, check the terminals.</p>  <p>Are the terminals clean?</p>	Go to step 10.	Clean up the terminals.
10	Checking the TRANSFER ASSY installation Reseat the TRANSFER ASSY. Is the image printed correctly?	End of work.	Go to step 11.
11	Checking the TONER DISPENSE MOTOR. Does the TONER DISPENSE MOTOR rotate normally? Checked by [Digital Output]-[DO-21(Control Panel)/ TONER MOTOR Y ON(PC)/ 23(Control Panel)/TONER MOTOR M ON(PC)/25(Control Panel)/TONER MOTOR C ON(PC)/27(Control Panel)/TONER MOTOR K ON(PC)] in diagnosis.	Replace the failure print cartridge.	<p>Replace the PWBA MCU. (Refer to Removal 30/Replacement 14) If not, replace the TONER DISPENSE MOTOR. (Refer to Removal 24/Replacement 20)</p>

FIP-1.P2 Blank print (No print)

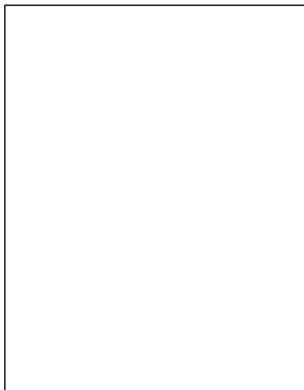
**Trouble substance**

The entire paper is printed pure white.

Possible causative parts

- TRANSFER ASSY (PL4.1.1)
- DISPENSER ASSY (PL5.1.12)
- HVPS (PL5.1.17)
- CARTRIDGE ASSY (PL5.1.18(K)/PL5.1.19 (C)/PL5.1.20 (M)/PL5.1.21 (Y))
- KIT ROS ASSY (PL5.1.99)
- PWBA MCU (PL9.1.20)
- PWBA ESS (PL9.1.27)

Before commencing troubleshooting, check the paper transfer path. Make sure there is no foreign materials on the transfer path, such as staples, paper clips, scraps of paper and so on.

Step	Check	Yes	No
1	Checking the blank print. Print the Contamination Check page. Is the image printed correctly?	Check the print data which the problem generated.	Go to step 2.
2	Checking the print cartridge installation. Is the installed print cartridge the DELL cartridge?	Go to step 3.	Replace to the DELL cartridge and print ten sheets [Test Print]-[Toner Pal-let Check] in diagnosis.
3	Checking the paper Is the installed paper with a new and dry one?	Go to step 4.	Replace the paper with a new and dry.
4	Checking the Test Pattern. Is the image printed correctly? Checked by [Test Print] - [Test Pattern 600] in diagnosis.	Replace the PWBA ESS. (Refer to Removal 26/Replacement 18)	Go to step 5.
5	Checking the laser beam path. Are there any foreign substance between the ROS ASSY and the drum?	Remove the foreign substance	Go to step 6.
6	Checking the connection of the ROS ASSY. Reseat the connector (P/J 151) of the ROS ASSY. Is the image printed correctly?	End of work.	Go to step 7.
7	Checking the TRANSFER ASSY installation Reseat the TRANSFER ASSY. Is the image printed correctly?	End of work.	Go to step 8.

Step	Check	Yes	No
8	<p>Checking the TONER DISPENSE MOTOR. Does the TONER DISPENSE MOTOR rotate normally? Checked by [Digital Output]-[DO-21(Control Panel)/ TONER MOTOR Y ON(PC)/ 23(Control Panel)/TONER MOTOR M ON(PC)/25(Control Panel)/TONER MOTOR C ON(PC)/27(Control Panel)/TONER MOTOR K ON(PC)] in diagnosis.</p>	Go to step 9.	<p>Replace the PWBA MCU. (Refer to Removal 30/Replacement 14) If not, replace the TONER DIS- PENSE MOTOR (Refer to Removal 24/Replacement 20) and print ten sheets [Test Print]-[Toner Pal- let Check] in diag- nosis.</p>
9	<p>Checking the PWBA MCU installation Reseat the PWBA MCU. (Refer to Removal 30/Replace- ment 14) Is the image printed correctly?</p>	End of work.	Go to step 10.
10	<p>Checking the PWBA ESS installation Reseat the PWBA ESS. (Refer to Removal 26/Replace- ment 18) Is the image printed correctly?</p>	End of work.	Go to step 11.
11	<p>Checking the HVPS installation Reseat the HVPS. Is the image printed correctly?</p>	End of work.	Go to step 12.
12	<p>Checking after replacing the ROS ASSY Replace the ROS ASSY. (Refer to Removal 36/Replace- ment 8) Is the image printed correctly?</p>	End of work.	<p>Replace the PWBA ESS. (Refer to Removal 26/ Replacement 18)</p>

FIP-1.P3 Solid black

**Trouble substance**

The entire paper is printed jet-black.

Possible causative parts

- HVPS (PL5.1.17)
- CARTRIDGE ASSY (PL5.1.18(K)/PL5.1.19(C)/PL5.1.20 (M)/PL5.1.21 (Y))
- KIT ROS ASSY (PL5.1.99)
- PWBA MCU (PL9.1.20)
- PWBA ESS (PL9.1.27)

Before commencing troubleshooting, check the paper transfer path. Make sure there is no foreign materials on the transfer path, such as staples, paper clips, scraps of paper and so on.

Step	Check	Yes	No
1	Checking the solid black. Print the Contamination Check page. Is the image printed correctly?	Check the print data which the problem generated.	Go to step 2.
2	Checking the print cartridge installation. Is the installed print cartridge the DELL cartridge?	Go to step 3.	Replace to the DELL cartridge and print ten sheets [Test Print]-[Toner Pal-let Check] in diagnosis.
3	Checking the paper Is the installed paper with a new and dry one?	Go to step 4.	Replace the paper with a new and dry.
4	Checking the Test Pattern. Print the Test Pattern page. Is the image printed correctly? Checked by [Test Print] - [Test Pattern 600] in diagnosis.	Replace the PWBA ESS. (Refer to Removal 26/Replacement 18)	Go to step 5.
5	Checking the Grid2. Print the Grid2 page. Is the solid color printed? Checked by [Test Print] - [Grid2] in diagnosis.	Replace the toner cartridge of the color by which Solid was printed.	Go to step 6.
6	Checking the PWBA MCU installation Reseat the PWBA MCU. (Refer to Removal 30/Replacement 14.) Is the image printed correctly?	End of work.	Go to step 7.

Step	Check	Yes	No
7	Checking the PWBA ESS installation Reseat the PWBA ESS. (Refer to Removal 26/Replacement 18.) Is the image printed correctly?	End of work.	Go to step 8.
8	Checking the HVPS installation Reseat the HVPS. (Refer to Removal 34/Replacement 10.) Is the image printed correctly?	End of work.	Replace the PWBA ESS. (Refer to Removal 26/Replacement 18) If not, replace the PWBA MCU. (Refer to Removal 30/Replacement 14)

FIP-1.P4 Vertical blank lines (White stripes in paper transport direction)

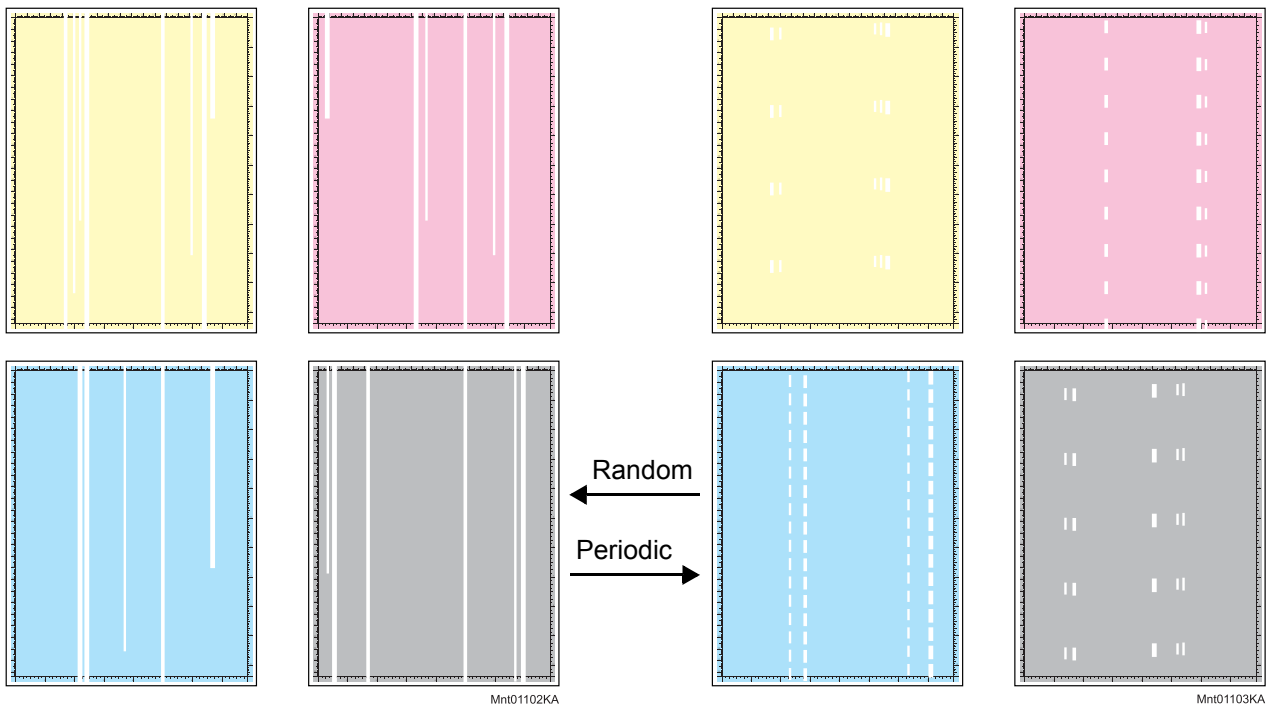

Trouble substance

There are some extremely faint or completely non-printed parts. Those non-printed parts cover a wide area vertically, along the paper feeding direction.

Possible causative parts

- TRANSFER ASSY (PL4.1.1)
- CARTRIDGE ASSY (PL5.1.18(K)/PL5.1.19(C)/PL5.1.20 (M)/PL5.1.21 (Y))
- KIT ROS ASSY (PL5.1.99)
- FUSER ASSY (PL6.1.10)

Before commencing troubleshooting, check the paper transfer path. Make sure there is no foreign materials on the transfer path, such as staples, paper clips, scraps of paper and so on.

Step	Check	Yes	No
1	Checking the Vertical blank lines. Print the Contamination Check page. Is the image printed correctly? Checked by [Test Print] - [contamination Check] in diagnosis.	Check the print data which the problem generated.	Go to step 2.
2	Checking the foreign substance and damage. Open the Front cover; check the surrounding area of the print cartridges and the TRANSFER ASSY. Are there any foreign substances?	Remove the foreign substance.	Go to step 3.

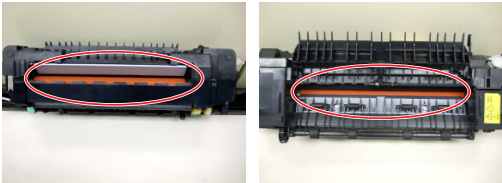
Step	Check	Yes	No
3	Measure the blank line pitch. Does the blank line pitch match any of the pitches in the printed table chart? Checked by [Test Print]- [Contamination check] in diagnosis.	Replace the corresponding parts. See [MQ Chart] of [4.2 Diagnosis Test Chart].	Go to step 4.
4	Checking the print cartridge Is the installed print cartridge the DELL cartridge?	Go to step 5.	Replace to the DELL cartridge and print ten sheets [Test Print]-[Toner Pallet Check] in diagnosis.
5	Checking the paper Is the installed paper with a new and dry one?	Go to step 6.	Replace the paper with a new and dry.
6	Checking the surface of TRANSFER ASSY. Are there any damages on the surface of TRANSFER ASSY?	Replace the TRANSFER ASSY. (Refer to Removal 4/ Replacement 40)	Go to step 7.
7	Checking the foreign substance. Remove the Fuser. Warning: Start the operation after the FUSER ASSY has cooled down. Check the heat roll surface.  Are there any foreign substances?	Replace the FUSER ASSY. (Refer to Removal 8/Replacement 36)	Replace the printer.

FIP-1.P5 Horizontal band cross out (White stripes in the horizontal direction)

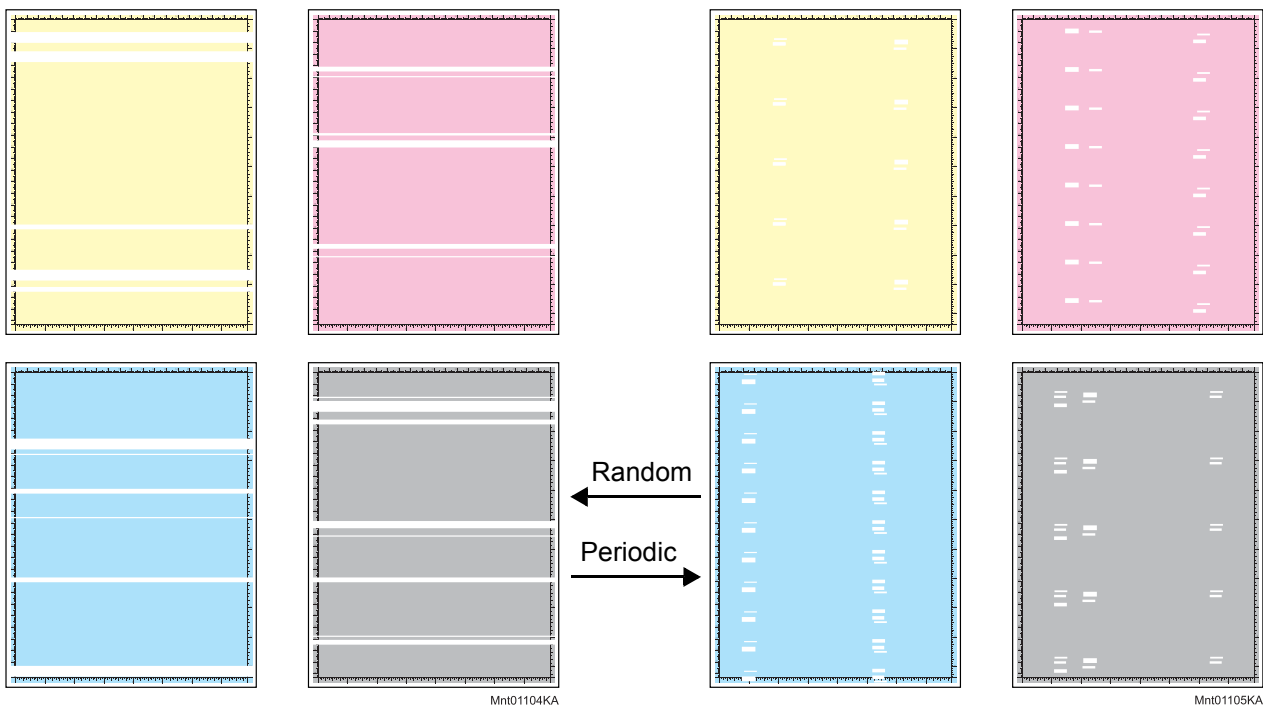

Trouble substance

There are some extremely faint or completely non-printed parts. Those non-printed parts cover a wide area horizontally, perpendicular to the paper feeding direction.

Possible causative parts

- TRANSFER ASSY (PL4.1.1)
- CARTRIDGE ASSY (PL5.1.18(K)/PL5.1.19(C)/PL5.1.20 (M)/PL5.1.21 (Y))
- FUSER ASSY (PL6.1.10)

Before commencing troubleshooting, check the paper transfer path. Make sure there is no foreign materials on the transfer path, such as staples, paper clips, scraps of paper and so on.

Step	Check	Yes	No
1	Checking the Horizontal band cross out. Print the Contamination Check page. Is the image printed correctly? Checked by [Test Print] - [contamination Check] in diagnosis.	Check the print data which the problem generated.	Go to step 2.
2	Measure the blank line pitch. Does the blank line pitch match any of the pitches in the printed table chart? Checked by [Test Print]- [Contamination check] in diagnosis.	Replace the corresponding parts. See [MQ Chart] of [4.2 Diagnosis Test Chart].	Go to step 3.

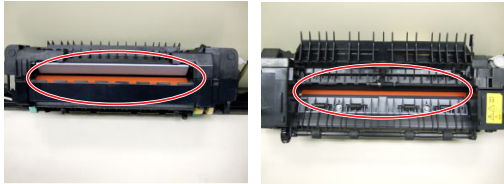
Step	Check	Yes	No
3	Checking the print cartridge Is the installed print cartridge the DELL cartridge?	Go to step 4.	Replace to the DELL cartridge and print ten sheets [Test Print]-[Toner Pallet Check] in diagnosis.
4	Checking the paper Is the installed paper with a new and dry one?	Go to step 5.	Replace the paper with a new and dry.
5	Checking the surface of TRANSFER ASSY. Are there any damages on the surface of TRANSFER ASSY?	Replace the TRANSFER ASSY. (Refer to Removal 4/ Replacement 40)	Go to step 6.
6	Checking the foreign substance. Remove the Fuser. Warning: Start the operation after the FUSER ASSY has cooled down. Check the heat roll surface.  Are there any foreign substances?	Replace the FUSER ASSY. (Refer to Removal 8/Replacement 36)	Go to step 7.
7	Checking the laser beam path. Are there any foreign substance between the ROS ASSY and the drum?	Remove the foreign substance	Replace the failure print cartridge.

FIP-1.P6 Vertical stripes

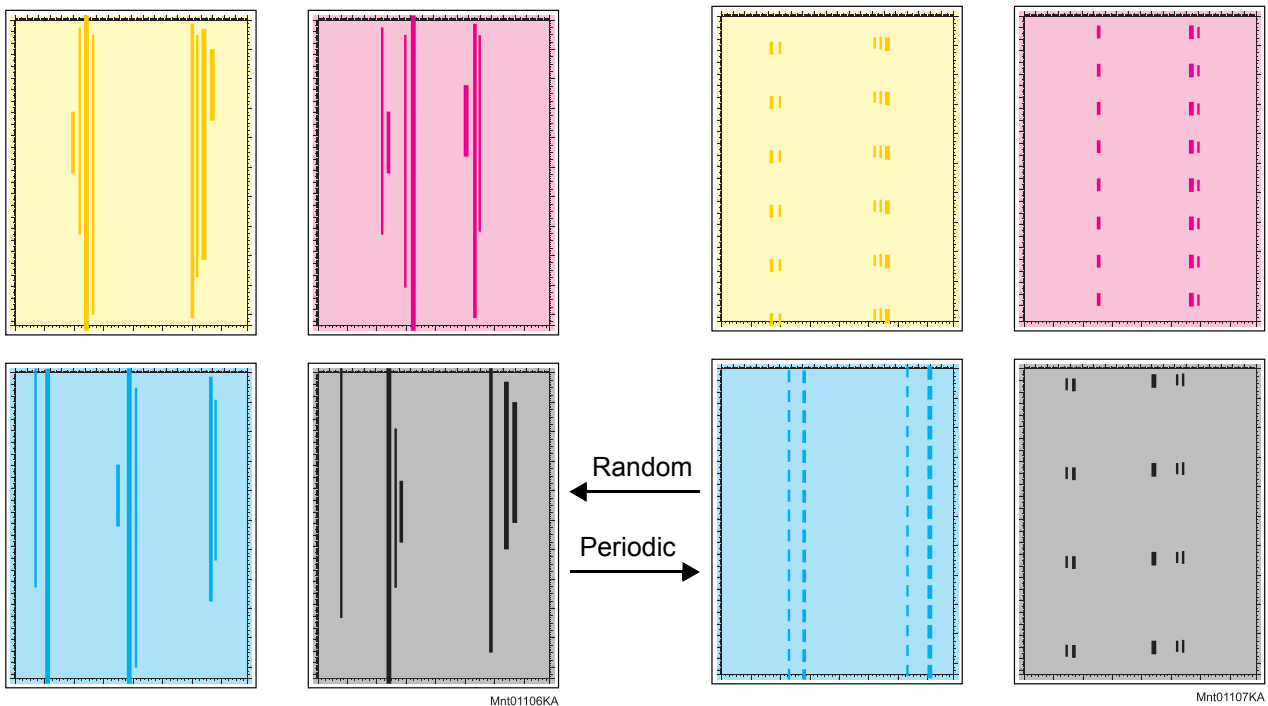

Trouble substance

There are vertical black stripes along the paper.

Possible causative parts

- TRANSFER ASSY (PL4.1.1)
- CARTRIDGE ASSY (PL5.1.18(K)/PL5.1.19(C)/PL5.1.20 (M)/PL5.1.21 (Y))
- FUSER ASSY (PL6.1.10)

NOTE

If the stripes at the top or back of the paper, replace the IBT ASSY only.

Before commencing troubleshooting, check the paper transfer path. Make sure there is no foreign materials on the transfer path, such as staples, paper clips, scraps of paper and so on.

Step	Check	Yes	No
1	Checking the Vertical stripes. Print the Contamination Check page. Is the image printed correctly? Checked by [Test Print] - [contamination Check] in diagnosis.	Check the print data which the problem generated.	Go to step 2.
2	Checking the foreign substance and damage. Open the Front cover; check the surrounding area of the print cartridges and the TRANSFER ASSY. Are there any foreign substances?	Remove the foreign substance.	Go to step 3.

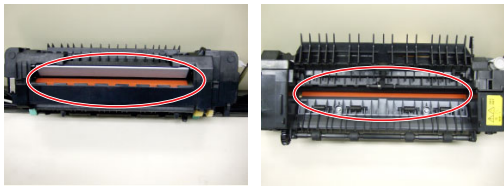
Step	Check	Yes	No
3	Measure the blank line pitch. Does the stripe pitch match any of the pitches in the printed table chart? Checked by [Test Print] - [Contamination check] in diagnosis.	Replace the corresponding parts. See [MQ Chart] of [4.2 Diagnosis Test Chart].	Go to step 4.
4	Does the stripe pitch match any of the pitches in the printed table chart? Is the installed print cartridge the DELL cartridge?	Go to step 5.	Replace to the DELL cartridge and print ten sheets [Test Print]-[Toner Pallet Check] in diagnosis.
5	Checking the drum damaged Are there any damage on the drums?	Replace the failure print cartridge.	Go to step 6.
6	Checking the surface of TRANSFER ASSY. Are there any damages on the surface of TRANSFER ASSY?	Replace the TRANSFER ASSY. (Refer to Removal 4/ Replacement 40)	Go to step 7.
7	Checking the foreign substance. Remove the Fuser. Warning: Start the operation after the FUSER ASSY has cooled down. Check the heat roll surface.  Are there any foreign substances?	Replace the FUSER ASSY. (Refer to Removal 8/Replacement 36)	Go to step 8.
8	Checking the after replacing the print cartridge Replace the failure print cartridge. Is the image printed correctly?	End of work.	Replace the FUSER ASSY.

FIP-1.P7 Horizontal stripes

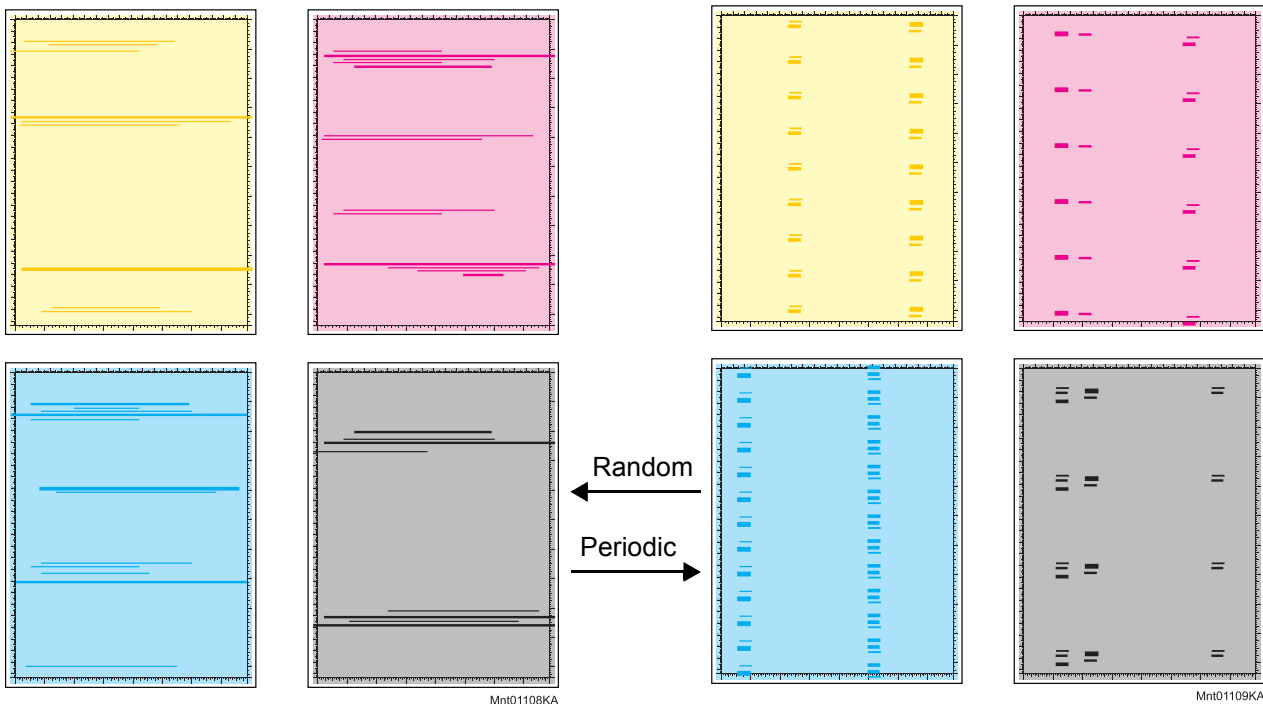

Trouble substance

There are horizontal black stripes (perpendicular to the paper path direction) along the paper.

Possible causative parts

- TRANSFER ASSY (PL4.1.1)
- CARTRIDGE ASSY (PL5.1.18(K)/PL5.1.19(C)/PL5.1.20 (M)/PL5.1.21 (Y))
- FUSER ASSY (PL6.1.10)

Before commencing troubleshooting, check the paper transfer path. Make sure there is no foreign materials on the transfer path, such as staples, paper clips, scraps of paper and so on.

Step	Check	Yes	No
1	Checking the Horizontal stripes. Print the Contamination Check page. Is the image printed correctly? Checked by [Test Print] - [contamination Check] in diagnosis.	Check the print data which the problem generated.	Go to step 2.
2	Checking the foreign substance and damage. Open the Front cover; check the surrounding area of the print cartridges and the TRANSFER ASSY. Are there any foreign substances?	Remove the foreign substance.	Go to step 3.
3	Measure the stripe pitch. Does the stripe pitch match any of the pitches in the printed table chart? Checked by [Test Print] - [Contamination check] in diagnosis.	Replace the corresponding parts. See [MQ Chart] of [4.2 Diagnosis Test Chart].	Go to step 4.

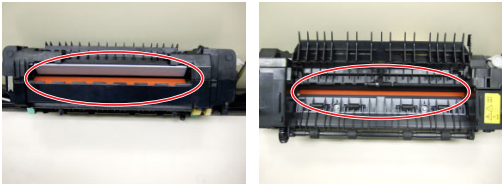
Step	Check	Yes	No
4	Checking after replacing the print cartridge Replace the failure print cartridge. Is the image printed correctly?	End of work.	Go to step 5.
5	Checking the surface of TRANSFER ASSY. Are there any damages on the surface of TRANSFER ASSY?	Replace the TRANSFER ASSY. (Refer to Removal 4/Replacement 40)	Go to step 6.
6	Checking the foreign substance. Remove the Fuser. Warning: Start the operation after the FUSER ASSY has cooled down. Check the heat roll surface.  Are there any foreign substances?	Replace the FUSER ASSY. (Refer to Removal 8/Replacement 36)	Replace the printer.

FIP-1.P8 Partial Deletion

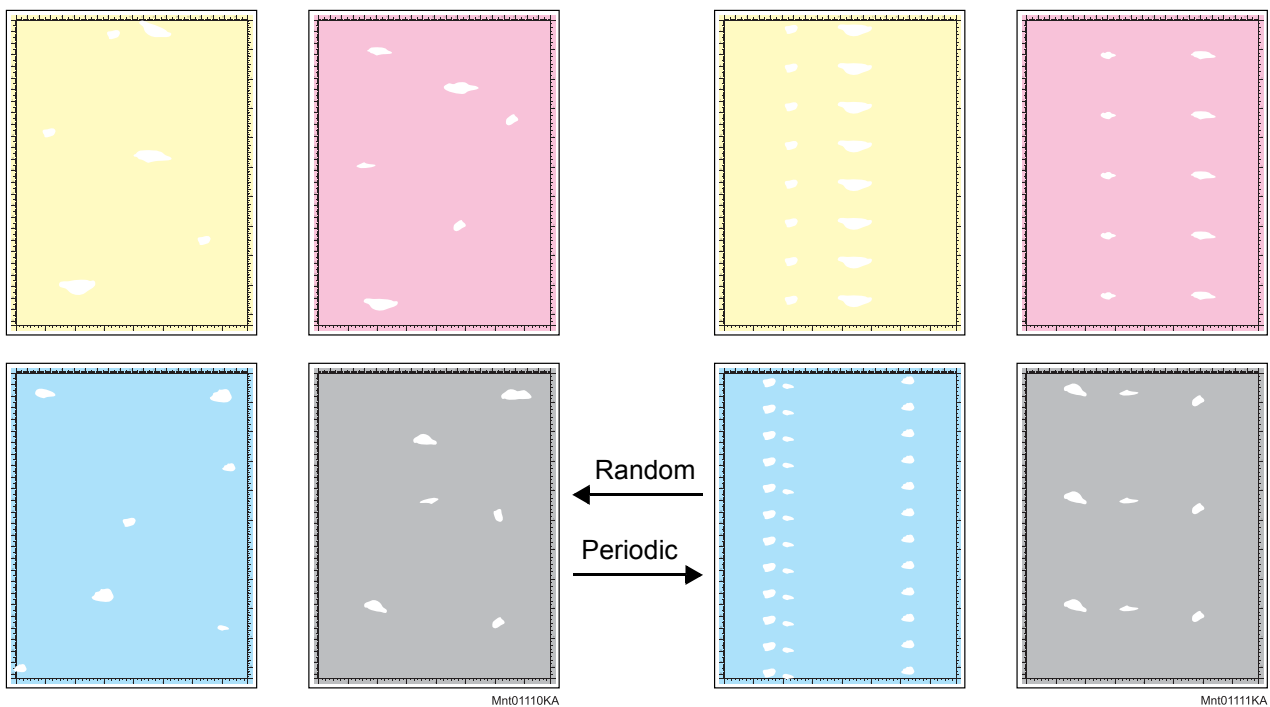
**Trouble substance**

There are some extremely faint or completely missing parts in a limited area on the paper.

Possible causative parts

- TRANSFER ASSY (PL4.1.1)
- CARTRIDGE ASSY (PL5.1.18(K)/PL5.1.19(C)/PL5.1.20 (M)/PL5.1.21 (Y))

Before commencing troubleshooting, check the paper transfer path. Make sure there is no foreign materials on the transfer path, such as staples, paper clips, scraps of paper and so on.

Step	Check	Yes	No
1	Checking the Partial Deletion. Print the Contamination Check page. Is the image printed correctly? Checked by [Test Print] - [contamination Check] in diagnosis.	Check the print data which the problem generated.	Go to step 2.
2	Measure the blank line pitch. Does the blank line pitch match any of the pitches in the printed table chart? Checked by [Test Print] - [Contamination check] in diagnosis.	Replace the corresponding parts. See [MQ Chart] of [4.2 Diagnosis Test Chart].	Go to step 3.
3	Checking the Tail Edge. Is partial deletion in Tail Edge? (Refer to NOTE.)	Go to step 4.	Go to step 5.

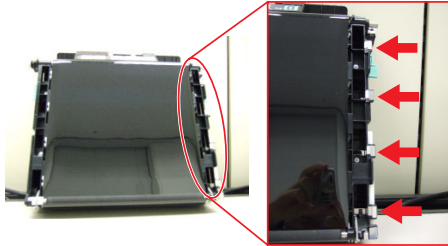
Step	Check	Yes	No
4	Checking after replace the FUSER ASSY. (Refer to Removal 8/Replacement 36.) Is the partial deletion in Tail Edge printed?	Replace the Printer.	End of work.
5	Checking the print cartridge. Is the installed print cartridge the DELL cartridge?	Go to step 6.	Replace to DELL cartridge.
6	Checking the paper Is the installed paper with the new and dry one?	Go to step 7.	Replace to the paper with the new and dry.
7	Checking the surface of TRANSFER ASSY. Are there any damages on the surface of TRANSFER ASSY?	Replace the TRANSFER ASSY. (Refer to Removal 4/Replacement 40)	Go to step 8.
8	Checking the high voltage terminal of the TRANSFER ASSY. Open the Front Cover, check the terminals.  Are the terminals clean?	Replace the printer.	Clean up the terminals.

NOTE

This partial deletion is called as "smudge". Can be seen A4 size and half tone print. The partial deletion sample of Tail Edge is shown below.

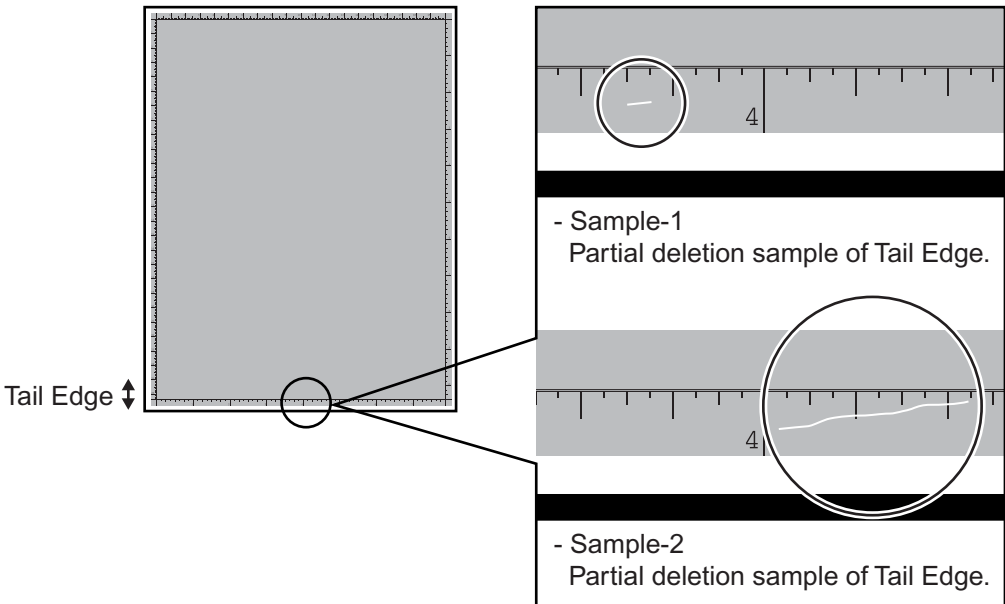

Zna05000KA

FIP-1.P9 Spots

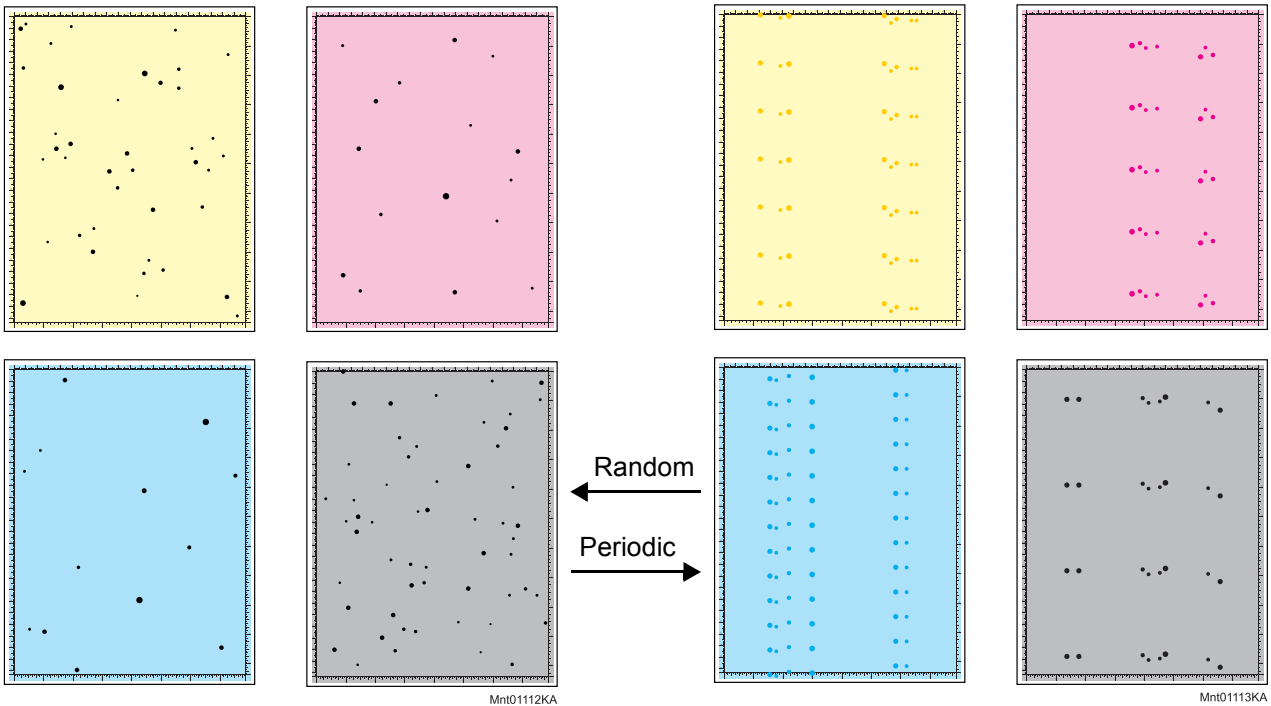

Trouble substance

There are toner spots all over the paper disorderedly.

Possible causative parts

- TRANSFER ASSY (PL4.1.1)
- CARTRIDGE ASSY (PL5.1.18(K)/PL5.1.19(C)/PL5.1.20 (M)/PL5.1.21 (Y))
- FUSER ASSY (PL61.1.10)

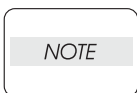

If the toner spot at the top or back of the paper, replace the IBT ASSY only.

Before commencing troubleshooting, check the paper transfer path. Make sure there is no foreign materials on the transfer path, such as staples, paper clips, scraps of paper and so on.

Step	Check	Yes	No
1	Checking the Spots. Print the Contamination Check page. Is the image printed correctly? Checked by [Test Print] - [contamination Check] in diagnosis.	Check the print data which the problem generated.	Go to step 2.
2	Checking the toner contamination. Open the Front Cover, check the surrounding area of the print cartridges, the TRANSFER ASSY and the Regi Rolls. Is there the toner contamination?	Clean the toner by the dry cloth or replace the contaminated parts.	Go to step 3.

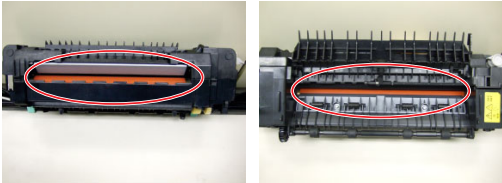
Step	Check	Yes	No
3	Clean the toner by the dry cloth or replace the contaminated parts. Does the spots pitch match any of the pitches in the printed table chart? Checked by [Test Print] - [Contamination check] in diagnosis.	Replace the corresponding parts. See [MQ Chart] of [4.2 Diagnosis Test Chart].	Go to step 4.
4	Checking the print cartridge. Is the installed print cartridge the DELL cartridge?	Go to step 5.	Replace to DELL cartridge.
5	Checking the foreign substance. Remove the Fuser. Warning: Start the operation after the FUSER ASSY has cooled down. Check the heat roll surface.  Are there any foreign substances?	Replace the FUSER ASSY. (Refer to Removal 8/Replacement 36)	Go to step 6.
6	Checking the paper path. Is there the contamination of the toner on the paper path?	Clean the paper path.	Replace the FUSER ASSY. (Refer to Removal 8/Replacement 36)

FIP-1.P10 Afterimage (Ghost)

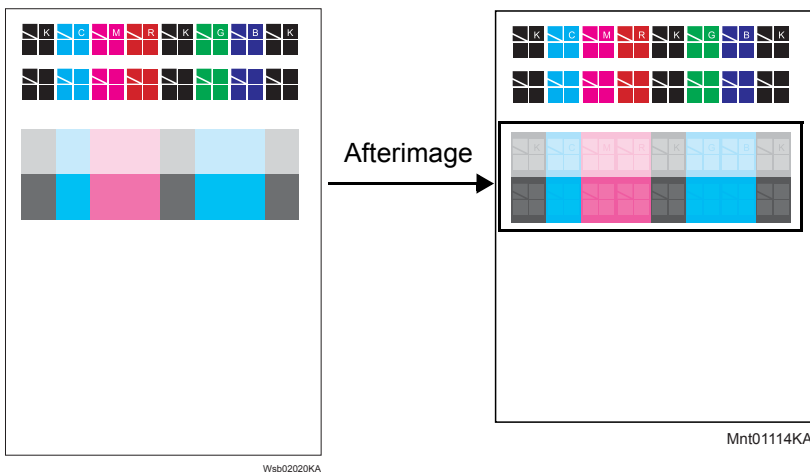
**Trouble substance**

The ghost appears on the paper. The ghost may be the image of the previous page, or a part of the page currently printing.

Possible causative parts

- TRANSFER ASSY (PL4.1.1)
- CARTRIDGE ASSY (PL5.1.18(K)/PL5.1.19(C)/PL5.1.20 (M)/PL5.1.21 (Y))
- FUSER ASSY (PL6.1.10)

Before commencing troubleshooting, check the paper transfer path. Make sure there is no foreign materials on the transfer path, such as staples, paper clips, scraps of paper and so on.

Step	Check	Yes	No
1	Checking the paper condition Is the paper dry and recommended paper?	Go to step 3.	Replace the paper with a new dry and recommended one, then go to step 2.
2	Is the image printed correctly?	End of work.	Go to step 3.
3	Checking the Afterimage(Ghost). Print the Ghost Configuration Page. Is the image printed correctly? Checked by [Ghost Configuration Chart] of the [Diagnosis] tab in Tool Box.	Check the print data which the problem generated.	Go to step 4.
4	Checking the Refresh Configuration page. Checked by [PHD Refresh Configuration Chart] of the [Diagnosis] tab in Tool Box. Is the image printed correctly?	End of work.	Go to step 5.
5	Checking the surface of the TRANSFER ASSY Are there any damages on the surface of the TRANSFER ASSY?	Replace the TRANSFER ASSY. (Refer to Removal 4/ Replacement 40)	Go to step 6.
6	Checking the TRANSFER ASSY for installation Reseat the TRANSFER ASSY. Is the image printed correctly?	End of work.	Go to step 7.

Step	Check	Yes	No
7	Checking the print cartridge installation Reseat the four print cartridges. Is the image printed correctly?	End of work.	Go to step 8.
8	Checking after replacing the print cartridge Replace the failure print cartridge. Is the image printed correctly?	End of work.	Replace the FUSER ASSY. (Refer to Removal 8/Replacement 36)

FIP-1.P11 Grey Background

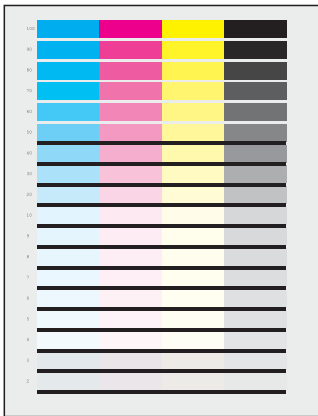

Mnt01115KA

Trouble substance

There is toner stain all over or a part of the page. The stain appears as very bright color (Y, M, C, K or etc.) stain.

Possible causative parts

- ROS ASSY (PL5.1.2)
- CARTRIDGE ASSY (PL5.1.18(K)/PL5.1.19(C)/PL5.1.20 (M)/PL5.1.21 (Y))

Before commencing troubleshooting, check the paper transfer path. Make sure there is no foreign materials on the transfer path, such as staples, paper clips, scraps of paper and so on.

Step	Check	Yes	No
1	Checking the Grey background. Print the Gradation Page. Is the image printed correctly? Checked by [Test Print] - [Gradation] in diagnosis.	End of work.	Go to step 2.
2	Checking the toner contamination. Open the Front Cover, check the surrounding area of the print cartridges, the TRANSFER ASSY and the Regi Rolls. Is there the toner contamination?	Clean the toner by the dry cloth or replace the contaminated parts.	Go to step 3.
3	Checking the print cartridge. Is the installed print cartridge the DELL cartridge?	Go to step 4.	Replace to DELL cartridge.
4	Checking the print cartridge installation Reseat the four print cartridges. Is the image printed correctly?	End of work.	Go to step 5.
5	Checking the after replacing the print cartridge Replace the print cartridge. Is the image printed correctly?	End of work.	Replace the ROS ASSY (Refer to Removal 36/Replacement 8) and Replace the HVPS (Refer to Removal 34/Replacement 10)

FIP-1.P12 Skew

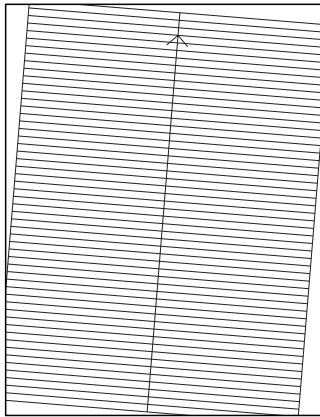

Mnt01116KA

Trouble substance

The printed image is not paralleled with both sides of the paper.

Possible causative parts

- SEPARATOR ROLLER ASSY MSI (PL2.1.3)
- KIT SEPARATOR and FEED ROLLER (PL2.2.99)
- ROLL ASSY FEED MSI (PL3.1.10)
- KIT FEEDER ASSY (PL3.2.99)
- TRANSFER ASSY (PL4.1.1)
- FEEDER ASSY DUP (PL11.1.1)
- KIT SEPARATOR and FEED ROLLER (PL12.3.99)

Before commencing troubleshooting, check the paper transfer path. Make sure there is no foreign materials on the transfer path, such as staples, paper clips, scraps of paper and so on.

Step	Check	Yes	No
1	Checking the paper condition Is the paper in the tray new and dry one?	Replace the paper with a new and dry one.	Go to step 2.
2	Checking the Front Cover latching Open and close the Front Cover. Does the error still occur when printing?	Go to step 3.	End of work.
3	Checking the foreign substance Open the Front Cover, check the surrounding area of the print cartridges, the TRANSFER ASSY and the Regi Rolls. Are there any foreign substances?	Remove the foreign substances.	Go to step 4.
4	Checking the surface of TRANSFER ASSY. Are there any damages on the surface of TRANSFER ASSY?	Replace the TRANSFER ASSY. (Refer to Removal 4/ Replacement 40)	Go to step 5.
5	Checking the skewed tray Is the skewed paper the MPF fed?	Go to step 6.	Go to step 12.
6	Checking the paper installation. Reseat the paper and reset the paper guide on the MPF. Does the error still occur when printing?	Go to step 7.	End of work.
7	Checking the paper Is the MPF feeding the envelope?	Go to step 8.	Go to step 9.
8	Checking the envelope setting Was the envelope inserted with the flap closed, air vacuumed, and short edge facing toward the printer?	Go to step 9.	Reseat the envelopes.
9	Checking the paper path. Is there the foreign substance on the paper path?	Remove the foreign substance.	Go to step 10.

Step	Check	Yes	No
10	Checking after replacing the feed roller Replace the ROLL ASSY FEED MSI. Does the error still occur when printing?	Go to step 11.	End of work.
11	Checking after replacing the roller Replace the SEPARATOR ROLLER ASSY MSI. (Refer to Removal 41/ Replacement 3) Does the error still occur when printing?	Replace the KIT FEEDER ASSY. (Refer to Removal 40/Replacement 4)	End of work.
12	Checking the skewed mode Is the skewed paper the duplex fed?	Go to step 13.	Go to step 15.
13	Checking the FEEDER ASSY DUP installation Reseat the CHUTE ASSY DUP. Does the error still occur when printing?	Go to step 14.	End of work.
14	Checking the paper path. Is there the foreign substance on the paper path?	Remove the foreign substance.	Replace the FEEDER ASSY DUP (Refer to Removal 5/Replacement 39.)
15	Checking the paper installation Reseat the paper in the paper cassette and reset the side and end guides. Does the error still occur when printing?	Go to step 16.	End of work.
16	Checking the paper path. Is there the foreign substance on the paper path?	Remove the foreign substance.	Go to step 17.
17	Checking after replacing the feed roller Replace the FEED ROLLER. Does the error still occur when printing?	Go to step 18.	End of work.
18	Checking after replacing the roller. Replace the SEPARATOR ROLLER ASSY MSI. Does the error still occur when printing?	Replace the KIT FEEDER ASSY. (Refer to Removal 40/Replacement 4)	End of work.

FIP-1.P13 Paper damage

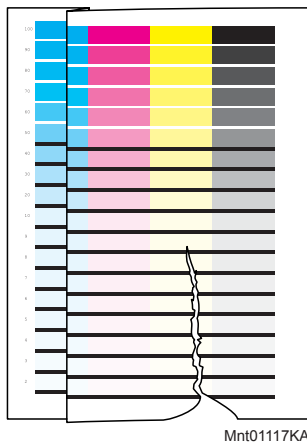
**Trouble substance**

The paper comes out from the printer wrinkled, folded or worn-out.

Possible causative parts

- SEPARATOR ROLLER ASSY MSI (PL2.1.3)
- KIT SEPARATOR and FEED ROLLER (PL2.2.99)
- ROLL ASSY FEED MSI (PL3.1.10)
- TRANSFER ASSY (PL4.1.1)
- FUSER ASSY (PL6.1.10)
- FEEDER ASSY DUP (PL11.1.1)
- KIT SEPARATOR and FEED ROLLER (PL12.3.99)

Before commencing troubleshooting, check the paper transfer path. Make sure there is no foreign materials on the transfer path, such as staples, paper clips, scraps of paper and so on.

Step	Check	Yes	No
1	Checking the paper condition Is the paper in the tray new and dry one?	Go to step 2.	Replace the paper with a new and dry one.
2	Checking the Front Cover latching Open and close the Front Cover. Does the error still occur when printing?	Go to step 3.	End of work.
3	Checking the foreign substance Open the Front cover; check the surrounding area of the print cartridges, the TRANSFER ASSY and the Regi Rolls. Are there any foreign substances?	Remove the foreign substances.	Go to step 4.
4	Checking the surface of TRANSFER ASSY. Are there any damages on the surface of TRANSFER ASSY?	Replace the TRANSFER ASSY. (Refer to Removal 4/ Replacement 40)	Go to step 5.
5	Checking the print cartridge installation Reseat the four print cartridges. Does the error still occur when printing?	Go to step 6.	End of work.
6	Checking the Fuser installation Reseat the Fuser. Does the error still occur when printing?	Go to step 7.	End of work.
7	Checking the skewed tray Is the skewed paper the MPF fed?	Go to step 8.	Go to step 13.
8	Checking the paper installation. Reseat the paper and reset the paper guide on the MPF. Does the error still occur when printing?	Go to step 9.	End of work.
9	Checking the paper Is the MPF feeding the envelope?	Go to step 10.	Go to step 11.

Step	Check	Yes	No
10	Checking the envelope setting Was the envelope inserted with the flap closed, air vacuumed, and short edge facing toward the printer?	Go to step 11.	Reseat the envelopes.
11	Checking the paper path. Is there the foreign substance on the paper path?	Remove the foreign substance.	Go to step 12.
12	Checking after replacing the feed roller Replace the ROLL ASSY FEED MSI. Does the error still occur when printing?	Replace the SEPARATOR ROLLER ASSY MSI. (Refer to Removal 41/Replacement 3)	End of work.
13	Checking the damaged mode Is the damaged paper the duplex fed?	Go to step 14.	Go to step 16.
14	Checking the FEEDER ASSY DUP installation Reseat the FEEDER ASSY DUP. Does the error still occur when printing?	Go to step 15.	End of work.
15	Checking the paper path. Is there the foreign substance on the paper path?	Remove the foreign substance.	Replace the FEEDER ASSY DUP (Refer to Removal 5/Replacement 39.)
16	Checking the paper installation Reseat the paper in the paper cassette and reset the side and end guides. Does the error still occur when printing?	Go to step 17.	End of work.
17	Checking the paper path. Is there the foreign substance on the paper path?	Remove the foreign substance.	Go to step 18.
18	Checking after replacing the feed roller Replace the FEED ROLLER. Does the error still occur when printing?	Replace the SEPARATOR ROLLER ASSY MSI. (Refer to Removal 41/Replacement 3)	End of work.

FIP-1.P14 Unfusing

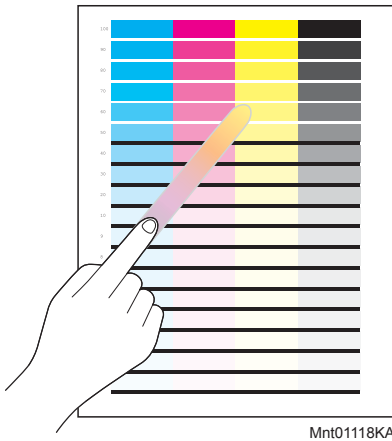
**Trouble substance**

The printed image is not fixed on the paper properly. The image easily comes off when rubbed.

Possible causative parts

- CARTRIDGE ASSY (PL5.1.18(K)/PL5.1.19(C)/PL5.1.20 (M)/PL5.1.21 (Y))
- FUSER ASSY (PL6.1.10)

Before commencing troubleshooting, check the paper transfer path. Make sure there is no foreign materials on the transfer path, such as staples, paper clips, scraps of paper and so on.

Step	Check	Yes	No
1	Checking the paper condition Is the paper in the tray new and dry one?	Go to step 2.	Replace the paper with a new and dry one.
2	Checking the print cartridge. Is the installed print cartridge the DELL cartridge?	Go to step 3.	Replace to the DELL cartridge.
3	Checking the FUSER installation Reset the FUSER. Is the image printed correctly?	End of work.	Replace the FUSER. (Refer to Removal 8/ Replacement 36)

FIP-1.P15 Color Registration (Color Shift)

- Troubleshooting of a control system

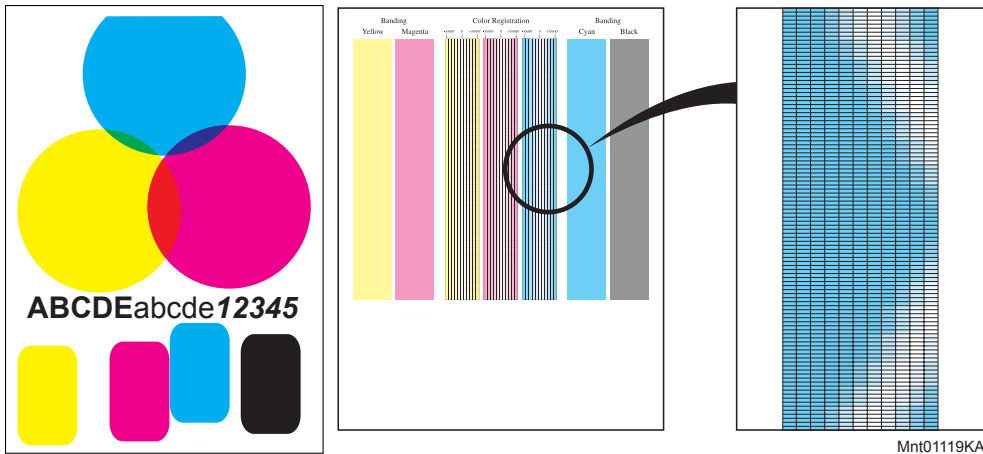
**Trouble substance**

A yellow or black image printed is not overlapped on a cyan or magenta image correctly.

Possible causative parts

- PWBA MCU (PL9.1.20)

Before commencing troubleshooting, check the paper transfer path. Make sure there is no foreign materials on the transfer path, such as staples, paper clips, scraps of paper and so on.

Step	Check	Yes	No
1	Checking the Color registration. Print the windows test page. Is the image printed correctly?	Check the print data which the problem generated.	Go to step 2.
2	Checking the printer installation Did the customer change the installation place of a printer?	Execute the [Auto Regi Adjust] in [Admin Menu].	Go to step 3.
3	Turn off and turn on the power. Print again. Is the image printed correctly?	End of work.	Go to step 4.
4	Checking the paper condition Is the paper in the tray new and dry one?	Go to step 5.	Replace the paper with a new and dry one.
5	Checking the printer Is the image printed correctly? Checked by [Test Print]- [Toner Pallet Check] in diagnosis.	Check the print data which the problem generated.	Go to step 6.
6	Checking the Regi adjustment. Execute the [Auto Regi Adjust] in [Admin Menu]. Is the image printed correctly?	End of work.	Go to step 7.

Step	Check	Yes	No
7	Checking the parameter value Did the client change the value of registration parameter?	Reset to the default value.	Replace the Printer.

- Troubleshooting of a paper feeding system



paper feeding is late.

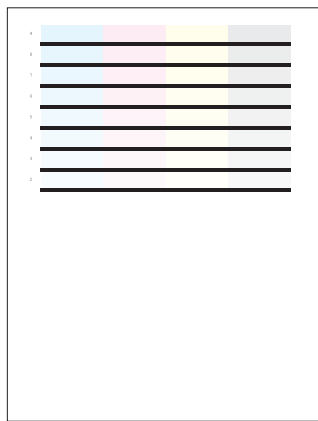

paper feeding is early.

Trouble substance

A yellow or black image printed is not overlapped on a cyan or magenta image correctly.

Possible causative parts

- FEEDER ASSY (PL3.2.1)

Before commencing troubleshooting, check the paper transfer path. Make sure there is no foreign materials on the transfer path, such as staples, paper clips, scraps of paper and so on.

Step	Check	Yes	No
1	Checking the Front Cover latching Open and close the Front Cover. Is the image printed correctly?	End of work.	Go to step 2.
2	Checking the foreign substance Open the Front Cover; check the surrounding area of the print cartridges, the TRANSFER ASSY and the Regi Rolls. Are there any foreign substances?	Remove the foreign substances.	Go to step 3.
3	Checking the print cartridge installation Reseat the four print cartridges. Is the image printed correctly?	End of work.	Go to step 4.
4	Checking the Regi Clutch for operation Does the regi clutch operate properly? Checked by [Digital Output]-[DO-29(Control Panel)/REGI CLUTCH ON(PC)] in diagnosis.	End of work.	Replace the FEEDER ASSY. (Refer to Removal 4/Replacement 40)

5. Abnormal Noise Trouble

5.1 Entry Chart for Abnormal Noise Troubleshooting

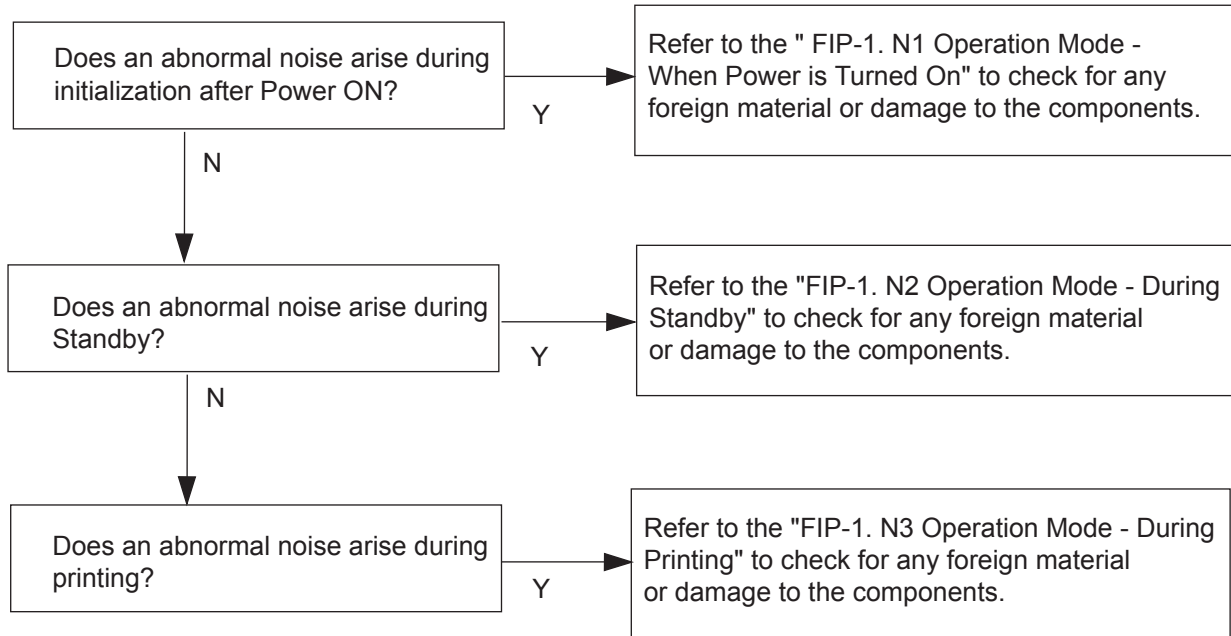

5.2 Operation Mode Table

FIP-1.N1 When Power is Turned On

Step	Check	Yes	No
	Possible causative parts: TRANSFER ASSY (PL4.1.1) CARTRIDGE ASSY (PL5.1.18 (K)/PL5.1.19 (C)/PL5.1.20 (M)/PL5.1.21 (Y)) FUSER ASSY (PL6.1.10) DRIVE ASSY MAIN (PL8.1.2) DRIVE ASSY PH (PL8.1.7) 500 OPTION FEEDER (PL12.1.1)		
1	Checking the Main Motor. Does the noise arise from the printer? Checked by [Digital Output]-[DO-0(Control Panel)/MAIN MOTOR(PC)] in diagnosis.	Go to step 2.	Go to step 5.
2	Checking the Print Cartridges installation Reseat all the Print Cartridges. Does the noise arise from the printer? Checked by [Digital Output]-[DO-0(Control Panel)/MAIN MOTOR(PC)] in diagnosis.	Go to step 3.	End of work.
3	Checking the TRANSFER ASSY installation Reseat the TRANSFER ASSY. Does the noise arise from the printer? Checked by [Digital Output]-[DO-0(Control Panel)/MAIN MOTOR(PC)] in diagnosis.	Go to step 4.	End of work.
4	Checking the DRIVE ASSY MAIN installation Reseat the DRIVE ASSY MAIN. (Refer to Removal 38/ Replacement 6) Does the noise arise from the printer? Checked by [Digital Output]-[DO-0(Control Panel)/MAIN MOTOR(PC)] in diagnosis.	Try replacing the Yellow, Magenta, Cyan, Black Print Cartridges, the TRANSFER ASSY and the DRIVE ASSY MAIN one after another.	End of work.
5	Checking the Sub Motor. Does the noise arise from the printer? Checked by [Digital Output]-[DO-5(Control Panel)/SUB MOTOR(PC)] in diagnosis.	Go to step 6.	Go to step 10.
6	Checking the FUSER ASSY installation Reseat the FUSER ASSY. Does the noise arise from the printer? Checked by [Digital Output]-[DO-5(Control Panel)/SUB MOTOR(PC)] in diagnosis.	Go to step 7.	End of work.
7	Checking the Print Cartridges installation Reseat all the Print Cartridges. Does the noise arise from the printer? Checked by [Digital Output]-[DO-5(Control Panel)/SUB MOTOR(PC)] in diagnosis.	Go to step 8.	End of work.

Step	Check	Yes	No
8	Checking the DRIVE ASSY K installation Reseat all the DRIVE ASSY K. Does the noise arise from the printer? Checked by [Digital Output]-[DO-5(Control Panel)/SUB MOTOR(PC)] in diagnosis.	Go to step 9.	End of work.
9	Checking the DRIVE ASSY MAIN installation Reseat the DRIVE ASSY MAIN. (Refer to Removal 38/ Replacement 6) Does the noise arise from the printer? Checked by [Digital Output]-[DO-5(Control Panel)/SUB MOTOR(PC)] in diagnosis.	Try replacing the FUSER ASSY,the Yellow, Magenta, Cyan, Black Print Cartridges , DRIVE ASSY K and the DRIVE ASSY MAIN one after another.	End of work.
10	Checking the DRIVE ASSY K. Does the noise arise from the printer? Checked by [Digital Output]-[DO-0 (Control Panel)/ MAIN MOTOR (PC)] and [Digital Output]-[DO-61 (Control Panel)/ K MODE SNR (PC)]in diagnosis.	Go to step 11.	Go to step 12.
11	Checking the DRIVE ASSY K installation Reseat the DRIVE ASSY K. Does the noise arise from the printer? Checked by [Digital Output]-[DO-0 (Control Panel)/ MAIN MOTOR (PC)] and [Digital Output]-[DO-61 (Control Panel)/ K MODE SNR (PC)]in diagnosis.	Try replacing the DRIVE ASSY K. (Refer to Removal 28/ Replacement 16)	End of work.
12	Checking the DRIVE ASSY PH. Does the noise arise from the printer? Checked by [Digital Output]-[DO-a (Control Panel)/PH MOTOR ON(PC)] in diagnosis.	Go to step 14.	End of work. If the option tray attached, it goes to step 13.
13	Checking the Option Feeder Motor Does the noise arise from the printer? Checked by [Digital Output]-[DO-19(Control Panel)/ OPTION FEEDER1 MOTOR ON(PC)] in diagnosis.	Try replacing the Option Feeder ASSY. (Refer to Removal 44/ Replacement 46)	End of work.
14	Checking the DRIVE ASSY PH installation Reseat the DRIVE ASSY PH. (Refer to Removal 17/ Replacement 27) Does the noise arise from the printer? Checked by [Digital Output]-[DO-a (Control Panel)/PH MOTOR ON(PC)] in diagnosis.	Try replacing the DRIVE ASSY PH. (Refer to Removal 17/ Replacement 27)	End of work.

FIP-1.N2 During Standby

Step	Check	Yes	No
	Possible causative parts: FAN MAIN (PL9.1.10) LVPS (PL9.1.40)		
1	Checking the FAN MAIN Does the noise arise from the printer? Checked by [Digital Output] - [DO-1e (Control Panel)/FAN ON(PC)] in diagnosis.	Replace the FAN MAIN. (Refer to Removal 32/Replacement 12)	Replace the PWBA LVPS. (Removal 35/Replacement 9)

FIP-1.N3 During Printing

Step	Check	Yes	No
	Possible causative parts: KIT SEPARATOR ROLLER ASSY MSI (PL2.1.99) KIT SEPARATOR AND FEED ROLLER (PL2.2.99) TRANSFER ASSY (PL4.1.1) CARTRIDGE ASSY (PL5.1.18/PL5.1.19/PL5.1.20/ PL5.1.21) FUSER ASSY (PL6.1.10) DRIVE ASSY MAIN (PL8.1.2) DRIVE ASSY PH (PL8.1.7) FEEDER ASSY DUP (PL11.1.1) 550 OPTION FEEDER (PL12.1.1)		
1	Checking the MPF Does the noise arise when feeding the paper from the MPF?	Go to step 2.	Go to step 3.
2	Checking the paper condition Replace the standard paper with a new and dry one Does the noise arise from the printer?	Replace the SEPARATOR ROLLER ASSY MSI. (Refer to Removal 41/ Replacement 3)	End of work.
3	Checking the feeder Does the noise arise when feeding the paper from the feeder?	Go to step 4.	Go to step 5.
4	Checking the paper condition Replace the standard paper with a new and dry one Does the noise arise from the printer?	Replace the SEPARATOR ROLLER. (Refer to Removal 42/ Replacement 2)	End of work.
5	Checking the Duplex Does the noise arise when feeding the paper from the Duplex?	Go to step 6.	Go to step 8.
6	Checking the DUPLEX ASSY installation Reseat the DUPLEX ASSY. Does the noise arise from the printer?	Try replacing the FEEDER ASSY DUP (Refer to Removal 5/Replacement 39.)	Go to step 7.
7	Checking the Duplex Motor Does the noise arise from the printer? Checked by [Digital Output]-[DO-13(Control Panel)/ DUPLEX MOTOR ON(PC)] in diagnosis.	Try replacing the FEEDER ASSY DUP (Refer to Removal 5/Replacement 39.)	End of work.
8	Checking the FUSER ASSY installation Reseat the FUSER ASSY. Does the noise arise from the printer?	Go to step 9.	End of work.

Step	Check	Yes	No
9	Checking the TRANSFER ASSY installation Reseat the TRANSFER ASSY. Does the noise arise from the printer?	Go to step 10.	End of work.
10	Checking the Print Cartridges installation Reseat the all Print Cartridges. Does the noise arise from the printer?	Go to step 11.	End of work.
11	Checking the DRIVE ASSY MAIN installation Reseat the DRIVE ASSY MAIN. (Refer to Removal 38/ Replacement 6) Does the noise arise from the printer?	Go to step 12.	End of work.
12	Checking the DRIVE ASSY PH installation Reseat the DRIVE ASSY PH. (Refer to Removal 17/ Replacement 27) Does the noise arise from the printer?	Go to step 13.	End of work.
13	Checking the Main Motor Does the noise arise from the printer? Checked by [Digital Output]-[DO-0(Control Panel)/MAIN MOTOR(PC)] in diagnosis.	Try replacing the DRIVE ASSY MAIN. (Refer to Removal 38/ Replacement 6)	Go to step 14.
14	Checking the Sub Motor Does the noise arise from the printer? Checked by [Digital Output]-[DO-5(Control Panel)/SUB MOTOR(PC)] in diagnosis.	Try replacing the DRIVE ASSY MAIN. (Refer to Removal 38/ Replacement 6)	Go to step 15.
15	Checking the DRIVE ASSY PH. Does the noise arise from the printer? Checked by [Digital Output]-[DO-a (Control Panel)/PH MOTOR ON(PC)] in diagnosis.	Try replacing the DRIVE ASSY PH. (Refer to Removal 17/ Replacement 27)	End of work. If the option tray attached, it goes to step 16.
16	Checking the Option Feeder Motor Does the noise arise from the printer? Checked by [Digital Output]-[DO-19(Control Panel)/ OPTION FEEDER1 MOTOR ON(PC)] in diagnosis.	Try replacing the Option Feeder ASSY. (Refer to Removal 44/ Replacement 46)	End of work.

6. Other FIP

Other FIP covers the power supply trouble FIP, except error code FIP, Noise FIP and image quality FIP.

FIP-AC

Step	Check	Yes	No
1	Checking the printer Does the motor noise occur when turning on the power? In this test, close the Front Cover.	Go to DC.	Go to step 2.
2	Checking the outlet Connect the power code with the other outlet. Does the printer is working?	End of work.	Go to step 3.
3	Checking the power code connection Reconnect the power code. Does the printer is working?	End of work.	Go to step 4.
4	Checking the connector of LVPS connecting Disconnect the power code and wait for one minute. Reseat the all connectors of LVPS. Does the printer is working?	End of work.	Go to step 5.
5	Checking the connector of MAIN SWITCH connecting Disconnect the power code and wait for one minute. Reseat the connector of MAIN SWITCH. Does the printer is working?	End of work.	Replace the LVPS. (Refer to Removal 35/ Replacement 9)

FIP-DC

Step	Check	Yes	No
1	Checking the printer Does the motor noise occur when turning on the power? In this test, close the Front Cover.	Go to step 2.	Go to step 5.
2	Checking the message on the Control Panel Does the message on the control panel appear?	End of work. If error message appeared, go to FIP.	Go to step 3.
3	Checking the connector of CONTROL PANEL connecting. Reseat the connector (P/ J220) of CONTROL PANEL. Does the CONTROL PANEL is working?	End of work.	Go to step 4.
4	Checking the PWBA ESS installation Reseat the PWBA ESS. (Refer to Removal 26/ Replacement 18) Does the message on the control panel appear?	End of work.	Replace the PWBA ESS and the Control Panel.
5	Go to FIP-AC. If not Checking the PWBA MCU installation Reseat the PWBA MCU. (Refer to Removal 30/ Replacement 14) Does the printer is working?	End of work.	Replace the LVPS. (Refer to Removal 35/ Replacement 9)

FIP-Multiple feed

Step	Check	Yes	No
1	Checking the MPF fed. Multi feed occurred in the MPF?	Go to step 2.	Go to step 3.
2	Checking the media Replace to the new paper. Does the multi feed still occur when printing?	Checking after replacing the END SEPARATOR ROLLER ASSEMBLY. Replace the SEPARATOR ROLLER ASSEMBLY. (Refer to Removal 41/ Replacement 3)	End of work.
3	Checking the media Replace to the new paper. Does the multi feed still occur when printing?	Replace the SEPARATOR ROLLER. (Refer to Removal 42/ Replacement 2)	End of work.

FIP-Control Panel Freezes

Step	Check	Remedy	
		Yes	No
	Possible causative parts PWBA ESS (PL9.1.27)		
1	Checking the operating environment. Is the printer connected to the Network?	Go to step 2.	Replace the Printer.
2	Checking the IP address. Can you change the IP address?	Go to step 5.	Go to step 3.
3	Checking the internet connectivity. Is there any internet connection available for your PC?	Go to step 4.	Replace the PWBA ESS. (Removal 26/ Replacement 18)
4	Updating the firmware to the latest version. Download the latest version of the firmware from the DELL Support Website, and execute the update. NOTE: Before updating the firmware to the latest version, reset the error following the steps of procedure described below. In addition, update the firmware by way of a USB storage. 1) Remove the network cable. 2) Connect the USB cable. 3) Turn the power off and on. Does the error persist when the power is turned off and on?	Replace the PWBA ESS. (Removal 26/ Replacement 18)	End of work.
5	Changing the IP address. Contact your system administrator for obtaining a new IP address. Refer to Reference_1 for details of how to change the IP address. Does the error persist when the power is turned off and on?	Replace the PWBA ESS. (Removal 26/ Replacement 18)	End of work.

Reference_1: Changing the IP address

- 1) Remove the network cable, and power off the printer and then on
- 2) Change the IP address on the Control Panel.
- 3) Plug the network cable back into the printer, and then turn the power on.
- 4) On the Control Panel, open [Admin] > [Network] > [TCP/IP], and confirm that the IP address has been changed.

Chapter 2 Operation of Diag. CONTENTS

1. Overview.....	2 - 1
1.1 Position of the Diag. in the Whole System.....	2 - 1
1.2 Operating This Software	2 - 1
2. Configuration	2 - 3
2.1 Control Panel Operation	2 - 3
2.2 CE Diag. Tool Operation.....	2 - 3
3. How to use Diag. Customer Mode (Control Panel Operation).....	2 - 4
3.1 Roles of the control panel in Diag.....	2 - 4
3.2 Entering diag. Customer mode	2 - 5
3.3 Selecting Diag. item	2 - 5
3.4 Change method parameters value.....	2 - 5
3.5 Executing/Exiting Diag. mode	2 - 5
3.6 Diag. mode menu tree	2 - 6
4. The Kind of Diag. and Contents of a Test (Control Panel Operation)	2 - 8
4.1 IOT Diag.....	2 - 8
4.1.1 Digital Input (DI) Test.....	2 - 8
4.1.2 Executing digital input (DI) test	2 - 8
4.1.3 Digital Output (DO) Test	2 - 20
4.1.4 Executing digital output (DO) test	2 - 20
4.2 Print Info.....	2 - 44
4.2.1 Executing Print Info.....	2 - 44
4.2.2 Config Page	2 - 44
4.2.3 Print Settings.....	2 - 44
4.3 Complete.....	2 - 44
4.3.1 Executing Print Info.....	2 - 44
4.4 Installation Set	2 - 45
4.4.1 Executing Installation Set.....	2 - 45
4.5 Test Print.....	2 - 46
4.5.1 Executing test print	2 - 46
4.5.2 No Image [IOT]	2 - 46
4.5.3 Test Pattern 600[IOT]	2 - 46
4.5.4 Grid2	2 - 47
4.5.5 Cyan 20%	2 - 48
4.5.6 Magenta 20%.....	2 - 48
4.5.7 Yellow 20%	2 - 49
4.5.8 Black 20%	2 - 49
4.5.9 CMY 20%.....	2 - 50
4.5.10 Gradation	2 - 51
4.5.11 Toner Pallet Check	2 - 52
4.5.12 Contamination Check.....	2 - 53
4.5.13 Parameter Setting.....	2 - 54
4.5.14 Printing the parameter list.....	2 - 56
5. How to use Customer Engineer Diag. (CE Diag. Tool Operation).....	2 - 57
5.1 Operating environment	2 - 57
5.2 Connection method	2 - 57

Chapter 2 Operation of Diag. CONTENTS

5.3 Activation and termination of the CE Diag.	2 - 58
5.4 Explanation of the CE Diag. screen	2 - 60
5.5 Selecting CE Diag. item	2 - 61
5.6 CE Diag. mode menu tree	2 - 62
6. The Kind of CE Diag. and Contents of a Test (CE Diag. Tool Operation).....	2 - 65
6.1 ESS Diag	2 - 65
6.2 Digital Input	2 - 67
6.3 Digital Output	2 - 78
6.4 IOT NVM Settings - Write	2 - 102
6.5 IOT NVM Settings - Read	2 - 103
6.6 Print Info.....	2 - 104
6.7 Installation Set	2 - 105
6.8 Test Print.....	2 - 107
6.8.1 No Image (IOT).....	2 - 107
6.8.2 Test Pat (IOT)	2 - 108
6.8.3 Grid2	2 - 109
6.8.4 Cyan 20%	2 - 110
6.8.5 Magenta 20%.....	2 - 110
6.8.6 Yellow 20%	2 - 111
6.8.7 Black 20%	2 - 111
6.8.8 CMY 20%.....	2 - 112
6.8.9 Gradation	2 - 113
6.8.10 Toner Pallet Check	2 - 114
6.8.11 Contamination Check.....	2 - 115
6.9 Parameter	2 - 116
6.9.1 Print	2 - 116
6.9.2 Registration.....	2 - 117
6.9.3 Toner	2 - 118
6.9.4 DTB.....	2 - 118
6.9.5 Sheets.....	2 - 118
6.9.6 Drum	2 - 118
6.9.7 Custom.....	2 - 118
6.9.8 PHD	2 - 119
6.9.9 Buttons.....	2 - 119

1. Overview

1.1 Position of the Diag. in the Whole System

Major functions of this diag. are as follows:

- IOT Diag
- Setting of parameters for registration in paper feeding direction and so on.

1.2 Operating This Software

There are the following two Diag. operations for operating this software:

- 1) Control Panel Operation

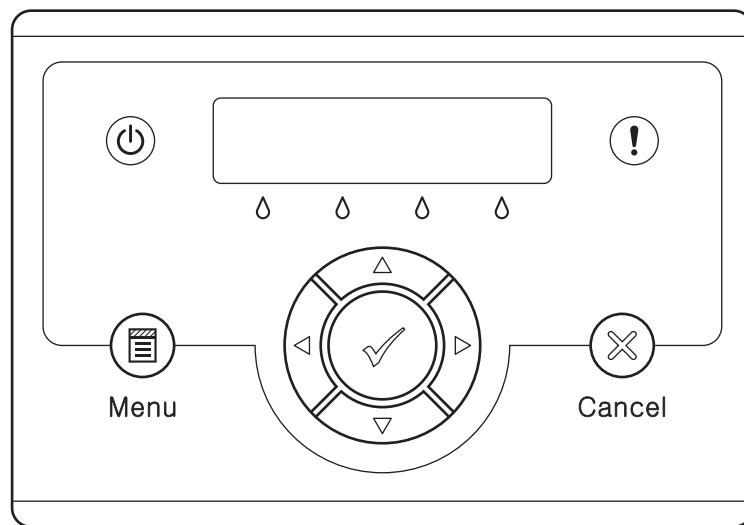

Zna02100KA

2) CE Diag. Tool Operation

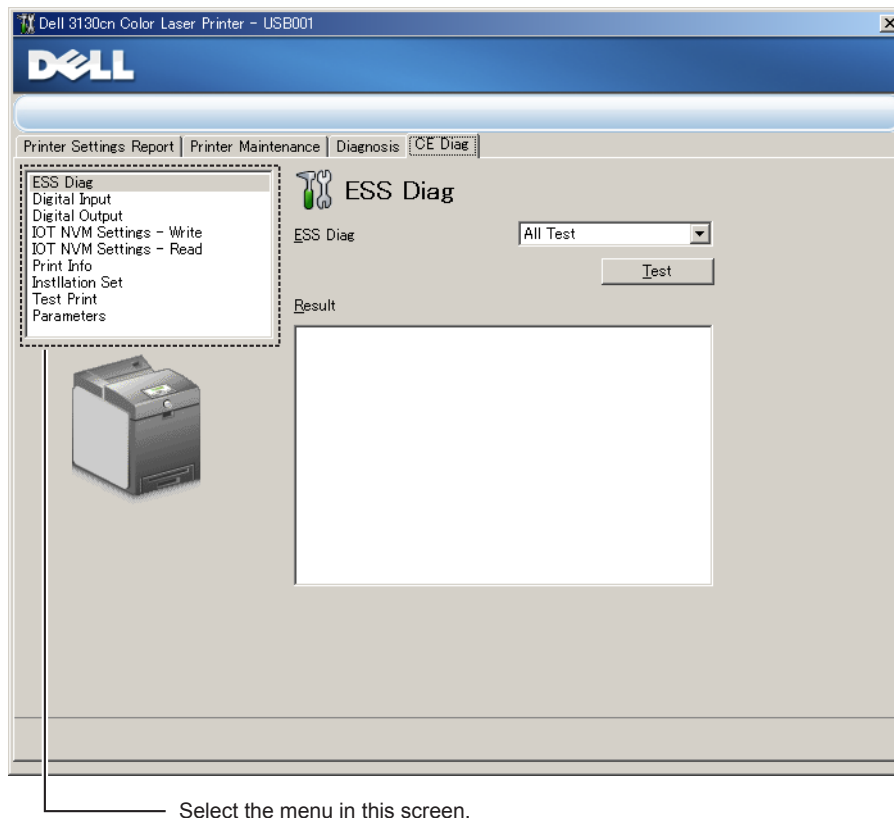

Select the menu in this screen.

This manual describes the operation of "Control Panel Operation" and "CE Diag. Tool Operation" respectively.

Described below are the contents of them:

- Control Panel Operation

- "3. How to Use Diag. Customer Mode (Control Panel Operation)"

- "4. The Kind of Diag. and Contents of a Test (Control Panel Operation)"

- CE Diag. Tool Operation

- "5. How to Use Customer Engineer Diag. (CE Diag. Tool Operation)"

- "6. The Kind of CE Diag. and Contents of a Test (CE Diag. Tool Operation)"

2. Configuration

2.1 Control Panel Operation

There are the following three modes for the Diag. operation from the control panel, varying according to aims, operators, and functions each.

This manual describes the operation of "Customer Mode".

Shippper Mode:

This mode intends to be used in the production line with the purpose to locate a chip that causes a problem.

Diagnosis time in the mode shall be as short as possible with consideration of production cost.

The mode shifts to the Developer mode (described later) after the ESS Diag.

This mode is protected password.

Customer Mode:

This mode intends to be used by customer who handle problems in field with the purpose to locate a replaceable unit that causes a problem.

Sorting problems on the basis of parts that can be replaced by the customer support center.

This is the base of this mode design, and that is why so many features.

The mode allows the user to execute the test prints, parameter settings and so on through the control panel.

Developer/CE (Customer Engineer) Mode:

This mode is for debugging by developers or CEs. It intends to be partially used in the production line.

The mode allows the user to execute the ESS diagnosis, test prints, parameter settings and so on through the debug terminal.

The functions are activated by commands sent from the serial terminal. Special tool (FX internal debugging terminal) is required to operate Developer mode.

This mode is protected password.

| 2.2 CE Diag. Tool Operation

The Diag. operation from the tool box on the PC targets customer engineers (CE) only.

| This manual describes the operation of [CE Diag.].

3. How to use Diag. Customer Mode (Control Panel Operation)

3.1 Roles of the control panel in Diag.

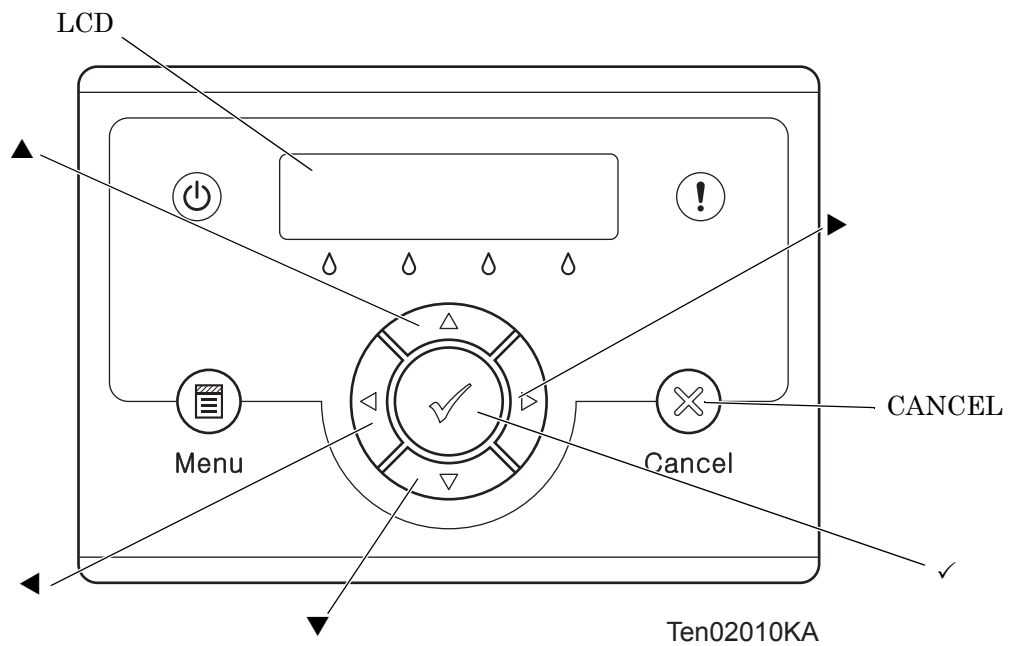

[LCD]:Displaying a diagnosis item and its result

[▲], [▼]:Selecting a diagnosis item/Selecting data at parameter setting

[◀], [▶]:Key moves the cursor to the left/right

[✓]: Determining a diagnosis item/Executing a diagnosis/Determining a parameter at parameter setting

[CANCEL]:Reseting a diagnosis item (Returning to the menu one level higher)
Terminating each digital input/output

3.2 Entering diag. Customer mode

- 1) Turn off the power.
- 2) Turn on the power while holding down “▲” and “▼” keys.
- 3) Release the fingers from these keys when “Diagnosing...” is displayed.
- 4) The “Customer Mode” and “IOT Diag” are displayed. (Entered the Diag. mode.)

3.3 Selecting Diag. item

The diagnosis setting items are configured as menus, which can be operated with the control panel keys. Arrow keys select menu items and “✓” key activates functions.

3.4 Change method parameters value

For parameter setting, pressing “✓” key after selecting an item from the menu displays the current setting value of the item. Then a numeric value selected by “▼” and “▲” keys are written into the NVM by “✓” key.

3.5 Executing/Exiting Diag. mode

The diagnosis can be executed by as follows.

- 1) A test item is displayed. “✓” key fixed the test item.
- 2) The display prompts the user to start the test. Press “✓” key and start the test.

The diagnosis can be stopped by as follows.

- 1) During the diagnosis test, press “CANCEL” key.
- 2) The diagnosis is stopped, and the display indicates the one step higher menu.

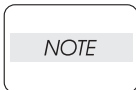

When error occurred during Diag. operations, the display returns to the menu selective state after displaying the error for about three seconds.

3.6 Diag. mode menu tree

Menu Tree of the Customer Mode is as follows

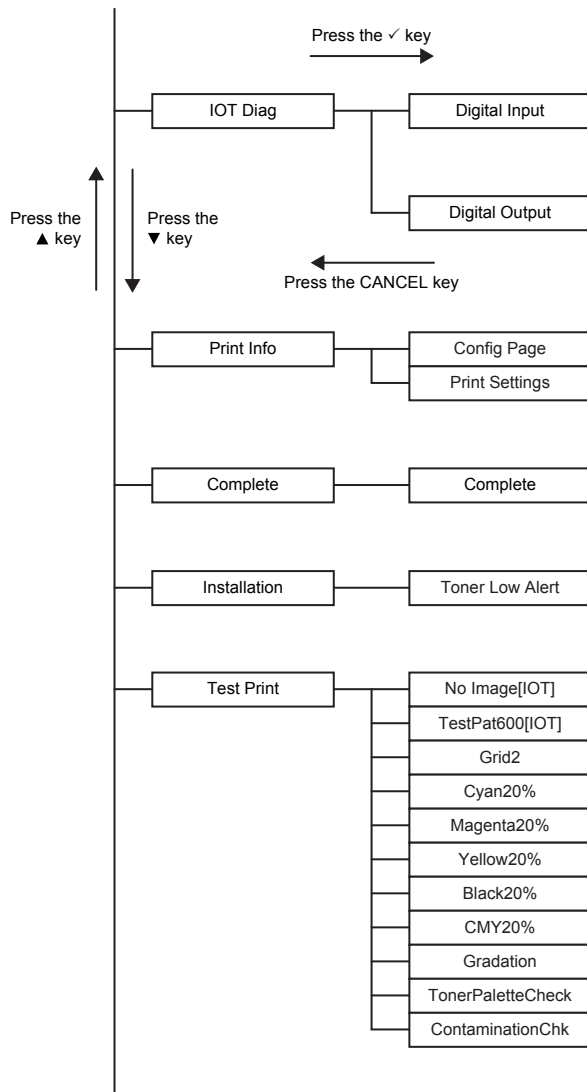

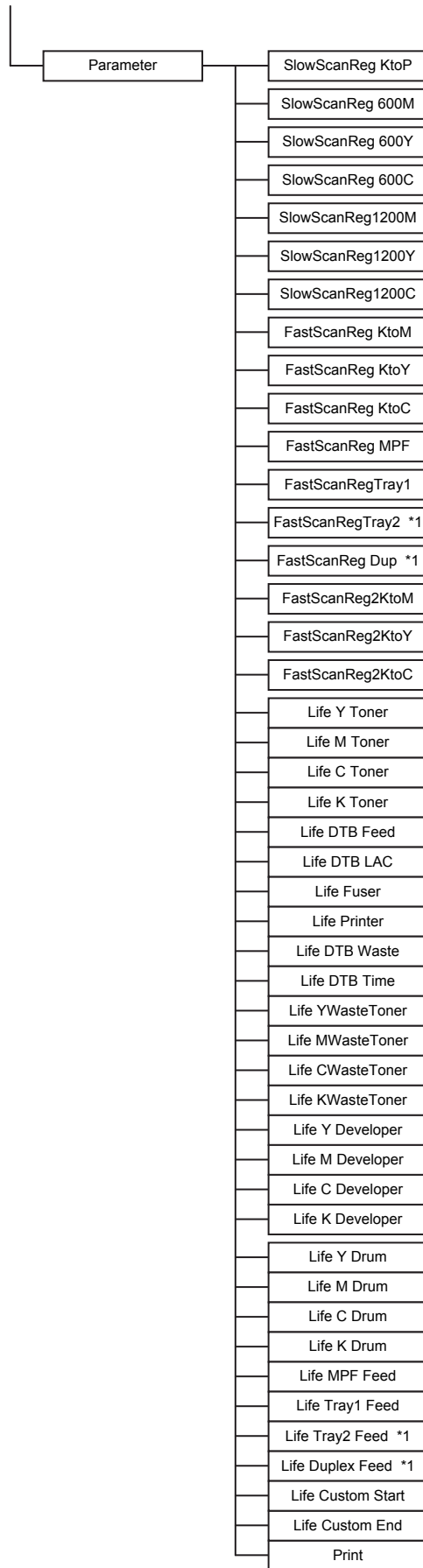

*1: Appears only when the optional Tray2 or Duplex is installed

4. The Kind of Diag. and Contents of a Test (Control Panel Operation)

4.1 IOT Diag

4.1.1 Digital Input (DI) Test

This function checks whether the DI components operate normally or not.

The DI test is performed for all the DI components.

Exit operation of the DI test makes the control panel display the Customer diag. function menu.

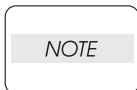

During the DI test, other Customer diag. functions can not be performed simultaneously. Therefore, the printer does not accept any operation except operations for the DI components and exit operation of the DI test.

At the start of the DI test, number “0” is displayed on the control panel. This number is counted up when a DI component is turned on from off, therefore it allows the user to know the component is active.

When a paper jam is occurred, or an error message or code is displayed, execute this test to locate the damaged parts.

The test will execute the DI Test codes of the components that are supposed to be faulty from the error details. (Refer to each FIP on Chapter 1.)

Test result: NG (Go to each FIP or replace the parts.)

OK (Turn off/on the main power.)

4.1.2 Executing digital input (DI) test

- 1) Turn off the power.
- 2) Turn on the power while holding down “▲” and “▼” keys.
- 3) Release the fingers from these keys when “Diagnosing...” is displayed.
- 4) The “Customer Mode” and “IOT Diag” are displayed. (Entered the Diag. mode.)
- 5) Press “✓” key.
- 6) Press “▼” key to select “Digital Input”, and then press “✓” key.
- 7) Press “▲” or “▼” key to select the test item.
- 8) Press “✓” key twice to execute the test.

Parameters for the Digital Input Test are as follows.

Code	Components
DI-0	K Mode Sensor
DI-1	Dup Jam sensor
DI-2	Exit Sensor
DI-3	Regi Sensor
DI-7	Front Cover Interlock Switch
DI-8	Yellow Toner Cartridge Sensor
DI-9	Magenta Toner Cartridge Sensor
DI-a	Black Toner Cartridge Sensor
DI-b	Cyan Toner Cartridge Sensor
DI-c	Tray2 Low Paper (Not Used)
DI-d	Tray 2 No Paper sensor

Code	Components
DI-e	Duplex Fan Alarm (Not Used)
DI-f	Tray 2 Feed Motor Alarm (Not Used)
DI-10	MPF No Paper Sensor
DI-11	Tray 1 No Paper Sensor
DI-12	Main Motor Alarm (Not Used)
DI-13	Sub Motor Alarm (Not Used)
DI-14	OHP Sensor (Not Used)
DI-15	Fan Alarm (Not Used)
DI-16	Feed Drive Alarm (Not Used)
DI-17	Deve Motor Alarm (Not Used)
DI-18	Tray 1 Paper Size Switch
DI-20	Tray 2 Paper Size Switch

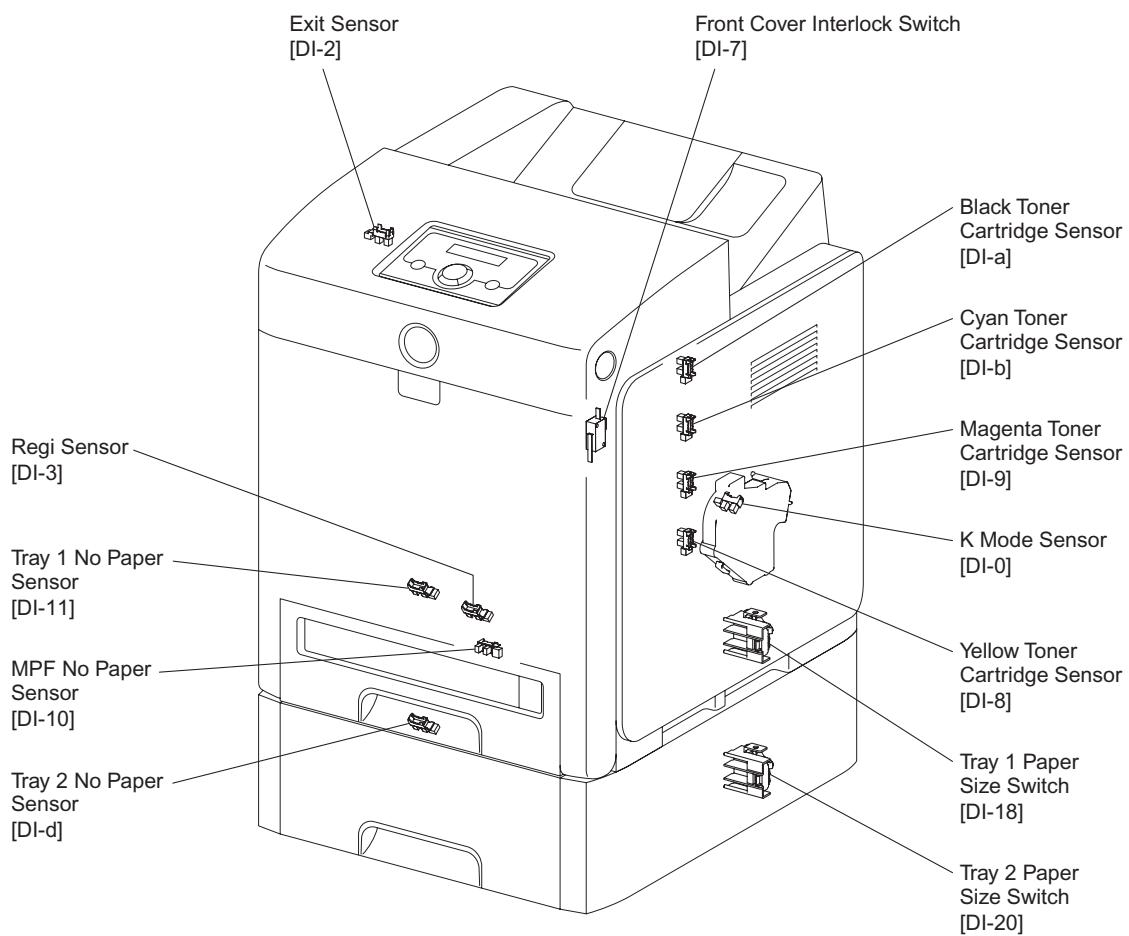

Zna02002KB

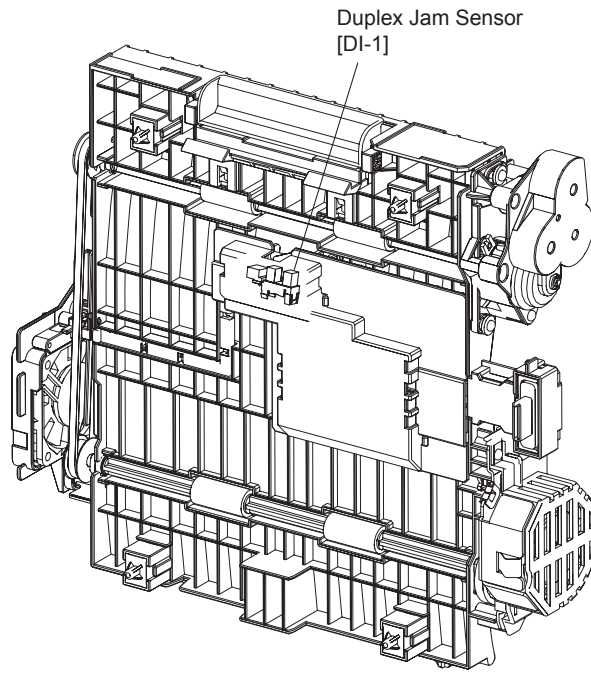

Kmy02042KA

- About Sensor

A transmissive type sensor is composed of the light-emitting side and the light-receiving side that are placed opposite to each other allowing the light to pass from the former to the latter. On the basis of whether or not the light path is blocked due to the actuator, etc., the sensor detects the paper absence/presence or the moving part position such as at the home position or elsewhere.

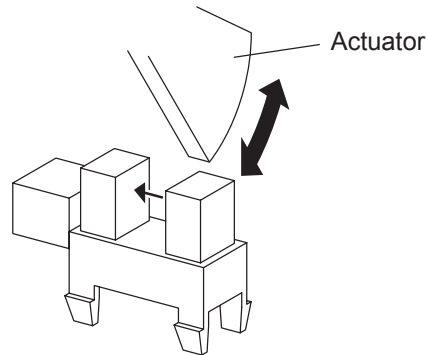

Leg_Sec02_016FA

- About Switch

A micro-switch closes the internal contacts via the button which is pushed down under the provided leaf spring which is held down by the actuator of the cover or door that is being closed. When the door or cover has been opened, the leaf spring returns to its original position and the button is pushed up by the spring in the switch, allowing the internal contacts to open.

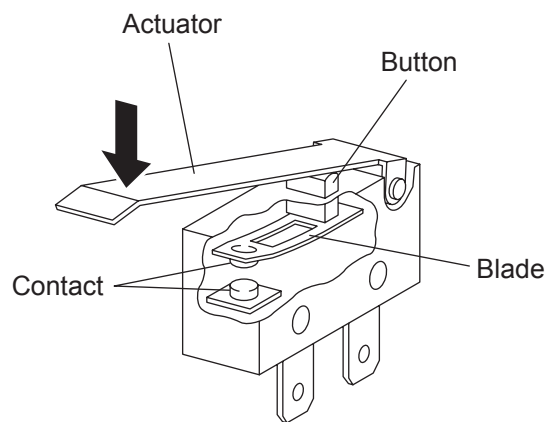

Leg_Sec02_018FA

-Checking the Sensor and Switch

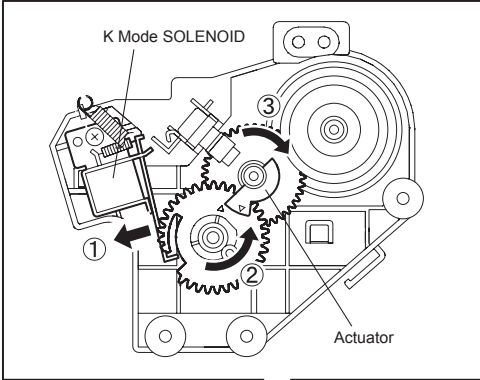
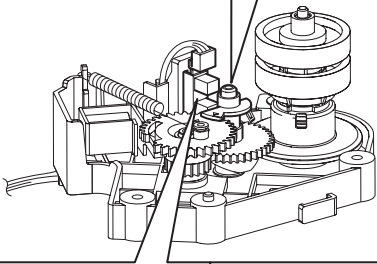
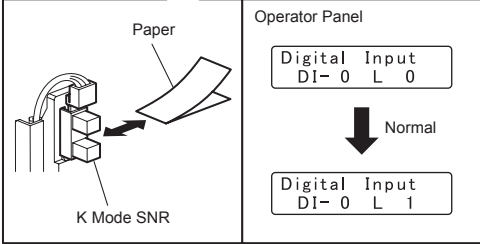
Sensor name (Diag. Code)	Confirmation procedures
<p>K Mode sensor (DI-0) (Color Mode Switching Sensor)</p>	<p>NOTE: This procedure is for the technical staff. When performing operation for five minutes or longer with the front cover open, remove all toner cartridges, and cover the drum to avoid exposure to light.</p> <ol style="list-style-type: none"> 1) Turn on the power and enter the Diagnostic Mode. 2) Execute the DI-0. 3) Open the Front Cover. 4) Remove the Cover Rear. 5) Remove the Cover Side R Assy. 6) Remove the Drive Assy K. 7) Press the lever mounted on the Solenoid to retract the actuator from the sensor. 8) Check the sensor. <div style="text-align: center;">    <p style="text-align: right; font-size: small;">Zna02050KA</p> </div> <ol style="list-style-type: none"> 9) Press the "Cancel" key to stop the test. 10) Replace the Drive Assy K. 11) Replace the Cover Side R Assy. 12) Replace the Cover Rear. 13) Close the Front Cover.

Sensor name (Diag. Code)	Confirmation procedures
Duplex Jam Sensor (DI-1)	<p>NOTE: When performing operation for five minutes or longer with the front cover open, remove all toner cartridges, and cover the drum to avoid exposure to light.</p> <ol style="list-style-type: none"> 1) Turn on the power and enter the Diagnostic Mode. 2) Execute the DI-1. 3) Open the Front Cover. 4) Remove the Transfer Belt. 5) Check the sensor. <div data-bbox="783 488 1267 1240" style="text-align: center;"> <p style="text-align: right; font-size: small;">Zna02003KA</p> </div> <ol style="list-style-type: none"> 6) Press the "Cancel" key to stop the test. 7) Replace the Transfer Belt. 8) Close the Front Cover.

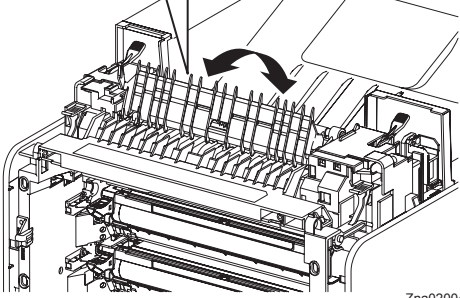
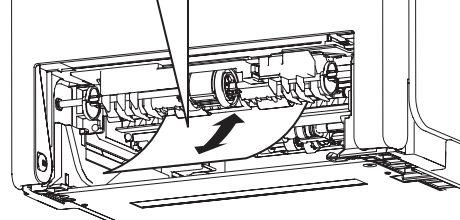
Sensor name (Diag. Code)	Confirmation procedures
Exit Sensor (DI-2)	<p>NOTE: Fuser is very hot, so pay sufficient attention at work to above burns, etc.</p> <ol style="list-style-type: none"> 1) Turn on the power and enter the Diagnostic Mode. 2) Execute the DI-2. 3) Open the Front Cover. 4) Check the sensor. <div data-bbox="767 421 1283 860" style="border: 1px solid black; padding: 5px;"> <p>Operator Panel</p> <div style="display: flex; align-items: center; justify-content: center;"> <div style="border: 1px solid black; padding: 2px; margin-right: 10px;">Digital Input DI- 2 L 0</div> <div style="margin-right: 10px;">Normal →</div> <div style="border: 1px solid black; padding: 2px;">Digital Input DI- 2 L 1</div> </div>  <p style="text-align: right; font-size: small;">Zna02004KA</p> </div> <ol style="list-style-type: none"> 5) Press the "Cancel" key to stop the test. 6) Close the Front Cover.
Regi Sensor (DI-3)	<ol style="list-style-type: none"> 1) Turn on the power and enter the Diagnostic Mode. 2) Execute the DI-3. 3) Remove the 250 paper cassette. 4) Insert the paper into the paper path of the Regi assy. <div data-bbox="767 1104 1283 1473" style="border: 1px solid black; padding: 5px;"> <p>Operator Panel</p> <div style="display: flex; align-items: center; justify-content: center;"> <div style="border: 1px solid black; padding: 2px; margin-right: 10px;">Digital Input DI- 3 L 0</div> <div style="margin-right: 10px;">Normal →</div> <div style="border: 1px solid black; padding: 2px;">Digital Input DI- 3 L 1</div> </div>  <p style="text-align: right; font-size: small;">Kmy02005KA</p> </div> <ol style="list-style-type: none"> 5) Press the "Cancel" key to stop the test. 6) Replace the 250 paper cassette.

Sensor name (Diag. Code)	Confirmation procedures
<p>Interlock Switch (DI-7)</p>	<ol style="list-style-type: none"> 1) Turn on the power and enter the Diagnostic Mode. 2) Execute the DI-7. 3) Check the Switch <div data-bbox="764 327 1283 882" style="text-align: center;"> <p>The diagram shows the Operator Panel with two digital input indicators: 'Digital Input DI-7 L 0' and 'Digital Input DI-7 L 1'. An arrow labeled 'Normal' points from the first indicator to the second. Below this, a cutaway view of the printer shows the front cover open, with a curved arrow pointing to the interlock switch mechanism inside.</p> <p style="text-align: right; font-size: small;">Zna02006KA</p> </div> <ol style="list-style-type: none"> 4) Press the "Cancel" key to stop the test. 5) Close the Front Cover.
<p>Yellow Toner Cartridge (DI-8)</p>	<p>NOTE: When performing operation for five minutes or longer with the front cover open, remove all toner cartridges, and cover the drum to avoid exposure to light.</p> <ol style="list-style-type: none"> 1) Turn on the power and enter the Diagnostic Mode. 2) Execute the DI-8. 3) Open the Front Cover 4) Check the Sensor. <div data-bbox="764 1238 1283 1816" style="text-align: center;"> <p>The diagram shows the Operator Panel with two digital input indicators: 'Digital Input DI-8 L 0' and 'Digital Input DI-8 L 1'. An arrow labeled 'Normal' points from the first indicator to the second. Below this, a cutaway view of the printer shows the front cover open, with an arrow pointing to the toner cartridge sensor area.</p> <p style="text-align: right; font-size: small;">Zna02007KA</p> </div> <ol style="list-style-type: none"> 5) Press the "Cancel" key to stop the test. 6) Close the Front Cover.

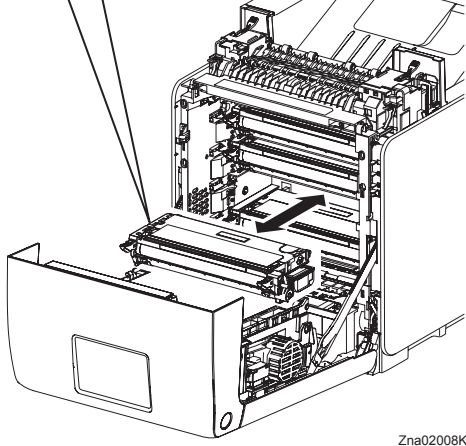
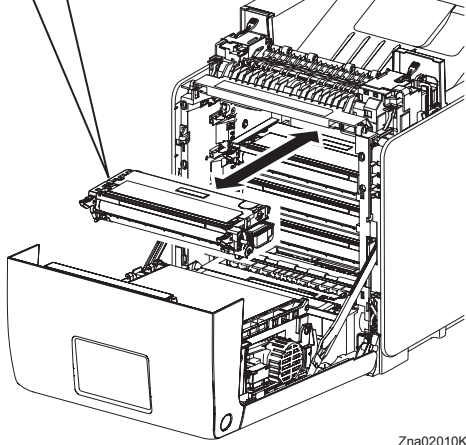
Sensor name (Diag. Code)	Confirmation procedures
<p>Magenta Toner Cartridge (DI-9)</p>	<p>NOTE: When performing operation for five minutes or longer with the front cover open, remove all toner cartridges, and cover the drum to avoid exposure to light.</p> <ol style="list-style-type: none"> 1) Turn on the power and enter the Diagnostic Mode. 2) Execute the DI-9. 3) Open the Front Cover 4) Check the Sensor. <div data-bbox="764 454 1283 1037" style="border: 1px solid black; padding: 5px;"> <p>Operator Panel</p> <p style="text-align: center;">Normal</p> <div style="display: flex; justify-content: space-around; align-items: center;"> <div style="border: 1px solid black; padding: 2px;">Digital Input DI- 9 L 0</div> <div style="font-size: 2em;">➔</div> <div style="border: 1px solid black; padding: 2px;">Digital Input DI- 9 L 1</div> </div>  <p style="text-align: right; font-size: small;">Zna02008KA</p> </div> <ol style="list-style-type: none"> 5) Press the "Cancel" key to stop the test. 6) Close the Front Cover.
<p>Black Toner Cartridge (DI-a)</p>	<p>NOTE: When performing operation for five minutes or longer with the front cover open, remove all toner cartridges, and cover the drum to avoid exposure to light.</p> <ol style="list-style-type: none"> 1) Turn on the power and enter the Diagnostic Mode. 2) Execute the DI-a. 3) Open the Front Cover 4) Check the Sensor. <div data-bbox="764 1386 1283 1968" style="border: 1px solid black; padding: 5px;"> <p>Operator Panel</p> <p style="text-align: center;">Normal</p> <div style="display: flex; justify-content: space-around; align-items: center;"> <div style="border: 1px solid black; padding: 2px;">Digital Input DI- a L 0</div> <div style="font-size: 2em;">➔</div> <div style="border: 1px solid black; padding: 2px;">Digital Input DI- a L 1</div> </div>  <p style="text-align: right; font-size: small;">Zna02010KA</p> </div> <ol style="list-style-type: none"> 5) Press the "Cancel" key to stop the test. 6) Close the Front Cover.

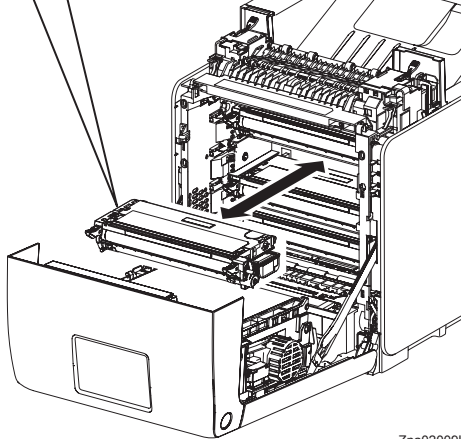
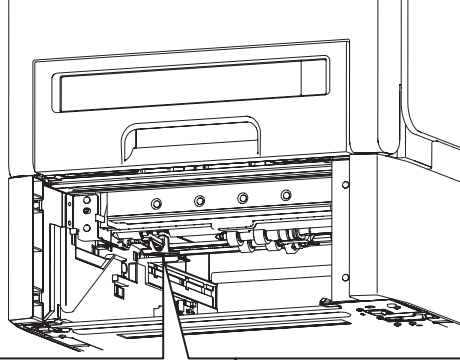
Sensor name (Diag. Code)	Confirmation procedures
<p>Cyan Toner Cartridge (DI-b)</p>	<p>NOTE: When performing operation for five minutes or longer with the front cover open, remove all toner cartridges, and cover the drum to avoid exposure to light.</p> <ol style="list-style-type: none"> 1) Turn on the power and enter the Diagnostic Mode. 2) Execute the DI-b. 3) Open the Front Cover 4) Check the Sensor. <div data-bbox="766 454 1284 1041" style="border: 1px solid black; padding: 5px;"> <p>Operator Panel</p> <div style="display: flex; align-items: center; justify-content: center;"> <div style="border: 1px solid black; padding: 2px; margin-right: 10px;">Digital Input DI- b L 0</div> <div style="margin-right: 10px;">Normal →</div> <div style="border: 1px solid black; padding: 2px;">Digital Input DI- b L 1</div> </div>  <p style="text-align: right; font-size: small;">Zna02009KA</p> </div> <ol style="list-style-type: none"> 5) Press the "Cancel" key to stop the test. 6) Close the Front Cover.
<p>Tray2 Low Paper (DI-c)</p>	<p>Internal signal.</p>
<p>Tray 2 No paper Sensor (DI-d)</p>	<p>NOTE: The no paper sensor is in the option feeder.</p> <ol style="list-style-type: none"> 1) Turn on the power and enter the Diagnostic Mode. 2) Execute the DI-d. 3) Remove the Paper Cassette. 4) Check the Sensor. <div data-bbox="782 1350 1268 1960" style="border: 1px solid black; padding: 5px;">  <div style="display: flex; align-items: center; justify-content: center;"> <div style="border: 1px solid black; padding: 2px; margin-right: 10px;">Digital Input DI- d H 0</div> <div style="margin-right: 10px;">Normal ↓</div> <div style="border: 1px solid black; padding: 2px;">Digital Input DI- d H 1</div> </div> <p style="text-align: right; font-size: small;">Kmy02011KA</p> </div> <ol style="list-style-type: none"> 5) Press the "Cancel" key to stop the test. 6) Replace the paper cassette.

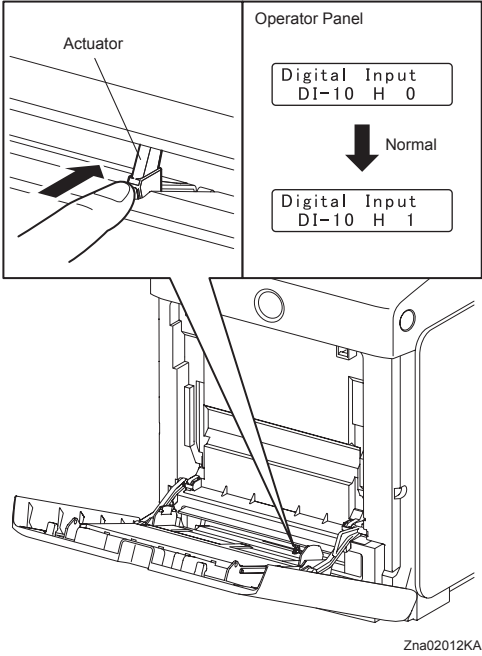
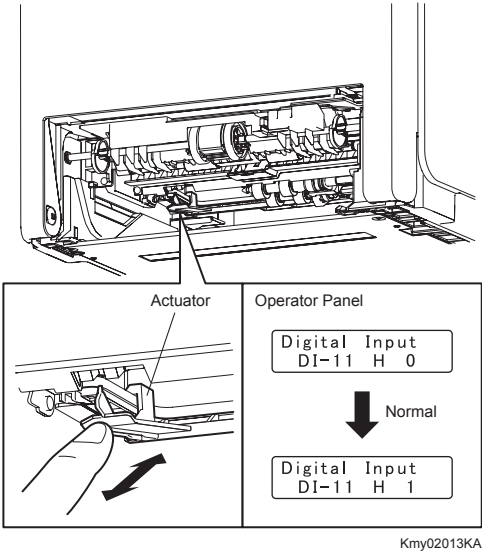
Sensor name (Diag. Code)	Confirmation procedures
Option Tray Feed Motor Alarm (DI-f)	Internal signal.
MPF No Paper Sensor (DI-10)	<p>NOTE: Remove the paper of the MPF before executing the test.</p> <ol style="list-style-type: none"> 1) Turn on the power and enter the Diagnostic Mode. 2) Execute the DI-10. 3) Open the MPF Cover. 4) Check the sensor. <div style="text-align: center;">  <p>The diagram shows a hand pointing to the actuator on the MPF cover. To the right, the Operator Panel displays 'Digital Input DI-10 H 0'. A downward arrow labeled 'Normal' points to a second display showing 'Digital Input DI-10 H 1'. Below this is a cutaway view of the MPF mechanism with the label 'Zna02012KA'.</p> </div> <ol style="list-style-type: none"> 5) Press the "Cancel" key to stop the test. 6) Close the MPF Cover.
Tray 1 No paper Sensor (DI-11)	<ol style="list-style-type: none"> 1) Turn on the power and enter the Diagnostic Mode. 2) Execute the DI-11. 3) Remove the paper cassette. 4) Check the sensor. <div style="text-align: center;">  <p>The diagram shows a hand pointing to the actuator on the tray. To the right, the Operator Panel displays 'Digital Input DI-11 H 0'. A downward arrow labeled 'Normal' points to a second display showing 'Digital Input DI-11 H 1'. Below this is a cutaway view of the tray mechanism with the label 'Kmy02013KA'.</p> </div> <ol style="list-style-type: none"> 5) Press the "Cancel key to stop the test. 6) Replace the paper cassette.
Main Motor Alarm (DI-12)	Internal signal.
Sub Motor Alarm (DI-13)	Internal signal.

Sensor name (Diag. Code)	Confirmation procedures
OHP Sensor (DI-14)	Not used
FAN Alarm (DI-15)	Internal signal.
PH Motor Alarm (DI-16)	Internal signal.
DEVE Motor Alarm (DI-17)	Internal signal.
Tray 1 Paper Size Switch (DI-18)	<ol style="list-style-type: none"> 1) Turn on the power and enter the Diagnostic Mode. 2) Execute the DI-18. 3) Check the switch. <div data-bbox="746 551 1300 1010" style="text-align: center;"> <p style="text-align: right; font-size: small;">Zna02014KA</p> </div> <ol style="list-style-type: none"> 4) Press the "Cancel key to stop the test. 5) Replace the paper cassette.
Tray 2 Paper Size Switch (DI-20)	<p>NOTE: The size switch is in the option feeder.</p> <ol style="list-style-type: none"> 1) Turn on the power and enter the Diagnostic Mode. 2) Execute the DI-20. 3) Check the switch. <div data-bbox="746 1379 1300 1861" style="text-align: center;"> <p style="text-align: right; font-size: small;">Kmy02015KA</p> </div> <ol style="list-style-type: none"> 4) Press the "Cancel key to stop the test. 5) Replace the paper cassette.

4.1.3 Digital Output (DO) Test

This function checks whether the DO components operate.

When the interlock is opened while the DO test is performed, each component ends to operate.

NOTE

In this Test Mode, each DO component can be turned individually. Therefore it allows the customer to check a component's operation from outside, and judge whether the component is normal or not.

When all the diag. functions are stopped, all the DO components can be turned off.

DO test can make each of the DO components operate simultaneously.

When a paper jam or PQ problem is occurred, or an error message or code is displayed, this test enables to look for the broken or damaged parts.

Test result: NG (Go to each FIP or replace the parts.)

OK (Turn off/on the main power.)

4.1.4 Executing digital output (DO) test

- 1) Turn off the power.
- 2) Turn on the power while holding down “▲” and “▼” keys.
- 3) Release the fingers from these keys when “Diagnosing...” is displayed.
- 4) The “Customer Mode” and “IOT Diag” are displayed. (Entered the Diag. mode.)
- 5) Press “✓” key.
- 6) Press “▼” key to select “Digital Output”, and then press “✓” key.
- 7) Press “▲” or “▼” key to select test item.
- 8) Press “✓” key to execute the test.

Parameters for the Digital Output Test are as follows.

Code	Components
DO-0,2	Main Motor
DO-5,7	Sub Motor
DO-a,c	PH Motor
DO-13,16	Duplex Motor
DO-19,1b	Tray 2 Feed Motor
DO-1e,1f	Fan
DO-21	Yellow Toner Motor
DO-23	Magenta Toner Motor
DO-25	Cyan Toner Motor
DO-27	Black Toner Motor
DO-29	Regi Clutch
DO-2b	MPF Turn Clutch
DO-2d	MPF Feed Solenoid
DO-2f	Tray 1 Feed Clutch
DO-31	Tray 2 Feed Clutch
DO-33	Tray 2 Turn Clutch
DO-35	Duplex Clutch
DO-37	ADC (CTD) Sensor Solenoid
DO-39	ADC (CTD) Sensor LED
DO-3b	OHP LED (Not Used)

Code	Components
DO-3d	Black Erase Lamp
DO-3f	Yellow, Magenta, Cyan Erase Lamp
DO-5b	Exit Clutch
DO-5d	Duplex Fan
DO-5F	Buzzer
DO-61	K Mode Solenoid

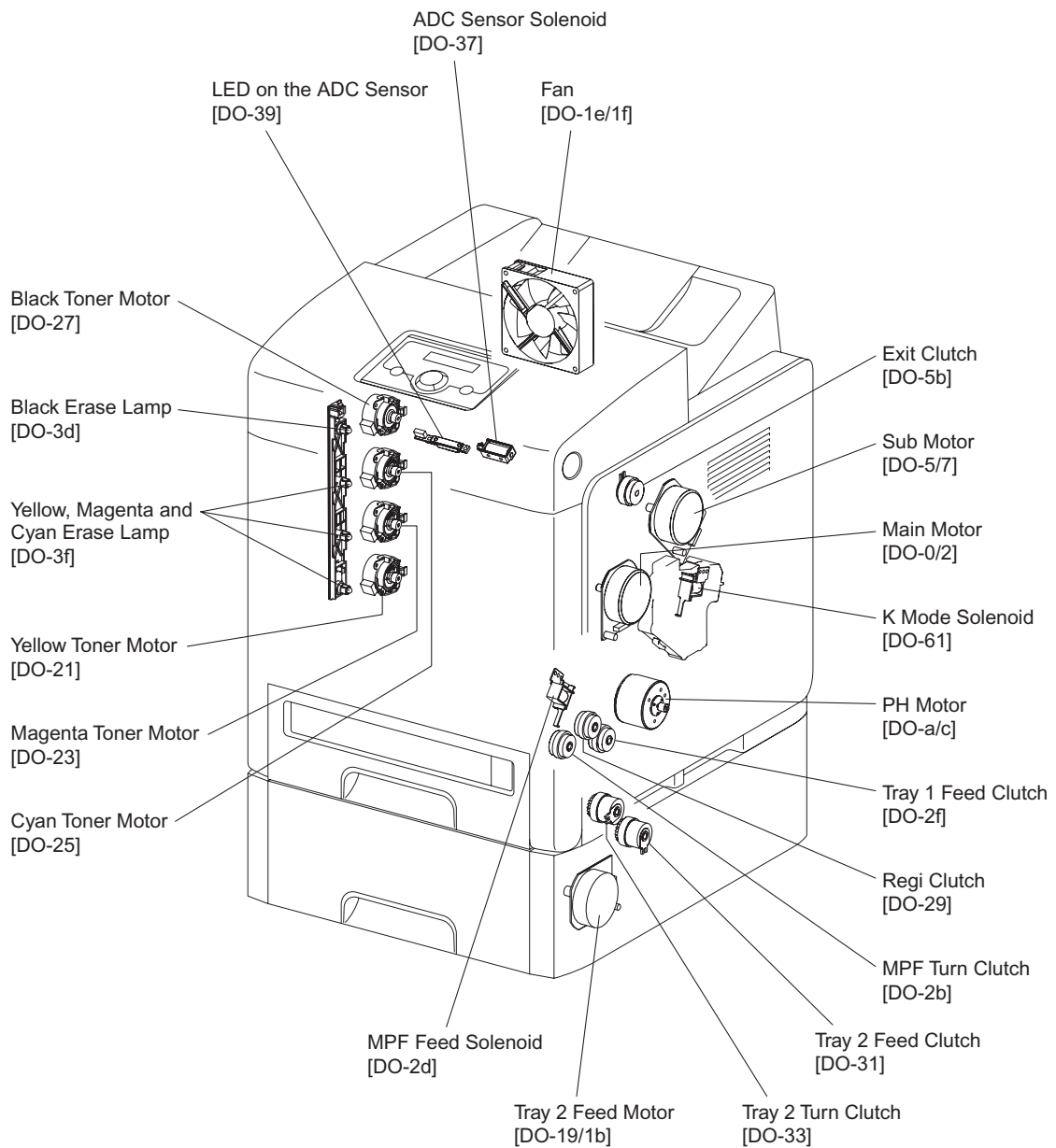

Zna02016KB

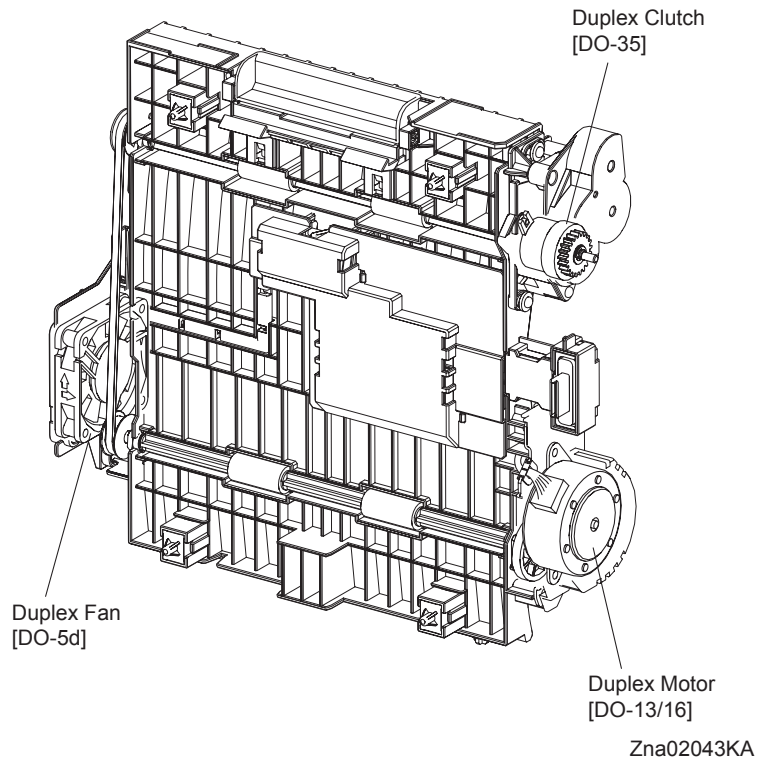

- About Clutch

The electromagnetic clutch in the printer controls the rotation of the roller by transferring or cutting the torque from the motor to the roller.

The electromagnetic clutch becomes an electromagnet by the passage of electric current through the coil inside the case and attracts the armature and gear to the rotating rotor, thereby rotating the gear.

Upon the loss of power to the coil, electromagnetic force is lost and the armature comes off the rotor, and the gear comes to rest.

The clutch makes so soft noises that you must be close the component to audibly confirm the operation of the component.

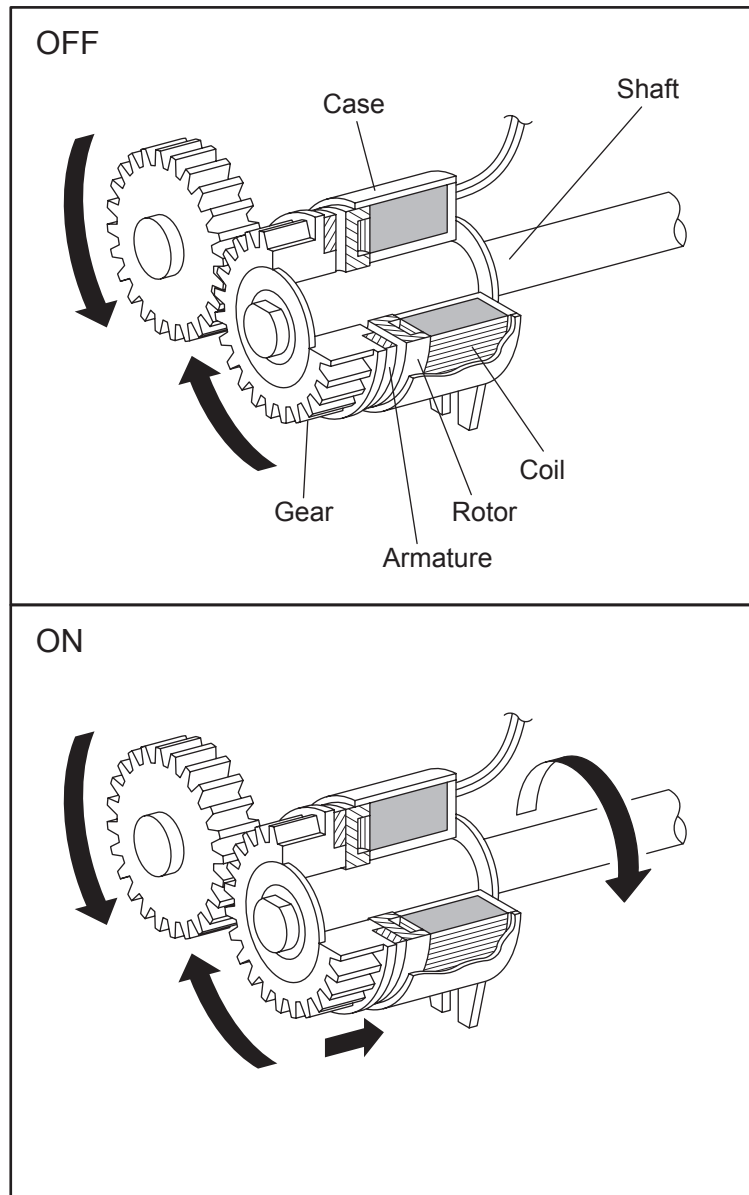

Leg_Sec02_050FA

- About Solenoid

The solenoid in the printer opens/closes the shutter or controls the position of the gear for transferring the torque of the motor to the roller.

A solenoid becomes an electromagnet by the passage of electric current through the coil inside the case and attracts the plunger.

Upon the loss of power to the coil, electromagnetic force is lost and the plunger is returned to its original position by spring action, thereby allowing the shutter to operate or the gear to move to the predefined position.

Unlike a clutch, a solenoid generates a loud operation noise.

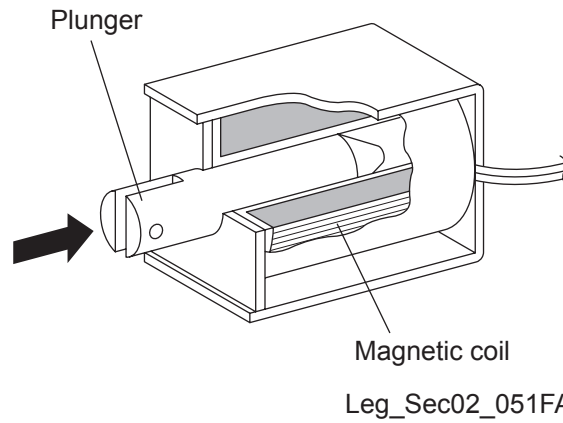

- Checking Motor, Clutch and Solenoid

NOTE

Before executing the DO test, close all covers and doors.

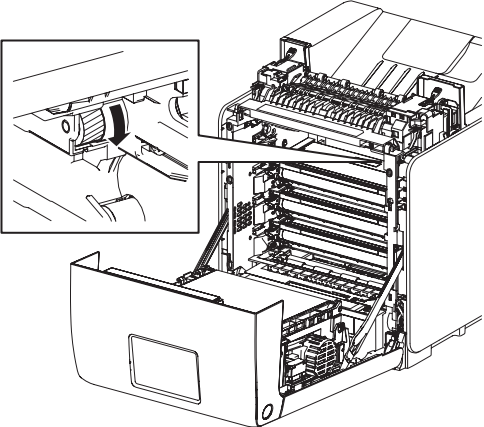
Clutch and Solenoid name (Diag. Code)	Confirmation procedure
Main Motor (DO-0/DO-2)	<p>NOTE: This procedure is for the technical staff. The customer check are the procedure 1, 5 and 6. The main motor is in the PC/DEVE DRIVE.</p> <p>When performing operation for five minutes or longer with the front cover open, remove all toner cartridges, and cover the drum to avoid exposure to light.</p> <p>The rotational speed of the motor is as follows. DO-2 (Half)<DO-0 (Full)</p> <ol style="list-style-type: none"> 1) Turn on the power and enter the Diagnostic Mode. 2) Open the Front Cover. 3) Remove the black toner cartridge. 4) Cheat the safety Interlock System. 5) Execute the DO-0. (The customer can confirm the motor noise only.) <div style="text-align: center;">  <p style="text-align: right; font-size: small;">Zna02017KA</p> </div> <ol style="list-style-type: none"> 6) Press the "Cancel" key to stop test. 7) Remove the cheater and replace the black toner cartridge. 8) Close the Front Cover.

Clutch and Solenoid name (Diag. Code)	Confirmation procedure
Sub Motor (DO-5/DO-7)	<p>NOTE: This procedure is for the technical staff. The customer check are the procedure 1, 5 and 6. The sub motor is in the PC/DEVE DRIVE.</p> <p>When performing operation for five minutes or longer with the front cover open, remove all toner cartridges, and cover the drum to avoid exposure to light.</p> <p>The rotational speed of the motor is as follows. DO-7 (Half)<DO-5 (Full)</p> <ol style="list-style-type: none"> 1) Turn on the power and enter the Diagnostic Mode. 2) Open the Front Cover. 3) Remove the all toner cartridges. 4) Cheat the safety Interlock System. 5) Execute the DO-5. (The customer can confirm the motor noise only.) <div data-bbox="746 712 1230 1189" style="text-align: center;"> </div> <p style="text-align: right; font-size: small;">Zna02018KA</p> <ol style="list-style-type: none"> 6) Press the "Cancel" key to stop test. 7) Remove the cheater and replace the all toner cartridges. 8) Close the Front Cover.

Clutch and Solenoid name (Diag. Code)	Confirmation procedure
PH Motor (DO-a/DO-c)	<p>NOTE: This procedure is for the technical staff. The customer check are the procedure 1, 4 and 5. The PH motor is in the FEED DRIVE. When performing operation for five minutes or longer with the front cover open, remove all toner cartridges, and cover the drum to avoid exposure to light.</p> <p>The rotational speed of the motor is as follows. DO-c (Half)<DO-a (Full)</p> <ol style="list-style-type: none"> 1) Turn on the power and enter the Diagnostic Mode. 2) Open the Front Cover. 3) Cheat the safety Interlock System. 4) Execute the DO-a. (The customer can confirm the motor noise only.) <div data-bbox="746 645 1225 1115" style="text-align: center;"> <p style="text-align: right; font-size: small;">Zna02019KA</p> </div> <ol style="list-style-type: none"> 5) Press the "Cancel" key to stop test. 6) Remove the cheater. 7) Close the Front Cover.

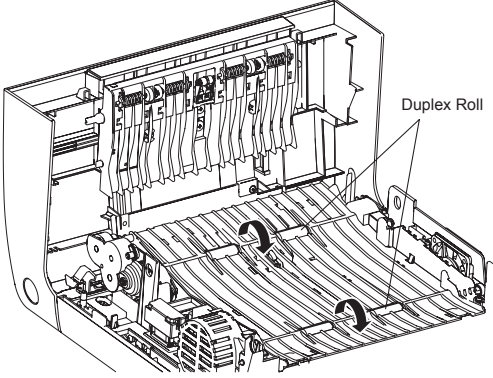
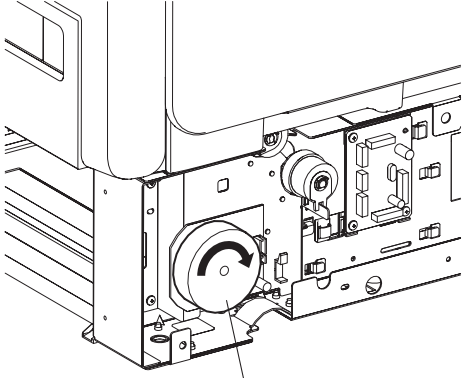
Clutch and Solenoid name (Diag. Code)	Confirmation procedure
<p>DUP Motor (DO-13/DO-16)</p>	<p>NOTE: This procedure is for the technical staff. The customer check are the procedure 1, 5 and 6. The DEVE motor is in the DUPLEX MODULE.</p> <p>When performing operation for five minutes or longer with the front cover open, remove all toner cartridges, and cover the drum to avoid exposure to light.</p> <p>The rotational speed of the motor is as follows. DO-16 (Half)<DO-13 (Full)</p> <ol style="list-style-type: none"> 1) Turn on the power and enter the Diagnostic Mode. 2) Open the Front Cover. 3) Cheat the safety Interlock System. 4) Remove the transfer belt. 5) Execute the DO-13. (The customer can confirm the motor noise only.)  <p style="text-align: right; font-size: small;">Kmy02021KA</p> <ol style="list-style-type: none"> 6) Press the "Cancel" key to stop test. 7) Remove the cheater and replace the transfer belt. 8) Close the Front Cover.
<p>Tray 2 Feed Motor (DO-19/ DO-1b)</p>	<p>NOTE: This procedure is for the technical staff. The customer check are the procedure 1, 4 and 5.</p> <p>The rotational speed of the motor is as follows. DO-1b (Half)<DO-19 (Half)</p> <ol style="list-style-type: none"> 1) turn on the power and enter the Diagnostic Mode. 2) Remove the Tray 2 paper cassette. 3) Remove the left side cover of the Tray 2. 4) Execute the DO-19. (The customer can confirm the motor noise only.)  <p style="text-align: right; font-size: small;">Kmy02022KA</p> <ol style="list-style-type: none"> 5) Press the "Cancel" key to stop the test. 6) Replace the left side cover of the Tray 2. 7) Replace the Tray 2 paper cassette.

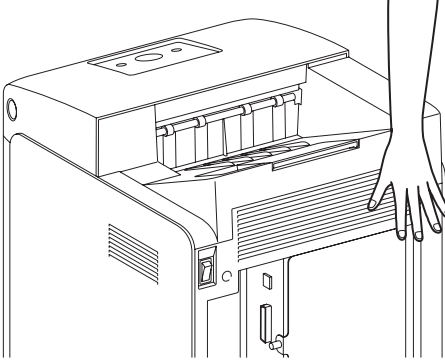
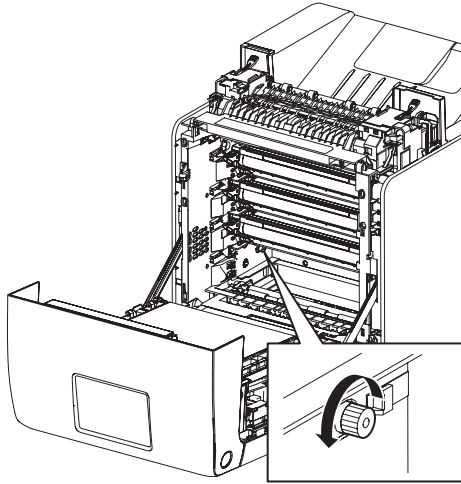
Clutch and Solenoid name (Diag. Code)	Confirmation procedure
Fan (DO-1e/1f)	<p>NOTE: The rotational speed of the fan is as follows. DO-1f (Low)<DO-1e (High)</p> <ol style="list-style-type: none"> 1) Turn on the power and enter the Diagnostic Mode. 2) Execute the DO-1e.  <p style="text-align: right; font-size: small;">Zna02023KA</p> <ol style="list-style-type: none"> 3) Press the "Cancel" key to stop test.
Yellow Toner Motor (DO-21)	<p>NOTE: This procedure is for the technical staff. The customer check are the procedure 1, 5 and 6. When performing operation for five minutes or longer with the front cover open, remove all toner cartridges, and cover the drum to avoid exposure to light.</p> <ol style="list-style-type: none"> 1) Turn on the power and enter the Diagnostic Mode. 2) Open the Front Cover. 3) Cheat the safety Interlock System. 4) Remove the yellow toner cartridge. 5) Execute the DO-21. (The customer can confirm the motor noise only.)  <p style="text-align: right; font-size: small;">Zna02024KA</p> <ol style="list-style-type: none"> 6) Press the "Cancel" key to stop test. 7) Replace the yellow toner cartridge. 8) Remove the cheater. 9) Close the Front Cover.

Clutch and Solenoid name (Diag. Code)	Confirmation procedure
Magenta Toner Motor (DO-23)	<p>NOTE: This procedure is for the technical staff. The customer check are the procedure 1, 5 and 6. When performing operation for five minutes or longer with the front cover open, remove all toner cartridges, and cover the drum to avoid exposure to light.</p> <ol style="list-style-type: none"> 1) Turn on the power and enter the Diagnostic Mode. 2) Open the Front Cover. 3) Remove the magenta toner cartridge. 4) Cheat the safety Interlock System. 5) Execute the DO-23. (The customer can confirm the motor noise only.) <div data-bbox="746 613 1209 1093" style="text-align: center;"> <p style="text-align: right; font-size: small;">Zna02025KA</p> </div> <ol style="list-style-type: none"> 6) Press the "Cancel" key to stop test. 7) Remove the cheater. 8) Replace the magenta toner cartridge. 9) Close the Front Cover.

Clutch and Solenoid name (Diag. Code)	Confirmation procedure
Cyan Toner Motor (DO-25)	<p>NOTE: This procedure is for the technical staff. The customer check are the procedure 1, 5 and 6. When performing operation for five minutes or longer with the front cover open, remove all toner cartridges, and cover the drum to avoid exposure to light.</p> <ol style="list-style-type: none"> 1) Turn on the power and enter the Diagnostic Mode. 2) Open the Front Cover. 3) Remove the cyan toner cartridge. 4) Cheat the safety Interlock System. 5) Execute the DO-25. (The customer can confirm the motor noise only.) <div data-bbox="746 613 1209 1093" style="text-align: center;"> <p style="text-align: right; font-size: small;">Zna02026KA</p> </div> <ol style="list-style-type: none"> 6) Press the "Cancel" key to stop test. 7) Remove the cheater. 8) Replace the cyan toner cartridge. 9) Close the Front Cover.

Clutch and Solenoid name (Diag. Code)	Confirmation procedure
Black Toner Motor (DO-27)	<p>NOTE: This procedure is for the technical staff. The customer check are the procedure 1, 5 and 6. When performing operation for five minutes or longer with the front cover open, remove all toner cartridges, and cover the drum to avoid exposure to light.</p> <ol style="list-style-type: none"> 1) Turn on the power and enter the Diagnostic Mode. 2) Open the Front Cover. 3) Remove the black toner cartridge. 4) Cheat the safety Interlock System. 5) Execute the DO-27. (The customer can confirm the motor noise only.) <div data-bbox="746 613 1209 1093" style="text-align: center;"> <p style="text-align: right; font-size: small;">Zna02027KA</p> </div> <ol style="list-style-type: none"> 6) Press the "Cancel" key to stop test. 7) Remove the cheater. 8) Replace the black toner cartridge. 9) Close the Front Cover.

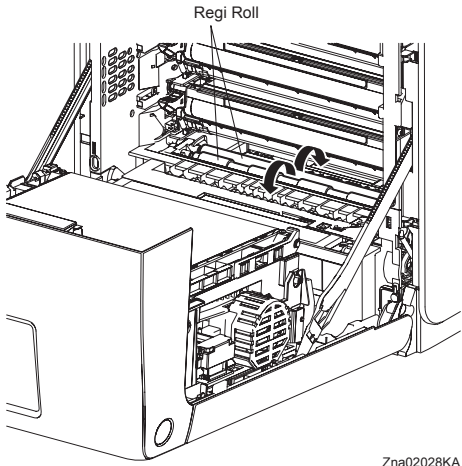
Clutch and Solenoid name (Diag. Code)	Confirmation procedure
Regi Clutch (DO-29)	<p>NOTE: When performing operation for five minutes or longer with the front cover open, remove all toner cartridges, and cover the drum to avoid exposure to light.</p> <ol style="list-style-type: none"> 1) Turn on the power and enter the Diagnostic Mode. 2) Execute the DO-29. Upon hitting the "return" key, the operating noise of the clutch will be heard. 3) Press the "Cancel" key to stop the clutch. <p>Combination test is as follows.</p> <p>NOTE: The regi roll rotates when the DO-a and the DO-29 are executed. This procedure is for the technical staff.</p> <ol style="list-style-type: none"> 1) Turn on the power and enter the Diagnostic Mode. 2) Open the Front Cover. 3) Cheat the safety Interlock System. 4) Execute the DO-a and the DO-29. <div style="text-align: center;">  </div> <ol style="list-style-type: none"> 5) Confirm the Regi Roll rotation. 6) Press the "Cancel" key to stop the clutch. 7) Press the "▼" key to display the DO-a. 8) Press the "Cancel" key to stop the motor. 9) Remove the cheater and close the Front Cover.

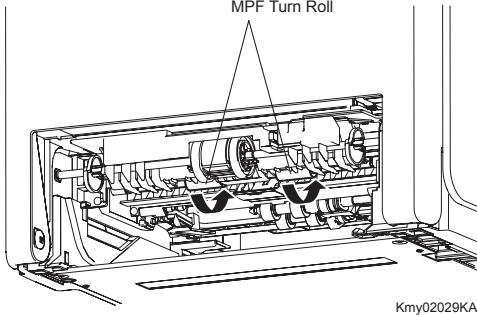
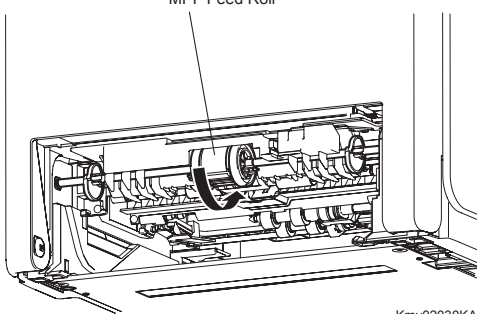
Clutch and Solenoid name (Diag. Code)	Confirmation procedure
MPF Turn Clutch (DO-2b)	<ol style="list-style-type: none"> 1) Turn on the power and enter the Diagnostic Mode. 2) Execute the DO-2b. Upon hitting the "return" key, the operating noise of the clutch will be heard. 3) Press the "Cancel" key to stop the clutch. <p>Combination test is as follows. NOTE: The MPF turn roll rotates when the DO-a and the DO-2b are executed. This procedure is for the technical staff.</p> <ol style="list-style-type: none"> 1) Turn on the power and enter the Diagnostic Mode. 2) Remove the Tray 1 paper cassette. 3) Execute the DO-a and the DO-2b.  <ol style="list-style-type: none"> 4) Confirm the Turn Roll rotation. 5) Press the "Cancel" key to stop the clutch. 6) Press the "▼" key to display the DO-a. 7) Press the "Cancel" key to stop the motor. 8) Replace the Tray 1 paper cassette.
MPF Feed Solenoid (DO-2d)	<ol style="list-style-type: none"> 1) Turn on the power and enter the Diagnostic Mode. 2) Execute the DO-2d. Upon hitting the "return" key, the operating noise of the solenoid will be heard. 3) Press the "Cancel" key to stop the solenoid. <p>Combination test is as follows. NOTE: The MPF feed roll rotates when the DO-a and the DO-2d are executed. This procedure is for the technical staff.</p> <ol style="list-style-type: none"> 1) Turn on the power and enter the Diagnostic Mode. 2) Remove the Tray 1 paper cassette. 3) Execute the DO-a and the DO-2d.  <ol style="list-style-type: none"> 4) Confirm the Feed Roll rotation. 5) Press the "Cancel" key to stop the clutch. 6) Press the "▼" key to display the DO-a. 7) Press the "Cancel" key to stop the motor. 8) Replace the Tray 1 paper cassette.

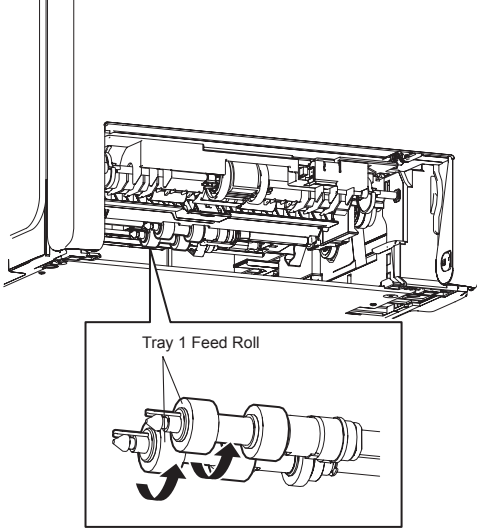
Clutch and Solenoid name (Diag. Code)	Confirmation procedure
Tray 1 Feed Clutch (DO-2f)	<ol style="list-style-type: none"> 1) Turn on the power and enter the Diagnostic Mode. 2) Execute the DO-2f. Upon hitting the "return" key, the operating noise of the clutch will be heard. 3) Press the "Cancel" key to stop the clutch. <p>Combination test is as follows. NOTE: The Tray 1 feed roll rotates when the DO-a and the DO-2f are executed. This procedure is for the technical staff.</p> <ol style="list-style-type: none"> 1) Turn on the power and enter the Diagnostic Mode. 2) Remove the Tray 1 paper cassette. 3) Execute the DO-a and the DO-2f. <div style="text-align: center;">  <p>The diagram consists of two parts. The upper part is a cutaway view of the printer's internal mechanism, showing the paper cassette area. A callout line points from the text 'Tray 1 Feed Roll' to a specific component. The lower part is a detailed close-up of the 'Tray 1 Feed Roll', which is a cylindrical roller with a textured surface. A curved arrow indicates its direction of rotation.</p> </div> <p style="text-align: right; font-size: small;">Kmy02031KA</p> <ol style="list-style-type: none"> 4) Confirm the feed Roll rotation. 5) Press the "Cancel" key to stop the clutch. 6) Press the "▼" key to display the DO-a. 7) Press the "Cancel" key to stop the motor. 8) Replace the Tray 1 paper cassette.

Clutch and Solenoid name (Diag. Code)	Confirmation procedure
Tray 2 Feed Clutch (DO-31)	<ol style="list-style-type: none"> 1) Turn on the power and enter the Diagnostic Mode. 2) Execute the DO-31. Upon hitting the "return" key, the operating noise of the clutch will be heard. 3) Press the "Cancel" key to stop the clutch. <p>Combination test is as follows. NOTE: The Tray 2 feed roll rotates when the DO-19 and the DO-31 are executed. This procedure is for the technical staff.</p> <ol style="list-style-type: none"> 1) Turn on the power and enter the Diagnostic Mode. 2) Remove the Tray 2 paper cassette. 3) Execute the DO-19 and the DO-31. <div data-bbox="742 600 1225 1191" style="text-align: center;"> <p style="text-align: center;">Tray 2 Feed Roll</p> </div> <p style="text-align: right; font-size: small;">Kmy02032KA</p> <ol style="list-style-type: none"> 4) Confirm the feed Roll rotation. 5) Press the "Cancel" key to stop the clutch. 6) Press the "▼" key to display the DO-19. 7) Press the "Cancel" key to stop the motor. 8) Replace the Tray 2 paper cassette.

Clutch and Solenoid name (Diag. Code)	Confirmation procedure
Tray 2 Turn Clutch (DO-33)	<ol style="list-style-type: none"> 1) Turn on the power and enter the Diagnostic Mode. 2) Execute the DO-33. Upon hitting the "return" key, the operating noise of the clutch will be heard. 3) Press the "Cancel" key to stop the clutch. <p>Combination test is as follows. NOTE: The Tray 2 turn roll rotates when the DO-19 and the DO-33 are executed. This procedure is for the technical staff.</p> <ol style="list-style-type: none"> 1) Turn on the power and enter the Diagnostic Mode. 2) Remove the Tray 1 paper cassette. 3) Execute the DO-19 and the DO-33. <div data-bbox="758 600 1214 1016" style="text-align: center;"> <p style="text-align: center;">Tray 2 Turn Roll</p> <p style="text-align: right; font-size: small;">Kmy02033KA</p> </div> <ol style="list-style-type: none"> 4) Confirm the Turn Roll rotation. 5) Press the "Cancel" key to stop the clutch. 6) Press the "▼" key to display the DO-19. 7) Press the "Cancel" key to stop the motor. 8) Replace the Tray 1 paper cassette.

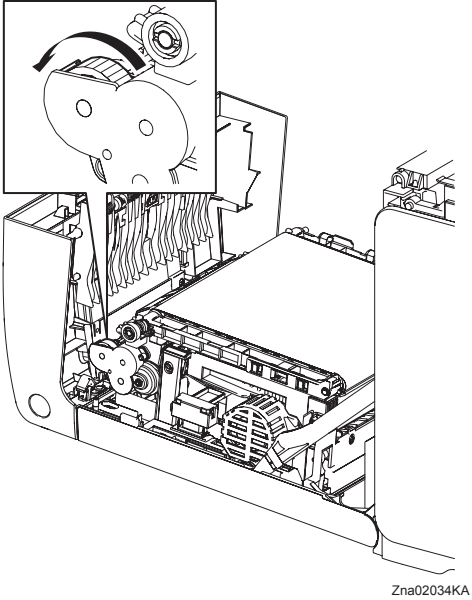
Clutch and Solenoid name (Diag. Code)	Confirmation procedure
Dup Clutch (DO-35)	<ol style="list-style-type: none"> 1) Turn on the power and enter the Diagnostic Mode. 2) Execute the DO-35. Upon hitting the "return" key, the operating noise of the clutch will be heard. 3) Press the "Cancel" key to stop the clutch. <p>Combination test is as follows. NOTE: The duplex gear rotates when the DO-13 and the DO-35 are executed. This procedure is for the technical staff. When performing operation for five minutes or longer with the front cover open, remove all toner cartridges, and cover the drum to avoid exposure to light.</p> <ol style="list-style-type: none"> 1) Turn on the power and enter the Diagnostic Mode. 2) Open the Front Cover. 3) Cheat the safety Interlock System. 4) Execute the DO-13 and the DO-35.  <ol style="list-style-type: none"> 5) Confirm the gear rotation. 6) Press the "Cancel" key to stop the clutch. 7) Press the "▼" key to display the DO-13. 8) Press the "Cancel" key to stop the motor. 9) Remove the cheater and close the Front Cover.

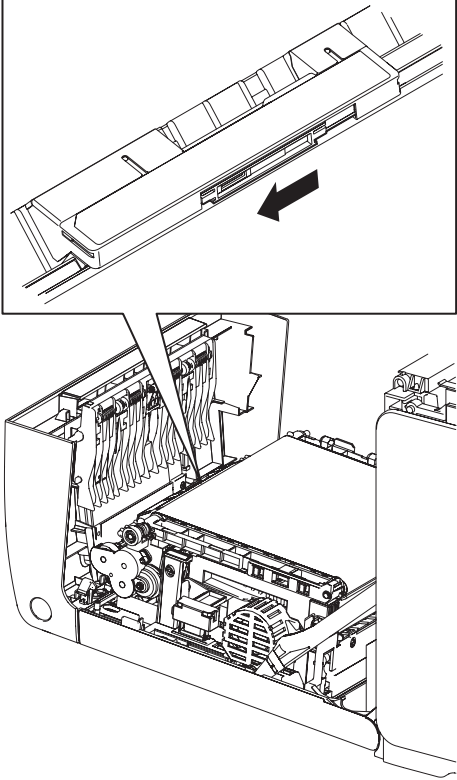
Clutch and Solenoid name (Diag. Code)	Confirmation procedure
ADC Sensor Solenoid (DO-37)	<p>NOTE: This procedure is for the technical staff. The customer check are the procedure 1, 4 and 5. When performing operation for five minutes or longer with the front cover open, remove all toner cartridges, and cover the drum to avoid exposure to light.</p> <ol style="list-style-type: none"> 1) Turn on the power and enter the Diagnostic Mode. 2) Open the Front Cover. 3) Cheat the safety Interlock System. 4) Execute the DO-37. (The customer can confirm the motor noise only.) <div style="text-align: center;">  <p style="text-align: right; font-size: small;">Zna02035KA</p> </div> <ol style="list-style-type: none"> 5) Press the "Cancel" key to stop the solenoid. 6) Remove the cheater and close the Front Cover.

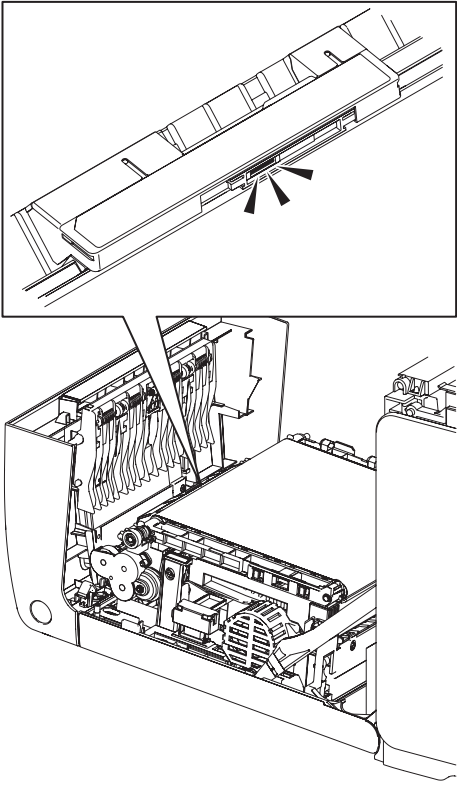
Clutch and Solenoid name (Diag. Code)	Confirmation procedure
ADC Sensor LED (DO-39)	<p>NOTE: This procedure is for the technical staff. When performing operation for five minutes or longer with the front cover open, remove all toner cartridges, and cover the drum to avoid exposure to light.</p> <ol style="list-style-type: none"> 1) Turn on the power and enter the Diagnostic Mode. 2) Open the Front Cover. 3) Cheat the safety Interlock System. 4) Execute the DO-39.  <p style="text-align: right; font-size: small;">Zna02036KA</p> <ol style="list-style-type: none"> 5) Press the "Cancel" key to stop the LED lighting. 6) Remove the cheater and close the Front Cover.
OHP Sensor LED (DO-3b)	Not used

Clutch and Solenoid name (Diag. Code)	Confirmation procedure
<p>Black Drum Erase Lamp (DO-3d)</p>	<p>NOTE: This procedure is for the technical staff. When performing operation for five minutes or longer with the front cover open, remove all toner cartridges, and cover the drum to avoid exposure to light.</p> <ol style="list-style-type: none"> 1) Turn on the power and enter the Diagnostic Mode. 2) Open the Front Cover. 3) Cheat the safety Interlock System. 4) Execute the DO-3d. <div data-bbox="756 517 1217 992" style="text-align: center;"> </div> <ol style="list-style-type: none"> 5) Press the "Cancel" key to stop the LED lighting. 6) Remove the cheater and close the Front Cover.
<p>Yellow, Magenta and Cyan Drum Erase Lamp (DO-3f)</p>	<p>NOTE: This procedure is for the technical staff. When performing operation for five minutes or longer with the front cover open, remove all toner cartridges, and cover the drum to avoid exposure to light.</p> <ol style="list-style-type: none"> 1) Turn on the power and enter the Diagnostic Mode. 2) Open the Front Cover. 3) Cheat the safety Interlock System. 4) Execute the DO-3f. <div data-bbox="727 1368 1246 1809" style="text-align: center;"> </div> <ol style="list-style-type: none"> 5) Press the "Cancel" key to stop the LED lighting. 6) Remove the cheater and close the Front Cover.

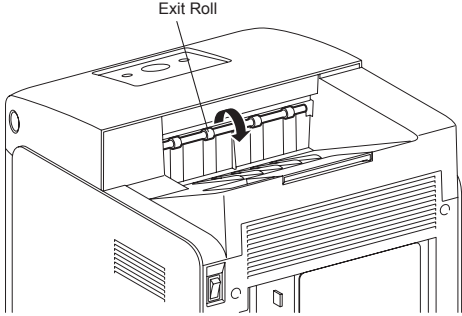
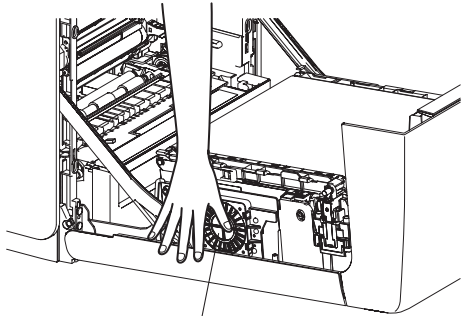
Clutch and Solenoid name (Diag. Code)	Confirmation procedure
Exit Clutch (DO-5b)	<p>1) Turn on the power and enter the Diagnostic Mode. 2) Execute the DO-5b. Upon hitting the "return" key, the operating noise of the clutch will be heard. 3) Press the "Cancel" key to stop the clutch.</p> <p>Combination test is as follows. NOTE: The exit roll rotates when the DO-0 and the DO-5b are executed. This procedure is for the technical staff. 1) Turn on the power and enter the Diagnostic Mode. 2) Execute the DO-0 and the DO-5b.</p>  <p style="text-align: right; font-size: small;">Zna02039KA</p> <p>3) Confirm the Exit Roll rotation. 4) Press the "Cancel" key to stop the clutch. 5) Press the "▼" key to display the DO-0. 6) Press the "Cancel" key to stop the motor.</p>
Duplex Fan (DO-5d)	<p>NOTE: This procedure is for the technical staff. The customer check are the procedure 1, 4 and 5. When performing operation for five minutes or longer with the front cover open, remove all toner cartridges, and cover the drum to avoid exposure to light.</p> <p>1) Turn on the power and enter the Diagnostic Mode. 2) Open the Front Cover. 3) Cheat the safety Interlock System. 4) Execute the DO-5d. (The customer can confirm the fan noise only.)</p>  <p style="text-align: right; font-size: small;">Duplex Fan Zna02040KA</p> <p>5) Press the "Cancel" key to stop the test. 6) Remove the cheater and close the Front Cover.</p>
Buzzer (DO-5F)	<p>1) Turn on the power and enter the Diagnostic Mode. 2) Execute the DO-5F. 3) Check the Buzzer. 4) Press the "Cancel" key to stop the test.</p>

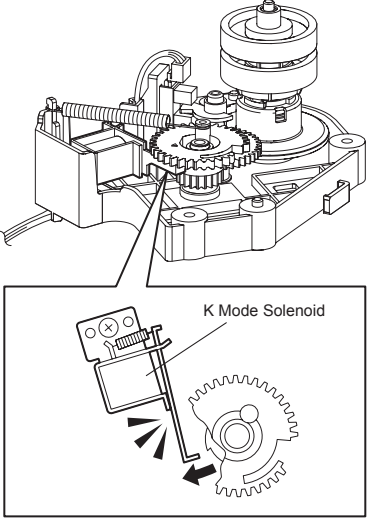
Clutch and Solenoid name (Diag. Code)	Confirmation procedure
<p>K Mode Solenoid (DO-61) (Color Mode Switching Solenoid)</p>	<p>NOTE: This procedure is for the technical staff. When performing operation for five minutes or longer with the front cover open, remove all toner cartridges, and cover the drum to avoid exposure to light.</p> <ol style="list-style-type: none"> 1) Open the Front Cover. 2) Remove the Cover Rear. 3) Remove the Cover Side R Assy. 4) Remove the Drive Assy K. 5) Cheat the Safety Interlock System. 6) Turn on the power and enter the Diagnostic Mode. 7) Execute the DO-61. <div style="text-align: center;">  <p style="text-align: right; font-size: small;">Zna02051KA</p> </div> <ol style="list-style-type: none"> 8) Check the K Mode SOLENOID movement. 9) Press the "Cancel" key to stop the test. 10) Replace the Safety Interlock System. 11) Replace the Drive Assy K. 12) Replace the Cover Side R Assy. 13) Replace the Cover Rear. 14) Close the Front Cover.

4.2 Print Info

Prints out the detailed printer settings and configuration information.

4.2.1 Executing Print Info

- 1) Turn off the power.
- 2) Turn on the power while holding down “▲” and “▼” keys.
- 3) Release the fingers from these keys when "Diagnosing..." is displayed.
- 4) The "Customer Mode" and "IOT Diag" are displayed. (Entered the Diag. mode.)
- 5) Press “▼” to select "Print Info", and then press “✓” key.
- 6) Press “▲” and “▼” key to select the item.
- 7) Press “✓” key twice to execute the setting.

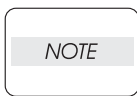

To exit the print or to returning to one step higher menu, press "CANCEL" key.

4.2.2 Config Page

The version of software of IOT and the printer configuration can be confirmed by executing this test.

4.2.3 Print Settings

The service tag, printing count value and error count value can be confirmed by executing this test.

4.3 Complete

Completes the diagnosis operation and reboot the data.

4.3.1 Executing Print Info

- 1) Turn off the power.
- 2) Turn on the power while holding down “▲” and “▼” keys.
- 3) Release the fingers from these keys when "Diagnosing..." is displayed.
- 4) The "Customer Mode" and "IOT Diag" are displayed. (Entered the Diag. mode.)
- 5) Press “▼” to select "Complete", and then press “✓” key.
- 6) Press “✓” key twice to execute the setting.

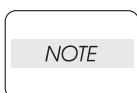

To exit the operation or to returning to one step higher menu, press "CANCEL" key.

4.4 Installation Set

Specifies whether or not Alarm display of Toner residual quantity is performed.

4.4.1 Executing Installation Set

- 1) Turn off the power.
- 2) Turn on the power while holding down “▲” and “▼” keys.
- 3) Release the fingers from these keys when "Diagnosing..." is displayed.
- 4) The "Customer Mode" and "IOT Diag" are displayed. (Entered the Diag. mode.)
- 5) Press “▼” to select "Installation Set", and then press “✓” key twice.
- 6) Press “▼” key to select the ON or OFF.
- 7) Press “✓” key to execute the setting.

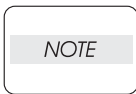

To exit the test or to returning to one step higher menu, press "CANCEL" key.

4.5 Test Print

Print an internal test pattern of the printer. If paper jam or paper empty occurs during the print, the test waits until they are resolved.

4.5.1 Executing test print

- 1) Turn off the power.
- 2) Turn on the power while holding down “▲” and “▼” keys.
- 3) Release the fingers from these keys when “Diagnosing...” is displayed.
- 4) The “Customer Mode” and “IOT Diag” are displayed. (Entered the Diag. mode.)
- 5) Press “▼” key to select “Test Print”, and then press “✓” key.
- 6) Press “▲” or “▼” key to select the test item.
- 7) Press “✓” key twice to execute the test.

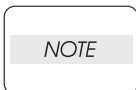

To exit the test or to returning to one step higher menu, press “CANCEL” key.

4.5.2 No Image [IOT]

Prints the blanked paper.

4.5.3 Test Pattern 600[IOT]

Prints the IOT built-in 600dpi pattern.

When the PQ problem occurred, this test enables to identify the problem as the printing process or the PWBA ESS related.

Compare the sample chart with the print.

Check result: NG (Check the printing process.) OK (Check the PWBA ESS related.)

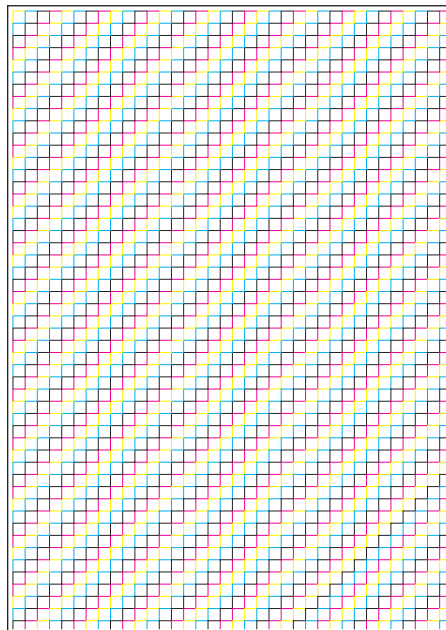

Kmy02001KA

4.5.4 Grid2

Prints the ESS built-in grid pattern.

When the PQ problem occurred, this test enables to identify the problem as printer-related or otherwise.

Compare the sample chart with the print.

Check result: NG (Check the printing process and PWBA ESS-related.) OK (Check the network, cable, PC and so on.)



Leg_Sec02_004FA

4.5.5 Cyan 20%

Outputs cyan 20% paint on the whole area of a A4 paper.

When the PQ problem occurred, this test enables to identify the problem as the cyan toner or another color.

Compare the sample chart with the print.

Check result: NG (Check the cyan toner-related.) OK (Check another toner.)

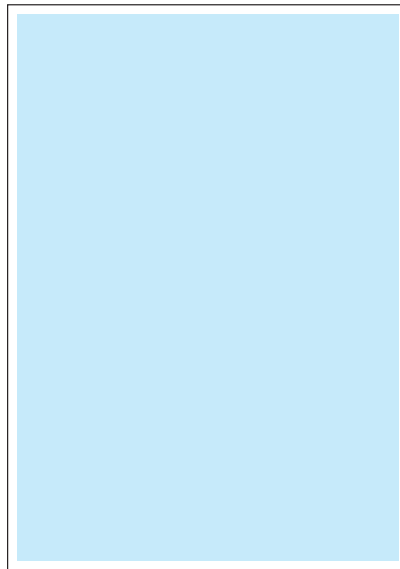

Leg_Sec02_005FA

4.5.6 Magenta 20%

Outputs magenta 20% paint on the whole area of a A4 paper.

When the PQ problem occurred, this test enables to identify the problem as the magenta toner or another color.

Compare the sample chart with the print.

Check result: NG (Check the magenta toner-related.) OK (Check another toner.)

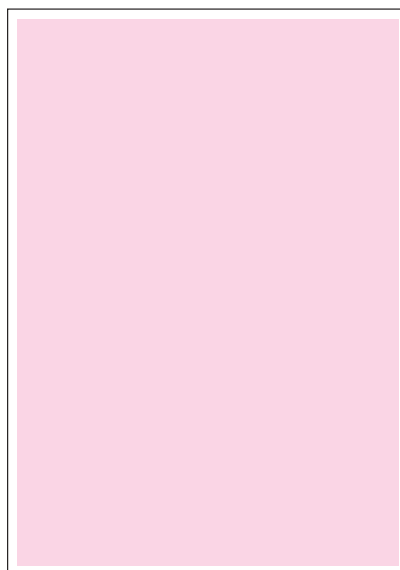

Leg_Sec02_006FA

4.5.7 Yellow 20%

Outputs yellow 20% paint on the whole area of a A4 paper.

When the PQ problem occurred, this test enables to identify the problem as the yellow toner or another color.

Compare the sample chart with the print.

Check result: NG (Check the yellow toner-related.) OK (Check another toner.)

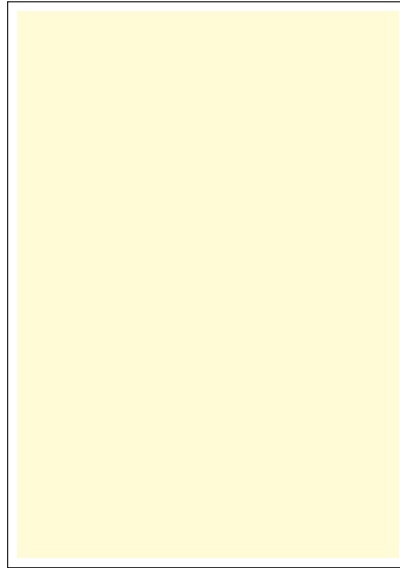

Leg_Sec02_007FA

4.5.8 Black 20%

Outputs black 20% paint on the whole area of a A4 paper.

When the PQ problem occurred, this test enables to identify the problem as the black toner or another color.

Compare the sample chart with the print.

Check result: NG (Check the black toner-related.) OK (Check another toner.)

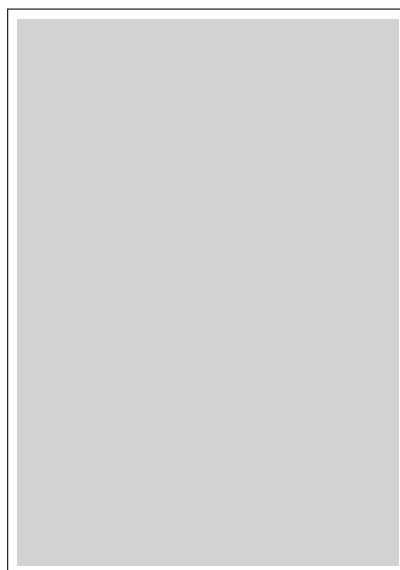

Leg_Sec02_008FA

4.5.9 CMY 20%

Outputs C/M/Y 20% paint on the whole area of a A4 paper.

When the PQ problem occurred, this test enables to identify the problem as the balance of three color toners or otherwise.

Compare the sample chart with the print.

Check result: NG (Check the yellow, magenta or cyan toner-related.) OK (Check black toner.)

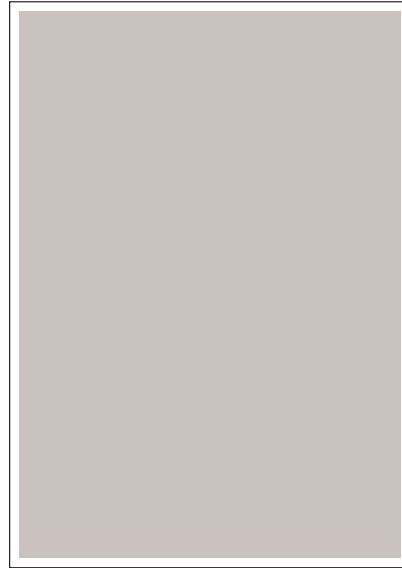

Leg_Sec02_009FA

4.5.10 Gradation

Outputs the tone pattern from 2% to 100% on a A4 paper for each of 4 colors.

When the PQ problem occurred, this test enables to identify the problem as the printing process or PWBA ESS-related.

Compare the sample chart with the print.

Check result: NG (Check the printing process.) OK (Check the PWBA ESS-related.)

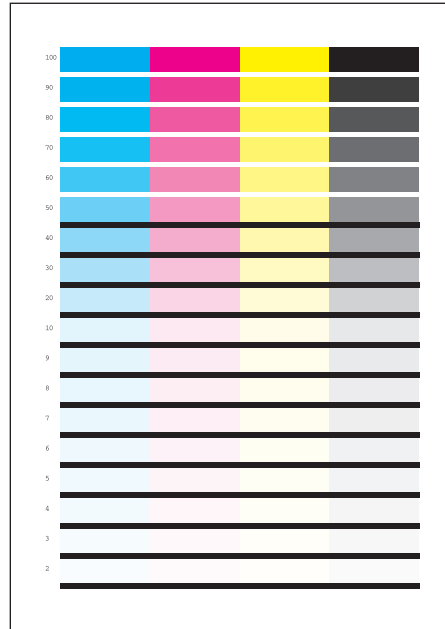

Leg_Sec02_010FA

4.5.11 Toner Pallet Check

Outputs each 100% density color pattern of Y/M/C/K.

When the PQ problem occurred in the picture or photo printing, this test enables to identify the problem as the toner or another.

Compare the sample chart with the print.

Check result: NG (Check the problem toner-related.) OK (Check the print job or print data.)

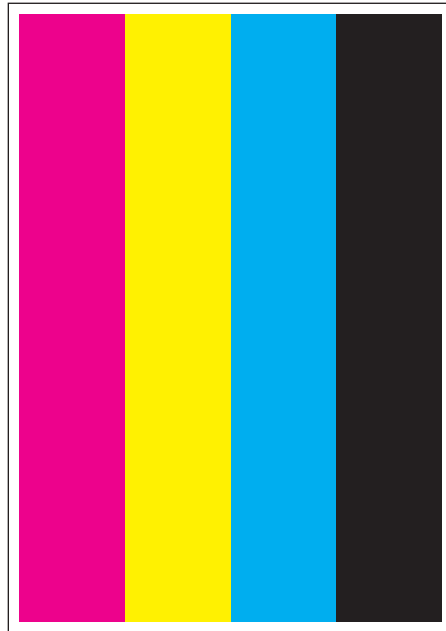

Leg_Sec02_011FA

4.5.12 Contamination Check

Allows you to check the print for any regular lines or toner spots when encountering PQ problems. From the difference in the interval of regular lines or spots, you can determine the parts that have caused the trouble.

Page 1 to 4: Prints the scale patterns in vertical and horizontal directions for evaluating regularity and intervals.

Page 5: Prints the list of intervals by component fault.

Page 1

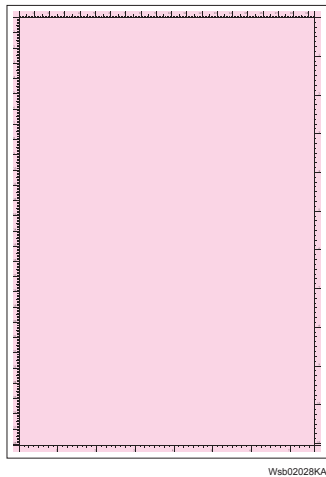

Page 2

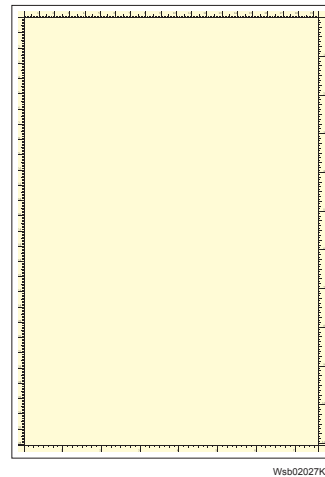

Page 3

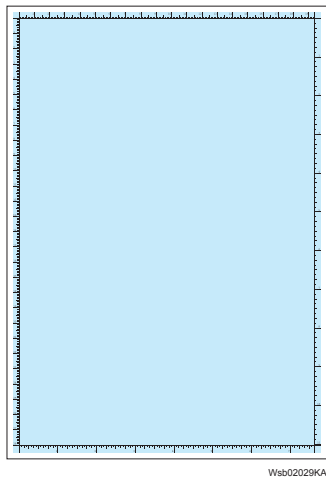

Page 4

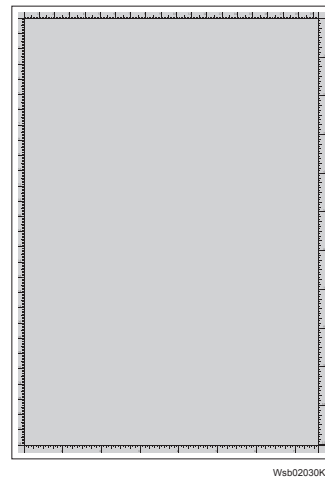

Page 5

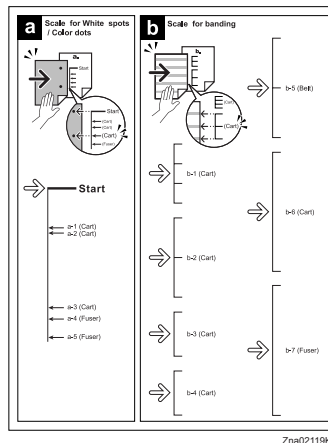

Zna02119KA

4.5.13 Parameter Setting

This function reads/writes the following parameters stored in the printer.

Item	Range	Description
Slow Scan Reg K to P	-128 to 127	Sets the registration in the paper feeding direction.
Slow Scan Reg 600 M,Y,C	-30 ~ 30	
Slow Scan Reg1200 M,Y,C	-60 ~ 60	
Fast Scan Reg K to M, Y or C	-30 ~ 30	Sets the registration in the scanning direction.
Fast Scan Reg MPF, Tray1, Tray2 or Duplex	-30 ~ 30	
Fast Scan Reg2 KtoM , Y or C	-1 ~ 2	
Life Counter	-	Reads the life counter and the printer.

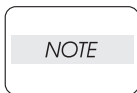

Print the parameter list using the Print function of Parameter Menu in diagnosis before changing the value of the registration.

Parameter	Function	Default	Adjustable range
Slow Scan Reg K to P (Shifts 0.17mm/1count)	Black registration adjustment	--	-128 to 127
Slow Scan Reg 600 M,Y,C (Shifts 0.042mm/1count)	Color registration adjustment (600 and 1200 dpi)	--	-30 to 30
Slow Scan Reg1200 M,Y,C (Shifts 0.021mm/1count)			-60 to 60
Fast Scan Reg K to M, Y or C (Shifts 0.042mm/1count)	Color registration adjustment Calculation of adjustment is shown below. (exp. Yellow) (Value of Fast Scan Reg K to Y + Value of Fast Scan Reg2 K to Y)/4	--	-30 to 30
Fast Scan Reg2 K to M, C or Y (Shifts 0.01mm/1count)		--	-1 to 2
Fast Scan Reg MPF, Tray1 or Tray2 (Shifts 0.17mm/1count)	Black registration adjustment at side 1 print	--	-30 to 30
Fast Scan Reg Dup (Shifts 0.17mm/1count)	Black registration adjustment at side 2 print	--	-30 to 30

NOTE

The default values are different in each printer.

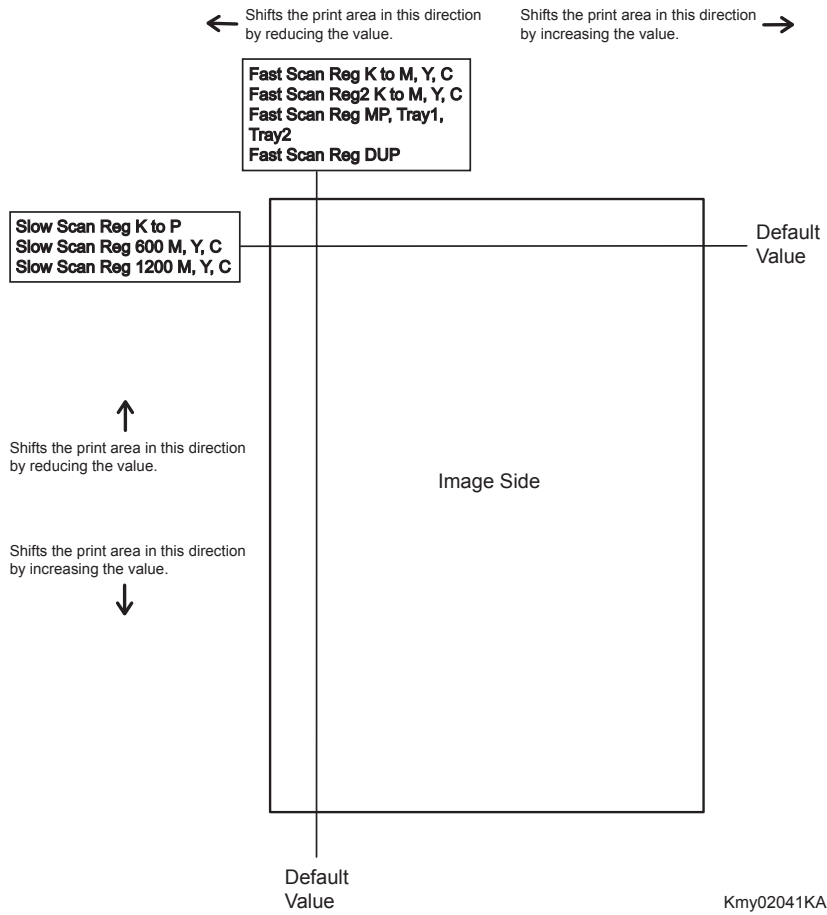

Reference Counter Values

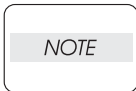

These counter values are reference only. Do not use as the official value.

Counter Name	Value of life warning
Life Y Toner (Dispense time)	-
Life M Toner (Dispense time)	-
Life C Toner (Dispense time)	-
Life K Toner (Dispense time)	-
Life DTB (Transfer Belt) 1 (Paper feeding count)	100000
Life Fuser (Paper feeding count)	100000
Life Printer (Paper feeding count)	-
Life DTB (Transfer Belt) 2 (Waste Toner cleaning count)	120000
Life DTB (Transfer Belt) 3 (Cycle count)	14000000
Life Y Waste Toner (Waste Toner cleaning count)	18000
Life M Waste Toner (Waste Toner cleaning count)	18000
Life C Waste Toner (Waste Toner cleaning count)	18000
Life K Waste Toner (Waste Toner cleaning count)	18000
Life Y Developer (Cycle count)	2500000
Life M Developer (Cycle count)	2500000
Life C Developer (Cycle count)	2500000
Life K Developer (Cycle count)	2500000
Life Y Drum (Cycle count)	3500000
Life M Drum (Cycle count)	3500000
Life C Drum (Cycle count)	3500000
Life K Drum (Cycle count)	3000000
Life MPF Feed	-
Life Tray 1 Feed	-
Life Duplex Feed	-
Print	-

4.5.14 Printing the parameter list

This function prints the parameter values and life counter values stored in the IOT.

| 5. How to use Customer Engineer Diag. (CE Diag. Tool Operation)

5.1 Operating environment

CE Diag. runs under the OS (Operating System) environment described below:

| Windows 2000/XP/Server 2003/Vista/Server 2008

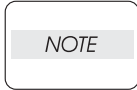

Confirm the specification of PC before using the CE Diag. because each CE Diag. tool for 64 bit PC and for 32 bit PC exists.

5.2 Connection method

| Standalone connection: Connection with a standard USB connector cable

5.3 Activation and termination of the CE Diag.

- 1) The Select port screen appears on the display when the icon () is double-clicked.

DLC10DZ.exe

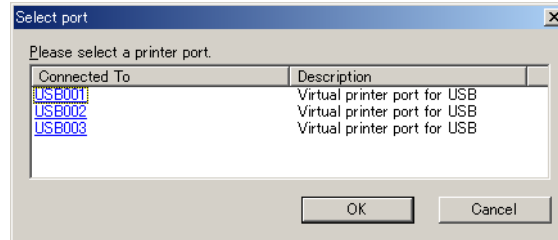

- 2) CE Diag. screen appears on the display when the [OK] is clicked.

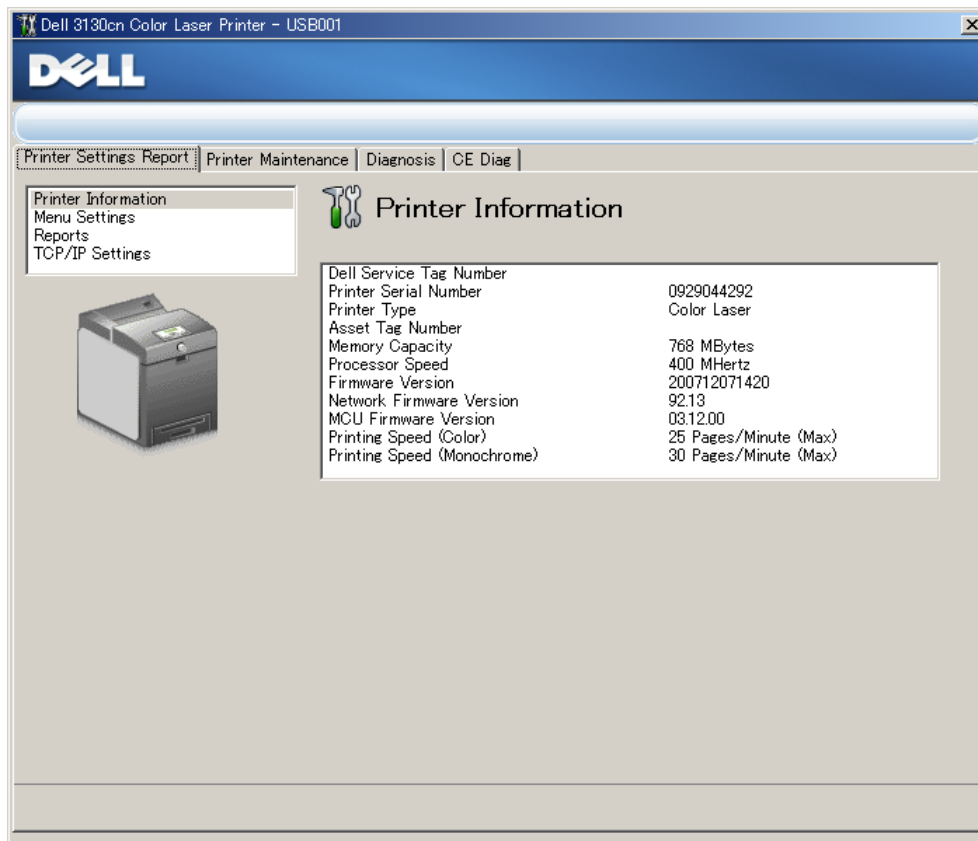

NOTE

In the case where the power to the printer stays OFF when activating the CE Diag. or where the power to the printer is turned OFF while the CE Diag. is running, the tool cannot be used giving the error message shown below:

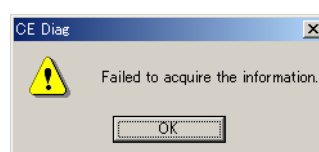

NOTE

To execute the CE Diag. menu, the CE Diag. requires entry of user password once. Under the default setting, no password is set. However, when the menu cannot be executed, the user-specified password needs to be entered.

- 3) To terminate the CE Diag., the message screen appears on the display when the CLOSE button at the upper right of the screen is clicked. CE Diag. is terminated when the [OK] is clicked on the message screen.

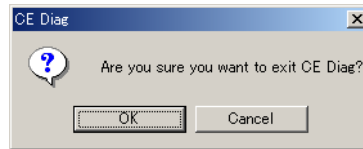

5.4 Explanation of the CE Diag. screen

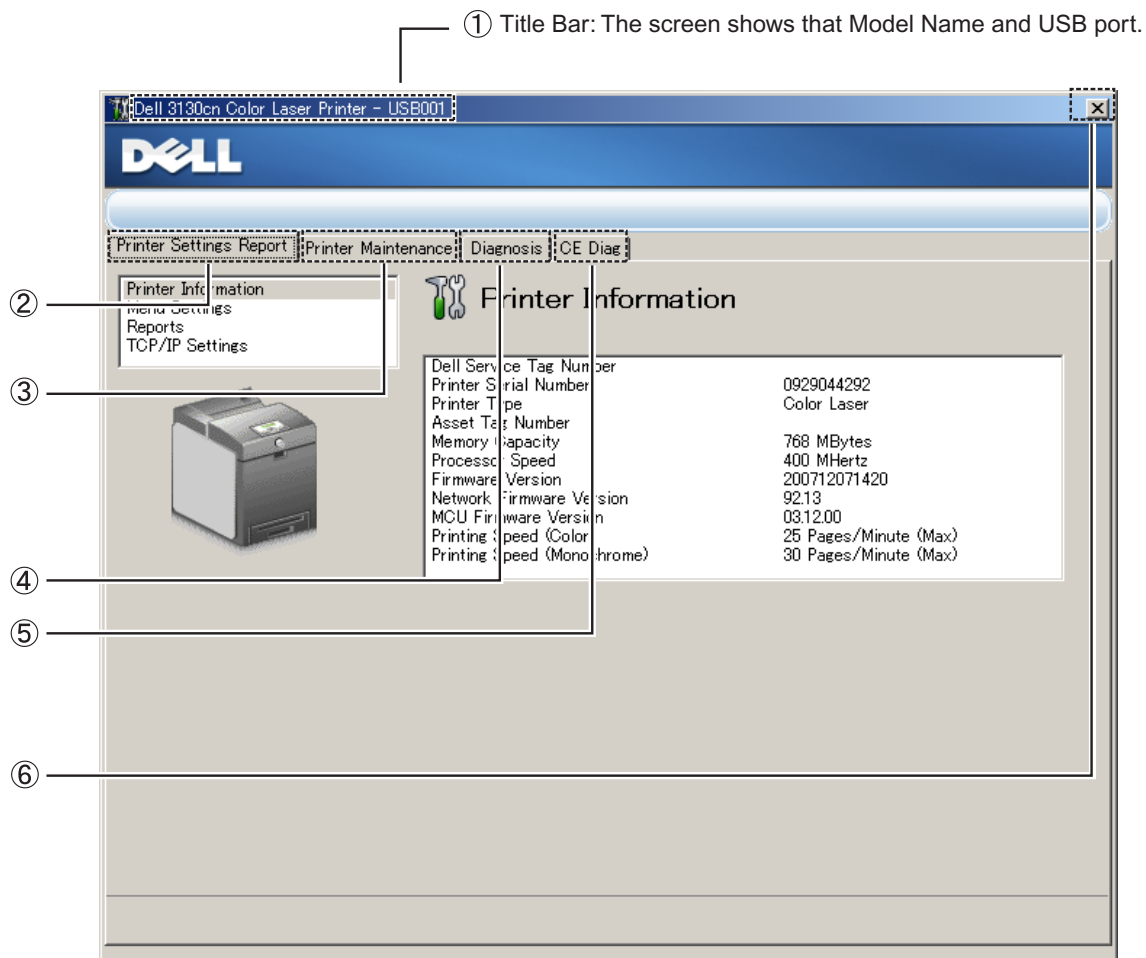

- ② Printer Setting Report: Indicates the settings for the printer set items, and prints out the settings' description.
- ③ Printer Maintenance: Changes the settings for the printer set items.
- ④ Diagnosis: Outputs the test charts incorporated in the printer, and checks the functions.
- NOTE: The aforementioned three tools refer to the operation explanation about the [Tool Box] given in the User Guide.**
- ⑤ CE Diag.: Checks the operation of internal parts of the printer, prints out the printer information, changes the adjusted values, and implements other functions.
- ⑥ The CE Diag screen is closed by clicking this box.

5.5 Selecting CE Diag. item

CE Diag. screen appears on the display when the [CE Diag.] tab is clicked.

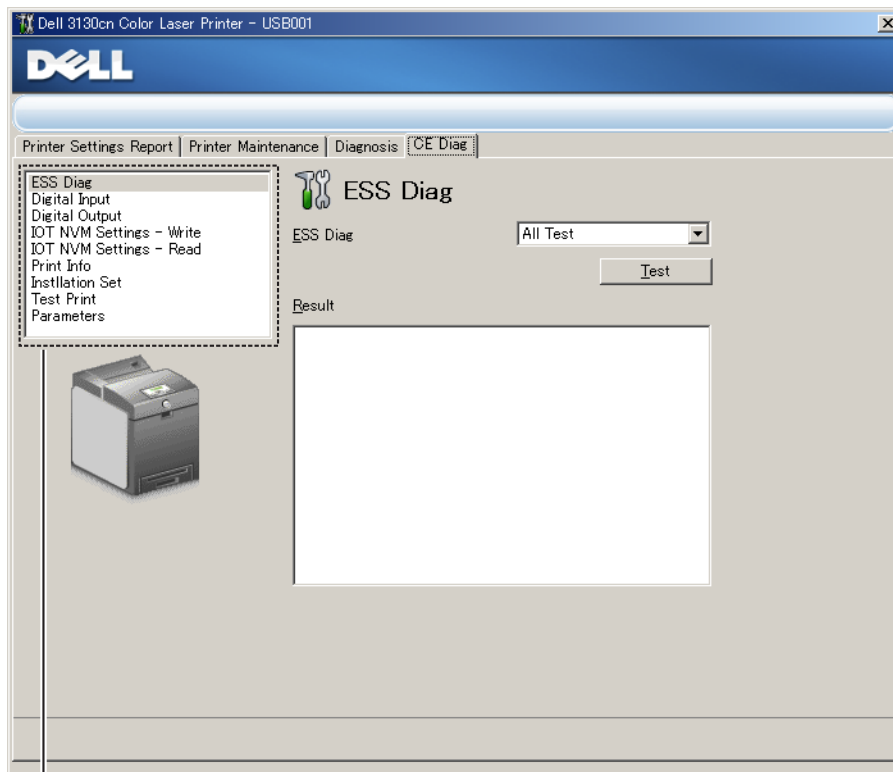

Select the menu in this screen.

5.6 CE Diag. mode menu tree

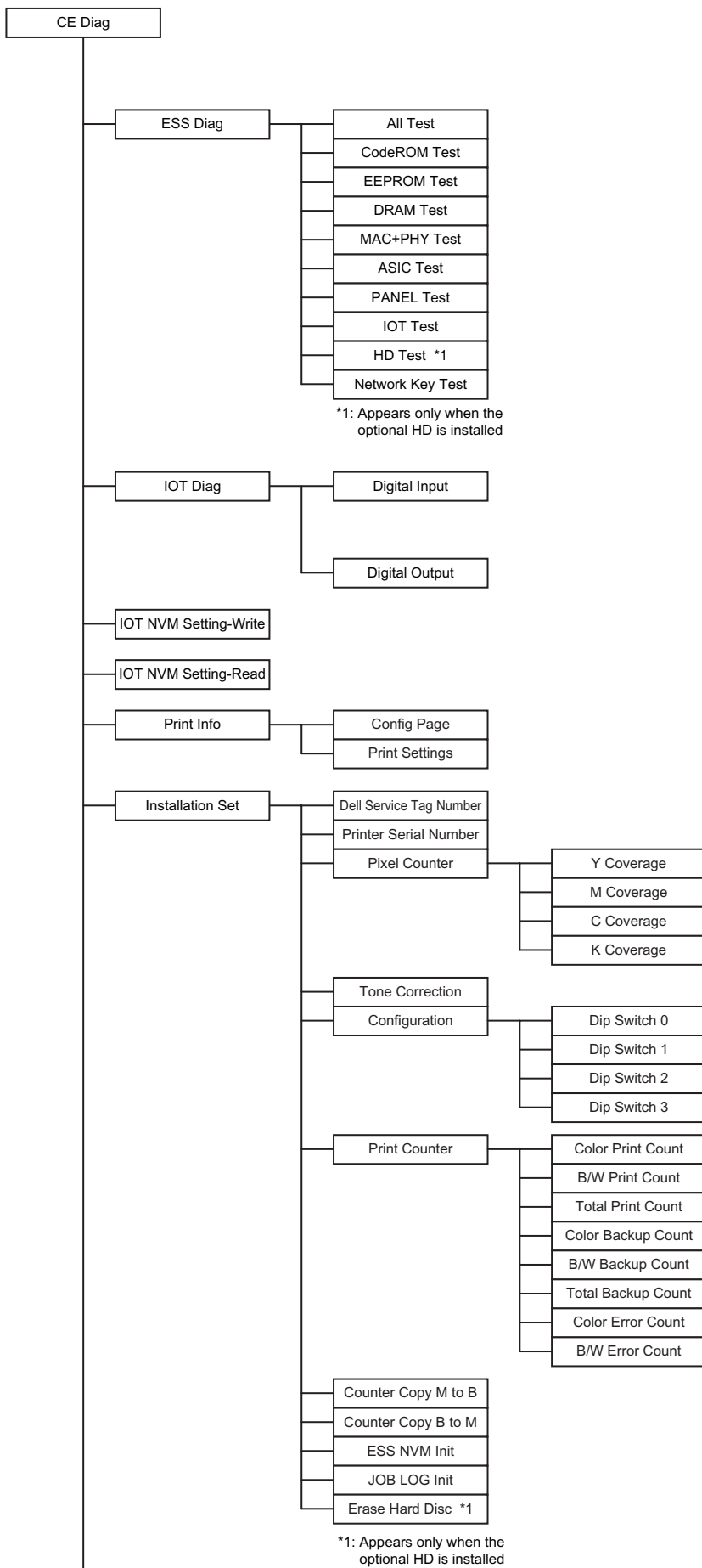

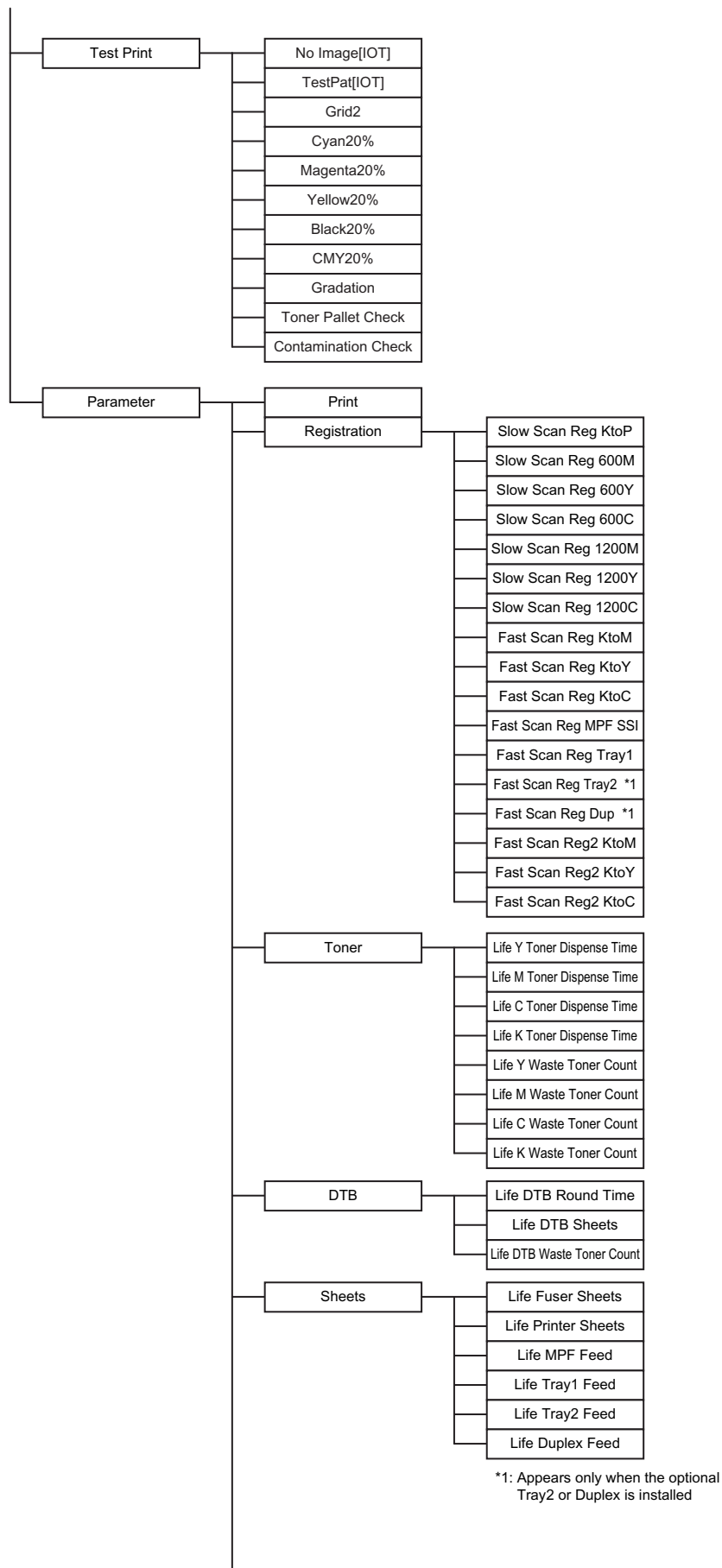

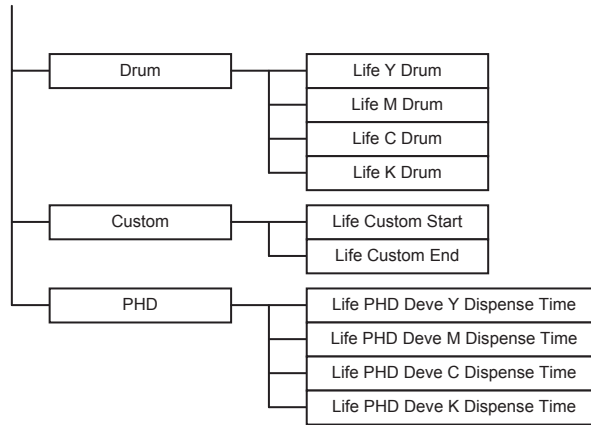

6. The Kind of CE Diag. and Contents of a Test (CE Diag. Tool Operation)

6.1 ESS Diag

The following screen appears on the display when the ESS Diag. is selected. Menus can be selected from the drop down listbox. To execute a test, the [Test] button on the screen should be clicked. Test results are displayed on the [Result] excluding the [MAC+PHY Test] and [Panel Test] results.

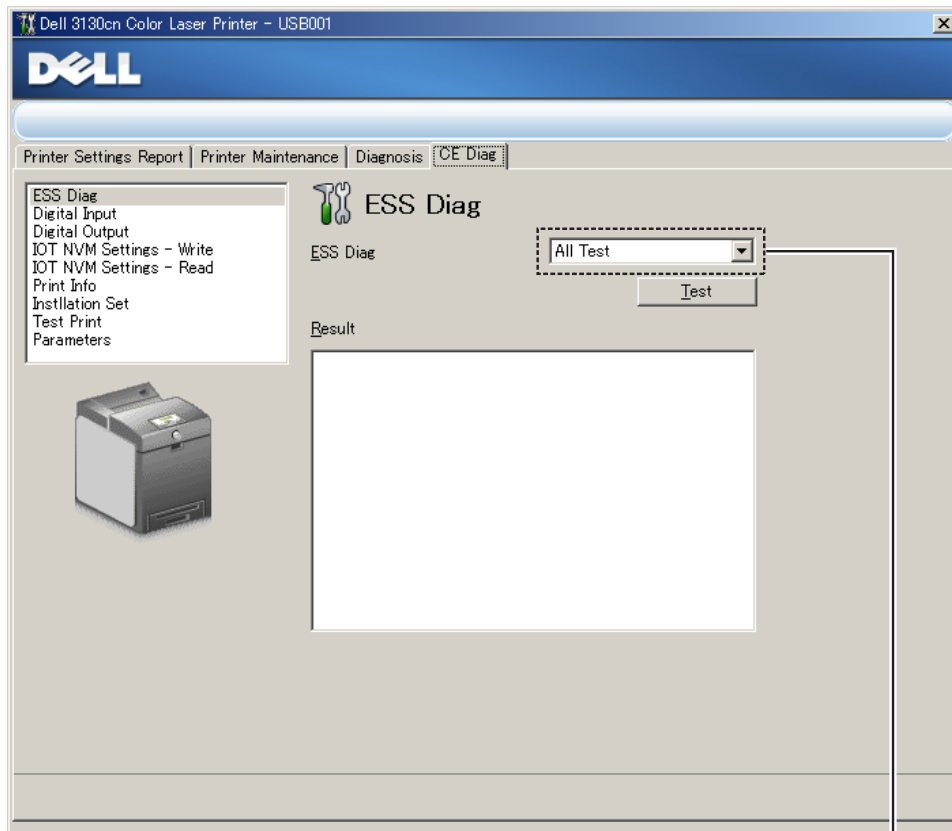

Drop down Listbox

NOTE

Do not open and shut the front cover, execute the print, and click the button on the Diag screen while executing ESS Diag.

Item	Function
All Test	This test executes the all tests of the ESS diagnostic except the MAC+PHY test and PANEL test.
Code ROM Test	Calculates the ROM checksum and compares it with the value stored in the ROM. Executes this test when the 016-317 error occurred. Test result: NG (Go to FIP.) OK (Turn off/on the main power.)
EEP ROM Test	Performs write/read/verify on the diag. area of the EEPROM. Executes this test when the 016-327 and 016-323 errors occurred. Test result: NG (Go to each FIP.) OK (Turn off/on the main power.)
DRAM Test	Tests OPEN/SHORT with the address line of the DRAM. Performs write/read/verify on the entire DRAM. Executes this test when the 016-315 and 016-700 errors occurred. Test result: NG (Go to each FIP.) OK (Turn off/on the main power.)

Item	Function																											
MAC+PHY Test	PHY Internal loopback test. Executes this test when the 016-340, 016-344, 016-345, 016-346 and 016-347 errors occurred. Test result: NG (Go to each FIP.) OK (Turn off/on the main power.) MAC: Media Access Control PHY: Physical Layer																											
ASIC Test	ASIC Register check. Executes this test when the 016-313 error occurred. Test result: NG (Go to FIP.) OK (Turn off/on the main power.)																											
PANEL Test	<p>Tests the LEDs and buttons of the control panel. This test checks input and output of the control panel. When buttons are pressed in the manner shown in the following table, the test displays the corresponding contents on the LED and LCD.</p> <table border="1"> <thead> <tr> <th>Button</th> <th>LED</th> <th>LCD</th> </tr> </thead> <tbody> <tr> <td>▲</td> <td>■ ■</td> <td>Displays " UP " on the LCD.</td> </tr> <tr> <td>▼</td> <td>■ ■</td> <td>Displays " DOWN " on the LCD.</td> </tr> <tr> <td>◀</td> <td>■ □</td> <td>Displays " LEFT " on the LCD.</td> </tr> <tr> <td>▶</td> <td>■ □</td> <td>Displays " RIGHT " on the LCD.</td> </tr> <tr> <td>✓</td> <td>□ ■</td> <td>Displays " SET " on the LCD.</td> </tr> <tr> <td>MENU</td> <td>□ ■</td> <td>Displays " MENU " on the LCD.</td> </tr> <tr> <td>CANCEL</td> <td>□ □</td> <td>Displays " CANCEL " on the LCD.</td> </tr> <tr> <td>▲ ▼ pressed at the same time</td> <td>- (The test is completed)</td> <td>Displays " Start " on the LCD.</td> </tr> </tbody> </table> <p>□ □ Indicates left side square is the Ready LED (Green) and right side square is the Alarm LED (Amber). □ Not lighting ■ Lighting</p>	Button	LED	LCD	▲	■ ■	Displays " UP " on the LCD.	▼	■ ■	Displays " DOWN " on the LCD.	◀	■ □	Displays " LEFT " on the LCD.	▶	■ □	Displays " RIGHT " on the LCD.	✓	□ ■	Displays " SET " on the LCD.	MENU	□ ■	Displays " MENU " on the LCD.	CANCEL	□ □	Displays " CANCEL " on the LCD.	▲ ▼ pressed at the same time	- (The test is completed)	Displays " Start " on the LCD.
Button	LED	LCD																										
▲	■ ■	Displays " UP " on the LCD.																										
▼	■ ■	Displays " DOWN " on the LCD.																										
◀	■ □	Displays " LEFT " on the LCD.																										
▶	■ □	Displays " RIGHT " on the LCD.																										
✓	□ ■	Displays " SET " on the LCD.																										
MENU	□ ■	Displays " MENU " on the LCD.																										
CANCEL	□ □	Displays " CANCEL " on the LCD.																										
▲ ▼ pressed at the same time	- (The test is completed)	Displays " Start " on the LCD.																										
IOT Test	Communication test with the IOT. Executes this test when the 016-370 error occurred. Test result: NG (Go to FIP.) OK (Turn off/on the main power.)																											
HD Test	Checks whether the optional HD is inserted or not, and then executes the Device Diagnostic Command. Executes this test when the 016-312 error occurred. Test result: NG (Go to FIP.) OK (Turn off/on the main power.)																											
Network Key Test	Diagnosis whether there is failures or not in the interface with the H/W key (Network Protocol Adapter). NOTE: Check to be sure that the printer is installed with the optional Network key before starting testing. Executes this test when the 016-365 error occurred. Test result: NG (Go to FIP.) OK (Turn off/on the main power.)																											

6.2 Digital Input

This function checks whether the DI components operate normally or not. The DI test is performed for all the DI components. A component should be selected from the drop down listbox. [Start] button shown on the screen should be clicked. [LOW] or [HIGH] is displayed on the [Result] screen. The component operation is checked in such a way that the component status is changed from [LOW] to [HIGH] and vice versa by operating the actuator or opening/closing the door. To stop the operation, the [Stop] button on the screen should be clicked.

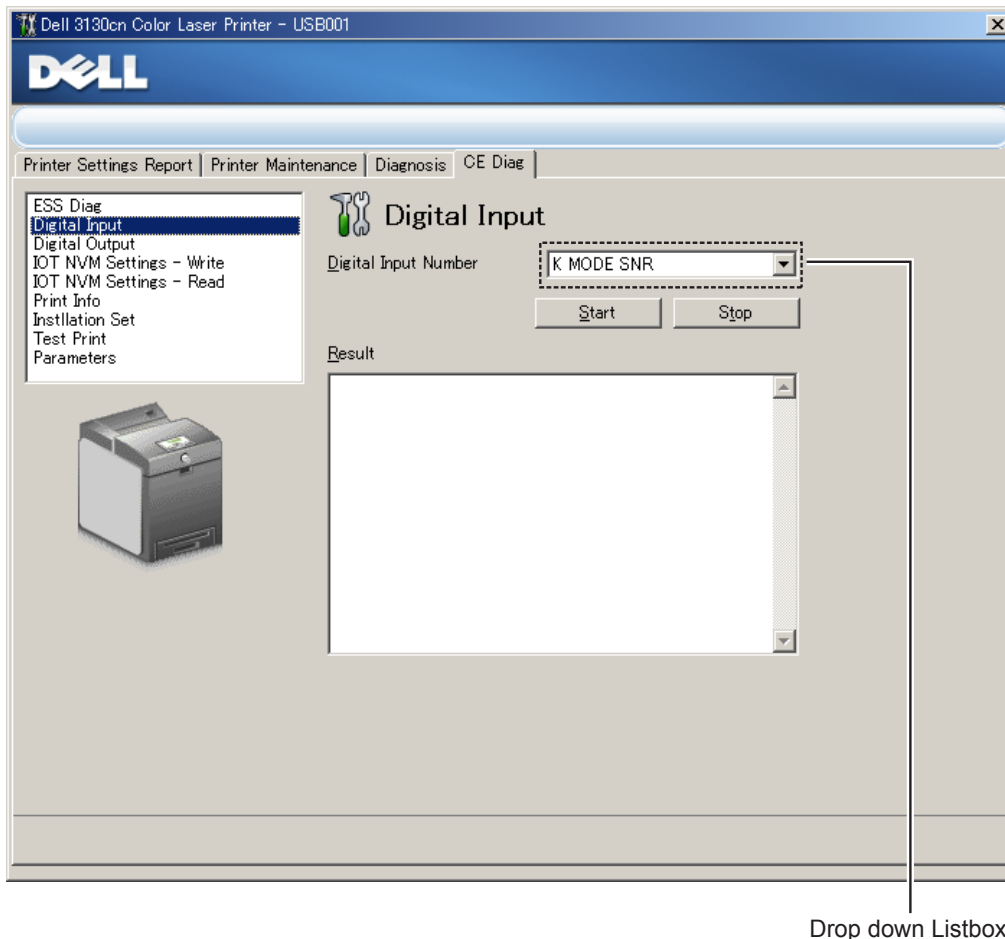

Items for the Digital Input Test are as follows.

Item
K MODE SNR
DUP SNR
EXIT SNR
REGI SNR
IL OPEN
CRU Y
CRU M
CRU K
CRU C
CST2 LOW PAPER(Not Used)
CST2 NO PAPER
DUP FAN ALARM(Not Used)

Item
FDR MOTOR ALM(Not Used)
MSI NO PAPER
CST1 NO PAPER
MAI MOTOR ALM(Not Used)
SUB MOT ALM(Not Used)
OHP SNR (Not Used)
FAN ALM (Not Used)
PH MOTOR ALM (Not Used)
DEVE MOTOR ALM(Not Used)
CASSETTE1 SIZE
CASSETTE2 SIZE

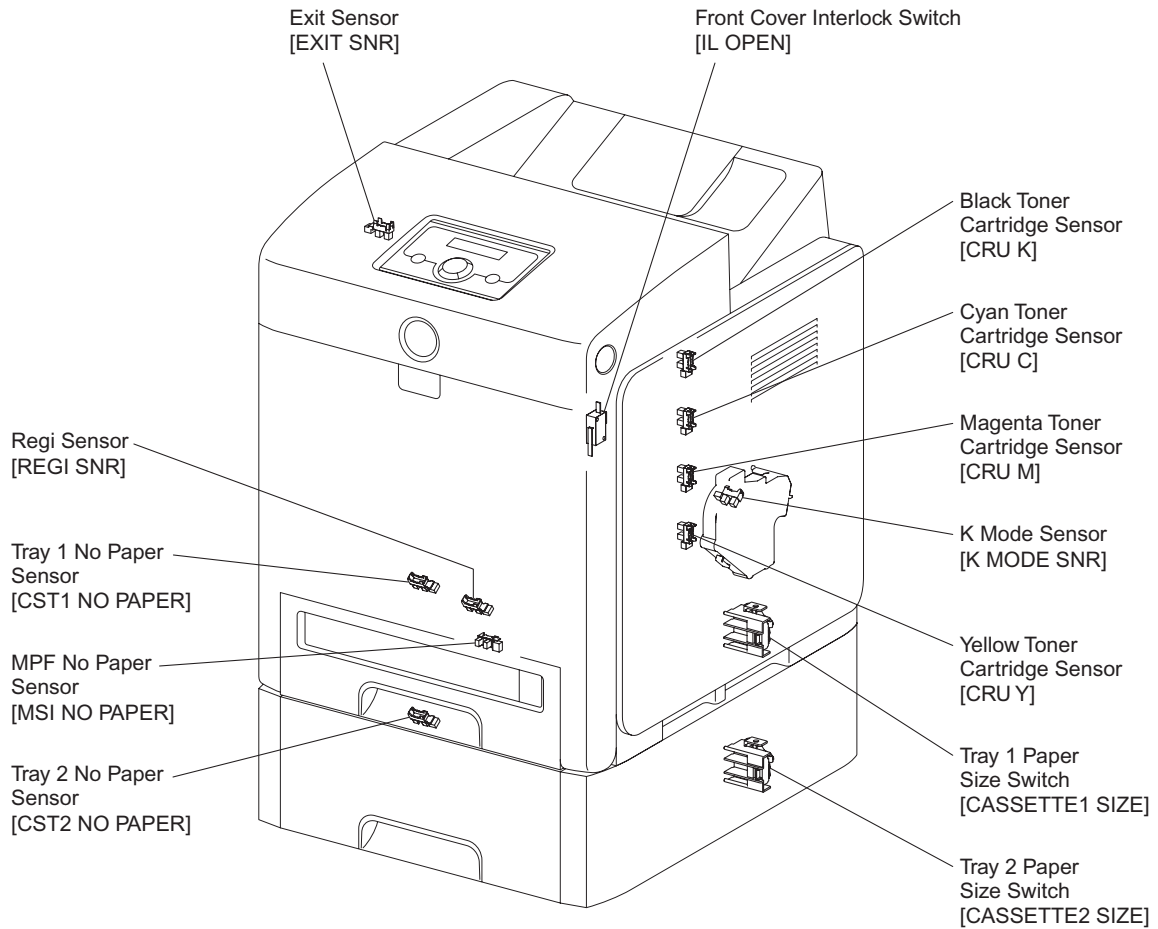

Zna02115KB

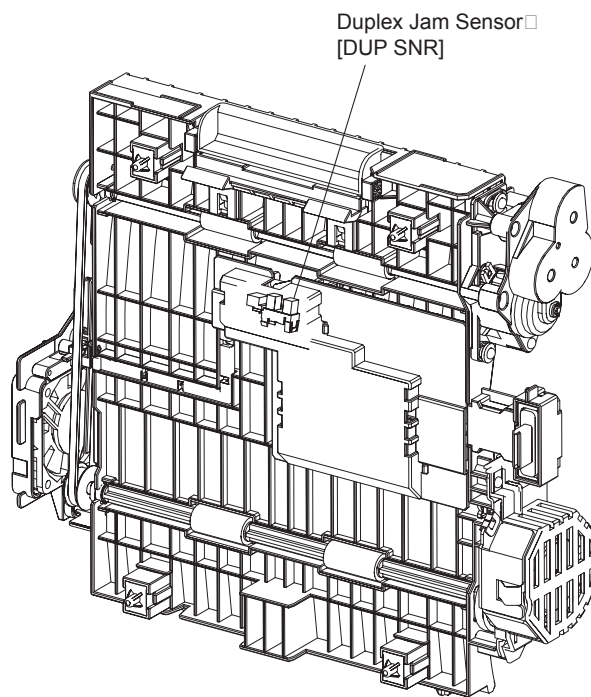

Zna02118KB

- About Sensor

A transmissive type sensor is composed of the light-emitting side and the light-receiving side that are placed opposite to each other allowing the light to pass from the former to the latter. On the basis of whether or not the light path is blocked due to the actuator, etc., the sensor detects the paper absence/presence or the moving part position such as at the home position or elsewhere.

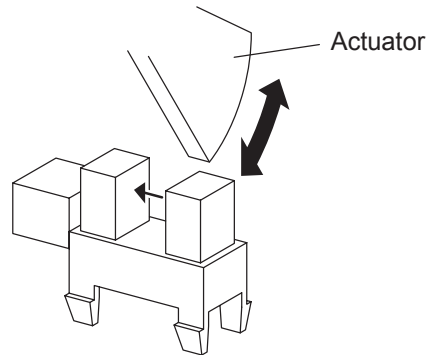

Leg_Sec02_016FA

- About Switch

A micro-switch closes the internal contacts via the button which is pushed down under the provided leaf spring which is held down by the actuator of the cover or door that is being closed. When the door or cover has been opened, the leaf spring returns to its original position and the button is pushed up by the spring in the switch, allowing the internal contacts to open.

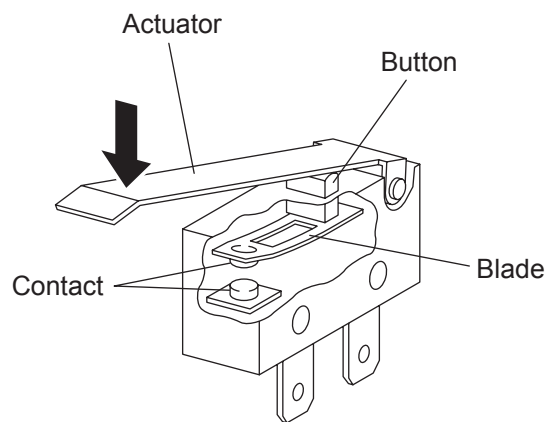

Leg_Sec02_018FA

-Checking the Sensor and Switch

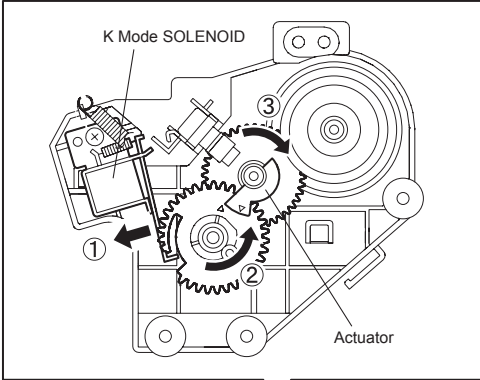
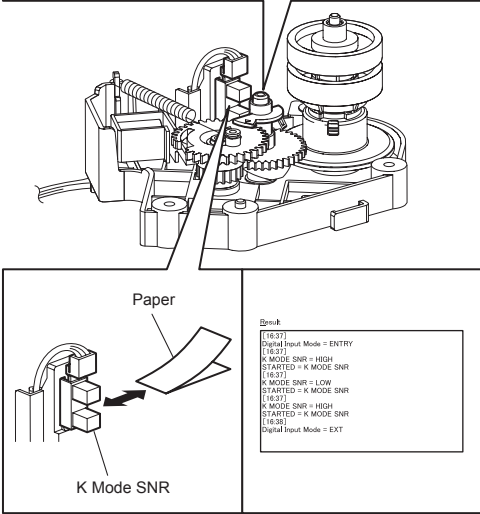
Item	Confirmation procedures
<p>K MODE SNR (Color Mode Switching Sensor)</p>	<p>NOTE: This procedure is for the technical staff. When performing operation for five minutes or longer with the front cover open, remove all toner cartridges, and cover the drum to avoid exposure to light.</p> <ol style="list-style-type: none"> 1) Turn on the power and enter the CE Diag. 2) Execute the K MODE SNR. 3) Open the Front Cover. 4) Remove the Cover Rear. 5) Remove the Cover Side R Assy. 6) Remove the Drive Assy K. 7) Press the lever mounted on the Solenoid to retract the actuator from the sensor. 8) Check the sensor. <div style="text-align: center;">  </div> <div style="text-align: center;">  </div> <div style="text-align: right; font-size: small;">Zna02101KA</div> <ol style="list-style-type: none"> 9) Click the Stop button to stop the test. 10) Replace the Drive Assy K. 11) Replace the Cover Side R Assy. 12) Replace the Cover Rear. 13) Close the Front Cover.

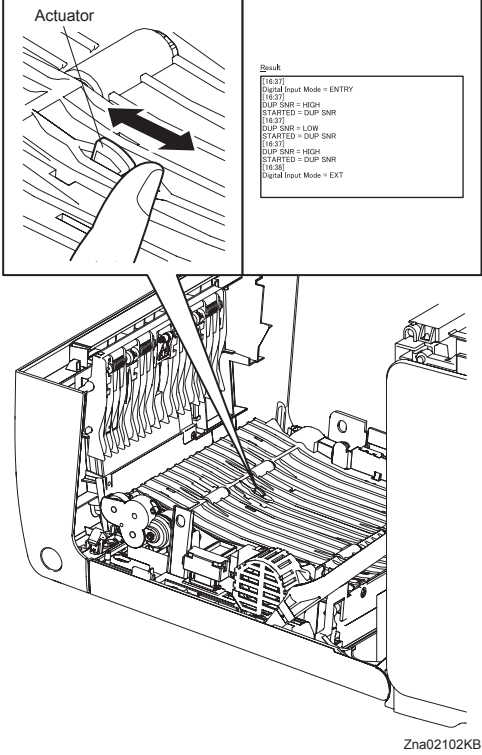
Item	Confirmation procedures
DUP SNR	<p>NOTE:When performing operation for five minutes or longer with the front cover open, remove all toner cartridges, and cover the drum to avoid exposure to light.</p> <ol style="list-style-type: none"> 1) Turn on the power and enter the CE Diag. 2) Execute the DUP SNR. 3) Open the Front Cover. 4) Remove the Transfer Belt. 5) Check the sensor. <div data-bbox="783 488 1267 1240" style="border: 1px solid black; padding: 5px;">  <p style="text-align: right; font-size: small;">Zna02102KB</p> </div> <ol style="list-style-type: none"> 6) Click the stop button to stop the test. 7) Replace the Transfer Belt. 8) Close the Front Cover.

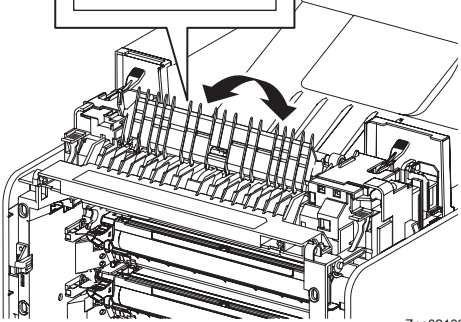
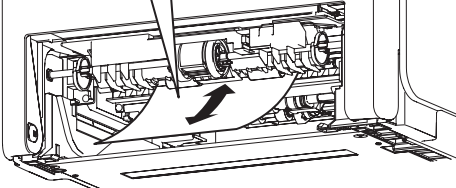
Item	Confirmation procedures
<p>EXIT SNR</p>	<p>NOTE: Fuser is very hot, so pay sufficient attention at work to above burns, etc.</p> <ol style="list-style-type: none"> 1) Turn on the power and enter the CE Diag. 2) Execute the EXIT SNR. 3) Open the Front Cover. 4) Check the sensor. <div data-bbox="836 421 1078 577" style="border: 1px solid black; padding: 5px; margin: 10px 0;"> <pre> Result [16.37] Digital Input Mode = ENTRY [16.37] EXIT SNR = HIGH STARTED = EXIT SNR [16.37] EXIT SNR = LOW STARTED = EXIT SNR [16.37] EXIT SNR = HIGH STARTED = EXIT SNR [16.38] Digital Input Mode = EXT </pre> </div>  <p style="text-align: right; font-size: small;">Zna02103KB</p> <ol style="list-style-type: none"> 5) Click the stop button to stop the test. 6) Close the Front Cover.
<p>REGI SNR</p>	<ol style="list-style-type: none"> 1) Turn on the power and enter the CE Diag. 2) Execute the REGI SNR. 3) Remove the 250 paper cassette. 4) Insert the paper into the paper path of the Regi assy. <div data-bbox="826 1128 1066 1285" style="border: 1px solid black; padding: 5px; margin: 10px 0;"> <pre> Result [16.37] Digital Input Mode = ENTRY [16.37] REGI SNR = HIGH STARTED = REGI SNR [16.37] REGI SNR = LOW STARTED = REGI SNR [16.37] REGI SNR = HIGH STARTED = REGI SNR [16.38] Digital Input Mode = EXT </pre> </div>  <p style="text-align: right; font-size: small;">Zna02104KA</p> <ol style="list-style-type: none"> 5) Click the stop button to stop the test. 6) Replace the 250 paper cassette.

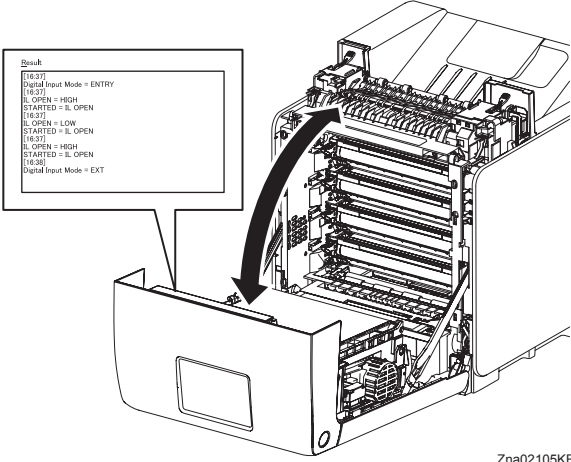
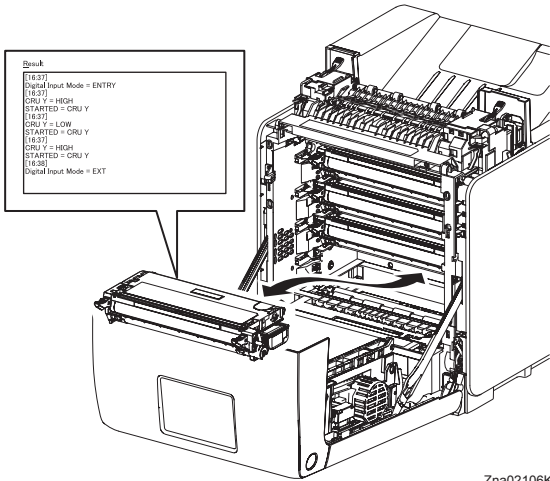
Item	Confirmation procedures
<p>IL OPEN</p>	<ol style="list-style-type: none"> 1) Turn on the power and enter the CE Diag. 2) Execute the IL OPEN. 3) Check the Switch <div style="text-align: center;">  <p style="text-align: right; font-size: small;">Zna02105KB</p> </div> <ol style="list-style-type: none"> 4) Click the stop button to stop the test. 5) Close the Front Cover.
<p>CRU Y</p>	<p>NOTE: When performing operation for five minutes or longer with the front cover open, remove all toner cartridges, and cover the drum to avoid exposure to light.</p> <ol style="list-style-type: none"> 1) Turn on the power and enter the CE Diag. 2) Execute the CRU Y. 3) Open the Front Cover 4) Check the Sensor. <div style="text-align: center;">  <p style="text-align: right; font-size: small;">Zna02106KB</p> </div> <ol style="list-style-type: none"> 5) Click the stop button to stop the test. 6) Close the Front Cover.

Item	Confirmation procedures
<p>CRU M</p>	<p>NOTE: When performing operation for five minutes or longer with the front cover open, remove all toner cartridges, and cover the drum to avoid exposure to light.</p> <ol style="list-style-type: none"> 1) Turn on the power and enter the CE Diag. 2) Execute the CRU M. 3) Open the Front Cover 4) Check the Sensor. <div data-bbox="746 454 1295 929" style="text-align: center;"> <p style="text-align: right; font-size: small;">Zna02107KB</p> </div> <ol style="list-style-type: none"> 5) Click the stop button to stop the test. 6) Close the Front Cover.
<p>CRU K</p>	<p>NOTE: When performing operation for five minutes or longer with the front cover open, remove all toner cartridges, and cover the drum to avoid exposure to light.</p> <ol style="list-style-type: none"> 1) Turn on the power and enter the CE Diag. 2) Execute the CRU K. 3) Open the Front Cover 4) Check the Sensor. <div data-bbox="746 1283 1295 1758" style="text-align: center;"> <p style="text-align: right; font-size: small;">Zna02108KB</p> </div> <ol style="list-style-type: none"> 5) Click the stop button to stop the test. 6) Close the Front Cover.

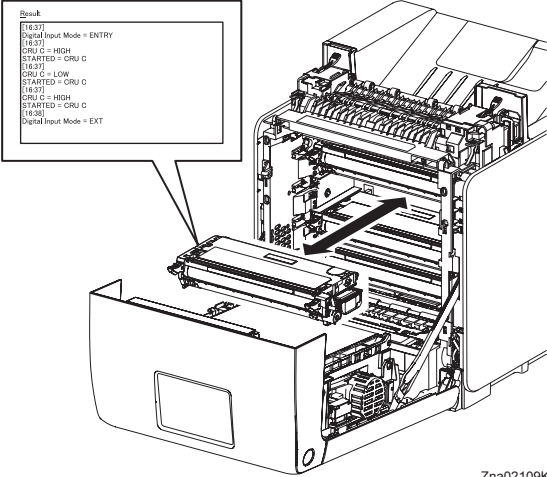
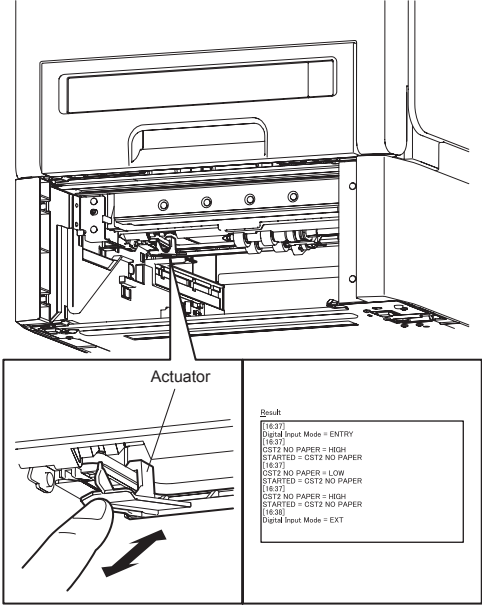
Item	Confirmation procedures
<p>CRU C</p>	<p>NOTE: When performing operation for five minutes or longer with the front cover open, remove all toner cartridges, and cover the drum to avoid exposure to light.</p> <ol style="list-style-type: none"> 1) Turn on the power and enter the CE Diag. 2) Execute the CRU C. 3) Open the Front Cover 4) Check the Sensor.  <p style="text-align: right;">Zna02109KB</p> <ol style="list-style-type: none"> 5) Click the stop button to stop the test. 6) Close the Front Cover.
<p>CST2 NO PAPER</p>	<p>NOTE: The no paper senser is in the option feeder.</p> <ol style="list-style-type: none"> 1) Turn on the power and enter the CE Diag. 2) Execute the CST2 NO PAPER. 3) Remove the Paper Cassette. 4) Check the Sensor.  <p style="text-align: right;">Zna02110KA</p> <ol style="list-style-type: none"> 5) Click the stop button to stop the test. 6) Replace the paper cassette.

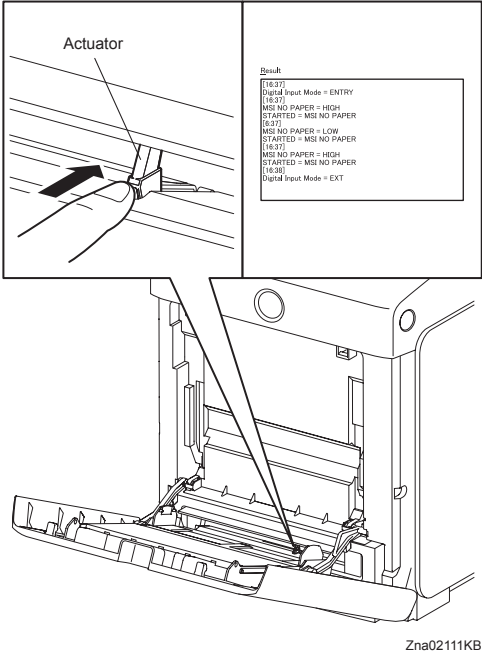
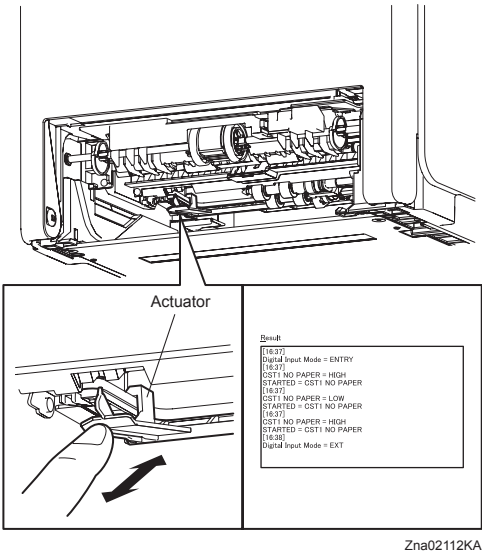
Item	Confirmation procedures
<p>MSI NO PAPER</p>	<p>NOTE: Remove the paper of the MPF before executing the test.</p> <ol style="list-style-type: none"> 1) Turn on the power and enter the CE Diag. 2) Execute the MSI NO PAPER. 3) Open the MPF Cover. 4) Check the sensor. <div data-bbox="783 389 1267 1041" style="border: 1px solid black; padding: 5px;">  <p>The diagram shows a hand pointing to the actuator on the MPF cover. The result screen displays the following text:</p> <pre> Result [16.37] Digital Input Mode = ENTRY [16.37] MSI NO PAPER = HIGH STARTED = MSI NO PAPER [16.37] MSI NO PAPER = LOW STARTED = MSI NO PAPER [16.37] MSI NO PAPER = HIGH STARTED = MSI NO PAPER [16.38] Digital Input Mode = EXT </pre> <p style="text-align: right;">Zna02111KB</p> </div> <ol style="list-style-type: none"> 5) Click the stop button to stop the test. 6) Close the MPF Cover.
<p>CST1 NO PAPER</p>	<ol style="list-style-type: none"> 1) Turn on the power and enter the CE Diag. 2) Execute the CST1 NO PAPER. 3) Remove the paper cassette. 4) Check the sensor. <div data-bbox="783 1279 1267 1832" style="border: 1px solid black; padding: 5px;">  <p>The diagram shows a hand pointing to the actuator on the paper cassette. The result screen displays the following text:</p> <pre> Result [16.37] Digital Input Mode = ENTRY [16.37] CST1 NO PAPER = HIGH STARTED = CST1 NO PAPER [16.37] CST1 NO PAPER = LOW STARTED = CST1 NO PAPER [16.37] CST1 NO PAPER = HIGH STARTED = CST1 NO PAPER [16.38] Digital Input Mode = EXT </pre> <p style="text-align: right;">Zna02112KA</p> </div> <ol style="list-style-type: none"> 5) Click the stop button to stop the test. 6) Replace the paper cassette.

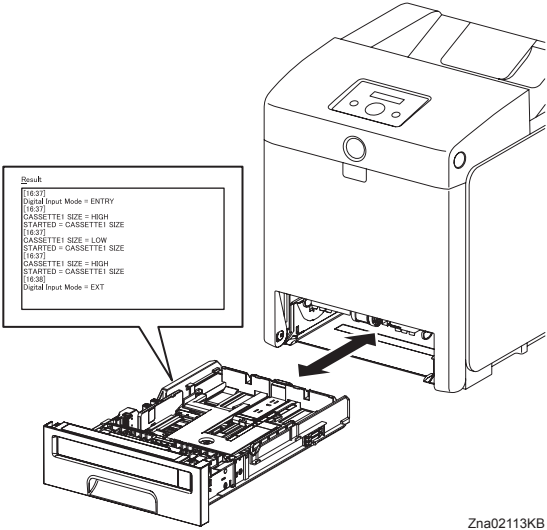
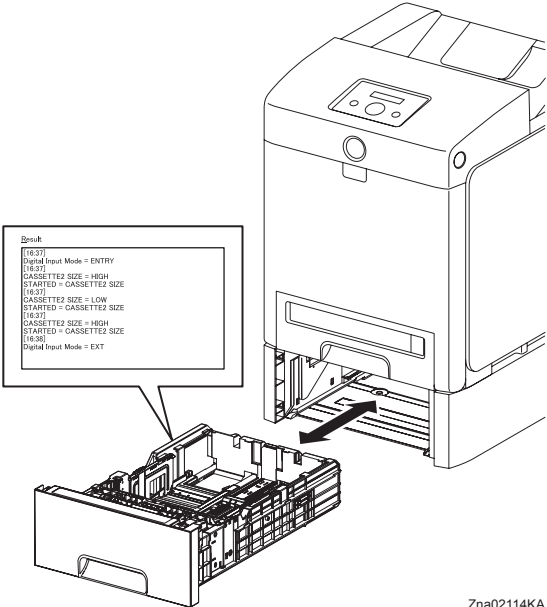
Item	Confirmation procedures
<p>CASSETTE 1 SIZE</p>	<ol style="list-style-type: none"> 1) Turn on the power and enter the CE Diag. 2) Execute the CASSETTE 1 SIZE. 3) Check the switch.  <ol style="list-style-type: none"> 4) Click the stop button to stop the test. 5) Replace the paper cassette.
<p>CASSETTE 2 SIZE</p>	<p>NOTE: The size switch is in the option feeder.</p> <ol style="list-style-type: none"> 1) Turn on the power and enter the CE Diag. 2) Execute the CASSETTE 2 SIZE. 3) Check the switch.  <ol style="list-style-type: none"> 4) Click the stop button to stop the test. 5) Replace the paper cassette.

6.3 Digital Output

This function checks whether the DO components operate. A component should be selected from the drop down listbox, and the [Start] button on the screen should be clicked. As many as ten different components can be simultaneously operated. However, it is recommended to operate one or two components at a time since simultaneous operation of many different components can break them. To stop the operation, the [Stop] button on the screen should be clicked.

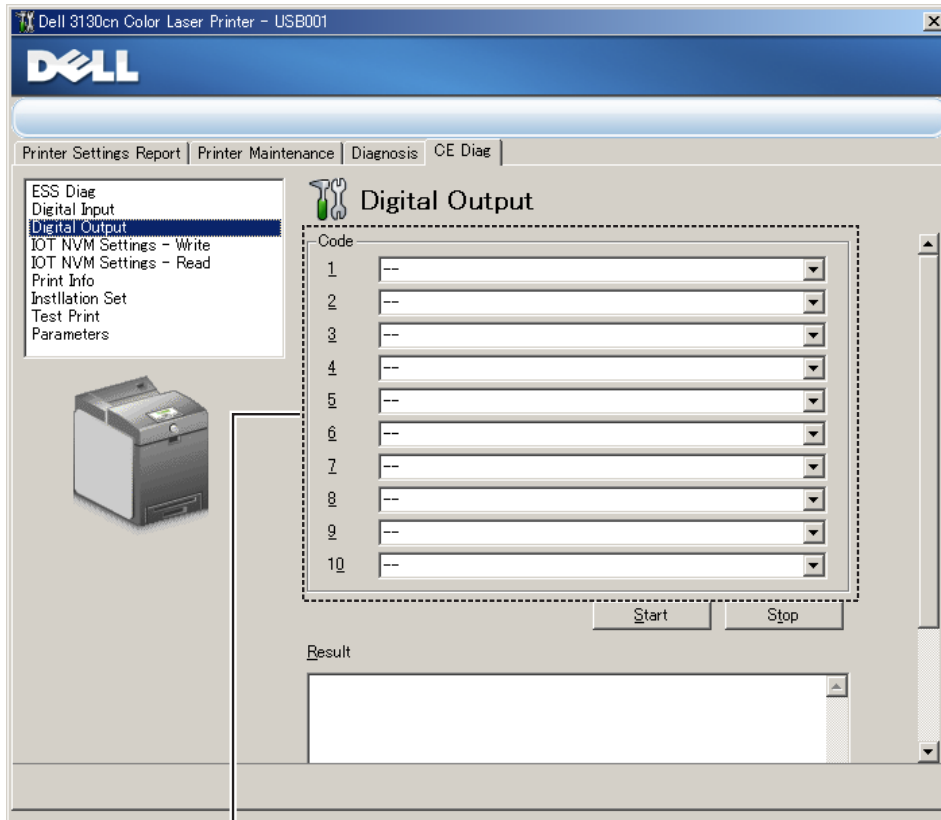

Drop down Listbox

Items for the Digital Output Test are as follows.

Item
MAIN MOTOR(FULL/ HALF)
SUB MOTOR(FULL/ HALF)
PH MOTOR ON(FULL/ HALF)
DUPLEX MOTOR ON(FULL/ HALF)
OPTION FEEDER 1 MOTOR ON(FULL/ HALF)
FAN ON(HIGH/ LOW)
TONER MOTOR Y ON
TONER MOTOR M ON
TONER MOTOR C ON
TONER MOTOR K ON
REGI CLUTCH ON
MSI TURN CLUTCH ON
MSI FEED CLUTCH ON

Item
CASSETTE1 FEED CLUTCH ON
CASSETTE2 FEED CLUTCH ON
CASSETTE2 TURN CLUTCH ON
DUPLEX CLUTCH ON
CTD SOLENOID ON
CTD SENSOR ON
OHP LED ON(Not Used)
ERASE K ON
ERASE YMC ON
EXIT CLUTCH ON
DUPLEX FAN ON
BUZZER ON
K MODE CLUTCH ON

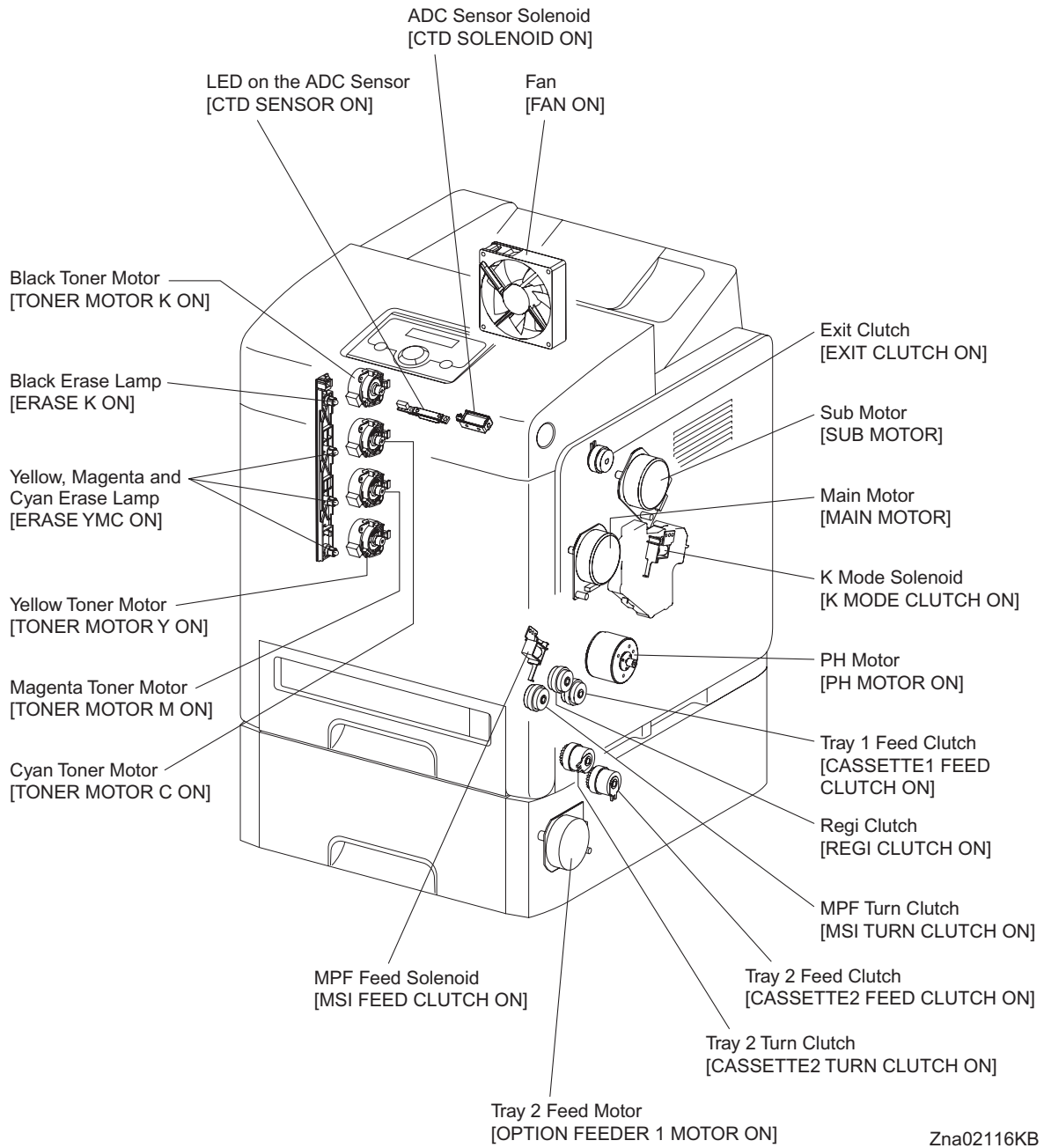

Zna02116KB

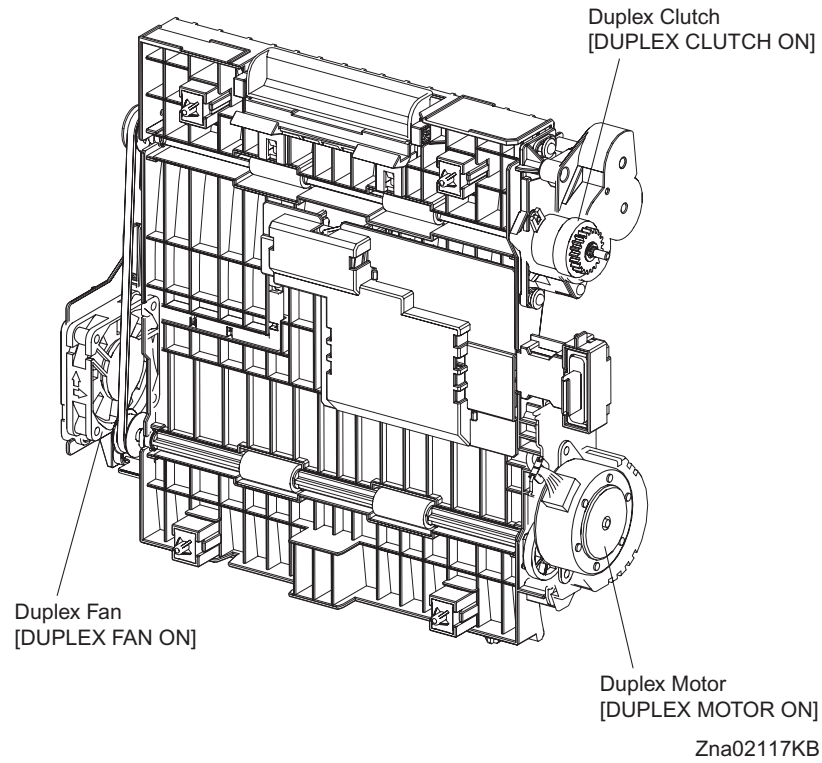

NOTE

The use of [CF K ON]/[CF YMC ON]/[DBAC ON/DBDC Y ON]/[DBDC M ON]/[DBDC C ON/DBDC K ON]/[TR Y ON]/[TR M ON]/[TR C ON/TR K ON]/[AD PLUS ON]/[HV ON] is prohibited to avoid shock hazards since they are high-voltage outputs for forming toner images.

- About Clutch

The electromagnetic clutch in the printer controls the rotation of the roller by transferring or cutting the torque from the motor to the roller.

The electromagnetic clutch becomes an electromagnet by the passage of electric current through the coil inside the case and attracts the armature and gear to the rotating rotor, thereby rotating the gear.

Upon the loss of power to the coil, electromagnetic force is lost and the armature comes off the rotor, and the gear comes to rest.

The clutch makes so soft noises that you must be close the component to audibly confirm the operation of the component.

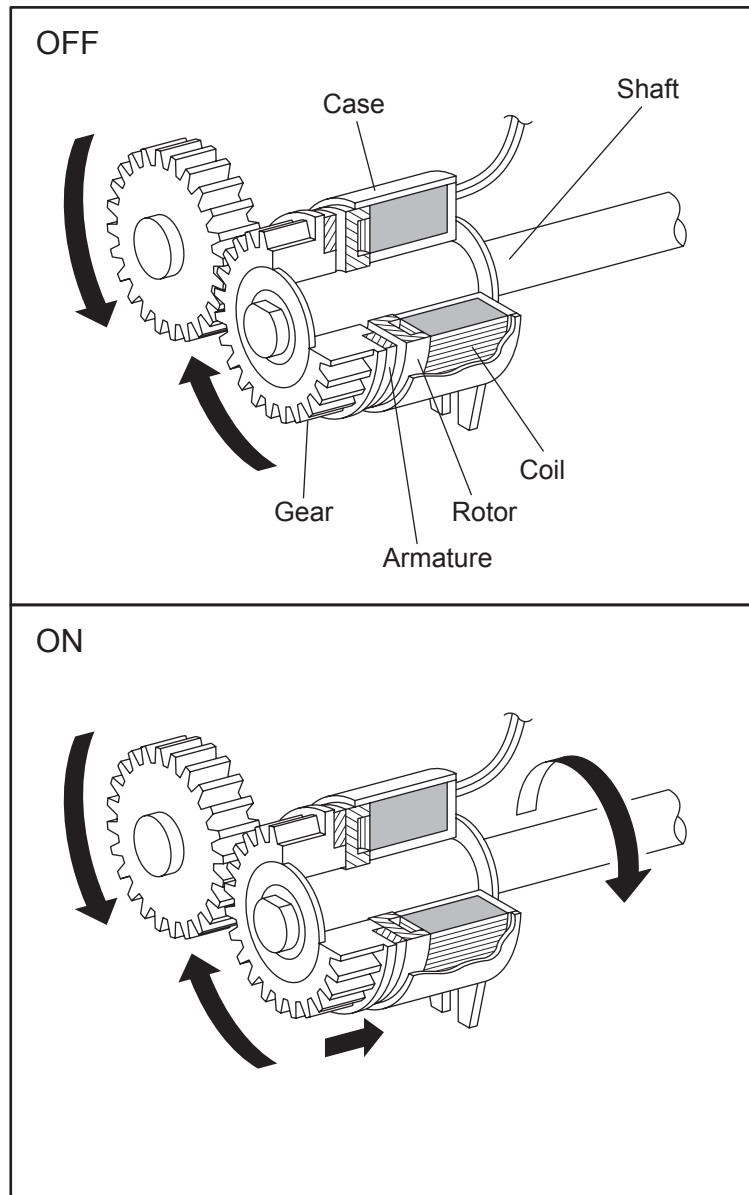

Leg_Sec02_050FA

- About Solenoid

The solenoid in the printer opens/closes the shutter or controls the position of the gear for transferring the torque of the motor to the roller.

A solenoid becomes an electromagnet by the passage of electric current through the coil inside the case and attracts the plunger.

Upon the loss of power to the coil, electromagnetic force is lost and the plunger is returned to its original position by spring action, thereby allowing the shutter to operate or the gear to move to the predefined position.

Unlike a clutch, a solenoid generates a loud operation noise.

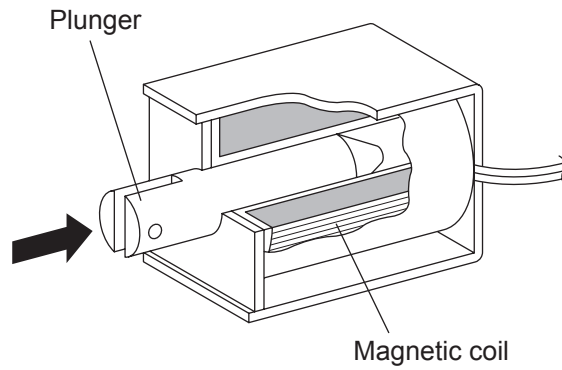

Leg_Sec02_051FA

- Checking Motor, Clutch and Solenoid

NOTE

Before executing the DO test, close all covers and doors.

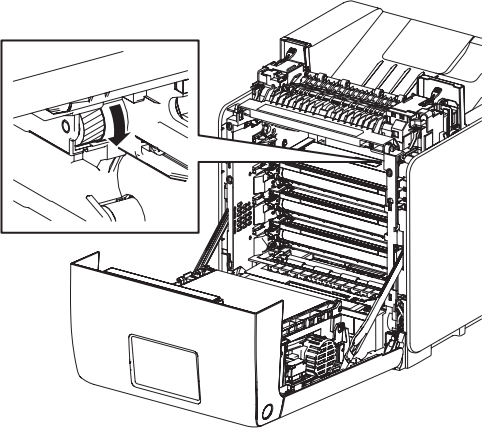
Item	Confirmation procedure
<p>MAIN MOTOR (FULL/ HALF)</p>	<p>NOTE: This procedure is for the technical staff. The customer check are the procedure 1, 5 and 6. The main motor is in the PC/DEVE DRIVE.</p> <p>When performing operation for five minutes or longer with the front cover open, remove all toner cartridges, and cover the drum to avoid exposure to light.</p> <ol style="list-style-type: none"> 1) Turn on the power and enter the CE Diag. 2) Open the Front Cover. 3) Remove the black toner cartridge. 4) Cheat the safety Interlock System. 5) Execute the MAIN MOTOR (FULL). (The customer can confirm the motor noise only.) <div style="text-align: center;">  <p style="text-align: right; font-size: small;">Zna02017KA</p> </div> <ol style="list-style-type: none"> 6) Click the stop button to stop test. 7) Remove the cheater and replace the black toner cartridge. 8) Close the Front Cover.

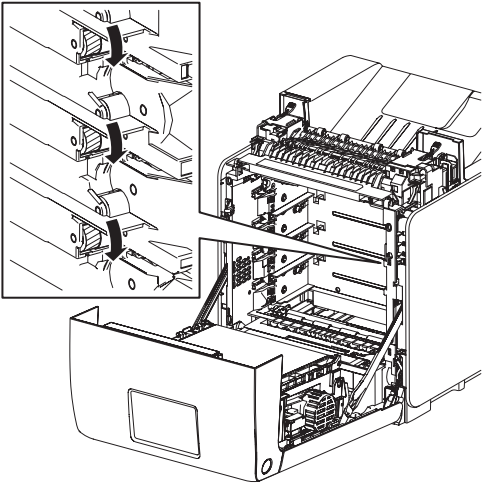
Item	Confirmation procedure
SUB MOTOR (FULL/HALF)	<p>NOTE: This procedure is for the technical staff. The customer check are the procedure 1, 5 and 6. The sub motor is in the PC/DEVE DRIVE.</p> <p>When performing operation for five minutes or longer with the front cover open, remove all toner cartridges, and cover the drum to avoid exposure to light.</p> <ol style="list-style-type: none"> 1) Turn on the power and enter the CE Diag. 2) Open the Front Cover. 3) Remove the all toner cartridges. 4) Cheat the safety Interlock System. 5) Execute the SUB MOTOR (FULL). (The customer can confirm the motor noise only.)  <p style="text-align: right; font-size: small;">Zna02018KA</p> <ol style="list-style-type: none"> 6) Click the stop button to stop test. 7) Remove the cheater and replace the all toner cartridges. 8) Close the Front Cover.

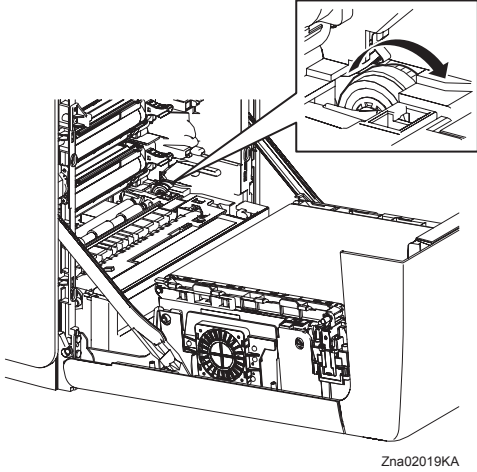
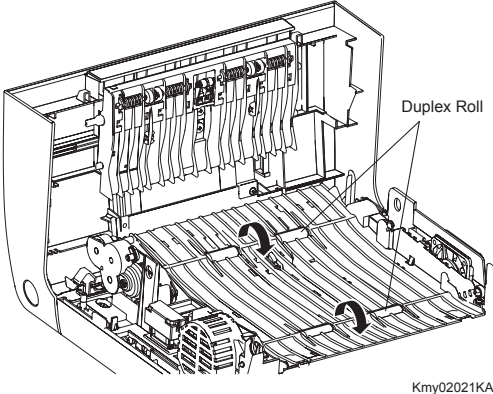
Item	Confirmation procedure
<p>PH MOTOR ON (FULL/ HALF)</p>	<p>NOTE: This procedure is for the technical staff. The customer check are the procedure 1, 4 and 5. The PH motor is in the FEED DRIVE. When performing operation for five minutes or longer with the front cover open, remove all toner cartridges, and cover the drum to avoid exposure to light.</p> <ol style="list-style-type: none"> 1) Turn on the power and enter the CE Diag. 2) Open the Front Cover. 3) Cheat the safety Interlock System. 4) Execute the PH MOTOR ON (FULL). (The customer can confirm the motor noise only.)  <ol style="list-style-type: none"> 5) Click the stop button to stop test. 6) Remove the cheater. 7) Close the Front Cover.
<p>DUPLEX MOTOR ON (FULL/HALF)</p>	<p>NOTE: This procedure is for the technical staff. The customer check are the procedure 1, 5 and 6. The DEVE motor is in the DUPLEX MODULE. When performing operation for five minutes or longer with the front cover open, remove all toner cartridges, and cover the drum to avoid exposure to light.</p> <ol style="list-style-type: none"> 1) Turn on the power and enter the CE Diag. 2) Open the Front Cover. 3) Cheat the safety Interlock System. 4) Remove the transfer belt. 5) Execute the DUPLEX MOTOR ON (FULL). (The customer can confirm the motor noise only.)  <ol style="list-style-type: none"> 6) Click the stop button to stop test. 7) Remove the cheater and replace the transfer belt. 8) Close the Front Cover.

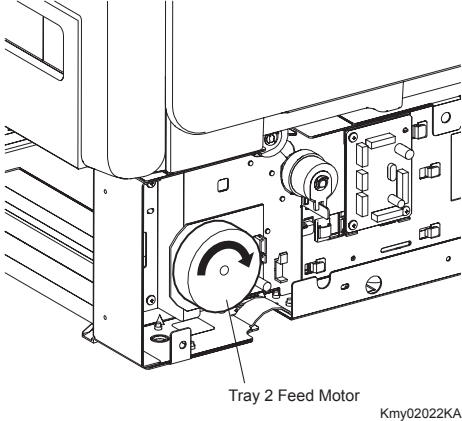
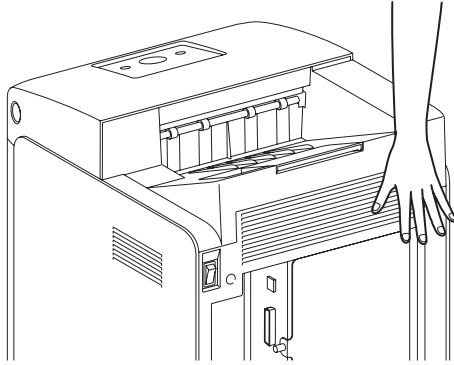
Item	Confirmation procedure
<p>OPTION FEEDER 1 MOTOR ON (FULL/HALF)</p>	<p>NOTE: This procedure is for the technical staff. The customer check are the procedure 1, 4 and 5.</p> <ol style="list-style-type: none"> 1) turn on the power and enter the CE Diag. 2) Remove the Tray 2 paper cassette. 3) Remove the left side cover of the Tray 2. 4) Execute the OPTION FEEDER 1 MOTOR ON (FULL). (The customer can confirm the motor noise only.)  <ol style="list-style-type: none"> 5) Click the stop button to stop test. 6) Replace the left side cover of the Tray 2. 7) Replace the Tray 2 paper cassette.
<p>FAN ON (HIGH/LOW)</p>	<p>NOTE: The rotational speed of the fan is as follows.</p> <ol style="list-style-type: none"> 1) Turn on the power and enter the CE Diag. 2) Execute the FAN ON (HIGH).  <ol style="list-style-type: none"> 3) Click the stop button to stop test.

Item	Confirmation procedure
<p>TONER MOTOR Y ON</p>	<p>NOTE: This procedure is for the technical staff. The customer check are the procedure 1, 5 and 6. When performing operation for five minutes or longer with the front cover open, remove all toner cartridges, and cover the drum to avoid exposure to light.</p> <ol style="list-style-type: none"> 1) Turn on the power and enter the CE Diag. 2) Open the Front Cover. 3) Cheat the safety Interlock System. 4) Remove the yellow toner cartridge. 5) Execute the TONER MOTOR Y ON. (The customer can confirm the motor noise only.) <div data-bbox="746 577 1209 1061" style="text-align: center;"> <p style="text-align: right; font-size: small;">Zna02024KA</p> </div> <ol style="list-style-type: none"> 6) Click the stop button to stop test. 7) Replace the yellow toner cartridge. 8) Remove the cheater. 9) Close the Front Cover.

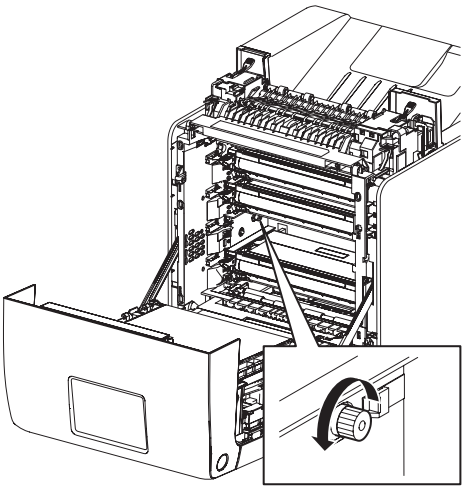
Item	Confirmation procedure
<p>TONER MOTOR M ON</p>	<p>NOTE: This procedure is for the technical staff. The customer check are the procedure 1, 5 and 6. When performing operation for five minutes or longer with the front cover open, remove all toner cartridges, and cover the drum to avoid exposure to light.</p> <ol style="list-style-type: none"> 1) Turn on the power and enter the CE Diag. 2) Open the Front Cover. 3) Remove the magenta toner cartridge. 4) Cheat the safety Interlock System. 5) Execute the TONER MOTOR M ON. (The customer can confirm the motor noise only.)  <p style="text-align: right; font-size: small;">Zna02025KA</p> <ol style="list-style-type: none"> 6) Click the stop button to stop test. 7) Remove the cheater. 8) Replace the magenta toner cartridge. 9) Close the Front Cover.

Item	Confirmation procedure
<p>TONER MOTOR C ON</p>	<p>NOTE: This procedure is for the technical staff. The customer check are the procedure 1, 5 and 6. When performing operation for five minutes or longer with the front cover open, remove all toner cartridges, and cover the drum to avoid exposure to light.</p> <ol style="list-style-type: none"> 1) Turn on the power and enter the CE Diag. 2) Open the Front Cover. 3) Remove the cyan toner cartridge. 4) Cheat the safety Interlock System. 5) Execute the TONER MOTOR C ON. (The customer can confirm the motor noise only.) <div data-bbox="746 577 1209 1057" style="text-align: center;"> </div> <p style="text-align: right; font-size: small;">Zna02026KA</p> <ol style="list-style-type: none"> 6) Click the stop button to stop test. 7) Remove the cheater. 8) Replace the cyan toner cartridge. 9) Close the Front Cover.

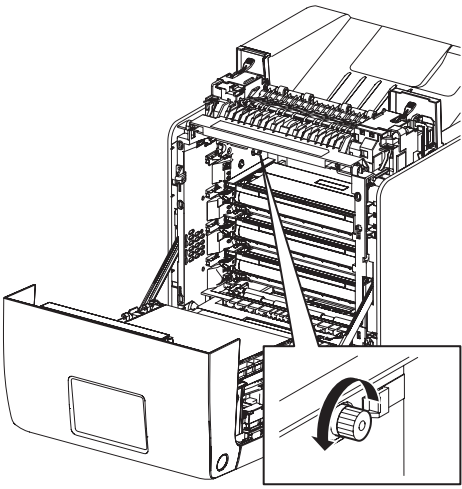
Item	Confirmation procedure
<p>TONER MOTOR K ON</p>	<p>NOTE: This procedure is for the technical staff. The customer check are the procedure 1, 5 and 6. When performing operation for five minutes or longer with the front cover open, remove all toner cartridges, and cover the drum to avoid exposure to light.</p> <ol style="list-style-type: none"> 1) Turn on the power and enter the CE Diag. 2) Open the Front Cover. 3) Remove the black toner cartridge. 4) Cheat the safety Interlock System. 5) Execute the TONER MOTOR K ON. (The customer can confirm the motor noise only.)  <p style="text-align: right; font-size: small;">Zna02027KA</p> <ol style="list-style-type: none"> 6) Click the stop button to stop test. 7) Remove the cheater. 8) Replace the black toner cartridge. 9) Close the Front Cover.

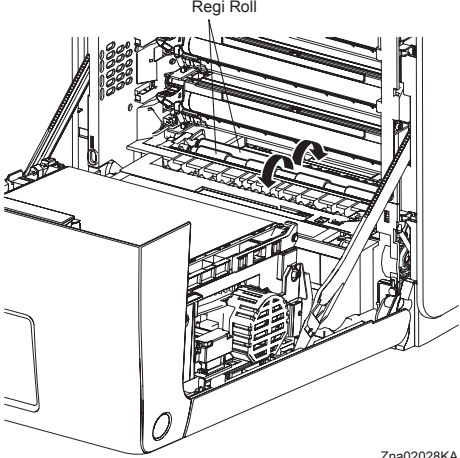
Item	Confirmation procedure
REGI CLUTCH ON	<p>NOTE: When performing operation for five minutes or longer with the front cover open, remove all toner cartridges, and cover the drum to avoid exposure to light.</p> <ol style="list-style-type: none"> 1) Turn on the power and enter the CE Diag. 2) Execute the REGI CLUTCH ON. Upon hitting the Start button, the operating noise of the clutch will be heard. 3) Click the stop button to stop the clutch. <p>Combination test is as follows.</p> <p>NOTE: The regi roll rotates when the PH MOTOR ON (FULL) and the REGI CLUTCH ON are executed. This procedure is for the technical staff.</p> <ol style="list-style-type: none"> 1) Turn on the power and enter the Diagnostic Mode. 2) Open the Front Cover. 3) Cheat the safety Interlock System. 4) Execute the PH MOTOR ON (FULL) and the REGI CLUTCH ON. <div style="text-align: center;">  </div> <ol style="list-style-type: none"> 5) Confirm the Regi Roll rotation. 6) Click the stop button to stop the clutch. 7) Remove the cheater and close the Front Cover.

Item	Confirmation procedure
<p>MSI TURN CLUTCH ON</p>	<ol style="list-style-type: none"> 1) Turn on the power and enter the CE Diag. 2) Execute the MSI TURN CLUTCH ON. Upon hitting the Start button, the operating noise of the clutch will be heard. 3) Click the stop button to stop the clutch. <p>Combination test is as follows. NOTE: The MPF turn roll rotates when the PH MOTOR ON (FULL) and the MSI TURN CLUTCH ON are executed. This procedure is for the technical staff.</p> <ol style="list-style-type: none"> 1) Turn on the power and enter the CE Diag. 2) Remove the Tray 1 paper cassette. 3) Execute the PH MOTOR ON (FULL) and the MSI TURN CLUTCH ON. <div data-bbox="746 636 1225 954" style="text-align: center;"> <p style="text-align: right; font-size: small;">Kmy02029KA</p> </div> <ol style="list-style-type: none"> 4) Confirm the Turn Roll rotation. 5) Click the stop button to stop the clutch. 6) Replace the Tray 1 paper cassette.
<p>MSI FEED CLUTCH ON</p>	<ol style="list-style-type: none"> 1) Turn on the power and enter the CE Diag. 2) Execute the MSI FEED CLUTCH ON. Upon hitting the Start button, the operating noise of the solenoid will be heard. 3) Click the stop button to stop the solenoid. <p>Combination test is as follows. NOTE: The MPF feed roll rotates when the PH MOTOR ON (FULL) and the MSI FEED CLUTCH ON are executed. This procedure is for the technical staff.</p> <ol style="list-style-type: none"> 1) Turn on the power and enter the CE Diag. 2) Remove the Tray 1 paper cassette. 3) Execute the PH MOTOR ON (FULL) and the MSI FEED CLUTCH ON. <div data-bbox="746 1525 1225 1843" style="text-align: center;"> <p style="text-align: right; font-size: small;">Kmy02030KA</p> </div> <ol style="list-style-type: none"> 4) Confirm the Feed Roll rotation. 5) Click the stop button to stop the clutch. 6) Replace the Tray 1 paper cassette.

Item	Confirmation procedure
<p>CASSETTE 1 FEED CLUTCH ON</p>	<ol style="list-style-type: none"> 1) Turn on the power and enter the CE Diag. 2) Execute the CASSETTE 1 FEED CLUTCH ON. Upon hitting the Start button, the operating noise of the clutch will be heard. 3) Click the stop button to stop the clutch. <p>Combination test is as follows. NOTE: The Tray 1 feed roll rotates when the PH MOTOR ON (FULL) and the CASSETTE 1 FEED CLUTCH ON are executed. This procedure is for the technical staff.</p> <ol style="list-style-type: none"> 1) Turn on the power and enter the CE Diag. 2) Remove the Tray 1 paper cassette. 3) Execute the PH MOTOR ON (FULL) and the CASSETTE 1 FEED CLUTCH ON. <div data-bbox="746 667 1225 1198" style="text-align: center;"> <p>Tray 1 Feed Roll</p> </div> <p style="text-align: right; font-size: small;">Kmy02031KA</p> <ol style="list-style-type: none"> 4) Confirm the feed Roll rotation. 5) Click the stop button to stop the clutch. 6) Replace the Tray 1 paper cassette.

Item	Confirmation procedure
<p>CASSETTE 2 FEED CLUTCH ON</p>	<ol style="list-style-type: none"> 1) Turn on the power and enter the CE Diag. 2) Execute the CASSETTE 2 FEED CLUTCH ON. Upon hitting the Start button, the operating noise of the clutch will be heard. 3) Click the stop button to stop the clutch. <p>Combination test is as follows. NOTE: The Tray 2 feed roll rotates when the OPTION FEEDER 1 MOTOR ON (FULL) and the CASSETTE 2 FEED CLUTCH ON are executed. This procedure is for the technical staff.</p> <ol style="list-style-type: none"> 1) Turn on the power and enter the CE Diag. 2) Remove the Tray 2 paper cassette. 3) Execute the OPTION FEEDER 1 MOTOR ON (FULL) and the CASSETTE 2 FEED CLUTCH ON. <div data-bbox="742 667 1225 1256" style="text-align: center;"> <p style="text-align: center;">Tray 2 Feed Roll</p> <p style="text-align: right; font-size: small;">Kmy02032KA</p> </div> <ol style="list-style-type: none"> 4) Confirm the feed Roll rotation. 5) Click the stop button to stop the clutch. 6) Replace the Tray 2 paper cassette.

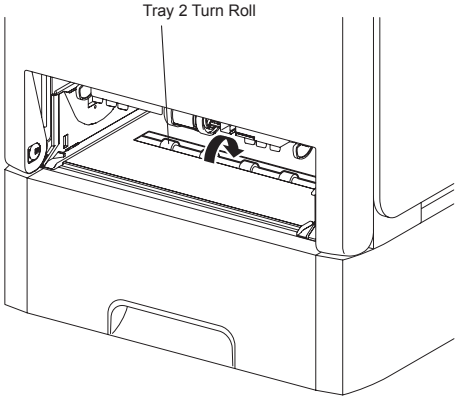
Item	Confirmation procedure
<p>CASSETTE 2 TURN CLUTCH ON</p>	<ol style="list-style-type: none"> 1) Turn on the power and enter the CE Diag. 2) Execute the CASSETTE 2 TURN CLUTCH ON. Upon hitting the Start button, the operating noise of the clutch will be heard. 3) Click the stop button to stop the clutch. <p>Combination test is as follows. NOTE: The Tray 2 turn roll rotates when the OPTION FEEDER ! MOTOR ON (FULL) and the CASSETTE 2 TURN CLUTCH ON are executed. This procedure is for the technical staff.</p> <ol style="list-style-type: none"> 1) Turn on the power and enter the CE Diag. 2) Remove the Tray 1 paper cassette. 3) Execute the OPTION FEEDER ! MOTOR ON (FULL) and the CASSETTE 2 TURN CLUTCH ON. <div style="text-align: center;">  </div> <ol style="list-style-type: none"> 4) Confirm the Turn Roll rotation. 5) Click the stop button to stop the clutch. 6) Replace the Tray 1 paper cassette.

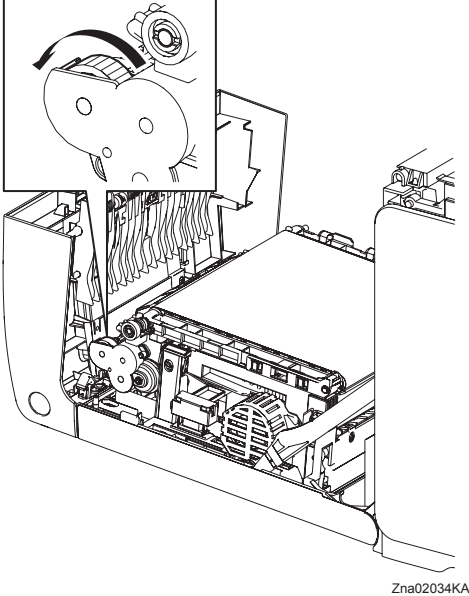
Item	Confirmation procedure
<p>DUPLEX CLUTCH ON</p>	<ol style="list-style-type: none"> 1) Turn on the power and enter the CE Diag. 2) Execute the DUPLEX CLUTCH ON. Upon hitting the Start button, the operating noise of the clutch will be heard. 3) Click the stop button to stop the clutch. <p>Combination test is as follows. NOTE: The duplex gear rotates when the DUPLEX MOTOR ON (FULL) and the DUPLEX CLUTCH ON are executed. This procedure is for the technical staff. When performing operation for five minutes or longer with the front cover open, remove all toner cartridges, and cover the drum to avoid exposure to light.</p> <ol style="list-style-type: none"> 1) Turn on the power and enter the CE Diag. 2) Open the Front Cover. 3) Cheat the safety Interlock System. 4) Execute the DUPLEX MOTOR ON (FULL) and the DUPLEX CLUTCH ON.  <p style="text-align: right; font-size: small;">Zna02034KA</p> <ol style="list-style-type: none"> 5) Confirm the gear rotation. 6) Click the stop button to stop the clutch. 7) Remove the cheater and close the Front Cover.

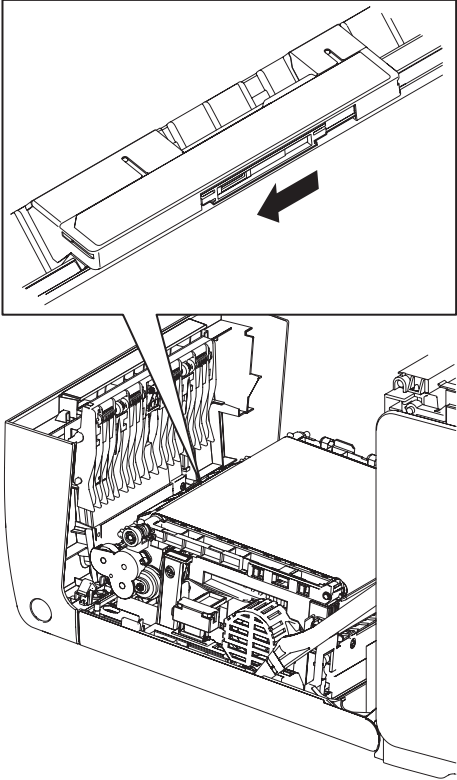
Item	Confirmation procedure
CTD SOLENOID ON	<p>NOTE: This procedure is for the technical staff. The customer check are the procedure 1, 4 and 5.</p> <p>When performing operation for five minutes or longer with the front cover open, remove all toner cartridges, and cover the drum to avoid exposure to light.</p> <ol style="list-style-type: none"> 1) Turn on the power and enter the CE Diag. 2) Open the Front Cover. 3) Cheat the safety Interlock System. 4) Execute the CTD SOLENOID ON. (The customer can confirm the motor noise only.)  <p style="text-align: right; font-size: small;">Zna02035KA</p> <ol style="list-style-type: none"> 5) Click the stop button to stop the solenoid. 6) Remove the cheater and close the Front Cover.

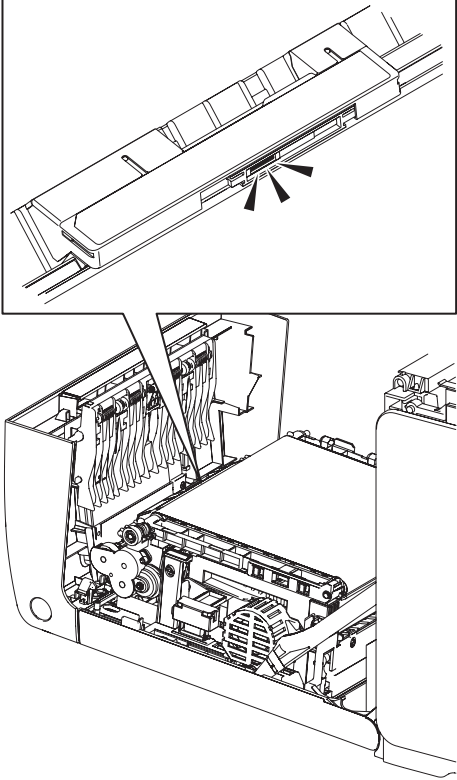
Item	Confirmation procedure
CTD SENSOR ON	<p>NOTE: This procedure is for the technical staff. When performing operation for five minutes or longer with the front cover open, remove all toner cartridges, and cover the drum to avoid exposure to light.</p> <ol style="list-style-type: none"> 1) Turn on the power and enter the CE Diag. 2) Open the Front Cover. 3) Cheat the safety Interlock System. 4) Execute the CTD SENSOR ON.  <p style="text-align: right; font-size: small;">Zna02036KA</p> <ol style="list-style-type: none"> 5) Click the stop button to stop the LED lighting. 6) Remove the cheater and close the Front Cover.

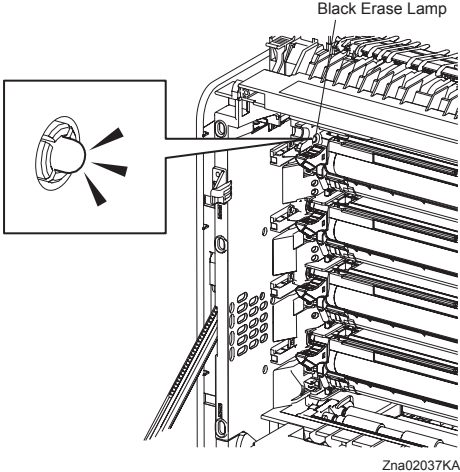
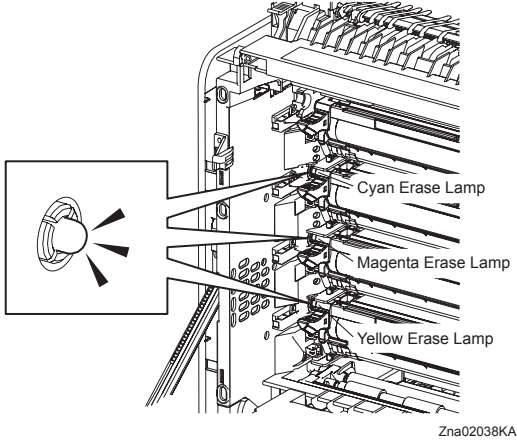
Item	Confirmation procedure
ERACE K ON	<p>NOTE: This procedure is for the technical staff. When performing operation for five minutes or longer with the front cover open, remove all toner cartridges, and cover the drum to avoid exposure to light.</p> <ol style="list-style-type: none"> 1) Turn on the power and enter the CE Diag. 2) Open the Front Cover. 3) Cheat the safety Interlock System. 4) Execute the ERACE K ON.  <ol style="list-style-type: none"> 5) Click the stop button to stop the LED lighting. 6) Remove the cheater and close the Front Cover.
ERACE YMC ON	<p>NOTE: This procedure is for the technical staff. When performing operation for five minutes or longer with the front cover open, remove all toner cartridges, and cover the drum to avoid exposure to light.</p> <ol style="list-style-type: none"> 1) Turn on the power and enter the CE Diag. 2) Open the Front Cover. 3) Cheat the safety Interlock System. 4) Execute the ERACE YMC ON.  <ol style="list-style-type: none"> 5) Click the stop button to stop the LED lighting. 6) Remove the cheater and close the Front Cover.

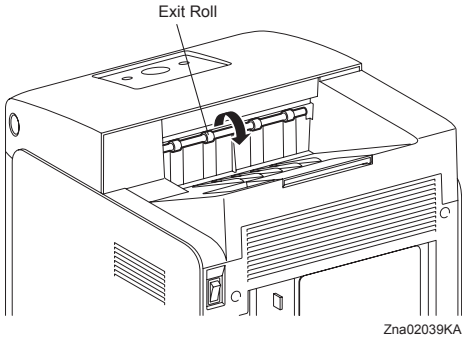
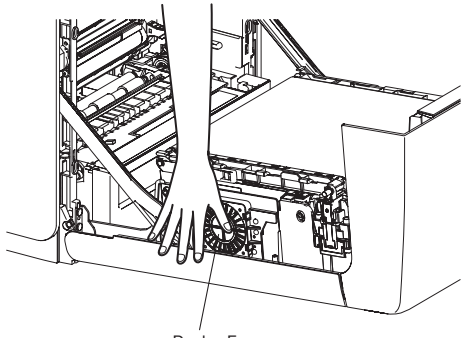
Item	Confirmation procedure
<p>EXIT CLUTCH ON</p>	<ol style="list-style-type: none"> 1) Turn on the power and enter the CE Diag. 2) Execute the EXIT CLUTCH ON. Upon hitting the Start button, the operating noise of the clutch will be heard. 3) Click the stop button to stop the clutch. <p>Combination test is as follows. NOTE: The exit roll rotates when the MAIN MOTOR (FULL) and the EXIT CLUTCH ON are executed. This procedure is for the technical staff.</p> <ol style="list-style-type: none"> 1) Turn on the power and enter the CE Diag. 2) Execute the MAIN MOTOR (FULL) and the EXIT CLUTCH ON.  <p style="text-align: right; font-size: small;">Zna02039KA</p> <ol style="list-style-type: none"> 3) Confirm the Exit Roll rotation. 4) Click the stop button to stop the clutch.
<p>DUPLEX FAN ON</p>	<p>NOTE: This procedure is for the technical staff. The customer check are the procedure 1, 4 and 5.</p> <p>When performing operation for five minutes or longer with the front cover open, remove all toner cartridges, and cover the drum to avoid exposure to light.</p> <ol style="list-style-type: none"> 1) Turn on the power and enter the CE Diag. 2) Open the Front Cover. 3) Cheat the safety Interlock System. 4) Execute the DUPLEX FAN ON. (The customer can confirm the fan noise only.)  <p style="text-align: right; font-size: small;">Zna02040KA</p> <ol style="list-style-type: none"> 5) Click the stop button to stop the test. 6) Remove the cheater and close the Front Cover.
<p>BUZZER ON</p>	<ol style="list-style-type: none"> 1) Turn on the power and enter the CE Diag. 2) Execute the BUZZER ON. 3) Check the Buzzer Tone. 4) Click the stop button to stop the test.

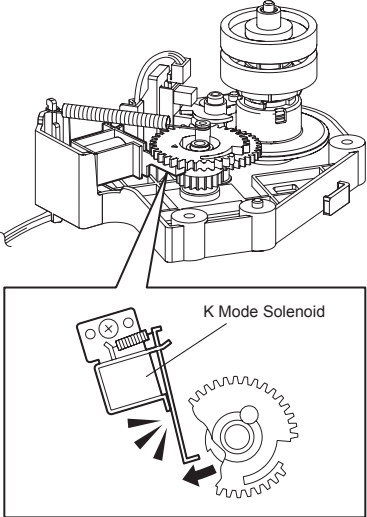
Item	Confirmation procedure
<p>K MODE CLUTCH ON (Color Mode Switching Solenoid)</p>	<p>NOTE: This procedure is for the technical staff. When performing operation for five minutes or longer with the front cover open, remove all toner cartridges, and cover the drum to avoid exposure to light.</p> <ol style="list-style-type: none"> 1) Open the Front Cover. 2) Remove the Cover Rear. 3) Remove the Cover Side R Assy. 4) Remove the Drive Assy K. 5) Cheat the Safety Interlock System. 6) Turn on the power and enter the CE Diag. 7) Execute the K MODE CLUTCH ON. <div style="text-align: center;">  <p style="text-align: right; font-size: small;">Zna02051KA</p> </div> <ol style="list-style-type: none"> 8) Check the K MODE SOLENOID movement. 9) Click the stop button to stop the test. 10) Replace the Safety Interlock System. 11) Replace the Drive Assy K. 12) Replace the Cover Side R Assy. 13) Replace the Cover Rear. 14) Close the Front Cover.

6.4 IOT NVM Settings - Write

Menu used for changing the settings for internal data of the printer.

This operation is prohibited since it can damage the internal data.

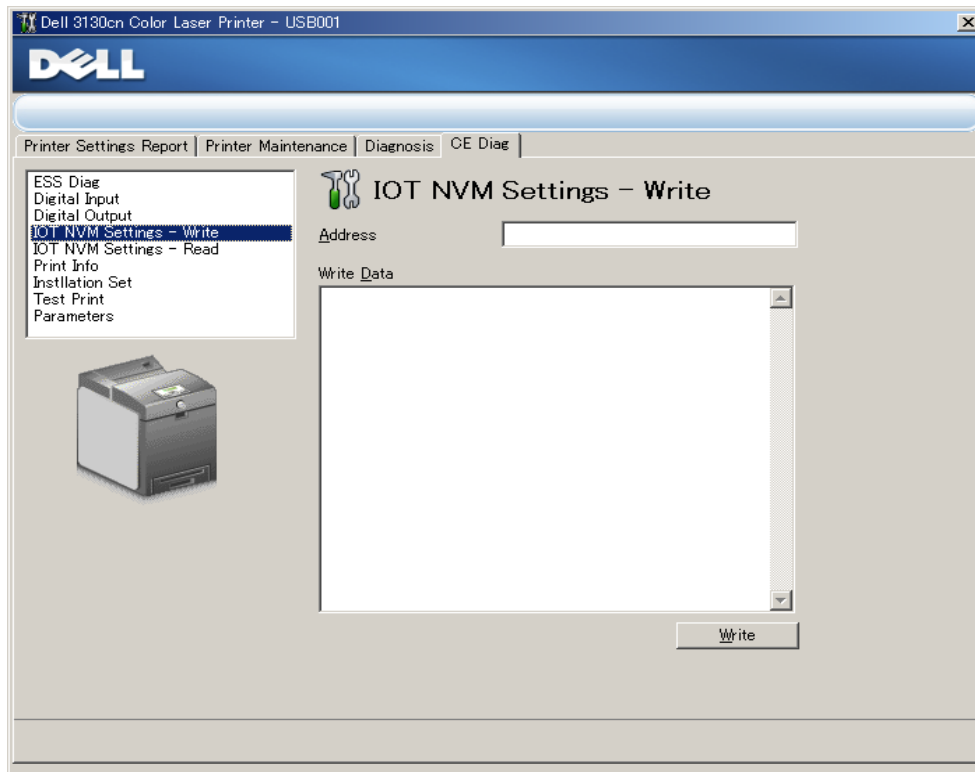

6.5 IOT NVM Settings - Read

Menu used for confirming the internal data of the printer.

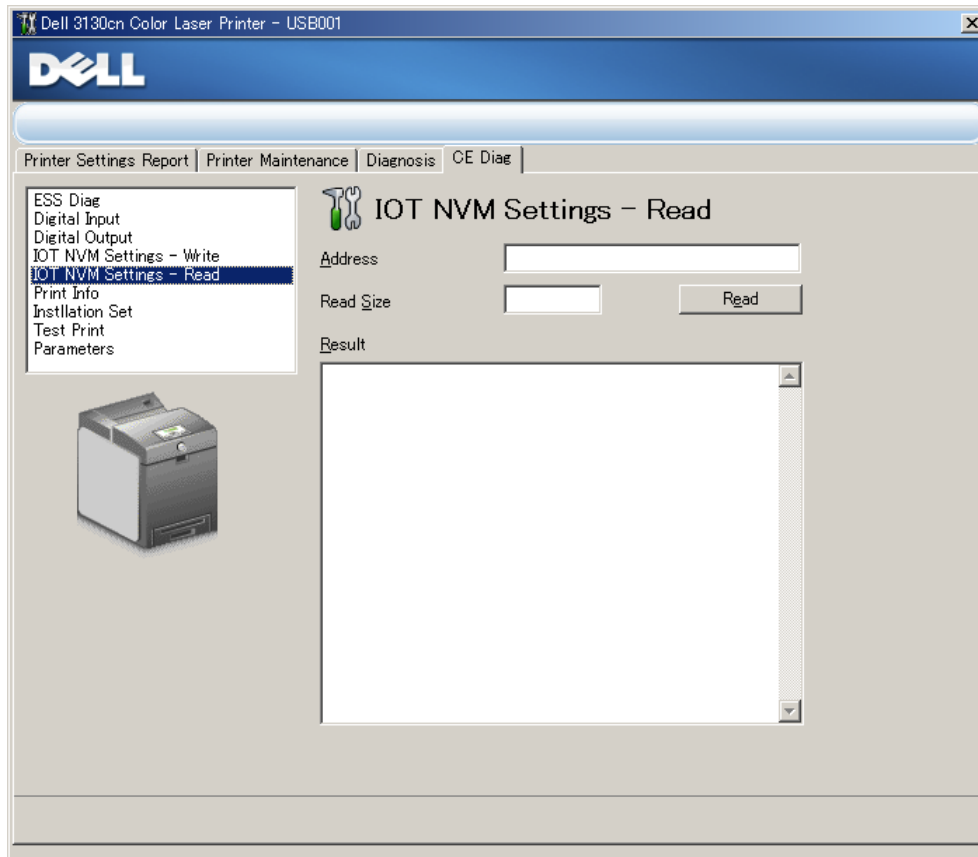

6.6 Print Info

Prints out the detailed printer settings and configuration information.

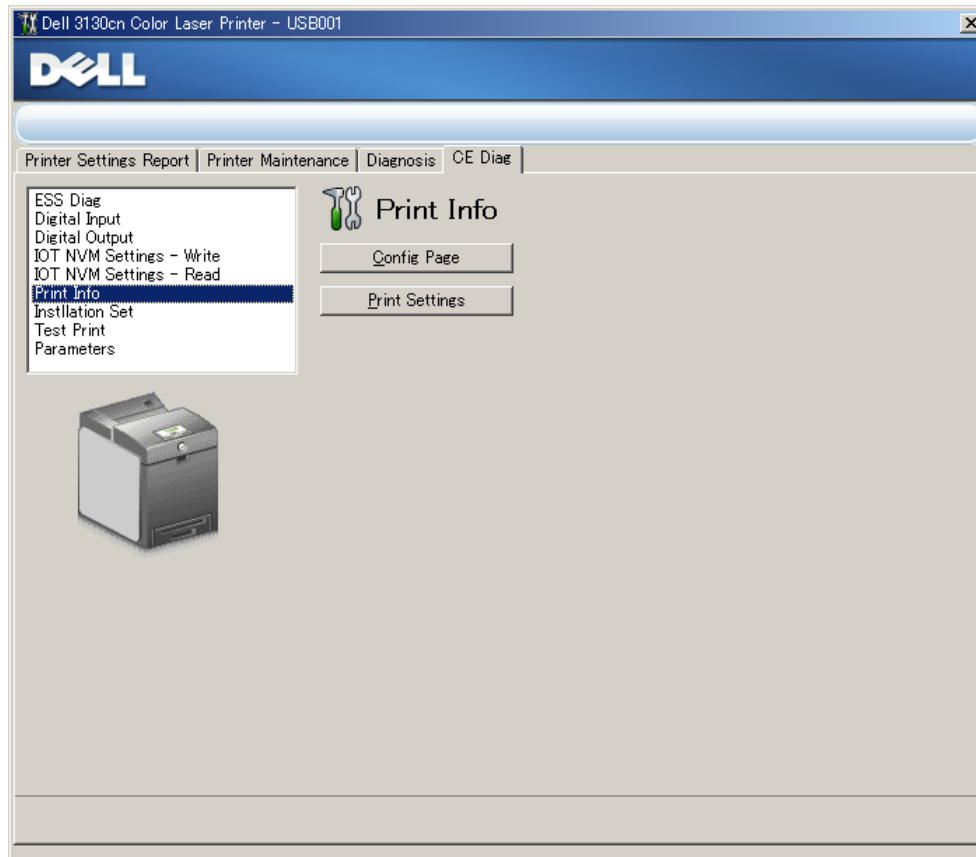

Item	Function
Config Page	The version of software of printer and the configuration can be confirmed by executing this test. Push the [Config Page] button to print the "config. Page".
Print Setting	The service tag, printing count value and error count value can be confirmed by executing this test. Push the [Print Setting] button to print the "Print Settings".

6.7 Installation Set

Displays values on the counters of the printer and sets service tags.

Clicking [Apply new settings] or [Restart printer to apply new settings] button after the setting is completed determines the contents of setting changes.

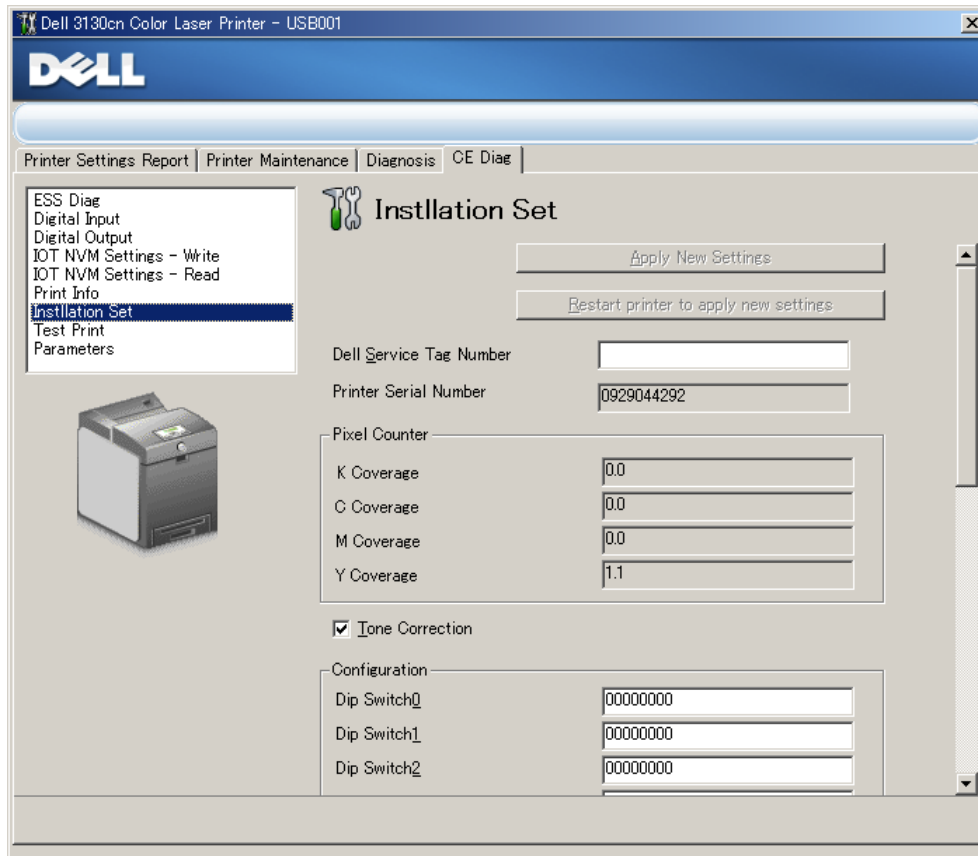

Item	Function
Dell Service Tag Number	Enters the printer service tag number.
Printer Serial Number	Serial number of the printer. (read only)
Pixel Counter	Pixel count values of colors Y/M/C/K. (read only)
Tone Correction	Specifies whether or not tone correction is performed. When the checkmark is placed in the checkbox, tone correction is performed.
Configuration	The use of "Configuration" is prohibited since it is a tool for design development.
Print Counter	Displays the respective counter values in the master NVM and backup NVM. (read only)
Counter Copy M to B	Copies the counter value in the master NVM of the ESS PWBA to the backup NVM of the ESS PWBA.
Counter Copy B to M	Copies the counter value in the backup NVM of the ESS PWBA to the master NVM of the ESS PWBA.
ESS NVM Init	Initializes the NVM of ESS.
JOB LOG Init	Initializes the print job history. This operation is to be carried out where necessary.
Erase Hard Disk	Initializes the Hard Disk.

Item	Function
[Apply New Settings] button	This button should be clicked to move to any other setting menu from the current menu in operation. NOTE: After completion of all operations, "Restart printer to apply new settings" button should be clicked without exceptions.
[Restart printer to apply new settings] button	This button should be clicked after completion of setting change. The restart of a printer is required in order to confirm this setup.

6.8 Test Print

Print an internal test pattern of the printer. If paper jam or paper empty occurs during the print, the test waits until they are resolved.

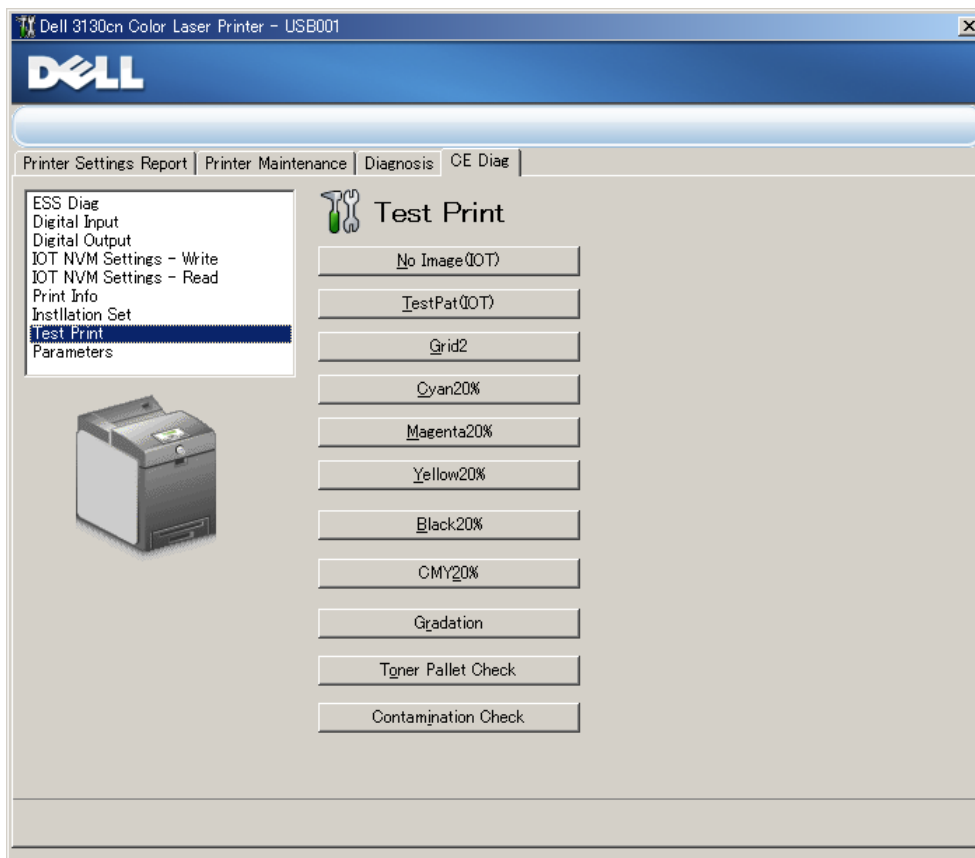

6.8.1 No Image (IOT)

Prints the blanked paper.

6.8.2 Test Pat (IOT)

Prints the IOT built-in 600dpi pattern.

When the PQ problem occurred, this test enables to identify the problem as the printing process or the PWBA ESS related.

Compare the sample chart with the print.

Check result: NG (Check the printing process.) OK (Check the PWBA ESS related.)

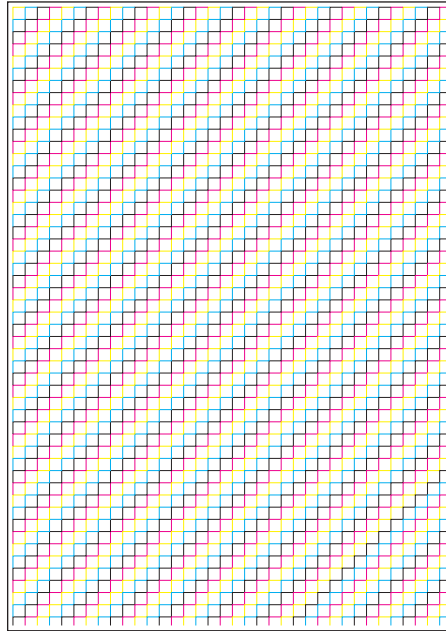

Kmy02001KA

6.8.3 Grid2

Prints the ESS built-in grid pattern.

When the PQ problem occurred, this test enables to identify the problem as printer-related or otherwise.

Compare the sample chart with the print.

Check result: NG (Check the printing process and PWBA ESS-related.) OK (Check the network, cable, PC and so on.)



Leg_Sec02_004FA

6.8.4 Cyan 20%

Outputs cyan 20% paint on the whole area of a A4 paper.

When the PQ problem occurred, this test enables to identify the problem as the cyan toner or another color.

Compare the sample chart with the print.

Check result: NG (Check the cyan toner-related.) OK (Check another toner.)

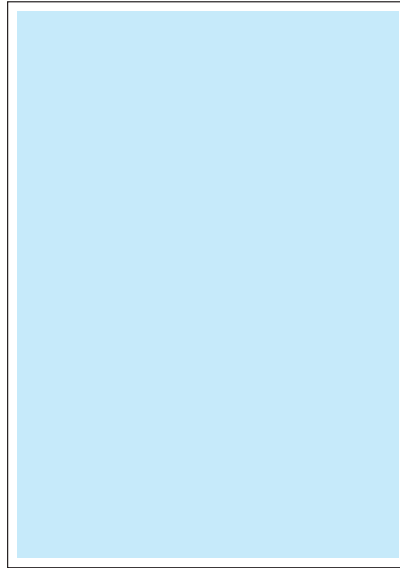

Leg_Sec02_005FA

6.8.5 Magenta 20%

Outputs magenta 20% paint on the whole area of a A4 paper.

When the PQ problem occurred, this test enables to identify the problem as the magenta toner or another color.

Compare the sample chart with the print.

Check result: NG (Check the magenta toner-related.) OK (Check another toner.)

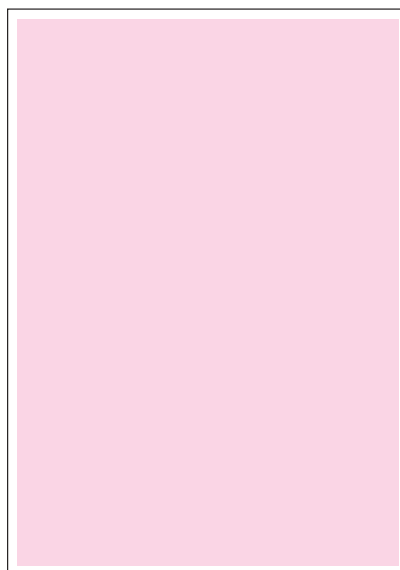

Leg_Sec02_006FA

6.8.6 Yellow 20%

Outputs yellow 20% paint on the whole area of a A4 paper.

When the PQ problem occurred, this test enables to identify the problem as the yellow toner or another color.

Compare the sample chart with the print.

Check result: NG (Check the yellow toner-related.) OK (Check another toner.)

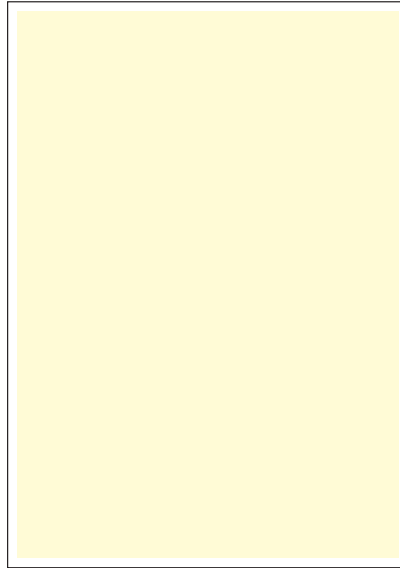

Leg_Sec02_007FA

6.8.7 Black 20%

Outputs black 20% paint on the whole area of a A4 paper.

When the PQ problem occurred, this test enables to identify the problem as the black toner or another color.

Compare the sample chart with the print.

Check result: NG (Check the black toner-related.) OK (Check another toner.)

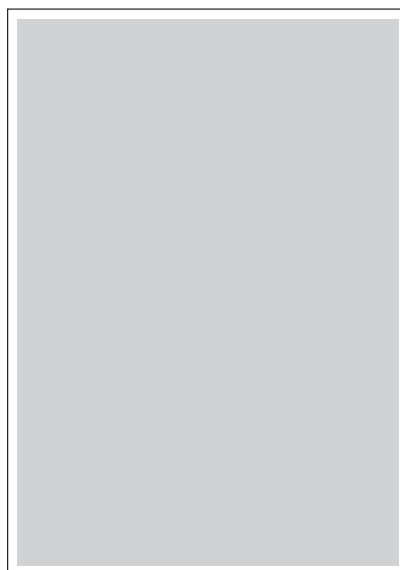

Leg_Sec02_008FA

6.8.8 CMY 20%

Outputs C/M/Y 20% paint on the whole area of a A4 paper.

When the PQ problem occurred, this test enables to identify the problem as the balance of three color toners or otherwise.

Compare the sample chart with the print.

Check result: NG (Check the yellow, magenta or cyan toner-related.) OK (Check black toner.)

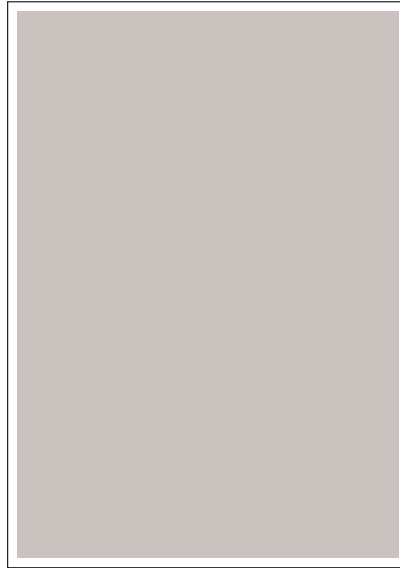

Leg_Sec02_009FA

6.8.9 Gradation

Outputs the tone pattern from 2% to 100% on a A4 paper for each of 4 colors.

When the PQ problem occurred, this test enables to identify the problem as the printing process or PWBA ESS-related.

Compare the sample chart with the print.

Check result: NG (Check the printing process.) OK (Check the PWBA ESS-related.)

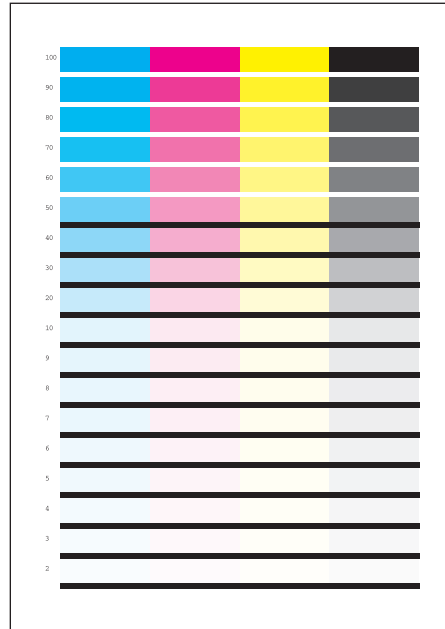

Leg_Sec02_010FA

6.8.10 Toner Pallet Check

Outputs each 100% density color pattern of Y/M/C/K.

When the PQ problem occurred in the picture or photo printing, this test enables to identify the problem as the toner or another.

Compare the sample chart with the print.

Check result: NG (Check the problem toner-related.) OK (Check the print job or print data.)

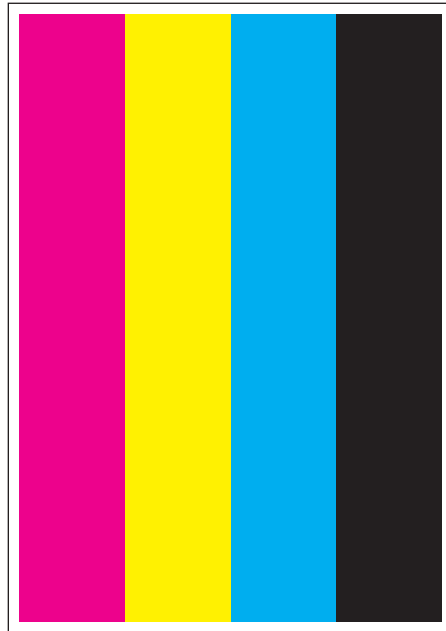

Leg_Sec02_011FA

6.8.11 Contamination Check

Allows you to check the print for any regular lines or toner spots when encountering PQ problems. From the difference in the interval of regular lines or spots, you can determine the parts that have caused the trouble.

Page 1 to 4: Prints the scale patterns in vertical and horizontal directions for evaluating regularity and intervals.

Page 5: Prints the list of intervals by component fault.

Page 1

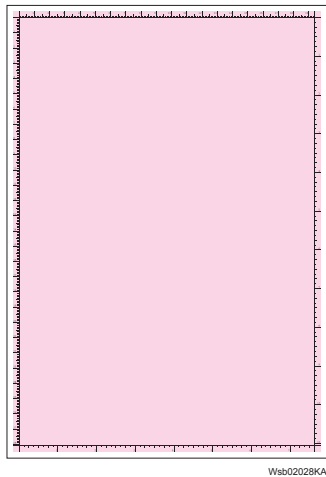

Page 2

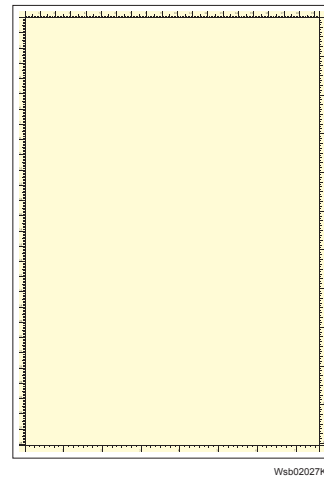

Page 3

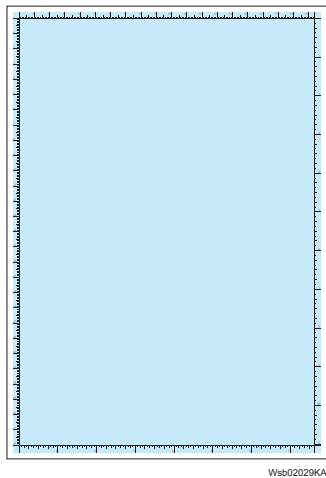

Page 4

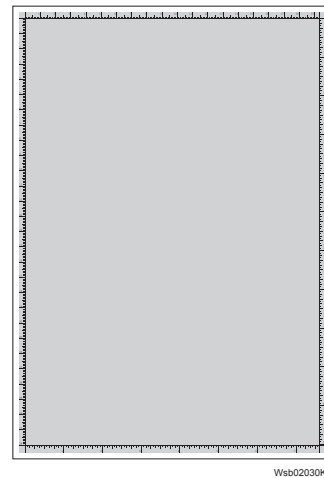

Page 5

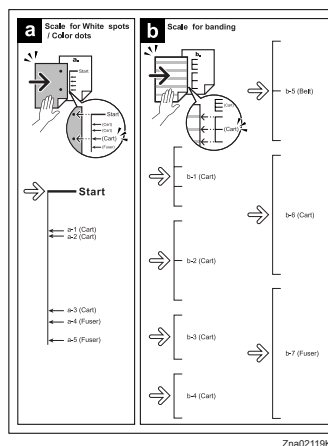

6.9 Parameter

This function reads/writes the following parameters stored in the printer.

Clicking [Apply new settings] or [Restart printer to apply new settings] button after the setting is completed determines the contents of setting change.

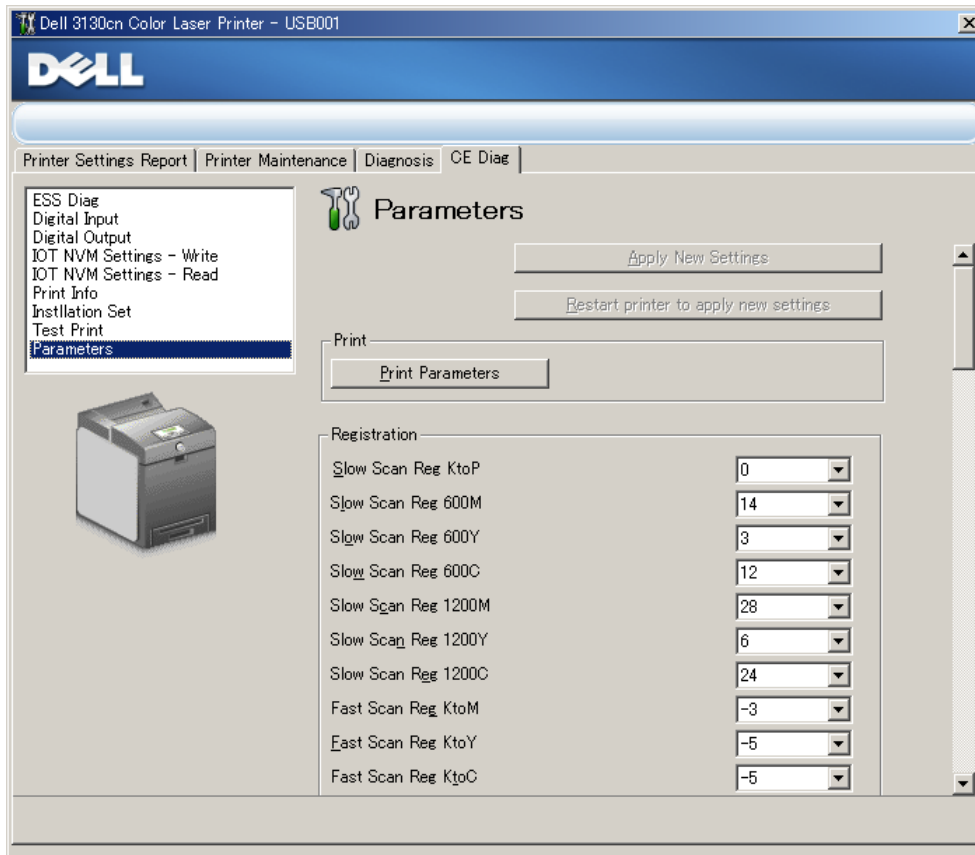

6.9.1 Print

Prints out the current parameter settings.

6.9.2 Registration

This function reads/writes the following parameters stored in the printer.

Item	Range	Description
Slow Scan Reg K to P	-128 to 127	Sets the registration in the paper feeding direction.
Slow Scan Reg 600 M,Y,C	-30 ~ 30	
Slow Scan Reg1200 M,Y,C	-60 ~ 60	
Fast Scan Reg K to M, Y or C	-30 ~ 30	Sets the registration in the scanning direction.
Fast Scan Reg MPF, Tray1, Tray2 or Duplex	-30 ~ 30	
Fast Scan Reg2 KtoM , Y or C	-1 ~ 2	
Life Counter	-	Reads the life counter and the printer.

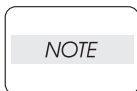

Print the parameter list using the Print function of Parameter Menu in diagnosis before changing the value of the registration.

Parameter	Function	Default	Adjustable range
Slow Scan Reg K to P (Shifts 0.17mm/1count)	Black registration adjustment	--	-128 to 127
Slow Scan Reg 600 M,Y,C (Shifts 0.042mm/1count)	Color registration adjustment (600 and 1200 dpi)	--	-30 to 30
Slow Scan Reg1200 M,Y,C (Shifts 0.021mm/1count)			-60 to 60
Fast Scan Reg K to M, Y or C (Shifts 0.042mm/1count)	Color registration adjustment Calculation of adjustment is shown below. (exp. Yellow) (Value of Fast Scan Reg K to Y + Value of Fast Scan Reg2 K to Y)/4	--	-30 to 30
Fast Scan Reg2 K to M, C or Y (Shifts 0.01mm/1count)		--	-1 to 2
Fast Scan Reg MPF, Tray1 or Tray2 (Shifts 0.17mm/1count)	Black registration adjustment at side 1 print	--	-30 to 30
Fast Scan Reg Dup (Shifts 0.17mm/1count)	Black registration adjustment at side 2 print	--	-30 to 30

NOTE

The default values are different in each printer.

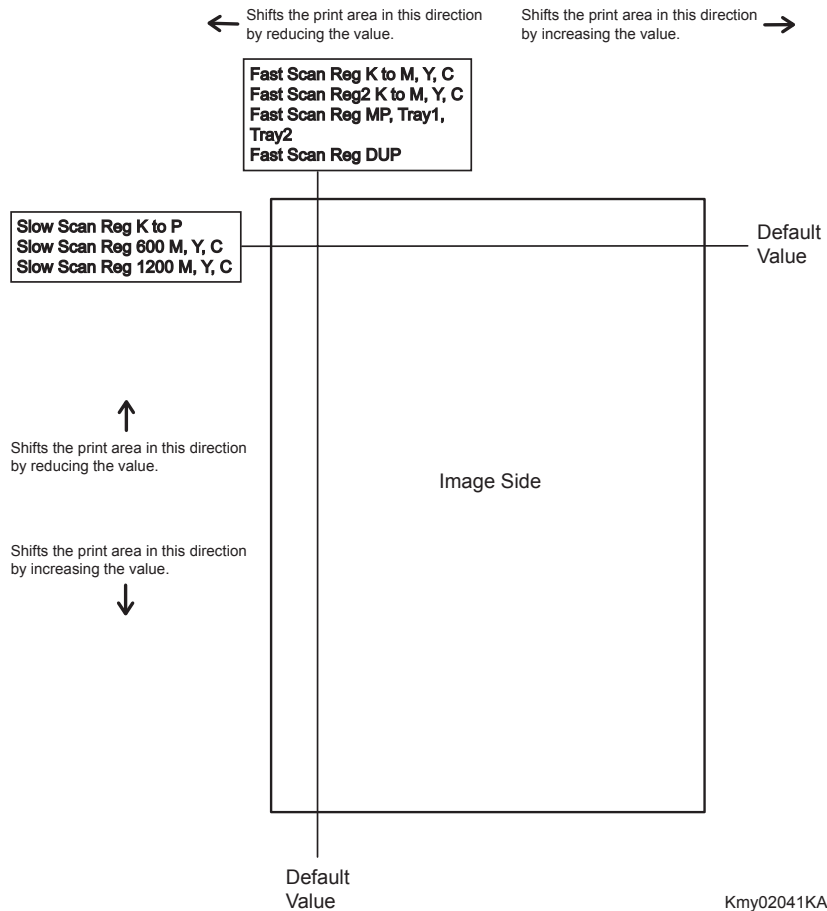

6.9.3 Toner

Displays the Toner Dispense time and Toner Clearing count. (read only)

6.9.4 DTB

Displays the operating time of the Transfer Belt, the number of sheets fed and Toner Cleaning count. (read only)

The Initialize buttons are to be used only when replacing the Transfer Belt.

6.9.5 Sheets

Displays the counter value of sheets fed from Fuser, Printer, SSF (SSI), Tray 1, Tray 2 and Duplex. (read only)

Initialize buttons excluding [Life Fuser Sheets] are not to be used. [Life Fuser Sheets] is to be initialized when replacing the Fuser.

6.9.6 Drum

The rotating time of the Drum appears. (read only)

6.9.7 Custom

Information of the Custom appears. (read only)

6.9.8 PHD

The dispensing time of each developer in the PHD unit and the number of the B&W printing appear. (read only)

6.9.9 Buttons

- [Apply New Settings] button

This button should be clicked to move to any other setting menu from the current menu in operation.

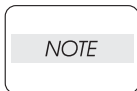

After completion of all operations, "Restart printer to apply new settings" button should be clicked without exceptions.

- [Restart printer to apply new] button

This button should be clicked after completion of setting change.

The restart of a printer is required in order to confirm this setup.

Reference Counter Values

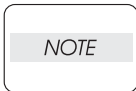

These counter values are reference only. Do not use as the official value.

Counter Name	Value of life warning
Life Y Toner (Dispense time)	-
Life M Toner (Dispense time)	-
Life C Toner (Dispense time)	-
Life K Toner (Dispense time)	-
Life DTB (Transfer Belt) 1 (Paper feeding count)	100000
Life Fuser (Paper feeding count)	100000
Life Printer (Paper feeding count)	-
Life DTB (Transfer Belt) 2 (Waste Toner cleaning count)	120000
Life DTB (Transfer Belt) 3 (Cycle count)	14000000
Life Y Waste Toner (Waste Toner cleaning count)	18000
Life M Waste Toner (Waste Toner cleaning count)	18000
Life C Waste Toner (Waste Toner cleaning count)	18000
Life K Waste Toner (Waste Toner cleaning count)	18000
Life Y Developer (Cycle count)	2500000
Life M Developer (Cycle count)	2500000
Life C Developer (Cycle count)	2500000
Life K Developer (Cycle count)	2500000
Life Y Drum (Cycle count)	3500000
Life M Drum (Cycle count)	3500000
Life C Drum (Cycle count)	3500000
Life K Drum (Cycle count)	3000000
Life MPF Feed	-
Life Tray 1 Feed	-
Life Duplex Feed	-
Print	-

Chapter 3 Removal and Replacement Procedures (RRPs) CONTENTS

1. Removal and Replacement Procedures (RRPs)	3 - 1
1.1 Before starting service procedure	3 - 1
1.2 General notes	3 - 3
1.2 Removal Flows	3 - 4
1.2 Replacement Flows	3 - 5
2. Removal Steps	3 - 6
Removal 1 COVER EXTENDER (PL1.1.9).....	3 - 6
Removal 2 MPF COVER (PL1.2.99).....	3 - 7
Removal 3 TRAY REAR COVER (PL1.1.5).....	3 - 8
Removal 4 TRANSFER BELT (PL4.1.1).....	3 - 10
Removal 5 DUPLEX MODULE (PL11.1.1)	3 - 12
Removal 6 TONER CARTRIDGE (K), (C), (M), (Y) (PL5.1.18-21)	3 - 13
Removal 7 DUPLEX GATE (PL6.1.13).....	3 - 14
Removal 8 FUSER (PL6.1.10).....	3 - 15
Removal 9 CHUTE ASSY EXIT OUT (PL6.1.1)	3 - 16
Removal 10 REAR COVER (PL1.1.4).....	3 - 17
Removal 11 RIGHT COVER (PL1.1.6).....	3 - 18
Removal 12 LEVER FUSER D (PL6.1.18)	3 - 19
Removal 13 OPERATOR PANEL (PL1.2.97).....	3 - 20
Removal 14 FRONT COVER (PL1.2.98).....	3 - 24
Removal 15 MPF FEED SOLENOID (PL3.1.98)	3 - 26
Removal 16 ROLL ASSY MSI (PL3.1.8).....	3 - 28
Removal 17 FEED DRIVE ASSEMBLY (PL8.1.7)	3 - 30
Removal 18 SIZE SWITCH ASSEMBLY (PL7.1.18)	3 - 33
Removal 19 BREAKER GFI INLET (PL9.1.43).....	3 - 34
Removal 20 LEFT COVER (PL1.1.7)	3 - 35
Removal 21 LEVER FUSER AD (PL6.1.19)	3 - 36
Removal 22 ARM ASSEMBLY (PL7.1.98).....	3 - 38
Removal 23 LED ASSEMBLY (PL5.1.15).....	3 - 42
Removal 24 TONER DISPENSER MOTOR (PL5.1.12)	3 - 44
Removal 25 SHIELD ASSY ESS (PL9.1.45)	3 - 46
Removal 26 ELECTRONIC SUB-SYSTEM CONTROL BOARD (PL9.1.27)	3 - 48
Removal 27 SHIELD MCU (PL9.1.42).....	3 - 49
Removal 28 DRIVE ASSY K (PL8.1.10).....	3 - 50
Removal 29 HUMIDITY SENSOR (PL9.1.19)	3 - 53
Removal 30 MACHINE CONTROL UNIT (PL9.1.20)	3 - 54
Removal 31 TOP COVER (PL1.1.1).....	3 - 56
Removal 32 FAN (PL9.1.10).....	3 - 57
Removal 33 HARN ASSY AC IN (PL9.1.16).....	3 - 58
Removal 34 HIGH VOLTAGE POWER SUPPLY (PL5.1.17)	3 - 60
Removal 35 LOW VOLTAGE POWER SUPPLY (PL9.1.4).....	3 - 62
Removal 36 ROS (PL5.1.99)	3 - 66
Removal 37 INTERLOCK SWITCH (PL9.1.3)	3 - 70
Removal 38 PHOTOCONDUCTOR (PC) / DEVELOPER (DEV) DRIVE (PL8.1.2).....	3 - 72
Removal 39 TONER CARTRIDGE SENSOR ASSEMBLY (K), (C), (M), (Y) (PL5.1.4).....	3 - 76

Chapter 3 Removal and Replacement Procedures (RRPs) CONTENTS

Removal 40 INTEGRATED FEEDER ASSEMBLY (PL3.2.99).....	3 - 78
Removal 41 MPF SEPARATOR ROLLER ASSEMBLY (PL2.1.99)	3 - 81
Removal 42 KIT SEPARATOR ROLLER & FEED ROLLER (PL2.2.99)	3 - 82
Removal 43 MPF ROLLER (PL3.1.99)	3 - 84
Removal 44 550 SHEET FEEDER ASSEMBLY (PL12.1.1)	3 - 85
Removal 45 550 TRAY REAR COVER (PL12.1.4).....	3 - 86
Removal 46 550 TRAY FEED ROLLER (PL12.3.29) & 550 TRAY SEPARATOR ROLLER (PL12.5.17)	3 - 8□
Removal 47 MEMORY CARD (PL9.1.30).....	3 - 90
Removal 48 NETWORK PROTOCOL ADAPTER (PL9.1.46)	3 - 91
Removal 49 HARD DISK (PL9.1.47)	3 - 92
Removal 50 WIRELESS PRINTER ADAPTER (PL9.1.32).....	3 - 93
3. Replacement Steps	3 - 94
Replacement 1 MPF ROLLER (PL3.1.99).....	3 - 94
Replacement 2 KIT SEPARATOR ROLLER & FEED ROLLER (PL2.2.99)	3 - 96
Replacement 3 MPF SEPARATOR ROLLER ASSEMBLY (PL2.1.3)	3 - 98
Replacement 4 INTEGRATED FEEDER ASSEMBLY (PL3.2.99).....	3 - 100
Replacement 5 TONER CARTRIDGE SENSOR ASSEMBLY (K), (C), (M), (Y) (PL5.1.4).....	3 - 103
Replacement 6 PHOTOCODUCTOR (PC) / DEVELOPER (DEV) DRIVE (PL8.1.2).....	3 - 104
Replacement 7 INTERLOCK SWITCH (PL9.1.3)	3 - 106
Replacement 8 ROS (PL5.1.99)	3 - 108
Replacement 9 LOW VOLTAGE POWER SUPPLY (PL9.1.4)	3 - 113
Replacement 10 HIGH VOLTAGE POWER SUPPLY (PL5.1.17)	3 - 117
Replacement 11 HARN ASSY AC IN (PL9.1.16).....	3 - 119
Replacement 12 FAN (PL9.1.10).....	3 - 121
Replacement 13 TOP COVER (PL1.1.1).....	3 - 122
Replacement 14 MACHINE CONTROL UNIT (PL9.1.20)	3 - 123
Replacement 15 HUMIDITY SENSOR (PL9.1.19)	3 - 125
Replacement 16 DRIVE ASSY K (PL8.1.10).....	3 - 127
Replacement 17 SHIELD MCU (PL9.1.42).....	3 - 130
Replacement 18 ELECTRONIC SUB-SYSTEM CONTROL BOARD (PL9.1.27).....	3 - 131
Replacement 19 SHIELD ASSY ESS (PL9.1.45).....	3 - 135
Replacement 20 TONER DISPENSER MOTOR (PL5.1.12)	3 - 137
Replacement 21 LED ASSEMBLY (PL5.1.15).....	3 - 139
Replacement 22 ARM ASSEMBLY (PL7.1.98).....	3 - 141
Replacement 23 LEVER FUSER AD (PL6.1.19)	3 - 145
Replacement 24 LEFT COVER (PL1.1.7)	3 - 146
Replacement 25 BREAKER GFI INLET (PL9.1.43).....	3 - 147
Replacement 26 SIZE SWITCH ASSEMBLY (PL7.1.18)	3 - 148
Replacement 27 FEED DRIVE ASSEMBLY (PL8.1.7)	3 - 149
Replacement 28 ROLL ASSY MSI (PL3.1.8).....	3 - 153
Replacement 29 MPF FEED SOLENOID (PL3.1.98)	3 - 155
Replacement 30 FRONT COVER (PL1.2.98).....	3 - 157
Replacement 31 OPERATOR PANEL (PL1.2.97)	3 - 159
Replacement 32 LEVER FUSER D (PL6.1.18)	3 - 163





Chapter 3 Removal and Replacement Procedures (RRPs) CONTENTS

Replacement 33 RIGHT COVER (PL1.1.6)	3 - 164
Replacement 34 REAR COVER (PL1.1.4)	3 - 165
Replacement 35 CHUTE ASSY EXIT OUT (PL6.1.1)	3 - 166
Replacement 36 FUSER (PL6.1.10).....	3 - 167
Replacement 37 DUPLEX GATE (PL6.1.13).....	3 - 168
Replacement 38 TONER CARTRIDGE (K), (C), (M), (Y) (PL5.1.18)	3 - 169
Replacement 39 DUPLEX MODULE (PL11.1.1)	3 - 170
Replacement 40 TRANSFER BELT (PL4.1.1).....	3 - 171
Replacement 41 TRAY REAR COVER (PL1.1.5).....	3 - 173
Replacement 42 MPF COVER (PL1.2.99).....	3 - 174
Replacement 43 COVER EXTENDER (PL1.1.9).....	3 - 175
Replacement 44 550 TRAY FEED ROLLER (PL12.3.29) & 550 TRAY SEPARATOR ROLLER (PL12.5.17)	3 - 177
Replacement 45 550 TRAY REAR COVER (PL12.1.4).....	3 - 179
Replacement 46 550 SHEET FEEDER ASSEMBLY (PL12.1.1)	3 - 180
Replacement 47 WIRELESS PRINTER ADAPTER (PL9.1.32).....	3 - 181
Replacement 48 HARD DISK (PL9.1.47)	3 - 182
Replacement 49 NETWORK PROTOCOL ADAPTER (PL9.1.46)	3 - 183
Replacement 50 MEMORY CARD (PL9.1.30).....	3 - 184

1. Removal and Replacement Procedures (RRPs)

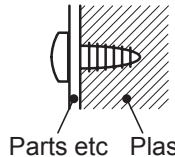
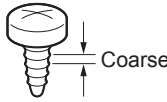
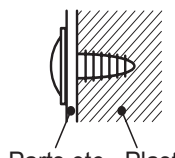
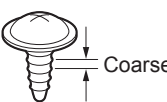
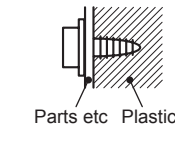
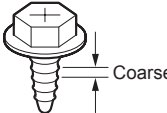
1.1 Before starting service procedure

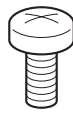
- Start the procedure after turning off the power and removing the power cord from the outlet.
- When performing the service operation around the FUSER ASSY, ensure that FUSER ASSY and its surrounding area have cooled down sufficiently.
- Pay sufficient attention to the parts during the procedure because they may be broken or may not perform their functions properly if unreasonable force is applied.
- Since various types of screws are used, ensure that the right screws are used in their right positions. Use special caution not to confuse the screws for plastic and the ones for sheet metal, because using the wrong type of screw may result in damage to the screw threads or other troubles.

No.	Type	Application	Shape	How to distinguish	Points to be noted	Major application locations
1	Screw for plastic Silver, tap	Plastic  Parts etc Plastic	 Coarse	<ul style="list-style-type: none"> • Silver-colored • Thread is coarser than that of the sheet metal type. • Screw tip is thin. 	Oblique screwing damages the thread because this screw cuts female threads in the base material as it goes in.	
2	Screw for plastic Silver, with flange, tap	Plastic  Parts etc Plastic	 Coarse	<ul style="list-style-type: none"> • Silver-colored • With flange • Thread is coarser than that of the sheet metal type. • Screw tip is thin. 	Oblique screwing damages the thread because this screw cuts female threads in the base material as it goes in.	• Chute assy exit out
3	Screw for plastic Silver, tap, with flange	Plastic  Parts etc Plastic	 Coarse	<ul style="list-style-type: none"> • Silver-colored • It has a flange. • Screw thread is coarse comparing to the sheet metal type. • Screw tip is thin. 	As it has a function to cut the thread by itself, if the screw is inserted in an angle and tightened, the screw thread will be damaged.	<ul style="list-style-type: none"> • LEVER FUSER D • LEVER FUSER AD
4	Screw for metal sheet silver	Sheet metal  Parts etc Sheet metal		<ul style="list-style-type: none"> • Silver-colored • Diameter of the thread section is uniform. 		
5	Screw for metal sheet Silver, with an external tooth washer	Sheet metal  Parts etc Sheet metal		<ul style="list-style-type: none"> • Silver-colored • Provided with an external tooth washer. • Diameter of the thread section is uniform. 		• Mounting positions of the ground wires.

Chapter 3 Removal and Replacement Procedures (RRPs)

- Wear a wristband or the like as far as possible to remove static electricity of the human body.
- Keep the front cover closed. Buzzer goes off when the machine is left powered on with the front cover open for five minutes or longer to prevent the drum deterioration due to exposure to light.
- When removing the toner cartridge in a removal/replacement operation, cover the drum to keep it from being exposed to light.
- Remove PAPER TRAY, TRANSFER BELT, TONER CARTRIDGE, and FUSER, and put them in a place where they do not affect the procedure. (Note that the service procedures can be performed with those parts in place depending on the target section of removal/replacement.).

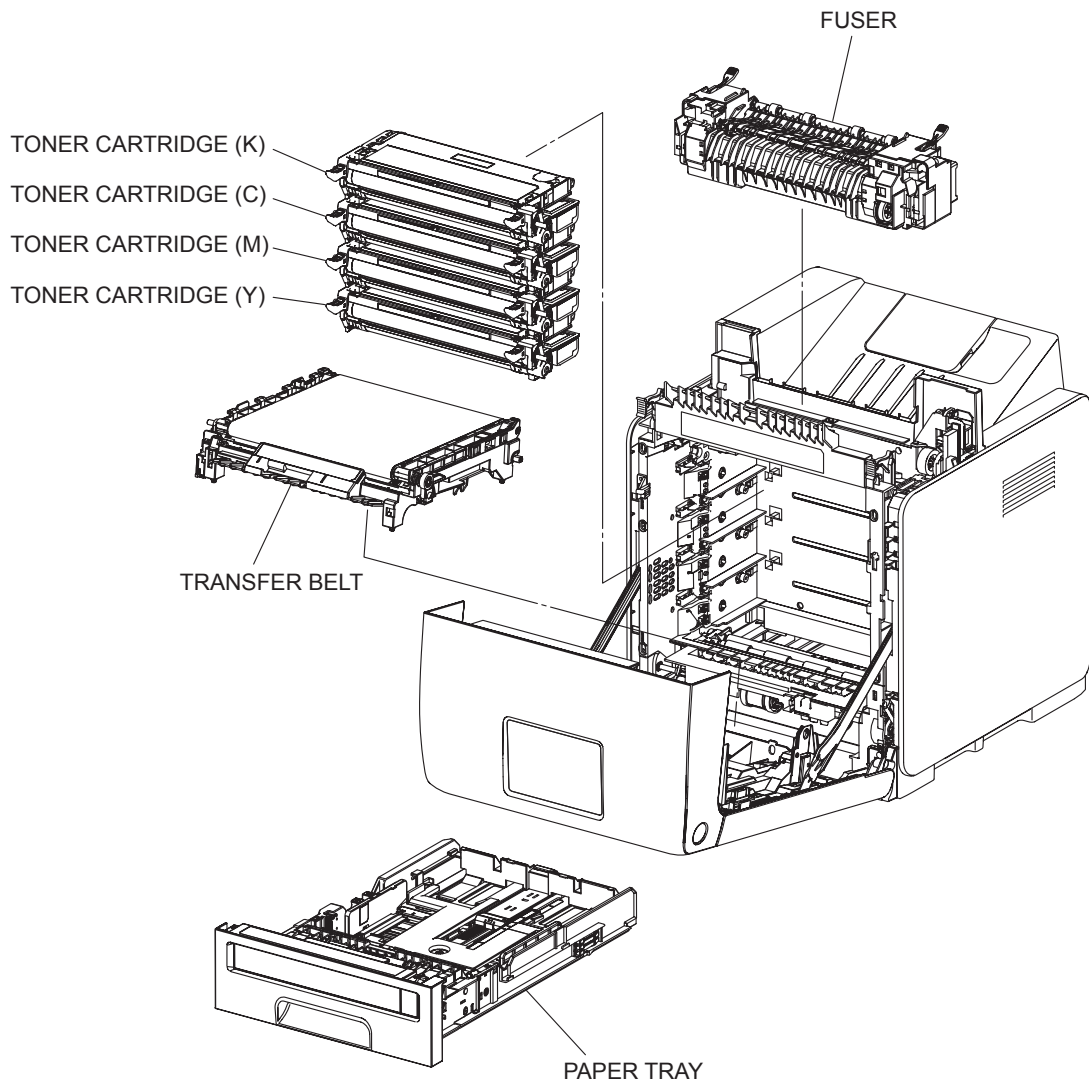

Zna03001KB

1.2 General notes

- The string “(PL X.Y.Z)” suffixed to the part name in the procedure denotes that the part corresponds to the plate (PL) “X.Y”, item “Z” of [Engineering Parts list], and its shape and fitting position can be checked in [Engineering Parts list].
- Directional descriptions used in the procedures are defined as follows:
 - Front : Direction toward you when facing the front of the printer.
 - Rear : Direction opposite to the front when facing the front of the printer.
 - Left : Left-hand direction when facing the front of the printer.
 - Right : Right-hand direction when facing the front of the printer.

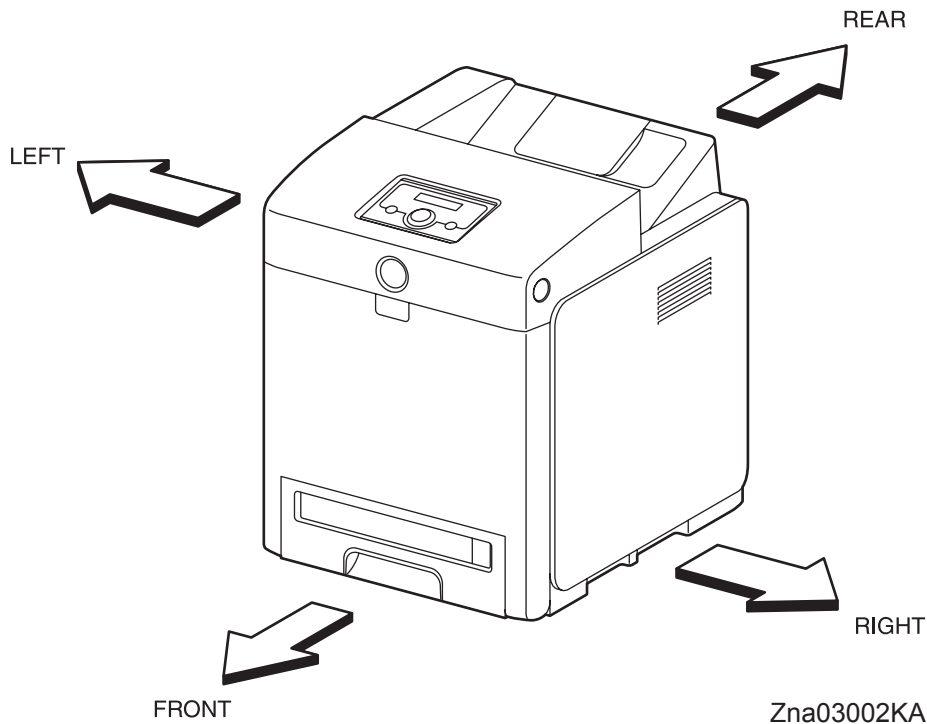
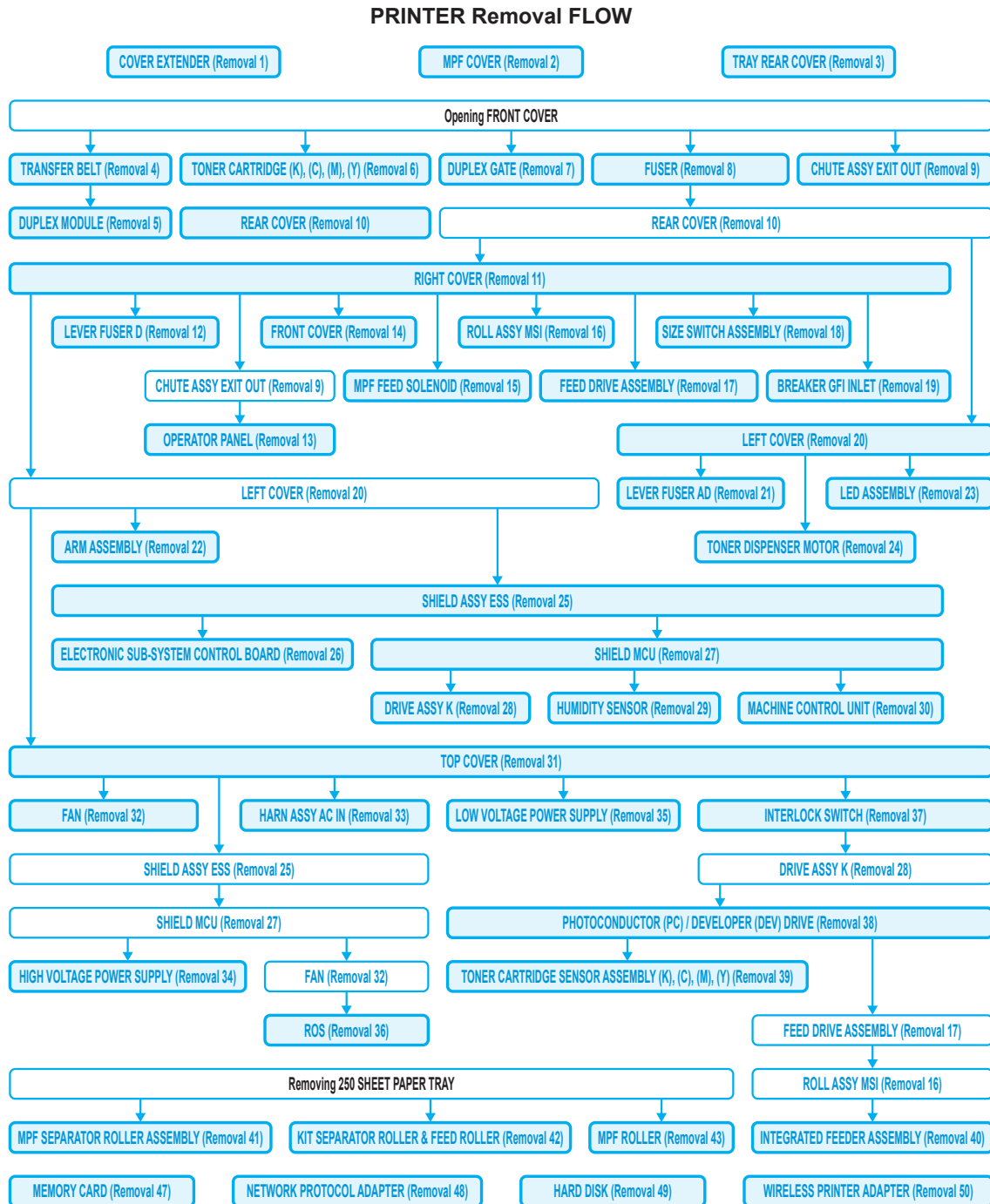

Figure: Definitions of Printer Orientation

- The string “(RRP X.Y)” that appears in or at the end of the procedure denotes that the related service procedure is described in [RRP X.Y].
- Screws shown in the illustrations are to be unscrewed and removed using a Phillips head (cross-slot) screwdriver, unless otherwise specified.
- Black arrows shown in the illustrations denote moving directions. When numbers are assigned to these arrows, they refer to the order in the procedure.
- Refer to [Chapter 4 Plug/Jack (P/J) Connector Locations] for the positions of connectors (P/J).

Removal Flows

The components not connected with arrows in the flow below can be removed independently.



550 SHEET FEEDER ASSEMBLY Removal FLOW

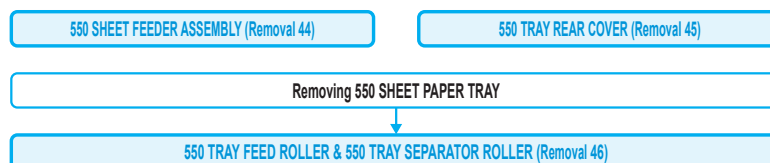

Replacement Flows

The components not connected with arrows in the flow below can be replaced independently. However, the rear cover is an exception when it was removed together with other parts.

PRINTER Replacement FLOW

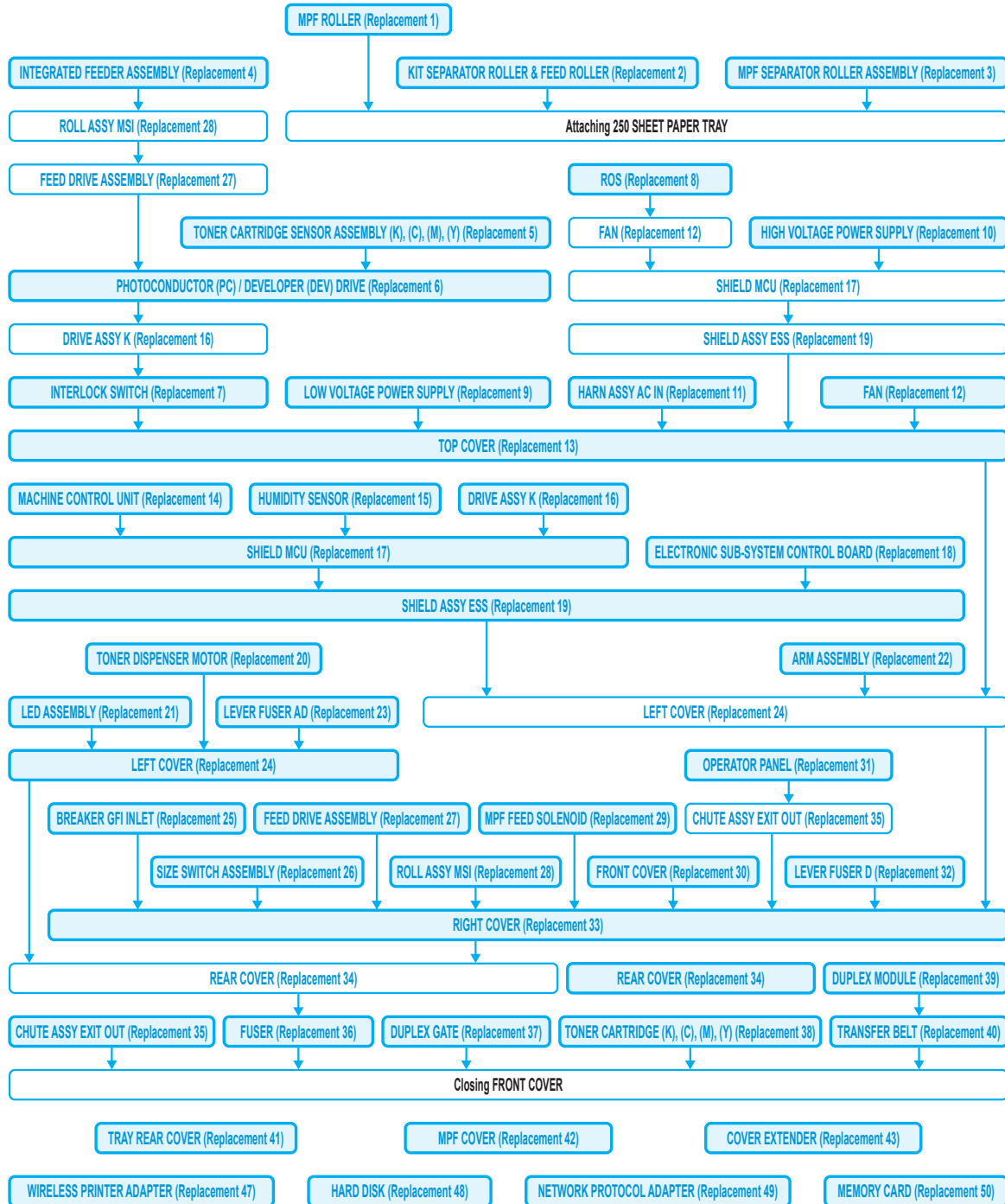

550 SHEET FEEDER ASSEMBLY Replacement FLOW

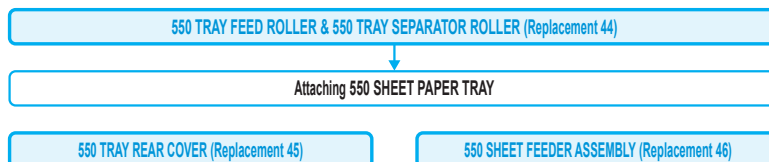

2. Removal Steps

Removal 1 COVER EXTENDER (PL1.1.9)

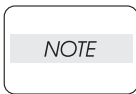

When performing the step described below, take care not to damage the bosses on the COVER EXTENDER.

- 1) Open the COVER EXTENDER (PL1.1.9).

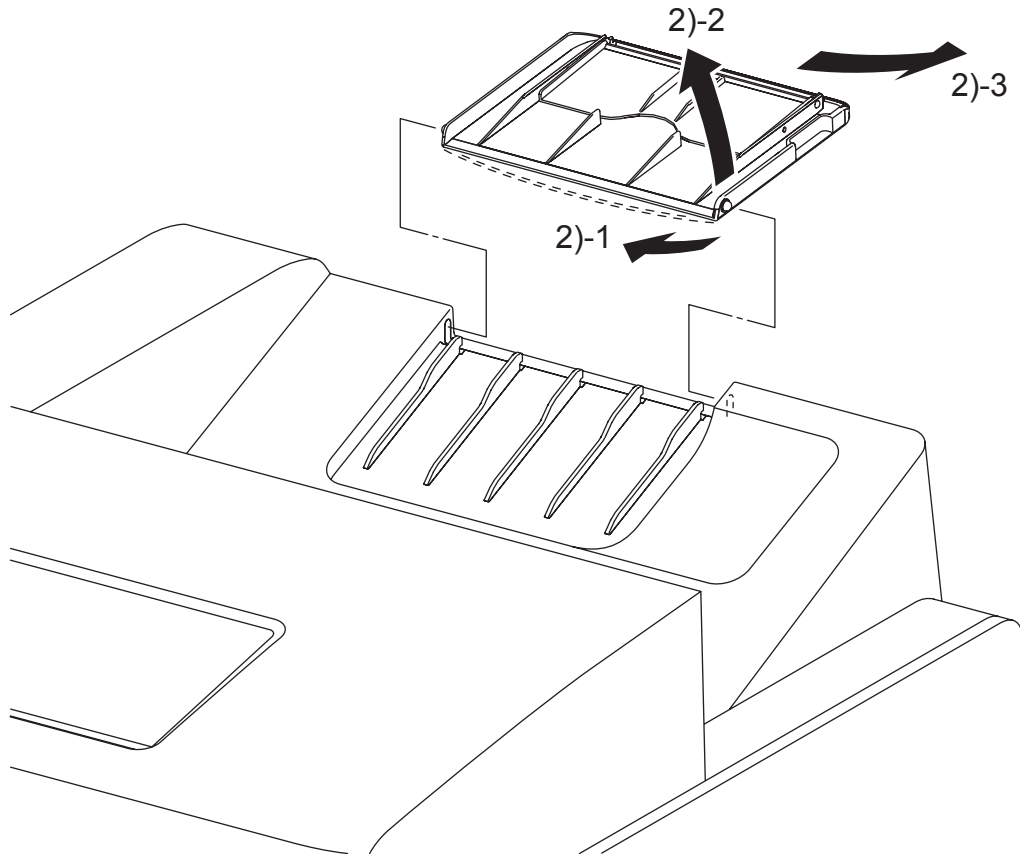

Zna03003KA

- 2) Remove the COVER EXTENDER (PL1.1.9) by bending it and removing its left and right bosses from the holes on the TOP COVER (PL1.1.1).

**For the replacement procedure of this part, go to:
Replacement 43 COVER EXTENDER (PL1.1.9)**

Removal 2 MPF COVER (PL1.2.99)

- 1) Open the MPF COVER (PL1.2.24).

NOTE

When performing the step described below, take care not to drop or damage the MPF COVER.

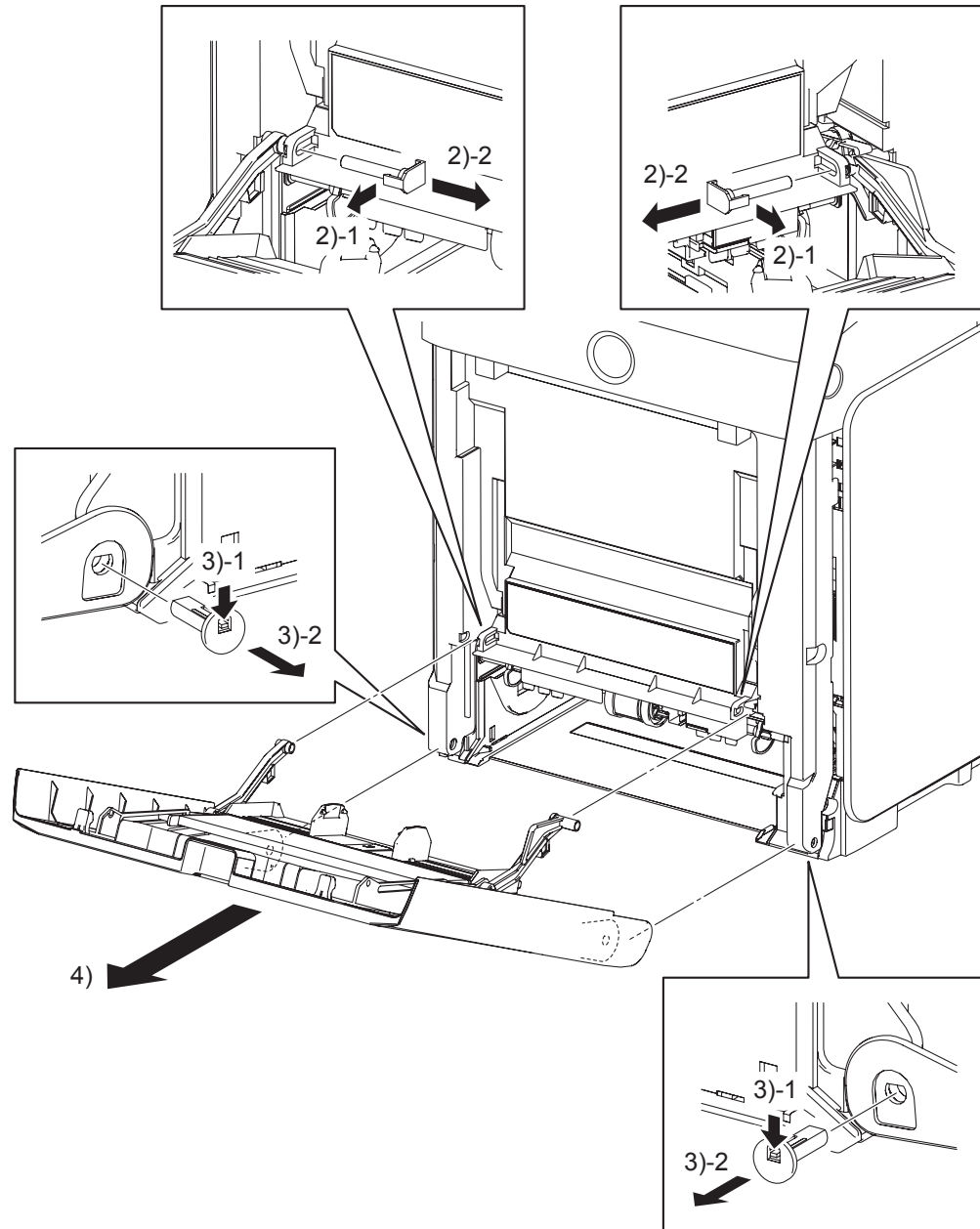

Zna03004KA

- 2) Release the hooks on the PIN PIVOT MSIs (PL1.2.17) that pivot the LINK ASSY MSIs (pivoted to the TRAY ASSY MSI BASE at the other end) to the FRONT COVER (PL1.2.1) at the two locations on the left and right, and then pull out the PIN PIVOT MSIs to the inside.
- 3) Release the hooks on the SHAFT PIVOT MSIs (PL1.2.30) that pivot the MPF COVER to the printer at the two locations on the left and right, and then pull out the SHAFT PIVOT MSIs to the inside.
- 4) Remove the MPF COVER from the printer.

Removal 3 TRAY REAR COVER (PL1.1.5)

- 1) Pull the TRAY REAR COVER (PL1.1.5) backward until it stops.

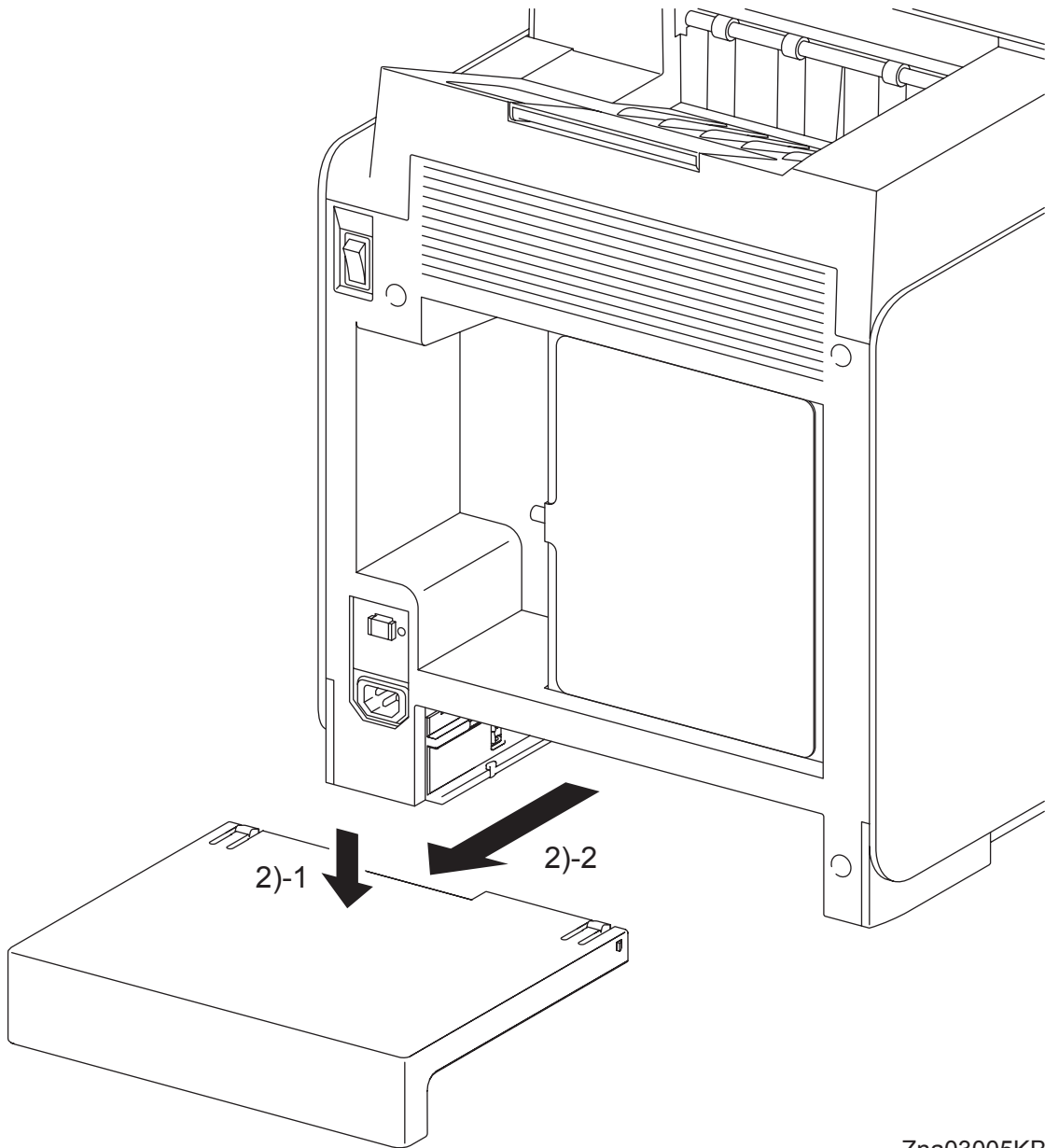

Zna03005KB

- 2) Release the two hooks by depressing the center of the TRAY REAR COVER, and then remove the TRAY REAR COVER from the printer.

Blank Page

Removal 4 TRANSFER BELT (PL4.1.1)

- 1) Open the FRONT COVER (PL1.2.1).

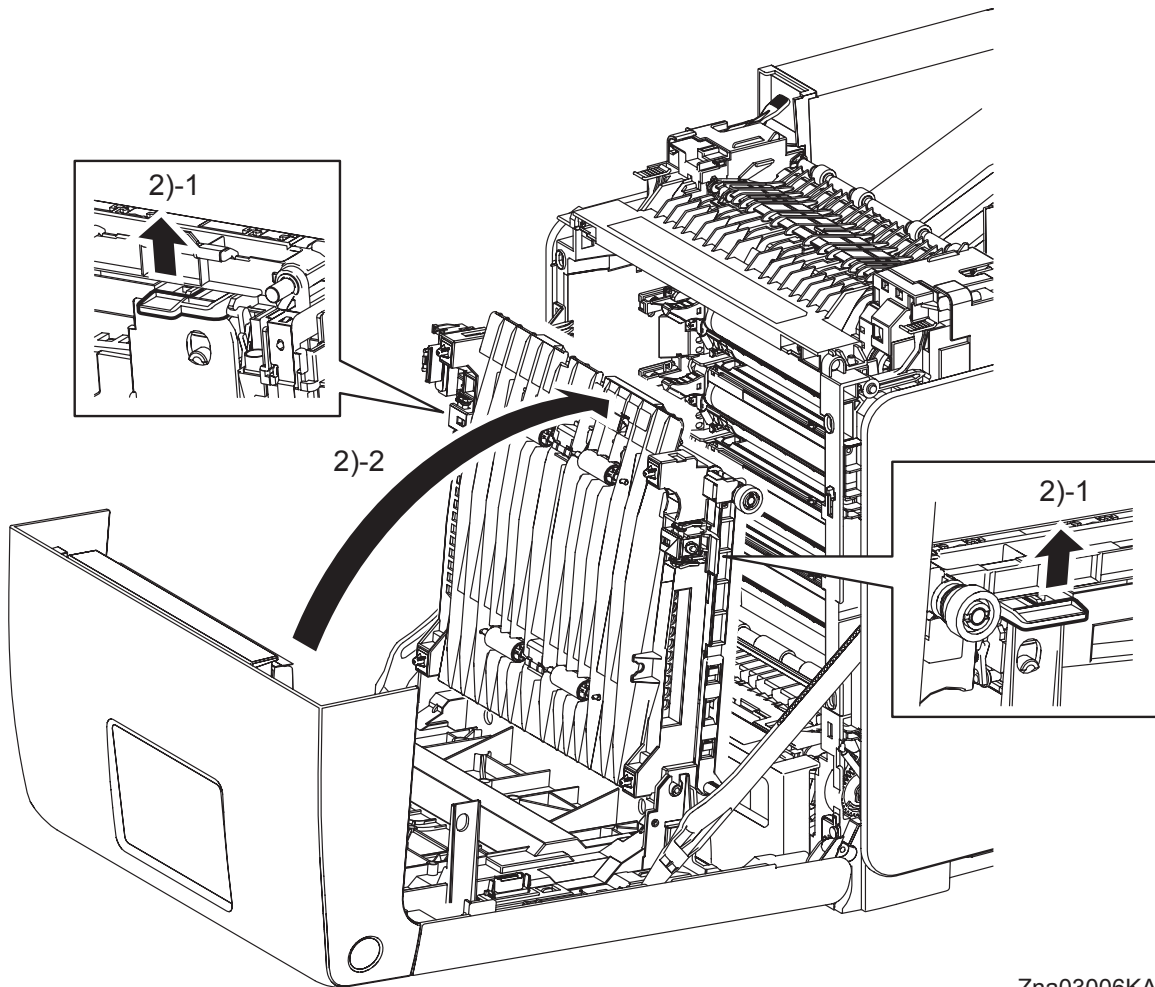

Zna03006KA

- 2) Release the lock by pulling up the levers on the left and right sides of the TRANSFER BELT (PL4.1.1). Raise the TRANSFER BELT upright.

Continues to the next page.

Removal 4 TRANSFER BELT (PL4.1.1)

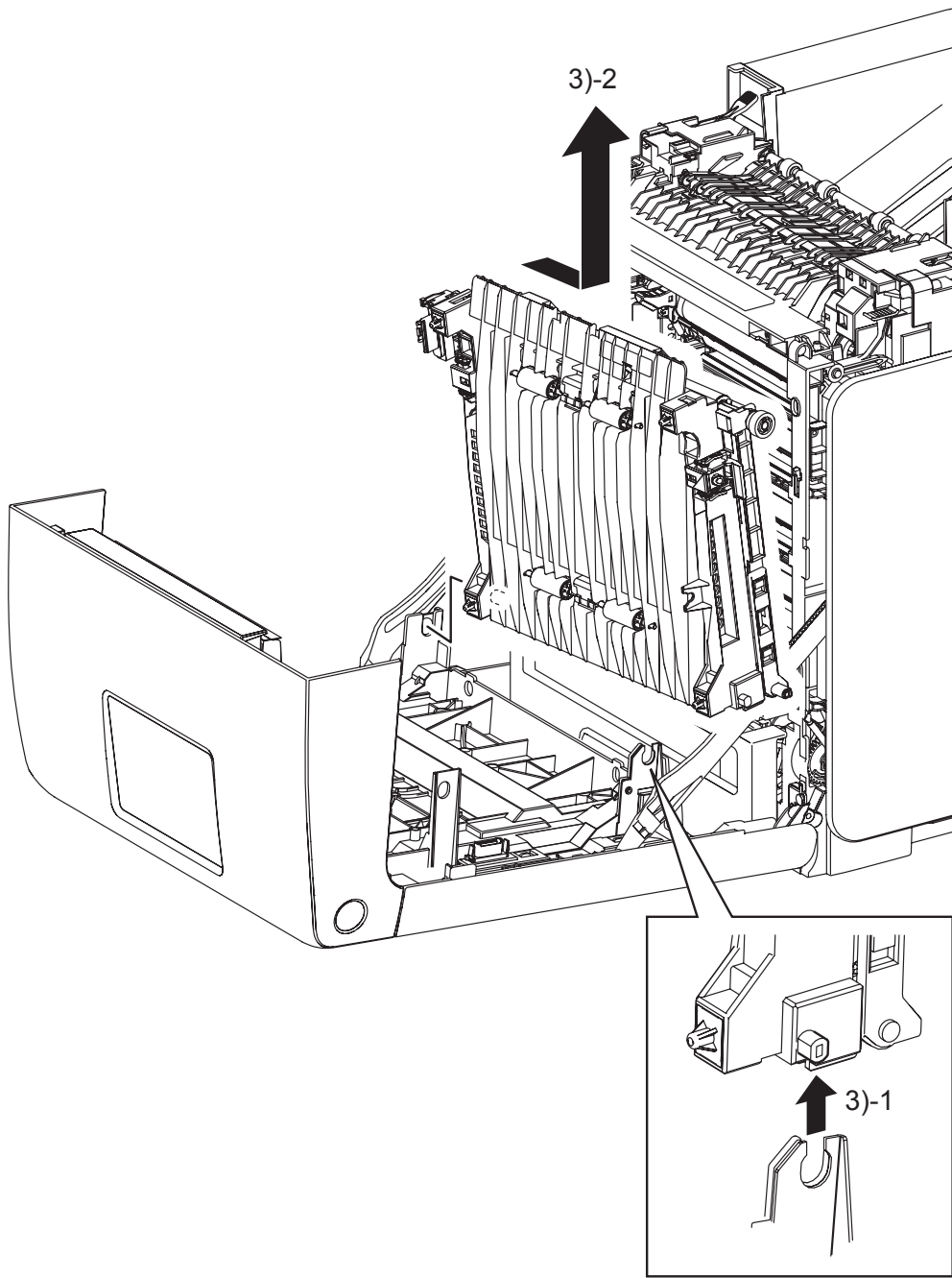

Zna03007KA

- 3) Remove the TRANSFER BELT by releasing the left side lug on the TRANSFER BELT from the U-shaped notch of the FRONT COVER and pulling out the right side lug on the TRANSFER BELT from the hole on the FRONT COVER.

Go to the next removal step:

Removal 5 DUPLEX MODULE (PL11.1.1)

Removal 5 DUPLEX MODULE (PL11.1.1)

Steps 1 and 2 are for reference. Before removing this component, check that Steps 1 and 2 have been performed.

- 1) Open the FRONT COVER (PL1.2.1).
- 2) Remove the TRANSFER BELT. (Removal 4)

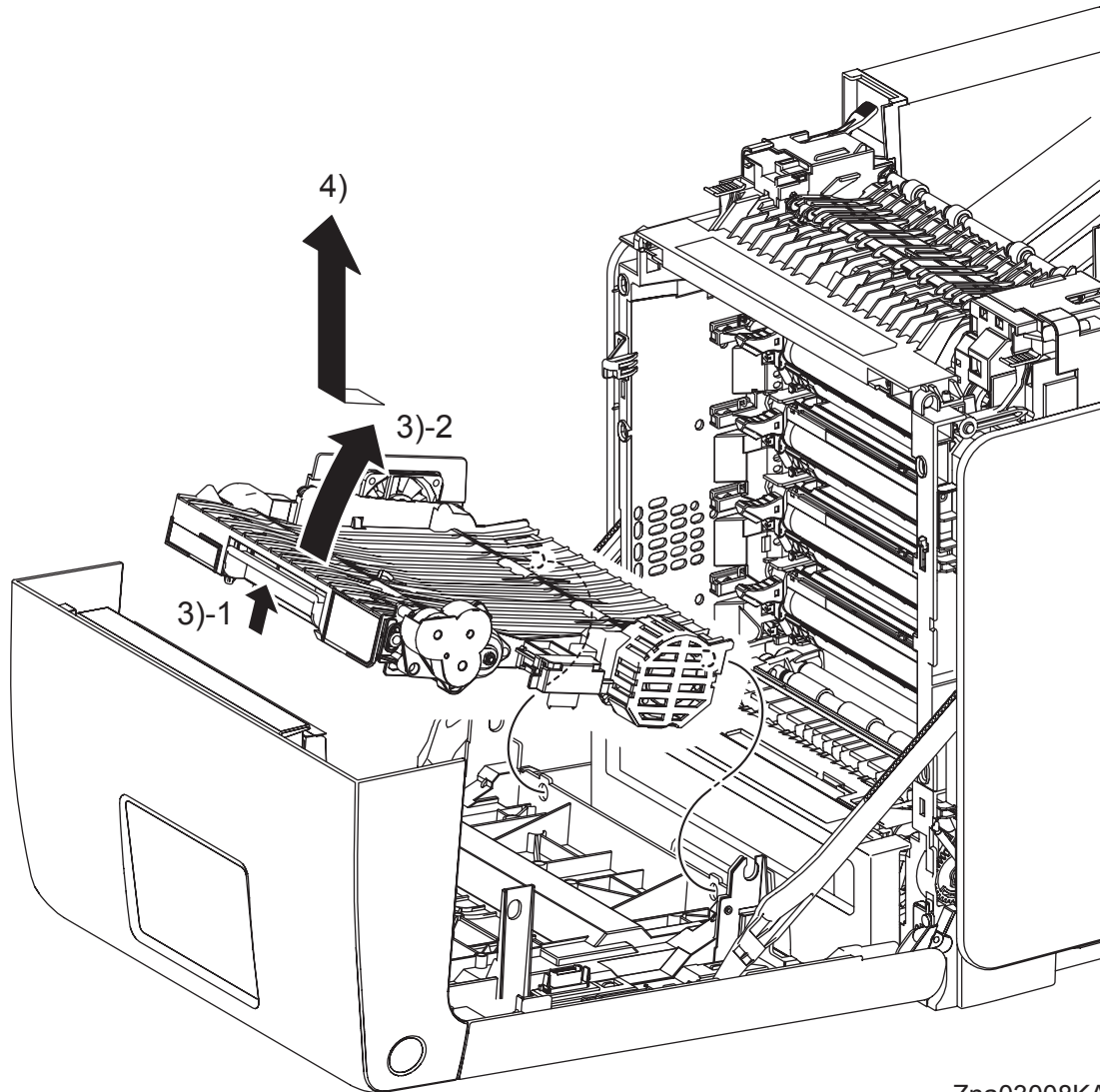

Zna03008KA

- 3) Release the lock by pulling the lever of the DUPLEX MODULE (PL11.1.1), and then raise the DUPLEX MODULE.
- 4) Release the two bosses on the backside of the DUPLEX MODULE from the holes on the FRONT COVER, and then remove the DUPLEX MODULE.

Removal 6 TONER CARTRIDGE (K), (C), (M), (Y) (PL5.1.18-21)

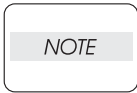

Described below is the removal procedure common among the TONER CARTRIDGES (C), (M), (Y), and (K).

Step 1 is for reference. Before removing this component, check that Step 1 has been performed.

- 1) Open the FRONT COVER (PL1.2.1).

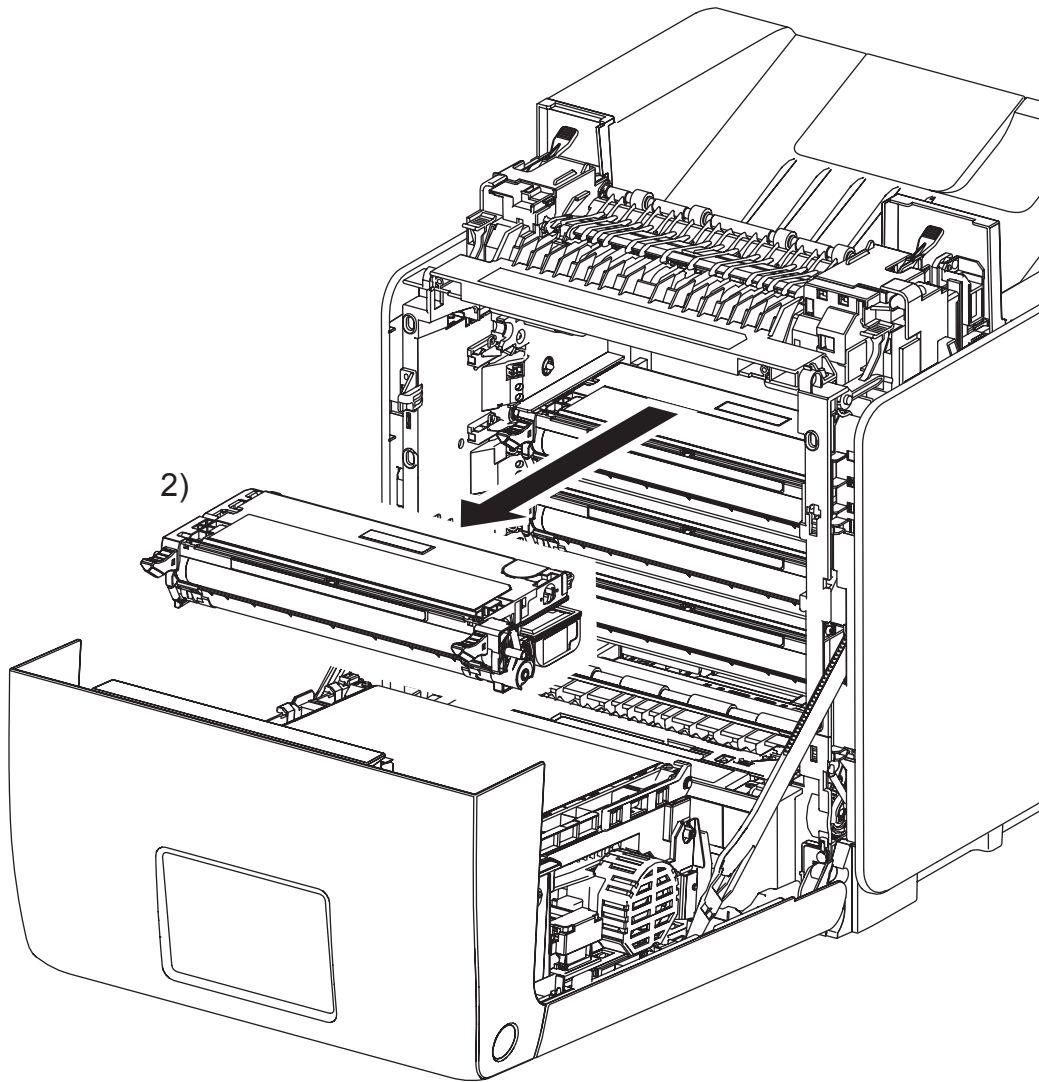

Zna03009KB

- 2) Remove the TONER CARTRIDGE toward you by pulling it by the left and right handles.

Removal 7 DUPLEX GATE (PL6.1.13)

NOTE

The FUSER part is very hot. Take added care not to get burned when performing the service operation.

- 1) Open the FRONT COVER (PL1.2.1).

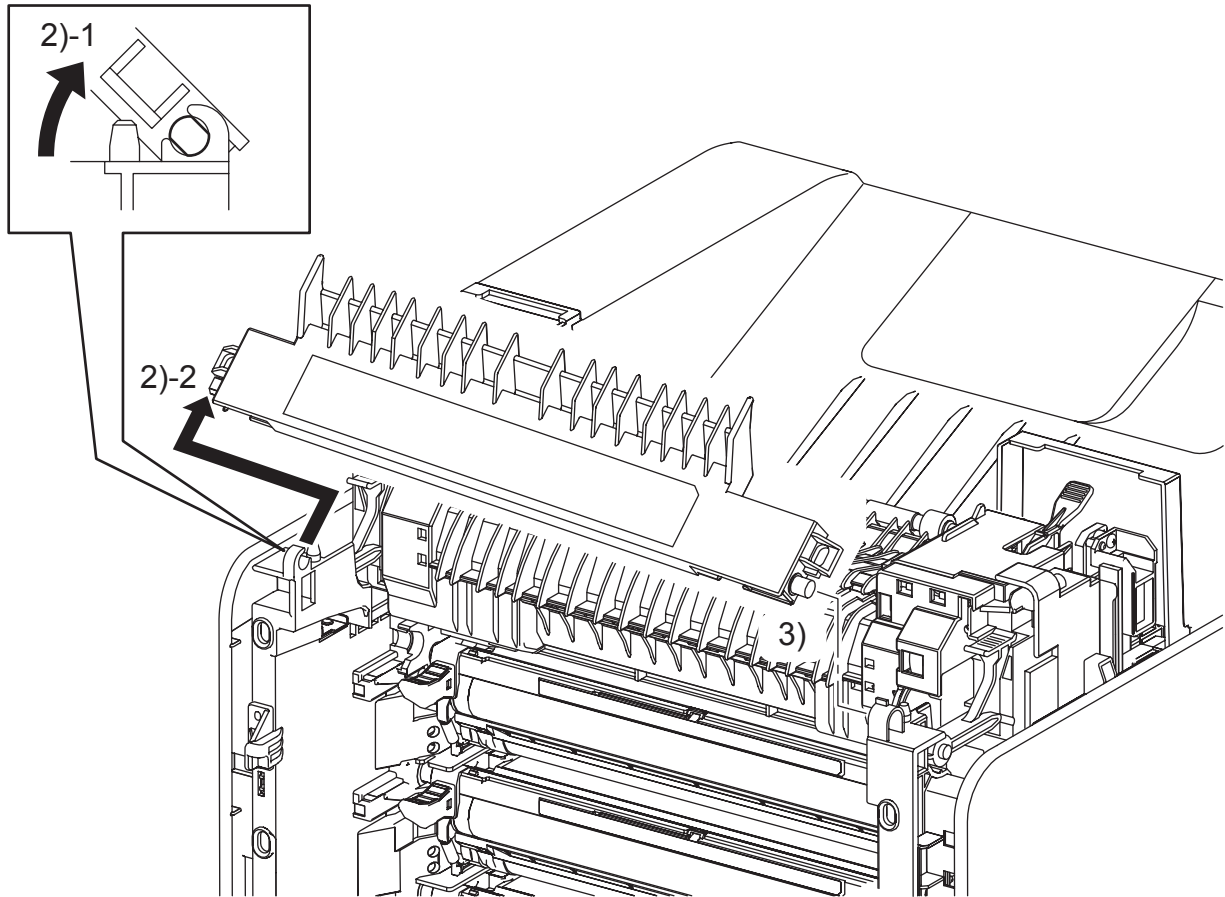

Zna03010KB

- 2) Open the DUPLEX GATE (PL6.1.13) to about 45 degrees so that the flat faces of the left side pivot of the DUPLEX GATE comes parallel with the U-shaped notch. Pull out the left side pivot of the DUPLEX GATE from the U-shaped notch diagonally backward.
- 3) Pull out the right side pivot of the DUPLEX GATE from the hole on the printer.

Removal 8 FUSER (PL6.1.10)

NOTE

The FUSER part is very hot. Take added care not to get burned when performing the service operation.

- 1) Open the FRONT COVER (PL1.2.1).

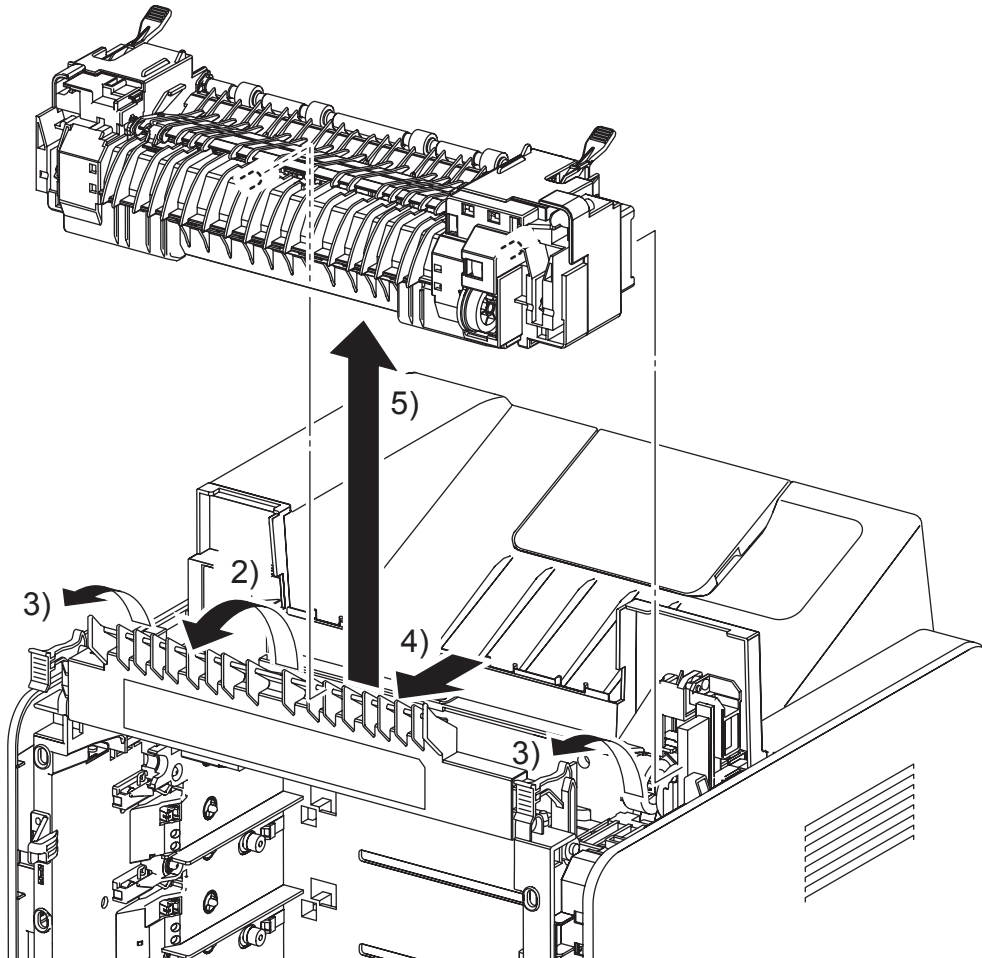

Zna03011KB

- 2) Open the DUPLEX GATE (PL6.1.13).
- 3) Lift the LEVER FUSER D (PL6.1.18) and LEVER FUSER AD (PL6.1.19) up to release the lock of FUSER (PL6.1.10).
- 4) Shift the FUSER toward you to disengage the FUSER connector (P/J171).
- 5) Remove the FUSER from the printer.

Removal 9 CHUTE ASSY EXIT OUT (PL6.1.1)

- 1) Open the FRONT COVER (PL1.2.1).

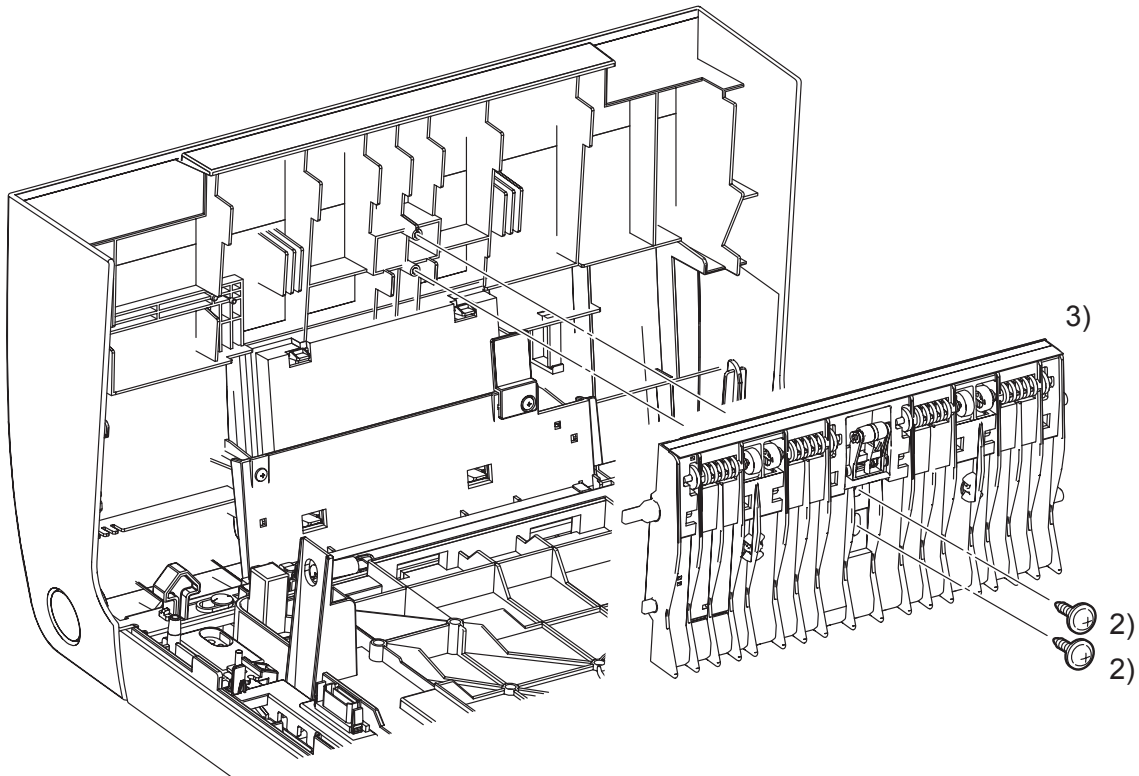

Kmy03013KA

- 2) Remove two screws (silver, with flange, tap, 10mm) that fix the CHUTE ASSY EXIT OUT (PL6.1.1) to the FRONT COVER.
- 3) Remove the CHUTE ASSY EXIT OUT from the FRONT COVER.

Removal 10 REAR COVER (PL1.1.4)

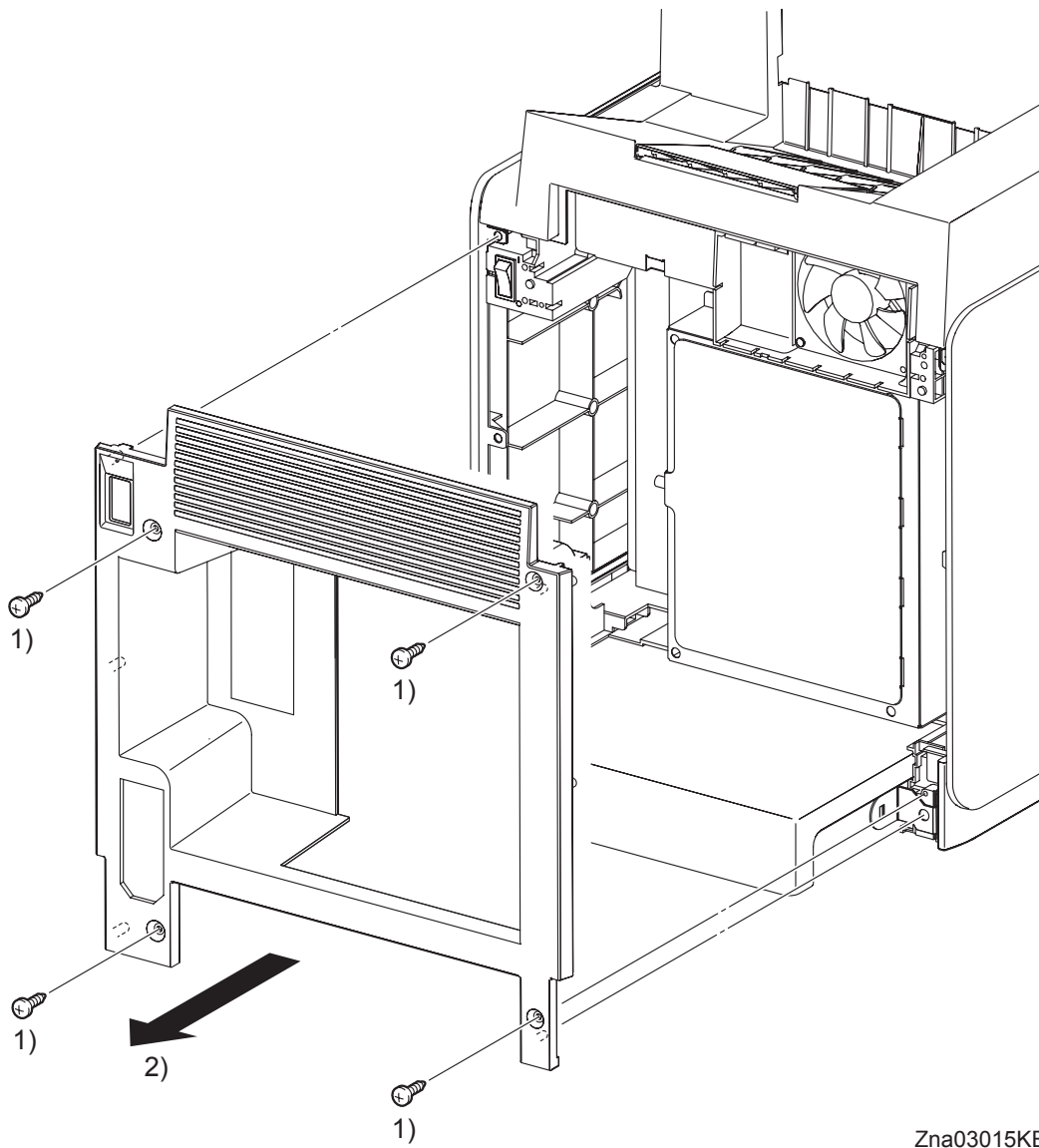

- 1) Remove four screws (silver, tap, 10mm) that fix the REAR COVER (PL1.1.4) to the printer
- 2) Remove the REAR COVER from the printer.

Go to the next removal step:

Removal 11 RIGHT COVER (PL1.1.6) or Removal 20 LEFT COVER (PL1.1.7)

Removal 11 RIGHT COVER (PL1.1.6)

Steps 1 through 3 are for reference. Before removing this component, check that Steps 1 through 3 have been performed.

- 1) Open the FRONT COVER (PL1.2.1).
- 2) Remove the FUSER. (Removal 8)
- 3) Remove the REAR COVER. (Removal 10)

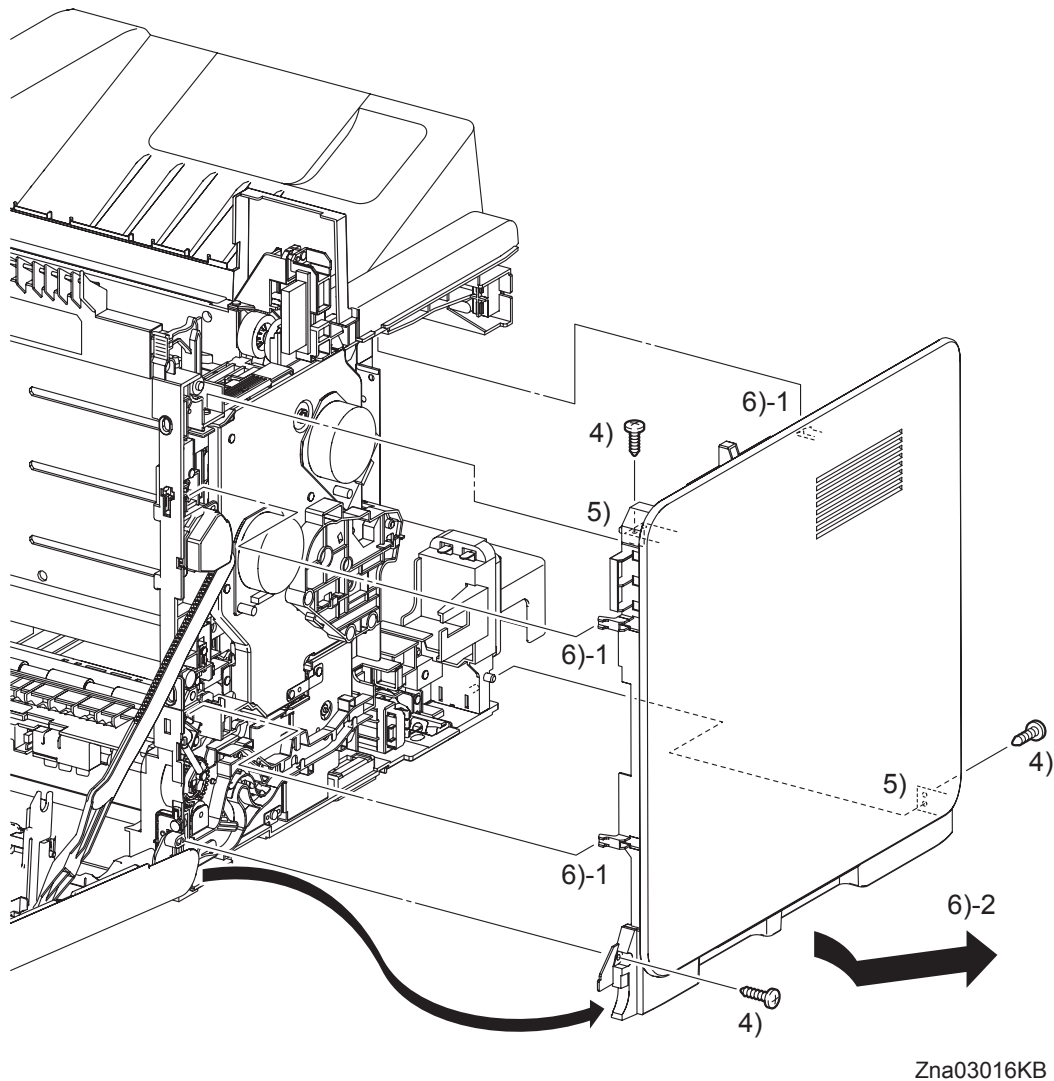

- 4) Remove three screws (silver, tap, 10mm) that fix the RIGHT COVER (PL1.1.6) to the printer.
- 5) Release the two holes on the RIGHT COVER from the bosses on the printer.
- 6) Release the one backside hook and two frontside hooks on the RIGHT COVER, and then remove the RIGHT COVER diagonally backward.

Go to the next removal step:

Removal 12 LEVER FUSER D (PL6.1.18), Removal 13 OPERATOR PANEL (PL1.2.97), Removal 14 FRONT COVER (PL1.2.98), Removal 15 MPF FEED SOLENOID (PL3.1.98), Removal 16 ROLL ASSY MSI (PL3.1.8), Removal 17 FEED DRIVE ASSEMBLY (PL8.1.7), Removal 18 SIZE SWITCH ASSEMBLY (PL7.1.18), Removal 19 BREAKER GFI INLET (PL9.1.43)

Removal 12 LEVER FUSER D (PL6.1.18)

Steps 1 through 4 are for reference. Before removing this component, check that Steps 1 through 4 have been performed.

- 1) Open the FRONT COVER (PL1.2.1).
- 2) Remove the FUSER. (Removal 8)
- 3) Remove the REAR COVER. (Removal 10)
- 4) Remove the RIGHT COVER. (Removal 11)

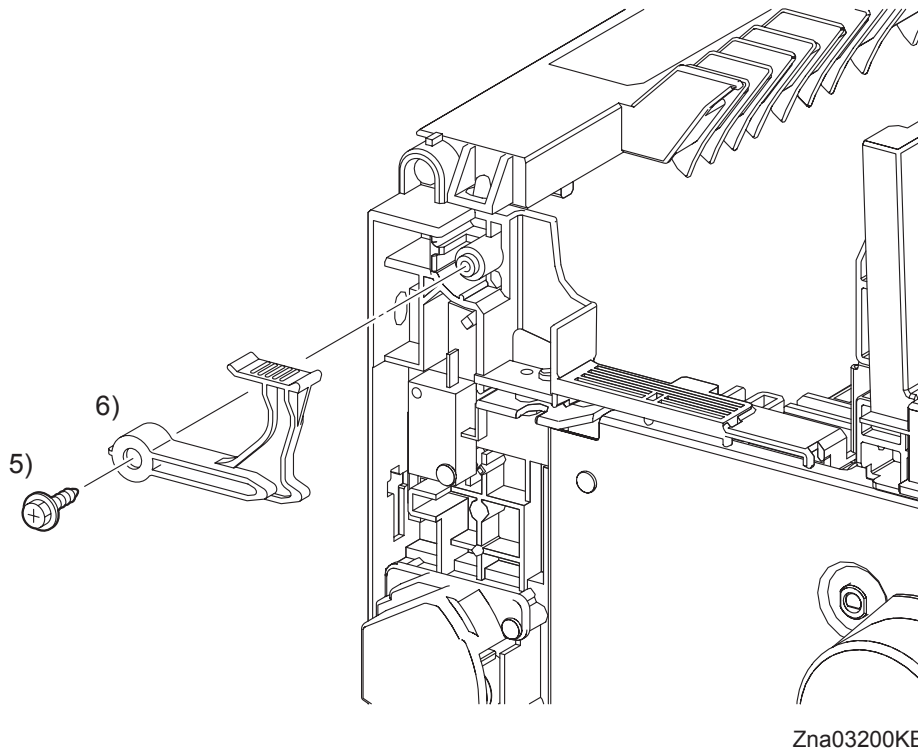

- 5) Remove the one screw (silver, with flange, tap, 10mm) that fixes the LEVER FUSER D (PL6.1.18) to the printer.
- 6) Remove the LEVER FUSER D from the printer.

Removal 13 OPERATOR PANEL (PL1.2.97)

Steps 1 through 5 are for reference. Before removing this component, check that Steps 1 and 2 have been performed.

When removing the OPERATOR PANEL only, perform Steps 1, 5, 6, 7, 8, and 9.

- 1) Open the FRONT COVER (PL1.2.1).
- 2) Remove the FUSER. (Removal 8)
- 3) Remove the REAR COVER. (Removal 10)
- 4) Remove the RIGHT COVER. (Removal 11)
- 5) Remove the CHUTE ASSY EXIT OUT. (Removal 9)

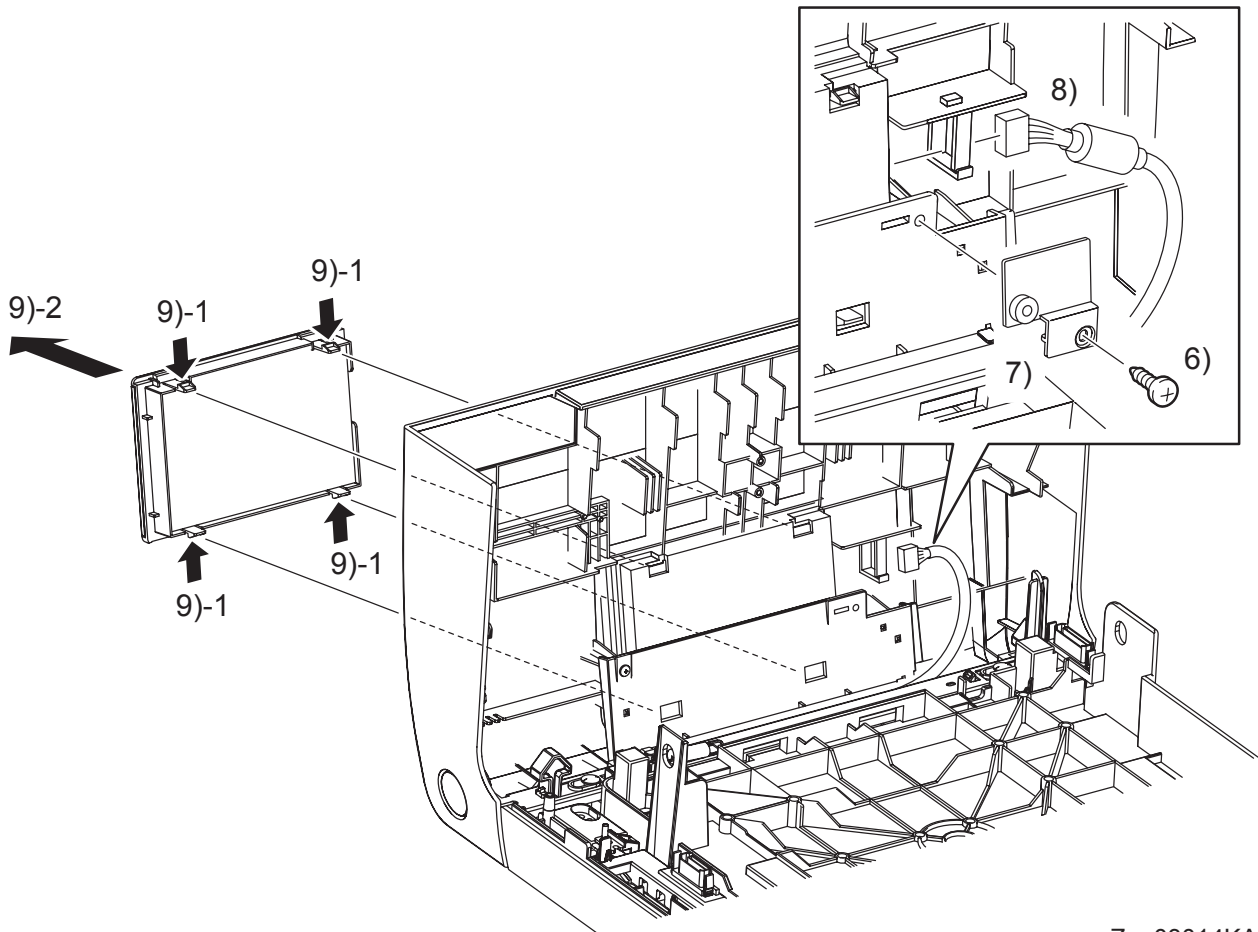

Zna03014KA

- 6) Remove the one screw (silver, tap, 10mm) that fixes the BRACKET HARNESS (PL1.2.34) to the FRONT COVER.
- 7) Remove the BRACKET HARNESS from the FRONT COVER.
- 8) Release the clamp that fixes the core of the HARNESS ASSY OPEPANE (PL1.2.15), and then disengage the connector (P/J220) of the OPERATOR PANEL (PL1.2.16).

NOTE

When performing the step described below, take care not to drop or damage the OPERATOR PANEL.

- 9) Remove the OPERATOR PANEL by releasing the four hooks that fix the OPERATOR PANEL to the printer.

Continues to the next page.

Removal 13 OPERATOR PANEL (PL1.2.97)

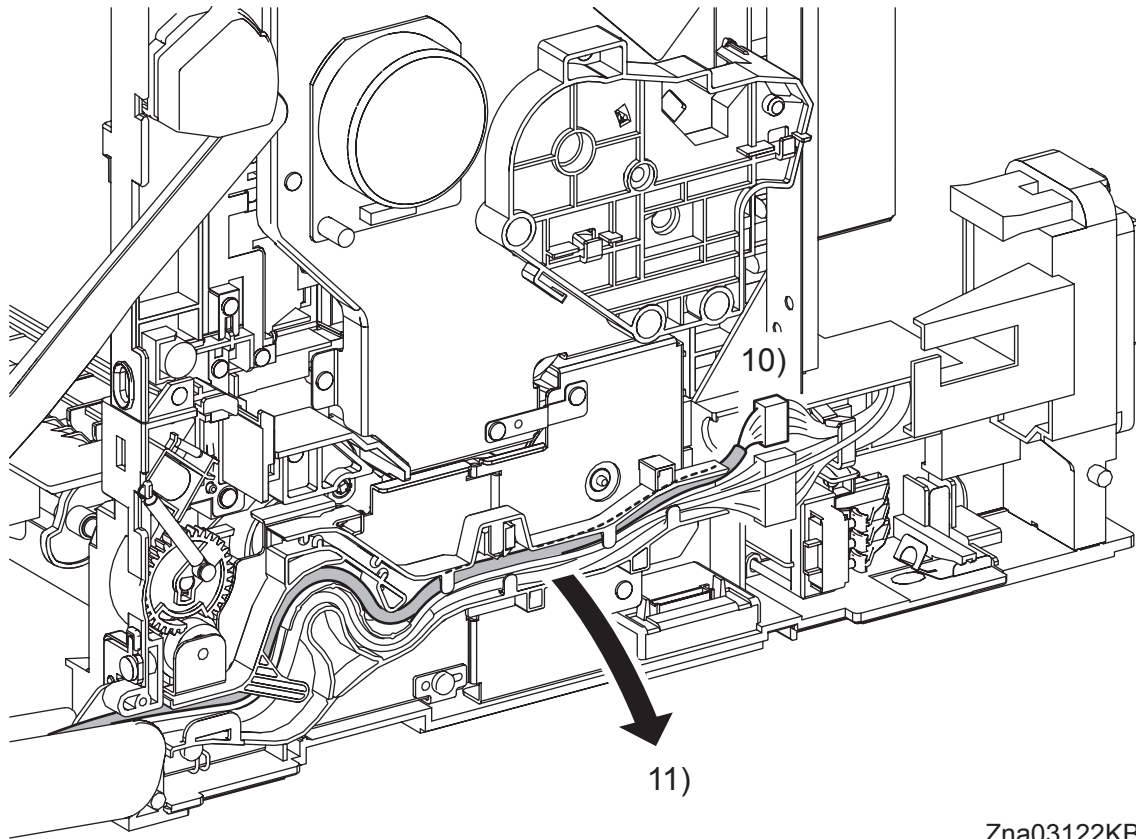

Zna03122KB

- 10) Disengage the connector (P/J2900) of the HARNASS ASSY OPEPANE.
- 11) Release the HARNASS ASSY OPEPANE from the DUCT ASSY DRV PH (PL8.1.8).

Continues to the next page.

Removal 13 OPERATOR PANEL (PL1.2.97)

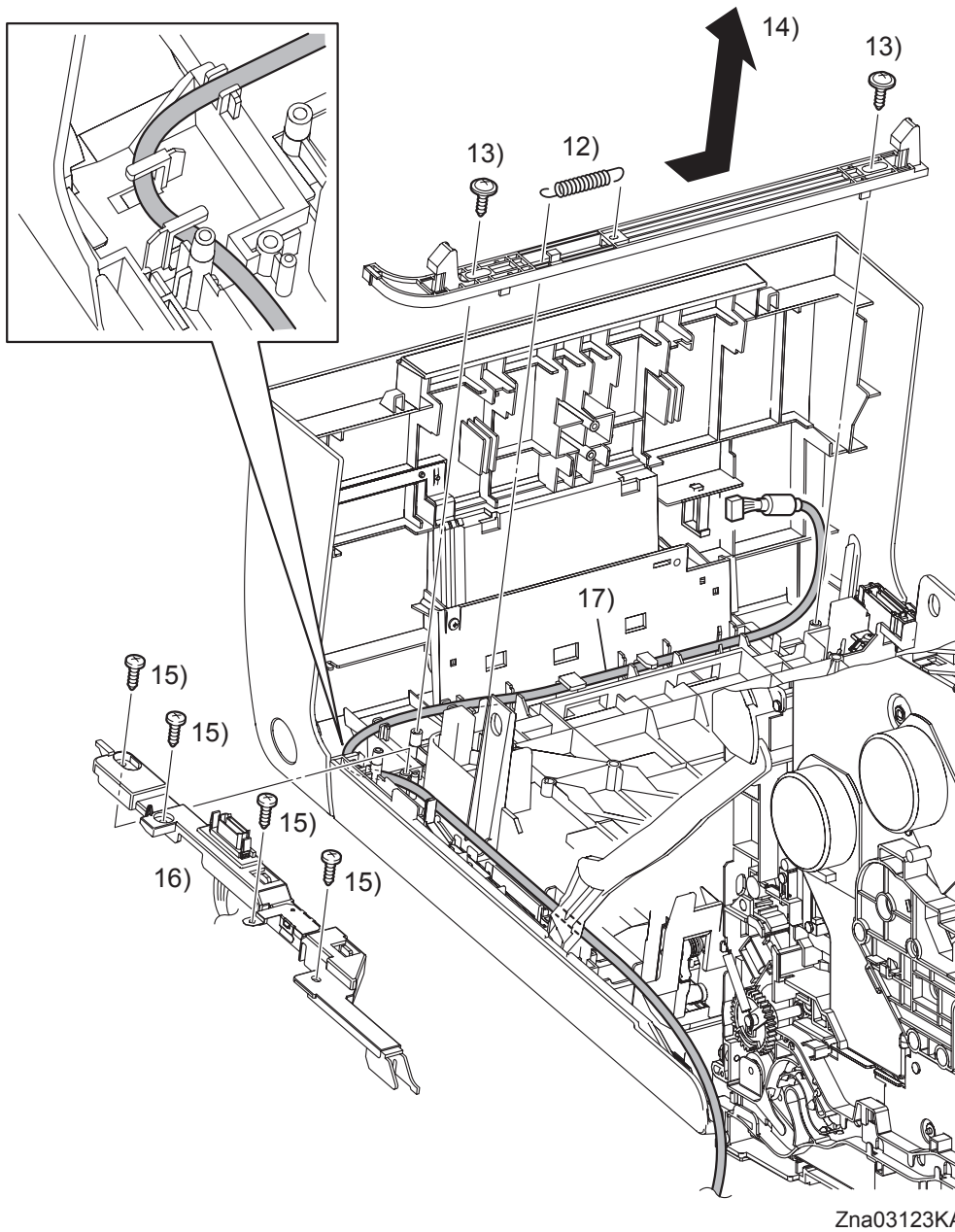

- 12) Remove the SPRING LATCH (PL1.2.3) from the hooks on the LATCH FRONT (PL1.2.4) and the FRONT COVER.
- 13) Remove two screws (silver, with flange, tap, 10mm) that fix the LATCH FRONT to the FRONT COVER.
- 14) Slide the LATCH FRONT to the left, and then remove the LATCH FRONT from the FRONT COVER.
- 15) Remove the four screws (silver, tap, 10mm) that fix the COVER HARNESS (PL1.2.5) to the FRONT COVER.

NOTE

Take care not to move the COVER HARNESS away from the FRONT COVER too far because the COVER HARNESS is secured to the HARNESS ASSY FRONT COVER.

- 16) Remove the COVER HARNESS from the FRONT COVER.
- 17) Remove the HARNESS ASSY OPEPANE from the FRONT COVER.

Blank Page

Removal 14 FRONT COVER (PL1.2.98)

NOTE

The procedures described below must be performed with the MPF COVER (PL1.2.24) attached to the FRONT COVER (PL1.2.1).

Steps 1 through 4 are for reference. Before removing this component, check that Steps 1 through 4 have been performed.

- 1) Open the FRONT COVER (PL1.2.1).
- 2) Remove the FUSER. (Removal 8)
- 3) Remove the REAR COVER. (Removal 10)
- 4) Remove the RIGHT COVER. (Removal 11)

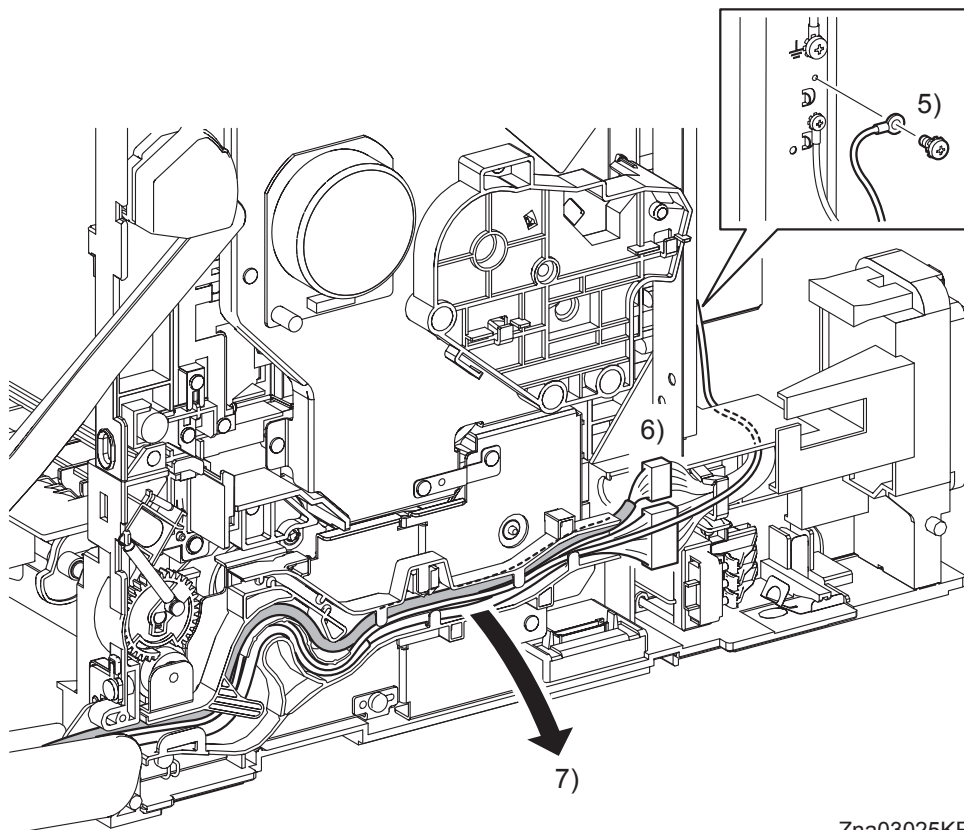

- 5) Remove the one screw (silver, with washer, 6mm) that fixes to the printer the ground wire of the HARNESS ASSY FRONT COVER (PL1.2.11).

NOTE

When performing the step below, leave the junction connector on the printer side cable.

- 6) Disengage the connector (P/J2900) of the HARNESS ASSY OPEPANE (PL1.2.15) and the connector (P/J272) of the HARNESS ASSY FRONT COVER.
- 7) Release the HARNESS ASSY OPEPANE and the HARNESS ASSY FRONT COVER from the DUCT ASSY DRV PH (PL8.1.8).

Continues to the next page.

Removal 14 FRONT COVER (PL1.2.98)

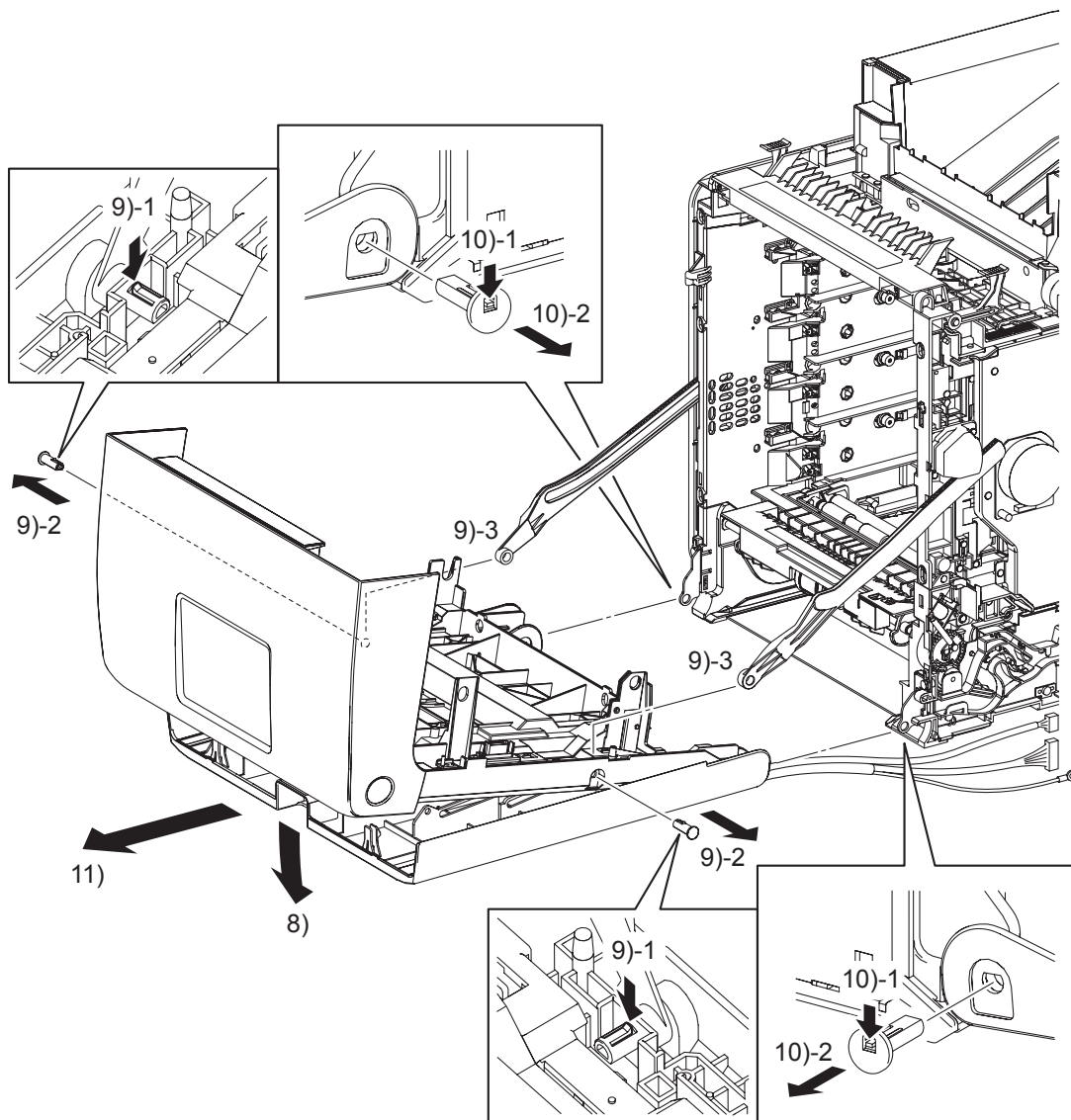

Zna03026KB

- 8) Open the MPF COVER (PL1.2.24).

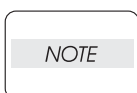

When performing the step described below, take care not to drop and break the FRONT COVER.

- 9) Release the hook of SHAFT PIVOT (PL1.2.8) on the left and right sides of the FRONT COVER, and then pull out the SHAFT PIVOT to the outside while holding the FRONT COVER. Remove the FRONT COVER from the LINK L (PL7.1.3) and LINK R (PL7.1.13) on the printer.
- 10) Release the hook of the SHAFT PIVOT MSI (PL1.2.30) that fixes the left and right sides of the FRONT COVER and the MPF COVER to the printer, and then pull out the SHAFT PIVOT MSI to the inside.
- 11) Remove the FRONT COVER together with the MPF COVER.

Removal 15 MPF FEED SOLENOID (PL3.1.98)

Steps 1 through 4 are for reference. Before removing this component, check that Steps 1 through 4 have been performed.

- 1) Open the FRONT COVER (PL1.2.1).
- 2) Remove the FUSER. (Removal 8)
- 3) Remove the REAR COVER. (Removal 10)
- 4) Remove the RIGHT COVER. (Removal 11)

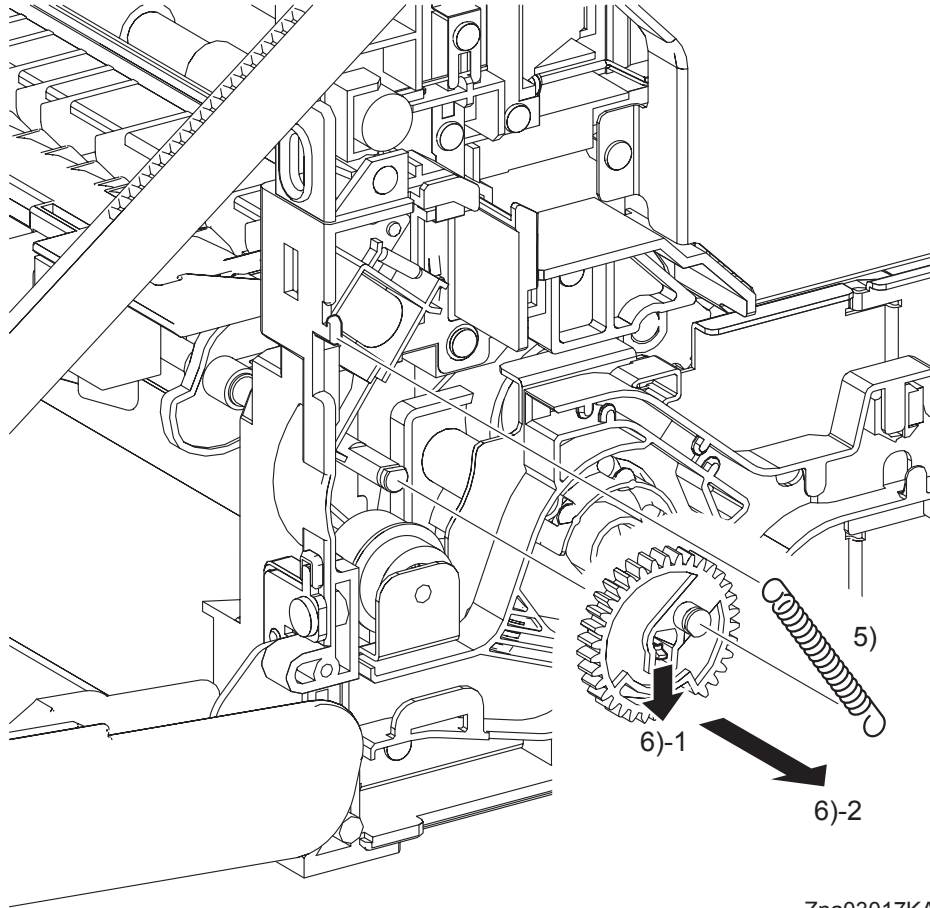

- 5) Remove the SPRING FEED MSI (PL3.1.4) from the printer.
- 6) Remove the GEAR MSI (PL3.1.5) from the SHAFT MSI (PL3.1.12) by releasing the hook on the GEAR MSI.

Continues to the next page.

Removal 15 MPF FEED SOLENOID (PL3.1.98)

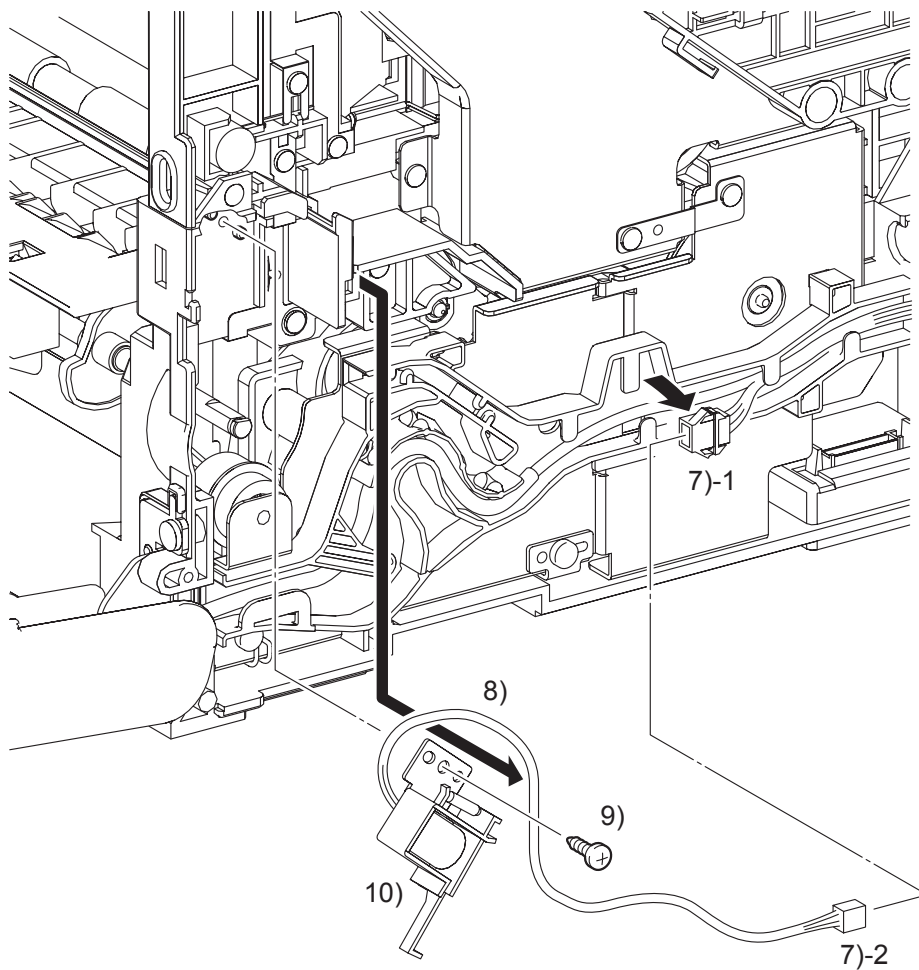

Zna03018KB

NOTE

When performing the step below, leave the junction connector on the printer side cable.

- 7) Disengage the connector (P/J234) of the MPF FEED SOLENOID (PL3.1.3).
- 8) Remove the harness of the MPF FEED SOLENOID from the DUCT ASSY DRV PH (PL8.1.8).
- 9) Remove the one screw (silver, tap, 8mm) that fixes the MPF FEED SOLENOID to the printer.
- 10) Remove the MPF FEED SOLENOID from the printer.

Removal 16 ROLL ASSY MSI (PL3.1.8)

Steps 1 through 4 are for reference. Before removing this component, check that Steps 1 through 4 have been performed.

- 1) Open the FRONT COVER (PL1.2.1).
- 2) Remove the FUSER. (Removal 8)
- 3) Remove the REAR COVER. (Removal 10)
- 4) Remove the RIGHT COVER. (Removal 11)

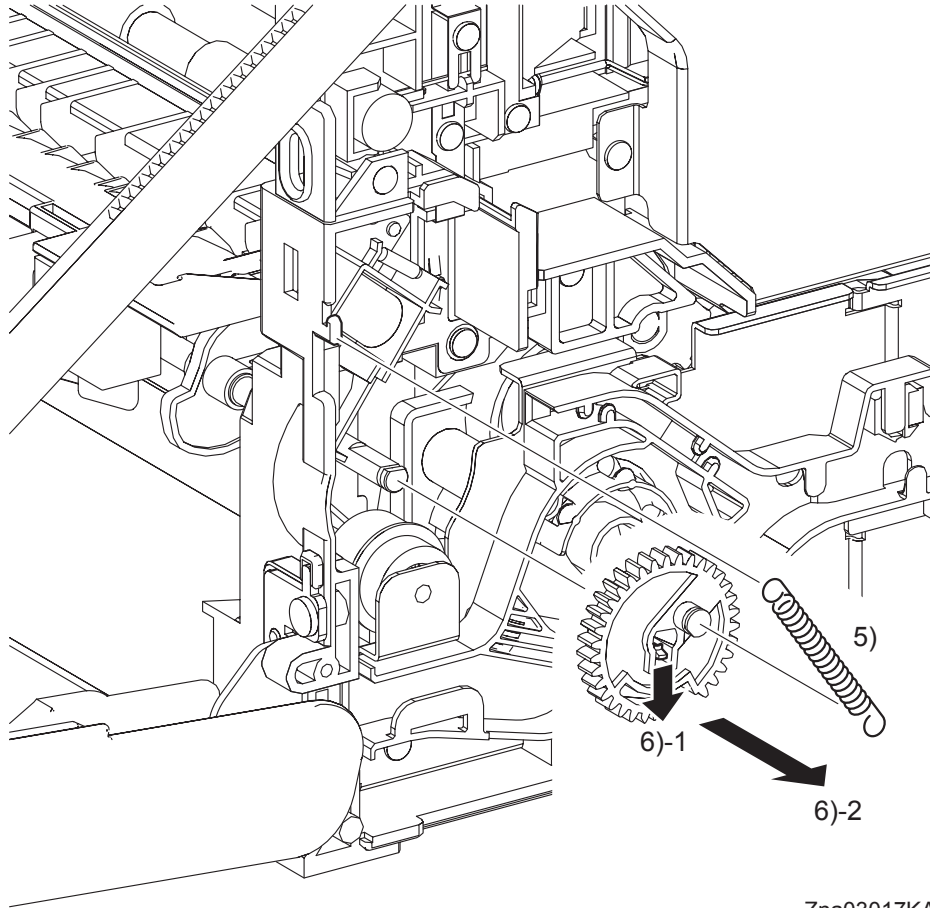

- 5) Remove the SPRING FEED MSI (PL3.1.4) from the printer.
- 6) Remove the GEAR MSI (PL3.1.5) from the SHAFT MSI (PL3.1.12) by releasing the hook on the GEAR MSI.

Continues to the next page.

Removal 16 ROLL ASSY MSI (PL3.1.8)

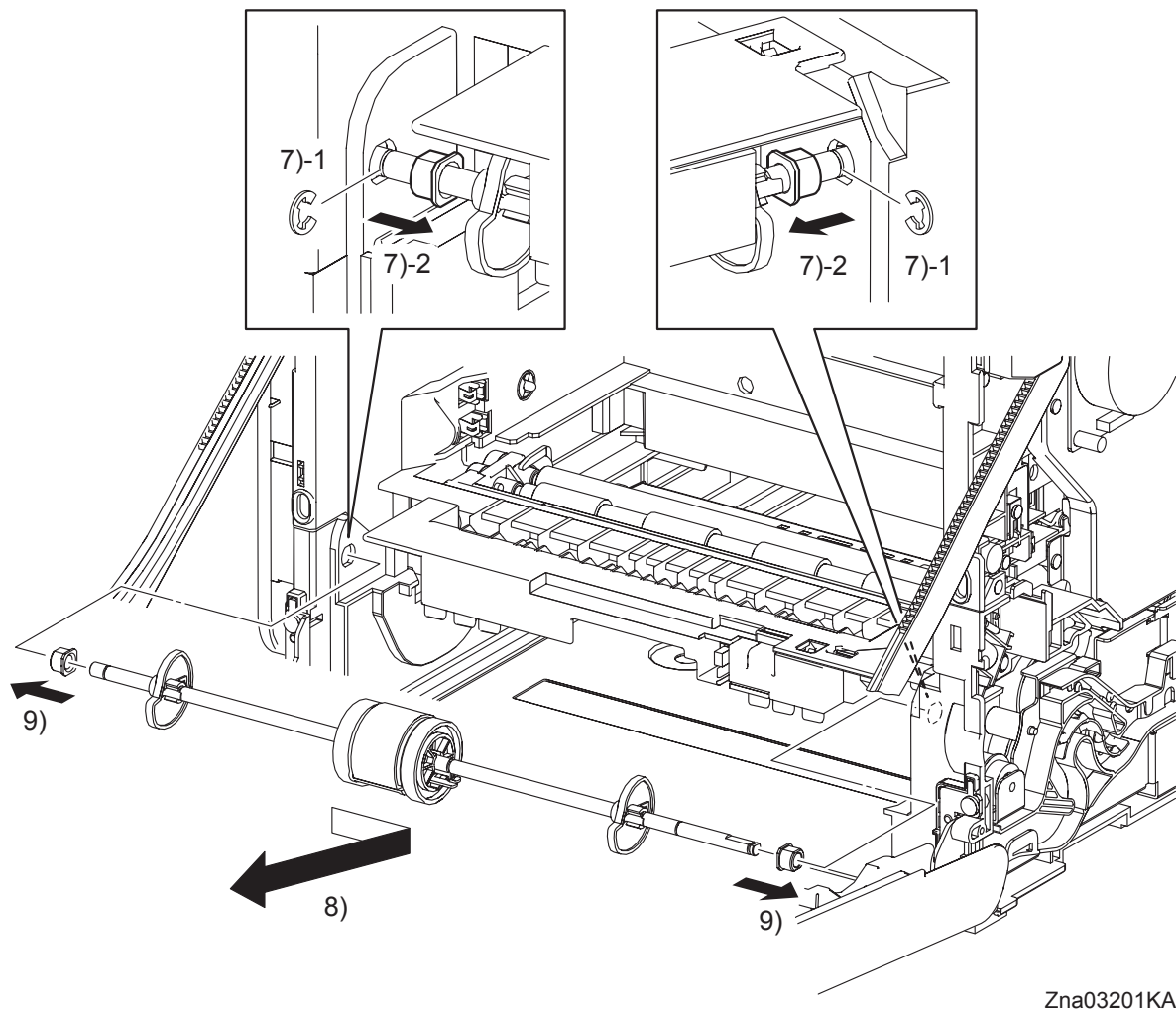

Zna03201KA

- 7) Remove the e-rings that fix the BEARING on the left and right sides of the ROLL ASSY MSI (PL3.1.8), and then remove the BEARING to the inside.

NOTE

When performing the step described below, take care not to drop and lose the BEARING EARTH and the BEARING.

- 8) Remove the ROLL ASSY MSI by sliding it to the right and pulling out its left side shaft from the left side hole on the printer and then pulling it out to the lower left.
- 9) Remove the BEARING EARTH (PL3.1.6) and the BEARING (PL3.1.13) from the ROLL ASSY MSI.

Removal 17 FEED DRIVE ASSEMBLY (PL8.1.7)

Steps 1 through 4 are for reference. Before removing this component, check that Steps 1 through 4 have been performed.

- 1) Open the FRONT COVER (PL1.2.1).
- 2) Remove the FUSER. (Removal 8)
- 3) Remove the REAR COVER. (Removal 10)
- 4) Remove the RIGHT COVER. (Removal 11)

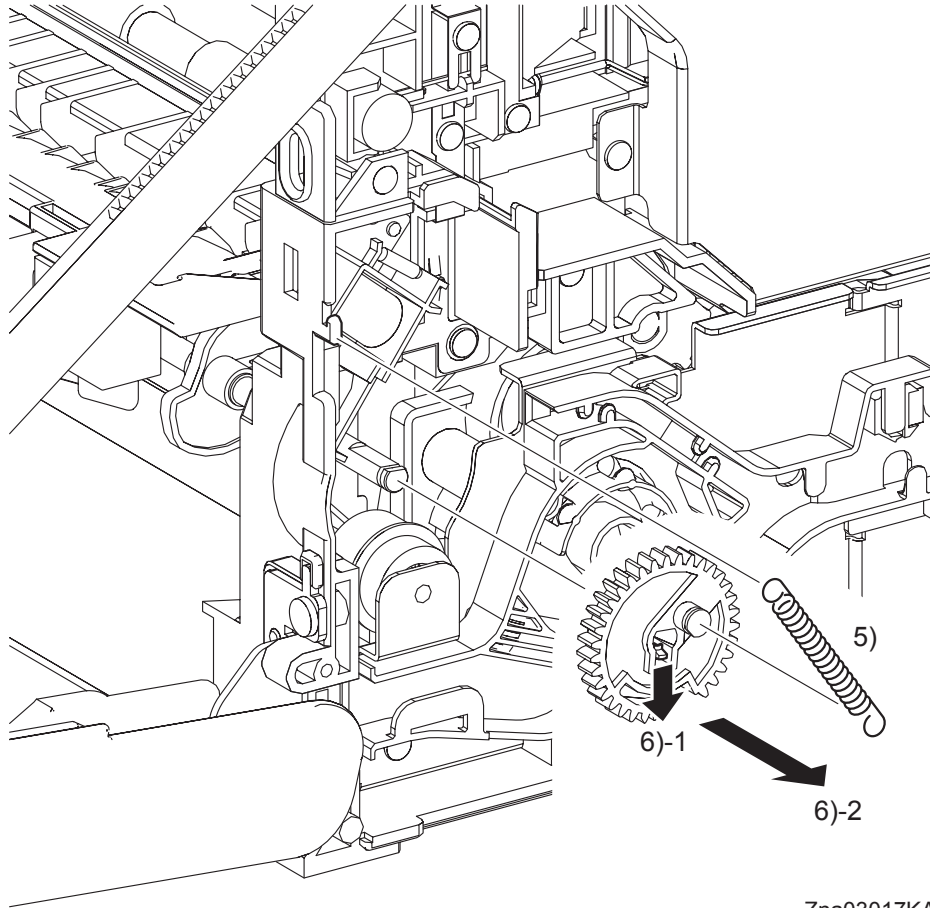

- 5) Remove the SPRING FEED MSI (PL3.1.4) from the printer.
- 6) Remove the GEAR MSI (PL3.1.5) from the SHAFT MSI (PL3.1.12) by releasing the hook on the GEAR MSI.
- 7) Remove all the harnesses from the DUCT ASSY DRV PH (PL8.1.8).

Continues to the next page.

Removal 17 FEED DRIVE ASSEMBLY (PL8.1.7)

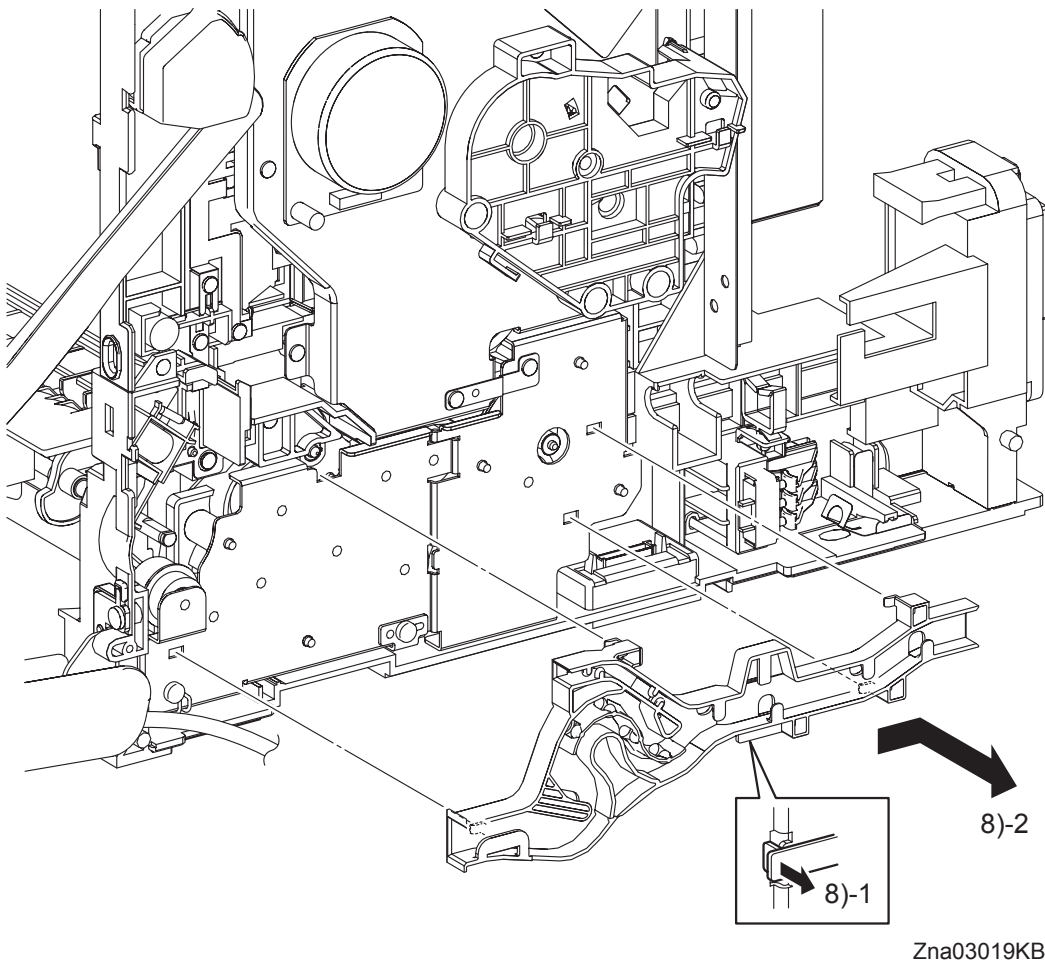

- 8) Remove the DUCT ASSY DRV PH from the FEED DRIVE ASSEMBLY (PL8.1.7) by releasing the hook on the DUCT ASSY DRV PH and moving it slightly backward.

Continues to the next page.

Removal 17 FEED DRIVE ASSEMBLY (PL8.1.7)

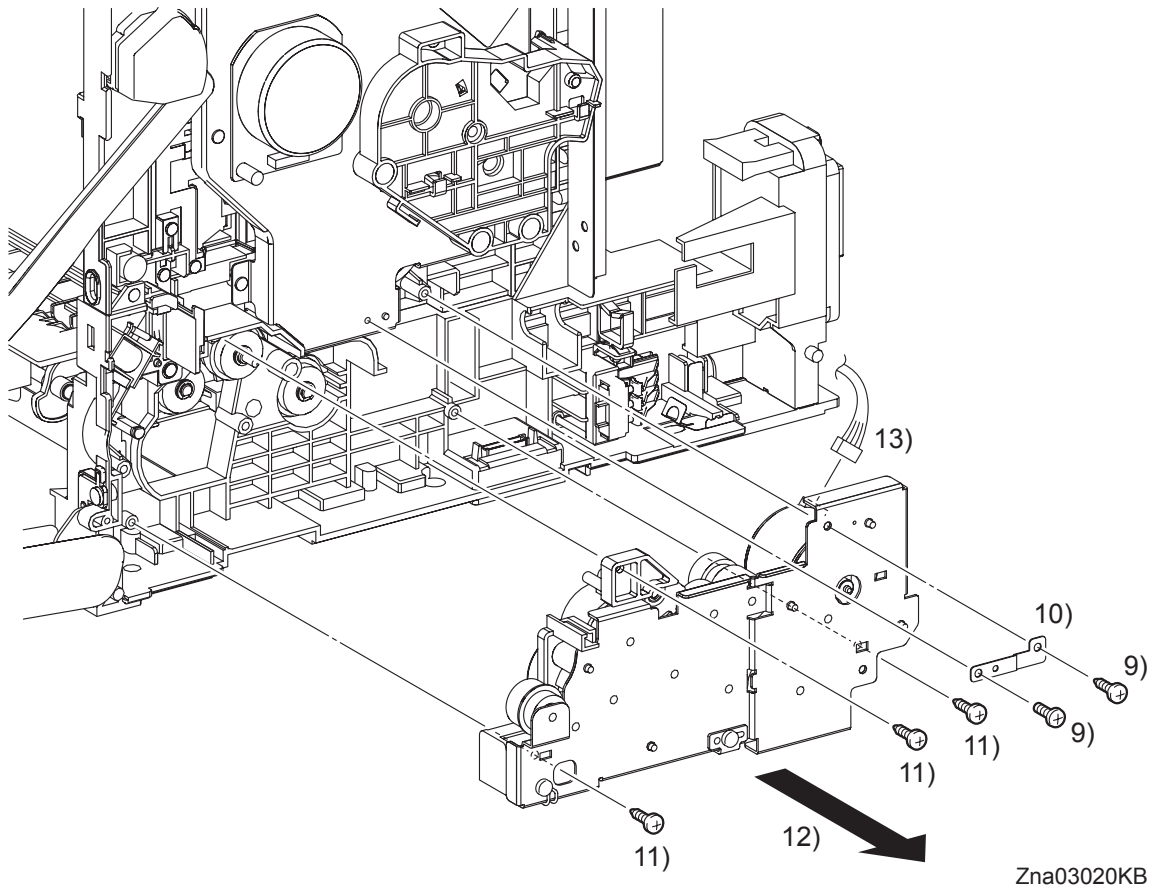

- 9) Remove the one screw (silver, 6mm) and the one screw (silver, tap, 10mm) that fix the PLATE EARTH DRV MP (PL8.1.11) to the PHOTOCONDUCTOR (PC) / DEVELOPER (DEV) DRIVE (PL8.1.2) and FEED DRIVE ASSEMBLY.
- 10) Remove the PLATE EARTH DRV MP from the printer.
- 11) Remove the three screws (silver, tap, 10mm) that fix the FEED DRIVE ASSEMBLY to the printer.

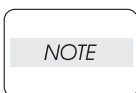

When performing the step described below, take care not to move the FEED DRIVE ASSEMBLY from the printer too far because they are connected with the harness.

- 12) Remove the FEED DRIVE ASSEMBLY from the printer.
- 13) Disengage the connector (P/J251) of the FEED DRIVE ASSEMBLY.

Removal 18 SIZE SWITCH ASSEMBLY (PL7.1.18)

Steps 1 through 4 are for reference. Before removing this component, check that Steps 1 through 4 have been performed.

- 1) Open the FRONT COVER (PL1.2.1).
- 2) Remove the FUSER. (Removal 8)
- 3) Remove the REAR COVER. (Removal 10)
- 4) Remove the RIGHT COVER. (Removal 11)

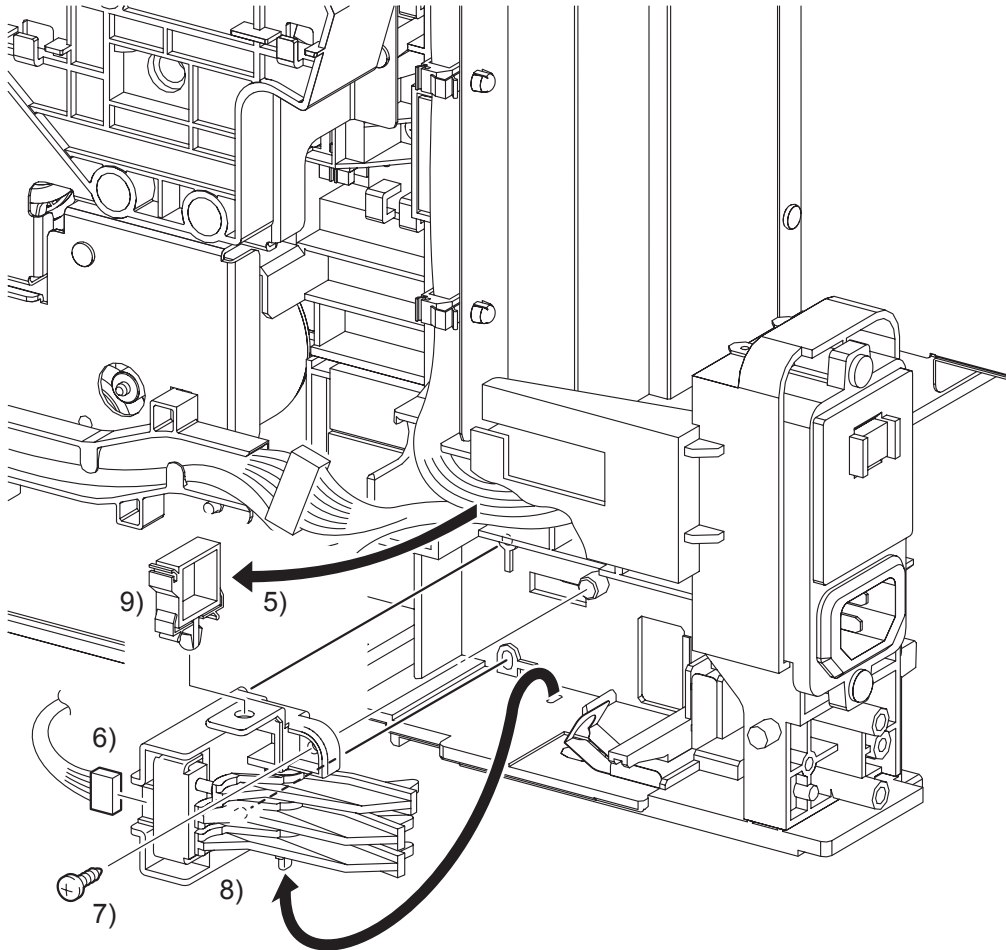

Zna03029KA

- 5) Release the clamp on the SIZE SWITCH ASSEMBLY (PL7.1.18), and then remove the harness.
- 6) Disengage the connector (P/J291) of the SIZE SWITCH ASSEMBLY.
- 7) Remove the one screw (silver, tap, 10mm) that fixes the SIZE SWITCH ASSEMBLY to the printer.
- 8) Remove the SIZE SWITCH ASSEMBLY by releasing the two bosses and the backside tab of the SIZE SWITCH ASSEMBLY from the holes on the printer.
- 9) Remove the clamp from the SIZE SWITCH ASSEMBLY.

Removal 19 BREAKER GFI INLET (PL9.1.43)

Steps 1 through 4 are for reference. Before removing this component, check that Steps 1 through 4 have been performed.

- 1) Open the FRONT COVER (PL1.2.1).
- 2) Remove the FUSER. (Removal 8)
- 3) Remove the REAR COVER. (Removal 10)
- 4) Remove the RIGHT COVER. (Removal 11)

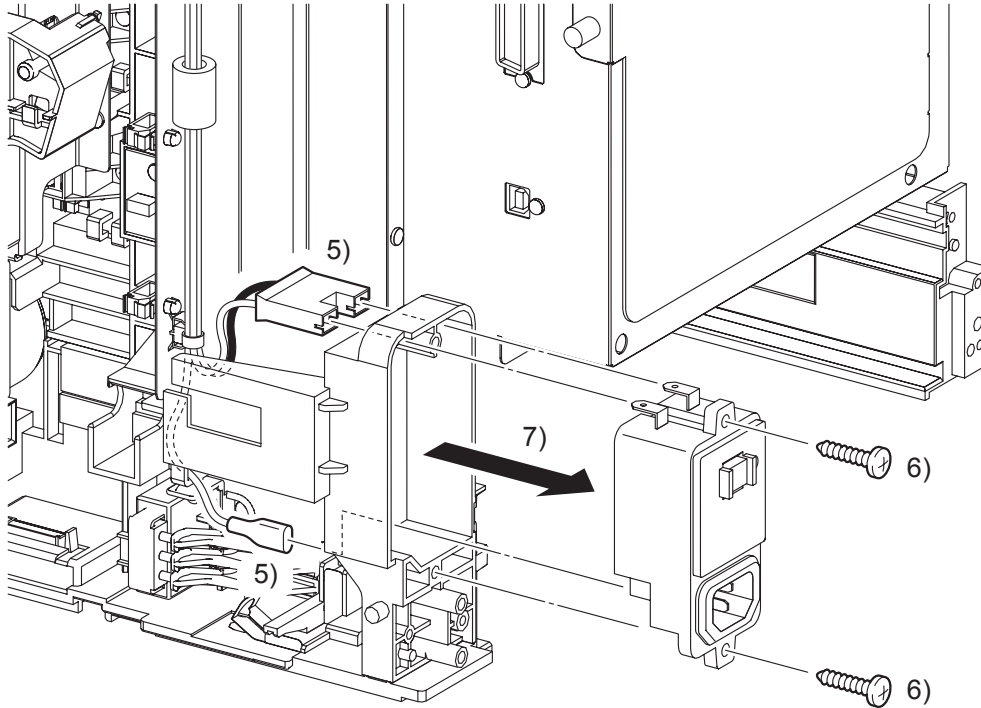

Zna03202KA

- 5) Disengage the connector (P/J482) and the FASTON terminal (FS483) on the BREAKER GFI INLET (PL9.1.43).
- 6) Remove the two screws (silver, tap, 16mm) that fix the BREAKER GFI INLET to the printer.
- 7) Remove the BREAKER GFI INLET from the printer.

Removal 20 LEFT COVER (PL1.1.7)

Steps 1 through 3 are for reference. Before removing this component, check that Steps 1 through 3 have been performed.

- 1) Open the FRONT COVER (PL1.2.1).
- 2) Remove the FUSER. (Removal 8)
- 3) Remove the REAR COVER. (Removal 10)

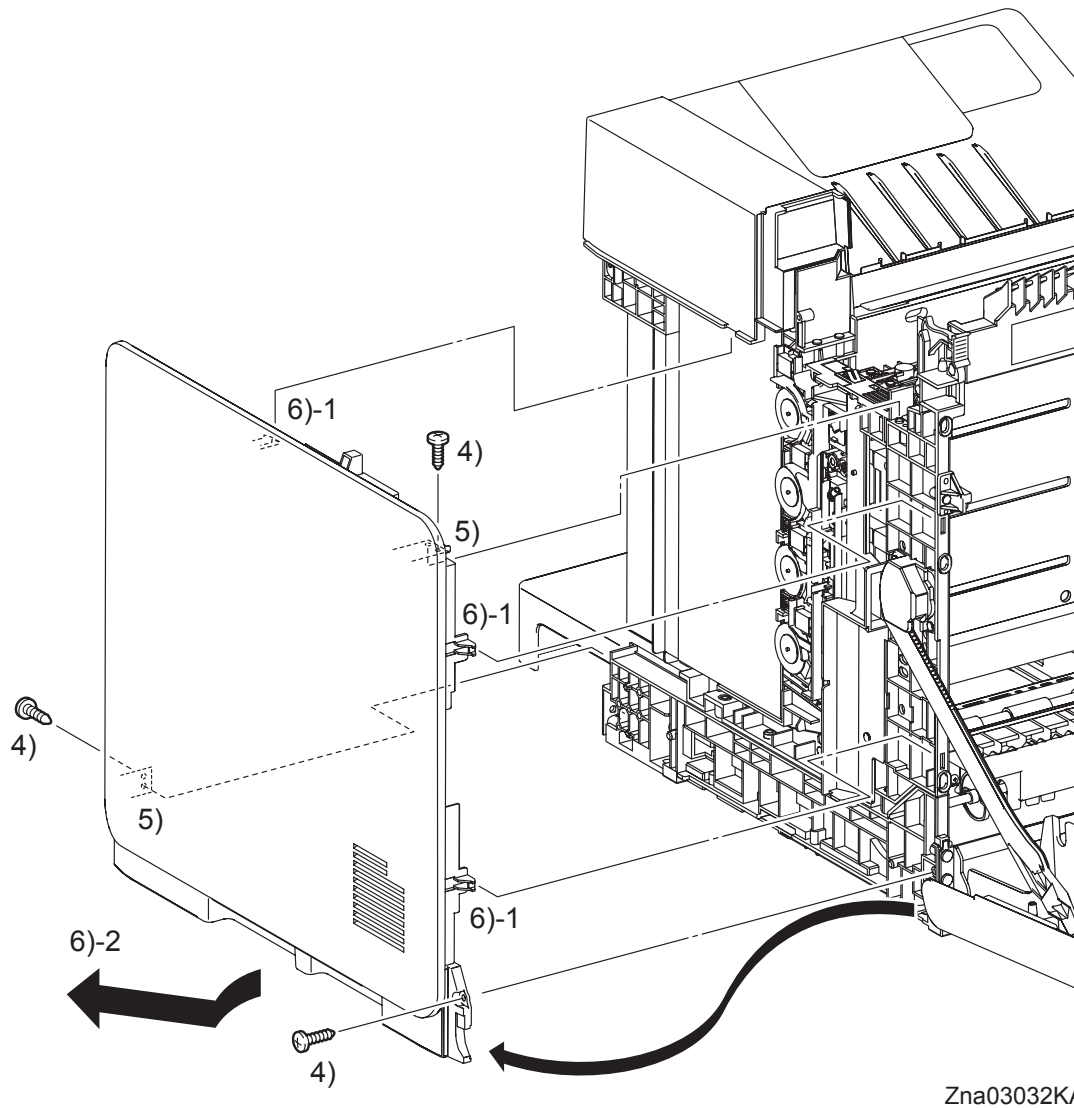

- 4) Remove three screws (silver, tap, 10mm) that fix the LEFT COVER (PL1.1.7) to the printer.
- 5) Release the two holes on the LEFT COVER from the bosses on the printer.
- 6) Release the one backside hook and two front side hooks on the LEFT COVER, and then remove the LEFT COVER from the printer by moving it diagonally backward.

Go to the next removal step:

Removal 21 LEVER FUSER AD (PL6.1.19), Removal 22 ARM ASSEMBLY (PL7.1.98), Removal 23 LED ASSEMBLY (PL5.1.15), Removal 24 TONER DISPENSER MOTOR (PL5.1.12), Removal 25 SHIELD ASSY ESS (PL9.1.45), Removal 31 TOP COVER (PL1.1.1)

Removal 21 LEVER FUSER AD (PL6.1.19)

Steps 1 through 4 are for reference. Before removing this component, check that Steps 1 through 4 have been performed.

- 1) Open the FRONT COVER (PL1.2.1).
- 2) Remove the FUSER. (Removal 8)
- 3) Remove the REAR COVER. (Removal 10)
- 4) Remove the LEFT COVER. (Removal 20)

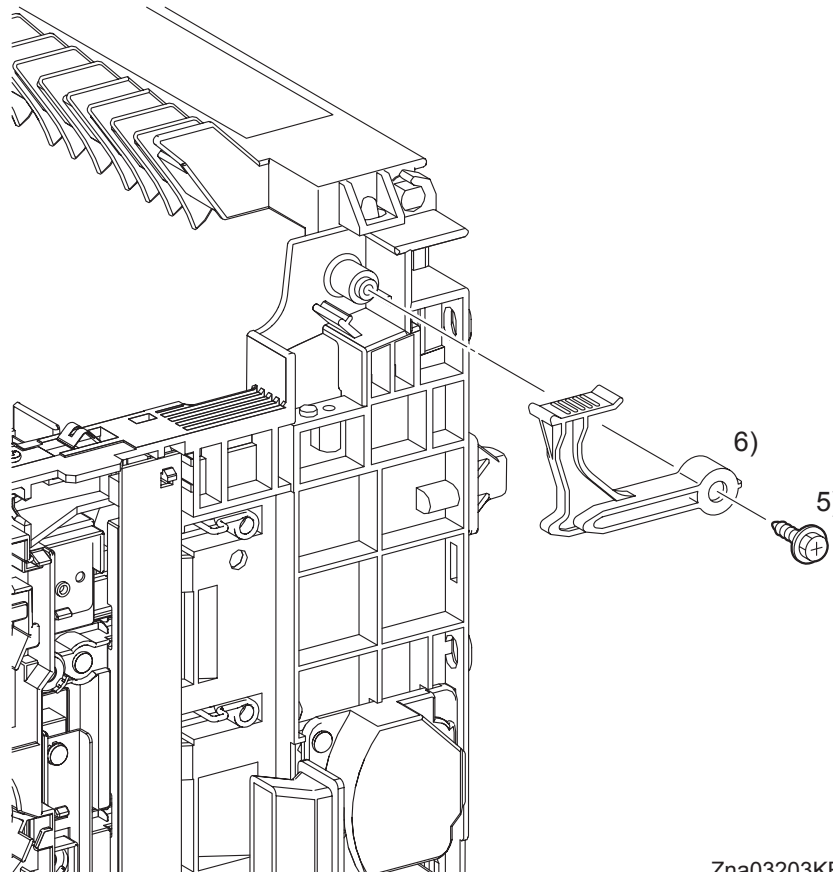

Zna03203KB

- 5) Remove the one screw (silver, with flange, tap, 10mm) that fixes the LEVER FUSER AD (PL6.1.19) to the printer.
- 6) Remove the LEVER FUSER AD from the printer.

Blank Page

Removal 22 ARM ASSEMBLY (PL7.1.98)

Steps 1 through 5 are for reference. Before removing this component, check that Steps 1 through 5 have been performed.

- 1) Open the FRONT COVER (PL1.2.1).
- 2) Remove the FUSER. (Removal 8)
- 3) Remove the REAR COVER. (Removal 10)
- 4) Remove the RIGHT COVER. (Removal 11)
- 5) Remove the LEFT COVER. (Removal 20)

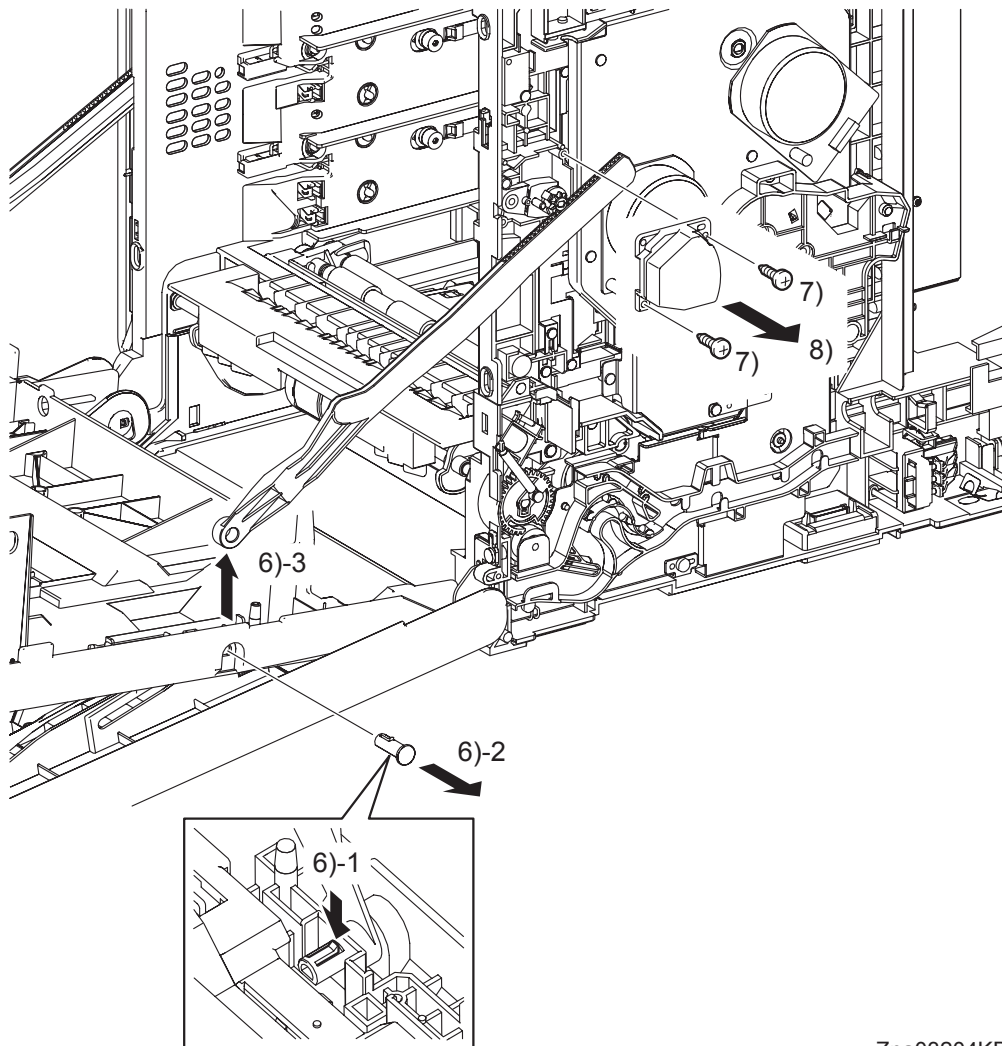

Zna03204KB

- 6) Release the hook of the SHAFT PIVOT (PL1.2.8) that fixes the LINK R (PL7.1.13) to the FRONT COVER (PL1.2.1), and then pull the SHAFT PIVOT to the outside and remove the LINK R from the FRONT COVER.
- 7) Remove the two screws (silver, tap, 10mm) that fix the SUPPORT LINK R (PL7.1.12) to the printer.
- 8) Remove the SUPPORT LINK R from the printer.

Continues to the next page.

Removal 22 ARM ASSEMBLY (PL7.1.98)

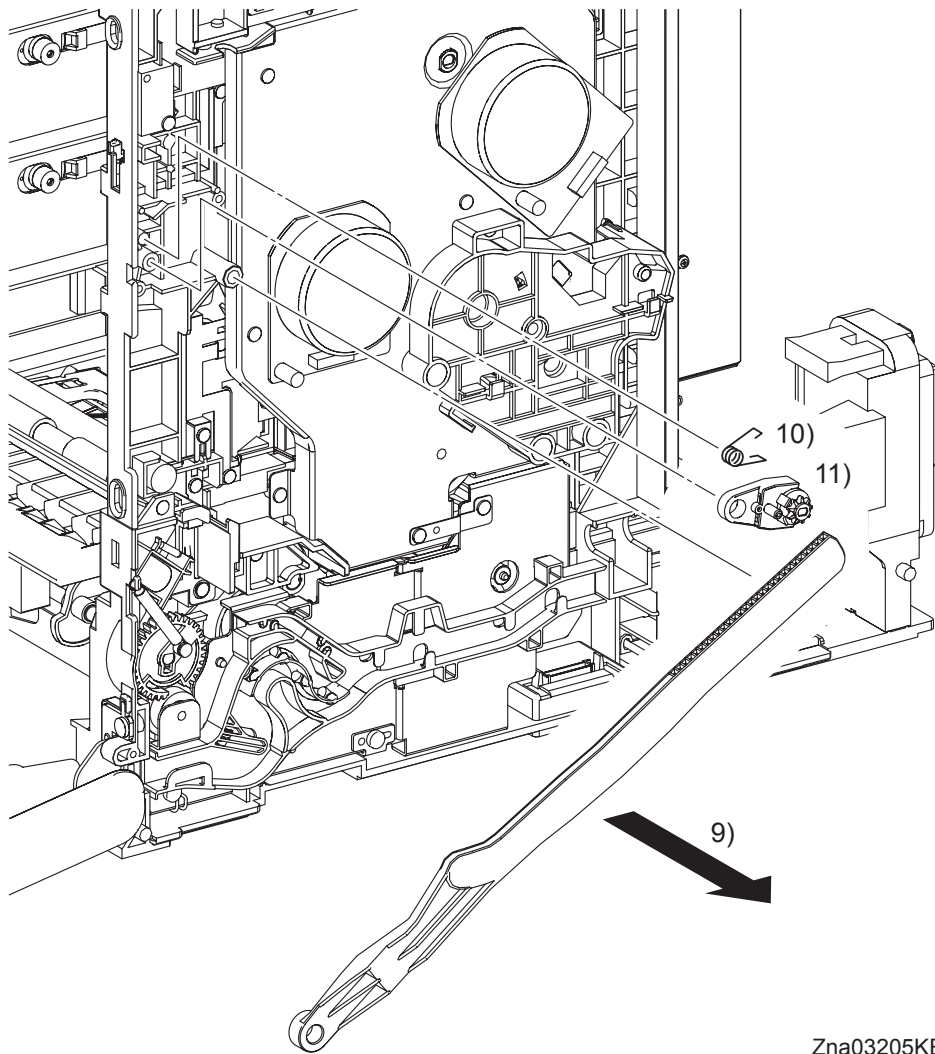

Zna03205KB

- 9) Remove the LINK R from the printer.
- 10) Remove the SPRING SUPPORT (PL7.1.8) from the printer.
- 11) Remove the HOLDER DAMPER (PL7.1.6) from the printer together with the DAMPER OIL (PL7.1.7).

NOTE

When performing the step describe below, take care not to drop or damage the FRONT COVER.

Continues to the next page.

Removal 22 ARM ASSEMBLY (PL7.1.98)

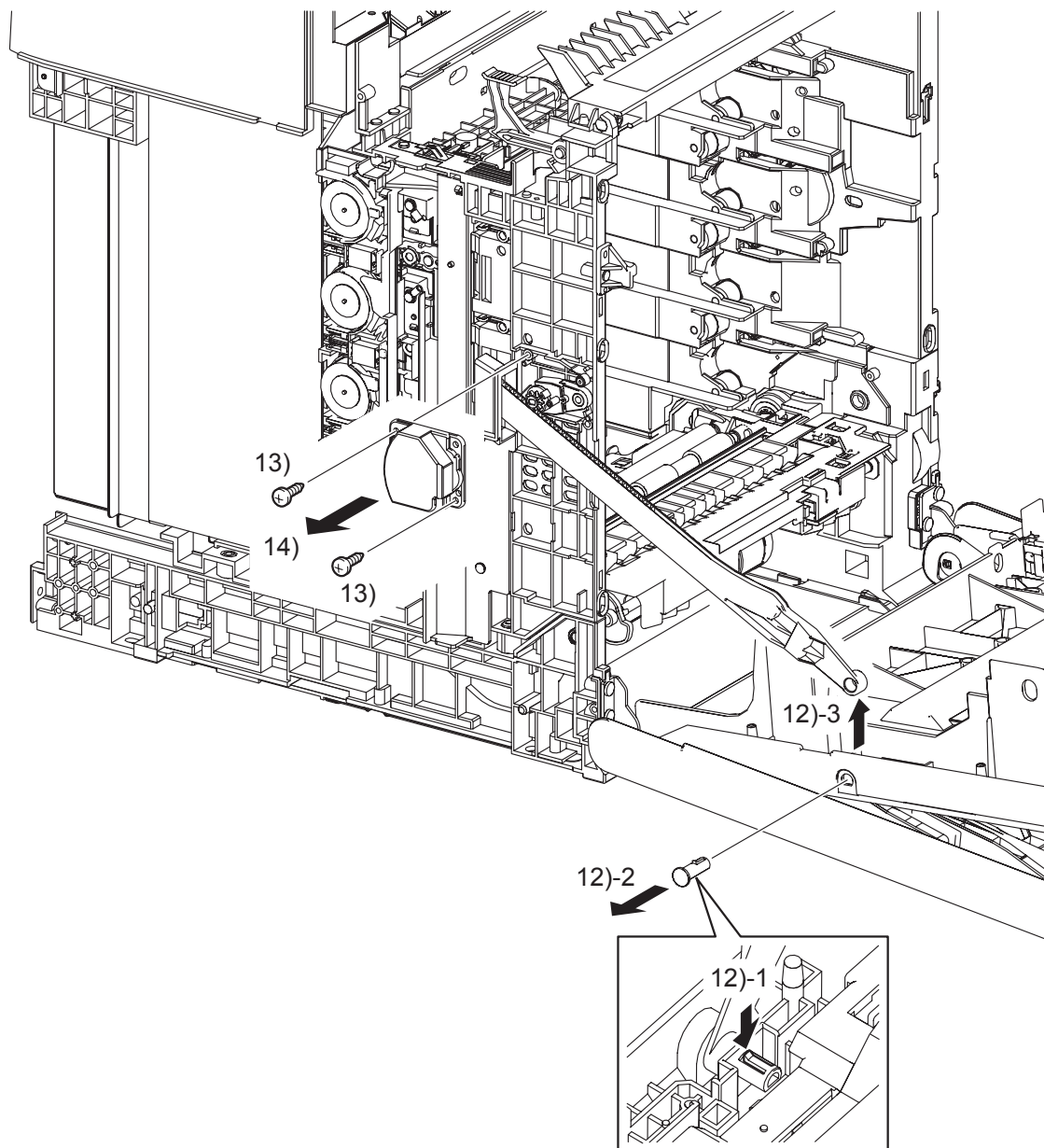

Zna03206KB

- 12) Release the hook of the SHAFT PIVOT that fixes the LINK L (PL7.1.3) to the FRONT COVER, and then remove the LINK L from the FRONT COVER by pulling the SHAFT PIVOT to the outside.
- 13) Remove the two screws (silver, tap, 10mm) that fix the SUPPORT LINK L (PL7.1.2) to the printer.
- 14) Remove the SUPPORT LINK L from the printer.

Continues to the next page.

Removal 22 ARM ASSEMBLY (PL7.1.98)

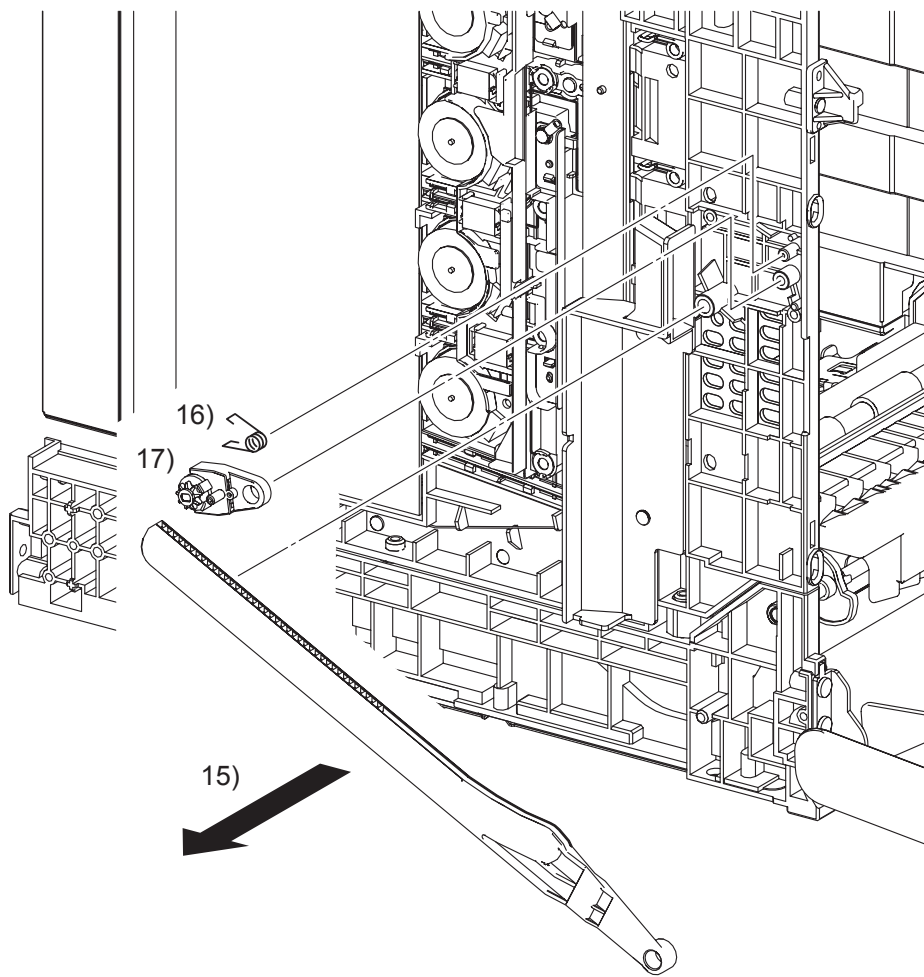

Zna03207KB

- 15) Remove the LINK L from the printer.
- 16) Remove the SPRING SUPPORT (PL7.1.8) from the printer.
- 17) Remove the HOLDER DAMPER (PL7.1.6) from the printer together with the DAMPER OIL

Removal 23 LED ASSEMBLY (PL5.1.15)

Steps 1 through 4 are for reference. Before removing this component, check that Steps 1 through 4 have been performed.

- 1) Open the FRONT COVER (PL1.2.1).
- 2) Remove the FUSER. (Removal 8)
- 3) Remove the REAR COVER. (Removal 10)
- 4) Remove the LEFT COVER. (Removal 20)

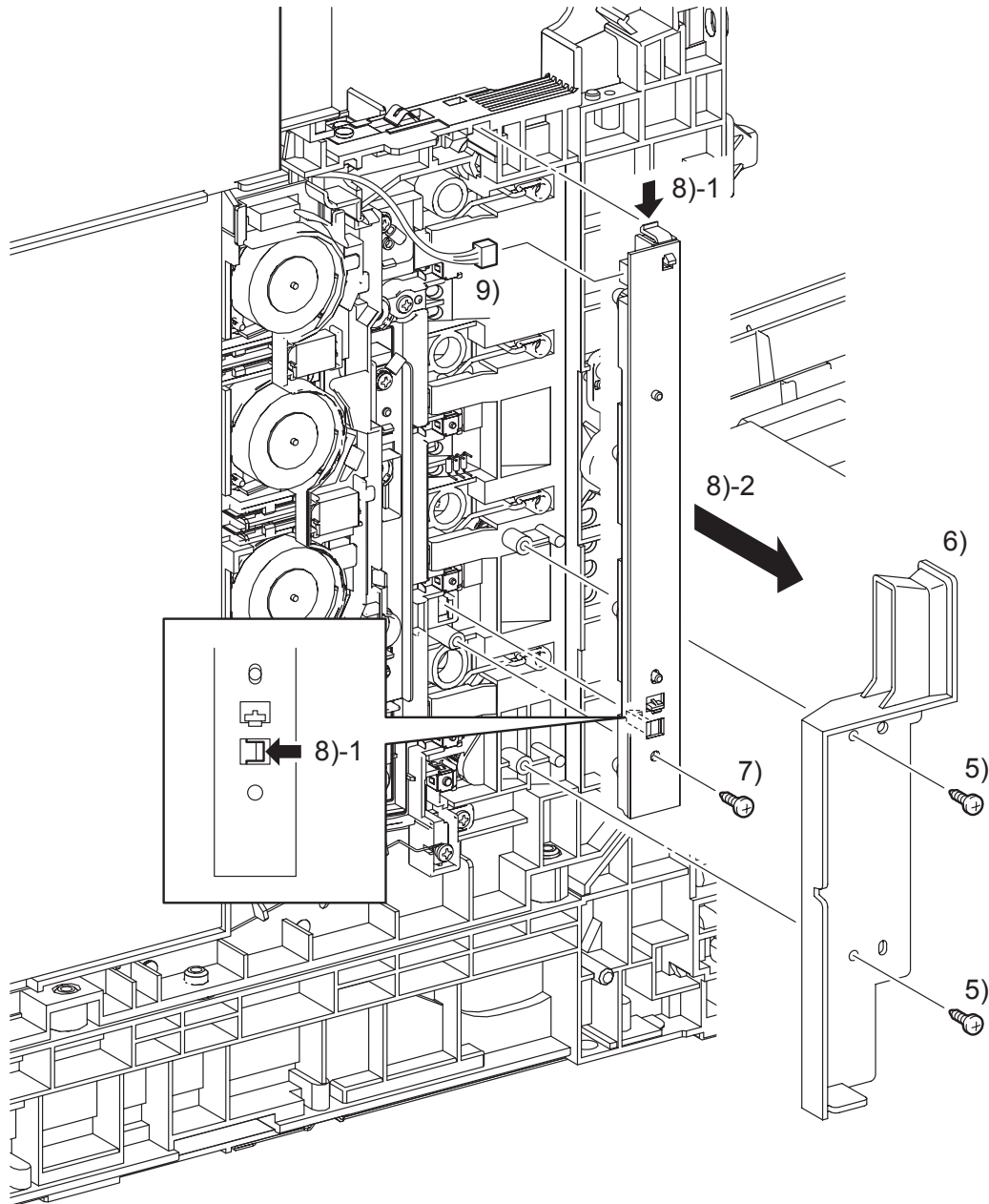

Zna03037KA

- 5) Remove two screws (silver, tap, 10mm) that fix the DUCT SIDE L (PL7.1.23) to the printer.
- 6) Remove the DUCT SIDE L from the printer.
- 7) Remove one screw (silver, tap, 10mm) that fixes the LED ASSEMBLY (PL5.1.15) to the printer.
- 8) Remove the LED ASSEMBLY from the printer by releasing its two hooks.
- 9) Disengage the connector (P/J141) of the LED ASSEMBLY.

Blank Page

Removal 24 TONER DISPENSER MOTOR (PL5.1.12)

NOTE

Described below is the removal procedure common among the TONER DISPENSER MOTORS (C), (M), (Y), and (K).

Steps 1 through 4 are for reference. Before removing this component, check that Steps 1 through 4 have been performed.

- 1) Open the FRONT COVER (PL1.2.1).
- 2) Remove the FUSER. (Removal 8)
- 3) Remove the REAR COVER. (Removal 10)
- 4) Remove the LEFT COVER. (Removal 20)

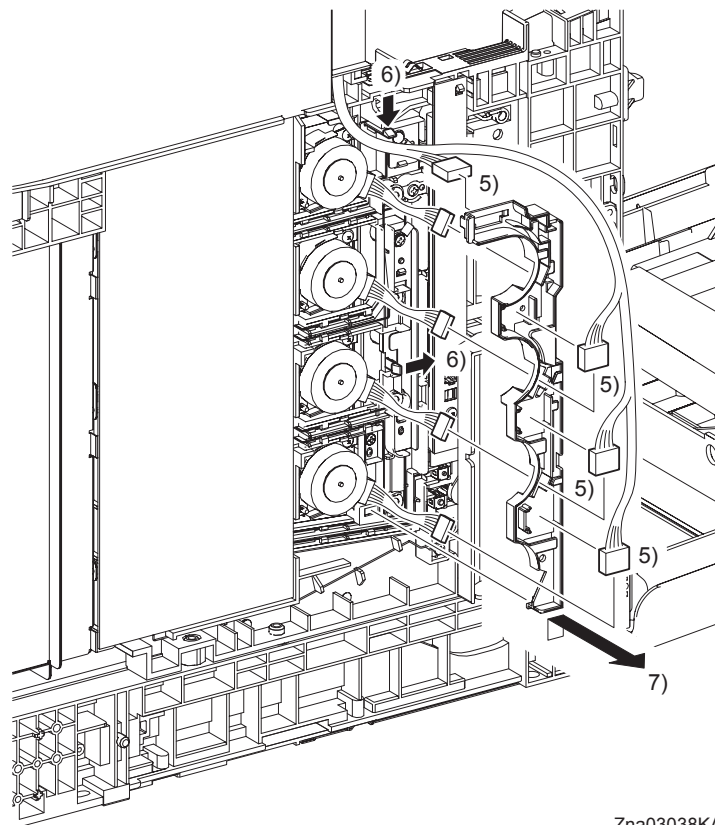

Zna03038KA

NOTE

When performing the step below, leave the junction connector on the printer side cable.

- 5) Release the four sets of connectors and harness of the TONER DISPENSER MOTOR (PL5.1.12) from the DUCT HARNESS MOT (PL5.1.16), and disengage the four sets of connectors of the TONER DISPENSER MOTOR.
- 6) Release two hooks that fix the DUCT HARNESS MOT to the printer.
- 7) Release the lug on the DUCT HARNESS MOT from the printer by moving the DUCT HARNESS MOT slightly upward. Pass the four sets connectors of the TONER DISPENSER MOTOR through the hole on the DUCT HARNESS MOT, and then remove the DUCT HARNESS MOT.

Continues to the next page.

Removal 24 TONER DISPENSER MOTOR (PL5.1.12)

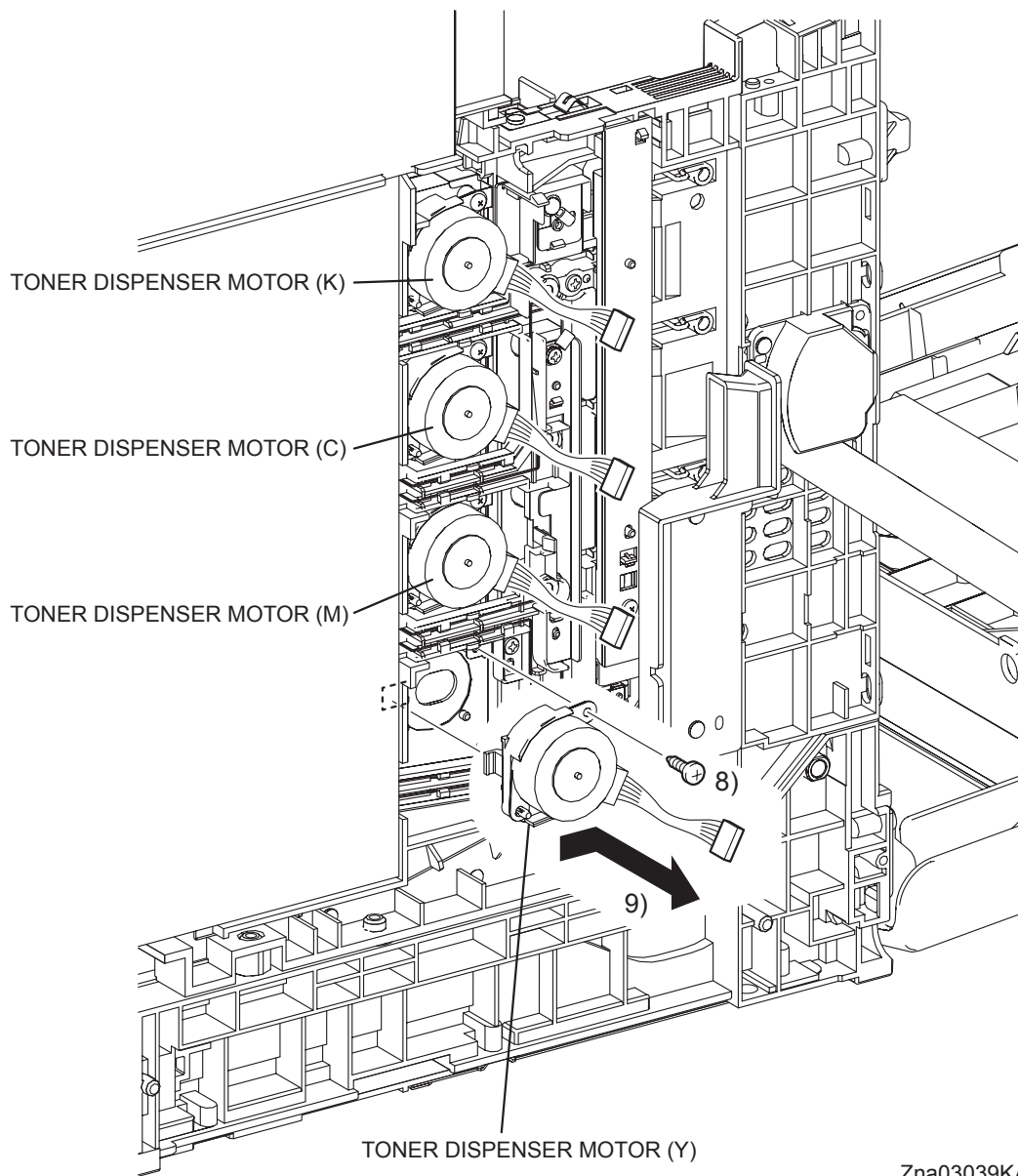

Zna03039KA

- 8) Remove the one screw (silver, tap, 10mm) that fixes the TONER DISPENSER MOTOR to the printer.
- 9) Release the lug on the TONER DISPENSER MOTOR by moving the TONER DISPENSER MOTOR slightly upward. Remove the TONER DISPENSER MOTOR from the printer.

Removal 25 SHIELD ASSY ESS (PL9.1.45)

NOTE

If there are the WIRELESS PRINTER ADAPTER and the HARD DISC on the ELECTRONIC SUB-SYSTEM CONTROL BOARD, remove it before working.

Steps 1 through 5 are for reference. Before removing this component, check that Steps 1 through 5 have been performed.

- 1) Open the FRONT COVER (PL1.2.1).
- 2) Remove the FUSER. (Removal 8)
- 3) Remove the REAR COVER. (Removal 10)
- 4) Remove the RIGHT COVER. (Removal 11)
- 5) Remove the LEFT COVER. (Removal 20)

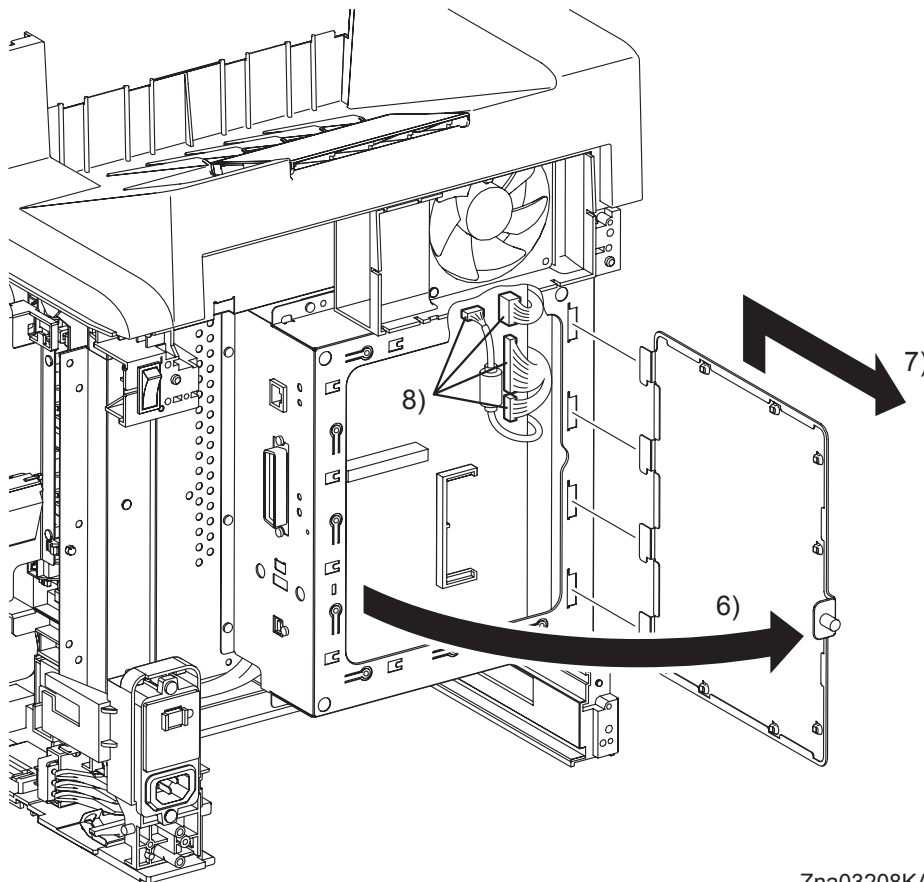

Zna03208KA

- 6) Loosen the SCREW KNURLING (PL9.1.44) and open the SHIELD WINDOW (PL9.1.21).
- 7) Lift the SHIELD WINDOW slightly up to release the four tabs of the SHIELD WINDOW from the holes of the SHIELD ESS (PL9.1.25)
- 8) Disengage all the connectors of the ELECTRONIC SUB-SYSTEM CONTROL BOARD (PL9.1.27).

Continues to the next page.

Removal 25 SHIELD ASSY ESS (PL9.1.45)

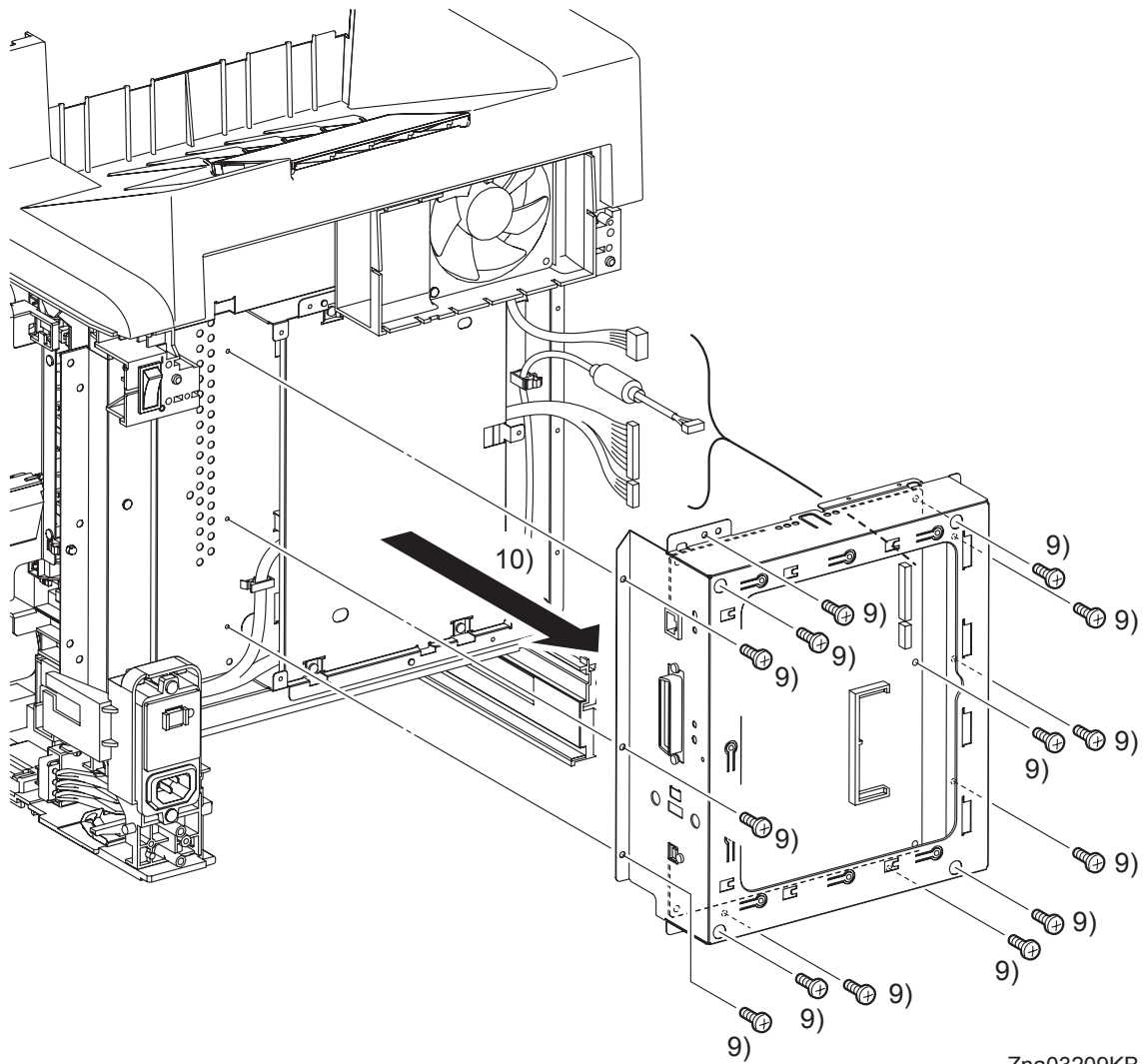

Zna03209KB

- 9) Remove the fourteen screws (silver, 6mm) that fix the SHIELD ASSY ESS (PL9.1.45) to the printer.
- 10) Remove the SHIELD ASSY ESS from the printer.

Go to the next removal step:

Removal 26 ELECTRONIC SUB-SYSTEM CONTROL BOARD (PL9.1.27), Removal 27 SHIELD MCU (PL9.1.42)

Removal 26 ELECTRONIC SUB-SYSTEM CONTROL BOARD (PL9.1.27)

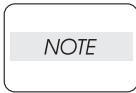

Use a wristband to protect the PWB from electrostatic damage.

Steps 1 through 6 are for reference. Before removing this component, check that Steps 1 through 6 have been performed.

- 1) Open the FRONT COVER (PL1.2.1).
- 2) Remove the FUSER. (Removal 8)
- 3) Remove the REAR COVER. (Removal 10)
- 4) Remove the RIGHT COVER. (Removal 11)
- 5) Remove the LEFT COVER. (Removal 20)

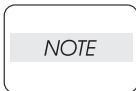

If there are the WIRELESS PRINTER ADAPTER and the HARD DISC on the ELECTRONIC SUB-SYSTEM CONTROL BOARD, remove it before removing the SHIELD ASSY ESS.

- 6) Remove the SHIELD ASSY ESS. (Removal 25)

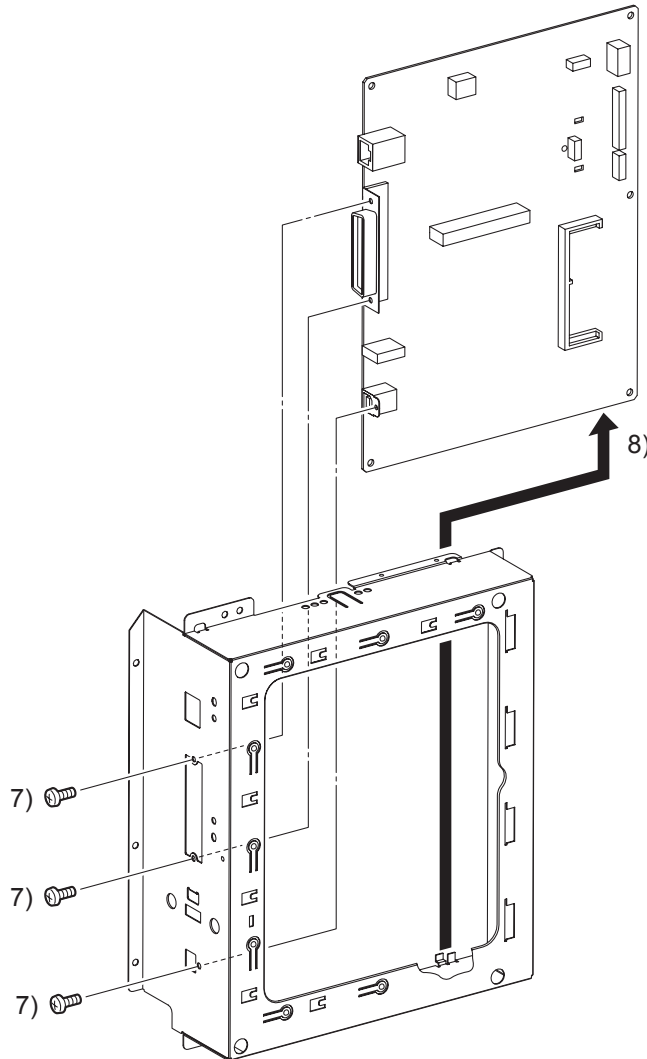

Zna03210KB

- 7) Remove all the screws that fix the connectors of the ELECTRONIC SUB-SYSTEM CONTROL BOARD (PL9.1.27) to the SHIELD ESS (PL9.1.25).
- 8) Remove the ELECTRONIC SUB-SYSTEM CONTROL BOARD from the SHIELD ESS.

Removal 27 SHIELD MCU (PL9.1.42)

Steps 1 through 6 are for reference. Before removing this component, check that Steps 1 through 6 have been performed.

- 1) Open the FRONT COVER (PL1.2.1).
- 2) Remove the FUSER. (Removal 8)
- 3) Remove the REAR COVER. (Removal 10)
- 4) Remove the RIGHT COVER. (Removal 11)
- 5) Remove the LEFT COVER. (Removal 20)
- 6) Remove the SHIELD ASSY ESS. (Removal 25)

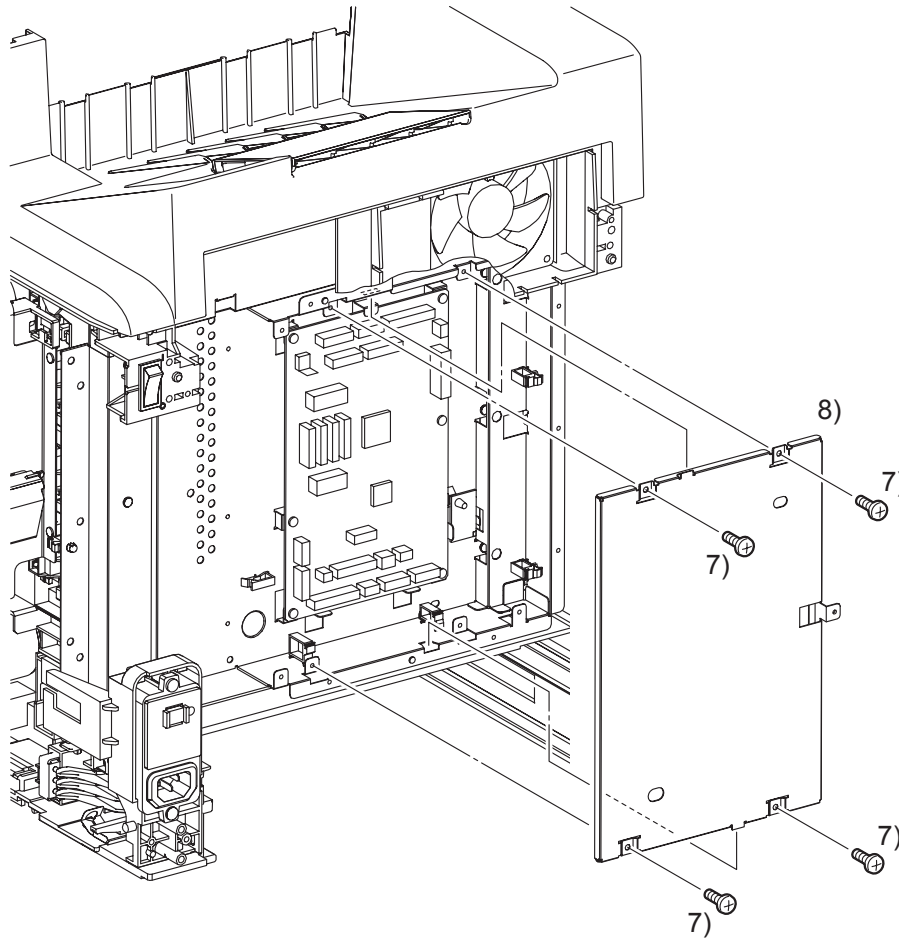

Zna03211KA

- 7) Remove the four screws (silver, 6mm) that fix the SHIELD MCU (PL9.1.42) to the printer.
- 8) Release the two tabs of the SHIELD MCU from the holes of the SHIELD REAR, and then remove the SHIELD MCU from the printer.

Go to the next removal step:

**Removal 28 DRIVE ASSY K (PL8.1.10), Removal 29 HUMIDITY SENSOR (PL9.1.19),
Removal 30 MACHINE CONTROL UNIT (PL9.1.20)**

Removal 28 DRIVE ASSY K (PL8.1.10)

Steps 1 through 7 are for reference. Before removing this component, check that Steps 1 through 7 have been performed.

- 1) Open the FRONT COVER (PL1.2.1).
- 2) Remove the FUSER. (Removal 8)
- 3) Remove the REAR COVER. (Removal 10)
- 4) Remove the RIGHT COVER. (Removal 11)
- 5) Remove the LEFT COVER. (Removal 20)
- 6) Remove the SHIELD ASSY ESS. (Removal 25)
- 7) Remove the SHIELD MCU. (Removal 27)

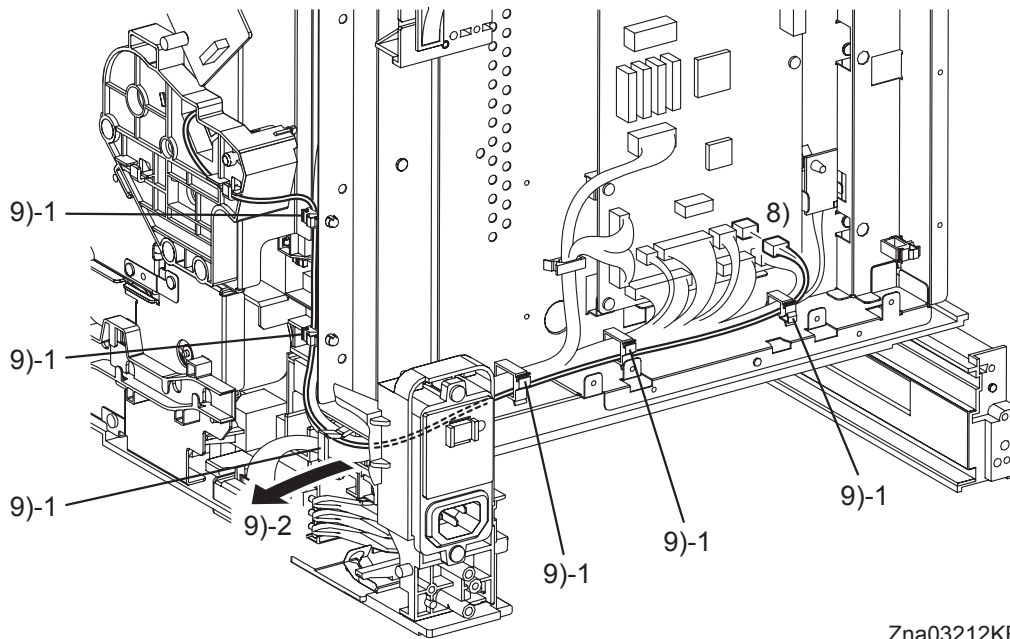

- 8) Disengage the connector (P/J20) on the MACHINE CONTROL UNIT (PL9.1.20).
- 9) Release the harness of the K Mode Sensor from the six clamps, and then put the harness into the hole of the frame to remove it.

Continues to the next page.

Removal 28 DRIVE ASSY K (PL8.1.10)

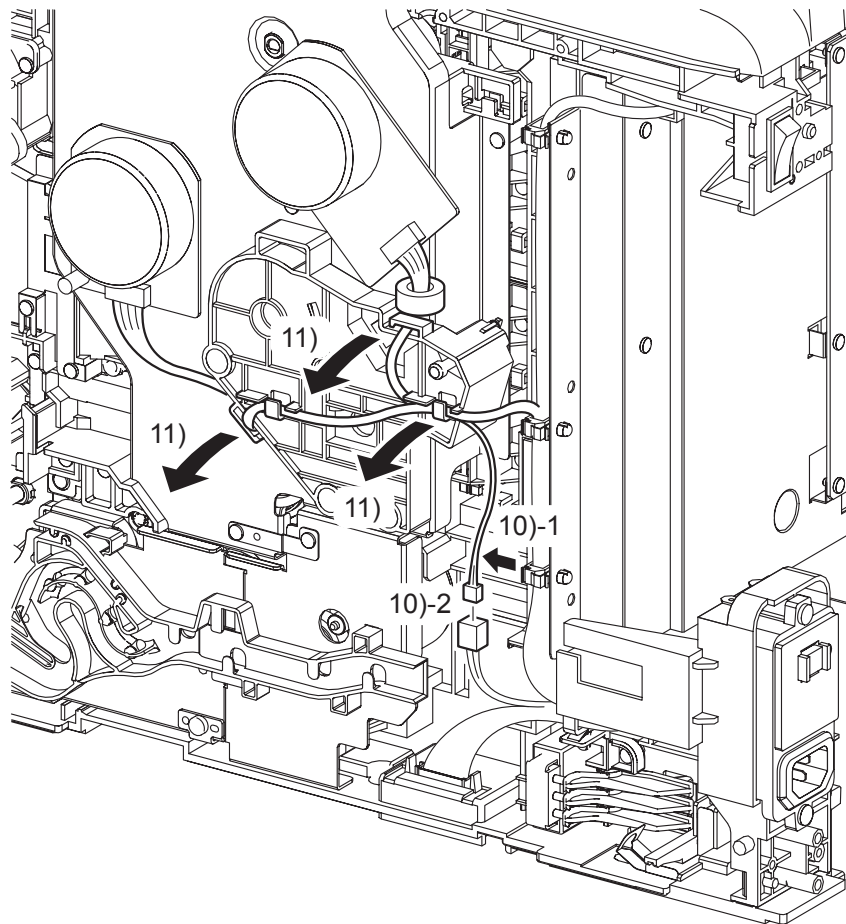

Zna03213KB

NOTE

When performing the step below, leave the junction connector on the printer side cable.

- 10) Release the harness of the K Mode Solenoid in the DRIVE ASSY from the clamp, and then disengage the connector (P/J241).
- 11) Release the harness connected to the Main Motor and the Sub Motor in the PHOTOCONDUCTOR (PC) / DEVELOPER (DEV) DRIVE (PL8.1.2) from the hook of the DRIVE ASSY K.

Continues to the next page.

Removal 28 DRIVE ASSY K (PL8.1.10)

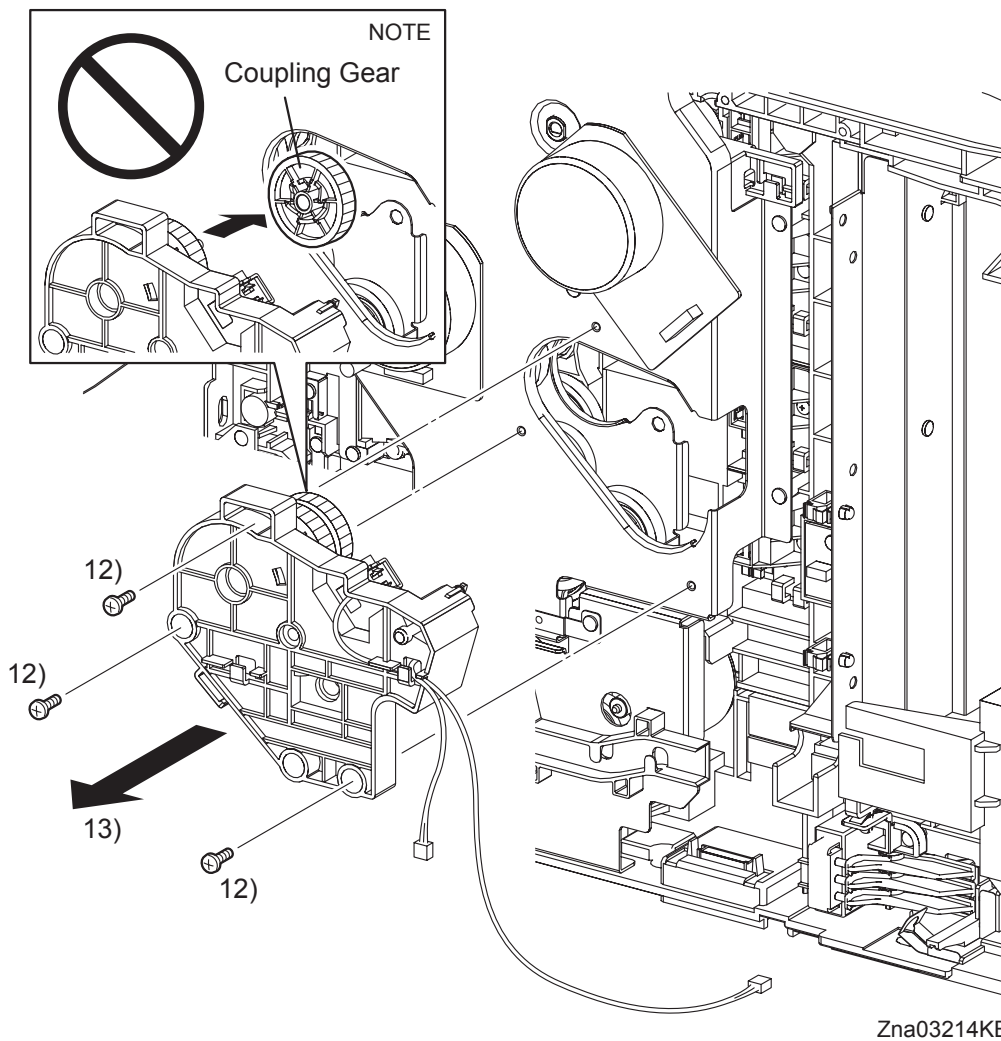

- 12) Remove the three screws (silver, 6mm) that fix the DRIVE ASSY K to the PHOTOCONDUCTOR (PC) / DEVELOPER (DEV) DRIVE.

NOTE

When carrying out the work described next procedure, take care not to drop the coupling gear to inside.

- 13) Remove the DRIVE ASSY K from the printer.

Removal 29 HUMIDITY SENSOR (PL9.1.19)

Steps 1 through 7 are for reference. Before removing this component, check that Steps 1 through 7 have been performed.

- 1) Open the FRONT COVER (PL1.2.1).
- 2) Remove the FUSER. (Removal 8)
- 3) Remove the REAR COVER. (Removal 10)
- 4) Remove the RIGHT COVER. (Removal 11)
- 5) Remove the LEFT COVER. (Removal 20)
- 6) Remove the SHIELD ASSY ESS. (Removal 25)
- 7) Remove the SHIELD MCU. (Removal 27)

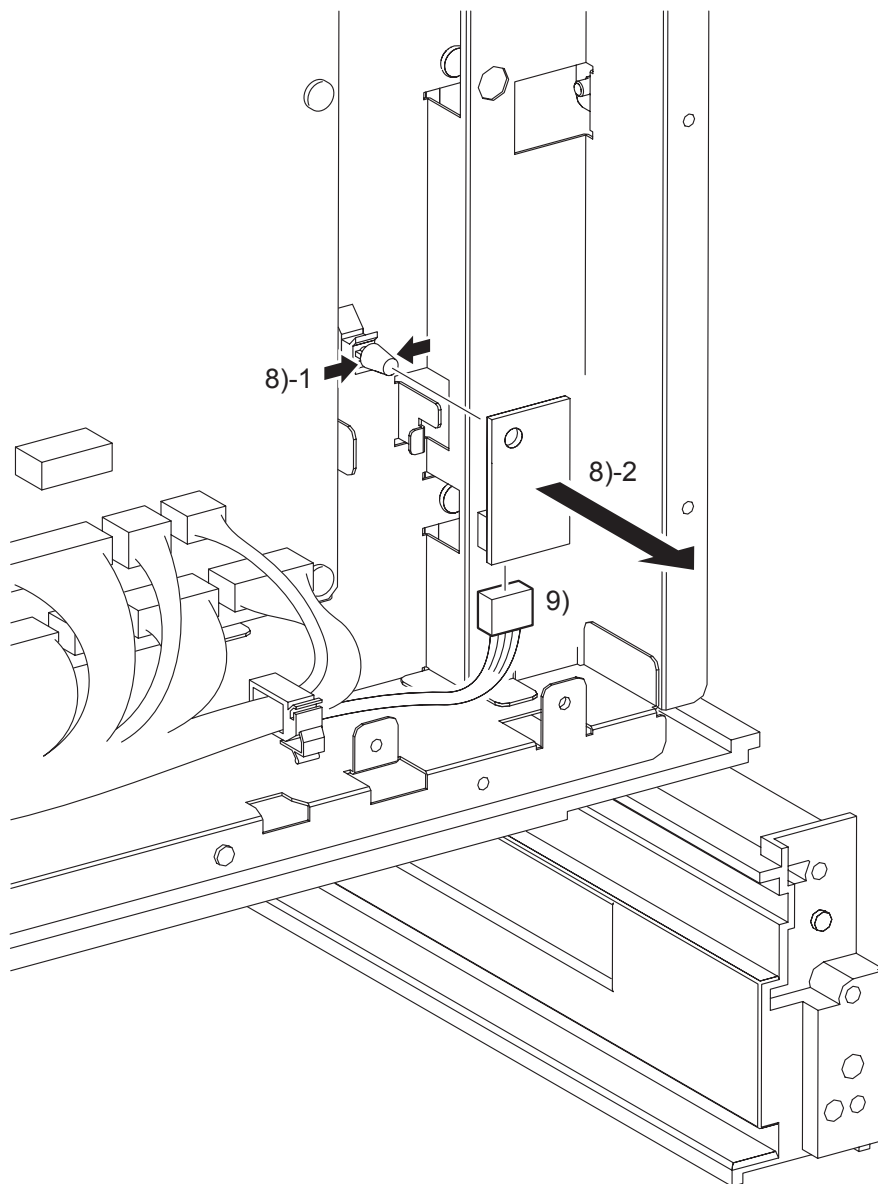

Zna03041KA

- 8) Release the hook of the SPACER (PL9.1.18), and then remove the HUMIDITY SENSOR from the printer.
- 9) Disengage the connector (P/J261) of the HUMIDITY SENSOR (PL9.1.19).

Removal 30 MACHINE CONTROL UNIT (PL9.1.20)

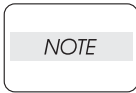

Never fail to perform the diagnostic operation described below. Otherwise the data will be lost in the worst case.

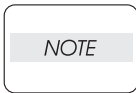

Use a wristband to protect the PWB from electrostatic damage.

- 1) Perform NVM Save to evacuate the MCU data.
- 2) Turn on the power while pressing the ► key, ◀ key, and [MENU] key on the control panel.
- 3) Enter the password, press the ▲ key twice, and press the ✓ key once. The diagnostic screen comes up.
- 4) Press the ▼ key several times until "IOT Diag" is displayed. Press the ✓ key once.
- 5) Press the ▼ key several until "NVM Settings" is displayed. Press the ✓ key once.
- 6) Press the ▼ key several times until "SaveNVM to ESS" is displayed. Press the ✓ key once.
- 7) Press the ✓ key twice, and SaveNVM to ESS is performed.
- 8) After SaveNVM to ESS is complete, press the [CANCEL] key several times until "IOT Diag" is displayed.
- 9) Press the ▼ key several times until "Complete" is displayed.
- 10) Press the ✓ key three times. "Ready to Print" is displayed.
- 11) Turn off the power.
- 12) Remove the POWER CORD from the AC outlet.

Steps 13 through 18 are for reference. Before removing this component, check that Steps 13 through 18 have been performed.

- 13) Remove the FUSER. (Removal 8)
- 14) Remove the REAR COVER. (Removal 10)
- 15) Remove the RIGHT COVER. (Removal 11)
- 16) Remove the LEFT COVER. (Removal 20)
- 17) Remove the SHIELD ASSY ESS. (Removal 25)
- 18) Remove the SHIELD MCU. (Removal 27)

Continues to the next page.

Removal 30 MACHINE CONTROL UNIT (PL9.1.20)

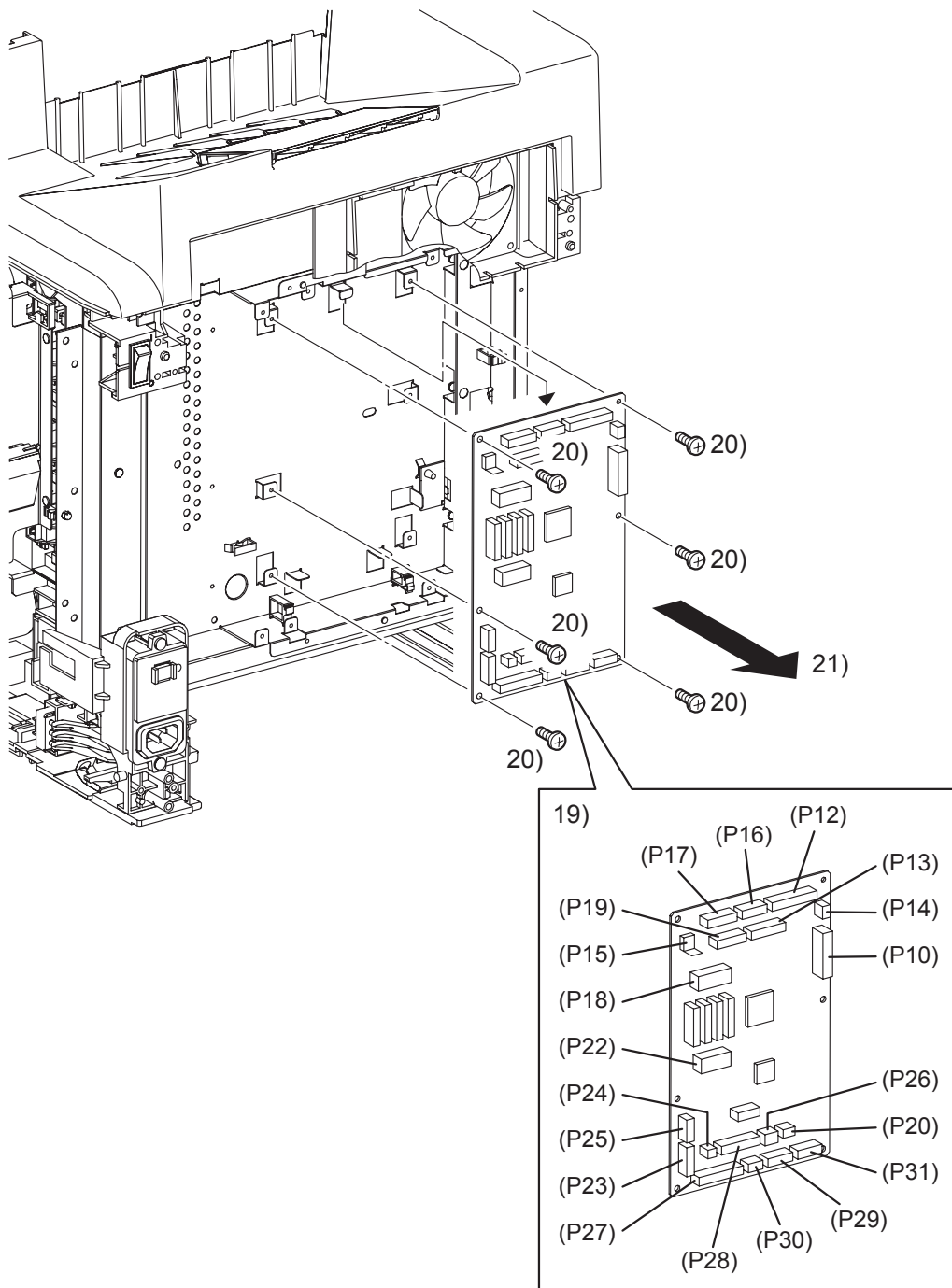

Zna03042KA

- 19) Disengage all the connectors of the MACHINE CONTROL UNIT (PL9.1.20).
- 20) Remove six screws (silver, 6mm) that fix the MACHINE CONTROL UNIT to the printer.
- 21) Remove the MACHINE CONTROL UNIT from the printer.

Removal 31 TOP COVER (PL1.1.1)

Steps 1 through 5 are for reference. Before removing this component, check that Steps 1 through 5 have been performed.

- 1) Open the FRONT COVER (PL1.2.1).
- 2) Remove the FUSER. (Removal 8)
- 3) Remove the REAR COVER. (Removal 10)
- 4) Remove the RIGHT COVER. (Removal 11)
- 5) Remove the LEFT COVER. (Removal 20)

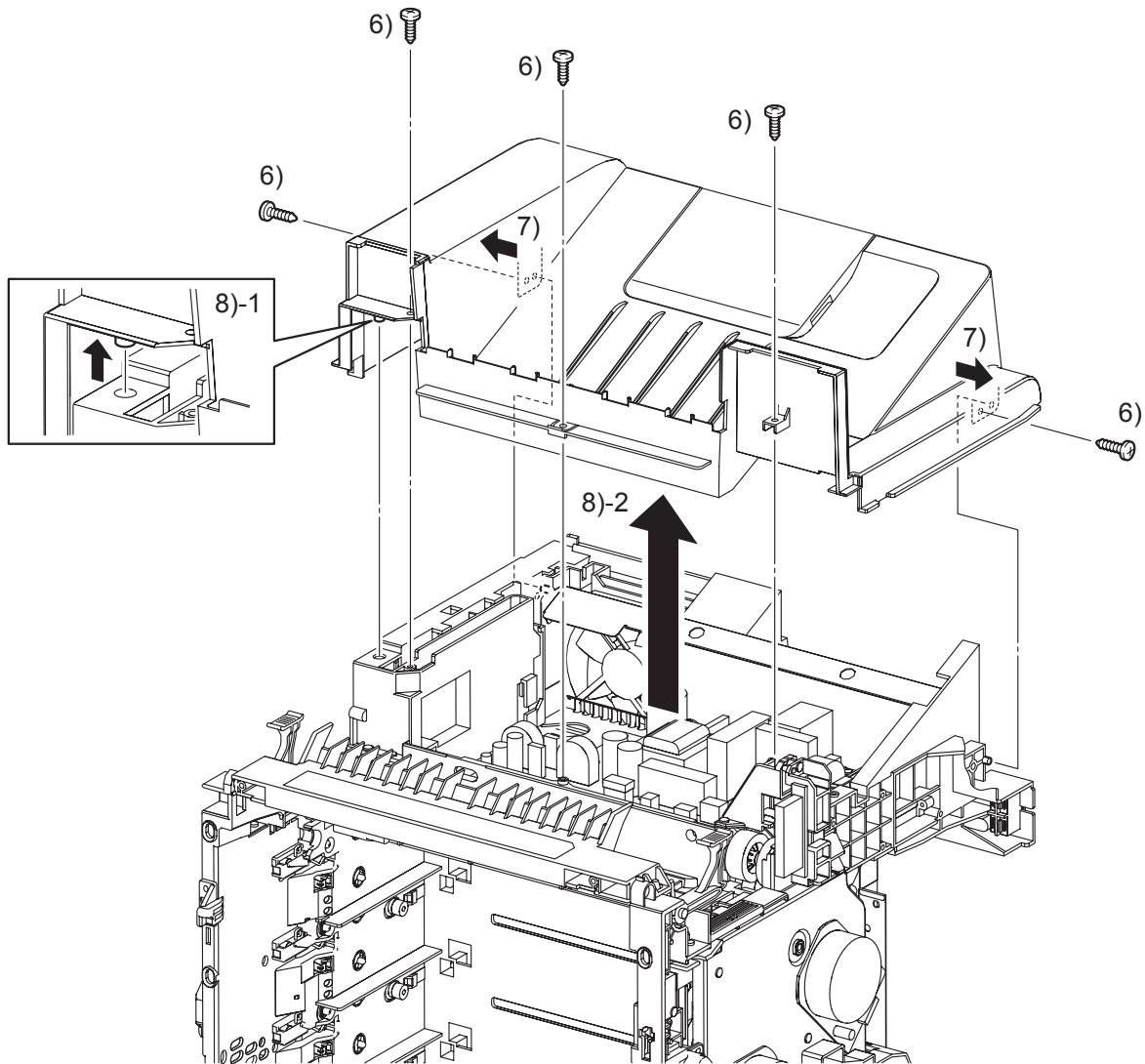

Zna03043KB

- 6) Remove the five screws (silver, tap, 10mm) that fix the TOP COVER (PL1.1.1) to the printer.
- 7) Disengage the two holes of the TOP COVER from the left and right bosses of the printer.
- 8) Lift up the TOP COVER to disengage the front and left bosses of the TOP COVER from the holes of the printer. Remove it.

Go to the next removal step:

Removal 32 FAN (PL9.1.10) or Removal 37 INTERLOCK SWITCH (PL9.1.3)

Removal 32 FAN (PL9.1.10)

Steps 1 through 6 are for reference. Before removing this component, check that Steps 1 through 6 have been performed.

- 1) Open the FRONT COVER (PL1.2.1).
- 2) Remove the FUSER. (Removal 8)
- 3) Remove the REAR COVER. (Removal 10)
- 4) Remove the RIGHT COVER. (Removal 11)
- 5) Remove the LEFT COVER. (Removal 20)
- 6) Remove the TOP COVER. (Removal 31)

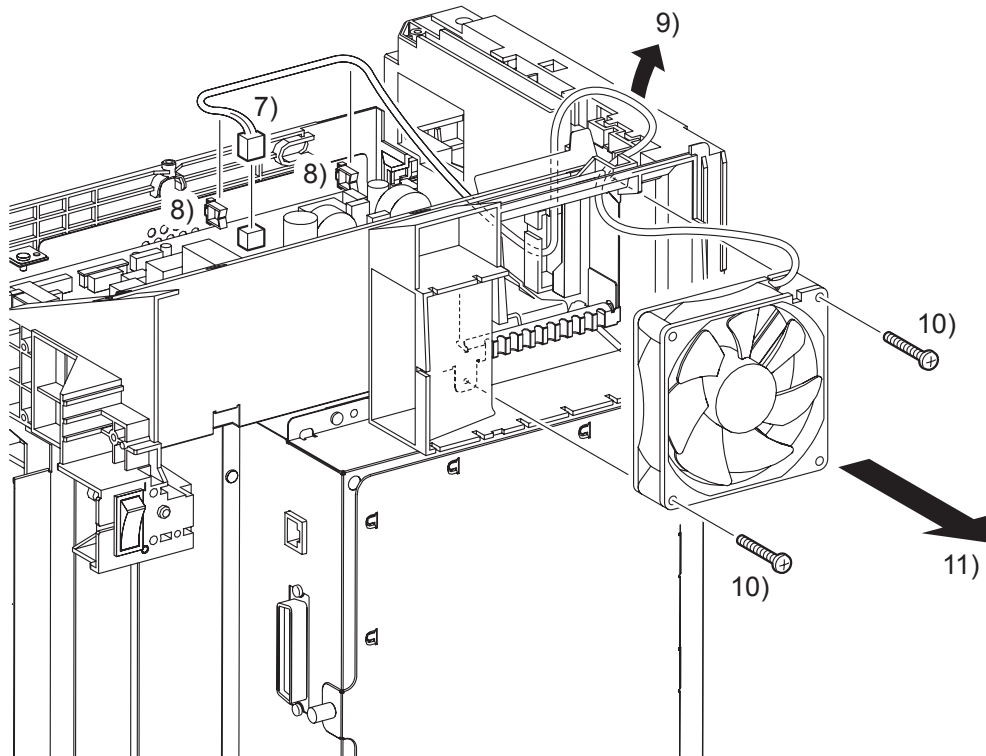

Zna03044KA

- 7) Disengage the connector (P/J503) of the FAN (PL9.1.10) on the LOW VOLTAGE POWER SUPPLY (PL9.1.4).
- 8) Remove the harness of the FAN by releasing the clamps.
- 9) Release the harness of the FAN from the hook of the printer.
- 10) Remove the two screws (silver, 30mm) that fix the FAN to the printer.
- 11) Remove the FAN from the printer.

Removal 33 HARN ASSY AC IN (PL9.1.16)

Steps 1 through 6 are for reference. Before removing this component, check that Steps 1 through 6 have been performed.

- 1) Open the FRONT COVER (PL1.2.1).
- 2) Remove the FUSER. (Removal 8)
- 3) Remove the REAR COVER. (Removal 10)
- 4) Remove the RIGHT COVER. (Removal 11)
- 5) Remove the LEFT COVER. (Removal 20)
- 6) Remove the TOP COVER. (Removal 31)

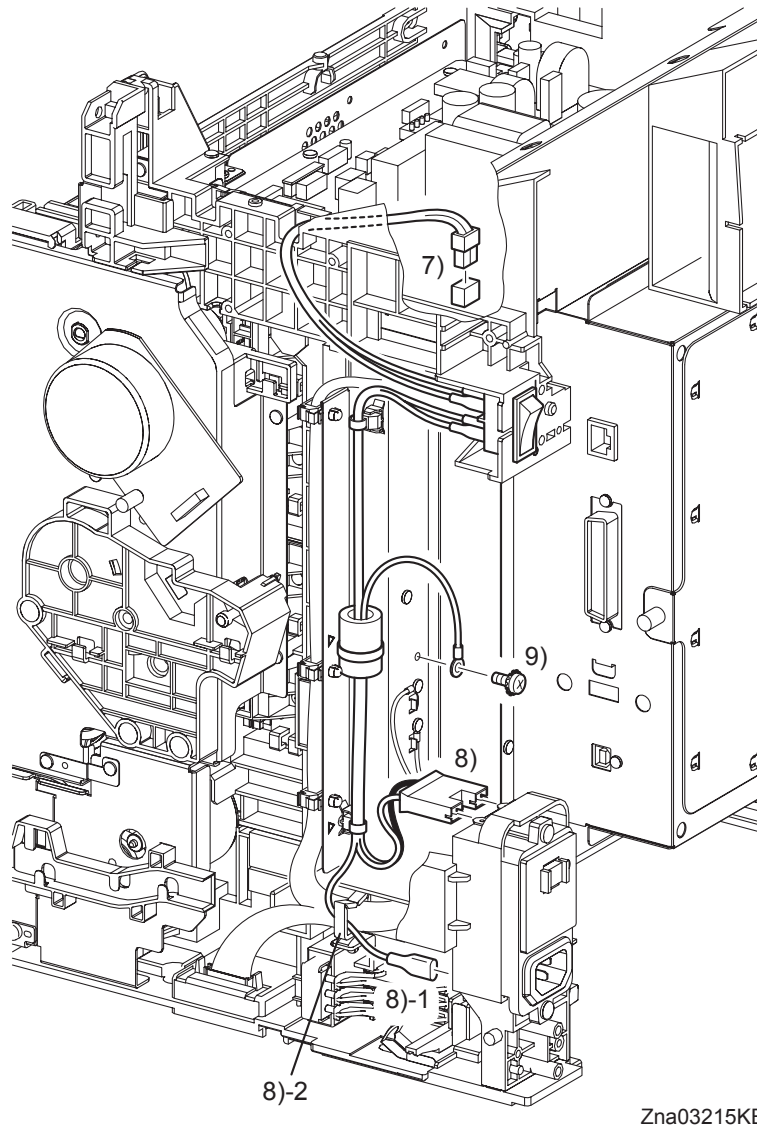

Zna03215KB

- 7) Disengage the connector (P/J48) on the LOW VOLTAGE POWER SUPPLY (PL9.1.4).
- 8) Disengage the connector (P/J482) and FASTON terminal (FS483) on the BREAKER GFI INLET (PL9.1.43), and then release the grounding wire of the HARN ASSY AC IN (PL9.1.16) from the clamp.
- 9) Remove the one screw (silver, with washer, M4, 6mm) that fixes the grounding terminal of the HARN ASSY AC IN to the printer.

Continues to the next page.

Removal 33 HARN ASSY AC IN (PL9.1.16)

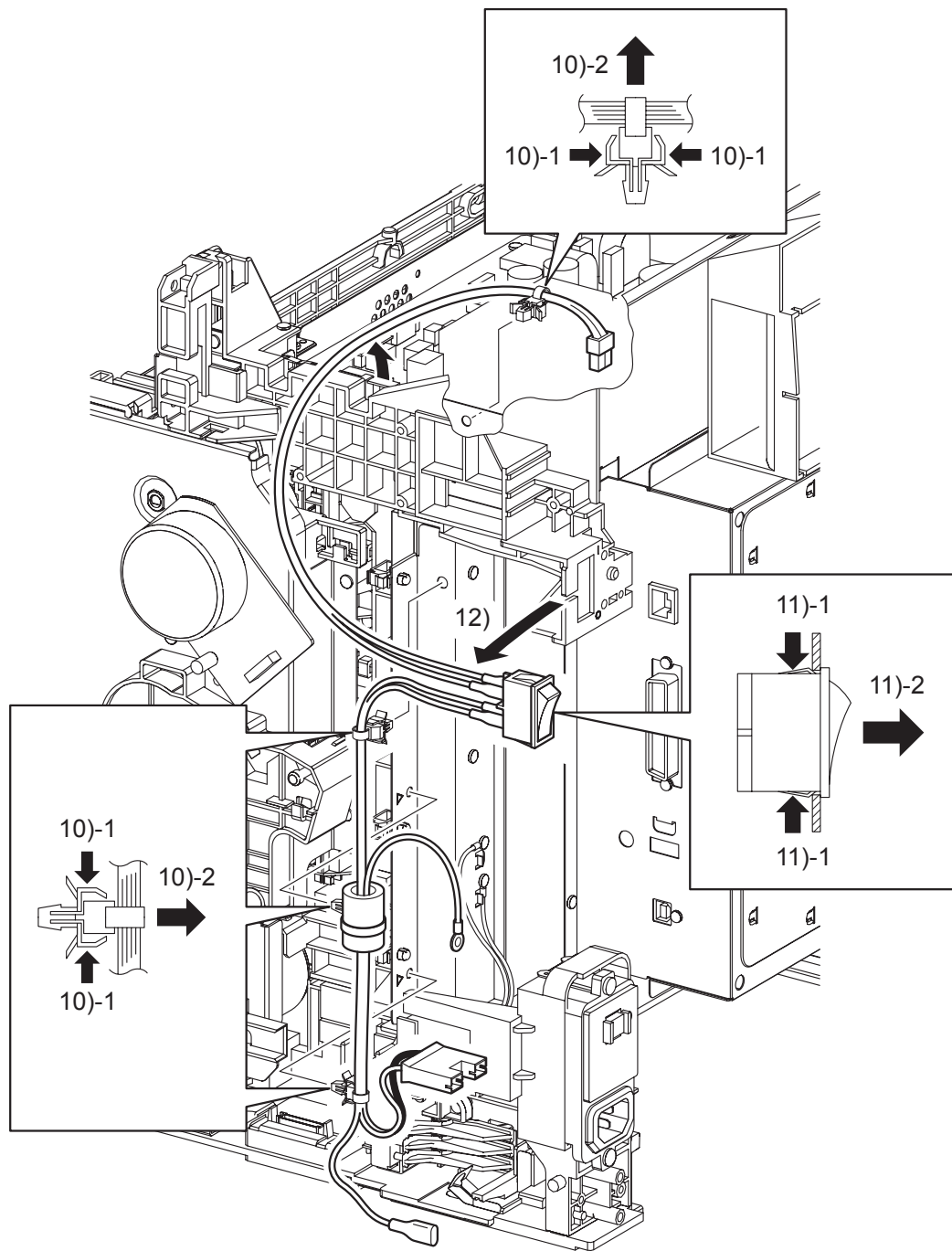

Zna03216KB

- 10) Release the harness of the HARN ASSY AC IN from the four clamps.
- 11) Release the hook of the POWER SWITCH to remove the POWER SWITCH from the printer.
- 12) Remove the HARN ASSY AC IN from the printer.

Removal 34 HIGH VOLTAGE POWER SUPPLY (PL5.1.17)

NOTE

Use a wristband to protect the PWB from electrostatic damage.

Steps 1 through 8 are for reference. Before removing this component, check that Steps 1 through 8 have been performed.

- 1) Open the FRONT COVER. (PL1.2.1).
- 2) Remove the FUSER. (Removal 8)
- 3) Remove the REAR COVER. (Removal 10)
- 4) Remove the RIGHT COVER. (Removal 11)
- 5) Remove the LEFT COVER. (Removal 20)
- 6) Remove the TOP COVER. (Removal 31)
- 7) Remove the SHIELD ASSY ESS. (Removal 25)
- 8) Remove the SHIELD MCU. (Removal 27)

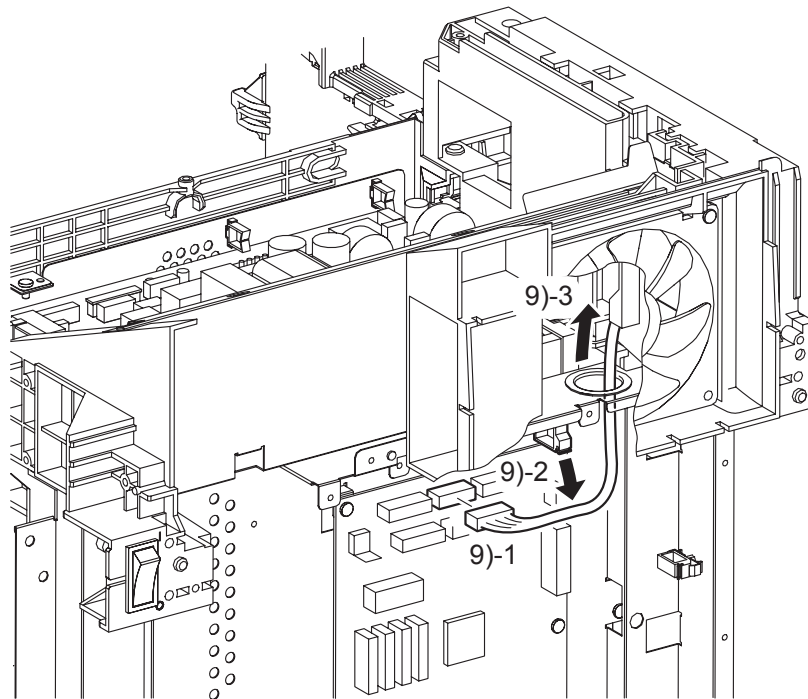

Zna03045KA

- 9) Disengage the connector (P/J16) of the HIGH VOLTAGE POWER SUPPLY (PL5.1.17) on the MACHINE CONTROL UNIT (PL9.1.20), and then pass the connector through the hole on the SHIELD REAR (PL9.1.11).

Continues to the next page.

Removal 34 HIGH VOLTAGE POWER SUPPLY (PL5.1.17)

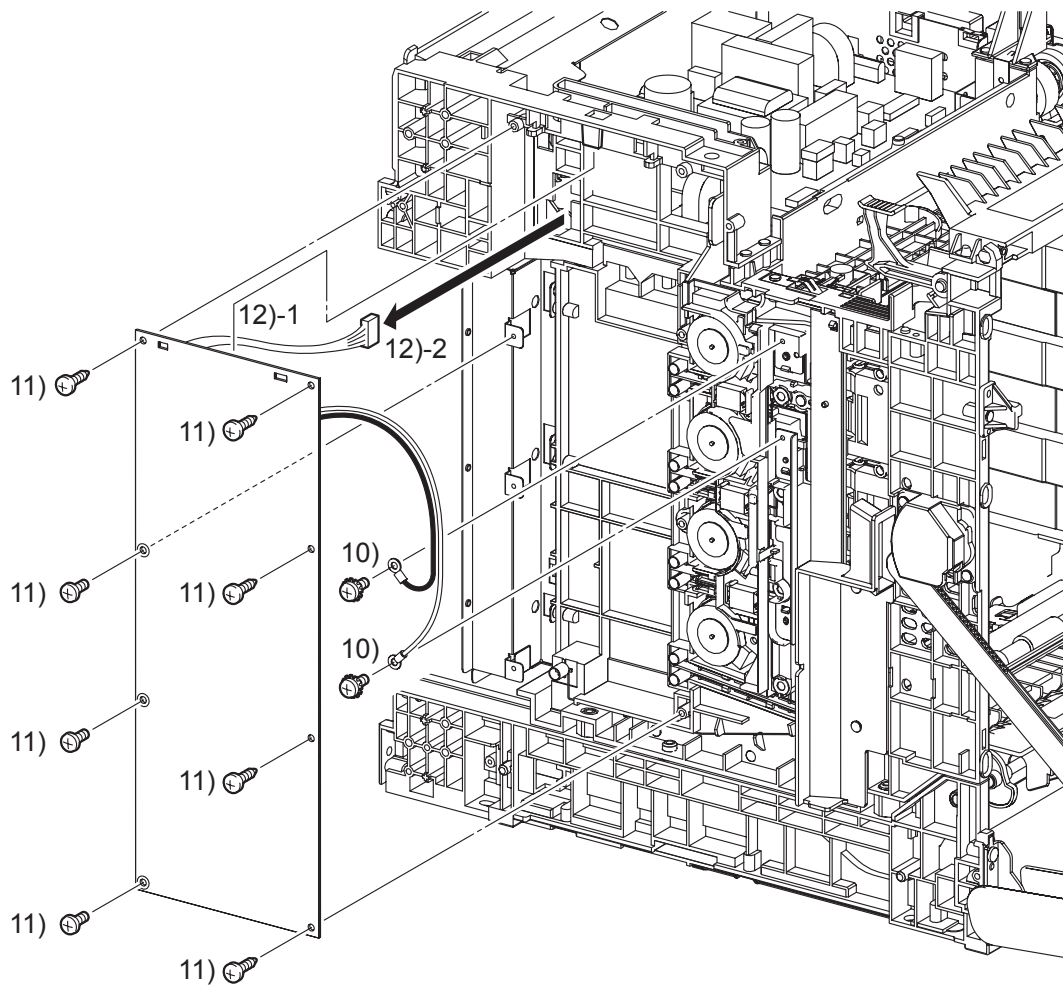

Zna03046KB

- 10) Remove the two screws (silver, with washer, 6mm) that fix the two harnesses of the HIGH VOLTAGE POWER SUPPLY.
- 11) Remove five screws (silver, tap, 10mm) and three screws (silver, 6mm) that fix the HIGH VOLTAGE POWER SUPPLY to the printer.
- 12) Remove the HIGH VOLTAGE POWER SUPPLY by releasing the upper part of the HIGH VOLTAGE POWER SUPPLY from the two lugs on the printer. Pull out the connector of the HIGH VOLTAGE POWER SUPPLY from the hole on the printer.

Removal 35 LOW VOLTAGE POWER SUPPLY (PL9.1.4)

NOTE

Use a wristband to protect the PWB from electrostatic damage.

Steps 1 through 6 are for reference. Before removing this component, check that Steps 1 through 6 have been performed.

- 1) Open the FRONT COVER (PL1.2.1).
- 2) Remove the FUSER. (Removal 8)
- 3) Remove the REAR COVER. (Removal 10)
- 4) Remove the RIGHT COVER. (Removal 11)
- 5) Remove the LEFT COVER. (Removal 20)
- 6) Remove the TOP COVER. (Removal 31)

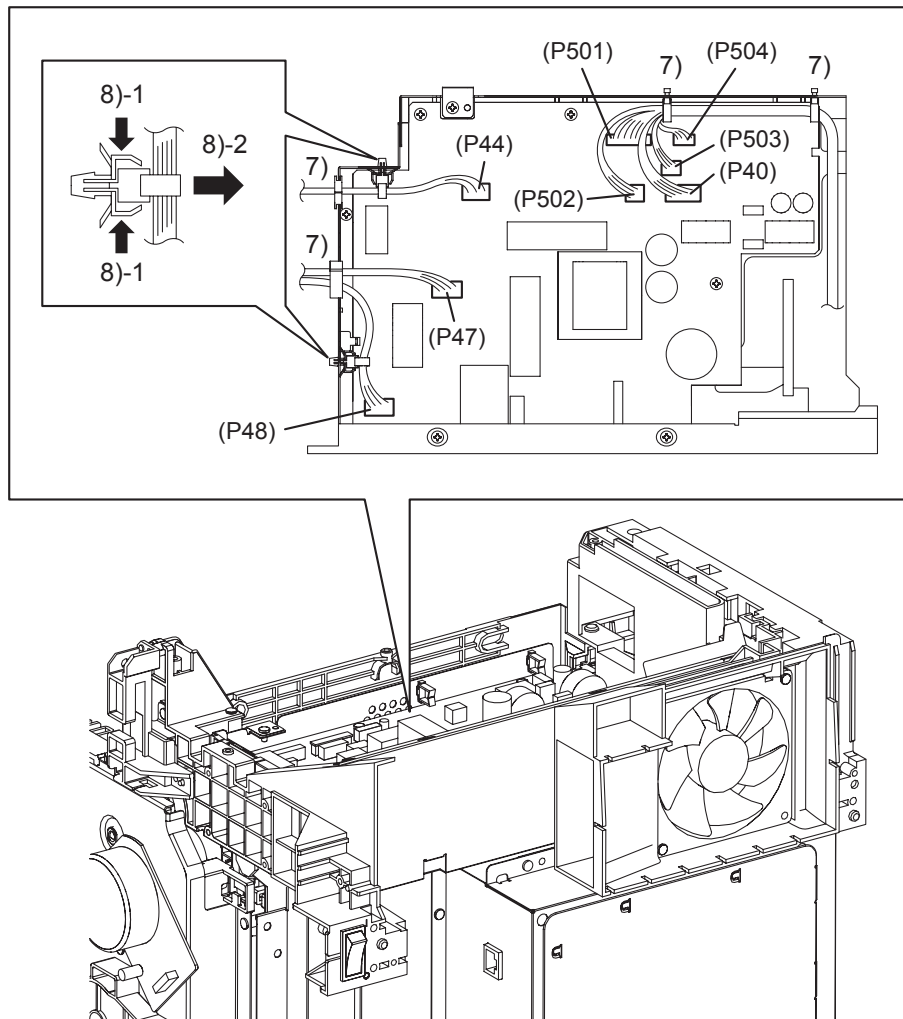

Zna03217KA

- 7) Disengage all the connectors of the LOW VOLTAGE POWER SUPPLY (PL9.1.4), and then release the harness from the clamps.
- 8) From the SHIELD LVPS (PL9.1.9), remove the clamp that fixes the harness of the INTER-LOCK SWITCH (PL9.1.3) and the clamp that fixes the harness of the HARN ASSY AC IN (PL9.1.16).

Continues to the next page.

Removal 35 LOW VOLTAGE POWER SUPPLY (PL9.1.4)

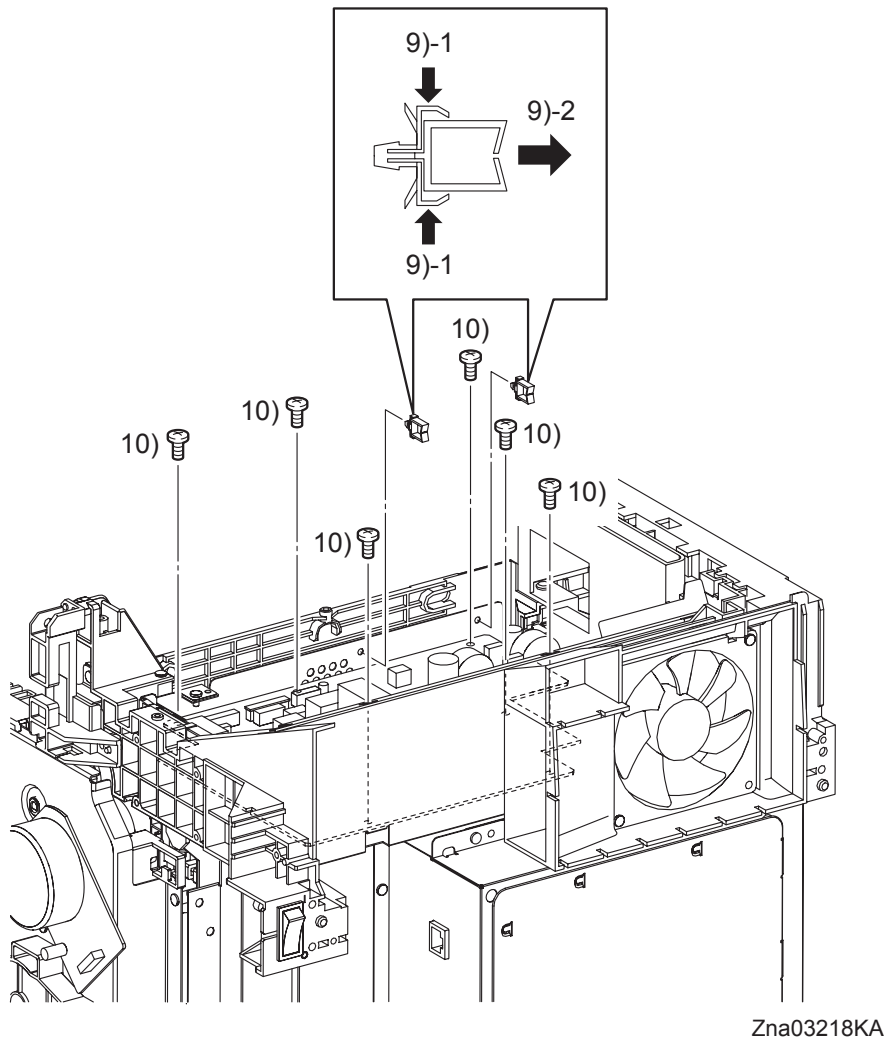

- 9) Remove the two clamps on the SHIELD LVPS.
- 10) Remove six screws (silver, 6mm) that fix the LOW VOLTAGE POWER SUPPLY to the SHIELD LVPS.

Continues to the next page.

Removal 35 LOW VOLTAGE POWER SUPPLY (PL9.1.4)

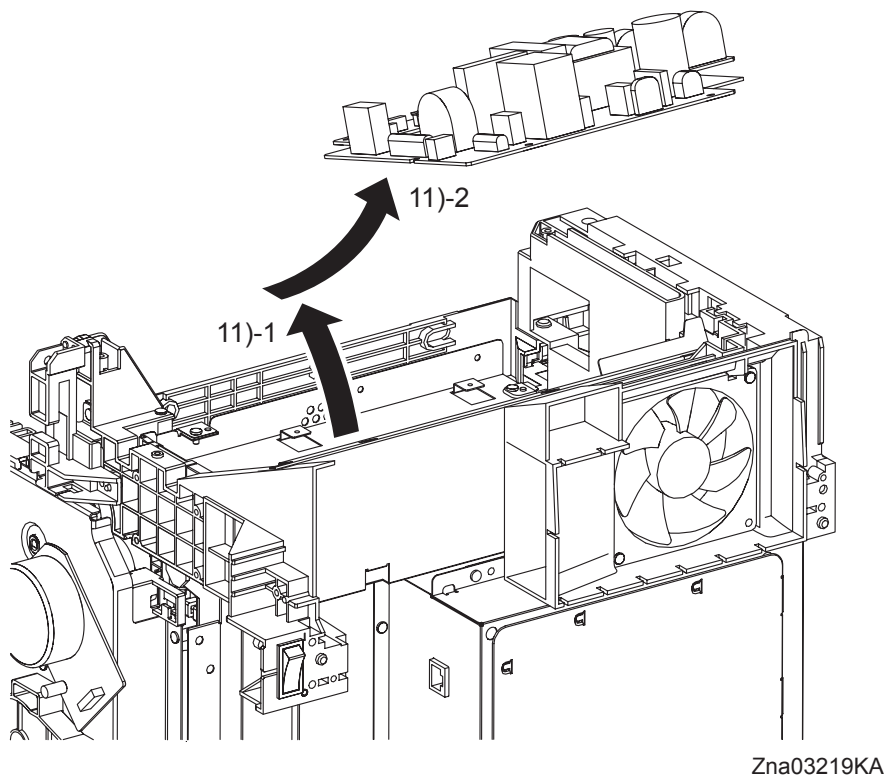

- 11) Shift the LOW VOLTAGE POWER SUPPLY to the left side while holding up the rear side of the LOW VOLTAGE POWER SUPPLY, and then remove the LOW VOLTAGE POWER SUPPLY from the printer.

Blank Page

Removal 36 ROS (PL5.1.99)

Steps 1 through 9 are for reference. Before removing this component, check that Steps 1 through 9 have been performed.

- 1) Open the FRONT COVER (PL1.2.1).
- 2) Remove the FUSER. (Removal 8)
- 3) Remove the REAR COVER. (Removal 10)
- 4) Remove the RIGHT COVER. (Removal 11)
- 5) Remove the LEFT COVER. (Removal 20)
- 6) Remove the TOP COVER. (Removal 31)
- 7) Remove the SHIELD ASSY ESS. (Removal 25)
- 8) Remove the SHIELD MCU. (Removal 27)
- 9) Remove the FAN. (Removal 32)

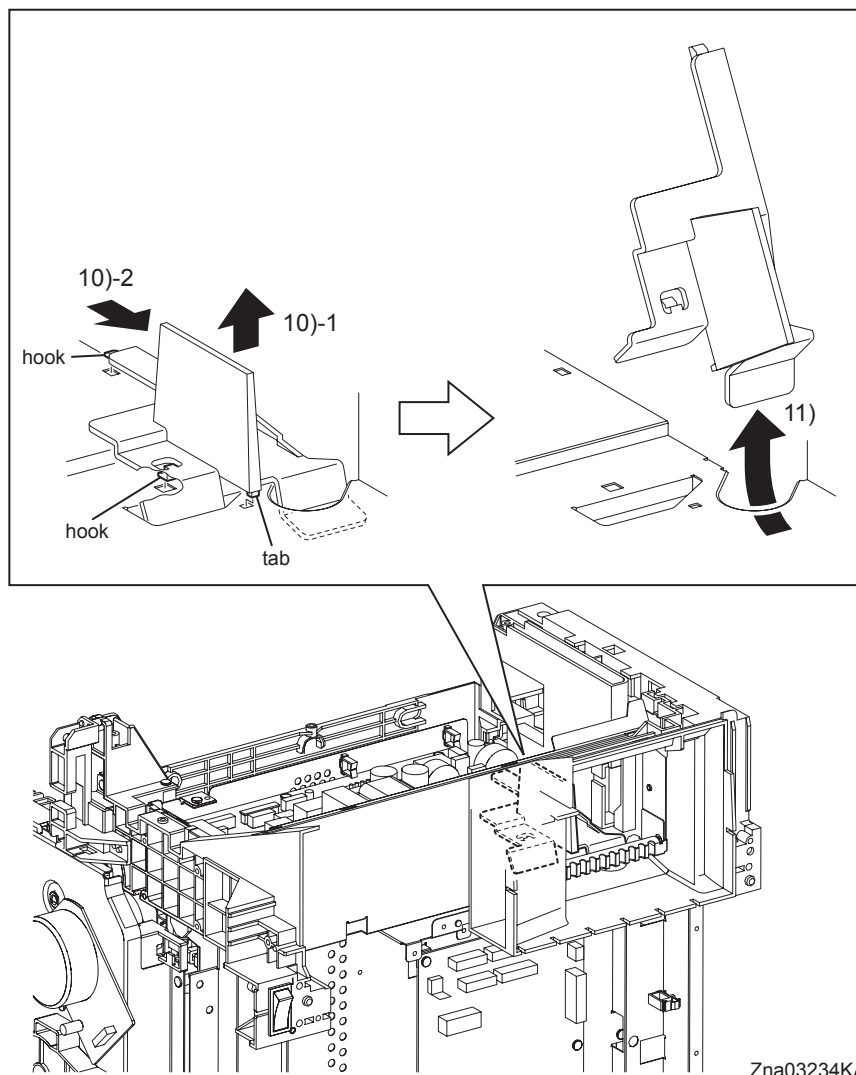

- 10) Raise the DUCT AIRFLOW (PL9.1.41) slightly until its tab is released from the hole on the SHIELD LVPS(PL9.1.9), and then move the DUCT AIRFLOW rearward until its two hooks are released.
- 11) Remove the DUCT AIRFLOW from the printer.

Continues to the next page.

Removal 36 ROS (PL5.1.99)

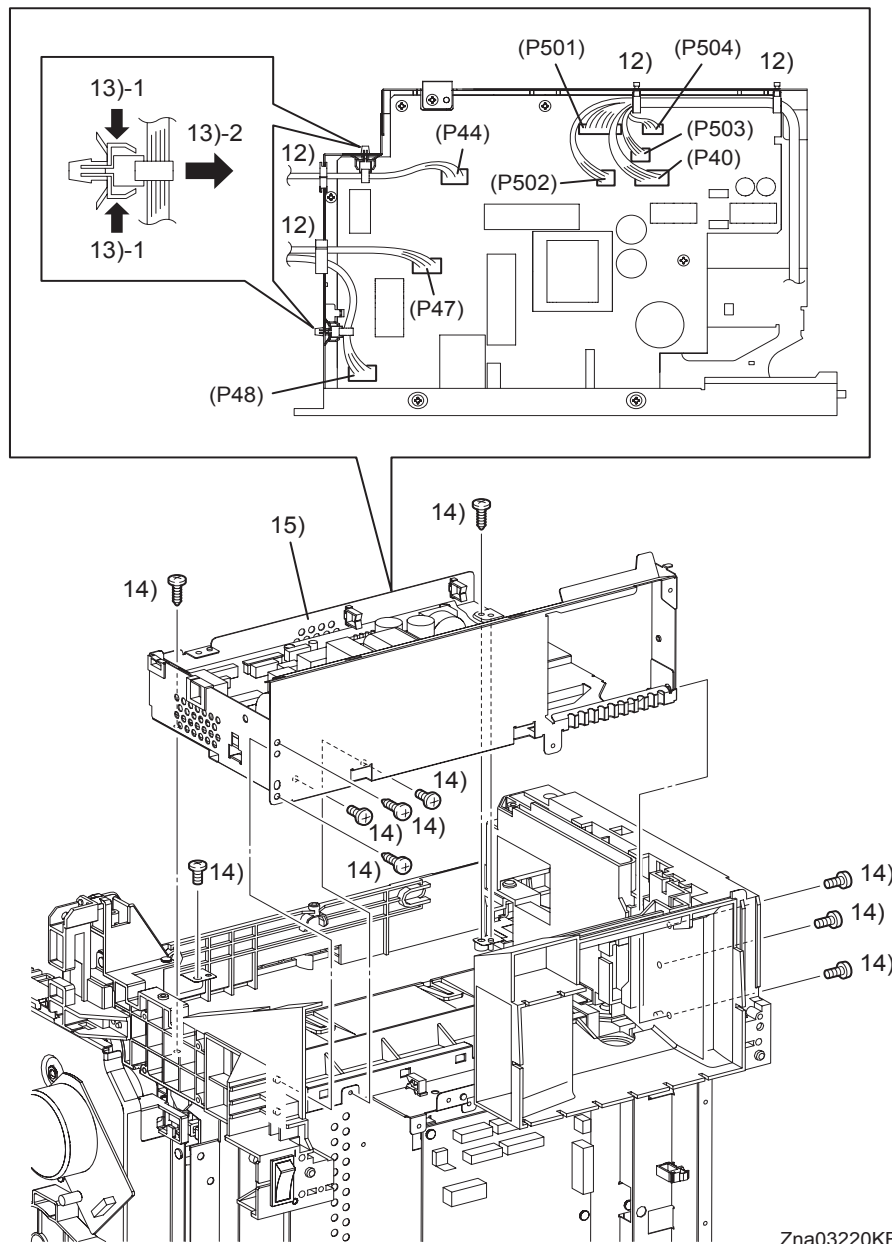

Zna03220KB

- 12) Disengage all the connectors of the LOW VOLTAGE POWER SUPPLY (PL9.1.4), and then release the harness from the clamps.
- 13) From the SHIELD LVPS, remove the clamp that fixes the harness of the INTERLOCK SWITCH (PL9.1.3) and the clamp that fixes the harness of the HARN ASSY AC IN (PL9.1.16).
- 14) Remove the six screws (silver, 6mm), the two screws (silver, tap, 8mm) and the two screws (silver, tap, 10mm) that fix the LVPS ASSY (PL9.1.40) to the printer.
- 15) Release the three holes of the SHIELD LVPS from the bosses of the printer, lift the LVPS ASSY up and remove it.

Continues to the next page.

Removal 36 ROS (PL5.1.99)

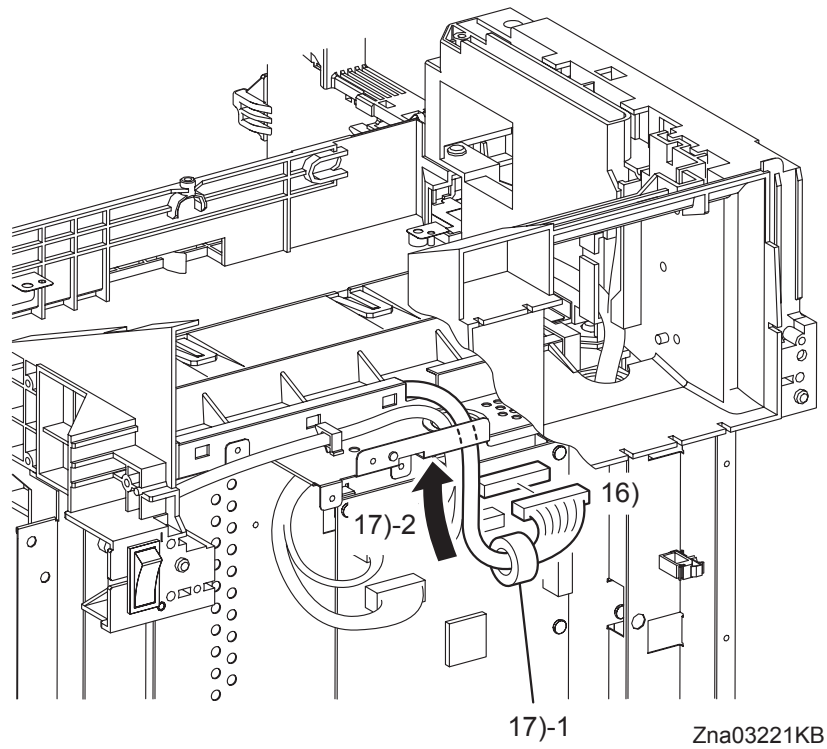

- 16) Disengage the connector (P/J12) of the ROS (PL5.1.2) from the MACHINE CONTROL UNIT (PL9.1.20).
- 17) Remove the CORE (PL5.1.22) from the harness of the ROS, and then pull out the connector through the hole on the SHIELD REAR (PL9.1.11).

Continues to the next page.

Removal 36 ROS (PL5.1.99)

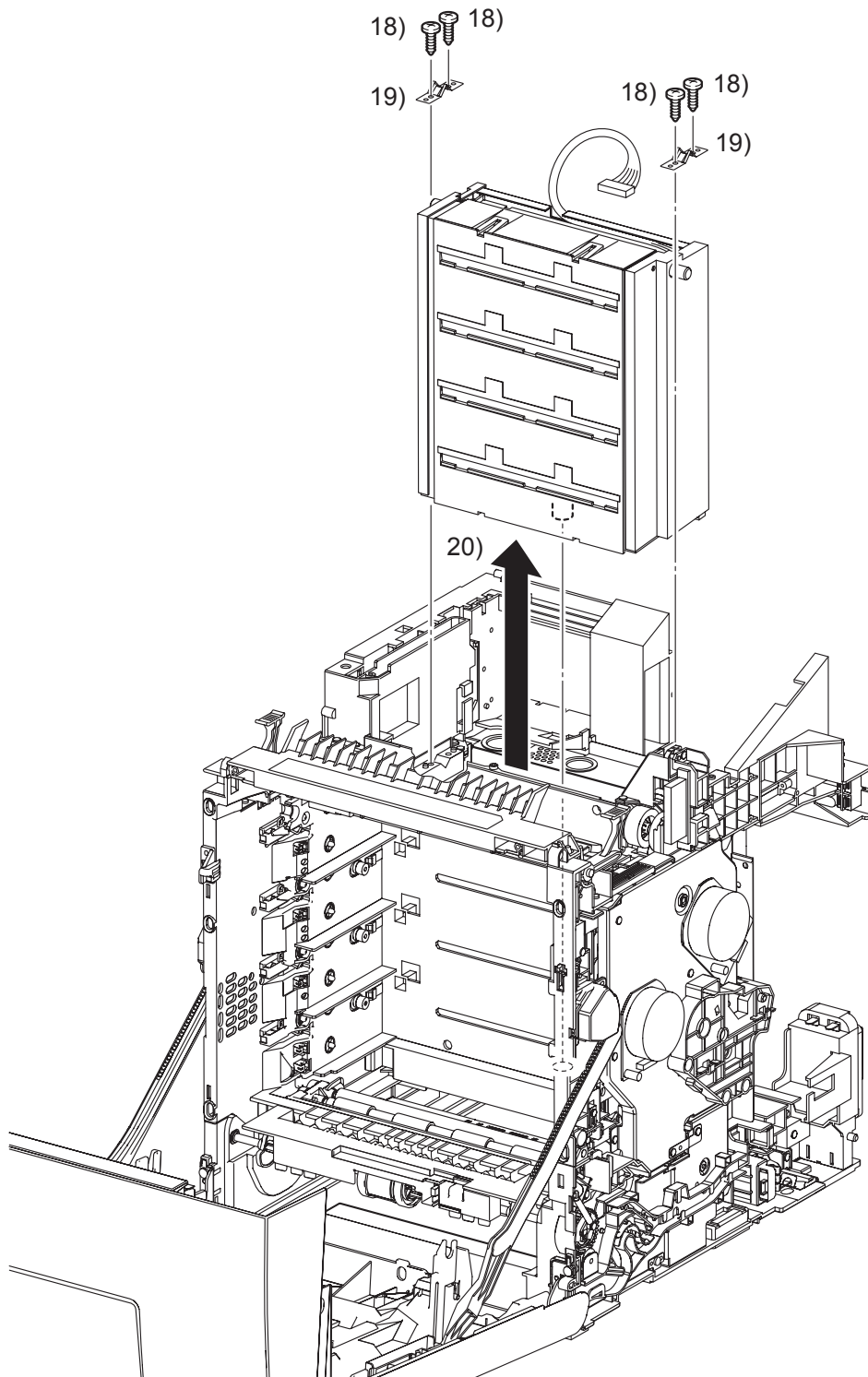

Zna03222KB

- 18) Remove the four screws (silver, tap, 10mm) that fix the two SPRING ROSs (PL5.1.1) to the printer at the left and right sides.
- 19) Remove the left and right SPRING ROSs from the printer.
- 20) Remove the ROS from the printer by pulling it up slowly.

Removal 37 INTERLOCK SWITCH (PL9.1.3)

Steps 1 through 6 are for reference. Before removing this component, check that Steps 1 through 6 have been performed.

- 1) Open the FRONT COVER (PL1.2.1).
- 2) Remove the FUSER. (Removal 8)
- 3) Remove the REAR COVER. (Removal 10)
- 4) Remove the RIGHT COVER. (Removal 11)
- 5) Remove the LEFT COVER. (Removal 20)
- 6) Remove the TOP COVER. (Removal 31)

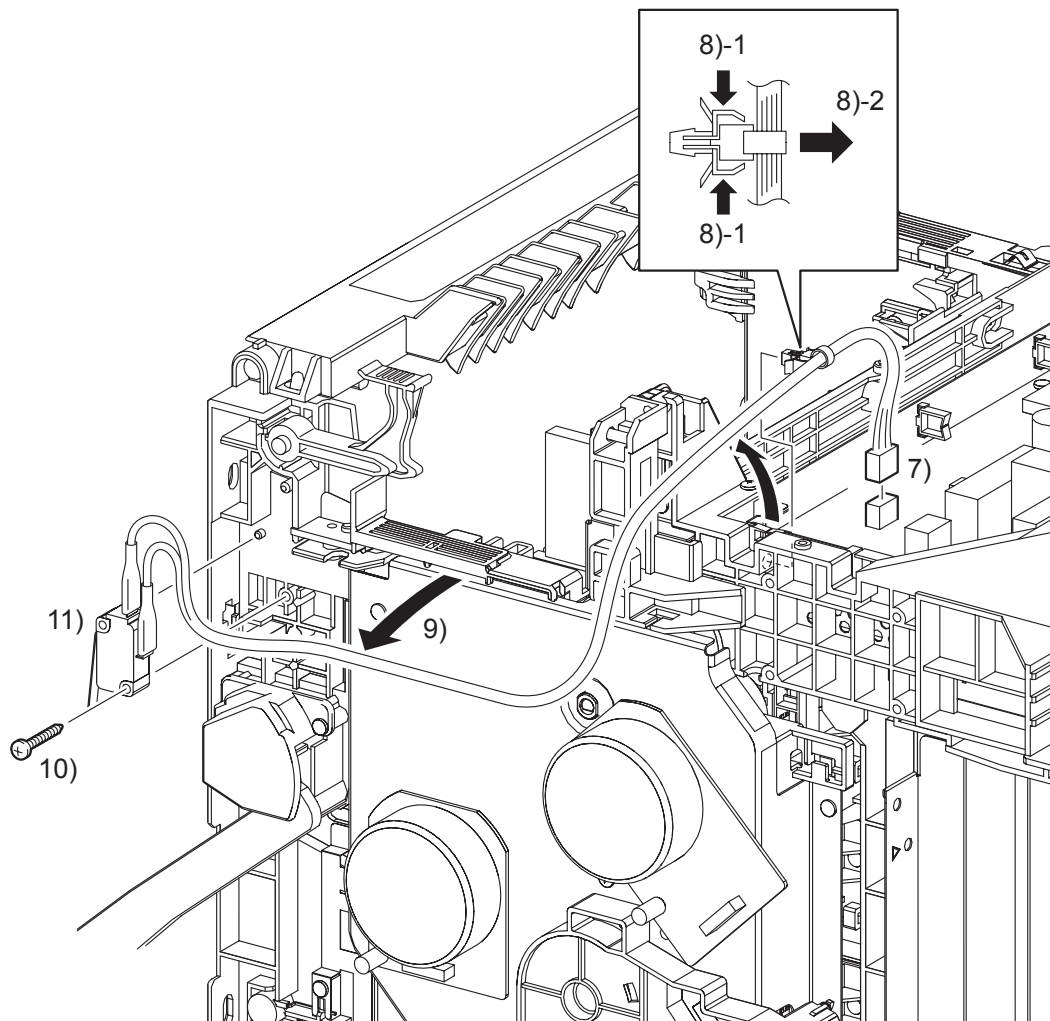

Zna03050KB

- 7) Disengage the connector (P/J44) of the INTERLOCK SWITCH on the LOW VOLTAGE POWER SUPPLY (PL9.1.4).
- 8) Remove the clamp on the SHIELD LVPS (PL9.1.9) that fix the harness of the INTERLOCK SWITCH.
- 9) Remove the harness of the INTERLOCK SWITCH from the duct of the printer.
- 10) Remove the one screw (silver, tap, 16mm) that fixes the INTERLOCK SWITCH to the printer.
- 11) Remove the INTERLOCK SWITCH.

Go to the next removal step:

Removal 38 PHOTOCOnductor (PC) / DEVELOPER (DEV) DRIVE (PL8.1.2)

Blank Page

Removal 38 PHOTOCOnductor (PC) / DEVELOPER (DEV) DRIVE (PL8.1.2)

Steps 1 through 8 are for reference. Before removing this component, check that Steps 1 through 8 have been performed.

- 1) Open the FRONT COVER (PL1.2.1).
- 2) Remove the FUSER. (Removal 8)
- 3) Remove the REAR COVER. (Removal 10)
- 4) Remove the RIGHT COVER. (Removal 11)
- 5) Remove the LEFT COVER. (Removal 20)
- 6) Remove the TOP COVER. (Removal 31)

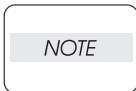

When performing the step described below, it is not necessary to disengage the connector of the INTERLOCK SWITCH.

- 7) Remove the INTERLOCK SWITCH. (Removal 37)

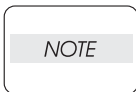

When performing the step described below, it is not necessary to disengage the connector of the DRIVE ASSY K.

- 8) Remove the DRIVE ASSY K. (Removal 28)

Continues to the next page.

Removal 38 PHOTOCONDUCTOR (PC) / DEVELOPER (DEV) DRIVE (PL8.1.2)

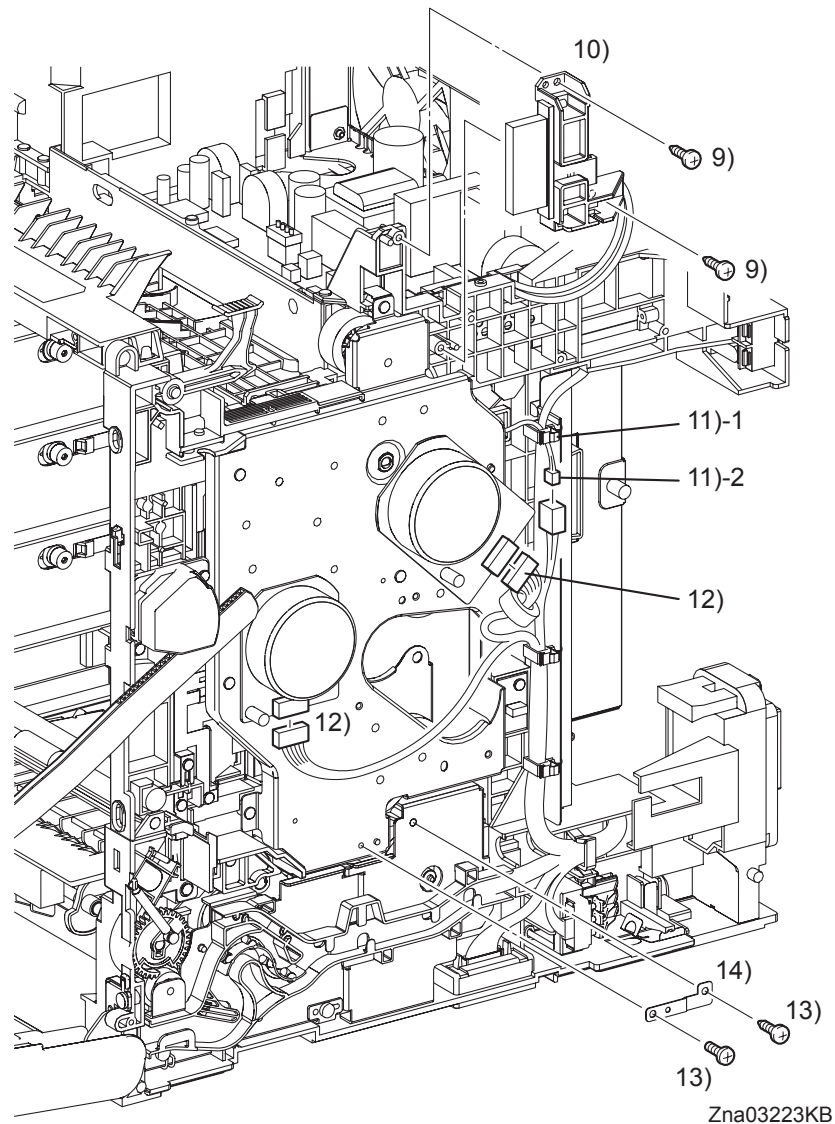

- 9) Remove two screws (silver, tap, 10mm) that fix the BRACKET FUSER (PL6.1.12) to the printer.

NOTE

When performing the step described below, take care not to move the BRACKET FUSER from the printer too far because they are connected with the harness.

- 10) Remove the BRACKET FUSER from the printer.

NOTE

When performing the step below, leave the junction connector on the printer side cable.

- 11) Release the harness of the Exit Clutch in the PHOTOCONDUCTOR (PC) / DEVELOPER (DEV) DRIVE (PL8.1.2) from the clamp, and then disengage the connector (P/J235).
- 12) Disengage the Main Motor connector (P/J222) and the Sub Motor connector (P/J221).
- 13) Remove the one screw (silver, 6mm) and the one screw (silver, tap, 10mm) that fix the PLATE EARTH DRV MP (PL8.1.11) to the PHOTOCONDUCTOR (PC) / DEVELOPER (DEV) DRIVE and FEED DRIVE ASSEMBLY (PL8.1.7).
- 14) Remove the PLATE EARTH DRV MP from the printer.

Continues to the next page.

Removal 38 PHOTOCONDUCTOR (PC) / DEVELOPER (DEV) DRIVE (PL8.1.2)

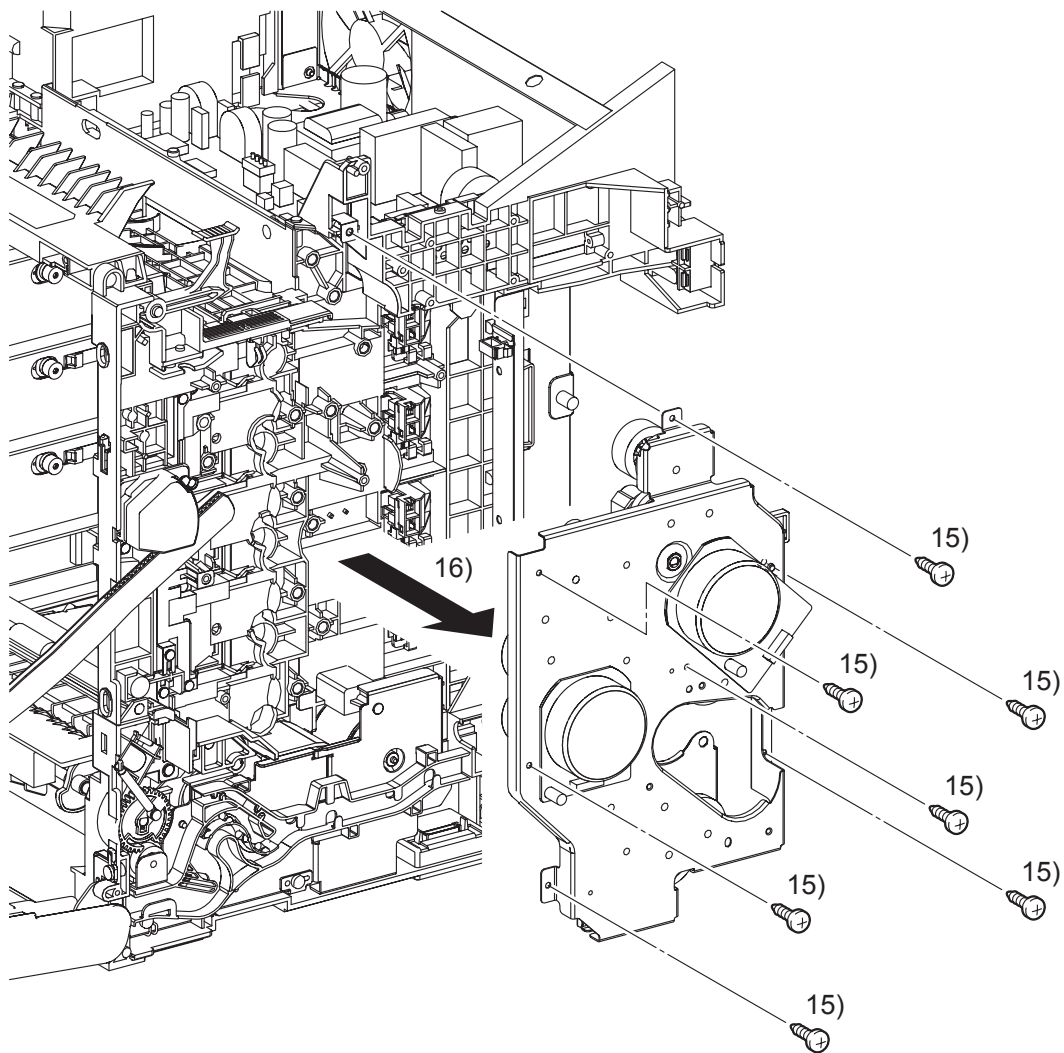

Zna03224KB

- 15) Remove the seven screws (silver, tap, 10mm) that fix the PHOTOCONDUCTOR (PC) / DEVELOPER (DEV) DRIVE to the printer.
- 16) Remove the PHOTOCONDUCTOR (PC) / DEVELOPER (DEV) DRIVE from the printer.

Go to the next removal step:

Removal 39 TONER CARTRIDGE SENSOR ASSEMBLY (K), (C), (M), (Y) (PL5.1.4)

Blank Page

Removal 39 TONER CARTRIDGE SENSOR ASSEMBLY (K), (C), (M), (Y) (PL5.1.4)

NOTE

Described below is the removal procedure common among the TONER CARTRIDGE SENSOR ASSEMBLYs (C), (M), (Y), and (K).

Steps 1 through 9 are for reference. Before removing this component, check that Steps 1 through 9 have been performed.

- 1) Open the FRONT COVER (PL1.2.1).
- 2) Remove the FUSER. (Removal 8)
- 3) Remove the REAR COVER. (Removal 10)
- 4) Remove the RIGHT COVER. (Removal 11)
- 5) Remove the LEFT COVER. (Removal 20)
- 6) Remove the TOP COVER. (Removal 31)
- 7) Remove the INTERLOCK SWITCH. (Removal 37)
- 8) Remove the DRIVE ASSY K. (Removal 28)
- 9) Remove the PHOTOCOnductor (PC) / DEVELOPER (DEV) DRIVE. (Removal 38)

Continues to the next page.

Removal 39 TONER CARTRIDGE SENSOR ASSEMBLY (K), (C), (M), (Y) (PL5.1.4)

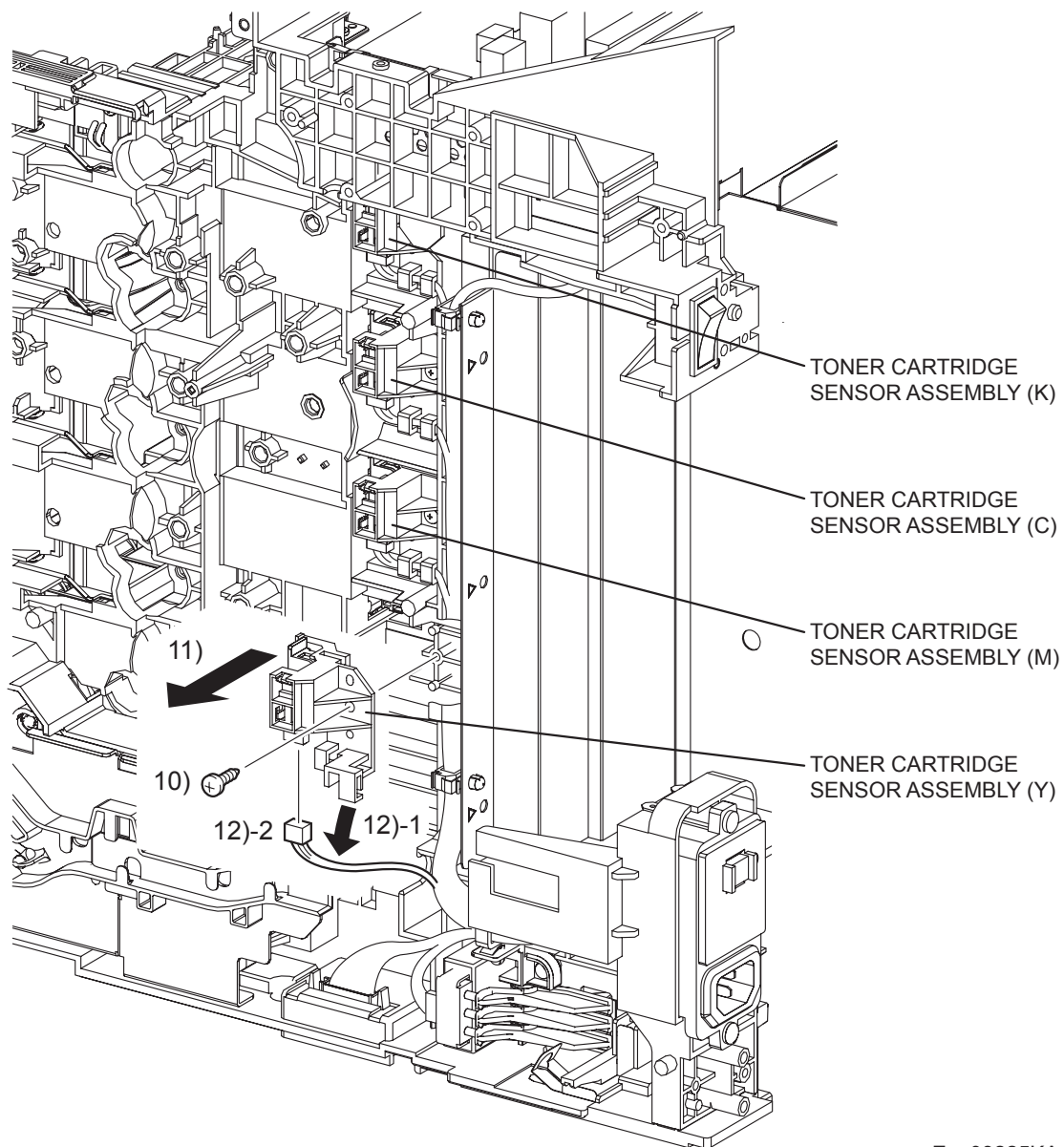

Zna03225KA

- 10) Remove the one screw (silver, tap, 10mm) that fixes the TONER CARTRIDGE SENSOR ASSEMBLY (PL5.1.4) to the printer.
- 11) Remove the TONER CARTRIDGE SENSOR ASSEMBLY from the printer.
- 12) Release the harness from the hook of the TONER CARTRIDGE SENSOR ASSEMBLY, and then disengage the connector.

Removal 40 INTEGRATED FEEDER ASSEMBLY (PL3.2.99)

Steps 1 through 11 are for reference. Before removing this component, check that Steps 1 through 11 have been performed.

- 1) Open the FRONT COVER (PL1.2.1).
- 2) Remove the FUSER. (Removal 8)
- 3) Remove the REAR COVER. (Removal 10)
- 4) Remove the RIGHT COVER. (Removal 11)
- 5) Remove the LEFT COVER. (Removal 20)
- 6) Remove the TOP COVER. (Removal 31)
- 7) Remove the INTERLOCK SWITCH. (Removal 37)
- 8) Remove the DRIVE ASSY K. (Removal 28)
- 9) Remove the PHOTOCODUCTOR (PC) / DEVELOPER (DEV) DRIVE. (Removal 38)
- 10) Remove the FEED DRIVE ASSEMBLY. (Removal 17)
- 11) Remove the ROLL ASSY MSI. (Removal 16)

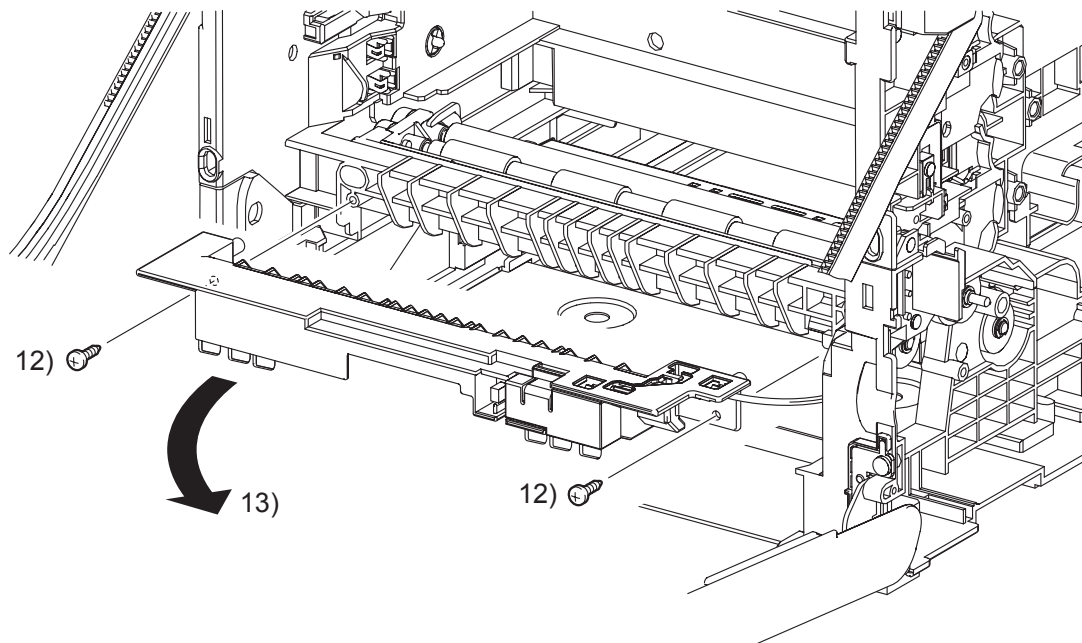

Zna03226KA

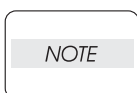

When performing the step described below, it is not necessary to remove the SENSOR PHOTO (PL3.1.15) and COVER SNR (PL3.1.16).

- 12) Remove two screws (silver, tap, 10mm) that fix the CHUTE MSI (PL3.1.14) to the printer.

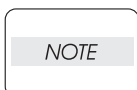

When performing the step described below, take care not to move the CHUTE MSI from the printer too far because they are connected with the harness.

- 13) Remove the CHUTE MSI from the printer.

Continues to the next page.

Removal 40 INTEGRATED FEEDER ASSEMBLY (PL3.2.99)

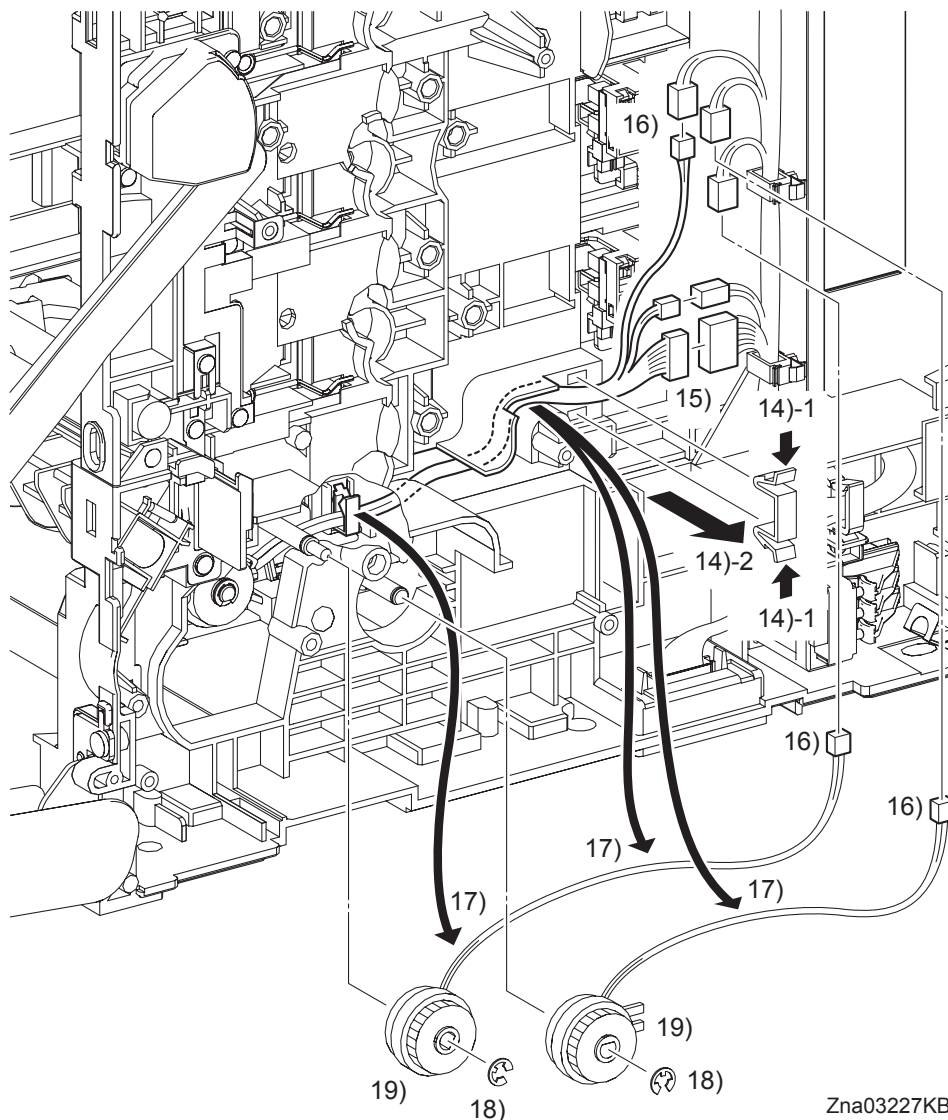

- 14) Release the two hooks of the CLAMP (PL3.1.20), remove the CLAMP from the printer.

NOTE

When performing the step below, leave the junction connector on the printer side cable.

- 15) Disengage the connectors (P/J292 and P/J301) of the INTEGRATED FEEDER ASSEMBLY (PL3.2.1).
- 16) Disengage the connector (P/J231) of the CLUTCH ASSY PH REGI (PL3.2.23), the connector (P/J233) of the CLUTCH ASSY PH FEED (PL3.2.24), and the connector (P/J232) of the CLUTCH ASSY PH TURN (PL.3.2.25).
- 17) Release the each harness from the clamp on the INTEGRATED FEEDER ASSEMBLY and the hook of the printer.
- 18) Remove the e-rings that fix the CLUTCH ASSY PH REGI and the CLUTCH ASSY PH FEED to the INTEGRATED FEEDER ASSEMBLY.
- 19) Remove the CLUTCH ASSY PH REGI and the CLUTCH ASSY PH FEED from the INTEGRATED FEEDER ASSEMBLY.

Continues to the next page.

Removal 40 INTEGRATED FEEDER ASSEMBLY (PL3.2.99)

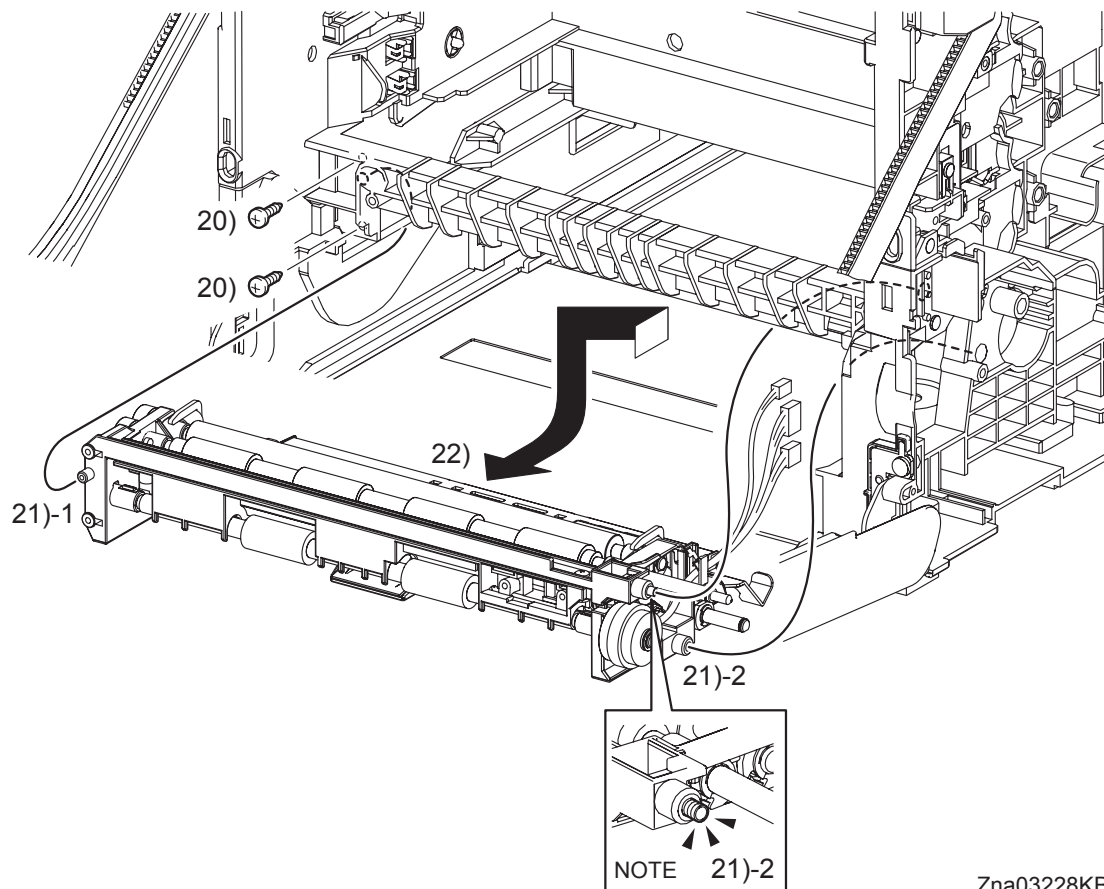

Zna03228KB

- 20) Remove two screws (silver, tap, 10mm) that fix the INTEGRATED FEEDER ASSEMBLY to the printer.

NOTE

When performing the step described below, take care not to drop and lose the SPRING EARTH on the right side of the INTEGRATED FEEDER ASSEMBLY.

- 21) Release the left side boss on the INTEGRATED FEEDER ASSEMBLY from the hole on the printer. Move the INTEGRATED FEEDER ASSEMBLY slightly backward to the left and release the two bosses (One is provided with the SPRING EARTH.) on the right side from the hole on the printer.
- 22) Remove the INTEGRATED FEEDER ASSEMBLY from the printer by pulling out its right pivot and clutch from the hole on the printer.

Removal 41 MPF SEPARATOR ROLLER ASSEMBLY (PL2.1.99)

- 1) Remove the 250 SHEET PAPER TRAY (PL2.1.1) from the printer.

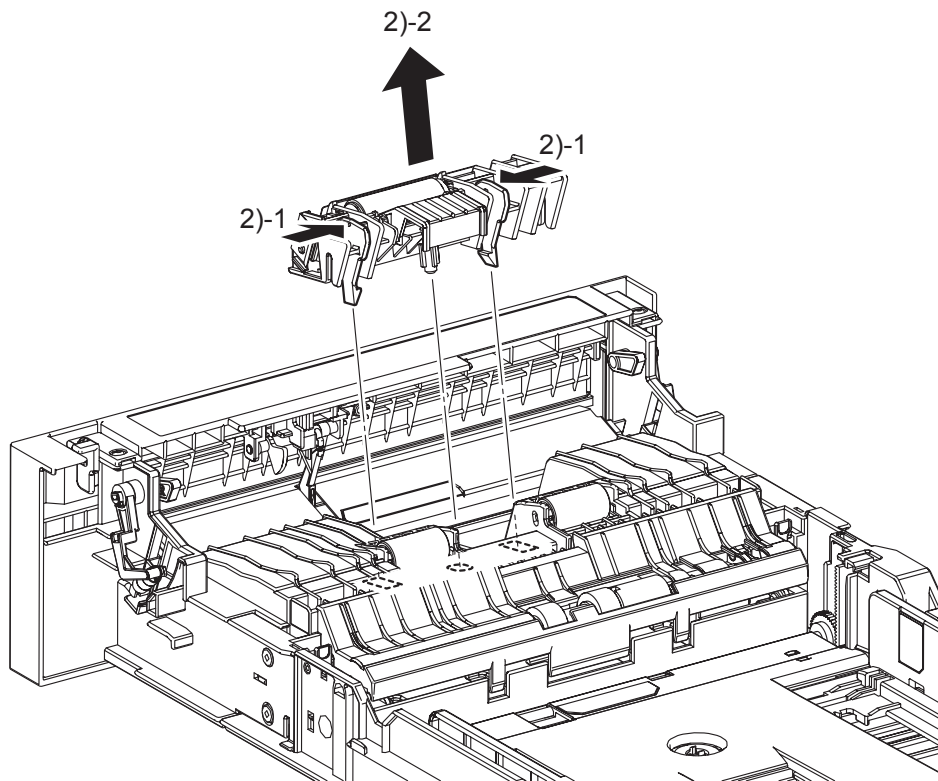

Zna03054KB

- 2) Release the two hooks of the MPF SEPARATOR ROLLER ASSEMBLY (PL2.1.3) and then remove the MPF SEPARATOR ROLLER ASSEMBLY from the 250 SHEET PAPER TRAY.

Removal 42 KIT SEPARATOR ROLLER & FEED ROLLER (PL2.2.99)

NOTE

When replacing the SEPARATOR ROLLER or the FEED ROLLER replace the SEPARATOR ROLLER and the two FEED ROLLERS at the same time.

- 1) Remove the 250 SHEET PAPER TRAY (PL2.1.1) from the printer.

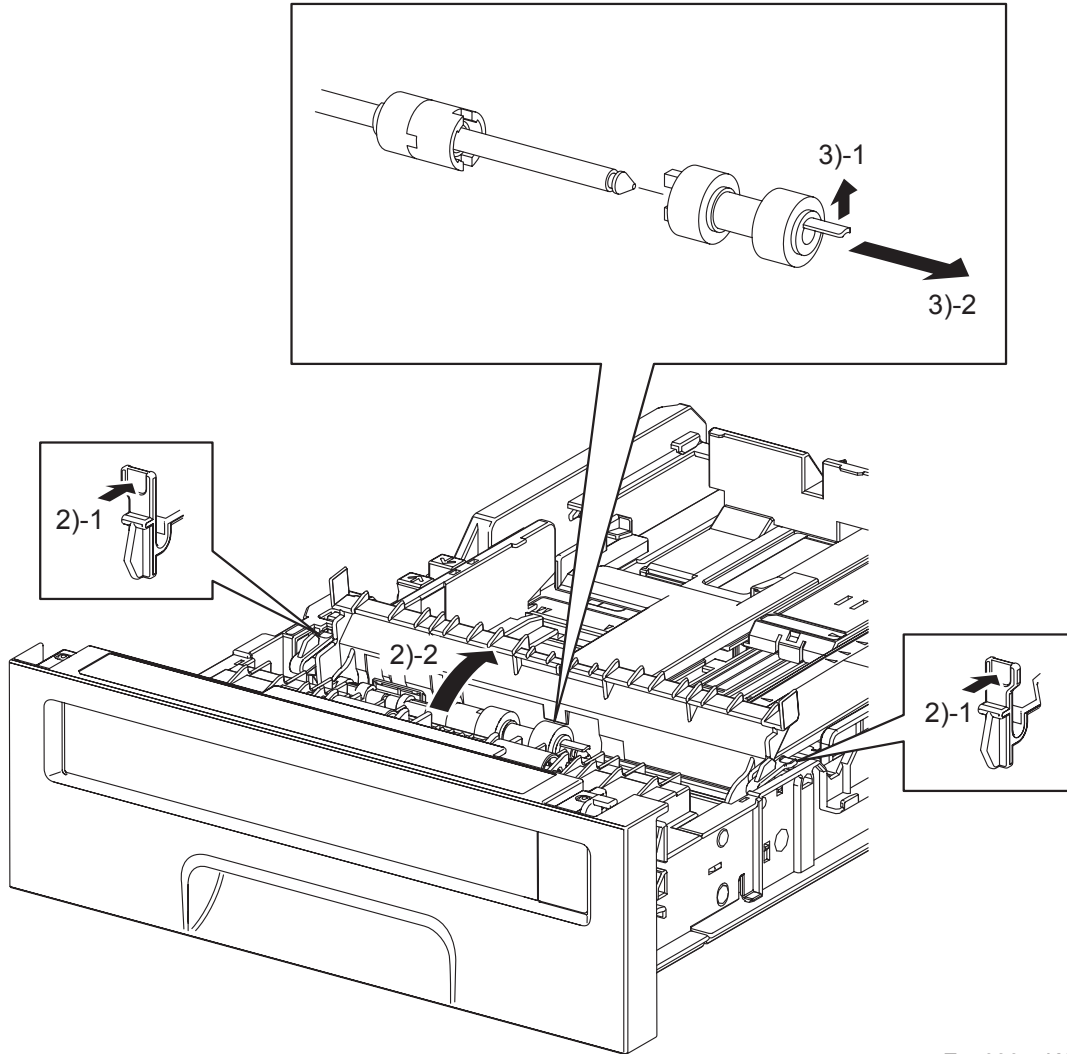

Zna03055KA

- 2) Release the left and right hooks of the CVR SPRTR CST (PL2.2.13), and then open the CVR SPRTR CST.
- 3) Release the hook of the SEPARATOR ROLLER (PL2.2.17), and then remove the SEPARATOR ROLLER from the SHAFT SEPARATOR (PL2.2.15).

Continues to the next page.

Removal 42 KIT SEPARATOR ROLLER & FEED ROLLER (PL2.2.99)

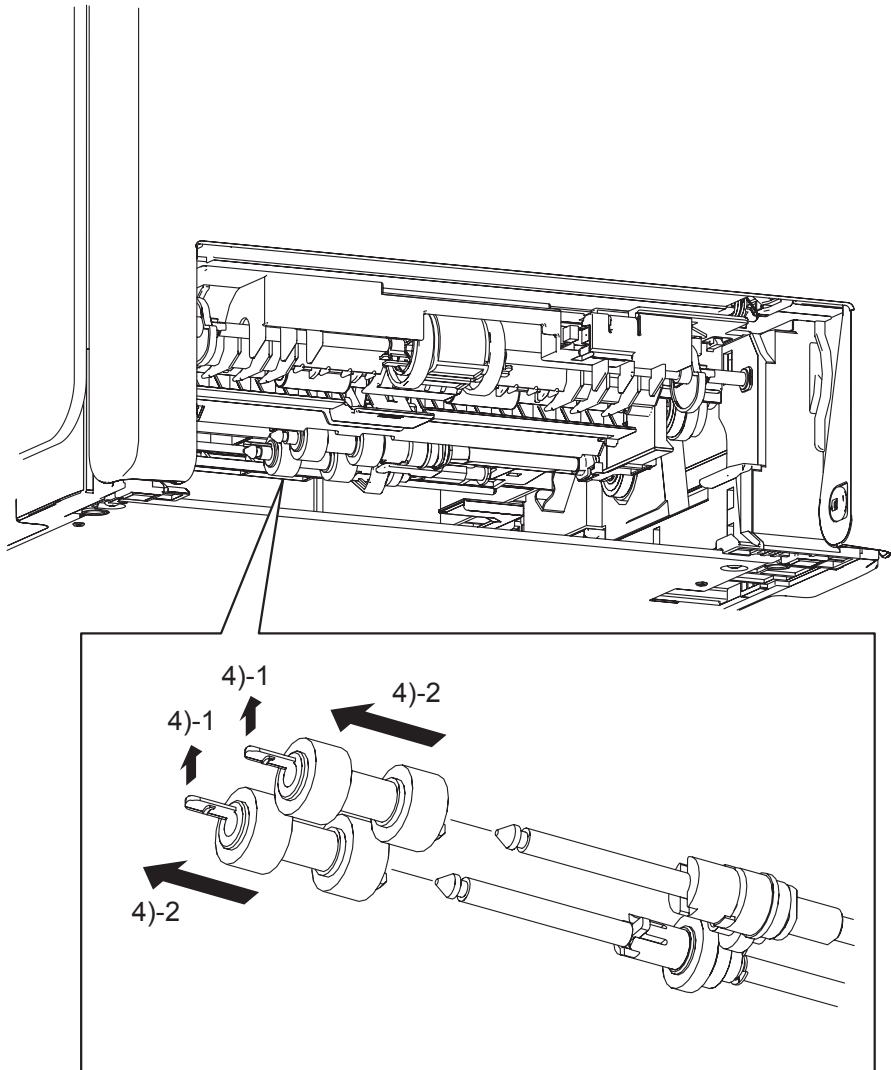

Zna03229KA

- 4) Release the hooks of the FEED ROLLERS (PL3.2.53) and remove the FEED ROLLERS from the shafts.

Removal 43 MPF ROLLER (PL3.1.99)

- 1) Remove the 250 SHEET PAPER TRAY (PL2.1.1) from the printer.

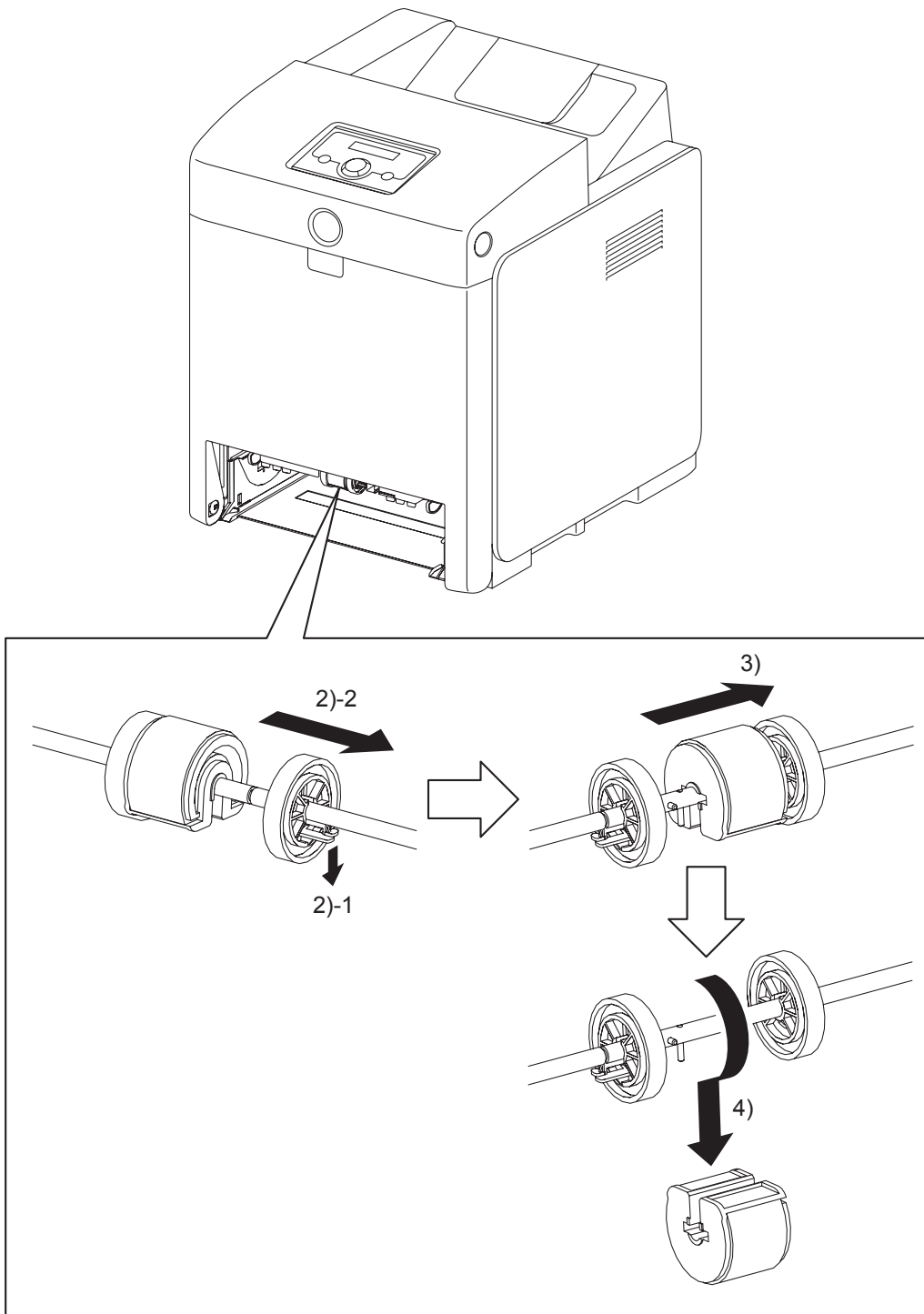

Zna03056KA

- 2) Release the hook of the ROLL CORE MSI (PL3.1.9) on the right of the MPF ROLLER (PL 3.2.10), and slide the ROLL CORE MSI to the right.
- 3) Release the groove on the MPF ROLLER from the vertical pin mounted on the SHAFT MSI (PL3.1.12) by sliding the MPF ROLLER to the right.
- 4) Remove the MPF ROLLER from the SHAFT MSI by rotating the MPF ROLLER 180 degrees.

Removal 44 550 SHEET FEEDER ASSEMBLY (PL12.1.1)

- 1) Remove the 250 SHEET PAPER TRAY (PL2.1.1) of the printer.

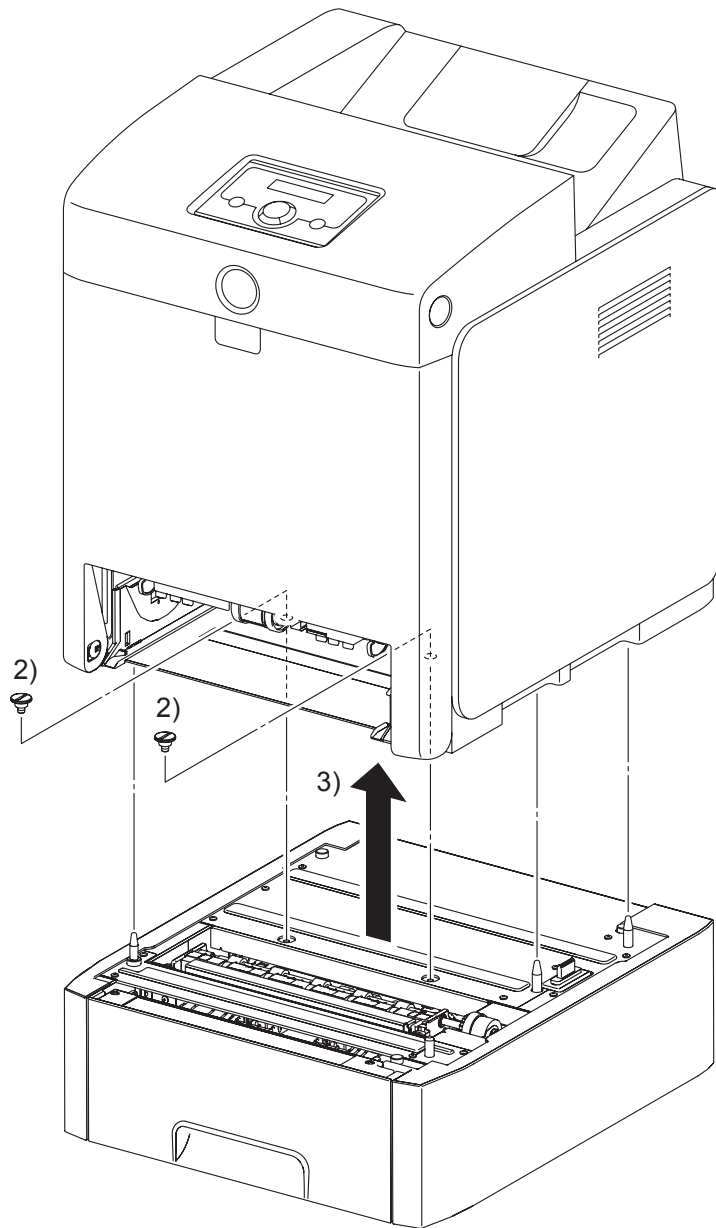

Zna03058KA

- 2) Remove two FEEDER SCREWS (PL12.1.3) that fix the 550 SHEET FEEDER ASSEMBLY (PL12.1.1) to the printer.

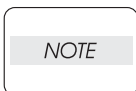

The printer must be lifted by two people.

- 3) Lift up the printer to separate it from the 550 SHEET FEEDER ASSEMBLY.

Removal 45 550 TRAY REAR COVER (PL12.1.4)

- 1) Pull the 550 TRAY REAR COVER backward until it stops

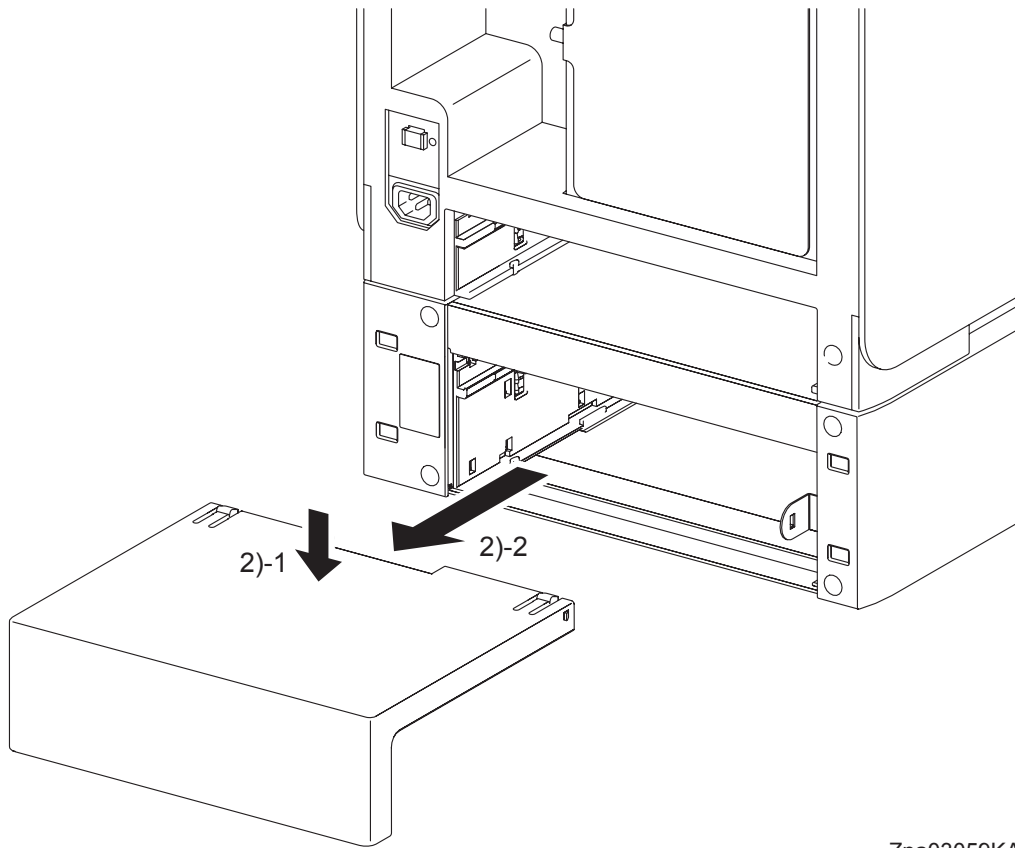

Zna03059KA

- 2) Release the two hooks by depressing the center of the 550 TRAY REAR COVER, and then remove the 550 TRAY REAR COVER from the 550 SHEET FEEDER ASSEMBLY (PL12.1.1).

Blank Page

Removal 46 550 TRAY FEED ROLLER (PL12.3.29) & 550 TRAY SEPARATOR ROLLER (PL12.5.17)

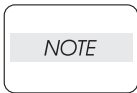

When replacing the 550 TRAY SEPARATOR ROLLER or the 550 TRAY FEED ROLLER replace the 550 TRAY SEPARATOR ROLLER and the two 550 TRAY FEED ROLLERS at the same time.

- 1) Remove the 550 SHEET PAPER TRAY (PL12.4.1) from the 550 SHEET FEEDER ASSEMBLY (PL12.1.1).

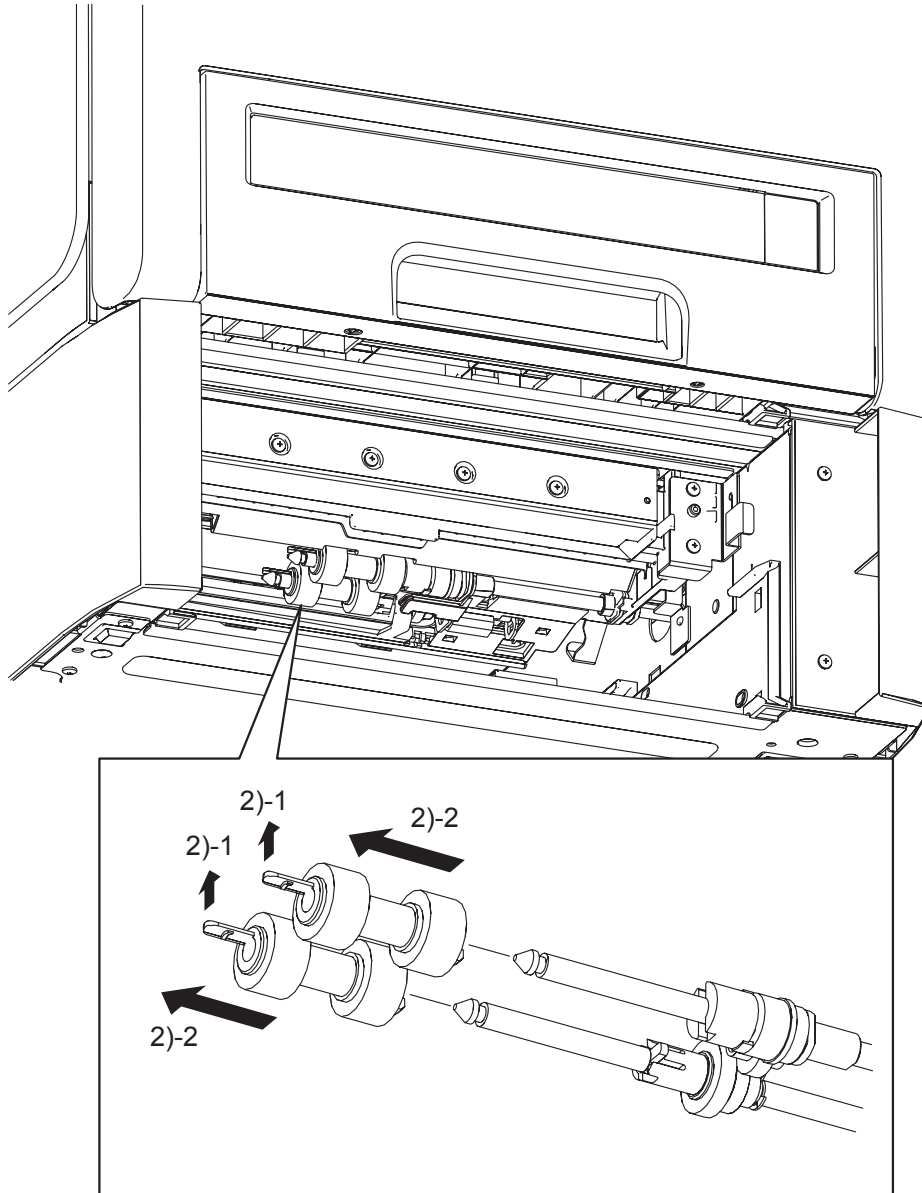

Kmy03060KA

- 2) Release the hooks of the 550 TRAY FEED ROLLERS (PL12.3.29), and then remove the 550 TRAY FEED ROLLERS from the shafts.

Continues to the next page.

Removal 46 550 TRAY FEED ROLLER (PL12.3.29) & 550 TRAY SEPARATOR ROLLER (PL12.5.17)

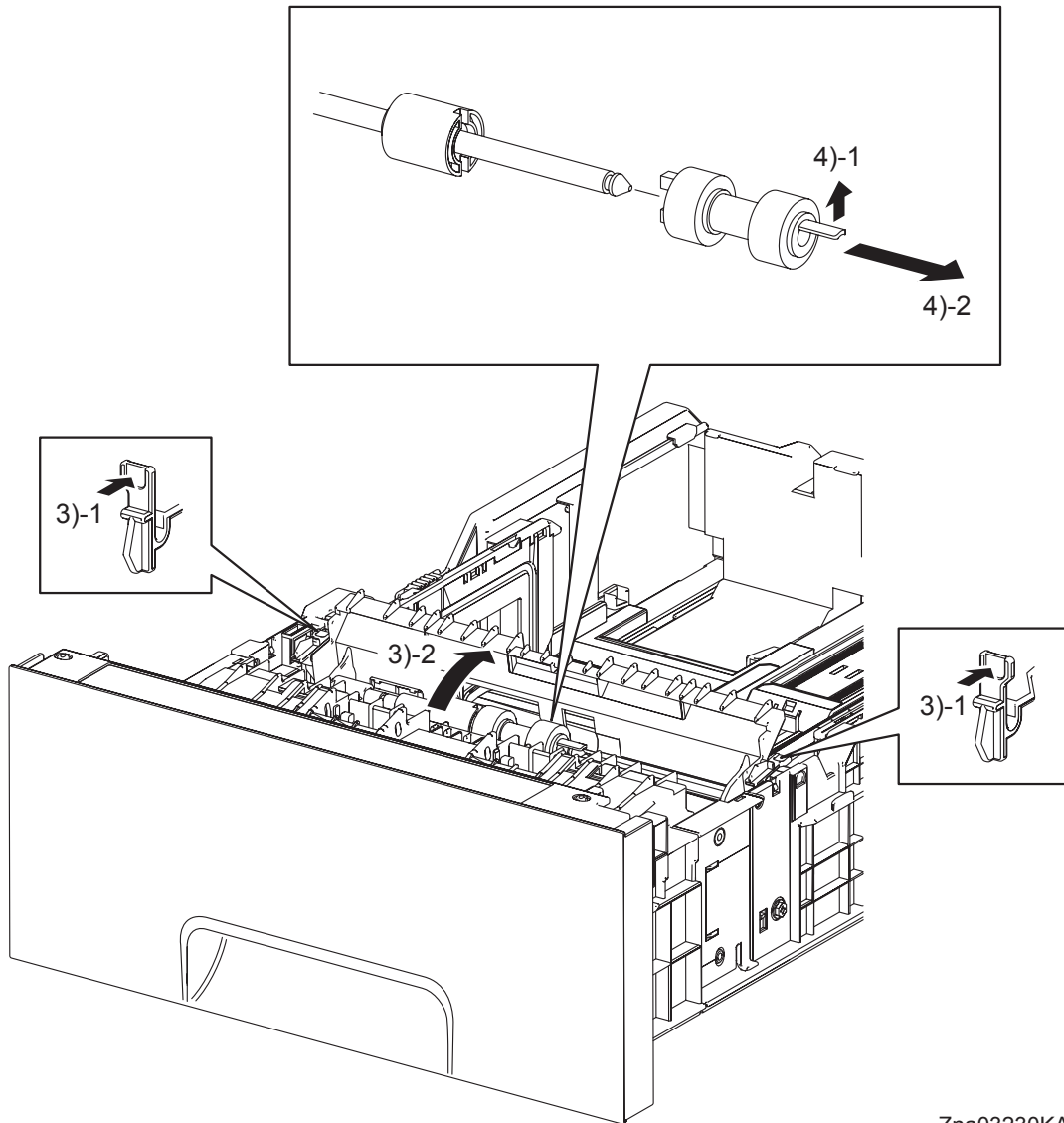

Zna03230KA

- 3) Release the left and right hooks of the CVR SPRTR CST (PL12.5.13), and then open the CVR SPRTR CST.
- 4) Release the hook of the 550 TRAY SEPARATOR ROLLER (PL12.5.17), and then remove the 550 TRAY SEPARATOR ROLLER from the SHAFT RETARD (PL12.5.15).

Removal 47 MEMORY CARD (PL9.1.30)

NOTE

Use a wristband to protect the MEMORY CARD from electrostatic damage.

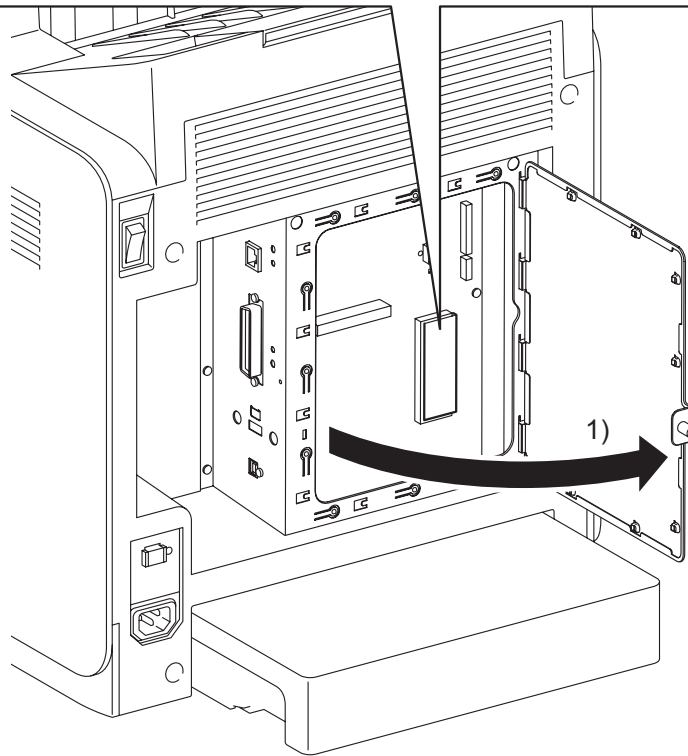
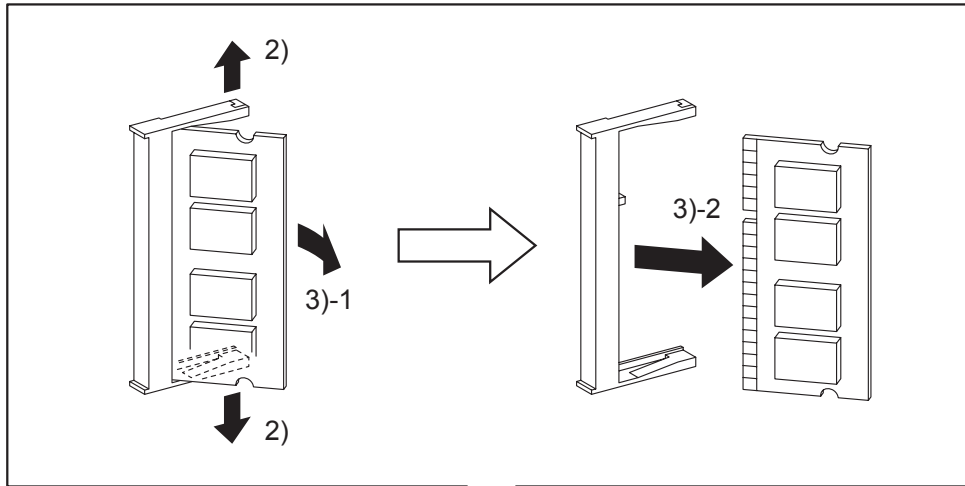

Zna03127KB

- 1) Loosen the SCREW KNURLING (PL9.1.44), and then open the SHIELD WINDOW (PL9.1.21).
- 2) Gently spread open both the tabs on the socket holding the MEMORY CARD (PL9.1.30) until the MEMORY CARD pops up slightly.
- 3) Remove the MEMORY CARD.

Removal 48 NETWORK PROTOCOL ADAPTER (PL9.1.46)

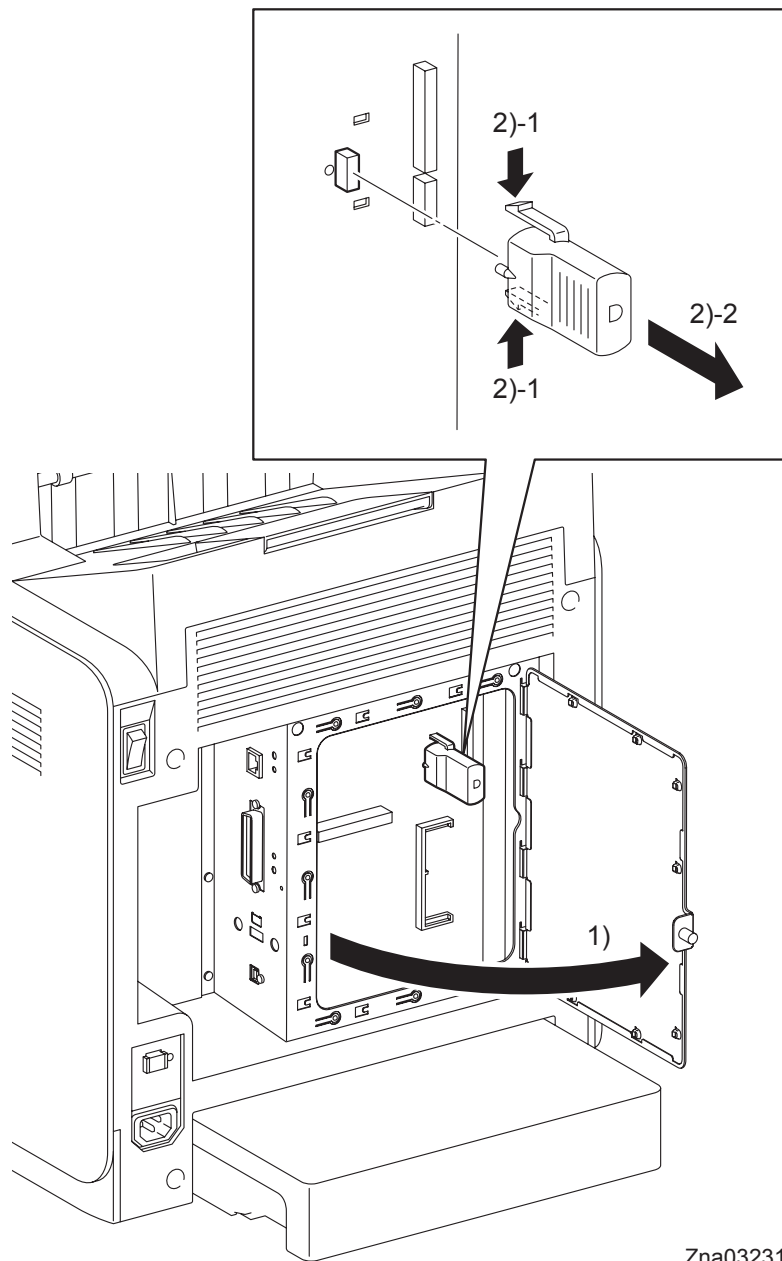

Zna03231KB

- 1) Loosen the SCREW KNURLING (PL9.1.44), and then open the SHIELD WINDOW (PL9.1.21).
- 2) Release the two hooks of the NETWORK PROTOCOL ADAPTER (PL9.1.46) to remove the NETWORK PROTOCOL ADAPTER from the ELECTRONIC SUB-SYSTEM CONTROL BOARD (PL9.1.27).

Removal 49 HARD DISK (PL9.1.47)

NOTE

Use a wristband to protect the HDD from electrostatic damage.

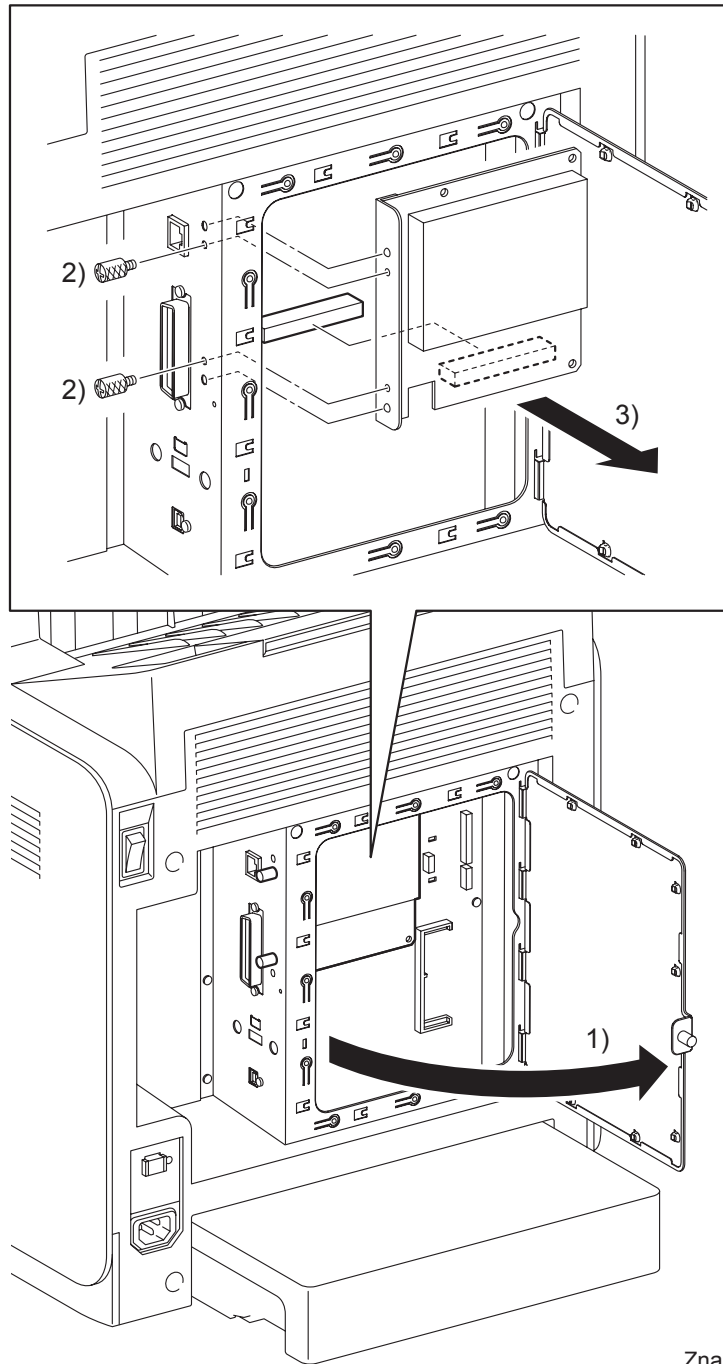

Zna03232KB

- 1) Loosen the SCREW KNURLING (PL9.1.44), and then open the SHIELD WINDOW (PL9.1.21).
- 2) Remove the two SCREW KNURLINGS (PL9.1.22) that fix the HARD DISK (PL9.1.47) to the printer.
- 3) Remove the HARD DISK from the ELECTRONIC SUB-SYSTEM CONTROL BOARD (PL9.1.27).

Removal 50 WIRELESS PRINTER ADAPTER (PL9.1.32)

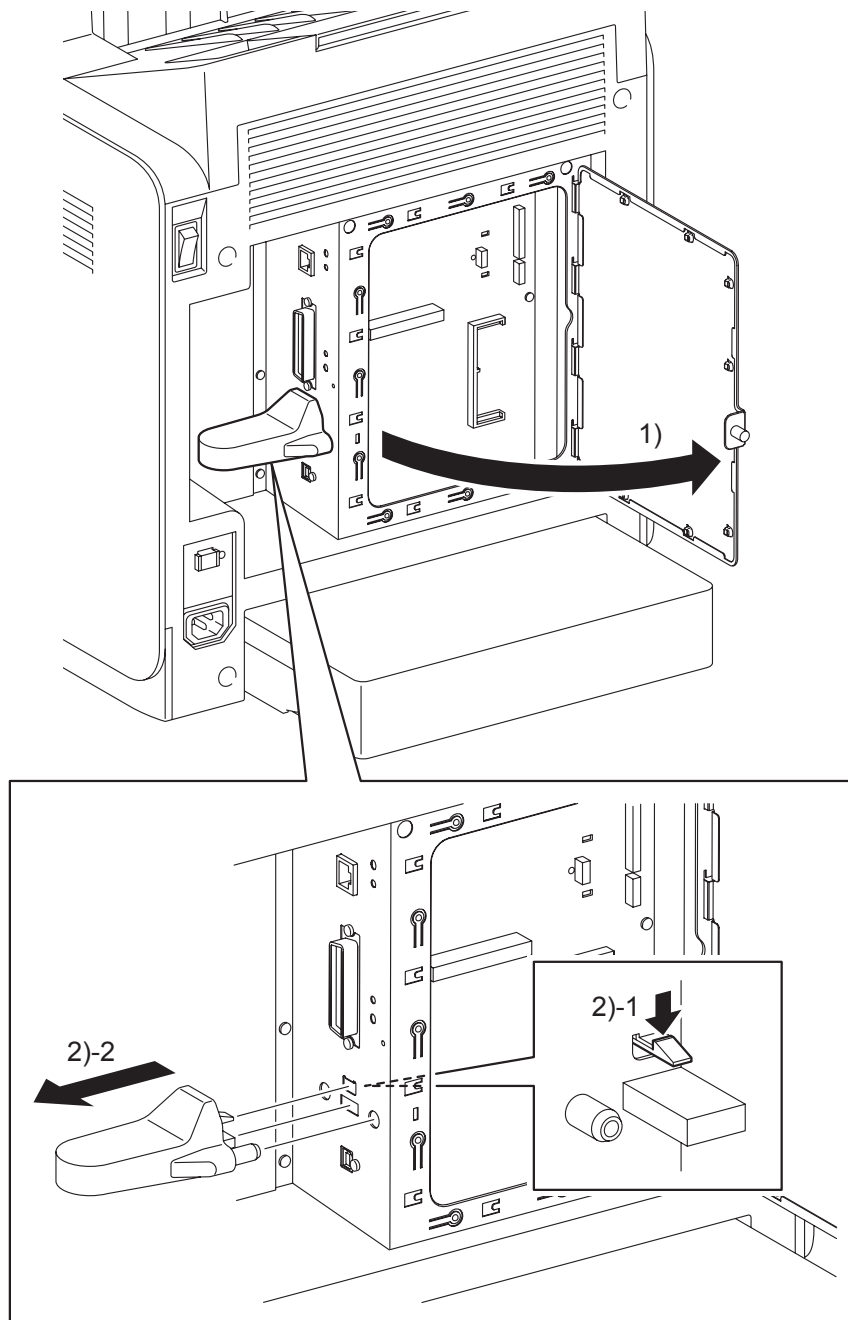

Zna03233KB

- 1) Loosen the SCREW KNURLING (PL9.1.44), and then open the SHIELD WINDOW (PL9.1.21).
- 2) Release the one hook of the WIRELESS PRINTER ADAPTER (PL9.1.32) to remove the WIRELESS PRINTER ADAPTER from the ELECTRONIC SUB-SYSTEM CONTROL BOARD (PL9.1.27).

3. Replacement Steps

Replacement 1 MPF ROLLER (PL3.1.99)

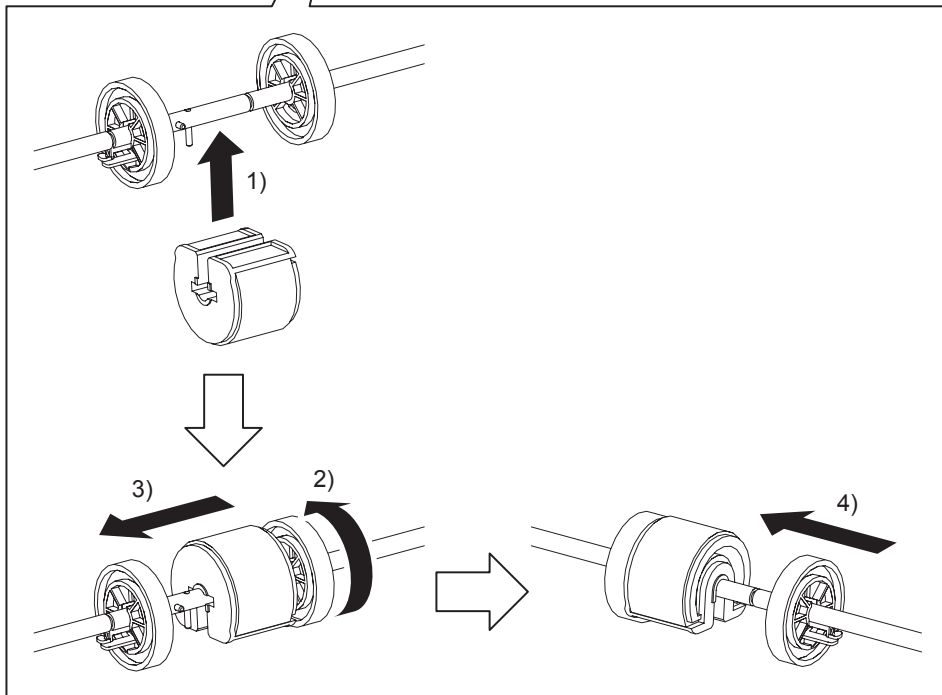
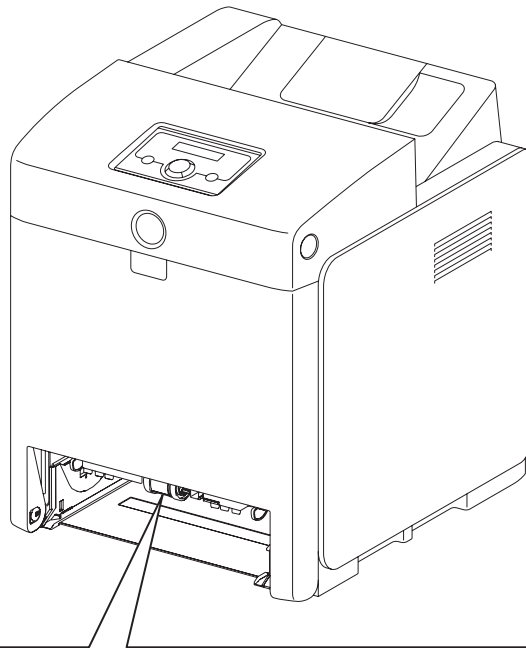

Zna03116KA

- 1) Fit the MPF ROLLER to the SHAFT MSI with the groove of the MPF ROLLER facing upward.
- 2) Rotate the MPF ROLLER 180 degrees so that the pin on the SHAFT MSI is aligned with the groove on the MPF ROLLER.
- 3) Slide the MPF ROLLER to the right so that the MPF ROLLER covers the pin on the SHAFT MSI.
- 4) Slide the right ROLL CORE MSI to the left. Secure the hook on the ROLL CORE MSI into the groove on the SHAFT MSI.
- 5) Replace the 250 SHEET PAPER TRAY to the printer.

Blank Page

Replacement 2 KIT SEPARATOR ROLLER & FEED ROLLER (PL2.2.99)

NOTE

When replacing the SEPARATOR ROLLER or the FEED ROLLER replace the SEPARATOR ROLLER and the two FEED ROLLERS at the same time.

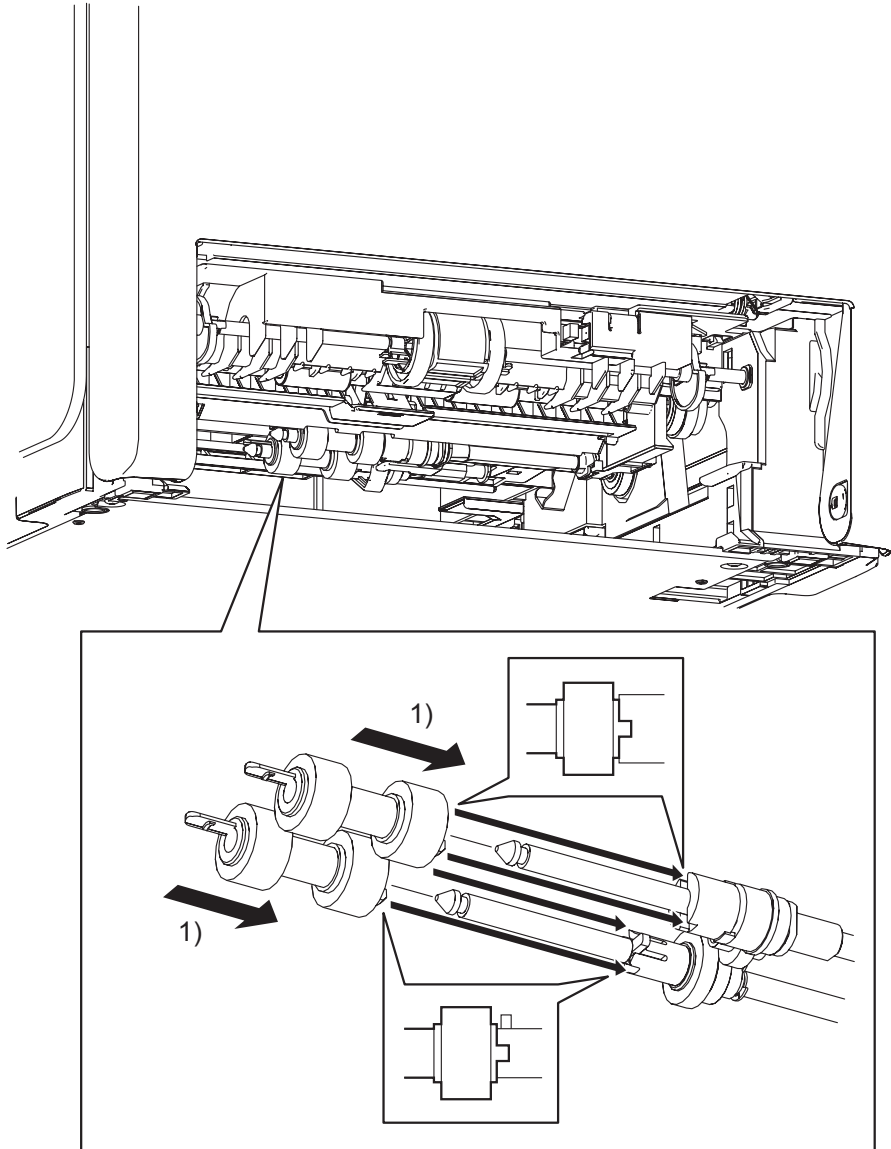

Kmy03117KA

- 1) Slide the FEED ROLLERS onto the shafts so that the lugs on the FEED ROLLERS are mated with the notches on the GEAR NUDGER A4 (PL3.2.46) and CLUTCH ONEWAY FEED (PL3.2.52). Lock the hooks on the other end of the FEED ROLLERS into the grooves on the shafts.

Continues to the next page.

Replacement 2 KIT SEPARATOR ROLLER & FEED ROLLER (PL2.2.99)

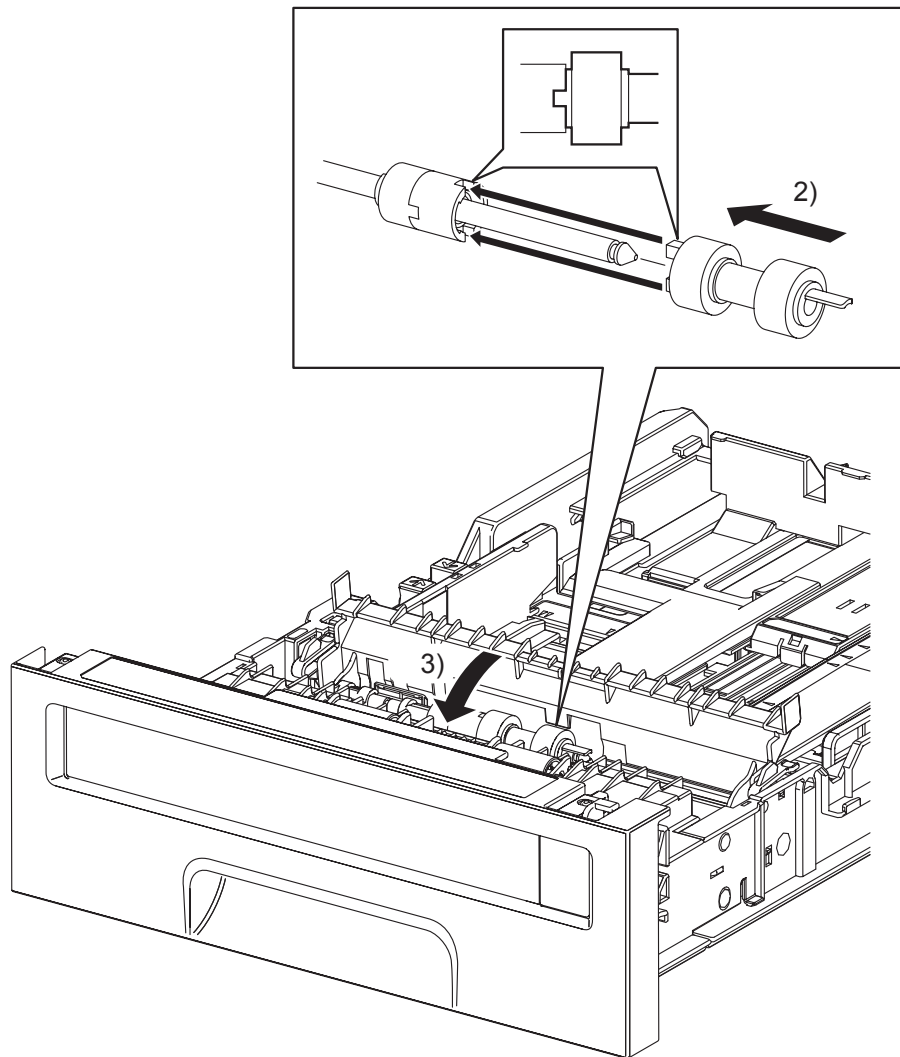

Zna03300KB

- 2) Slide the SEPARATOR ROLLER onto the SHAFT SEPARATOR so that the lug on the SEPARATOR ROLLER is mated with the notch on the CLUTCH FRICTION SPRTR (PL2.2.16). Secure the hook on the other end of the SEPARATOR ROLLER into the groove on the SHAFT SEPARATOR.
- 3) Close the CVR SPRTR CST.
- 4) Replace the 250 SHEET PAPER TRAY to the printer.

Replacement 3 MPF SEPARATOR ROLLER ASSEMBLY (PL2.1.3)

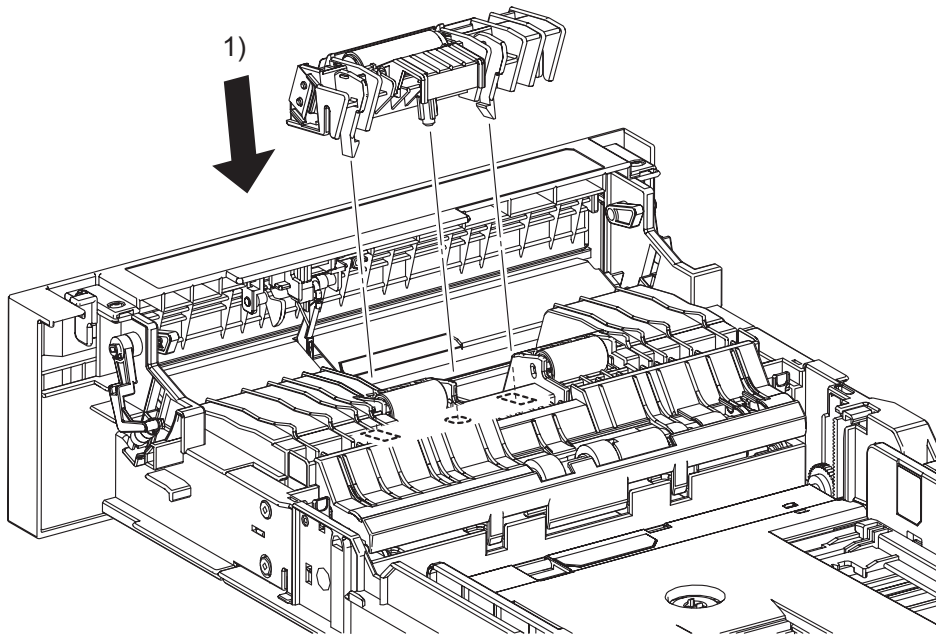

Zna03114KA

- 1) Replace the MPF SEPARATOR ROLLER ASSEMBLY by mating the bosses of the MPF SEPARATOR ROLLER ASSEMBLY with the holes of the 250 SHEET PAPER TRAY. Secure the MPF SEPARATOR ROLLER ASSEMBLY with the two backside hooks.
- 2) Replace the 250 SHEET PAPER TRAY to the printer.

Blank Page

Replacement 4 INTEGRATED FEEDER ASSEMBLY (PL3.2.99)

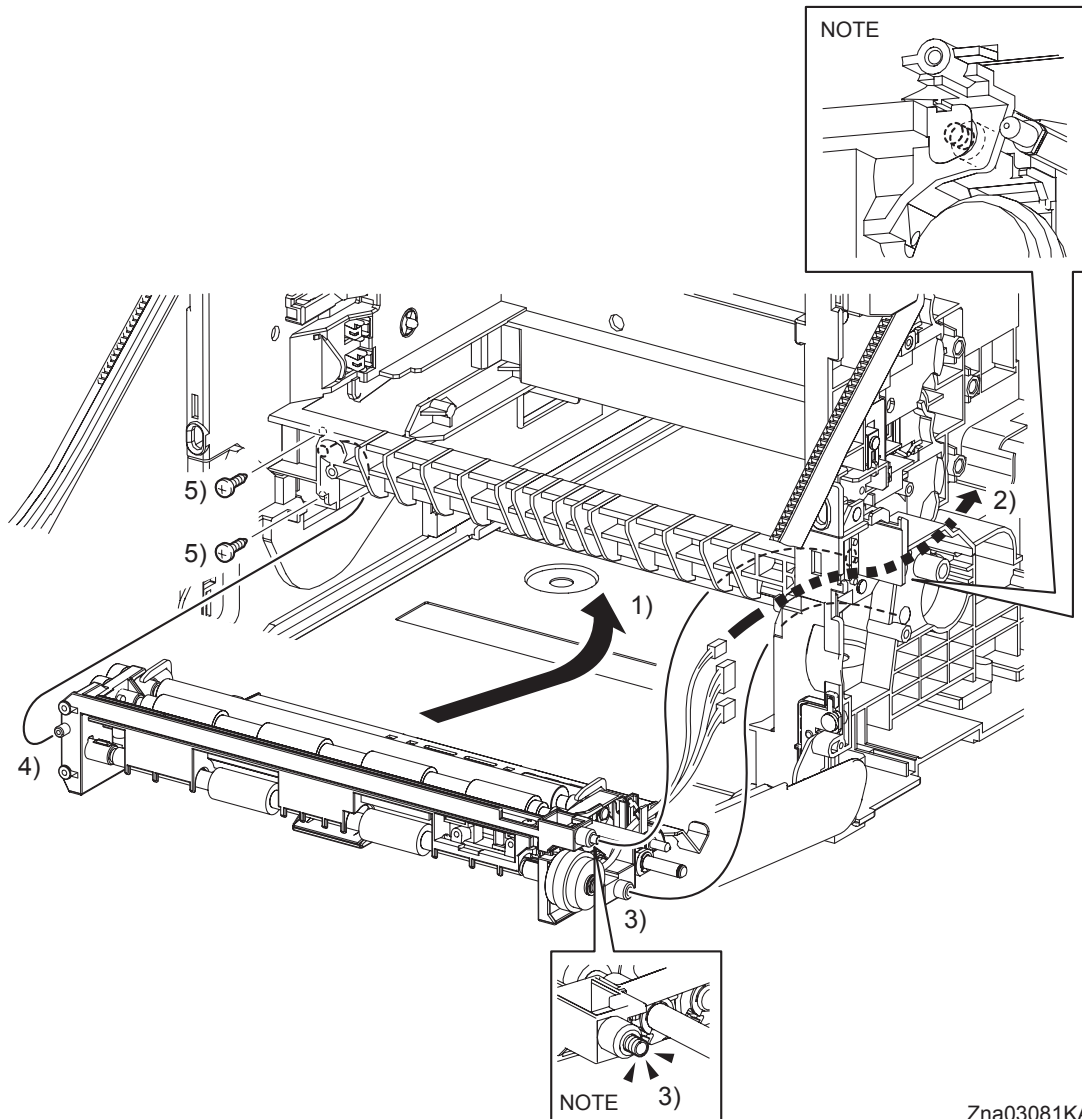

Zna03081KA

NOTE

When performing the step described below, take care not to drop and lose the SPRING EARTH on the right side of the INTEGRATED FEEDER ASSEMBLY.

NOTE

When performing the step described below, check that the SPRING EARTH on the right side of the INTEGRATED FEEDER ASSEMBLY is in contact with the PLATE EARTH of the printer.

- 1) Insert the INTEGRATED FEEDER ASSEMBLY diagonally into the printer so that the right side of the INTEGRATED FEEDER ASSEMBLY goes in first.
- 2) Route the harness with the two connectors coming from the INTEGRATED FEEDER ASSEMBLY and the connector of the CLUTCH ASSY PH TURN out of the hole on the printer from inside.
- 3) Insert the bearing, the clutch and the two bosses (One is provided with the SPRING EARTH.) on the right side of the INTEGRATED FEEDER ASSEMBLY to the holes on the printer.
- 4) Insert the left side boss of the INTEGRATED FEEDER ASSEMBLY into the hole on the printer.
- 5) Secure the INTEGRATED FEEDER ASSEMBLY to the printer using the two screws (silver, tap, 10mm).

Continues to the next page.

Replacement 4 INTEGRATED FEEDER ASSEMBLY (PL3.2.99)

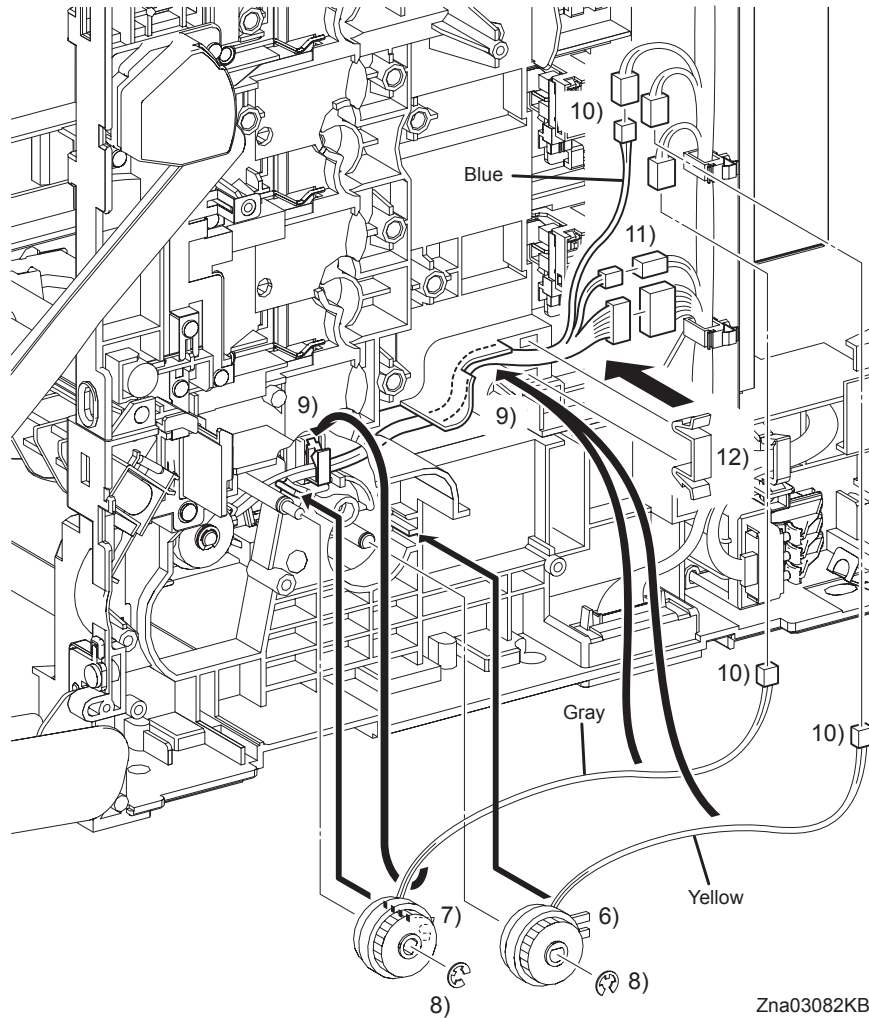
**NOTE**

When replacing the CLUTCH, match the harness color of the CLUTCH with that of the fitting groove of the CLUTCH.

The harness color of the CLUTCH ASSY PH REGI is gray.

The harness color of the CLUTCH ASSY PH FEED is yellow.

The harness color of the CLUTCH ASSY PH TURN is blue.

- 6) Replace the CLUTCH ASSY PH FEED to the INTEGRATED FEEDER ASSEMBLY by mating the fitting groove the CLUTCH ASSY PH FEED with the lug on the INTEGRATED FEEDER ASSEMBLY.
- 7) Replace the CLUTCH ASSY PH REGI to the printer by mating the fitting groove on the CLUTCH ASSY PH REGI with the lug on the printer.
- 8) Replace the CLUTCH ASSY PH REGI and CLUTCH ASSY PH FEED to the INTEGRATED FEEDER ASSEMBLY using the e-rings.
- 9) Route the harnesses along the printer and bind them with the clamps on the INTEGRATED FEEDER ASSEMBLY and the printer.

NOTE

When engaging the connectors of the CLUTCHes, match the color of the CLUTCH harness with that of the harness on the printer side.

- 10) Engage the connector (P/J231) of the CLUTCH ASSY PH REGI, the connector (P/J233) of the CLUTCH ASSY PH FEED, and the connector (P/J232) of the CLUTCH ASSY PH TURN.
- 11) Engage the connectors (P/J292 and P/J301) of the INTEGRATED FEEDER ASSEMBLY.
- 12) Attach the CLAMP to the frame of the printer, secure the harness using the CLAMP.

Continues to the next page.

Replacement 4 INTEGRATED FEEDER ASSEMBLY (PL3.2.99)

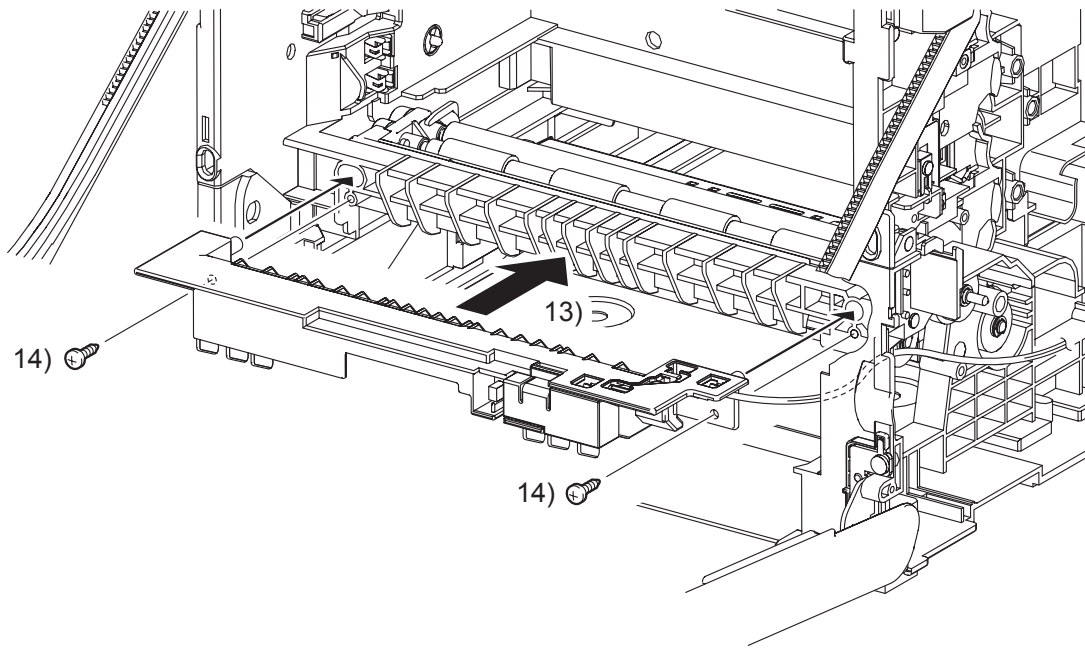

NOTE

When performing the step described below, ensure that the harness will not be caught between the CHUTE MSI and the printer.

- 13) Replace the CHUTE MSI by mating the two bosses on the CHUTE MSI with the holes on the printer.
- 14) Secure the CHUTE MSI to the printer using the two screws (silver, tap, 10mm).

Go to the next replacement step:

Replacement 28 ROLL ASSY MSI (PL3.1.8)

Replacement 5 TONER CARTRIDGE SENSOR ASSEMBLY (K), (C), (M), (Y) (PL5.1.4)

NOTE

Described below is the replacement procedure common among TONER CARTRIDGE SENSOR ASSYS (C), (M), (Y), and (K).

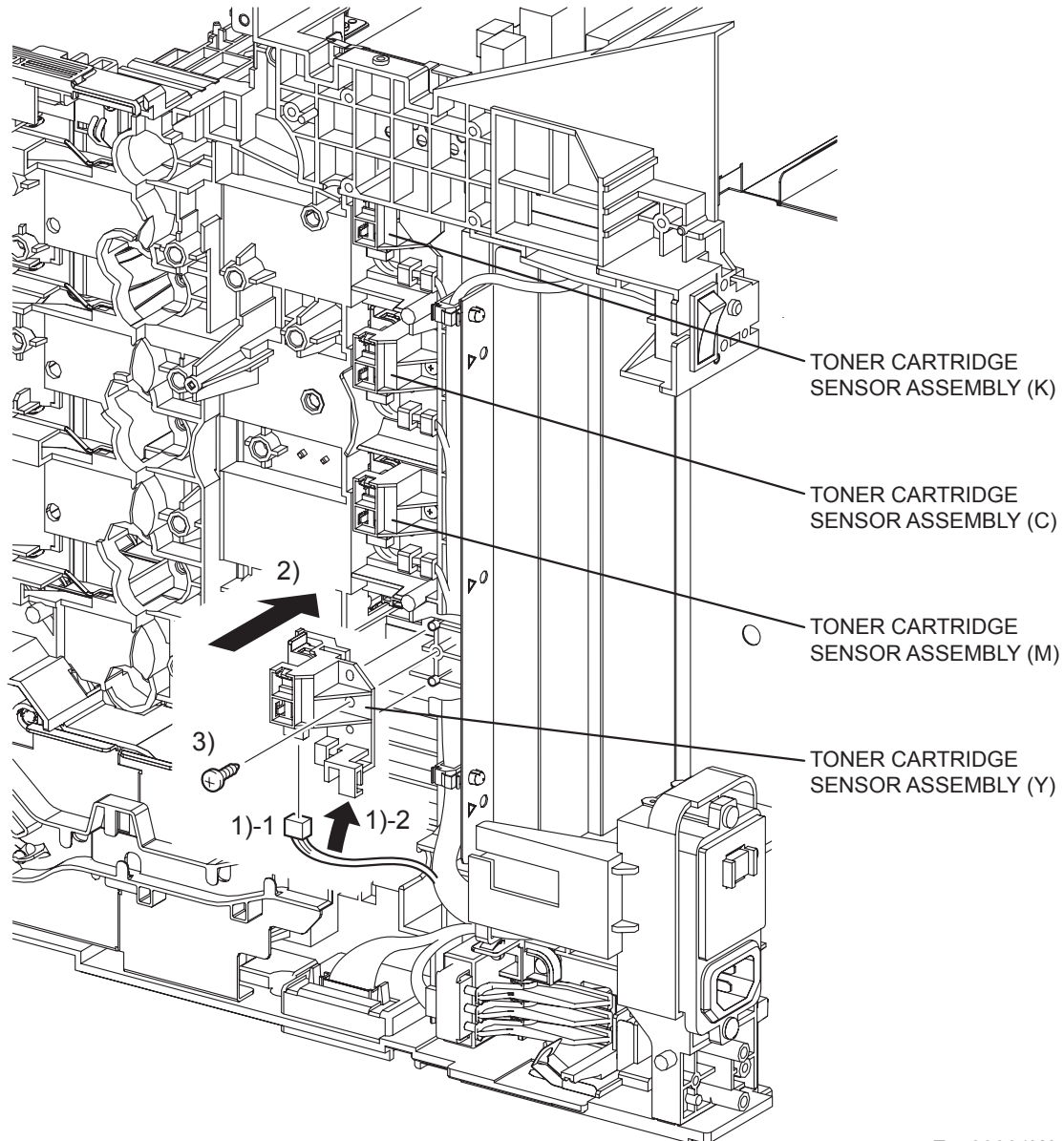

Zna03301KA

- 1) Engage the connector of the TONER CARTRIDGE SENSOR ASSEMBLY, and then route the harness to hook of the TONER CARTRIDGE SENSOR ASSEMBLY.
- 2) Mate the two holes on the TONER CARTRIDGE SENSOR ASSEMBLY with the bosses on the printer.
- 3) Secure the TONER CARTRIDGE SENSOR ASSEMBLY to the printer using the one screw (silver, tap, 10mm).

Go to the next replacement step:

Replacement 6 PHOTOCOnductor (PC) / DEVELOPER (DEV) DRIVE (PL8.1.2)

Replacement 6 PHOTOCONDUCTOR (PC) / DEVELOPER (DEV) DRIVE (PL8.1.2)

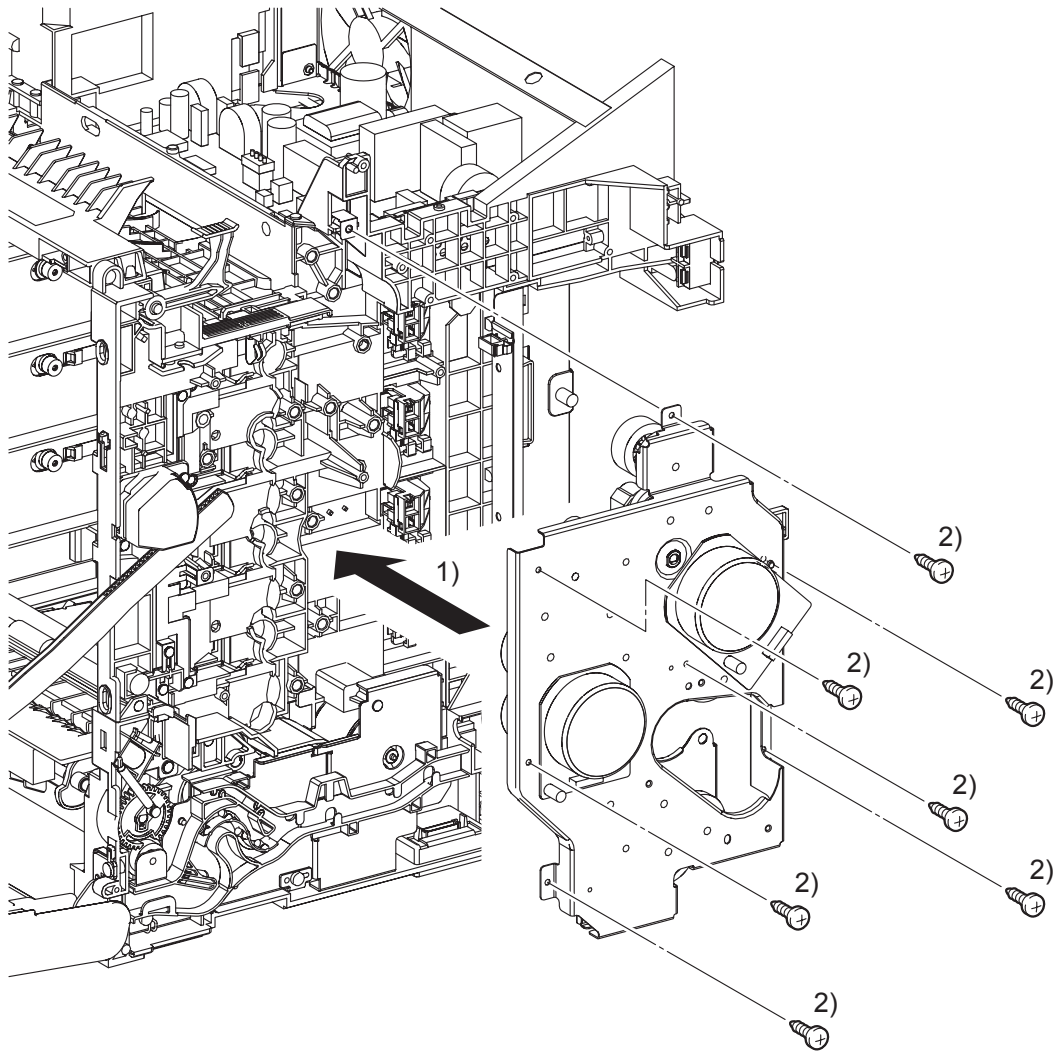

Zna03302KB

- 1) Replace the PHOTOCONDUCTOR (PC) / DEVELOPER (DEV) DRIVE by aligning the gear of each drive of the PHOTOCONDUCTOR (PC) / DEVELOPER (DEV) DRIVE with the holes on the printer.
- 2) Secure the PHOTOCONDUCTOR (PC) / DEVELOPER (DEV) DRIVE to the printer using the seven screws (silver, tap, 10mm).

Continues to the next page.

Replacement 6 PHOTOCONDUCTOR (PC) / DEVELOPER (DEV) DRIVE (PL8.1.2)

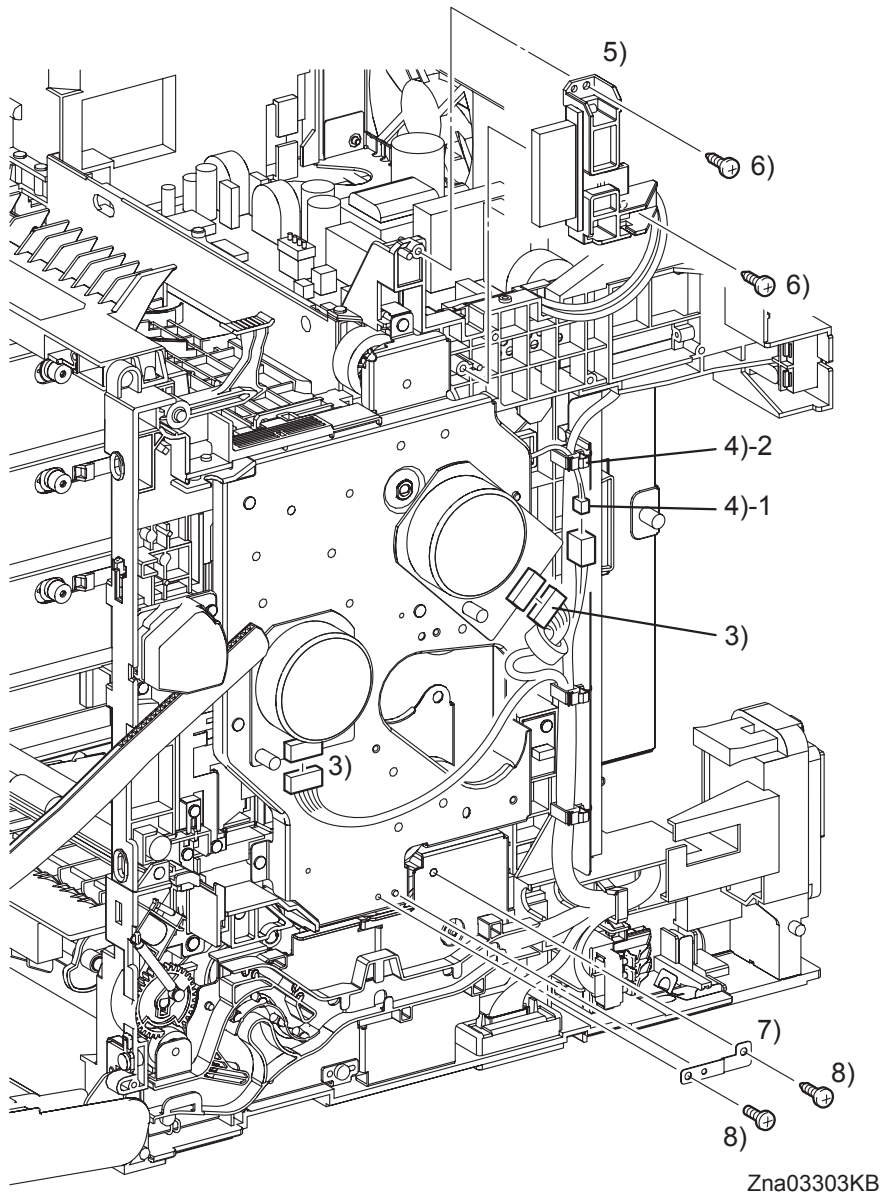

- 3) Engage the two connectors with the Main Motor and the Sub Motor.
- 4) Engage the connector (P/J235) of the Exit Clutch in the PHOTOCONDUCTOR (PC) / DEVELOPER (DEV) DRIVE, and then fix the harness using the clamp.
- 5) Replace the BRACKET FUSER by mating its two holes with the bosses on the printer.
- 6) Secure the BRACKET FUSER using the two screws (silver, tap, 10mm).
- 7) Mate the one hole on the PLATE EARTH DRV MP with the boss on the PHOTOCONDUCTOR (PC) / DEVELOPER (DEV) DRIVE.
- 8) Secure the PLATE EARTH DRV MP to the PHOTOCONDUCTOR (PC) / DEVELOPER (DEV) DRIVE and FEED DRIVE ASSEMBLY using the one screw (silver, 6mm) and the one screw (silver, tap, 10mm).

Go to the next replacement step:

Replacement 16 DRIVE ASSY K (PL8.1.10)

Replacement 7 INTERLOCK SWITCH (PL9.1.3)

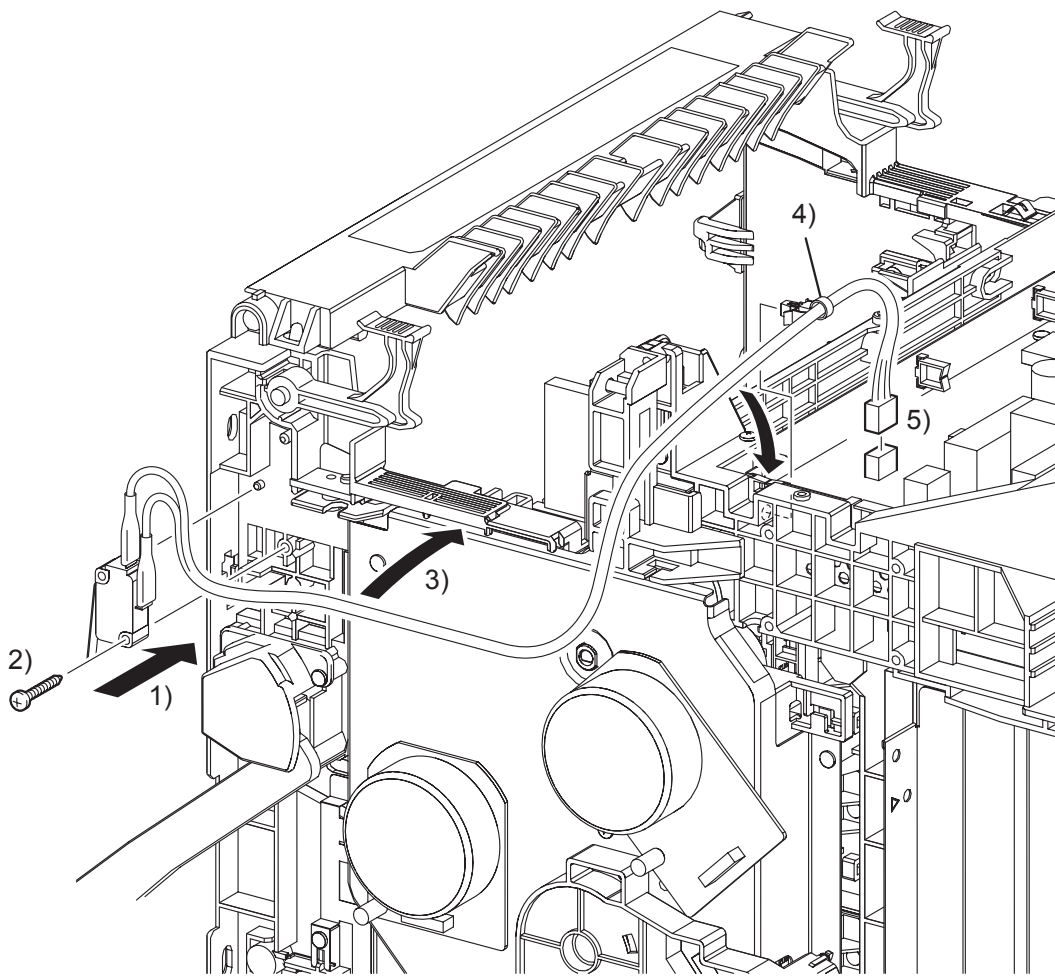

Zna03110KB

- 1) Replace the INTERLOCK SWITCH by mating the hole on the INTERLOCK SWITCH with the boss on the printer.
- 2) Secure the INTERLOCK SWITCH to the printer using the one screw (silver, tap, 16mm).
- 3) Route the harness of the INTERLOCK SWITCH to the duct of the printer.
- 4) Replace the clamp that fixes the harness of the INTERLOCK SWITCH to the SHIELD LVPS.
- 5) Engage the connector (P/J44) of the INTERLOCK SWITCH to the LOW VOLTAGE POWER SUPPLY.

Go to the next replacement step:

Replacement 13 TOP COVER (PL1.1.1)

Blank Page

Replacement 8 ROS (PL5.1.99)

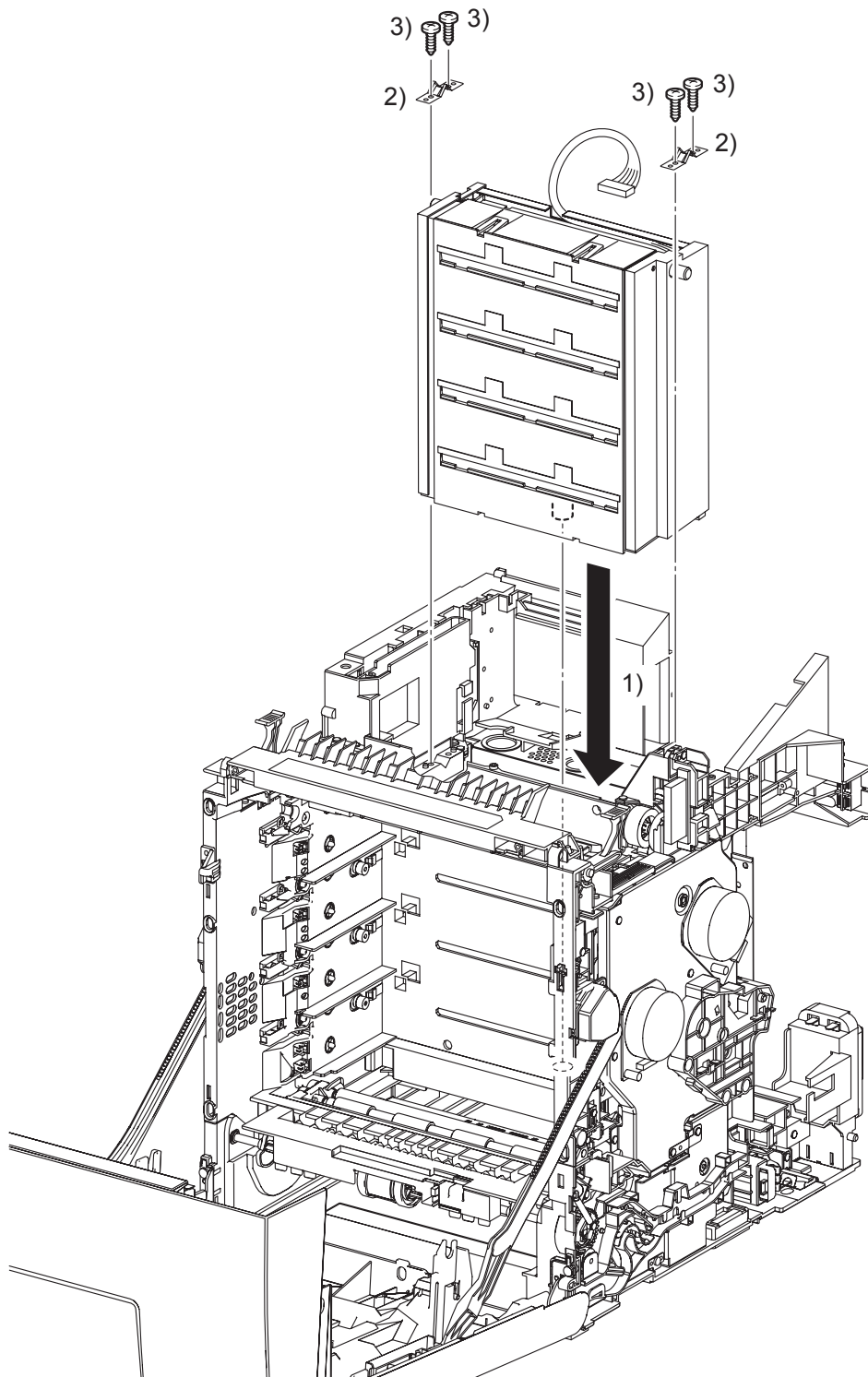

Zna03304KB

- 1) Insert the ROS by mating the backside boss of the ROS with the hole on the printer.
- 2) Place the two SPRING ROSs onto the left and right side bosses on the ROS so that the holes of SPRING ROSs are mated with the bosses on the printer.
- 3) Secure the SPRING ROSs to the printer using the four screws (silver, tap, 10mm).

Continues to the next page.

Replacement 8 ROS (PL5.1.99)

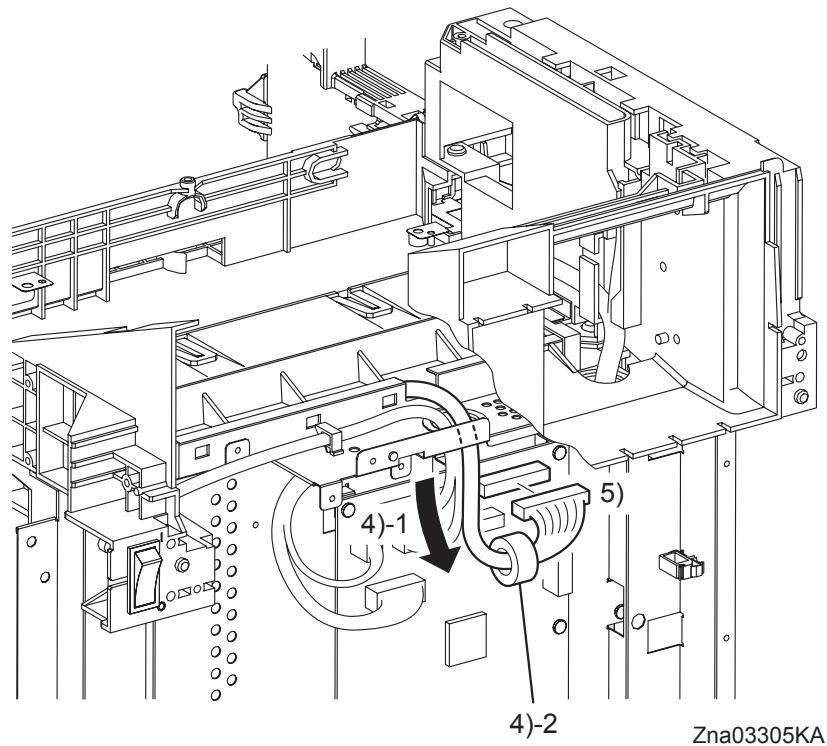

- 4) Pass the connector of the ROS through the hole on the SHIELD REAR, and then replace the CORE to the harness of the ROS.
- 5) Engage the connector (P/J12) of the ROS with the connector on the MACHINE CONTROL UNIT.

Continues to the next page.

Replacement 8 ROS (PL5.1.99)

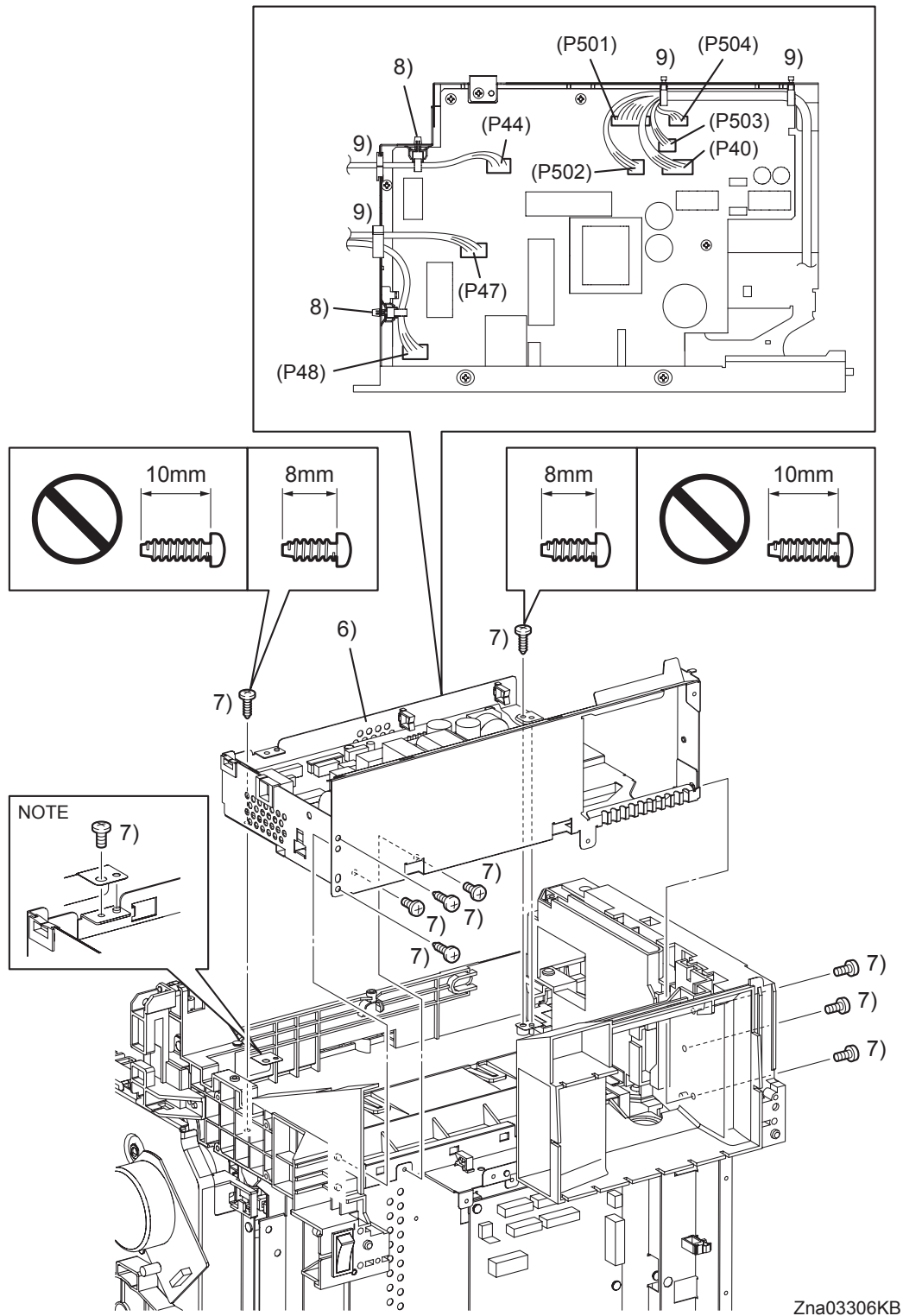

NOTE

When securing the one positions shown in the figure, make sure that the SHIELD LVPS is under the PLATE EARTH.

Continues to the next page.

- 6) Replace the LVPS ASSY to the printer by mating the three holes on the SHIELD LVPS with the bosses on the printer.

NOTE

Ensure the 8mm screws are used to secure the upper side of the LVPS ASSY. Use of 10mm screws will damage the frame.

- 7) Secure the LVPS ASSY to the printer using the six screws (silver, 6mm), the two screws (silver, tap, 8mm) and the two screws (silver, tap, 10mm).
- 8) Replace the clamps that fix the harness of the INTERLOCK SWITCH and HARN ASSY AC IN to the SHIELD LVPS.
- 9) Engage all the connectors of the LOW VOLTAGE POWER SUPPLY, and then secure the harness with the clamps.

Continues to the next page.

Replacement 8 ROS (PL5.1.99)

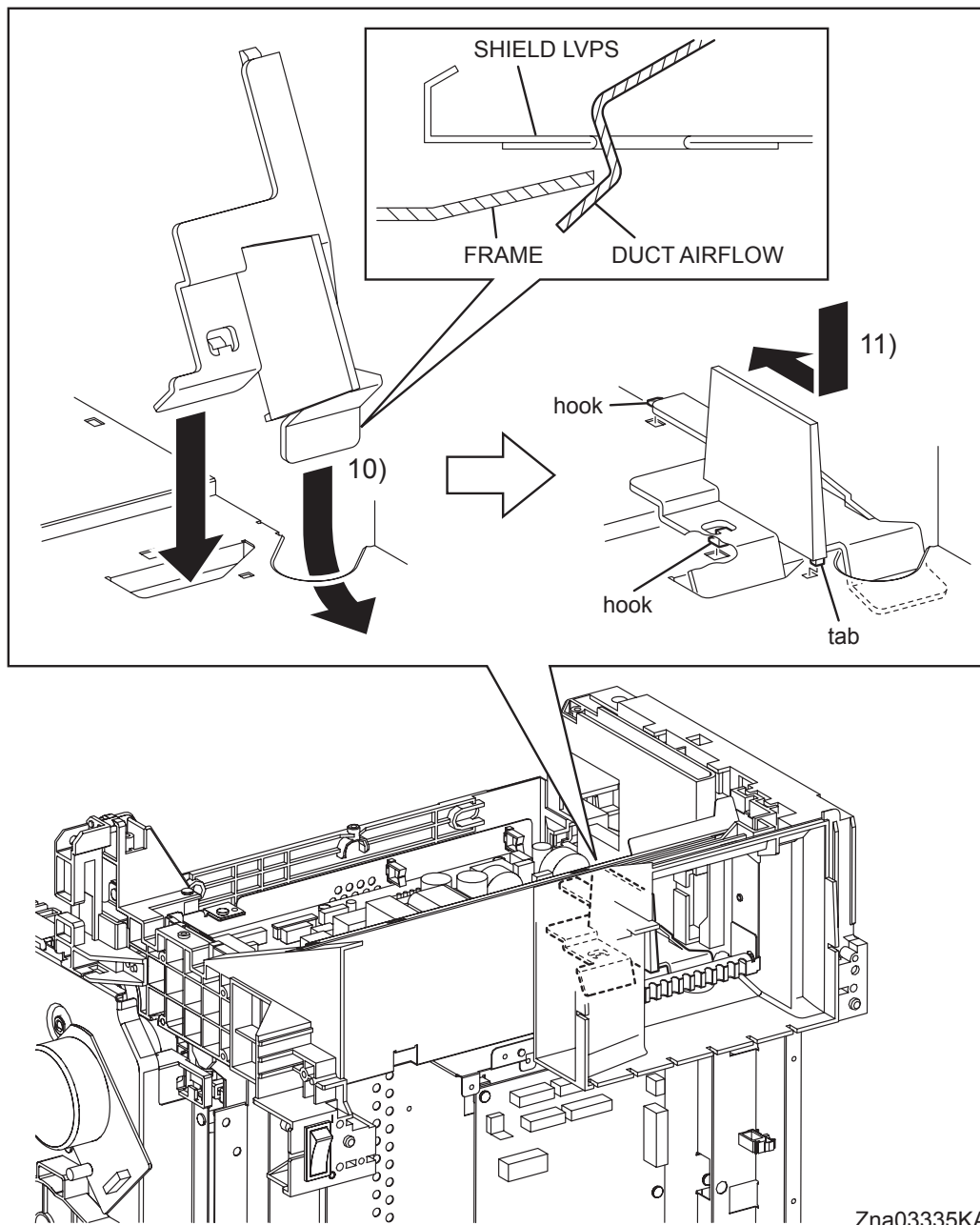

- 10) Install the DUCT AIRFLOW to the printer by slipping in its rear end underneath the frame.
- 11) Mate the two hooks of the DUCT AIRFLOW with the holes of the SHIELD LVPS. Move the DUCT AIRFLOW forward until it is secured onto the SHIELD LVPS at the two hooks and one tab.

**Go to the next replacement step:
Replacement 12 FAN (PL9.1.10)**

Replacement 9 LOW VOLTAGE POWER SUPPLY (PL9.1.4)

NOTE

Use a wristband to protect the PWB from electrostatic damage.

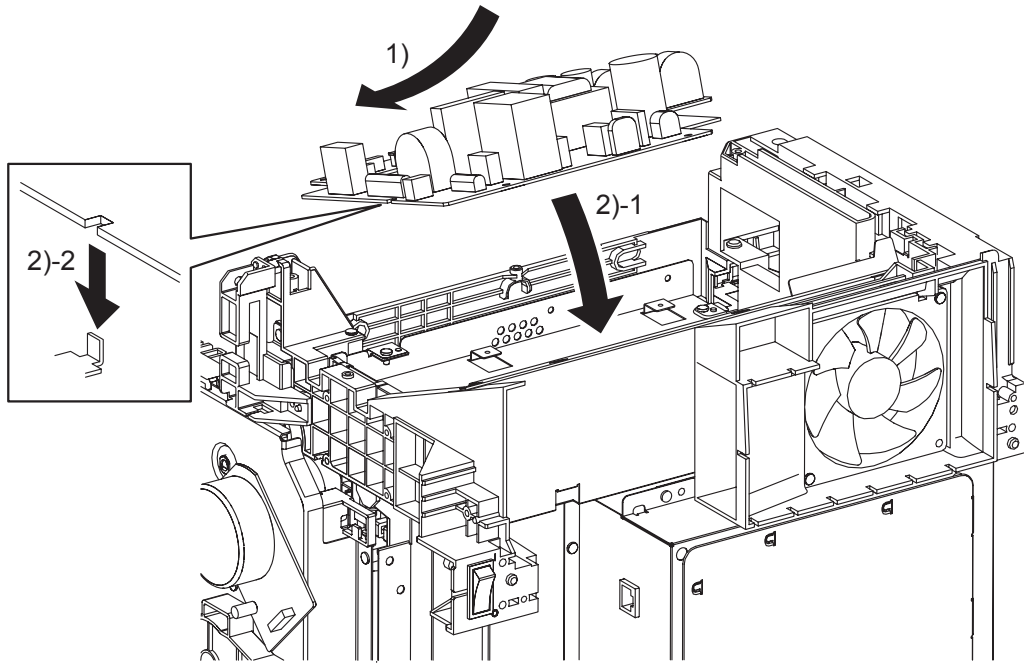

Zna03307KA

- 1) Put the LOW VOLTAGE POWER SUPPLY on the SHIELD LVPS with holding up the rear side of the LOW VOLTAGE POWER SUPPLY.
- 2) Mate the notch of the LOW VOLTAGE POWER SUPPLY to the tab of the SHIELD LVPS to attach the LOW VOLTAGE POWER SUPPLY.

Continues to the next page.

Replacement 9 LOW VOLTAGE POWER SUPPLY (PL9.1.4)

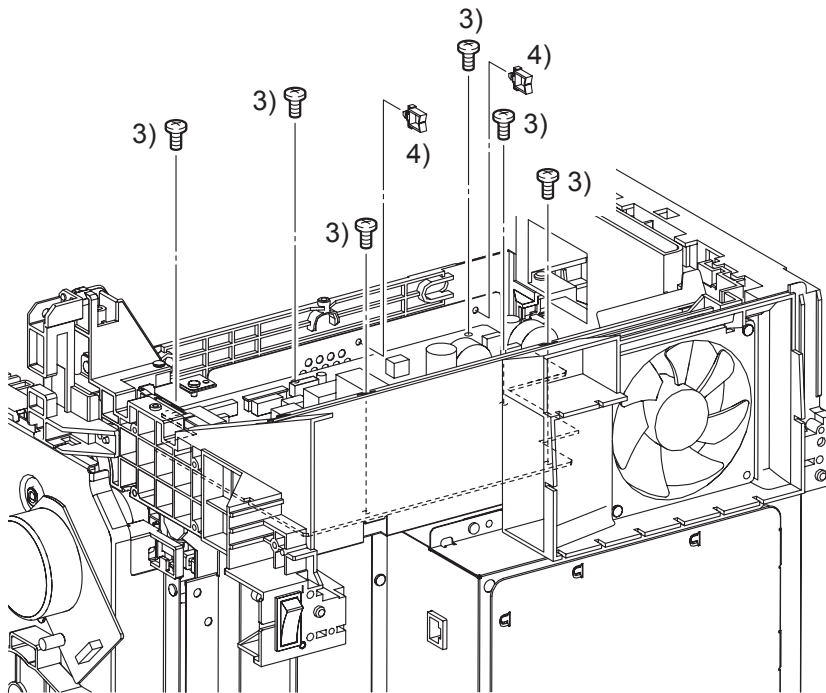

Zna03308KA

- 3) Secure the LOW VOLTAGE POWER SUPPLY to the SHIELD LVPS using the six screws (silver, 6mm).
- 4) Attach the two clamps to the SHIELD LVPS.

Continues to the next page.

Replacement 9 LOW VOLTAGE POWER SUPPLY (PL9.1.4)

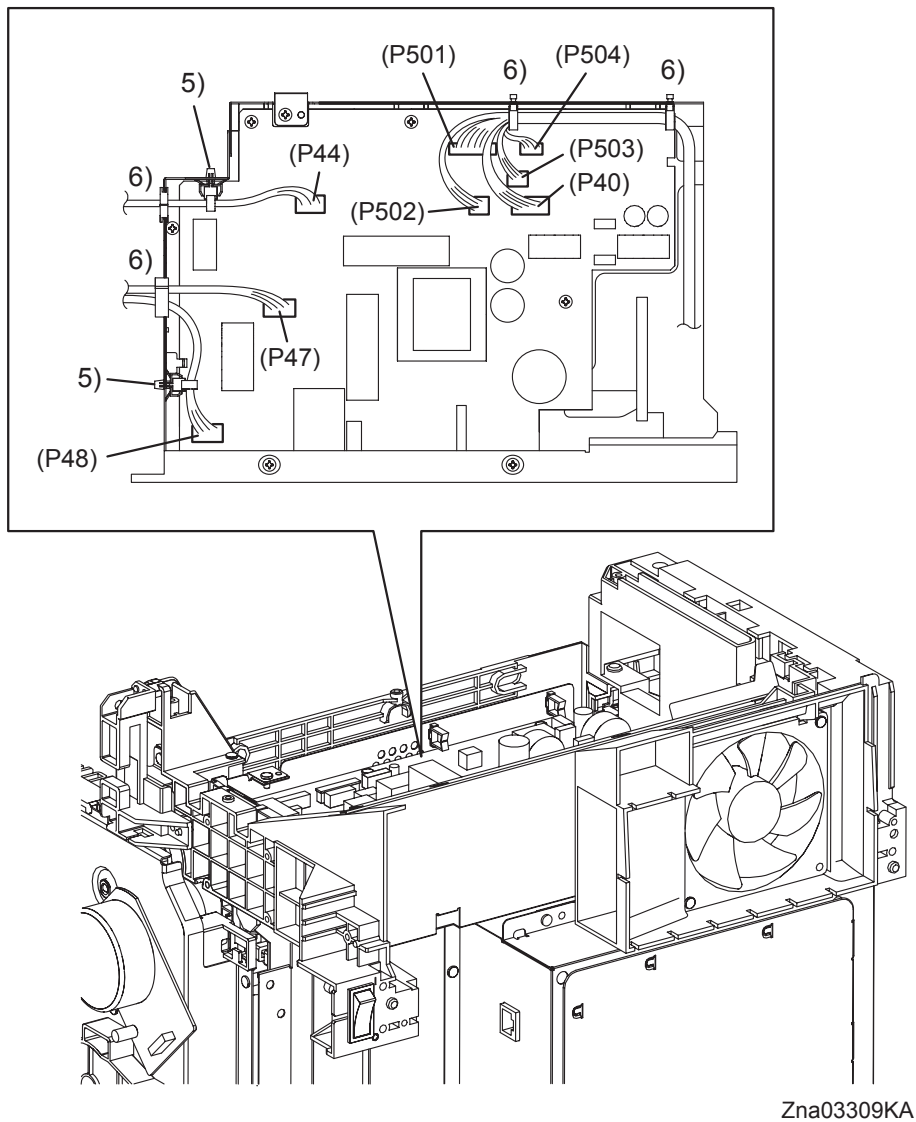

- 5) Replace the clamps that fix the harness of the INTERLOCK SWITCH and HARN ASSY AC IN to the SHIELD LVPS.
- 6) Engage all the connectors of the LOW VOLTAGE POWER SUPPLY, and then secure the harness with the clamps.

**Go to the next replacement step:
Replacement 13 TOP COVER (PL1.1.1)**

Blank Page

Replacement 10 HIGH VOLTAGE POWER SUPPLY (PL5.1.17)

NOTE

Use a wristband to protect the PWB from electrostatic damage.

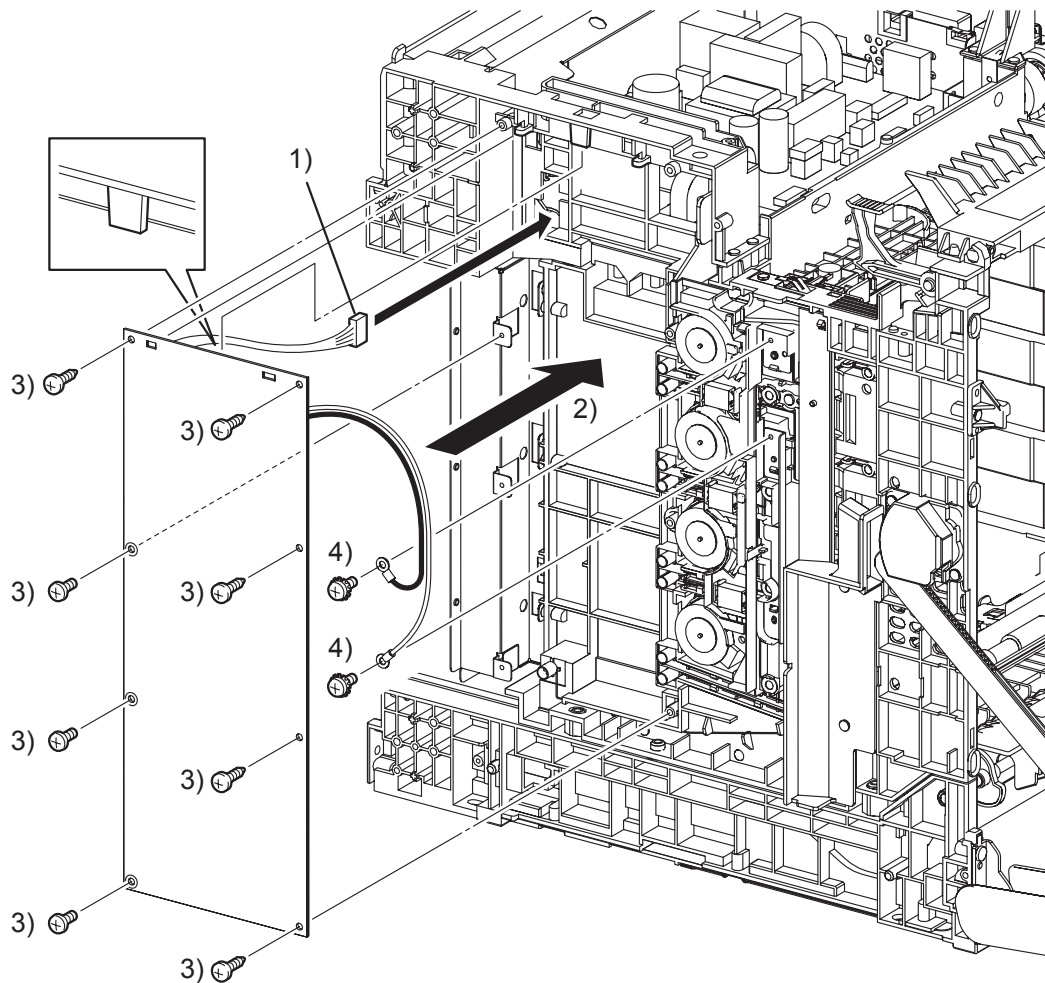

Zna03105KB

- 1) Pass the connector of the HIGH VOLTAGE POWER SUPPLY through the hole of the printer.
- 2) Replace the HIGH VOLTAGE POWER SUPPLY by mating the two holes on the upper part of the HIGH VOLTAGE POWER SUPPLY with the bosses on the printer and inserting the upper part of the HIGH VOLTAGE POWER SUPPLY into the backside tab on the printer.

NOTE

In the step described below, out of the screw fixing positions of the HIGH VOLTAGE POWER SUPPLY, the three screw fixing positions with white bearing surfaces must be fixed with the 6mm silver screws.

- 3) Secure the HIGH VOLTAGE POWER SUPPLY with the five screws (silver, tap, 10mm) and the three screws (silver, 6mm).

NOTE

When performing the step described below, secure the red harness on the upper side and secure the white harness on the lower side.

- 4) Secure the two harnesses of the HIGH VOLTAGE POWER SUPPLY using the two screws (silver, with washer, 6mm).

Continues to the next page.

Replacement 10 HIGH VOLTAGE POWER SUPPLY (PL5.1.17)

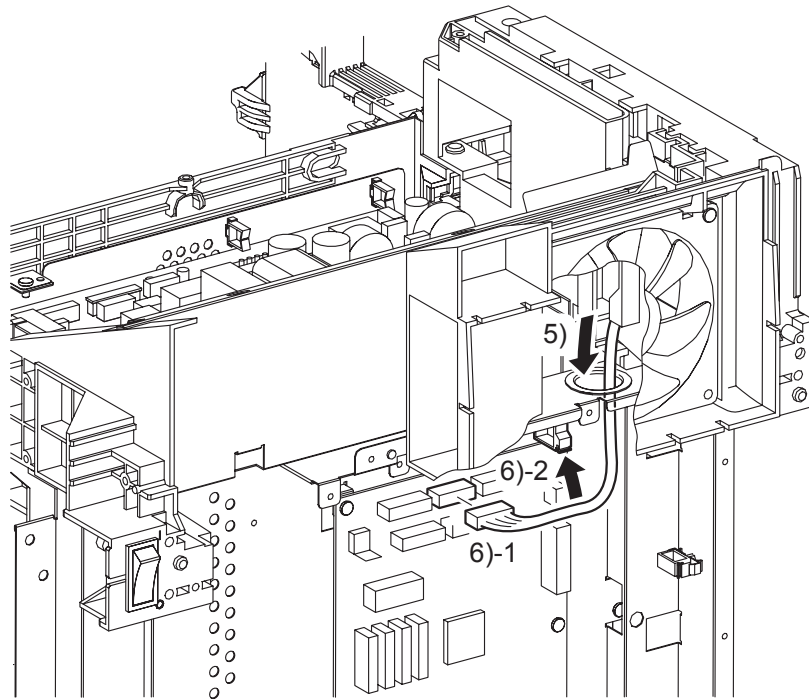

Zna03106KA

- 5) Route the harness of the HIGH VOLTAGE POWER SUPPLY to the printer and pass the connector into the hole on the SHIELD REAR.
- 6) Engage the connector (J16) of the HIGH VOLTAGE POWER SUPPLY to the connector (P16) of the MACHINE CONTROL UNIT.

Go to the next replacement step:

Replacement 13 TOP COVER (PL1.1.1)

Replacement 11 HARN ASSY AC IN (PL9.1.16)

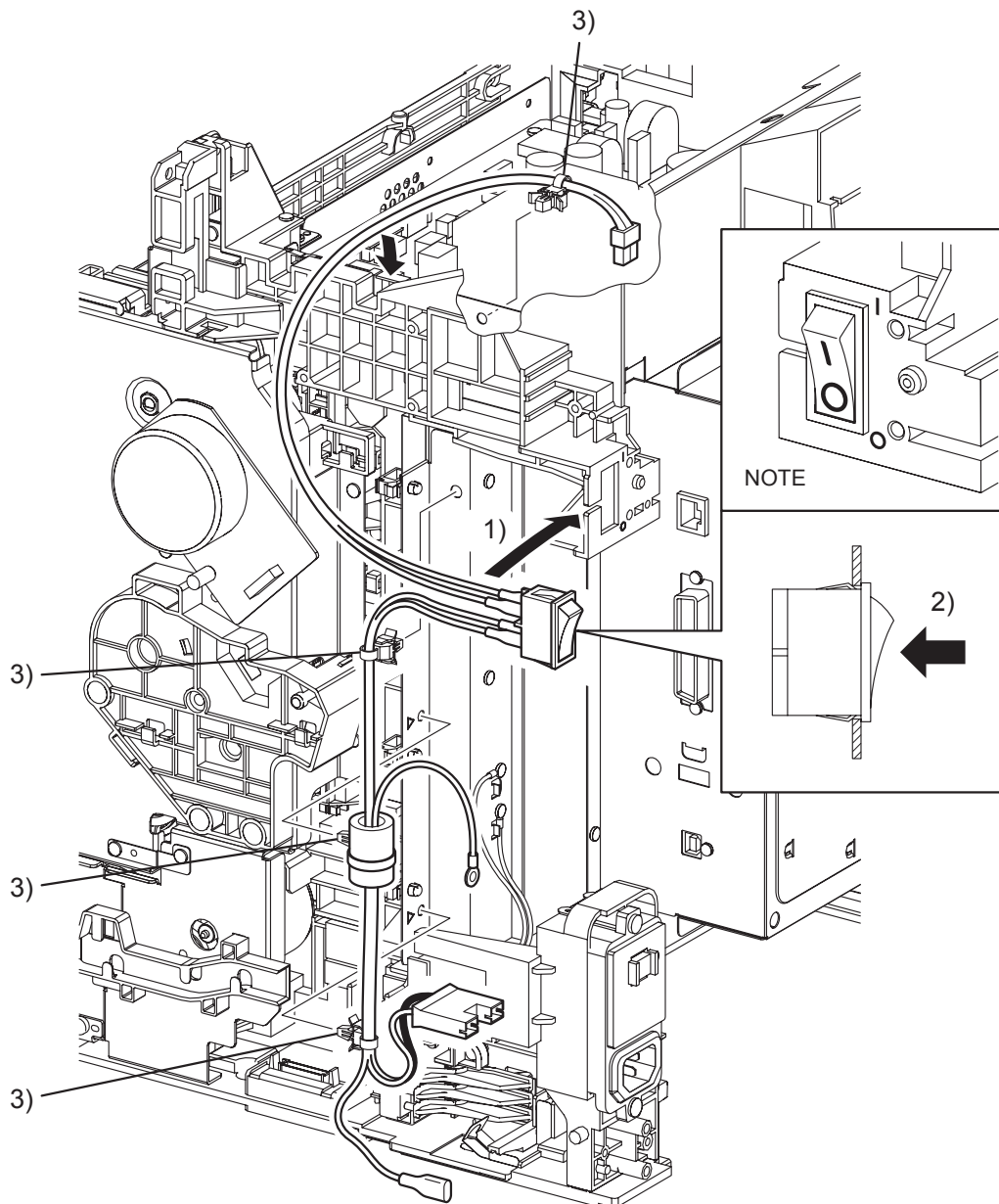

- 1) Pass the HARN ASSY AC IN into the inside of the printer, through the notch of the printer.

NOTE

When replacing the POWER SWITCH, match the ON/OFF mark of the POWER SWITCH with the mark on the FRAME.

- 2) Replace the POWER SWITCH to the printer, and secure with the hook.

NOTE

The delta mark is stamped on each clamp mounting hole of SHIELD REAR.

- 3) Attach the four clamps to the holes on the SHIELD LVPS and the SHIELD REAR.

Continues to the next page.

Replacement 11 HARN ASSY AC IN (PL9.1.16)

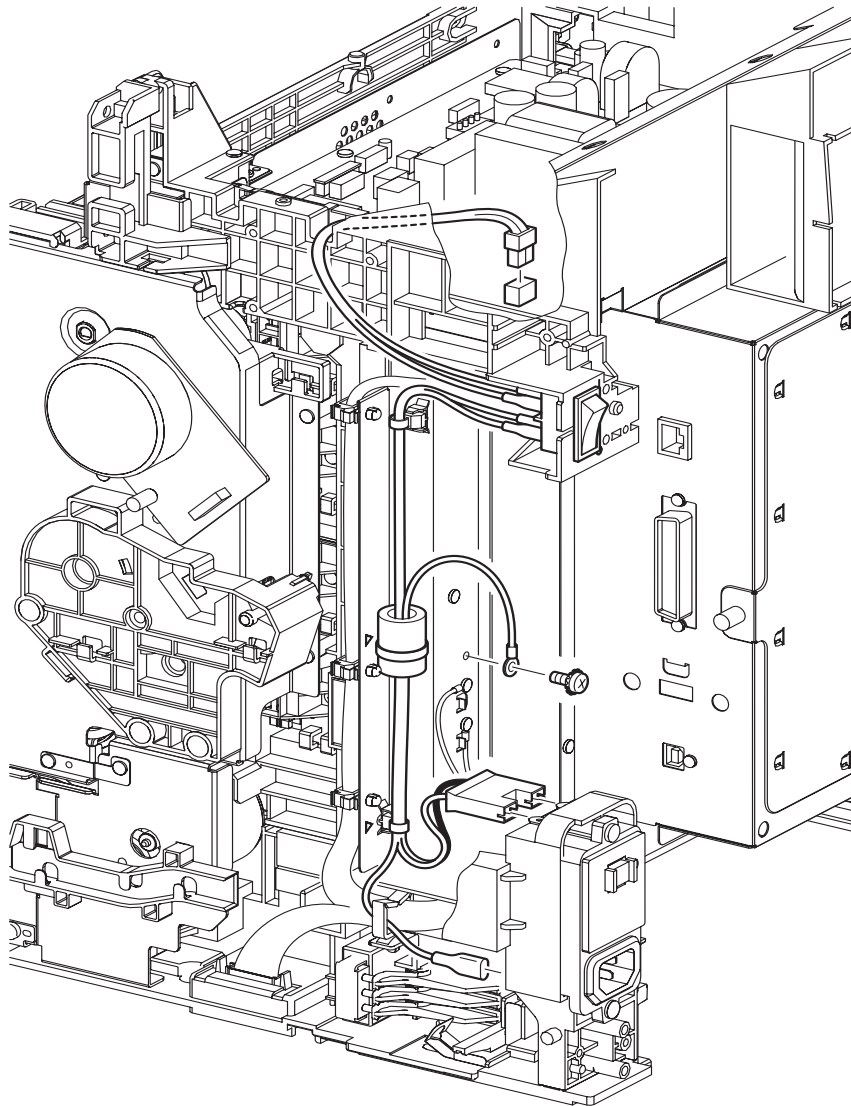

Zna03311KB

NOTE

Attach the grounding terminal of the HARN ASSY AC IN to the hole of grounding mark.

- 4) Fix the grounding terminal of the HARN ASSY AC IN using the one screw (silver, with washer, M4, 6mm).
- 5) Engage the FASTON terminal (FS483) of the HARN ASSY AC IN with the BREAKER GFI INLET, and then fix the grounding wire using the clamp.

NOTE

When performing the step describe below, do not confuse the connector fitting position.

- 6) Engage the connector (P/J482) of the HARN ASSY AC IN to the BREAKER GFI INLET.
- 7) Engage the connector (P/J48) of the HARN ASSY AC IN to the LOW VOLTAGE POWER SUPPLY.

Go to the next replacement step:

Replacement 13 TOP COVER (PL1.1.1)

Replacement 12 FAN (PL9.1.10)

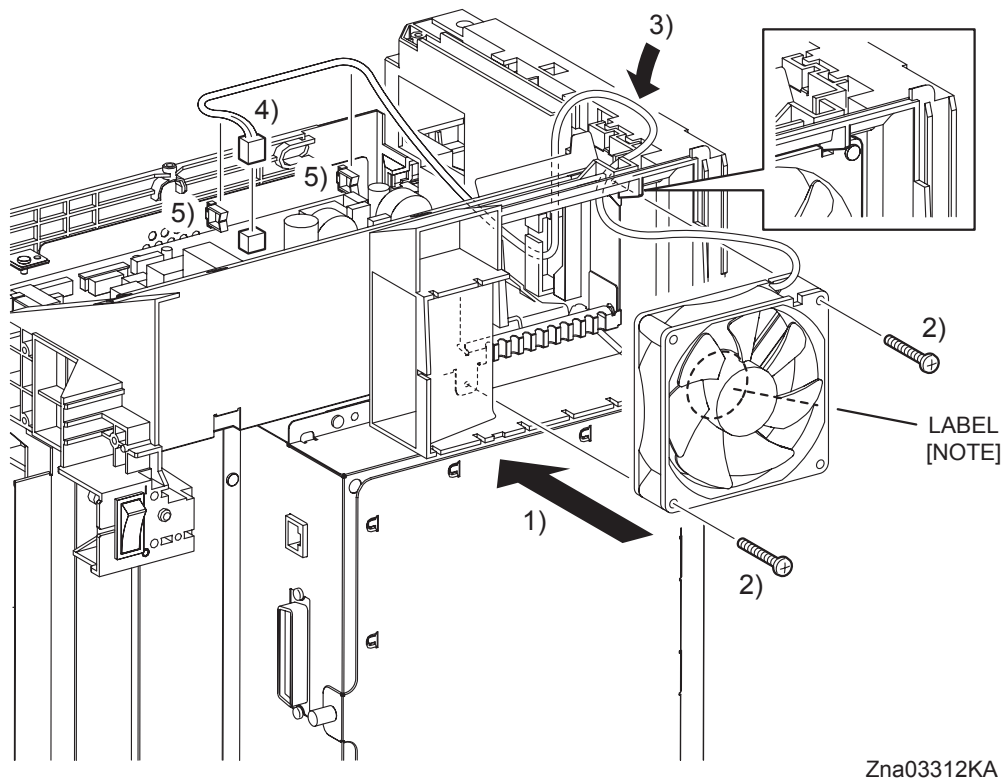
**NOTE**

When performing the step described below, take care to check the orientation of the FAN. (Attach the FAN so that its labeled surface faces front.)

NOTE

When performing the step describe below, ensure that the harness of the FAN will not be caught between the FAN and the SHIELD LVPS.

- 1) Mate the notch of the FAN with the rib of the printer and attach the FAN to the printer.
- 2) Secure the FAN to the printer using the two screws (silver, 30mm).
- 3) Route the harness of the FAN to the hook on the frame.
- 4) Engage the connector (P/J503) of the FAN to the LOW VOLTAGE POWER SUPPLY.
- 5) Secure the harness of the FAN with the clamp.

Go to the next replacement step:

Replacement 13 TOP COVER (PL1.1.1)

Replacement 13 TOP COVER (PL1.1.1)

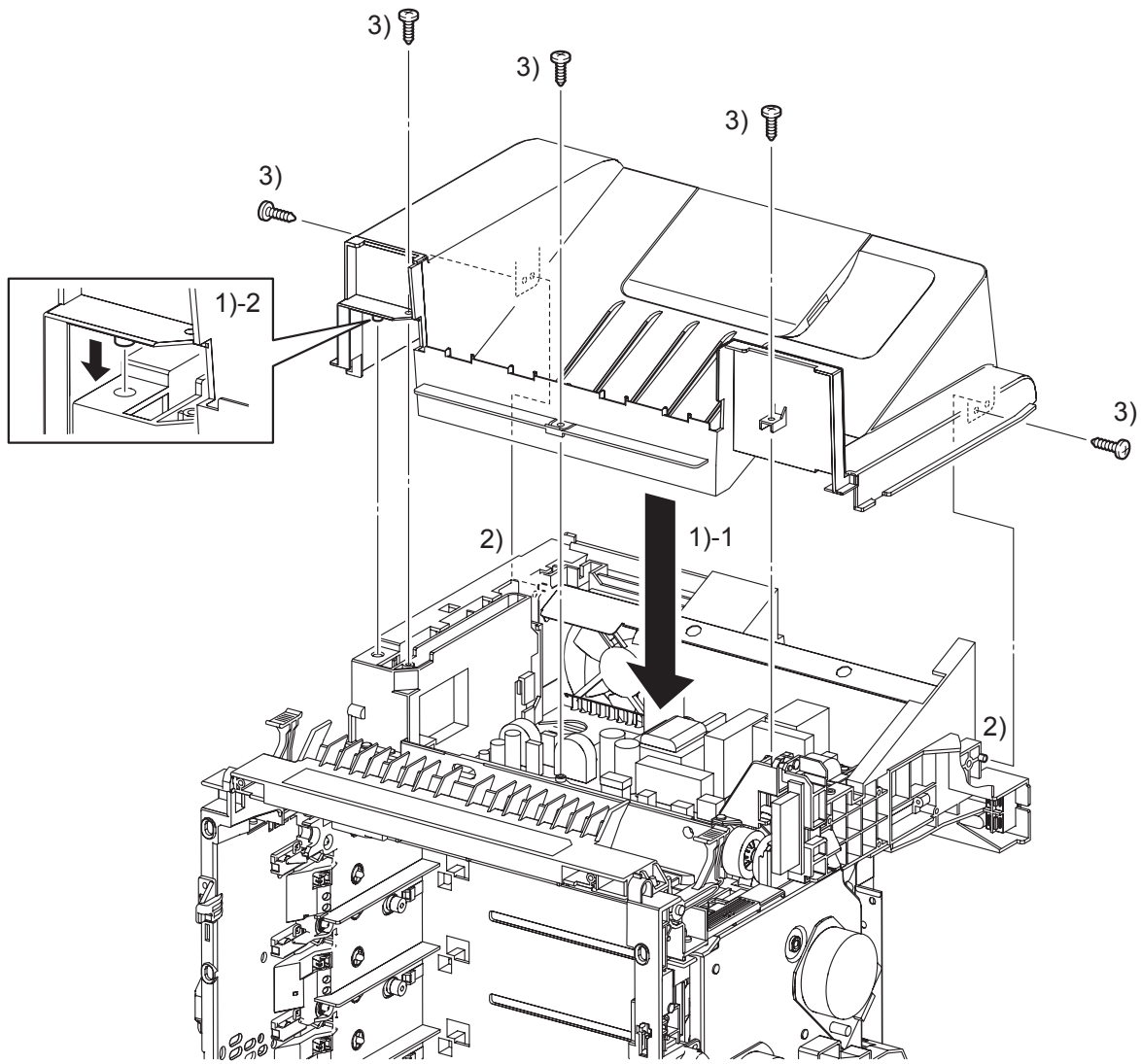

Zna03103KB

- 1) Mate the left side boss of the TOP COVER with the hole of the printer, set the TOP COVER to the printer.
- 2) Mate the holes of the TOP COVER with the left and right bosses of the printer, attach the TOP COVER.
- 3) Fix the TOP COVER to the printer with the five screws (silver, tap, 10mm).

Go to the next replacement step:

Replacement 24 LEFT COVER (PL1.1.7)

Replacement 14 MACHINE CONTROL UNIT (PL9.1.20)

NOTE

Use a wristband to protect the PWB from electrostatic damage.

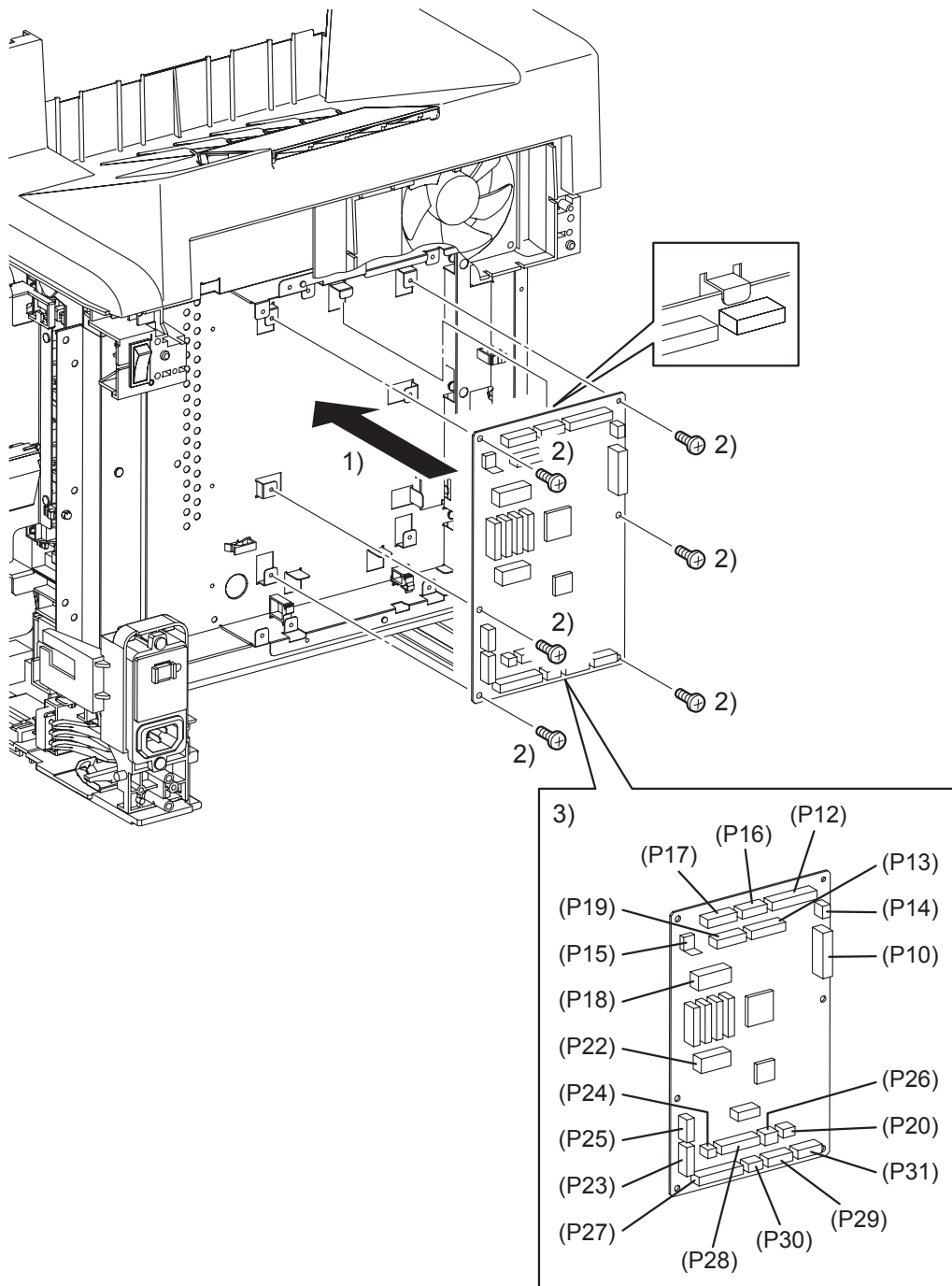

Zna03102KA

- 1) Replace the MACHINE CONTROL UNIT to the printer.
- 2) Secure the MACHINE CONTROL UNIT using the six screws (silver, 6mm).
- 3) Engage all the connectors of the MACHINE CONTROL UNIT.

Continues to the next page.

Replacement 14 MACHINE CONTROL UNIT (PL9.1.20)**NOTE**

When the MACHINE CONTROL UNIT is replaced with a new one, perform the following steps. (After completing all the steps up to Replacement 50.)

- 4) Plug in the power cord to the outlet, and power on the printer.
- 5) Perform the diagnostic operation of NVM Load, and write the data into MCU.
- 6) Turn on the power while pressing the ► key, the ◀ key and the [MENU] key on the control panel.
- 7) Enter the password, push the ▲ key twice and push the ✓ key once. The diagnostic screen comes up.
- 8) Press the ▼ key several times until “IOT Diag” is displayed. Press the ✓ key once.
- 9) Press the ▼ key several times until “NVM Settings” is displayed. Press the ✓ key once.
- 10) Press the ▼ key several times until “LoadNVM from ESS” is displayed. Press the ✓ key once.
- 11) Press the ✓ key twice, and LoadNVM from ESS is performed.
- 12) After the LoadNVM from ESS is complete, press the [CANCEL] key several times until “IOT Diag” is displayed.
- 13) Press the ▼ key several times until “Complete” is displayed.
- 14) Press the ✓ key three times, and “Ready to Print” is displayed.

Go to the next replacement step:

Replacement 17 SHIELD MCU (PL9.1.42)

Replacement 15 HUMIDITY SENSOR (PL9.1.19)

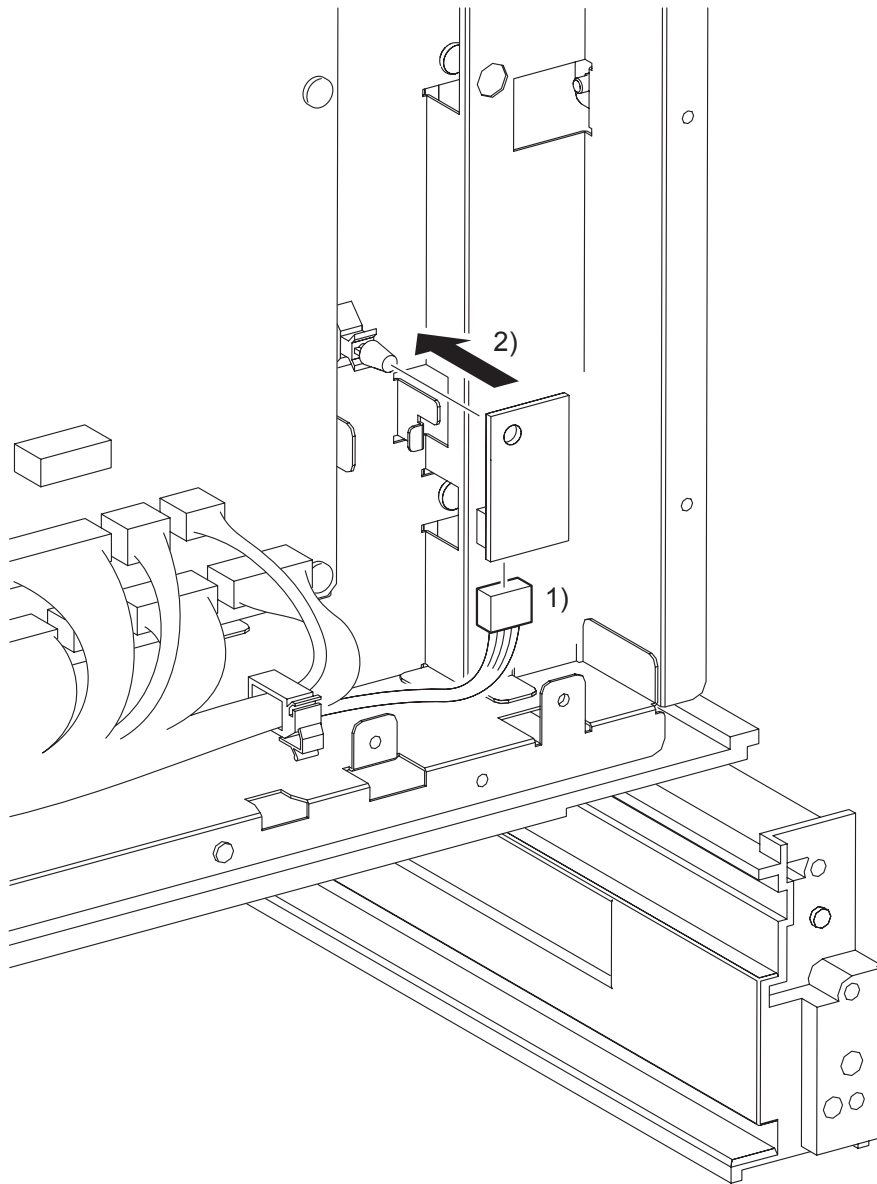

Zna03101KA

- 1) Engage the connector (P/J261) of the HUMIDITY SENSOR.
- 2) Replace the HUMIDITY SENSOR to the printer, and secure with the hook of the SPACER.

**Go to the next replacement step:
Replacement 17 SHIELD MCU (PL9.1.42)**

Blank Page

Replacement 16 DRIVE ASSY K (PL8.1.10)

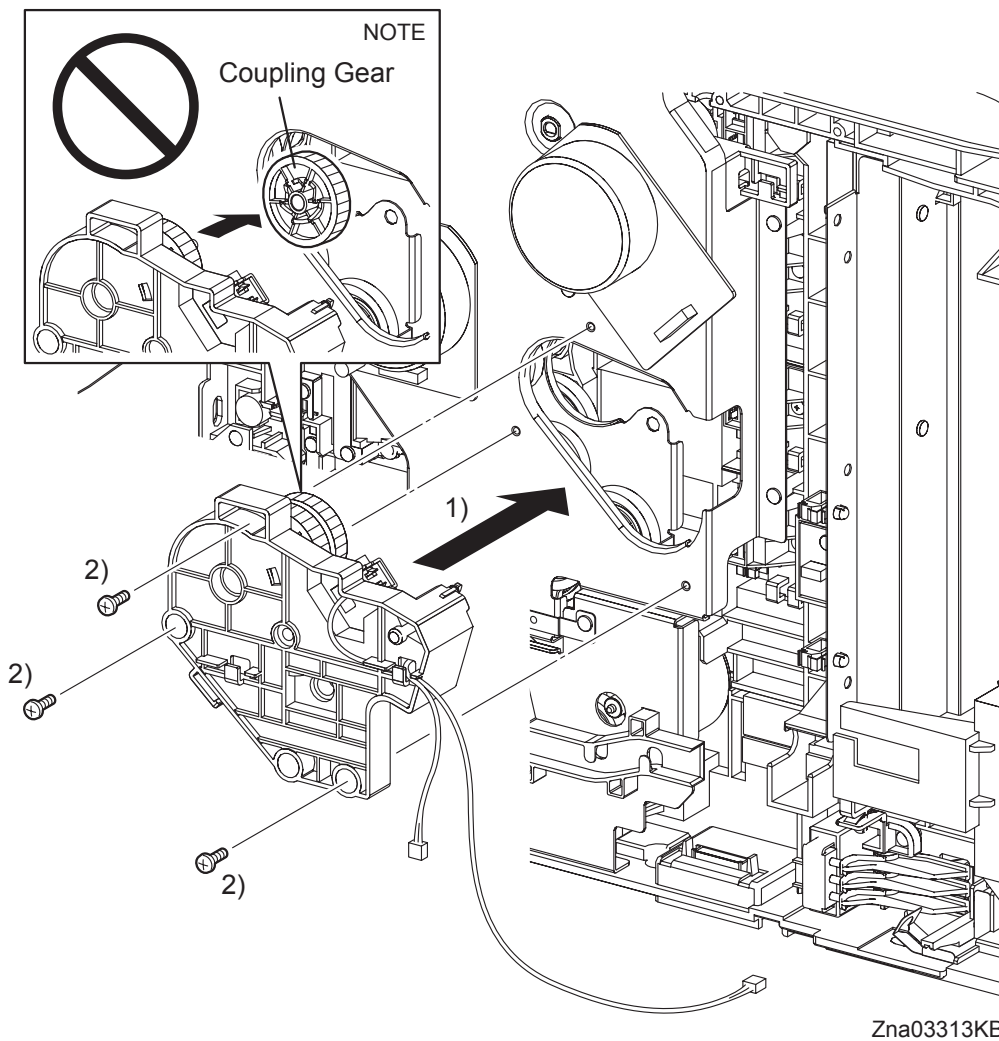

Zna03313KB

NOTE

When carrying out the work described next procedure, take care not to drop the coupling gear to inside.

- 1) Replace the DRIVE ASSY K to the PHOTOCONDUCTOR (PC) / DEVELOPER (DEV) DRIVE.
- 2) Secure the DRIVE ASSY K to the PHOTOCONDUCTOR (PC) / DEVELOPER (DEV) DRIVE using the three screws (silver, 6mm).

Continues to the next page.

Replacement 16 DRIVE ASSY K (PL8.1.10)

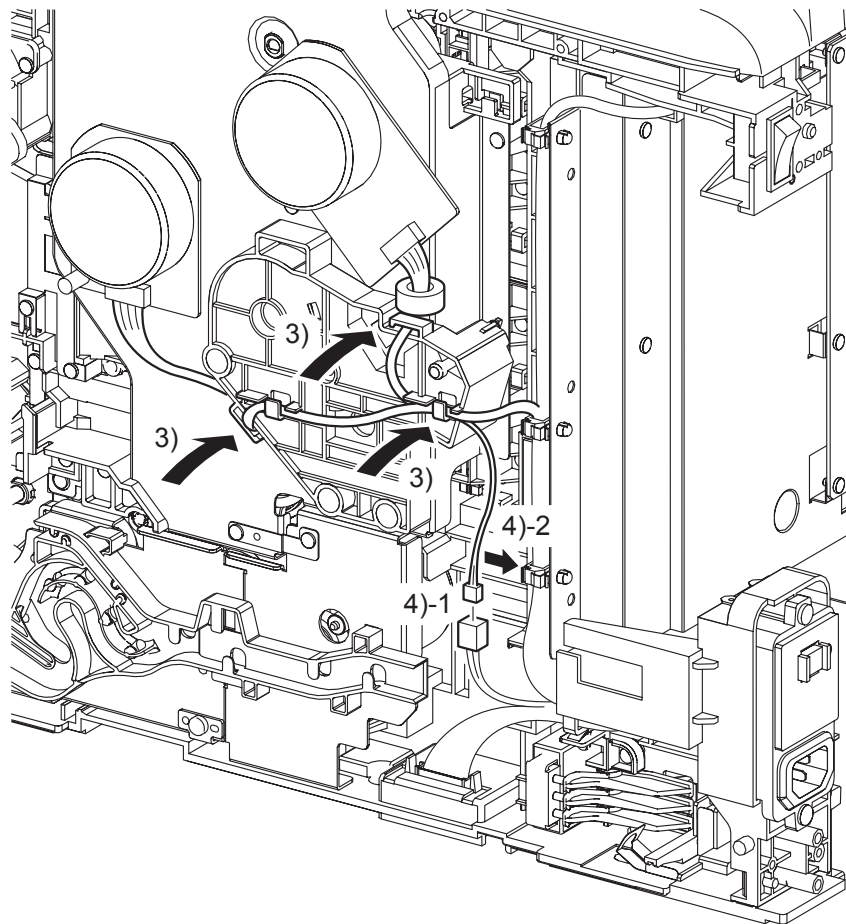

Zna03314KB

- 3) Route the connecting harness of the Main Motor and the Sub Motor to the hook on the DRIVE ASSY K.
- 4) Engage the connector (P/J241) of the K Mode Solenoid in the DRIVE ASSY K, and then fix the harness using the clamp.

Continues to the next page.

Replacement 16 DRIVE ASSY K (PL8.1.10)

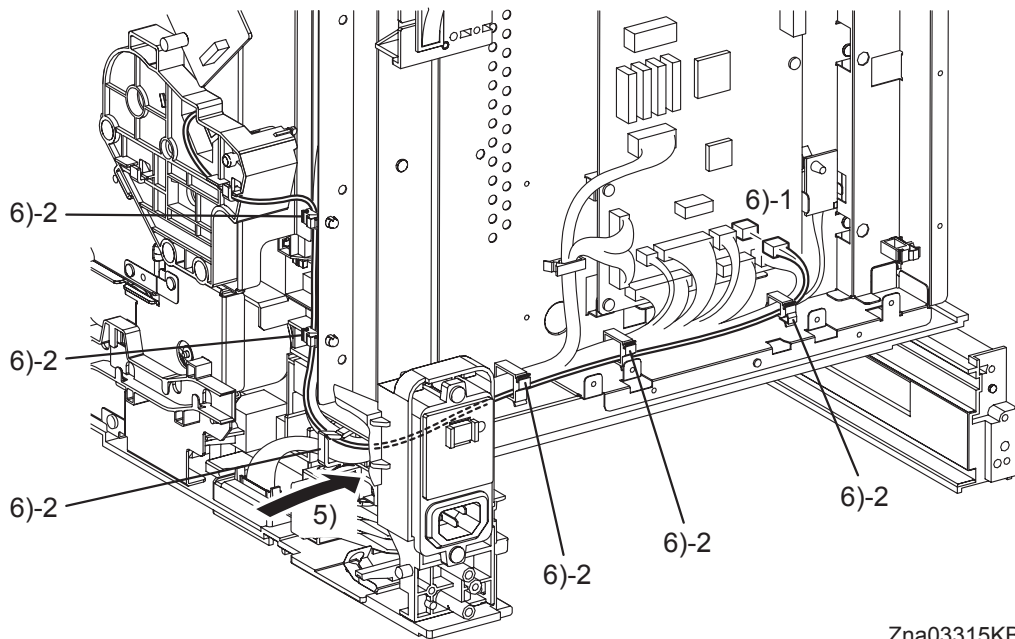

Zna03315KB

- 5) Route the harness of the K Mode Sensor in the DRIVE ASSY K into the inside through the hole of the frame.
- 6) Engage the connector (P/J20) of the K Mode Sensor to the MACHINE CONTROL UNIT, and then fix the harness using the six clamps.

Go to the next replacement step:

Replacement 17 SHIELD MCU (PL9.1.42)

Replacement 17 SHIELD MCU (PL9.1.42)

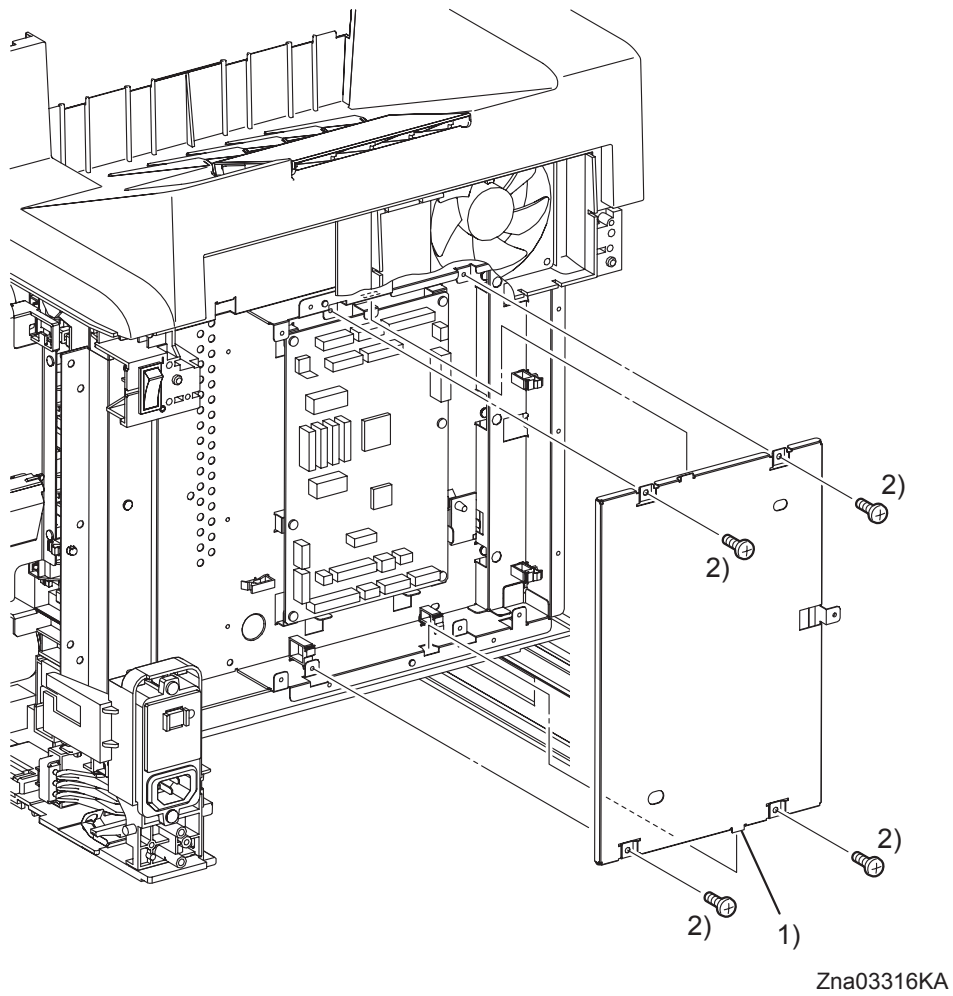

- 1) Engage the two tabs of the SHIELD MCU to the holes of the SHIELD REAR, and then attach the SHIELD MCU to the printer.
- 2) Secure the SHIELD MCU to the printer using the four screws (silver, 6mm).

Go to the next replacement step:

Replacement 19 SHIELD ASSY ESS (PL9.1.45)

Replacement 18 ELECTRONIC SUB-SYSTEM CONTROL BOARD (PL9.1.27)

NOTE

Use a wristband to protect the PWB from electrostatic damage.

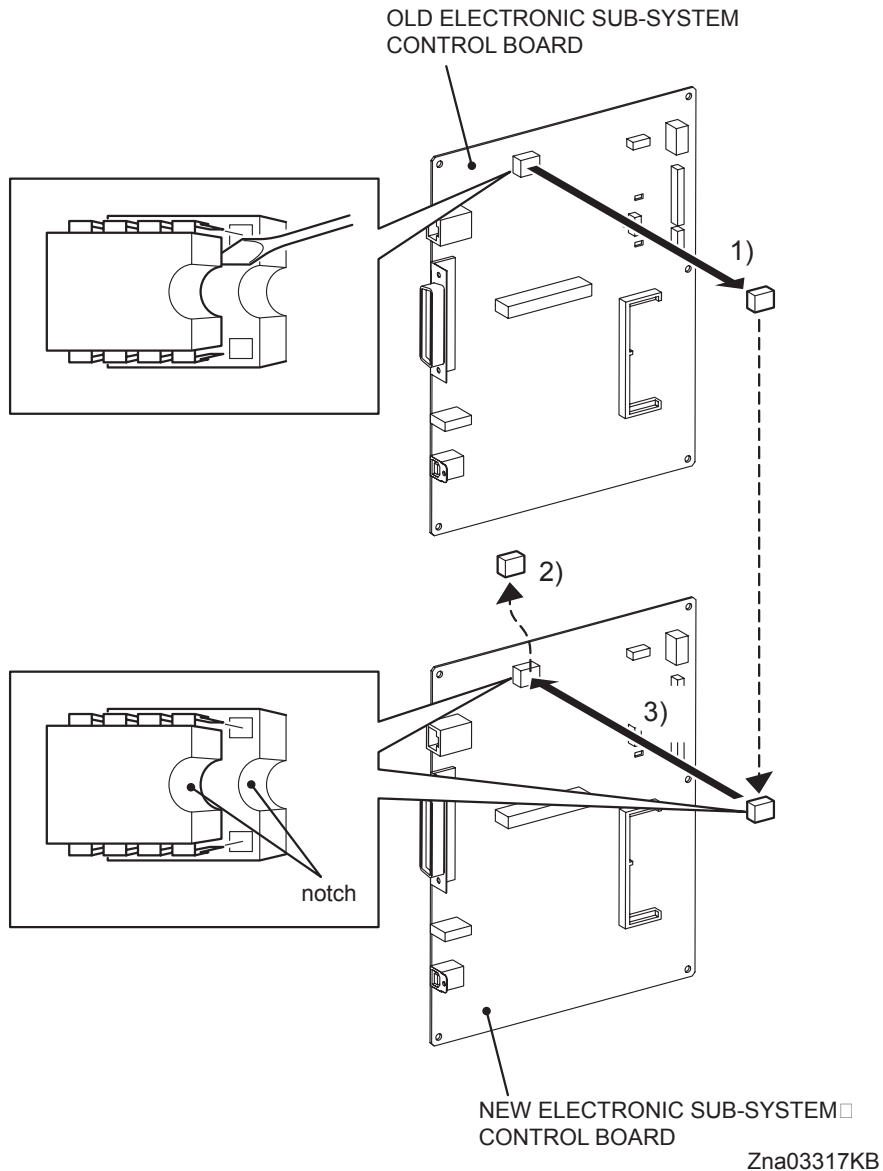

NOTE

When the ELECTRONIC SUB-SYSTEM CONTROL BOARD is replaced with a new one, the replacement steps 1) to 3) are required. These steps are not required when no replacement is performed.

NOTE

Do not press the PWB when removing the NVM ROM.

NOTE

Take care not to bend the terminal section of NVM when performing the step described below.

Continues to the next page.

Replacement 18 ELECTRONIC SUB-SYSTEM CONTROL BOARD (PL9.1.27)

- 1) Remove the NVM, using a miniature screwdriver or the like, from the IC socket on the old ELECTRONIC SUB-SYSTEM CONTROL BOARD that was removed from the printer.
- 2) Remove the NVM from the IC socket on the new ELECTRONIC SUB-SYSTEM CONTROL BOARD using a miniature screwdriver or the like.

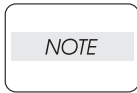

Do not use the NVM removed from the new ELECTRONIC SUB-SYSTEM CONTROL BOARD.

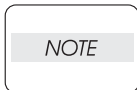

Ensure that the orientation of the NVM is correct when performing the following step.

- 3) Install the NVM that was removed from old ELECTRONIC SUB-SYSTEM CONTROL BOARD on the IC socket of the new ELECTRONIC SUB-SYSTEM CONTROL BOARD with its notch aligned with the notch in the IC socket.

Continues to the next page.

Replacement 18 ELECTRONIC SUB-SYSTEM CONTROL BOARD (PL9.1.27)

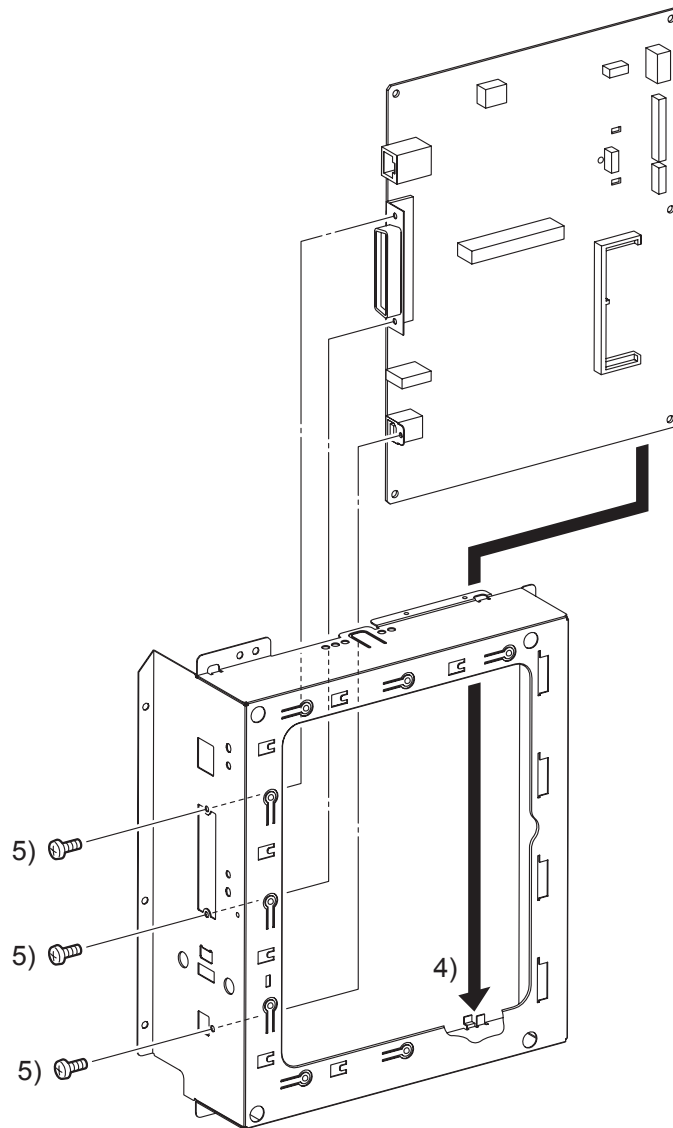

Zna03318KB

- 4) Replace the SHIELD ESS to the ELECTRONIC SUB-SYSTEM CONTROL BOARD.
- 5) Secure the SHIELD ESS to the connectors of the ELECTRONIC SUB-SYSTEM CONTROL BOARD with the screws.

Go to the next replacement step:

Replacement 19 SHIELD ASSY ESS (PL9.1.45)

Blank Page

Replacement 19 SHIELD ASSY ESS (PL9.1.45)

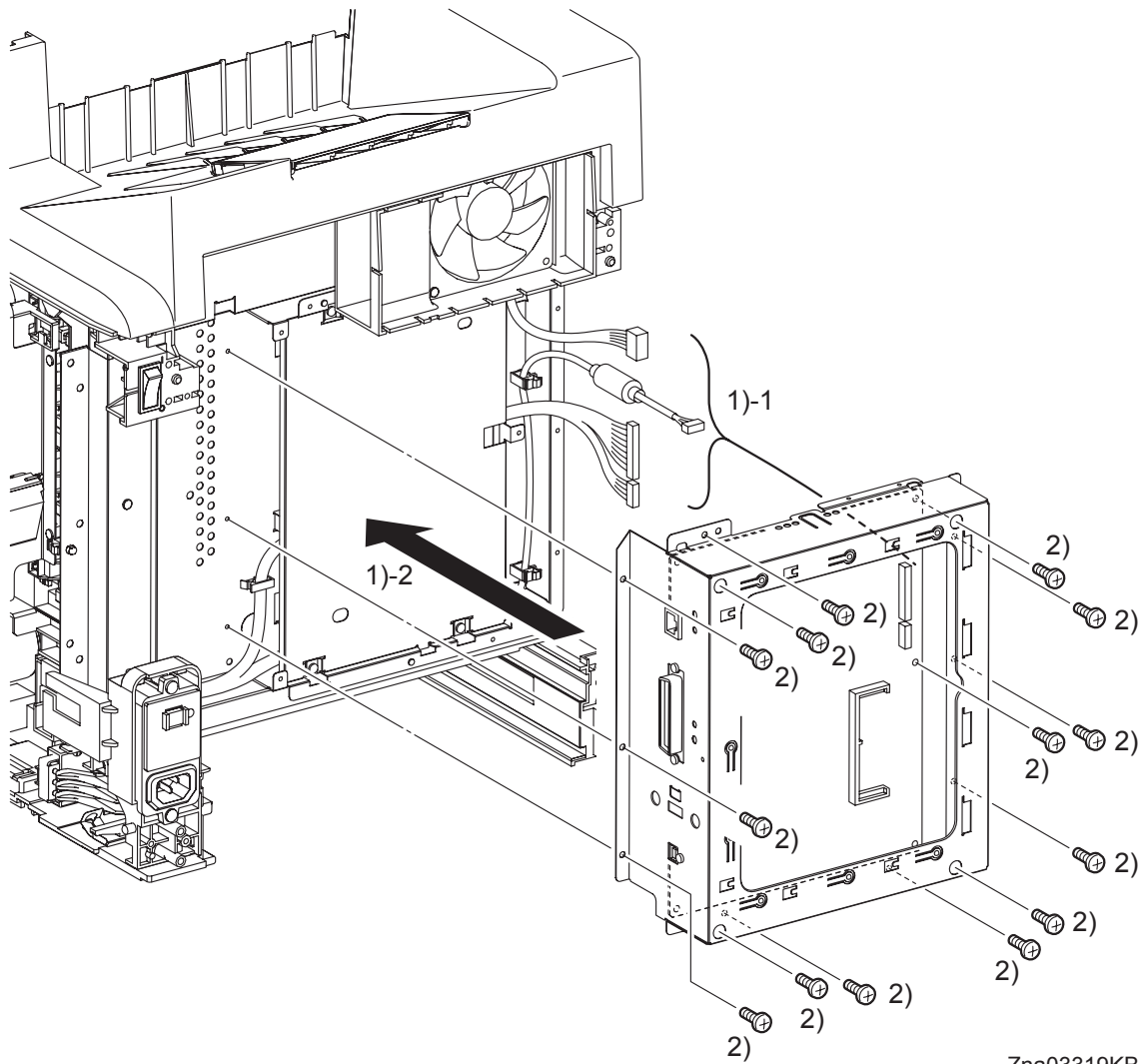

Zna03319KB

NOTE

When performing the step described below, ensure that the harness will not be caught between the printer and the SHIELD ASSY ESS.

- 1) Route the four connectors to between the ELECTRONIC SUB-SYSTEM CONTROL BOARD and the SHIELD ESS, and then attach the SHIELD ASSY ESS to the printer.
- 2) Secure the SHIELD ASSY ESS to the printer using the fourteen screws (silver, 6mm).

Continues to the next page.

Replacement 19 SHIELD ASSY ESS (PL9.1.45)

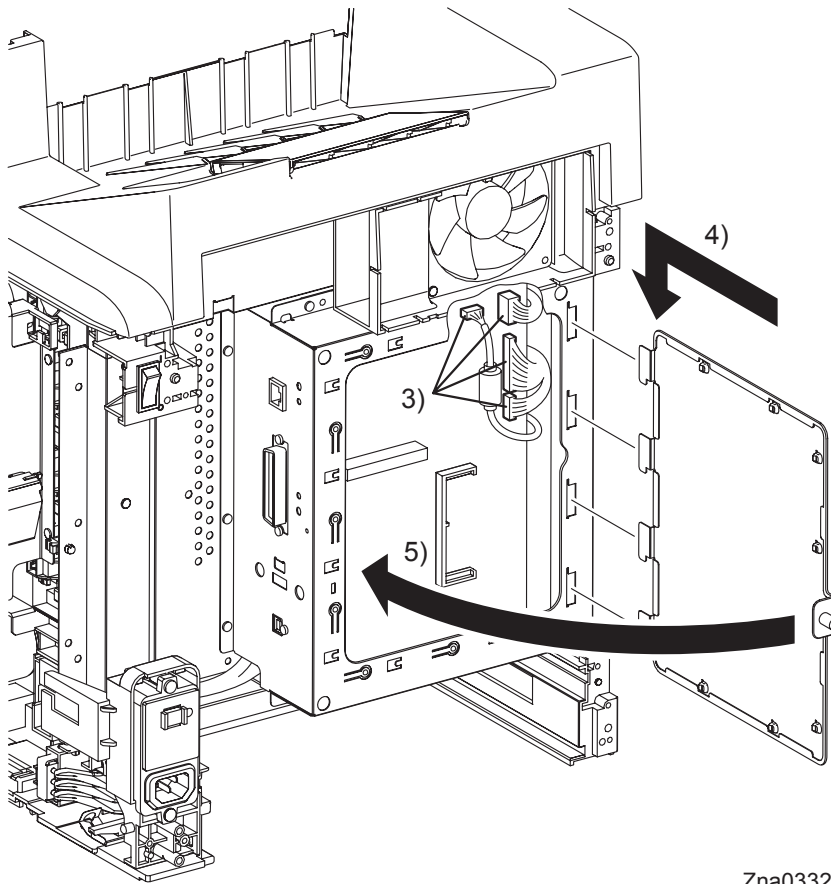

Zna03320KA

- 3) Engage all the connectors of the ELECTRONIC SUB-SYSTEM CONTROL BOARD.
- 4) Engage the four tabs of SHIELD WINDOW to the holes of the SHIELD ESS with opening the SHIELD WINDOW.
- 5) Close the SHIELD WINDOW and secure the SCREW KNURLING.

**Go to the next replacement step:
Replacement 24 LEFT COVER (PL1.1.7)**

Replacement 20 TONER DISPENSER MOTOR (PL5.1.12)

NOTE

Described below is the replacement procedure common among TONER DISPENSER MOTORS (C), (M), (Y), and (K).

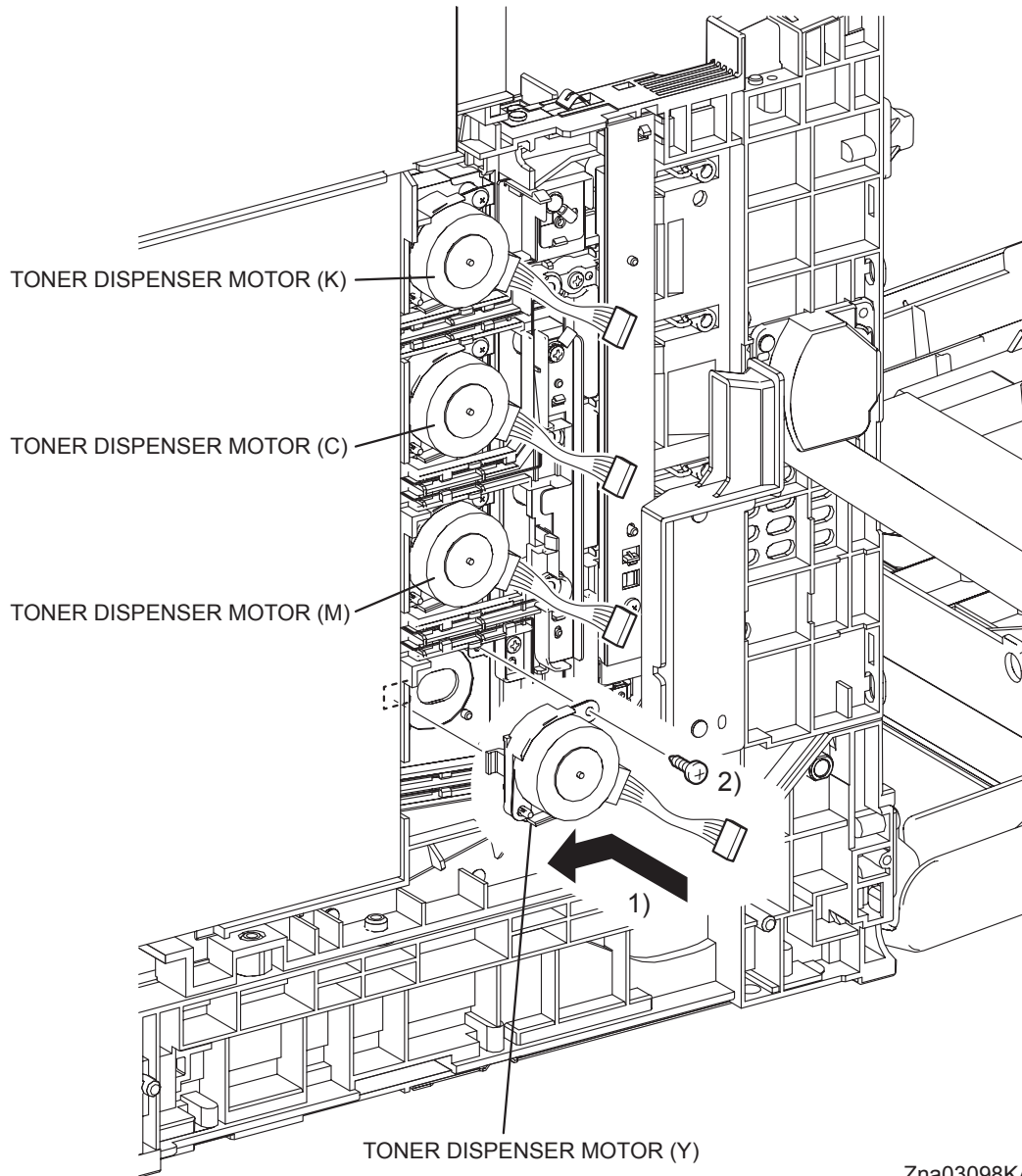

Zna03098KA

- 1) Replace the TONER DISPENSER MOTOR to the printer by mating the tab of the TONER DISPENSER MOTOR with the hole on the printer and moving it slightly backward.
- 2) Secure the TONER DISPENSER MOTOR to the printer using the one screw (silver, tap, 10mm).

Continues to the next page.

Replacement 20 TONER DISPENSER MOTOR (PL5.1.12)

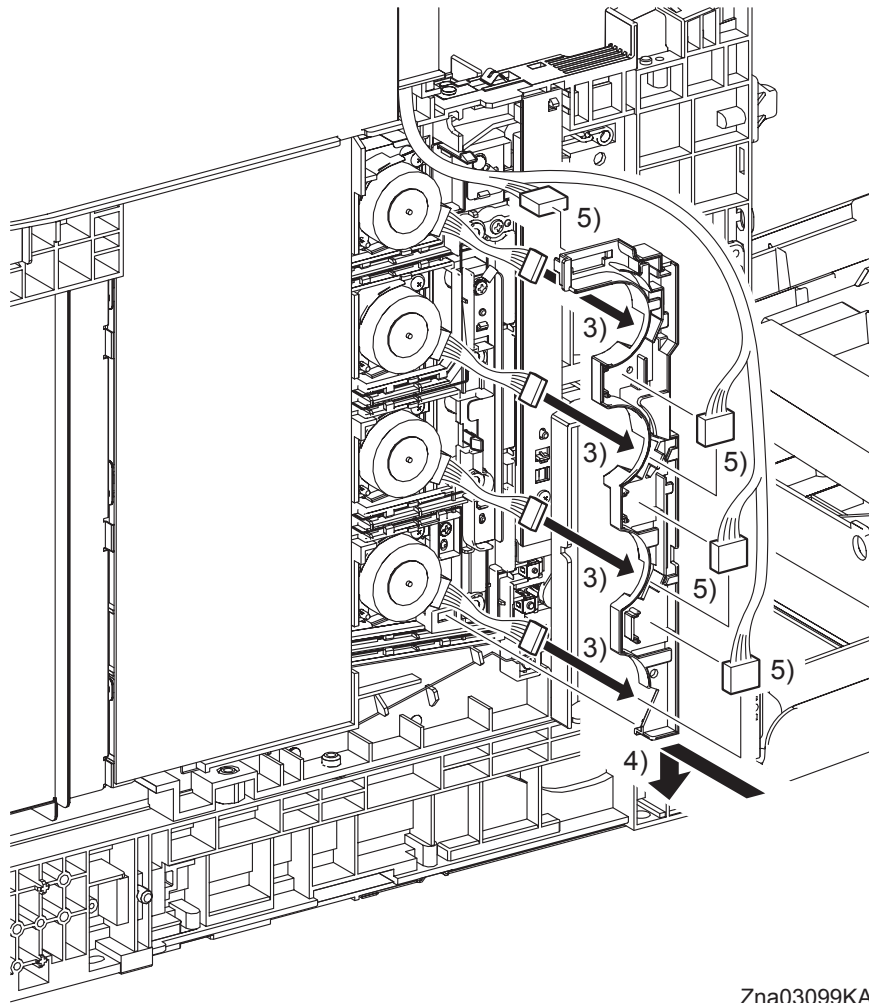

Zna03099KA

- 3) Pass the four sets of connectors of the TONER DISPENSER MOTOR through the hole of the DUCT HARNESS MOT.
- 4) Mate the tab of the DUCT HARNESS MOT with the hole on the printer, and secure the DUCT HARNESS MOT with the two hooks on the printer.
- 5) Engage the four sets of connectors of the TONER DISPENSER MOTOR and route the harness along the DUCT HARNESS MOT.

Go to the next replacement step:

Replacement 24 LEFT COVER (PL1.1.7)

Replacement 21 LED ASSEMBLY (PL5.1.15)

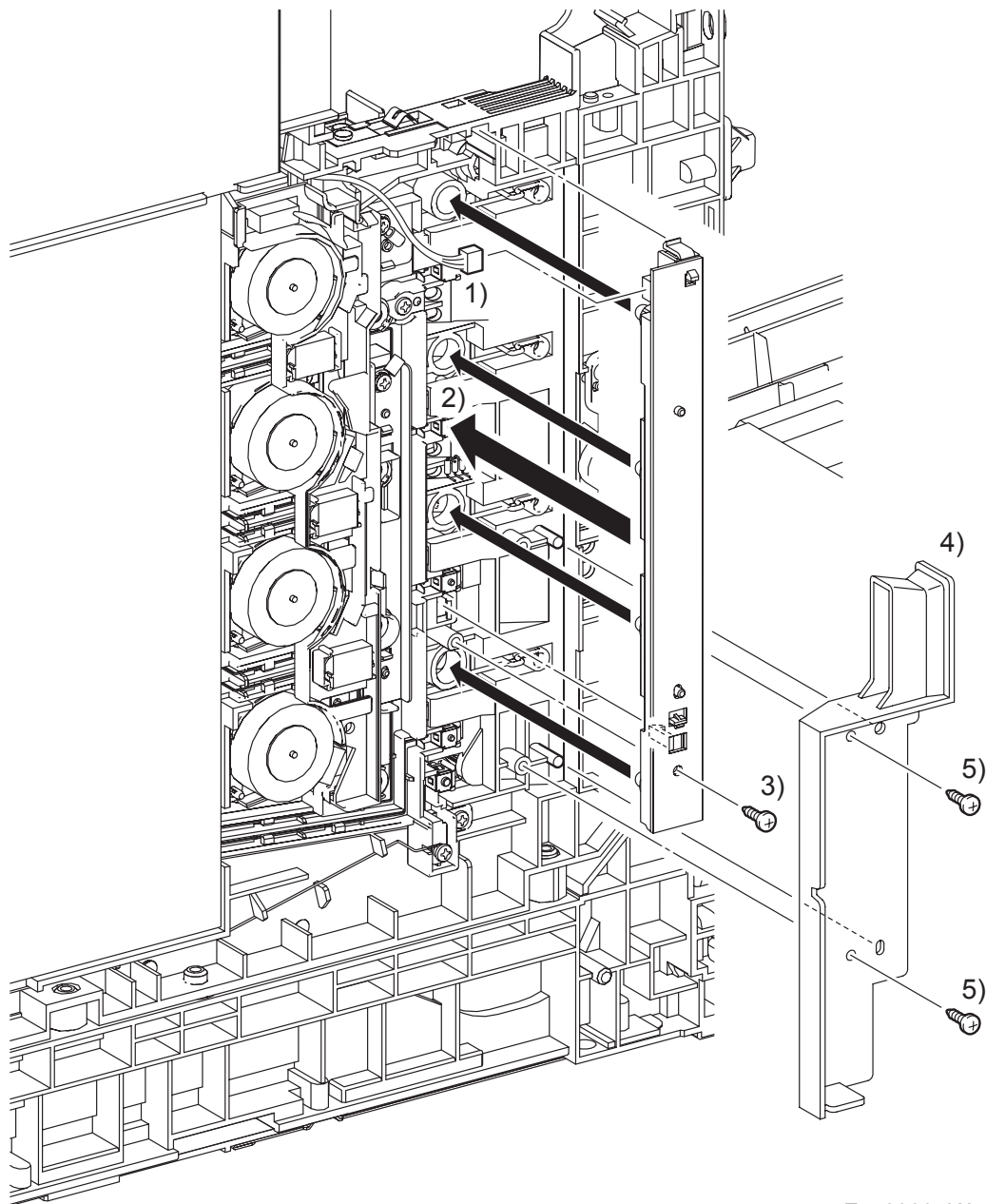

Zna03097KA

- 1) Engage the connector (P/J141) of the LED ASSEMBLY.
- 2) Mate the four LEDs on the LED ASSEMBLY with the holes on the printer, and then secure the LED ASSEMBLY at the two hooks.
- 3) Fix the LED ASSEMBLY to the printer using the one screw (silver, tap, 10mm).
- 4) Replace the DUCT SIDE L by mating the two holes on the DUCT SIDE L with the bosses on the printer.
- 5) Secure the DUCT SIDE L to the printer using the two screws (silver, tap, 10mm).

Go to the next replacement step:

Replacement 24 LEFT COVER (PL1.1.7)

Blank Page

Replacement 22 ARM ASSEMBLY (PL7.1.98)

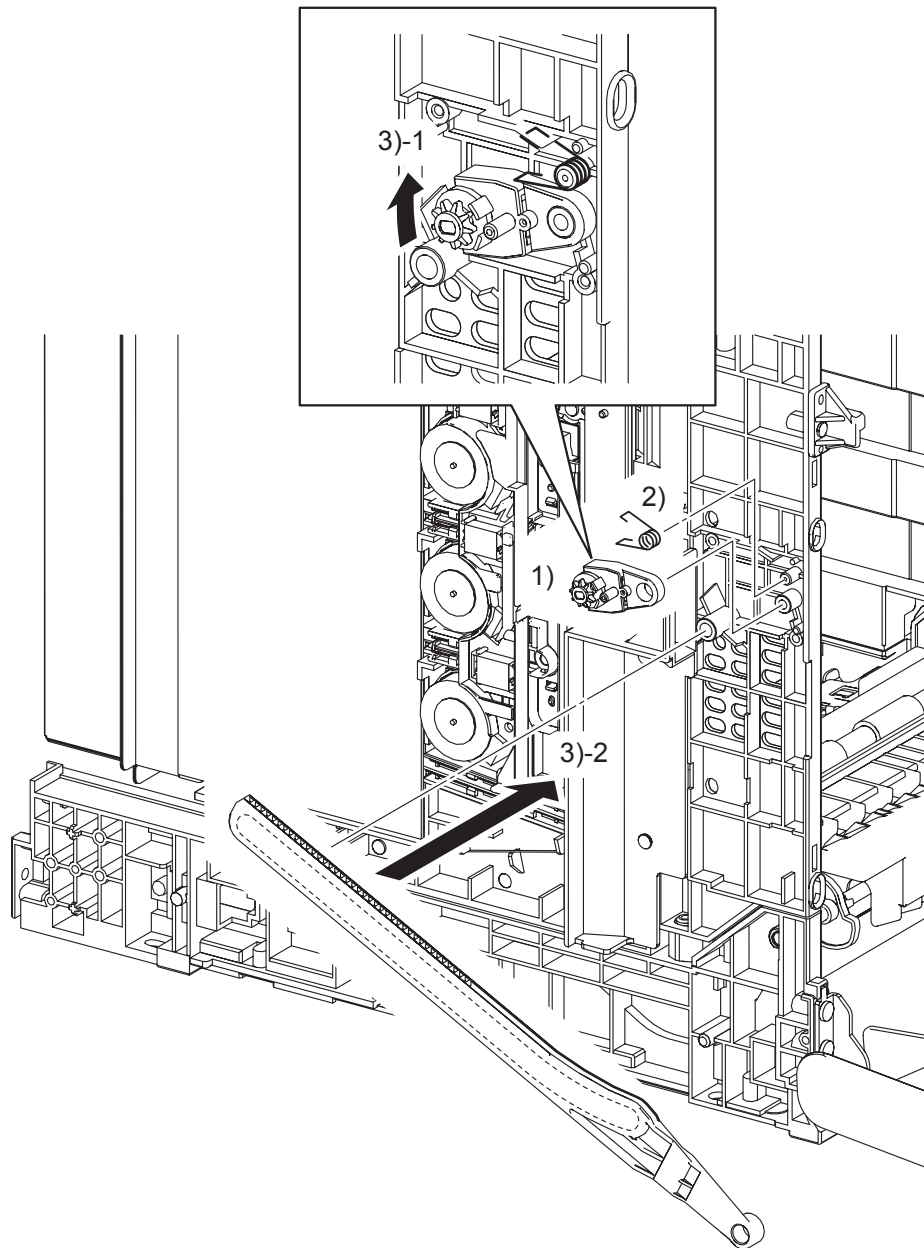

Zna03321KB

- 1) Replace the HOLDER DAMPER to the printer together with the DAMPER OIL.
- 2) Replace the SPRING SUPPORT to the printer
- 3) Replace the LINK L by mating the backside groove on the LINK L with the boss on the printer and pulling the DAMPER OIL slightly upward.

Continues to the next page.

Replacement 22 ARM ASSEMBLY (PL7.1.98)

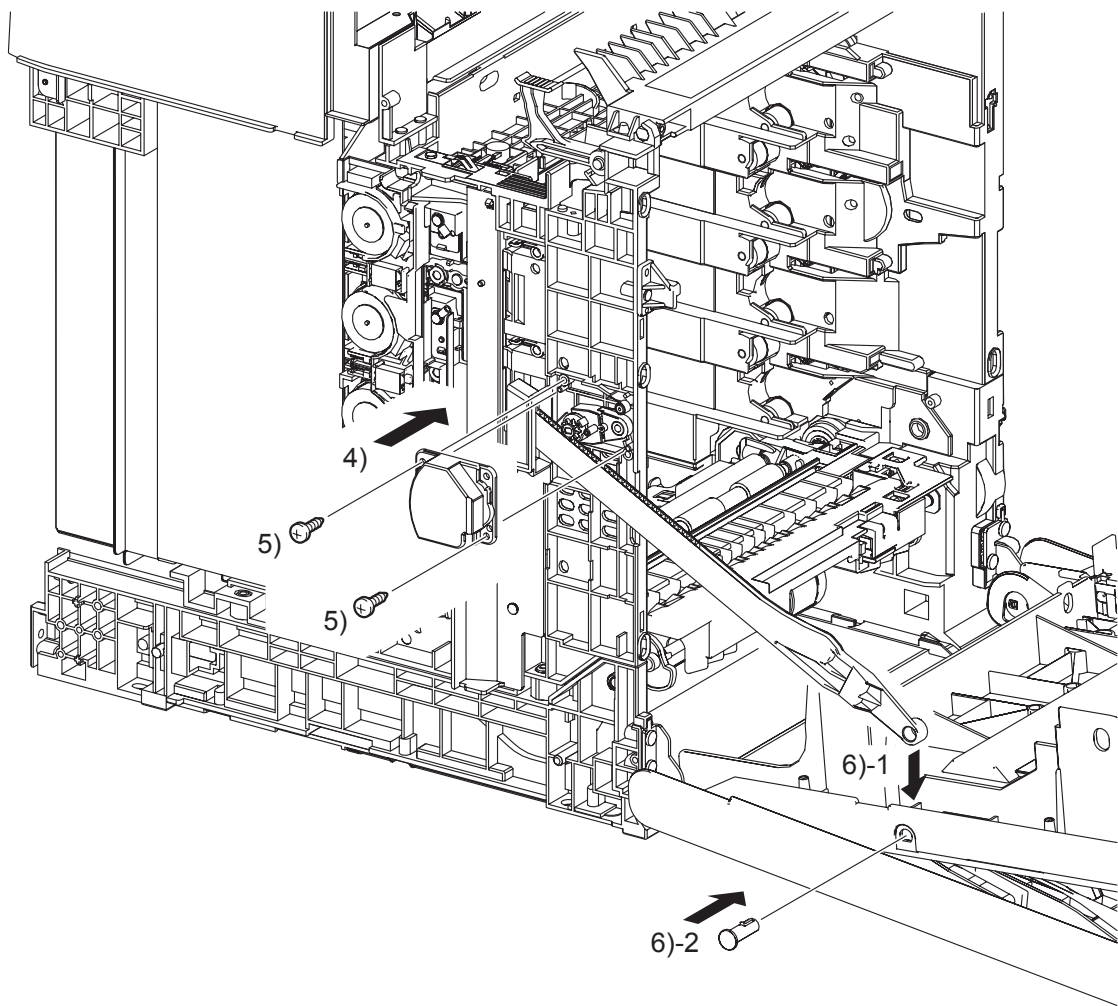

Zna03322KB

- 4) Replace the SUPPORT LINK L by mating the two holes of the SUPPORT LINK L with the bosses on the printer.
- 5) Secure the SUPPORT LINK L using the two screws (silver, tap, 10mm).
- 6) Mate the fitting hole on the LINK L with the left side fitting hole on the FRONT COVER. Insert the SHAFT PIVOT and secure with the hook.

Continues to the next page.

Replacement 22 ARM ASSEMBLY (PL7.1.98)

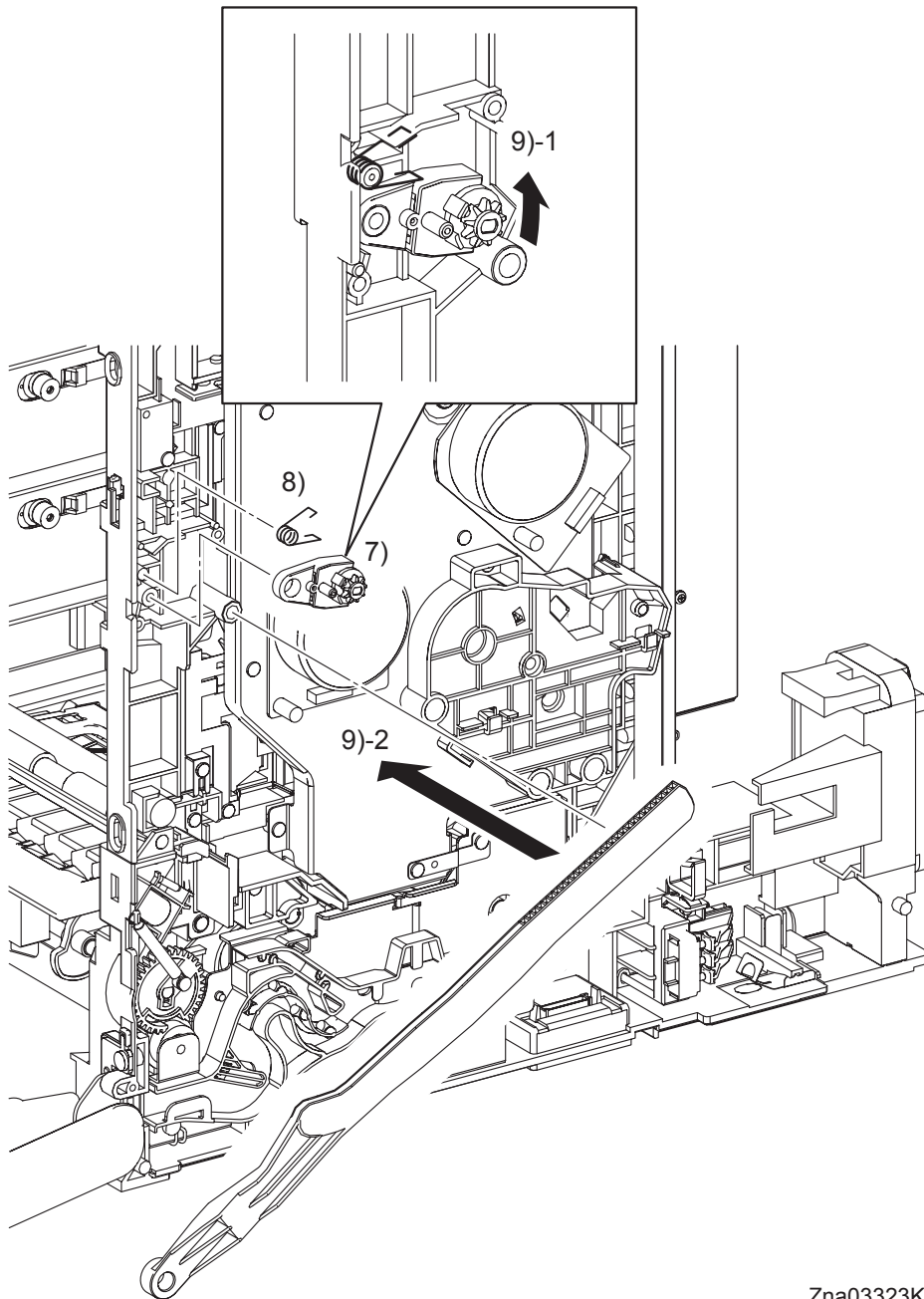

Zna03323KB

- 7) Replace the HOLDER DAMPER to the printer together with the DAMPER OIL.
- 8) Replace the SPRING SUPPORT to the printer.
- 9) Replace the LINK R by mating the backside groove on the LINK R with the boss on the printer and then pulling the DAMPER OIL slightly upward.

Continues to the next page.

Replacement 22 ARM ASSEMBLY (PL7.1.98)

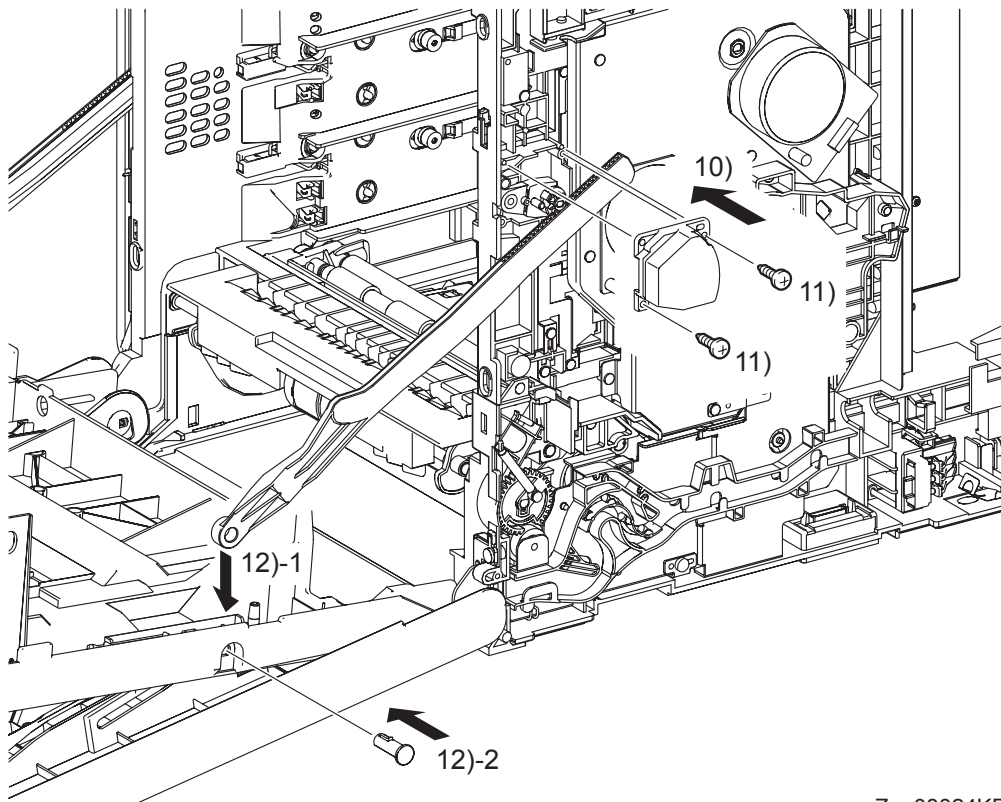

Zna03324KB

- 10) Replace the SUPPORT LINK R by mating the two holes on the SUPPORT LINK R with the bosses on the printer.
- 11) Secure the SUPPORT LINK R to the printer using the two screws (silver, tap, 10mm).
- 12) Mate the fitting hole on the LINK R with the right side fitting hole on the FRONT COVER. Insert the SHAFT PIVOT and secure using the hook.

Go to the next replacement step:

Replacement 24 LEFT COVER (PL1.1.7)

Replacement 23 LEVER FUSER AD (PL6.1.19)

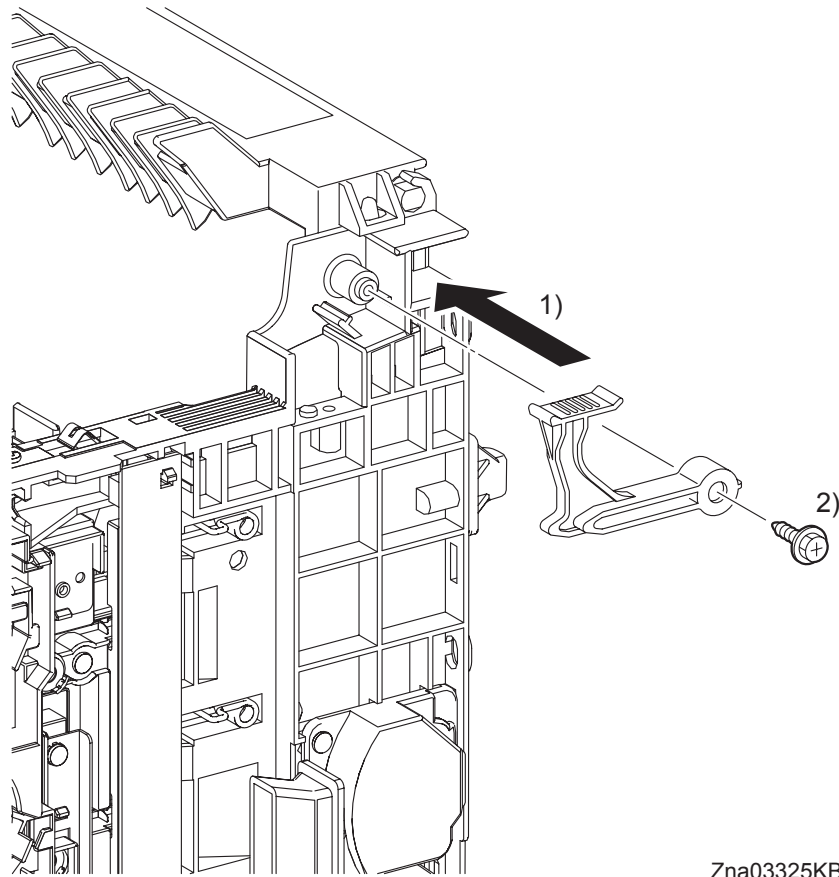

Zna03325KB

- 1) Attach the LEVER FUSER AD to the printer.
- 2) Secure the LEVER FUSER AD to the printer using the one screw (silver, with flange, tap, 10mm).

Go to the next replacement step:

Replacement 24 LEFT COVER (PL1.1.7)

Replacement 24 LEFT COVER (PL1.1.7)

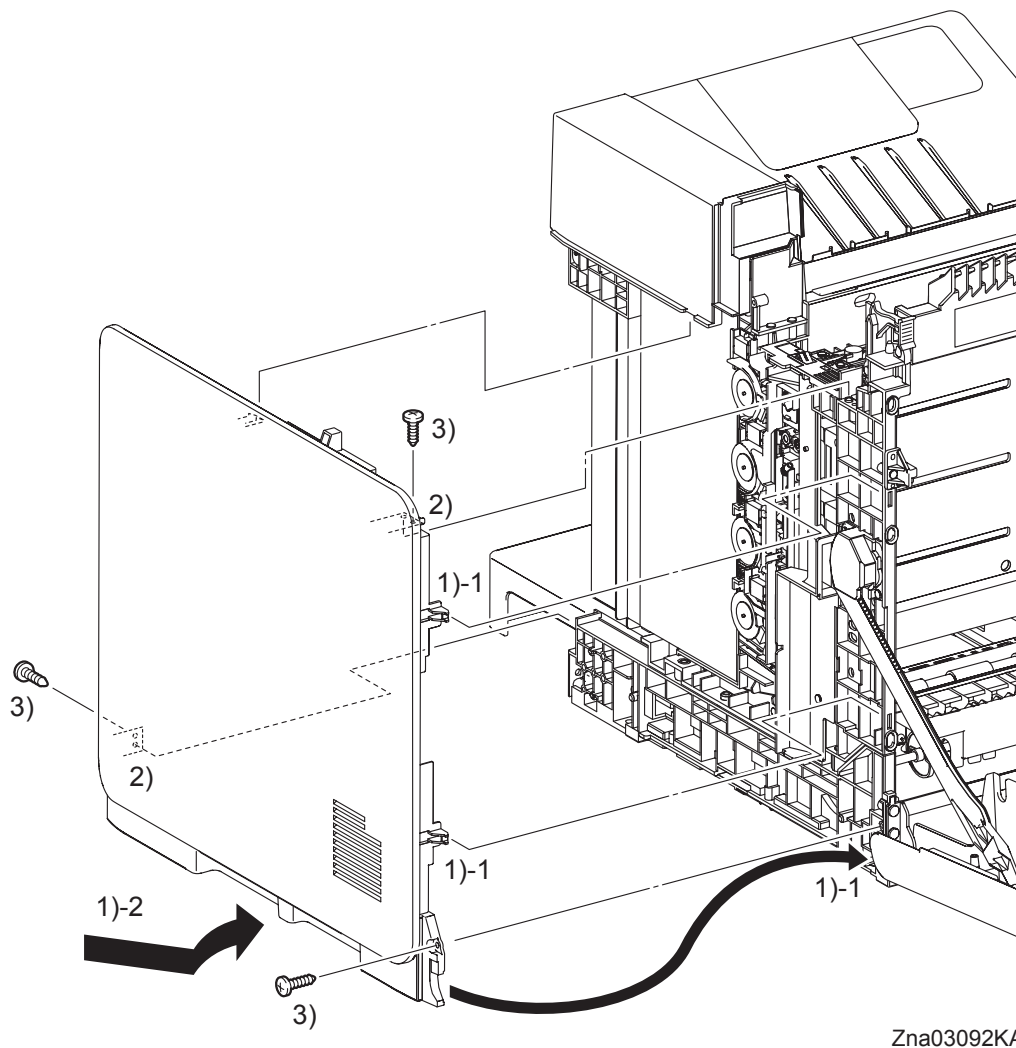

- 1) Insert the front side of the LEFT COVER between the FRONT COVER and the printer, and mate the two front side hooks of the LEFT COVER with the printer.
- 2) Mate the holes on the LEFT COVER with the two bosses on the printer.
- 3) Secure the LEFT COVER to the printer using the three screws (silver, tap, 10mm).

Next Replacement steps.

Replacement 33 RIGHT COVER (PL1.1.6) or Replacement 34 REAR COVER (PL1.1.4)

Replacement 25 BREAKER GFI INLET (PL9.1.43)

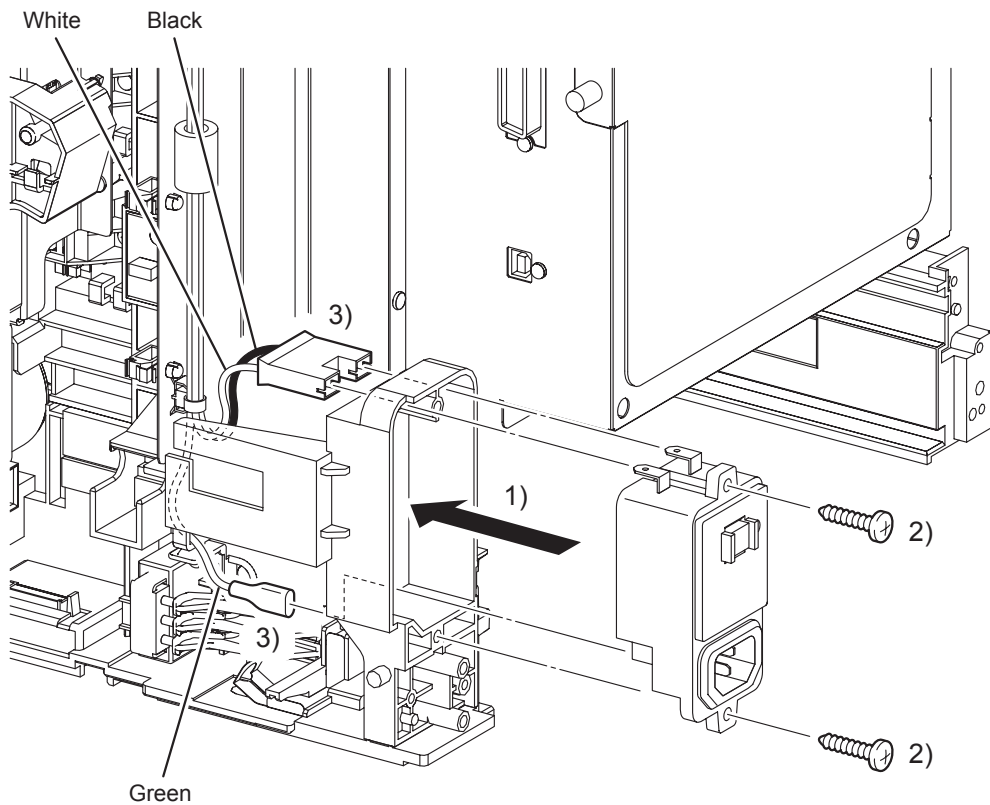

Zna03326KA

- 1) Attach the BREAKER GFI INLET to the printer.
- 2) Secure the BREAKER GFI INLET to the printer using the two screws (silver, tap, 16mm).

NOTE

When performing the step describe below, do not confuse the connector fitting position.

- 3) Engage the connector (P/J482) and the FASTON terminal (FS483) of the BREAKER GFI INLET.

Next Replacement steps.

Replacement 33 RIGHT COVER (PL1.1.6)

Replacement 26 SIZE SWITCH ASSEMBLY (PL7.1.18)

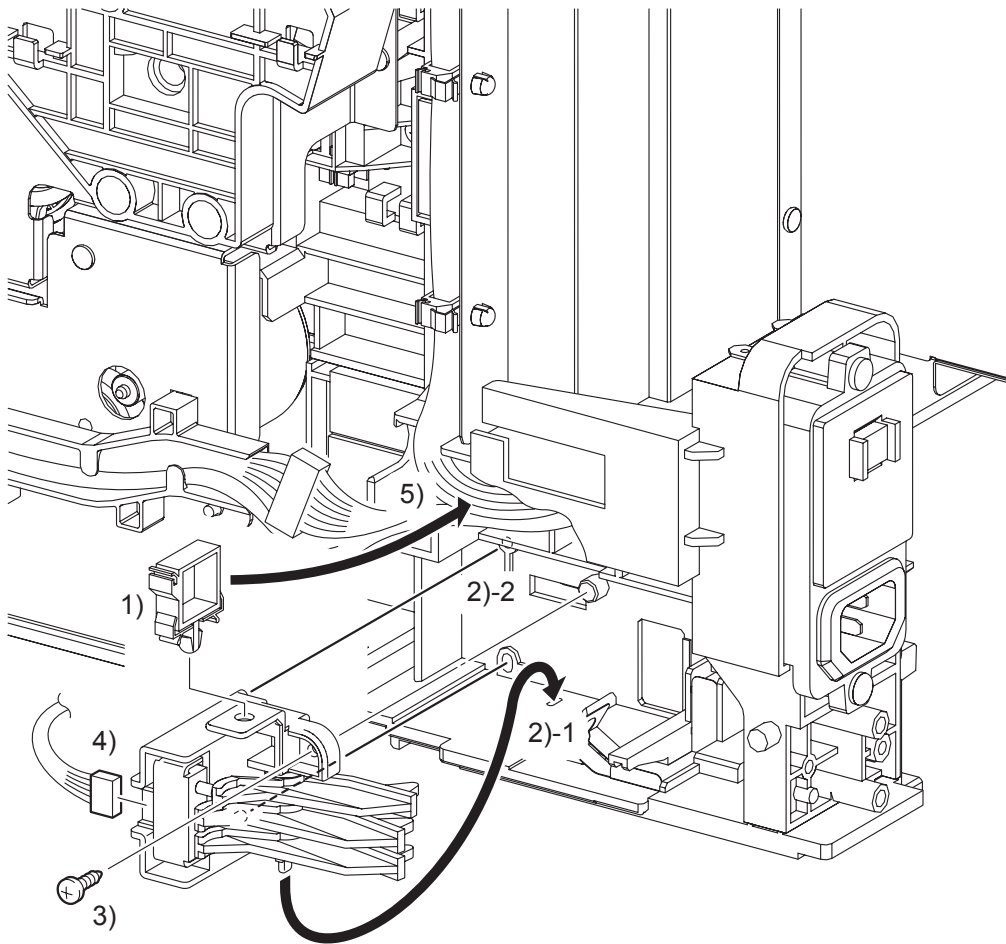

Zna03089KA

- 1) Replace the clamp to the SIZE SWITCH ASSEMBLY.
- 2) Insert the backside tab of the SIZE SWITCH ASSEMBLY into the hole on the printer and insert the two bosses of the SIZE SWITCH ASSEMBLY into the holes on the printer.
- 3) Secure the SIZE SWITCH ASSEMBLY to the printer using the one screw (silver, tap, 10mm).
- 4) Engage the connector (P/J291) of the SIZE SWITCH ASSEMBLY.
- 5) Secure the harness using the clamp of the SIZE SWITCH ASSEMBLY.

Go to the next replacement step:

Replacement 33 RIGHT COVER (PL1.1.6)

Replacement 27 FEED DRIVE ASSEMBLY (PL8.1.7)

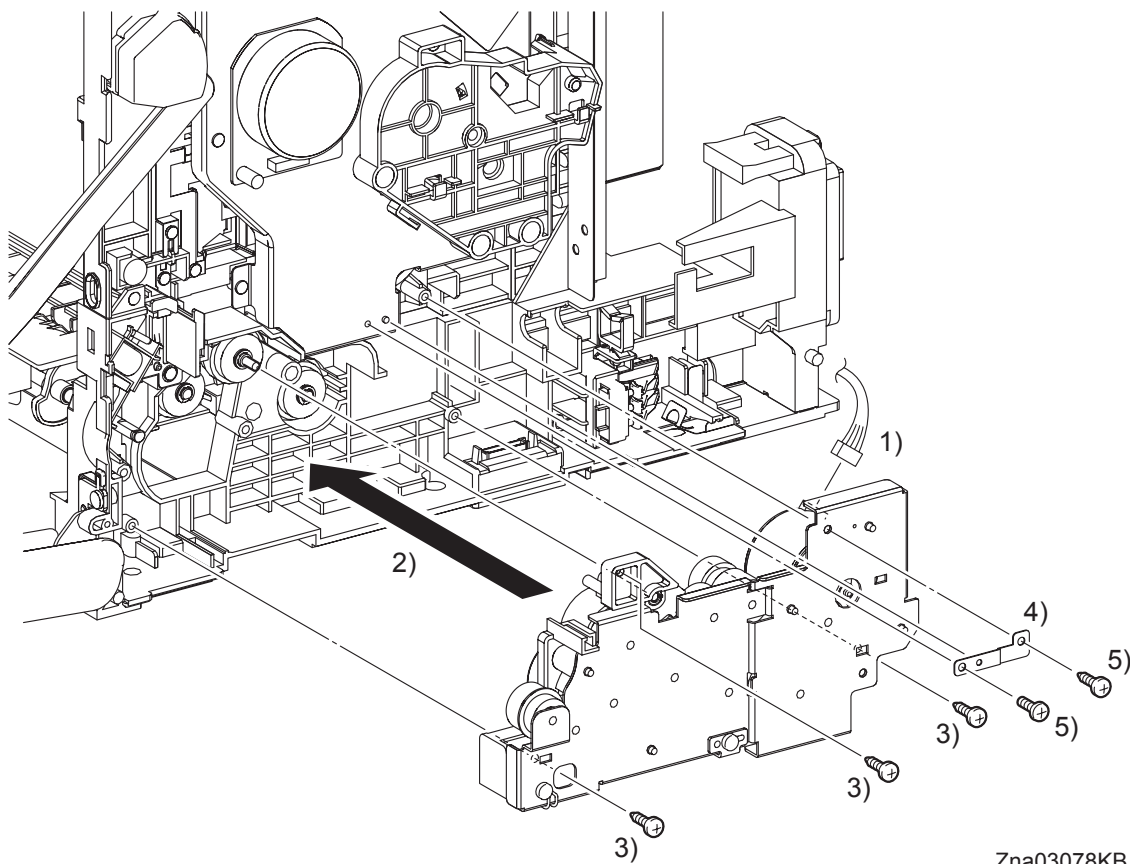

Zna03078KB

- 1) Engage the connector (P/J251) of the FEED DRIVE ASSEMBLY.
- 2) Engage the BEARING of the FEED DRIVE ASSEMBLY with the shaft of the ROLL REGI RUBBER (PL3.2.7), and then attach the FEED DRIVE ASSEMBLY to the printer.
- 3) Secure the FEED DRIVE ASSEMBLY to the printer using the three screws (silver, tap, 10mm).
- 4) Mate the one hole on the PLATE EARTH DRV MP with the boss on the PHOTOCONDUCTOR (PC) / DEVELOPER (DEV) DRIVE.
- 5) Secure the PLATE EARTH DRV MP to the PHOTOCONDUCTOR (PC) / DEVELOPER (DEV) DRIVE and FEED DRIVE ASSEMBLY using the one screw (silver, 6mm) and the one screw (silver, tap, 10mm).

Continues to the next page.

Replacement 27 FEED DRIVE ASSEMBLY (PL8.1.7)

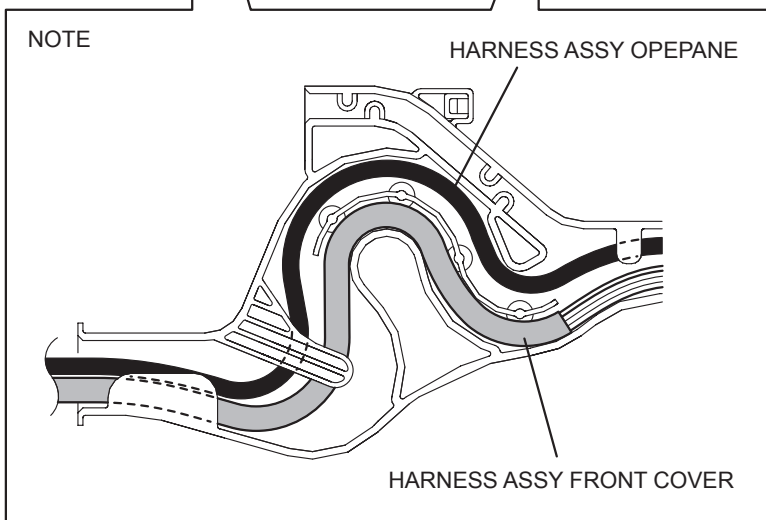
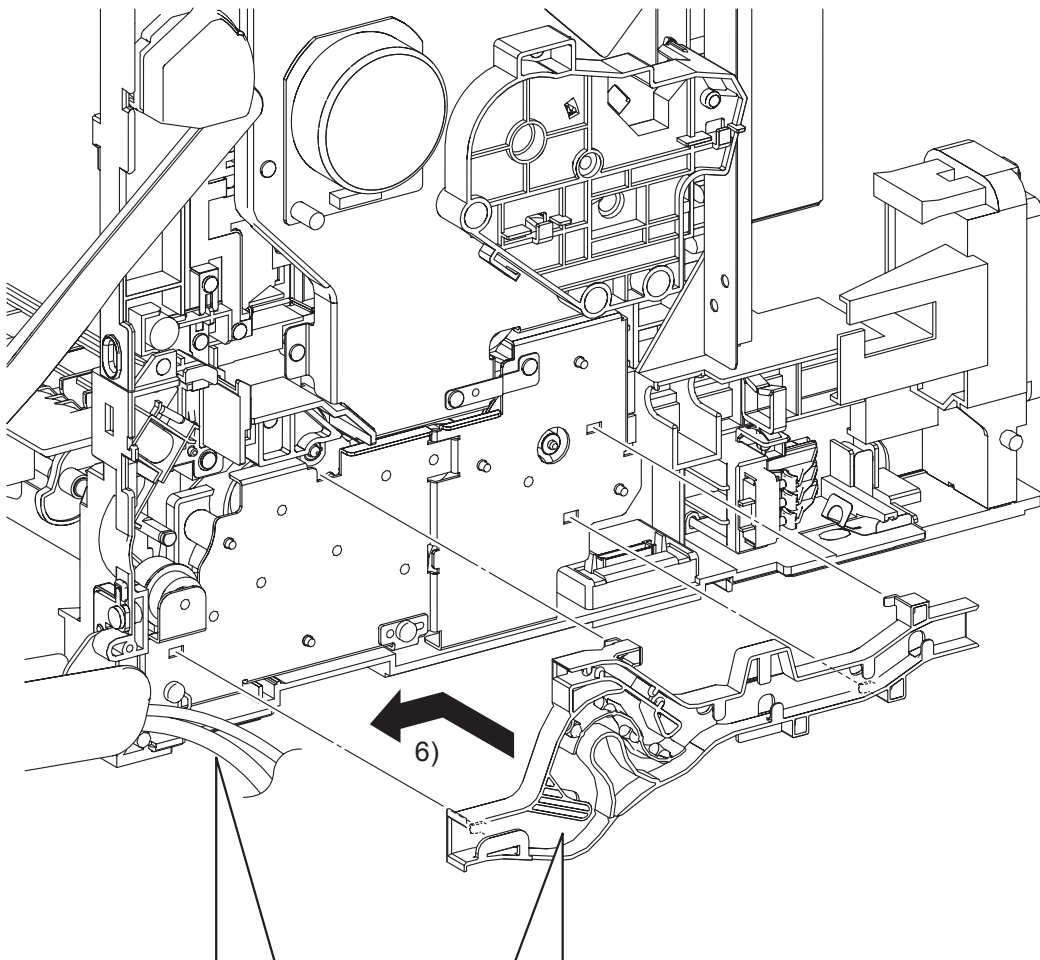

Zna03079KB

- 6) Mate the four hooks on the DUCT ASSY DRV PH with the holes on the FEED DRIVE ASSY. Secure the DUCT ASSY DRV PH by moving it forward allowing the hooks to lock into place.

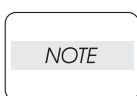

When performing the step below, route the HARNESS ASSY OPEPANE over the HARNESS ASSY FRONT COVER.

- 7) Route all the harnesses along the DUCT ASSY DRV PH.

Continues to the next page.

Replacement 27 FEED DRIVE ASSEMBLY (PL8.1.7)

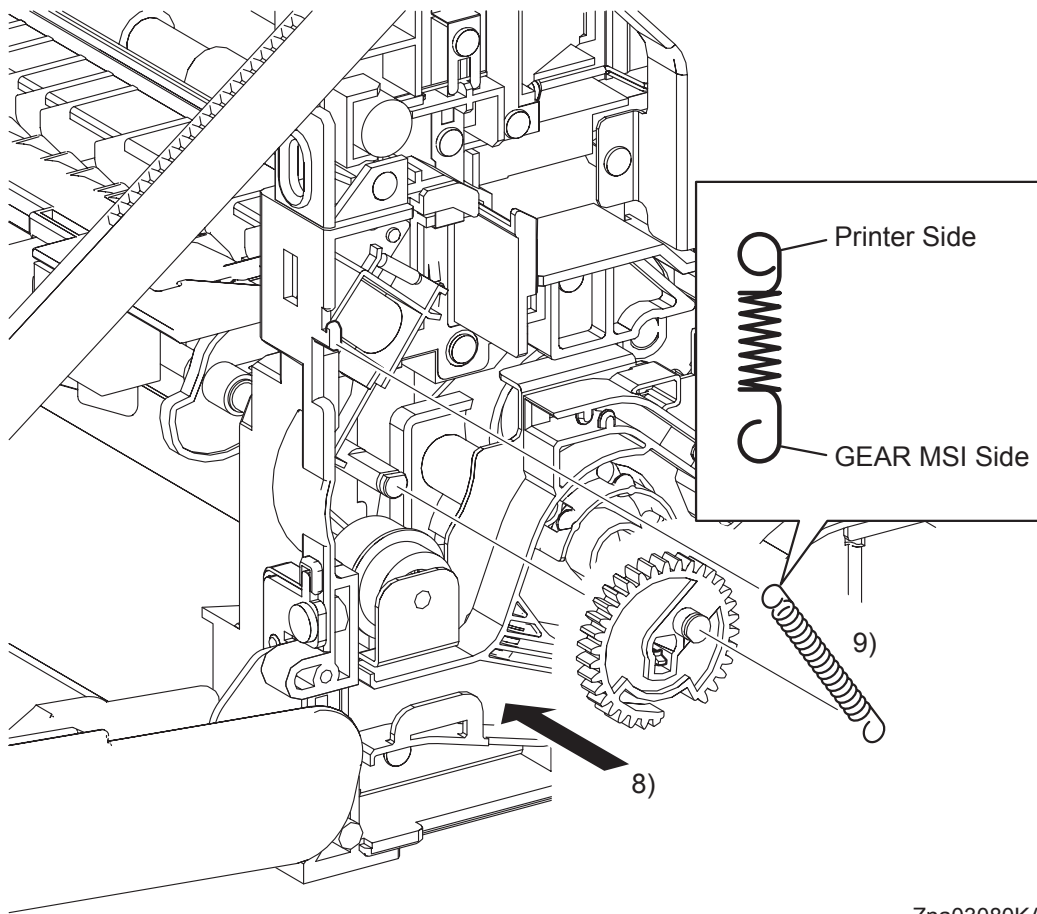

Zna03080KA

NOTE

When performing the step described below, turn the flat surface of the SHAFT MSI face upward for ease of work.

- 8) Replace the GEAR MSI to the SHAFT MSI and lock the hook of the GEAR MSI into the groove of the SHAFT MSI.

NOTE

When performing the step described below, pay attention to the orientation of the SPRING FEED MSI. Ensure that the longer J-shaped hook of the SPRING FEED MSI is anchored to the GEAR MSI.

- 9) Anchor the SPRING FEED MSI to the GEAR MSI and the printer.

**Go to the next replacement step:
Replacement 33 RIGHT COVER (PL1.1.6)**

Blank Page

Replacement 28 ROLL ASSY MSI (PL3.1.8)

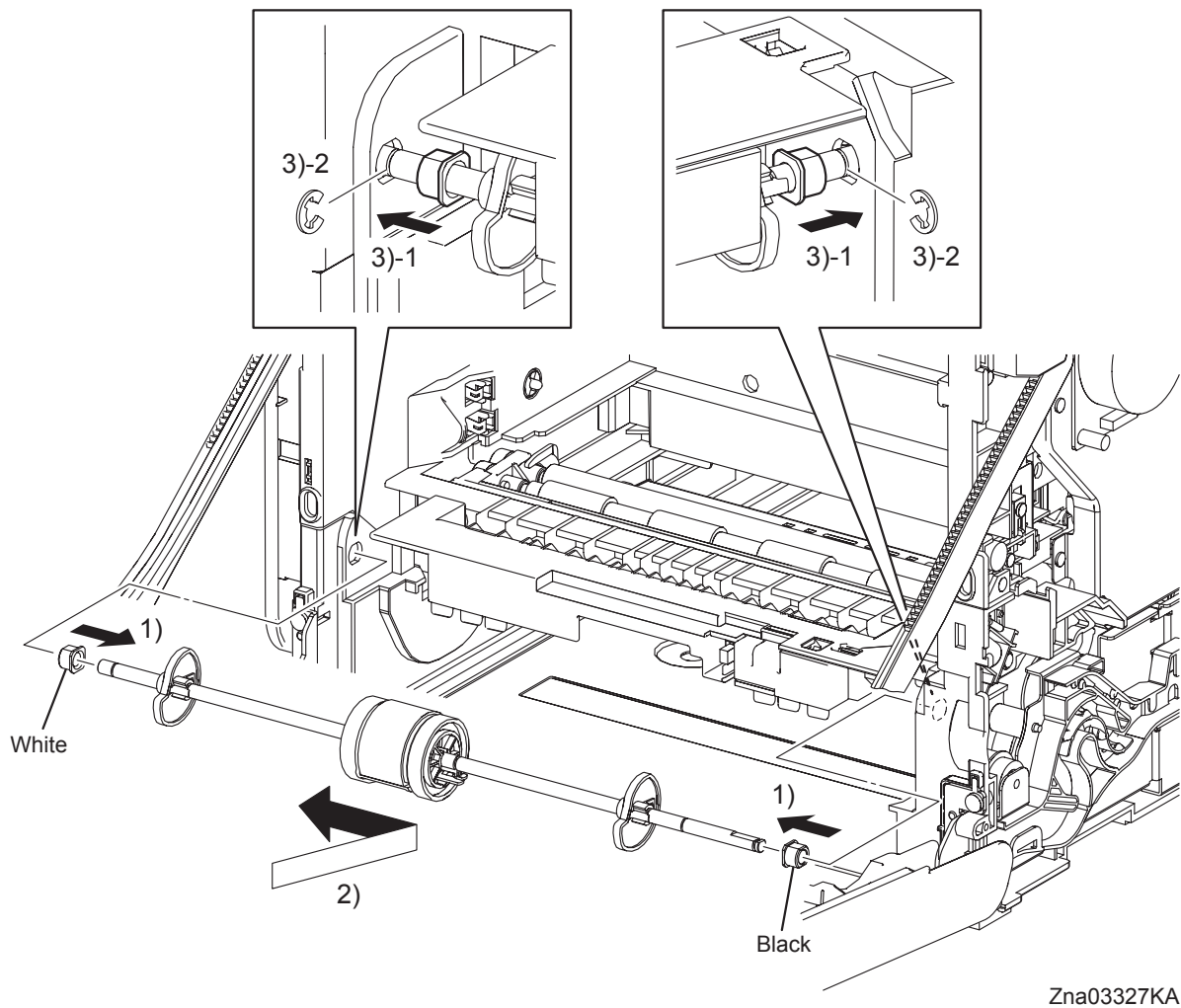

Zna03327KA

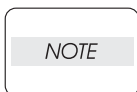

When performing the step described below, ensure that the color of each BEARING is correct.

The color of the right BEARING is black.

The color of the left BEARING is white.

- 1) Attach the BEARING EARTH and the BEARING to the ROLL ASSY MSI.
- 2) Replace the ROLL ASSY MSI to the printer by inserting the right and left ends of the ROLL ASSY MSI into the holes on the printer.
- 3) Slide the left and right of the BEARINGS outward into the holes on the printer, and secure using the e-rings.

Continues to the next page.

Replacement 28 ROLL ASSY MSI (PL3.1.8)

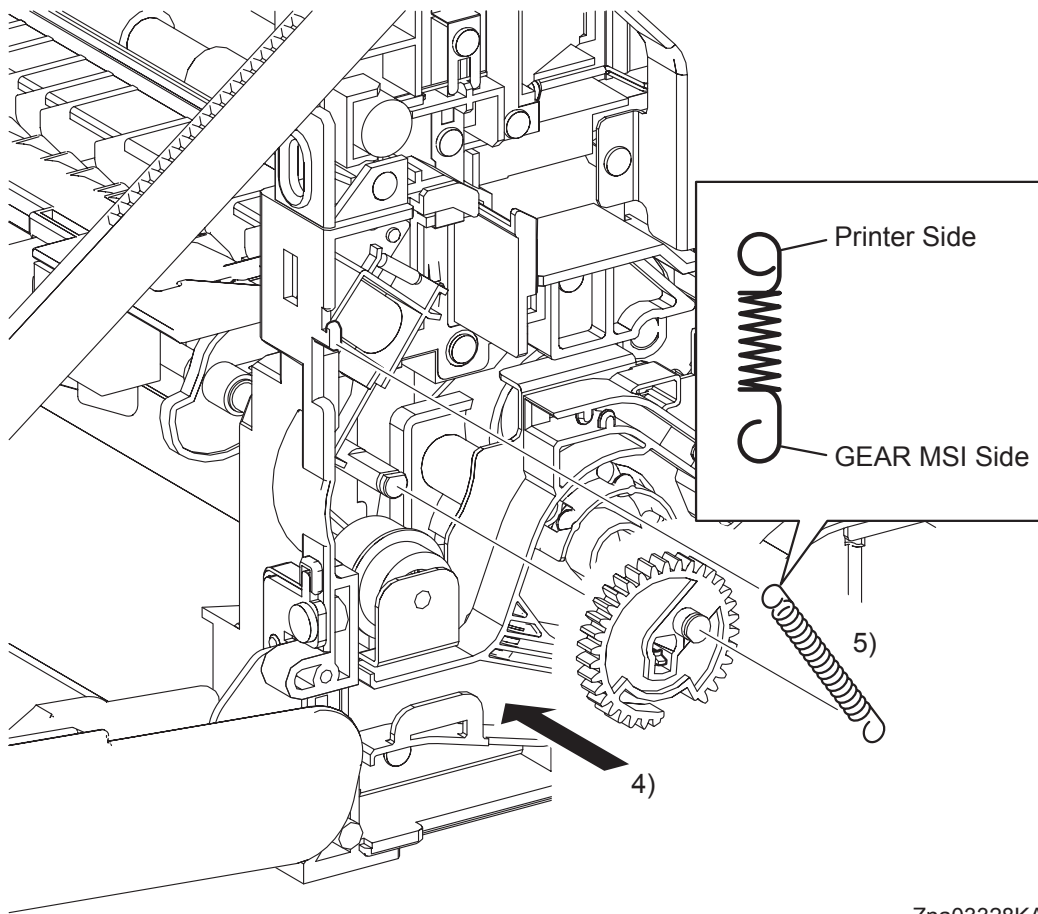

Zna03328KA

NOTE

When performing the step described below, turn the flat surface of the SHAFT MSI face upward for ease of work.

- 4) Replace the GEAR MSI to the SHAFT MSI and lock the hook of the GEAR MSI into the groove of the SHAFT MSI.

NOTE

When performing the step described below, pay attention to the orientation of the SPRING FEED MSI. Ensure that the longer J-shaped hook of the SPRING FEED MSI is anchored to the GEAR MSI.

- 5) Anchor the SPRING FEED MSI to the GEAR MSI and the printer.

**Go to the next replacement step:
Replacement 33 RIGHT COVER (PL1.1.6)**

Replacement 29 MPF FEED SOLENOID (PL3.1.98)

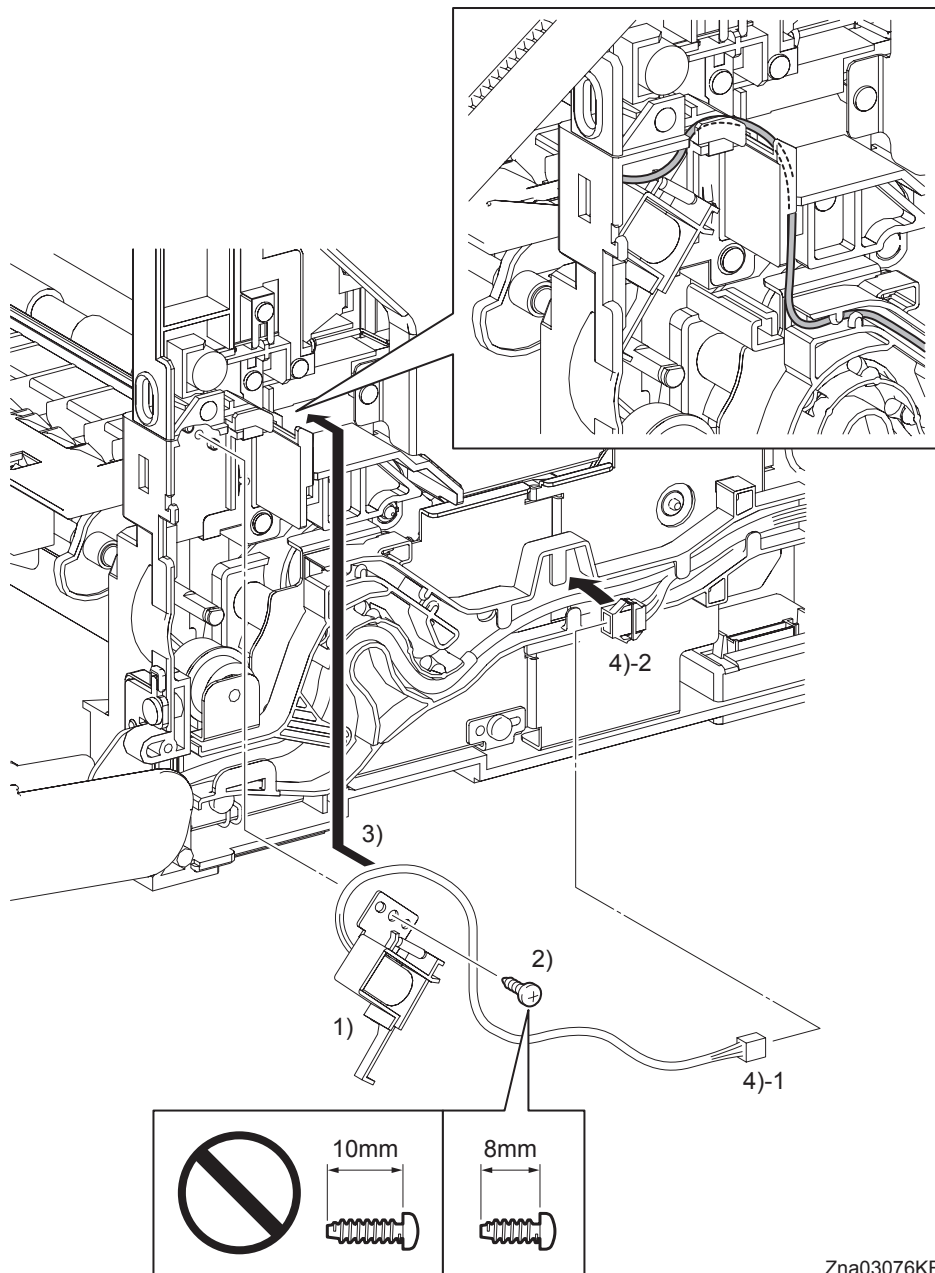

Zna03076KB

- 1) Replace the MPF FEED SOLENOID to the printer by mating the two holes on the MPF FEED SOLENOID with the bosses on the printer.

NOTE

Ensure that 8mm screws are used to secure the MPF FEED SOLENOID. Use of 10mm screws will damage the frame.

- 2) Secure the MPF FEED SOLENOID to the printer using the one screw (silver, tap, 8mm).
- 3) Route the harness of the MPF FEED SOLENOID to the DUCT ASSY DRV PH.

NOTE

The harness color of the MPF FEED SOLENOID (gray) does not match that of the printer (yellow).

- 4) Engage the connector (P/J234) of the MPF FEED SOLENOID.

Continues to the next page.

Replacement 29 MPF FEED SOLENOID (PL3.1.98)

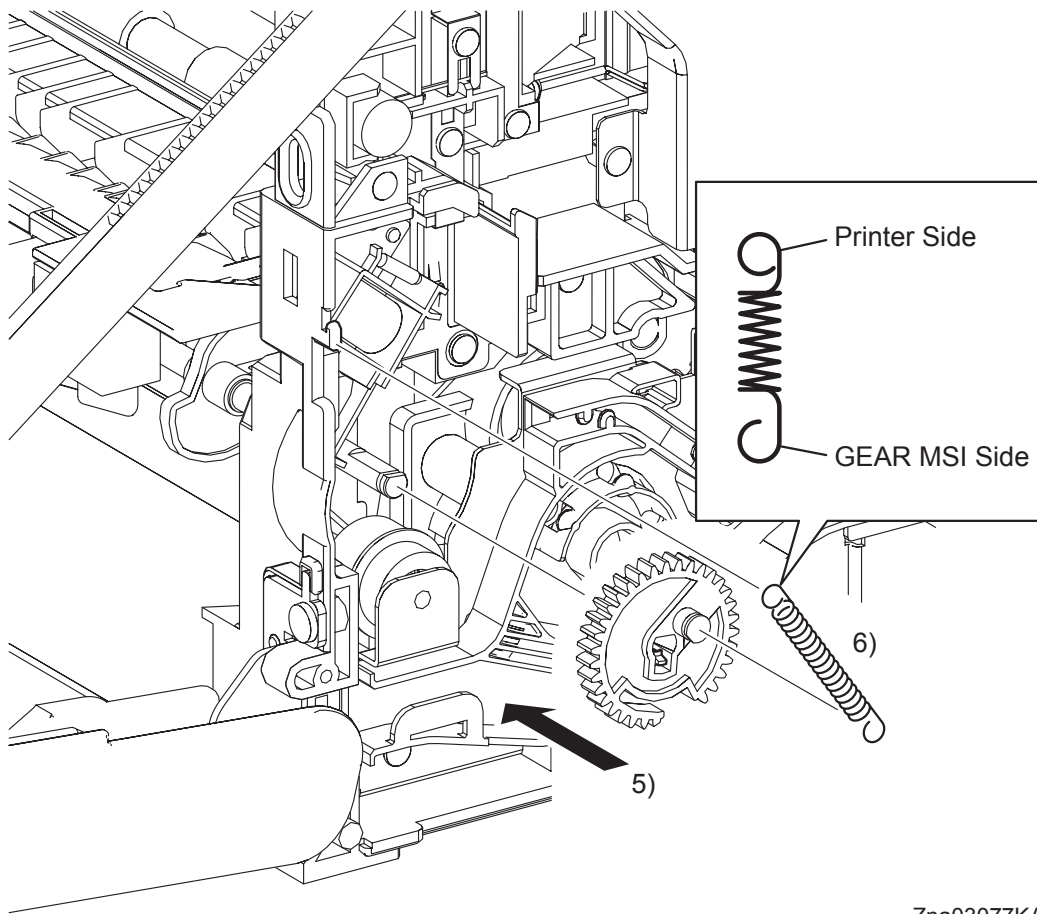

Zna03077KA

NOTE

When carrying out the work shown below, it is easier to put the D-cut surface of the SHAFT MSI on the top.

- 5) Replace the GEAR MSI to the SHAFT MSI and lock the hook on the GEAR MSI into the groove on the SHAFT MSI.

NOTE

When carrying out the work shown below, pay attention to attach the SPRING FEED MSI in the right direction.

Attach the hyperelliptic side of the SPRING FEED MSI to the GEAR MSI.

- 6) Anchor the SPRING FEED MSI to the printer and GEAR MSI.

**Go to the next replacement step:
Replacement 33 RIGHT COVER (PL1.1.6)**

Replacement 30 FRONT COVER (PL1.2.98)

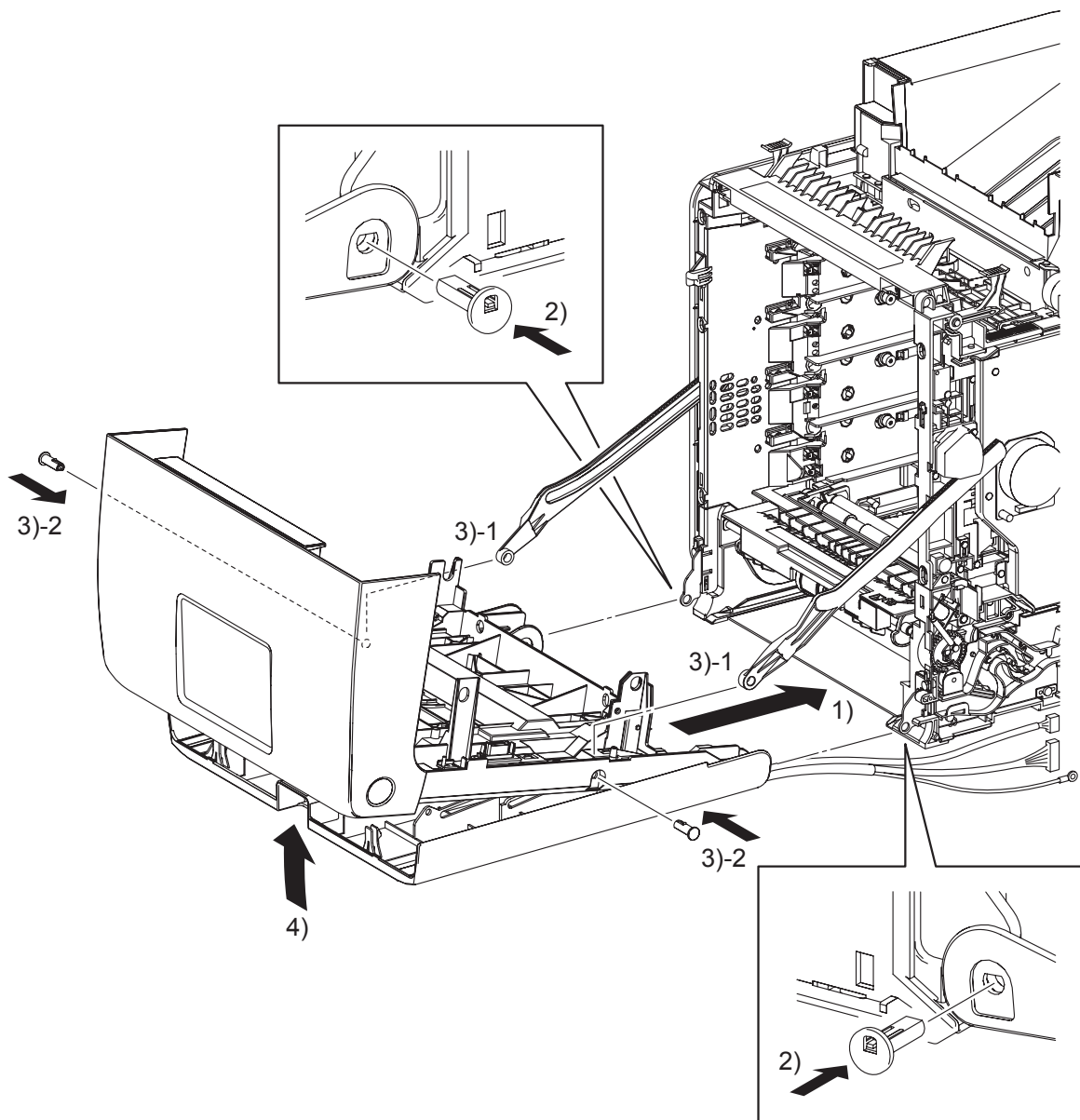

Zna03085KB

- 1) Align the left and right side holes on the FRONT COVER and MPF COVER to the fitting holes on the printer.
- 2) Insert the SHAFT PIVOT MSIs into the left and right sides fitting holes of the FRONT COVER and the MPF COVER, and then secure the SHAFT PIVOT MSIs with the hooks.
- 3) Align the left and right side fitting holes of the FRONT COVER with the fitting hole of the LINK L and the LINK R, and then insert the SHAFT PIVOTS. Secure the SHAFT PIVOTS with the hooks.
- 4) Close the MPF COVER.

Continues to the next page.

Replacement 30 FRONT COVER (PL1.2.98)

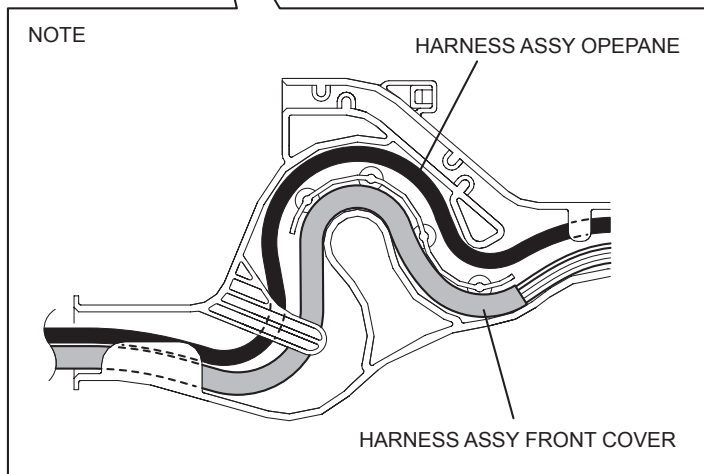
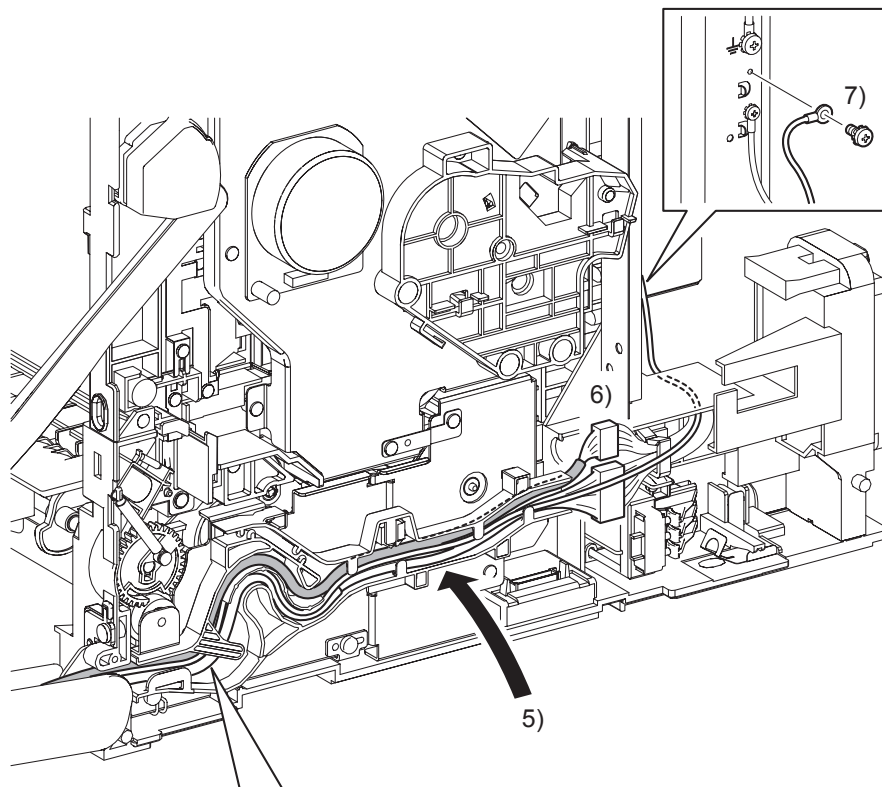

Zna03086KB

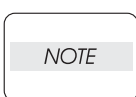

When performing the step below, route the HARNESS ASSY OPEPANE over the HARNESS ASSY FRONT COVER.

- 5) Route the HARNESS ASSY OPEPANE and the HARNESS ASSY FRONT COVER along the DUCT ASSY DRV PH.
- 6) Engage the connector (P/J272) of the HARNESS ASSY FRONT COVER and the connector (P/J2900) of the HARNESS ASSY OPEPANE.
- 7) Secure the ground wire of the HARNESS ASSY FRONT COVER to the printer using the one screw (silver, with washer, 6mm).

Go to the next replacement step:

Replacement 33 RIGHT COVER (PL1.1.6)

Replacement 31 OPERATOR PANEL (PL1.2.97)

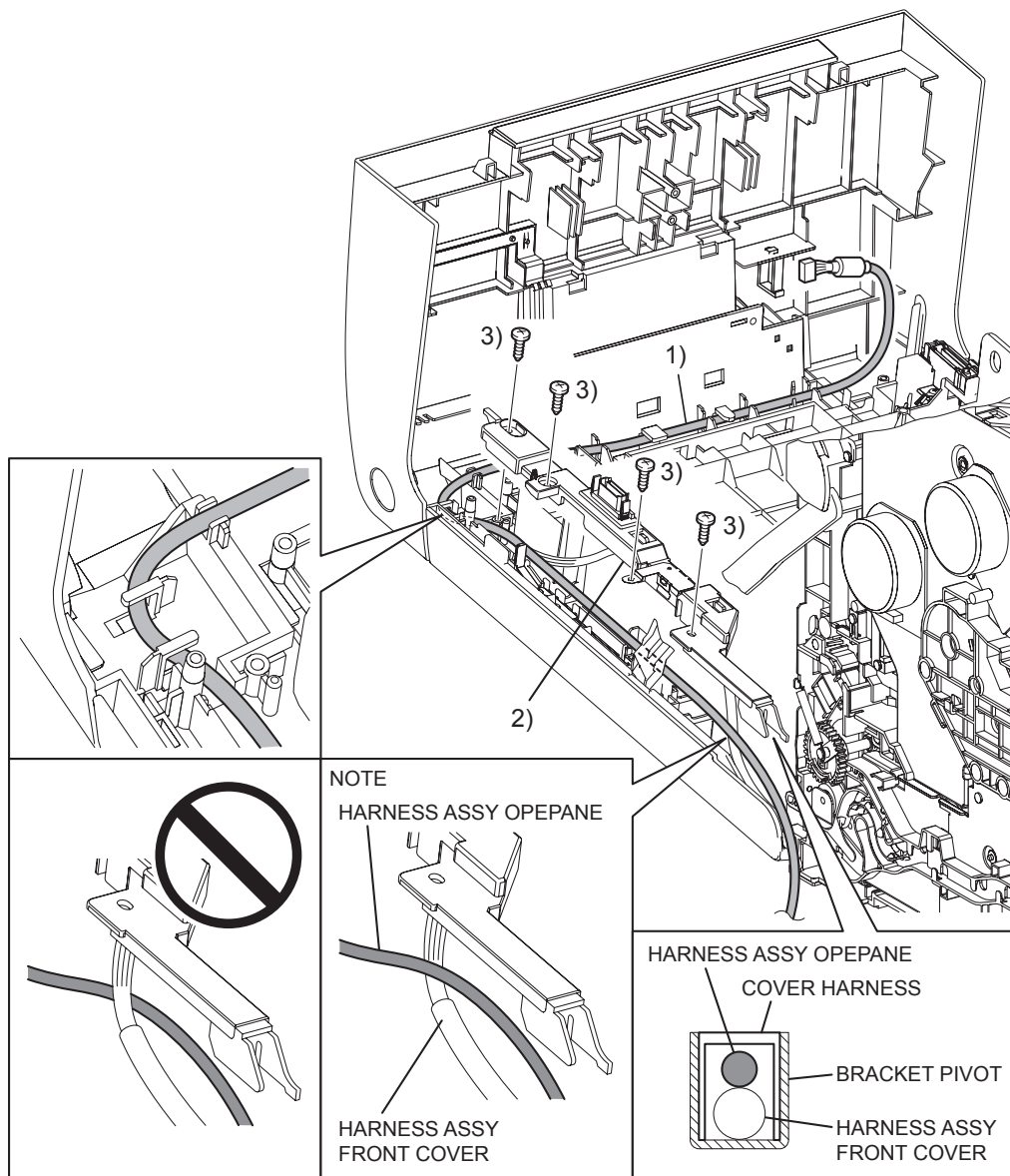

Zna03125KA

- 1) Route the HARNESS ASSY OPEPANE through the notch on the lib of the FRONT COVER and the hook.

NOTE

When performing the step below, route the HARNESS ASSY OPEPANE so that it crosses the HARNESS ASSY FRONT COVER.

- 2) Replace the COVER HARNESS by mating the hole of the COVER HARNESS with the boss on the FRONT COVER.

NOTE

When performing the step below, check that the HARNESS ASSY OPEPANE is routed over.

- 3) Secure the COVER HARNESS to the FRONT COVER using the four screws (silver, tap, 10mm).

Continues to the next page.

Replacement 31 OPERATOR PANEL (PL1.2.97)

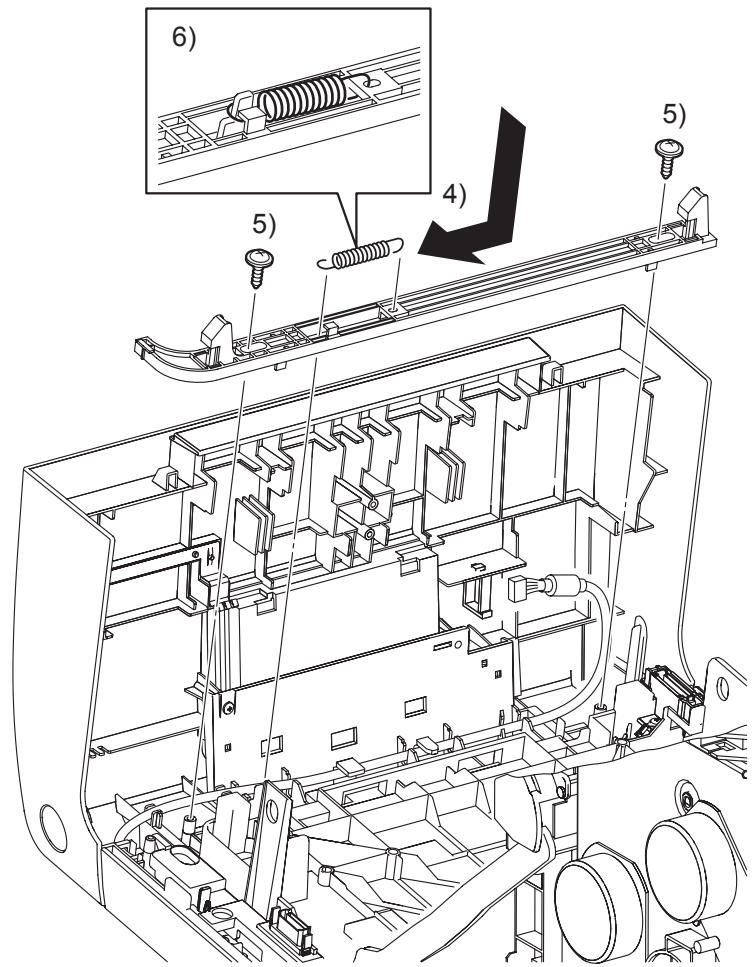

Zna03133KA

- 4) Replace the LATCH FRONT to the FRONT COVER by mating the two holes of the LATCH FRONT with the studs on the FRONT COVER
- 5) Secure the LATCH FRONT to the FRONT COVER using the two screws (silver, with flange, tap, 10mm).
- 6) Anchor the SPRING LATCH to the hole on the LATCH FRONT and the peg on the FRONT COVER.

Continues to the next page.

Replacement 31 OPERATOR PANEL (PL1.2.97)

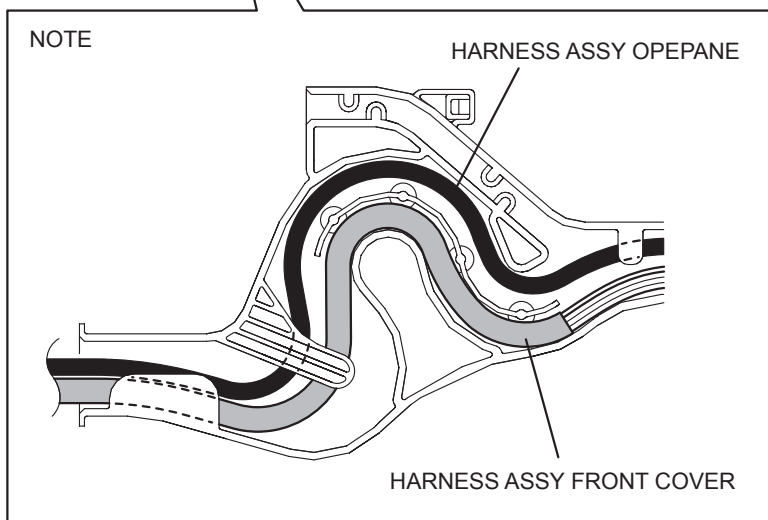
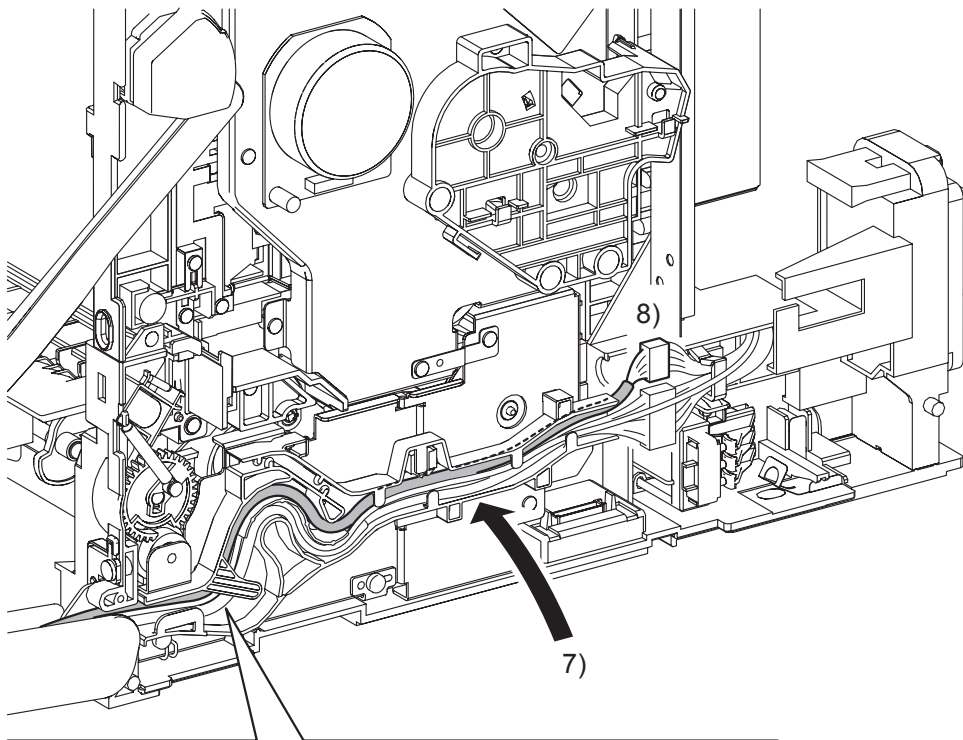

Zna03126KB

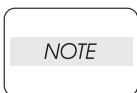

When performing the step below, rote the HARNESS ASSY OPEPANE on the most outward position.

- 7) Route the HARNESS ASSY OPEPANE along the DUCT ASSY DRV PH.
- 8) Engage the connector (P/J2900) of the HARNESS ASSY OPEPANE.

Continues to the next page.

Replacement 31 OPERATOR PANEL (PL1.2.97)

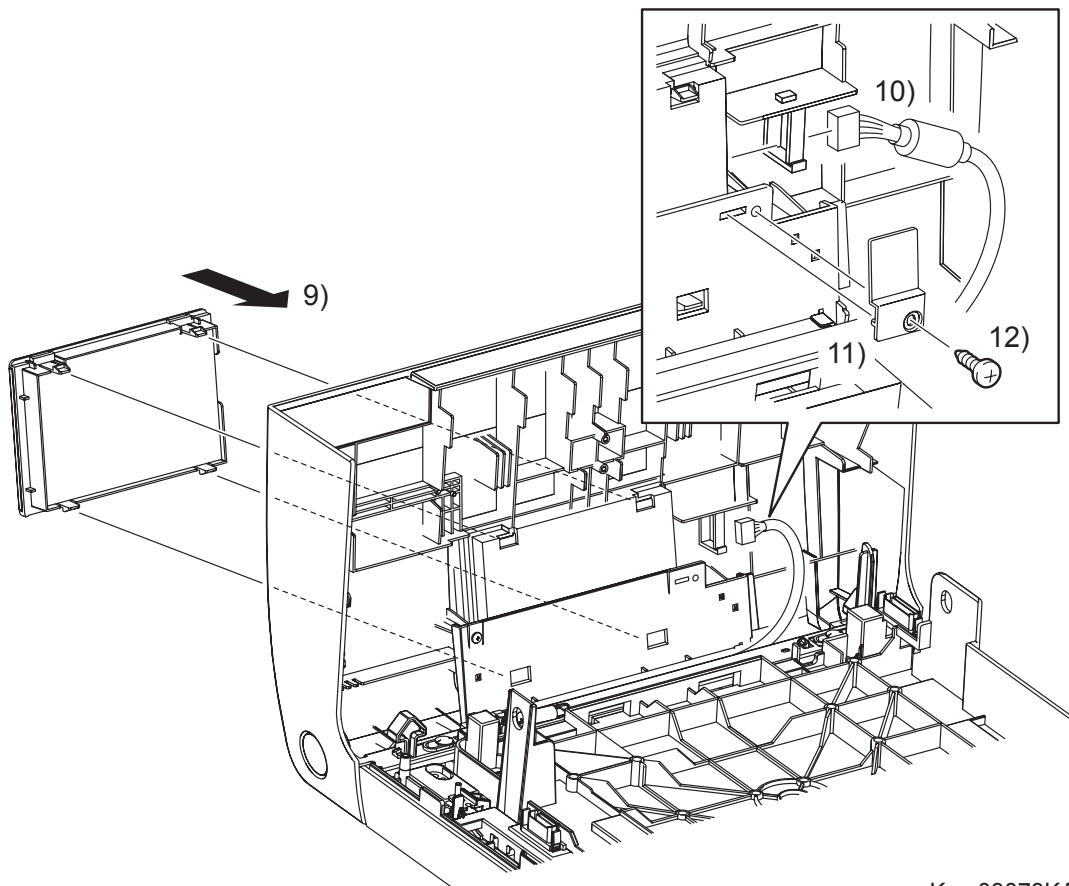

Kmy03073KA

- 9) Replace the OPERATOR PANEL to the FRONT COVER and secure at the four hooks.
- 10) Engage the connector (P/J220) of the OPERATOR PANEL, and then fix the core of the HARNESS ASSY OPEPANE with the clamp.
- 11) Replace the BRACKET HARNESS by mating the lug on the BRACKET HARNESS with the hole of the FRONT COVER,
- 12) Secure the BRACKET HARNESS to the FRONT COVER using the one screw (silver, tap, 10mm).

Go to the next replacement step:

Replacement 33 RIGHT COVER (PL1.1.6)

Replacement 32 LEVER FUSER D (PL6.1.18)

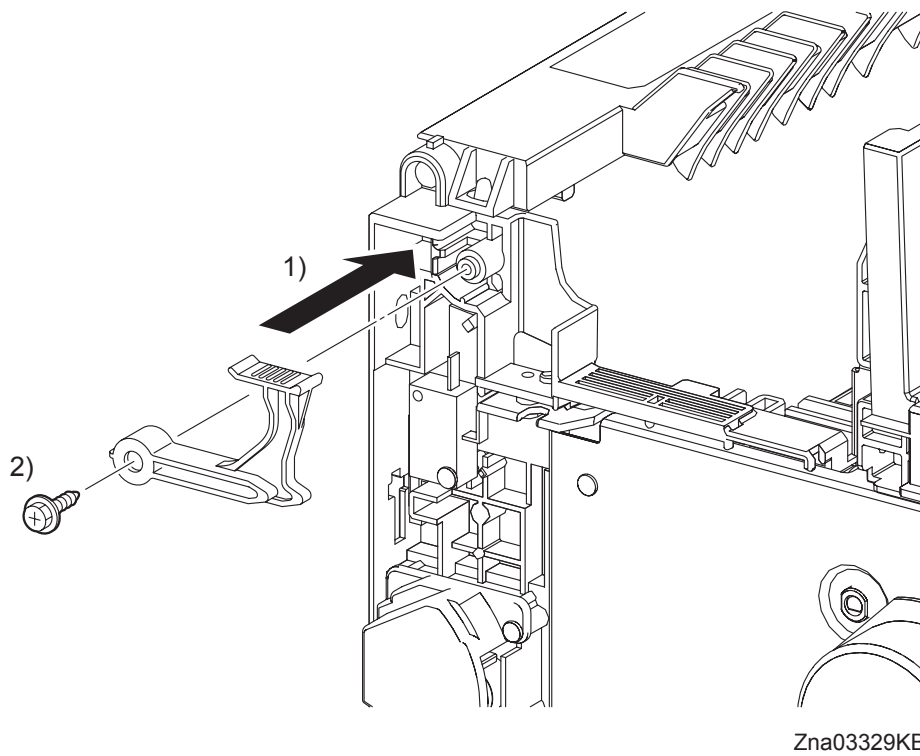

- 1) Attach the LEVER FUSER D to the printer.
- 2) Secure the LEVER FUSER D to the printer using the one screw (silver, with flange, tap, 10mm).

**Go to the next replacement step:
Replacement 33 RIGHT COVER (PL1.1.6)**

Replacement 33 RIGHT COVER (PL1.1.6)

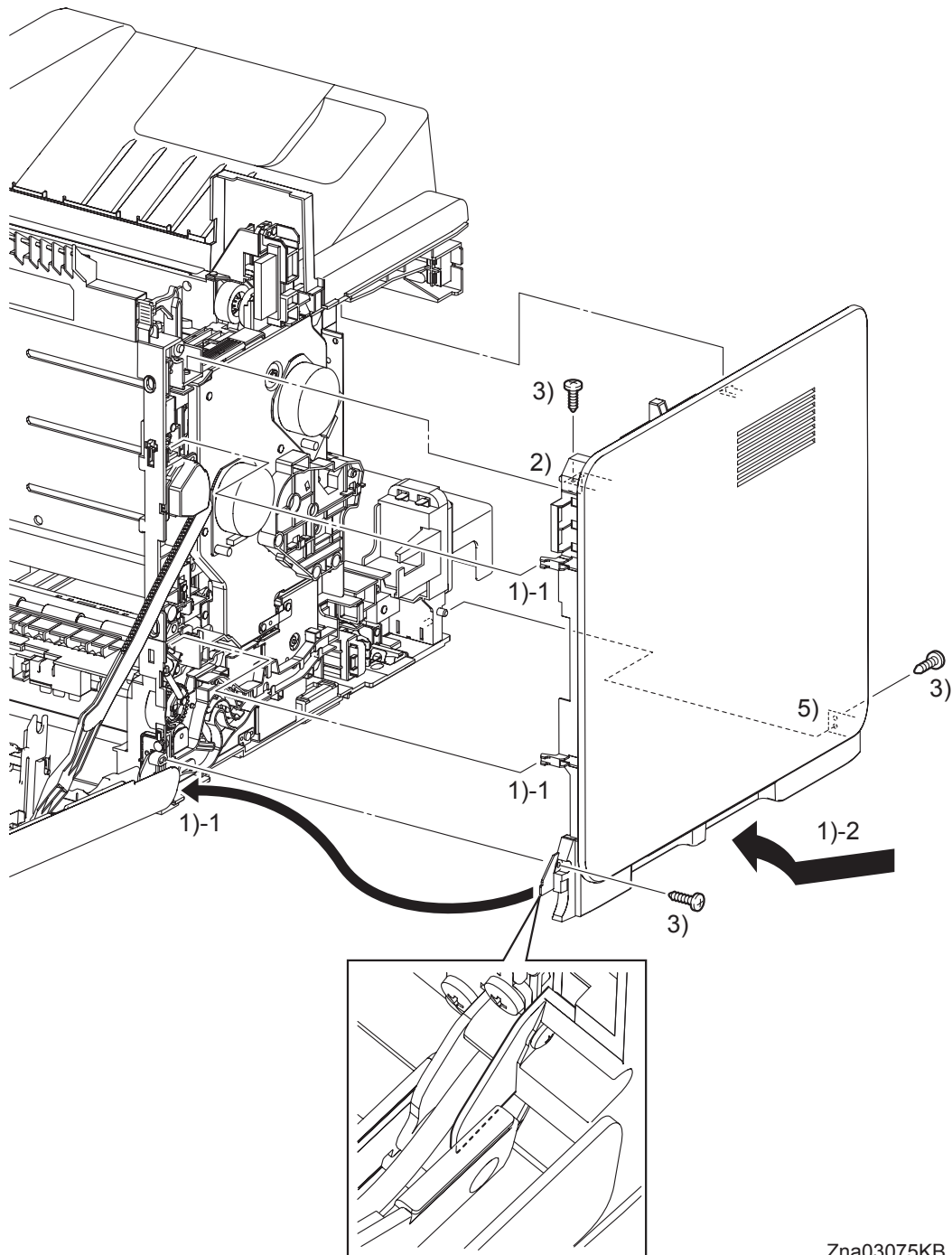

Zna03075KB

- 1) Insert the front side of the RIGHT COVER between the FRONT COVER and the printer. Mate the two front side hooks of the RIGHT COVER with the holes on the printer.
- 2) Mate the holes of the RIGHT COVER with the two bosses on the printer.
- 3) Secure the RIGHT COVER to the printer using the three screws (silver, tap, 10mm).

Go to the next replacement step:

Replacement 34 REAR COVER (PL1.1.4)

Replacement 34 REAR COVER (PL1.1.4)

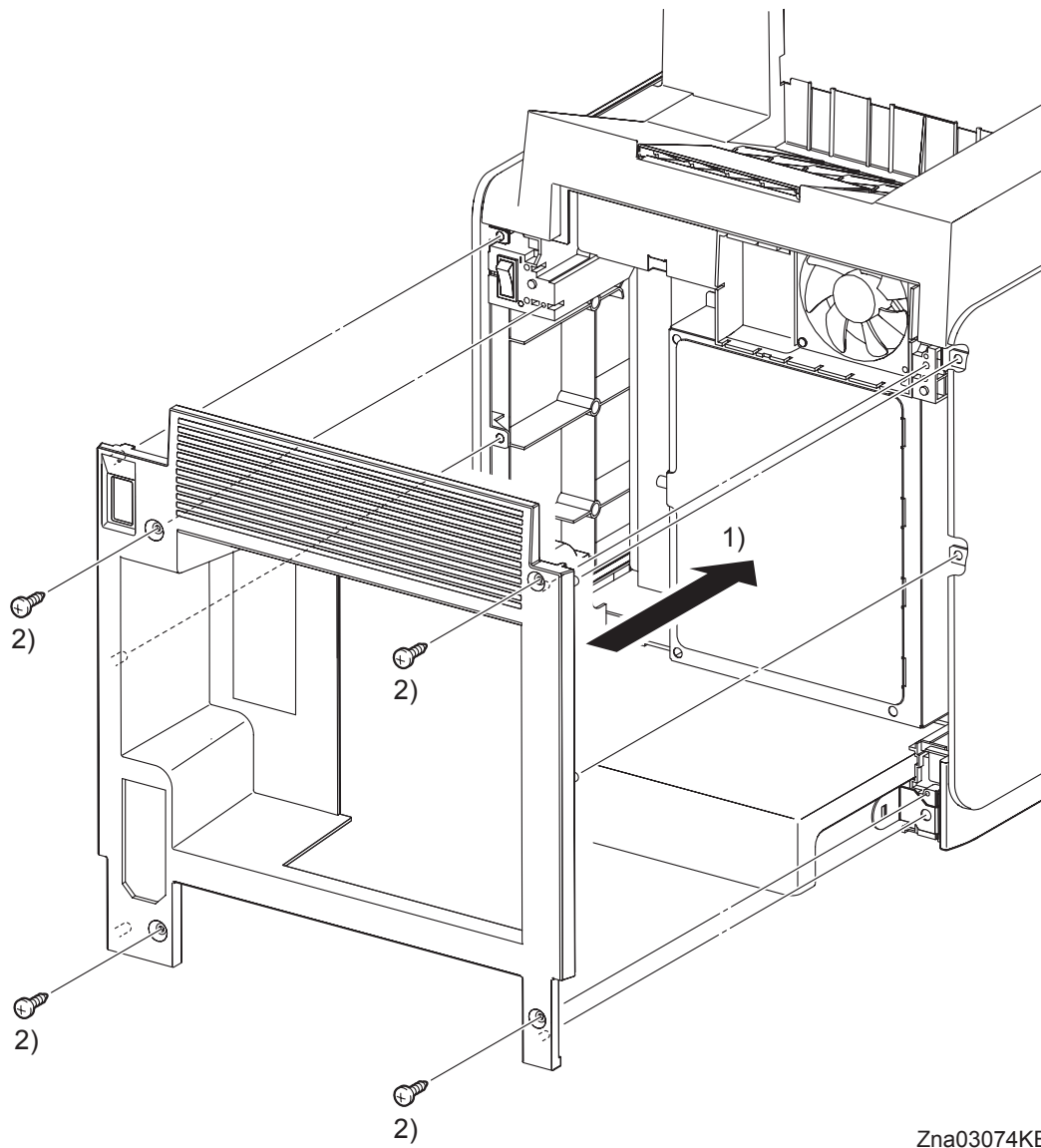

Zna03074KB

- 1) Replace the REAR COVER by mating the six bosses on the REAR COVER with the holes on the printer, the RIGHT COVER (PL1.1.6), and the LEFT COVER (PL1.1.7).
- 2) Secure the REAR COVER to the printer using the four screws (silver, tap, 10mm).

**Go to the next replacement step:
Replacement 36 FUSER (PL6.1.10)**

Replacement 35 CHUTE ASSY EXIT OUT (PL6.1.1)

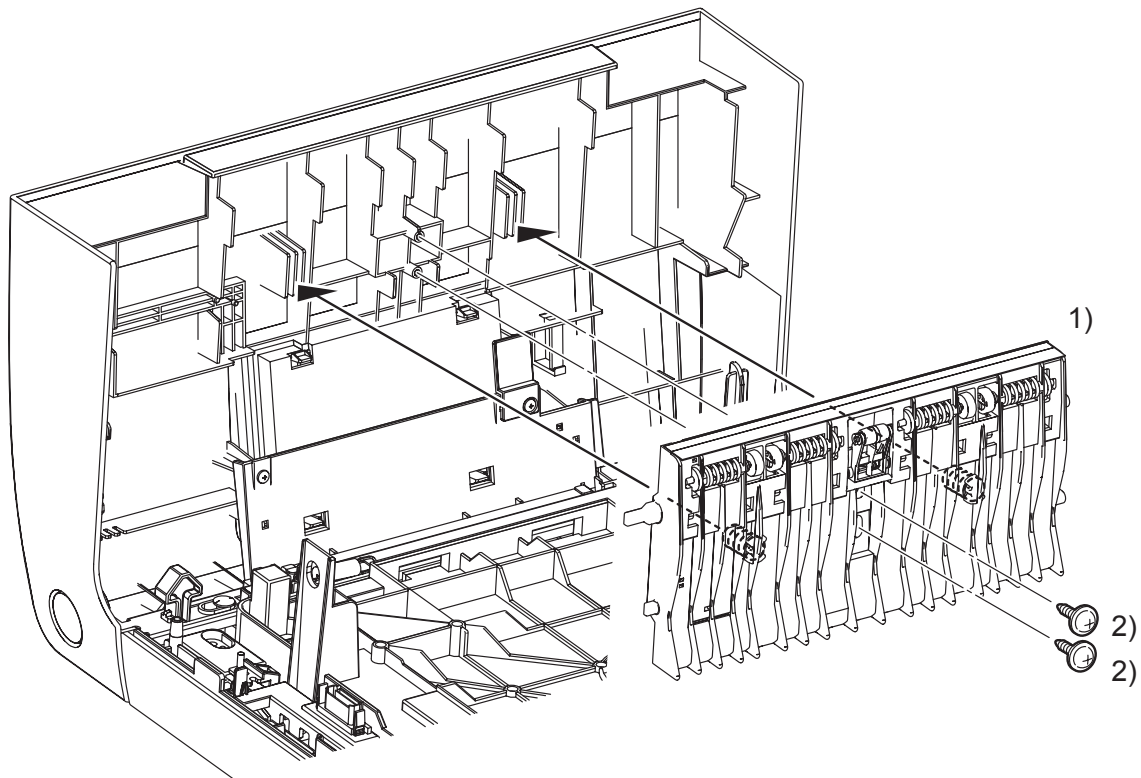

Kmy03072KA

- 1) Replace the CHUTE ASSY EXIT OUT to the FRONT COVER by mating the two springs of the CHUTE ASSY EXIT OUT with the ribs on the FRONT COVER.
- 2) Secure the CHUTE ASSY EXIT OUT to the FRONT COVER using the two screws (silver, with flange, tap, 10mm).
- 3) Close the FRONT COVER.

Replacement 36 FUSER (PL6.1.10)

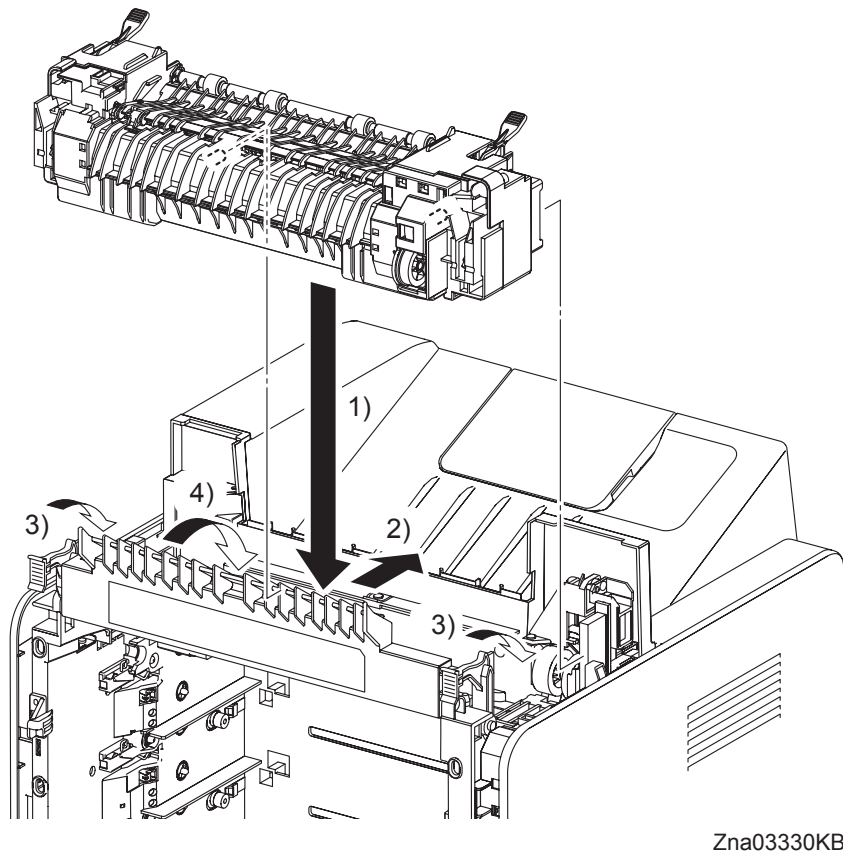

- 1) Put the FUSER on the printer.
- 2) Insert the two rear side bosses of the FUSER into the holes on the printer by moving the FUSER slightly backward.
- 3) Push down the LEVER FUSER D and the LEVER FUSER AD to lock the FUSER.
- 4) Close the DUPLEX GATE.
- 5) Close the FRONT COVER.

Replacement 37 DUPLEX GATE (PL6.1.13)

NOTE

The FUSER part is very hot. Take added care not to get burned when performing the service operation.

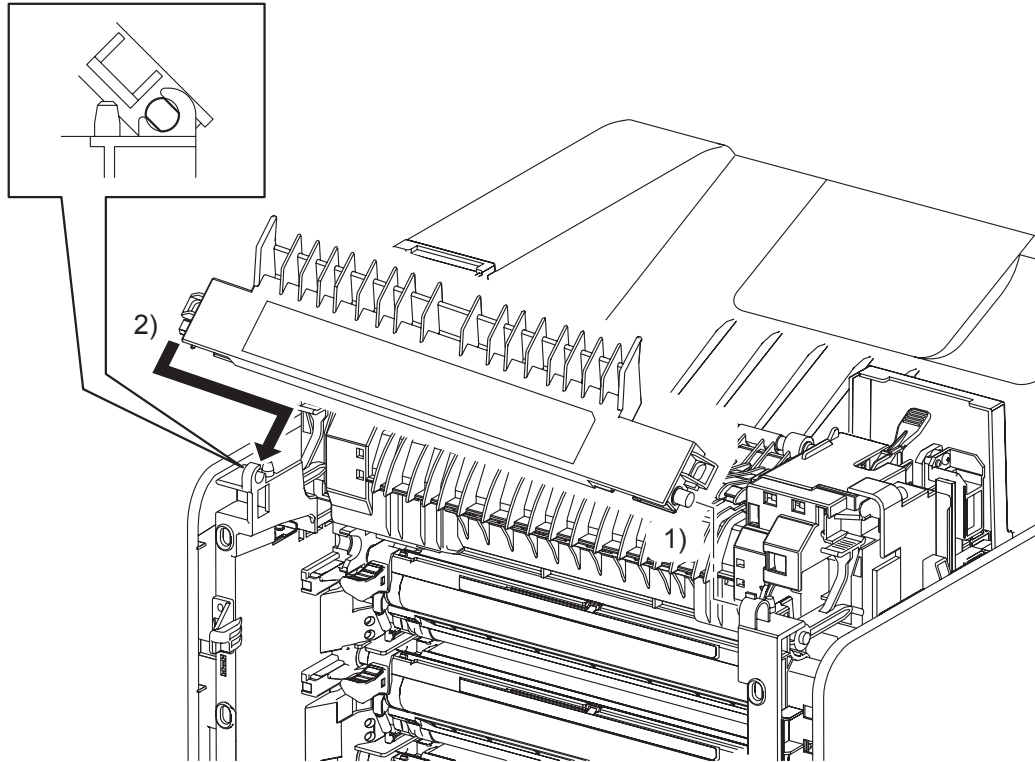

Zna03069KB

- 1) Insert the right side boss of the DUPLEX GATE with the hole of the printer.
- 2) Open the DUPLEX GATE (PL6.1.13) to about 45 degrees so that the flat faces of the left side pivot of the DUPLEX GATE comes parallel with the U-shaped notch. Push in the left side pivot of the DUPLEX GATE into the U-shaped notch diagonally forward.
- 3) Close the DUPLEX GATE.
- 4) Close the FRONT COVER.

Replacement 38 TONER CARTRIDGE (K), (C), (M), (Y) (PL5.1.18)

NOTE

Described below is the replacement procedure common among TONER CARTRIDGES (C), (M), (Y), and (K).

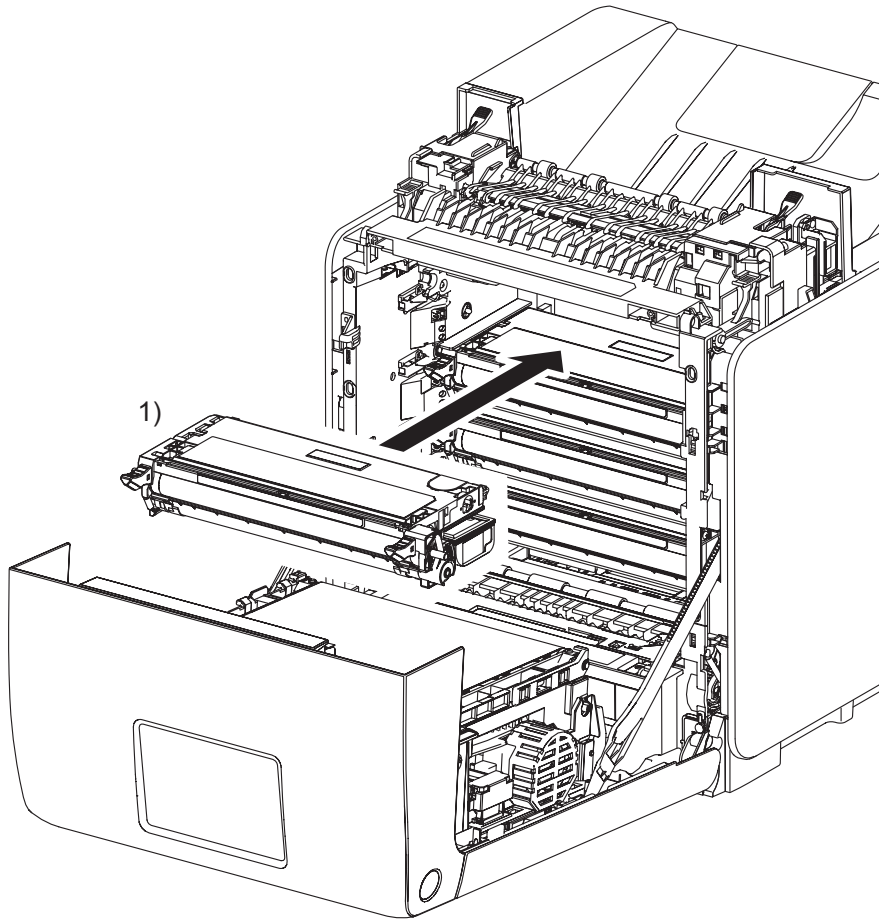

Zna03068KB

NOTE

If all the TONER CARTRIDGES are removed, attach them in the order of Yellow, Magenta, Cyan, and Black from the bottom.

- 1) Replace the TONER CARTRIDGE inserting it by the left and right handles along the guide on the printer.
- 2) Close the FRONT COVER.

Replacement 39 DUPLEX MODULE (PL11.1.1)

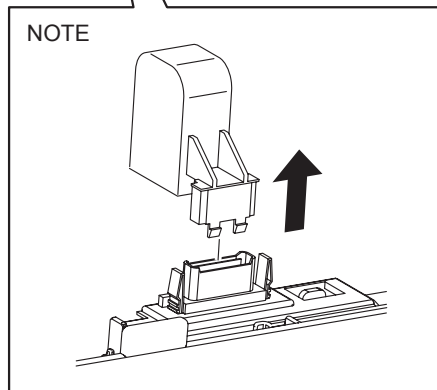
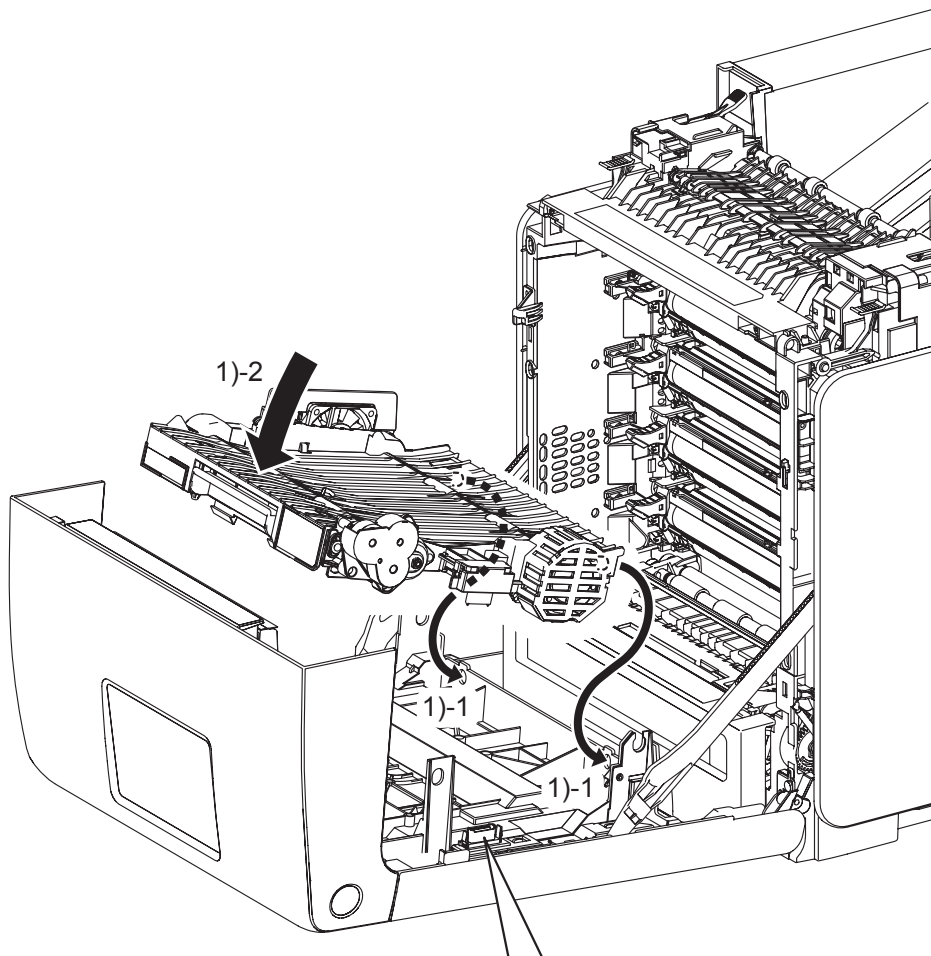

Zna03067KB

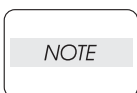

Remove the CAP CONNECTOR DRAWER (PL1.2.38) of the connector of the FRONT COVER when installing new DUPLEX MODULE.

- 1) Replace the DUPLEX MODULE slowly by mating the two backside bosses of the DUPLEX MODULE with the holes on the FRONT COVER, and then secure with the lever.

**Go to the next replacement step:
Replacement 40 TRANSFER BELT (PL4.1.1)**

Replacement 40 TRANSFER BELT (PL4.1.1)

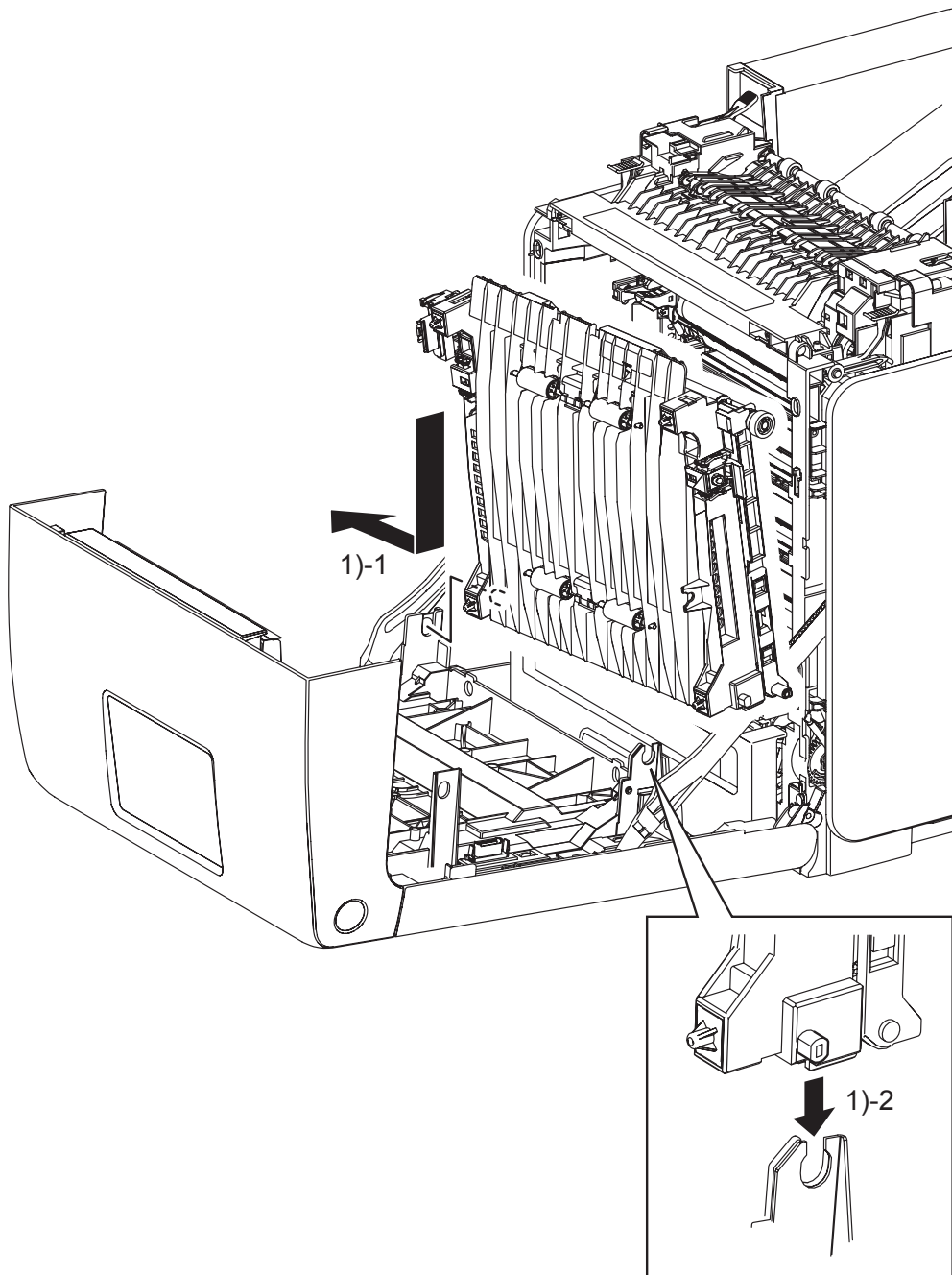

Zna03065KA

- 1) Replace the TRANSFER BELT by inserting the right side boss on the TRANSFER BELT into the hole on the FRONT COVER and then inserting the left side boss on the TRANSFER BELT into the U-shaped groove on the FRONT COVER.

Continues to the next page.

Replacement 40 TRANSFER BELT (PL4.1.1)

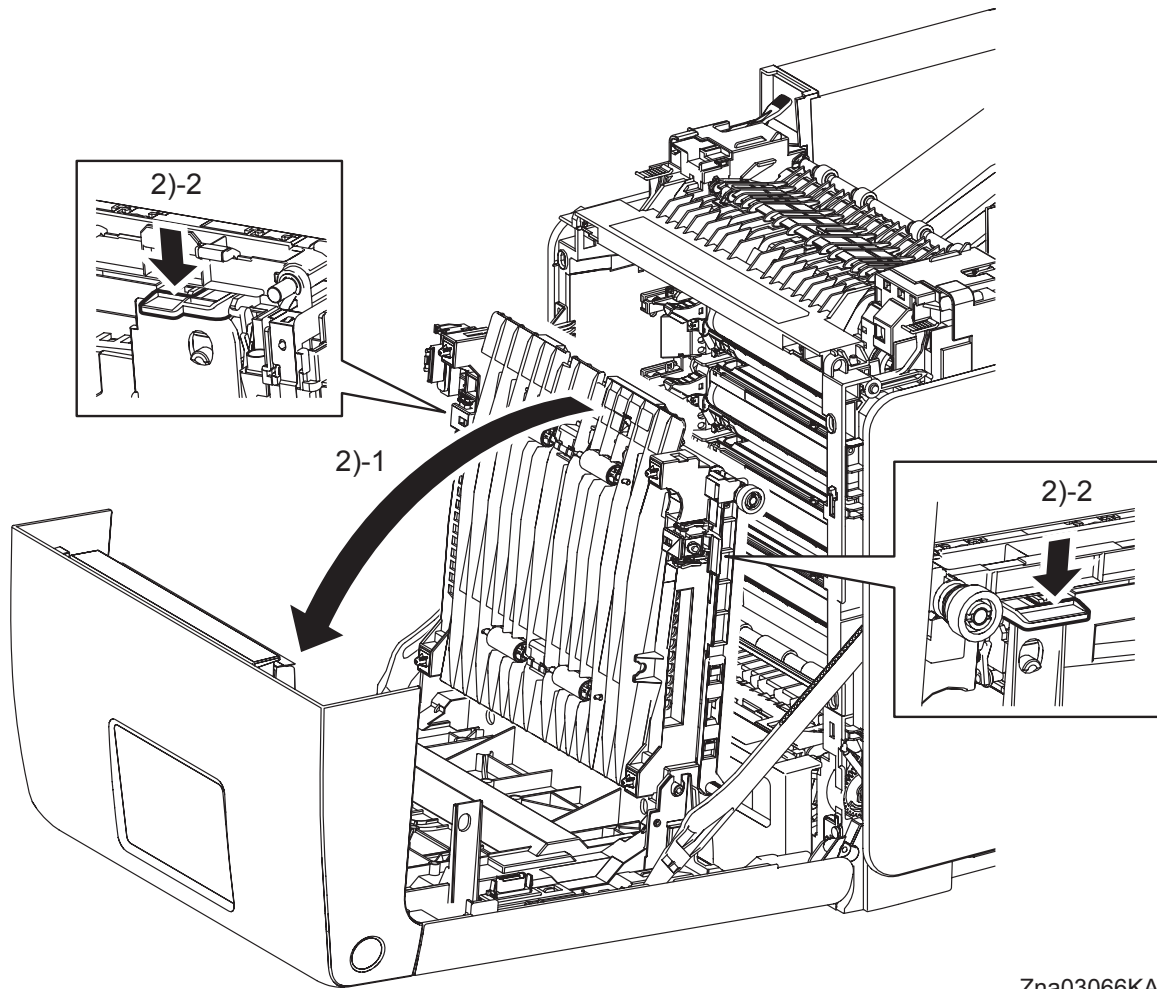

Zna03066KA

- 2) Tilt the TRANSFER BELT slowly, and then secure with the left and right levers.
- 3) Close the FRONT COVER.

Replacement 41 TRAY REAR COVER (PL1.1.5)

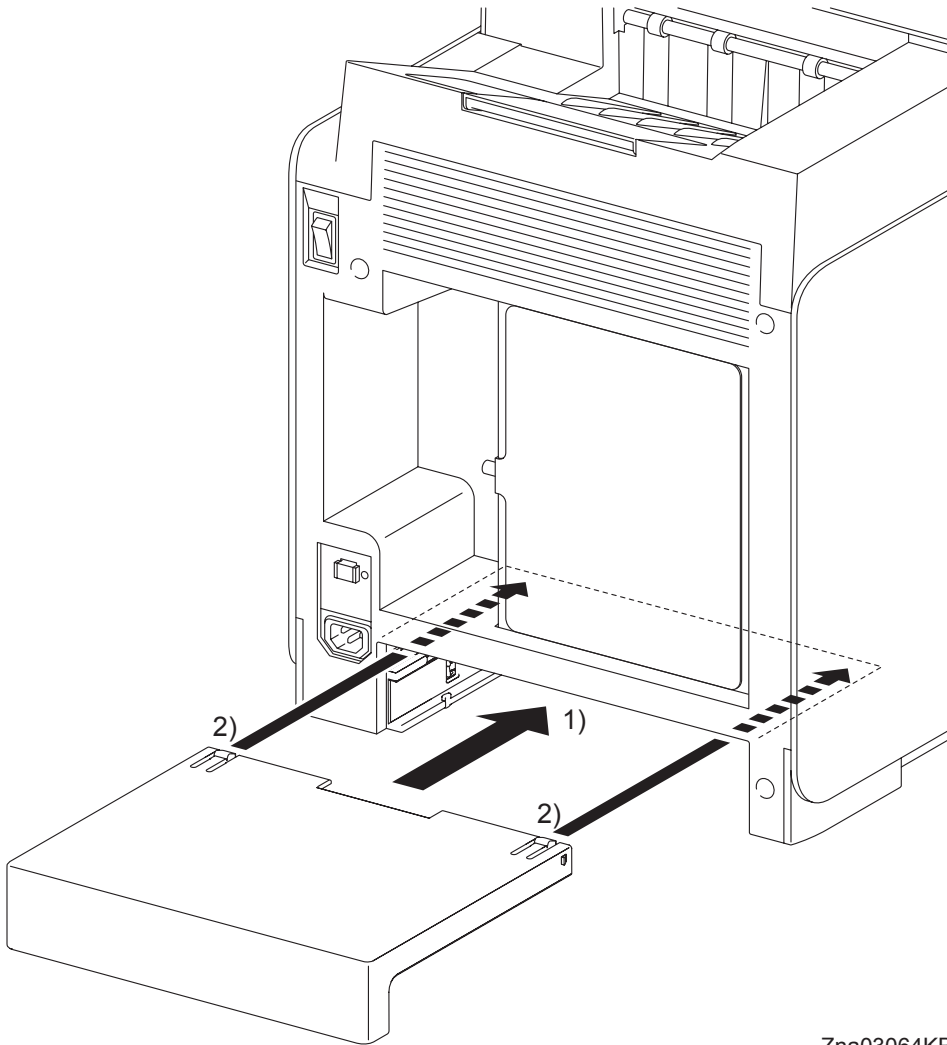

Zna03064KB

- 1) Insert the TRAY REAR COVER into the printer.
- 2) Secure by locking the two front hooks on TRAY REAR COVER to the printer.

Replacement 42 MPF COVER (PL1.2.99)

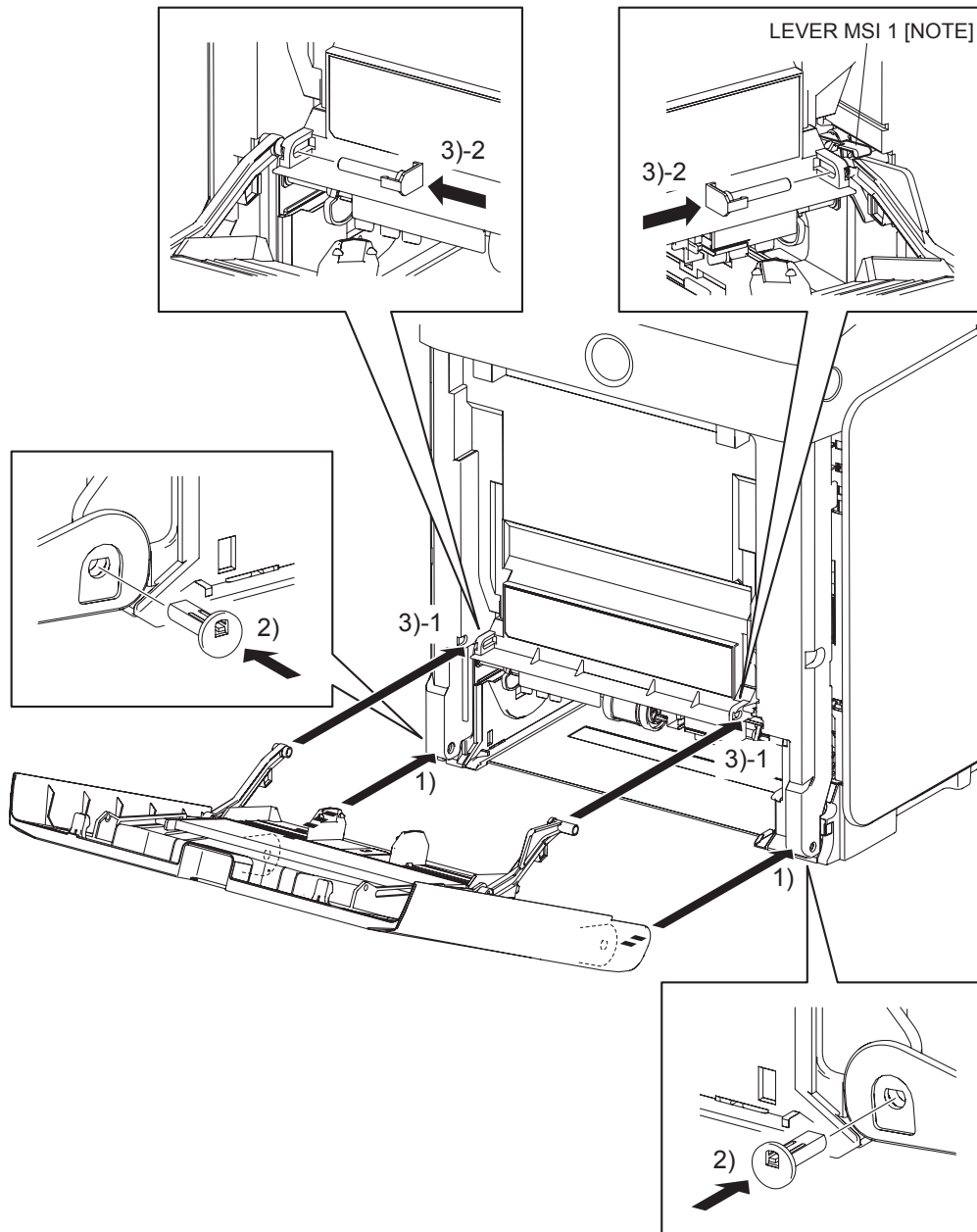

Zna03063KA

- 1) Replace the MPF COVER to the FRONT COVER by mating the left and right side fitting holes on the MPF COVER with the holes on the FRONT COVER.
- 2) Insert the SHAFT PIVOT MSI into the left and right side fitting holes on the MPF COVER, and then secure the SHAFT PIVOT MSI with the hook.

NOTE

When performing the step described below, make sure that the LEVER MSI 1 is on the LINK ASSY MSI R.

- 3) Mate the LINK ASSY MSIs on the left and right sides of the MPF COVER with the fitting holes on the FRONT COVER. Insert the PIN PIVOT MSI and secure with the hook.
- 4) Close the MPF COVER.

Replacement 43 COVER EXTENDER (PL1.1.9)

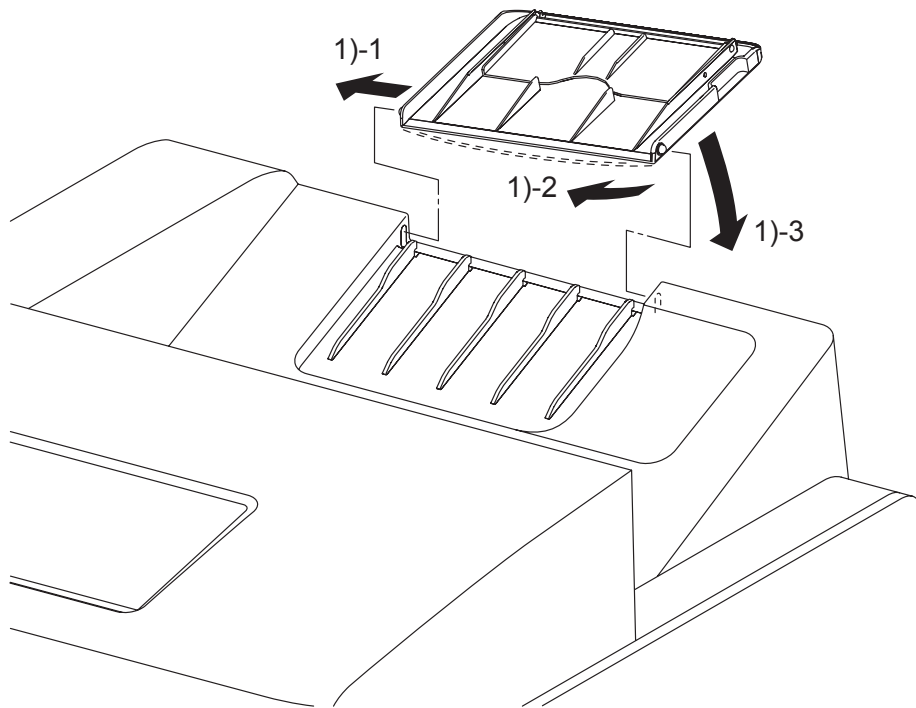

Zna03062KA

NOTE

When performing the step described below, take care not to damage the boss of the COVER EXTENDER.

- 1) Insert one of the bosses of the COVER EXTENDER, at its open position, into the hole on the TOP COVER, and then bend the COVER EXTENDER to slip the other boss into place.
- 2) Close the COVER EXTENDER.

Blank Page

Replacement 44 550 TRAY FEED ROLLER (PL12.3.29) & 550 TRAY SEPARATOR ROLLER (PL12.5.17)

NOTE

When replacing the 550 TRAY SEPARATOR ROLLER or the 550 TRAY FEED ROLLER replace the 550 TRAY SEPARATOR ROLLER and the two 550 TRAY FEED ROLLERS at the same time.

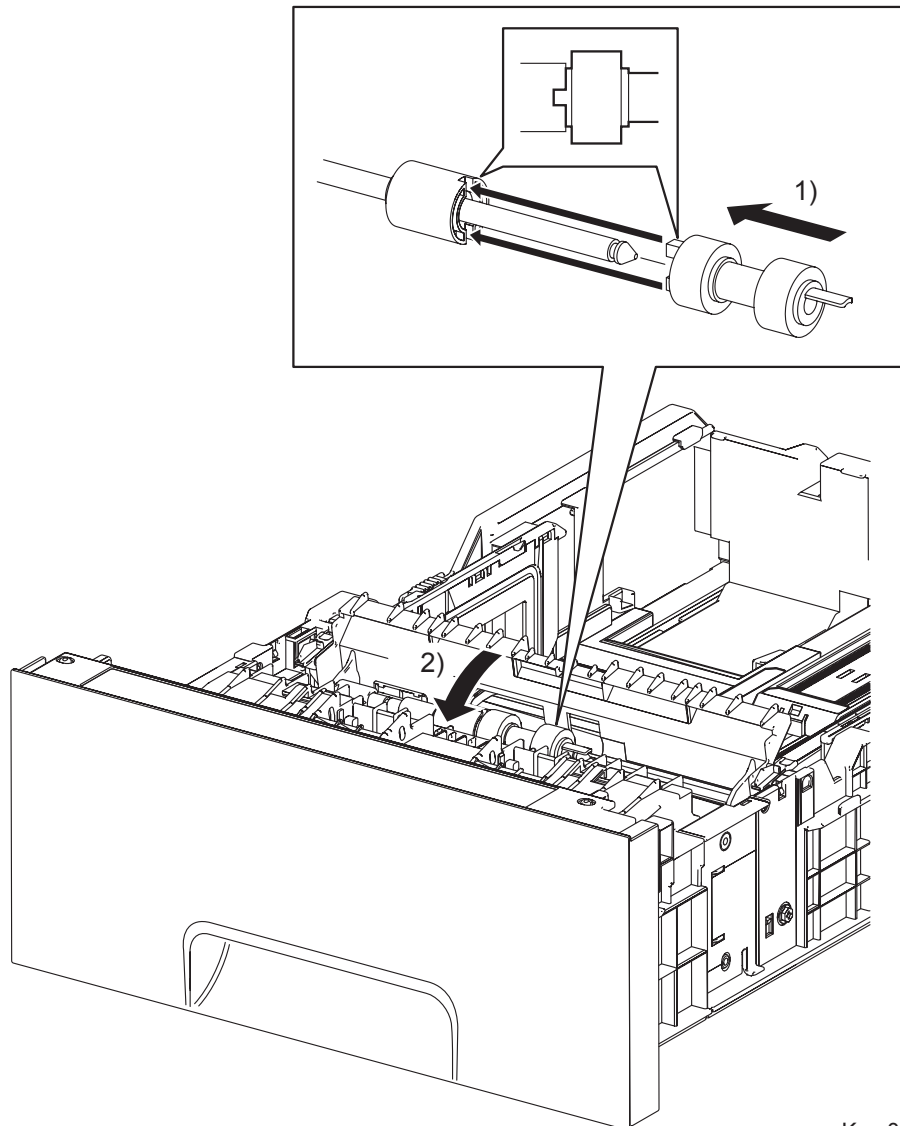

Kmy03121KA

- 1) Slide the 550 TRAY SEPARATOR ROLLER onto the SHAFT SEPARATOR so that the lug on the 550 TRAY SEPARATOR ROLLER is mated with the notch on the CLUTCH FRICTION SPRTR (PL12.5.16). Lock the hook on the other end of the 550 TRAY SEPARATOR ROLLER into the groove on the SHAFT SEPARATOR.
- 2) Close the CVR SPRTR CST.

Continues to the next page.

Replacement 44 550 TRAY FEED ROLLER (PL12.3.29) & 550 TRAY SEPARATOR ROLLER (PL12.5.17)

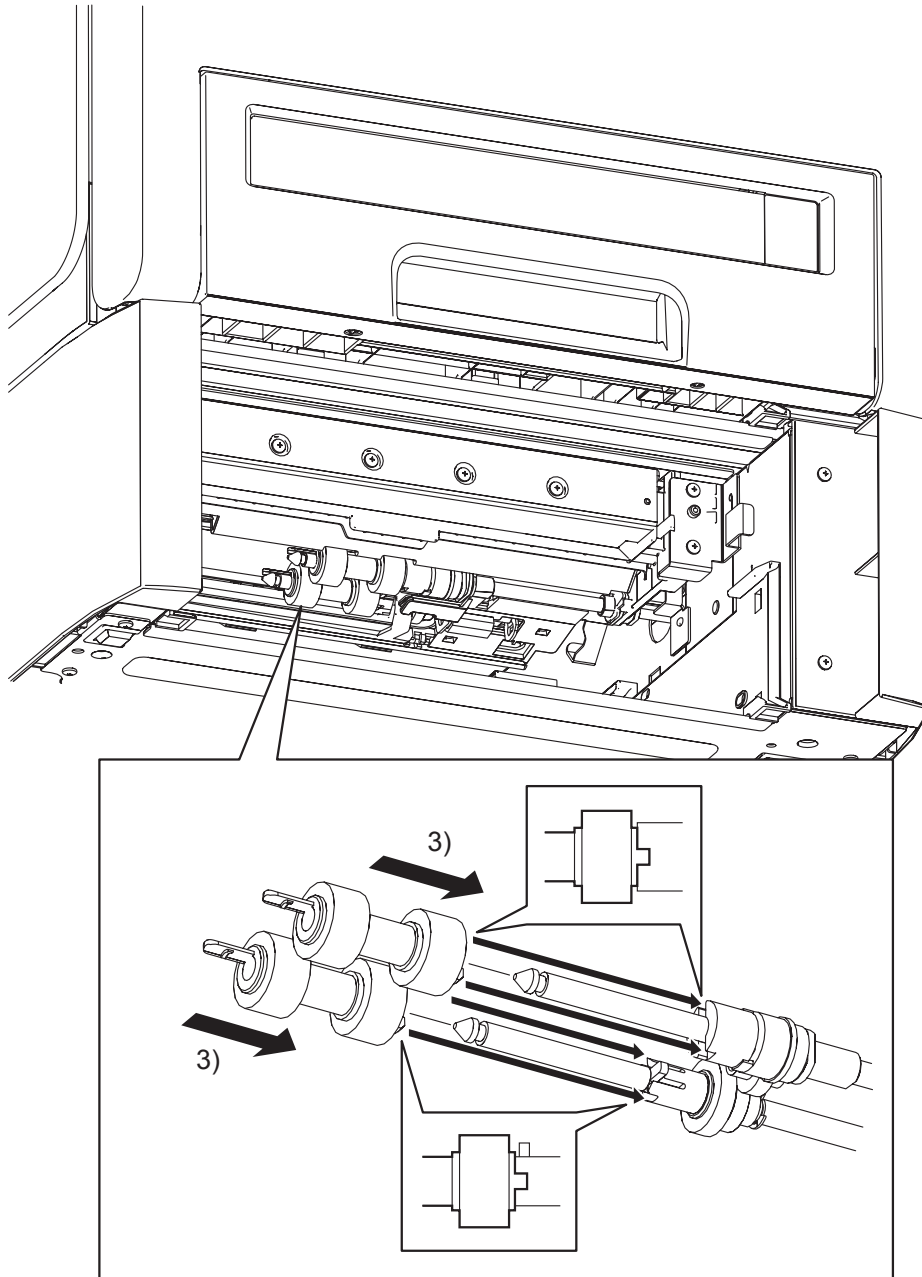

Zna03331KA

- 3) Slide the 550 TRAY FEED ROLLERS onto the shafts so that the lugs on the 550 TRAY FEED ROLLERS are mated with the notches on the ROLL ASSY GEAR NUDGERS (PL12.3.22) and CLUTCH ONE WAY FEED (PL12.3.28). Lock the hooks on the other end of the 550 TRAY FEED ROLLERS into the grooves on the shafts.
- 4) Replace the 550 SHEET PAPER TRAY to the 550 SHEET FEEDER ASSEMBLY.

Replacement 45 550 TRAY REAR COVER (PL12.1.4)

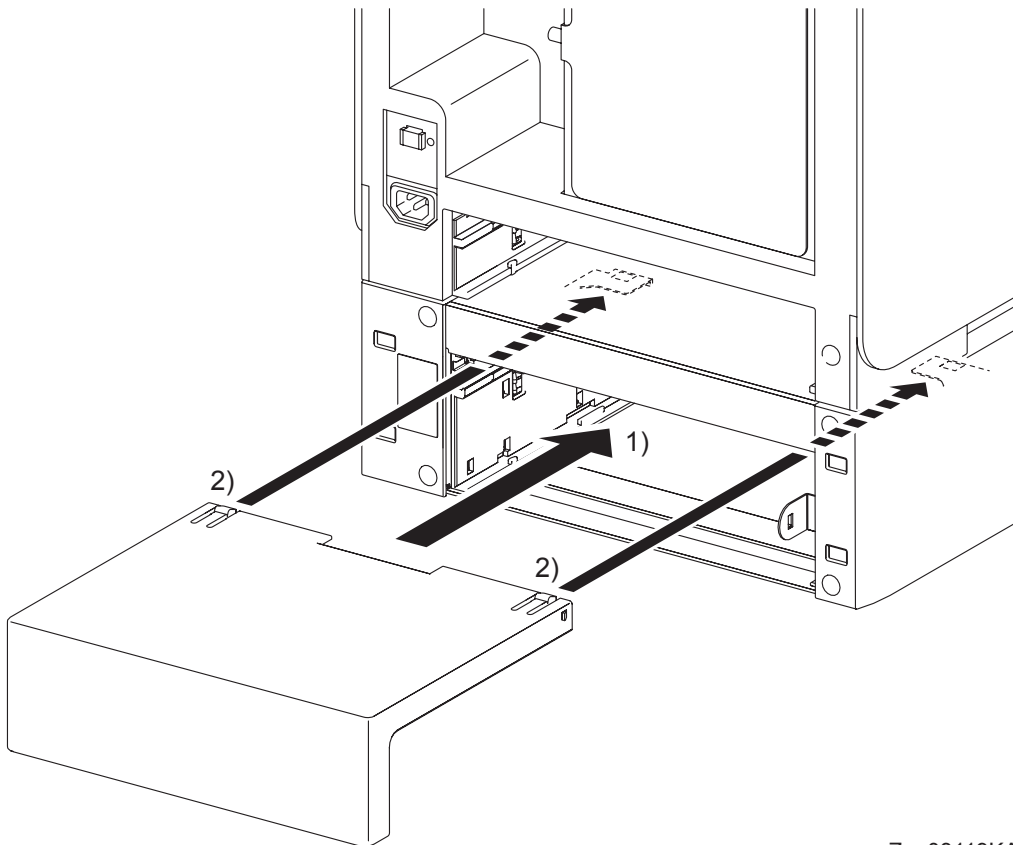

Zna03119KA

- 1) Insert the 550 TRAY REAR COVER into the 550 SHEET FEEDER ASSEMBLY.
- 2) Push the 550 TRAY REAR COVER frontward until it is locked to the 550 SHEET FEEDER ASSEMBLY at the two hooks on its front edge.

Replacement 46 550 SHEET FEEDER ASSEMBLY (PL12.1.1)

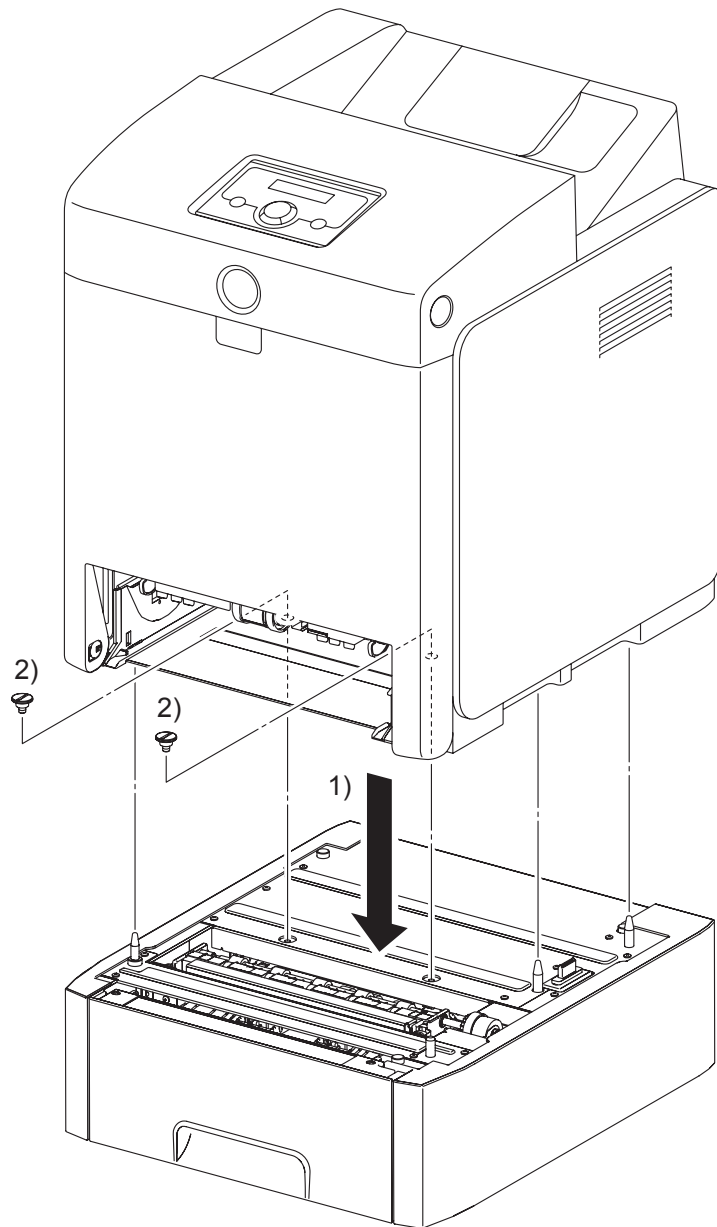

Zna03118KA

NOTE

The printer must be lifted by two people.

- 1) Place the printer on the 550 SHEET FEEDER ASSEMBLY with the four holes on the bottom of the printer aligned with the studs on the 550 SHEET FEEDER ASSEMBLY.
- 2) Secure the printer to the 550 SHEET FEEDER ASSEMBLY using the two FEEDER SCREWS.
- 3) Replace the 250 SHEET PAPER TRAY to the printer.

Replacement 47 WIRELESS PRINTER ADAPTER (PL9.1.32)

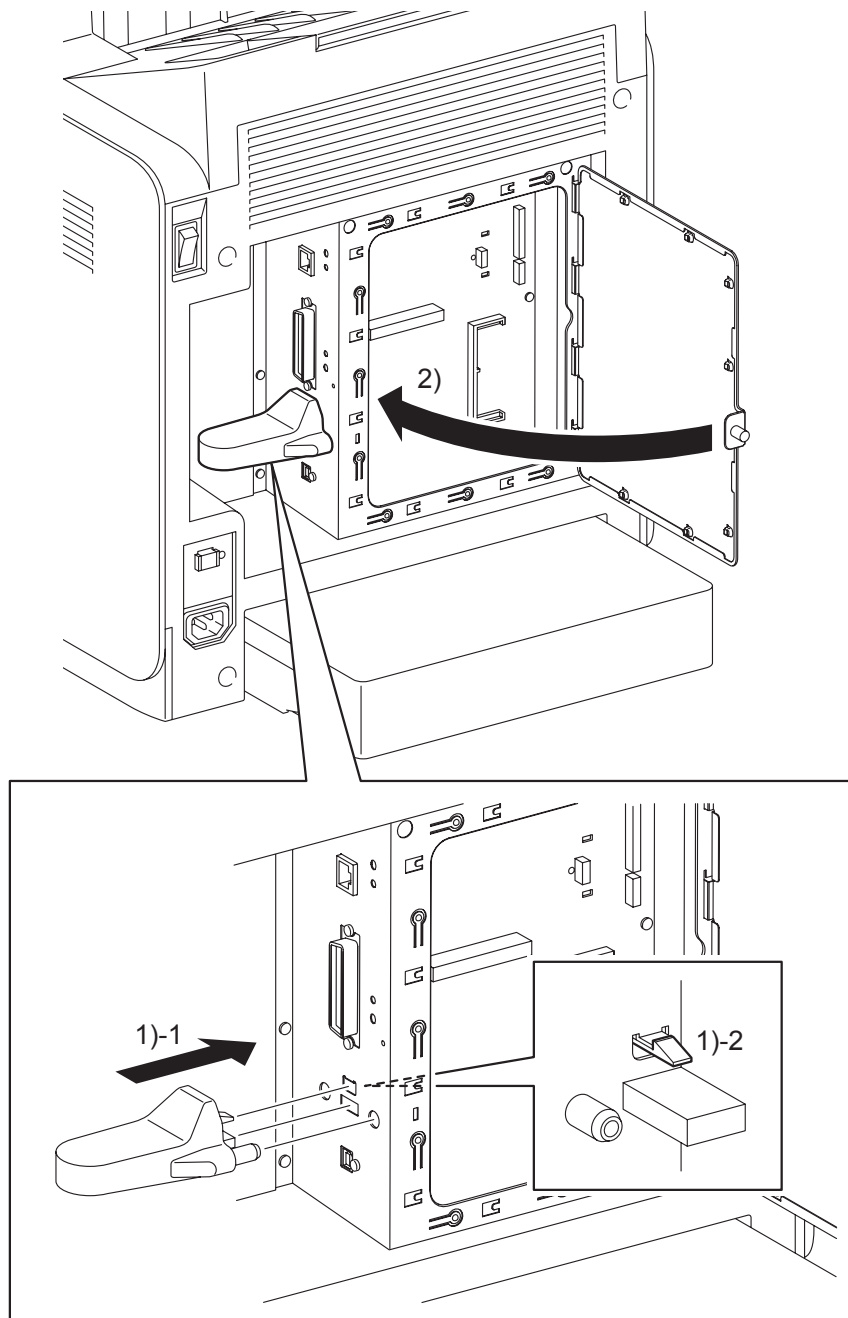

Zna03332KB

- 1) Attach the WIRELESS PRINTER ADAPTER to the ELECTRONIC SUB-SYSTEM CONTROL BOARD and fix it.
- 2) Close the SHIELD WINDOW and secure the SCREW KNURLING.

Replacement 48 HARD DISK (PL9.1.47)

NOTE

Use a wristband to protect the HDD from electrostatic damage.

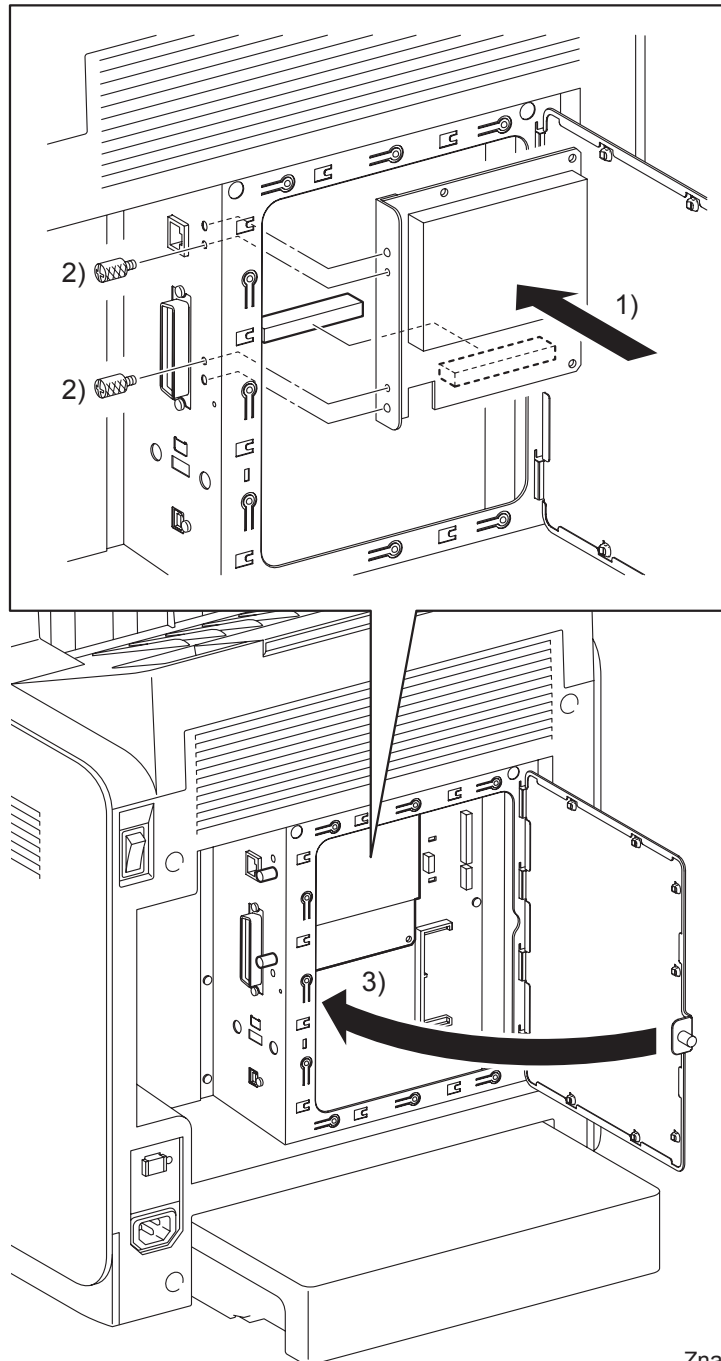

Zna03333KB

- 1) Mate the two bosses on the HARD DISK with the holes on the printer, and then replace the HARD DISK to the ELECTRONIC SUB-SYSTEM CONTROL BOARD.
- 2) Secure the HARD DISK to the printer using the two SCREW KNURLINGS (PL9.1.22).
- 3) Close the SHIELD WINDOW and secure the SCREW KNURLING.

Replacement 49 NETWORK PROTOCOL ADAPTER (PL9.1.46)

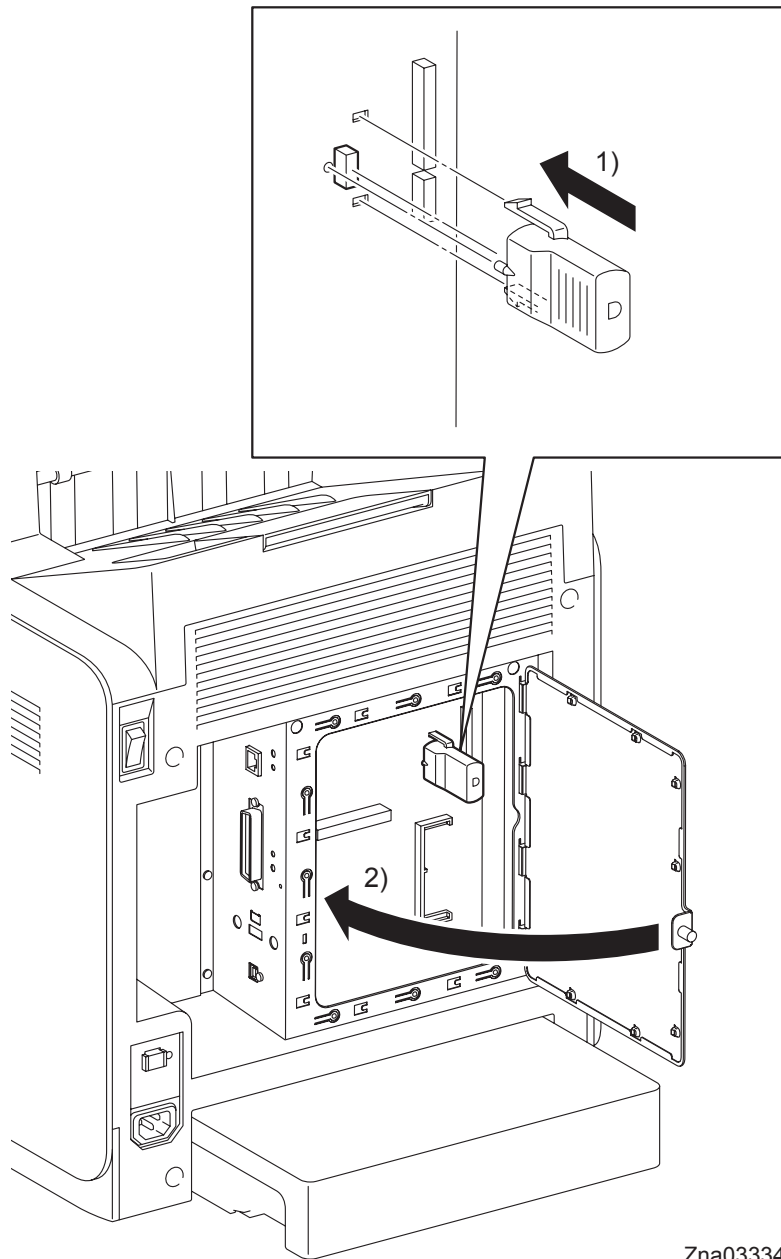

Zna03334KB

- 1) Engage the NETWORK PROTOCOL ADAPTER to the connector (J16) on the ELECTRONIC SUB-SYSTEM CONTROL BOARD and fix it.
- 2) Close the SHIELD WINDOW and secure the SCREW KNURLING.

Replacement 50 MEMORY CARD (PL9.1.30)

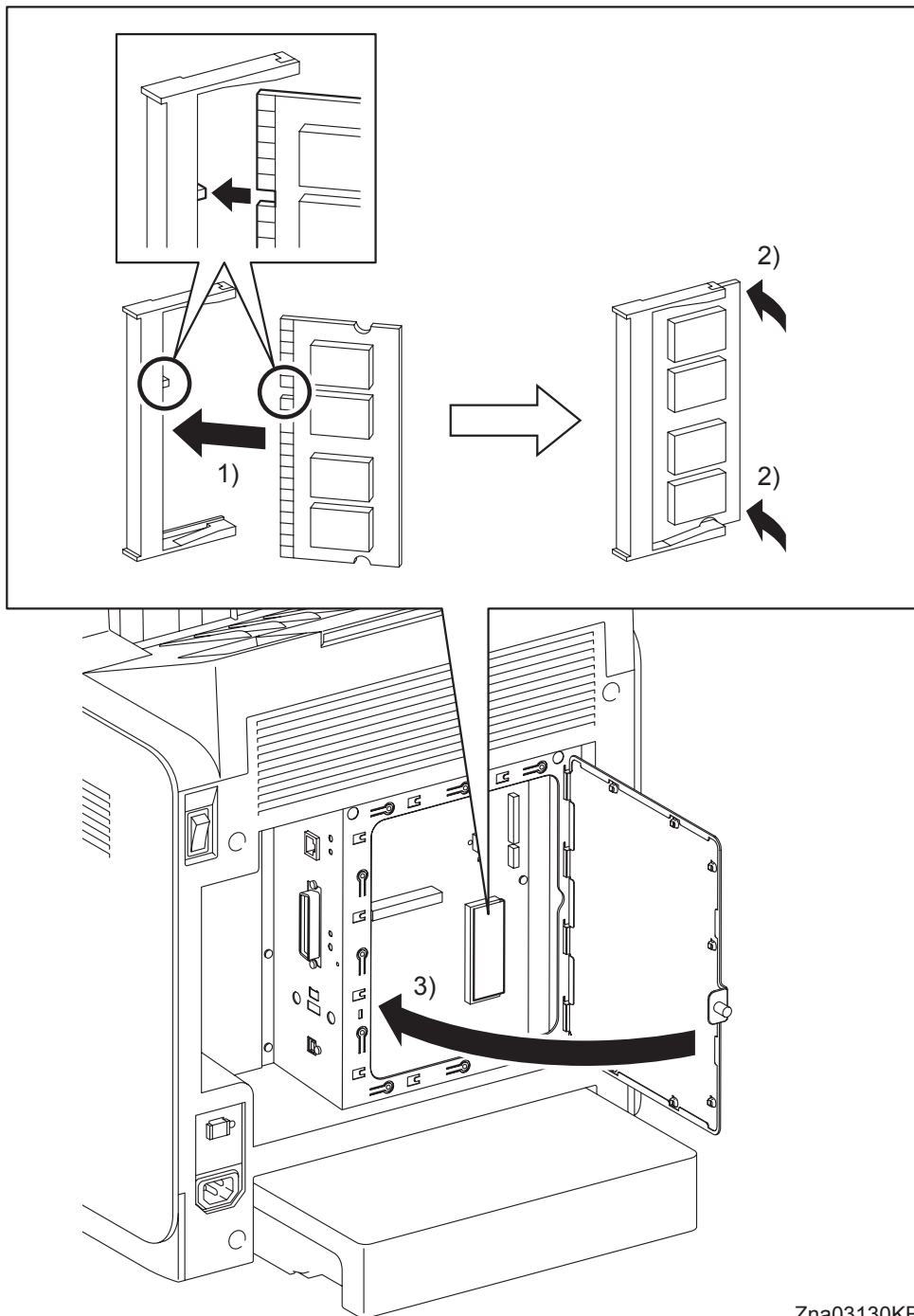

Zna03130KB

- 1) Fit the MEMORY CARD into the socket by mating the notch of the MEMORY CARD with the lug on the socket.
- 2) Push the MEMORY CARD toward the ELECTRONIC SUB-SYSTEM CONTROL BOARD until it snaps into place.
- 3) Close the SHIELD WINDOW and secure the SCREW KNURLING.

Chapter 4 Plug/Jack(P/J) Connector Locations CONTENTS

1. Connector [P (plug) / J (jack)].....	4 - 1
1.1 List of P/J	4 - 1
1.2 IOT P/J layout diagram	4 - 5
1.3 DUPLEX P/J layout diagram.....	4 - 9
1.4 OPTION FEEDER P/J layout diagram.....	4 - 10

1. Connector [P (plug) / J (jack)]

1.1 List of P/J

IOT

P/J	Coordinates	Remarks
3	E-138	Connects ELECTRONIC SUB-SYSTEM CONTROL BOARD and HARD DISK
10	J-157	Connects MACHINE CONTROL UNIT and IF Harness Assembly
12	J-157	Connects MACHINE CONTROL UNIT and ROS Harness Assembly
13	I-157	Connects MACHINE CONTROL UNIT and LV TOP Harness Assembly
14	J-157	Connects MACHINE CONTROL UNIT and LV TOP Harness Assembly
15	I-157	Connects MACHINE CONTROL UNIT and LV TOP Harness Assembly
16	I-157	Connects MACHINE CONTROL UNIT and HIGH VOLTAGE POWER SUPPLY
16	F-138	Connects ELECTRONIC SUB-SYSTEM CONTROL BOARD and NETWORK PROTOCOL ADAPTER
17	I-157	Connects MACHINE CONTROL UNIT and FUSER Harness Assembly
18	I-157	Connects MACHINE CONTROL UNIT and LV TOP Harness Assembly
19	I-157	Connects MACHINE CONTROL UNIT and CRU SNR Harness Assembly
20	J-158	Connects MACHINE CONTROL UNIT and DRIVE ASSY K (K SNR Harness Assembly)
22	I-158	Connects MACHINE CONTROL UNIT and R SIDE Harness Assembly
23	I-159	Connects MACHINE CONTROL UNIT and R SIDE Harness Assembly
24	I-159	Connects MACHINE CONTROL UNIT and R SIDE Harness Assembly
25	I-158	Connects MACHINE CONTROL UNIT and R SIDE Harness Assembly
26	J-159	Connects MACHINE CONTROL UNIT and HUM Harness Assembly
27	I-159	Connects MACHINE CONTROL UNIT and R SIDE Harness Assembly
28	I-159	Connects MACHINE CONTROL UNIT and R SIDE Harness Assembly
29	J-159	Connects MACHINE CONTROL UNIT and R SIDE Harness Assembly
29	F-138	Connects ELECTRONIC SUB-SYSTEM CONTROL BOARD and ESS Harness Assembly
30	I-159	Connects MACHINE CONTROL UNIT and R SIDE Harness Assembly
31	J-159	Connects MACHINE CONTROL UNIT and CRUM Harness Assembly
40	F-149	Connects LOW VOLTAGE POWER SUPPLY and LV TOP Harness Assembly
44	E-149	Connects LOW VOLTAGE POWER SUPPLY and INTERLOCK SWITCH
47	E-150	Connects LOW VOLTAGE POWER SUPPLY and FUSER Harness Assembly
48	E-150	Connects LOW VOLTAGE POWER SUPPLY and AC IN Harness Assembly
101	F-138	Connects ELECTRONIC SUB-SYSTEM CONTROL BOARD and IF Harness Assembly
101	I-158	Not Connects (Debug only)
111	F-139	Connects ELECTRONIC SUB-SYSTEM CONTROL BOARD and IF Harness Assembly
141	I-136	Connects LED ASSEMBLY and LV TOP Harness Assembly
144	C-108	Connects PWBA EEPROM (BELT) and BELT Harness Assembly (TRANSFER BELT)
144	D-153	Connects PWBA EEPROM (XPRO) and R SIDE Harness Assembly
151	H-122	Connects ROS and ROS Harness Assembly
161	G-136	Connects HIGH VOLTAGE POWER SUPPLY and MACHINE CONTROL UNIT

P/J	Coordinates	Remarks
171	H-106	Connects FUSER and FUSER Harness Assembly
181	I-139	Connects TONER DISPENSER (Y) and LV TOP Harness Assembly
182	H-138	Connects TONER DISPENSER (M) and LV TOP Harness Assembly
183	H-136	Connects TONER DISPENSER (K) and LV TOP Harness Assembly
184	H-137	Connects TONER DISPENSER (C) and LV TOP Harness Assembly
191	H-124	Connects TONER CARTRIDGE SENSOR ASSEMBLY (Y) and CRU SNR Harness Assembly
192	H-124	Connects TONER CARTRIDGE SENSOR ASSEMBLY (M) and CRU SNR Harness Assembly
193	H-122	Connects TONER CARTRIDGE SENSOR ASSEMBLY (K) and CRU SNR Harness Assembly
194	H-123	Connects TONER CARTRIDGE SENSOR ASSEMBLY (C) and CRU SNR Harness Assembly
201	H-108	Connects DRIVE ASSY K (K Mode Sensor) and K SNR Harness Assembly
220	D-105	Connects OPERATOR PANEL and OPEPANE Harness Assembly
221	H-108	Connects PHOTOCONDUCTOR (PC) / DEVELOPER (DEV) DRIVE (Sub Motor) and R SIDE Harness Assembly
222	G-109	Connects PHOTOCONDUCTOR (PC) / DEVELOPER (DEV) DRIVE (Main Motor) and R SIDE Harness Assembly
231	I-124	Connects INTEGRATED FEEDER ASSEMBLY (REGI Clutch) and R SIDE Harness Assembly
232	H-124	Connects INTEGRATED FEEDER ASSEMBLY (Turn Clutch) and R SIDE Harness Assembly
233	H-123	Connects INTEGRATED FEEDER ASSEMBLY (CST Feed Clutch) and R SIDE Harness Assembly
234	H-111	Connects MPF FEED SOLENOID and R SIDE Harness Assembly
235	I-107	Connects PHOTOCONDUCTOR (PC) / DEVELOPER (DEV) DRIVE (Exit Clutch) and R SIDE Harness Assembly
241	I-109	Connects DRIVE ASSY K (K Mode Solenoid) and R SIDE Harness Assembly
251	H-110	Connects FEED DRIVE ASSEMBLY (PH Motor) and R SIDE Harness Assembly
261	H-152	Connects HUMIDITY SENSOR and HUM Harness Assembly
272	I-110	Connects FRONT COVER Harness Assembly and R SIDE Harness Assembly
281	H-126	Connects R SIDE Harness Assembly and 550 SHEET FEEDER ASSEMBLY (FDR UNIT Harness Assembly)
282	I-109	Connects MSI NPP Harness Assembly and R SIDE Harness Assembly
291	I-125	Connects SIZE SWITCH ASSEMBLY and R SIDE Harness Assembly
292	H-125	Connects INTEGRATED FEEDER ASSEMBLY (REGI SNR Harness Assembly) and R SIDE Harness Assembly
301	H-124	Connects INTEGRATED FEEDER ASSEMBLY (TEN SNR Harness Assembly) and R SIDE Harness Assembly
311	G-124	Connects CRUM Sensor (Y) and CRUM Harness Assembly
312	G-123	Connects CRUM Sensor (M) and CRUM Harness Assembly
313	G-122	Connects CRUM Sensor (C) and CRUM Harness Assembly
314	G-122	Connects CRUM Sensor (K) and CRUM Harness Assembly
401	F-138	Connects ELECTRONIC SUB-SYSTEM CONTROL BOARD and LV TOP Harness Assembly
482	E-153	Connects BREAKER GFI INLET and AC IN Harness Assembly
483	E-154	Connects BREAKER GFI INLET and AC IN Harness Assembly

P/J	Coordinates	Remarks
501	F-149	Connects LOW VOLTAGE POWER SUPPLY and LV TOP Harness Assembly
502	F-149	Connects LOW VOLTAGE POWER SUPPLY and LV TOP Harness Assembly
503	F-149	Connects LOW VOLTAGE POWER SUPPLY and FAN
504	F-149	Connects LOW VOLTAGE POWER SUPPLY and LV TOP Harness Assembly
2411	F-125	Connects INTEGRATED FEEDER ASSEMBLY (PWBA TEN SNR) and TEN SNR Harness Assembly
2721	B-107	Connects TRANSFER BELT and FRONT COVER Harness Assembly
2821	E-110	Connects MSI No Paper Sensor and MSI NPP Harness Assembly
2900	I-110	Connects OPEPANE Harness Assembly and ESS Harness Assembly
2921	D-125	Connects INTEGRATED FEEDER ASSEMBLY (CST No Paper Sensor) and REGI SNR Harness Assembly
2922	E-125	Connects INTEGRATED FEEDER ASSEMBLY (REGI Sensor) and REGI SNR Harness Assembly
5041	F-138	Not Connects (Used in production process only)
27212	D-106	Connects ADC Sensor and BELT Harness Assembly (TRANSFER BELT)
27213	D-107	Connects ADC Solenoid and BELT Harness Assembly (TRANSFER BELT)

DUP

P/J	Coordinates	Remarks
1	E-168	Not Connects (Debug only)
427	F-168	Connects PWBA DUP and FAN DUP
428	F-168	Connects PWBA DUP and DUP UNIT Harness Assembly
429	F-169	Connects PWBA DUP and MOTOR ASSY DUP
430	F-168	Connects PWBA DUP and DUP SNR Harness Assembly
431	F-168	Connects PWBA DUP and DUP Clutch
2720	I-169	Connects DUPLEX MODULE (DUP UNIT Harness Assembly) and PRINTER
4301	E-167	Connects DUP Jam Sensor and DUP SNR Harness Assembly

OPT FEEDER

P/J	Coordinates	Remarks
1	G-180	Not Connects (Debug only)
281	H-183	Connects 550 SHEET FEEDER ASSEMBLY (FDR UNIT Harness Assembly) and PRINTER
419	G-180	Connects PWBA OPT FDR and FDR UNIT Harness Assembly
420	G-180	Connects PWBA OPT FDR and C2 TURN Harness Assembly
421	G-179	Connects PWBA OPT FDR and C2 CHUTE Harness Assembly
422	G-179	Connects PWBA OPT FDR and C2 MOT Harness Assembly
423	G-180	Not Connects
4201	H-185	Connects C2 TURN CLUTCH and C2 TURN Harness Assembly
4202	H-185	Not Connects
4211	I-184	Connects SWITCH ASSY SIZE OPT and C2 CHUTE Harness Assembly
4212	H-184	Connects C2 CHUTE Harness Assembly and C2 NO PAPER Harness Assembly
4213	H-185	Connects C2 FEED CLUTCH and C2 CHUTE Harness Assembly
4221	G-185	Connects DRIVE ASSY OPT FDR (OPT FDR Motor) and C2 MOT Harness Assembly

P/J	Coordinates	Remarks
4222	G-185	Connects DRIVE ASSY OPT FDR (OPT FDR Motor) and C2 MOT Harness Assembly
42121	D-183	Connects C2 CST No Paper Sensor and C2 NO PAPER Harness Assembly

1.2 IOT P/J layout diagram

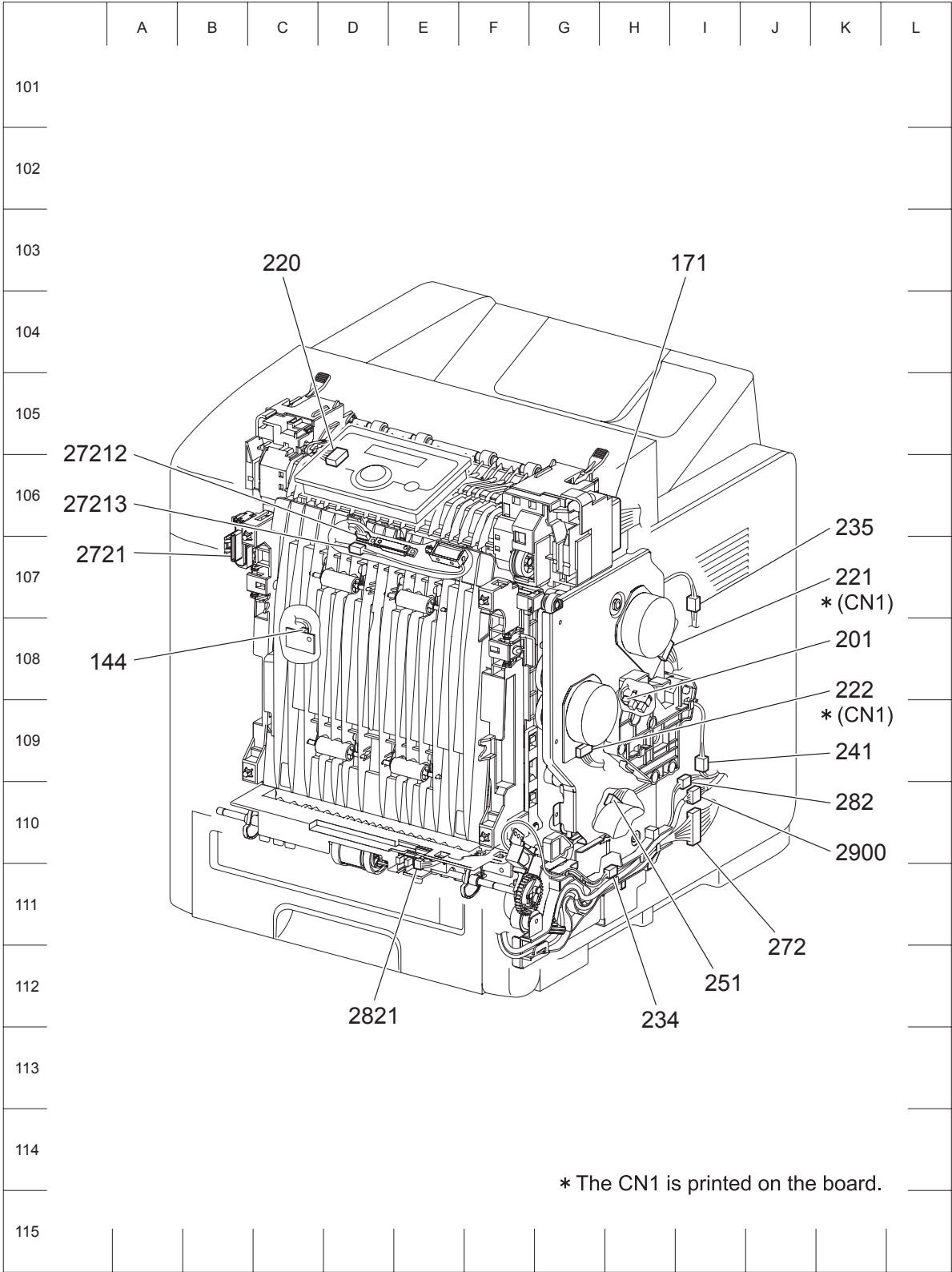

Zna04001KB

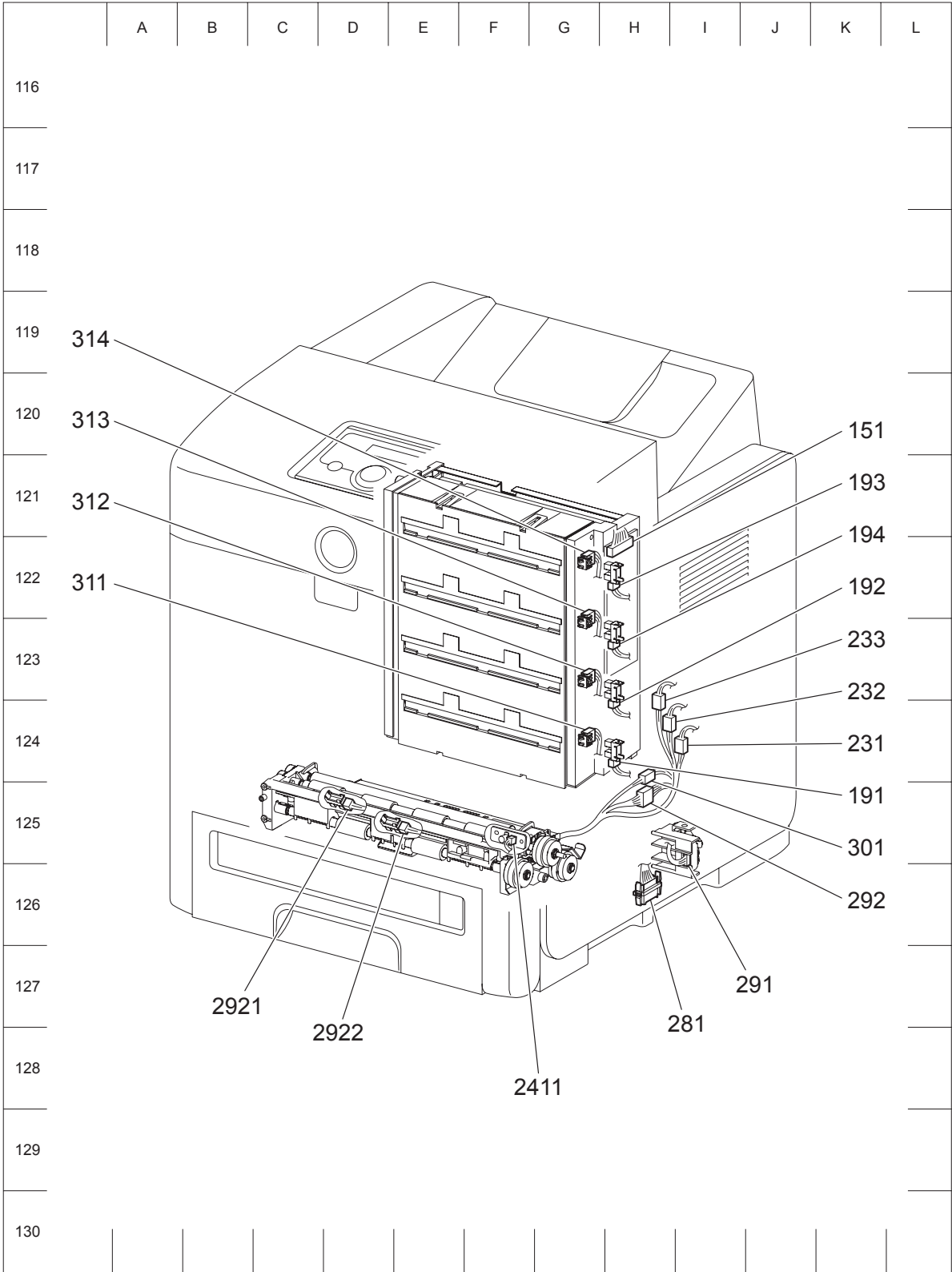

Zna04002KB

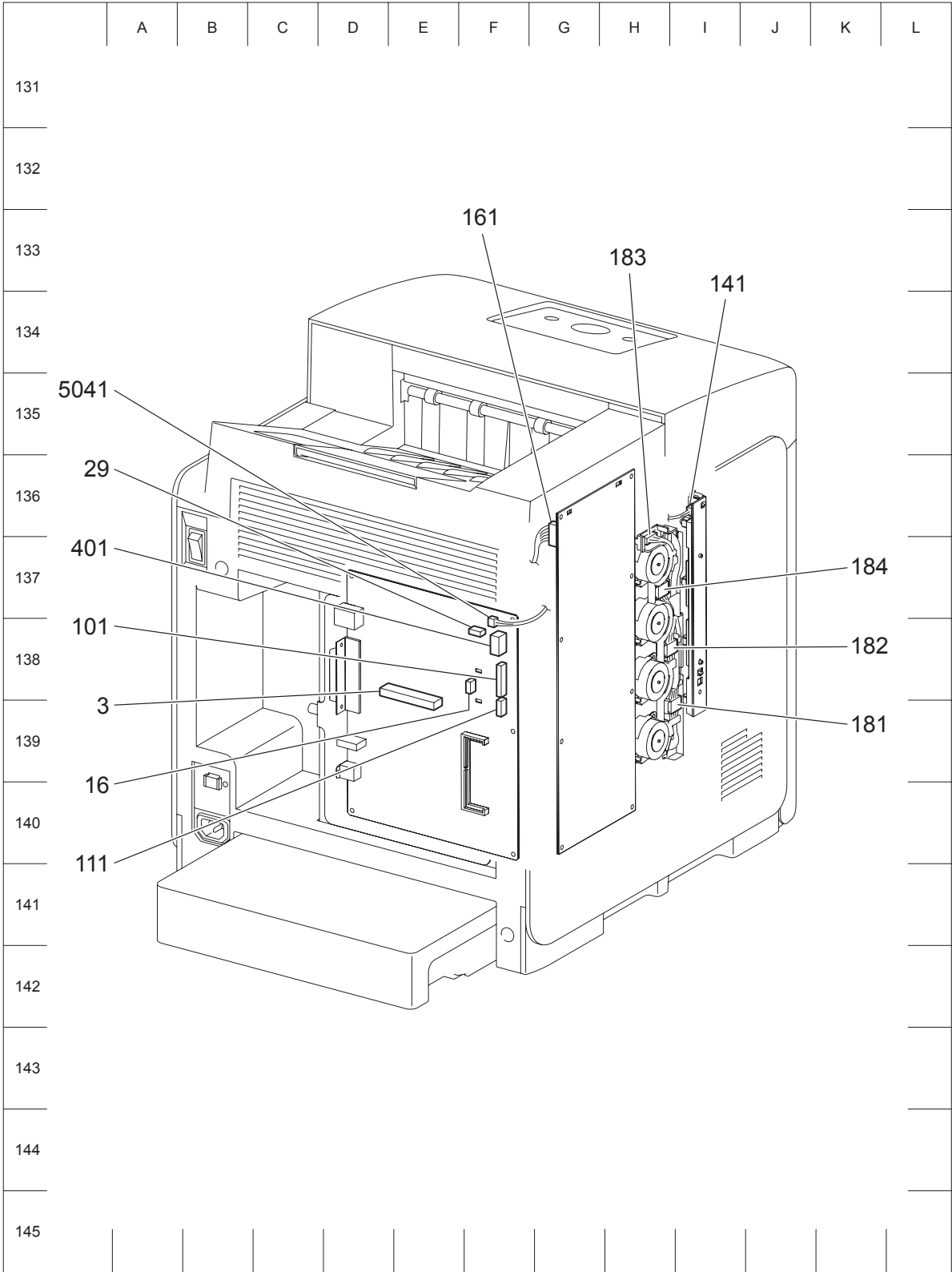

Zna04003KB

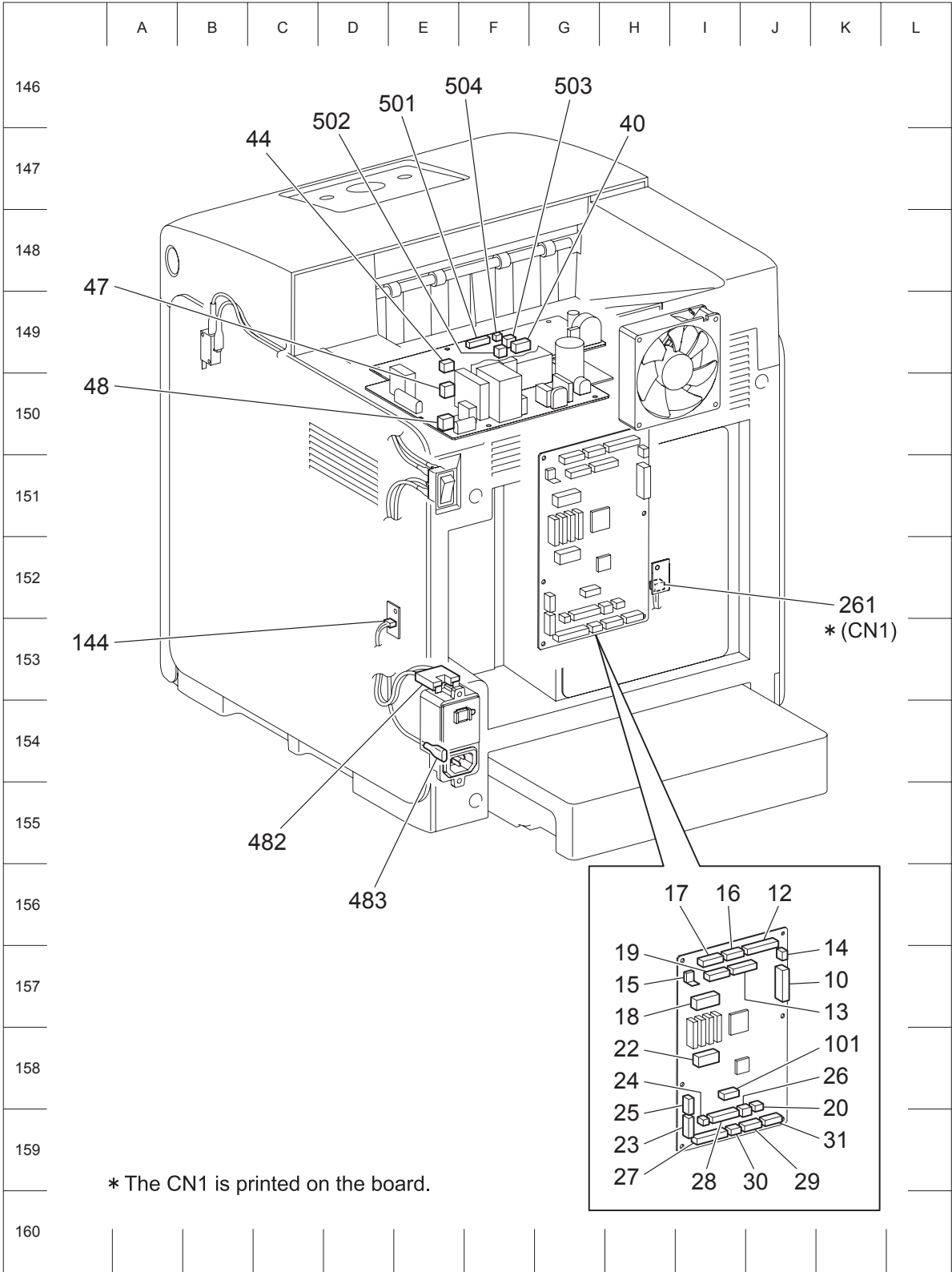

Zna04004KB

1.3 DUPLEX P/J layout diagram

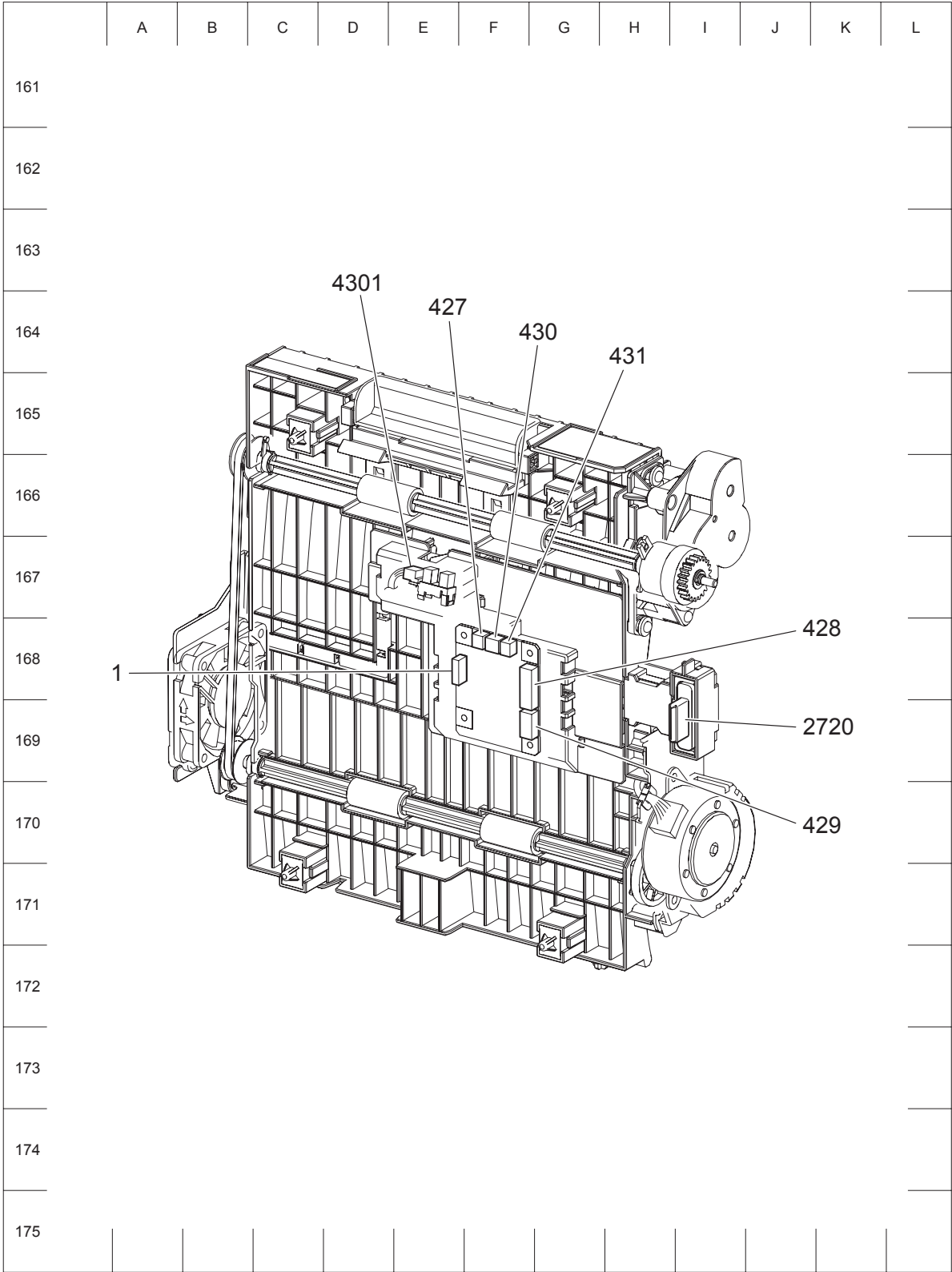

Kmy04005KA

1.4 OPTION FEEDER P/J layout diagram

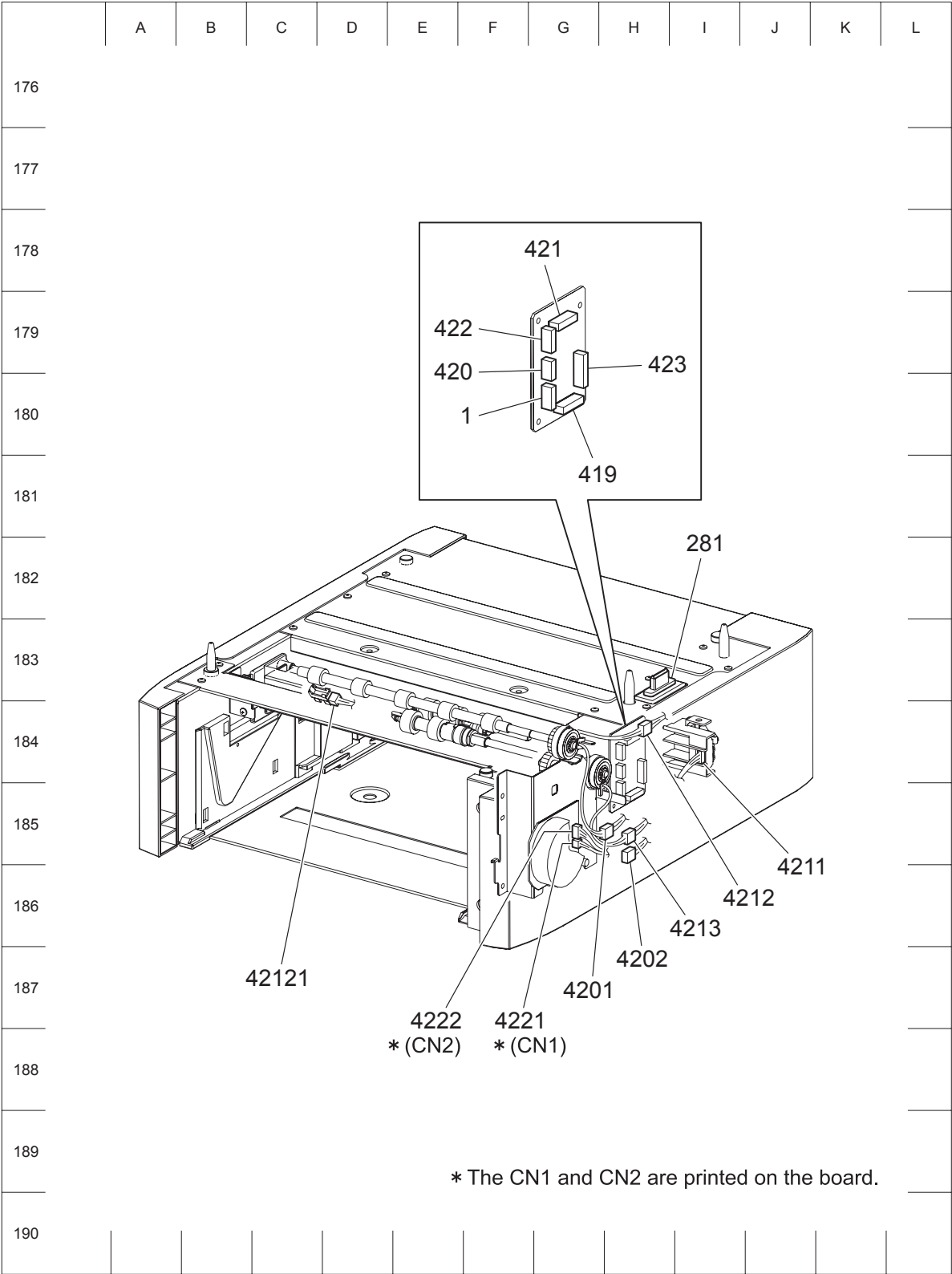

Zna04006KA

Blank page

Chapter 5 Parts List CONTENTS

1. Parts List.....	5 - 1
1.1 Caution for use of spare parts illustration	5 - 1
1.2 Caution for use of engineering parts list	5 - 1
Customer Replaceable Parts Illustration.....	5 - 2
Engineering parts list	5 - 8
PL1.1 Cover (1/2) [Illustration]	5 - 8
PL1.1 Cover (1/2) [List]	5 - 9
PL1.2 Cover (2/2) [Illustration]	5 - 10
PL1.2 Cover (2/2) [List]	5 - 11
PL2.1 Paper Cassette (1/2) [Illustration]	5 - 12
PL2.1 Paper Cassette (1/2) [List]	5 - 13
PL2.2 Paper Cassette (2/2) [Illustration]	5 - 14
PL2.2 Paper Cassette (2/2) [List]	5 - 15
PL3.1 Paper Feeder (1/2) [Illustration]	5 - 16
PL3.1 Paper Feeder (1/2) [List]	5 - 17
PL3.2 Paper Feeder (2/2) [Illustration]	5 - 18
PL3.2 Paper Feeder (2/2) [List]	5 - 19
PL4.1 Transfer [Illustration]	5 - 20
PL4.1 Transfer [List]	5 - 21
PL5.1 Xerographics [Illustration]	5 - 22
PL5.1 Xerographics [List]	5 - 23
PL6.1 Fuser & Exit [Illustration]	5 - 24
PL6.1 Fuser & Exit [List]	5 - 25
PL7.1 Frame [Illustration]	5 - 26
PL7.1 Frame [List]	5 - 27
PL8.1 Drive [Illustration]	5 - 28
PL8.1 Drive [List]	5 - 29
PL9.1 Electrical [Illustration]	5 - 30
PL9.1 Electrical [List]	5 - 31
PL10.1 Harness [Illustration]	5 - 32
PL10.1 Harness [List]	5 - 33
PL11.1 Duplex (Option) (1/2) [Illustration]	5 - 34
PL11.1 Duplex (Option) (1/2) [List]	5 - 35
PL11.2 Duplex (Option) (2/2) [Illustration]	5 - 36
PL11.2 Duplex (Option) (2/2) [List]	5 - 37
PL12.1 550 Feeder (Option) (1/5) [Illustration]	5 - 38
PL12.1 550 Feeder (Option) (1/5) [List]	5 - 39
PL12.2 550 Feeder (Option) (2/5) [Illustration]	5 - 40
PL12.2 550 Feeder (Option) (2/5) [List]	5 - 41
PL12.3 550 Feeder (Option) (3/5) [Illustration]	5 - 42
PL12.3 550 Feeder (Option) (3/5) [List]	5 - 43
PL12.4 550 Feeder (Option) (4/5) [Illustration]	5 - 44
PL12.4 550 Feeder (Option) (4/5) [List]	5 - 45
PL12.5 550 Feeder (Option) (5/5) [Illustration]	5 - 46
PL12.5 550 Feeder (Option) (5/5) [List]	5 - 47

Chapter 5 Parts List CONTENTS

Blank Page

1. Parts List

1.1 Caution for use of spare parts illustration

- Available spare parts are shown in the illustration by name.
- [Ref PL X.Y.Z] shown below the part name denotes the item is "Z" in the plate "PL X.Y" of the engineering part list.
- For the detailed composition of the KIT parts, check with the engineering part list.

1.2 Caution for use of engineering parts list

- The figures indicating the illustrations are the item No. in the list and present correspondence between the illustrations and parts.
- The notation of PL "X.Y.Z" is composed of the plate (PL), item "X.Y", and parts "Z".
- The alphabet characters in the illustrations represent screws and clips as follows:
"S": screw, "E": E-ring, "KL": KL clip, "C": C-ring, and "N": nut
- "▼" mark in the illustrations are attached to items indicating assembly parts in the illustrations.
- Encircled alphabetical figures in the illustrations indicate interrupted leader lines. Same characters in the illustrations represent lines to be connected.
- The mark "(with 2-5)" attached to assembly parts on the illustrations and lists represents that the items "2, 3, 4, and 5" of that plate are contained and the mark "(with 2-5, PL6.1.1)" represent that the item "2, 3, 4, and 5" of that plate and the item "1" of the plate "6.1" are contained.
- The mark "[Ref PLX.Y.Z]" attached to parts in the illustrations and lists represents that the parts is the same as the parts of the item "Z" of the plate "X.Y".
- The mark "*" attached to parts in the list represents "Note" or "Reference" about that parts is contained in the same page.

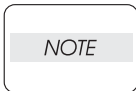

For spare parts, refer to the "Spare parts list" which is issued separately.

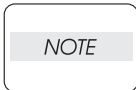

For the connector (P/J), parts such as harness, wire, etc. in the list, refer to "Chapter 7, Electric wiring"

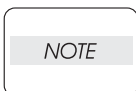

It should be noted that configuration of parts may be different or some parts are not used depending on specifications of OEM.

Customer Replaceable Parts Illustration

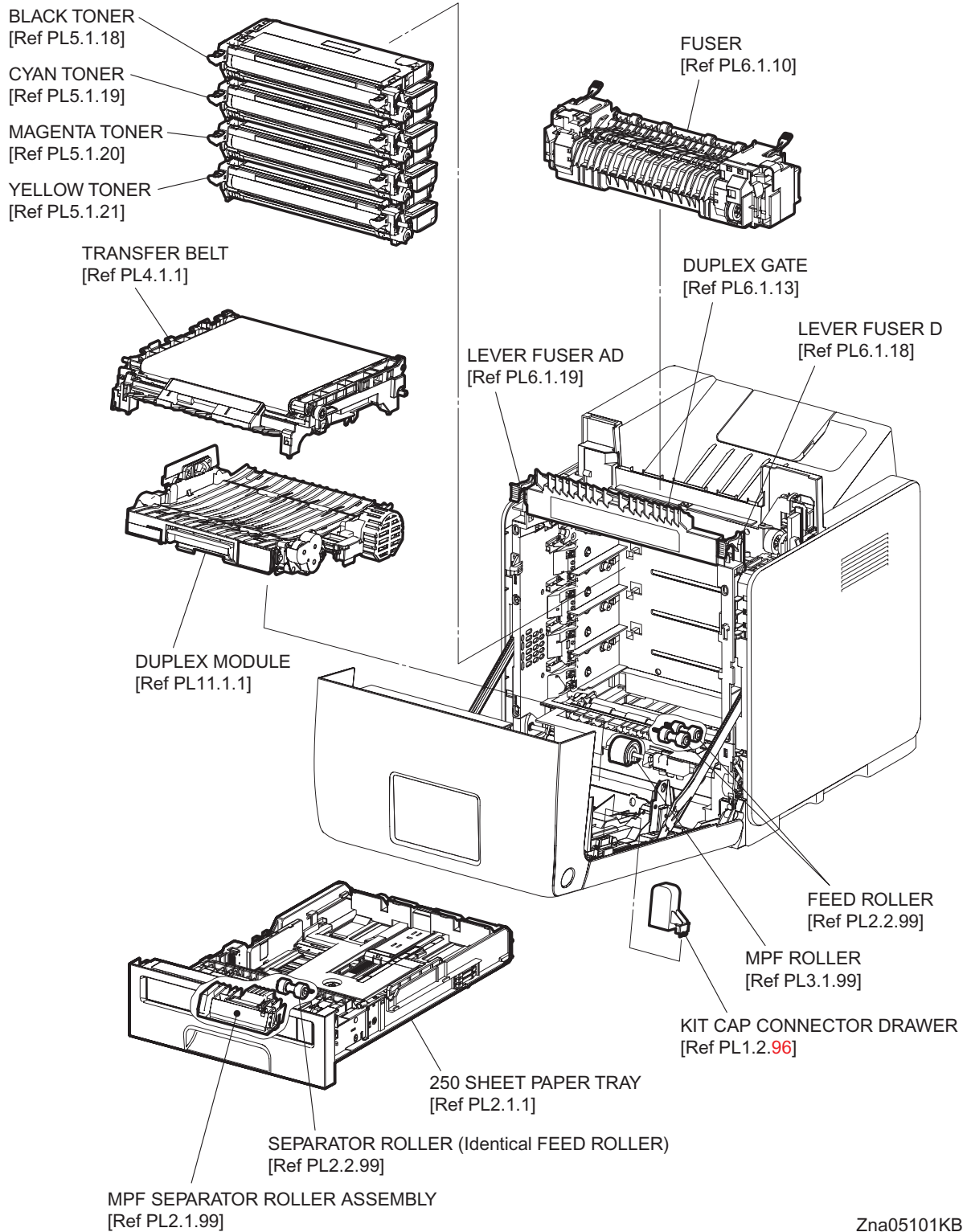

Zna05101KB

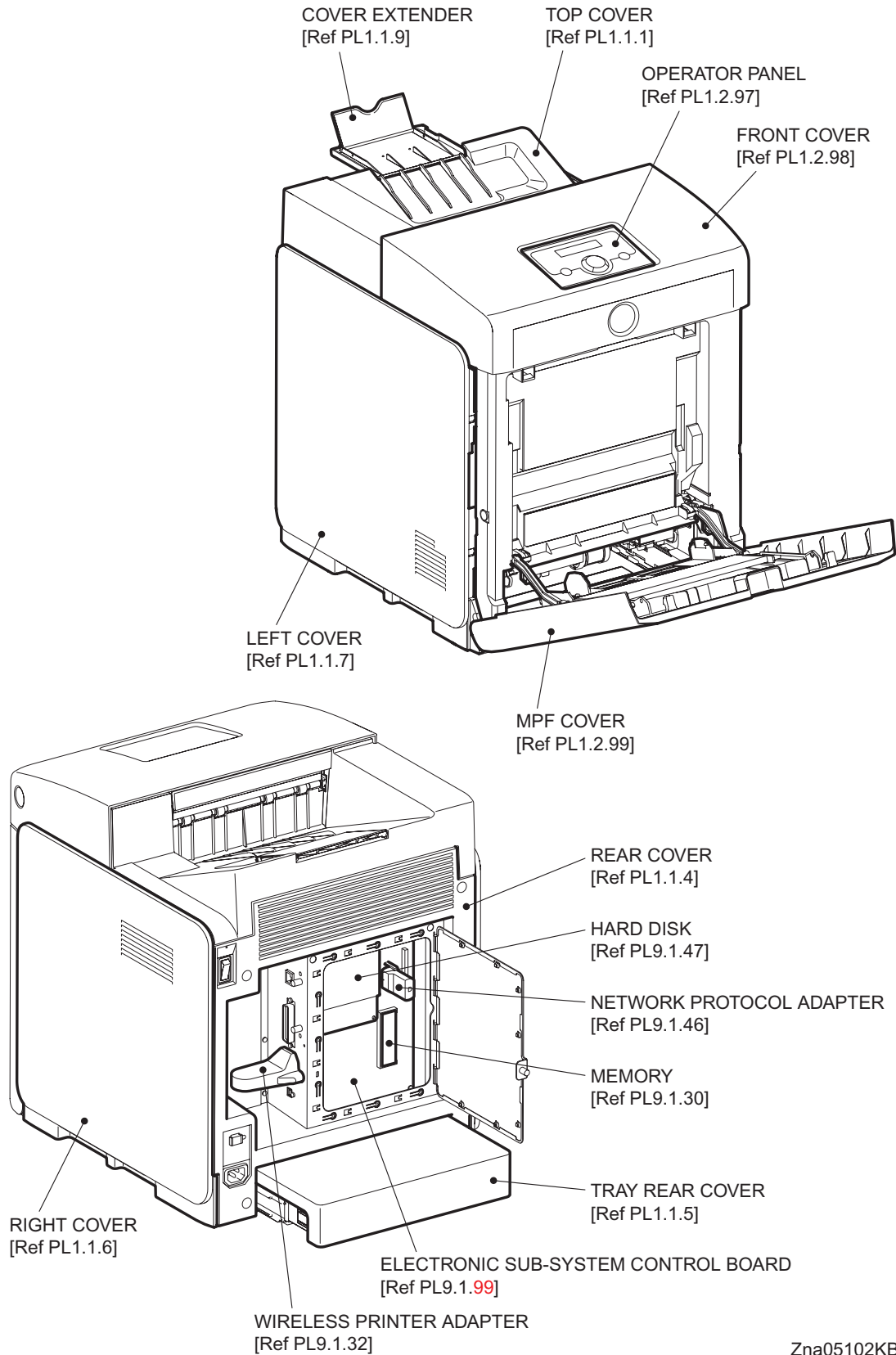

Zna05102KB

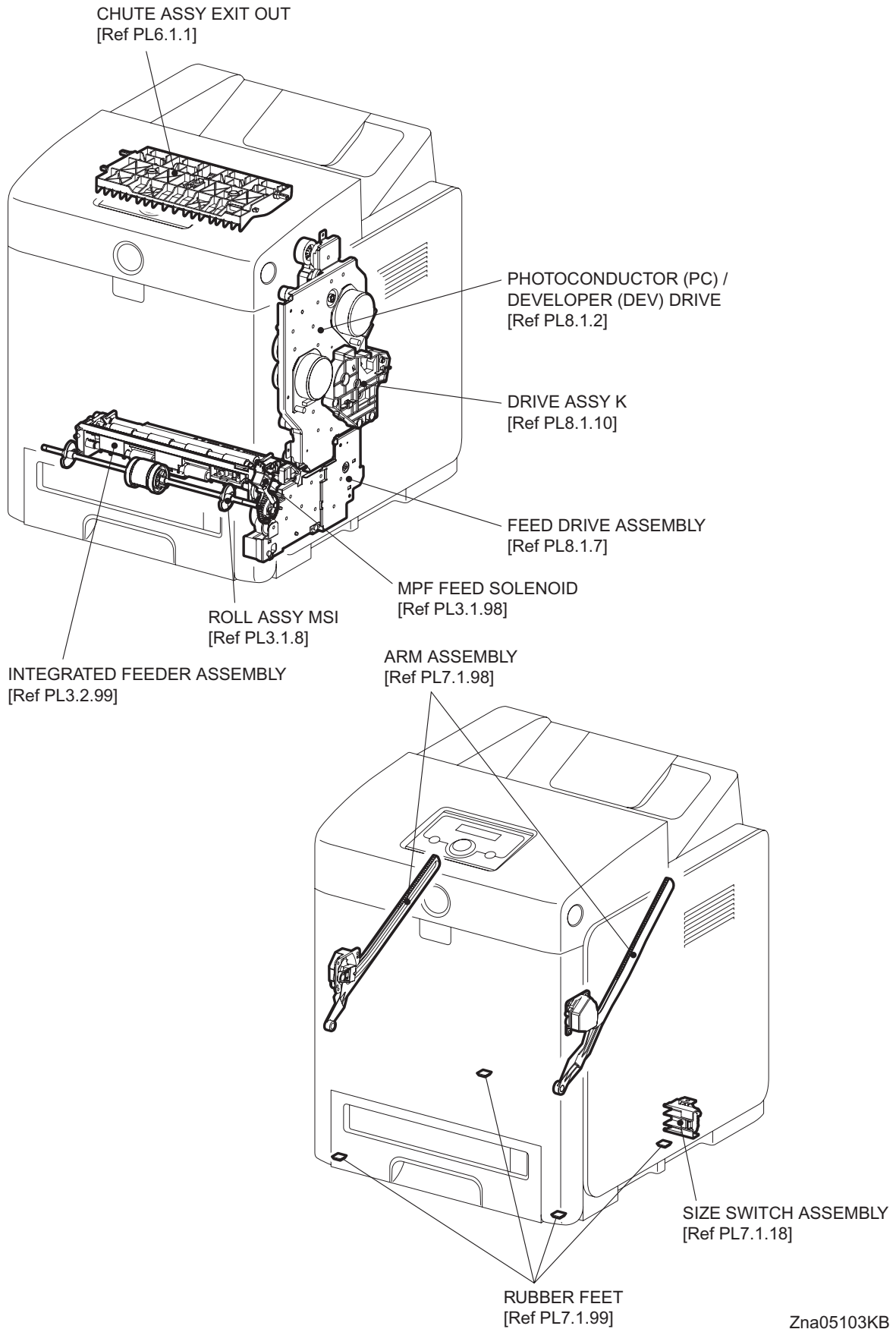

Zna05103KB

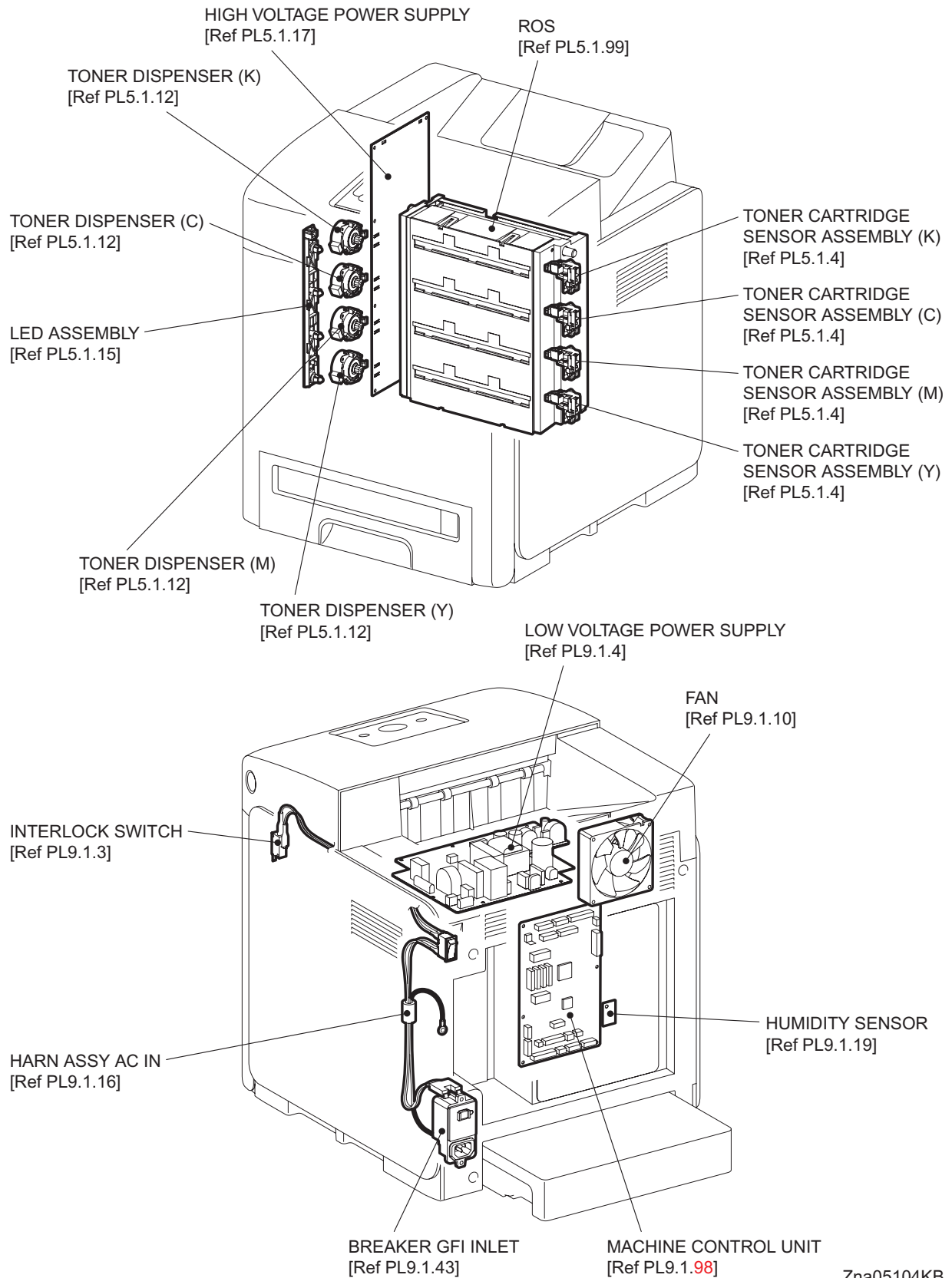

Zna05104KB

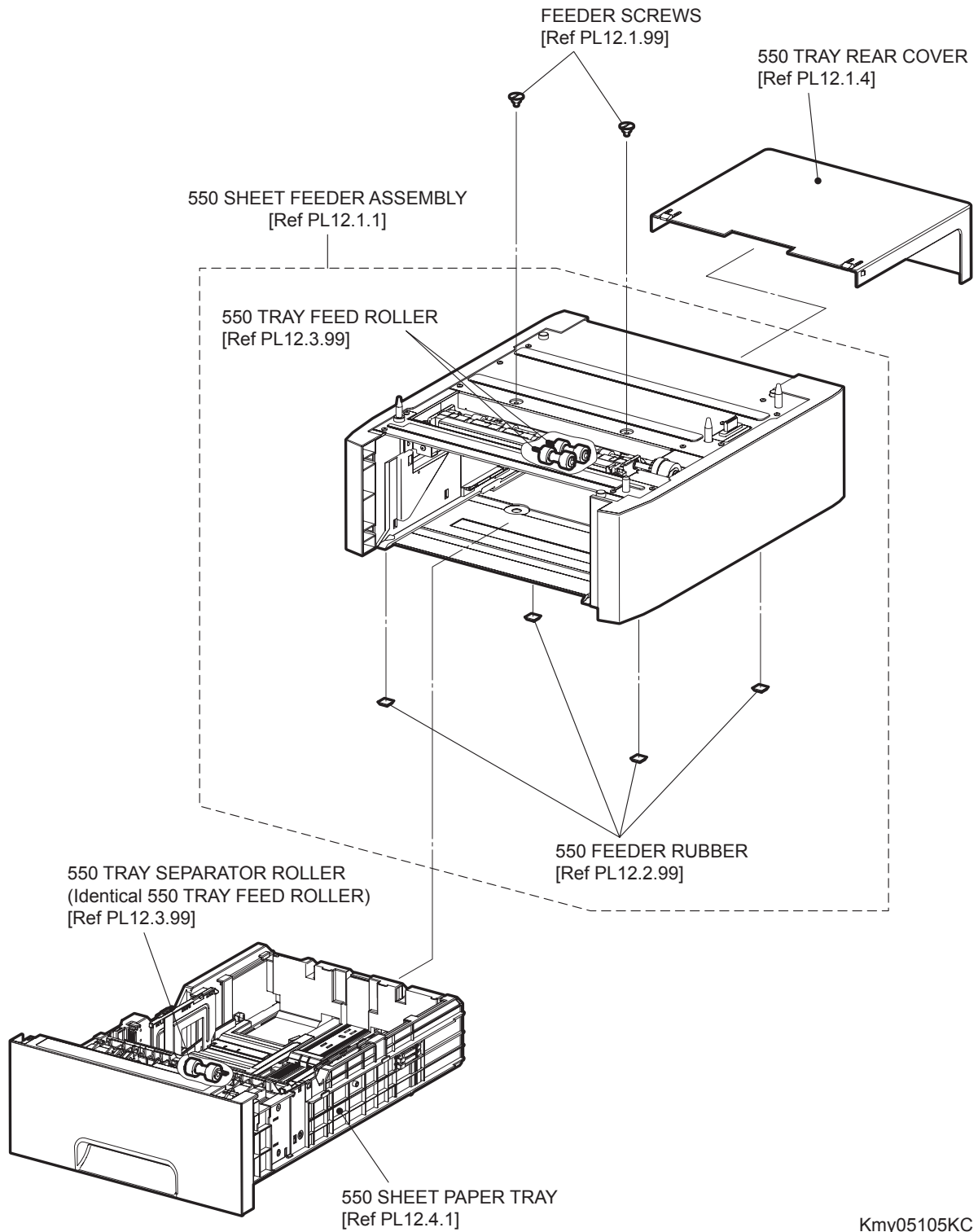

Kmy05105KC

Blank Page

Engineering parts list

PL1.1 Cover (1/2) [Illustration]

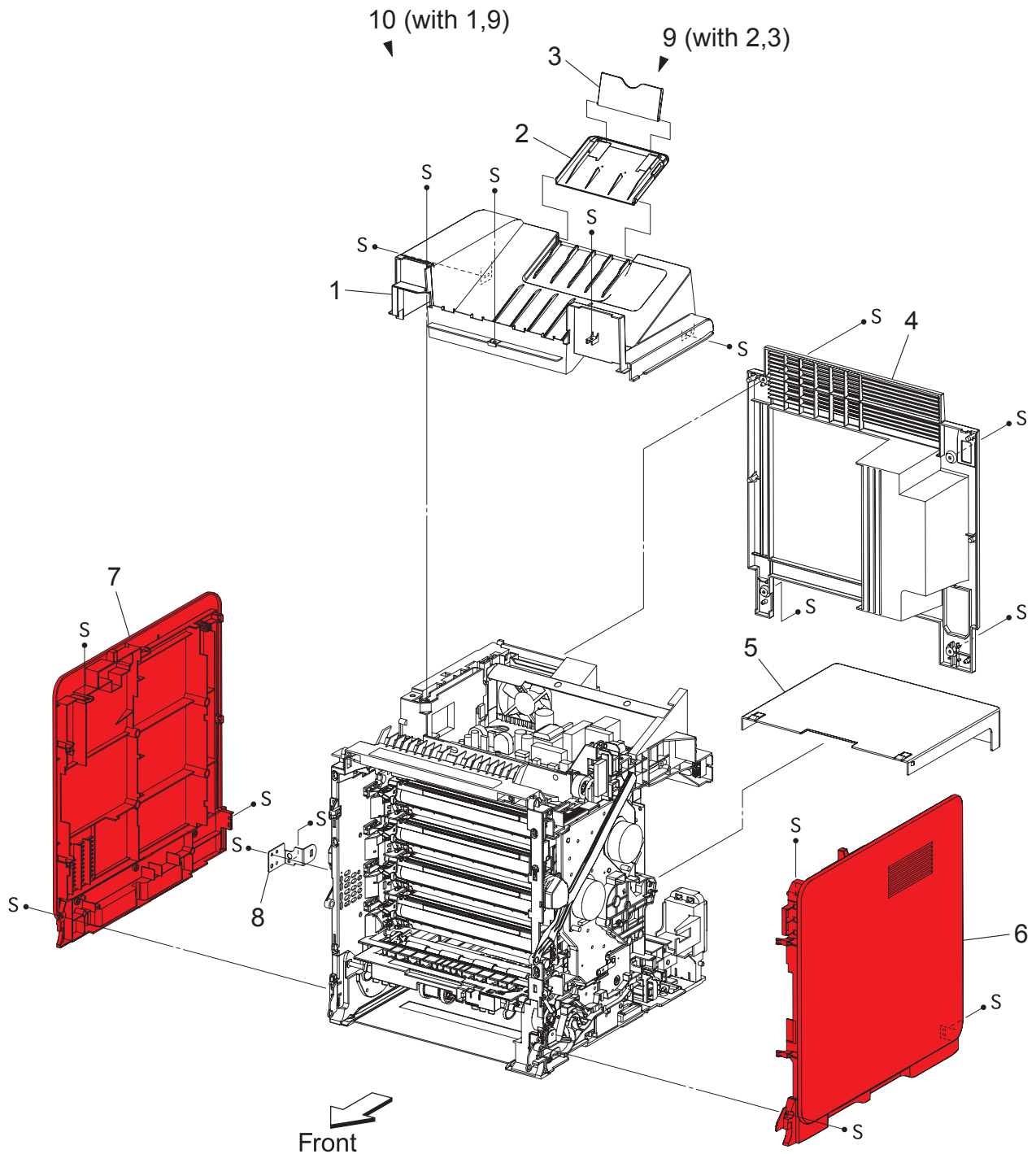

Zna05001KB

PL1.1 Cover (1/2) [List]

Item	Parts name
1	COVER TOP
2	COVER EXTENSION 1
3	COVER EXTENSION 2
4	COVER REAR
5	COVER CST
6	COVER SIDE R ASSY
7	COVER SIDE L ASSY
8	BRACKET RCB
9	COVER ASSY EXTENDER (with 2,3)
10	COVER ASSY TOP (with 1,9)

PL1.2 Cover (2/2) [Illustration]

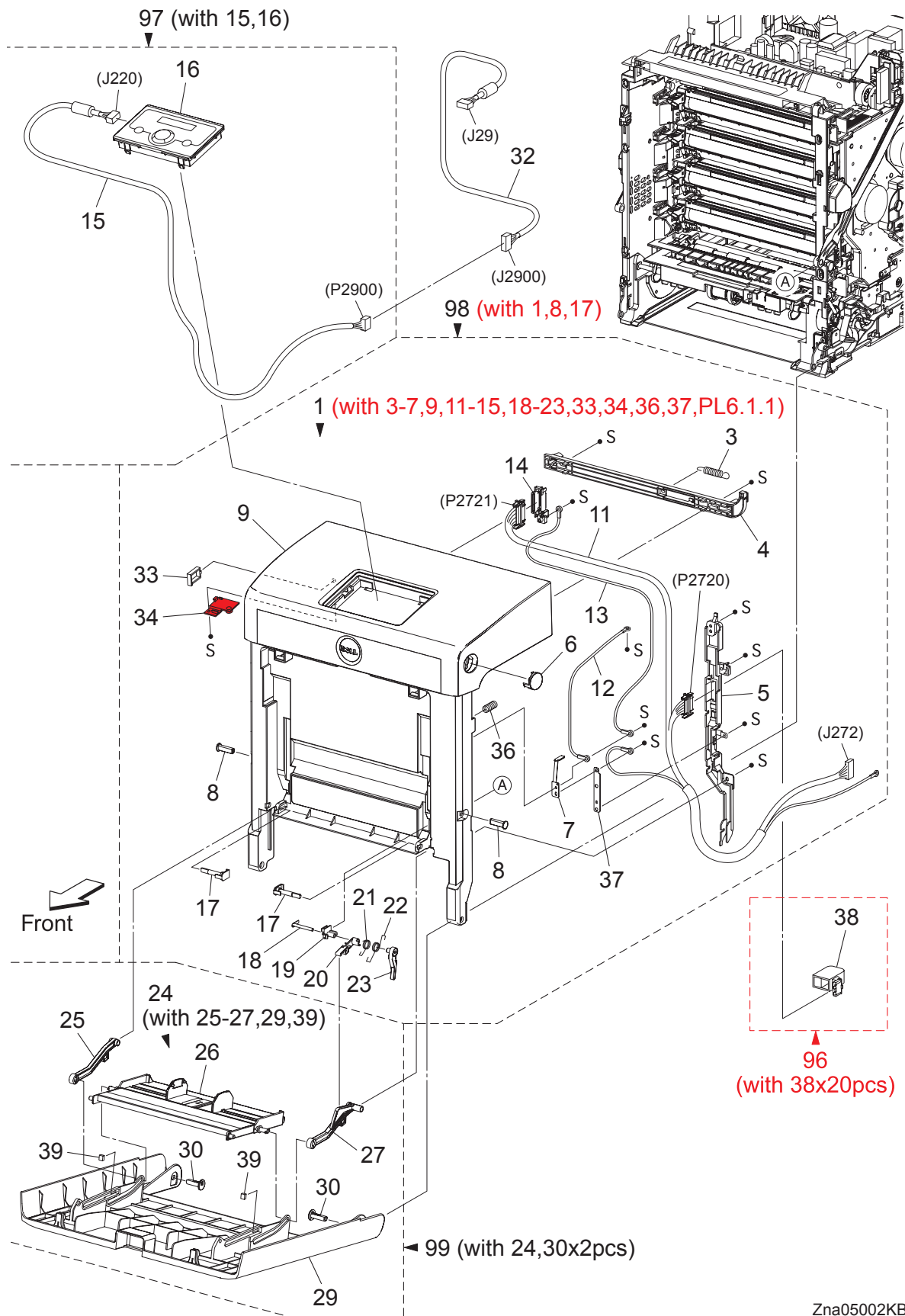

Zna05002KB

PL1.2 Cover (2/2) [List]

Item	Parts name
1	COVER ASSY FRONT (with 3-7,9,11-15,18-23,33,34,36,37,PL6.1.1)
2	--
3	SPRING LATCH
4	LATCH FRONT
5	COVER HARNESS
6	BUTTON TOP
7	CONTACT FRONT
8	SHAFT PIVOT
9	COVER FRONT ASSY
10	--
11	HARNESS ASSY FRONT COVER (J272-P2720,P2721,T4322-T43221)
12	HARNESS ASSY FRONT COVER EARTH 1 (T4321-T43210)
13	HARNESS ASSY DRAWER EARTH
14	HOLDER DRAWER
15	HARNESS ASSY OPEPANE (J220-P2900)
16	CONSOLE PANEL
17	PIN PIVOT MSI
18	SHAFT LEVER
19	PLATE PIVOT
20	LEVER MSI 1
21	SPRING LEVER MSI
22	SPRING LEVER LINK
23	LEVER MSI 2
24	COVER ASSY MSI (with 25-27,29,39)
25	LINK MSI L
26	TRAY ASSY MSI BASE
27	LINK MSI R
28	--
29	COVER MSI
30	SHAFT PIVOT MSI
31	--
32	HARNESS ASSY ESS (J29-J2900)
33	CLAMP RLWT-4V0
34	BRACKET HARNESS
35	--
36	SPRING
37	PLATE EARTH FC
38	CAP CONNECTOR DRAWER (Remove the connector when installing the Duplex Unit.)
39	PAD COVER MSI
96	KIT CAP CONNECTOR DRAWER (with 38x20pcs)
97	KIT OPERATOR PANEL (with 15,16)
98	KIT COVER ASSY FRONT (with 1,8,17)
99	KIT COVER ASSY MSI (with 24,30x2pcs)

PL2.1 Paper Cassette (1/2) [Illustration]

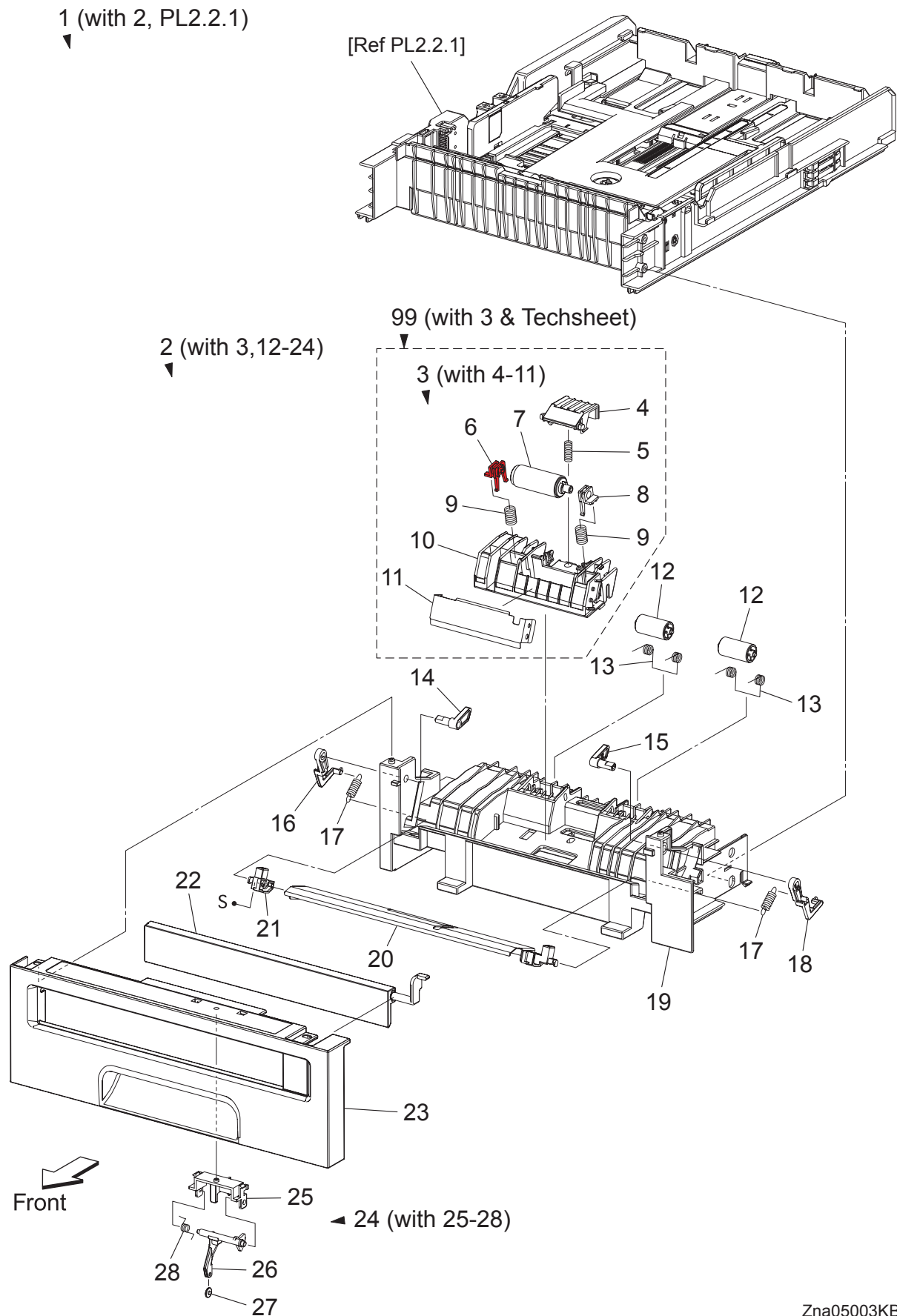

Zna05003KB

PL2.1 Paper Cassette (1/2) [List]

Item	Parts name
1	CASSETTE ASSY 250 (with 2, PL2.2.1)
2	CASSETTE ASSY FRONT (with 3,12-24)
3	SEPARATOR ROLLER ASSY MSI (with 4-11)
4	CHUTE SEPARATOR
5	SPRING CHUTE
6	BEARING SEPARATOR L
7	SEPARATOR ROLLER MSI
8	BEARING SEPARATOR R
9	SPRING SEPARATOR 200
10	HOLDER SEPARATOR MSI
11	PLATE SEPARATOR
12	ROLL PINCH TURN
13	SPRING PINCH TURN
14	FOLLOWER L
15	FOLLOWER R
16	ARM L
17	SPRING NF MSI
18	ARM R
19	HOUSING BASE FR 250
20	PLATE ASSY BOTTOM
21	HOLDER ASSY MSI L
22	COVER FRONT MSI
23	HANDLE CST 250
24	ACTUATOR ASSY MSI (with 25-28)
25	HOLDER ACTUATOR
26	ACTUATOR NO PAPER MSI
27	ROLL ACTUATOR NO PAPER
28	SPRING NO PAPER
99	KIT SEPARATOR ROLLER ASSY MSI (with 3 & Techsheet)

PL2.2 Paper Cassette (2/2) [Illustration]

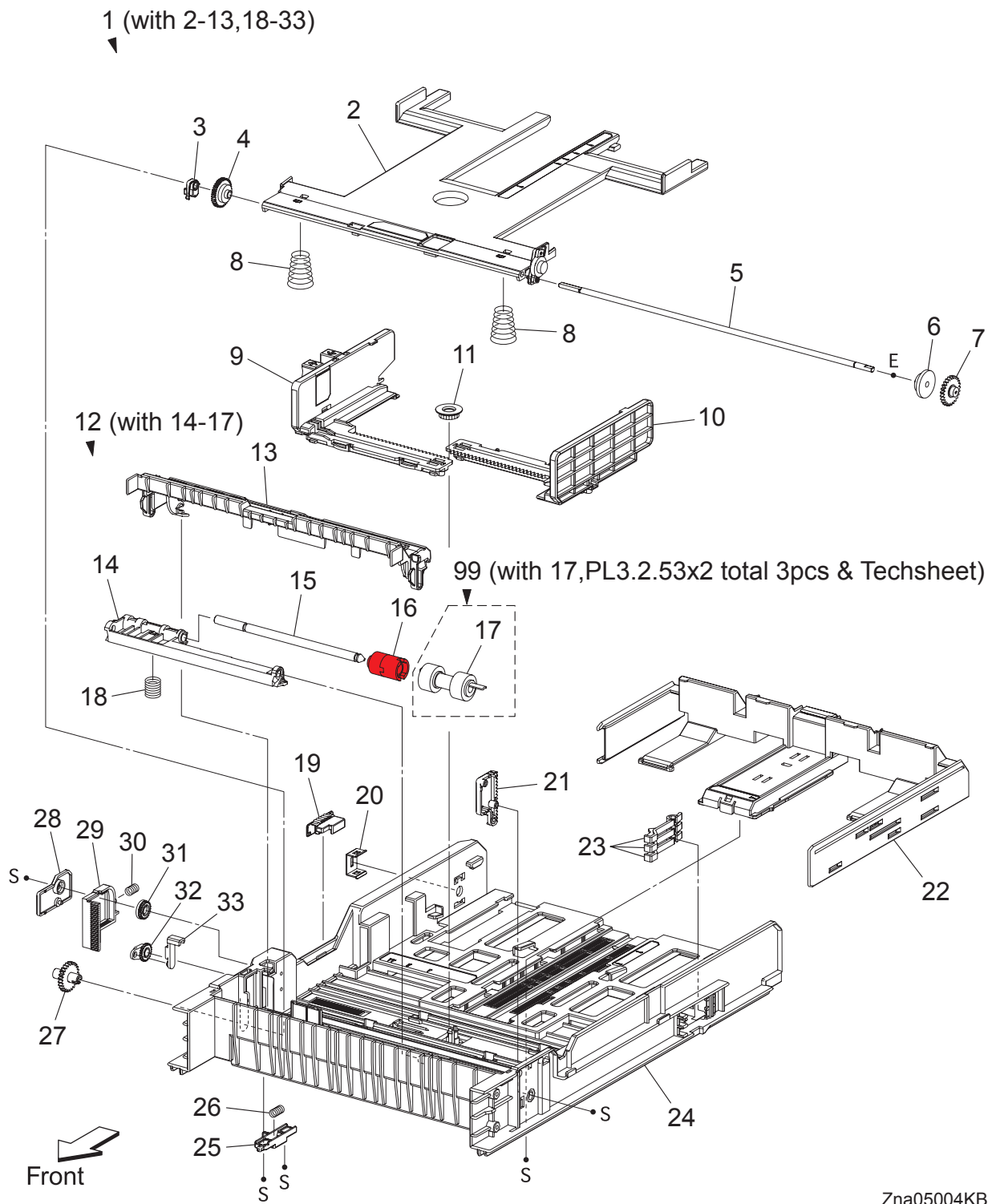

PL2.2 Paper Cassette (2/2) [List]

Item	Parts name
1	CASSETTE ASSY REAR 250 (with 2-13,18-33)
2	PLATE ASSY BTM A4
3	STOPPER PB
4	GEAR BTM LOCK ONEWAY
5	SHAFT PB A4
6	GEAR BTM DMP ONEWAY
7	GEAR PB L
8	SPRING BTM UP 250 A4
9	GUIDE ASSY SIDE R 250
10	GUIDE SIDE L 250
11	GEAR PINION
12	HOLDER ASSY SEPARATOR (with 14-17)
13	CVR SPRTR CST
14	HOLDER SEPARATOR
15	SHAFT SEPARATOR
16	CLUTCH FRICTION SPRTR
17	SEPARATOR ROLLER
18	SPRING SEPARATOR
19	SWITCH SIZE SET
20	PLATE LOCK CST
21	PLATE GEAR LOCK 250
22	GUIDE ASSY CST END 250
23	ACTUATOR SIZE
24	HSG BASE RE 250
25	ACTUATOR RLS PB
26	SPRING STOPPER GEAR
27	GEAR PB R
28	COVER BTM UP 250
29	RACK BTM LOCK 250
30	SPRING BTM LOCK
31	GEAR BTM LOCK PINION
32	GEAR LEVER BTM LOCK
33	LEVER BTM LOCK
99	KIT SEPARATOR and FEED ROLLER (with 17, PL3.2.53x2 total 3pcs & Techsheet) *1

*1 : Periodic Replacing Parts (100KPV)

PL3.1 Paper Feeder (1/2) [Illustration]

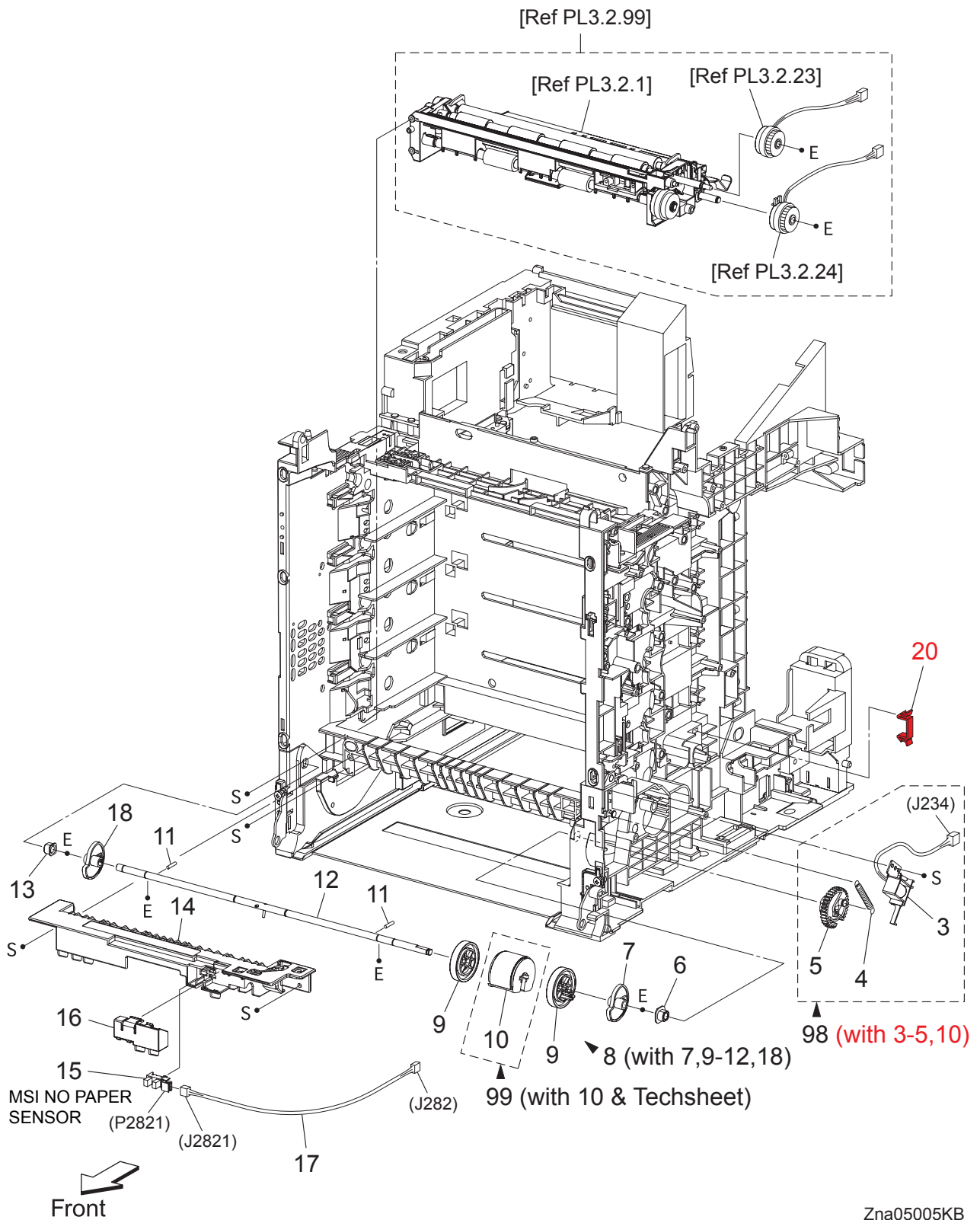

Zna05005KB

PL3.1 Paper Feeder (1/2) [List]

Item	Parts name
1	--
2	--
3	SOLENOID FEED MSI
4	SPRING FEED MSI
5	GEAR MSI
6	BEARING EARTH
7	CAM MSI R
8	ROLL ASSY MSI (with 7,9-12,18)
9	ROLL CORE MSI
10	ROLL ASSY FEED MSI
11	PIN DOWEL
12	SHAFT MSI
13	BEARING
14	CHUTE MSI
15	SENSOR PHOTO (MSI NO PAPER SENSOR)
16	COVER SNR
17	HARN ASSY MSI NPP (J282-J2821)
18	CAM MSI L
19	--
20	CLAMP RFC-11V0
98	KIT ROLL & SOLENOID FEED MSI (with 3-5,10)
99	KIT ROLL ASSY FEED MSI (with 10 & Techsheet)

PL3.2 Paper Feeder (2/2) [Illustration]

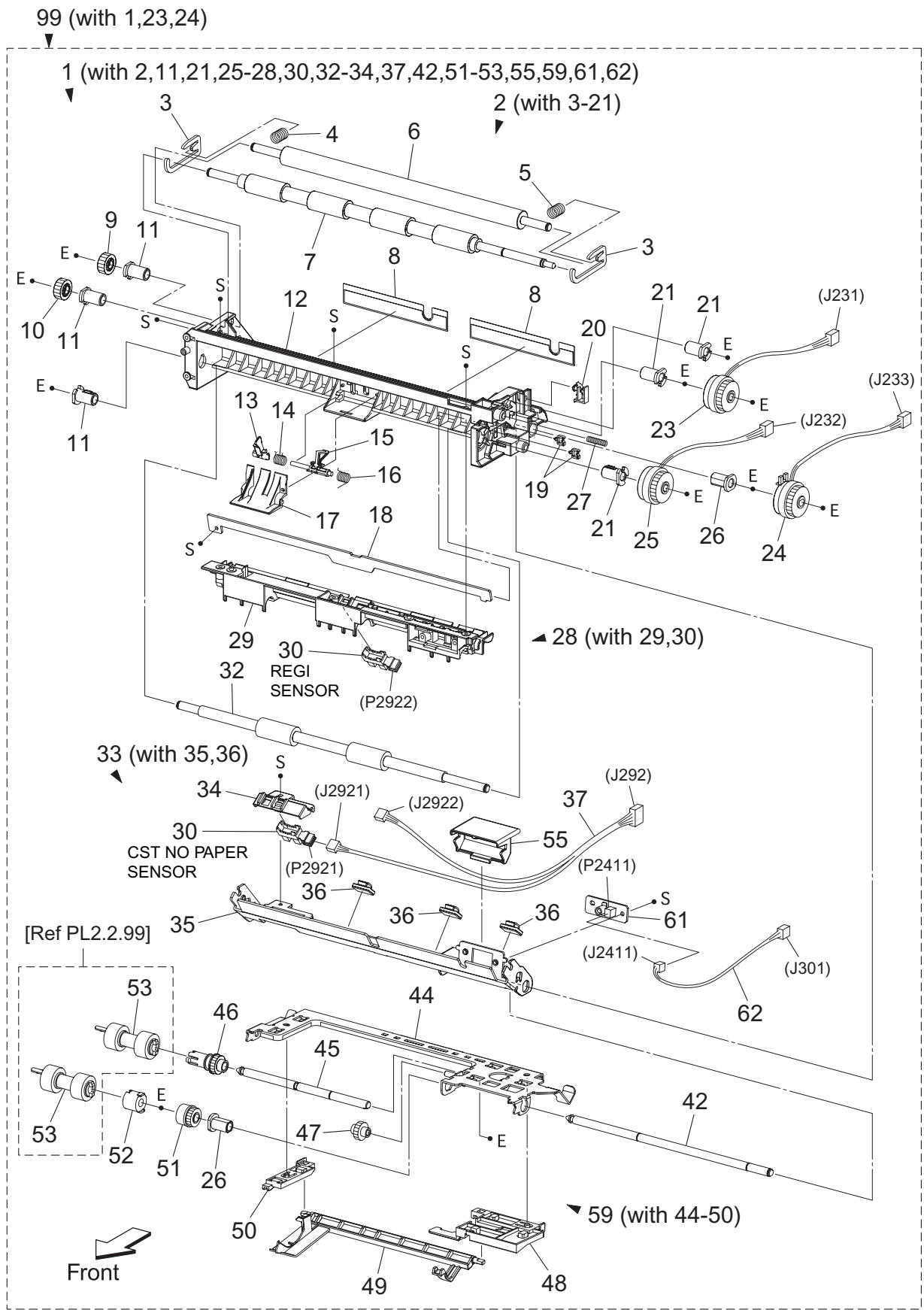

Zna05006KB

PL3.2 Paper Feeder (2/2) [List]

Item	Parts name
1	FEEDER ASSY (with 2,11,21,25-28,30,32-34,37,42,51-53,55,59,61,62)
2	CHUTE ASSY REGI (with 3-21)
3	BRACKET NIP
4	SPRING REGI L
5	SPRING REGI R
6	ROLL REGI METAL
7	ROLL REGI RUBBER
8	FILM INLET L
9	GEAR REGI METAL
10	GEAR REGI RUBBER
11	BEARING REGI
12	CHUTE REGI
13	ACTUATOR A
14	SPRING REGI SNSR A
15	ACTUATOR B
16	SPRING REGI SNSR B
17	COVER ACTUATOR
18	CHUTE SEPARATOR BTM
19	CLAMP MINI-SADDLE
20	CLAMP
21	BEARING REGI E
22	--
23	CLUTCH ASSY PH REGI
24	CLUTCH ASSY PH FEED
25	CLUTCH ASSY PH TURN
26	BEARING NUDGER
27	SPRING EARTH
28	CHUTE ASSY REGI UPPER (with 29,30)
29	CHUTE REGI UPPER
30	SENSOR PHOTO (REGI SENSOR, CST NO PAPER SENSOR)
31	--
32	ROLL ASSY TURN
33	CHUTE ASSY TOP (with 35,36)
34	HOLDER NOSNSR
35	CHUTE ASSY SEPARATOR
36	CLAMP
37	HARN ASSY REGI SNR (J292-J2921,J2922)
38	--
39	--
40	--
41	--
42	SHAFT FEED
43	--
44	SUPPORT NUDGER ASSY
45	SHAFT NUDGER
46	GEAR NUDGER A4
47	GEAR IDLER NUDGER
48	HOLDER NO PAPER L A4
49	ACTUATOR NO PAPER A4
50	HOLDER NO PAPER R A4
51	CLUTCH ONEWAY NUDGER
52	CLUTCH ONEWAY FEED
53	ROLL ASSY FEED
54	--
55	COVER OHP SNR
56	--
57	--
58	--
59	NUDGER ASSY (with 44-50)
60	--
61	PWBA TEM SNR
62	HARN ASSY TEM SNR (J301-J2411)
99	KIT FEEDER ASSY (with 1,23,24)

PL4.1 Transfer [Illustration]

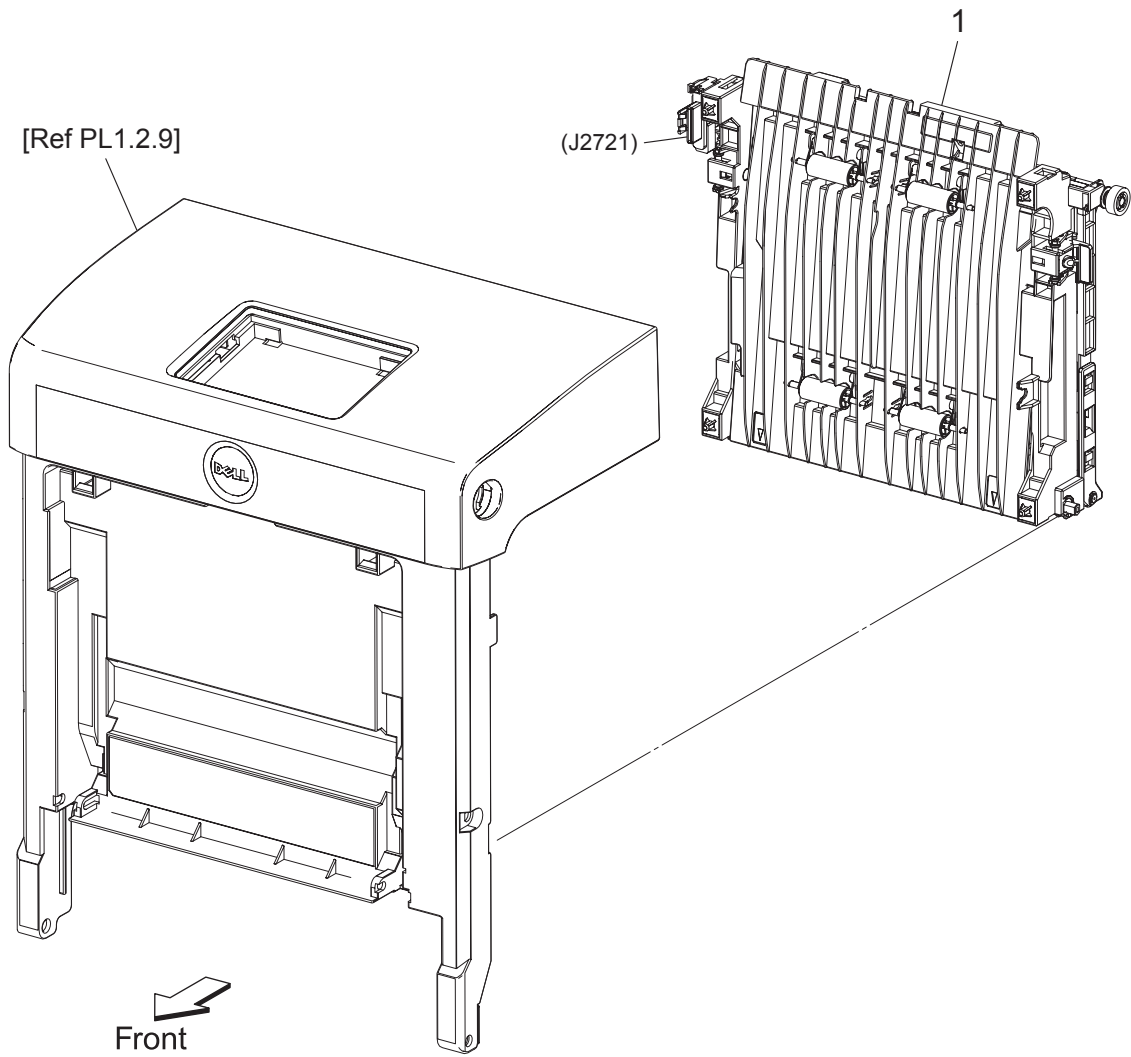

PL4.1 Transfer [List]

Item	Parts name
1	TRANSFER ASSY (KIT BELT CRU) *1
2	--
3	--
4	--
5	--
6	--
7	--

*1 : Periodic Replacing Parts (100KPV)

PL5.1 Xerographics [Illustration]

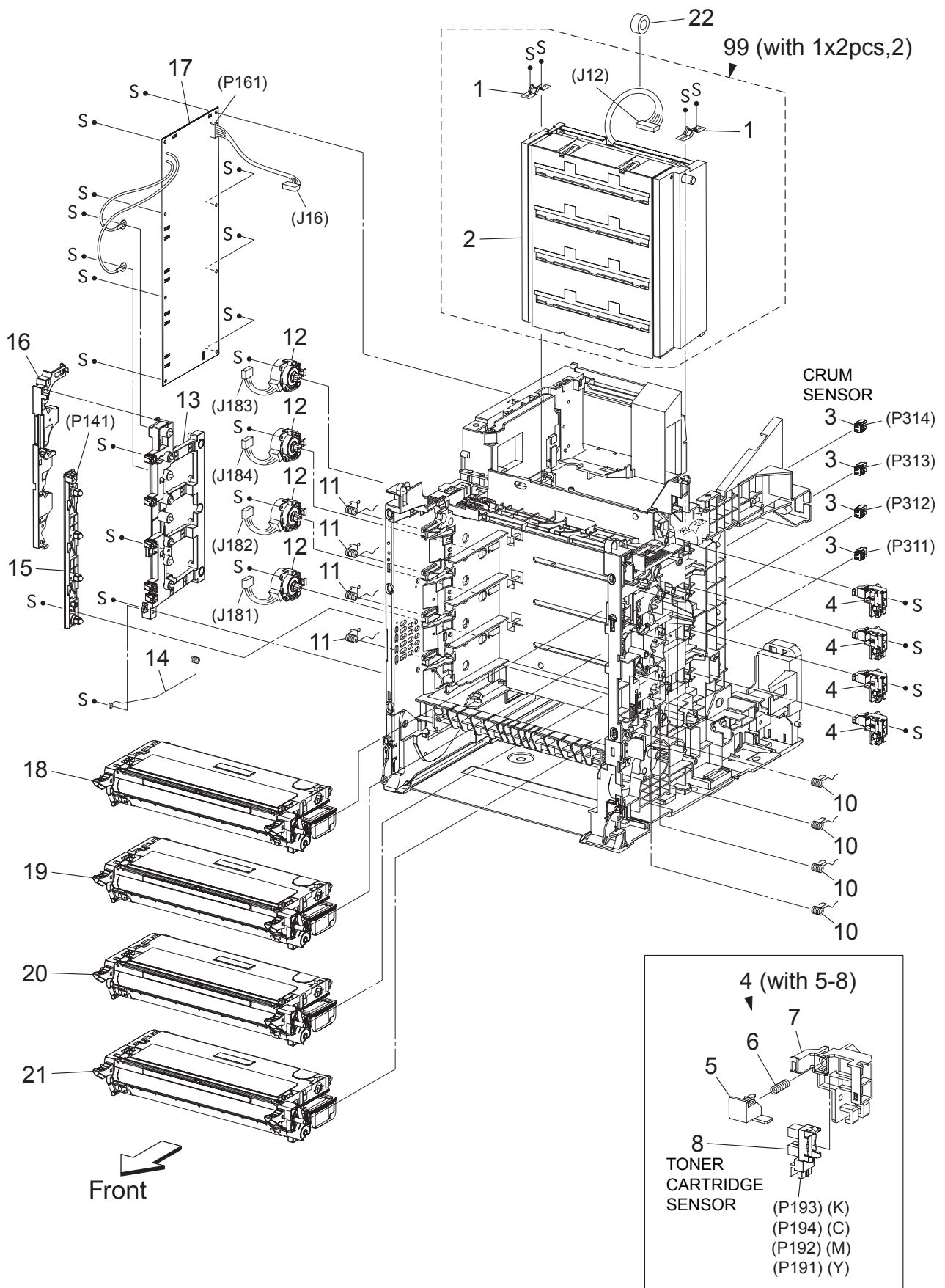

Zna05010KB

PL5.1 Xerographics [List]

Item	Parts name
1	SPRING ROS
2	ROS ASSY
3	CONNECTOR CRUM
4	SENSOR ASSY CRU (with 5-8)
5	ACTUATOR CRU
6	SPRING CRU
7	BRACKET ACTUATOR
8	SENSOR PHOTO (TONER CARTRIDGE SENSOR)
9	--
10	SPRING CRU R
11	SPRING CRU L
12	DISPENSER ASSY
13	BIAS ASSY
14	SPRING ESA ROLL
15	LED ASSY
16	DUCT HARNESS MOT
17	HVPS
18	CARTRIDGE ASSY (K) (with Techsheet) *1
19	CARTRIDGE ASSY (C) (with Techsheet) *2
20	CARTRIDGE ASSY (M) (with Techsheet) *2
21	CARTRIDGE ASSY (Y) (with Techsheet) *2
22	CORE
23	--
99	KIT ROS ASSY (with 1x2pcs, 2)

*1 : Periodic Replacing Parts (4KPV/9KPV)

*2 : Periodic Replacing Parts (3KPV/9KPV)

PL6.1 Fuser & Exit [Illustration]

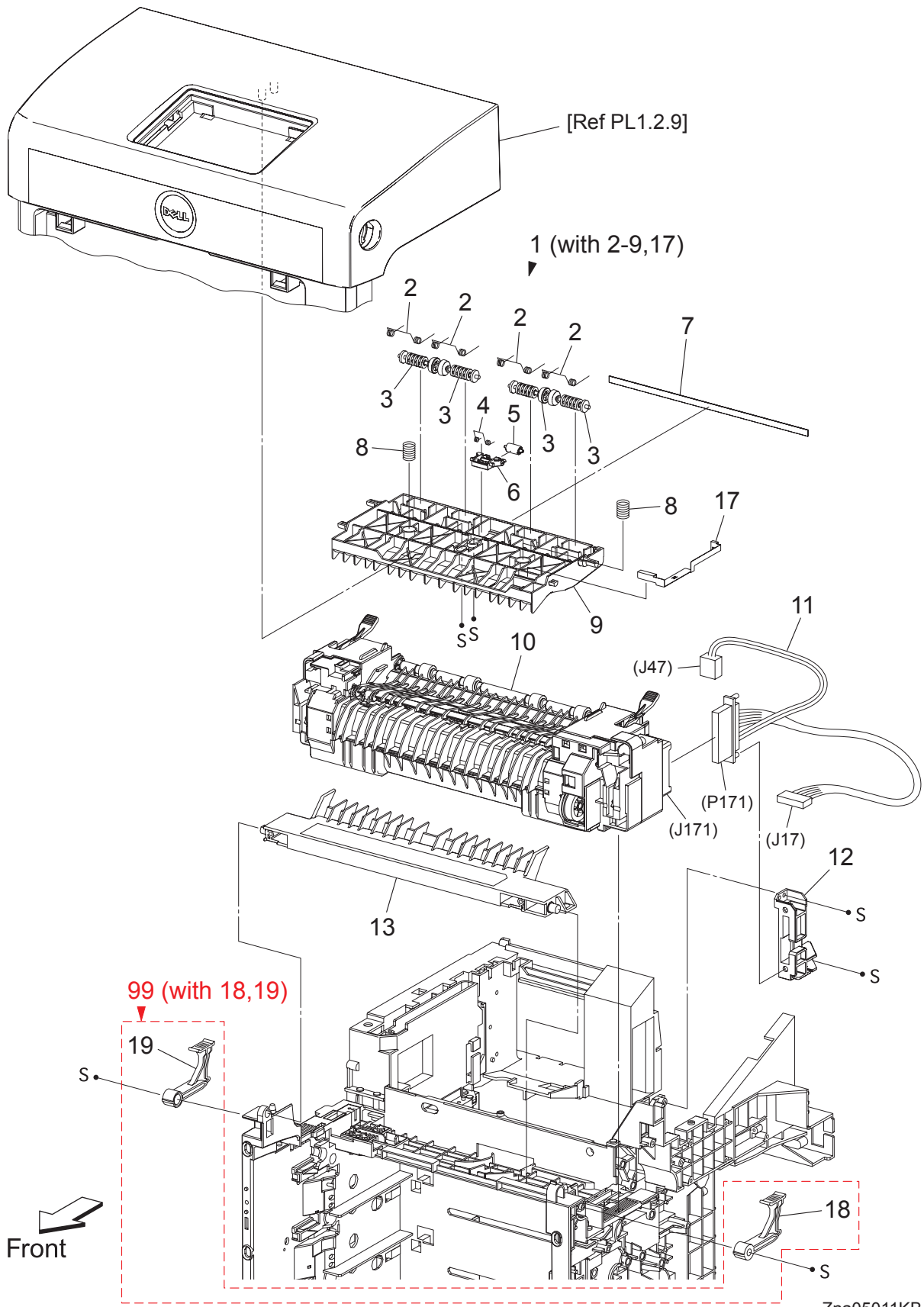

Zna05011KB

PL6.1 Fuser & Exit [List]

Item	Parts name
1	CHUTE ASSY EXIT OUT (with 2-9,17)
2	SPRING PINCH EXIT OUT
3	ROLL PINCH EXIT
4	SPRING CORRUGATE
5	ROLL CORRUGATE
6	HOLDER CORRUGATE
7	ELIMINATOR EXIT
8	SPRING CHUTE OUT
9	CHUTE EXIT OUT
10	FUSER ASSY (with Techsheet) *1
11	HARN ASSY FUSER (P171-J17,J47)
12	BRACKET FUSER
13	CHUTE DUP GATE
14	--
15	--
16	--
17	PLATE EARTH EXIT
18	LEVER FUSER D
19	LEVER FUSER AD

99 **KIT LEVER FUSER (with 18,19)**

*1 : Periodic Replacing Parts (100KPV)

PL7.1 Frame [Illustration]

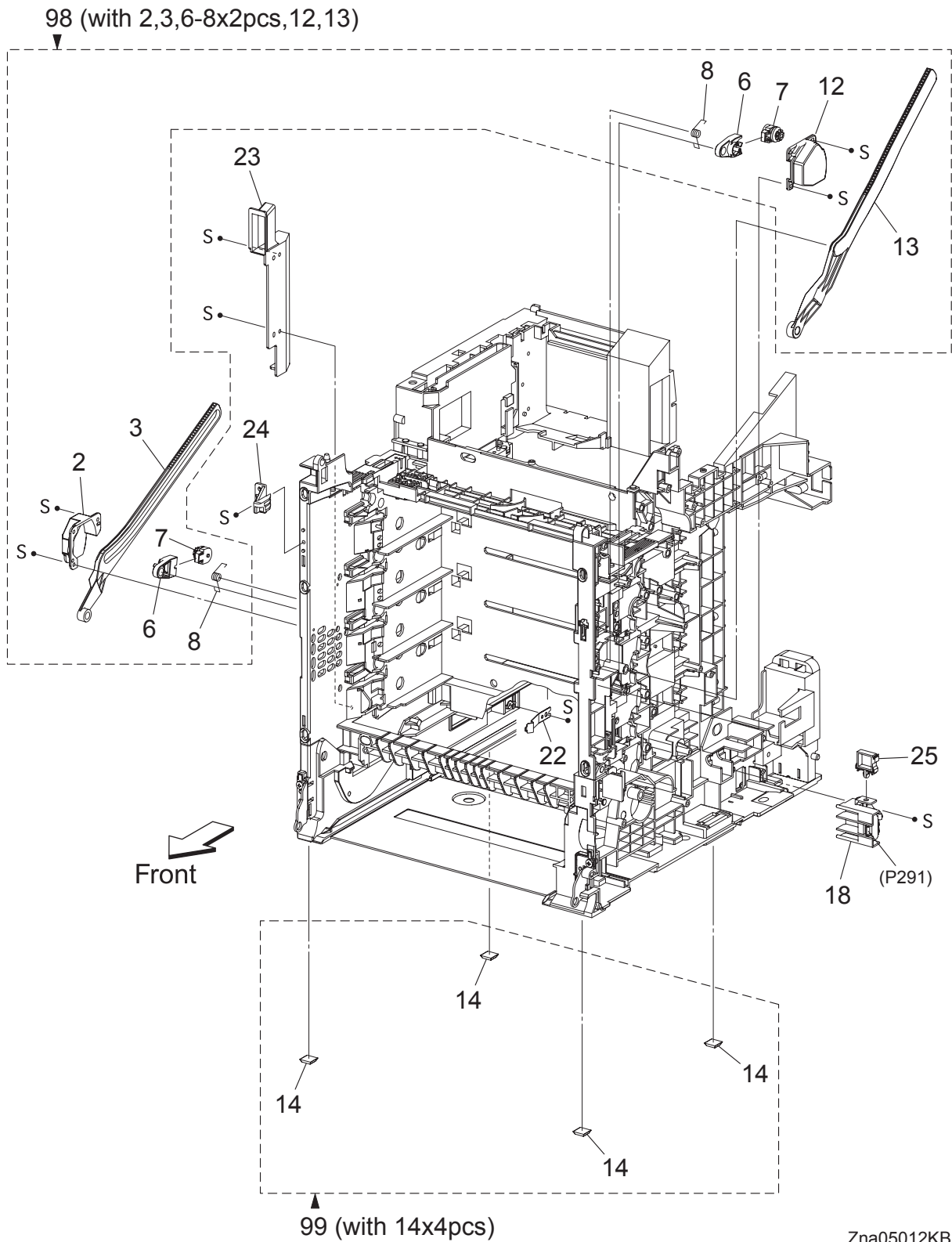

Zna05012KB

PL7.1 Frame [List]

Item	Parts name
1	--
2	SUPPORT LINK L
3	LINK L
4	--
5	--
6	HOLDER DAMPER
7	DAMPER OIL
8	SPRING SUPPORT
9	--
10	--
11	--
12	SUPPORT LINK R
13	LINK R
14	FOOT
15	--
16	--
17	--
18	SWITCH ASSY SIZE
19	--
20	--
21	--
22	SPRING CST LOCK
23	DUCT SIDE L
24	STOPPER FRAME L
25	CLAMP LOCKING
97	--
98	KIT LINK ASSY R & L (with 2,3,6-8x2pcs,12,13)
99	KIT FOOT ASSY (with 14x4pcs)

PL8.1 Drive [Illustration]

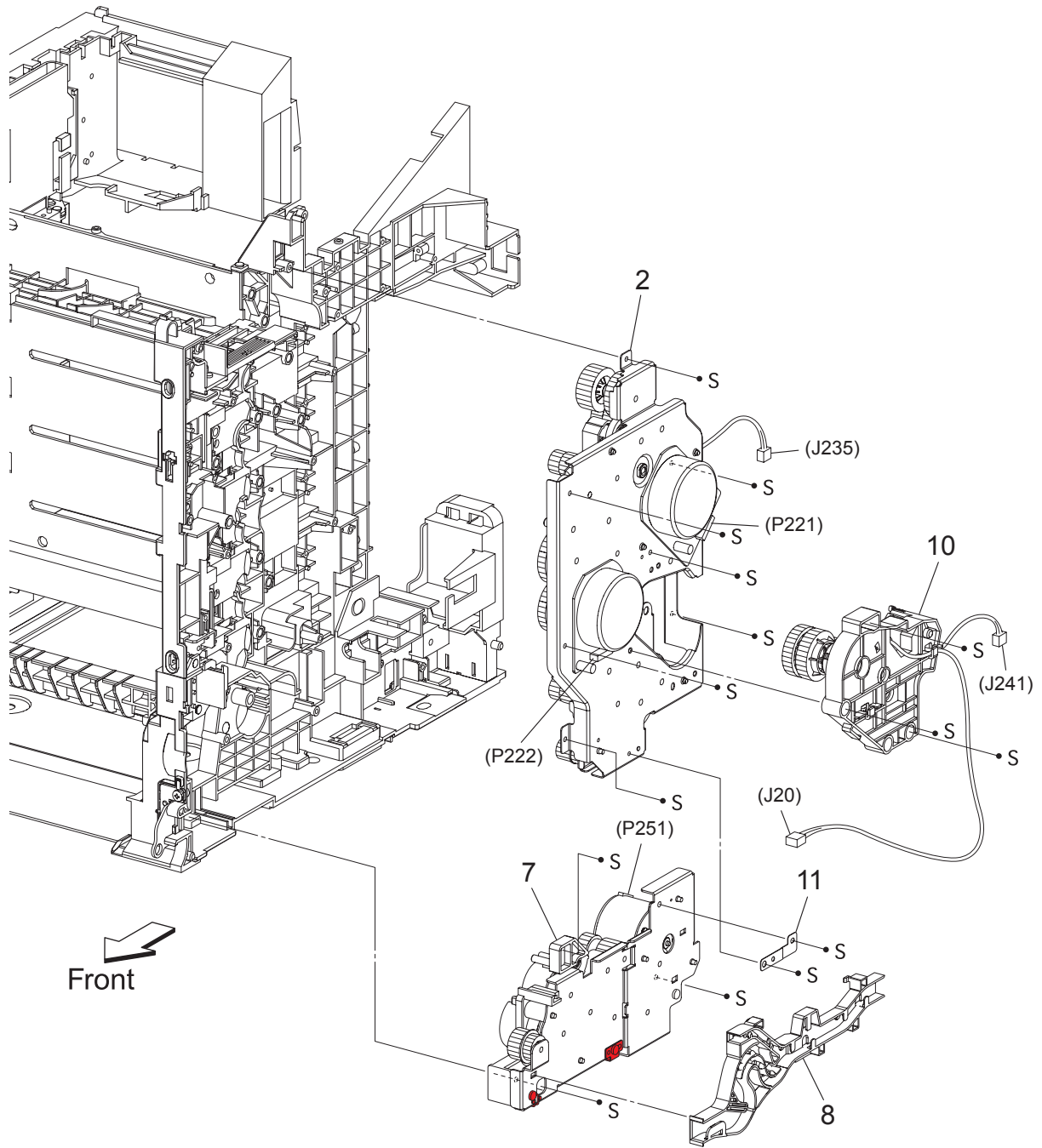

Zna05013KB

PL8.1 Drive [List]

Item	Parts name
1	--
2	DRIVE ASSY MAIN
3	--
4	--
5	--
6	--
7	DRIVE ASSY PH
8	DUCT ASSY DRV PH
9	--
10	DRIVE ASSY K
11	PLATE EARTH DRV MP

PL9.1 Electrical [Illustration]

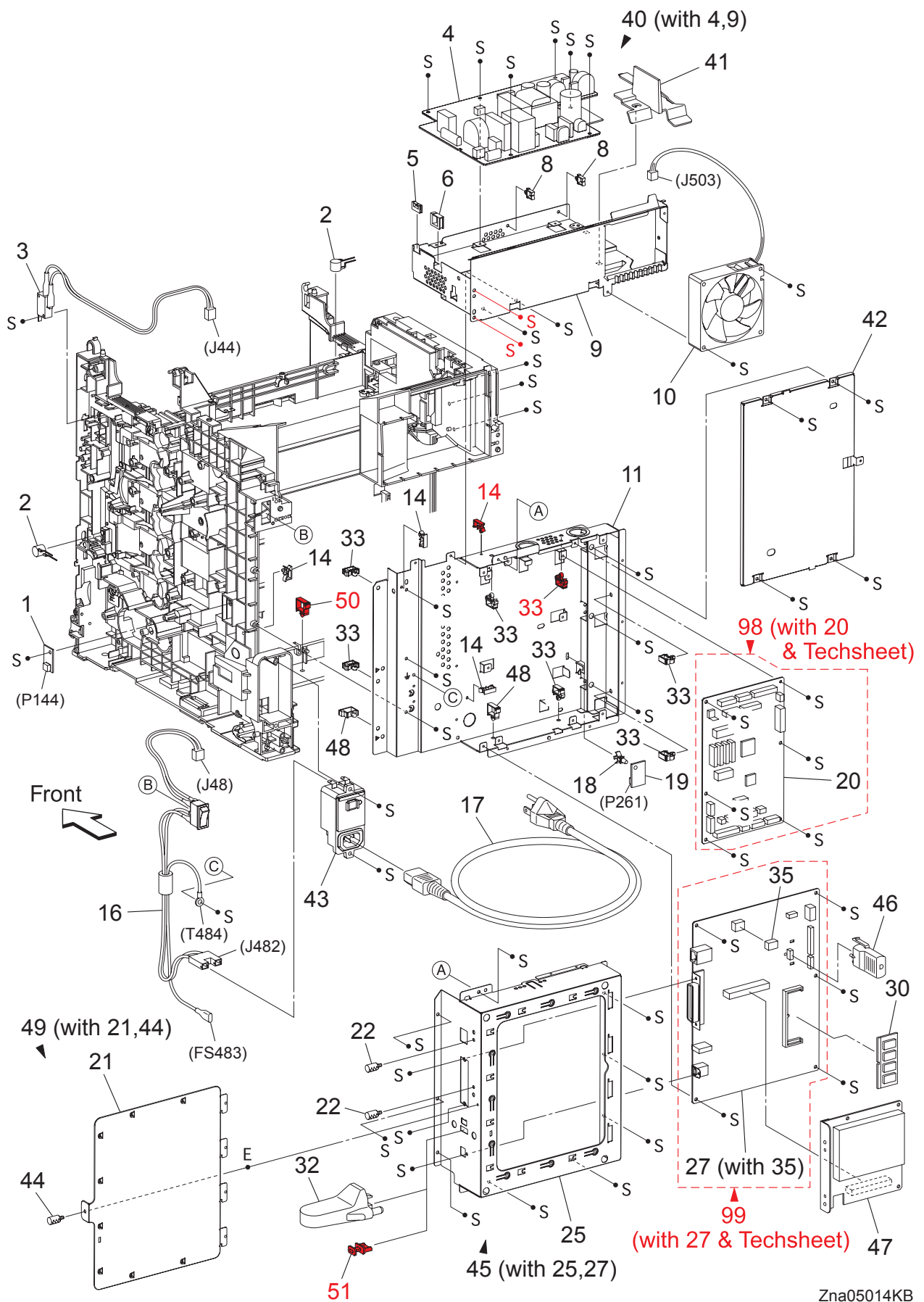

Zna05014KB

PL9.1 Electrical [List]

Item	Parts name
1	PWBA EEPROM(XPRO)
2	VARISTOR
3	HARN ASSY INTERLOCK (INTERLOCK SWITCH-J44)
4	LVPS
5	EDGE SADDLE ES-0510
6	EDGE SADDLE LENS-1010
7	--
8	CLAMP RMS-3V0
9	SHIELD LVPS
10	FAN MAIN
11	SHIELD REAR
12	--
13	--
14	CLAMP MST-10V0
15	--
16	HARN ASSY AC IN (SWITCH POWER-J48,J482,FS483-T484)
17	POWER CORD
18	SPACER RCBT-11S
19	SENSOR HUM
20	PWBA MCU
21	SHIELD WINDOW
22	SCREW KNURLING (OPTION HDD KIT)
23	--
24	--
25	SHIELD ESS
26	--
27	PWBA ESS (with 35)
28	--
29	--
30	MEMORY CARD (OPTION)
31	--
32	WIRELESS PRINTER ADAPTER (OPTION)
33	CLAMP RLWC-1SV0
34	--
35	NVM ROM
36	--
37	--
38	--
39	--
40	LVPS ASSY (with 4,9)
41	DUCT AIRFLOW
42	SHIELD MCU
43	BREAKER GFI INLET
44	SCREW KNURLING
45	SHIELD ASSY ESS (with 25,27)
46	NETWORK PROTOCOL ADAPTER (OPTION)
47	HDD ASSY (OPTION)
48	CLAMP LOCKING
49	SHIELD ASSY WINDOW (with 21,44)
50	CLAMP LOCKING
51	CAP USB
98	KIT PWBA MCU (with 20 & Techsheet)
99	KIT PWBA ESS (with 27 & Techsheet)

PL10.1 Harness [Illustration]

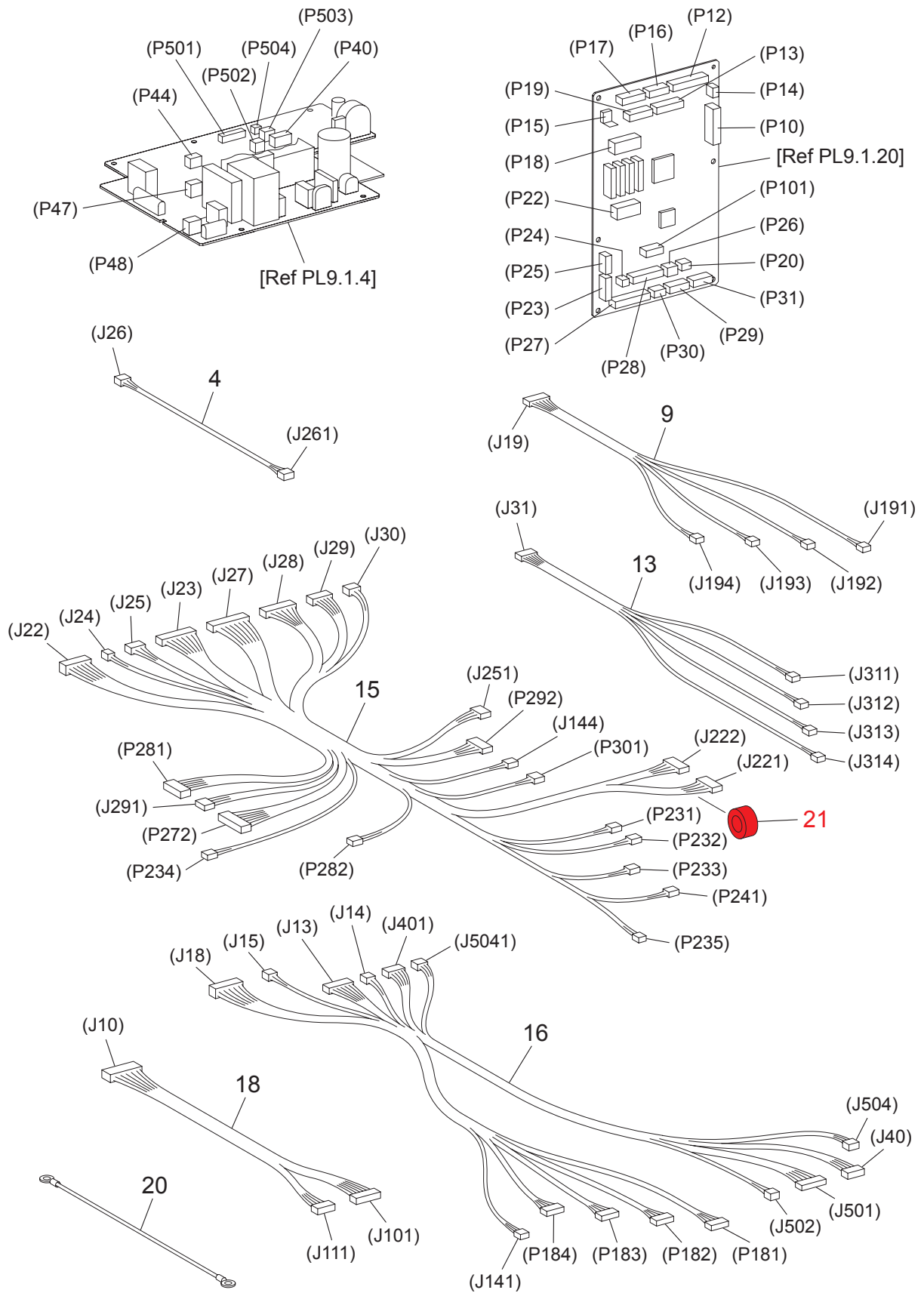

Zna05015KB

PL10.1 Harness [List]

Item	Parts name
1	--
2	--
3	--
4	HARN ASSY HUM (J26-J261)
5	--
6	--
7	--
8	--
9	HARN ASSY CRU SNR (J19-J191,J192,J193,J194)
10	--
11	--
12	--
13	HARN ASSY CRUM (J31-J311,J312,J313,J314)
14	--
15	HARN ASSY R SIDE (J22,J23,J24,J25,J27,J28,J29,J30-J144,J221,J222,P231,P232, P233,P234,P235,P241,J251,P272,P281,P282,J291,P292,P301)
16	HARN ASSY LV TOP (J13,J14,J15,J18,J401,J5041-J141,P181,P182,P183,P184,J40, J501,J502,J504)
17	--
18	HARN ASSY IF (J10-J101,J111)
19	--
20	HARN ASSY BTM EARTH
21	CORE

I

PL11.1 Duplex (Option) (1/2) [Illustration]

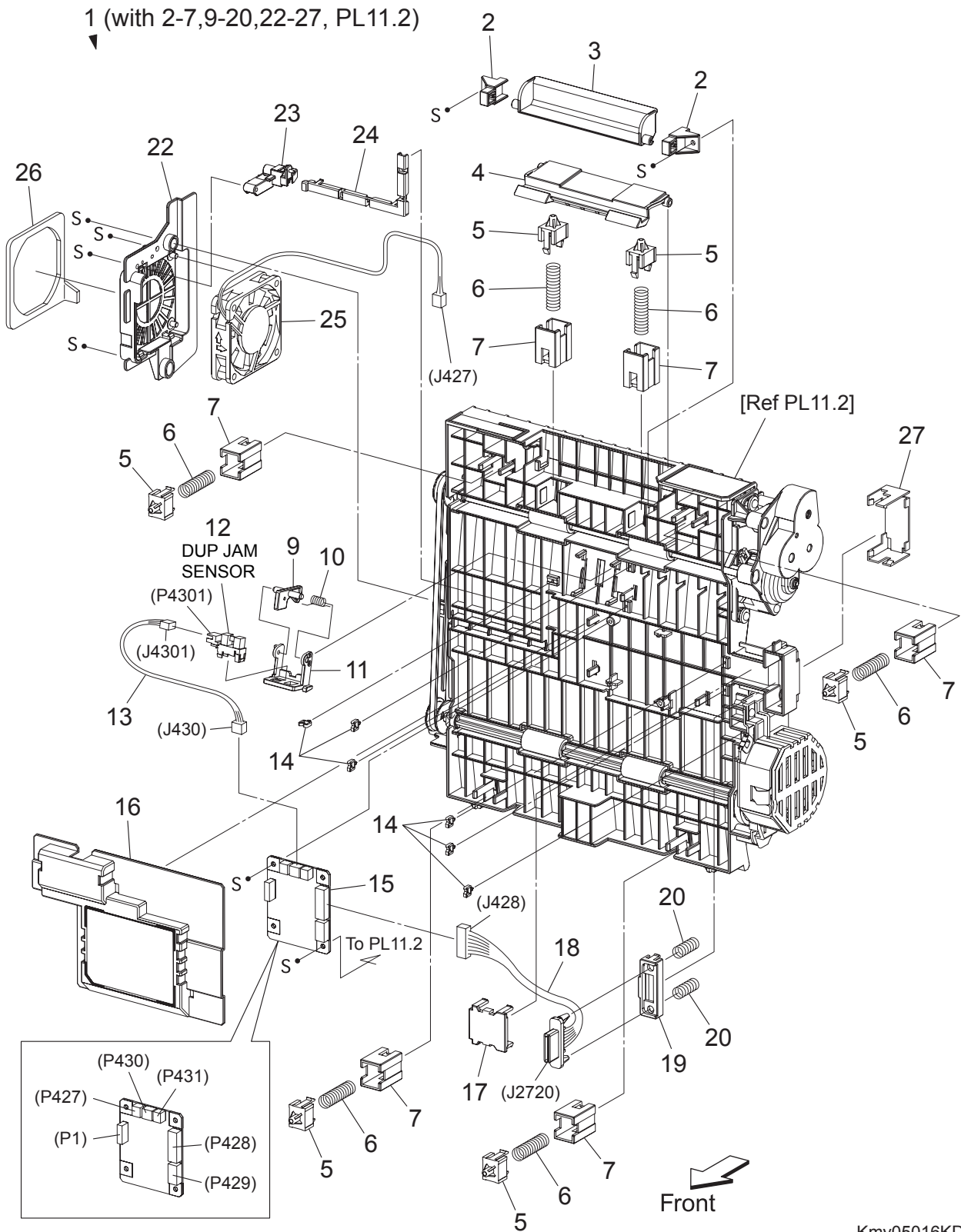

Kmy05016KD

PL11.1 Duplex (Option) (1/2) [List]

Item	Parts name
1	FEEDER ASSY DUP (KIT DUPLEX MODULE) (with 2-7,9-20,22-27, PL11.2)
2	STOPPER LATCH DUP
3	HANDLE LATCH DUP
4	LATCH DUP
5	HOLDER MAIN
6	SPRING CHUTE DUP
7	BRACKET HOLDER DUP
8	--
9	ACTUATOR DUP
10	SPRING SENSOR DUP
11	HOLDER SENSOR DUP
12	SENSOR PHOTO (DUP JAM SENSOR)
13	HARN ASSY DUP SNR (J430-J4301)
14	CLAMP MINI
15	PWBA DUP-H
16	COVER PWBA DUP
17	COVER CONNECT DUP
18	HARN ASSY DUP UNIT (J428-J2720)
19	HOLDER CONNECT DUP
20	SPRING CONNECT DUP
21	--
22	BRACKET FAN DUP
23	COVER HARNESS FAN
24	COVER HARNESS CHUTE
25	FAN DUP
26	SEAL DUP
27	COVER CHUTE DUP

PL11.2 Duplex (Option) (2/2) [Illustration]

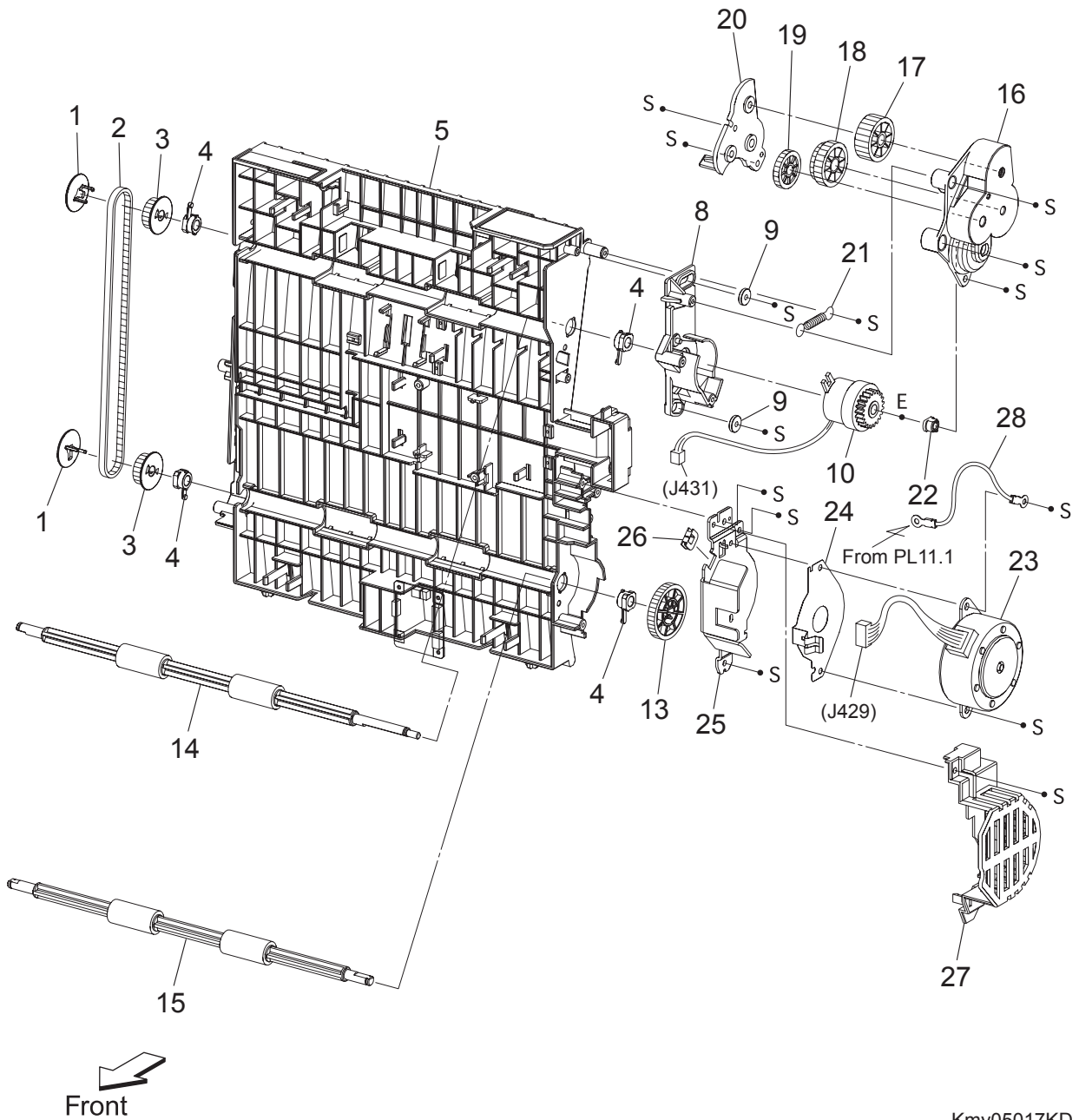

Kmy05017KD

PL11.2 Duplex (Option) (2/2) [List]

Item	Parts name
1	FLANGE PULLEY UP
2	BELT DUP 3M-128Z
3	PULLEY DUP 3M-20T
4	BEARING DUP
5	CHUTE DUP
6	--
7	--
8	BRACKET CLUTCH DUP
9	WASHER DUP CLUTCH
10	CLUTCH DUP
11	--
12	--
13	GEAR DUP 40Z-M0.8
14	ROLL ASSY DUP-1
15	ROLL ASSY DUP-2
16	COVER GEAR DUP
17	GEAR DUP 25Z FUSER
18	GEAR DUP 21Z-25Z
19	GEAR DUP 21Z
20	PLATE GEAR
21	SPRING DUP
22	BEARING
23	MOTOR ASSY DUP
24	PLATE EARTH DUP
25	BRACKET MOTOR DUP
26	BUSH SADDLE
27	COVER DRIVE DUP
28	HARN ASSY DUP EARTH (T432-T4320)

PL12.1 550 Feeder (Option) (1/5) [Illustration]

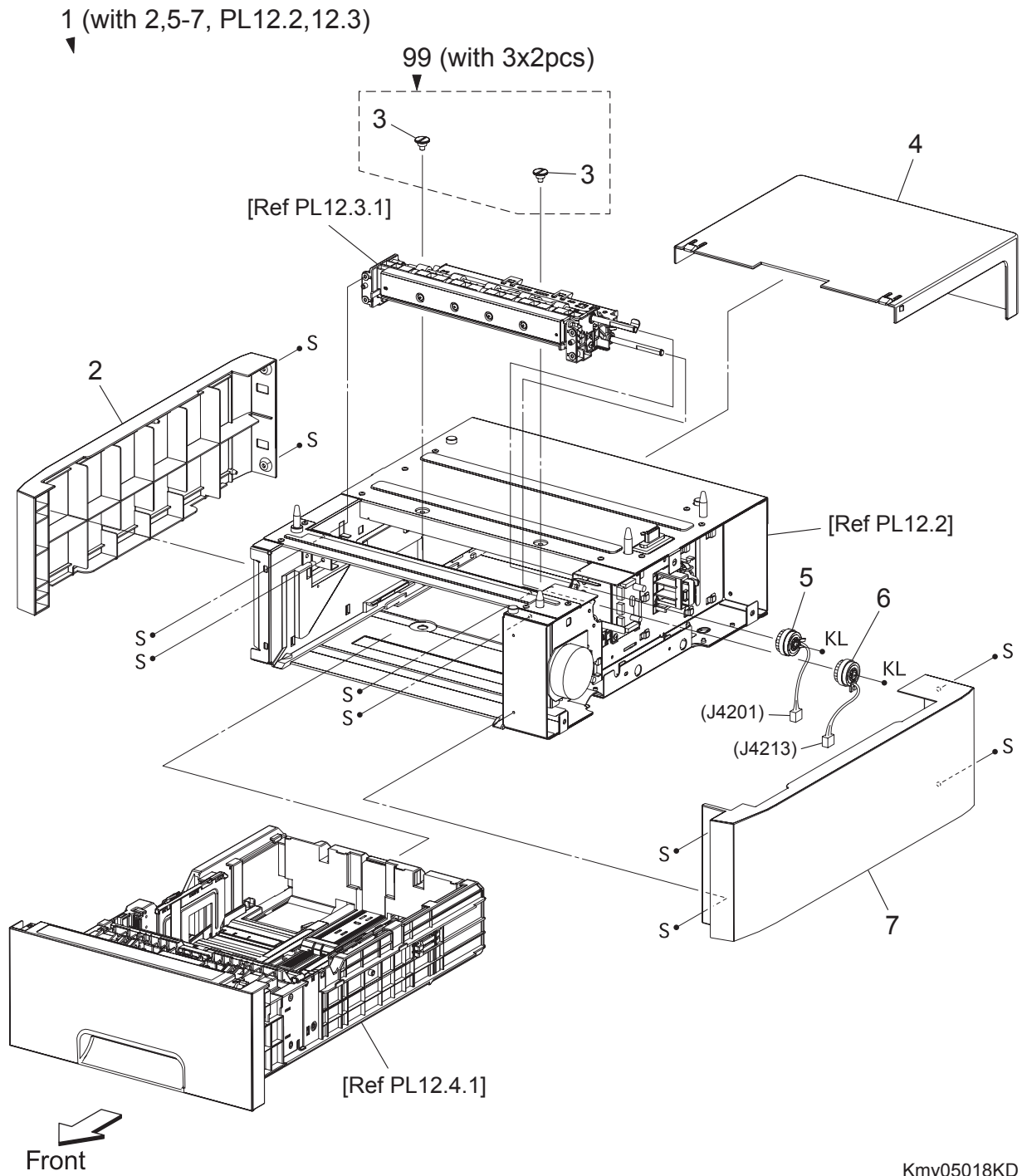

PL12.1 550 Feeder (Option) (1/5) [List]

Item	Parts name
1	550 OPTION FEEDER (with 2,5-7, PL12.2, 12.3)
2	COVER LEFT
3	SCREW JOINT
4	COVER CST 550
5	CLUTCH ASSY TURN OPT
6	CLUTCH ASSY FEED OPT
7	COVER RIGHT
99	KIT SCREW JOINT (with 3x2pcs)

PL12.2 550 Feeder (Option) (2/5) [List]

Item	Parts name
1	FRAME ASSY OPT
2	--
3	HARN ASSY FDR UNIT (J281-J419)
4	BRACKET LOCK
5	SWITCH ASSY SIZE OPT
6	PWBA OPT FDR
7	HARN ASSY C2 CHUTE (J421-J4211,P4212,P4213)
8	HARN ASSY C2 TURN (J420-P4201,P4202)
9	HARN ASSY C2 MOT (J422-J4221,J4222)
10	DRIVE ASSY OPT FDR
11	GUIDE TRAY R 550
12	GUIDE ASSY 550 L (with 13,17)
13	GUIDE TRAY L 550
14	--
15	FOOT
16	CLAMP MINI
17	SPRING CST LOCK
18	CLAMP LOCKING
99	KIT FOOT ASSY (with 15x4pcs)

PL12.3 550 Feeder (Option) (3/5) [Illustration]

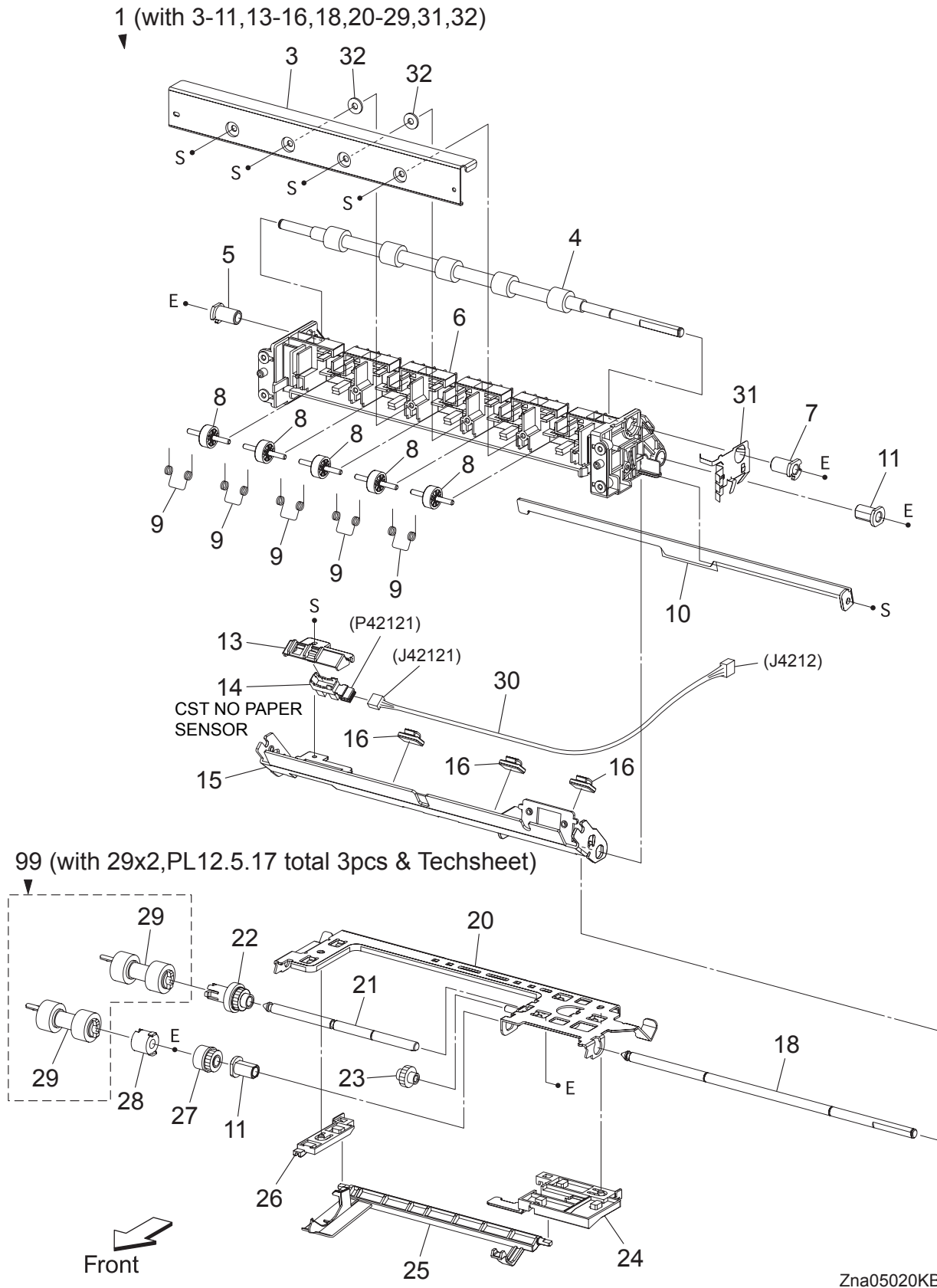

Zna05020KB

PL12.3 550 Feeder (Option) (3/5) [List]

Item	Parts name
1	FDR ASSY OPT (with 3-11,13-16,18,20-29,31,32)
2	--
3	COVER CHUTE
4	ROLL ASSY TURN
5	BEARING REGI
6	CHUTE FDR OPT
7	BEARING REGI E
8	ROLL PINCH TURN
9	SPRING PINCH TURN
10	CHUTE ASSY BTM
11	BEARING NUDGER
12	--
13	HOLDER NO SNSR
14	SENSOR PHOTO (CST NO PAPER SENSOR)
15	CHUTE ASSY SEPARATOR
16	CLAMP
17	--
18	SHAFT FEED OPT
19	--
20	SUPPORT NUDGER ASSY
21	SHAFT NUDGER
22	ROLL ASSY GEAR NUDGER
23	GEAR IDLER NUDGER
24	HOLDER NO PAPER L A4
25	ACTUATOR NO PAPER A4
26	HOLDER NO PAPER R A4
27	CLUTCH ONEWAY NUDGER
28	CLUTCH ONEWAY FEED
29	ROLL ASSY FEED
30	HARN ASSY C2 NO PAPER (J4212-J42121)
31	PLATE EARTH OPT
32	WASHER
99	KIT SEPARATOR and FEED ROLLER (with 29x2, PL12.5.17 total 3pcs & Techsheet) *1

*1 : Periodic Replacing Parts (100KPV)

PL12.4 550 Feeder (Option) (4/5) [Illustration]

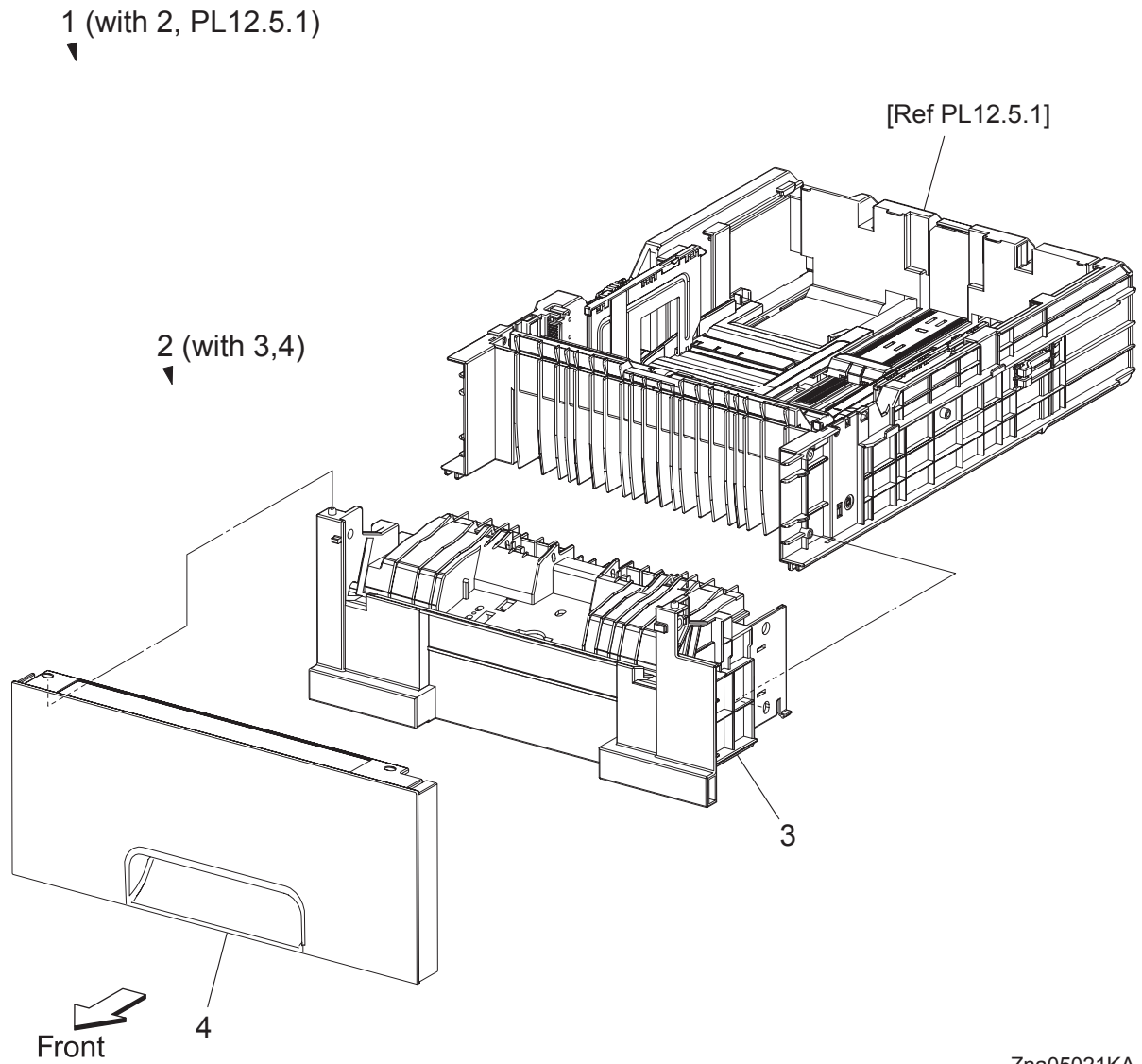

PL12.4 550 Feeder (Option) (4/5) [List]

Item	Parts name
1	CASSETTE ASSY 550 OPT (with 2, PL12.5.1)
2	CASSETTE ASSY FRONT 550 OPT (with 3,4)
3	HOUSING BASE FR 550
4	HANDLE CST 550 OPT

PL12.5 550 Feeder (Option) (5/5) [List]

Item	Parts name
1	CASSETTE ASSY REAR 550 (with 2-13,18-34)
2	PLATE ASSY BTM A4
3	STOPPER PB
4	GEAR BTM LOCK ONEWAY
5	SHAFT PB A4
6	GEAR BTM DMP ONEWAY
7	GEAR PB L
8	SPRING BTM UP 550 A4
9	GUIDE ASSY SIDE R 550 A4
10	GUIDE ASSY SIDE L 550 A4
11	GEAR PINION
12	HOLDER ASSY SEPARATOR (with 14-17)
13	CVR SPRTR CST
14	HOLDER SEPARATOR
15	SHAFT SEPARATOR
16	CLUTCH FRICTION SPRTR
17	SEPARATOR ROLLER
18	SPRING SEPARATOR
19	SWITCH SIZE SET
20	PLATE LOCK CST
21	PLATE GEAR LOCK 550
22	GUIDE ASSY CST END 550
23	ACTUATOR SIZE
24	HSG BASE RE 550
25	ACTUATOR RLS PB
26	SPRING STOPPER GEAR
27	GEAR PB R
28	COVER BTM UP 550
29	RACK BTM LOCK 550
30	SPRING BTM LOCK
31	GEAR BTM LOCK PINION
32	GEAR LEVER BTM LOCK
33	LEVER BTM LOCK
34	GEAR 40 BTM LOCK

Chapter 6 Principles of Operation CONTENTS

1. Printing Process	6 - 1
1.1 Summary of Printing Process	6 - 1
1.2 Schematic Diagram for Printing Processes	6 - 2
1.3 Description of Printing Process Techniques	6 - 3
1.3.1 Charging with electricity	6 - 3
1.3.2 Exposure.....	6 - 4
1.3.3 Development.....	6 - 6
1.3.4 Transfer (Drum -> Paper)	6 - 8
1.3.5 Cleaning (TONER CARTRIDGE).....	6 - 10
1.3.6 Fusing	6 - 11
2. Paper Path.....	6 - 12
2.1 Paper Path	6 - 12
2.2 Layout of Paper Path	6 - 13
3. Functions of Major Functional Components	6 - 14
3.1 Paper Cassette	6 - 14
3.1.1 Major functions.....	6 - 14
3.1.2 Reference diagram	6 - 15
3.1.3 Multiple Sheet Feed Prevention.....	6 - 16
3.1.4 Reference diagram	6 - 16
3.1.5 Bottom Plate Moving.....	6 - 17
3.2 Paper Feeder	6 - 18
3.2.1 Major functions.....	6 - 18
3.2.2 Reference diagram	6 - 19
3.3 MPF & Regi Assy.....	6 - 20
3.3.1 Major functions.....	6 - 20
3.3.2 Reference diagram	6 - 21
3.3.3 Multiple Sheet Feed Prevention.....	6 - 22
3.3.4 Reference diagram	6 - 22
3.3.5 Lead-edge Registration.....	6 - 23
3.3.6 Reference diagram	6 - 23
3.3.7 Paper detection by the Regi Sensor	6 - 24
3.3.8 Reference diagram	6 - 24
3.4 Transfer Belt & Fuser.....	6 - 26
3.4.1 Major functions.....	6 - 26
3.4.2 Reference diagram	6 - 27
3.5 PRINTHEAD	6 - 28
3.5.1 Major functions.....	6 - 28
3.5.2 Reference diagram	6 - 29
3.6 TONER CARTRIDGE	6 - 30
3.6.1 Major functions.....	6 - 30
3.6.2 Reference diagram	6 - 31
3.7 Drive.....	6 - 32
3.7.1 Major functions.....	6 - 32
3.7.2 Reference diagram	6 - 34
3.8 Electrical	6 - 36

Chapter 6 Principles of Operation CONTENTS

3.8.1 Major functions.....	6 - 36
3.8.2 Reference diagram	6 - 37
3.8.3 Data Flow.....	6 - 38
3.9 Duplex.....	6 - 40
3.9.1 Major functions.....	6 - 40
3.9.2 Reference diagram	6 - 41
3.10 550 Paper Feeder	6 - 42
3.10.1 Major functions (Paper Cassette)	6 - 42
3.10.2 Reference diagram	6 - 42
3.10.3 Multiple paper feed prevention.....	6 - 43
3.10.4 Reference diagram	6 - 43
3.10.5 Bottom Plate Moving.....	6 - 44
3.10.6 Major functions (Feeder).....	6 - 46
3.10.7 Reference diagram	6 - 47
4. MODES	6 - 48
4.1 Operation Modes	6 - 48
5. Control	6 - 49
5.1 Control of Paper Size.....	6 - 49
5.2 Selective Control on Paper Cassette.....	6 - 49
5.3 PRINTHEAD Light Quantity Control	6 - 49
5.4 Process Control	6 - 50
5.4.1 Potential Control	6 - 50
5.4.2 Toner Density Control.....	6 - 51
5.4.3 High Area Coverage Mode	6 - 51
5.4.4 Admix Mode.....	6 - 51
5.4.5 ADC Sensor Adjustment.....	6 - 51
5.5 Color Registration Control.....	6 - 52
5.6 Fuser Control	6 - 53
5.6.1 Fuser temperature control.....	6 - 53
5.6.2 Cooling down	6 - 53
5.6.3 Sensor Warm-up.....	6 - 53
6. Drive Transmission Route	6 - 54
6.1 PHOTOCONDUCTOR (PC)/DEVELOPER (DEV) DRIVE.....	6 - 54
6.2 TONER DISPENSER (Y, M, C, K).....	6 - 60
6.3 FEED DRIVE ASSEMBLY	6 - 62
6.4 DRIVE ASSY DUP	6 - 64
6.5 DRIVE ASSY OPT FDR.....	6 - 66

1. Printing Process

1.1 Summary of Printing Process

This printer is a "Full-color laser printer" which applies the principle of an electrophotographic recording system. The tandem system comprising the four color TONER CARTRIDGES of yellow, magenta, cyan and black (Y, M, C and K) creates the toner image.

Printing processes of this printer is composed of the basic steps as follows.

- (1) Charge: Drum surface is charged with electricity.
- (2) Exposure: Image unit is exposed to laser beams.
- (3) Development: Image is developed with toner.
- (4) Transfer: Four-color finished toner image on the Drum is transferred onto the paper.
- (5) Cleaning: Remaining toner on the drum is collected.
- (6) Fusing: Toner on the paper is fixed by heat and pressure.
- (7) Cleaning: Remaining toner on the belt is collected.

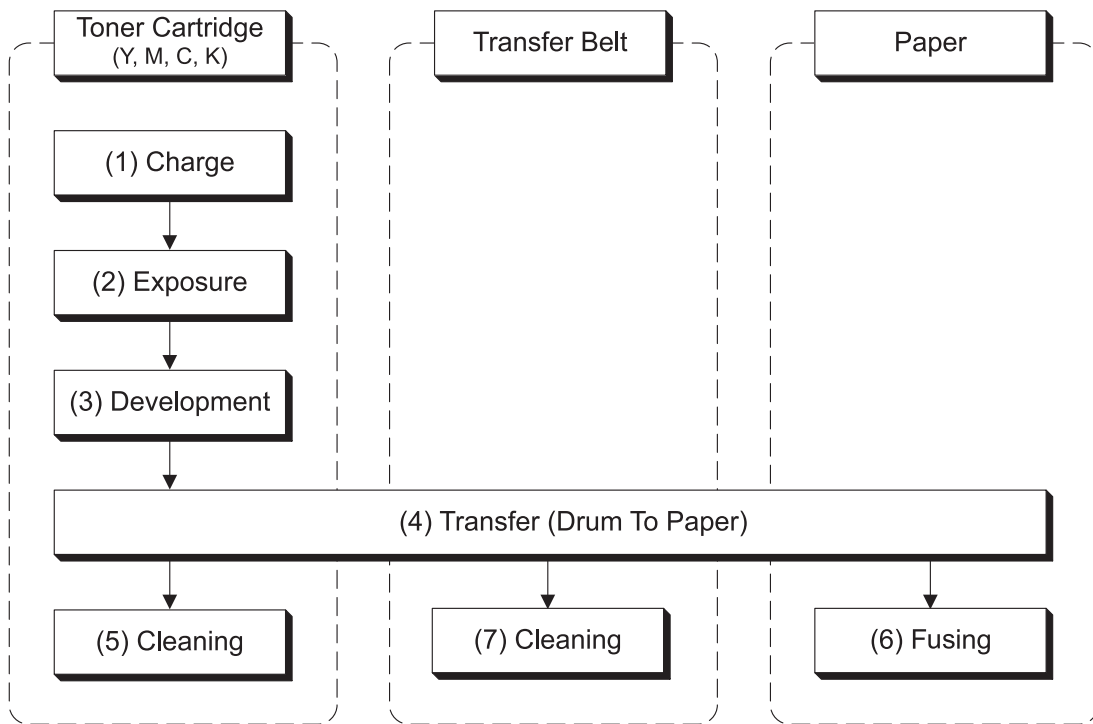

Zna06001KA

1.2 Schematic Diagram for Printing Processes

Outline of printing processes is shown in the figure below.

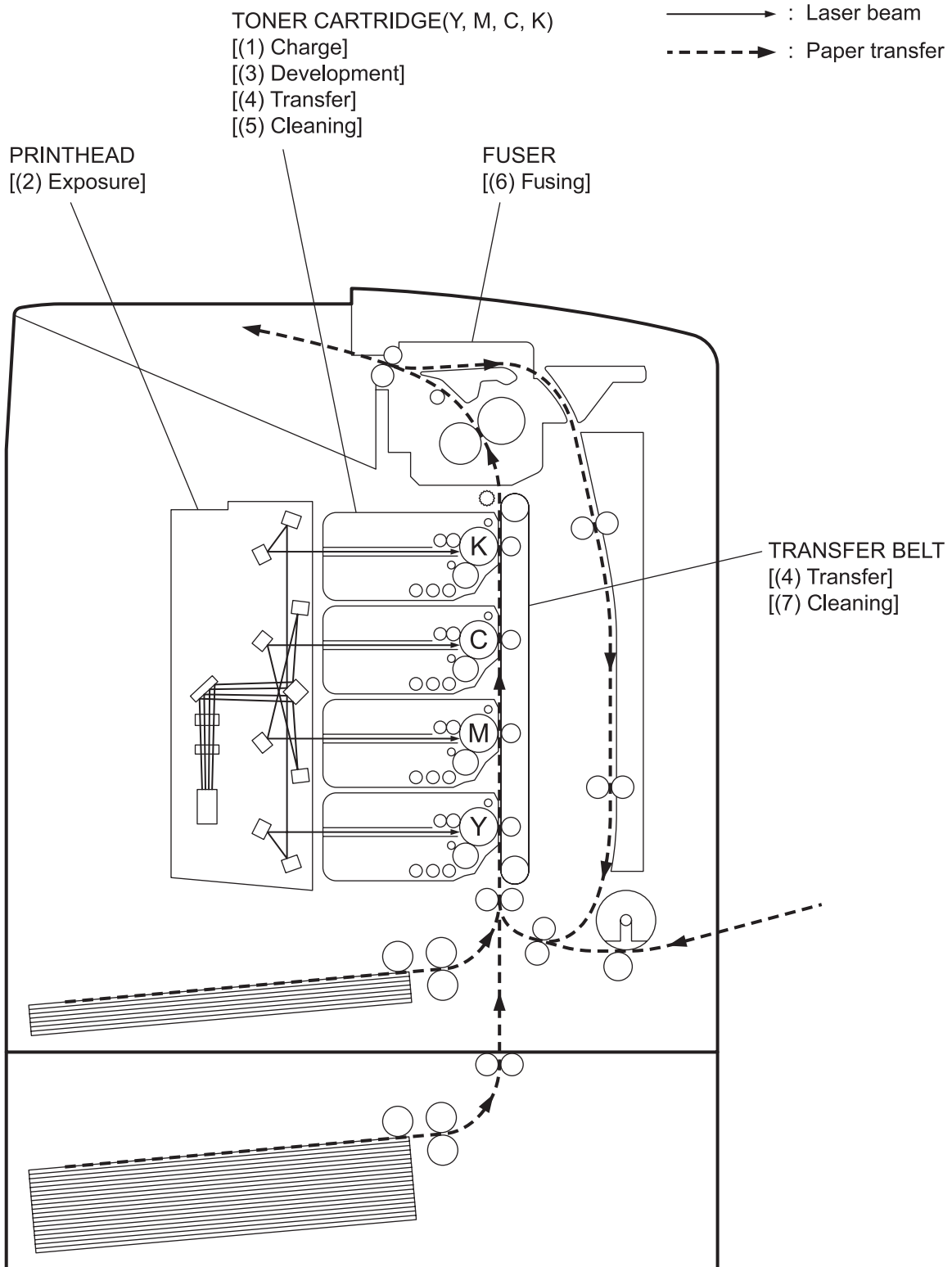

Zna06002KB

1.3 Description of Printing Process Techniques

1.3.1 Charging with electricity

In the charging process, the drum surface rotating at a constant speed is charged uniformly with negative electricity by the discharge from BCR (Bias Charge Roll).

This process is performed in parallel for yellow, magenta, cyan and black colors.

- The BCR is kept in contact with the drum and rotates following the rotations of the drum. BCR is a conductive roll, receives discharge voltage from the High Voltage Power Supply (HVPS) and discharges a negative DC voltage.
- The drum surface is uniformly and negatively charged with DC bias voltage. The drum surface is a photoreceptor (which is an insulator in the dark and a conductor in the light) and the drum inside is composed of a conductor.
- The Cleaning Roll is a sponge, which contacts with the BCR to catch the toner.

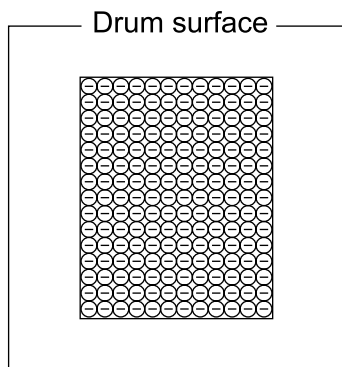
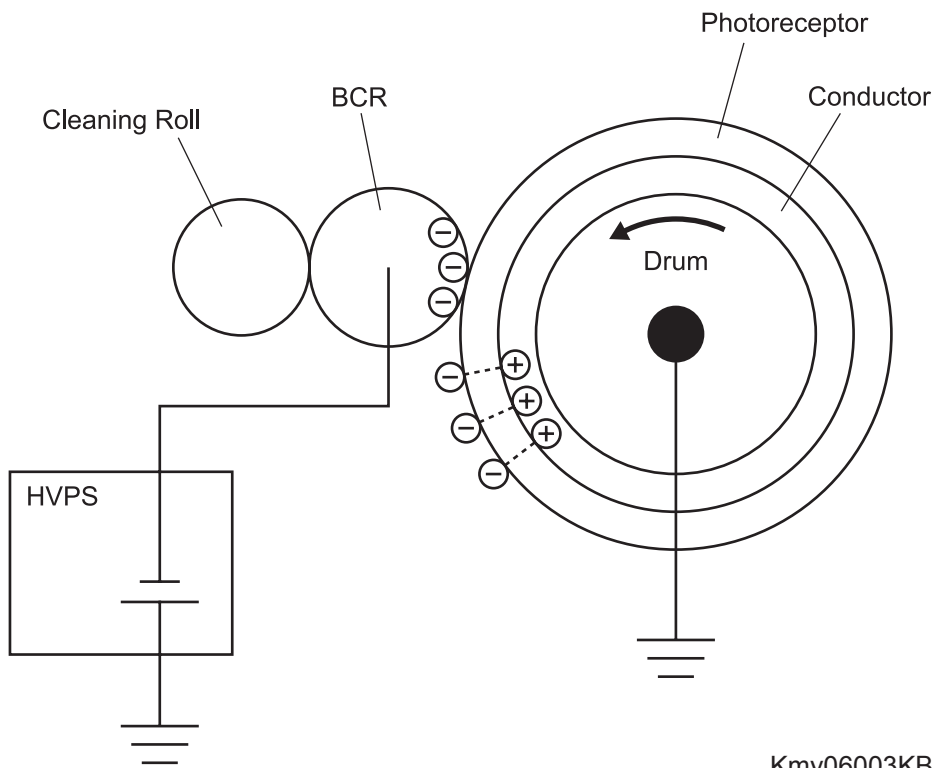

engine principle0005FA

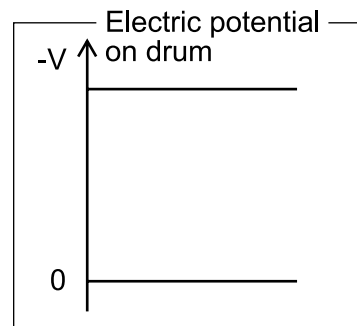

engine principle0006FA

1.3.2 Exposure

In the exposure process, the drum surface charged negatively is scanned by laser beams to form invisible electrostatic latent image on the drum surface.

This process is performed in parallel for yellow, magenta, cyan and black colors.

- Laser beams are emitted from the laser diode in the PRINTHEAD. By the rotating polygon mirror, fixed mirror and lens attached to the Scanner Motor Assy of the PRINTHEAD, the surface of each color drum is scanned from end to end in the axial direction.

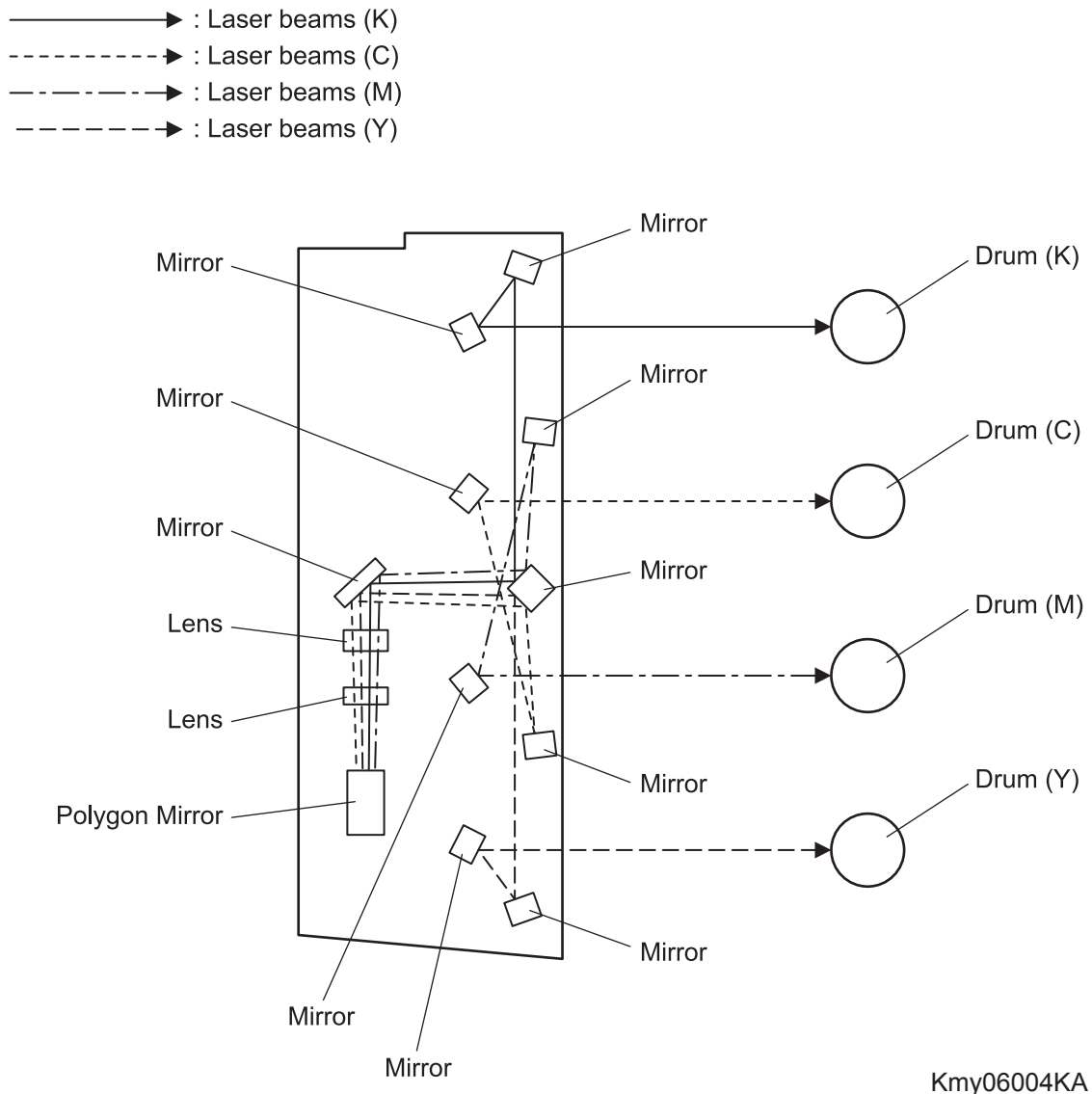

- The laser beam is irradiated according to the printing data (image data) output from the printer controller. The laser beam is output only when printing data is pixels (micro points composing characters or pictures). (The laser diode lights up for parts to be developed by toner, and not for parts that are not to be developed.)

The drum surface irradiated by the laser beam becomes a conductor, and the negative charge on the drum surface flows to the positive side and the charges cancel each other out so that the potential on the drum surface drops. The part on the surface where potential drops becomes the electrostatic latent image.

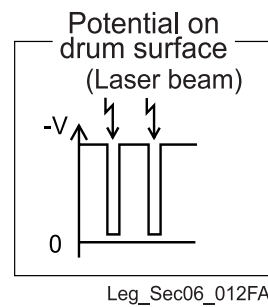
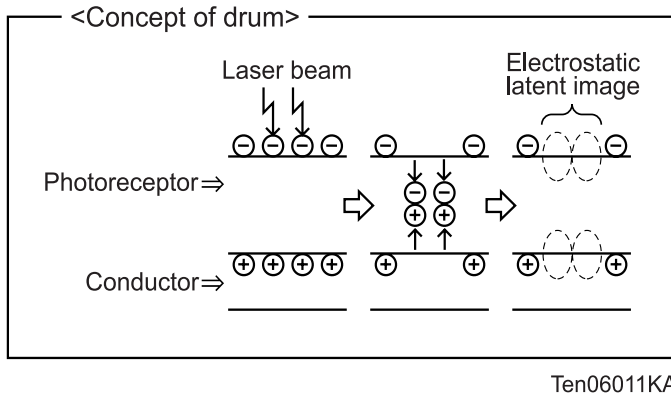
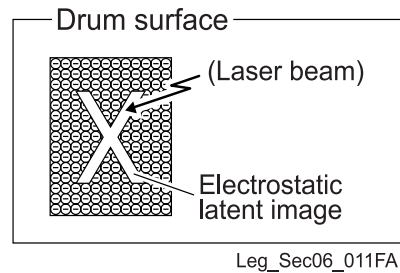
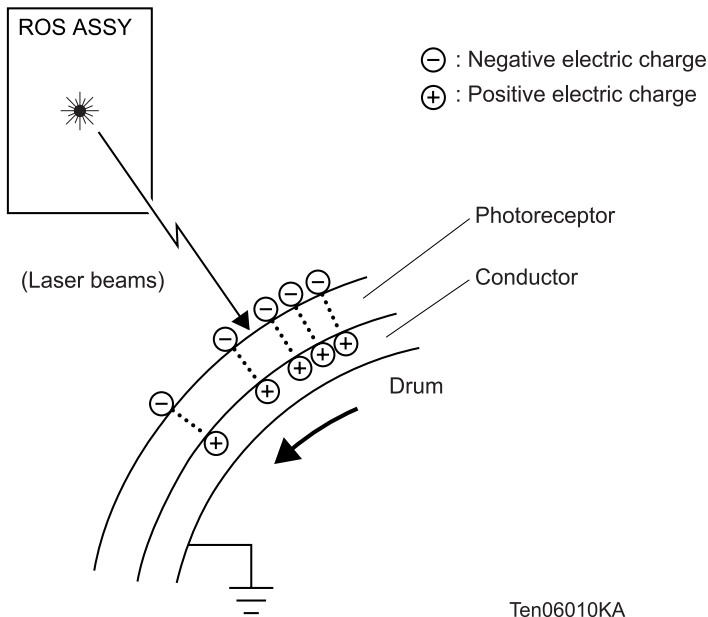

1.3.3 Development

In the development process, toner is electrically attached to the invisible electrostatic latent image on the drum surface to form visible toner image on the drum.

This process is performed in parallel for yellow, magenta, cyan and black color independently.

- The toner in the toner cartridge part is agitated by the built-in Agitator and fed into the developer part. The Auger is driven by the toner motor and the deve motor in the PHOTOCONDUCTOR (PC)/DEVELOPER (DEV) DRIVE. The amount of toner to be consumed according to the print count is calculated and that amount is fed into the developer. This is called "toner dispensation", which is controlled by two types of control, "PCDC" and "ADC". ([Refer to 5.4.2 Toner Density Control](#))
- The toner fed into the developer part and the carrier in the developer part are agitated by the Auger, and supplied to the Magnet Roll arranged in the vicinity of the drum surface. The toner and carrier are charged by friction due to the agitation (toner in negative, carrier in positive), and they are attracted to one another electrically. As the carrier is a magnetic substance, it is attracted to the Magnet Roll having a magnetic force and a homogeneous layer is formed by the Trimmer Bar.
- The magnet roll is covered by a thin semi-conductive sleeve over the surface. DB (Developing Bias) voltage is supplied to this semiconductor sleeve from the High Voltage Power Supply (HVPS). DB voltage is negative DC voltage combined with AC voltage. The magnet roll is kept at a constant negative voltage against the photoreceptor layer of the drum by DC voltage. Therefore, at the area surface where the negative electric charge on the drum does not decrease, potential is lower than the magnet roll, while the potential is higher than the magnet roll at the area where the negative charge on the drum surface decreases. The AC voltage shakes the developer on the magnet roll surface Stimulating the toner to fly to the drum.
Thus, the toner charged negatively is attracted only to the drum surface area where the negative charge has decreased below that of the magnet roll (electrostatic latent image) and the toner image is formed on the drum.
Once the toner is adhered on the drum, the negative charge of the toner-bearing portion increases, which decreases the potential and the toner-attracting force of that portion.

- ⊖ : Negative electric charge
- ⊕ : Positive electric charge
- : Toner
- : Carrier

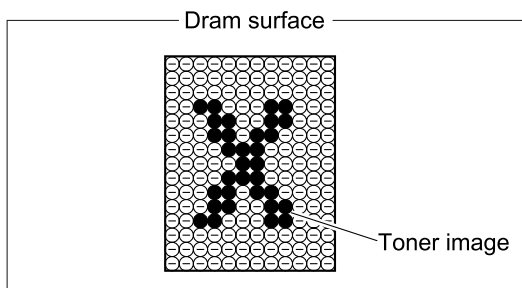
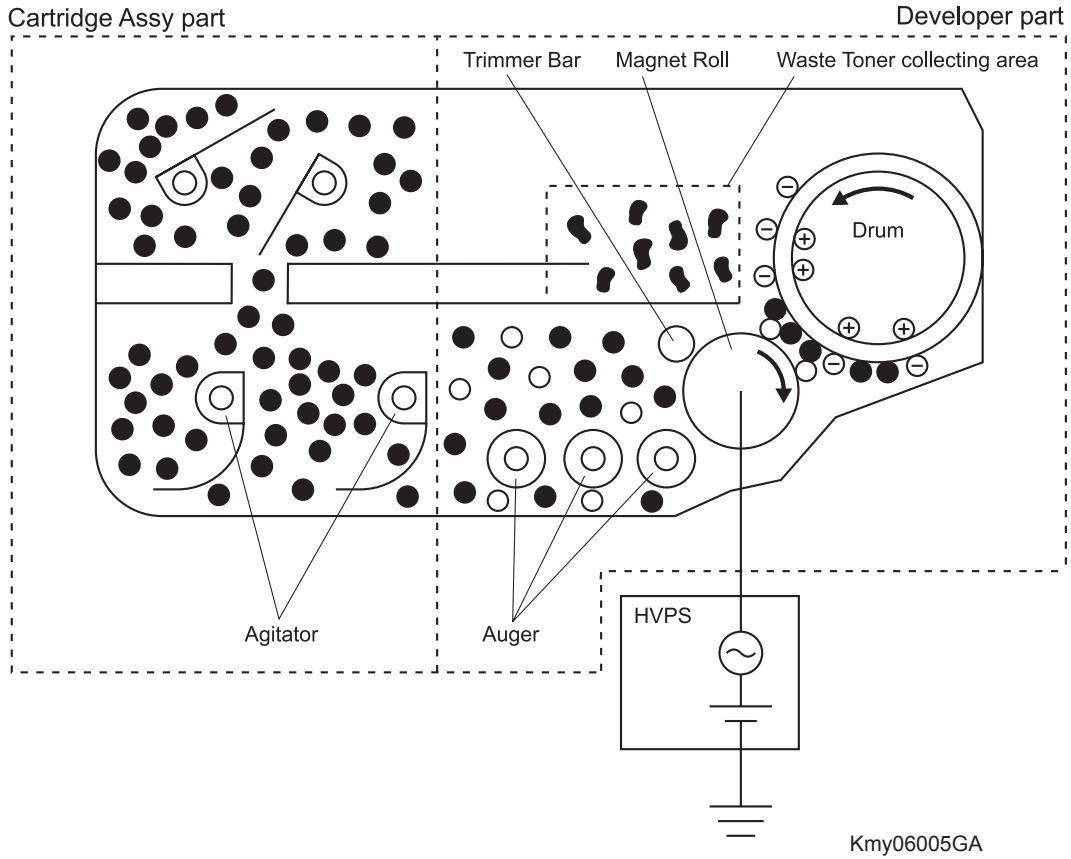

engine principle0013FA

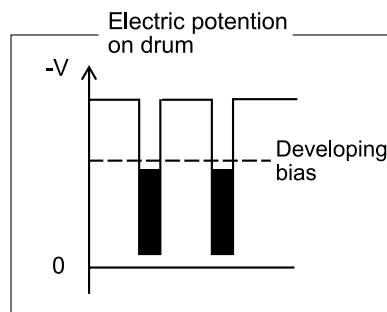

engine principle0014FA

1.3.4 Transfer (Drum -> Paper)

In the transfer process, toner image formed on the drum surface is transferred onto the surface of the paper. The toner is transferred onto the paper in the order of Y, M, C, and K.

- BTR

The BTR (Bias Transfer Roll) is a conductive roll, to which the positive voltage is applied from the High Voltage Power Supply (HVPS). The BTR contacts the rear side of the Belt and applies the positive voltage to the Belt.

- Belt

The Belt is a conductive belt, to which the positive voltage is applied from the BTR. After the negatively charged toner image on the drum surface is drawn by the positive charge on the belt, it is transferred from the drum to the paper. The Belt feeds the paper to the direction of FUSER.

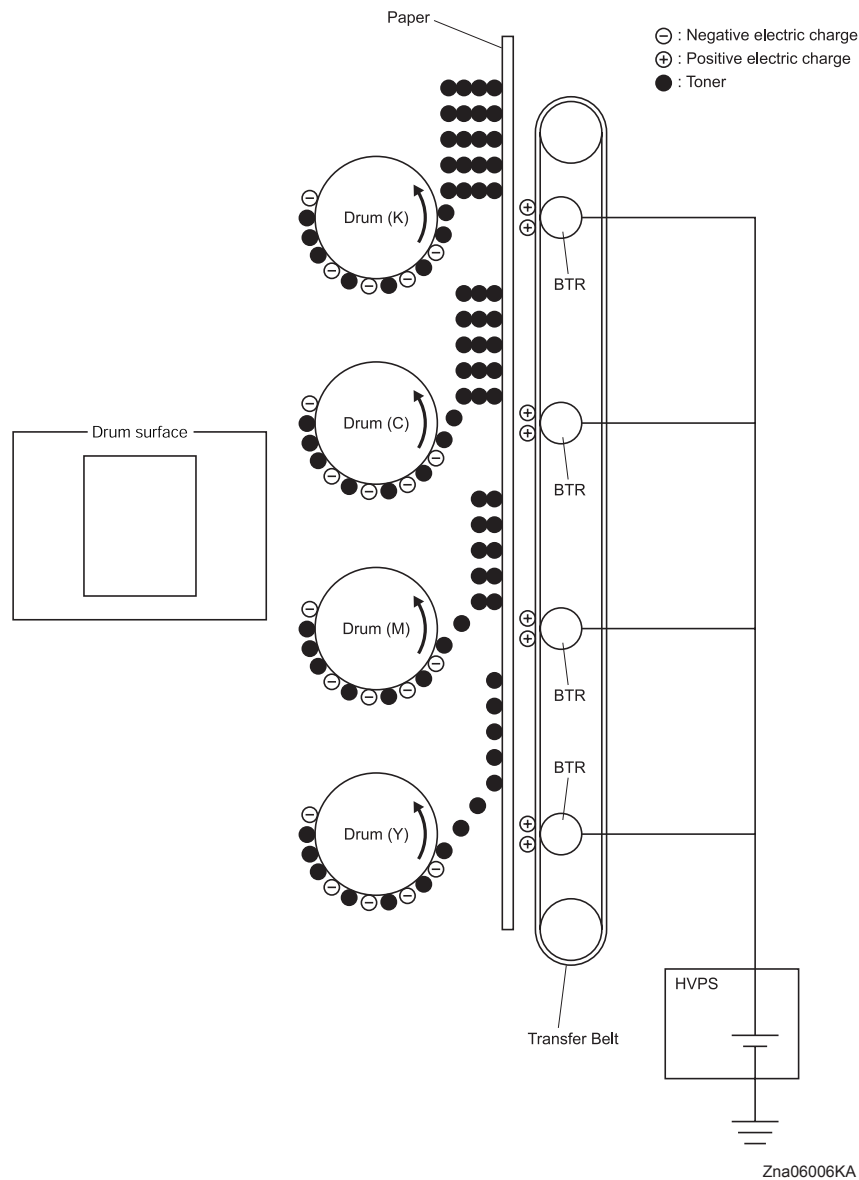

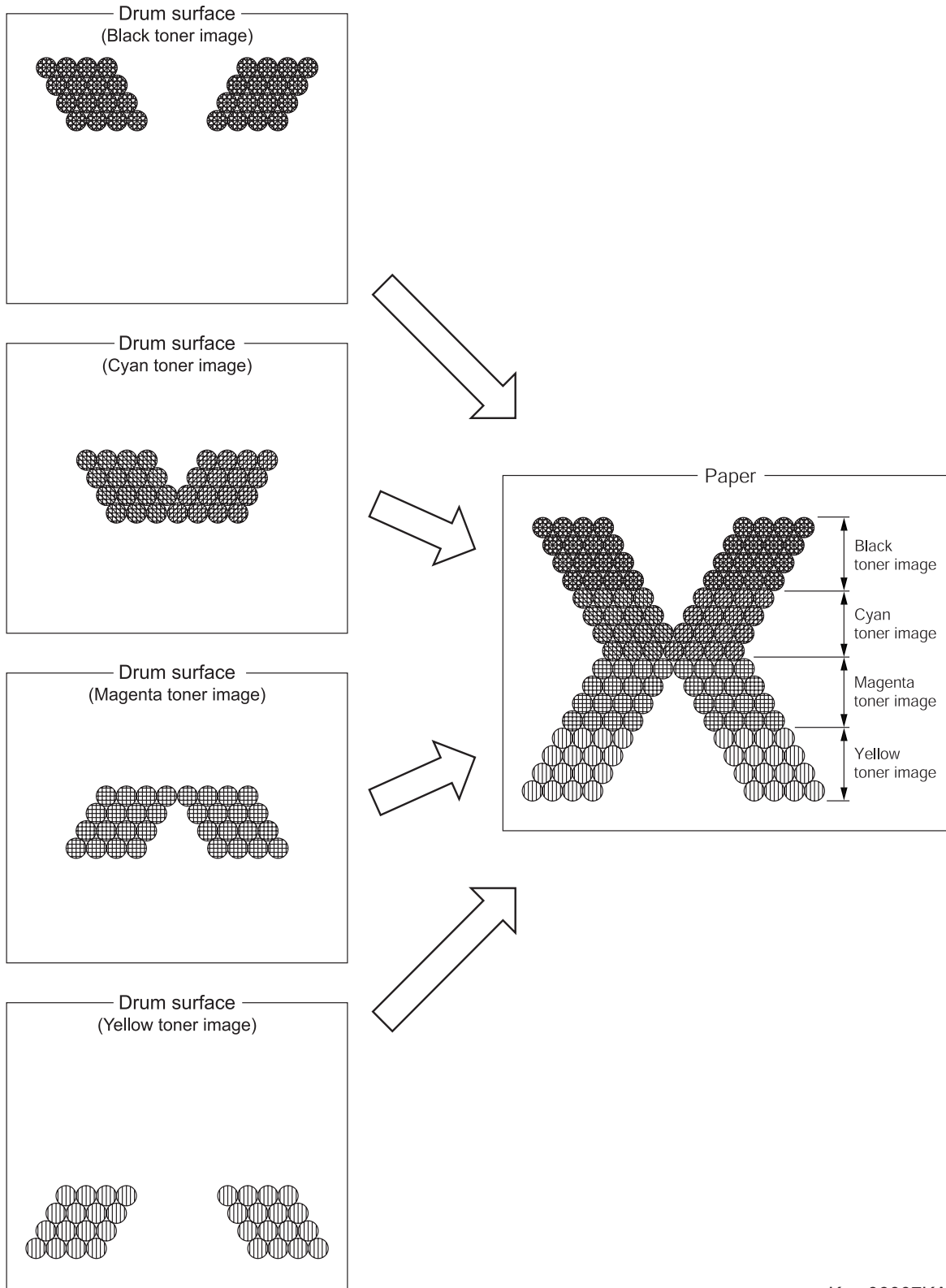

Kmy06007KA

1.3.5 Cleaning (TONER CARTRIDGE)

In the cleaning (TONER CARTRIDGE) process, excess toner is removed from the drum and BCR surfaces, while excess charge is also eliminated from the drum surface.

- Drum cleaning
The cleaning blade contacts the surface of the drum collecting the excess toner by scraping.
- Cleaning Roll
The Cleaning Roll contacts the surface of the BCR collecting the excess toner by scraping.
- Charge cleaning
When the drum is charged by BCR, any excess charge hinders the drum surface from being uniformly charged, which may lead to print quality problems.
The excess charge on the surface of the drum is eliminated by irradiating the light of the Erase Lamp (LED ASSEMBLY).

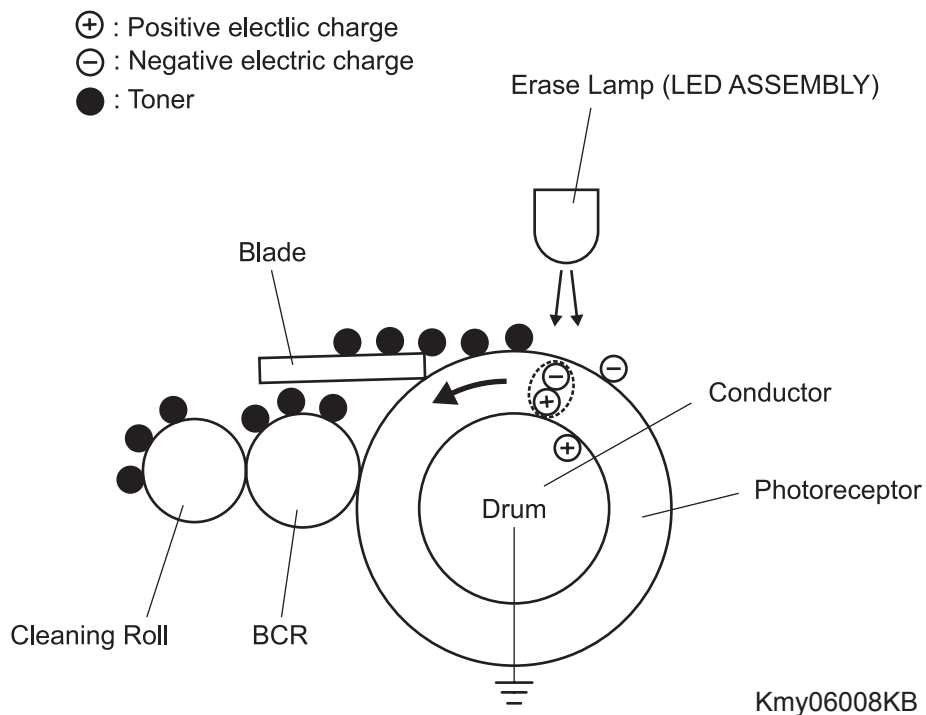

I

1.3.6 Fusing

In the fusing process, toner is fixed on the paper by heat and pressure.

- Since the finished toner image transferred from the belt can be easily broken by a finger touch, the toner image must be fixed on the paper with the FUSER (fusing unit). The toner particles are melted by the HEAT ROLL heated by the Heater lamp and is deposited on the paper under pressure given by the belt opposed against the heat roll.

Conditions to be met to light up the Heater Lamp

	Warm up	Stand by	Printing
Main Heater Lamp	ON	ON/OFF	ON/OFF

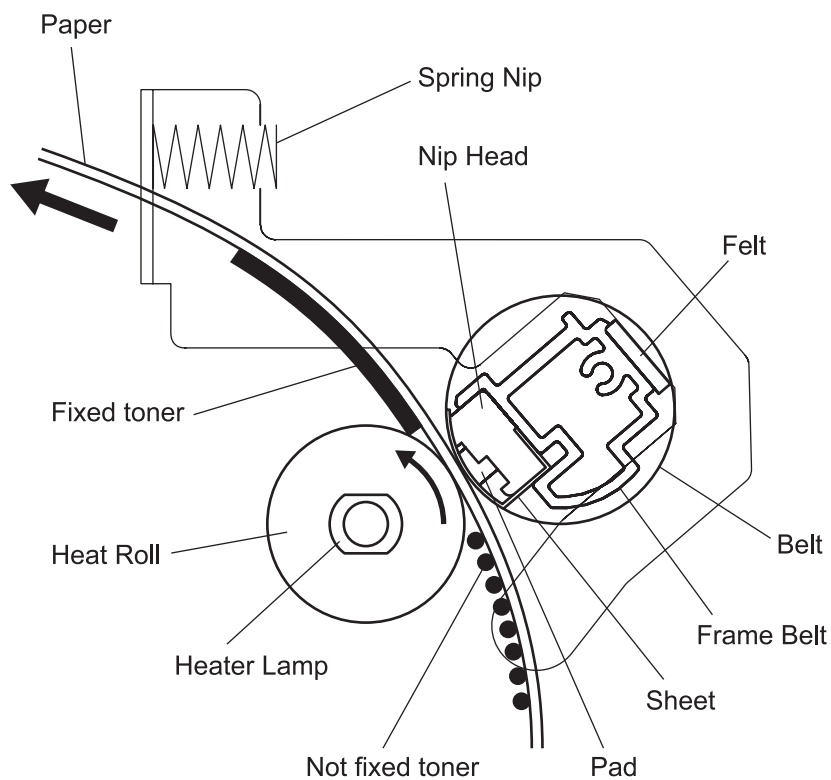

Kmy06010KA

2. Paper Path

2.1 Paper Path

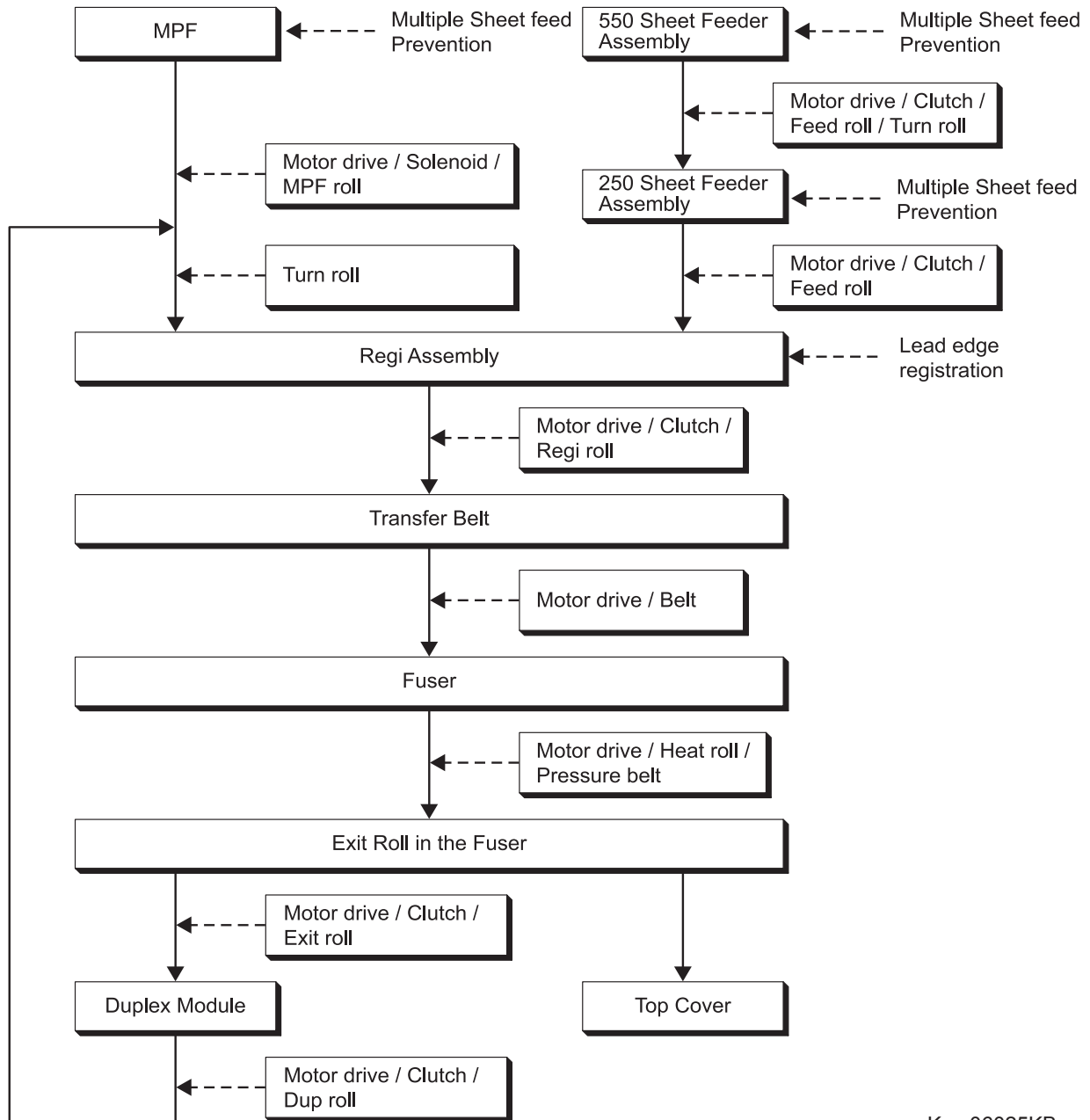

Kmy06025KB

2.2 Layout of Paper Path

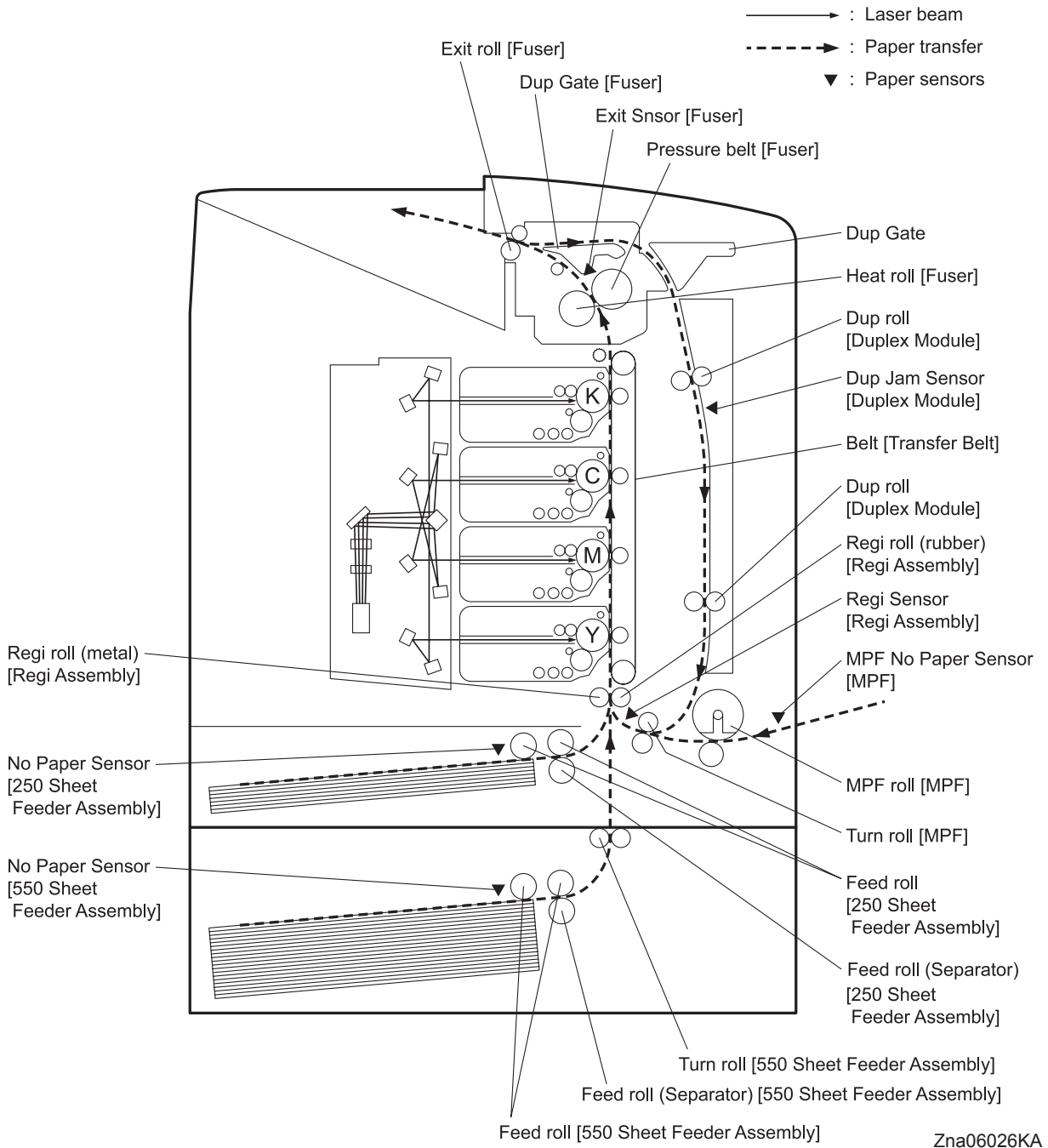

3. Functions of Major Functional Components

Major functional components of the printer are described below with illustrations.

These components are classified into the following blocks based on the configuration of the printer.

- Paper Cassette
- Paper Feeder
- MPF & Regi Assy
- Transfer Belt & Fuser
- PRINTHEAD
- TONER CARTRIDGE
- Drive
- Electrical
- Duplex
- 550 Paper Feeder

3.1 Paper Cassette

3.1.1 Major functions

- Guide Side (R/L)
The Guide Side Assy (R/L) can move at a right angle to the paper transfer direction to align the paper width.

- End Guide
The Guide End Assy can move in the paper transfer direction to determine the paper size. The ON/OFF of SIZE SWITCH ASSEMBLY ([Refer to 5.1 Control of Paper Size](#)) varies according to the Guide End Assy position to detect the paper size.

- FEED ROLLER (SEPARATOR)
The FEED ROLLER (SEPARATOR) and the FEED ROLLER pinch the paper to prevent multiple sheet feed.

- Bottom Plate
Bottom plate is locked to the bottom side when paper cassette is pulled out from the paper feeder and unlocked when paper cassette is installed to the paper feeder. Pushes the paper against the feed roll using a spring tension.

3.1.2 Reference diagram

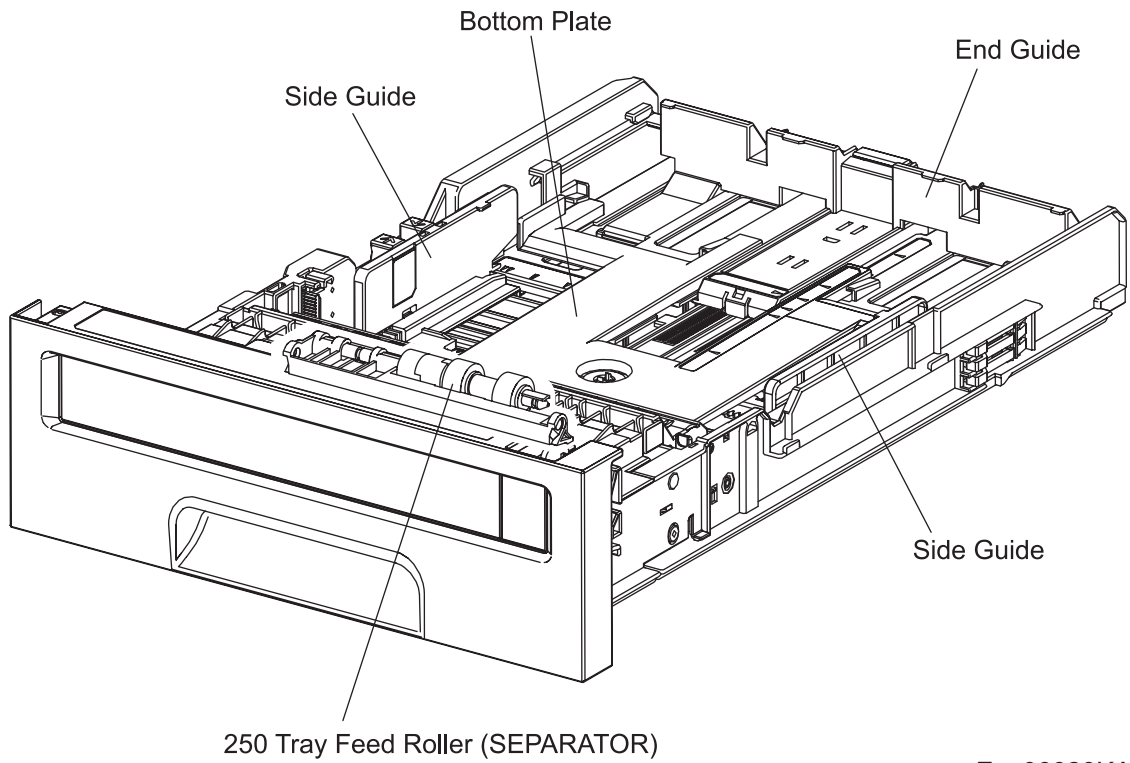

Zna06029KA

3.1.3 Multiple Sheet Feed Prevention

The sheets set in a tray or cassette are occasionally stuck together along the edges. The stuck sheets cause a multiple sheet feed or a jam. The sheets are fed by the Nudger Roll to a position between the Feed Roll and the Separator Roll. Normally, when only one sheet is fed, both the Feed Roll and Separator Roll rotate to allow the sheet to pass. However, when two sheets are fed concurrently, only the Feed Roll rotates and the Separator Roll is locked thereby allowing the upper sheet to pass by being separated from the lower sheet that is stopped by the friction with the Separator Roll at rest.

The Separator Roll is being pushed toward the Feed Roll by spring pressure, and controlled by the torque limiter (Clutch Assy Friction) with which it is coupled.

3.1.4 Reference diagram

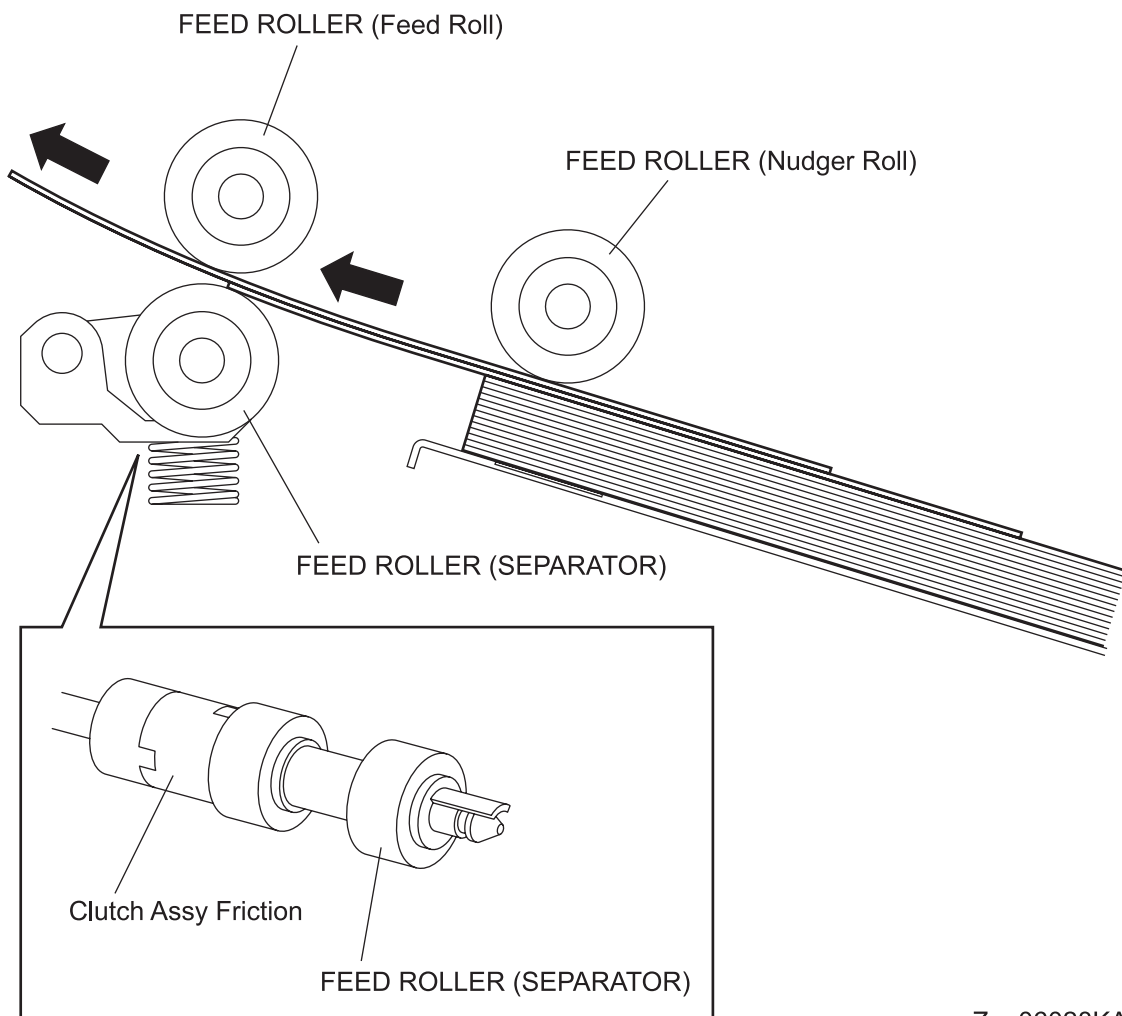

Zna06028KA

3.1.5 Bottom Plate Moving

Inserting the paper tray into the feeder section unlocks the GEAR BTM LOCK ONEWAY. When the paper tray is pushed in until it stops, the gear teeth of the RACK BTM LOCK and GEAR BTM LOCK ONEWAY are out of engagement allowing the PLATE ASSY BTM to rise by the spring pressure of the SPRING BTM UP.

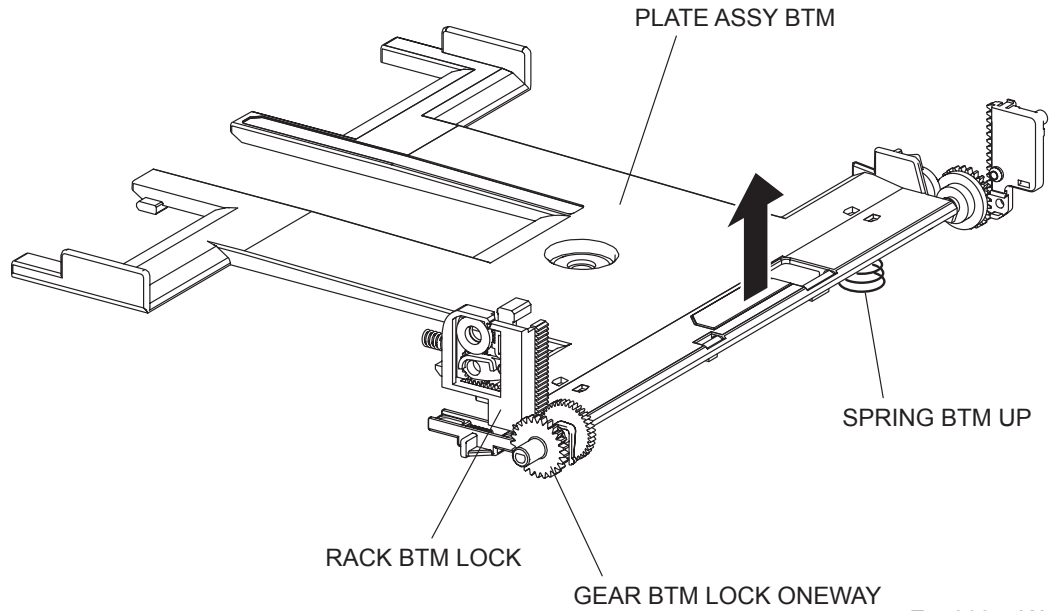

Zna06054KA

3.2 Paper Feeder

3.2.1 Major functions

- SIZE SWITCH ASSEMBLY

SIZE SWITCH ASSEMBLY detects paper size and the presence/absence of the paper tray.

(Refer to 5.1 Control of Paper Size for the combination of switches.)

The paper size is decided at the position of the END GUIDE.

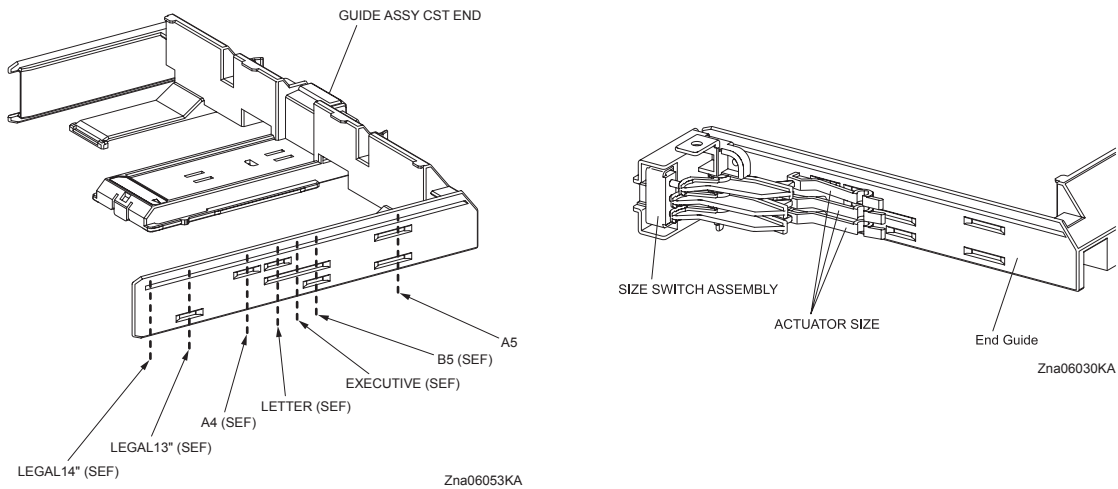

- SENSOR PHOTO (No Paper Sensor)

Detects the presence/absence of paper in the paper tray based on the position of ACTUATOR NO PAPER. (No paper: Sensor beam is intercepted)

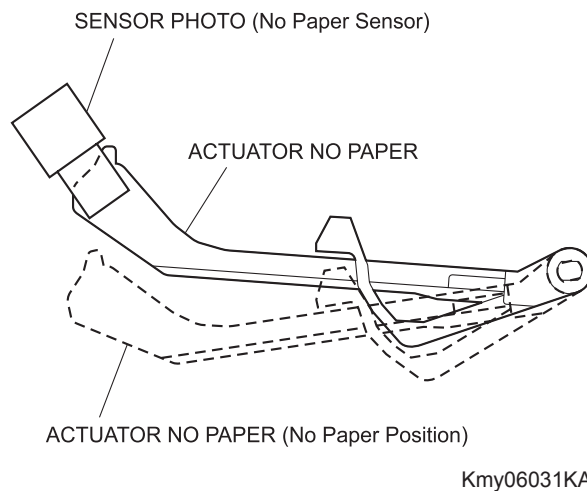

- CLUTCH ASSY FEED

Transmits the drive from the FEED DRIVE ASSEMBLY to FEED ROLLER. (Refer to 6.3 FEED DRIVE ASSEMBLY)

- FEED ROLLER

When the CLUTCH ASSY FEED operates, the FEED ROLLER starts rotating and the FEED ROLLER feeds the paper. (Refer to 6.3 FEED DRIVE ASSEMBLY)

3.2.2 Reference diagram

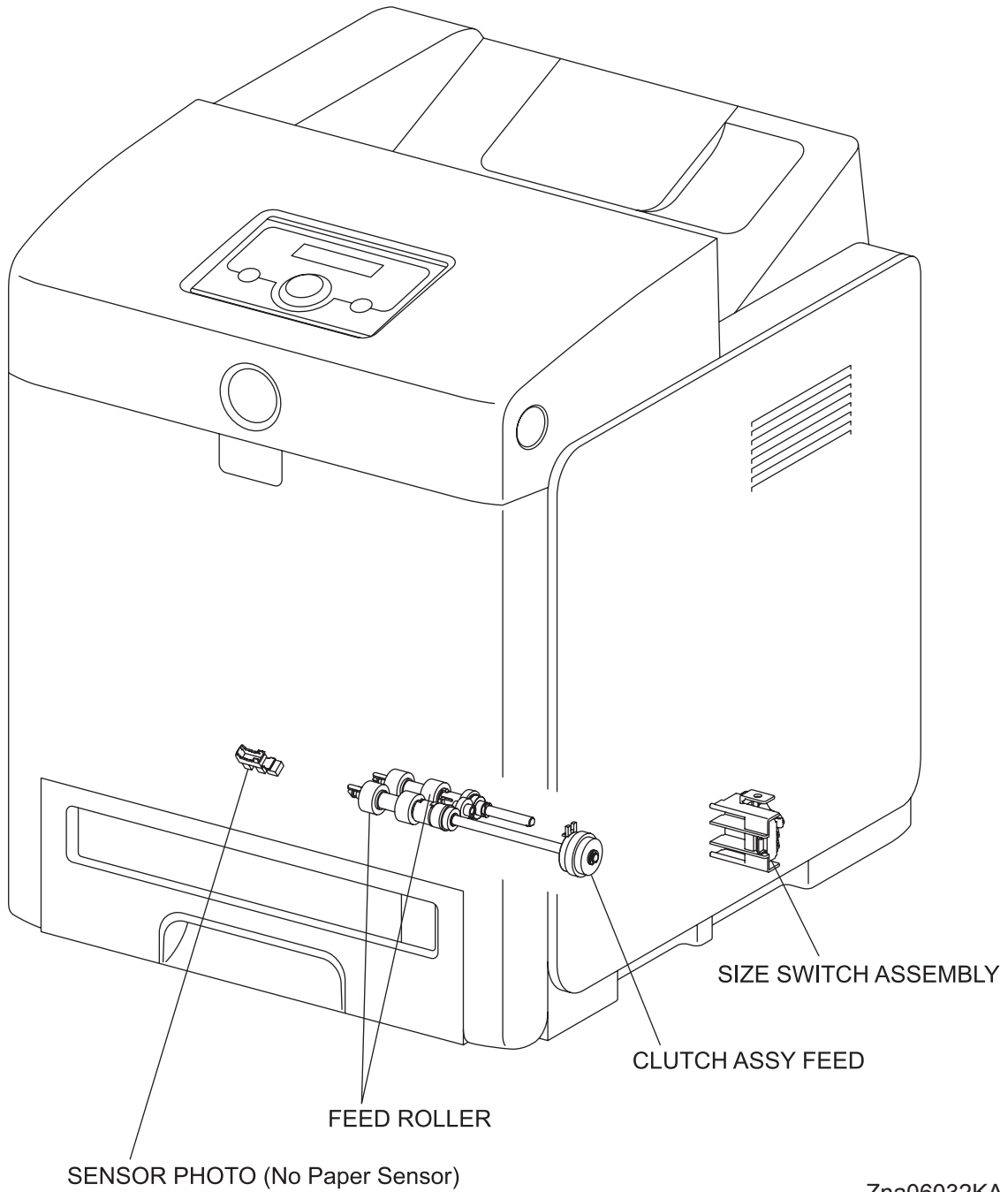

Zna06032KA

3.3 MPF & Regi Assy

3.3.1 Major functions

- MPF FEED SOLENOID

Controls the drive from the FEED DRIVE ASSEMBLY to the MPF ROLLER. (Refer to 6.3 FEED DRIVE ASSEMBLY)

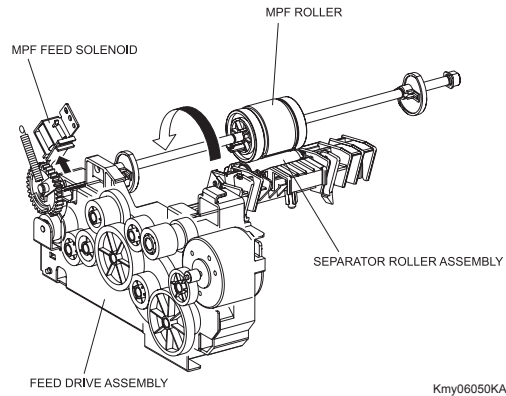

- CLUTCH ASSY TURN

Transmits the drive from the FEED DRIVE ASSEMBLY to the ROLL ASSY TURN. (Refer to 6.3 FEED DRIVE ASSEMBLY)

- ROLL ASSY TURN

The ROLL ASSY TURN is rotated by the drive from the FEED DRIVE ASSEMBLY through the CLUTCH ASSY TURN to feed the paper from the MPF or Duplex to the CHUTE ASSY REGI. (Refer to 6.3 FEED DRIVE ASSEMBLY)

- SENSOR PHOTO (MPF No Paper Sensor)

Detects presence/absence of paper in the MPF tray by the change in actuator position.

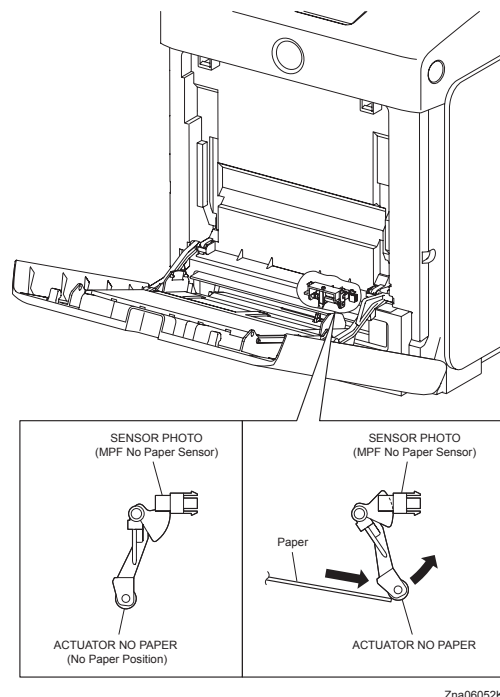

- SENSOR PHOTO (Regi Sensor)

It detects when the paper front end reaches the CHUTE ASSY REGI.

When the paper feeds from the MPF, Regi Sensor is measuring the paper length (size).

The ON time of Regi Sensor is converted into the paper length.

ON: The paper activates the actuator.

- CLUTCH ASSY REGI

CLUTCH ASSY REGI transmits the driving power from the PHOTOCOnductor (PC)/ DEVELOPER (DEV) DRIVE to ROLL REGI RUBBER, and transports the paper from the tray, MPF and duplex path toward the toner cartridge direction. (Refer to 6.3 FEED DRIVE ASSEMBLY)

The timing of sheet feed from the Regi Assy is adjusted by the duration of the CLUTCH ASSY REGI operation so that the toner image on the drum can be transferred to the appropriate position on the sheet.

3.3.2 Reference diagram

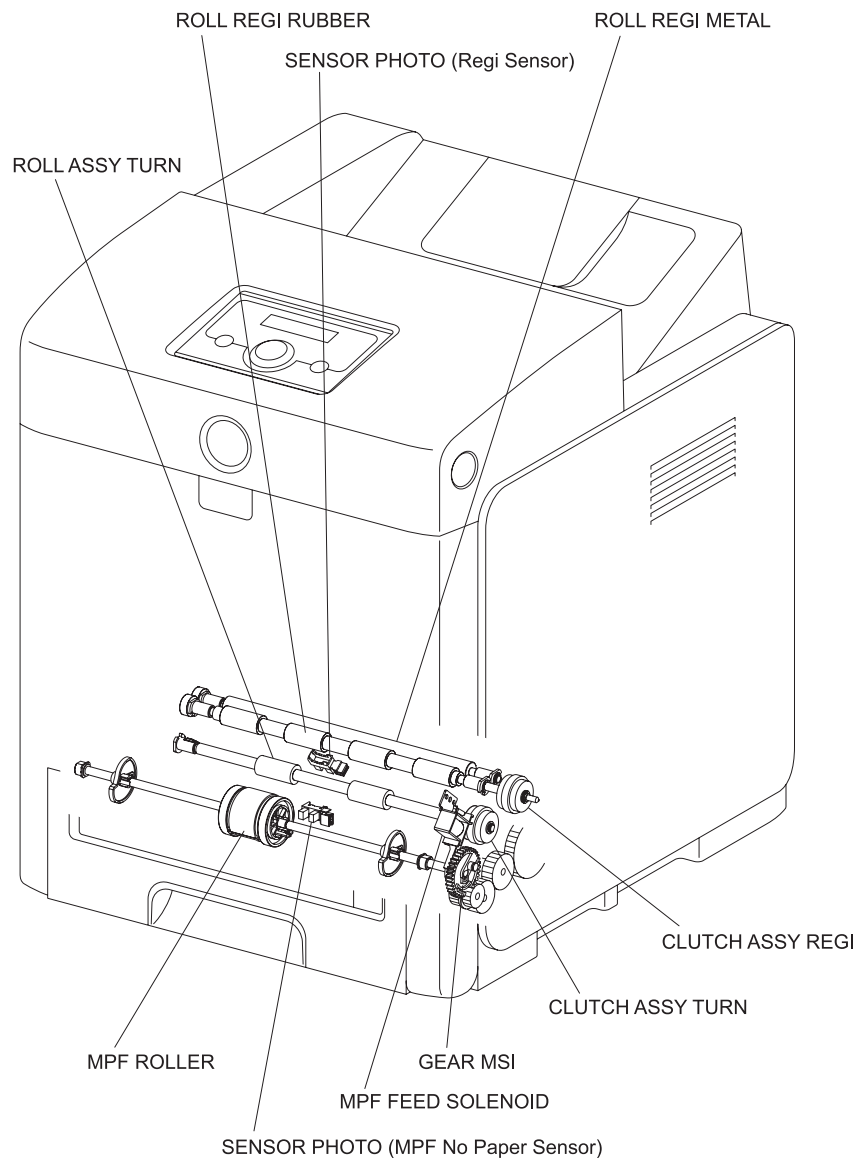

Zna06033KA

3.3.3 Multiple Sheet Feed Prevention

The sheets set in the MPF are occasionally stuck together at the edges. The stuck sheets cause a multiple sheet feed or a jam. Normally, when only one sheet is fed, both the MPF ROLLER and SEPARATOR ROLLER rotate to allow the sheet to pass. However, when two sheets are fed concurrently, only the MPF ROLLER rotates and the SEPARATOR ROLLER is locked thereby allowing the upper sheet to pass by being separated from the lower sheet that is stopped by the friction with the SEPARATOR ROLLER at rest.

The SEPARATOR ROLLER is being pushed toward the MPF ROLLER by spring pressure, and controlled by the torque limiter with which it is coupled..

3.3.4 Reference diagram

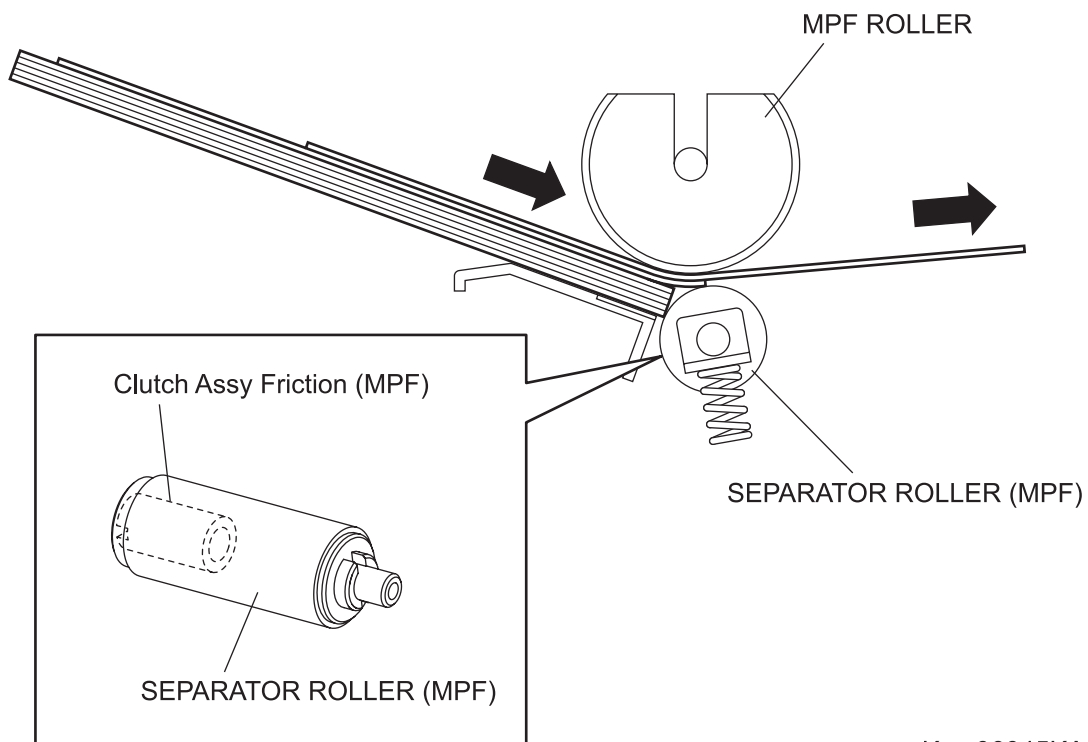

Kmy06045KA

3.3.5 Lead-edge Registration

When a sheet is fed from the MPF or Tray to the toner transfer position, the registration of the sheet may not be correctly maintained due to such troubles as misalignment of lead edges in the tray/cassette. To avoid this trouble, the lead edge position needs to be aligned at the Regi part before the sheet is fed to the toner transfer position.

By thrusting the edge of the sheet coming out of the MPF or Tray against the REGI ROLL that is at rest, the lead edge of the sheet is registered.

3.3.6 Reference diagram

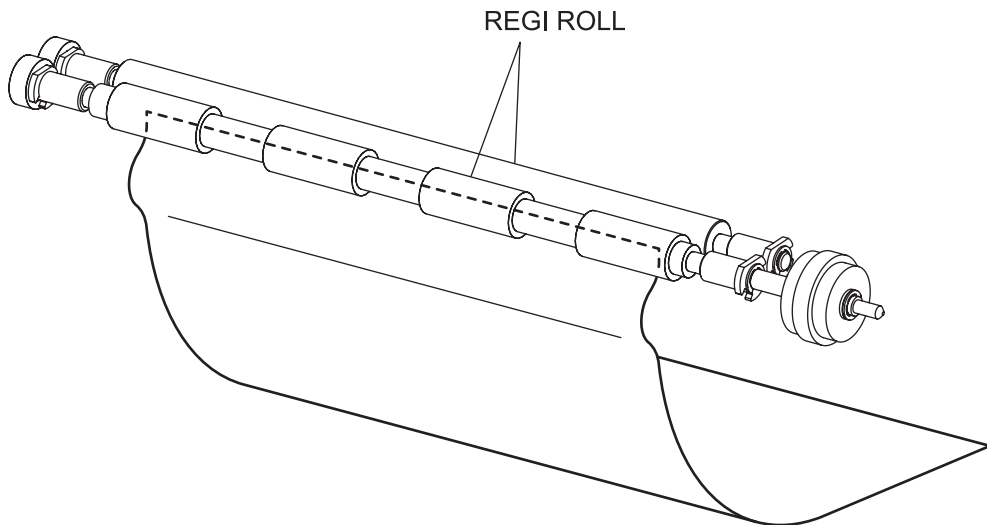

Kmy06034KA

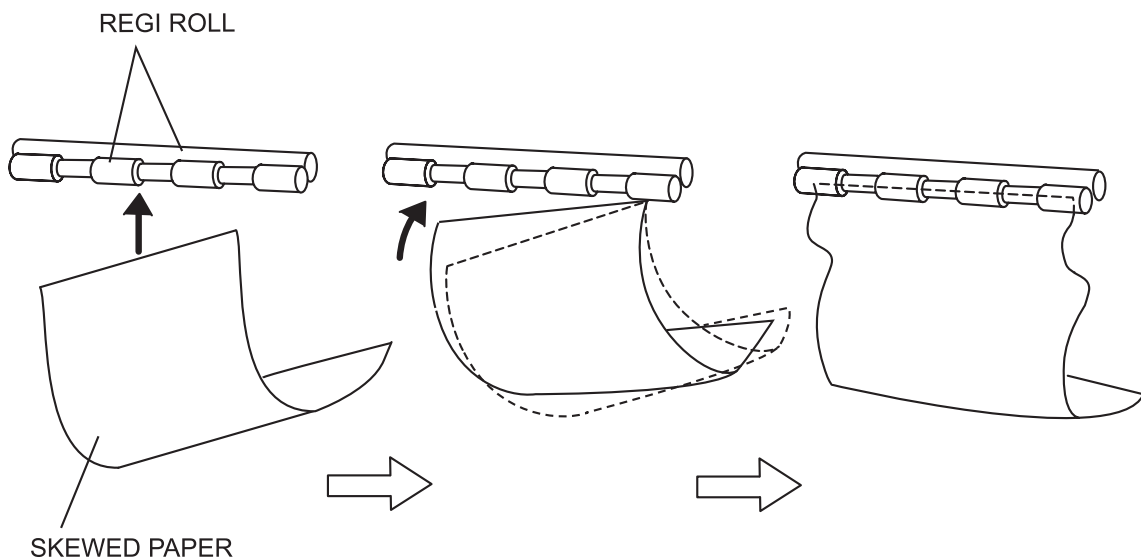

Kmy06049KA

3.3.7 Paper detection by the Regi Sensor

Since the paper path from the MPF/Duplex to the Regi Sensor and that from the Paper Tray to the Regi Sensor are different, the Regi Sensor is provided with the Actuator A and Actuator B.

The Actuator A detects the sheet fed from the MPF/Duplex.

The Actuator B detects the sheet fed from the Paper Tray.

However, the movement of the Actuator A does not affect the Actuator B.

3.3.8 Reference diagram

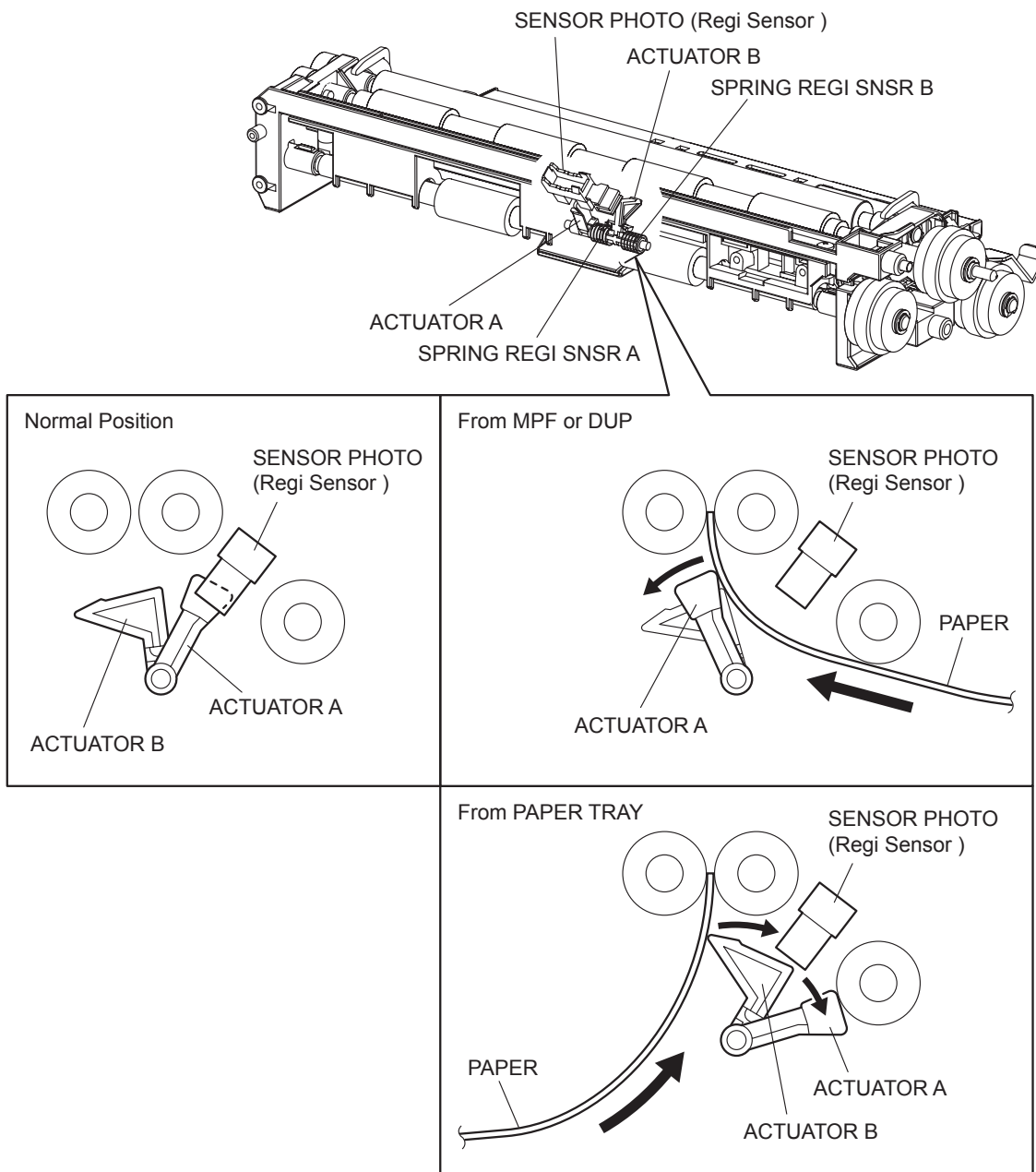

Kmy06057KA

Blank Page

3.4 Transfer Belt & Fuser

3.4.1 Major functions

- FUSER

The FUSER fixes toner which was transferred onto the paper but not fixed by the heat and pressure and feeds paper before and after being fixed.

The FUSER mainly consists of the following parts:

- Heat Roll
- Heater Lamp
- Thermostat
- Temp. Sensor
- Pressure Belt
- Roll Assy Exit
- Exit Sensor

- Exit Sensor

Detects passage of print after fixed based on the change of position of the actuator.

- Transfer Belt

• Belt

Belt feeds the paper to the direction of FUSER

• SENSOR ADC

SENSOR ADC reads the toner patch on the BELT, and converts it to voltage value. Voltage value is used to control the density of toner. (Refer to 5.4.1 Potential Control)

• ADC Solenoid

When turned on, the ADC Solenoid activates the PAD ADC to wipe the ADC Sensor surface clean of contaminants. To activate the PAD ADC, the ADC Solenoid must be turned on for a fixed duration before the ADC Sensor starts reading the toner patches.

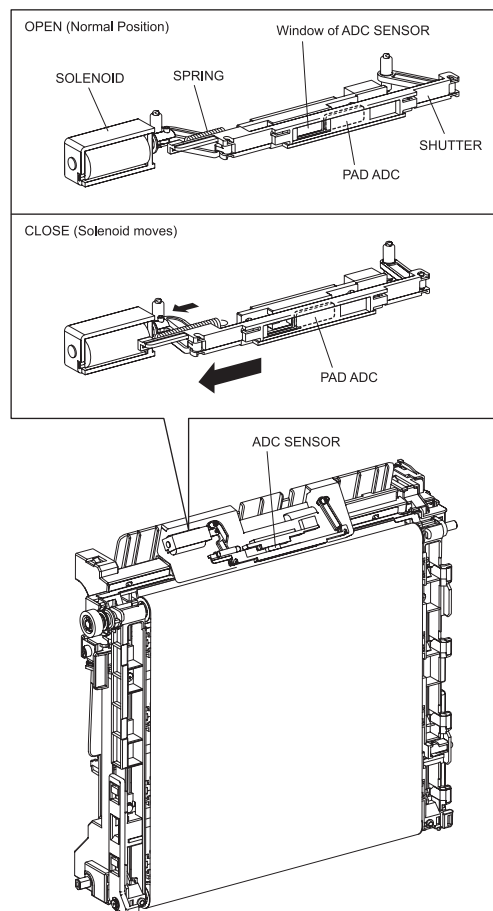

Zna06048KA

3.4.2 Reference diagram

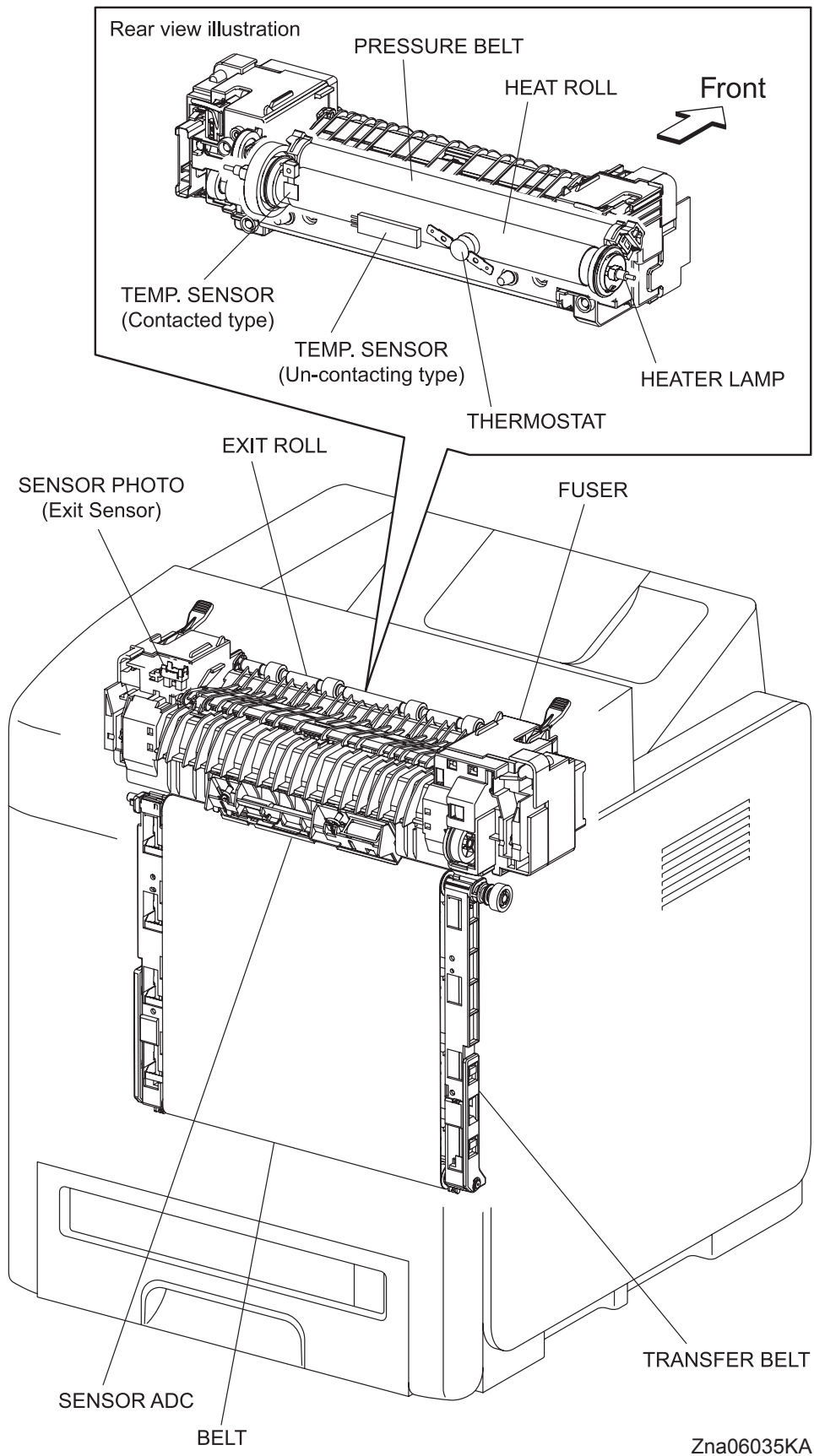

3.5 PRINTHEAD

3.5.1 Major functions

- PRINTHEAD

PRINTHEAD is an exposure unit that generates laser beams to form electrostatic latent image on the drum surface.

In this manual, the PRINTHEAD is referred to as PRINTHEAD.

The PRINTHEAD mainly consists of the following parts:

- LD PWB
- Scanner ASSY
- SOS PWB
- Lens
- Mirror
- Window

* LD PWB

The LD PWB is comprised of four LDs (laser diodes) corresponding to Y, M, C, and K.

Each LD converts the electric signals of incoming image data into laser wave or pulse. In order to stabilize the laser light quantity during formation of an electrostatic latent image, the PWBA LD always monitors the laser light quantity to adjust it to the appropriate level. This is called "APC (auto power control)".

* Scanner Assy

The Scanner Assy is comprised of the Scanner Motor that rotates at a constant speed and the Polygon Mirror that is mounted on the motor shaft.

The laser light output from the LD is irradiated onto the Polygon Mirror via the Mirror.

The Polygon Mirror, provided with twelve reflecting mirror faces, changes the reflection angle of the laser light as it rotates by the Scanner Motor, thereby allowing the laser light to scan the drum along its axial direction. Scanning is performed using one reflecting mirror face for each line.

* Mirror

* Window

* Lens

The laser light reflected from the Polygon Mirror reaches the drum surface via the Lens, Mirror, and Window. The Lens corrects aberration, the Mirror secures an optical path, and the Window prevents foreign matters from entering the ROS.

* SOS PWB

The SOS sensor on the SOS (start of scan) PWB converts an incoming laser beam, upon detection, to an electric signal as the reference signal for starting scanning and transmits this signal to the PWBA MCU.

The SOS sensor signals are used to synchronize the starting point of the laser-beam scanning with the starting point of the image writing.

3.5.2 Reference diagram

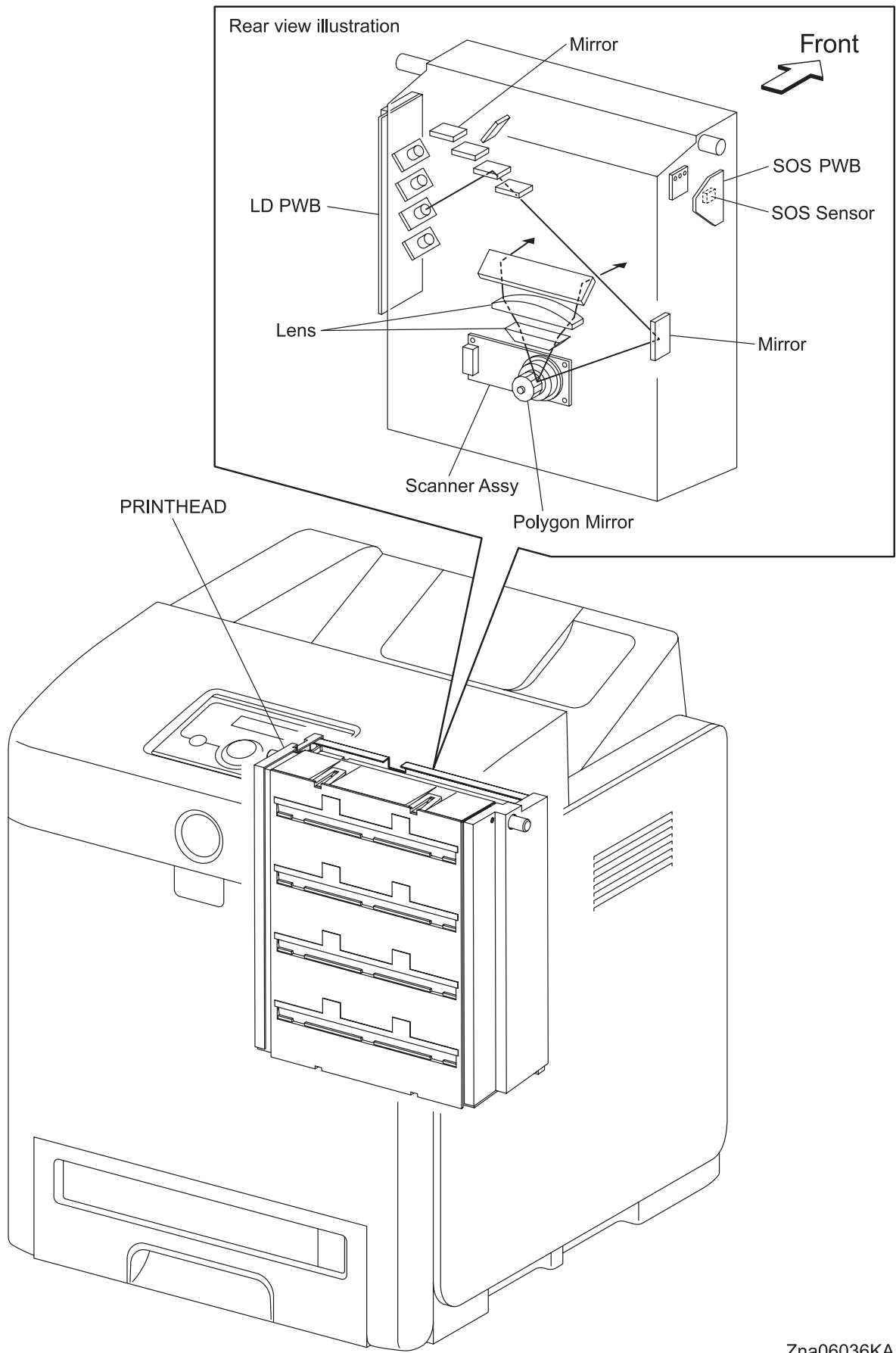

Zna06036KA

3.6 TONER CARTRIDGE

3.6.1 Major functions

- CRUM (Customer Replaceable Unit Memory) SENSOR
The CRUM SENSOR reads and writes the data of the CRUM.
Printer specific information is stored.

- SENSOR PHOTO (TONER CARTRIDGE Sensor Y/M/C/K)
Detects presence/absence of the TONER CARTRIDGE.

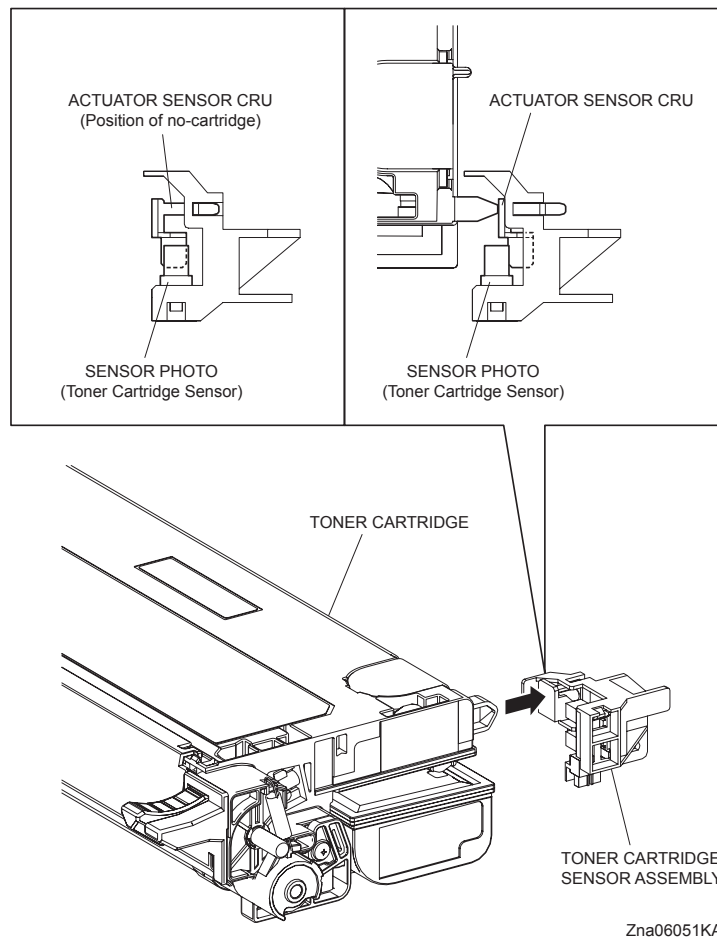

- DISPENSE MOTOR (Y/M/C/K)
The dispense motor supplies the drive to the Agitator and Auger in the TONER CARTRIDGE, and supplies toner to the developer part in the TONER CARTRIDGE.

- TONER CARTRIDGE (Y)
- TONER CARTRIDGE (M)
- TONER CARTRIDGE (C)
- TONER CARTRIDGE (K)
The TONER CARTRIDGE is constituted from the toner cartridge, developer and the drum.

- Erase Lamp (LED ASSEMBLY)
The light of the LED passes through the lens of the TONER CARTRIDGE, and irradiates the drum.
The light of the LED eliminates the charge on the drum.

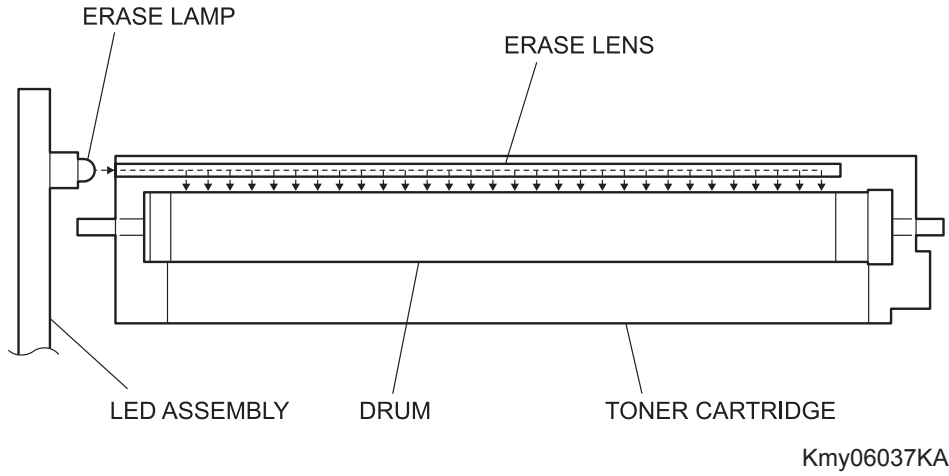

3.6.2 Reference diagram

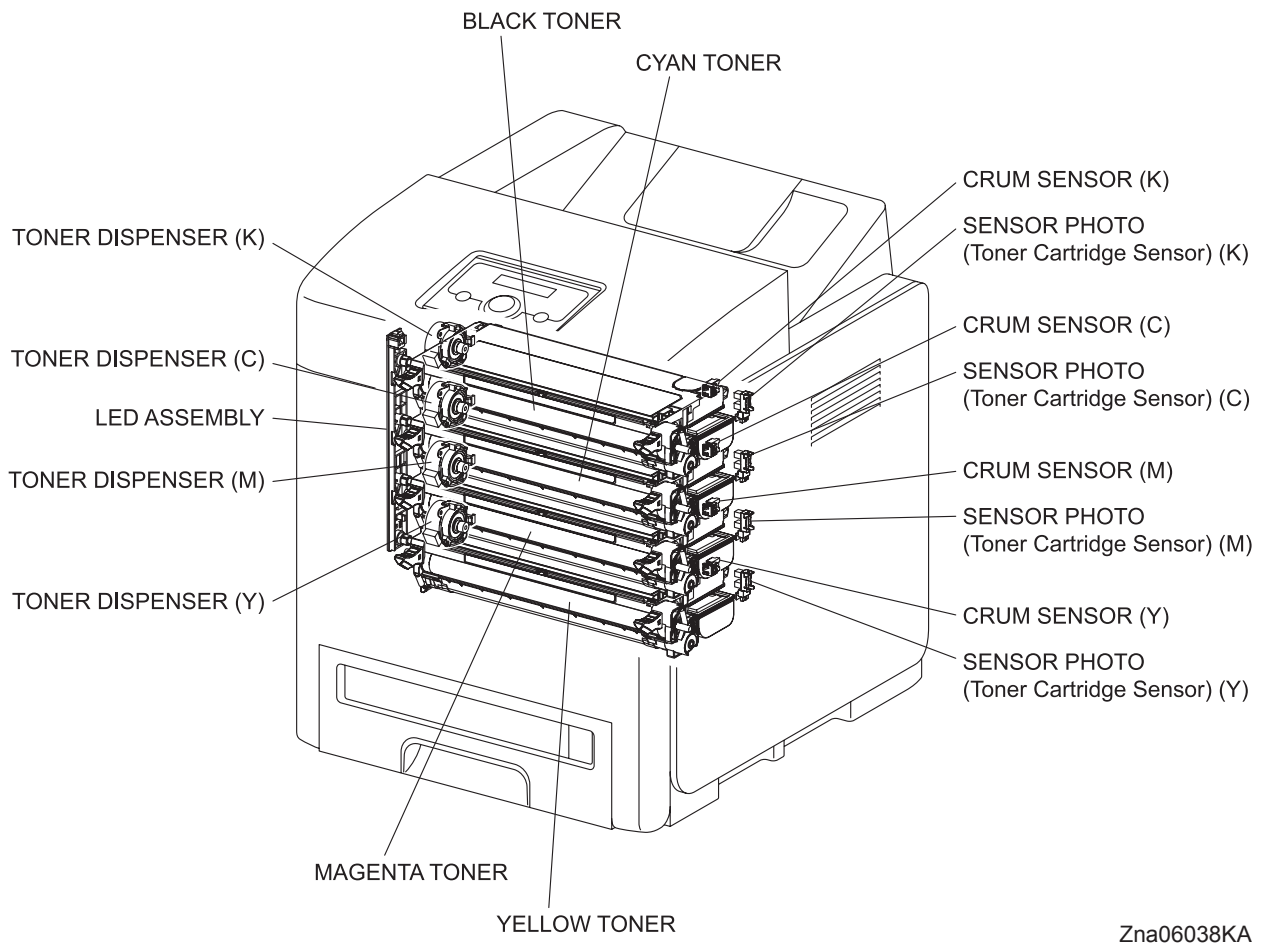

3.7 Drive

3.7.1 Major functions

- PHOTOCONDUCTOR (PC)/DEVELOPER (DEV) DRIVE (Refer to 6.1 PHOTOCONDUCTOR (PC)/DEVELOPER (DEV) DRIVE)

Supplies the drive to parts as follows.

- Main Motor
 - Yellow, Magenta, Cyan and Black Drum
 - Transfer Belt
- Sub Motor
 - Fuser
 - Yellow, Magenta, Cyan and Black Developer

- DRIVE ASSY K

The transmission channel is changed by the COLOR MODE SWITCHING SOLENOID in the DRIVE ASSY K to allow the driving force of the SUB MOTOR to reach the C/M/Y Developer only.

This is performed to ensure that the Yellow, Magenta, and Cyan Developers cannot be rotated by the DRIVE ASSY SUB during B/W printing.

The COLOR MODE SWITCHING SENSOR detects the status of the transmission route (whether it is set for B/W or full color).

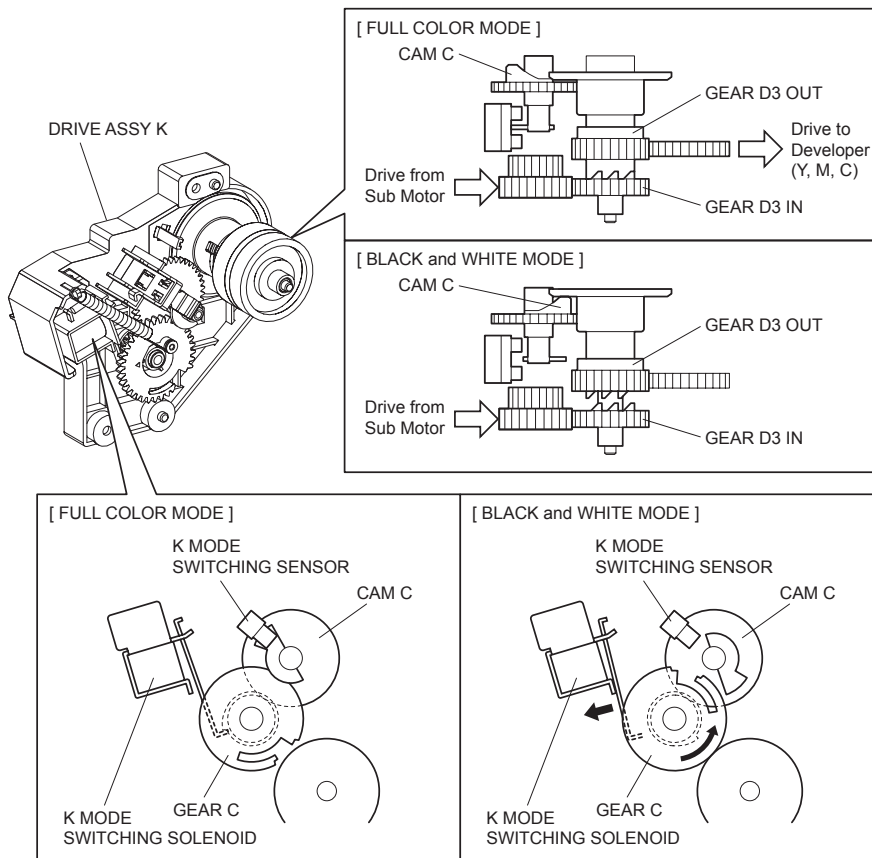

Zna06100KA

- Clutch Assy Exit

Transmits the drive from the Sub Motor to the Roll Assy Exit in the FUSER.

In the backside printing, the exit clutch stops.

Exit Roll is driven by Duplex Motor. (Refer to 6.1 PHOTOCONDUCTOR (PC)/DEVELOPER (DEV) DRIVE [SIMPLEX MODE] and 6.4 DRIVE ASSY DUP)

- FEED DRIVE ASSEMBLY

- Standard Cassette
- MPF
- Regi Assy

3.7.2 Reference diagram

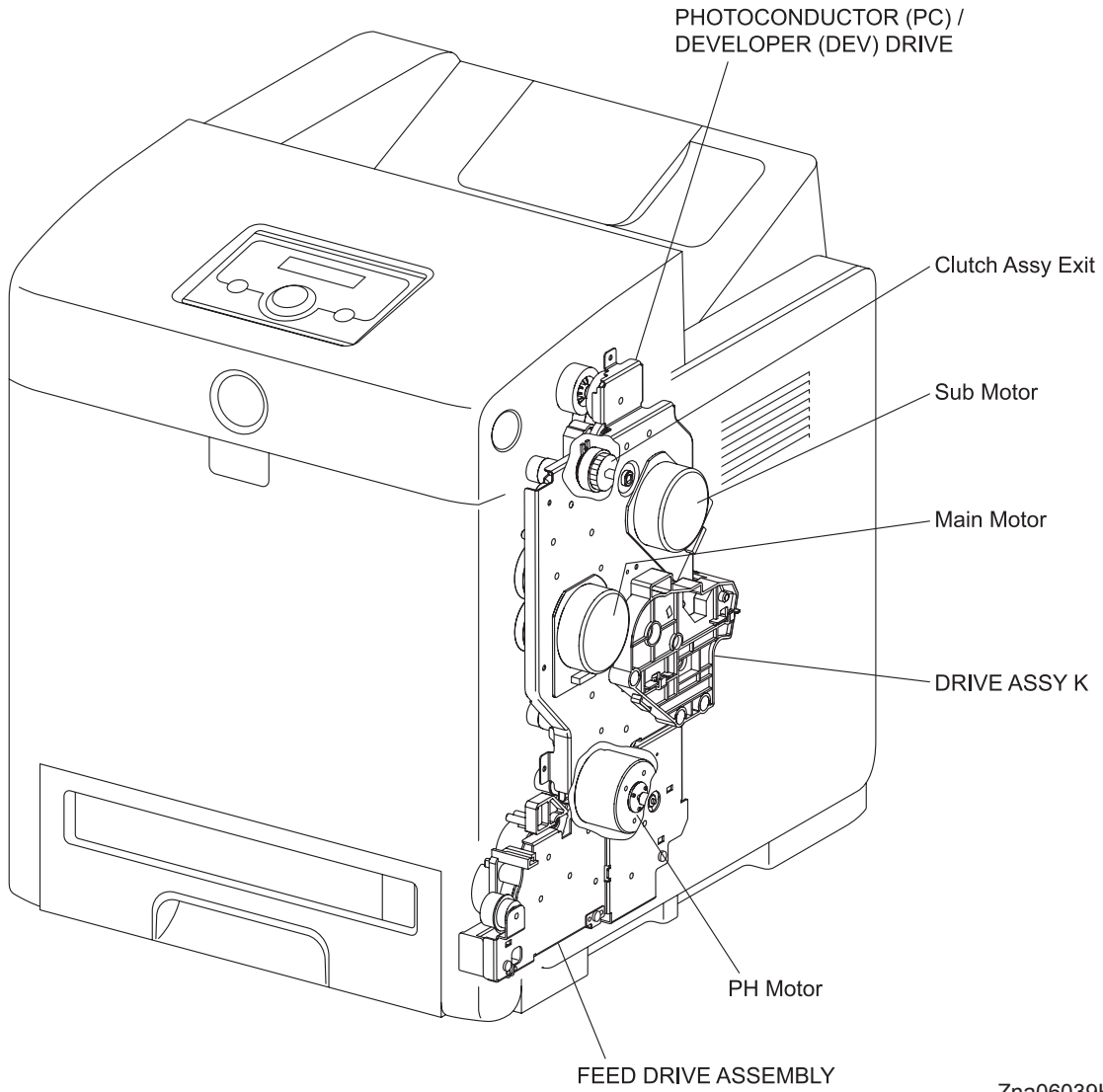

Zna06039KB

Blank Page

3.8 Electrical

3.8.1 Major functions

- FAN
Dissipates heat out of the printer to prevent the printer from overheating.
- SWITCH
The SWITCH turns ON/OFF the AC power supply of the printer.
- Low Voltage Power Supply (LVPS)
The LVPS is provided in two types, 100/120V and 230V.
Supplies AC power from the power source to the FUSER heater and generates and supplies stable low voltage DC power used for the logic circuit, etc.
LVPS contains control circuit for the heater of the FUSER, in addition to the power circuit.
- Machine Control Unit (MCU)
Controls printing operation based on the communication with the print controller and information from the sensor/switch.
Major functions are as follows:
 - Communication with the ESS.
 - Receive of information from the sensors or switches.
 - Control of Motor in PHOTOCODUCTOR (PC)/DEVELOPER (DEV) DRIVE and FEED DRIVE ASSEMBLY.
 - Distributing low voltage DC power output from LVPS to each component
 - Control of PRINTHEAD
- High Voltage Power Supply (HVPS)
Supplies high voltage to the following parts in the Transfer Belt and TONER CARTRIDGE to perform charging, development, and primary transfer.
 - BCR
 - BTR
 - Developer
 - ESA
- PWBA EEPROM
Information unique to the printer is stored.
- Electronic Sub System (ESS)
The ESS connected to the MCU controls the entire system (Diagnostic, Interface and Image processing).
- HUMIDITY SENSOR
HUMIDITY SENSOR reads the temperature/humidity within the printer and converts the values to voltage values.

- OPERATOR PANEL
OPERATOR PANEL displays the state of the printer using LCD or LED, operates the printer using the switch.
- INTERLOCK SWITCH
INTERLOCK SWITCH is a switch that cuts the +24VDC power supply to the HVPS or Motor, etc. upon the opening of the Front Cover.

3.8.2 Reference diagram

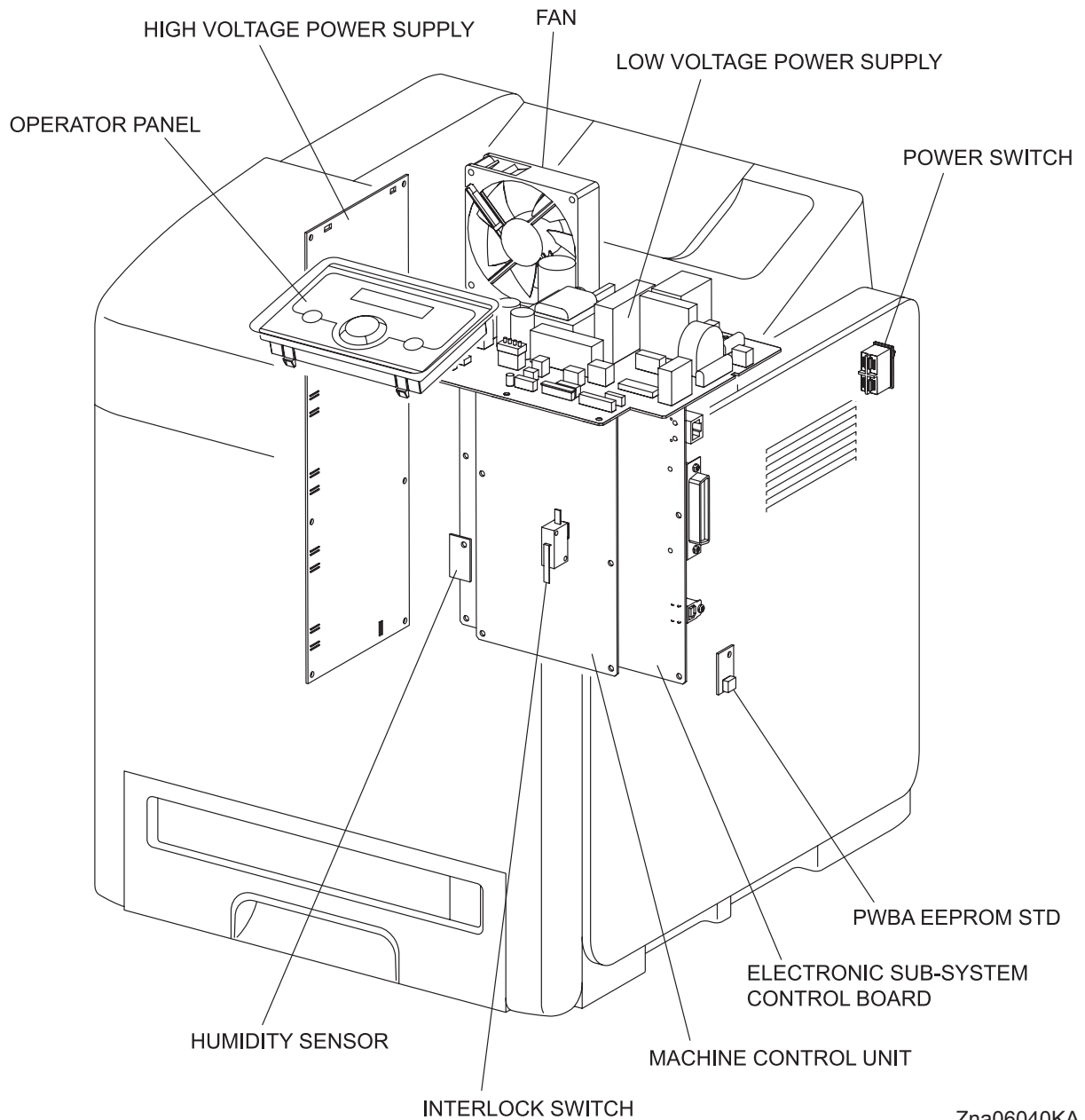

Zna06040KA

3.8.3 Data Flow

Print data (electric signal) from the printer controller flows as shown below until it is turned into a print.

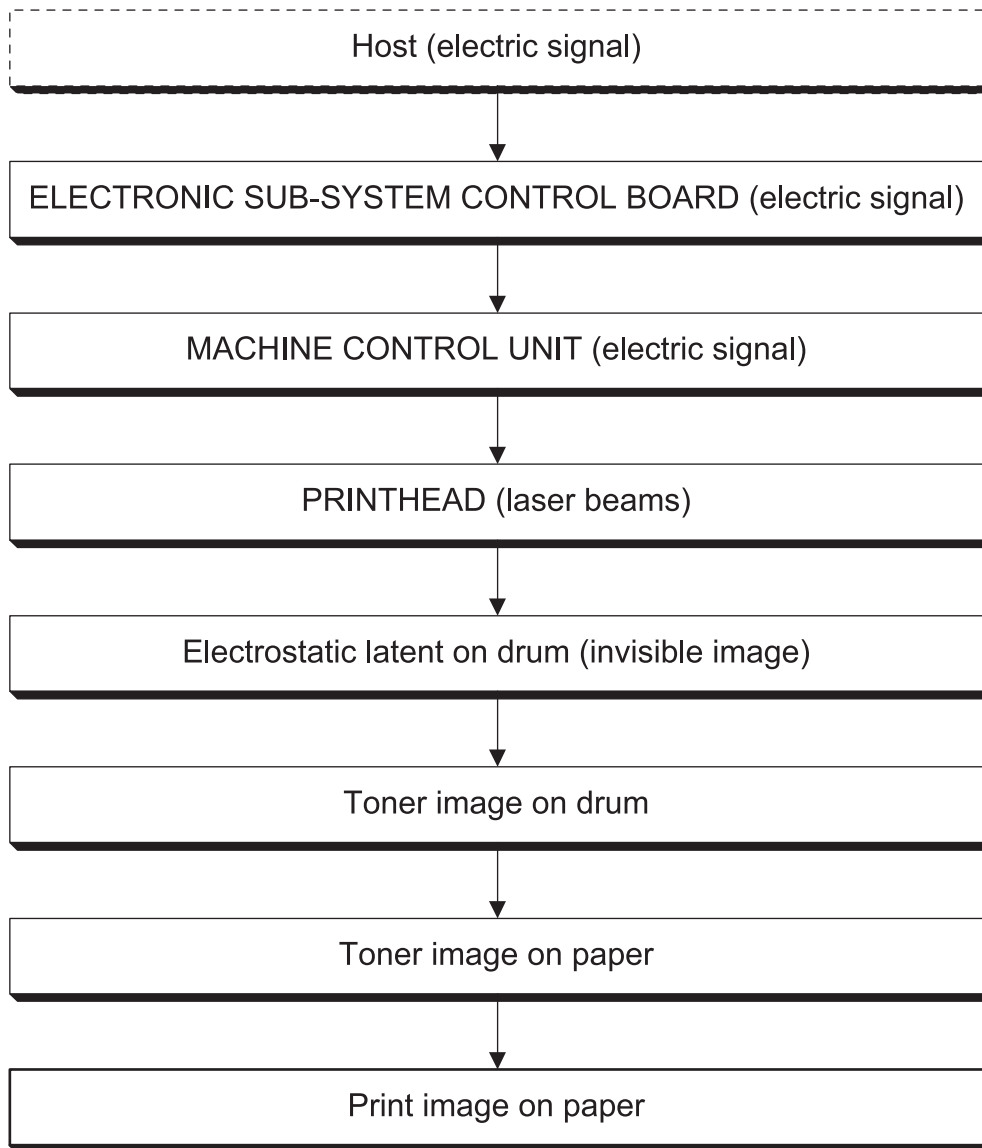

Kmy06011KA

Blank Page

3.9 Duplex

3.9.1 Major functions

- SENSOR PHOTO (DUP Jam Sensor)
The DUP Jam SENSOR detects that the paper is carried to duplex part.

- CLUTCH DUP
Transmits the drive from the MOTOR DUP to Roll Assy Exit in the FUSER.
When the clutch operates, the Roll Assy Exit rotates in the reverse direction.
The clutch is stopped when the paper reached the Duplex.

- DRIVE ASSY DUP
The DRIVE ASSY DUP supplies the driving power to the Lower Roll (ROLL ASSY DUP2), Upper Roll (ROLL ASSY DUP1) and Roll Assy Exit of Fuser. ([Refer to 6.4 DRIVE ASSY DUP](#))

- PWBA DUP
The PWBA DUP controls motor, sensor and clutch.

- FAN DUP
The FAN DUP is cooling inside of printer.

3.9.2 Reference diagram

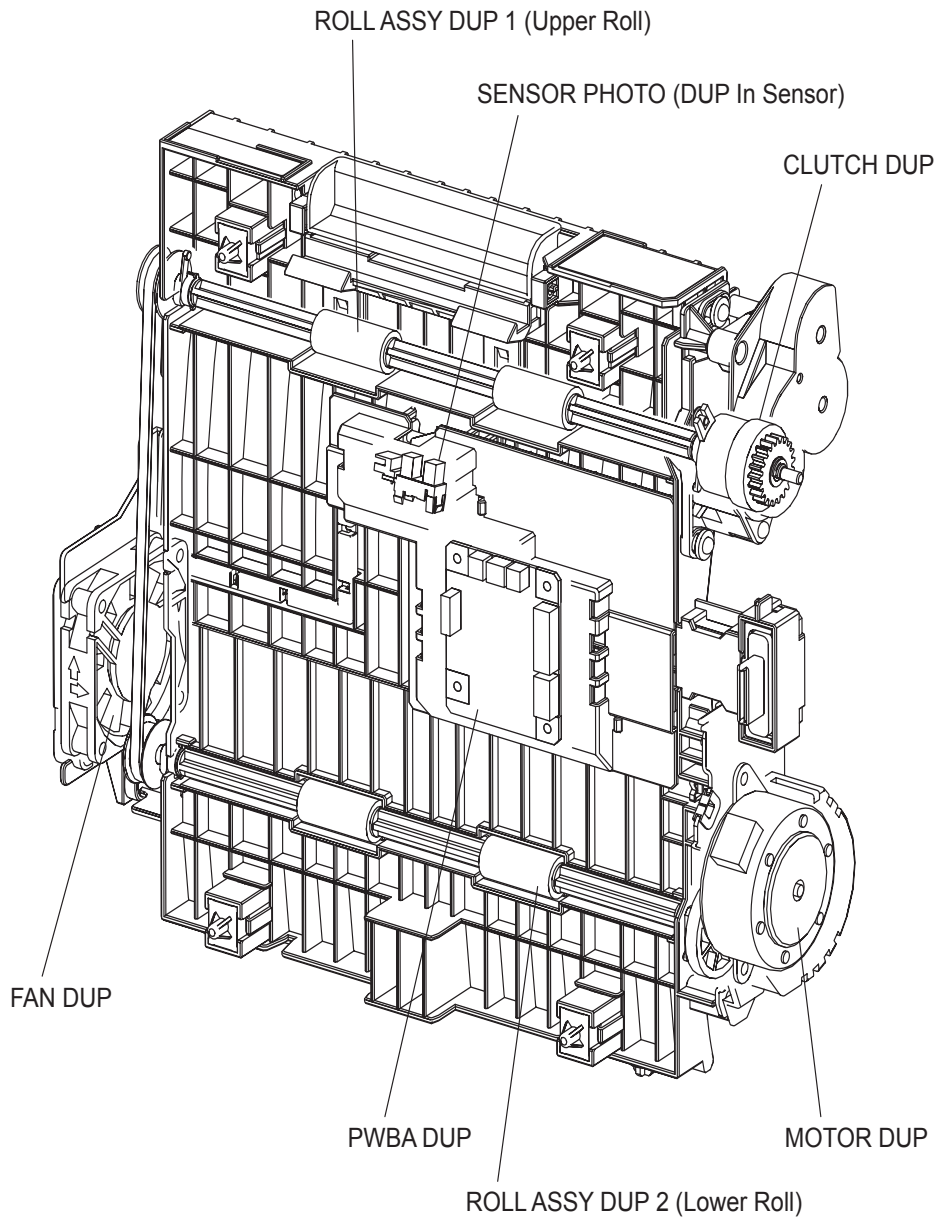

Kmy06041KA

3.10 550 Paper Feeder

3.10.1 Major functions (Paper Cassette)

- Side Guide (R/L)
The Guide Side Assy (R/L) can move at a right angle to the paper transfer direction to align the paper width.

- End Guide
The Guide End Assy can move in the paper transfer direction to determine the paper size. The ON/OFF of SIZE SWITCH ASSEMBLY (Refer to 5.1 Control of Paper Size) varies according to the Guide End Assy position to detect the paper size.

- FEED ROLLER (SEPARATOR)
The FEED ROLLER (SEPARATOR) and the FEED ROLLER (PICK UP ASSY) pinch the paper to feed.

- Bottom Plate
Bottom plate is locked to bottom side when paper cassette is pulled out from the paper feeder and unlocked when the paper cassette is installed to the paper feeder. Pushes the paper against the feed roll using a spring tension.

3.10.2 Reference diagram

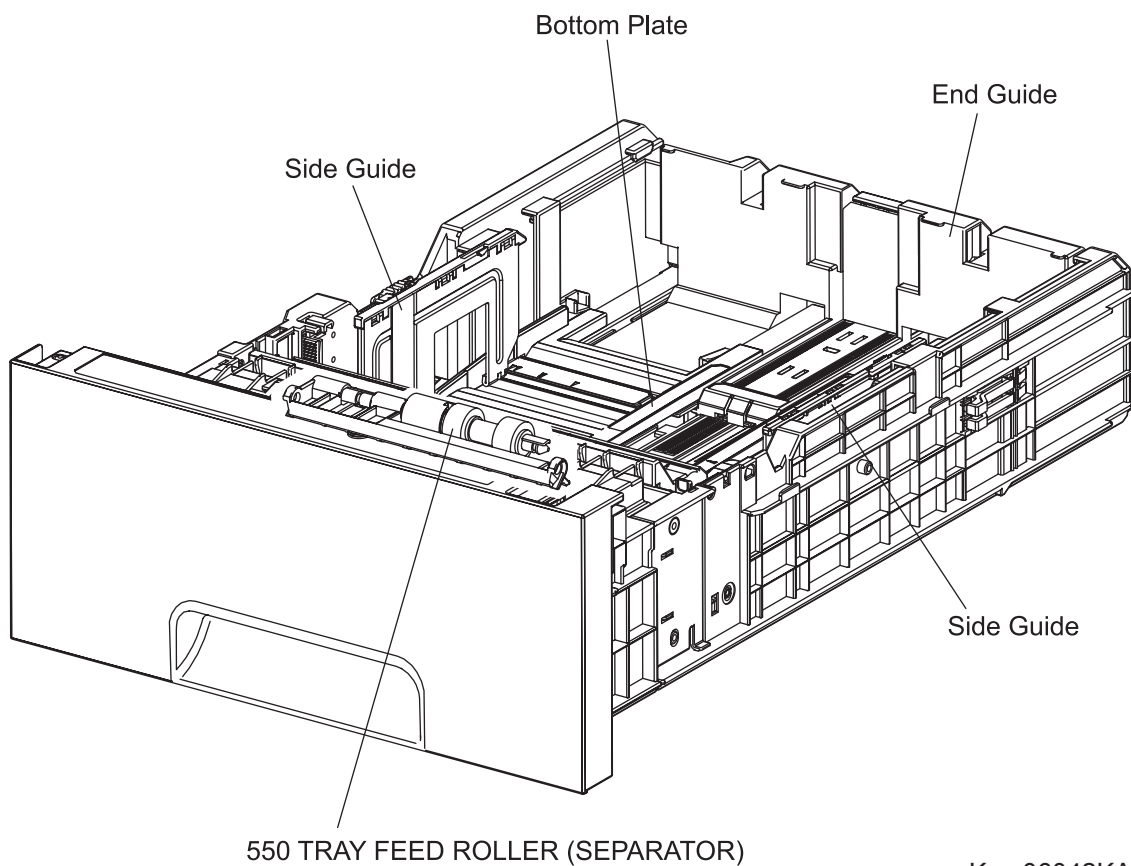

Kmy06042KA

3.10.3 Multiple paper feed prevention

The sheets set in a tray or cassette are occasionally stuck together along the edges. The stuck sheets cause a multiple sheet feed or a jam. The sheets are fed by the Nudger Roll to a position between the Feed Roll and the Separator Roll. Normally, when only one sheet is fed, both the Feed Roll and Separator Roll rotate to allow the sheet to pass. However, when two sheets are fed concurrently, only the Feed Roll rotates and the Separator Roll is locked thereby allowing the upper sheet to pass by being separated from the lower sheet that is stopped by the friction with the Separator Roll at rest.

The Separator Roll is being pushed toward the Feed Roll by spring pressure, and controlled by the torque limiter (Clutch Assy Friction) with which it is coupled.

3.10.4 Reference diagram

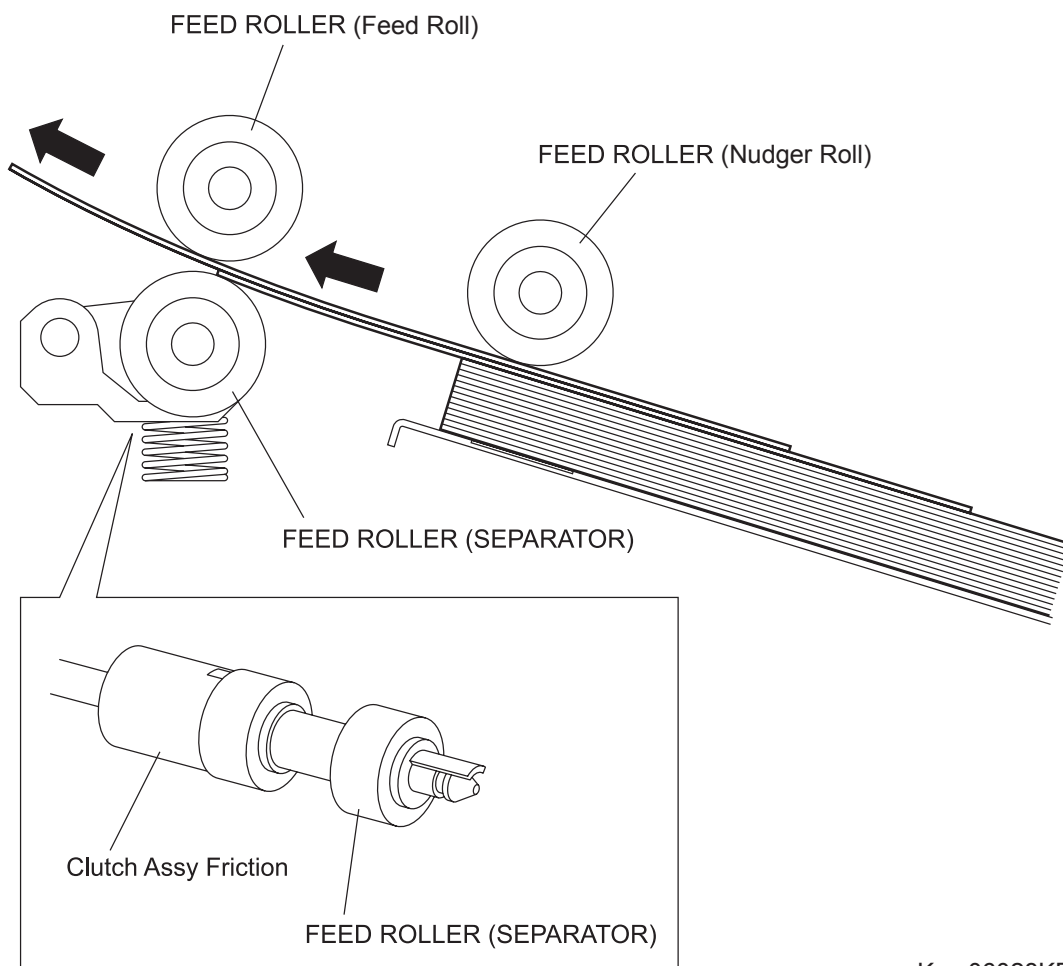

Kmy06028KB

3.10.5 Bottom Plate Moving

Inserting the paper tray into the feeder section unlocks the GEAR BTM LOCK ONEWAY. When the paper tray is pushed in until it stops, the gear teeth of the RACK BTM LOCK and GEAR BTM LOCK ONEWAY are out of engagement allowing the PLATE ASSY BTM to rise by the spring pressure of the SPRING BTM UP.

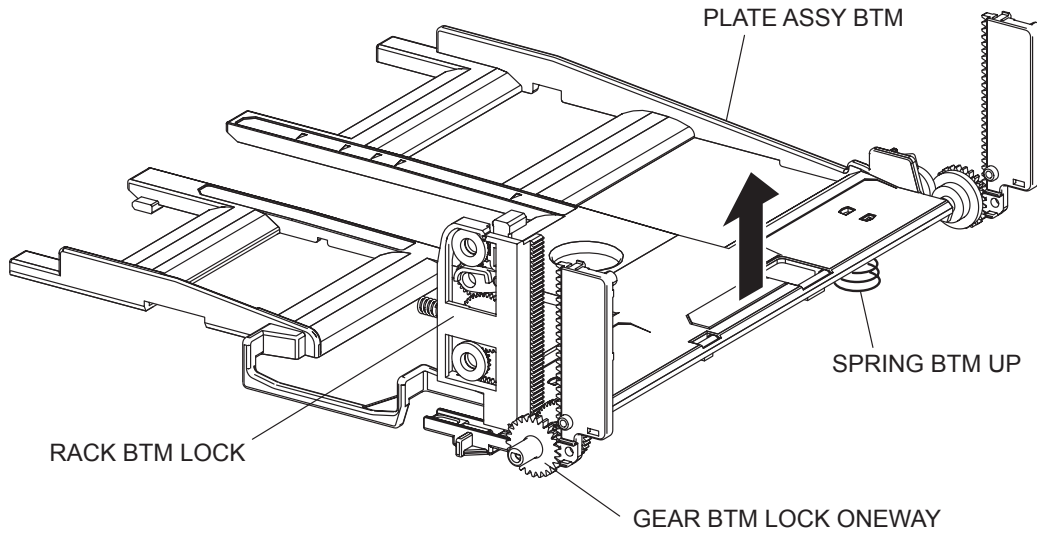

Kmy06023EA

Blank Page

3.10.6 Major functions (Feeder)

- SIZE SWITCH ASSEMBLY

SIZE SWITCH ASSEMBLY detects the paper size and presence/absence of the paper tray.

(Refer to 5.1 Control of Paper Size for the combination of switches.)

The paper size is decided at the position of the END GUIDE.

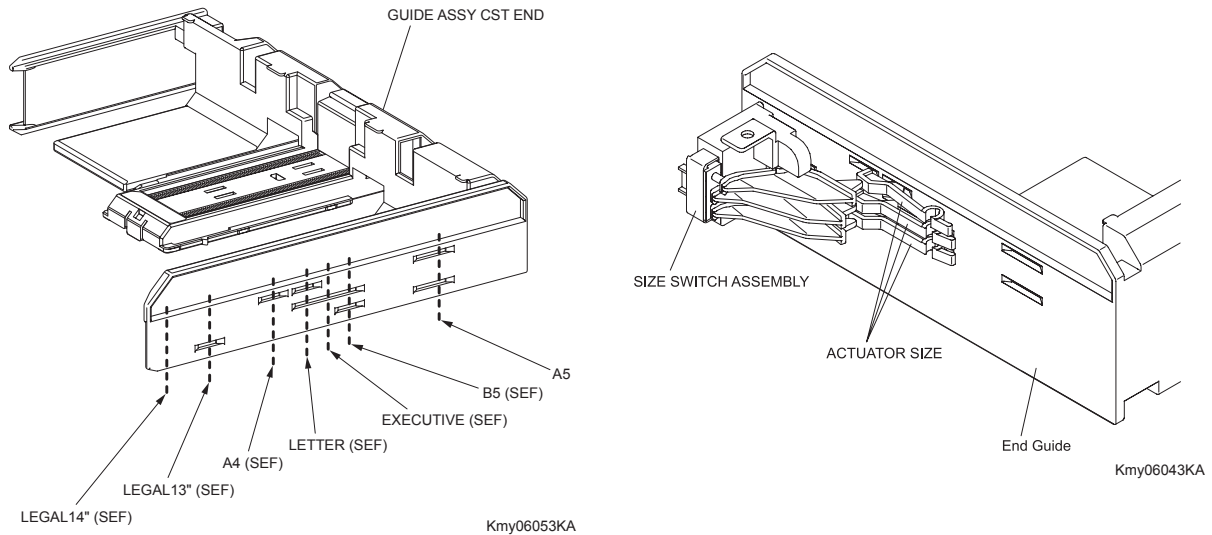

- SENSOR PHOTO (No Paper Sensor)

Detects the presence/absence of paper in the paper tray based on the position of ACTUATOR NO PAPER. (No paper: Sensor beam is intercepted)

- CLUTCH ASSY FEED

Transmits the drive from the DRIVE ASSY OPTION FEEDER to FEED ROLLER. (PICK UP ASSY)
(Refer to 6.5 DRIVE ASSY OPT FDR)

- FEED ROLLER

When the CLUTCH ASSY FEED operates, the FEED ROLLER starts rotating and the FEED ROLLER feeds the paper. (Refer to 6.5 DRIVE ASSY OPT FDR)

- CLUTCH ASSY TURN

Transmits the drive from the DRIVE ASSY OPTION FEEDER to ROLL ASSY TURN.

- ROLL ASSY TURN

The ROLL ASSY TURN rotates by the drive from DRIVE ASSY OPTION FEEDER through the CLUTCH ASSY TURN to feed the paper from the paper tray to the printer.

- DRIVE ASSY OPTION FEEDER

The MOTOR OPTION FEEDER is driving the rolls of the option feeder. (Refer to 6.5 DRIVE ASSY OPT FDR)

- PWBA OPTION FEEDER

The PWBA OPTION FEEDER controls motor, sensor and clutch.

3.10.7 Reference diagram

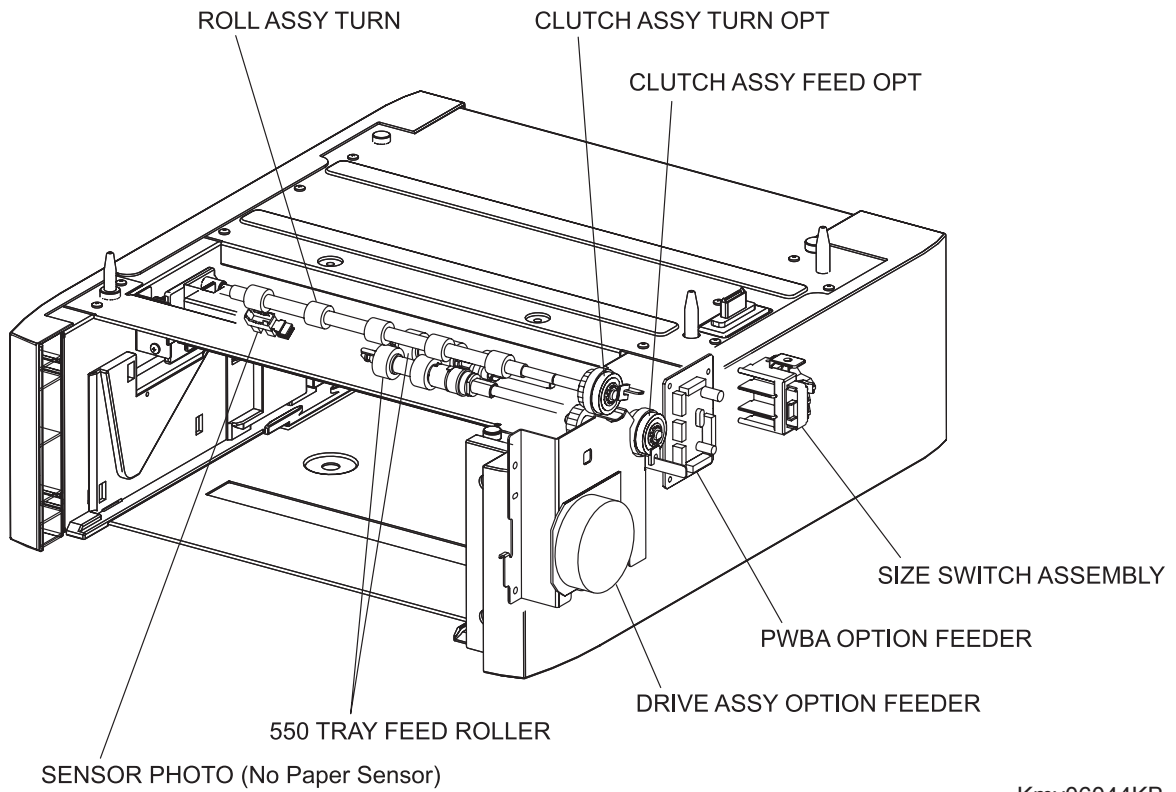

4. MODES

4.1 Operation Modes

For the operation of the printer, the following five modes are provided.

- DIAG TEST mode
The printer is ready for receiving diagnostic commands, or the printer diagnostic function is operating.
- WAIT mode
The printer is under the adjustment of print quality.
- READY mode
The printer is ready for printing.
- PRINTING mode
The printer is under printing.
- ERROR mode
Any error was detected in the printer.
- Initializing mode
New parts have been just set to the printer (initializing with a new Deve Unit).
- Checking Unit mode
Printer is under checking consumable units.

5. Control

5.1 Control of Paper Size

"ON/OFF of Paper Size Switch of SIZE SWITCH ASSEMBLY" and "Diag Tool indication data" are shown in the table below.

NOTE

Paper Size Switches are indicated as SW1, SW2, and SW3 from the above one.

Paper Size	Paper Size Switch			Diag indication data
	SW1	SW2	SW3	
LEGAL14" (SEF)	ON	ON	ON	00
LEGAL13" (SEF)	ON	ON	OFF	01
EXECUTIVE (SEF)	ON	OFF	ON	02
B5 (SEF)	ON	OFF	OFF	03
A4 (SEF)	OFF	ON	ON	04
LETTER (SEF)	OFF	OFF	ON	06
A5	OFF	ON	OFF	05
No cassette	OFF	OFF	OFF	07

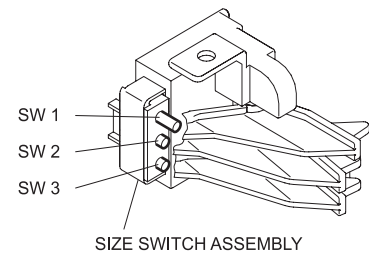

ON: The actuator is pushing the size switch.

5.2 Selective Control on Paper Cassette

The preferred paper cassette selected after powering on can be changed via the printer settings. The default is Tray1 (TBD).

NOTE

The paper feeder by the paper tray under the printer is called "Tray 1", and the optional TRAY is called "Tray 2".

5.3 PRINTHEAD Light Quantity Control

The image data are entered to the laser diodes in the PRINTHEAD as electric signals (data are expressed with high and low voltage values), and the laser diodes convert the image data from electric signals to optical signals (data are expressed with blinking laser beams).

Variations in light quantity of laser beams or variations in optical system (such as lenses) or drum sensitivity cannot attain a proper electrostatic image, therefore, the laser beam light quantity is monitored and controlled by the laser diodes.

The PRINTHEAD in this printer has four laser diodes for yellow, magenta, cyan, and black respectively, and the light quantity is automatically adjusted for each color.

5.4 Process Control

For a stable printing, the parameters related to the image forming must be corrected as necessary. The control of the entire printing process including parameter correction control is called "process control". Mainly, the process control is performed in the following two methods, both of which are performed after every 30 cumulative prints upon termination of a print run or during a continuous run.:

- Potential control
- Toner density control

To supplement these two controls, the following controls are provided:

- High Area Coverage Mode
- Admix Mode

5.4.1 Potential Control

To attain stable printing image density, the drum charging voltage, the developing DC voltage and the PRINT HEAD light amount are adjusted according to the developing capability of each color carrier that varies momentarily. The adjusted drum charging voltage, the developing DC voltage and the PRINT HEAD light amount are fed back to keep the printing image density constant.

The outline of control is as follows.

- 1) The HUMIDITY SENSOR (temperature and humidity sensor) detects the temperature and humidity.
- 2) The patches of respective colors (yellow, magenta, cyan, and black) for the potential control are generated and transferred on the Belt.
- 3) The ADC Sensor (density sensor) detects the density of the patch on Belt.
- 4) The drum charging voltage, the developing DC voltage and the PRINT HEAD light amount are adjusted for each color according to the detected patch density.

5.4.2 Toner Density Control

The toner density must be kept constant to attain stable printing image. The control system for this purpose is called toner density control.

1) PCDC (Pixel Count Dispense Control)

The quantity of the toner to be consumed in the developing process is calculated by counting the video signals entered to the PRINthead. The quantity of the toner to be consumed is calculated by the toner dispensing time. The toner motor is driven based on the calculated toner dispensing time when supplying the toner to the developer.

2) ADC (Auto Density Control)

The patches of respective colors (yellow, magenta, cyan, and black) for the toner density control are generated under specified potential condition, and transferred on the Belt. The ADC Sensor measures this density. The measured value is compared with the reference value. If the toner density is lower, the toner dispense quantity is increased at the next printing, or if the toner density is higher, the toner dispense quantity is reduced at the next printing. The toner dispense quantity is calculated by the toner dispense time. This calculation is made for each color.

5.4.3 High Area Coverage Mode

A continuous printing of any image of area coverage exceeding extra toner dispense capability causes the toner density in the developer to be lowered.

The High Area Coverage Mode postpones the next page feed and dispenses the toner during this time, if the toner dispense time reached the specified value during a continuous printing.

5.4.4 Admix Mode

This mode prevents the toner density from being lowered, whenever the value of the toner density control patch measured by the ADC Sensor falls far below the standard value, by performing extra toner dispensation. If the toner density level cannot be recovered even after this operation, it is judged that the toner has run out.

5.4.5 ADC Sensor Adjustment

The ADC Sensor is a reflection type sensor that irradiates the light from its LED onto the target and detects the reflected light at its photoreceptor and outputs electric signals responsive to the amount of the detected light. To ensure an accurate patch density measurement, the surfaces of the ADC Sensor is cleaned to remove soil due to toner, etc., and the light amount adjustment is made so that the reflected light amount satisfies the prescribed value, when creating the patch for potential control and toner density control.

5.5 Color Registration Control

The printer uses a tandem system where the drums and developers are arranged respectively for each of yellow, magenta, cyan, and black colors. Since the images are formed on the drum of each color to be overlaid one another, a color shift may occur. The color registration control calculates how much the registration is shifted, and adjusts the PRINTHEAD write timing.

The lateral registration control adjusts all of four colors in lateral directions.

The color registration control is made from a change in inside temperature and the print count at the execution of the process control.

The control is outlined below:

- 1) With no toner on the Belt, the output value of ADC Sensor is measured to determine the threshold value.
- 2) The patches for color registration control are generated on the Belt. These patches are composed of 10mm lines of K, C, K, M, K, and Y in this order.

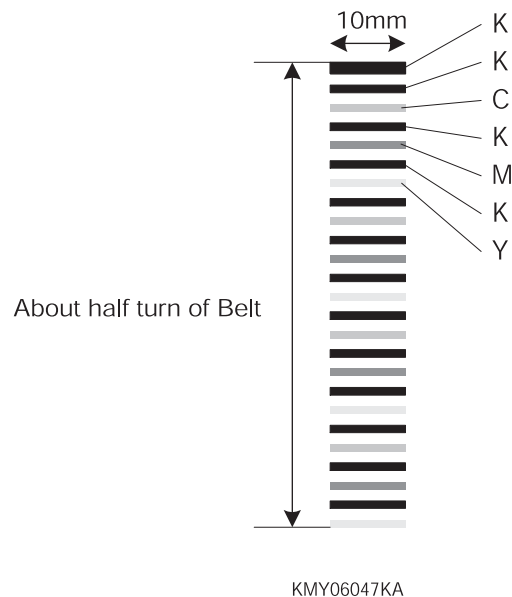

- 3) The density of patches generated by the ADC Sensor is read.
- 4) The shift correction amount is calculated from the threshold value determined in 1) and the patch density measured in 3).
- 5) The PRINTHEAD write timing is changed according to the shift correction amount.

5.6 Fuser Control

5.6.1 Fuser temperature control

As for the fuser temperature control, the target temperature is set, then the Heat Roll surface temperature is controlled so that it can meet the target value by turning on/off the Heater Lamp.

Temperature of individual area of the Heat Roll is detected by the Fuser Non-Contact Sensor (NCS) in the middle of the Heat Roll and the Temp Sensor at the edge of it. When the temperature detected is higher than the target value, the Heater Lamp will be turned OFF. When the temperature is below the target value, the Heater Lamp will be turned ON.

The target temperature setting varies depending on the time of Warm-up, Printing, or Process Control. The target temperature varies according to such environmental factors as the interior temperature detected by the Sensor Hum Temp.

5.6.2 Cooling down

As the printing continues, the temperature distribution in the Heat Roll becomes uneven both in the paper feed and non-paper feed areas. Cooling Down suspends paper feeding for a certain period of time so that the Heat Roll temperature distribution can be uniform.

When the temperature of the Heat Roll edge is high, cooling down is performed to lower the temperature to the target value.

5.6.3 Sensor Warm-up

The Fuser NCS (Non Contact Sensor) at the center of the Heat Roll will lose its accuracy of detecting temperature when the temperature of the Sensor itself is below -5°C . Therefore, the Sensor will be warmed up when the temperature is below -5°C . This action is called Sensor Warm-up.

6. Drive Transmission Route

6.1 PHOTOCONDUCTOR (PC)/DEVELOPER (DEV) DRIVE

Rotation power of the PHOTOCONDUCTOR (PC)/DEVELOPER (DEV) DRIVE is transmitted through the route below.

[BLACK and WHITE MODE]

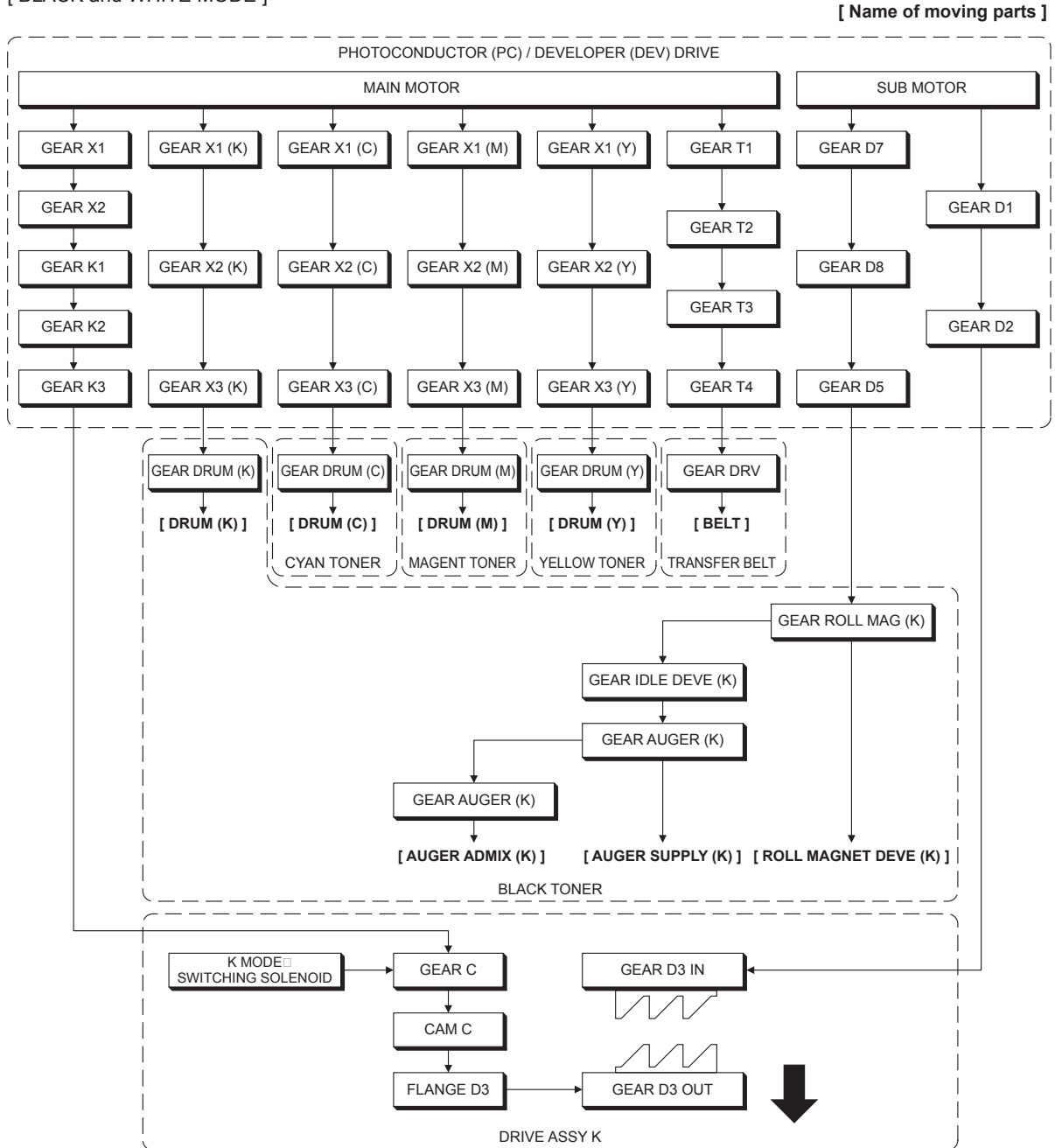

Zna06012KA

[BLACK and WHITE MODE]

[Name of moving parts]

▬ : Indicates the engagement of gears.

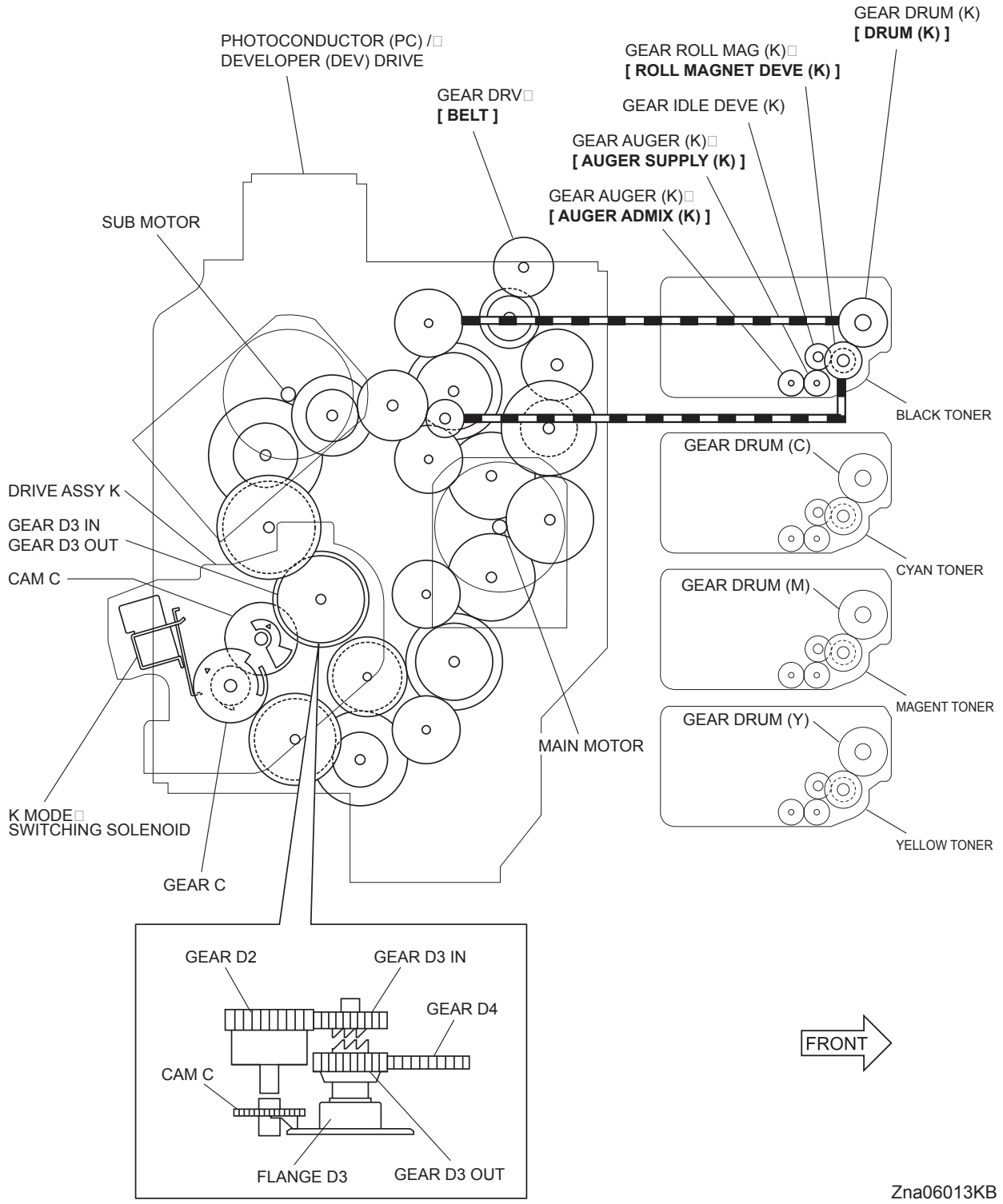

Zna06013KB

[FULL COLOR MODE]

[Name of moving parts]

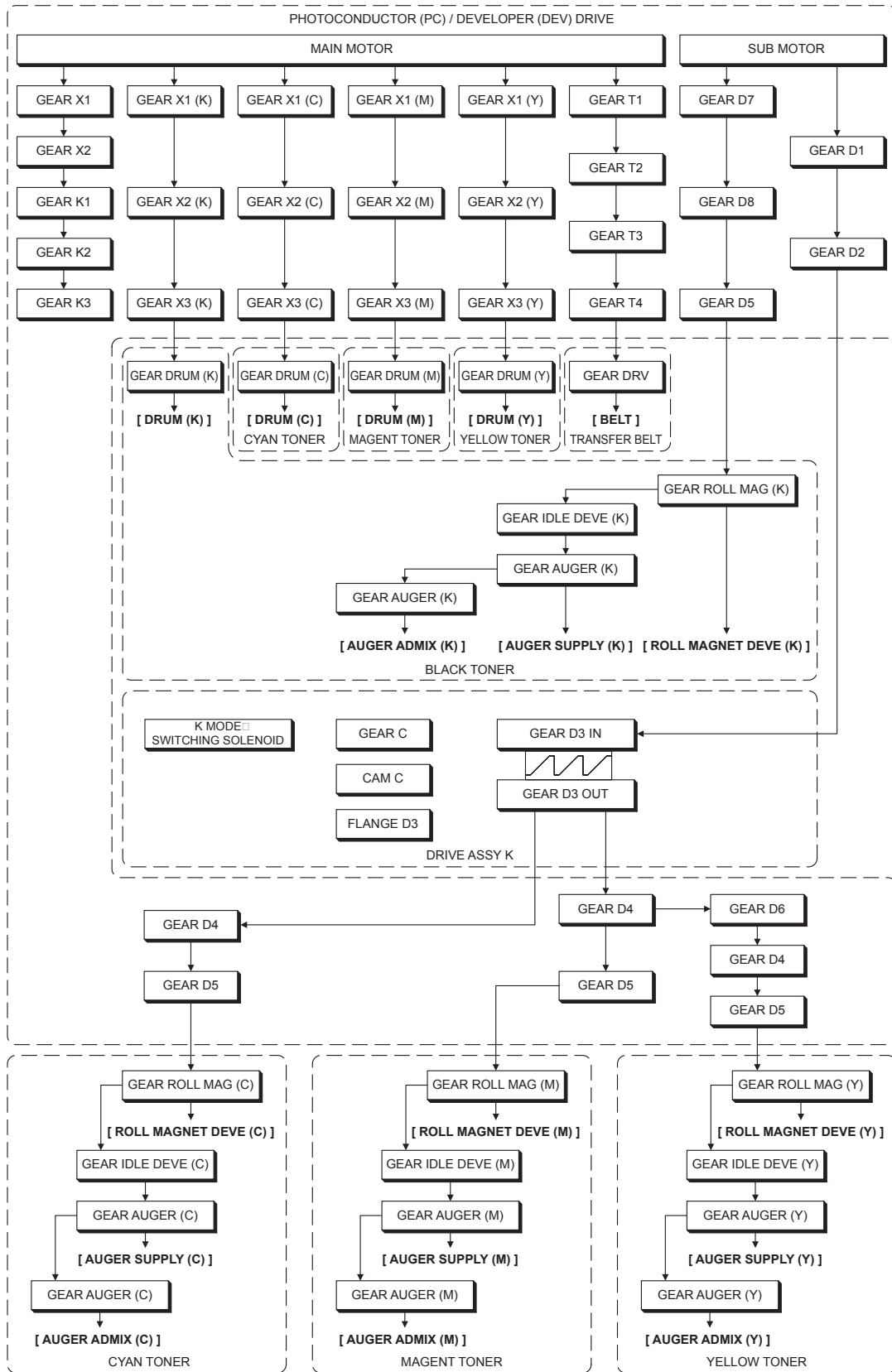

Zna06014KB

[BLACK and WHITE MODE]

[Name of moving parts]

▬ : Indicates the engagement of gears.

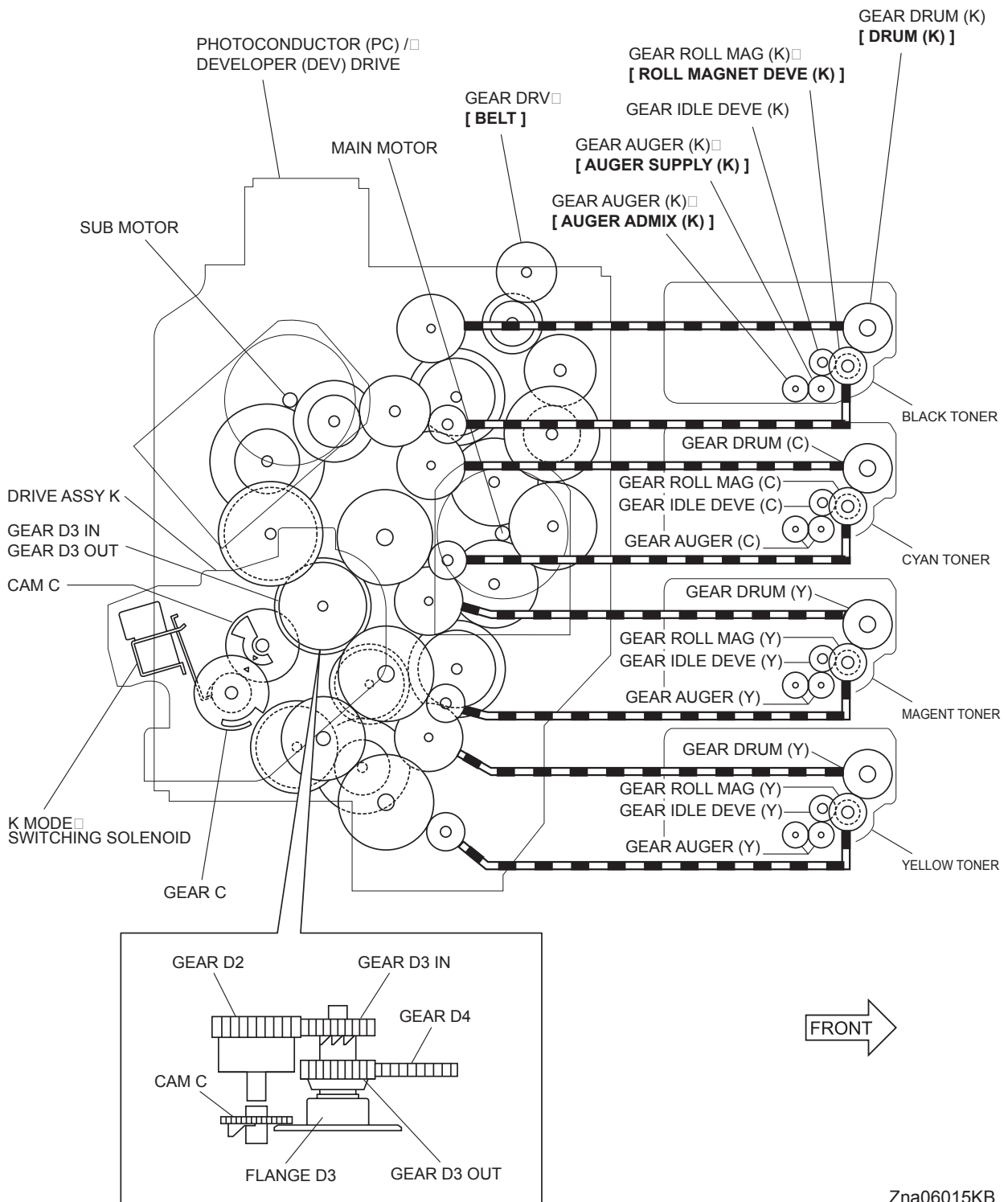

Zna06015KB

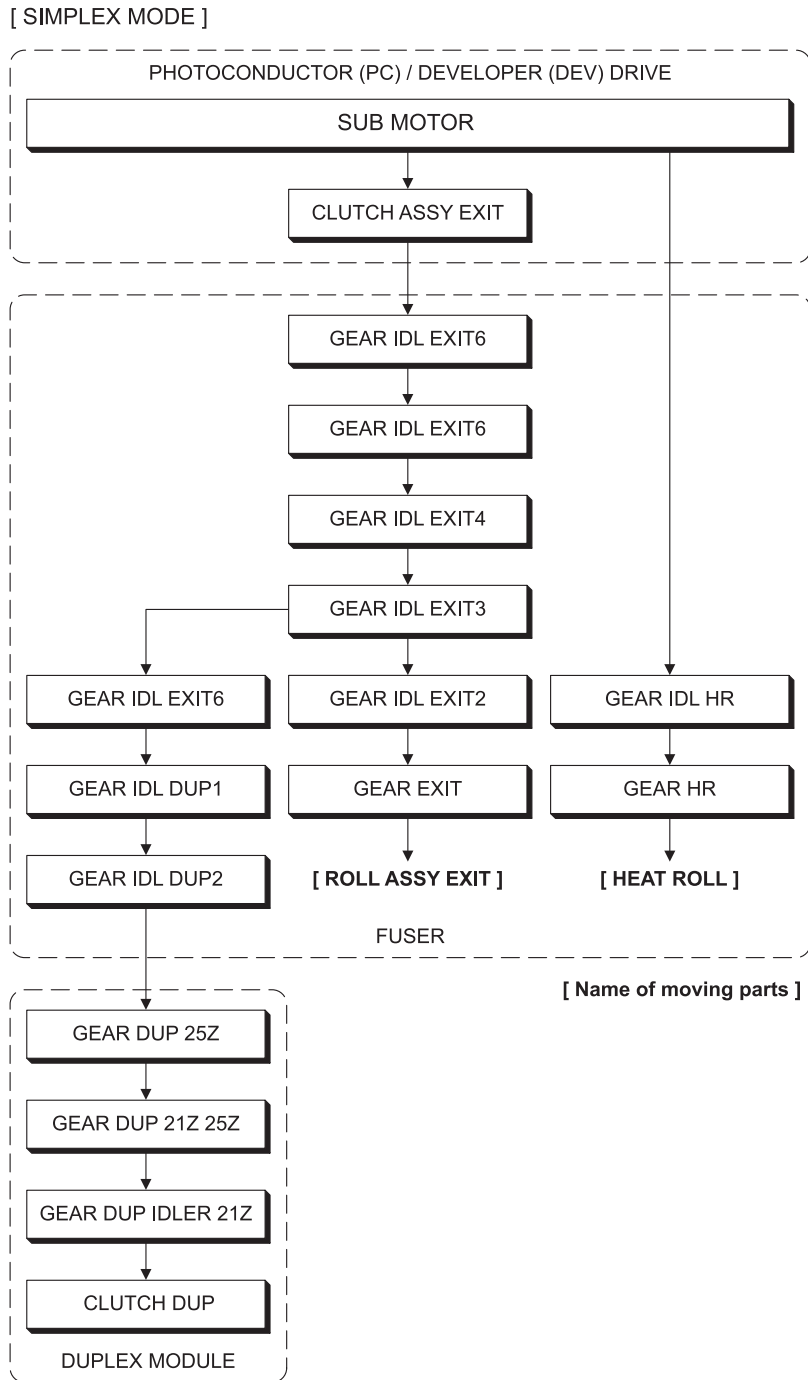

Zna06016KB

[SIMPEX MODE]

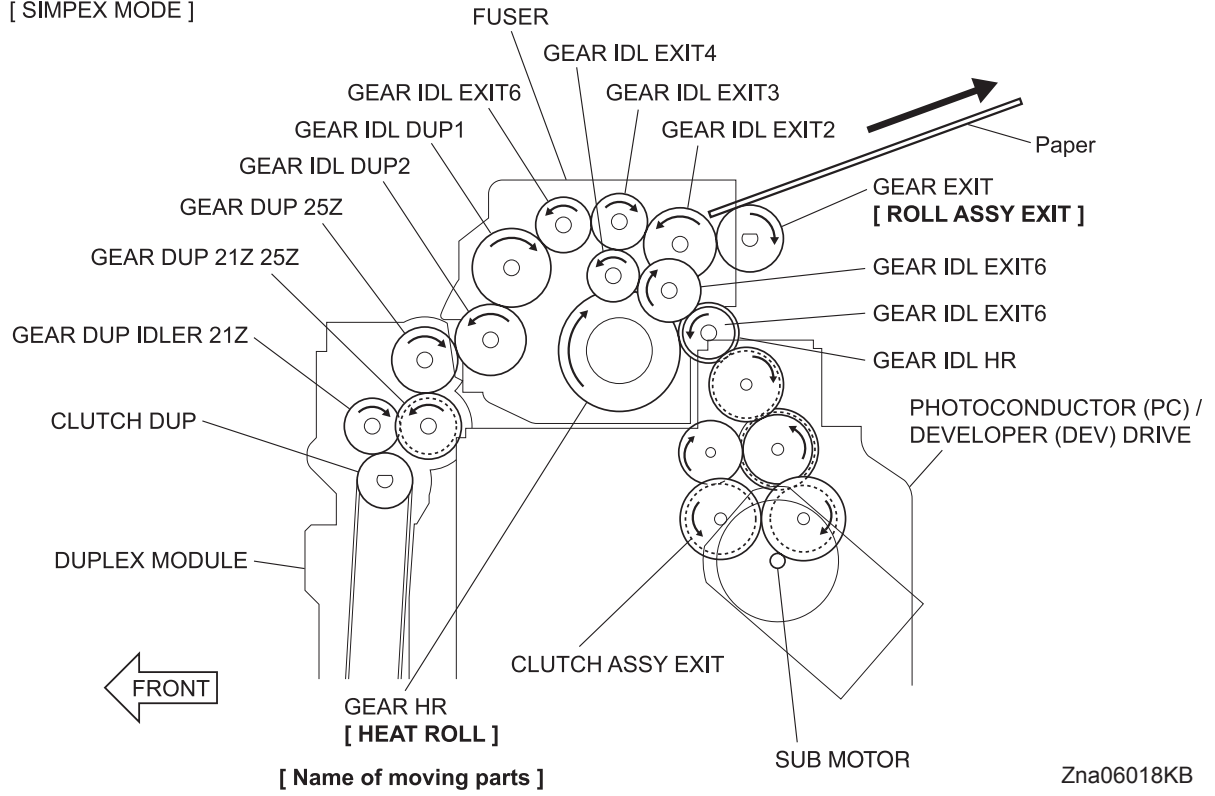

Zna06018KB

6.2 TONER DISPENSER (Y, M, C, K)

Rotation power of the TONER DISPENSER drives the agitator and the auger in the TONER CARTRIDGE.

The operation is common among the TONER DISPENSER Y, M, C and K.

[TONER CARTRIDGE]

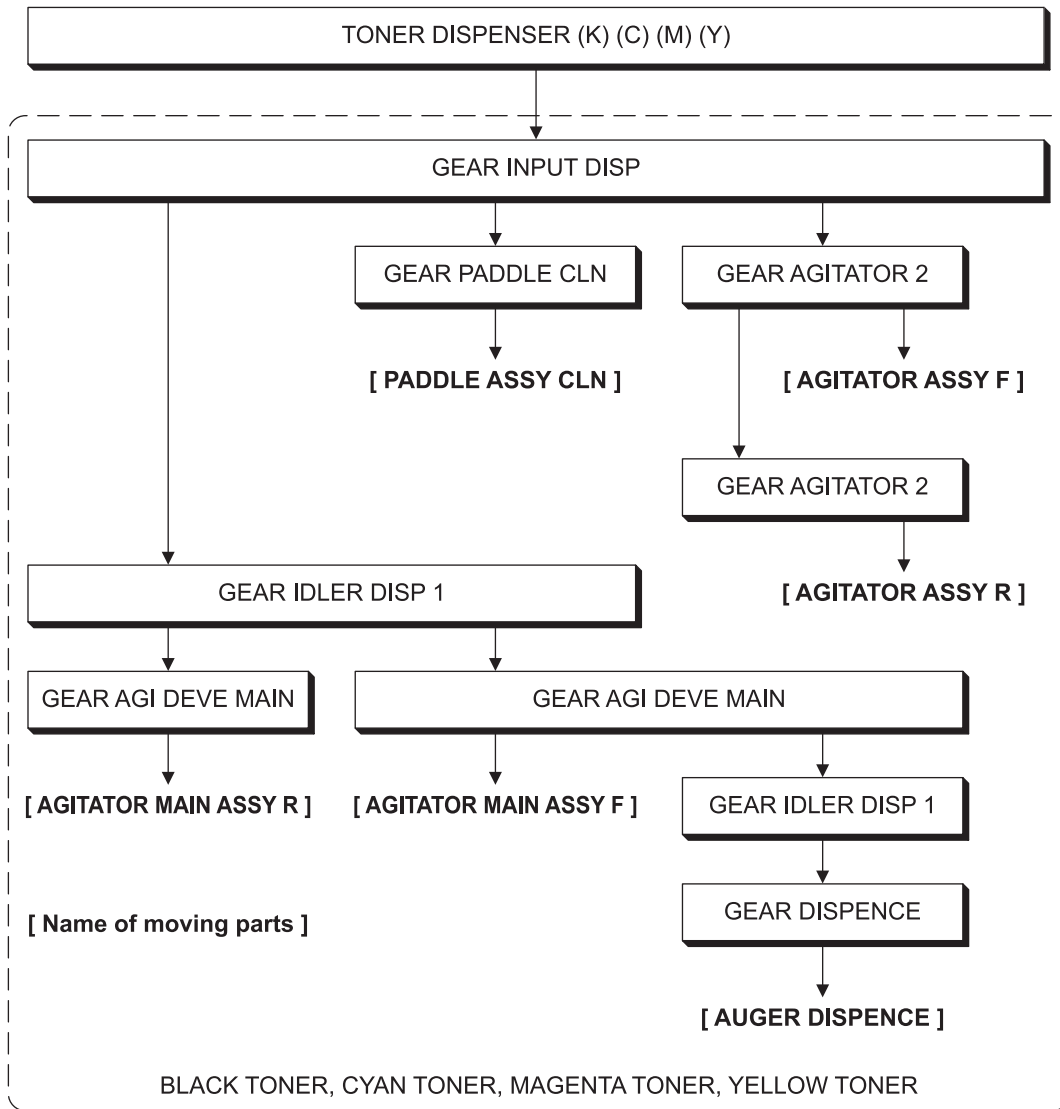

Kmy06021KA

[TONER CARTRIDGE]

GEAR AGITATOR 2
[AGITATOR ASSY R]

GEAR AGITATOR 2
[AGITATOR ASSY F]

TONER DISPENSER (K) (C) (M) (Y)

GEAR PADDLE CLN
[PADDLE ASSY CLN]

[Name of moving parts]

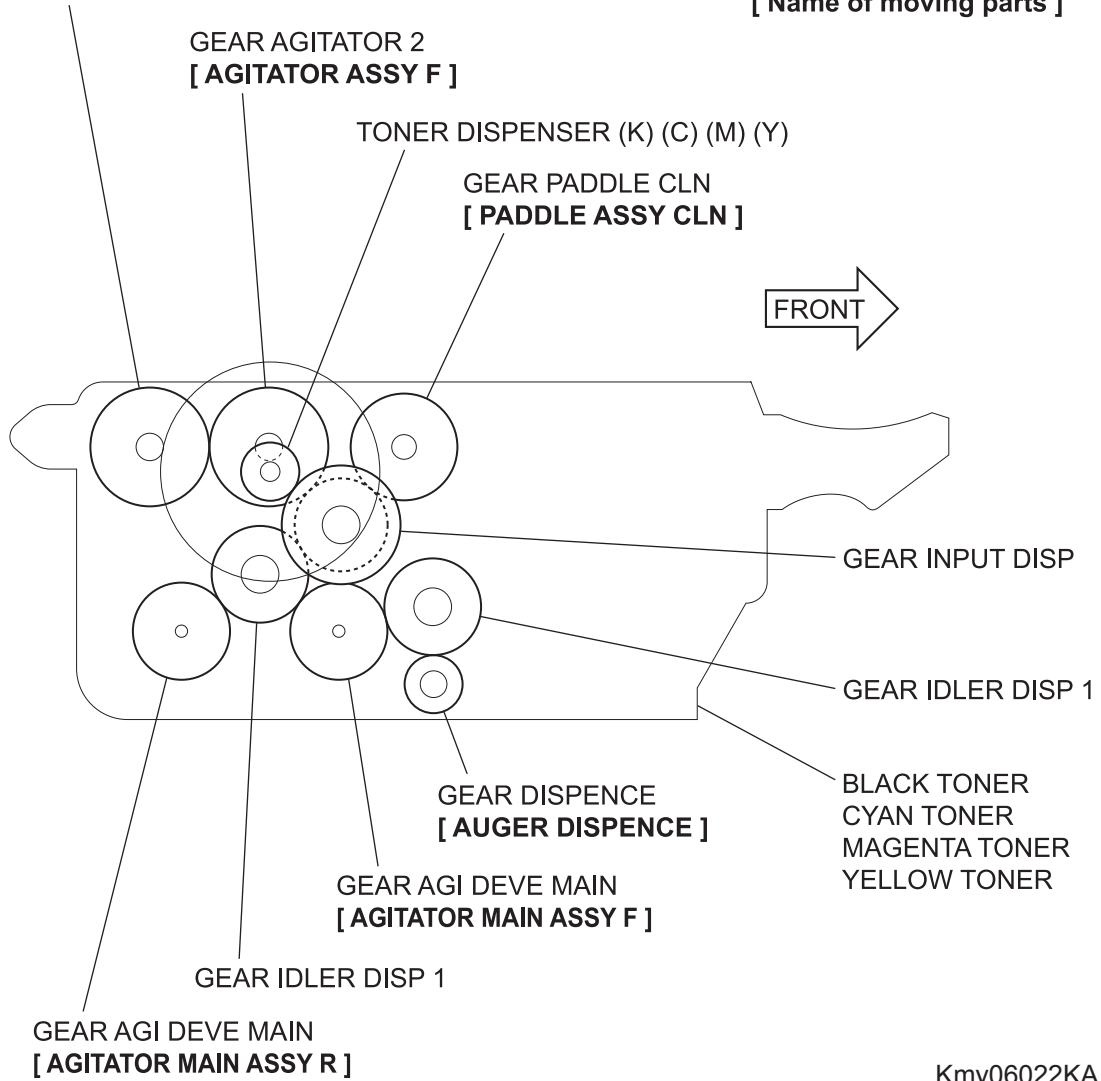

GEAR INPUT DISP

GEAR IDLER DISP 1

BLACK TONER
CYAN TONER
MAGENTA TONER
YELLOW TONER

GEAR DISPENCE
[AUGER DISPENCE]

GEAR AGI DEVE MAIN
[AGITATOR MAIN ASSY F]

GEAR IDLER DISP 1

GEAR AGI DEVE MAIN
[AGITATOR MAIN ASSY R]

Kmy06022KA

6.3 FEED DRIVE ASSEMBLY

Rotation power of the FEED DRIVE ASSEMBLY is transmitted through the route below.

[PAPER HANDLING]

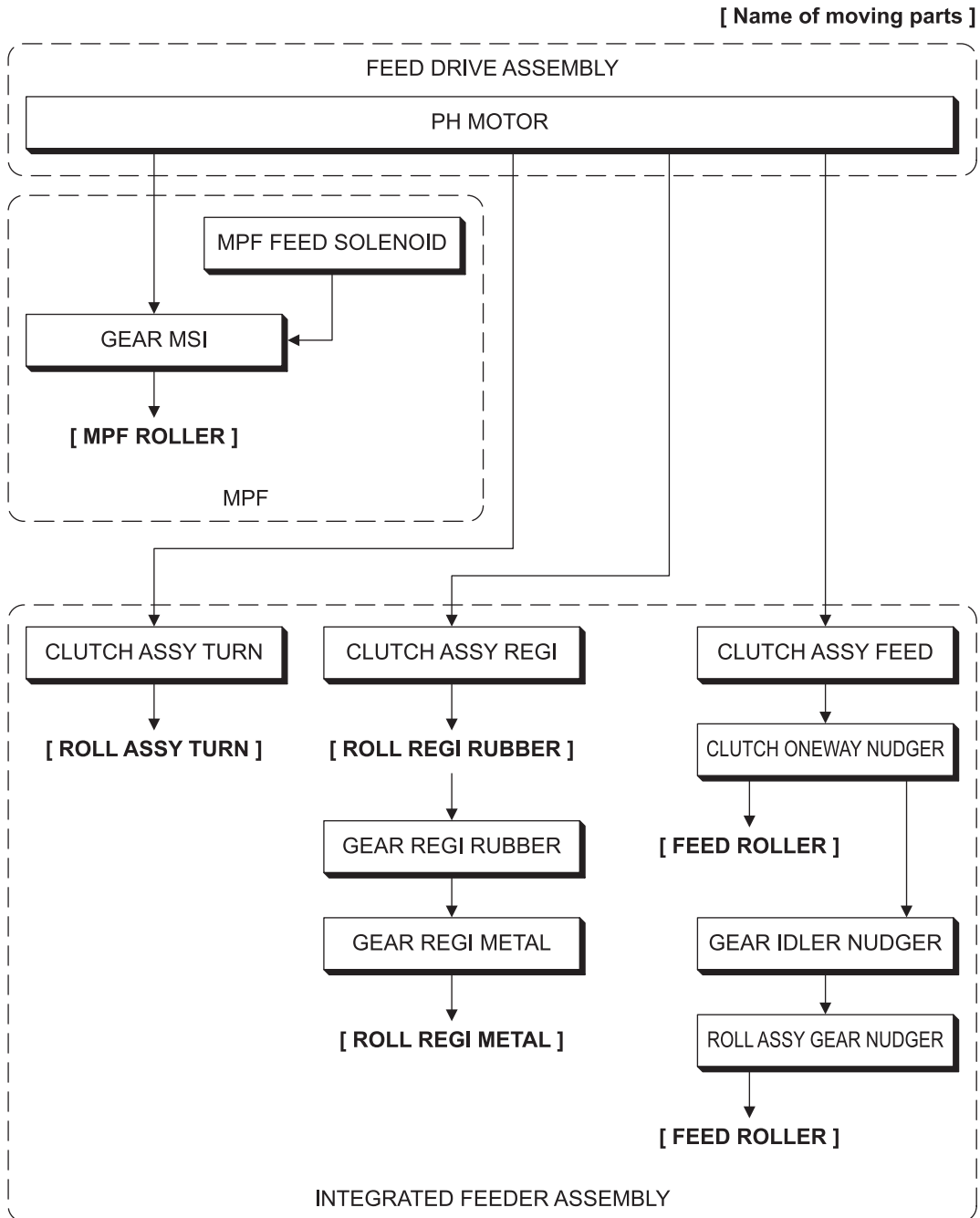

Kmy06019KA

[PAPER HANDLING]

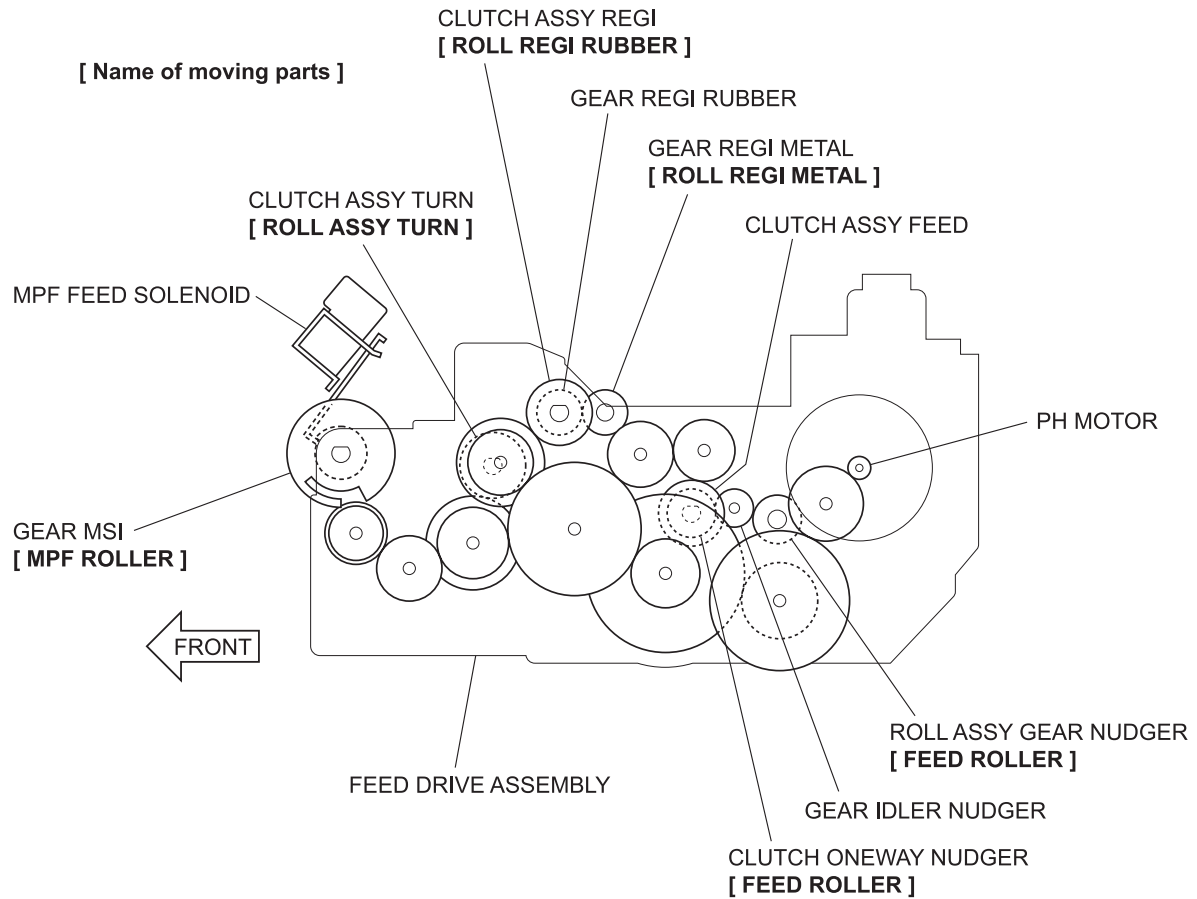

Kmy06020KA

6.4 DRIVE ASSY DUP

Rotation power of the DRIVE ASSY DUP is transmitted through the route below.

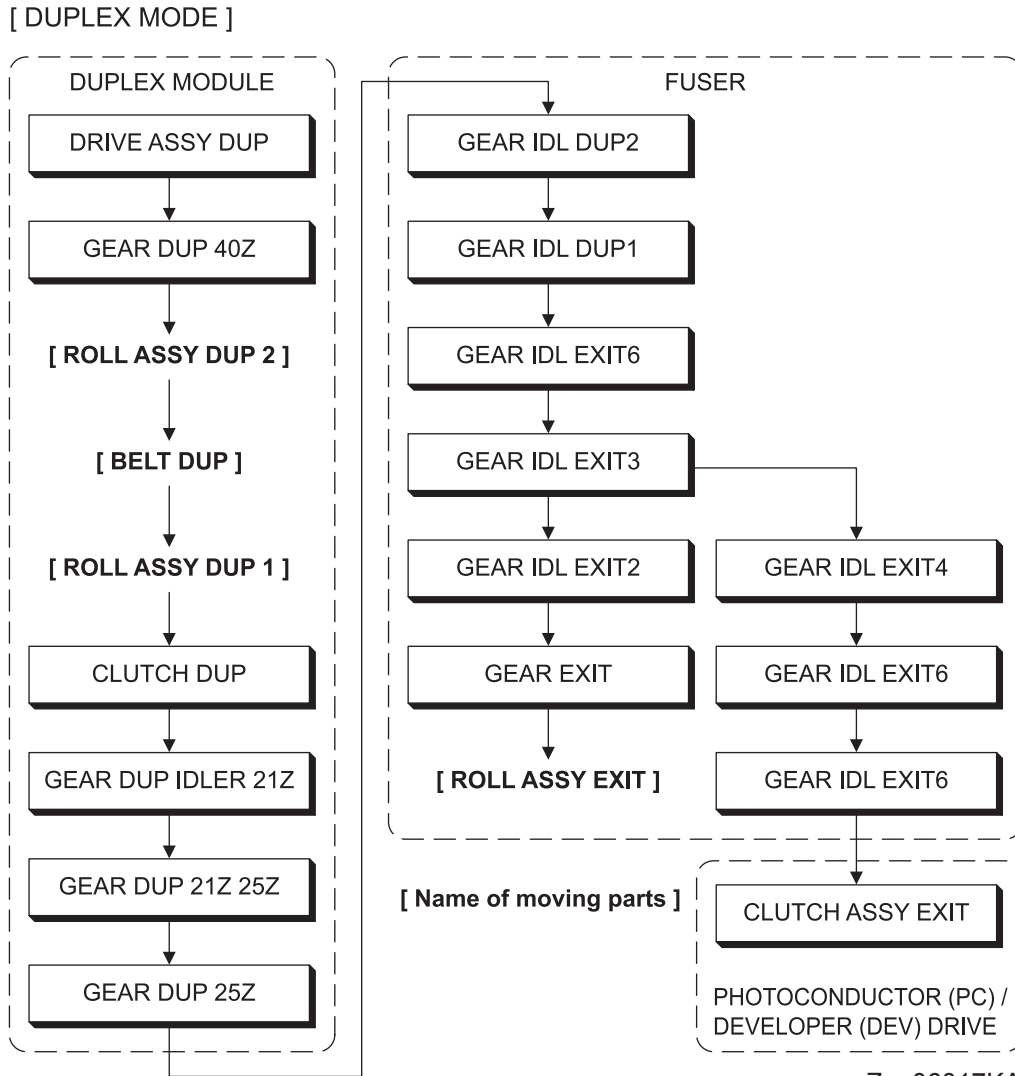

Zna06017KA

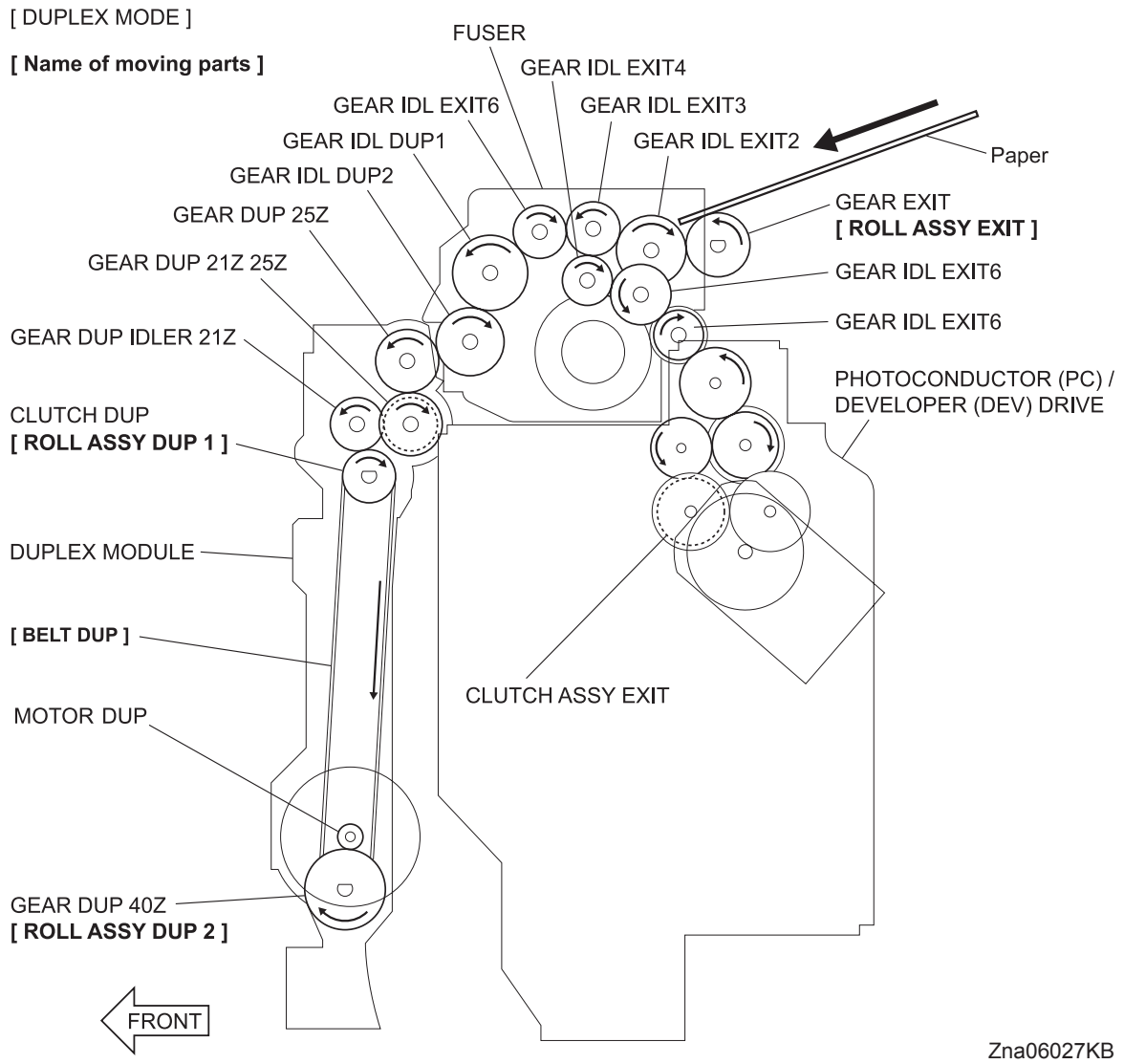

Zna06027KB

6.5 DRIVE ASSY OPT FDR

Rotation power of the DRIVE ASSY OPT FDR is transmitted through the route below.

[550 OPTION FEEDER]

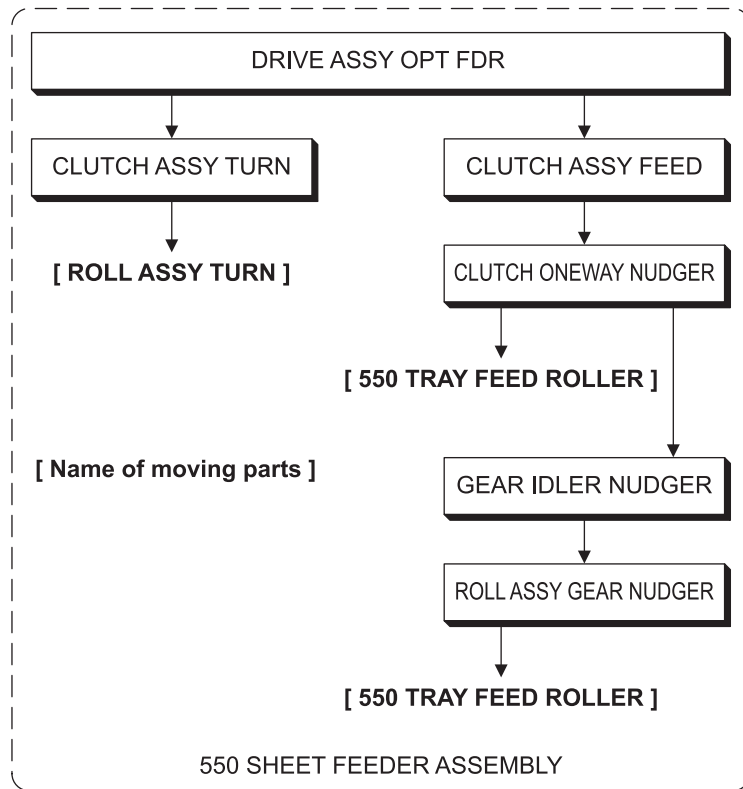

Kmy06023KA

[550 OPTION FEEDER]

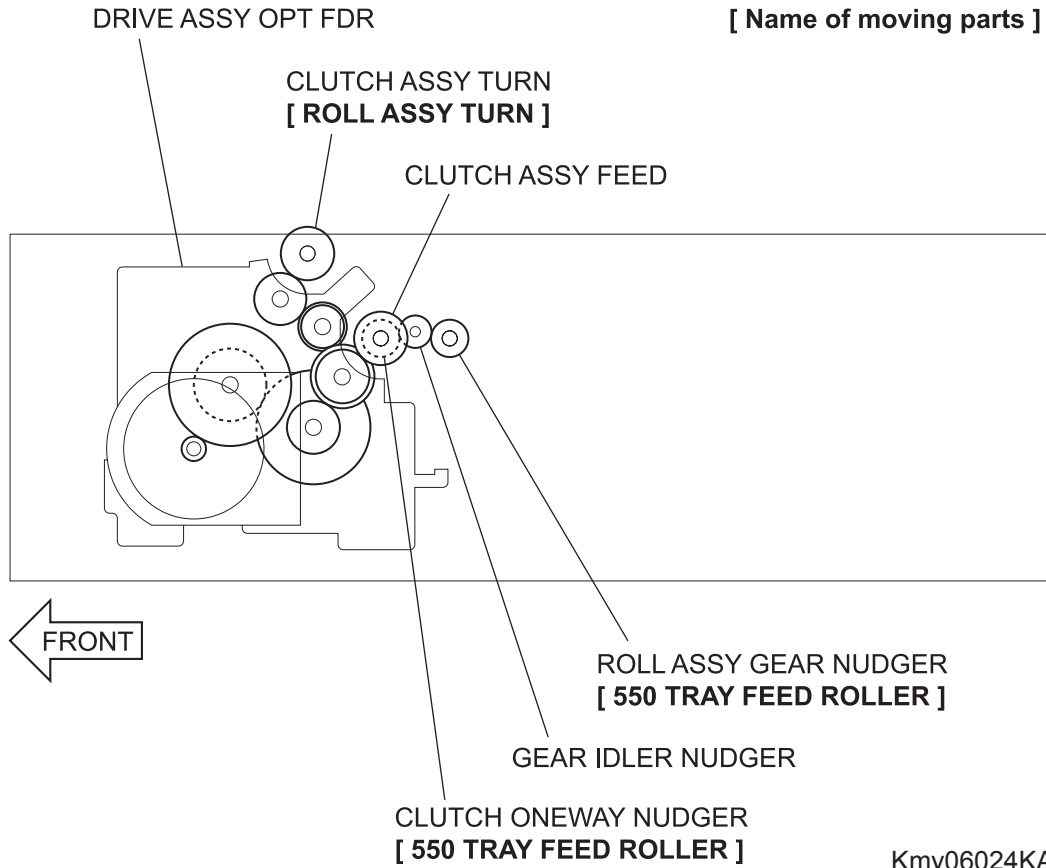

Chapter 7 Wiring Diagrams and Signal Information CONTENTS

1. Connection Wiring Diagram..... 7 - 1

 1.1 Symbols in the General Connection Wiring Diagram..... 7 - 1

 1.2 General Wiring Diagram 7 - 2

2. Interconnection Wiring Diagram of Parts..... 7 - 3

 2.1 Notes on Using the Wiring Diagram between Parts..... 7 - 3

 2.2 Configuration of the Interconnection Wiring Diagram of Parts..... 7 - 5

 § 1 DC POWER SUPPLY 7 - 7

 § 2 MSI®I 7 - 9

 § 3 DRIVE 7 - 11

 § 4 FEEDER 7 - 13

 § 5 ROS 7 - 15

 § 6 XEROGRAPHIC 7 - 17

 § 7 HIGH VOLTAGE 7 - 19

 § 8 DEVELOPER 7 - 21

 § 9 FUSER..... 7 - 23

 § 10 CONTROLLER 7 - 25







 § 11 550 FEEDER 7 - 27

 § 12 DUPLEX..... 7 - 29

1. Connection Wiring Diagram

1.1 Symbols in the General Connection Wiring Diagram

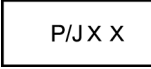
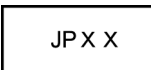
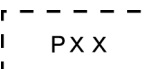
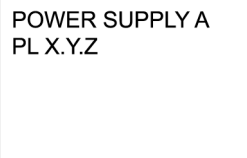
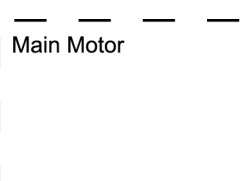
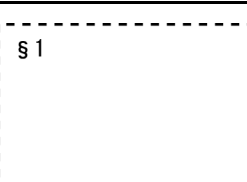
The symbols in the general connection wiring diagram are described below.

Symbol	Description
	Represents an interconnection between parts using wiring harness or wire.
	Represents an interconnection which differs according to the specifications.
	Represents an interconnection between parts using a conductive member such as a plate spring.
	Represents a connection between parts by tightening of a screw.
	Indicates a frame ground.
	Represents a connector. The connector No. is indicated inside the box.
	Represents a connection terminal with a plate spring on the printed circuit board. The connector (terminal) No. is indicated inside the box.
	Represents a connector directly connected to the printed circuit board. The connector No. is indicated inside the box.
	The box containing a part name represents a part. "PL X.Y.Z" indicates the item "Z" of the plate (PL) "X.Y" described in Chapter 5 "Parts List."
	Represents a functional part within a part, and indicates the name of the functional part.
	Represents a section in "2. Interconnection Wiring Diagram of Parts," and indicates its section No.
	Represents a screw for fixing wiring harness and a conductive member such as a plate spring.
	Represents a conductive member such as a plate spring.

1.2 General Wiring Diagram

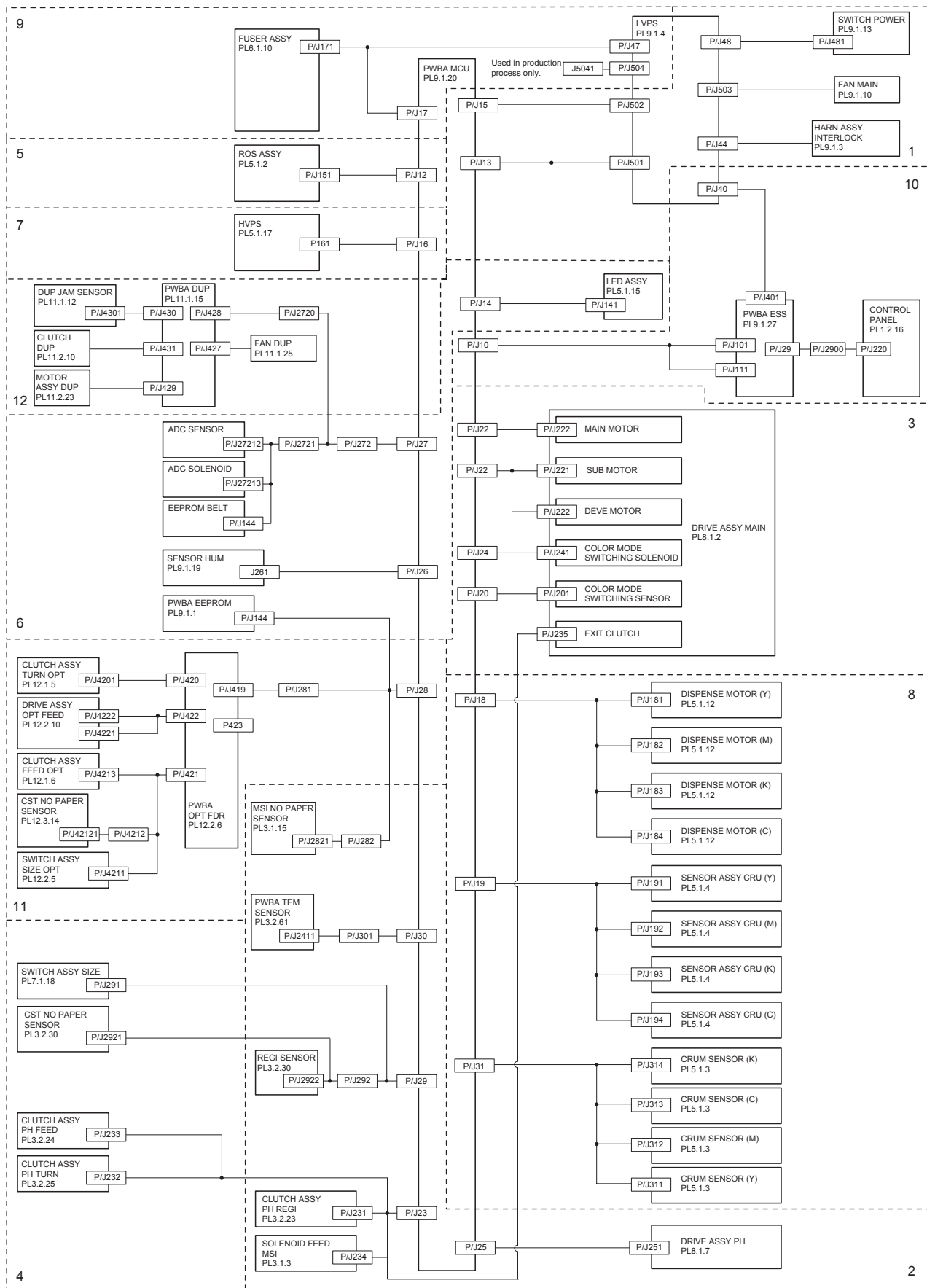



ZNA07001KA

2. Interconnection Wiring Diagram of Parts

2.1 Notes on Using the Wiring Diagram between Parts

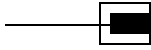
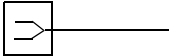
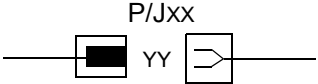
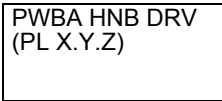
The following describes the legend of the wiring diagrams between parts shown on the following pages.

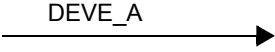
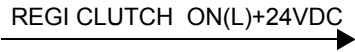
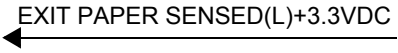
Symbols	Description
	Denotes a plug.
	Denotes a jack.
	Denotes Pin yy and Jack yy of the connector Pxx and Jxx.
	Denotes the parts. PL X.Y.Z implies the item "Z" of plate (PL) "X.Y" in Chapter 5. Parts List.
	Denotes functional parts attached with functional parts name.
	Denotes the control and its outline in PWB.
	Denotes a connection between parts with harnesses or wires, attached with signal name/contents.
	Denotes the function, and logic value of the signal to operate the function (Low: L, High: H). The given voltage is for signal in high status. The arrow indicates the direction of signal.
	Denotes the function, and logic value of the signal when the function operated (Low: L, High: H). The given voltage is for signal in high status. The arrow indicates the direction of signal.

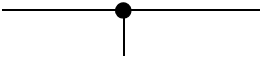
Symbols	Description
	Denotes a connection between wires.
I/L +24VDC	Denotes DC voltage when the interlock switch in HNB MCU WITH CPU turns on.
+5VDC +3.3VDC	Denotes DC voltage.
SG	Denotes signal ground.
AG	Denotes analog ground.
RTN	Denotes the return.

2.2 Configuration of the Interconnection Wiring Diagram of Parts

The interconnection wiring diagram is divided into 12 sections. § 1 to § 12 indicate details of the interconnections of parts.

§ 1 DC POWER SUPPLY

Connections of LVPS with PWBA MCU.

Connections of SWITCH POWER with LVPS.

Connections of FAN MAIN with LVPS.

Connections of HARN ASSY INTERLOCK with LVPS.

§ 2 MSI & REGI

Connections of DRIVE ASSY PH with PWBA MCU.

Connections of CLUTCH ASSY PH REGI with PWBA MCU.

Connections of SOLENOID FEED MSI with PWBA MCU.

Connections of REGI SENSOR with PWBA MCU.

Connections of TEMP. SENSOR with PWBA MCU.

Connections of MSI NO PAPER SENSOR with PWBA MCU.

§ 3 DRIVE

Connections of MAIN DRIVE ASSY with PWBA MCU.

§ 4 FEEDER

Connections of CST NO PAPER SENSOR with PWBA MCU.

Connections of SWITCH ASSY SIZE with PWBA MCU.

Connections of CLUTCH ASSY PH FEED with PWBA MCU.

Connections of CLUTCH ASSY PH TURN with PWBA MCU.

§ 5 ROS

Connections of ROS ASSY with PWBA MCU.

§ 6 XEROGRAPHIC

Connections of ADC SENSOR with PWBA MCU.

Connections of ADC SOLENOID with PWBA MCU.

Connections of EEPROM BELT with PWBA MCU.

Connections of SENSOR HUM with PWBA MCU.

Connections of PWBA EEPROM (XPRO) with PWBA MCU.

Connections of LED ASSY with PWBA MCU.

§ 7 HIGH VOLTAGE

Connections of HVPS with PWBA MCU.

§ 8 DEVELOPER

Connections of DISPENSE MOTOR (Y) with PWBA MCU.
Connections of DISPENSE MOTOR (M) with PWBA MCU.
Connections of DISPENSE MOTOR (C) with PWBA MCU.
Connections of DISPENSE MOTOR (K) with PWBA MCU.
Connections of SENSOR ASSY CRU (Y) with PWBA MCU.
Connections of SENSOR ASSY CRU (M) with PWBA MCU.
Connections of SENSOR ASSY CRU (C) with PWBA MCU.
Connections of SENSOR ASSY CRU (K) with PWBA MCU.
Connections of CRUM SENSOR (Y) with PWBA MCU.
Connections of CRUM SENSOR (M) with PWBA MCU.
Connections of CRUM SENSOR (C) with PWBA MCU.
Connections of CRUM SENSOR (K) with PWBA MCU.

§ 9 FUSER

Connections of FUSER ASSY with PWBA MCU.
Connections of FUSER ASSY with LVPS.
Connections of PWBA MCU with LVPS.

§ 10 CONTROLLER

Connections of PWBA ESS with PWBA MCU.
Connections of CONTROL PANEL with PWBA ESS.
Connections of LVPS with PWBA ESS.

§ 11 550 FEEDER

Connections of PWBA OPT FDR with PWBA MCU.
Connections of CLUTCH ASSY TURN OPT with PWBA OPT FDR.
Connections of DRIVE ASSY OPT FDR with PWBA OPT FDR.
Connections of CLUTCH ASSY FEED OPT with PWBA OPT FDR.
Connections of CST NO PAPER SENSOR with PWBA OPT FDR.
Connections of SWITCH ASSY SIZE OPT with PWBA OPT FDR.

§ 12 DUPLEX

Connections of PWBA DUP-H with PWBA MCU.
Connections of DUP JAM SENSOR with PWBA DUP-H.
Connections of CLUTCH DUP with PWBA DUP-H.
Connections of MOTOR ASSY DUP with PWBA DUP-H.
Connections of FAN DUP with PWBA DUP-H.

§ 1 DC POWER SUPPLY

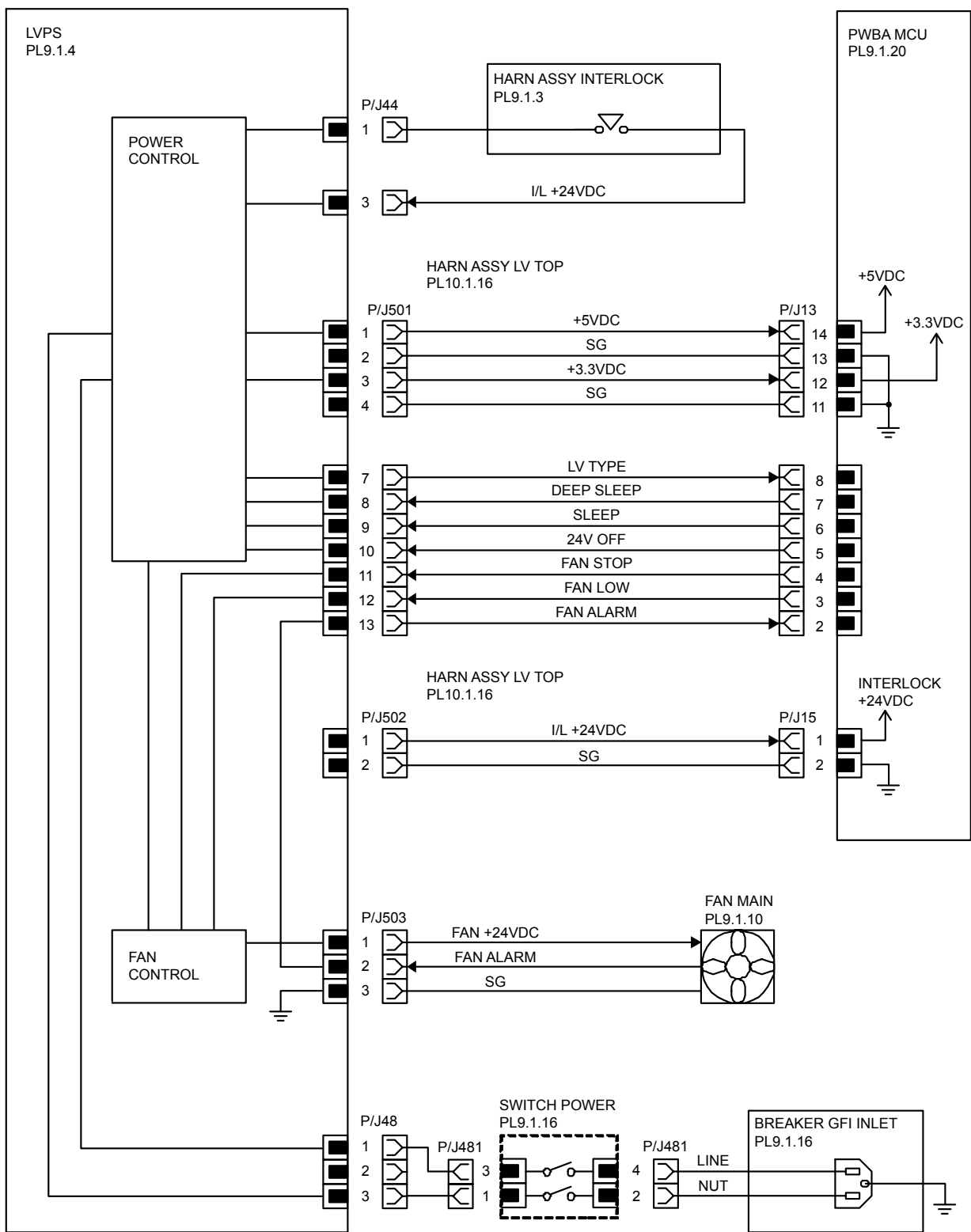

ZNA07002KA

Signal line name	Description
LV TYPE DEEP SLEEP SLEEP 24V OFF	Control signal of the LVPS
FAN STOP FAN LOW FAN ALARM	Drive control signal of the SIDE FAN

- LVPS overcurrent protection circuit

This circuit stops all outputs, if the power supply voltage 24VDC, 5VDC, or 3.3VDC is shorted.

The circuit is reset, when after the cause of short was removed, the power is turned off, and then on again after certain time.

- LVPS overvoltage protection circuit

This circuit stops all outputs, if the power supply voltage 24VDC, 5VDC, or 3.3VDC exceeds the specified voltage respectively.

At this time, the operating point is 32VDC(TBD) or less for 24VDC, 7VDC(TBD) or less for 5VDC, or 4.4VDC(TBD) or less for 3.3VDC.

The circuit is reset, when the power is turned off, and then on again after certain time.

- Sleep mode and deep sleep mode

The output of the following power supply are stopped according to the these signals.

Output Signal	+24VDC	+5VDC	+3.3VDC
Sleep	OFF	OFF	ON
Deep sleep	OFF	OFF	OFF

§ 2 MSI®I

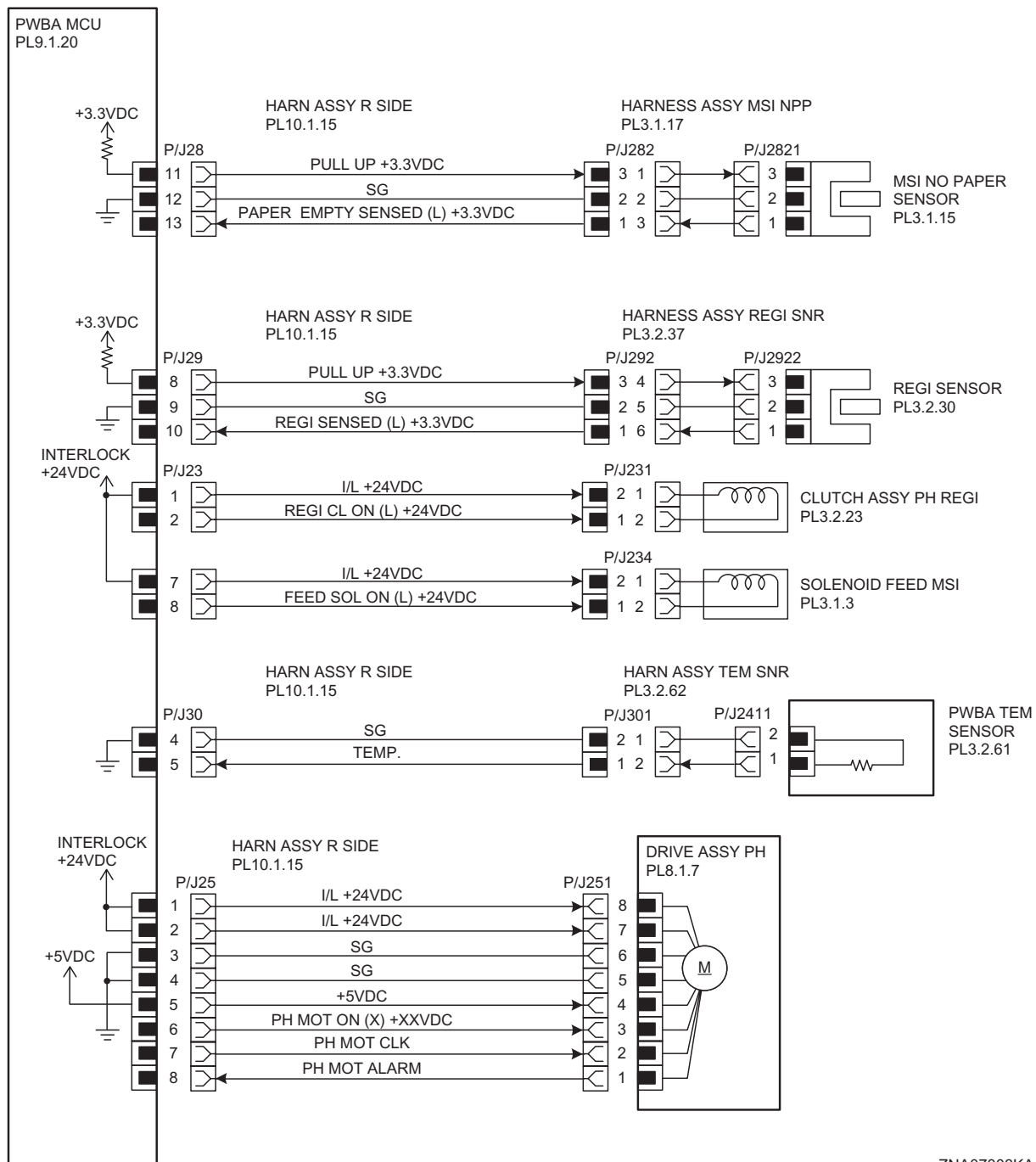

ZNA07003KA

Signal line name	Description
PAPER EMPTY SENSED (L) +3.3VDC	Paper detect signal of the MSI by the Sensor Photo (MSI NO PAPER SENSOR)
REGI SENSED (L) +3.3VDC	Paper detect signal of the Regi part by the Sensor Photo (REGI SENSOR)
REGI CL ON (L) +24VDC	ON/OFF signal of the REGI CLUTCH
FEED SOL ON (L) +24VDC	ON/OFF signal of the MSI FEED SOLENOID
TEMP.	Data on temperature inside the printer.
PH MOT ON (X) +XXVDC PH MOT CLK PH MOT ALARM	Drive control signal of the DRIVE ASSY PH

§ 3 DRIVE

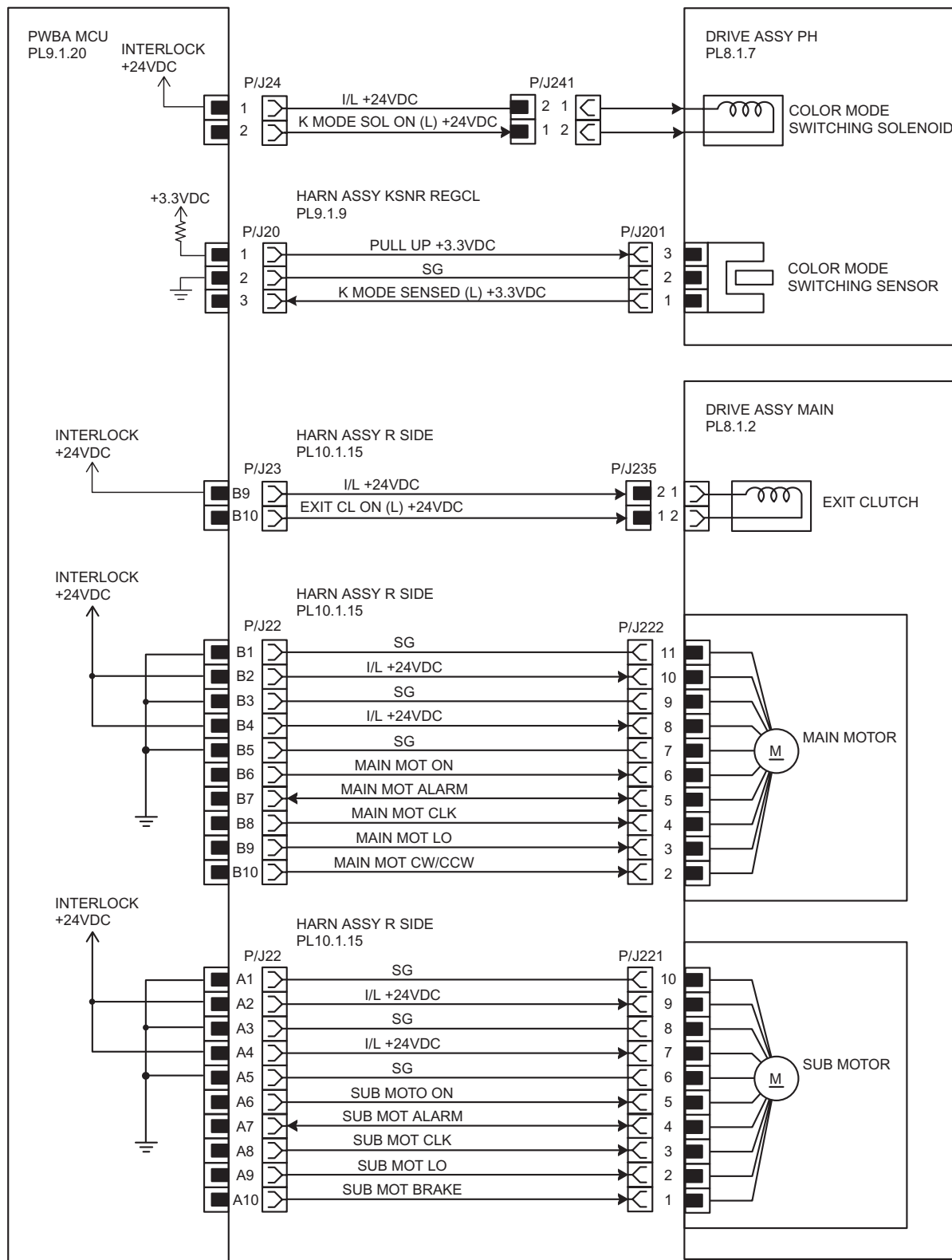

ZNA07004KA

Signal line name	Description
K MODE SOL ON (L) +24VDC	ON/OFF signal of the COLOR MODE SWITCHING SOLENOID
K MODE SENSED (L) +3.3VDC	Color mode detect signal of the DRIVE ASSY PH by the Sensor Photo (COLOR MODE SWITCHING SENSOR)
MAIN MOT ON MAIN MOT ALARM MAIN MOT CLK MAIN MOT LO MAIN MOT CW/CCW	Drive control signal of the MAIN MOTOR
SUB MOT ON SUB MOT ALARM SUB MOT CLK SUB MOT LO SUB MOT BRAKE	Drive control signal of the SUB MOTOR
EXIT CL ON (L) +24VDC	ON/OFF signal of the EXIT CLUTCH

§ 4 FEEDER

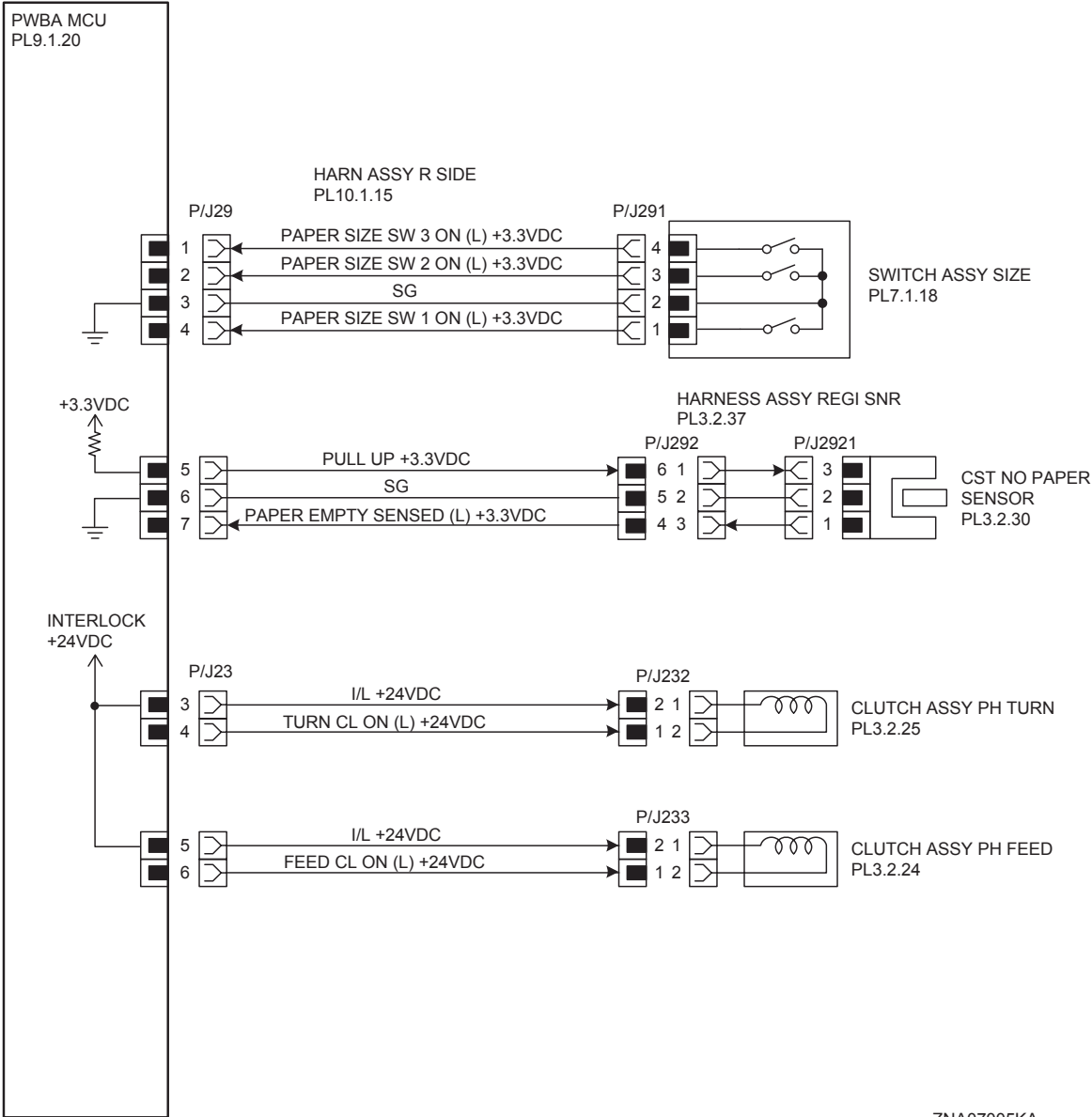

ZNA07005KA

Signal line name	Description
PAPER SIZE SW 1 ON (L) +3.3VDC PAPER SIZE SW 2 ON (L) +3.3VDC PAPER SIZE SW 3 ON (L) +3.3VDC	ON/OFF signal of the SWITCH ASSY SIZE
PAPER EMPTY SENSED (L) +3.3VDC	Paper detect signal of the Feeder by the Sensor Photo (NO PAPER SENSOR)
TURN CL ON (L) +24VDC	ON/OFF signal of the TURN CLUTCH
FEED CL ON (L) +24VDC	ON/OFF signal of the FEED CLUTCH

- Outline of SWITCH ASSY SIZE

The paper size is determined by a combination of ON/OFF statuses of the SW 1, SW 2, and SW 3 switches of SWITCH ASSY SIZE.

Paper size	Switches		
	SW 1	SW 2	SW 3
LEGAL 14" (SEF)	ON	ON	ON
LEGAL 13" (SEF)	ON	ON	OFF
EXECUTIVE (SEF)	ON	OFF	ON
B5 (SEF)	ON	OFF	OFF
A4 (SEF)	OFF	ON	ON
LETTER (SEF)	OFF	OFF	ON
A5	OFF	ON	OFF
No cassette	OFF	OFF	OFF

ON : The actuator is pushing the size switch.

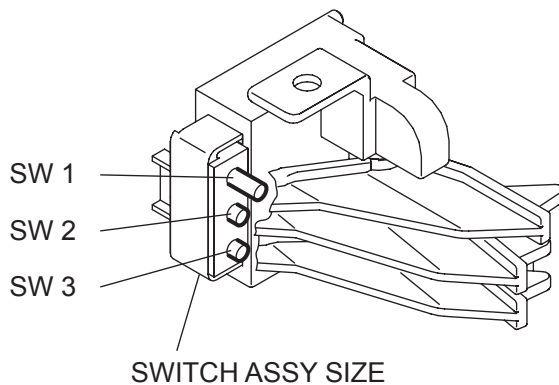

KMY07014KA

§ 5 ROS

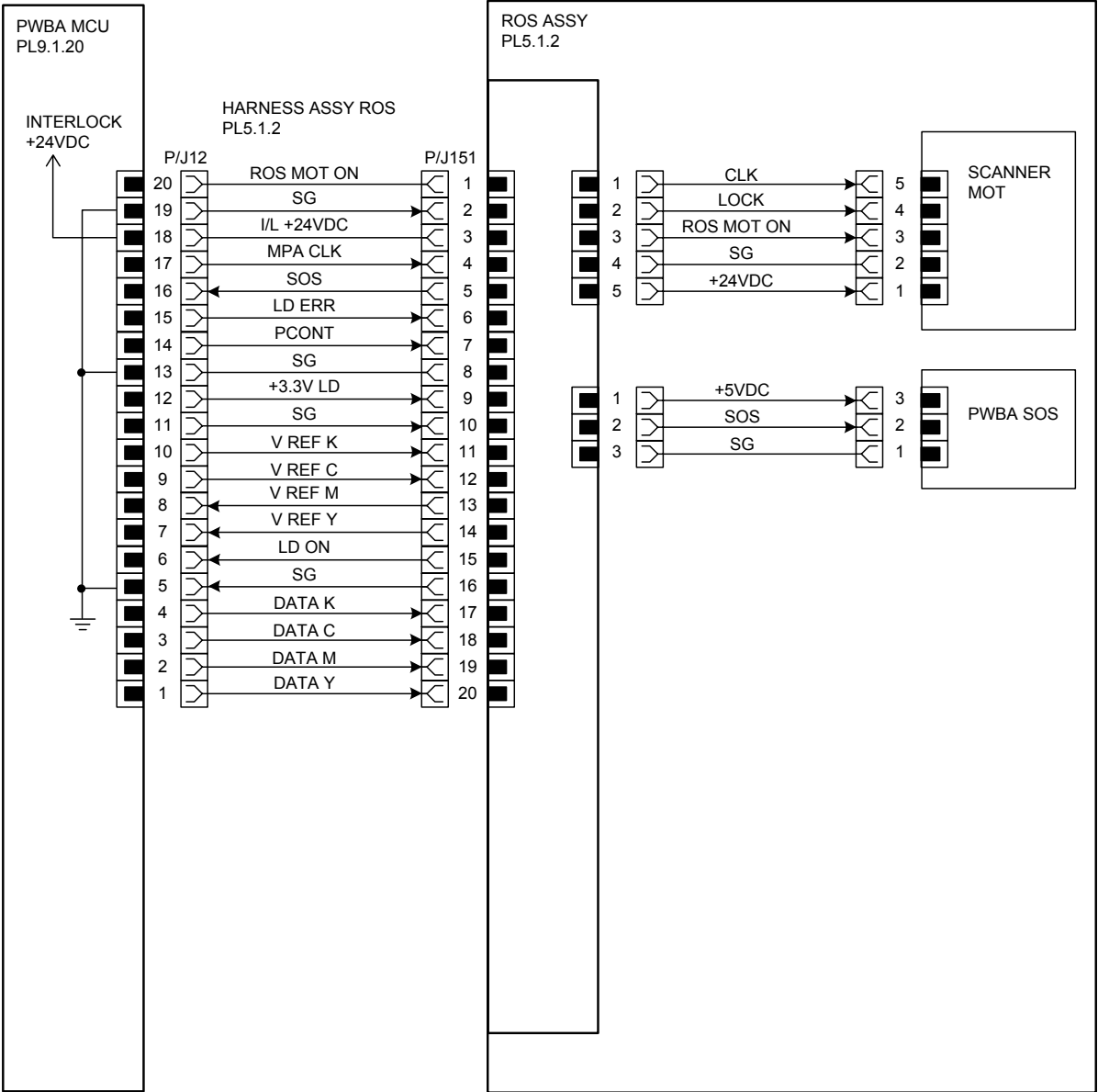

ZNA07006KA

Signal line name	Description
ROS MOT ON	Drive control signal of the ROS MOTOR
SOS	Reference signal for scan start of LASER
V REF K V REF C V REF M V REF Y	Emission control signal of the laser diode
DATA K DATA C DATA M DATA Y	Video signal of the laser diode

§ 6 XEROGRAPHIC

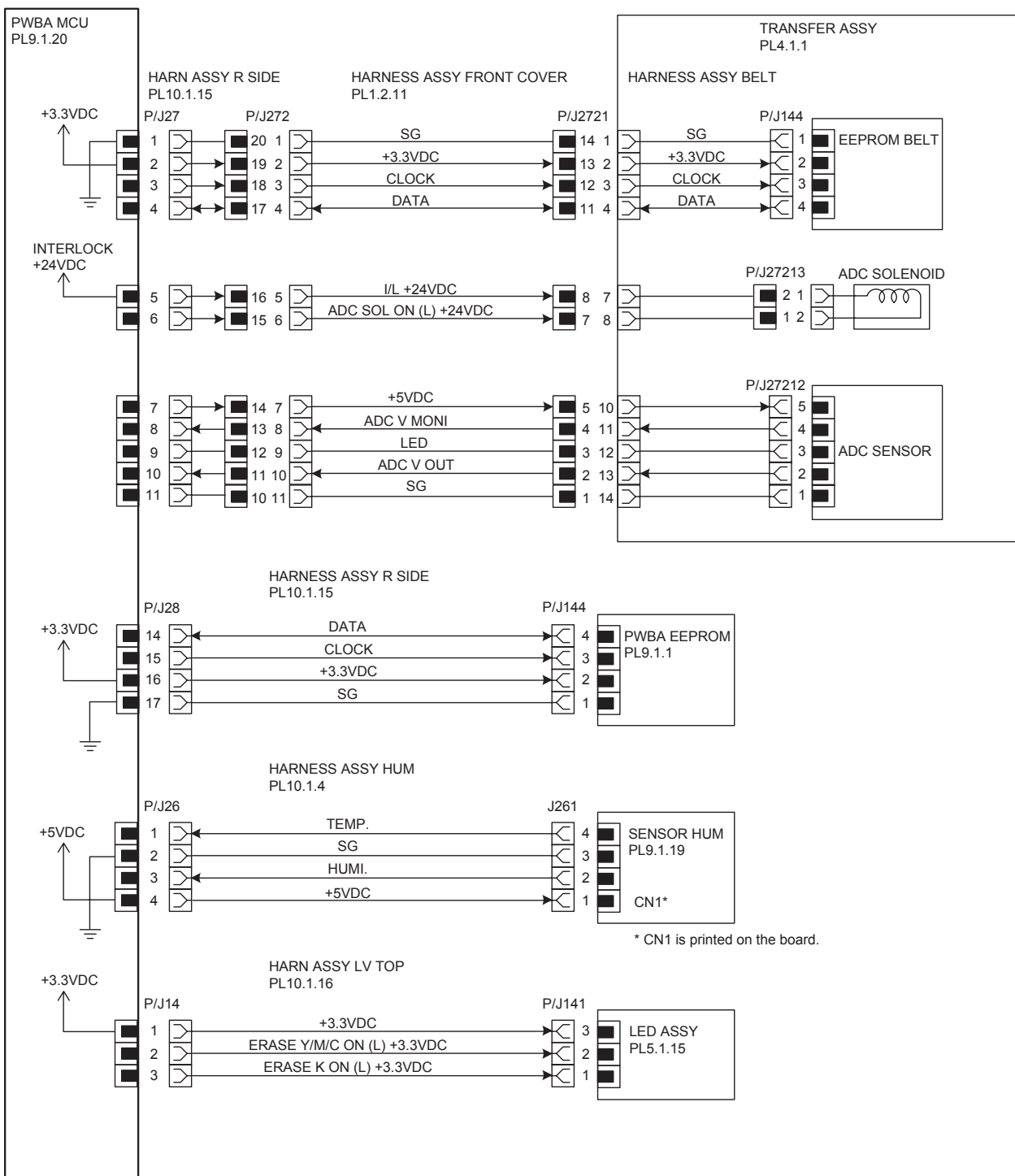

ZNA07007KA

Signal line name	Description
CLOCK DATA	Control signal of the EEPROM BELT
ADC SOL ON (L) +24VDC	ON/OFF signal of the ADC SOLENOID
ADC SENSOR	Toner patch density data measured by the ADC SENSOR (Analog value)
LED REM	Remote signal of the LED of ADC SENSOR
ADC V MONI	Control signal of the ADC SENSOR
DATA CLOCK	Control signal of the EEPROM XPRO
TEMP.	Temperature data in the printer by the TEMP./HUM. SENSOR (Analog value)
HUMI.	Humidity data in the printer by the TEMP./HUM. SENSOR (Analog value)
ERASE K ON (L) +3.3VDC ERASE Y/M/C ON (L) +3.3VDC	ON/OFF signal of the ERASE LAMP

§ 7 HIGH VOLTAGE

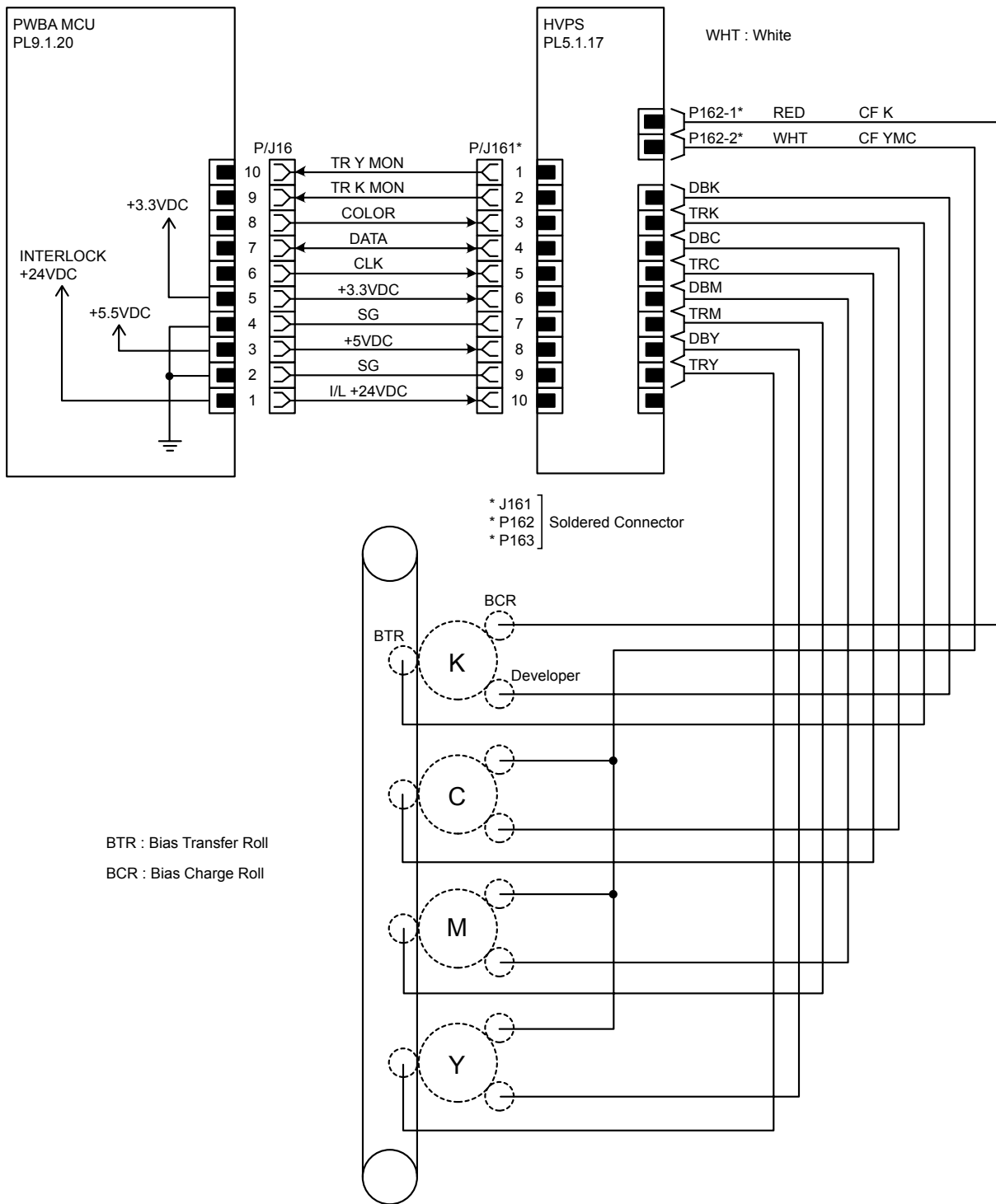

ZNA07008KA

Signal line name	Description
TR Y MON TR K MON COLOR DATA CLK	Control signal of the HVPS

§ 8 DEVELOPER

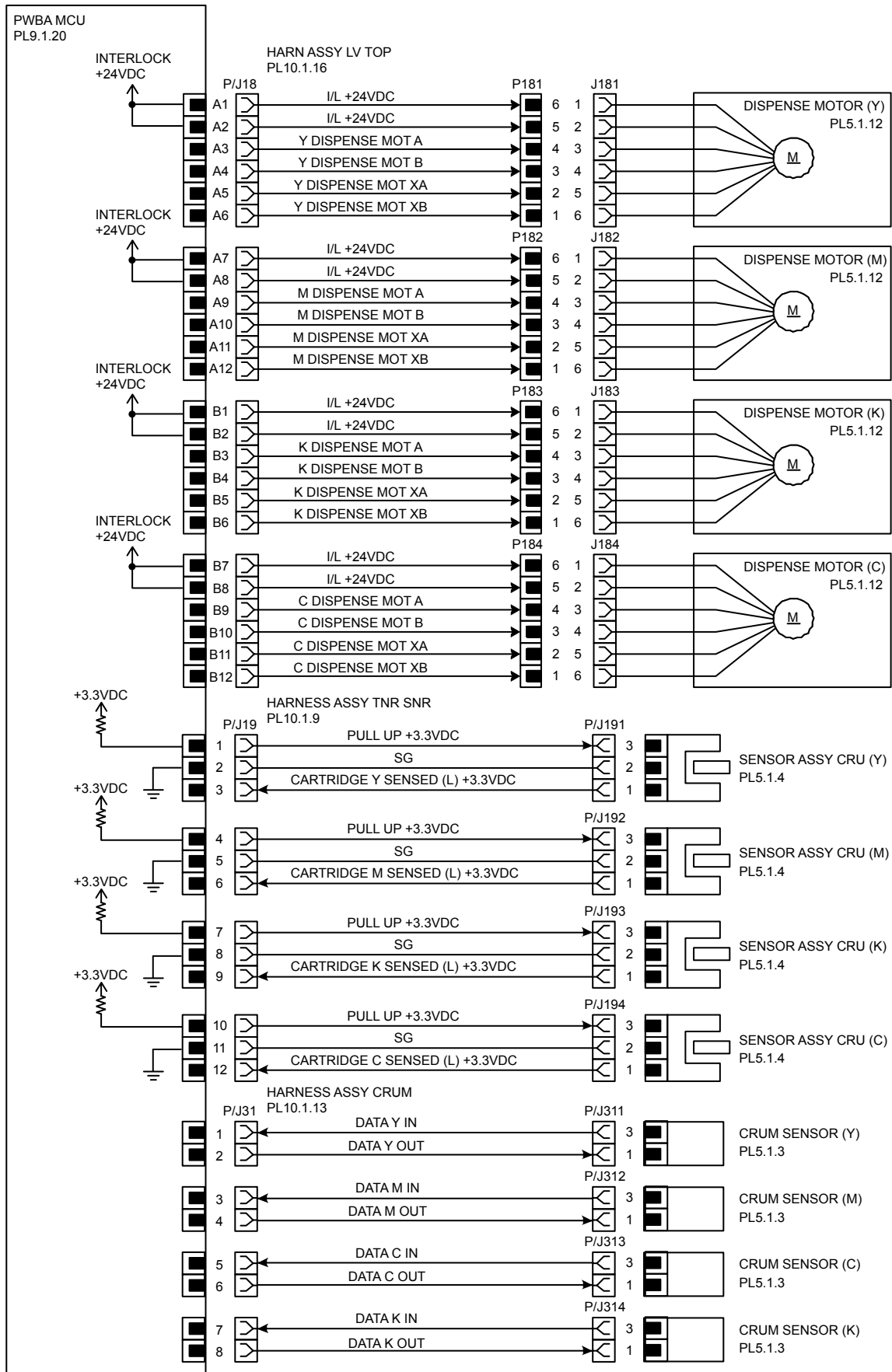

KMY07009KA

Signal line name	Description
Y DISPENSE MOT A Y DISPENSE MOT B Y DISPENSE MOT XA Y DISPENSE MOT XB	Drive control signal of the DISPENSE MOTOR (Y)
M DISPENSE MOT A M DISPENSE MOT B M DISPENSE MOT XA M DISPENSE MOT XB	Drive control signal of the DISPENSE MOTOR (M)
K DISPENSE MOT A K DISPENSE MOT B K DISPENSE MOT XA K DISPENSE MOT XB	Drive control signal of the DISPENSE MOTOR (K)
C DISPENSE MOT A C DISPENSE MOT B C DISPENSE MOT XA C DISPENSE MOT XB	Drive control signal of the DISPENSE MOTOR (C)
CARTRIDGE Y SENSED (L) +3.3VDC	Detection signal of the CRU SENSOR (Y)
CARTRIDGE M SENSED (L) +3.3VDC	Detection signal of the CRU SENSOR (M)
CARTRIDGE K SENSED (L) +3.3VDC	Detection signal of the CRU SENSOR (K)
CARTRIDGE C SENSED (L) +3.3VDC	Detection signal of the CRU SENSOR (C)
DATA Y IN DATA Y OUT	Control signal of the CRUM SENSOR (Y)
DATA M IN DATA M OUT	Control signal of the CRUM SENSOR (M)
DATA C IN DATA C OUT	Control signal of the CRUM SENSOR (C)
DATA K IN DATA K OUT	Control signal of the CRUM SENSOR (K)

§ 9 FUSER

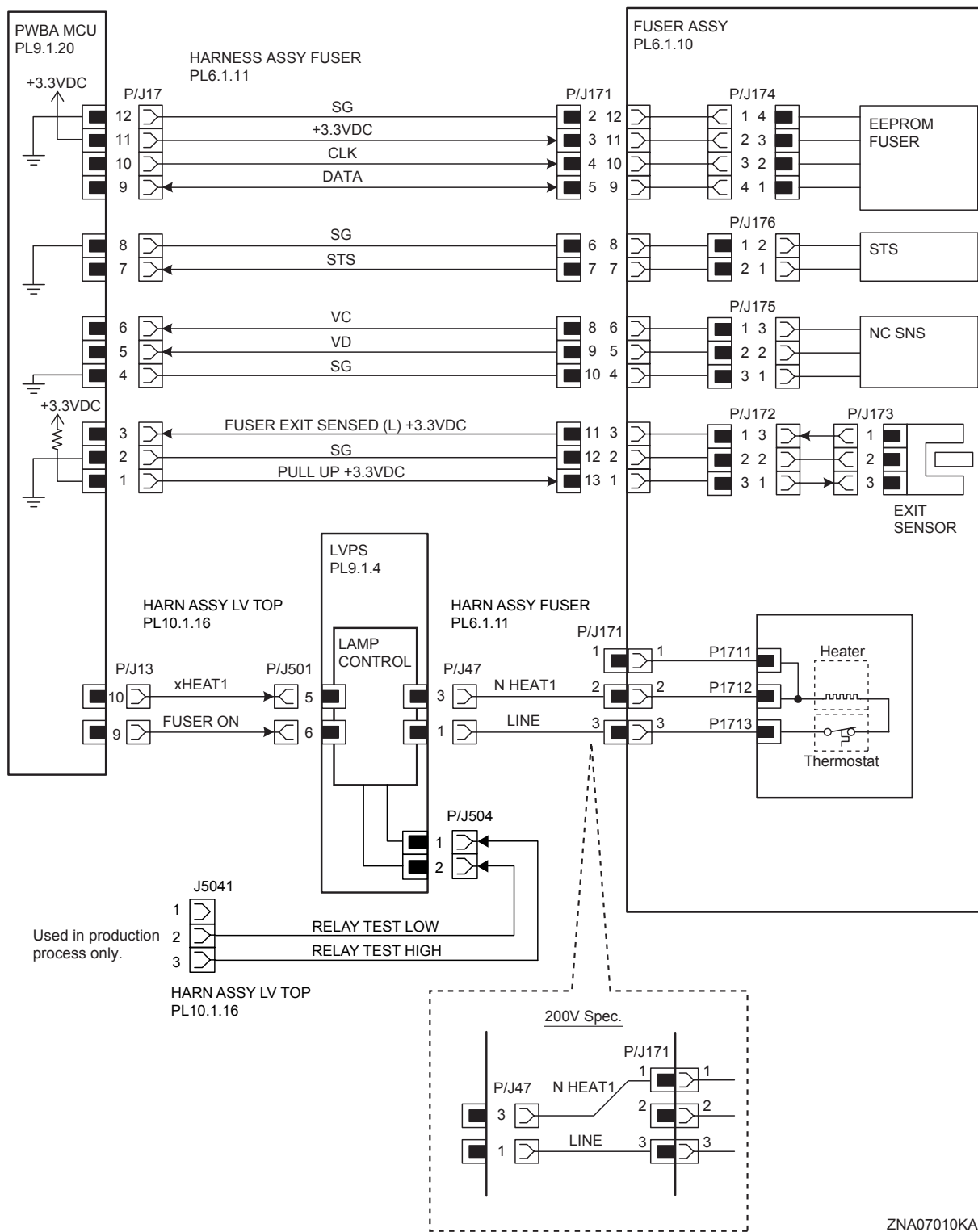

ZNA07010KA

Signal line name	Description
CLK DATA	Control signal of the EEPROM FUSER
STS	Heat Roll surface temperature data measured by Temp. Sensor for detecting high temperature (analog value)
VC VD	Temperature data measured by Temp. Sensor for controlling temperature (analog value)
FUSER EXIT SENSED (L) +3.3VDC	Paper detect signal of the Fuser Exit by the Sensor Photo (EXIT SENSOR)
FUSER ON	Lighting signal of Fuser Lamp
RELAY TEST LOW RELAY TEST HIGH	Test signal of the LVPS (Used in production process only)

§ 10 CONTROLLER

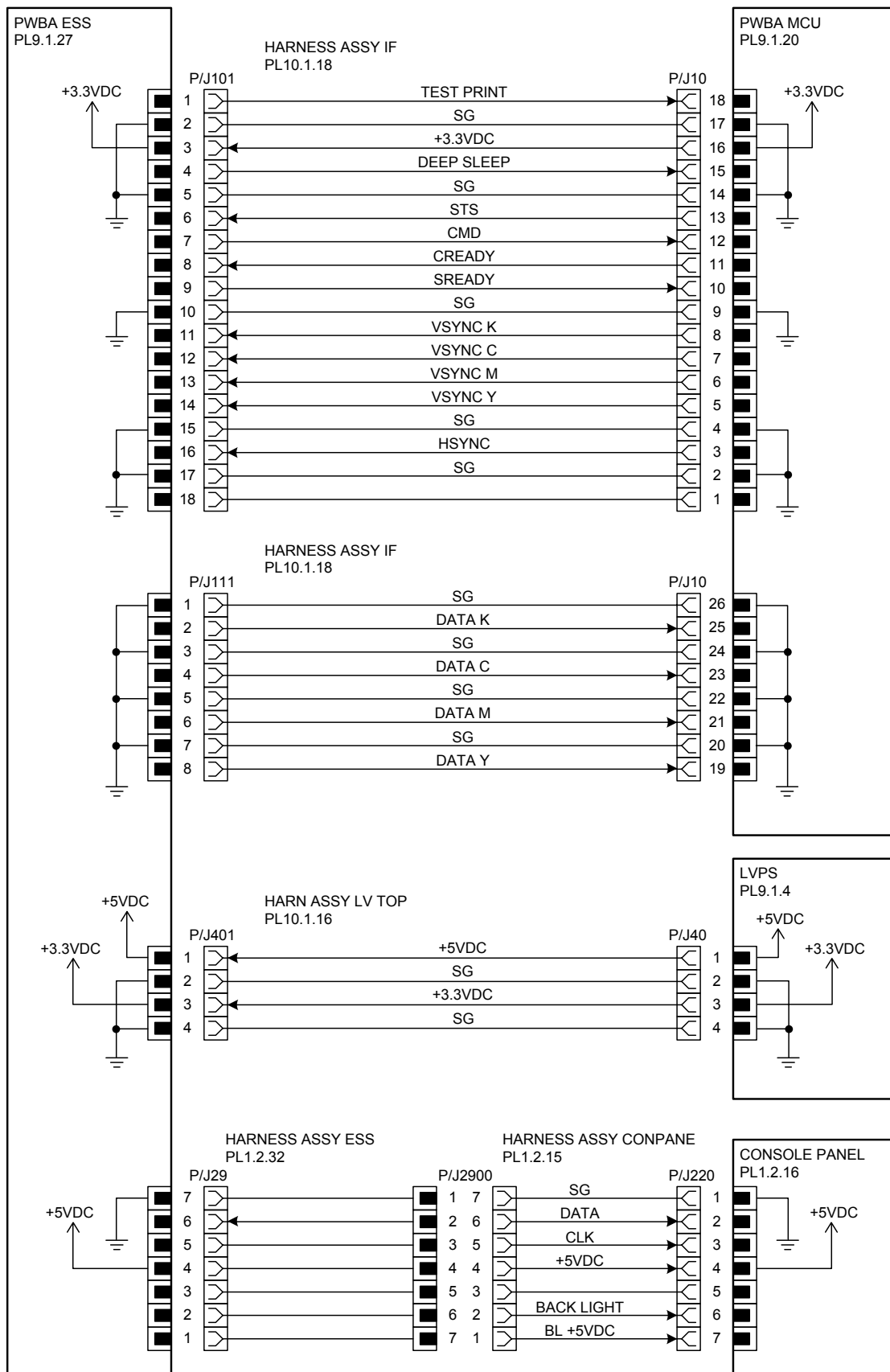

ZNA07011KA

Signal line name	Description
TEST PRINT	Control signal for the TEST PRINT mode
DEEP SLEEP	Control signal for the DEEP SLEEP mode
STS	Status signal transmitted fro the PWBA MCU to the PWBA ESS
CMD	Command signal transmitted from the PWBA ESS to the PWBA MCU
CREADY SREADY	Signal for indicating weather or not the printer is ready for receiving command signal
VSYNC K VSYNC C VSYNC M VSYNC Y	Signal for indicating registration position of each of images Y, M, C and K
HSYNC	Signal for data
DATA K DATA C DATA M DATA Y	Video data of four colors
DATA CLK BACK LIGHT BL +5VDC	Control signal of the CONTROL PANEL

§ 11 550 FEEDER

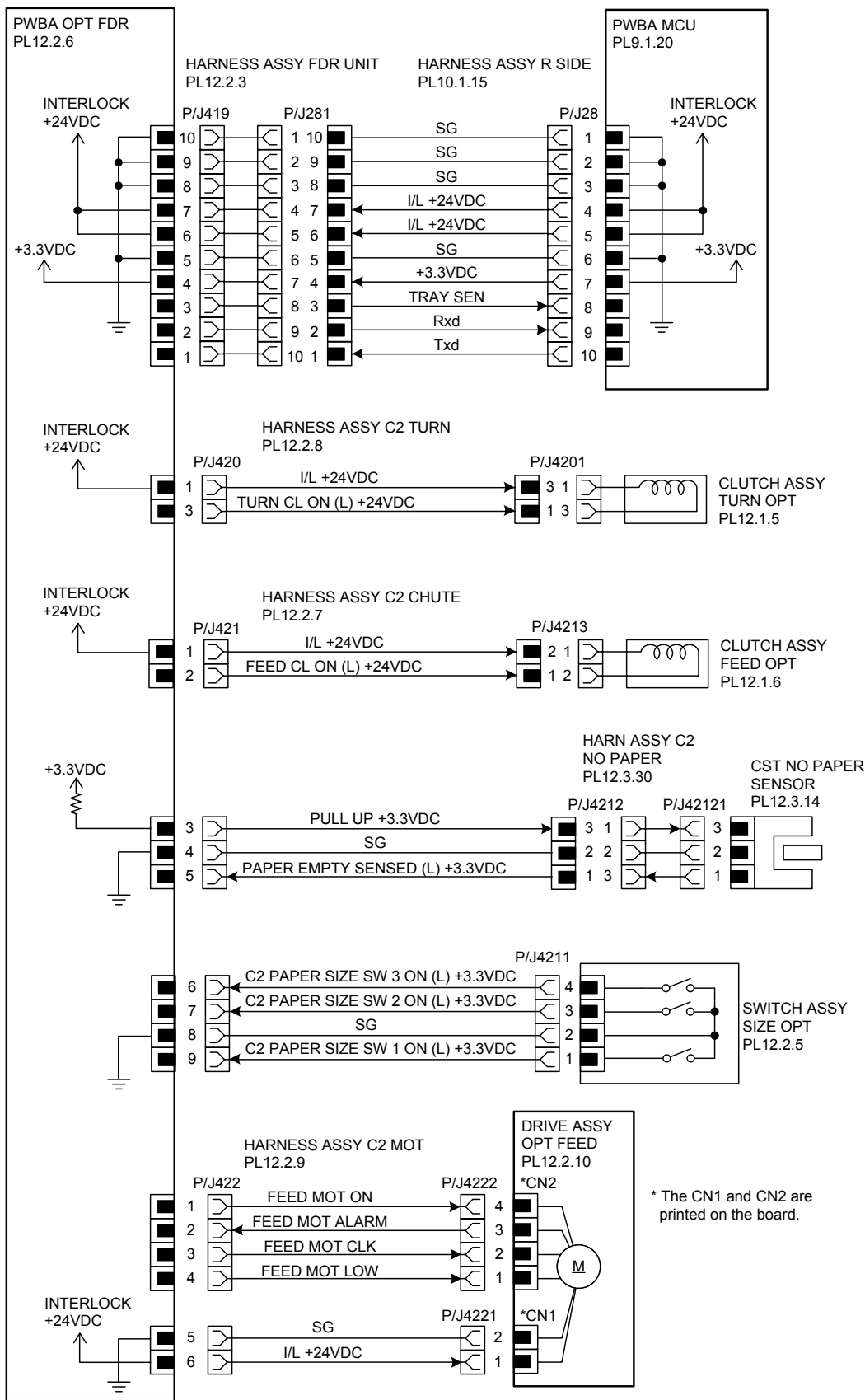

ZNA07012KA

Signal line name	Description
TRAY SEN Rxd Txd	Control signal of the PWBA FEEDER
TURN CL ON (L) +24VDC	ON/OFF signal of the TURN CLUTCH
FEED CL ON (L) +24VDC	ON/OFF signal of the FEED CLUTCH
PAPER EMPTY SENSED (L) +3.3VDC	Paper detect signal of the Feeder by the Sensor Photo (NO PAPER SENSOR)
PAPER SIZE SW 1 ON (L) +3.3VDC PAPER SIZE SW 2 ON (L) +3.3VDC PAPER SIZE SW 3 ON (L) +3.3VDC	ON/OFF signal of the SWITCH ASSY SIZE
FEED MOT ON FEED MOT ALARM FEED MOT CLK FEED MOT LOW	Drive control signal of the FEED MOTOR

- Outline of SWITCH ASSY SIZE

The paper size is determined by a combination of ON/OFF statuses of the SW 1, SW 2, and SW 3 switches of SWITCH ASSY SIZE.

Paper size	Switches		
	SW 1	SW 2	SW 3
LEGAL 14" (SEF)	ON	ON	ON
LEGAL 13" (SEF)	ON	ON	OFF
EXECUTIVE (SEF)	ON	OFF	ON
B5 (SEF)	ON	OFF	OFF
A4 (SEF)	OFF	ON	ON
LETTER (SEF)	OFF	OFF	ON
A5	OFF	ON	OFF
No cassette	OFF	OFF	OFF

ON : The actuator is pushing the size switch.

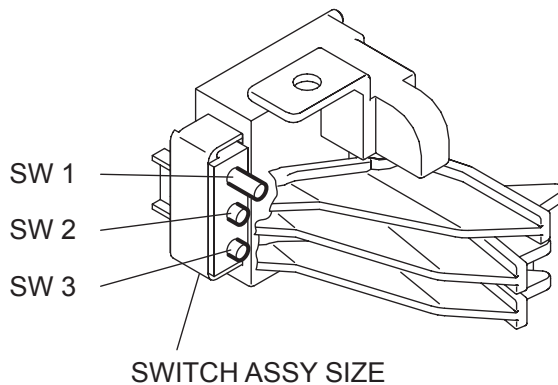

KMY07014KA

§ 12 DUPLEX

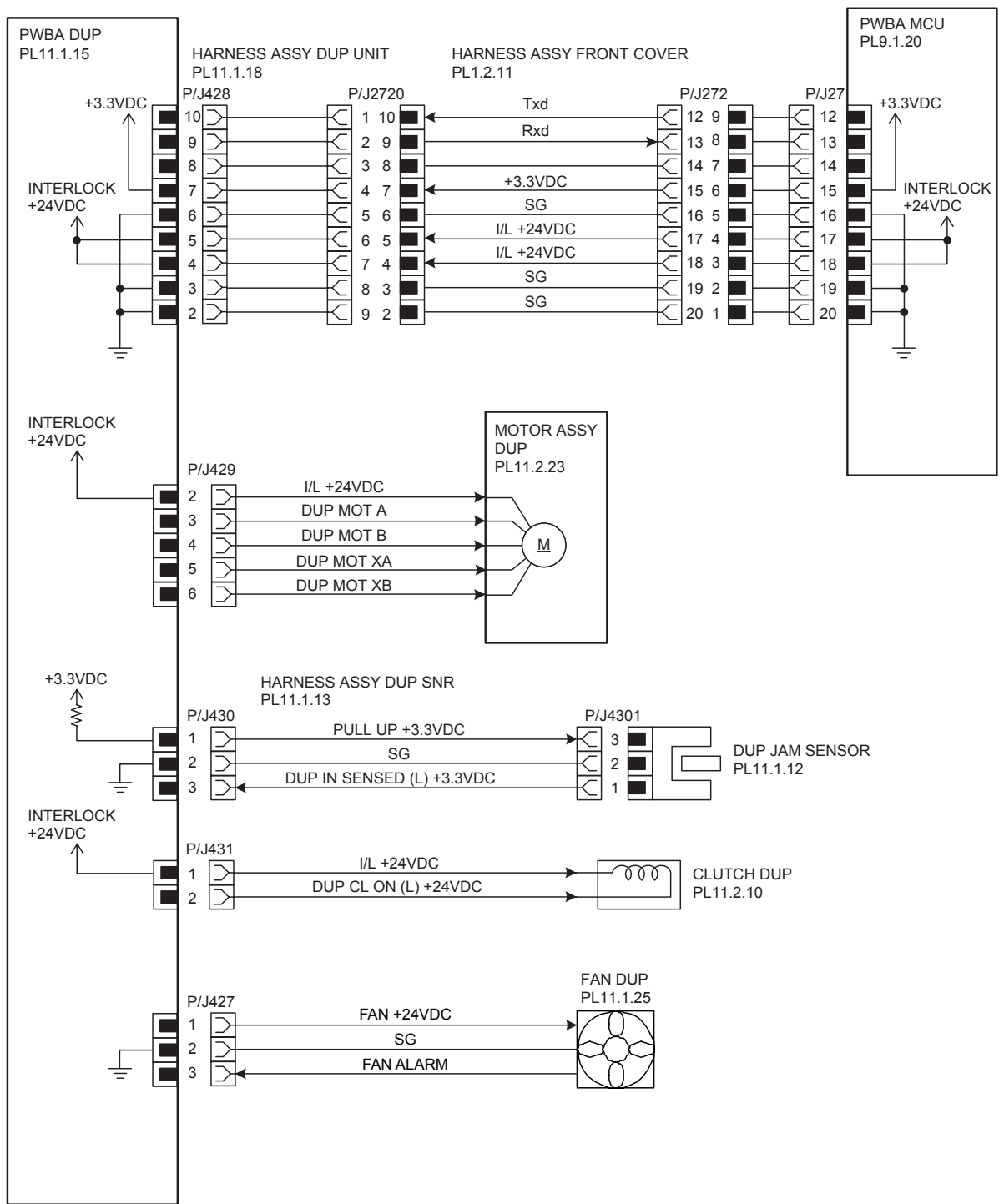

ZNA07013KA

Signal line name	Description
Txd Rxd	Control signal of the PWBA DUP
DUP MOT A DUP MOT B DUP MOT XA DUP MOT XB	Drive control signal of the DUP MOTOR
DUP IN SENSED (L) +3.3VDC	Paper detect signal of the Duplex by the Sensor Photo (DUP JAM SENSOR)
DUP CL ON (L) +24VDC	ON/OFF signal of the DUP CLUTCH
FAN +24VDC FAN ALARM	Drive control signal of the DUP FAN

Chapter 8 Printer Specifications CONTENTS

1. Configuration of Printer.....	8 - 1
1.1 Basic Configuration.....	8 - 1
1.2 Functional Configuration.....	8 - 1
2. Electrical Properties.....	8 - 2
2.1 Power Source.....	8 - 2
2.2 Power Consumption.....	8 - 2
2.3 Rush Current.....	8 - 2
3. Mechanical Properties.....	8 - 3
3.1 Dimensions/Mass of Printer.....	8 - 3
3.2 Dimensions/Mass of Paper Tray.....	8 - 3
3.3 Dimensions/Mass of Duplex.....	8 - 4
3.4 Dimensions/Mass of Consumables and CRUs.....	8 - 5
3.4.1 TRANSFER BELT.....	8 - 5
3.4.2 FUSER CRU.....	8 - 5
3.4.3 Black toner cartridge.....	8 - 5
3.4.4 Yellow toner cartridge.....	8 - 5
3.4.5 Magenta toner cartridge.....	8 - 5
3.4.6 Cyan toner cartridge.....	8 - 6
3.5 Installation Space (min. installation space).....	8 - 6
4. Functions.....	8 - 8
4.1 Recording System.....	8 - 8
4.2 Exposure System.....	8 - 8
4.3 Development System.....	8 - 8
4.4 Fixing System.....	8 - 8
4.5 Resolution.....	8 - 8
4.6 Operation Mode.....	8 - 8
4.7 Warm-up Time.....	8 - 9
4.8 FPOT (First Print Output Time).....	8 - 9
4.9 Continuous Printing Speed.....	8 - 10
4.10 Input Properties.....	8 - 11
4.10.1 Paper pick-up system.....	8 - 11
4.10.2 Paper pick-up capacity.....	8 - 11
4.11 Output Properties.....	8 - 12
4.11.1 Paper delivery system.....	8 - 12
4.11.2 Paper delivery capacity.....	8 - 12
4.11.3 Delivery paper size/mass.....	8 - 12
4.11.4 Full stack detection.....	8 - 12
4.12 Paper.....	8 - 13
4.12.1 Paper type.....	8 - 13
4.12.2 Paper mass.....	8 - 13
4.12.3 Paper size.....	8 - 13
5. Consumables.....	8 - 14
5.1 Items of Consumables.....	8 - 14
5.2 Consumable Life.....	8 - 14
5.3 Periodic Replacing Parts (Reference).....	8 - 14

Chapter 8 Printer Specifications CONTENTS

6. Operating Environment.....	8 - 16
6.1 Installation Temperature / Humidity	8 - 16
6.2 Installation Altitude.....	8 - 16
6.3 Installation Horizontality	8 - 16
6.4 Ambient Lighting	8 - 16
6.5 Storage Temperature of a Toner Cartridge.....	8 - 16
7. Safety / Environment Conditions	8 - 17
7.1 Safety Standard	8 - 17
7.2 Laser Safety Standard	8 - 17
7.3 EMI.....	8 - 17
7.4 Noise.....	8 - 17
8. Print image Quality	8 - 18
8.1 Image Quality Guarantee Conditions.....	8 - 18
8.1.1 Environmental conditions.....	8 - 18
8.1.2 Guaranteed paper.....	8 - 18
8.1.3 Paper condition	8 - 18
8.1.4 Printer condition	8 - 18
8.1.5 Image quality guaranteed area	8 - 18
8.1.6 Criterion	8 - 18
9. Option	8 - 19
9.1 Options to be Installed by Users	8 - 19
10. ESS Specification	8 - 20
10.1 External Interface.....	8 - 20
10.1.1 USB	8 - 20
10.1.2 Ethernet	8 - 20
10.1.3 IEEE1284.....	8 - 20
10.1.4 Wireless	8 - 20
10.1.5 Interface Specification.....	8 - 21
10.2 Network Protocol.....	8 - 21
10.2.1 Printing Protocol.....	8 - 21
10.2.2 Other Protocols	8 - 22
10.3 Decomposer.....	8 - 24
10.3.1 PDL/Emulation	8 - 24
10.3.2 Font.....	8 - 24
10.3.3 Form Overlay	8 - 24
10.3.4 Image Area	8 - 24
10.4 Job Control.....	8 - 25
10.4.1 Cancel Print	8 - 25
10.4.2 Job Recovery	8 - 25
10.4.3 Job Time Out	8 - 25
10.4.4 Secure Print (/Store Print).....	8 - 25
10.4.5 Proof Print.....	8 - 25
10.4.6 IP Filter.....	8 - 25
10.4.7 Dell ColorTrack	8 - 25
10.5 Logging	8 - 26

Chapter 8 Printer Specifications CONTENTS

10.5.1 Job Logging	8 - 26
10.5.2 Error Logging	8 - 26
10.5.3 Billing Count.....	8 - 26
10.6 ID Print	8 - 26
10.7 3rd Party Mode	8 - 27
10.8 Utility Print.....	8 - 28
10.8.1 Printer Settings List.....	8 - 28
10.8.2 Panel Settings List Print.....	8 - 28
10.8.3 Font List Print.....	8 - 28
10.8.4 Job Log Print.....	8 - 28

Chapter 8 Printer Specifications CONTENTS

1. Configuration of Printer

1.1 Basic Configuration

The printer has the following basic configurations depending on the destination.

- print engine main unit (MSI and 250 feeder unit as the standard paper feeding)
- consumables (CRU)

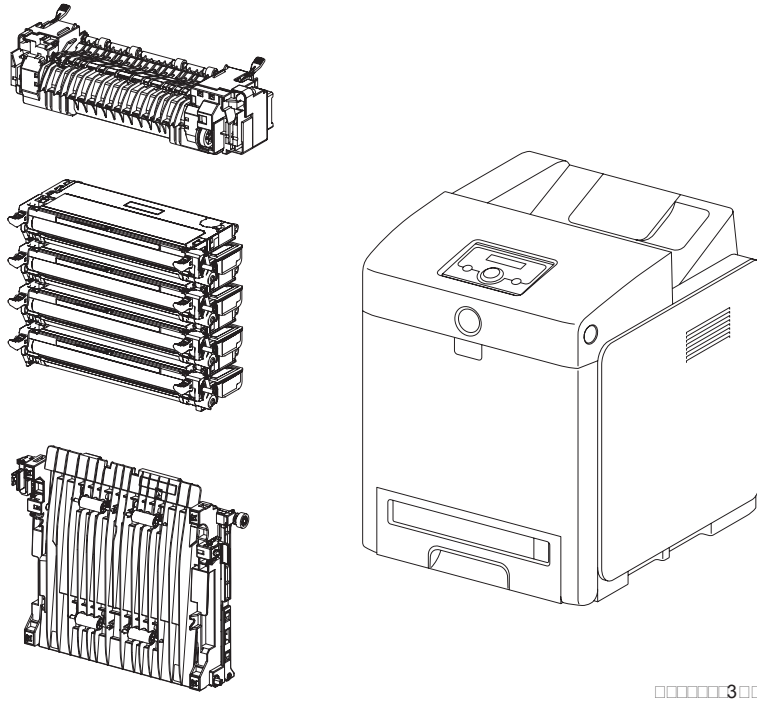

1.2 Functional Configuration

Functional configuration of this printer is shown below.

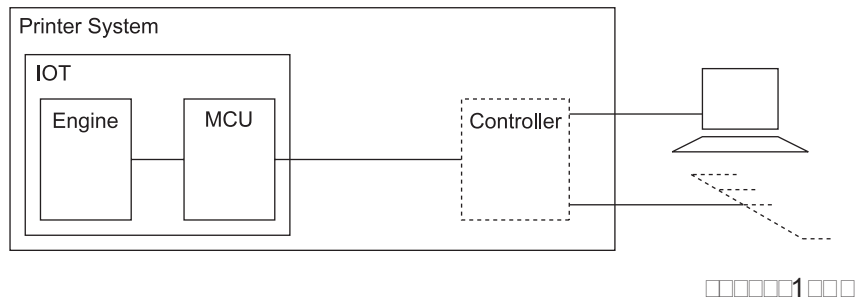

2. Electrical Properties

2.1 Power Source

Two types of power source as follows are available for this printer, which are selected according to the specifications.

- 100V/115V printer:..... voltage: 100-127VAC $\pm 10\%$ (90 ~ 135V), frequency: 50/60Hz ± 3 Hz
- 220/240V printer: voltage: 220-240VAC $\pm 10\%$ (198 ~ 264V), frequency: 50/60Hz ± 3 Hz

2.2 Power Consumption

Power consumption in each operation mode at rated voltage input

Operation mode	Average (Wh/h)
Running mode (F/C)	890 or less
Running mode (B/W)	890 or less
Ready mode	890 ^{*1} or less
Low power mode	9 or less

*1: Full option configuration

2.3 Rush Current

When the power switch is turned on, the inrush current shall be maximum 50Amp (Cold start)/135Amp (Hot start) at first 2.5msec, and 80Amp (110V/220V) / 85Amp (100V) within 10msec

3. Mechanical Properties

3.1 Dimensions/Mass of Printer

Width(mm)	Depth(mm)	Height(mm)	Mass(kg)
400	504	470	27.2 or less

* Including MSI with its cover being closed. And the ejection stacker is also being contained in the main unit.

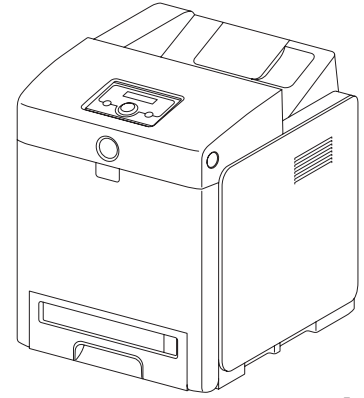

□□□□□5□□

3.2 Dimensions/Mass of Paper Tray

Tray	Width(mm)	Depth(mm)	Height(mm)	Mass(kg)
For 550 sheet	388	506.7	134.4	7.6 or less

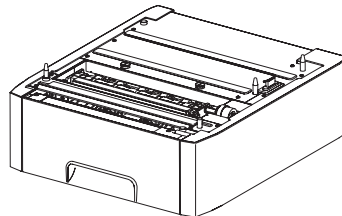

□□□□□□□□

3.3 Dimensions/Mass of Duplex

Width(mm)	Depth(mm)	Height(mm)	Mass(kg)
283	319	78	1.0 or less

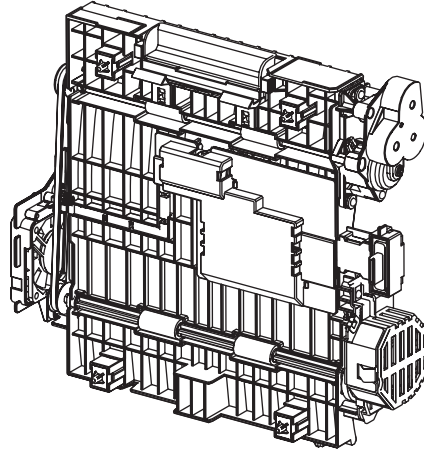

□ □ □ □ □ 7 □ □

3.4 Dimensions/Mass of Consumables and CRUs

3.4.1 TRANSFER BELT

Width: 317mm
 Depth: 278mm
 Height: 79mm
 Mass: 1.29kg

Reference: *The TRANSFER BELT has CRUM (CRU memory) to record information.*

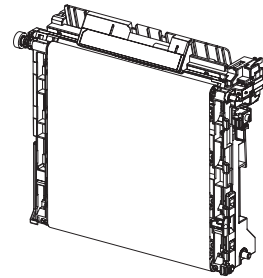

3.4.2 FUSER CRU

Width: 393mm
 Depth: 121mm
 Height: 130mm
 Mass: 1.5kg

Reference: *The FUSER has CRUM (CRU memory) to record information.*

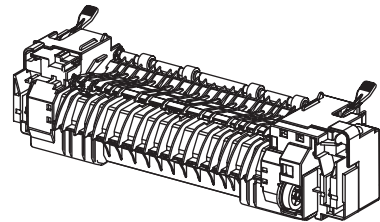

3.4.3 Black toner cartridge

Width: 303.8mm
 Depth: 150mm
 Height: 53.8mm
 Mass: 1.03 (4K)/1.10 (9K) kg

Reference: *The Black toner cartridge has CRUM (CRU memory) to record information.*

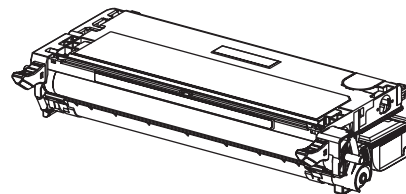

3.4.4 Yellow toner cartridge

Width: 303.8mm
 Depth: 150mm
 Height: 53.8mm
 Mass: 1.01 (3K)/1.10 (9K) kg

Reference: *The Yellow toner cartridge has CRUM (CRU memory) to record information.*

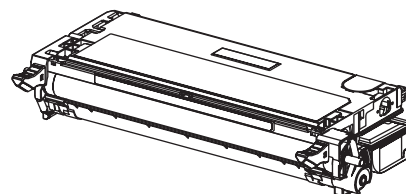

3.4.5 Magenta toner cartridge

Width: 303.8mm
 Depth: 150mm
 Height: 53.8mm
 Mass: 1.03 (4K)/1.10 (9K) kg

Reference: *The Magenta toner cartridge has CRUM (CRU memory) to record information.*

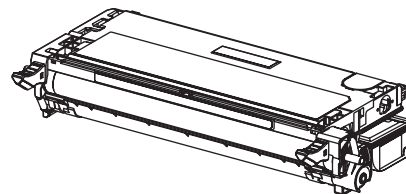

3.4.6 Cyan toner cartridge

Width: 303.8mm
Depth: 150mm
Height: 53.8mm
Mass: 1.03 (4K)/1.10 (9K) kg

Reference:The Cyan toner cartridge has **CRUM (CRU memory)** to record information.

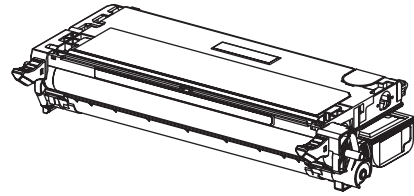

□□□□□□1□□□

3.5 Installation Space (min. installation space)

Minimum space as shown below is required to install the printer when it is used for normal objects.
(Space occupied by the operator is not included.)

Top view

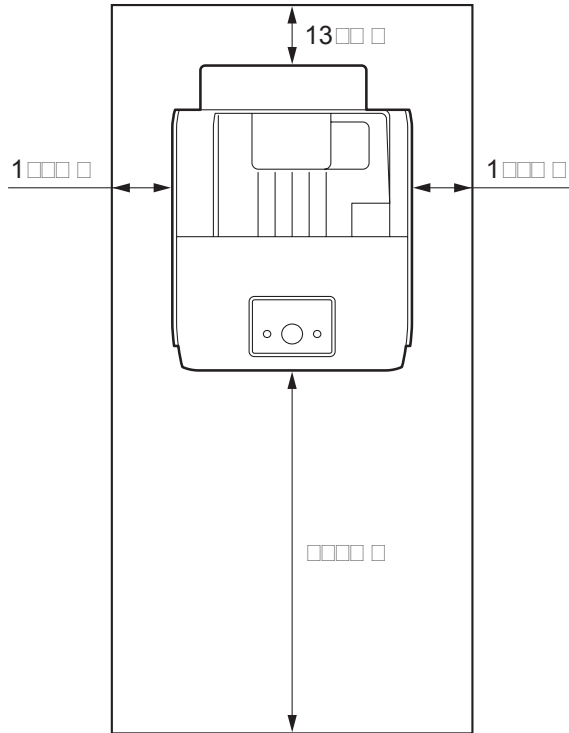

□□□□□□11□□

Front view

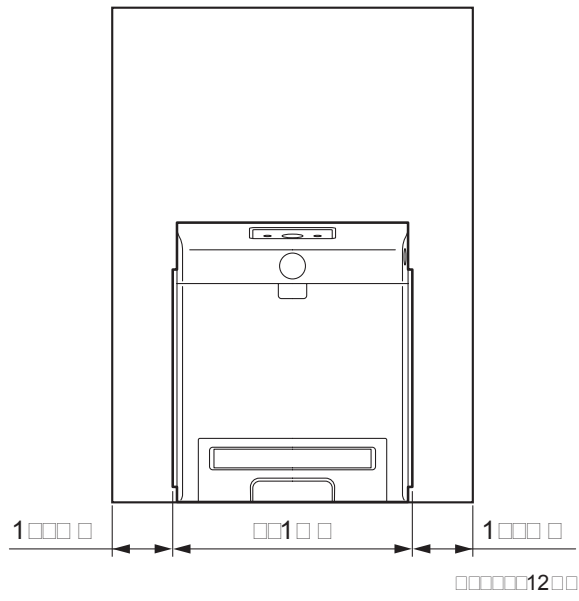

Side view

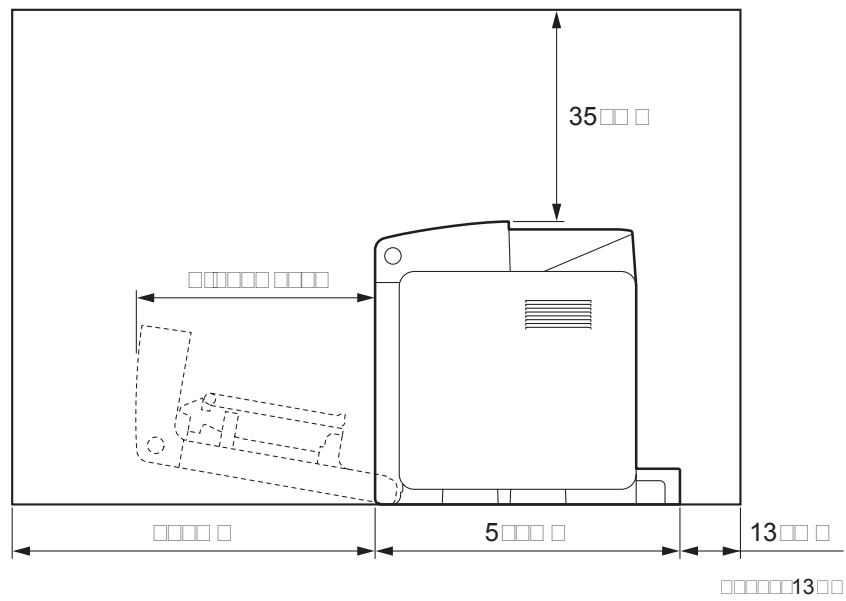

4. Functions

4.1 Recording System

Electro-photographic system employing OPC drum and direct transfer by the transport belt

4.2 Exposure System

Semiconductor four laser beams scanning system

4.3 Development System

Development with dry type 2-component developer

4.4 Fixing System

Thermal fixing system by Free Belt Nip Fusing (FBNF)

4.5 Resolution

- Main scanning direction: by the printer controller
- Sub scanning direction: 600 dots/25.4mm (fixed)

4.6 Operation Mode

The printer can be operated in either of 4 operation modes. The modes are switched over by command from the printer controller or change of printer operation, etc.

Proceeding from power ON, low power mode or sleep mode to standby mode will take place after going through a warm up stage.

- Running mode

State in running or recording operation

Fixing system:	Held at operating temperature.
Exposure system:	Operating status
Recording system:	Operating status

- Ready mode

Ready state

Fixing system:	Held at ready temperature.
Exposure system:	Stop status
Recording system:	Stop status

- Sleep mode

Complete resting state. Compatible to E-Star and BAM requirement.

Fixing system:	Stop status
Exposure system:	Stop status
Recording system:	Stop status

- Deep sleep mode

Resting state from the sleep state. Compatible to E-Star and BAM requirement.

Fixing system:	Stop status
Exposure system:	Stop status
Recording system:	Stop status

4.7 Warm-up Time

When nominal voltage (100V, 115V, 220V) is applied, the printer will proceed to standby mode from POWER-ON within 30 seconds.

Reference: Measured at 22°C, 55% RH, nominal voltage.

4.8 FPOT (First Print Output Time)

FPOT time of the printer is shown in the table below.

The time required for the first sheet of paper to be delivered after the PRINT indication is given is calculated on the following conditions (rounded to one decimal place).

- IOT performance that the controller does not have IOT wait.
- The printer is in the standby mode. (ROS MOTOR OFF, FUSER READY)
- Paper is A4 SEF
- Except when process control is operating*1

*1: Process controller operation is process controls such as TC control, electric potential control, cleaning cycle, registration control, and so on. Sometimes, the engine stops feeding papers for a certain period of time while continuous printing for these operations.

Color Mode	Paper Tray	FPOT (Sec.)
B/W	MPF	16 sec. or less
	Standard tray	16 sec. or less
	Optional 2nd tray	16.5 sec. or less
Color	MPF	17 sec. or less
	Standard tray	17 sec. or less
	Optional 2nd tray	17.5 sec. or less

4.9 Continuous Printing Speed

The continuous printing speed is shown in the below.

OS	PDL	Test Chart	Paper Size	Paper Type	Paper Tray	Color/BW	Duplex/Simplex	Average Print Speed
XP	PCL6	J11E	A4/Letter SEF	Plain paper	MPF	Color	Simplex	56 sec. or less
XP	PCL6	J11E	A4/Letter SEF	Plain paper	MPF	BW	Simplex	38 sec. or less
XP	PCL6	J11E	A4/Letter SEF	Plain paper	MPF	Color	Duplex	80 sec. or less
XP	PCL6	J11E	A4/Letter SEF	Plain paper	MPF	BW	Duplex	56 sec. or less
XP	PCL6	J11E	A4/Letter SEF	Plain paper	Tray1	Color	Simplex	56 sec. or less
XP	PCL6	J11E	A4/Letter SEF	Plain paper	Tray1	BW	Simplex	38 sec. or less
XP	PCL6	J11E	A4/Letter SEF	Plain paper	Tray1	Color	Duplex	79 sec. or less
XP	PCL6	J11E	A4/Letter SEF	Plain paper	Tray1	BW	Duplex	56 sec. or less
XP	PCL6	J11E	A4/Letter SEF	Plain paper	Tray2	Color	Simplex	57 sec. or less
XP	PCL6	J11E	A4/Letter SEF	Plain paper	Tray2	BW	Simplex	38.5 sec. or less
XP	PCL6	J11E	A4/Letter SEF	Plain paper	Tray2	Color	Duplex	80 sec. or less
XP	PCL6	J11E	A4/Letter SEF	Plain paper	Tray2	BW	Duplex	57 sec. or less
OSX	PS	J11E	A4/Letter SEF	Plain paper	Tray1	Color	Simplex	435 sec. or less
OSX	PS	J11E	A4/Letter SEF	Plain paper	Tray1	BW	Simplex	355 sec. or less
OSX	PS	J9E	A4/Letter SEF	Plain paper	Tray1	Color	Simplex	77 sec. or less
OSX	PS	J9E	A4/Letter SEF	Plain paper	Tray1	BW	Simplex	71 sec. or less
OSX	PS	J11E	A4/Letter SEF	Plain paper	Tray1	Color	Duplex	442 sec. or less
OSX	PS	J11E	A4/Letter SEF	Plain paper	Tray1	B/W	Duplex	400 sec. or less
OSX	PS	J9E x2	A4/Letter SEF	Plain paper	Tray1	Color	Duplex	151 sec. or less
OSX	PS	J9E x2	A4/Letter SEF	Plain paper	Tray1	BW	Duplex	135 sec. or less

4.10 Input Properties

4.10.1 Paper pick-up system

- Paper pick-up with paper tray
Feeding method of this printer is ARRF method.

- MSI paper pick-up
Feeding method of this printer is S-ARRF method.

- Duplex paper feeder unit
It can be installed as an option, and it enables duplex printing. Selection of Duplex Feeder Unit is designated from the controller.

4.10.2 Paper pick-up capacity

- Paper pick-up with paper tray
 - 550 sheet Paper Tray : 550 sheets or below 59.4mm of standard paper
 - 250 sheet Paper Tray : 250 sheets or below 27.6mm of standard paper

- MSI paper pick-up
150 sheets or below 15mm of standard paper

4.11 Output Properties

4.11.1 Paper delivery system

Paper can be delivered by the following method.

- FACE DOWN delivery

4.11.2 Paper delivery capacity

- FACE DOWN delivery
250 sheets (Letter/A4 standard paper)

4.11.3 Delivery paper size/mass

- FACE DOWN delivery
All paper sizes applicable to this printer

4.11.4 Full stack detection

non

4.12 Paper

4.12.1 Paper type

Paper which can be used with this printer is classified into standard paper, general paper and special paper.

- Standard paper

Using this type of paper is recommended. Reliability, operability and print image quality are the application range of the specifications.

Following paper is the standard paper.

	B/W	F/C
For domestic market	P	C2
For overseas market	4200DP	X-pressions

- General paper

General paper is plain paper except standard paper and special paper, and its reliability and running performance are within the specification, but the print image quality is out of the specification.

- Special paper

Special paper except for plain paper. Reliability and operability are the applicable range of specifications but the print image quality is out of the applicable range of specifications.

4.12.2 Paper mass

- Paper feed from paper tray

"60 to 216 gsm" (16 lb to 80 lb)

- Paper feed from MSI

"60 to 216 gsm" (16 lb to 80 lb)

4.12.3 Paper size

Paper size which can be set to each paper pick-up unit is shown in the table below.

Cassette	Paper size
550 Sheet Paper Tray	A5, B5 (JIS, IOS), A4, Letter, Executive, Legal, Folio Minimum size Width 148mm (5.82 in) × Length 210mm (8.26 in) Maximum size Width 215.9mm (8.5 in) × Length 355.6mm (14 in)
250 Sheet Paper Tray	A5, B5 (JIS, IOS), A4, Letter, Executive, Legal, Folio Minimum size Width 148mm (5.82 in) × Length 210mm (8.26 in) Maximum size Width 215.9mm (8.5 in) × Length 355.6mm (14 in)
MSI Tray	A5, B5 (JIS, IOS), A4, Letter, Executive, Legal, Folio, Envelope, Monarch, DL, C5, Yokei size2, Yokei size3, Yokei size4, Yochokei size3, Choikei size3, Japanese post card Minimum size Width 76.2mm (3 in) × Length 127mm (5 in) Maximum size Width 220mm (8.66 in) × Length 355.6mm (14 in)

5. Consumables

Consumables are usually replaced by costumers. In the event of recovery of failure attributable to consumables or isolation of failure, you may replace them.

5.1 Items of Consumables

- Black toner cartridge
Cartridge to supply black toner to the development unit.
Black toner cartridge has CRUM (CRU memory) to record information.
- Yellow toner cartridge
Cartridge to supply yellow toner to the development unit.
Yellow toner cartridge has CRUM (CRU memory) to record information.
- Magenta toner cartridge
Cartridge to supply magenta toner to the development unit.
Magenta toner cartridge has CRUM (CRU memory) to record information.
- Cyan toner cartridge
Cartridge to supply cyan toner to the development unit.
Cyan toner cartridge has CRUM (CRU memory) to record information.

5.2 Consumable Life

- Black toner cartridge: 4kPV
- Yellow toner cartridge: 3kPV
- Magenta toner cartridge: 3kPV
- Cyan toner cartridge: 3kPV

5.3 Periodic Replacing Parts (Reference)

- FEED ROLLER (250/550 Feeder) 100kPV
- TRANSFER BELT 100kPV
- FUSER 100kPV

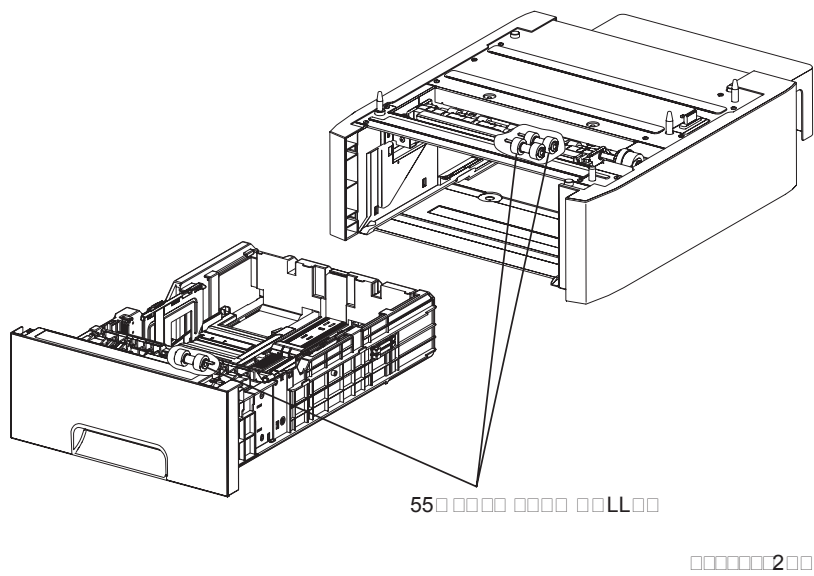
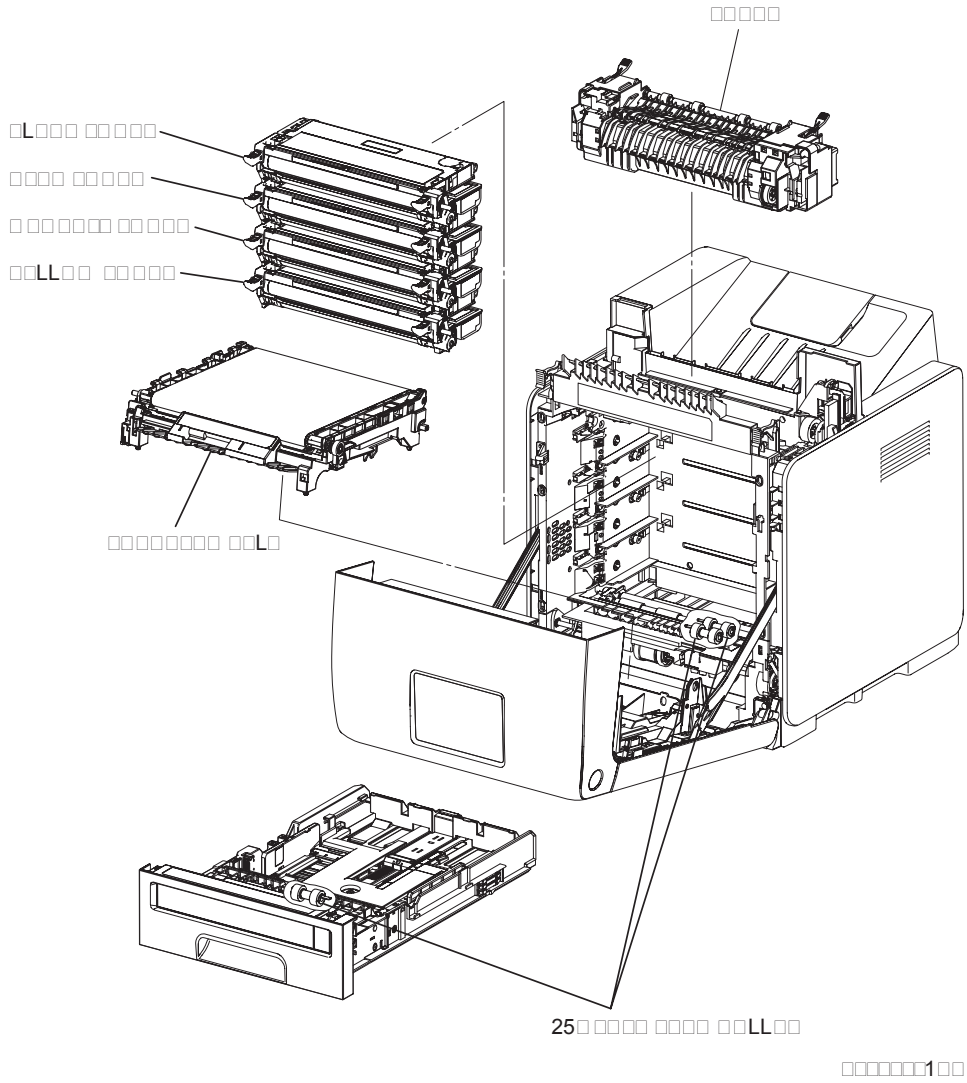

6. Operating Environment

6.1 Installation Temperature / Humidity

Installation temperature and humidity on the condition without condensation is as follows.

At operating: 10-35 °C, 15-85%RH (No condensation)

At standby: minus 20-40 °C, 5-85%RH (No condensation)

6.2 Installation Altitude

0 to 3,100m

6.3 Installation Horizontality

Longitudinal levelness of table surface on which the printer is installed:1 degree or under

Lateral levelness of table surface on which the printer is installed :1 degree or under

6.4 Ambient Lighting

3000 Lux or less (without no direct sun beams)

6.5 Storage Temperature of a Toner Cartridge

The guaranteed period of the print cartridge before unpacked is as follows:

Normal conditions: 24 months under 0 to 35°C, 15 to 80% RH.

Harsh conditions: Up to one month under -20 to 0°C and 35 to 40°C, 5 to 15% RH and 80 to 95% RH.

The storage altitude shall be 0 to 3100m. Can be extended to 0 to 15000m when shipped by air.

(Provided that the cargo bay is pressurized to 70.9275Kpa or higher.)

7. Safety / Environment Conditions

7.1 Safety Standard

- 100V / 110V system
UL60950
CSA C22.2 No.60950-00
- 220V system
IEC60950 / EN60950 2000

7.2 Laser Safety Standard

- 100V / 110V system
FDA21CFR Chapter 1, Subchapter J, Section 1010, 1040
- 220V system
IEC60825-1 Amendment 1 + Amendment 2 / EN60825-1 Amendment 1 + Amendment 2 Class 1, Laser Product

7.3 EMI

- 100V / 110V system (US)
FCC Part 15, Subpart B, Class B
- 220V system (EC)
EN55022 (CISPR Publication 22), Class B

7.4 Noise

Noise of printing is as follows.

Printer \ Noise	Engine		Full option (Engine+Duplex/500Feeder)	
	Sound power Level (B)	Impulse Sound Power Level (B)	Sound power Level(B)	Impulse Sound Power Level (B)
	LWA	LWAI	LWA	LWAI
During printing	6.3	6.6	6.6	7.1
During Standby	4.0	-	4.0	-

8. Print image Quality

8.1 Image Quality Guarantee Conditions

The image quality is specified and guaranteed under the following conditions.

8.1.1 Environmental conditions

Environment condition for evaluating image quality

Temperature: 15-28 °C

Humidity: 20-70%RH

8.1.2 Guaranteed paper

The print image quality specified here is guaranteed with standard paper fed from the paper tray.

Evaluation is performed with the maximum size of each standard paper.

- Xerox 4200DP 201b letter (Black and White)

- Xerox Digital Color Xpression 24lb letter (Color)

8.1.3 Paper condition

The paper used is fresh paper immediately after unpacked, which has been left in the operating environment for 12 hours before unpacking.

8.1.4 Printer condition

The print image quality specified in this section is guaranteed with the printer in normal condition.

8.1.5 Image quality guaranteed area

The print image quality specified in this section is guaranteed in the guaranteed image quality area specified in this manual. (Refer to Chapter 1)

8.1.6 Criterion

The print image quality is guaranteed with the Spec. In rate = 90% ($\gamma = 90\%$).

9. Option

9.1 Options to be Installed by Users

Users can install the following units.

- 550 Feeder Unit
- Duplex Unit
- HDD Unit
- Expansion memory (512MB/1024MB)
- Network Protocol Adapter
- Wireless Printer Adapter

10. ESS Specification

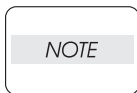

In order for the printer to apply to the Windows Vista, it is necessary to download firmware from the DELL website.

10.1 External Interface

10.1.1 USB

Item	Specification
Connector	Type-B x 1
Protocol	USB2.0, HighSpeed
Supported Client	Windows 2000 / XP / x64 XP / Server2003 / x64 Server2003/Vista / x64 Vista / Server2008(TBD) / x64 Server2008(TBD) PC with USB MacOS X PC with USB Linux PC with USB

10.1.2 Ethernet

Item	Specification
Connection	10 Base-T/100 Base-TX
Protocol	See "10.2 Network Protocol" for details
Supported Client	Windows NT 4.0/2000/XP/x64XP/Server 2003/x64Server2003/Vista / x64 Vista/ Server2008(TBD) / x64 Server2008(TBD) PC Mac OS X PC Linux/Unix PC

10.1.3 IEEE1284

Item	Specification
Connection	Centronics 36pin x 1
Protocol	Standard, Nibble, ECP
Supported Client	Windows NT4.0/2000/XP/x64XP/Server 2003/x64Server2003/Vista / x64 Vista/ Server2008(TBD) / x64 Server2008(TBD) PC Linux PC

10.1.4 Wireless

multi-protocol Card is required.

Item	Specification
Connection	802.11b/802.11g
Protocol	See "10.2 Network Protocol" for details
Supported Client	Windows NT 4.0/2000/XP/x64XP/Server 2003/x64Server2003/Vista / x64 Vista/ Server2008(TBD) / x64 Server2008(TBD) PC Mac OS X PC Linux PC* ¹
Security Protocol	64(40-bit key)/128(104-bit key) WEP,WPA-PSK(TKIP,AES), WPA2-PSK(AES) (IEEE802.1x attestation Function of WPA-1x non-corresponds)

*1: Connection to the Linux machine is not guaranteed. Only for infrastructure connection and when Linux terminal is connected with Wired LAN connection.

10.1.5 Interface Specification

Option Configuration	Interface that can be operated			
	USB	IEEE1284	Ethernet	IEEE802.11b/11g (Wireless)
Not installed	Yes	Yes	Yes	No
Installed	Yes	Yes	No	Yes

*Protocol: See "10.2 Network Protocol" for details

10.2 Network Protocol

10.2.1 Printing Protocol

Protocol	Transport	Maximum Session ^{*2}	Supported Client
LPD	TCP/IP	1	Windows NT 4.0/2000/XP/x64 XP/Server 2003/ x64 Server20033/Vista/x64 Vista/ Server2008(TBD) / x64 Server2008(TBD) Mac OSX Linux ^{*4} Unix ^{*4}
Port9100	TCP/IP	1	Windows NT 4.0/2000/XP/x64 XP/Server 2003/ x64 Server20033/Vista/x64 Vista/ Server2008(TBD) / x64 Server2008(TBD)
IPP ^{*5}	TCP/IP	5	Windows NT 4.0/2000/XP/x64 XP/Server 2003/ x64 Server20033/Vista/x64 Vista/ Server2008(TBD) / x64 Server2008(TBD) Mac OS 10.3
SMB ^{*5}	TCP/IP	5	Windows NT 4.0/2000/XP/x64 XP/Server 2003/ x64 Server20033/Vista/x64 Vista/ Server2008(TBD) / x64 Server2008(TBD)
	NetBEUI	5	Windows NT 4.0/2000,
NetWare (P-Server) ^{*5}	NCP/IPX TCP/IP ^{*1}	1	NetWare3.12, 3.2, (NDS unsupported) NetWare4.1, 4.11, 4.2, 5, 5.1,6,6.5 ^{*3}
EtherTalk ^{*5}	ATP/DDP	1	Mac OSX

*1: Available for versions later than NetWare5

*2: Maximum session is defined as the number of print request acceptable at the same time.

*3: NetWare 6.5 is required to apply support pack 1.1 or later provided by Novell.

*4: Supported if a driver provided by FX is used.

*5: Available only Network protocol Adapter is installed.

10.2.2 Other Protocols

Protocol	Transport	Support
SNMP	UDP/IP	[Supported MIB] MIB-II (RFC1213) HostResources MIB (RFC1514) PrinterMIB (RFC1759) XCM Printer Port Monitor MIB
	IPX	
HTTP/HTTPS	TCP/IP	[Client] (Windows NT4.0/2000/XP/Vista) Internet Explorer 6.x or 7x Firefox x 2.0 (Mac OS 10.2 or later) Safari 2.x Firefox 2.x JavaScript must be set/ready to operate on the above browsers.
DHCP	UDP/IP	[Supported OS] Windows NT 4.0 Server, Windows 2000 Server, Windows Server 2003, Windows x64 server 2003, Windows Server2008(TBD) , Windows x64 Server2008(TBD), Linux (RedHat Enterprise Linux ES4/5, SuSE Enterprise Linux 10). Unix (Solaris 9)
BOOTP	UDP/IP	[Supported OS] Windows NT 4.0 Server, Windows 2000 Server, Windows Server 2003, Windows x64 server 2003, Windows Server2008(TBD) , Windows x64 Server2008(TBD), Unix (Solaris 9)
RARP	TCP/IP	[Supported OS] Unix (Solaris 9)
AutoIP	TCP/IP	[Software] Installer
WINS	TCP/IP	[Supported OS] Windows NT 4.0 Server, Windows 2000 Server, Windows Server 2003, Windows x64 server 2003, Windows Server2008(TBD) , Windows x64 Server2008(TBD)
SMTP	TCP/IP	E-mail Alert [Supported Mail Server] LotusNotes, MS-Exchange, Eudora
Telnet	TCP/IP	[Supported OS] Windows 2000, Windows 2000 Server, Windows XP, Windows x64 XP, Windows Server 2003, Windows x64 server 2003, Vista, x64 Vista, Windows Server2008(TBD), Windows x64 Server2008(TBD), Mac OSX 10.3, 10.4, 10.5 Unix(Solaris9)
WSD	TCP/IP	[Supported OS] Vista/x64 Vista/ Server2008(TBD) / x64 Server2008(TBD)
Bonjour(mDNS)*1	UDP/IP	[Supported OS] Mac OS 10.2 or later

DDNS ^{*1}	TCP/IP	[Supported OS] Windows NT 4.0 Server, Windows 2000 Server, Windows Server 2003, Windows x64 server 2003, Windows Server2008(TBD), Windows x64 Server2008(TBD), Unix (Solaris 9)
--------------------	--------	---

*1: Available only Network protocol Adapter is installed.

10.3 Decomposer

10.3.1 PDL/Emulation

Decomposer is still PCL. However printer can accept the job generated only by the own printer driver.

Interface/Protocol	PDL/Emulation		
	PCL5c	PCL6	PS3
USB	Yes	Yes	Yes
1284	Yes	Yes	Yes
Lpd	Yes	Yes	Yes
Port9100	Yes	Yes	Yes
IPP	Yes	Yes	Yes
SMB* ¹	Yes	Yes	Yes
NetWare (P-Server)* ¹	Yes	Yes	Yes
EtherTalk (A-PAP)* ¹	No	No	Yes

Yes: Supported No: Not supported

*1: Available only Network protocol Adapter is installed.

10.3.2 Font

81 fonts and 36 Symbol Sets for PCL and 136 fonts for PS3 are available as built-in font.

10.3.3 Form Overlay

The function for writing PCL5 forms is supported.

10.3.4 Image Area

Usable Area Size	Maximum : 215.9mm (8.5 in.) x 355.6mm (14 in.)
Unprintable Area	4.1 mm each from four edges (left, right, top and bottom) of paper For DL LEF, 6.1mm from left and right edges, 4.1 mm from top and bottom edges are not printable
Printable Area	Maximum : 207.9mm (8.18 in.) x 347.6mm (13.68 in.)
Print Image Quality Guaranteed Area	Same as Printable Area

10.4 Job Control

10.4.1 Cancel Print

A print job in process can be cancelled at the operation panel.

10.4.2 Job Recovery

When a job fails due to a paper jam, the printer automatically restarts the job after the jammed paper is removed.

10.4.3 Job Time Out

When job transmission is interrupted for a certain period of time (Time can be changed at the operation panel and unlimited time can be selected), the print data is deleted as an error.

10.4.4 Secure Print (/Store Print)

When memory is expanded (512MB or more) or HDD is installed, the printer holds print data, including a user password (12 digits) specified in the printer driver, user name and document name, in memory. The data is not printed until the same password, user name and document name are specified at the printer UI. The user can select whether the data is cleared or not after being printed. The data remains in the printer as long as it is not cleared. The data on the memory is cleared when the printer is turned off. The data on the HDD is not cleared even the printer is turned off. The user can omit entering a password (This is called Store Print). *This function is not available for MAC OS X 10.2.8.

10.4.5 Proof Print

When memory is expanded (512MB or more) or HDD is installed, proof print can be selected only when multiple sets of prints are specified in the printer driver. The printer prints only the first set of the print data including a user name and document name specified in the printer driver. Then the user can select whether the remaining sets are printed or not (the remaining data is cleared) when the same user name and document name are entered at the printer UI. The data remains in the printer as long as it is not cleared. The data on the memory is cleared when the printer is turned off. The data on the HDD is not cleared even the printer is turned off. *This function is not available for MAC OS X 10.2.8 and Linux which use CPUS.

10.4.6 IP Filter

The user can select to accept or reject jobs for the specified IP address. Up to 5 IP addresses can be specified.

IP filter is available only to LPD and Port9100.

10.4.7 Dell ColorTrack

Dell ColorTrack is a function to specify the availability of color print and to limit print volume per user. Only administrators are allowed to make limitation settings from the EWS. User name and password is embedded in the print job in order to identify who the job is sent from. User name and password are entered by user from the printer driver.

10.5 Logging

10.5.1 Job Logging

The printer can retain up to 20 job logs. Job log can be printed instantly according to the user's request or automatically printed when the number of the retained job logs has reached 20. Job log includes the following information:

- Job sent date and time*
- Input interface (USB, Lpd etc.)
- Document name (File name) *
- Output color
- User name/Host name*
- Number of printed pages (Color/B/W)
- Number of printed impressions (Color/B/W)
- Paper size
- Result (Successful, Error, etc.)

*Not displayed for PS.

10.5.2 Error Logging

The printer can retain up to 42 jam errors and up to 42 fatal errors.

The user can print error log by the panel operation.

Jam error log includes the following information:

- TOTAL PV when jam has occurred
- Name of jam

Fatal error log includes the following information:

- TOTAL PV when error has occurred
- Error code

10.5.3 Billing Count

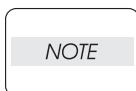

- **The same data is stored in two or more addresses in one IC. Datacheck (checksum etc.) is conducted.**

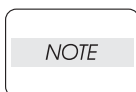

- **When ESS is replaced, IC can be transferred. (IC is mounted on socket)**

Counter	Description
Color Print Counter	Count the number of page printed in color (7 digits)
B/W Print Counter	Count the number of page printed in B/W (7 digits)
Total Print Counter	Count the total number of page printed in color and B/W (7 digits)

10.6 ID Print

User name can be printed. The printing position can be selected from upper right, upper left, lower right and lower left (Only for PCL6).

The user selects using the operation panel whether user name is printed or not and where it is printed.

10.7 3rd Party Mode

When life of toner cartridge has ended, the printer stops accepting print request (life of toner cartridge is counted by the counter in CRUM). Taking into consideration that some users use refilled toner cartridges, the printer can accept print request by the user's panel operation even if life of toner cartridge has ended. When the mode has changed so that the printer does not stop even after life of toner cartridge ends, the printer displays a message on the operation panel to inform the user of the mode change. When the printer operates in this mode, print image quality is not guaranteed. Also, remaining toner level is not displayed (as CRUM data can not be guaranteed).

10.8 Utility Print

10.8.1 Printer Settings List

Printer Settings List can be printed according to the user's request.

Printer Settings List is printed in B/W in the automatically selected paper tray.

Printer Settings List includes the following information:

Items on the list are slightly different from below when wireless LAN option is installed.

[Title]

Product name (Logo)

[General]

Printer Name, Service tag, Asset Number, Memory capacity, Printer language, Number of fonts available, PDL name and version, ESS version, IOT version, Boot version, Color print volume, B/W print volume, Default paper size, Default paper type for plain paper, Default paper type for label, Default panel display language

[Network]

Network firmware version, MAC address, Ethernet Setting (10 or 100base & half or full)

IPv4 (IP address, Subnet Mask, Gateway Address, Address Status)

IPv6 (Address Manul Configuration, Auto Configuration, Status)

IPX/SPX: Frame type, Network address

IP Filter: Address, Mask, Mode

WirelessSetting* (SSID, Network Type, Link Quality, Link Channel)

IEEE802.1x: Authentication settings

Other supported protocols

*Listed when wireless Printer Adapter is installed

[Printer Options]

"Network Protocol Adapter" Yes or No (If available, version)

"Available Paper Tray" (Tray 1, Tray 2, MPF)

"HDD Unit" Yes or No

[Print Volume]

Print volume for each paper size

10.8.2 Panel Settings List Print

Panel Settings List can be printed by the user's operation.

Panel Settings List is printed in B/W in the automatically selected paper tray.

10.8.3 Font List Print

PCL or PS Font List can be printed by the user's operation.

Font List is printed in the automatically selected paper tray.

10.8.4 Job Log Print

The user can print Job Log by requesting instant print or by setting auto print.

Job Log is printed in B/W in the automatically selected paper tray.

MFG P/N	MFG Part Description	CRU or FRU	Qty in a box	Dell P/N	Dell Part Description
TONER / INK					
675K66570	CARTRIDGE ASSY-4K_K MLK	CRU	1	G910C	BLACK TONER CARTRIDGE 4K 3130CN
675K66910	CARTRIDGE ASSY-9K_K MLK	CRU	1	H516C	BLACK TONER CARTRIDGE 9K 3130CN
675K66560	CARTRIDGE ASSY-3K_C MLK	CRU	1	G907C	CYAN TONER CARTRIDGE 3K 3130CN
675K66900	CARTRIDGE ASSY-9K_C MLK	CRU	1	H513C	CYAN TONER CARTRIDGE 9K 3130CN
675K66550	CARTRIDGE ASSY-3K_M MLK	CRU	1	G908C	MAGENTA TONER CARTRIDGE 3K 3130CN
675K66890	CARTRIDGE ASSY-9K_M MLK	CRU	1	H514C	MAGENTA TONER CARTRIDGE 9K 3130CN
675K66540	CARTRIDGE ASSY-3K_Y MLK	CRU	1	G909C	YELLOW TONER CARTRIDGE 3K 3130CN
675K66880	CARTRIDGE ASSY-9K_Y MLK	CRU	1	H515C	YELLOW TONER CARTRIDGE 9K 3130CN

FUSER AND ACESSORIES					
126K25342	FUSER ASSY MLK 100V	CRU	1	M507D	FUSER 100V 3130CN FOR JAPAN
126K24932	FUSER ASSY MLK 115V	CRU	1	M508D	FUSER 115V 3130CN FOR AMERICAS
126K25352	FUSER ASSY MLK 230V	CRU	1	M509D	FUSER 230V 3130CN FOR EUROPE
675K70090	KIT LEVER FUSER MLK	FRU	2	P832D	FUSER HOLDING LEVERS (LEFT & RIGHT) 3130CN

SERVICE KITS					
675K67863	MAINTENANCE KIT 100V (FUSER, TRANSFER ASSY, FEED ROLLx3)	CRU		N605D	SERVICE KIT FUSER TRANSFER BELT FEED ROLLER 110V 3130CN FOR JAPAN
675K67843	MAINTENANCE KIT 115V (FUSER, TRANSFER ASSY, FEED ROLLx3)	CRU		N606D	SERVICE KIT FUSER TRANSFER BELT FEED ROLLER 115V 3130CN FOR AMERICAS
675K67853	MAINTENANCE KIT 230V (FUSER, TRANSFER ASSY, FEED ROLLx3)	CRU		N607D	SERVICE KIT FUSER TRANSFER BELT FEED ROLLER 230V 3130CN FOR EUROPE

OPTIONS					
675K69080	NETWORK PROTOCOL ADAPTOR (OPTION)	CRU	1	K129C	NETWORK PROTOCOL ADAPTER CARD (OPTION) 3130CN
675K14633	HDD ASSY (OPTION)	CRU	1	KF672	HARDDISK 40GB (OPTION) 51XXCN/3130CN
675K69090	WIRELESS PRINTER ADAPTER (OPTION)	CRU	1	K871C	WIRELESS CARD (OPTION) 3130CN/2130CN
675K51932	KIT-DUPLEX MODULE (with 2-7,9-20,22-26,PL11.2)	CRU	1	HG445	DUPLEXER 311XCN/3130CN

DOCUMENTATION, DRIVERS AND APPLICATIONS					
675K59570	KIT DOC US (SP) MLK	CRU	1	R423D	DOCUMENT KIT IN ENGLISH, FRENCH, SPANISH FOR AMERICAS 3130CN
675K68390	KIT DOC EMEA (SP) MLK	CRU	1	R429D	DOCUMENT KIT FOR EUROPE 3130CN
675K68070	KIT DOC JPN (SP) MLK	CRU	1	R425D	DOCUMENT KIT IN ENGLISH, FRENCH, SPANISH FOR AUSTRALIA & JAPAN 3130CN
675K58050	KIT DOC TAA (SP) MLK	CRU	1	R424D	DOCUMENT KIT FOR 110V TAA 3130CN

DUPLEXER					
054K39000	CHUTE DUP GATE MLK	FRU	1	P442D	DUPLEX CHUTE GATE 3130CN

TRANSFER BELT					
064K92913	TRANSFER ASSY MLK (KIT-BELT CRU)	CRU	1	R298D	TRANSFER BELT 3130CN

ROLLER					
675K68970	KIT SEPARATOR ROLLER ASSY MSI MLK (with 3&Techsheet)	CRU		P443D	MULTI-PAPER FEEDER SEPARATOR ROLLER 3130CN

675K35500	KIT SEPARATOR & FEED ROLLER (with 17,PL3.2.53 x 2 total 3pcs & Techsheet)	CRU		RG399	TRAY SEPARATOR & FEED ROLLER 3130CN
-----------	--	-----	--	-------	--

FEEDER, TRAY AND TRAY HOUSING

050K61375	CASSETTE ASSY 250 MLK (with 2, PL2.2.1)	CRU	1	P445D	PAPER TRAY 250 SHEET 3130CN
050K58004	CASSETTE ASSY 550 (with 2,PL12.5.1)	CRU	1	UG197	PAPER TRAY 550 SHEET 3110CN/3130CN
059K57540	550 FEEDER (with 2,5-7,PL12.2,12.3)	CRU	1	TG147	PAPER TRAY HOUSING 550 SHEET 3110CN/3130CN

PLASTICS

802E94193	COVER CST 550	CRU	1	HH956	PAPER TRAY HOUSING 550 SHEET BACK COVER
675K68950	KIT-COVER ASSY FRONT MLK (with 3-9,11-15,17-23,33,3436,37 PL6.1.1)	FRU		T098D	PRINTER FRONT COVER
675K68960	KIT-COVER ASSY MSI MLK (with 24,30x2pcs, 39)	FRU		N611D	MULTI-PAPER FEEDER COVER

ELECTRICAL / ELECTRONICS BOARDS AND CARDS

105K23240	HVPS MLK	FRU	1	R306D	HIGH VOLTAGE POWER BOARD 3130CN
105K23660	LVPS MLK 100/115V	FRU	1	N619D	LOW VOLTAGE POWER BOARD 100V/115V 3130CN FOR JAPAN & AMERICAS
105K23670	LVPS MLK 230V	FRU	1	M517D	LOW VOLTAGE POWER BOARD 230V 3130CN FOR EUROPE
675K69050	KIT PWBA MCU MLK	FRU	1	X786D	MACHINE CONTROL UNIT BOARD 3130CN
675K69060	KIT PWBA ESS MLK	FRU	1	Y507D	ESS BOARD 3130CN

FAN AND ACESSORIES

127E84800	FAN MAIN	FRU	1	UG084	FAN 24V 3130CN
-----------	----------	-----	---	-------	----------------

MEMORY

KTD667200/512	KINGSTON	CRU		JK997	MEMORY KIT 512MB , 667MHZ, DDR2
KTD667200/1G	KINGSTON	CRU		DP904	MEMORY KIT, 1GB, 667MHZ, DDR2

MISCELLANOUS HARDWARE

675K68920	KIT-OPERATOR PANEL MLK US (with 15.16)	FRU	1	T103D	OPERATOR DISPLAY PANEL FOR AMERICAS 3130CN
675K68930	KIT-OPERATOR PANEL MLK EU (with 15,16)	FRU	1	R314D	OPERATOR DISPLAY PANEL FOR EUROPE 3130CN
675K68940	KIT-OPERATOR PANEL MLK JP (with 15,16)	FRU	1	N623D	OPERATOR DISPLAY PANEL FOR JAPAN 3130CN
675K68990	KIT ROLL & SOLENOID FEED MSI MLK (with 3-5)	FRU		P450D	MULTI-PAPER FEED FEEDER SOLENIOD 3130CN
675K69000	KIT ROLL ASSY FEED MSI MLK (with 10&Techsheet)	CRU		T104D	MULTI-PAPER FEED FEED ROLLER 3130CN
130K72260	SENSOR ASSY CRU MLK (with 5-8)	FRU	4	R315D	TONER CARTRIDGE SENSOR 3130CN
675K69020	KIT ROS ASSY MLK (with 1x2pcs,2,Screwsx5)	FRU	1	P451D	ROS 3130CN
110K15270	SWITCH ASSY SIZE MLK	FRU	1	N625D	PAPER SIZE SENSOR SWITCH 3130CN
675K69040	KIT LINK ASSY R&L MLK (with 2,3,6-8,12,13)	FRU		M530D	LEFT & RIGHT ARM HOLDING MFP COVER 3130CN
962K64510	HARN ASSY MLK (INTERLOCK SWITCH-J44)	FRU	1	M531D	FRONT COVER INTERLOCK SWITCH 3130CN
130E87990	SENSOR HUM	FRU	1	PG716	HUMIDITY SENSOR 3130CN
675K69010	KIT FEEDER ASSY MLK (with 1,23,24,)	FRU		R319D	INTEGRATED FEEDER 3130CN
675K35410	KIT SCREW JOINT(with 3x2pcs)	CRU	2	TG064	PAPER TRAY 550 SHEET HOUSING SCREW X 2 3130CN
007K14796	DRIVE ASSY MAIN MLK	FRU	1	R311D	MAIN DEVELOPER MOTOR 3130CN
007K15420	DRIVE ASSY PH MLK	FRU	1	P448D	MAIN DRIVE ASSEMBLY 3130CN
007K14801	DRIVE ASSY K MLK	FRU	1	P827D	BLACK DEVELOPER MOTOR 3130CN

BASE UNIT

999SF270F		CRU	1	F270F	PRINTER FOR SERVICE WHOLE UNIT EXCHANGE 110V AMERICAS 3130CN
999SF271F		CRU	1	F271F	PRINTER FOR SERVICE WHOLE UNIT EXCHANGE 110V TAA 3130CN

999SX999D		CRU	1	X999D	PRINTER FOR SERVICE WHOLE UNIT EXCHANGE 220V EUROPE 3130CN
999SC826D		CRU	1	C826D	PRINTER FOR SERVICE WHOLE UNIT EXCHANGE 220V AUSTRALIA 3130CN
999SY700D		CRU	1	Y700D	PRINTER FOR SERVICE WHOLE UNIT EXCHANGE 100V JAPAN 3130CN

Notes

CRU : Customer Replaceable Units - refers to parts that can easily be replaced by the customer without sending an onsite technician.

FRU : Field Replaceable Unit - a part that can be replaced or added by onsite technician.