



Dell 3115cn **Service Manual**

23 Mar 2009

**Information in this document is subject to change without notice.
2010 Dell Inc. All rights reserved.**

Reproduction in any manner whatsoever without the written permission of Dell Inc. is strictly forbidden.
Trademarks used in this text: Dell and the DELL logo are trademarks of Dell Inc.

Other trademarks and trade names may be used in this document to refer to the entities claiming the marks and names of their products. Dell Inc. disclaims any proprietary interest in trademarks and trade names other than its own.

Version record

Refer to the portion indicated by change bar in each section.

Also refer to the reasons in table below.

Version	Issue date	Note
1 st	November 28, 2006	1 st issued
2 nd	March 20, 2007	2 nd version issued <u>Section 1, FIP</u> The contents were improved. <u>Section 2, Operation of Diagnostic</u> The contents were improved. <u>Section 3, RRP</u> The contents were improved. <u>Section 4, P/J Locations</u> The contents were improved. <u>Section 5, Parts List</u> The contents were improved. <u>Section 7, Wiring</u> The contents were improved. <u>Section 8, Specifications</u> The contents were improved.
3rd	March 23, 2009	3rd version issued <u>Section 5, Parts List</u> The contents were improved.

Cautions

Operation contents of this document may be subject to modification without notice.

Dell Inc. will not assume responsibility for accidental or incidental damages resulting from technical or editorial errors or omissions in this manual, the issue of this manual, the execution of descriptions in this manual, or the use of this manual.

This document is protected by copyright. Do not photocopy or duplicate any part of this document in any form without written permission from Dell Inc.

1. About this manual

This manual is a standard service manual of Dell Inc. containing information required for maintenance of this laser printer (standard specifications).

2. Marks giving caution

Maintenance operations requiring special cautions or additional information regarding descriptions in this manual are presented as "Warning," "Caution," or "Note," depending on their nature.



If instructions are not observed, death or serious injury may result.



If instructions are not observed, injuries to workers or physical damage to assets (including this laser printer) may result.

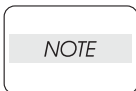

Essentials for procedures, steps, rules, and others.

Reference Incidental information to descriptions.

3. Related documents

- Instruction manuals (standard manuals)

Describe the operation and handling of this laser printer.

- Performance specifications

Describe in detail various specifications of this laser printer.

(In the event of a discrepancy between this manual and the performance specifications, the performance specifications take precedence.)

- Spare parts list

Information on maintenance parts (spare parts) for this laser printer.

4. Safety

To prevent possible accidents during maintenance operation, you should observe strictly the "Warning" and "Caution" information in this manual.

Avoid dangerous operations and operations out of the scope of this manual.

Various processes not covered by this manual may be required in actual operations, and should be performed carefully, always giving attention to safety.

4.1 Power source

Keep the power plug disconnected during the maintenance operation to prevent electric shock, burns and other damages.

If the power supply should be kept connected to measure voltage or for other similar reasons, take sufficient care to prevent electric shock, by following the procedures in this manual.



While the printer is on, never touch live parts if not required.



Power is supplied to the power switch / inlet even while the printer is off. Never touch its live components.



Do not touch live parts unless otherwise specified.

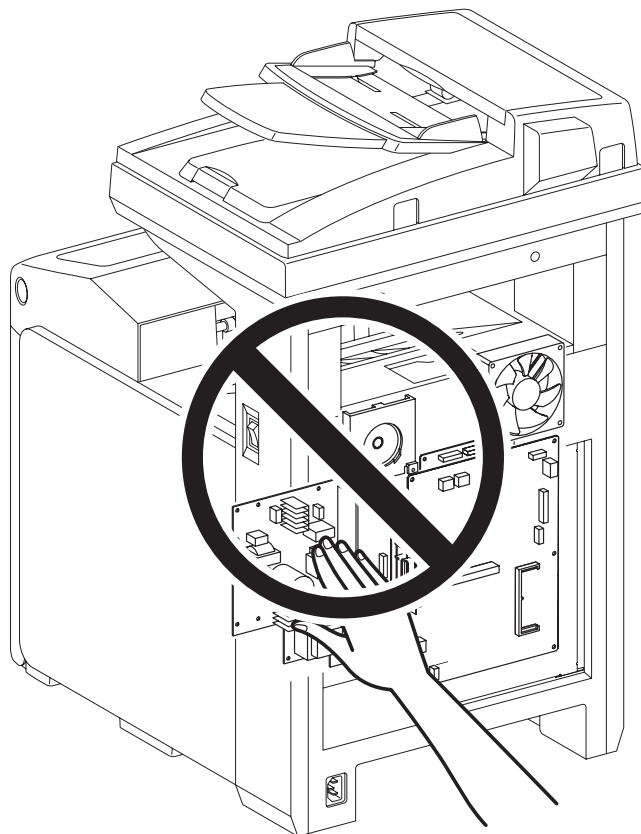

Gnb00002KB

4.2 Driving units

When servicing gears or other driving units, be sure to turn them OFF and plug off. Drive them manually when required.



Never touch the gears or other driving units while the printer is running.

4.3 High-temperature units

When servicing high-temperature units (securing unit, etc.), be sure to turn them off to prevent burns, injuries and other troubles. Remove the power plug and start service processes after they have cooled down sufficiently.



Because high-temperature units are still hot after they complete an operation, wait at least 40 minutes before starting maintenance service.

4.4 Battery

Lithium Battery is used in the following component.

- PWBA HYUI



***There is a danger of a new battery exploding if it is incorrectly installed.
Replace the battery only with the same or equivalent type recommended by the
manufacturer.***

Dispose the battery according to the manufacturer's instruction.

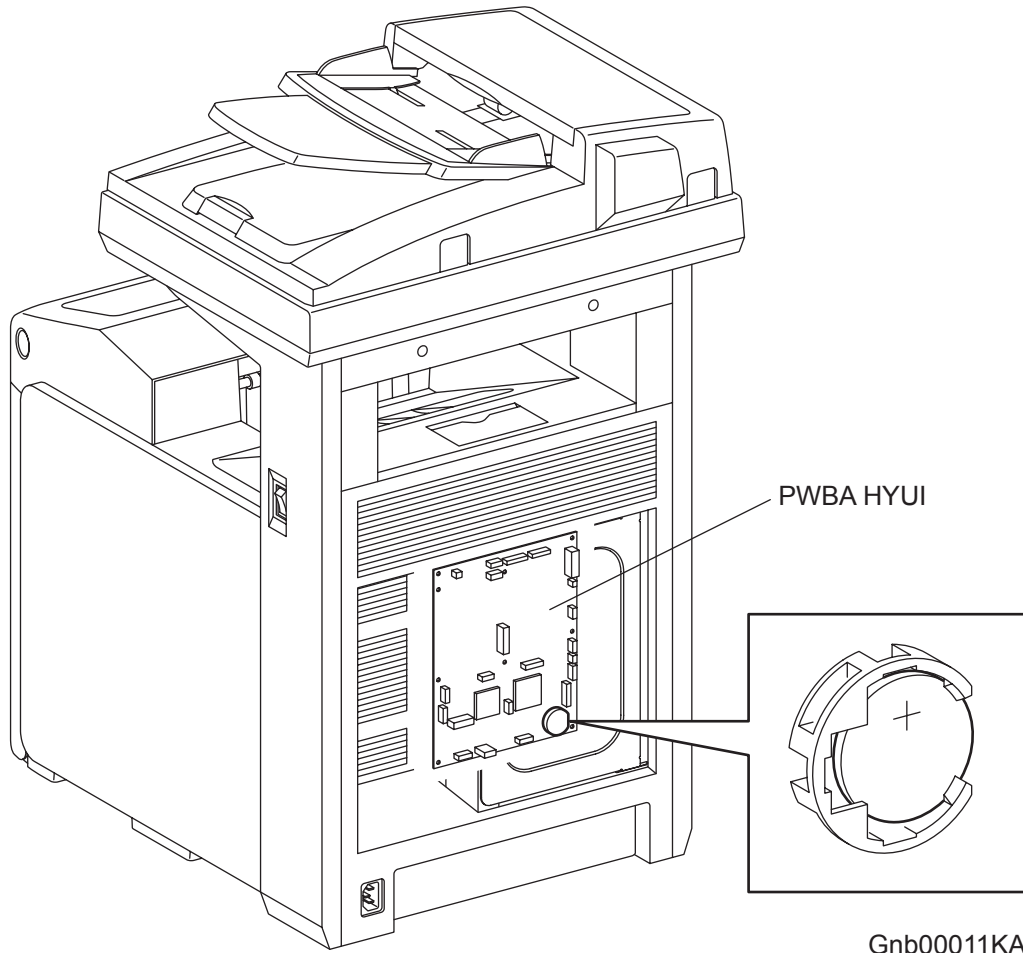

4.5 Laser beams



- *If your eyes are exposed to laser beams, you may lose your eyesight.*
- *Never open the cover if the warning label for laser beams is attached there.*
- *Before disassembling and reassembling this laser printer, be sure to turn it OFF.*
- *When servicing this laser printer while it is running, be sure to follow the procedures specified in this manual.*
- *You should be well aware that the laser beams are capable of injuring you and other people near the printer.*

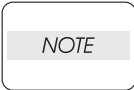

Laser beams have features as follows:

- Frequencies are smaller in width than other beams (sun and electric bulbs) and phases are uniform so that high monochromatic and convergence performance can be obtained and thin beams of light can reach places at a long distance.
- Being highly converged, the laser beams exert a heating action that may be harmful to human body.

Reference: *The laser beams of this laser printer are invisible rays.*

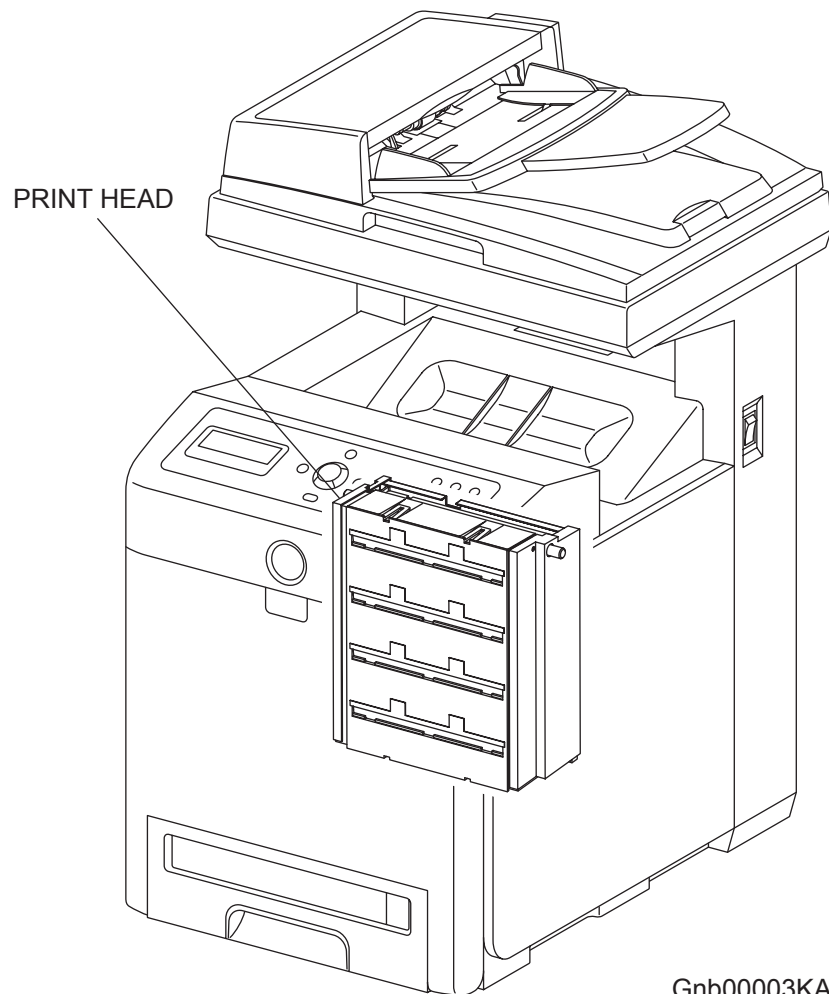

Gnb00003KA

4.6 Warning/caution labels

Warning labels and caution labels are attached to this laser printer to prevent accidents. Check those labels for their peeling or stains when servicing the printer.

4.6.1 Caution label for high-temperature units

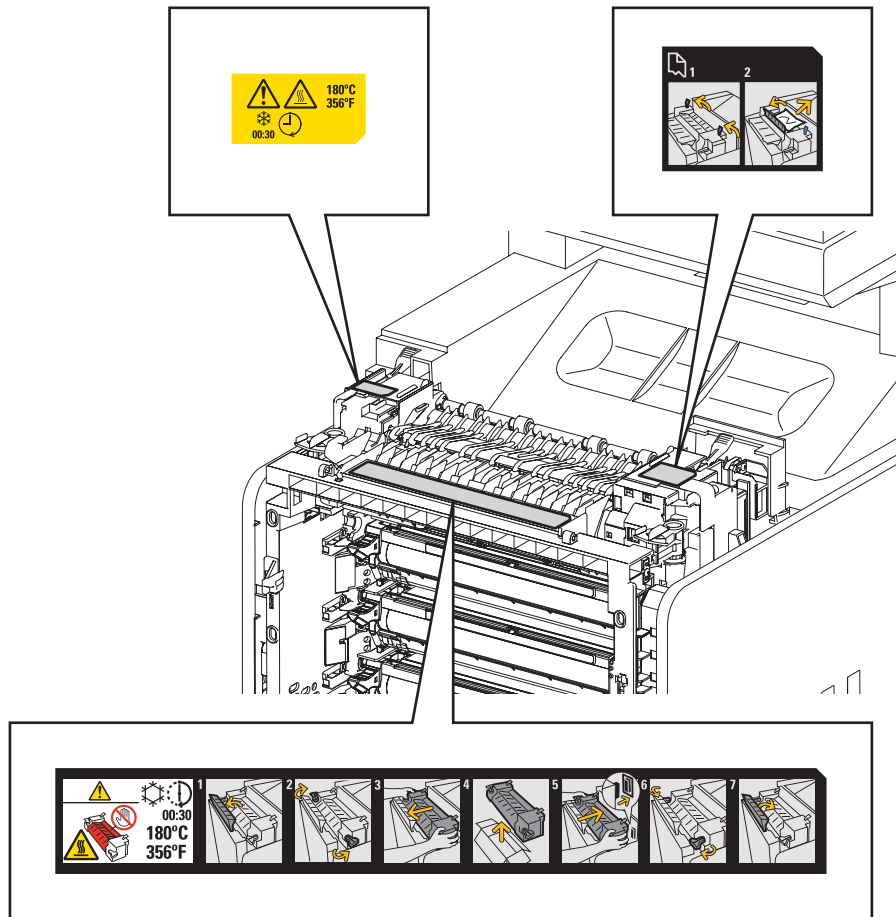

Gnb00004KA

4.6.2 Caution label for toner cartridges

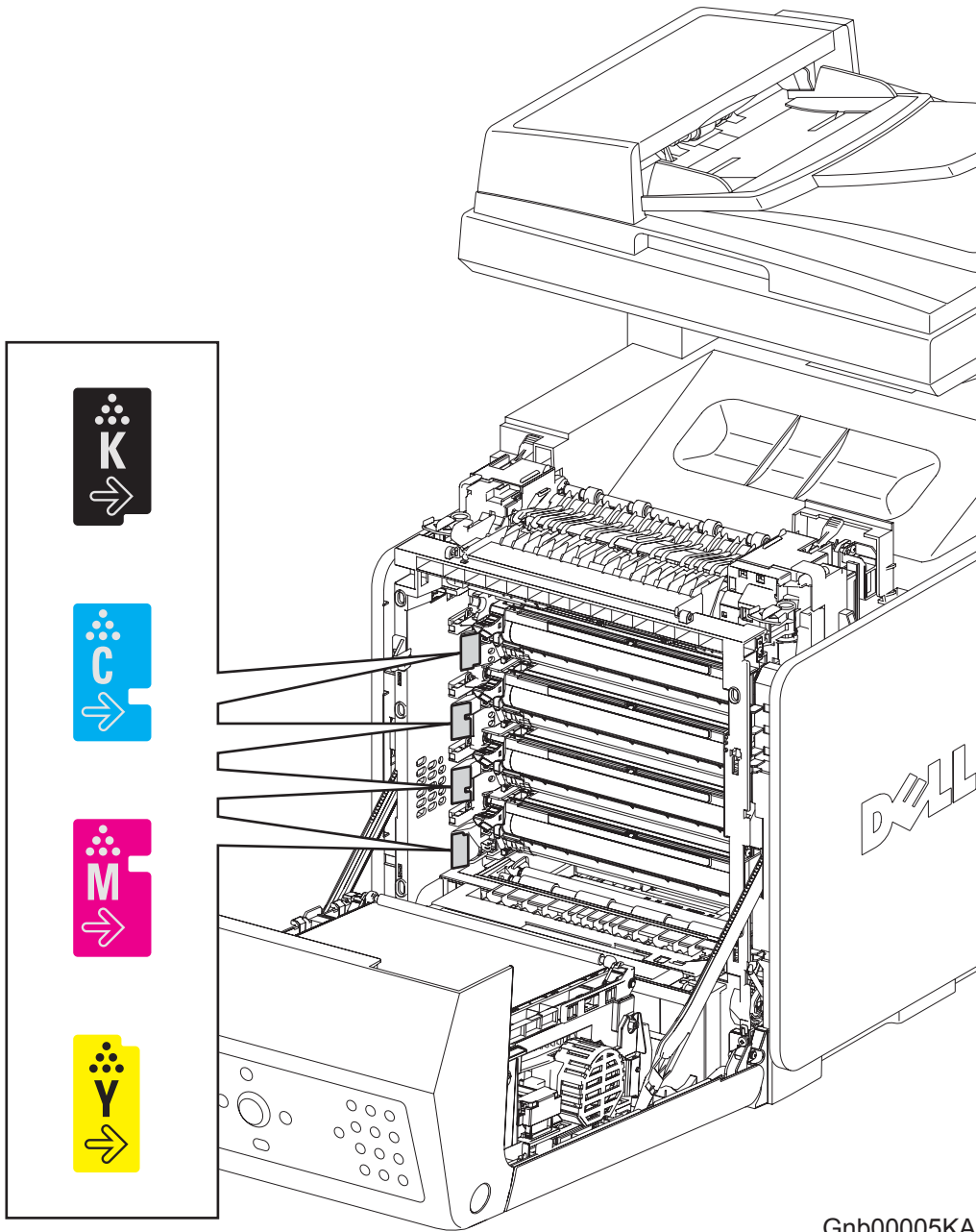

Gnb00005KA

Dell® 3110cn Standard Capacity Black Cartridge PF028
 Black Toner Cartridge / Cartucho de toner negro / Cartuccia del toner color Nero
 Tonerkassette schwarz / Cartuchos de toner negro

Order Supplies at: www.dell.com/supplies

Dell is a trademark of Dell Inc. For warranty questions, see the limited warranty statements included with your printer documentation.

Dell® 3110cn Standard Capacity Cyan Cartridge RF012
 Cyan Toner Cartridge / Cartucho de toner cyan / Cartuccia del toner color Ciano
 Tonerkassette cyan / Cartuchos de toner cyan

Order Supplies at: www.dell.com/supplies

Dell is a trademark of Dell Inc. For warranty questions, see the limited warranty statements included with your printer documentation.

Dell® 3110cn Standard Capacity Magenta Cartridge MF790
 Magenta Toner Cartridge / Cartucho de toner magenta / Cartuccia del toner color Magenta
 Tonerkassette magenta / Cartuchos de toner magenta

Order Supplies at: www.dell.com/supplies

Dell is a trademark of Dell Inc. For warranty questions, see the limited warranty statements included with your printer documentation.

Dell® 3110cn Standard Capacity Yellow Cartridge NF555
 Yellow Toner Cartridge / Cartucho de toner jaune / Cartuccia del toner color Giallo
 Tonerkassette gelb / Cartuchos de toner amarillo

Order Supplies at: www.dell.com/supplies

Dell is a trademark of Dell Inc. For warranty questions, see the limited warranty statements included with your printer documentation.

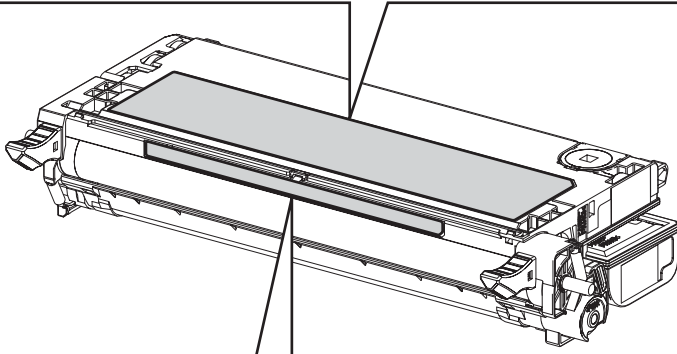

Kmy00006A

4.6.3 Caution label for MPF

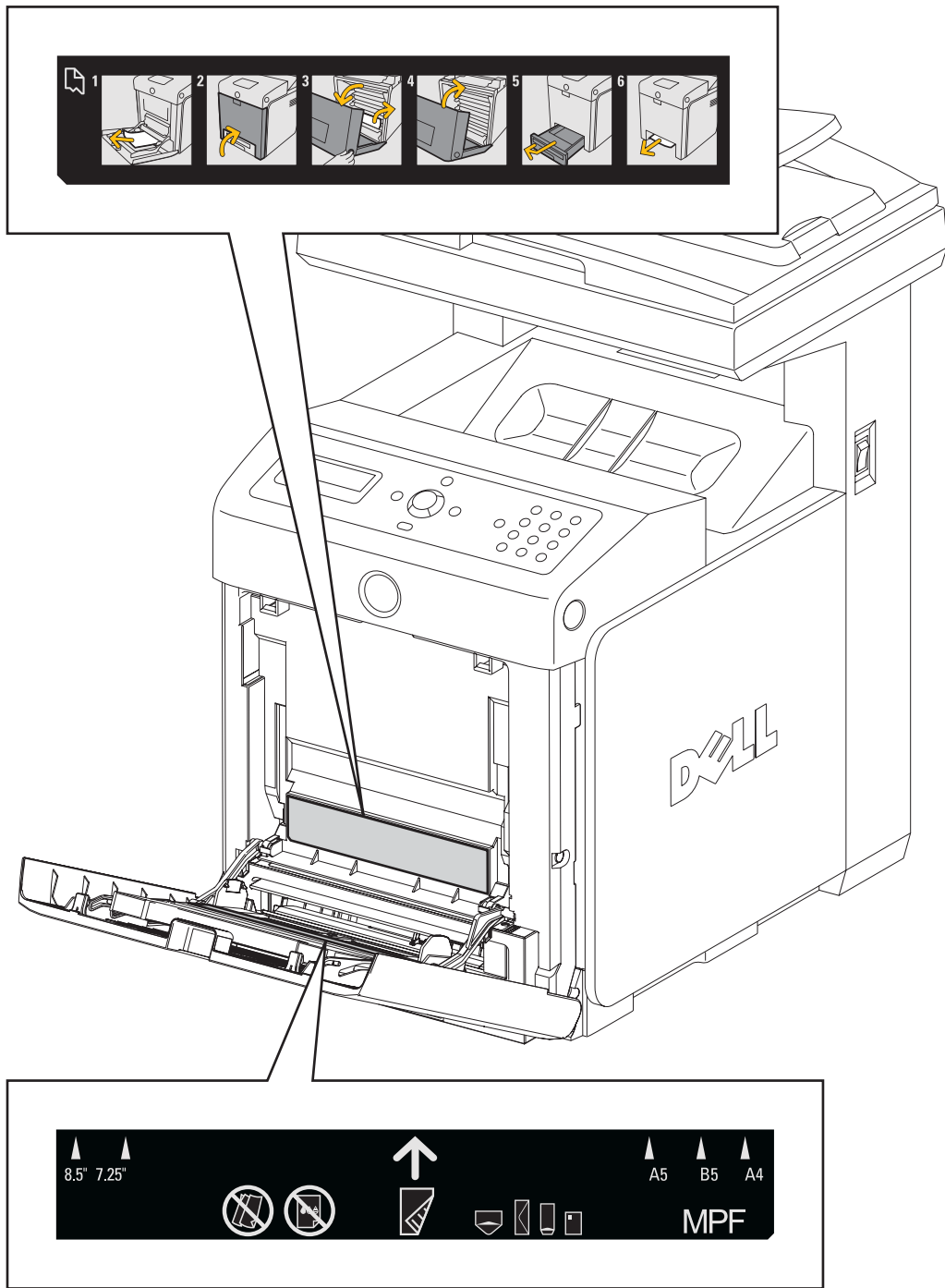

Gnb00008KA

4.6.4 Caution label for Print HEAD

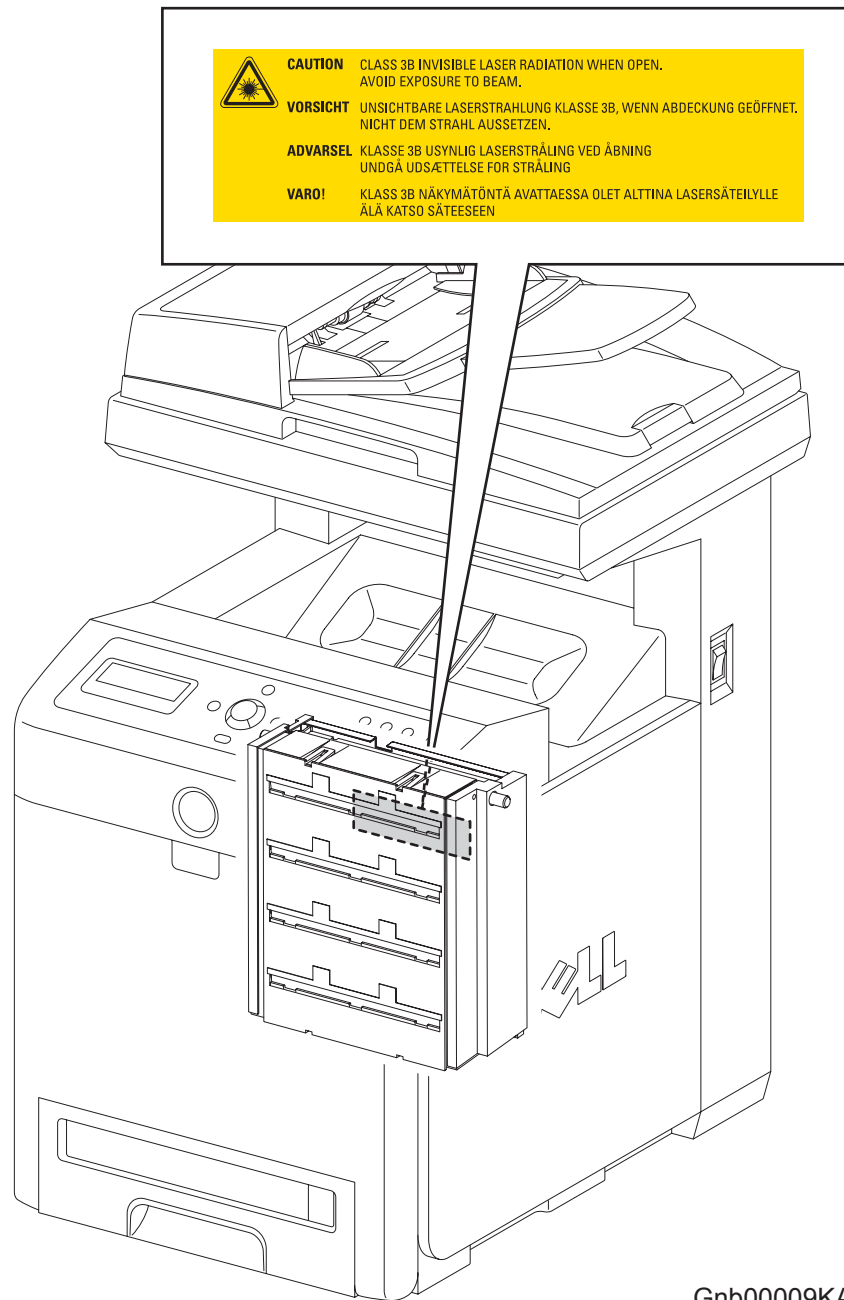

4.6.5 Caution label for Transfer Belt

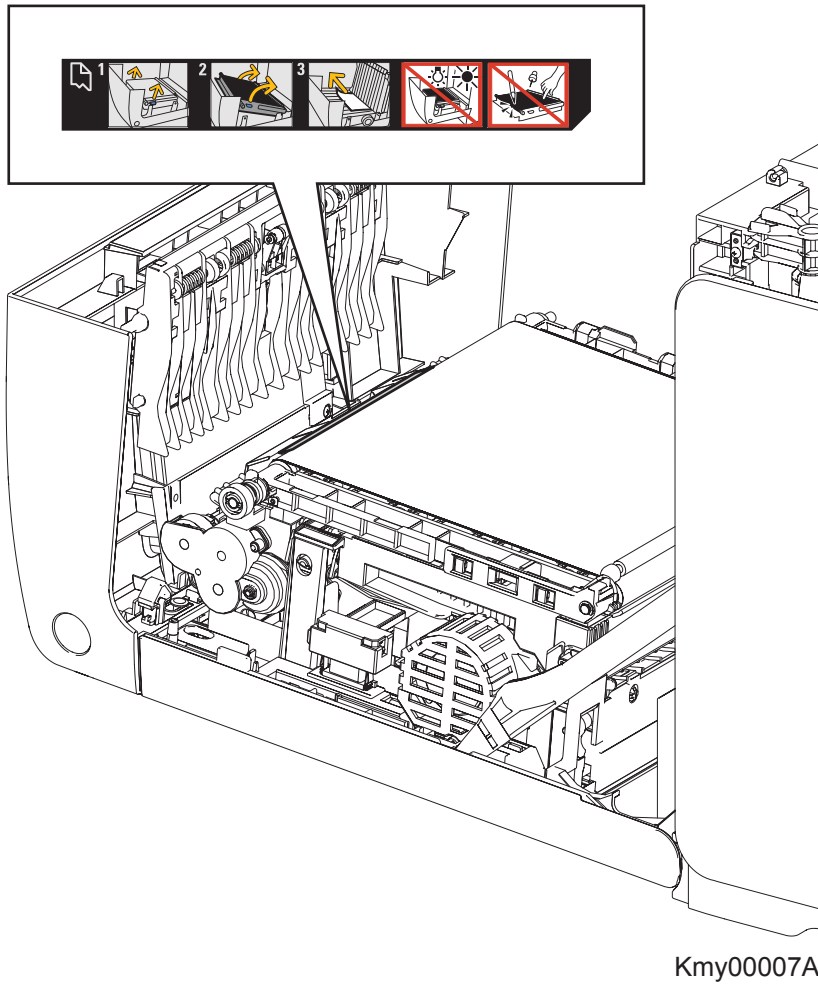

Kmy00007A

4.6.6 Caution label for Duplex

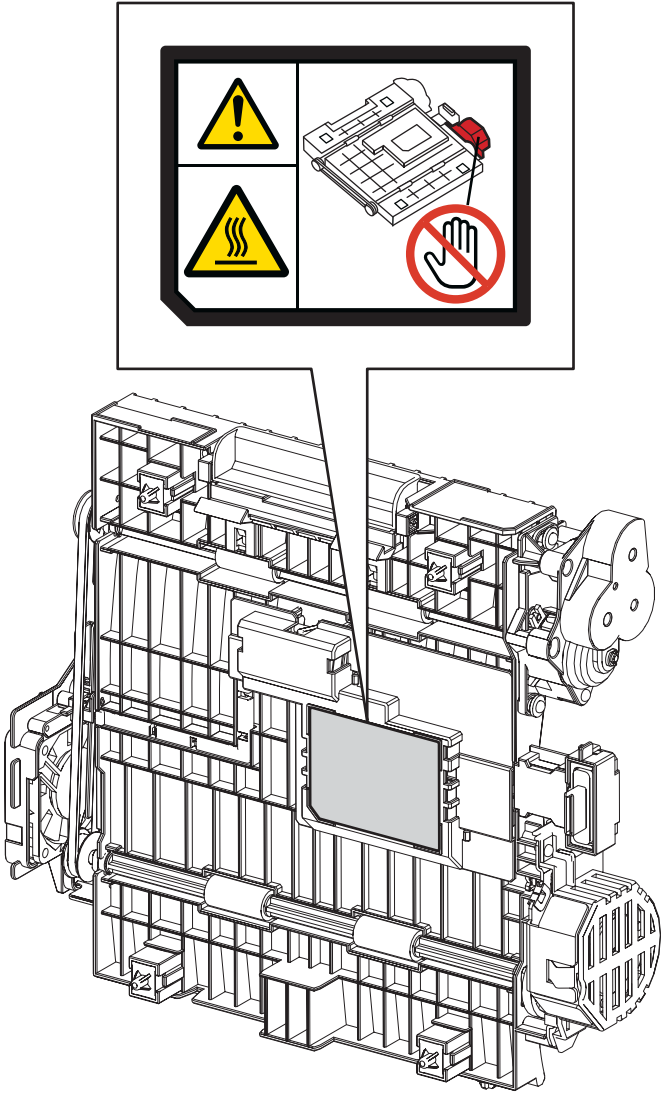

Kmy00011GA

Unpacking the Printer



The printer must be carried horizontally with two or more persons.



Take extreme care to avoid personal injuries.

Check visually the printer for evidence of any damages.

Peel all tapes off the printer.

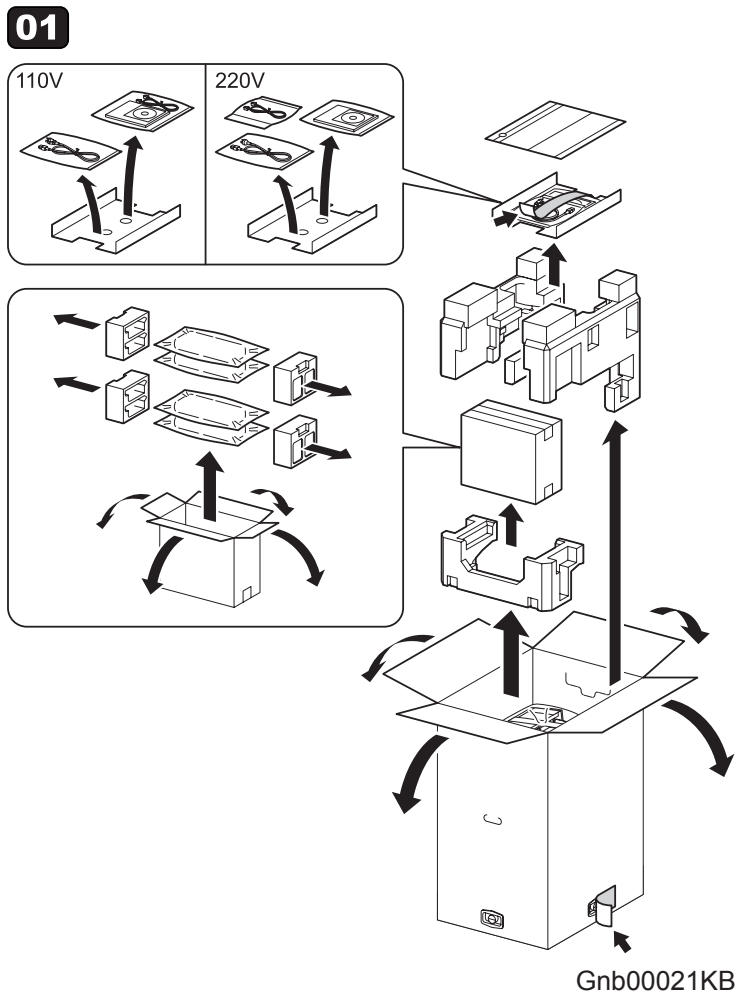

02

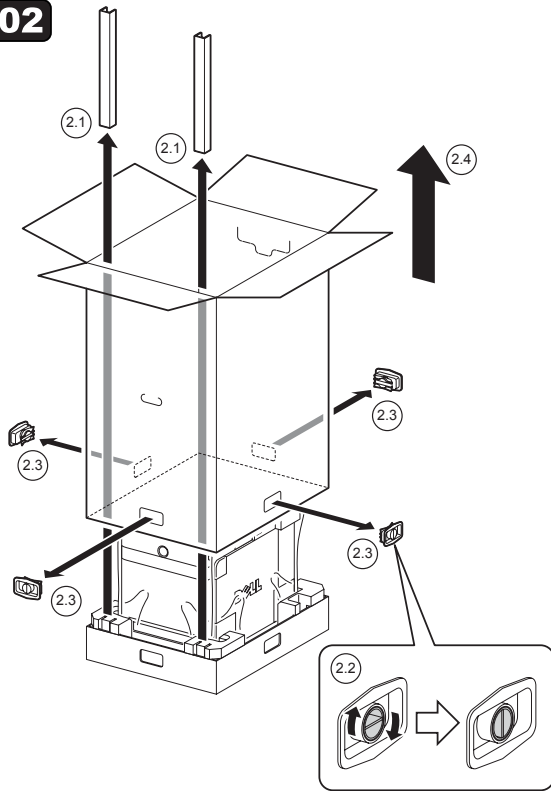

Gnb00022KB

03

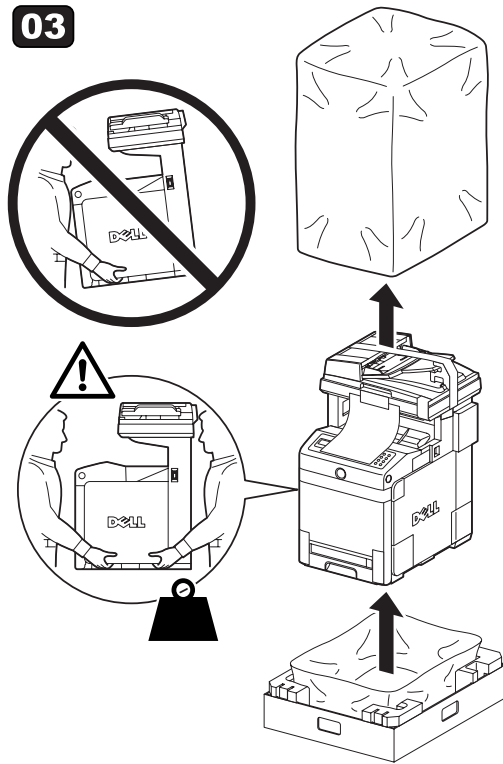

Gnb00023KA

04

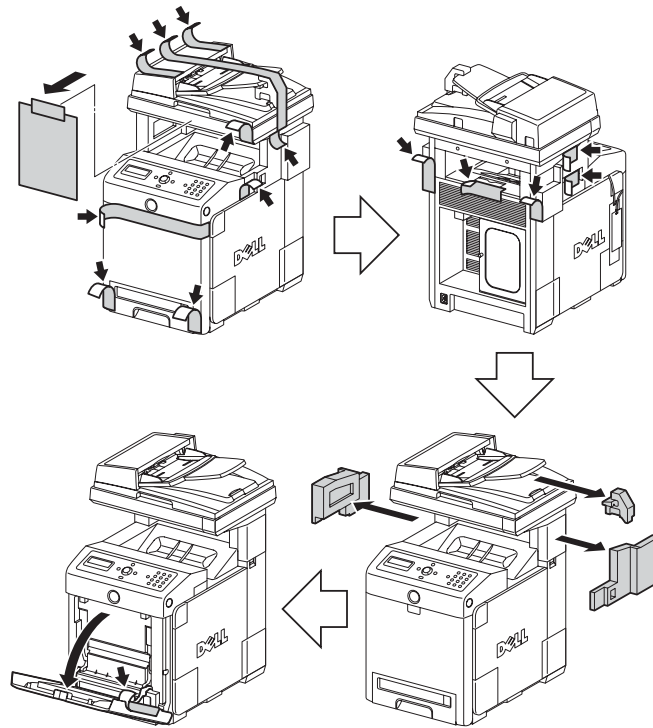

Gnb00024KA

05

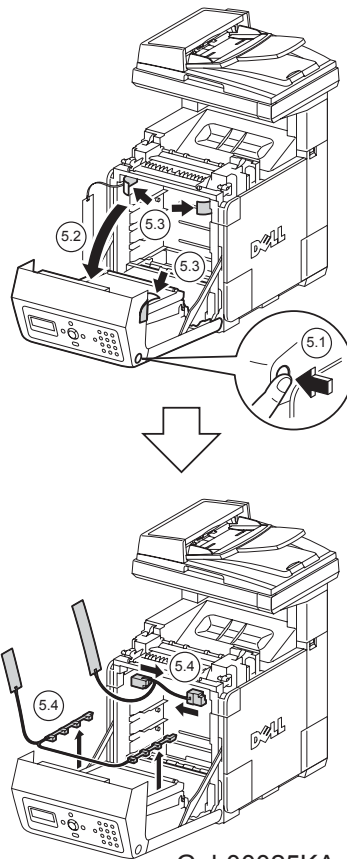

Gnb00025KA

06

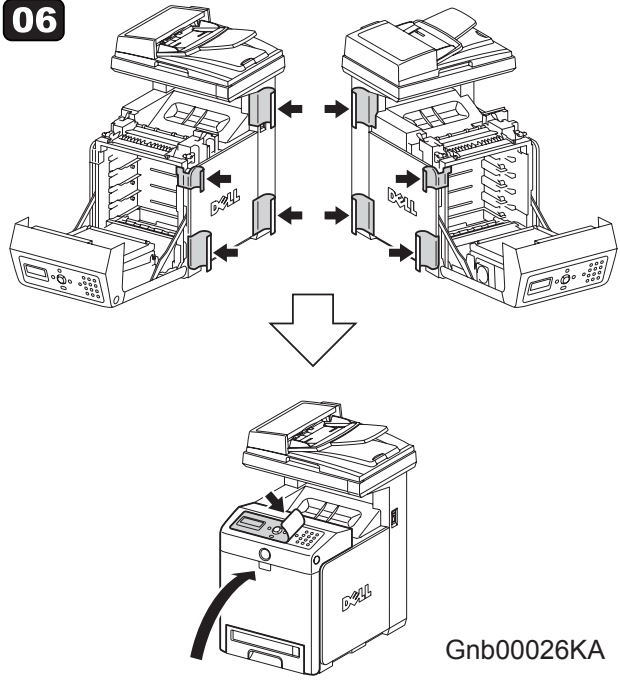

07

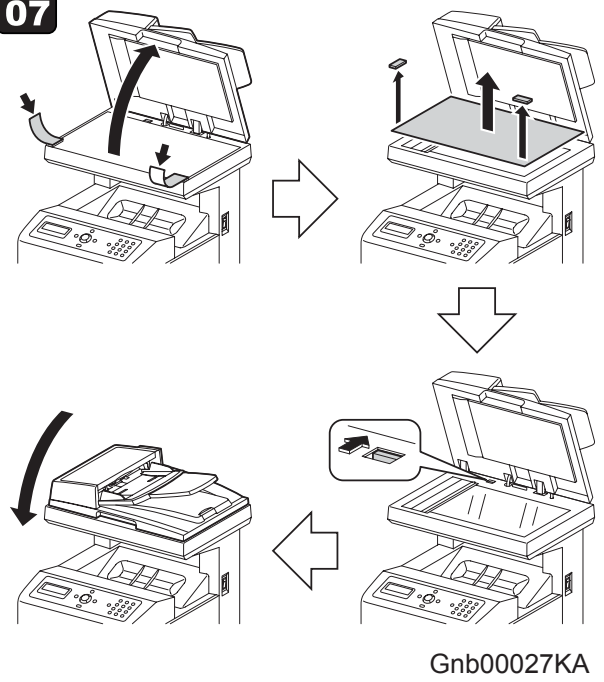

TABLE OF CONTENTS

1. About this manual.....	ii
2. Marks giving caution.....	ii
3. Related documents.....	ii
4. Safety	iii
4.1 Power source	iii
4.2 Driving units	iv
4.3 High-temperature units	iv
4.4 Battery.....	v
4.5 Laser beams	vi
4.6 Warning/caution labels.....	vii
4.6.1 Caution label for high-temperature units.....	vii
4.6.2 Caution label for toner cartridges.....	viii
4.6.3 Caution label for MPF	x
4.6.4 Caution label for Print HEAD	xi
4.6.5 Caution label for Transfer Belt	xii
4.6.6 Caution label for Duplex.....	xiii
Unpacking the Printer.....	xiv
Chapter 1 Troubleshooting.....	1 - 1
Chapter 2 Operation of Diagnostic	2 - 1
Chapter 3 Removal and Replacement Procedures	3 - 1
Chapter 4 Plug/Jack(P/J) Connector Locations.....	4 - 1
Chapter 5 Parts List.....	5 - 1
Chapter 6 Principles of Operation	6 - 1
Chapter 7 Wiring Diagrams and Signal Information	7 - 1
Chapter 8 Printer Specifications	8 - 1

Chapter 1 Troubleshooting CONTENTS

1. Troubleshooting Procedures	1 - 1
1.1 Flow of Troubleshooting	1 - 1
1.2 Confirm Installation Status	1 - 1
1.3 Cautions for Service Operations	1 - 2
1.4 Cautions for Implementing FIP	1 - 2
1.5 Items to Confirm before FIP Troubleshooting	1 - 3
1.5.1 Basic Printer Problems	1 - 3
1.5.2 Display Problems	1 - 4
1.5.3 Printing Problems	1 - 4
1.5.4 Print Media Guidelines	1 - 5
1.5.5 ADF Media Guidelines	1 - 8
2. Installing Fax Machine	1 - 9
2.1 Items to be checked before installation	1 - 9
2.2 Menus to be configured at installation	1 - 10
2.3 Fax Troubleshooting	1 - 11
2.3.1 FIP at Installation/Relocation	1 - 11
2.3.2 FIP after Installation (with transmissions/receptions fail after continuous normal operation)	1 - 16
2.3.3 FIP for Color Fax	1 - 21
3. Fault Isolation Procedure for Fax	1 - 23
3.1 Fault Occurs	1 - 23
3.2 Obtaining Printer Information	1 - 24
3.3 Transmission Fault	1 - 26
3.4 Reception Fault	1 - 27
3.5 Understanding Protocol Monitor	1 - 29
3.5.1 Overview of Communication Protocol	1 - 29
3.5.2 Overview of Protocol Monitor	1 - 32
3.5.3 FIP Using Protocol Monitor Report Analysis	1 - 38
4. Other Problems	1 - 43
5. FIP	1 - 44
5.1 FIP	1 - 44
5.2 Flow of FIP	1 - 44
5.3 Status Code List	1 - 45
5.4 LCD Display	1 - 66
6. Error Code FIP	1 - 83
FIP-1. 1 Restart Printer 001-360/001-363	1 - 83
FIP-1. 2 Restart Printer 001-361/001-363	1 - 84
FIP-1. 3 Restart Printer 003-341/003-342/003-343/003-344/003-345/ 003-346/003-347/003-348/003-349/003-350	1 - 85
FIP-1. 4 Restart Printer 003-356	1 - 86
FIP-1. 5 Restart Printer 004-310	1 - 88
FIP-1. 6 Restart Printer 004-311	1 - 89
FIP-1. 7 Restart Printer 006-370/006-371/006-372/006-373/006-374/006-375/006-376/ 006-377/006-378/006-379/006-380/006-381/006-382/006-383/006-384	1 - 90

Chapter 1 Troubleshooting CONTENTS

FIP-1. 8	Restart Printer 007-340/007-345/007-346/007-347/007-348/007-355/007-356/ 007-357/007-358/007-359/007-360/007-365/007-366//007-367/007-368/007-370	1 - 91
FIP-1. 9	Restart Printer 007-341/007-345/007-349/007-350/007-351/007-355/007-356/ 007-357/007-361/007-362/007-363/007-365/007-366/007-367/007-369/007-370	1 - 92
FIP-1. 10	Restart Printer 007-342/007-346/007-349/007-352/007-353/007-355/007-358/ 007-359/007-361/007-362/007-364/007-365/007-366/007-368/007-369/007-370	1 - 93
FIP-1. 11	Restart Printer 007-343/007-347/007-350/007-352/007-354/007-356/007-358/ 007-360/007-361/007-363/007-364/007-365/007-367/007-368/007-369/007-370	1 - 94
FIP-1. 12	Restart Printer 007-344/007-348/007-351/007-353/007-354/007-357/007-359/ 007-360/007-362/007-363/007-364/007-366/007-367/007-368/007-369/007-370	1 - 95
FIP-1. 13	Restart Printer 009-360/009-361/009-362/009-363	1 - 96
FIP-1. 14	Restart Printer 009-654	1 - 97
FIP-1. 15	Restart Printer 009-655	1 - 98
FIP-1. 16	Insert Fuser 010-317	1 - 100
FIP-1. 17	Replace Fuser 010-351/Restart Printer 010-351	1 - 101
FIP-1. 18	Restart Printer 010-354	1 - 102
FIP-1. 19	Restart Printer 010-377/010-378/010-379/010-380/010-381/010-382/010-383/ 010-384/010-385/010-386/010-387/010-388/010-389/010-390/010-391/ 010-392/010-393/010-394/010-395/010-396/010-397	1 - 103
FIP-1. 20	Restart Printer 016-300/016-301/016-310/016-313/016-315/016-317/016-317/ 016-323/016-327/016-340/016-344/016-345/016-346/016-347/016-348/016-349/ Erase Flash Err. 016-392/Write Flash Err. 016-393/Verify Error 016-394/ PCL Error 016-720	1 - 104
FIP-1. 21	Restart Printer 016-302	1 - 105
FIP-1. 22	Restart Printer 016-316/016-318	1 - 107
FIP-1. 23	Restart Printer 016-330/016-331/016-332/016-333/016-334/016-335/016-336/ 016-337/Restart Printer 016-360/Network Error 016-770	1 - 108
FIP-1. 24	Restart Printer 016-338	1 - 109
FIP-1. 25	Restart Printer 016-350	1 - 110
FIP-1. 26	Restart Printer 016-370	1 - 111
FIP-1. 27	Restart Printer 016-397	1 - 112
FIP-1. 28	Restart Printer 016-398 /117-313/117-323/117-324/117-325/001-326/117-329 117-354/117-355/117-356/117-357/117-358/117-359/117-360	1 - 113
FIP-1. 29	Restart Printer 062-311/062-321/062-360/062-371/117-352	1 - 114
FIP-1. 30	Restart Printer 062-320/062-324	1 - 115
FIP-1. 31	Communication 034-508/034-509/034-510 / Restart Printer 062-322/062-393	1 - 116
FIP-1. 32	Restart Printer 062-323/123-314	1 - 117
FIP-1. 33	Restart Printer 093-964	1 - 119
FIP-1. 34	016-986/017-971/017-972/017-973/017-974/017-975/017-976/017-977/ 017-978/017-979/017-980/017-986/017-987/017-989/033-502/033-513/033-751/ 033-764/033-765/033-766/033-767/033-768/033-770/033-771/033-774/033-776/ 033-779/033-780/033-781/033-785/033-786/033-787/033-788/033-789/033-790/ 033-791/035-730/035-771/035-777/035-779/102-380/116-396/116-987/117-310/ 117-311/117-312/117-314/117-315/117-316/117-317/117-318/117-319/117-320/ 117-321/117-322/117-327/117-328/117-330/117-331/117-332/117-333/117-334/ 117-335/117-336/117-337/117-338/117-339/117-340/117-341/117-342/117-343/	

Chapter 1 Troubleshooting CONTENTS

	117-344/117-345/117-346/117-347/117-348/117-349/117-350/117-351/117-353/ 117-362/117-363/133-231/133-234/133-235/133-236/133-237/133-238/133-239/ 133-240/133-241/133-242/133-243/133-244/133-245/133-246/133-247/133-248/ 133-249/133-250/133-251/133-252/133-253/133-255/133-256/133-257/133-258/ 133-259/133-260/133-261/133-262/133-263/133-264/133-265/133-266/133-267/ 133-268/133-269/133-270/133-271/133-272/133-273/133-274/133-275/133-276/ 133-277/133-278/133-279/133-280/133-281/133-282/133-283/133-284/133-285/ 133-286/133-287/133-288/133-289/133-290/133-512/Controller Initialize	1 - 120
FIP-1. 35	Restart Printer 133-232/134-211/134-212/Busy 033-752/ Communication 033-753/033-754/033-755/033-756/033-757/033-758/033-759/ 033-760/033-761/034-742/035-706/Codec Error 033-769/033-772/ No Dial Tone 035-749	1 - 122
FIP-1. 36	Restart Printer 133-254/Memory Full 017-970/033-503	1 - 123
FIP-1. 37	Paper Jam 071-100/Illegal Settings (Copy Select Tray Broken)	1 - 124
FIP-1. 38	Paper Jam 072-100/Illegal Settings (Copy Select Tray Broken)	1 - 127
FIP-1. 39	Paper Jam 075-100/Illegal Settings (Copy Select Tray Broken)	1 - 131
FIP-1. 40	Paper Jam 077-900/077-901	1 - 134
FIP-1. 41	Paper Jam 077-903	1 - 138
FIP-1. 42	Paper Jam 077-907	1 - 139
FIP-1. 43	Load Tray N or MPF 024-910/024-911/024-914/ Illegal Settings (Copy Select Tray Broken)	1 - 142
FIP-1. 44	Load Tray N or MPF 024-965/024-966/024-969/ Illegal Settings (Copy Select Tray Broken)	1 - 144
FIP-1. 45	CRUM ID 009-367/009-368/009-369/009-370	1 - 147
FIP-1. 46	Tape on XXX Cart 093-919/093-920/093-921/093-922	1 - 148
FIP-1. 47	Replace Cart. 093-930	1 - 149
FIP-1. 48	Replace Cart. 093-931	1 - 150
FIP-1. 49	Replace Cart. 093-932	1 - 151
FIP-1. 50	Replace Cart. 093-933	1 - 152
FIP-1. 51	Ready to Print 093-423	1 - 153
FIP-1. 52	Ready to Print 093-424	1 - 154
FIP-1. 53	Ready to Print 093-425	1 - 155
FIP-1. 54	Ready to Print 093-426	1 - 156
FIP-1. 55	Insert PrintCart 093-970	1 - 157
FIP-1. 56	Insert PrintCart 093-971	1 - 158
FIP-1. 57	Insert PrintCart 093-972	1 - 159
FIP-1. 58	Insert PrintCart 093-973	1 - 160
FIP-1. 59	CRUM ID 009-371/Insert Belt Unit 094-910	1 - 161
FIP-1. 60	Copy Scan Fax 094-422	1 - 162
FIP-1. 61	Belt Unit 094-911	1 - 163
FIP-1. 62	Restart Printer 010-359	1 - 164
FIP-1. 63	Copy Scan Fax 010-421	1 - 165
FIP-1. 64	Tray Detached 024-946/024-947 / Load Tray 1 077-912/ Illegal Settings (Copy Select Tray Broken)/Illegal Settings (Copy Select Tray Remove)/Illegal Settings (Copy Select Tray Exit)	1 - 166
FIP-1. 65	Close FrontCover 077-300	1 - 168

Chapter 1 Troubleshooting CONTENTS

FIP-1. 66	SMTP Error 016-503/016-764/POP Error 016-504/POP Login Error 016-505/ SMTP Login Error 016-506/016-507Address Error 016-767/ From Address Error 016-768/SMB/FTP Error 016-781/016-783/016-784/ 016-787/016-788/016-789/Login Error 016-782/Network Error 016-786/ Network Not Ready 016-790	1 - 169
FIP-1. 67	Network Not Ready 016-794	1 - 171
FIP-1. 68	PCScan Time Out 017-988	1 - 172
FIP-1. 69	Communication 033-500/033-511/033-782/033-799/034-730/035-702/035-704/ 035-705/035-708/035-709/035-710/035-716/035-717/035-728/035-729/035-737/ 035-797/035-739/035-740/035-741/035-742/035-772/035-780/ Codec Error 033-514/033-515/033-516/Buffer 033-775/033-777/033-784/ No Answer 035-718	1 - 174
FIP-1. 70	Codec Error 033-501 / Communication 034-515/035-792	1 - 175
FIP-1. 71	Codec Error 033-510	1 - 176
FIP-1. 72	Password Error 033-517	1 - 177
FIP-1. 73	Communication 033-762	1 - 178
FIP-1. 74	Communication 033-763	1 - 179
FIP-1. 75	Codec Error 033-773	1 - 180
FIP-1. 76	Communication 035-720	1 - 182
FIP-1. 77	Illegal Data 033-783/034-799/No Dial Tone 035-746/035-773/035-774	1 - 183
FIP-1. 78	No Answer 035-701	1 - 184
FIP-1. 79	Busy 035-781	1 - 186
FIP-1. 80	Accumulation Limit	1 - 187
FIP-1. 81	Illegal Settings (Copy Dup Size Limit)	1 - 188
FIP-1. 82	Illegal Settings (Copy Dup Medium NG)	1 - 189
FIP-1. 83	Confirm 062-790	1 - 190
FIP-1. 84	Paper Jam 005-110/005-121	1 - 192
FIP-1. 85	Cover Open 005-301/Paper Jam 005-302	1 - 194
FIP-1. 86	Invalid ID 016-383/Range Chk Error 016-384/Header Error 016-385/ Check Sum Error 016-386/Format Error 016-387	1 - 195
FIP-1. 87	MPC Error 016-388/MPC Detached 016-389/MPC Com. Failed 016-390	1 - 196
FIP-1. 88	Out of Memory 016-700/Disk Full 016-980	1 - 198
FIP-1. 89	Invalid User 016-757/Disabled Func 016-758/Reached Limits 016-759	1 - 199
FIP-1. 90	Invalid Job 016-799	1 - 200
FIP-1. 91	Over Heat 042-700/Copy Scan Fax 142-700	1 - 201
FIP-1. 92	Copy Scan Fax 193-700	1 - 202
FIP-1. 93	Electrical Noise	1 - 203
7.	Image Quality Troubles	1 - 204
7.1	Flow of Image Quality Troubleshooting	1 - 204
7.2	Items to Confirm before Image Quality Troubleshooting	1 - 207
7.2.1	Print Quality Problems	1 - 207
7.3	Print Image Quality Specifications	1 - 208
7.4	Image Quality FIP	1 - 212
FIP-1.P1	Faint print (Low contrast)	1 - 212
FIP-1.P2	Blank print (No print)	1 - 216

Chapter 1 Troubleshooting CONTENTS

FIP-1.P3	Solid black	1 - 222
FIP-1.P4	Vertical blank lines (White stripes in paper transport direction)	1 - 227
FIP-1.P5	Horizontal band cross out (White stripes in the horizontal direction)	1 - 233
FIP-1.P6	Vertical stripes	1 - 239
FIP-1.P7	Horizontal stripes	1 - 245
FIP-1.P8	Partial lack	1 - 251
FIP-1.P9	Spots	1 - 257
FIP-1.P10	Afterimage	1 - 263
FIP-1.P11	Background (Fog)	1 - 267
FIP-1.P12	Skew	1 - 271
FIP-1.P13	Paper damage	1 - 278
FIP-1.P14	No fix	1 - 285
FIP-1.P15	Color Registration (Color Shift)	1 - 287
FIP-1.P16	Hunting	1 - 291
FIP-1.P17	Magnification incorrect	1 - 293
8.	Abnormal Noise Troubles	1 - 295
8.1	Flow of Abnormal Noise Troubleshooting	1 - 295
8.2	Operation Mode	1 - 296
FIP-1.N1	When Power is Turned On	1 - 296
FIP-1.N2	During Standby	1 - 301
FIP-1.N3	During Printing	1 - 302
9.	Other FIPs	1 - 308
FIP-AC		1 - 308
FIP-DC		1 - 310
FIP-Multiple feed		1 - 311
FIP-Document source selection fault		1 - 313

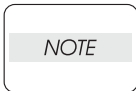

The troubleshooting procedures in this manual assume implementation of diagnostics. However, since this manual is organized so that troubleshooting can be performed without diagnostics, read and understand fully the procedures you may need before starting.

1. Troubleshooting Procedures

After confirming the problem, go to the Fault Isolation Procedure (FIP), Operation of Diagnostic (Chapter 2), Wiring Diagrams (Chapter 7), and Principles of Operation (Chapter 6).

1.1 Flow of Troubleshooting

Flow of the troubleshooting is as follows:

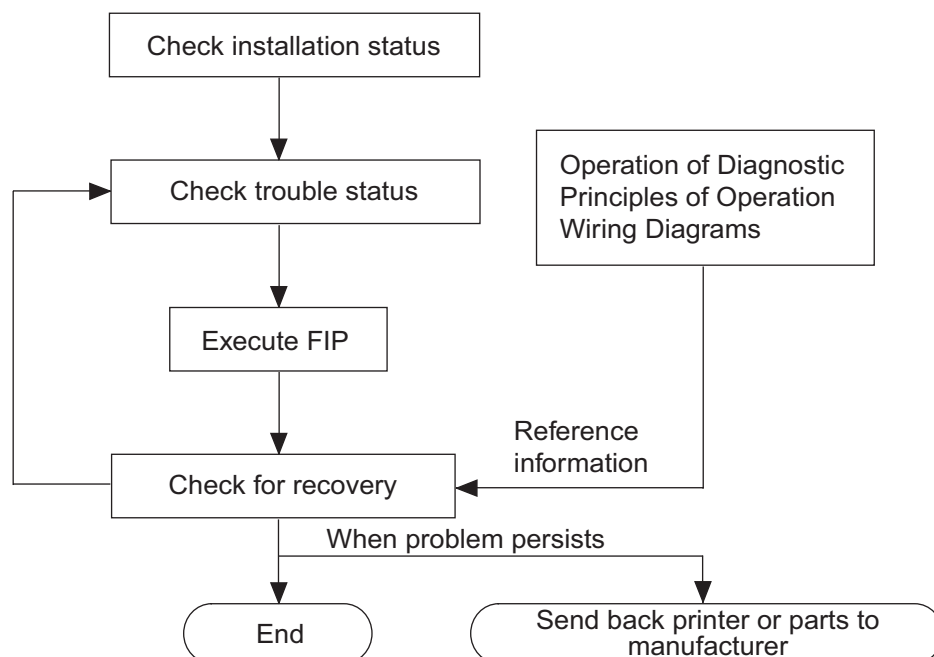

1.2 Confirm Installation Status

Be sure to check the following items before starting the troubleshooting procedures:

- 1) The power supply voltage is within the specifications (measure the voltage at the electric outlet).
- 2) Power cord is free from breakage, short-circuit, disconnected wire, or improper wiring.
- 3) The laser printer is properly grounded.
- 4) The laser printer is not installed at a place subjected to too high temperature, too high humidity, too low temperature, too low humidity or rapid change of temperature.
- 5) The laser printer is not installed close to water service, humidifier, heat generating unit, or fire, in very dusty place, or a place exposed to air flow from the air conditioning system.
- 6) The laser printer is not installed in a place where explosive or inflammable atmosphere may develop.

- 7) The laser printer is not installed under direct sunbeams.
- 8) The laser printer is installed in a well-ventilated place.
- 9) The laser printer is installed on a rigid and stable surface.
- 10) The paper used meets specifications (standard paper is recommendable).
- 11) The laser printer is handled properly.
- 12) The parts which should be periodically replaced are replaced each time when the specified number of sheets have been printed.

1.3 Cautions for Service Operations

- 1) Be sure to remove the power cord unless otherwise required.



***If the printer is kept ON, never touch the conductive parts unless otherwise required.
The power switch and inlet are live even while the power supply is cut off. Never touch the live parts.***

- 2) When checking some parts with covers removed and with the interlock and power switches ON, remove the connector (P/J601) on the ROS ASSY unless otherwise required.



When checking some parts with covers removed and with the interlock and power switches ON, laser beams may be irradiated from the ROS ASSY. For safety, be sure to remove the connector (P/J151) unless otherwise required.

- 3) When checking some parts with the Front Cover removed and power ON, be sure to remove the connector (P/J16) on the PWBA MCU unless otherwise required.



***When checking some parts with the Front Cover removed and power ON, high voltage may be applied by the HVPS. Be sure to remove the connector (P/J16) on the PWBA MCU beforehand.
When connecting the connector (P/J16) on the PWBA MCU according to the instructions of the FIP, never touch the HVPS and high voltage parts.***

- 4) When using Diag. tools or other tools of high voltage, be sure to keep them covered unless otherwise specified.



***When using Diag. Tool or other tools of high voltage, never touch high voltage parts.
When using Diag. Tool or other high voltage tools, be sure to follow the instructions in this manual.***

- 5) When operating the driving units using the Diag or other tools, be sure to keep them covered unless otherwise specified.



When operating the driving units using the Diag. or other tools, never touch the driving units. When operating the driving units using Diag. or other tools, be sure to follow the instructions in this manual.

- 6) When touching hot parts, be careful not to burn yourself.
- 7) Wear a wrist band or the like to remove static buildup from your body.

1.4 Cautions for Implementing FIP

- 1) It is assumed in the FIP that the printer controller (PWBA ESS) is normally functioning. If any trouble cannot be corrected by troubleshooting, replace the printer controller with a normal one and check for proper operation again.
If the problem persists, try replacing the major parts (possible causative parts) first, and then the related parts.

- 2) When troubleshooting according to the FIP, normal PWBA MCU, HVPS, LVPS, FUSER ASSY, BELT ASSY and others may be necessary for isolation of failed parts. Prepare them in advance.
- 3) In the initial phases of FIP, check all items that can be simply checked.
- 4) In the initial phases of FIP, check not only the major parts but also their constitutive parts and the related parts.
- 5) When working with the printer, be sure to remove the power cord unless otherwise required. Never touch live parts unless required, while the power cord is connected.
- 6) Connector condition is denoted as follows:
 - [P/J12]→Mated plug and jack of the connector (P/J12).
 - [P12]→Plug of the connector (P/J12) (except when attached directly to the board).
 - [J12]→Jack of the connector (P/J12) (except when attached directly to the board).
- 7) [P/J1-2PIN <=> P/J3-4PIN] in the FIP denotes a measurement with the positive side of the measuring instrument connected to [2PIN] of [P/J1] and the negative side to [4PIN] of [P/J3].
- 8) [P/J1<=> P/J2] in the FIP denotes measurements at all terminals existing between [P/J1] and [P/J2] as shown in "Wiring Diagrams".
- 9) When a voltage measurement is involved in [P/J1-2PIN <=> P/J3-4PIN] in the FIP, the negative side [P/J3-4PIN] is one of AG (analog ground), SG (signal ground), and RTN (return). Therefore, after checking conductivity between AGs, SGs, or RTNs respectively, the negative side can be connected to the PIN of AG, SG or RTN instead of [P/J3-4PIN].
- 10) Use a proprietary tool to measure the voltage of miniature connectors. Handle the tool with care, as the leading edge of the tool is pointed.
- 11) When measuring the voltage, set the BELT ASSY, toner cartridge and paper cassette, close the COVERS and power ON unless otherwise specified.
- 12) Numerical values in the FIP are only for guideline purposes. Approximate values are acceptable.
- 13) Note that the parts specified in the FIP to be removed and their removal process are not specifically referred to here.
- 14) "Replacement" in the FIP denotes that the suspicious parts or their parent part (high assy) is to be replaced and checked.
- 15) The FIP describes the first cassette on the lower part of the printer as "Tray 1," and the second cassette as "Tray 2".
- 16) The FIP procedure varies depending on specifications. Correct troubles according to the instructions in the FIP.
- 17) Troubleshooting of some optional parts must be performed according to the manuals for those parts. Have the relevant manuals at hand.

1.5 Items to Confirm before FIP Troubleshooting

1.5.1 Basic Printer Problems

Some printer problems can be easy to resolve. If a problem occurs with your printer, check each of the following:

- 1) If a message is displayed on the LCD of operator panel, see "2.3 Status Code List" or "2.4 LSCD Display".
- 2) The printer power cable is plugged into the printer and a properly grounded electrical outlet.
- 3) The printer power is ON.
- 4) The electrical outlet is not turned off at any switch or breaker.

- 5) Other electrical equipment plugged into the outlet is working.
- 6) All options are properly installed.
- 7) If you have checked all of the above and still have a problem, turn off the printer, wait for 10 seconds, and then turn on the printer. This often solves the problem.

1.5.2 Display Problems

- 1) If the operator panel displays only diamonds or is blank, check and try the action below.
 - a) Turn off the printer, wait for 10 seconds, and turn on the printer.
 - b) Self Test Message appears on the operator panel. When the test is completed, "Ready to Print" is displayed.
- 2) If menu settings changed from the operator panel have no effect, check and try the actions below. Settings in the software program, the printer driver, or the printer utilities are overriding the settings made on the operator panel.
 - a) Change the menu settings from the printer driver, the printer utilities, or the software program instead of the operator panel.
 - b) Disable the settings in the printer driver, the printer utilities, or the software program so you can change settings on the operator panel.

1.5.3 Printing Problems

- 1) If a job did not print correct or incorrect characters were printed, check and try the actions below.
 - a) Make sure "Ready to Print" appears on the operator panel before sending a job to print. Press **Menu** to return to "Ready to Print".
 - b) Make sure print media is loaded in the printer. Press **Menu** to return to "Ready to Print".
 - c) Verify that you are using the correct printer driver.
 - d) Make sure you are using the correct Ethernet or USB cables and it securely connected at the back of the printer.
 - e) Verify that the correct print media size is selected.
 - f) If using a print spooler, verify that the spooler has not stalled.
 - g) Check the printer interface from the "Configure" menu. Determine the host interface you are using. Print a Panel Setting page to verify that the current interfaces settings are correct.
 - h) Output fonts will not print correctly using the PCL driver in its default mode. To correct this problem, use PostScript driver when using the PCL driver.
- 2) If secure print is not available or not printing, refer to the requirements below.
 - a) Minimum 256 MB is required.
 - b) RAM Disk must be enabled using the operation panel.
 - c) The number of secure print jobs your printer can store is dependent on the job size including number of pages, graphics, color attributes, and the amount of memory installed. To decrease this number, add additional memory.
- 3) If print media misfeeds or multiple feeds occur, check and try the actions below.
 - a) Make sure the print media you are using meets the specifications for your printer. Refer to "**1.5.4 Print Media Guidelines**".
 - b) Flex print media before loading it any of the sources.
 - c) Make sure the print media is loaded correctly.
 - d) Make sure the width and length guides on the print media sources are adjusted correctly.
 - e) If the print media are overfilled in sources, reduce the amount of media.

- f) Load the recommended print side correctly for the type of print media you are using.
 - g) Turn the print media over or around and try printing again to see if feeding improves (especially thickness).
 - h) Check the print media type loaded in the source, and refill only one type of print media, if print media types are mixed.
 - i) Refill a new ream of print media, if some reams are mixed.
 - j) Remove the top and bottom sheets of a ream before loading the print media.
 - k) Load a print media source only when it is empty.
- 4) If envelope misfeeds or multiple feeds occur, check and try the action below.
 - a) Remove the stack of envelopes from the multiple purpose feeder (MPF).
 - b) Try to load the single envelope to the multiple purpose feeder (MPF).
 - 5) If page breaks in unexpected places, check and try the action below.
 - a) Check the "Job Timeout" in the Basic Settings menu and increase the setting.
 - 6) If a job prints from the wrong source or on the wrong print media, check and try the action below.
 - a) Check the "Paper Size" and "Paper Type" in the Tray Settings menu on the printer operator panel and in the printer driver.

1.5.4 Print Media Guidelines

Print media is paper, transparencies, labels, envelopes, coated paper among others. Your printer provides high-quality printing on a variety of print media. Selecting the appropriate print media for your printer helps avoid printing troubles. This section describes how to select print media, how to care for print media, and how to load the print media in the optional 250-sheet tray module or 550-sheet tray module.

Paper

For the best print quality in color, use 75 g/m² (20 lb.) xerographic, grain long paper. For the best print quality in black and white, use 90 g/m² (24 lb.) xerographic, grain long paper. Before buying large quantities of any print media, Dell recommends trying a sample first.

When loading paper, identify the recommended print side on the paper package, and load the paper accordingly. See "Loading Print Media in Optional Trays" and "Loading the Multipurpose Feeder" for detailed loading instructions.

Paper Characteristics

The following paper characteristics affect print quality and reliability. Dell recommends that you follow these guidelines when evaluating new paper stock.

Weight

The tray automatically feeds paper weights from 60 to 216 g/m² (16 to 57.6 lb. bond) grain long. The multipurpose feeder automatically feeds paper weights from 60 to 216 g/m² (16 to 56 lb. bond) grain long. Paper lighter than 60 g/m² (16 lb.) might not be stiff enough to feed properly, and could cause paper jams. For best performance, use 75 g/m² (20 lb. bond) grain long paper.

Curl

Curl is the tendency of print media to curve at its edges. Excessive curl can cause paper feeding problems. Curl usually occurs after the paper passes through the printer, where it is exposed to high temperatures. Storing paper unwrapped in humid conditions, even in the paper tray, can contribute to paper curling prior to printing and cause feeding problems.

Smoothness

The degree of paper smoothness directly affects print quality. If the paper is too rough, the toner does not fuse to the paper properly, resulting in poor print quality. If the paper is too smooth, it can cause paper feeding problems. Smoothness between 150 and 250 Sheffield points produces the best print quality.

Moisture Content

The amount of moisture in the paper affects both print quality and the ability of the printer to feed the paper properly. Leave the paper in its original packaging until you are ready to use it. This limits the exposure of the paper to moisture changes that can degrade its performance.

Grain Direction

Grain refers to the alignment of the paper fibers in a sheet of paper. Grain is either grain long, running the length of the paper, or grain short, running the width of the paper. For 60 to 135 g/m² (16 to 36 lb. bond) paper, grain long fibers are recommended. For papers heavier than 135 g/m² (36 lb. bond), grain short is preferred.

Fiber Content

Most high-quality xerographic paper is made from 100% chemically pulped wood. Paper containing fibers such as cotton possess characteristics that can result in degraded paper handling.

Recommended Paper

To ensure the best print quality and feed reliability, use 75 g/m² (20 lb.) xerographic paper. Business papers designed for general business use also provide acceptable print quality.

Always print several samples before buying large quantities of any type of print media. When choosing any print media, you should consider the weight, fiber content, and color.

The laser printing process heats paper to high temperatures of 225°C (437°F) for Magnetic Ink Character Recognition (MICR) applications, and 205°C (401°F) for non-MICR applications. Only use paper able to withstand these temperatures without discoloring, bleeding, or releasing hazardous emissions. Check with the manufacturer or vendor to determine whether the paper you have chosen is acceptable for laser printers.

Unacceptable Paper

The following paper types are not recommended for use with the printer:

- 1) Chemically treated papers used to make copies without carbon paper, also known as carbonless papers, carbonless copy paper (CCP), or no carbon required (NCR) paper
- 2) Preprinted papers with chemicals that may contaminate the printer
- 3) Preprinted papers that can be affected by the temperature in the printer fuser
- 4) Preprinted papers that require a registration (the precise print location on the page) greater than ±0.09 in., such as optical character recognition (OCR) forms

In some cases, you can adjust registration with your software program to successfully print on these forms.

- 5) Coated papers (erasable bond), synthetic papers, thermal papers
- 6) Rough-edged, rough or heavily textured surface papers or curled papers
- 7) Recycled papers containing more than 25% post-consumer waste that do not meet DIN 19 309
- 8) Multiple-part forms or documents
- 9) Label paper with Cut

Selecting Paper

Proper paper selection helps prevent jams and ensures trouble-free printing.

To help avoid jams or poor print quality:

1. Always use new, undamaged paper.
2. Before loading the paper, identify the recommended print side of the paper. This information is usually indicated on the paper package.
3. Do not use paper that you have cut or trimmed yourself.
4. Do not mix print media sizes, weights, or types in the same source. This may result in a paper jam.
5. Do not remove trays while a job is printing or Printing is displayed on the operator panel.

6. Make sure the Paper Type and Paper Size settings are correct.
7. Make sure the paper is properly loaded in the tray.
8. Flex paper back and forth, and then fan them. Straighten the edges of the stack on a level surface.
9. When curl is excessive, with plain paper, turn it over and reset it.

Identifying Print Media Sources and Specifications

The following tables provide information on standard and optional print media sources.

Print Media Sizes and Support Y: Yes N: No

	Multipurpose Feeder	250-sheet Tray	Optional 550-sheet Tray
A4	Y	Y	Y
A5	Y	Y	Y
B5	Y	Y	Y
Letter	Y	Y	Y
Folio (8.5 x 13 in.)	Y	Y	Y
Legal (8.5 x 14 in.)	Y	Y	Y
Executive	Y	Y	Y
COM-10 envelope	Y	N	N
Monarch	Y	N	N
C5	Y	N	N
DL	Y	N	N
User-specified print media	Y	N	N

Print Media Supported Y: Yes N: No

	Multipurpose Feeder	250-sheet Tray	Optional 550-sheet Tray
Plain Paper Light (60-76gsm)	Y	Y	Y
Plain Paper Normal (80gms)	Y	Y	Y
Plain Paper Thick (82-98gms)	Y	Y	Y
Covers Normal (106-163gms)	Y	Y	Y
Covers Thick (164-216gms)	Y	Y	Y
Transparency	Y	N	N
Labels	Y	Y	Y
Coated Normal (106-163gms)	Y	Y	Y
Coated Thick (164-216gms)	Y	Y	Y
Envelope	Y	N	N
Recycled Paper	Y	Y	Y

1.5.5 ADF Media Guidelines

Although ADF accepts various types of originals, using inappropriate originals causes jam or damages the originals themselves.

Described in this section is a guideline for selecting originals suitable for ADF.

Recommended Originals

For ADF, cut sheets of plain paper are recommended.

Weight: 50 - 124g/m²

Minimum size: Main scanning direction: 148mm, sub-scanning direction: 210mm

Maximum size: Main scanning direction: 215.9mm, sub-scanning direction: 355.6mm

Special Originals

- 1) Special originals listed below can be fed via ADF, but are not guaranteed for image quality, jam rate, etc.
- 2) Thermal paper
- 3) Originals having too smooth surfaces (coated paper, etc.)
- 4) Originals having too rough surfaces.
- 5) Originals that are fresh from printing.
- 6) Pre-punched originals (loose-leaf paper, etc.)
- 7) Originals that are folded (bi-fold, z-fold, etc.)
- 8) Any originals having holes, slits, or other openings, or having an irregular shape.

Unacceptable Originals

Unacceptable originals listed below cannot be fed via ADF. Using these originals causes a jam, damages the originals themselves, or renders ADF out of order or damaged.

- 1) Originals bound with staples, clips, and others.
- 2) Originals on which paper slips or tapes are stuck.
- 3) Photograph
- 4) Transparency film
- 5) Originals on which oily or glue-like substance is stuck .
- 6) Originals whose curl height is 10mm or more and whose ratio between the curl height and curl length is 1/4 or more.
- 7) Originals whose fold is 5mm or more in height and 20mm or less in length.
- 8) Originals whose weight is less than 50g/m², or 124g/m² or more.
- 9) Any originals other than the recommended originals and special originals described above.

2. Installing Fax Machine

Plugging in the telephone cable is not enough to render a fax machine ready for use. Various settings are required depending on the subscriber's environment including line type, phone system (home use or corporate use), and telephone service contract with the telephone company. You should also note that a line that shows no problem with a telephone or PC fax/modem may not function successfully with a fax machine. This section describes items to be checked before installing a fax machine and how to configure the fax properly for the telephone line.

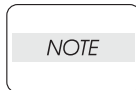

Before installing a fax machine, remove all other devices connected on the telephone line such as PC, Voice Mail devices, etc. After the fax installation is complete, connect them according to the User's Guide.

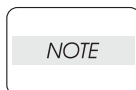

Some devices may not function after a fax is added on the line. For details, refer to the User's Guide.

2.1 Items to be checked before installation

Checking the telephone line

There are three types of telephone line: touch tone dialing, pulse dialing (10PPM), and pulse dialing (20PPM). To check the line type, confirm the setting via the fax menu and actually dial a number using the multifunction printer's dialer or another telephone.

Check whether the line is an analog subscriber line directly connected to the PSTN (Public Switched Telephone Network) or an extension line of an in-house phone system (so-called PBX). When, in some cases, a fax call cannot be relayed to the public telephone network via an in-house phone line, prepare a new analog public telephone line.



When your telephone line is part of a digital subscriber network (DSL, ISDN, etc.), it cannot be directly connected to a fax machine (must be connected via a terminal adapter, etc.).



When your line is one of the following, a transmission/reception error may occur.

A line connected to PC fax/modem, other fax machine, cordless telephone, credit card terminal, and data modem (A line conflict may occur).

A line provided with a service for screening out or intercepting unwanted calls (Voice Mail, Privacy Block, Security Screen, Anonymous Call Rejection, Privacy Manager, etc.).

2.2 Menus to be configured at installation

NOTE

When you forgot the Admin password, you can initialize the password by powering on the printer while pressing the Menu key. Since the initialization also resets all other settings, remember to write down the settings before performing this procedure.

Required Setting Items

Printer Menu	Menu Content (Default item is underlined)
Line Type	Line type setting * <u>PSTN</u> : Public Switched Telephone Network * PBX: Private Branch Exchange
Dialing Type	Dialing type setting * <u>PB</u> : Pushbutton (touch tone) dialing * DP(10PPS): Pulse dialing at 10PPS * DP(20PPS): Pulse dialing at 20PPS
Ans Select	Answering mode selection * TEL Mode: You must receive a fax manually * FAX Mode: The multifunction printer receives a fax automatically * <u>TEL/FAX Mode</u> : The multifunction printer automatically switches between an external telephone and the fax reception mode. * Ans/FAX Mode: The multifunction printer automatically switches between an external answering machine and the fax reception mode. * DRPD Mode: Available when DRPD service is provided with your telephone line.
Country	Selection of the country where the multifunction printer is used. (Selectable from 29 countries including the United States) Canada, Colombia, Mexico, Puerto Rico, <u>United States</u> , Algeria, Austria, Belgium, Denmark, France, Germany, Ireland, Italy, Liechtenstein, Luxembourg, Netherlands EU, Norway, South Africa, Spain, Sweden, Switzerland, United Kingdom, Egypt, Jordan, Russia, Saudi Arabia, Tunisia, Turkey, UAE
G3ID	Contains your telephone number, which is printed at the top of each page sent from your multifunction printer. This feature is available when you set Send Header to on, and must be set to on when you set DM Prevention to on.

Environment-specific setting

Printer Menu	Menu Content (Default item is underlined)
DRPD Pattern	DRPD settings for fax detection to be configured when the Ans Select menu is set to DRPD (Distinctive Ring Pattern Detection). * <u>Disable</u> : Disable DRPD * Pattern 1 to 5: Register one of the DRPD patterns provided by your telephone company.

The settings described above are the minimum required settings for connecting a fax machine to the telephone line. Refer to the User's Guide for further settings.

NOTE

Using [Speed Dial] under [Phone Book] may cause communication errors. Avoid this option as much as possible.
When dialing with a prefix, a pause should be inserted between the prefix and the phone number.

2.3 Fax Troubleshooting

2.3.1 FIP at Installation/Relocation

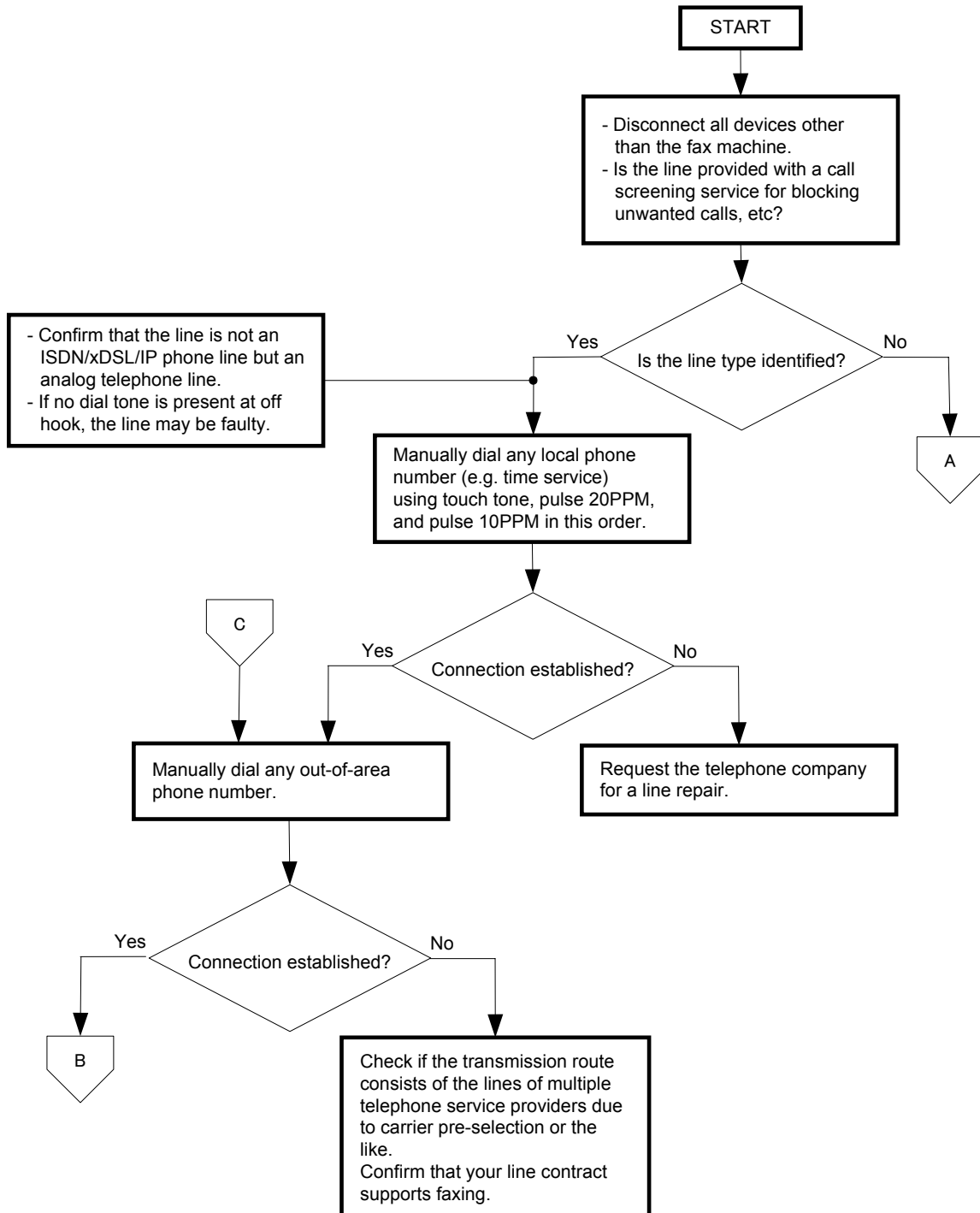

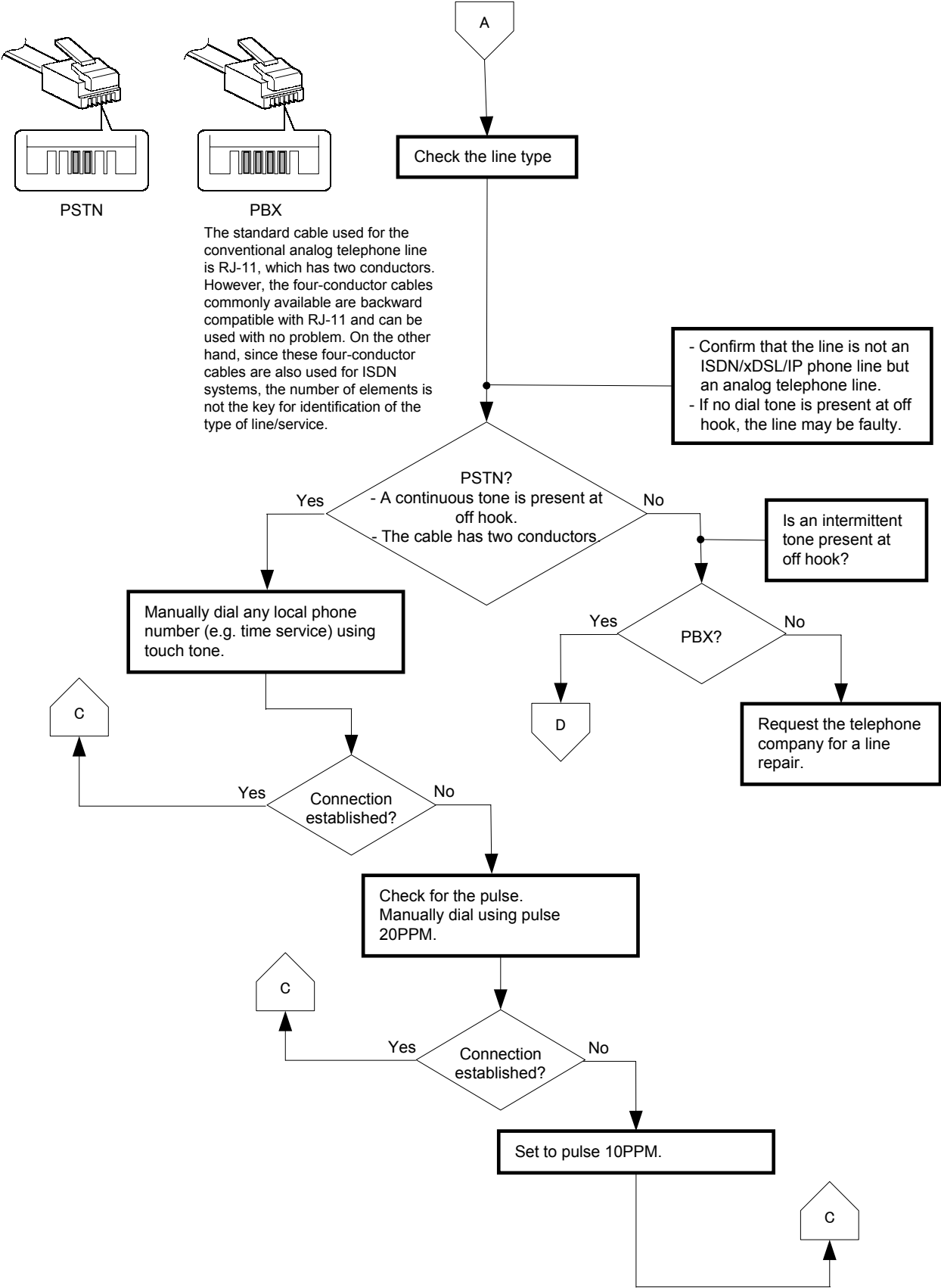

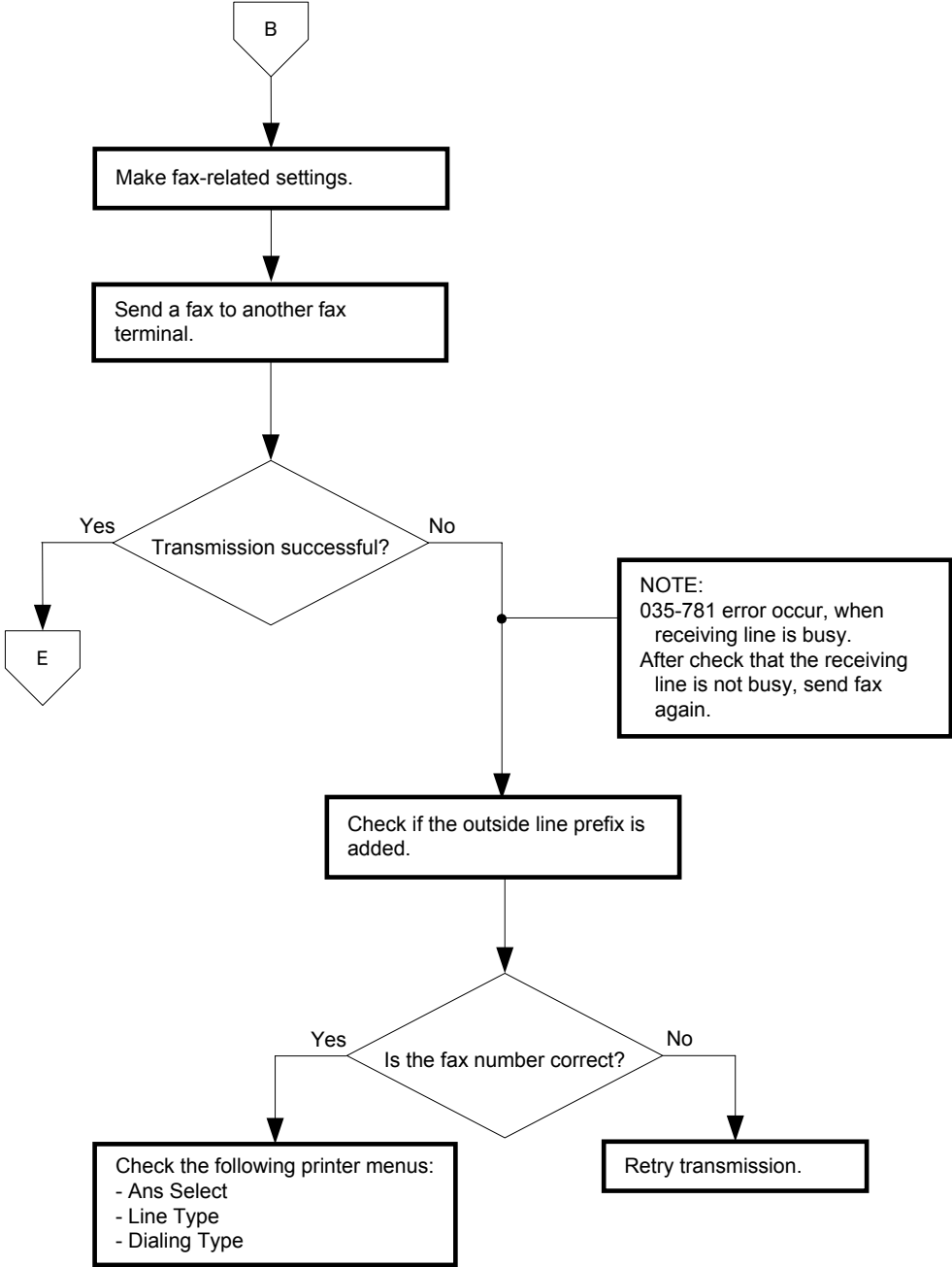

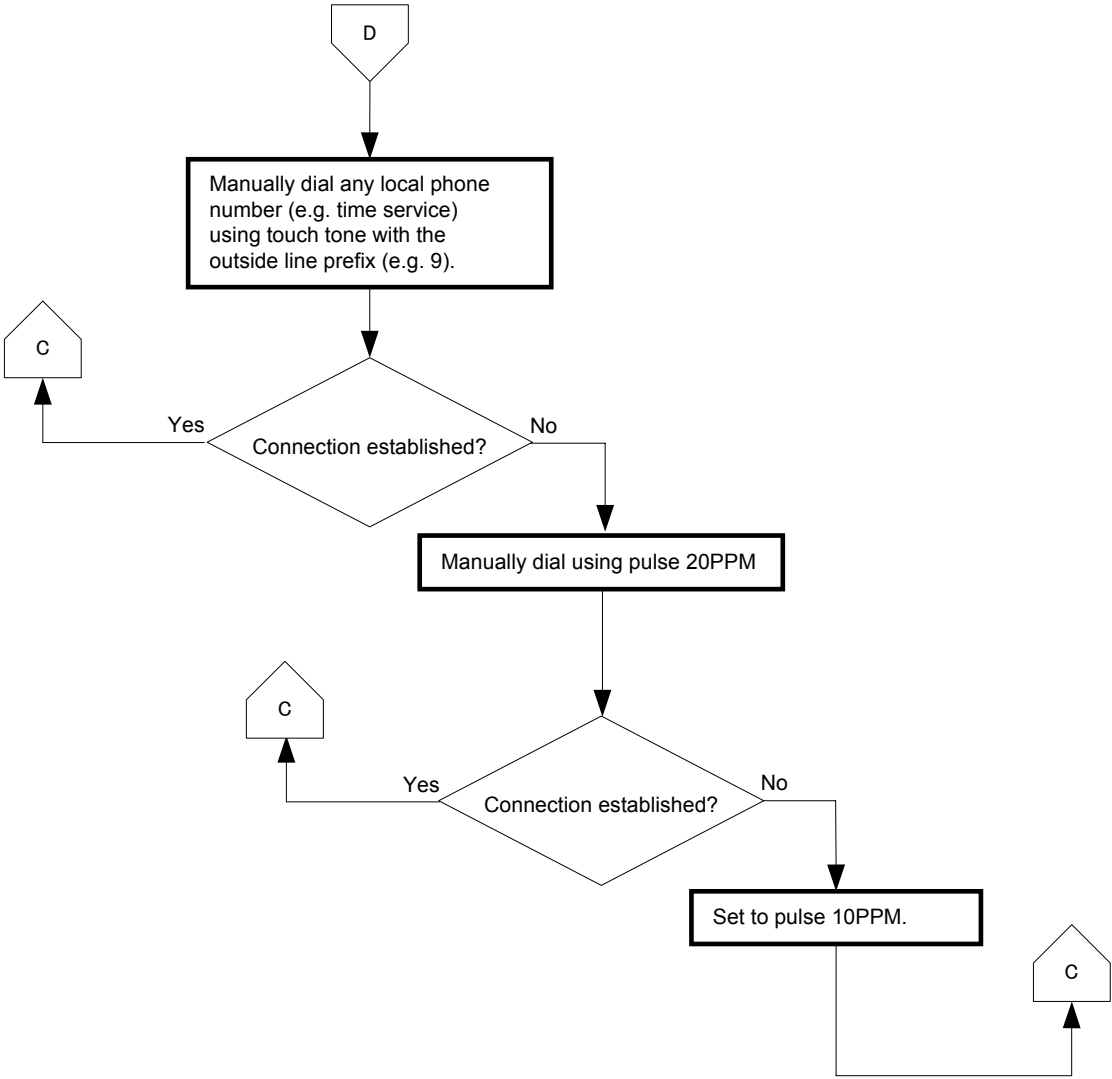

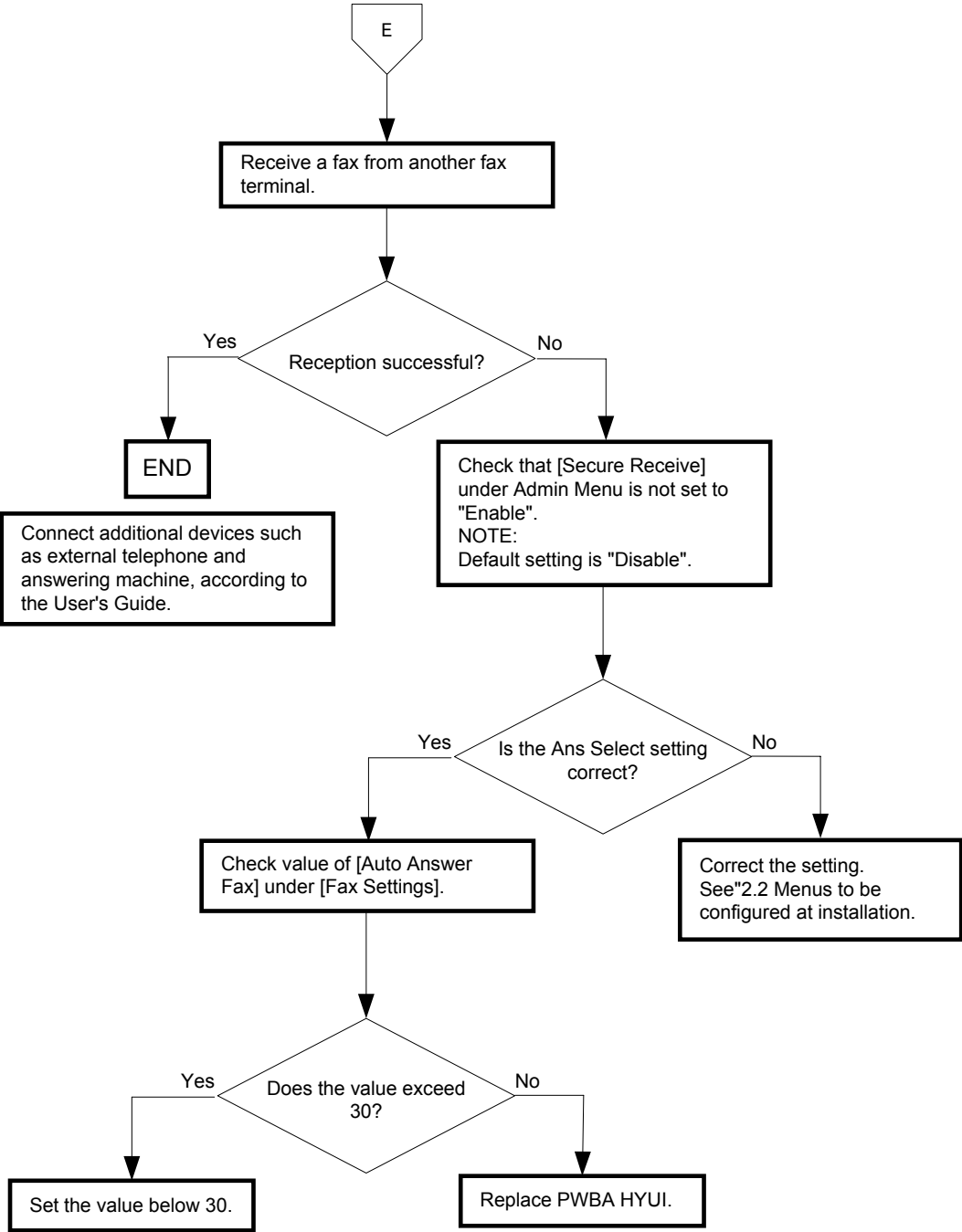

Connect additional devices such as external telephone and answering machine, according to the User's Guide.

2.3.2 FIP after Installation (when transmissions/receptions fail after continuous normal operation)

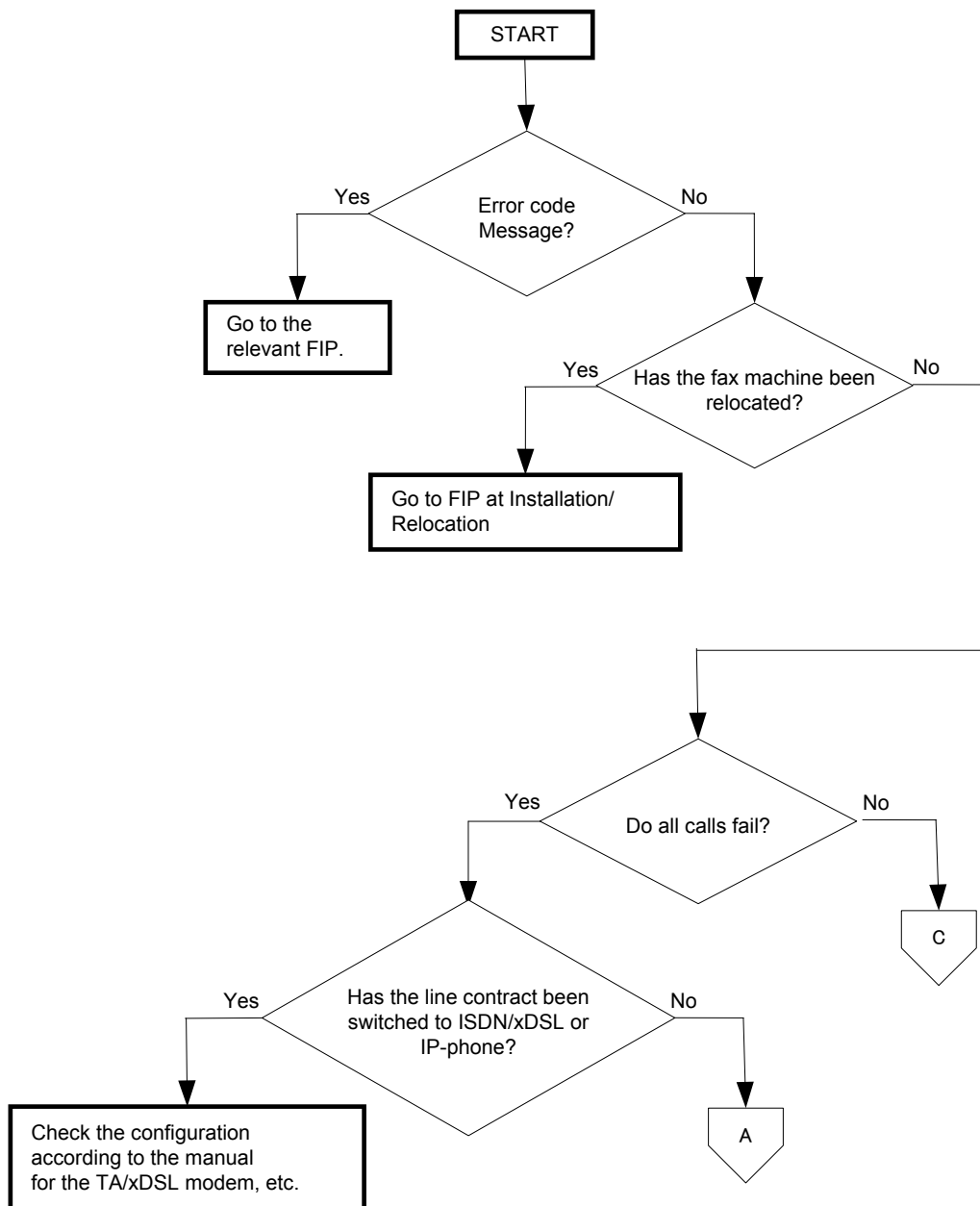

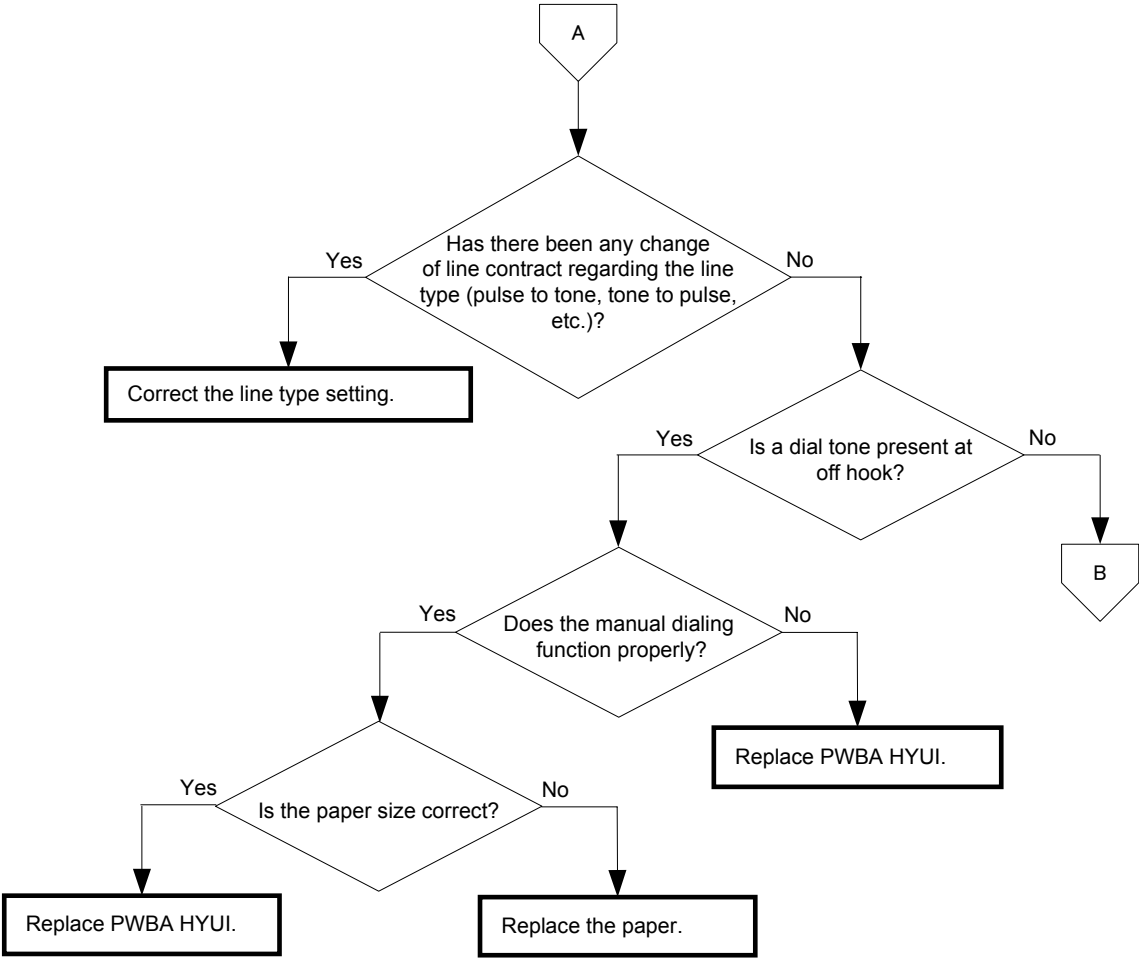

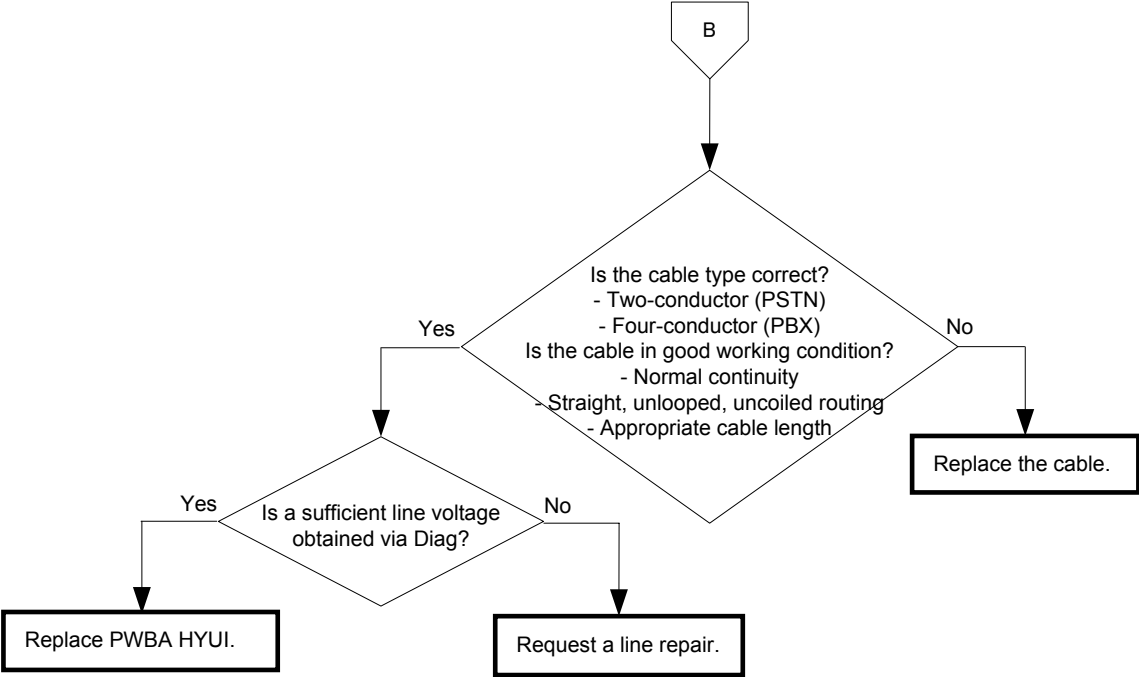

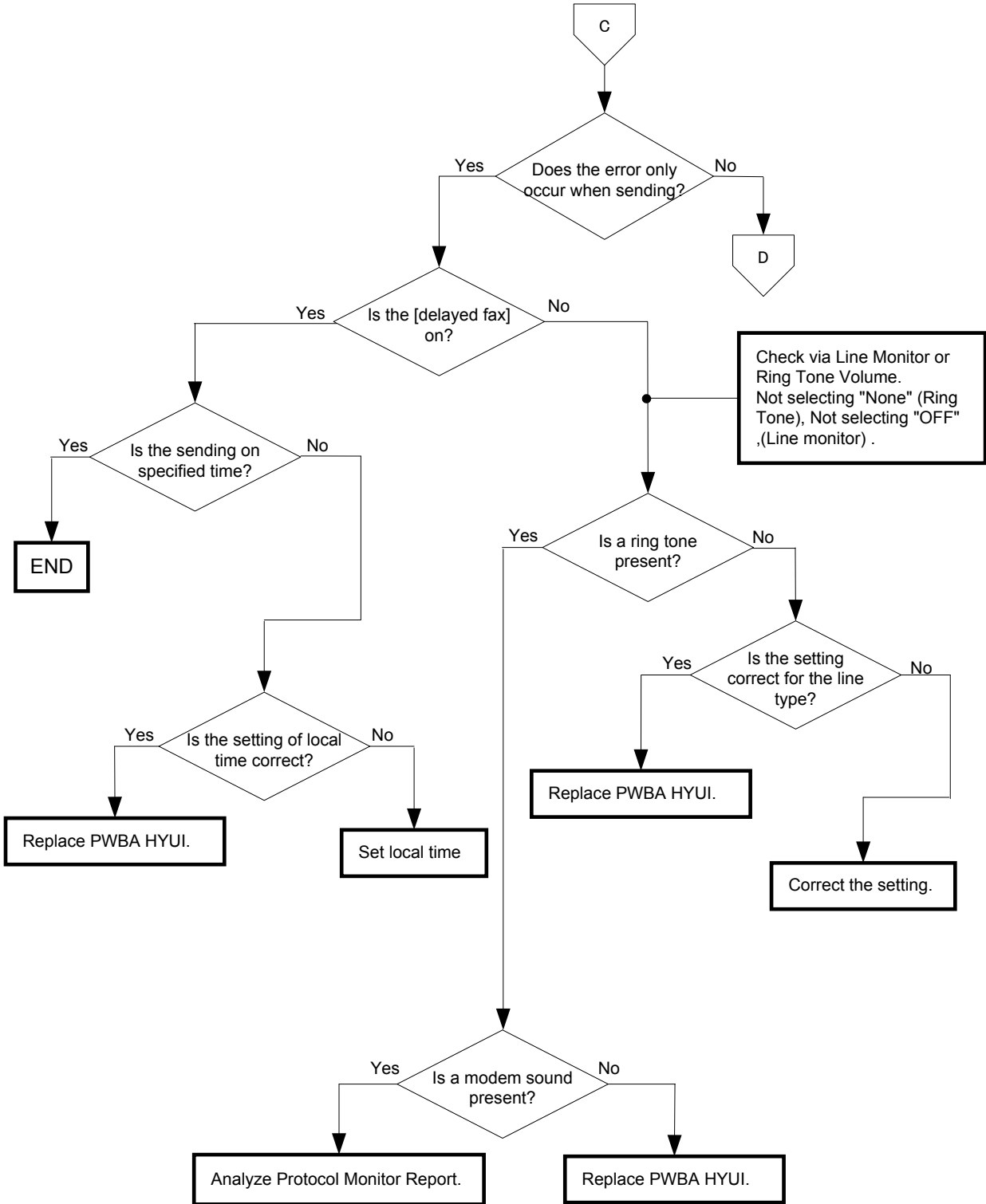

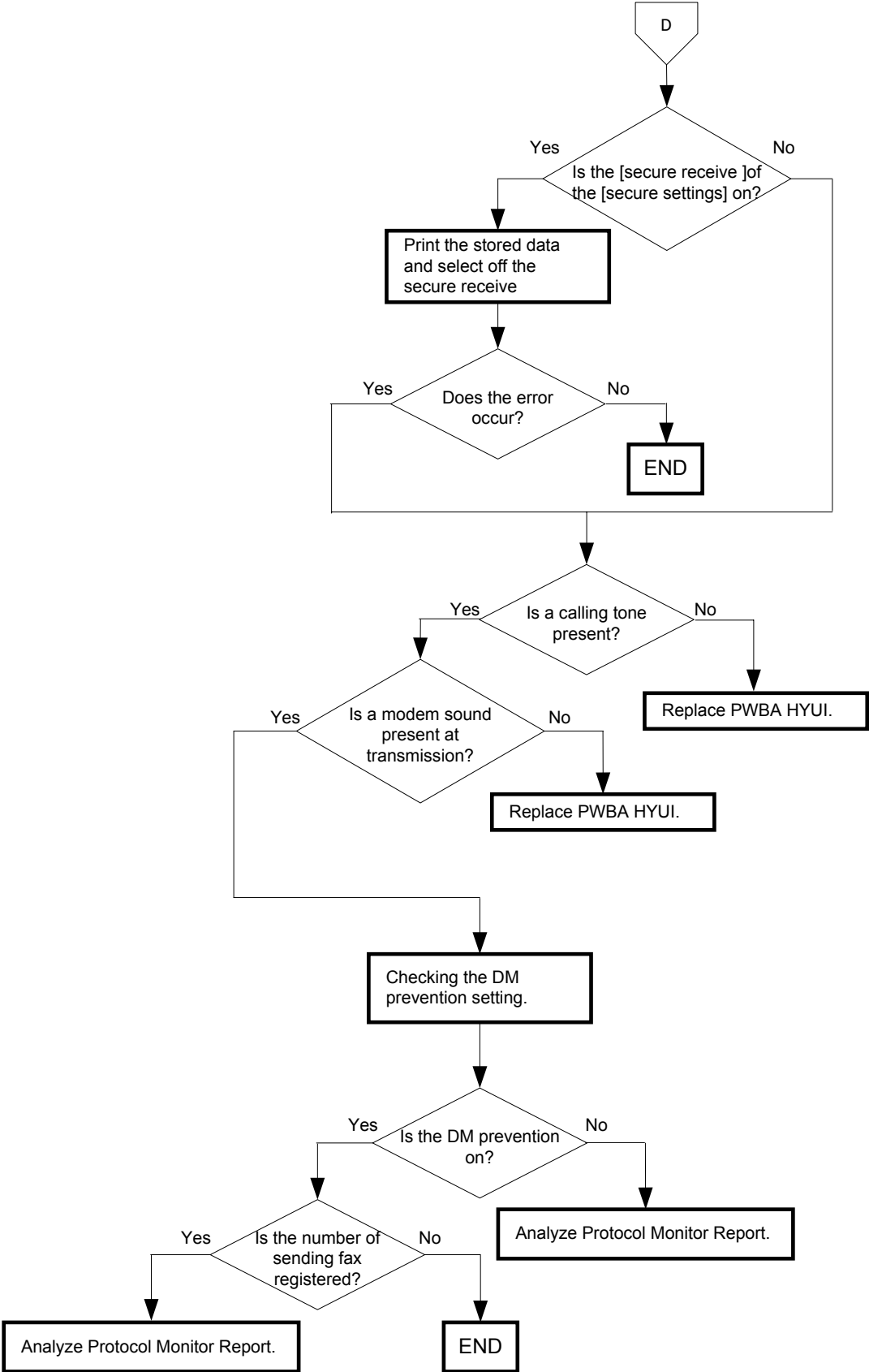

2.3.3 FIP for Color Fax

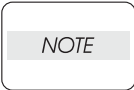

- When using Color FAX, there will be limitations as listed below.
- Color FAX cannot be used while receiving or transmitting a FAX.
 - When reading a document to be FAX transmitted in the platen mode, only one page can be transmitted.
 - If the FAX machine on the other party side is made by other supplier or other model of DELL, there may be a case that color transmission or color reception of FAX cannot be made.
 - In case an error occurs during Color FAX transmission, the process will be completed as is. There will be no retransmission.
 - Color FAX cannot be used by Direct FAX.
 - The data of Color FAX cannot be transferred to other parties.

Possible causative parts: PWBA HYUI (PL13.4.1)

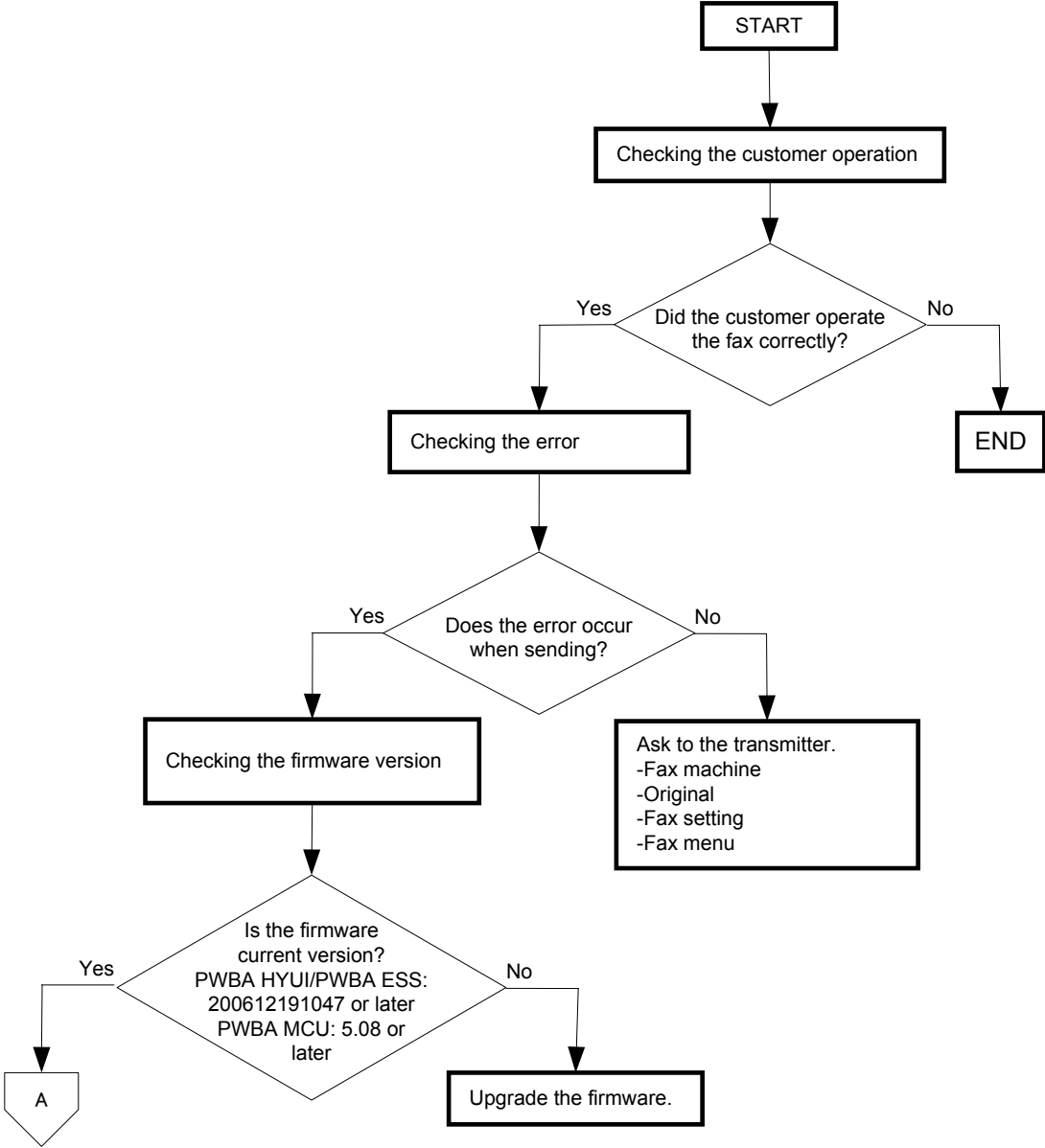

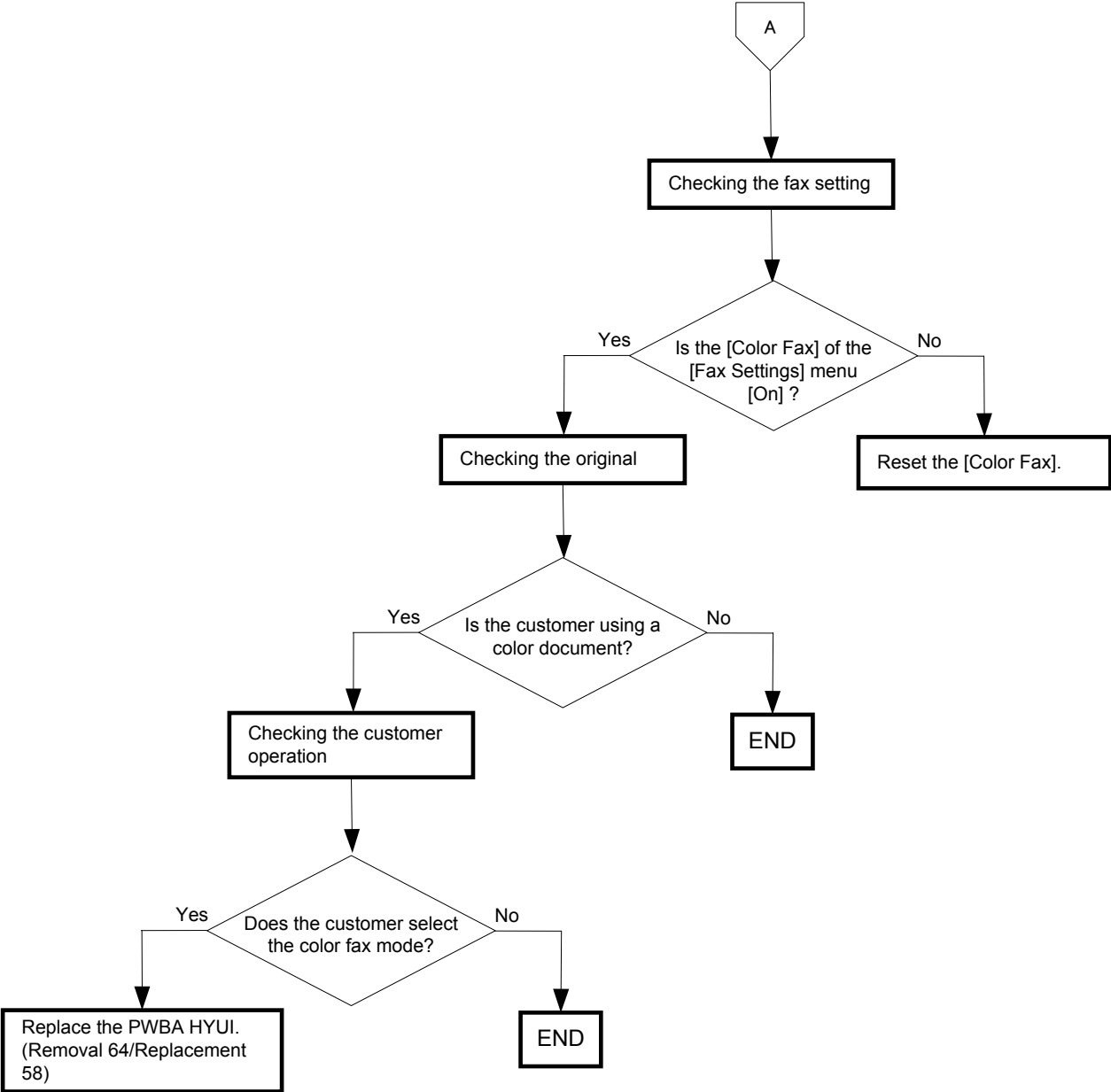

3. Fault Isolation Procedure for Fax

Because a fax machine is composed of multiple blocks, pinpointing a fault is problematic.

This section describes a quick fault isolation procedure.

3.1 Fault Occurs

First, try using the copy function. If satisfactory prints are obtained via the copy function, it is not likely that the fax itself is faulty. The fault is likely in the telephone line or the terminal at the other end. If the fault is in the telephone line, first retry sending. If there is no improvement, contact the telephone company. If the prints obtained via the copy function have problems, the next step is to determine whether the fault is in the scanner or printer by operating each unit separately via a computer.

3.2 Obtaining Printer Information

There are some printable menus available for checking the trouble information, firmware version, etc. The information thus available can be used for troubleshooting and are required when contacting the call center.

- Fax Activity Report

Allows you to check the time, destination station number, mode, or error absence/presence regarding fax transmission/reception.

Procedures

- 1) Select [Setup] > [Admin Menu], and enter the password.
- 2) Select [Admin report] > [Active report].
- 3) Execute [Active report].

This can indicate send mode is well.

Dell® MFP Laser 3115cn
Fax Activity Report

Page: 1 (Last Page)

Local Name: _____
Company Logo: _____

Horizon Inc

** Send **

No.	Job#	Remote Stat.on	Start time	Dura	Pages	Mode	Contents	Result
1	0767	7853624	01*28:09:31	16"	1/1	SG3		Done
2	0777	18437442007	10:26	2*47"	13/13	SG3		Done
Total 14								

** Received **

No.	Job#	Remote Stat.on	Start time	Dura	Pages	Mode	Contents	Result
1	0757	6153540	01*26:09:15	1*00"	1	KCM		Done
2	0758	SG3	09:16	10"	-	SG3		033-510
3	0759	757 kkkkkkk	09:16	21"	-	SG3		033-510
4	0760	843 kkk kkkk	09:21	15"	-	SG3		033-510
5	0761	SG3	09:21	16"	-	SG3		033-510
6	0762	757 kkkkkkk	09:22	28"	1	SG3		033-510
7	0763	843kkkkkkk	09:23	36"	2	SG3		Done
8	0764	910kkkkkkk	09:24	38"	1	KCM		Done
9	0765	843 kkk kkkk	09:26	23"	-	SG3		033-510
10	0766	757 kkkkkkk	09:27	25"	-	SG3		033-510
Total 25								

Can monitor the status history.

Can monitor the status history.

Dell® MFP Laser 3115cn
Fax Activity Report

Page: 1 (Last Page)

Local Name: _____
Company Logo: _____

** Send **

No.	Job#	Remote Stat.on	Start time	Dura	Pages	Mode	Contents	Result
1	0005	471kkkkkkkk	12*22:18:07	00"	-/2			Cancelled
2	0006	966kkkkkk	18:09	00"	-/2			Auto Resend
3	0006	966kkkkkk	18:11	00"	-/2			Cancelled
4	0007	966kkkkkk	18:13	00"	-/2			Auto Resend
5	0007	966kkkkkk	18:16	00"	-/2			Send Again
6	0009	966kkkkkk	18:33	00"	-/2			Auto Resend
7	0009	966kkkkkk	18:35	00"	-/2			Send Again
8	-	966kkkkkk	12*26:12:21	66"	-			Cancelled
9	0011	966kkkkkk	13:42	00"	-/2			Resend
10	0011	7966kkkkkk	13:45	00"	-/2			Cancelled
Total 0								

** Received **

No.	Job#	Remote Stat.on	Start time	Dura	Pages	Mode	Contents	Result
1	0002	Dell Inc	12*21:16:12	22"	2	SG3		Done
2	0003	716kkkkkkk	16:44	22"	2	SG3		Done
3	0004	716 kkk kkkk	12*21:13:01	1*31"	2	SG3		Done
Total 6								

- System Setting

Allows you to check the setting values, software version, etc.

Especially, the firmware version is required for troubleshooting with the call center.

Procedures

- 1) Select [Setup] > [Reports] > [System Settings].
- 2) Execute [System Settings].

FM version

Dell® MFP Laser 3115cn
System settings

Page:1 (Last Page)

General

Printer Name	DELL42961F	Port Status	UDP	Enable
Service Tag	13DG981	E-Mail Alert	Port Status	Enable
Asset Tag Number	1666Pages	EMS	Port Status	Enable
Total Impressions	2587Pages	IP Filter		off
Color Impressions	1430 Pages			
Black Impressions	0927110697			
Serial Number	1298B			
Memory Capacity				
Printer Language				
PCL5	200405291421			
PCL6	200606291423			
PostScript				
Members of Fonts Available				
PCL	RomanAIFonts			
PostScript	Roman136Fonts			
PostScript Version	1015.103			
PostScript serial number	37439416			
Firmware Version	200610021008			
Boot Version	200606081411			
Engine Version	05.06.00			
IOS (v.04.00)				
PostScript CRD Version	200607271136			
IIT Version	200608021702			
IPP Version	200610011602			
Default Paper	Letter			
Default Plain	Normal			
Default Label	Normal			
Default Language	English			

Printer Options

Paper Tray	Tray 1.NPP
------------	------------

Print Volume

Letter	1666Pages
B5	0Pages
A5	0Pages
A4	0Pages
Executive	0Pages
8.5 x 13"	0Pages
Legal	0Pages
Envelope #10	0Pages
Monarch	0Pages
DL	0Pages
C5	0Pages
Others	0Pages

Wired Network

Firm Version	5.15
(Onboard NIC)	
MAC Address	08.00.17.42.36.11
Ethernet	Unknown (Auto)
TCP/IP	
Get IP Address	pane)
IP Address	192.168.1.112
Subnet Mask	255.255.255.0
Gateway Address	192.168.1.1
Status	Ready

Can confirm if connected with network. IP address will vary in case of DHCP.

- Error History Report

Allows you to check the history of errors occurred on the printer.

Procedures

- 1) Select [Setup] > [Reports] > [Error History].
- 2) Execute [Error History].

Dell® MFP Laser 3115cn
Error History Report

Page:1 (Last Page)

System Fail History

No.	Total print Count	Chain-Link
1	3	016-300 0x08000014 0x40081890 200610021008
2	3	016-300 0x18000028 0x40080868 200610021008

Paper Jam History

Can monitor the status history.

3.3 Transmission Fault

1) Problem with printing quality at the receiving fax, such as corrupt image, lines in image, top/bottom cut off.

a) If copy function is normal

Cause: Degraded telephone line connection caused by noise, etc.; or a fault in the receiving fax's printer.

Corrective Action: Determine whether the fault is in the telephone line or at the receiving fax by trying copy function at the receiving fax.

NOTE

If the telephone line condition is degraded, white horizontal lines, missing rows, and/or top/bottom cut-off may occur.

NOTE

Branch connections or incoming call (call waiting) may also cause image corruption.

b) If copy function is faulty

Cause: Dirt or fault in scanner.

Corrective Action: Clean the platen glass or repair the scanner. If the original was sent from the ADF, try executing a copy with the original placed on the platen glass. If this solves the problem, the fault is in the ADF.

2) Cannot dial

Cause: Incorrect connection. Incorrect setup of dial type and/or line type.

Corrective Action: Correct the connection. Reset the dial type and/or line type to correct settings.

3.4 Reception Fault

1) Cannot receive

a) Answering mode is incorrect.

Cause: The answering mode is set to "TEL Mode". (Panel Menu: Fax Settings > Ans Select)

Corrective Action: Change the answering mode to any mode other than "TEL Mode".

b) Fax memory is full.

Cause: An attempt was made to send document data in excess of the available memory capacity.

Corrective Action: On the receiving side, wait until the current fax job is printed completely.

On the sending side, wait until the current fax job is sent out completely.

c) Printer displays some fault message.

Cause: A fault occurred in the printer.

Corrective Action: Solve the fault.

d) Distinctive ring pattern detection fails.

Cause: The distinctive ring pattern set for the DRPD mode is incorrect (applicable only in USA and Canada).

Corrective Action: Check the ring patterns provided by the telephone service provider, and select the correct pattern for fax.

e) Cannot detect CNG signal.

Cause: The communication fails in TEL/FAX mode or Ans/FAX Mode.

Corrective Action: Ground the printer properly.

f) Cannot detect off-hook.

Cause: Fails to detect off-hook in Ans/FAX mode.

Corrective Action: Set [Extel Hook Thresh] to "higher". A detection of an off-hook can be checked by the change of panel display upon the off-hook of an external telephone.

2) Problem with printing quality, such as corrupt image, lines in image, top/bottom cut off.

a) If copy function is normal

Cause: Degraded telephone line connection caused by noise, etc., or a fault in the sending fax's scanner.

Corrective Action: Determine whether the fault is in the telephone line or at the sending fax by trying copy function at the sending fax.

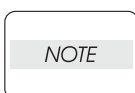

If the telephone line condition is degraded, white horizontal lines, missing rows, and/or top/bottom cut-off may occur.

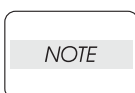

Branch connections or an incoming call (call waiting) may also cause image corruption.

b) If copy function is faulty

Cause: Dirt or fault in printer.

Corrective Action: Clean all parts of the printer or repair the printer.

3) No response signal sent

Cause: Incorrect connection. Incorrect reception mode.

Corrective Action: Correct the connection. Reset receive mode to correct settings.

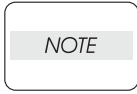

If a call is made to the fax from a telephone, and the fax does not emit its ringing sound, a telephone line fault is highly probable.

To check for a ring tone, an external telephone must be connected.

3.5 Understanding Protocol Monitor

3.5.1 Overview of Communication Protocol

In the context of information technology, a protocol refers to an agreed-upon set of special rules to be adhered to by endpoints attempting to establish a telecommunication connection.

The communication protocol for the G3 fax specifications is stipulated by an international specification known as ITU-T Recommendation T.30.

All G3 fax machines conform to this protocol when exchanging signals to establish a communication.

Outlined below is the flow of a typical G3 fax session of a one-page document.

The entire G3 fax session consists of the following five phases from “Phase A” to “Phase E”:

- Phase A: Call Establishment
- Phase B: Capability Negotiations
- Phase C: Image Data Transfer.
- Phase D: Post-transfer Procedure
- Phase E: Call Release

G3 Fax Session

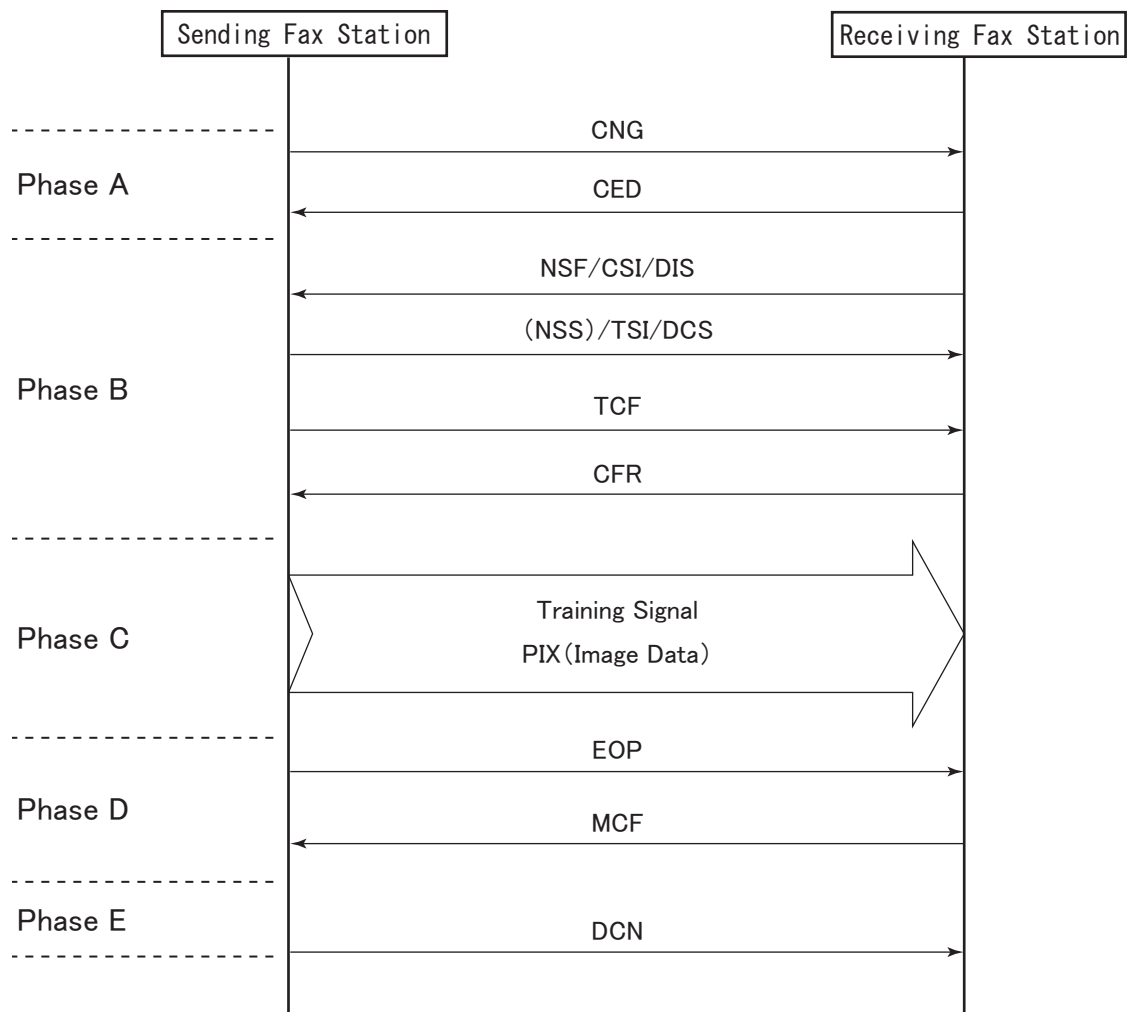

Gnb06029KA

Each phase is detailed below:

Phase A - Call Establishment

In order for a fax call to be established, both ends of the line must recognize that the other end is a non-voice (fax) terminal. Since G3 fax communication is intended for a transmission over the conventional voice network, a fax communication must be initiated via audible tones.

The sending side sends out a Calling Tone (CNG. 1100Hz for 0.5 sec.), which identifies itself as a fax terminal. Then, the receiving side responds with a Called Station Identification (CED. 2100Hz for 3 sec.) to identify itself as an available fax terminal. Thus, a fax call is established between the two terminals.

Phase B - Capability Negotiations

The receiving side presents all of the capabilities it has to offer by sending out NSF/CSI/DIS signals. Then, the sending side responds with NSS/TSI/DSC signals to declare what it has selected from the capabilities presented by the receiving side.

The sending side sends out a training signal (TCF) to adjust the modem to the maximum transmission rate available. Upon a successful reception of TCF, the receiving side responds with CFR, which indicates that the receiving side is ready for receiving image data. In the event of an anomalous TCF reception, the receiving side responds with FTT, which requests retransmission of NSS/TSI/DCS and TCF signals.

Phase C - Image Data Transfer

The sending side transmits the image data based on the parameters agreed upon in Phase B. Also carried out are the signaling control procedures including synchronization, error detection/correction, and line supervision.

Phase D - Post-transfer Procedure

In the post-transfer procedure, the sending side checks its status after the completion of Phase C and sends an appropriate signal to return the session to the previous phases. When there are more pages to follow, the sending side sends out MPS and the session returns to Phase C. When there are more pages to follow and the subsequent page is to be sent in a different mode, the sending side sends out EOM and the session returns to Phase B. The session proceeds to Phase E only when the receiving side receives EOP indicating that the sending side has completed transmission of the entire document. Therefore, the session may show a looped sequence such as ABCDCD . . . E, ABCDCDCDCD . . . E, etc., depending on the remainder of the document or the transmission parameters for the subsequent page.

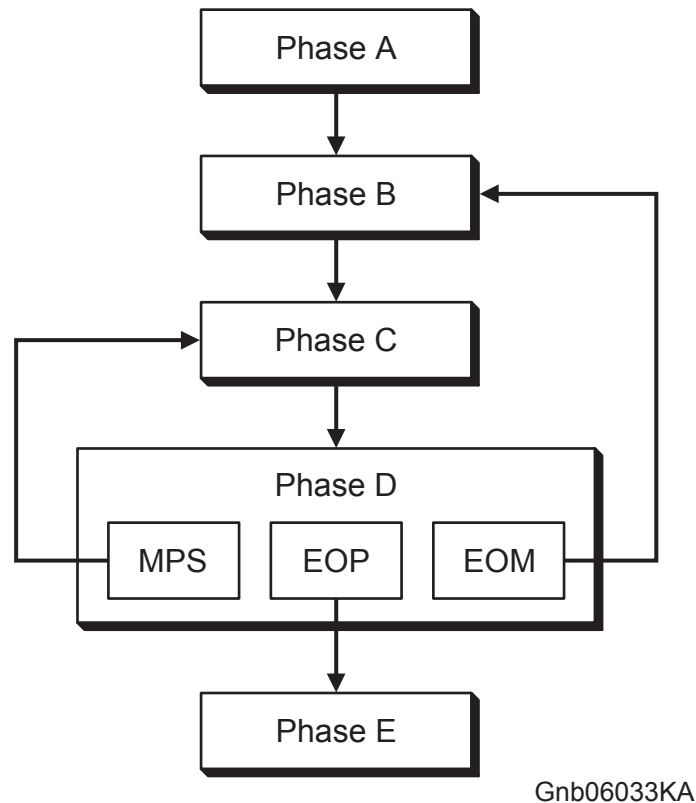

When the image data has been successfully received, the receiving side sends out MCF to prompt for subsequent image data transmission. When the received image data contains permissible errors, the receiving side responds with RTP. When unacceptable errors are detected, the receiving side responds with RTN.

To a signal requesting operator intervention, the receiving side responds with PIP when the image data has been received successfully. When the image data contains unacceptable errors, the receiving side responds with PIN. When retransmission is required in ECM* mode, the receiving side responds with PPR.

Phase E - Call Release

This phase terminates the entire fax session and releases the line. Before releasing the line, the sending side sends out DCN, which expects no response.

* ECM (Error Correction Mode)

A transmission method that manages the encoded data by dividing it in units called frames and by numbering them. In the event of image corruption due to noise, etc., image quality can be corrected by retransmitting only the corrupted units specified by number.

Multiple frames form a unit called block. One block transmitted, or multiple frames retransmitted are called partial page.

To use ECM mode, both the sending and receiving sides must have ECM feature.

Descriptions of Signals

Signal Name	Description
CNG (Calling Tone)	A signal sent out by the sending side to notify that the incoming call is a fax transmission. Upon detecting this signal, the receiving side starts the fax reception procedure.
CED (Called Station Identification)	A signal sent out by the receiving side as a response to an incoming call to notify that the receiving side is an available non-voice (fax) terminal, thereby allowing the sending side to determine that the call was successfully answered.
NSF (Non-Standard Facilities)	An optional signal sent out by the receiving side. Contains ITU member country code, manufacturer code, type code, and manufacturer-specific capabilities. The manufacturer-specific capabilities information is used to notify that the receiving side can offer some capabilities that are not covered by ITU-T T.30 and supported only between fax terminals of the same manufacturer, such as high-quality mode, high-speed mode, and proprietary ECM mode.
CSI (Called Subscriber Identification)	An optional signal sent out by the receiving side. Contains the receiving side's identification information such as an international telephone number. The sending side records this information as the destination station number in its communication results
DIS (Digital Identification Signal)	A signal that describes all of the G3-compliant capabilities of the receiving side. Contains transmission rate, sub-scanning line density, coding capability (MH/MR/MMR/JBIG), paper size (width/length), minimum transmission time per line, and ECM capability.
NSS (Non-Standard Set-up)	An optional signal sent out in response to NSF sent from the receiving side. Recorded only when the call is established in a manufacturer-specific mode.
TSI (Transmitting Subscriber Identification)	An optional signal sent out by the sending side. Contains the sending side's identification information such as an international telephone number.
DCS (Digital Command Signal)	A signal sent out by the sending side in response to DIS. Contains transmission parameters that the sending side selected from the receiving side's capabilities presented via DIS.
NSC (Non-Standard Facilities Command)	An optional signal sent out by the sending side to notify that the manufacturer-specific communication mode presented by the receiving side has been adopted for the current session. The information elements are the same as those of NSF.
CIG (Calling Subscriber Identification)	An optional signal sent out by the sending side. Contains the sending side's identification information such as an international telephone number. The information elements are the same as those of CSI.
DTC (Digital Transmit Command)	A signal sent out by the sending side, in response to the capability announcement via DIS, to make a polling request to the receiving side. The information elements are the same as those of DIS.
TCF (Training Check Frame)	A signal sent out by the sending side to determine the maximum acceptable transmission rate. Continuous "0"s are transmitted for 1.5 seconds \pm 10%. The data signaling rate is selected from 14400, 9600, 7200, 4800, 2400, and 1200.
CFR (Confirmation to Receive)	A signal sent out by the receiving side to notify that TCF was successfully received and that the receiving side is ready to receive the image data.
FTT (Failure to Train)	A signal sent out by the receiving side to notify that TCF was not received successfully ("1" was received). Upon detecting this signal, the sending side retransmits TCF. This is called "modem retraining." When the second retraining fails, the sending side retransmits TCF at a rate re-established by sending out DCS (NSS, CIG).

Signal Name	Description
PIX	A signal indicating that the image data is being transmitted.
EOP (End of Procedure)	A signal sent out by the sending side to notify that the entire document has been transmitted.
PRI-EOP or PEOP (Procedure Interrupt - End of Procedure)	An EOP signal that requires operator intervention.
MPS (Multi-Page Signal)	A signal sent out by the sending side to notify that one page has been sent and there are more pages to follow.
PRI-MPS or PMPS (Procedure Interrupt - Multi-Page Signal)	An MPS signal that requires operator intervention.
EOM (End of Message)	A signal sent out by the sending side to notify that one page of the document has been transmitted and that the subsequent page is to be transmitted using different parameters (image quality, etc).
PRI-EOM or PEOM (Procedure Interrupt - End of Message)	An EOM signal that requires operator intervention.
MCF (Message Confirmation)	A signal sent out by the receiving side to notify that the image data was successfully received and that the receiving side is ready to receive subsequent image data.
RTP (Retrain Positive)	A signal sent out by the receiving side to notify that the image data was successfully received and that modem retraining is required before receiving subsequent image data.
RTN (Retrain Negative)	A signal sent out by the receiving side to notify that the image data was not successfully received and that modem retraining is required before receiving subsequent image data.
DCN (Disconnect)	A signal sent out by the sending side to notify that the line is about to be released.
PPS (Partial Page Signal)	A signal sent out by the sending side in ECM mode to indicate the end of one block. Appears as one of the following depending on the sending side status.
PPS.NULL	A signal sent out by the sending side in ECM mode to notify that one of the blocks contained in the current page has been transmitted and there are more blocks to follow.
PPS.EOP	A signal sent out by the sending side in ECM mode to notify that the entire document has been transmitted.
PPS.PEOP	A PPS.EOP signal that requires operator intervention.
PPS.MPS	A signal sent out by the sending side in ECM mode to notify that one page of the document has been transmitted and there are more pages to follow.
PPS.PMPS	A PPS.MPS that requires operator intervention.
PPS.EOM	A signal sent out by the sending side in ECM mode to notify that one page of the document has been transmitted and that the subsequent page is to be transmitted using different parameters (image quality, etc).
PPS.PEOM	A PPS.EOM signal that requires operator intervention.
PPR (Partial Page Request)	A signal sent out by the receiving side in ECM mode to request for retransmission of a block that was not successfully received due to noise, etc. Contains the frame number (256 bit) of the target frame.

Signal Name	Description
EOR (End of Retransmission)	A signal sent out by the sending side in ECM mode to notify that the retransmission request (PPR) for the same block has been received for the predetermined number of times (typically four times) and that the sending side will discontinue the retransmission of the relevant block. Appears as one of the following depending on the sending side status.
EOR.NULL	A signal sent out by the sending side in ECM mode to notify that the retransmission request (PPR) for the same block has been received for the predetermined number of times and the sending side will discontinue the retransmission of the relevant block, but that the transmission of the subsequent block will be started.
EOR.EOP	A signal sent out by the sending side in ECM mode to notify that the retransmission request (PPR) for the same block has been received for the predetermined number of times and the sending side will discontinue the retransmission of the relevant block, but that the entire document has already been transmitted.
EOR.PEOP	An EOR.EOP signal that requires operator intervention.
EOR.MPS	A signal sent out by the sending side in ECM mode to notify that the retransmission request (PPR) for the same block has been received for the predetermined number of times and the sending side will discontinue the retransmission of the relevant block, but that one or more pages of the document will remain unsent.
EOR.PMPS	An EOR.MPS signal that requires operator intervention.
EOR.EOM	A signal sent out by the sending side in ECM mode to notify that the retransmission request (PPR) for the same block has been received for the predetermined number of times and the sending side will discontinue the retransmission of the relevant block, but that one page of the document has been transmitted and the subsequent page is to be transmitted using different parameters (image quality, etc).
EOR.PEOM	An EOR.EOM signal that requires operator intervention.
ERR (Response to End of Retransmission)	A signal sent out by the receiving side to notify that any EOR signal was received.
CTC (Continue to Correct)	A signal sent out by the sending side in ECM mode to notify that the sending side will continue to retransmit the requested block at a newly set signaling rate, as a response to the retransmission request (PPR) received for the same block for the predetermined number of times.
CTR (Response to Continue to Correct)	A signal sent out by the receiving side to notify that a CTC signal was received.
RNR (Receive Not Ready)	A signal sent out by the receiving side in ECM mode to request the sending side to hold on the image data transmission until the receiving side becomes ready for reception.
RR (Receive Ready)	A signal sent out by the sending side to notify that an RNR signal was received.
CRP (Command Repeat)	A signal sent out by the receiving side to notify that the previous signal was received in error and should be retransmitted.
PIP (Procedural Interrupt Positive)	A signal sent out by the receiving side to notify that the image data was successfully received but that further transmissions are not possible without operator intervention.
PIN (Procedural Interrupt Negative)	A signal sent out by the receiving side to notify that the image data was not received satisfactorily (detected unacceptable errors) and that further transmissions are not possible without operator intervention.

Signal Name	Description
CI (Call Indicator)	An optional signal defined in ITU-T Recommendation V.8. Sent out by the sending side to initiate a data transmission session defined in ITU-T Recommendation V.34.
ANSam (Modified Answer Tone)	An amplitude-modulated sinewave signal at 2100 Hz defined in ITU-T Recommendation V.8. Sent out by the receiving side to indicate that it supports CM/JM exchanges. If ANSam is detected, the sending side transmits no signal for a period (T_e) allowed for disabling of network echo-control equipment, and then sends out CM. Unless ANSam is detected, the sending side does not send out CM.
CM (Call Menu)	A signal defined in ITU-T Recommendation V.8. Sent out by the sending side when the interval T_e has elapsed, to indicate the required call function and available modulation modes.
JM (Joint Menu)	A signal defined in ITU-T Recommendation V.8. Sent out by the receiving side when a minimum of two identical CM sequences have been detected. If the call function indicated in CM is available on the receiving side, JM indicates the same call function as indicated in CM. If not, JM may indicate a different call function. JM also includes all modulation modes that are both indicated in CM and available on the receiving side. If the modulation modes indicated in CM do not match those available on the receiving side, the JM sequence includes the same number of modulation-mode octets as CM and shows zero for all modulation modes.
CJ (CM Terminator)	A signal defined in ITU-T Recommendation V.8. Sent out by the sending side when a minimum of two identical JM sequences have been detected. After sending out CJ, the sending side transmits silence for a predetermined period before proceeding to the next phase.

Arrow Symbol Semantics

Protocol Monitor displays various symbols in combination with arrows (--> / <--) depending on the communication status. Listed below are examples of symbols and their semantics. They may vary depending on the model.

Some models display simple arrows (→ / ←) without symbols in Protocol Monitor.

Signals sent:

Symbol	Semantics	Relevance to Dell 3115cn
-->	Normal.	Yes
-->	Underrun was detected at the MODEM.	No
-F>	STOP instruction was given during image data transmission.	No
-@>	FTT was forcefully sent out.	No

Signals received:

Symbol	Semantics	Relevance to Dell 3115cn
<--	Normal.	Yes
<x-	A CRC error was detected.	No
<#-	An aborted sequence was detected.	No
<!-	No carrier was detected for 1.5 seconds during image data reception.	No
<=-	No carrier was detected for 150 milliseconds during image data reception.	No
</-	FSK was detected during TCF signal reception.	No
<+-	An overrun was detected at the modem.	No
<A-	Failed to detect EOL during the 10-second timeout.	No
<B-	Buffer became full during image reception.	No
<C-	Failed to detect any normal line for 60 seconds during image data reception.	No
<D-	Failed to decode normal lines for 60 seconds after image data reception.	No
<E-	Interframe timeout occurred during image data reception in ECM mode.	No
<F-	STOP instruction was given during image data reception.	No

3.5.3 FIP Using Protocol Monitor Report Analysis

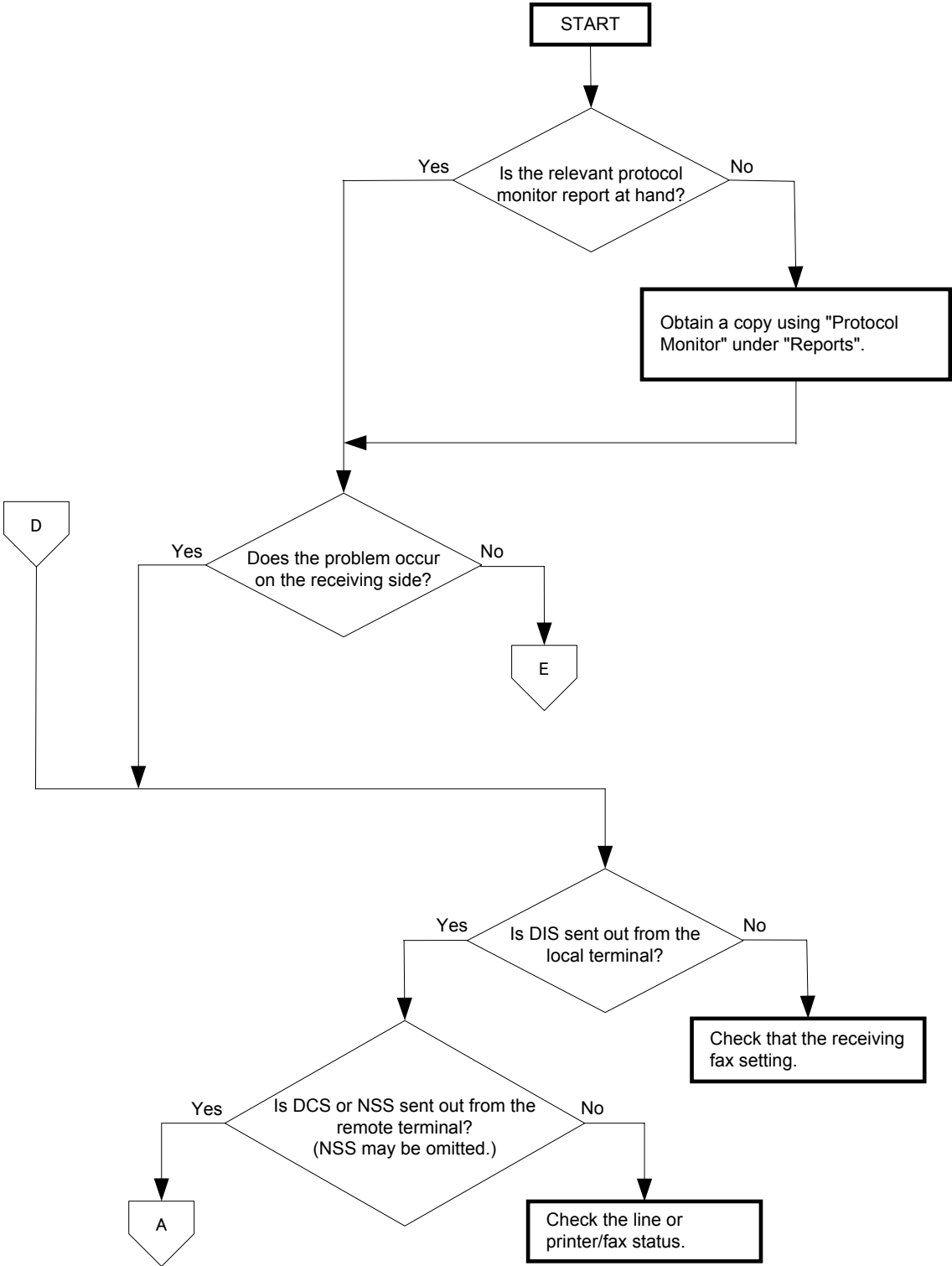

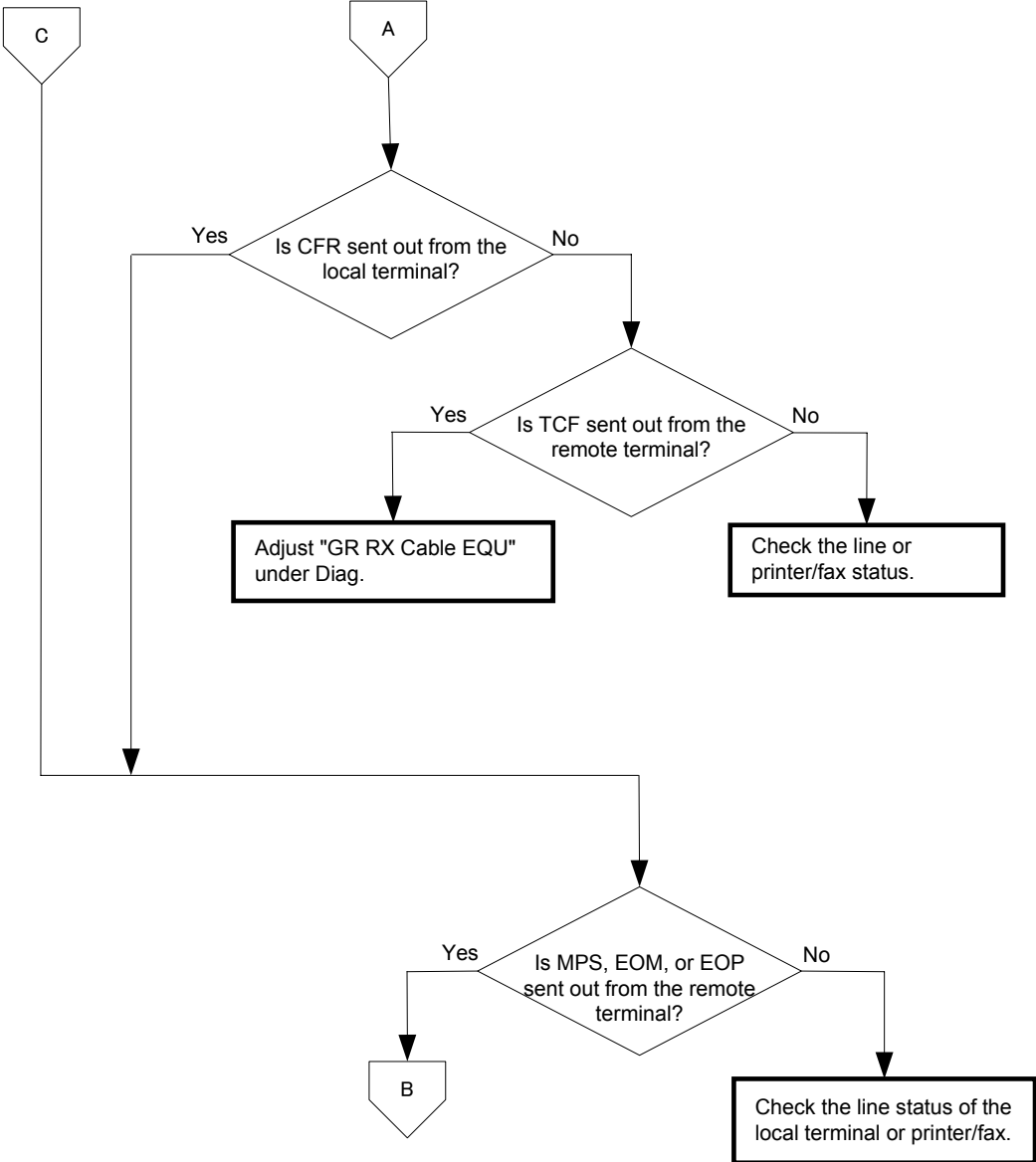

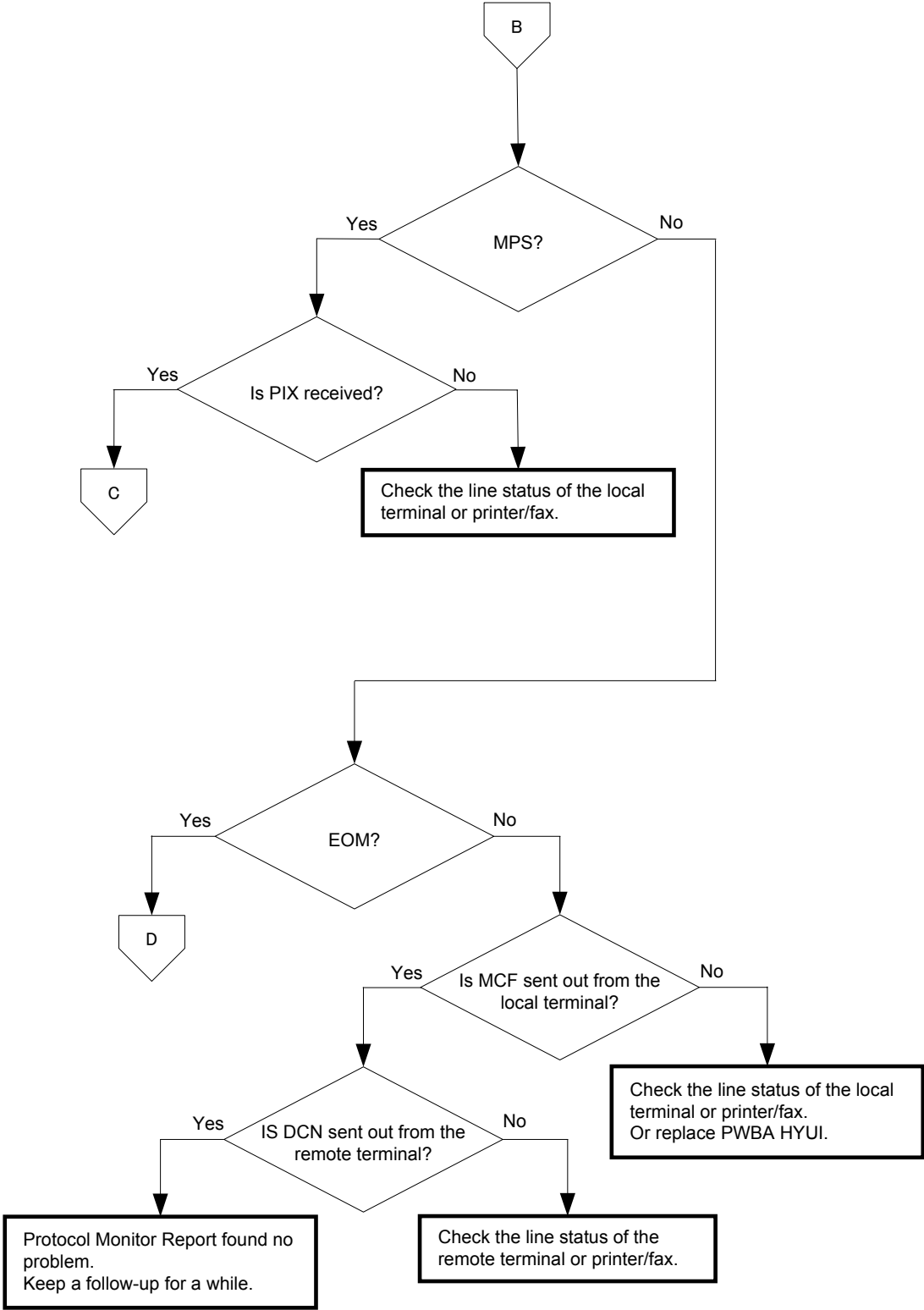

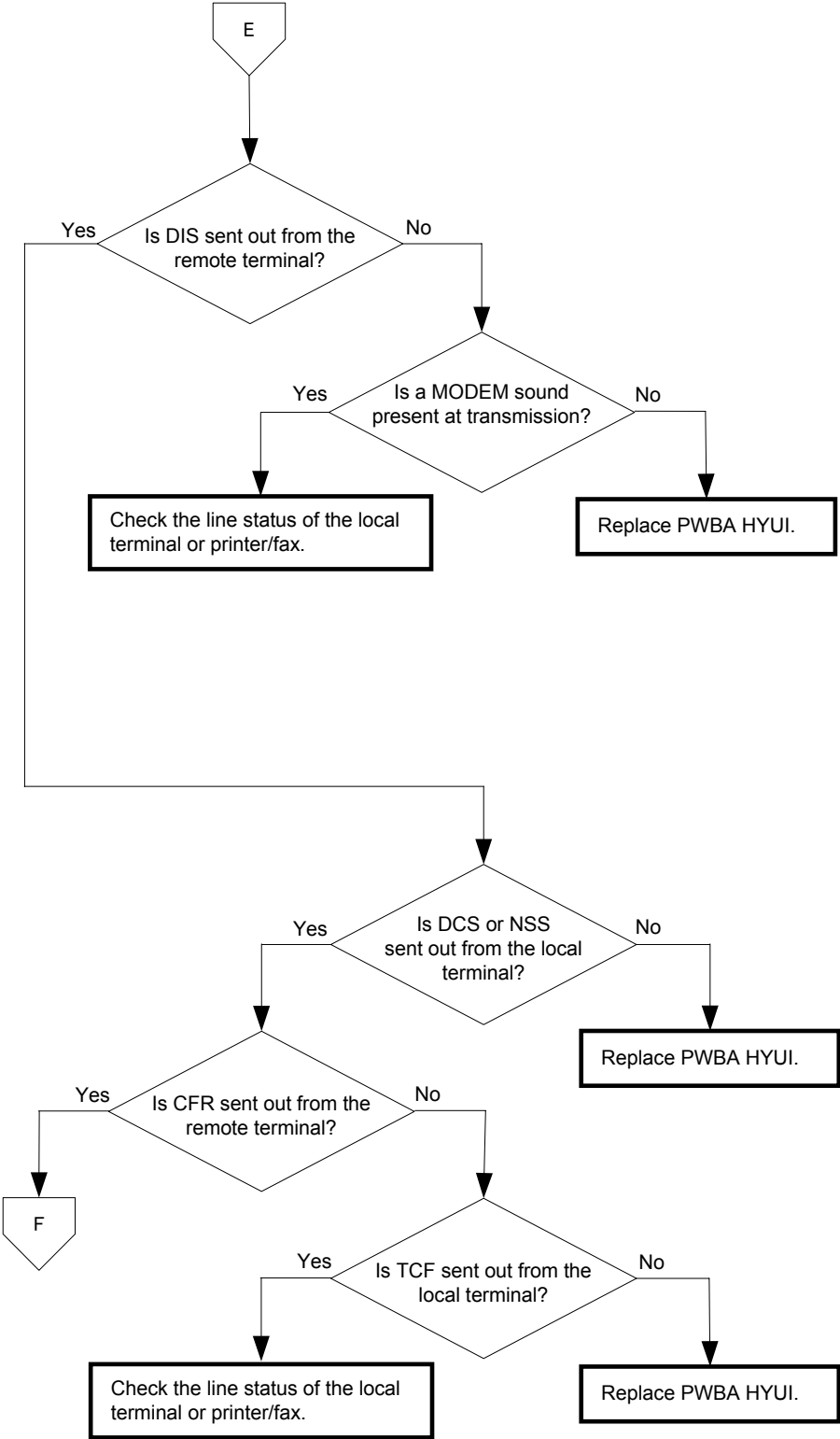

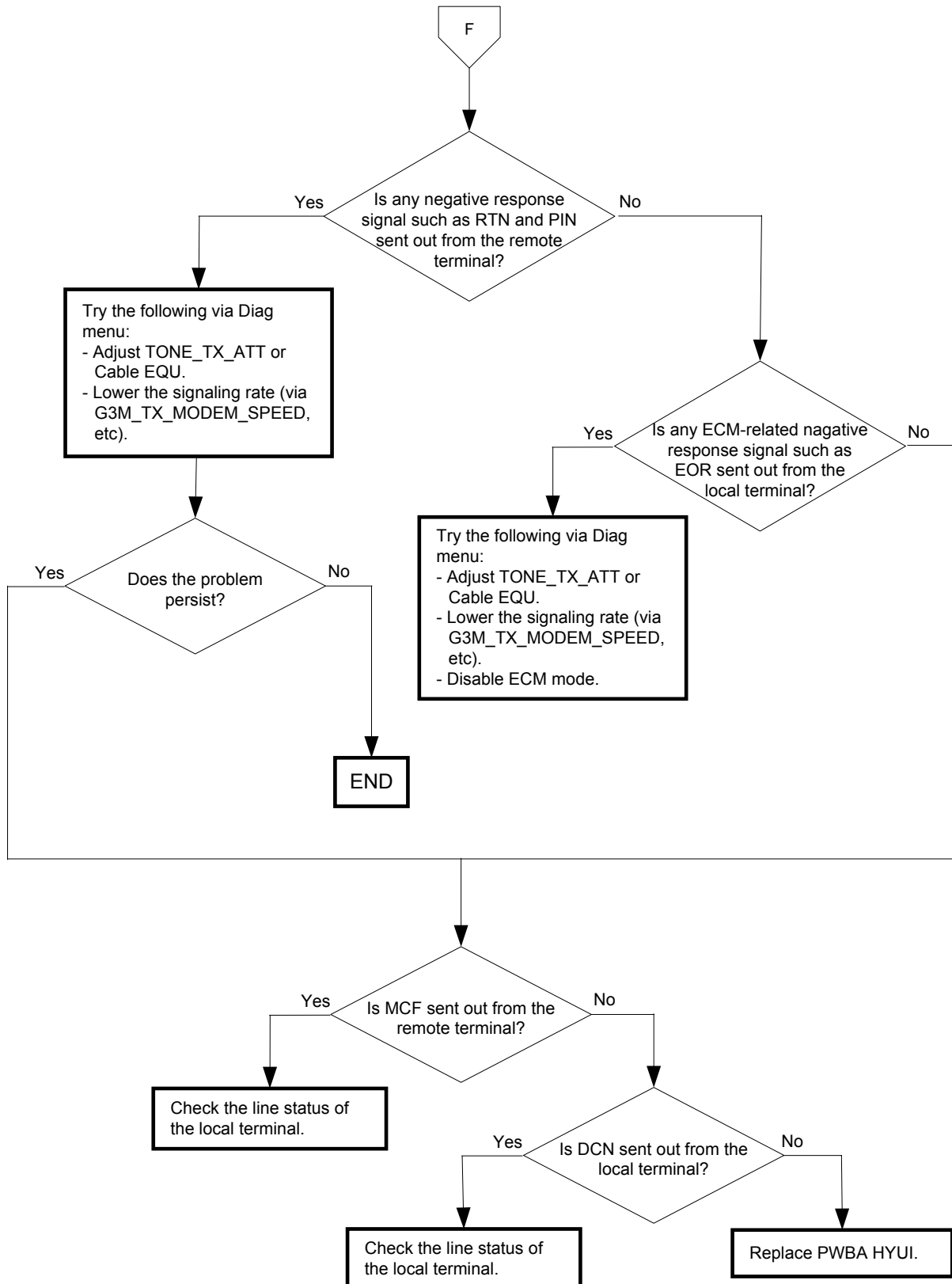

4. Other Problems

- Branch Connection (Parallel Connection)

During fax reception, if the handset of another telephone on a branch connection is lifted, the received image may be corrupted or a transmission error may occur. Branch connection may also interfere with caller identification, call waiting, the receiving operation of connected telephones.

- Call Waiting

If a call comes in during fax transmission/reception, the image may be corrupted.

- DSL (Digital Subscriber Line)

DSL, a high-speed digital transmission method using existing telephone lines, has several types. These include ADSL (Asymmetric Digital Subscriber Line) with differing upstream and downstream transmission speeds, SDSL (Symmetric Digital Subscriber Line) with symmetrical upstream and downstream transmission speeds, and VDSL (Very high bit rate Digital Subscriber Line) which features higher speed. However, because the line is used for both voice and data transmission, various problems may occur, such as noise during spoken conversation, low sound volume, and mis-dialing. Replacing the splitter may improve the situation.

- Noise

If electronic equipment (television, computer, microwave, etc.) or devices equipped with motors are located near a fax machine, noise from them may degrade the line condition.

Also, a telephone line, acting as an antenna, may absorb electric waves generated from wireless or broadcasting equipment.

Because fax data is audio data, the line quality affects the quality/stability of image data as well as that of conversation.

- Grounding

Improving the grounding may help to increase the communication speed.

If a two-conductor power cable is used for a 115V model, replace the cable with the three-conductor cable supplied with the product.

5. FIP

5.1 FIP

The FIP is the first step for trouble diagnosis. The FIP allows you to isolate various troubles including error codes, and guides you through the troubleshooting procedure.

5.2 Flow of FIP

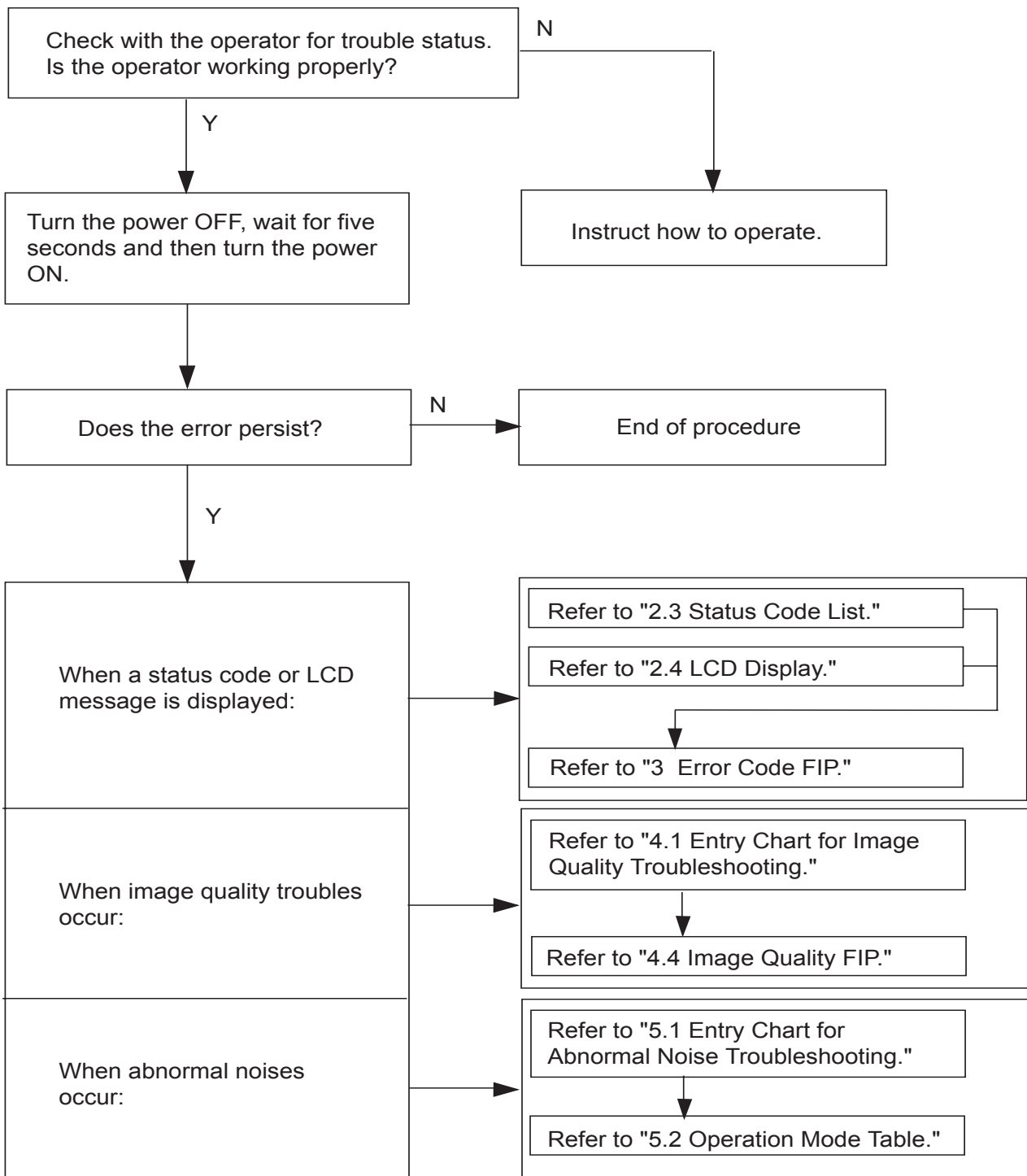

5.3 Status Code List

Error Message	Error Contents	Relevant FIP
001-360 Printer Restart Printer Contact Support If Message Returns	<IOT Fan Motor Failure> Rear Fan Motor error is detected	FIP-1. 1
001-361 Printer Restart Printer Contact Support If Message Returns	<IOT Fan Motor Failure> Duplexer Fan Motor error is detected	FIP-1. 2
001-363 Printer Restart Printer Contact Support If Message Returns	<IOT Fan Motor Failure> 001-360 and 001-361 errors are detected.	FIP-1. 1 FIP-1. 2
003-341 Printer Restart Printer Contact Support If Message Returns	<IOT Firmware Error> Firmware error occurs.	FIP-1. 3
003-342 Printer Restart Printer Contact Support If Message Returns	<IOT Firmware Error> Firmware error occurs.	FIP-1. 3
003-343 Printer Restart Printer Contact Support If Message Returns	<IOT Firmware Error> Firmware error occurs.	FIP-1. 3
003-344 Printer Restart Printer Contact Support If Message Returns	<IOT Firmware Error> Firmware error occurs.	FIP-1. 3
003-345 Printer Restart Printer Contact Support If Message Returns	<IOT Firmware Error> Firmware error occurs.	FIP-1. 3
003-346 Printer Restart Printer Contact Support If Message Returns	<IOT Stored Data Error> The error is detected by Stored Data.	FIP-1. 3
003-347 Printer Restart Printer Contact Support If Message Returns	<IOT Stored Data Checksum Error> Checksum error in Stored Data.	FIP-1. 3
003-348 Printer Restart Printer Contact Support If Message Returns	<IOT NVM illegal data> MCU NVM illegal data.	FIP-1. 3
003-349 Printer Restart Printer Contact Support If Message Returns	<IOT Firmware Error> Firmware error occurs.	FIP-1. 3

Error Message	Error Contents	Relevant FIP
003-350 Printer Restart Printer Contact Support If Message Returns	<IOT Firmware Error> Firmware error occurs.	FIP-1. 3
003-356 Printer Restart Printer Contact Support If Message Returns	<IOT NVRAM Error> The error is detected by MCU NVRAM check.	FIP-1. 4
004-310 Printer Restart Printer Reseat Feeder Contact Support	<IOT Option Feeder Failure> The error is detected by Option Feeder communication check.	FIP-1. 5
004-311 Printer Restart Printer Reseat Duplexer Contact Support	<IOT Option Duplexer Failure> The error is detected by Option Duplexer check.	FIP-1. 6
006-370 Printer Restart Printer Contact Support If Message Returns	<IOT ROS Failure> The rotational error is detected by ROS Motor check.	FIP-1. 7
006-371 Printer Restart Printer Contact Support If Message Returns	<IOT ROS Failure> The interval of SOS signal is longer than the specified value.	FIP-1. 7
006-372 Printer Restart Printer Contact Support If Message Returns	<IOT ROS Failure> The interval of SOS signal is shorter than the specified value	FIP-1. 7
006-373 Printer Restart Printer Contact Support If Message Returns	<IOT ROS Failure> The Laser power is lower than the specified value.	FIP-1. 7
006-374 Printer Restart Printer Contact Support If Message Returns	<IOT ROS Failure> 006-370 and 006-371 errors occurred.	FIP-1. 7
006-375 Printer Restart Printer Contact Support If Message Returns	<IOT ROS Failure> 006-370 and 006-372 errors occurred.	FIP-1. 7
006-376 Printer Restart Printer Contact Support If Message Returns	<IOT ROS Failure> 006-370 and 006-373 errors occurred.	FIP-1. 7
006-377 Printer Restart Printer Contact Support If Message Returns	<IOT ROS Failure> 006-371 and 006-372 errors occurred.	FIP-1. 7

Error Message	Error Contents	Relevant FIP
006-378 Printer Restart Printer Contact Support If Message Returns	<IOT ROS Failure> 006-371 and 006-373 errors occurred.	FIP-1. 7
006-379 Printer Restart Printer Contact Support If Message Returns	<IOT ROS Failure> 006-372 and 006-373 errors occurred.	FIP-1. 7
006-380 Printer Restart Printer Contact Support If Message Returns	<IOT ROS Failure> 006-370, 006-371 and 006-372 errors occurred.	FIP-1. 7
006-381 Printer Restart Printer Contact Support If Message Returns	<IOT ROS Failure> 006-370, 006-371 and 006-373 errors occurred.	FIP-1. 7
006-382 Printer Restart Printer Contact Support If Message Returns	<IOT ROS Failure> 006-370, 006-372 and 006-373 errors occurred.	FIP-1. 7
006-383 Printer Restart Printer Contact Support If Message Returns	<IOT ROS Failure> 006-371, 006-372 and 006-373 errors occurred.	FIP-1. 7
006-384 Printer Restart Printer Contact Support If Message Returns	<IOT ROS Failure> 006-370, 006-371, 006-372 and 006-373 errors occurred.	FIP-1. 7
007-340 Printer Restart Printer Contact Support If Message Returns	<IOT Motor Failure> Main Motor failure is detected.	FIP-1. 8
007-341 Printer Restart Printer Contact Support If Message Returns	<IOT Motor Failure> Sub Motor failure is detected.	FIP-1. 9
007-342 Printer Restart Printer Contact Support If Message Returns	<IOT Motor Failure> DEVE Motor failure is detected.	FIP-1. 10
007-343 Printer Restart Printer Contact Support If Message Returns	<IOT Motor Failure> PH Motor failure is detected.	FIP-1. 11
007-344 Printer Restart Printer Contact Support If Message Returns	<IOT Motor Failure> Option Feeder Motor failure is detected.	FIP-1. 12

Error Message	Error Contents	Relevant FIP
007-345 Printer Restart Printer Contact Support If Message Returns	<IOT Motor Failure> 007-340 and 007-341 errors occurred.	FIP-1. 8 FIP-1. 9
007-346 Printer Restart Printer Contact Support If Message Returns	<IOT Motor Failure> 007-340 and 007-342 errors occurred.	FIP-1. 8 FIP-1. 10
007-347 Printer Restart Printer Contact Support If Message Returns	<IOT Motor Failure> 007-340 and 007-343 errors occurred.	FIP-1. 8 FIP-1. 11
007-348 Printer Restart Printer Contact Support If Message Returns	<IOT Motor Failure> 007-340 and 007-344 errors occurred.	FIP-1. 8 FIP-1. 12
007-349 Printer Restart Printer Contact Support If Message Returns	<IOT Motor Failure> 007-341 and 007-342 errors occurred.	FIP-1. 9 FIP-1. 10
007-350 Printer Restart Printer Contact Support If Message Returns	<IOT Motor Failure> 007-341 and 007-343 errors occurred.	FIP-1. 9 FIP-1. 11
007-351 Printer Restart Printer Contact Support If Message Returns	<IOT Motor Failure> 007-341 and 007-344 errors occurred.	FIP-1. 9 FIP-1. 12
007-352 Printer Restart Printer Contact Support If Message Returns	<IOT Motor Failure> 007-342 and 007-343 errors occurred.	FIP-1. 10 FIP-1. 11
007-353 Printer Restart Printer Contact Support If Message Returns	<IOT Motor Failure> 007-342 and 007-344 errors occurred.	FIP-1. 10 FIP-1. 12
007-354 Printer Restart Printer Contact Support If Message Returns	<IOT Motor Failure> 007-343 and 007-344 errors occurred.	FIP-1. 11 FIP-1. 12
007-355 Printer Restart Printer Contact Support If Message Returns	<IOT Motor Failure> 007-340, 007-341 and 007-342 errors occurred.	FIP-1. 8 FIP-1. 9 FIP-1. 10
007-356 Printer Restart Printer Contact Support If Message Returns	<IOT Motor Failure> 007-340, 007-341 and 007-343 errors occurred.	FIP-1. 8 FIP-1. 9 FIP-1. 11

Error Message	Error Contents	Relevant FIP
007-357 Printer Restart Printer Contact Support If Message Returns	<IOT Motor Failure> 007-340, 007-341 and 007-344 errors occurred.	FIP-1. 8 FIP-1. 9 FIP-1. 12
007-358 Printer Restart Printer Contact Support If Message Returns	<IOT Motor Failure> 007-340, 007-342 and 007-343 errors occurred.	FIP-1. 8 FIP-1. 10 FIP-1. 11
007-359 Printer Restart Printer Contact Support If Message Returns	<IOT Motor Failure> 007-340, 007-342 and 007-344 errors occurred.	FIP-1. 8 FIP-1. 10 FIP-1. 12
007-360 Printer Restart Printer Contact Support If Message Returns	<IOT Motor Failure> 007-340, 007-343 and 007-344 errors occurred.	FIP-1. 8 FIP-1. 11 FIP-1. 12
007-361 Printer Restart Printer Contact Support If Message Returns	<IOT Motor Failure> 007-341, 007-342 and 007-343 errors occurred.	FIP-1. 9 FIP-1. 10 FIP-1. 11
007-362 Printer Restart Printer Contact Support If Message Returns	<IOT Motor Failure> 007-341, 007-342 and 007-344 errors occurred.	FIP-1. 9 FIP-1. 10 FIP-1. 12
007-363 Printer Restart Printer Contact Support If Message Returns	<IOT Motor Failure> 007-341, 007-343 and 007-344 errors occurred.	FIP-1. 9 FIP-1. 11 FIP-1. 12
007-364 Printer Restart Printer Contact Support If Message Returns	<IOT Motor Failure> 007-342, 007-343 and 007-344 errors occurred.	FIP-1. 10 FIP-1. 11 FIP-1. 12
007-365 Printer Restart Printer Contact Support If Message Returns	<IOT Motor Failure> 007-340, 007-341, 007-342 and 007-343 errors occurred.	FIP-1. 8 FIP-1. 9 FIP-1. 10 FIP-1. 11
007-366 Printer Restart Printer Contact Support If Message Returns	<IOT Motor Failure> 007-340, 007-341, 007-342 and 007-344 errors occurred.	FIP-1. 8 FIP-1. 9 FIP-1. 10 FIP-1. 12
007-367 Printer Restart Printer Contact Support If Message Returns	<IOT Motor Failure> 007-340, 007-341, 007-343 and 007-344 errors occurred.	FIP-1. 8 FIP-1. 9 FIP-1. 11 FIP-1. 12
007-368 Printer Restart Printer Contact Support If Message Returns	<IOT Motor Failure> 007-340, 007-342, 007-343 and 007-344 errors occurred.	FIP-1. 8 FIP-1. 10 FIP-1. 11 FIP-1. 12

Error Message	Error Contents	Relevant FIP
007-369 Printer Restart Printer Contact Support If Message Returns	<IOT Motor Failure> 007-341, 007-342, 007-343 and 007-344 errors occurred.	FIP-1. 9 FIP-1. 10 FIP-1. 11 FIP-1. 12
007-370 Printer Restart Printer Contact Support If Message Returns	<IOT Motor Failure> 007-340, 007-341, 007-342, 007-343 and 007-344 errors occurred.	FIP-1. 8 FIP-1. 9 FIP-1. 10 FIP-1. 11 FIP-1. 12
009-360 Printer Restart Printer Reseat Y Cart. Contact Support	<IOT (Y) Toner CRUM Error> Yellow Toner CRUM communication error is detected.	FIP-1. 13
009-361 Printer Restart Printer Reseat M Cart. Contact Support	<IOT (M) Toner CRUM Error> Magenta Toner CRUM communication error is detected.	FIP-1. 13
009-362 Printer Restart Printer Reseat C Cart. Contact Support	<IOT (C) Toner CRUM Error> Cyan Toner CRUM communication error is detected.	FIP-1. 13
009-363 Printer Restart Printer Reseat K Cart. Contact Support	<IOT (K) Toner CRUM Error> Black Toner CRUM communication error is detected.	FIP-1. 13
009-654 Printer Restart Printer Contact Support If Message Returns	<IOT ADC Sensor Error> ADC sensor sensed the high density.	FIP-1. 14
009-655 Printer Restart Printer Contact Support If Message Returns	<IOT ADC Sensor Error> ADC sensor sensed the low density.	FIP-1. 15
010-317 Printer Restart Printer Reseat Fuser Contact Support	<IOT Fuser Detached> Fuser detached is detected.	FIP-1. 16
010-351 Printer Replace Fuser Replace Fuser	<IOT Fuser Life Over> Fuser Life Over is detected.	FIP-1. 17
010-354 Printer Restart Printer Contact Support If Message Returns	<IOT environment Sensor Error> Temperature Sensor Error is detected.	FIP-1. 18
010-377 Printer Restart Printer Reseat Fuser Contact Support	<IOT Fuser Failure> The NC sensor circuit is defective in the MCU. NC: No Contact	FIP-1. 19

Error Message	Error Contents	Relevant FIP
010-378 Printer Restart Printer Reseat Fuser Contact Support	<IOT Fuser Failure> The circuit of the NC sensor is opened. NC: No Contact	FIP-1. 19
010-379 Printer Restart Printer Reseat Fuser Contact Support	<IOT Fuser Failure> The output value of the NC sensor is the abnormal value. NC: No Contact	FIP-1. 19
010-380 Printer Restart Printer Reseat Fuser Contact Support	<IOT Fuser Failure> The circuit of the NC sensor is opened. NC: No Contact	FIP-1. 19
010-381 Printer Restart Printer Reseat Fuser Contact Support	<IOT Fuser Failure> The output value of the NC sensor is the abnormal value. NC: No Contact	FIP-1. 19
010-382 Printer Restart Printer Reseat Fuser Contact Support	<IOT Fuser Failure> NC sensor or ST sensor sensed high temp. NC: No contact/ST: Soft Touch	FIP-1. 19
010-383 Printer Restart Printer Reseat Fuser Contact Support	<IOT Fuser Failure> NC sensor or ST sensor sensed high temp. NC: No contact/ST: Soft Touch	FIP-1. 19
010-384 Printer Restart Printer Reseat Fuser Contact Support	<IOT Fuser Failure> In the correction of the NC sensor output value, it became the abnormal value. NC: No Contact	FIP-1. 19
010-385 Printer Restart Printer Reseat Fuser Contact Support	<IOT Fuser Failure> NC sensor sensed high temp. NC: No contact	FIP-1. 19
010-386 Printer Restart Printer Reseat Fuser Contact Support	<IOT Fuser Failure> The circuit of the ST sensor is opened. ST: Soft Touch	FIP-1. 19
010-387 Printer Restart Printer Reseat Fuser Contact Support	<IOT Fuser Failure> ST sensor sensed high temp. ST: Soft Touch	FIP-1. 19
010-388 Printer Restart Printer Reseat Fuser Contact Support	<IOT Fuser Failure> ST sensor sensed low temp. ST: Soft Touch	FIP-1. 19
010-389 Printer Restart Printer Reseat Fuser Contact Support	<IOT Fuser Failure> NC sensor sensed low temp. NC: No Contact	FIP-1. 19

Error Message	Error Contents	Relevant FIP
010-390 Printer Restart Printer Reseat Fuser Contact Support	<IOT Fuser Failure> Fuser warming up time is longer than the specified value. (at the printing)	FIP-1. 19
010-391 Printer Restart Printer Reseat Fuser Contact Support	<IOT Fuser Failure> Adjusting time of NC sensor is longer than the specified value.	FIP-1. 19
010-392 Printer Restart Printer Reseat Fuser Contact Support	Fuser warming up time is longer than the specified value. (standby)	FIP-1. 19
010-393 Printer Restart Printer Reseat Fuser Contact Support	<IOT Fuser Failure> ST sensor sensed high temp. and cut off the fuser power. ST: Soft Touch	FIP-1. 19
010-394 Printer Restart Printer Reseat Fuser Contact Support	<IOT Fuser Failure> NC sensor sensed high temp. and cut off the fuser power. NC: No Contact	FIP-1. 19
010-395 Printer Restart Printer Reseat Fuser Contact Support	<IOT Fuser Failure> Fuser power is cut off by the errors.	FIP-1. 19
010-396 Printer Restart Printer Reseat Fuser Contact Support	<IOT Fuser Failure> Fuser power is cut off by the errors.	FIP-1. 19
010-397 Printer Restart Printer Contact Support If Message Returns	<IOT Fuser Failure> Fuser power is cut off by the errors.	FIP-1. 19
016-300 Printer Restart Printer Contact Support If Message Returns	<ESS Data Cache Error> CPU data cache error.	FIP-1. 20
016-301 Printer Restart Printer Contact Support If Message Returns	<ESS Instruction Cache Error> CPU instruction cache error.	FIP-1. 20
016-302 Printer Restart Printer Contact Support If Message Returns	<ESS Illegal Exception> CPU illegal expansion.	FIP-1. 21
016-310 Printer Restart Printer Contact Support If Message Returns	<ESS FontROM Error (Main)> Checksum error in the built-in font ROM.	FIP-1. 20

Error Message	Error Contents	Relevant FIP
016-313 Printer Restart Printer Contact Support If Message Returns	<ASIC Fail> The error is detected by ASIC error.	FIP-1. 20
016-315 Printer Restart Printer Contact Support If Message Returns	<ESS On-Baord RAM W/R Check Fail> The error is detected by on board RAM W/R check during initialization.	FIP-1. 20
016-316 Printer Restart Printer Reseat Memory Contact Support	<ESS DIMM Slot RAM W/R Check Fail> The error is detected by DIMM slot RAM W/R check during initialization.	FIP-1. 22
016-317 Printer Restart Printer Contact Support If Message Returns	<ESS ROM Check (Main) Fail> Checksum error in the main program ROM.	FIP-1. 20
016-318 Printer Restart Printer Reseat Memory Contact Support	<ESS DIMM Slot RAM Error> The error is detected by DIMM slot check during initialization.	FIP-1. 22
016-323 Printer Restart Printer Contact Support If Message Returns	<ESS NVRAM 1 W/R Check Fail> The fail is detected by NVRAM 1 W/R check during initialization.	FIP-1. 20
016-327 Printer Restart Printer Contact Support If Message Returns	<ESS NVRAM 1 SIZE And ID Check Fail> The error is detected by consistency check between the NVRAM size required by the system and its actual size, and by consistency check of the ID recorded when turning ON the power.	FIP-1. 20
016-330 Printer Restart Printer Reseat MPC Contact Support	<MPC-ESS Communication Fail> Communication fail between MPC and ESS	FIP-1. 23
016-331 Printer Restart Printer Reseat MPC Contact Support	<MPC Flash ROM Boot Module Checksum Error> Checksum error in MPC Flash ROM.	FIP-1. 23
016-332 Printer Restart Printer Reseat MPC Contact Support	<MPC RAM R/W Test Error> The error is detected by MPC RAM R/W check.	FIP-1. 23
016-333 Printer Restart Printer Reseat MPC Contact Support	<MPC Flash ROM Application Module Checksum Error> Checksum error in the MPC Flash ROM.	FIP-1. 23
016-334 Printer Restart Printer Reseat MPC Contact Support	<MPC MAC Address Checksum Error> Checksum error in the MPC MAC address.	FIP-1. 23

Error Message	Error Contents	Relevant FIP
016-335 Printer Restart Printer Reseat MPC Contact Support	<MPC Ethernet BIST parity/RAM R/W Error> The error is detected by MPC Ethernet BIST parity RAM R/W check.	FIP-1. 23
016-336 Printer Restart Printer Reseat MPC Contact Support	<MPC Internal Loopback Error> The error is detected by Loopback test.	FIP-1. 23
016-337 Printer Restart Printer Reseat MPC Contact Support	<MPC Fatal Error> The error is detected by MPC check.	FIP-1. 23
016-338 Printer Restart Printer Reseat Wireless Contact Support	<Wireless Option Error> The error is detected by Wireless option check.	FIP-1. 24
016-340 Printer Restart Printer Contact Support If Message Returns	<On Board Network Communication Fail> Communication error between CPU network and ESS F/W.	FIP-1. 20
016-344 Printer Restart Printer Contact Support If Message Returns	<On Board Network MAC Address Checksum Error> Checksum error in the Network MAC address.	FIP-1. 20
016-345 Printer Restart Printer Contact Support If Message Returns	<On Board Network Ethernet BIST parity/RAM R/W Error> The error is detected by network Ethernet parity RAM R/W check.	FIP-1. 20
016-346 Printer Restart Printer Contact Support If Message Returns	<On Board Network Internal Loopback Error> The error is detected by on board Network Internal Loopback check.	FIP-1. 20
016-347 Printer Restart Printer Contact Support If Message Returns	<On Board Network Fatal Error> The fatal error is detected by On Board Network check.	FIP-1. 20
016-348 Printer Restart Printer Contact Support If Message Returns	<On Board Network OS Error> The error is detected by On Board Network OS.	FIP-1. 20
016-349 Printer Restart Printer Contact Support If Message Returns	<On Board Network VxWORKS Error> The error is detected by On Board VxWORKS.	FIP-1. 20
016-350 Printer Restart Printer Reseat Parallel Contact Support	<IEEE1284 Data Error> The error is detected by IEEE1284 controller.	FIP-1. 25

Error Message	Error Contents	Relevant FIP
016-360 Printer Restart Printer Reseat MPC Contact Support	<PCI Option #0 Fail> Detection error of PCI option 0.	FIP-1. 23
016-370 Printer Restart Printer Contact Support If Message Returns	<IOT-ESS Communication Fail> Communication fail between IOT and ESS.	FIP-1. 26
016-397 Printer Restart Printer Contact Support If Message Returns	<Mail Size Error> Transmission failed because the outgoing mail size exceeds Max E-Mail Size.	FIP-1. 27
016-398 Printer Restart Printer Contact Support If Message Returns	<Communication Timeout> Communication Timeout with AIO.	FIP-1. 28
062-311 System Restart Printer Contact Support If Message Returns	<IIT Initializing Error> The IIT initializing error occurred.	FIP-1. 29
062-320 System Restart Printer Contact Support If Message Returns	<Scanner Error> The image acquisition error occurred	FIP-1.30
062-321 System Restart Printer Contact Support If Message Returns	<IIT Initializing Error> -The IIT initializing error occurred. -The Carriage Lock error occurred.	FIP-1. 29
062-322 System Restart Printer Contact Support If Message Returns	<Parameter Error> Abnormality of the parameter.	FIP-1. 31
062-323 System Restart Printer Contact Support If Message Returns	<Panel Setting Parameter NG> Copy Start Parameter error occurred.	FIP-1. 32
062-324 System Restart Printer Contact Support If Message Returns	<IIT Memory Over Flow> Out of Memory for IIT.	FIP-1. 30
062-360 System Restart Printer Contact Support If Message Returns	<HP Sensor Error> The Scanner Home Position error occurred.	FIP-1. 29
062-371 System Restart Printer Contact Support If Message Returns	<IIT Lamp Error> The IIT Fault Lamp error occurred.	FIP-1. 29

Error Message	Error Contents	Relevant FIP
093-964 Printer Restart Printer Reseat Fuser Contact Support	<IOT Fuser CRUM ID Error> Fuser CRUM communication error is detected.	FIP-1. 33
062-393 System Restart Printer Contact Support If Message Returns	<CCD ASIC Error> The CCD ASIC communication error occurred.	FIP-1. 31
102-380 System Restart Printer Contact Support If Message Returns	<UI Task Error> The UI task error occurred.	FIP-1. 34
116-396 Scan Restart Printer Contact Support If Message Returns	<Software Bug> -Fatal Maillib Related Error. -Other File2Net Lib Error. -Fatal Format Lib Related Error.	FIP-1. 34
116-987 Scan Restart Printer Contact Support If Message Returns	<Software Bag> A fatal error related to the format library.	FIP-1. 34
117-310 System Restart Printer Contact Support If Message Returns	<Main Program Sum Error> The main program sum error occurred.	FIP-1. 34
117-311 System Restart Printer Contact Support If Message Returns	<Parameter Sum Error> The parameter sum error occurred.	FIP-1. 34
117-312 System Restart Printer Contact Support If Message Returns	<Download Program Sum Error> The download program sum error occurred.	FIP-1. 34
117-313 System Restart Printer Contact Support If Message Returns	<Data Send Error> Failed in the ESS data transfer.	FIP-1. 28
117-314 System Restart Printer Contact Support If Message Returns	<Report Program Error> The Report Creating Program error occurred.	FIP-1. 34
117-315 System Restart Printer Contact Support If Message Returns	<EEPROM Driver Error> The EEPROM Driver program error occurred.	FIP-1. 34
117-316 System Restart Printer Contact Support If Message Returns	<RTC Driver Error> The RTC Driver program error occurred.	FIP-1. 34

Error Message	Error Contents	Relevant FIP
117-317 System Restart Printer Contact Support If Message Returns	<Flex RISC Driver Error> The Flex RISC Driver program error occurred.	FIP-1. 34
117-318 System Restart Printer Contact Support If Message Returns	<Flash ROM Driver Error> The Flash ROM Driver program error occurred.	FIP-1. 34
117-319 System Restart Printer Contact Support If Message Returns	<Panel Driver Error> The Panel Driver program error occurred.	FIP-1. 34
117-320 System Restart Printer Contact Support If Message Returns	<Debug Serial Driver Error> The Debug Serial Driver program error occurred.	FIP-1. 34
117-321 System Restart Printer Contact Support If Message Returns	<Speaker Driver Error> The Speaker Driver program error occurred.	FIP-1. 34
117-322 System Restart Printer Contact Support If Message Returns	<SYSMGR Task Error> The SYSMGR task error occurred.	FIP-1. 34
117-323 System Restart Printer Contact Support If Message Returns	<ESSMGR Task Error> The ESSMGR task error occurred. AIF SET failure.	FIP-1. 28
117-324 System Restart Printer Contact Support If Message Returns	<ESSSUB1 Task Error> The ESSSUB1 task error occurred.	FIP-1. 28
117-325 System Restart Printer Contact Support If Message Returns	<ESSSUB2 Task Error> The ESSSUB2 task error occurred.	FIP-1. 28
117-326 System Restart Printer Contact Support If Message Returns	<ESSSUB3 Task Error> The ESSSUB3 task error occurred.	FIP-1. 28
117-327 System Restart Printer Contact Support If Message Returns	<MDIAL Task Error> The MDIAL task error occurred.	FIP-1. 34
117-328 System Restart Printer Contact Support If Message Returns	<MSCAM Task Error> The MSCAM task error occurred.	FIP-1. 34

Error Message	Error Contents	Relevant FIP
117-329 System Restart Printer Contact Support If Message Returns	<PRINT Task Error> The PRINT task error occurred.	FIP-1. 28
117-330 System Restart Printer Contact Support If Message Returns	<JPEG Task Error> The JPEG task error occurred.	FIP-1. 34
117-331 System Restart Printer Contact Support If Message Returns	<DSP MAIN Task Error> The DSP MAIN task error occurred.	FIP-1. 34
117-332 System Restart Printer Contact Support If Message Returns	<DSP SCAN Task Error> The DSP SCAN task error occurred.	FIP-1. 34
117-333 System Restart Printer Contact Support If Message Returns	<DSP FAX Task Error> The DSP FAX task error occurred.	FIP-1. 34
117-334 System Restart Printer Contact Support If Message Returns	<DSP ROTA Task Error> The DSP ROTA task error occurred.	FIP-1. 34
117-335 System Restart Printer Contact Support If Message Returns	<DFAX Task Error> The DFAX task error occurred.	FIP-1. 34
117-336 System Restart Printer Contact Support If Message Returns	<PULL Task Error> The PULL task error occurred.	FIP-1. 34
117-337 System Restart Printer Contact Support If Message Returns	<IITTX Task Error> The IITTX task error occurred.	FIP-1. 34
117-338 System Restart Printer Contact Support If Message Returns	<SCH STBY Task Error> The SCH STBY task error occurred.	FIP-1. 34
117-339 System Restart Printer Contact Support If Message Returns	<RCV STBY Task Error> The RCV STBY task error occurred.	FIP-1. 34
117-340 System Restart Printer Contact Support If Message Returns	<HOOK Task Error> The HOOK task error occurred.	FIP-1. 34

Error Message	Error Contents	Relevant FIP
117-341 System Restart Printer Contact Support If Message Returns	<TXCORD Task error> The TXCORD task error occurred.	FIP-1. 34
117-342 System Restart Printer Contact Support If Message Returns	<RXCORD Task error> The RXCORD task error occurred.	FIP-1. 34
117-343 System Restart Printer Contact Support If Message Returns	<JBIG Task error> The JBIG task error occurred.	FIP-1. 34
117-344 System Restart Printer Contact Support If Message Returns	<FLASHFILE task error> The FLASHFILE task error occurred.	FIP-1. 34
117-345 System Restart Printer Contact Support If Message Returns	<RTC Task Error> The RTC task error occurred.	FIP-1. 34
117-346 System Restart Printer Contact Support If Message Returns	<MHR Task Error> The MHR task error occurred.	FIP-1. 34
117-347 System Restart Printer Contact Support If Message Returns	<MON Task Error> The MON task error occurred.	FIP-1. 34
117-348 System Restart Printer Contact Support If Message Returns	<IITRX Task Error> The IITRX task error occurred.	FIP-1. 34
117-349 System Restart Printer Contact Support If Message Returns	<SCANMGR Task Error> The SCANMGR task error occurred.	FIP-1. 34
117-350 System Restart Printer Contact Support If Message Returns	<Task Error> The task initializing (start up) error occurred.	FIP-1. 34
117-351 System Restart Printer Contact Support If Message Returns	<USB Device Error> The USB device fault occurred.	FIP-1. 34
117-352 System Restart Printer Contact Support If Message Returns	<AIOC-IIT Communication Error> The Communication error between the AIOC and the IIT.	FIP-1. 29

Error Message	Error Contents	Relevant FIP
117-353 System Restart Printer Contact Support If Message Returns	<SDRAM R/W Error> The SDRAM R/W error at System Boot.	FIP-1. 34
117-354 System Restart Printer Contact Support If Message Returns	<ESSMGR Task Error> Failed in AIF SET.	FIP-1. 28
117-355 System Restart Printer Contact Support If Message Returns	<ESSMGR Task Error> The Service FunctionID out of range.	FIP-1. 28
117-356 System Restart Printer Contact Support If Message Returns	<ESSSUB1 Task Error> Failed to Write USB P0.	FIP-1. 28
117-357 System Restart Printer Contact Support If Message Returns	<ESSSUB1 Task Error> Failed to Write USB P1.	FIP-1. 28
117-358 System Restart Printer Contact Support If Message Returns	<ESSSUB1 Task Error> Failed to Write USB P2.	FIP-1. 28
117-359 System Restart Printer Contact Support If Message Returns	<CE Task Error> The CE task error occurred.	FIP-1. 28
117-360 System Restart Printer Contact Support If Message Returns	<DFAX Task Error> Data inconsistency between AIOC and ESS.	FIP-1. 28
117-362 System Restart Printer Contact Support If Message Returns	<EEPROM Sum Check Error> The EEPROM Check Sum error occurred.	FIP-1. 34
117-363 System Restart Printer Contact Support If Message Returns	<NVM Sum Check Error> The NVM Check Sum error occurred.	FIP-1. 34
123-314 System Restart Printer Contact Support If Message Returns	<Panel Power On Error> The power on sequence of the FAX controller does not start within one minute after activating the panel.	FIP-1. 32
133-231 System Restart Printer Contact Support If Message Returns	<TFAXCOM Data Receive I/F Error> The data processing interface error on T FAXCOM.	FIP-1. 34

Error Message	Error Contents	Relevant FIP
133-232 System Restart Printer Contact Support If Message Returns	<Non-ECM Receive Data Write Time Out Error> Timeout error of incoming data writing at the non-ECM mode.	FIP-1. 35
133-234 System Restart Printer Contact Support If Message Returns	<JBIG Parameter Error> The JBIG parameter setting error occurred.	FIP-1. 34
133-235 System Restart Printer Contact Support If Message Returns	<MHR Parameter Error> The MHR parameter setting error occurred.	FIP-1. 34
133-236 Fax Restart Printer Contact Support If Message Returns	<MHR Encode Error> The encoding error at the MHR	FIP-1. 34
133-237 Fax Restart Printer Contact Support If Message Returns	<MHR Input Buffer Error> The Data error at MHR Input Buffer.	FIP-1. 34
133-238 Fax Restart Printer Contact Support If Message Returns	<MHR Output Buffer Error> The Data error at MHR Output Buffer	FIP-1. 34
133-239 Fax Restart Printer Contact Support If Message Returns	<FAX ECM Buffer Address Error> The FAX ECM Buffer Read/Write Address error occurred.	FIP-1. 34
133-240 Fax Restart Printer Contact Support If Message Returns	<Resolution Change Error> The FAX Resolution Conversion error at Sending/Receiving	FIP-1. 34
133-241 Fax Restart Printer Contact Support If Message Returns	<Memory Pool Get Error> The Memory Pool acquisition error occurred. (OS error)	FIP-1. 34
133-242 Fax Restart Printer Contact Support If Message Returns	<Memory Pool Release Error> The Memory Pool release error occurred. (OS error)	FIP-1. 34
133-243 Fax Restart Printer Contact Support If Message Returns	<Message Send Error> The Message communication error occurred. (OS error)	FIP-1. 34
133-244 Fax Restart Printer Contact Support If Message Returns	<Message Receive Error> The Message reception error occurred. (OS error)	FIP-1. 34

Error Message	Error Contents	Relevant FIP
133-245 Fax Restart Printer Contact Support If Message Returns	<FAXCOM Task Error> The FAXCOM task error occurred.	FIP-1. 34
133-246 Fax Restart Printer Contact Support If Message Returns	<Memory Pool Get Error> The Memory Pool acquisition error occurred. (OS error)	FIP-1. 34
133-247 Fax Restart Printer Contact Support If Message Returns	<Message Send Error> The communication error occurred. (OS error)	FIP-1. 34
133-248 Fax Restart Printer Contact Support If Message Returns	<Memory Pool Release Error> The Memory Pool release error occurred. (OS error)	FIP-1. 34
133-249 Fax Restart Printer Contact Support If Message Returns	<Message Receive Error> The Message receive error occurred. (OS error)	FIP-1. 34
133-250 Fax Restart Printer Contact Support If Message Returns	<OS Call Error> The OS Call Error occurred.	FIP-1. 34
133-251 Fax Restart Printer Contact Support If Message Returns	<File Open Error> The File Open error occurred.	FIP-1. 34
133-252 Fax Restart Printer Contact Support If Message Returns	<File Close Error> The File Close error occurred.	FIP-1. 34
133-253 Fax Restart Printer Contact Support If Message Returns	<File Erase Error> The File Erasing error occurred.	FIP-1. 34
133-254 Fax Restart Printer Contact Support If Message Returns	<Memory Full> Out of Memory for Faxing.	FIP-1. 36
133-255 Fax Restart Printer Contact Support If Message Returns	<Memory Pool Get Error> The Memory Pool acquisition error occurred. (OS error)	FIP-1. 34
133-256 Fax Restart Printer Contact Support If Message Returns	<Message Send Error> The Message transmission error occurred. (OS error)	FIP-1. 34

Error Message	Error Contents	Relevant FIP
133-257 Fax Restart Printer Contact Support If Message Returns	<Memory Pool Release Error> The Memory Pool release error occurred. (OS error)	FIP-1. 34
133-258 Fax Restart Printer Contact Support If Message Returns	<Message Receive Error> The Message receiving error occurred. (OS error)	FIP-1. 34
133-259 Fax Restart Printer Contact Support If Message Returns	<OS Call Error> The OS Call error occurred.	FIP-1. 34
133-260 Fax Restart Printer Contact Support If Message Returns	<File Open Error> The File Open error occurred.	FIP-1. 34
133-261 Fax Restart Printer Contact Support If Message Returns	<File Close Error> The File Close error occurred.	FIP-1. 34
133-262 Fax Restart Printer Contact Support If Message Returns	<File Erase Error> The File Erasing error occurred.	FIP-1. 34
133-263 Fax Restart Printer Contact Support If Message Returns	<Memory Pool Get Error> The Memory Pool acquisition error occurred. (OS error)	FIP-1. 34
133-264 Fax Restart Printer Contact Support If Message Returns	<Message Send Error> The Message sending error occurred. (OS error)	FIP-1. 34
133-265 Fax Restart Printer Contact Support If Message Returns	<Memory Pool Release Error> The Memory Pool release error occurred. (OS error)	FIP-1. 34
133-266 Fax Restart Printer Contact Support If Message Returns	<Message Receive Error> The Message receiving error occurred. (OS error)	FIP-1. 34
133-267 Fax Restart Printer Contact Support If Message Returns	<OS Call Error> The OS Call error occurred.	FIP-1. 34
133-268 Fax Restart Printer Contact Support If Message Returns	<File Open Error> The File Open error occurred.	FIP-1. 34

Error Message	Error Contents	Relevant FIP
133-269 Fax Restart Printer Contact Support If Message Returns	<File Close Error> The File Close error occurred.	FIP-1. 34
133-270 Fax Restart Printer Contact Support If Message Returns	<File Erase Error> The File Erase error occurred.	FIP-1. 34
133-271 Fax Restart Printer Contact Support If Message Returns	<Memory Pool Get Error> The Memory Pool acquisition error occurred. (OS error)	FIP-1. 34
133-272 Fax Restart Printer Contact Support If Message Returns	<Message Send Error> The Message send error occurred. (OS error)	FIP-1. 34
133-273 Fax Restart Printer Contact Support If Message Returns	<Memory Pool Release Error> The Memory Pool release error occurred. (OS error)	FIP-1. 34
133-274 Fax Restart Printer Contact Support If Message Returns	<Message Receive Error> The Message receive error occurred. (OS error)	FIP-1. 34
133-275 Fax Restart Printer Contact Support If Message Returns	<OS Call Error> The OS Call error occurred.	FIP-1. 34
133-276 Fax Restart Printer Contact Support If Message Returns	<File Open Error> The File Open error occurred.	FIP-1. 34
133-277 Fax Restart Printer Contact Support If Message Returns	<File Close Error> The File Close error occurred.	FIP-1. 34
133-278 Fax Restart Printer Contact Support If Message Returns	<File Erase Error> The File Erase error occurred.	FIP-1. 34
133-279 Fax Restart Printer Contact Support If Message Returns	<FAX CODEC I/F Error> The FAX CODEC I/F error occurred.	FIP-1. 34
133-280 Fax Restart Printer Contact Support If Message Returns	<Error FAX TIME> The FAX TIMER error occurred.	FIP-1. 34

Error Message	Error Contents	Relevant FIP
133-281 Fax Restart Printer Contact Support If Message Returns	<Power Off Report Create Fail> Failed to Create Power Off Report.	FIP-1. 34
133-282 Fax Restart Printer Contact Support If Message Returns	<Memory Pool Get Error> The Memory Pool acquisition error occurred. (OS error)	FIP-1. 34
133-283 Fax Restart Printer Contact Support If Message Returns	<Message Send Error> The Message send error occurred. (OS error)	FIP-1. 34
133-284 Fax Restart Printer Contact Support If Message Returns	<Memory Pool Release Error> The Memory Pool release error occurred. (OS error)	FIP-1. 34
133-285 Fax Restart Printer Contact Support If Message Returns	<Message Receive Error> The Message receive error occurred. (OS error)	FIP-1. 34
133-286 Fax Restart Printer Contact Support If Message Returns	<OS Call Error> The OS CALL error occurred.	FIP-1. 34
133-287 Fax Restart Printer Contact Support If Message Returns	<File Open Error> The File Open error occurred.	FIP-1. 34
133-288 Fax Restart Printer Contact Support If Message Returns	<File Close Error> The File Close error occurred.	FIP-1. 34
133-289 Fax Restart Printer Contact Support If Message Returns	<File Erase Error> The File Erase error occurred.	FIP-1. 34
133-290 Fax Restart Printer Contact Support If Message Returns	<Print Decode Error> A decoding error occurred three times consecutively during the decoding of JBIG data.	FIP-1. 34
134-211 Fax Restart Printer Contact Support If Message Returns	<PWBA AIOC MODEM Error> The PWBA AIOC MODEM error occurred. (MODEM error)	FIP-1. 35
134-212 Fax Restart Printer Contact Support If Message Returns	<NCU Parts Error> The PWBA NCU parts error occurred.	FIP-1. 35

5.4 LCD Display

Problem	Error Message	Error Contents	Relevant FIP
Paper Jam	Paper Jam 071-100 Printer Open Tray1 Remove Paper ↕ Flip Open & close Front Cover	<IOT 250 Feeder Misfeed JAM> The Regi sensor is not turned on within the specified time.	FIP-1. 37
	Paper Jam 072-100 Printer Open Tray2 Remove Paper ↕ Flip Open & close Front Cover	<IOT Option Feeder Misfeed JAM> The Regi sensor is not turned on within the specified time.	FIP-1. 38
	Paper Jam 075-100 Printer Check MPF Remove Paper ↕ Flip Open & close Front Cover	<IOT MPF Misfeed JAM> The Regi sensor is not turned on within the specified time.	FIP-1. 39
	Paper Jam 077-900 Printer Open Front Cover Remove Paper	<IOT Remaining Paper JAM> -The paper remains at the Exit Sensor. -The paper does not reach the Exit Sensor within the specified time. -The paper passed Exit Sensor earlier than the specified times.	FIP-1. 40
	Paper Jam 077-901 Printer Open Front Cover Remove Paper	<IOT Remaining Paper JAM> -The paper remains at the Regi Sensor. -The paper does not reach the Exit Sensor within the specified time after the Regi Sensor is ON. -The paper does not pass through the Regi Sensor within the specified time.	FIP-1. 40
	Paper Jam 077-903 Printer Open Tray1 Remove Paper ↕ Flip Open & close Front Cover	<IOT Feed JAM> The arrival time of the regi sensor is early than the specified time.	FIP-1. 41
	Paper Jam 077-907 Printer Open Front Cover & Belt Unit ↕ Flip Remove Paper	<IOT Remaining Paper JAM> -The paper remains at the Dup Jam Sensor. -The paper reached Dup Jam Sensor earlier than the specified time. -The paper passed Dup Jam Sensor earlier than the specified time. -The paper does not pass through the Dup Jam Sensor within the specified time. -The paper does not reach the Regi Sensor within the specified time, after the Dup Jam Sensor is ON.	FIP-1. 42

Problem	Error Message	Error Contents	Relevant FIP
Paper Setting	Load Tray N or MPF 024-910, 024-911, 024-914 Printer Load Tray N or MPF XX ↕ Flip Load Tray N or MPF YY NOTE: 024-910: Tray 1 024-911: Tray 2 024-914: MPF	<IOT Paper Size Mismatch> The paper size mismatch is detected	FIP-1. 43
	Load Tray N or MPF 024-965, 024-966, 024-969 Printer Load Tray N or MPF XX ↕ Flip Load Tray N or MPF YY NOTE: 024-965: Tray 1 024-966: Tray 2 024-969: MPF XX: Paper Size YY: Paper Type	<IOT No Suitable Paper> The specified tray is paper empty, size mismatch or type mismatch.	FIP-1. 44
Toner	CRUM ID 009-367, 009-368, 009-369, 009-370 Printer Reseat XXX Cartridge NOTE: 009-367: Cyan Toner 009-368: Magenta Toner 009-369: Yellow Toner 009-370: Black Toner XXX: Toner color	<IOT Toner Cartridge ID Error> The toner CRUM ID error is detected.	FIP-1. 45

Problem	Error Message	Error Contents	Relevant FIP
Toner	Tape on XXX Cart 093-919, 093-920, 093-921, 093-922 Printer Remove tape From XXX Cart NOTE: 093-919: Yellow Toner 093-920: Magenta Toner 093-921: Cyan Toner 093-922: Black Toner XXX: Toner color	<IOT Toner Tape Staying> The toner tape staying is detected. (When the new toner cartridge is installed.)	FIP-1. 46
	Replace Cart. 093-930, 093-931, 093-932, 093-933 Printer Replace XXX Cartridge NOTE: 093-930: Yellow Toner 093-931: Magenta Toner 093-932: Cyan Toner 093-933: Black Toner XXX: Toner color	<IOT Toner Cartridge Life Over> The toner cartridge has reached the replacement time.	FIP-1. 47 Y FIP-1. 48 M FIP-1. 49 C FIP-1. 50 K
	Copy Scan Fax 093-423, 093-424, 093-425, 093-426 Printer XXX Cartridge Is close to Life NOTE: 093-423: Yellow Toner 093-424: Magenta Toner 093-425: Cyan Toner 093-426: Black Toner	<IOT Toner Cartridge Near Empty> The toner cartridge is going to reach the replace- ment time.	FIP-1. 51 Y FIP-1. 52 M FIP-1. 53 C FIP-1. 54 K
	Insert Print Cart. 093-970, 093-971, 093-972, 093-973 Printer Insert XXX Cartridge NOTE: 093-970: Yellow Toner 093-971: Magenta Toner 093-972: Cyan Toner 093-973: Black Toner XXX: Toner color	<IOT Toner Cartridge Detached> The yellow, magenta, cyan or black Toner Cartridge detached is detected.	FIP-1. 55 Y FIP-1. 56 M FIP-1. 57 C FIP-1. 58 K

Problem	Error Message	Error Contents	Relevant FIP
Belt	CRUM ID 009-371 Printer Reseat Belt Unit	<IOT Belt Unit CRUM ID Error> The Belt Unit CRUM ID error is detected.	FIP-1. 59
	Copy Scan Fax 094-422 Printer Belt Unit Is close to Life	<IOT Belt Unit Life Warning> The Belt Unit is going to reach the replacement time.	FIP-1. 60
	Insert Belt Unit 094-910 Printer Insert Belt Unit	<IOT Belt Unit Detached> The Belt Unit Detached is detected.	FIP-1. 59
	Belt Unit 094-911 Printer Replace Belt Unit	<IOT Belt Unit Life Over> The Belt Unit has reached the replacement time.	FIP-1. 61
Fuser	010-351 Restart Printer Reseat Fuser Contact Support	<IOT Fuser Life Over> The Fuser has reached the replacement time.	FIP-1. 17
	010-359 Restart Printer Reseat Fuser Contact Support	<IOT Fuser CRUM ID Error> The Fuser CRUM ID error is detected.	FIP-1. 62
	Copy Scan Fax 010-421 Printer Replace Fuser Soon	<IOT Fuser Life Warning> The Fuser is going to reach the replacement time.	FIP-1. 63
Tray	Tray Detached 024-946, 024-947 Printer Push In Tray N NOTE: 024-946: Tray 1 024-947: tray 2 N: Tray number	<IOT Tray Detached> The paper cassette is detached.	FIP-1. 64
	Load Tray 1 077-912 Printer Push In Tray 1	<Upper Cassette Detached> The Tray 1 paper cassette is detached when the tray 2 is specified.	FIP-1. 64
Cover Open	Close FrontCover 077-300 Printer Front Cover Is Open	<IOT Cover Front Open> The Front Cover is open.	FIP-1. 65
Server	SMTP Error 016-503 Scan Press ✓	<SMTP Error> Failed to Resolve SMTP Server Name at Mail Reception.	FIP-1. 66
	POP Error 016-504 Scan Press ✓	<POP3 Error> Failed to Resolve POP3 Server Name at Mail Reception.	FIP-1. 66
	POP Login Error 016-505 Scan Press ✓	<POP3 Error> Failed to Login to POP3 Server at Mail Reception.	FIP-1. 66

Problem	Error Message	Error Contents	Relevant FIP
Server	SMTP Login Error 016-506 Scan Press ✓	<SMTP Error> Required User Parameter Not Set.	FIP-1. 66
	SMTP Login Error 016-507 Scan Press ✓	<SMTP Error> Failed to Login to SMTP Server at Mail Transmission.	FIP-1. 66
	SMTP Error 016-764 Scan Press ✓	<SMTP Error> Error Connecting to SMTP Server.	FIP-1. 66
	SMTP Server Full 016-765 Scan Press ✓	<SMTP Error> SMTP Server Disk Space Full.	Check the server side
	SMTP Error 016-766 Scan Press ✓	<SMTP Error> SMTP Server File System Error.	Check the server side
	Address Error 016-767 Scan Press ✓	<Email Address Error> Invalid Recipient Email Address.	FIP-1. 66
	From Address Error 016-768 Scan Press ✓	<Email Address Error> Invalid Sender Email Address.	FIP-1. 66
	SMB/FTP Error 016-781 Scan Press ✓	<SMTP/FTP Error> Timeout Error at Connection Start.	FIP-1. 66
	Login Error 016-782 Scan Press ✓	<Login Error> Login Error.	FIP-1. 66 or Check the server side
	SMB/FTP Error 016-783 Scan Press ✓	<Server Path Error> Specified Server Path Not Found.	FIP-1. 66 or Check the server side
	SMB/FTP Error 016-784 Scan Press ✓	<SMB/FTP Error> Error Writing to Server at File Transfer.	FIP-1. 66 or Check the server side
	Server Full 016-785 Scan Press ✓	<Disk Full> File Transfer Failed due to FTP/SMB Server Disk Space Full.	Check the server side
	Network Error 016-786 Scan Press ✓	<Network Error> Time Out Error at Data Transmission/Reception.	FIP-1. 66 or Check the server side
	SMB/FTP Error 016-787 Scan Press ✓	<SMB/FTP Error> Failed to Create Directory.	FIP-1. 66 or Check the server side
	SMB/FTP Error 016-788 Scan Press ✓	<SMB/FTP Error> Error due to Duplicated Filename.	FIP-1. 66
SMB/FTP Error 016-789 Scan Press ✓	<SMB/FTP Error> Error after File Transmission.	FIP-1. 66	

Problem	Error Message	Error Contents	Relevant FIP
Server	Network Not Ready 016-790 Scan Press ✓	<Network Error> F2N Module Starting Up or IP Address Not Determined.	FIP-1. 66
	Network Not Ready 016-794 Scan Press ✓	<Network Error> Failed to Run ScanToSMB due to SMB over TCP not running.Occurs only when MPC is installed.	FIP-1. 67
	Mail Size Limits 016-985 Scan Press ✓	<Mail Size Error> Mail Size Error	Check the server side
	File Size Limits 016-986 Scan Press ✓	<File Size Error> Exceeded Format-specific Size Limit after Conversion.	FIP-1. 34
FAX	Memory Full 017-970 System Job Failure Press ✓	<Out of memory> Out of Memory for AIOC.	FIP-1. 36
	H/W Error 017-971 System Job Failure Press ✓	<Flash ROM Error> Write error at Image Data FlashROM.	FIP-1. 34
	H/W Error 017-972 System Job Failure Press ✓	<Flash ROM Error> Erase error at Image Data FlashROM.	FIP-1. 34
	H/W Error 017-973 System Job Failure Press ✓	<Flash ROM Error> Suspend error at Image Data FlashROM.	FIP-1. 34
	H/W Error 017-974 System Job Failure Press ✓	<Flash ROM Error> Resume error at Image Data FlashROM.	FIP-1. 34
	File Error 017-975 System Job Failure Press ✓	<File Error> File Handle Count exceeds Limit.	FIP-1. 34
	File Error 017-976 System Job Failure Press ✓	<File Error> File Count Exceeds Manageable Limit.	FIP-1. 34
	File Error 017-977 System Job Failure Press ✓	<File Error> Document Count exceeds Manageable Limit.	FIP-1. 34
	File Error 017-978 System Job Failure Press ✓	<File Error> Document Page Count exceeds Limit	FIP-1. 34
	File Error 017-979 System Job Failure Press ✓	<File Error> File Double open.	FIP-1. 34

Problem	Error Message	Error Contents	Relevant FIP
FAX	Report error 017-980 System Job Failure Press ✓	<Report File Open/Close Error> Failed to Open/Close Report File.	FIP-1. 34
	File Error 017-986 System Job Failure Press ✓	<File Error> Empty File created.	FIP-1. 34
	File Error 017-987 System Job Failure Press ✓	<File Error> File read error due to Buffer overflow.	FIP-1. 34
	PCScan Time Out 017-988 Scan Job Failure Press ✓	<PC Scan Time Out> Timeout at ScanToApplication start.	FIP-1. 68
	File Error 017-989 System Job Failure Press ✓	<File Size Over> The Writing File Size exceeds the buffer size.	FIP-1. 34
	Communication 033-500 Fax Job Failure Press ✓	<FAX RX JPEG Data Limit Over> The Incoming FAX JPEG Decoded Data exceeds System Data Limit.	FIP-1. 69
	Codec Error 033-501 Fax Job Failure Press ✓	<CODEC Error> The Codec Process Aborted by Read error during Manual Dialing.	FIP-1. 70
	File Error 033-502 Fax Job Failure Press ✓	<File Open Error> The File Open error occurred.	FIP-1. 34
	Memory Full 033-503 Fax Job Failure Press ✓	<Memory Full> Memory Full at Reception.	FIP-1. 36
	Codec Error 033-510 Fax Job Failure Press ✓	<CODEC Error> The Decoded Line Count per Stripe error at JBIG Data Decoding.	FIP-1. 71
	Communication 033-511 Fax Job Failure Press ✓	<Communication Error> The MH/HR/MMR Received as 0 Line.	FIP-1. 69
	Communication 033-513 Fax Job Failure Press ✓	<Communication Error> Communication Interrupted due to Memory Full.	FIP-1. 34
	Codec Error 033-514 Fax Job Failure Press ✓	<JPEG DNL/SOF0 Error> Line Number Unavailable at JPEG Reception.	FIP-1. 69

Problem	Error Message	Error Contents	Relevant FIP
FAX	Codec Error 033-515 Fax Job Failure Press ✓	<JBIG Nf Error> Color/BW Multivalued Info Unavailable at JPEG Reception.	FIP-1. 69
	Codes Error 033-516 Fax Job Failure Press ✓	<JPEG EOI Error> Failed to Detect EOI at JPEG Reception.	FIP-1. 69
	Password Error 033-517 Fax Job Failure If Message Returns	<DFAX Password Error> The password for DFAX does not match the password for Fax/Scan Lock.	FIP-1. 72
	Communication 033-751 Fax Job Failure Press ✓	<Over Run> The incoming data overrun at the MODEM.	FIP-1. 34
	Busy 033-752 Fax Job Failure Press ✓	<During Call Busy Tone> The busy tone was received while calling the external telephone at the TEL/FAX mode.	FIP-1. 35
	Communication 033-753 Fax Job Failure Press ✓	<CJ Not Detection> The CJ cannot be detected.	FIP-1. 35
	Communication 033-754 Fax Job Failure Press ✓	<V8 Error> The V8 error occurred.	FIP-1. 35
	Communication 033-755 Fax Job Failure Press ✓	<Phase2 Error> The Phase 2 (Line Probing) error occurred.	FIP-1. 35
	Communication 033-756 Fax Job Failure Press ✓	<Phase3 Error> The Phase 3 (Primary Channel Equalizer Trimming) error occurred.	FIP-1. 35
	Communication 033-757 Fax Job Failure Press ✓	<Primary Channel Synchronization Error> The Primary Channel re-Synchronization error occurred.	FIP-1. 35
	Communication 033-758 Fax Job Failure Press ✓	<Control Channel Synchronization Error> The Control Channel re-Synchronization error occurred.	FIP-1. 35
	Communication 033-759 Fax Job Failure Press ✓	<Control Channel Retrain Error> The Control Channel Retrain Error occurred.	FIP-1. 35
	Communication 033-760 Fax Job Failure Press ✓	<Control Channel OFF Time Out> The Control Channel OFF time out occurred.	FIP-1. 35

Problem	Error Message	Error Contents	Relevant FIP
FAX	Communication 033-761 Fax Job Failure Press ✓	<Primary Channel OFF Time Out> The Primary Channel OFF time out occurred.	FIP-1. 35
	Communication 033-762 Fax Job Failure Press ✓	<DM Prevention Function Receive Refuse> The incoming data was rejected by the DM prevention function.	FIP-1. 73
	Communication 033-763 Fax Job Failure Press ✓	<Manual Transmission Read Manuscript Not Do> Read Timeout at Manual Dialing.	FIP-1. 74
	Communication 033-764 Fax Job Failure Press ✓	<Draw Data Create Not Do> Graphics Process Timeout at Fax Sending.	FIP-1. 34
	Codec Error 033-765 Fax Job Failure Press ✓	<File Pointer Error> Read/Write File Pointer Error at Encoding/Decoding.	FIP-1. 34
	Codec Error 033-766 Fax Job Failure Press ✓	<Target File Opening> The Target File Empty at Decoding.	FIP-1. 34
	Codec Error 033-767 Fax Job Failure Press ✓	<MMR MN86064 Decode Error> The Decode error of MN86064 at MMR Decoding.	FIP-1. 34
	Codec Error 033-768 Fax Job Failure Press ✓	<ATMove Counter Over> The ATMove Count per Stripe 5 or more	FIP-1. 34
	Codec Error 033-769 Fax Job Failure Press ✓	<JBIG NEWLEN Marker Error> The NEWLEN marker was not detected	FIP-1. 35
	Codec Error 033-770 Fax Job Failure Press ✓	<YD Error> The YD error at JBIG encoding.	FIP-1. 34
	Codec Error 033-771 Fax Job Failure Press ✓	<Abort Marker Error> The Abort Marker error at JBIG decoding.	FIP-1. 34
	Codec Error 033-772 Fax Job Failure Press ✓	<Undefined Marker Error> The undefined marker was detected.	FIP-1. 35
	Codec Error 033-773 Fax Job Failure Press ✓	<BIH Error> The BHI was abnormal at JBIG decoding.	FIP-1. 75

Problem	Error Message	Error Contents	Relevant FIP
FAX	Buffer 033-774 Fax Job Failure Press ✓	<FAX TX Encode Output Buffer Over> The JBIG Encode Output Buffer overflow at FAX sending.	FIP-1. 34
	Buffer 033-775 Fax Job Failure Press ✓	<FAX RX Encode Output Buffer Over> The JBIG Encode Output Buffer overflow at Fax Receiving.	FIP-1. 69
	Buffer 033-776 Scan Job Failure Press ✓	<SCAN Encode Output Buffer Over> The JBIG Encode Output Buffer overflow at Accumulation of Outgoing FAX or D-FAX.	FIP-1. 34
	Buffer 033-777 Fax Job Failure Press ✓	<FAX RX Decode Input Buffer Over> The Incoming FAX Buffer overflow at Copy from ECM to JBIG Decode.	FIP-1. 69
	Report error 033-779 Fax Press ✓	<Log File Create Fail> Failed to Create Communication Log File.	FIP-1. 34
	Report error 033-780 Fax Press ✓	<Report File Create Error> Failed to Create Report and Log Files etc.	FIP-1. 34
	Communication 033-781 Fax Job Failure Press ✓	<Parameter Error> FAX-Task Interface Parametric error occurred.	FIP-1. 34
	Communication 033-782 Fax Job Failure Press ✓	<NSS/DCS Function disagreement> The Incoming NSS/DCS Function Not supported.	FIP-1. 69
	Illegal Data 033-783 Fax Job Failure Press ✓	<Illegal Dial Data> Invalid Dial Data.	FIP-1. 77
	Buffer 033-784 Fax Job Failure Press ✓	<Buffer Error> The Incoming FAX Buffer overflow at JBIG Decode Output.	FIP-1. 69
	Buffer 033-785 Scan Job Failure Press ✓	<Buffer Error > The MHR Decode Output Buffer overflow at Push-Scan	FIP-1. 34
	Codec Error 033-786 Fax Job Failure Press ✓	<CODEC Error > The Decode-BIH Line Count Inconsistency at JBIG Data Decoding.	FIP-1. 34
	Memory Full 033-787 Fax Job Failure Press ✓	<HAKKO Table FULL> The Calling Table is full.	FIP-1. 34
	Memory Full 033-788 Fax Job Failure Press ✓	<Memory Full> Exceeds the memory capacity.	FIP-1. 34

Problem	Error Message	Error Contents	Relevant FIP
FAX	Cancel 033-789 Fax Job Canceled Press ✓	<Cancel> The Cancellation occurred.	FIP-1. 34
	Cancel 033-790 Fax Job Canceled Press ✓	<Cancel> The Cancel occurred.	FIP-1. 34
	Cancel 033-791 Fax Job Canceled Press ✓	<Cancel> The Cancel occurred.	FIP-1. 34
	Communication 033-799 Fax Job Failure Press ✓	<Line Count Limit Over> The Line Count per Page Exceeds Limit at MH/HR/ MMR Reception.	FIP-1. 69
	Communication 034-508 Fax Job Failure Press ✓	<Command Refuse Signal Send> The Communication Aborted Sending Command Rejection Code.	FIP-1. 31
	Communication 034-509 Fax Job Failure Press ✓	<Process Ignore Signal Receive> The Communication Aborted Receiving Invalid Pro- cedure Code.	FIP-1. 31
	Communication 034-510 Fax Job Failure Press ✓	<Command Refuse Signal Receive> The Communication Aborted Receiving Command Rejection Code.	FIP-1. 31
	Communication 034-515 Fax Job Failure Press ✓	<DIS DCS Illegal Command Receive> Unsupported Command received.	FIP-1. 70
	Communication 034-730 Fax Job Failure Press ✓	<Circuit Collision> Circuit Conflict.	FIP-1. 69
	Communication 034-742 Fax Job Failure Press ✓	<Under Run> The transmitted data under-run at the MODEM.	FIP-1. 35
	Illegal Data 034-799 Fax Job Failure Press ✓	<No Dial Data> The Autodial Started but No Data Ready.	FIP-1. 77
	No Answer 035-701 Fax Job Failure Press ✓	<Send T1 Time Out> The T1 Time Out error occurred at the data is trans- mitting.	FIP-1. 78

Problem	Error Message	Error Contents	Relevant FIP
FAX	Communication 035-702 Fax Job Failure Press ✓	<Receive DCN> Receiving the DCN.	FIP-1. 69
	Communication 035-704 Fax Job Failure Press ✓	<Not Send Ability> Source Lacking Send Capacity.	FIP-1. 69
	Communication 035-705 Fax Job Failure Press ✓	<DCS/NSS Resend Over> Exceeds the predetermined value of the resending.	FIP-1. 69
	Communication 035-706 Fax Job Failure Press ✓	<Fall Back Error> The Fall Back error occurred.	FIP-1. 35
	Communication 035-708 Fax Job Failure Press ✓	<Post Message Resend Over> Exceeds the predetermined value of the resending.	FIP-1. 69
	Communication 035-709 Fax Job Failure Press ✓	<G3 Send RTN/PIN Receive> Received RTN/PIN at G3 Transmission.	FIP-1. 69
	Communication 035-710 Fax Job Failure Press ✓	<Receive PIN> Received PIN. (Except the EOR)	FIP-1. 69
	Communication 035-716 Fax Job Failure Press ✓	<T2 Time Out> The T2 Time Out occurred.	FIP-1. 69
	Communication 035-717 Fax Job Failure Press ✓	<G3 Receive RTN Send> Received RTN at G3 Transmission.	FIP-1. 69
	No Answer 035-718 Fax Job Failure Press ✓	<Receive T1 Time Out> The T1 Time Out error occurred at receiving the data.	FIP-1. 69
	Communication 035-720 Fax Job Failure Press ✓	<Not Receive Ability> Source Lacking Receive Capacity	FIP-1. 76
	Communication 035-728 Fax Job Failure Press ✓	<G3 EOL Not Receive> Unable to Receive EOL for 13 sec at G3 Reception.	FIP-1. 69
	Communication 035-729 Fax Job Failure Press ✓	<Career Cut> Career Interrupted.	FIP-1. 69

Problem	Error Message	Error Contents	Relevant FIP
FAX	Communication 035-730 Fax Job Failure Press ✓	<RS Request CS NOT ON> The Modem CS not turning on to RS Request at High-Speed Training.	FIP-1. 34
	Communication 035-737 Fax Job Failure Press ✓	<CTC/EOR Resend Over> Exceeds the predetermined value of the resending.	FIP-1. 69
	Communication 035-739 Fax Job Failure Press ✓	<T5 Time Out> The T5 Time Out error occurred.	FIP-1. 69
	Communication 035-740 Fax Job Failure Press ✓	<ECM Send EOR-Q Send> Sent EOR-Q at ECM transmission.	FIP-1. 69
	Communication 035-741 Fax Job Failure Press ✓	<ECM Flame Time Out> The flame Timeout at ECM.	FIP-1. 69
	Communication 035-742 Fax Job Failure Press ✓	<ECM Receive EOR-Q Receive> Received EOR-Q at ECM.	FIP-1. 69
	No Dial Tone 035-746 Fax Job Failure Press ✓	<Before Dial first Dial Tone> Failed to Detect Dial Tone before Dialing.	FIP-1. 77
	No Dial Tone 035-749 Fax Job Failure Press ✓	<End Dial Not Response> No Response after Dialing.	FIP-1. 35
	Communication 035-771 Fax Job Failure Press ✓	<FSK CS NOT ON> The CS does not turn on at the FSK.	FIP-1. 34
	Communication 035-772 Fax Job Failure Press ✓	<ECM Illegal Frame Receive> Received Illegal Flame at ECM.	FIP-1. 69
	No Dial Tone 035-773 Fax Job Failure Press ✓	<Before Dial Second Dial Tone> Failed to Detect Second Dial Tone before Dialing	FIP-1. 77
	No Dial Tone 035-774 Fax Job Failure Press ✓	<During Dial Second Dial> Failed to Detect Second Dial Tone during Dialing.	FIP-1. 77
	Communication 035-777 Fax Job Failure Press ✓	<RTC Not Detect> No RTC Detected at Decoding.	FIP-1. 34

Problem	Error Message	Error Contents	Relevant FIP
FAX	File Error 035-779 Fax Job Failure Press ✓	<FAX FWD document change error> Document Change Error at forwarding FAX.	FIP-1. 34
	Communication 035-780 Fax Job Failure Press ✓	<G3 Drawing Information Undetectable> Unable to Detect Normal Line within 1 min after starting G3 Reception.	FIP-1. 69
	Busy 035-781 Fax Job Failure Press ✓	<Busy Tone Error> Detected Busy Tone after Dialing.	FIP-1. 79
	Communication 035-792 Fax Job Failure Press ✓	<JM Not Detection> The JM cannot be detected.	FIP-1. 70
	Communication 133-512 Fax Job Failure Press ✓	<Modem Parameter Exchange Error> The Modem Parameter Exchange error occurred.	FIP-1. 34
	Accumulation Limit Not Stored For Last Sheet Press ✓	<FAX Send Count Limit> The Outgoing FAX exceeds store limit.	FIP-1. 80
	Controller Initialized NVM	<SRAM R/W Error> The SRAM R/W error at System Boot.	FIP-1. 34
	Controller Initialized NVM	<EEPROM R/W Error> The EEPROM R/W error at System Boot.	FIP-1. 34
	Illegal Settings This is unavailable when Tray(Size) is selected	<Copy Dup Size Limit> Copy Duplex Disabled due to Invalid Size.	FIP-1. 81
	Illegal Settings This is unavailable when Tray(Media) is selected	<Copy Dup Medium NG> Copy Duplex Disabled due to Invalid Paper Type.	FIP-1. 82
COPY	Confirm 062-790 Deleted by Limit Press ✓	<Copy Limit> Unable to continue due to copy limitation.	FIP-1. 83
	Illegal Settings This is unavailable when Tray(No Paper) is selected	<Copy Select Tray No Paper> Unable to Start due to No Paper.	FIP-1. 44

Problem	Error Message	Error Contents	Relevant FIP
COPY	Illegal Settings This is unavailable when Tray(Remove) is selected	<Copy Select Tray Remove> Unable to Start due to Tray Disengaged.	FIP-1. 64
	Illegal Settings This is unavailable when Tray(Broken) is selected	<Copy Select Tray Broken> Unable to Start due to Tray Fault.	FIP-1. 37, 38, 39, 43 or 64
	Illegal Settings This is unavailable when Tray(No Tray) is selected	<Copy Select Tray Exist> Unable to Start due to Tray Not Found.	FIP-1. 64
ADF	Paper Jam 005-110 Open ADF Cover and Clear Jam	<PICKUP JAM> The Pick Up jam occurred.	FIP-1. 84
	Paper Jam 005-121 Open ADF Cover and Clear Jam	<ADF JAM> The ADF jam occurred.	FIP-1. 84
	Cover Open 005-301 Close ADF Cover	<ADF Cover Open> The ADF Cover is open.	FIP-1. 85
	Paper Jam 005-302 Scanner Cover	<Scanner Cover Open> The Scanner Cover is open.	FIP-1. 85

Problem	Error Message	Error Contents	Relevant FIP
Other	Invalid ID 016-383 Printer Data Violation Press ✓	<Download Error> The ID of the downloaded file is invalid.	FIP-1. 86
	Range Chk Error 016-384 Printer Data Violation Press ✓	<Download Error> The address of the write destination is invalid.	FIP-1. 86
	Header Error 016-385 Printer Data Violation Press ✓	<Download Error> The header information is invalid.	FIP-1. 86
	Check Sum Error 016-386 Printer Data Violation Press ✓	<Download Error> The checksum is invalid.	FIP-1. 86
	Format Error 016-387 Printer Data Violation Press ✓	<Download Error> The format is invalid.	FIP-1. 86
	MPC Error 016-388 Printer Reset MPC Press ✓	<MPC Download Error> Failed to start MPC download mode at MPC download.	FIP-1. 87
	MPC Detached 016-389 Printer Reset MPC Press ✓	<MPC Download Error> MPC Download was attempted without MPC mounted.	FIP-1. 87
	MPC Com. Failed 016-390 Printer Reset MPC Press ✓	<MPC Download Error> Communication error occurred between MPC and ESS during download.	FIP-1. 87
	Erase Flash Err. 016-392 Printer Contact Support If Message Returns	<Download Error> An error occurred erasing the Flash.	FIP-1. 20
	Write Flash Err. 016-393 Printer Contact Support If Message Returns	<Download Error> An error occurred writing to the Flash.	FIP-1. 20
	Verify Error 016-394 Printer Contact Support If Message Returns	<Download Error> An error occurred verifying the Flash.	FIP-1. 20
	Out of Memory 016-700 Printer Job too Large Press Set	<Memory Over flow> Exceeds the memory capacity.	FIP-1. 88
	PCL Error 016-720 Printer Data Violation Press Set	<PDL Error> PDL error occurs.	FIP-1. 20

Problem	Error Message	Error Contents	Relevant FIP
Other	Invalid User 016-757 Printer Account Denied Press ✓	<Auditron Error> The user is not registered to any account.	FIP-1. 89
	Disabled Func 016-758 Printer Denied Col print Press ✓	<Auditron Error> An invalid account was detected.	FIP-1. 89
	Reached Limits 016-759 Printer Over your limits Press ✓	<Auditron Error> The number of registered users exceeded its upper limit.	FIP-1. 89
	Network Error 016-770 Scan Press ✓	<MPC Firmware Error> The MPC Firmware Version Disagreement.	FIP-1. 23
	Invalid Job 016-799 Printer Data Violation Press Set	<Job Environment Violation> Detects violation data for the print condition.	FIP-1. 90
	Disk Full 016-980 Printer Job too Large Press Set	<Memory Over flow> Exceeds the memory capacity.	FIP-1. 88
	Over Heat 042-700 Printer cooling down Please Wait...	<IOT Over Heat Stop> The temp. sensor in OHP SENSOR sensed high temperature.	FIP-1. 91
	Copy Scan Fax 142-700 Printer Over Heat Turned Halfmode	<IOT Over Heat Warning> The printing mode becomes half speed mode, by the high temperature. The temp. sensor in OHP SENSOR sensed high temperature.	FIP-1. 91
	Copy Scan Fax 193-700 Printer non-DELL Toner Installed	<Custom Toner Mode> The printer is in custom toner mode.	FIP-1. 92

6. Error Code FIP

FIP-1.1 Restart Printer 001-360/001-363

Possible causative parts:FAN MAIN (PL13.5.10)
LVPS (PL13.5.14)
PWBA MCU (PL9.1.20)

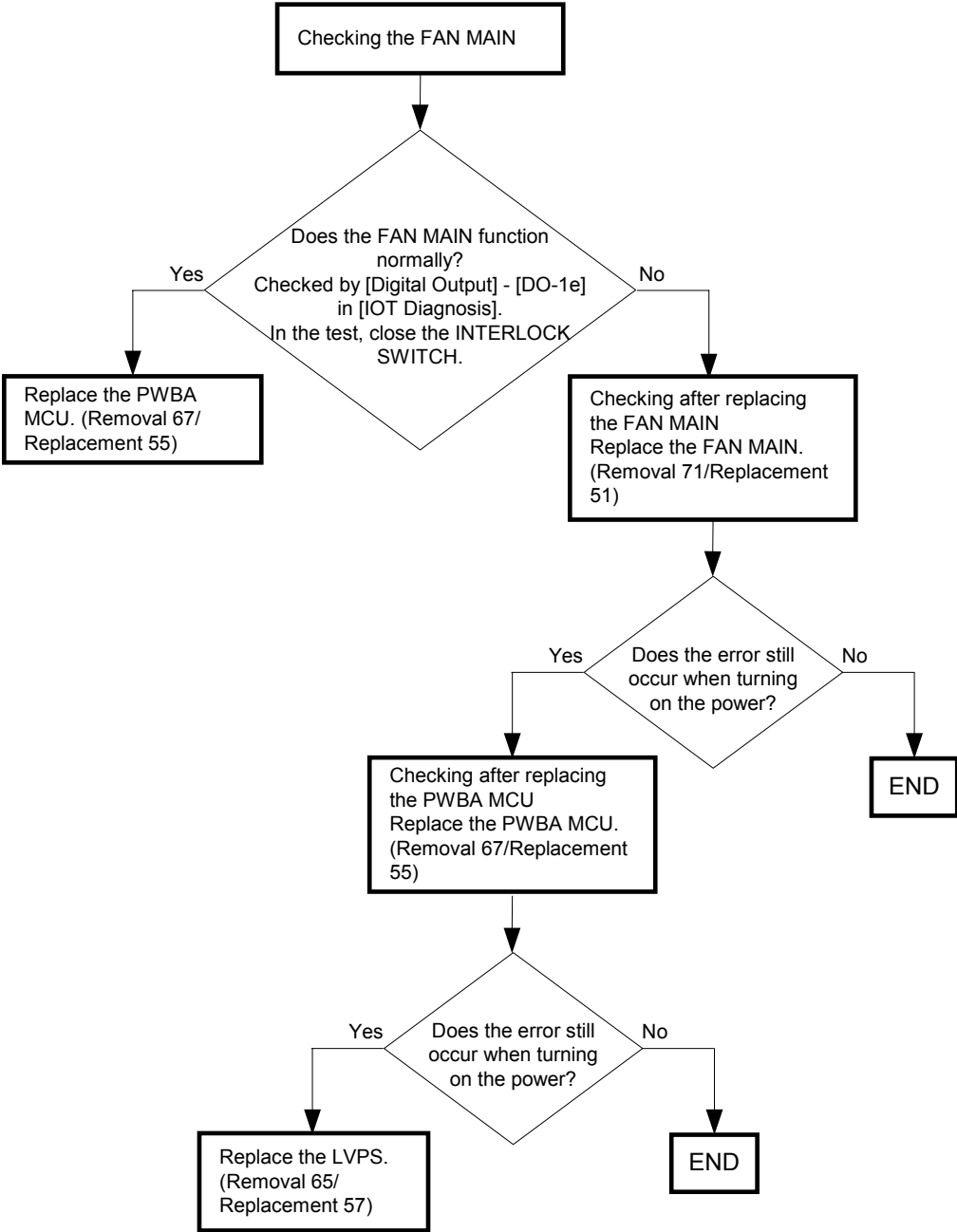

FIP-1.2 Restart Printer 001-361/001-363

Possible causative parts:PWBA MCU (PL9.1.20)
CHUTE ASSY DUP (PL11.1.1)

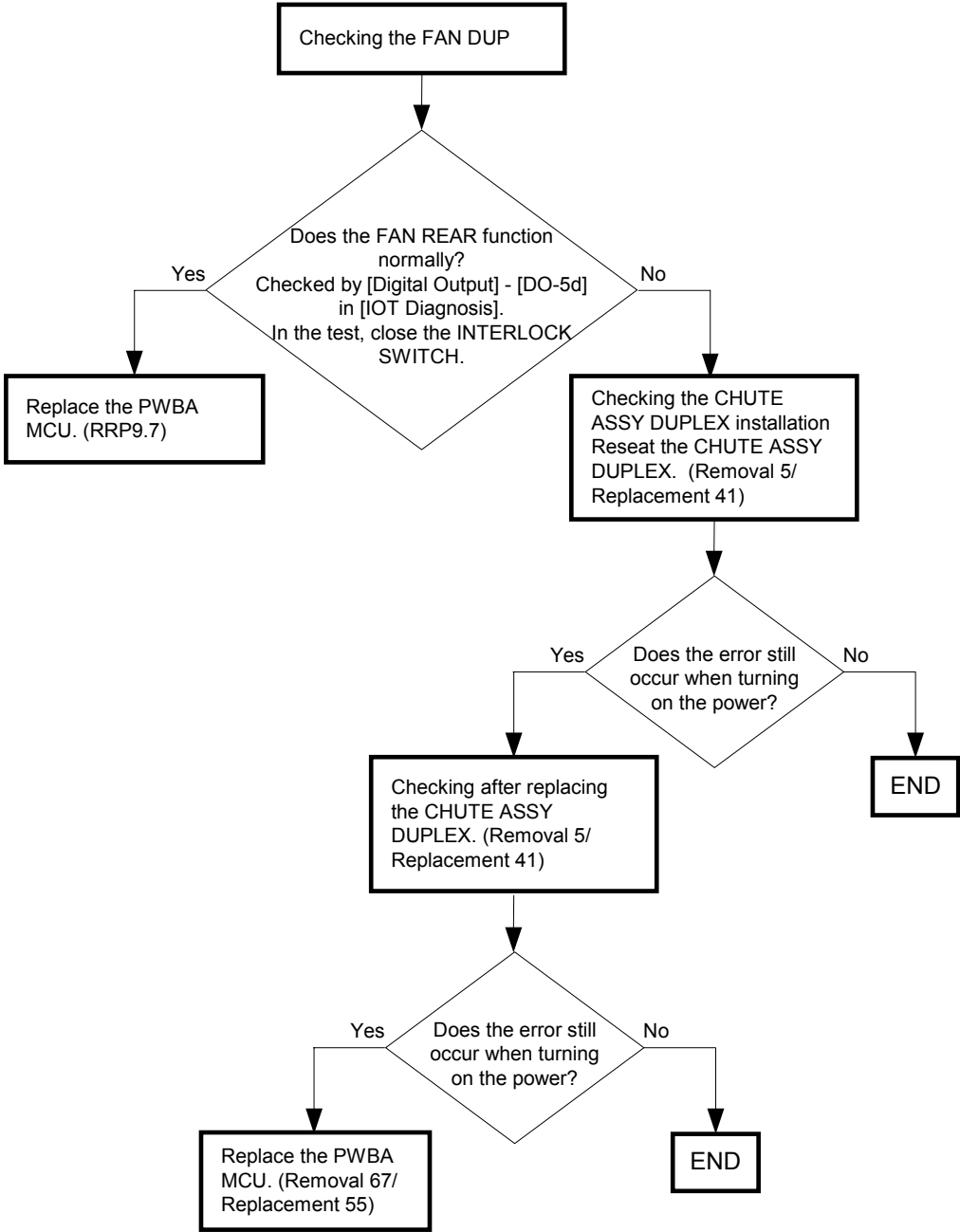

FIP-1. 3 Restart Printer 003-341/003-342/003-343/003-344/003-345/
003-346/003-347/003-348/003-349/003-350

Possible causative parts:PWBA MCU (PL9.1.20)

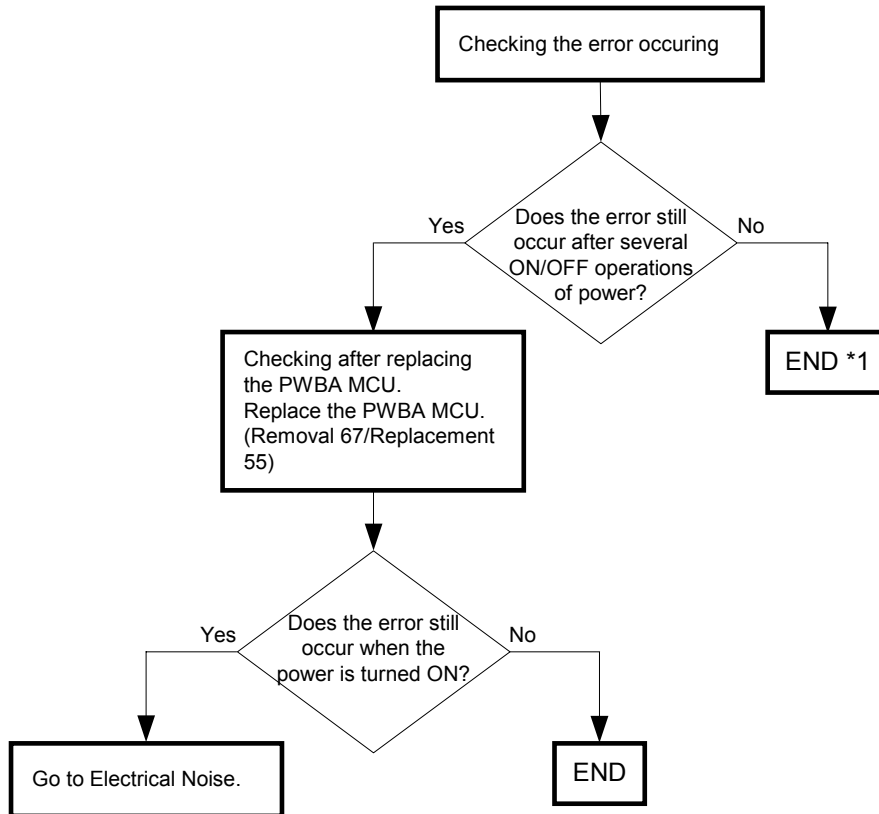

*1: Some external noise is suspected. Go to [FIP-1. 87 Electrical Noise] to check for any noise disturbance.

FIP-1. 4 Restart Printer 003-356

Possible causative parts:TRANSFER BELT (PL4.1.1)
PWBA HVPS (PL5.1.17)
FUSER (PL6.1.10)
PWBA EEPROM STD (PL13.5.1)
PWBA MCU (PL13.5.13)

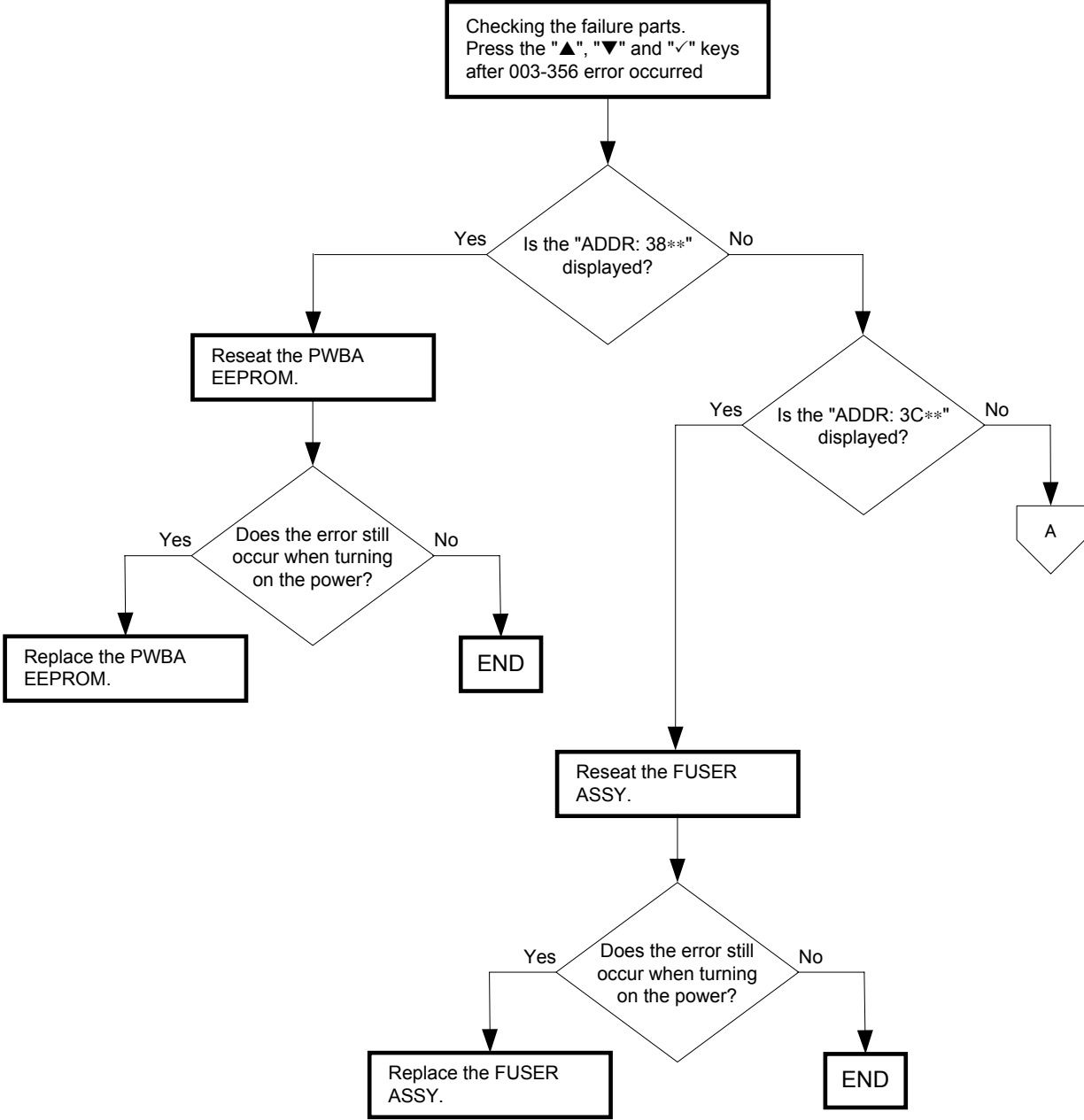

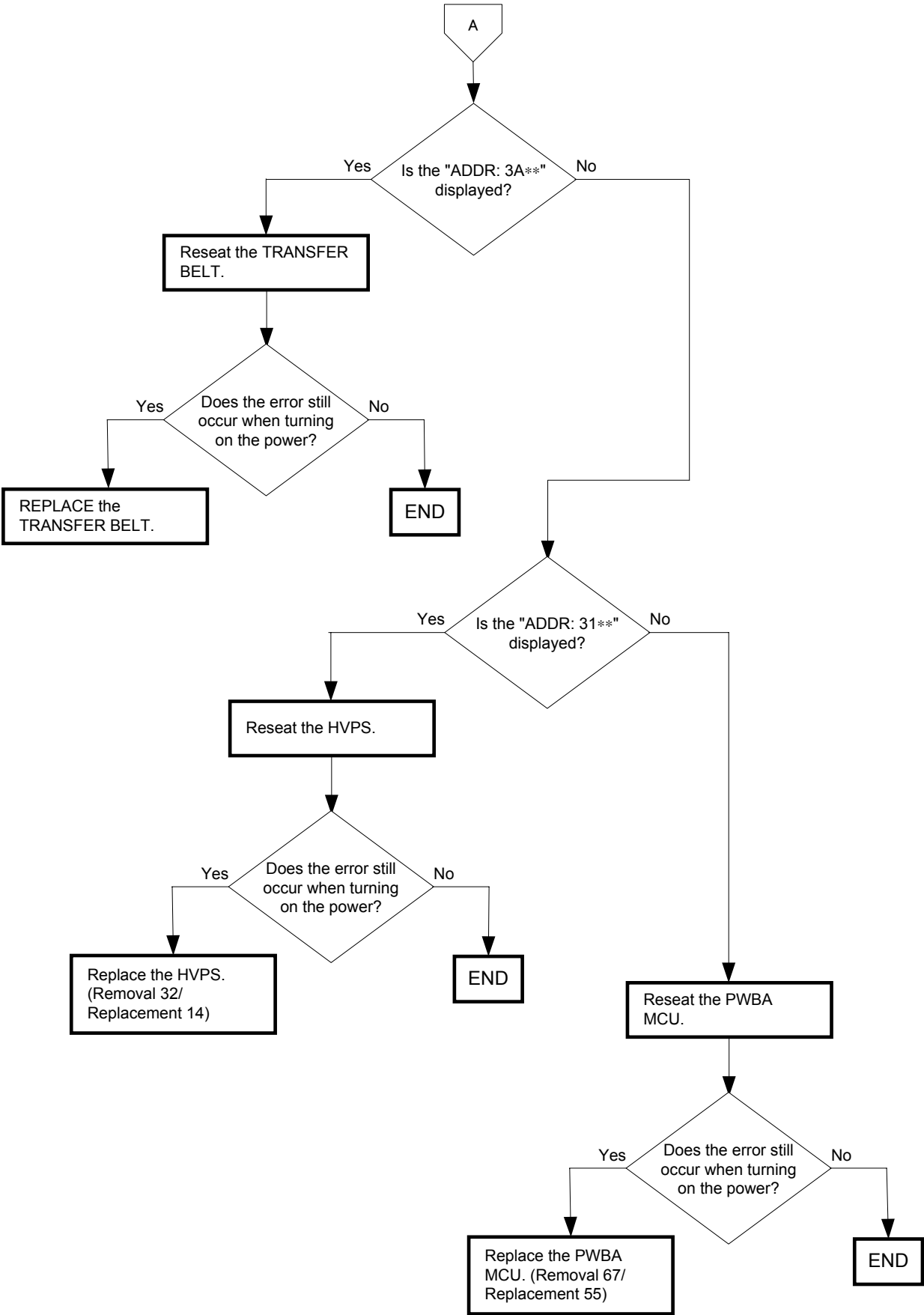

FIP-1. 5 Restart Printer 004-310

Possible causative parts:PWBA MCU (PL9.1.20)
OPTION FEEDER ASSY (PL12.1.1)

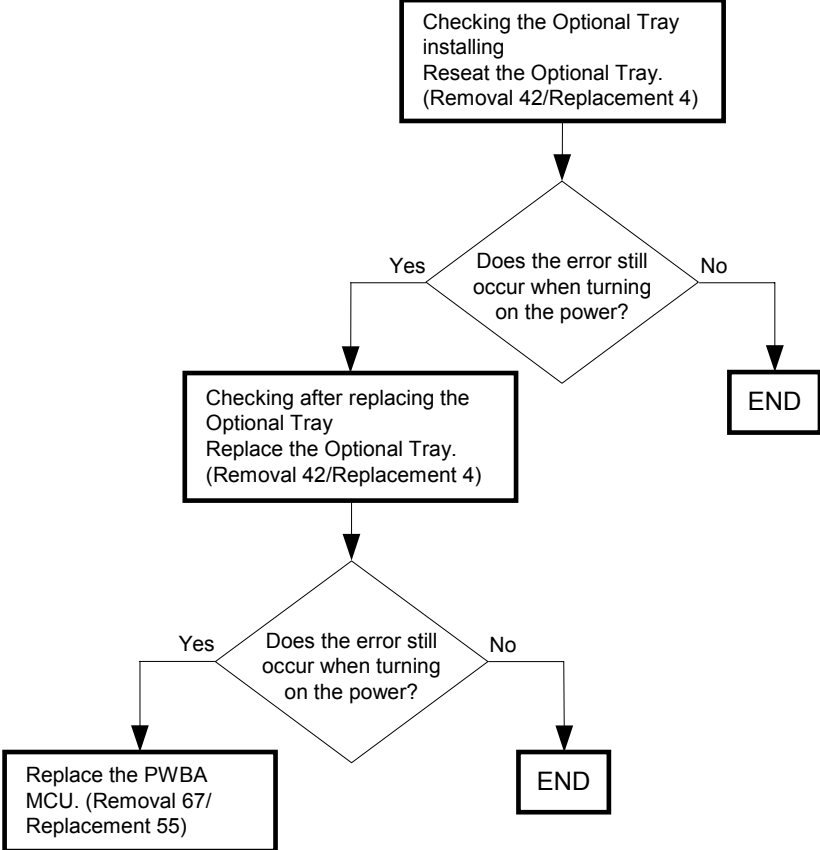

FIP-1.6 Restart Printer 004-311

Possible causative parts:PWBA MCU (PL9.1.20)
DUPLEX ASSY (PL11.1.1)

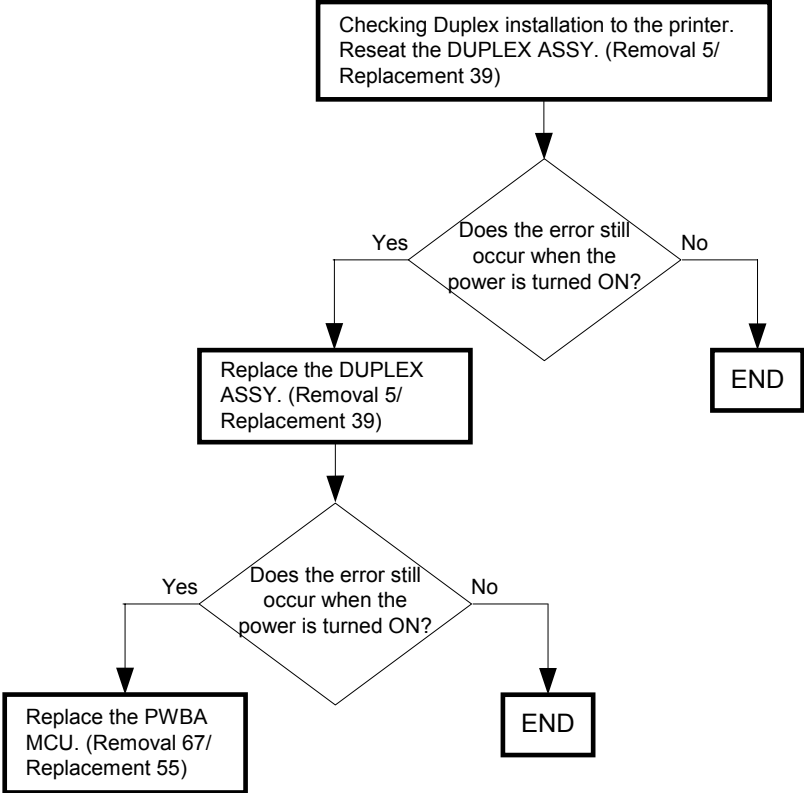

FIP-1.7 Restart Printer 006-370/006-371/006-372/006-373/006-374/006-375/006-376/
006-377/006-378/006-379/006-380/006-381/006-382/006-383/006-384

Possible causative parts:ROS ASSY (PL13.3.12)
PWBA MCU (PL9.1.20)

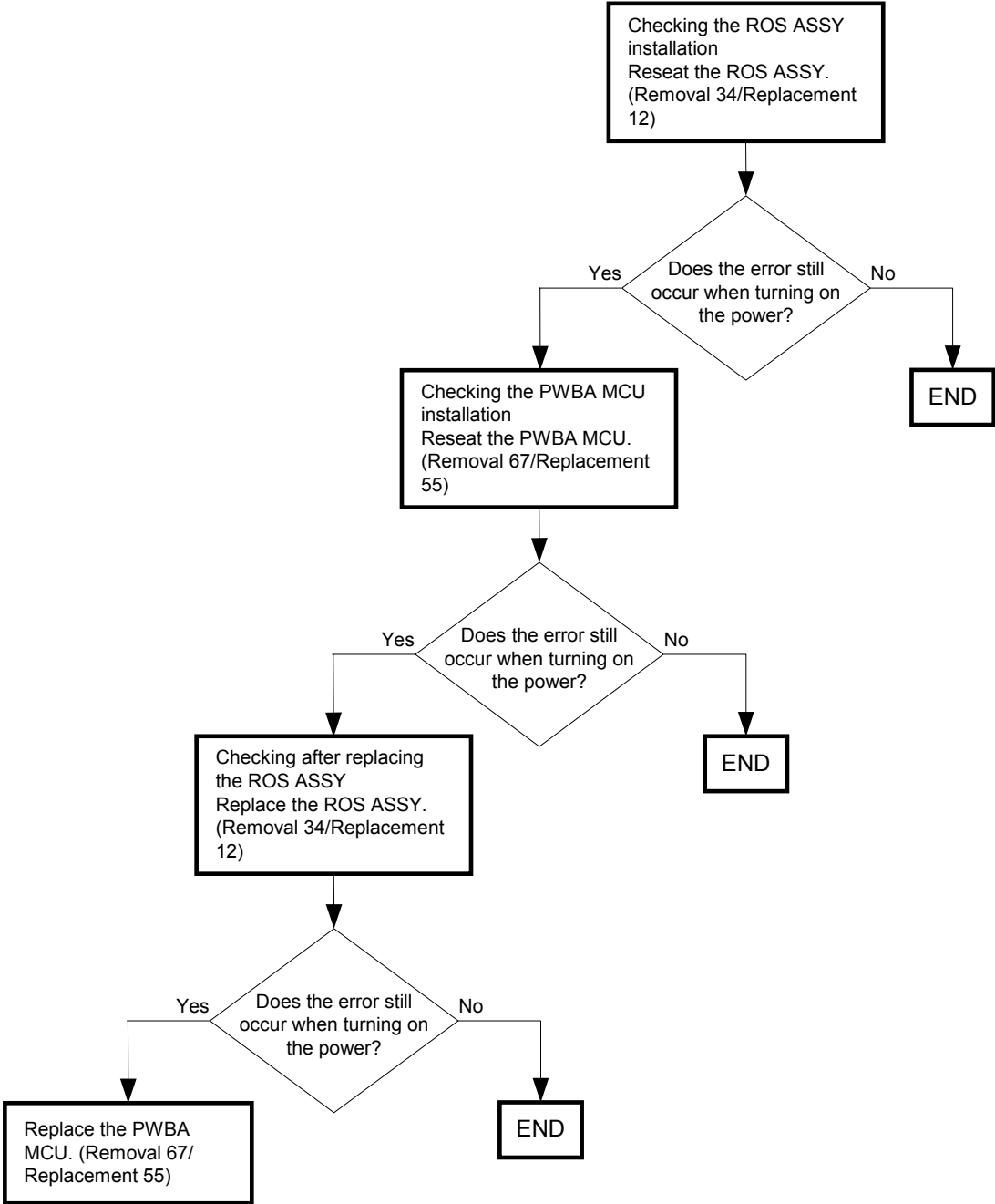

FIP-1. 8 Restart Printer 007-340/007-345/007-346/007-347/007-348/007-355/007-356/
007-357/007-358/007-359/007-360/007-365/007-366//007-367/007-368/007-370

Possible causative parts:DRIVE ASSY MAIN (PL8.1.1)
PWBA MCU (PL9.1.20)

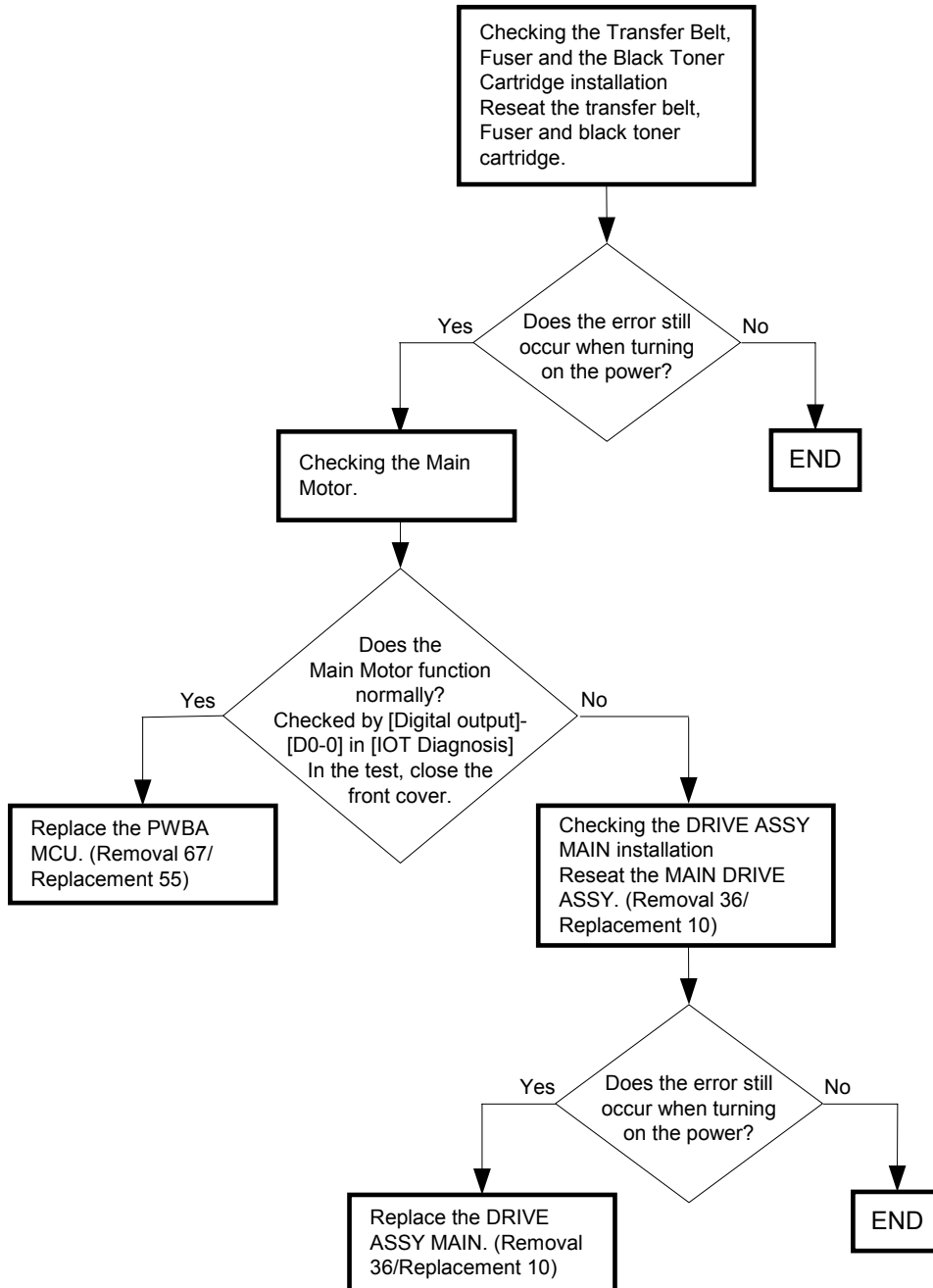

FIP-1.9 Restart Printer 007-341/007-345/007-349/007-350/007-351/007-355/007-356/
007-357/007-361/007-362/007-363/007-365/007-366/007-367/007-369/007-370

Possible causative parts:DRIVE ASSY MAIN (PL8.1.1)
PWBA MCU (PL9.1.20)

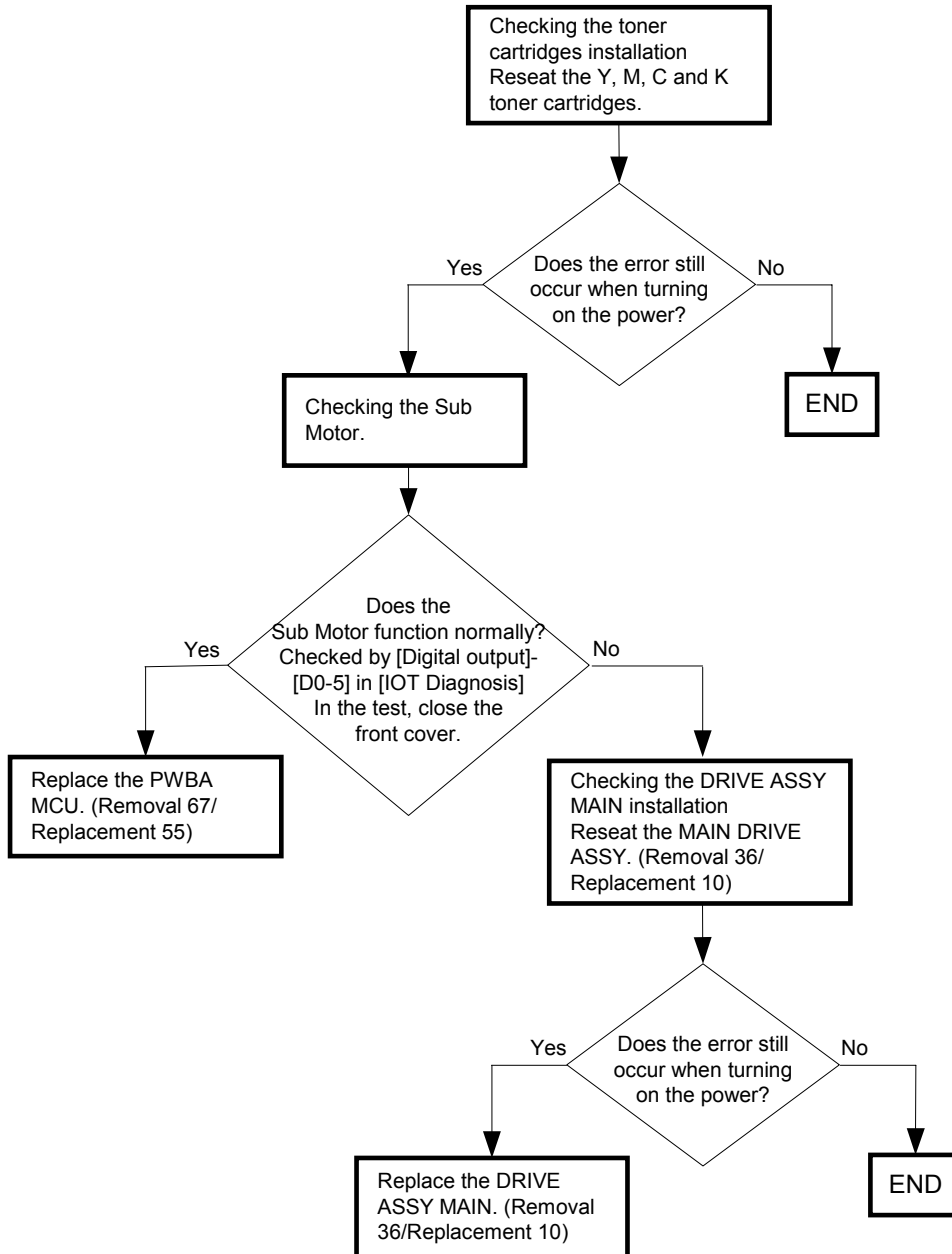

FIP-1. 10 Restart Printer 007-342/007-346/007-349/007-352/007-353/007-355/007-358/
007-359/007-361/007-362/007-364/007-365/007-366/007-368/007-369/007-370

Possible causative parts:DRIVE ASSY MAIN (PL8.1.1)
PWBA MCU (PL9.1.20)

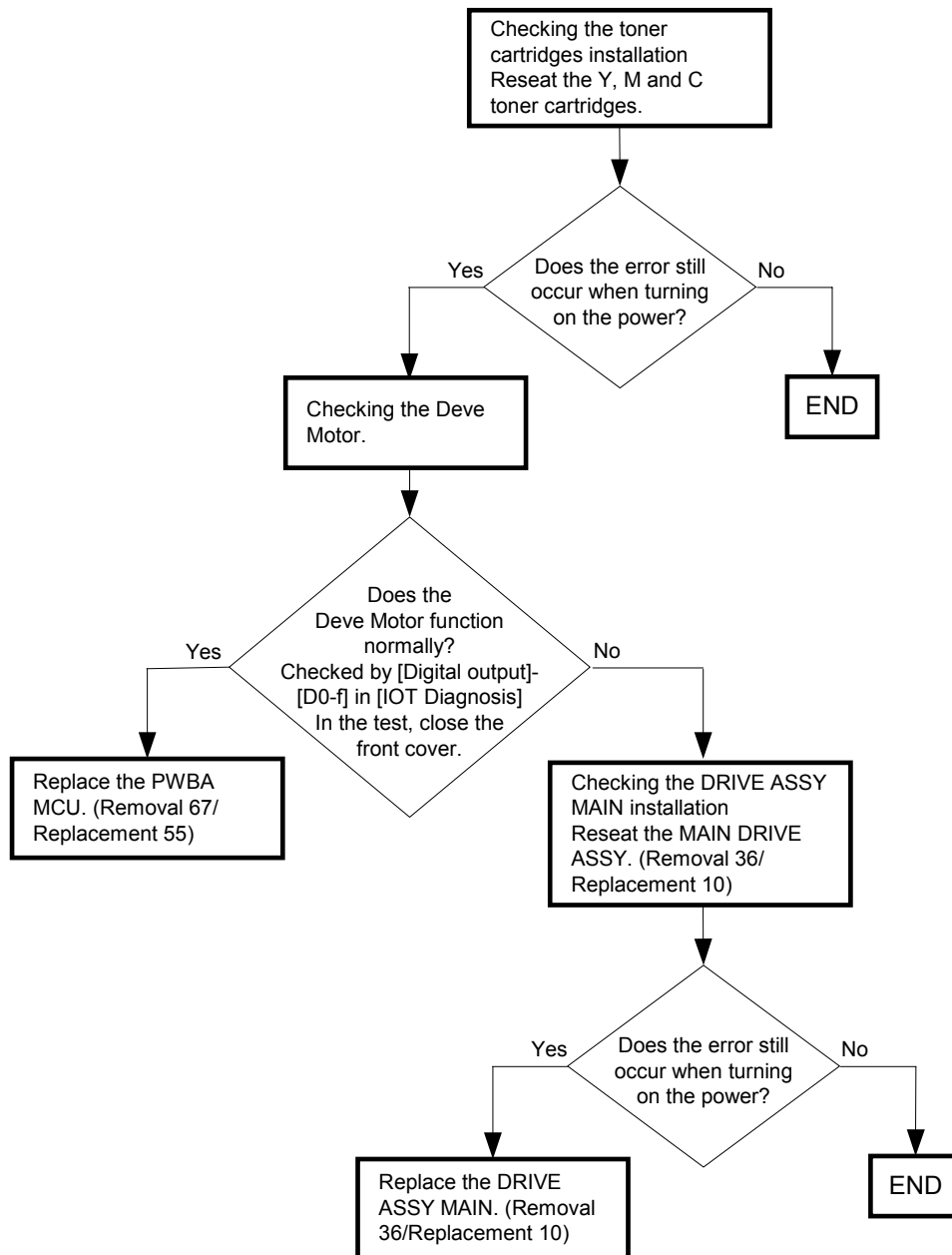

FIP-1. 11 Restart Printer 007-343/007-347/007-350/007-352/007-354/007-356/007-358/
007-360/007-361/007-363/007-364/007-365/007-367/007-368/007-369/007-370

Possible causative parts:FEEDER ASSY (PL3.2.99)
DRIVE ASSY PH (PL8.1.8)
PWBA MCU (PL9.1.20)

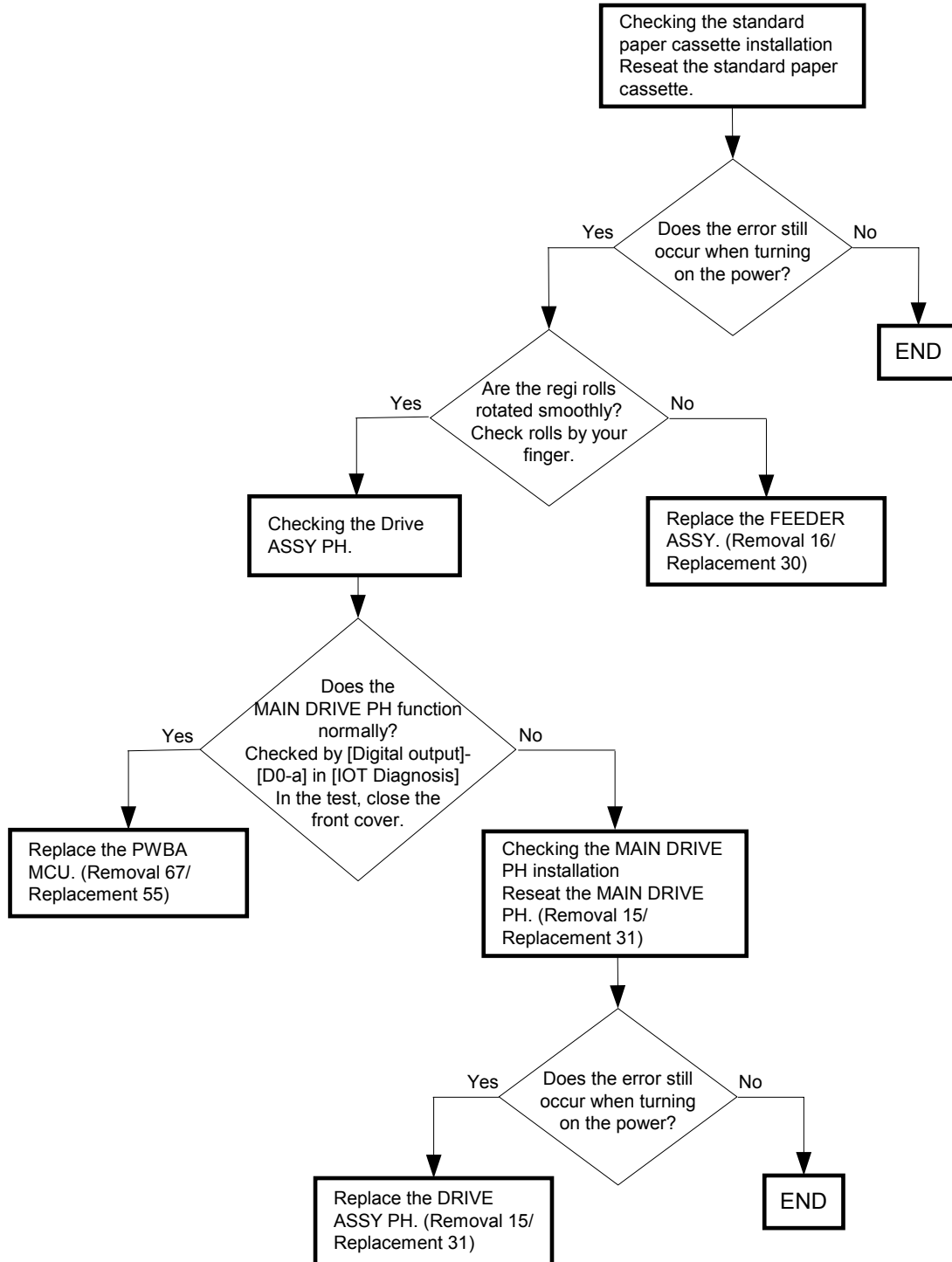

FIP-1. 12 Restart Printer 007-344/007-348/007-351/007-353/007-354/007-357/007-359/
007-360/007-362/007-363/007-364/007-366/007-367/007-368/007-369/007-370

Possible causative parts:PWBA MCU (PL9.1.20)
550 OPTION FEEDER (PL13.7.1)

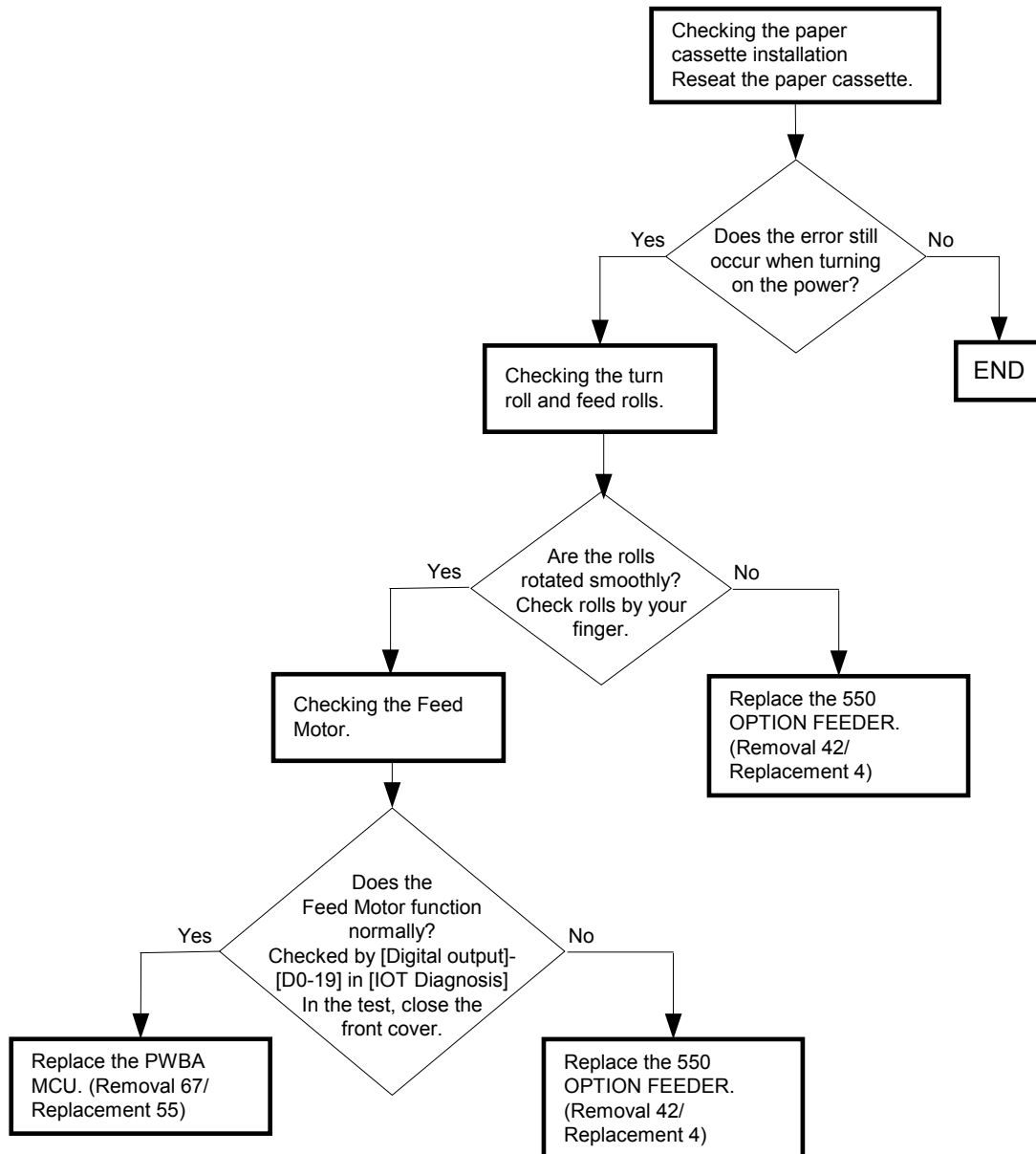

FIP-1. 13 Restart Printer 009-360/009-361/009-362/009-363

Possible causative parts:CONNECTOR CRUM (PL5.1.3)
CARTRIDGE ASSY K (PL5.1.18)
CARTRIDGE ASSY C (PL5.1.19)
CARTRIDGE ASSY M (PL5.1.20)
CARTRIDGE ASSY Y (PL5.1.21)
PWBA MCU (PL9.1.20)

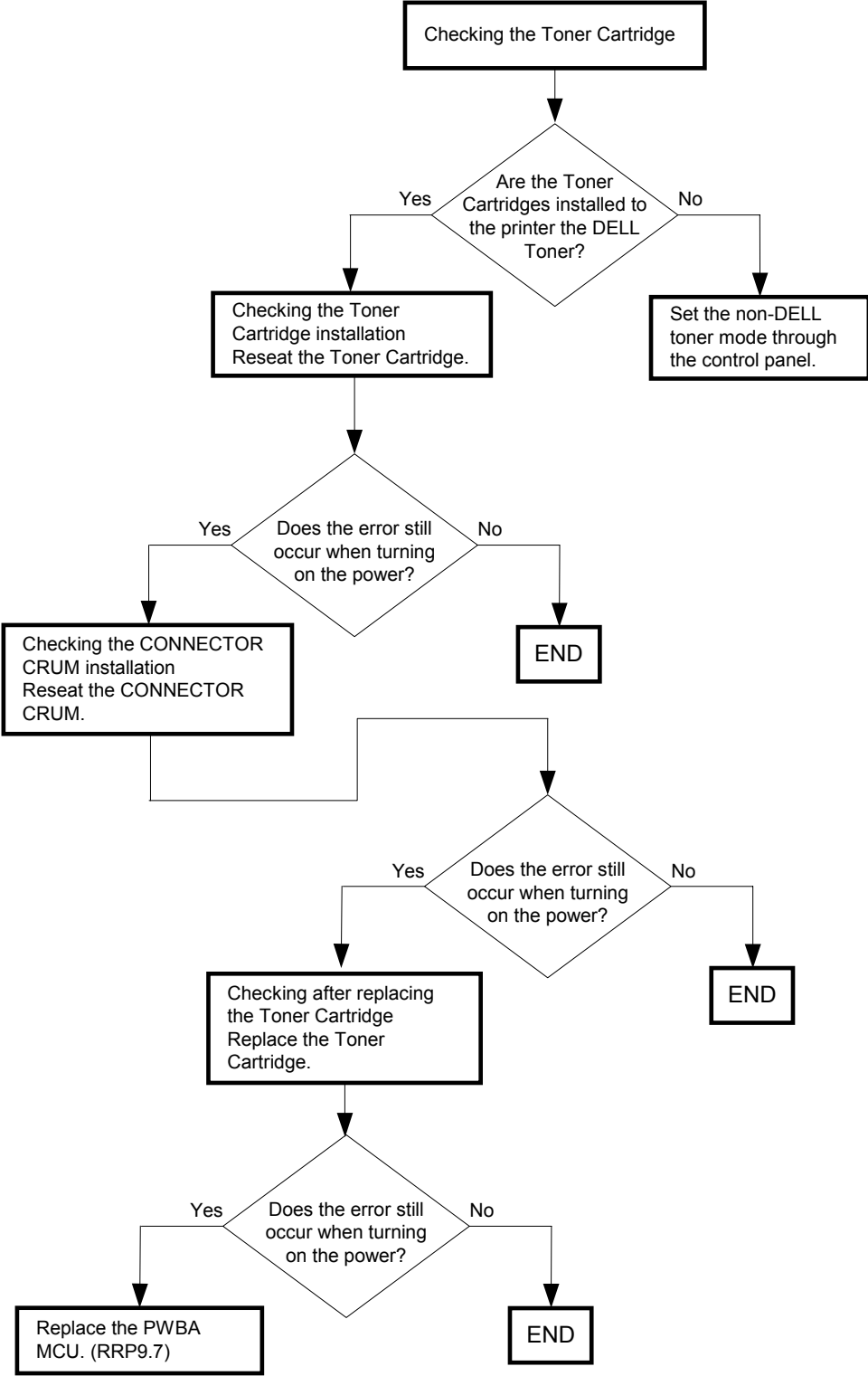

FIP-1. 14 Restart Printer 009-654

Possible causative parts:BELT CRU (PL4.1.1)
 CARTRIDGE ASSY (PL5.1.18 (K)/5.1.19 (C)/5.1.20 (M)/5.1.21 (Y))
 DRIVE ASSY MAIN (PL8.1.2)
 PWBA MCU (PL9.1.20)

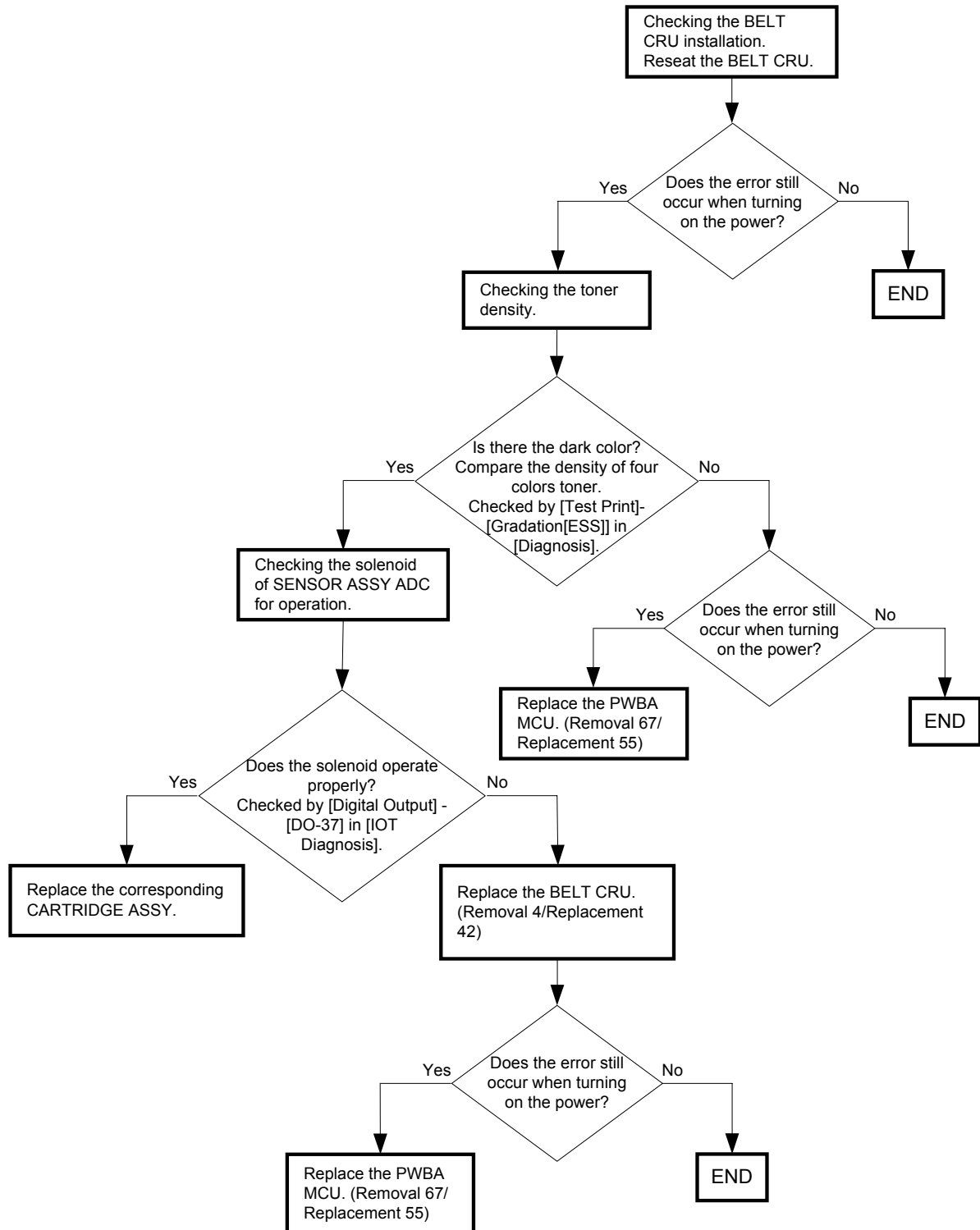

FIP-1. 15 Restart Printer 009-655

Possible causative parts:BELT CRU (PL4.1.1)
ROS ASSY (PL13.3.12)
CARTRIDGE ASSY (PL5.1.18 (K)/5.1.19 (C)/5.1.20 (M)/5.1.21 (Y))
PWBA MCU (PL9.1.20)

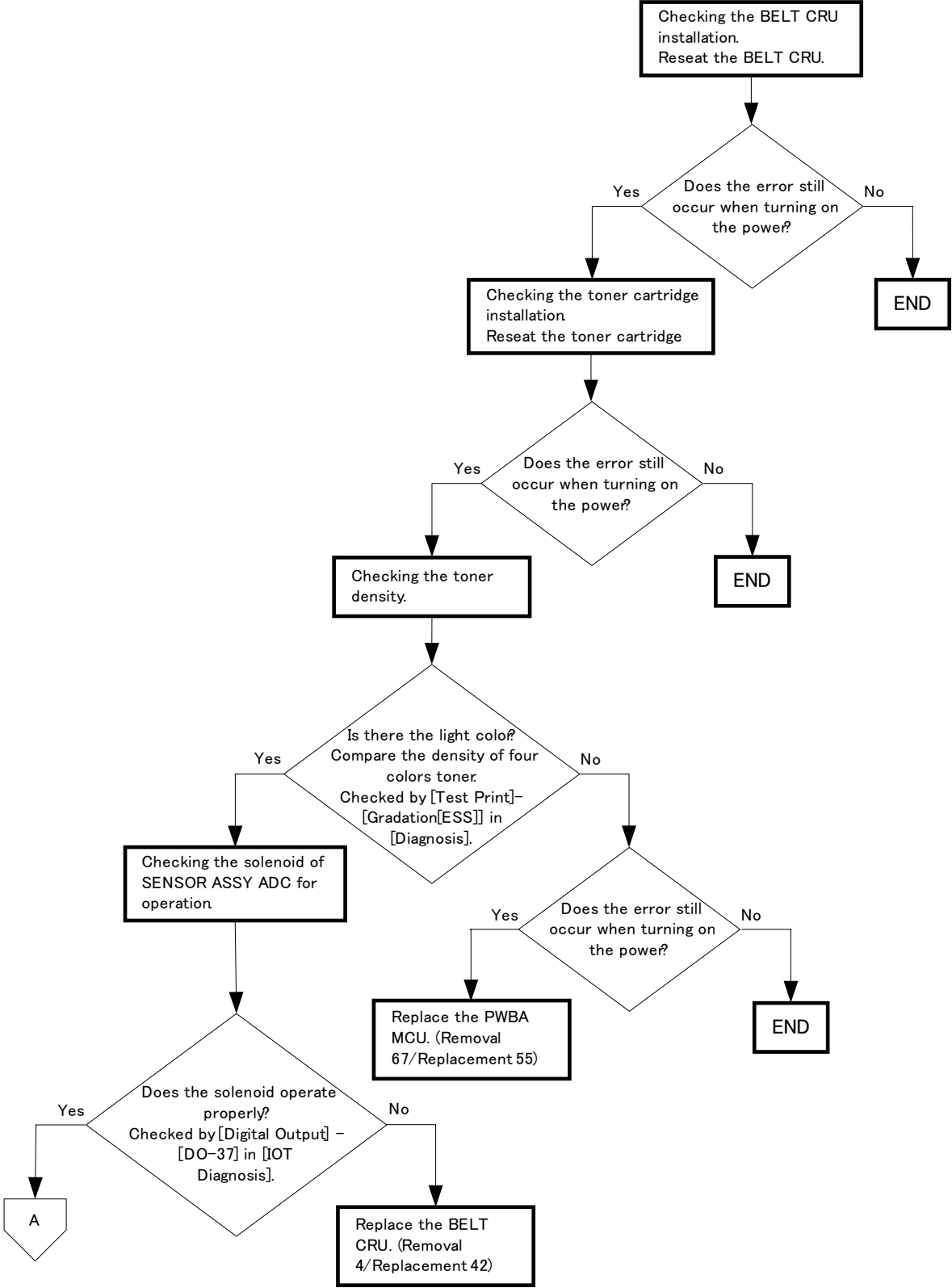

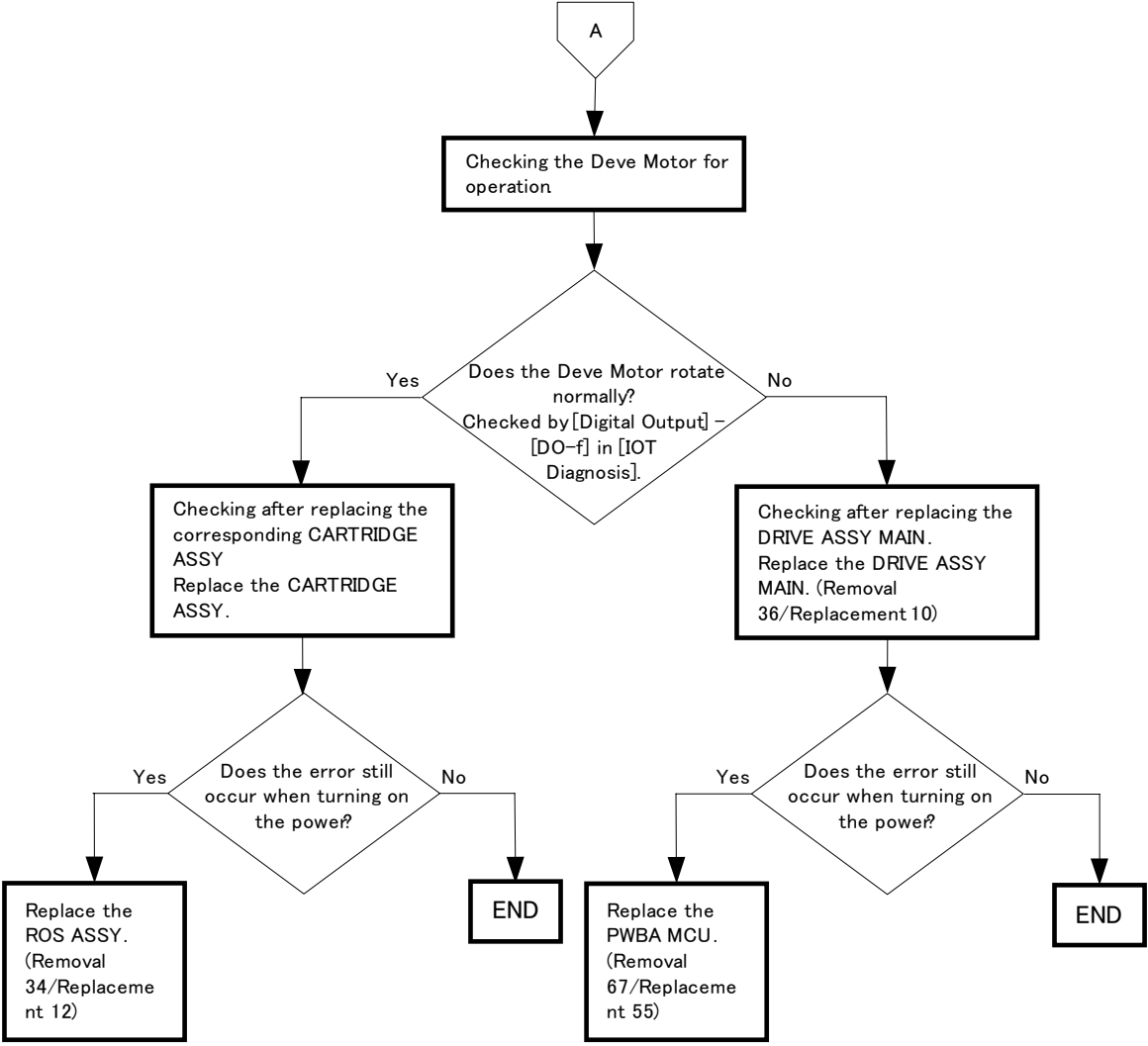

FIP-1. 16 Insert Fuser 010-317

Possible causative parts:FUSER ASSY (PL6.1.10)
PWBA MCU (PL9.1.20)

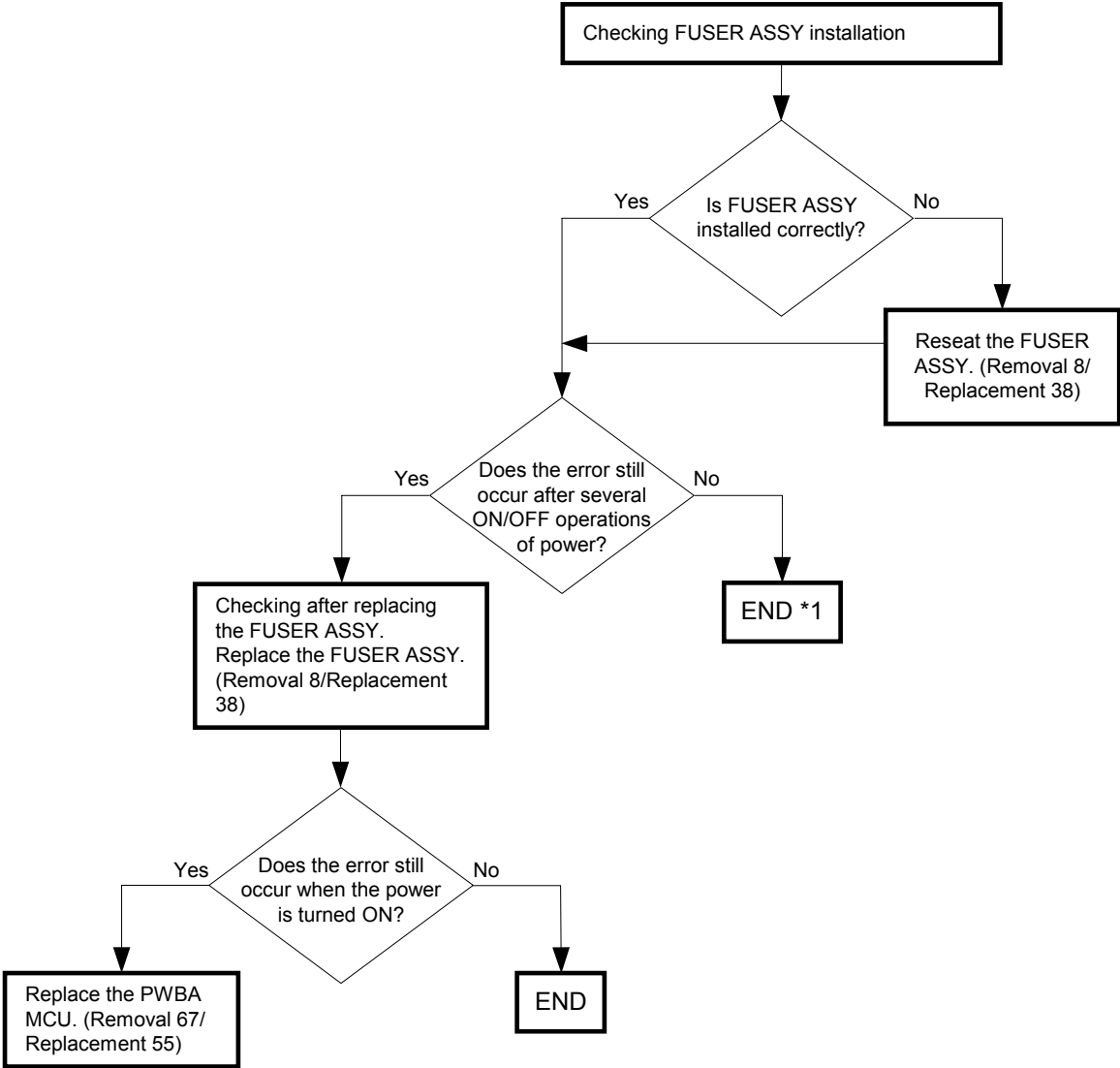

*1: Some external noise is suspected. Go to [FIP-1. 87 Electrical Noise] to check for any noise disturbance.

FIP-1. 17 Replace Fuser 010-351/Restart Printer 010-351

Possible causative parts:FUSER ASSY (PL6.1.10)
PWBA MCU (PL9.1.20)

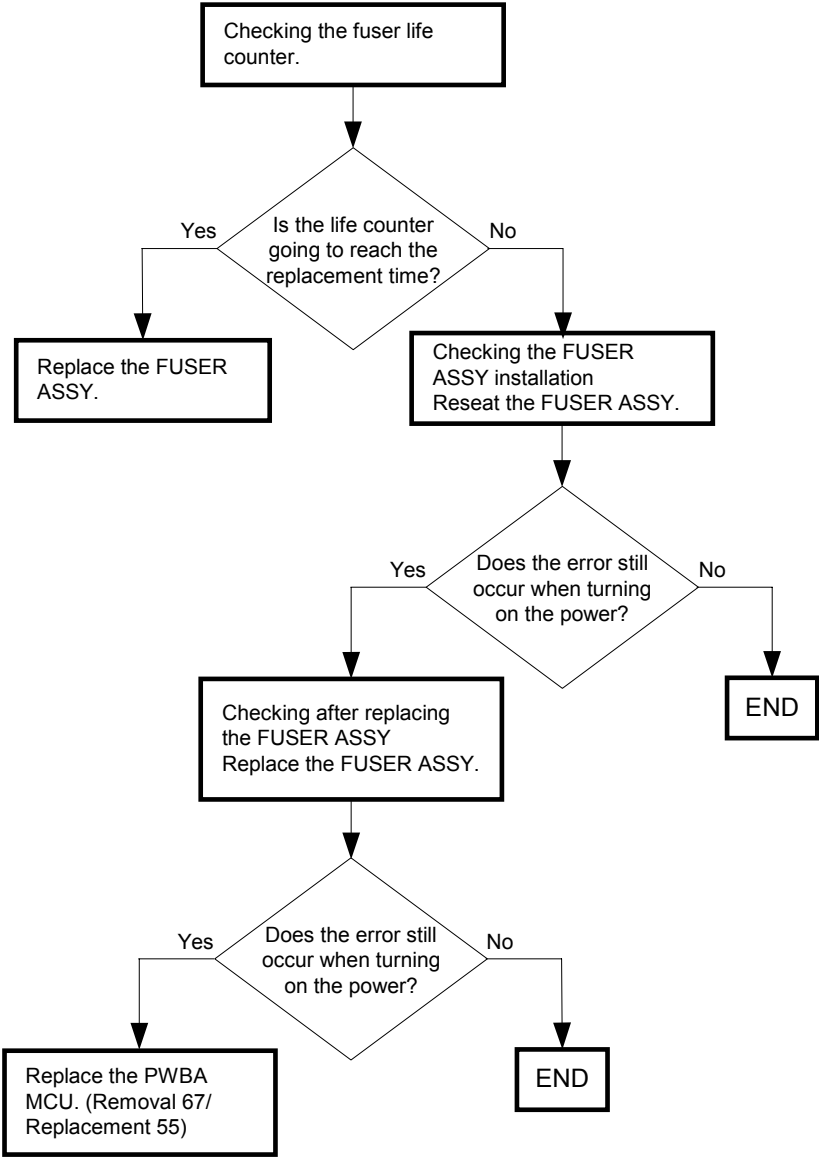

FIP-1. 18 Restart Printer 010-354

Possible causative parts:SENSOR HUM (PL13.5.11)
PWBA MCU (PL9.1.20)

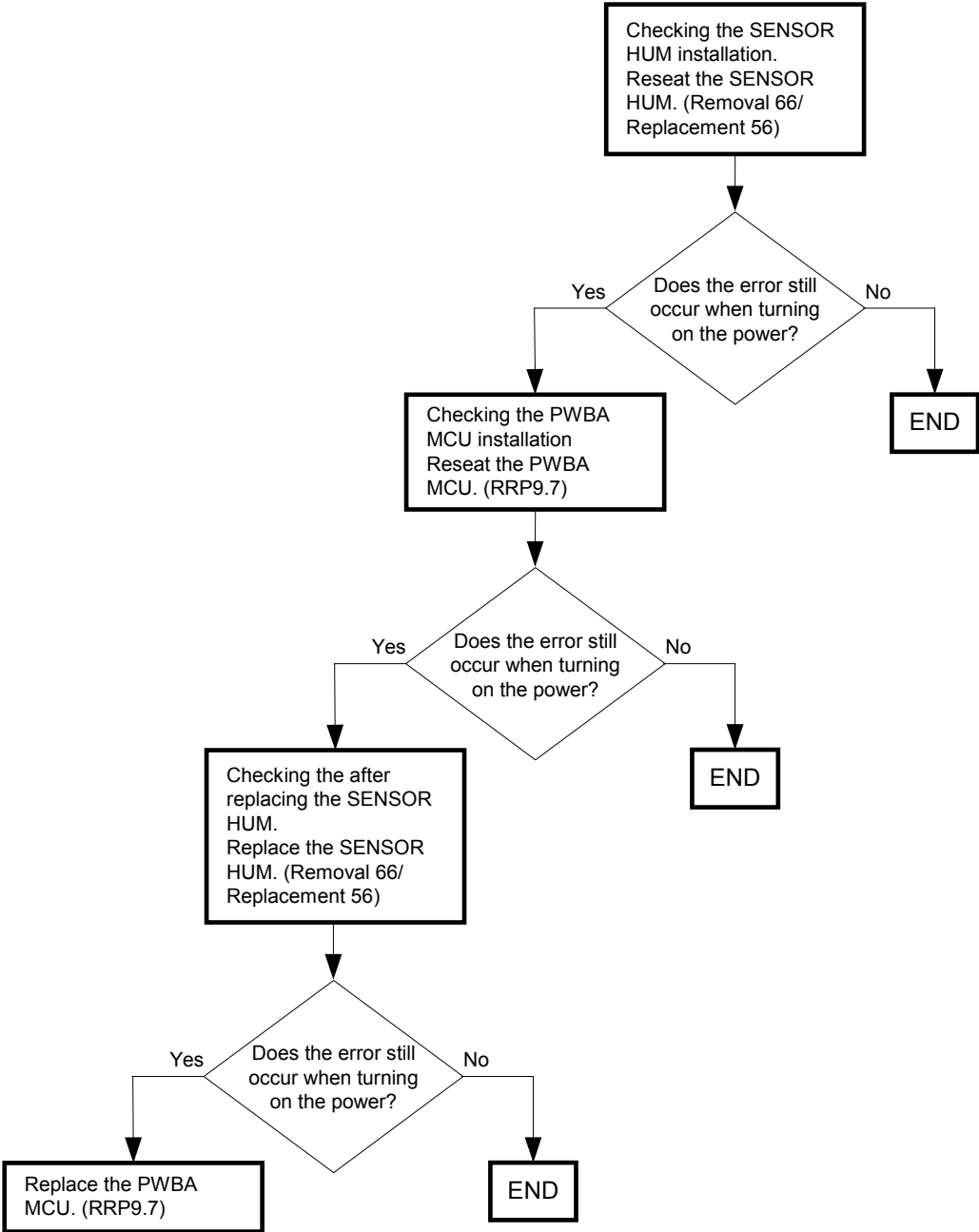

FIP-1. 19 Restart Printer 010-377/010-378/010-379/010-380/010-381/010-382/010-383/
 010-384/010-385/010-386/010-387/010-388/010-389/010-390/010-391/
 010-392/010-393/010-394/010-395/010-396/010-397

Possible causative parts:FUSER ASSY (PL6.1.10)
 LVPS (PL13.5.14)
 PWBA MCU (PL9.1.20)

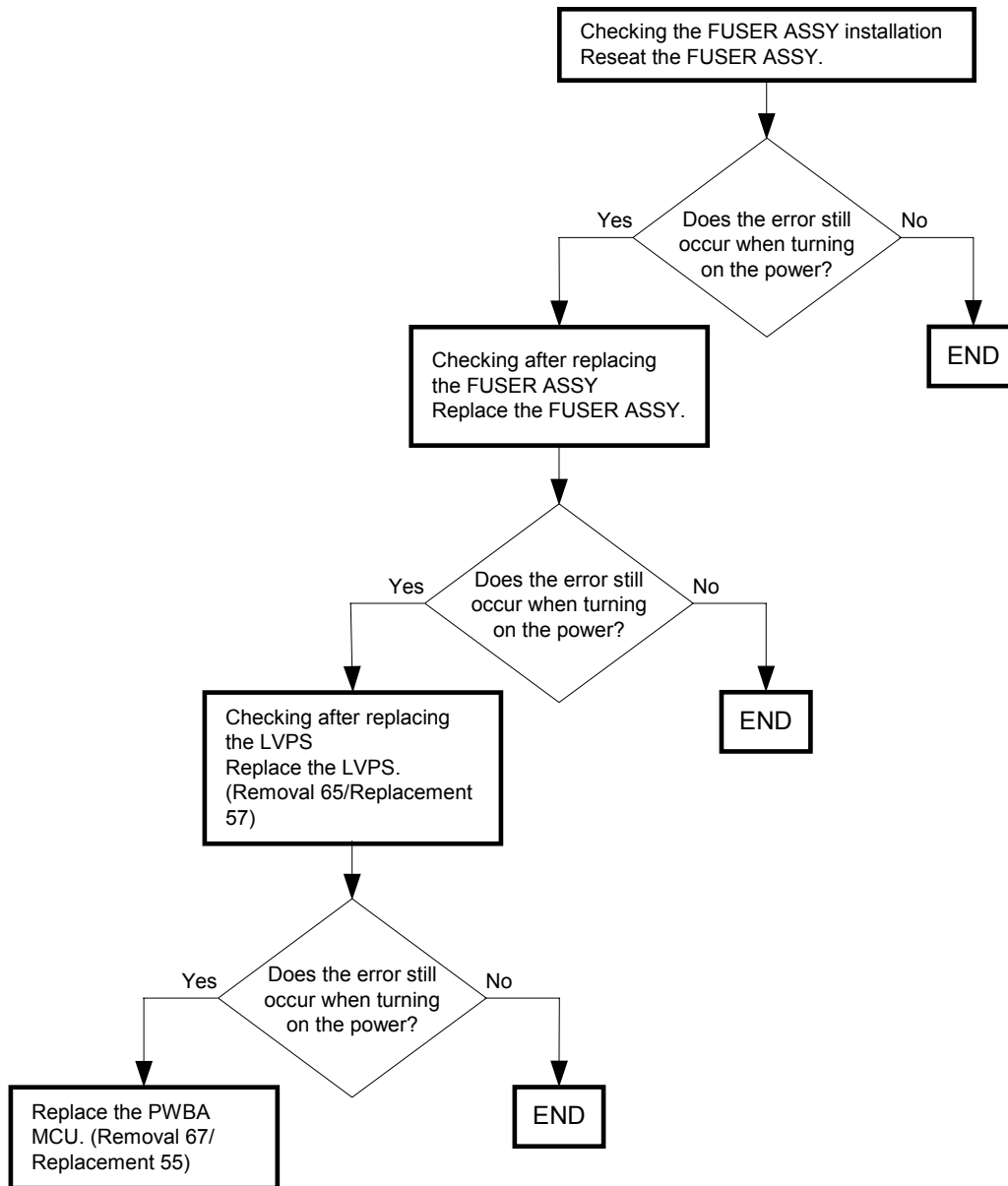

FIP-1. 20 Restart Printer 016-300/016-301/016-310/016-313/016-315/016-317/016-317/
016-323/016-327/016-340/016-344/016-345/016-346/016-347/016-348/016-349/
Erase Flash Err. 016-392/Write Flash Err. 016-393/Verify Error 016-394/
PCL Error 016-720

Possible causative parts:PWBA ESS (PL13.4.20)

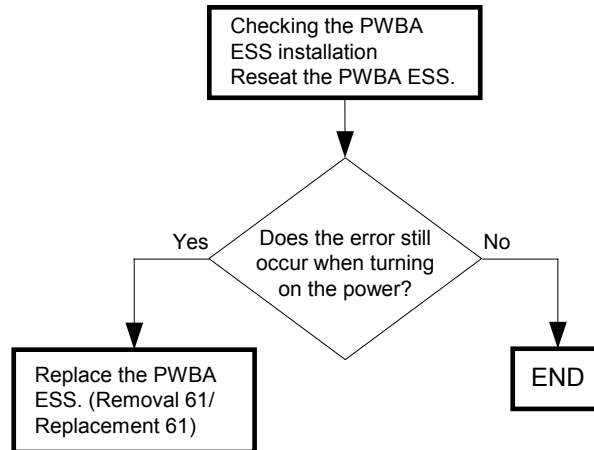

FIP-1. 21 Restart Printer 016-302

NOTE

If the customer connected the PC and printer using the USB cable, check the USB connection and printer connector damage.

Possible causative parts:PWBA ESS (PL13.4.20)

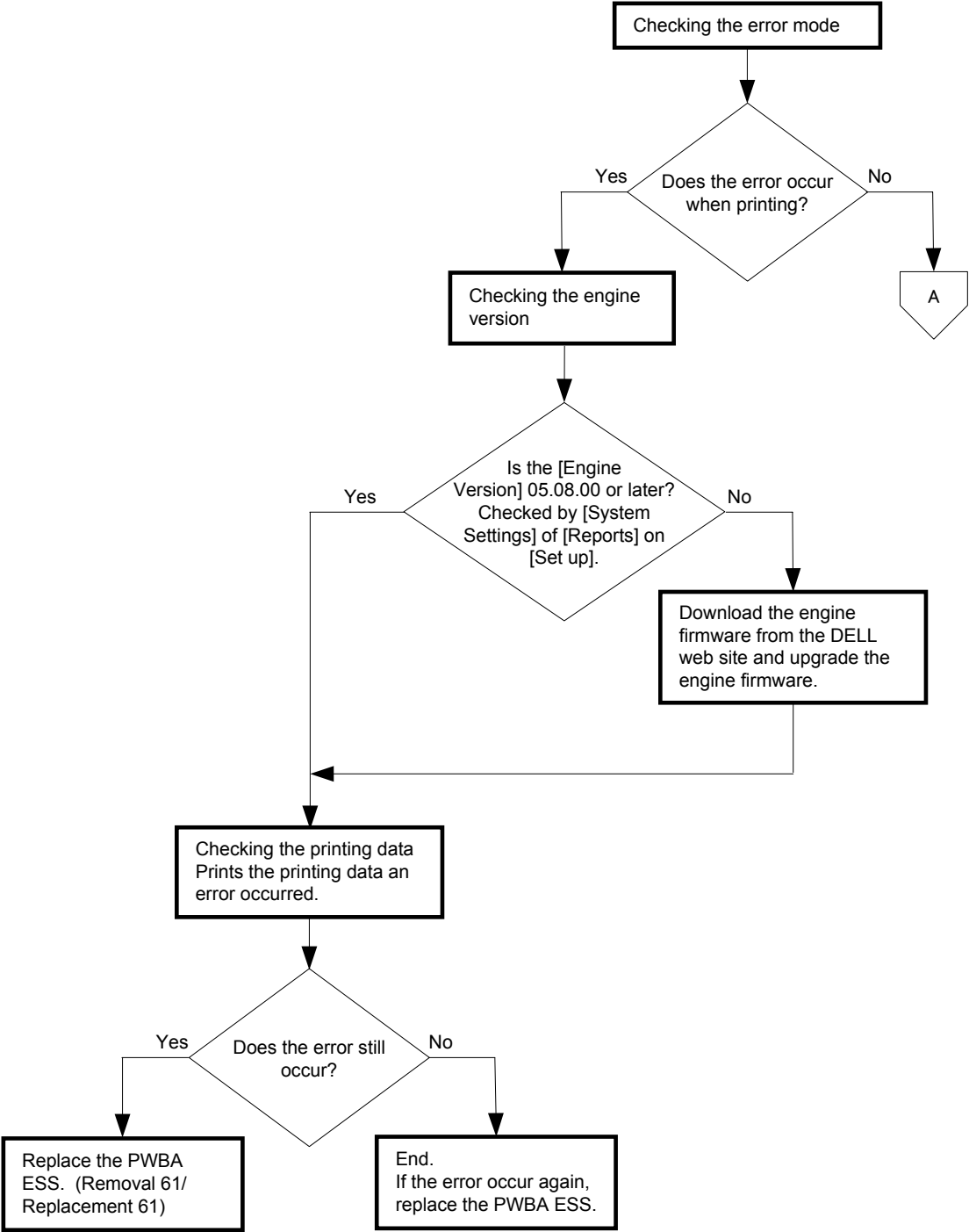

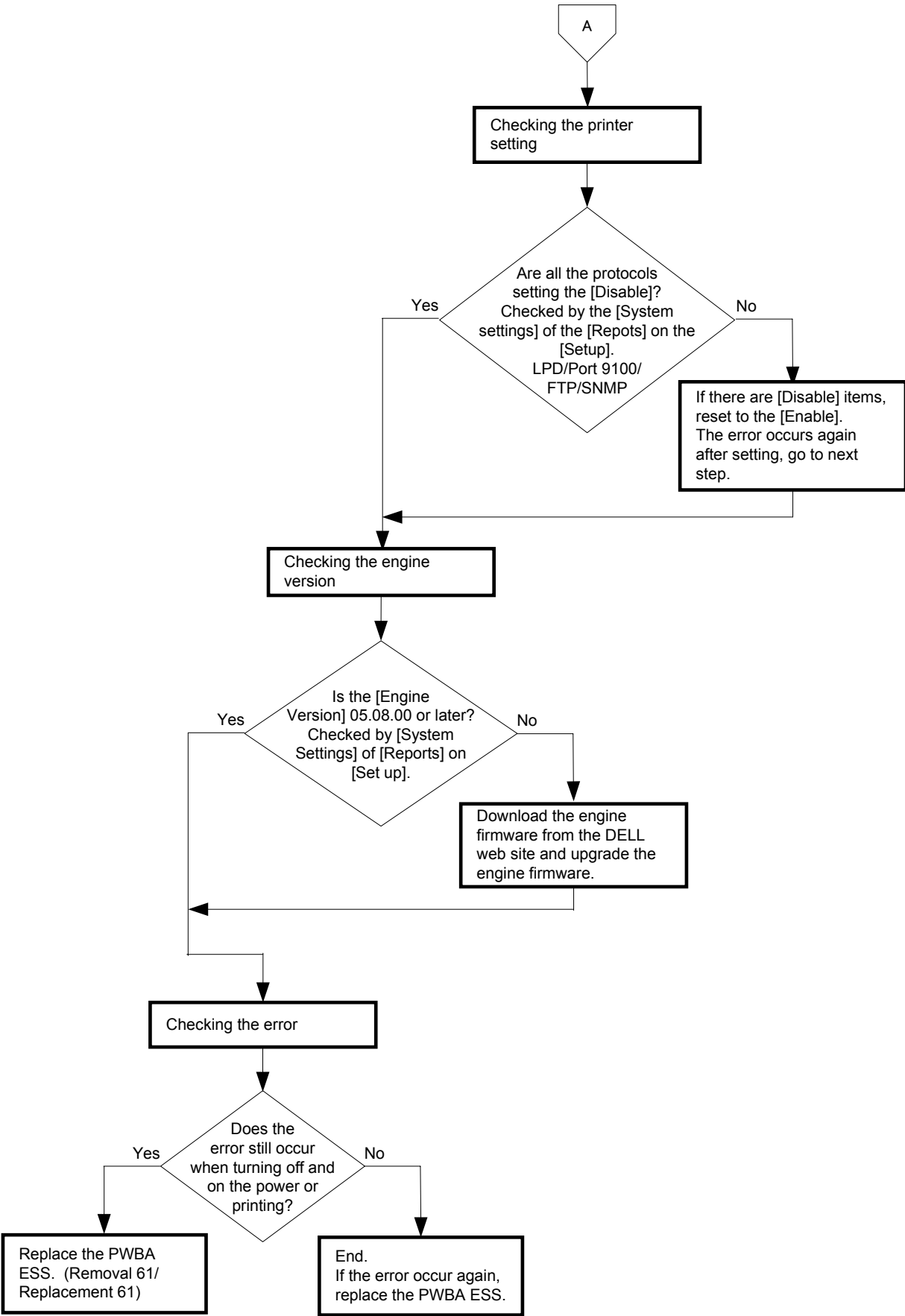

FIP-1. 22 Restart Printer 016-316/016-318

Possible causative parts:Memory Card (option)
PWBA ESS (PL13.4.20)

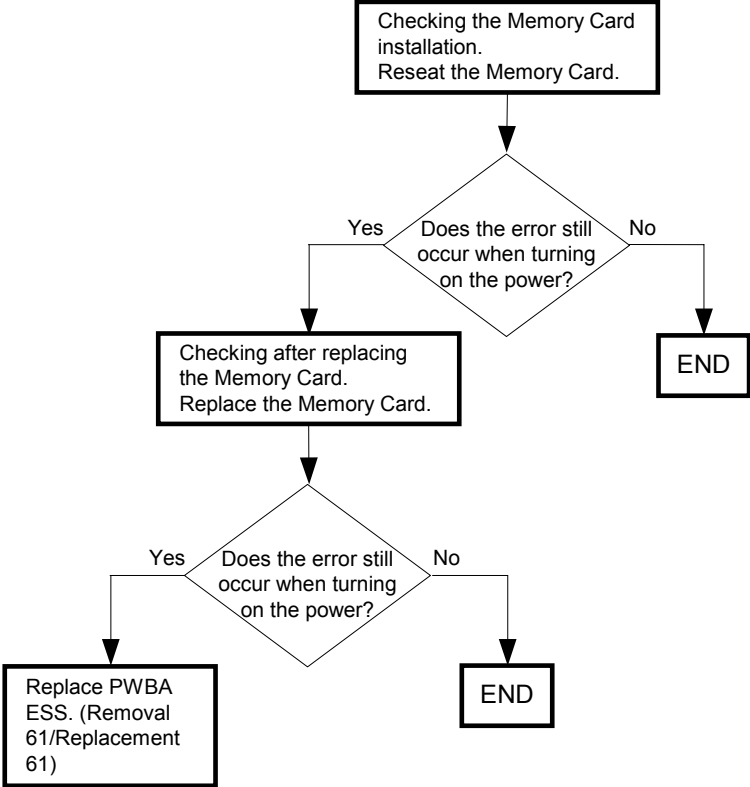

FIP-1. 23 Restart Printer 016-330/016-331/016-332/016-333/016-334/016-335/016-336/
016-337/Restart Printer 016-360/Network Error 016-770

Possible causative parts:Multi Protocol Card (option)
PWBA ESS (PL13.4.20)

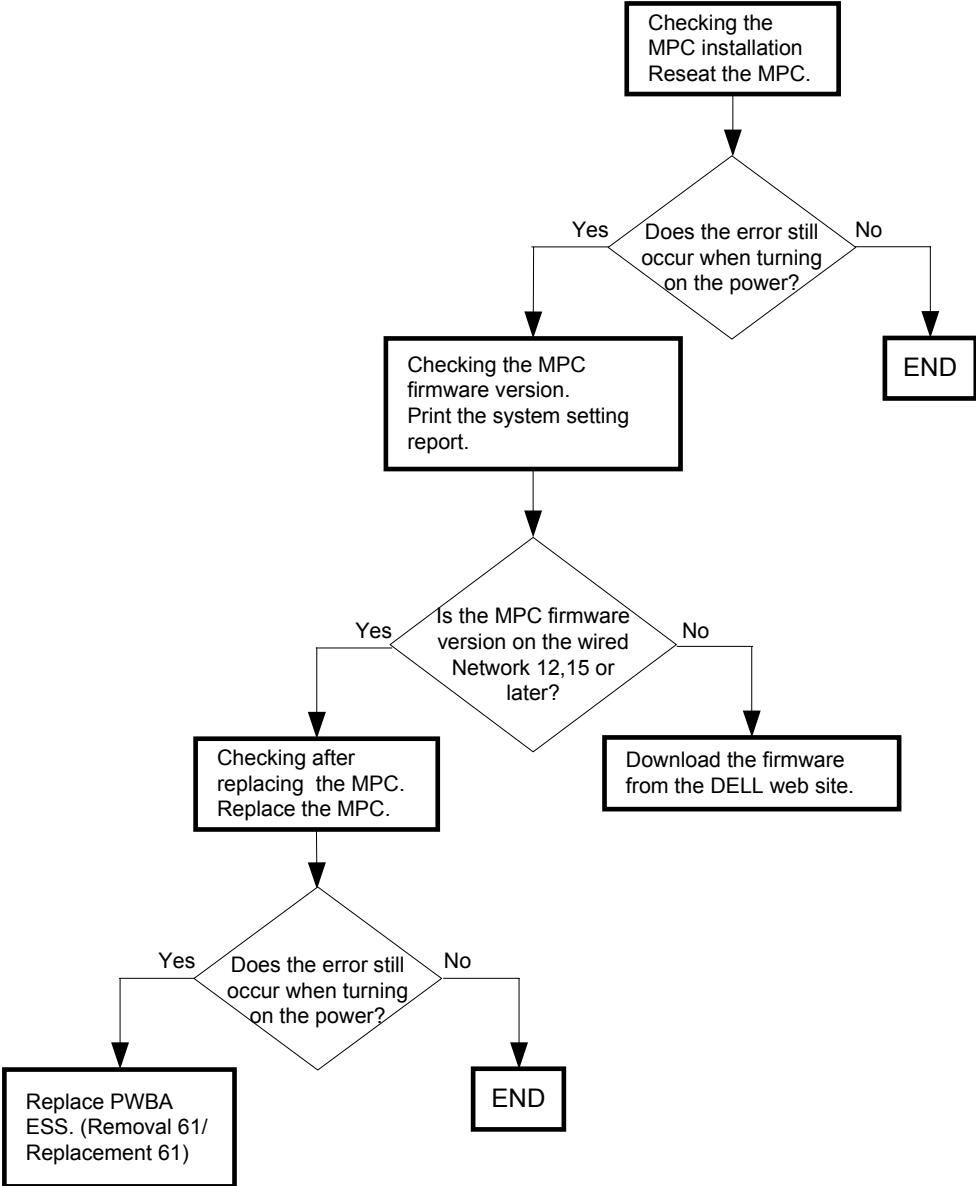

FIP-1. 24 Restart Printer 016-338

Possible causative parts:Option Wireless Printer Adapter
Option MPC Board

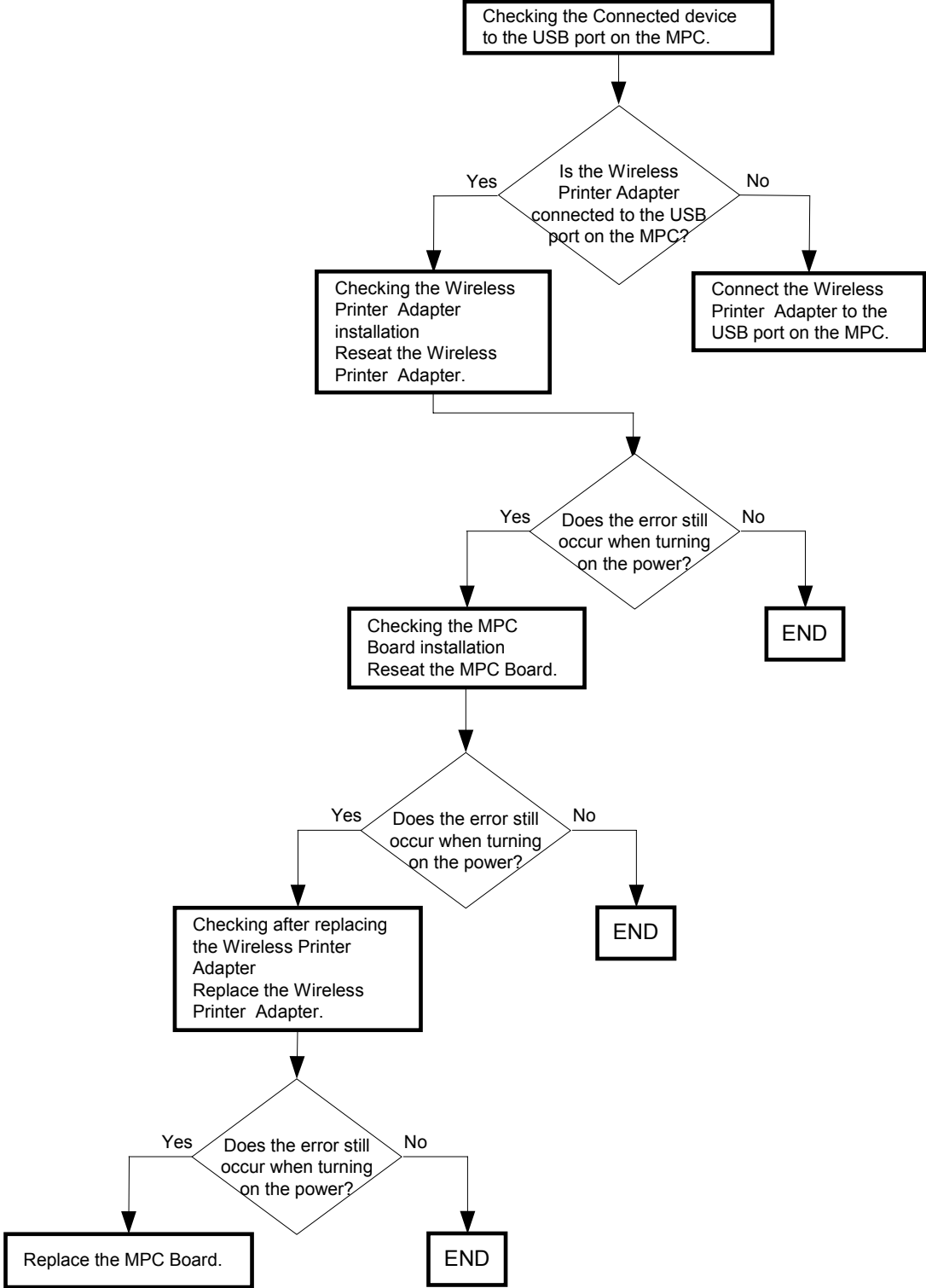

FIP-1. 25 Restart Printer 016-350

Possible causative parts:PWBA ESS (PL13.4.20)
IEEE 1284 Cable

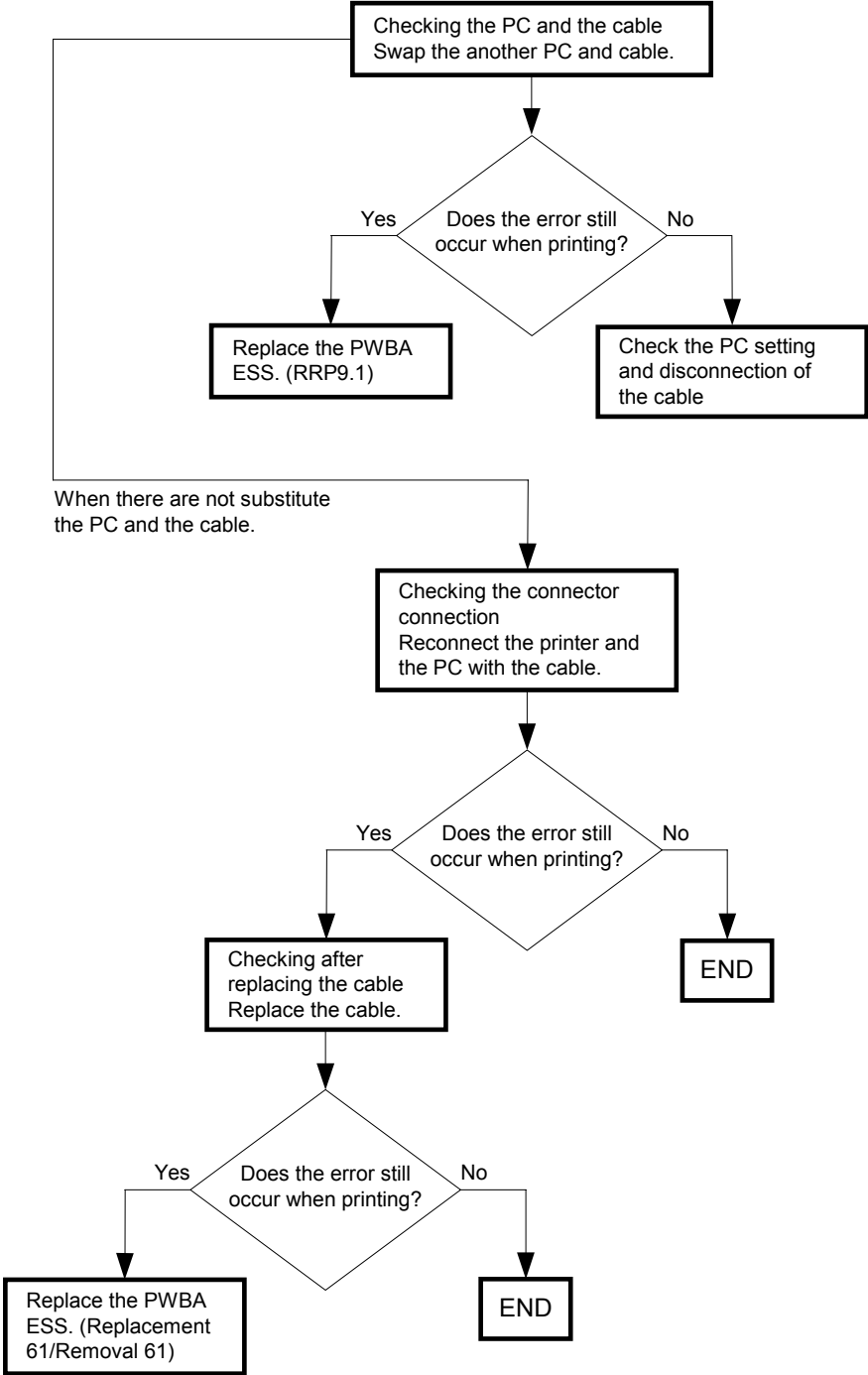

FIP-1. 26 Restart Printer 016-370

Possible causative parts:PWBA MCU (PL9.1.20)
PWBA ESS (PL13.4.20)

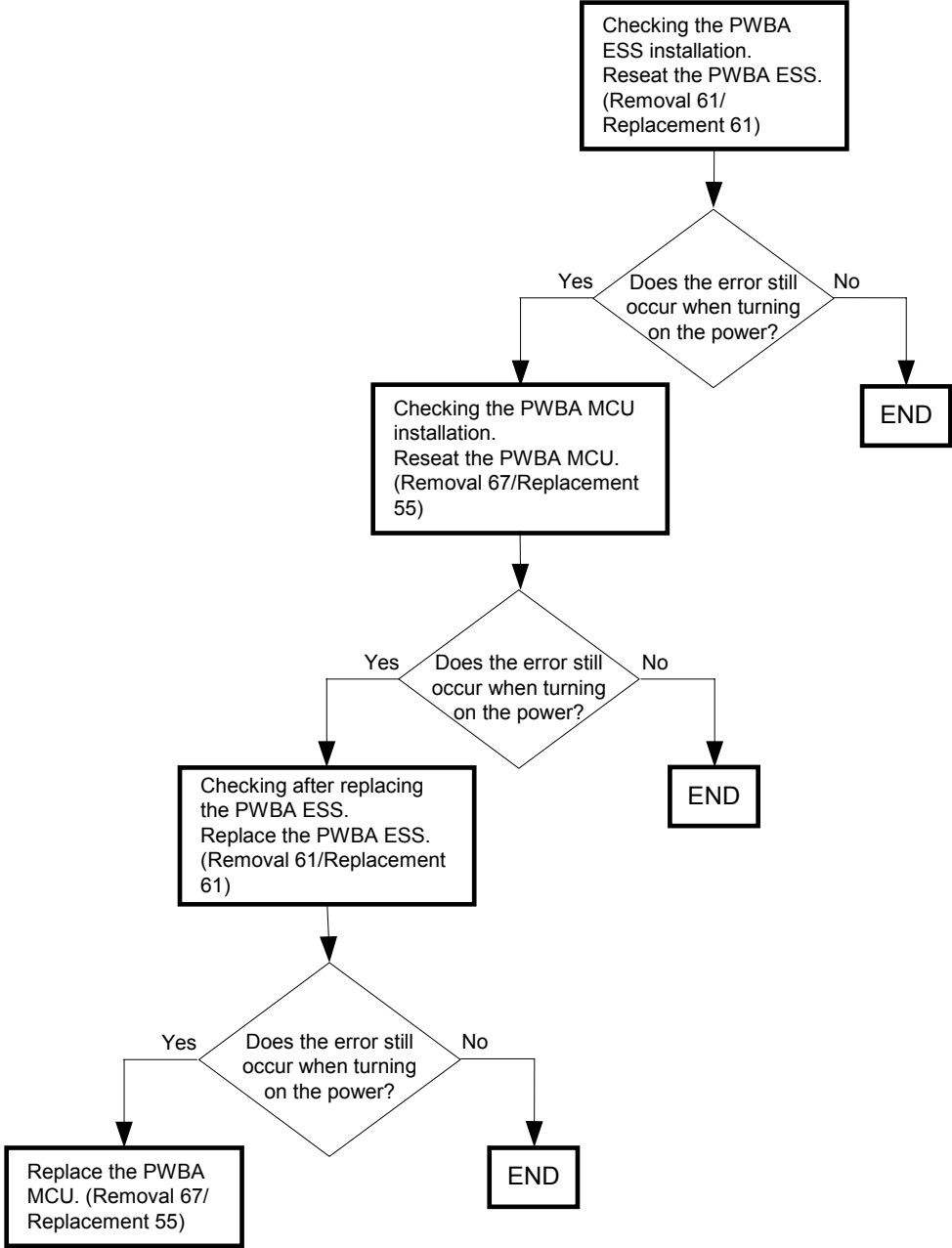

FIP-1. 27 Restart Printer 016-397

Possible causative parts: PWBA HYUI. (PL 13.4.1)

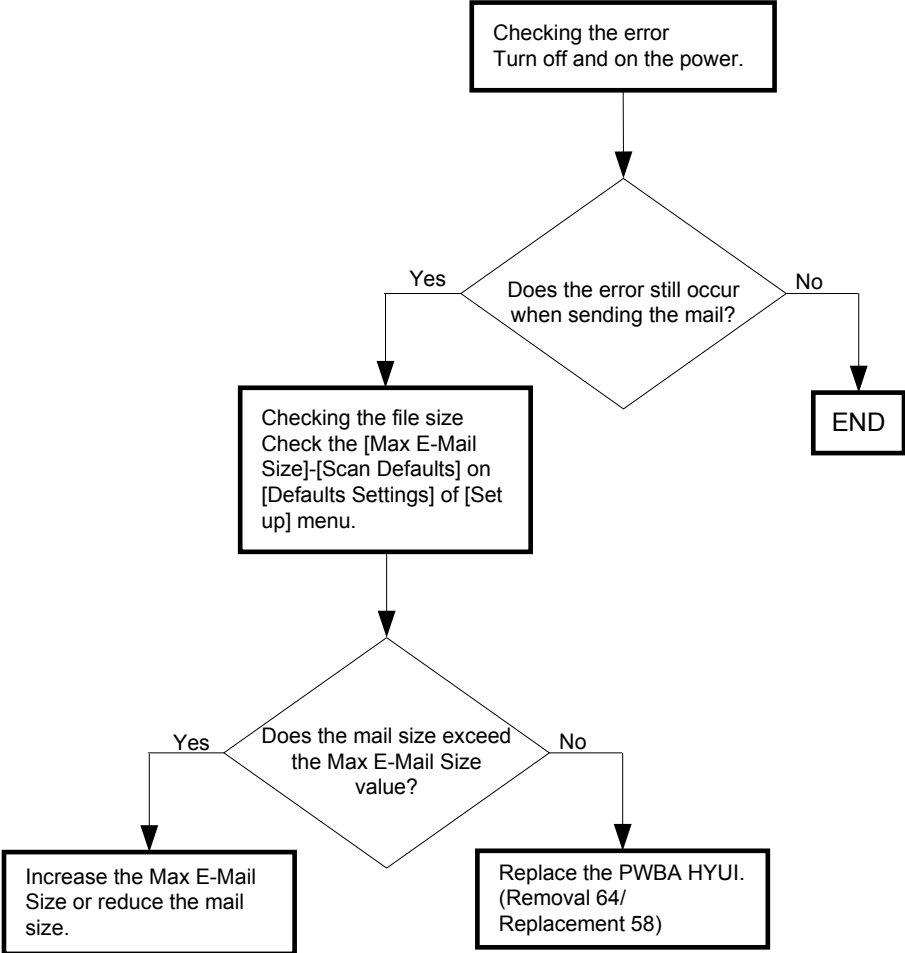

FIP-1. 28 Restart Printer 016-398 /117-313/117-323/117-324/117-325/001-326/117-329
117-354/117-355/117-356/117-357/117-358/117-359/117-360

Possible causative parts: PWBA HYUI (PL13.4.1)
PWBA ESS(PL13.4.20)

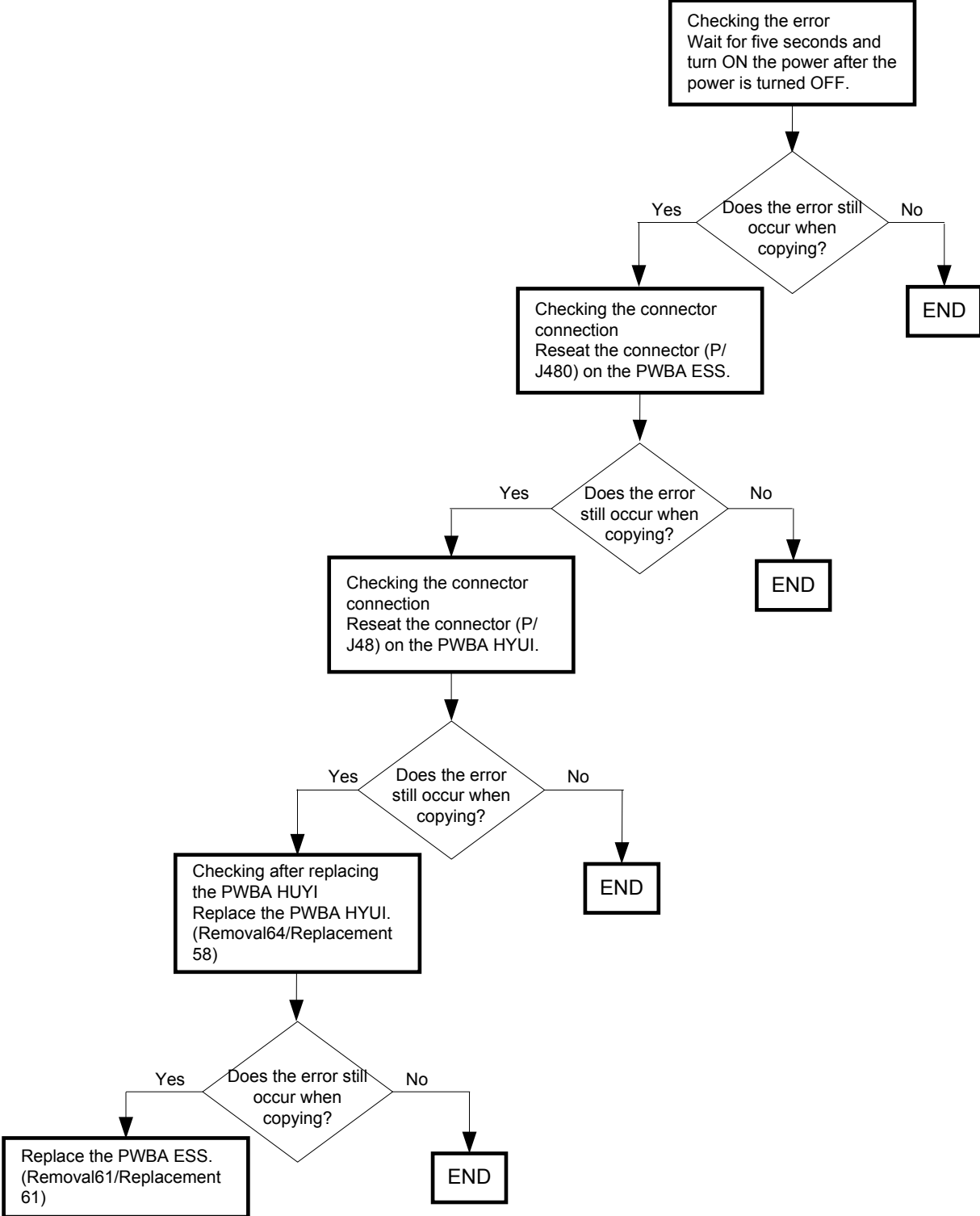

FIP-1. 29 Restart Printer 062-311/062-321/062-360/062-371/117-352

Possible causative parts: PWBA HYUI (PL13.4.1)
ADF SCANNER ASSY (PL13.8.1)

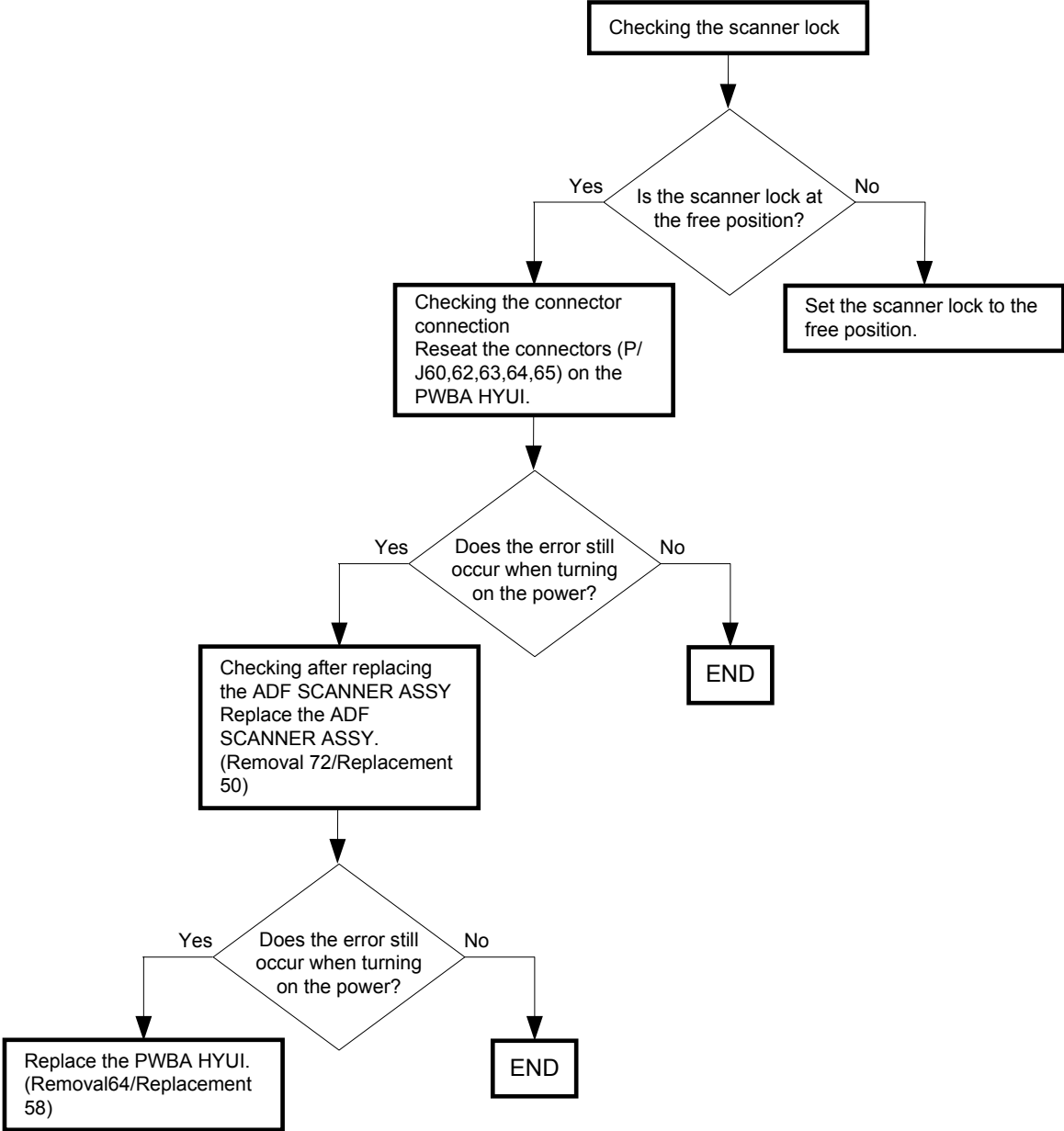

FIP-1. 30 Restart Printer 062-320/062-324

Possible causative parts: PWBA HYUI (PL13.4.1)
ADF SCANNER ASSY (PL13.8.1)

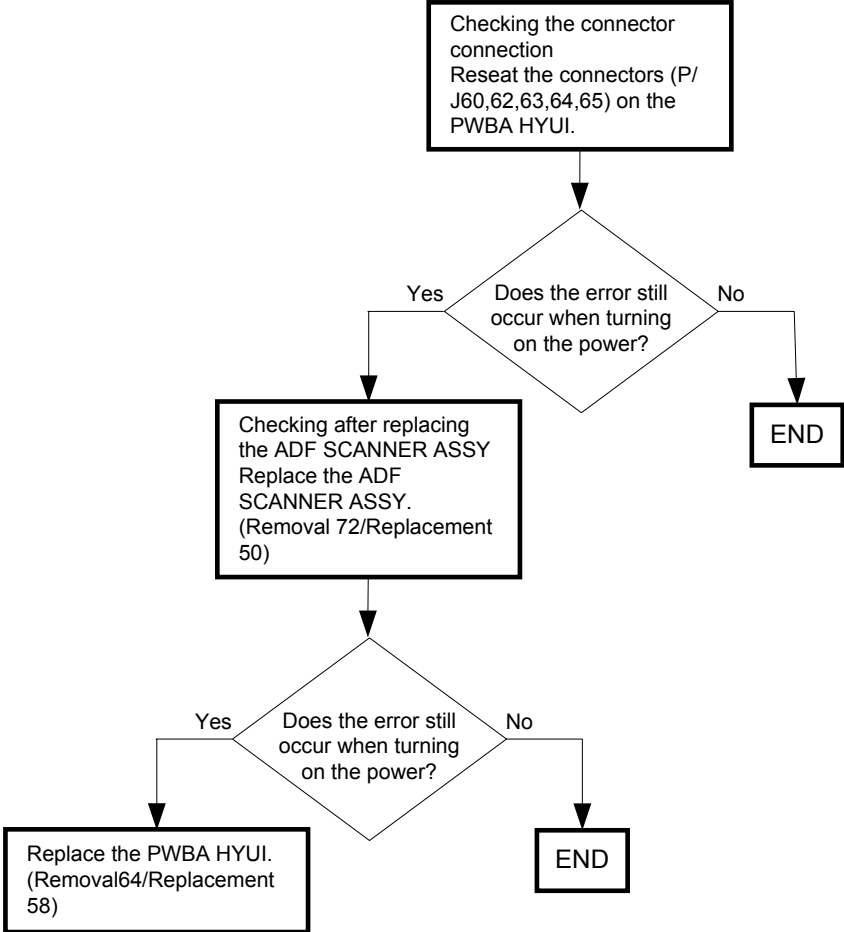

FIP-1. 31 Communication 034-508/034-509/034-510 / Restart Printer 062-322/062-393

Possible causative parts: PWBA HYUI (PL 13.4.1)

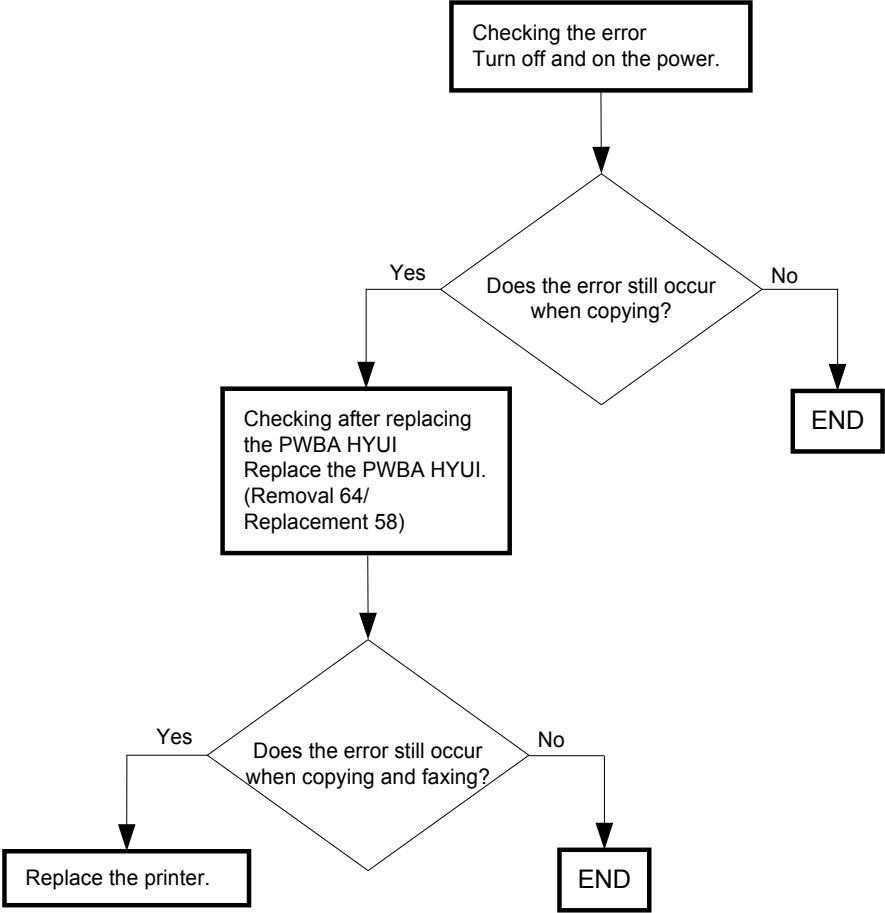

FIP-1. 32 Restart Printer 062-323/123-314

Possible causative parts: CONSOLE PANEL (PL13.2.2)
PWBA HYUI (PL13.4.1)

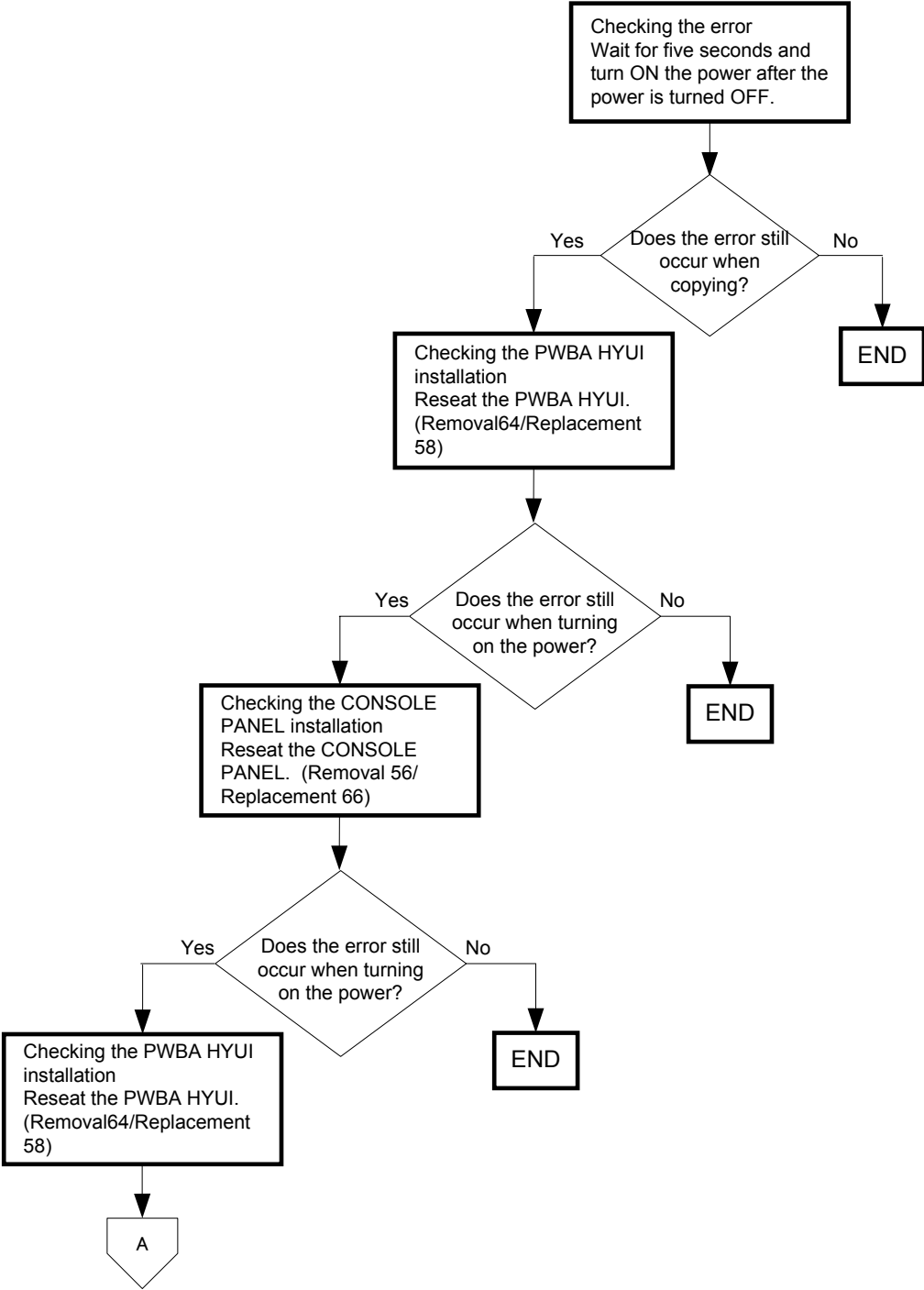

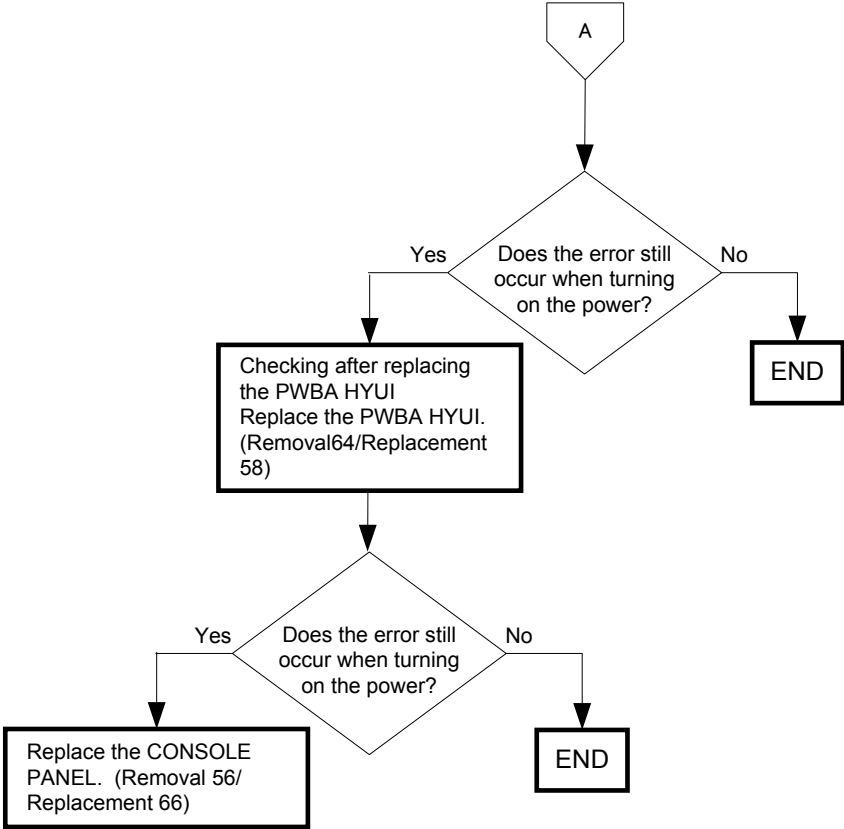

FIP-1. 33 Restart Printer 093-964

Possible causative parts:FUSER ASSY (PL6.1.10)
PWBA MCU (PL9.1.20)

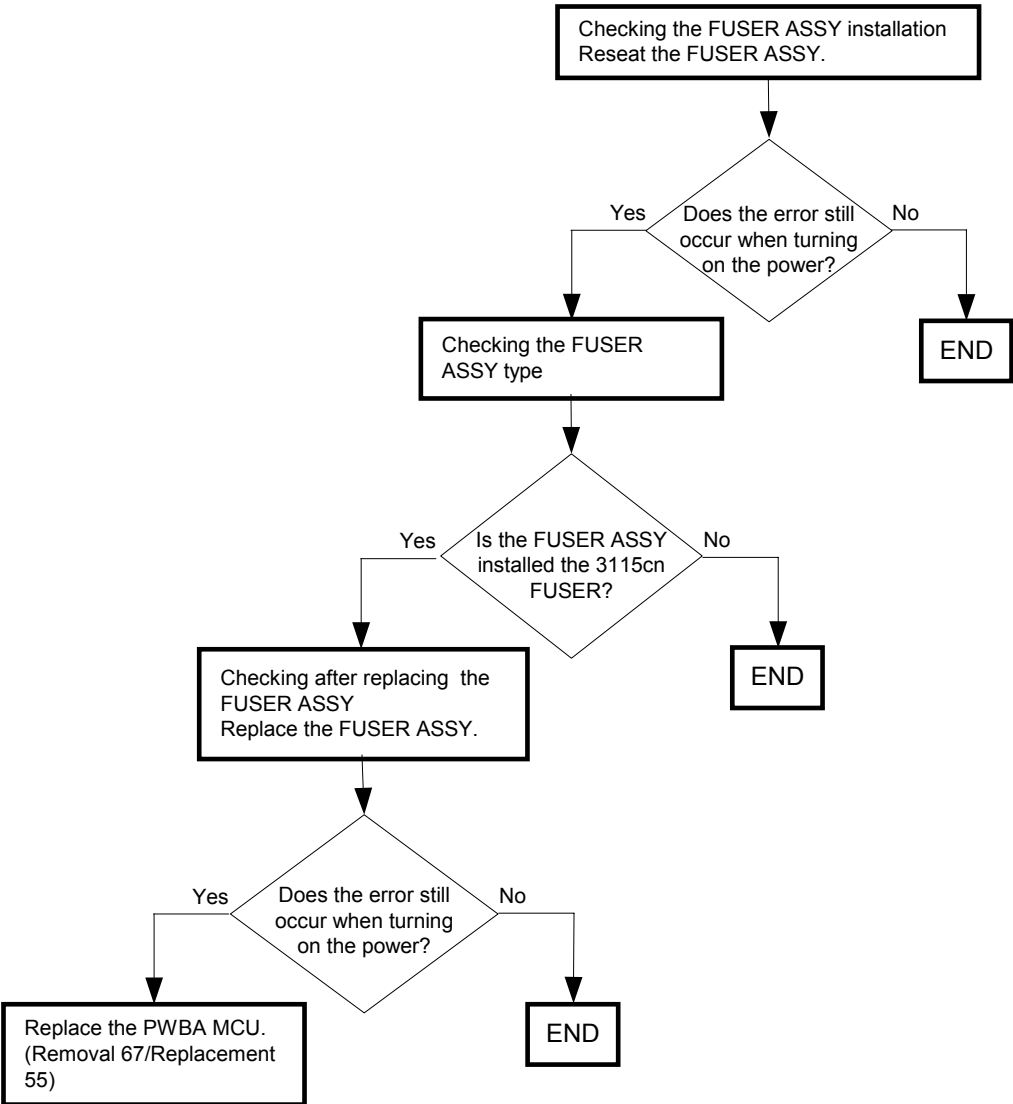

FIP-1. 34 016-986/017-971/017-972/017-973/017-974/017-975/017-976/017-977/
017-978/017-979/017-980/017-986/017-987/017-989/033-502/033-513/033-751/
033-764/033-765/033-766/033-767/033-768/033-770/033-771/033-774/033-776/
033-779/033-780/033-781/033-785/033-786/033-787/033-788/033-789/033-790/
033-791/035-730/035-771/035-777/035-779/102-380/116-396/116-987/117-310/
117-311/117-312/117-314/117-315/117-316/117-317/117-318/117-319/117-320/
117-321/117-322/117-327/117-328/117-330/117-331/117-332/117-333/117-334/
117-335/117-336/117-337/117-338/117-339/117-340/117-341/117-342/117-343/
117-344/117-345/117-346/117-347/117-348/117-349/117-350/117-351/117-353/
117-362/117-363/133-231/133-234/133-235/133-236/133-237/133-238/133-239/
133-240/133-241/133-242/133-243/133-244/133-245/133-246/133-247/133-248/
133-249/133-250/133-251/133-252/133-253/133-255/133-256/133-257/133-258/
133-259/133-260/133-261/133-262/133-263/133-264/133-265/133-266/133-267/
133-268/133-269/133-270/133-271/133-272/133-273/133-274/133-275/133-276/
133-277/133-278/133-279/133-280/133-281/133-282/133-283/133-284/133-285/
133-286/133-287/133-288/133-289/133-290/133-512/Controller Initialize

NOTE

Regarding a fax error, a communication test is available between the customer and Dell, thereby allowing you to analyze the trouble. The communication test can be performed from the customer to the Dell site for transmission errors, and from the Dell site to the customer for reception errors.

Possible causative parts: PWBA HYUI (PL13.4.1)

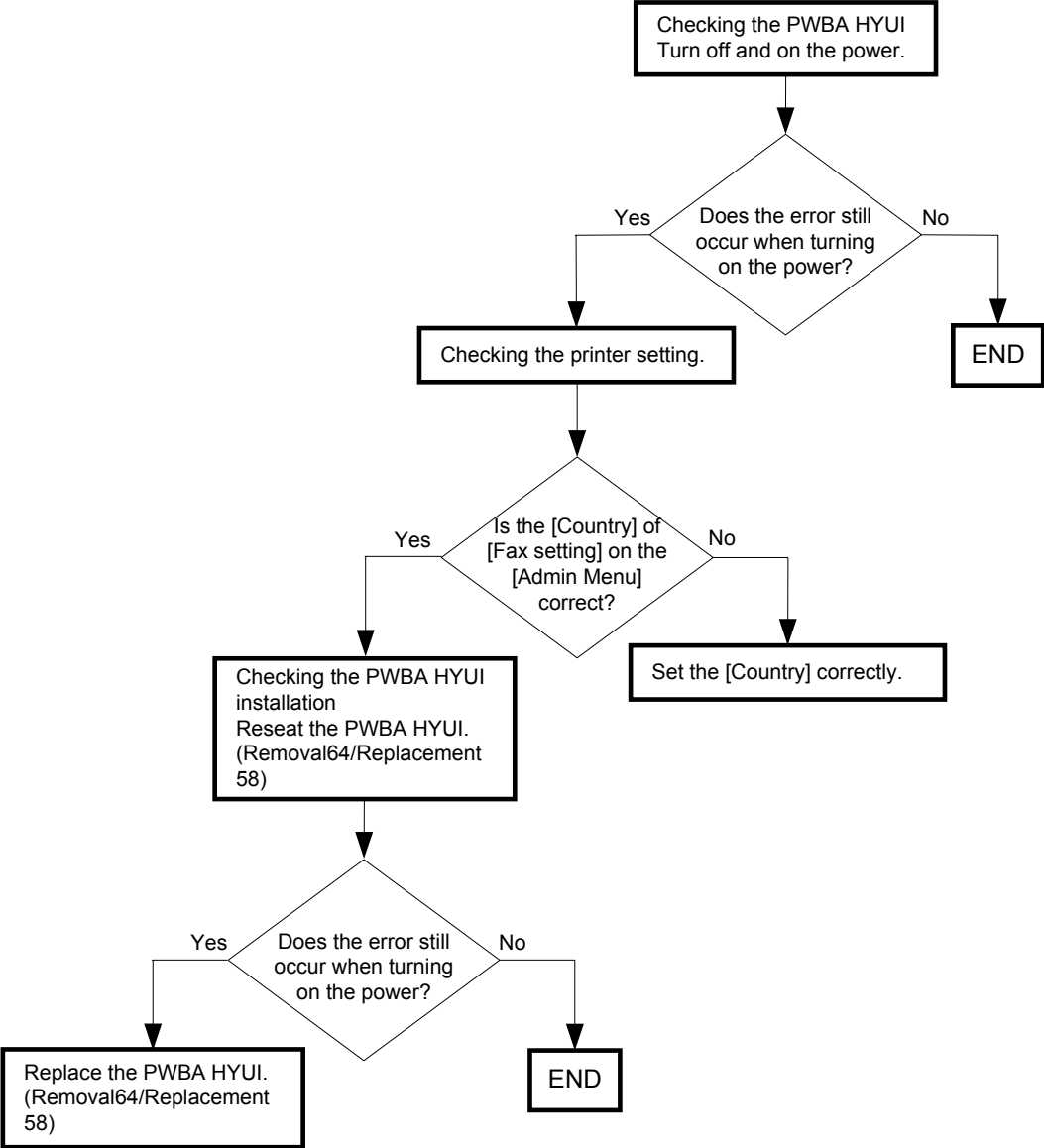

FIP-1. 35 Restart Printer 133-232/134-211/134-212/Busy 033-752/
Communication 033-753/033-754/033-755/033-756/033-757/033-758/033-759/
033-760/033-761/034-742/035-706/Codec Error 033-769/033-772/
No Dial Tone 035-749

NOTE

Regarding a fax error, a communication test is available between the customer and Dell, thereby allowing you to analyze the trouble. The communication test can be performed from the customer to the Dell site for transmission errors, and from the Dell site to the customer for reception errors.

Possible causative parts: PWBA HYUI (PL13.4.1)

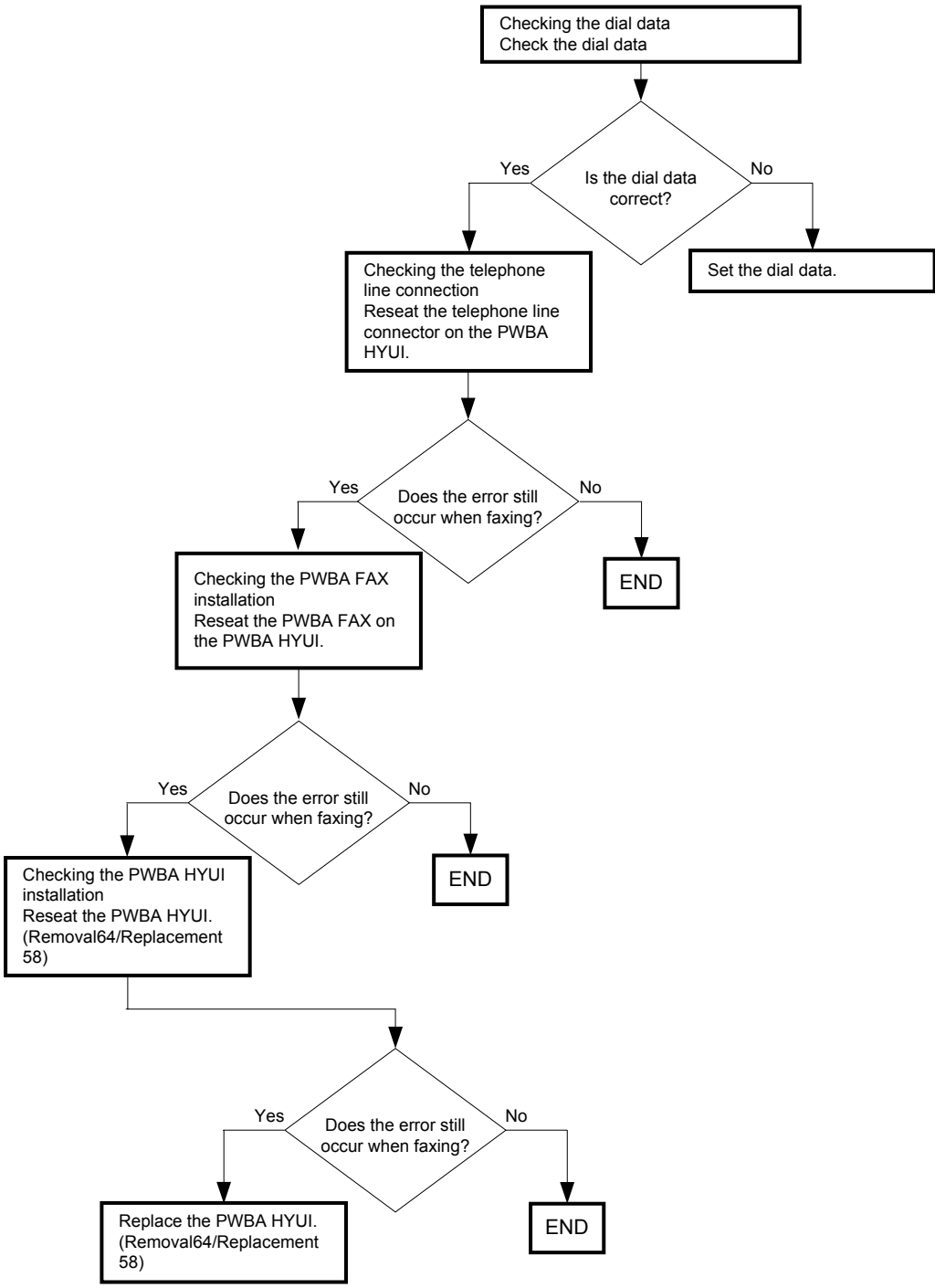

FIP-1. 36 Restart Printer 133-254/Memory Full 017-970/033-503

Possible causative parts:PWBA HYUI (PL 13.4.1)

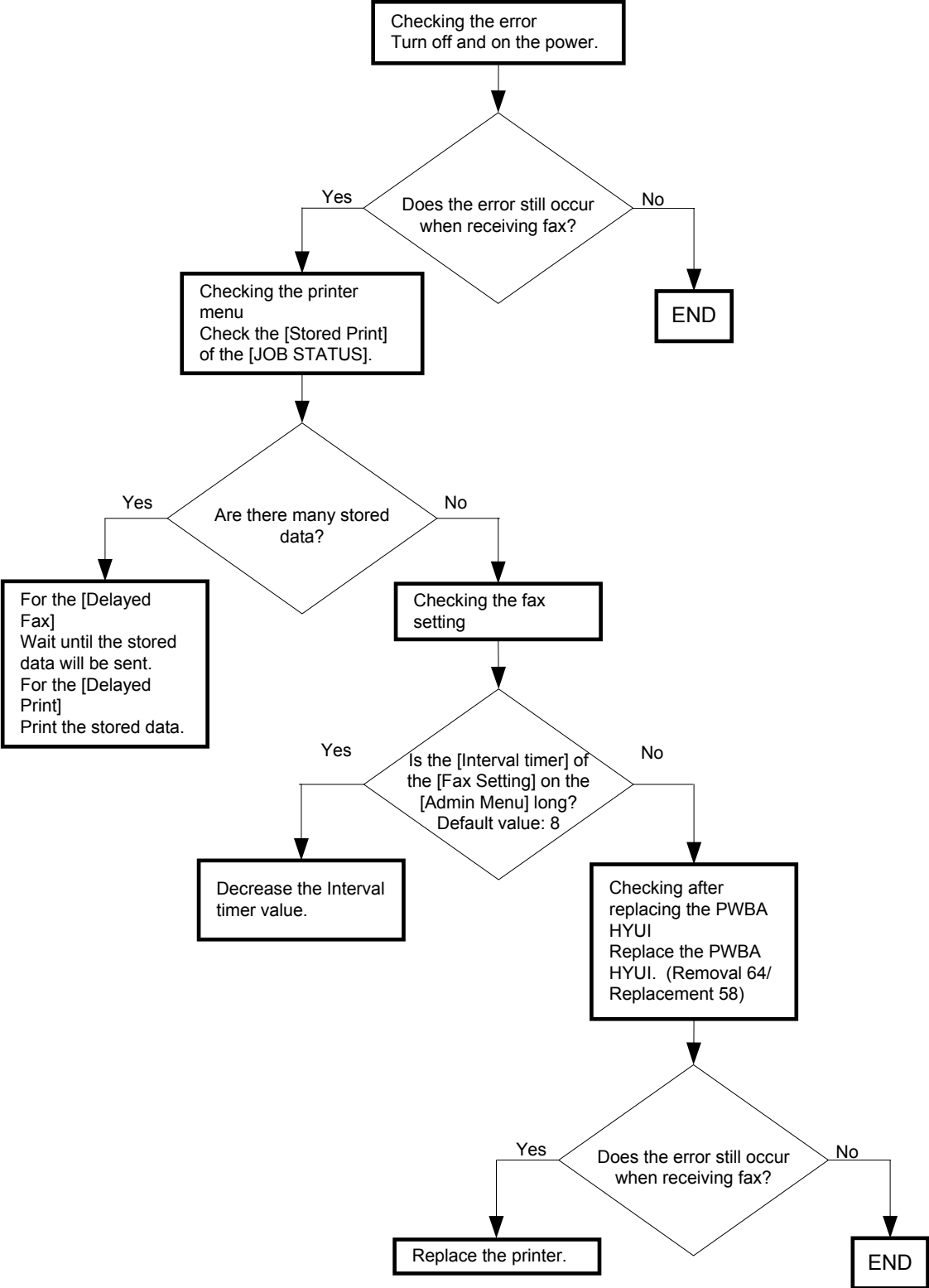

FIP-1. 37 Paper Jam 071-100/Illegal Settings (Copy Select Tray Broken)

Possible causative parts: 250 PAPER CASSETTE ASSY (PL2.2.99)
KIT ROLLER (PL2.2.99)
KIT FEEDER (PL3.2.99)
DRIVE ASSY PH (PL8.1.7)
PWBA MCU (PL9.1.20)

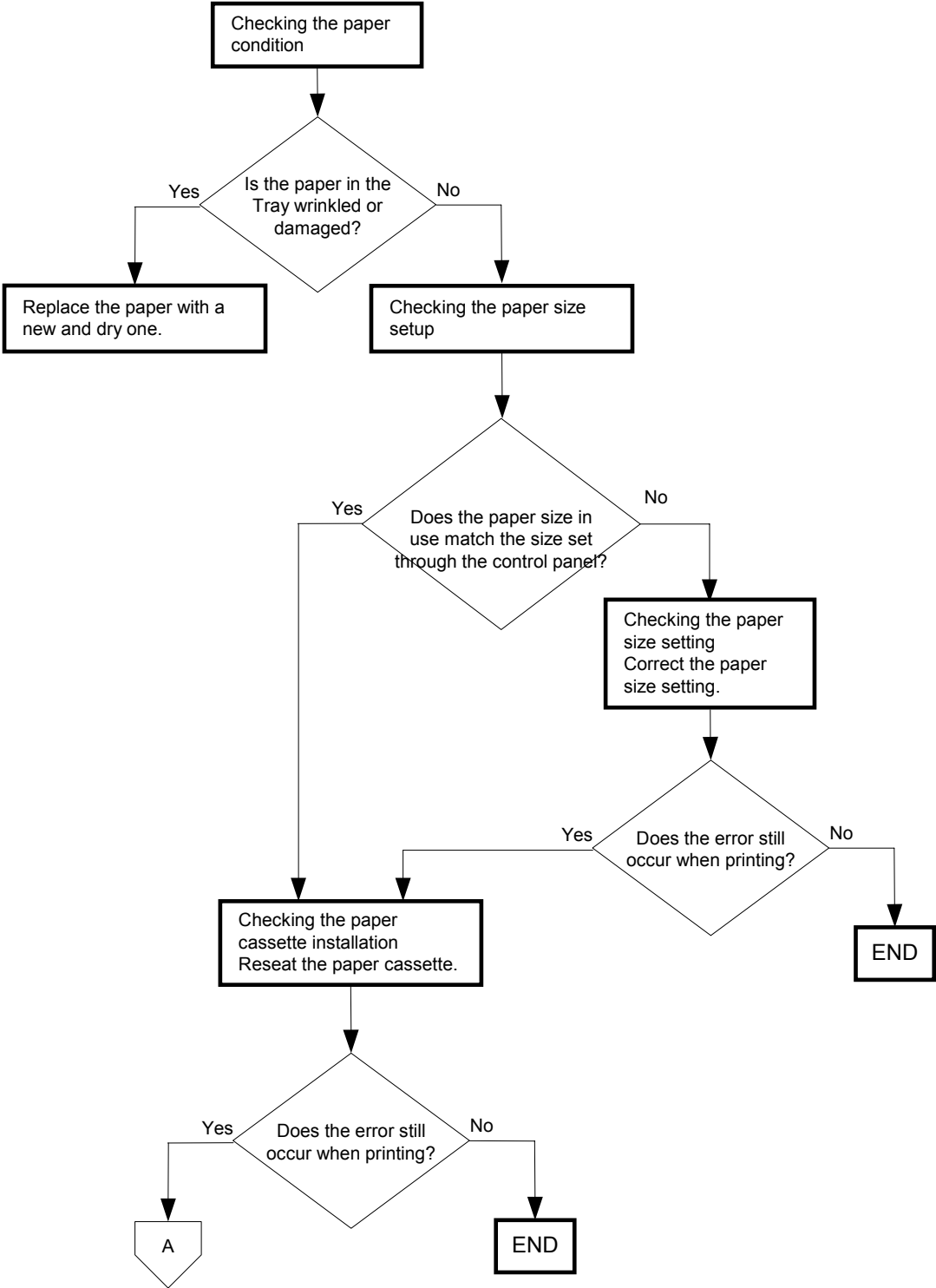

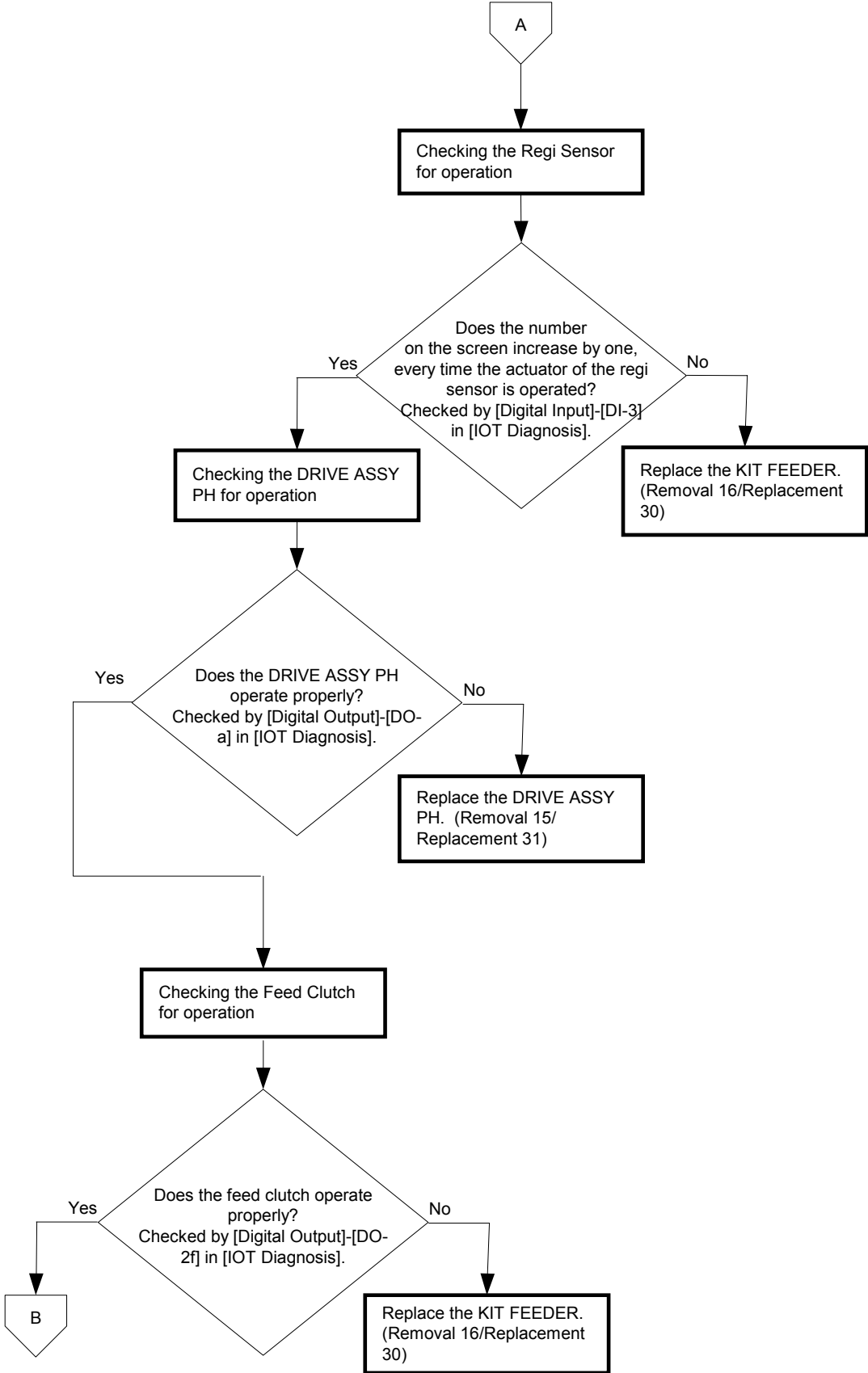

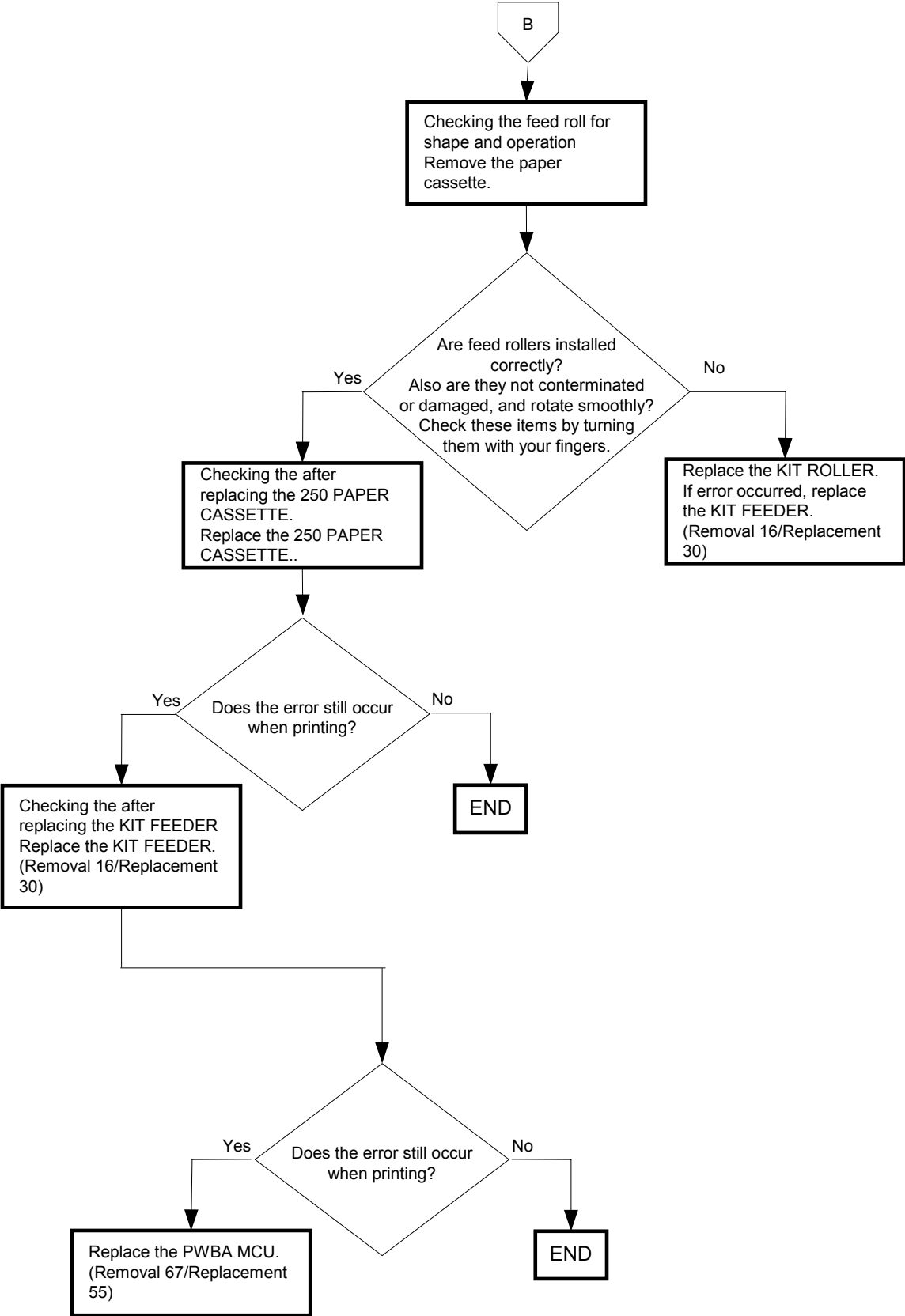

FIP-1. 38 Paper Jam 072-100/Illegal Settings (Copy Select Tray Boken)

Possible causative parts:KIT FEEDER (PL3.2.99)
550 PAPER CASSETTE ASSY (PL12.4.1)
KIT ROLLER (PL12.3.99)
550 OPTION FEEDER (PL13.7.1)
PWBA MCU (PL9.1.20)

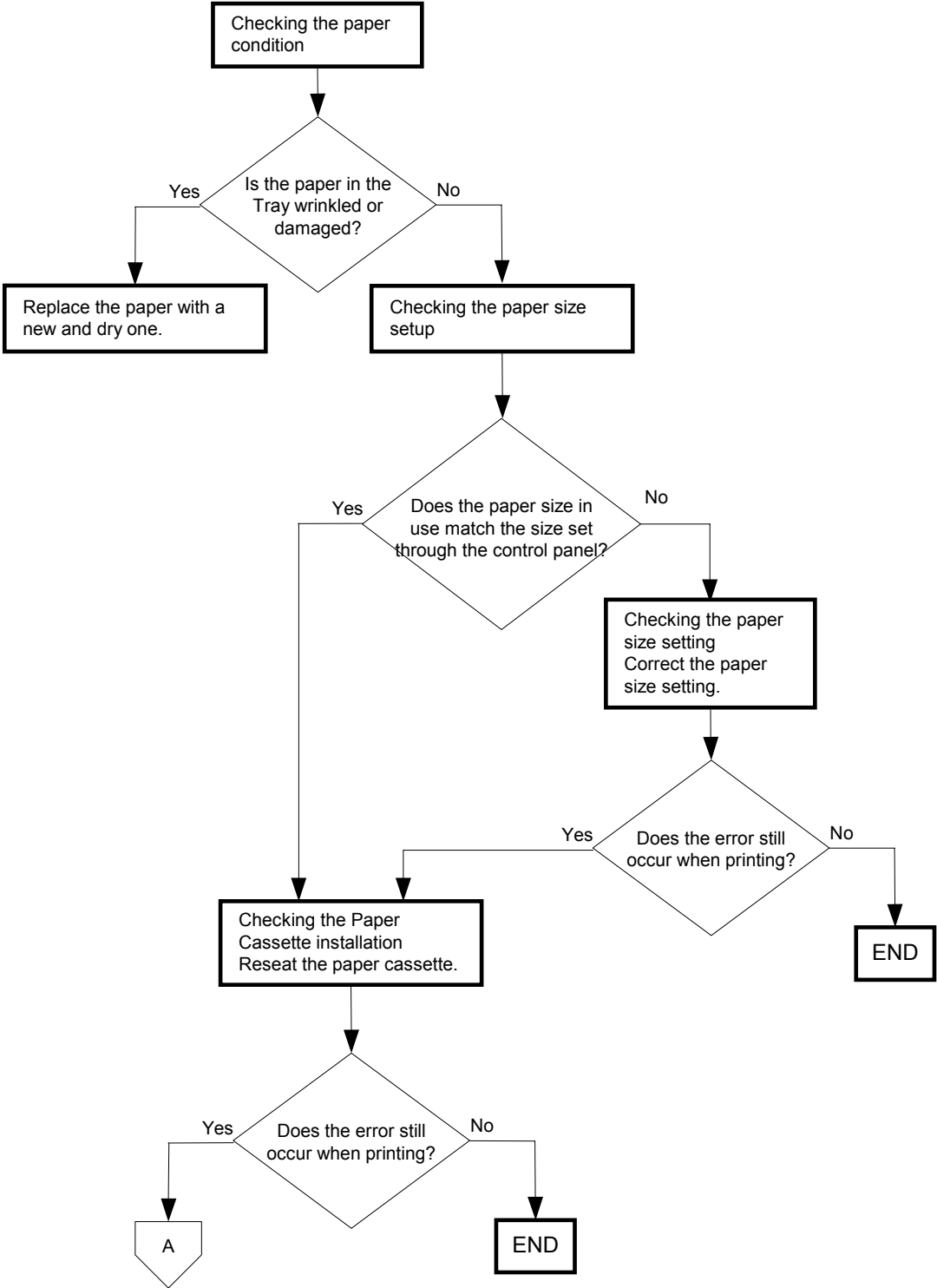

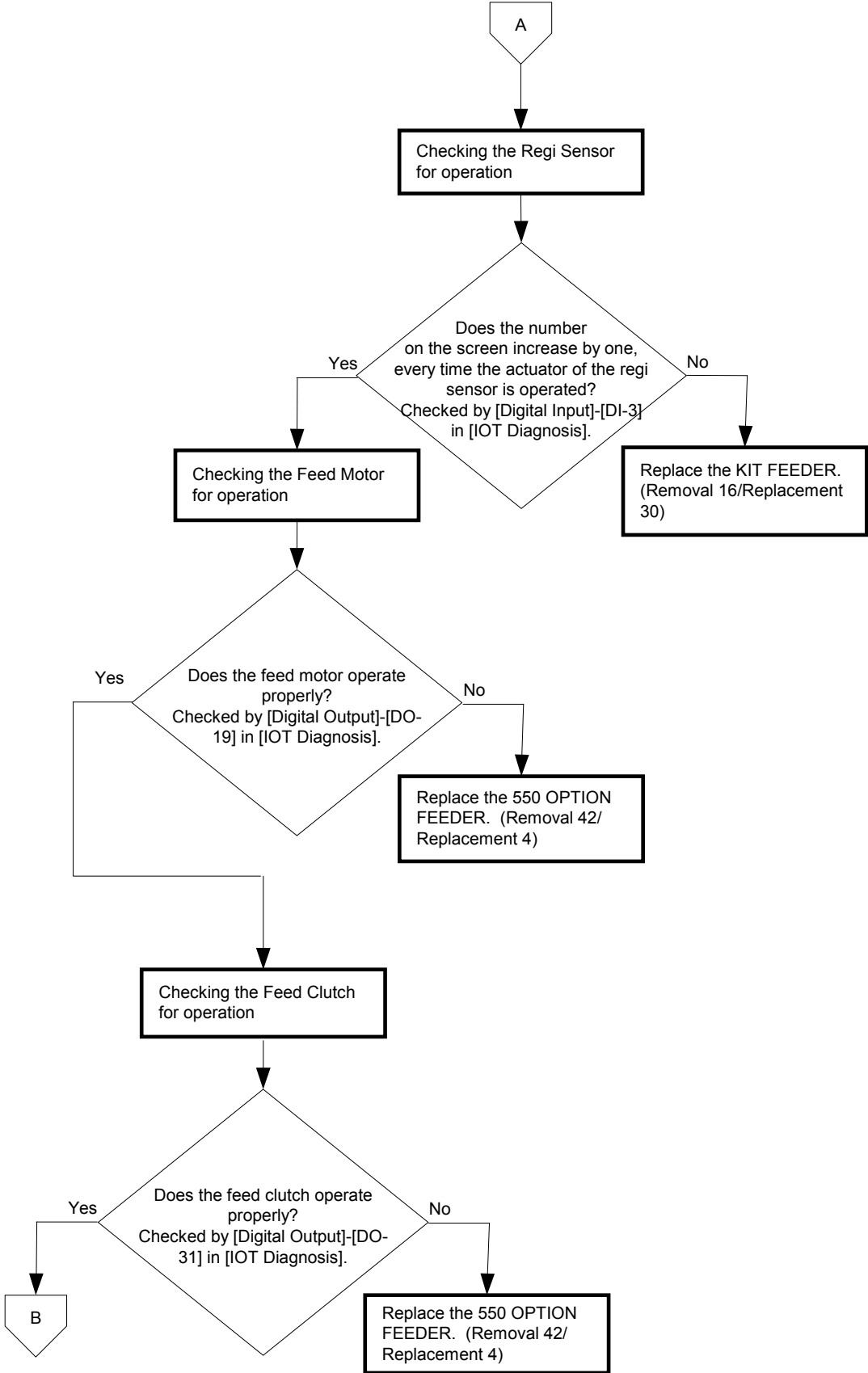

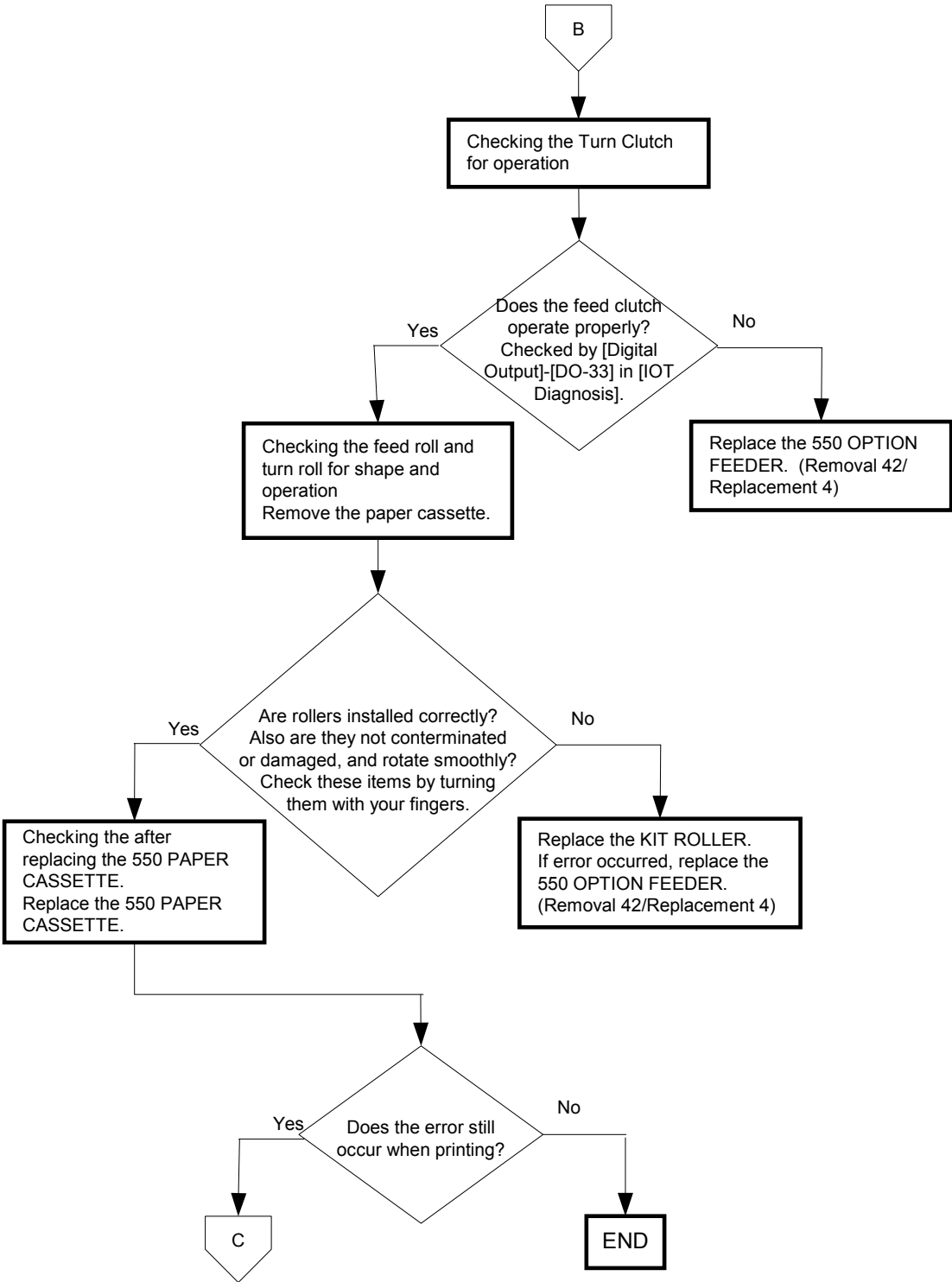

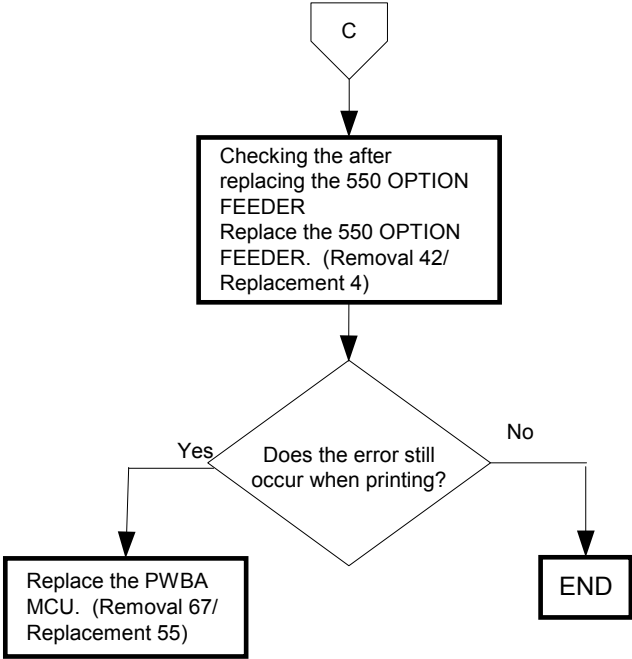

FIP-1. 39 Paper Jam 075-100/Illegal Settings (Copy Select Tray Boken)

Possible causative parts: 250 PAPER CASSETTE ASSY (PL2.2.99)
KIT ROLLER (PL2.2.99)
KIT SOLENOID FEED MSI (PL3.1.98)
KIT FEED ROLL MSI (PL3.1.99)
DRIVE ASSY PH (PL8.1.7)
PWBA MCU (PL9.1.20)

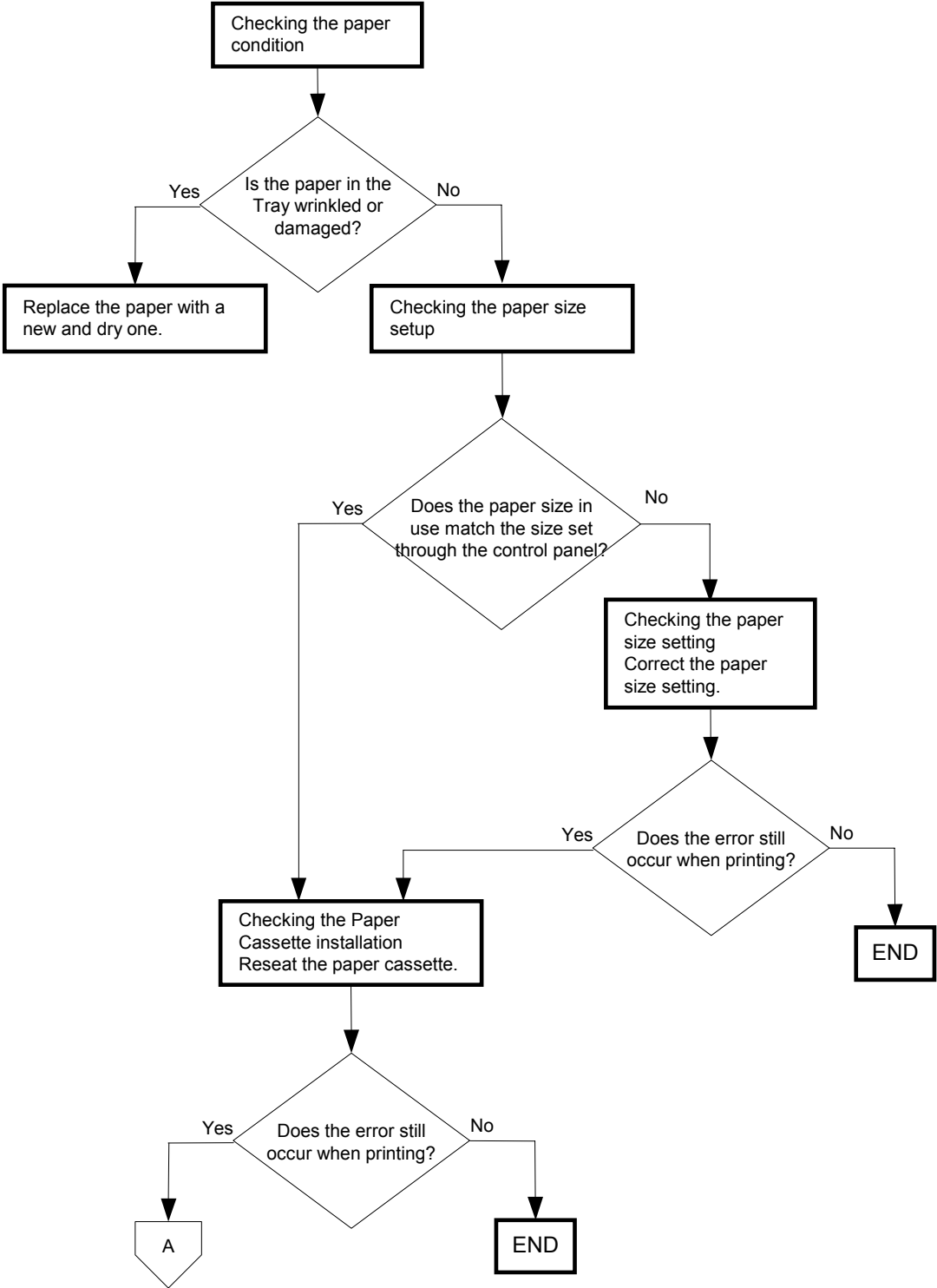

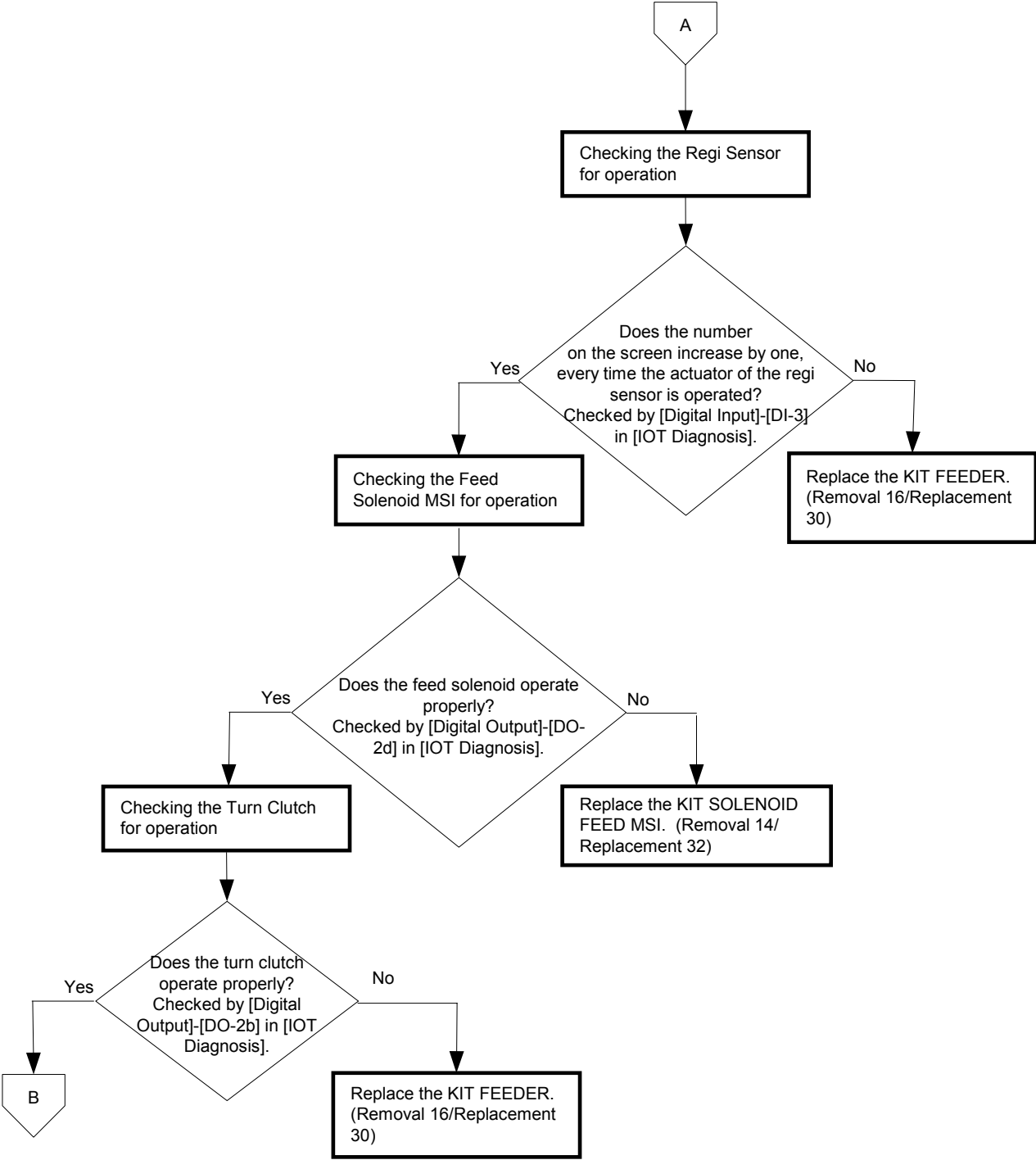

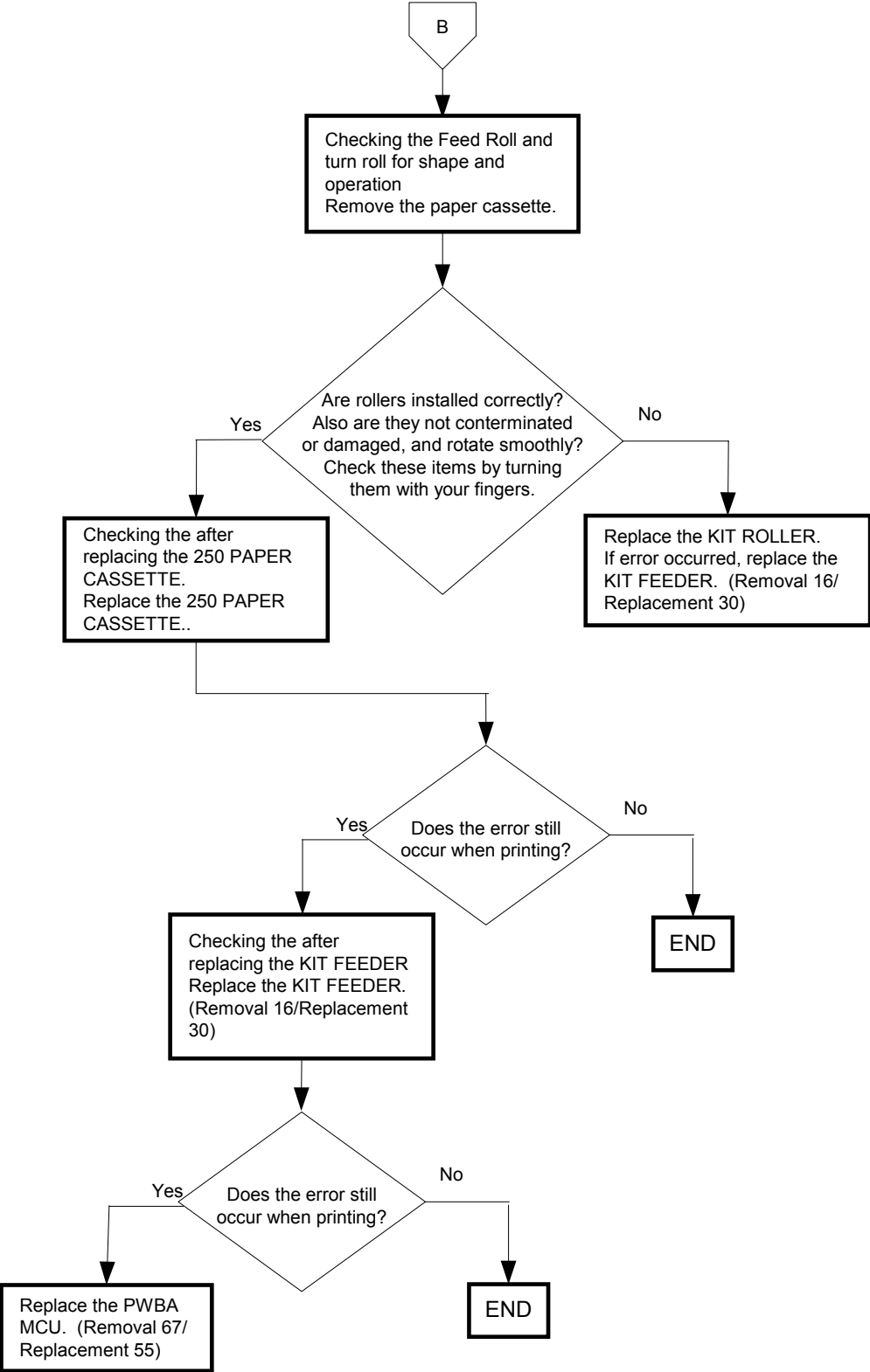

FIP-1. 40 Paper Jam 077-900/077-901

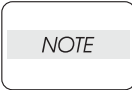

If the paper actually loaded in the tray or cassette does not match the [Paper Tray] setting under [Tray Setting], continuing printing in that status may cause a jam eventually.

- Possible causative parts:KIT FEEDER (PL3.2.99)
- FUSER ASSY (PL6.1.10)
- DRIVE ASSY MAIN (PL8.1.2)
- DRIVE ASSY PH (PL8.1.7)
- PWBA MCU (PL9.1.20)

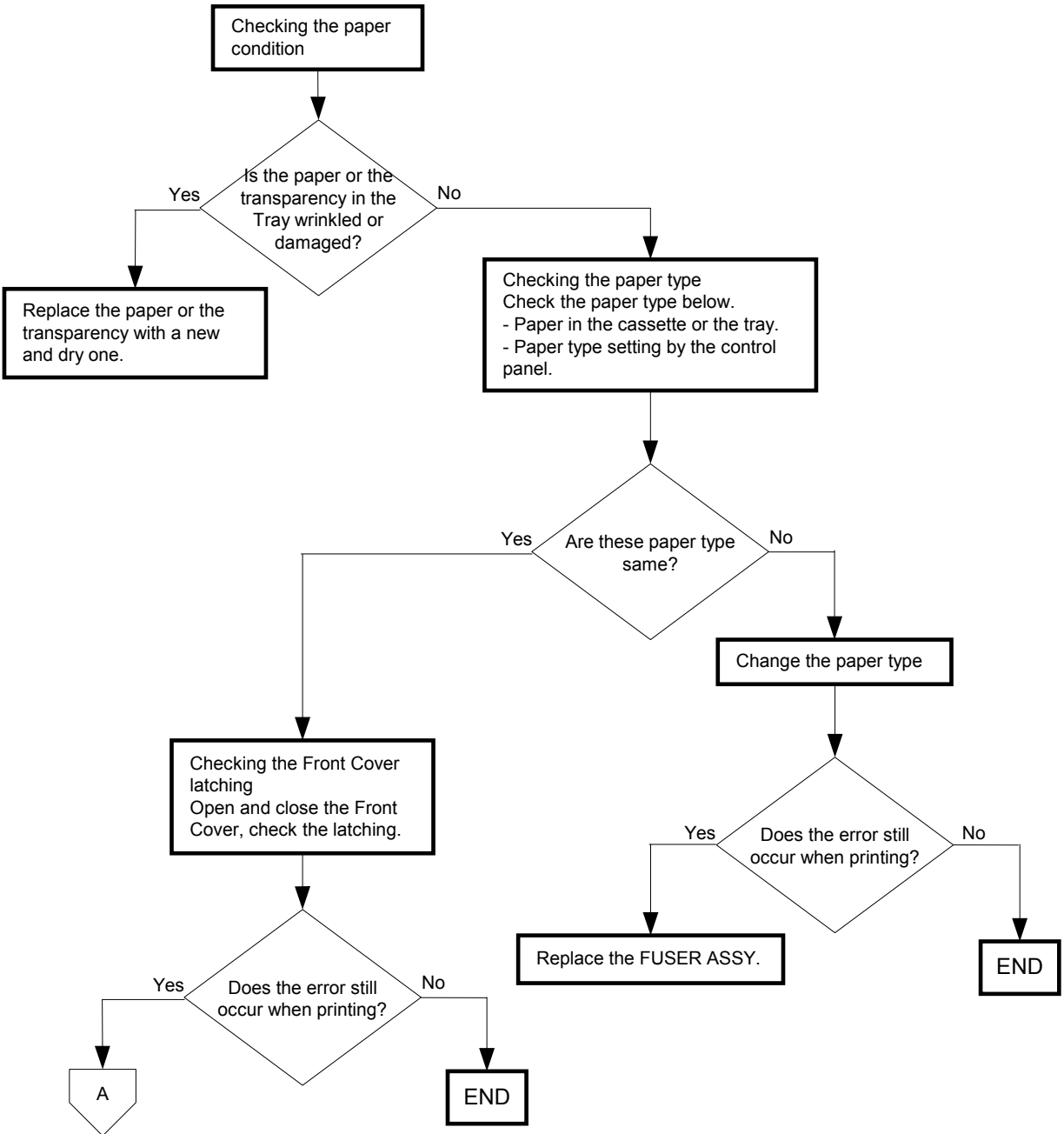

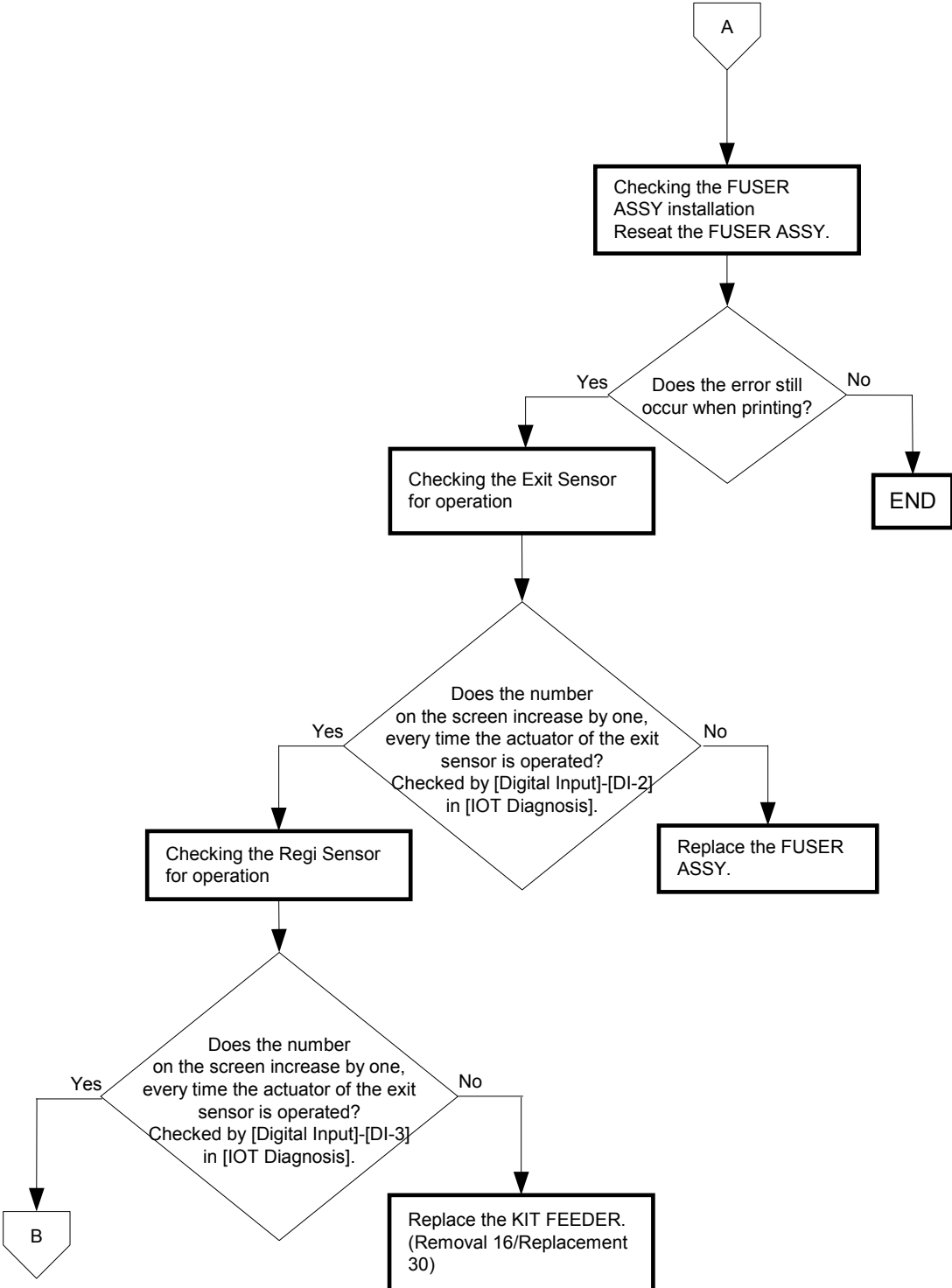

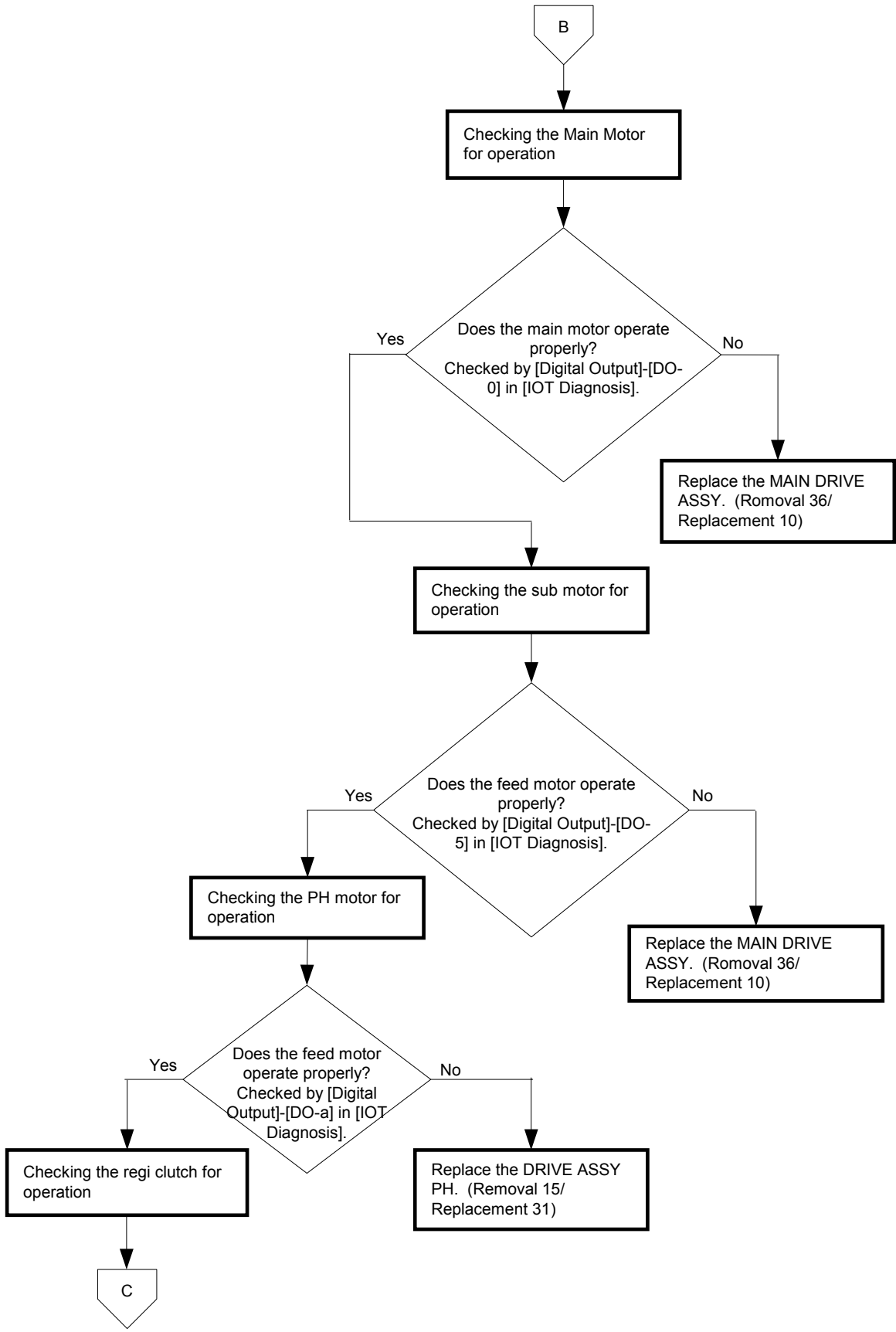

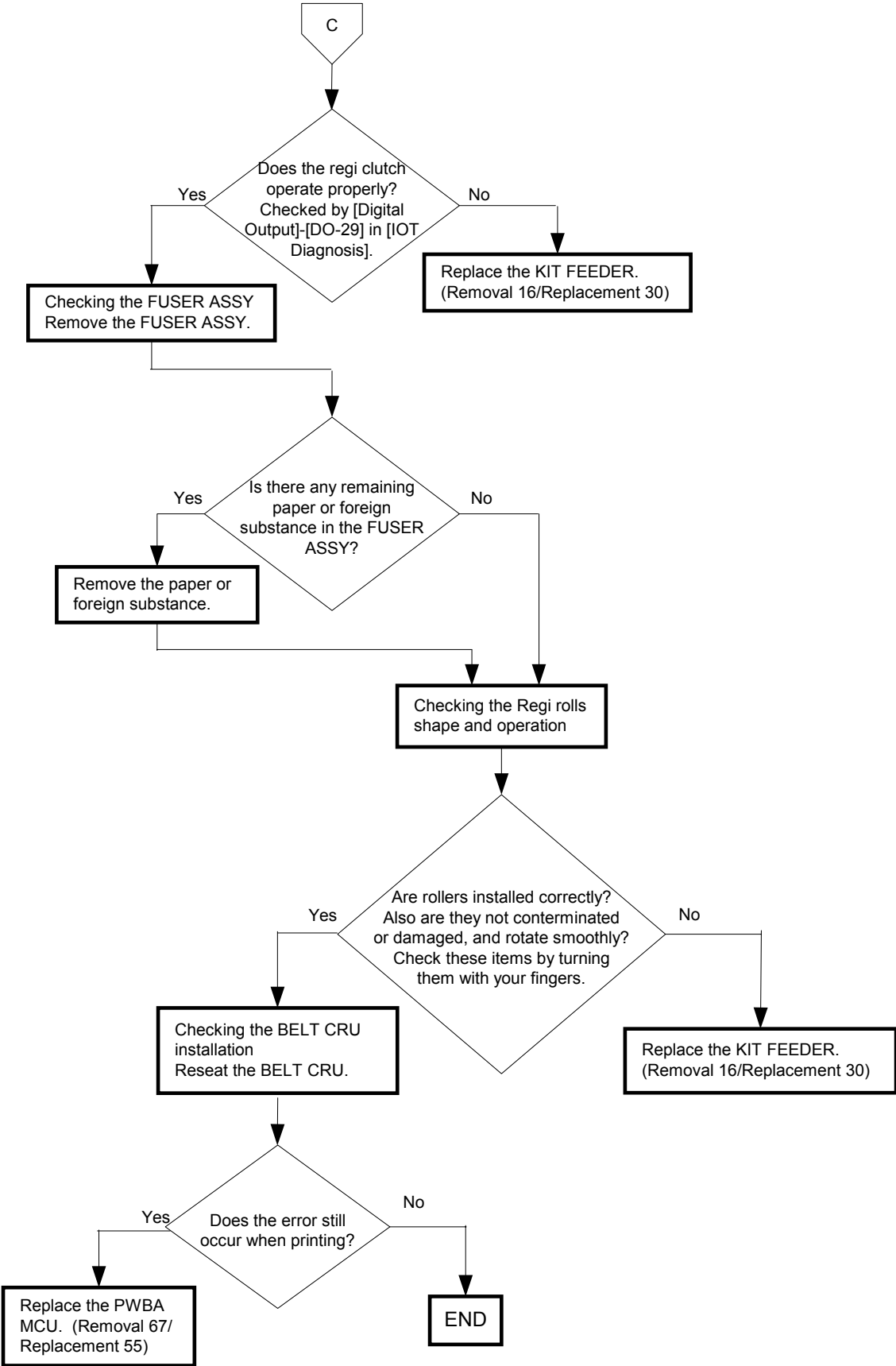

FIP-1. 41 Paper Jam 077-903

Possible causative parts:KIT FEEDER (PL3.2.99)
DRIVE ASSY PH (PL8.1.7)
PWBA MCU (PL9.1.20)

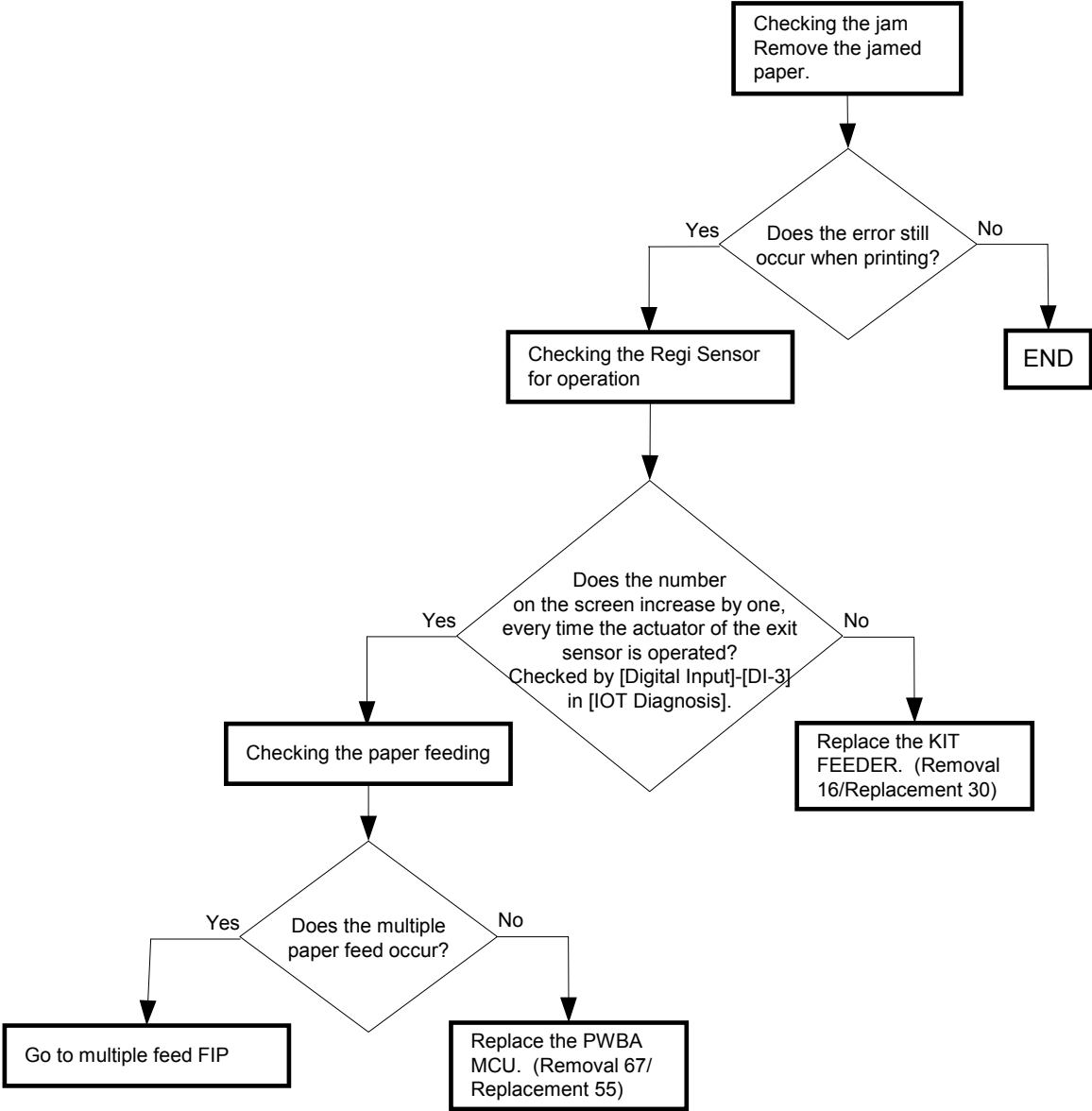

FIP-1. 42 Paper Jam 077-907

- Possible causative parts:KIT FEEDER (PL3.2.99)
- FUSER ASSY (PL6.1.10)
- CHUTE DUP GATE (PL6.1.13)
- DRIVE ASSY MAIN (PL8.1.2)
- DRIVE ASSY PH (PL8.1.7)
- PWBA MCU (PL9.1.20)
- CHUTE ASSY DUP (PL11.1.1)

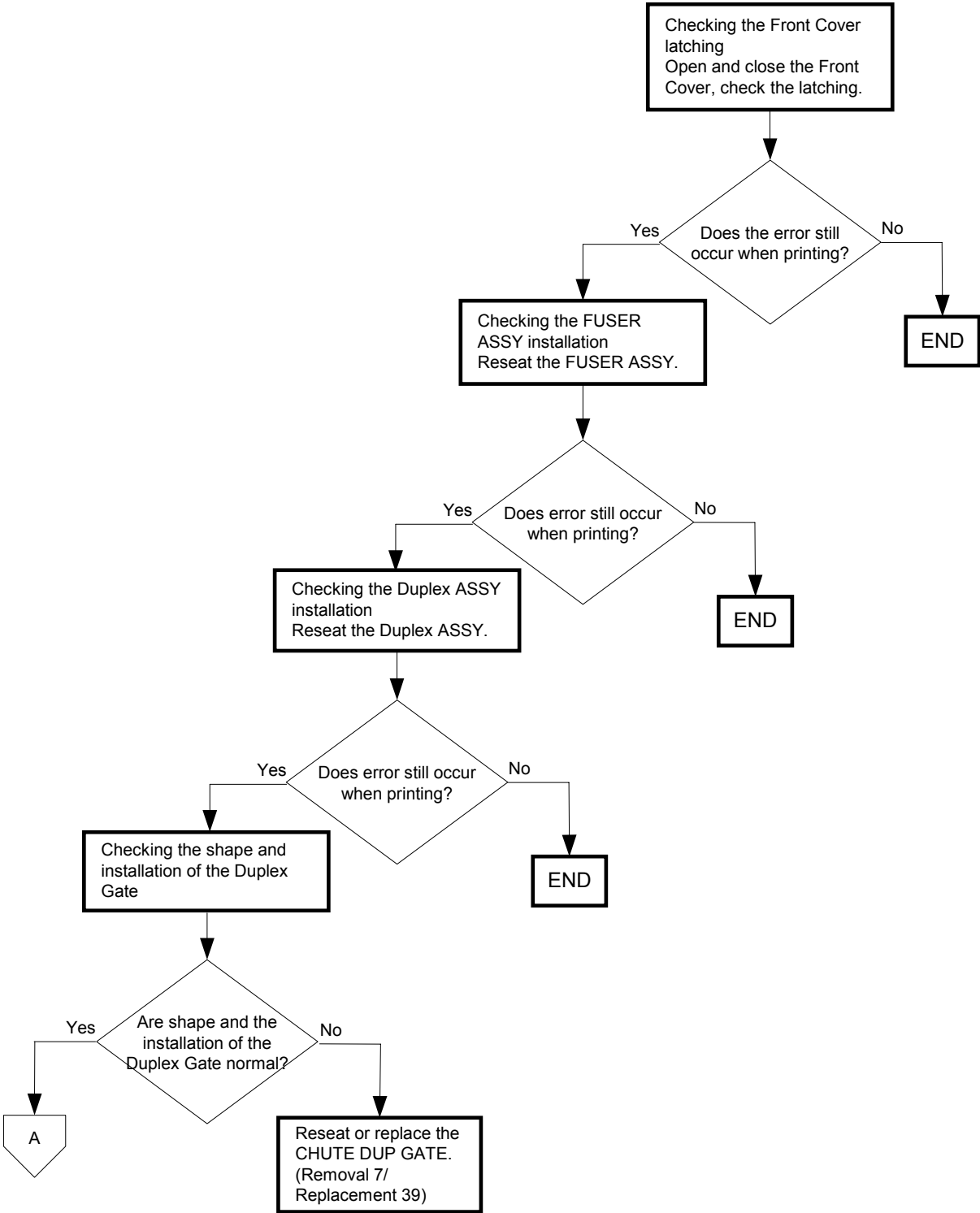

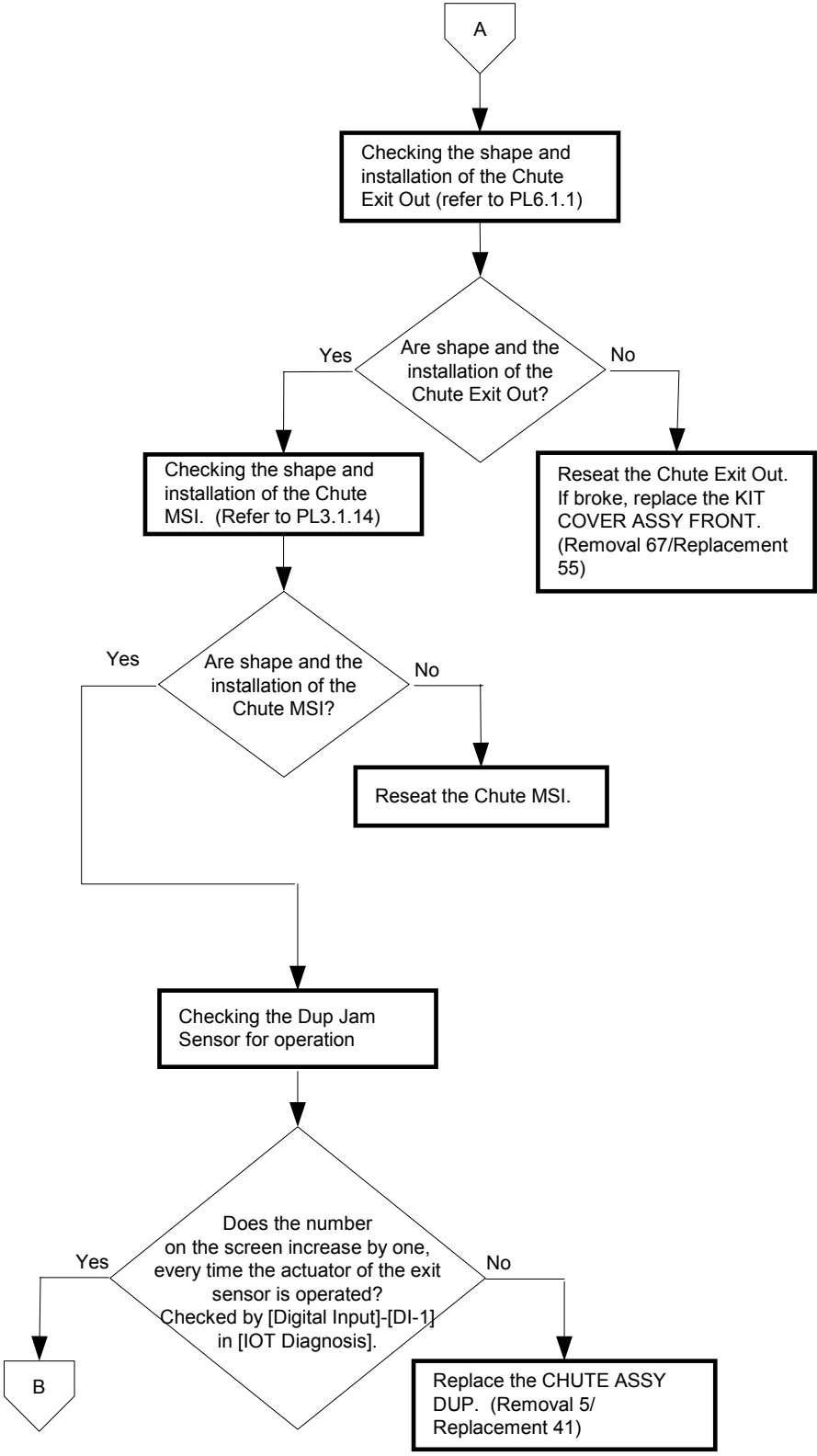

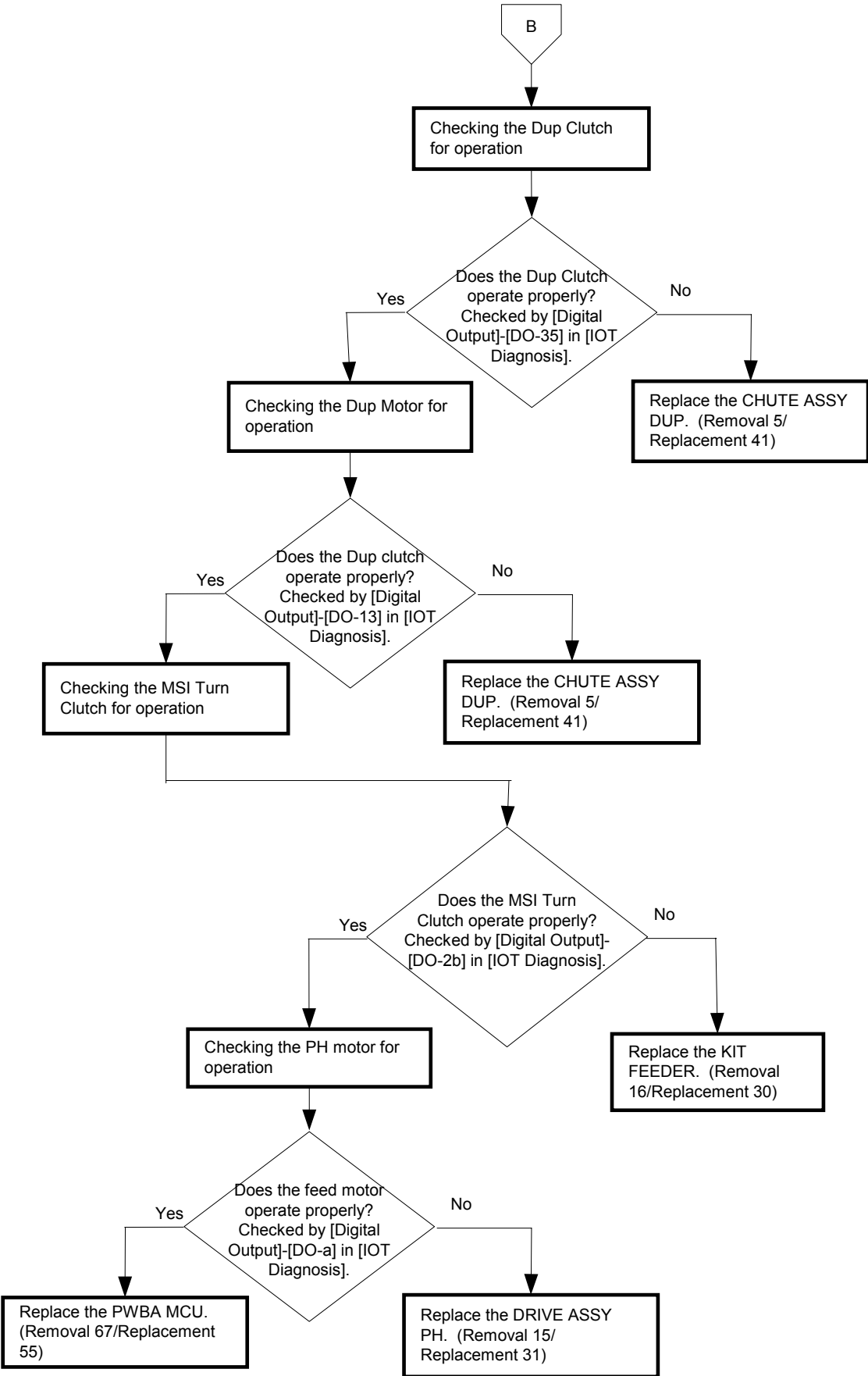

FIP-1. 43 Load Tray N or MPF 024-910/024-911/024-914/
Illegal Settings (Copy Select Tray Boken)

Possible causative parts: CASSETTE ASSY 250 (PL2.1.1)
FEEDER ASSY (PL3.2.99)
PWBA MCU (PL9.1.20)
CASSETTE ASSY 500 (PL12.4.1)

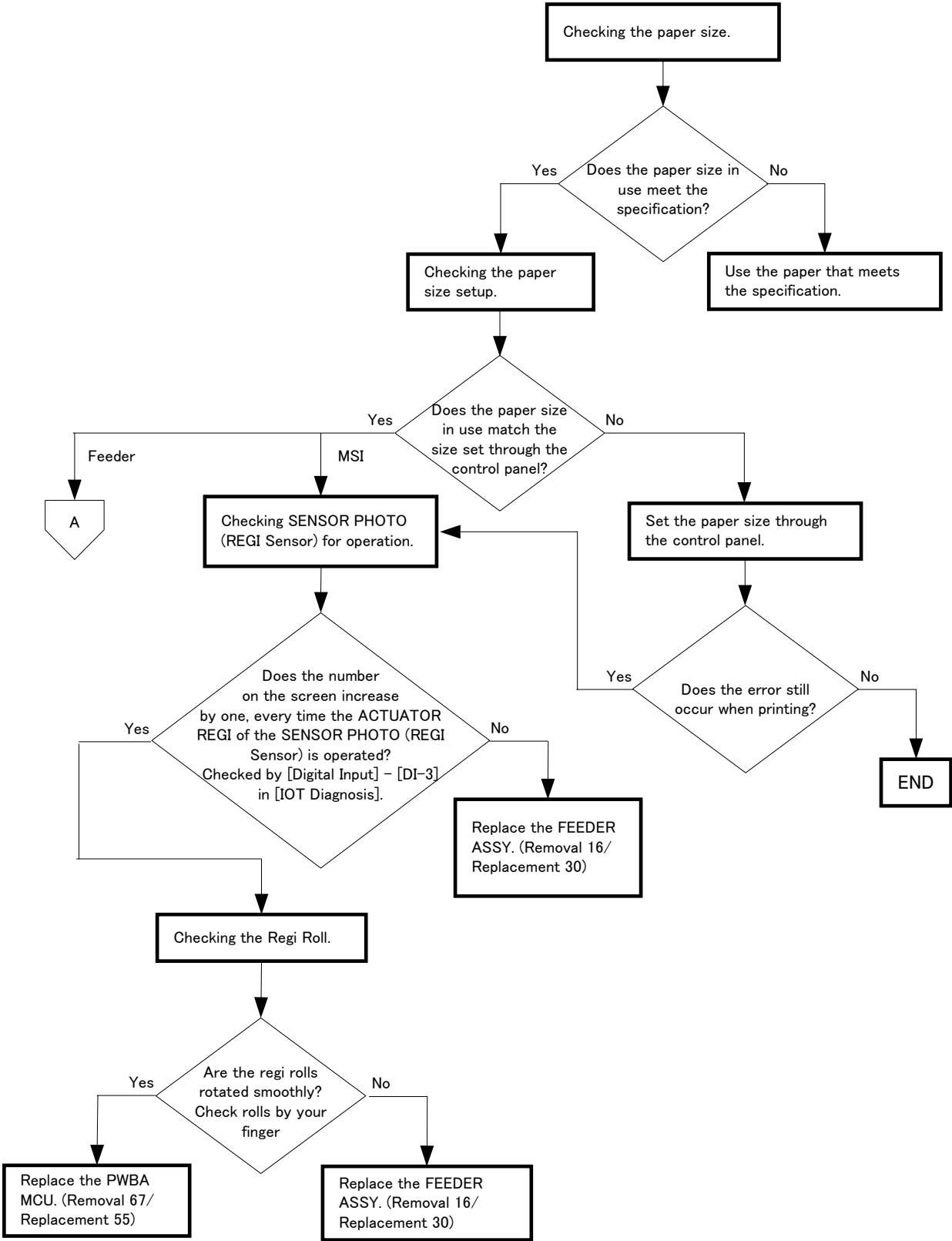

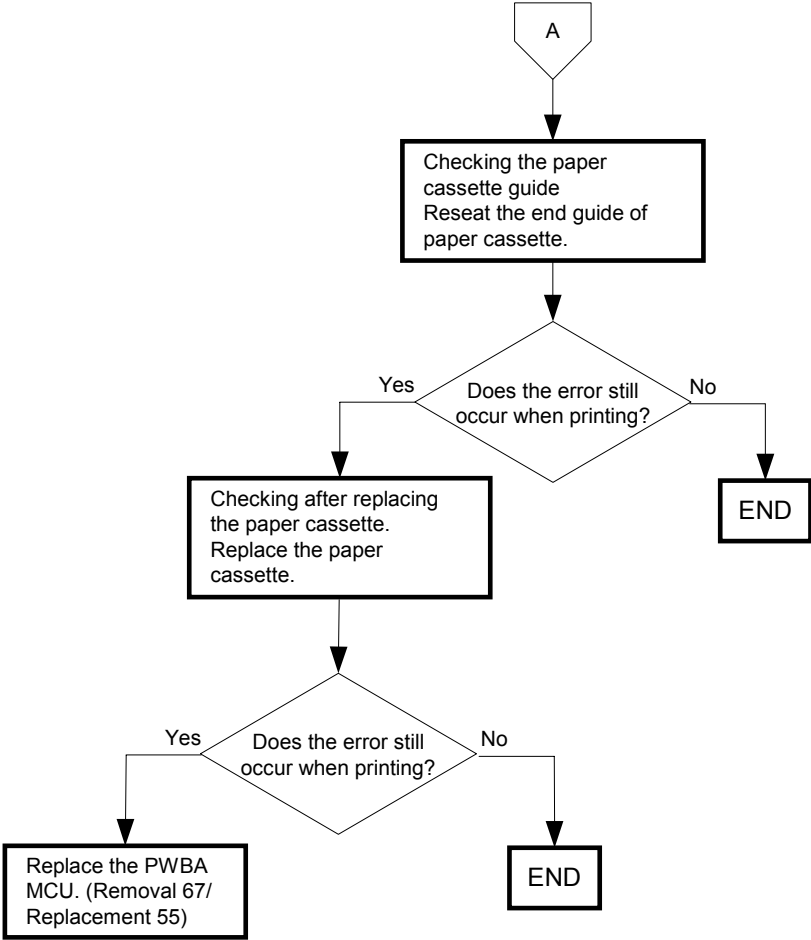

FIP-1. 44 Load Tray N or MPF 024-965/024-966/024-969/
Illegal Settings (Copy Select Tray Boken)

Possible causative parts: CASSETTE ASSY 250 (PL2.1.1)
FEEDER ASSY (PL3.2.99)
PWBA MCU (PL9.1.20)
550 OPTION FEEDER (PL13.7.1)

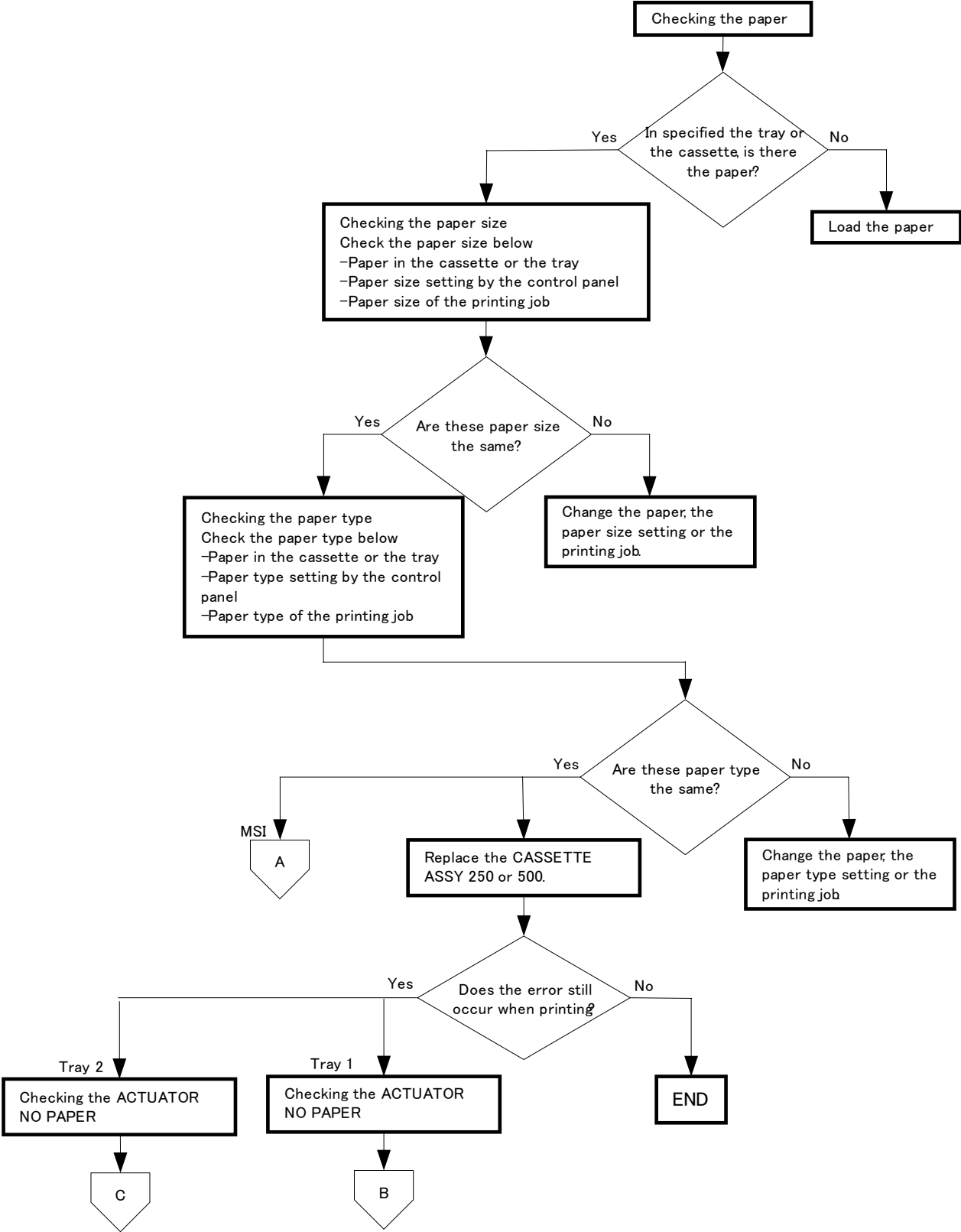

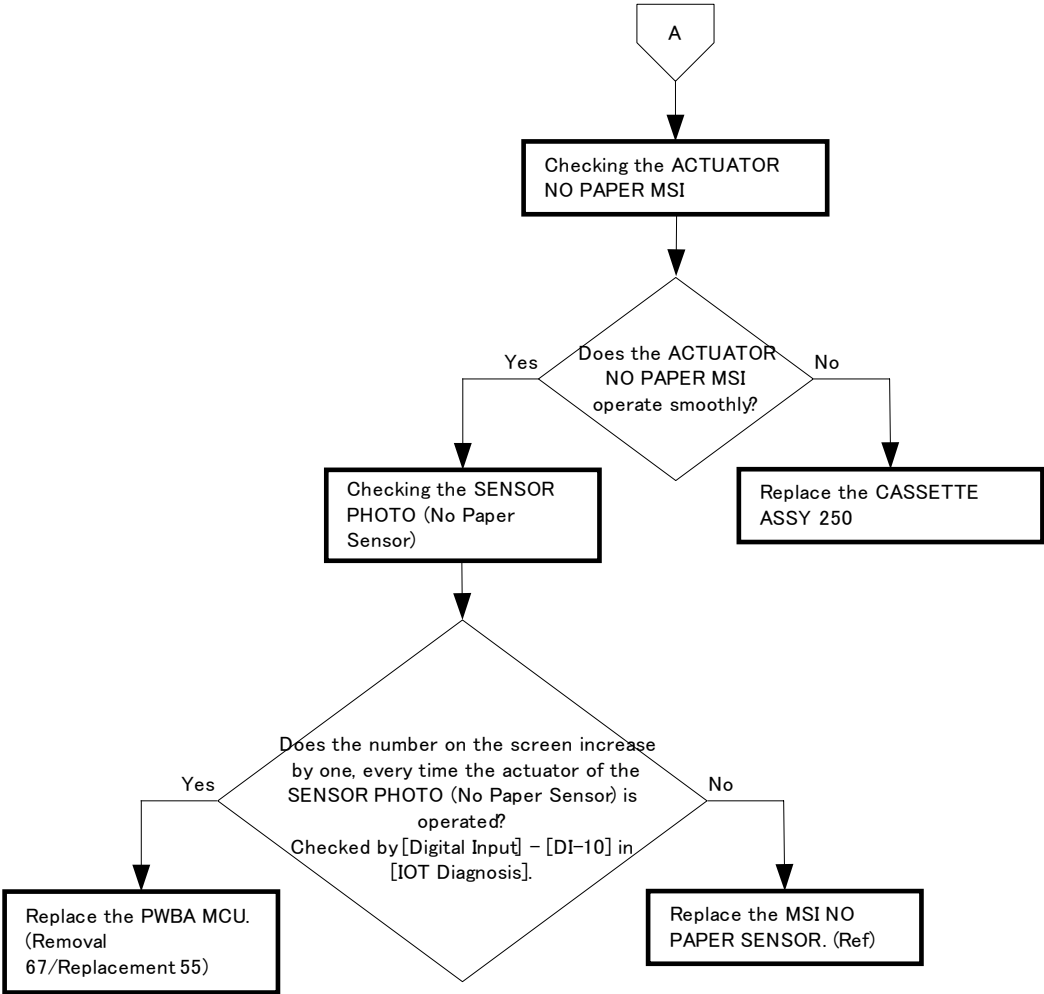

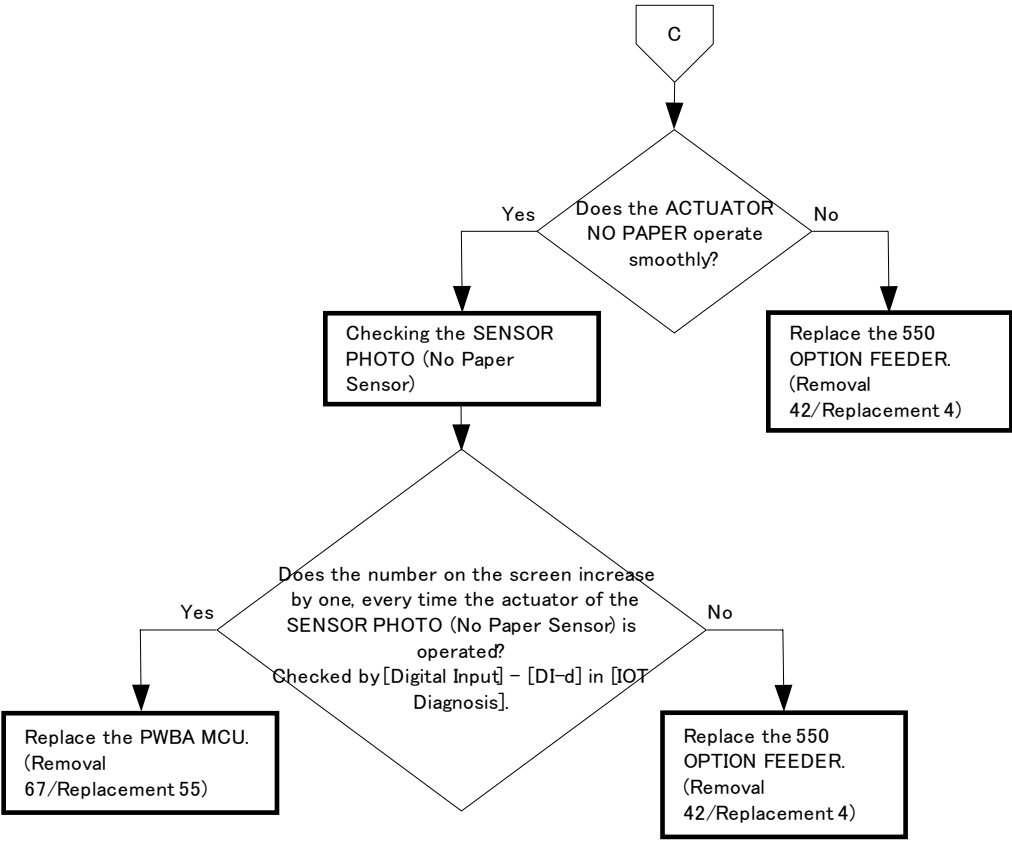
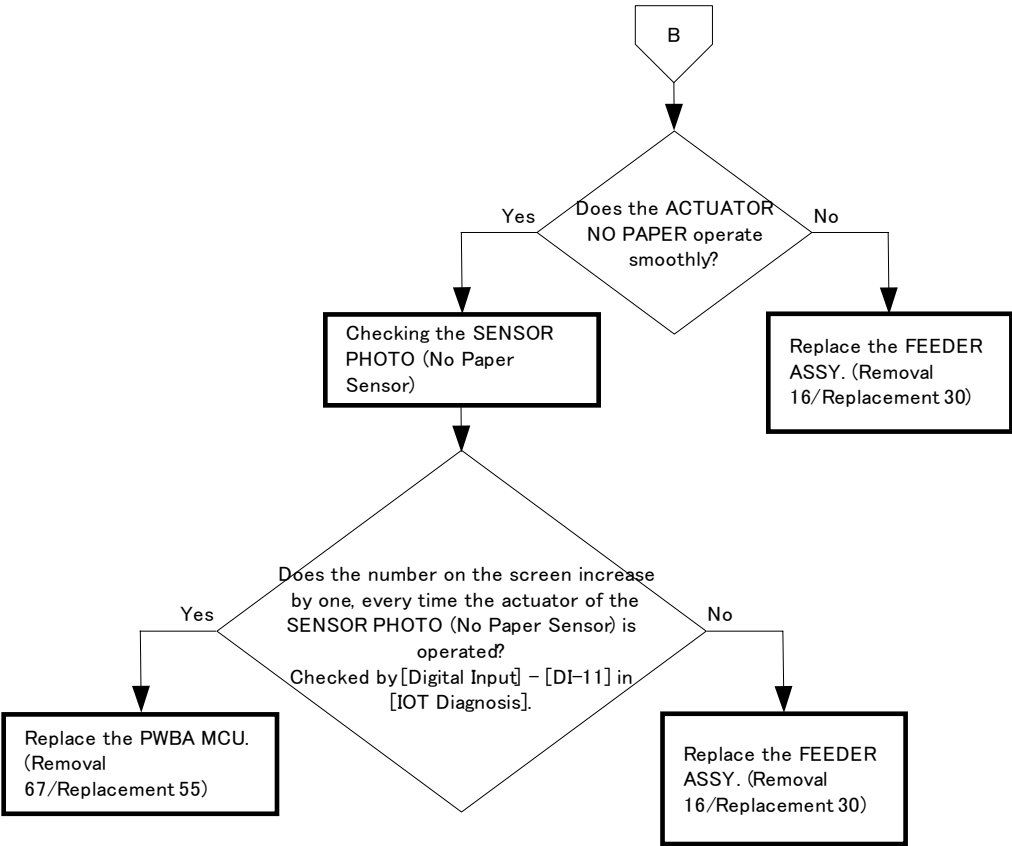

FIP-1. 45 CRUM ID 009-367/009-368/009-369/009-370

Possible causative parts: CARTRIDGE ASSY K (PL5.1.18)
CARTRIDGE ASSY C (PL5.1.19)
CARTRIDGE ASSY M (PL5.1.20)
CARTRIDGE ASSY Y (PL5.1.21)
PWBA MCU (PL9.1.20)

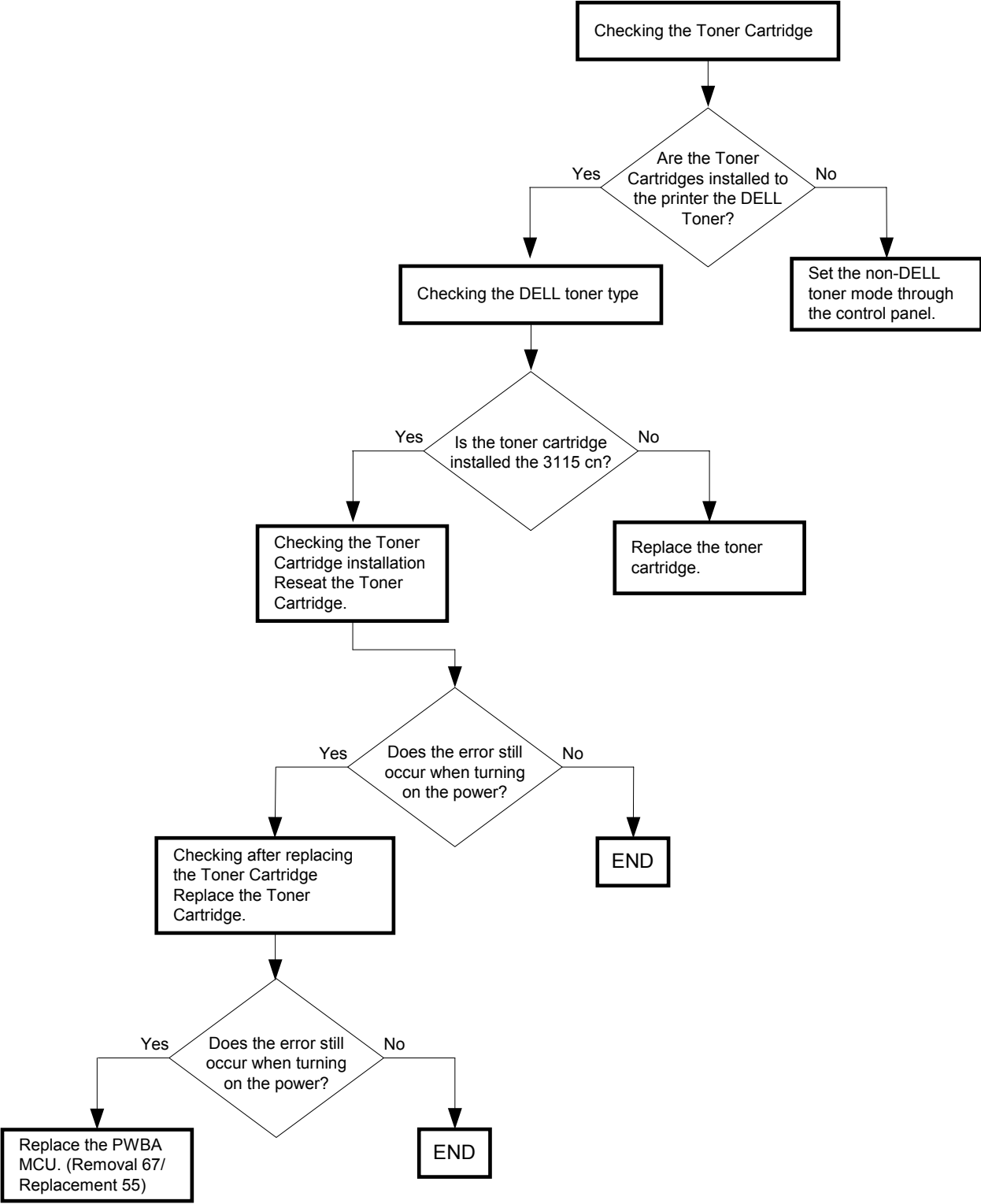

FIP-1. 46 Tape on XXX Cart 093-919/093-920/093-921/093-922

Possible causative parts: CARTRIDGE ASSY K (PL5.1.18)
CARTRIDGE ASSY C (PL5.1.19)
CARTRIDGE ASSY M (PL5.1.20)
CARTRIDGE ASSY Y (PL5.1.21)

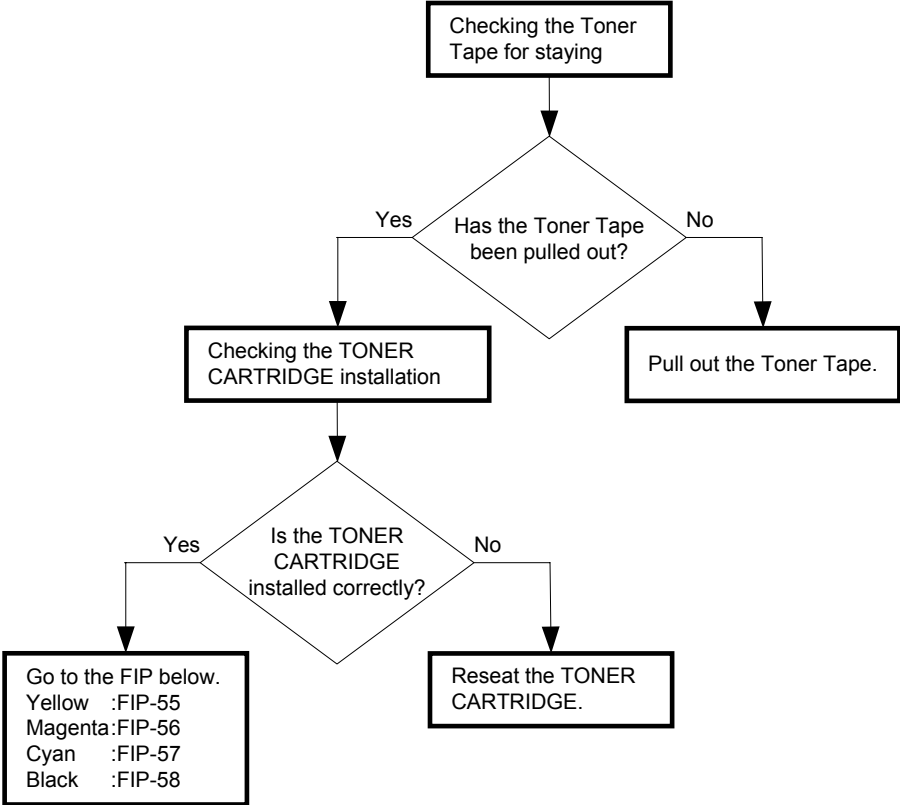

FIP-1. 47 Replace Cart. 093-930

Possible causative parts: CARTRIDGE ASSY Y (PL5.1.21)
PWBA MCU (PL9.1.20)

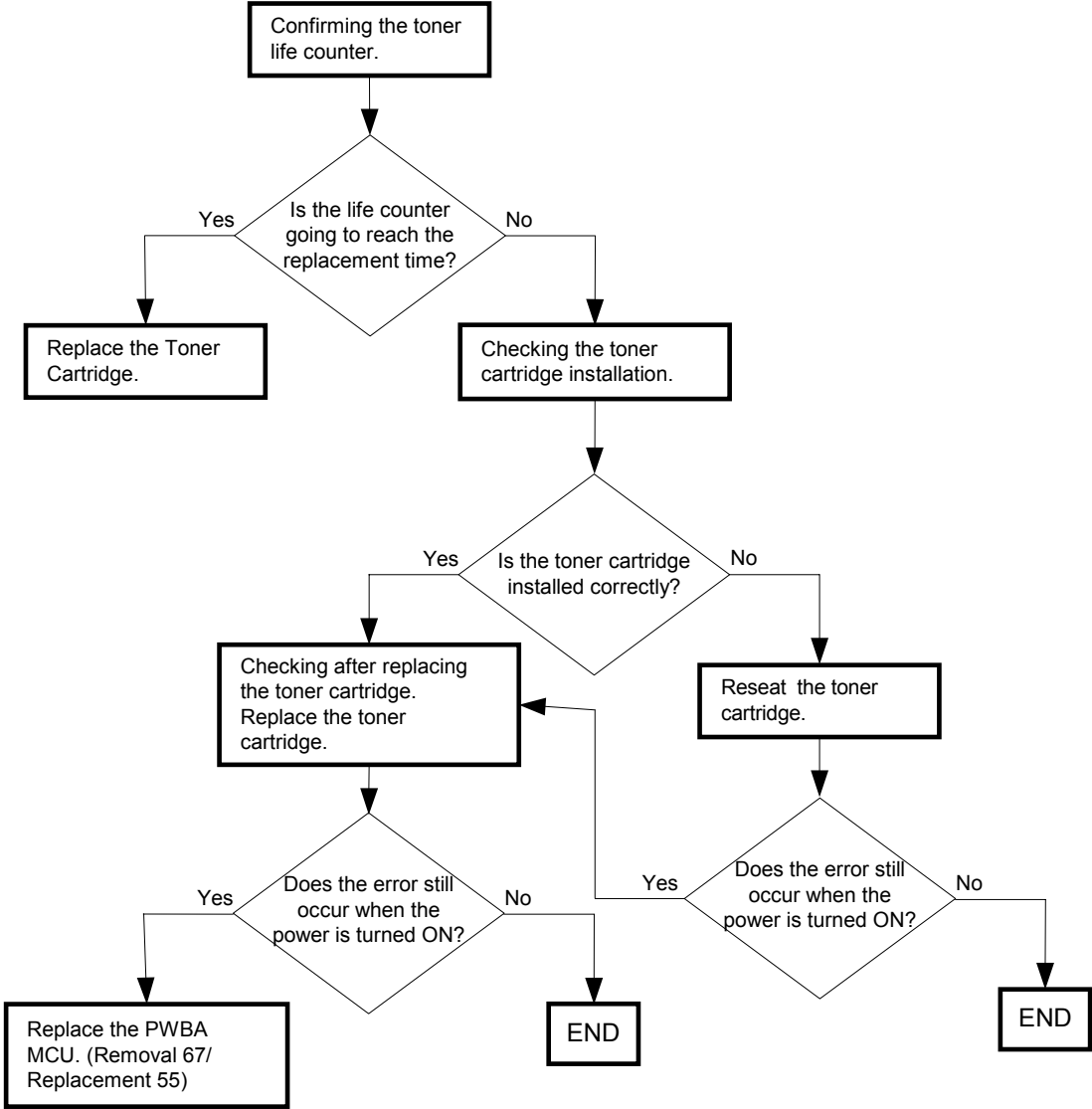

FIP-1. 48 Replace Cart. 093-931

Possible causative parts: CARTRIDGE ASSY M (PL5.1.20)
PWBA MCU (PL9.1.20)

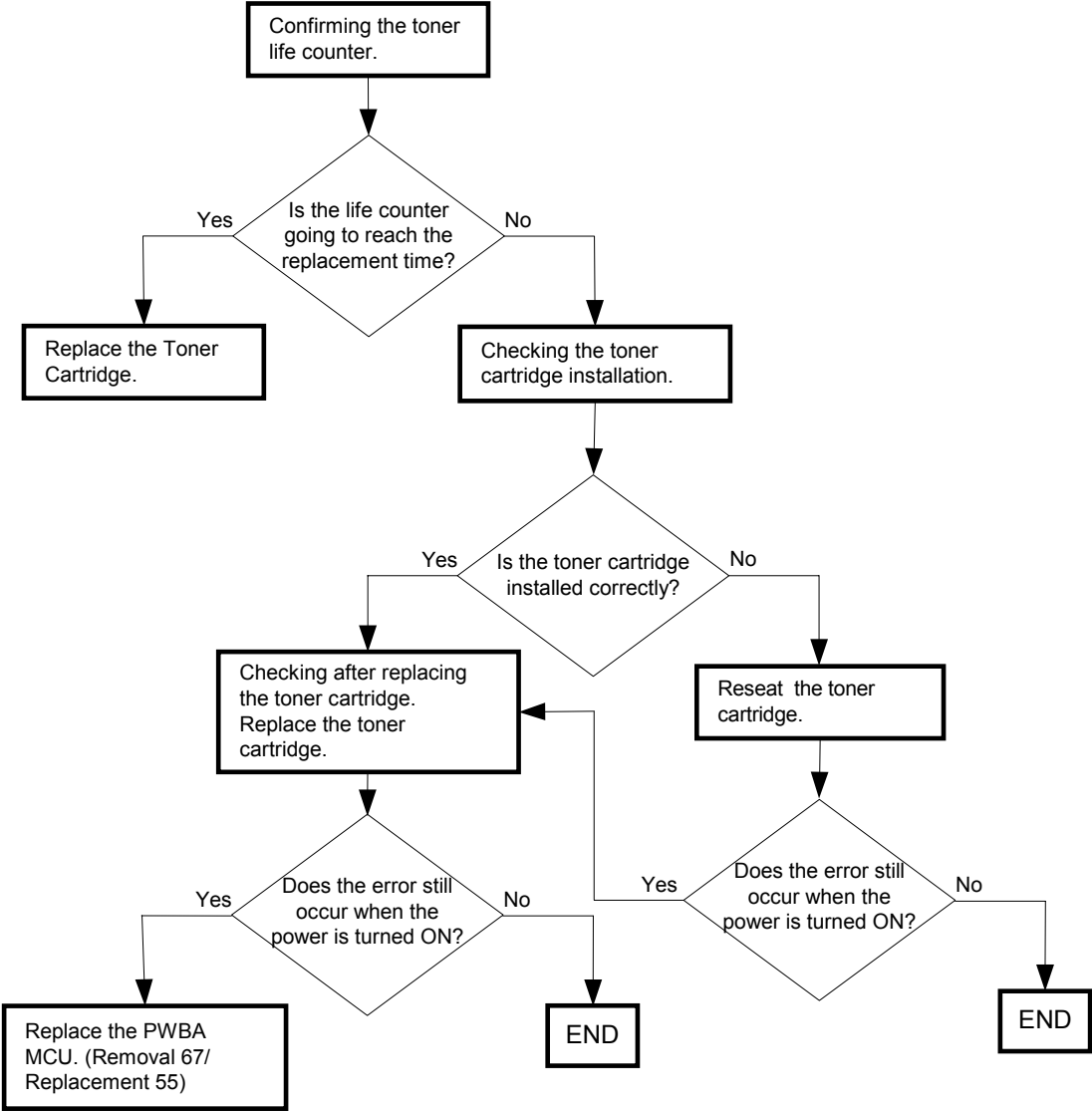

FIP-1. 49 Replace Cart. 093-932

Possible causative parts: CARTRIDGE ASSY C (PL5.1.19)
PWBA MCU (PL9.1.20)

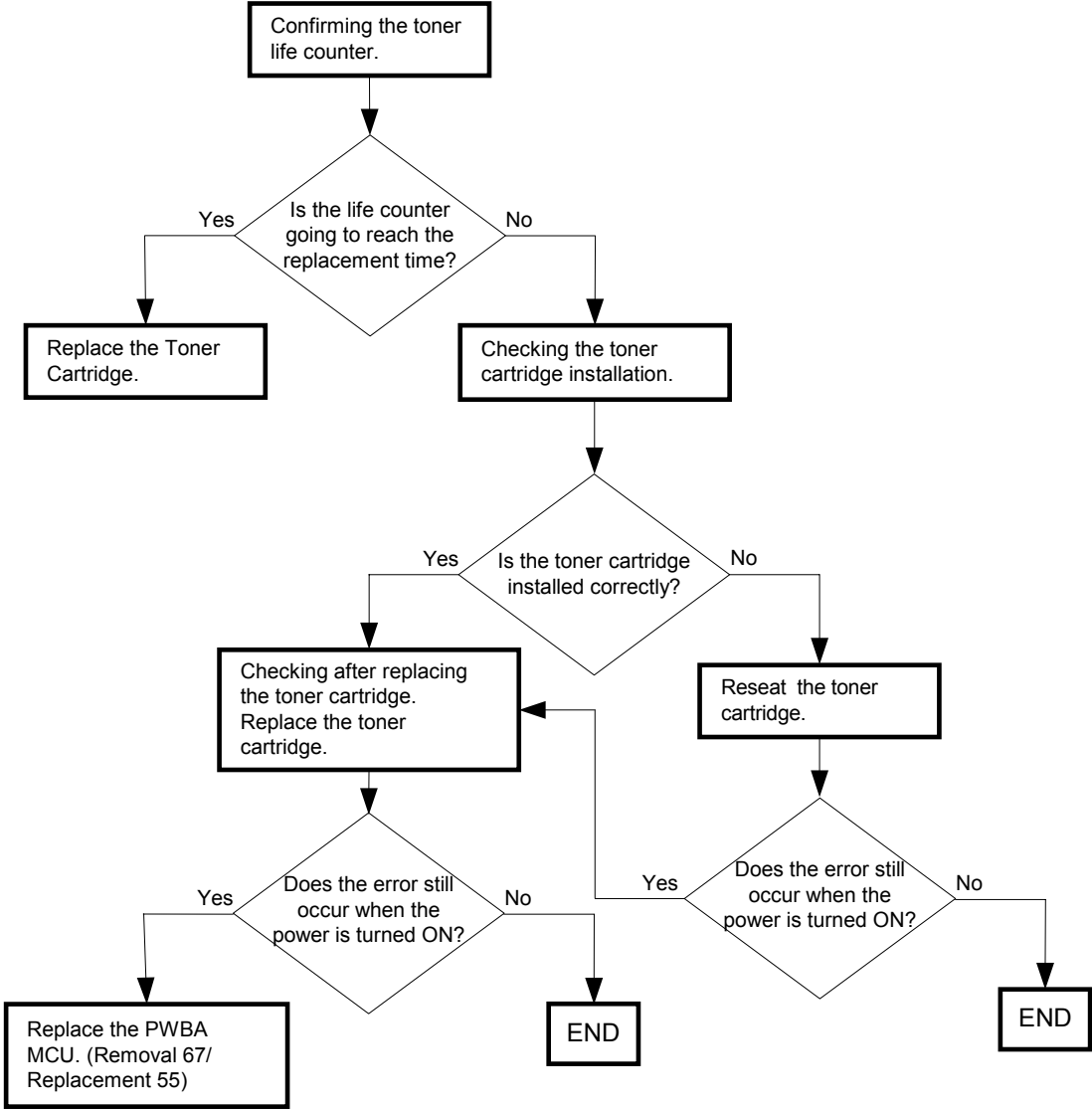

FIP-1. 50 Replace Cart. 093-933

Possible causative parts: CARTRIDGE ASSY K (PL5.1.18)
PWBA MCU (PL9.1.20)

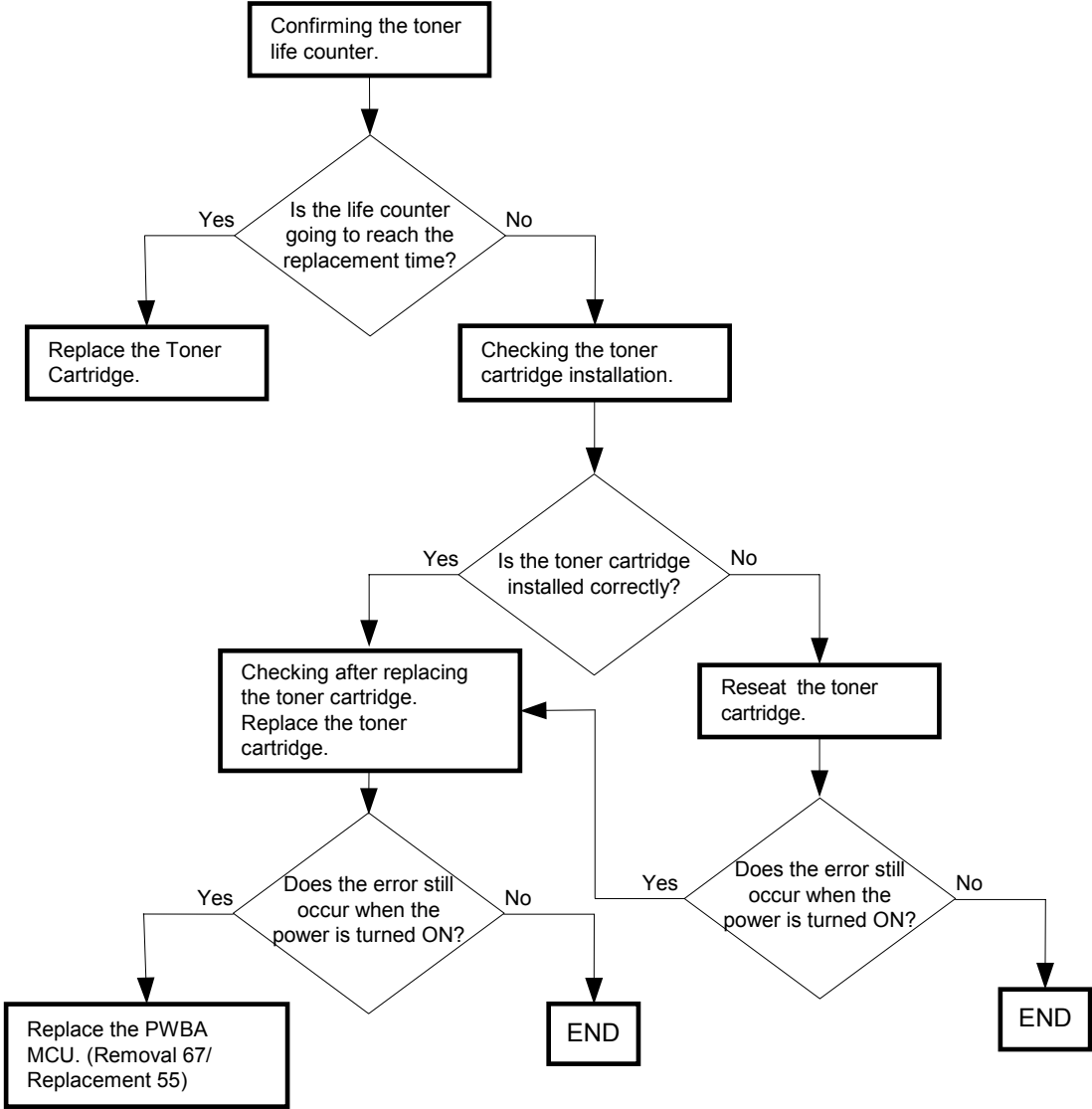

FIP-1. 51 Ready to Print 093-423

Possible causative parts: CARTRIDGE ASSY Y (PL5.1.21)
PWBA MCU (PL9.1.20)

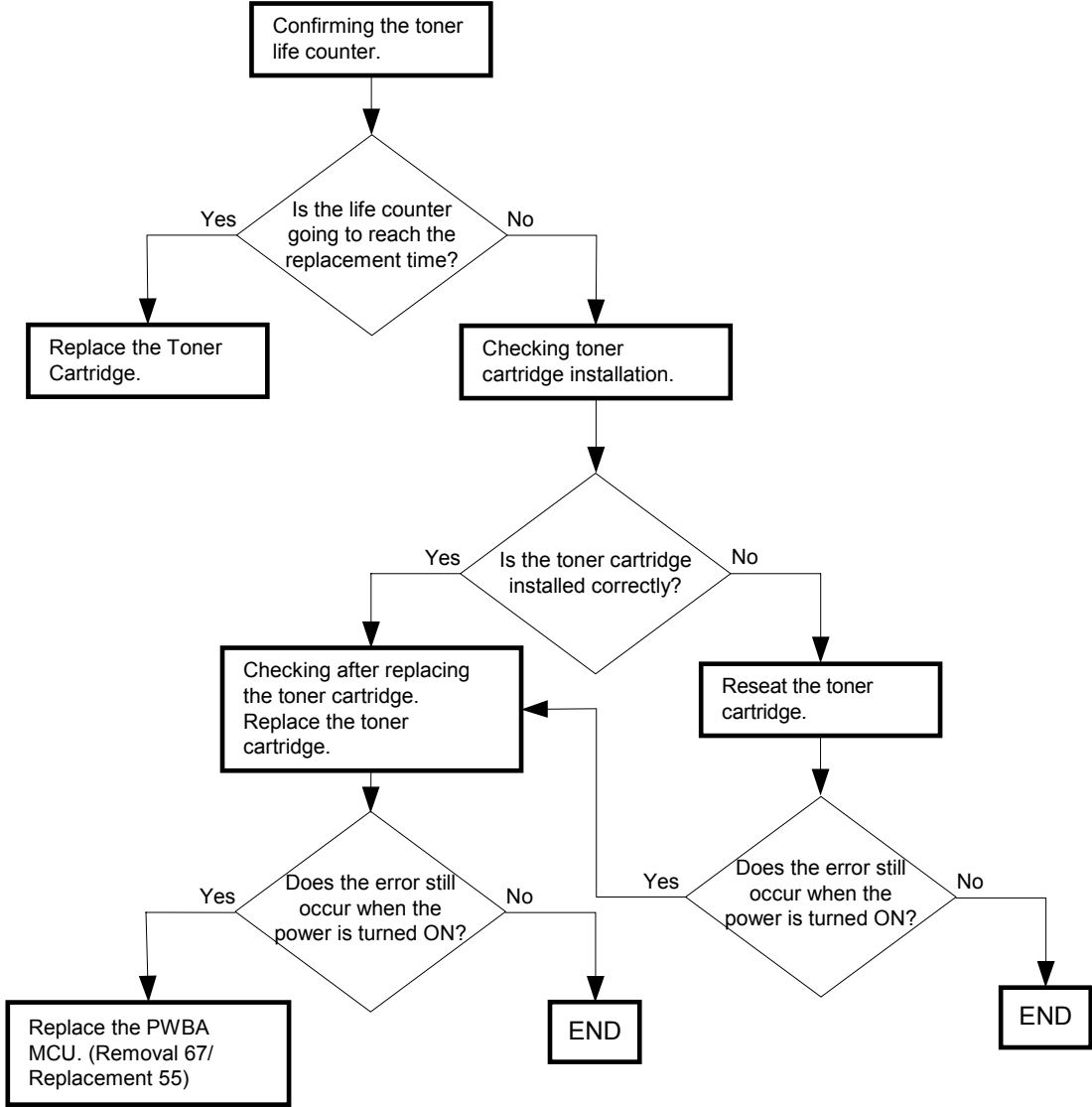

FIP-1. 52 Ready to Print 093-424

Possible causative parts: CARTRIDGE ASSY M (PL5.1.20)
PWBA MCU (PL9.1.20)

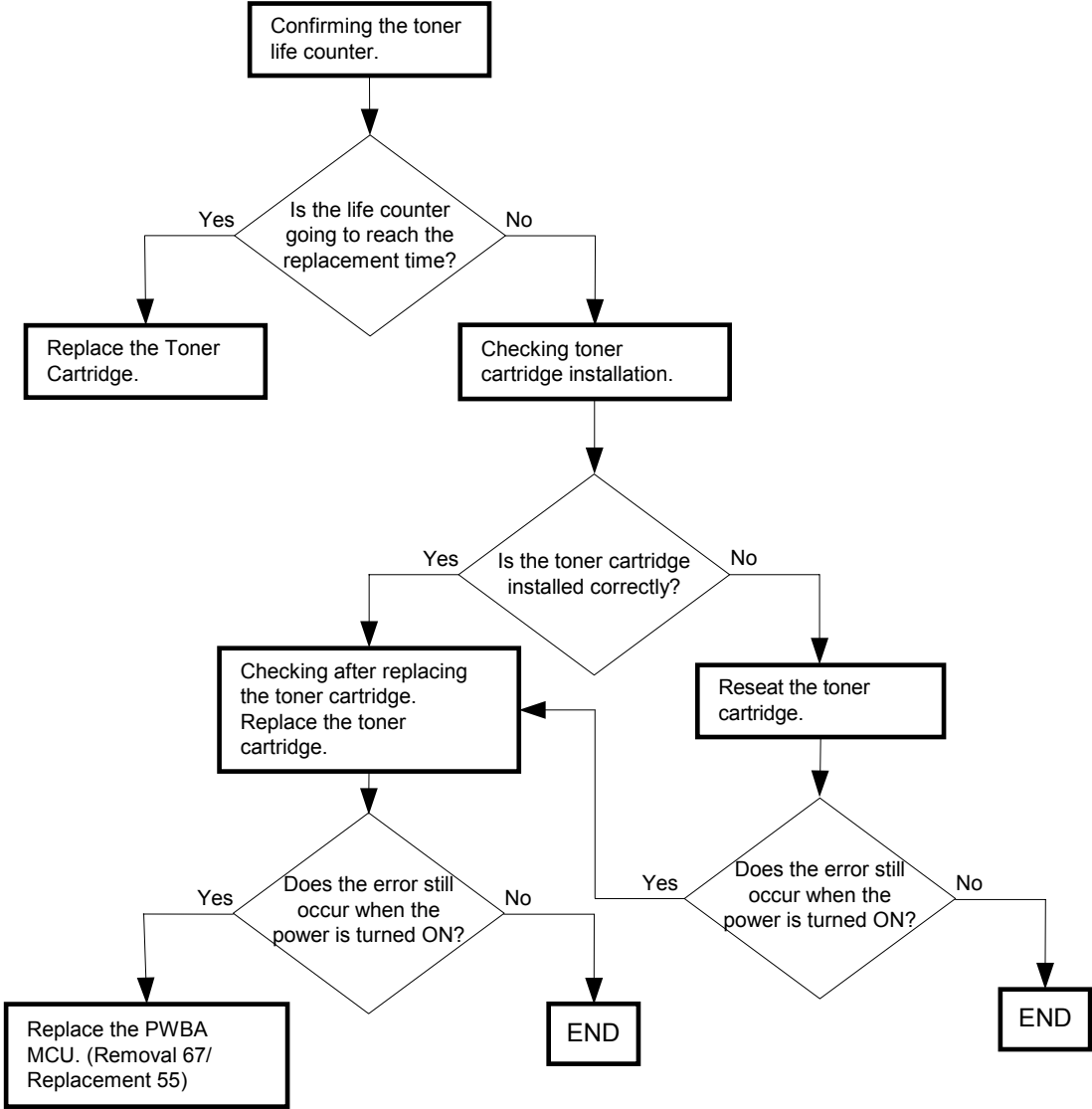

FIP-1. 53 Ready to Print 093-425

Possible causative parts: CARTRIDGE ASSY C (PL5.1.19)
PWBA MCU (PL9.1.20)

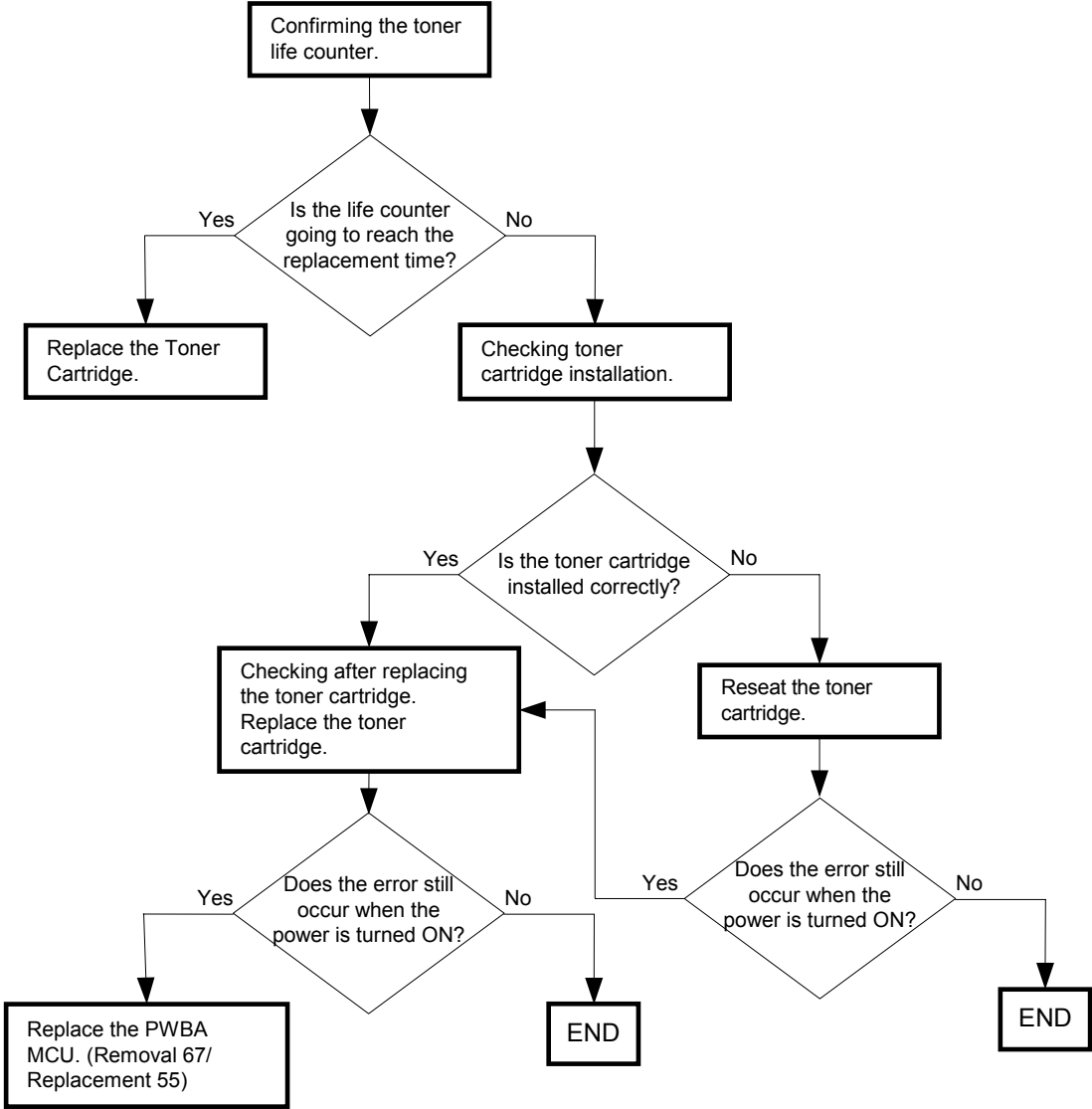

FIP-1. 54 Ready to Print 093-426

Possible causative parts: CARTRIDGE ASSY K (PL5.1.18)
PWBA MCU (PL9.1.20)

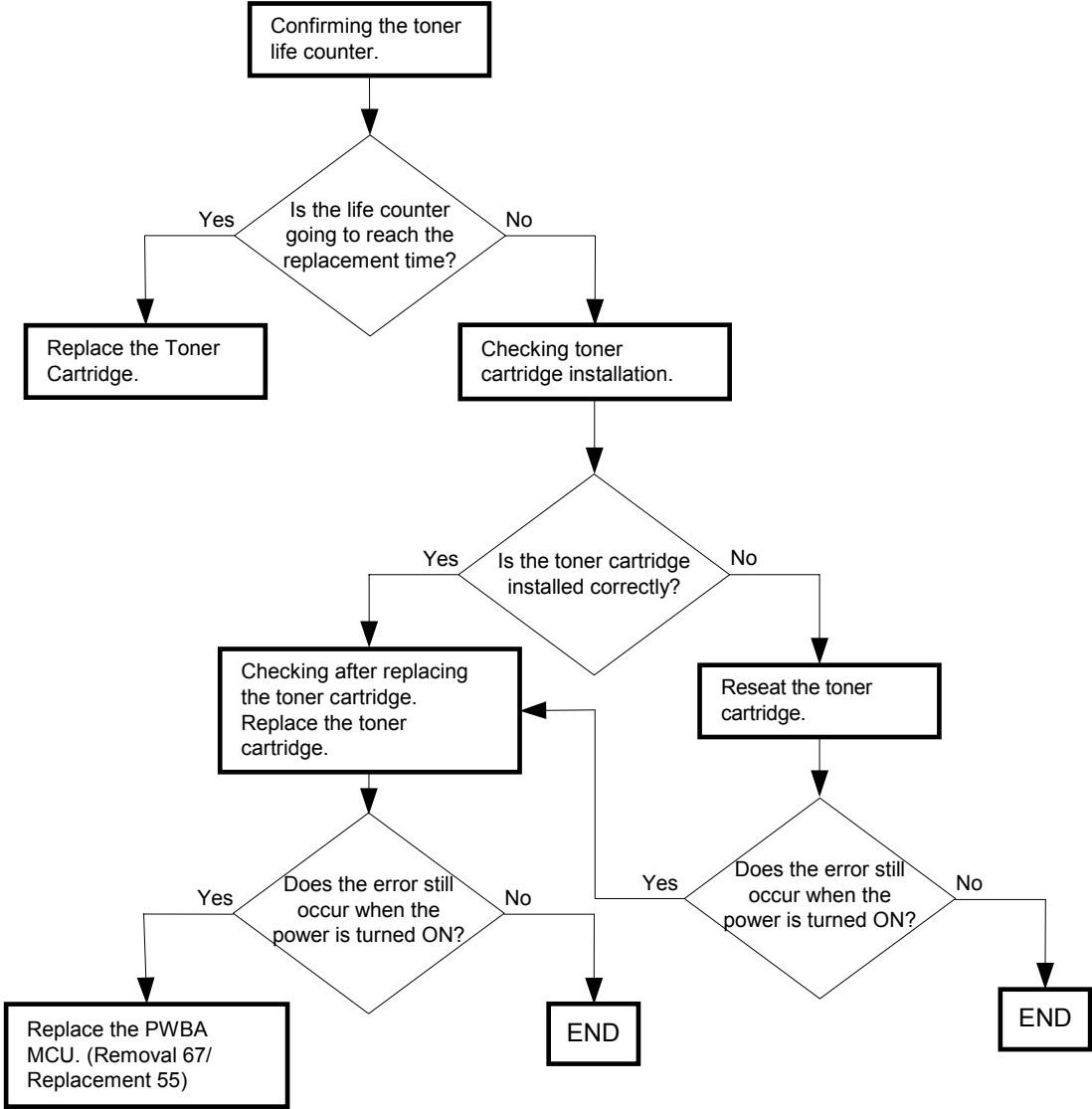

FIP-1. 55 Insert PrintCart 093-970

Possible causative parts: CARTRIDGE ASSY (Y) (PL5.1.21)
SENSOR ASSY CRU (PL5.1.4)
PWBA MCU (PL9.1.20)

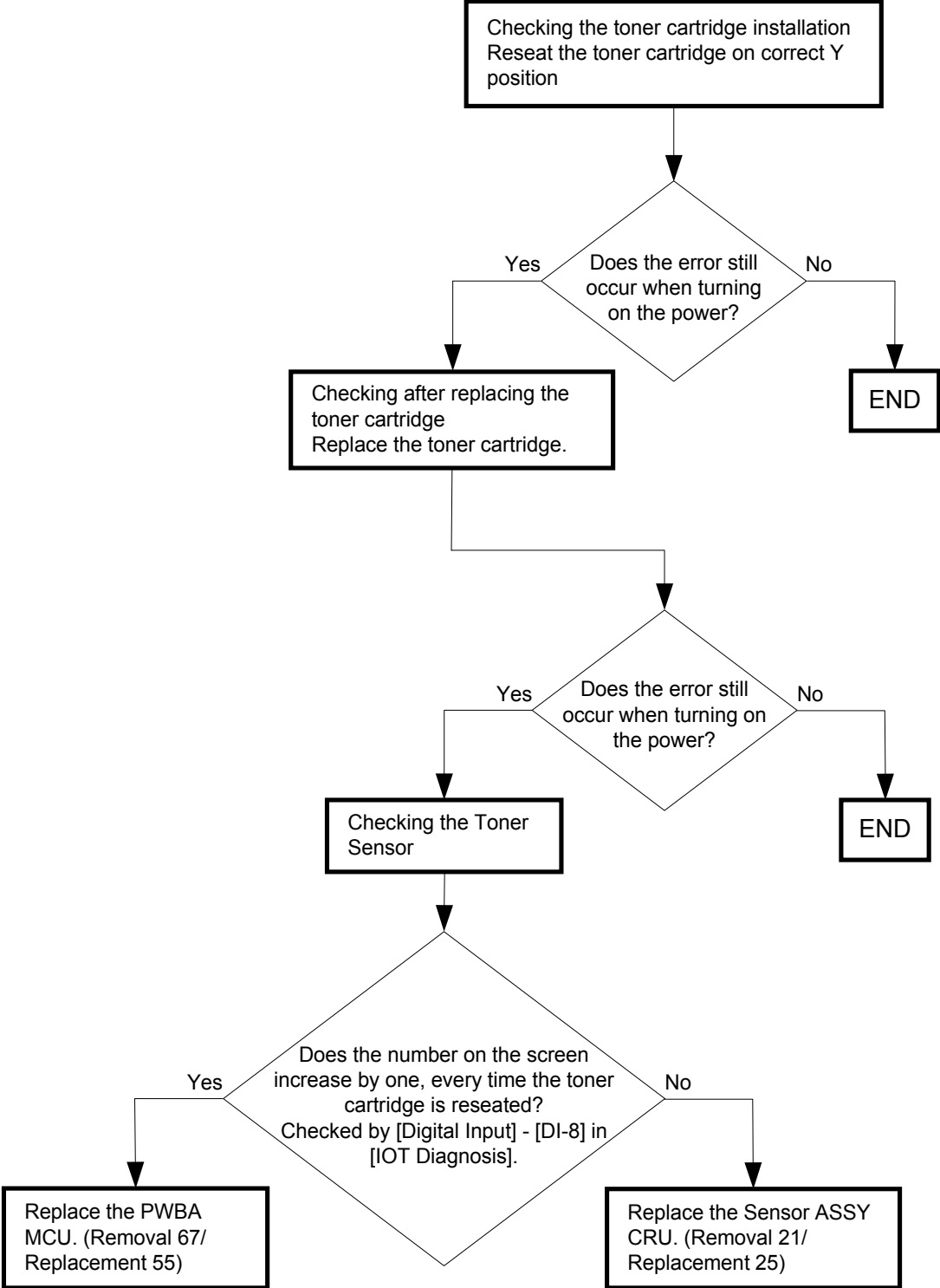

FIP-1. 56 Insert PrintCart 093-971

Possible causative parts: CARTRIDGE ASSY (M) (PL5.1.20)
SENSOR ASSY CRU (PL5.1.4)
PWBA MCU (PL9.1.20)

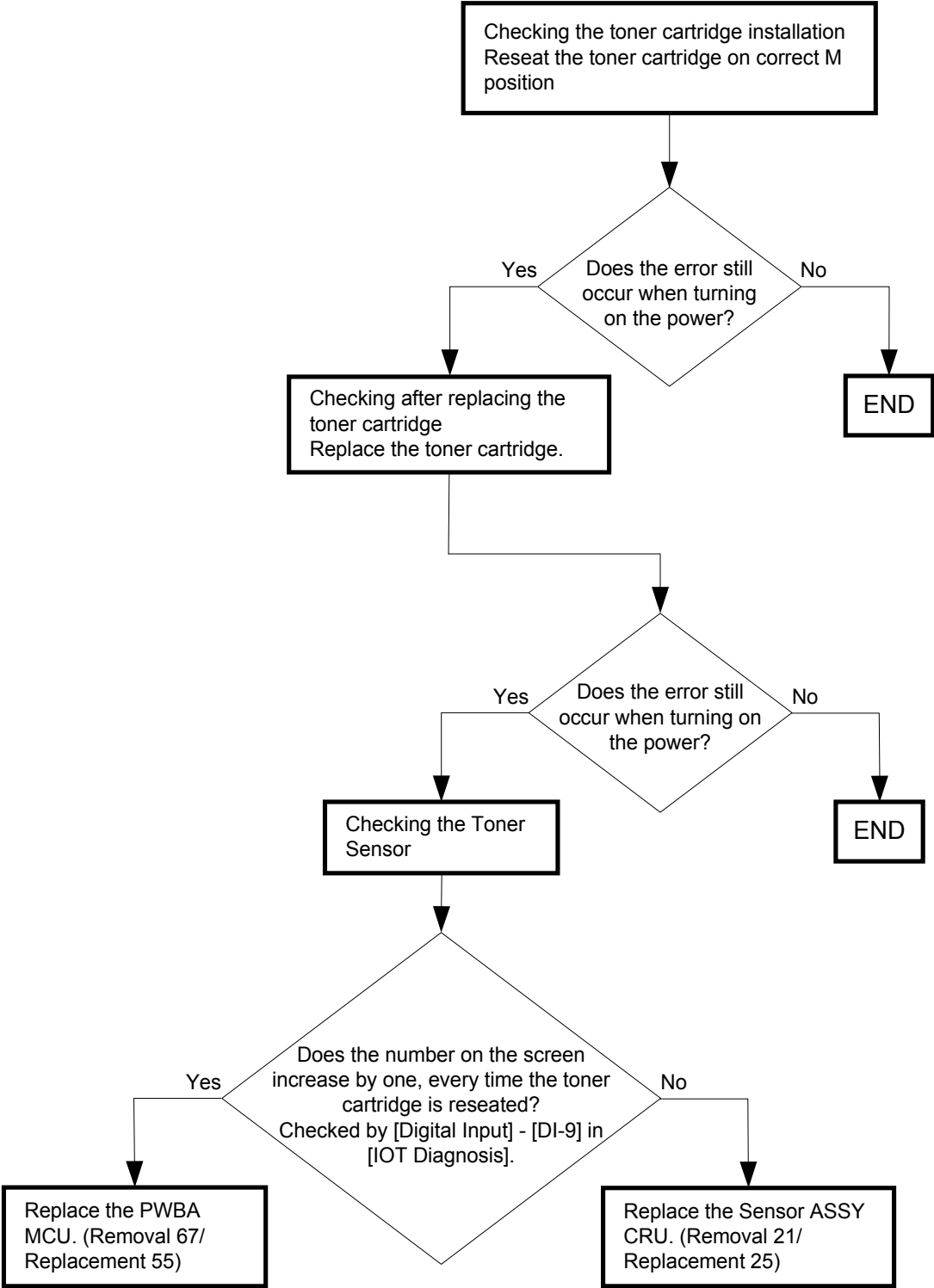

FIP-1. 57 Insert PrintCart 093-972

Possible causative parts: CARTRIDGE ASSY (C) (PL5.1.19)
SENSOR ASSY CRU (PL5.1.4)
PWBA MCU (PL9.1.20)

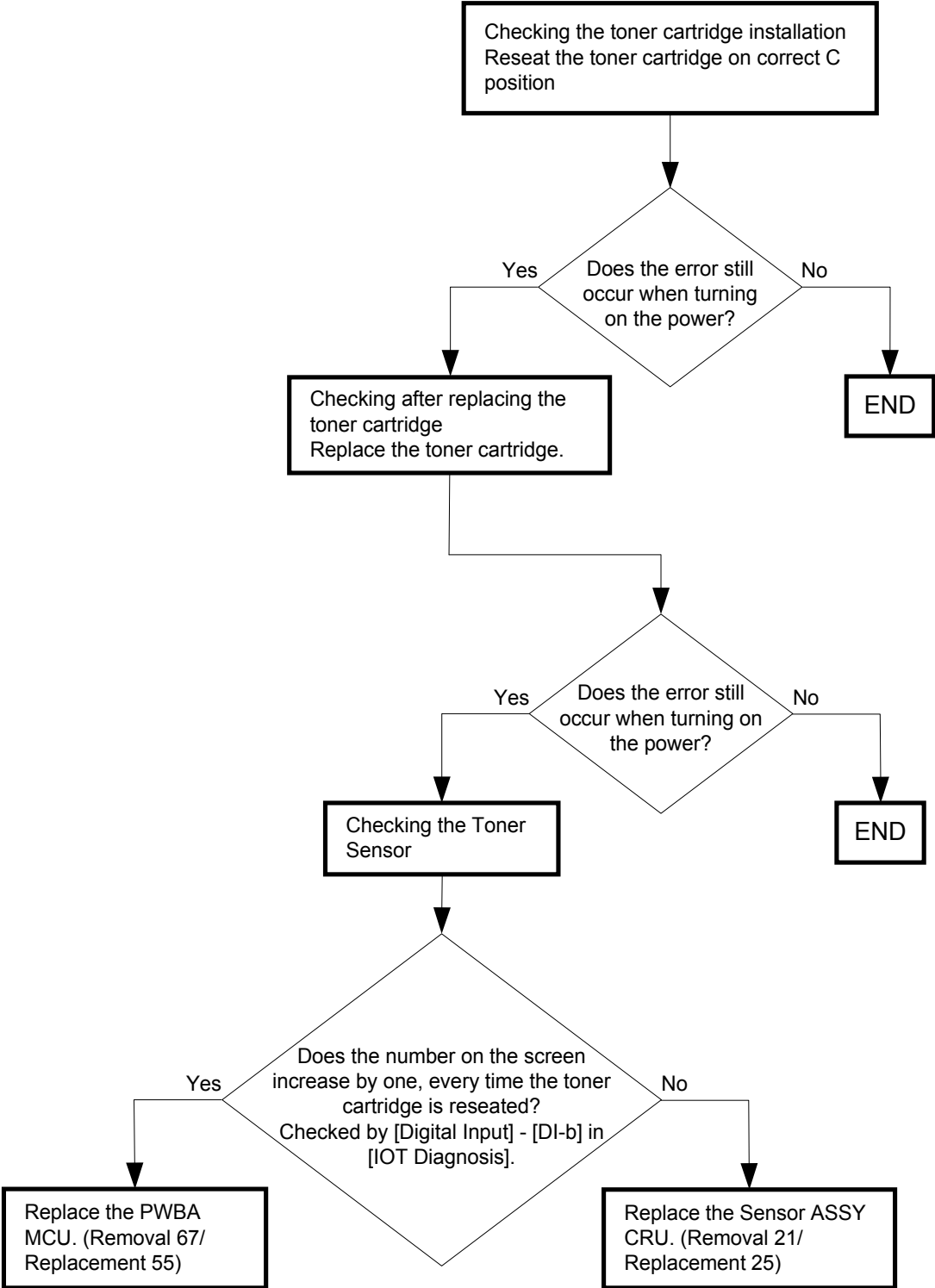

FIP-1. 58 Insert PrintCart 093-973

Possible causative parts: CARTRIDGE ASSY (K) (PL5.1.18)
SENSOR ASSY CRU (PL5.1.4)
PWBA MCU (PL9.1.20)

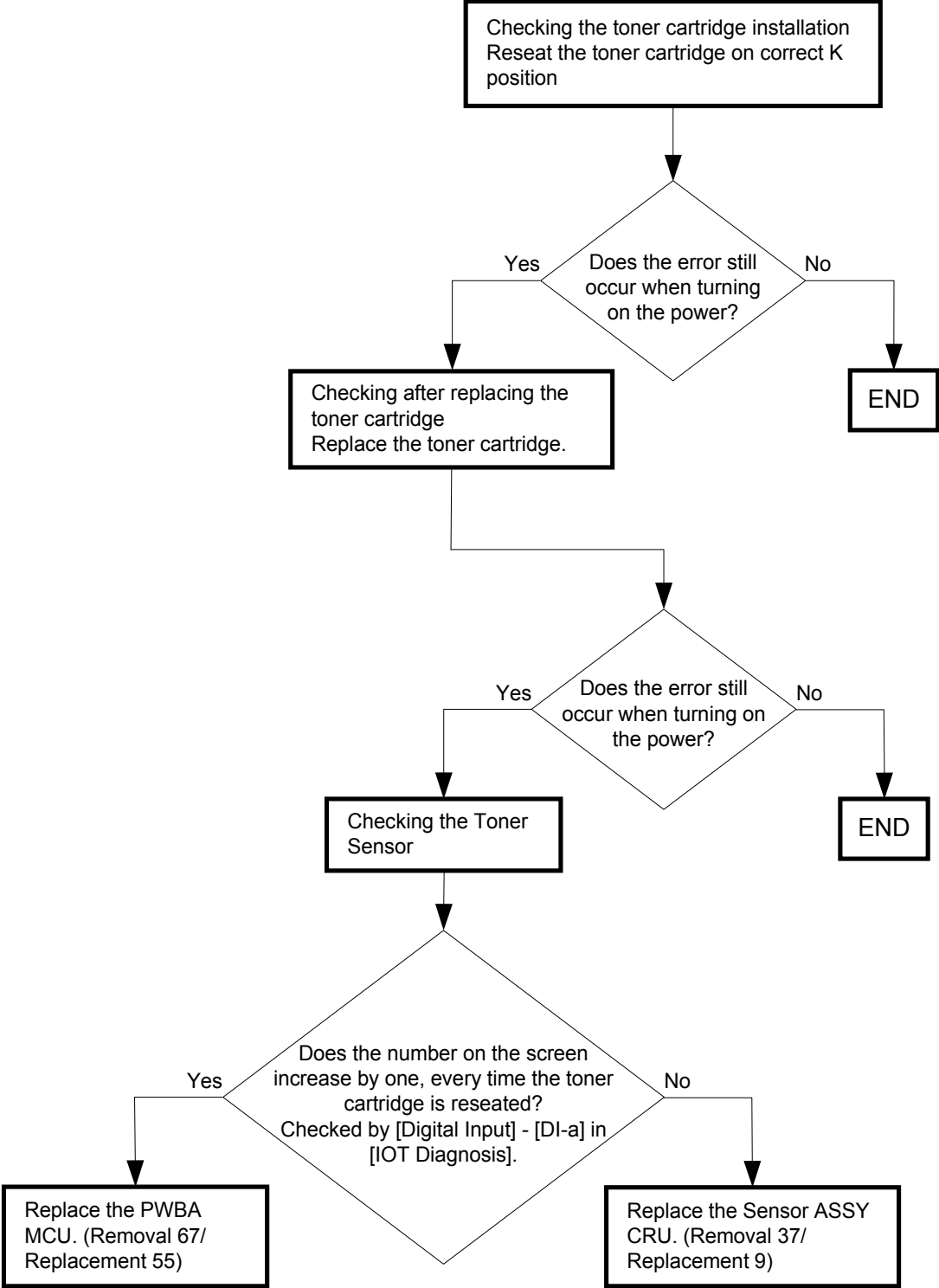

FIP-1. 59 CRUM ID 009-371/Insert Belt Unit 094-910

Possible causative parts:BELT CRU (PL4.1.1)
PWBA MCU (PL9.1.20)

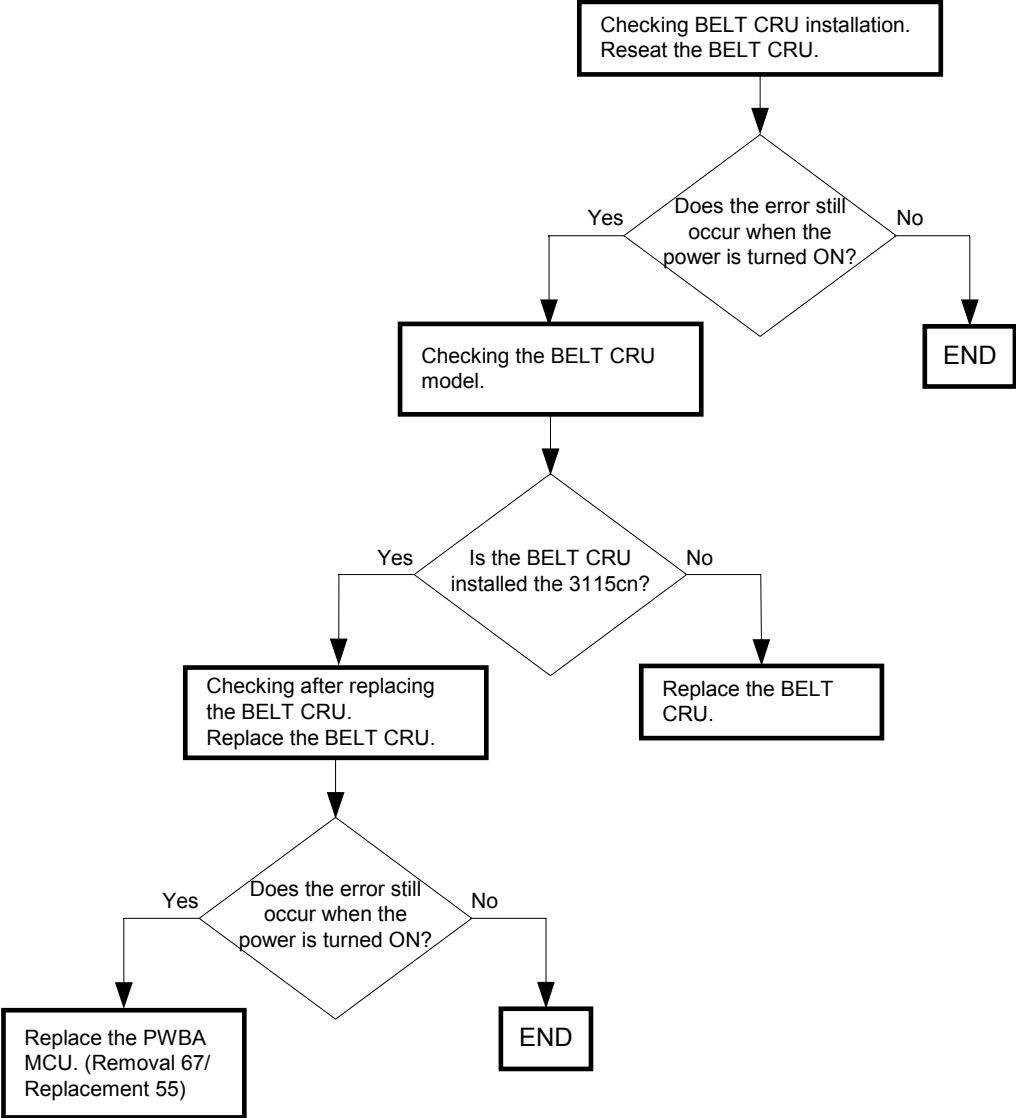

FIP-1. 60 Copy Scan Fax 094-422

Possible causative parts:BELT CRU (PL4.1.1)
PWBA MCU (PL9.1.20)

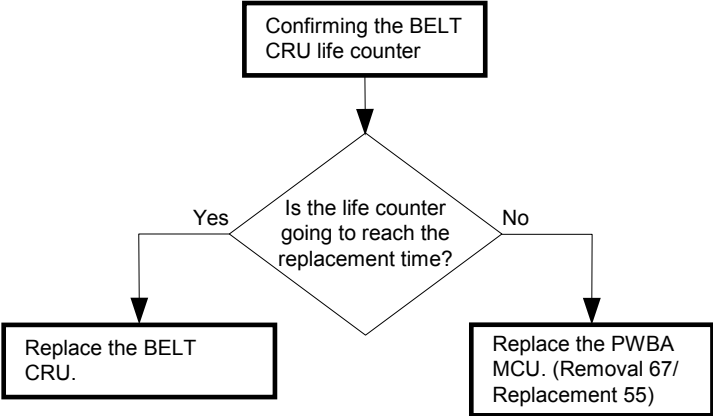

FIP-1. 61 Belt Unit 094-911

Possible causative parts:BELT CRU (PL4.1.1)
PWBA MCU (PL9.1.20)

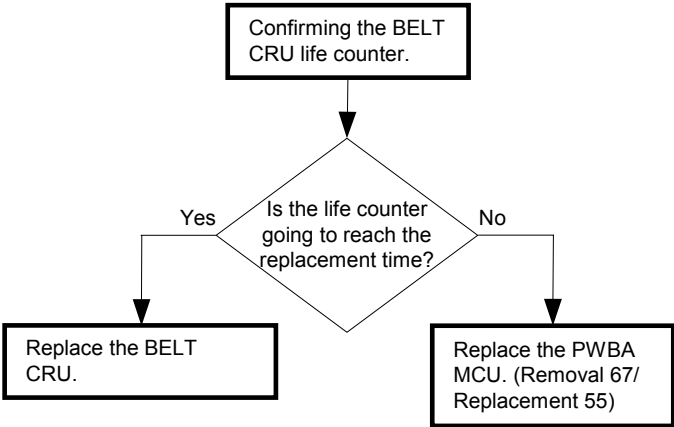

FIP-1. 62 Restart Printer 010-359

Possible causative parts:FUSER ASSY (PL6.1.10)
PWBA MCU (PL9.1.20)

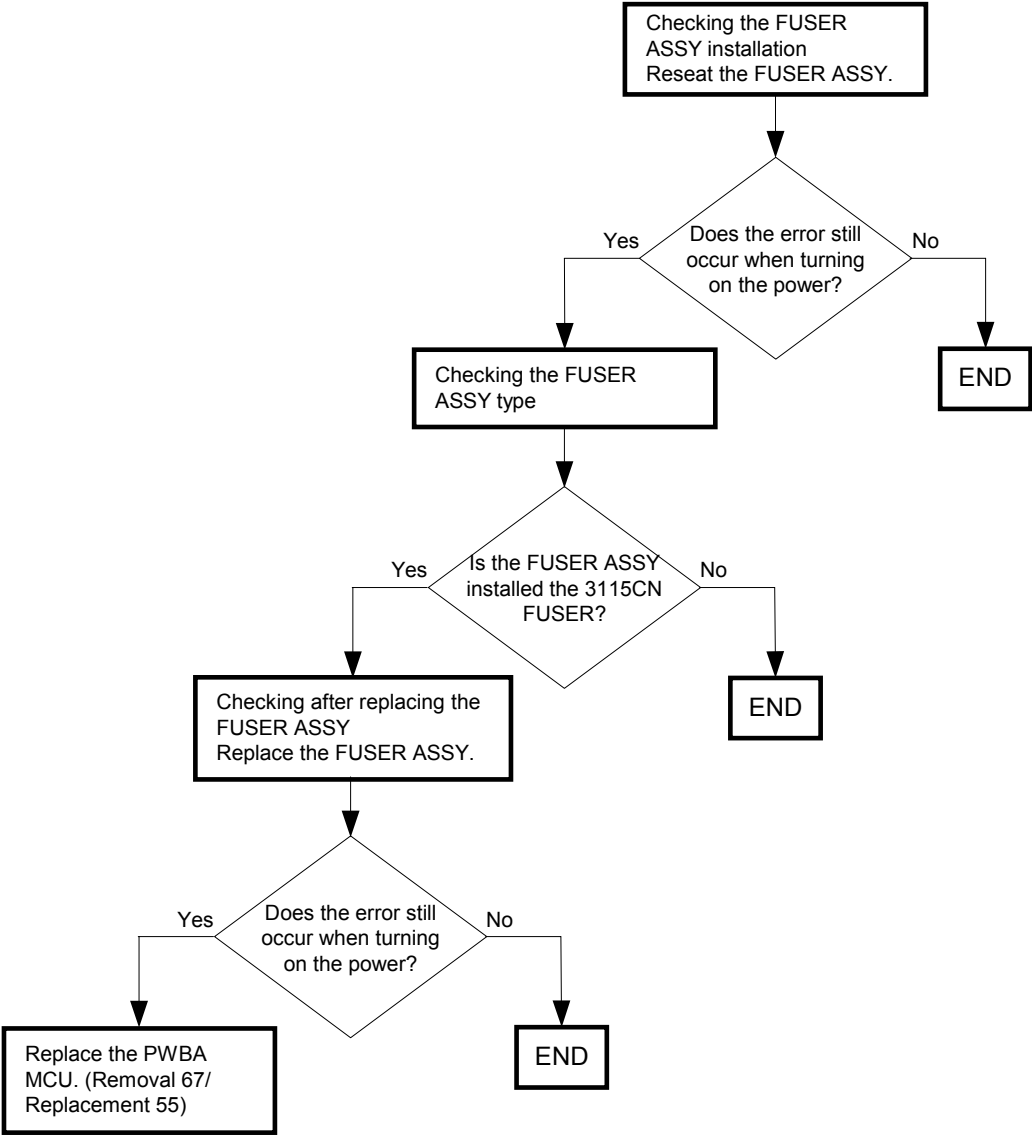

FIP-1. 63 Copy Scan Fax 010-421

Possible causative parts:FUSER ASSY (PL6.1.10)
PWBA MCU (PL9.1.20)

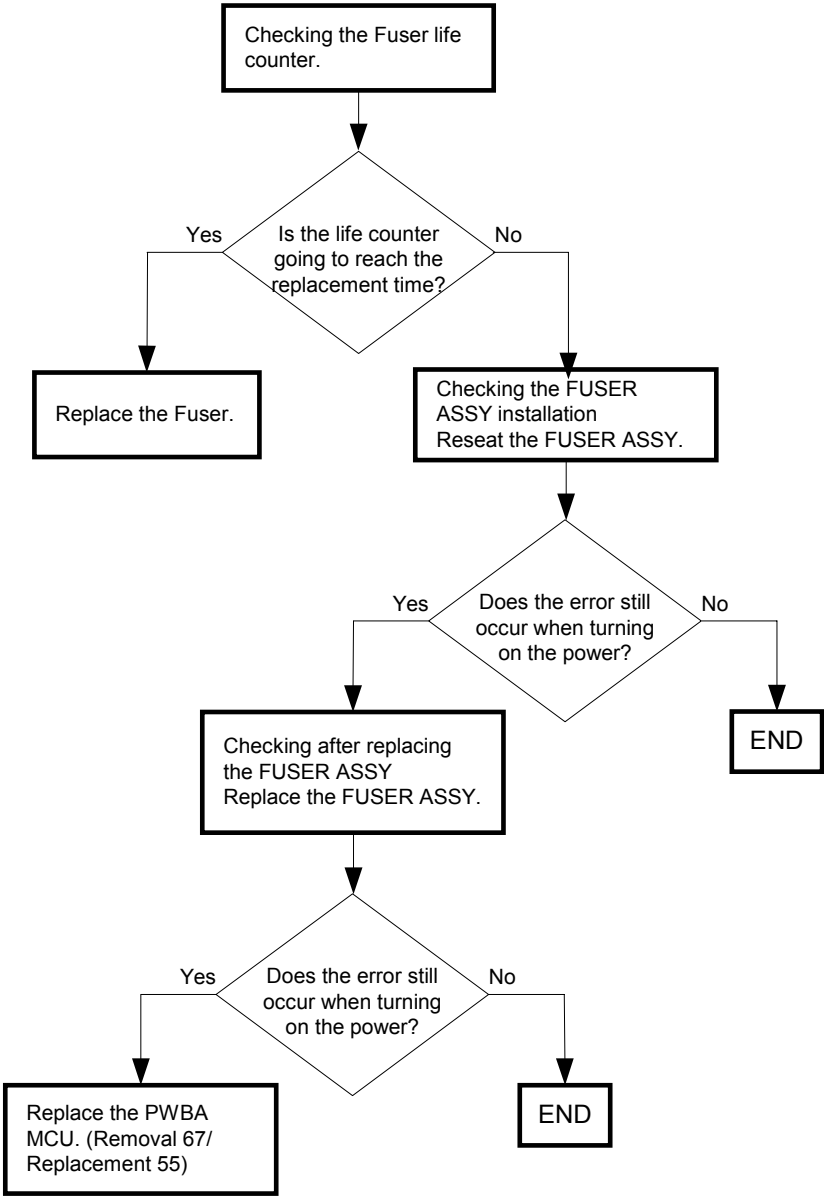

FIP-1. 64 Tray Detached 024-946/024-947 / Load Tray 1 077-912/
 Illegal Settings (Copy Select Tray Broken)/Illegal Settings
 (Copy Select Tray Remove)/Illegal Settings (Copy Select Tray Exit)

Possible causative parts: CASSETTE ASSY 250 (PL2.1.1)
 SWITCH ASSY SIZE (PL7.1.18)
 PWBA MCU (PL9.1.20)
 550 OPTION FEEDER (PL13.7.1)
 CASSETTE ASSY 550 (PL12.4.1)

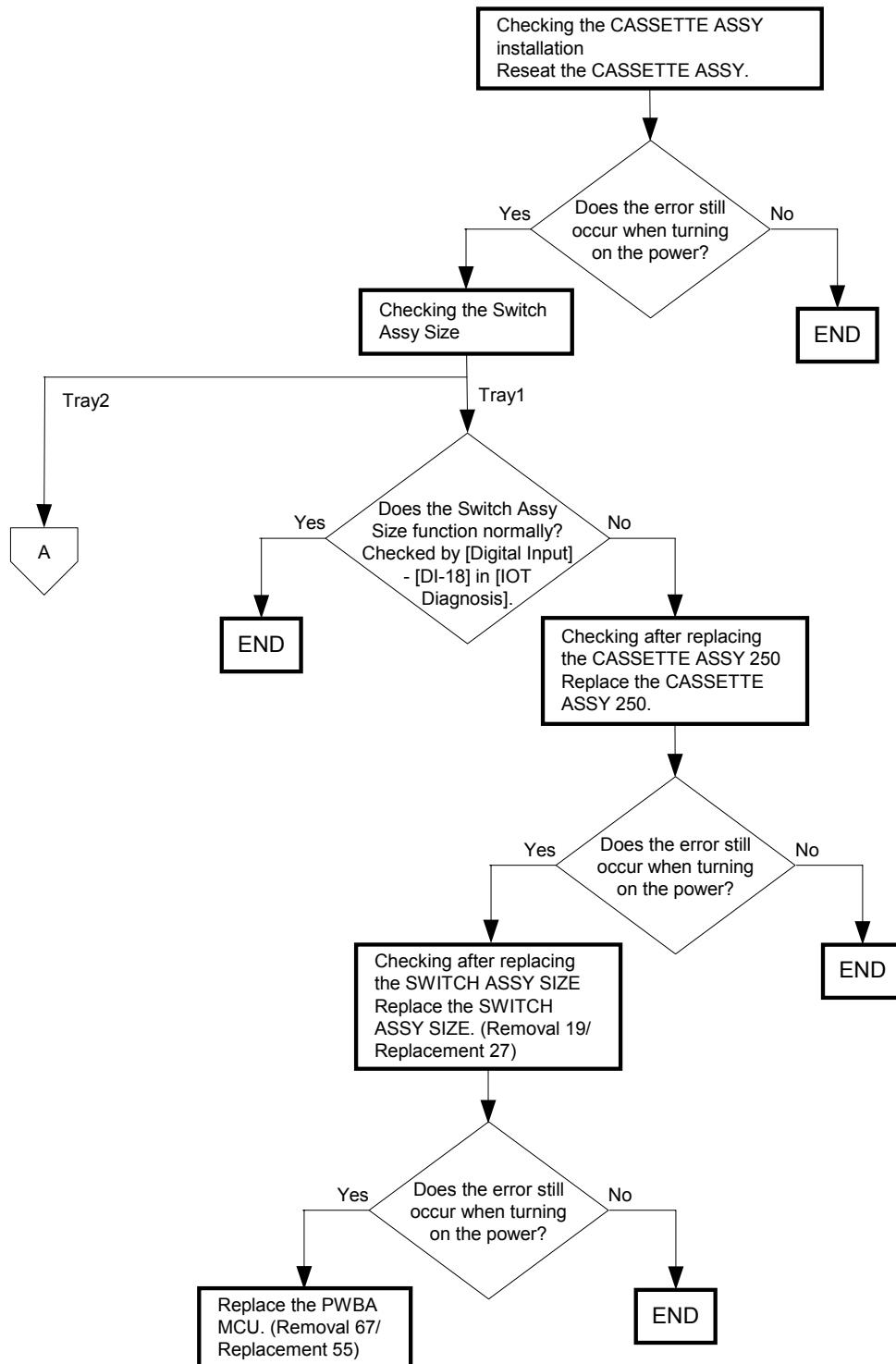

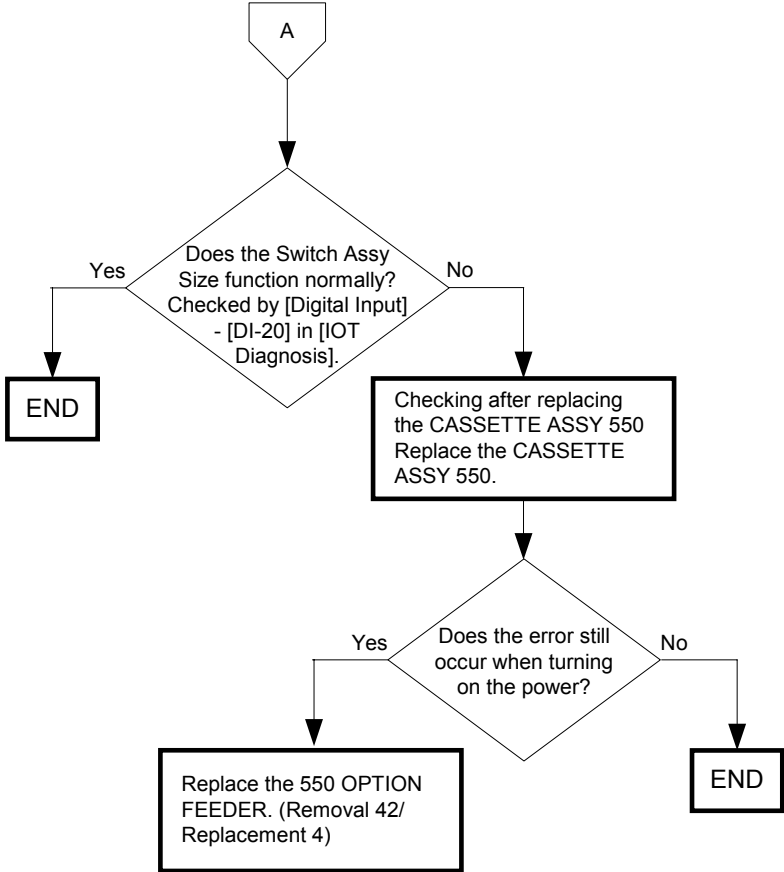

FIP-1. 65 Close FrontCover 077-300

Possible causative parts:COVER ASSY FRONT (PL13.2.98)
HARN ASSY INTERLOCK (PL9.1.3)
PWBA MCU (PL9.1.20)

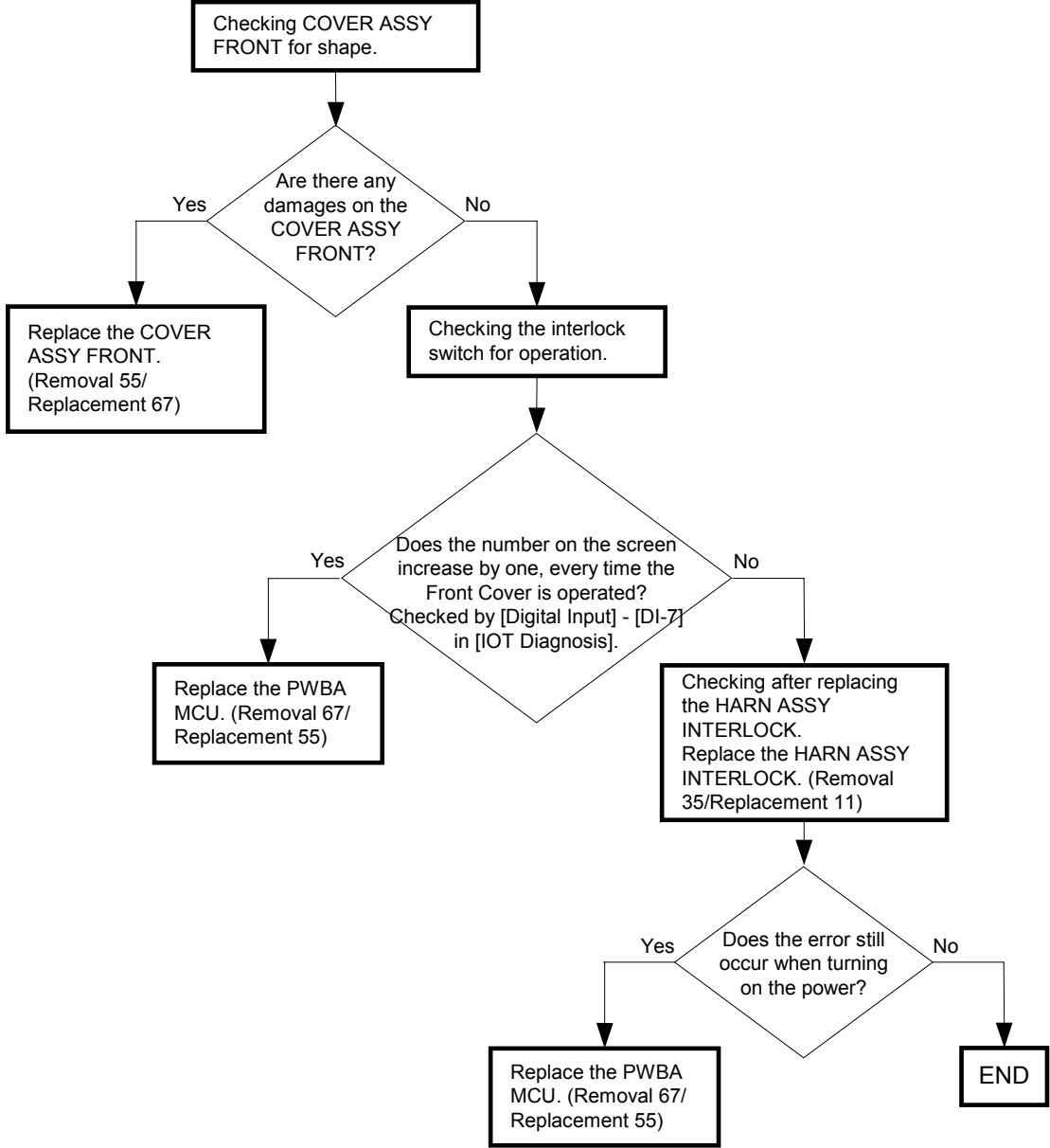

FIP-1. 66 SMTP Error 016-503/016-764/POP Error 016-504/POP Login Error 016-505/
SMTP Login Error 016-506/016-507Address Error 016-767/
From Address Error 016-768/SMB/FTP Error 016-781/016-783/016-784/
016-787/016-788/016-789/Login Error 016-782/Network Error 016-786/
Network Not Ready 016-790

Possible causative parts: PWBA HYUI (PL13.4.1)
PWBA ESS(PL13.4.20)

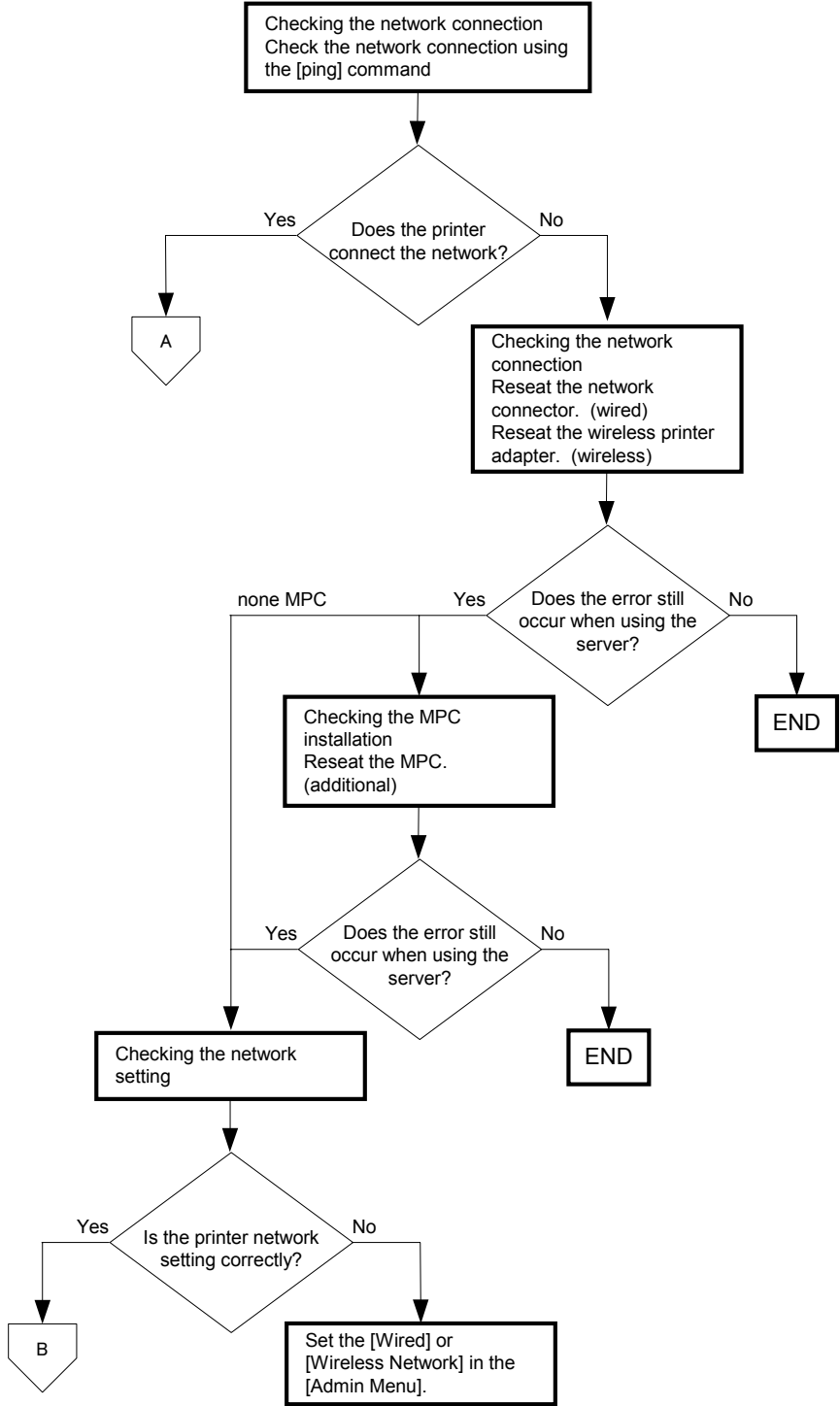

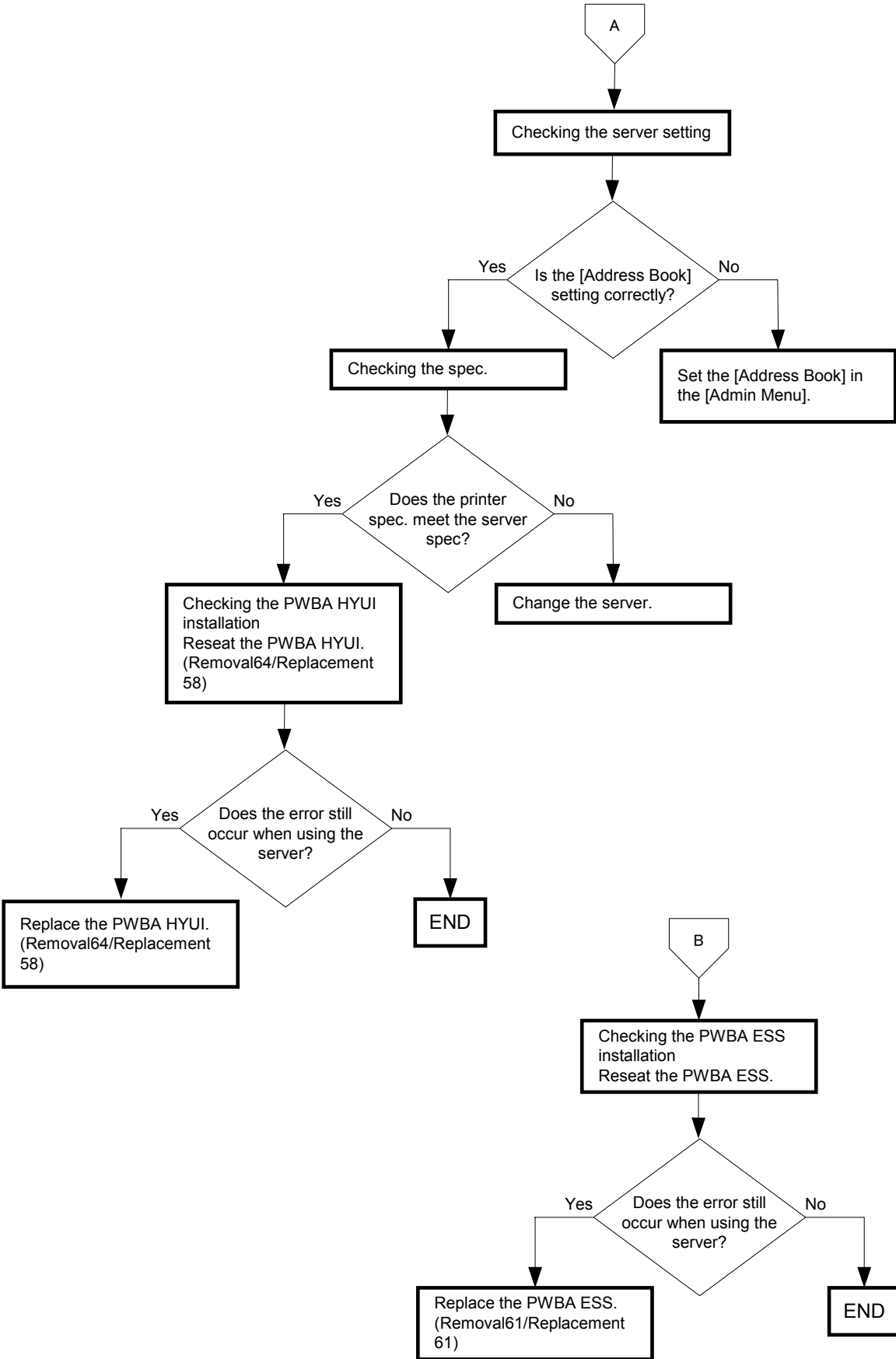

FIP-1. 67 Network Not Ready 016-794

Possible Causative parts:PWBA ESS (PL13.4.20)

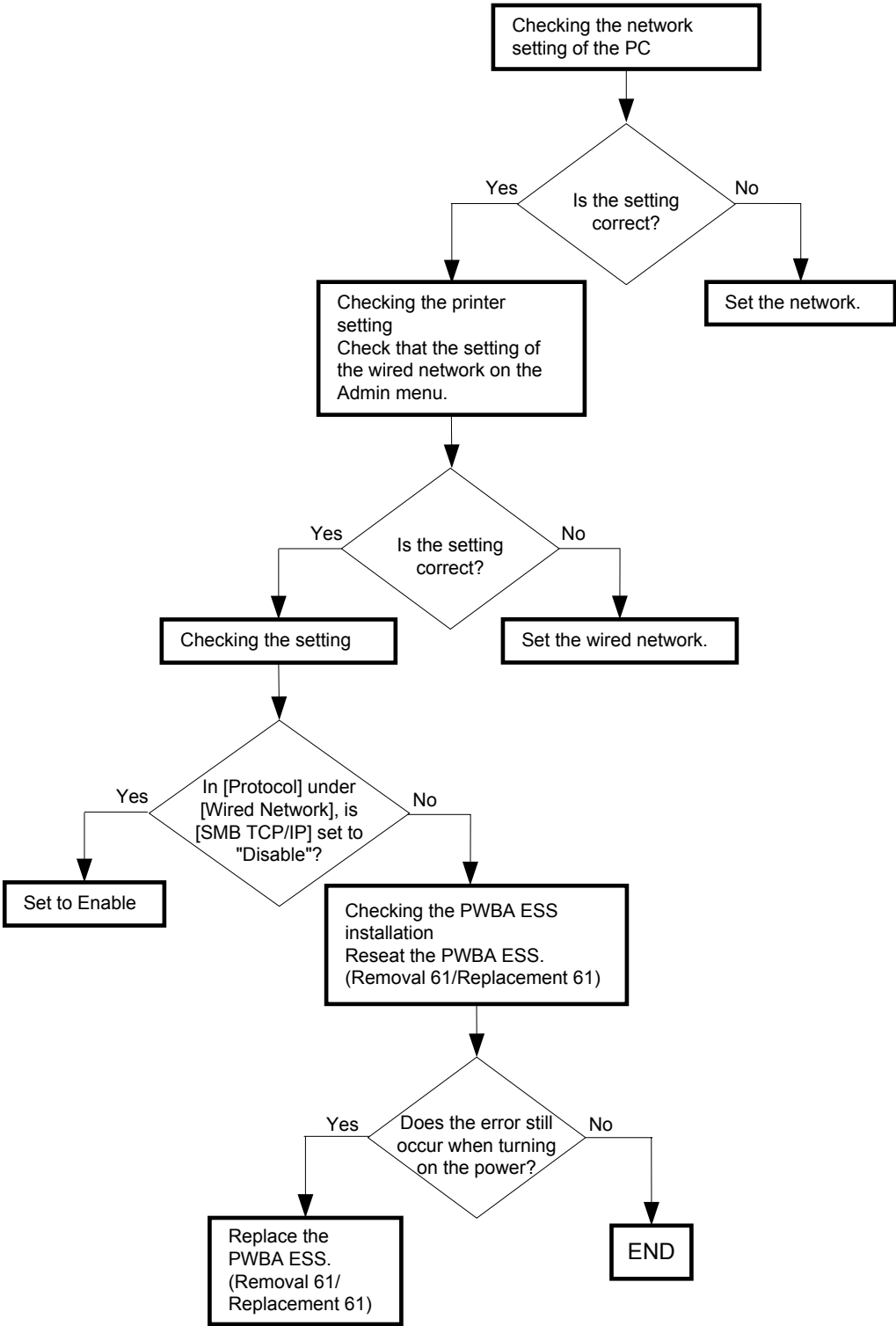

FIP-1. 68 PCScan Time Out 017-988

NOTE

The 017-988 error occurs by the following causes.
-No destination folder exists in the PC.
-Black and white scanning was performed with JPEG specified as the image format.
-There was no request from the PC within 30 seconds after [Scan to Application] was set via the printer menu.

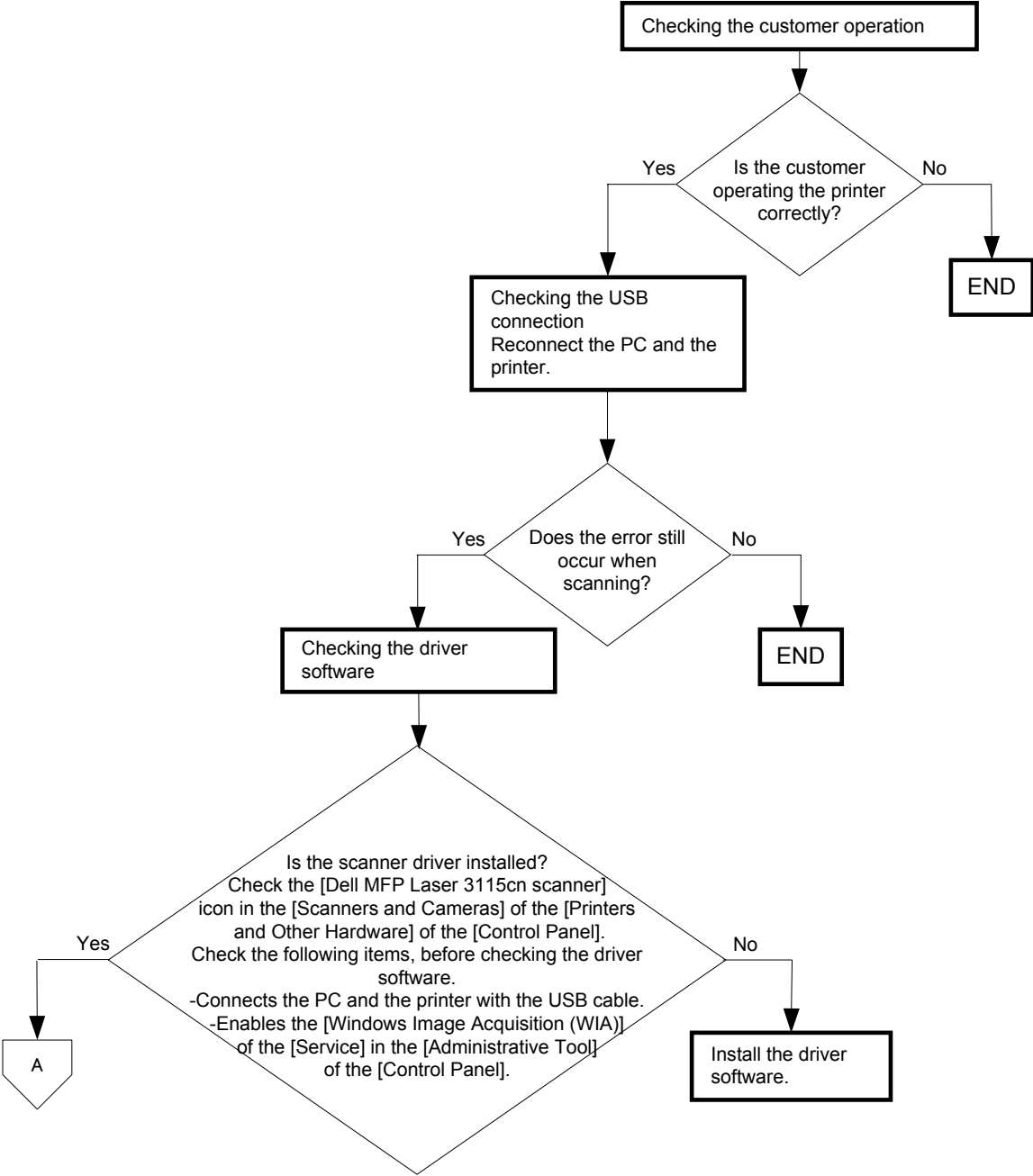

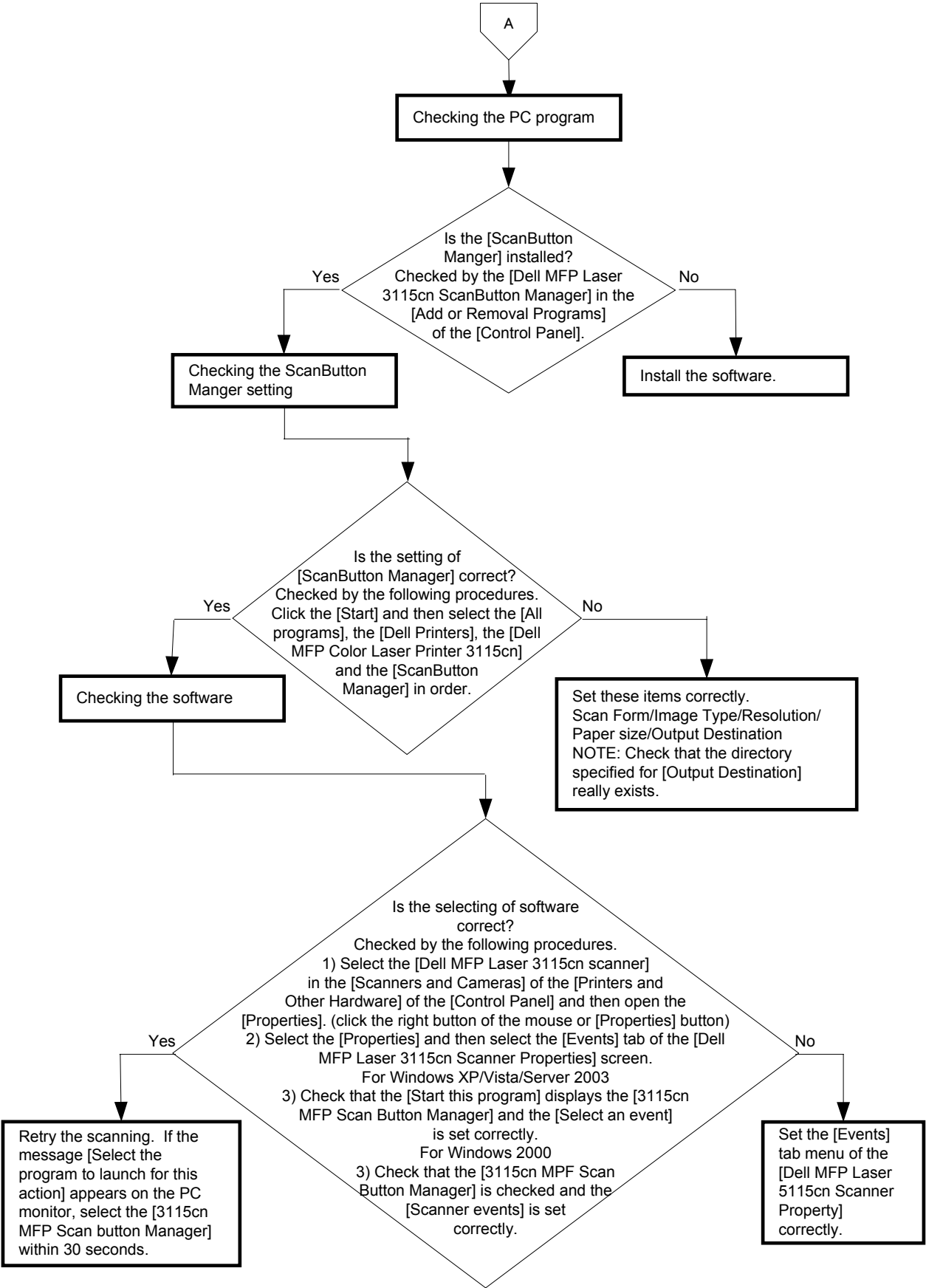

FIP-1. 69 Communication 033-500/033-511/033-782/033-799/034-730/035-702/035-704/
 035-705/035-708/035-709/035-710/035-716/035-717/035-728/035-729/035-737/
 035-797/035-739/035-740/035-741/035-742/035-772/035-780/
 Codec Error 033-514/033-515/033-516/Buffer 033-775/033-777/033-784/
 No Answer 035-718

NOTE

Regarding a fax error, a communication test is available between the customer and Dell, thereby allowing you to analyze the trouble. The communication test can be performed from the customer to the Dell site for transmission errors, and from the Dell site to the customer for reception errors.

Possible causative parts: PWBA HYUI (PL13.4.1)

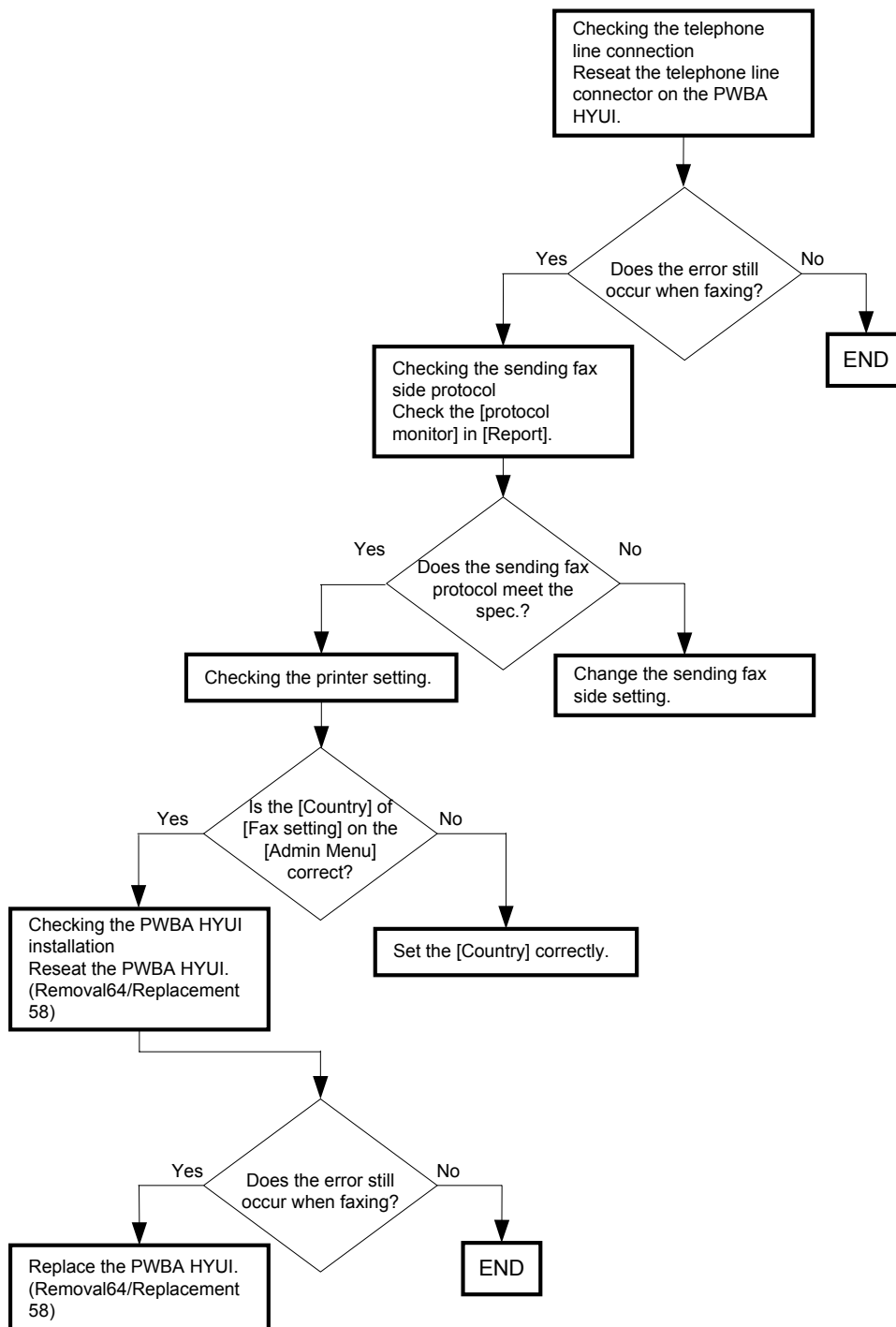

FIP-1. 70 Codec Error 033-501 / Communication 034-515/035-792

Possible causative parts: PWBA HYUI (PL13.4.1)
ADF SCANNER ASSY (PL13.8.1)

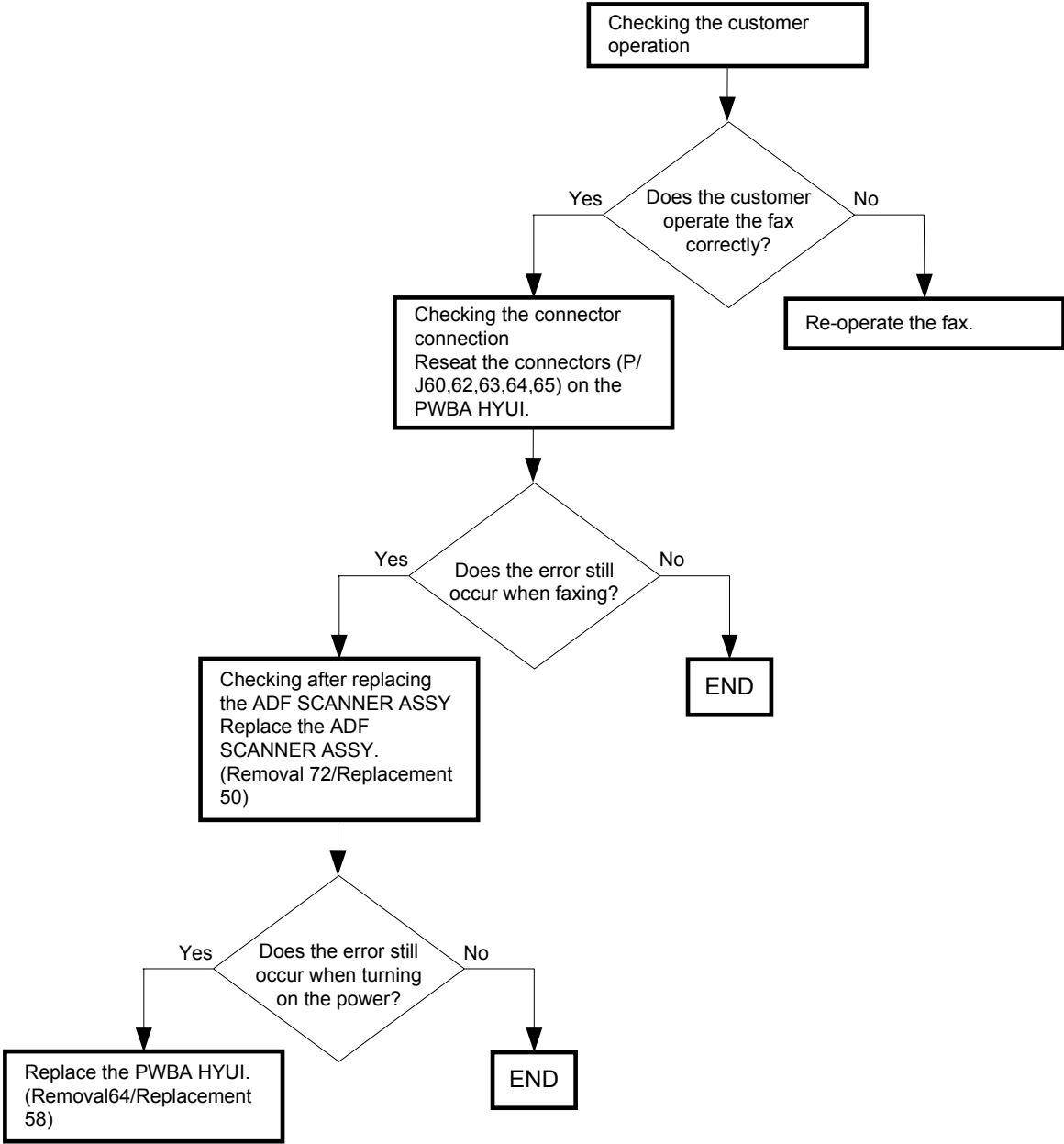

FIP-1.71 Codec Error 033-510

NOTE

Regarding a fax error, a communication test is available between the customer and Dell, thereby allowing you to analyze the trouble.

Possible causative parts: PWBA HYUI (PL13.4.1)

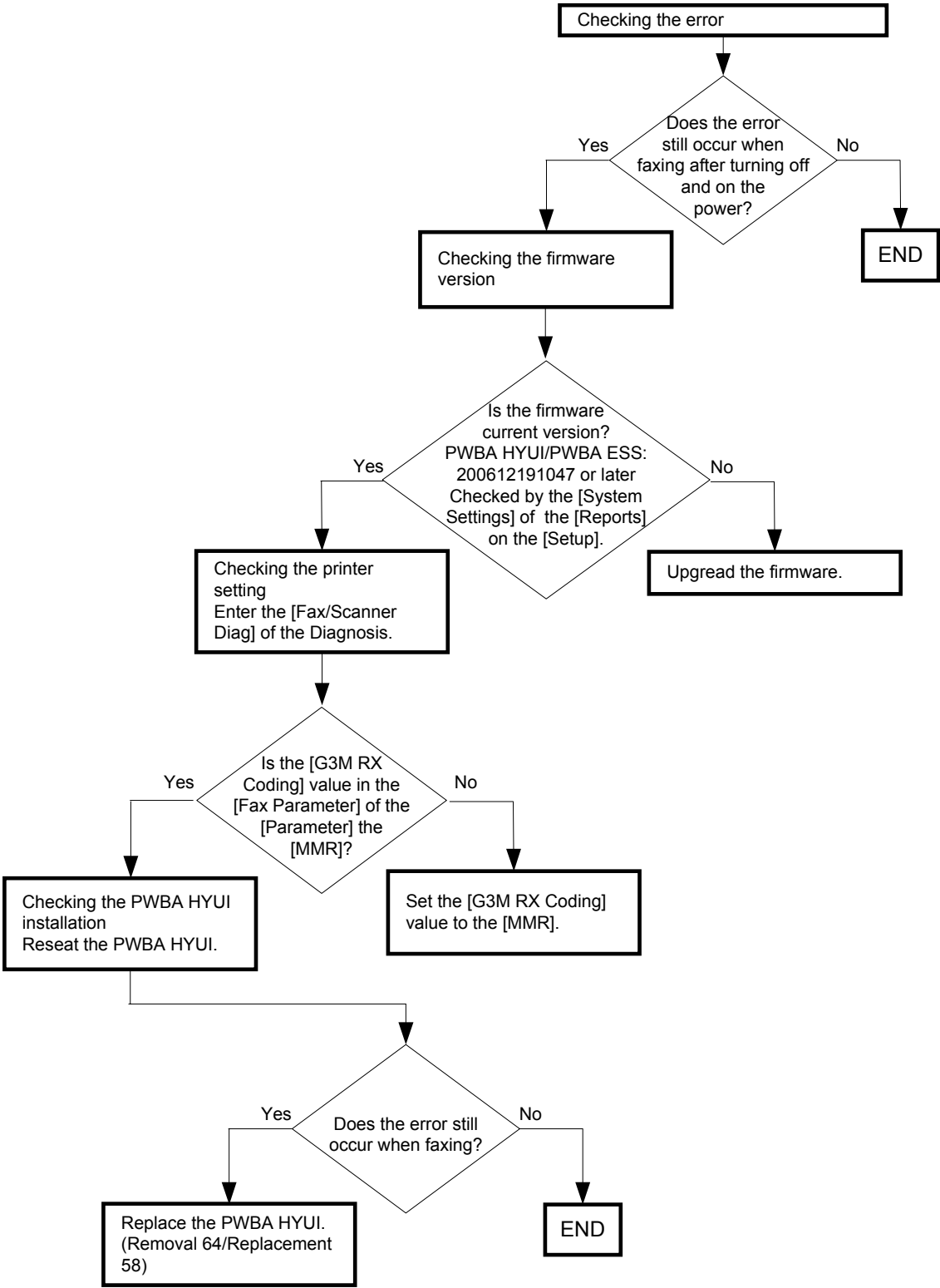

FIP-1. 72 Password Error 033-517

Possible Causative parts:PWBA HYUI. (PL13.4.1)

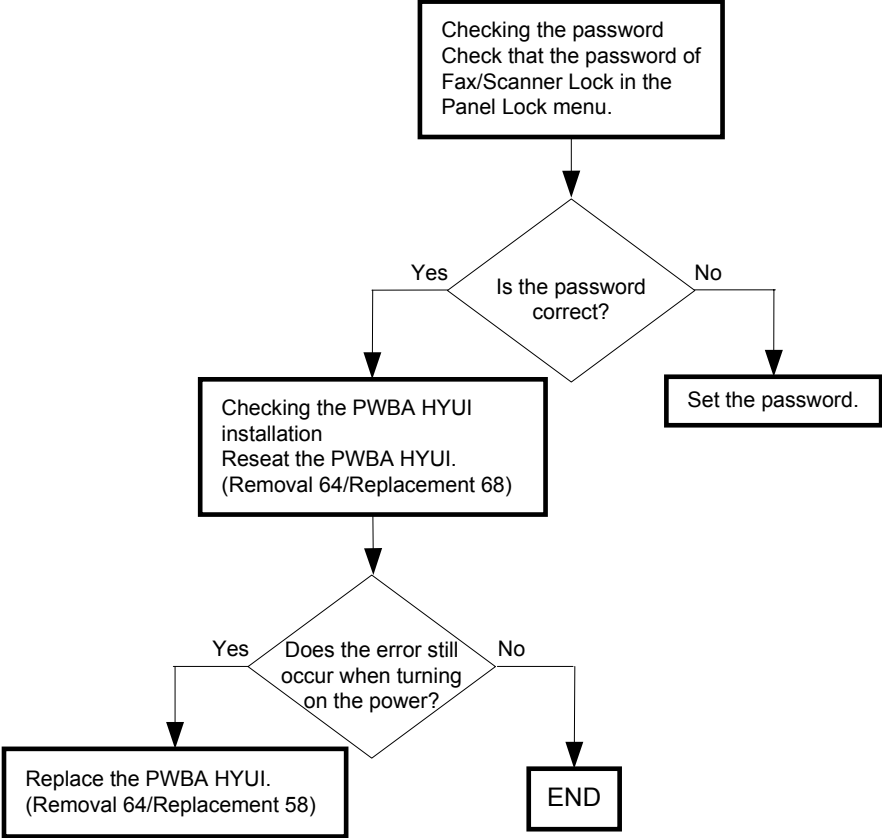

FIP-1. 73 Communication 033-762

Possible causative parts: PWBA HYUI (PL13.4.1)

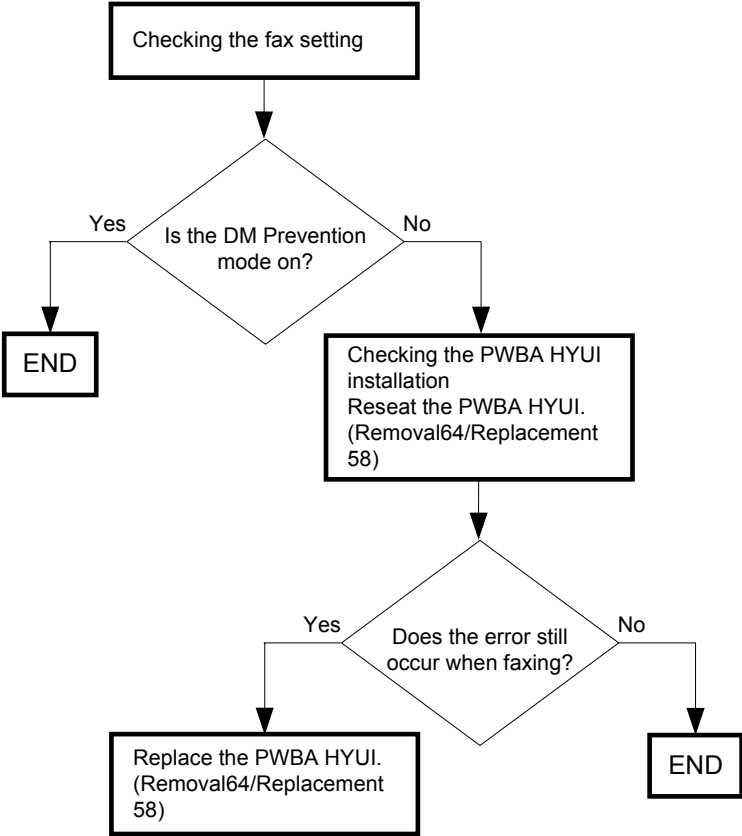

FIP-1.74 Communication 033-763

Possible causative parts: PWBA HYUI (PL 13.4.1)

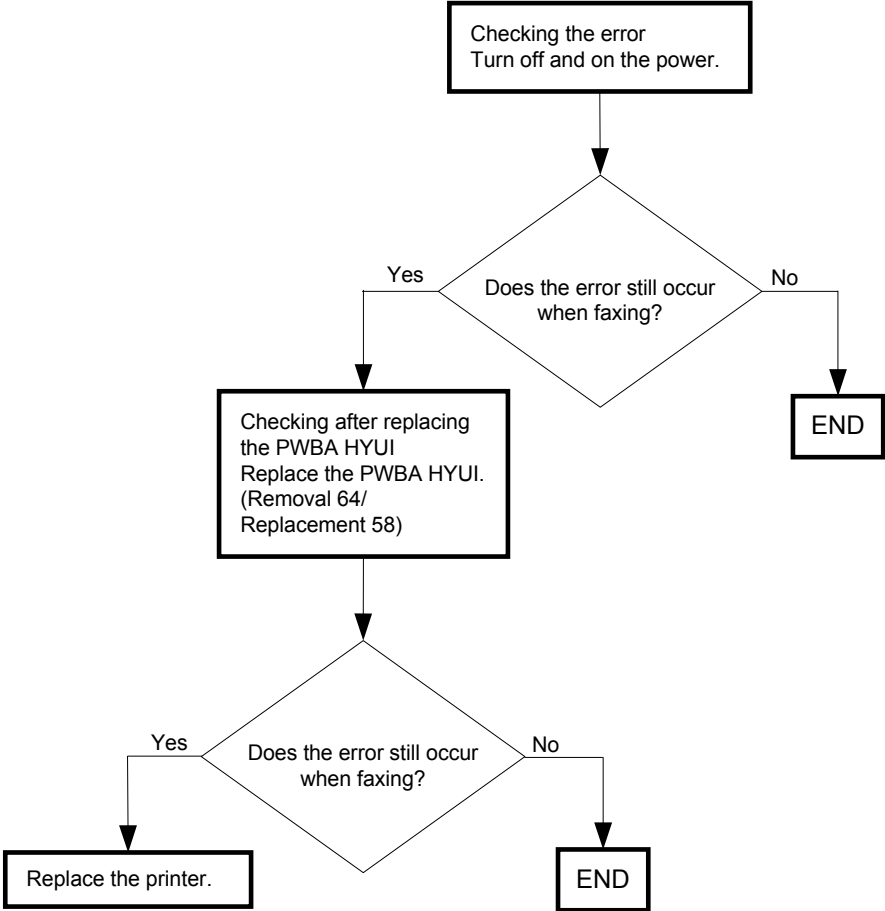

FIP-1. 75 Codec Error 033-773

NOTE

Regarding a fax error, a communication test is available between the customer and Dell, thereby allowing you to analyze the trouble.

Possible causative parts: PWBA HYUI (PL13.4.1)

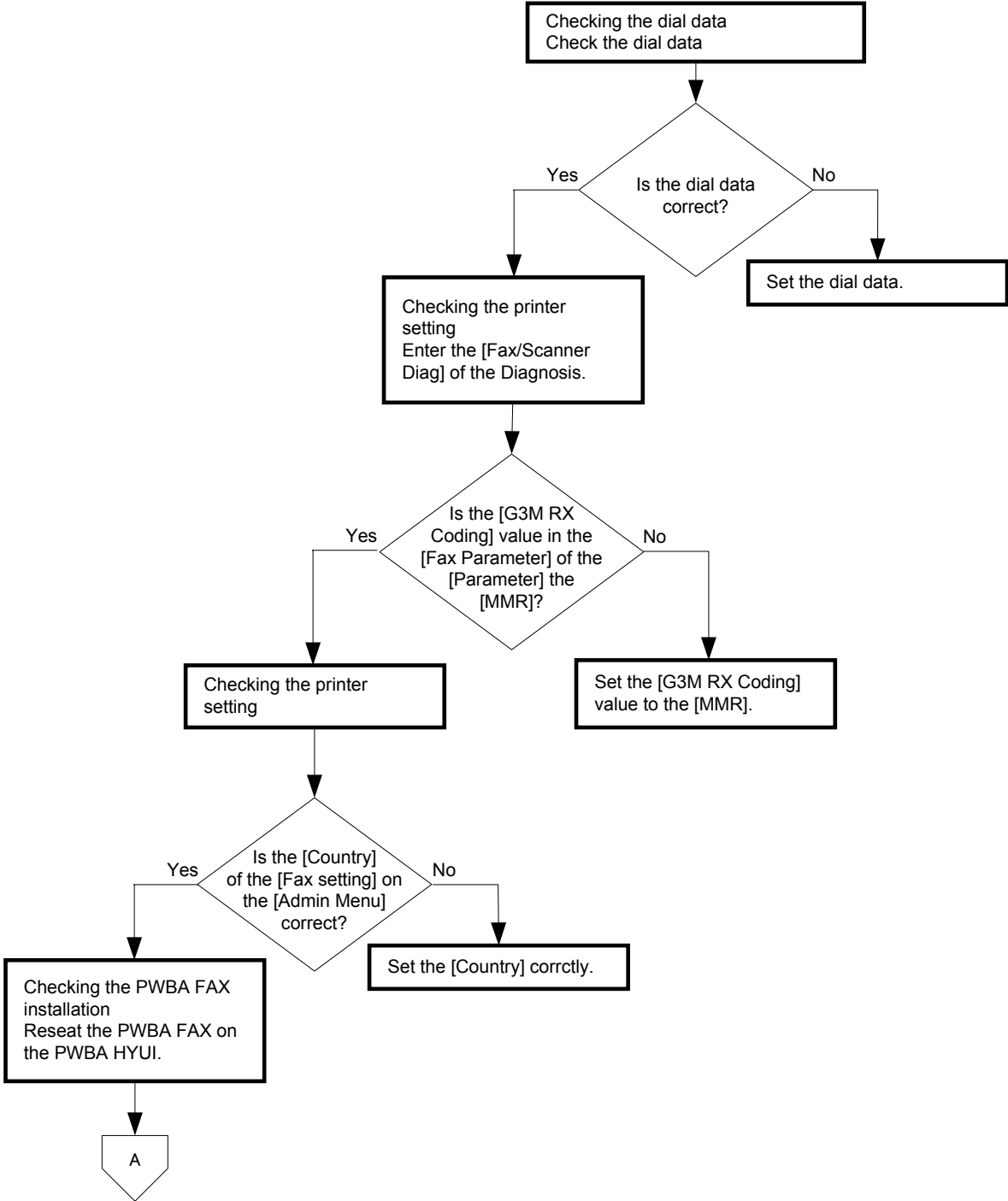

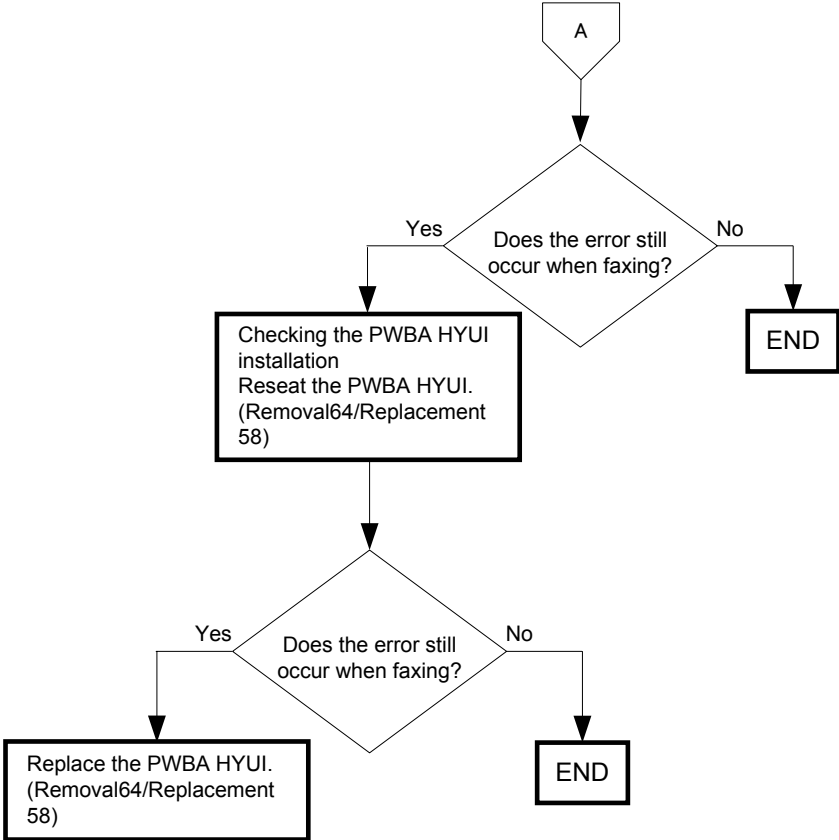

FIP-1. 76 Communication 035-720

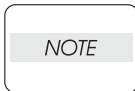

Regarding a fax error, a communication test is available between the customer and Dell, thereby allowing you to analyze the trouble. The communication test can be performed from the customer to the Dell site for transmission errors, and from the Dell site to the customer for reception errors.

Possible causative parts: PWBA HYUI (PL13.4.1)

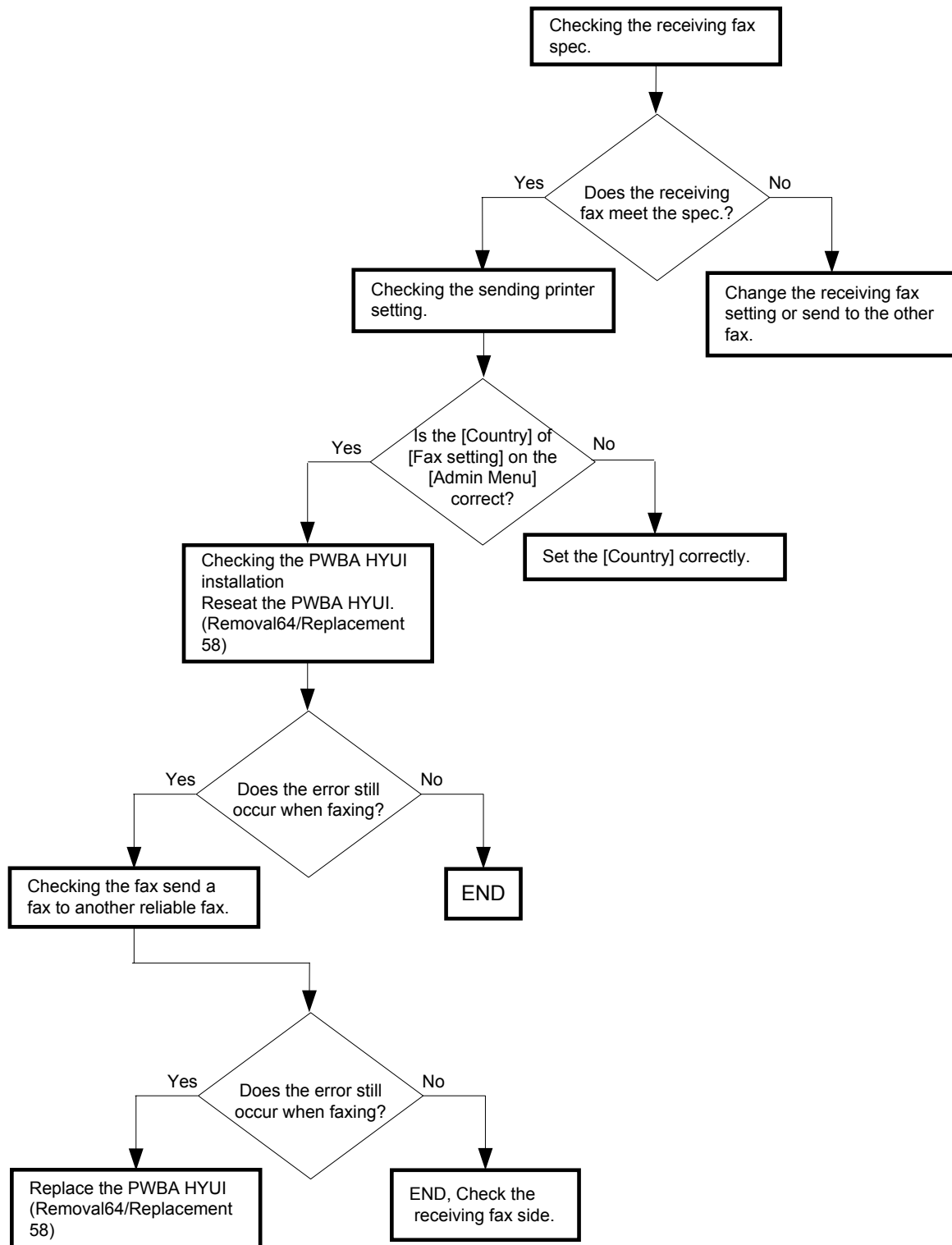

FIP-1. 77 Illegal Data 033-783/034-799/No Dial Tone 035-746/035-773/035-774

NOTE

Regarding a fax error, a communication test is available between the customer and Dell, thereby allowing you to analyze the trouble. The communication test can be performed from the customer to the Dell site for transmission errors, and from the Dell site to the customer for reception errors.

Possible causative parts: PWBA HYUI (PL13.4.1)

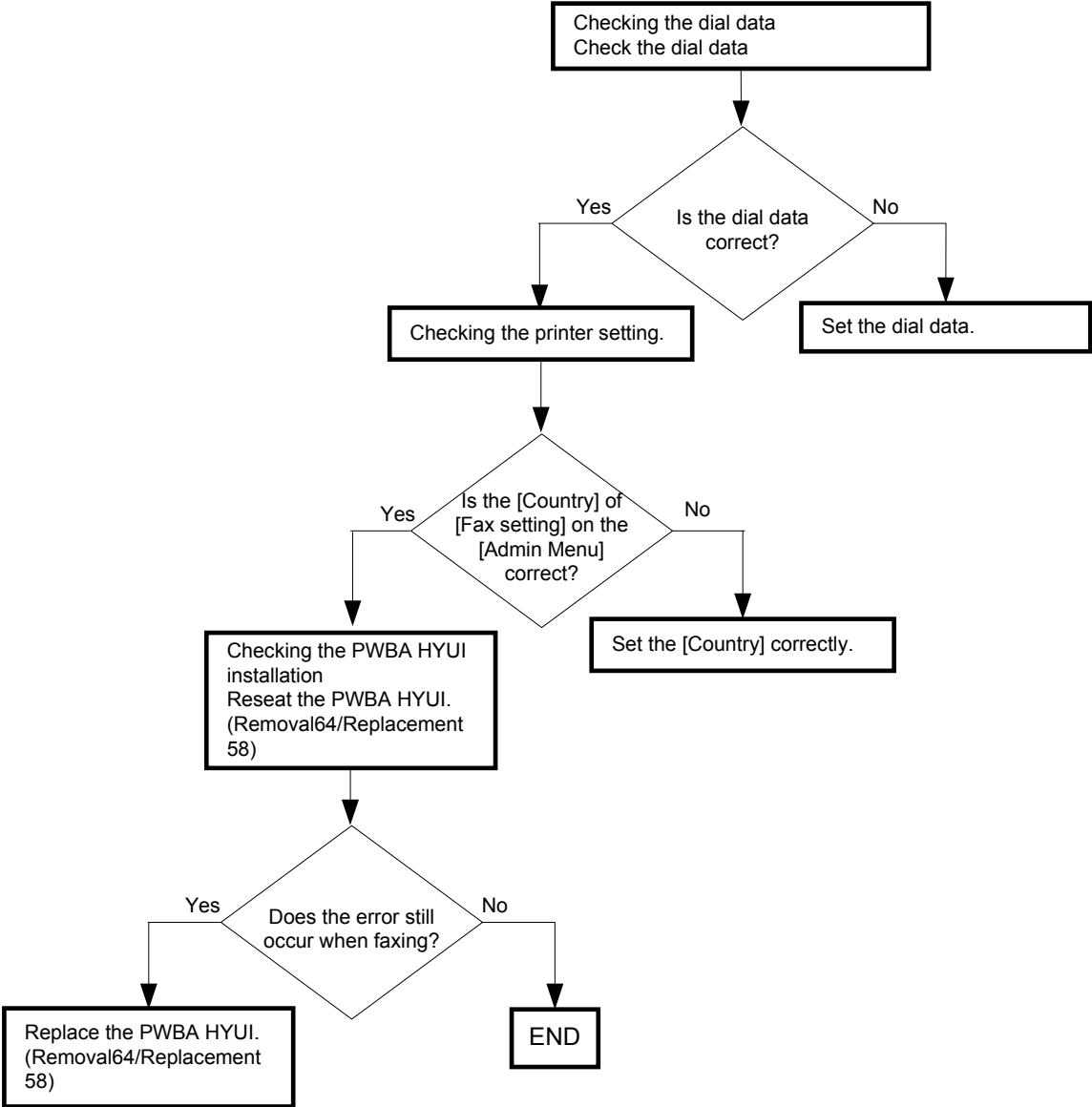

FIP-1.78 No Answer 035-701

NOTE

Regarding a fax error, a communication test is available between the customer and Dell, thereby allowing you to analyze the trouble.

Possible causative parts: PWBA HYUI (PL13.4.1)

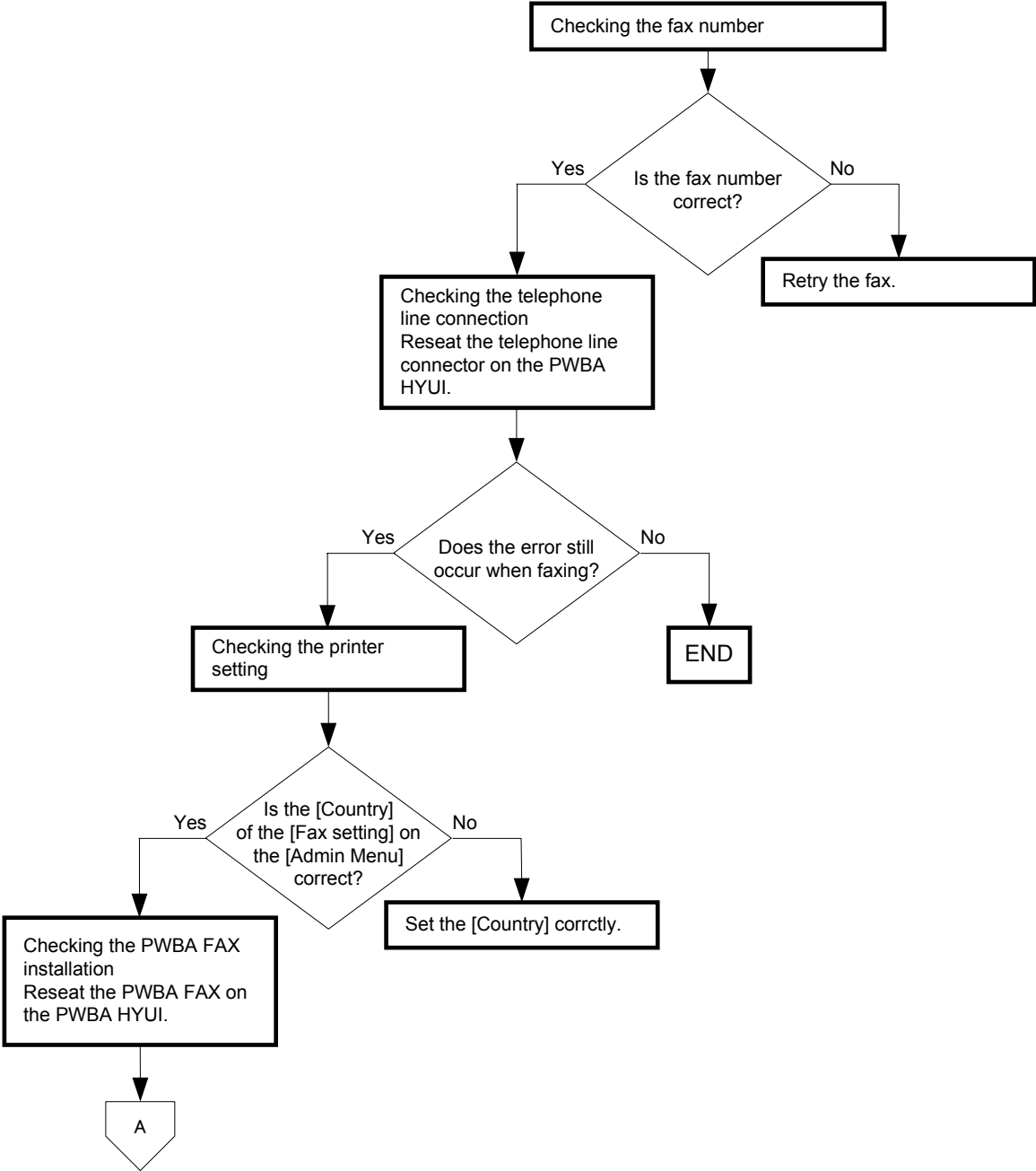

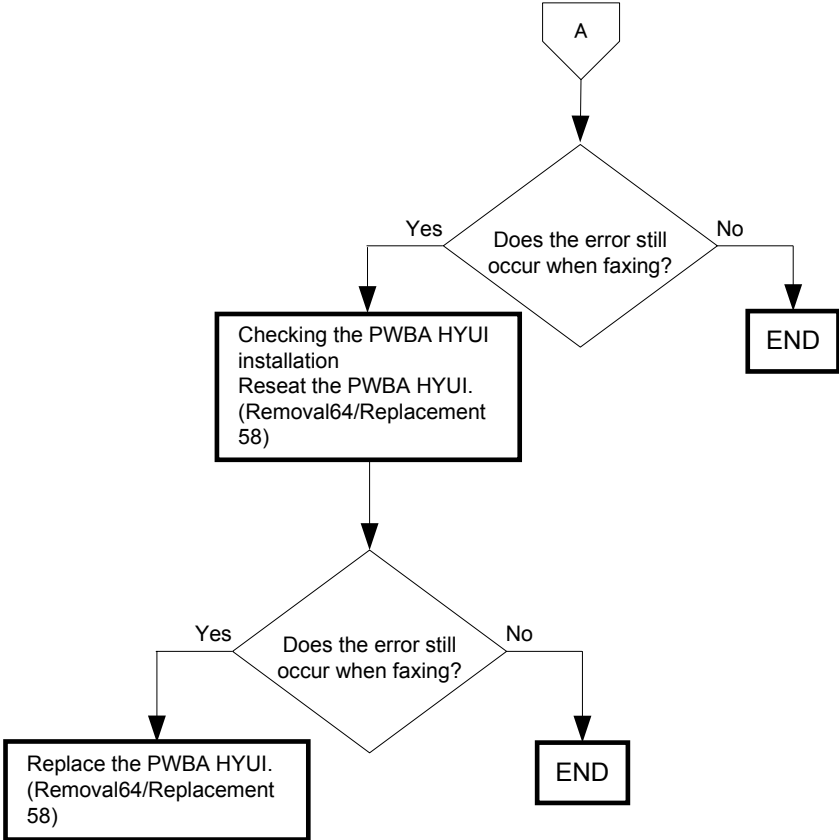

FIP-1.79 Busy 035-781

NOTE

Regarding a fax error, a communication test is available between the customer and Dell, thereby allowing you to analyze the trouble. The communication test can be performed from the customer to the Dell site for transmission errors, and from the Dell site to the customer for reception errors.

Possible causative parts: PWBA HYUI (PL13.4.1)

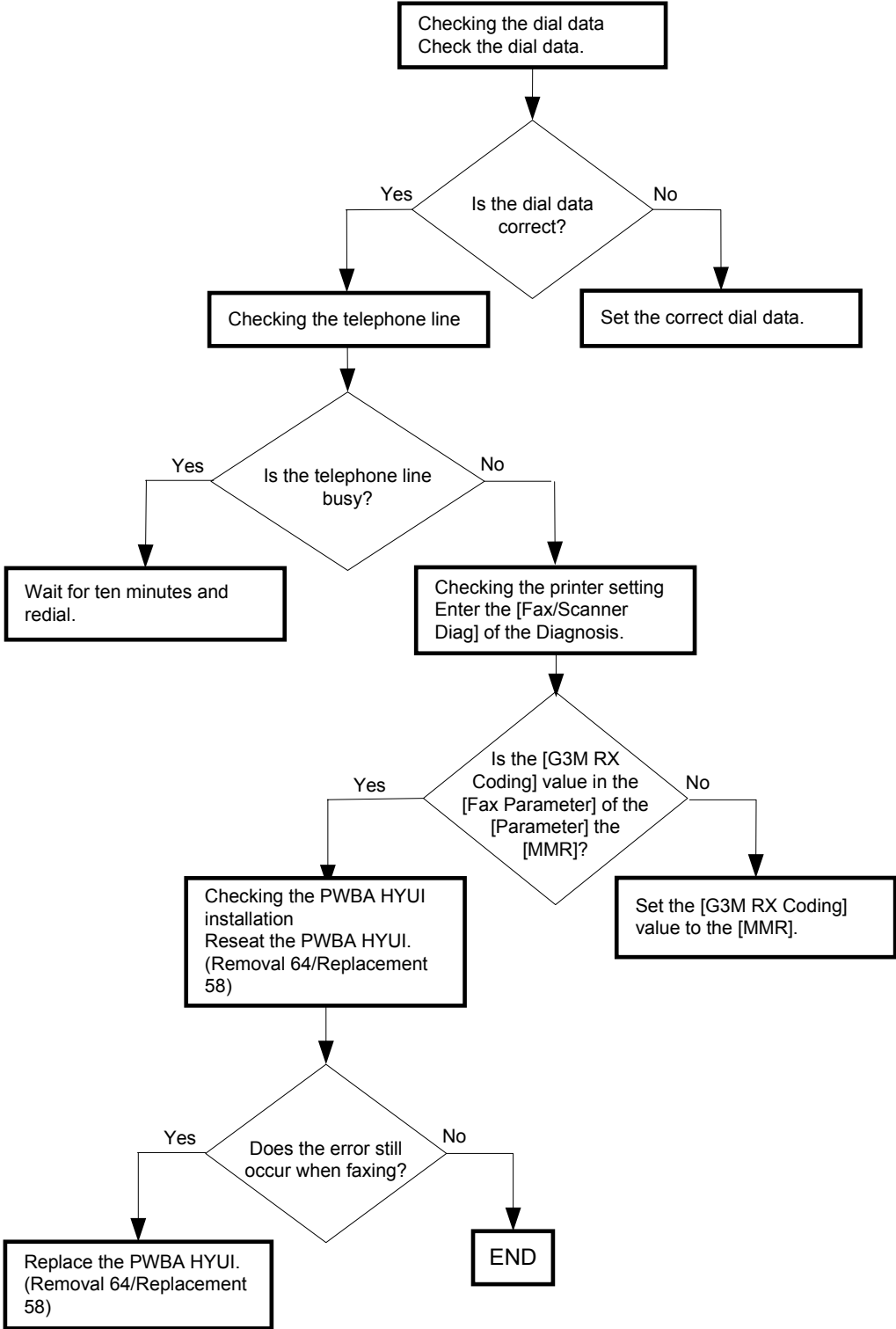

FIP-1. 80 Accumulation Limit

Possible causative parts: PWBA HYUI (PL13.4.1)

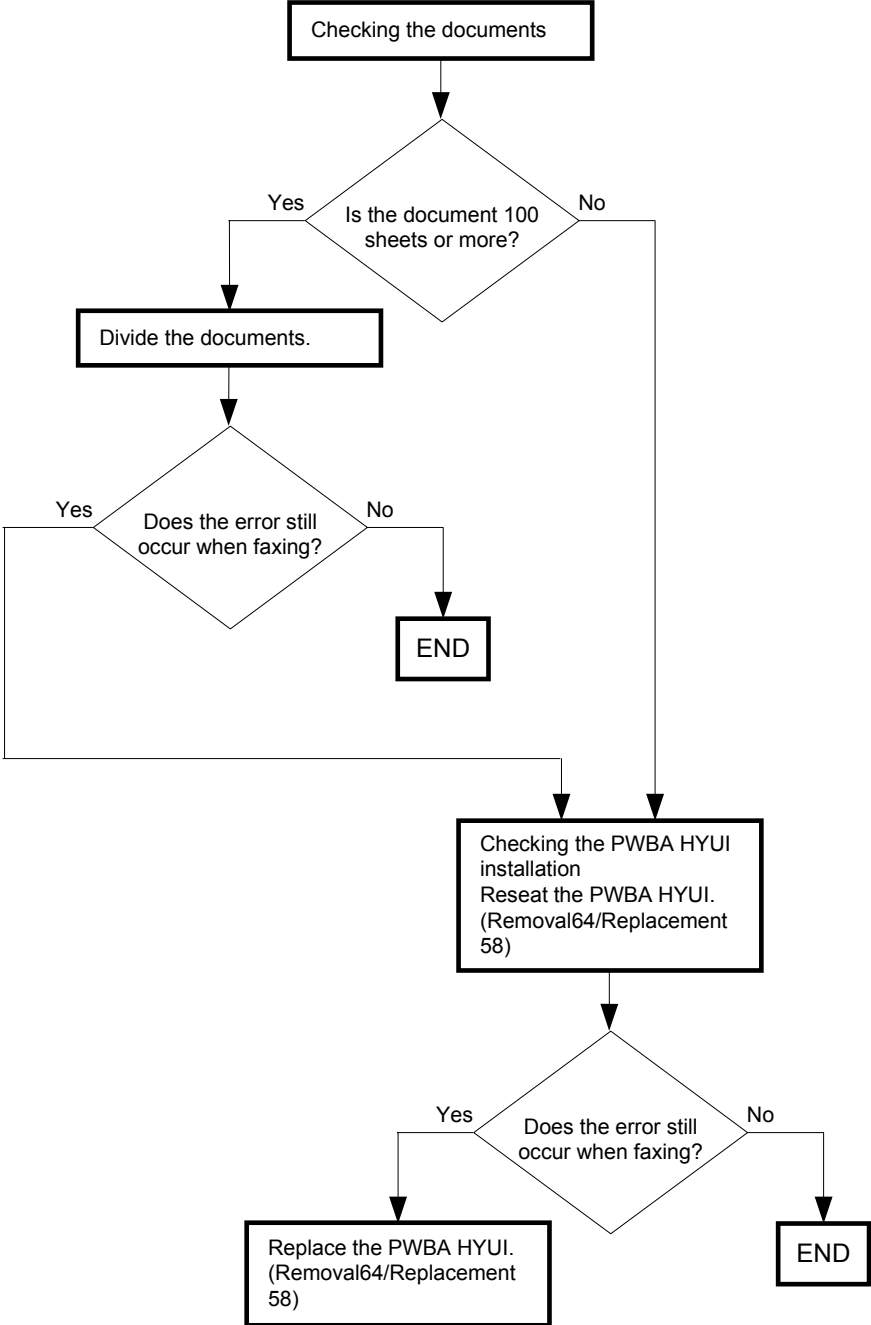

FIP-1. 81 Illegal Settings (Copy Dup Size Limit)

Possible causative parts: PWBA MCU (PL9.1.20)
PWBA HYUI (PL13.4.1)
PWBA ESS (PL13.4.20)

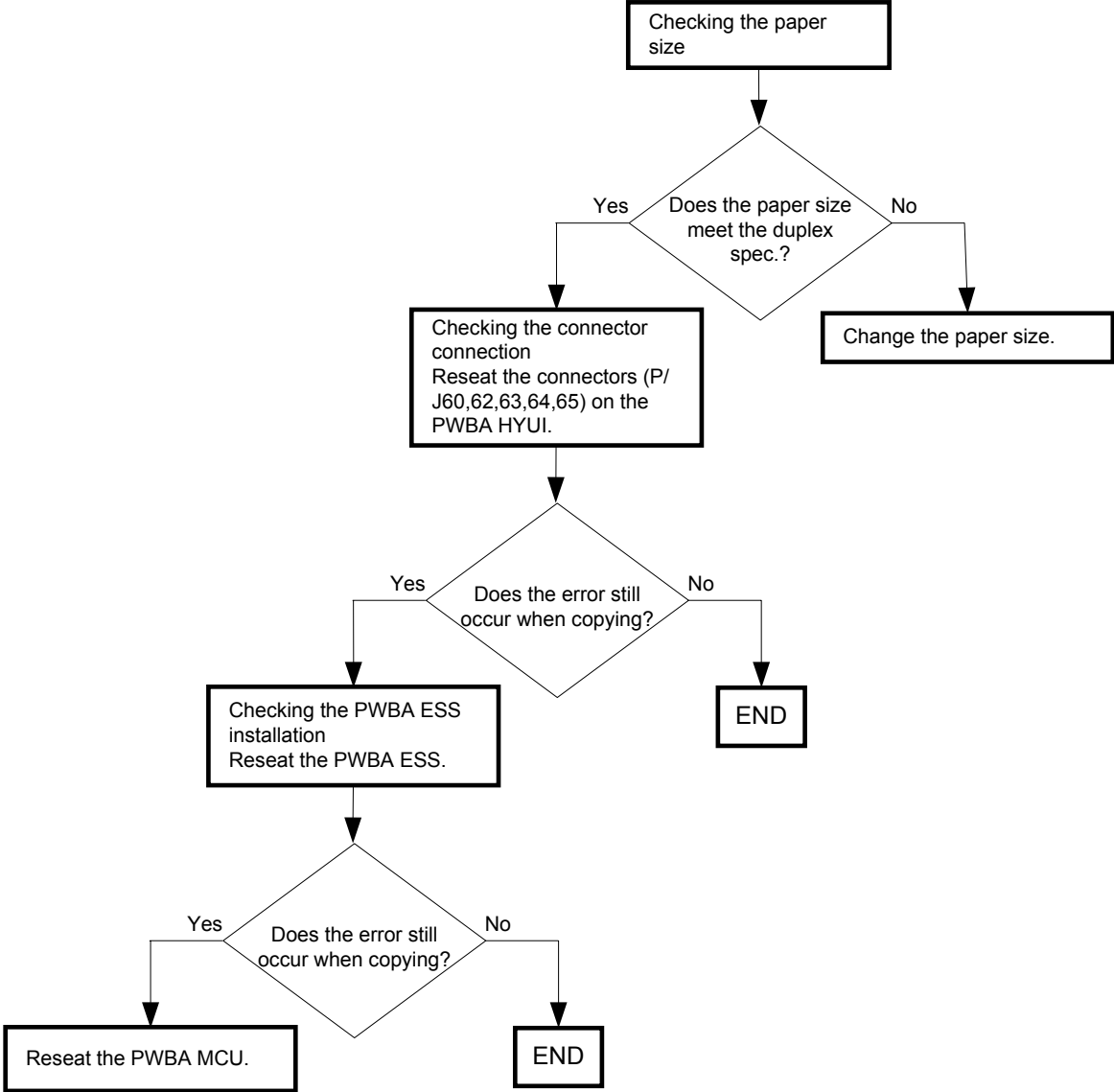

FIP-1. 82 Illegal Settings (Copy Dup Medium NG)

Possible causative parts: PWBA MCU (PL9.1.20)
PWBA HYUI (PL13.4.1)
PWBA ESS (PL13.4.20)

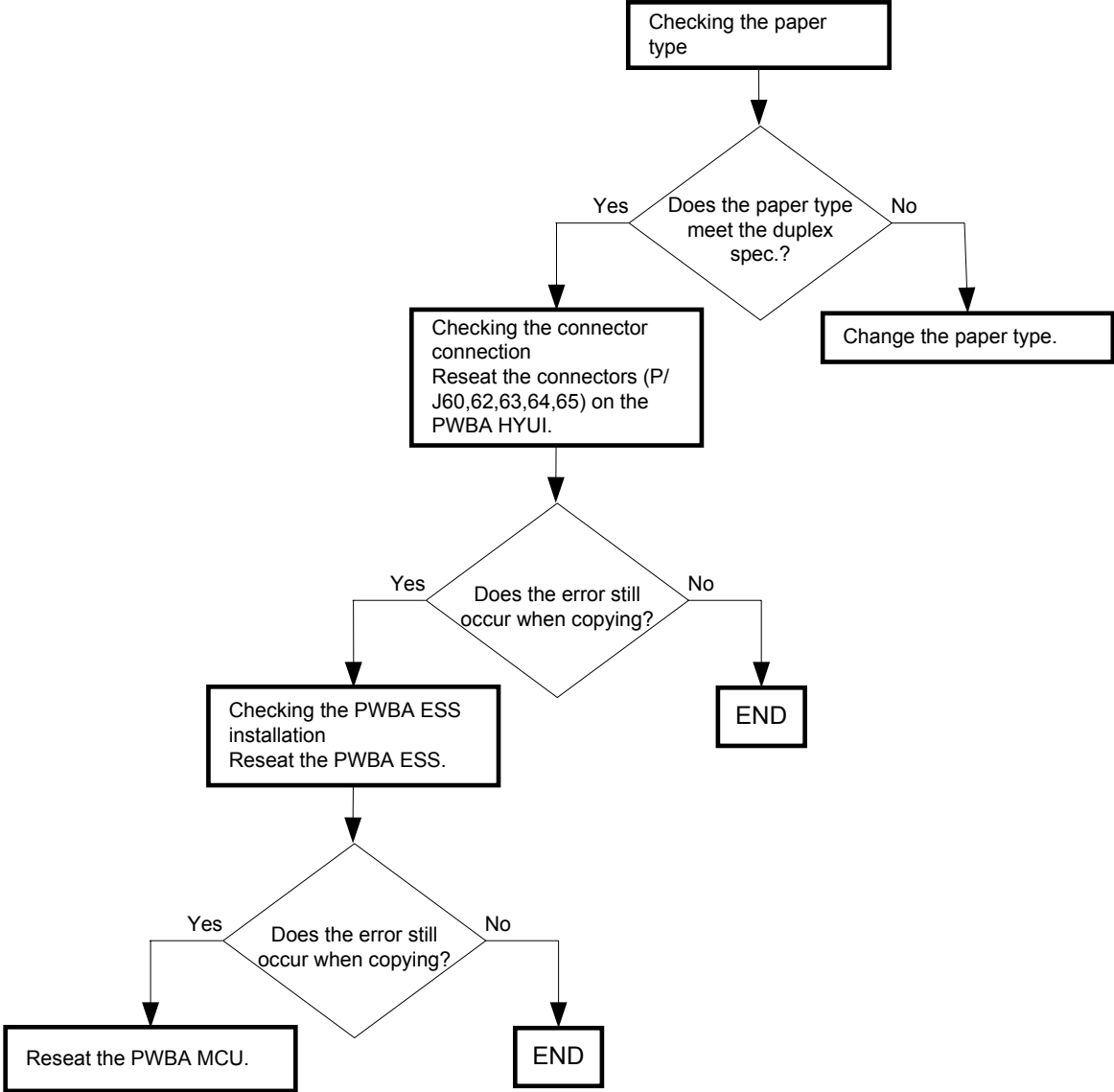

FIP-1. 83 Confirm 062-790

Possible causative parts: PWBA HYUI (PL 13.4.1)

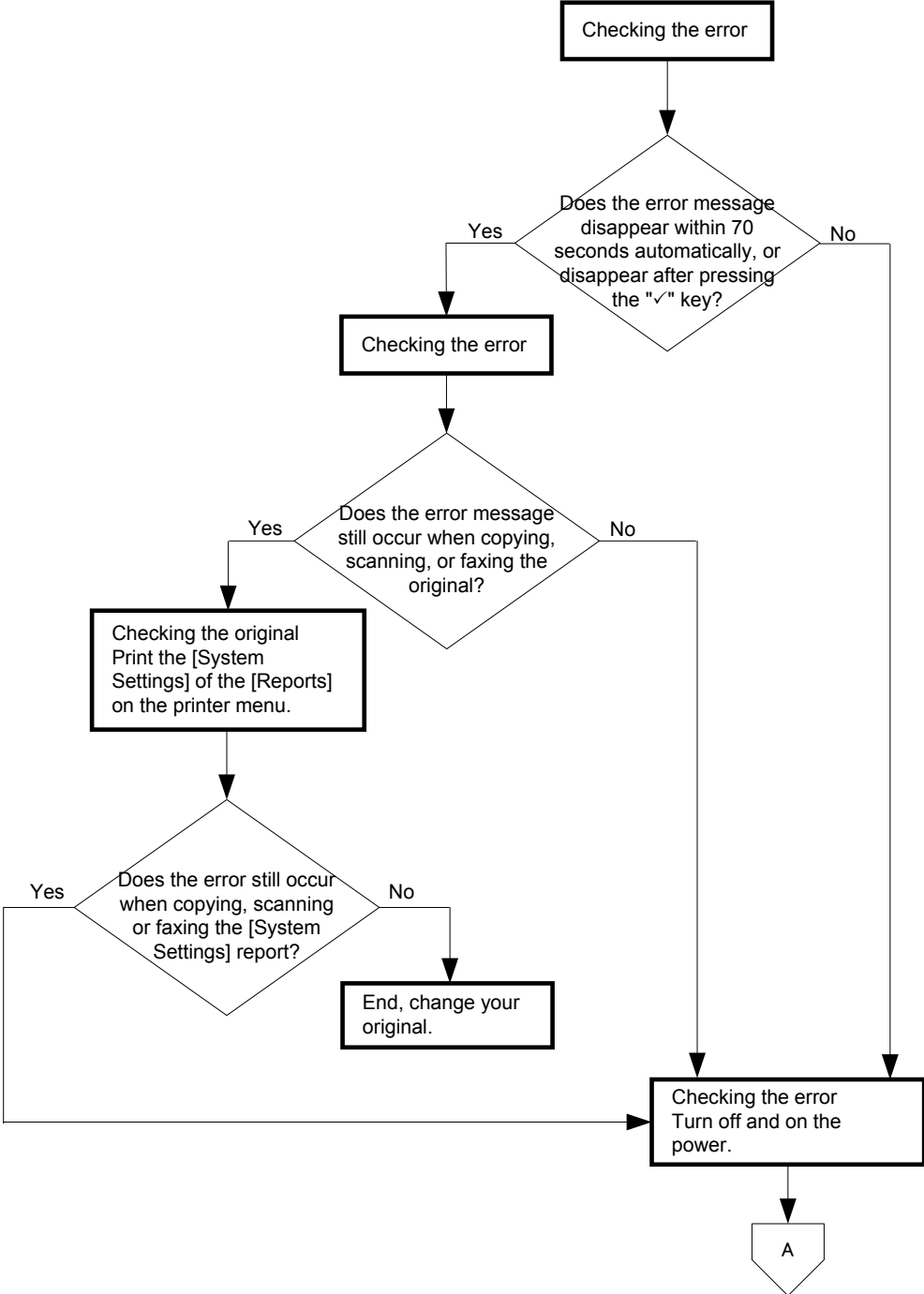

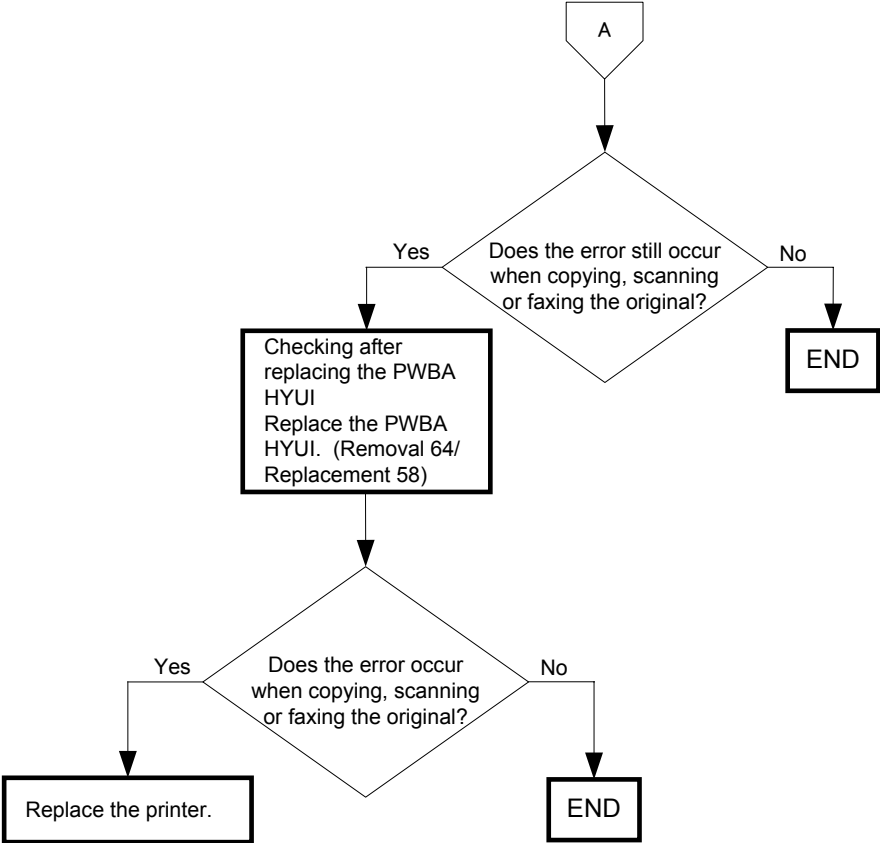

FIP-1. 84 Paper Jam 005-110/005-121

Possible causative parts: PWBA HYUI (PL13.4.1)
ADF SCANNER ASSY (PL13.8.1)
ADF FEED ROLLER (PL13.8.4)

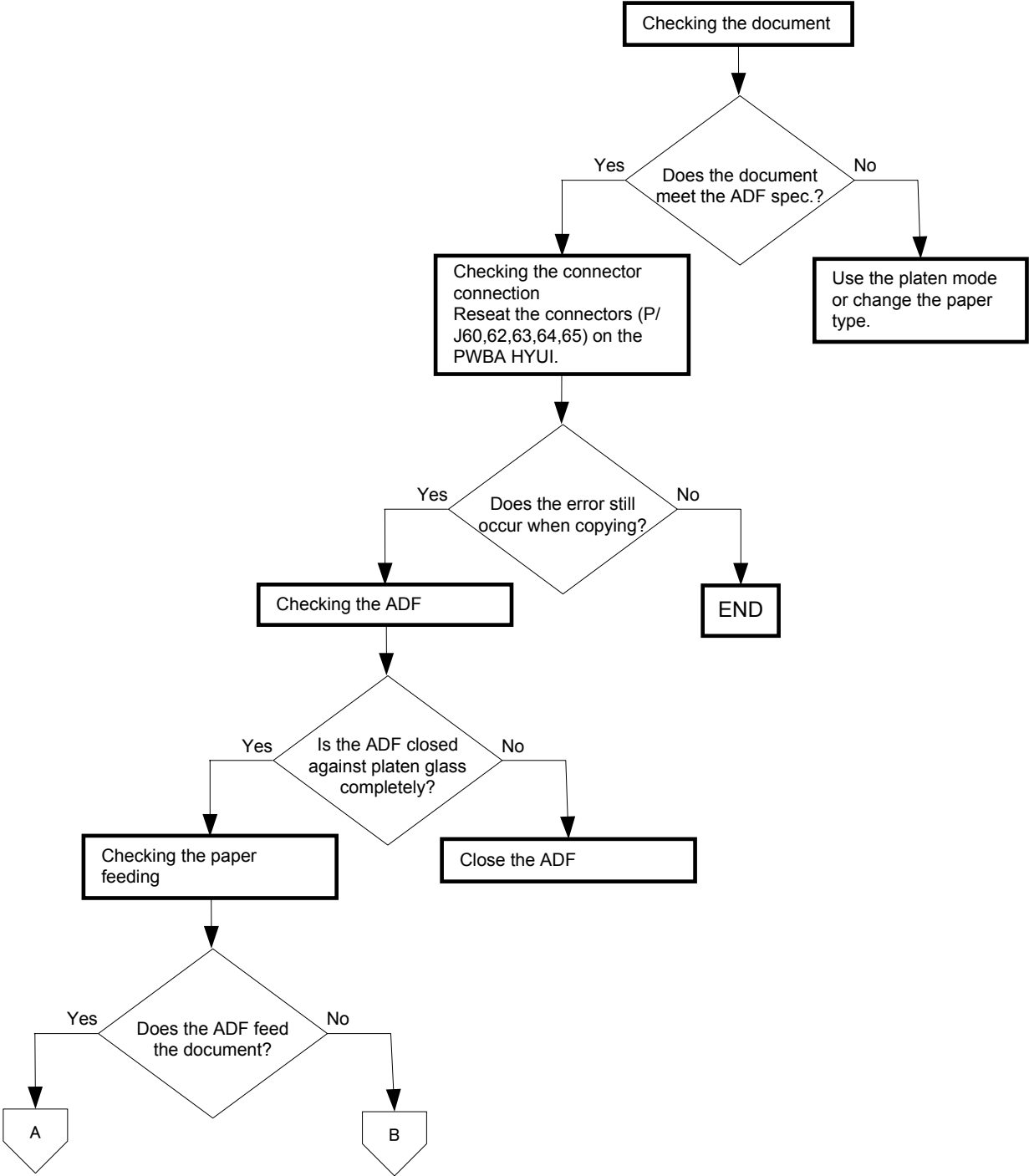

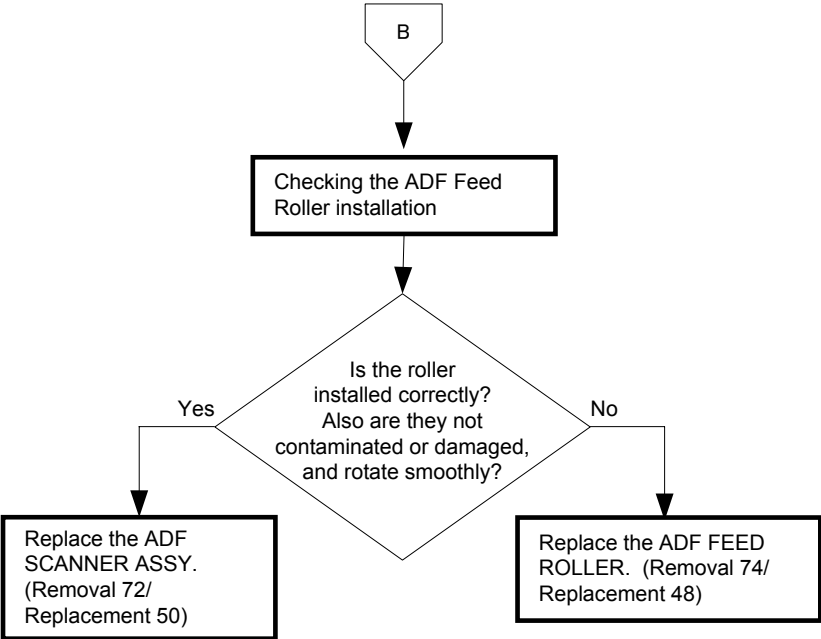
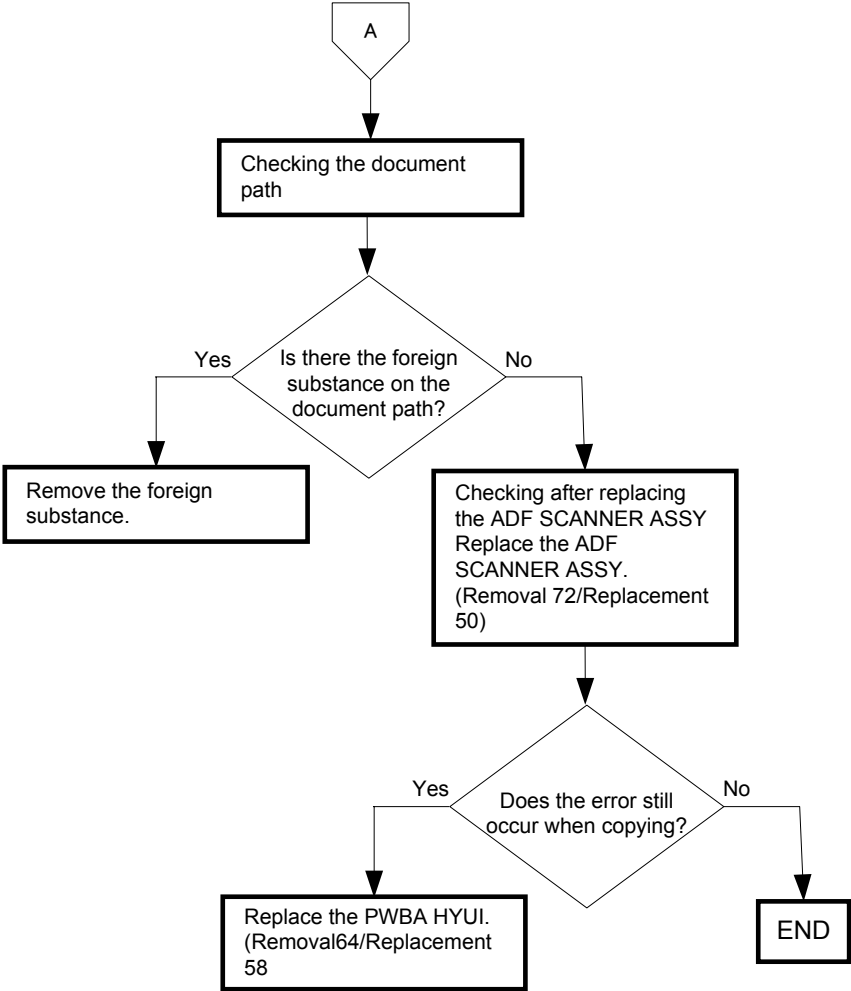

FIP-1. 85 Cover Open 005-301/Paper Jam 005-302

Possible causative parts: PWBA HYUI (PL13.4.1)
ADF SCANNER ASSY (PL13.8.1)

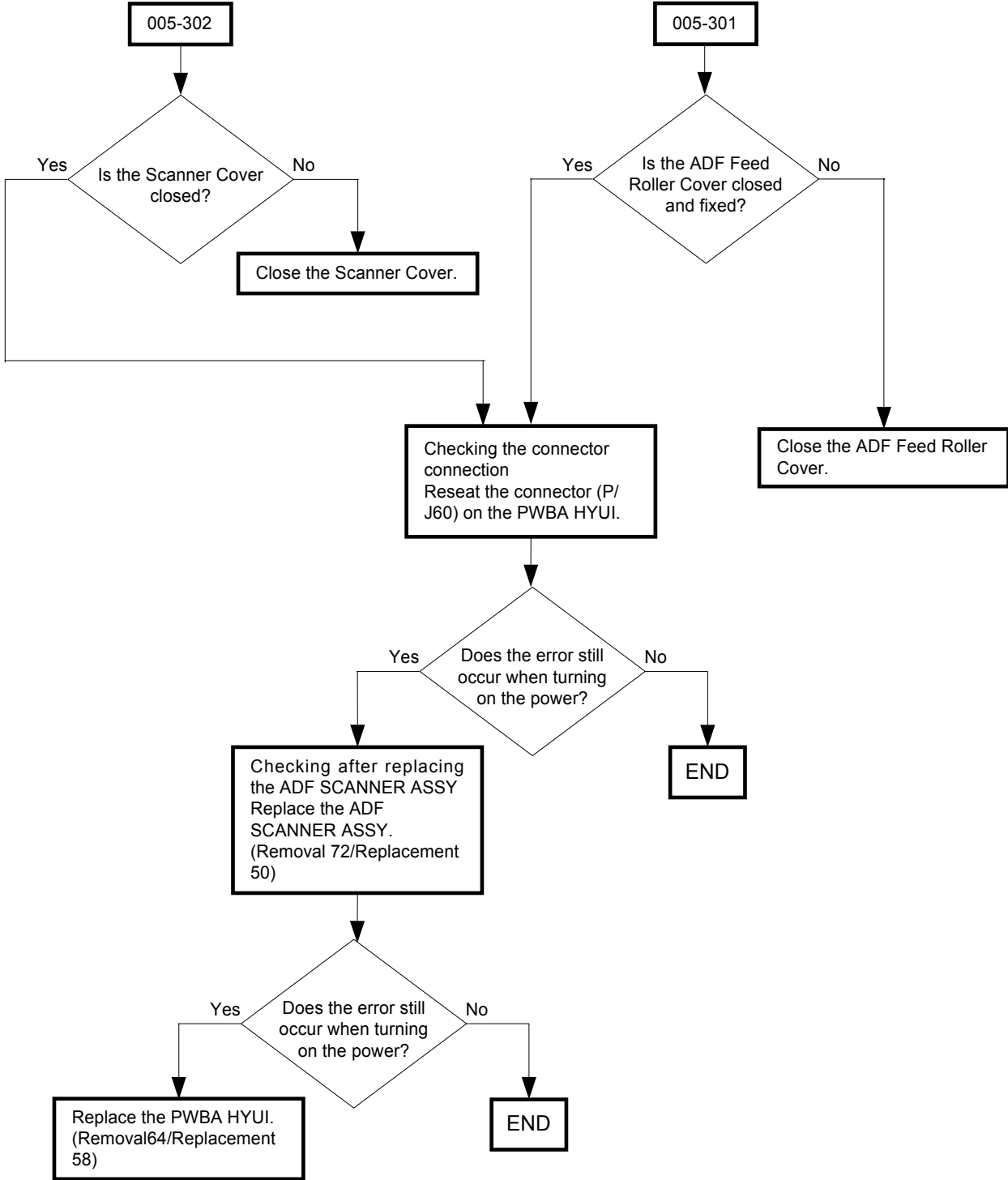

FIP-1. 86 Invalid ID 016-383/Range Chk Error 016-384/Header Error 016-385/
Check Sum Error 016-386/Format Error 016-387

Possible causative parts:PWBA ESS (PL13.4.20)

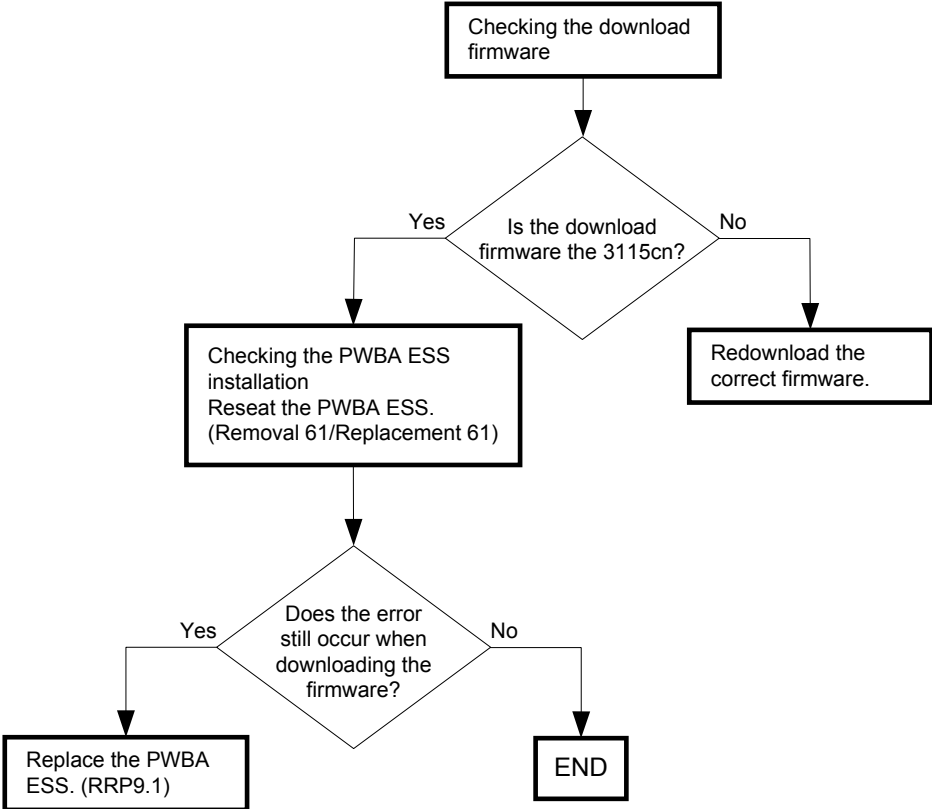

FIP-1. 87 MPC Error 016-388/MPC Detached 016-389/MPC Com. Failed 016-390

Possible causative parts:PWBA ESS (PL13.4.20)
MPC (PL13.4.23)

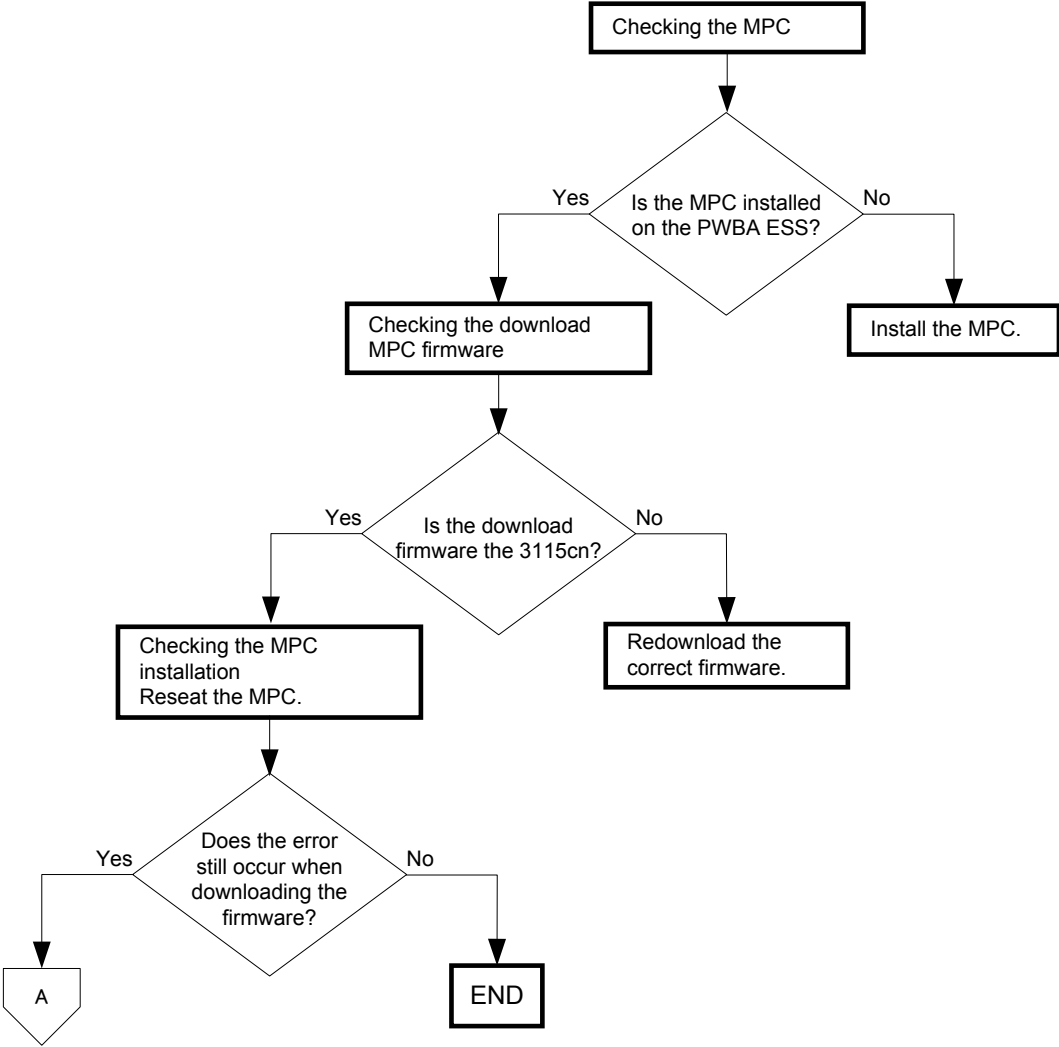

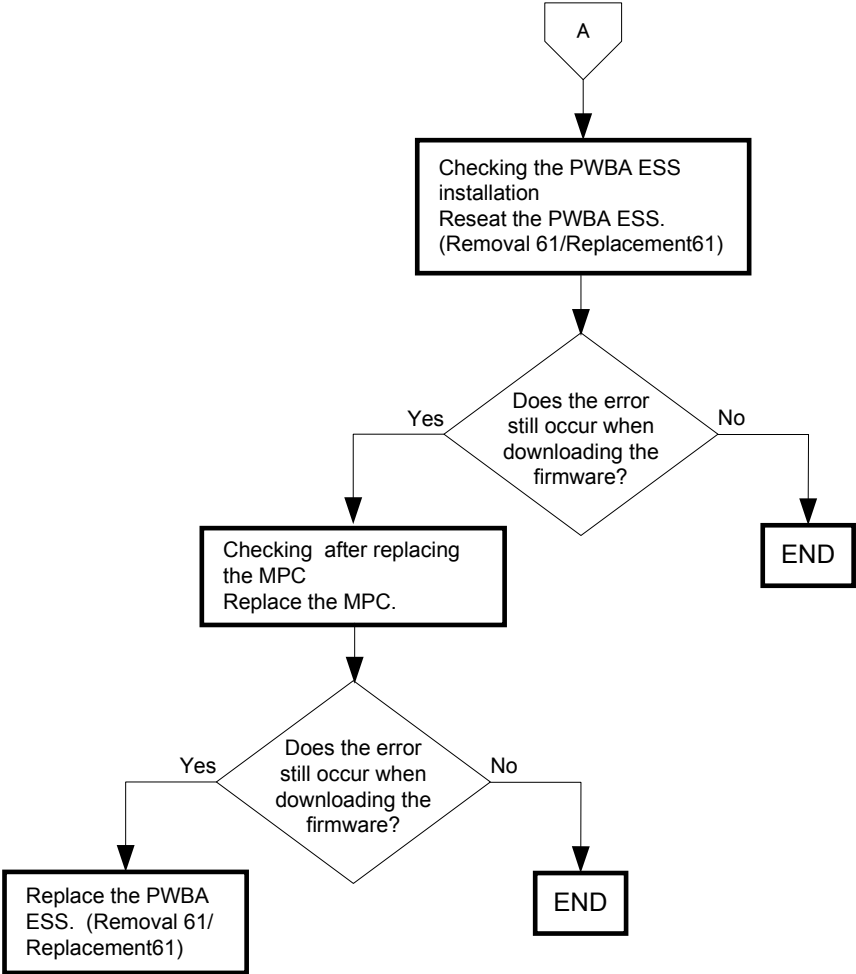

FIP-1. 88 Out of Memory 016-700/Disk Full 016-980

Possible causative parts:PWBA ESS (PL13.4.20)
Memory Card (Option)

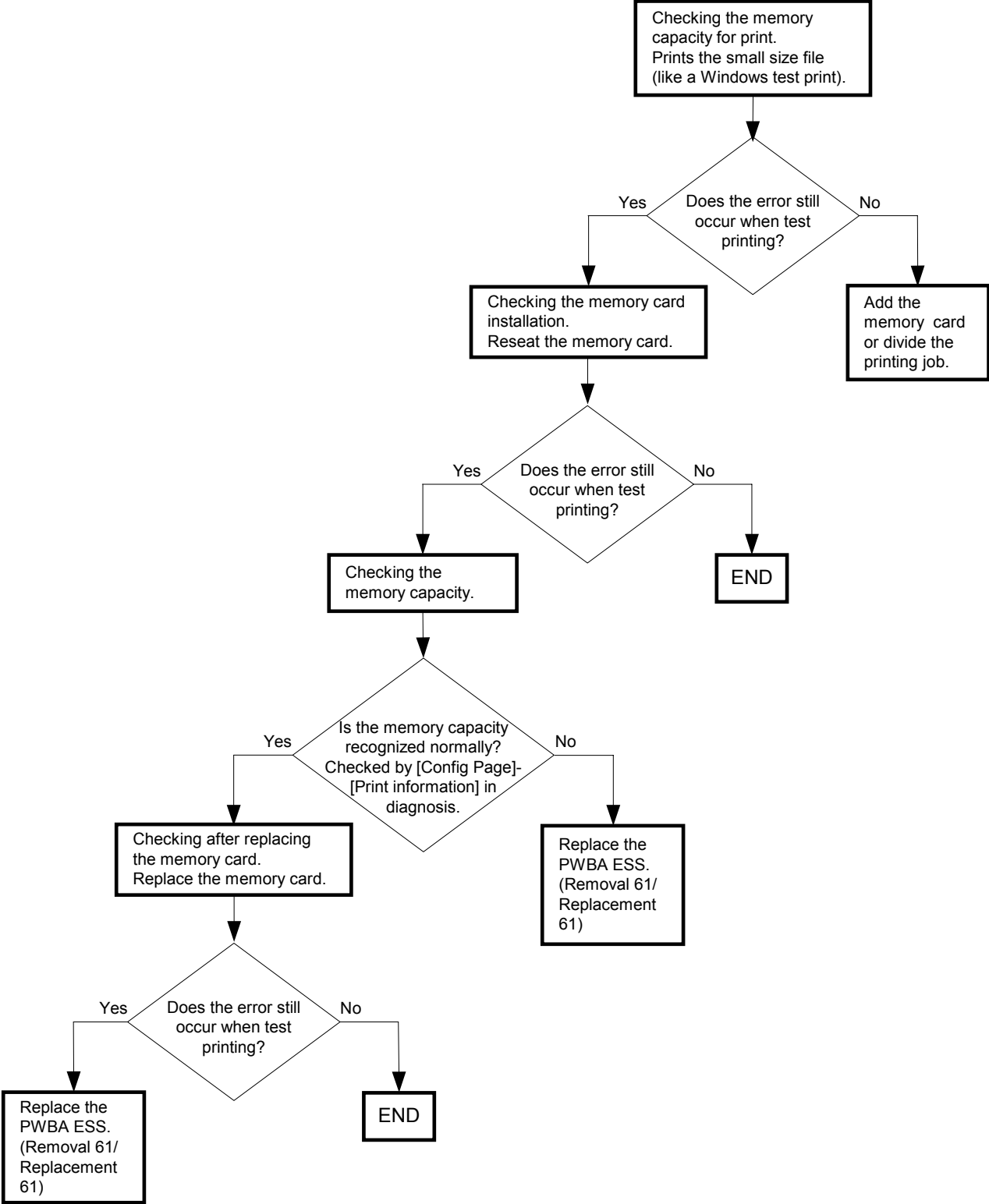

FIP-1. 89 Invalid User 016-757/Disabled Func 016-758/Reached Limits 016-759

Possible causative parts:PWBA ESS (PL13.4.20)

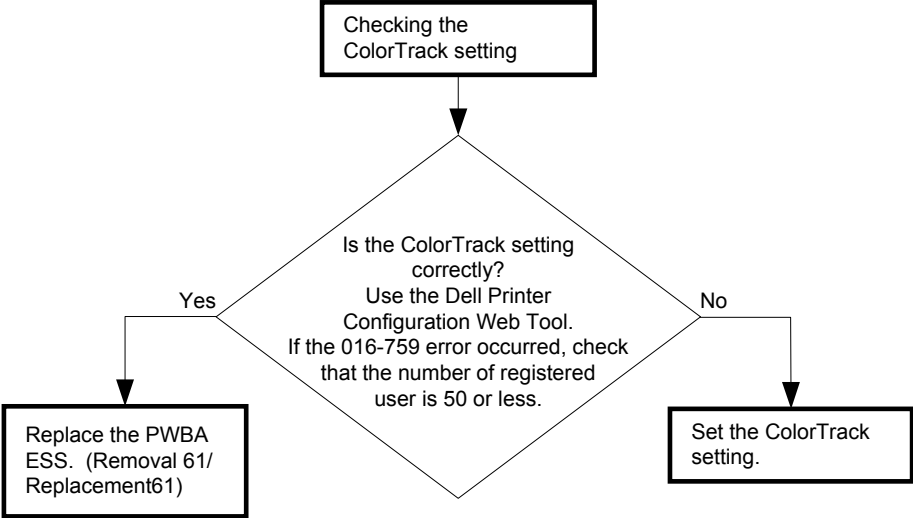

FIP-1. 90 Invalid Job 016-799

Possible causative parts:PWBA ESS (PL13.4.20)

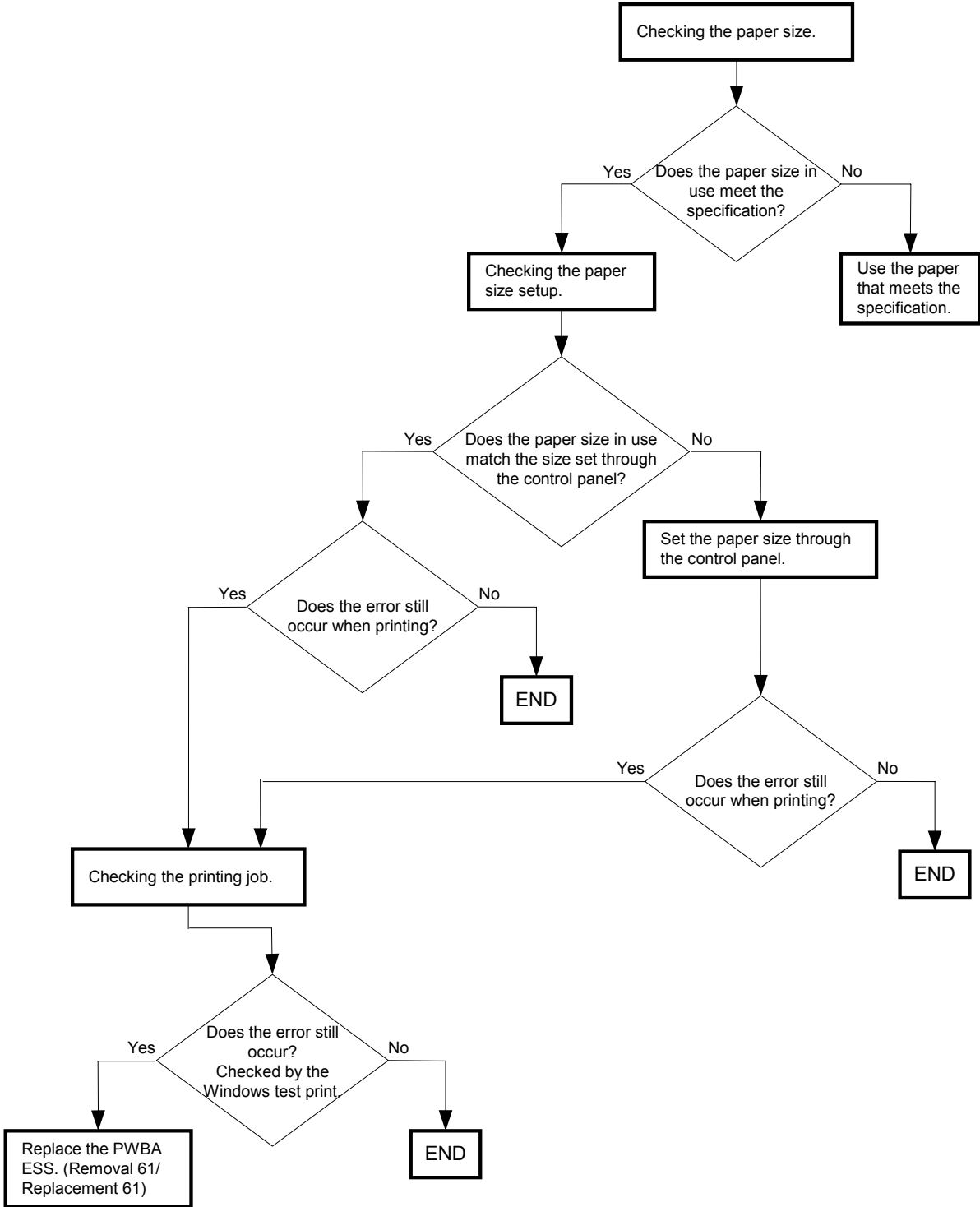

FIP-1. 91 Over Heat 042-700/Copy Scan Fax 142-700

Possible causative parts:KIT FEEDER (PL3.2.99)
PWBA MCU (PL9.1.20)

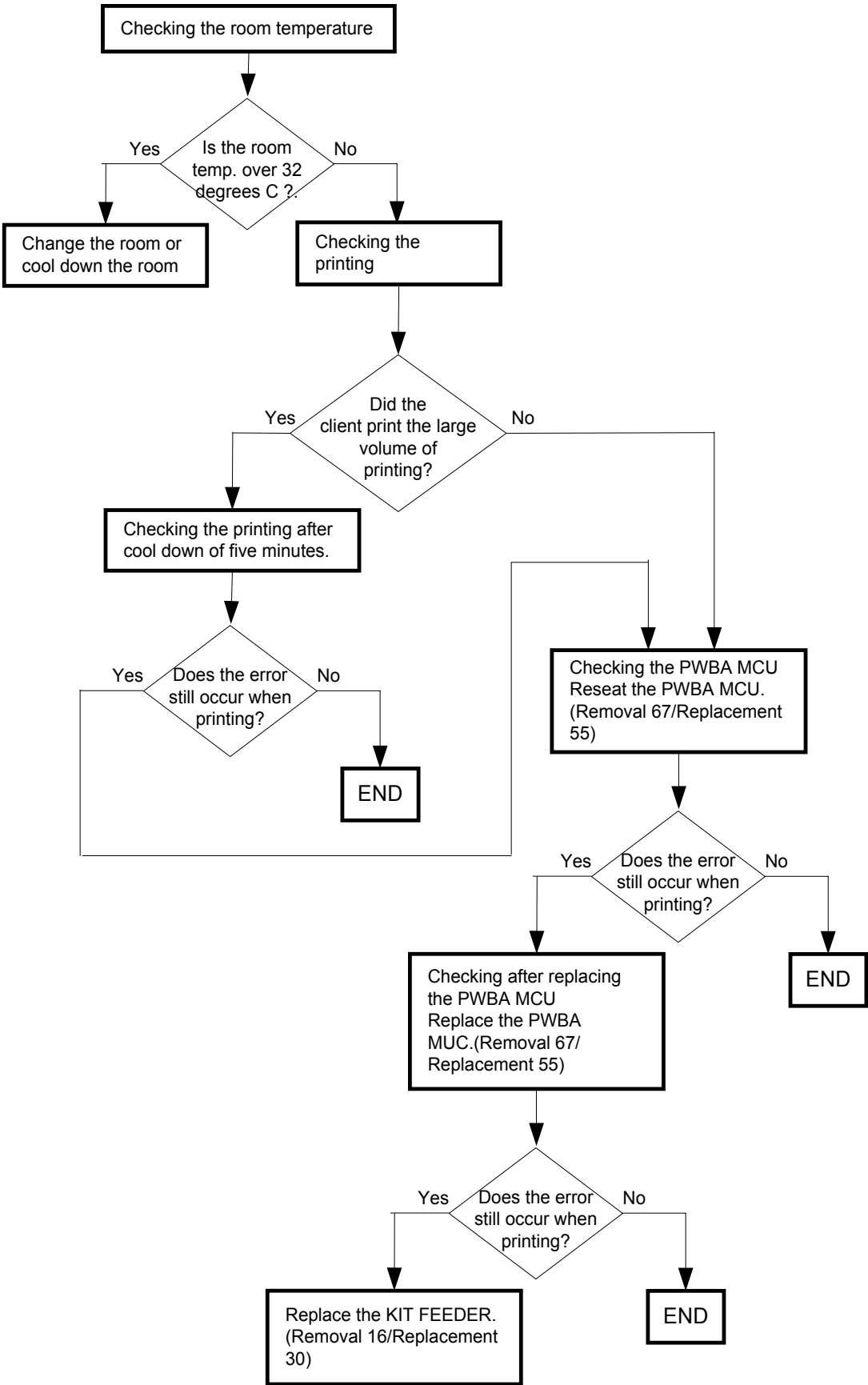

FIP-1. 92 Copy Scan Fax 193-700

Possible causative parts:PWBA ESS (PL13.4.20)

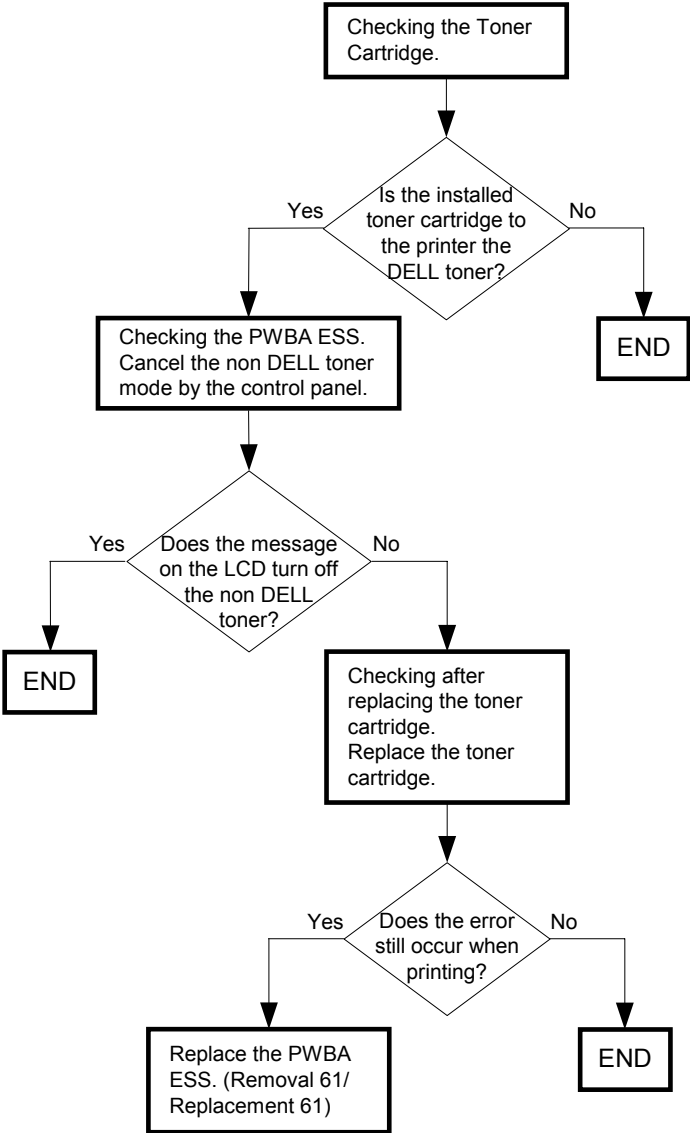

FIP-1. 93 Electrical Noise

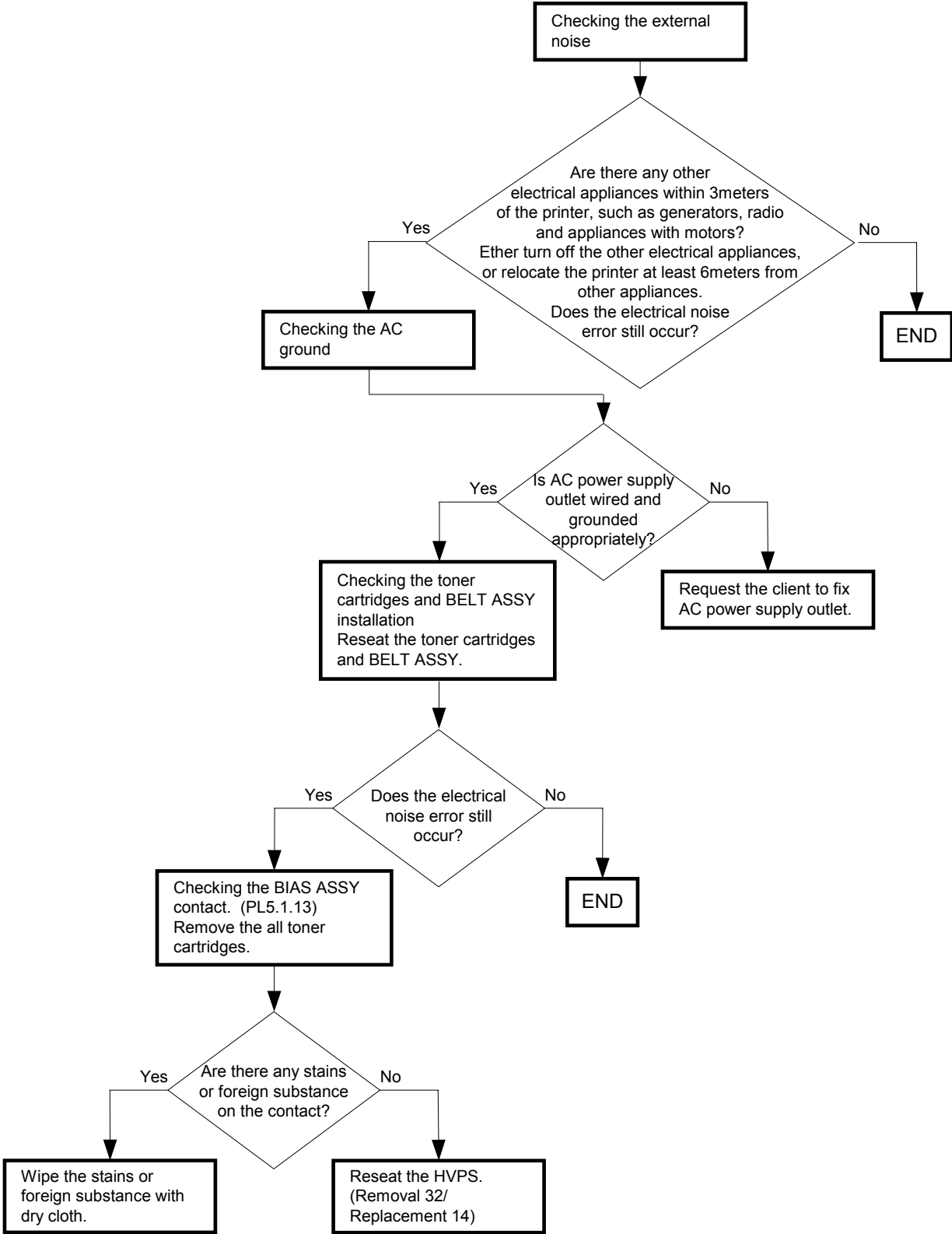

7. Image Quality Troubles

7.1 Flow of Image Quality Troubleshooting

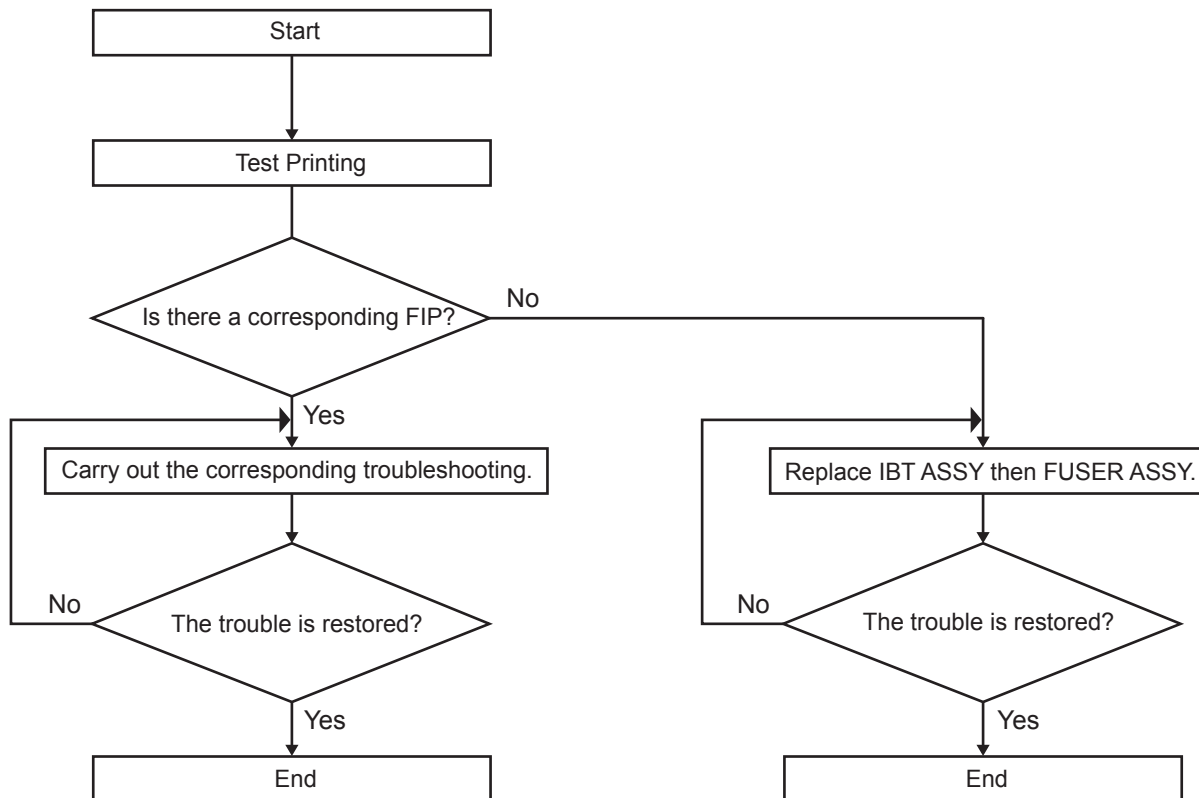

Leg_Sec001_001FA

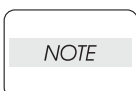

The descriptions here assume that the printer controller is under normal conditions. By running a print test with only the print engine allows you to simply isolate whether the printer controller or the print engine is faulty, so long as the trouble can be verified in the print results.

- Test print result with the engine only is normal. ---> Malfunction on Printer Controller side

- Test print result with the engine only is abnormal. ---> Malfunction on the engine side

When the printer controller is considered to be faulty, check by replacing the printer controller and interface cable with normal ones.

When the trouble persists even after replacement, check the host side, and perform and efficient troubleshooting using the image quality FIP for each phenomenon.

When a print quality trouble arises, obtain print samples to grasp and diagnose the trouble properly, and then perform an efficient troubleshooting using the image quality FIP for each phenomenon.

When the trouble persists even after the relevant image quality FIP is performed, check again with the image quality FIP and then try replacing [ESS and possible causative parts] one by one and perform a troubleshooting according to [Chapter 2 Operation of Diag.] and others.

Image quality FIP covers the typical image quality troubles as follows:

- FIP-1.P1 Faint print (Low contrast)
- FIP-1.P2 Blank print
- FIP-1.P3 Solid black
- FIP-1.P4 Vertical blank lines (White stripes in paper transport direction)
- FIP-1.P5 Horizontal band cross out (White stripes in the horizontal direction)
- FIP-1.P6 Vertical stripes
- FIP-1.P7 Horizontal stripes
- FIP-1.P8 Partial lack
- FIP-1.P9 Spots
- FIP-1.P10 Afterimage
- FIP-1.P11 Background (Fog)
- FIP-1.P12 Skew
- FIP-1.P13 Paper damage
- FIP-1.P14 No fix
- FIP-1.P15 Color Registration (Color Shift)
- FIP-1.P16 Hunting
- FIP-1.P17 Magnification incorrect

NOTE

Horizontal lines and/or spots that occur periodically are possibly caused by the trouble of a particular roll. In this case, measure the trouble interval on the test print, and compare it with the intervals in the table below to isolate the roll. Note that the interval does not necessarily match the circumference of the roll.

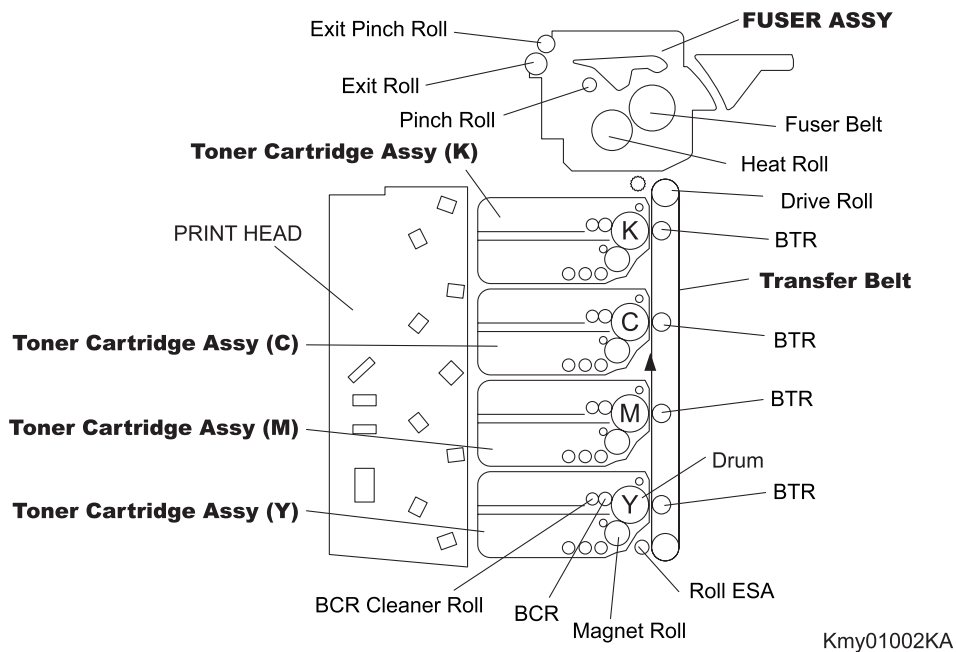

Roll	Parts name	PL No.	Roll diameter (mm)	Interval (mm)
Drum	Toner Cartridge ASSY	PL5.1.18/PL5.1.19/ PL5.1.20/PL5.1.21	24	75.4
BCR	Toner Cartridge ASSY	PL5.1.18/PL5.1.19/ PL5.1.20/PL5.1.21	9	28.8
BCR Cleaner Roll	Toner Cartridge ASSY	PL5.1.18/PL5.1.19/ PL5.1.20/PL5.1.21	8	25.9
Sleeve (K)	Toner Cartridge ASSY	PL5.1.18	16	25.2
Sleeve (Y,M,C)	Toner Cartridge ASSY	PL5.1.19/PL5.1.20/PL5.1.21	16	22.3
1st BTR	Transfer Belt	PL4.1.1	12	37.7
Roll ESA	Transfer Belt	PL4.1.1	9	28.3
Drive Roll	Transfer Belt	PL4.1.1	18.1	56.9
Fuser Roll	FUSER ASSY	PL6.1.10	26.32	82.7
Fuser Belt	FUSER ASSY	PL6.1.10	30	94.2
Pinch Roll	FUSER ASSY	PL6.1.10	6	18.8
Exit Roll	FUSER ASSY	PL6.1.10	13.75	43.2
Exit Pinch Roll	FUSER ASSY	PL6.1.10	10	31.4

7.2 Items to Confirm before Image Quality Troubleshooting

7.2.1 Print Quality Problems

Customers may need your help determining the cause of print quality issues such as streaking, fading, or dropouts. Here are some questions that may help you determine why your customer's printer is not printing optionally. First, confirm the following items to understand customer's operating condition.

1. Does your customer's print media fall within the printer specifications? (Refer to "**1.5.4 Print Media Guidelines**").
2. Is there enough toner?
3. Has the printer been cleaned recently?

Checking Printer Condition

Toner

Low toner can cause print quality problems such as fading, streaking, white lines, or dropouts.

Have your customer print a small document from a different application to replicate the problem and verify the amount of toner available for printing. When your customers print a document, the Laser Printer Status Monitor should display a dialog box that estimates the amount of toner left in the cartridge.

If the toner is low, your customers can something extend the cartridge life by removing the cartridge from the 3115cn, gently shaking it from side-to-side, and replacing it (Rocking the toner cartridge from side-to-side loosens toner that may get stuck).

Cleaning

Paper, toner, and dust particles can accumulate inside the 3115cn printer and cause print quality problems, such as smearing or toner specks. Clean inside the 3115cn to prevent these problems.

Prior Checks before Troubleshooting

Check the following items if any print quality problems occur before going to each troubleshooting. Those actions may solve problems easily and simply.

If the any problems below have occurred, check and take actions described in each item.

- 1) Color is out of alignment:
 - a) Clean inside of the printer.
 - b) If you install a new black cartridge and a Print Head cleaning has not been done, this problem will happen. Clean inside of the printer.
- 2) Print is too light:
 - a) The toner may be low. Confirm the amount of the toner and change the toner cartridges if necessary.
 - b) Set the **Draft Mode** check box to off in the Advanced in the printer driver.
 - c) If you are printing on an uneven print surface, change the Paper Type settings in the Tray Settings menu.
 - d) Verify that the correct print media is being used.
 - e) The drum cartridge may need to be replaced. Change the drum cartridge.
- 3) Toner smears or print comes off page:
 - a) If you are printing on an uneven print surface, change the Paper Type settings in the Tray Settings menu.
 - b) Verify that the print media is within the printer specifications. (Refer to "**1.5.4 Print Media Guidelines**").

- 4) Toner spots appear on the page/printing is blurred:
 - a) Check the toner cartridge to make sure it is installed correctly.
 - b) Change the toner cartridge.
- 5) Entire page is white:
 - a) Make sure the packaging material is removed from the toner cartridge.
 - b) Check the toner cartridge to make sure it is installed correctly.
 - c) The toner may be low. Change the toner cartridge.
- 6) Streaks appear on the page:
 - a) The toner may be low. Change the toner cartridge.
 - b) If you are using preprinted forms, make sure the toner can withstand temperatures of 0°C to 35°C.
- 7) Characters have jagged or uneven edges:
 - a) Change the **Print Mode** in the **Graphics** tab (or **Advanced** dialog box) to **Standard** in the printer driver.
 - b) If you are using downloaded fonts, verify that the fonts are supported by the printer, the host computer, and the software program.
- 8) Part or all of the page prints in black:
 - a) Check the toner cartridge to make sure it is installed correctly.
- 9) The job prints, but the top and side margins are incorrect:
 - a) Make sure the Paper Size setting in the Tray Settings is correct.
 - b) Make sure the margins are set correctly in your software program.
- 10) Printing on both ends of the transparencies is faded:
 - a) This occurs when the printer is operating in a location where relative humidity reaches 85% or more. Adjust the humidity or relocate the printer to an appropriate environment.

7.3 Print Image Quality Specifications

Conditions of Guaranteed Image Quality

The image quality shall be guaranteed under the following conditions.

1) Environmental Condition

Temperature: 10°C - 32°C

Humidity: 15% RH - 85% RH (85% RH at 28°C)

Note that defect may occur due to condensation after around 30 minutes if the printer is turned on in an critical environment such as 85% at 10°C.

2) Guaranteed Paper

The print image quality specified in this chapter shall be guaranteed when the standard paper is fed from the paper tray. The print image quality is evaluated on the maximum size of each standard paper.

Color print quality: X-Pression paper

Black and White quality: 4200 paper

3) Paper condition

The paper used shall be fresh from unpacking and shall have been left in the operating environment for 12 hours before unpacking.

4) Printer condition

The print image quality specified in this chapter is guaranteed with the printer in normal condition.

6) Criterion for judgment

90% of the prints shall be within the specifications ($\gamma=90\%$).

5) For **Color chart**, **Parallelism**, **Perpendicularity**, **Skew**, **Linearity**, **Magnification Error**, **Registration** and **Guaranteed Printing Area**, refer to each chart below.

Chart

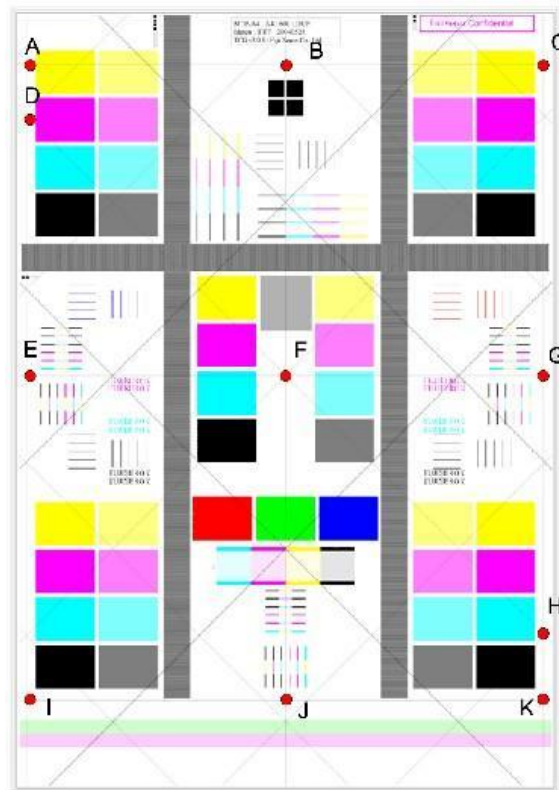

Parallelism

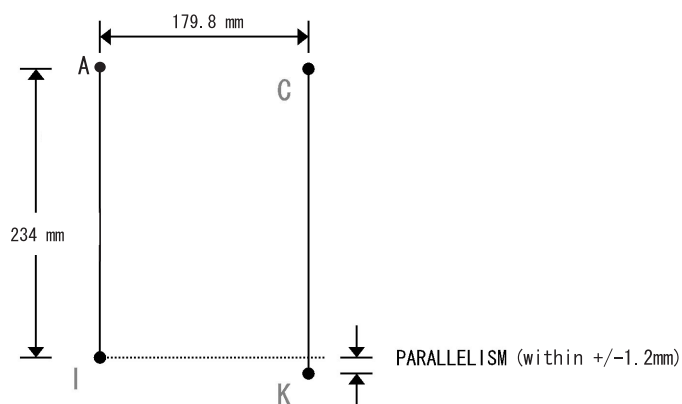

Perpendicularity

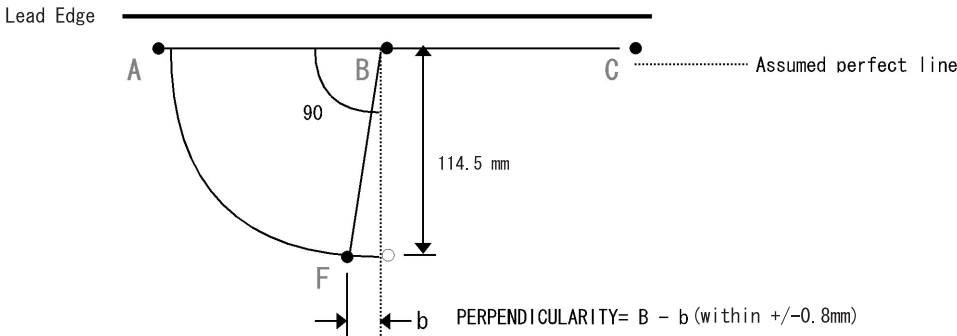

Skew

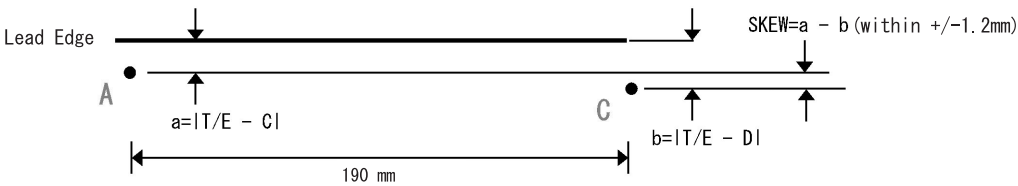

Linearity

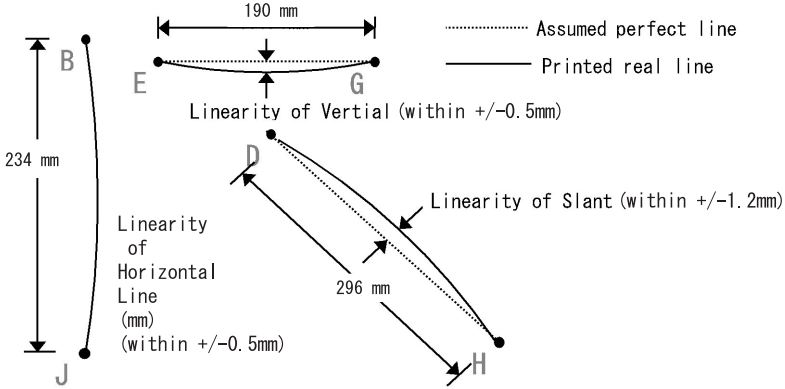

Magnification Error

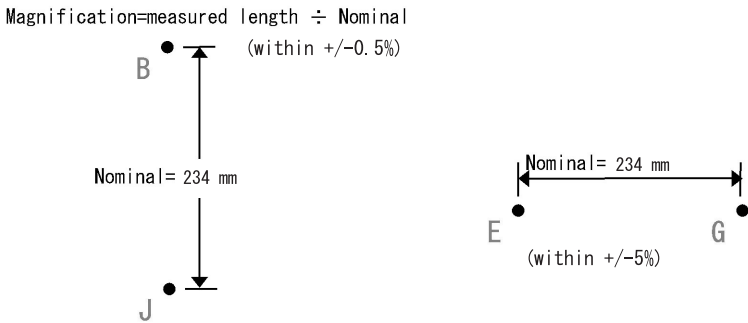

Registration

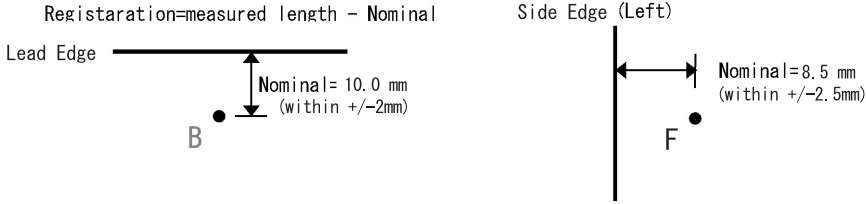

Guaranteed Printing Area

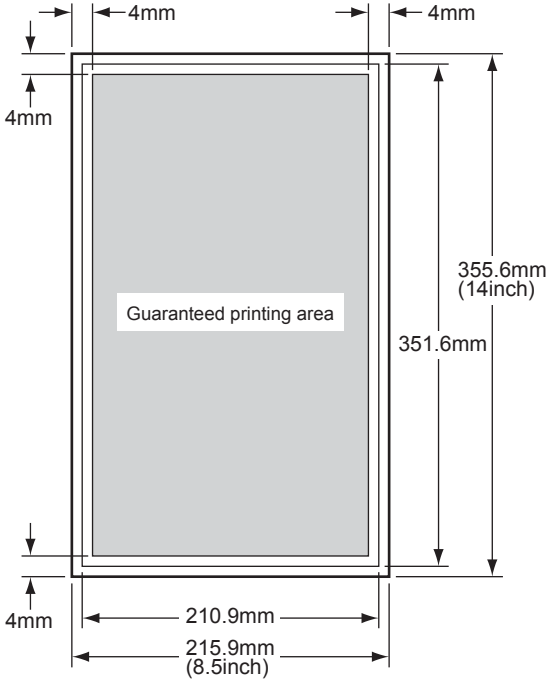

Kmy01001KA

7.4 Image Quality FIP

FIP-1.P1 Faint print (Low contrast)

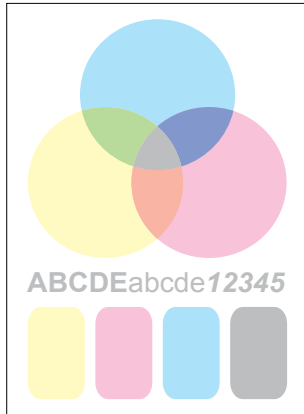

Trouble substance

The density of the image is entirely too faint.

ESS and possible causative parts

- TRANSFER ASSY (PL4.1.1)
- DISPENSOR ASSY (PL5.1.12)
- HVPS (PL5.1.17)
- CARTRIDGE ASSY (PL5.1.18(K)/PL5.1.19 (C)/PL5.1.20 (M)/PL5.1.21 (Y))
- KIT ROS ASSY (PL13.3.99)
- PWBA MCU (PL9.1.20)
- PWBA ESS (PL13.4.20)

Before starting troubleshooting, check the paper transfer path. Make sure that there is no foreign materials on the transfer path, such as staples, paper clips, scraps of paper and so on.

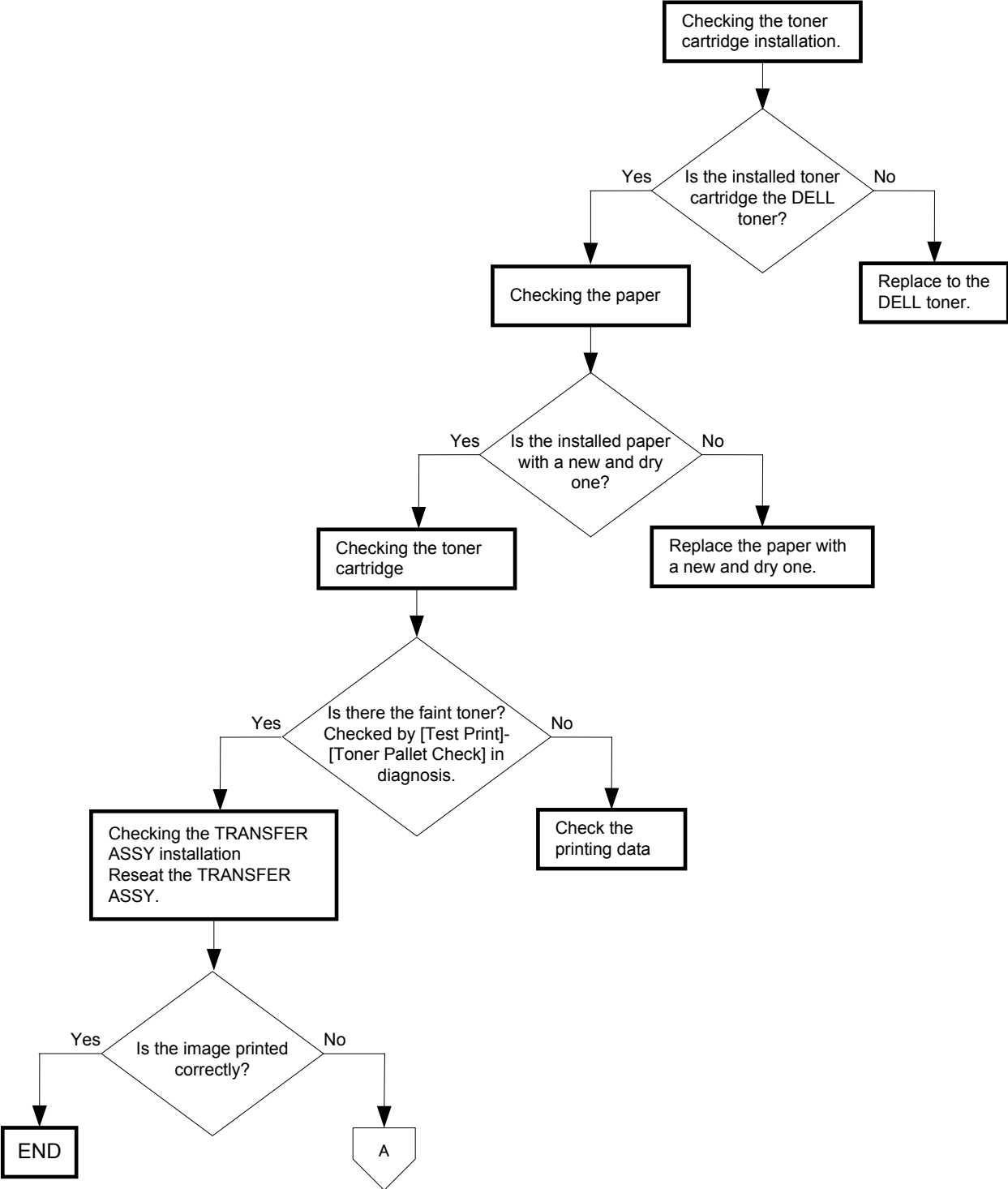

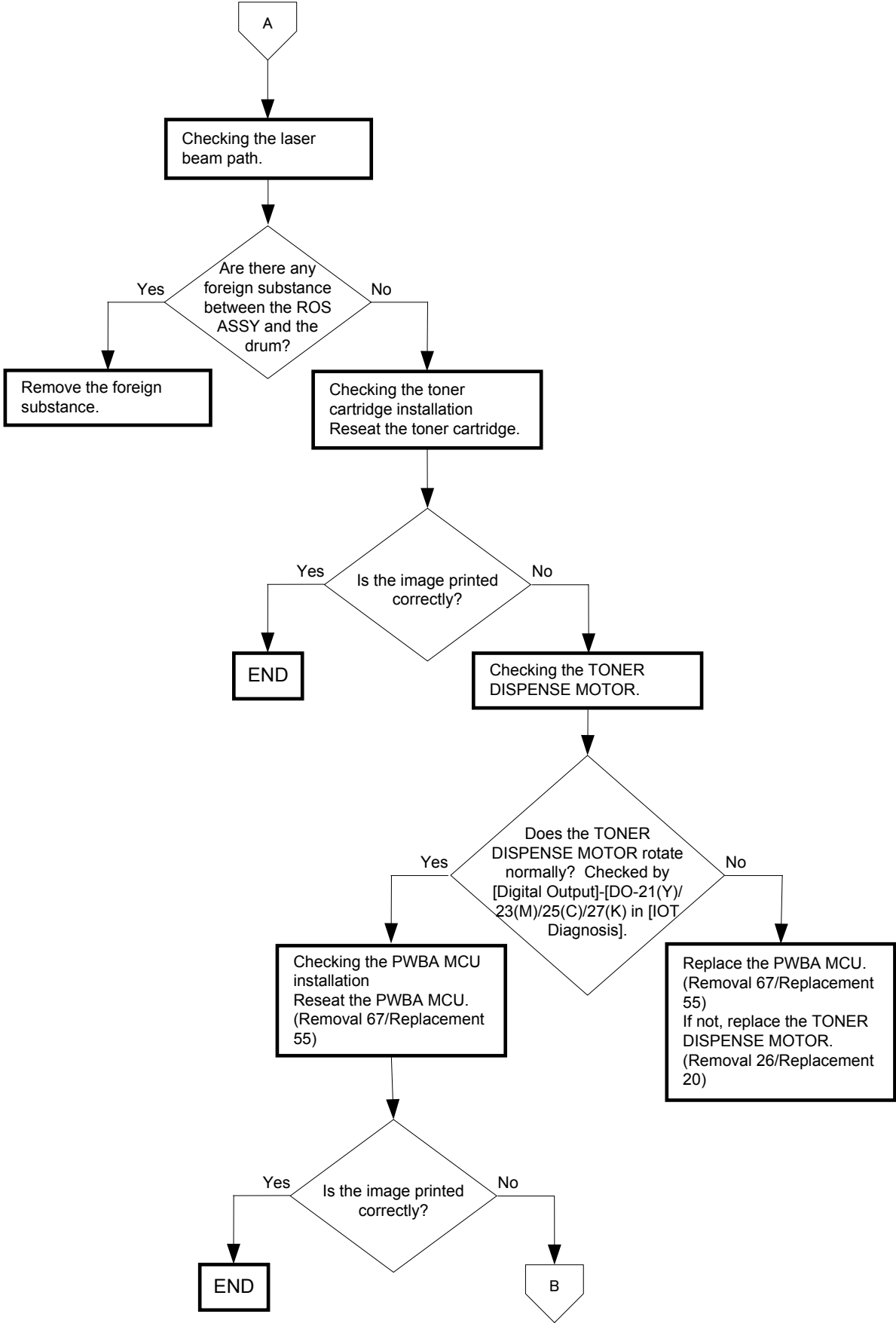

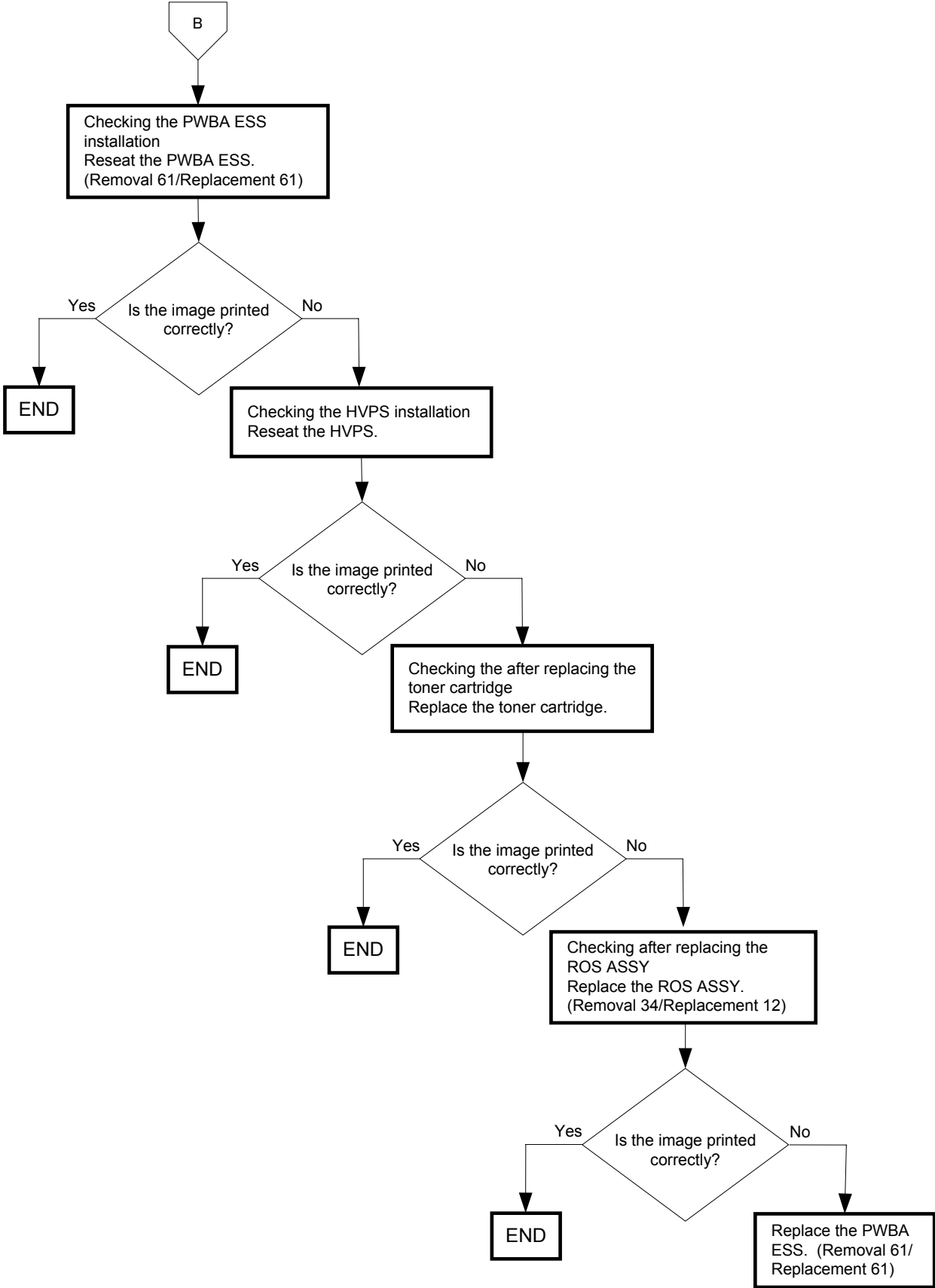

FIP-1.P2 Blank print (No print)

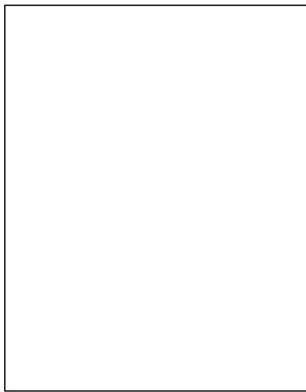

Leg_Sec001_003FA

Trouble substance

The entire paper is printed pure white.

ESS and possible causative parts

- TRANSFER ASSY (PL4.1.1)
- DISPENSOR ASSY (PL5.1.12)
- HVPS (PL5.1.17)
- CARTRIDGE ASSY (PL5.1.18(K)/PL5.1.19 (C)/PL5.1.20 (M)/PL5.1.21 (Y))
- KIT ROS ASSY (PL13.3.99)
- PWBA MCU (PL9.1.20)
- PWBA ESS (PL13.4.20)
- PWBA HYUI (PL13.4.1)
- ADF SCANNER ASSY (PL13.8.1)

Before starting troubleshooting, check the paper transfer path. Make sure that there is no foreign materials on the transfer path, such as staples, paper clips, scraps of paper and so on.

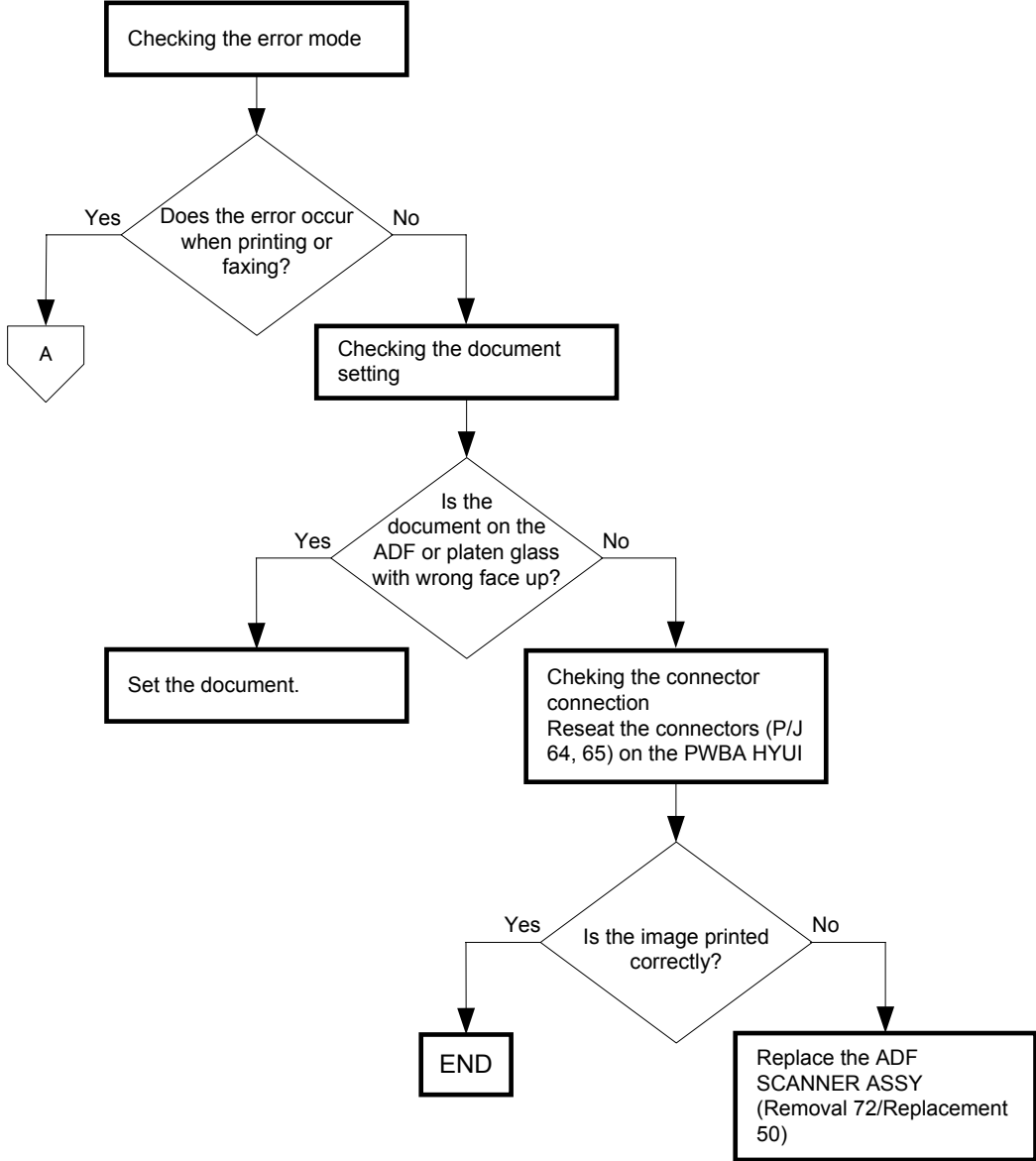

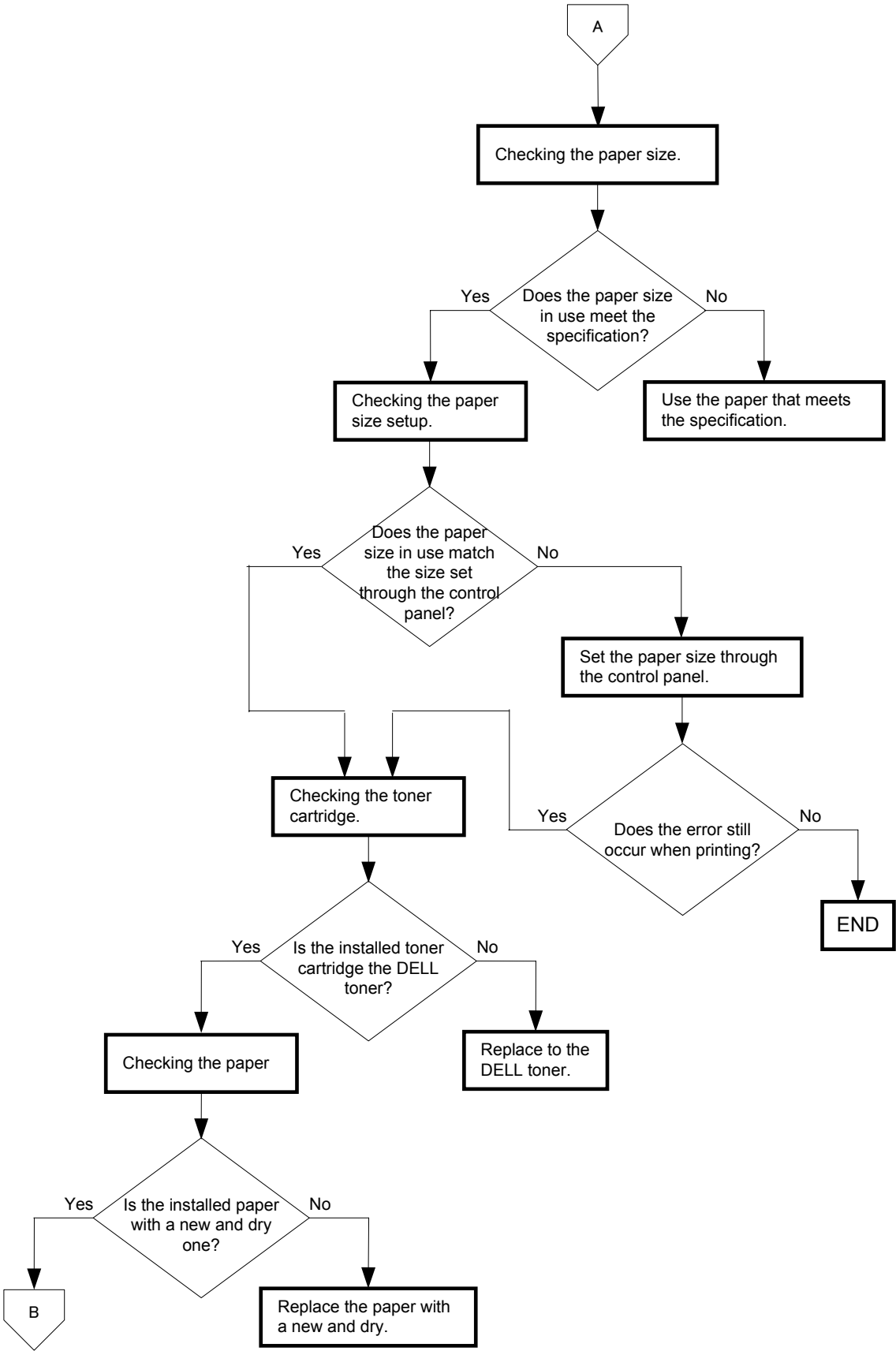

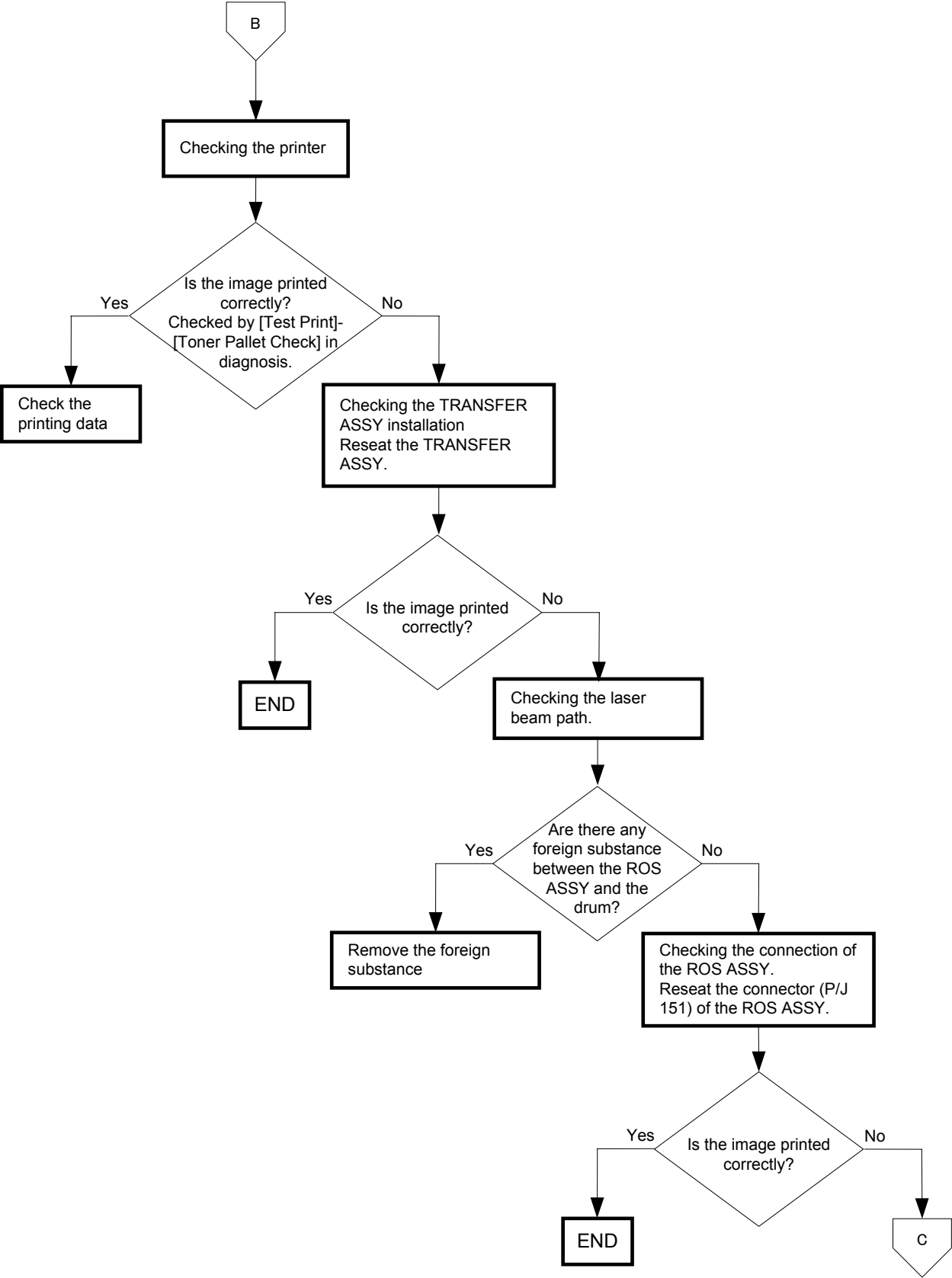

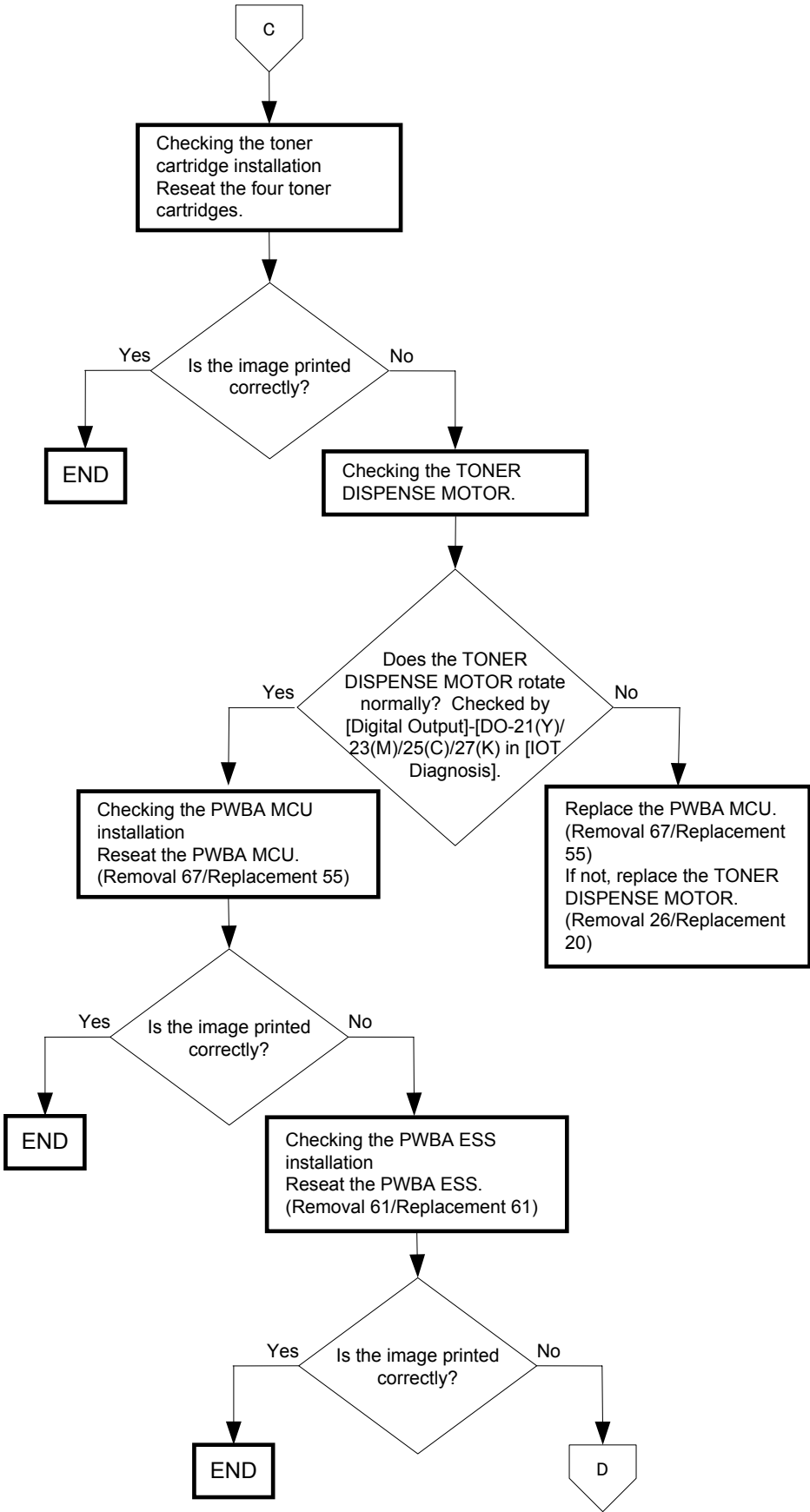

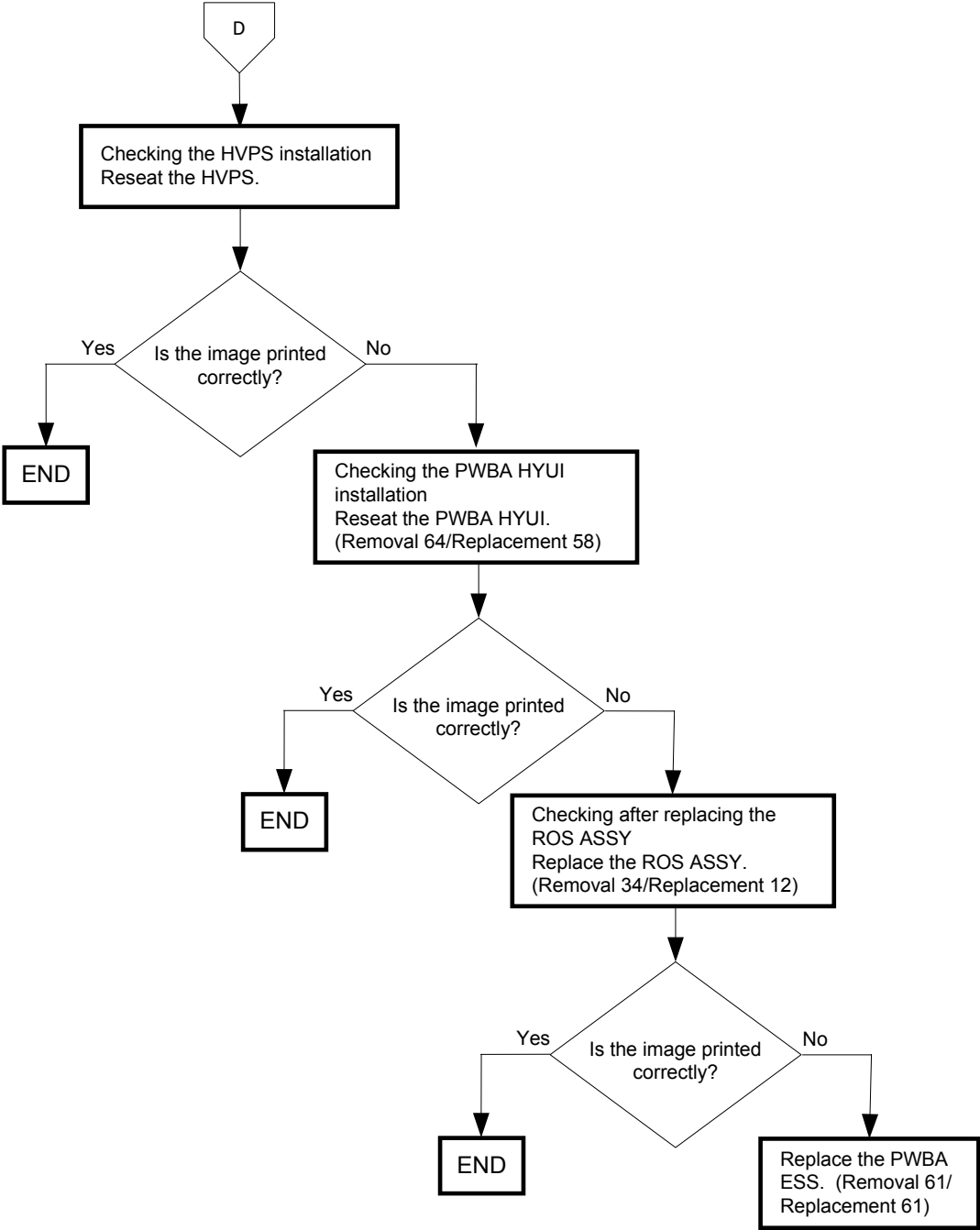

FIP-1.P3 Solid black

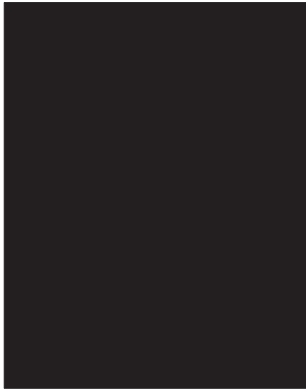

Leg_Sec001_004FA

Trouble substance

The entire paper is printed jet-black.

ESS and possible causative parts

- TRANSFER ASSY (PL4.1.1)
- HVPS (PL5.1.17)
- CARTRIDGE ASSY (PL5.1.18(K)/PL5.1.19(C)/PL5.1.20 (M)/PL5.1.21 (Y))
- KIT ROS ASSY (PL13.3.99)
- PWBA MCU (PL9.1.20)
- PWBA ESS (PL13.4.20)
- PWBA HYUI (PL13.4.1)
- ADF SCANNER ASSY (PL13.8.1)

Before starting troubleshooting, check the paper transfer path. Make sure that there is no foreign materials on the transfer path, such as staples, paper clips, scraps of paper and so on.

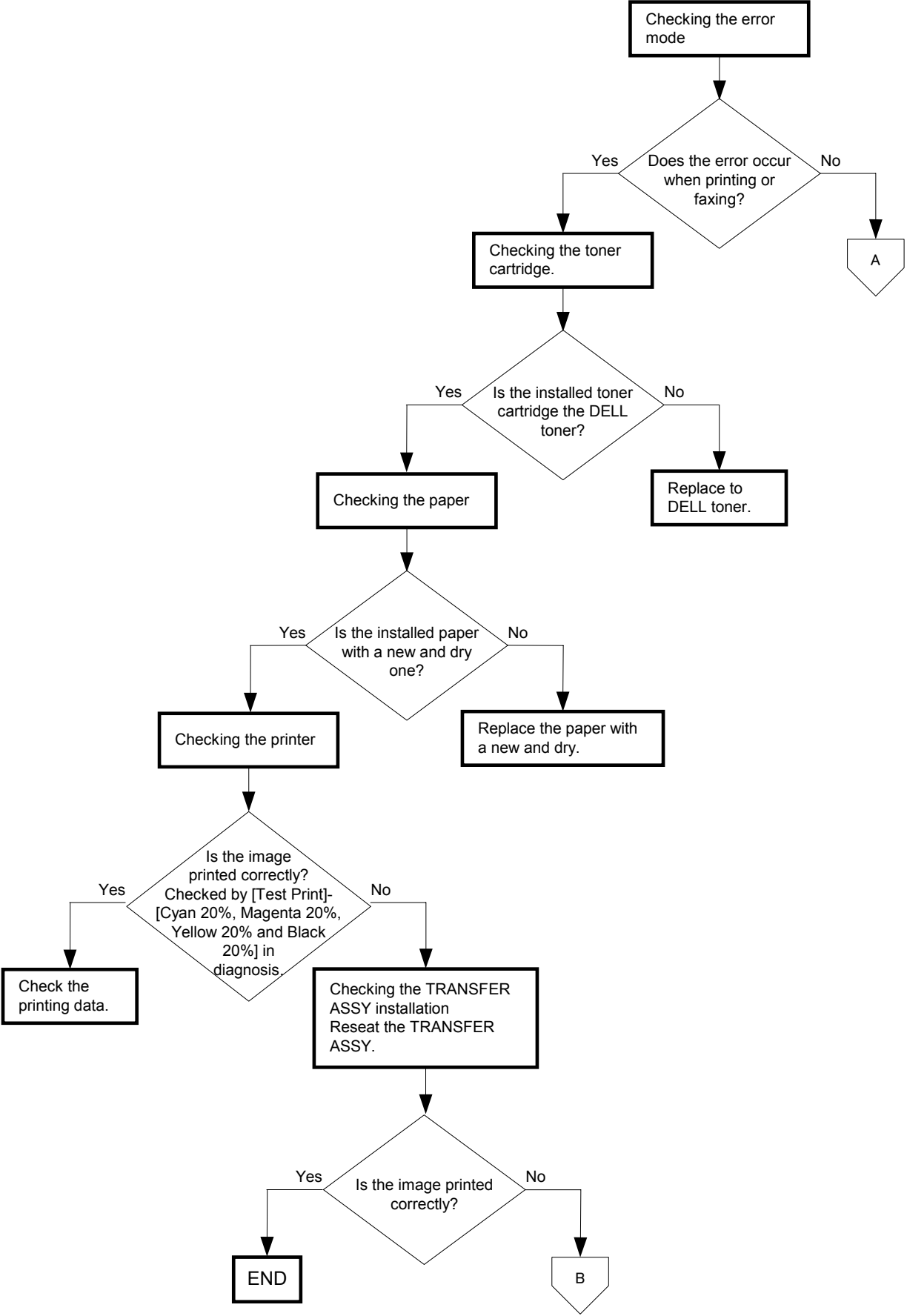

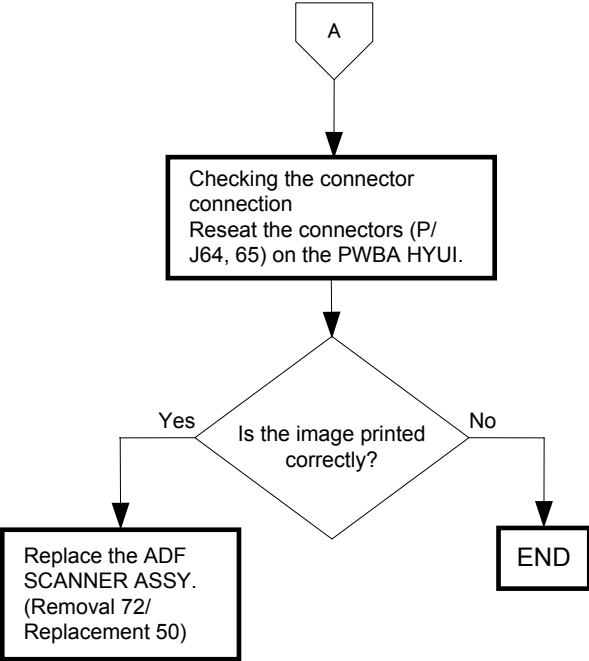

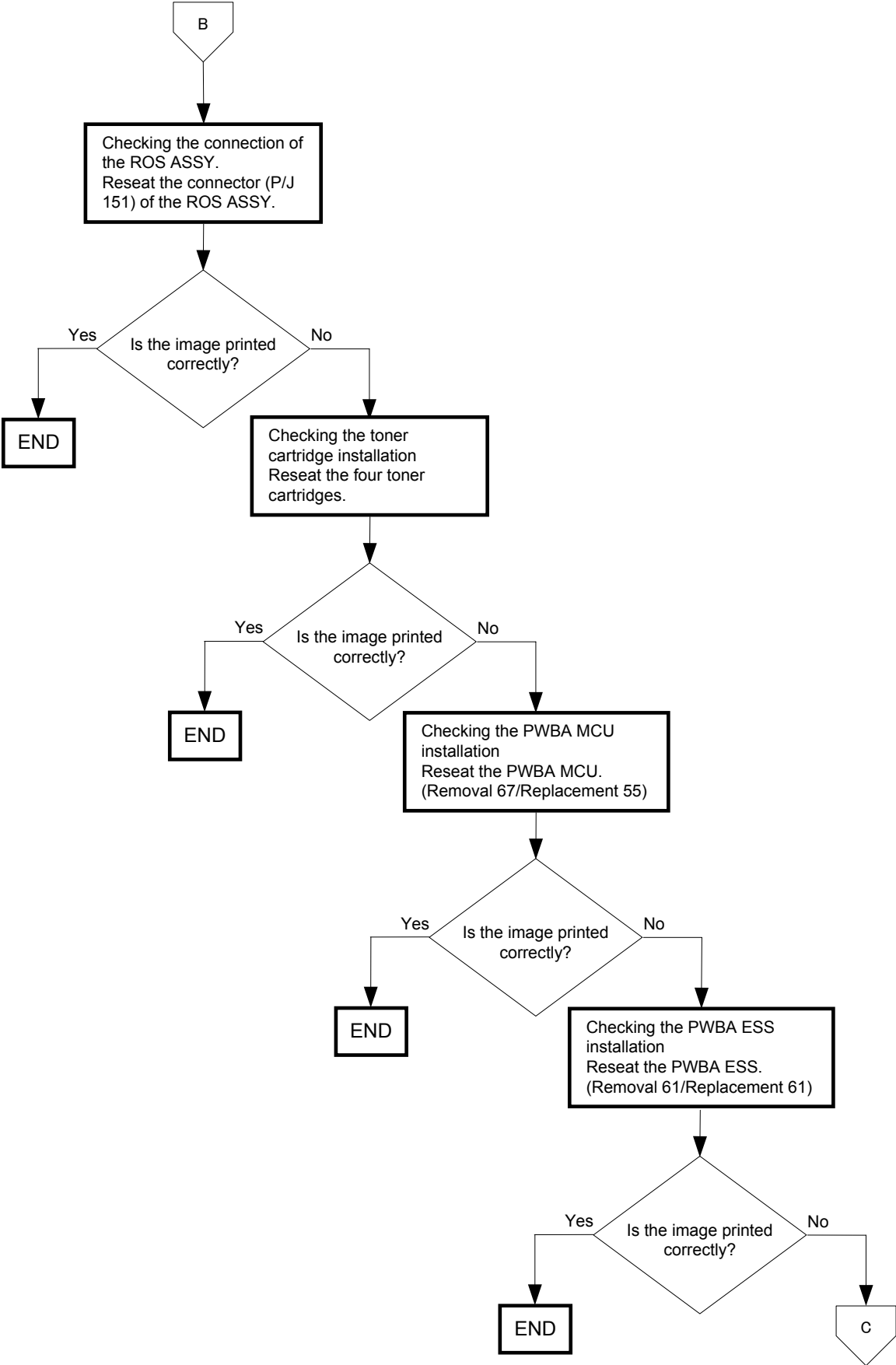

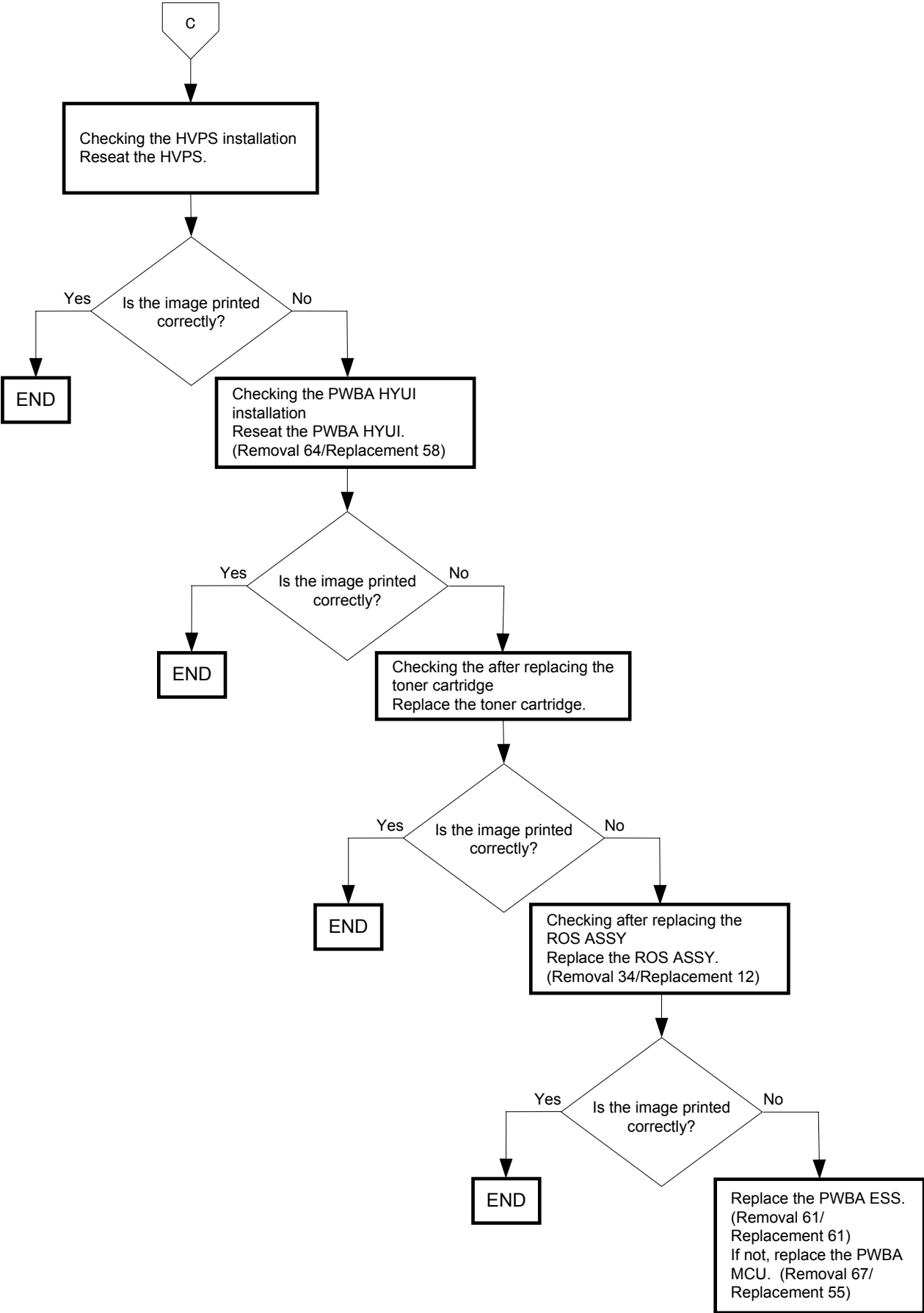

FIP-1.P4 Vertical blank lines (White stripes in paper transport direction)

**Trouble substance**

There are some extremely faint or completely non-printed parts. Those non-printed parts cover a wide area vertically, along the paper feeding direction.

ESS and possible causative parts

- TRANSFER ASSY (PL4.1.1)
- HVPS (PL5.1.17)
- CARTRIDGE ASSY (PL5.1.18(K)/PL5.1.19(C)/PL5.1.20 (M)/PL5.1.21 (Y))
- KIT ROS ASSY (PL13.3.99)
- PWBA MCU (PL9.1.20)
- PWBA ESS (PL13.4.20)

- PWBA HYUI (PL13.4.1)
- ADF SCANNER ASSY (PL13.8.1)

Before starting troubleshooting, check the paper transfer path. Make sure that there is no foreign materials on the transfer path, such as staples, paper clips, scraps of paper and so on.

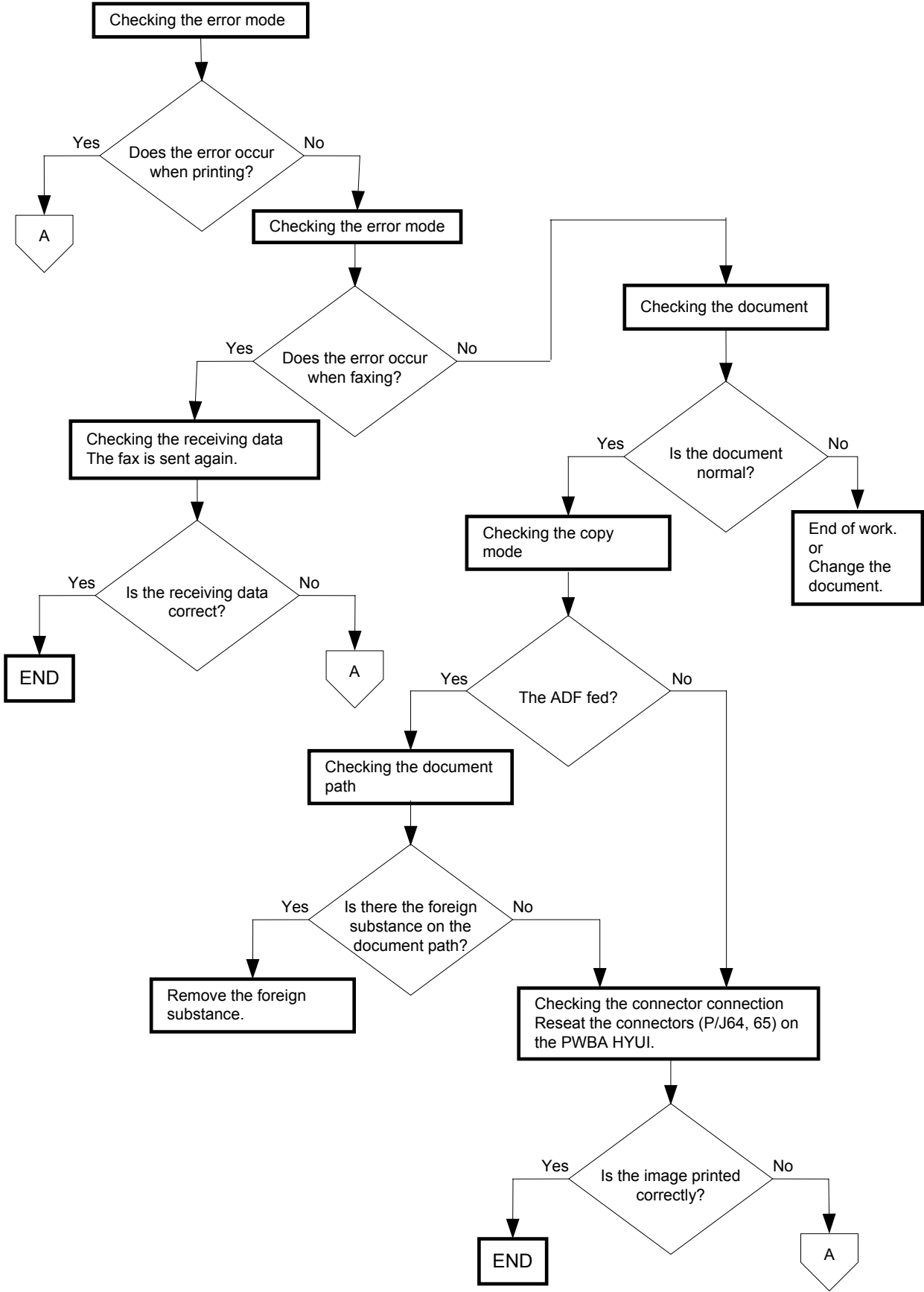

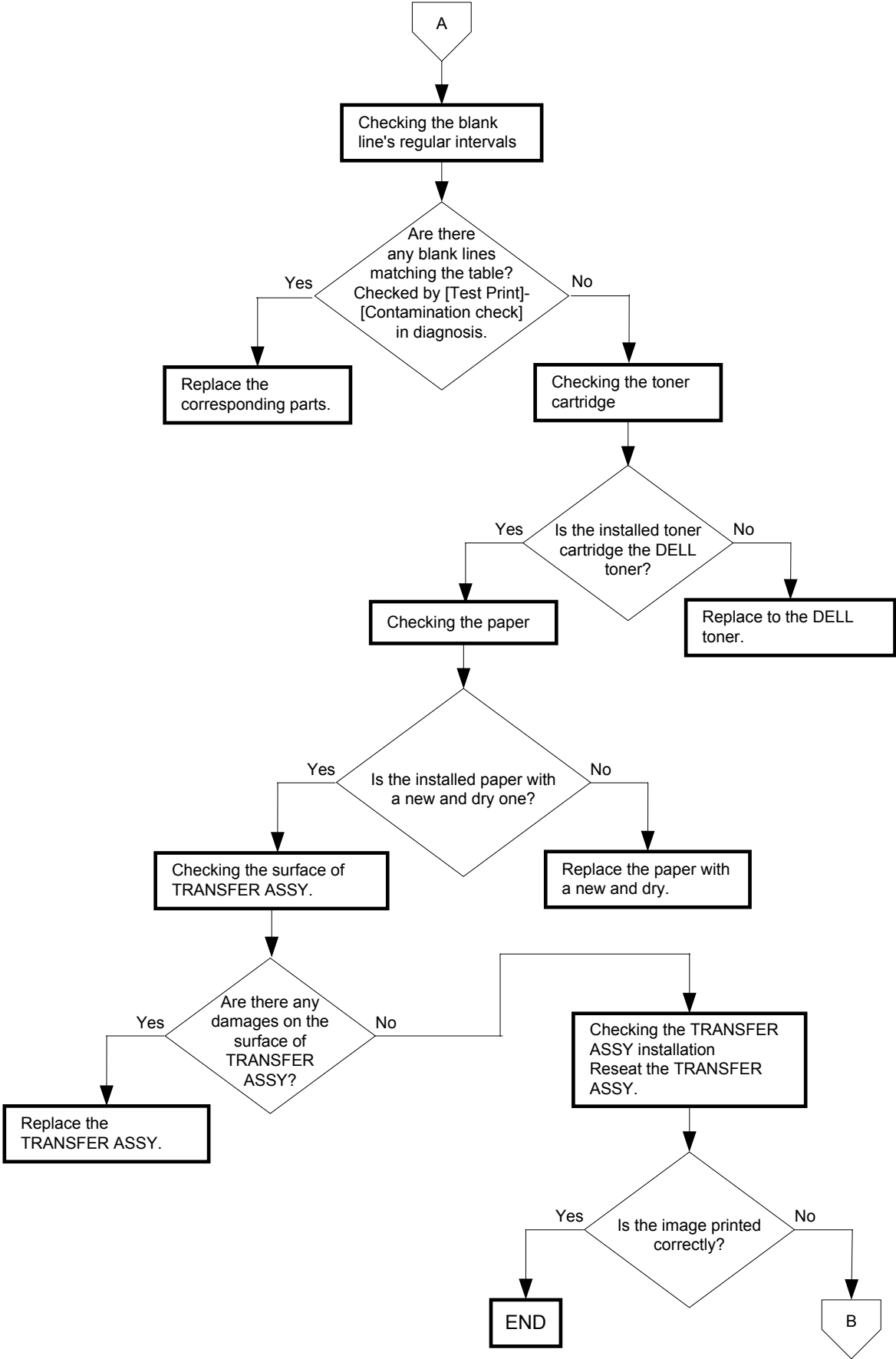

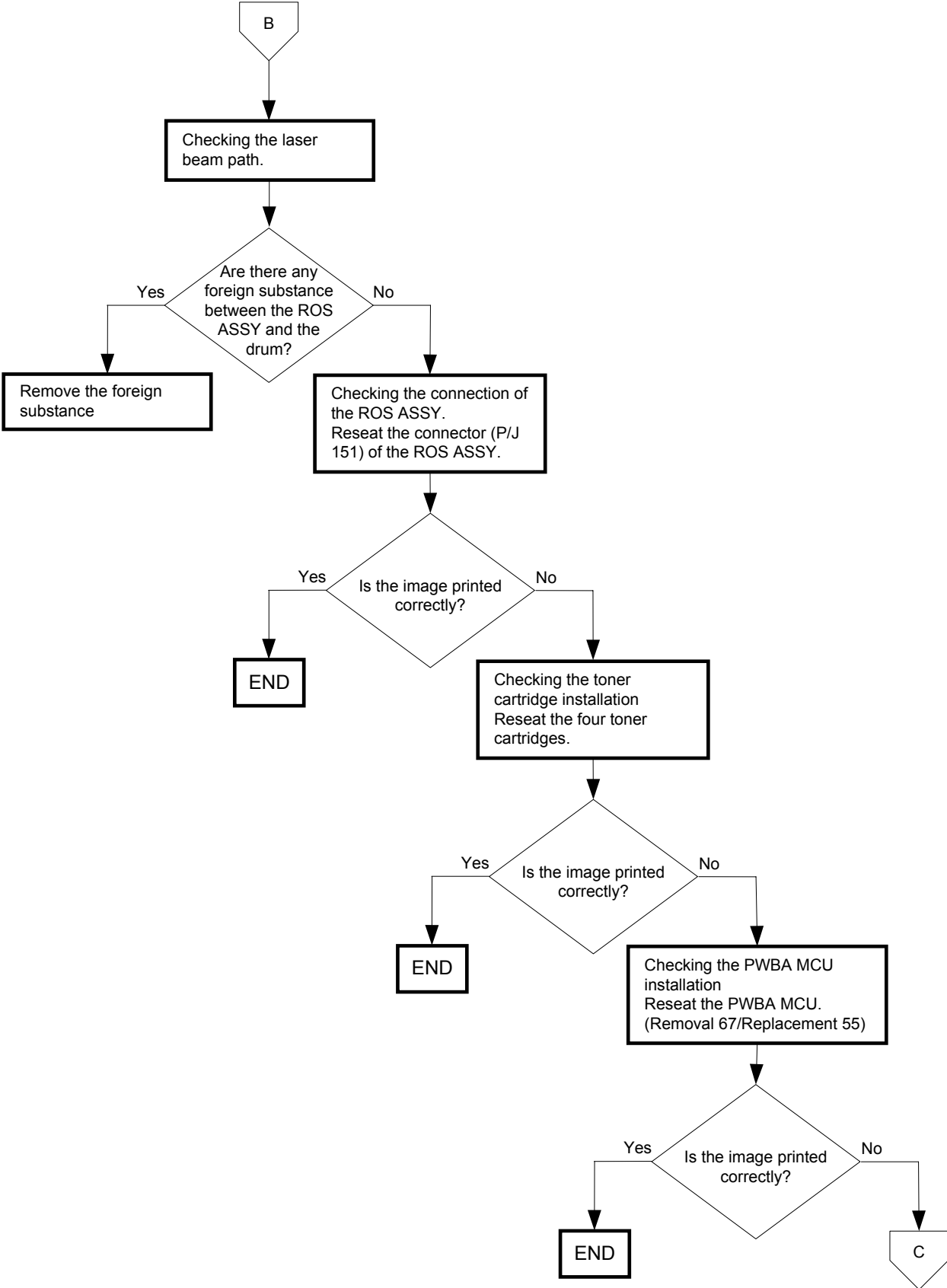

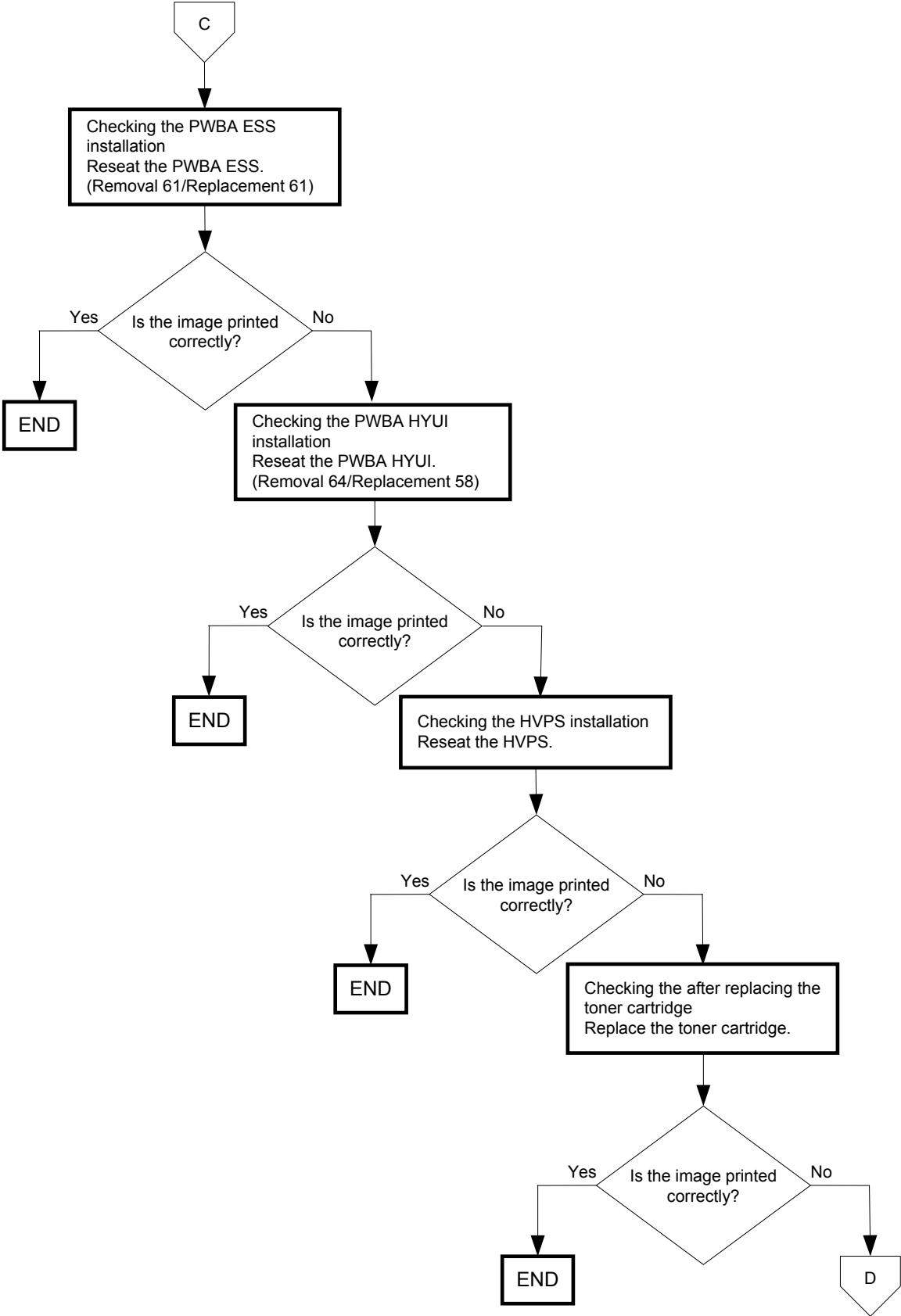

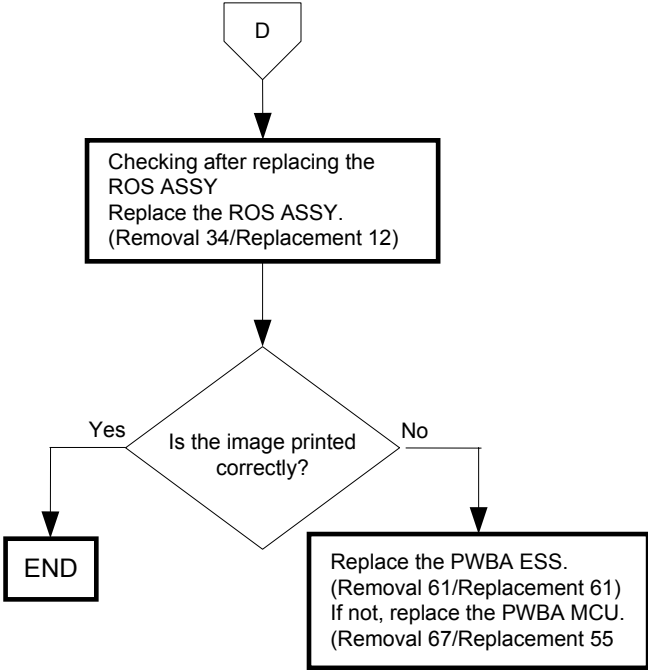

FIP-1.P5 Horizontal band cross out (White stripes in the horizontal direction)

**Trouble substance**

There are some extremely faint or completely non-printed parts. Those non-printed parts cover a wide area horizontally, perpendicular to the paper feeding direction.

ESS and possible causative parts

- TRANSFER ASSY (PL4.1.1)
- HVPS (PL5.1.17)
- CARTRIDGE ASSY (PL5.1.18(K)/PL5.1.19(C)/PL5.1.20 (M)/PL5.1.21 (Y))
- KIT ROS ASSY (PL13.3.99)
- PWBA MCU (PL9.1.20)
- PWBA ESS (PL13.4.20)
- PWBA HYUI (PL13.4.1)
- ADF SCANNER ASSY (PL13.8.1)

Before starting troubleshooting, check the paper transfer path. Make sure that there is no foreign materials on the transfer path, such as staples, paper clips, scraps of paper and so on.

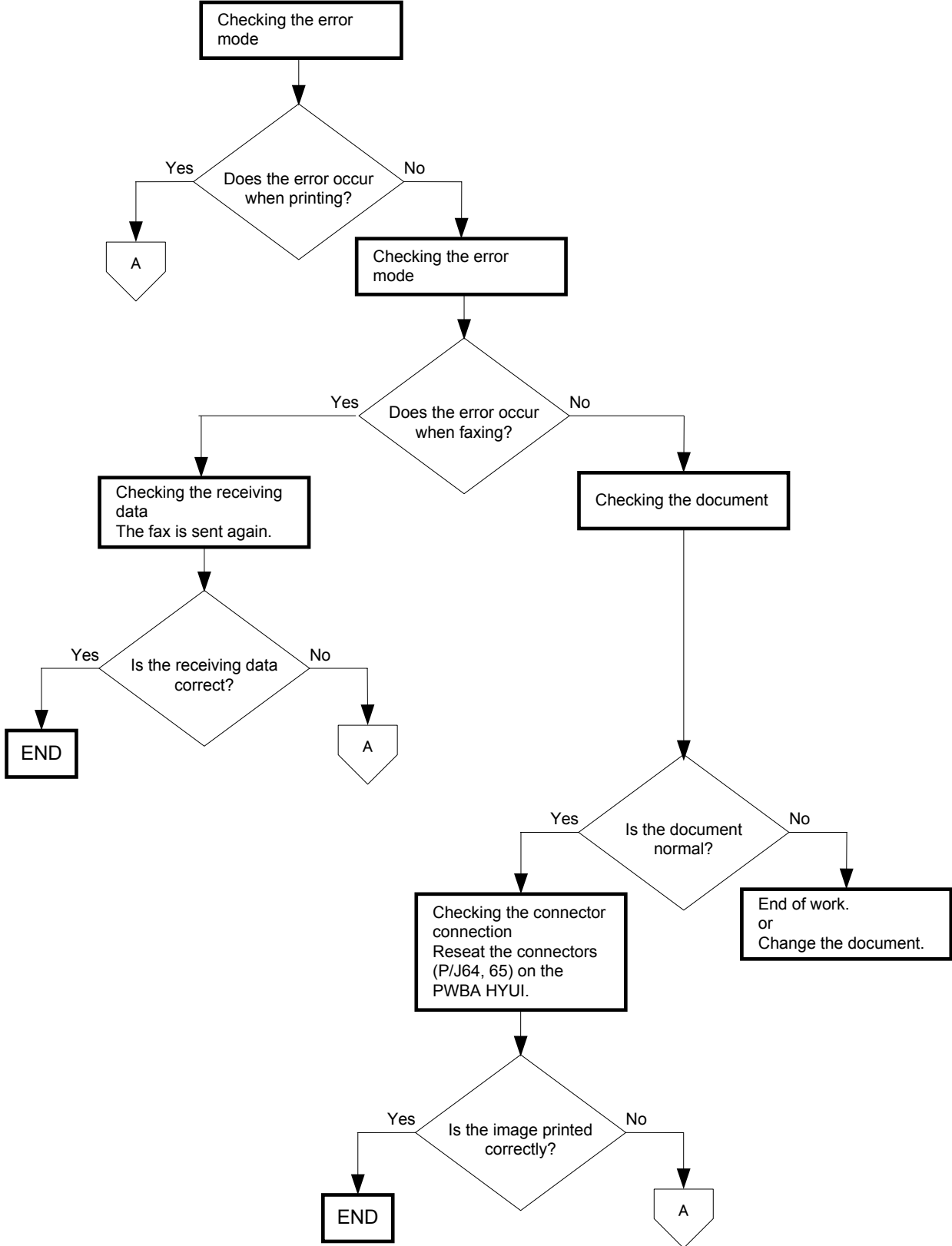

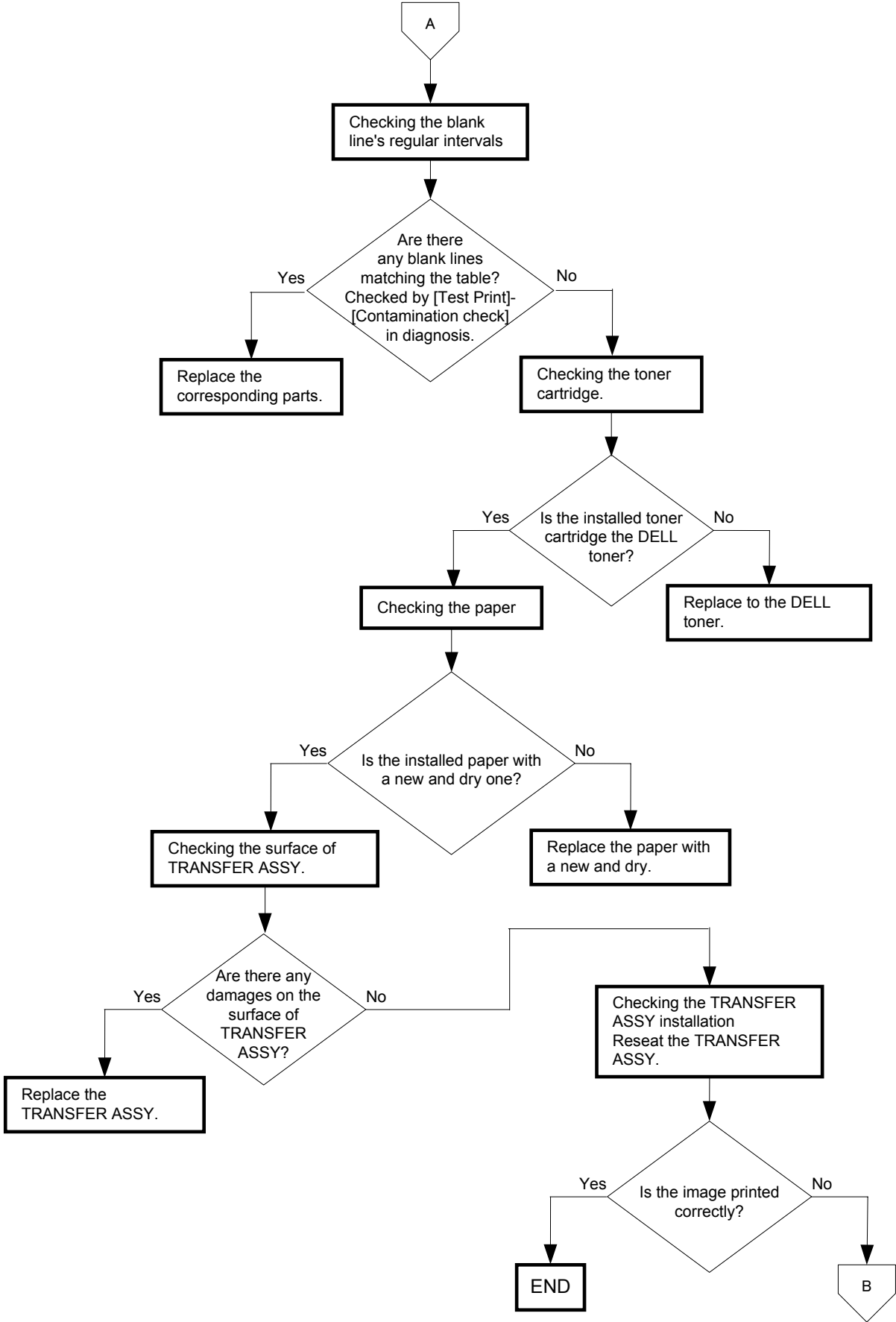

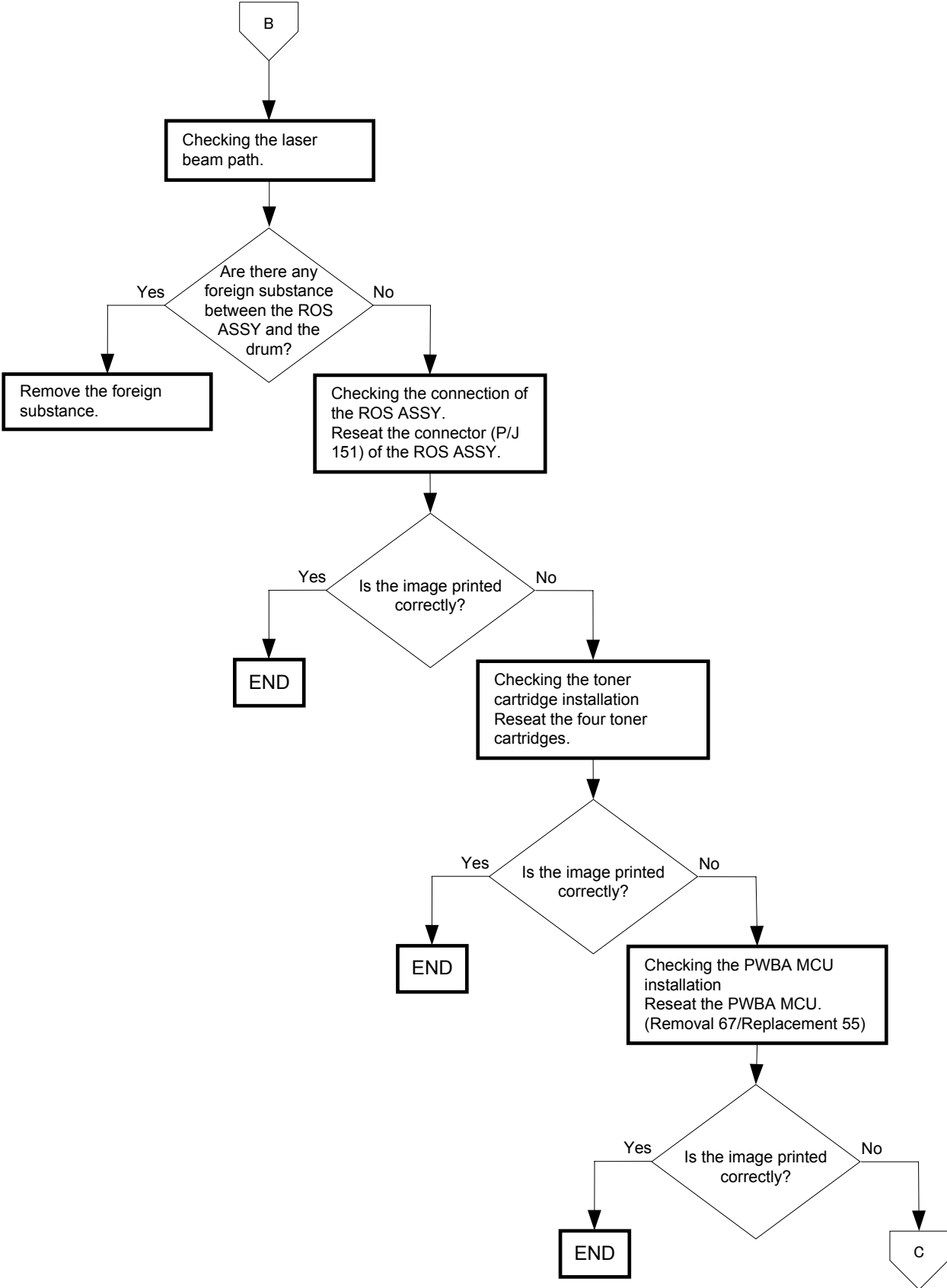

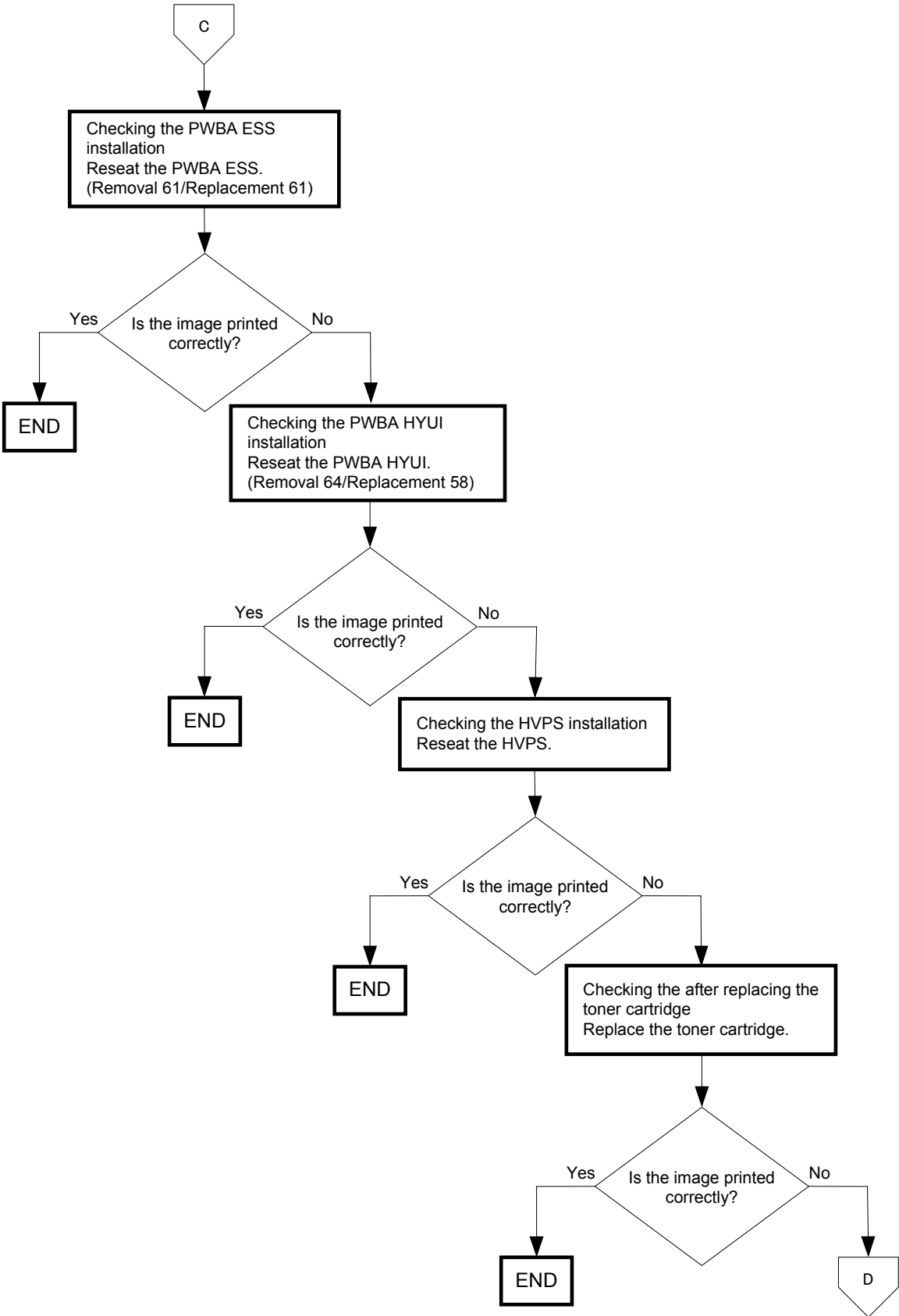

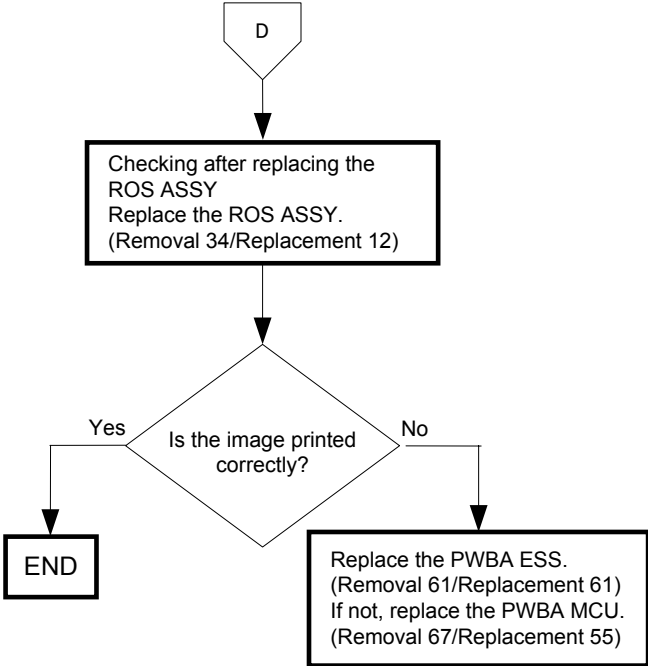

FIP-1.P6 Vertical stripes

**Trouble substance**

There are vertical black stripes along the paper.

ESS and possible causative parts

- TRANSFER ASSY (PL4.1.1)
- HVPS (PL5.1.17)
- CARTRIDGE ASSY (PL5.1.18(K)/PL5.1.19(C)/PL5.1.20 (M)/PL5.1.21 (Y))
- KIT ROS ASSY (PL13.3.99)
- FUSER ASSY (PL6.1.10)
- PWBA MCU (PL9.1.20)
- PWBA ESS (PL13.4.20)

- PWBA HYUI (PL13.4.1)
- ADF SCANNER ASSY (PL13.8.1)

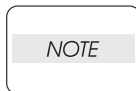

If the stripes appear at the top or back of the paper, replace the IBT ASSY only.

Before starting troubleshooting, check the paper transfer path. Make sure that there is no foreign materials on the transfer path, such as staples, paper clips, scraps of paper and so on.

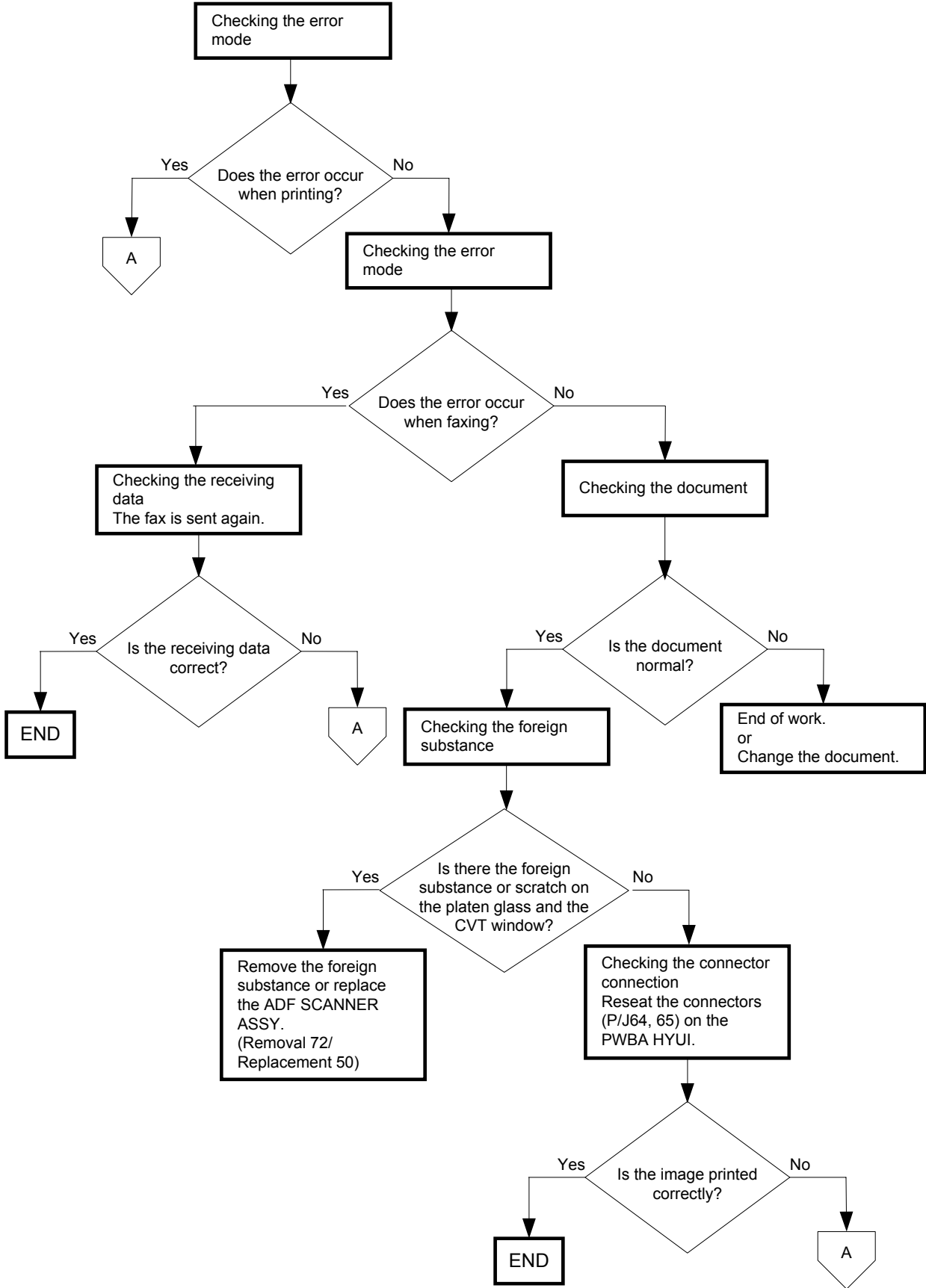

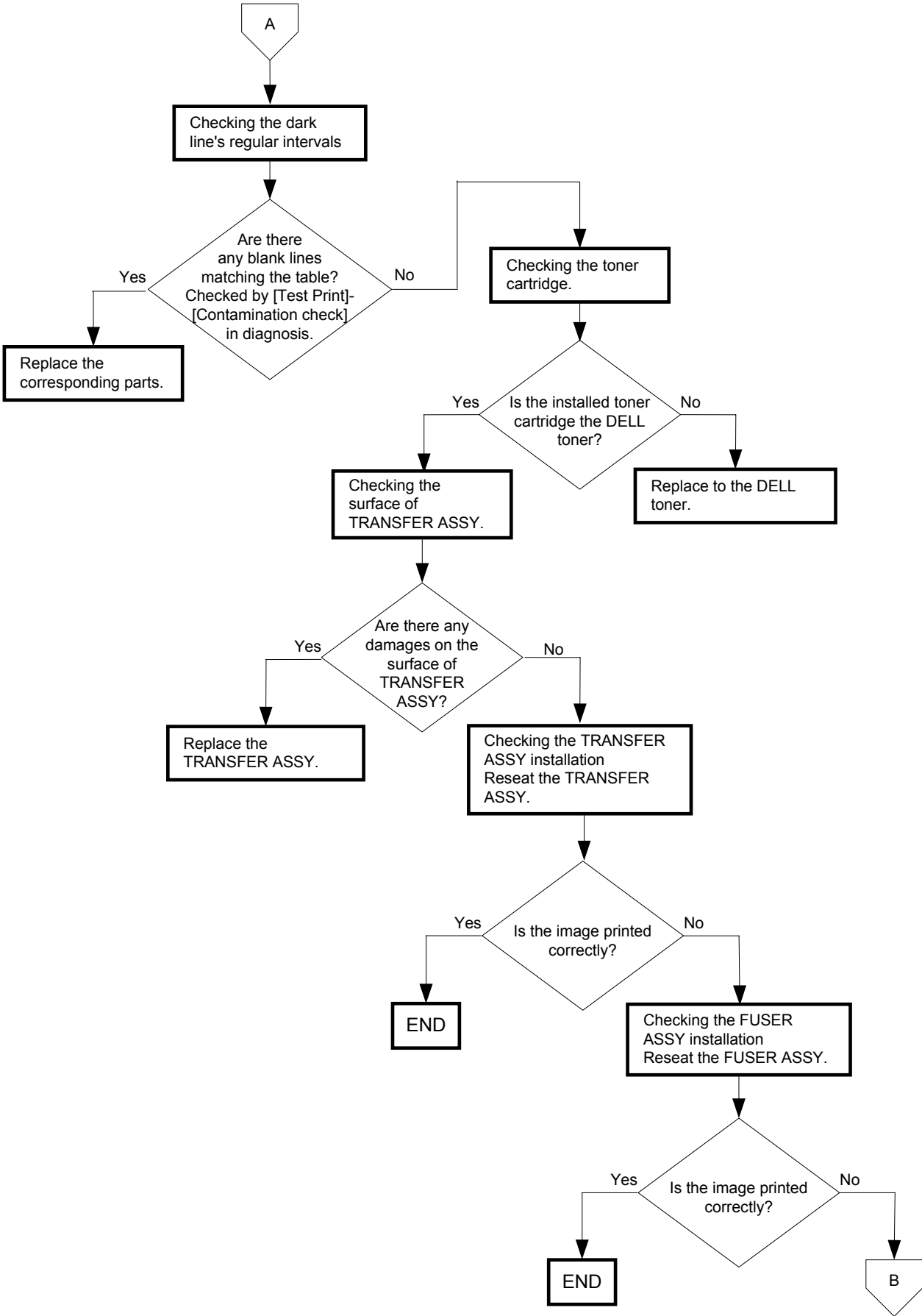

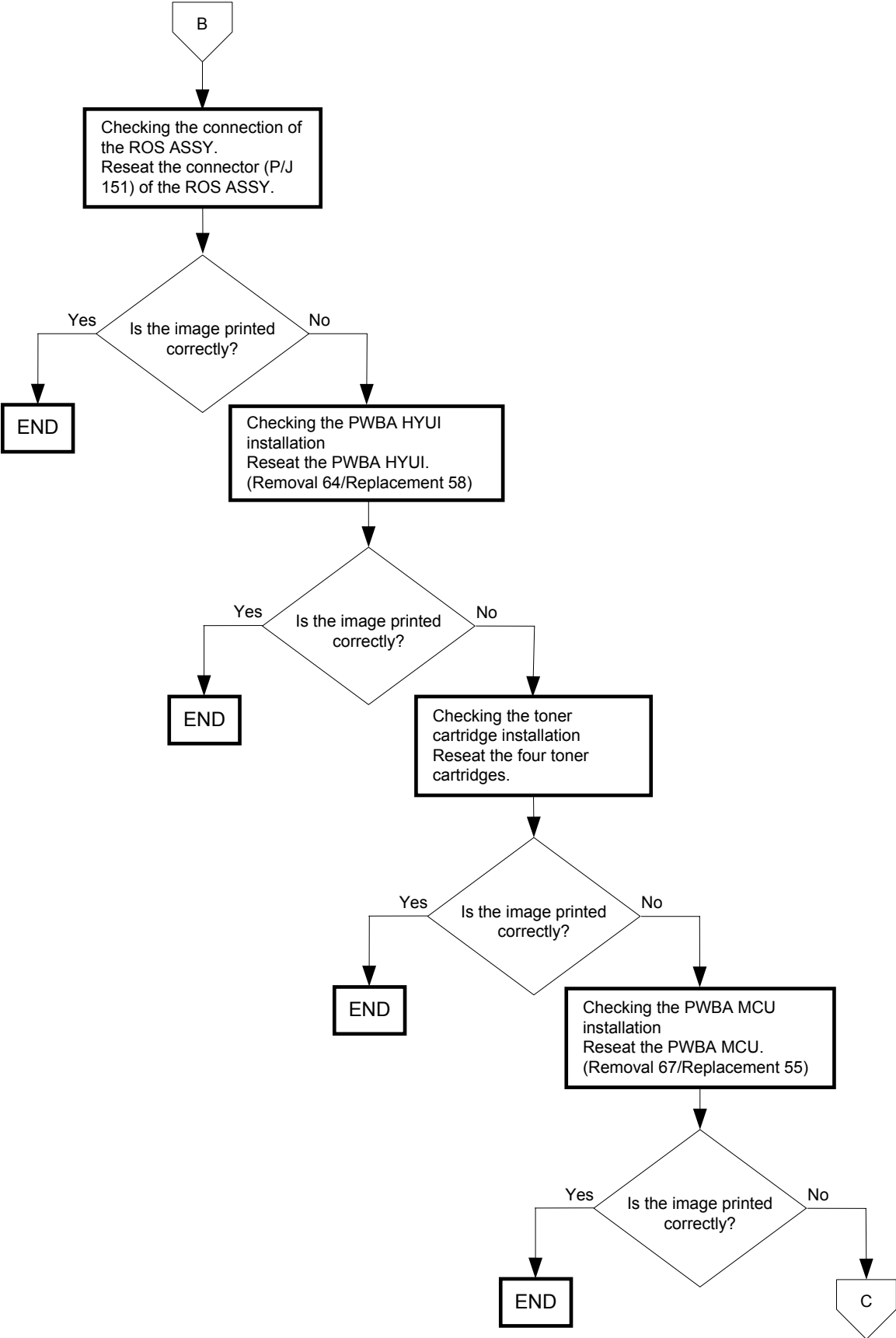

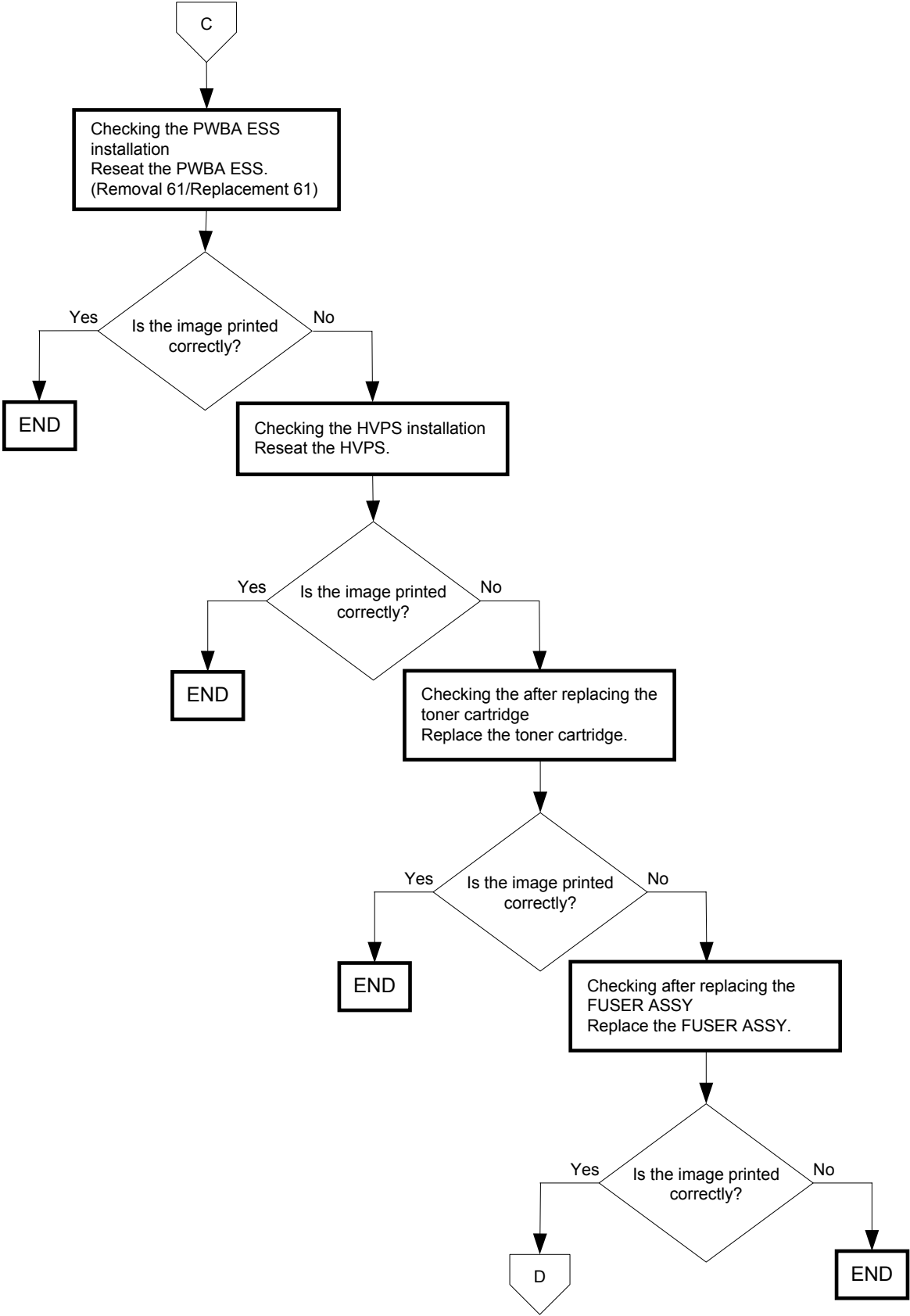

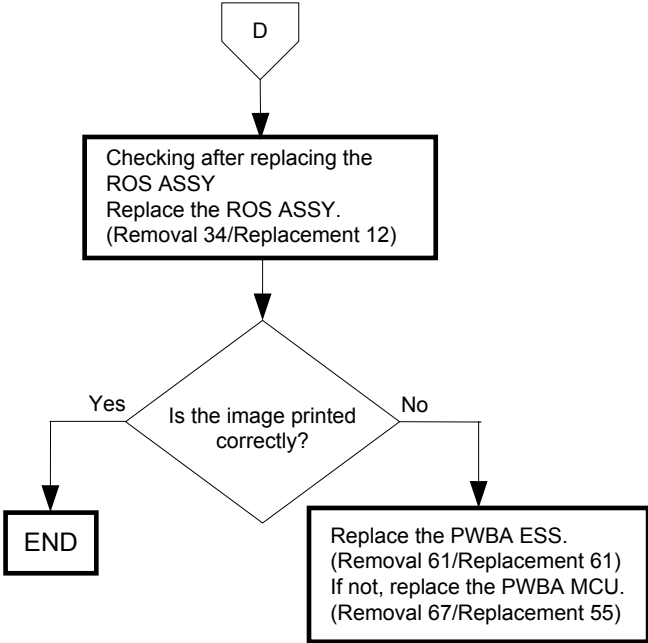

FIP-1.P7 Horizontal stripes

**Trouble substance**

There are horizontal black stripes (perpendicular to the paper path direction) along the paper.

ESS and possible causative parts

- TRANSFER ASSY (PL4.1.1)
- HVPS (PL5.1.17)
- CARTRIDGE ASSY (PL5.1.18(K)/PL5.1.19(C)/PL5.1.20 (M)/PL5.1.21 (Y))
- KIT ROS ASSY (PL13.3.99)
- FUSER ASSY (PL6.1.10)
- PWBA MCU (PL9.1.20)
- PWBA ESS (PL13.4.20)
- PWBA HYUI (PL13.4.1)
- ADF SCANNER ASSY (PL13.8.1)

Before starting troubleshooting, check the paper transfer path. Make sure that there is no foreign materials on the transfer path, such as staples, paper clips, scraps of paper and so on.

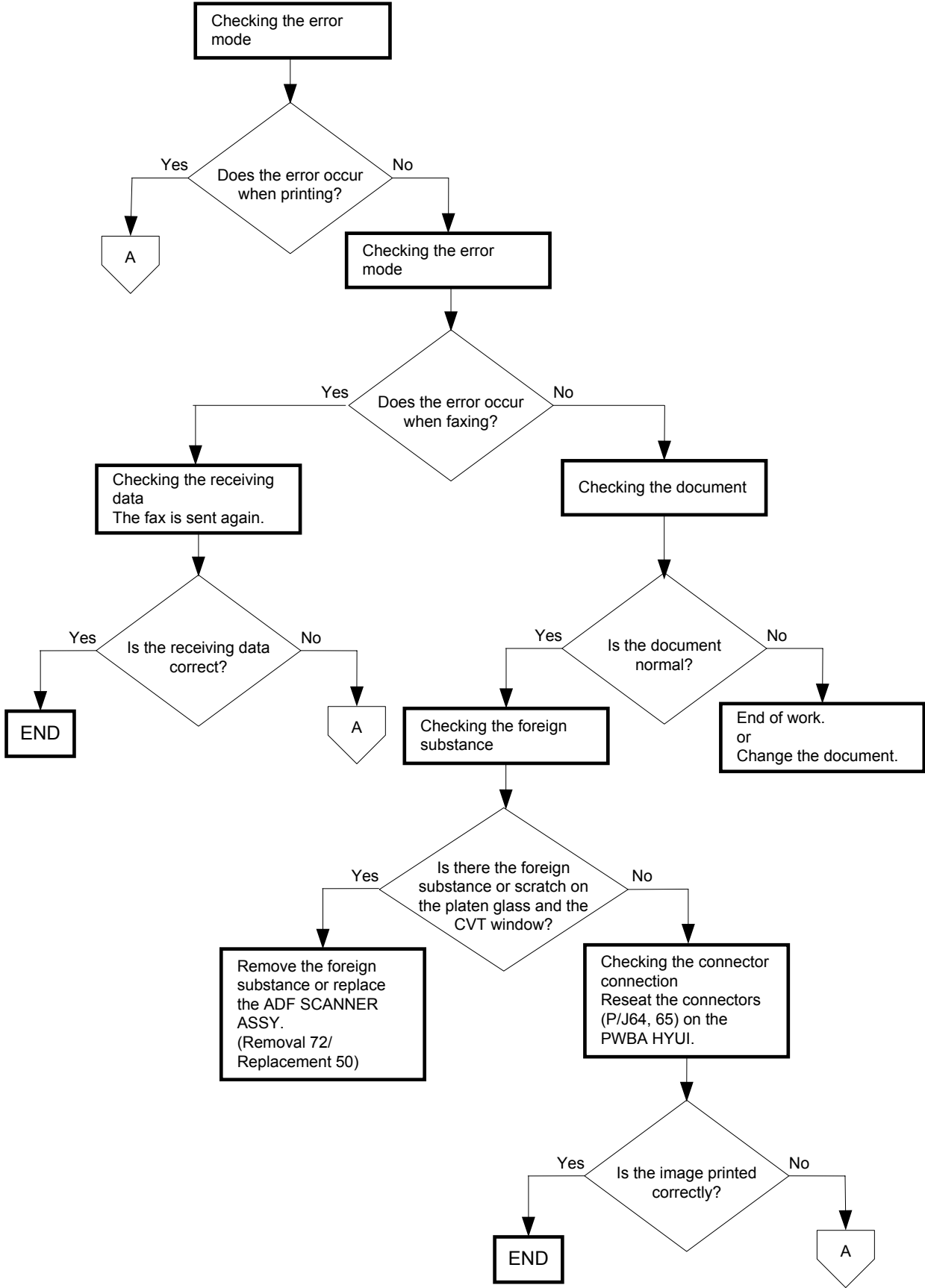

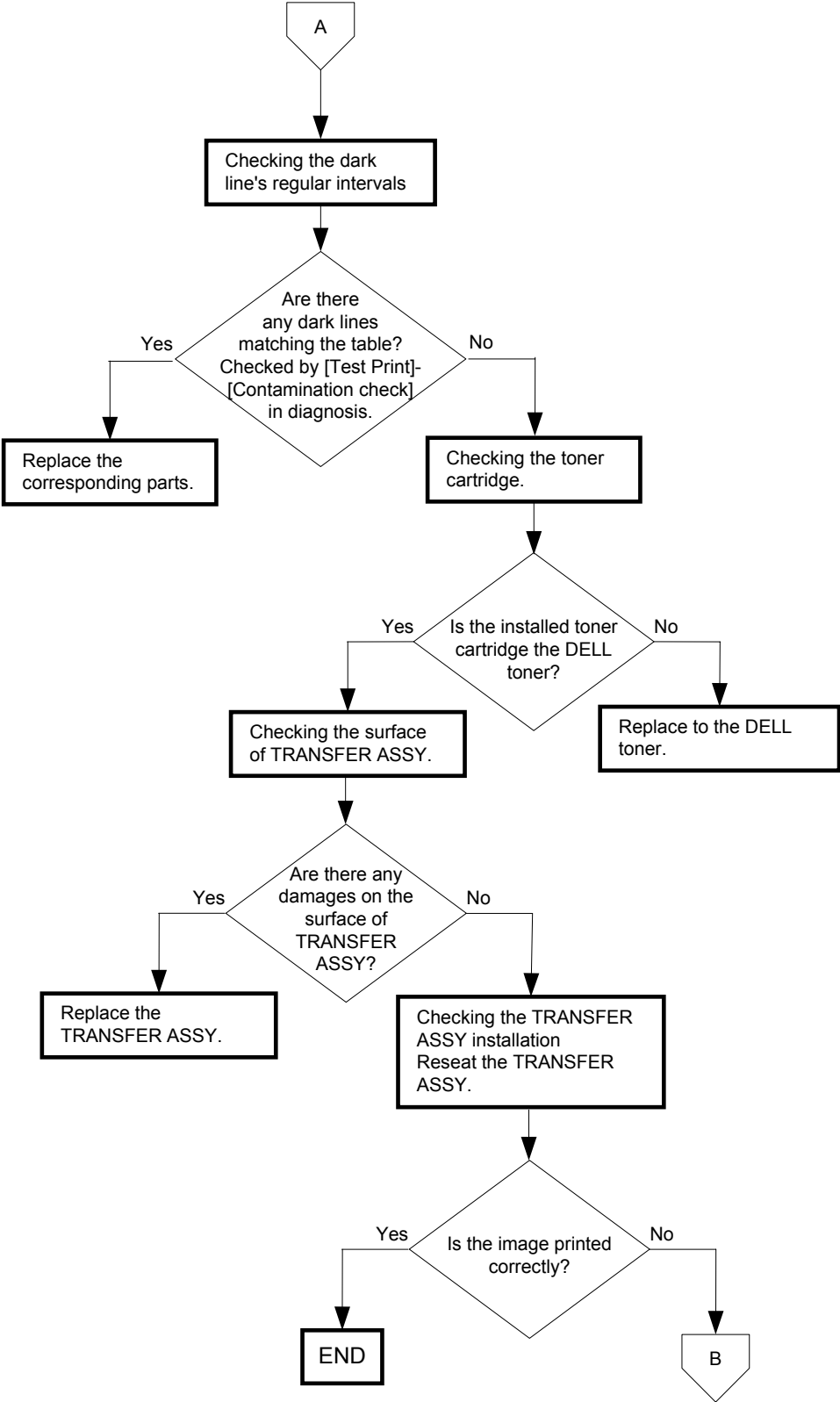

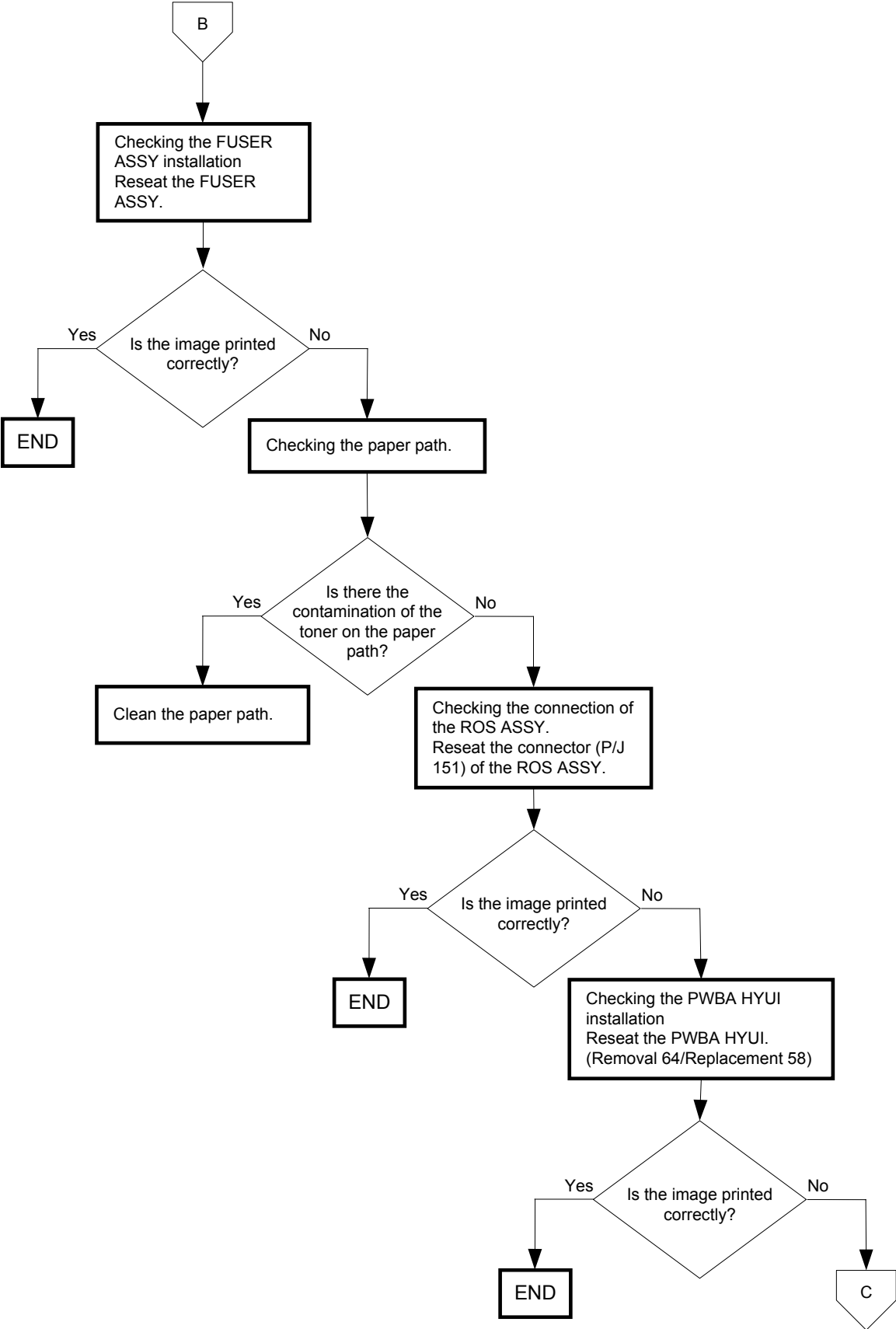

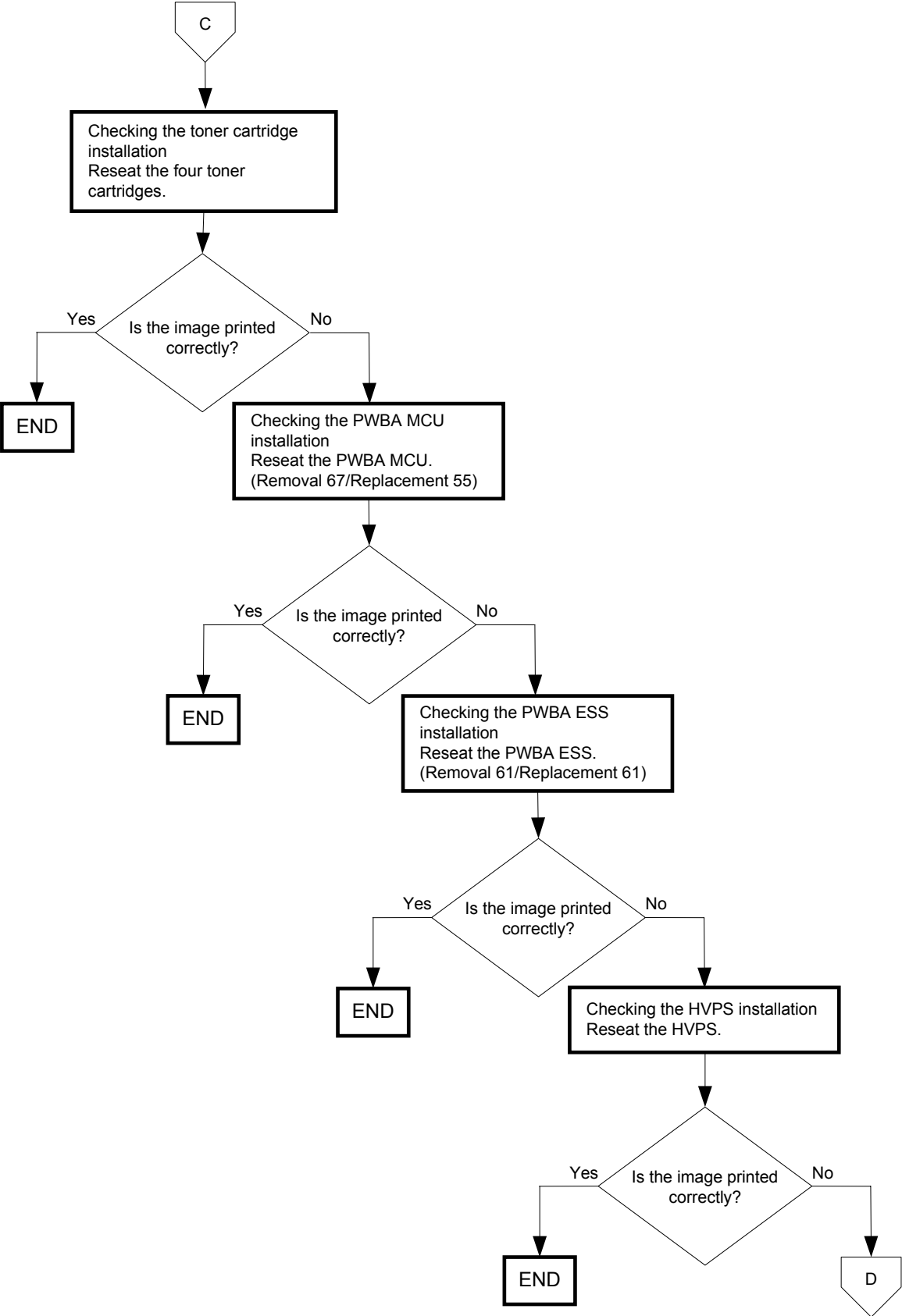

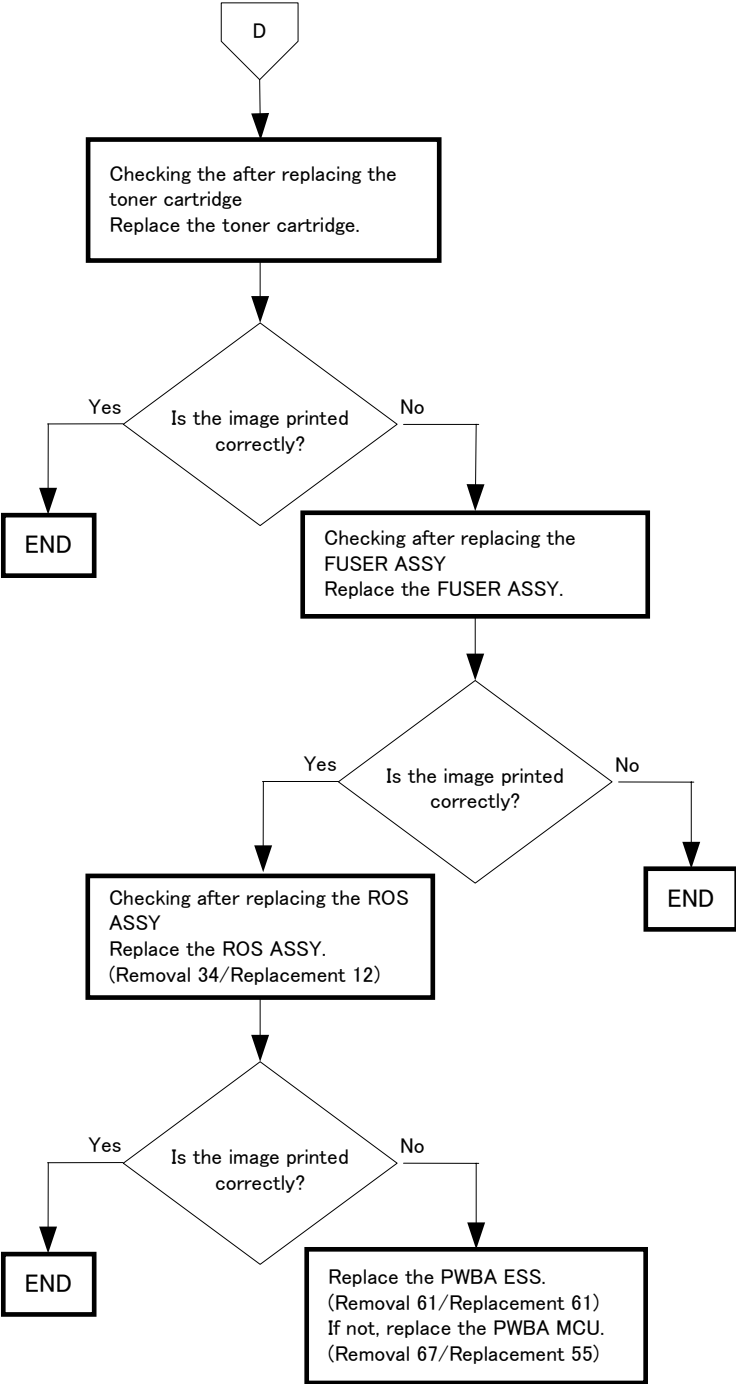

FIP-1.P8 Partial lack

**Trouble substance**

There are some extremely faint or completely missing parts in a limited area on the paper.

ESS and possible causative parts

- TRANSFER ASSY (PL4.1.1)
- HVPS (PL5.1.17)
- CARTRIDGE ASSY (PL5.1.18(K)/PL5.1.19(C)/PL5.1.20 (M)/PL5.1.21 (Y))
- KIT ROS ASSY (PL13.3.99)
- PWBA MCU (PL9.1.20)
- PWBA ESS (PL13.4.20)
- PWBA HYUI (PL13.4.1)
- ADF SCANNER ASSY (PL13.8.1)

Before starting troubleshooting, check the paper transfer path. Make sure that there is no foreign materials on the transfer path, such as staples, paper clips, scraps of paper and so on.

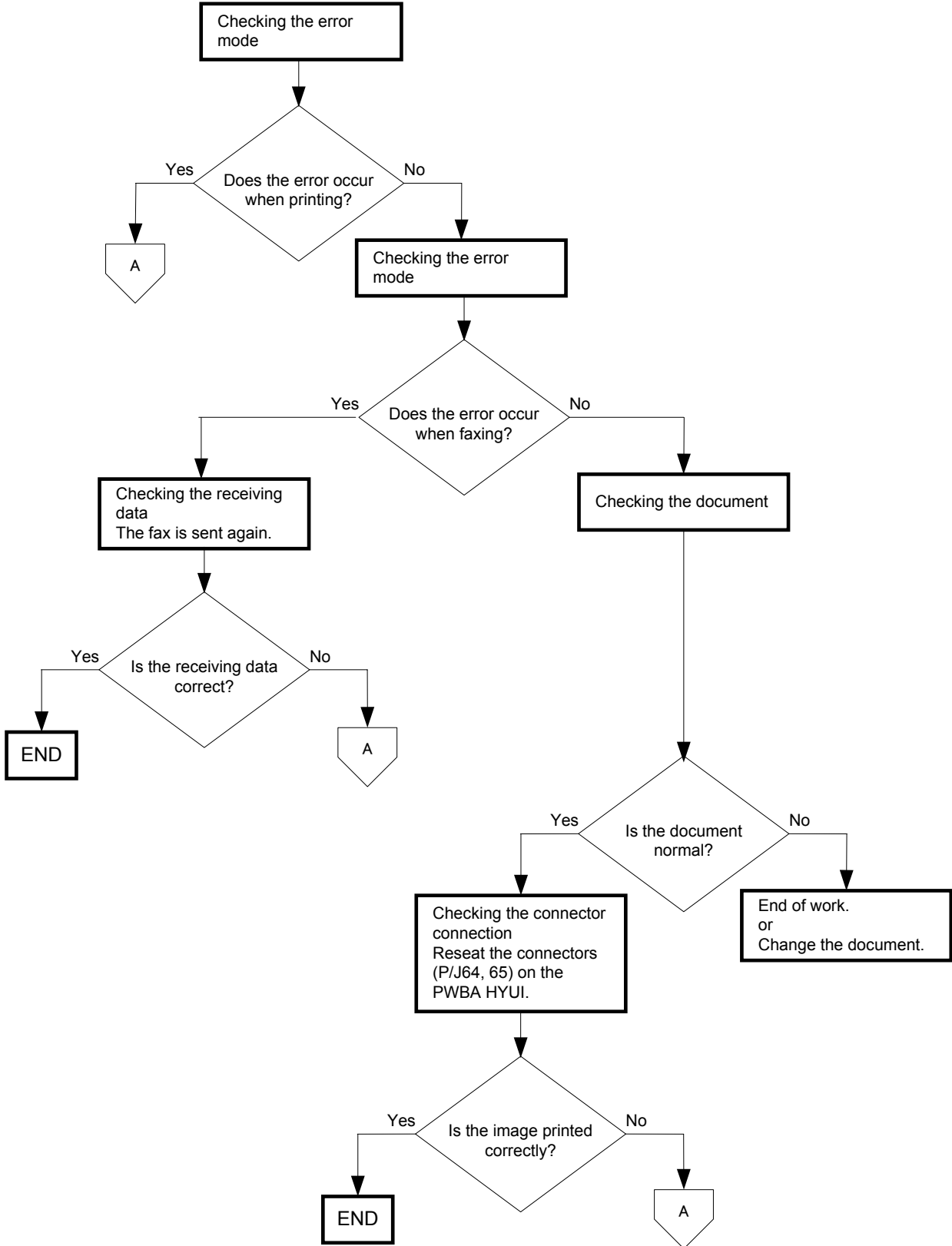

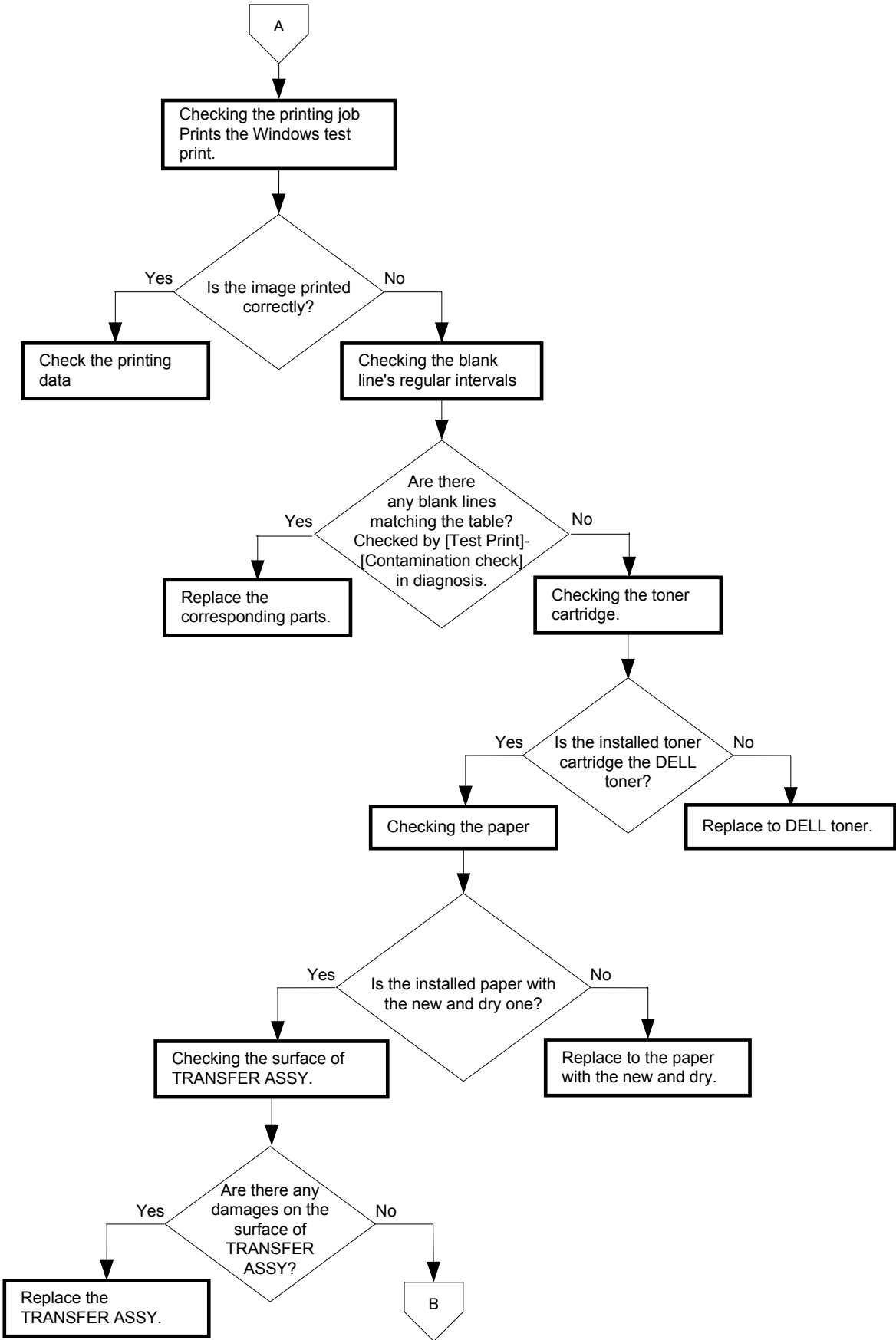

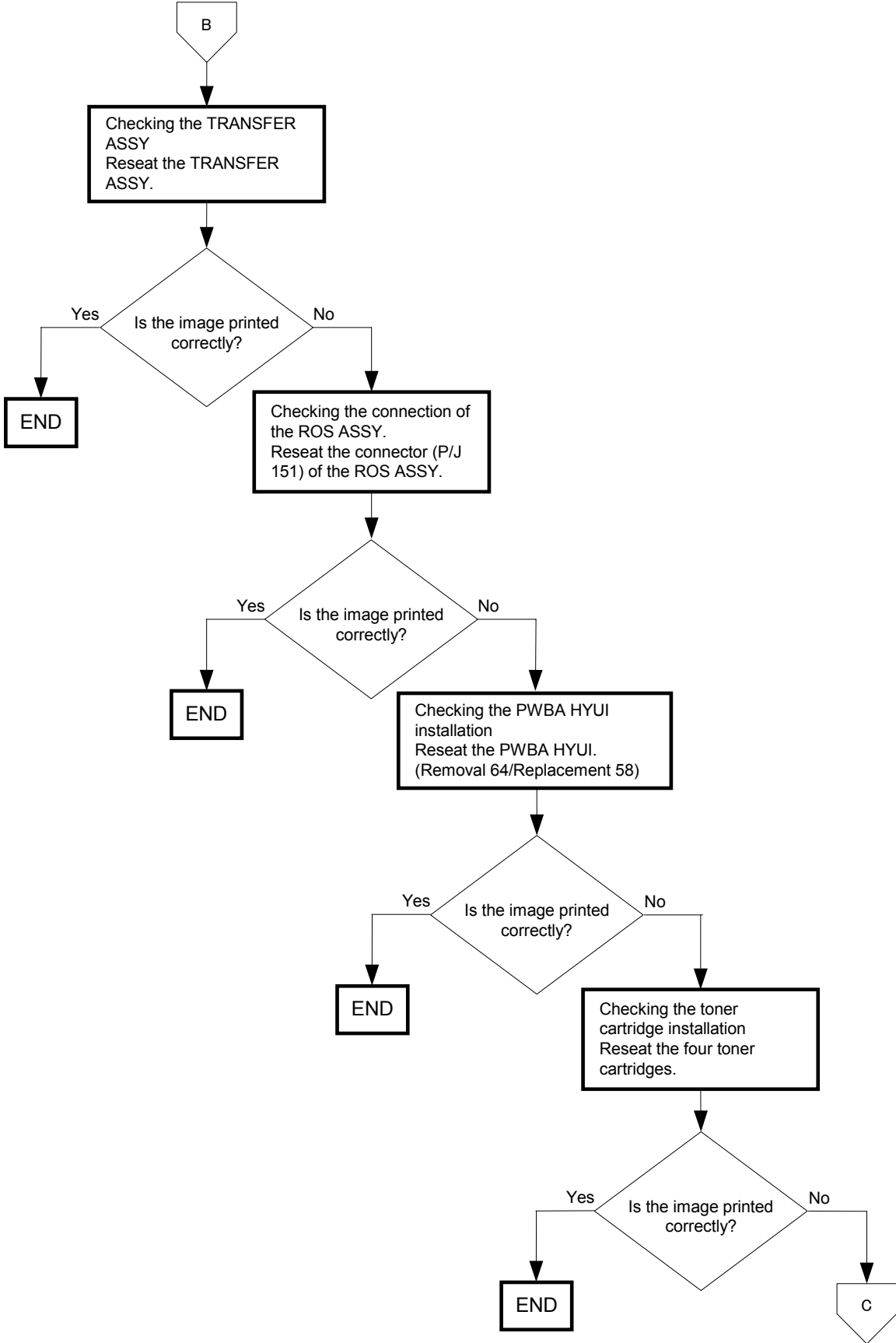

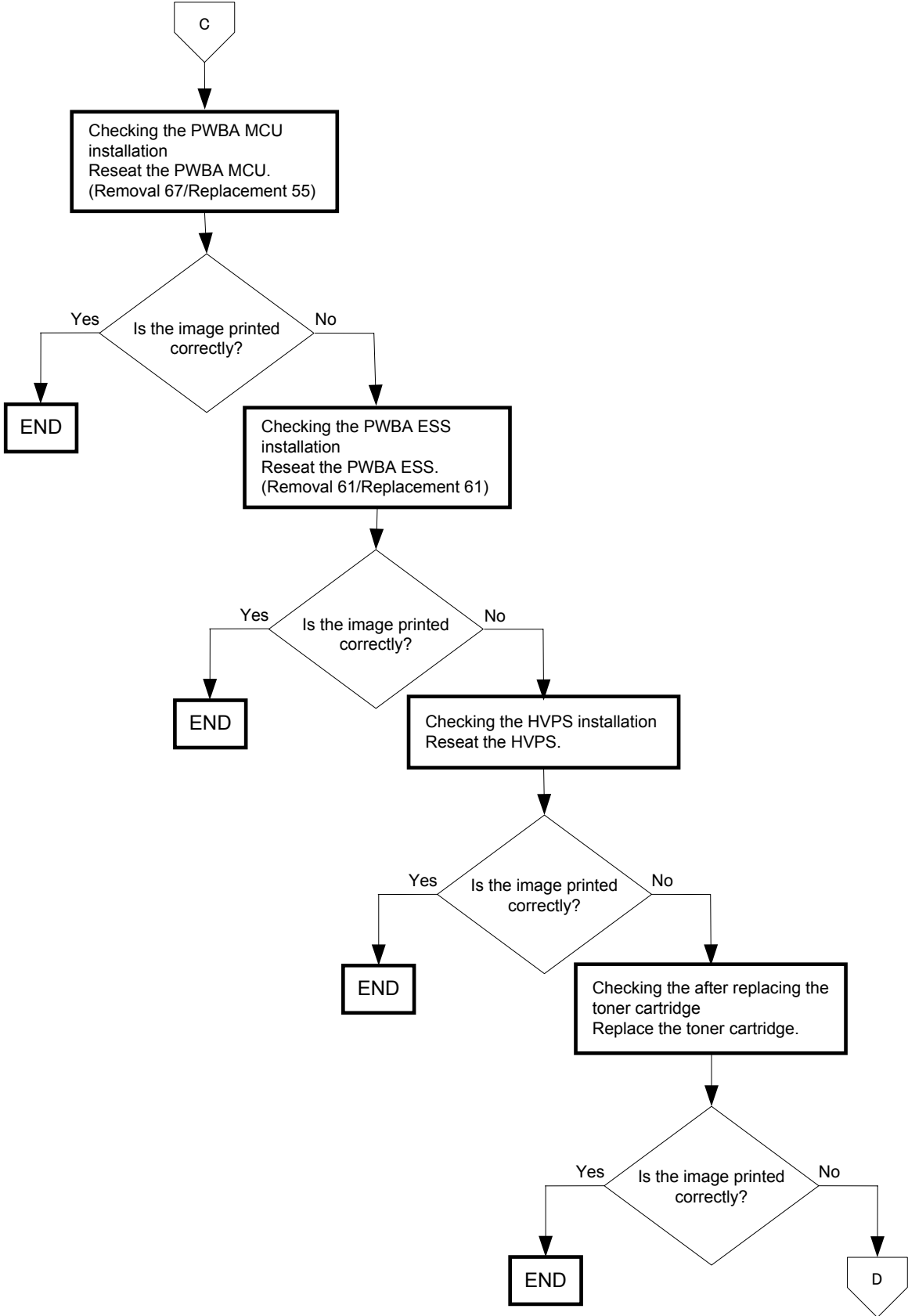

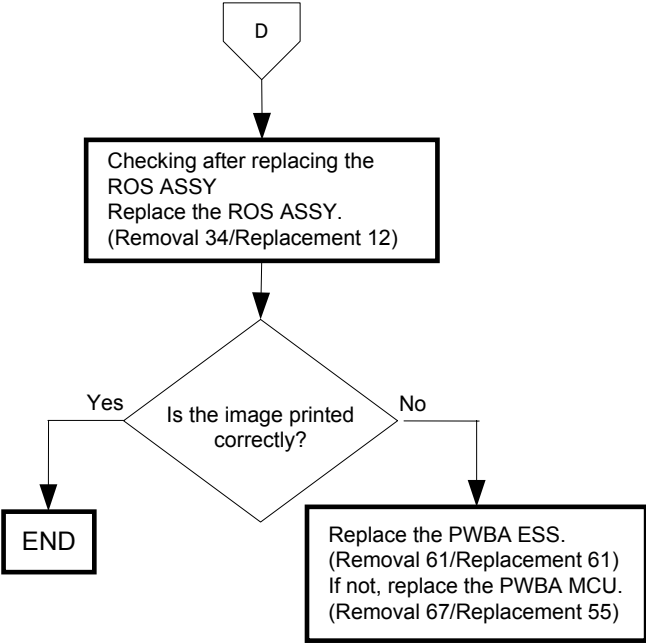

FIP-1.P9 Spots

**Trouble substance**

There are toner spots all over the paper disorderedly.

ESS and possible causative parts

- TRANSFER ASSY (PL4.1.1)
- HVPS (PL5.1.17)
- CARTRIDGE ASSY (PL5.1.18(K)/PL5.1.19(C)/PL5.1.20 (M)/PL5.1.21 (Y))
- KIT ROS ASSY (PL13.3.99)
- FUSER ASSY (PL61.1.10)
- PWBA MCU (PL9.1.20)
- PWBA ESS (PL13.4.20)

- PWBA HYUI (PL13.4.1)
- ADF SCANNER ASSY (PL13.8.1)

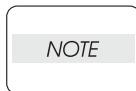

If the toner spot at the top or back of the paper, replace the IBT ASSY only.

Before starting troubleshooting, check the paper transfer path. Make sure that there is no foreign materials on the transfer path, such as staples, paper clips, scraps of paper and so on.

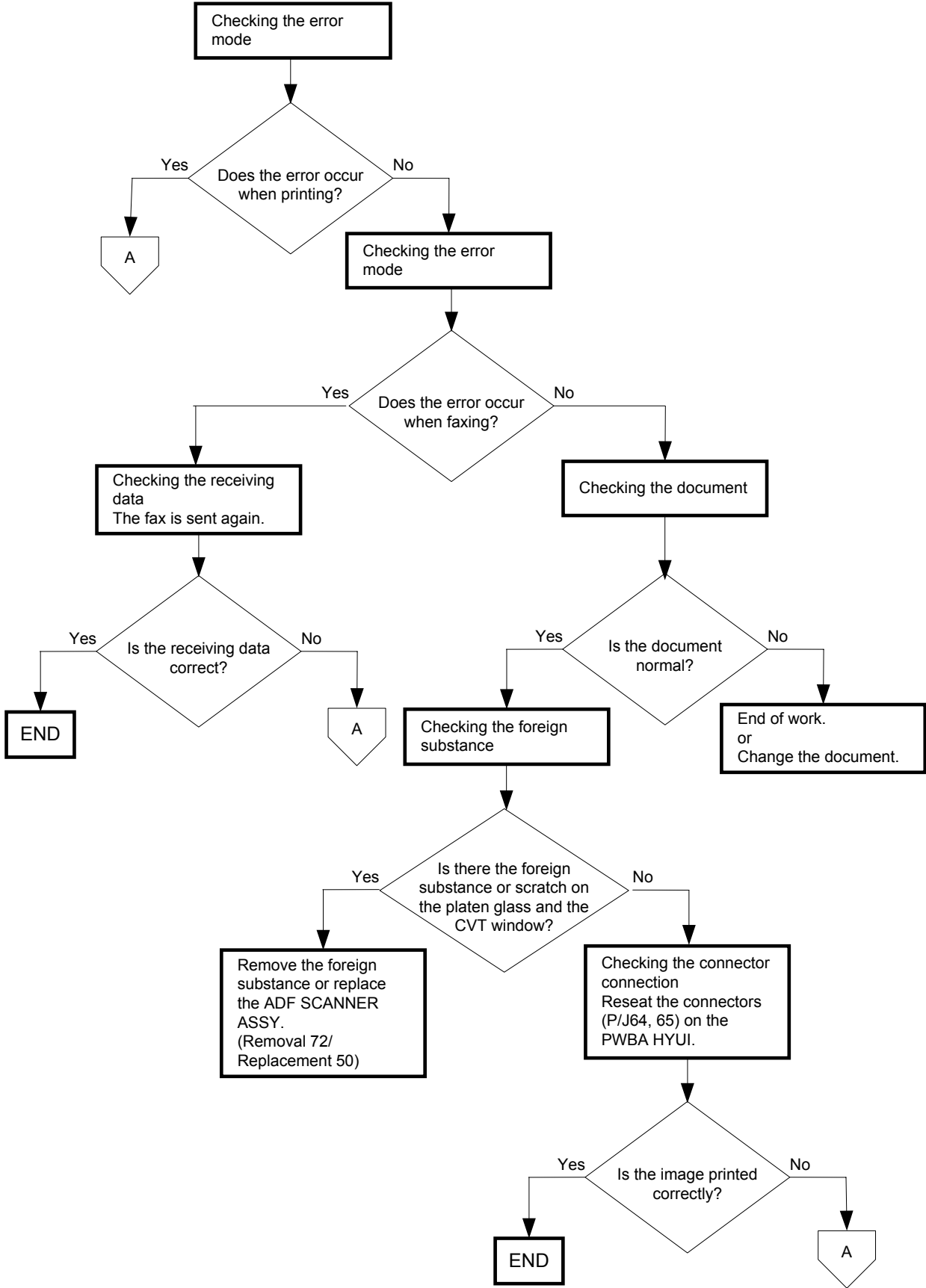

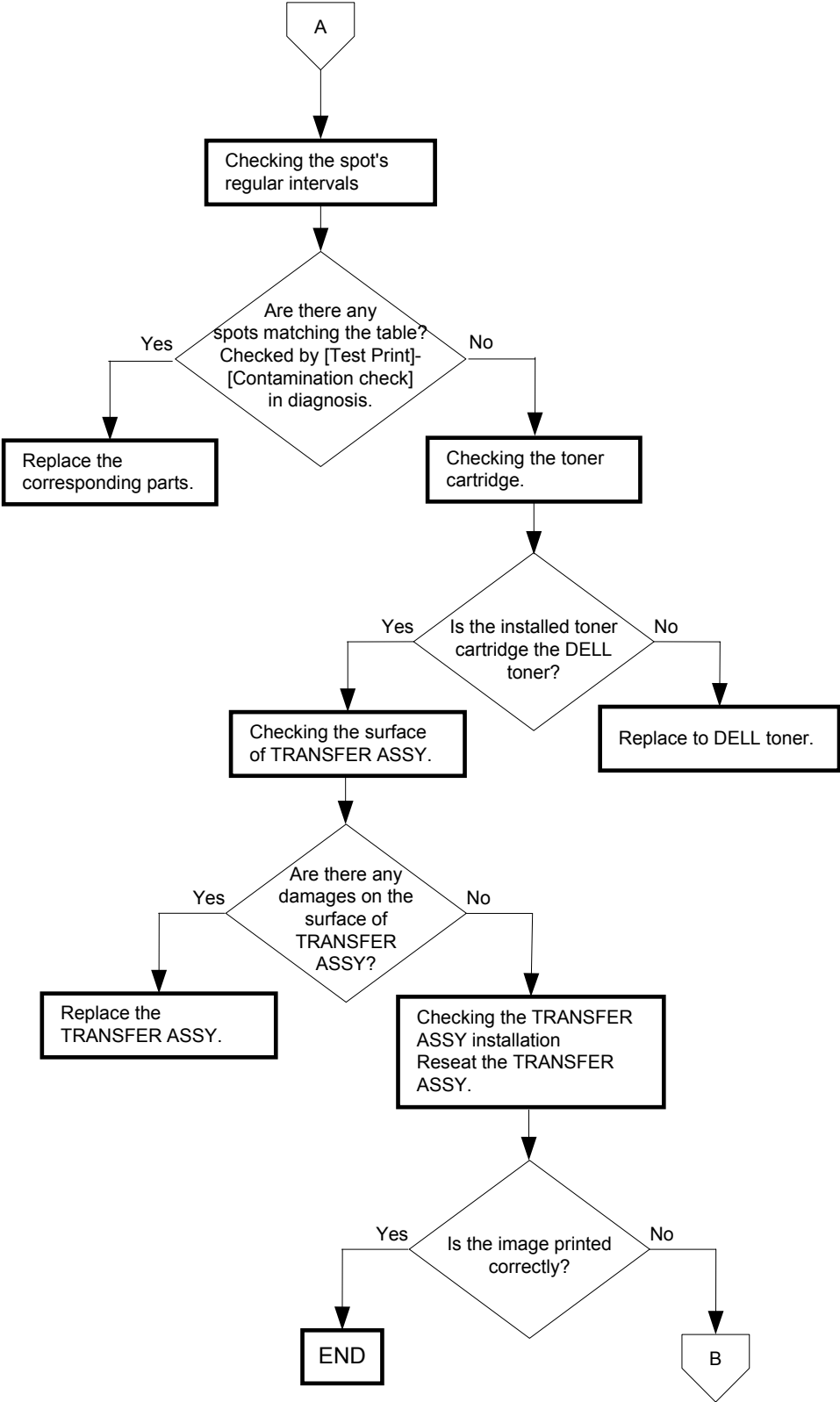

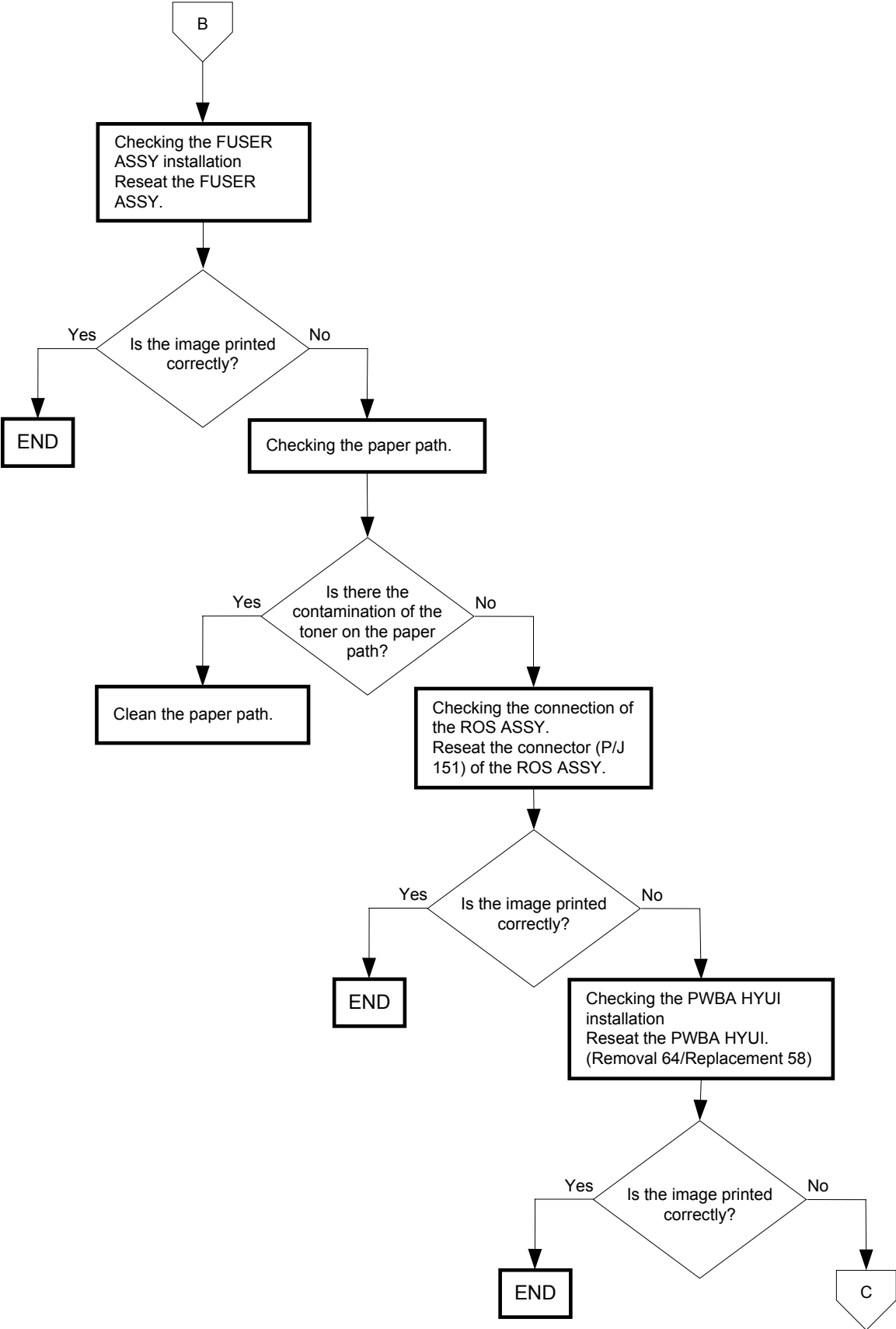

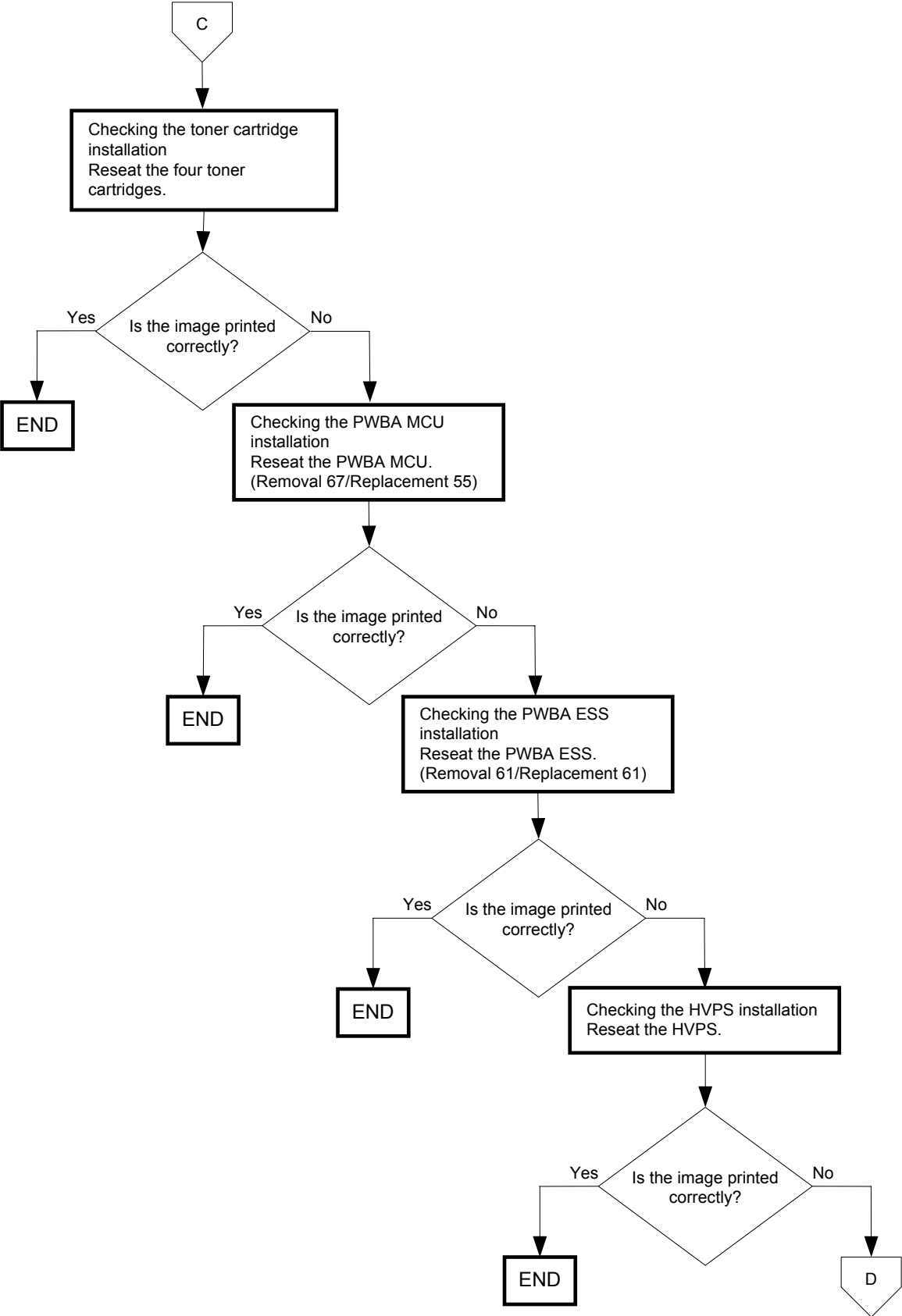

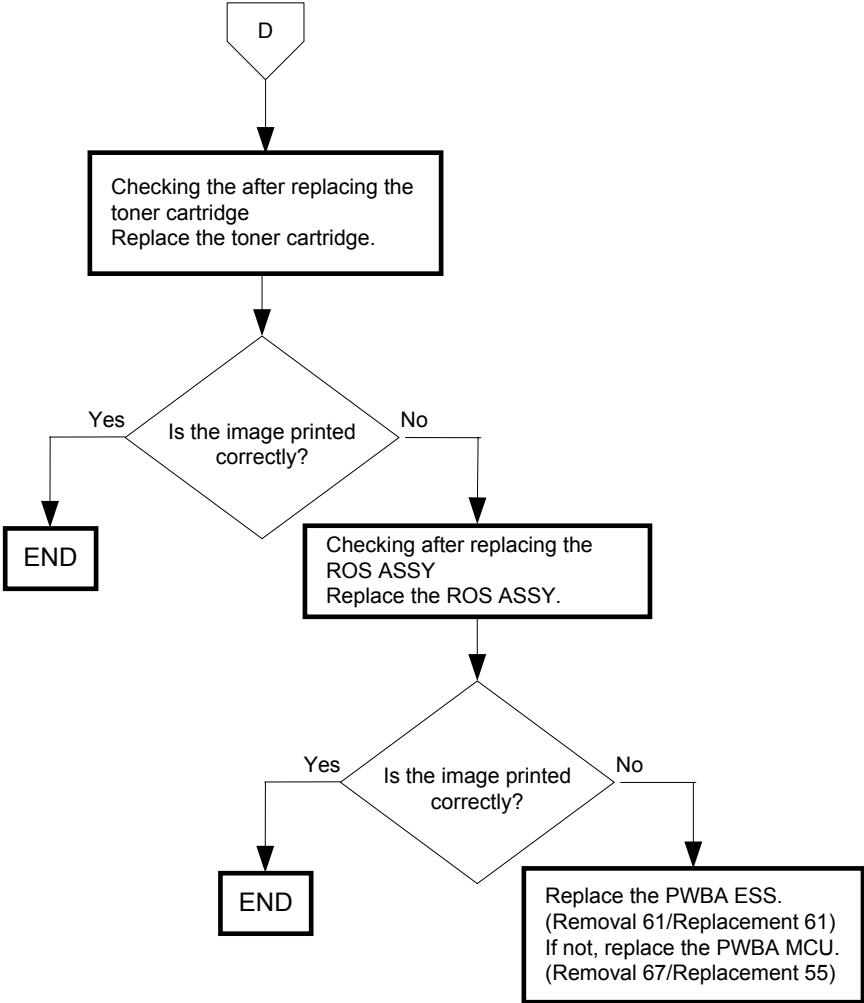

FIP-1.P10 Afterimage

**Trouble substance**

The ghost appears on the paper. The ghost may be the image of the previous page, or a part of the page currently printing.

ESS and possible causative parts

- TRANSFER ASSY (PL4.1.1)
- HVPS (PL5.1.17)
- CARTRIDGE ASSY (PL5.1.18(K)/PL5.1.19(C)/PL5.1.20 (M)/PL5.1.21 (Y))
- KIT ROS ASSY (PL13.3.99)
- FUSER ASSY (PL6.1.10)
- PWBA MCU (PL9.1.20)
- PWBA ESS (PL13.4.20)

Before starting troubleshooting, check the paper transfer path. Make sure that there is no foreign materials on the transfer path, such as staples, paper clips, scraps of paper and so on.

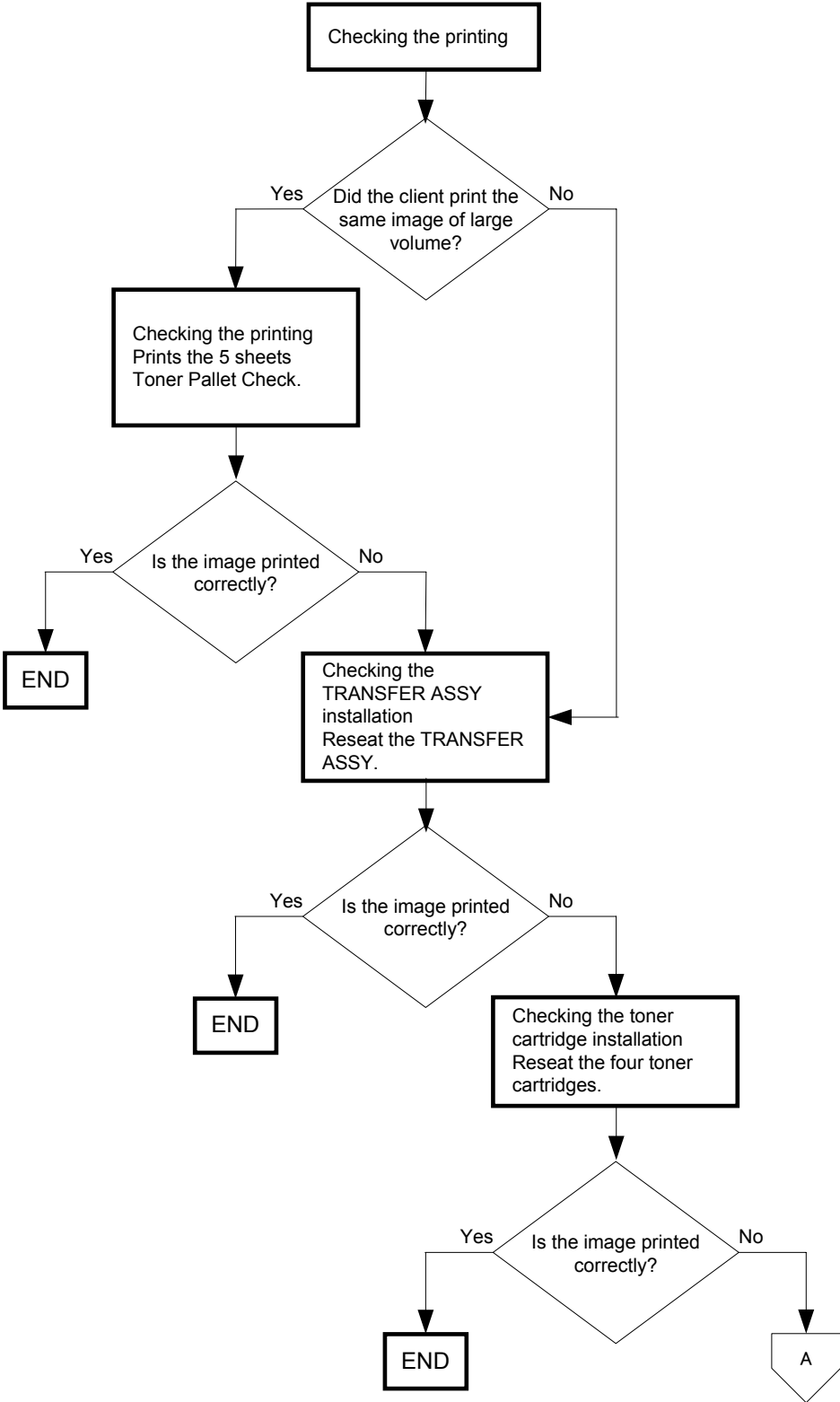

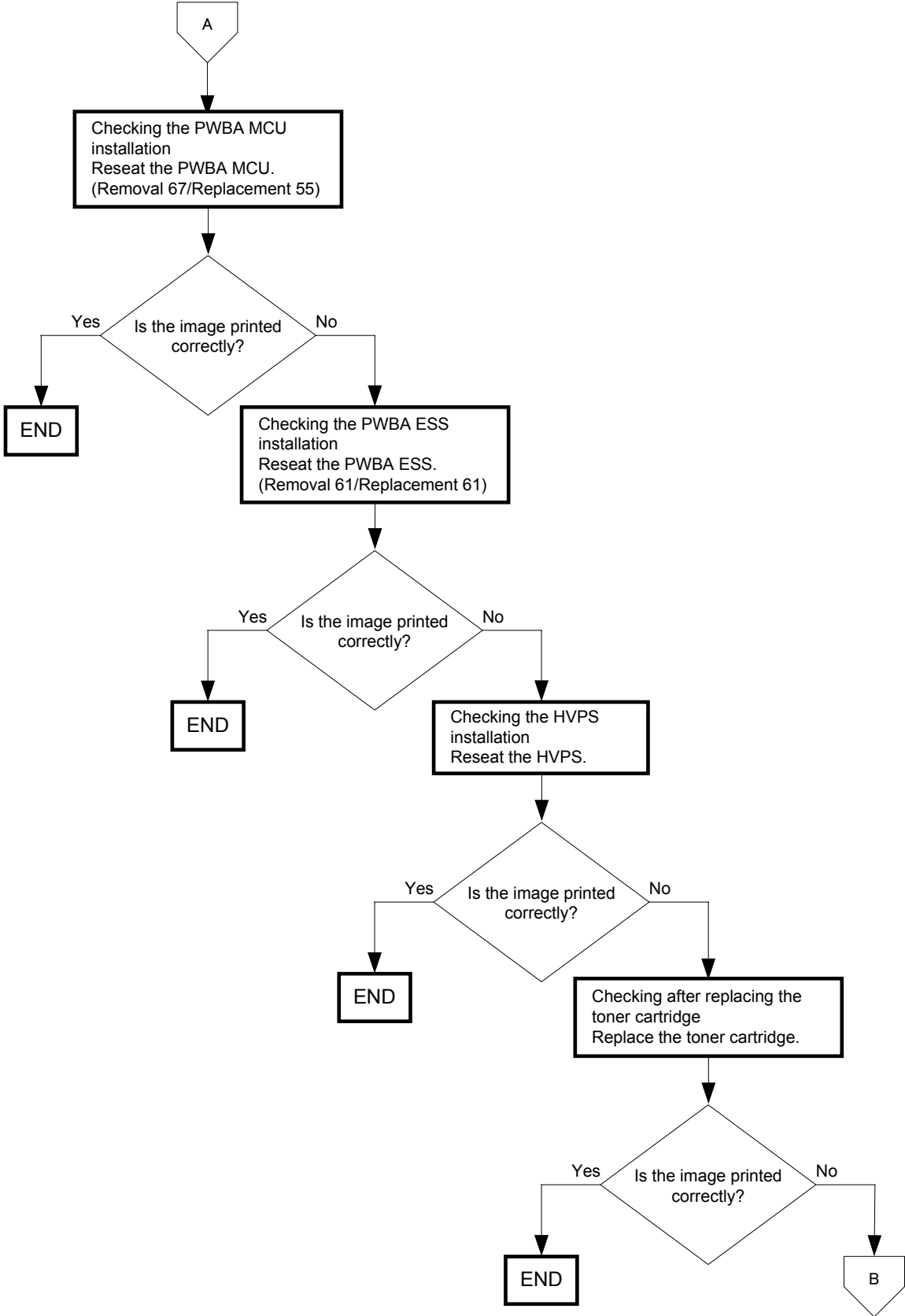

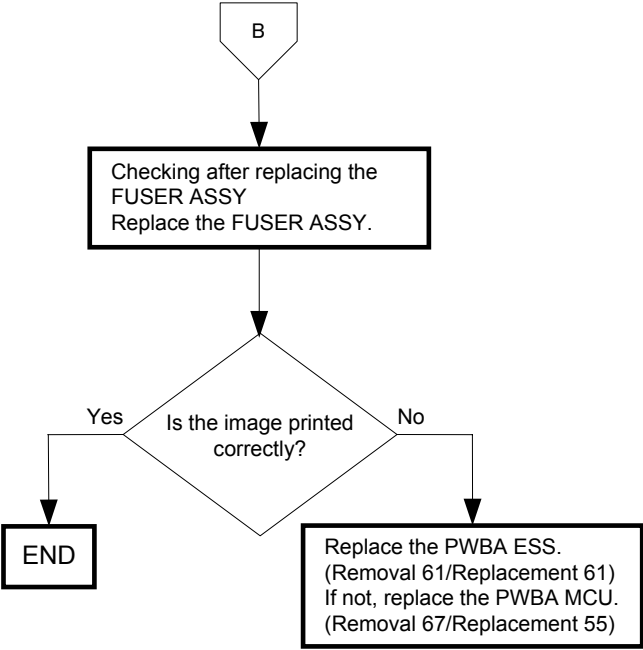

FIP-1.P11 Background (Fog)

**Trouble substance**

There is toner stain all over or a part of the page. The stain appears as very bright gray mono color or colors stain.

Possible causative parts

- TRANSFER ASSY (PL4.1.1)
- CARTRIDGE ASSY (PL5.1.18(K)/PL5.1.19(C)/PL5.1.20 (M)/PL5.1.21 (Y))

Before starting troubleshooting, check the paper transfer path. Make sure that there is no foreign materials on the transfer path, such as staples, paper clips, scraps of paper and so on.

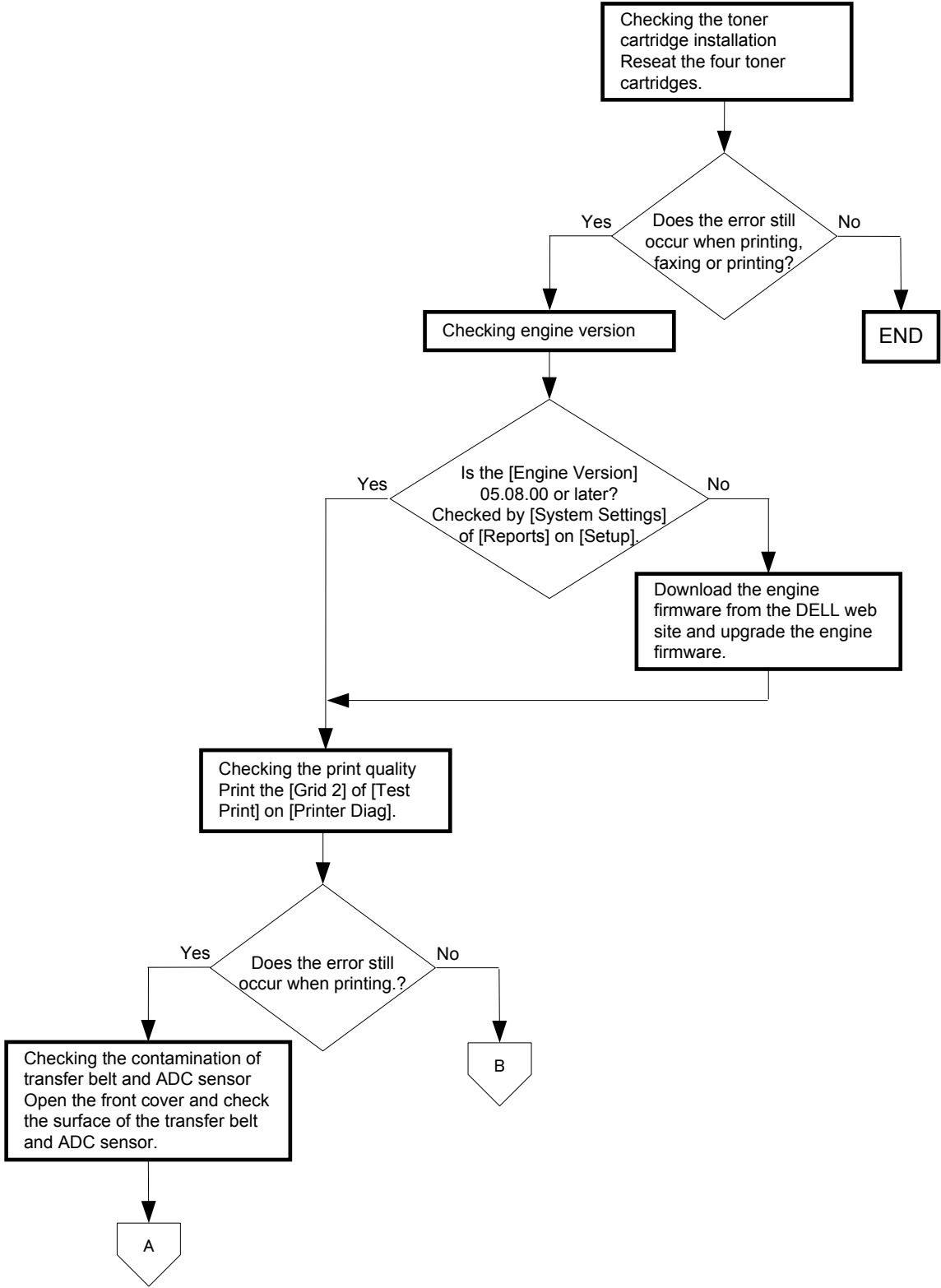

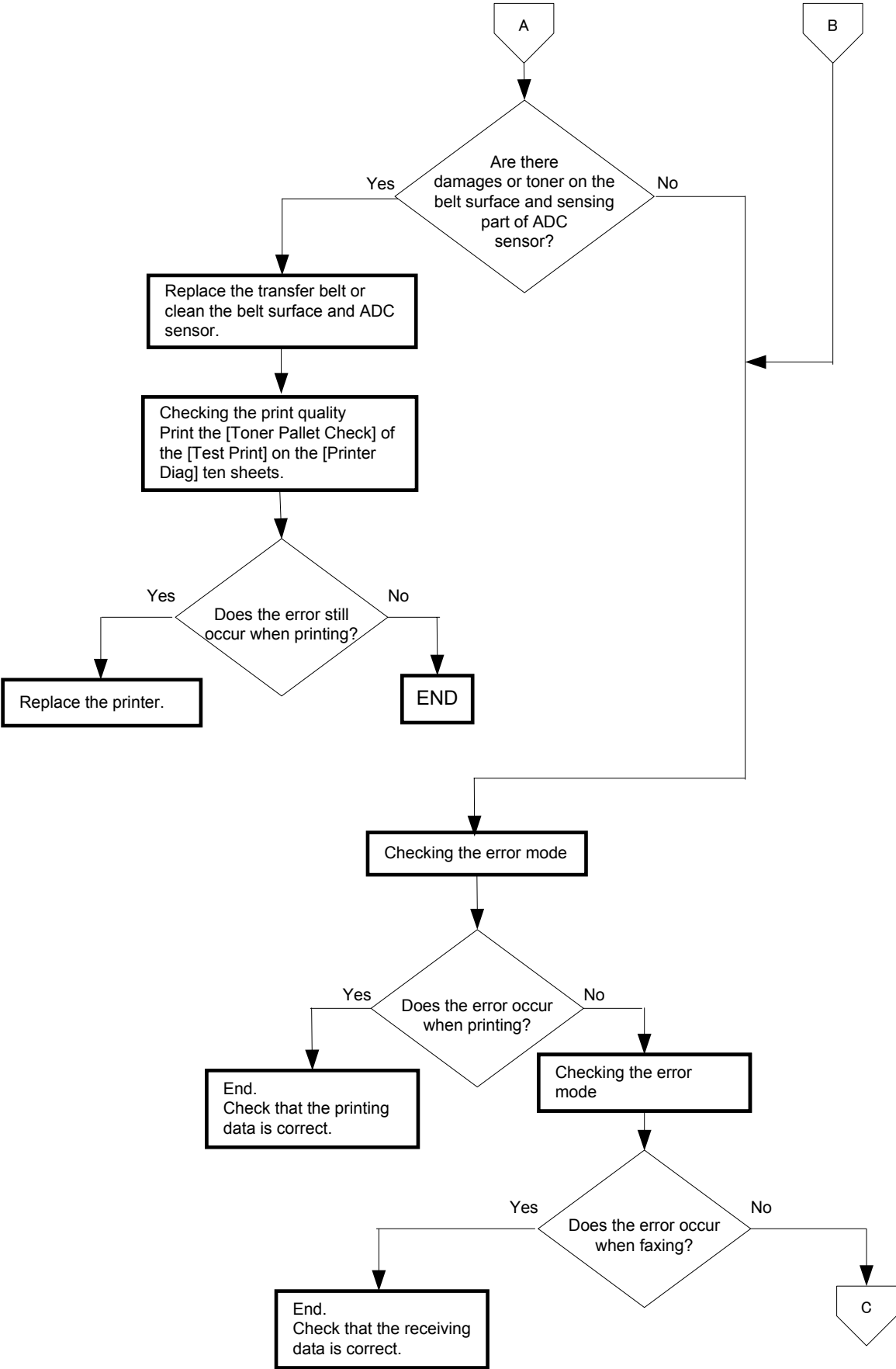

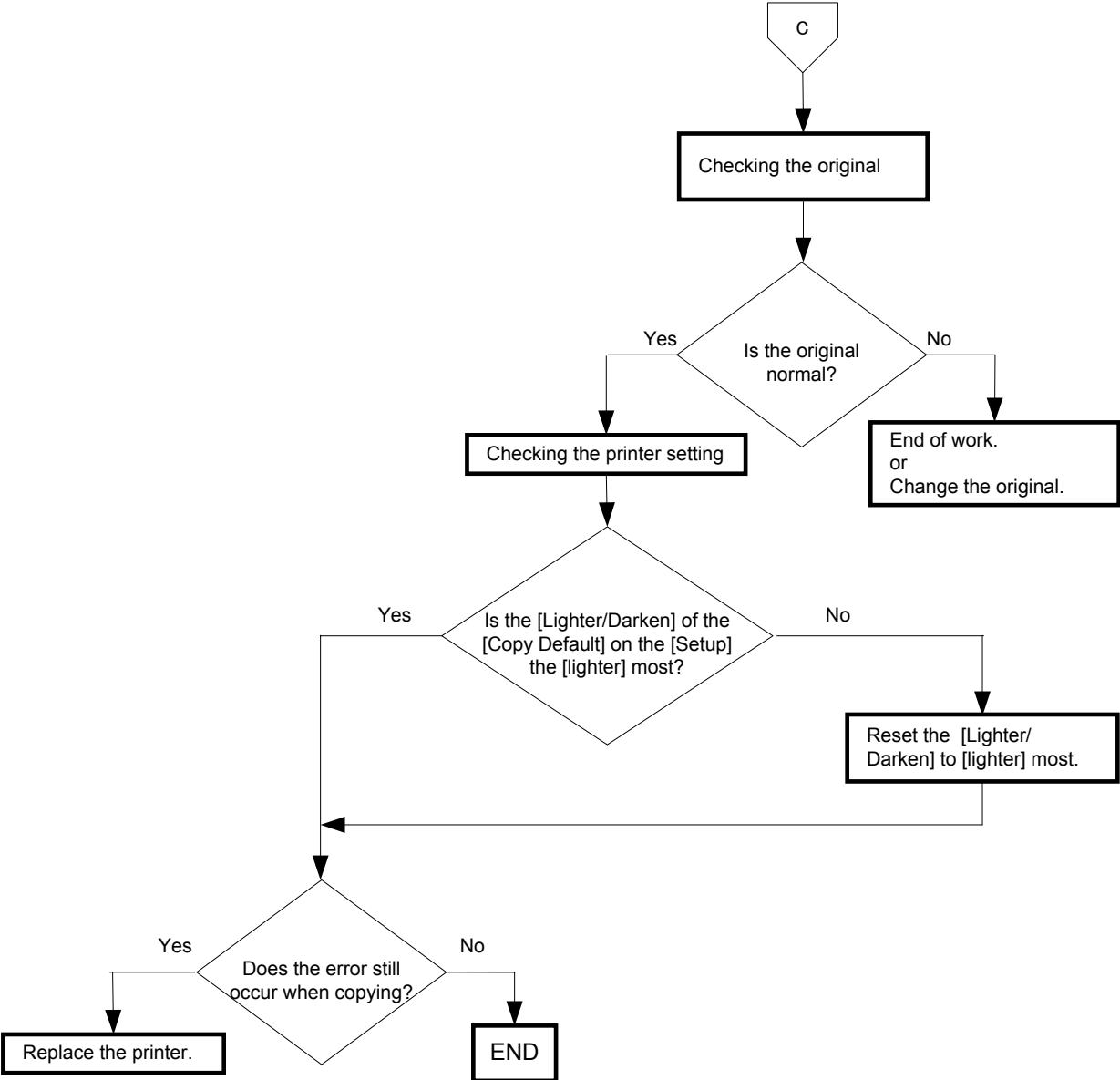

FIP-1.P12 Skew

**Trouble substance**

The printed image is not paralleled with both sides of the paper.

ESS and possible causative parts

- SEPARATOR ROLLER ASSY (PL2.1.3)
- KIT SEPARATOR and FEED ROLLER (PL2.2.99)
- ROLL ASSY FEED MSI (PL3.1.10)
- TRANSFER ASSY (PL4.1.1)
- CHUTE ASSY DUP (PL11.1.1)
- KIT SEPARATOR and FEED ROLLER (PL12.3.99)
- PWBA HYUI (PL13.4.1)
- ADF SCANNER ASSY (PL13.8.1)
- KIT ADF FEED ROLLER (PL13.8.99)

Before starting troubleshooting, check the paper transfer path. Make sure that there is no foreign materials on the transfer path, such as staples, paper clips, scraps of paper and so on.

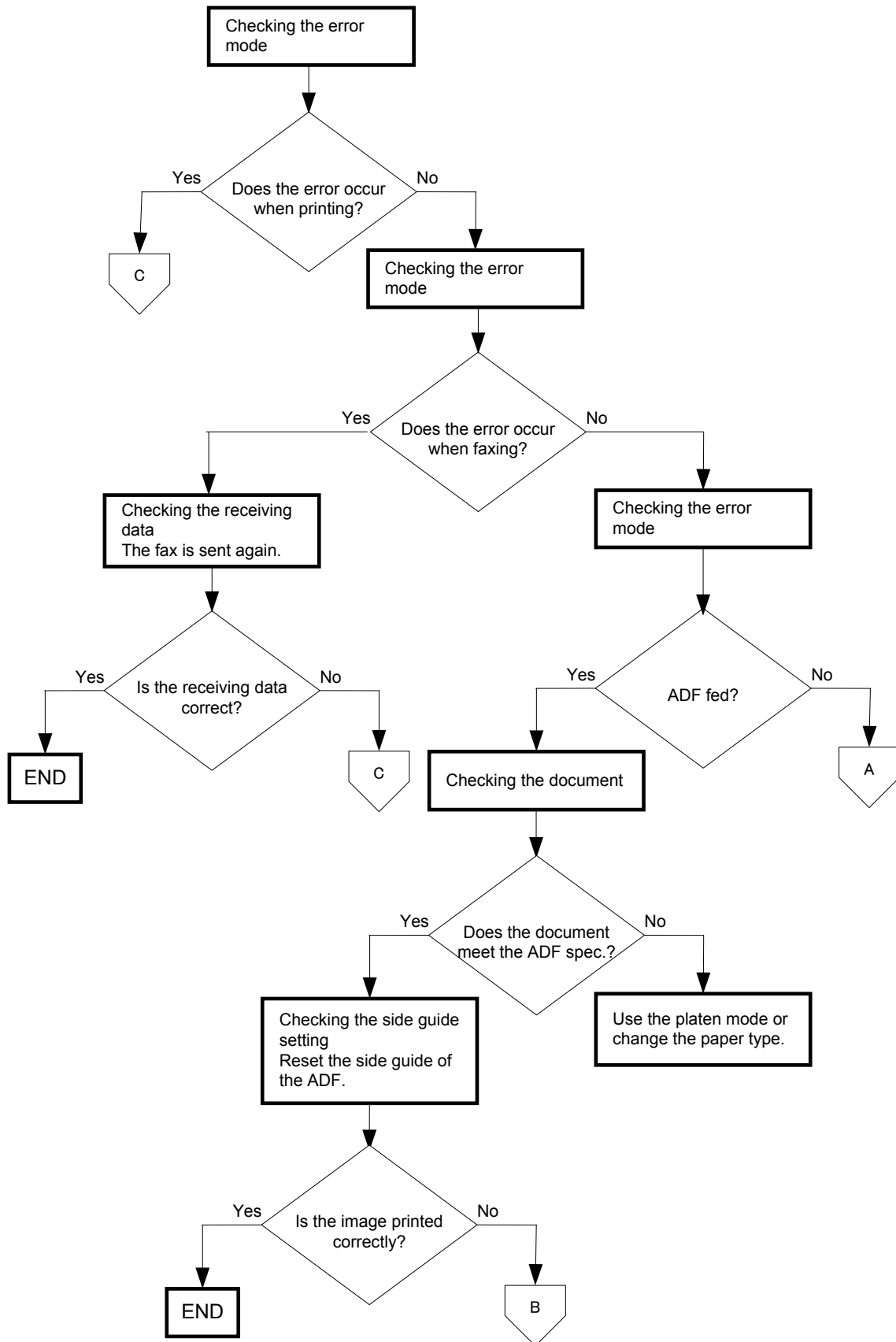

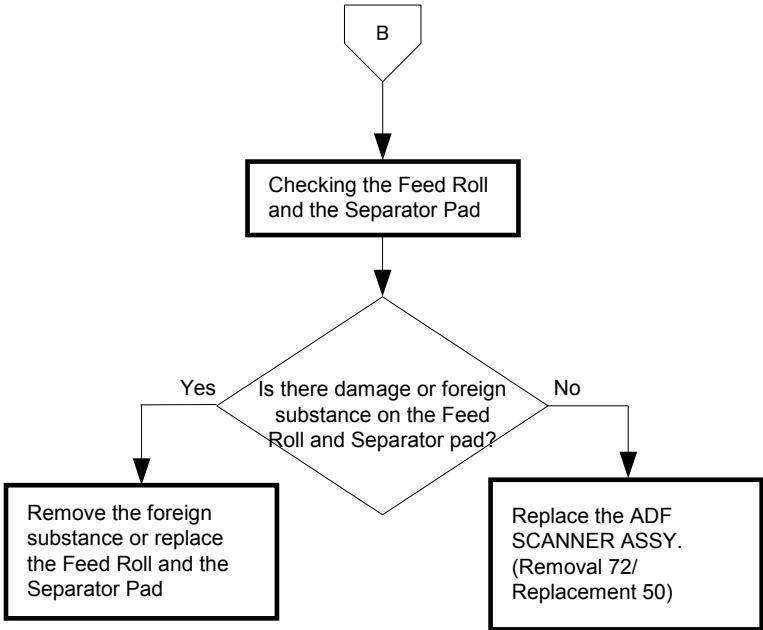
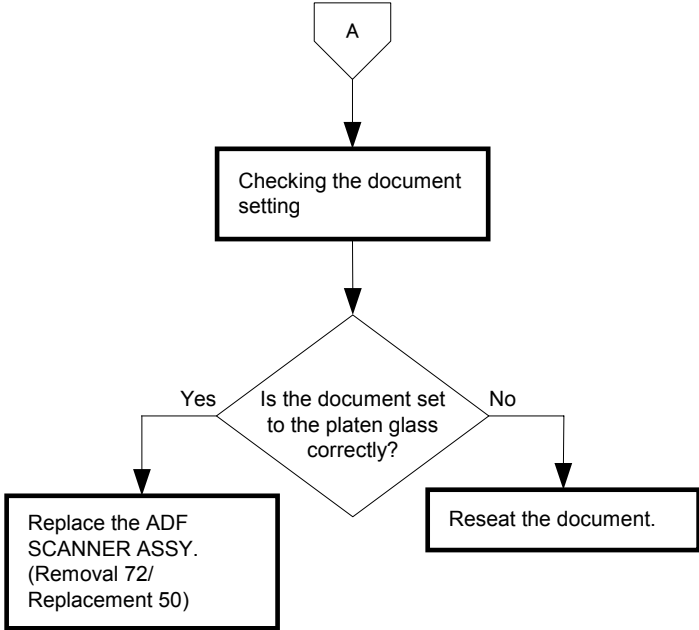

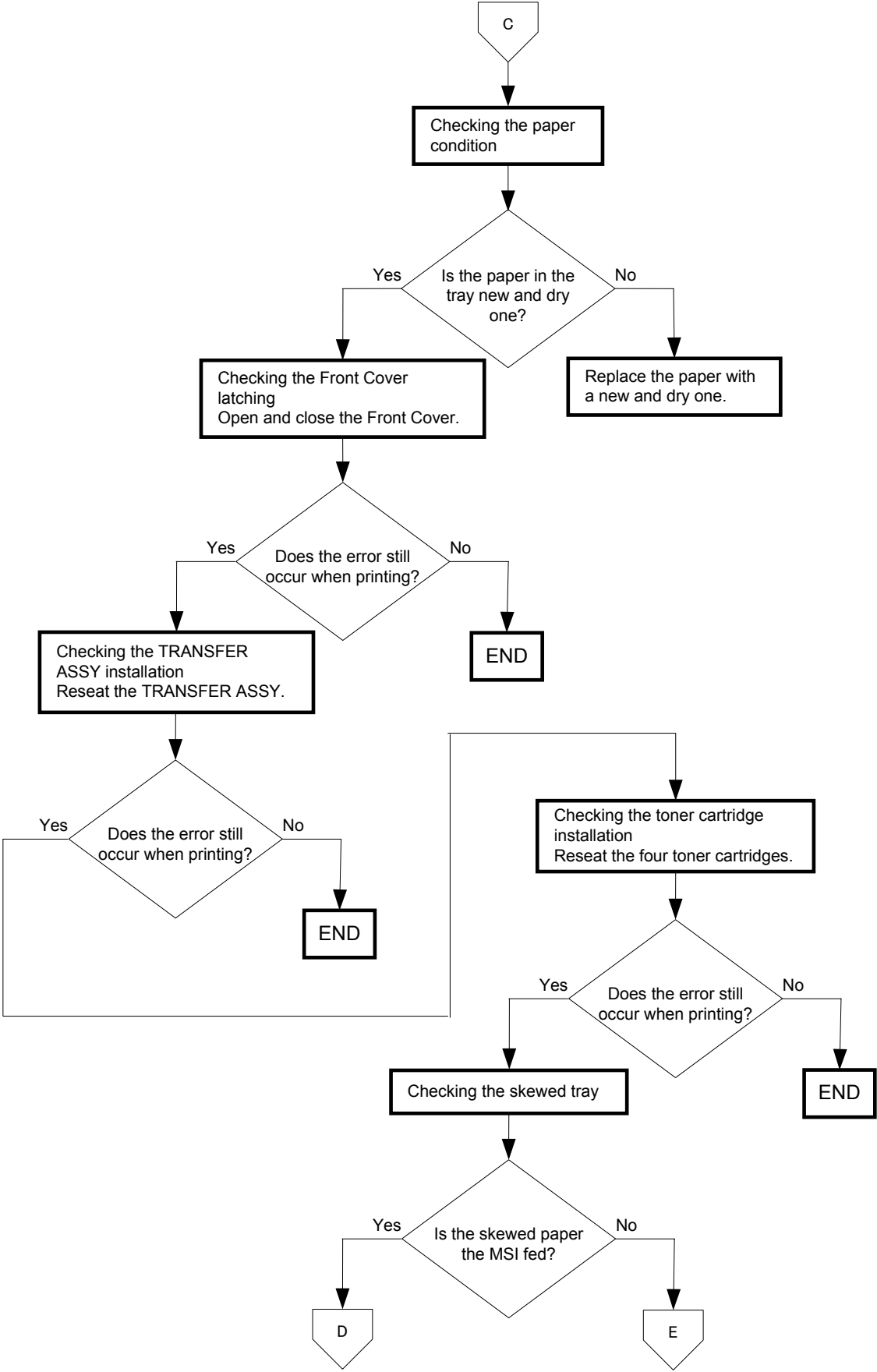

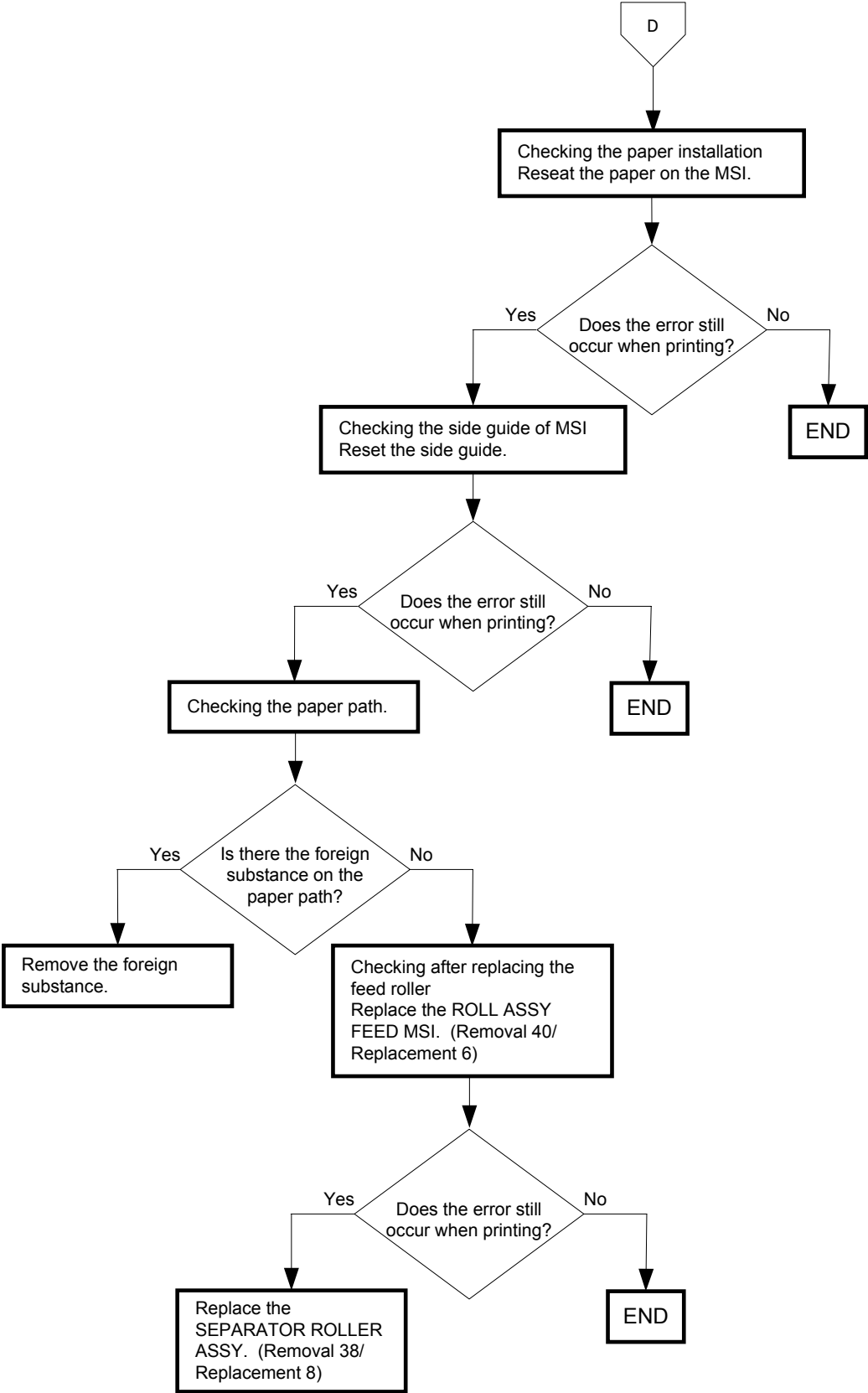

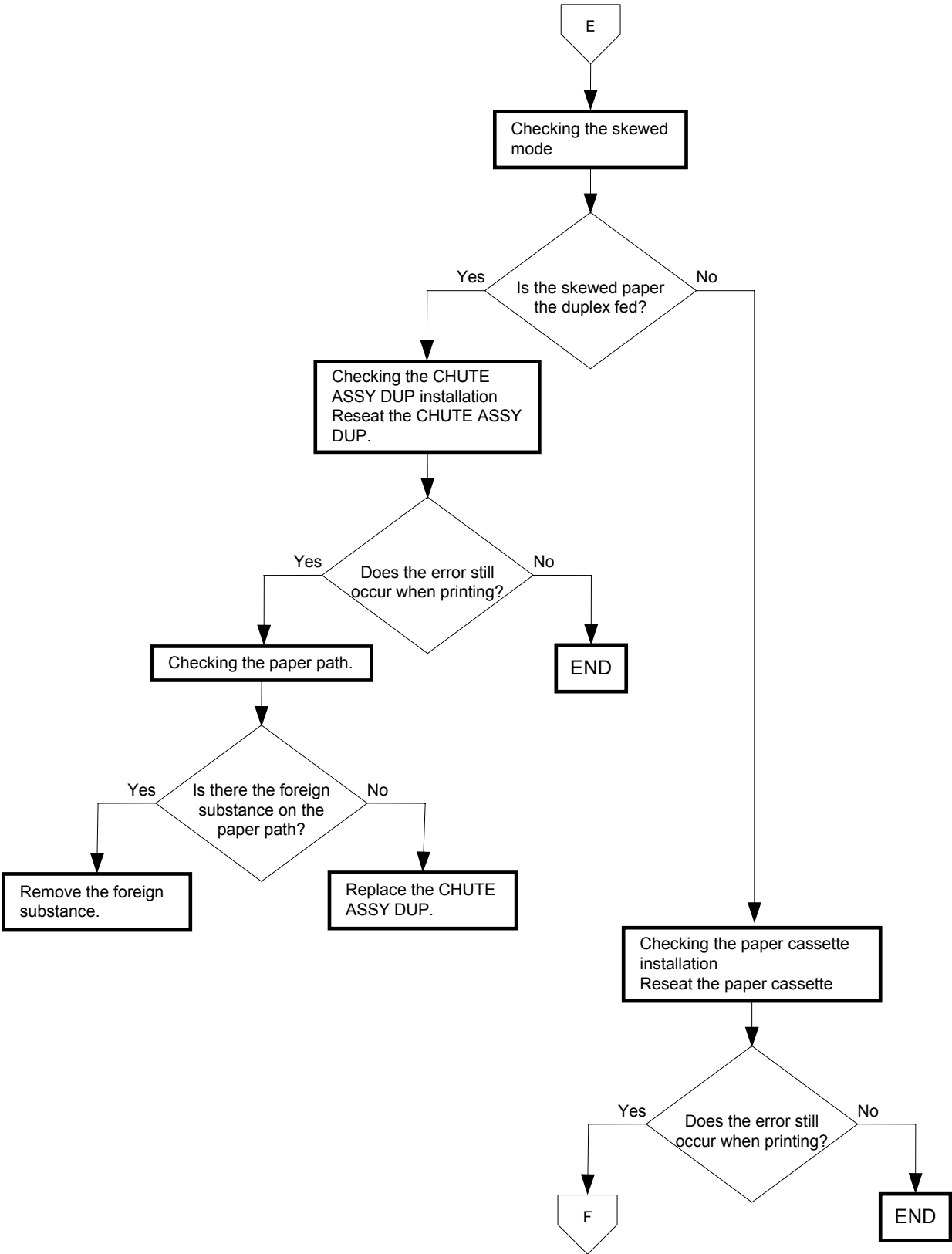

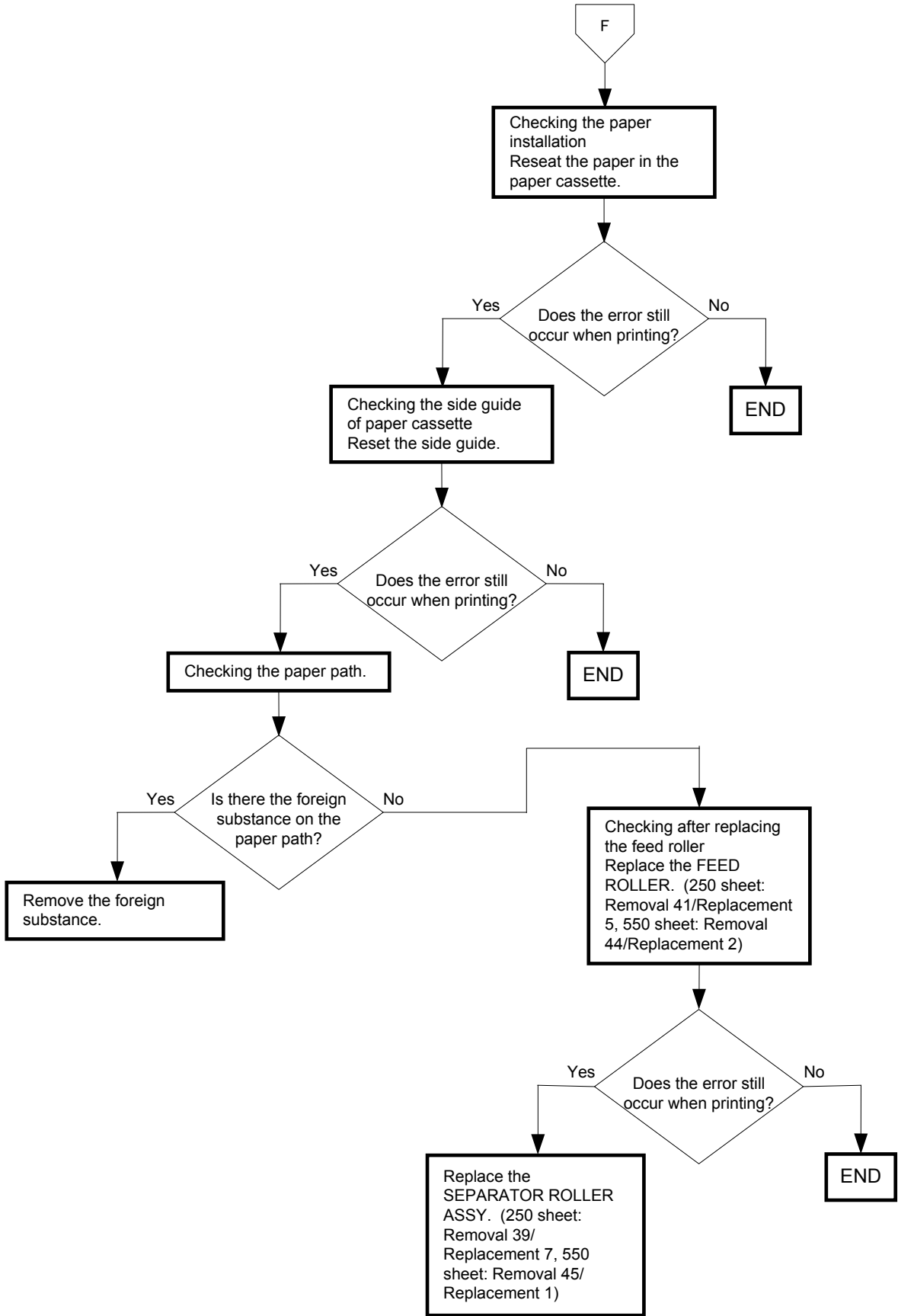

FIP-1.P13 Paper damage

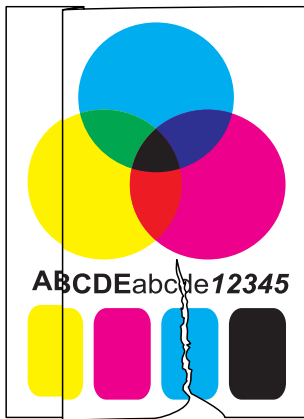
**Trouble substance**

The paper comes out from the printer wrinkled, folded or worn-out.

ESS and possible causative parts

- SEPARATOR ROLLER ASSY (PL2.1.3)
- KIT SEPARATOR and FEED ROLLER (PL2.2.99)
- CHUTE ASSY DUP (PL11.1.1)
- KIT SEPARATOR and FEED ROLLER (PL12.3.99)
- ADF SCANNER ASSY (PL13.8.1)
- KIT ADF FEED ROLLER (PL13.8.99)

Before starting troubleshooting, check the paper transfer path. Make sure that there is no foreign materials on the transfer path, such as staples, paper clips, scraps of paper and so on.

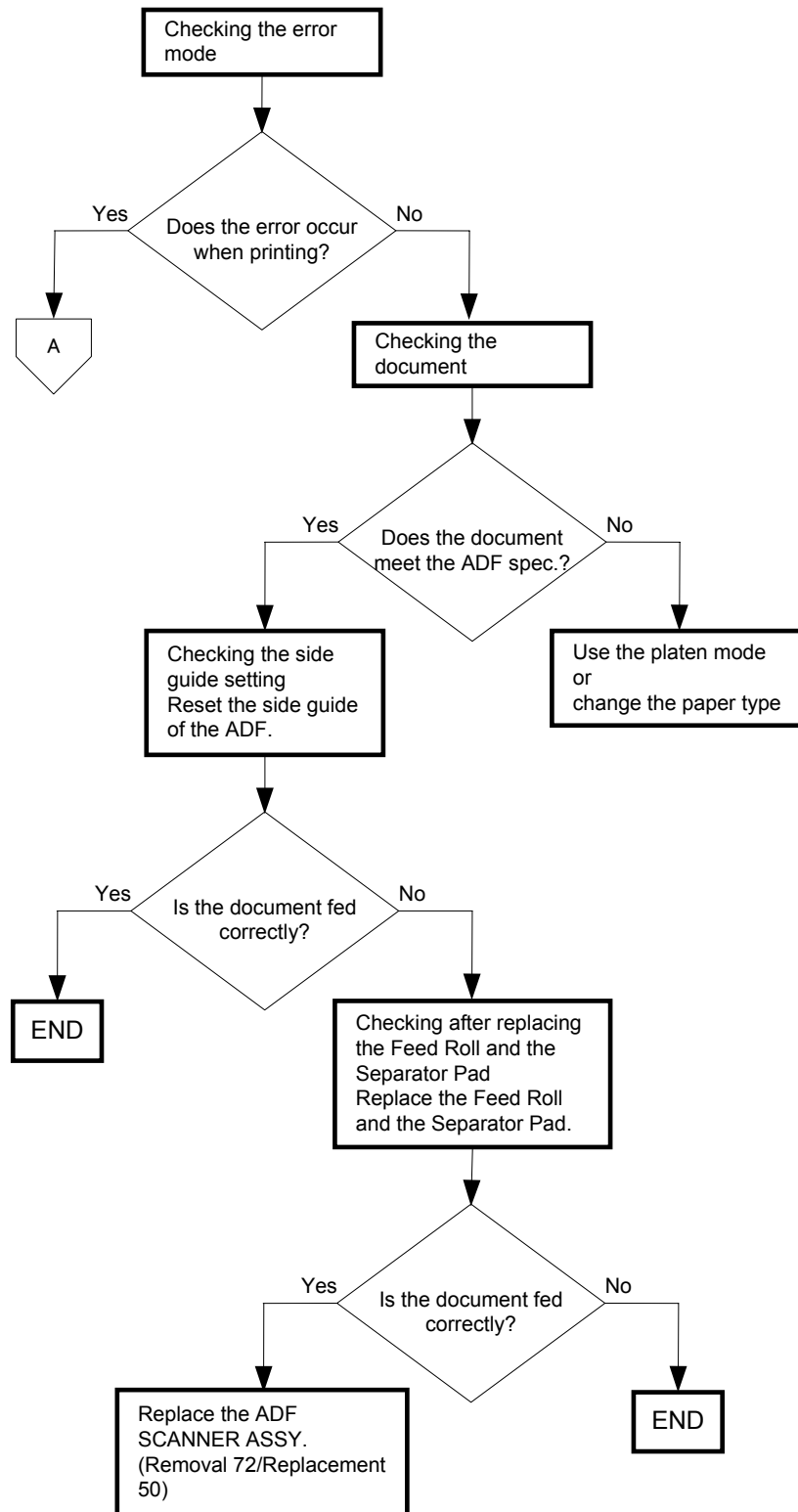

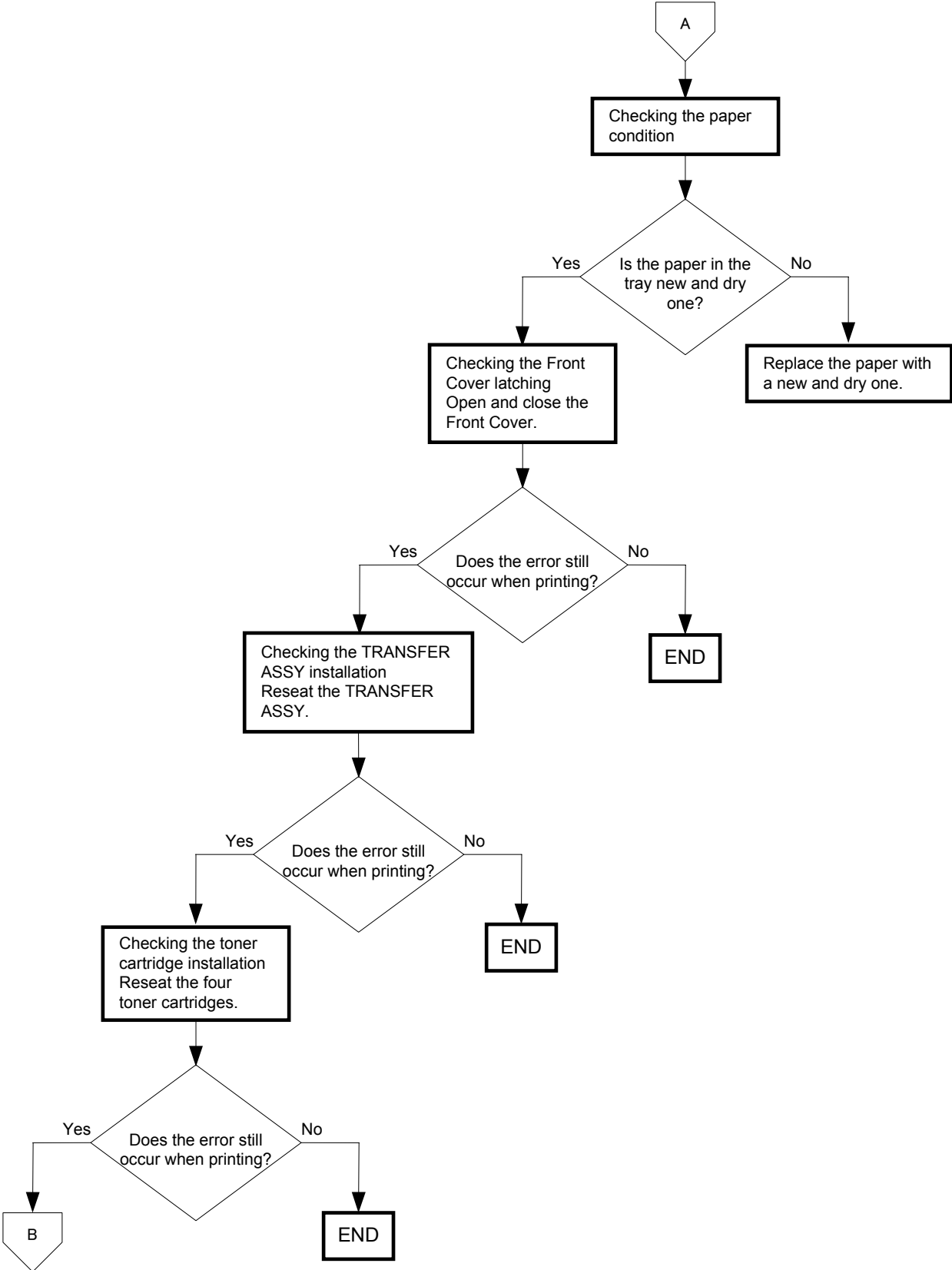

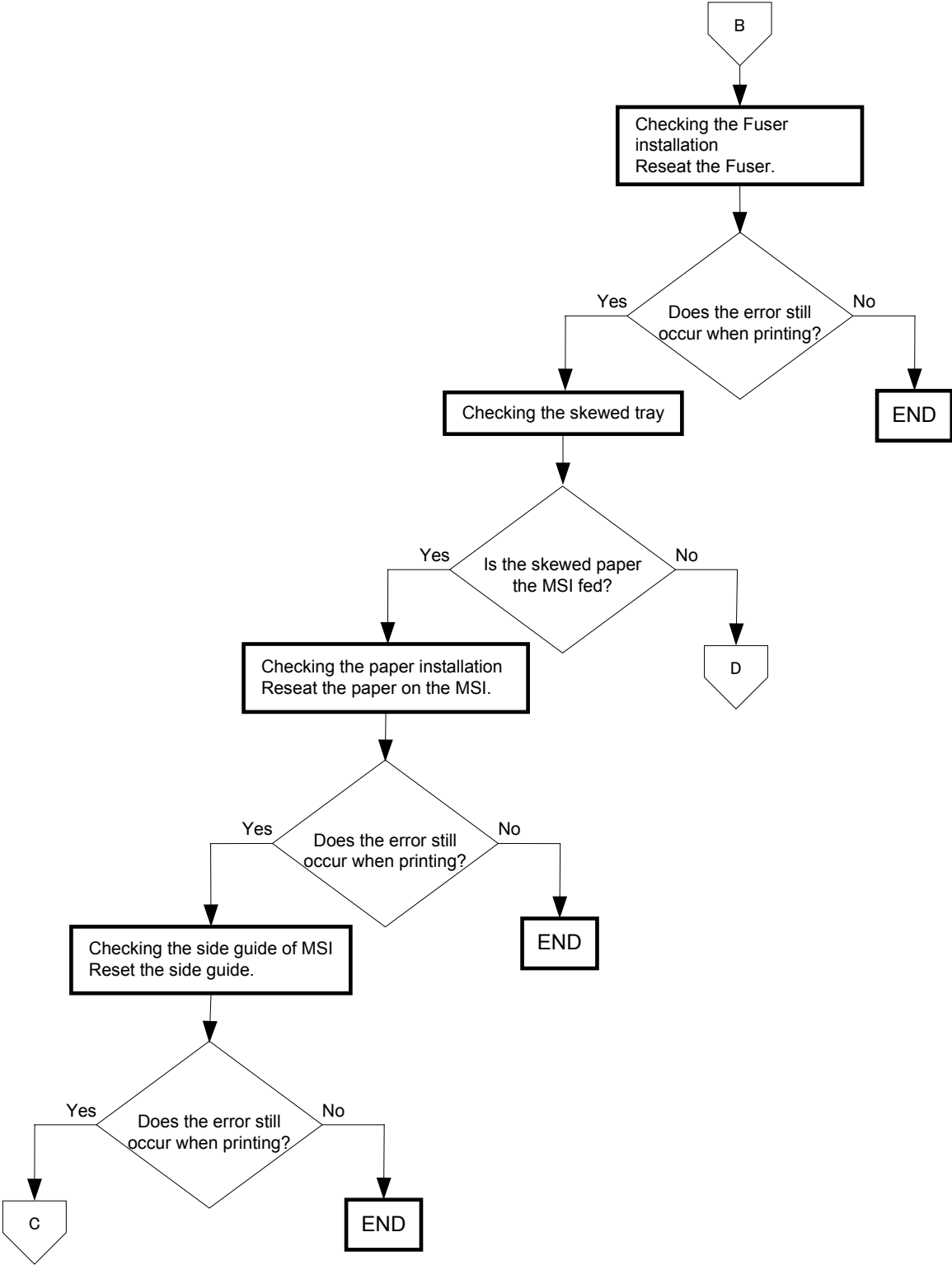

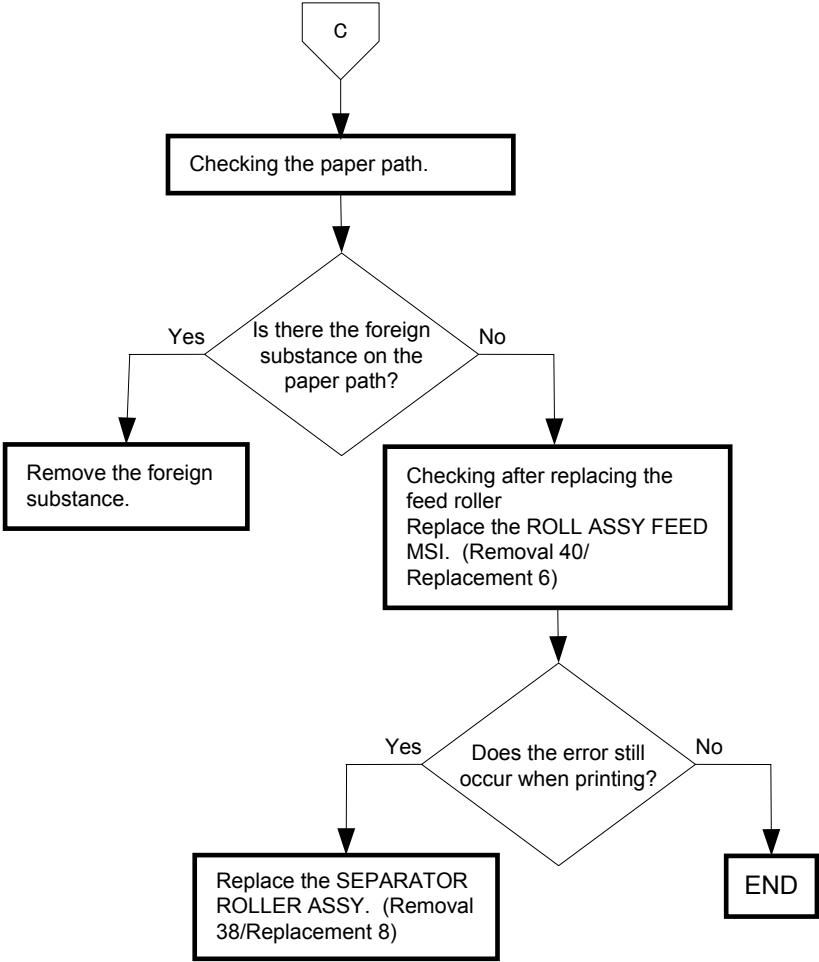

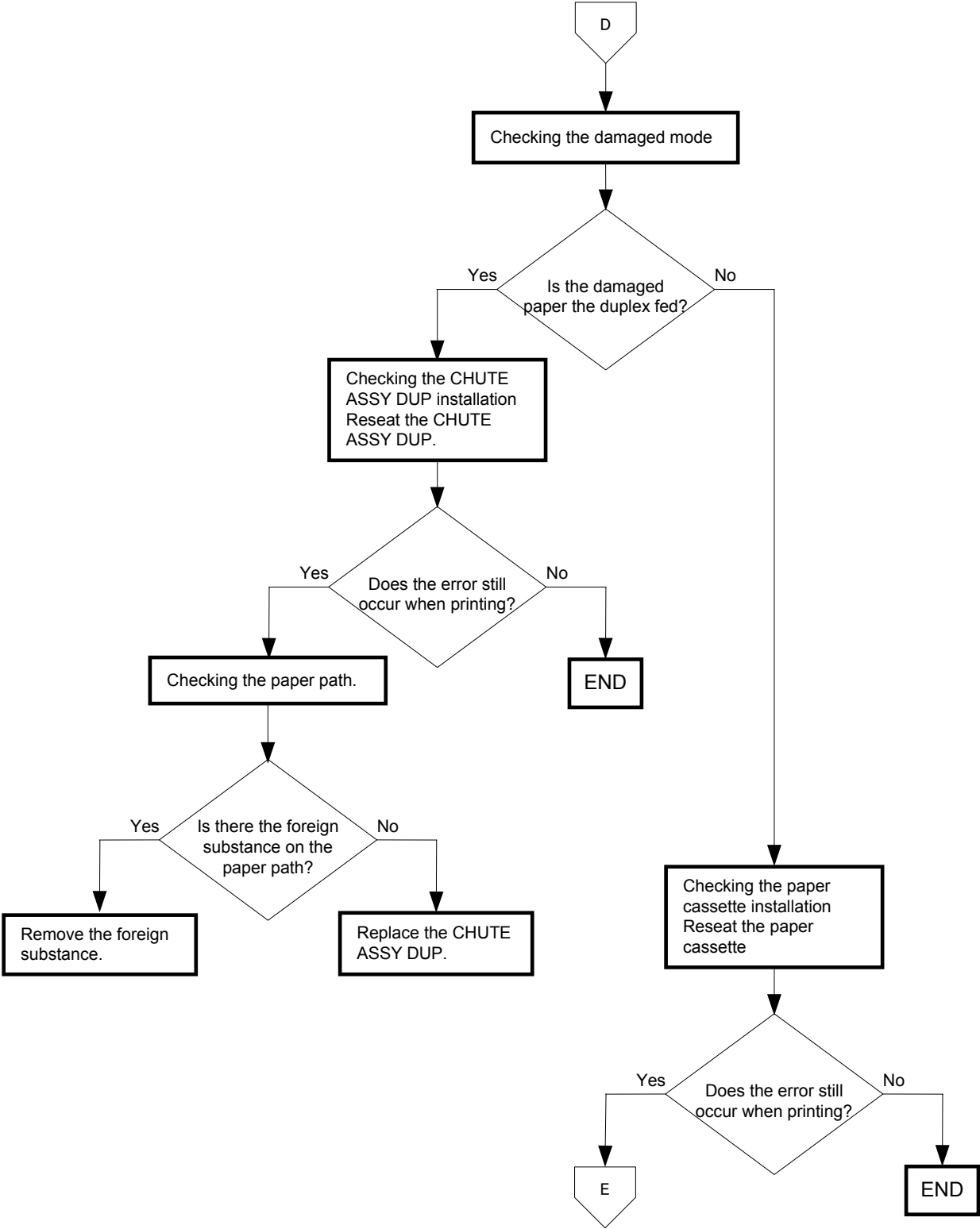

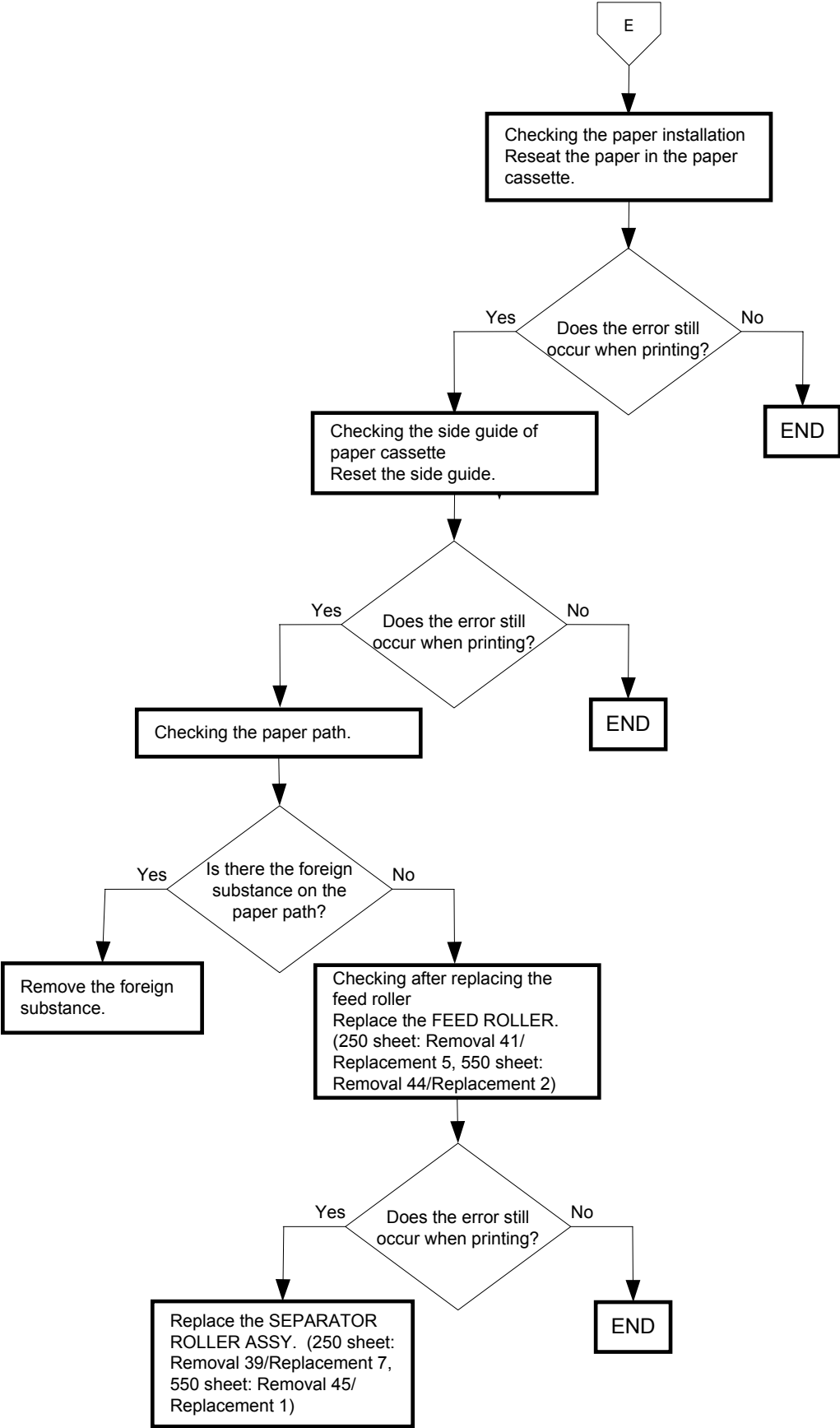

FIP-1.P14 No fix

**Trouble substance**

The printed image is not fixed on the paper properly. The image easily comes off when rubbed.

ESS and possible causative parts

- FUSER ASSY (PL6.1.10)

Before starting troubleshooting, check the paper transfer path. Make sure that there is no foreign materials on the transfer path, such as staples, paper clips, scraps of paper and so on.

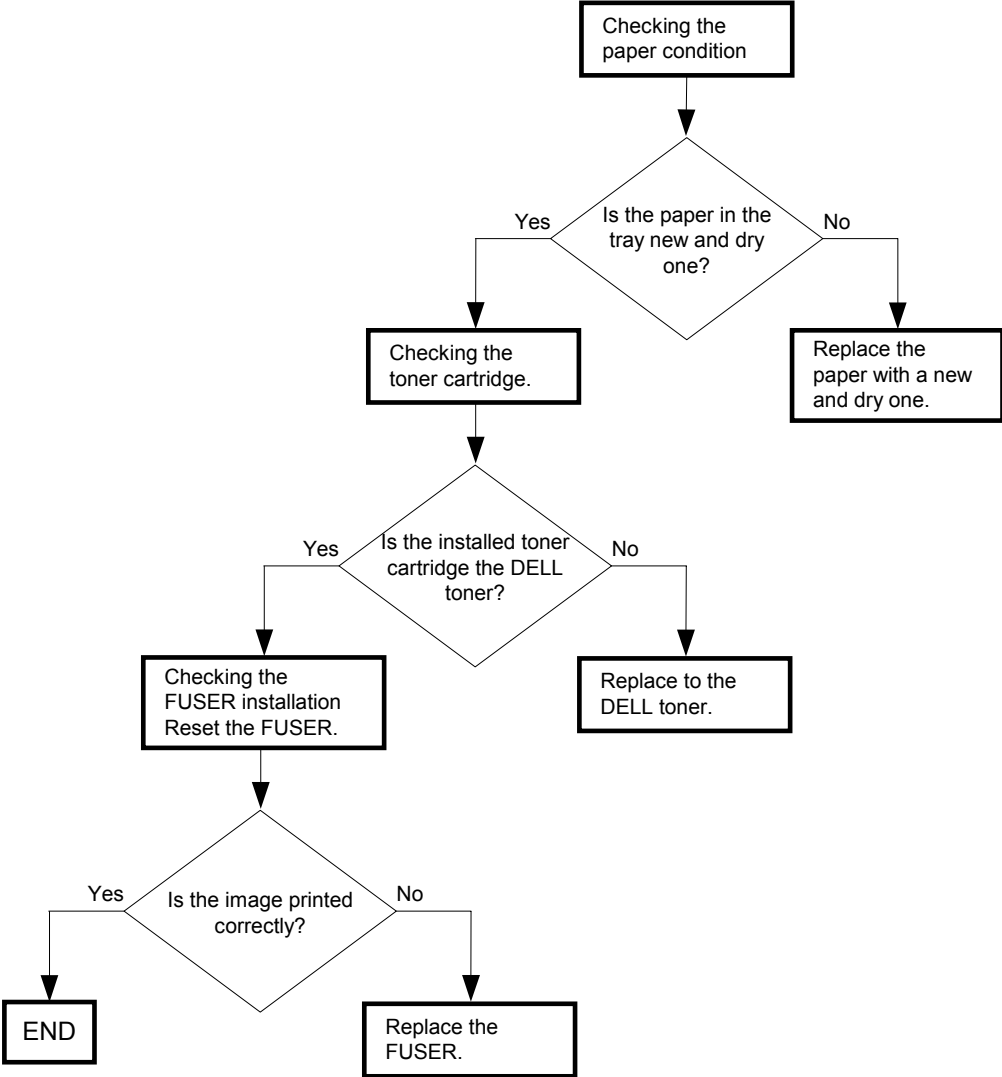

FIP-1.P15 Color Registration (Color Shift)



Trouble substance

A yellow or black image printed is not overlapped on a cyan or magenta image correctly.

ESS and possible causative parts

- FEEDER ASSY (PL3.2.1)

Before starting troubleshooting, check the paper transfer path. Make sure that there is no foreign materials on the transfer path, such as staples, paper clips, scraps of paper and so on.

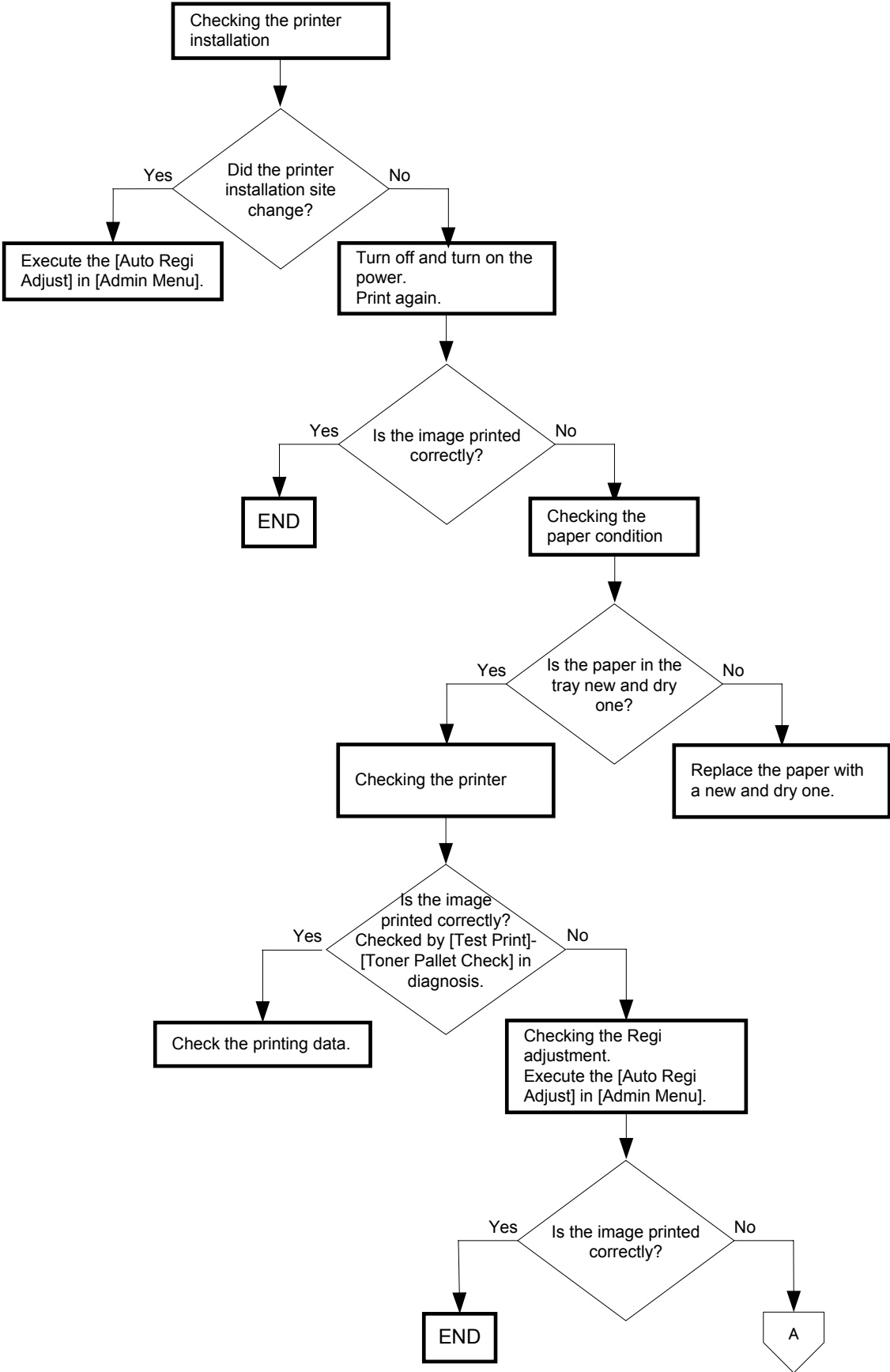

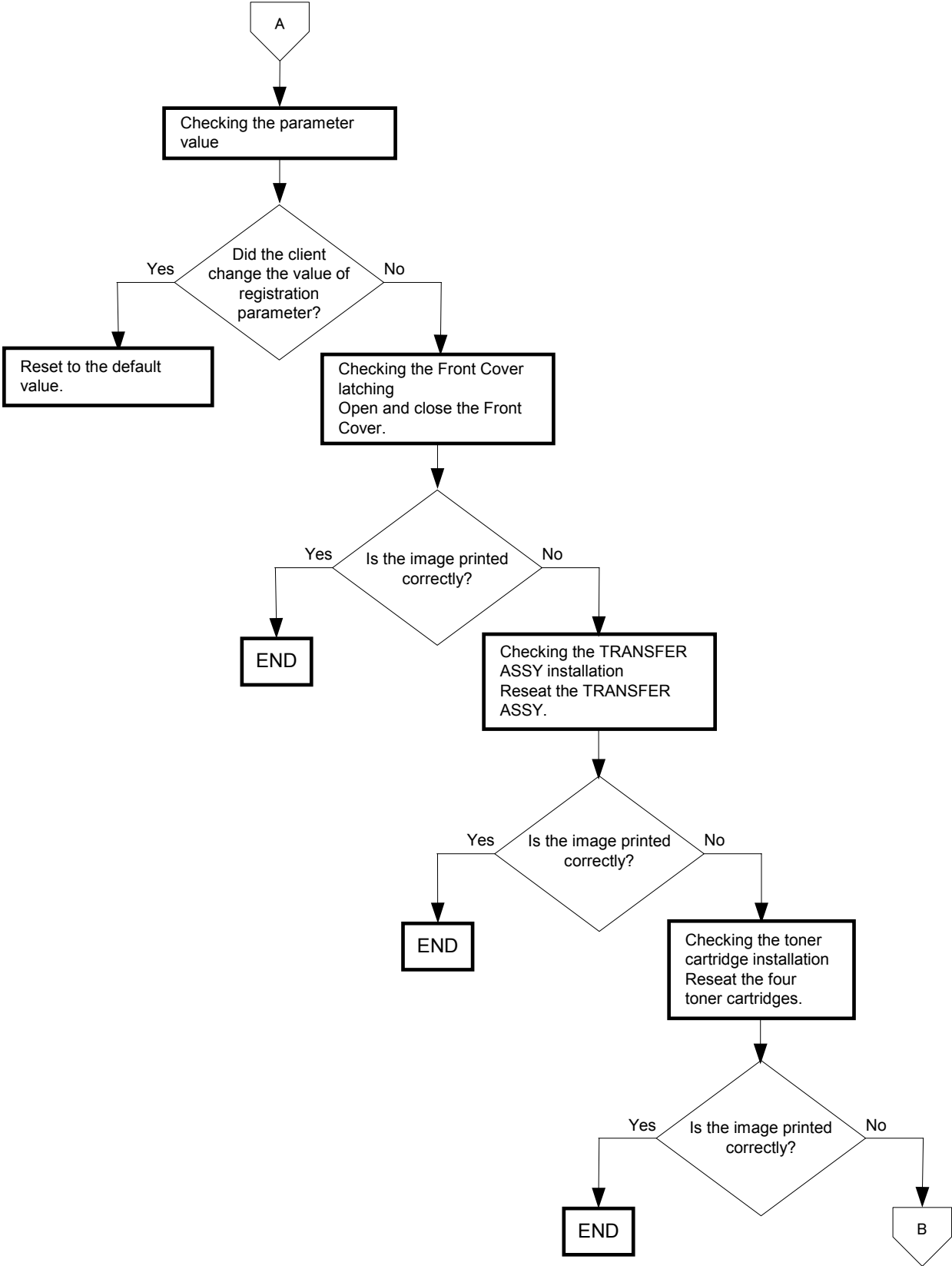

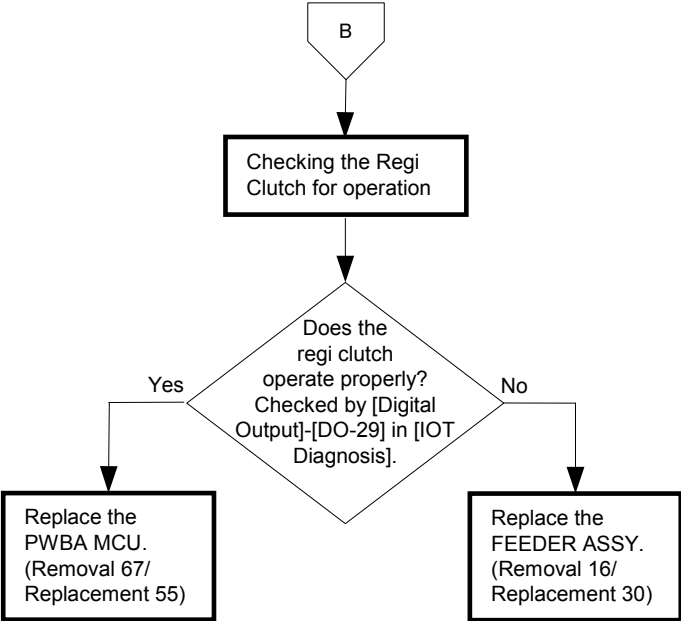

FIP-1.P16 Hunting



Trouble substance

Vertical undulation of the image with respect to the feeding direction, such as wavy column line.

ESS and possible causative parts

-ADF SCANNER ASSY (PL13.8.1)

Possible causative parts: ADF SCANNER ASSY(PL13.8.1)

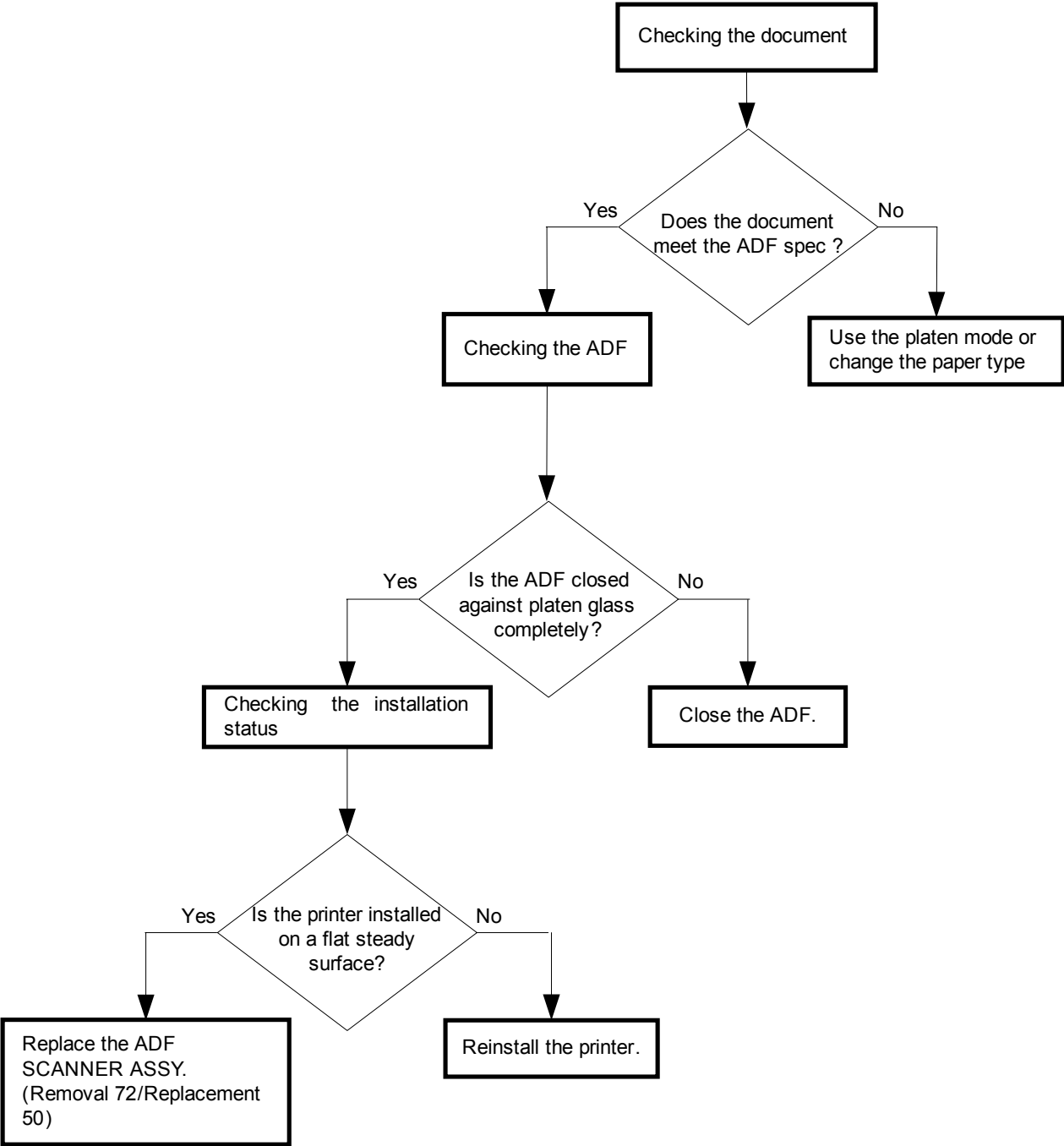

FIP-1.P17 Magnification incorrect



Trouble substance

Incorrect magnification when copying with the ADF feeding.

ESS and possible causative parts

- ADF SCANNER ASSY (PL13.8.1)

Possible causative parts: ADF SCANNER ASSY(PL13.8.1)

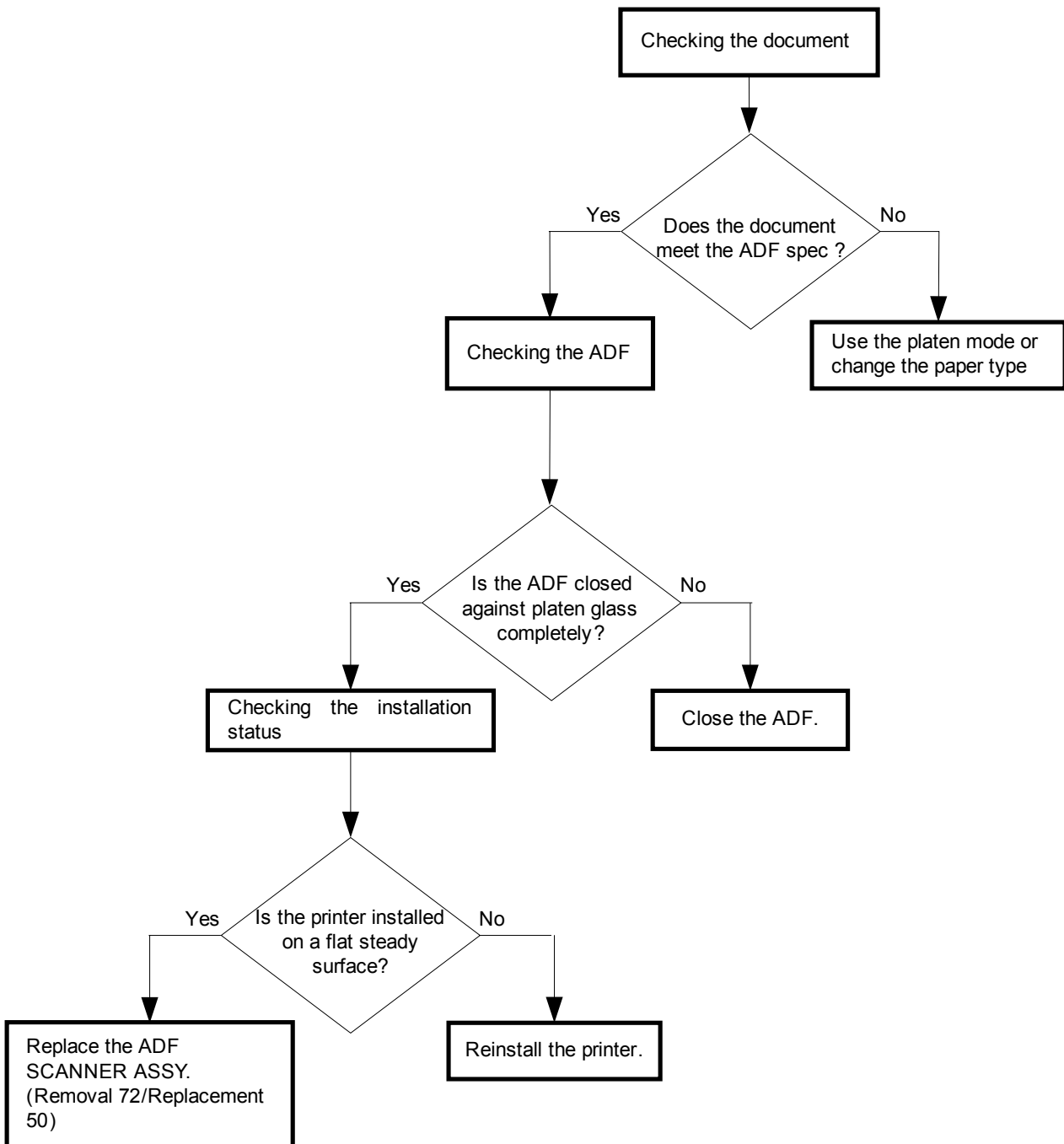

8. Abnormal Noise Troubles

8.1 Flow of Abnormal Noise Troubleshooting

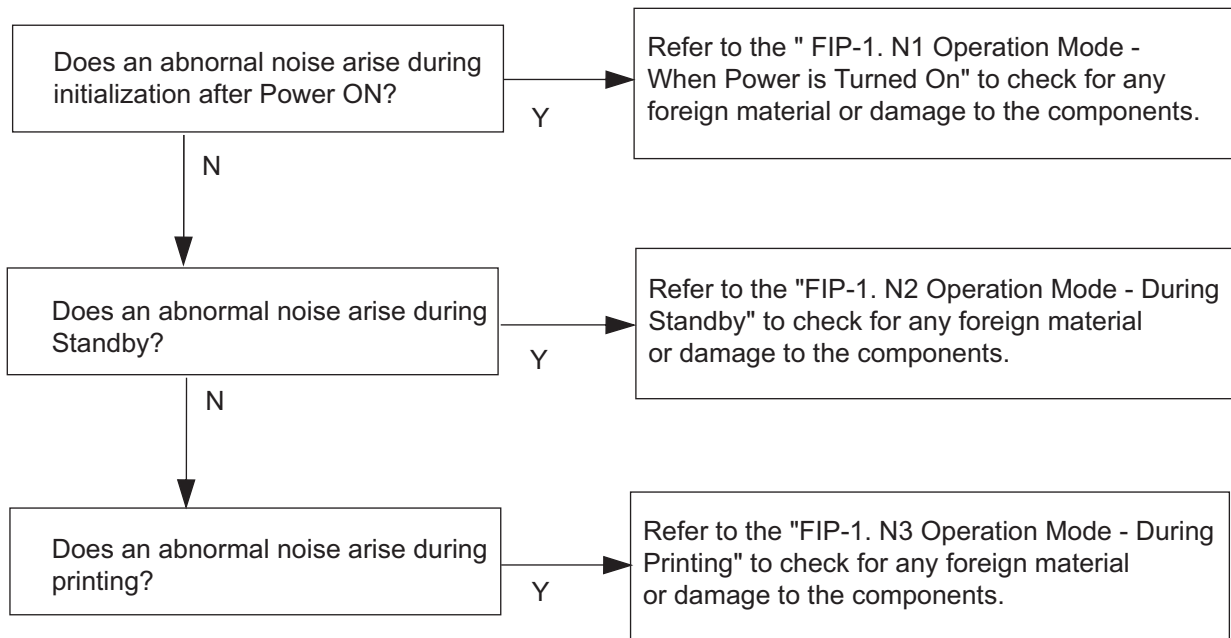

8.2 Operation Mode

FIP-1.N1 When Power is Turned On

Possible causative parts:BELT CRU (PL4.1.1)
CARTRIDGE ASSY (PL5.1.18 (K)/PL5.1.19 (C)/PL5.1.20 (M)/PL5.1.21 (Y))
FUSER ASSY (PL6.1.10)
DRIVE ASSY MAIN (PL8.1.2)
DRIVE ASSY PH (PL8.1.7)
550 OPTION FEEDER (PL13.7.1)

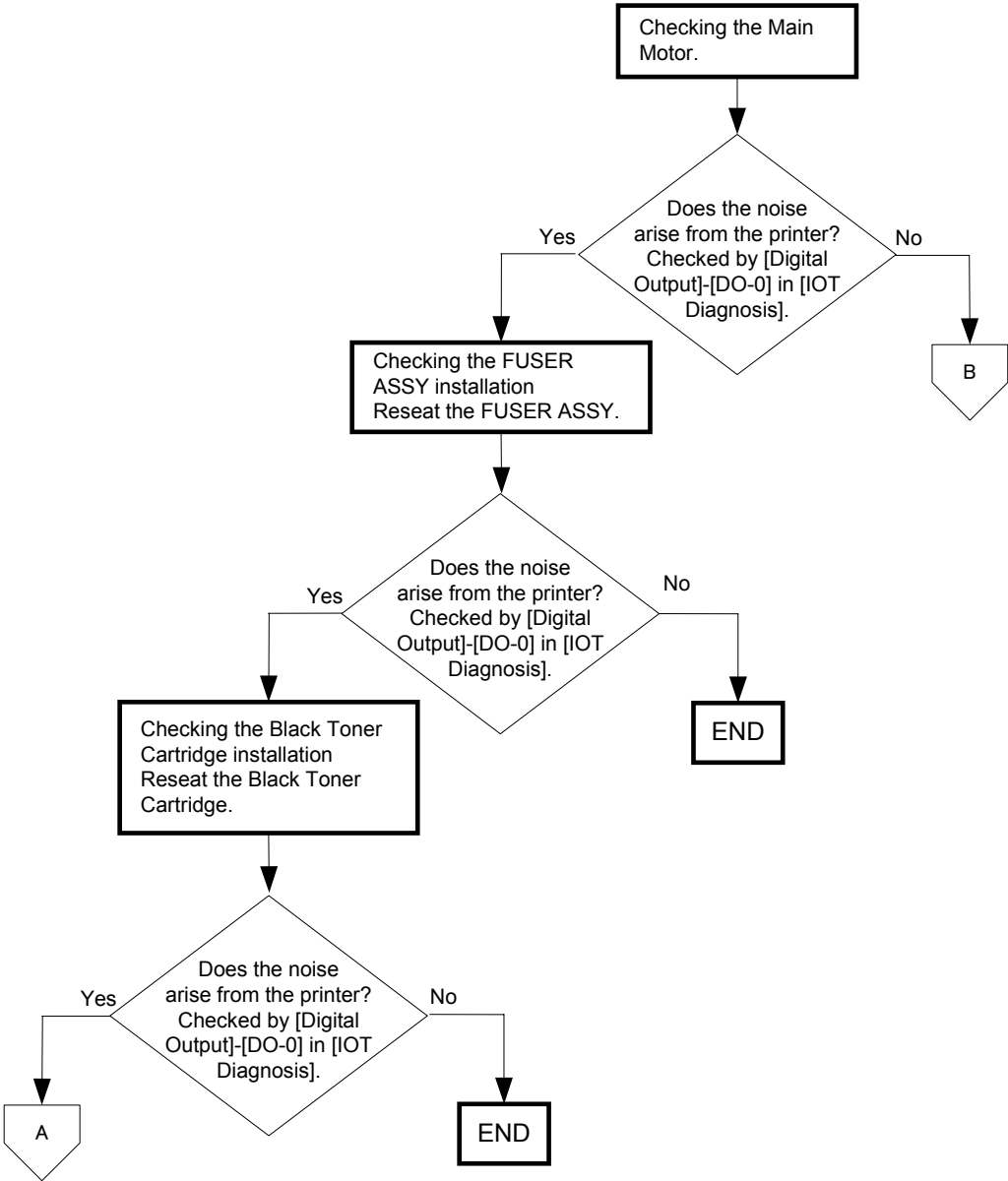

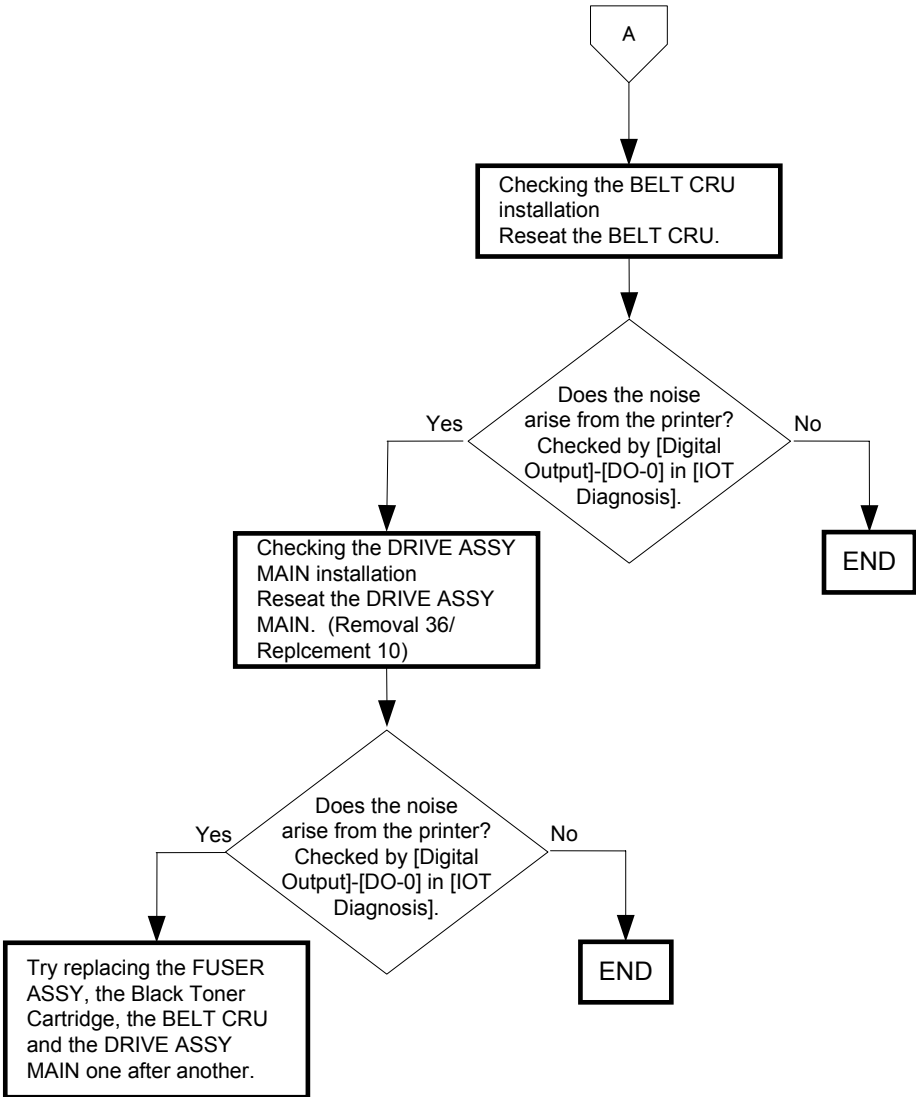

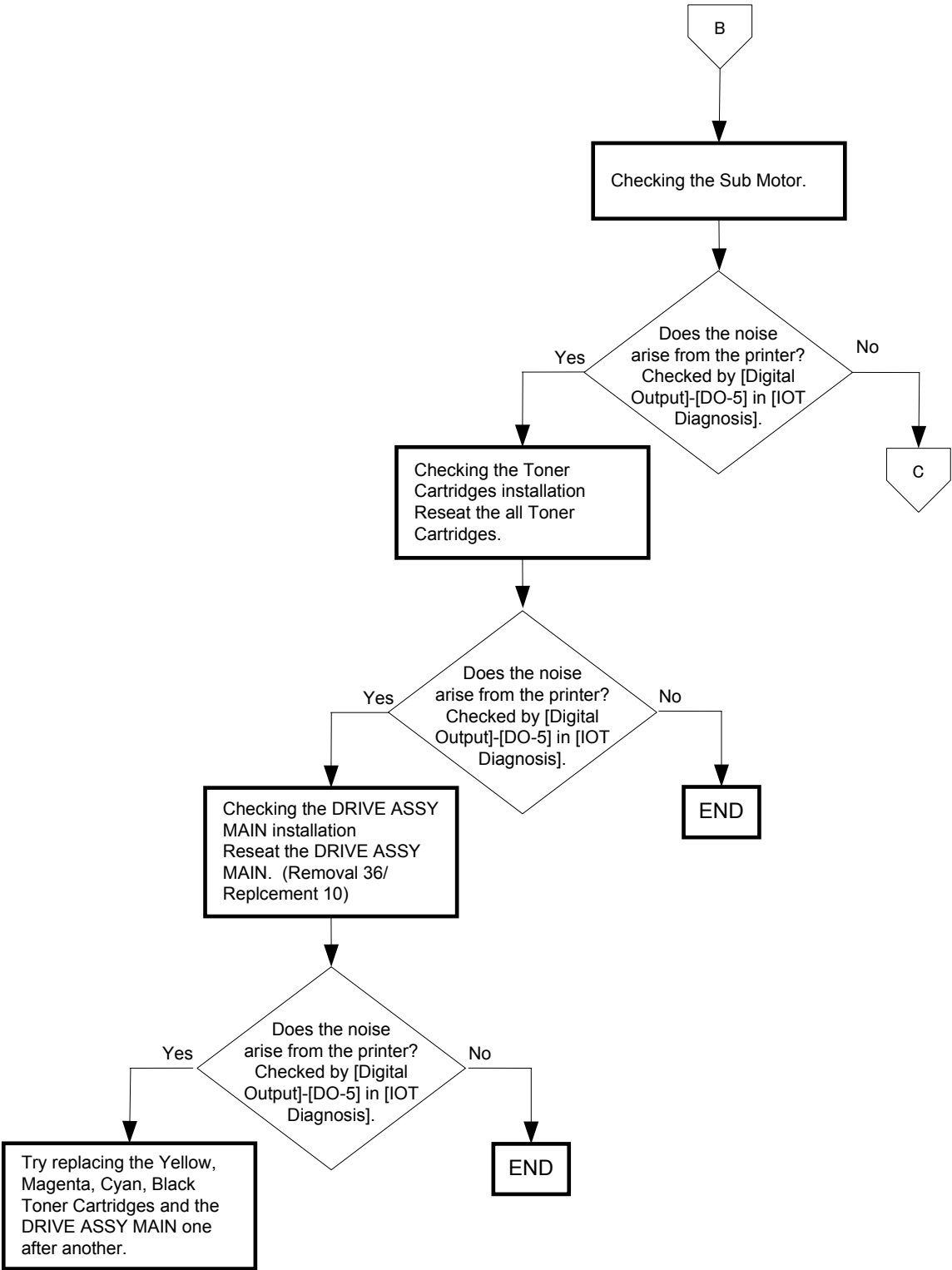

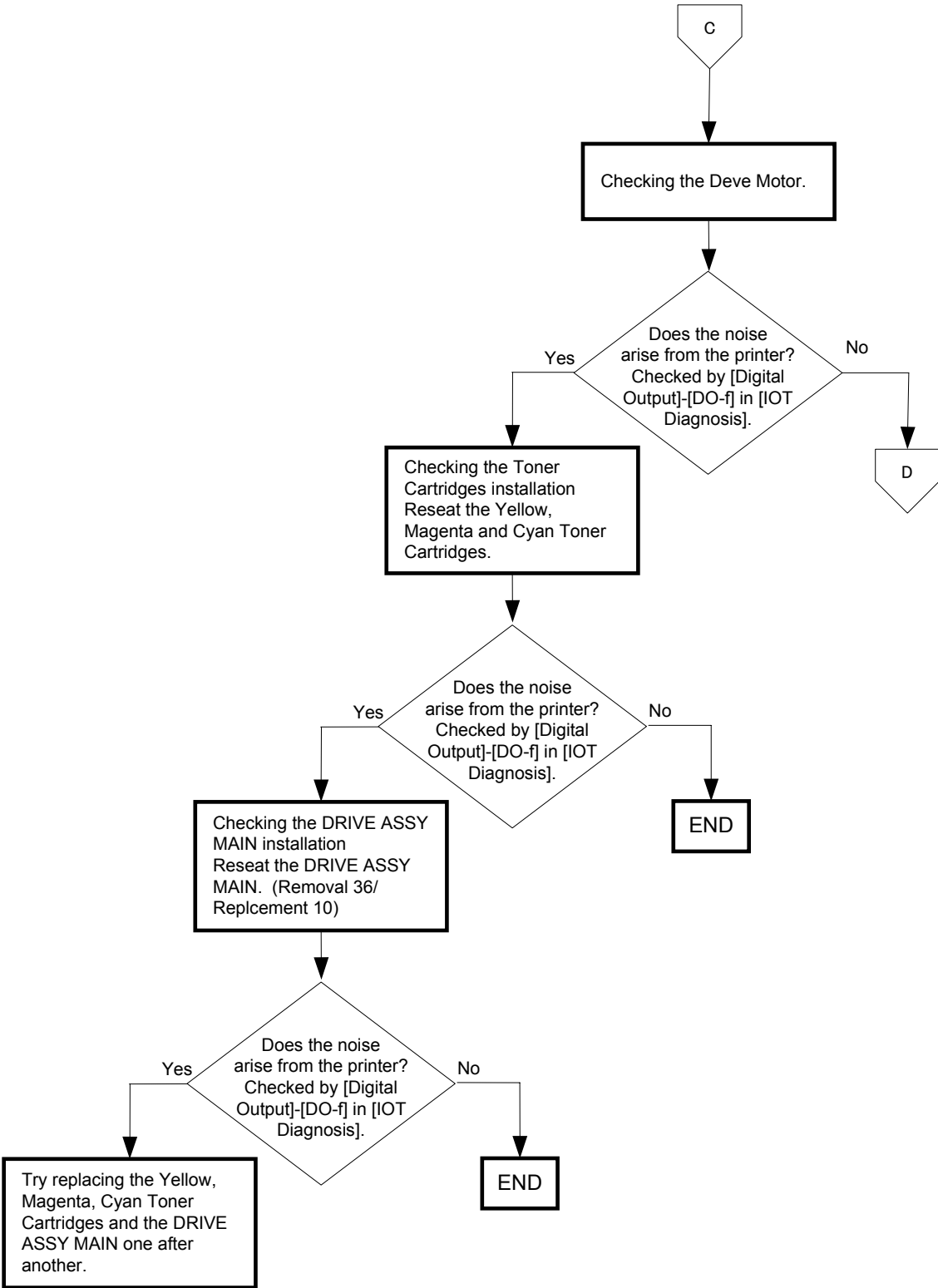

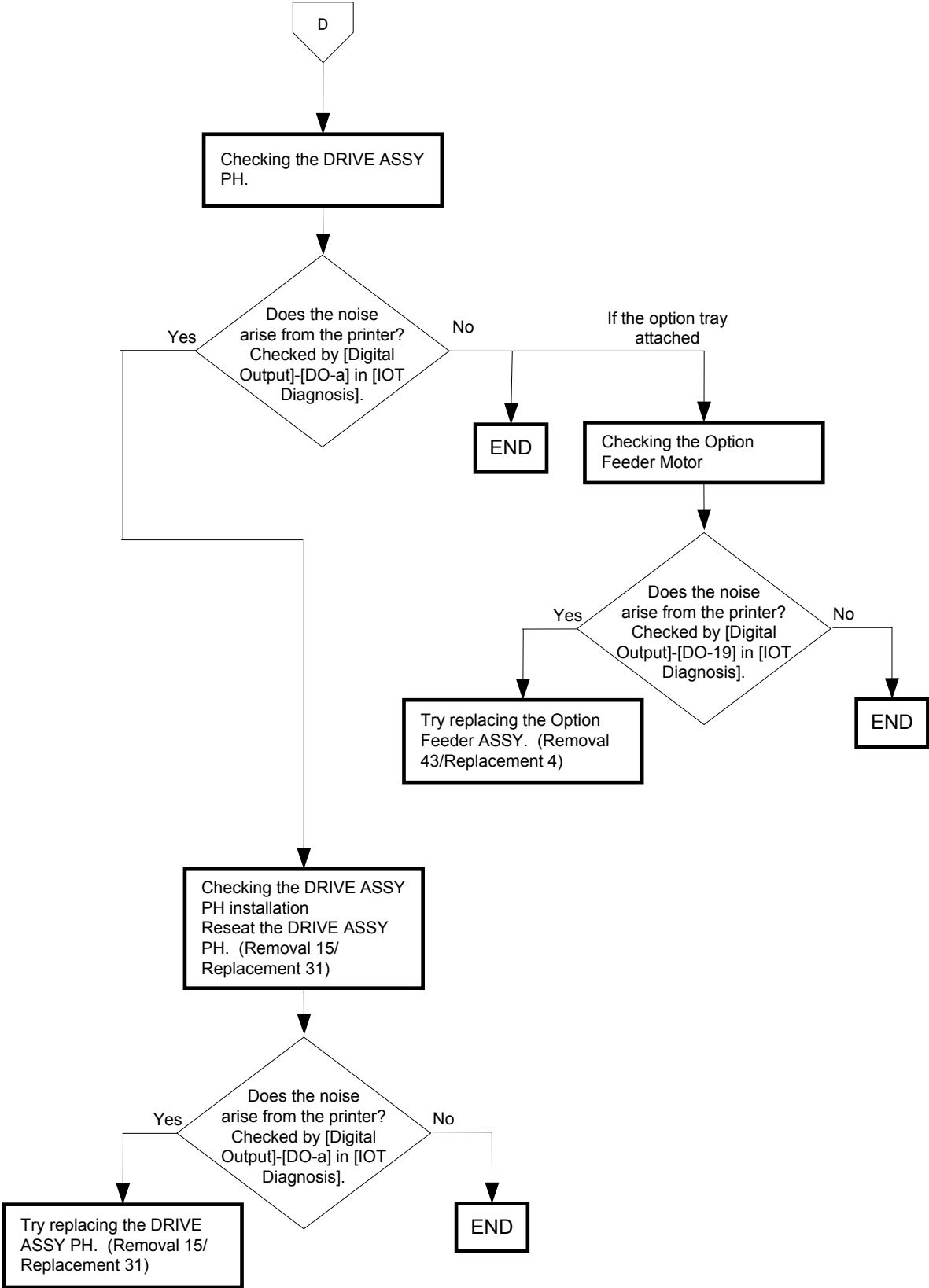

FIP-1.N2 During Standby

Possible causative parts:FAN MAIN (PL13.5.10)
LVPS (PL13.5.14)

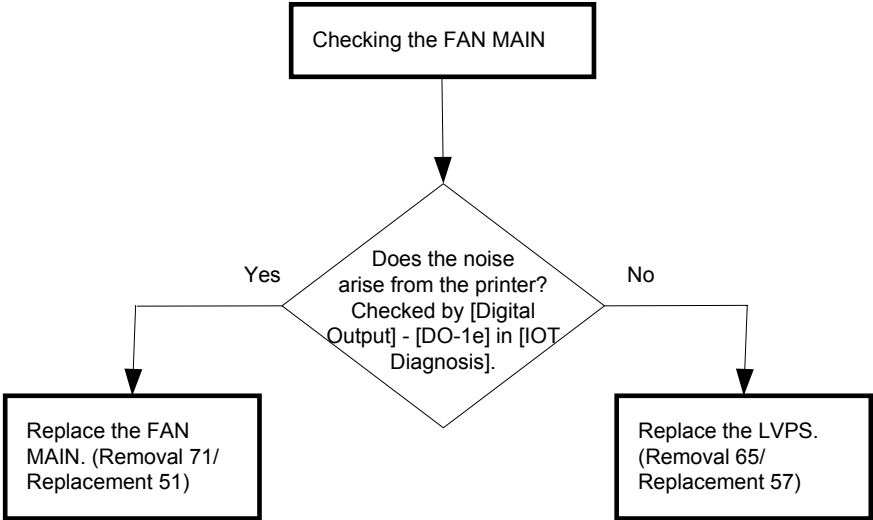

FIP-1.N3 During Printing

Possible causative parts:KIT SEPARATOR ROLLER ASSEMBLY (PL2.1.99)
 KIT SEPARATOR AND FEED ROLLER (PL2.2.99)
 BELT UNIT (PL4.1.1)
 CARTRIDGE ASSY (PL5.1.18/PL5.1.19/PL5.1.20/PL5.1.21)
 FUSER ASSY (PL6.1.10)
 DRIVE ASSY MAIN (PL8.1.2)
 DRIVE ASSY PH (PL8.1.7)
 CHUTE ASSY DUP (PL11.1.1)
 550 OPTION FEEDER (PL13.7.1)
 KIT ADF FEED ROLLER (PL13.8.99)

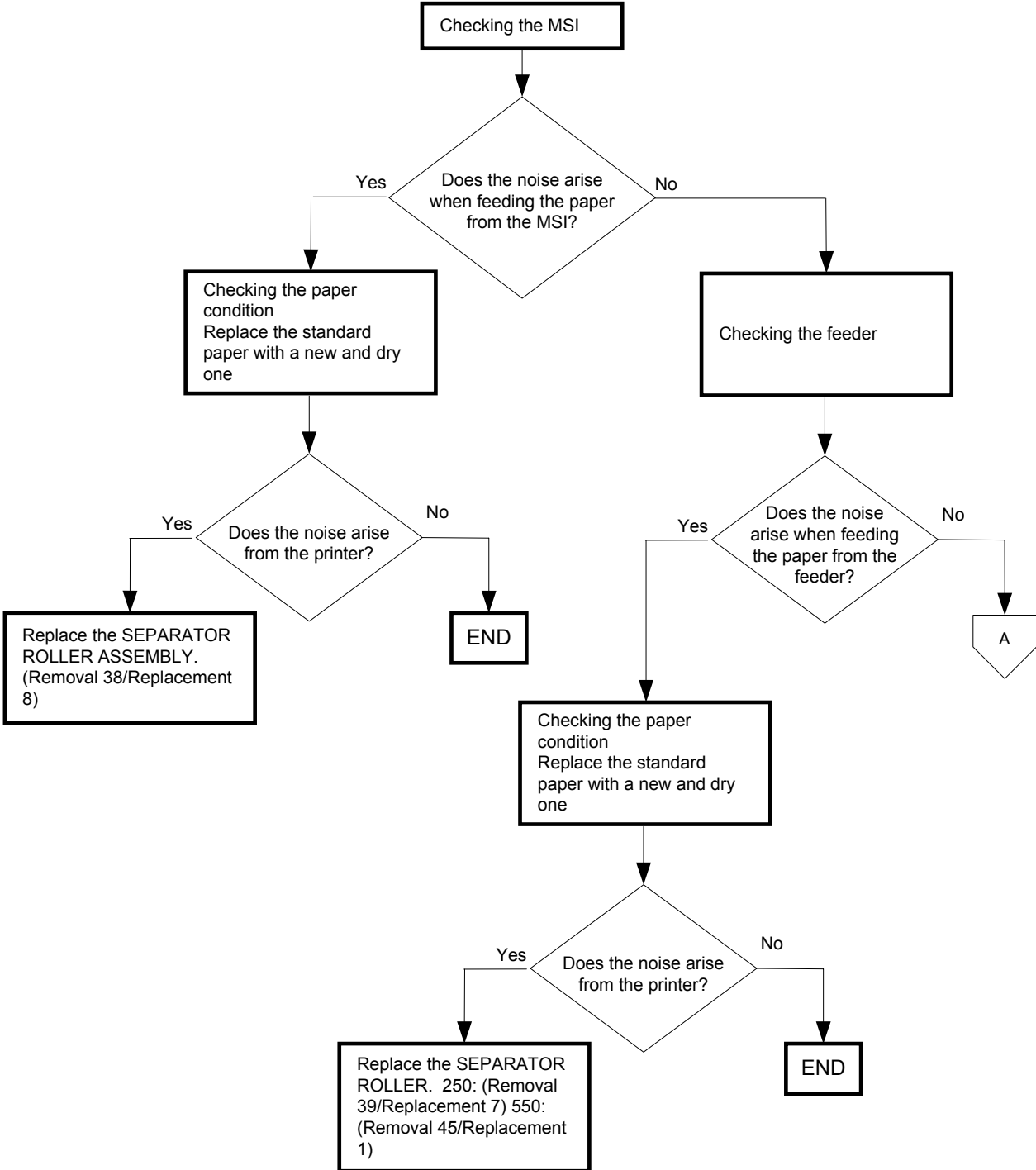

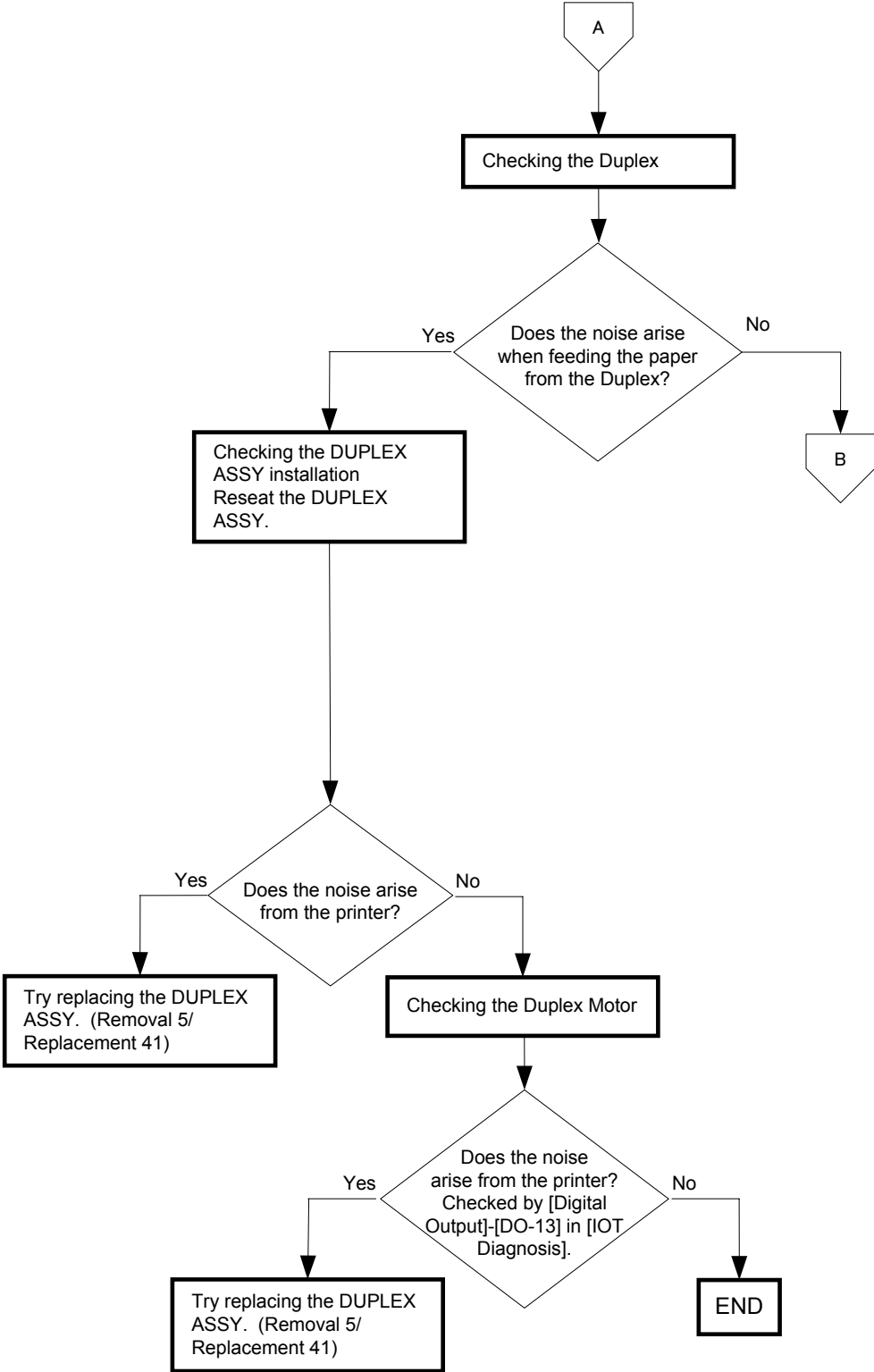

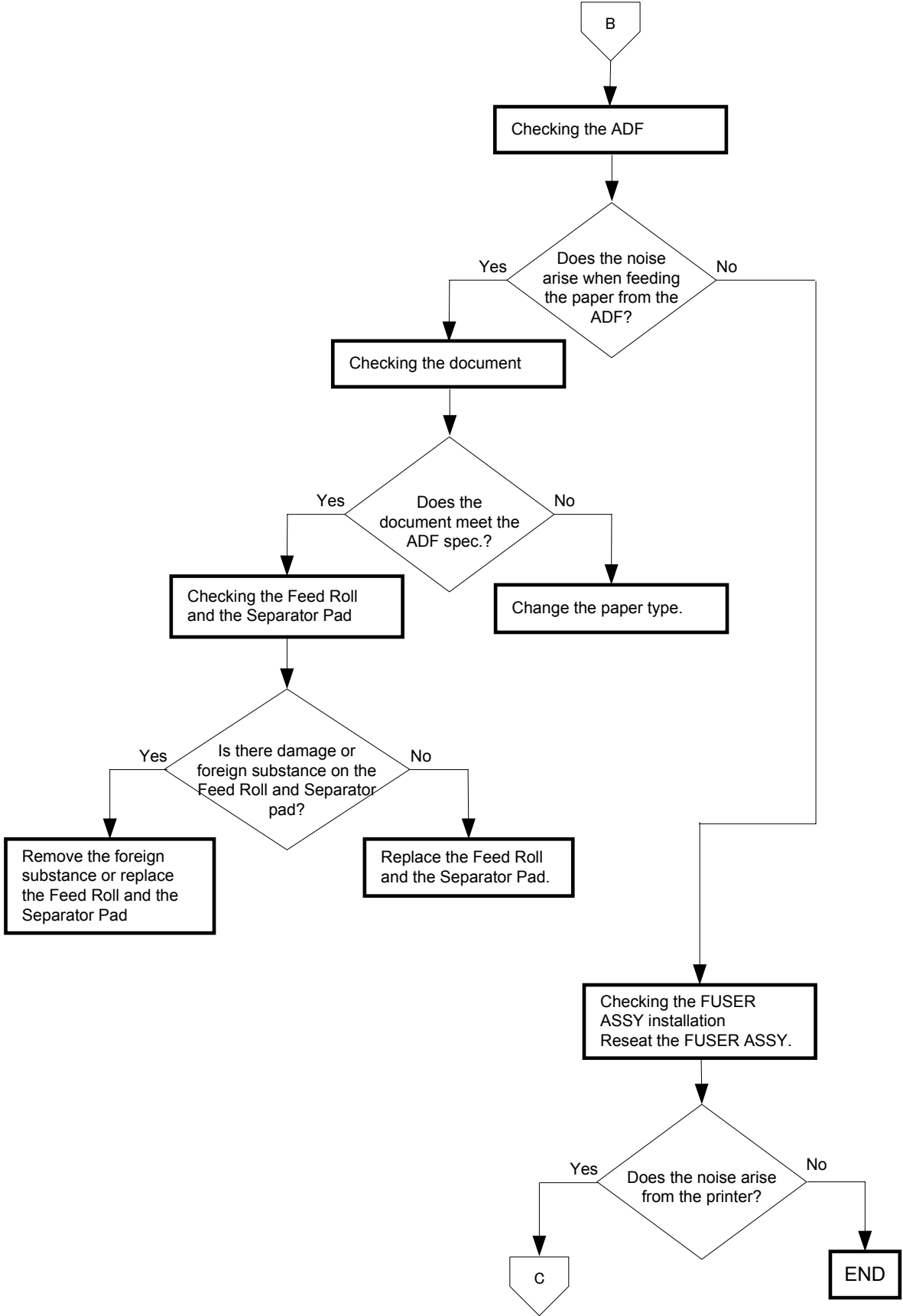

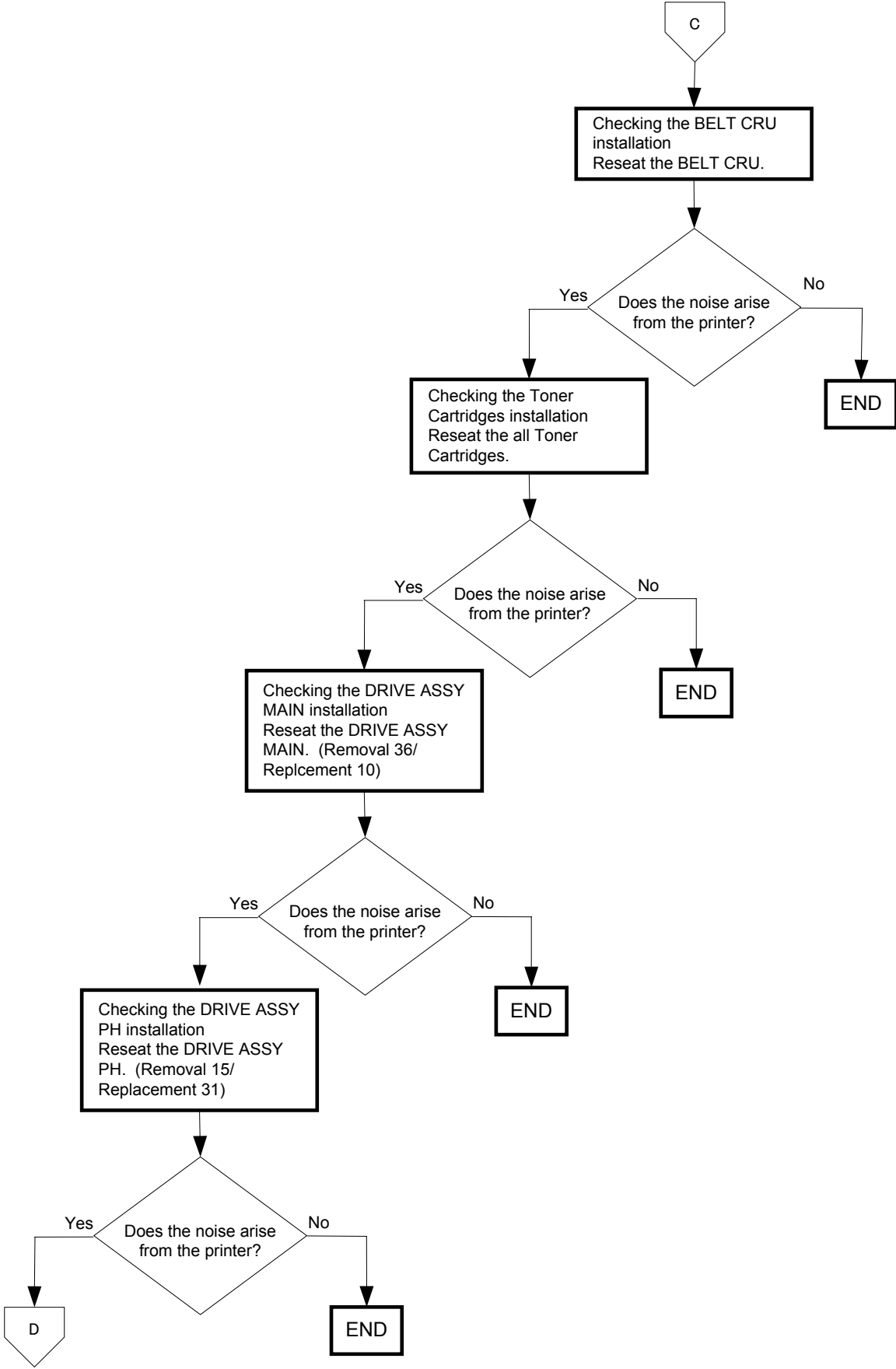

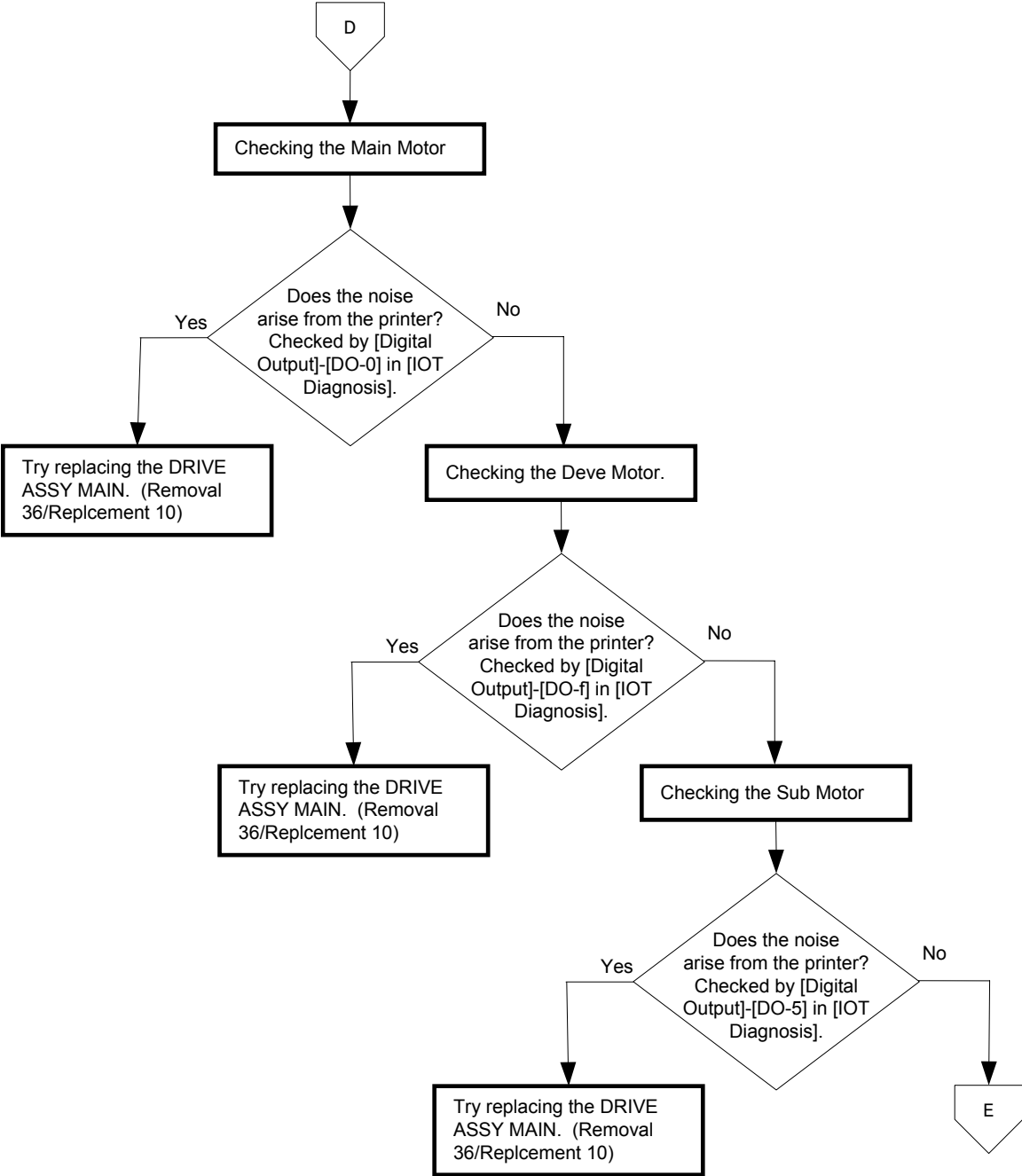

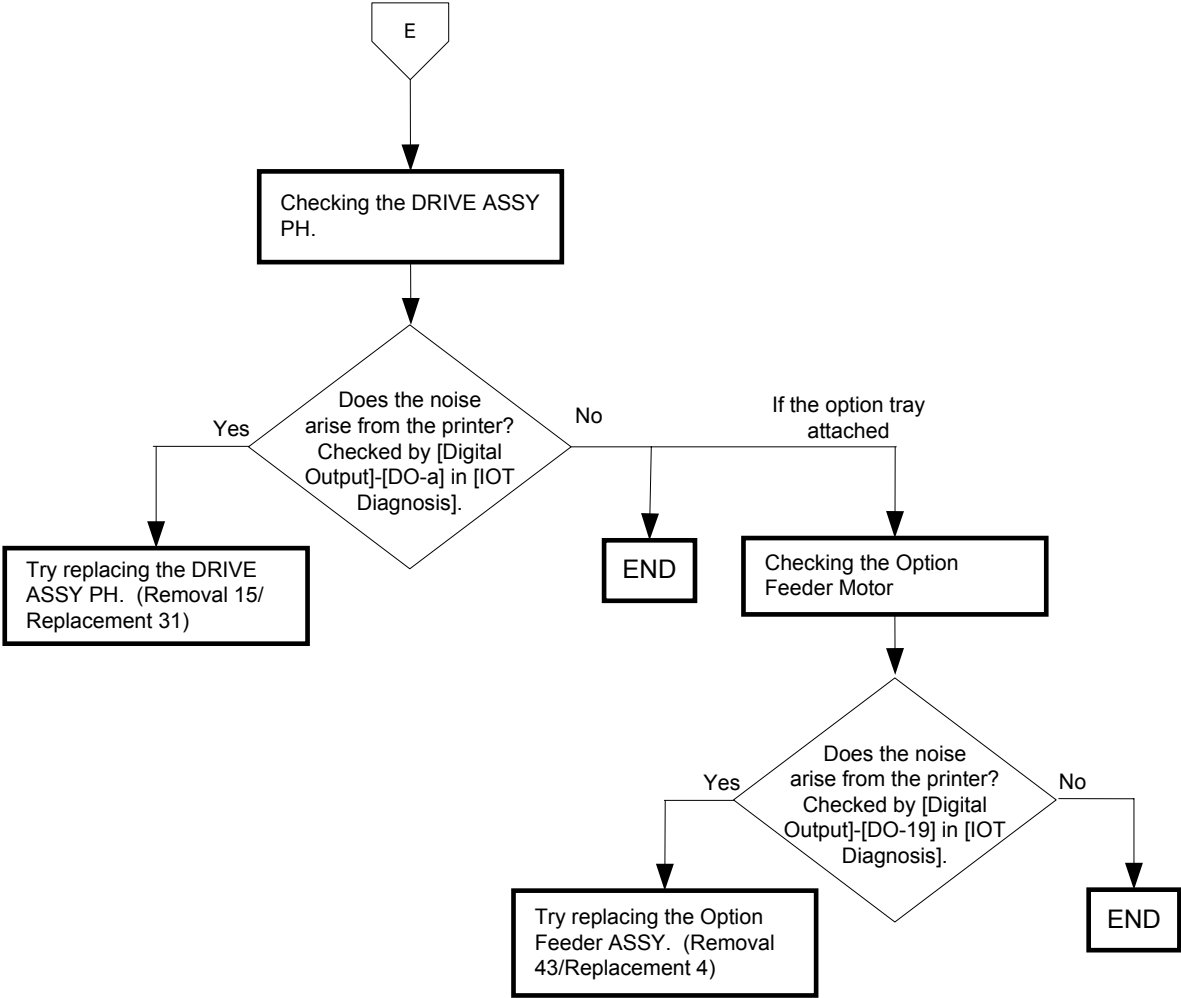

9. Other FIPs

Shown below are the FIPs for power supply troubles and multiple feed.

FIP-AC

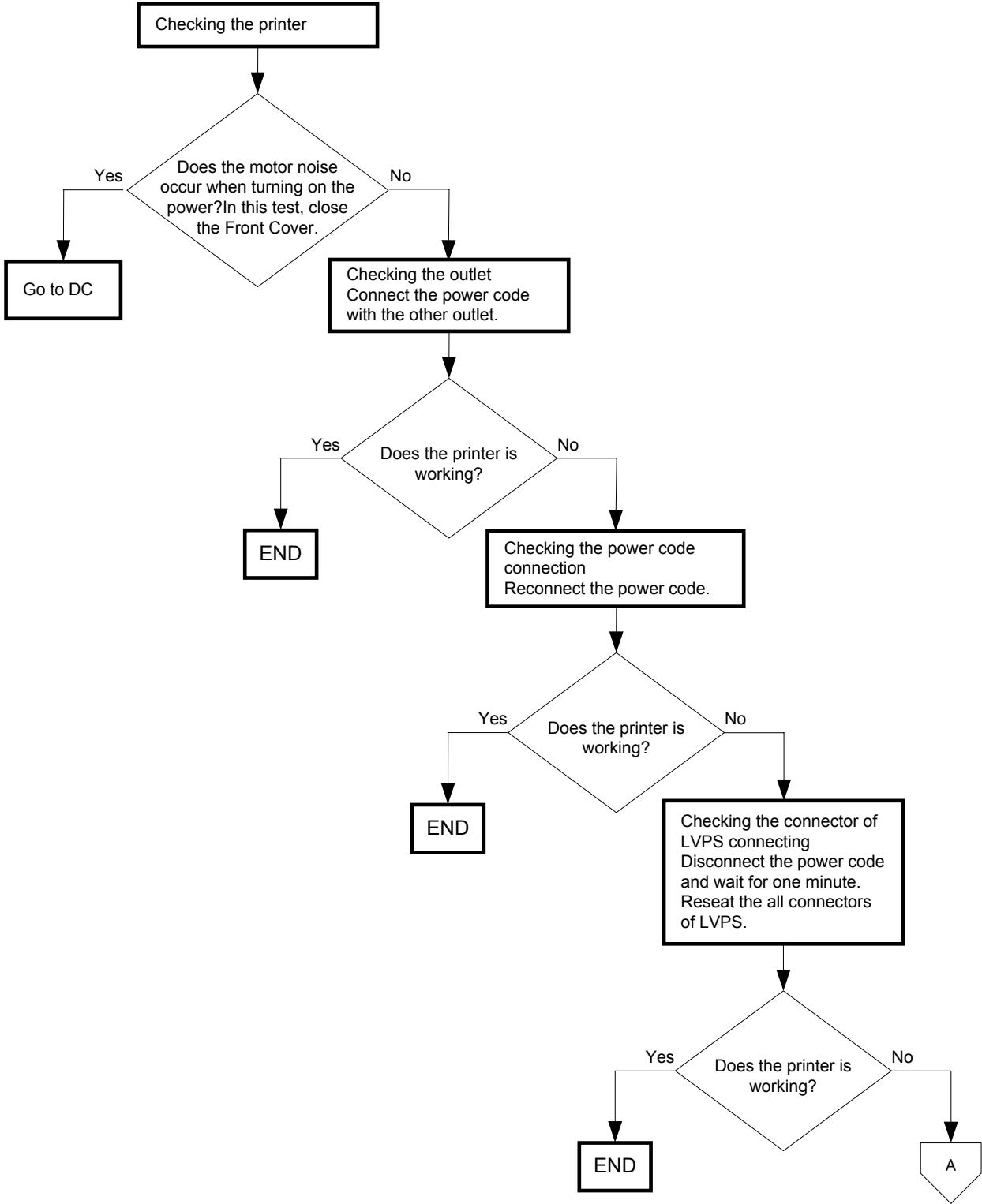

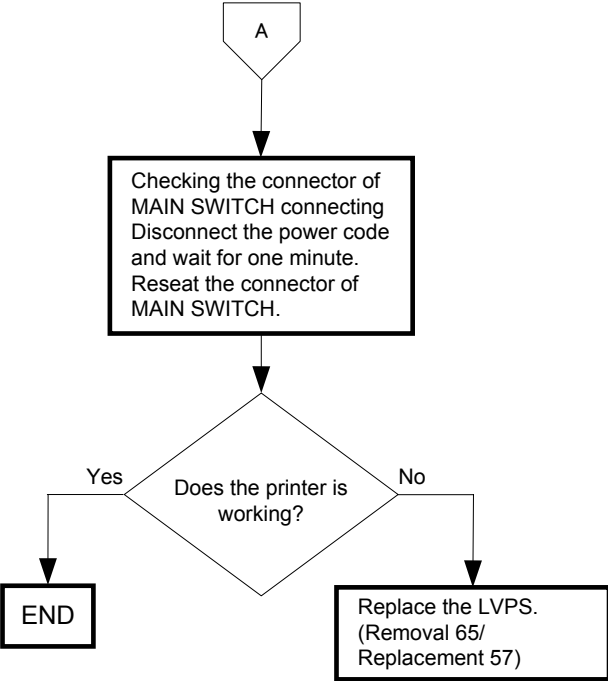

FIP-DC

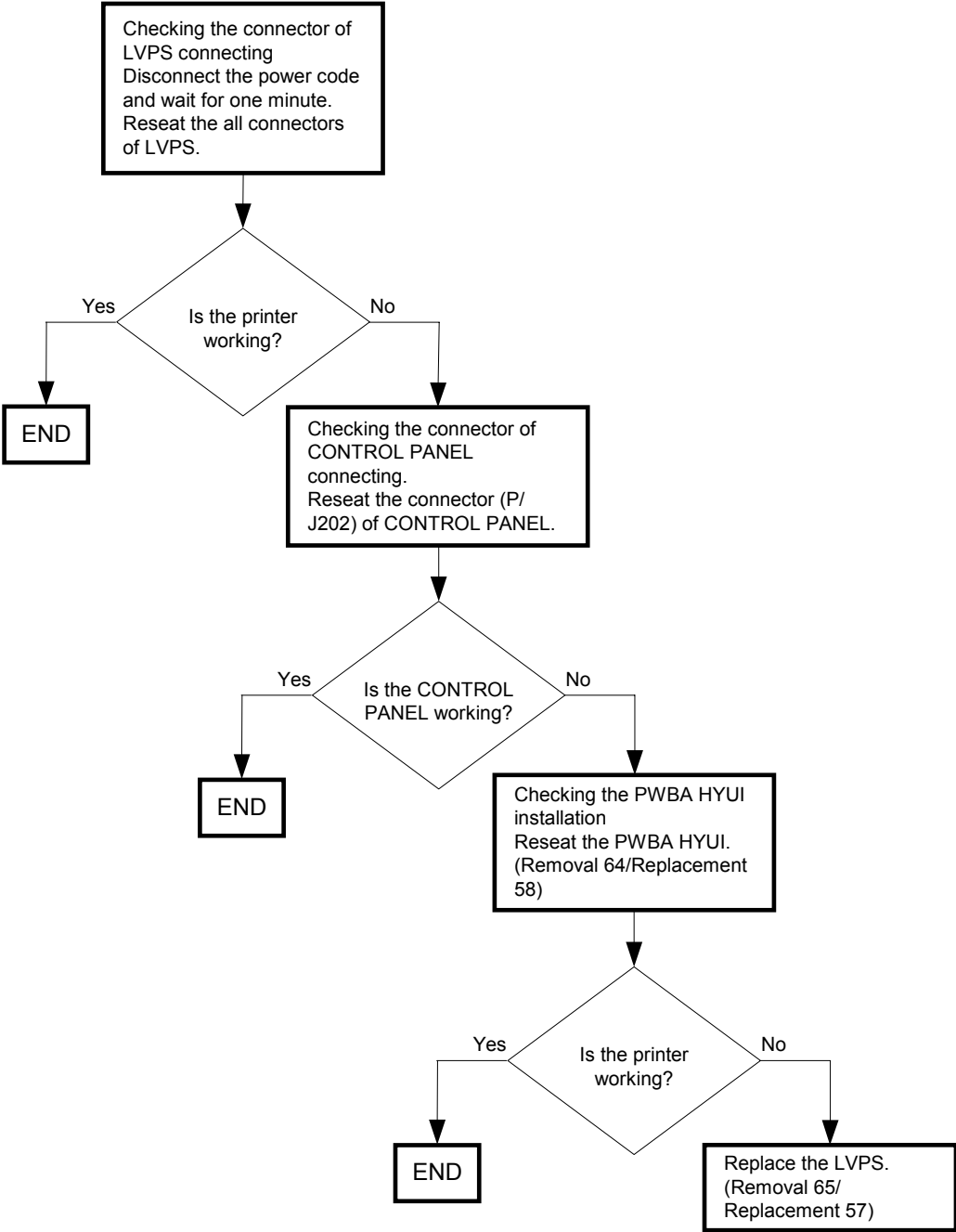

FIP-Multiple feed

Possible causative parts:KIT SEPARATOR ROLLER ASSEMBLY (PL2.1.99)
KIT SEPARATOR AND FEEDER ROLLER (PL2.2.99/PL12.3.99)

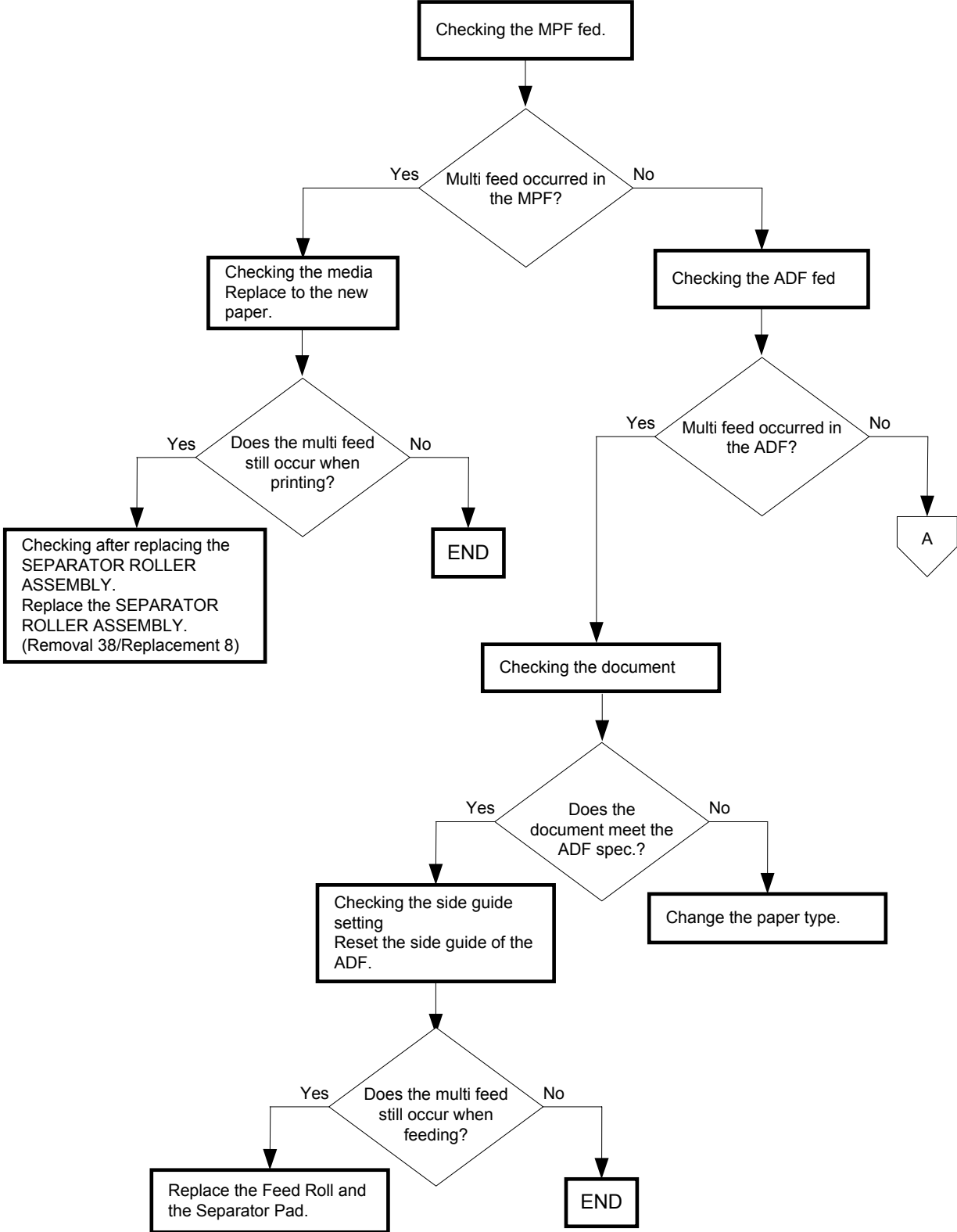

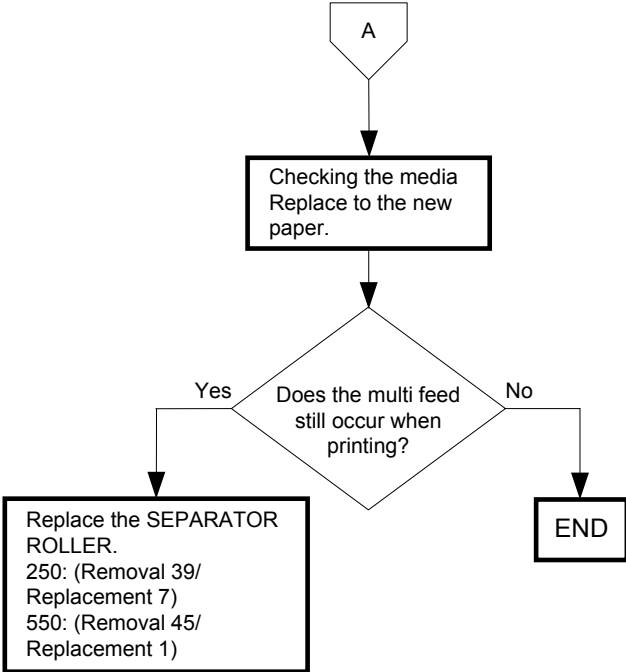

FIP-Document source selection fault

NOTE

Although the original is set on the ADF, copying will not start due to [Auto fit] setting.

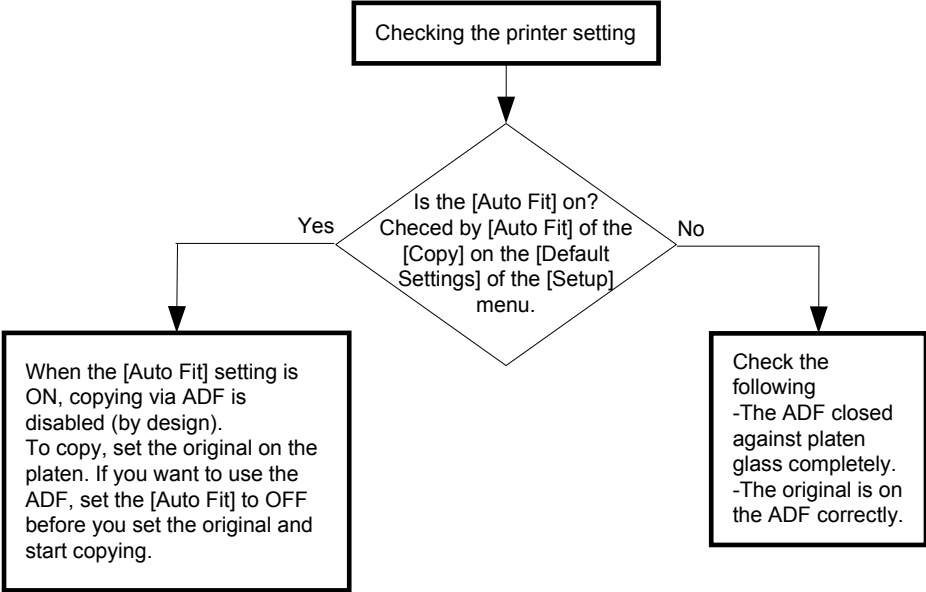

Chapter 2 Operation of Diag. CONTENTS

1. Overview.....	2 - 1
1.1 Position of the Diag. in the Whole System.....	2 - 1
2. Configuration	2 - 2
3. How to use Diag. Customer Mode.....	2 - 3
3.1 Roles of the control panel in Diag.	2 - 3
3.2 Entering diag. Customer mode	2 - 4
3.3 Selecting Diag. mode	2 - 4
3.4 Selecting Diag. item	2 - 4
3.5 Change method parameters value.....	2 - 4
3.6 Executing/Exiting Diag. mode	2 - 4
3.7 Diag. mode menu tree	2 - 5
4. The Kind of Diag. and Contents of a Test	2 - 9
4.1 FAX Scanner Diag.	2 - 9
4.1.1 Executing FAX Scanner Diag	2 - 9
4.1.2 Information.....	2 - 9
4.1.3 Scanner Maintenance	2 - 9
4.1.4 Parameter	2 - 10
4.1.5 BackUp Data.....	2 - 14
4.1.6 Complete.....	2 - 14
4.2 Printer Diag	2 - 15
4.2.1 ESS Diag	2 - 15
4.2.1.1 Executing ESS diagnosis.....	2 - 15
4.2.1.2 All Test.....	2 - 15
4.2.1.3 CodeROM Test.....	2 - 15
4.2.1.4 FontROM Test	2 - 16
4.2.1.5 EEPROM Test	2 - 16
4.2.1.6 DRAM Test	2 - 16
4.2.1.7 MAC+PHY Test	2 - 17
4.2.1.8 ASIC Test	2 - 17
4.2.1.9 IOT Test.....	2 - 17
4.3 IOT Diag.....	2 - 18
4.3.1 Digital Input (DI) Test.....	2 - 18
4.3.2 Executing digital input (DI) test	2 - 18
4.3.3 Digital Output (DO) Test	2 - 29
4.3.4 Executing digital output (DO) test	2 - 29
4.4 Print Info.....	2 - 53
4.4.1 Config Page	2 - 53
4.4.2 Print Settings.....	2 - 53
4.5 Complete.....	2 - 53
4.5.1 Complete.....	2 - 53
4.6 Test Print.....	2 - 54
4.6.1 Executing test print	2 - 54
4.6.2 No Image [IOT]	2 - 54
4.6.3 Test Pattern 600[IOT]	2 - 54
4.6.4 Grid2	2 - 55

Chapter 2 Operation of Diag. CONTENTS

4.6.5 Cyan 20%	2 - 56
4.6.6 Magenta 20%	2 - 56
4.6.7 Yellow 20%	2 - 57
4.6.8 Black 20%	2 - 57
4.6.9 CMY 20%	2 - 58
4.6.10 Gradation	2 - 59
4.6.11 Toner Pallet Check	2 - 60
4.6.12 Contamination Check.....	2 - 61
4.6.13 Parameter Setting	2 - 62
4.6.14 Printing the parameter list.....	2 - 64

1. Overview

1.1 Position of the Diag. in the Whole System

Major functions of this diag. are as follows:

- ESS diagnosis to locate a chip which causes a problem
- IOT Diag
- Setting of parameters for registration in paper feeding direction and so on.

2. Configuration

The diagnosis provides three modes that have their respective uses (purposes), target operators, and functions.

Shippper Mode:

This mode intends to be used in the production line with the purpose to locate a chip that causes a problem.

Diagnosis time in the mode shall be as short as possible with consideration of production cost.

The mode shifts to the Developer mode (described later) after the ESS Diag.

This mode is protected password.

Customer Mode:

This mode intends to be used by customer who handle problems in field with the purpose to locate a replaceable unit that causes a problem.

Sorting problems on the basis of parts that can be replaced by the customer support center.

This is the base of this mode design, and that is why so many features.

The mode allows the user to execute the ESS diagnosis, test prints, parameter settings FAX, Scanner and so on through the control panel.

Developer/CE (Customer Engineer) Mode:

This mode is for debugging by developers or CEs. It intends to be partially used in the production line.

The mode allows the user to execute the ESS diagnosis, test prints, parameter settings and so on through the debug terminal.

The functions are activated by commands sent from the serial terminal. Special tool (FX internal debugging terminal) is required to operate Developer mode.

This mode is protected password.

3. How to use Diag. Customer Mode

3.1 Roles of the control panel in Diag.

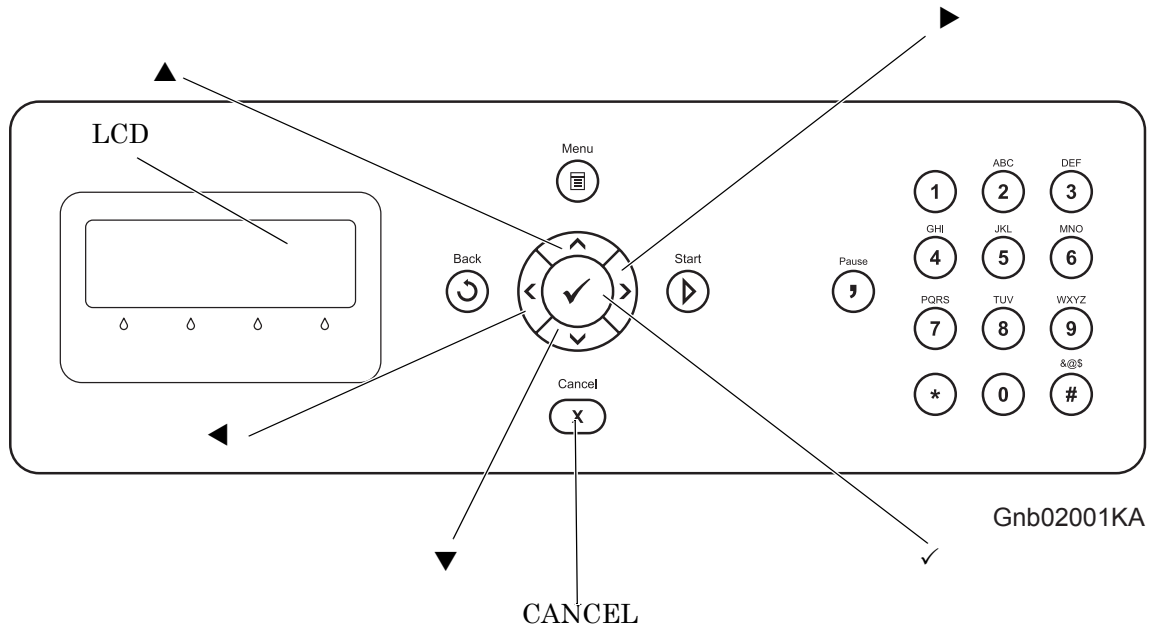

- [LCD]: Displaying a diagnosis item and its result
- [▲], [▼]: Selecting a diagnosis item/Selecting data at parameter setting
- [◀], [▶]: Key moves the cursor to the left/right
- [✓]: Determining a diagnosis item/Executing a diagnosis/Determining a parameter at parameter setting
- [CANCEL]: Resetting a diagnosis item (Returning to the menu one level higher)
Terminating each digital input/output

3.2 Entering diag. Customer mode

- 1) Turn off the power.
- 2) Turn on the power while holding down “▲” and “▼” keys.
- 3) Release the fingers from these keys when “Please wait...” is displayed.
- 4) The “Customer Mode”, “FAX/Scanner Diag” and “Printer Diag” are displayed. (Entered the Diag. mode.)

3.3 Selecting Diag. mode

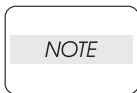

Once FAX/Scanner Diag or Printer Diag is selected, the diag mode cannot be changed. To change the diag mode, exit the selected diag mode and enter the diag mode again.

There are two diag modes in the customer diag.

-FAX/Scanner Diag

The menu of the FAX, ADF and Scanner relation.

-Printer Diag

The menu of the printer relation.

3.4 Selecting Diag. item

The diagnosis setting items are configured as menus, which can be operated with the control panel keys. Arrow keys select menu items and “✓” key activates functions.

3.5 Change method parameters value

For parameter setting, pressing “✓” key after selecting an item from the menu displays the current setting value of the item. Then a numeric value selected by “▼” and “▲” keys are written into the NVM by “✓” key.

3.6 Executing/Exiting Diag. mode

The diagnosis can be executed by as follows.

- 1) A test item is displayed. “✓” key fixed the test item.
- 2) The display prompts the user to start the test. Press “✓” key and start the test.

The diagnosis can be stopped by as follows.

- 1) During the diagnosis test, press “CANCEL” key.
- 2) The diagnosis is stopped, and the display indicates the one step higher menu.

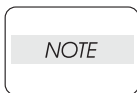

If an error occurs during the diag. sequence, the diagnosis displays the error and stops, leaving the remaining items unperformed.

Pressing “CANCEL” or “✓” key releases the error display, and then the menu items are displayed.

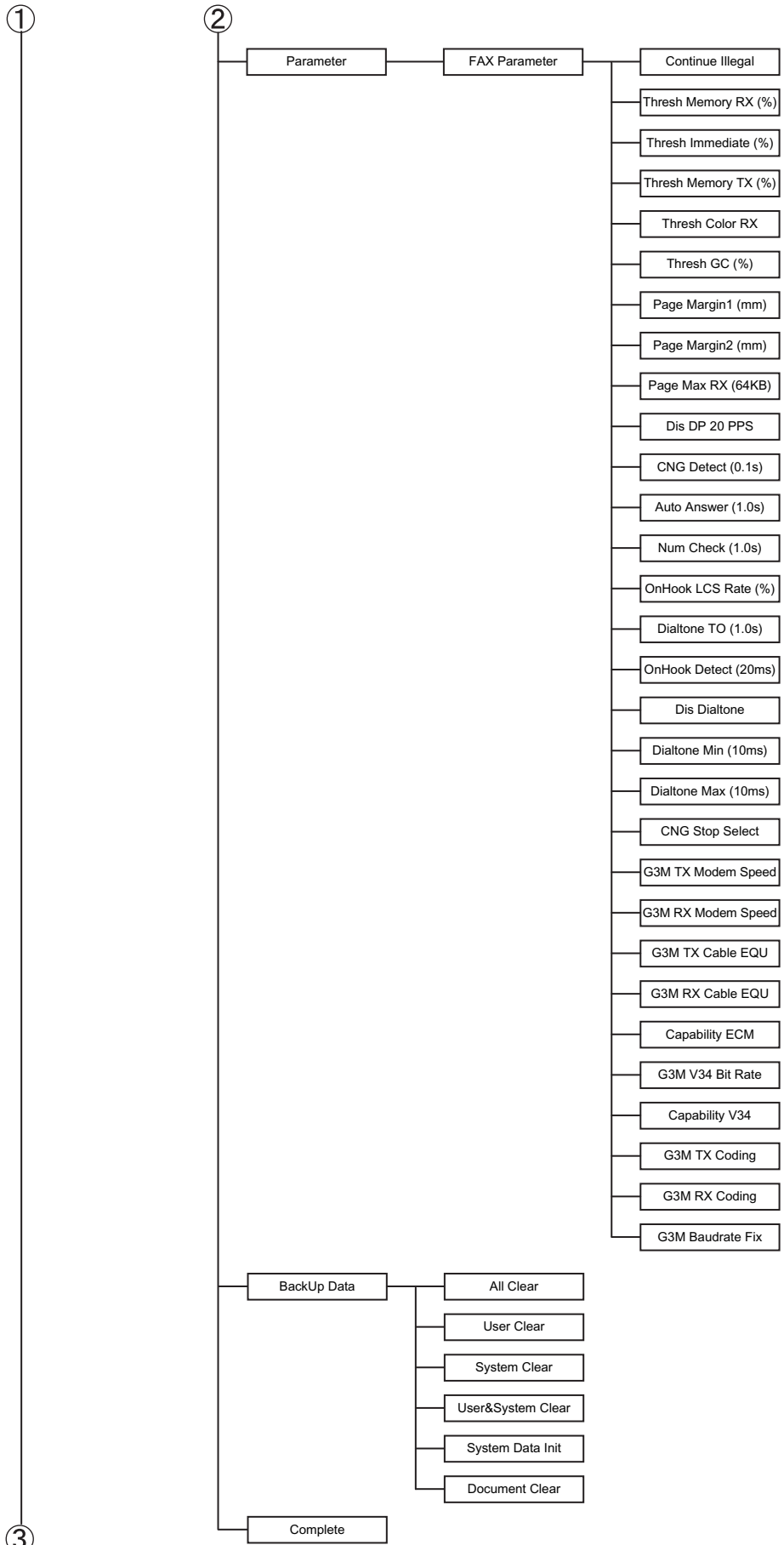

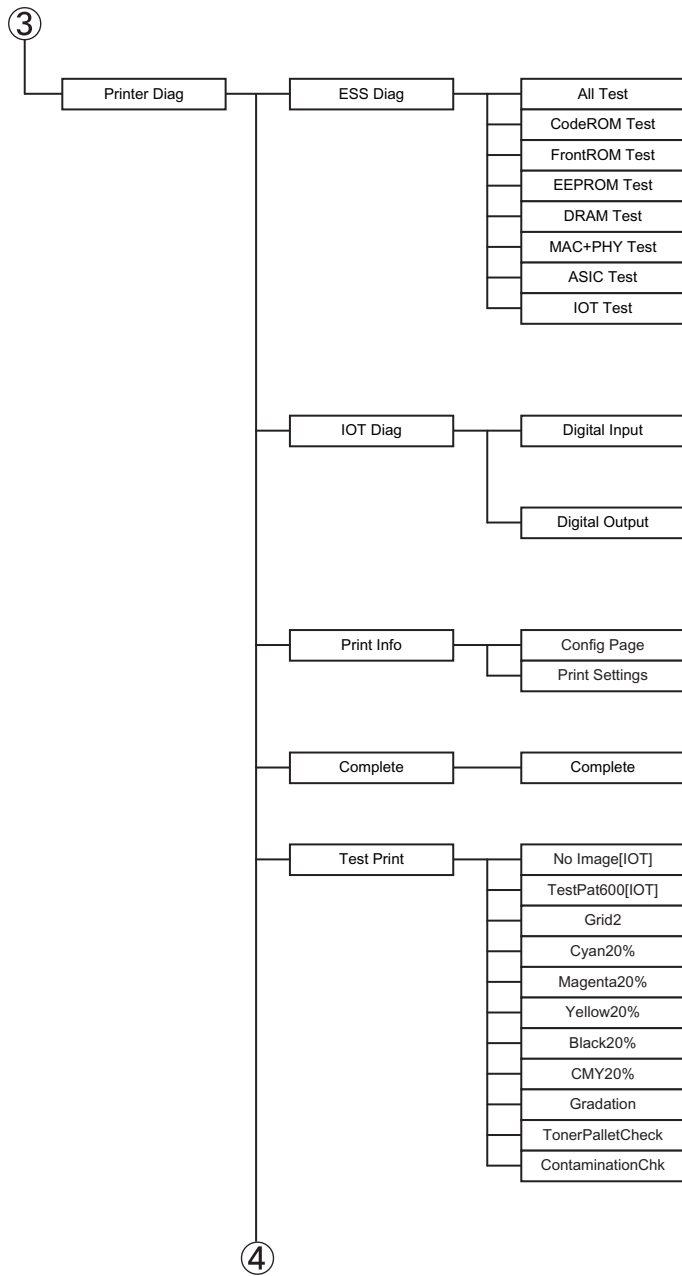

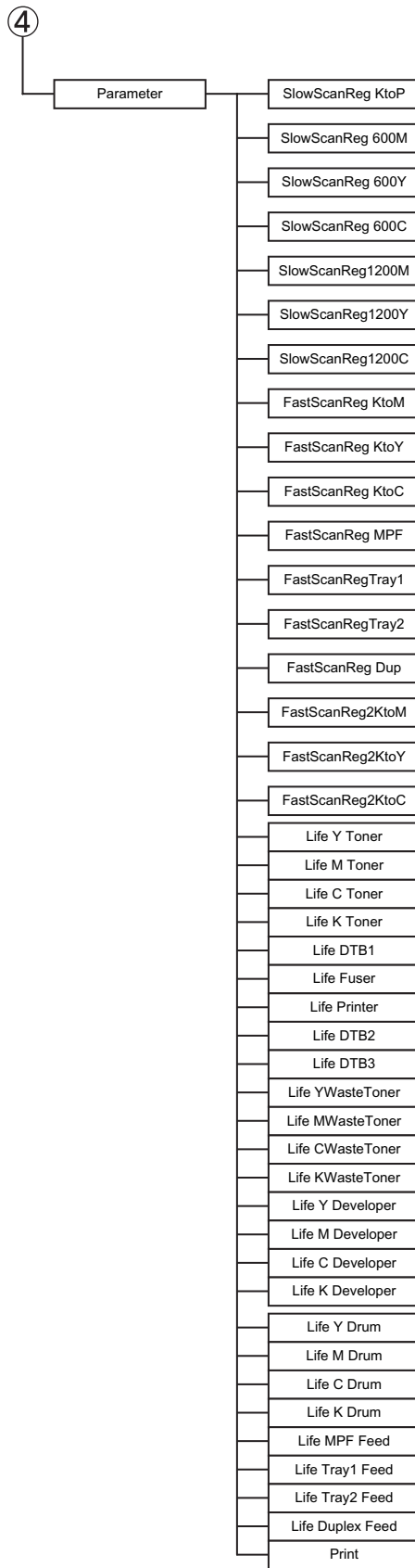

4. The Kind of Diag. and Contents of a Test

4.1 FAX Scanner Diag.

4.1.1 Executing FAX Scanner Diag

- 1) Turn off the power.
- 2) Turn on the power while holding down “▲” and “▼” keys.
- 3) Release the fingers from the keys when “Please wait...” is displayed.
- 4) The “FAX /Scanner Diag” and “Printer Diag” are displayed. (Entered the Customer Diag. mode.)
- 5) Press “✓” key. (Entered the FAX /Scanner Diag. mode.)
- 6) Press “▲” or “▼” key to select the test item.
- 7) Press “✓” key twice to execute the test.

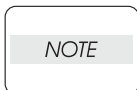

To exit the test or to return to one step higher menu, press "CANCEL" key.

4.1.2 Information

- Scan Counter

The value of scan count is displayed. FB: Scanning of platen mode/ADF: Scanning of ADF mode.

- Version

The software versions are displayed.

Main	Main program version
Param	Parameter version
Boot	Boot program version
Dload	Down load program version
IIT	Scanner and ADF control program version
Panel	Control panel program version

4.1.3 Scanner Maintenance

- White Balance

Enables automatic calibration of the correction value for platen scanning (FB) and ADF scanning (ADF).

- Parameter

Enables manual calibration of the registration adjustment value or correction value. Use this menu to enter the correction value when replacing the scanner.

- Counter Clear

Initializes the counter value of platen scanning (FB) and ADF scanning (ADF). Use this menu to enter the correction value when replacing the scanner.

4.1.4 Parameter

- Continue Illegal

Specifies how to handle the document data when the document data in the transmission queue overflows the memory.

Clear	Delete the document data.
Transmit	Place the portion of the document data up to the memory limit in the transmission queue.

- Thresh Memory RX (%)

Sets the amount of memory to be left free when the received document data is stored. When the remaining memory amount falls below this threshold, data reception is denied.

The value can be set in the range of 0 to 100. The smaller the value, the larger the memory capacity becomes

- Thresh Immediate (%)

Sets the remaining memory amount threshold that triggers immediate output. Immediate output refers to an automatic image data output that is performed to accommodate the overflowing data when the incoming document data exceeds the memory capacity.

The value can be set in the range of 0 to 99. The larger the value, the sooner the immediate output is initiated.

- Thresh Memory TX (%)

Sets the amount of memory to be left free when the document data is placed in the transmission queue.

The value can be set in the range of 0 to 100. The smaller the value, the larger the memory capacity for transmission queue becomes.

- Thresh Color RX

Sets the amount of memory to be left free when the received color FAX data is stored. Below are the setting values:

0.5Mbyte/1.0Mbyte/1.5Mbyte

- Thresh GC (%)

Sets the remaining memory amount in the Flash file system for image data storage that triggers the "garbage collection"

- Page Margin1 (mm), Page Margin2 (mm)

Sets the page size margin that allows a larger-than-standard size document to be handled as a standard size document. The document is reduced to the standard size, assuming it is larger than the standards size by the set value.

The value can be set in the range of 0 to 127. When the value is 10, the margin is 10 mm.

- Page Max RX (64KB)

Sets the maximum reception capacity per page for color FAX data. The value can be set in the range of 0 to 64 in 64Kbyte steps.

- Dis DP 20PPS

Sets whether or not to enable 20PPS dial pulse. When 20PPS is disabled in this menu, any 20PPS setting in other menu will be overridden with 10PPS.

- CNG Detect (0.1s)

Sets the CNG detection duration for telephone-FAX switching.

The value can be set in the range of 0 to 255. When the value is 100, the detecting time is 10 sec.

- Auto Answer (1.0s)

Sets the ringing tone duration of the external telephone terminal for FAX-telephone switching.

The value can be set in the range of 0 to 255. When the value is 100, the ringing tone duration is 100 sec.

- Num Check (1.0s)

Inhibits autodialing for a specified duration when different sets of document data bound for the same destination are placed consecutively in the transmission queue. This pause allows the receiving side to make time for processing.

The value can be set in the range of 0 to 255. When the value is 10, the autodialing pause is 10 sec.

- OnHook LCS Rate (%)

This parameter is used for auto-adjustment of off-hook detection threshold of the external telephone.

- Dial tone TO (1.0s)

Sets the duration for detecting the dial tone. The value can be set in the range of 0 to 255. When the value is 10, the dial tone is detected for 10 sec.

- OnHook Detect (20ms)

Sets the detecting duration for a valid onhook signal. The value can be set in the range of 10 to 255. When the value is 10, the onhook detecting duration is 200 msec. Any onhook signal shorter than the set time is invalid.

- Dis Dial tone

Sets whether or not to enable dial tone pattern detection.

- Dial tone Min (10ms)

Sets the minimum limit of dial tone pattern detection duration.

- Dial tone Max (10ms)

Sets the maximum limit of dial tone pattern detection duration.

- CNG Stop Select

Sets the conditions for stopping CNG transmission. Below are the setting conditions:

CED&V21	When CED and V.21 preamble are detected.
CED	When CED is detected.
V21	When V.21 preamble is detected.

- G3M TX Modem Speed

Sets the signaling rate for transmission. The signaling rates are as follows:

Fallback Partner	The rate falls back below the maximum capability of the receiving side.
Fallback V27ter	The rate falls back below 2400bps of the V27ter mode.
V27ter	2400bps, 4800bps
V29	7200bps, 9600bps
V33	12000bps, 14400bps
V17	7200bps, 9600bps, 12000bps, 144000bps

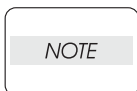

Data signaling rate can also be set via G3M Baud rate Fix. When different rates are set via G3M TX Modem Speed and G3M Baud rate Fix, the latter takes precedence.

- G3M RX Modem Speed

Sets the signaling rate for reception. Below are the signaling rates:

V27ter+V29+V33+V17/V27ter (2400bps)/V27ter (2400bps, 4800bps)/V29 (7200bps, 9600bps)/
V27ter+V29/V27ter+V29+V33

- G3M TX Cable EQU

Sets the cable amplitude equalizer value for transmission. Below are the setting values:

0db	Equivalent to a cable length of 0km.
4db	Equivalent to a cable length of 1.8km.
8db	Equivalent to a cable length of 3.6km.
12db	Equivalent to a cable length of 7.2km.

- G3M RX Cable EQU

Sets the cable amplitude equalizer value for reception (applicable to V17, V29, and V27ter). Below are the setting values:

0db	Equivalent to a cable length of 0km.
4db	Equivalent to a cable length of 1.8km.
8db	Equivalent to a cable length of 3.6km.
12db	Equivalent to a cable length of 7.2km.

- Capability ECM

Sets whether or not to enable ECM.

0: Disabled, 1: Enabled.

- G3M V34 Bit Rate

Sets the signaling rate for the Super G3 (V34) mode.

The value can be set in the range of 2400bps to 33600bps in 14 steps. Below are the signaling rates:

2400/4800/7200/9600/12000/14400/16800/19200/21600/24000/26400/28800/31200/33600

- Capability V34

Sets the communication capability of the Super G3 (V34) mode.

- G3M TX Coding

Sets the data encoding method for transmission. When the encoding method set here is not supported by the receiving side, the receiving side's method is adopted. Below are the encoding methods:

MH/MR/ MMR/JBIG

- G3M RX Coding

Sets the data encoding method for reception. Below are the encoding methods:

MH/MR/ MMR/JBIG

- G3M Baud rate Fix

Sets the signaling rate for transmission. Below are the signaling rates:

Disable/2400bps/4800bps/7200

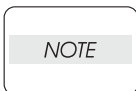

Data signaling rate can also be set via G3M TX Modem Speed. When different rates are set via G3M Baud rate Fix and G3M TM Modem Speed, the former takes precedence.

4.1.5 BackUp Data

Initializes or clears the backup data.

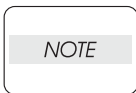

When performing this procedure, make sure that you have selected the right country.

-All Clear

Clears all of the backup data.

- User Clear

Clears the stored document data and the address information. Initializes the system data.

- System Clear

Clears the stored document data, the communication management data and the history. Initializes the system data.

- User & System Clear

Clears the stored document data, the address information, the communication management data and the history. Initializes the system data.

- System Data Init

Initializes the system data.

- Document Clear

Clears the stored document data

4.1.6 Complete

Exits the diagnostics and returns to normal operation, taking the changes of the data into effect.

4.2 Printer Diag

4.2.1 ESS Diag

This section describes how to perform each test of the ESS Diag in detail.

4.2.1.1 Executing ESS diagnosis

- 1) Turn off the power.
- 2) Turn on the power while holding down “▲” and “▼” keys.
- 3) Release the fingers from these keys when “Please wait...” is displayed.
- 4) The “Customer Mode” “FAX/Scanner Diag” and “Printer Diag” are displayed. (Entered the Diag. mode.)
- 5) Select “Printer Diag” and press “✓” key.
- 6) Select “ESS Diag”.
- 7) Press “✓” key.
- 8) Press “▲” or “▼” key to select the test item.
- 9) Press “✓” key twice to execute the test.

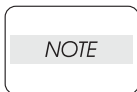

To exit the test or to returning to one step higher menu, press “CANCEL” key.

4.2.1.2 All Test

Executes the ESS Diag except the following.

This test executes the all tests of the ESS diagnostic except the MAC+PHY test and PANEL test.

Normal	Error
CHECK OK	*** ERROR

***:Displays the test name that became error.

(CodeROM/FontROM/EEPROM/DRAM/ASIC/IOT/HD)

4.2.1.3 CodeROM Test

Calculates the ROM checksum and compares it with the value stored in the ROM.

Executes this test when the 016-317 error occurred.

Test result: NG (Go to FIP.) OK (Turn off/on the main power.)

This test calculates the checksum of the each ROM, and compares it with the valid checksum value stored in the corresponding chip beforehand. When the checksum is identical to the stored value, this test judges the chip is normal.

Normal	Error
CHECK OK	CodeROM #* ERROR S=xxxx V=yyyy (xxxx:calculated value yyyy:ROM stored value *:0,1)

4.2.1.4 FontROM Test

Calculates the Font ROM checksum and compares it with the value stored in the FontROM.

Executes this test when the 016-310 error occurred.

Test result: NG (Go to FIP.) OK (Turn off/on the main power.)

This test calculates the checksum of the each FontROM, and compares it with the valid checksum value stored in the corresponding chip beforehand. When the checksum is identical to the stored value, this test judges the chip is normal.

Normal	Error
CHECK OK	FontROM ERROR S=xxxx V=yyyy (xxxx:calculated value yyyy:ROM stored value)

4.2.1.5 EEPROM Test

Performs write/read/verify on the diag. area of the EEPROM.

Executes this test when the 016-327 and 016-323 errors occurred.

Test result: NG (Go to each FIP.) OK (Turn off/on the main power.)

The test performs read/write/verify of the test patterns (0xff,0xaa, 0x55 and 0x00) on one byte at every 0x400 from the first address of EEPROM.

Normal	Error
CHECK OK	EEPROM ID* ERROR (ID*:1,2)

4.2.1.6 DRAM Test

Tests OPEN/SHORT with the address line of the DRAM.

Performs write/read/verify on the entire DRAM.

Executes this test when the 016-315, 016-316, 016-318 and 016-332 errors occurred.

Test result: NG (Go to each FIP.) OK (Turn off/on the main power.)

When the optional DRAM SIMM is checked and found, it checks the optional memory area.

First, the test performs read/write/verify of the increment data for the whole tested area by the word. Then, it performs read/write/verify of the test patterns (0xffffffff, 0xaaaaaaaa, 0x55555555, 0x00000000) for the whole tested area by the word.

Normal	Error
CHECK OK	DRAM slot* ERROR (*AF0,1)

4.2.1.7 MAC+PHY Test

MAC: Media Access Control

PHY: Physical Layer

PHY Internal loopback test

Executes this test when the 016-334, 016-340, 016-344, 016-345 and 016-346 errors occurred.

Test result: NG (Go to each FIP.) OK (Turn off/on the main power.)

PHY Internal loopback test

Normal	Error
CHECK OK	MAC+PHY ERROR

4.2.1.8 ASIC Test

Register check

Executes this test when the 016-313 error occurred.

Test result: NG (Go to FIP.) OK (Turn off/on the main power.)

ASIC register check.

Normal	Error
CHECK OK	ERROR

4.2.1.9 IOT Test

Communication test with the IOT

Executes this test when the 016-370 error occurred.

Test result: NG (Go to FIP.) OK (Turn off/on the main power.)

This test checks communication with the IOT. Then it reads the status register of the IOT to check whether commands can be exchanged with the IOT.

It sends the following command to read the status register, and checks whether the appropriate response returns.

Read ROM Revision No

Normal	Error
CHECK OK	IOT ERROR

4.3 IOT Diag

4.3.1 Digital Input (DI) Test

This function checks whether the DI components operate normally or not.

The DI test is performed for all the DI components.

Exit operation of the DI test makes the control panel display the Customer diag. function menu.

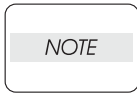

During the DI test, other Customer diag. functions can not be performed simultaneously. Therefore, the printer does not accept any operation except operations for the DI components and exit operation of the DI test.

At the start of the DI test, number “0” is displayed on the control panel. This number is counted up when a DI component is turned on from off, therefore it allows the user to know the component is active.

When a paper jam is occurred, or an error message or code is displayed, execute this test to locate the damaged parts.

The test will execute the DI Test codes of the components that are supposed to be faulty from the error details. (Refer to each FIP on Chapter 1.)

Test result: NG (Go to each FIP or replace the parts.)

OK (Turn off/on the main power.)

4.3.2 Executing digital input (DI) test

- 1) Turn off the power.
- 2) Turn on the power while holding down “▲” and “▼” keys.
- 3) Release the fingers from these keys when “Please wait...” is displayed.
- 4) The “Customer Mode”, “FAX/Scanner Diag” and “Printer Diag” are displayed. (Entered the Diag. mode.)
- 5) Press “▼” to select “Printer Diag”, and press “✓” key.
- 6) Press “▼” to select “IOT Diag”, and then press “✓” key.
- 7) Press “▼” key to select “Digital Input”, and then press “✓” key.
- 8) Press “▲” or “▼” key to select the test item.
- 9) Press “✓” key twice to execute the test.

Parameters for the Digital Input Test are as follows.

Code	Components
DI-1	Dup Jam sensor
DI-2	Exit Sensor
DI-3	Regi Sensor
DI-4	ROS Ready (Not Used)
DI-7	Front Cover Interlock Switch
DI-8	Yellow Toner Cartridge Sensor
DI-9	Magenta Toner Cartridge Sensor
DI-a	Black Toner Cartridge Sensor
DI-b	Cyan Toner Cartridge Sensor
DI-d	Tray 2 No Paper sensor
DI-e	Duplex Fan Alarm (Not Used)
DI-f	Teay 2 Feed Motor Alarm (Not Used)

Code	Components
DI-10	MPF No Paper Sensor
DI-11	Tray 1 No Paper Sensor
DI-12	Main Motor Alarm (Not Used)
DI-13	Sub Motor Alarm (Not Used)
DI-14	OHP Sensor (Not Used)
DI-15	Fan Alarm (Not Used)
DI-16	Feed Drive Alarm (Not Used)
DI-17	Deve Motor Alarm (Not Used)
DI-18	Tray 1 Paper Size Switch
DI-20	Tray 2 Paper Size Switch

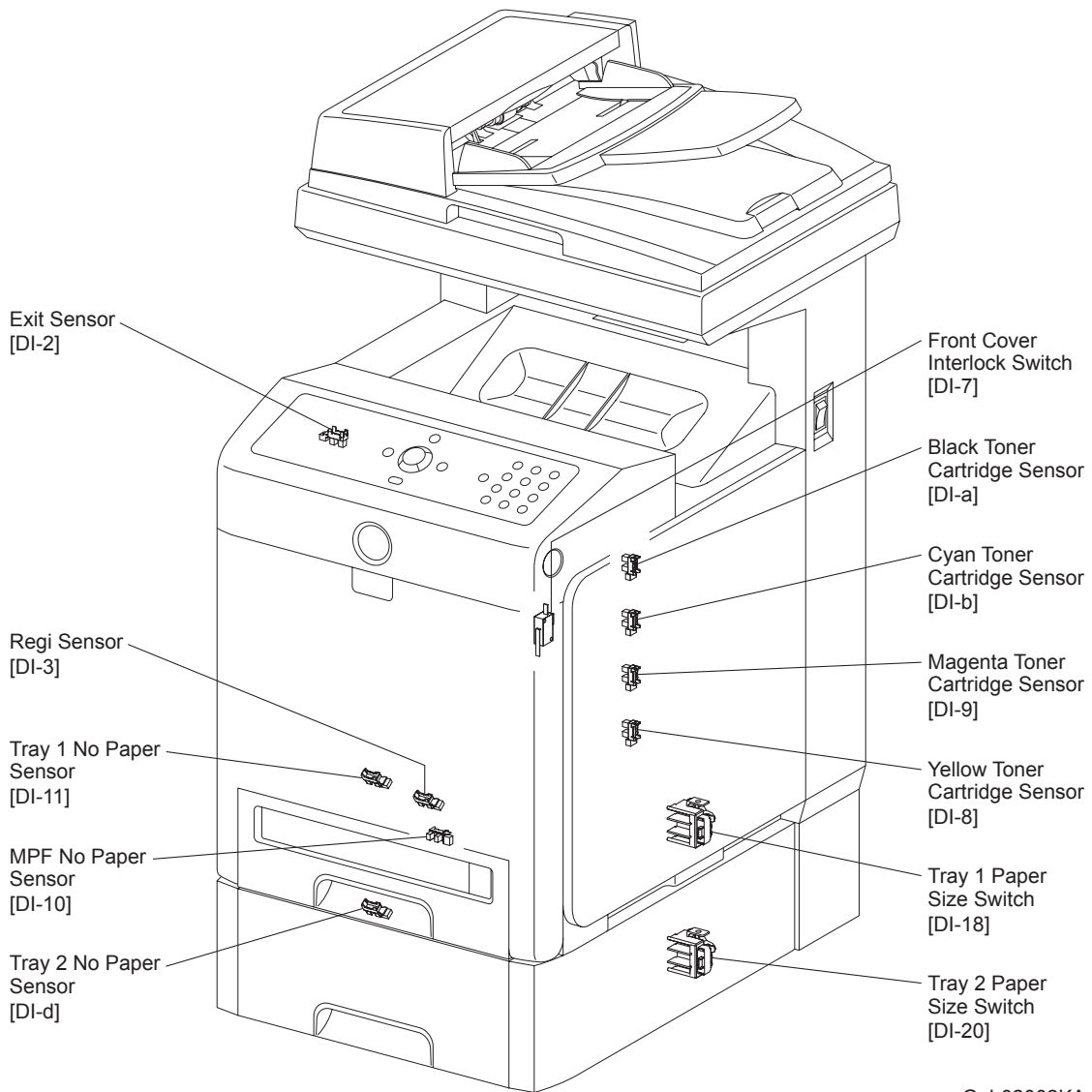

Gnb02002KA

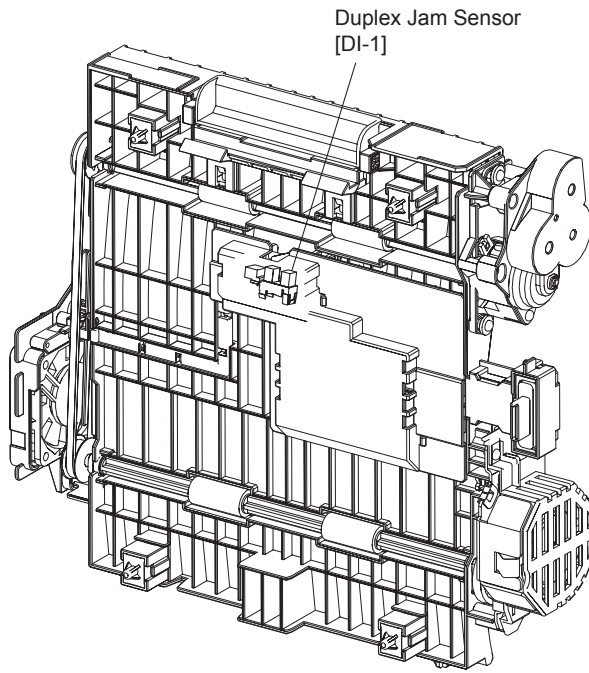

Kmy02042KA

- About Sensor

A transmissive type sensor is composed of the light-emitting side and the light-receiving side that are placed opposite to each other allowing the light to pass from the former to the latter. On the basis of whether or not the light path is blocked due to the actuator, etc., the sensor detects the paper absence/presence or the moving part position such as at the home position or elsewhere.

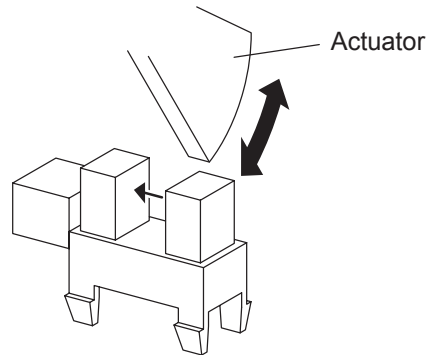

Leg_Sec02_016FA

- About Switch

A micro-switch closes the internal contacts via the button which is pushed down under the provided leaf spring which is held down by the actuator of the cover or door that is being closed. When the door or cover has been opened, the leaf spring returns to its original position and the button is pushed up by the spring in the switch, allowing the internal contacts to open.

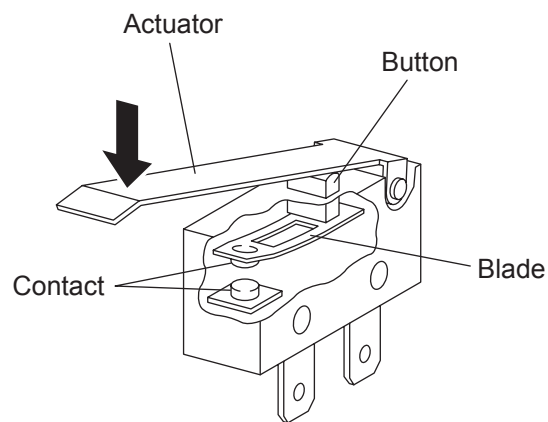

Leg_Sec02_018FA

-Checking the Sensor and Switch

Sensor name (Diag. Code)	Confirmation procedures
<p>Duplex Jam Sensor (DI-1)</p>	<p>NOTE:When performing operation for five minutes or longer with the front cover open, remove all toner cartridges, and cover the drum to avoid exposure to light.</p> <ol style="list-style-type: none"> 1) Turn on the power and enter the Printer Diag. 2) Execute the DI-1. 3) Open the Front Cover. 4) Remove the Transfer Belt. 5) Check the sensor. <div data-bbox="783 539 1265 819" style="border: 1px solid black; padding: 5px; margin: 10px 0;"> </div> <p style="text-align: right; font-size: small;">Kmy02003KA</p> <ol style="list-style-type: none"> 6) Press the "Cancel" key to stop the test. 7) Replace the Transfer Belt. 8) Close the Front Cover.

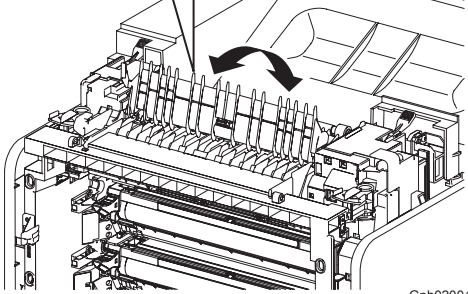
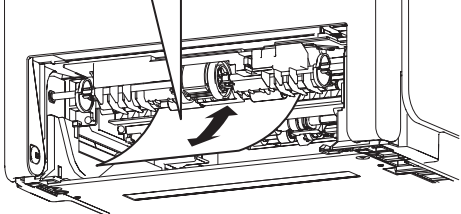
Sensor name (Diag. Code)	Confirmation procedures			
Exit Sensor (DI-2)	<p>NOTE: Fuser is very hot, so pay sufficient attention at work to above burns, etc.</p> <ol style="list-style-type: none"> 1) Turn on the power and enter the Printer Diag. 2) Execute the DI-2. 3) Open the Front Cover. 4) Check the sensor. <div data-bbox="764 414 1281 851" style="border: 1px solid black; padding: 5px;"> <p>Operator Panel</p> <table style="width: 100%; border-collapse: collapse;"> <tr> <td style="border: 1px solid black; padding: 2px;">Digital Input DI- 2 L 0</td> <td style="text-align: center; padding: 0 10px;">Normal ➔</td> <td style="border: 1px solid black; padding: 2px;">Digital Input DI- 2 L 1</td> </tr> </table>  <p style="text-align: right; font-size: small;">Gnb02004KA</p> </div> <ol style="list-style-type: none"> 5) Press the "Cancel" key to stop the test. 6) Close the Front Cover. 	Digital Input DI- 2 L 0	Normal ➔	Digital Input DI- 2 L 1
Digital Input DI- 2 L 0	Normal ➔	Digital Input DI- 2 L 1		
Regi Sensor (DI-3)	<ol style="list-style-type: none"> 1) Turn on the power and enter the Printer Diag. 2) Execute the DI-3. 3) Remove the 250 paper cassette. 4) Insert the paper into the paper path of the Regi assy. <div data-bbox="764 1099 1281 1473" style="border: 1px solid black; padding: 5px;"> <p>Operator Panel</p> <table style="width: 100%; border-collapse: collapse;"> <tr> <td style="border: 1px solid black; padding: 2px;">Digital Input DI- 3 L 0</td> <td style="text-align: center; padding: 0 10px;">Normal ➔</td> <td style="border: 1px solid black; padding: 2px;">Digital Input DI- 3 L 1</td> </tr> </table>  <p style="text-align: right; font-size: small;">Kmy02005KA</p> </div> <ol style="list-style-type: none"> 5) Press the "Cancel" key to stop the test. 6) Replace the 250 paper cassette. 	Digital Input DI- 3 L 0	Normal ➔	Digital Input DI- 3 L 1
Digital Input DI- 3 L 0	Normal ➔	Digital Input DI- 3 L 1		
ROS Ready (DI-4)	Internal signal.			

Sensor name (Diag. Code)	Confirmation procedures
Interlock Switch (DI-7)	<ol style="list-style-type: none"> 1) Turn on the power and enter the Printer Diag. 2) Execute the DI-7. 3) Check the Switch <div data-bbox="767 315 1286 875" style="text-align: center;"> <p>Operator Panel</p> <p>Digital Input DI- 7 L 0 → Normal → Digital Input DI- 7 L 1</p> <p>Gnb02006KA</p> </div> <ol style="list-style-type: none"> 4) Press the "Cancel" key to stop the test. 5) Close the Front Cover.
Yellow Toner Cartridge (DI-8)	<p>NOTE: When performing operation for five minutes or longer with the front cover open, remove all toner cartridges, and cover the drum to avoid exposure to light.</p> <ol style="list-style-type: none"> 1) Turn on the power and enter the Printer Diag. 2) Execute the DI-8. 3) Open the Front Cover 4) Check the Sensor. <div data-bbox="767 1223 1286 1794" style="text-align: center;"> <p>Operator Panel</p> <p>Digital Input DI- 8 L 0 → Normal → Digital Input DI- 8 L 1</p> <p>Gnb02007KA</p> </div> <ol style="list-style-type: none"> 5) Press the "Cancel" key to stop the test. 6) Close the Front Cover.

Sensor name (Diag. Code)	Confirmation procedures
<p>Magenta Toner Cartridge (DI-9)</p>	<p>NOTE: When performing operation for five minutes or longer with the front cover open, remove all toner cartridges, and cover the drum to avoid exposure to light.</p> <ol style="list-style-type: none"> 1) Turn on the power and enter the Printer Diag. 2) Execute the DI-9. 3) Open the Front Cover 4) Check the Sensor. <div data-bbox="767 443 1283 1025" style="text-align: center;"> <p style="text-align: right; font-size: small;">Gnb02008KA</p> </div> <ol style="list-style-type: none"> 5) Press the "Cancel" key to stop the test. 6) Close the Front Cover.
<p>Black Toner Cartridge (DI-a)</p>	<p>NOTE: When performing operation for five minutes or longer with the front cover open, remove all toner cartridges, and cover the drum to avoid exposure to light.</p> <ol style="list-style-type: none"> 1) Turn on the power and enter the Printer Diag. 2) Execute the DI-a. 3) Open the Front Cover 4) Check the Sensor. <div data-bbox="767 1368 1283 1951" style="text-align: center;"> <p style="text-align: right; font-size: small;">Gnb02010KA</p> </div> <ol style="list-style-type: none"> 5) Press the "Cancel" key to stop the test. 6) Close the Front Cover.

Sensor name (Diag. Code)	Confirmation procedures
<p>Cyan Toner Cartridge (DI-b)</p>	<p>NOTE: When performing operation for five minutes or longer with the front cover open, remove all toner cartridges, and cover the drum to avoid exposure to light.</p> <ol style="list-style-type: none"> 1) Turn on the power and enter the Printer Diag. 2) Execute the DI-b. 3) Open the Front Cover 4) Check the Sensor. <div data-bbox="762 443 1283 1025" style="text-align: center;"> <p style="text-align: right; font-size: small;">Gnb02009KA</p> </div> <ol style="list-style-type: none"> 5) Press the "Cancel" key to stop the test. 6) Close the Front Cover.
<p>Tray 2 No paper Sensor (DI-d)</p>	<p>NOTE: The no paper sensor is in the option feeder.</p> <ol style="list-style-type: none"> 1) Turn on the power and enter the Printer Diag. 2) Execute the DI-d. 3) Remove the Paper Cassete. 4) Check the Sensor. <div data-bbox="783 1308 1267 1912" style="text-align: center;"> <p style="text-align: right; font-size: small;">Kmy02011KA</p> </div> <ol style="list-style-type: none"> 5) Press the "Cancel" key to stop the test. 6) Replace the paper cassette.

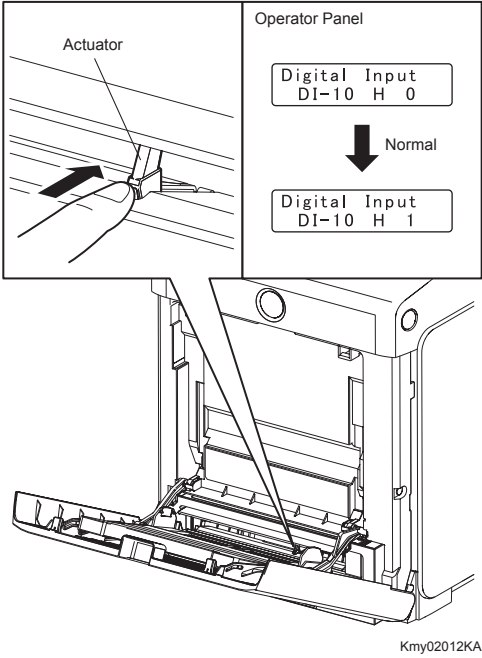
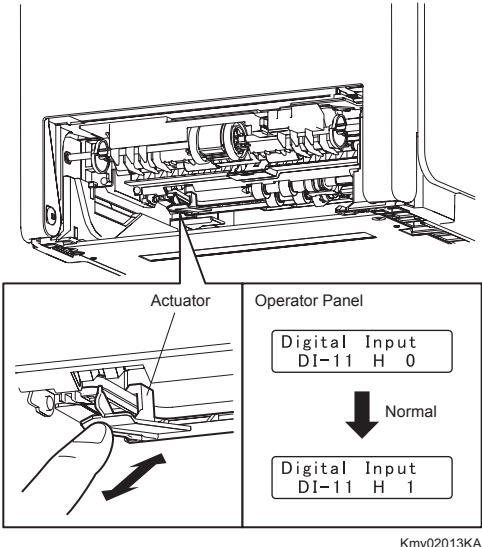
Sensor name (Diag. Code)	Confirmation procedures
Option Tray Feed Motor Alarm (DI-f)	Internal signal.
MPF No Paper Sensor (DI-10)	<p>NOTE: Remove the paper of the MPF before executing the test.</p> <ol style="list-style-type: none"> 1) Turn on the power and enter the Printer Diag. 2) Execute the DI-10. 3) Open the MPF Cover. 4) Check the sensor. <div style="text-align: center;">  <p>The diagram shows a hand pointing to the actuator on the MPF cover. To the right, the Operator Panel displays 'Digital Input DI-10 H 0'. A downward arrow labeled 'Normal' points to 'Digital Input DI-10 H 1'. Below this is a detailed view of the MPF mechanism with the actuator highlighted.</p> <p style="text-align: right; font-size: small;">Kmy02012KA</p> </div> <ol style="list-style-type: none"> 5) Press the "Cancel" key to stop the test. 6) Close the MPF Cover.
Tray 1 No paper Sensor (DI-11)	<ol style="list-style-type: none"> 1) Turn on the power and enter the Printer Diag. 2) Execute the DI-11. 3) Remove the paper cassette. 4) Check the sensor. <div style="text-align: center;">  <p>The diagram shows a hand pointing to the actuator on the paper cassette. To the right, the Operator Panel displays 'Digital Input DI-11 H 0'. A downward arrow labeled 'Normal' points to 'Digital Input DI-11 H 1'. Below this is a detailed view of the paper cassette mechanism with the actuator highlighted.</p> <p style="text-align: right; font-size: small;">Kmy02013KA</p> </div> <ol style="list-style-type: none"> 5) Press the "Cancel" key to stop the test. 6) Replace the paper cassette.
Main Motor Alarm (DI-12)	Internal signal.
Sub Motor Alarm (DI-13)	Internal signal.

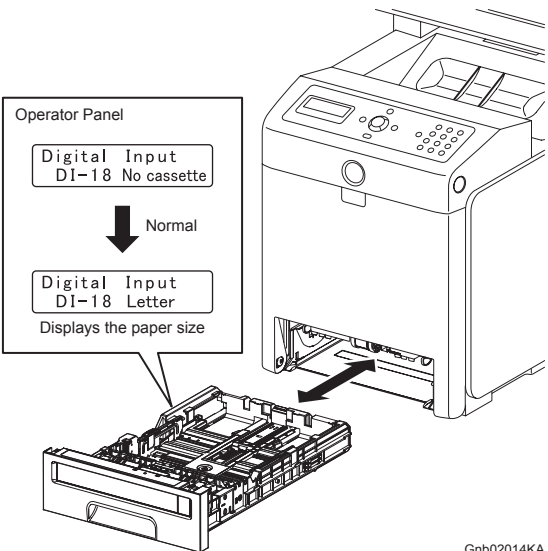
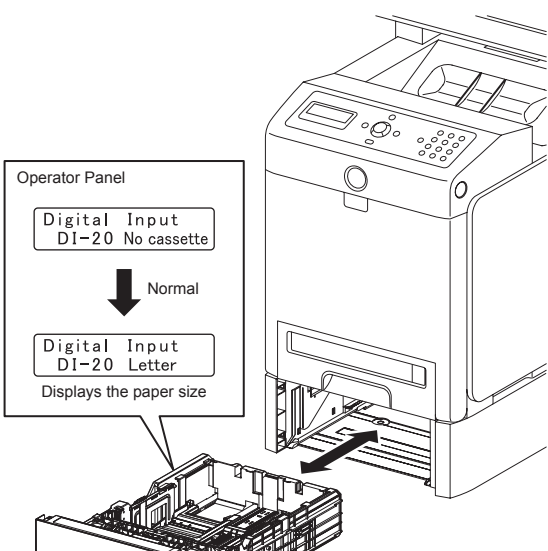
Sensor name (Diag. Code)	Confirmation procedures
OHP Sensor (DI-14)	Not used
FAN Alarm (DI-15)	Internal signal.
PH Motor Alarm (DI-16)	Internal signal.
DEVE Motor Alarm (DI-17)	Internal signal.
Tray 1 Paper Size Switch (DI-18)	<ol style="list-style-type: none"> 1) Turn on the power and enter the Printer Diag. 2) Execute the DI-18. 3) Check the switch.  <p style="text-align: right; font-size: small;">Gnb02014KA</p> <ol style="list-style-type: none"> 4) Press the "Cancel" key to stop the test. 5) Replace the paper cassette.
Tray 2 Paper Size Switch (DI-20)	<p>NOTE: The size switch is in the option feeder.</p> <ol style="list-style-type: none"> 1) Turn on the power and enter the Printer Diag. 2) Execute the DI-20. 3) Check the switch.  <p style="text-align: right; font-size: small;">Gnb02015KA</p> <ol style="list-style-type: none"> 4) Press the "Cancel" key to stop the test. 5) Replace the paper cassette.

4.3.3 Digital Output (DO) Test

This function checks whether the DO components operate.

When the interlock is opened while the DO test is performed, each component ends to operate.

NOTE

In this Test Mode, each DO component can be turned individually. Therefore it allows the customer to check a component's operation from outside, and judge whether the component is normal or not.

When all the diag. functions are stopped, all the DO components can be turned off. DO test can make each of the DO components operate simultaneously.

When a paper jam or PQ problem is occurred, or an error message or code is displayed, this test enables to look for the broken or damaged parts.

Test result: NG (Go to each FIP or replace the parts.)

OK (Turn off/on the main power.)

4.3.4 Executing digital output (DO) test

- 1) Turn off the power.
- 2) Turn on the power while holding down “▲” and “▼” keys.
- 3) Release the fingers from these keys when “Please wait...” is displayed.
- 4) The “Customer Mode”, “FAX Scanner Diag” and “Printer Diag” are displayed. (Entered the Diag. mode.)
- 5) Press “▼” to select “Printer Diag”, and press “✓” key.
- 6) Press “▼” key to select “IOT Diag”, and then press “✓” key.
- 7) Press “▼” key to select “Digital Output”, and then press “✓” key.
- 8) Press “▲” or “▼” key to select test item.
- 9) Press “✓” key to execute the test.

Parameters for the Digital Output Test are as follows.

Code	Components
DO-0,1,2,3	Main Motor
DO-5,6,7,8	Sub Motor
DO-a,b,c,d	Feed Drive
DO-f,10,11	Deve Motor
DO-13,14,16,17	Duplex Motor
DO-19,1a,1b,1c	Teay 2 Feed Motor
DO-1e,1f	Fan
DO-21	Yellow Toner Motor
DO-23	Magenta Toner Motor
DO-25	Cyan Toner Motor
DO-27	Black Toner Motor
DO-29	Regi Clutch
DO-2B	MPF Turn Clutch
DO-2d	MPF Feed Solenoid
DO-2f	Tray 1 Feed Clutch
DO-31	Tray 2 Feed Clutch
DO-33	Tray 2 Turn Clutch
DO-35	Duplex Clutch

Code	Components
DO-37	ADC (CTD) Sensor Solenoid
DO-39	ADC (CTD) Sensor LED
DO-3b	OHP LED (Not Used)
DO-3d	Black Erase Lamp
DO-3f	Yellow, Magenta, Cyan Erase Lamp
DO-5b	Exit Clutch
DO-5d	Duplex Fan

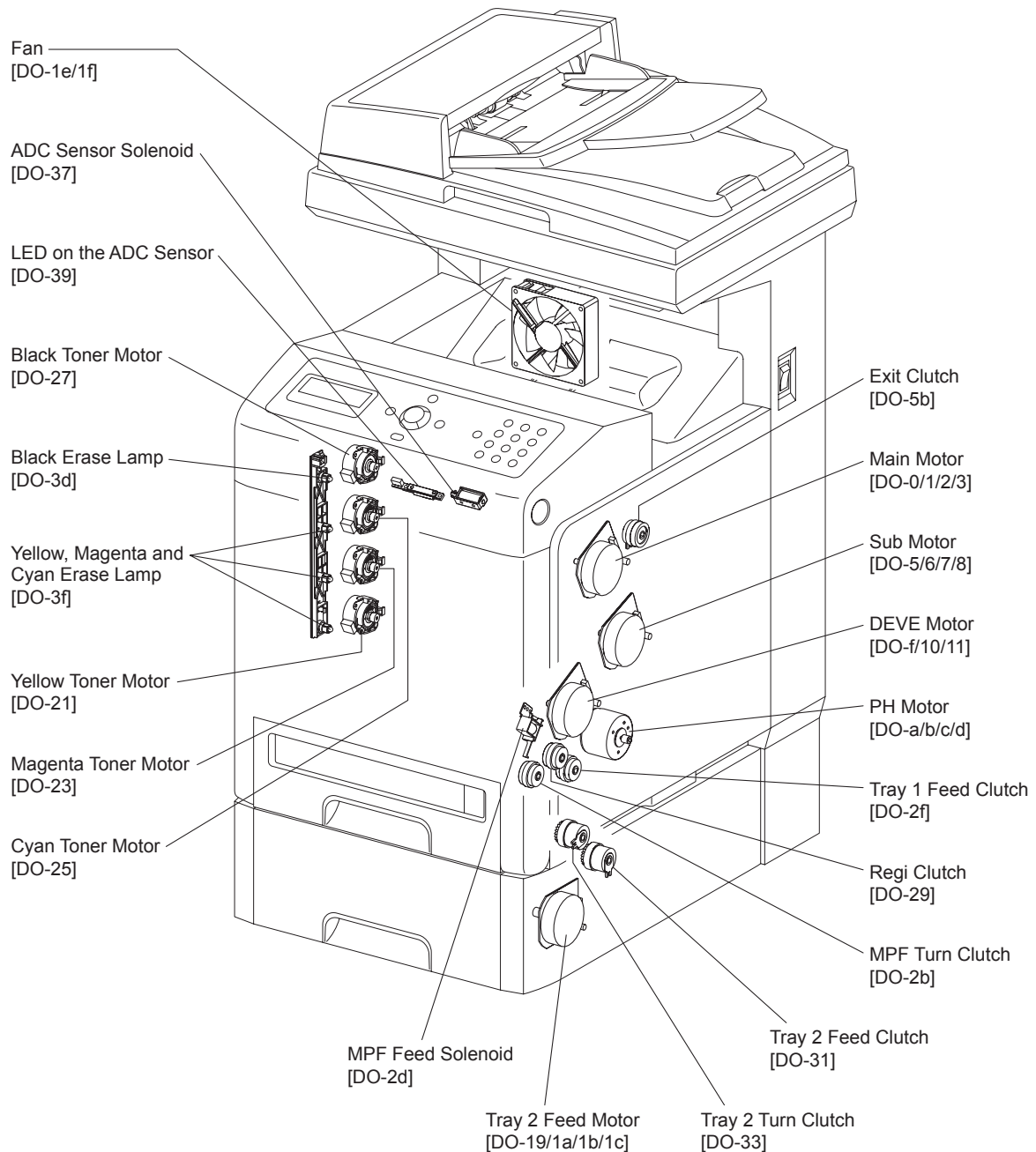

Gnb02016KA

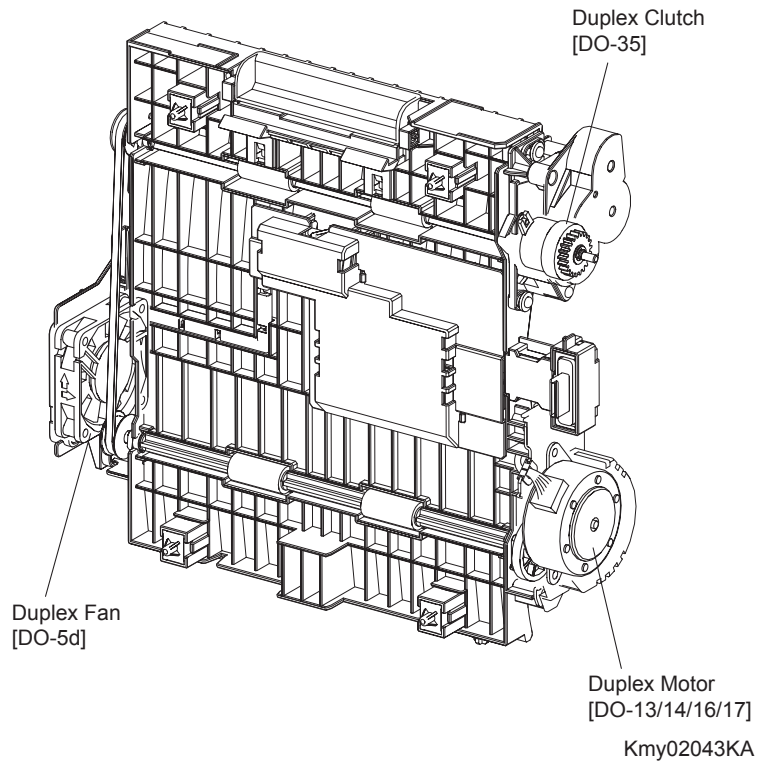

- About Clutch

The electromagnetic clutch in the printer controls the rotation of the roller by transferring or cutting the torque from the motor to the roller.

The electromagnetic clutch becomes an electromagnet by the passage of electric current through the coil inside the case and attracts the armature and gear to the rotating rotor, thereby rotating the gear.

Upon the loss of power to the coil, electromagnetic force is lost and the armature comes off the rotor, and the gear comes to rest.

The clutch makes so soft noises that you must be close the component to audibly confirm the operation of the component.

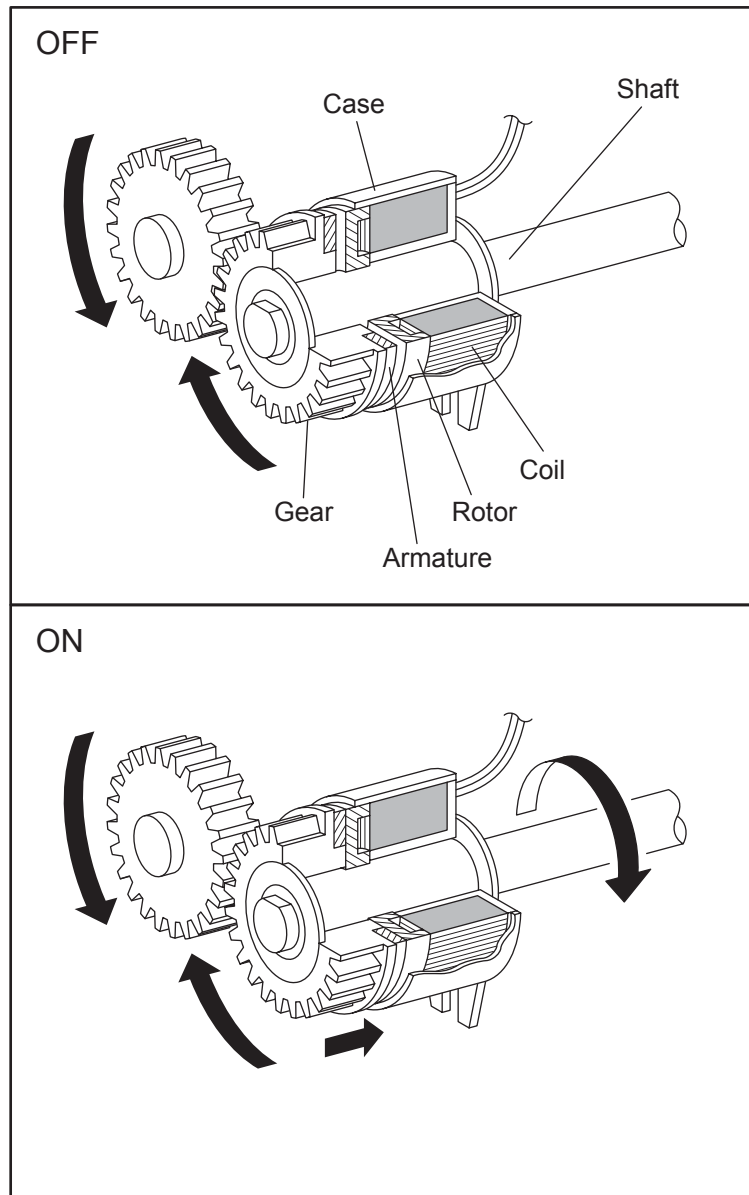

Leg_Sec02_050FA

- About Solenoid

The solenoid in the printer opens/closes the shutter or controls the position of the gear for transferring the torque of the motor to the roller.

A solenoid becomes an electromagnet by the passage of electric current through the coil inside the case and attracts the plunger.

Upon the loss of power to the coil, electromagnetic force is lost and the plunger is returned to its original position by spring action, thereby allowing the shutter to operate or the gear to move to the predefined position.

Unlike a clutch, a solenoid generates a loud operation noise.

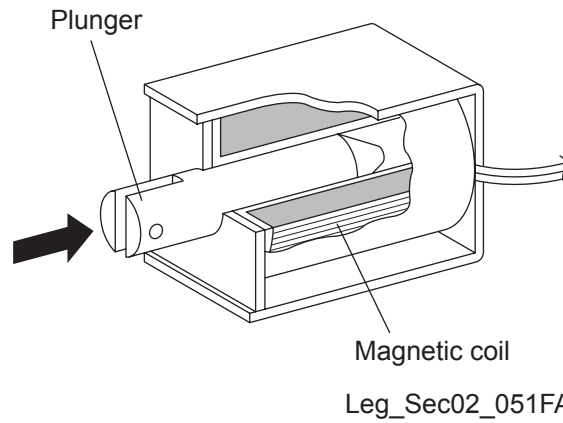

- Checking Motor, Clutch and Solenoid

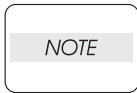

Before executing the DO test, close all covers and doors.

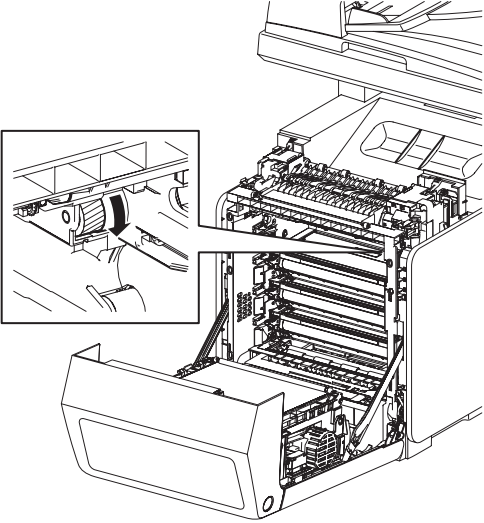
Clutch and Solenoid name (Diag. Code)	Confirmation procedure
<p>Main Motor (DO-0/DO-1/DO-2/DO-3)</p>	<p>NOTE: This procedure is for the technical staff. The customer check is the procedure 1, 5 and 6. The main motor is in the PC/DEVE DRIVE.</p> <p>When performing operation for five minutes or longer with the front cover open, remove all toner cartridges, and cover the drum to avoid exposure to light.</p> <p>The rotational speed of the motor is as follows. DO-3<DO-2<DO-0<DO-1</p> <ol style="list-style-type: none"> 1) Turn on the power and enter the Printer Diag. 2) Open the Front Cover. 3) Remove the black toner cartridge. 4) Cheat the safety Interlock System. 5) Execute the DO-0. (The customer can confirm the motor noise only.)  <p style="text-align: right; font-size: small;">Gnb02017KA</p> <ol style="list-style-type: none"> 6) Press the "Cancel" key to stop test. 7) Remove the cheater and replace the black toner cartridge. 8) Close the Front Cover.

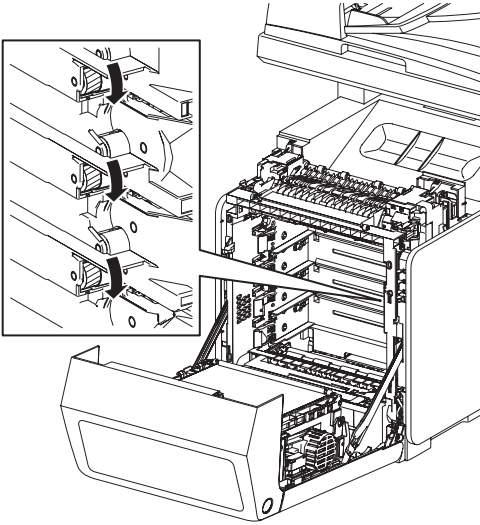
Clutch and Solenoid name (Diag. Code)	Confirmation procedure
Sub Motor (DO-5/DO-6/DO-7/ DO-8)	<p>NOTE: This procedure is for the technical staff. The customer check is the procedure 1, 5 and 6. The sub motor is in the PC/DEVE DRIVE. When performing operation for five minutes or longer with the front cover open, remove all toner cartridges, and cover the drum to avoid exposure to light.</p> <p>The rotational speed of the motor is as follows. DO-8<DO-7<DO-5<DO-6</p> <ol style="list-style-type: none"> 1) Turn on the power and enter the Printer Diag. 2) Open the Front Cover. 3) Remove the all toner cartridges. 4) Cheat the safety Interlock System. 5) Execute the DO-5. (The customer can confirm the motor noise only.)  <p style="text-align: right; font-size: small;">Gnb02018KA</p> <ol style="list-style-type: none"> 6) Press the "Cancel" key to stop test. 7) Remove the cheater and replace the all toner cartridges. 8) Close the Front Cover.

Clutch and Solenoid name (Diag. Code)	Confirmation procedure
PH Motor (DO-a/DO-b/DO-c/ DO-d)	<p>NOTE: This procedure is for the technical staff. The customer check is the procedure 1, 4 and 5. The PH motor is in the FEED DRIVE. When performing operation for five minutes or longer with the front cover open, remove all toner cartridges, and cover the drum to avoid exposure to light.</p> <p>The rotational speed of the motor is as follows. DO-d<DO-c<DO-a<DO-b</p> <ol style="list-style-type: none"> 1) Turn on the power and enter the Printer Diag. 2) Open the Front Cover. 3) Cheat the safety Interlock System. 4) Execute the DO-a. (The customer can confirm the motor noise only.) <div data-bbox="746 636 1225 1106" style="text-align: center;"> <p style="text-align: right; font-size: small;">Kmy02019KA</p> </div> <ol style="list-style-type: none"> 5) Press the "Cancel" key to stop test. 6) Remove the cheater. 7) Close the Front Cover.

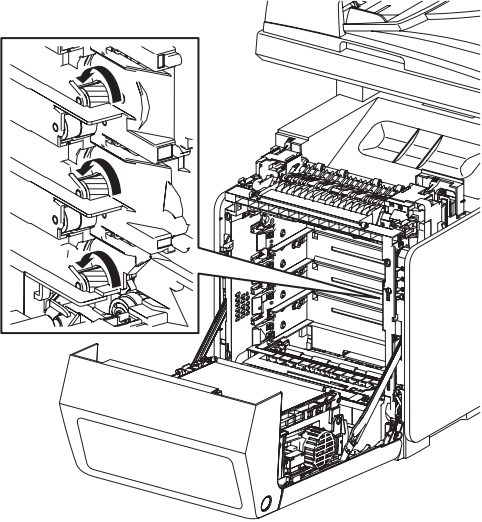
Clutch and Solenoid name (Diag. Code)	Confirmation procedure
<p>DEVE Motor (DO-f/DO-10/ DO-11)</p>	<p>NOTE: This procedure is for the technical staff. The customer check is the procedure 1, 5 and 6. The DEVE motor is in the PC/DEVE DRIVE.</p> <p>When performing operation for five minutes or longer with the front cover open, remove all toner cartridges, and cover the drum to avoid exposure to light.</p> <p>The rotational speed of the motor is as follows. DO-11<DO-10<DO-f</p> <ol style="list-style-type: none"> 1) Turn on the power and enter the Printer Diag. 2) Open the Front Cover. 3) Remove the yellow, magenta and cyan toner cartridges. 4) Cheat the safety Interlock System. 5) Execute the DO-f. (The customer can confirm the motor noise only.)  <p style="text-align: right; font-size: small;">Gnb02020KA</p> <ol style="list-style-type: none"> 6) Press the "Cancel" key to stop test. 7) Remove the cheater and replace the yellow, magenta and cyan toner cartridges. 8) Close the Front Cover.

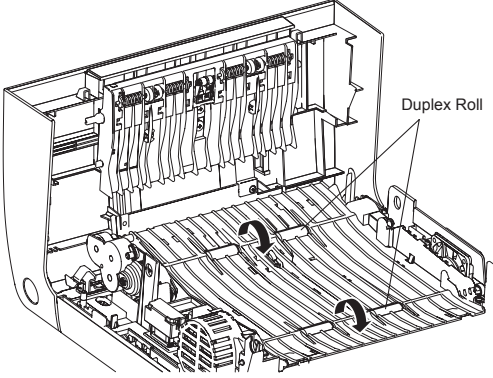
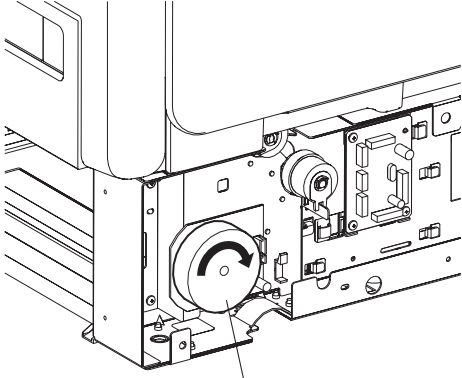
Clutch and Solenoid name (Diag. Code)	Confirmation procedure
<p>DUP Motor (DO-13/DO-14/ DO-16/DO-17)</p>	<p>NOTE: This procedure is for the technical staff. The customer check is the procedure 1, 5 and 6. The DUP motor is in the DUPLEX MODULE.</p> <p>When performing operation for five minutes or longer with the front cover open, remove all toner cartridges, and cover the drum to avoid exposure to light.</p> <p>The rotational speed of the motor is as follows. DO-17<DO-16<DO-14<DO-13</p> <ol style="list-style-type: none"> 1) Turn on the power and enter the Printer Diag. 2) Open the Front Cover. 3) Cheat the safety Interlock System. 4) Remove the transfer belt. 5) Execute the DO-13. (The customer can confirm the motor noise only.)  <p style="text-align: right; font-size: small;">Kmy02021KA</p> <ol style="list-style-type: none"> 6) Press the "Cancel" key to stop test. 7) Remove the cheater and replace the transfer belt. 8) Close the Front Cover.
<p>Tray 2 Feed Motor (DO-19/ DO-1a/DO-1b/Do-1c)</p>	<p>NOTE: This procedure is for the technical staff. The customer check is the procedure 1, 4 and 5.</p> <p>The rotational speed of the motor is as follows. DO-1c<DO-1b<DO-19<DO-1a</p> <ol style="list-style-type: none"> 1) turn on the power and enter the Printer Diag. 2) Remove the Tray 2 paper cassette. 3) Remove the left side cover of the Tray 2. 4) Execute the DO-19. (The customer can confirm the motor noise only.)  <p style="text-align: right; font-size: small;">Kmy02022KA</p> <ol style="list-style-type: none"> 5) Press the "Cancel" key to stop the test. 6) Replace the left side cover of the Tray 2. 7) Replace the Tray 2 paper cassette.

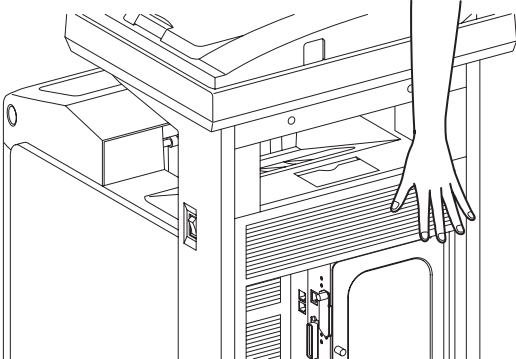
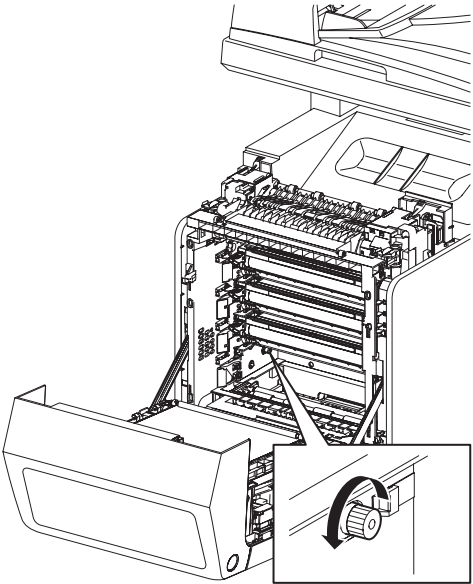
Clutch and Solenoid name (Diag. Code)	Confirmation procedure
Fan (DO-1e/1f)	<p>NOTE: The rotational speed of the fan is as follows. DO-1f<DO-1e</p> <ol style="list-style-type: none"> 1) Turn on the power and enter the Printer Diag. 2) Execute the DO-1e.  <p style="text-align: right; font-size: small;">Gnb02023KA</p>
Yellow Toner Motor (DO-21)	<p>NOTE: This procedure is for the technical staff. The customer check is the procedure 1, 5 and 6. When performing operation for five minutes or longer with the front cover open, remove all toner cartridges, and cover the drum to avoid exposure to light.</p> <ol style="list-style-type: none"> 1) Turn on the power and enter the Printer Diag. 2) Open the Front Cover. 3) Cheat the safety Interlock System. 4) Remove the yellow toner cartridge. 5) Execute the DO-21. (The customer can confirm the motor noise only.)  <p style="text-align: right; font-size: small;">Gnb02024KA</p> <ol style="list-style-type: none"> 6) Press the "Cancel" key to stop test. 7) Replace the yellow toner cartridge. 8) Remove the cheater. 9) Close the Front Cover.

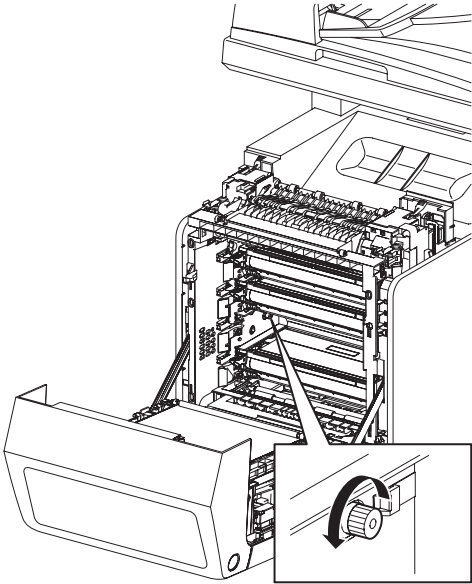
Clutch and Solenoid name (Diag. Code)	Confirmation procedure
Magenta Toner Motor (DO-23)	<p>NOTE: This procedure is for the technical staff. The customer check is the procedure 1, 5 and 6. When performing operation for five minutes or longer with the front cover open, remove all toner cartridges, and cover the drum to avoid exposure to light.</p> <ol style="list-style-type: none"> 1) Turn on the power and enter the Printer Diag. 2) Open the Front Cover. 3) Remove the magenta toner cartridge. 4) Cheat the safety Interlock System. 5) Execute the DO-23. (The customer can confirm the motor noise only.)  <p style="text-align: right; font-size: small;">Gnb02025KA</p> <ol style="list-style-type: none"> 6) Press the "Cancel" key to stop test. 7) Remove the cheater. 8) Replace the magenta toner cartridge. 9) Close the Front Cover.

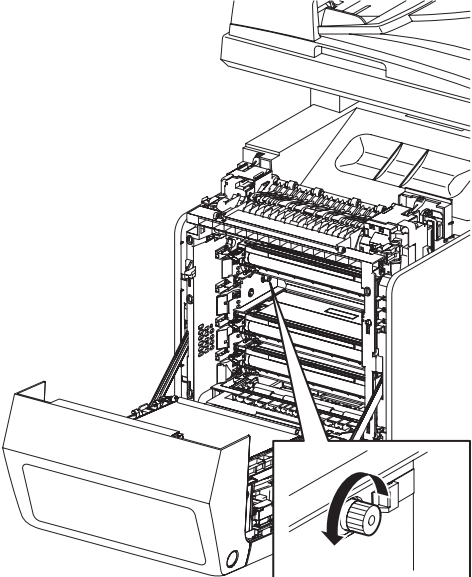
Clutch and Solenoid name (Diag. Code)	Confirmation procedure
Cyan Toner Motor (DO-25)	<p>NOTE: This procedure is for the technical staff. The customer check is the procedure 1, 5 and 6. When performing operation for five minutes or longer with the front cover open, remove all toner cartridges, and cover the drum to avoid exposure to light.</p> <ol style="list-style-type: none"> 1) Turn on the power and enter the Printer Diag. 2) Open the Front Cover. 3) Remove the cyan toner cartridge. 4) Cheat the safety Interlock System. 5) Execute the DO-25. (The customer can confirm the motor noise only.)  <p style="text-align: right; font-size: small;">Gnb02026KA</p> <ol style="list-style-type: none"> 6) Press the "Cancel" key to stop test. 7) Remove the cheater. 8) Replace the cyan toner cartridge. 9) Close the Front Cover.

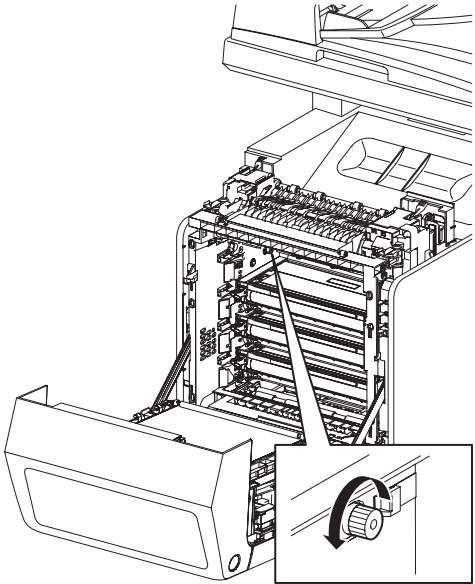
Clutch and Solenoid name (Diag. Code)	Confirmation procedure
Black Toner Motor (DO-27)	<p>NOTE: This procedure is for the technical staff. The customer check is the procedure 1, 5 and 6.</p> <p>When performing operation for five minutes or longer with the front cover open, remove all toner cartridges, and cover the drum to avoid exposure to light.</p> <ol style="list-style-type: none"> 1) Turn on the power and enter the Printer Diag. 2) Open the Front Cover. 3) Remove the black toner cartridge. 4) Cheat the safety Interlock System. 5) Execute the DO-27. (The customer can confirm the motor noise only.)  <p style="text-align: right; font-size: small;">Gnb02027KA</p> <ol style="list-style-type: none"> 6) Press the "Cancel" key to stop test. 7) Remove the cheater. 8) Replace the black toner cartridge. 9) Close the Front Cover.

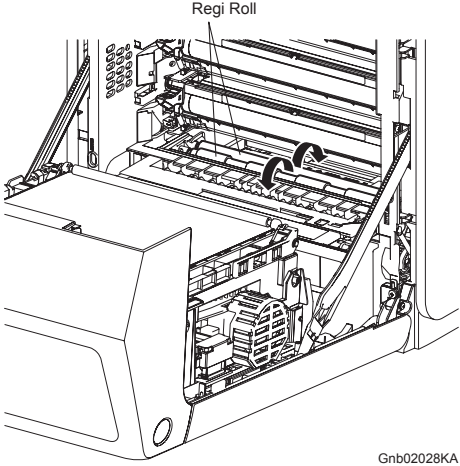
Clutch and Solenoid name (Diag. Code)	Confirmation procedure
Regi Clutch (DO-29)	<p>NOTE: When performing operation for five minutes or longer with the front cover open, remove all toner cartridges, and cover the drum to avoid exposure to light.</p> <ol style="list-style-type: none"> 1) Turn on the power and enter the Printer Diag. 2) Execute the DO-29. Upon hitting the "return" key, the operating noise of the clutch will be heard. 3) Press the "Cancel" key to stop the clutch. <p>Combination test is as follows.</p> <p>NOTE: The regi roll rotates when the DO-a and the DO-29 are executed. This procedure is for the technical staff.</p> <ol style="list-style-type: none"> 1) Turn on the power and enter the Printer Diag. 2) Open the Front Cover. 3) Cheat the safety Interlock System. 4) Execute the DO-a and the DO-29. <div style="text-align: center;">  </div> <ol style="list-style-type: none"> 5) Confirm the Regi Roll rotation. 6) Press the "Cancel" key to stop the clutch. 7) Press the "▼" key to display the DO-a. 8) Press the "Cancel" key to stop the motor. 9) Remove the cheter and close the Front Cover.

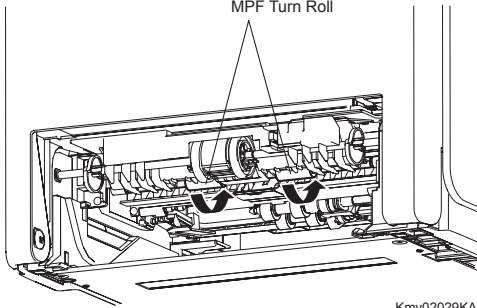
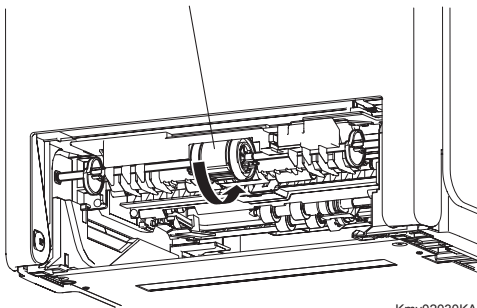
Clutch and Solenoid name (Diag. Code)	Confirmation procedure
MPF Turn Clutch (DO-2b)	<ol style="list-style-type: none"> 1) Turn on the power and enter the Printer Diag. 2) Execute the DO-2b. Upon hitting the "return" key, the operating noise of the clutch will be heard. 3) Press the "Cancel" key to stop the clutch. <p>Combination test is as follows. NOTE: The MPF turn roll rotates when the DO-a and the DO-2b are executed. This procedure is for the technical staff.</p> <ol style="list-style-type: none"> 1) Turn on the power and enter the Printer Diag. 2) Remove the Tray 1 paper cassette. 3) Execute the DO-a and the DO-2b.  <p style="text-align: right; font-size: small;">Kmy02029KA</p> <ol style="list-style-type: none"> 4) Confirm the Turn Roll rotation. 5) Press the "Cancel" key to stop the clutch. 6) Press the "▼" key to display the DO-a. 7) Press the "Cancel" key to stop the motor. 8) Replace the Tray 1 paper cassette.
MPF Feed Solenoid (DO-2d)	<ol style="list-style-type: none"> 1) Turn on the power and enter the Printer Diag. 2) Execute the DO-2d. Upon hitting the "return" key, the operating noise of the solenoid will be heard. 3) Press the "Cancel" key to stop the solenoid. <p>Combination test is as follows. NOTE: The MPF feed roll rotates when the DO-a and the DO-2d are executed. This procedure is for the technical staff.</p> <ol style="list-style-type: none"> 1) Turn on the power and enter the Printer Diag. 2) Remove the Tray 1 paper cassette. 3) Execute the DO-a and the DO-2d.  <p style="text-align: right; font-size: small;">Kmy02030KA</p> <ol style="list-style-type: none"> 4) Confirm the Feed Roll rotation. 5) Press the "Cancel" key to stop the clutch. 6) Press the "▼" key to display the DO-a. 7) Press the "Cancel" key to stop the motor. 8) Replace the Tray 1 paper cassette.

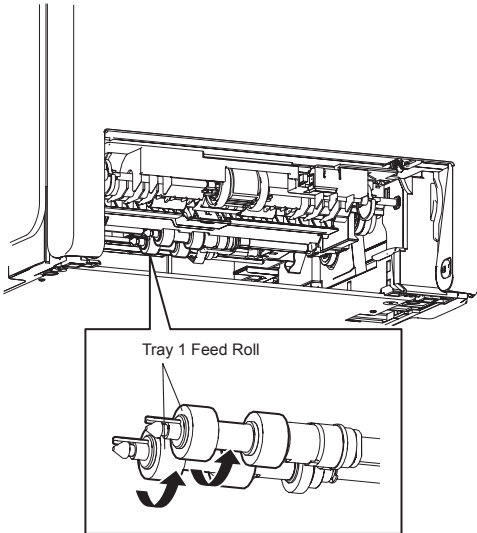
Clutch and Solenoid name (Diag. Code)	Confirmation procedure
Tray 1 Feed Clutch (DO-2f)	<ol style="list-style-type: none"> 1) Turn on the power and enter the Printer Diag. 2) Execute the DO-2f. Upon hitting the "return" key, the operating noise of the clutch will be heard. 3) Press the "Cancel" key to stop the clutch. <p>Combination test is as follows. NOTE: The Tray 1 feed roll rotates when the DO-a and the DO-2f are executed. This procedure is for the technical staff.</p> <ol style="list-style-type: none"> 1) Turn on the power and enter the Printer Diag. 2) Remove the Tray 1 paper cassette. 3) Execute the DO-a and the DO-2f. <div style="text-align: center;">  <p style="text-align: center;">Tray 1 Feed Roll</p> <p style="text-align: right; font-size: small;">Kmy02031KA</p> </div> <ol style="list-style-type: none"> 4) Confirm the feed Roll rotation. 5) Press the "Cancel" key to stop the clutch. 6) Press the "▼" key to display the DO-a. 7) Press the "Cancel" key to stop the motor. 8) Replace the Tray 1 paper cassette.

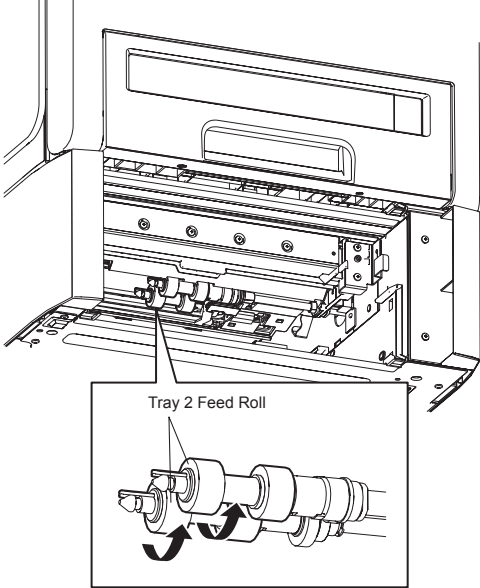
Clutch and Solenoid name (Diag. Code)	Confirmation procedure
Tray 2 Feed Clutch (DO-31)	<ol style="list-style-type: none"> 1) Turn on the power and enter the Printer Diag. 2) Execute the DO-31. Upon hitting the "return" key, the operating noise of the clutch will be heard. 3) Press the "Cancel" key to stop the clutch. <p>Combination test is as follows. NOTE: The Tray 2 feed roll rotates when the DO-19 and the DO-31 are executed. This procedure is for the technical staff.</p> <ol style="list-style-type: none"> 1) Turn on the power and enter the Printer Diag. 2) Remove the Tray 2 paper cassette. 3) Execute the DO-19 and the DO-31.  <p style="text-align: right; font-size: small;">Kmy02032KA</p> <ol style="list-style-type: none"> 4) Confirm the feed Roll rotation. 5) Press the "Cancel" key to stop the clutch. 6) Press the "▼" key to display the DO-19. 7) Press the "Cancel" key to stop the motor. 8) Replace the Tray 2 paper cassette.

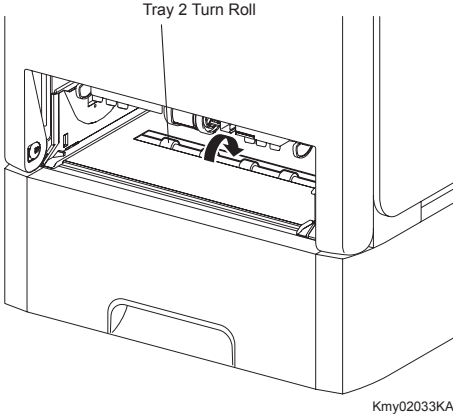
Clutch and Solenoid name (Diag. Code)	Confirmation procedure
Tray 2 Turn Clutch (DO-33)	<ol style="list-style-type: none"> 1) Turn on the power and enter the Printer Diag. 2) Execute the DO-33. Upon hitting the "return" key, the operating noise of the clutch will be heard. 3) Press the "Cancel" key to stop the clutch. <p>Combination test is as follows. NOTE: The Tray 2 turn roll rotates when the DO-19 and the DO-33 are executed. This procedure is for the technical staff.</p> <ol style="list-style-type: none"> 1) Turn on the power and enter the Printer Diag. 2) Remove the Tray 1 paper cassette. 3) Execute the DO-19 and the DO-33. <div style="text-align: center;">  <p style="text-align: center;">Tray 2 Turn Roll</p> <p style="text-align: right; font-size: small;">Kmy02033KA</p> </div> <ol style="list-style-type: none"> 4) Confirm the Turn Roll rotation. 5) Press the "Cancel" key to stop the clutch. 6) Press the "▼" key to display the DO-19. 7) Press the "Cancel" key to stop the motor. 8) Replace the Tray 1 paper cassette.

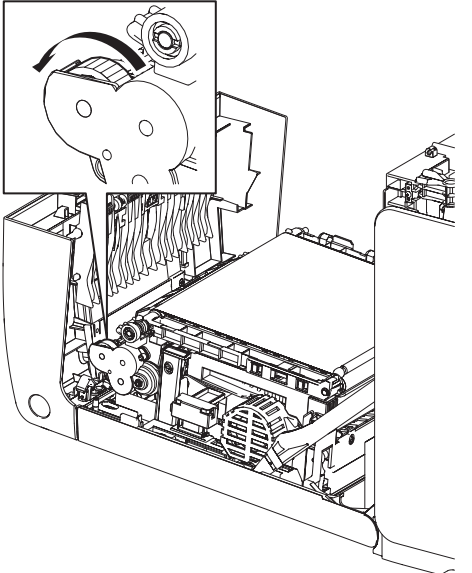
Clutch and Solenoid name (Diag. Code)	Confirmation procedure
Dup Clutch (DO-35)	<ol style="list-style-type: none"> 1) Turn on the power and enter the Printer Diag. 2) Execute the DO-35. Upon hitting the "return" key, the operating noise of the clutch will be heard. 3) Press the "Cancel" key to stop the clutch. <p>Combination test is as follows. NOTE: The duplex gear rotates when the DO-13 and the DO-35 are executed. This procedure is for the technical staff. When performing operation for five minutes or longer with the front cover open, remove all toner cartridges, and cover the drum to avoid exposure to light.</p> <ol style="list-style-type: none"> 1) Turn on the power and enter the Printer Diag. 2) Open the Front Cover. 3) Cheat the safety Interlock System. 4) Execute the DO-13 and the DO-35.  <ol style="list-style-type: none"> 5) Confirm the gear rotation. 6) Press the "Cancel" key to stop the clutch. 7) Press the "▼" key to display the DO-13. 8) Press the "Cancel" key to stop the motor. 9) Remove the cheater and close the Front Cover.

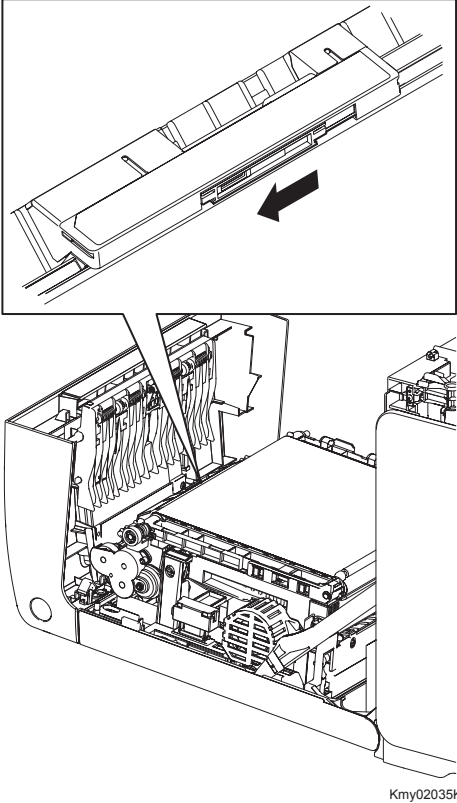
Clutch and Solenoid name (Diag. Code)	Confirmation procedure
ADC Sensor Solenoid (DO-37)	<p>NOTE: This procedure is for the technical staff. The customer check is the procedure 1, 4 and 5. When performing operation for five minutes or longer with the front cover open, remove all toner cartridges, and cover the drum to avoid exposure to light.</p> <ol style="list-style-type: none"> 1) Turn on the power and enter the Printer Diag. 2) Open the Front Cover. 3) Cheat the safety Interlock System. 4) Execute the DO-37. (The customer can confirm the motor noise only.)  <ol style="list-style-type: none"> 5) Press the "Cancel" key to stop the solenoid. 6) Remove the cheater and close the Front Cover.

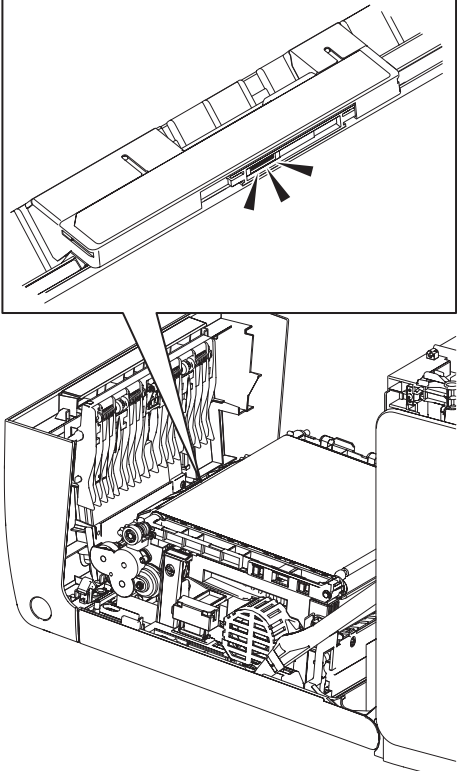
Clutch and Solenoid name (Diag. Code)	Confirmation procedure
ADC Sensor LED (DO-39)	<p>NOTE: This procedure is for the technical staff. When performing operation for five minutes or longer with the front cover open, remove all toner cartridges, and cover the drum to avoid exposure to light.</p> <ol style="list-style-type: none"> 1) Turn on the power and enter the Printer Diag. 2) Open the Front Cover. 3) Cheat the safety Interlock System. 4) Execute the DO-39.  <p style="text-align: right; font-size: small;">Kmy02036KA</p> <ol style="list-style-type: none"> 5) Press the "Cancel" key to stop the LED lighting. 6) Remove the cheater and close the Front Cover.
OHP Sensor LED (DO-3b)	Not used

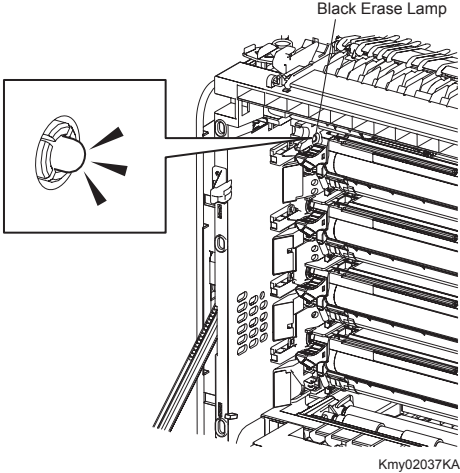
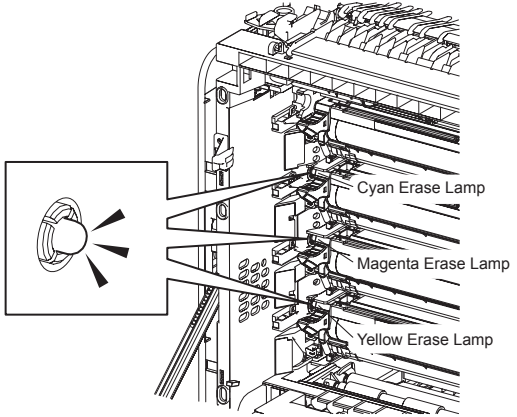
Clutch and Solenoid name (Diag. Code)	Confirmation procedure
<p>Black Drum Erase Lamp (DO-3d)</p>	<p>NOTE: This procedure is for the technical staff. When performing operation for five minutes or longer with the front cover open, remove all toner cartridges, and cover the drum to avoid exposure to light.</p> <ol style="list-style-type: none"> 1) Turn on the power and enter the Printer Diag. 2) Open the Front Cover. 3) Cheat the safety Interlock System. 4) Execute the DO-3d.  <p style="text-align: right; font-size: small;">Kmy02037KA</p> <ol style="list-style-type: none"> 5) Press the "Cancel" key to stop the LED lighting. 6) Remove the cheater and close the Front Cover.
<p>Yellow, Magenta and Cyan Drum Erase Lamp (DO-3f)</p>	<p>NOTE: This procedure is for the technical staff. When performing operation for five minutes or longer with the front cover open, remove all toner cartridges, and cover the drum to avoid exposure to light.</p> <ol style="list-style-type: none"> 1) Turn on the power and enter the Printer Diag. 2) Open the Front Cover. 3) Cheat the safety Interlock System. 4) Execute the DO-3f.  <p style="text-align: right; font-size: small;">Kmy02038KA</p> <ol style="list-style-type: none"> 5) Press the "Cancel" key to stop the LED lighting. 6) Remove the cheater and close the Front Cover.

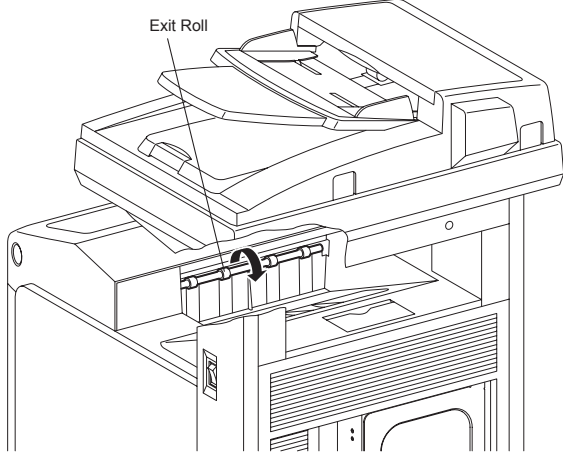
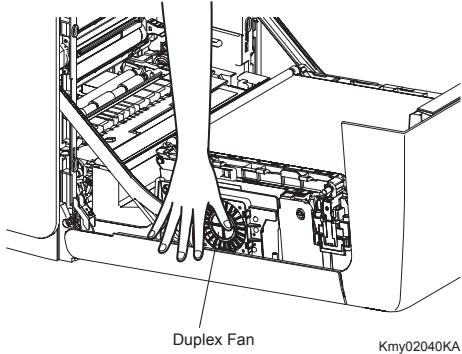
Clutch and Solenoid name (Diag. Code)	Confirmation procedure
Exit Clutch (DO-5b)	<ol style="list-style-type: none"> 1) Turn on the power and enter the Printer Diag. 2) Execute the DO-5b. Upon hitting the "return" key, the operating noise of the clutch will be heard. 3) Press the "Cancel" key to stop the clutch. <p>Combination test is as follows. NOTE: The exit roll rotates when the DO-0 and the DO-5b are executed. This procedure is for the technical staff.</p> <ol style="list-style-type: none"> 1) Turn on the power and enter the Printer Diag. 2) Execute the DO-0 and the DO-5b.  <p style="text-align: right; font-size: small;">Gnb02039KA</p> <ol style="list-style-type: none"> 3) Confirm the Exit Roll rotation. 4) Press the "Cancel" key to stop the clutch. 5) Press the "▼" key to display the DO-0. 6) Press the "Cancel" key to stop the motor.
Duplex Fan (DO-5d)	<p>NOTE: This procedure is for the technical staff. The customer check is the procedure 1, 4 and 5.</p> <p>When performing operation for five minutes or longer with the front cover open, remove all toner cartridges, and cover the drum to avoid exposure to light.</p> <ol style="list-style-type: none"> 1) Turn on the power and enter the Printer Diag. 2) Open the Front Cover. 3) Cheat the safety Interlock System. 4) Execute the DO-5d. (The customer can confirm the fan noise only.)  <p style="text-align: right; font-size: small;">Kmy02040KA</p> <ol style="list-style-type: none"> 5) Press the "Cancel" key to stop the test. 6) Remove the cheater and close the Front Cover.

4.4 Print Info

4.4.1 Config Page

The version of software of IOT and the printer configuration can be confirmed by executing this test.

4.4.2 Print Settings

The service tag, printing count value and error count value can be confirmed by executing this test.

4.5 Complete

4.5.1 Complete

Completes the diagnosis operation and reboot the data.

4.6 Test Print

Print an internal test pattern of the printer. If paper jam or paper empty occurs during the print, the test waits until they are resolved.

4.6.1 Executing test print

- 1) Turn off the power.
- 2) Turn on the power while holding down “▲” and “▼” keys.
- 3) Release the fingers from these keys when “Please wait...” is displayed.
- 4) The “Customer Mode”, “FAX Scanner” and “Printer Diag” are displayed. (Entered the Diag. mode.)
- 5) Press “▼” key to select “Printer Diag”, and press “✓” key.
- 6) Press “▼” key to select “Test Print”, and then press “✓” key.
- 7) Press “▲” or “▼” key to select the test item.
- 8) Press “✓” key twice to execute the test.

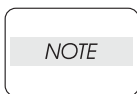

To exit the test or to returning to one step higher menu, press “CANCEL” key.

4.6.2 No Image [IOT]

Prints the blanked paper.

4.6.3 Test Pattern 600[IOT]

Prints the IOT built-in 600dpi pattern.

When the PQ problem occurred, this test enables to identify the problem as the printing process or the PWBA ESS related.

Compare the sample chart with the print.

Check result: NG (Check the printing process.) OK (Check the PWBA ESS related.)

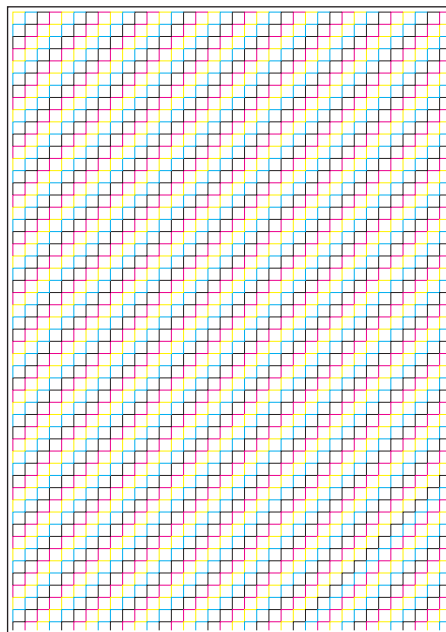

Kmy02001KA

4.6.4 Grid2

Prints the ESS built-in grid pattern.

When the PQ problem occurred, this test enables to identify the problem as printer-related or otherwise.

Compare the sample chart with the print.

Check result: NG (Check the printing process and PWBA ESS-related.) OK (Check the network, cable, PC and so on.)



Leg_Sec02_004FA

4.6.5 Cyan 20%

Outputs cyan 20% paint on the whole area of a A4 paper.

When the PQ problem occurred, this test enables to identify the problem as the cyan toner or another color.

Compare the sample chart with the print.

Check result: NG (Check the cyan toner-related.) OK (Check another toner.)

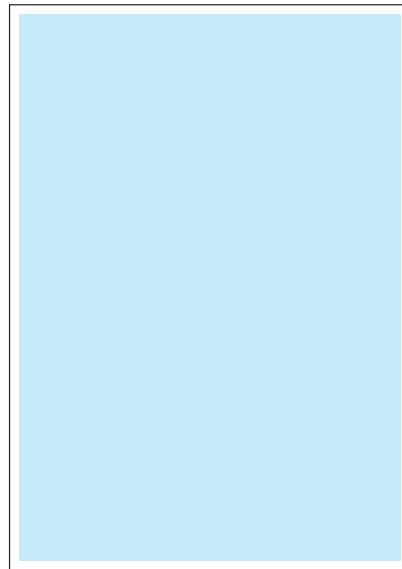

Leg_Sec02_005FA

4.6.6 Magenta 20%

Outputs magenta 20% paint on the whole area of a A4 paper.

When the PQ problem occurred, this test enables to identify the problem as the magenta toner or another color.

Compare the sample chart with the print.

Check result: NG (Check the magenta toner-related.) OK (Check another toner.)

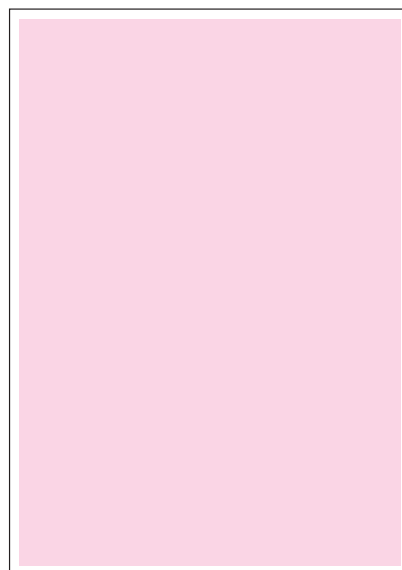

Leg_Sec02_006FA

4.6.7 Yellow 20%

Outputs yellow 20% paint on the whole area of a A4 paper.

When the PQ problem occurred, this test enables to identify the problem as the yellow toner or another color.

Compare the sample chart with the print.

Check result: NG (Check the yellow toner-related.) OK (Check another toner.)

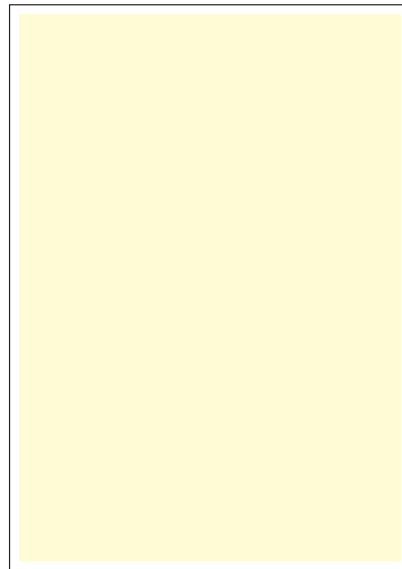

Leg_Sec02_007FA

4.6.8 Black 20%

Outputs black 20% paint on the whole area of a A4 paper.

When the PQ problem occurred, this test enables to identify the problem as the black toner or another color.

Compare the sample chart with the print.

Check result: NG (Check the black toner-related.) OK (Check another toner.)

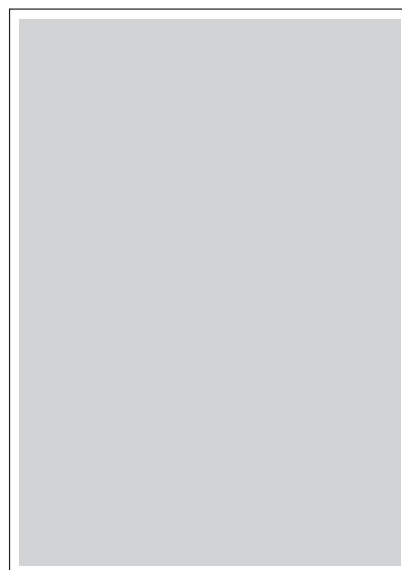

Leg_Sec02_008FA

4.6.9 CMY 20%

Outputs C/M/Y 20% paint on the whole area of a A4 paper.

When the PQ problem occurred, this test enables to identify the problem as the balance of three color toners or otherwise.

Compare the sample chart with the print.

Check result: NG (Check the yellow, magenta or cyan toner-related.) OK (Check black toner.)

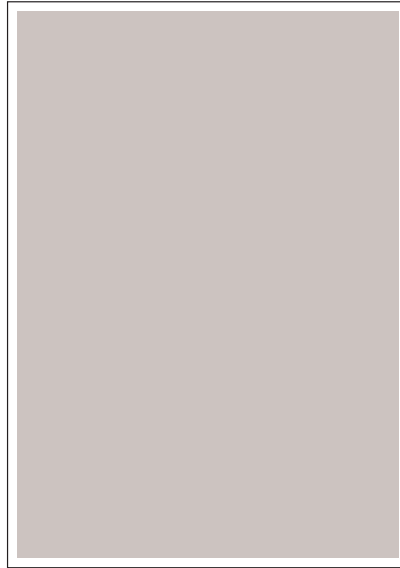

Leg_Sec02_009FA

4.6.10 Gradation

Outputs the tone pattern from 2% to 100% on a A4 paper for each of 4 colors.

When the PQ problem occurred, this test enables to identify the problem as the printing process or PWBA ESS-related.

Compare the sample chart with the print.

Check result: NG (Check the printing process.) OK (Check the PWBA ESS-related.)

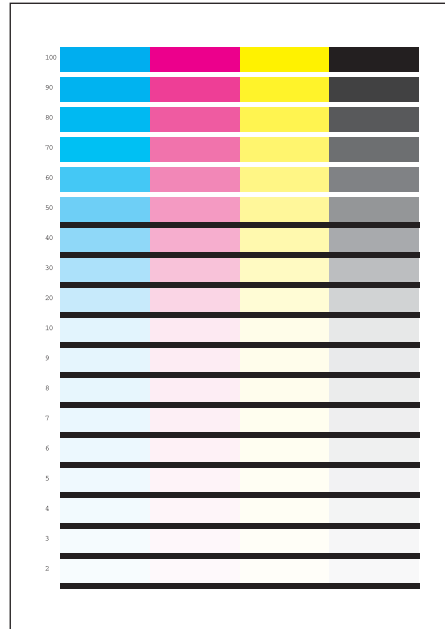

Leg_Sec02_010FA

4.6.11 Toner Pallet Check

Outputs each 100% density color pattern of Y/M/C/K.

When the PQ problem occurred in the picture or photo printing, this test enables to identify the problem as the toner or another.

Compare the sample chart with the print.

Check result: NG (Check the problem toner-related.) OK (Check the print job or print data.)

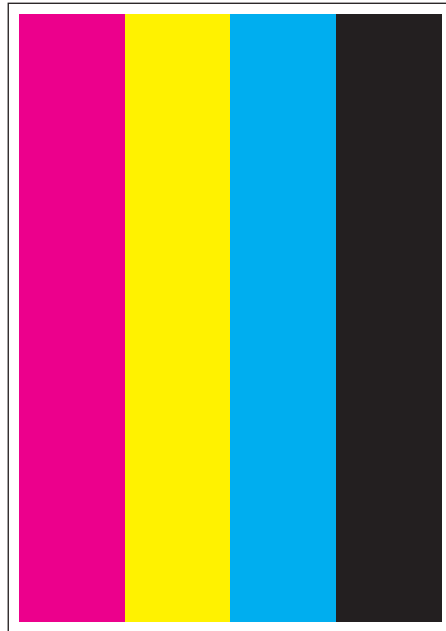

Leg_Sec02_011FA

4.6.12 Contamination Check

Allows you to check the print for any regular lines or toner spots when encountering PQ problems. From the difference in the interval of regular lines or spots, you can determine the parts that have caused the trouble.

Page 1 to 4: Prints the scale patterns in vertical and horizontal directions for evaluating regularity and intervals.

Page 5: Prints the list of intervals by component fault.

Page 1

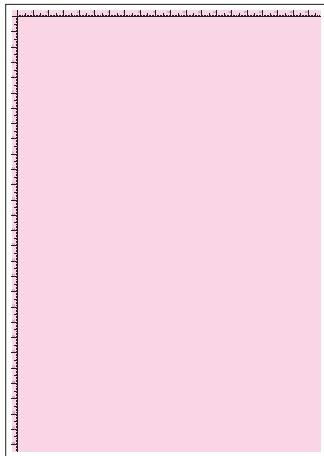

Leg_Sec02_012FA

Page 2

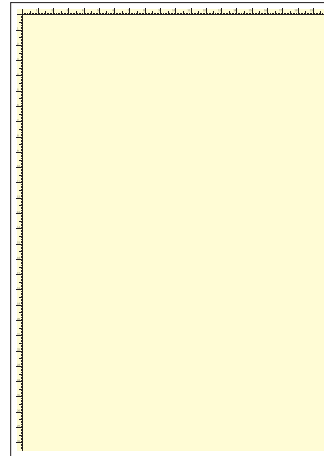

Leg_Sec02_071FA

Page 3

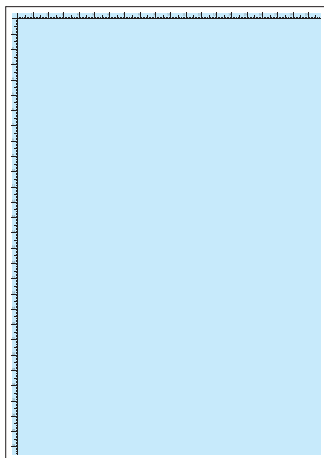

Leg_Sec02_072FA

Page 4

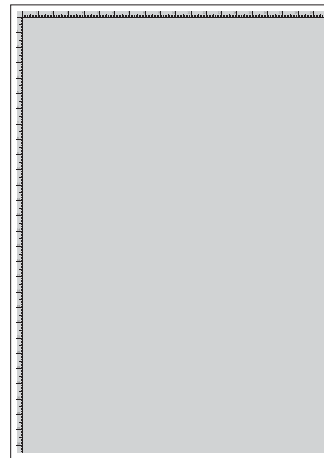

Leg_Sec02_073FA

Page 5

Color Laser 3110cn Components/CRU

Pitch (interval)	Dell Component Name
75.4 mm	Print Cartridge
28.8 mm	Print Cartridge
25.9 mm	Print Cartridge
37.7 mm	Print Cartridge
25.2 mm	Print Cartridge
22.3 mm	Print Cartridge
28.3 mm	Transfer Unit
56.9 mm	Transfer Unit
82.7 mm	Fuser Unit
94.2 mm	Fuser Unit
18.8 mm	Fuser Unit
43.2 mm	Fuser Unit
31.4 mm	Roll Pinch Exit

4.6.13 Parameter Setting

This function reads/writes the following parameters stored in the printer.

Item	Renge	Description
Slow Scan Reg K to P	-128 to 127	Sets the registration in the paper feeding direction.
Slow Scan Reg 600 Y/M/C	-30 to 30	
Slow Scan Reg 1200 Y/M/C	-60 to 60	
First Scan Reg (all items)	-30 to 30	Sets the registration in the scanning direction.
Life Counter	-	Reads the life counter and the printer.

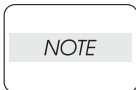

Print the parameter list using the Print function of Parameter Menu in diagnosis before changing the value of the registration.

Parameter	Function	Default	Adjustable range
Slow Scan Reg K to P (Shifts 0.17mm/1count)	Black registration adjustment	--	-128 to 127
Slow Scan Reg 600 M,Y,C (Shifts 0.042mm/1count)	Color registration adjustment (600 and 1200 dpi)	--	-60 to 60
Slow Scan Reg1200 M,Y,C (Shifts 0.021mm/1count)			
Fast Scan Reg K to M, Y or C (Shifts 0.042mm/1count)	Color registration adjustment Calculation of adjustment is shown below. (exp. Yellow) (Value of Fast Scan Reg K to Y + Value of Fast Scan Reg2 K to Y)/4	--	-30 to 30
Fast Scan Reg2 K to M, C or Y (Shifts 0.01mm/1count)		--	-1 to 2
Fast Scan Reg MPF, Tray1 or Tray2 (Shifts 0.17mm/1count)	Black registration adjustment at side 1 print	--	-30 to 30
Fast Scan Reg Dup (Shifts 0.17mm/1count)	Black registration adjustment at side 2 print	--	-30 to 30

NOTE

The default values are different in each printer.

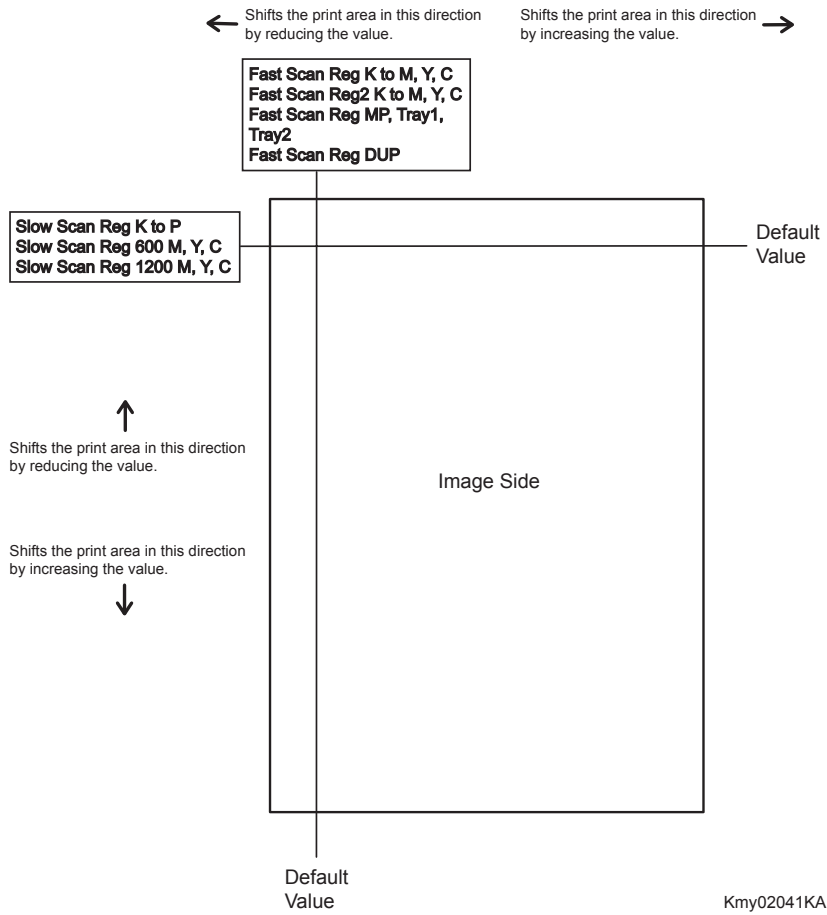

Reference Counter Values

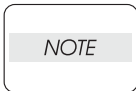

These counter values are reference only. Do not use as the official value.

Counter Name	Value of life warning
Life Y Toner (Dispense time)	-
Life M Toner (Dispense time)	-
Life C Toner (Dispense time)	-
Life K Toner (Dispense time)	-
Life DTB (Transfer Belt) 1 (Paper feeding count)	100000
Life Fuser (Paper feeding count)	100000
Life Printer (Paper feeding count)	-
Life DTB (Transfer Belt) 2 (Waste Toner cleaning count)	200000
Life DTB (Transfer Belt) 3 (Cycle count)	14000000
Life Y Waste Toner (Waste Toner cleaning count)	18000
Life M Waste Toner (Waste Toner cleaning count)	18000
Life C Waste Toner (Waste Toner cleaning count)	18000
Life K Waste Toner (Waste Toner cleaning count)	18000
Life Y Developer (Cycle count)	2500000
Life M Developer (Cycle count)	2500000
Life C Developer (Cycle count)	2500000
Life K Developer (Cycle count)	2500000
Life Y Drum (Cycle count)	3000000
Life M Drum (Cycle count)	3000000
Life C Drum (Cycle count)	3000000
Life K Drum (Cycle count)	3000000
Life MPF Feed	-
Life Tray 1 Feed	-
Life Duplex Feed	-
Print	-

4.6.14 Printing the parameter list

This function prints the parameter values and life counter values stored in the IOT.

Chapter 3 Removal and Replacement Procedures (RRPs) CONTENTS

1. Removal and Replacement Procedures (RRPs)	3 - 1
1.1 Before starting service procedure	3 - 1
1.2 General notes	3 - 3
1.2 Removal Flows	3 - 4
1.2 Replacement Flows	3 - 6
2. Removal Steps	3 - 8
Removal 1 Blank.....	3 - 8
Removal 2 MPF COVER (PL13.2.99).....	3 - 9
Removal 3 TRAY REAR COVER (PL13.1.7).....	3 - 10
Removal 4 TRANSFER BELT (PL4.1.1).....	3 - 11
Removal 5 DUPLEX MODULE (PL11.1.1)	3 - 13
Removal 6 TONER CARTRIDGE (K), (C), (M), (Y) (PL5.1.18-21).....	3 - 14
Removal 7 DUPLEX GATE (PL6.1.13).....	3 - 15
Removal 8 FUSER (PL6.1.10).....	3 - 16
Removal 9 SPUR ASSEMBLY (PL7.1.1).....	3 - 17
Removal 10 CHUTE ASSY EXIT OUT (PL6.1.1)	3 - 18
Removal 11 Blank.....	3 - 19
Removal 12 Blank.....	3 - 20
Removal 13 Blank.....	3 - 21
Removal 14 MPF FEED SOLENOID (PL3.1.98)	3 - 22
Removal 15 FEED DRIVE ASSEMBLY (PL8.1.7)	3 - 24
Removal 16 INTEGRATED FEEDER ASSEMBLY (PL3.2.99).....	3 - 27
Removal 17 Blank.....	3 - 31
Removal 18 RIGHT ARM ASSEMBLY (PL13.3.98)	3 - 32
Removal 19 SIZE SWITCH ASSEMBLY (PL7.1.18)	3 - 34
Removal 20 Blank.....	3 - 35
Removal 21 TONER CARTRIDGE SENSOR ASSEMBLY (C), (M), (Y) (PL5.1.4)	3 - 36
Removal 22 Blank.....	3 - 37
Removal 23 Blank.....	3 - 38
Removal 24 LEFT ARM ASSEMBLY (PL7.1.97).....	3 - 39
Removal 25 LED ASSEMBLY (PL5.1.15).....	3 - 41
Removal 26 TONER DISPENSER MOTOR (PL5.1.12)	3 - 42
Removal 27 Blank.....	3 - 44
Removal 28 Blank.....	3 - 45
Removal 29 Blank.....	3 - 46
Removal 30 Blank.....	3 - 47
Removal 31 Blank.....	3 - 48
Removal 32 HIGH VOLTAGE POWER SUPPLY (PL5.1.17)	3 - 49
Removal 33 Blank.....	3 - 53
Removal 34 PRINT HEAD (PL13.3.99)	3 - 54
Removal 35 Blank.....	3 - 57
Removal 36 PHOTOCONDUCTOR (PC) / DEVELOPER (DEV) DRIVE (PL8.1.2).....	3 - 58
Removal 37 TONER CARTRIDGE SENSOR ASSEMBLY (K) (PL5.1.4).....	3 - 61
Removal 38 MPF SEPARATOR ROLLER ASSEMBLY (PL2.1.3)	3 - 62
Removal 39 SEPARATOR ROLLER (PL2.2.17) (Same as the FEED ROLLER).....	3 - 63

Chapter 3 Removal and Replacement Procedures (RRPs) CONTENTS

Removal 40 MPF ROLLER (PL3.1.10)	3 - 64
Removal 41 FEED ROLLER (PL3.2.53)	3 - 65
Removal 42 550 SHEET FEEDER ASSEMBLY (PL13.7.1)	3 - 66
Removal 43 550 TRAY REAR COVER (PL13.7.4)	3 - 67
Removal 44 550 TRAY FEED ROLLER (PL12.3.29)	3 - 68
Removal 45 550 TRAY SEPARATOR ROLLER (PL12.5.17) (Same as the 550 TRAY FEED ROLLER)	3 - 69
Removal 46 MEMORY CARD (PL13.4.22)	3 - 70
Removal 47 MULTI PROTOCOL CARD (PL13.4.23)	3 - 71
Removal 48 COVER EXTENDER (PL13.1.2)	3 - 72
Removal 49 REAR COVER (PL13.1.6)	3 - 73
Removal 50 COVER BOTTOM (PL13.1.5)	3 - 74
Removal 51 COVER POLE IN R (PL13.1.4)	3 - 75
Removal 52 COVER POLE R (PL13.1.8)	3 - 76
Removal 53 POWER SWITCH (PL13.5.4)	3 - 77
Removal 54 RIGHT COVER (PL13.1.9)	3 - 78
Removal 55 FRONT COVER (PL13.2.98)	3 - 79
Removal 56 OPERATOR PANEL (PL13.2.97)	3 - 81
Removal 57 COVER POLE IN L (PL13.1.3)	3 - 85
Removal 58 COVER POLE L (PL13.1.11)	3 - 86
Removal 59 LEFT COVER (PL13.1.10)	3 - 87
Removal 60 BOX ASSY PRT AIO (PL13.4.13)	3 - 88
Removal 61 ELECTRONIC SUB-SYSTEM CONTROL BOARD (PL13.4.20)	3 - 90
Removal 62 BOX ASSY FAX AIO (PL13.4.4)	3 - 91
Removal 63 PWBA FAX (PL13.4.3)	3 - 93
Removal 64 PWBA HYUI (PL13.4.1)	3 - 94
Removal 65 LOW VOLTAGE POWER SUPPLY (PL13.5.14)	3 - 95
Removal 66 HUMIDITY SENSOR (PL13.5.11)	3 - 96
Removal 67 MACHINE CONTROL UNIT (PL13.5.13)	3 - 97
Removal 68 TOP COVER (PL13.1.1)	3 - 99
Removal 69 SPEAKER ASSY (PL13.5.6)	3 - 100
Removal 70 INTERLOCK SWITCH (PL13.5.3)	3 - 101
Removal 71 FAN (PL13.5.10)	3 - 102
Removal 72 ADF SCANNER ASSY (PL13.8.1)	3 - 104
Removal 73 ADF ASSY (PL13.8.2), SCANNER ASSY (PL13.8.7)	3 - 109
Removal 74 ADF FEED ROLLER (PL13.8.3), ADF SEPARATOR PAD (PL13.8.5), ADF SEPARATOR SPRING (PL13.8.6)	3 - 110
Removal 75 KIT TRAY MAIN (PL13.8.10)	3 - 112
3. Replacement Steps	3 - 113
Replacement 1 550 TRAY SEPARATOR ROLLER (PL12.5.17) (Same as the 550 TRAY FEED ROLLER)	3 - 113
Replacement 2 550 TRAY FEED ROLLER (PL12.3.29)	3 - 114
Replacement 3 550 TRAY REAR COVER (PL13.7.4)	3 - 115
Replacement 4 550 SHEET FEEDER ASSEMBLY (PL13.7.1)	3 - 116
Replacement 5 FEED ROLLER (PL3.2.53)	3 - 117

Chapter 3 Removal and Replacement Procedures (RRPs) CONTENTS

Replacement 6 MPF ROLLER (PL3.1.10)	3 - 118
Replacement 7 SEPARATOR ROLLER (PL2.2.17) (Same as the FEED ROLLER).....	3 - 119
Replacement 8 MPF SEPARATOR ROLLER ASSEMBLY (PL2.1.3)	3 - 120
Replacement 9 TONER CARTRIDGE SENSOR ASSEMBLY (K) (PL5.1.4).....	3 - 121
Replacement 10 PHOTOCONDUCTOR (PC) / DEVELOPER (DEV) DRIVE (PL8.1.2).....	3 - 122
Replacement 11 Blank.....	3 - 124
Replacement 12 PRINT HEAD (PL13.3.99)	3 - 125
Replacement 13 Blank.....	3 - 128
Replacement 14 HIGH VOLTAGE POWER SUPPLY (PL5.1.17)	3 - 129
Replacement 15 Blank.....	3 - 132
Replacement 16 Blank.....	3 - 133
Replacement 17 Blank.....	3 - 134
Replacement 18 Blank.....	3 - 135
Replacement 19 Blank.....	3 - 136
Replacement 20 TONER DISPENSER MOTOR (PL5.1.12)	3 - 137
Replacement 21 LED ASSEMBLY (PL5.1.15).....	3 - 139
Replacement 22 LEFT ARM ASSEMBLY (PL7.1.97).....	3 - 140
Replacement 23 Blank.....	3 - 142
Replacement 24 Blank.....	3 - 143
Replacement 25 TONER CARTRIDGE SENSOR ASSEMBLY (C), (M), (Y) (PL5.1.4)	3 - 144
Replacement 26 Blank.....	3 - 145
Replacement 27 SIZE SWITCH ASSEMBLY (PL7.1.18)	3 - 146
Replacement 28 RIGHT ARM ASSEMBLY (PL13.3.98)	3 - 147
Replacement 29 Blank.....	3 - 149
Replacement 30 INTEGRATED FEEDER ASSEMBLY (PL3.2.99).....	3 - 150
Replacement 31 FEED DRIVE ASSEMBLY (PL8.1.7).....	3 - 154
Replacement 32 MPF FEED SOLENOID (PL3.1.98)	3 - 157
Replacement 33 Blank.....	3 - 159
Replacement 34 Blank.....	3 - 160
Replacement 35 Blank.....	3 - 161
Replacement 36 CHUTE ASSY EXIT OUT (PL6.1.1)	3 - 162
Replacement 37 SPUR ASSEMBLY (PL7.1.1).....	3 - 163
Replacement 38 FUSER (PL6.1.10).....	3 - 164
Replacement 39 DUPLEX GATE (PL6.1.13).....	3 - 165
Replacement 40 TONER CARTRIDGE (K), (C), (M), (Y) (PL5.1.18 ~ 21).....	3 - 166
Replacement 41 DUPLEX MODULE (PL11.1.1)	3 - 167
Replacement 42 TRANSFER BELT (PL4.1.1).....	3 - 168
Replacement 43 TRAY REAR COVER (PL13.1.7).....	3 - 170
Replacement 44 MPF COVER (PL13.2.99).....	3 - 171
Replacement 45 Blank.....	3 - 173
Replacement 46 MULTI PROTOCOL CARD (PL13.4.23).....	3 - 174
Replacement 47 MEMORY CARD (PL13.4.22).....	3 - 175
Replacement 48 ADF FEED ROLLER (PL13.8.3), ADF SEPARATOR PAD (PL13.8.5), ADF SEPARATOR SPRING (PL13.8.6).....	3 - 176
Replacement 49 ADF ASSY (PL13.8.2), SCANNER ASSY (PL13.8.7)	3 - 178
Replacement 50 ADF SCANNER ASSY (PL13.8.1).....	3 - 179





Chapter 3 Removal and Replacement Procedures (RRPs) CONTENTS

Replacement 51 FAN (PL13.5.10).....	3 - 186
Replacement 52 INTERLOCK SWITCH (PL13.5.3)	3 - 188
Replacement 53 SPEAKER ASSY (PL13.5.6)	3 - 189
Replacement 54 TOP COVER (PL13.1.1).....	3 - 190
Replacement 55 MACHINE CONTROL UNIT (PL13.5.13)	3 - 191
Replacement 56 HUMIDITY SENSOR (PL13.5.11)	3 - 193
Replacement 57 LOW VOLTAGE POWER SUPPLY (PL13.5.14).....	3 - 194
Replacement 58 PWBA HYUI (PL13.4.1).....	3 - 196
Replacement 59 PWBA FAX (PL13.4.3)	3 - 199
Replacement 60 BOX ASSY FAX AIO (PL13.4.4).....	3 - 200
Replacement 61 ELECTRONIC SUB-SYSTEM CONTROL BOARD (PL13.4.20)	3 - 203
Replacement 62 BOX ASSY PRT AIO (PL13.4.13)	3 - 206
Replacement 63 LEFT COVER (PL13.1.10)	3 - 208
Replacement 64 COVER POLE L (PL13.1.11).....	3 - 209
Replacement 65 COVER POLE IN L (PL13.1.3).....	3 - 210
Replacement 66 OPERATOR PANEL (PL13.2.97).....	3 - 211
Replacement 67 FRONT COVER (PL13.2.98).....	3 - 216
Replacement 68 RIGHT COVER (PL13.1.9).....	3 - 218
Replacement 69 POWER SWITCH (PL13.5.4)	3 - 219
Replacement 70 COVER POLE R (PL13.1.8).....	3 - 220
Replacement 71 COVER POLE IN R (PL13.1.4)	3 - 221
Replacement 72 COVER BOTTOM (PL13.1.5).....	3 - 222
Replacement 73 REAR COVER (PL13.1.6)	3 - 223
Replacement 74 COVER EXTENDER (PL13.1.2).....	3 - 224
Replacement 75 KIT TRAY MAIN (PL13.8.10).....	3 - 225

1. Removal and Replacement Procedures (RRPs)

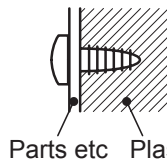
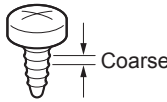
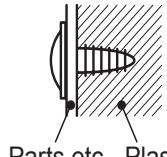
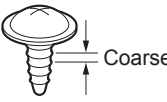
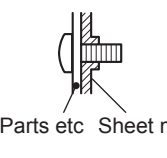
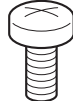
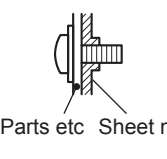
1.1 Before starting service procedure

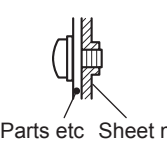
- Start the procedure after turning off the power and removing the power cord from the outlet.
- When performing the service operation around the FUSER ASSY, ensure that FUSER ASSY and its surrounding area have cooled down sufficiently.
- Pay sufficient attention to the parts during the procedure because they may be broken or may not perform their functions properly if unreasonable force is applied.
- Since various types of screws are used, ensure that the right screws are used in their right positions. Use special caution not to confuse the screws for plastic and the ones for sheet metal, because using the wrong type of screw may result in damage to the screw threads or other troubles.

No.	Type	Application	Shape	How to distinguish	Points to be noted	Major application locations
1	Screw for plastic Silver, tap	Plastic  Parts etc Plastic	 Coarse	<ul style="list-style-type: none"> • Silver-colored • Thread is coarser than that of the sheet metal type. • Screw tip is thin. 	Oblique screwing damages the thread because this screw cuts female threads in the base material as it goes in.	
2	Screw for plastic Silver, with flange, tap	Plastic  Parts etc Plastic	 Coarse	<ul style="list-style-type: none"> • Silver-colored • With flange • Thread is coarser than that of the sheet metal type. • Screw tip is thin. 	Oblique screwing damages the thread because this screw cuts female threads in the base material as it goes in.	<ul style="list-style-type: none"> • Chute assy exit out
3	Screw for metal sheet Silver	Sheet metal  Parts etc Sheet metal		<ul style="list-style-type: none"> • Silver-colored • Diameter of the thread section is uniform. 		
4	Screw for metal sheet Silver, with flange	Sheet metal  Parts etc Sheet metal		<ul style="list-style-type: none"> • Gold-colored • With flange • Diameter of the thread section is uniform. 		<ul style="list-style-type: none"> • Rear cover
5	Screw for metal sheet Silver, with an external tooth washer	Sheet metal  Parts etc Sheet metal		<ul style="list-style-type: none"> • Silver-colored • Provided with an external tooth washer. • Diameter of the thread section is uniform. 		<ul style="list-style-type: none"> • Mounting positions of the ground wires.

Chapter 3 Removal and Replacement Procedures (RRPs)

- Wear a wristband or the like as far as possible to remove static electricity of the human body.
- Keep the front cover closed. Buzzer goes off when the machine is left powered on with the front cover open for five minutes or longer to prevent the drum deterioration due to exposure to light.
- When removing the toner cartridge in a removal/replacement operation, cover the drum to keep it from being exposed to light.
- Remove PAPER TRAY, TRANSFER BELT, TONER CARTRIDGE, and FUSER, and put them in a place where they do not affect the procedure. (Note that the service procedures can be performed with those parts in place depending on the target section of removal/replacement.)

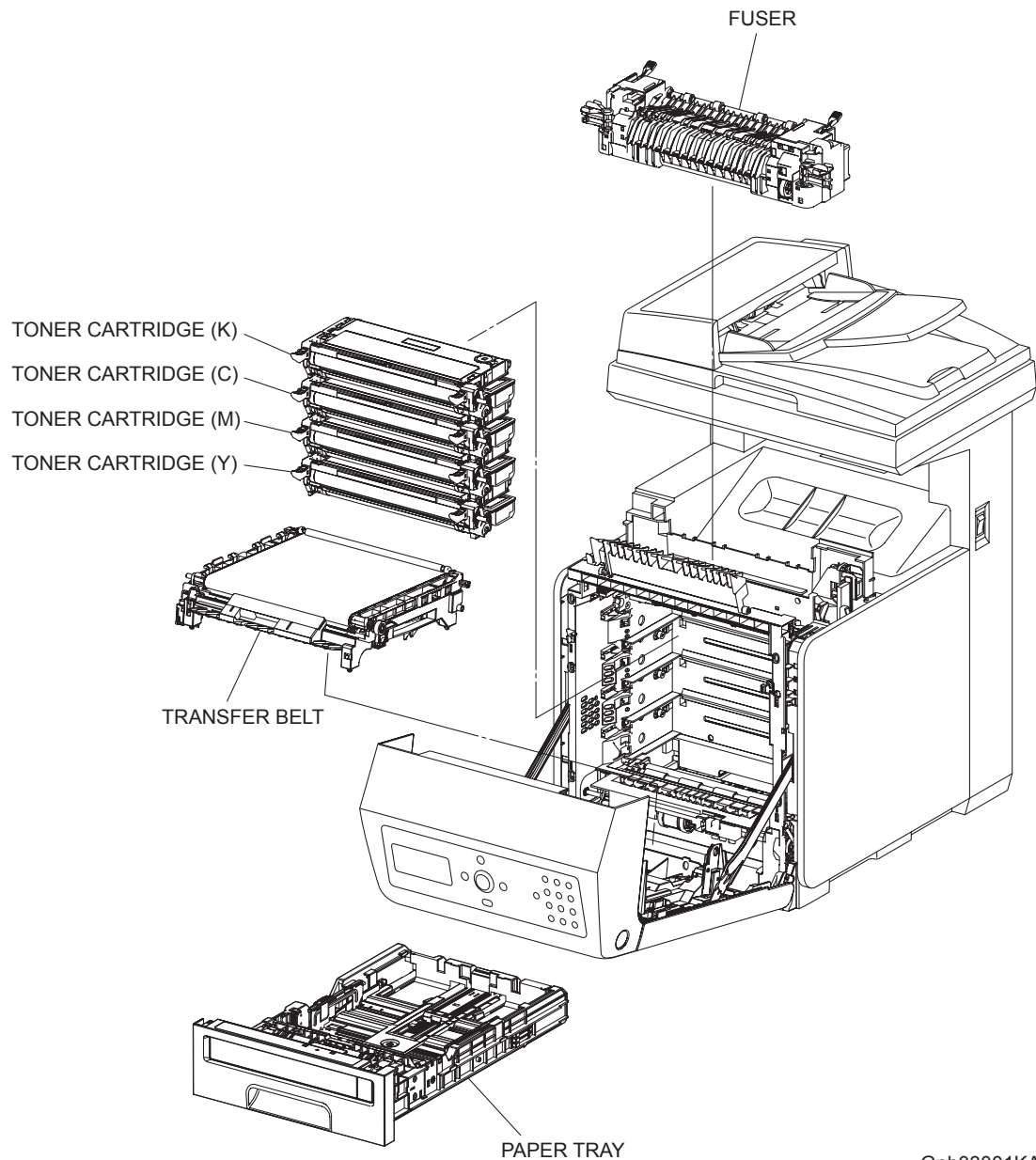

Gnb03001KA

1.2 General notes

- The string “(PL X.Y.Z)” suffixed to the part name in the procedure denotes that the part corresponds to the plate (PL) “X.Y”, item “Z” of [Engineering Parts list], and its shape and fitting position can be checked in [Engineering Parts list].
- Directional descriptions used in the procedures are defined as follows:
 - Front : Direction toward you when facing the front of the printer.
 - Rear : Direction opposite to the front when facing the front of the printer.
 - Left : Left-hand direction when facing the front of the printer.
 - Right : Right-hand direction when facing the front of the printer.

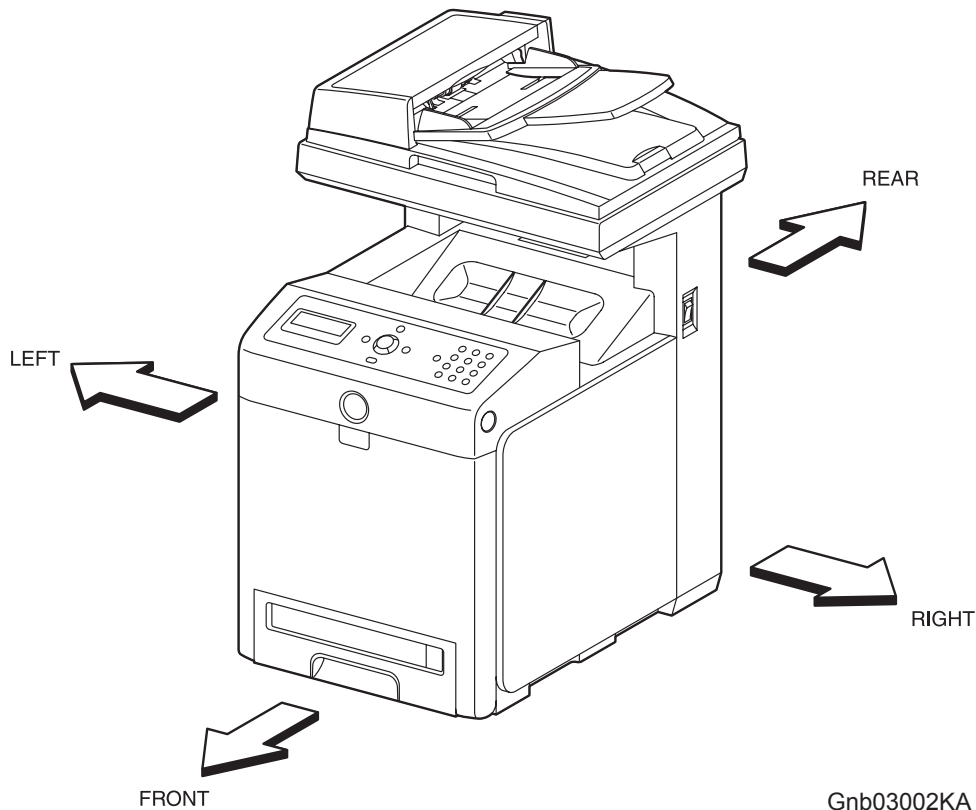

Gnb03002KA

Figure: Definitions of Printer Orientation

- The string “(RRP X.Y)” that appears in or at the end of the procedure denotes that the related service procedure is described in [RRP X.Y].
- Screws shown in the illustrations are to be unscrewed and removed using a Phillips head (cross-slot) screwdriver, unless otherwise specified.
- Black arrows shown in the illustrations denote moving directions. When numbers are assigned to these arrows, they refer to the order in the procedure.
- Refer to [Chapter 4 Plug/Jack (P/J) Connector Locations] for the positions of connectors (P/J).

Removal Flows

The components not connected with arrows in the flow below can be removed independently.

PRINTER Removal FLOW

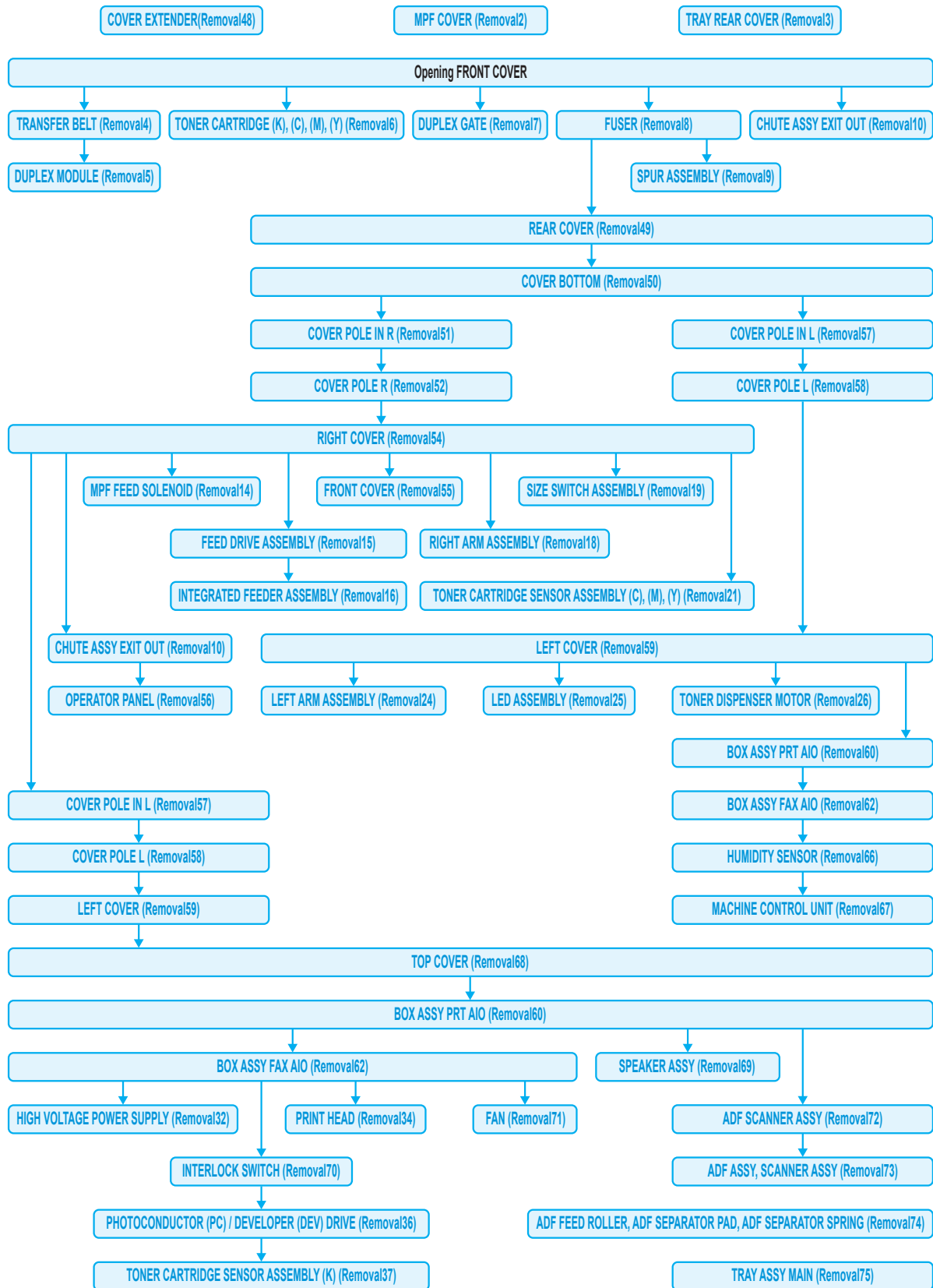

PRINTER(Rear Pole Side) Removal FLOW

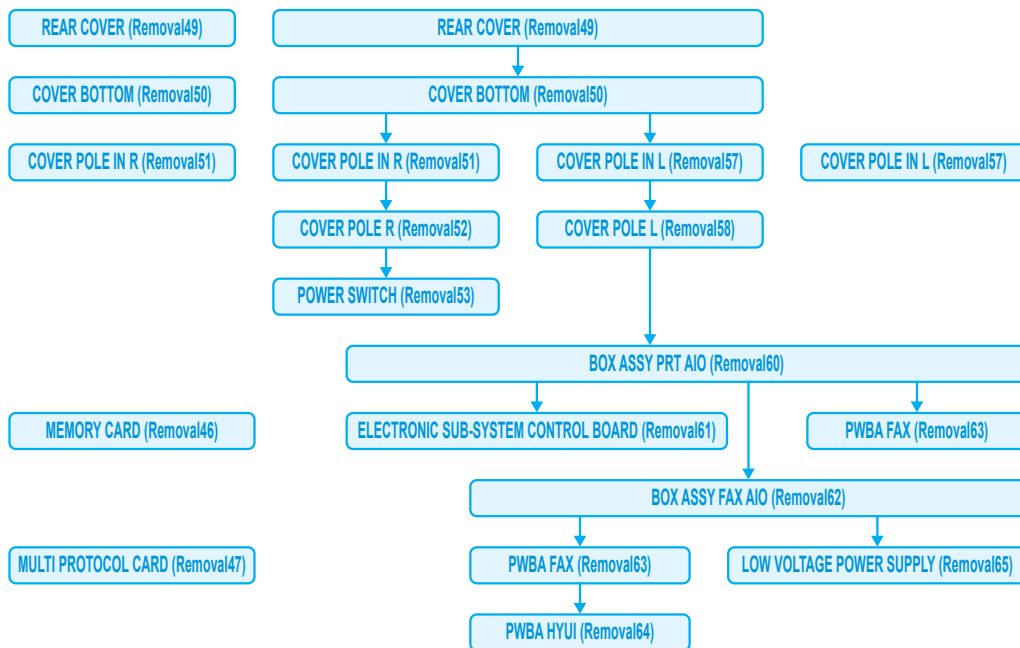

PRINTER(MPF Roller &FEED Roller) Removal FLOW

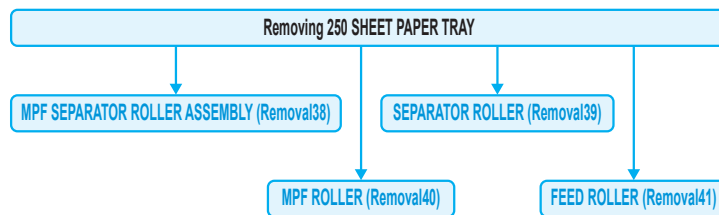

550 SHEET FEEDER ASSEMBLY Removal FLOW

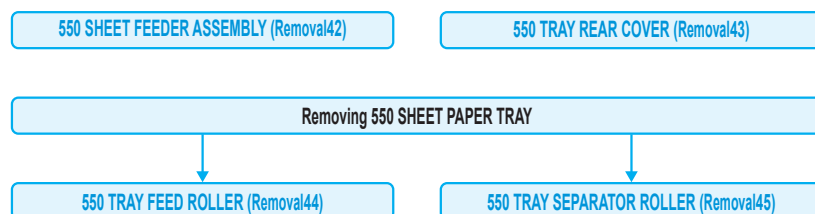

Replacement Flows

The components not connected with arrows in the flow below can be replaced independently. However, the rear cover is an exception when it was removed together with other parts.

550 SHEET FEEDER ASSEMBLY Replacement FLOW

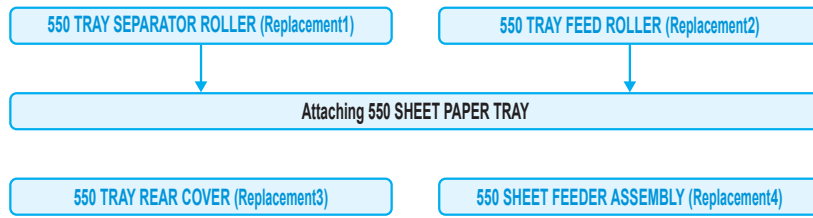

PRINTER(MPF Roller & FEED Roller) Replacement FLOW

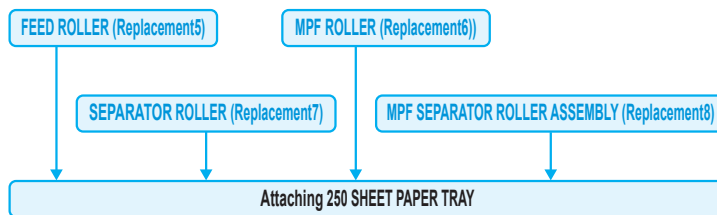

PRINTER(Rear Pole Side) Replacement FLOW

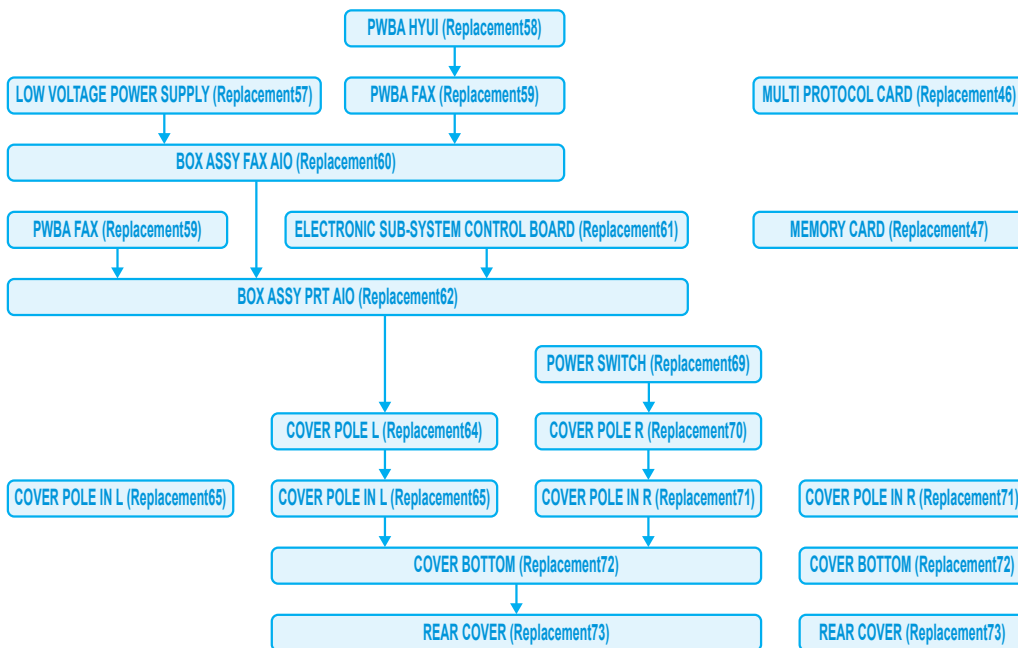

PRINTER Replacement FLOW

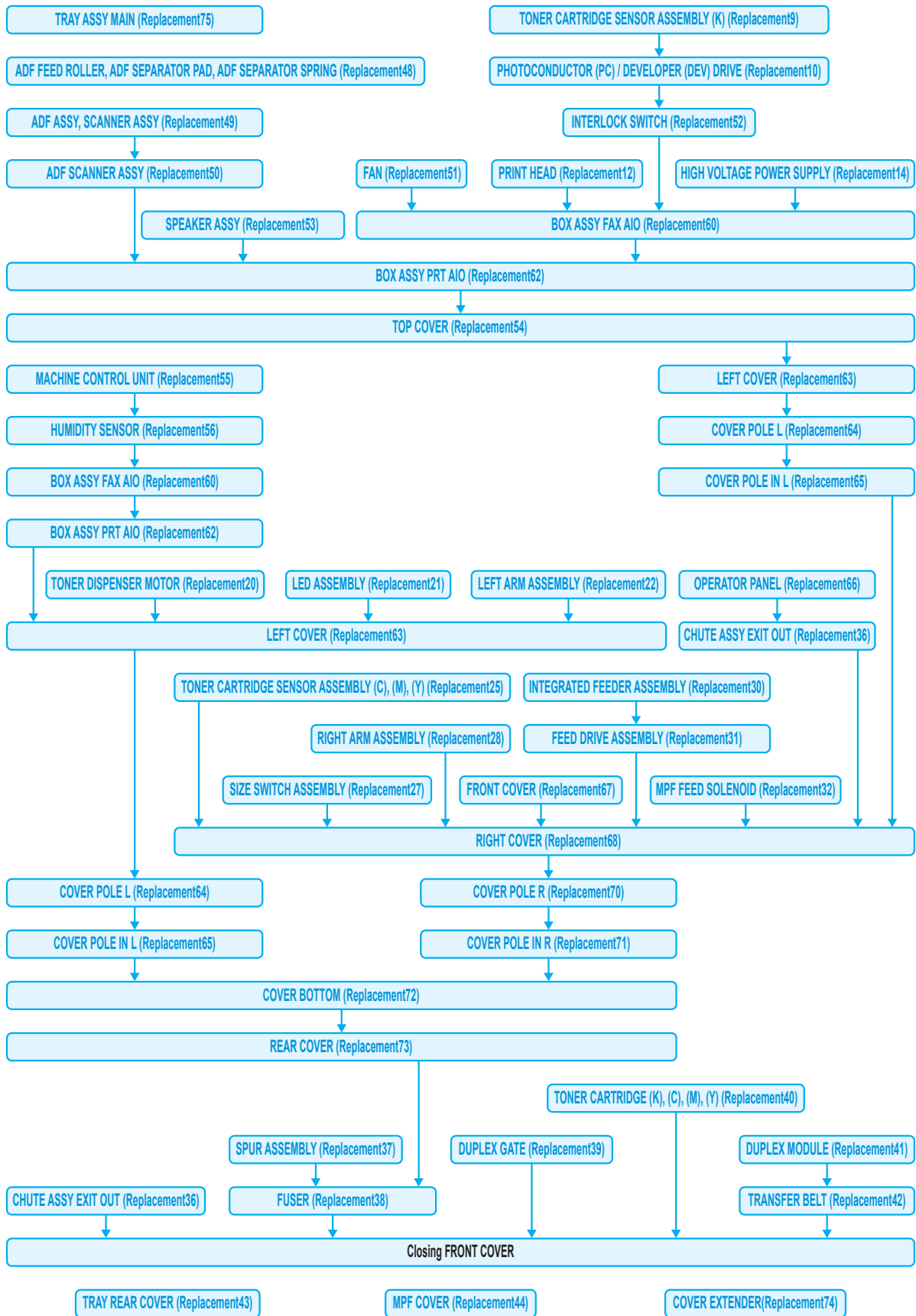

2. Removal Steps

Removal 1 Blank

Removal 2 MPF COVER (PL13.2.99)

- 1) Open the MPF COVER (PL13.2.26).

NOTE

When performing the step described below, take care not to drop or damage the MPF COVER.

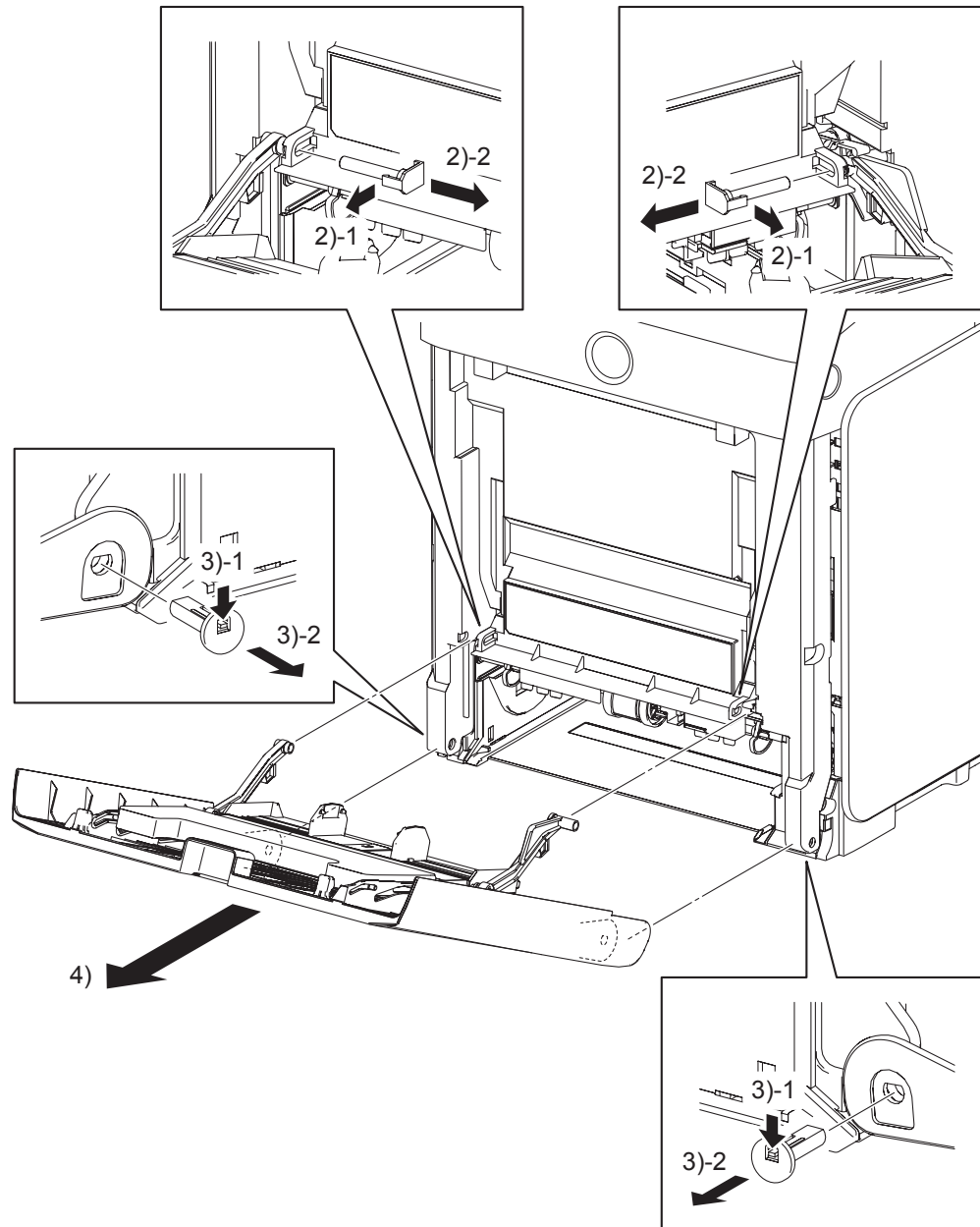

Kmy03004KA

- 2) Release the hooks on the PIN PIVOT MSIs (PL13.2.17) that pivot the LINK ASSY MSIs (pivoted to the TRAY ASSI MSI BASE at the other end) to the FRONT COVER (PL.1.2.1) at the two locations on the left and right, and then pull out the PIN PIVOT MSIs to the inside.
- 3) Release the hooks on the SHAFT PIVOT MSIs (PL13.2.33) that pivot the MPF COVER to the printer at the two locations on the left and right, and then pull out the SHAFT PIVOT MSIs to the inside.
- 4) Remove the MPF COVER from the printer.

Removal 3 TRAY REAR COVER (PL13.1.7)

- 1) Pull the TRAY REAR COVER (PL13.1.7) backward until it stops.

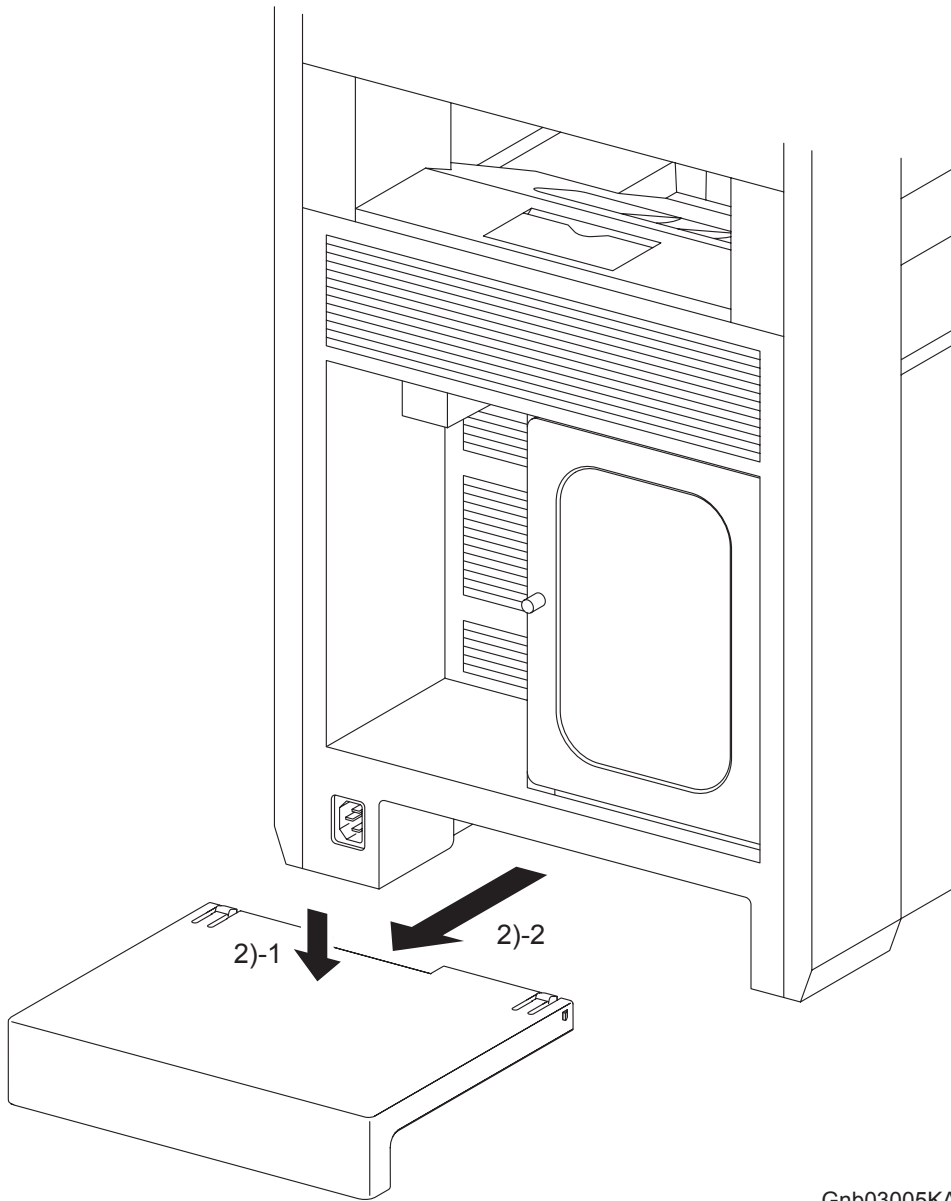

Gnb03005KA

- 2) Release the two hooks by depressing the center of the TRAY REAR COVER, and then remove the TRAY REAR COVER from the printer.

Removal 4 TRANSFER BELT (PL4.1.1)

- 1) Open the FRONT COVER (PL13.2.1).

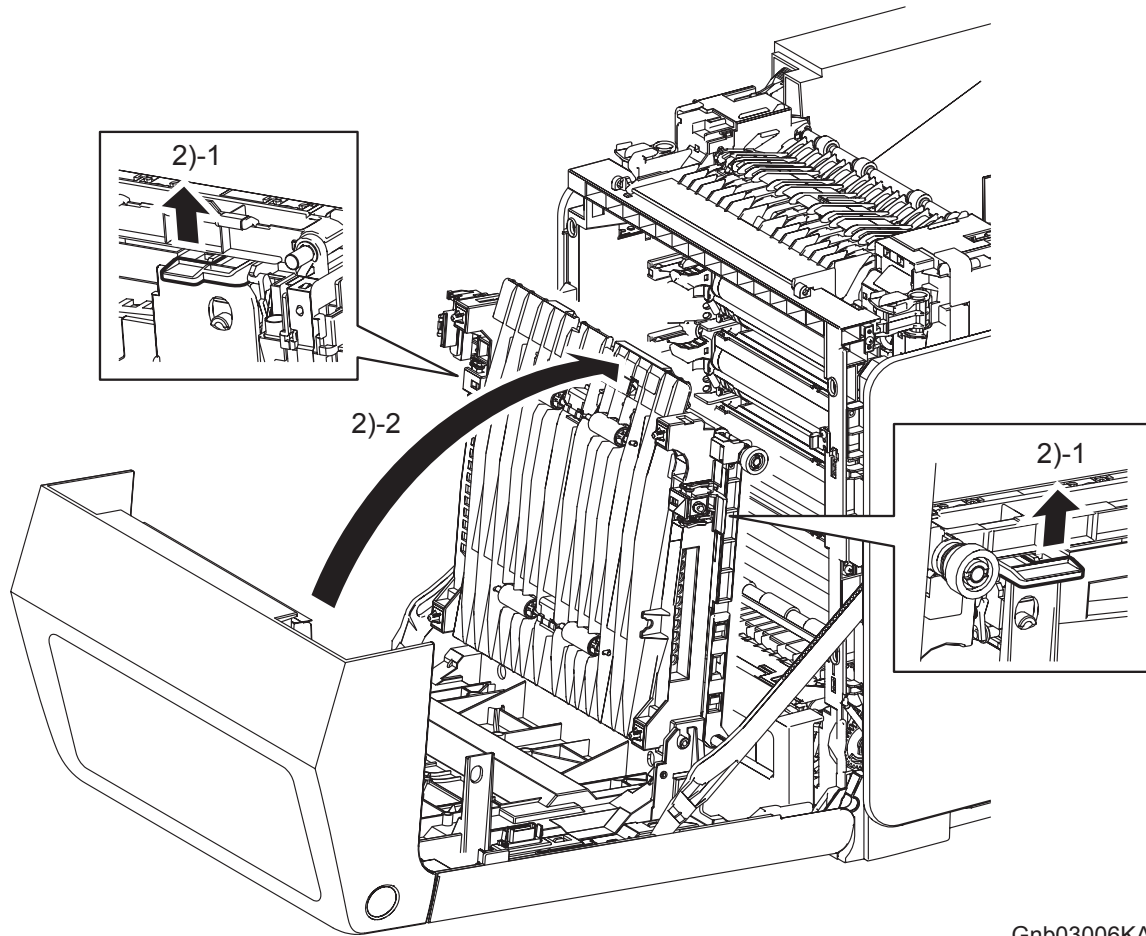

Gnb03006KA

- 2) Release the lock by pulling up the levers on the left and right sides of the TRANSFER BELT (PL4.1.1). Raise the TRANSFER BELT upright.

Continues to the next page.

Removal 4 TRANSFER BELT (PL4.1.1)

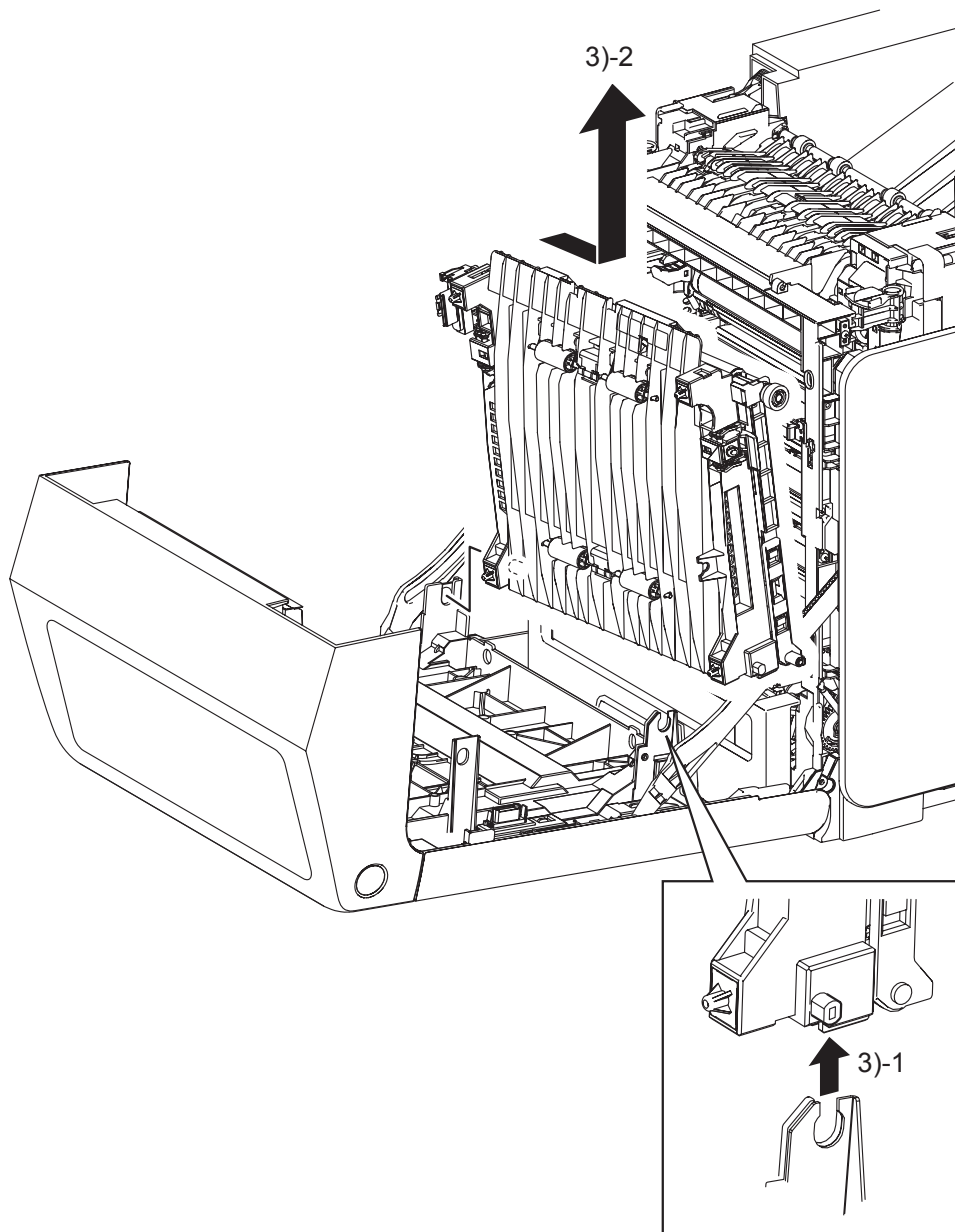

Gnb03007KA

- 3) Remove the TRANSFER BELT by releasing the right side lug on the TRANSFER BELT from the U-shaped notch of the FRONT COVER and pulling out the left side lug on the TRANSFER BELT from the hole on the FRONT COVER.

Go to the next removal step:

Removal 5 DUPLEX MODULE (PL11.1.1)

Removal 5 DUPLEX MODULE (PL11.1.1)

Steps 1 and 2 are for reference. Before removing this component, check that Steps 1 and 2 have been performed.

- 1) Open the FRONT COVER (PL13.2.1).
- 2) Remove the TRANSFER BELT. (Removal 4)

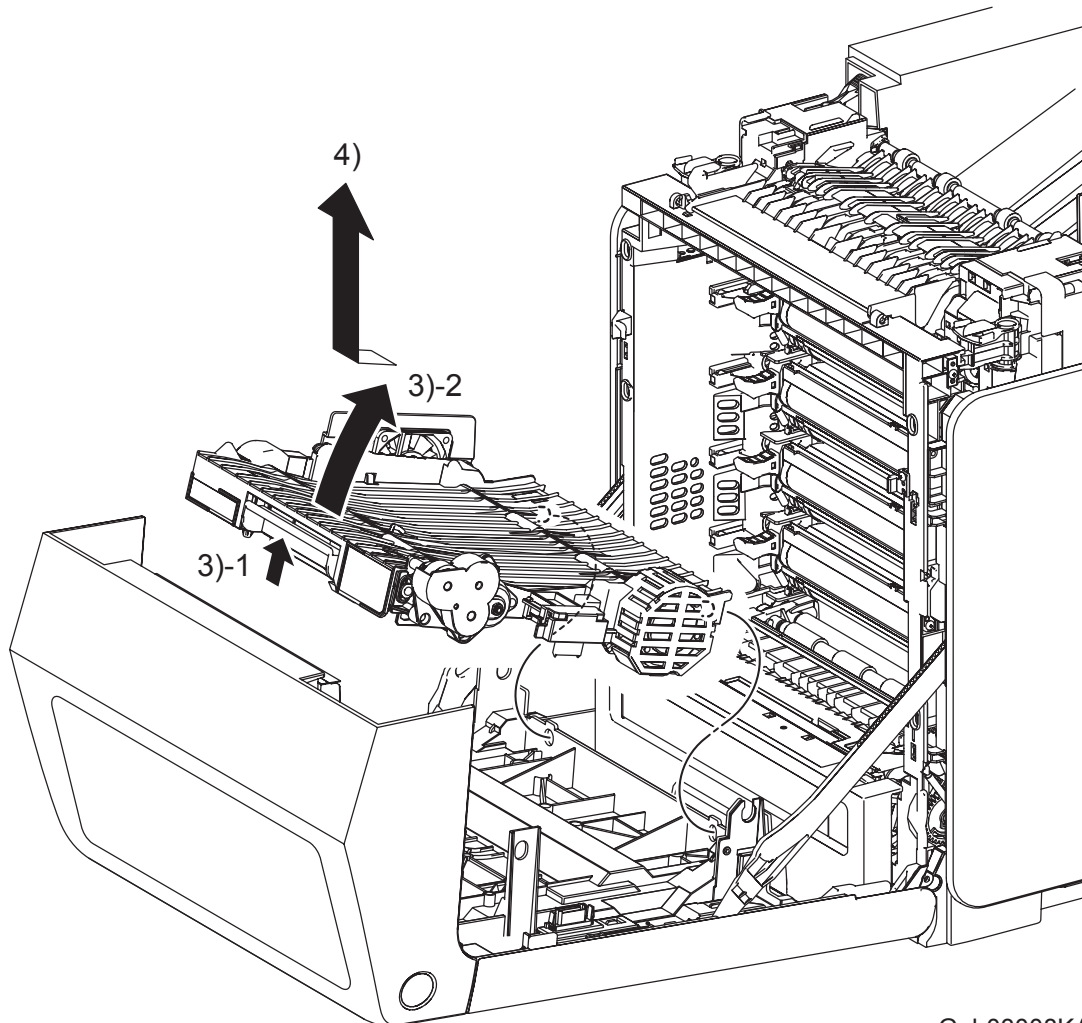

Gnb03008KA

- 3) Release the lock by pulling the lever of the DUPLEX MODULE (PL11.1.1), and then raise the DUPLEX MODULE.
- 4) Release the two bosses on the backside of the DUPLEX MODULE from the holes on the FRONT COVER, and then remove the DUPLEX MODULE.

Removal 6 TONER CARTRIDGE (K), (C), (M), (Y) (PL5.1.18-21)

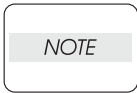

Described below is the removal procedure common among the TONER CARTRIDGES (C), (M), (Y), and (K).

Step 1 is for reference. Before removing this component, check that Step 1 has been performed.

- 1) Open the FRONT COVER (PL13.2.1).

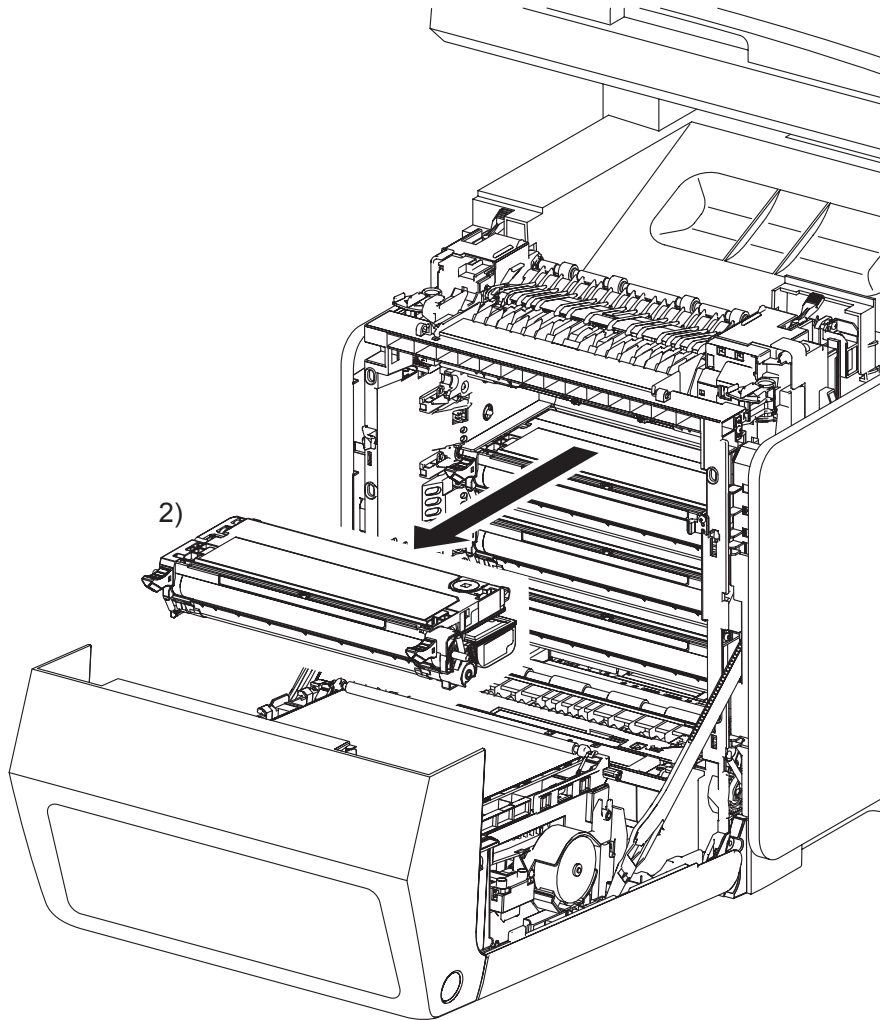

Gnb03009KA

- 2) Remove the TONER CARTRIDGE toward you by pulling it by the left and right handles.

Removal 7 DUPLEX GATE (PL6.1.13)

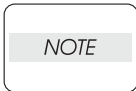

The FUSER part is very hot. Take added care not to get burned when performing the service operation.

- 1) Open the FRONT COVER (PL13.2.1).

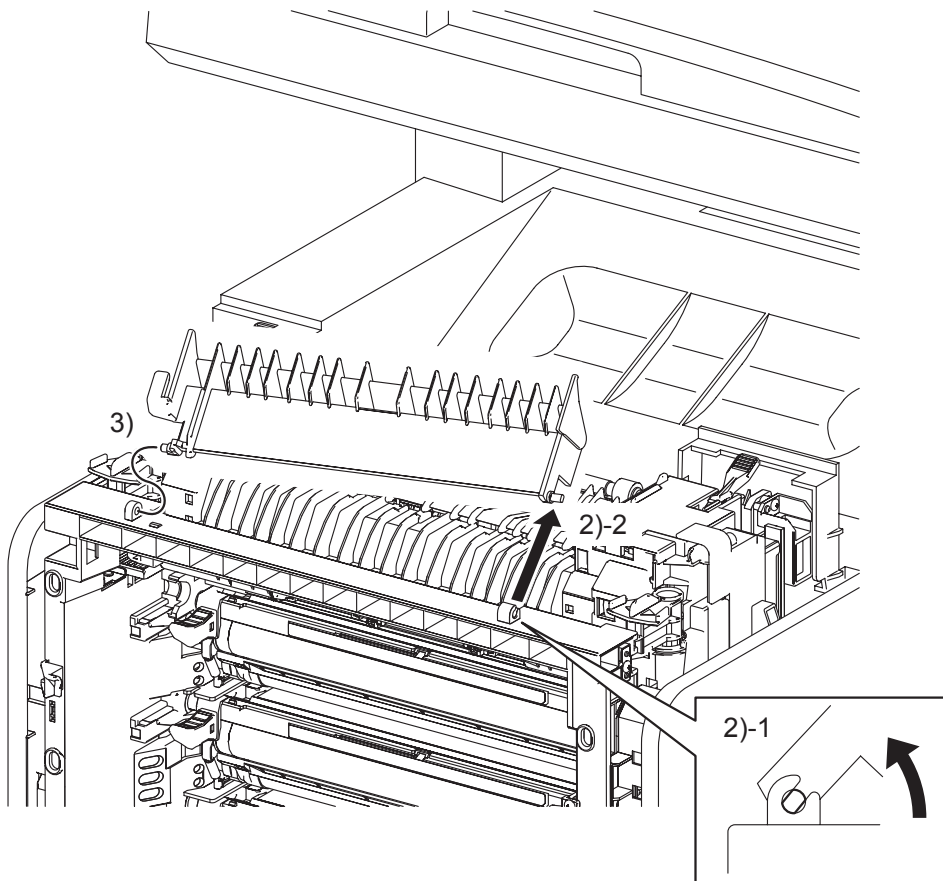

Gnb03010KA

- 2) Open the DUPLEX GATE (PL6.1.13) to about 45 degrees so that the flat faces of the right side pivot of the DUPLEX GATE comes parallel with the U-shaped notch. Pull out the right side pivot of the DUPLEX GATE from the U-shaped notch diagonally backward.
- 3) Pull out the left side pivot of the DUPLEX GATE from the hole on the printer.

Removal 8 FUSER (PL6.1.10)

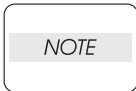

The FUSER part is very hot. Take added care not to get burned when performing the service operation.

- 1) Open the FRONT COVER (PL13.2.1).

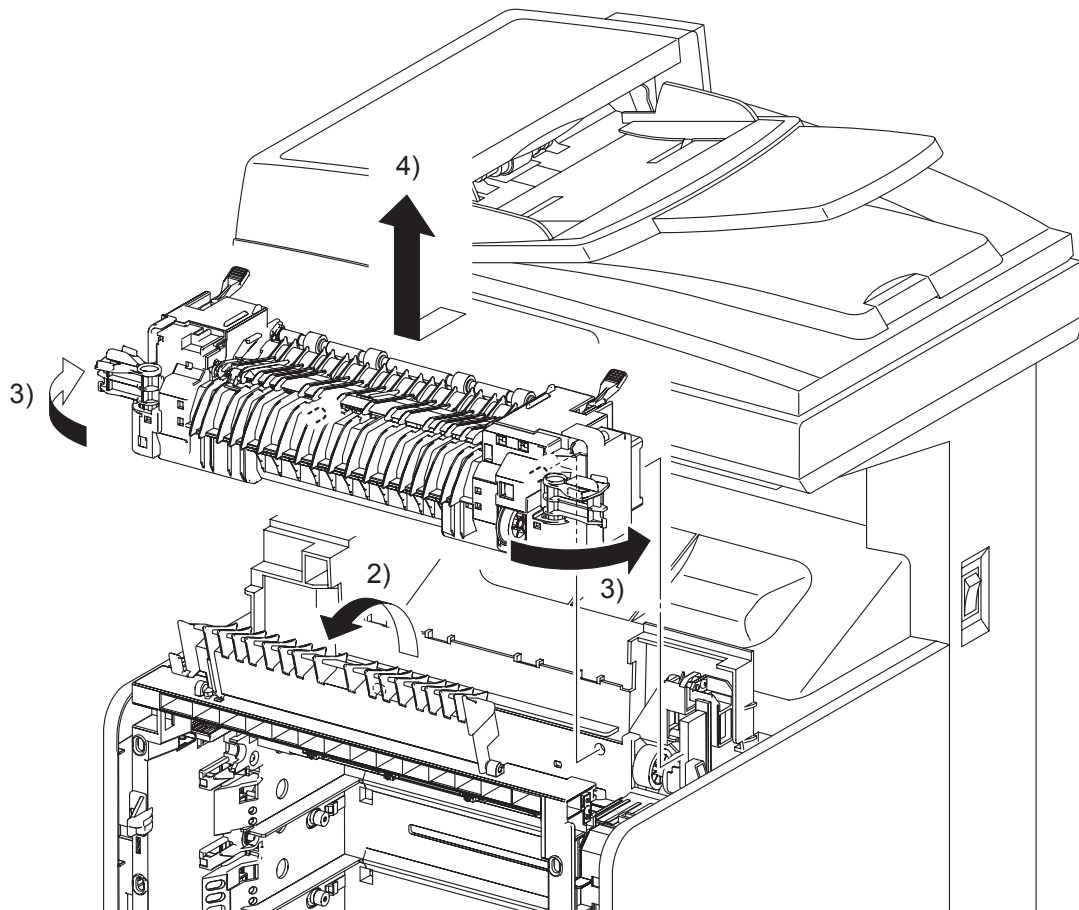

Gnb03011KA

- 2) Open the DUPLEX GATE (PL6.1.13).
- 3) Release the lock by rotating the left and right levers of the FUSER (PL6.1.10) to the outside direction.
- 4) Disengage the bosses and connector (P/J171) of the FUSER by moving the FUSER slightly toward you. Remove the FUSER upward.

Go to the next removal step:

Removal 9 SPUR ASSEMBLY (PL7.1.1)

Removal 9 SPUR ASSEMBLY (PL7.1.1)

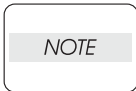

Described below is the removal procedure common between the left and right sides of the SPUR ASSEMBLY.

Steps 1 and 2 are for reference. Before removing this component, check that Steps 1 and 2 have been performed.

- 1) Open the FRONT COVER (PL13.2.1).
- 2) Remove the FUSER. (Removal 8)

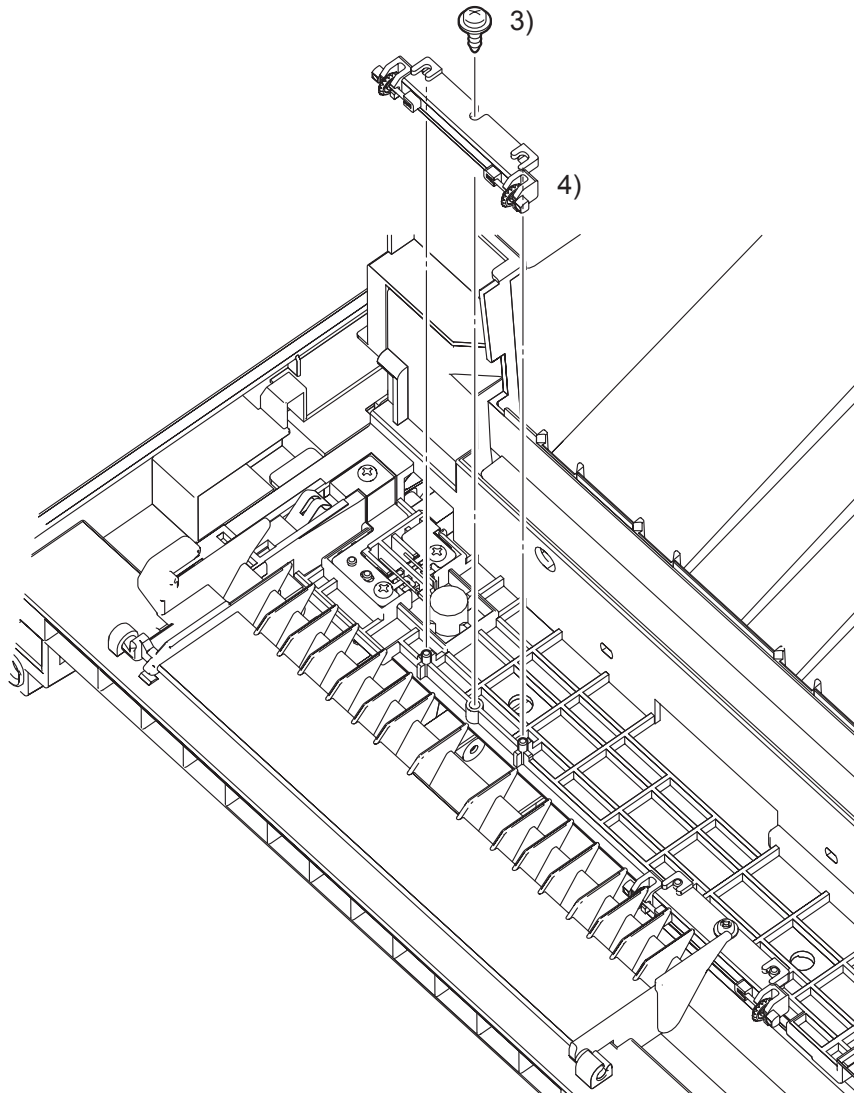

Kmy03012KA

- 3) Remove the one screw (silver, with flange, tap, 8mm) that fixes the SPUR ASSEMBLY to the printer.
- 4) Remove the SPUR ASSEMBLY from the printer.

Removal 10 CHUTE ASSY EXIT OUT (PL6.1.1)

- 1) Open the FRONT COVER (PL13.2.1).

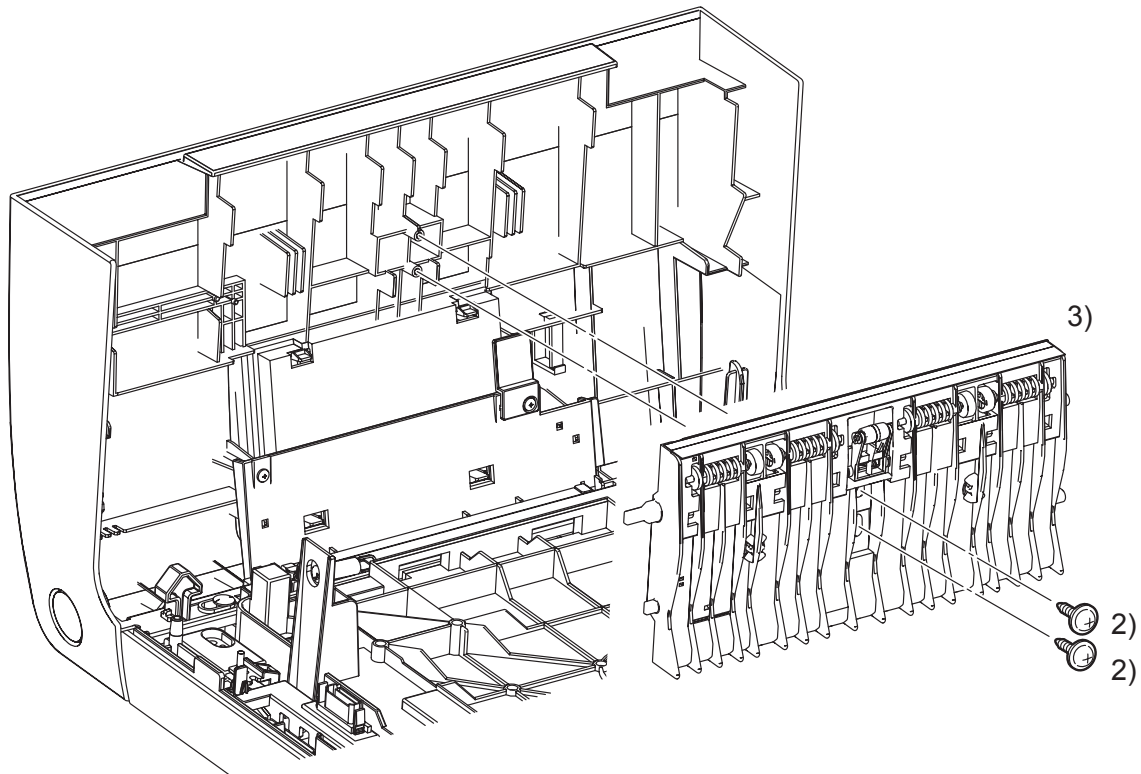

Kmy03013KA

- 2) Remove two screws (silver, with flange, tap, 10mm) that fix the CHUTE ASSY EXIT OUT (PL6.1.1) to the FRONT COVER.
- 3) Remove the CHUTE ASSY EXIT OUT from the FRONT COVER.

Go to the next removal step:

Removal 56 OPERATOR PANEL (PL13.2.97)

Removal 11 Blank

Removal 12 Blank

Removal 13 Blank

Removal 14 MPF FEED SOLENOID (PL3.1.98)

Steps 1 through 7 are for reference. Before removing this component, check that Steps 1 through 7 have been performed.

- 1) Open FRONT COVER (PL13.2.1).
- 2) Remove the FUSER.(Removal 8)
- 3) Remove the REAR COVER. (Removal 49)
- 4) Remove the COVER BOTTOM. (Removal 50)
- 5) Remove the COVER POLE IN R.(Removal 51)
- 6) Remove the COVER POLE R.(Removal 52)
- 7) Remove the RIGHT COVER. (Removal 54)

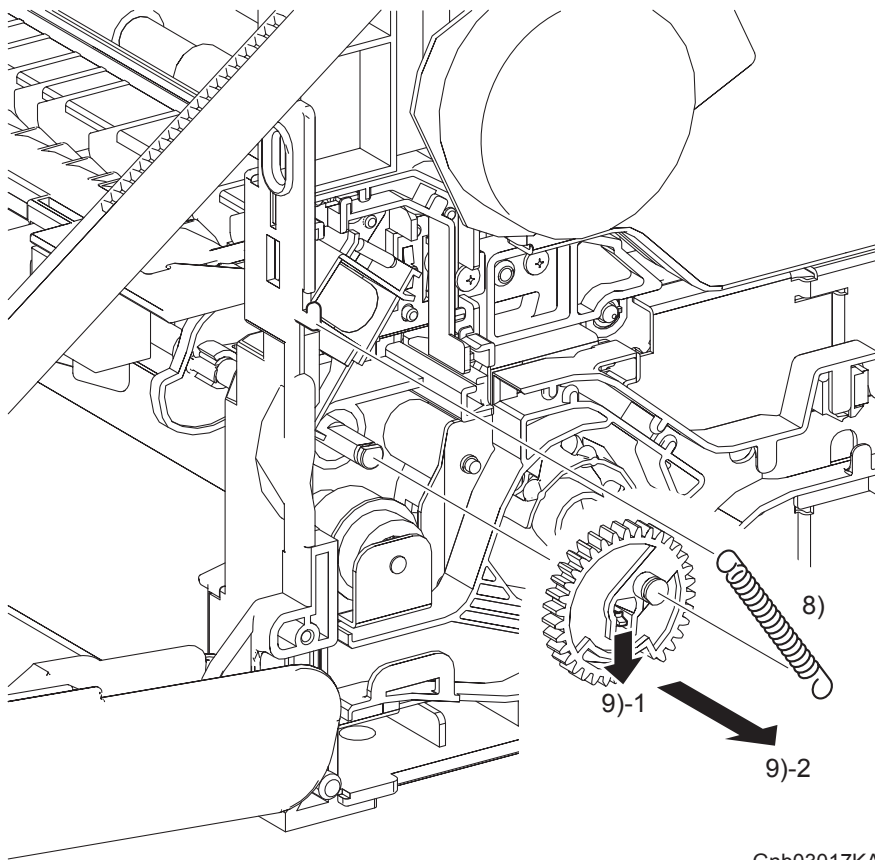

- 8) Remove the SPRING FEED MSI (PL3.1.4) from the printer.
- 9) Remove the GEAR MSI from the SHAFT MSI (PL3.1.12) by releasing the hook on the GEAR MSI (PL3.1.5).

Continues to the next page.

Removal 14 MPF FEED SOLENOID (PL3.1.98)

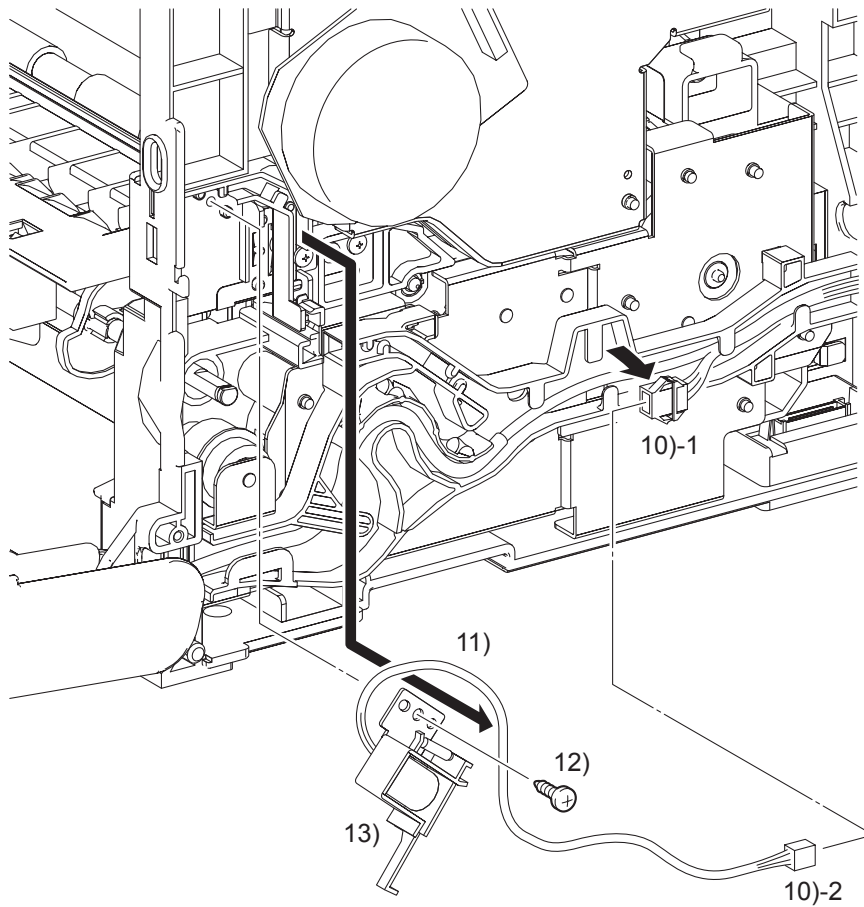

Gnb03018KA

NOTE

When performing the step below, leave the junction connector on the printer side cable.

- 10) Disengage the connector (P/J256) of the MPF FEED SOLENOID (PL3.1.3).
- 11) Remove the harness of the MPF FEED SOLENOID from the DUCT MSI SOL (PL3.1.2) and DUCT DRV PH (PL8.1.8).
- 12) Remove the one screw (silver, tap, 8mm) that fixes the MPF FEED SOLENOID to the printer.
- 13) Remove the MPF FEED SOLENOID from the printer.

Removal 15 FEED DRIVE ASSEMBLY (PL8.1.7)

Steps 1 through 7 are for reference. Before removing this component, check that Steps 1 through 7 have been performed.

- 1) Open FRONT COVER (PL13.2.1).
- 2) Remove the FUSER.(Removal 8)
- 3) Remove the REAR COVER. (Removal 49)
- 4) Remove the COVER BOTTOM. (Removal 50)
- 5) Remove the COVER POLE IN R.(Removal 51)
- 6) Remove the COVER POLE R.(Removal 52)
- 7) Remove the RIGHT COVER. (Removal 54)

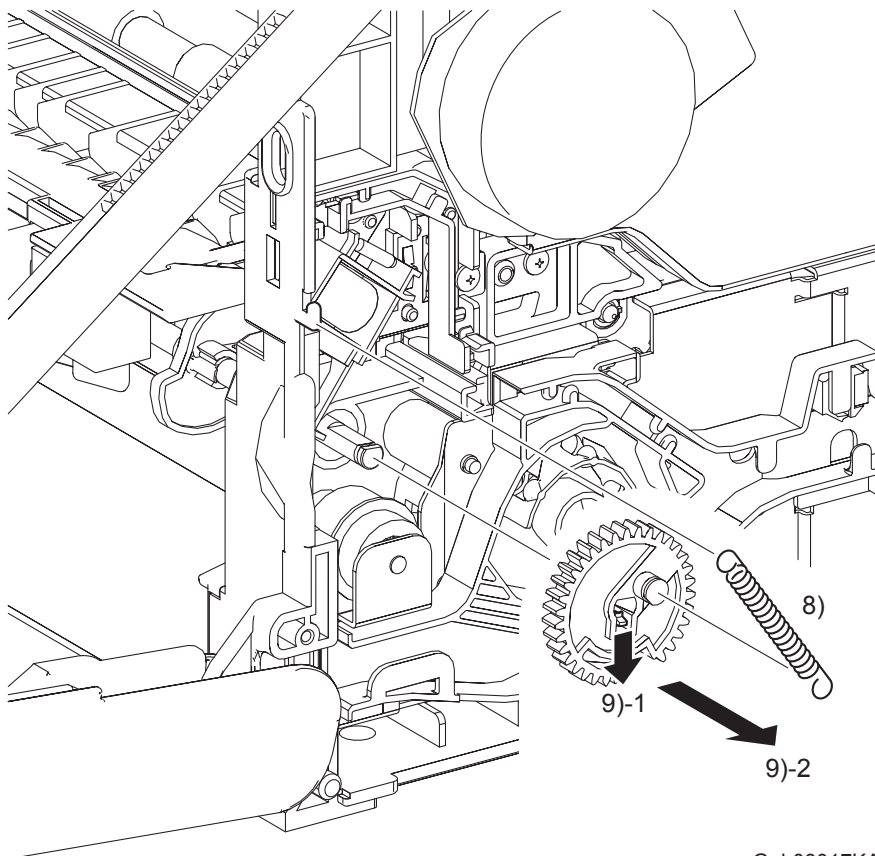

Gnb03017KA

- 8) Remove the SPRING FEED MSI (PL3.1.4) from the printer.
- 9) Remove the GEAR MSI from the SHAFT MSI (PL3.1.12) by releasing the hook on the GEAR MSI (PL3.1.5).
- 10) Remove all the harnesses from the DUCT DRV PH (PL8.1.8).

Continues to the next page.

Removal 15 FEED DRIVE ASSEMBLY (PL8.1.7)

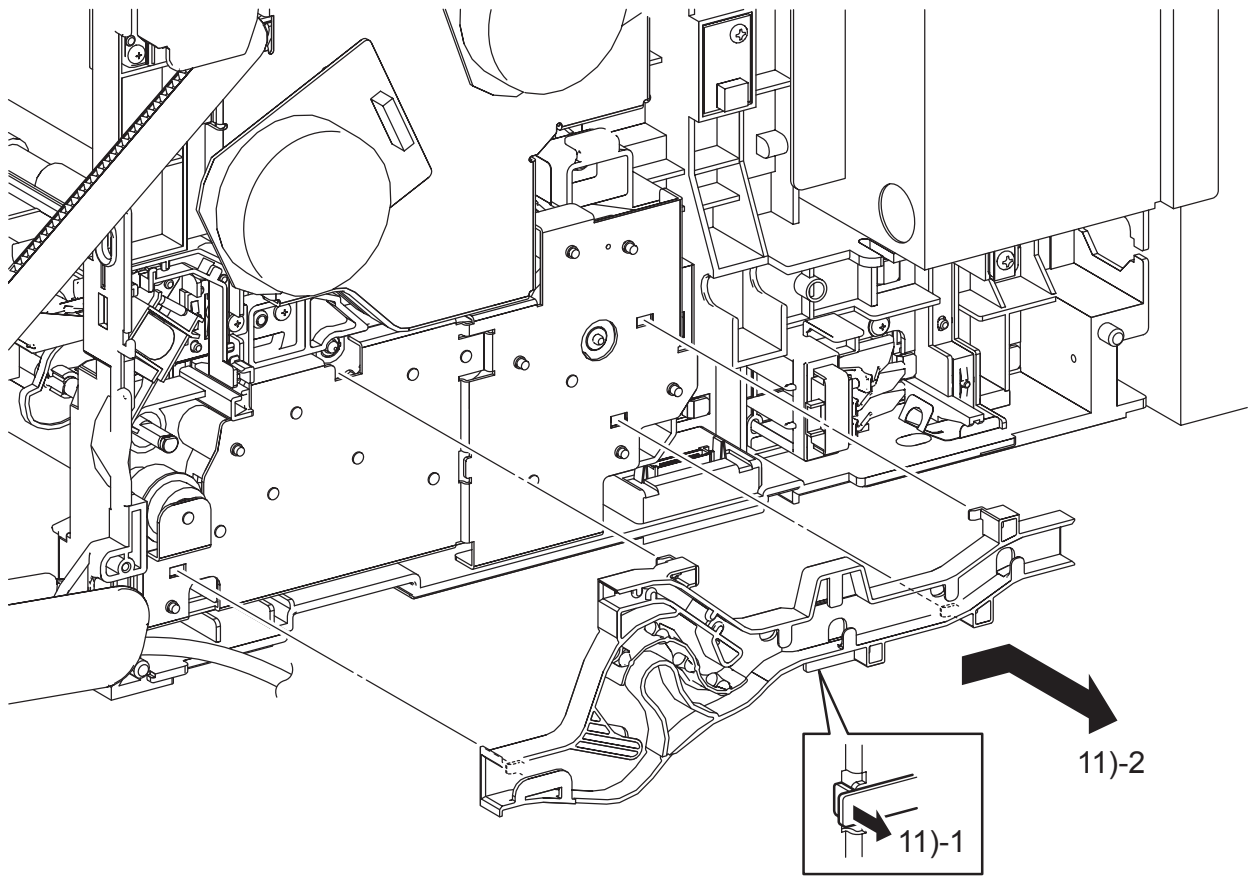

Gnb03019KA

- 11) Remove the DUCT DRV PH from the FEED DRIVE ASSEMBLY (PL8.1.7) by releasing the hook on the DUCT DRV PH and moving it slightly backward.

Continues to the next page.

Removal 15 FEED DRIVE ASSEMBLY (PL8.1.7)

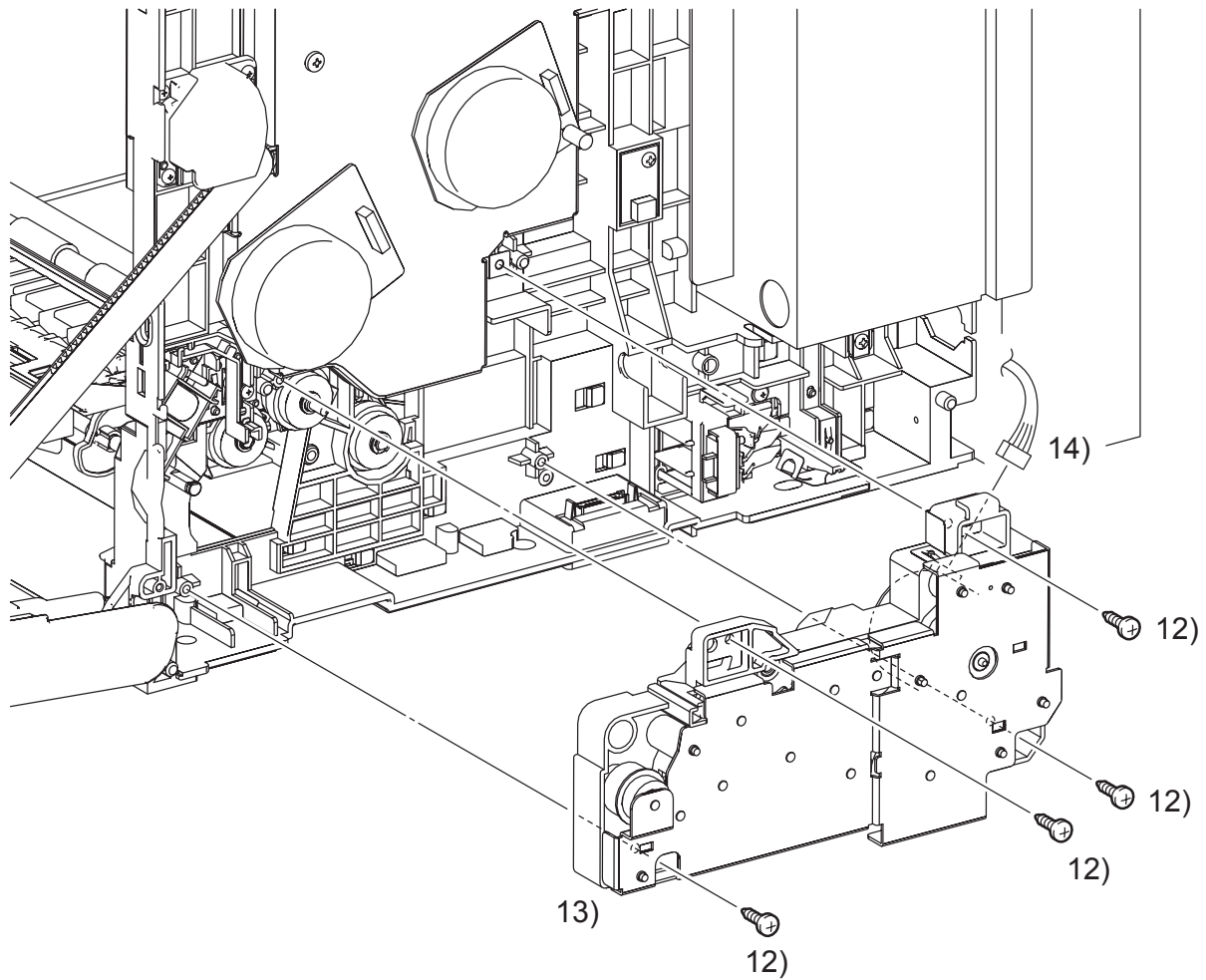

Gnb03020KA

- 12) Remove the four screws (silver, tap, 10mm) that fix the FEED DRIVE ASSEMBLY to the printer.

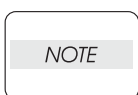

When performing the step described below, take care not to move the FEED DRIVE ASSEMBLY from the printer too far because they are connected with the harness.

- 13) Remove the FEED DRIVE ASSEMBLY from the printer.
 14) Disengage the connector (P/J251) of the FEED DRIVE ASSEMBLY.

Go to the next removal step:

Removal 16 INTEGRATED FEEDER ASSEMBLY (PL3.2.99)

Removal 16 INTEGRATED FEEDER ASSEMBLY (PL3.2.99)

Steps 1 through 8 are for reference. Before removing this component, check that Steps 1 through 8 have been performed.

- 1) Open FRONT COVER (PL13.2.1).
- 2) Remove the FUSER.(Removal 8)
- 3) Remove the REAR COVER. (Removal 49)
- 4) Remove the COVER BOTTOM. (Removal 50)
- 5) Remove the COVER POLE IN R.(Removal 51)
- 6) Remove the COVER POLE R.(Removal 52)
- 7) Remove the RIGHT COVER. (Removal 54)
- 8) Remove the FEED DRIVE ASSEMBLY. (Removal 15)

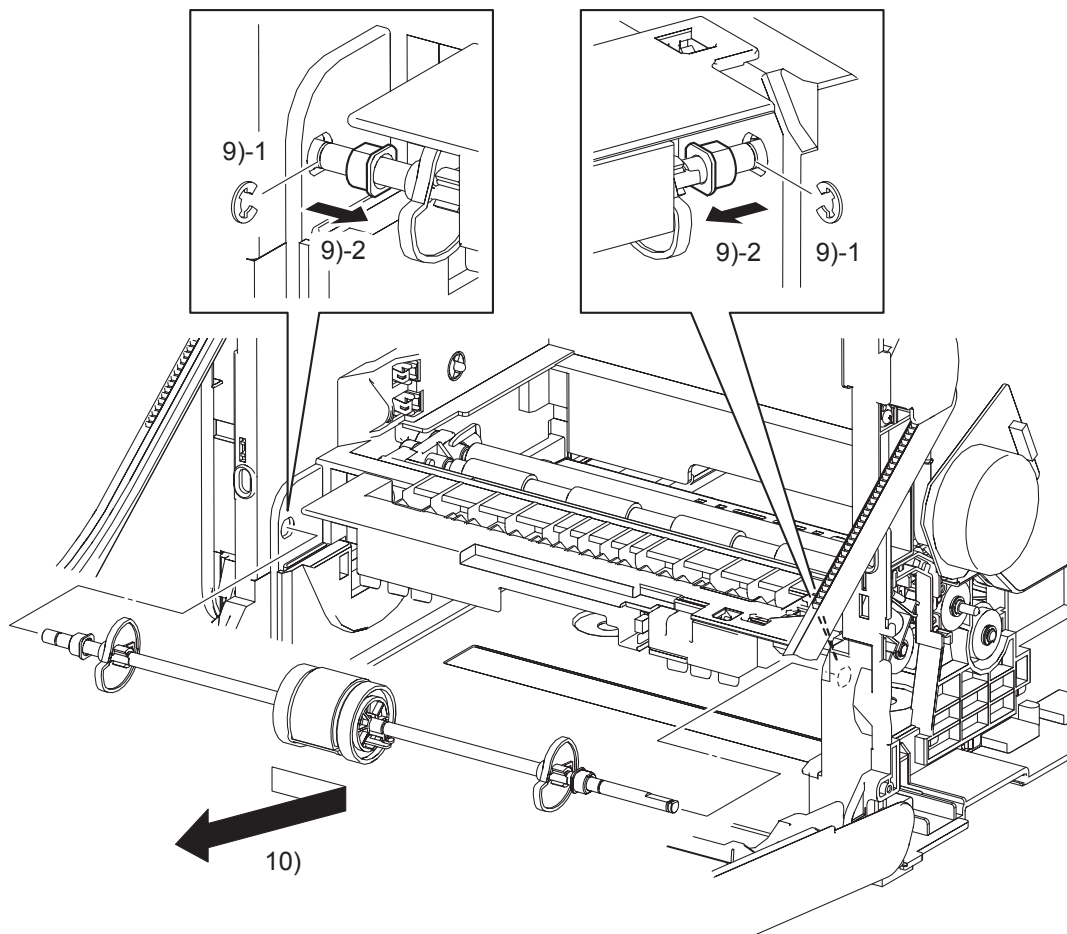

Gnb03021KA

- 9) Remove the e-rings that fix the BEARINGS on the left and right sides of the ROLL ASSY MSI (PL3.1.8), and then remove the BEARINGS to the inside.

NOTE

When performing the step described below, take care not to drop and lose the BEARING EARTH (PL3.1.6) and the BEARING (PL3.1.13).

- 10) Remove the ROLL ASSY MSI by sliding it to the right and pulling out its left side shaft from the left side hole on the printer and then pulling it out to the lower left.

Continues to the next page.

Removal 16 INTEGRATED FEEDER ASSEMBLY (PL3.2.99)

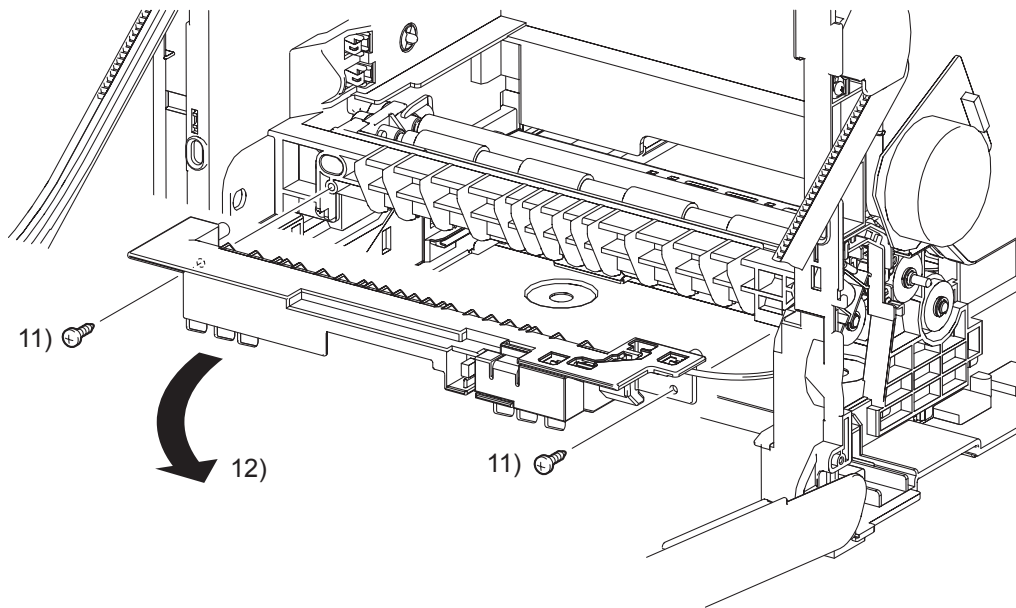

NOTE

When performing the step described below, it is not necessary to remove the SENSOR PHOTO (PL3.1.15) and COVER SNR (PL3.1.16).

11) Remove the two screws (silver, tap, 10mm) that fix the CHUTE MSI (PL3.1.14) to the printer.

NOTE

When performing the step described below, take care not to move the CHUTE MSI from the printer too far because they are connected with the harness.

12) Remove the CHUTE MSI from the printer.

Continues to the next page.

Removal 16 INTEGRATED FEEDER ASSEMBLY (PL3.2.99)

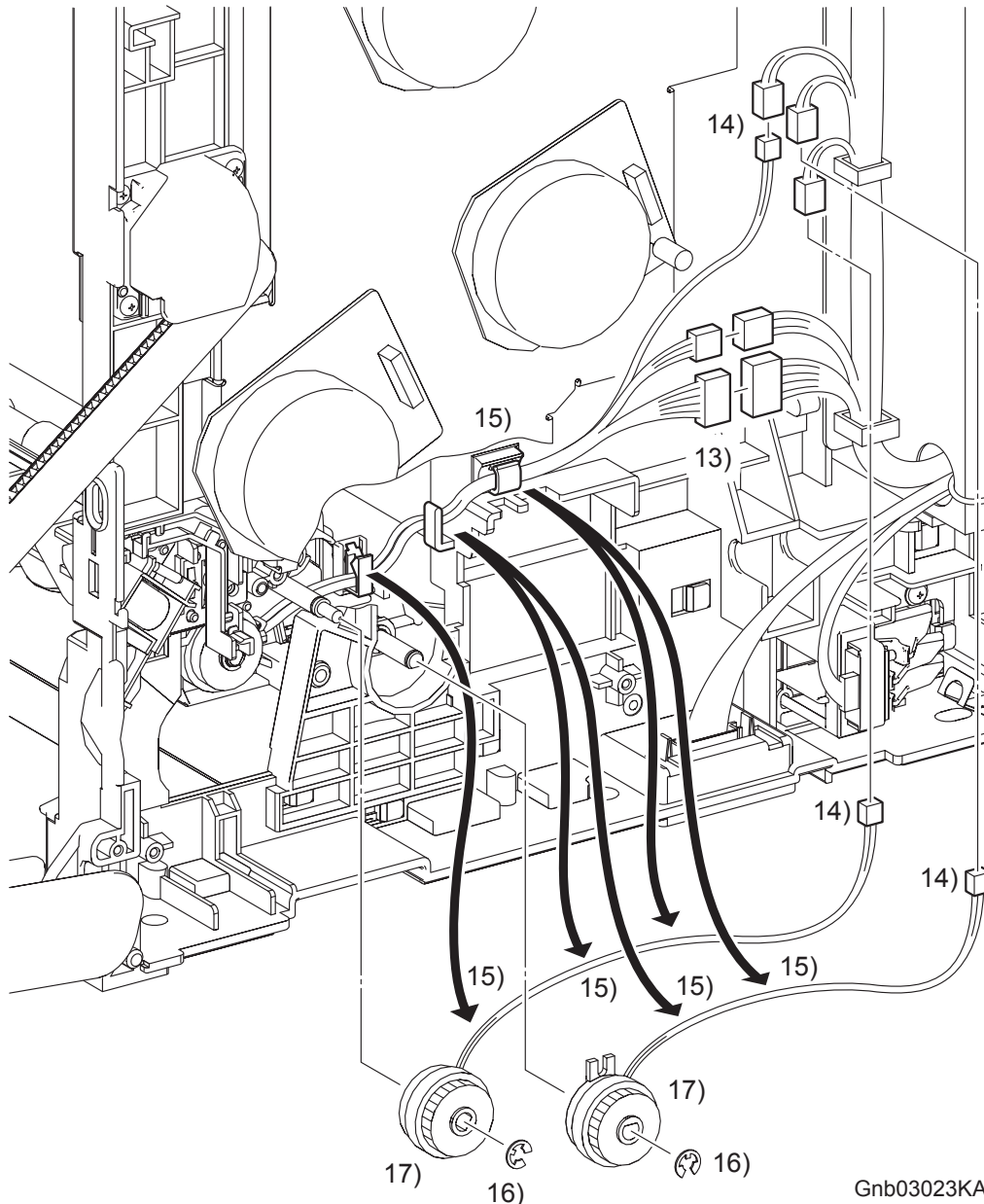

NOTE

When performing the step below, leave the junction connector on the printer side cable.

- 13) Disengage the connectors (P/J232 and P/J241) of the INTEGRATED FEEDER ASSEMBLY (PL3.2.1).
- 14) Disengage the connector (P/J233) of the CLUTCH ASSY PH REGI (PL3.2.23), the connector (P/J235) of the CLUTCH ASSY PH FEED (PL3.2.24), and the connector (P/J234) of the CLUTCH ASSY PH TURN (PL3.2.25).
- 15) Release the each harness from the clamps on the INTEGRATED FEEDER ASSEMBLY and printer.
- 16) Remove the e-rings that fix the CLUTCH ASSY PH REGI and the CLUTCH ASSY PH FEED to the INTEGRATED FEEDER ASSEMBLY.
- 17) Remove the CLUTCH ASSY PH REGI and the CLUTCH ASSY PH FEED from the INTEGRATED FEEDER ASSEMBLY.

Continues to the next page.

Removal 16 INTEGRATED FEEDER ASSEMBLY (PL3.2.99)

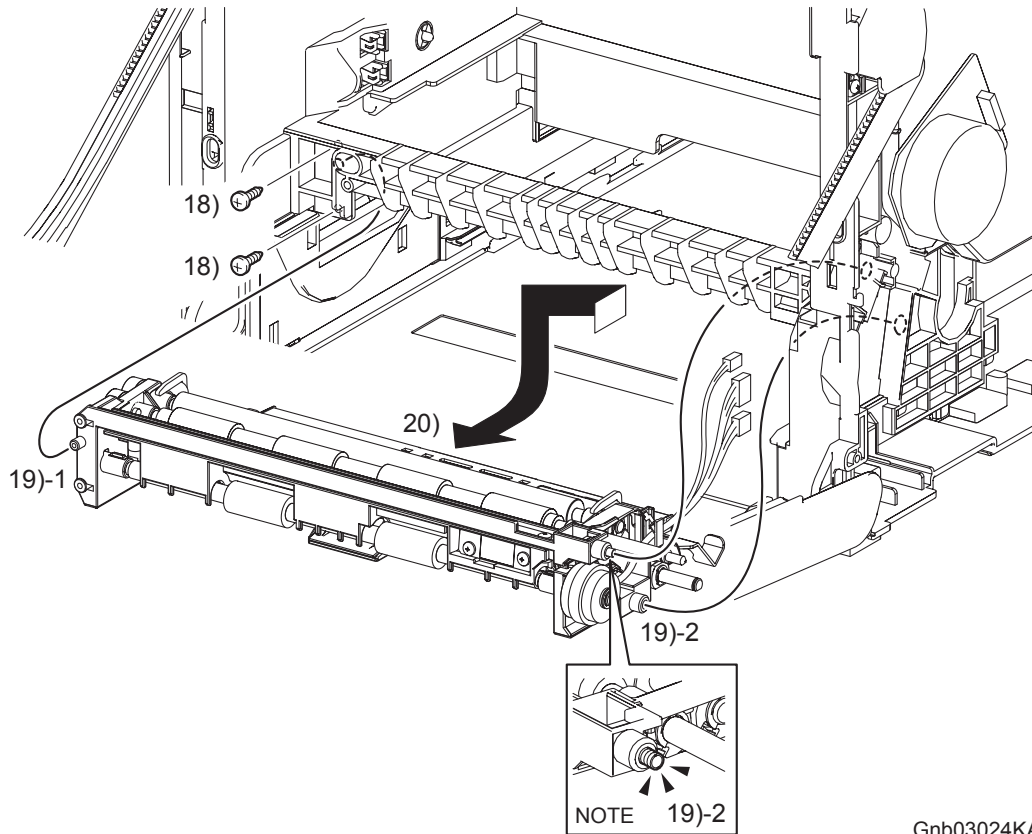

Gnb03024KA

NOTE

When using a screwdriver in the step below, you may want to close the FRONT COVER for ease of work.

- 18) Remove the two screws (silver, tap, 10mm) that fix the INTEGRATED FEEDER ASSEMBLY to the printer.

NOTE

When performing the step described below, take care not to drop and lose the SPRING EARTH on the right side of the INTEGRATED FEEDER ASSEMBLY.

- 19) Release the left side boss on the INTEGRATED FEEDER ASSEMBLY from the hole on the printer. Move the INTEGRATED FEEDER ASSEMBLY slightly backward to the left and release the two bosses (One is provided with the SPRING EARTH.) on the right side from the hole on the printer.
- 20) Remove the INTEGRATED FEEDER ASSEMBLY from the printer by pulling out its right pivot and clutch from the hole on the printer.

Removal 17 Blank

Removal 18 RIGHT ARM ASSEMBLY (PL13.3.98)

Steps 1 through 7 are for reference. Before removing this component, check that Steps 1 through 7 have been performed.

- 1) Open FRONT COVER (PL13.2.1).
- 2) Remove the FUSER. (Removal 8)
- 3) Remove the REAR COVER. (Removal 49)
- 4) Remove the COVER BOTTOM. (Removal 50)
- 5) Remove the COVER POLE IN R. (Removal 51)
- 6) Remove the COVER POLE R. (Removal 52)
- 7) Remove the RIGHT COVER. (Removal 54)

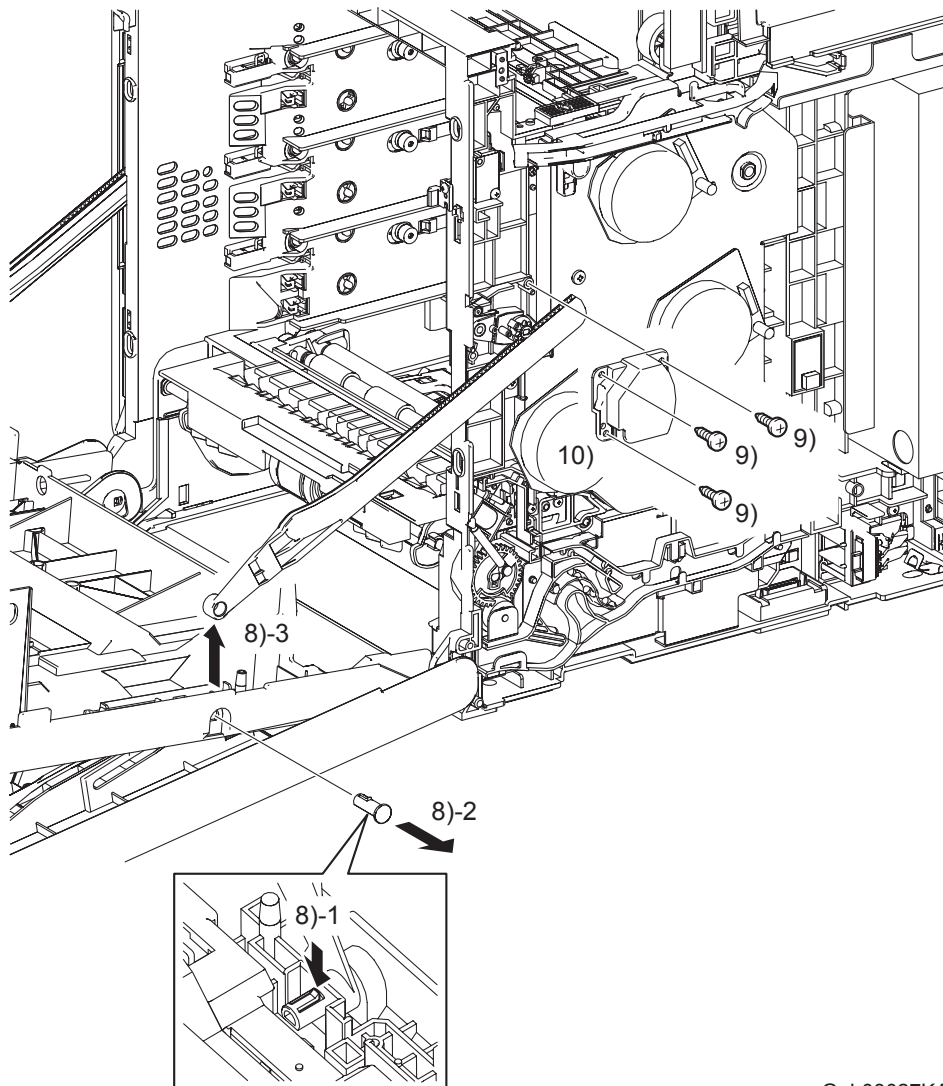

Gnb03027KA

- 8) Release the hook of the SHAFT PIVOT (PL13.2.10) that fixes the LINK R (PL13.3.20) to the FRONT COVER (PL13.2.1), and then pull the SHAFT PIVOT to the outside and remove the LINK R from the FRONT COVER.
- 9) Remove three screws (silver, tap, 8mm) that fix the SUPPORT LINK R (PL13.3.15) to the printer.
- 10) Remove the SUPPORT LINK R from the printer.

Continues to the next page.

Removal 18 RIGHT ARM ASSEMBLY (PL13.3.98)

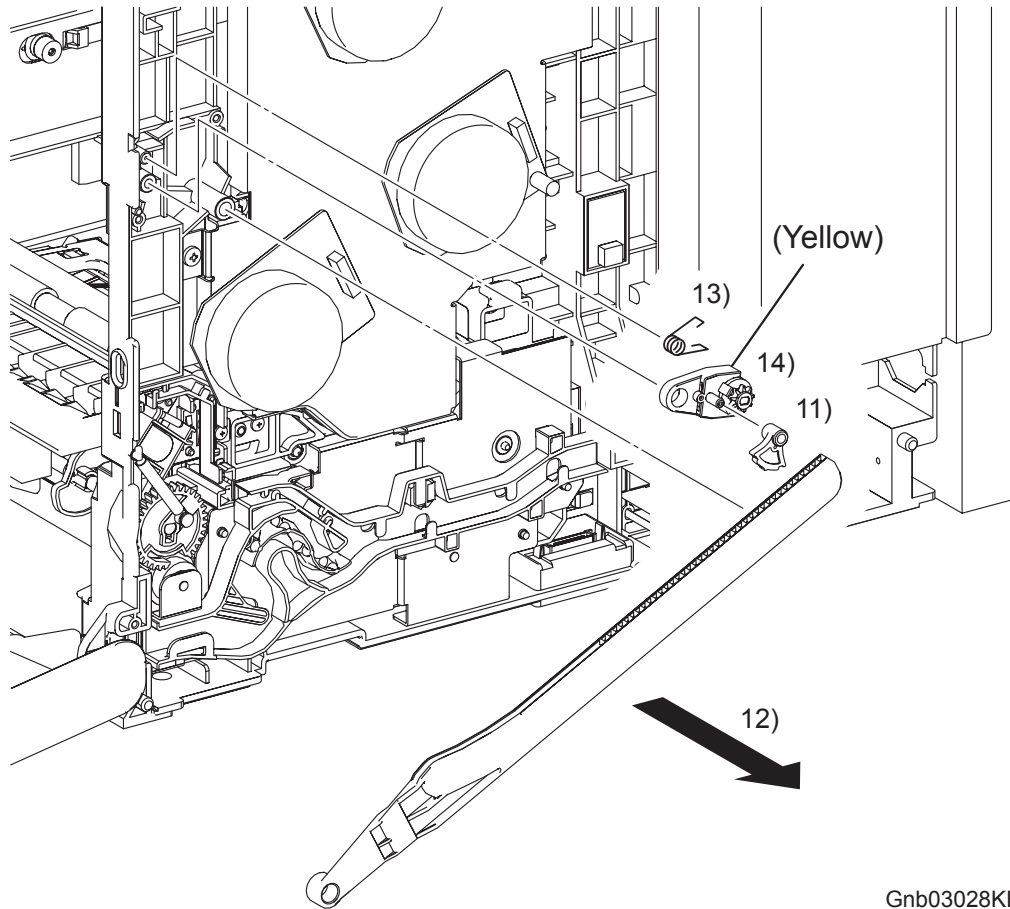

Gnb03028KB

- 11) Remove the LEVER RELEASE (PL13.3.17) from the printer.
- 12) Remove the LINK R from the printer.
- 13) Remove the SPRING SUPPORT (PL13.3.16) from the printer.
- 14) Remove the HOLDER DAMPER H (PL13.3.18) from the printer together with the DAMPER OIL H (PL13.3.19).

Removal 19 SIZE SWITCH ASSEMBLY (PL7.1.18)

Steps 1 through 7 are for reference. Before removing this component, check that Steps 1 through 7 have been performed.

- 1) Open FRONT COVER (PL13.2.1).
- 2) Remove the FUSER.(Removal 8)
- 3) Remove the REAR COVER. (Removal 49)
- 4) Remove the COVER BOTTOM. (Removal 50)
- 5) Remove the COVER POLE IN R.(Removal 51)
- 6) Remove the COVER POLE R.(Removal 52)
- 7) Remove the RIGHT COVER. (Removal 54)

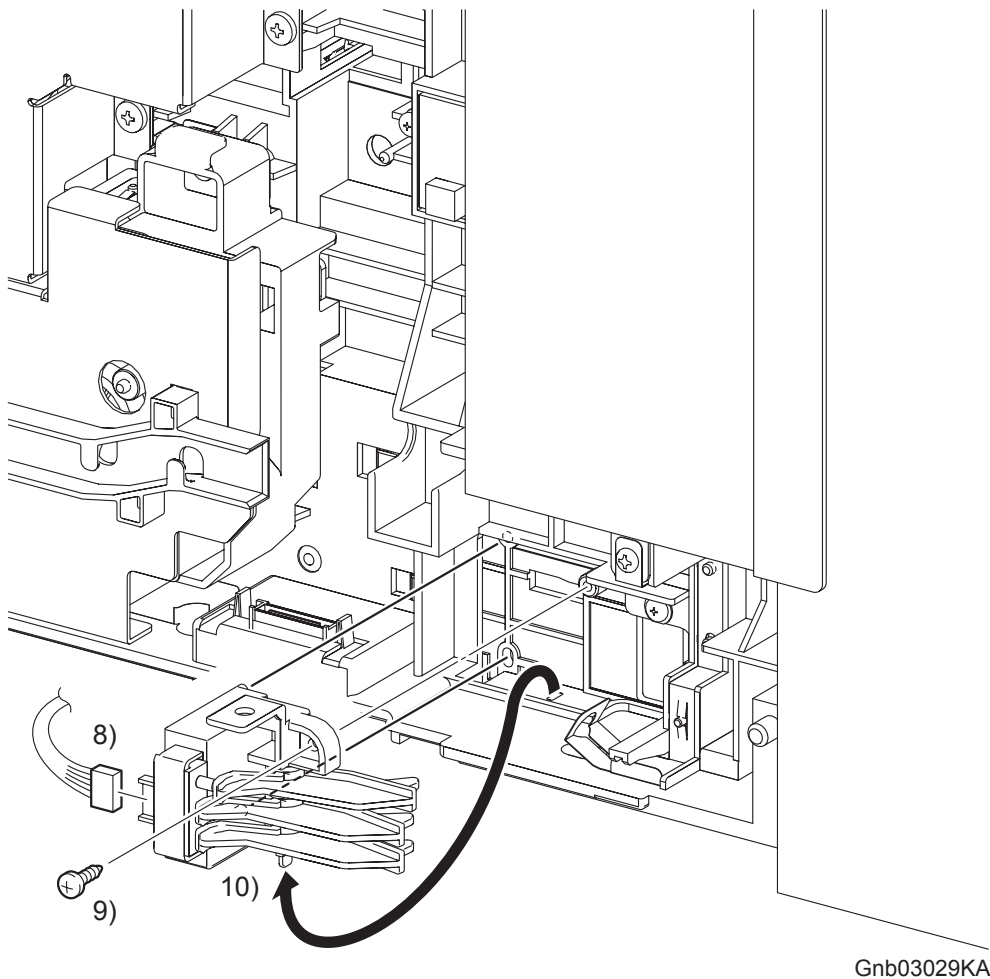

- 8) Disengage the connector (P/J231) of the SIZE SWITCH ASSEMBLY.
- 9) Remove the one screw (silver, tap, 10mm) that fixes the SIZE SWITCH ASSEMBLY to the printer.
- 10) Remove the SIZE SWITCH ASSEMBLY by releasing the two bosses and the underside tab of the SIZE SWITCH ASSEMBLY from the holes on the printer.

Removal 20 Blank

Removal 21 TONER CARTRIDGE SENSOR ASSEMBLY (C), (M), (Y) (PL5.1.4)

NOTE

Described below is the removal procedure common among TONER CARTRIDGE SENSOR ASSYs (C), (M), and (Y).

Steps 1 through 7 are for reference. Before removing this component, check that Steps 1 through 7 have been performed.

- 1) Open FRONT COVER (PL13.2.1).
- 2) Remove the FUSER.(Removal 8)
- 3) Remove the REAR COVER. (Removal 49)
- 4) Remove the COVER BOTTOM. (Removal 50)
- 5) Remove the COVER POLE IN R.(Removal 51)
- 6) Remove the COVER POLE R.(Removal 52)
- 7) Remove the RIGHT COVER. (Removal 54)

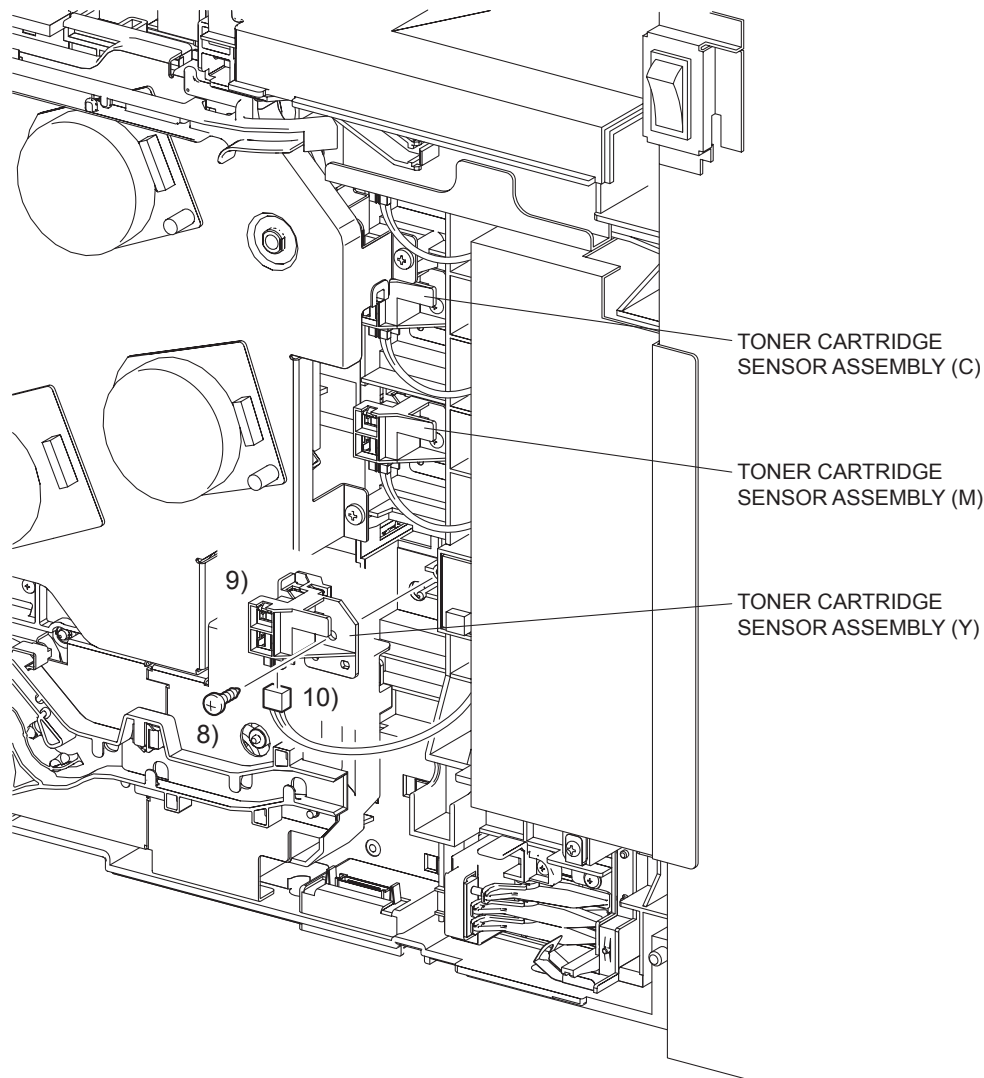

Gnb03031KA

- 8) Remove the one screw (silver, tap, 10mm) that fixes the TONER CARTRIDGE ASSEMBLY (PL5.1.4) to the printer.
- 9) Remove the TONER CARTRIDGE ASSEMBLY from the printer.
- 10) Disengage the connector of the TONER CARTRIDGE ASSEMBLY.

Removal 22 Blank

Removal 23 Blank

Removal 24 LEFT ARM ASSEMBLY (PL7.1.97)

Steps 1 through 7 are for reference. Before removing this component, check that Steps 1 through 7 have been performed.

- 1) Open FRONT COVER (PL13.2.1).
- 2) Remove the FUSER. (Removal 8)
- 3) Remove the REAR COVER. (Removal 49)
- 4) Remove the COVER BOTTOM. (Removal 50)
- 5) Remove the COVER POLE IN L. (Removal 57)
- 6) Remove the COVER POLE L. (Removal 58)
- 7) Remove the LEFT COVER. (Removal 59)

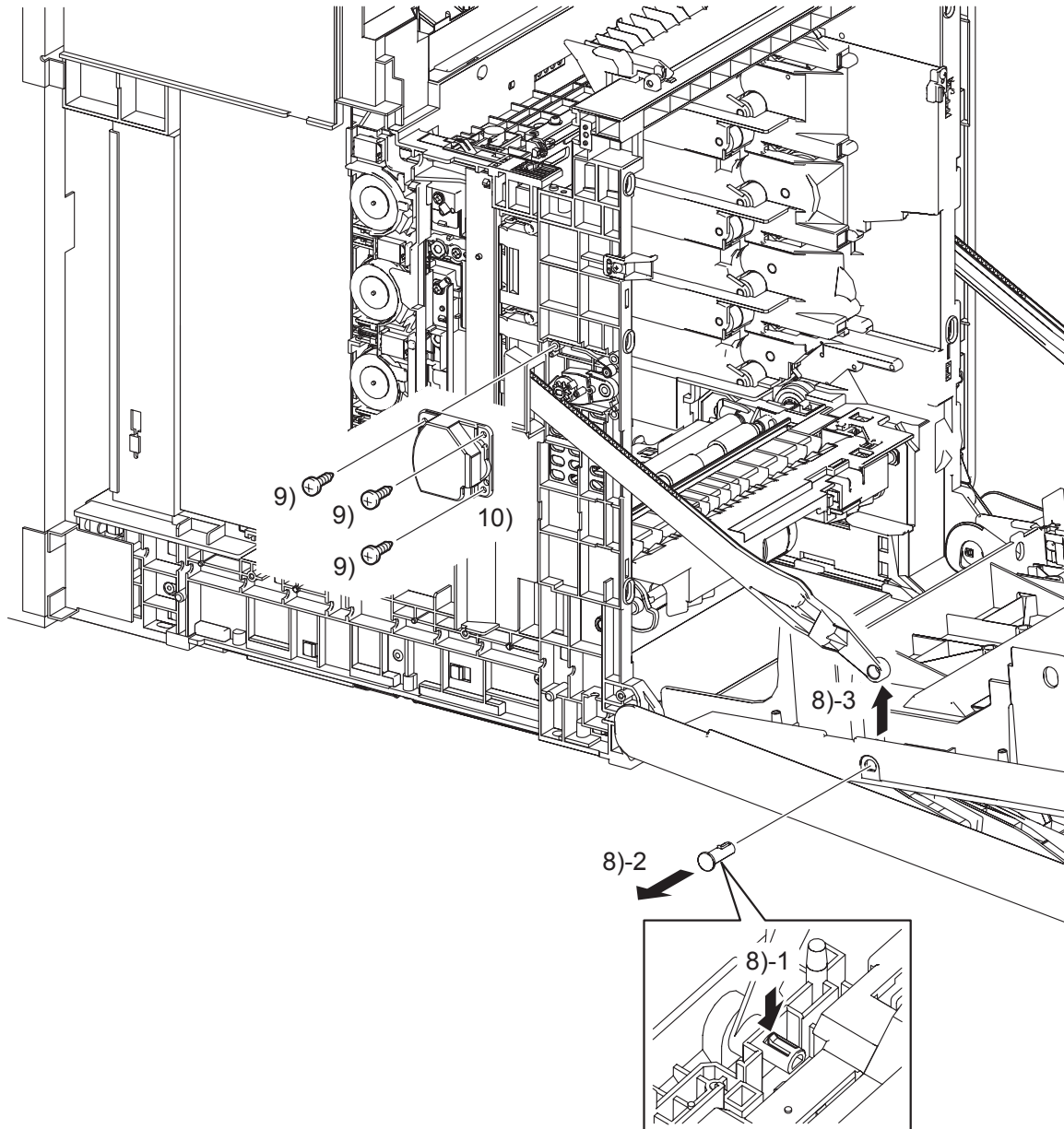

Gnb03035KA

- 8) Release the hook of the SHAFT PIVOT (PL13.2.10) that fixes the LINK L to the FRONT COVER (PL13.2.1), and then remove the LINK L from the FRONT COVER by pulling the SHAFT PIVOT to the outside.
- 9) Remove the three screws (silver, tap, 8mm) that fix the SUPPORT LINK L (PL7.1.2) to the printer.
- 10) Remove the SUPPORT LINK L from the printer.

Continues to the next page.

Removal 24 LEFT ARM ASSEMBLY (PL7.1.97)

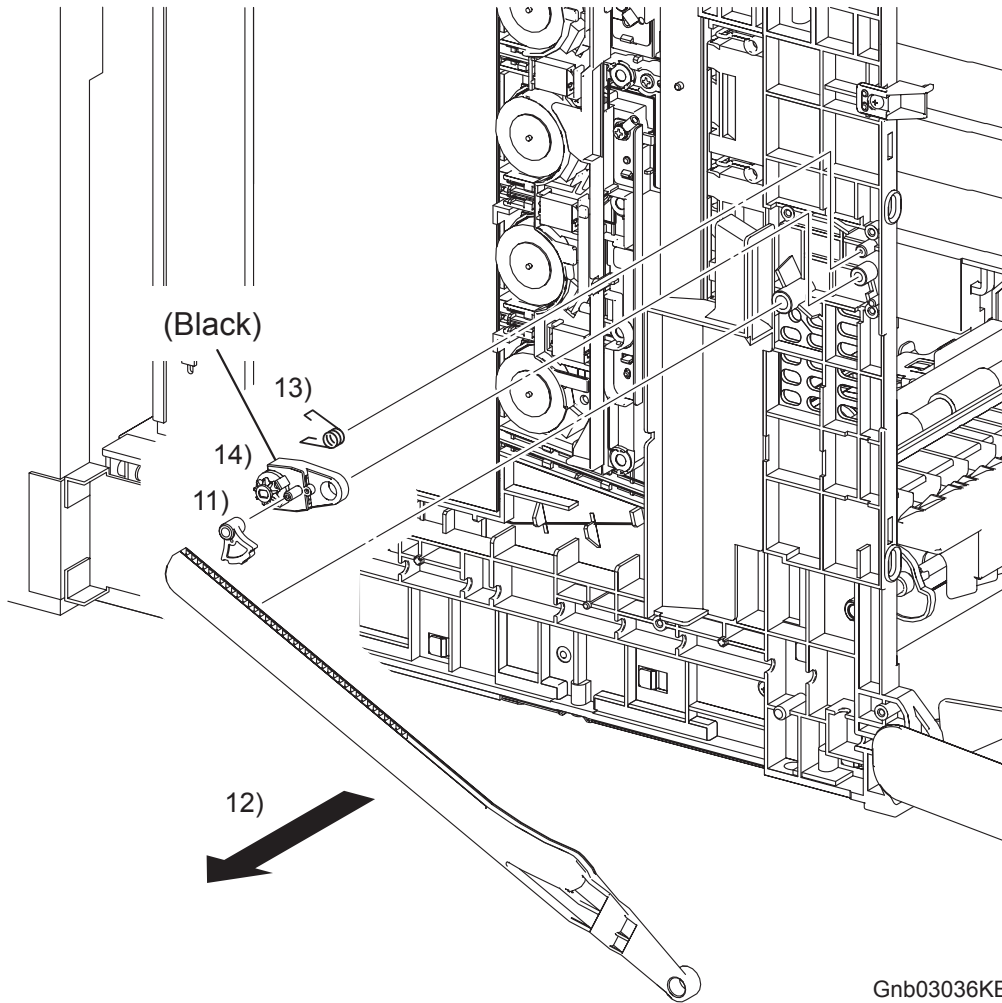

Gnb03036KB

- 11) Remove the LEVER RELEASE (PL7.1.4) from the printer.
- 12) Remove the LINK L from the printer.
- 13) Remove the SPRING SUPPORT (PL7.1.8) from the printer.
- 14) Remove the HOLDER DAMPER (PL7.1.6) from the printer together with the DAMPER OIL (PL7.1.7).

Removal 25 LED ASSEMBLY (PL5.1.15)

Steps 1 through 7 are for reference. Before removing this component, check that Steps 1 through 7 have been performed.

- 1) Open FRONT COVER (PL13.2.1).
- 2) Remove the FUSER. (Removal 8)
- 3) Remove the REAR COVER. (Removal 49)
- 4) Remove the COVER BOTTOM. (Removal 50)
- 5) Remove the COVER POLE IN L. (Removal 57)
- 6) Remove the COVER POLE L. (Removal 58)
- 7) Remove the LEFT COVER. (Removal 59)

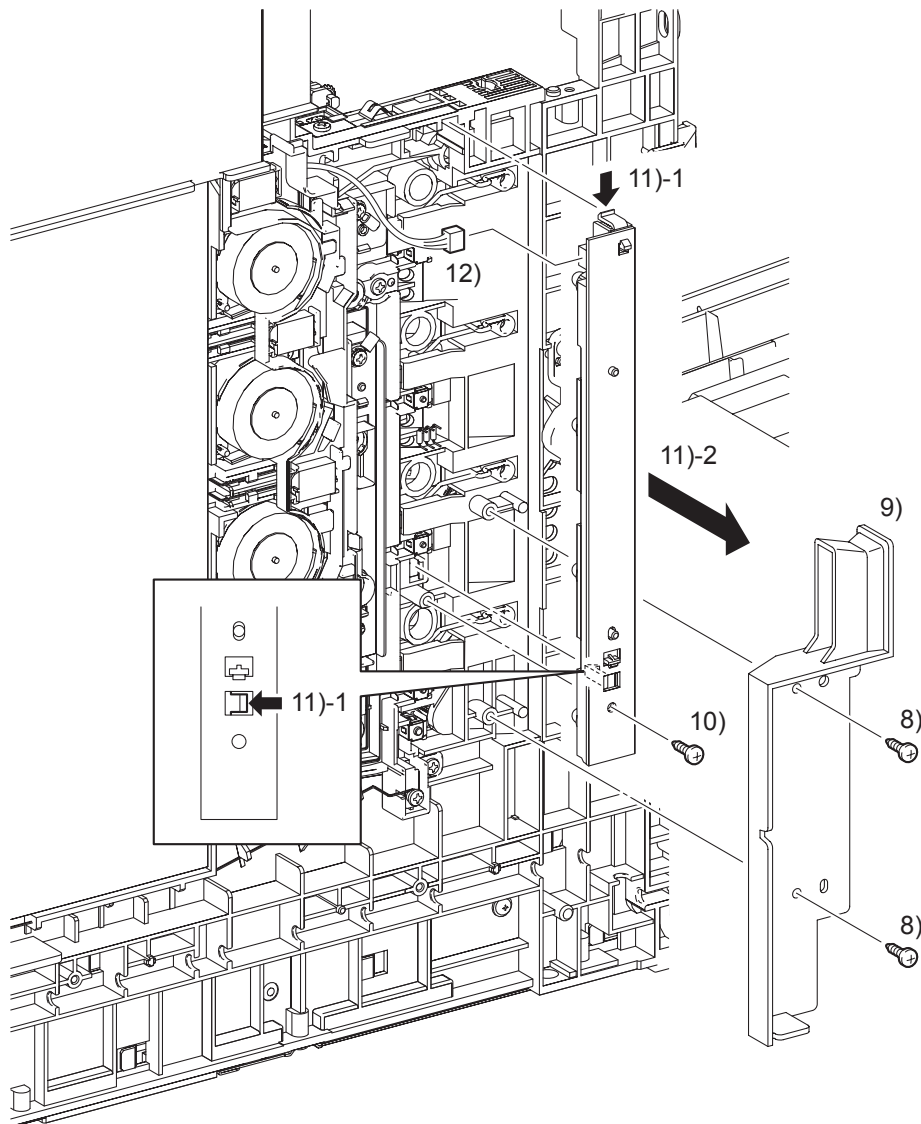

Gnb03037KA

- 8) Remove the two screws (silver, tap, 8mm) that fix the DUCT SIDE L (PL7.1.23) to the printer.
- 9) Remove the DUCT SIDE L from the printer.
- 10) Remove the one screw (silver, tap, 10mm) that fixes the LED ASSEMBLY (PL5.1.15) to the printer.
- 11) Remove the LED ASSEMBLY from the printer by releasing its two hooks.
- 12) Disengage the connector (P/J141) of the LED ASSEMBLY.

Removal 26 TONER DISPENSER MOTOR (PL5.1.12)

NOTE

Described below is the removal procedure common among the TONER DISPENSER MOTORS (C), (M), (Y), and (K).

Steps 1 through 7 are for reference. Before removing this component, check that Steps 1 through 7 have been performed.

- 1) Open FRONT COVER (PL13.2.1).
- 2) Remove the FUSER. (Removal 8)
- 3) Remove the REAR COVER. (Removal 49)
- 4) Remove the COVER BOTTOM. (Removal 50)
- 5) Remove the COVER POLE IN L. (Removal 57)
- 6) Remove the COVER POLE L. (Removal 58)
- 7) Remove the LEFT COVER. (Removal 59)

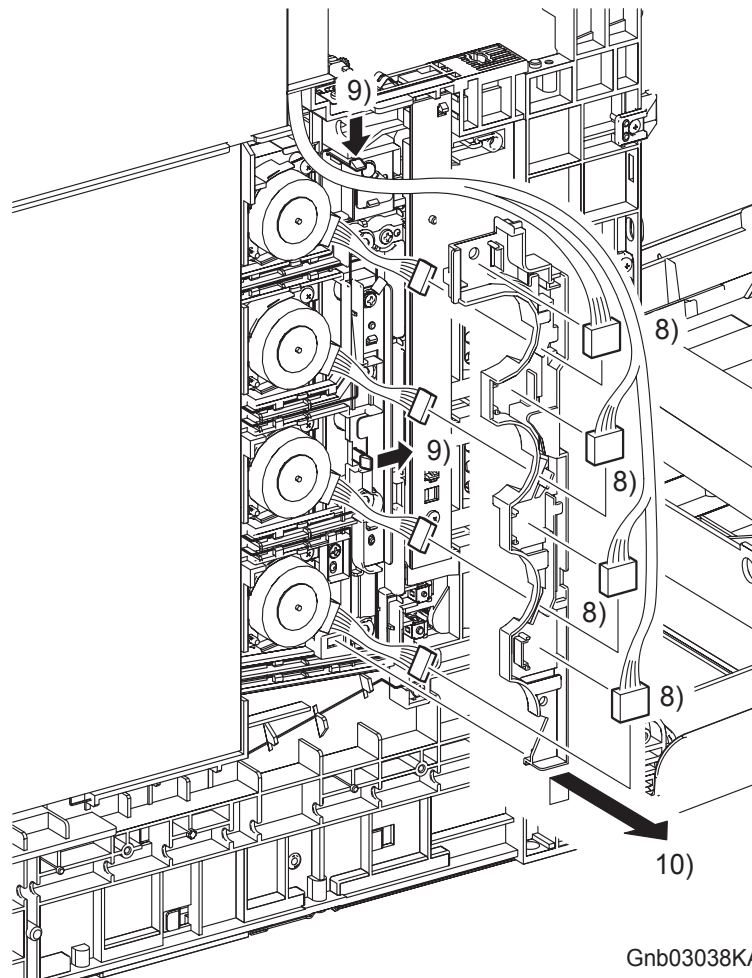

Gnb03038KA

NOTE

When performing the step below, leave the junction connector on the printer side cable.

- 8) Release the four sets of connectors and harness of the TONER DISPENSER (PL5.1.12) from the DUCT HARNESS MOT (PL5.1.16), and disengage the four sets of connectors of the TONER DISPENSER MOTOR.
- 9) Release two hooks that fix the DUCT HARNESS MOT to the printer.
- 10) Release the lug on the DUCT HARNESS MOT from the printer by moving the DUCT HARNESS MOT slightly upward. Pass the four sets connectors of the TONER DISPENSER MOTOR through the hole on the DUCT HARNESS MOT, and then remove the DUCT HARNESS MOT.

Continues to the next page.

Removal 26 TONER DISPENSER MOTOR (PL5.1.12)

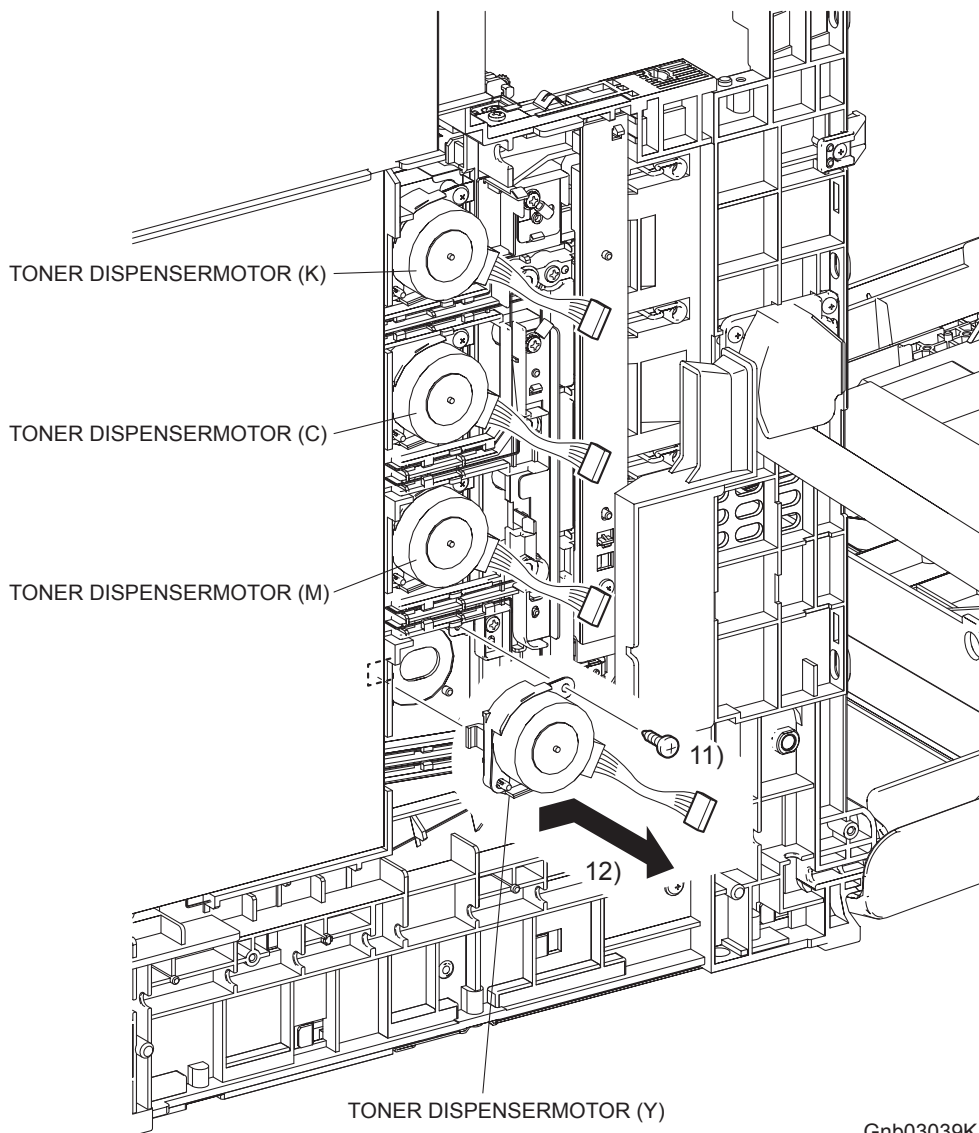

Gnb03039KA

- 11) Remove the one screw (silver, tap, 10mm) that fixes the TONER DISPENSER MOTOR to the printer.
- 12) Release the lug on the TONER DISPENSER MOTOR by moving the TONER DISPENSER MOTOR slightly toward you. Remove the TONER DISPENSER MOTOR from the printer.

Removal 27 Blank

Removal 28 Blank

Removal 29 Blank

Removal 30 Blank

Removal 31 Blank

Removal 32 HIGH VOLTAGE POWER SUPPLY (PL5.1.17)

Steps 1 through 14 are for reference. Before removing this component, check that Steps 1 through 14 have been performed.

- 1) Open FRONT COVER (PL13.2.1).
- 2) Remove the FUSER.(Removal 8)
- 3) Remove the REAR COVER. (Removal 49)
- 4) Remove the COVER BOTTOM. (Removal 50)
- 5) Remove the COVER POLE IN R.(Removal 51)
- 6) Remove the COVER POLE R.(Removal 52)
- 7) Remove the RIGHT COVER. (Removal 54)
- 8) Remove the COVER POLE IN L. (Removal 57)
- 9) Remove the COVER POLE L. (Removal 58)
- 10) Remove the LEFT COVER. (Removal 59)
- 11) Remove the TOP COVER. (Removal 68)
- 12) Remove the BOX ASSY PRT AIO. (Removal 60)
- 13) Remove the BOX ASSY FAX AIO. (Removal 62)

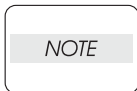

When performing the step described below, it is not necessary to remove the connector and harness of the FAN

- 14) Remove the FAN.(Removal 71)

I

Continues to the next page.

Removal 32 HIGH VOLTAGE POWER SUPPLY (PL5.1.17)

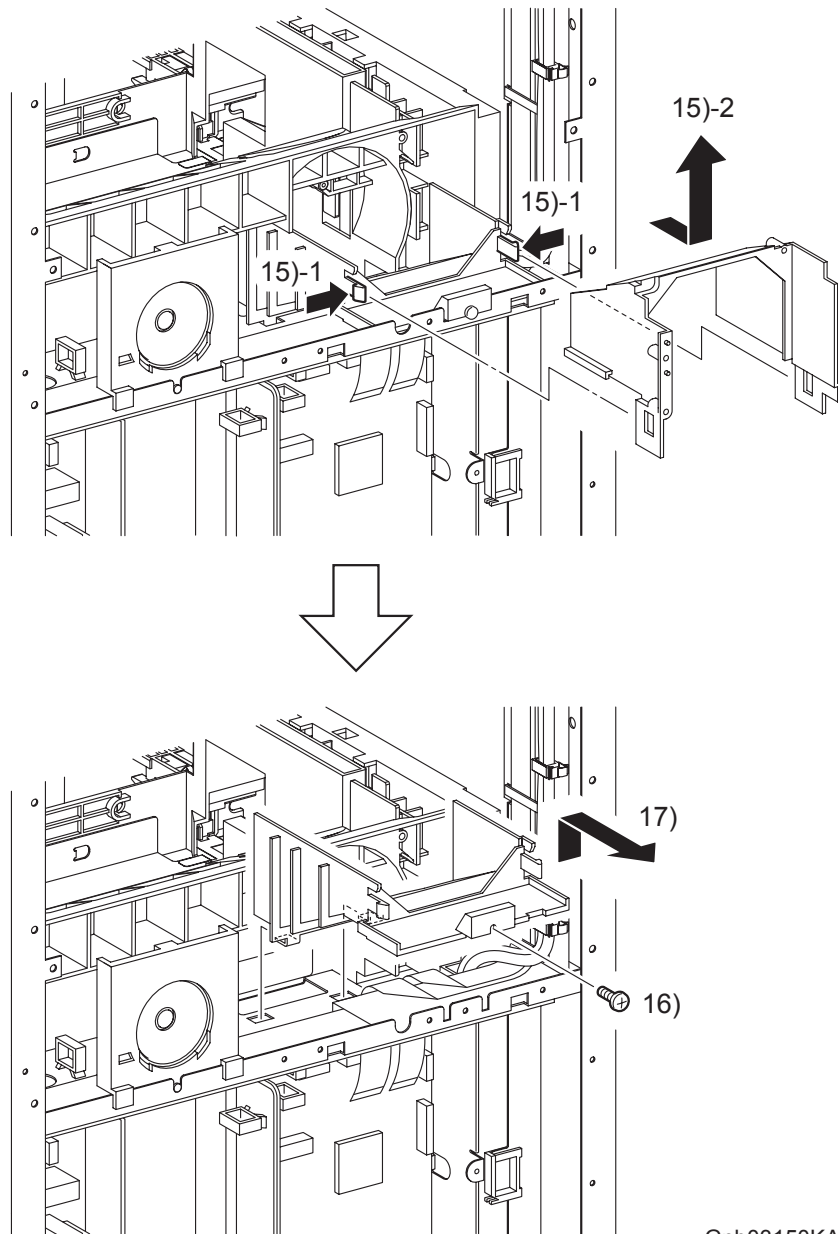

Gnb03150KA

- 15) Release the two hooks of the DUCT LOWER (PL13.5.8) that fix the DUCT UPPER (PL13.5.7), and then slide the DUCT UPPER backward to remove it.
- 16) Remove the one screw (silver, 6mm) that fixes the DUCT LOWER to the printer.
- 17) Release the two hooks on the bottom of the DUCT LOWER from the holes of the printer, and remove the DUCT LOWER.

Continues to the next page.

Removal 32 HIGH VOLTAGE POWER SUPPLY (PL5.1.17)

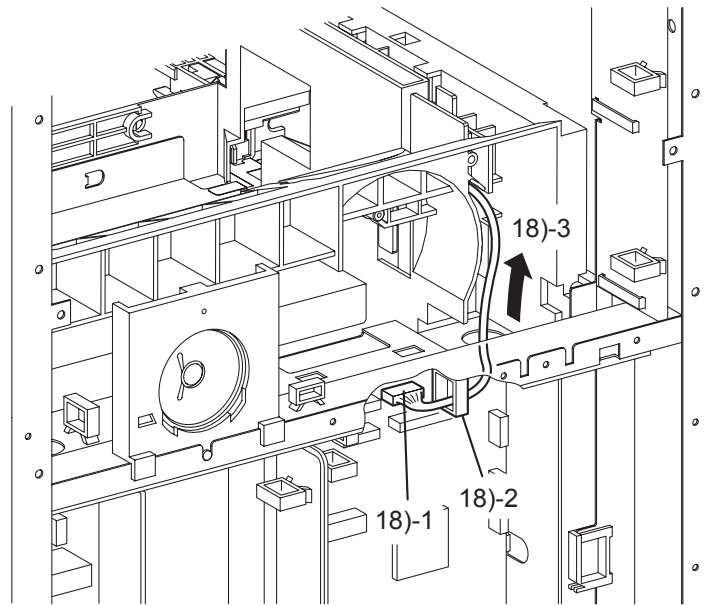

Gnb03045KA

- 18) Disengage the connector (P/J16) of the HIGH VOLTAGE POWER SUPPLY (PL5.1.17) from the MACHINE CONTROL UNIT (PL13.5.13).

Continues to the next page.

Removal 32 HIGH VOLTAGE POWER SUPPLY (PL5.1.17)

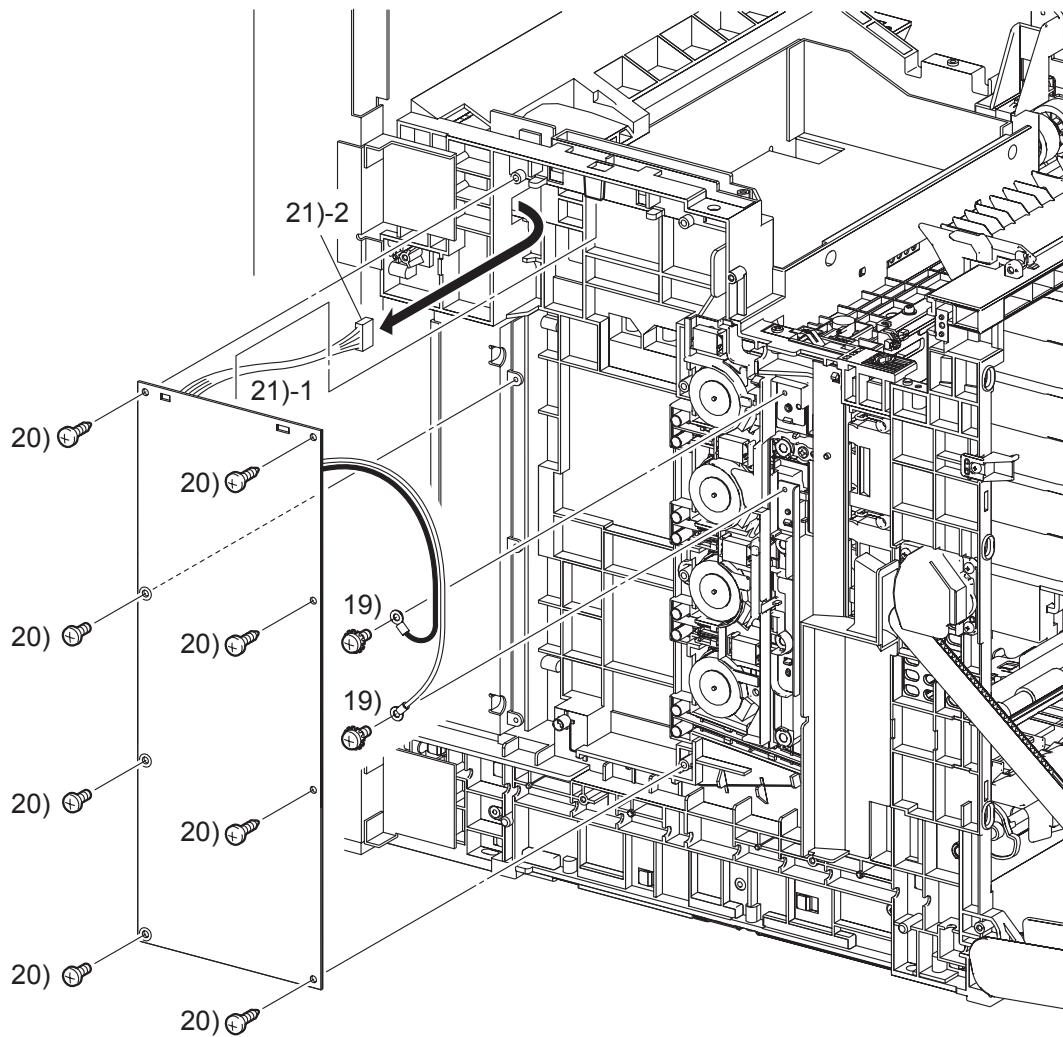

Gnb03046KA

- 19) Remove the two screws (silver, with washer, 6mm) that fix the two harnesses of the HIGH VOLTAGE POWER SUPPLY.
- 20) Remove the five screws (silver, tap, 10mm) and the three screws (silver, 6mm) that fix the HIGH VOLTAGE POWER SUPPLY to the printer.
- 21) Remove the HIGH VOLTAGE POWER SUPPLY by releasing the upper part of the HIGH VOLTAGE POWER SUPPLY from the two lugs on the printer. Pull out the connector of the HIGH VOLTAGE POWER SUPPLY from the hole on the printer.

Removal 33 Blank

Removal 34 PRINT HEAD (PL13.3.99)

Steps 1 through 13 are for reference. Before removing this component, check that Steps 1 through 13 have been performed.

- 1) Open FRONT COVER (PL13.2.1).
- 2) Remove the FUSER.(Removal 8)
- 3) Remove the REAR COVER. (Removal 49)
- 4) Remove the COVER BOTTOM. (Removal 50)
- 5) Remove the COVER POLE IN R.(Removal 51)
- 6) Remove the COVER POLE R.(Removal 52)
- 7) Remove the RIGHT COVER. (Removal 54)
- 8) Remove the COVER POLE IN L. (Removal 57)
- 9) Remove the COVER POLE L. (Removal 58)
- 10) Remove the LEFT COVER. (Removal 59)
- 11) Remove the TOP COVER. (Removal 68)
- 12) Remove the BOX ASSY PRT AIO. (Removal 60)
- 13) Remove the BOX ASSY FAX AIO. (Removal 62)

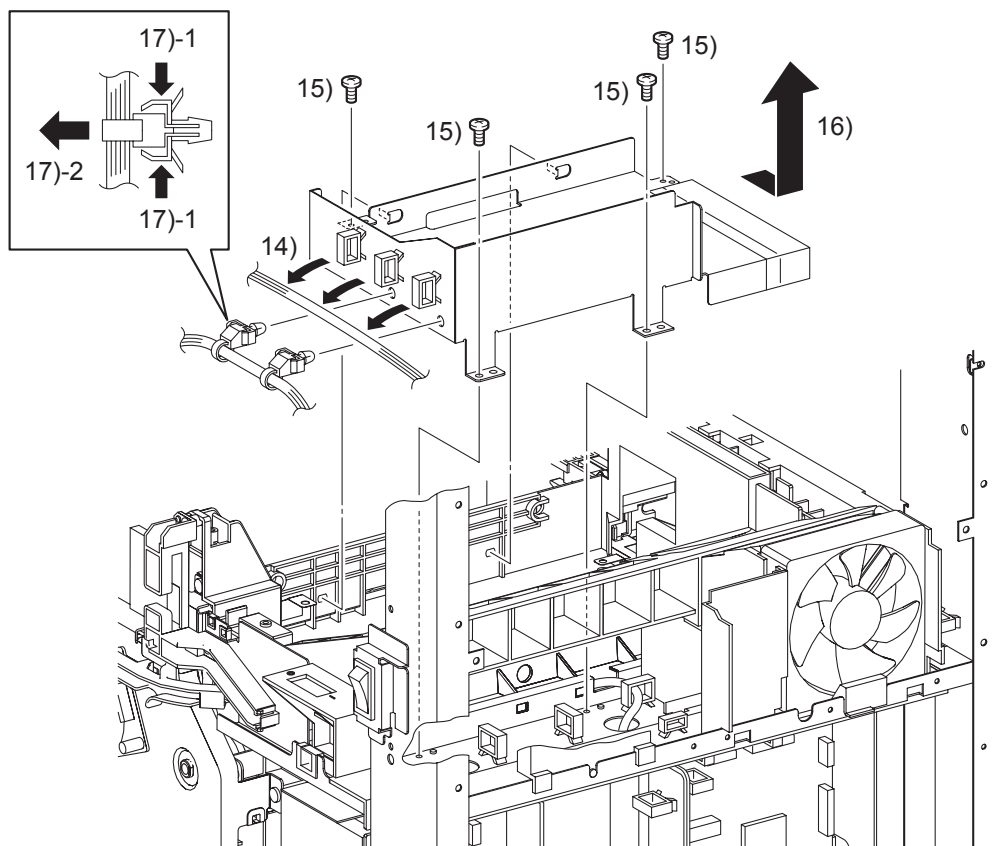

Gnb03151KA

- 14) Release the harness of the HARN ASSY FUSER AIO (PL13.6.5) from the three clamps on the FRAME ASSY EARTH (PL13.3.2).
- 15) Remove the four screws (silver, 6mm) that fix the FRAME ASSY EARTH to the printer.
- 16) Pull up the two hooks on the front side of the FRAME ASSY EARTH from the holes of the printer by sliding the FRAME ASSY EARTH backward, and then remove the FRAME ASSY EARTH.
- 17) Remove the two clamps on the harness of the HARN ASSY FUSER AIO from the FRAME ASSY EARTH.

Continues to the next page.

Removal 34 PRINT HEAD (PL13.3.99)

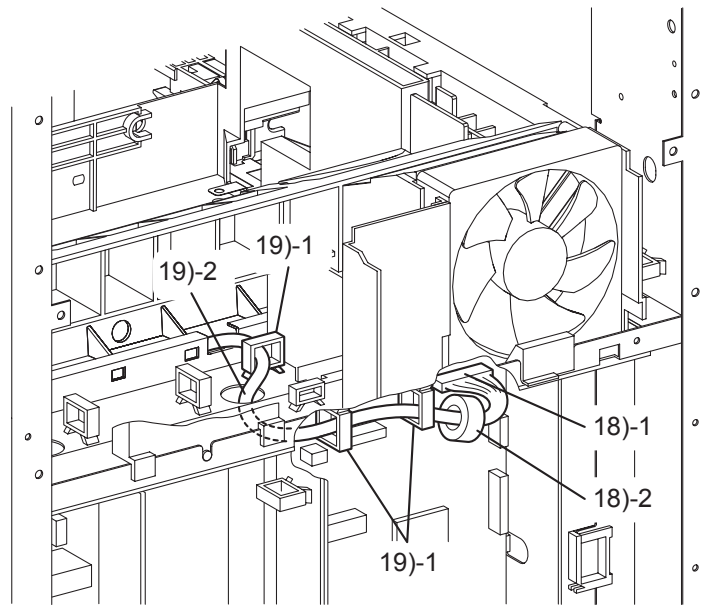

Gnb03131KA

- 18) Disengage the connector (P/J12) of the PRINT HEAD (PL13.3.12) from the MACHINE CONTROL UNIT (PL13.5.13), remove the CORE (PL13.3.13) from the harness.
- 19) Release the harness of the PRINT HEAD from the three clamps, and then pull the harness from the hole of the printer.

Continues to the next page.

Removal 34 PRINT HEAD (PL13.3.99)

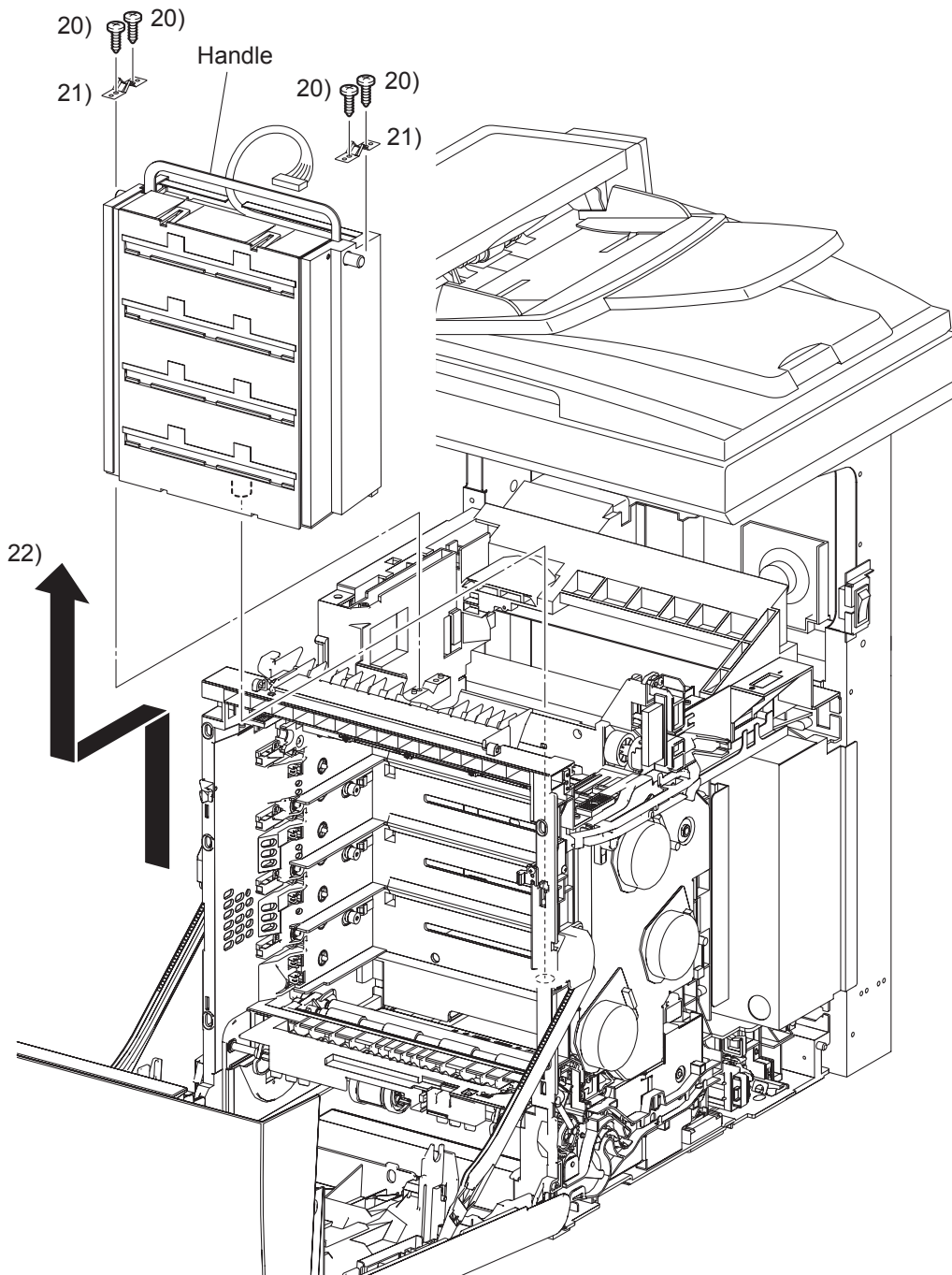

Gnb03049KA

- 20) Remove the four screws (silver, tap, 10mm) that fix the two SPRING ROSs (PL. 13.3.11) to the printer at the left and right sides.
- 21) Remove the left and right SPRING ROSs from the printer.
- 22) Remove the PRINT HEAD from the printer by pulling it up slowly by the handle.

Removal 35 Blank

Removal 36 PHOTOCODUCTOR (PC) / DEVELOPER (DEV) DRIVE (PL8.1.2)

Steps 1 through 12 are for reference. Before removing this component, check that Steps 1 through 12 have been performed.

- 1) Open FRONT COVER (PL13.2.1).
- 2) Remove the FUSER.(Removal 8)
- 3) Remove the REAR COVER. (Removal 49)
- 4) Remove the COVER BOTTOM. (Removal 50)
- 5) Remove the COVER POLE IN R. (Removal 51)
- 6) Remove the COVER POLE R.(Removal 52)
- 7) Remove the RIGHT COVER. (Removal 54)
- 8) Remove the COVER POLE IN L. (Removal 57)
- 9) Remove the COVER POLE L. (Removal 58)
- 10) Remove the LEFT COVER. (Removal 59)
- 11) Remove the TOP COVER. (Removal 68)

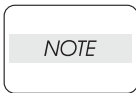

When performing the step described below, it is not necessary to disengage the connector of the INTERLOCK SWITCH.

- 12) Remove the INTERLOCK SWITCH. (Removal 70)

Continues to the next page.

Removal 36 PHOTOCONDUCTOR (PC) / DEVELOPER (DEV) DRIVE (PL8.1.2)

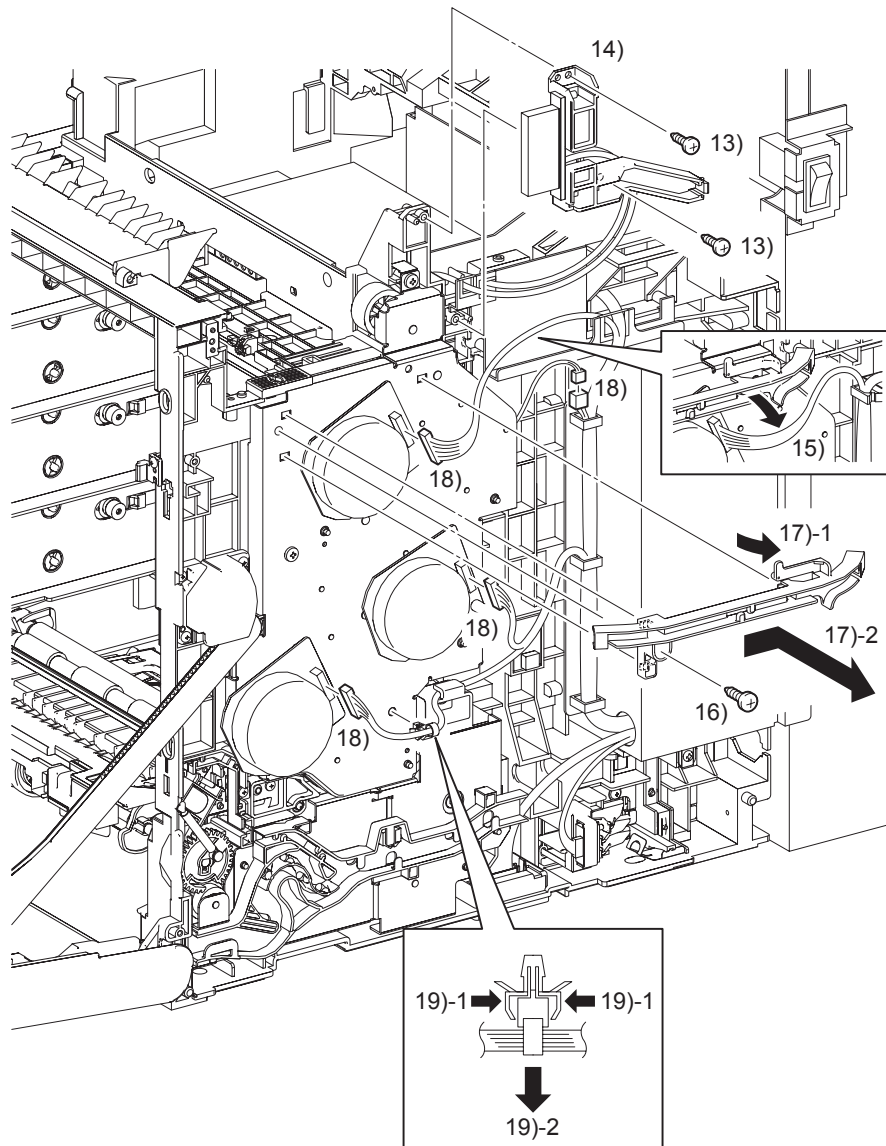

Gnb03051KA

- 13) Remove the two screws (silver, tap, 10mm) that fix the BRACKET FUSER (PL6.1.12) to the printer.

NOTE

When performing the step described below, take care not to move the BRACKET FUSER from the printer too far because they are connected with the harness.

- 14) Remove the BRACKET FUSER from the printer.
- 15) Release the harness of the PHOTOCONDUCTOR (PC) / DEVELOPER (DEV) DRIVE (PL8.1.2) from the DUCT DRV MAIN (PL8.1.9).
- 16) Remove the one screw (silver, tap, 10mm) that fixes PHOTOCONDUCTOR (PC) / DEVELOPER (DEV) DRIVE to the printer.
- 17) Remove the DUCT DRV MAIN from the PHOTOCONDUCTOR (PC) / DEVELOPER (DEV) DRIVE by releasing the bosses on the DUCT DRV MAIN and sliding the DUCT DRV MAIN backward.
- 18) Disengage the four connectors (P/J211, P/J221, P/J222, and P/J2761) from the PHOTOCONDUCTOR (PC) / DEVELOPER (DEV) DRIVE.
- 19) Remove the harness from the PHOTOCONDUCTOR (PC) / DEVELOPER (DEV) DRIVE together with the clamp.

Continues to the next page.

Removal 36 PHOTOCONDUCTOR (PC) / DEVELOPER (DEV) DRIVE (PL8.1.2)

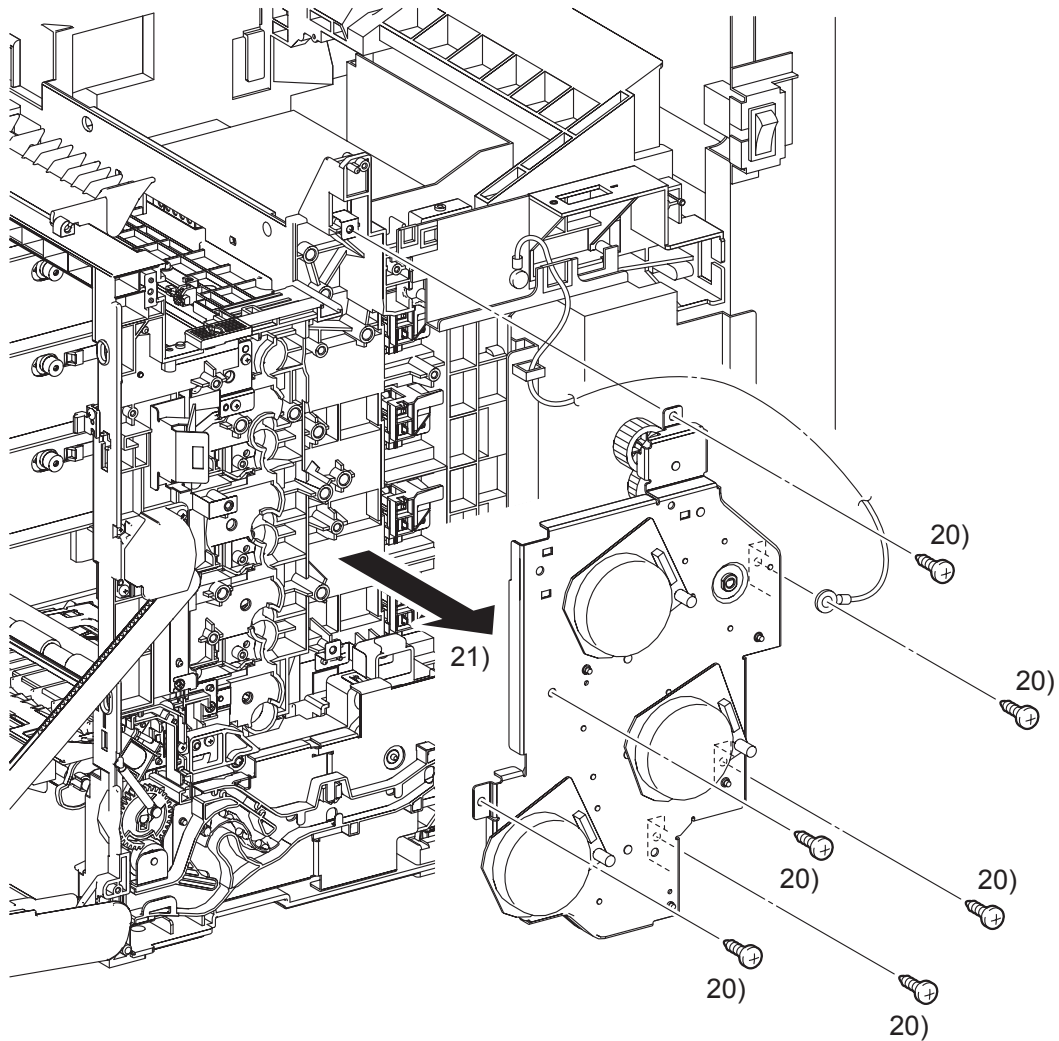

Gnb03052KB

- 20) Remove the six screws (silver, tap, 10mm) that fix the PHOTOCONDUCTOR (PC) / DEVELOPER (DEV) DRIVE to the printer.
- 21) Remove the PHOTOCONDUCTOR (PC) / DEVELOPER (DEV) DRIVE from the printer.

Go to the next removal step:

Removal 37 TONER CARTRIDGE SENSOR ASSEMBLY (K) (PL5.1.4)

Removal 37 TONER CARTRIDGE SENSOR ASSEMBLY (K) (PL5.1.4)

Steps 1 through 13 are for reference. Before removing this component, check that Steps 1 through 13 have been performed.

- 1) Open FRONT COVER (PL13.2.1).
- 2) Remove the FUSER.(Removal 8)
- 3) Remove the REAR COVER. (Removal 49)
- 4) Remove the COVER BOTTOM. (Removal 50)
- 5) Remove the COVER POLE IN R. (Removal 51)
- 6) Remove the COVER POLE R.(Removal 52)
- 7) Remove the RIGHT COVER. (Removal 54)
- 8) Remove the COVER POLE IN L. (Removal 57)
- 9) Remove the COVER POLE L. (Removal 58)
- 10) Remove the LEFT COVER. (Removal 59)
- 11) Remove the TOP COVER. (Removal 68)
- 12) Remove the INTERLOCK SWITCH. (Removal 70)
- 13) Remove the PHTOTCONDUCTOR (PC) / DEVELOPER (DEV) DRIVE. (Removal 36)

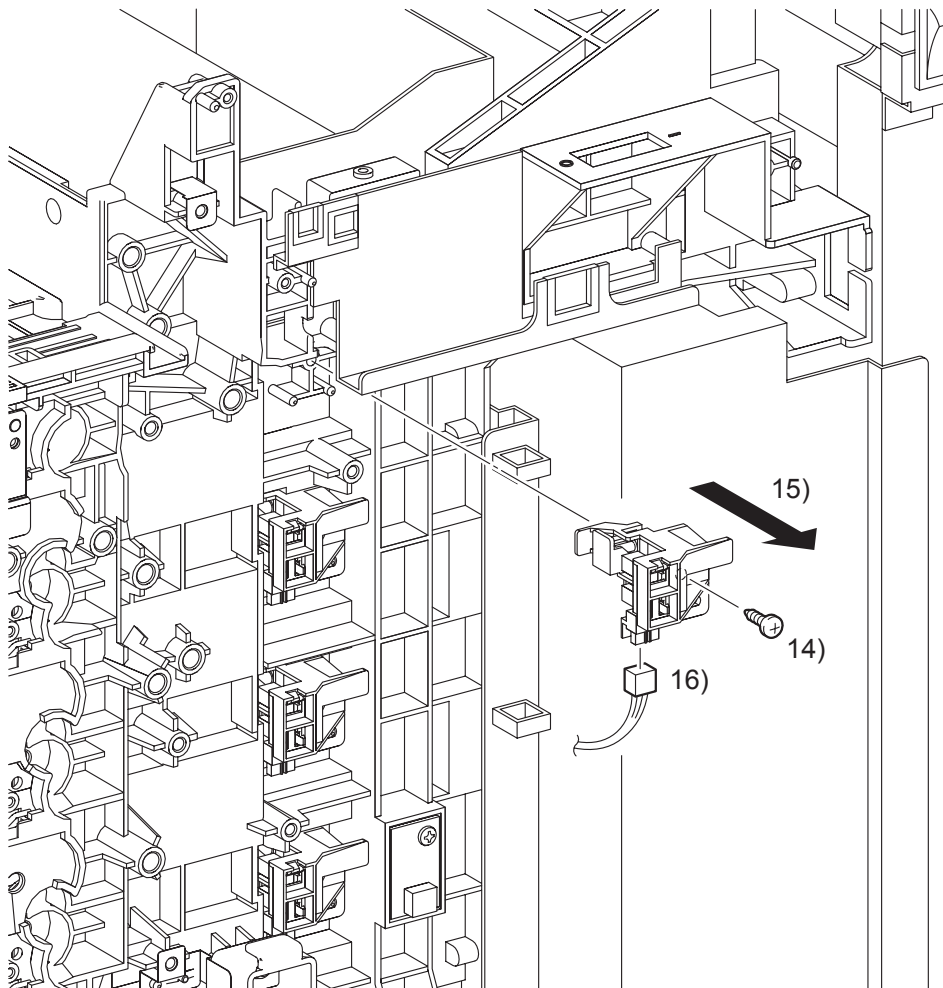

Gnb03053KA

- 14) Remove the one screw (silver, tap, 10mm) that fixes the TONER CARTRIDGE SENSOR ASSEMBLY (K) (PL5.1.4) to the printer.
- 15) Remove the TONER CARTRIDGE SENSOR ASSEMBLY (K) from the printer.
- 16) Disengage the connector (P/J193) of the TONER CARTRIDGE SENSOR ASSEMBLY (K).

Removal 38 MPF SEPARATOR ROLLER ASSEMBLY (PL2.1.3)

- 1) Remove the 250 SHEET PAPER TRAY (PL2.1.1) from the printer.

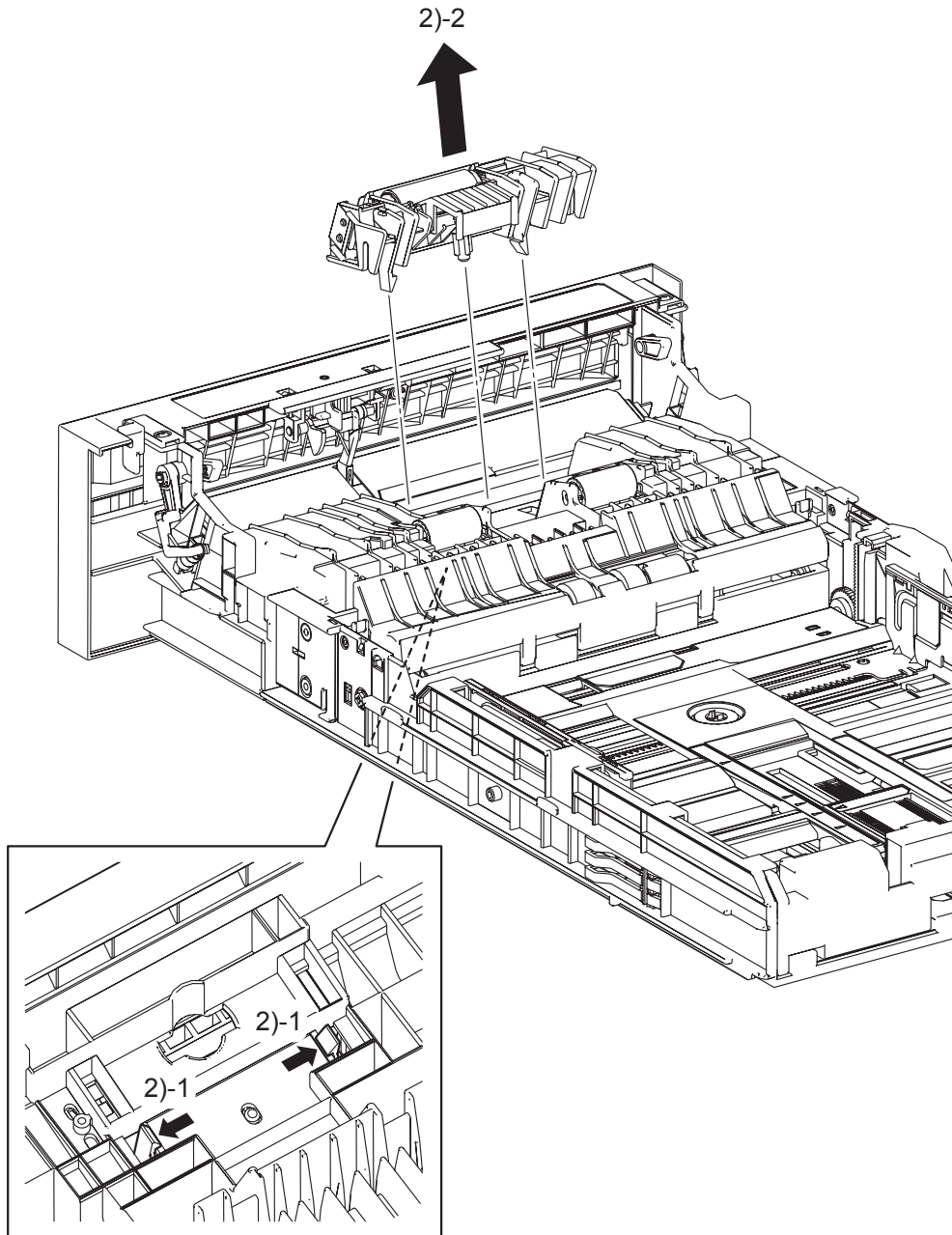

Kmy03054KA

- 2) Release the two backside hooks of the MPF SEPARATOR ROLLER ASSEMBLY (PL2.1.3) and then remove the MPF SEPARATOR ROLLER ASSEMBLY from the 250 SHEET PAPER TRAY.

Removal 39 SEPARATOR ROLLER (PL2.2.17) (Same as the FEED ROLLER)

- 1) Remove the 250 SHEET PAPER TRAY (PL2.1.1) from the printer.

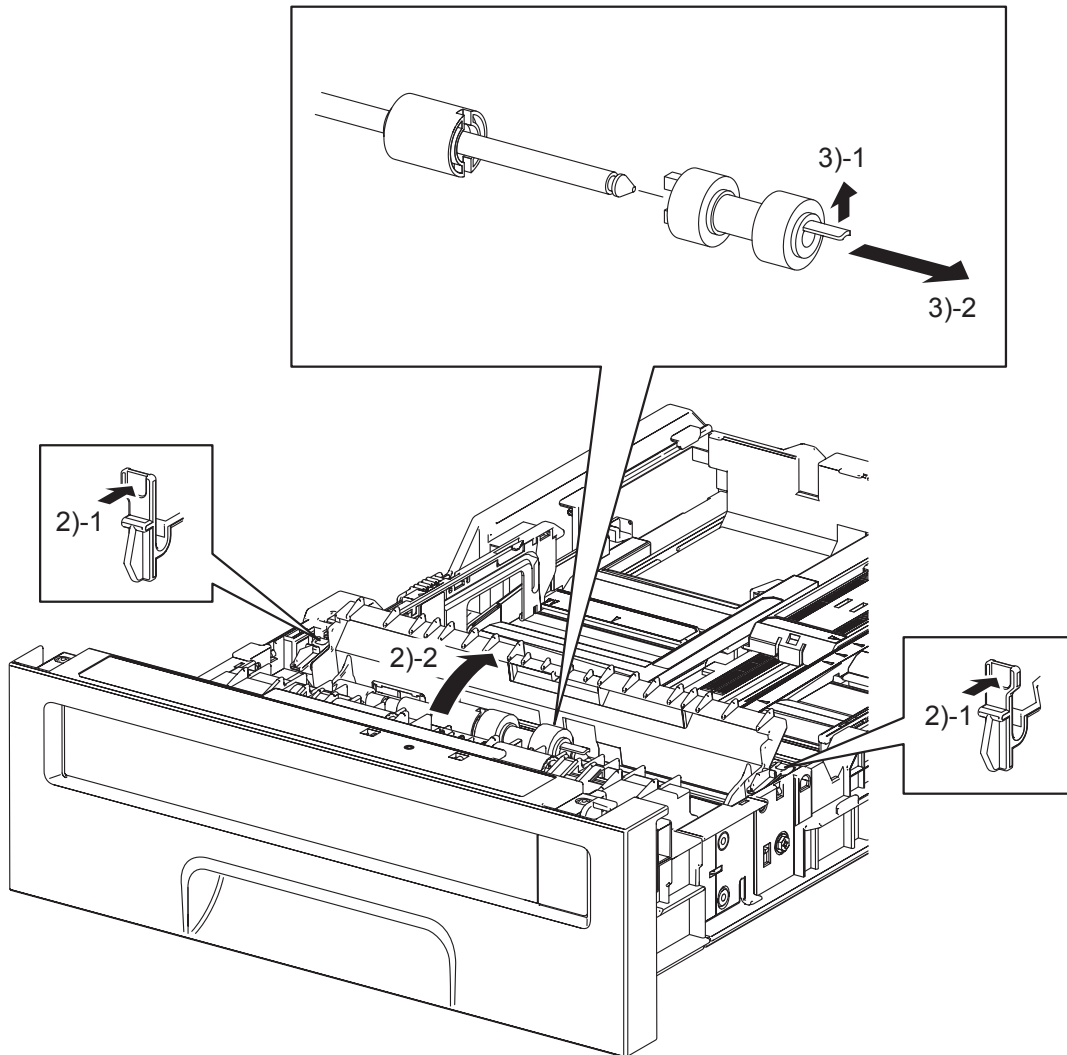

Kmy03055KA

- 2) Release the left and right hooks of the CVR RTD CST (PL2.2.13), and then open the CVR RTD CST.
- 3) Release the hook of the SEPARATOR ROLLER (PL2.2.17), and then remove the SEPARATOR ROLLER from the SHAFT RETARD (PL2.2.15).

Removal 40 MPF ROLLER (PL3.1.10)

- 1) Remove the 250 SHEET PAPER TRAY (PL2.1.1) from the printer.

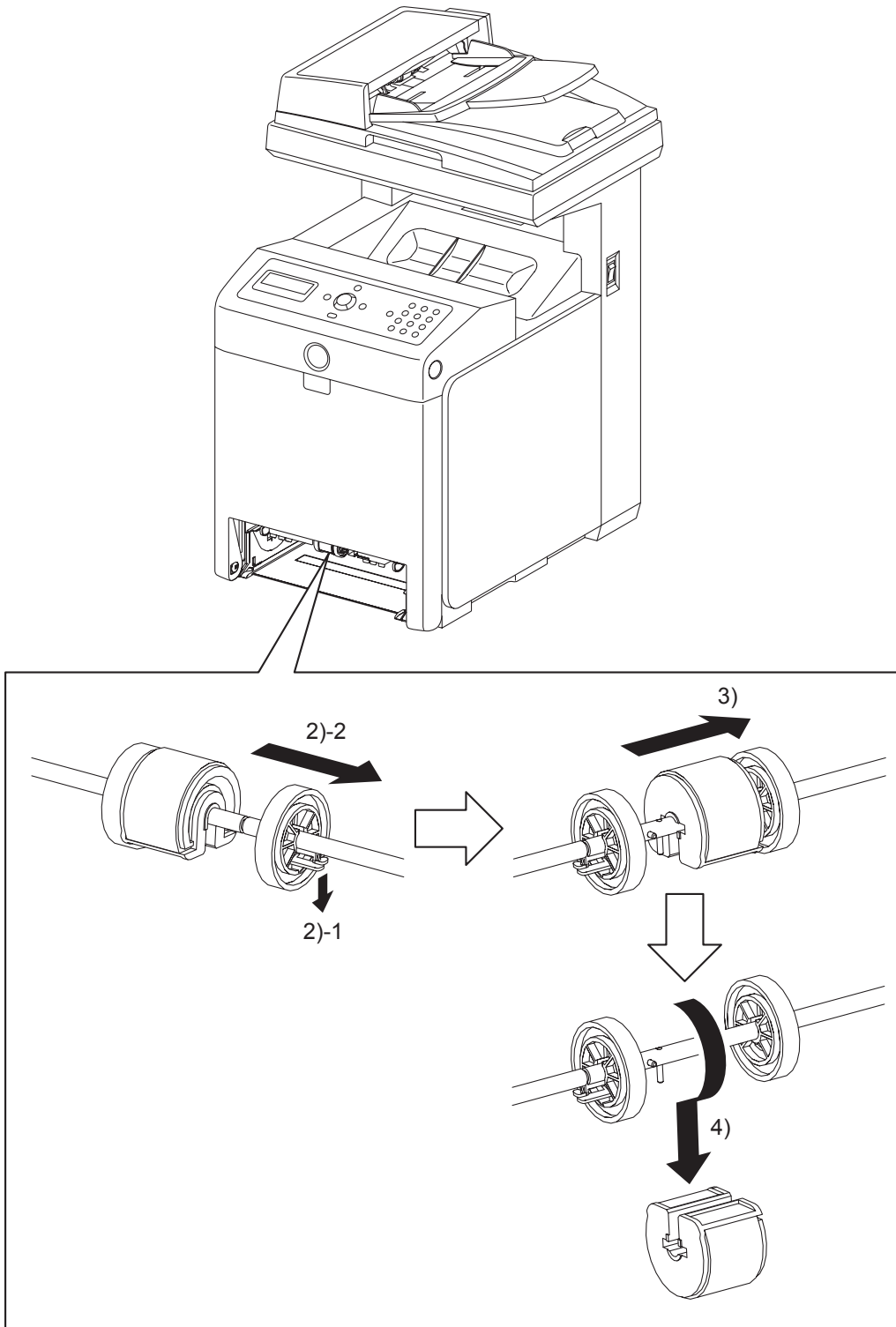

Gnb03056KA

- 2) Release the hook of the ROLL CORE MSI (PL3.1.9) on the right of the MPF ROLLER (PL 3.2.10), and slide the ROLL CORE MSI to the right.
- 3) Release the groove on the MPF ROLLER from the vertical pin mounted on the SHAFT MSI (PL3.1.12) by sliding the MPF ROLLER to the right.
- 4) Remove the MPF ROLLER from the SHAFT MSI by rotating the MPF ROLLER 180 degrees.

Removal 41 FEED ROLLER (PL3.2.53)

- 1) Remove the 250 SHEET PAPER TRAY (PL2.1.1) from the printer.

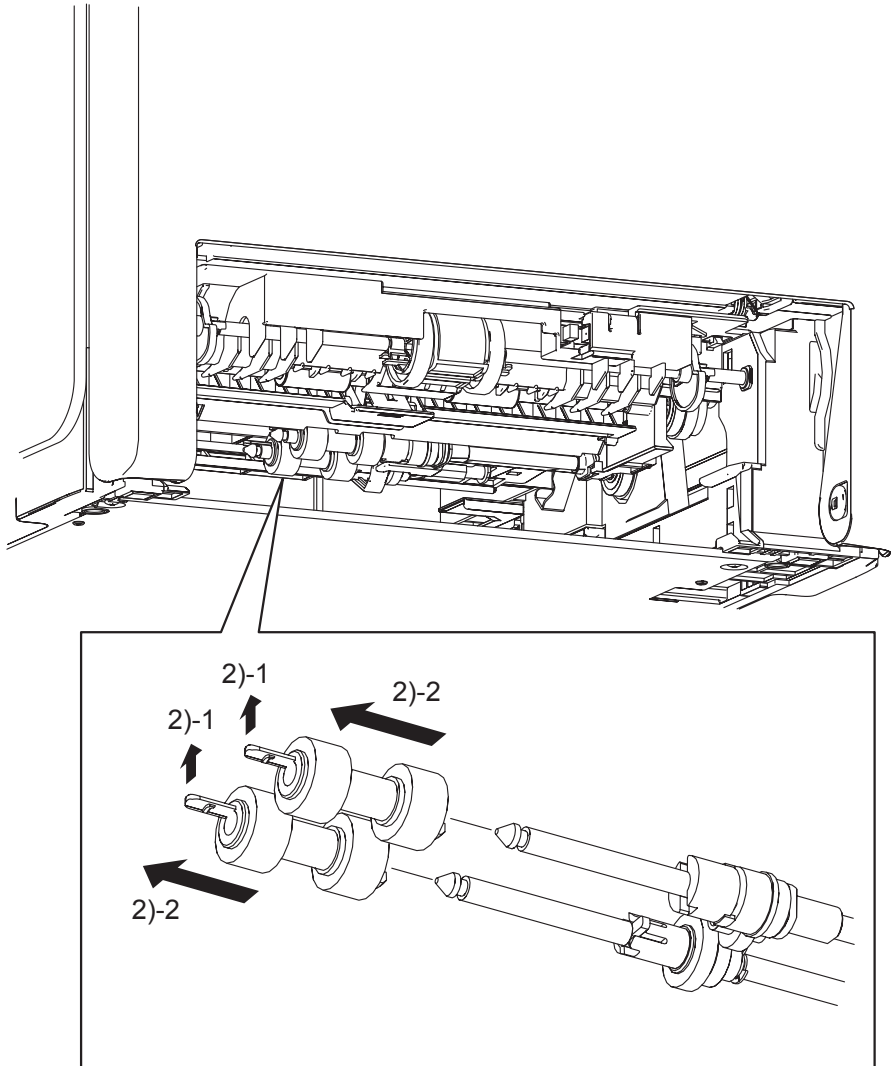

Kmy03057KA

- 2) Release the hooks of the FEED ROLLERS (PL3.2.53) and remove the FEED ROLLERS from the shafts.

Removal 42 550 SHEET FEEDER ASSEMBLY (PL13.7.1)

- 1) Remove the 250 SHEET PAPER TRAY (PL2.1.1) of the printer.

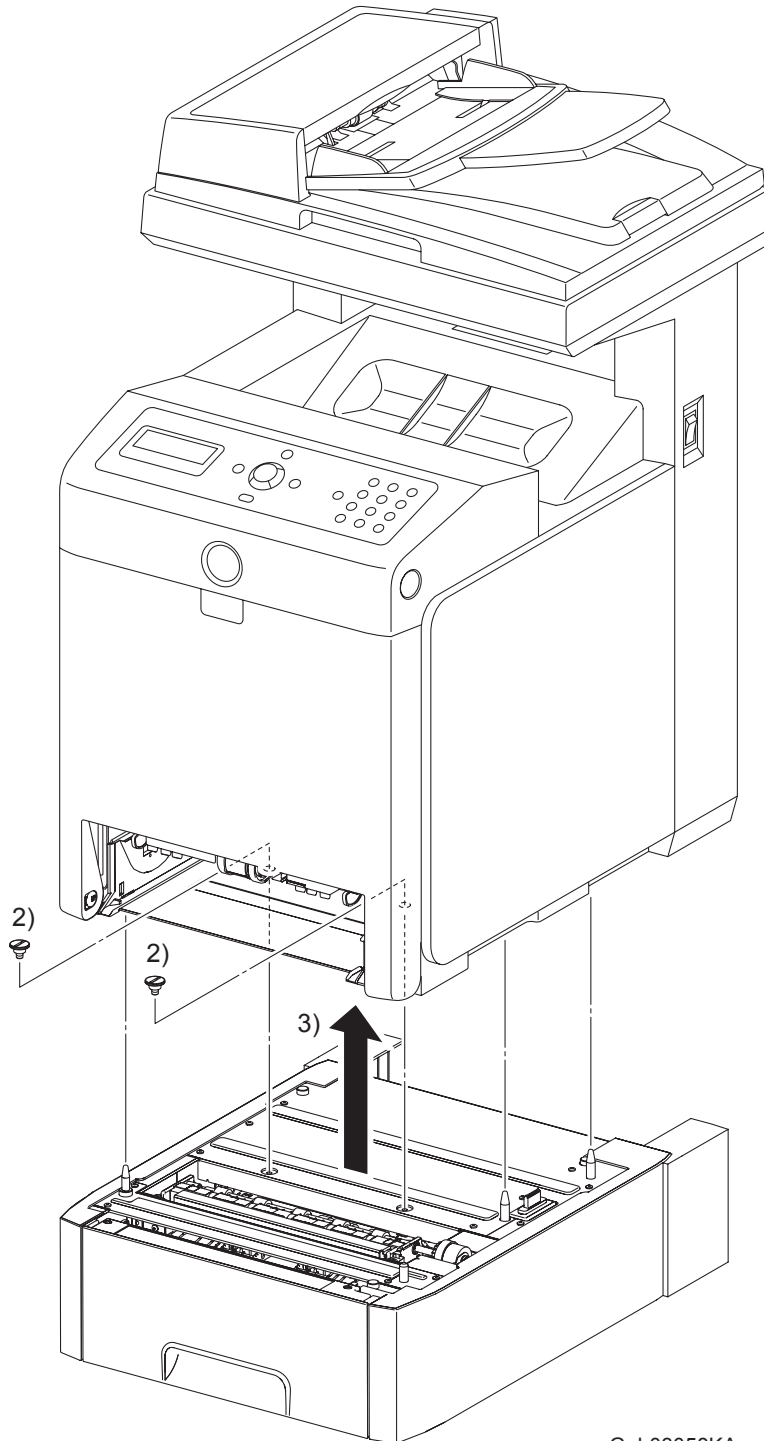

Gnb03058KA

- 2) Remove the two FEEDER SCREWS (PL13.7.3) that fix the 550 SHEET FEEDER ASSEMBLY (PL13.7.1) to the printer.

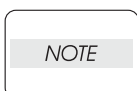

The printer must be lifted by two people.

- 3) Lift up the printer to separate it from the 550 SHEET FEEDER ASSEMBLY.

Removal 43 550 TRAY REAR COVER (PL13.7.4)

- 1) Pull the 550 TRAY REAR COVER backward until it stops

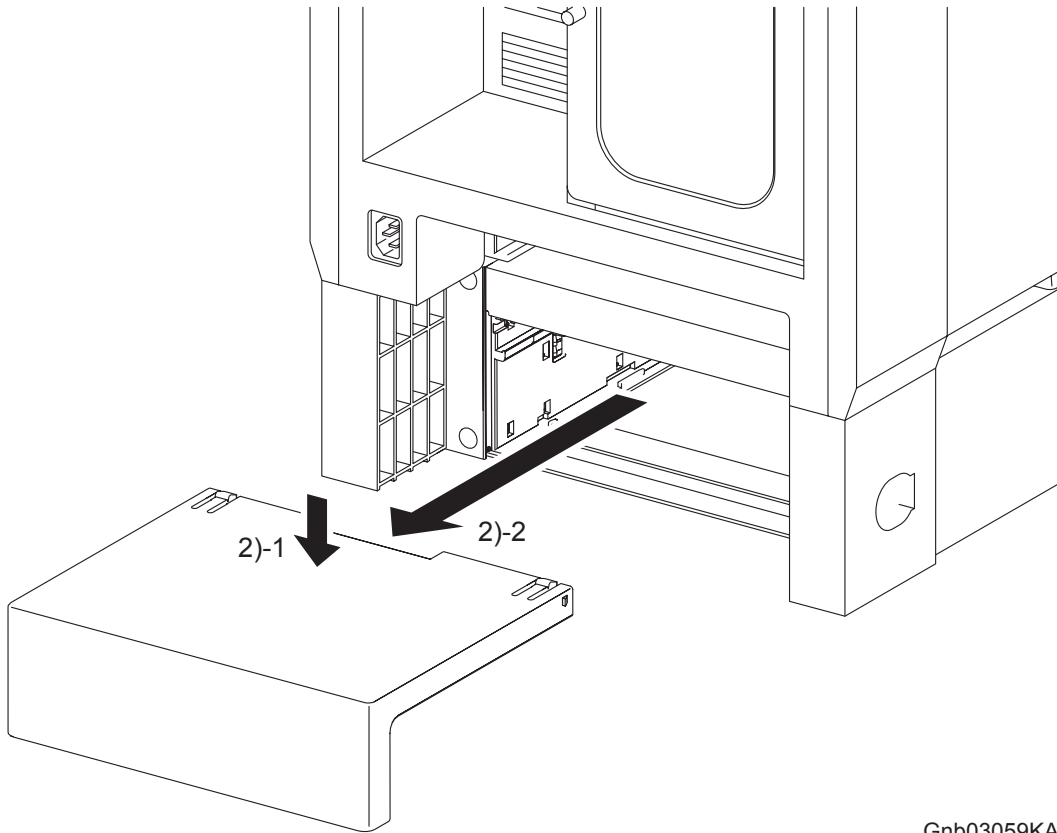

Gnb03059KA

- 2) Release the two hooks by depressing the center of the 550 TRAY REAR COVER, and then remove the 550 TRAY REAR COVER from the 550 SHEET FEEDER ASSEMBLY (PL13.7.1).

Removal 44 550 TRAY FEED ROLLER (PL12.3.29)

- 1) Remove the 550 SHEET PAPER TRAY (PL12.4.1) from the 550 SHEET FEEDER ASSEMBLY (PL13.7.1).

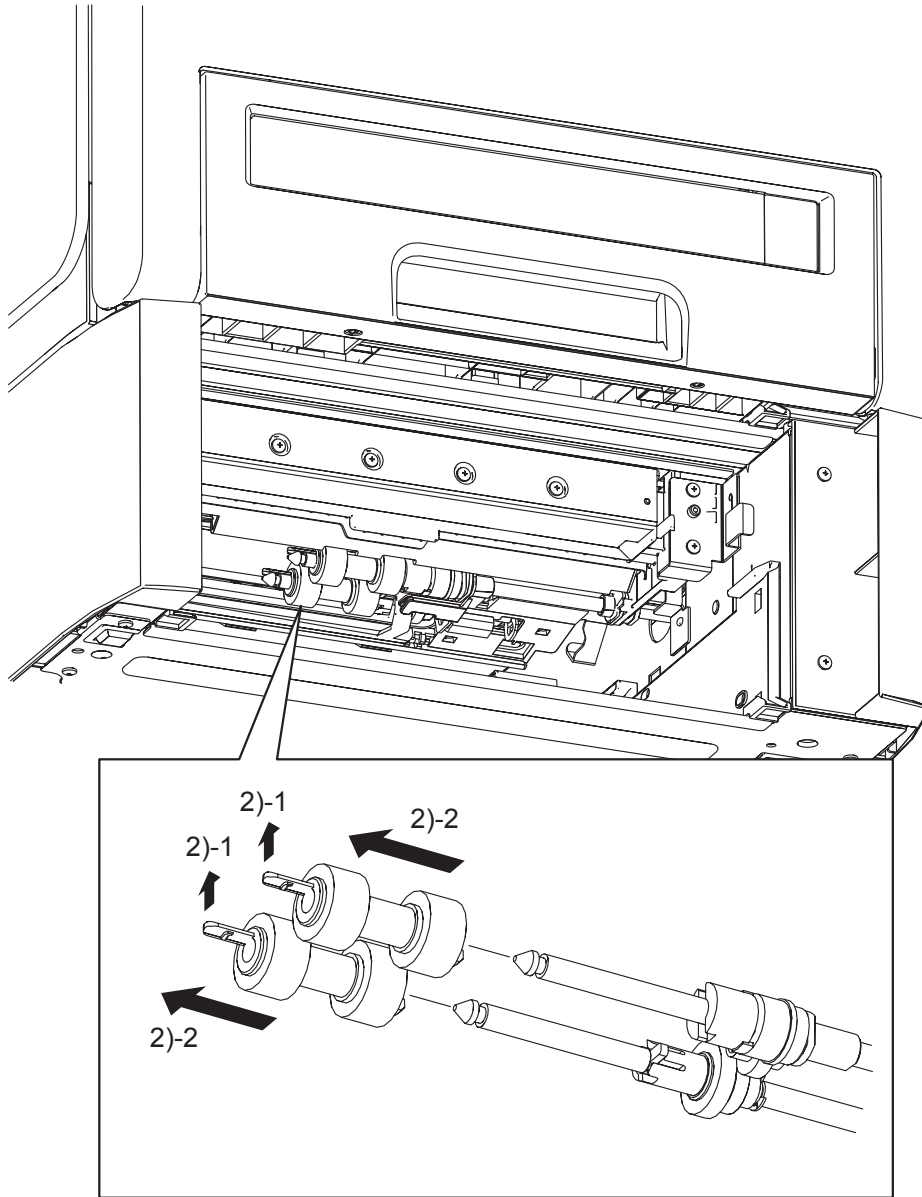

Kmy03060KA

- 2) Release the hooks of the 550 TRAY FEED ROLLERS (PL12.3.29), and then remove the 550 TRAY FEED ROLLERS from the shafts.

Removal 45 550 TRAY SEPARATOR ROLLER (PL12.5.17) (Same as the 550 TRAY FEED ROLLER)

- 1) Remove the 550 SHEET PAPER TRAY (PL12.4.1) from the 550 SHEET FEEDER ASSEMBLY (PL13.7.1).

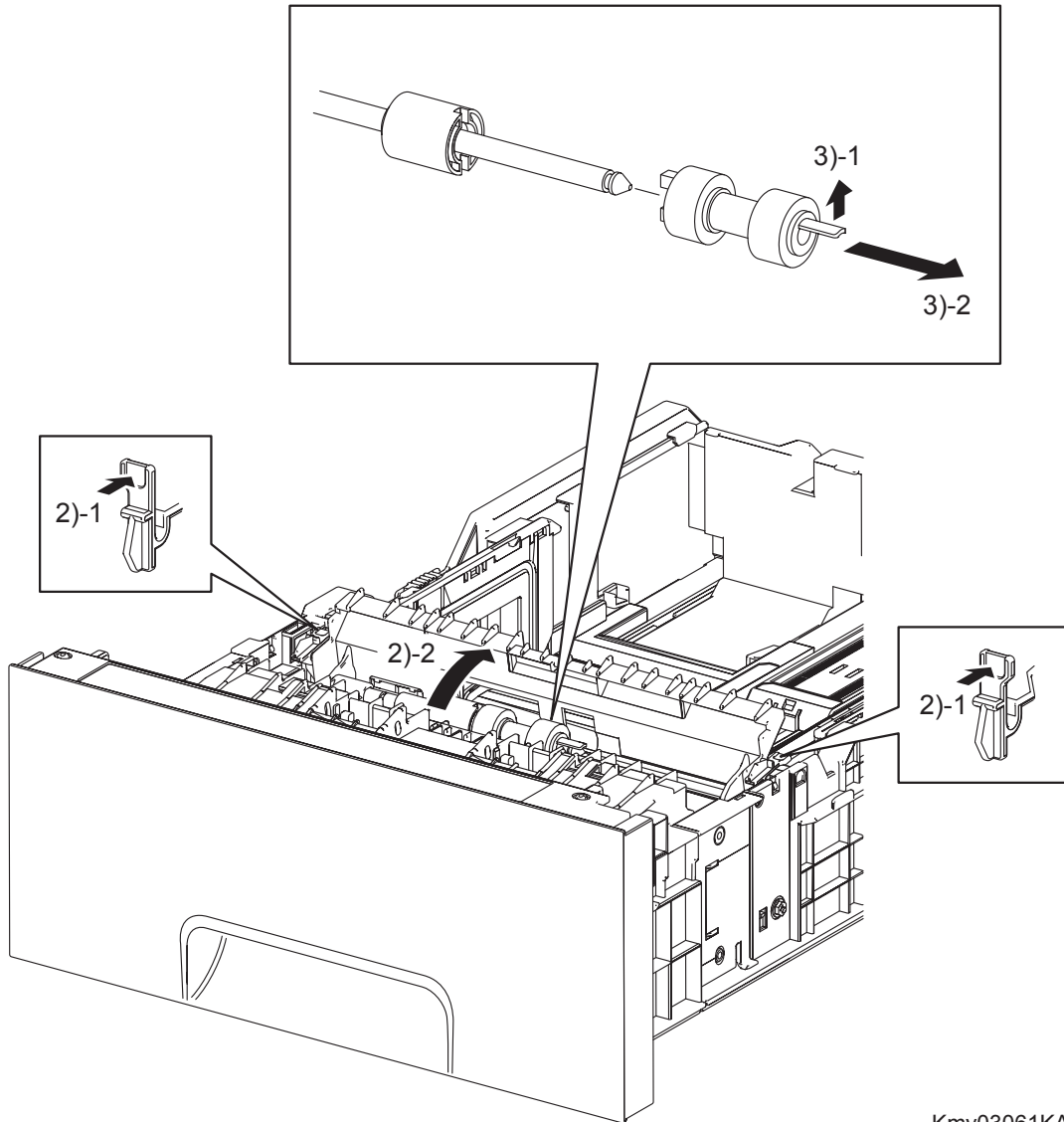

Kmy03061KA

- 2) Release the left and right hooks of the CVR RTD CST (PL12.5.13), and then open the CVR RTD CST.
- 3) Release the hook of the 550 TRAY SEPARATOR ROLLER (PL12.5.17), and then remove the 550 TRAY SEPARATOR ROLLER from the SHAFT RETARD (PL12.5.15).

Removal 46 MEMORY CARD (PL13.4.22)

NOTE

Use a wristband to protect the MEMORY CARD from electrostatic damage.

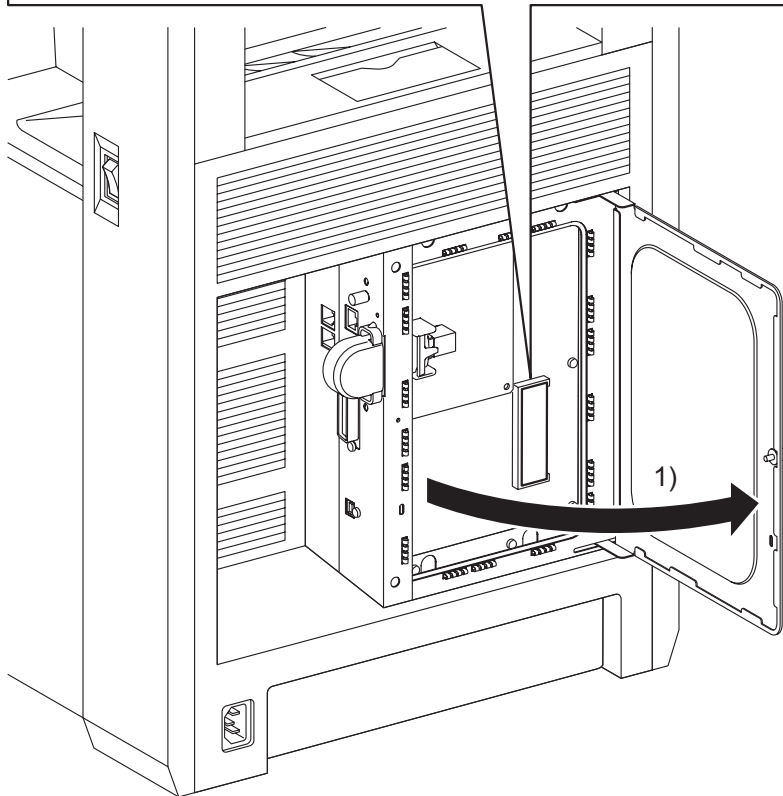
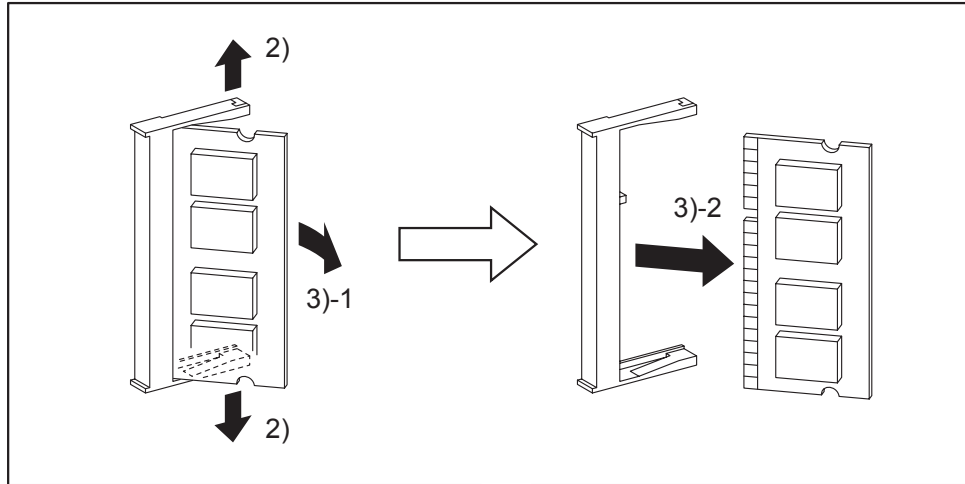

Gnb03127KA

- 1) Loosen the SCREW KNURLING (PL13.4.12), and then open the PLATE WINDOW ESS (PL13.4.10).
- 2) Gently spread open both the tabs on the socket holding the MEMORY CARD (PL13.4.22) until the MEMORY CARD pops up slightly.
- 3) Remove the MEMORY CARD.

Removal 47 MULTI PROTOCOL CARD (PL13.4.23)

NOTE

Use a wristband to protect the MPC from electrostatic damage.

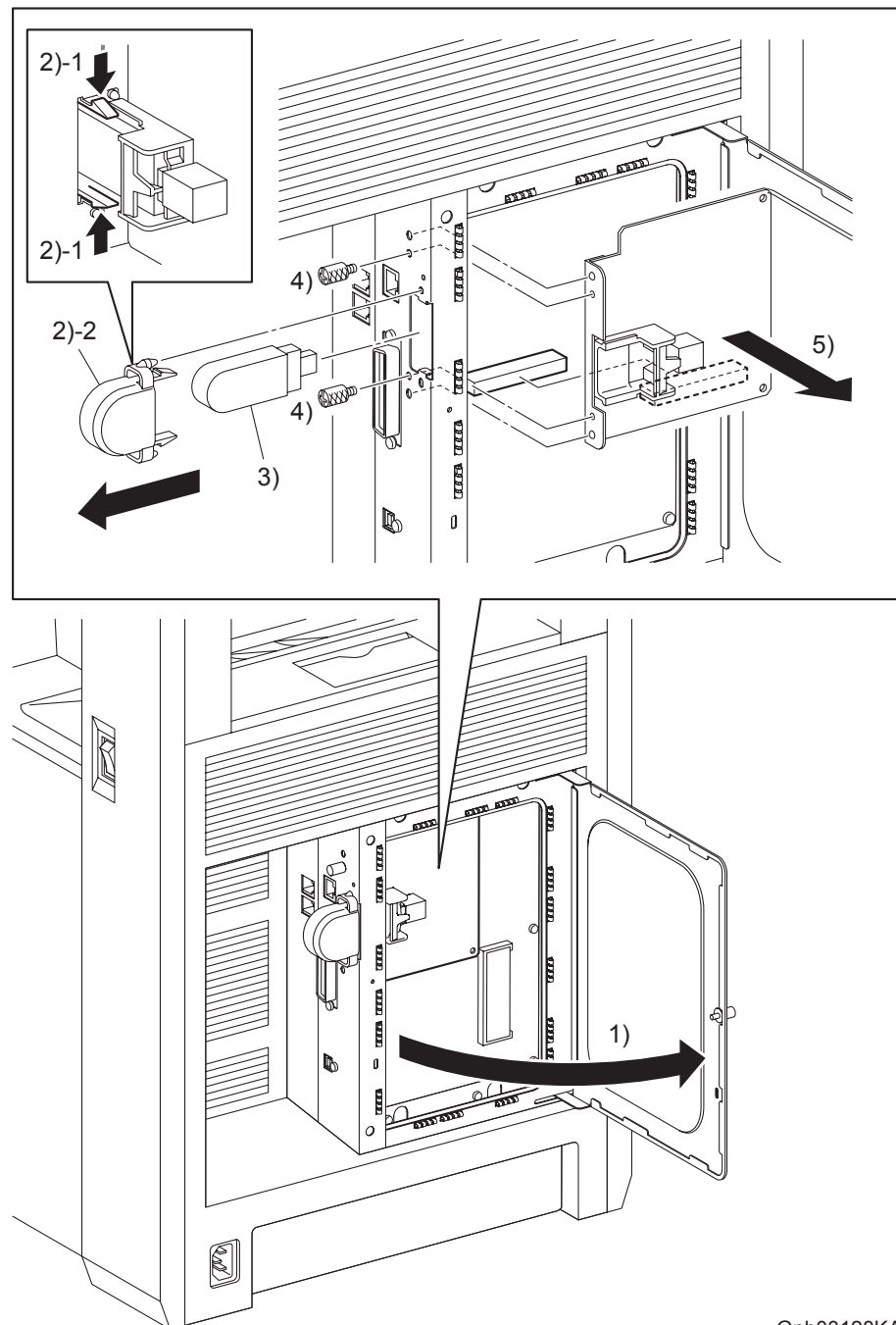

Gnb03128KA

- 1) Loosen the SCREW KNURLING (PL13.4.12), and then open the PLATE WINDOW (PL13.4.10).
- 2) Remove the COVER USB (PL13.4.25) from the printer by releasing its two hooks.
- 3) Remove the WIRELESS PRINTER ADAPTER (PL9.1.32) from the MULTI PROTOCOL CARD (PL13.4.23).
- 4) Remove the two SCREW KNURLINGS (PL13.4.12) that fix the MULTI PROTOCOL CARD to the printer.
- 5) Remove the MULTI PROTOCOL CARD from the ELECTRONIC SUB-SYSTEM CONTROL BOARD (PL13.4.20).

Removal 48 COVER EXTENDER (PL13.1.2)

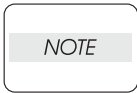

When performing the step described below, take care not to damage the bosses on the COVER EXTENDER.

- 1) Open the COVER EXTENDER (PL13.1.2).

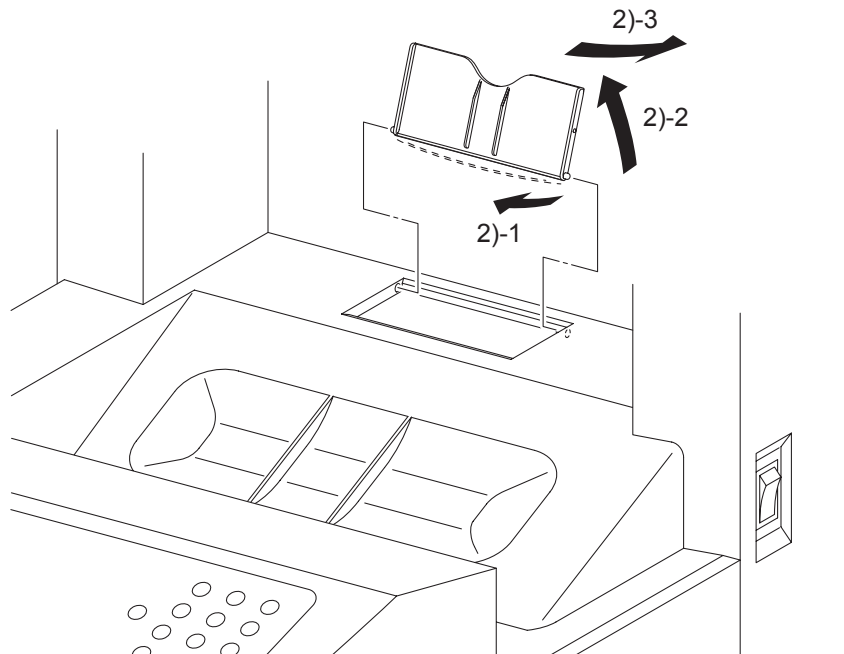

Gnb03003KA

- 2) Remove the COVER EXTENDER by bending it and removing its left and right bosses from the holes on the TOP COVER. (PL13.1.1)

For the replacement procedure of this part, go to:

Replacement 74 COVER EXTENDER (PL13.1.2)

Removal 49 REAR COVER (PL13.1.6)

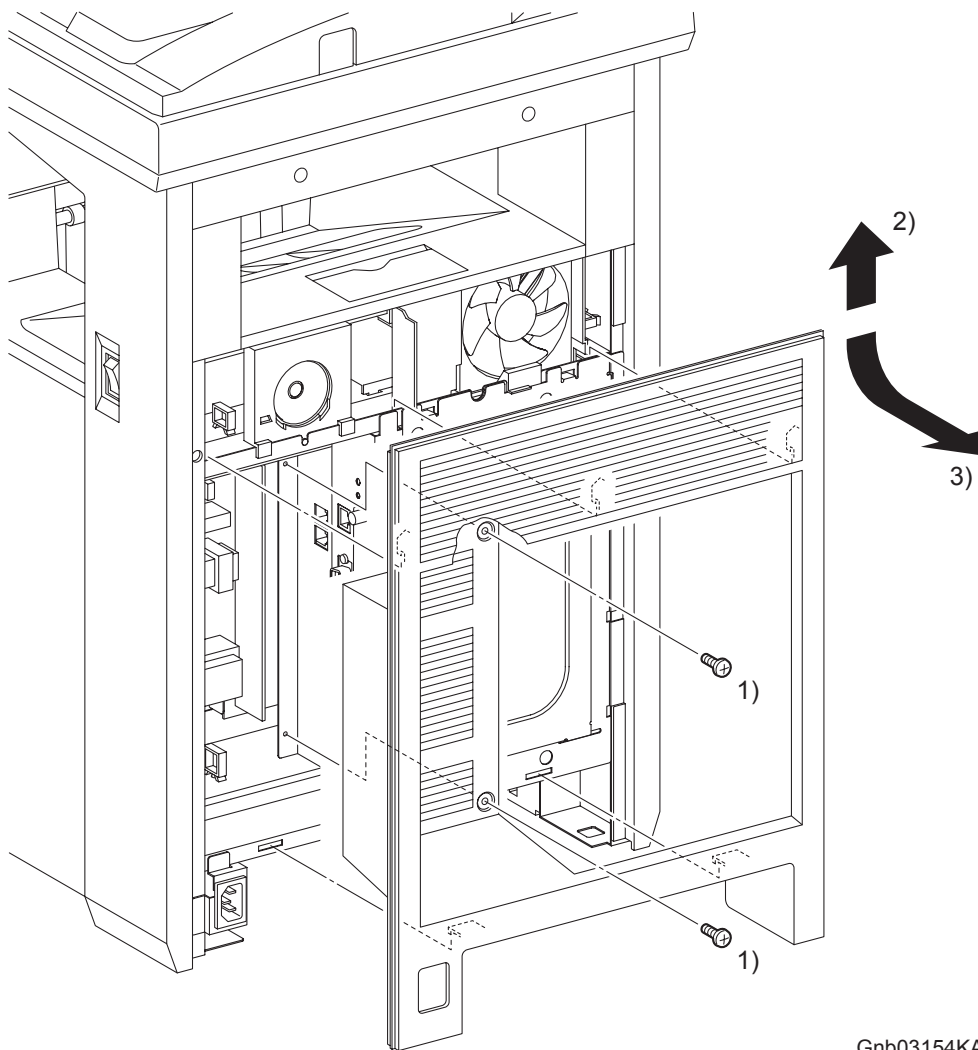

Gnb03154KA

- 1) Remove the two screws (silver, 6mm) that fix the REAR COVER (PL13.1.6) to the printer.
- 2) Release the five hooks on the backside of the REAR COVER from the printer by lifting up the REAR COVER slightly.
- 3) Remove the REAR COVER from the printer by releasing the rim on the upper section of the REAR COVER from the inside of the TOP COVER (PL13.1.1).

Go to the next removal step:

Removal 50 COVER BOTTOM (PL13.1.5)

Removal 50 COVER BOTTOM (PL13.1.5)

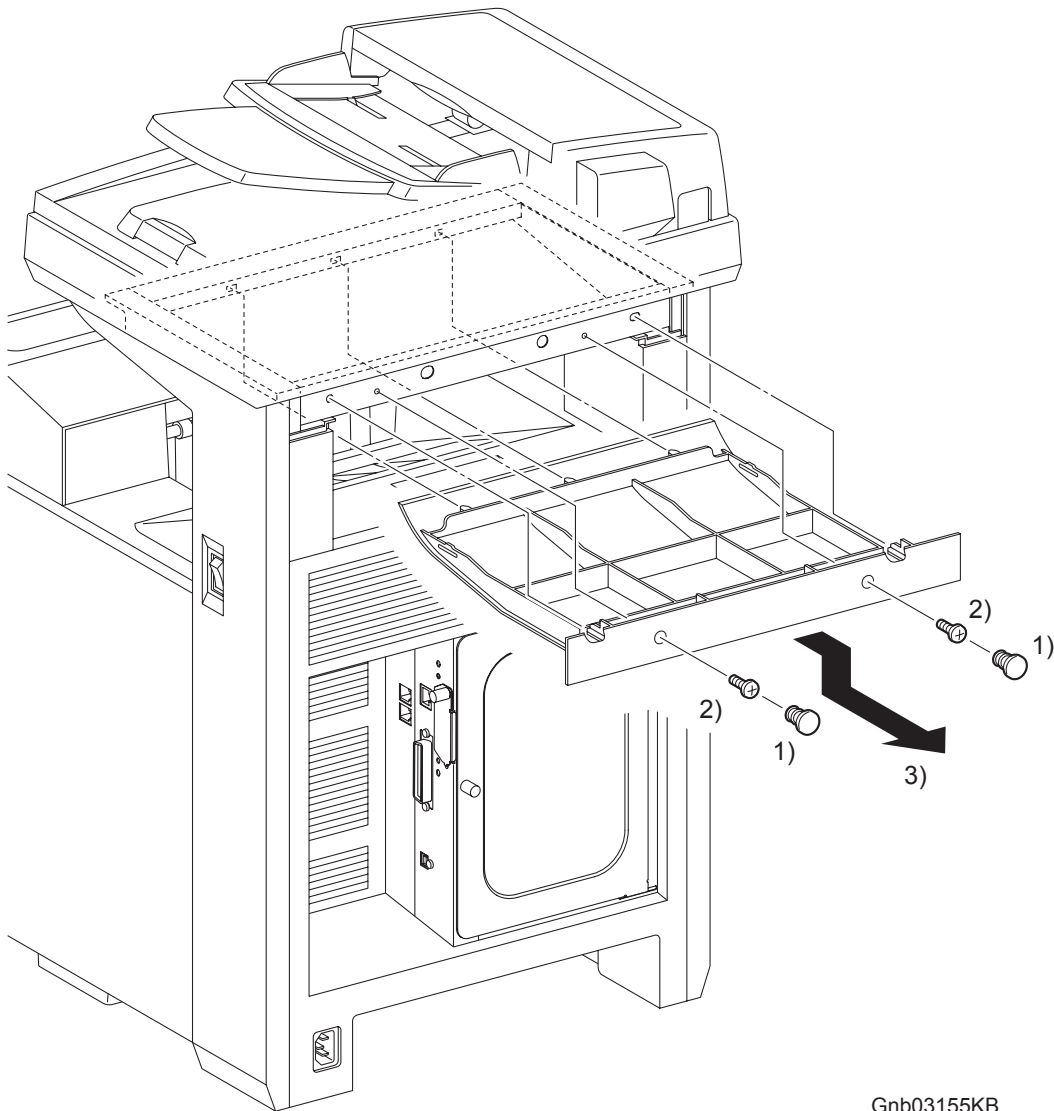

Gnb03155KB

- 1) Remove the two CAP SCREWS (PL13.1.12) from the screw holes of the COVER BOTTOM (PL13.1.5).
- 2) Remove the two screws (silver, 6mm) that fix the COVER BOTTOM to the printer.
- 3) Release the five lugs on the COVER BOTTOM by sliding the COVER BOTTOM backward, and then remove the COVER BOTTOM from the printer.

Go to the next removal steps:

Removal 51 COVER POLE IN R (PL13.1.4) or Removal 58 COVER POLE L (PL13.1.11)

Removal 51 COVER POLE IN R (PL13.1.4)

Step 1 is for reference. Before removing this component, check that Step 1 has been performed.

- 1) Remove the COVER BOTTOM. (Removal 50)

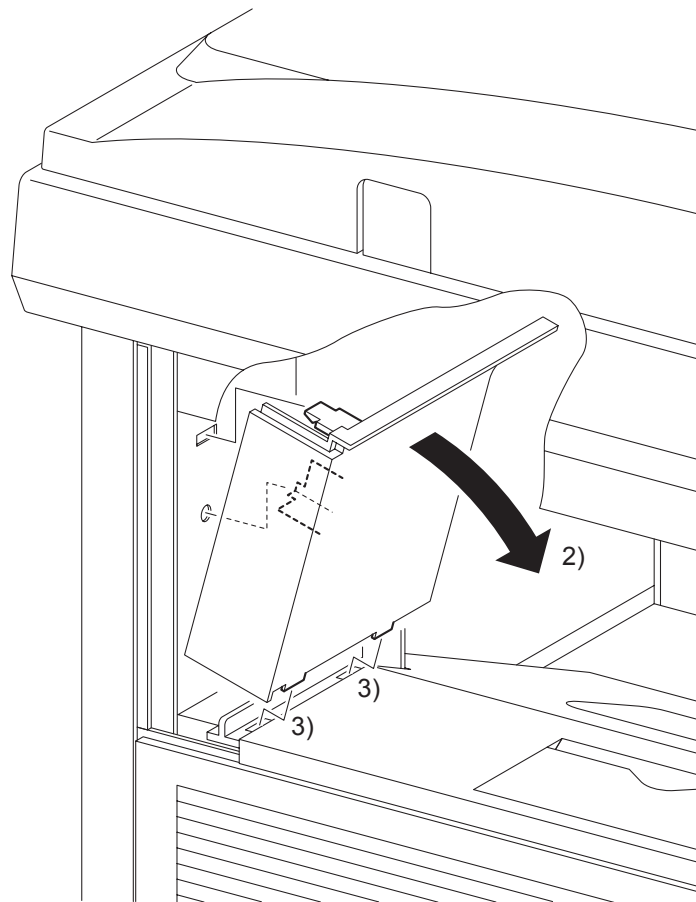

Gnb03156KA

- 2) Release the one hook on the rear side of the COVER POLE IN R (PL13.1.4) from the printer by tilting the COVER POLE IN R inward.
- 3) Remove the COVER POLE IN R from the printer by releasing the two hooks on the underside of the COVER POLE IN R from the holes on the TOP COVER (PL13.1.1).

Go to the next removal step:

Removal 52 COVER POLE R (PL13.1.8)

Removal 52 COVER POLE R (PL13.1.8)

Steps 1 through 3 are for reference. Before removing this component, check that Steps 1 through 3 have been performed.

- 1) Remove the REAR COVER. (Removal 49)
- 2) Remove the COVER BOTTOM. (Removal 50)
- 3) Remove the COVER POLE IN R. (Removal 51)

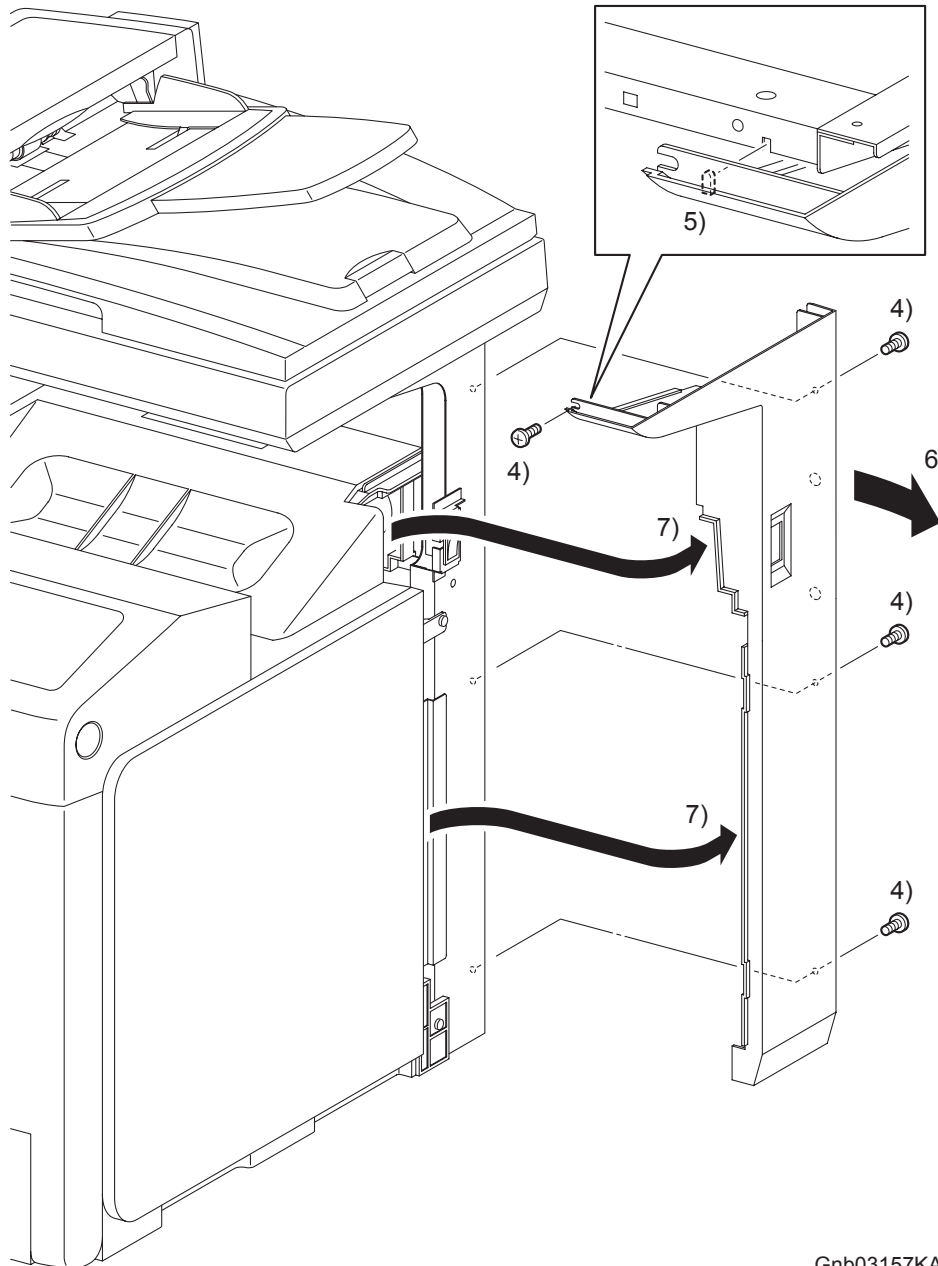

Gnb03157KA

- 4) Remove the four screws (silver, 6mm) that fix the COVER POLE R (PL13.1.8) to the printer.
- 5) Release from the printer the lugs on the screw mounting positions on the front section of the COVER POLE R.
- 6) Slide the rear section of the COVER POLE R outward.
- 7) Remove the COVER POLE R from the printer by releasing the rims on the front section of the COVER POLE R from the TOP COVER (PL13.1.1) and from the inside of the RIGHT COVER (PL13.1.9)

Go to the next removal steps:

Removal 53 POWER SWITCH (PL13.5.4) or Removal 54 RIGHT COVER (PL13.1.9)

Removal 53 POWER SWITCH (PL13.5.4)

Steps 1 through 4 are for reference. Before removing this component, check that Steps 1 through 4 have been performed.

- 1) Remove the REAR COVER. (Removal 49)
- 2) Remove the COVER BOTTOM. (Removal 50)
- 3) Remove the COVER POLE IN R. (Removal 51)
- 4) Remove the COVER POLE R. (Removal 52)

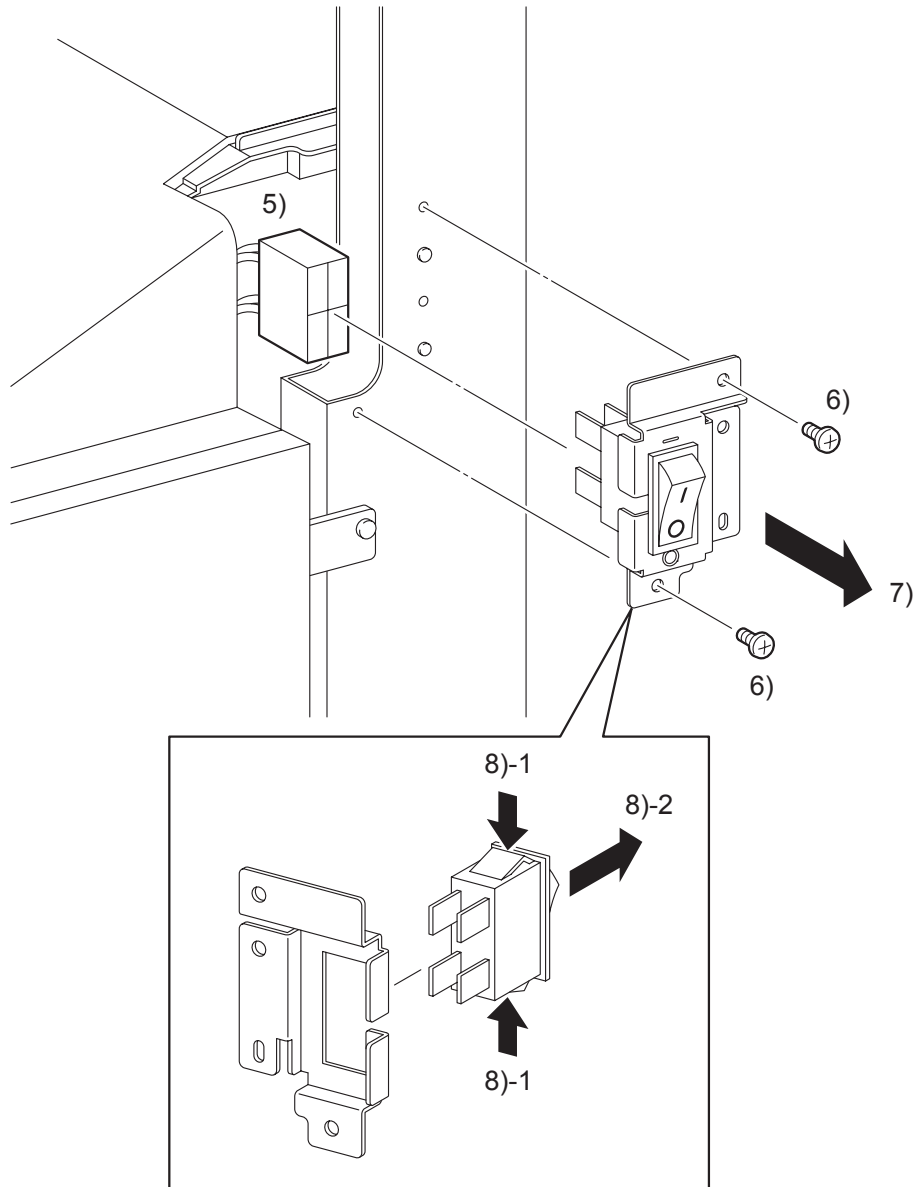

Gnb03158KA

- 5) Disengage the connector (P/J481) of the POWER SWITCH (PL13.5.4).
- 6) Remove the two screws (silver, 6mm) that fix the BRACKET MAIN SW (PL13.5.5) to the printer.
- 7) Remove the BRACKET MAIN SW from the printer together with the POWER SWITCH.
- 8) Remove the POWER SWITCH from the BRACKET MAIN SW by releasing the hooks on the POWER SWITCH.

Removal 54 RIGHT COVER (PL13.1.9)

Steps 1 through 6 are for reference. Before removing this component, check that Steps 1 through 6 have been performed.

- 1) Open the FRONT COVER (PL13.2.1).
- 2) Remove the FUSER. (Removal 8)
- 3) Remove the REAR COVER. (Removal 49)
- 4) Remove the COVER BOTTOM. (Removal 50)
- 5) Remove the COVER POLE IN R. (Removal 51)
- 6) Remove the COVER POLE R. (Removal 52)

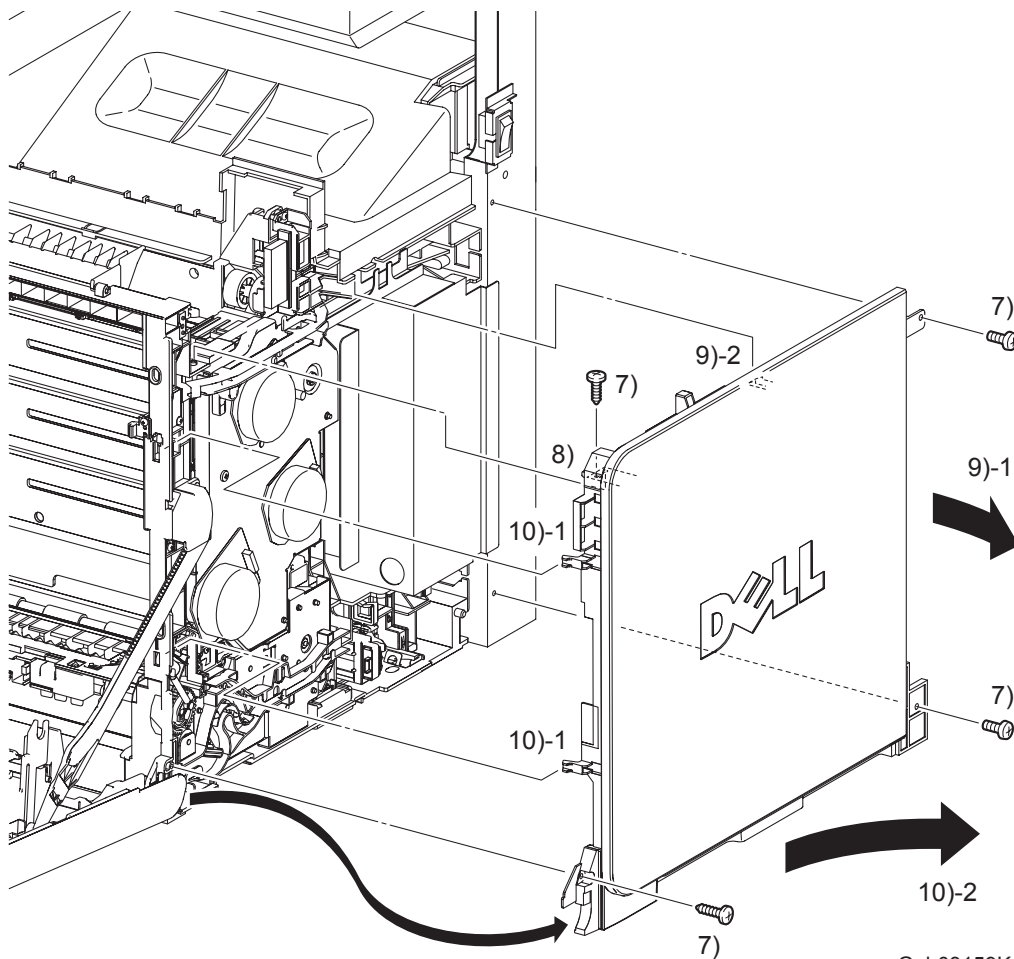

Gnb03159KA

- 7) Remove the two screws (silver, tap, 10mm) and the two screws (silver, 6mm) that fix the RIGHT COVER (PL13.1.9) to the printer.
- 8) Release the holes on the screw mounting positions on the top side of the RIGHT COVER from the bosses on the printer.
- 9) Release from the printer the one hook on the rear side of the RIGHT COVER by sliding the rear of the RIGHT COVER slightly outward.
- 10) Release from the printer the two hooks on the front section of the RIGHT COVER by sliding the RIGHT COVER diagonally backward, and then remove the RIGHT COVER from the printer.

Go to the next removal steps:

Removal 14 MPF FEED SOLENOID (PL3.1.98), Removal 15 FEED DRIVE ASSEMBLY (PL8.1.7), Removal 18 RIGHT ARM ASSEMBLY (PL13.3.98), Removal 19 SIZE SWITCH ASSEMBLY (PL7.1.18), Removal 21 TONER CARTRIDGE SENSOR ASSEMBLY (C), (M), (Y) (PL5.1.4), Removal 55 FRONT COVER (PL13.2.98), Removal 56 OPERATOR PANEL (PL13.2.97) or Removal 57 COVER POLE IN L (PL13.1.3)

Removal 55 FRONT COVER (PL13.2.98)

NOTE

The procedures described below must be performed with the MPF COVER (PL13.2.26) attached to the FRONT COVER (PL13.2.1).

Steps 1 through 7 are for reference. Before removing this component, check that Steps 1 through 7 have been performed.

- 1) Open FRONT COVER (PL13.2.1).
- 2) Remove the FUSER.(Removal 8)
- 3) Remove the REAR COVER. (Removal 49)
- 4) Remove the COVER BOTTOM. (Removal 50)
- 5) Remove the COVER POLE IN R.(Removal 51)
- 6) Remove the COVER POLE R.(Removal 52)
- 7) Remove the RIGHT COVER. (Removal 54)

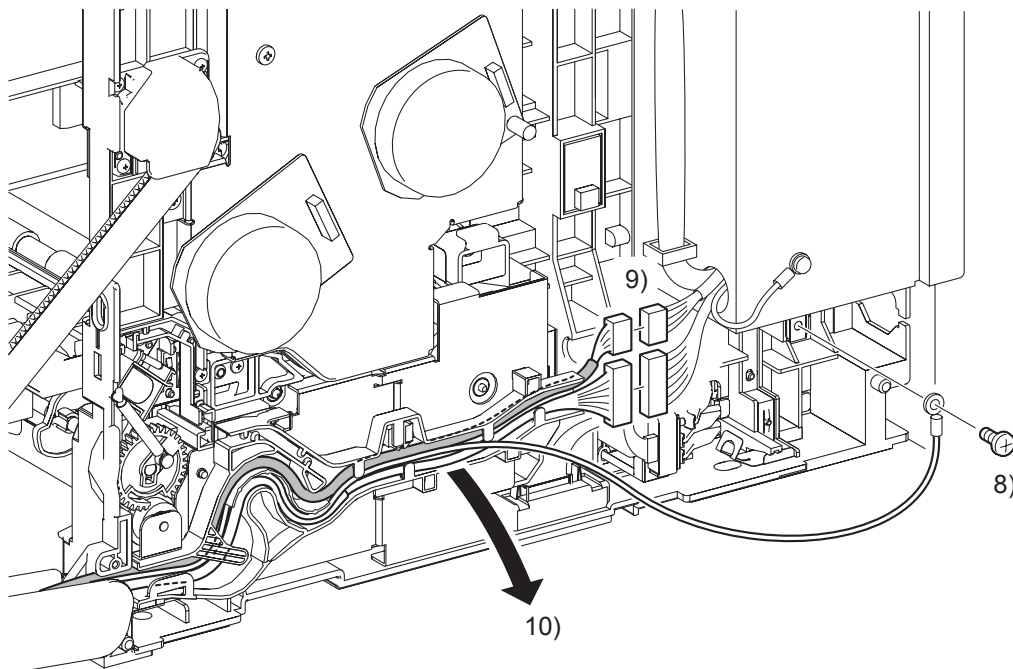

Gnb03025KA

- 8) Remove the one screw (silver, 6mm) that fixes to the printer the ground wire of the HARNESS ASSY FRONT COVER (PL13.2.13).

NOTE

When performing the step below, leave the junction connector on the printer side cable.

- 9) Disengage the connector (P/J5301) of the HARNESS ASSY A-OP-OPP (PL13.2.24) and the connector (P/J272) of the HARNESS ASSY FRONT COVER.
- 10) Release the HARNESS ASSY A-OP-OPP and HARNESS ASSY FRONT COVER from the DUCT DRV PH (PL8.1.8).

Continues to the next page.

Removal 55 FRONT COVER (PL13.2.98)

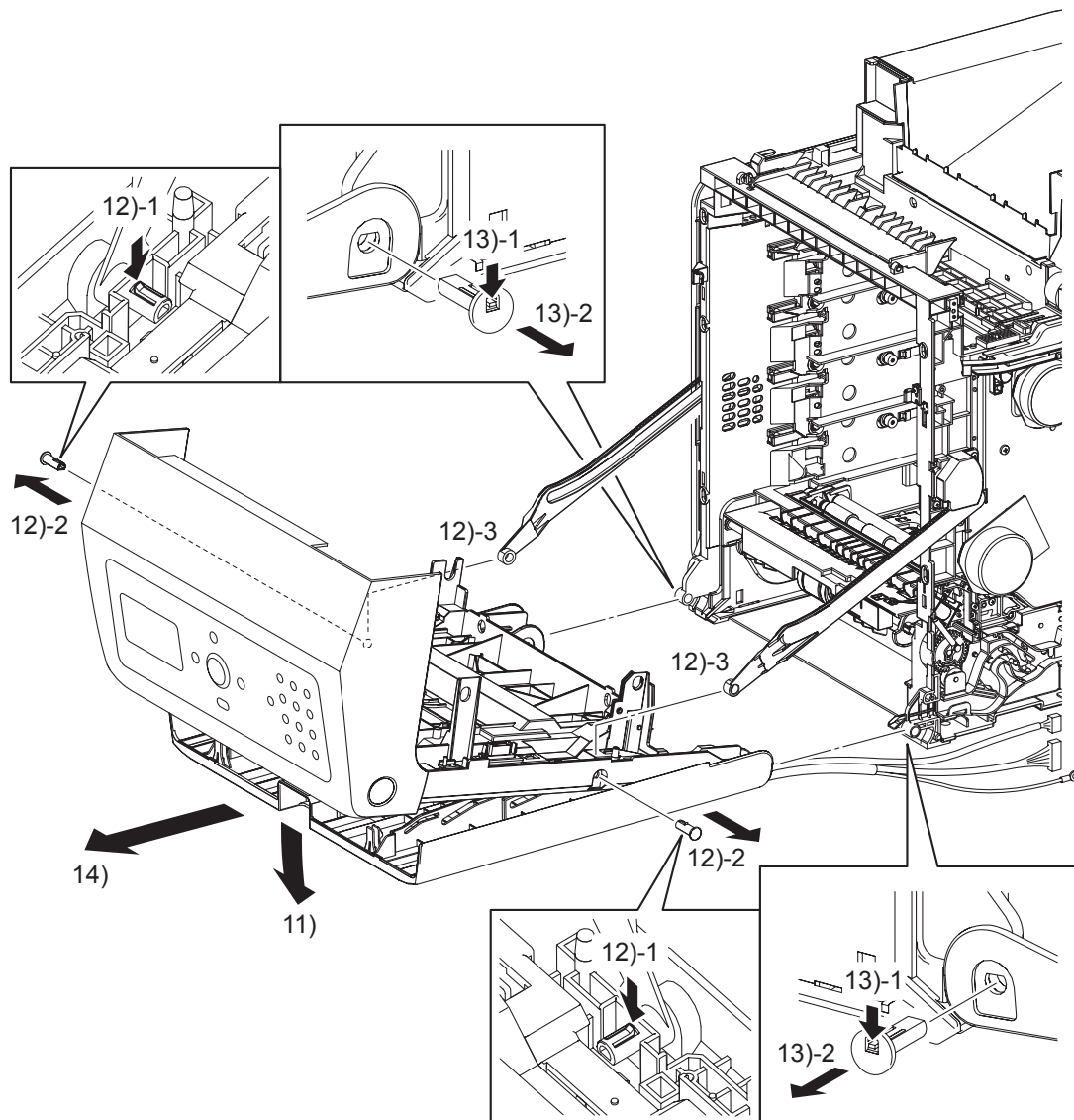

Gnb03026KB

- 11) Open the MPF COVER (PL13.2.26).

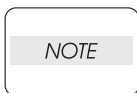

When performing the step described below, take care not to drop and break the FRONT COVER.

- 12) Release the hook of SHAFT PIVOT (PL13.2.10) on the left and right sides of the FRONT COVER, and then pull out the SHAFT PIVOT to the outside while holding the FRONT COVER. Remove the FRONT COVER from the LINK L (PL7.1.3) and LINK R (PL13.3.20) on the printer.
- 13) Release the hook of the SHAFT PIVOT MSI (PL13.2.33) that fixes the left and right sides of the FRONT COVER and the MPF COVER to the printer, and then pull out the SHAFT PIVOT MSI to the inside.
- 14) Remove the FRONT COVER together with the MPF COVER.

Removal 56 OPERATOR PANEL (PL13.2.97)

Steps 1 through 8 are for reference. Before removing this component, check that Steps 1 through 8 have been performed.

- 1) Open the FRONT COVER (PL13.2.1).
- 2) Remove the FUSER. (Removal 8)
- 3) Remove the REAR COVER. (Removal 49)
- 4) Remove the COVER BOTTOM. (Removal 50)
- 5) Remove the COVER POLE IN R. (Removal 51)
- 6) Remove the COVER POLE R. (Removal 52)
- 7) Remove the RIGHT COVER. (Removal 54)
- 8) Remove the CHUTE ASSY EXIT OUT. (Removal 10)

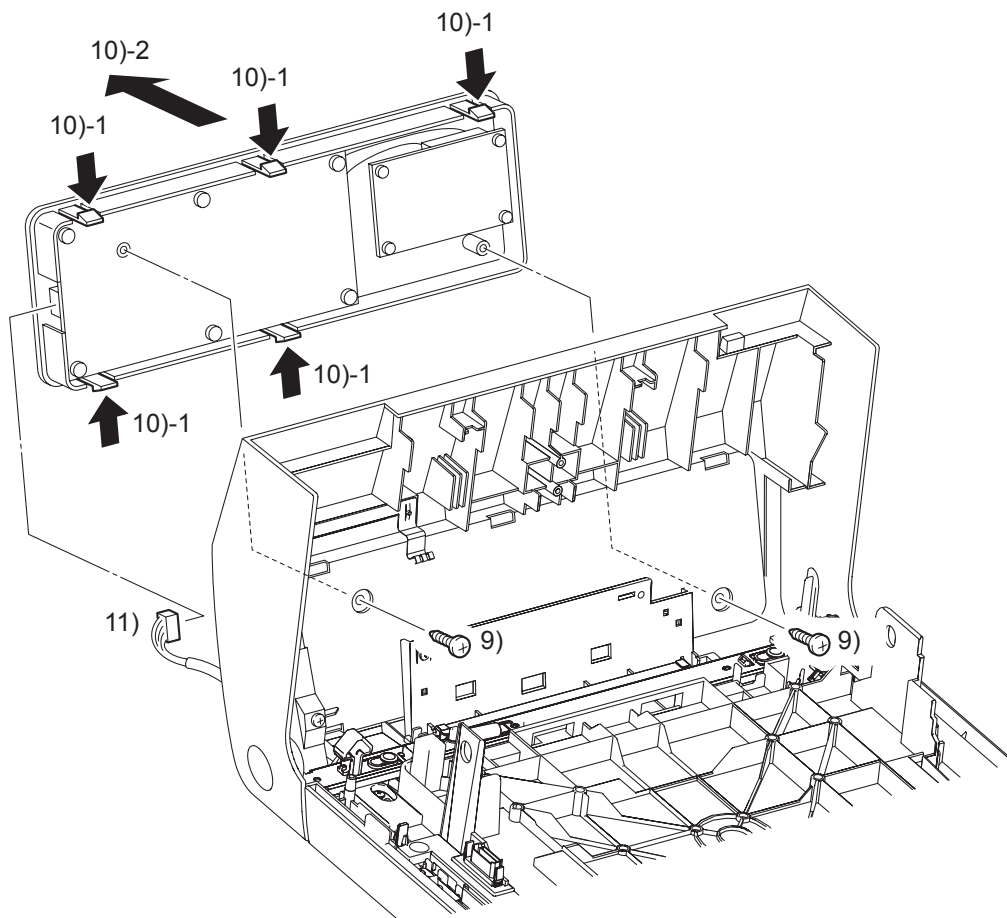

Gnb03161KA

- 9) Remove the two screws (silver, tap, 10mm) that fix the OPERATOR PANEL (PL13.2.2) to the FRONT COVER.

NOTE

Take care not to move the OPERATOR PANEL away from the FRONT COVER too far because the OPERATOR PANEL is secured to the HARNESS ASSY FRONT COVER.

NOTE

When performing the step described below, take care not to drop or damage the OPERATOR PANEL.

- 10) Remove the OPERATOR PANEL from the FRONT COVER by releasing the five hooks.
- 11) Disengage the connector of the OPERATOR PANEL (P/J202), and then remove the OPERATOR PANEL.

Continues to the next page.

Removal 56 OPERATOR PANEL (PL13.2.97)

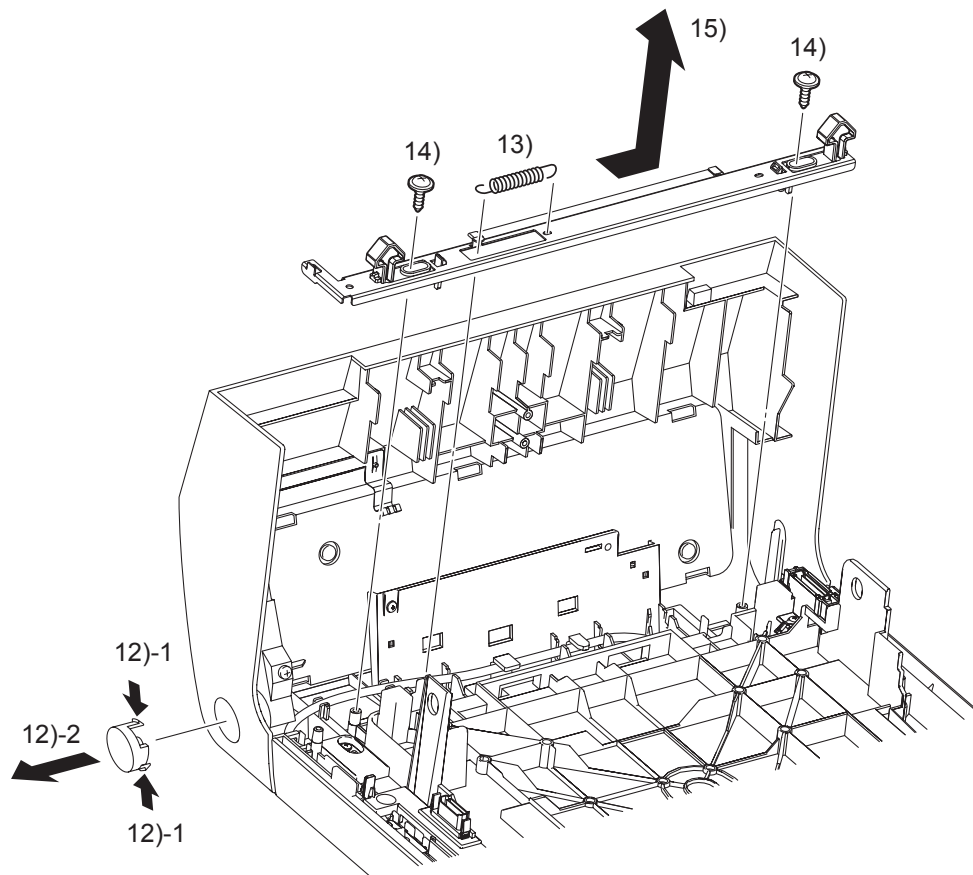

Gnb03160KA

- 12) Remove the BUTTON TOP by releasing the two hooks that fix the BUTTON TOP (PL13.2.8) to the FRONT COVER (PL13.2.1).
- 13) Remove the SPRING LATCH (PL13.2.6) from the hooks on the PLATE LATCH (PL13.2.5) and the FRONT COVER.
- 14) Remove the two screws (silver, with flange, tap, 10mm) that fix the left and right sides of the LATCH FRONT (PL13.2.4) to the FRONT COVER.
- 15) Slide the PLATE LATCH and LATCH FRONT to the left, and then remove the PLATE LATCH and LATCH FRONT from the FRONT COVER.

Continues to the next page.

Removal 56 OPERATOR PANEL (PL13.2.97)

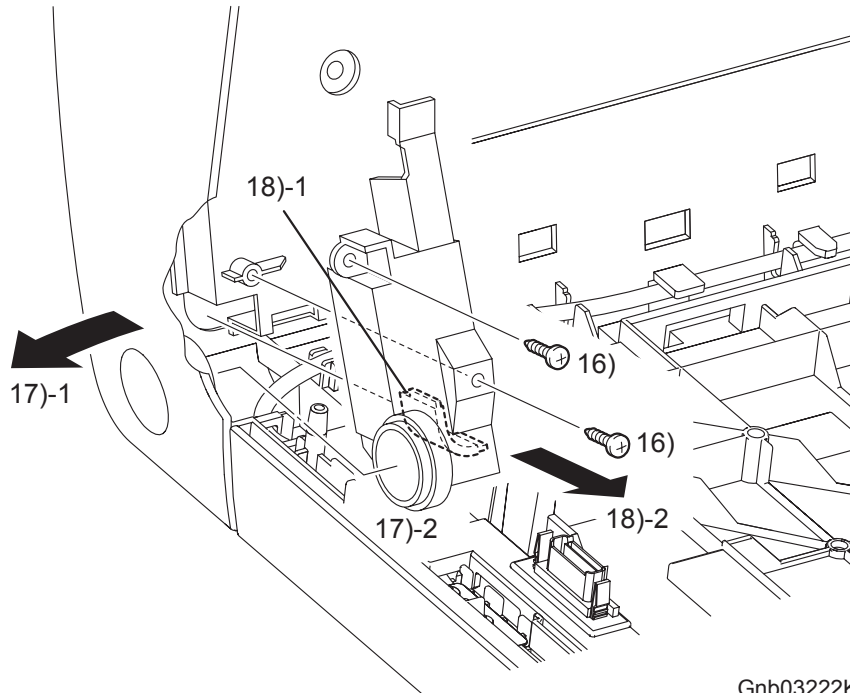

Gnb03222KA

- 16) Remove the two screws (silver, tap, 10mm) that fix the COVER HARNESS (PL13.2.11) to the FRONT COVER.
- 17) Release the rim of the BUTTON TOP from the FRONT COVER by spreading the FRONT COVER.
- 18) Remove the COVER HARNESS from the FRONT COVER by releasing the rim of the COVER HARNESS.

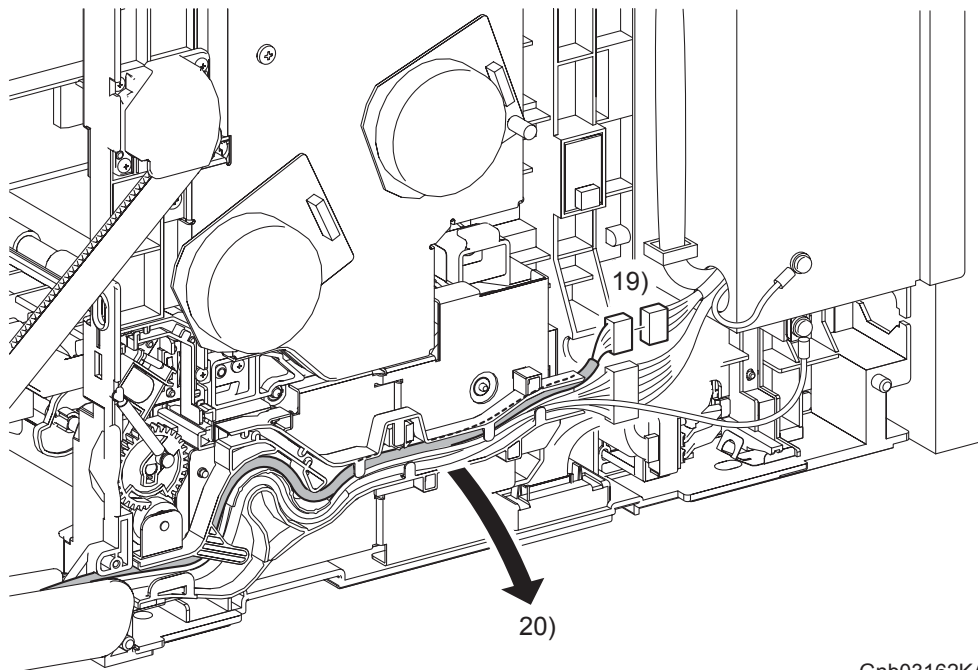

Gnb03162KA

- 19) Disengage the connector (P/J5301) of the HARNESS ASSY A-OP-OPP (PL13.2.24).
- 20) Release the HARNESS ASSY A-OP-OPP from the DUCT DRV PH (PL8.1.8).

Continues to the next page.

Removal 56 OPERATOR PANEL (PL13.2.97)

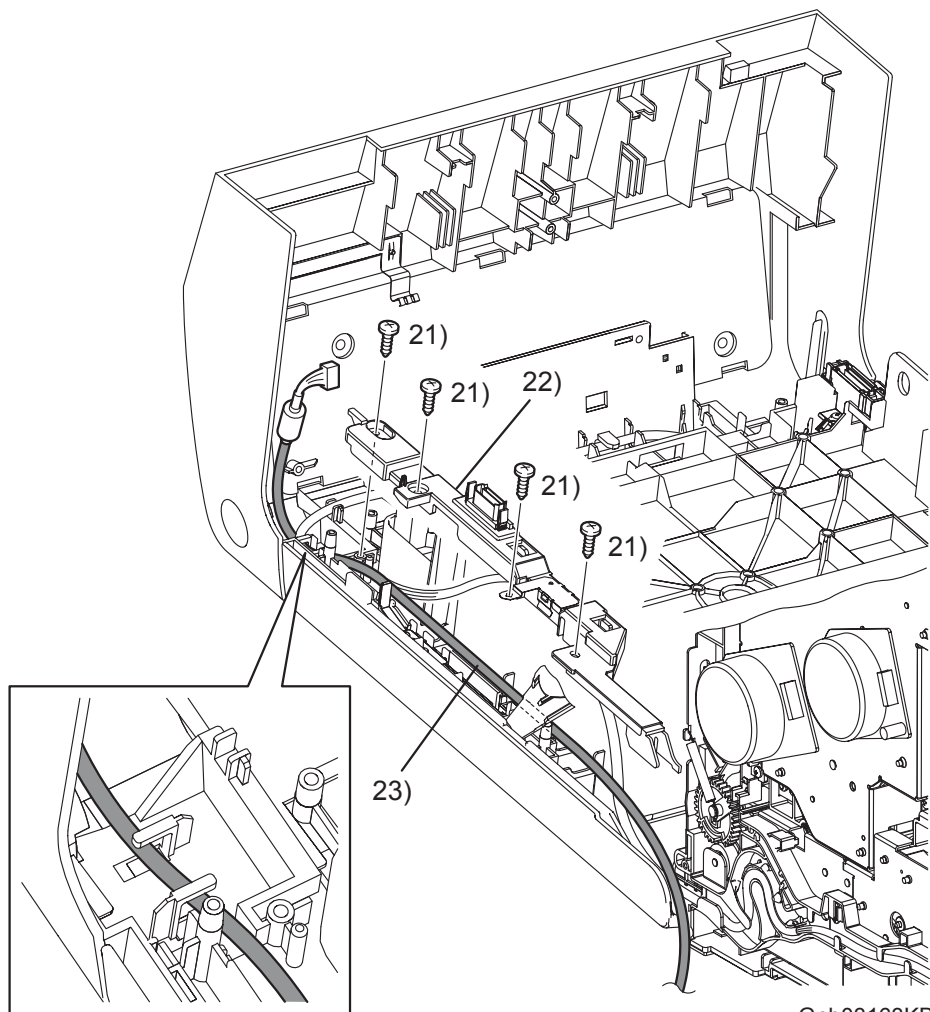

- 21) Remove the four screws (silver, tap, 8mm) that fix the COVER HARNESS (PL13.2.7) to the FRONT COVER.
- 22) Remove the COVER HARNESS from the FRONT COVER.
- 23) Remove the HARNESS ASSY A-OP-OPP from the FRONT COVER.

Removal 57 COVER POLE IN L (PL13.1.3)

Step 1 is for reference. Before removing this component, check that Step 1 has been performed.

- 1) Remove the COVER BOTTOM. (Removal 50)

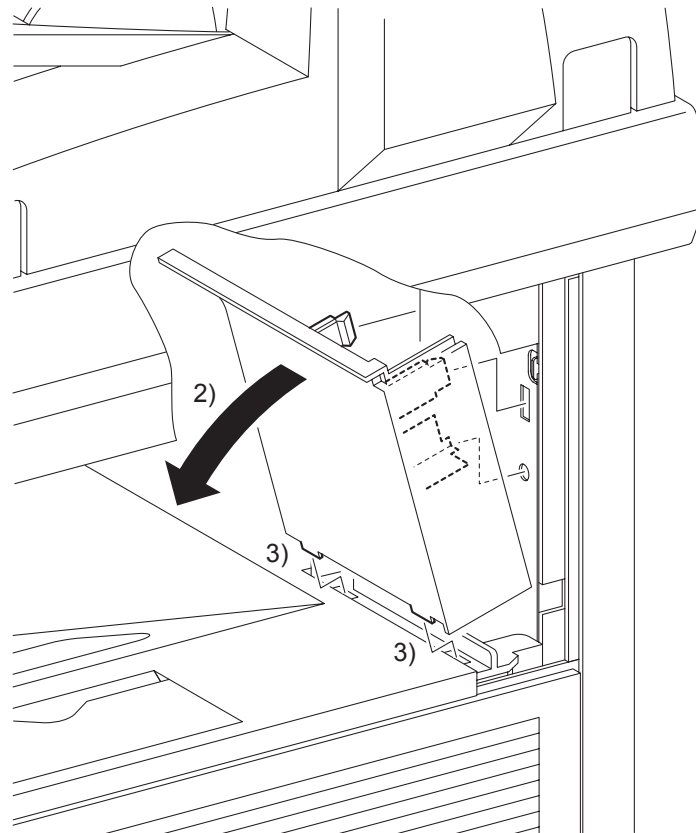

Gnb03164KA

- 2) Release the two hooks on the rear side of the COVER POLE IN L (PL13.1.3) from the printer by tilting the COVER POLE IN L inward.
- 3) Remove the COVER POLE IN L from the printer by releasing the two hooks on the underside of the COVER POLE IN L from the holes on the TOP COVER (PL13.1.1).

Go to the next removal step:

Removal 58 COVER POLE L (PL13.1.11)

Removal 58 COVER POLE L (PL13.1.11)

Steps 1 through 3 are for reference. Before removing this component, check that Steps 1 through 3 have been performed.

- 1) Remove the REAR COVER. (Removal 49)
- 2) Remove the COVER BOTTOM. (Removal 50)
- 3) Remove the COVER POLE IN L. (Removal 57)

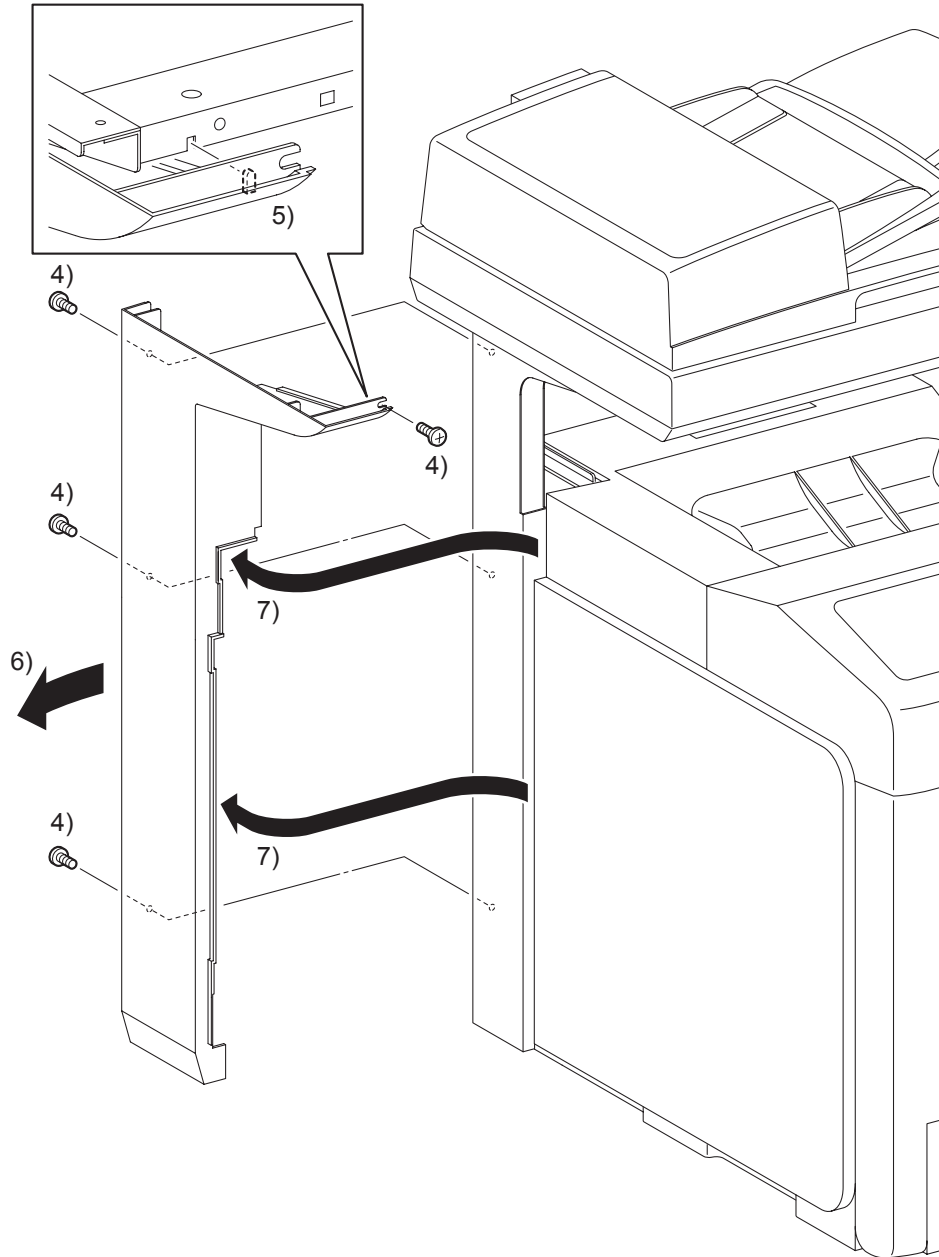

Gnb03165KA

- 4) Remove the four screws (silver, 6mm) that fix the COVER POLE L (PL13.1.11) to the printer.
- 5) Release from the printer the lugs on the screw mounting positions on the front section of the COVER POLE L.
- 6) Slide the rear section of the COVER POLE L outward.
- 7) Remove the COVER POLE L from the printer by releasing the rim on the front section of the COVER POLE L from the TOP COVER (PL13.1.1) and from the inside of the LEFT COVER (PL13.1.10).

Go to the next removal steps:

Removal 59 LEFT COVER (PL13.1.10) or Removal 60 BOX ASSY PRT AIO (PL13.4.13)

Removal 59 LEFT COVER (PL13.1.10)

Steps 1 through 6 are for reference. Before removing this component, check that Steps 1 through 6 have been performed.

- 1) Open FRONT COVER (PL13.2.1).
- 2) Remove the FUSER. (Removal 8)
- 3) Remove the REAR COVER. (Removal 49)
- 4) Remove the COVER BOTTOM. (Removal 50)
- 5) Remove the COVER POLE IN L. (Removal 57)
- 6) Remove the COVER POLE L. (Removal 58)

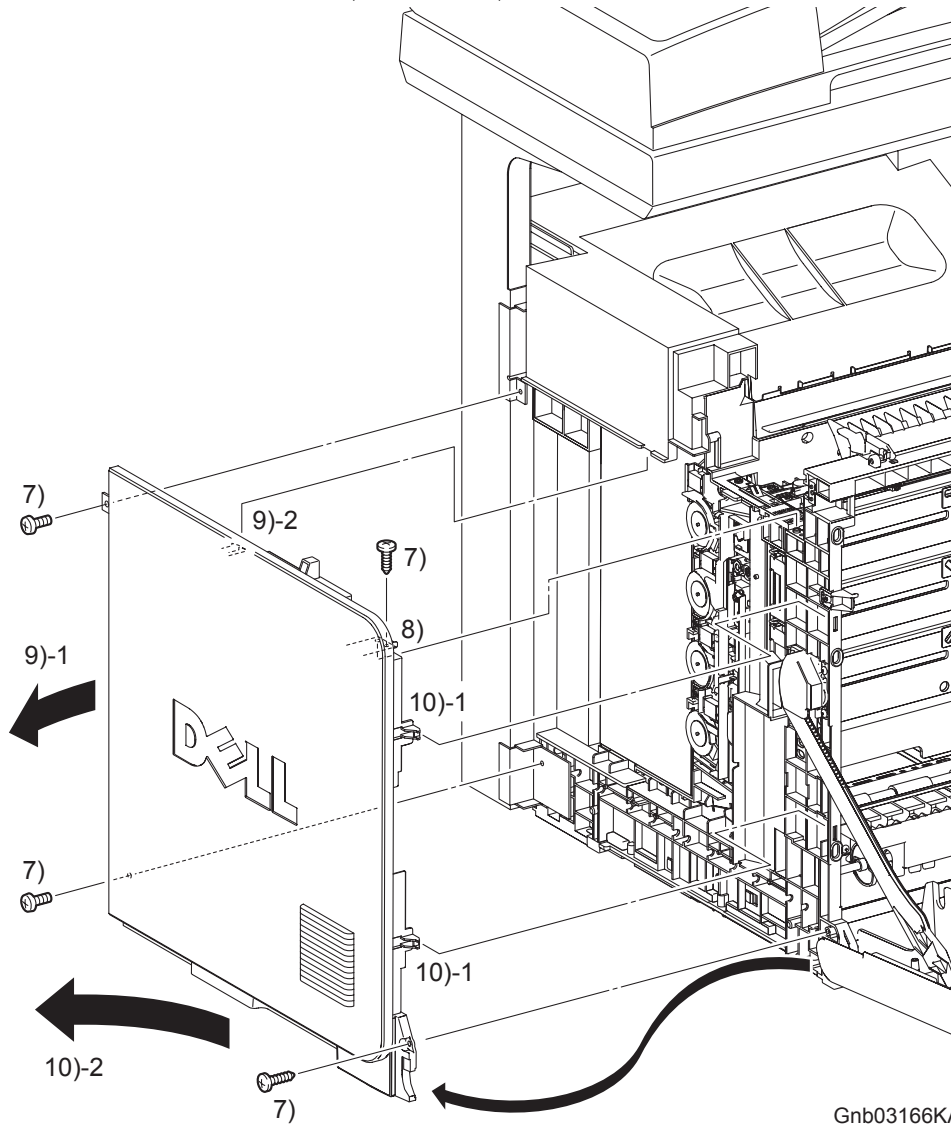

- 7) Remove the two screws (silver, tap, 10mm) and the two screws (silver, 6mm) that fix the LEFT COVER (PL13.1.10) to the printer.
- 8) Release the holes on the screw mounting positions of the top side of the LEFT COVER from the bosses on the printer.
- 9) Release from the printer the one hook on the rear side of the LEFT COVER by sliding the rear section of the LEFT COVER outward.
- 10) Release the two hooks on the front section of the LEFT COVER by sliding the LEFT COVER diagonally backward, and then remove the LEFT COVER.

Go to the next removal steps:

Removal 24 LEFT ARM ASSEMBLY (PL7.1.97), Removal 25 LED ASSEMBLY (PL5.1.15), Removal 26 TONER DISPENSER MOTOR (PL5.1.12), Removal 60 BOX ASSY PRT AIO (PL13.4.13) or Removal 68 TOP COVER (PL13.1.1)

Removal 60 BOX ASSY PRT AIO (PL13.4.13)

Steps 1 through 4 are for reference. Before removing this component, check that Steps 1 through 4 have been performed.

- 1) Remove the REAR COVER. (Removal 49)
- 2) Remove the COVER BOTTOM. (Removal 50)
- 3) Remove the COVER POLE IN L. (Removal 57)
- 4) Remove the COVER POLE L. (Removal 58)

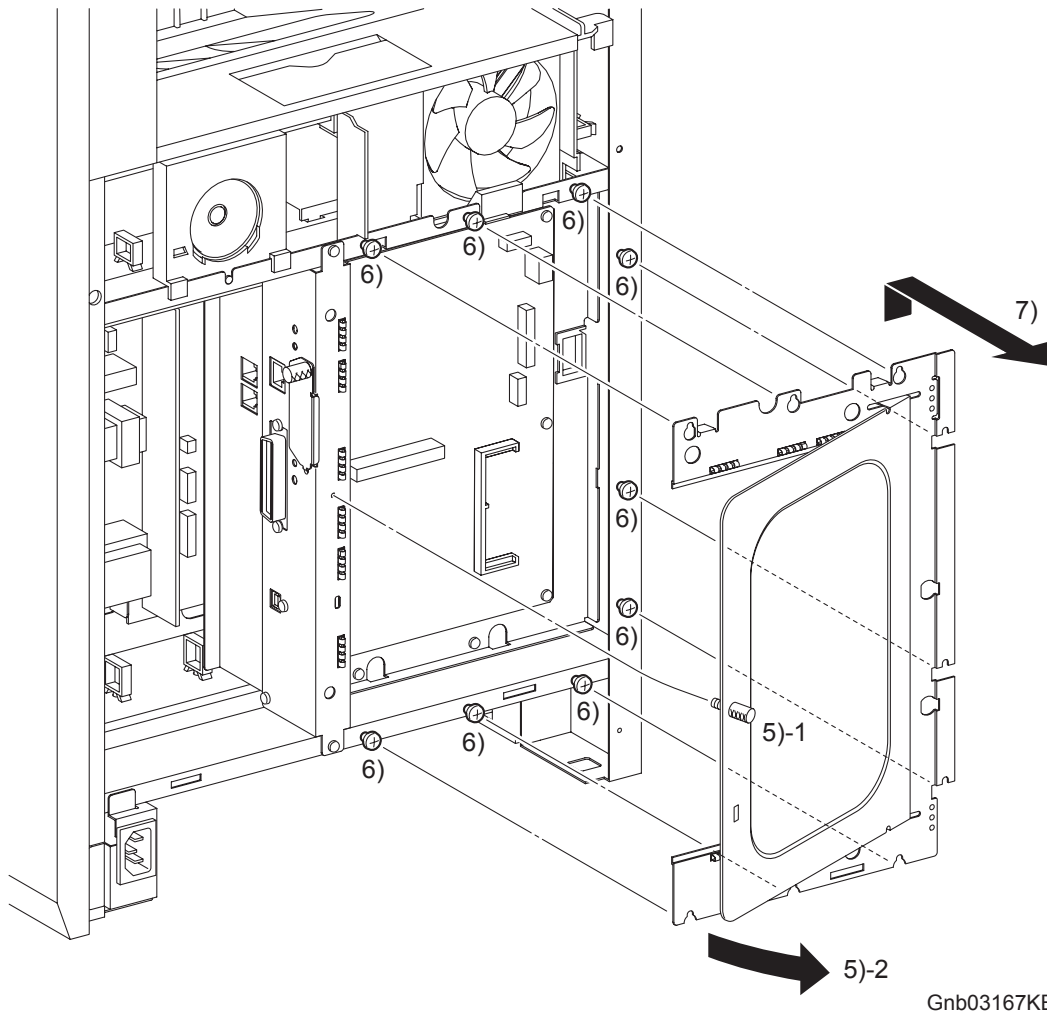

- 5) Loosen the SCREW KNURLING (PL13.4.12), and then open the PLATE WINDOW ESS (PL13.4.10).
- 6) Loosen the nine screws that fix the SHIELD ASSY ESS WINDOW (PL13.4.7) to the printer.
- 7) Remove the SHIELD ASSY ESS WINDOW from the printer by sliding the SHIELD slightly upward until the U-shaped grooves on the SHIELD ASSY ESS WINDOW are disengaged from the nine screws.

Continues to the next page.

Removal 60 BOX ASSY PRT AIO (PL13.4.13)

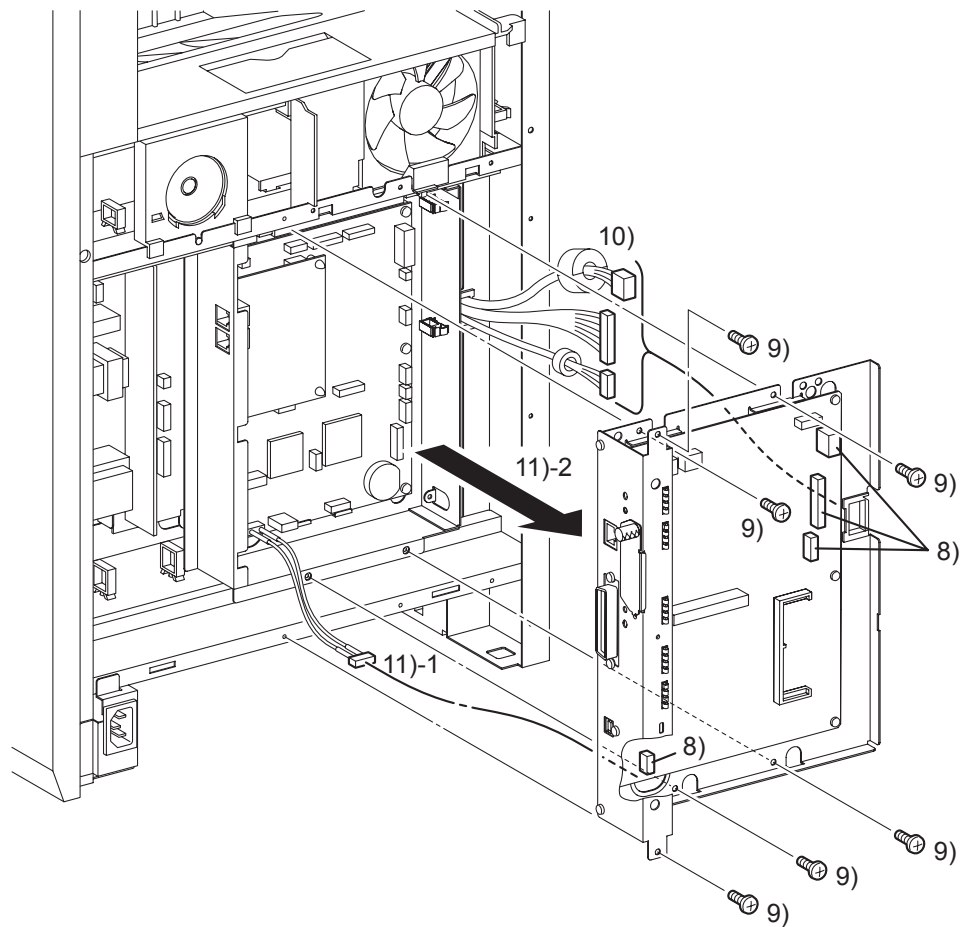

Gnb03168KB

- 8) Disengage all the connectors of the ELECTRONIC SUB-SYSTEM CONTROL BOARD (PL13.4.20).
- 9) Remove the six screws (silver,6mm) that fix the BOX ASSY PRT AIO (PL13.4.13) to the printer.
- 10) Pull out the BOX ASSY PRT AIO slightly forward, and then release the three harnesses on the right from the CLAMP SADDLE LES-1017 (PL13.4.19).
- 11) Disengage the connector of the HARNESS ASSY AIO-ESS (PL13.6.14) from the ELECTRONIC SUB-SYSTEM CONTROL BOARD. Remove from the printer the BOX ASSY PRT AIO together with the ELECTRONIC SUB-SYSTEM CONTROL BOARD while pulling out the HARNESS ASSY AIO-ESS through the hole on the BOX ASSY PRT AIO.

Go to the next removal steps:

Removal 61 ELECTRONIC SUB-SYSTEM CONTROL BOARD (PL13.4.20), Removal 62 BOX ASSY FAX AIO (PL13.4.4), Removal 63 PWBA FAX (PL13.4.3), Removal 69 SPEAKER ASSY (PL13.5.6) or Removal 72 ADF SCANNER ASSY (PL13.8.1)

Removal 61 ELECTRONIC SUB-SYSTEM CONTROL BOARD (PL13.4.20)

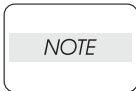

Use a wristband to protect the PWB from electrostatic damage.

Steps 1 through 5 are for reference. Before removing this component, check that Steps 1 through 5 have been performed.

- 1) Remove the REAR COVER. (Removal 49)
- 2) Remove the COVER BOTTOM. (Removal 50)
- 3) Remove the COVER POLE IN L. (Removal 57)
- 4) Remove the COVER POLE L. (Removal 58)
- 5) Remove the BOX ASSY PRT AIO. (Removal 60)

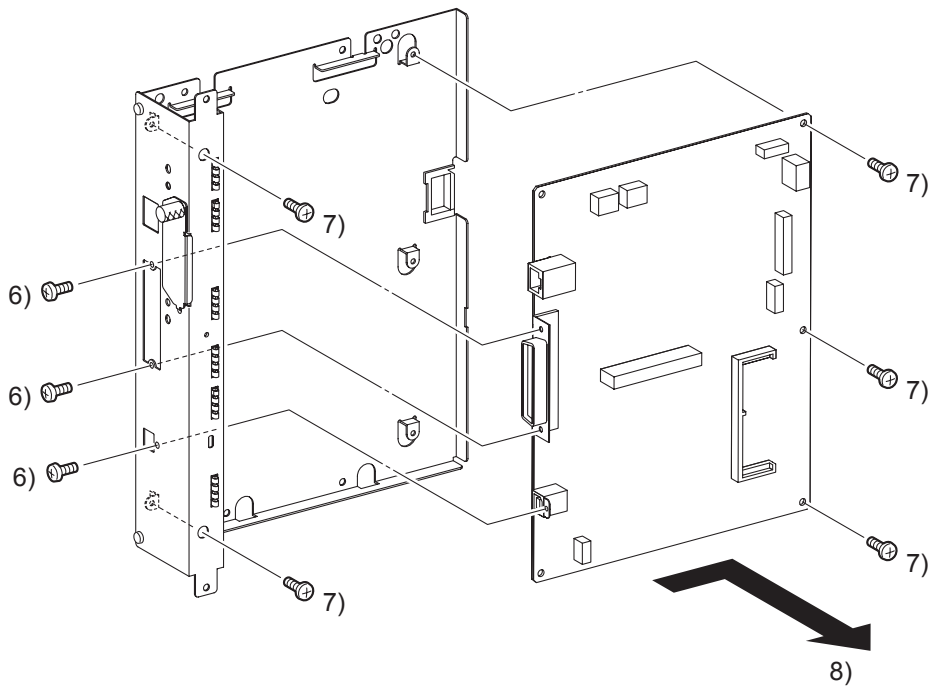

Gnb03169KB

- 6) Remove the three screws (silver, 6mm) that fix the connector section of the ELECTRONIC SUB-SYSTEM CONTROL BOARD (PL13.4.20) to the BOX ASSY PRT AIO (PL13.4.13).
- 7) Remove the five screws (silver, 6mm) that fix the ELECTRONIC SUB-SYSTEM CONTROL BOARD to the BOX ASSY PRT AIO.
- 8) Remove the ELECTRONIC SUB-SYSTEM CONTROL BOARD from the BOX ASSY PRT AIO.

Removal 62 BOX ASSY FAX AIO (PL13.4.4)

Steps 1 through 5 are for reference. Before removing this component, check that Steps 1 through 5 have been performed.

- 1) Remove the REAR COVER. (Removal 49)
- 2) Remove the COVER BOTTOM. (Removal 50)
- 3) Remove the COVER POLE IN L. (Removal 57)
- 4) Remove the COVER POLE L. (Removal 58)
- 5) Remove the BOX ASSY PRT AIO. (Removal 60)

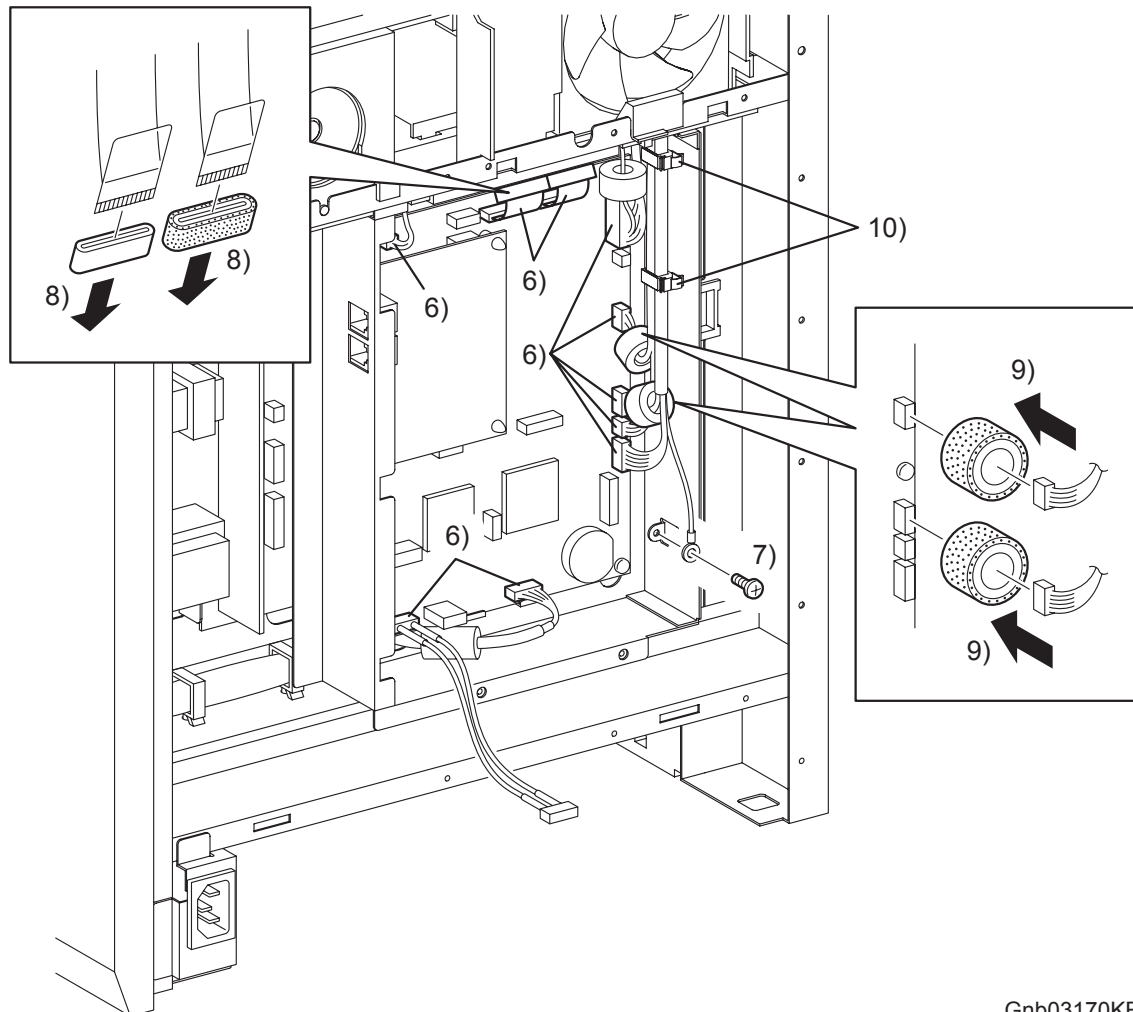

Gnb03170KB

- 6) Disengage all the connectors of the PWBA HYUI (PL13.4.1).
- 7) Remove the one screw (silver, 6mm) that fixes the ground wire of the ADF SCANNER ASSY (PL13.8.1) to the BOX ASSY FAX AIO (PL.13.4.4).
- 8) Remove the CORE FCR27-12-1.3 (PL13.8.13) and the CORE ASSY FCR27 (PL13.8.12) from the two flat cables.
- 9) Remove the two CORE ASSY SC-18 (PL13.8.14) on the connectors (J62, J63) from the harness.
- 10) Release the harnesses from the clamps.

Continues to the next page.

Removal 62 BOX ASSY FAX AIO (PL13.4.4)

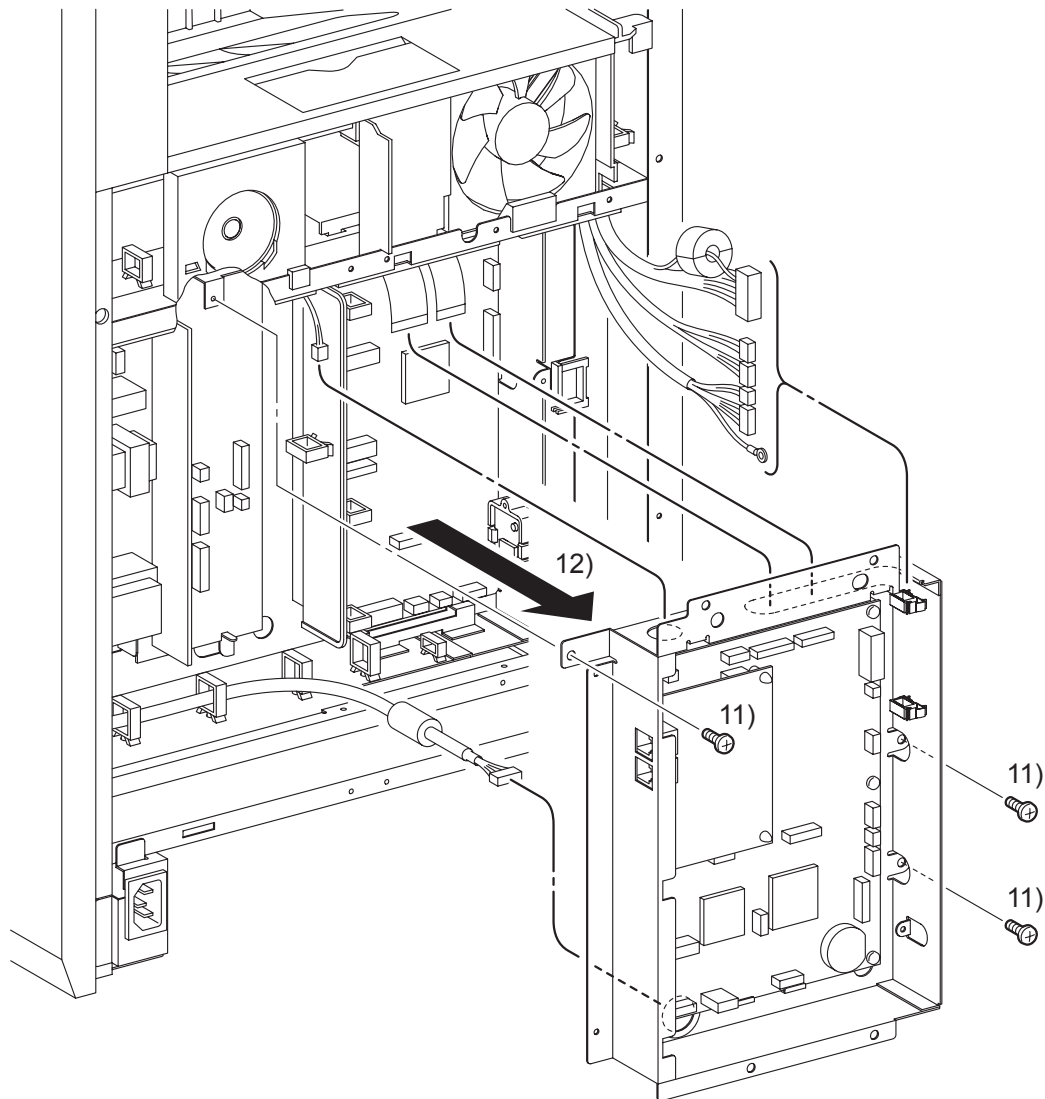

Gnb03171KB

- 11) Remove the three screws (silver, 6mm) that fix the BOX ASSY FAX AIO to the printer.
- 12) Remove from the printer the BOX ASSY FAX AIO together with the PWBA HYUI and PWBA FAX (PL13.4.2) while pulling out the harnesses through the hole on the BOX ASSY FAX AIO.

Go to the next removal steps:

Removal 63 PWBA FAX (PL13.4.3), Removal 64 PWBA HYUI (PL13.4.1), Removal 65 LOW VOLTAGE POWER SUPPLY (PL13.5.14), Removal 66 HUMIDITY SENSOR (PL13.5.11), Removal 70 INTERLOCK SWITCH (PL13.5.3) or Removal 71 FAN (PL13.5.10)

Removal 63 PWBA FAX (PL13.4.3)

Steps 1 through 5 are for reference. Before removing this component, check that Steps 1 through 5 have been performed.

- 1) Remove the REAR COVER. (Removal 49)
- 2) Remove the COVER BOTTOM. (Removal 50)
- 3) Remove the COVER POLE IN L. (Removal 57)
- 4) Remove the COVER POLE L. (Removal 58)
- 5) Remove the BOX ASSY PRT AIO. (Removal 60)

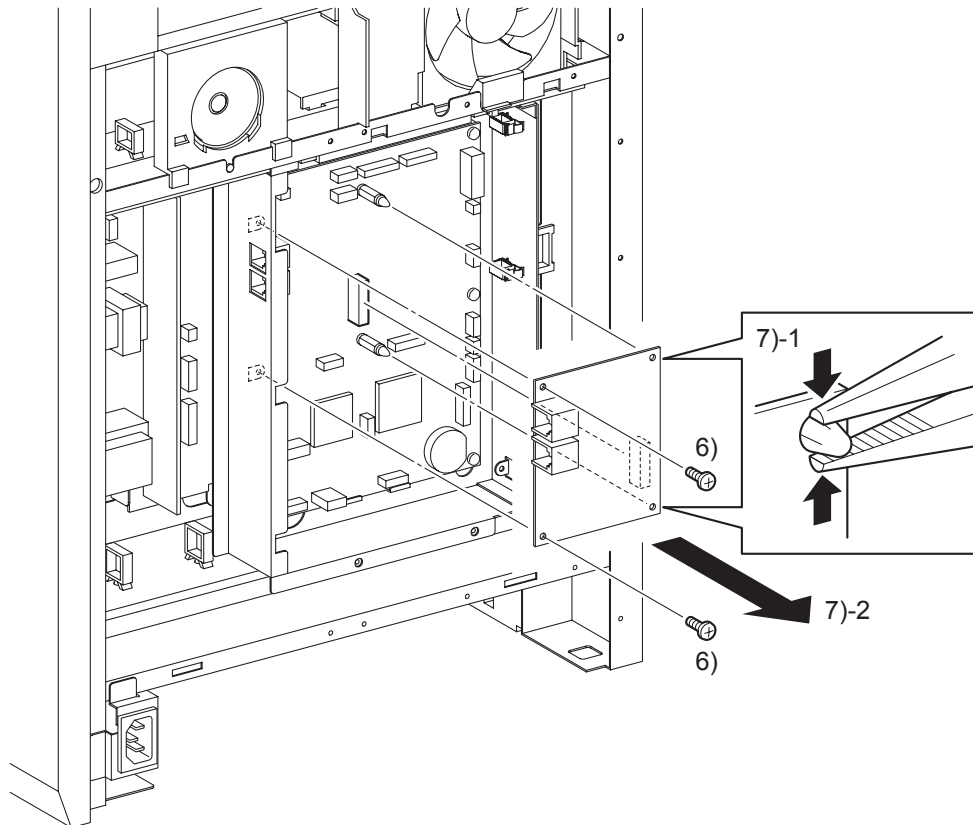

Gnb03172KA

- 6) Remove the two screws (silver, 6mm) that fix the PWBA FAX (PL13.4.3) to the BOX ASSY FAX AIO (PL13.4.4).
- 7) Remove the PWBA FAX from the PWBA HYUI (PL.13.4.1) by releasing the hooks on the SUPPORT FAXs (PL13.4.2).

Removal 64 PWBA HYUI (PL13.4.1)

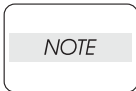

Use a wristband to protect the PWB from electrostatic damage.

Steps 1 through 7 are for reference. Before removing this component, check that Steps 1 through 7 have been performed.

- 1) Remove the REAR COVER. (Removal 49)
- 2) Remove the COVER BOTTOM. (Removal 50)
- 3) Remove the COVER POLE IN L. (Removal 57)
- 4) Remove the COVER POLE L. (Removal 58)
- 5) Remove the BOX ASSY PRT AIO. (Removal 60)
- 6) Remove the BOX ASSY FAX AIO. (Removal 62)
- 7) Remove the PWBA FAX. (Removal 63)

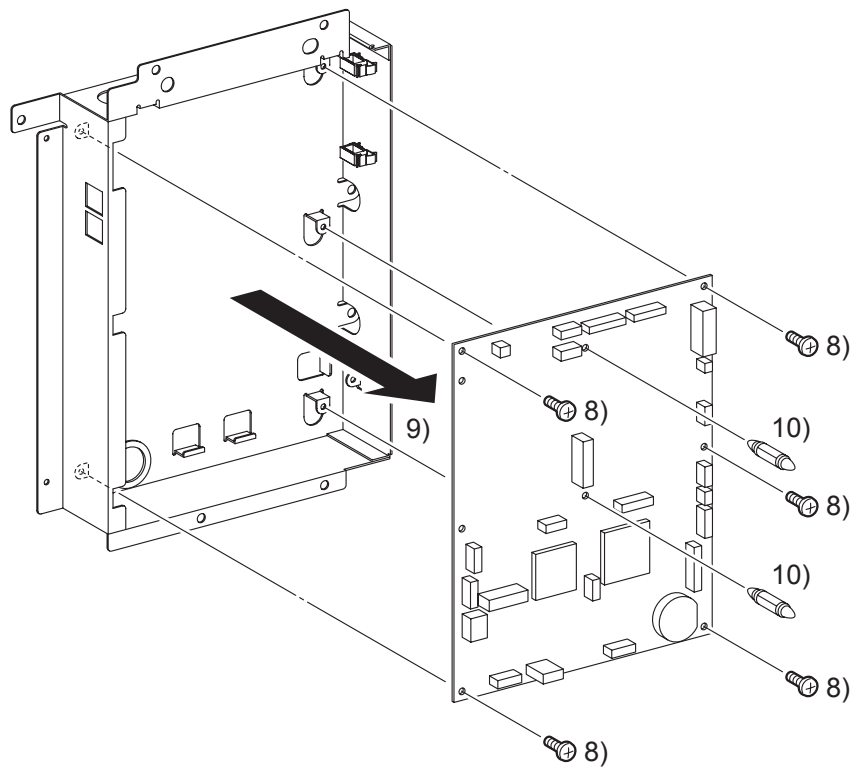

- 8) Remove the five screws (silver, 6mm) that fix the PWBA HYUI (PL13.4.1) to the BOX ASSY FAX AIO (PL13.4.4).
- 9) Remove the PWBA HYUI from the BOX ASSY FAX AIO.
- 10) Remove the SUPPORT FAXs (PL13.4.2) from the PWBA HYUI by releasing the hooks.

Removal 65 LOW VOLTAGE POWER SUPPLY (PL13.5.14)

Steps 1 through 6 are for reference. Before removing this component, check that Steps 1 through 6 have been performed.

- 1) Remove the REAR COVER. (Removal 49)
- 2) Remove the COVER BOTTOM. (Removal 50)
- 3) Remove the COVER POLE IN L. (Removal 57)
- 4) Remove the COVER POLE L. (Removal 58)
- 5) Remove the BOX ASSY PRT AIO. (Removal 60)
- 6) Remove the BOX ASSY FAX AIO. (Removal 62)

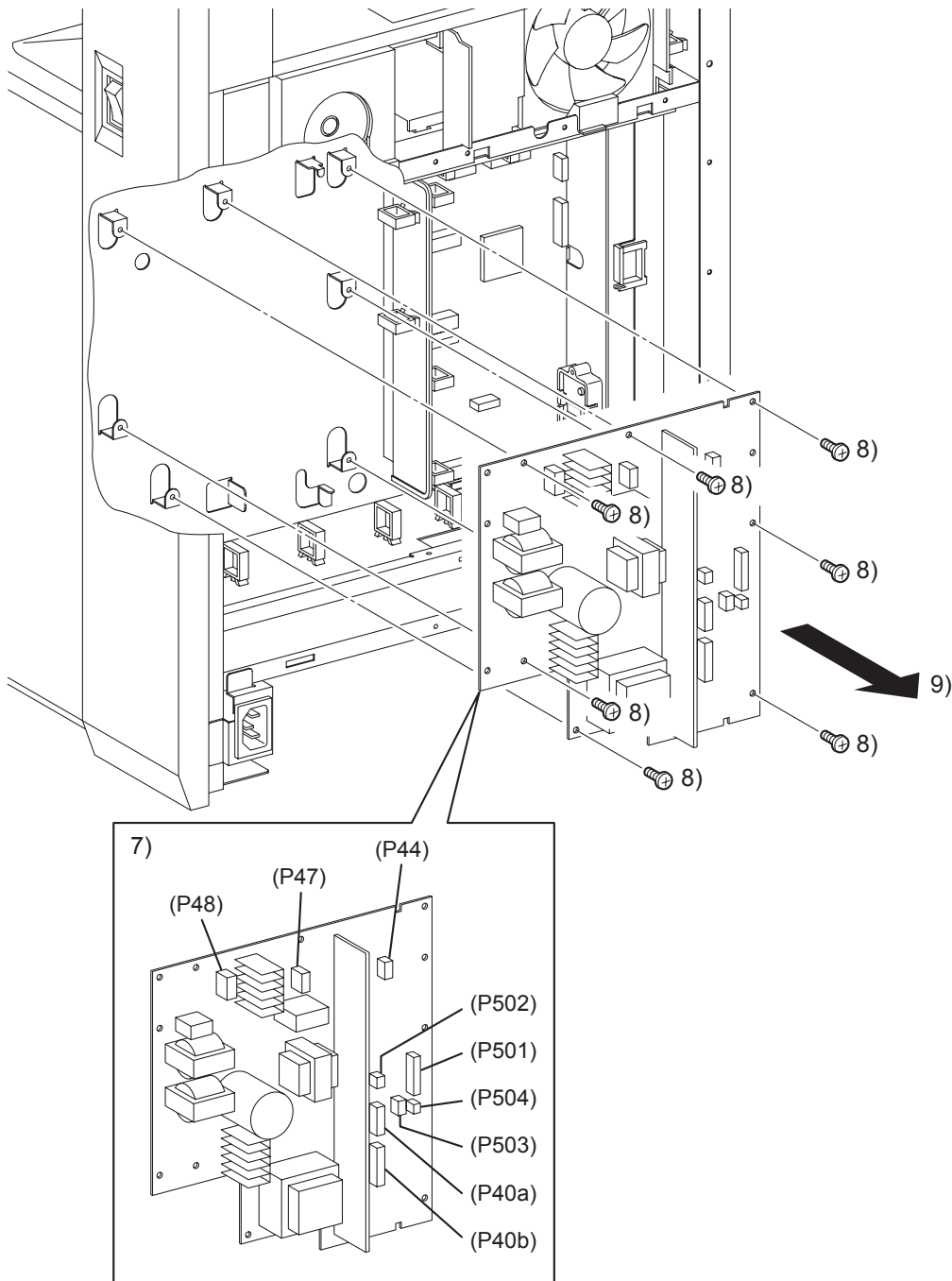

Gnb03174KA

- 7) Disengage all the connectors of the LOW VOLTAGE POWER SUPPLY (PL13.5.14).
- 8) Remove the seven screws (silver, 6mm) that fix the LOW VOLTAGE POWER SUPPLY to the printer.
- 9) Remove the LOW VOLTAGE POWER SUPPLY from the printer.

Removal 66 HUMIDITY SENSOR (PL13.5.11)

Steps 1 through 9 are for reference. Before removing this component, check that Steps 1 through 9 have been performed.

- 1) Open the FRONT COVER (PL13.2.1).
- 2) Remove the FUSER. (Removal 8)
- 3) Remove the REAR COVER. (Removal 49)
- 4) Remove the COVER BOTTOM. (Removal 50)
- 5) Remove the COVER POLE IN L. (Removal 57)
- 6) Remove the COVER POLE L. (Removal 58)
- 7) Remove the LEFT COVER. (Removal 59)
- 8) Remove the BOX ASSY PRT AIO. (Removal 60)
- 9) Remove the BOX ASSY FAX AIO. (Removal 62)

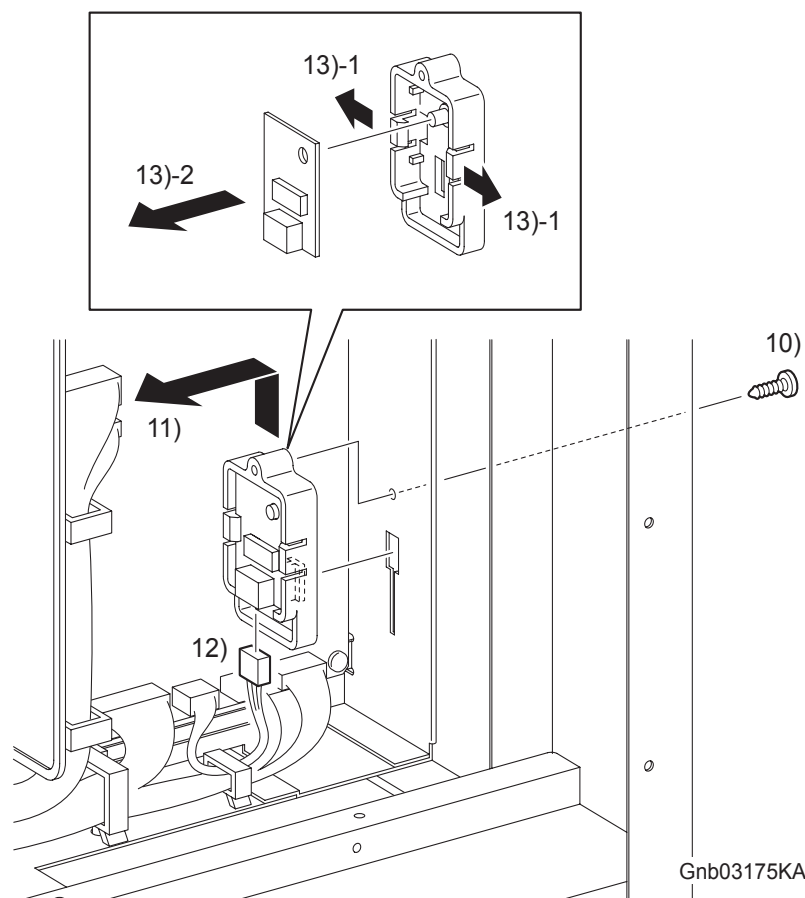

- 10) Remove the one screw (silver, tap, 10mm) that fixes the BRACKET SENSOR HUM (PL13.5.12) to the printer.
- 11) Remove the BRACKET SENSOR HUM together with the HUMIDITY SENSOR (PL13.5.11) by sliding the BRACKET SENSOR HUM upward until its hooks are released from the holes on the printer.
- 12) Disengage the connector (P/J261) of the HUMIDITY SENSOR.
- 13) Remove the HUMIDITY SENSOR from the BRACKET SENSOR HUM by releasing the hooks on the BRACKET SENSOR HUM.

Go to the next removal step:

Removal 67 MACHINE CONTROL UNIT (PL13.5.13)

Removal 67 MACHINE CONTROL UNIT (PL13.5.13)

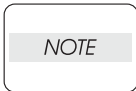

Never fail to perform the diagnostic operation described below. Otherwise the data will be lost in the worst case.

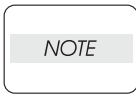

Use a wristband to protect the PWB from electrostatic damage.

- 1) Perform NVM Save to evacuate the MCU data.
- 2) Turn on the power while pressing the ► key, ◀ key, and [MENU] key on the control panel.
- 3) Enter the password, press the ▲ key twice, and press the ✓ key once. The diagnostic screen comes up.
- 4) Press the ▼ key several times until " IOT Diag "is displayed. Press the ✓ key once.
- 5) Press the ▼ key several until " NVM Settings "is displayed. Press the ✓ key once.
- 6) Press the ▼ key several times until " NVM Save "is displayed. Press the ✓ key once.
- 7) Press the ✓ key twice, and NVM Save is performed.
- 8) After NVM Save is complete, press the [CANCEL] key several times until " IOT Diag "is displayed.
- 9) Press the ▼ key several times until " Complete "is displayed.
- 10) Press the ✓ key three times. " Ready to Print "is displayed.
- 11) Turn off the power.
- 12) Remove the POWER CORD from the AC outlet.

Steps 13 through 22 are for reference. Before removing this component, check that Steps 13 through 22 have been performed.

- 13) Open the FRONT COVER (PL13.2.1).
- 14) Remove the FUSER. (Removal 8)
- 15) Remove the REAR COVER. (Removal 49)
- 16) Remove the COVER BOTTOM. (Removal 50)
- 17) Remove the COVER POLE IN L. (Removal 57)
- 18) Remove the COVER POLE L. (Removal 58)
- 19) Remove the LEFT COVER. (Removal 59)
- 20) Remove the BOX ASSY PRT AIO. (Removal 60)
- 21) Remove the BOX ASSY FAX AIO. (Removal 62)
- 22) Remove the HUMIDITY SENSOR. (Removal 66)

Continues to the next page.

Removal 67 MACHINE CONTROL UNIT (PL13.5.13)

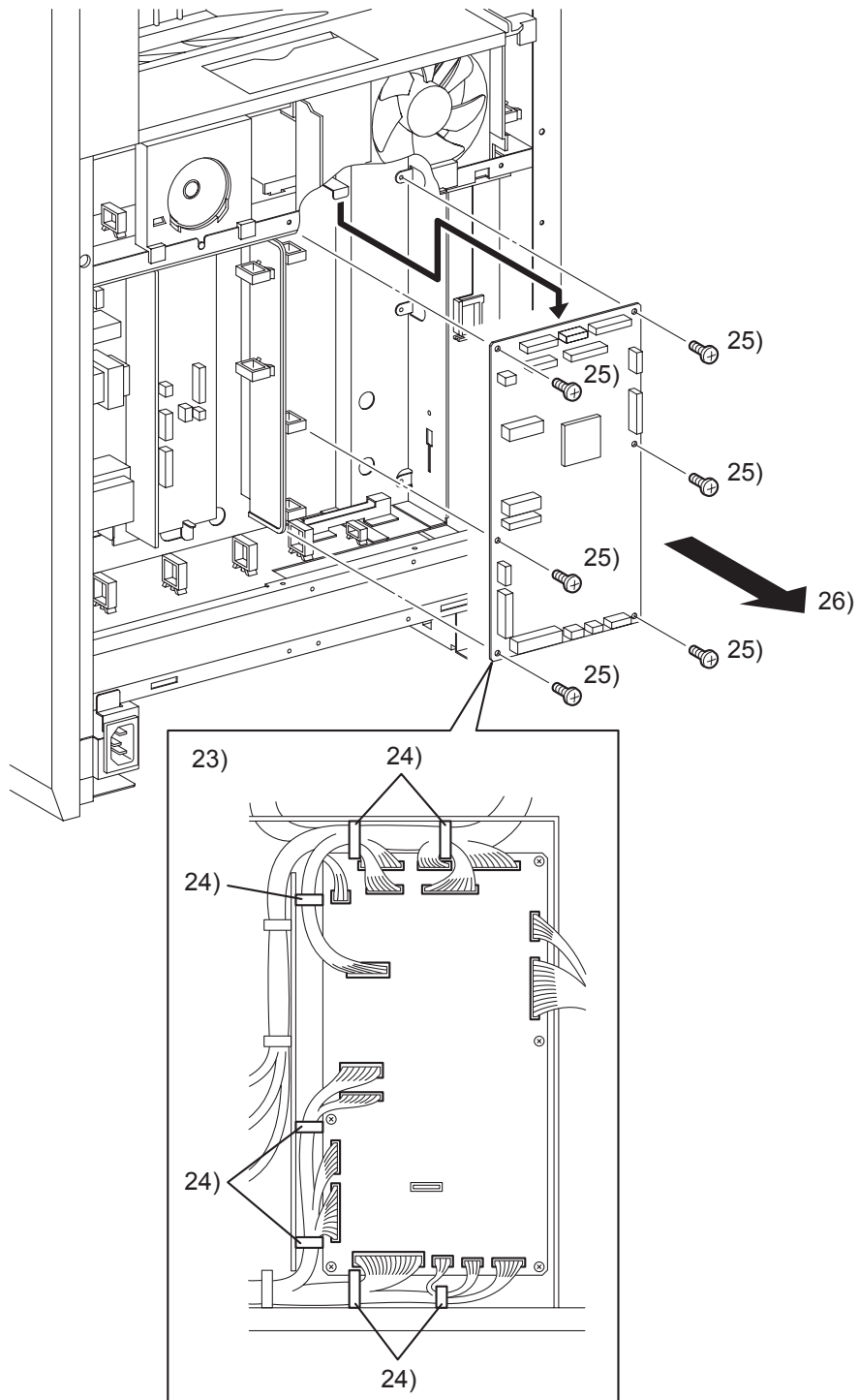

Gnb03176KA

- 23) Disengage all the connectors of the MACHINE CONTROL UNIT (PL13.5.13).
- 24) Release the harnesses from the clamps.
- 25) Remove the six screws (silver, 6mm) that fix the MACHINE CONTROL UNIT to the printer.
- 26) Remove the MACHINE CONTROL UNIT from the printer.

Removal 68 TOP COVER (PL13.1.1)

Steps 1 through 10 are for reference. Before removing this component, check that Steps 1 through 10 have been performed.

- 1) Open the FRONT COVER (PL13.2.1).
- 2) Remove the FUSER.(Removal 8)
- 3) Remove the REAR COVER. (Removal 49)
- 4) Remove the COVER BOTTOM. (Removal 50)
- 5) Remove the COVER POLE IN R.(Removal 51)
- 6) Remove the COVER POLE R.(Removal 52)
- 7) Remove the RIGHT COVER. (Removal 54)
- 8) Remove the COVER POLE IN L. (Removal 57)
- 9) Remove the COVER POLE L. (Removal 58)
- 10) Remove the LEFT COVER. (Removal 59)

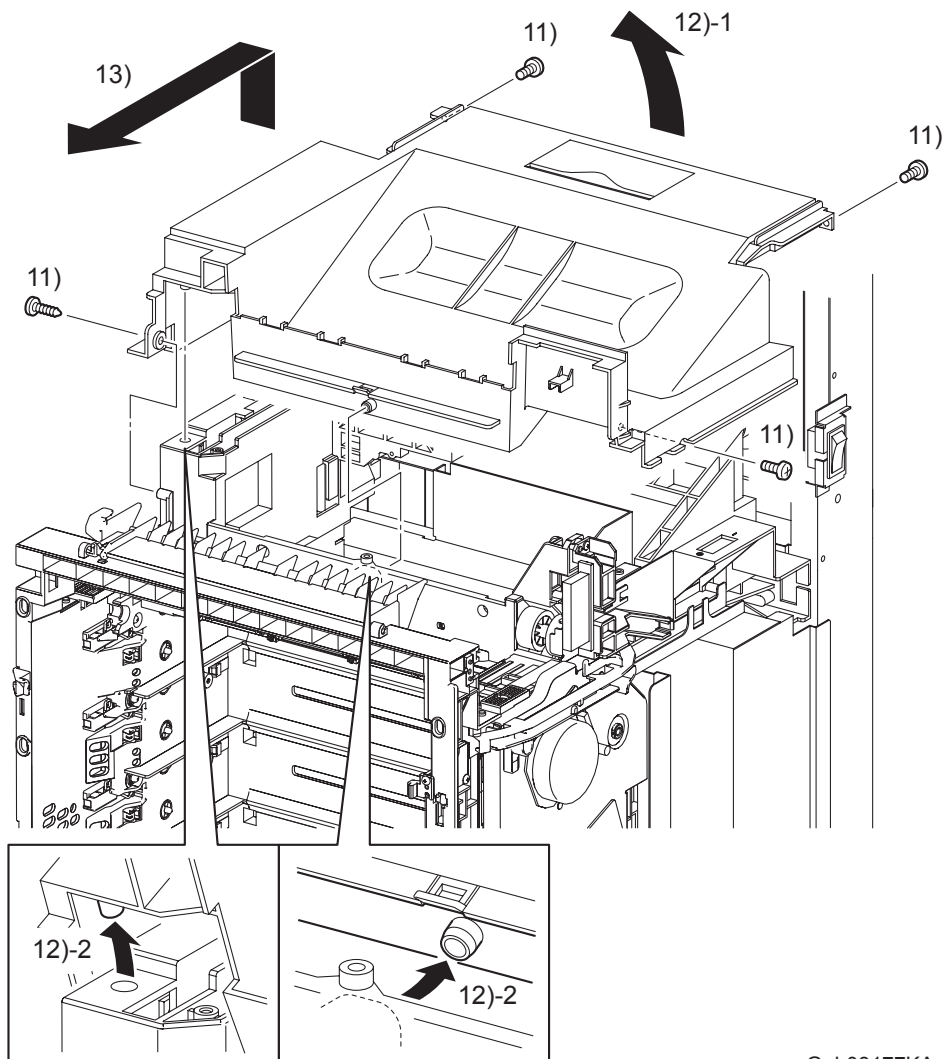

Gnb03177KA

- 11) Remove the three screws (silver, 6mm) and the one screw (silver, tap, 8mm) that fix the TOP COVER (PL13.1.1) to the printer.
- 12) Lift the rear end of the TOP COVER to release the two bosses on the center front and the left front on the TOP COVER from the hook and hole on the printer.
- 13) Lift the TOP COVER and slide it forward. Remove the TOP COVER from the printer.

Go to the next removal steps:

Removal 60 BOX ASSY PRT AIO (PL13.4.13) or Removal 70 INTERLOCK SWITCH (PL13.5.3)

Removal 69 SPEAKER ASSY (PL13.5.6)

Steps 1 through 12 are for reference. Before removing this component, check that Steps 1 through 12 have been performed.

- 1) Open the FRONT COVER (PL13.2.1).
- 2) Remove the FUSER.(Removal 8)
- 3) Remove the REAR COVER. (Removal 49)
- 4) Remove the COVER BOTTOM. (Removal 50)
- 5) Remove the COVER POLE IN R.(Removal 51)
- 6) Remove the COVER POLE R.(Removal 52)
- 7) Remove the RIGHT COVER. (Removal 54)
- 8) Remove the COVER POLE IN L. (Removal 57)
- 9) Remove the COVER POLE L. (Removal 58)
- 10) Remove the LEFT COVER. (Removal 59)
- 11) Remove the TOP COVER. (Removal 68)
- 12) Remove the BOX ASSY PRT AIO. (Removal 60)

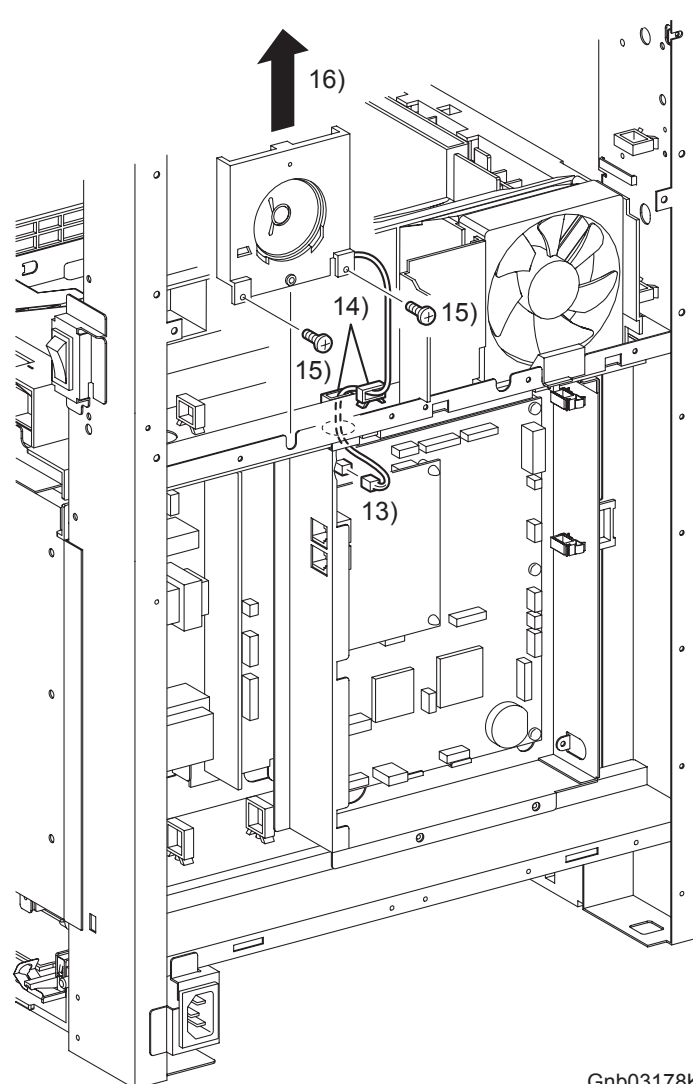

Gnb03178KA

- 13) Disengage the connector (P/J52) of the SPEAKER ASSY (PL13.5.6) from the PWBA HYUI (PL.13.4.1).
- 14) Release the harness of the SPEAKER ASSY from the two clamps and pull them out of the hole on the printer.
- 15) Remove the two screws (silver, 6mm) that fix the SPEAKER ASSY to the printer.
- 16) Remove the SPEAKER ASSY from the printer by sliding it upward.

Removal 70 INTERLOCK SWITCH (PL13.5.3)

Steps 1 through 13 are for reference. Before removing this component, check that Steps 1 through 13 have been performed.

- 1) Open the FRONT COVER (PL13.2.1).
- 2) Remove the FUSER.(Removal 8)
- 3) Remove the REAR COVER. (Removal 49)
- 4) Remove the COVER BOTTOM. (Removal 50)
- 5) Remove the COVER POLE IN R.(Removal 51)
- 6) Remove the COVER POLE R.(Removal 52)
- 7) Remove the RIGHT COVER. (Removal 54)
- 8) Remove the COVER POLE IN L. (Removal 57)
- 9) Remove the COVER POLE L. (Removal 58)
- 10) Remove the LEFT COVER. (Removal 59)
- 11) Remove the TOP COVER. (Removal 68)
- 12) Remove the BOX ASSY PRT AIO. (Removal 60)
- 13) Remove the BOX ASSY FAX AIO. (Removal 62)

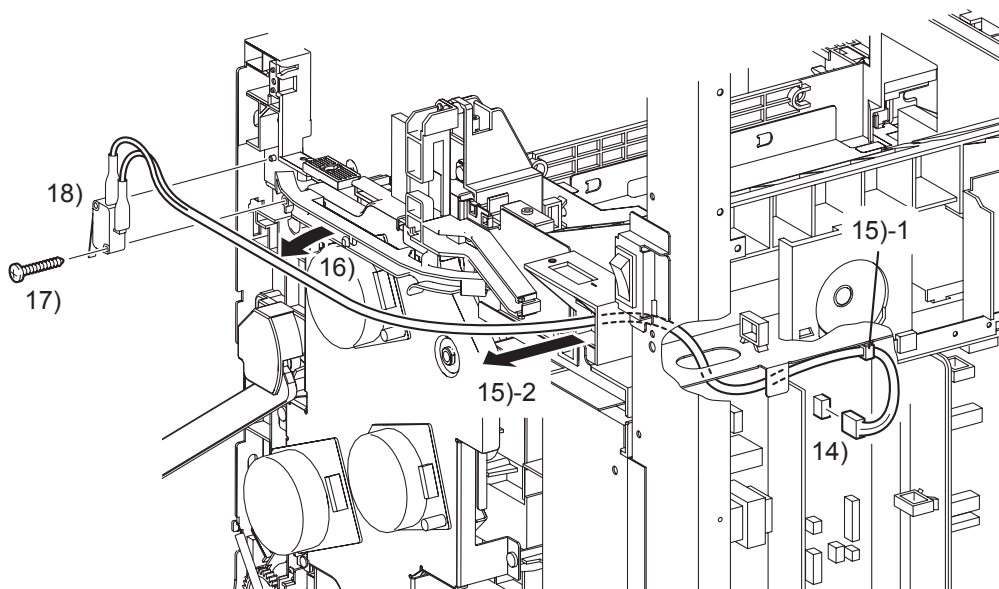

Gnb03179KA

- 14) Disengage the connector (P/J44) of the INTERLOCK SWITCH (PL13.5.3) from the LOW VOLTAGE POWER SUPPLY (PL13.5.14).
- 15) Release the harness of the INTERLOCK SWITCH from the one clamp and pull it out of the hole on the printer.
- 16) Remove the harness of the INTERLOCK SWITCH from the DUCT DRV MAIN.
- 17) Remove the one screw (silver, tap, 16mm) that fixes the INTERLOCK SWITCH to the printer.
- 18) Remove the INTERLOCK SWITCH.

Removal 71 FAN (PL13.5.10)

Steps 1 through 13 are for reference. Before removing this component, check that Steps 1 through 13 have been performed.

- 1) Open the FRONT COVER (PL13.2.1).
- 2) Remove the FUSER.(Removal 8)
- 3) Remove the REAR COVER. (Removal 49)
- 4) Remove the COVER BOTTOM. (Removal 50)
- 5) Remove the COVER POLE IN R.(Removal 51)
- 6) Remove the COVER POLE R.(Removal 52)
- 7) Remove the RIGHT COVER. (Removal 54)
- 8) Remove the COVER POLE IN L. (Removal 57)
- 9) Remove the COVER POLE L. (Removal 58)
- 10) Remove the LEFT COVER. (Removal 59)
- 11) Remove the TOP COVER. (Removal 68)
- 12) Remove the BOX ASSY PRT AIO. (Removal 60)
- 13) Remove the BOX ASSY FAX AIO. (Removal 62)

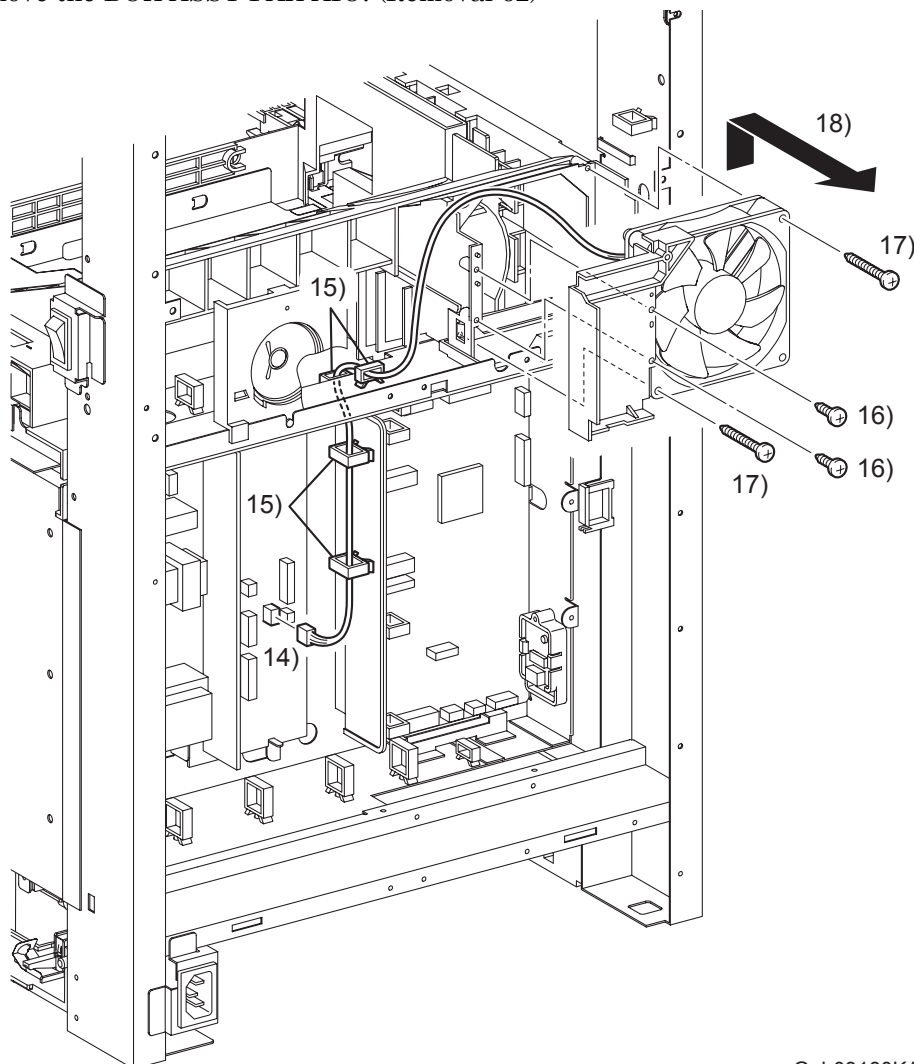

Gnb03180KA

- 14) Disengage the connector (P/J503) of the FAN (PL13.5.10) from the LOW VOLTAGE POWER SUPPLY (PL13.5.14).
- 15) Release the harness of the FAN from the four clamps and pull it out of the hole on the printer.
- 16) Remove the two screws (silver, tap, 8mm) that fix the PLATE DUCT (PL13.5.9) to the printer.
- 17) Remove the two screws (silver, tap, 32mm) that fix the FAN to the printer.
- 18) Remove the PLATE DUCT and FAN from the printer.

Continues to the next page.

Removal 71 FAN (PL13.5.10)

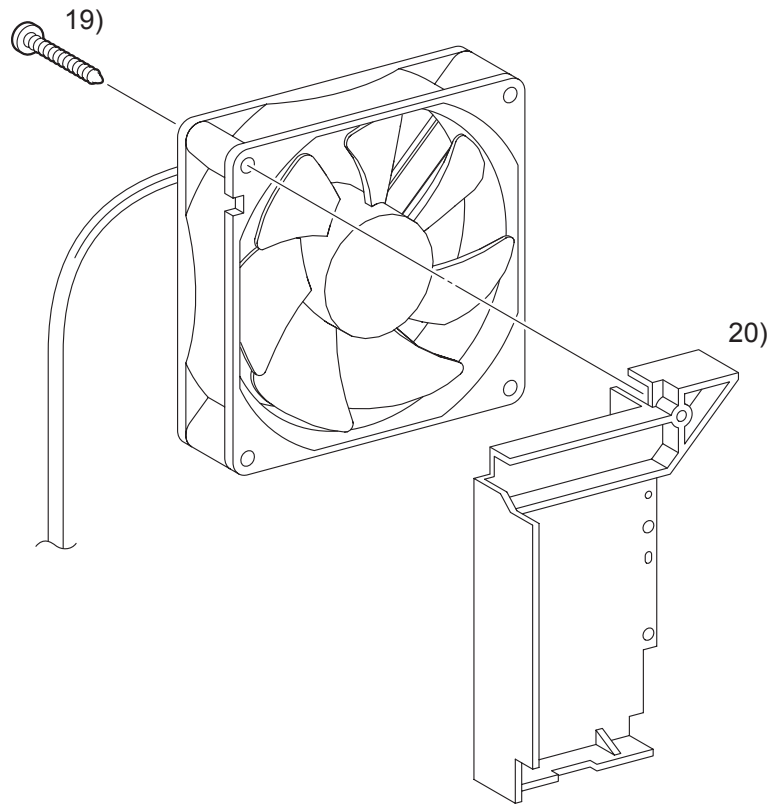

Gnb03226KA

- 19) Remove the one screw (silver, tap, 32mm) that fix the PLATE DUCT to the FAN.
- 20) Remove the PLATE DUCT from the FAN.

Removal 72 ADF SCANNER ASSY (PL13.8.1)

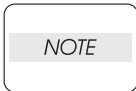

Before removing the ADF SCANNER (PL13.8.1), open the ADF ASSY (PL13.8.2) and move the carriage locking lever frontward to the locking position.

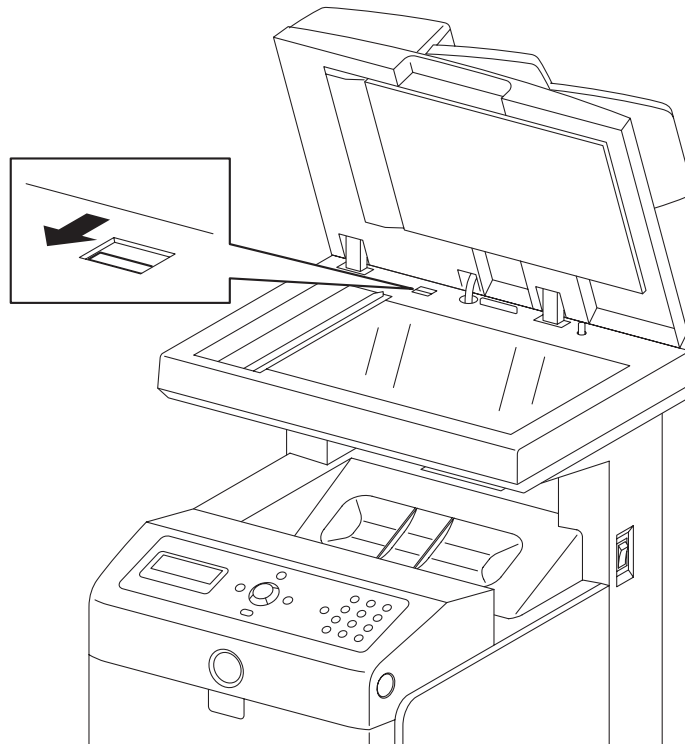

Gnb03228KA

Steps 1 through 13 are for reference. Before removing this component, check that Steps 1 through 13 have been performed.

- 1) Open the FRONT COVER (PL13.2.1).
- 2) Remove the FUSER.(Removal 8)
- 3) Remove the REAR COVER. (Removal 49)
- 4) Remove the COVER BOTTOM. (Removal 50)
- 5) Remove the COVER POLE IN R.(Removal 51)
- 6) Remove the COVER POLE R.(Removal 52)
- 7) Remove the RIGHT COVER. (Removal 54)
- 8) Remove the COVER POLE IN L. (Removal 57)
- 9) Remove the COVER POLE L. (Removal 58)
- 10) Remove the LEFT COVER. (Removal 59)
- 11) Remove the TOP COVER. (Removal 68)
- 12) Remove the BOX ASSY PRT AIO. (Removal 60)

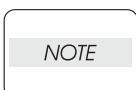

When performing the step described below, it is not necessary to remove the connector and harness of the FAN.

- 13) Remove the FAN. (Removal 71)

Removal 72 ADF SCANNER ASSY (PL13.8.1)

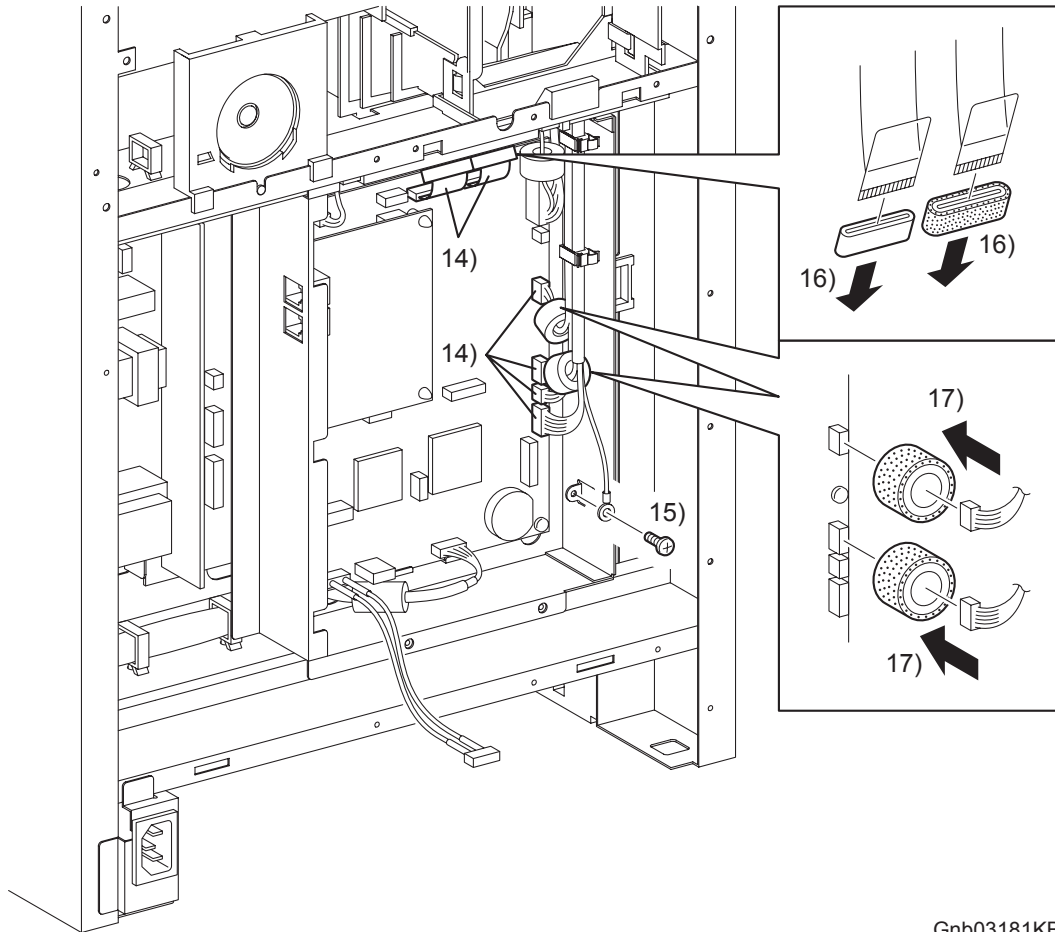

Gnb03181KB

- 14) Disengage the four connectors (P/J60,61,62,63) and two flat cables (P/J64,65) of the ADF SCANNER ASSY from the PWBA HYUI (PL13.4.1).
- 15) Remove the one screw (silver, 6mm) that fixes the ground wire of the ADF SCANNER ASSY to the BOX ASSY FAX AIO (PL13.4.4).
- 16) Remove the CORE FCR27-12-1.3 (PL13.8.13) and the CORE ASSY FCR27 (PL13.8.12) from the two flat cables.
- 17) Remove the two CORE ASSY SC-18 (PL13.8.14) on the connectors (J62, J63) from the harness.

Continues to the next page.

Removal 72 ADF SCANNER ASSY (PL13.8.1)

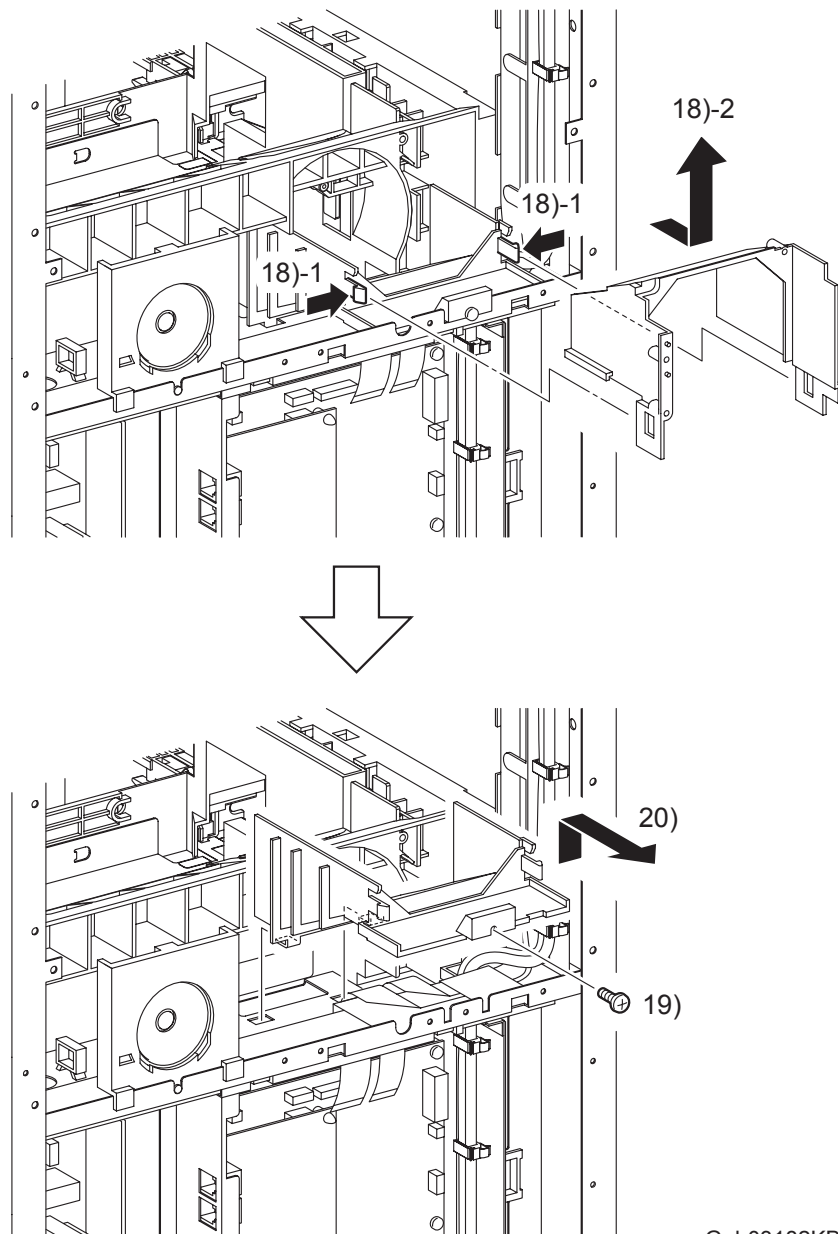

Gnb03182KB

- 18) Remove the DUCT UPPER by releasing the two hooks on the DUCT LOWER (PL13.5.8) and sliding the DUCT UPPER backward.
- 19) Remove the one screw (silver, 6mm) that fixes the DUCT LOWER to the printer.
- 20) Release the two hooks on the bottom of the DUCT LOWER from the holes of the printer, and remove the DUCT LOWER.

Continues to the next page.

Removal 72 ADF SCANNER ASSY (PL13.8.1)

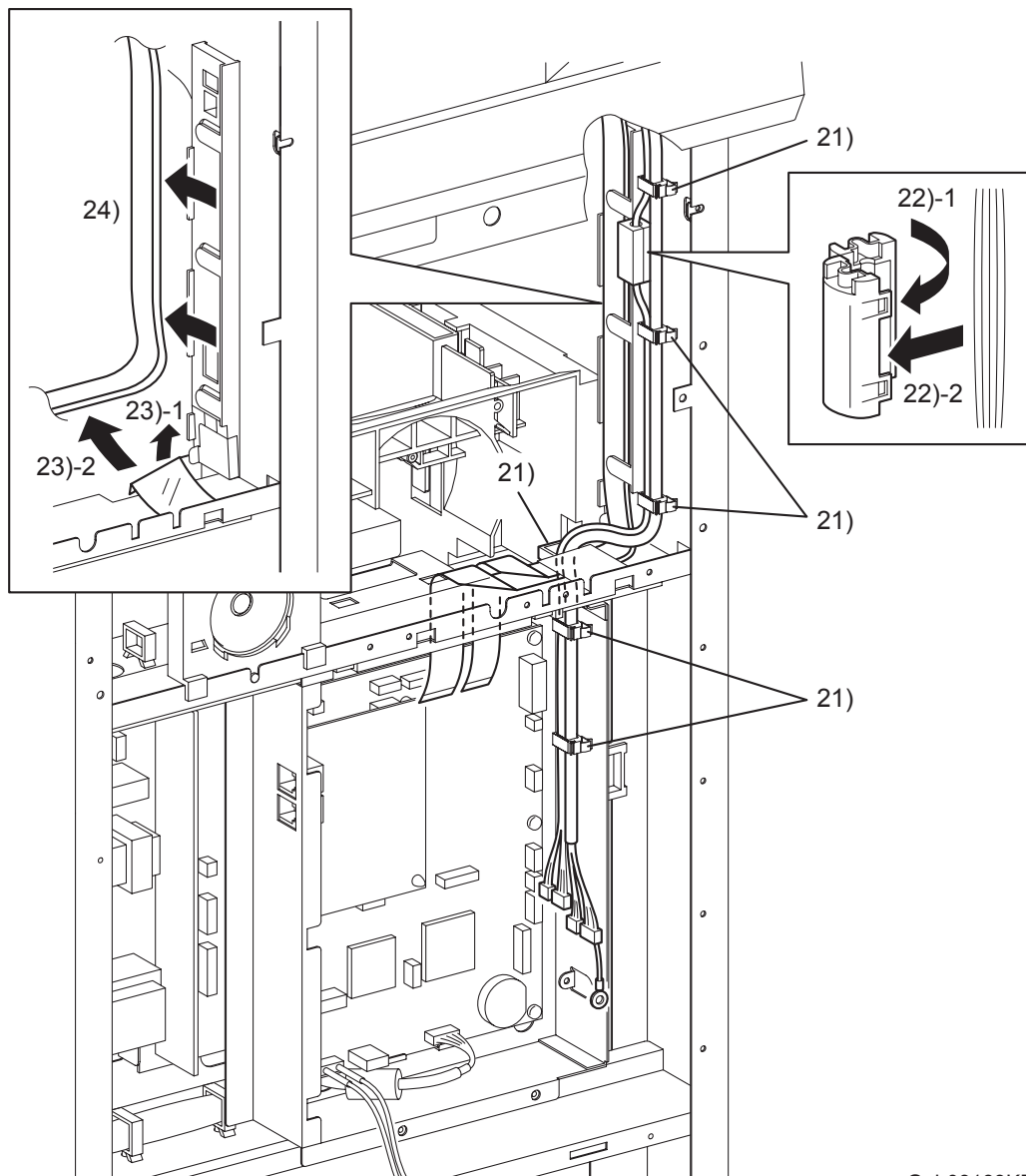

Gnb03183KB

- 21) Release the harness of the ADF SCANNER ASSY from the six clamps and pull it out of the slot on the PLATE ASSY FAX AIO (PL13.4.5).
- 22) Release the two hooks on the CORE SFT-25SN (PL13.8.11), remove the CORE SFT-25SN from the harness.
- 23) Release the two flat cables from the under side of the film.
- 24) Release the two flat cables from the SPACER ASSY FFC (PL13.3.14).

Continues to the next page.

Removal 72 ADF SCANNER ASSY (PL13.8.1)

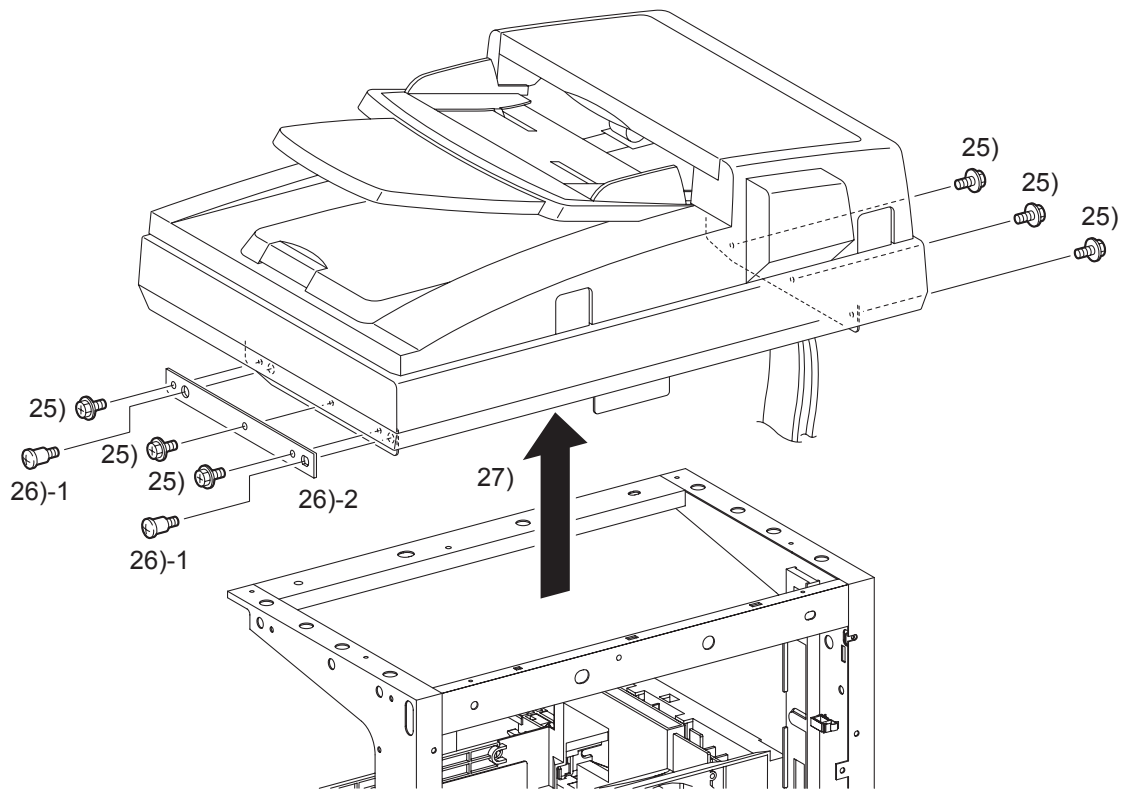

Gnb03184KB

- 25) Remove the six screws (silver, with flange, 6mm) that fix the ADF SCANNER ASSY to the printer.
- 26) Remove the PLATE SUB (PL13.8.8) from the printer by removing the two SCREWS (PL13.8.9).

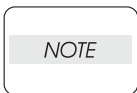

When performing the step described below, ensure that the harness of the ADF SCANNER ASSY will not be caught inside the printer.

- 27) Remove the ADF SCANNER ASSY from the printer by lifting it slowly upward.

Go to the next removal step:

Removal 73 ADF ASSY (PL13.8.2), SCANNER ASSY (PL13.8.7)

Removal 73 ADF ASSY (PL13.8.2), SCANNER ASSY (PL13.8.7)

Steps 1 through 14 are for reference. Before removing this component, check that Steps 1 through 14 have been performed.

- 1) Open the FRONT COVER (PL13.2.1).
- 2) Remove the FUSER.(Removal 8)
- 3) Remove the REAR COVER. (Removal 49)
- 4) Remove the COVER BOTTOM. (Removal 50)
- 5) Remove the COVER POLE IN R.(Removal 51)
- 6) Remove the COVER POLE R.(Removal 52)
- 7) Remove the RIGHT COVER. (Removal 54)
- 8) Remove the COVER POLE IN L. (Removal 57)
- 9) Remove the COVER POLE L. (Removal 58)
- 10) Remove the LEFT COVER. (Removal 59)
- 11) Remove the TOP COVER. (Removal 68)
- 12) Remove the BOX ASSY PRT AIO. (Removal 60)
- 13) Remove the FAN. (Removal 71)
- 14) Remove the ADF SCANNER ASSY. (Removal 72)

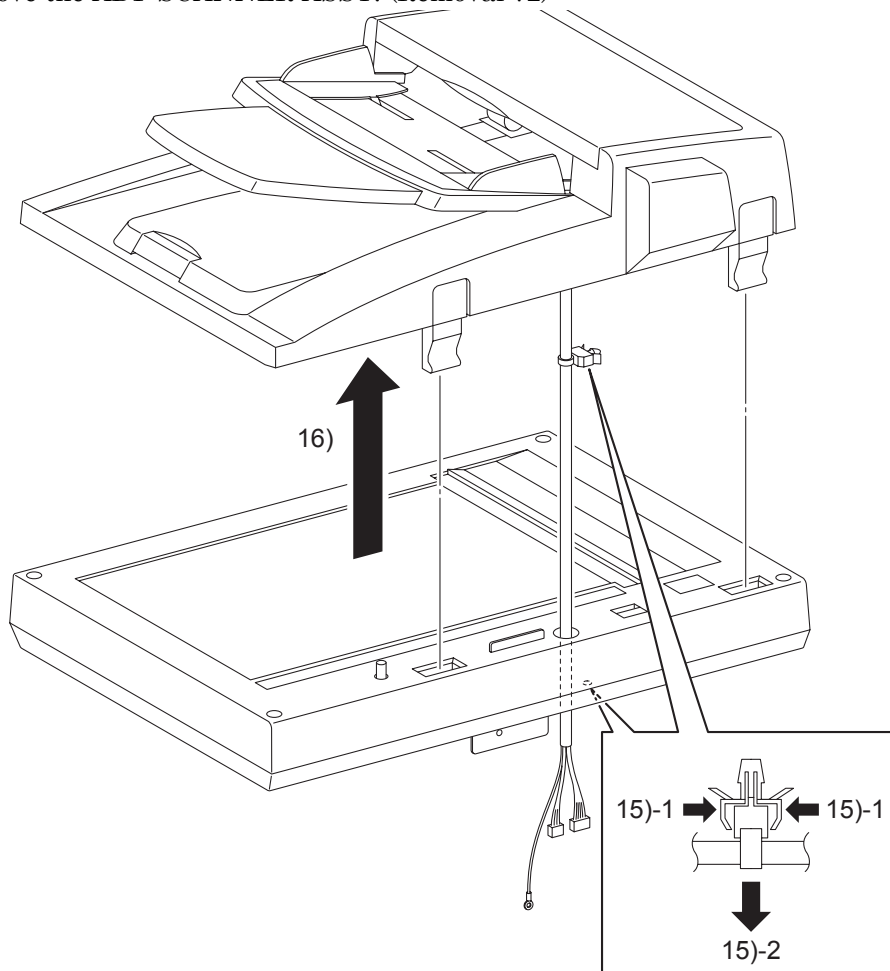

Gnb03185KA

NOTE

When placing the removed ADF SCANNER ASSY on a table, take care not to damage the harness of the ADF SCANNER ASSY by pinching it between the ADF SCANNER ASSY and the table.

- 15) Release the clamp that fixes the harness of the AFD ASSY (PL13.8.2) to the bottom of the ADF SCANNER ASSY (PL13.8.1).
- 16) Separate the AFD ASSY from the SCANNER ASSY by lifting up the AFD ASSY slowly until the harness of the AFD ASSY is pulled out of the hole on the SCANNER ASSY (PL13.8.7).

Removal 74 ADF FEED ROLLER (PL13.8.3), ADF SEPARATOR PAD (PL13.8.5), ADF SEPARATOR SPRING (PL13.8.6)

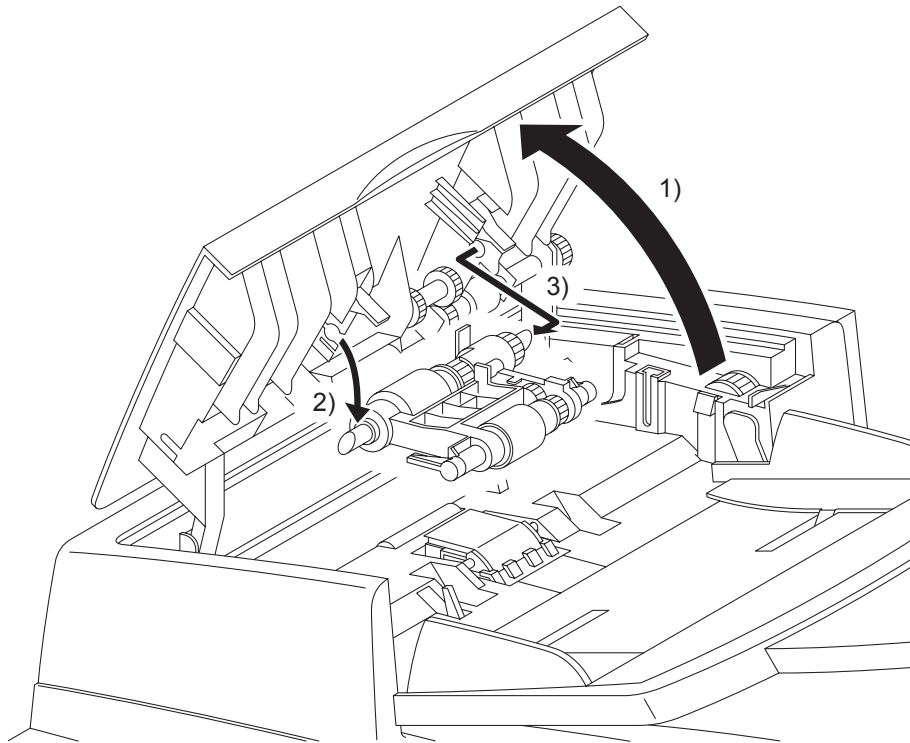

Gnb03186KA

- 1) Open the cover of the AFD ASSY (PL13.8.2).
- 2) Release the front shaft of the AFD FEED ROLLER (PL13.8.3) from the AFD ASSY.
- 3) Remove the ADF FEED ROLLER by releasing the rear shaft of the AFD FEED ROLLER from the AFD ASSY.

Continues to the next page.

Removal 74 ADF FEED ROLLER (PL13.8.3), ADF SEPARATOR PAD (PL13.8.5), ADF SEPARATOR SPRING (PL13.8.6)

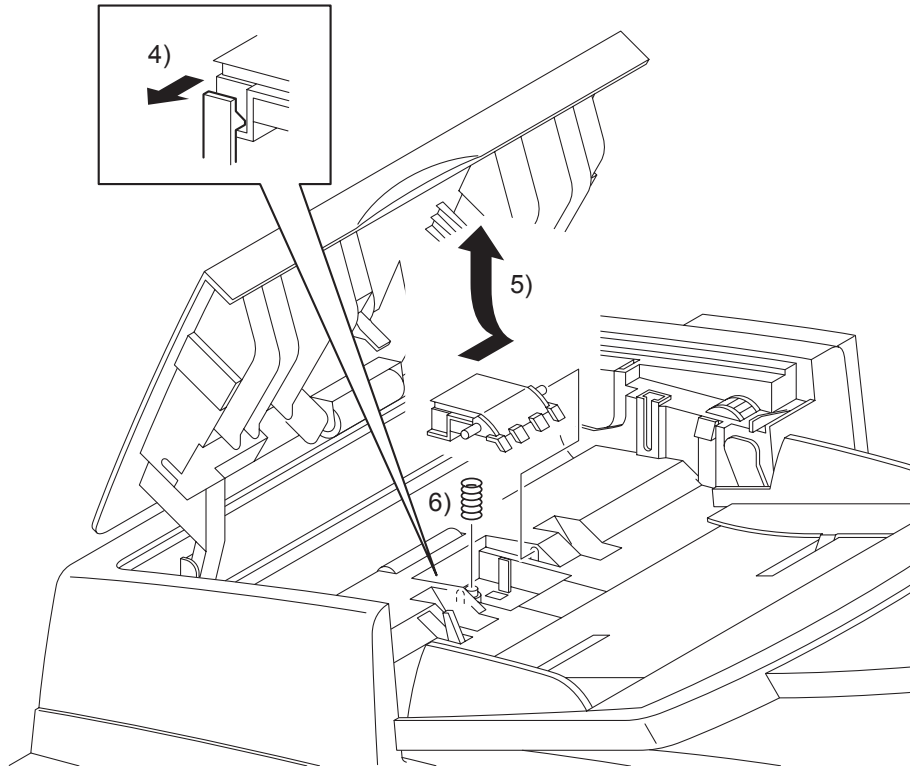

Gnb03187KA

- 4) Release the hook that fixes the AFD SEPARATOR PAD (PL13.8.5) to the AFD ASSY.
- 5) Slide the ADF SEPARATOR PAD backward until the front shaft of the ADF SEPARATOR PAD is released from the hole on the ADF ASSY, and then remove the ADF SEPARATOR PAD by releasing the rear shaft.
- 6) Remove the ADF SEPARATOR SPRING (PL13.8.6) from the boss on the ADF ASSY.

Removal 75 KIT TRAY MAIN (PL13.8.10)

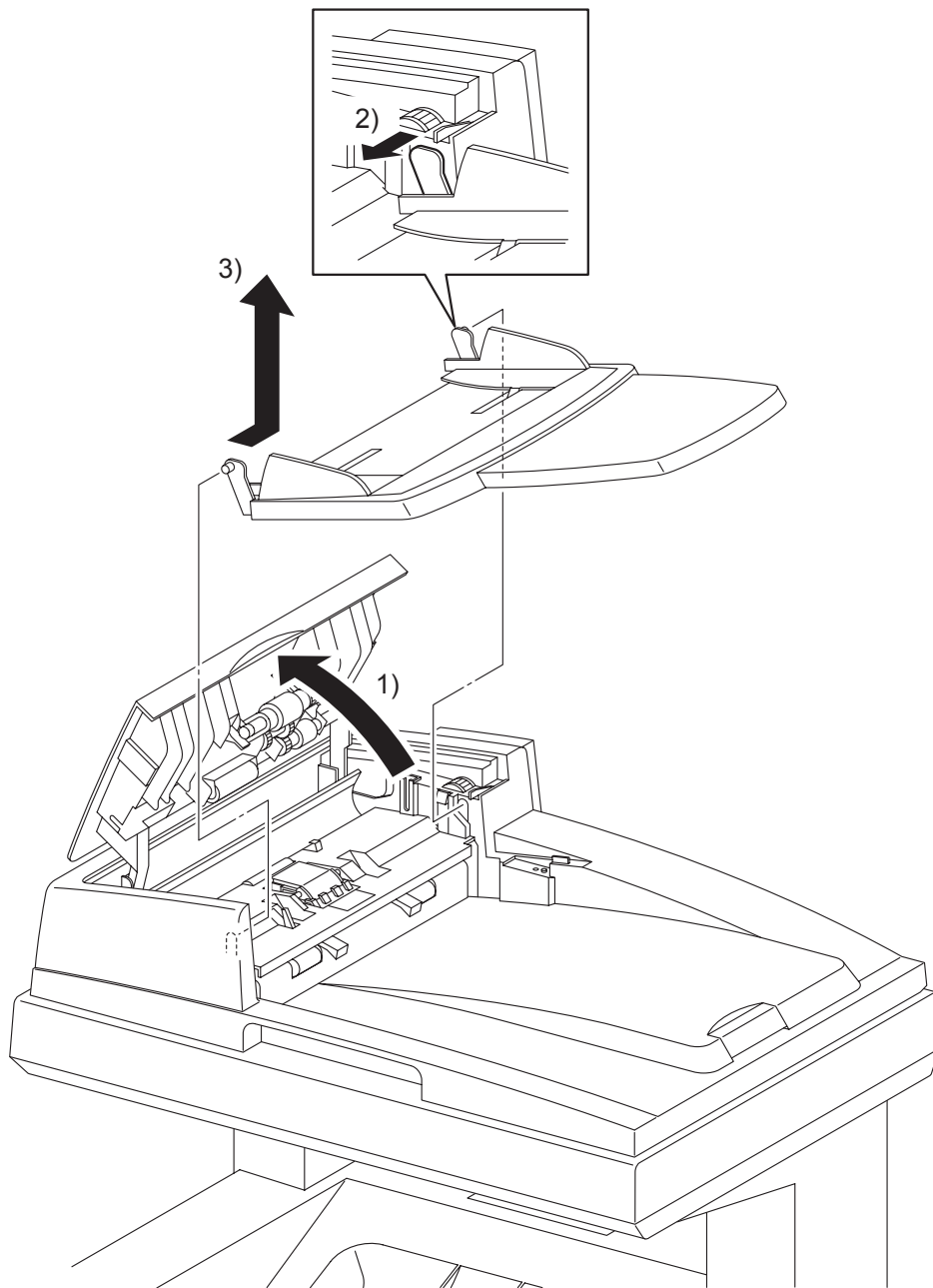

Gnb03224KA

- 1) Open the COVER of the ADF ASSY (PL13.8.2).
- 2) Bend the rear side mounting section of the KIT TRAY MAIN (PL13.8.10), release the boss of the KIT TRAY MAIN from the hole of the ADF ASSY (PL13.8.2).
- 3) Release the front side boss of the KIT TRAY MAIN from the hole of the ADF ASSY, remove the KIT TRAY MAIN.

3. Replacement Steps

Replacement 1 550 TRAY SEPARATOR ROLLER (PL12.5.17) (Same as the 550 TRAY FEED ROLLER)

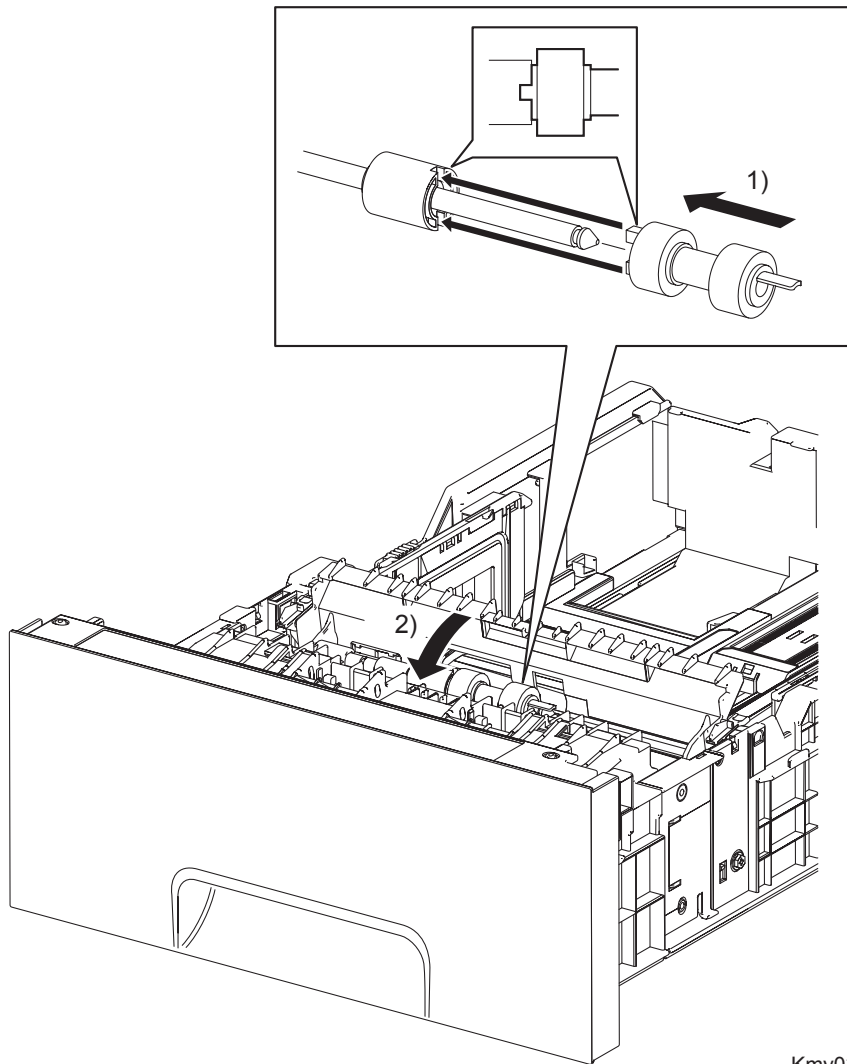

Kmy03121KA

- 1) Slide the 550 TRAY SEPARATOR ROLLER onto the SHAFT RETARD so that the lug on the 550 TRAY SEPARATOR ROLLER is mated with the notch on the CLUTCH FRICTION RET (PL12.5.16). Lock the hook on the other end of the 550 TRAY SEPARATOR ROLLER into the groove on the SHAFT RETARD.
- 2) Close the CVR RTD CST.
- 3) Replace the 550 SHEET PAPER TRAY to the 550 SHEET FEEDER ASSEMBLY.

Replacement 2 550 TRAY FEED ROLLER (PL12.3.29)

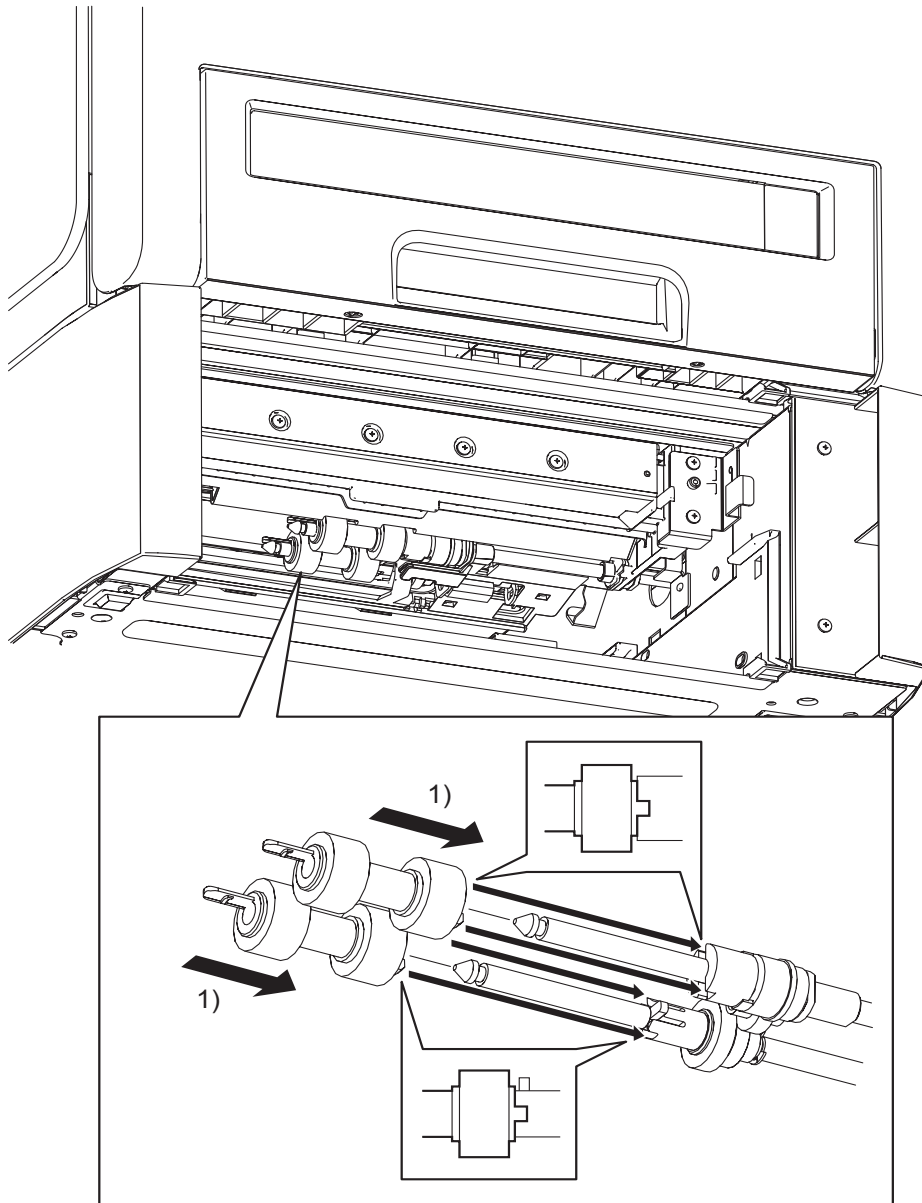

Kmy03120KA

- 1) Slide the 550 TRAY FEED ROLLERS onto the shafts so that the lugs on the 550 TRAY FEED ROLLERS are mated with the notches on the ROLL ASSY GEAR NUDGERS (PL12.3.22) and CLUTCH ONE WAY FEED (PL12.3.28). Lock the hooks on the other end of the 550 TRAY FEED ROLLERS into the grooves on the shafts.
- 2) Replace the 550 SHEET PAPER TRAY to the 550 SHEET FEEDER ASSEMBLY.

Replacement 3 550 TRAY REAR COVER (PL13.7.4)

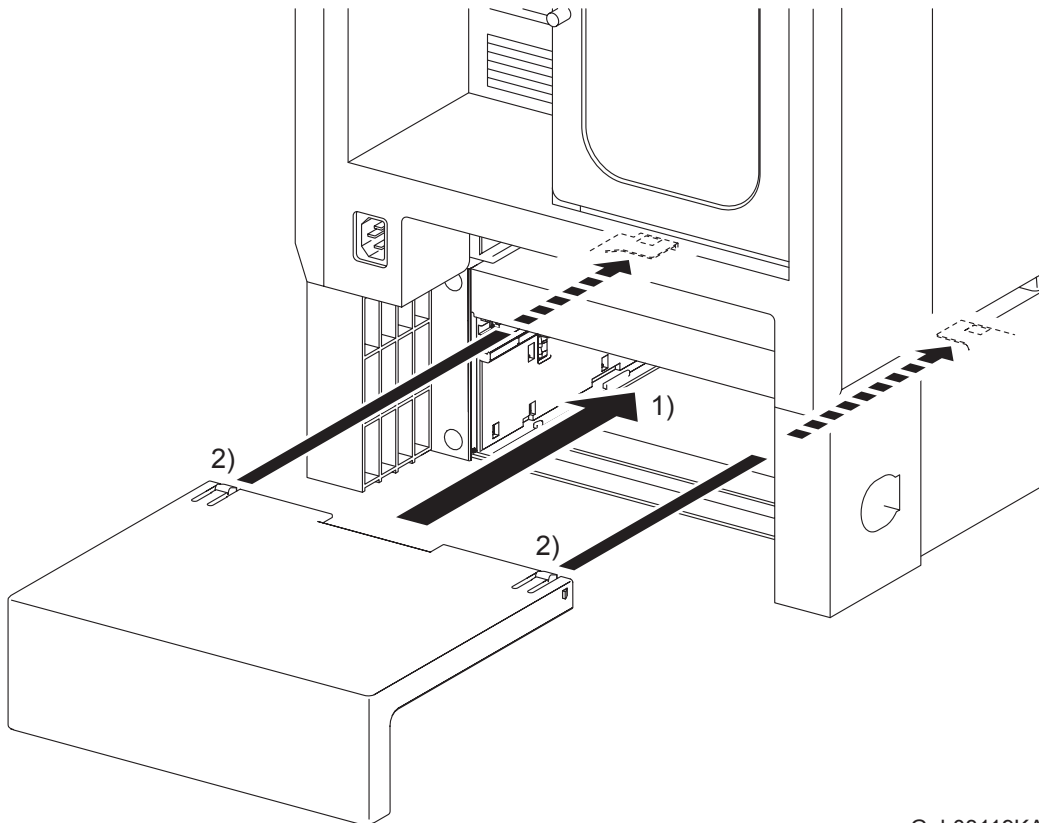

Gnb03119KA

- 1) Insert the 550 TRAY REAR COVER into the 550 SHEET FEEDER ASSEMBLY.
- 2) Push the 550 TRAY REAR COVER frontward until it is locked to the 550 SHEET FEEDER ASSEMBLY at the two hooks on its front edge.

Replacement 4 550 SHEET FEEDER ASSEMBLY (PL13.7.1)

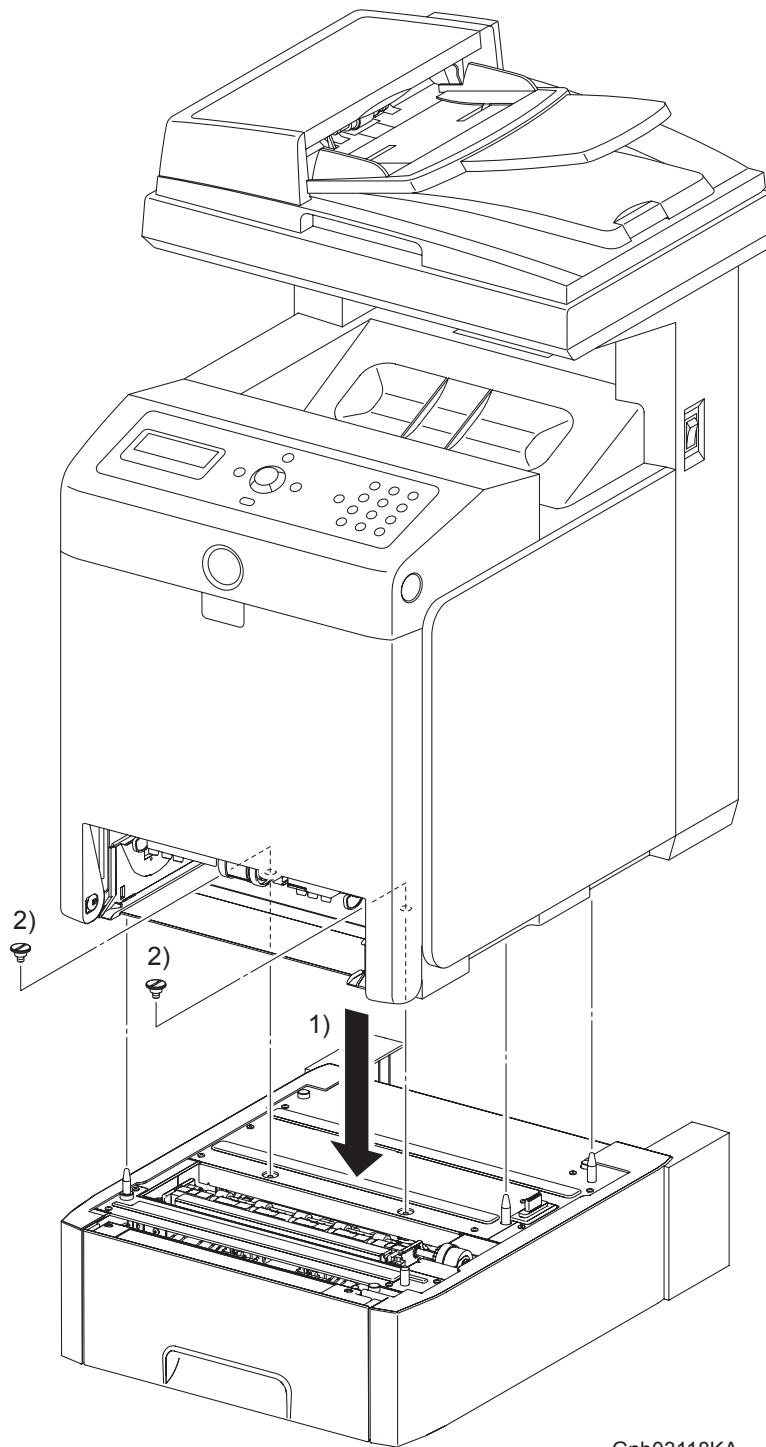

Gnb03118KA

NOTE

The printer must be lifted by two people.

- 1) Place the printer on the 550 SHEET FEEDER ASSEMBLY with the four holes on the bottom of the printer aligned with the studs on the 550 SHEET FEEDER ASSEMBLY.
- 2) Secure the printer to the 550 SHEET FEEDER ASSEMBLY using the two FEEDER SCREWS.
- 3) Replace the 250 SHEET PAPER TRAY to the printer.

Replacement 5 FEED ROLLER (PL3.2.53)

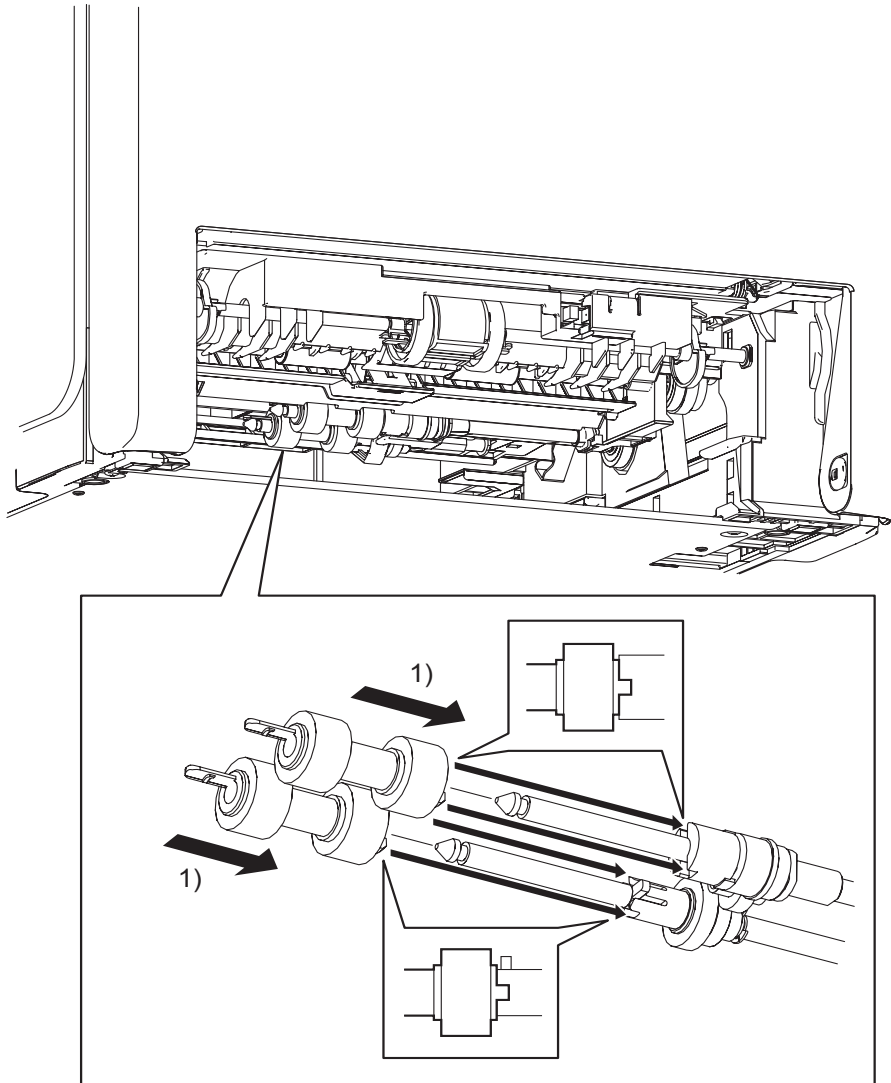

Kmy03117KA

- 1) Slide the FEED ROLLERS onto the shafts so that the lugs on the FEED ROLLERS are mated with the notches on the ROLL ASSY GEAR NUDGER (PL3.2.46) and CLUTCH ONEWAY FEED (PL3.2.52). Lock the hooks on the other end of the FEED ROLLERS into the grooves on the shafts.
- 2) Replace the 250 SHEET PAPER TRAY to the printer.

Replacement 6 MPF ROLLER (PL3.1.10)

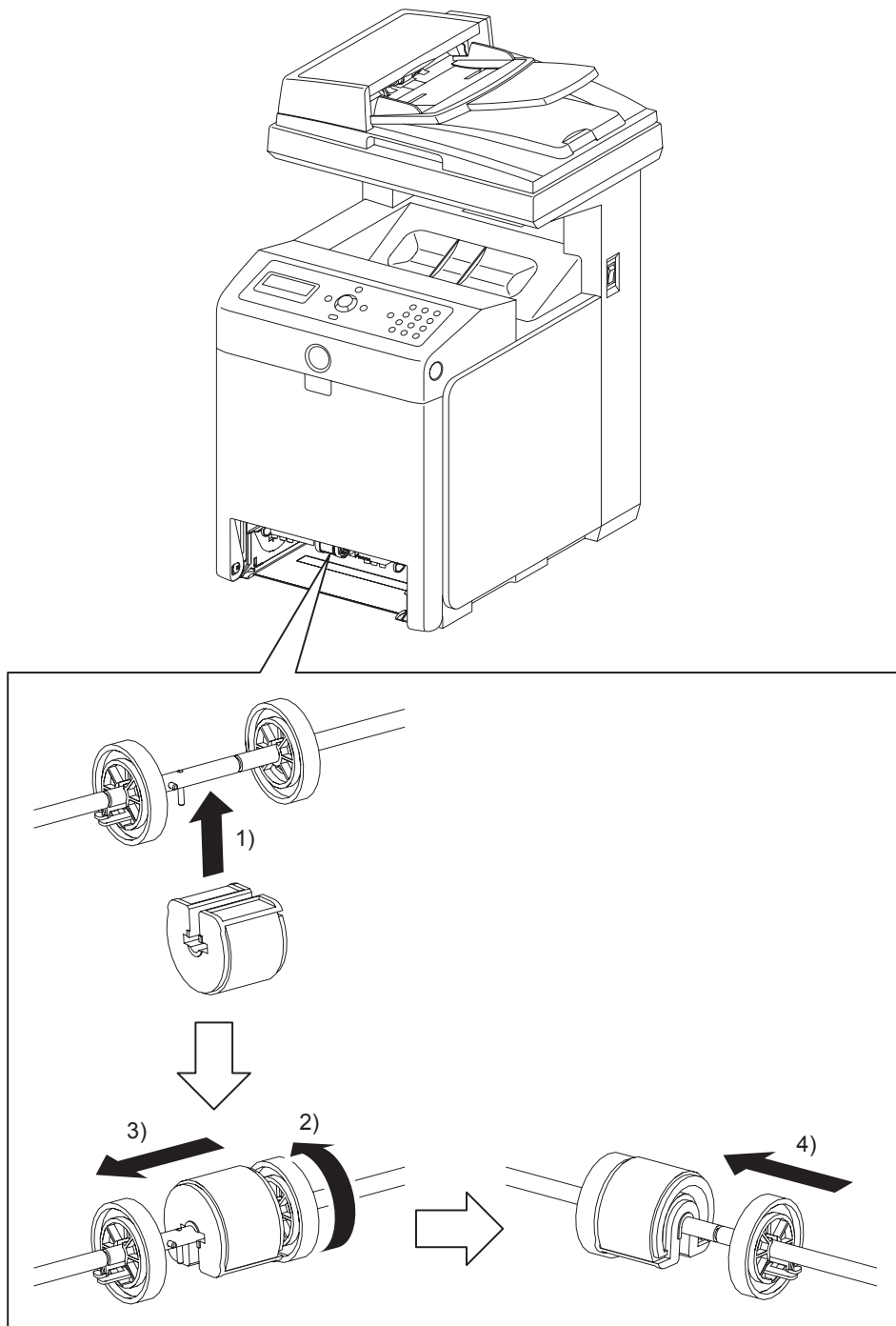

Gnb03116KA

- 1) Fit the MPF ROLLER to the SHAFT MSI with the groove of the MPF ROLLER facing upward.
- 2) Rotate the MPF ROLLER 180 degrees so that the pin on the SHAFT MSI is aligned with the groove on the MPF ROLLER.
- 3) Slide the MPF ROLLER to the right so that the MPF ROLLER covers the pin on the SHAFT MSI.
- 4) Slide the right ROLL CORE MSI to the left. Secure the hook on the ROLL CORE MSI into the groove on the SHAFT MSI.
- 5) Replace the 250 SHEET PAPER TRAY to the printer.

Replacement 7 SEPARATOR ROLLER (PL2.2.17) (Same as the FEED ROLLER)

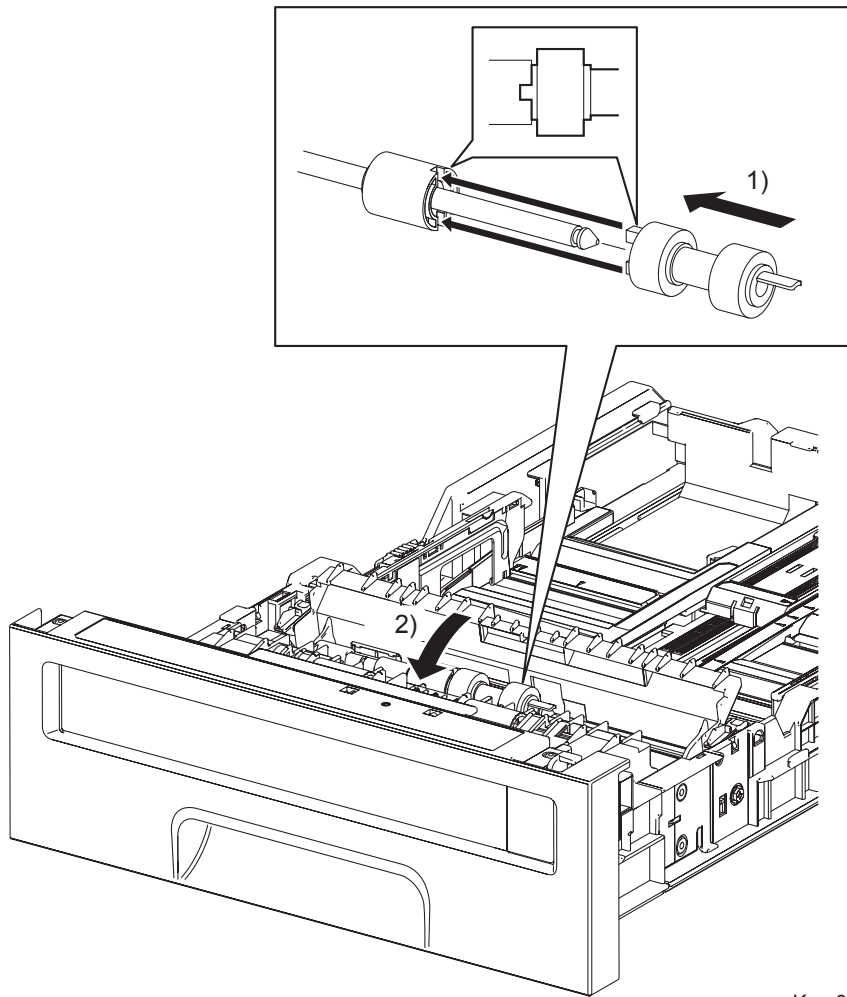

Kmy03115KA

- 1) Slide the SEPARATOR ROLLER onto the SHAFT RETARD so that the lug on the SEPARATOR ROLLER is mated with the notch on the CLUTCH FRICTION RET (PL2.2.16). Secure the hook on the other end of the SEPARATOR ROLLER into the groove on the SHAFT RETARD.
- 2) Close the CVR RTD CST.
- 3) Replace the 250 SHEET PAPER TRAY.

Replacement 8 MPF SEPARATOR ROLLER ASSEMBLY (PL2.1.3)

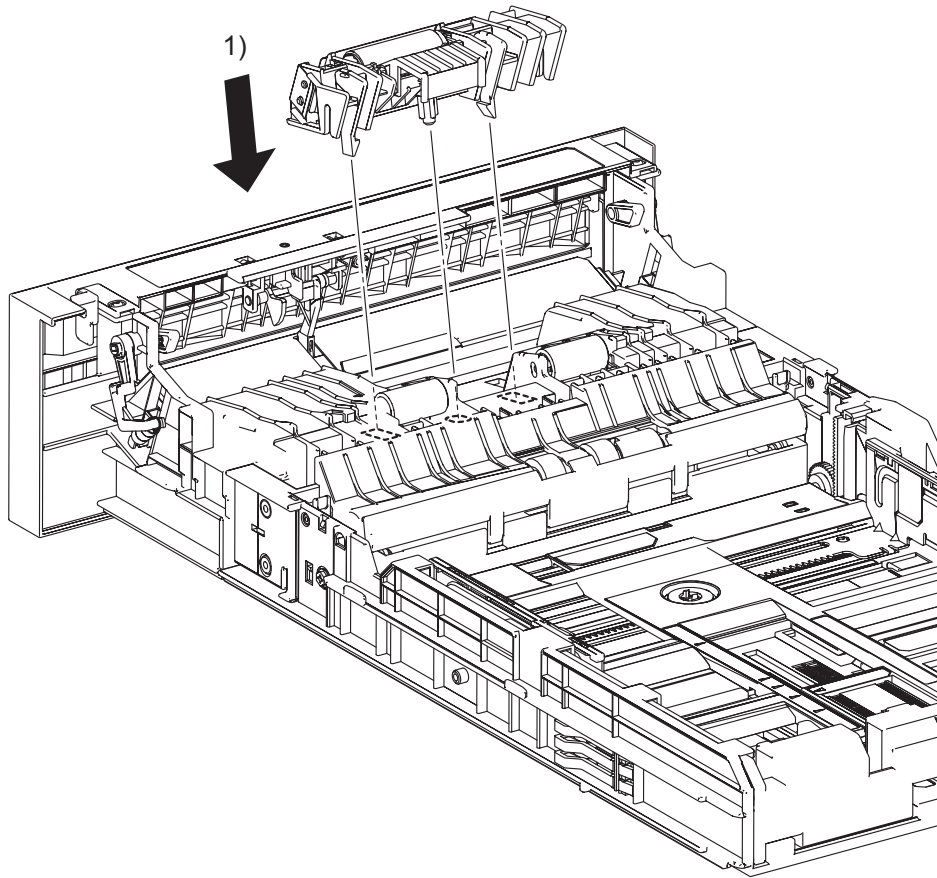

Kmy03114KA

- 1) Replace the MPF SEPARATOR ROLLER ASSEMBLY by mating the bosses of the MPF SEPARATOR ROLLER ASSEMBLY with the holes of the 250 SHEET PAPER TRAY. Secure the MPF SEPARATOR ROLLER ASSEMBLY with the two backside hooks.
- 2) Replace the 250 SHEET PAPER TRAY to the printer.

Replacement 9 TONER CARTRIDGE SENSOR ASSEMBLY (K) (PL5.1.4)

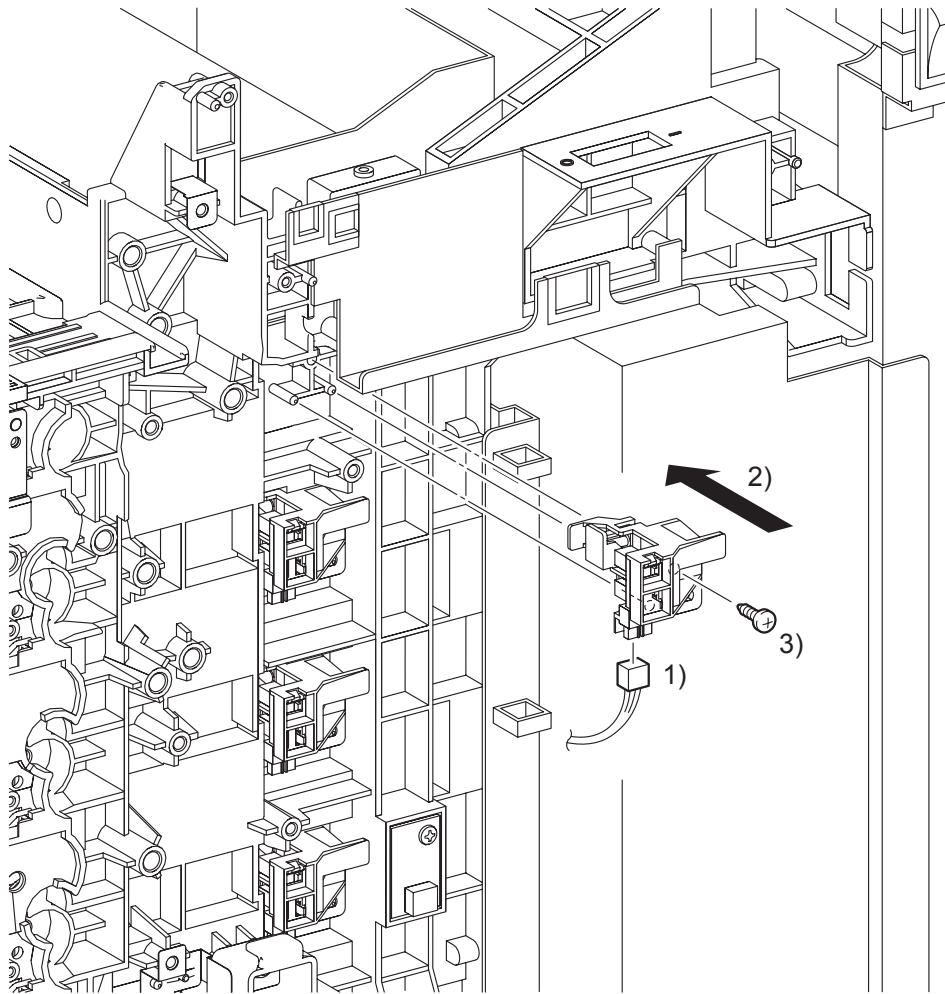

Gnb03113KA

- 1) Engage the connector (P/J193) of the TONER CARTRIDGE SENSOR ASSEMBLY (K).
- 2) Replace the TONER CARTRIDGE SENSOR ASSEMBLY (K) by mating the two holes on the TONER CARTRIDGE SENSOR ASSEMBLY (K) with the bosses on the printer,
- 3) Secure the TONER CARTRIDGE SENSOR ASSEMBLY (K) to the printer using the one screw (silver, tap, 10mm).

Go to the next replacement step:

Replacement 10 PHOTOCOnductor (PC) / DEVELOPER (DEV) DRIVE (PL8.1.2)

Replacement 10 PHOTOCONDUCTOR (PC) / DEVELOPER (DEV) DRIVE (PL8.1.2)

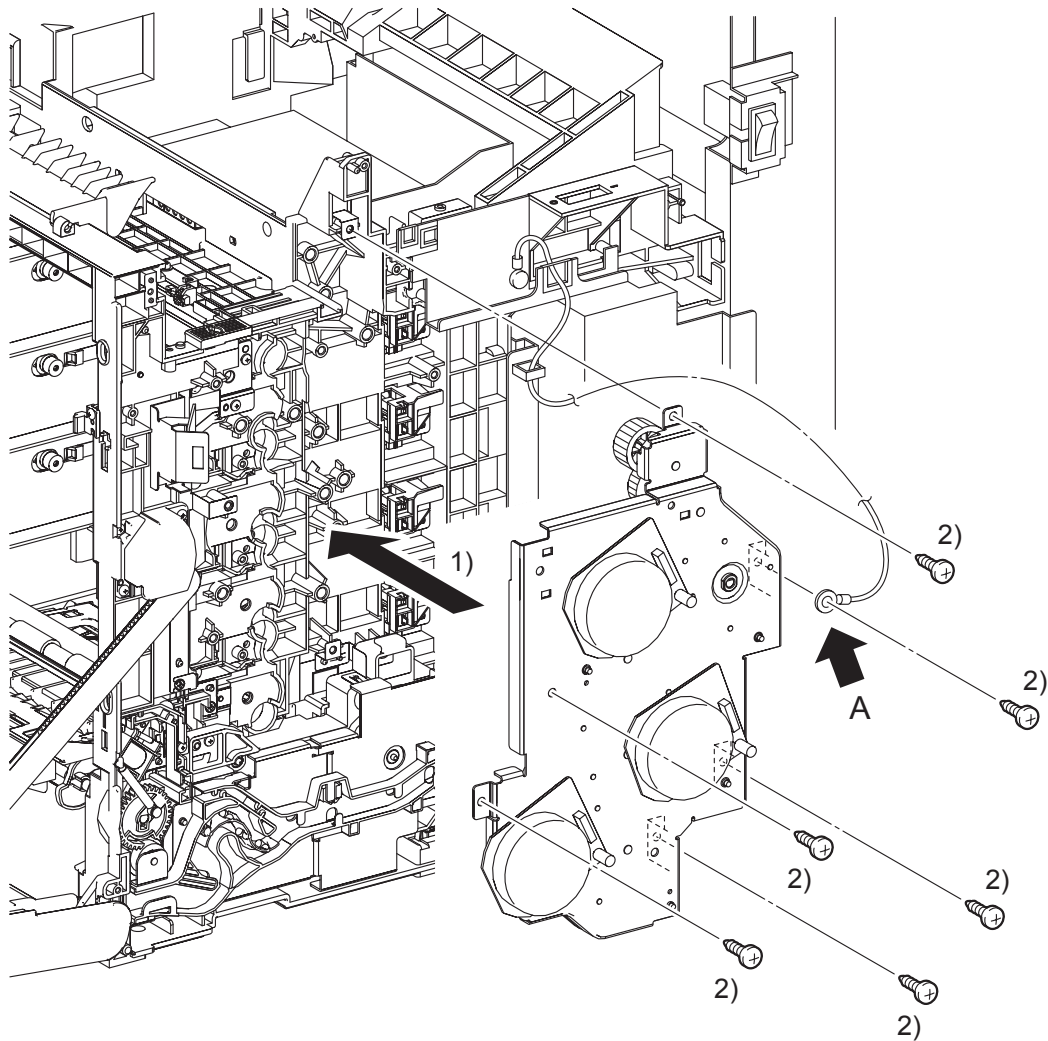

Gnb03111KB

NOTE

When securing at the point A shown in the illustration, ensure that the grounding wire is also secured with the same screw.

- 1) Replace the PHOTOCONDUCTOR (PC) / DEVELOPER (DEV) DRIVE by aligning the gear of each drive of the PHOTOCONDUCTOR (PC) / DEVELOPER (DEV) DRIVE with the holes on the printer.
- 2) Secure the PHOTOCONDUCTOR (PC) / DEVELOPER (DEV) DRIVE to the printer using the six screws (silver, tap, 10mm).

Continues to the next page.

Replacement 10 PHOTOCOnductor (PC) / DEVELOPER (DEV) DRIVE (PL8.1.2)

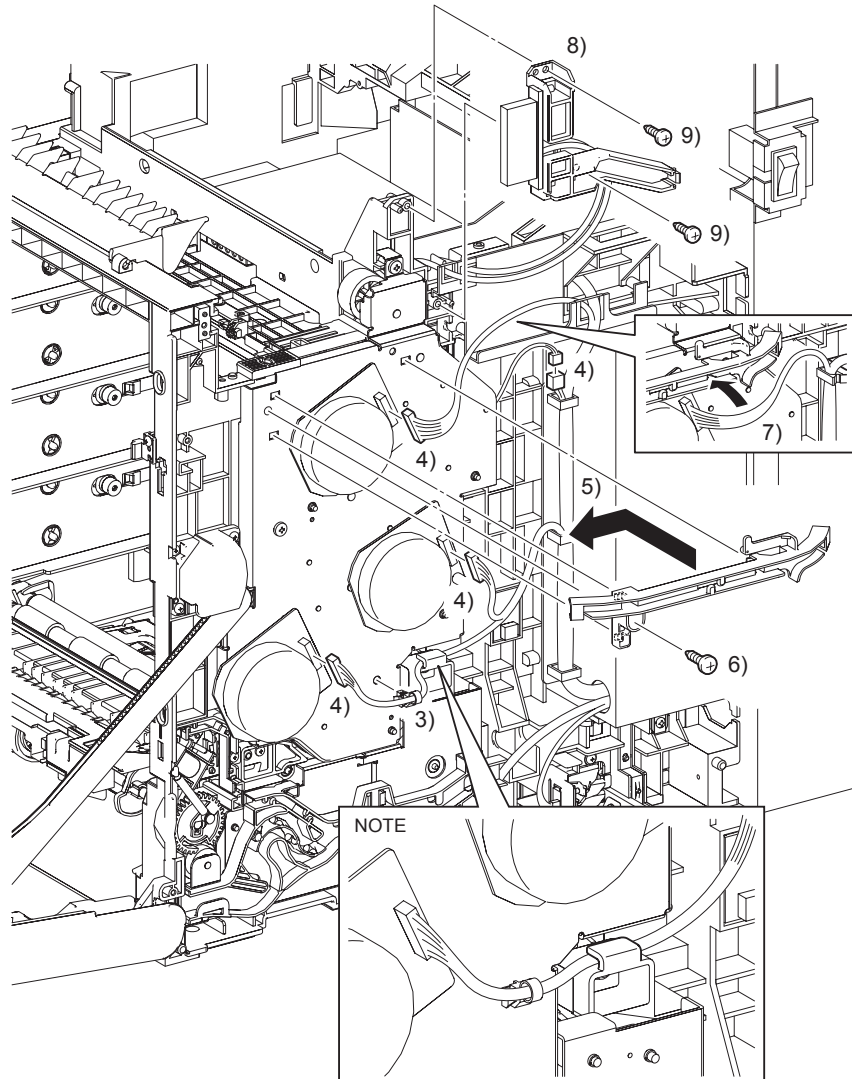

Gnb03112KA

NOTE

When performing the step described below, the harness of the connector to be engaged to the DEVE MOTOR must be routed through the hook above the FEED DRIVE ASSEMBLY (PL8.1.7).

- 3) Replace the clamp and harness together to the PHOTOCONDUCTOR (PC) / DEVELOPER (DEV) DRIVE.
- 4) Engage the connector (P/J211) of the MAIN MOTOR, the connector (P/J221) of the SUB MOTOR, the connector (P/J222) of the DEVE MOTOR, and the connector (P/J2761) of the EXIT CLUTCH in the PHOTOCONDUCTOR (PC) / DEVELOPER (DEV) DRIVE.
- 5) Replace the DUCT DRV MAIN by mating its three hooks into the holes on the PHOTOCONDUCTOR (PC) / DEVELOPER (DEV) DRIVE, and lock the bosses by sliding the DUCT DRV MAIN forward.
- 6) Replace the one remaining screw (silver, tap, 10mm) that fixes the PHOTOCONDUCTOR (PC) / DEVELOPER (DEV) DRIVE to the printer.
- 7) Route the harness of the PHOTOCONDUCTOR (PC) / DEVELOPER (DEV) DRIVE to the DUCT DRV MAIN.
- 8) Replace the BRACKET FUSER by mating its two holes with the bosses on the printer.
- 9) Secure the BRACKET FUSER using the two screws (silver, tap, 10mm).

**Go to the next replacement step:
Replacement 52 INTERLOCK SWITCH (PL13.5.3)**

Replacement 11 Blank

Replacement 12 PRINT HEAD (PL13.3.99)

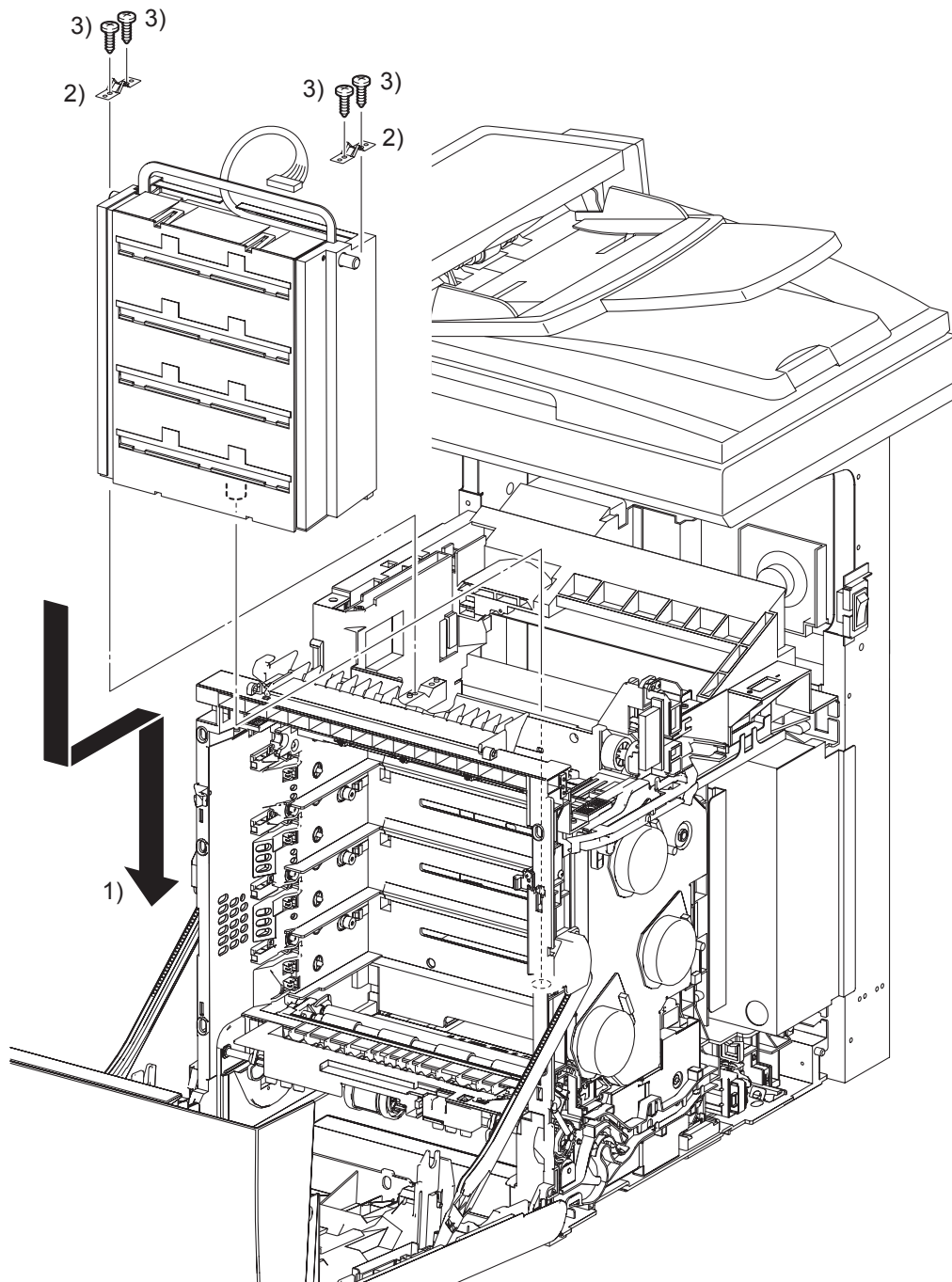

Gnb03109KA

- 1) Insert the PRINT HEAD by mating the underside boss of the PRINT HEAD with the hole on the printer.
- 2) Place the two SPRING ROSs onto the left and right side bosses on the PRINT HEAD so that the holes of SPRING ROSs are mated with the bosses on the printer.
- 3) Secure the SPRING ROSs to the printer using the four screws (silver, tap, 10mm).

Continues to the next page.

Replacement 12 PRINT HEAD (PL13.3.99)

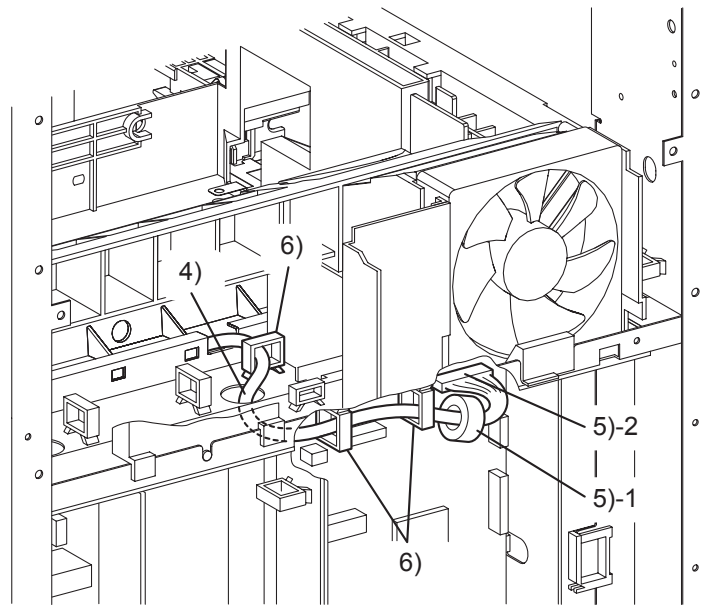

Gnb03132KA

- 4) Route the harness of the PRINT HEAD through the hole of the printer.
- 5) Replace the CORE to the harness of the PRINT HEAD, and then engage the connector (P/J12) to the connector of the MACHINE CONTROL UNIT.
- 6) Secure the harness of the PRNT HEAD with the three clamps.

Continues to the next page.

Replacement 12 PRINT HEAD (PL13.3.99)

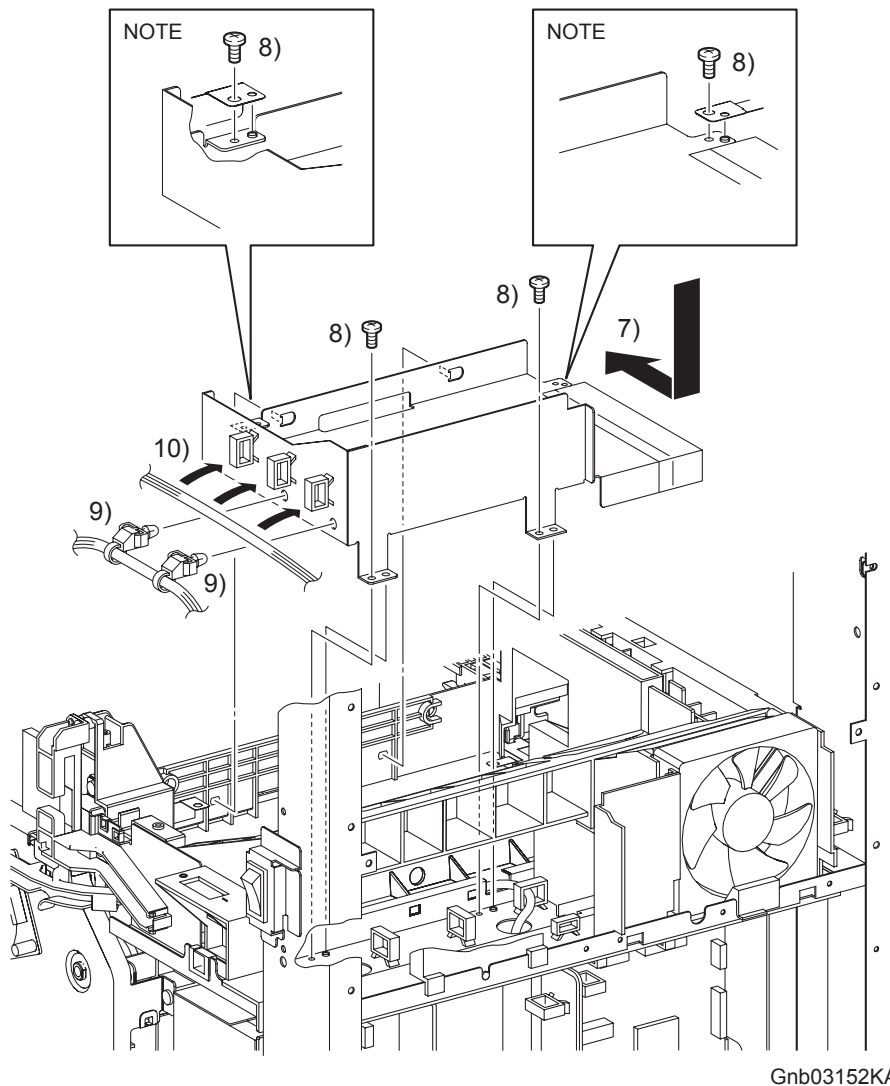

Gnb03152KA

NOTE

When securing the two positions shown in the figure, make sure that the FRAME ASSY EARTH is under the PLATE EARTH.

- 7) Mate the hole of the FRAME ASSY EARTH with the boss of the printer by inserting the two hooks on the front side of the FRAME ASSY EARTH into the holes of the printer.
- 8) Secure the FRAME ASSY EARTH to the printer using the four screws (silver, 6mm).
- 9) Replace the two clamps on the harness of the HARN ASSY FUSER AIO to the FRAME ASSY EARTH.
- 10) Secure the harness of the HARN ASSY FUSER AIO with the three clamps on the FRAME ASSY EARTH.

Go to the next replacement step:

Replacement 60 BOX ASSY FAX AIO (PL13.4.4)

Replacement 13 Blank

Replacement 14 HIGH VOLTAGE POWER SUPPLY (PL5.1.17)

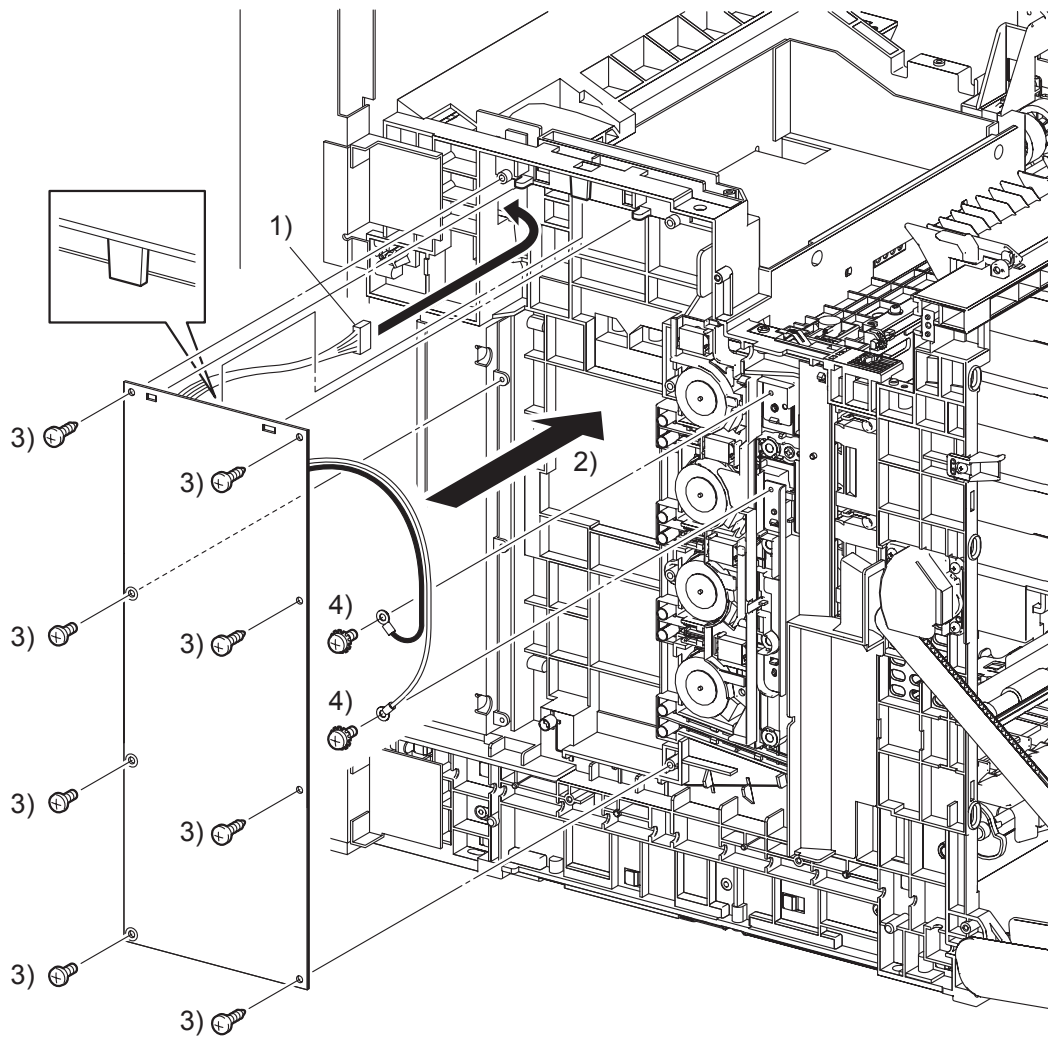

Gnb03105KA

- 1) Pass the connector of the HIGH VOLTAGE POWER SUPPLY through the hole on the printer.
- 2) Replace the HIGH VOLTAGE POWER SUPPLY by mating the two holes on the upper part of the HIGH VOLTAGE POWER SUPPLY with the bosses on the printer and inserting the upper part of the HIGH VOLTAGE POWER SUPPLY into the backside tab on the printer.

NOTE

In the step described below, out of the screw fixing positions of the HIGH VOLTAGE POWER SUPPLY, the three screw fixing positions with white bearing surfaces must be fixed with the 6mm silver screws.

- 3) Secure the HIGH VOLTAGE POWER SUPPLY with the five screws (silver, tap, 10mm) and the three screws (silver, 6mm).

NOTE

When performing the step described below, secure the red harness on the upper side and secure the white harness on the lower side.

- 4) Secure the two harnesses of the HIGH VOLTAGE POWER SUPPLY using the two screws (silver, with washer, 6mm).

Continues to the next page.

Replacement 14 HIGH VOLTAGE POWER SUPPLY (PL5.1.17)

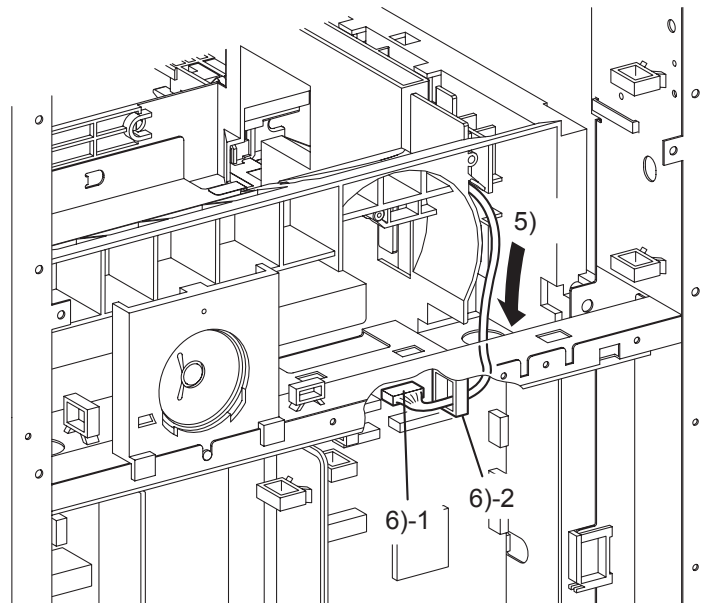

Gnb03106KA

- 5) Route the harness of the HIGH VOLTAGE POWER SUPPLY through the hole of the printer.
- 6) Engage the connector (P/J16) of the HIGH VOLTAGE POWER SUPPLY to the connector of the MACHINE CONTROL UNIT.

Continues to the next page.

Replacement 14 HIGH VOLTAGE POWER SUPPLY (PL5.1.17)

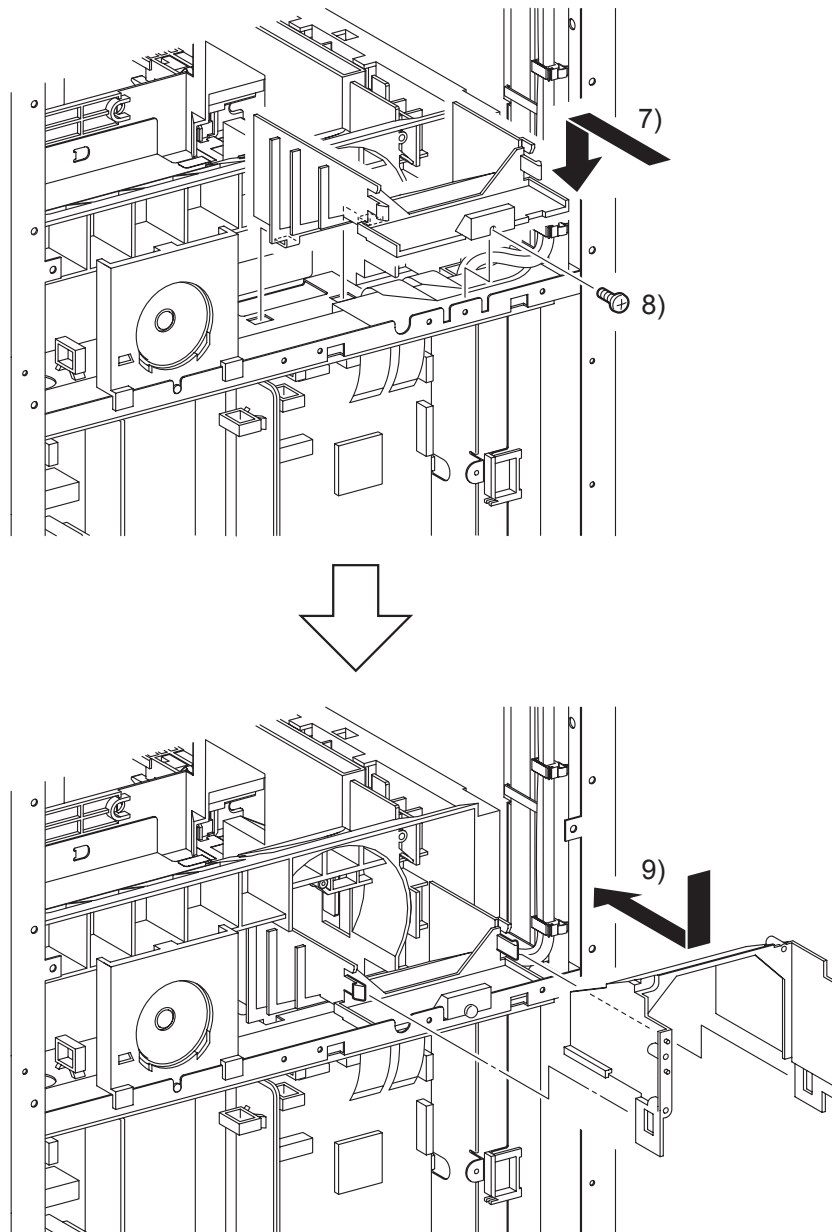

Gnb03153KA

- 7) Insert the two hooks of the DUCT LOWER into the hole of the printer, and then replace the DUCT LOWER to the printer.
- 8) Secure the DUCT LOWER to the printer using the one screw (silver, 6mm).
- 9) Place the DUCT UPPER on the DUCT LOWER. Slide the DUCT UPPER forward until the DUCT UPPER is hooked by the two hooks.

**Go to the next replacement step:
Replacement 51 FAN (PL13.5.10)**

Replacement 15 Blank

Replacement 16 Blank

Replacement 17 Blank

Replacement 18 Blank

Replacement 19 Blank

Replacement 20 TONER DISPENSER MOTOR (PL5.1.12)

NOTE

Described below is the replacement procedure common among TONER DISPENSER MOTORS (C), (M), (Y), and (K).

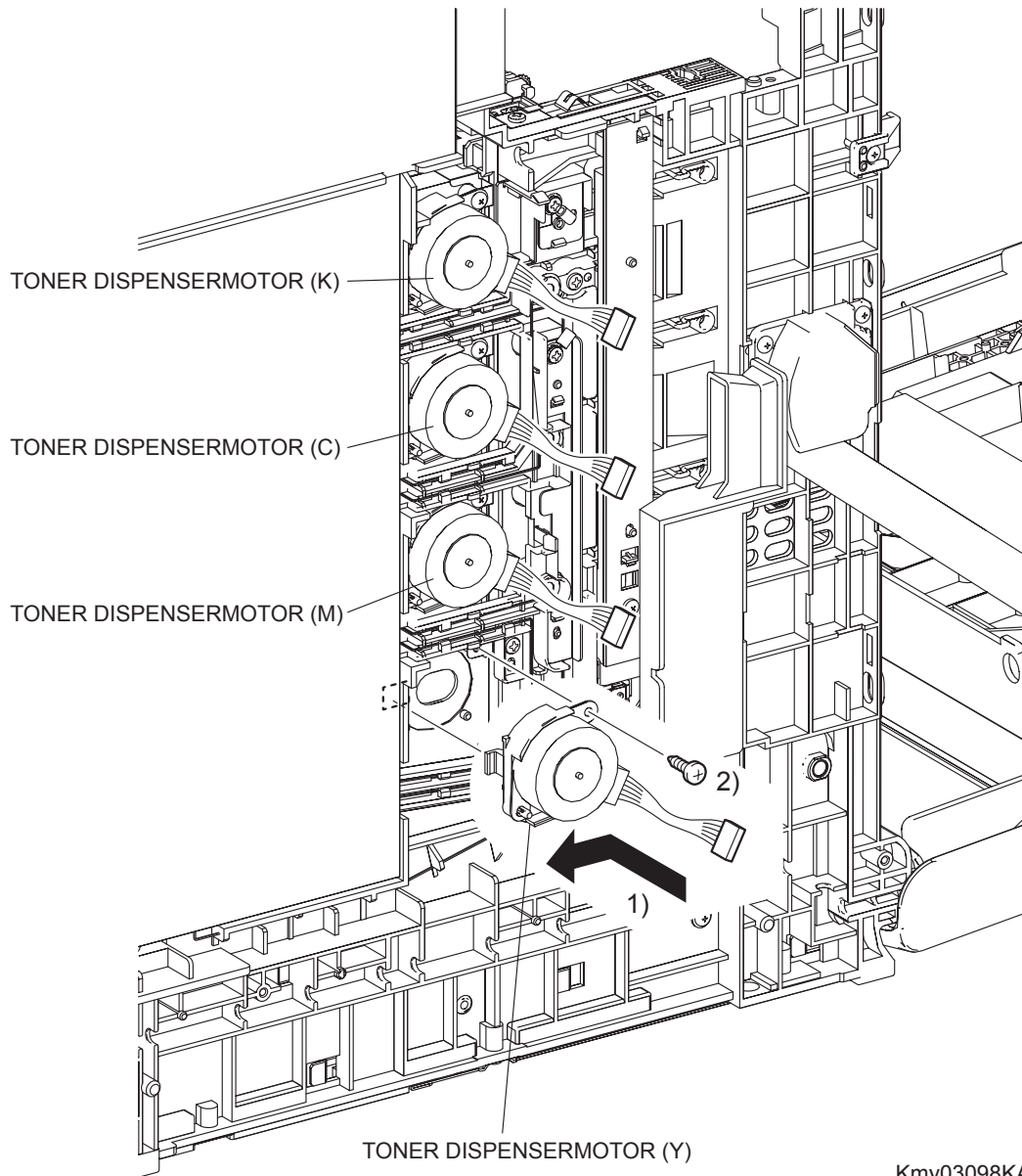

Kmy03098KA

- 1) Replace the TONER DISPENSER MOTOR to the printer by mating the tab of the TONER DISPENSER MOTOR with the hole on the printer and moving it slightly backward.
- 2) Secure the TONER DISPENSER MOTOR to the printer using the one screw (silver, tap, 10mm).

Continues to the next page.

Replacement 20 TONER DISPENSER MOTOR (PL5.1.12)

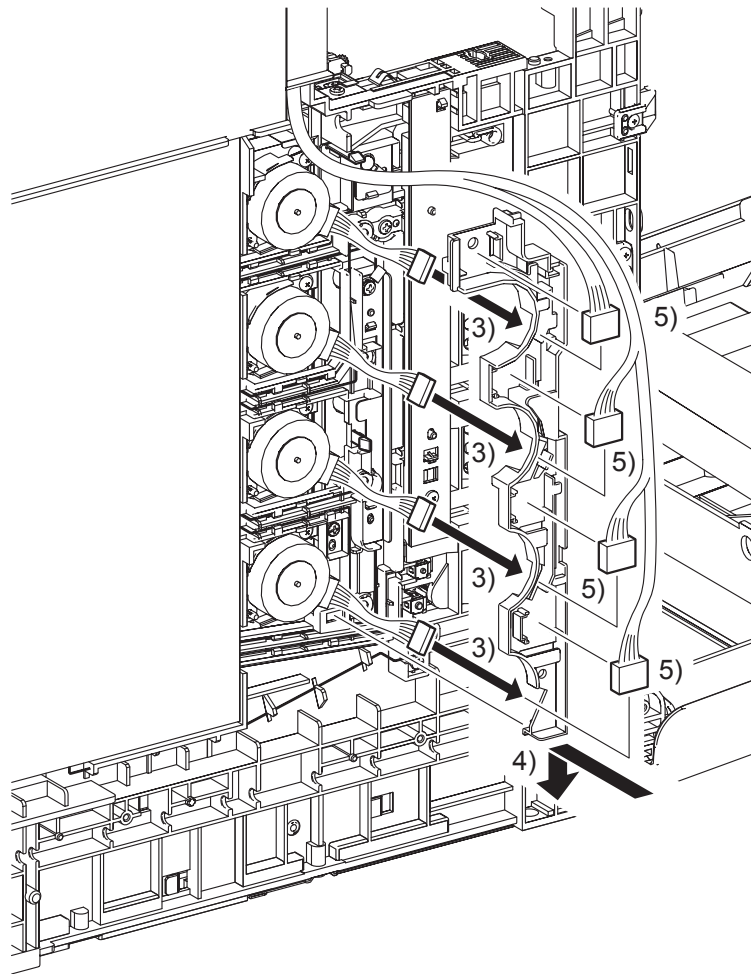

Gnb03099KA

- 3) Pass the four sets of connectors of the TONER DISPENSER MOTOR through the hole of the DUCT HARNESS MOT.
- 4) Mate the tab of the DUCT HARNESS MOT with the hole on the printer, and secure the DUCT HARNESS MOT with the two hooks on the printer.
- 5) Engage the four sets of connectors of the TONER DISPENSER MOTOR and route the harness along the DUCT HARNESS MOT.

Go to the next replacement step:

Replacement 63 LEFT COVER (PL13.1.10)

Replacement 21 LED ASSEMBLY (PL5.1.15)

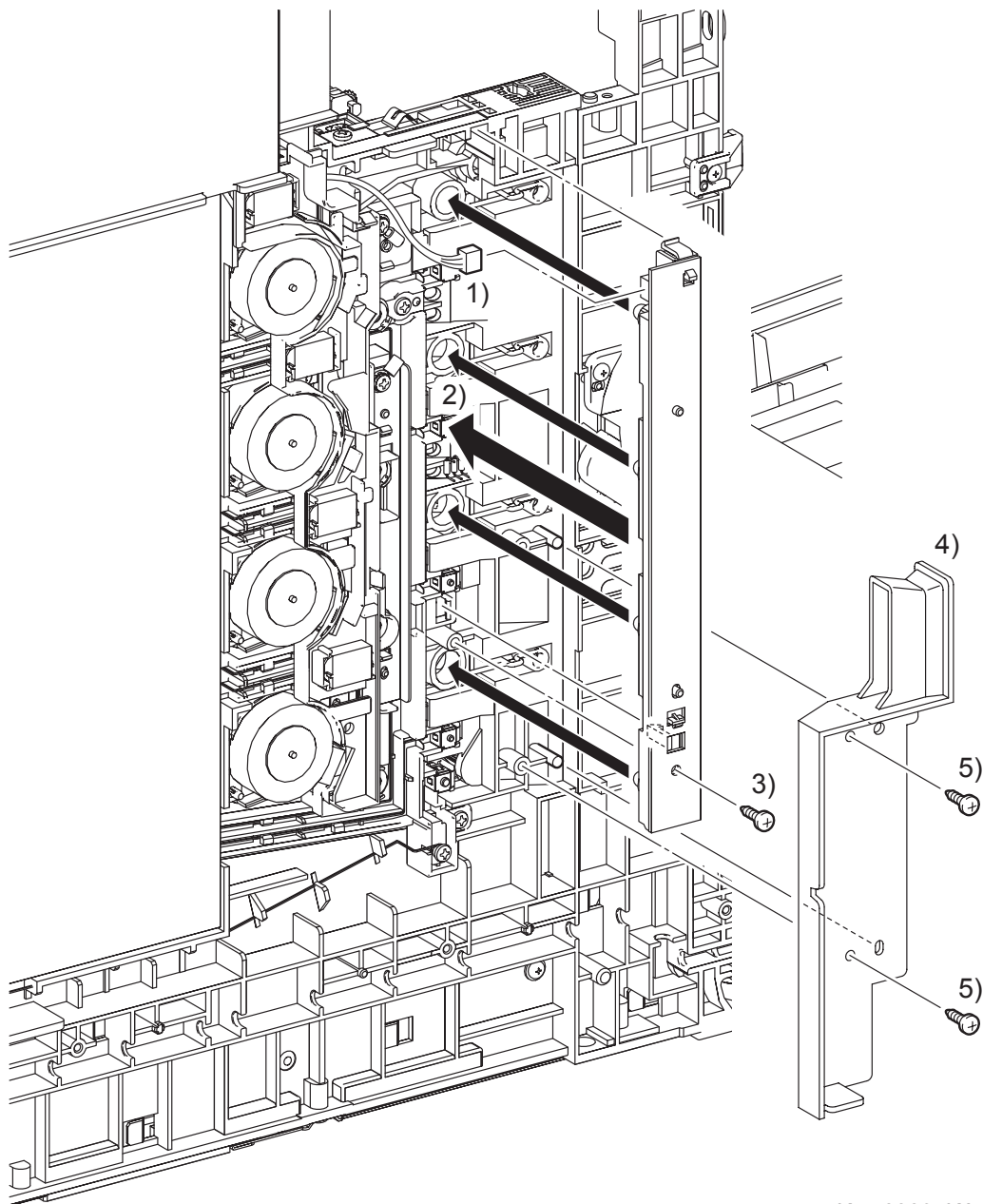

Kmy03097KA

- 1) Engage the connector (P/J141) of the LED ASSEMBLY.
- 2) Mate the four LEDs on the LED ASSEMBLY with the holes on the printer, and then secure the LED ASSEMBLY at the two hooks.
- 3) Fix the LED ASSEMBLY to the printer using the one screw (silver, tap, 10mm).
- 4) Replace the DUCT SIDE L by mating the two holes on the DUCT SIDE L with the bosses on the printer.
- 5) Secure the DUCT SIDE L to the printer using the two screws (silver, tap, 8mm).

Go to the next replacement step:

Replacement 63 LEFT COVER (PL13.1.10)

Replacement 22 LEFT ARM ASSEMBLY (PL7.1.97)

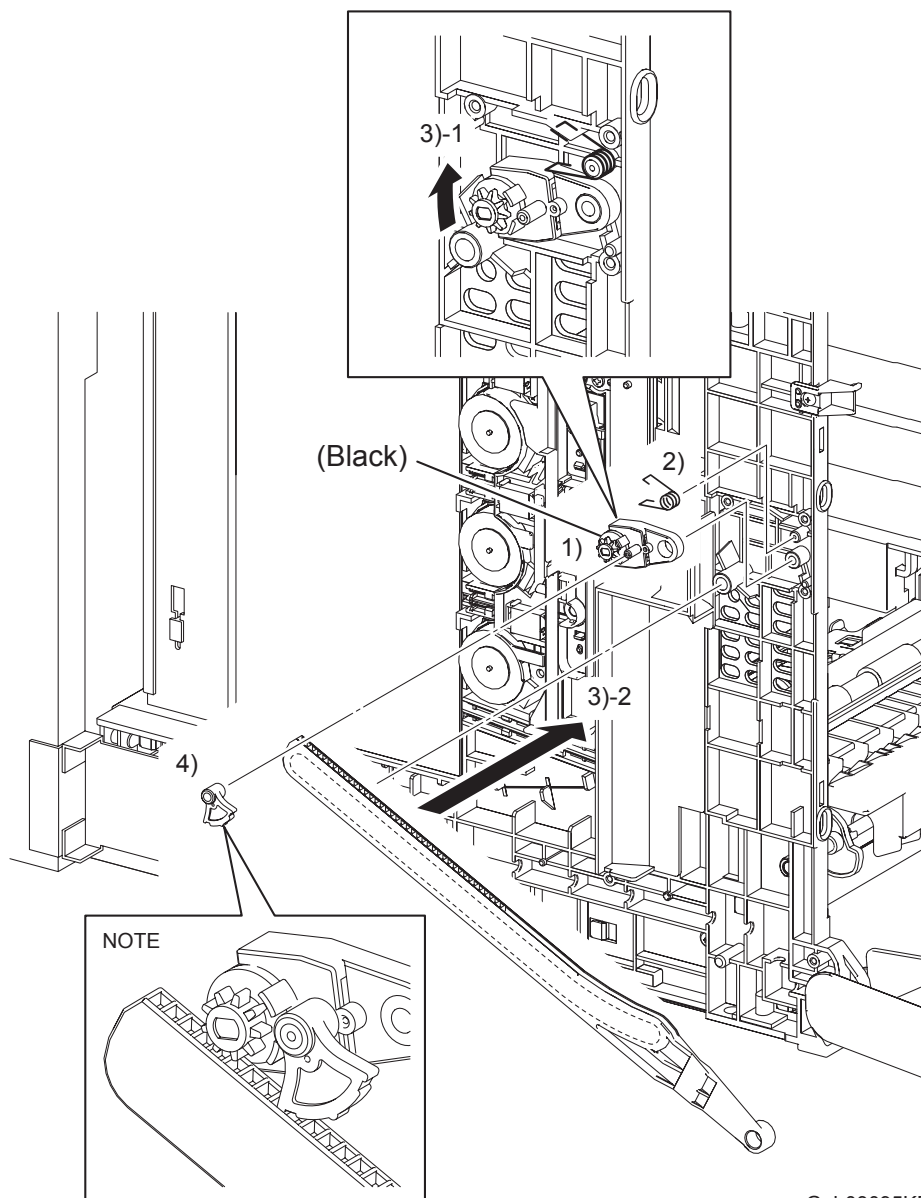

Gnb03095KB

NOTE

When the RIGHT ARM ASSEMBLY and LEFT ARM ASSEMBLY are removed at the same time, use caution not to confuse their securing positions.

The HOLDER DAMPER H and DAMPER OIL H for the RIGHT ARM ASSEMBLY are yellow, while the HOLDER DAMPER and DAMPER OIL for the LEFT ARM ASSEMBLY are black.

- 1) Replace the HOLDER DAMPER to the printer together with the DAMPER OIL.
- 2) Replace the SPRING SUPPORT to the printer
- 3) Replace the LINK L by mating the backside groove on the LINK L with the boss on the printer and pulling the DAMPER OIL slightly upward.

NOTE

When performing the step described below, pay attention to the orientation of the LEVER RELEASE. Ensure that the longer hollow boss of the LEVER RELEASE faces the HOLDER DAMPER.

- 4) Replace the LEVER RELEASE to the HOLDER DAMPER.

Continues to the next page.

Replacement 22 LEFT ARM ASSEMBLY (PL7.1.97)

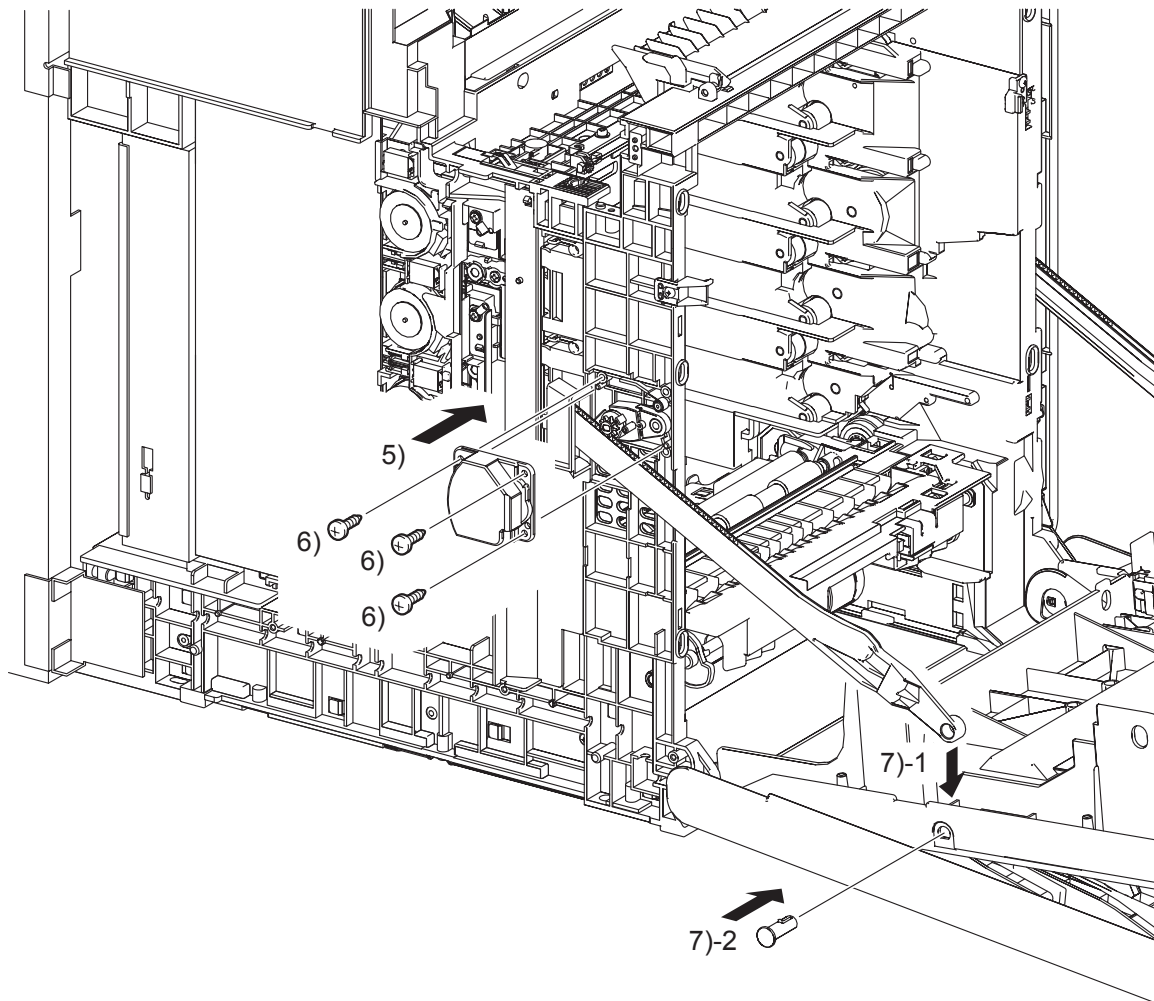

Gnb03096KA

- 5) Replace the SUPPORT LINK L by mating the two holes of the SUPPORT LINK L with the bosses on the printer.
- 6) Secure the SUPPORT LINK L using the three screws (silver, tap, 8mm).
- 7) Mate the fitting hole on the LINK L with the left side fitting hole on the FRONT COVER. Insert the SHAFT PIVOT and secure with the hook.

Go to the next replacement step:

Replacement 63 LEFT COVER (PL13.1.10)

Replacement 23 Blank

Replacement 24 Blank

Replacement 25 TONER CARTRIDGE SENSOR ASSEMBLY (C), (M), (Y) (PL5.1.4)

NOTE

Described below is the replacement procedure common among TONER CARTRIDGE SENSOR ASSYs (C), (M), and (Y).

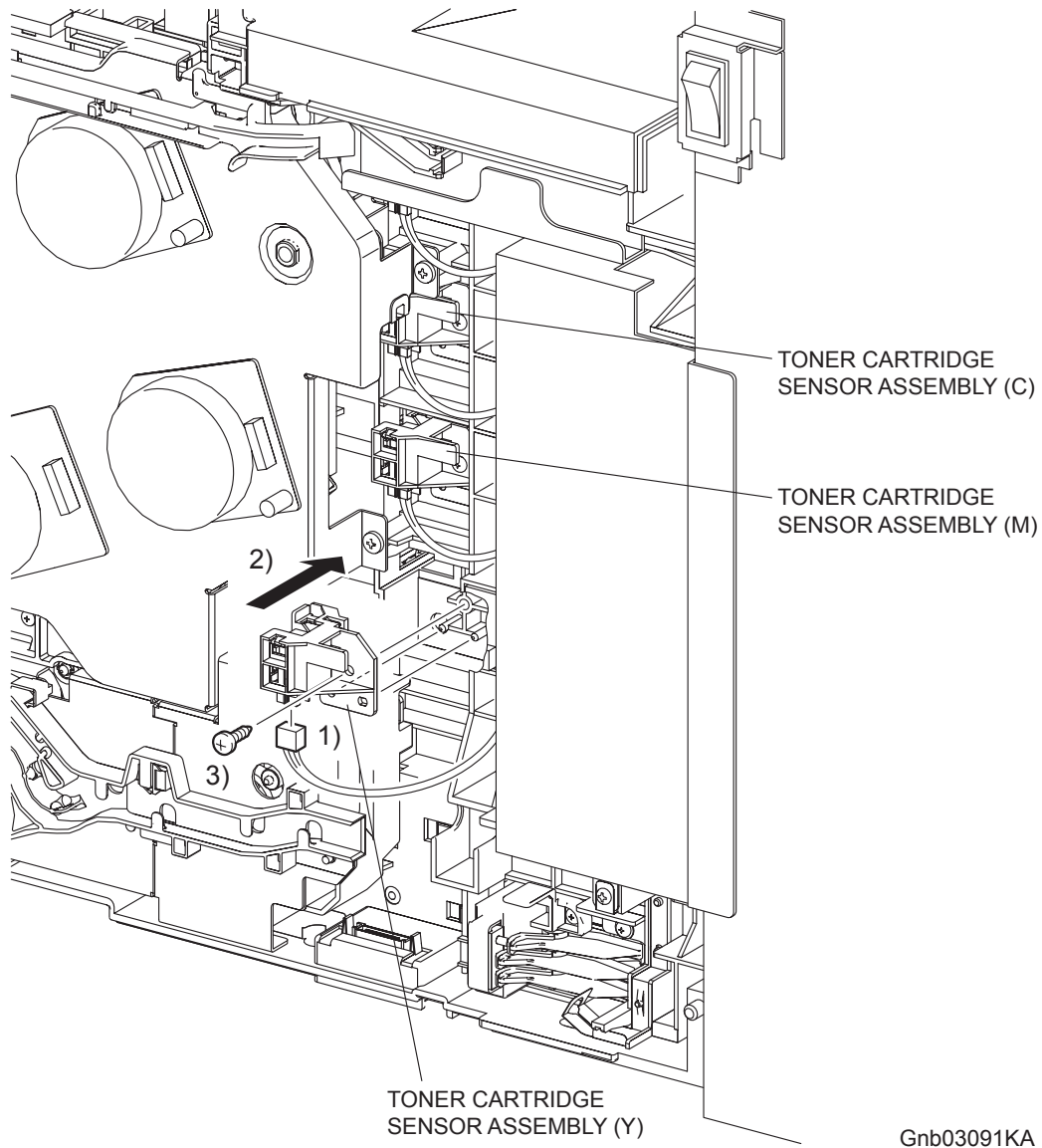

- 1) Engage the connector of the TONER CARTRIDGE SENSOR ASSEMBLY.
- 2) Mate the two holes on the TONER CARTRIDGE SENSOR ASSEMBLY with the bosses on the printer.
- 3) Secure the TONER CARTRIDGE SENSOR ASSEMBLY to the printer using the one screw (silver, tap, 10mm).

Go to the next replacement step:

Replacement 68 RIGHT COVER (PL13.1.9)

Replacement 26 Blank

Replacement 27 SIZE SWITCH ASSEMBLY (PL7.1.18)

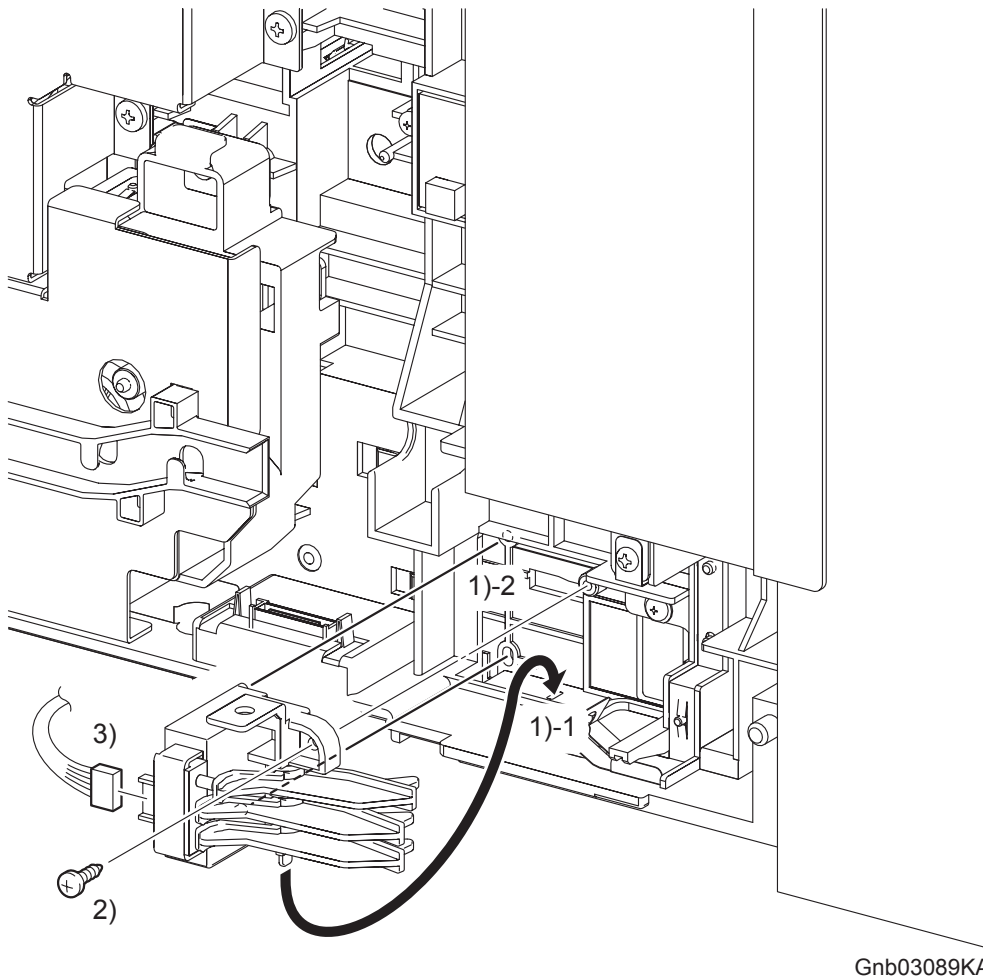

- 1) Insert the underside tab of the SIZE SWITCH ASSEMBLY into the hole on the printer and insert the two bosses of the SIZE SWITCH ASSEMBLY into the holes on the printer.
- 2) Secure the SIZE SWITCH ASSEMBLY to the printer using the one screw (silver, tap, 10mm).
- 3) Engage the connector (P/J231) of the SIZE SWITCH ASSEMBLY.

Go to the next replacement step:

Replacement 68 RIGHT COVER (PL13.1.9)

Replacement 28 RIGHT ARM ASSEMBLY (PL13.3.98)

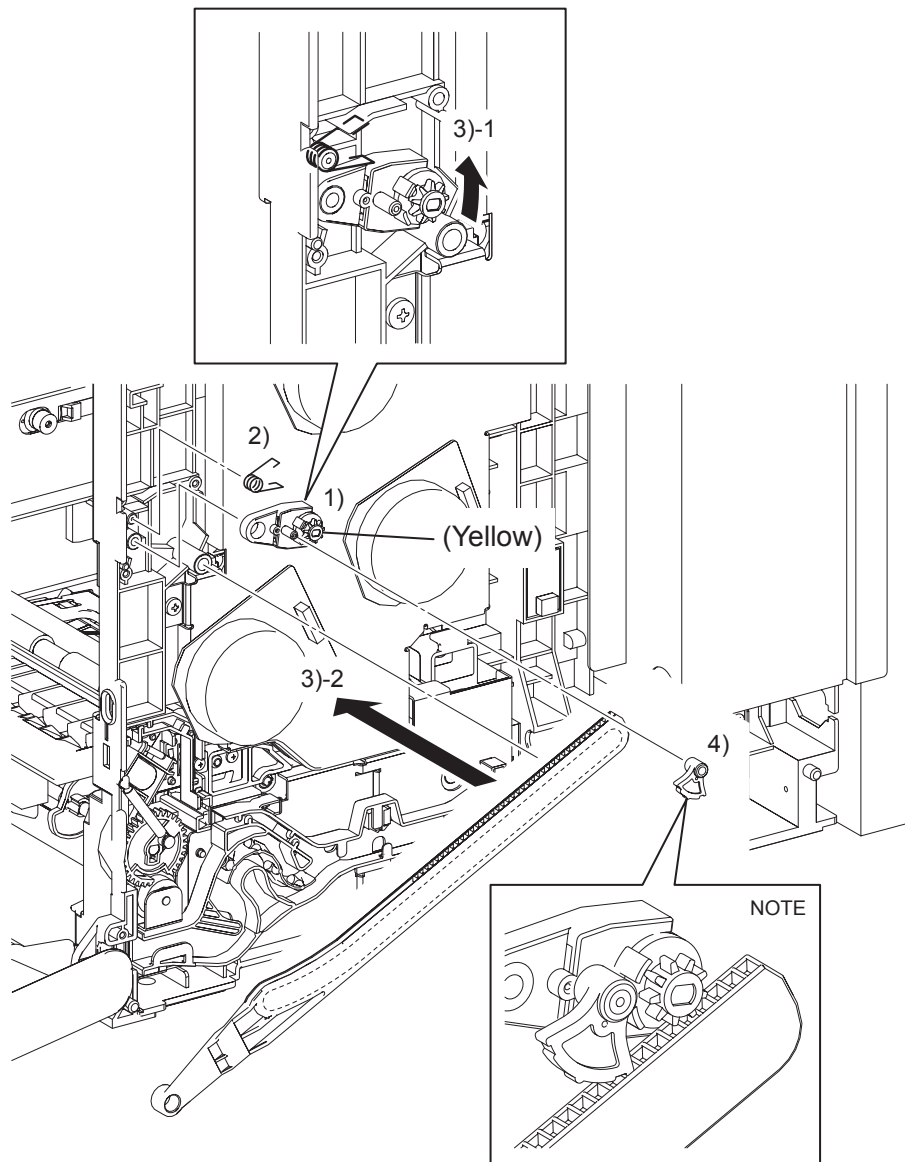

Gnb03087KB

NOTE

When the RIGHT ARM ASSEMBLY and LEFT ARM ASSEMBLY are removed at the same time, use caution not to confuse their securing positions.

The HOLDER DAMPER H and DAMPER OIL H for the RIGHT ARM ASSEMBLY are yellow, while the HOLDER DAMPER and DAMPER OIL for the LEFT ARM ASSEMBLY are black.

- 1) Replace the HOLDER DAMPER H to the printer together with the DAMPER OIL H.
- 2) Replace the SPRING SUPPORT to the printer.
- 3) Replace the LINK R by mating the backside groove on the LINK R with the boss on the printer and then pulling the DAMPER OIL H slightly upward.

NOTE

When performing the step described below, pay attention to the orientation of the LEVER RELEASE. Ensure that the longer hollow boss of the LEVER RELEASE faces the HOLDER DAMPER H.

- 4) Replace the LEVER RELEASE to the HOLDER DAMPER H.

Continues to the next page.

Replacement 28 RIGHT ARM ASSEMBLY (PL13.3.98)

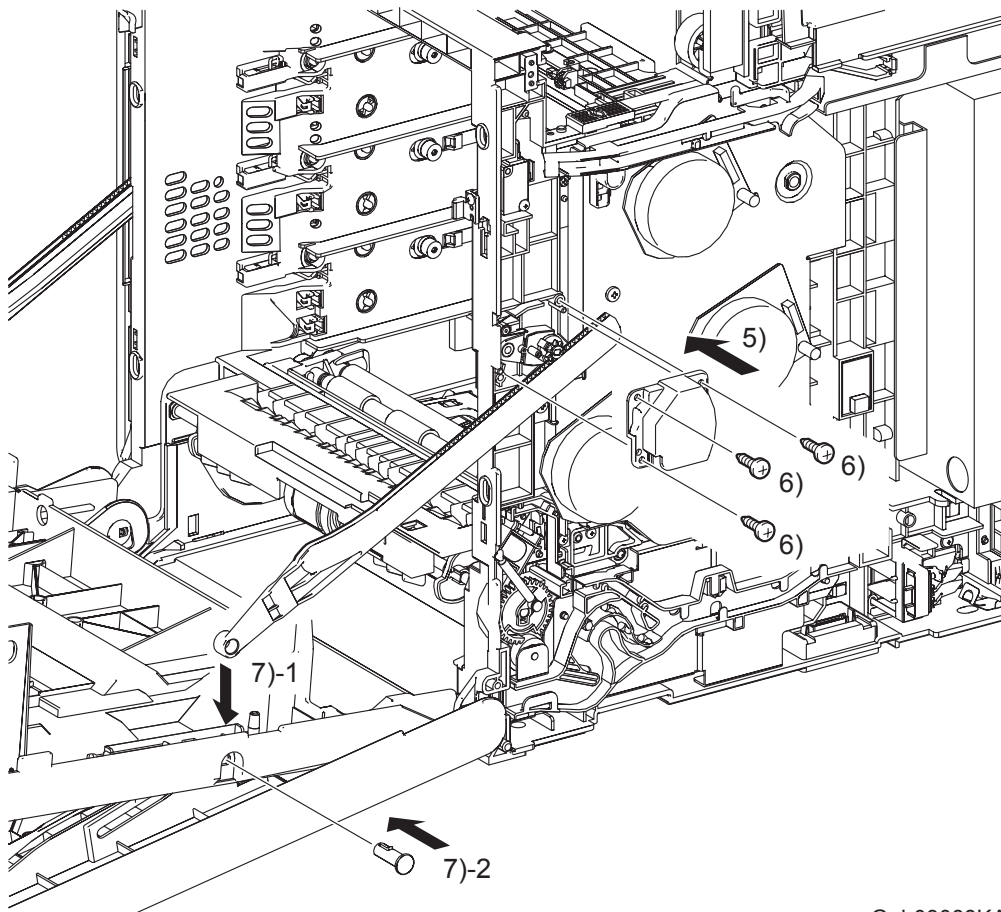

Gnb03088KA

- 5) Replace the SUPPORT LINK R by mating the two holes on the SUPPORT LINK R with the bosses on the printer.
- 6) Secure the SUPPORT LINK R to the printer using the three screws (silver, tap, 8mm).
- 7) Mate the fitting hole on the LINK R with the right side fitting hole on the FRONT COVER. Insert the SHAFT PIVOT and secure using the hook.

Go to the next replacement step:

Replacement 68 RIGHT COVER (PL13.1.9)

Replacement 29 Blank

Replacement 30 INTEGRATED FEEDER ASSEMBLY (PL3.2.99)

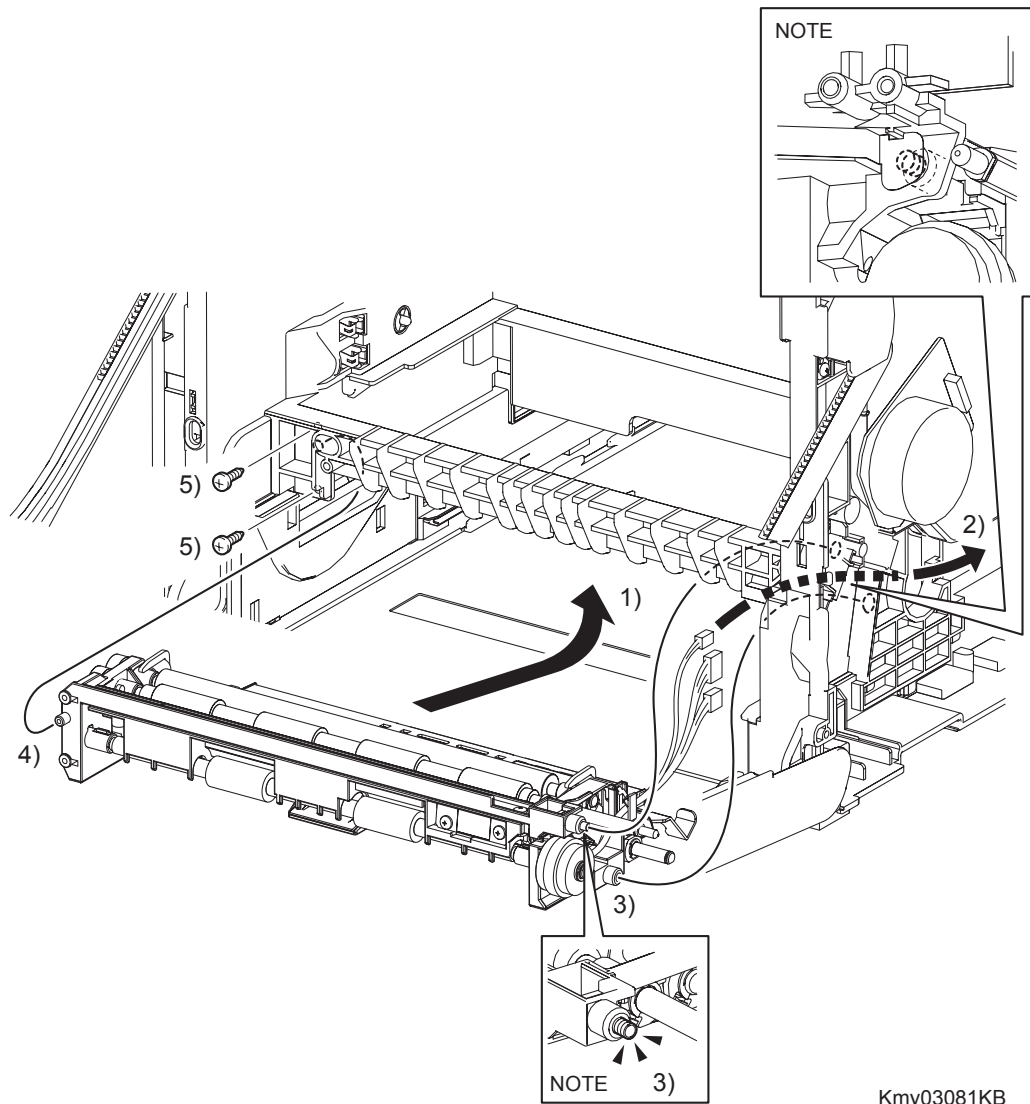

Kmy03081KB

NOTE

When performing the step described below, take care not to drop and lose the SPRING EARTH on the right side of the INTEGRATED FEEDER ASSEMBLY.

NOTE

When performing the step described below, check that the SPRING EARTH on the right side of the INTEGRATED FEEDER ASSEMBLY is in contact with the PLATE EARTH of the printer.

- 1) Insert the INTEGRATED FEEDER ASSEMBLY diagonally into the printer so that the right side of the INTEGRATED FEEDER ASSEMBLY goes in first.
- 2) Route the harness with the two connectors coming from the INTEGRATED FEEDER ASSEMBLY and the connector of the CLUTCH ASSY PH TURN out of the hole on the printer from inside.
- 3) Insert the bearing, the clutch and the two bosses (One is provided with the SPRING EARTH.) on the right side of the INTEGRATED FEEDER ASSEMBLY to the holes on the printer.
- 4) Insert the left side boss of the INTEGRATED FEEDER ASSEMBLY into the hole on the printer.
- 5) Secure the INTEGRATED FEEDER ASSEMBLY to the printer using the two screws (silver, tap, 10mm).

Continues to the next page.

Replacement 30 INTEGRATED FEEDER ASSEMBLY (PL3.2.99)

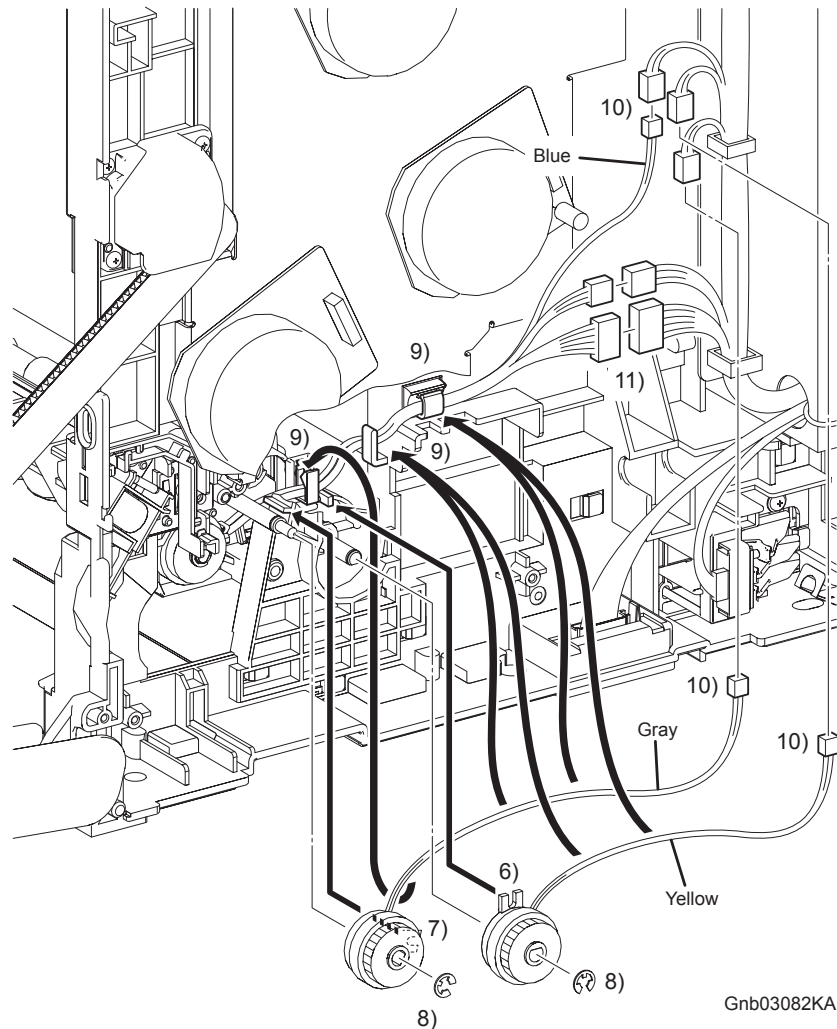
**NOTE**

When replacing the CLUTCH, match the harness color of the CLUTCH with that of the fitting groove of the CLUTCH.

The harness color of the CLUTCH ASSY PH REGI is gray.

The harness color of the CLUTCH ASSY PH FEED is yellow.

The harness color of the CLUTCH ASSY PH TURN is blue.

- 6) Replace the CLUTCH ASSY PH FEED to the INTEGRATED FEEDER ASSEMBLY by mating the fitting groove the CLUTCH ASSY PH FEED with the lug on the INTEGRATED FEEDER ASSEMBLY.
- 7) Replace the CLUTCH ASSY PH REGI to the printer by mating the fitting groove on the CLUTCH ASSY PH REGI with the lug on the printer.
- 8) Replace the CLUTCH ASSY PH REGI and CLUTCH ASSY PH FEED to the INTEGRATED FEEDER ASSEMBLY using the e-rings.
- 9) Route the harnesses along the printer and bind them with the clamps on the INTEGRATED FEEDER ASSEMBLY and the printer.

NOTE

When engaging the connectors of the CLUTCHes, match the color of the CLUTCH harness with that of the harness on the printer side.

- 10) Engage the connector (P/J233) of the CLUTCH ASSY PH REGI, the connector (P/J235) of the CLUTCH ASSY PH FEED, and the connector (P/J234) of the CLUTCH ASSY PH TURN.
- 11) Engage the connectors (P/J232 and P/J241) of the INTEGRATED FEEDER ASSEMBLY.

Continues to the next page.

Replacement 30 INTEGRATED FEEDER ASSEMBLY (PL3.2.99)

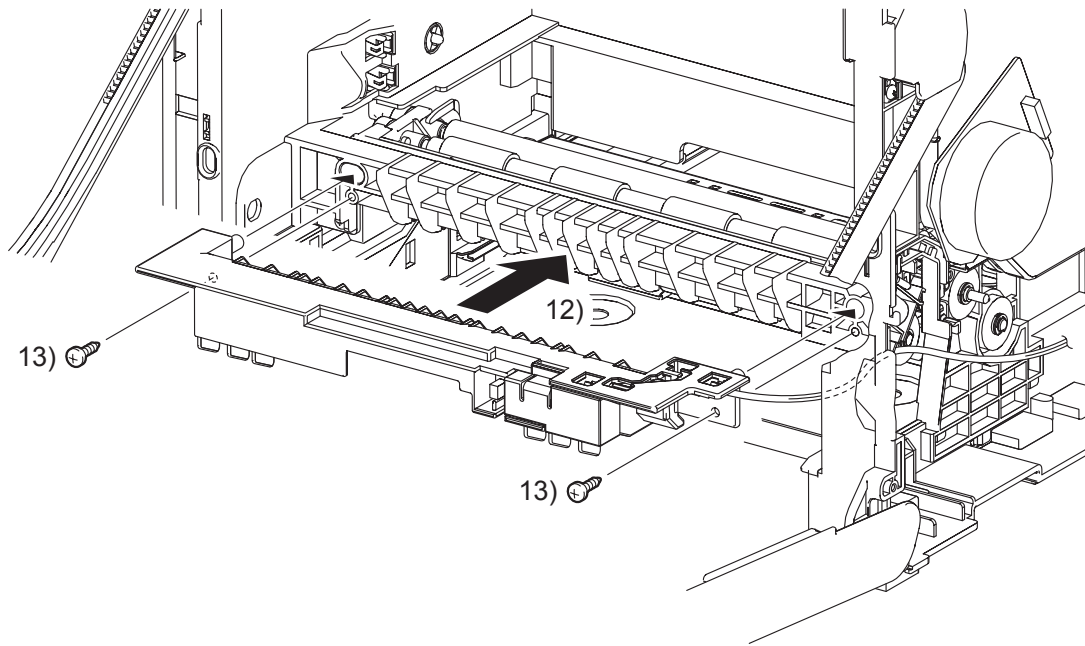

Kmy03083KB

NOTE

When performing the step described below, ensure that the harness will not be caught between the CHUTE MSI and the printer.

- 12) Replace the CHUTE MSI by mating the two bosses on the CHUTE MSI with the holes on the printer.
- 13) Secure the CHUTE MSI to the printer using the two screws (silver, tap, 10mm).

Continues to the next page.

Replacement 30 INTEGRATED FEEDER ASSEMBLY (PL3.2.99)

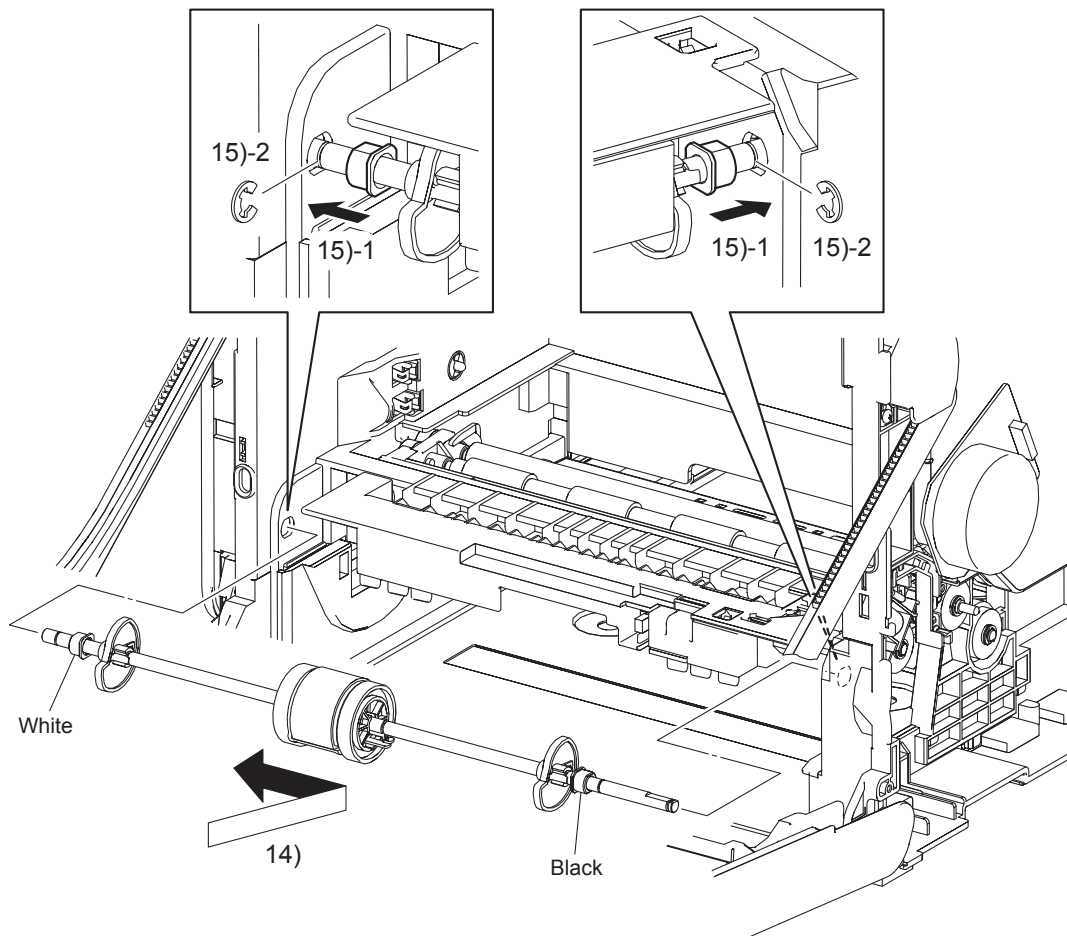

Kmy03084KB

NOTE

When performing the step described below, ensure that the color of each BEARING is correct.

The color of the right BEARING is black.

The color of the left BEARING is white.

- 14) Replace the ROLL ASSY MSI to the printer by inserting the right and left ends of the ROLL ASSY MSI into the holes on the printer.
- 15) Slide the left and right of the BEARINGs outward into the holes on the printer, and secure using the e-rings.

Go to the next replacement step:

Replacement 31 FEED DRIVE ASSEMBLY (PL8.1.7)

Replacement 31 FEED DRIVE ASSEMBLY (PL8.1.7)

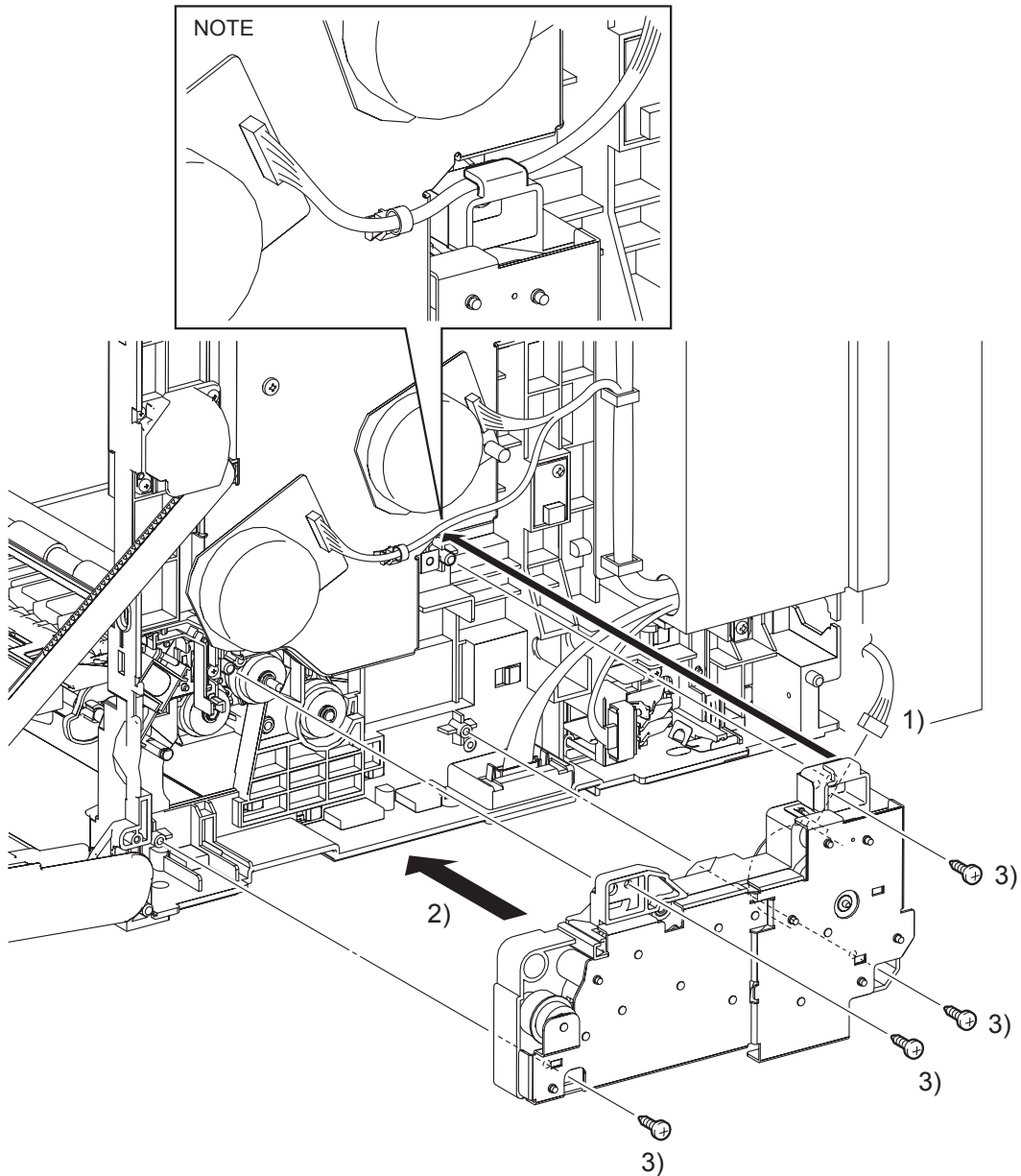

Gnb03078KA

- 1) Engage the connector (P/J251) of the FEED DRIVE ASSEMBLY.

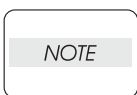

When performing the step described below, the harness of the connector to be engaged to the DEVE MOTOR of the PHOTOCONDUCTOR (PC) / DEVELOPER (DEV) DRIVE (PL8.1.2) must be routed through the hook above the FEED DRIVE ASSEMBLY.

- 2) Replace the FEED DRIVE ASSEMBLY by mating the two holes of the FEED DRIVE ASSEMBLY with the bosses on the printer.
- 3) Secure the FEED DRIVE ASSEMBLY to the printer using the four screws (silver, tap, 10mm).

Continues to the next page.

Replacement 31 FEED DRIVE ASSEMBLY (PL8.1.7)

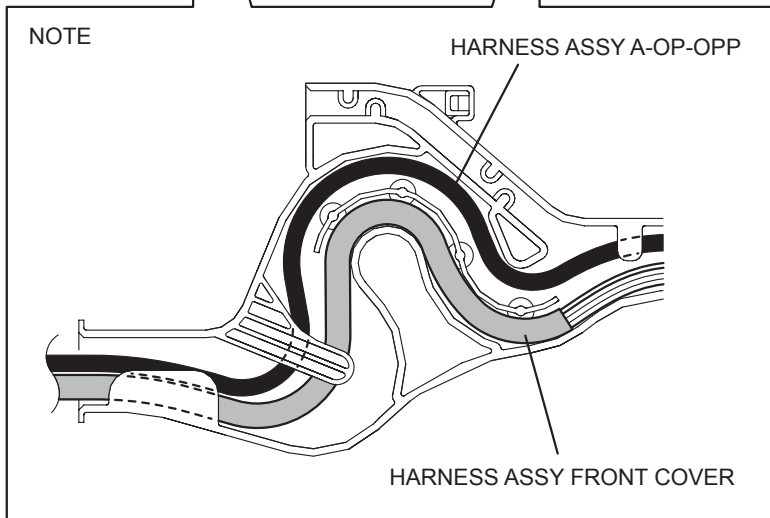
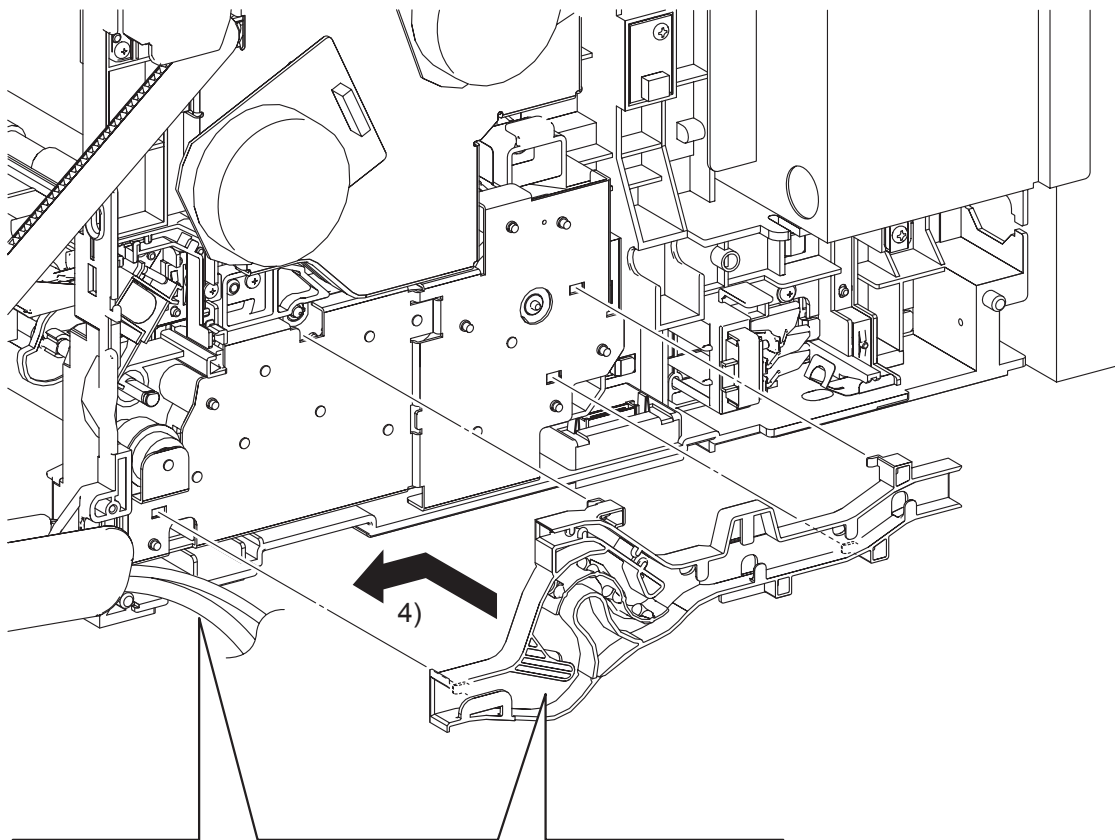

Gnb03079KB

- 4) Mate the four hooks on the DUCT DRV PH with the holes on the FEED DRIVE ASSY. Secure the DUCT DRV PH by moving it frontward allowing the hooks to lock into place.

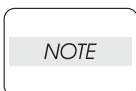

When performing the step below, route the HARNESS ASSY A-OP-OPP over the HARNESS ASSY FRONT COVER.

- 5) Route all the harnesses along the DUCT DRV PH.

Continues to the next page.

Replacement 31 FEED DRIVE ASSEMBLY (PL8.1.7)

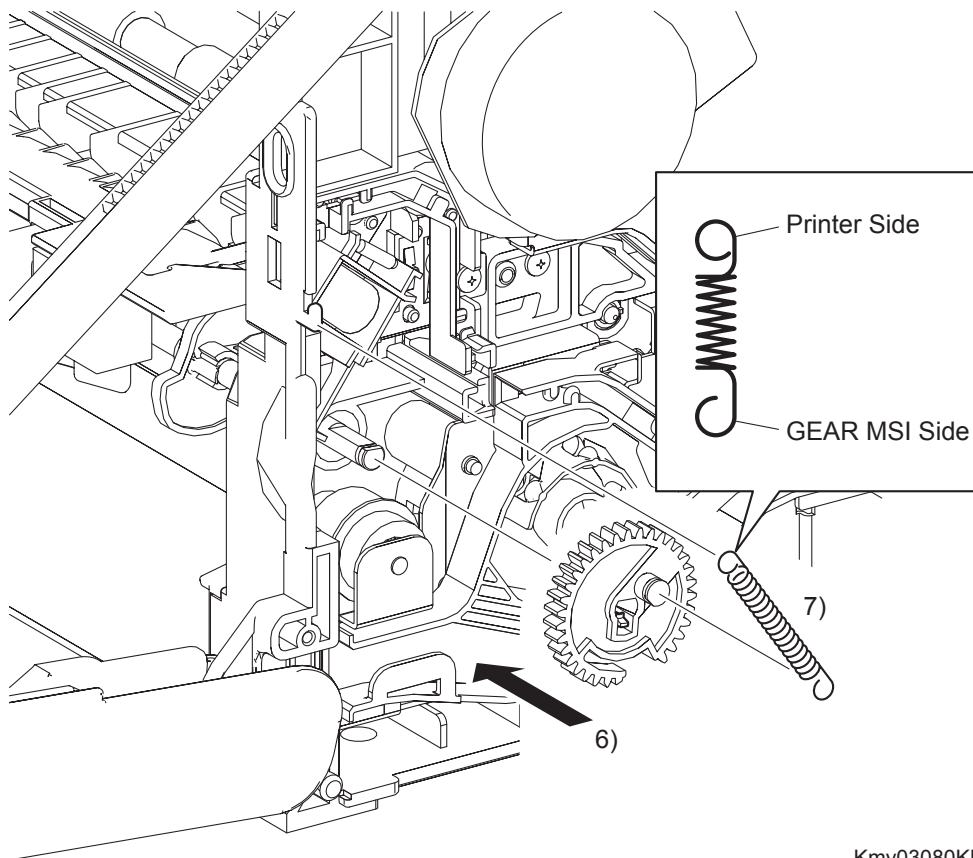

Kmy03080KB

NOTE

When performing the step described below, turn the flat surface of the SHAFT MSI face upward for ease of work.

- 6) Replace the GEAR MSI to the SHAFT MSI and lock the hook of the GEAR MSI into the groove of the SHAFT MSI.

NOTE

When performing the step described below, pay attention to the orientation of the SPRING FEED MSI. Ensure that the longer J-shaped hook of the SPRING FEED MSI is anchored to the GEAR MSI.

- 7) Anchor the SPRING FEED MSI to the GEAR MSI and the printer.

Go to the next replacement step:

Replacement 68 RIGHT COVER (PL13.1.9)

Replacement 32 MPF FEED SOLENOID (PL3.1.98)

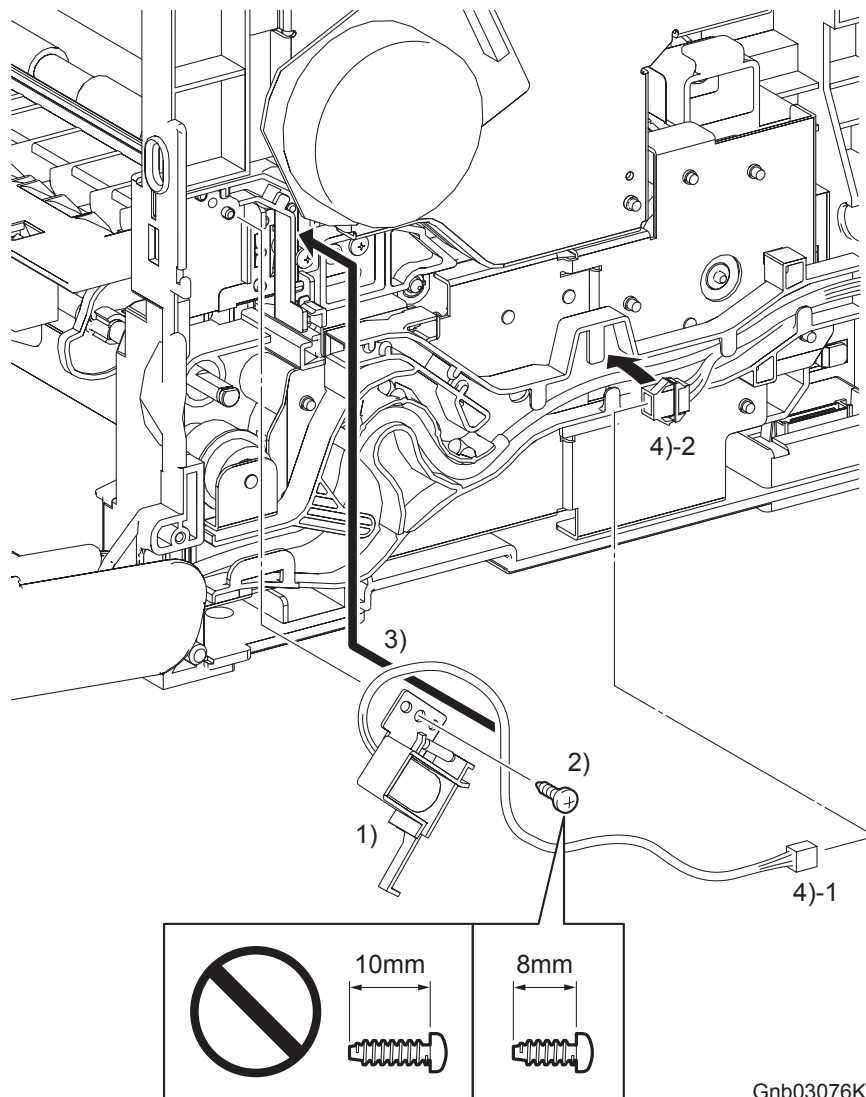

Gnb03076KB

- 1) Replace the MPF FEED SOLENOID to the printer by mating the two holes on the MPF FEED SOLENOID with the bosses on the printer.

NOTE

Ensure that 8mm screws are used to secure the MPF FEED SOLENOID. Use of 10mm screws will damage the frame.

- 2) Secure the MPF FEED SOLENOID to the printer using the one screw (silver, tap, 8mm).
- 3) Route the harness of the MPF FEED SOLENOID to the DUCT MSI SOL and DUCT DRV PH.

NOTE

The harness color of the MPF FEED SOLENOID (gray) does not match that of the printer (yellow).

- 4) Engage the connector (P/J256) of the MPF FEED SOLENOID.

Continues to the next page.

Replacement 32 MPF FEED SOLENOID (PL3.1.98)

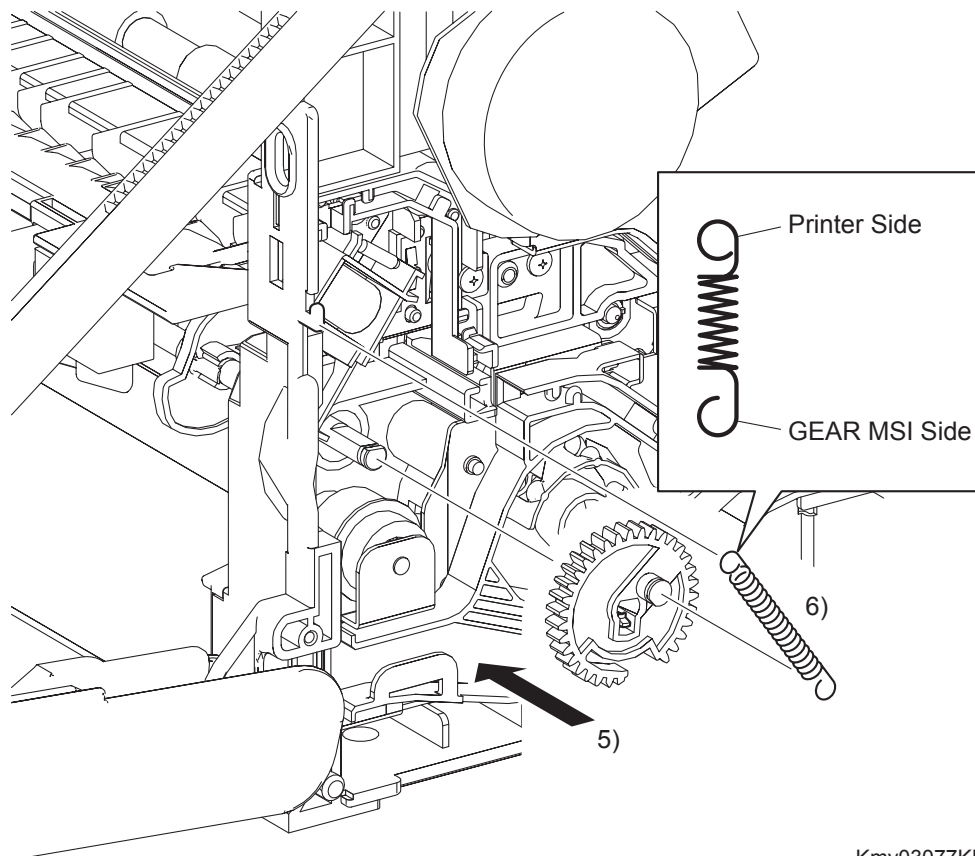

Kmy03077KB

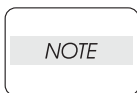

When carrying out the work shown below, it is easier to put the D-cut surface of the SHAFT MSI on the top.

- 5) Replace the GEAR MSI to the SHAFT MSI and lock the hook on the GEAR MSI into the groove on the SHAFT MSI.

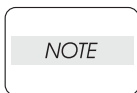

When carrying out the work shown below, pay attention to attach the SPRING FEED MSI in the right direction.

Attach the hyperelliptic side of the SPRING FEED MSI to the GEAR MSI.

- 6) Anchor the SPRING FEED MSI to the printer and GEAR MSI.

Go to the next replacement step:

Replacement 68 RIGHT COVER (PL13.1.9)

Replacement 33 Blank

Replacement 34 Blank

Replacement 35 Blank

Replacement 36 CHUTE ASSY EXIT OUT (PL6.1.1)

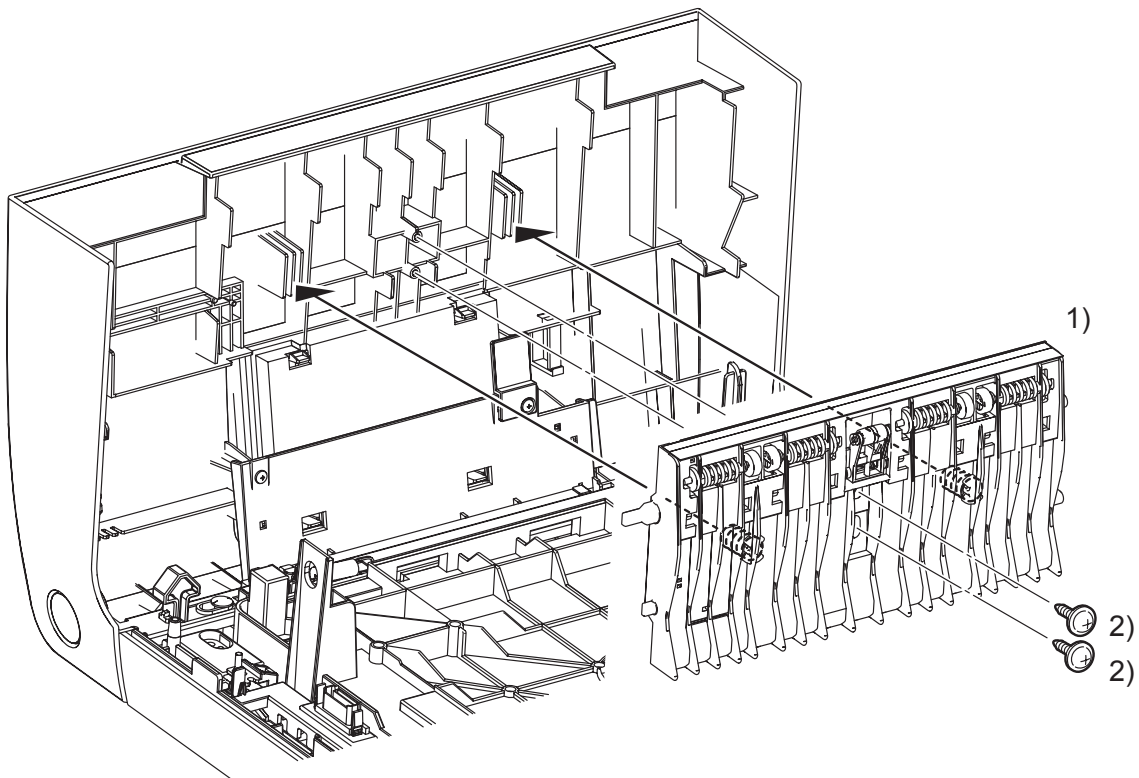

Kmy03072KA

- 1) Replace the CHUTE ASSY EXIT OUT to the FRONT COVER by mating the two springs of the CHUTE ASSY EXIT OUT with the ribs on the FRONT COVER.
- 2) Secure the CHUTE ASSY EXIT OUT to the FRONT COVER using the two screws (silver, with flange, tap, 10mm).
- 3) Close the FRONT COVER.

Replacement 37 SPUR ASSEMBLY (PL7.1.1)

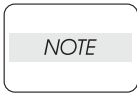

Described below is the removal procedure common between the left and right sides of the SPUR ASSEMBLY.

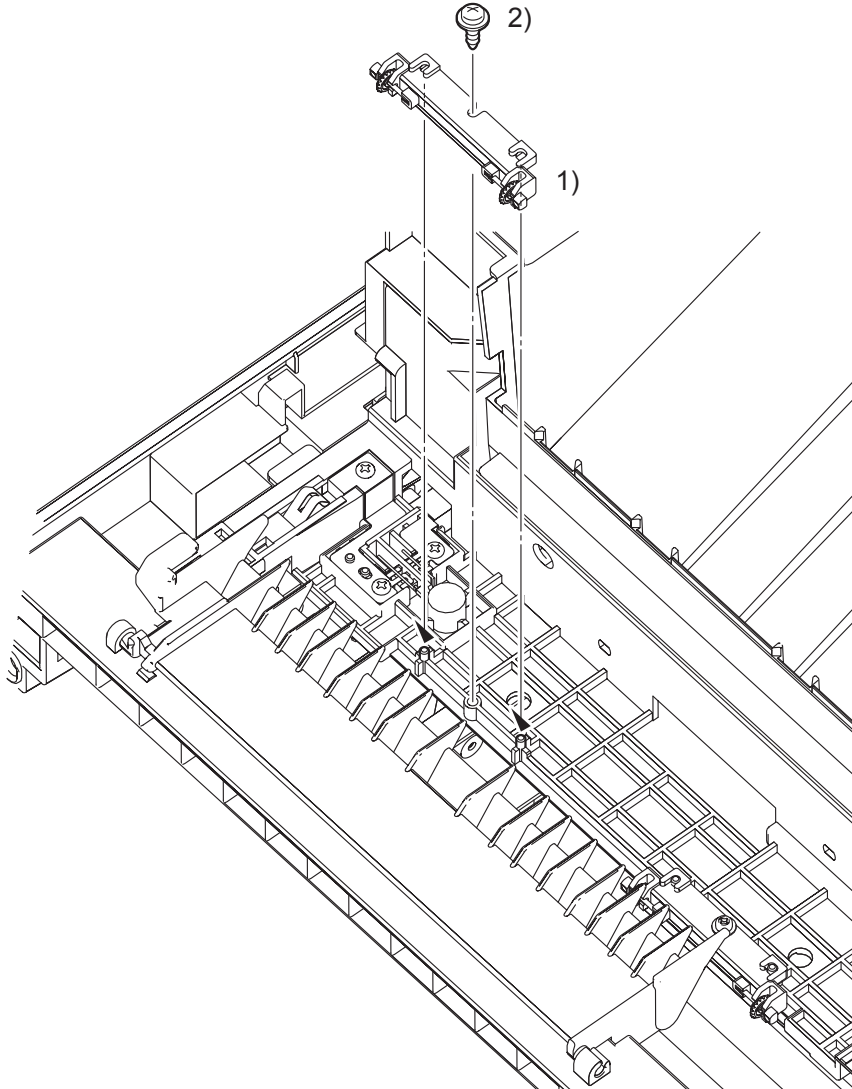

Kmy03071KA

- 1) Replace the SPUR ASSEMBLY to the printer by mating the two holes on the SPUR ASSEMBLY with the bosses on the printer.
- 2) Secure the SPUR ASSEMBLY to the printer with the one screw (silver, with flange, tap, 8mm).

**Go to the next replacement step:
Replacement 38 FUSER (PL6.1.10)**

Replacement 38 FUSER (PL6.1.10)

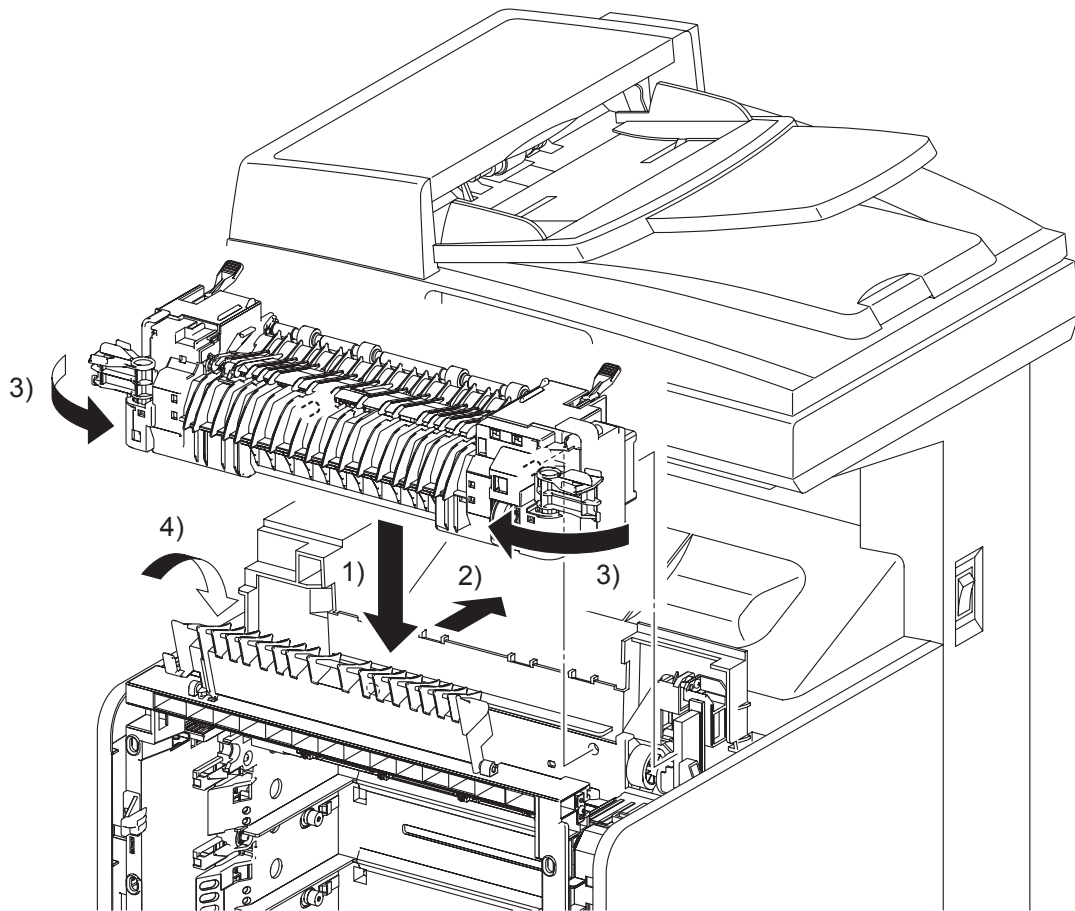

Gnb03070KA

- 1) Put the FUSER on the printer.
- 2) Insert the two rear side bosses of the FUSER into the holes on the printer by moving the FUSER slightly backward, engage the connector (P/J171) of the FUSER.
- 3) Rotate the left and right levers of the FUSER inward.
- 4) Close the DUPLEX GATE.
- 5) Close the FRONT COVER.

Replacement 39 DUPLEX GATE (PL6.1.13)

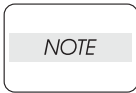

The FUSER part is very hot. Take added care not to get burned when performing the service operation.

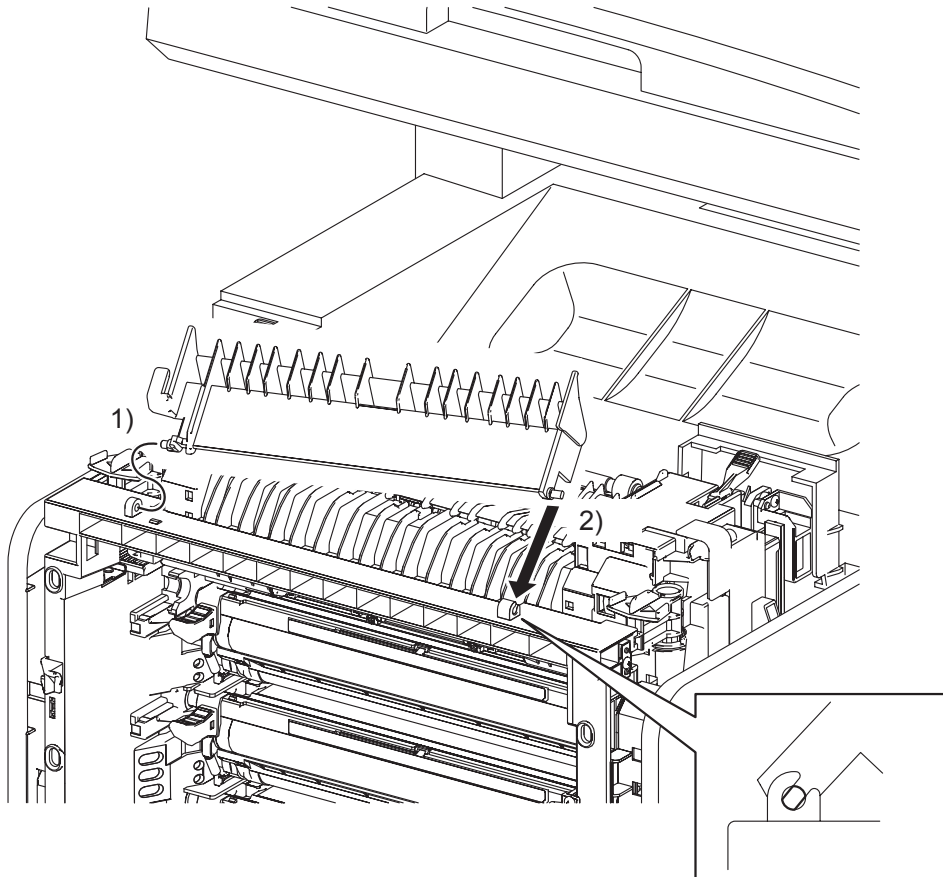

Gnb03069KA

- 1) Insert the left side boss of the DUPLEX GATE with the hole of the printer.
- 2) Open the DUPLEX GATE (PL6.1.13) to about 45 degrees so that the flat faces of the right side pivot of the DUPLEX GATE comes parallel with the U-shaped notch. Push in the right side pivot of the DUPLEX GATE into the U-shaped notch diagonally forward.
- 3) Close the DUPLEX GATE.
- 4) Close the FRONT COVER.

Replacement 40 TONER CARTRIDGE (K), (C), (M), (Y) (PL5.1.18 ~ 21)

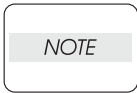

Described below is the replacement procedure common among TONER CARTRIDGES (C), (M), (Y), and (K).

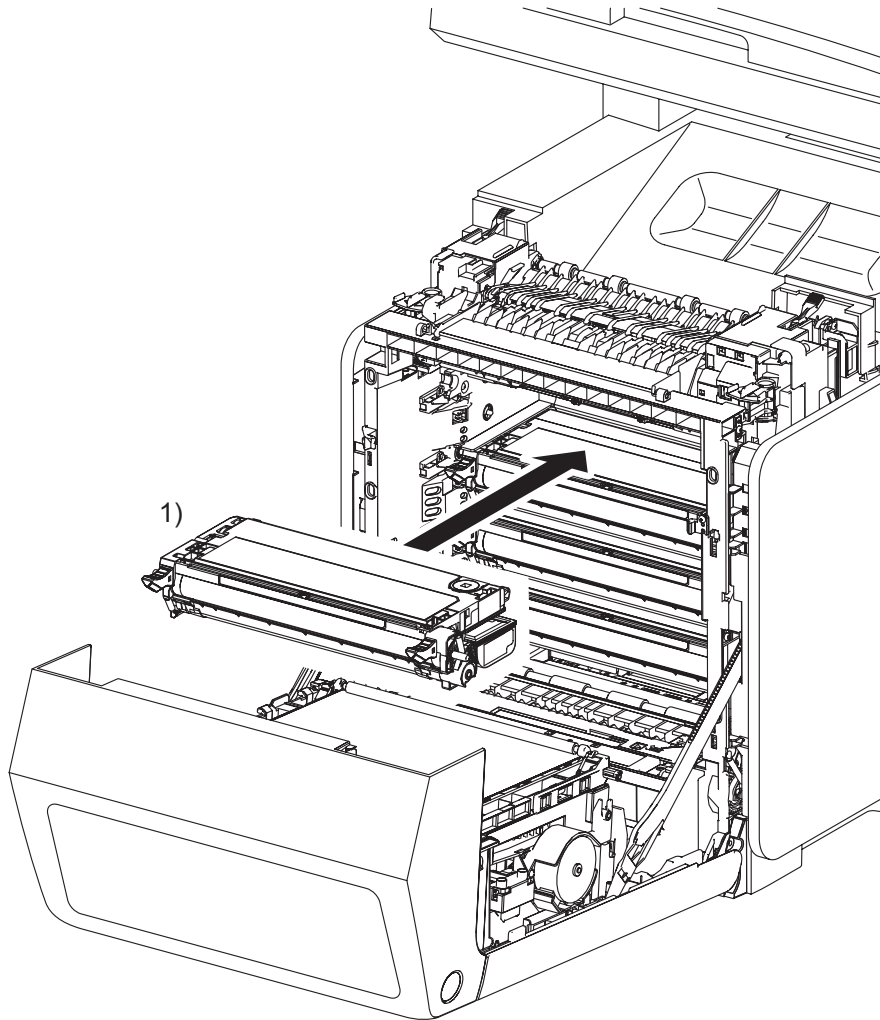

Gnb03068KA

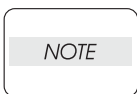

If all the TONER CARTRIDGES are removed, attach them in the order of Yellow, Magenta, Cyan, and Black from the bottom.

- 1) Replace the TONER CARTRIDGE inserting it by the left and right handles along the guide on the printer.
- 2) Close the FRONT COVER.

Replacement 41 DUPLEX MODULE (PL11.1.1)

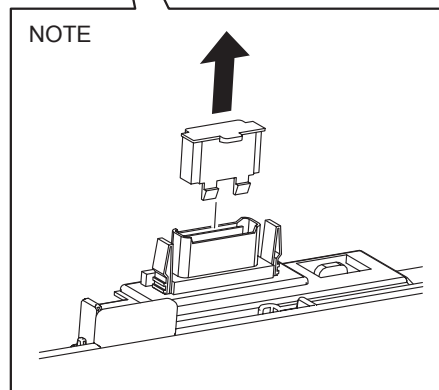
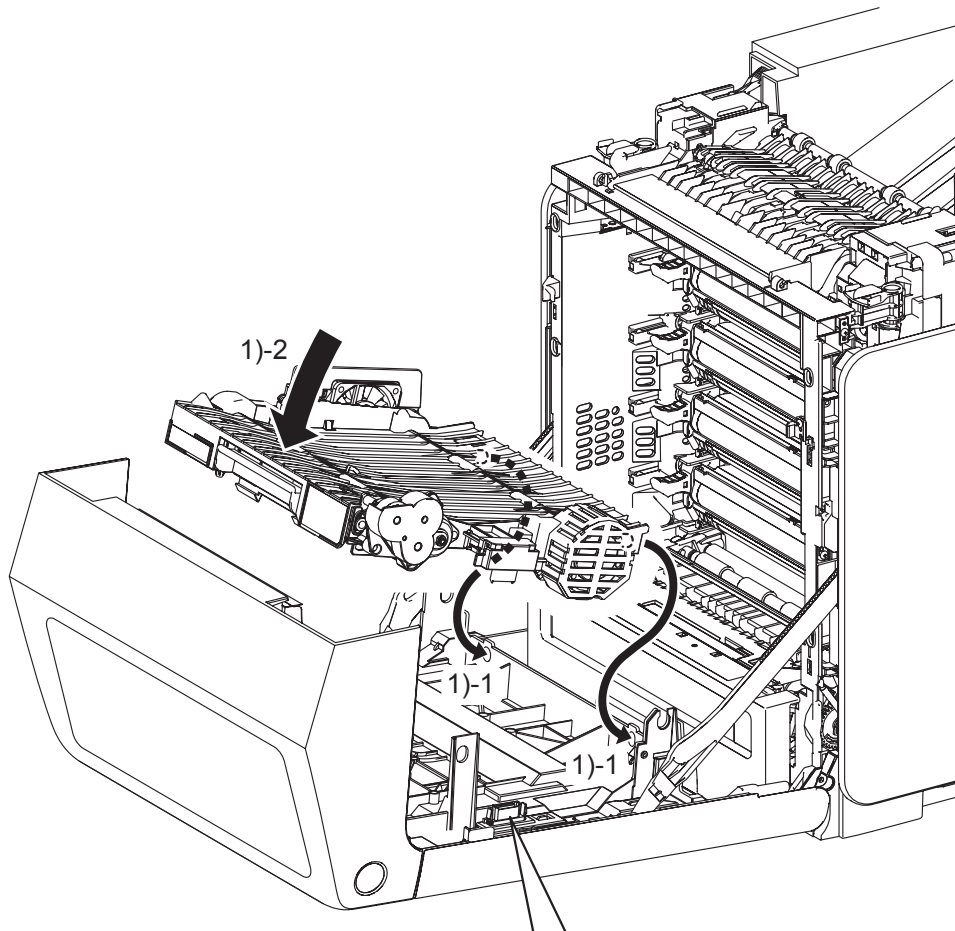

Gnb03067KB

NOTE

Remove the DUP CONNECTOR CAP (PL13.2.38) on the connector of the FRONT COVER when installing new DUPLEX MODULE.

- 1) Replace the DUPLEX MODULE slowly by mating the two backside bosses of the DUPLEX MODULE with the holes on the FRONT COVER, and then secure with the lever.

Go to the next replacement step:

Replacement 42 TRANSFER BELT (PL4.1.1)

Replacement 42 TRANSFER BELT (PL4.1.1)

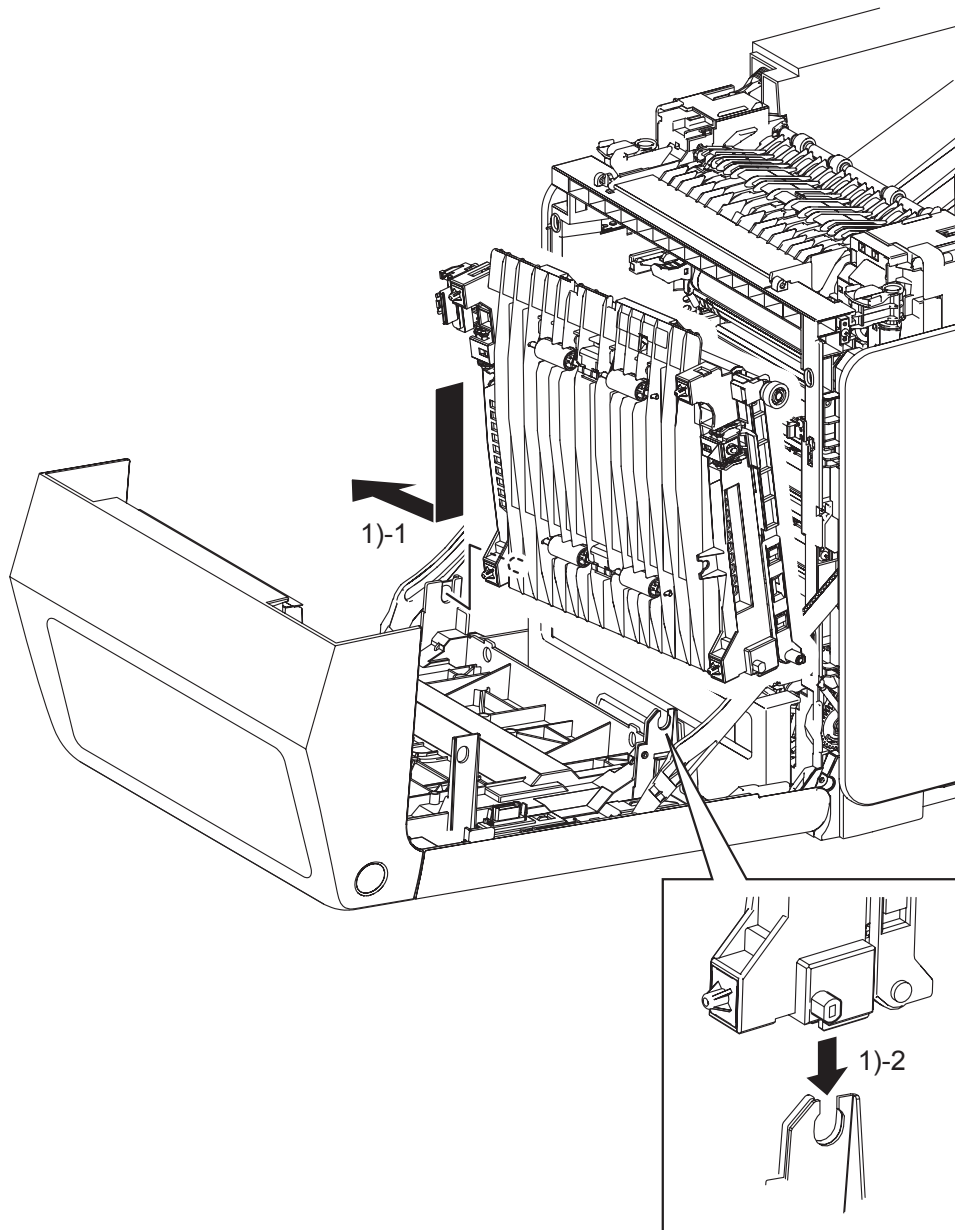

Gnb03065KA

- 1) Replace the TRANSFER BELT by inserting the left side boss on the TRANSFER BELT into the hole on the FRONT COVER and then inserting the right side boss on the TRANSFER BELT into the U-shaped groove on the FRONT COVER.

Continues to the next page.

Replacement 42 TRANSFER BELT (PL4.1.1)

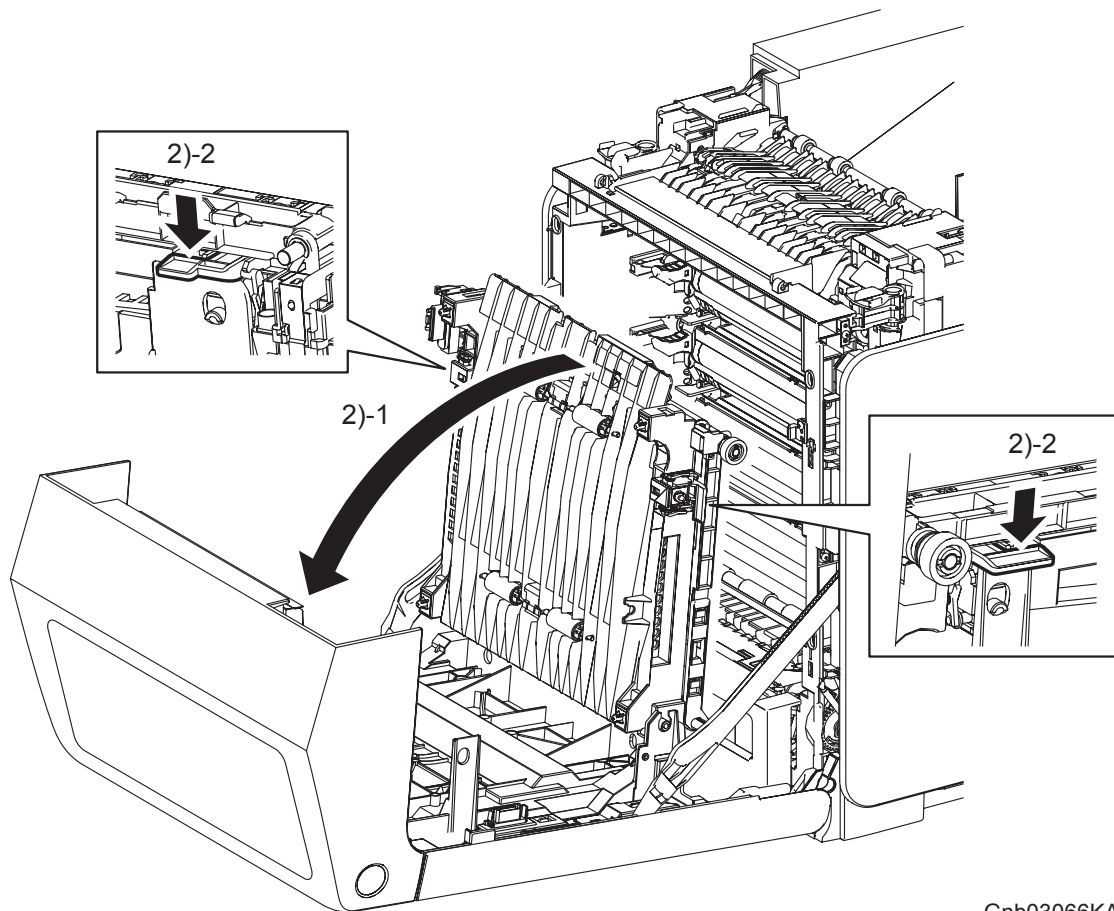

Gnb03066KA

- 2) Tilt the TRANSFER BELT slowly, and then secure with the left and right levers.
- 3) Close the FRONT COVER.

Replacement 43 TRAY REAR COVER (PL13.1.7)

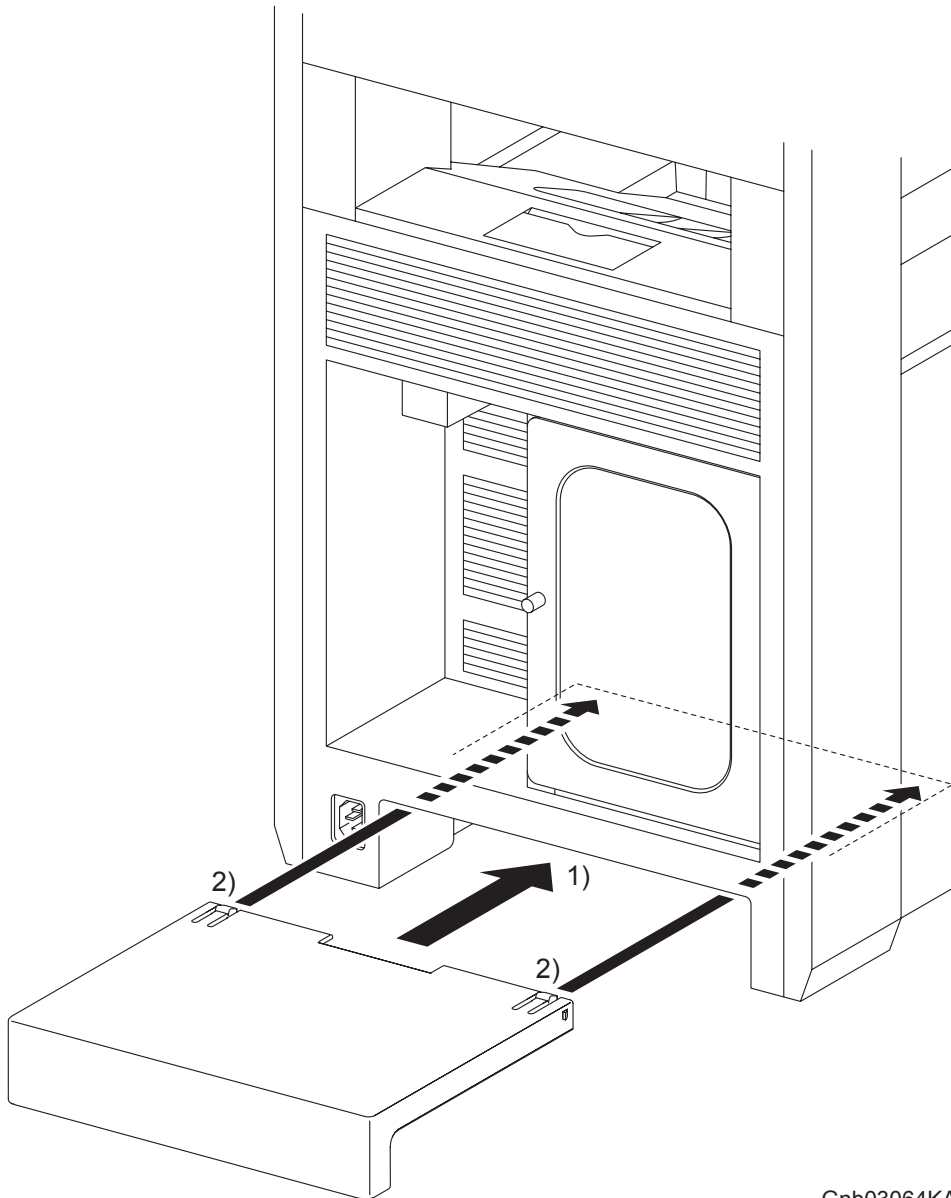

Gnb03064KA

- 1) Insert the TRAY REAR COVER into the printer.
- 2) Secure by locking the two front hooks on TRAY REAR COVER to the printer.

Replacement 44 MPF COVER (PL13.2.99)

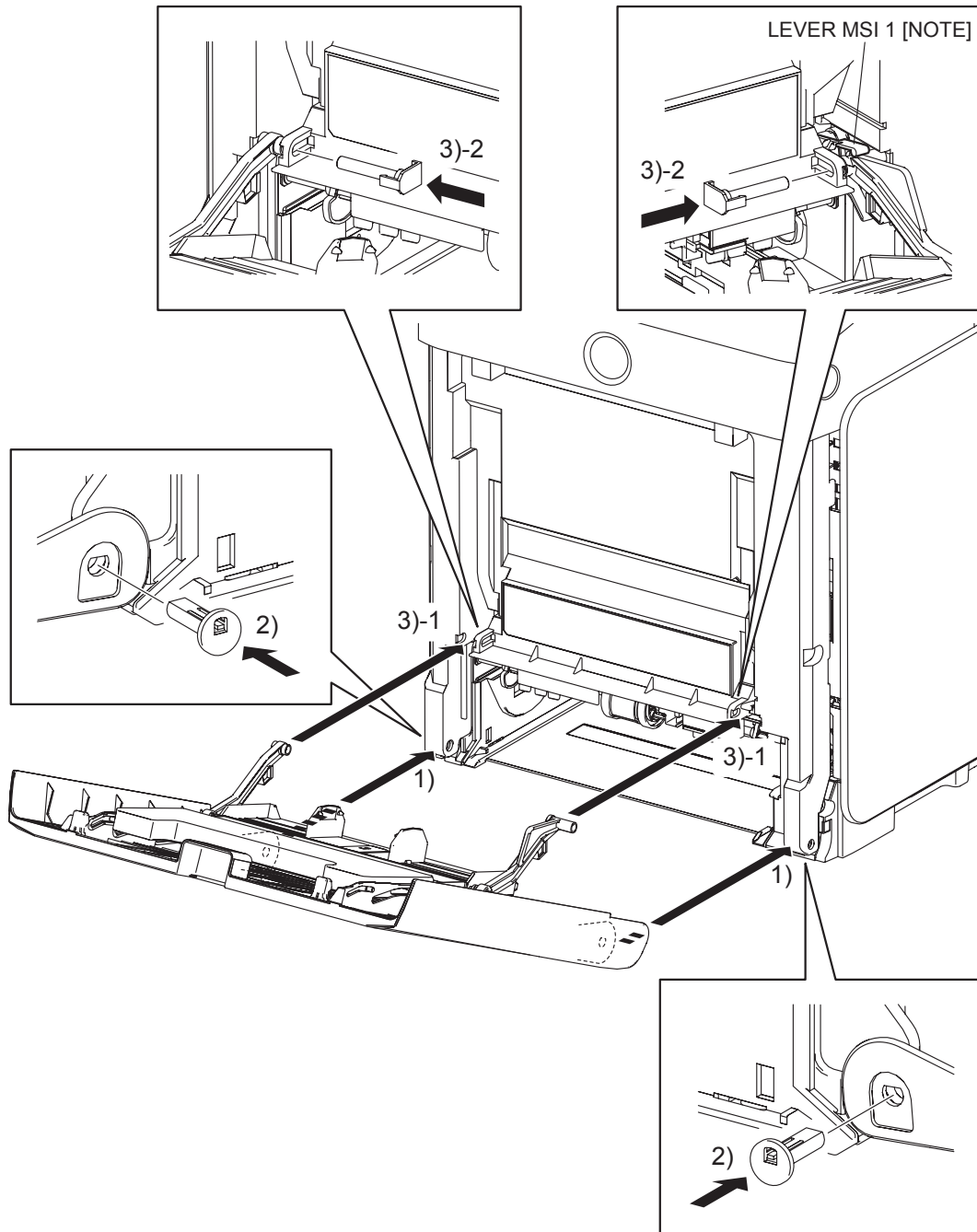

Kmy03063KA

Continues to the next page.

Replacement 44 MPF COVER (PL13.2.99)

- 1) Replace the MPF COVER to the FRONT COVER by mating the left and right side fitting holes on the MPF COVER with the holes on the FRONT COVER.
- 2) Insert the SHAFT PIVOT MSI into the left and right side fitting holes on the MPF COVER, and then secure the SHAFT PIVOT MSI with the hook.

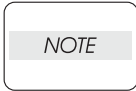

When performing the step described below, make sure that the LEVER MSI 1 is on the LINK ASSY MSI R.

- 3) Mate the LINK ASSY MSIs on the left and right sides of the MPF COVER with the fitting holes on the FRONT COVER. Insert the PIN PIVOT MSI and secure with the hook.
- 4) Close the MPF COVER.

Replacement 45 Blank

Replacement 46 MULTI PROTOCOL CARD (PL13.4.23)

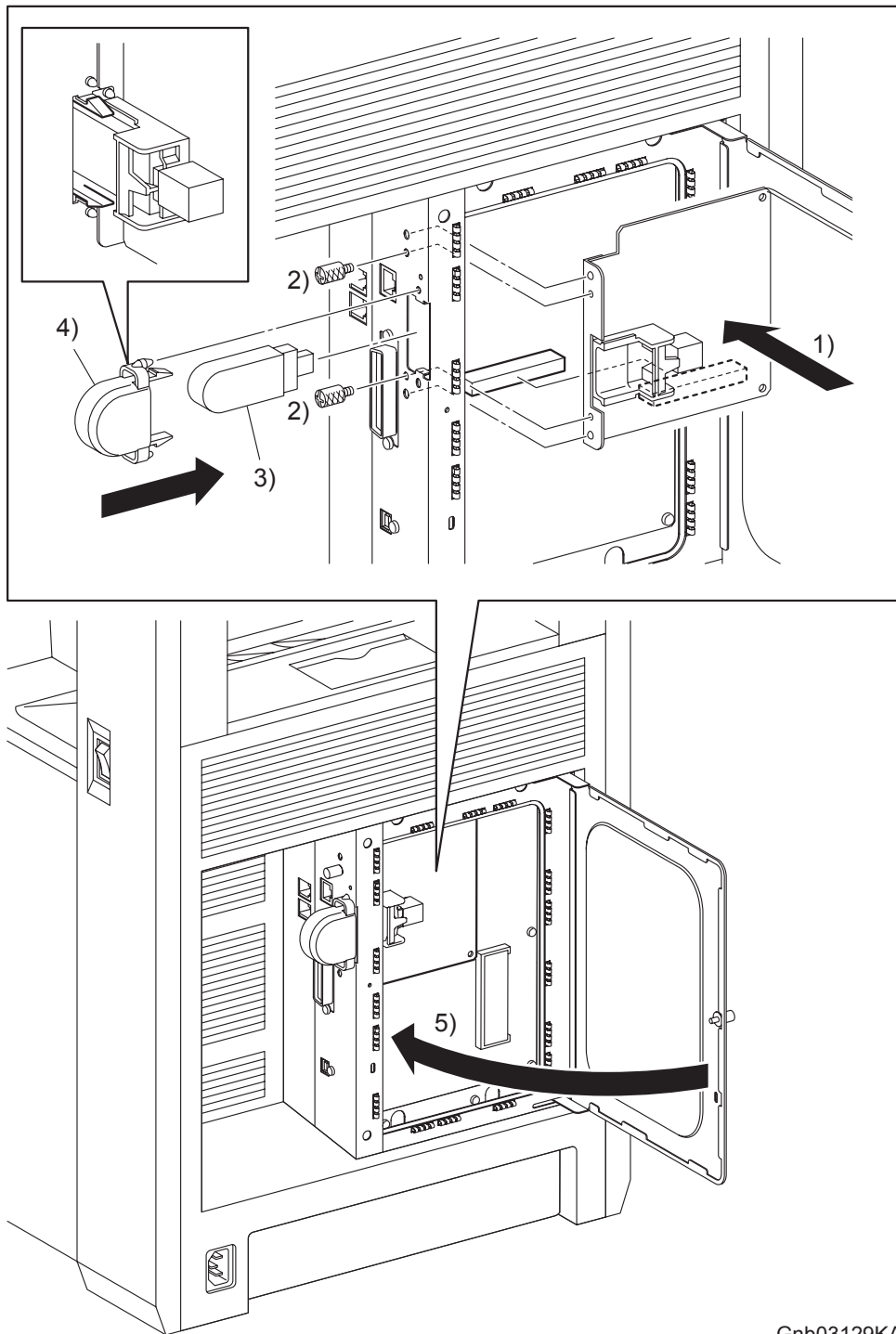

Gnb03129KA

- 1) Mate the two bosses on the MULTI PROTOCOL CARD with the holes on the printer, and then replace the MULTI PROTOCOL CARD to the ELECTRONIC SUB-SYSTEM CONTROL BOARD.
- 2) Secure the MULTI PROTOCOL CARD to the printer using the two SCREW KNURLINGS (PL13.4.12).
- 3) Replace the WIRELESS PRINTER ADAPTER to the MULTI PROTOCOL CARD.
- 4) Replace the COVER USB to the printer and secure with the hook.
- 5) Close the PLATE WINDOW ESS and secure the SCREW KNURLING.

Replacement 47 MEMORY CARD (PL13.4.22)

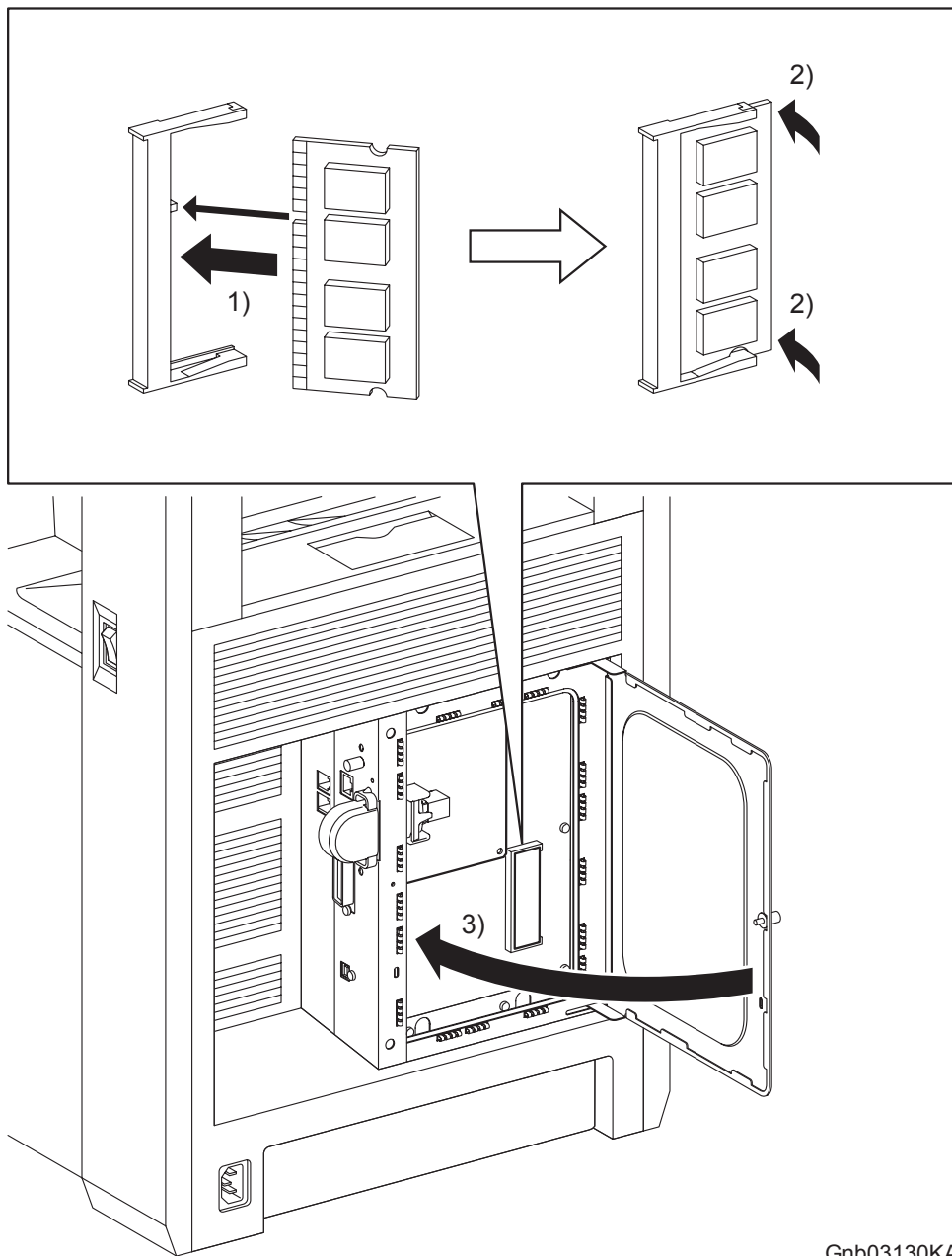

Gnb03130KA

- 1) Fit the MEMORY CARD into the socket by mating the notch of the MEMORY CARD with the lug on the socket.
- 2) Push the MEMORY CARD toward the ELECTRONIC SUB-SYSTEM CONTROL BOARD until it snaps into place.
- 3) Close the SHIELD WINDOW and secure the SCREW KNURLING.

Replacement 48 ADF FEED ROLLER (PL13.8.3), ADF SEPARATOR PAD (PL13.8.5),
ADF SEPARATOR SPRING (PL13.8.6)

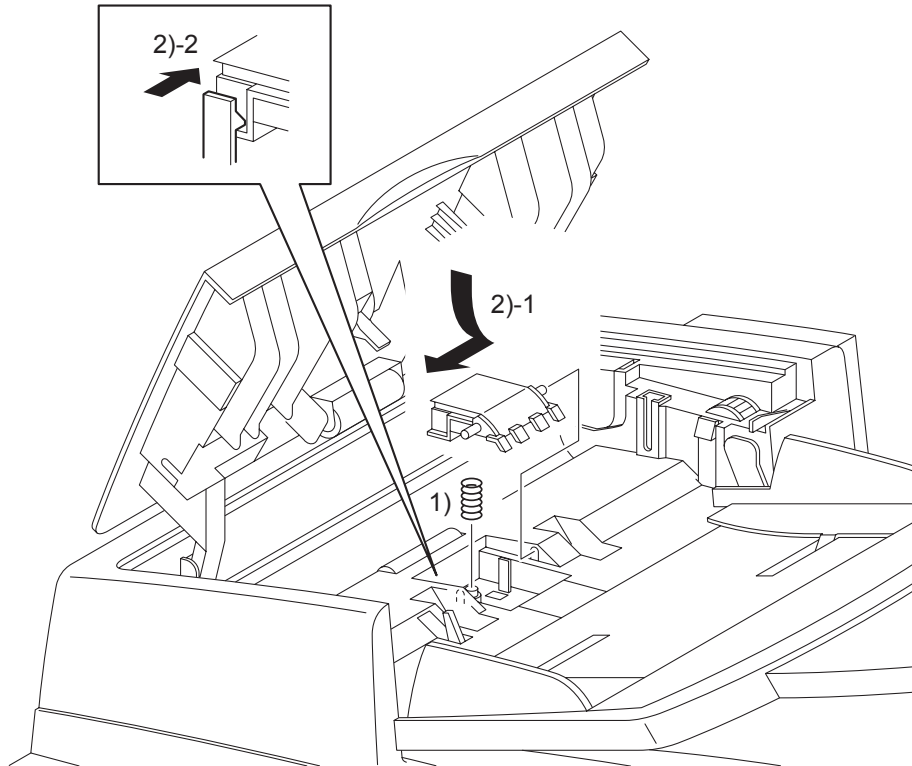

Gnb03188KA

- 1) Mate the ADF SEPARATOR SPRING with the lug of the ADF ASSY.
- 2) Insert the rear side shaft of the ADF SEPARATOR PAD into the bearing of the ADF ASSY, and then insert the front side shaft of the ADF SEPARATOR PAD into the bearing of the ADF ASSY. Secure the ADF SEPARATOR PAD with the hook.

Continues to the next page.

Replacement 48 ADF FEED ROLLER (PL13.8.3), ADF SEPARATOR PAD (PL13.8.5),
ADF SEPARATOR SPRING (PL13.8.6)

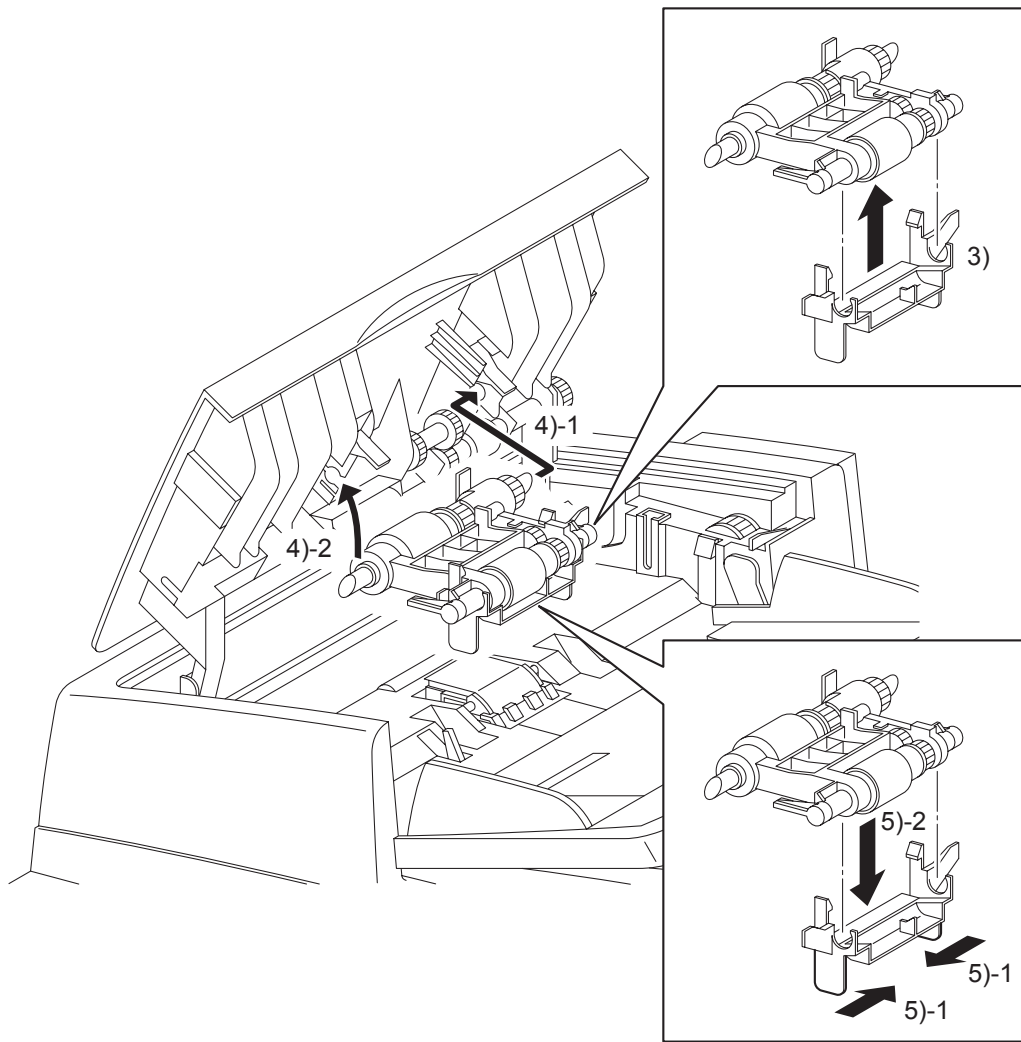

Gnb03189KA

- 3) Replace the ADF FEED ROLLER HOLDER (PL13.8.4) to the ADF FEED ROLLER.
- 4) Insert the rear side shaft of the ADF FEED ROLLER into the bearing of the ADF ASSY, and then insert the front side shaft of the ADF FEED ROLLER into the bearing of the ADF ASSY.
- 5) Remove the ADF FEED ROLLER HOLDER from the ADF FEED ROLLER by pinching the front and rear side tabs of the ADF FEED ROLLER HOLDER
- 6) Close the cover of the ADF ASSY.

Replacement 49 ADF ASSY (PL13.8.2), SCANNER ASSY (PL13.8.7)

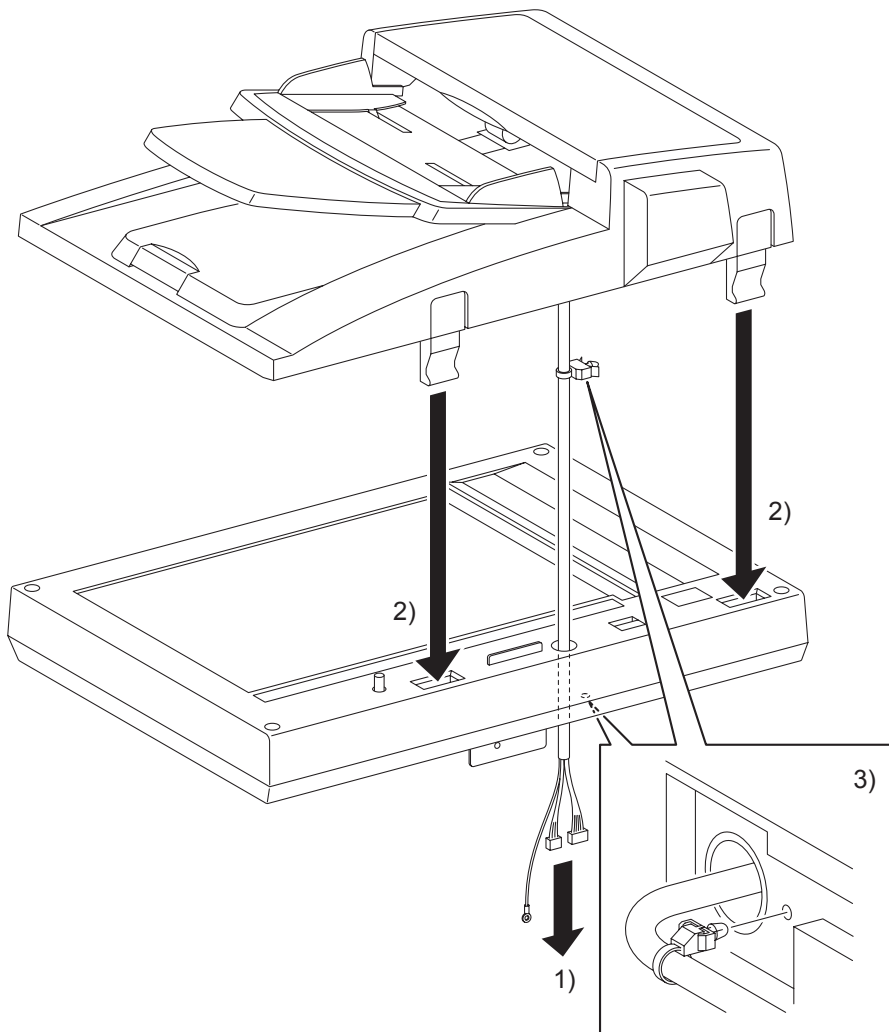

Gnb03190KA

- 1) Route the harness of the ADF ASSY through the hole of the SCANNER ASSY.
- 2) Replace the ADF ASSY to the SCANNER ASSY by inserting the left and right side hinges of the ADF ASSY into the holes of the SCANNER ASSY.
- 3) Replace the clamp on the harness of the ADF ASSY to the backside of the SCANNER ASSY.

Go to the next replacement step:

Replacement 50 ADF SCANNER ASSY (PL13.8.1)

Replacement 50 ADF SCANNER ASSY (PL13.8.1)

NOTE

When replacing the ADF SCANNER ASSY with a new one, ensure that a correction adjustment is performed on the new ADF SCANNER ASSY via Diag. The correction values for adjustment are provided on the label at the under side of the scanner.

NOTE

The steps described below should be performed before installing the new ADF SCANNER ASSY to the printer main body. Otherwise, these steps will be difficult to perform.

When checking the label on the scanner, take care not to damage the tray or other parts of the ADF SCANNER ASSY.

NOTE

The correction values in the illustration are examples only and not the actual values.

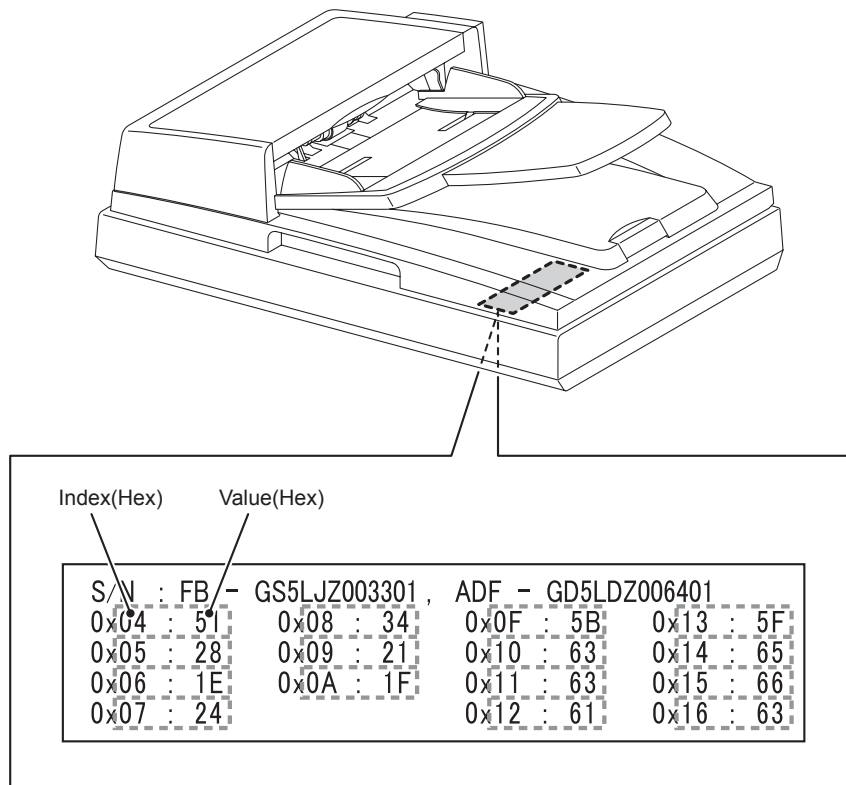

Gnb03229KA

- 1) Scanner parameter values are provided on the label at the bottom of the scanner. Note them down first so that you can refer to them from your operating position.

Replacement 50 ADF SCANNER ASSY (PL13.8.1)

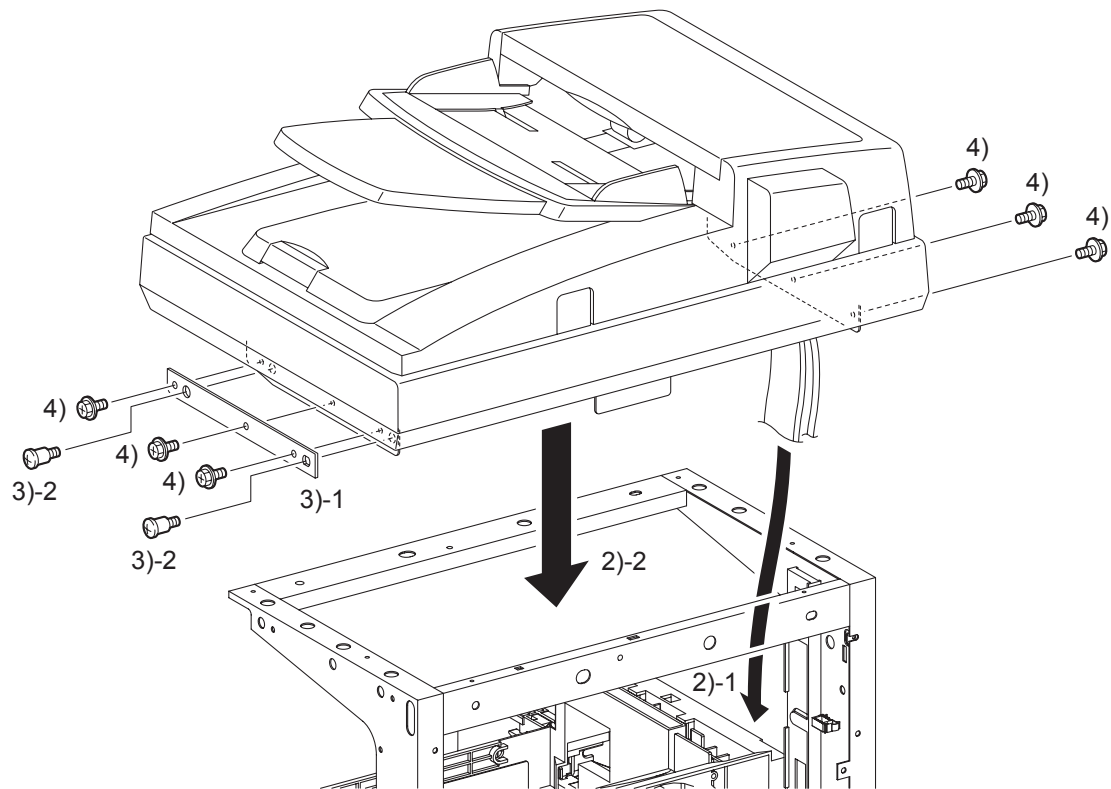

Gnb03191KB

NOTE

When performing the step described below, ensure that the harness will not be caught between the ADF SCANNER ASSY and the printer.

- 2) Route the harness and flat cables of the ADF SCANNER ASSY to the printer, and then replace the ADF SCANNER ASSY to the printer.

NOTE

When performing the step described below, ensure that the PLATE SUB is installed in direction as shown in the figure.

- 3) Secure the PLATE SUB to the printer using the two screws (PL13.8.9).
- 4) Secure the ADF SCANNER ASSY to the printer using the six screws (silver, with flange, 6mm).

Continues to the next page.

Replacement 50 ADF SCANNER ASSY (PL13.8.1)

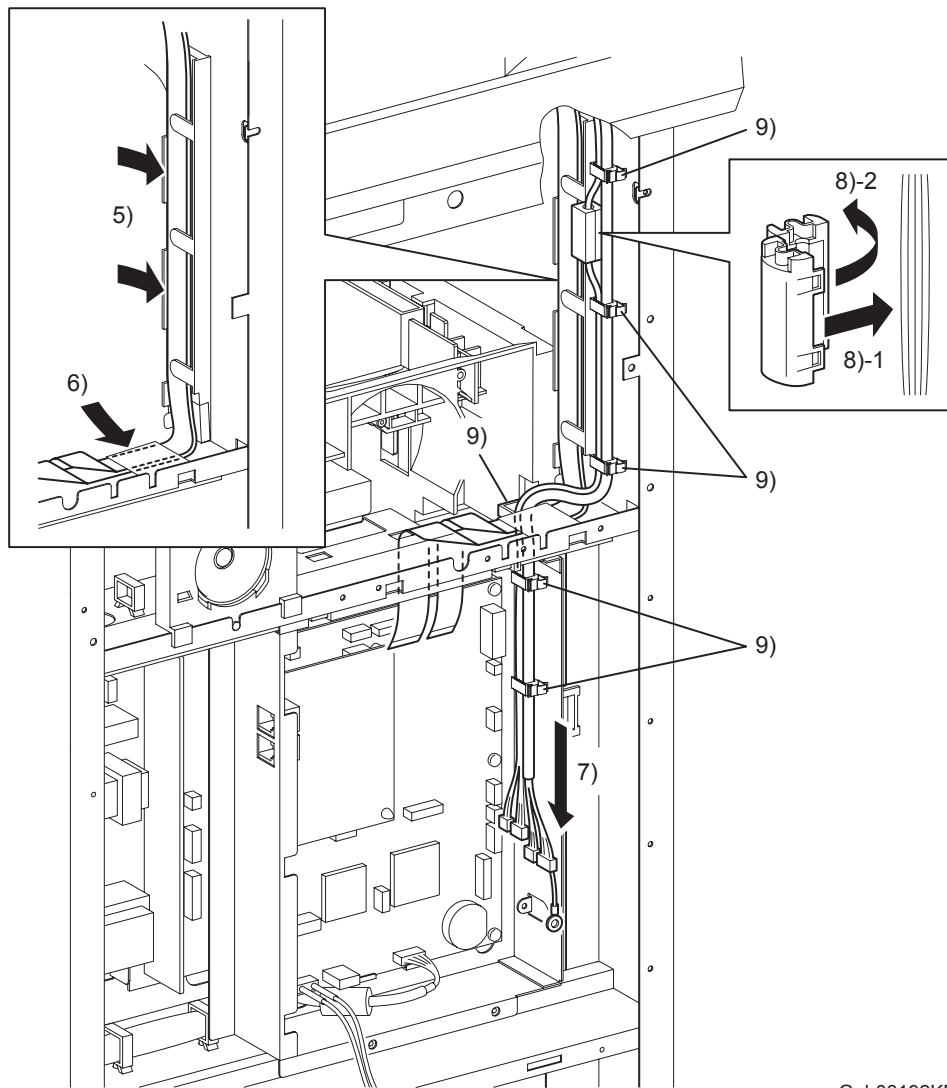

Gnb03192KB

NOTE

When performing the steps described below, ensure that the narrower flat cable comes on top of the wider one.

- 5) Route the two flat cables to the SPACER ASSY FF.
- 6) Route the two flat cables through the under side of the film.

NOTE

When performing the step described below, ensure that the harness comes on top at the point where the harness and flat cable of the ADF SCANNER ASSY overlap each other.

- 7) Route the harness of the ADF SCANNER ASSY to the printer through the slot of the PLATE ASSY FAX AIO.

NOTE

Attach the CORE SFT-25SN at the position shown in the illustration.

- 8) Attach the harness (not covered with a protection tube) coming from the SCANNER ASSY to the CORE SFT-25SN.
- 9) Secure the harness of the ADF SCANNER ASSY with the six clamps.

Continues to the next page.

Replacement 50 ADF SCANNER ASSY (PL13.8.1)

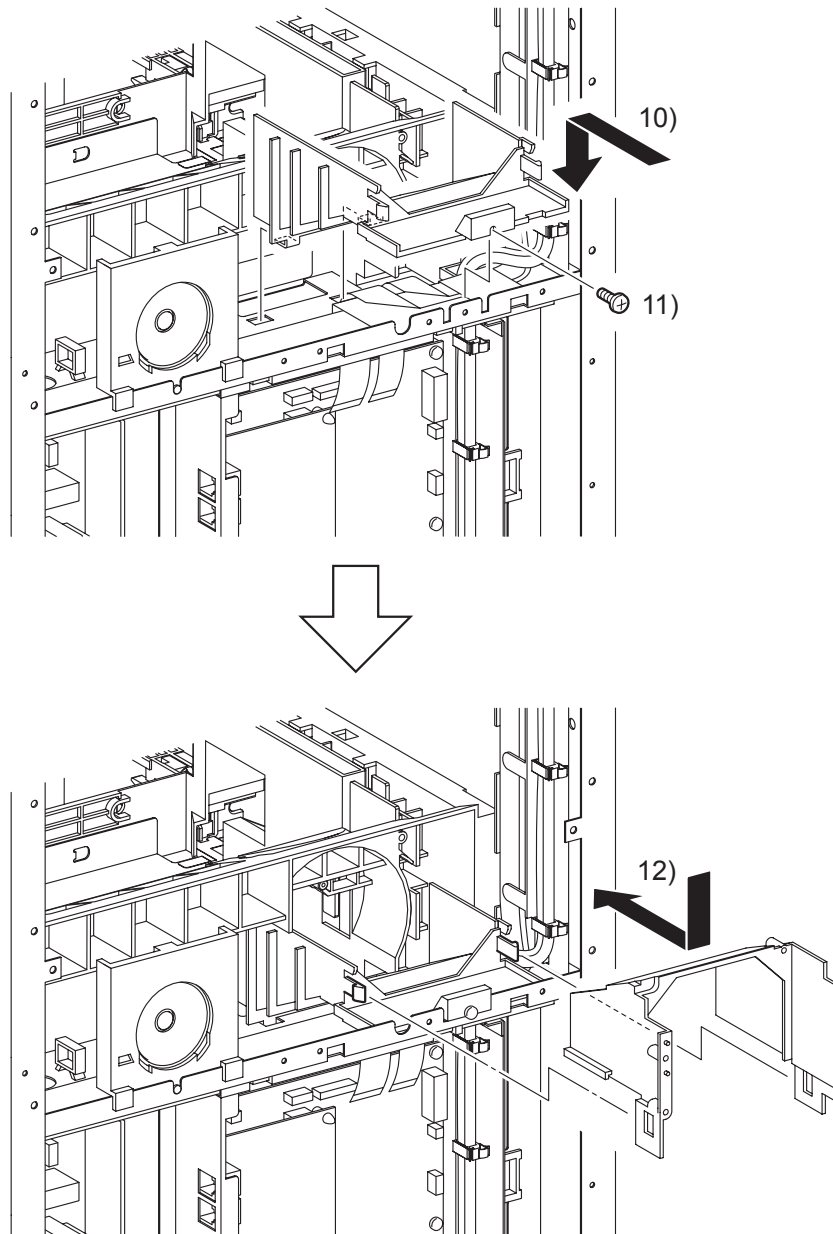

Gnb03193KB

- 10) Replace the DUCT LOWER to the printer by inserting the two hooks of the DUCT LOWER into the holes of the printer.
- 11) Secure the DUCT LOWER to the printer using the one screw (silver, 6mm).
- 12) Place the DUCT UPPER on the DUCT LOWER. Slide the DUCT UPPER forward until the DUCT UPPER is hooked by the two hooks.

Continues to the next page.

Replacement 50 ADF SCANNER ASSY (PL13.8.1)

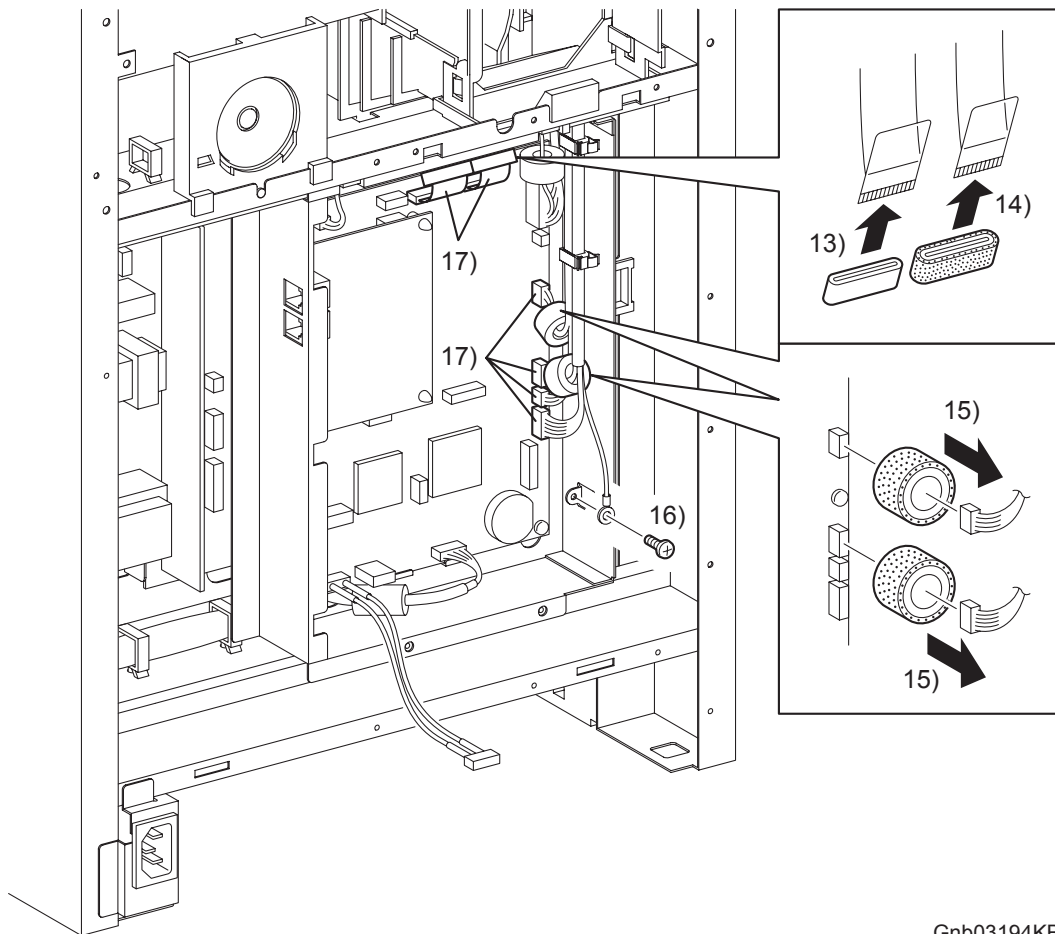

Gnb03194KB

- 13) Attach the CORE FRC27-12-1.3 to the wider flat cable.
- 14) Attach the CORE ASSY FRC27 to the narrower flat cable.
- 15) Attach the CORE ASSY SC-18 to each harness of the connectors (J62, J63).
- 16) Secure the grand wire of the ADF SCANNER ASSY to the BOX ASSY FAX AIO using the one screw (silver, 6mm).
- 17) Engage the four connectors (P/J60, 61, 62, 63) of the harness and connect the two flat cables (P/J64, 65) to the PWBA HYUI.

Replacement 50 ADF SCANNER ASSY (PL13.8.1)

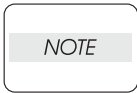

After all the replacement procedures (Replacement 75) are completed, open the ADF ASSY and move the carriage locking lever rearward to the releasing position.

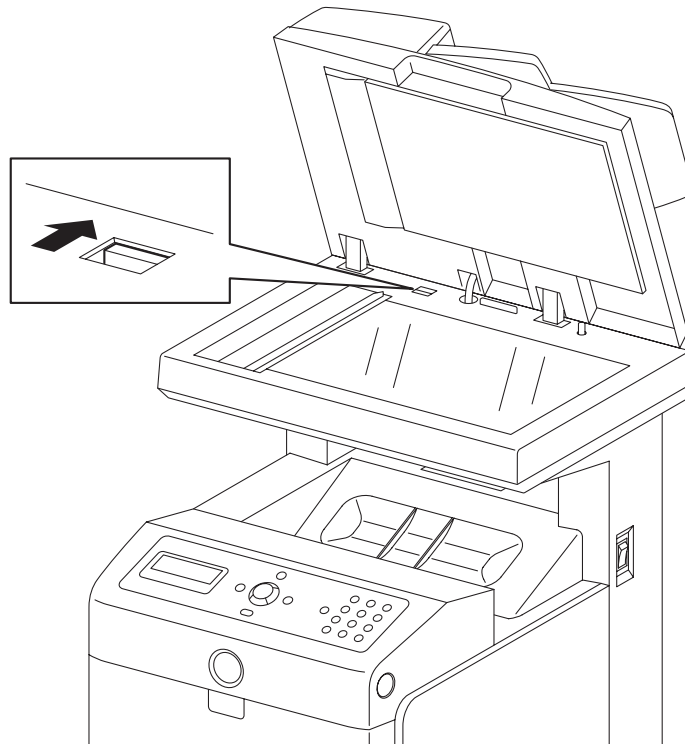

Gnb03230KA

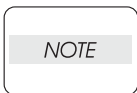

Steps 17) through 31) described below are the adjustment procedure to be performed after the ADF SCANNER ASSY is replaced.

- 18) Engage the power code with the printer and the outlet.
- 19) Turn on the power while holding down the "^" and the "v" keys.
- 20) Release the keys when "Please wait..." is displayed.
- 21) In "Customer Mode", "FAX/Scanner Diag" and "Printer Diag" are displayed.
- 22) Select the "FAX/Scanner Diag" and press the "✓" key.
- 23) Press the "v" key to select the "Scanner Maintenance" and press the "✓" key.
- 24) Press the "v" key to select the "Parameter" and press the "✓" key.

Replacement 50 ADF SCANNER ASSY (PL13.8.1)

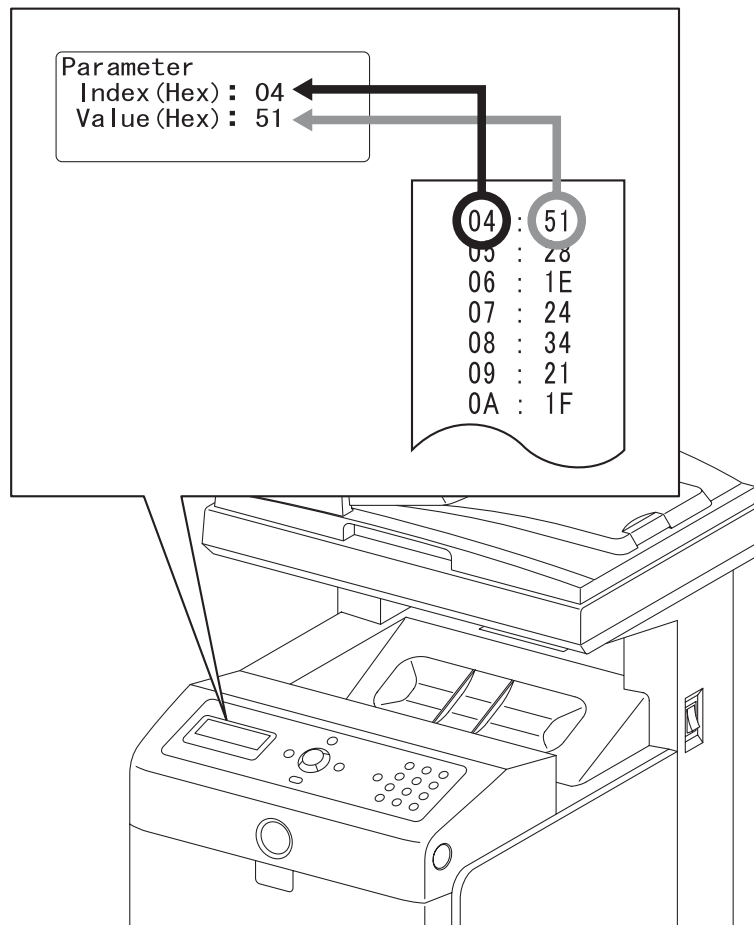

Gnb03231KA

- 25) Input the value of "Index (HEX)" from your note (using the arrow keys) and press the "✓" key.
- 26) Input the value of "Value (HEX)" from your note (using the arrow keys) and press the "✓" key.
- 27) Press the "Cancel" key to select the Index (HEX)".
- 28) Repeat these steps to input all the values you have noted down.
- 29) Press the "Cancel" key three times after setting all the values you have noted down.
- 30) Press the "▼" key to select the "Complete".
- 31) Press the "✓" key twice.
- 32) The Diag. mode menu returns to the main screen automatically.

**Go to the next replacement step:
Replacement 51 FAN (PL13.5.10)**

Replacement 51 FAN (PL13.5.10)

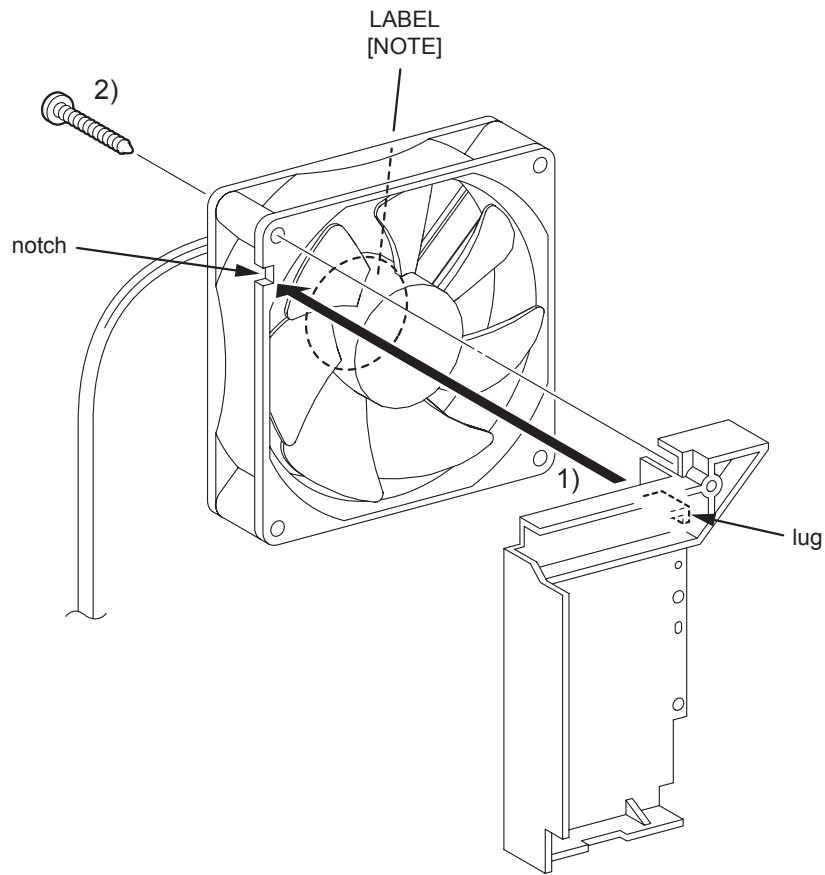

Gnb03227KA

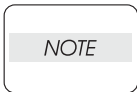

When performing the step described below, take care to check the orientation of the FAN. Replace the PLATE DUCT to the opposite side of the label surface.

- 1) Mate the lug of the PLATE DUCT with the notch of the FAN, and replace the PLATE DUCT to the FAN.
- 2) Secure the PLATE DUCT to the FAN using the one screw (silver,tap, 32mm).

Replacement 51 FAN (PL13.5.10)

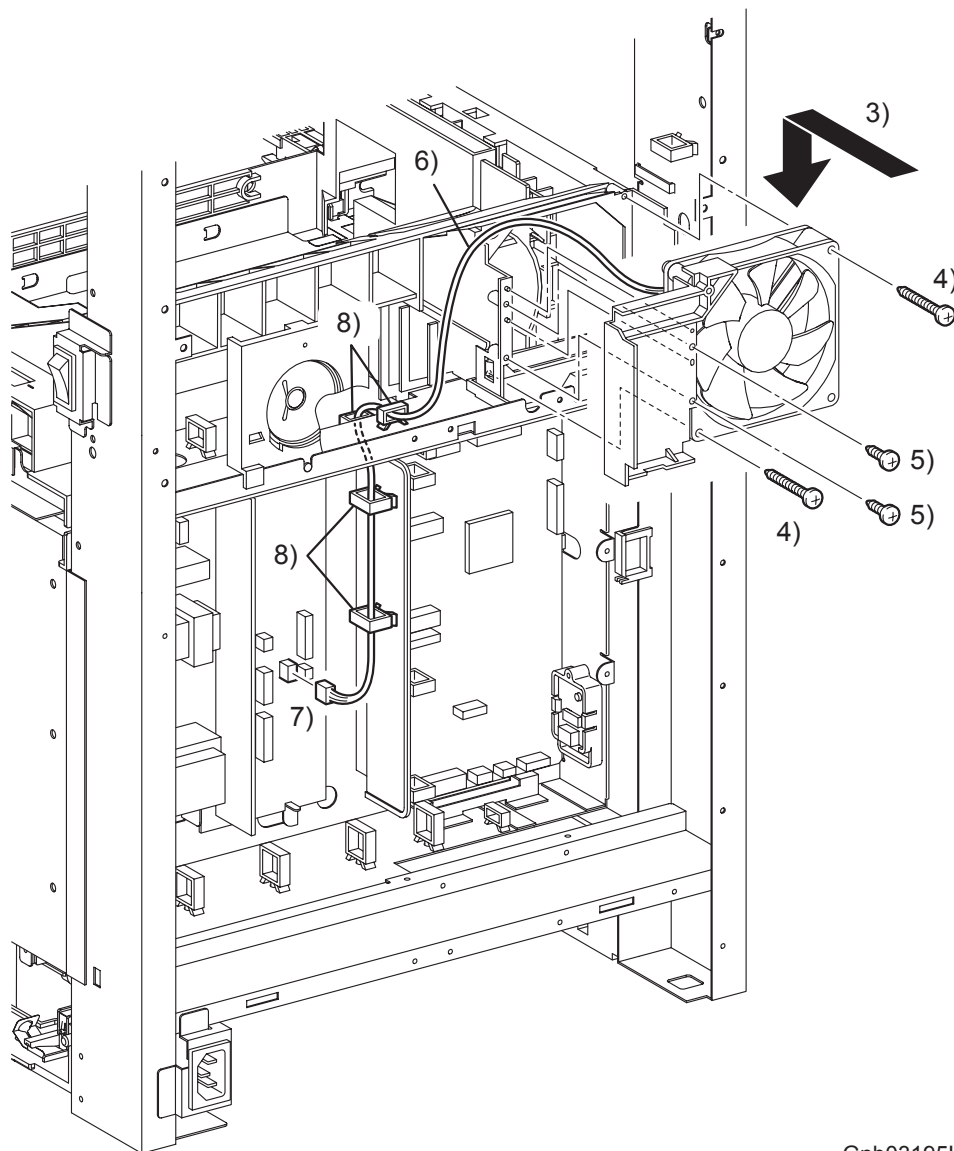

Gnb03195KA

- 3) Mate the two holes of the PLATE DUCT with the bosses of the DUCT UPPER, and replace the FAN to the printer together with PLATE DUCT.
- 4) Secure the FAN to the Printer using the two screws (silver, tap, 32mm).
- 5) Secure the PLATE DUCT to the printer using the two screws (silver, tap, 8mm).
- 6) Route the harness of the FAN to the printer through the slot.
- 7) Engage the connector (P/J503) of the FAN to the LOW VOLTAGE POWER SUPPLY.
- 8) Secure the harness of the FAN with the four clamps.

Go to the next replacement step:

Replacement 60 BOX ASSY FAX AIO (PL13.4.4)

Replacement 52 INTERLOCK SWITCH (PL13.5.3)

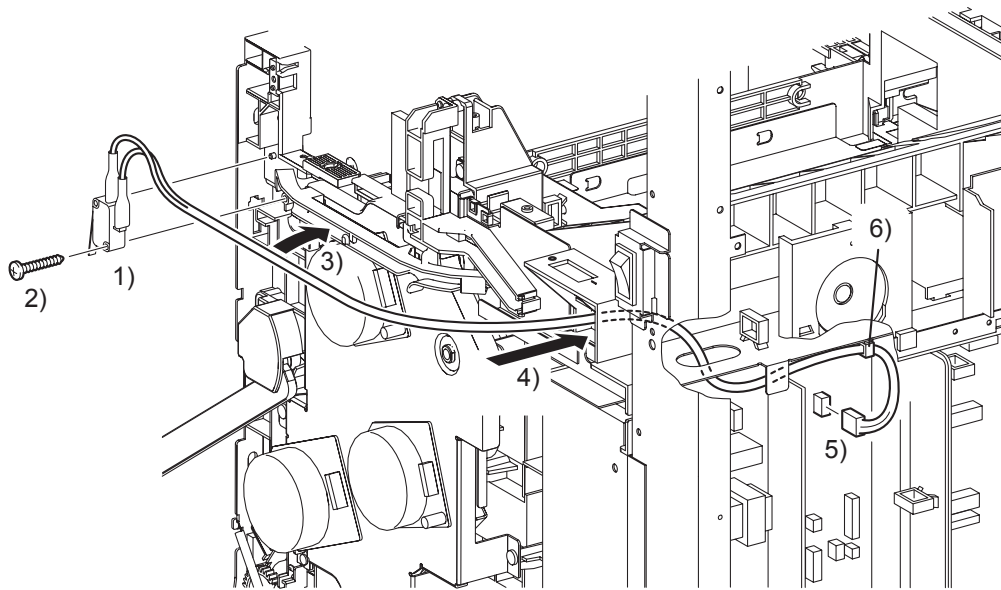

Gnb03196KA

- 1) Replace the INTERLOCK SWITCH by mating the hole on the INTERLOCK SWITCH with the boss on the printer.
- 2) Secure the INTERLOCK SWITCH to the printer using the one screw (silver, tap, 16mm).
- 3) Route the harness of the INTERLOCK SWITCH to the DUCT DRV MAIN.
- 4) Route the harness of the INTERLOCK SWITCH through the hole of the printer.
- 5) Engage the connector (P/J44) of the INTERLOCK SWITCH to the LOW VOLTAGE POWER SUPPLY.
- 6) Secure the harness of the INTERLOCK SWITCH with the one clamp.

Go to the next replacement step:

Replacement 60 BOX ASSY FAX AIO (PL13.4.4)

Replacement 53 SPEAKER ASSY (PL13.5.6)

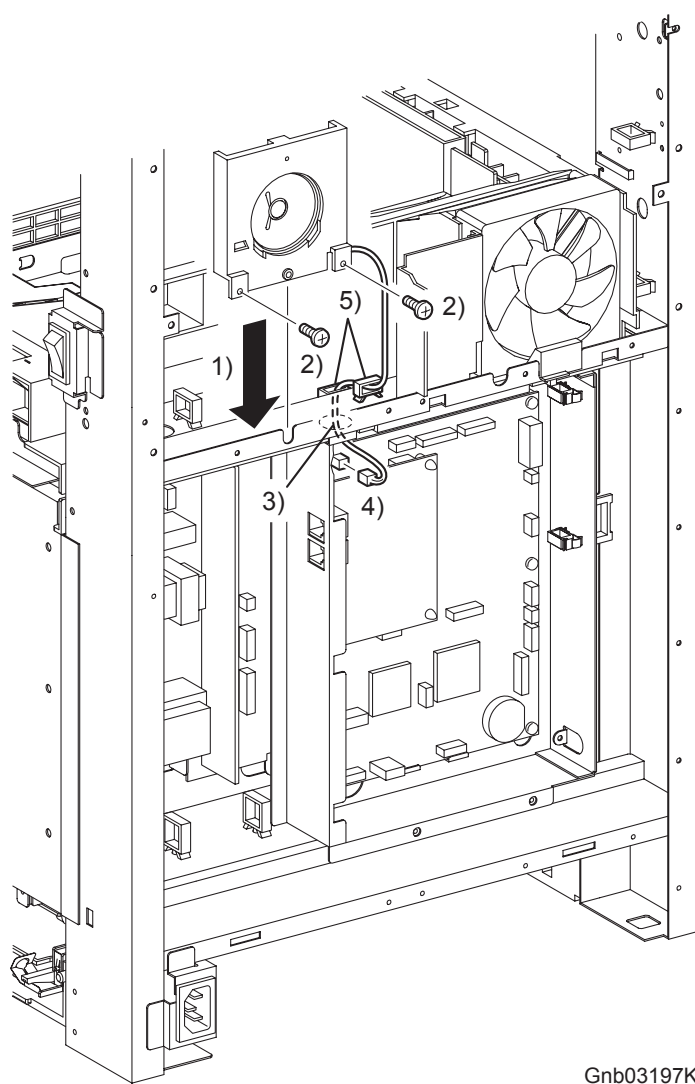

Gnb03197KA

- 1) Mate the lug of the SPEAKER ASSY with the U-shaped notch of printer frame.
- 2) Secure the SPEAKER ASSY to the printer using the two screws (silver, 6mm).
- 3) Route the harness of the SPEAKER ASSY through the hole of the printer.
- 4) Engage the connector (P/J52) to the connector of the PWBA HYUI.
- 5) Secure the harness of the SPEAKER ASSY with the two clamps.

Go to the next replacement step:

Replacement 62 BOX ASSY PRT AIO (PL13.4.13)

Replacement 54 TOP COVER (PL13.1.1)

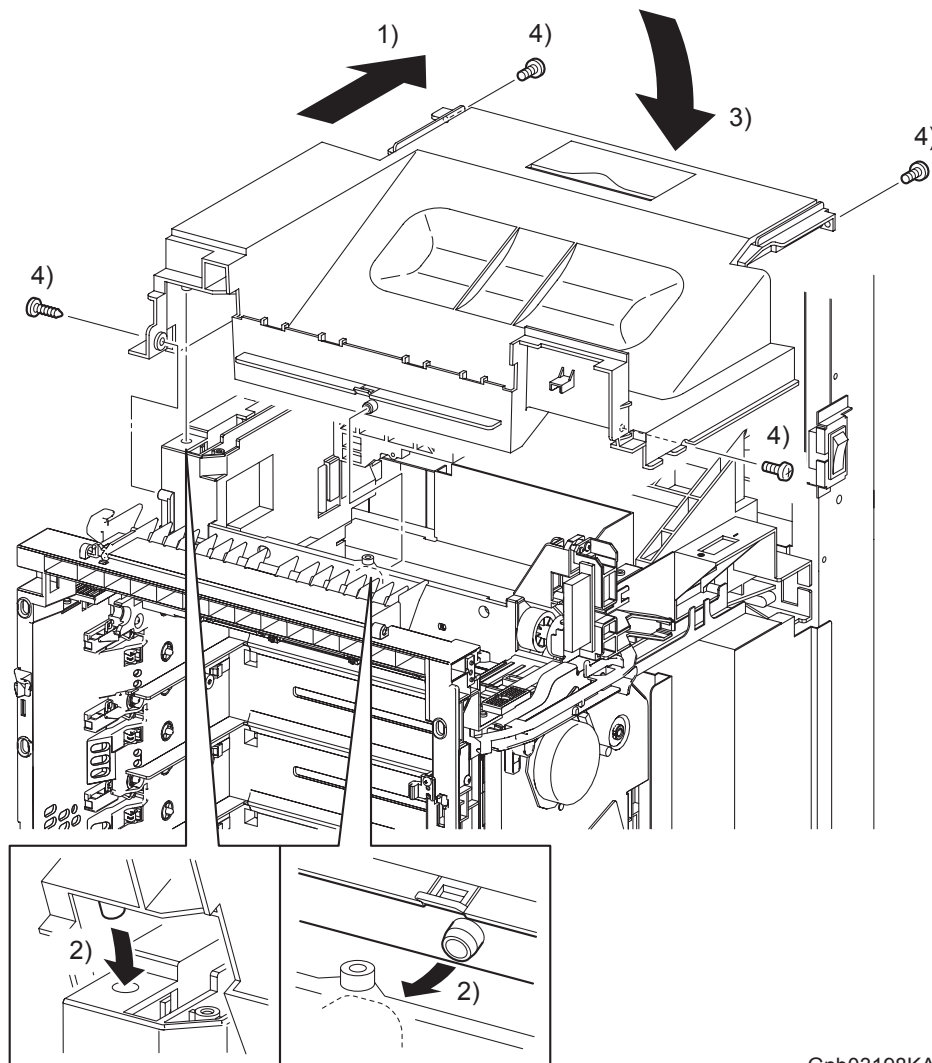

Gnb03198KA

- 1) Set the rear part of the TOP COVER to the printer by inserting it between the left side of the POLE and right side of the POLE.
- 2) Mate the two bosses on the center front and the left front on the TOP COVER with the hook and hole on the printer by tilting the TOP COVER forward.
- 3) Replace the TOP COVER to the printer by swinging the rear end of the TOP COVER down.

NOTE

When performing the step described below, take care to check the screw type. The one screw (silver, tap, 8mm) is used to secure the left side of the TOP COVER.

- 4) Secure the TOP COVER to the printer using the three screws (silver, 6mm) and the one screw (silver, tap, 8mm).

Go to the next replacement step:

Replacement 63 LEFT COVER (PL13.1.10)

Replacement 55 MACHINE CONTROL UNIT (PL13.5.13)

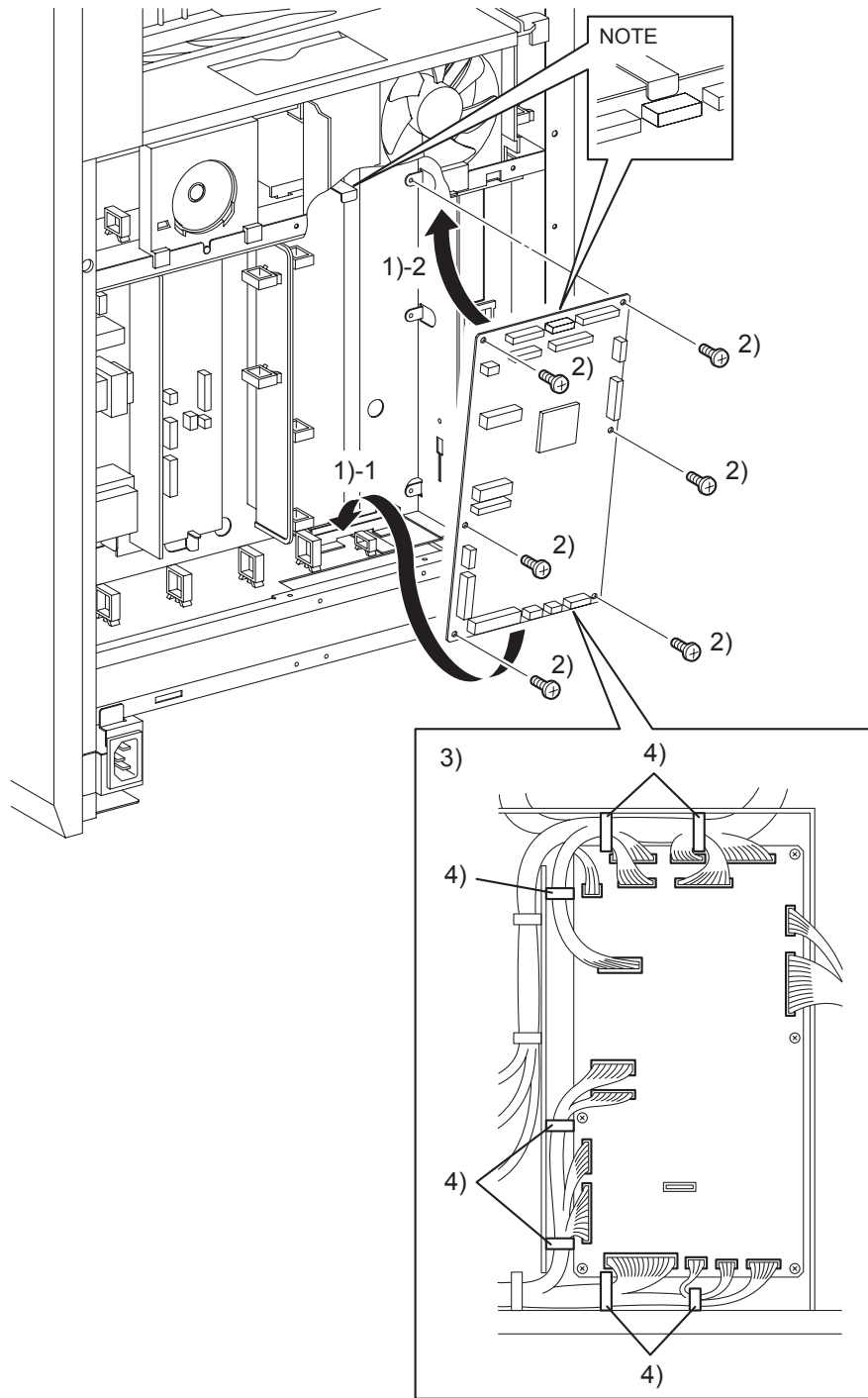

Gnb03199KA

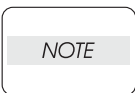

When performing the step described below, insert the upper part of the MACHINE CONTROL UNIT into the backside tab on the printer.

- 1) Replace the MACHINE CONTROL UNIT to the printer by shifting it upward after attaching the under part of the MACHINE CONTROL UNIT to the printer.
- 2) Secure the MACHINE CONTROL UNIT using the six screws (silver, 6mm).
- 3) Engage all the connectors of the MACHINE CONTROL UNIT.
- 4) Secure all the harness with the clamps.

Continues to the next page.

Replacement 55 MACHINE CONTROL UNIT (PL13.5.13)**NOTE**

When the MACHINE CONTROL UNIT is replaced with a new one, perform the following steps. (After completing all the steps up to Replacement 75.)

- 5) Plug in the power cord to the outlet, and power on the printer.
- 6) Perform the diagnostic operation of NVM Load, and write the data into MCU.
- 7) Turn on the power while pressing the ► key, the ◀ key and the [MENU] key on the control panel.
- 8) Enter the password, push the ▲ key twice and push the ✓ key once. The diagnostic screen comes up.
- 9) Press the ▼ key several times until “ IOT Diag ” is displayed. Press the ✓ key once.
- 10) Press the ▼ key several times until “ NVM Settings ” is displayed. Press the ✓ key once.
- 11) Press the ▼ key several times until “ NVM Load ” is displayed. Press the ✓ key once.
- 12) Press the ✓ key twice, and NVM Load is performed.
- 13) After the NVM Load is complete, press the [CANCEL] key several times until “ IOT Diag ” is displayed.
- 14) Press the ▼ key several times until “ Complete ” is displayed.
- 15) Press the ✓ key three times, and “ Ready to Print ” is displayed.

Go to the next replacement step:

Replacement 56 HUMIDITY SENSOR (PL13.5.11)

Replacement 56 HUMIDITY SENSOR (PL13.5.11)

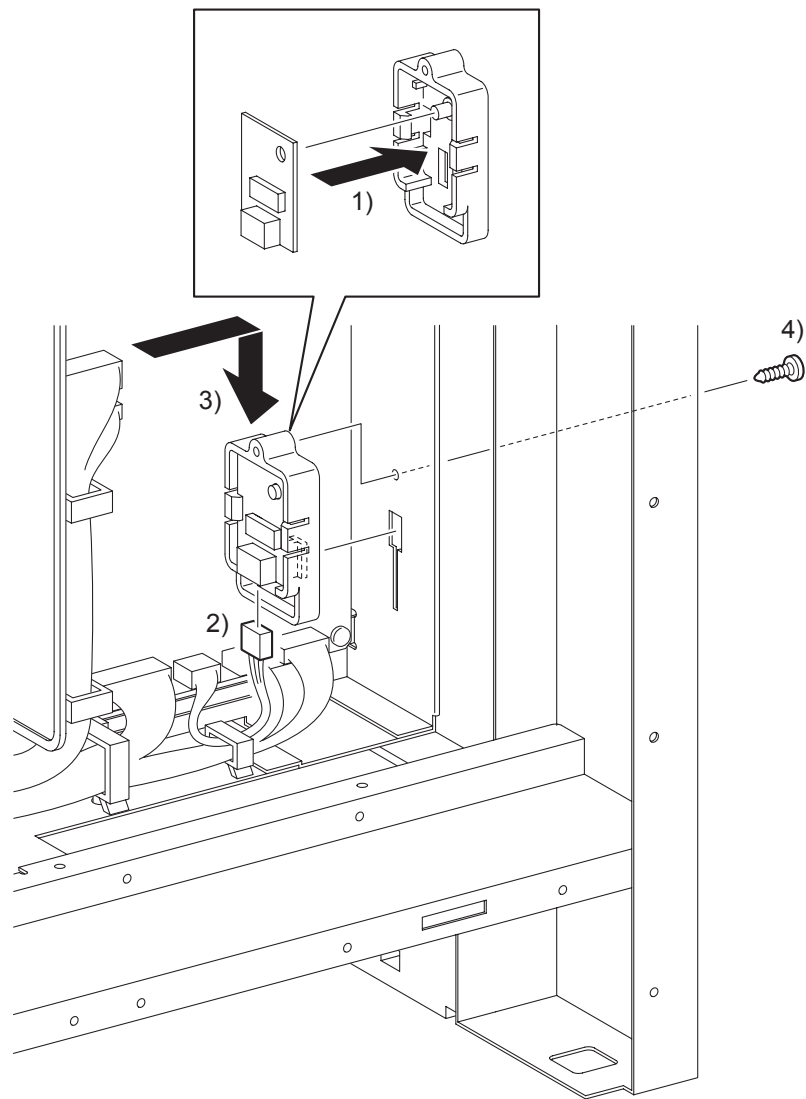

Gnb03200KA

- 1) Replace the HUMIDITY SENSOR by mating the hole on the HUMIDITY SENSOR with the boss on the BRACKET SENSOR HUM.
- 2) Engage the connector (P/J261) of the HUMIDITY SENSOR.
- 3) Mate the hook of the BRACKET SENSOR HUM with the hole of the printer, and then slide the BRACKET SENSOR HUM downward until stop it.
- 4) Secure the BRACKET SENSOR HUM using the one screw (silver, tap, 10mm).

Go to the next replacement step:

Replacement 60 BOX ASSY FAX AIO (PL13.4.4)

Replacement 57 LOW VOLTAGE POWER SUPPLY (PL13.5.14)

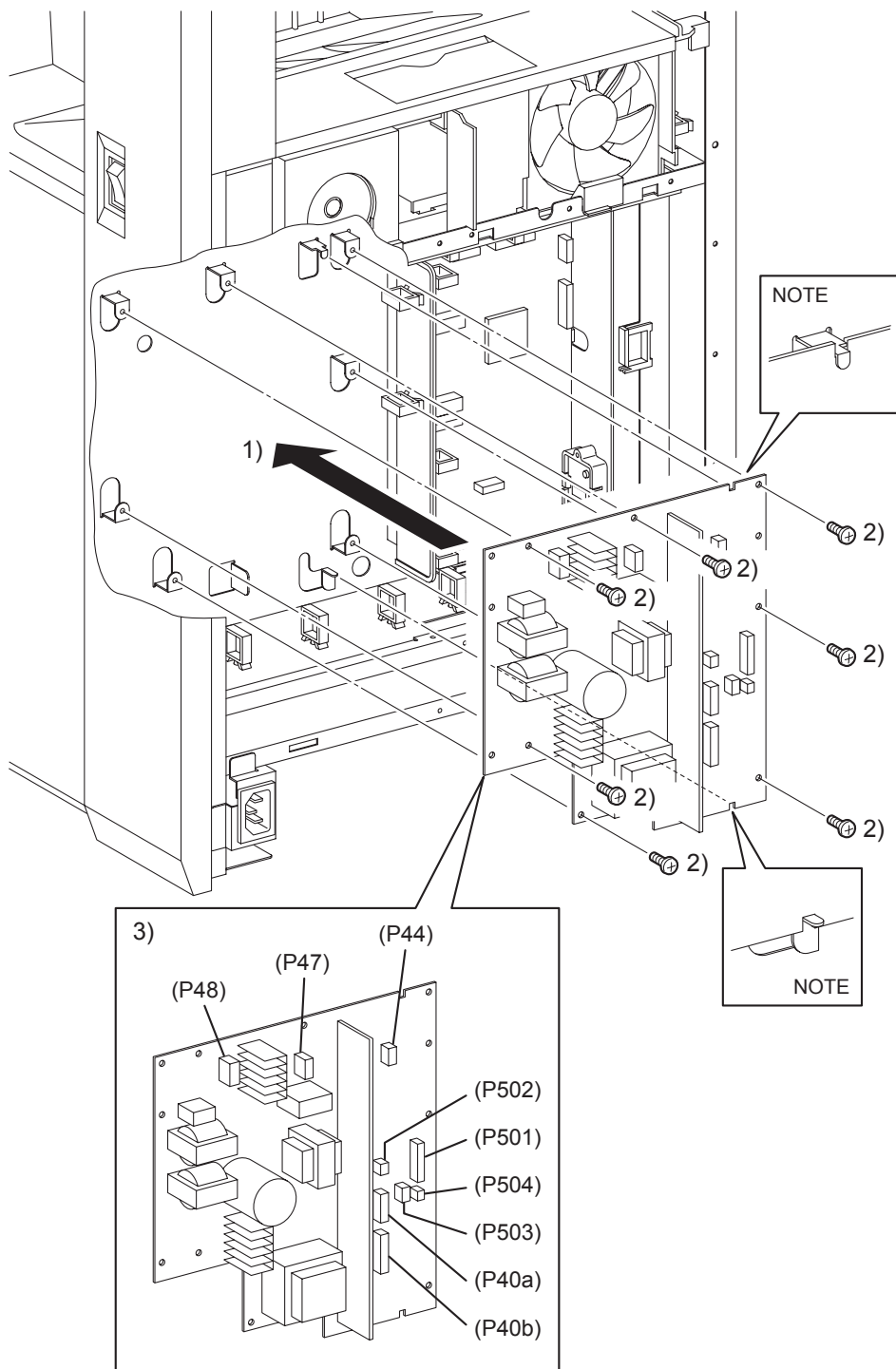

Gnb03201KA

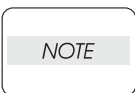

When performing the step described below, mate the two notches of the LOW VOLTAGE POWER SUPPLY with the hooks of the printer.

- 1) Replace the LOW VOLTAGE POWER SUPPLY to the printer.
- 2) Secure the LOW VOLTAGE POWER SUPPLY to the printer using the seven screws (silver, 6mm).
- 3) Engage all the connectors of the LOW VOLTAGE POWER SUPPLY.

Go to the next replacement step:

Replacement 60 BOX ASSY FAX AIO (PL13.4.4)

Blank Page

Replacement 58 PWBA HYUI (PL13.4.1)

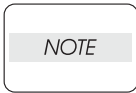

When the PWBA HYUI is replaced with a new one, the replacement steps 1) to 3) are required. These steps are not required when no replacement is performed.

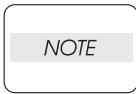

Do not press the PWB when removing the NVM ROM.

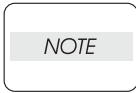

Take care not to bend the terminal section of NVM when performing the step described below.

- 1) Remove the NVM, using a miniature screwdriver or the like, from the IC socket on the old PWBA HYUI that was removed from the printer.
- 2) Remove the NVM from the IC socket on the new PWBA HYUI using a miniature screwdriver or the like.

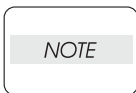

Do not use the NVM removed from the new PWBA HYUI.

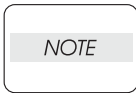

Ensure that the orientation of the NVM is correct when performing the following step.

- 3) Install the NVM that was removed from old PWBA HYUI on the IC socket of the new PWBA HYUI with its notch aligned with the notch in the IC socket.

Continues to the next page.

Replacement 58 PWBA HYUI (PL13.4.1)

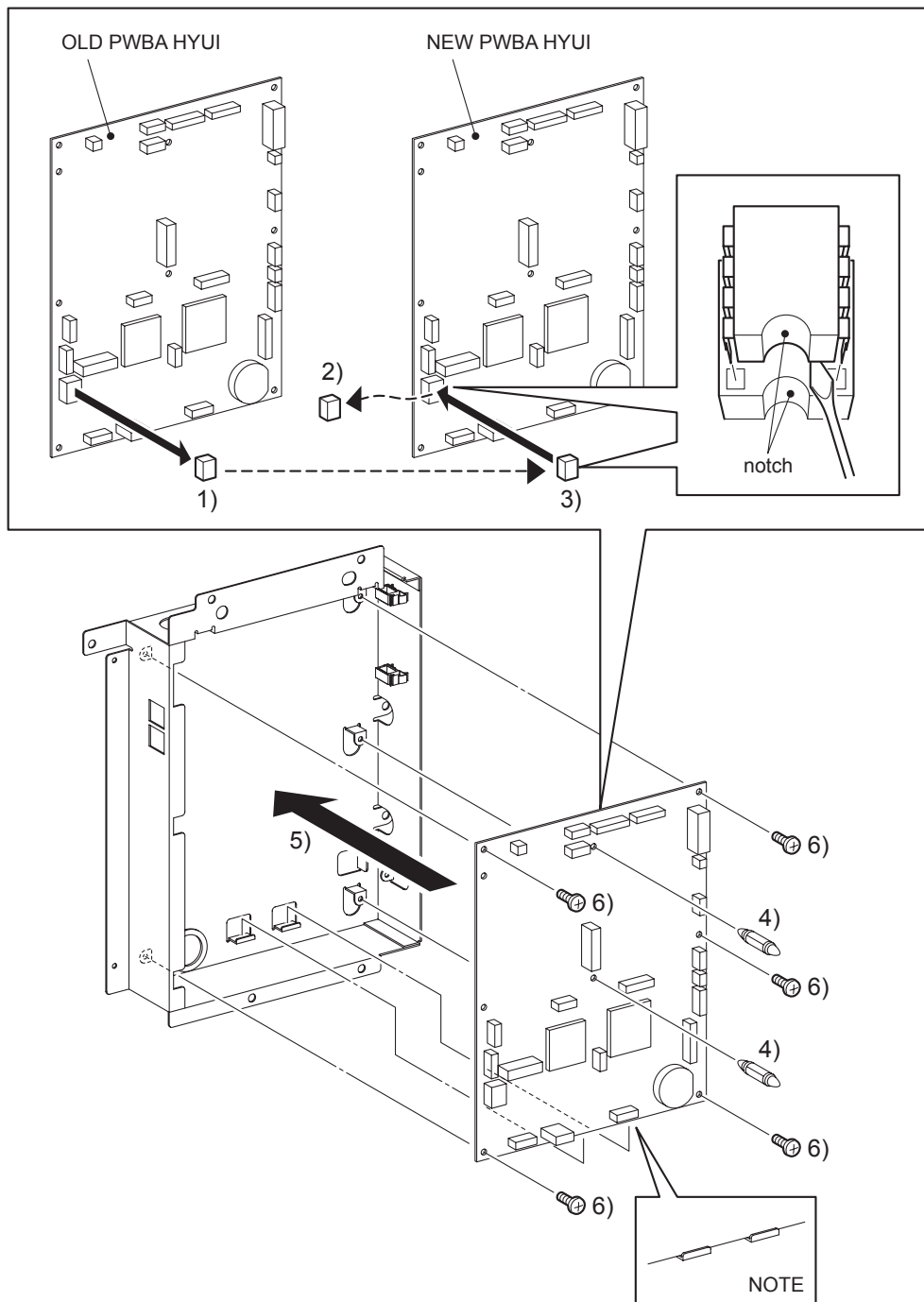

Gnb03202KA

- 4) Replace the two SUPPORT FAXs to the PWBA HYUI.

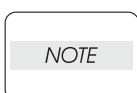

When performing the step described below, rest the under part of the PWBA HYUI upon the two hooks of the BOX ASSY FAX AIO.

- 5) Replace the PWBA HYUI to the BOX ASSY FAX AIO
 6) Secure the PWBA HYUI using the five screws (silver, 6mm).

Replacement 58 PWBA HYUI (PL13.4.1)

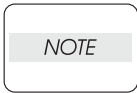

When the PWBA HYUI is replaced with a new one, perform the following steps. (After completing all the steps up to Replacement 75.)

- 7) Press the "▼" key to display the "SETUP", and then press the "✓" key.
- 8) Press the "▼" key to display the "Admin Menu", and then press the "✓" key.
- 9) Press the "▼" key to display the "Fax Settings", and then press the "✓" key.
- 10) Press the "▼" key to display the "Country", and then press the "✓" key.
- 11) Press the "<" or the ">" key to select your country, and then press the "✓" key.
- 12) Select the "Yes", and then press the "✓" key to start the system initialization.
- 13) Printer menu return to the main screen automatically.

Go to the next replacement step:

Replacement 59 PWBA FAX (PL13.4.3)

Replacement 59 PWBA FAX (PL13.4.3)

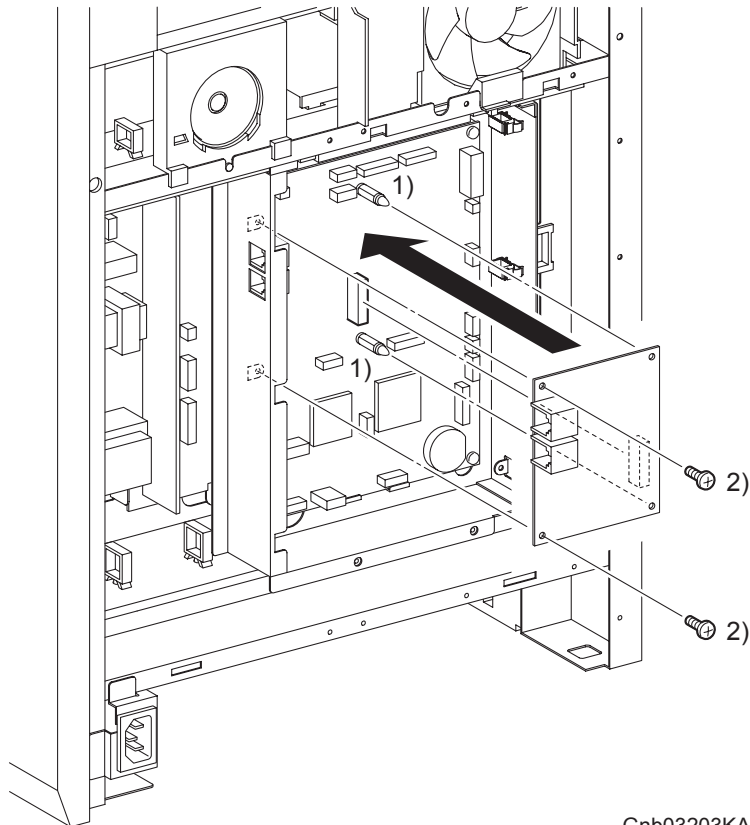

Gnb03203KA

- 1) Mate the two holes on the PWBA FAX with the two SUPPORT FAXs on the PWBA HYUI so that the connectors on the PWBA FAX are visible from the square holes on the BOX ASSY FAX AIO.
- 2) Secure the PWBA FAX using the two screws (silver, 6mm).

Go to the next replacement step:

Replacement 62 BOX ASSY PRT AIO (PL13.4.13)

Replacement 60 BOX ASSY FAX AIO (PL13.4.4)

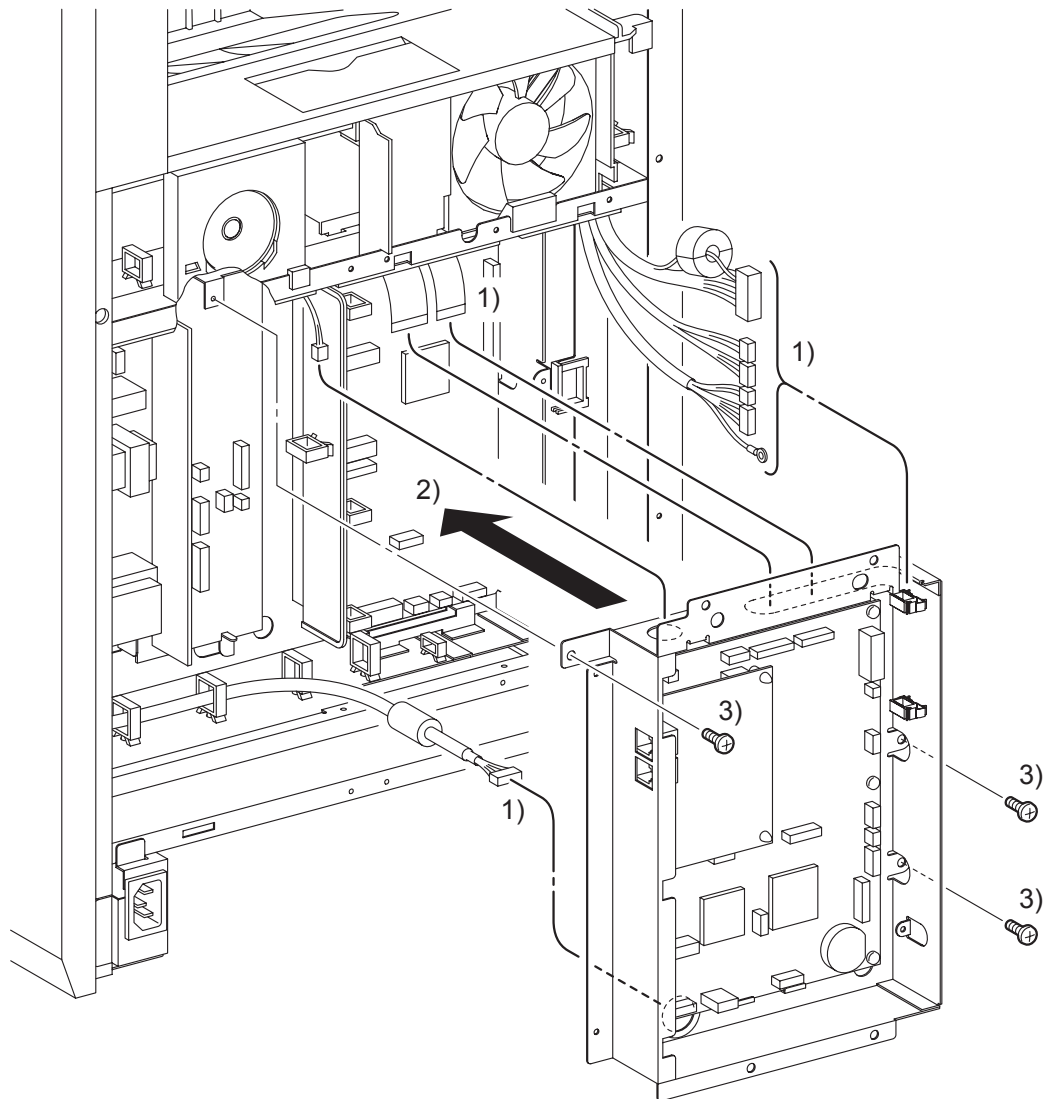

Gnb03204KB

- 1) Route all the harness through the holes of the BOX ASSY FAX AIO.

NOTE

When performing the step described below, ensure that the harness will not be caught between the BOX ASSY FAX AIO and the printer.

- 2) Replace the BOX ASSY FAX AIO to the printer together with the PWBA HYUI and the PWBA FAX by mating the two hooks of the BOX ASSY FAX AIO to the holes of the printer.
- 3) Secure the BOX ASSY FAX AIO to the printer using the three screws (silver, 6mm).

Continues to the next page.

Replacement 60 BOX ASSY FAX AIO (PL13.4.4)

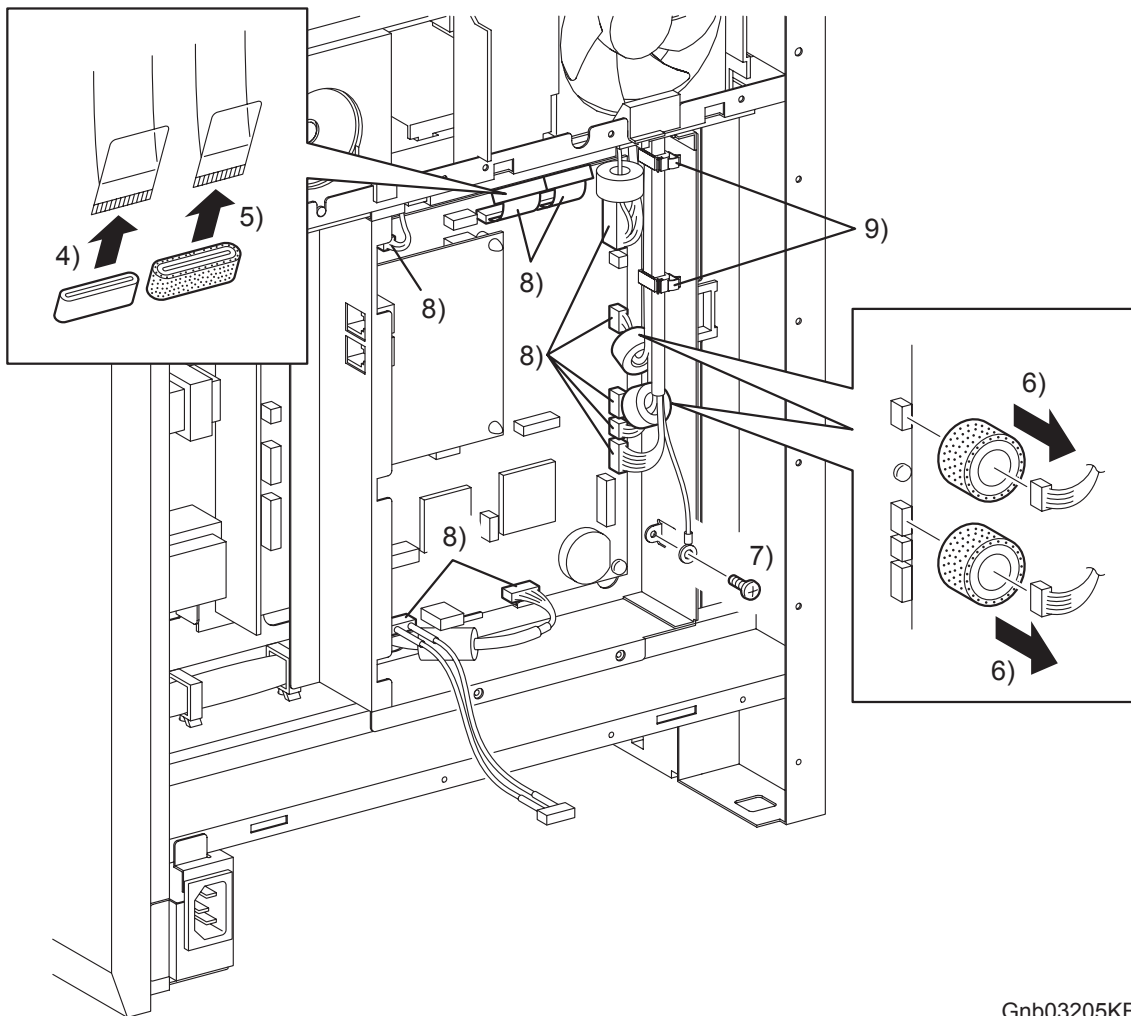

Gnb03205KB

- 4) Attach the CORE FRC27-12-1.3 to the wider flat cable.
- 5) Attach the CORE ASSY FRC27 to the narrower flat cable.
- 6) Attach the CORE ASSY SC-18 to each harness of the connectors (J62, J63).
- 7) Secure the grand wire of the ADF SCANNER ASSY to the BOX ASSY FAX AIO using the one screw (silver, 6mm).
- 8) Engage all the connectors of the PWBA HYUI.
- 9) Secure all the harness with the clamps.

Go to the next replacement step:

Replacement 62 BOX ASSY PRT AIO (PL13.4.13)

Blank Page

Replacement 61 ELECTRONIC SUB-SYSTEM CONTROL BOARD (PL13.4.20)

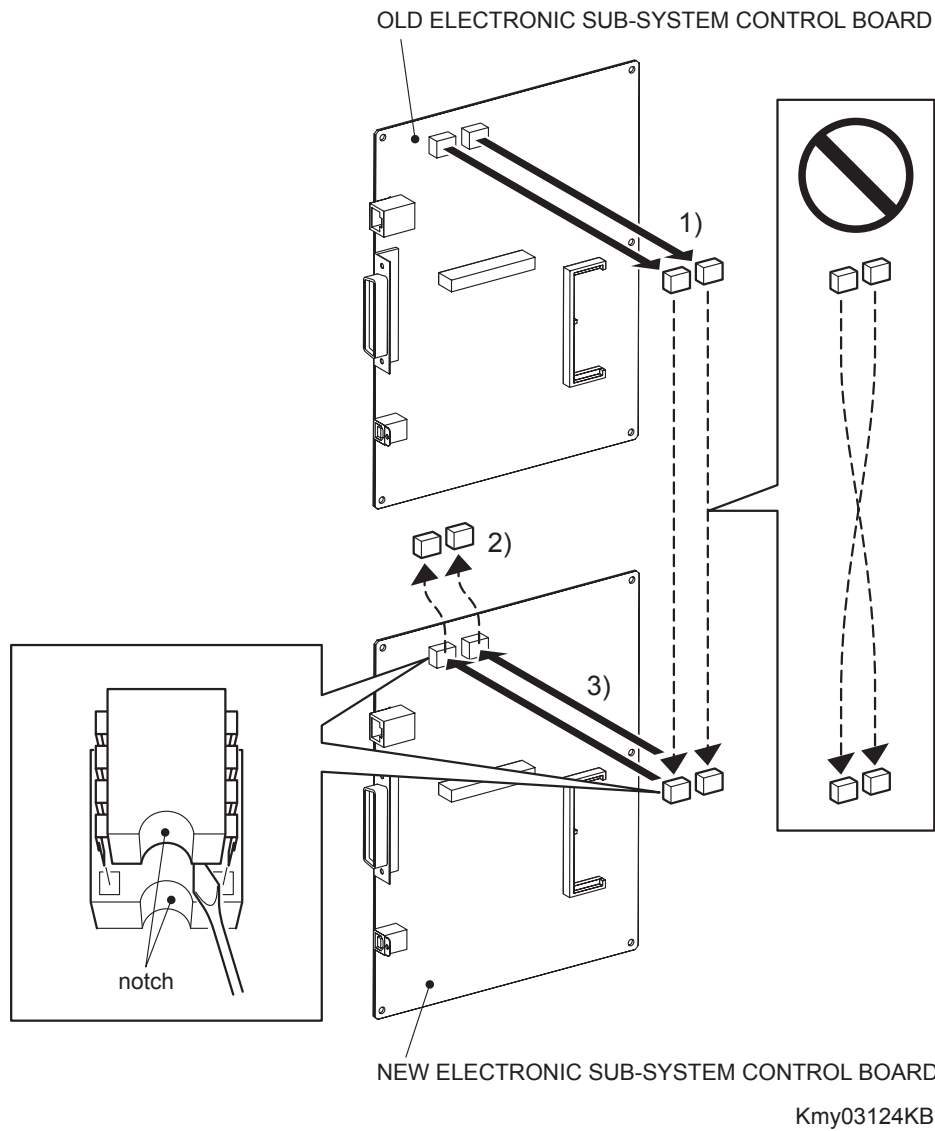

Continues to the next page.

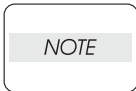
Replacement 61 ELECTRONIC SUB-SYSTEM CONTROL BOARD (PL13.4.20)

When the ELECTRONIC SUB-SYSTEM CONTROL BOARD is replaced with a new one, the replacement steps 1) to 3) are required. These steps are not required when no replacement is performed.

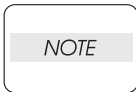

There are two NVM ROMs on the PWB. Do not confuse their fitting positions.

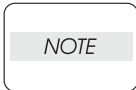

Do not press the PWB when removing the NVM ROM.

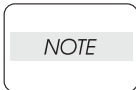

Take care not to bend the terminal section of NVM when performing the step described below.

- 1) Remove the NVM, using a miniature screwdriver or the like, from the IC socket on the old ELECTRONIC SUB-SYSTEM CONTROL BOARD that was removed from the printer.
- 2) Remove the NVM from the IC socket on the new ELECTRONIC SUB-SYSTEM CONTROL BOARD using a miniature screwdriver or the like.

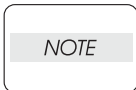

Do not use the NVM removed from the new ELECTRONIC SUB-SYSTEM CONTROL BOARD.

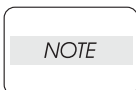

Ensure that the orientation of the NVM is correct when performing the following step.

- 3) Install the NVM that was removed from old ELECTRONIC SUB-SYSTEM CONTROL BOARD on the IC socket of the new ELECTRONIC SUB-SYSTEM CONTROL BOARD with its notch aligned with the notch in the IC socket.

Continues to the next page.

Replacement 61 ELECTRONIC SUB-SYSTEM CONTROL BOARD (PL13.4.20)

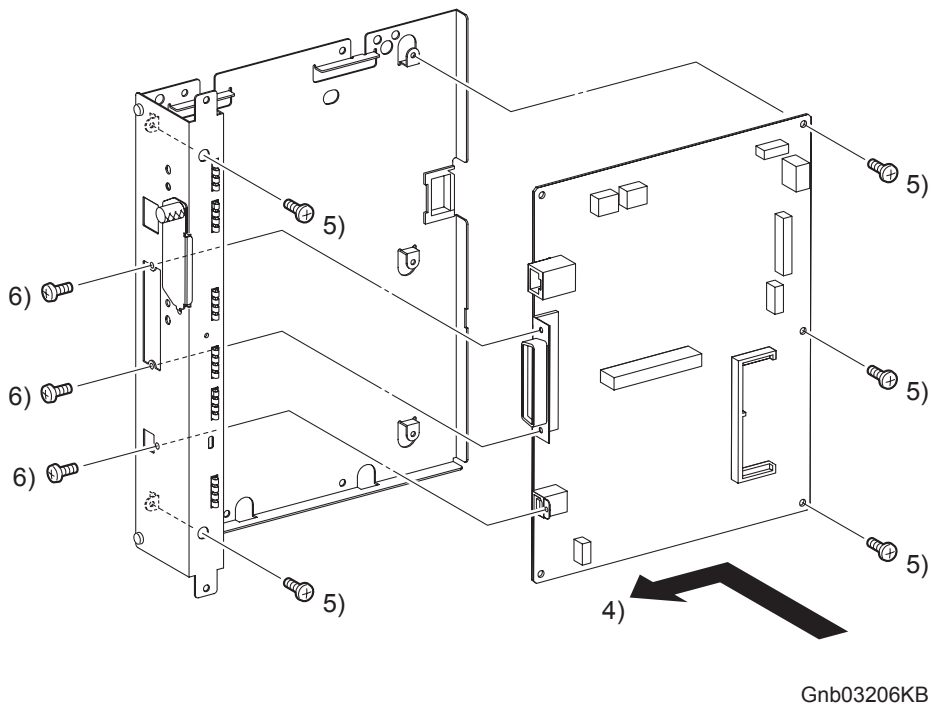

- 4) Replace the ELECTRONIC SUB-SYSTEM CONTROL BOARD to the BOX ASSY PRT AIO.
- 5) Secure the ELECTRONIC SUB-SYSTEM CONTROL BOARD to the BOX ASSY PRT AIO using the five screws (silver, 6mm).
- 6) Secure the connector section of the ELECTRONIC SUB-SYSTEM CONTROL BOARD to the BOX ASSY PRT AIO using the three screws (silver, 6mm).

Go to the next replacement step:

Replacement 62 BOX ASSY PRT AIO (PL13.4.13)

Replacement 62 BOX ASSY PRT AIO (PL13.4.13)

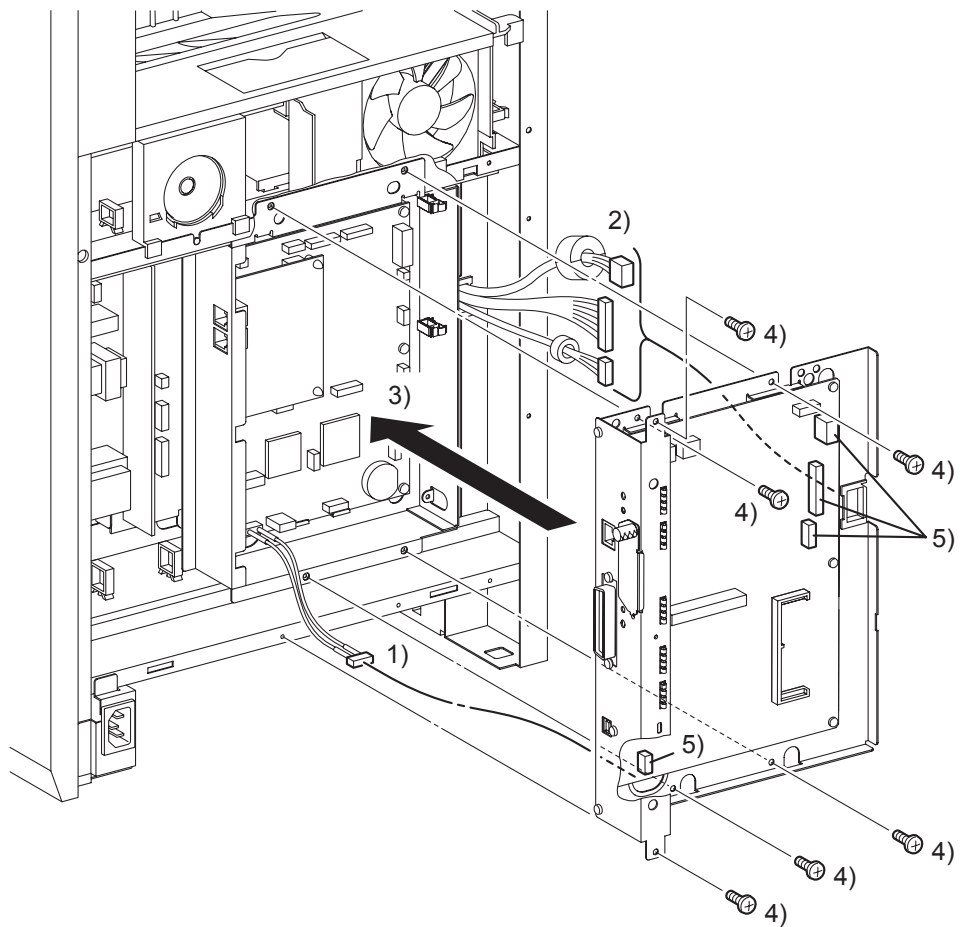

Gnb03207KB

- 1) Route the HARNESS ASSY AIO-ESS (PL13.6.14) through the hole of the BOX ASSY PRT AIO.
- 2) Route the two harness of the MACHINE CONTROL UNIT and the one harness of the LOW VOLTAGE POWER SUPPLY through the CLAMP SADDLE LES-1017.
- 3) Replace the BOX ASSY PRT AIO and the ELECTRONIC SUB-SYSTEM CONTROL BOARD to the printer by aligning the four holes of the BOX ASSY PRT AIO with the four holes of the BOX ASSY FAX AIO.
- 4) Secure the BOX ASSY PRT AIO to the printer using the six screws (silver, 6mm).
- 5) Engage all the connectors of the ELECTRONIC SUB-SYSTEM CONTROL BOARD.

Continues to the next page.

Replacement 62 BOX ASSY PRT AIO (PL13.4.13)

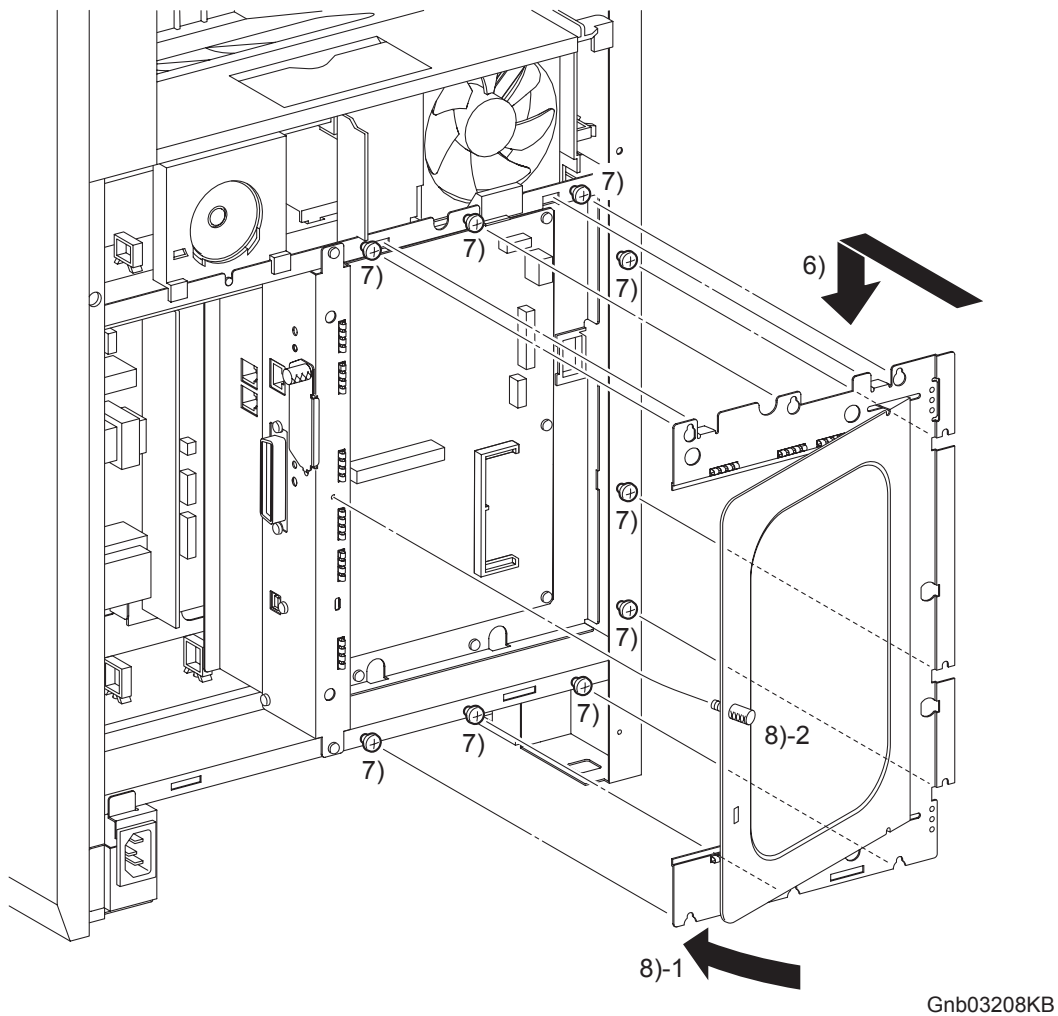

- 6) Replace the SHIELD ASSY ESS WINDOW to the printer by mating the two hooks of the SHIELD ASSY ESS WINDOW to the holes of the printer. Mate the six U-shaped notches of the SHIELD ASSY ESS WINDOW with the six screws on the printer.
- 7) Secure the SHIELD ASSY ESS WINDOW to the printer using the nine screws (silver, 6mm).
- 8) Close the SHIELD WINDOW and secure the SCREW KNURLING.

Go to the next replacement step:

Replacement 64 COVER POLE L (PL13.1.11)

Replacement 63 LEFT COVER (PL13.1.10)

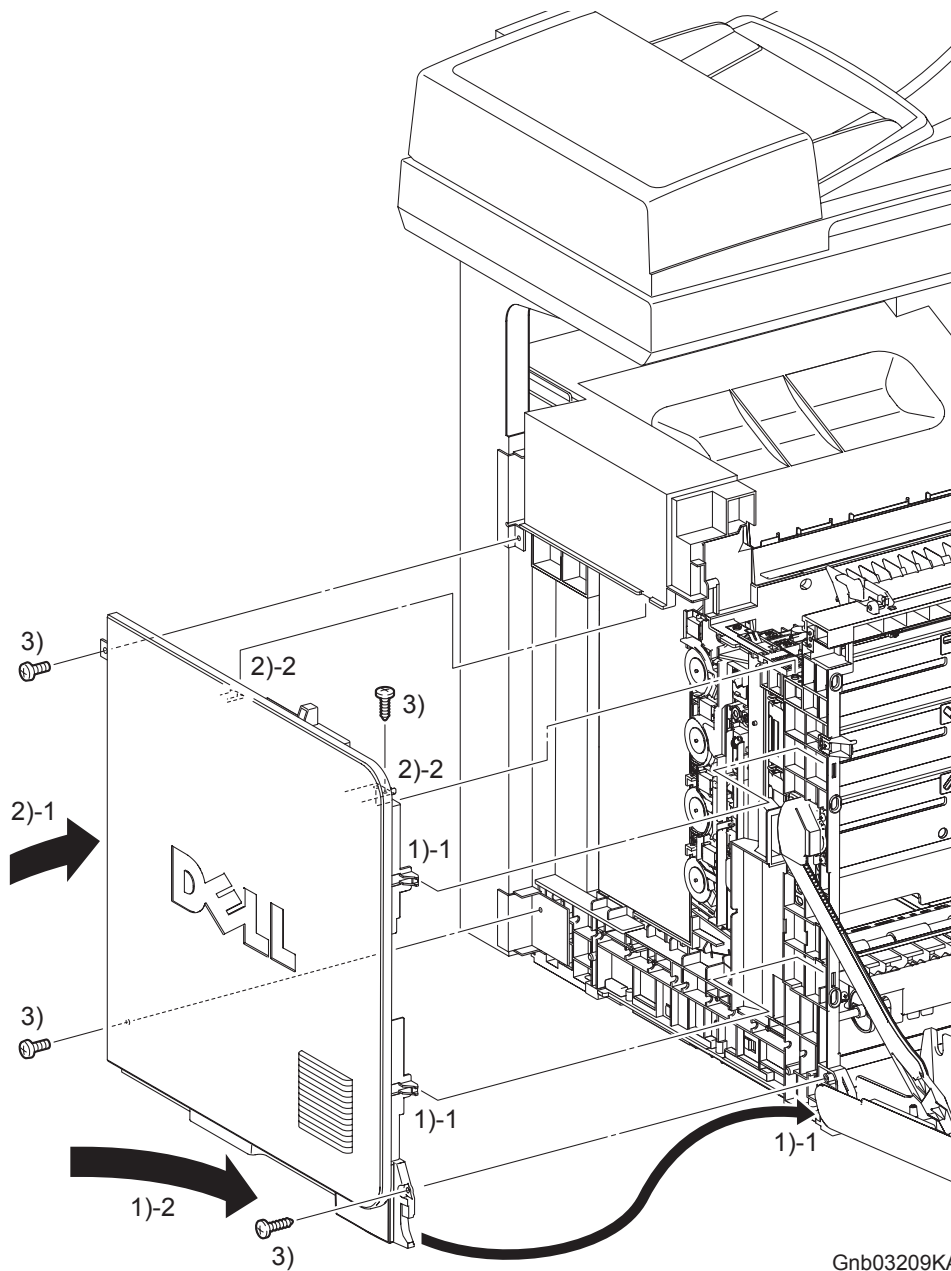

Gnb03209KA

- 1) Insert the front side of the LEFT COVER between the FRONT COVER and the printer, and mate the two front side hooks of the LEFT COVER with the printer.
- 2) Mate the mounting hole on the front side of the LEFT COVER with the boss of the printer, and then insert the backside hook on the rear side of the LEFT COVER into the hole of the printer.

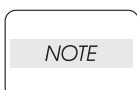

When performing the step described below, take care to check the screw type. The screws (silver, tap, 6mm) are used to secure the rear side of the LEFT COVER.

- 3) Secure the LEFT COVER to the printer using the two screws (silver, tap, 10mm) and the two screws (silver, 6mm).

Go to the next replacement step:

Replacement 64 COVER POLE L (PL13.1.11)

Replacement 64 COVER POLE L (PL13.1.11)

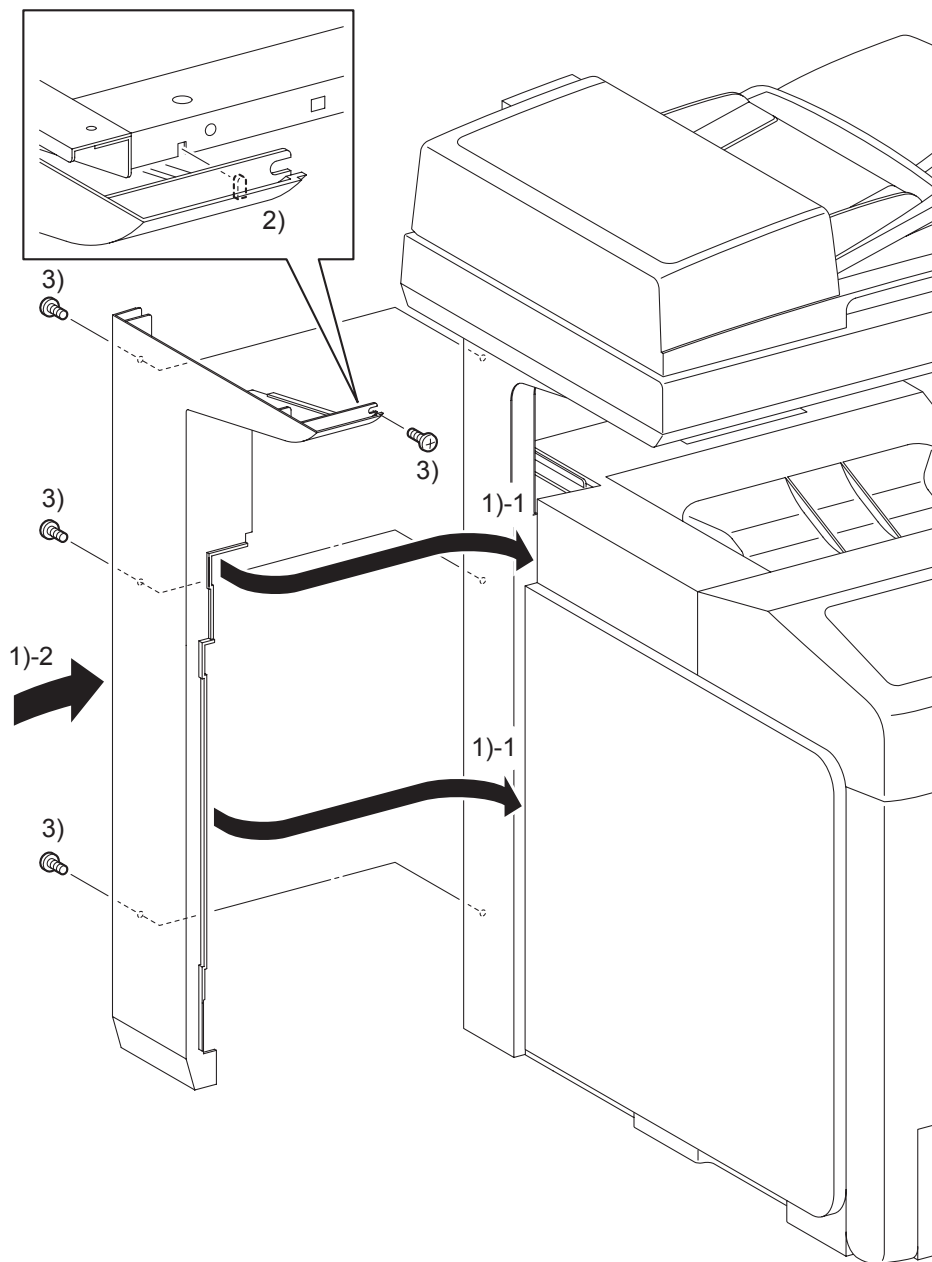

Gnb03210KA

- 1) Replace the COVER POLE L to the printer by inserting the rim on the front section of the COVER POLE L into the inside of the TOP COVER and the LEFT COVER.
- 2) Mate the lug of the front mounting section of the COVER POLE L with the notch of the printer.
- 3) Secure the COVER POLE L to the printer using the four screws (silver, 6mm).

Go to the next replacement step:

Replacement 65 COVER POLE IN L (PL13.1.3)

Replacement 65 COVER POLE IN L (PL13.1.3)

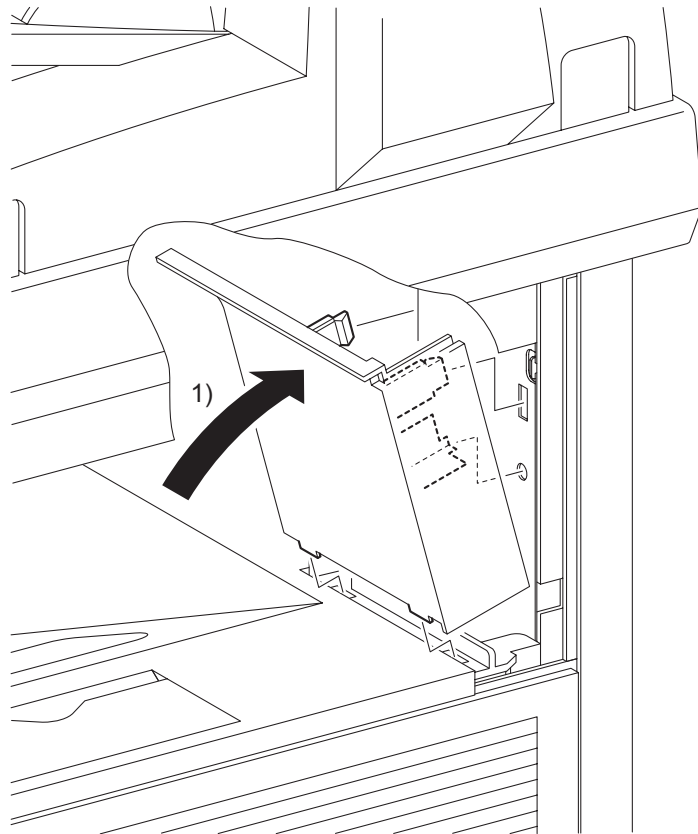

Gnb03211KA

- 1) Replace the COVER POLE IN L to the printer by mating the two hooks and the one lug on the COVER POLE IN L with the holes of the printer.

Go to the next replacement step:

Replacement 72 COVER BOTTOM (PL13.1.5)

Replacement 66 OPERATOR PANEL (PL13.2.97)

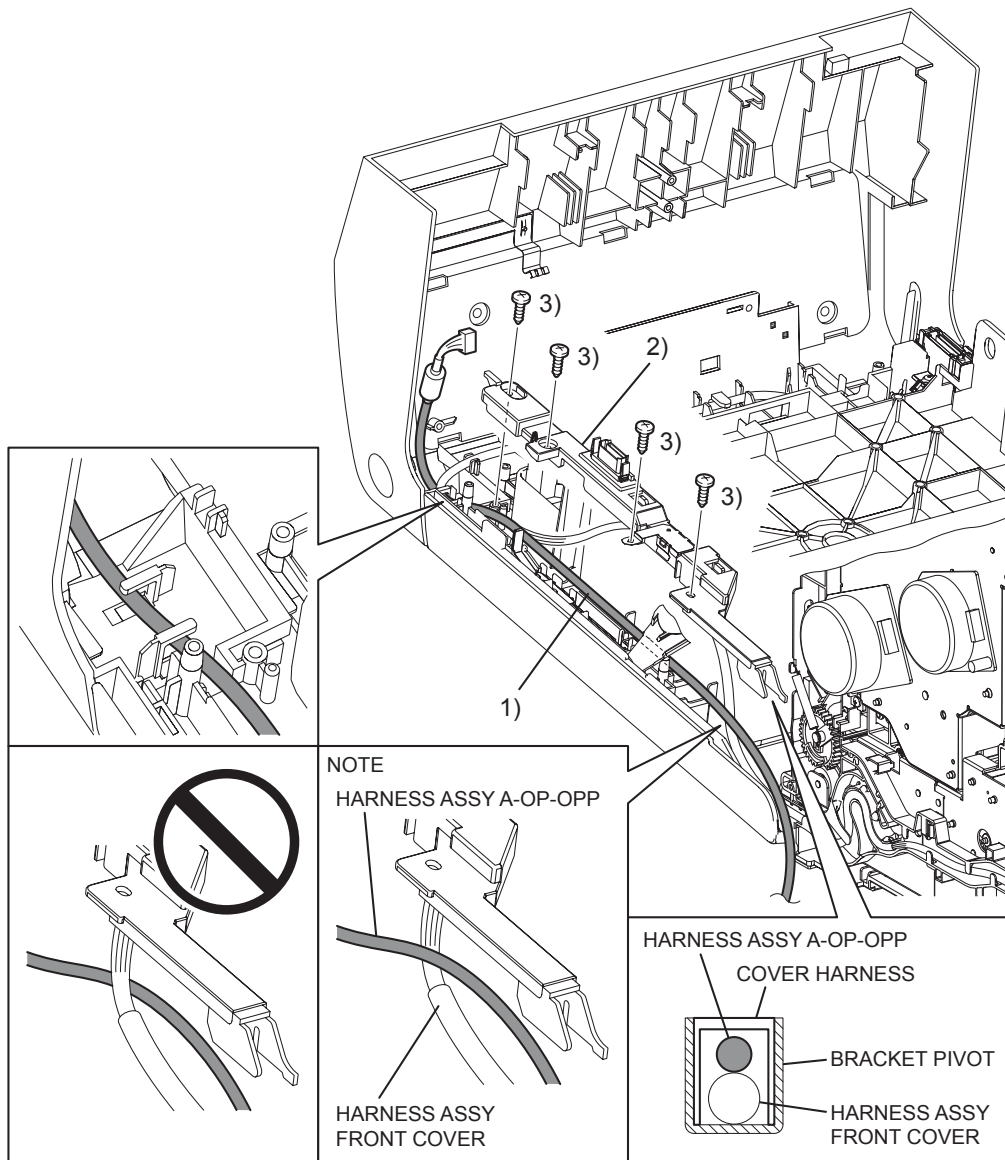

Gnb03212KB

- 1) Route the HARNESS ASSY A-OP-OPP through the notch on the lib of the FRONT COVER and the hook.

NOTE

When performing the step below, route the HARNESS ASSY A-OP-OPP so that it crosses the HARNESS ASSY FRONT COVER.

- 2) Replace the COVER HARNESS by mating the hole of the COVER HARNESS with the boss on the FRONT COVER.

NOTE

When performing the step below, check that the HARNESS ASSY A-OP-OPP is routed over.

- 3) Secure the COVER HARNESS to the FRONT COVER using the four screws (silver, tap, 8mm).

Continues to the next page.

Replacement 66 OPERATOR PANEL (PL13.2.97)

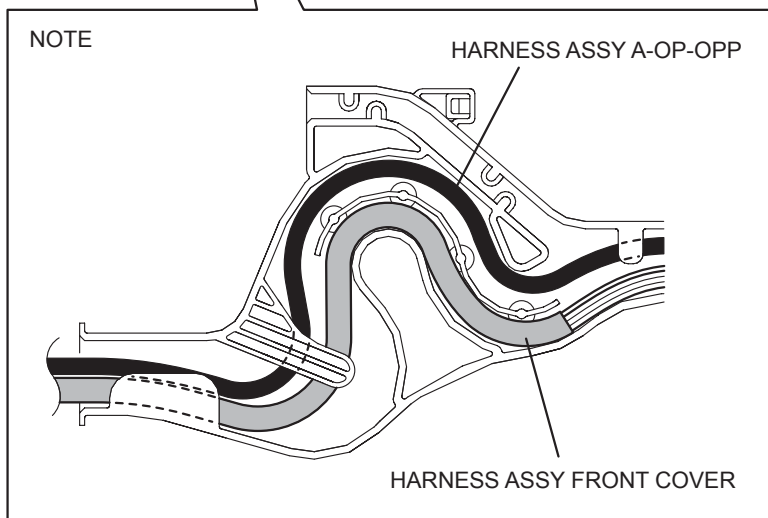
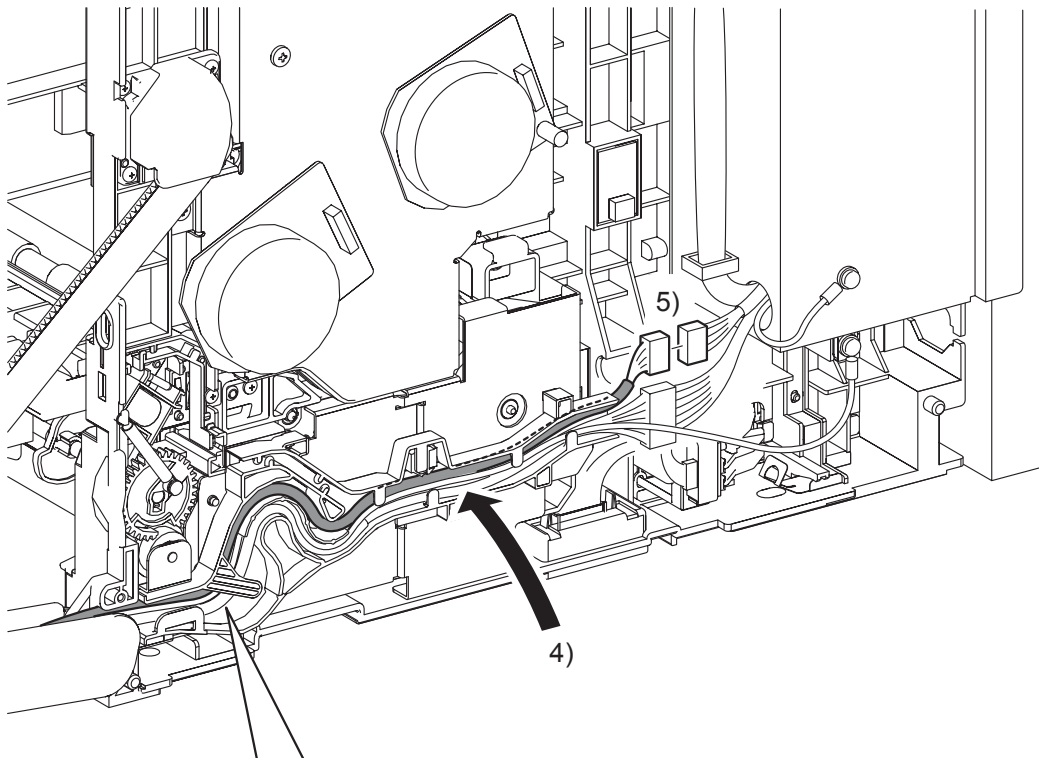

Gnb03213KB

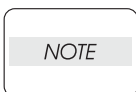

When performing the step below, route the HARNESS ASSY A-OP-OPP on the most outward position.

- 4) Route the HARNESS ASSY A-OP-OPP along the DUCT DRV PH.
- 5) Engage the connector (P/J5301) of the HARNESS ASSY A-OP-OPP.

Continues to the next page.

Replacement 66 OPERATOR PANEL (PL13.2.97)

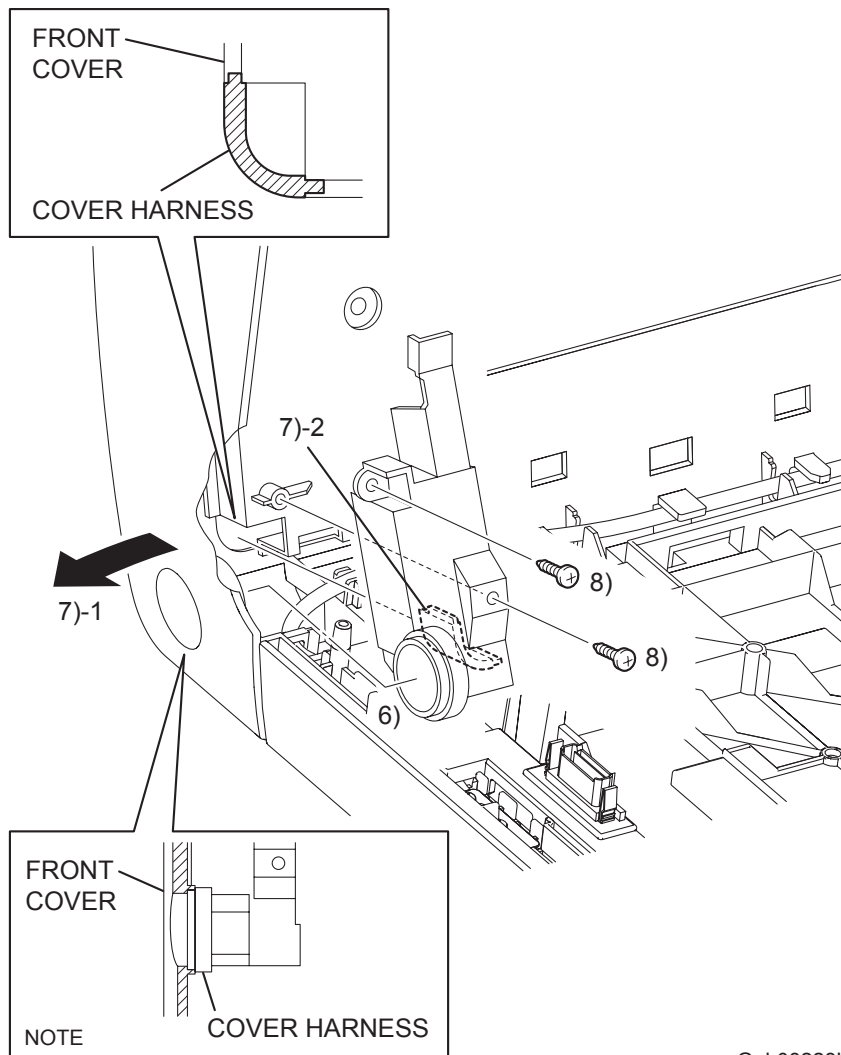

Gnb03223KA

NOTE

When performing the step described below, ensure that the **COVER HARNESS** is installed in location as shown in the figure.

- 6) Mate the rim of the **BUTTON TOP** with the hole of the **FRONT COVER**.
- 7) Put the rim of the **COVER HARNESS** into the **FRONT COVER** by spreading the **FRONT COVER**.
- 8) Secure the **COVER HARNESS** to the **FRONT COVER** using the two screws (silver, tap, 10mm).

Continues to the next page.

Replacement 66 OPERATOR PANEL (PL13.2.97)

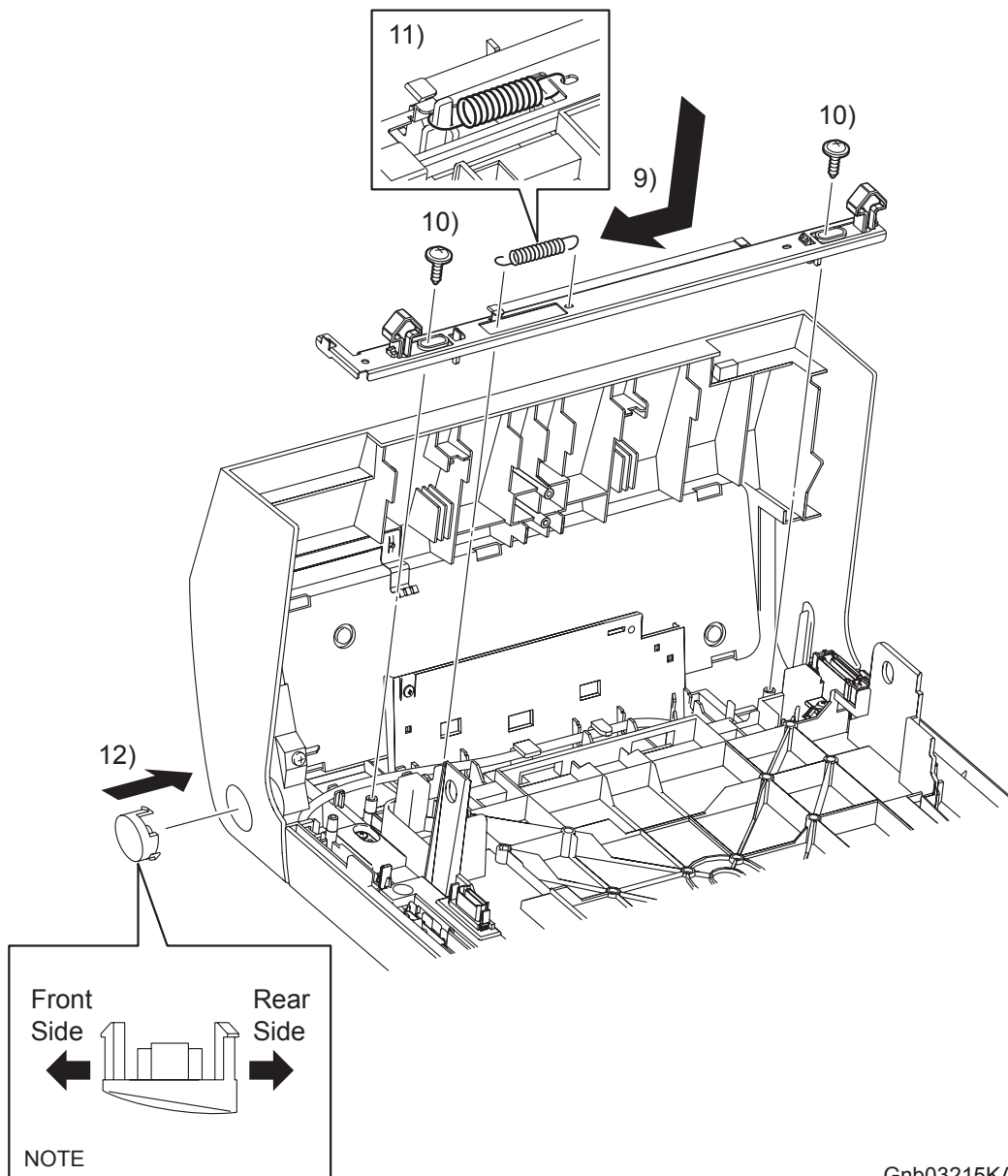

Gnb03215KA

- 9) Replace the LATCH FRONT to the FRONT COVER together with the PLATE LATCH by mating the left and right side slits of the LATCH FRONT with the studs on the FRONT COVER.
- 10) Secure the left and right sides of the LATCH FRONT to the FRONT COVER using the two screws (silver, with flange, tap, 10mm).
- 11) Anchor the SPRING LATCH to the hole on the PLATE LATCH and the peg on the FRONT COVER.

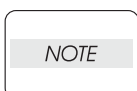

When performing the step described below, pay attention to the direction of installation. Replace the BUTTON TOP so that its thicker half comes behind and its top fits flush with the right side of the COVER FRONT ASSY.

- 12) Secure the BUTTON TOP to the FRONT COVER with the two hooks.

Continues to the next page.

Replacement 66 OPERATOR PANEL (PL13.2.97)

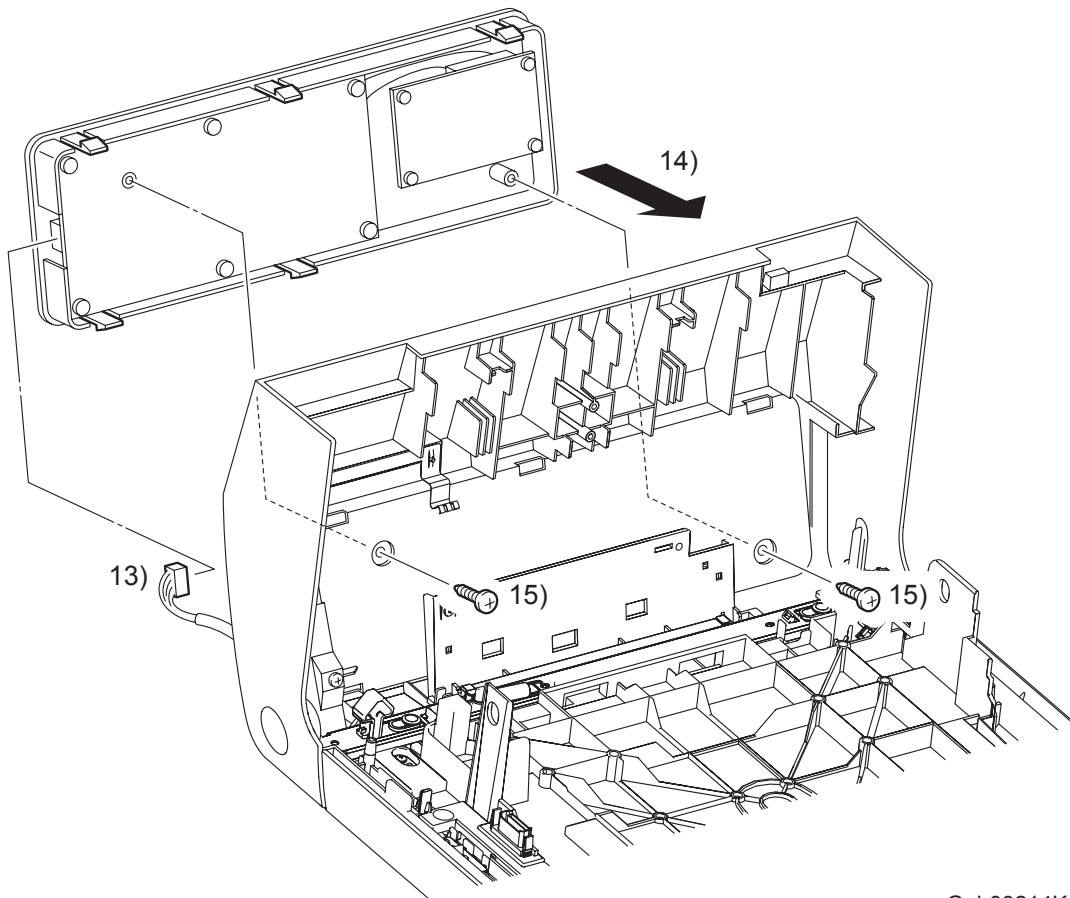

Gnb03214KA

- 13) Engage the connector (P/J202) the OPERATOR PANEL.
- 14) Secure the OPERATOR PANEL to the FRONT COVER with the five hooks of the OPERATOR PANEL.
- 15) Secure the OPERATOR PANEL to the FRONT COVER using the two screws (silver, tap, 10mm).

**Go to the next replacement step:
Replacement 36 CHUTE ASSY EXIT OUT (PL6.1.1)**

Replacement 67 FRONT COVER (PL13.2.98)

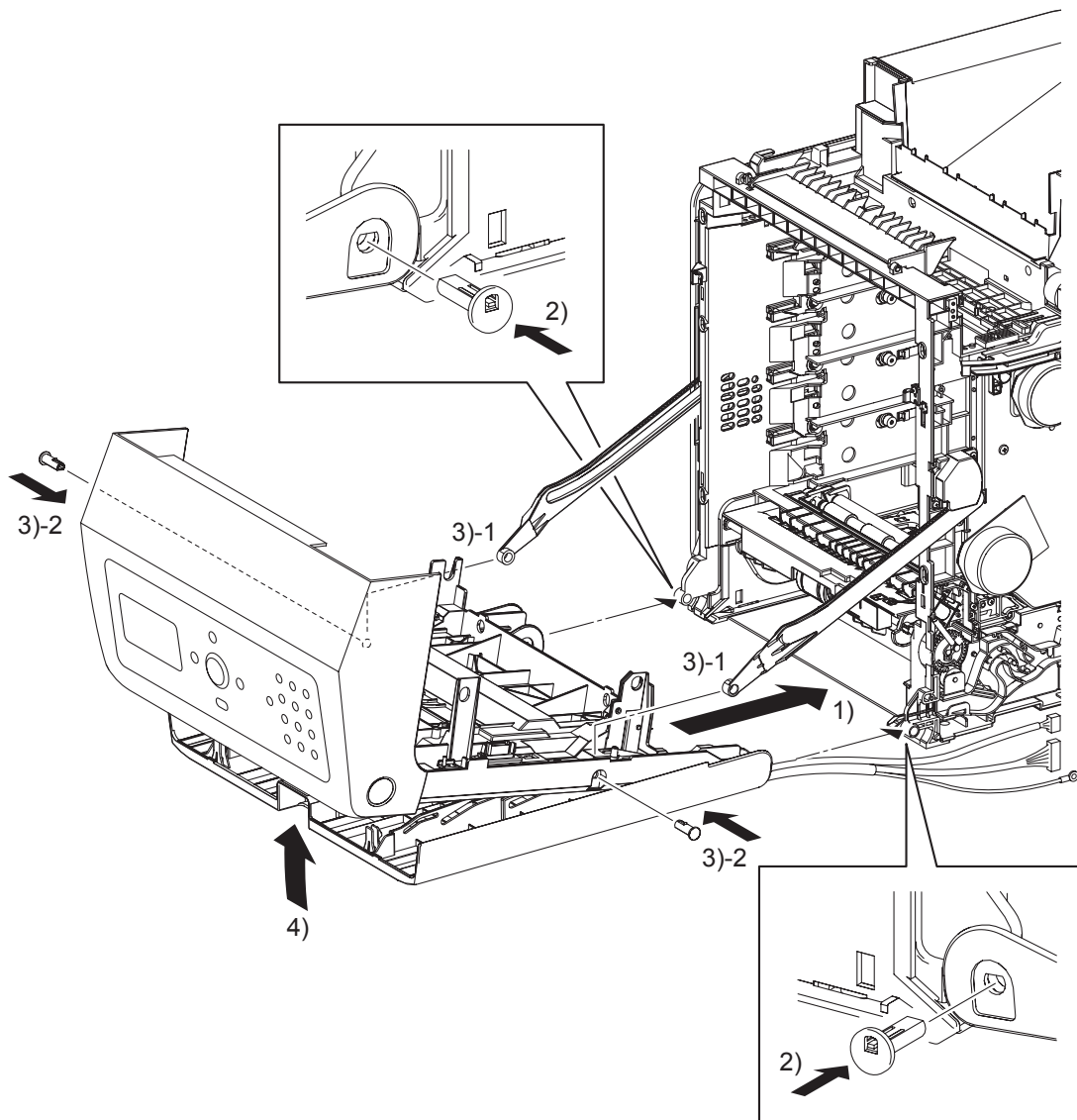

Gnb03085KB

- 1) Align the left and right side holes on the FRONT COVER and MPF COVER to the fitting holes on the printer.
- 2) Insert the SHAFT PIVOT MSIs into the left and right sides fitting holes of the FRONT COVER and the MPF COVER, and then secure the SHAFT PIVOT MSIs with the hooks.
- 3) Align the left and right side fitting holes of the FRONT COVER with the fitting hole of the LINK L and the LINK R, and then insert the SHAFT PIVOTS. Secure the SHAFT PIVOTS with the hooks.
- 4) Close the MPF COVER.

Continues to the next page.

Replacement 67 FRONT COVER (PL13.2.98)

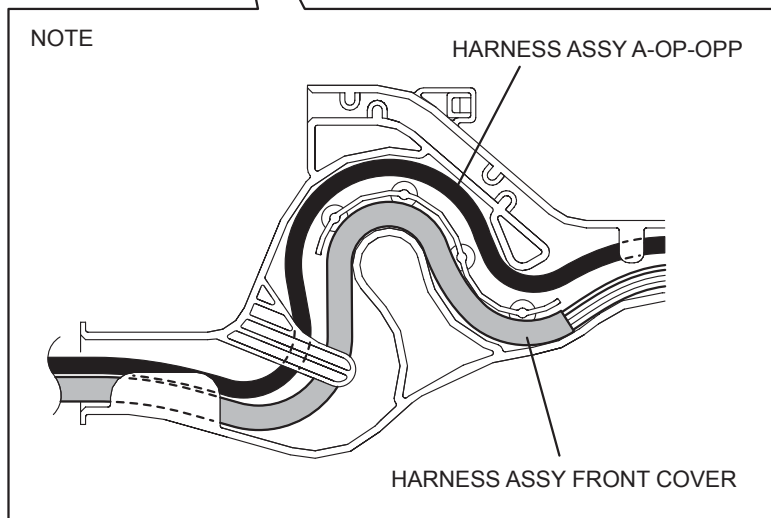
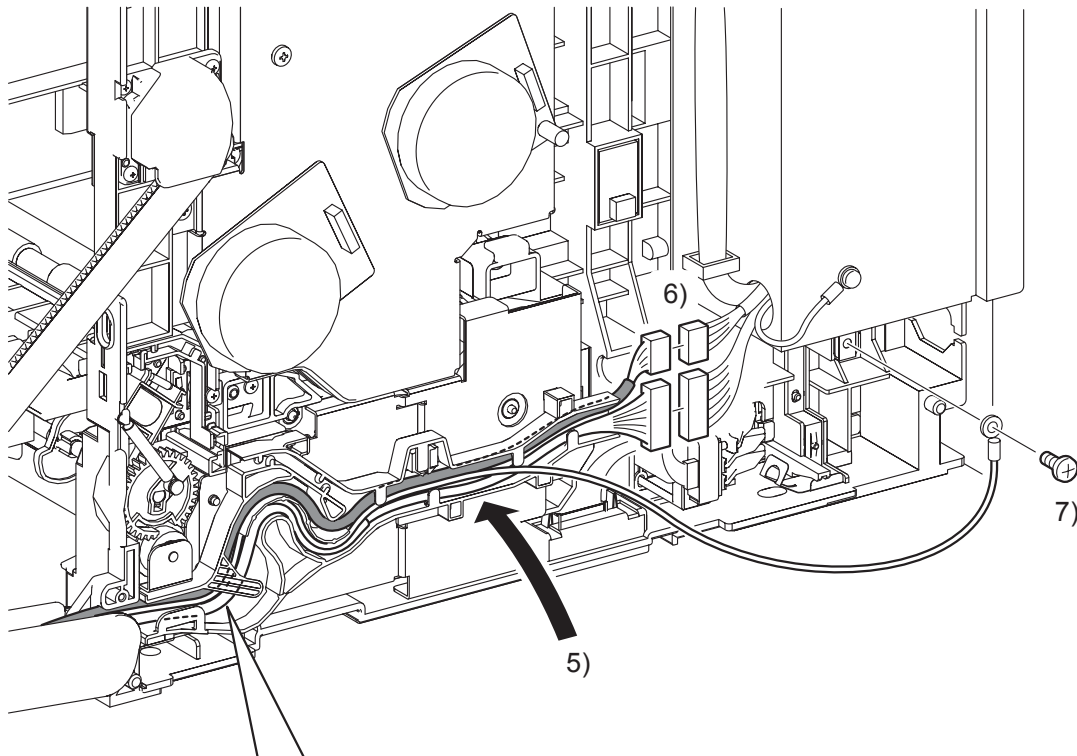

Gnb03086KB

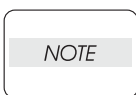

When performing the step below, route the HARNESS ASSY A-OP-OPP over the HARNESS ASSY FRONT COVER.

- 5) Route the HARNESS ASSY A-OP-OPP and the HARNESS ASSY FRONT COVER along the DUCT DRV PH.
- 6) Engage the connector (P/J272) of the HARNESS ASSY FRONT COVER and the connector (P/J5301) of the HARNESS ASSY A-OP-OPP.
- 7) Secure the grounding wire of the HARNESS ASSY FRONT COVER to the printer using the one screw (silver, 6mm).

Go to the next replacement step:

Replacement 68 RIGHT COVER (PL13.1.9)

Replacement 68 RIGHT COVER (PL13.1.9)

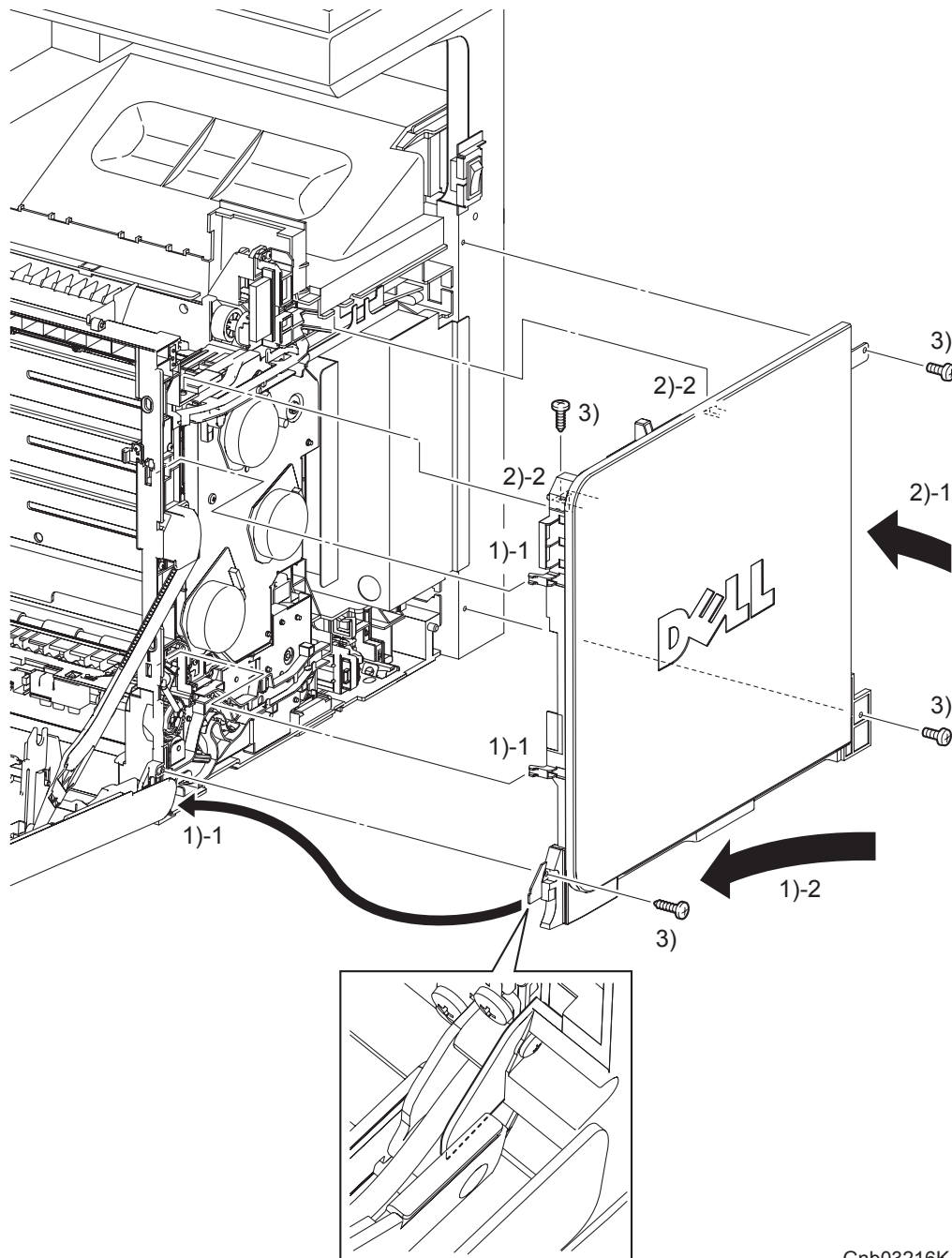

Gnb03216KA

- 1) Insert the front side of the RIGHT COVER between the FRONT COVER and the printer. Mate the two front side hooks of the RIGHT COVER with the holes on the printer.
- 2) Mate the mounting hole on the front side of the RIGHT COVER with the boss of the printer, and then insert the backside hook on the rear side of the RIGHT COVER into the hole of the printer.

NOTE

When performing the step described below, take care to check the screw type. The screws (silver, tap, 6mm) are used to secure the rear side of the RIGHT COVER.

- 3) Secure the RIGHT COVER to the RIGHT COVER to the printer using the two screws (silver, tap, 10mm) and the two screws (silver, 6mm).

Go to the next replacement step:

Replacement 70 COVER POLE R (PL13.1.8)

Replacement 69 POWER SWITCH (PL13.5.4)

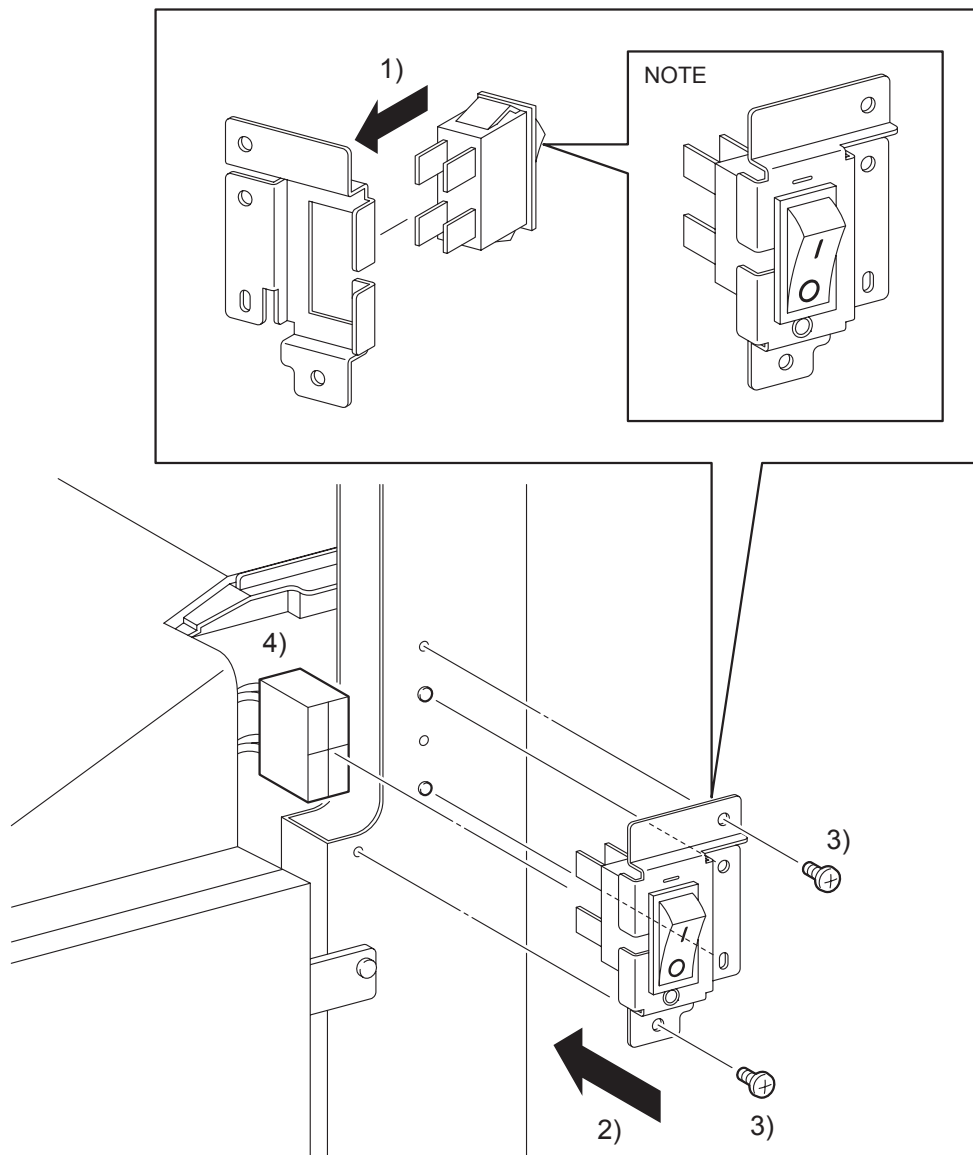

Gnb03217KA

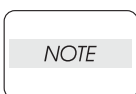

When replacing the POWER SWITCH, match the ON/OFF mark of the POWER SWITCH with the mark on the FRAME.

- 1) Replace the POWER SWITCH to the BRACKET MAIN SW, and secure with the hooks.
- 2) Mate the two holes on the BRACKET MAIN SW with the bosses on the printer.
- 3) Secure the BRACKET MAIN SW to the printer using the two screws (silver, 6mm).
- 4) Engage the connector (P/J481) of the POWER SWITCH.

Go to the next replacement step:

Replacement 70 COVER POLE R (PL13.1.8)

Replacement 70 COVER POLE R (PL13.1.8)

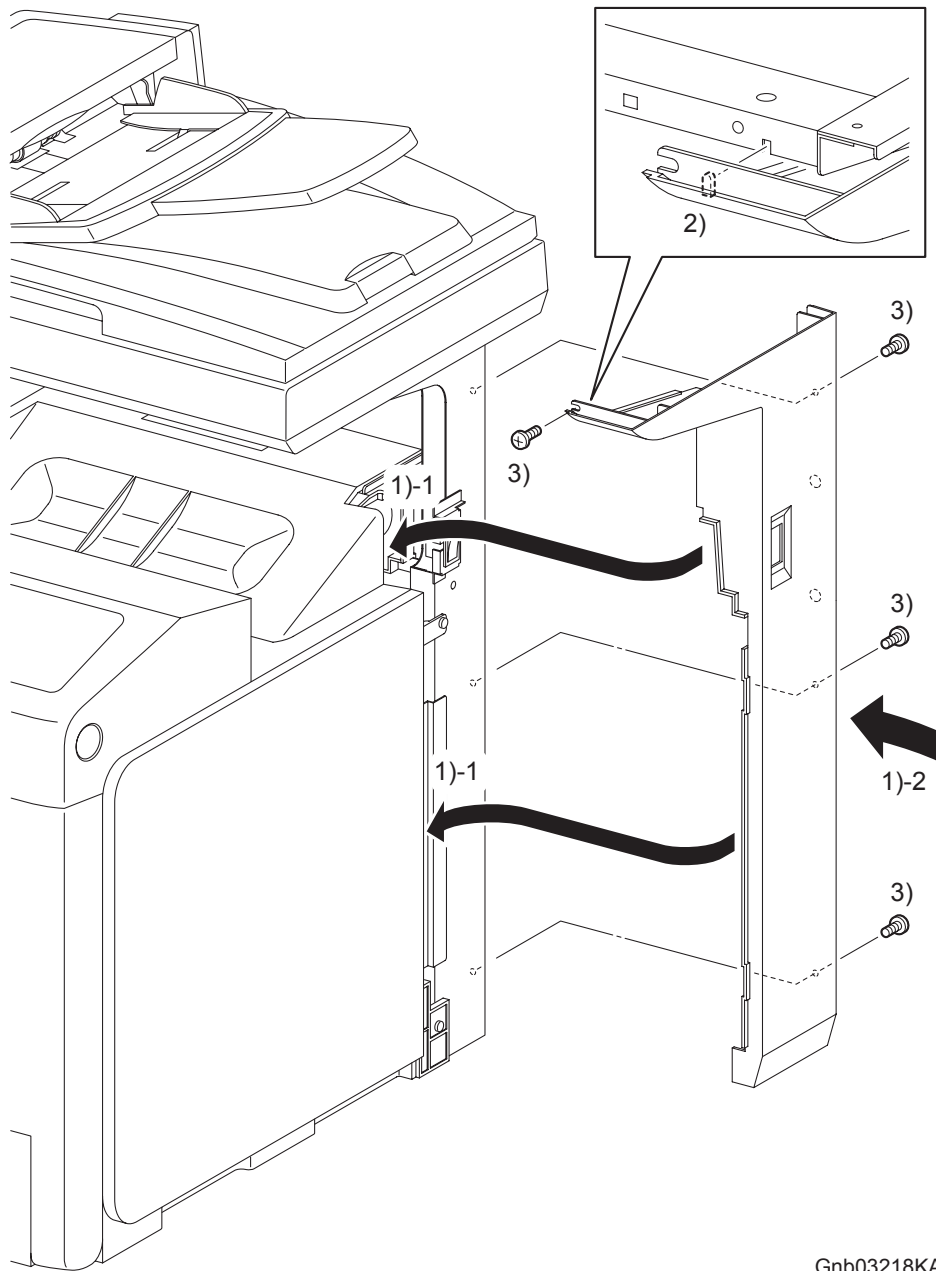

Gnb03218KA

- 1) Replace the COVER POLE R to the printer by inserting the rim on the front side of the COVER POLE R into the inside of the TOP COVER and the RIGHT COVER.
- 2) Mate the lug of the front mounting section of the COVER POLE R with the notch of the printer.
- 3) Secure the COVER POLE R to the printer using the four screws (silver, 6mm).

Go to the next replacement step:

Replacement 71 COVER POLE IN R (PL13.1.4)

Replacement 71 COVER POLE IN R (PL13.1.4)

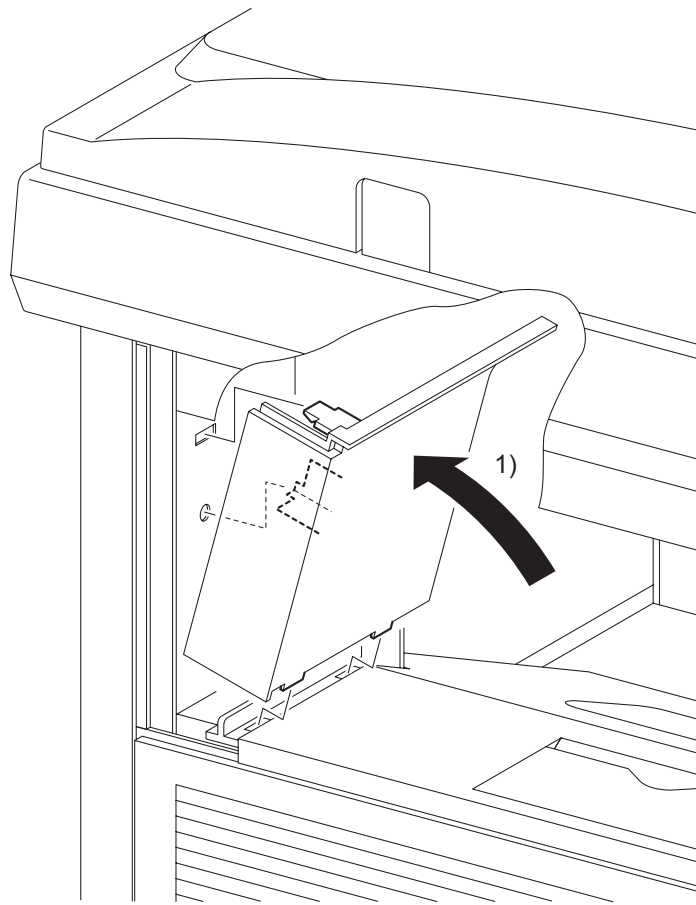

Gnb03219KA

- 1) Replace the COVER POLE IN R to the printer by mating the one hook and the one lug on the COVER POLE IN R with the holes of the printer.

Go to the next replacement step:

Replacement 72 COVER BOTTOM (PL13.1.5)

Replacement 72 COVER BOTTOM (PL13.1.5)

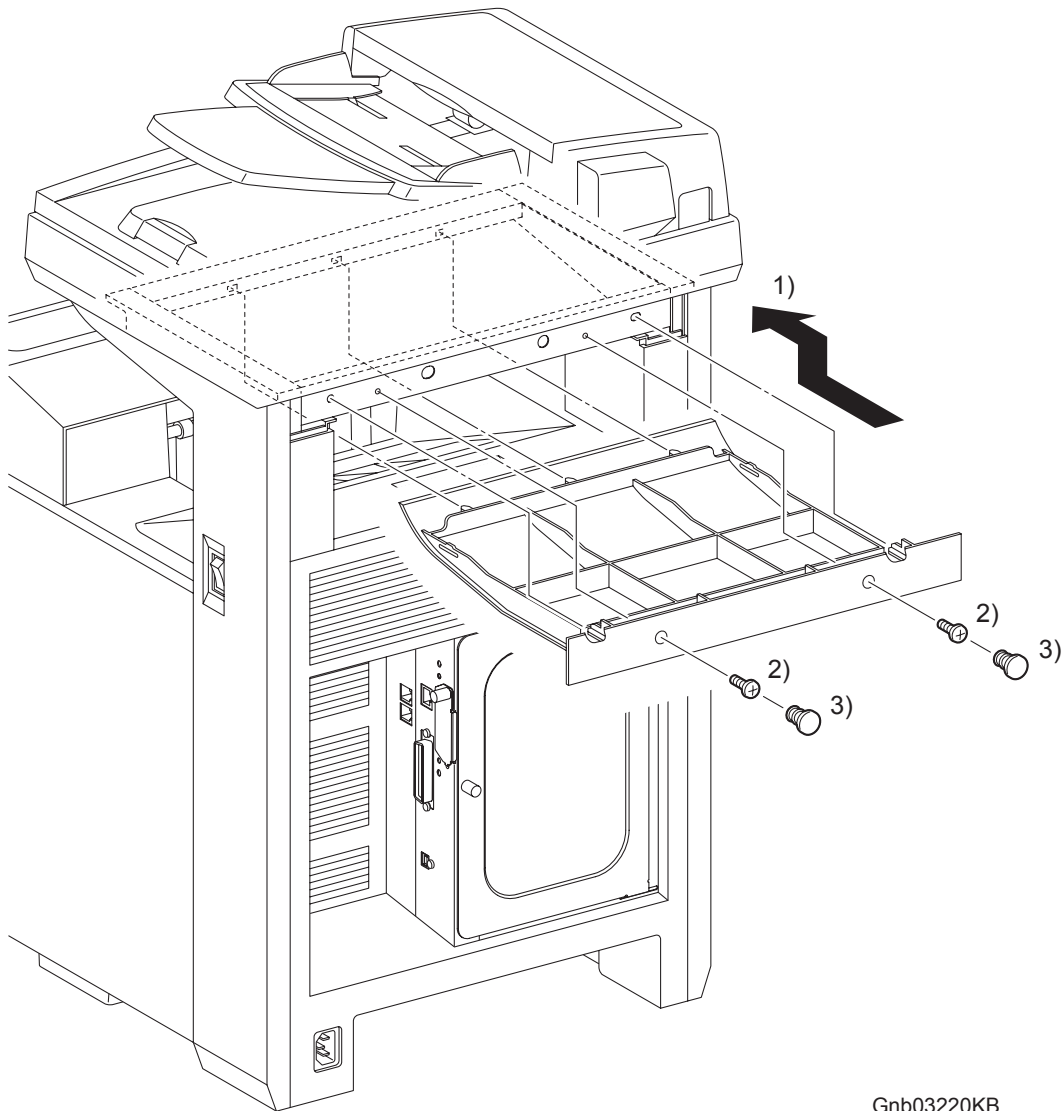

Gnb03220KB

- 1) Replace the COVER BOTTOM to printer by mating the five lugs of the COVER BOTTOM with the holes of the printer.
- 2) Secure the COVER BOTTOM to the printer using the two screws (silver, 6mm).
- 3) Attach the two CAP SCREWS to the holes of the screw.

Go to the next replacement step:

Replacement 73 REAR COVER (PL13.1.6)

Replacement 73 REAR COVER (PL13.1.6)

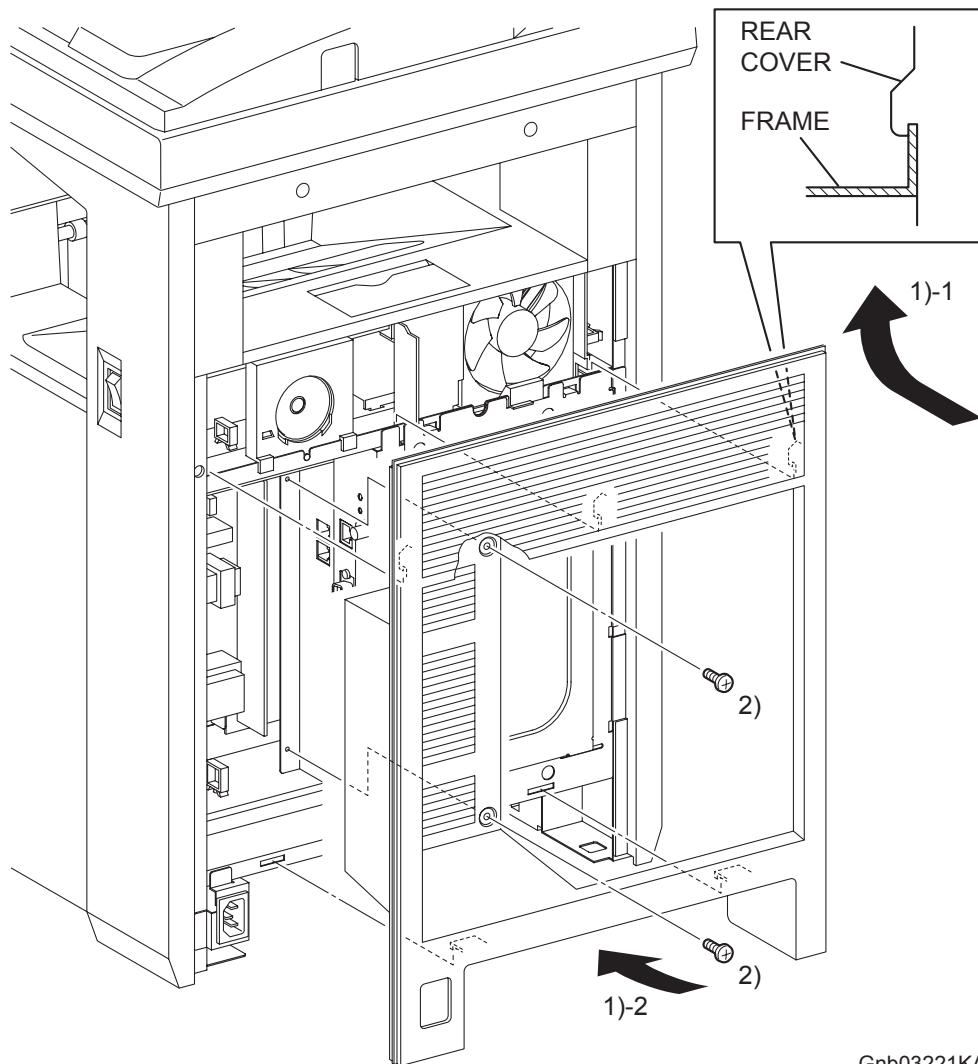

Gnb03221KA

- 1) Insert the rim on the upper side of the REAR COVER into the inside of the TOP COVER, and then secure the REAR COVER to the printer with the five hooks of the REAR COVER.
- 2) Secure the REAR COVER to the printer using the two screws (silver, 6mm).

**Go to the next replacement step:
Replacement 38 FUSER (PL6.1.10)**

Replacement 74 COVER EXTENDER (PL13.1.2)

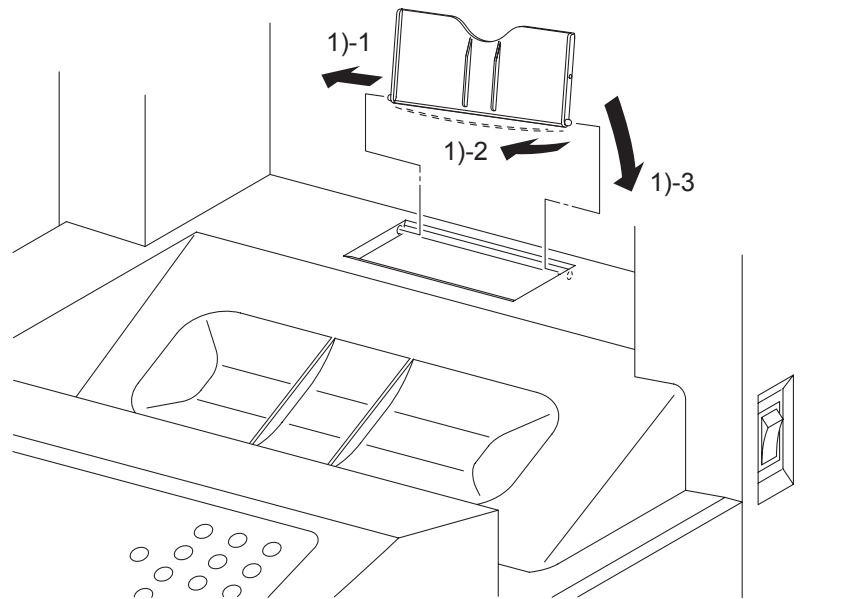

Gnb03062KA

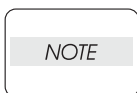

When performing the step described below, take care not to damage the boss of the COVER EXTENDER.

- 1) Insert one of the bosses of the COVER EXTENDER, at its open position, into the hole on the TOP COVER, and then bend the COVER EXTENDER to slip the other boss into place.
- 2) Close the COVER EXTENDER.

Replacement 75 KIT TRAY MAIN (PL13.8.10)

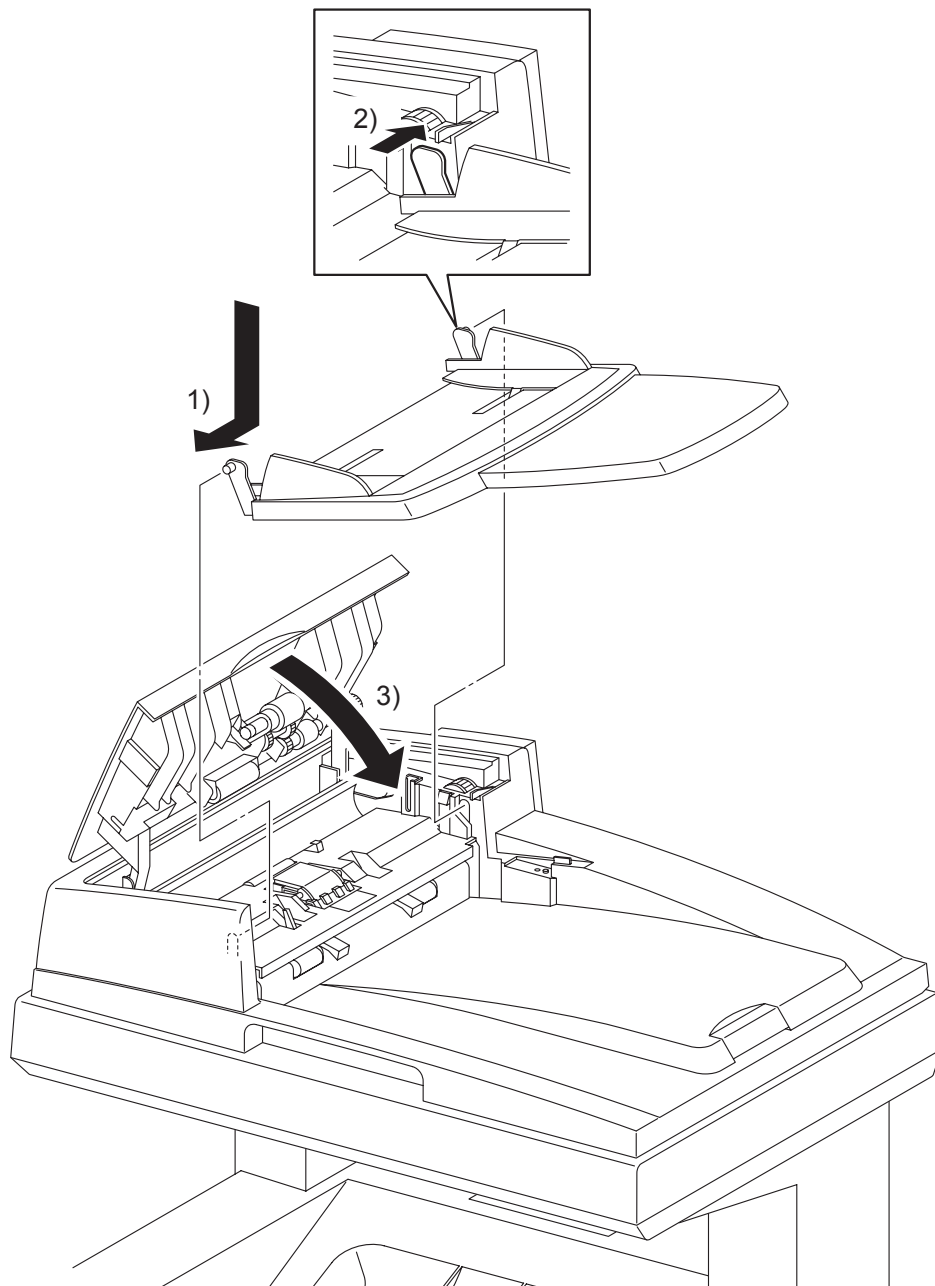

Gnb03225KA

- 1) Mate the front side boss of the KIT TRAY MAIN with the hole of the ADF ASSY.
- 2) Mate the boss of the KIT TRAY MAIN with the hole of the ADF ASSY by bending the rear side mounting section of the KIT TRAY MAIN.
- 3) Close the cover of the ADF ASSY.

Chapter 4 Plug/Jack(P/J) Connector Locations CONTENTS

1. Connector [P (plug) / J (jack)].....	4 - 1
1.1 List of P/J	4 - 1
1.2 IOT P/J layout diagram	4 - 5
1.3 DUPLEX P/J layout diagram.....	4 - 9
1.4 OPTION FEEDER P/J layout diagram.....	4 - 10

1. Connector [P (plug) / J (jack)]

1.1 List of P/J

IOT

P/J	Coordinates	Remarks
3	E-138	Connects ELECTRONIC SUB-SYSTEM CONTROL BOARD and MULTI PROTOCOL CARD
10	I-157	Connects MACHINE CONTROL UNIT and IF AIO Harness Assembly
11	I-157	Connects MACHINE CONTROL UNIT and VIDEO AIO Harness Assembly
12	I-156	Connects MACHINE CONTROL UNIT and ROS AIO Harness Assembly
14	I-156	Connects MACHINE CONTROL UNIT and LVPS AIO Harness Assembly
15	H-157	Connects MACHINE CONTROL UNIT and 24V AIO Harness Assembly
16	I-156	Connects MACHINE CONTROL UNIT and HIGH VOLTAGE POWER SUPPLY
17	I-156	Connects MACHINE CONTROL UNIT and FUSER AIO Harness Assembly
18	H-157	Connects MACHINE CONTROL UNIT and TNR MOT AIO Harness Assembly
19	I-157	Connects MACHINE CONTROL UNIT and TNR SNR AIO Harness Assembly
21	H-158	Connects MACHINE CONTROL UNIT and R SIDE AIO Harness Assembly
22	H-158	Connects MACHINE CONTROL UNIT and R SIDE AIO Harness Assembly
23	H-159	Connects MACHINE CONTROL UNIT and R SIDE AIO Harness Assembly
24	I-159	Connects MACHINE CONTROL UNIT and OHP AIO Harness Assembly
25	H-158	Connects MACHINE CONTROL UNIT and R SIDE AIO Harness Assembly
26	I-159	Connects MACHINE CONTROL UNIT and HUM Harness Assembly
27	I-159	Connects MACHINE CONTROL UNIT and R SIDE AIO Harness Assembly
31	I-159	Connects MACHINE CONTROL UNIT and CRUM AIO Harness Assembly
40a	F-153	Connects LOW VOLTAGE POWER SUPPLY and IF AIO Harness Assembly
40b	F-153	Connects LOW VOLTAGE POWER SUPPLY and ESS POWER AIO Harness Assembly
44	F-152	Connects LOW VOLTAGE POWER SUPPLY and INTERLOCK SWITCH
47	F-152	Connects LOW VOLTAGE POWER SUPPLY and FUSER AIO Harness Assembly
48	E-152	Connects LOW VOLTAGE POWER SUPPLY and INLET AIO Harness Assembly
48	H-144	Connects PWBA HYUI and AIO-ESS Harness Assembly
50	J-142	Connects PWBA HYUI and ESS POWER AIO Harness Assembly
52	H-141	Connects PWBA HYUI and SPEAKER ASSY
53	I-144	Connects PWBA HYUI and A-OP-ESS Harness Assembly
56	I-143	Connects PWBA HYUI and PWBA FAX
60	J-143	"Connects PWBA HYUI and ADF SCANNER ASSY (Empty Sensor, PCB Sensor)"
61	J-143	Connects PWBA HYUI and ADF SCANNER ASSY (ADF Open Sensor)
62	J-143	Connects PWBA HYUI and ADF SCANNER ASSY (ADF Motor)
63	J-143	Connects PWBA HYUI and ADF SCANNER ASSY (Scanner Motor)

P/J	Coordinates	Remarks
64	I-142	Connects PWBA HYUI and ADF SCANNER ASSY (PCB CCD)
65	J-142	Connects PWBA HYUI and ADF SCANNER ASSY (PCB CCD)
101	F-138	Connects ELECTRONIC SUB-SYSTEM CONTROL BOARD and IF AIO Harness Assembly
101	I-158	Not Connects (Debug only)
111	F-138	Connects ELECTRONIC SUB-SYSTEM CONTROL BOARD and VIDEO AIO Harness Assembly
121	G-123	Connects PRINT HEAD and ROS AIO Harness Assembly
141	I-136	Connects LED ASSEMBLY and LVPS AIO Harness Assembly
144	C-110	Connects PWBA EEPROM (BELT) and BELT Harness Assembly (TRANSFER BELT)
144	D-153	Connects PWBA EEPROM (XPRO) and R SIDE AIO Harness Assembly
161	G-136	Connects HIGH VOLTAGE POWER SUPPLY and MACHINE CONTROL UNIT
171	G-108	Connects FUSER and FUSER AIO Harness Assembly
181	I-138	Connects TONER DISPENSER (Y) and TNR MOT AIO Harness Assembly
182	I-137	Connects TONER DISPENSER (M) and TNR MOT AIO Harness Assembly
183	H-136	Connects TONER DISPENSER (K) and TNR MOT AIO Harness Assembly
184	H-137	Connects TONER DISPENSER (C) and TNR MOT AIO Harness Assembly
191	G-126	Connects TONER CARTRIDGE SENSOR ASSEMBLY (Y) and TNR SNR AIO Harness Assembly
192	G-125	Connects TONER CARTRIDGE SENSOR ASSEMBLY (M) and TNR SNR AIO Harness Assembly
193	G-124	Connects TONER CARTRIDGE SENSOR ASSEMBLY (K) and TNR SNR AIO Harness Assembly
194	G-124	Connects TONER CARTRIDGE SENSOR ASSEMBLY (C) and TNR SNR AIO Harness Assembly
202	F-108	Connects OPERATOR PANEL and A-OP-OPP Harness Assembly
211	G-109	Connects PHOTOCONDUCTOR(PC) / DEVELOPER(DEV) DRIVE (Main Motor) and R SIDE AIO Harness Assembly
221	G-110	Connects PHOTOCONDUCTOR(PC) / DEVELOPER(DEV) DRIVE (Sub Motor) and R SIDE AIO Harness Assembly
222	G-111	Connects PHOTOCONDUCTOR(PC) / DEVELOPER(DEV) DRIVE (Deve Motor) and R SIDE AIO Harness Assembly
231	H-127	Connects SIZE SWITCH ASSEMBLY and R SIDE AIO Harness Assembly
232	H-126	Connects INTEGRATED FEEDER ASSEMBLY (REGI SNR Harness Assembly) and R SIDE AIO Harness Assembly
233	H-125	Connects INTEGRATED FEEDER ASSEMBLY (REGI Clutch) and R SIDE AIO Harness Assembly
234	H-125	Connects INTEGRATED FEEDER ASSEMBLY (Turn Clutch) and R SIDE AIO Harness Assembly
235	H-124	Connects INTEGRATED FEEDER ASSEMBLY (CST Feed Clutch) and R SIDE AIO Harness Assembly
236	G-112	Connects MPF FEED SOLENOID and R SIDE AIO Harness Assembly
241	H-126	Connects OHP SNR Harness Assembly and OHP AIO Harness Assembly
251	G-111	Connects FEED DRIVE ASSEMBLY (PH Motor) and R SIDE AIO Harness Assembly
261	I-153	Connects HUMIDITY SENSOR and HUM Harness Assembly

P/J	Coordinates	Remarks
272	H-111	Connects FRONT COVER Harness Assembly and R SIDE AIO Harness Assembly
273	G-127	Connects R SIDE AIO Harness Assembly and 550 SHEET FEEDER ASSEMBLY (FDR UNIT Harness Assembly)
275	H-109	Connects MSI NPP Harness Assembly and R SIDE AIO Harness Assembly
276	H-110	Connects EXIT CLT Harness Assembly and R SIDE AIO Harness Assembly
311	G-125	Connects CRUM Sensor (Y) and CRUM AIO Harness Assembly
312	G-125	Connects CRUM Sensor (M) and CRUM AIO Harness Assembly
313	G-124	Connects CRUM Sensor (C) and CRUM AIO Harness Assembly
314	G-123	Connects CRUM Sensor (K) and CRUM AIO Harness Assembly
401	F-137	Connects ELECTRONIC SUB-SYSTEM CONTROL BOARD and IF AIO Harness Assembly
480	D-139	Connects ELECTRONIC SUB-SYSTEM CONTROL BOARD and AIO-ESS Harness Assembly
481	E-151	Connects POWER SWITCH and INLET AIO Harness Assembly
501	G-153	Connects LOW VOLTAGE POWER SUPPLY and LVPS AIO Harness Assembly
502	F-153	Connects LOW VOLTAGE POWER SUPPLY and 24V AIO Harness Assembly
503	G-153	Connects LOW VOLTAGE POWER SUPPLY and FAN
504	G-153	Connects LOW VOLTAGE POWER SUPPLY and IF AIO Harness Assembly
2321	D-126	Connects INTEGRATED FEEDER ASSEMBLY (CST No Paper Sensor) and REGI SNR Harness Assembly
2322	D-126	Connects INTEGRATED FEEDER ASSEMBLY (REGI Sensor) and REGI SNR Harness Assembly
2411	F-126	Connects PWBA OHP SNR and OHP SNR Harness Assembly
2412	E-127	Connects PWBA OHP LED and OHP SNR Harness Assembly
2721	B-108	Connects TRANSFER BELT and FRONT COVER Harness Assembly
2751	E-112	Connects MSI No Paper Sensor and MSI NPP Harness Assembly
2761	H-109	Connects PHOTOCONDUCTOR(PC) / DEVELOPER(DEV) DRIVE (Exit Clutch) and EXIT CLT Harness Assembly
5041	F-138	Not Connects (Used in production process only)
5301	H-111	Connects A-OP-OPP Harness Assembly and A-OP-ESS Harness Assembly
27212	D-108	Connects ADC Sensor and BELT Harness Assembly (TRANSFER BELT)
27213	D-108	Connects ADC Solenoid and BELT Harness Assembly (TRANSFER BELT)

DUP

P/J	Coordinates	Remarks
1	E-168	Not Connects (Debug only)
427	F-168	Connects PWBA DUP and FAN DUP
428	F-168	Connects PWBA DUP and DUP UNIT Harness Assembly
429	F-169	Connects PWBA DUP and MOTOR ASSY DUP
430	F-168	Connects PWBA DUP and DUP SNR Harness Assembly
431	F-168	Connects PWBA DUP and DUP Clutch
2720	I-169	Connects DUPLEX MODULE (DUP UNIT Harness Assembly) and PRINTER
4301	E-167	Connects DUP Jam Sensor and DUP SNR Harness Assembly

OPT FEEDER

P/J	Coordinates	Remarks
1	G-180	Not Connects (Debug only)
273	H-183	Connects 550 SHEET FEEDER ASSEMBLY (FDR UNIT Harness Assembly) and PRINTER
419	G-180	Connects PWBA OPT FDR and FDR UNIT Harness Assembly
420	G-180	Connects PWBA OPT FDR and C2 TURN Harness Assembly
421	G-179	Connects PWBA OPT FDR and C2 CHUTE Harness Assembly
422	G-179	Connects PWBA OPT FDR and C2 MOT Harness Assembly
423	G-180	Not Connects
4201	H-185	Connects C2 TURN CLUTCH and C2 TURN Harness Assembly
4202	H-185	Not Connects
4211	I-184	Connects SWITCH ASSY SIZE OPT and C2 CHUTE Harness Assembly
4212	H-184	Connects C2 CHUTE Harness Assembly and C2 NO PAPER Harness Assembly
4213	H-185	Connects C2 FEED CLUTCH and C2 CHUTE Harness Assembly
4221	G-185	Connects DRIVE ASSY OPT FDR (OPT FDR Motor) and C2 MOT Harness Assembly
4222	G-185	Connects DRIVE ASSY OPT FDR (OPT FDR Motor) and C2 MOT Harness Assembly
42121	D-183	Connects C2 CST No Paper Sensor and C2 NO PAPER Harness Assembly

1.2 IOT P/J layout diagram

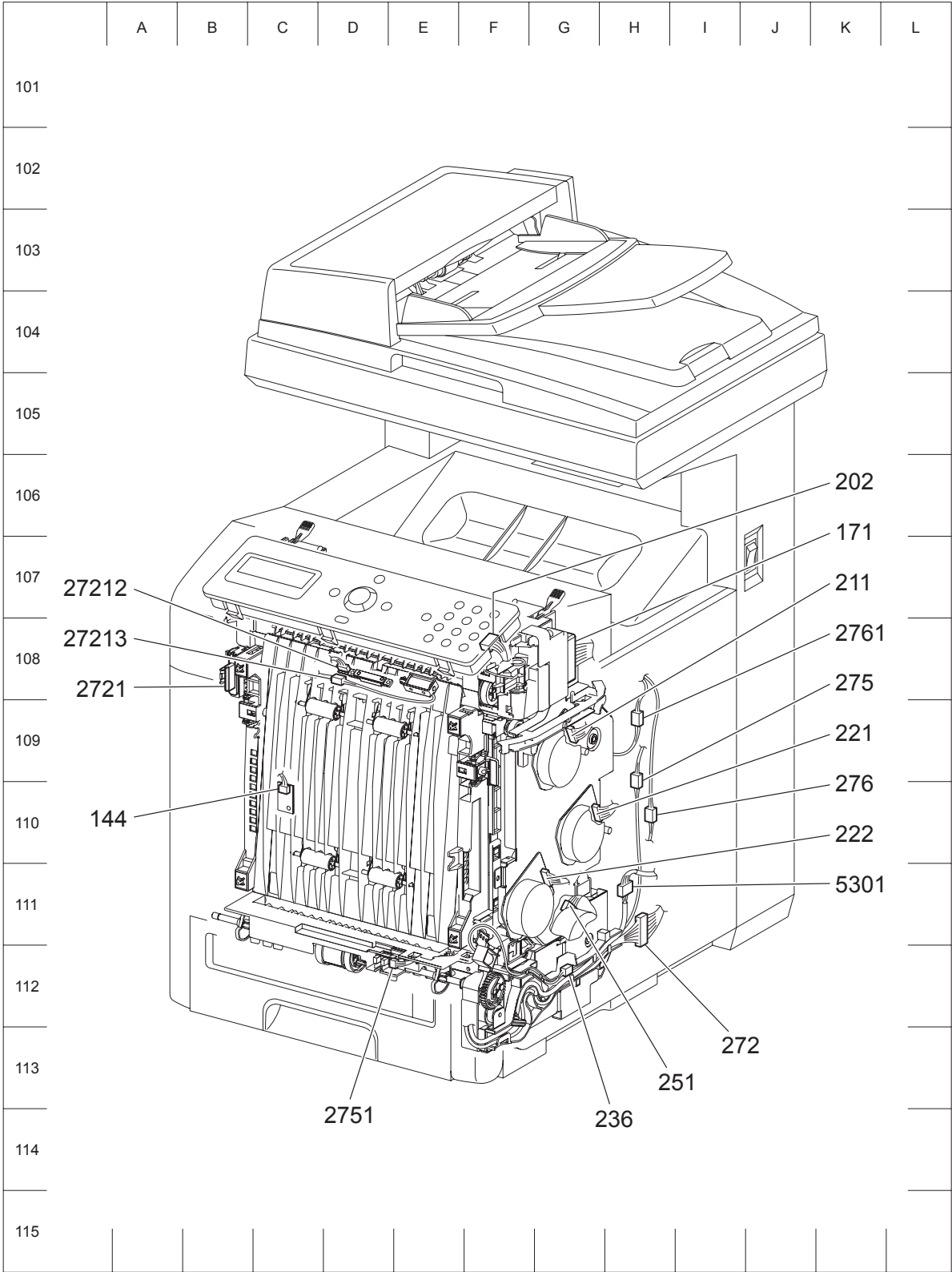

Gnb04001KA

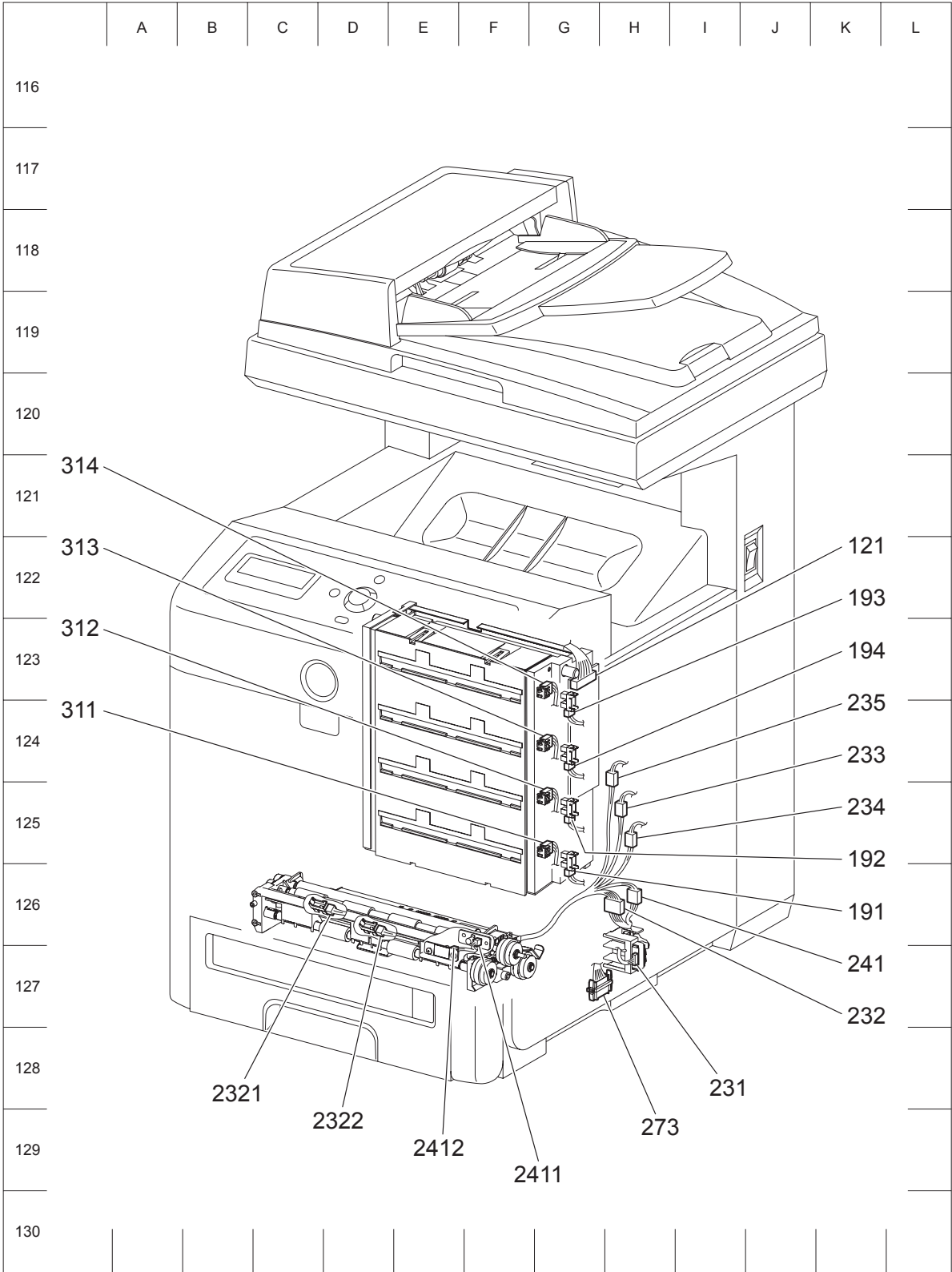

Gnb04002KA

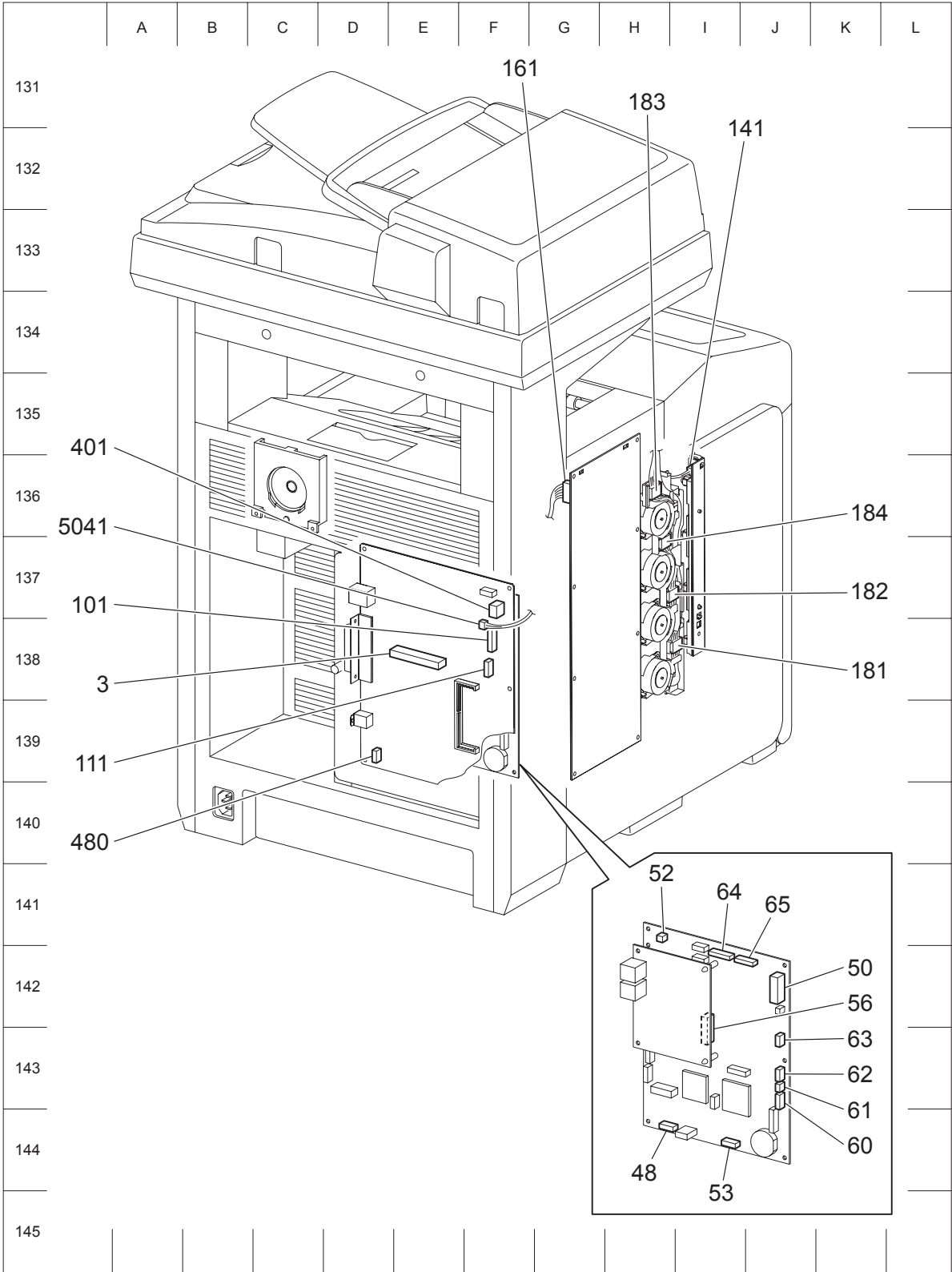

Gnb04003KB

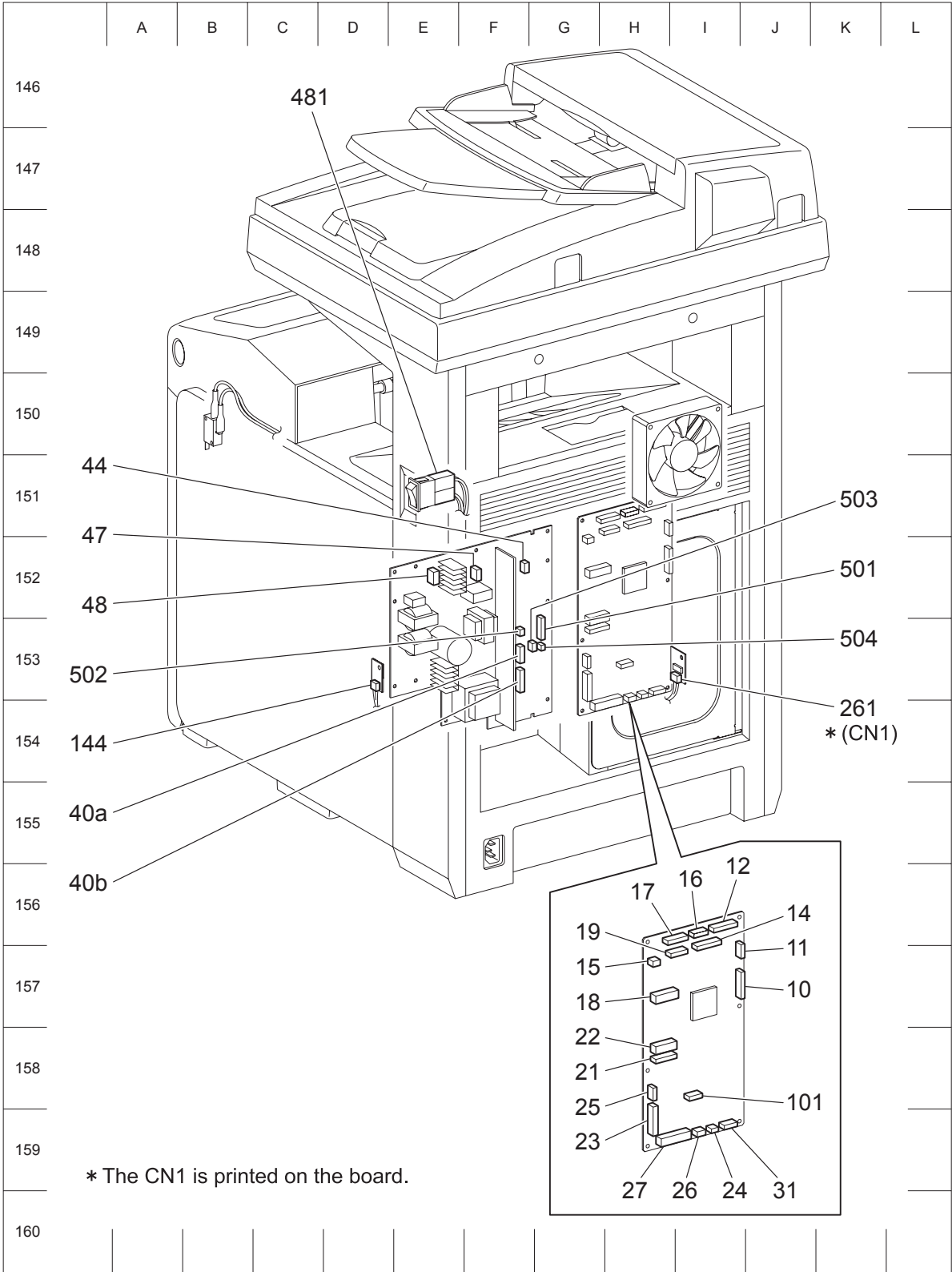

Kmy04004KA

1.3 DUPLEX P/J layout diagram

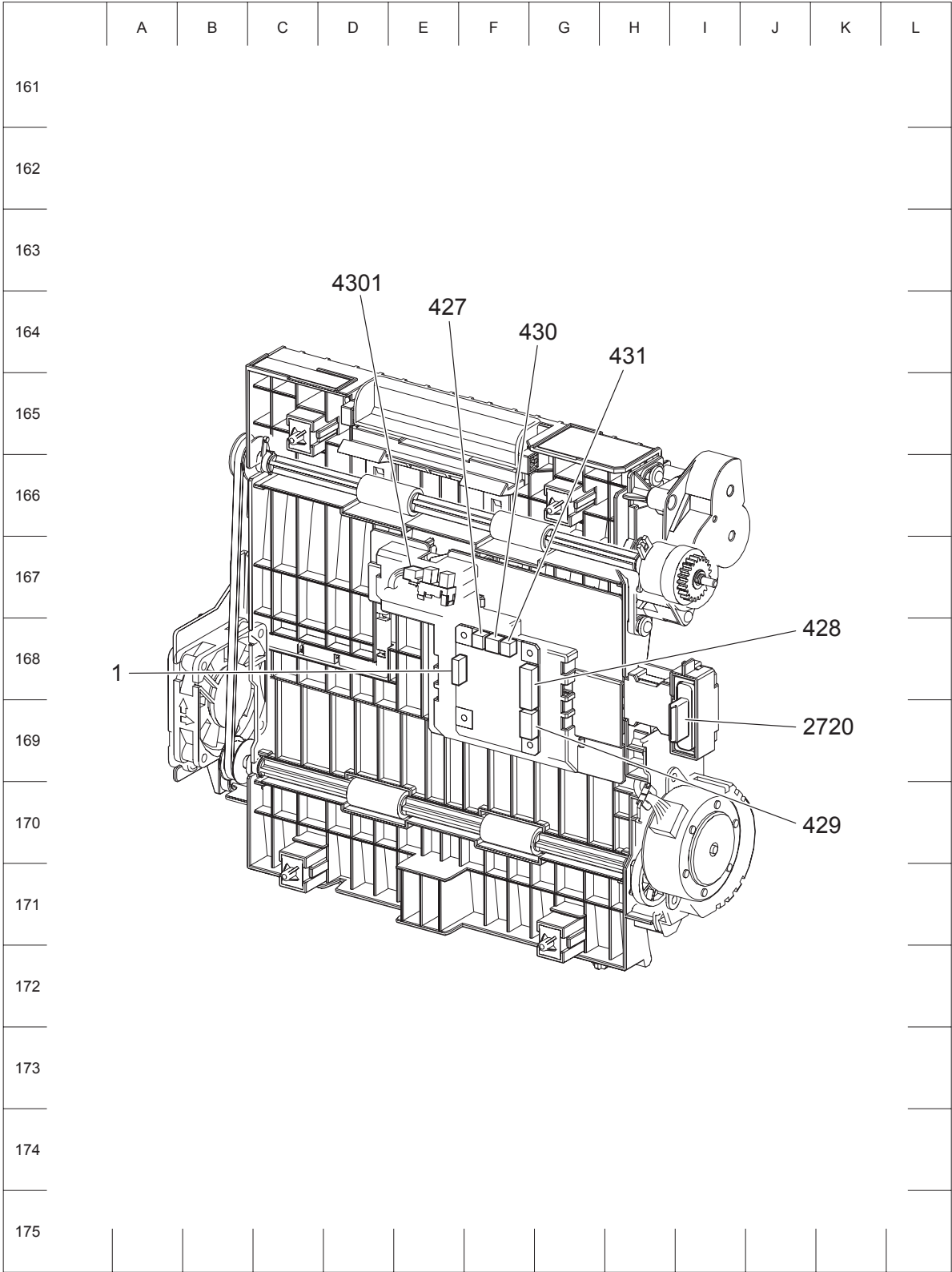

Kmy04005KA

1.4 OPTION FEEDER P/J layout diagram

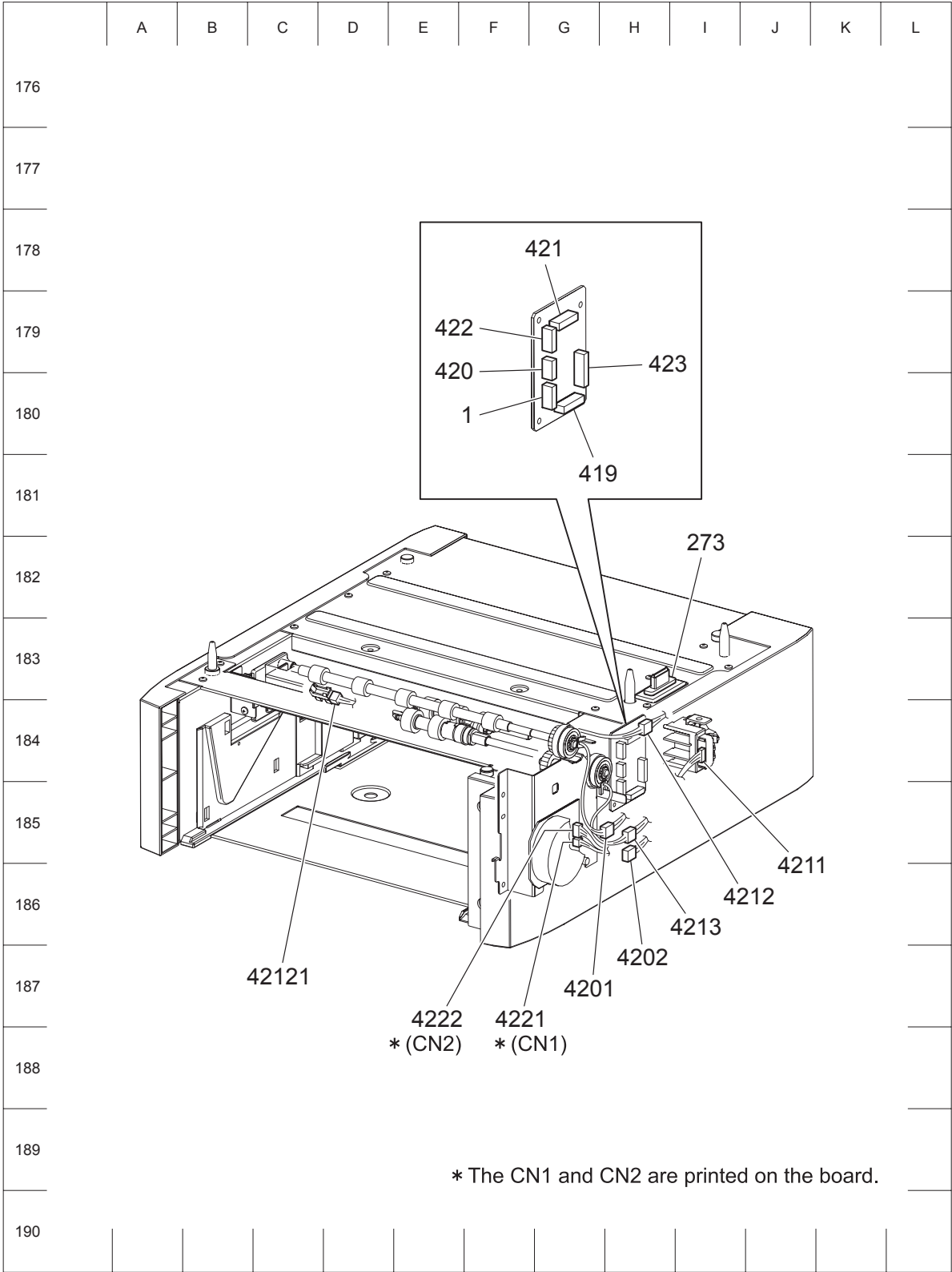

Kmy04006KB

Chapter 5 Parts List CONTENTS

1. Parts List.....	5 - 1
1.1 Caution for use of spare parts illustration	5 - 1
1.2 Caution for use of engineering parts list	5 - 1
Customer Replaceable Parts Illustration.....	5 - 2
Engineering parts list	5 - 10
PL1.1 Cover (1/2) [Illustration] (Reference)	5 - 10
PL1.1 Cover (1/2) [List] (Reference)	5 - 11
PL1.2 Cover (2/2) [Illustration] (Reference)	5 - 12
PL1.2 Cover (2/2) [List] (Reference)	5 - 13
PL2.1 Paper Cassette (1/2) [Illustration] (Reference)	5 - 14
PL2.1 Paper Cassette (1/2) [List] (Reference).....	5 - 15
PL2.2 Paper Cassette (2/2) [Illustration] (Reference)	5 - 16
PL2.2 Paper Cassette (2/2) [List] (Reference).....	5 - 17
PL3.1 Paper Feeder (1/2) [Illustration] (Reference).....	5 - 18
PL3.1 Paper Feeder (1/2) [List] (Reference).....	5 - 19
PL3.2 Paper Feeder (2/2) [Illustration] (Reference).....	5 - 20
PL3.2 Paper Feeder (2/2) [List] (Reference).....	5 - 21
PL4.1 Transfer [Illustration] (Reference).....	5 - 22
PL4.1 Transfer [List] (Reference).....	5 - 23
PL5.1 Xerographics [Illustration] (Reference).....	5 - 24
PL5.1 Xerographics [List] (Reference).....	5 - 25
PL6.1 Fuser & Exit [Illustration] (Reference).....	5 - 26
PL6.1 Fuser & Exit [List] (Reference)	5 - 27
PL7.1 Frame [Illustration] (Reference).....	5 - 28
PL7.1 Frame [List] (Reference).....	5 - 29
PL8.1 Drive [Illustration] (Reference).....	5 - 30
PL8.1 Drive [List] (Reference).....	5 - 31
PL9.1 Electrical [Illustration] (Reference).....	5 - 32
PL9.1 Electrical [List] (Reference)	5 - 33
PL10.1 Harness [Illustration] (Reference).....	5 - 34
PL10.1 Harness [List] (Reference).....	5 - 35
PL11.1 Duplex (Option) (1/2) [Illustration] (Reference).....	5 - 36
PL11.1 Duplex (Option) (1/2) [List] (Reference)	5 - 37
PL11.2 Duplex (Option) (2/2) [Illustration] (Reference).....	5 - 38
PL11.2 Duplex (Option) (2/2) [List] (Reference)	5 - 39
PL12.1 550 Feeder (Option) (1/5) [Illustration] (Reference)	5 - 40
PL12.1 550 Feeder (Option) (1/5) [List] (Reference)	5 - 41
PL12.2 550 Feeder (Option) (2/5) [Illustration] (Reference)	5 - 42
PL12.2 550 Feeder (Option) (2/5) [List] (Reference)	5 - 43
PL12.3 550 Feeder (Option) (3/5) [Illustration] (Reference)	5 - 44
PL12.3 550 Feeder (Option) (3/5) [List] (Reference)	5 - 45
PL12.4 550 Feeder (Option) (4/5) [Illustration] (Reference)	5 - 46
PL12.4 550 Feeder (Option) (4/5) [List] (Reference)	5 - 47
PL12.5 550 Feeder (Option) (5/5) [Illustration] (Reference)	5 - 48
PL12.5 550 Feeder (Option) (5/5) [List] (Reference)	5 - 49

Chapter 5 Parts List CONTENTS

PL13.1 Cover (With IIT) (1/2) [Illustration]	5 - 50
PL13.1 Cover (With IIT) (1/2) [List]	5 - 51
PL13.2 Cover (With IIT) (2/2) [Illustration]	5 - 52
PL13.2 Cover (With IIT) (2/2) [List]	5 - 53
PL13.3 Frame & ROS (With IIT) [Illustration]	5 - 54
PL13.3 Frame & ROS (With IIT) [List]	5 - 55
PL13.4 Electrical (With IIT) (1/2) [Illustration]	5 - 56
PL13.4 Electrical (With IIT) (1/2) [List]	5 - 57
PL13.5 Electrical (With IIT) (2/2) [Illustration]	5 - 58
PL13.5 Electrical (With IIT) (2/2) [List]	5 - 59
PL13.6 Harness (With IIT) [Illustration]	5 - 60
PL13.6 Harness (With IIT) [List]	5 - 61
PL13.7 550 Feeder (Option) (With IIT) [Illustration]	5 - 62
PL13.7 550 Feeder (Option) (With IIT) [List]	5 - 63
PL13.8 IIT ASSY [Illustration]	5 - 64
PL13.8 IIT ASSY [List]	5 - 65

1. Parts List

1.1 Caution for use of spare parts illustration

- Available spare parts are shown in the illustration by name.
- [Ref PL X.Y.Z] shown below the part name denotes the item is "Z" in the plate "PL X.Y" of the engineering part list.
- For the detailed composition of the KIT parts, check with the engineering part list.

1.2 Caution for use of engineering parts list

- The figures indicating the illustrations are the item No. in the list and present correspondence between the illustrations and parts.
- The notation of PL "X.Y.Z" is composed of the plate (PL), item "X.Y", and parts "Z".
- The alphabet characters in the illustrations represent screws and clips as follows:
"S": screw, "E": E-ring, "KL": KL clip, "C": C-ring, and "N": nut
- "▼" mark in the illustrations are attached to items indicating assembly parts in the illustrations.
- Encircled alphabetical figures in the illustrations indicate interrupted leader lines. Same characters in the illustrations represent lines to be connected.
- The mark "(with 2-5)" attached to assembly parts on the illustrations and lists represents that the items "2, 3, 4, and 5" of that plate are contained and the mark "(with 2-5, PL6.1.1)" represent that the item "2, 3, 4, and 5" of that plate and the item "1" of the plate "6.1" are contained.
- The mark "[Ref PLX.Y.Z]" attached to parts in the illustrations and lists represents that the parts is the same as the parts of the item "Z" of the plate "X.Y".
- The mark "*" attached to parts in the list represents "Note" or "Reference" about that parts is contained in the same page.

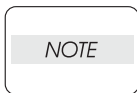

For spare parts, refer to the "Spare parts list" which is issued separately.

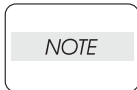

For the connector (P/J), parts such as harness, wire, etc. in the list, refer to "Chapter 7, Electric wiring"

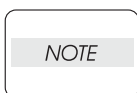

It should be noted that configuration of parts may be different or some parts are not used depending on specifications of OEM.

Customer Replaceable Parts Illustration

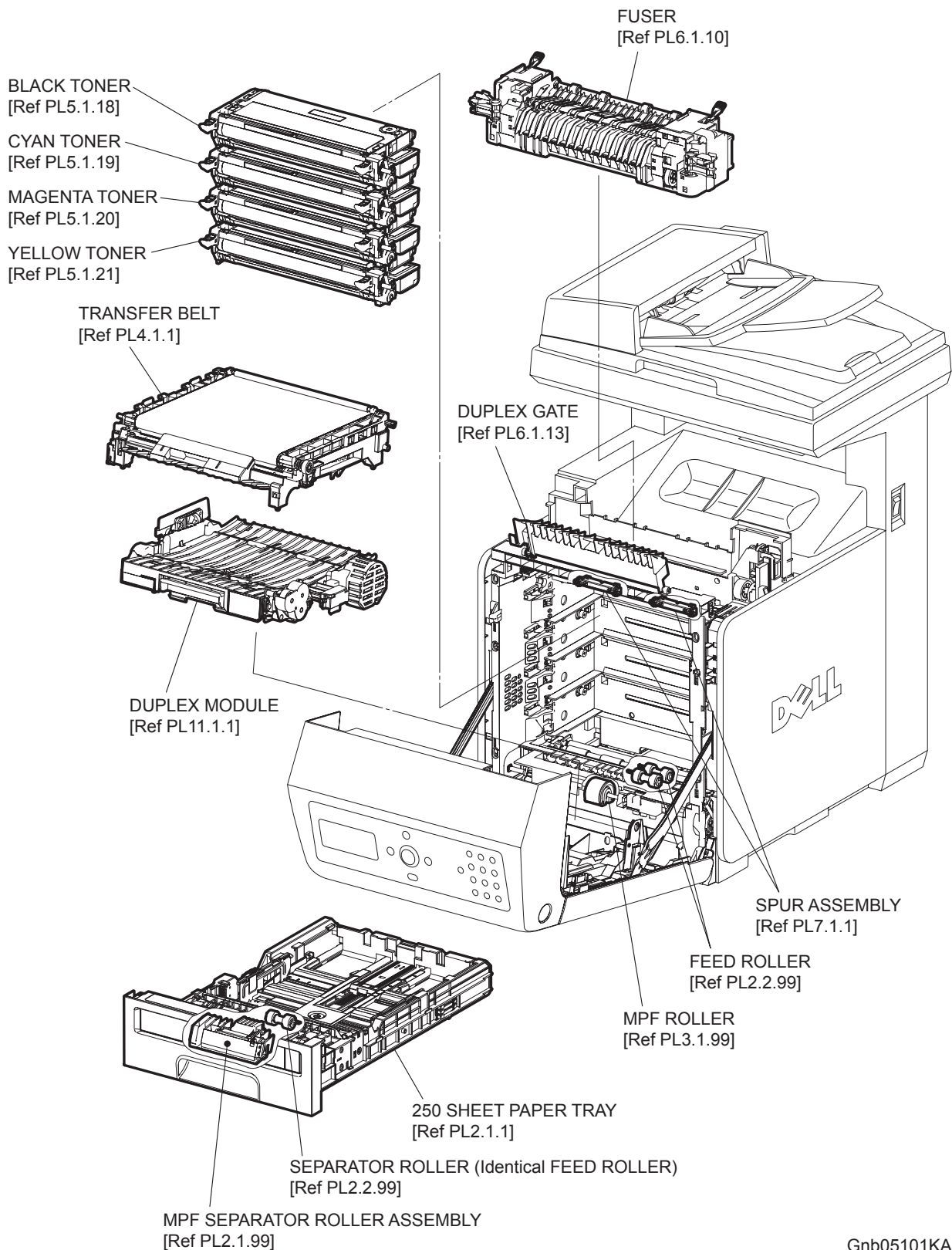

Gnb05101KA

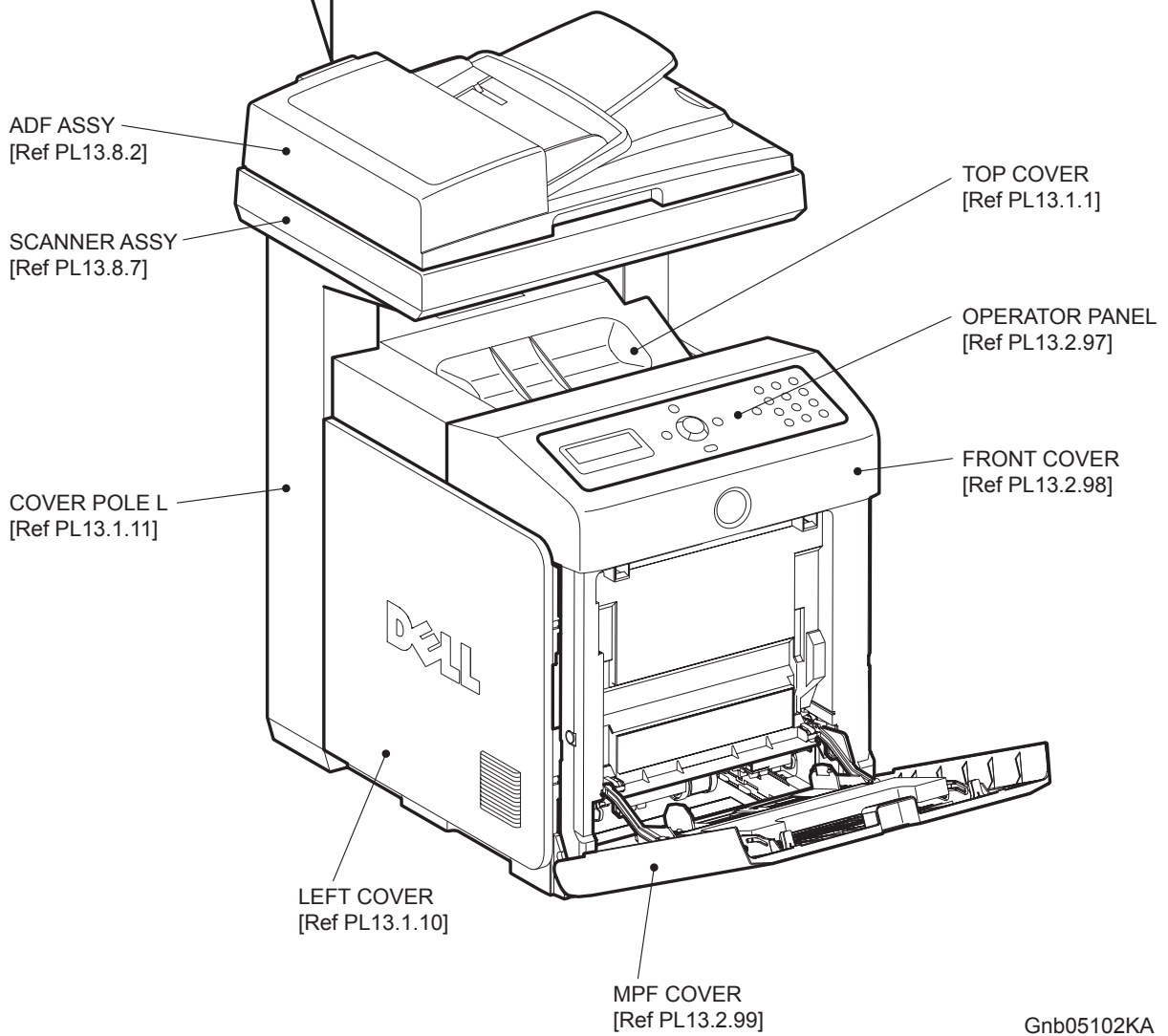
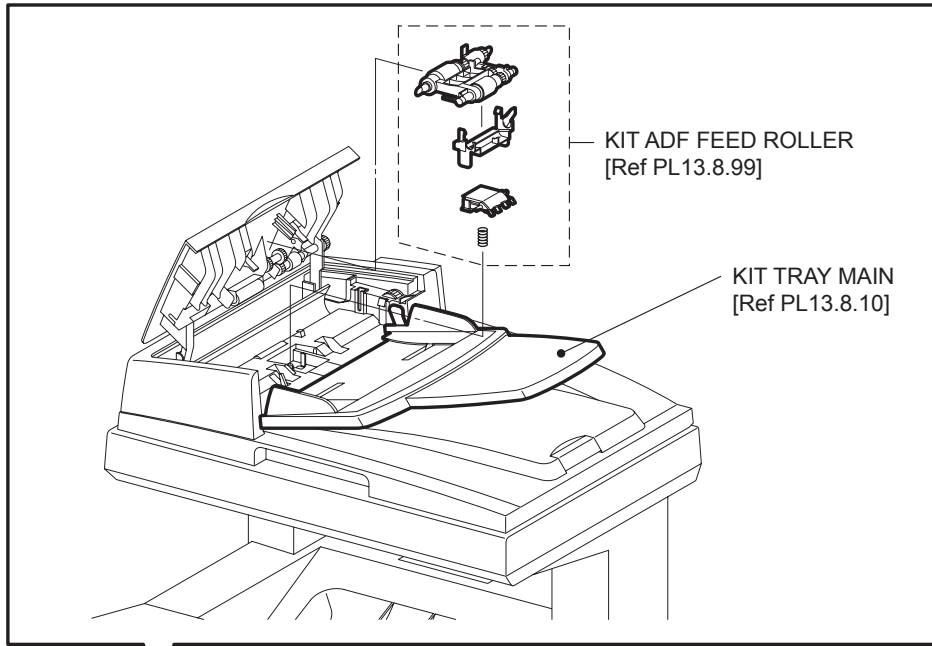

Gnb05102KA

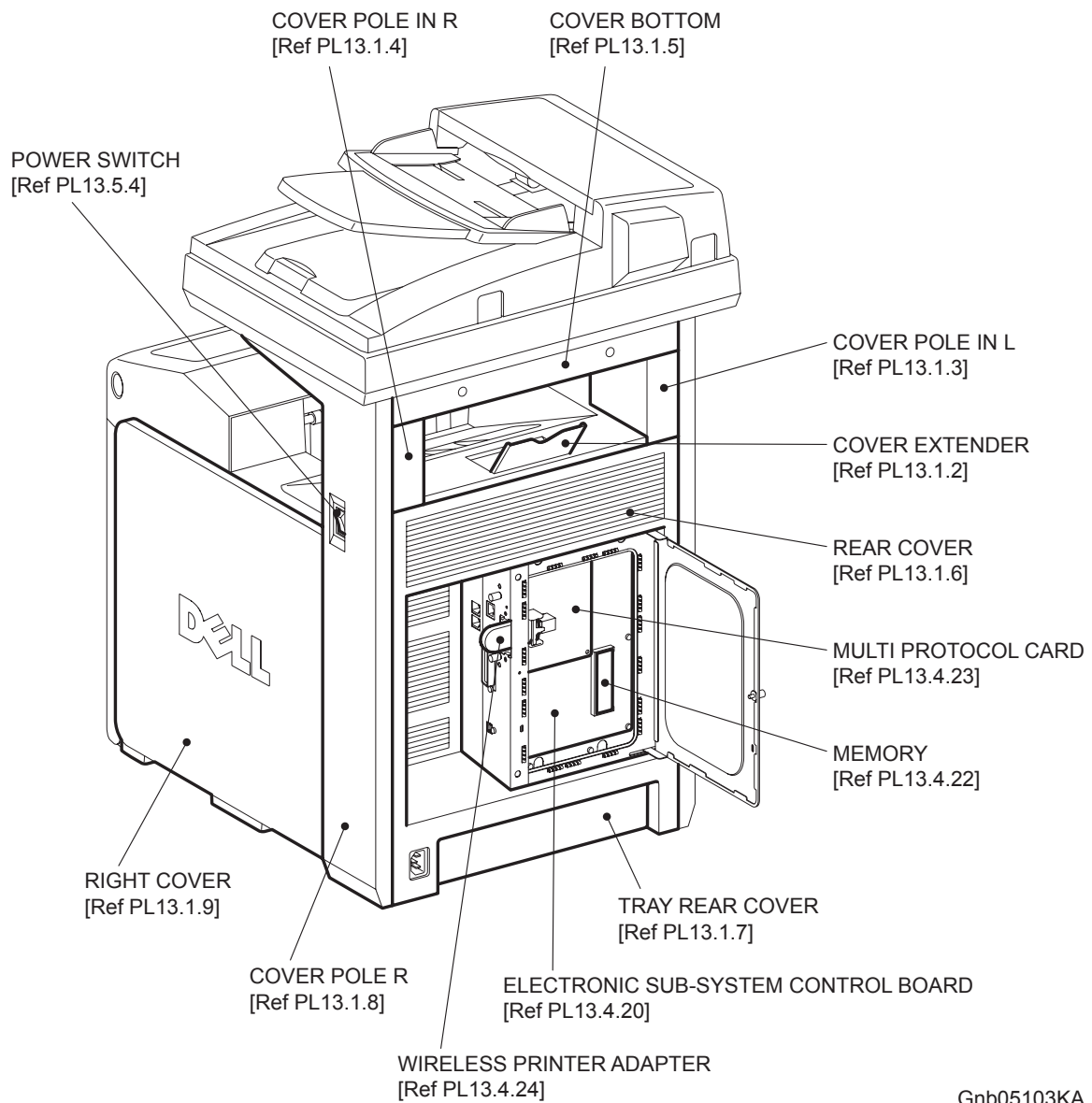

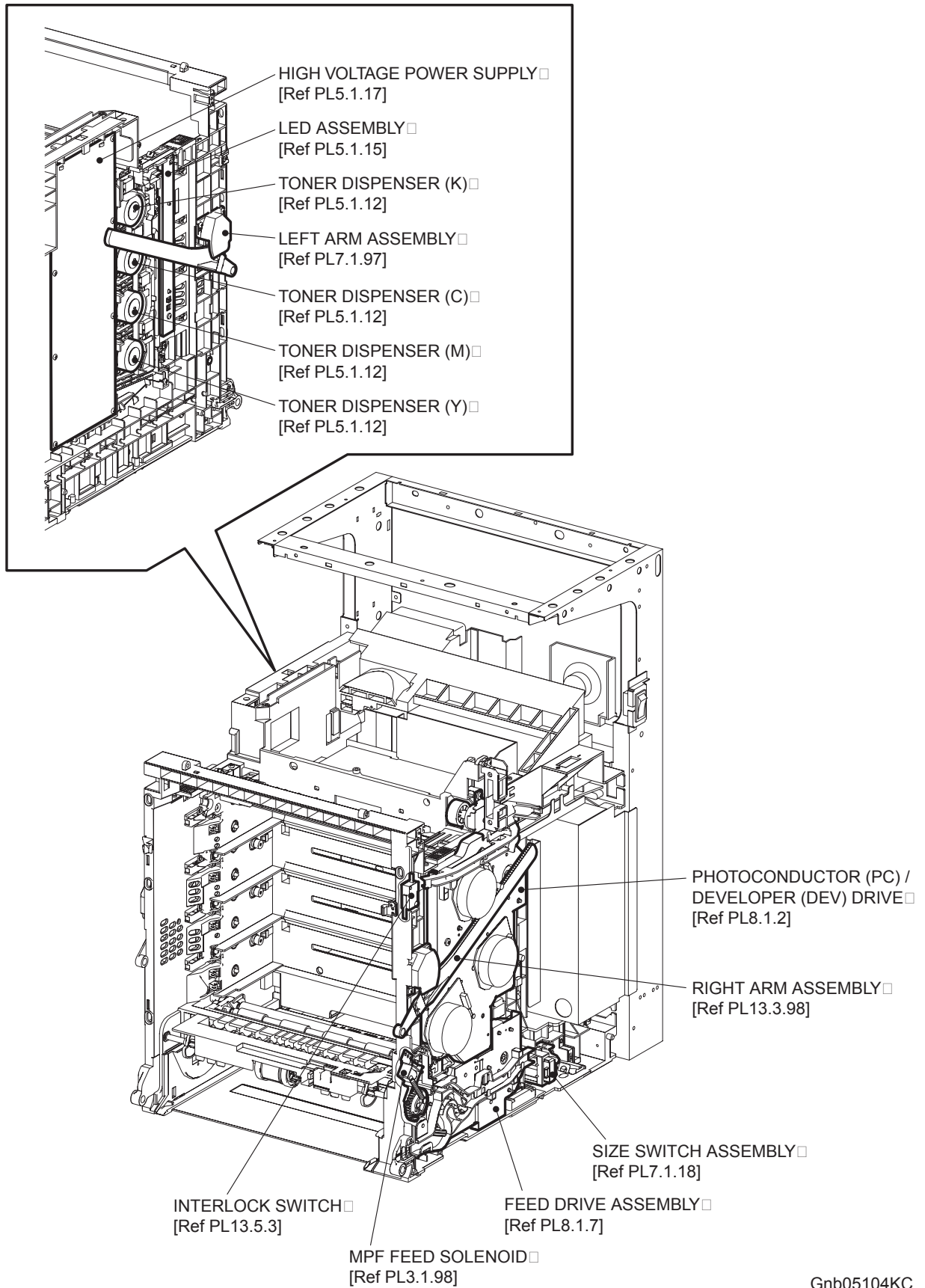

Gnb05104KC

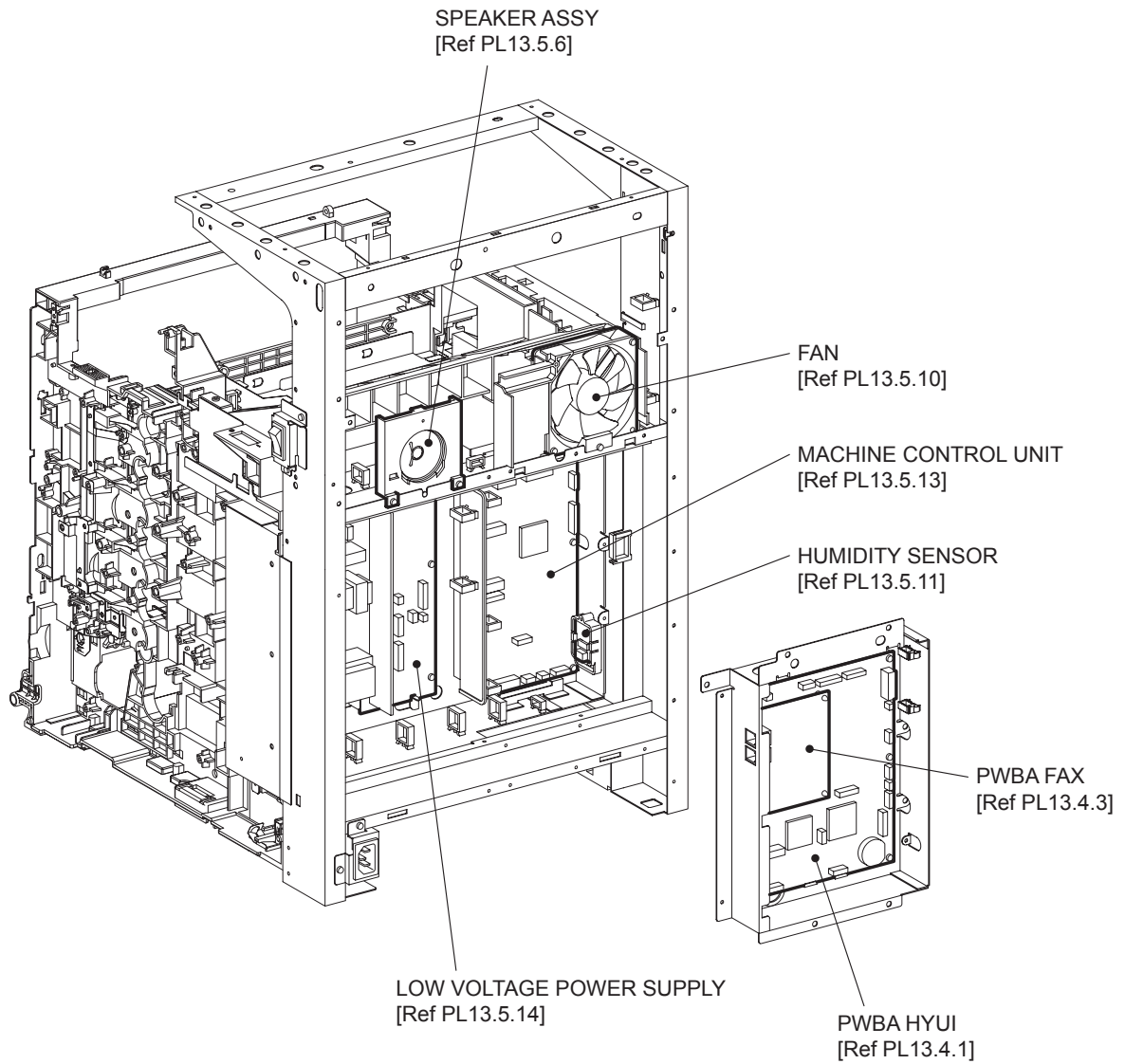

Gnb05105KA

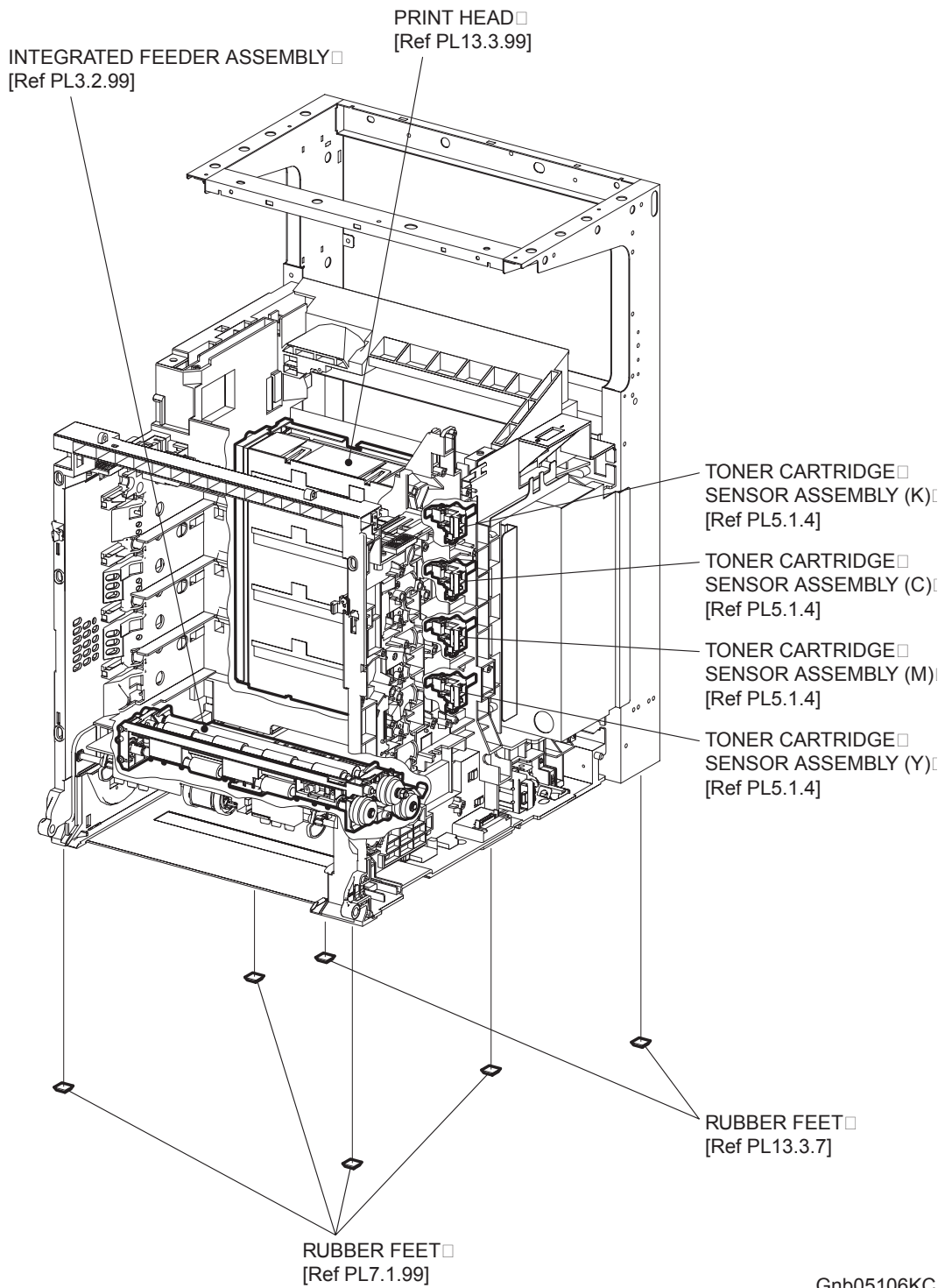

Gnb05106KC

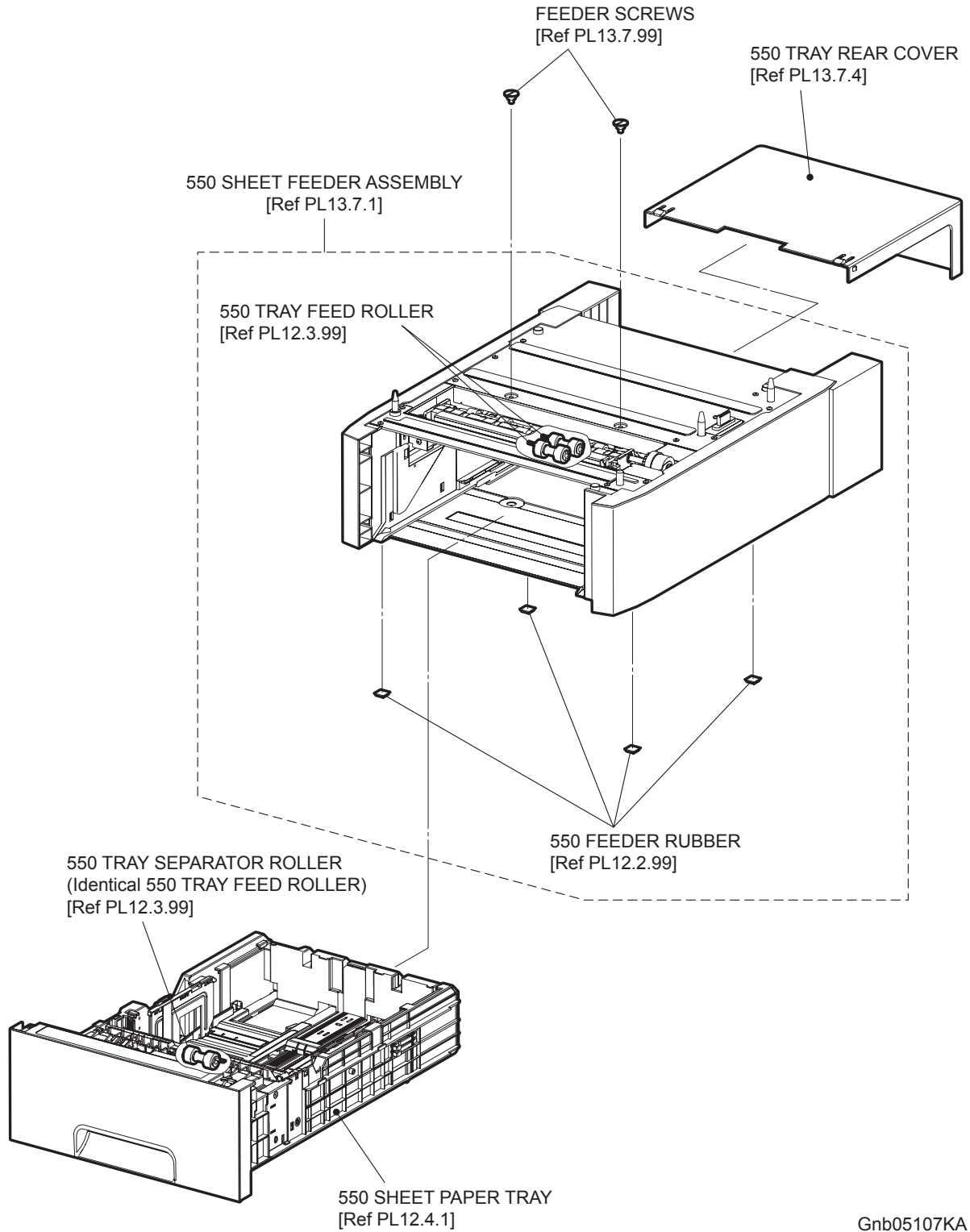

Gnb05107KA

Blank Page

Engineering parts list

PL1.1 Cover (1/2) [Illustration] (Reference)

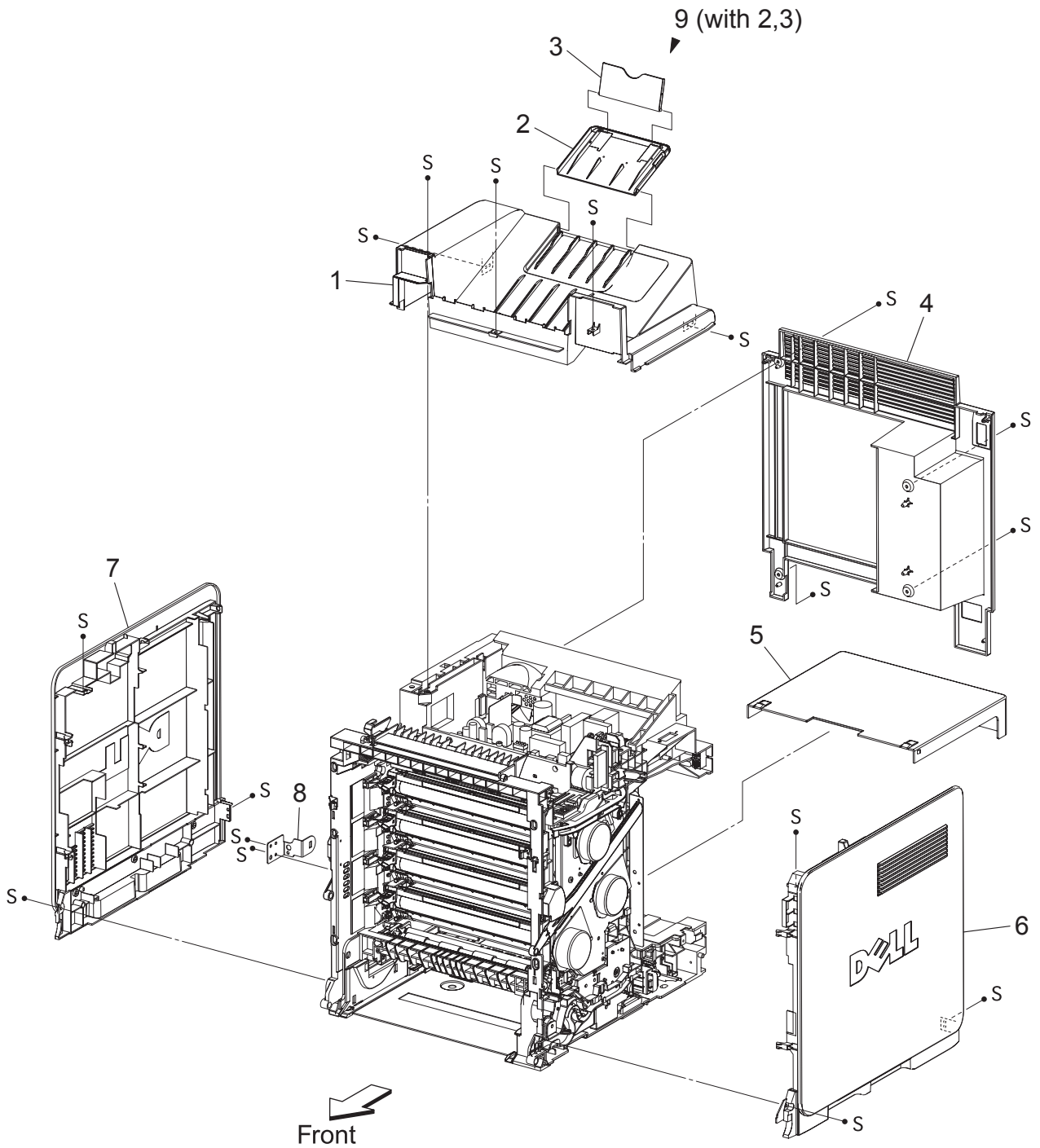

Kmy05001KC

PL1.1 Cover (1/2) [List] (Reference)

Item	Parts name
1	COVER TOP (Not used in Dell 3115cn)
2	COVER EXTENSION 1 (Not used in Dell 3115cn)
3	COVER EXTENSION 2
4	COVER REAR (Not used in Dell 3115cn)
5	COVER CST
6	COVER SIDE R ASSY (Not used in Dell 3115cn)
7	COVER SIDE L ASSY (Not used in Dell 3115cn)
8	BRACKET RCB (Not used in Dell 3115cn)
9	COVER ASSY EXTENDER (with 2,3) (Not used in Dell 3115cn)

PL1.2 Cover (2/2) [Illustration] (Reference)

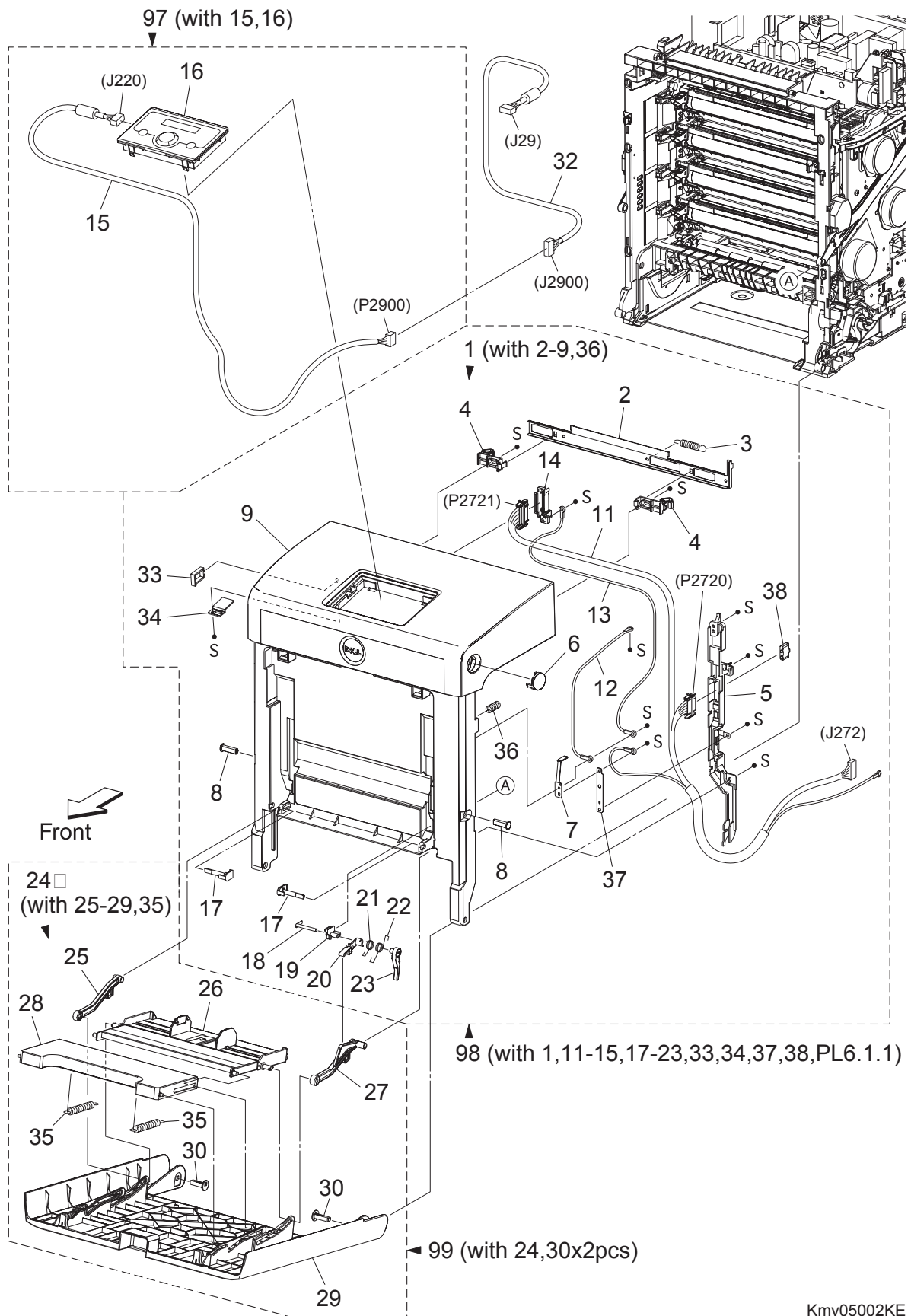

Kmy05002KE

PL1.2 Cover (2/2) [List] (Reference)

Item	Parts name
1	COVER ASSY FRONT (with 2-9,36) (Not used in Dell 3115cn)
2	PLATE LATCH
3	SPRING LATCH
4	LATCH FRONT
5	COVER HARNESS
6	BUTTON TOP
7	CONTACT FRONT
8	SHAFT PIVOT
9	COVER FRONT ASSY (Not used in Dell 3115cn)
10	--
11	HARNESS ASSY FRONT COVER (J272-P2720,P2721,T4322-T43221)
12	HARNESS ASSY FRONT COVER EARTH 1 (T4321-T43210)
13	HARNESS ASSY DRAWER EARTH (T4321-T43210)
14	HOLDER DRAWER
15	HARNESS ASSY OPEPANE (J220-P2900) (Not used in Dell 3115cn)
16	CONSOLE PANEL (Not used in Dell 3115cn)
17	PIN PIVOT MSI
18	SHAFT LEVER
19	PLATE PIVOT
20	LEVER MSI 1
21	SPRING LEVER MSI
22	SPRING LEVER LINK
23	LEVER MSI 2
24	COVER ASSY MSI (with 25-29,35)
25	LINK ASSY MSI L
26	TRAY ASSY MSI BASE
27	LINK ASSY MSI R
28	TRAY MSI
29	COVER MSI
30	SHAFT PIVOT MSI
31	--
32	HARNESS ASSY ESS (J29-J2900) (Not used in Dell 3115cn)
33	CLAMP RLWT-4V0 (Not used in Dell 3115cn)
34	BRACKET HARNESS (Not used in Dell 3115cn)
35	SPRING TRAY
36	SPRING
37	PLATE EARTH FC
38	DUP CONNECTOR CAP
97	KIT OPERATOR PANEL (with 15,16) (Not used in Dell 3115cn)
98	KIT COVER ASSY FRONT (with 1,11-15,17-23,33,34,37,38,PL6.1.1) (Not used in Dell 3115cn)
99	KIT COVER ASSY MSI (with 24,30x2pcs)

PL2.1 Paper Cassette (1/2) [Illustration] (Reference)

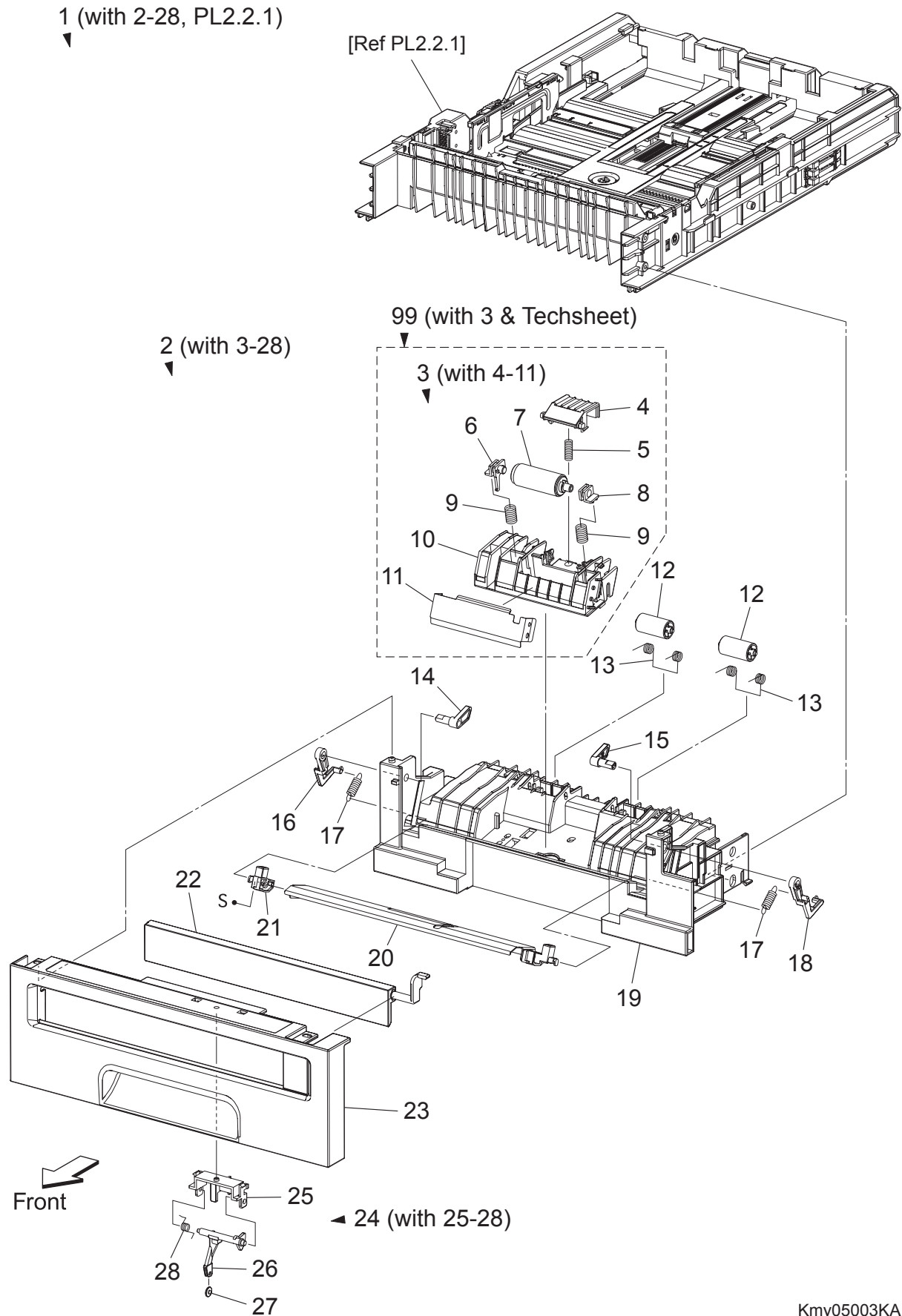

Kmy05003KA

PL2.1 Paper Cassette (1/2) [List] (Reference)

Item	Parts name
1	CASSETTE ASSY 250 (with 2-28, PL2.2.1)
2	CASSETTE ASSY FRONT (with 3-28)
3	SEPARATOR ROLLER ASSEMBLY (with 4-11)
4	CHUTE RETARD
5	SPRING CHUTE
6	BEARING RETARD L
7	SEPARATOR ROLLER
8	BEARING RETARD R
9	SPRING RETARD 200
10	HOLDER RETARD MSI
11	PLATE ASSY RETARD
12	ROLL PINCH TURN
13	SPRING PINCH TURN
14	FOLLOWER L
15	FOLLOWER R
16	ARM L
17	SPRING NF MSI
18	ARM R
19	HOUSING BASE FR 250
20	PLATE ASSY BOTTOM
21	HOLDER MSI L
22	COVER FRONT MSI
23	HANDLE CST
24	ACTUATOR ASSY MSI (with 25-28)
25	HOLDER ACTUATOR
26	ACTUATOR NO PAPER MSI
27	ROLL ACTUATOR NO PAPER
28	SPRING NO PAPER
99	KIT SEPARATOR ROLLER ASSEMBLY (with 3 & Techsheet)

PL2.2 Paper Cassette (2/2) [List] (Reference)

Item	Parts name
1	CASSETTE ASSY REAR 250 (with 2-33)
2	PLATE ASSY BTM A4
3	STOPPER PB
4	GEAR BTM LOCK ONEWAY
5	SHAFT PB A4
6	GEAR BTM DMP ONEWAY
7	GEAR PB L
8	SPRING BTM UP 250 A4
9	GUIDE ASSY SIDE R 250 A4
10	GUIDE ASSY SIDE L 250 A4
11	GEAR PINION
12	HOLDER ASSY RETARD (with 14-17)
13	CVR RTD CST
14	HOLDER RETARD
15	SHAFT RETARD
16	CLUTCH FRICTION RET
17	SEPARATOR ROLLER
18	SPRING RETARD
19	SWITCH SIZE SET
20	PLATE LOCK CST
21	PLATE GEAR LOCK 250
22	GUIDE ASSY CST END 250
23	ACTUATOR SIZE
24	HSG BASE RE 250
25	ACTUATOR RLS PB
26	SPRING STOPPER GEAR
27	GEAR PB R
28	COVER BTM UP 250
29	RACK BTM LOCK 250
30	SPRING BTM LOCK
31	GEAR BTM LOCK PINION
32	GEAR LEVER BTM LOCK
33	LEVER BTM LOCK
99	KIT SEPARATOR and FEED ROLLER (with 17, PL3.2.53x2pcs & Techsheet) *1

*1 : Periodic Replacing Parts (100KPV)

PL3.1 Paper Feeder (1/2) [Illustration] (Reference)

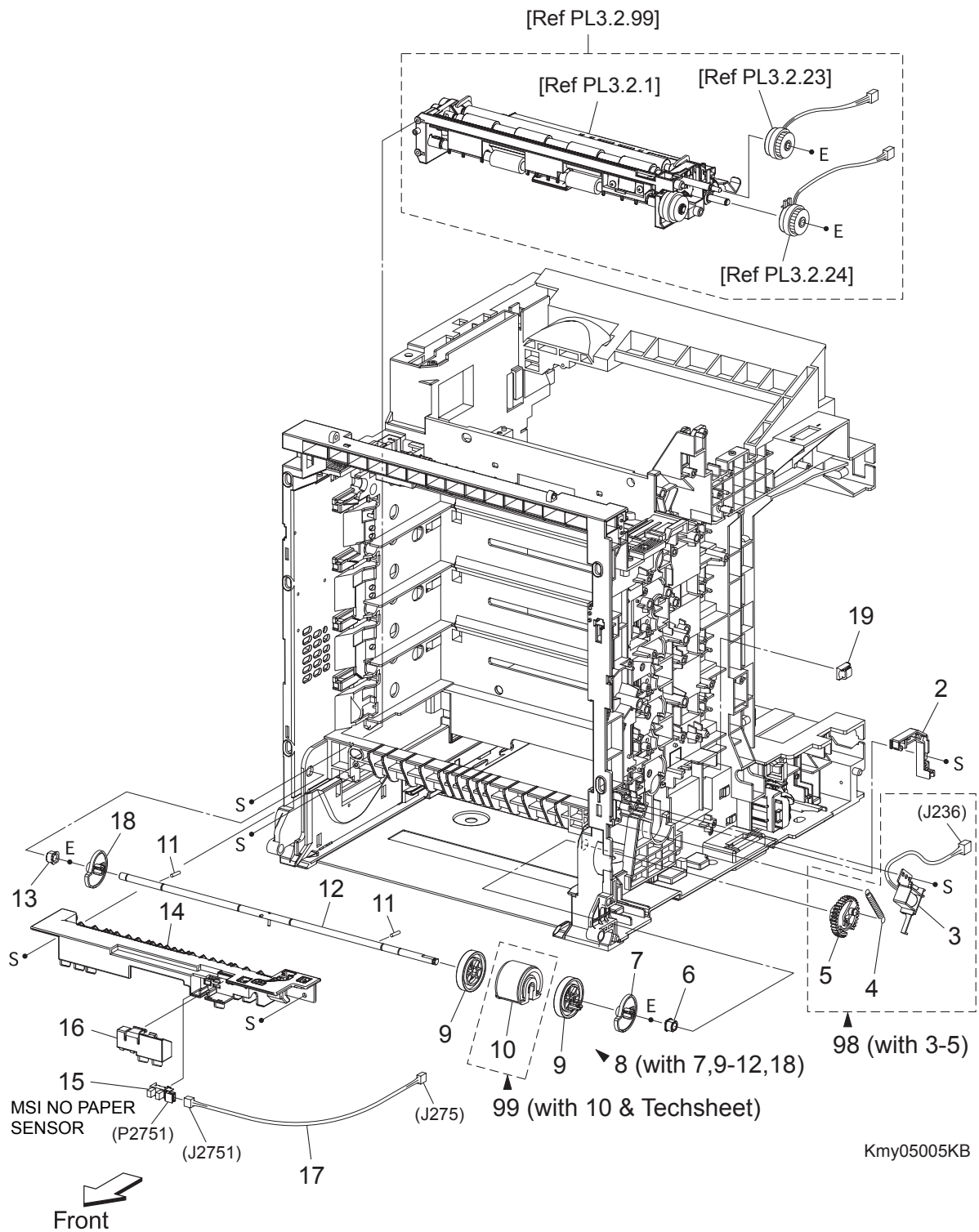

PL3.1 Paper Feeder (1/2) [List] (Reference)

Item	Parts name
1	--
2	DUCT MSI SOL
3	SOLENOID FEED MSI
4	SPRING FEED MSI
5	GEAR MSI
6	BEARING EARTH
7	CAM MSI R
8	ROLL ASSY MSI (with 7,9-12,18)
9	ROLL CORE MSI
10	ROLL ASSY FEED MSI
11	PIN DOWEL
12	SHAFT MSI
13	BEARING
14	CHUTE MSI
15	SENSOR PHOTO (MSI NO PAPER SENSOR)
16	COVER SNR
17	HARN ASSY MSI NPP (J275-J2751)
18	CAM MSI L
19	CLAMP
98	KIT SOLENOID FEED MSI (with 3-5)
99	KIT ROLL ASSY FEED MSI (with 10 & Techsheet)

PL3.2 Paper Feeder (2/2) [Illustration] (Reference)

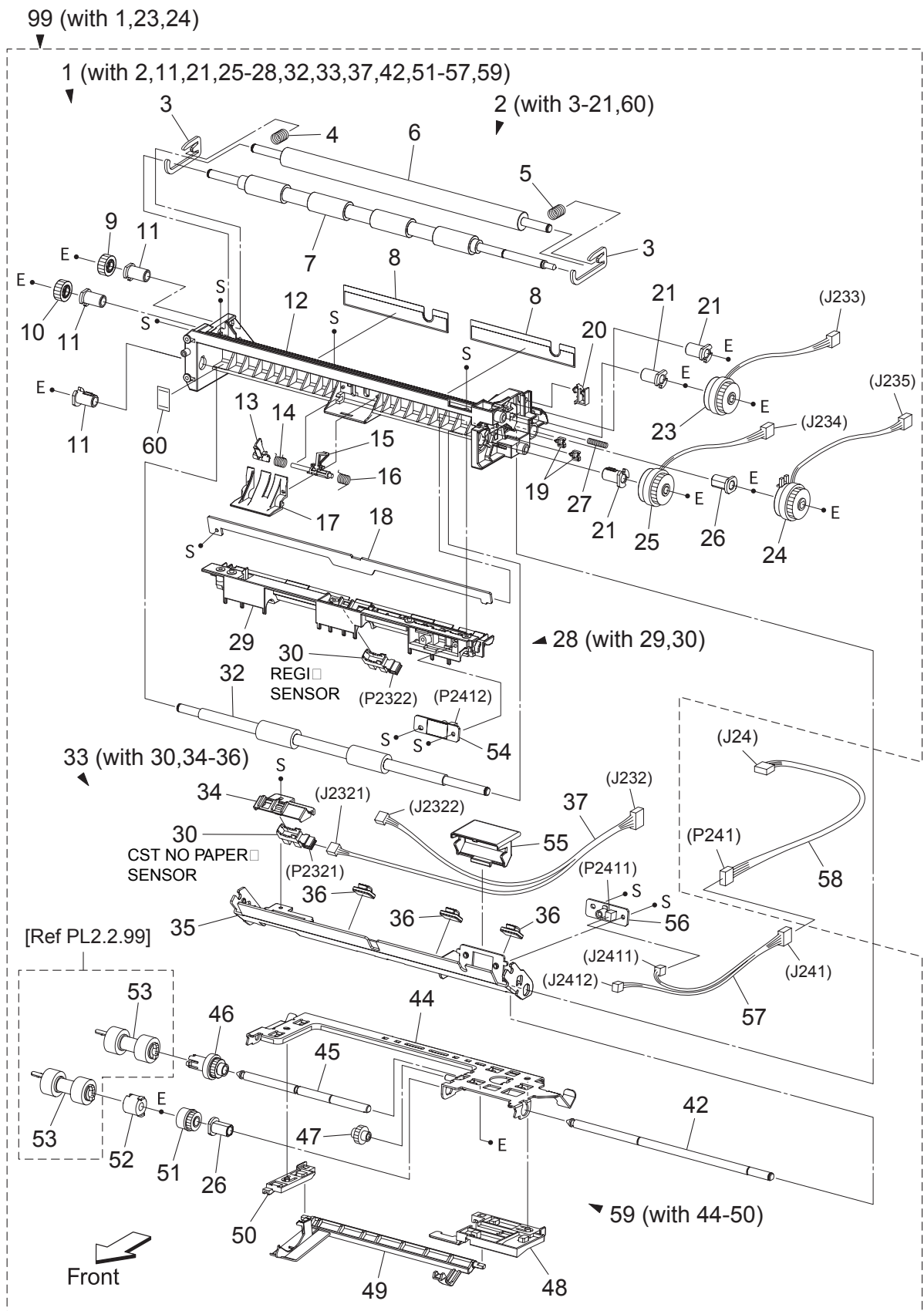

Kmy05006KE

PL3.2 Paper Feeder (2/2) [List] (Reference)

Item	Parts name
1	FEEDER ASSY (with 2,11,21,25-28,32,33,37,42,51-57,59)
2	CHUTE ASSY REGI (with 3-21,60)
3	BRACKET NIP
4	SPRING REGI L
5	SPRING REGI R
6	ROLL REGI METAL
7	ROLL REGI RUBBER
8	FILM INLET L
9	GEAR REGI METAL
10	GEAR REGI RUBBER
11	BEARING REGI
12	CHUTE REGI
13	ACTUATOR A
14	SPRING REGI SNSR A
15	ACTUATOR B
16	SPRING REGI SNSR B
17	COVER ACTUATOR
18	CHUTE RETARD BTM
19	CLAMP MINI-SADDLE
20	CLAMP
21	BEARING REGI E
22	--
23	CLUTCH ASSY PH REGI
24	CLUTCH ASSY PH FEED
25	CLUTCH ASSY PH TURN
26	BEARING NUDGER
27	SPRING EARTH
28	CHUTE ASSY REGI UPPER (with 29,30)
29	CHUTE REGI UPPER
30	SENSOR PHOTO (REGI SENSOR, CST NO PAPER SENSOR)
31	--
32	ROLL ASSY TURN
33	CHUTE ASSY TOP (with 30,34-36)
34	HOLDER NOSNSR
35	CHUTE ASSY RETARD
36	CLAMP
37	HARN ASSY REGI SNR (J232-J2321,J2322)
38	--
39	--
40	--
41	--
42	SHAFT FEED
43	--
44	SUPPORT NUDGER ASSY
45	SHAFT NUDGER
46	ROLL ASSY GEAR NUDGER
47	GEAR IDLER NUDGER
48	HOLDER NO PAPER L A4
49	ACTUATOR NO PAPER A4
50	HOLDER NO PAPER R A4
51	CLUTCH ONEWAY NUDGER
52	CLUTCH ONEWAY FEED
53	ROLL ASSY FEED
54	PWBA OHP LED
55	COVER OHP SNR
56	PWBA OHP SNR
57	HARN ASSY OHP SNR (J241-J2411,J2412)
58	HARN ASSY OHP (J24-P241) (Not used in Dell 3115cn)
59	NUDGER ASSY (with 44-50)
60	GUIDE FILM
99	KIT FEEDER ASSY (with 1,23,24)

PL4.1 Transfer [Illustration] (Reference)

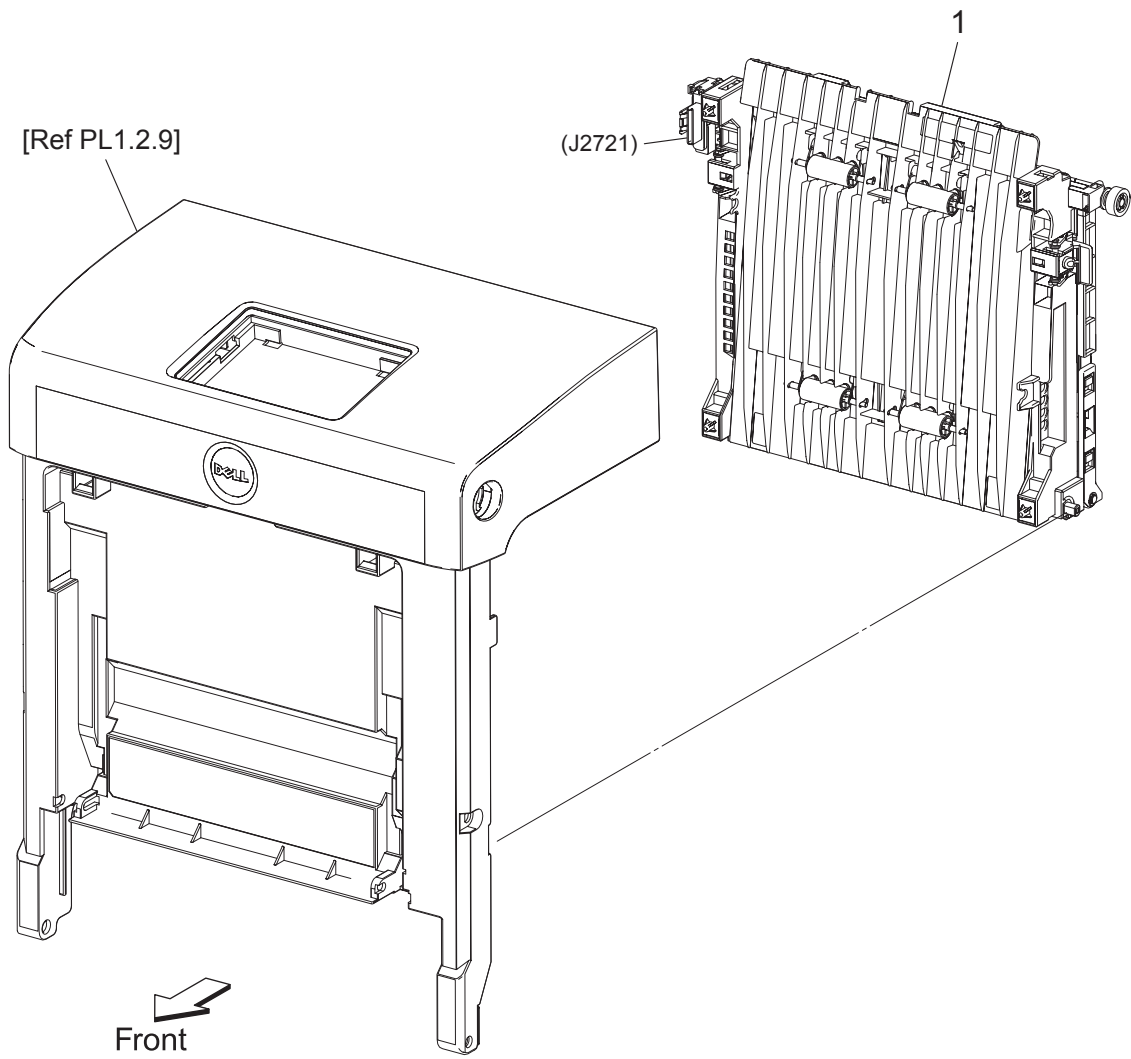

Kmy05007KA

PL4.1 Transfer [List] (Reference)

Item	Parts name
1	TRANSFER ASSY (KIT BELT CRU) *1
2	--
3	--
4	--
5	--
6	--
7	--

*1 : Periodic Replacing Parts (100KPV)

PL5.1 Xerographics [Illustration] (Reference)

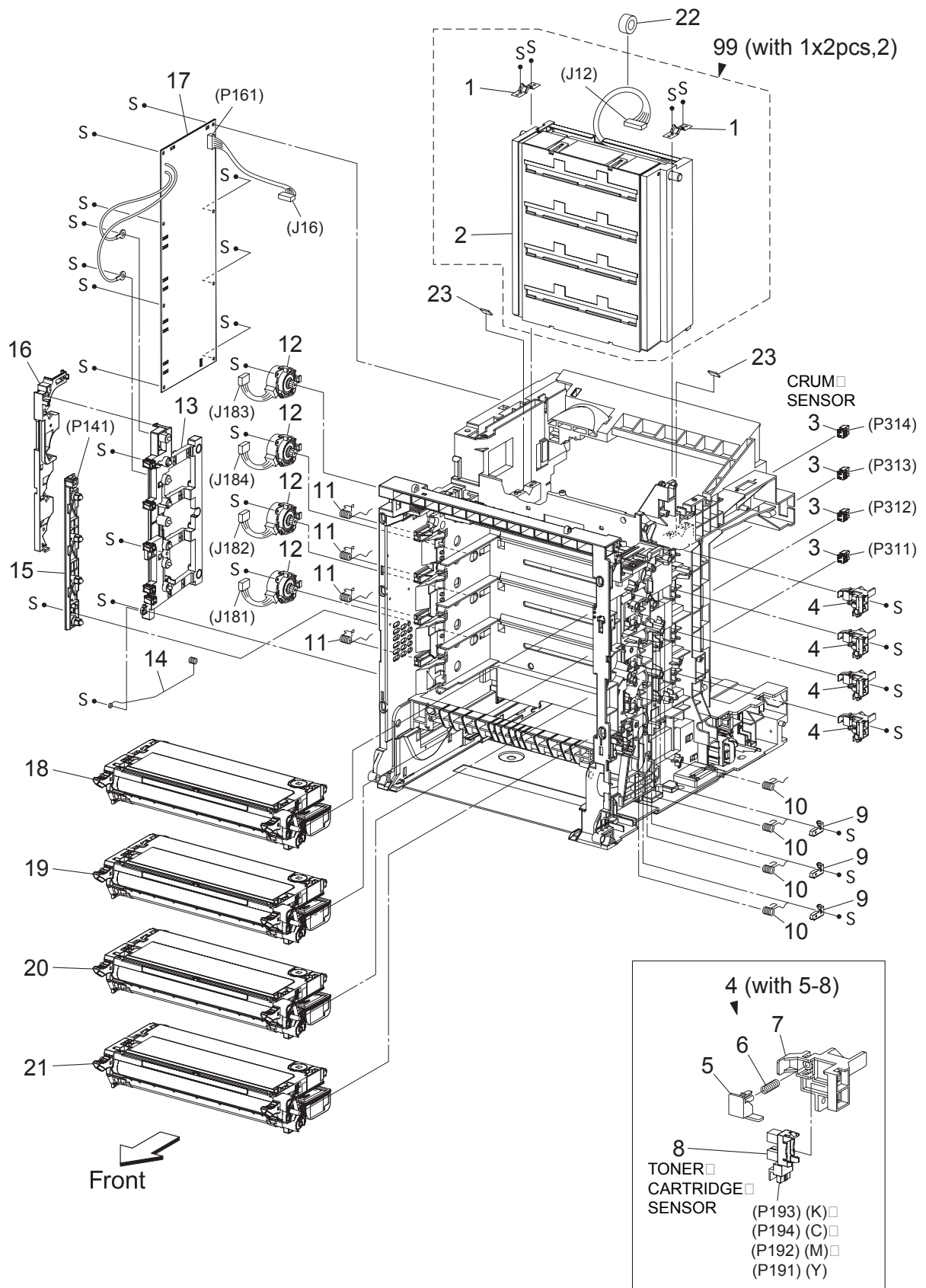

Kmy05010KD

PL5.1 Xerographics [List] (Reference)

Item	Parts name
1	SPRING ROS
2	ROS ASSY (Not used in Dell 3115cn)
3	CONNECTOR CRUM
4	SENSOR ASSY CRU (with 5-8)
5	ACTUATOR SENSOR CRU
6	SPRING CRU
7	BRACKET SENSOR CRU
8	SENSOR PHOTO (TONER CARTRIDGE SENSOR)
9	STOPPER SPRING
10	SPRING CRU R
11	SPRING CRU L
12	DISPENSER ASSY
13	BIAS ASSY
14	SPRING ESA ROLL
15	LED ASSY
16	DUCT HARNESS MOT
17	HVPS
18	CARTRIDGE ASSY (K) (with Techsheet) *1
19	CARTRIDGE ASSY (C) (with Techsheet) *2
20	CARTRIDGE ASSY (M) (with Techsheet) *2
21	CARTRIDGE ASSY (Y) (with Techsheet) *2
22	CORE
23	SPACER ROS SHAFT
99	KIT ROS ASSY (with 1x2pcs, 2) (Not used in Dell 3115cn)

*1 : Periodic Replacing Parts (5KPV/8KPV)

*2 : Periodic Replacing Parts (4KPV/8KPV)

PL6.1 Fuser & Exit [Illustration] (Reference)

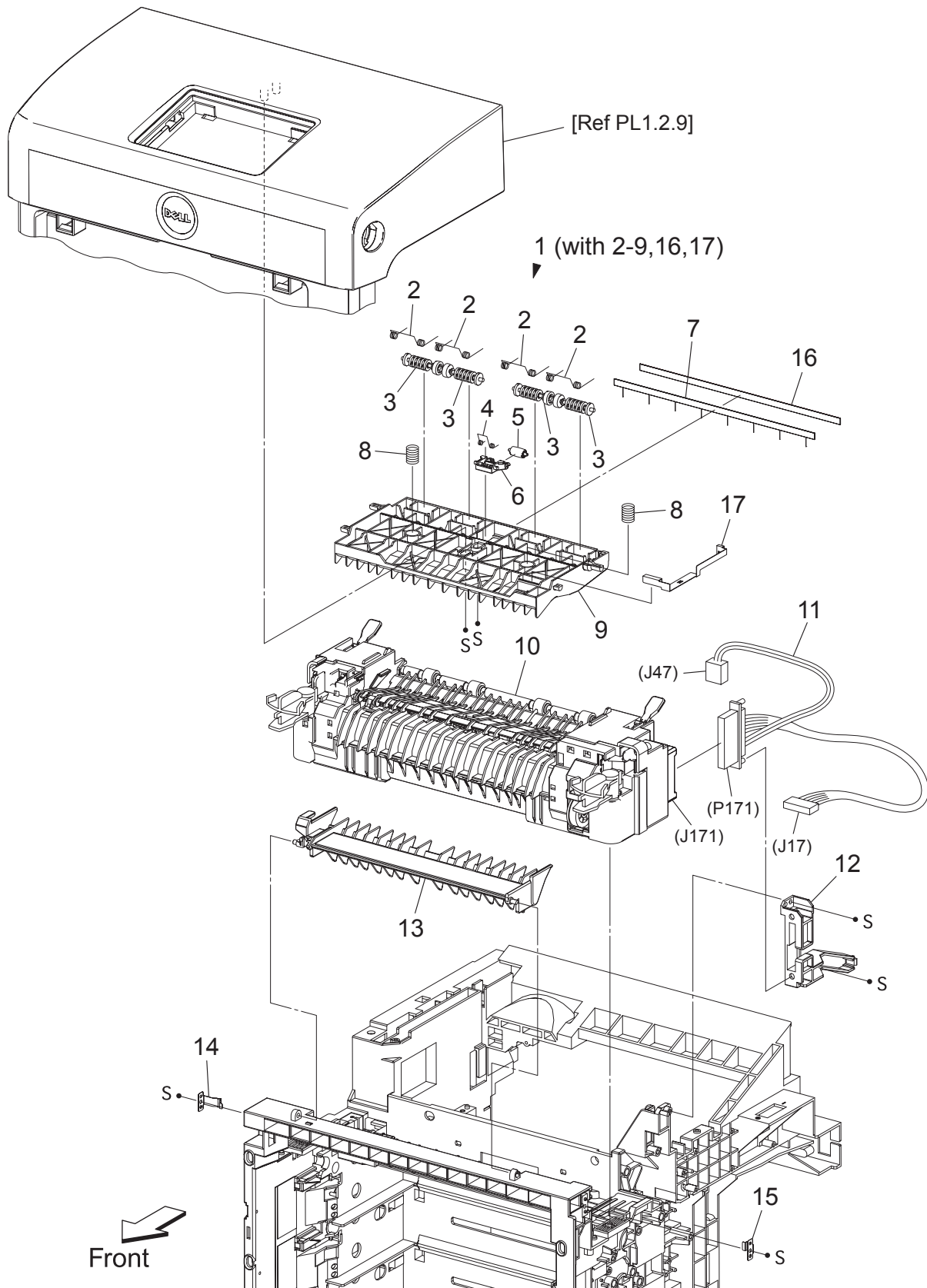

Kmy05011KB

PL6.1 Fuser & Exit [List] (Reference)

Item	Parts name
1	CHUTE ASSY EXIT OUT (with 2-9,16,17)
2	SPRING PINCH EXIT OUT
3	ROLL PINCH EXIT
4	SPRING CORR
5	ROLL CORRUGATE
6	HOLDER CORR 2
7	ELIMINATOR EXIT1
8	SPRING CHUTE OUT
9	CHUTE EXIT OUT 20
10	FUSER ASSY (with Techsheet) *1
11	HARN ASSY FUSER (P171-J17,J47) (Not used in Dell 3115cn)
12	BRACKET FUSER
13	CHUTE DUP GATE
14	PLATE LATCH FSR AD
15	PLATE LATCH FSR D
16	TAPE ELIMINATOR
17	PLATE EARTH EXIT

*1 : Periodic Replacing Parts (100KPV)

PL7.1 Frame [Illustration] (Reference)

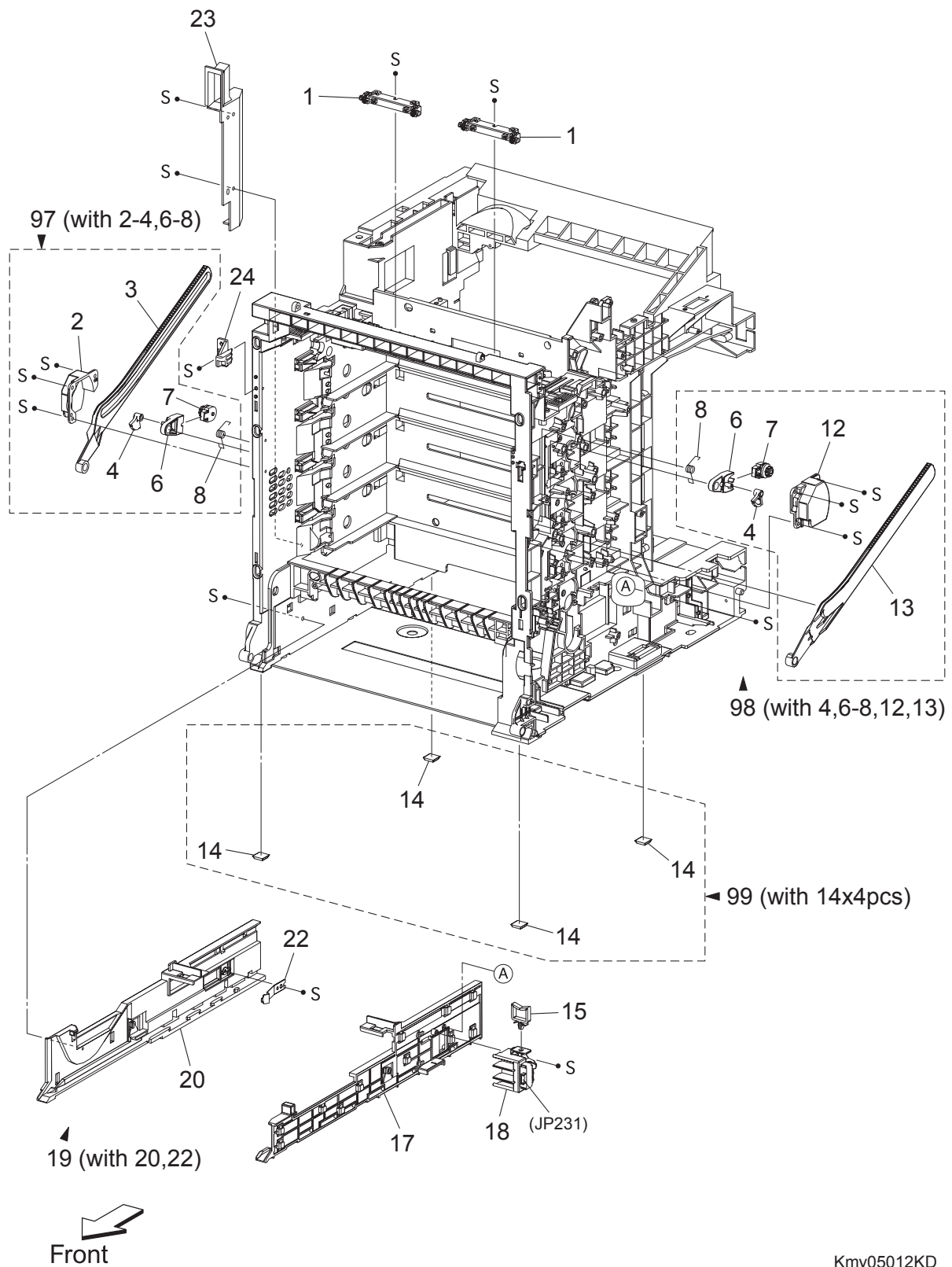

Kmy05012KD

PL7.1 Frame [List] (Reference)

Item	Parts name
1	WHEEL STAR ASSY
2	SUPPORT LINK L
3	LINK L
4	LEVER RELEASE
5	--
6	HOLDER DAMPER
7	DAMPER OIL
8	SPRING SUPPORT
9	--
10	--
11	--
12	SUPPORT LINK R
13	LINK R
14	FOOT
15	CLAMP WS-2W-V0 (Not used in Dell 3115cn)
16	--
17	GUIDE TRAY R 250
18	SWITCH ASSY SIZE
19	GUIDE CST ASSY L 250 (with 20,22)
20	GUIDE TRAY L 250
21	--
22	SPRING CST LOCK
23	DUCT SIDE L
24	STOPPER FRAME L
97	KIT LINK ASSY L (with 2-4,6-8)
98	KIT LINK ASSY R (with 4,6-8,12,13) (Not used in Dell 3115cn)
99	KIT FOOT ASSY (with 14x4pcs)

PL8.1 Drive [Illustration] (Reference)

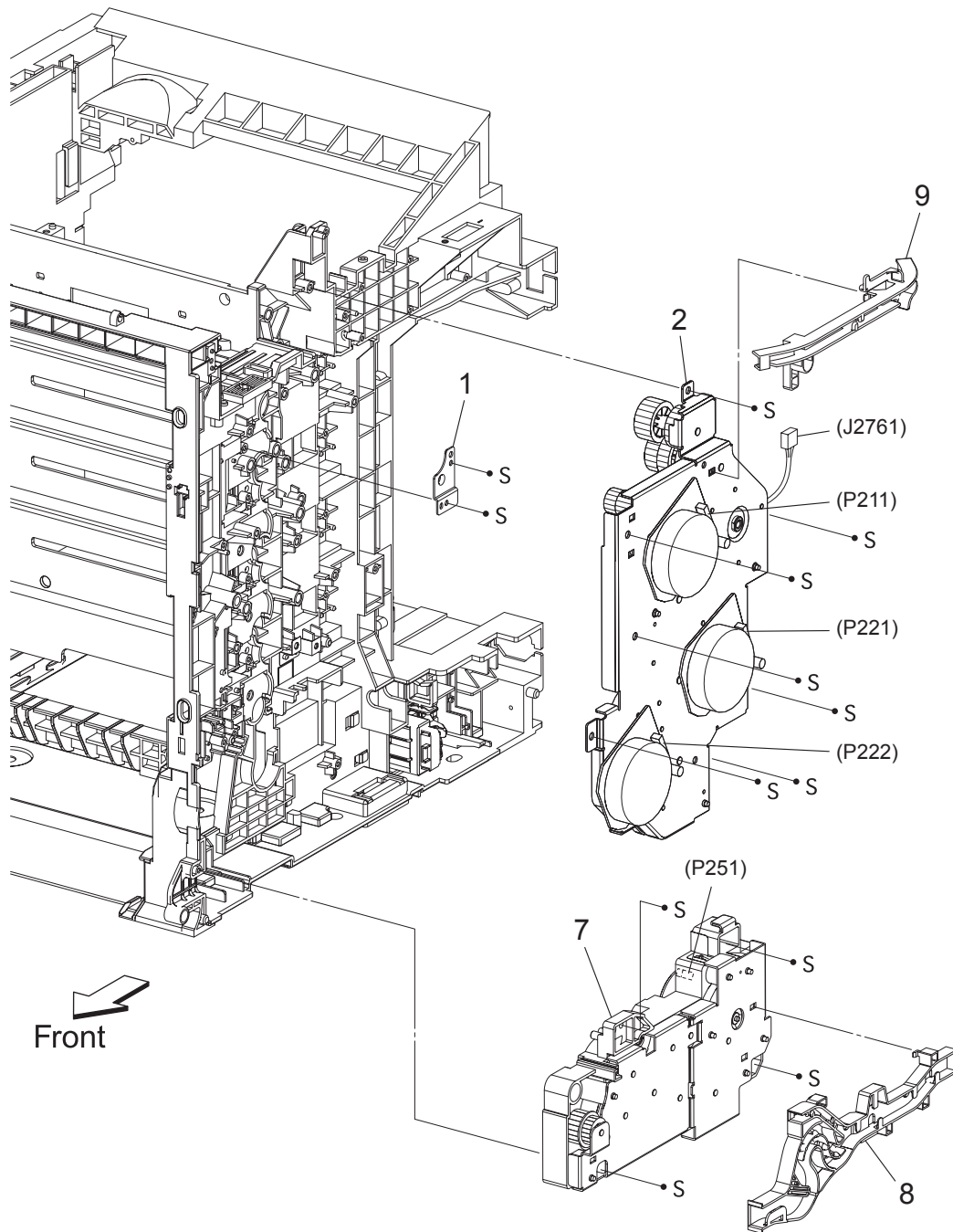

Kmy05013KA

PL8.1 Drive [List] (Reference)

Item	Parts name
1	BRACKET GEAR T1
2	DRIVE ASSY MAIN
3	--
4	--
5	--
6	--
7	DRIVE ASSY PH
8	DUCT DRV PH
9	DUCT DRV MAIN

PL9.1 Electrical [Illustration] (Reference)

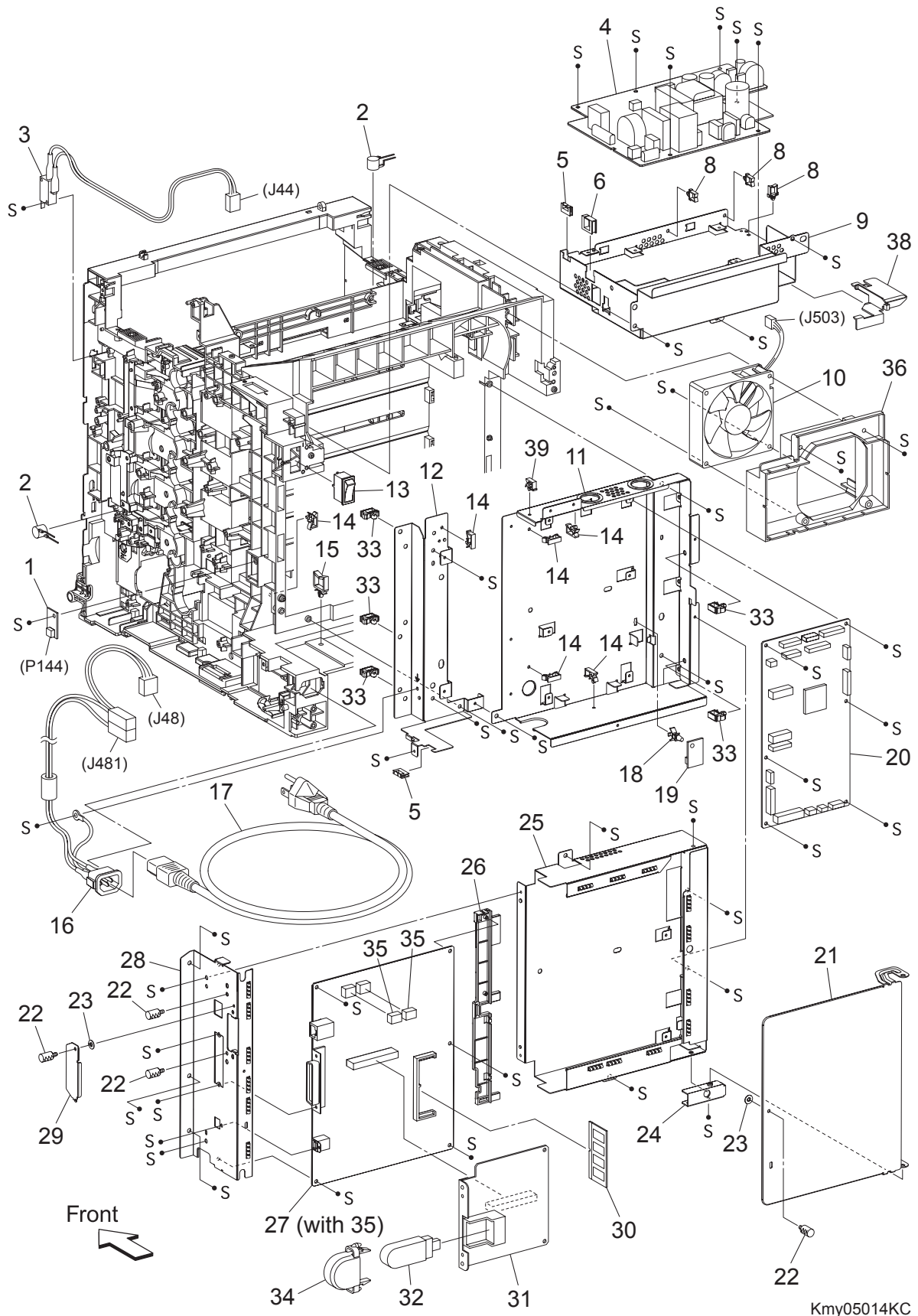

PL9.1 Electrical [List] (Reference)

Item	Parts name
1	PWBA EEPROM(XPRO)
2	VARISTOR
3	HARN ASSY INTERLOCK (Not used in Dell 3115cn)
4	LVPS (Not used in Dell 3115cn)
5	EDGE SADDLE ES-0510 (Not used in Dell 3115cn)
6	EDGE SADDLE LES-1010 (Not used in Dell 3115cn)
7	--
8	CLAMP RMS-3V0 (Not used in Dell 3115cn)
9	SHIELD LVPS (Not used in Dell 3115cn)
10	FAN MAIN
11	SHIELD MCU (Not used in Dell 3115cn)
12	PLATE REAR RH (Not used in Dell 3115cn)
13	SWITCH POWER
14	CLAMP MST-10V0 (Not used in Dell 3115cn)
15	CLAMP WS-2W-V0 (Not used in Dell 3115cn)
16	HARN ASSY INLET (J48-J481) (Not used in Dell 3115cn)
17	POWER CORD
18	SPACER RCBT-11S (Not used in Dell 3115cn)
19	SENSOR HUM
20	PWBA MCU (with Techsheet)
21	SHIELD WINDOW (Not used in Dell 3115cn)
22	SCREW KNURLING
23	WASHER
24	BRACKET PIVOT (Not used in Dell 3115cn)
25	SHIELD ASSY ESS (Not used in Dell 3115cn)
26	GUIDE ESS (Not used in Dell 3115cn)
27	PWBA ESS (with 35) (with Techsheet) (Not used in Dell 3115cn)
28	SHIELD ASSY IF (Not used in Dell 3115cn)
29	PLATE OPT
30	MEMORY CARD (OPTION)
31	MULTI PROTOCOL CARD (OPTION)
32	WIRELESS PRINTER ADAPTER (Installs to the MULTI PROTOCOL CARD.) (OPTION)
33	CLAMP RLWC-1SV0 (Not used in Dell 3115cn)
34	COVER USB (OPTION)
35	NVM ROM
36	DUCT FAN MAIN (Not used in Dell 3115cn)
37	--
38	DUCT ROS GUARD (Not used in Dell 3115cn)
39	CLAMP MST-5V0 (Not used in Dell 3115cn)

PL10.1 Harness [Illustration] (Reference)

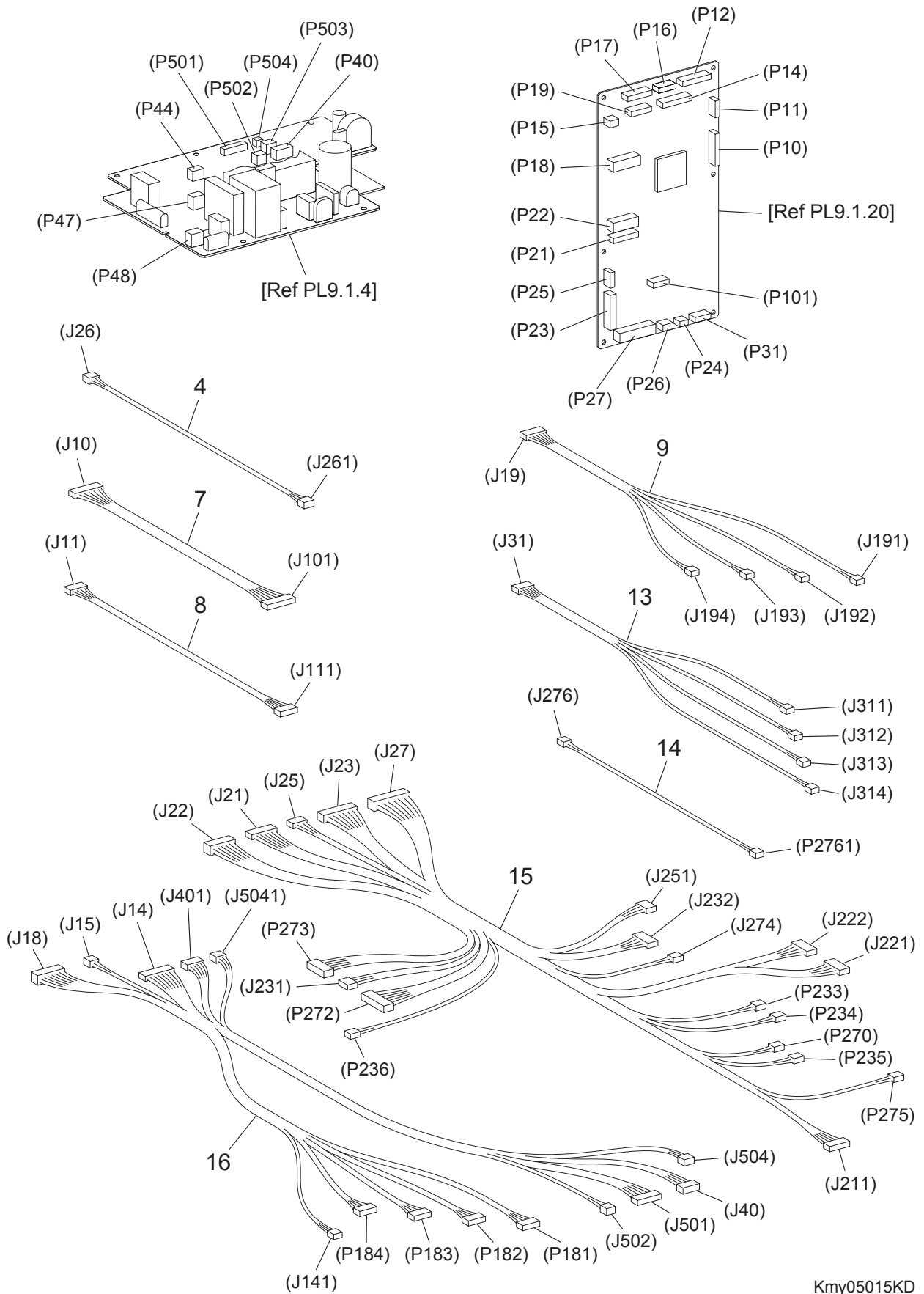

Kmy05015KD

PL10.1 Harness [List] (Reference)

Item	Parts name
1	--
2	--
3	--
4	HARN ASSY HUM (J26-J261)
5	--
6	--
7	HARN ASSY ESS (J10-J101) (Not used in Dell 3115cn)
8	HARN ASSY VIDEO (J11-J111) (Not used in Dell 3115cn)
9	HARN ASSY TNR SNR (J19-J191,J192,J193,J194) (Not used in Dell 3115cn)
10	--
11	--
12	--
13	HARN ASSY CRUM (J31-J311,J312,J313,J314) (Not used in Dell 3115cn)
14	HARN ASSY EXIT CLT (J276-P2761)
15	HARN ASSY R SIDE (J21,J22,J23,J25,J27-J211,J221,J222,J231,J232,P233,P234, P235,P236,J251,P272,P273,J274,P275,P276) (Not used in Dell 3115cn)
16	HARN ASSY LV TOP (J14,J15,J18,J401,J5041-J141,P181,P182,P183,P184,J40,J501, J502,J504) (Not used in Dell 3115cn)
17	--

PL11.1 Duplex (Option) (1/2) [Illustration] (Reference)

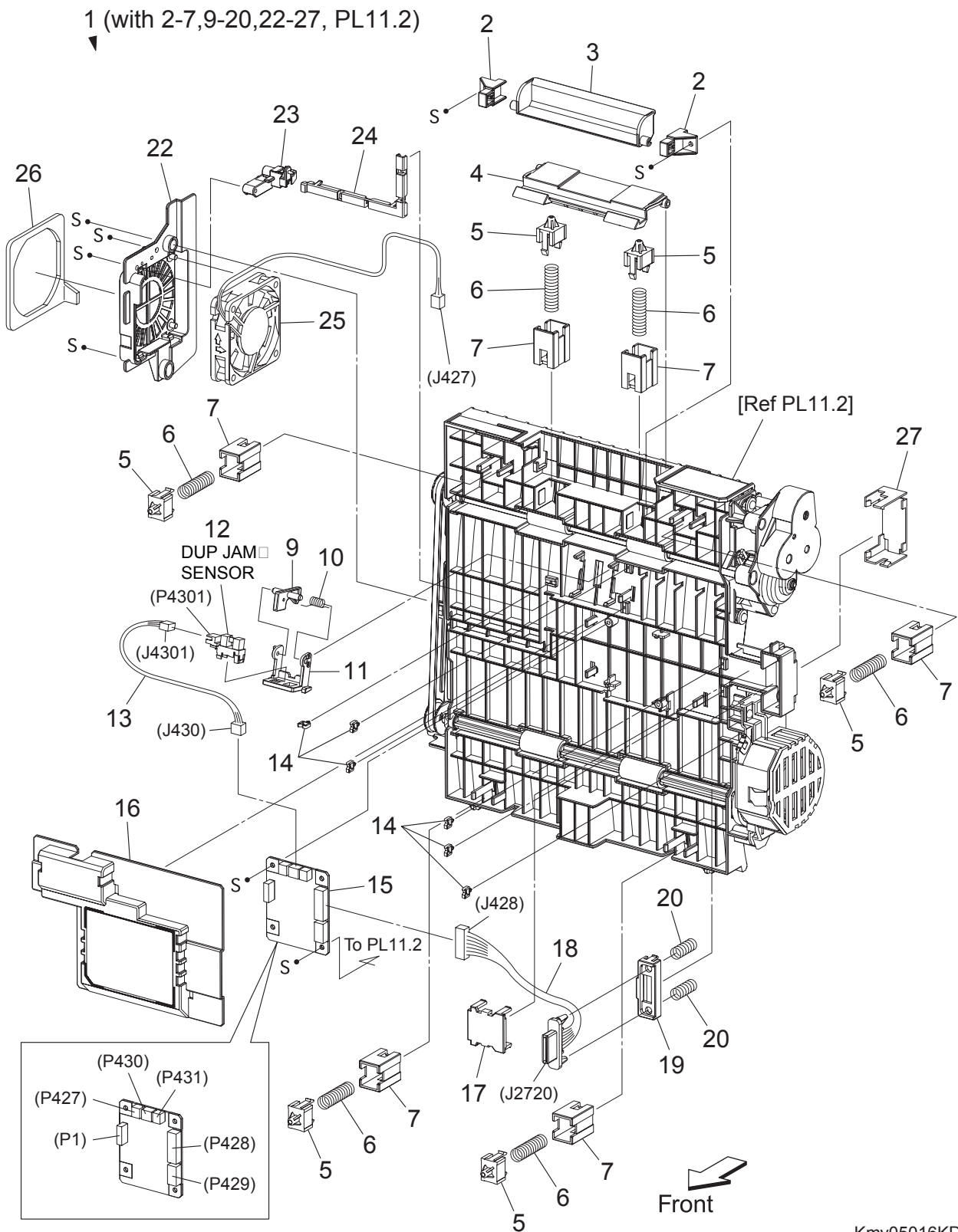

Kmy05016KD

PL11.1 Duplex (Option) (1/2) [List] (Reference)

Item	Parts name
1	FEEDER ASSY DUP (KIT DUPEX MODULE) (with 2-7,9-20,22-27, PL11.2)
2	STOPPER LATCH DUP
3	HANDLE LATCH DUP
4	LATCH DUP
5	HOLDER MAIN
6	SPRING CHUTE DUP
7	BRACKET HOLDER DUP
8	--
9	ACTUATOR DUP
10	SPRING SENSOR DUP
11	HOLDER SENSOR DUP
12	SENSOR PHOTO (DUP JAM SENSOR)
13	HARN ASSY DUP SNR (J430-J4301)
14	CLAMP MINI
15	PWBA DUP-H
16	COVER PWBA DUP
17	COVER CONNECT DUP
18	HARN ASSY DUP UNIT (J428-J2720)
19	HOLDER CONNECT DUP
20	SPRING CONNECT DUP
21	--
22	BRACKET FAN DUP
23	COVER HARNESS FAN
24	COVER HARNESS CHUTE
25	FAN DUP
26	SEAL DUP
27	COVER CHUTE DUP

PL11.2 Duplex (Option) (2/2) [List] (Reference)

Item	Parts name
1	FLANGE PULLEY UP
2	BELT DUP 3M-128Z
3	PULLEY DUP 3M-20T
4	BEARING DUP
5	CHUTE ASSY PH
6	--
7	--
8	BRACKET CLUTCH DUP
9	WASHER DUP CLUTCH
10	CLUTCH DUP
11	--
12	--
13	GEAR DUP 40Z-M0.8
14	ROLL ASSY DUP-1
15	ROLL ASSY DUP-2
16	COVER GEAR DUP
17	GEAR DUP 25Z FUSER
18	GEAR DUP 21Z-25Z
19	GEAR DUP 21Z
20	PLATE GEAR
21	SPRING DUP
22	BEARING
23	MOTOR ASSY DUP
24	PLATE EARTH DUP
25	BRACKET MOTOR DUP
26	BUSH SADDLE
27	COVER DRIVE DUP
28	HARN ASSY DUP EARTH (T432-T4320)

PL12.1 550 Feeder (Option) (1/5) [List] (Reference)

Item	Parts name
1	550 OPTION FEEDER (with 2,5-7, PL12.2,12.3) (Not used in Dell 3115cn)
2	COVER LEFT
3	SCREW JOINT
4	COVER CST 550
5	CLUTCH ASSY TURN OPT
6	CLUTCH ASSY FEED OPT
7	COVER RIGHT
99	KIT SCREW JOINT (with 3x2pcs)

PL12.2 550 Feeder (Option) (2/5) [Illustration] (Reference)

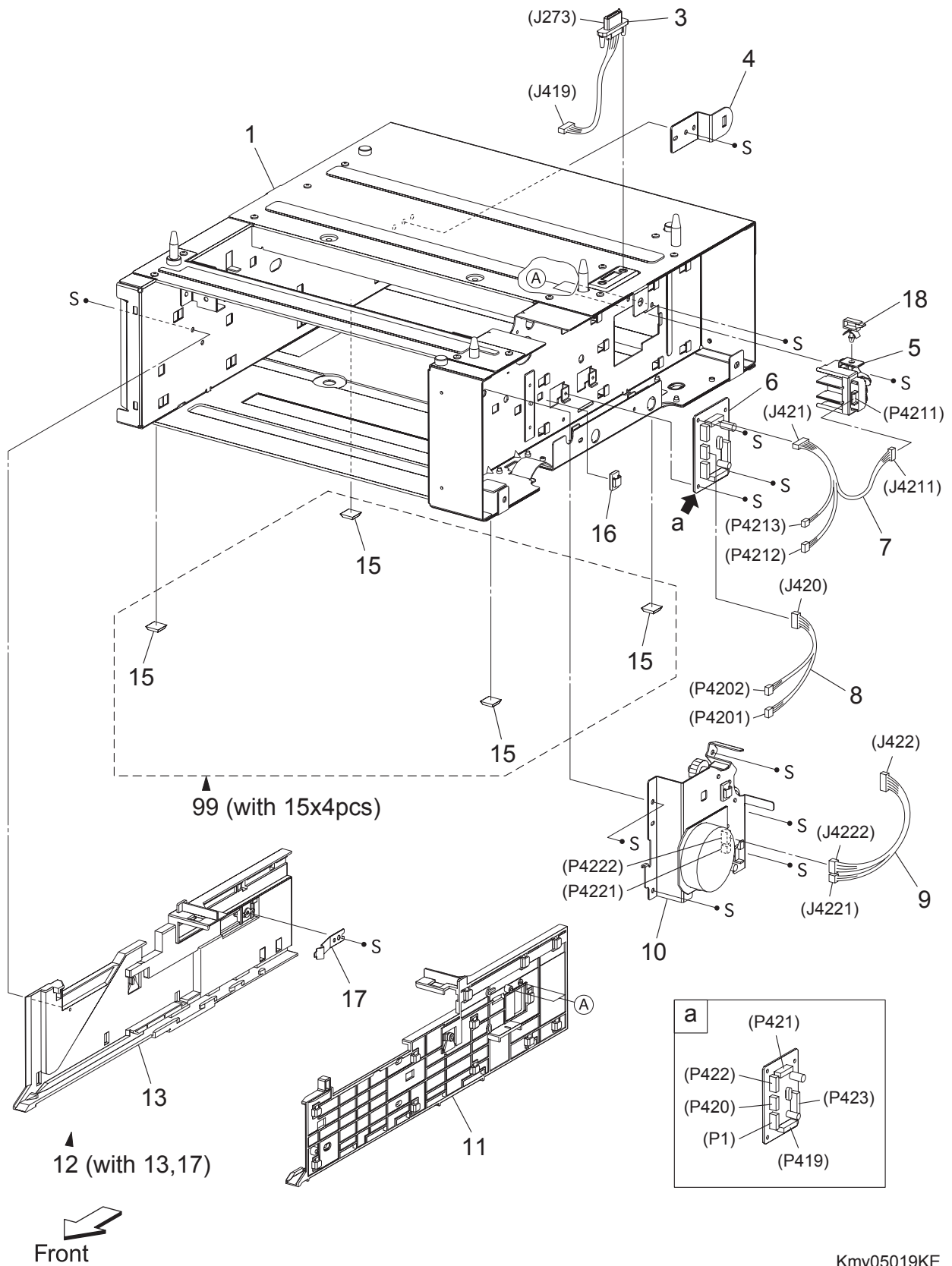

Kmy05019KE

PL12.2 550 Feeder (Option) (2/5) [List] (Reference)

Item	Parts name
1	FRAME ASSY OPT
2	--
3	HARN ASSY FDR UNIT (J273-J419)
4	BRACKET LOCK
5	SWITCH ASSY SIZE OPT
6	PWBA OPT FDR
7	HARN ASSY C2 CHUTE (J421-J4211,P4212,P4213)
8	HARN ASSY C2 TURN (J420-P4201,P4202)
9	HARN ASSY C2 MOT (J422-J4221,J4222)
10	DRIVE ASSY OPT FDR
11	GUIDE TRAY R 550
12	GUIDE ASSY 550 L (with 13,17)
13	GUIDE TRAY L 550
14	--
15	FOOT
16	CLAMP MINI
17	SPRING CST LOCK
18	CLAMP LOCKING
99	KIT FOOT ASSY (with 15x4pcs)

PL12.3 550 Feeder (Option) (3/5) [Illustration] (Reference)

1 (with 3-11,13-16,18,20-29,31)

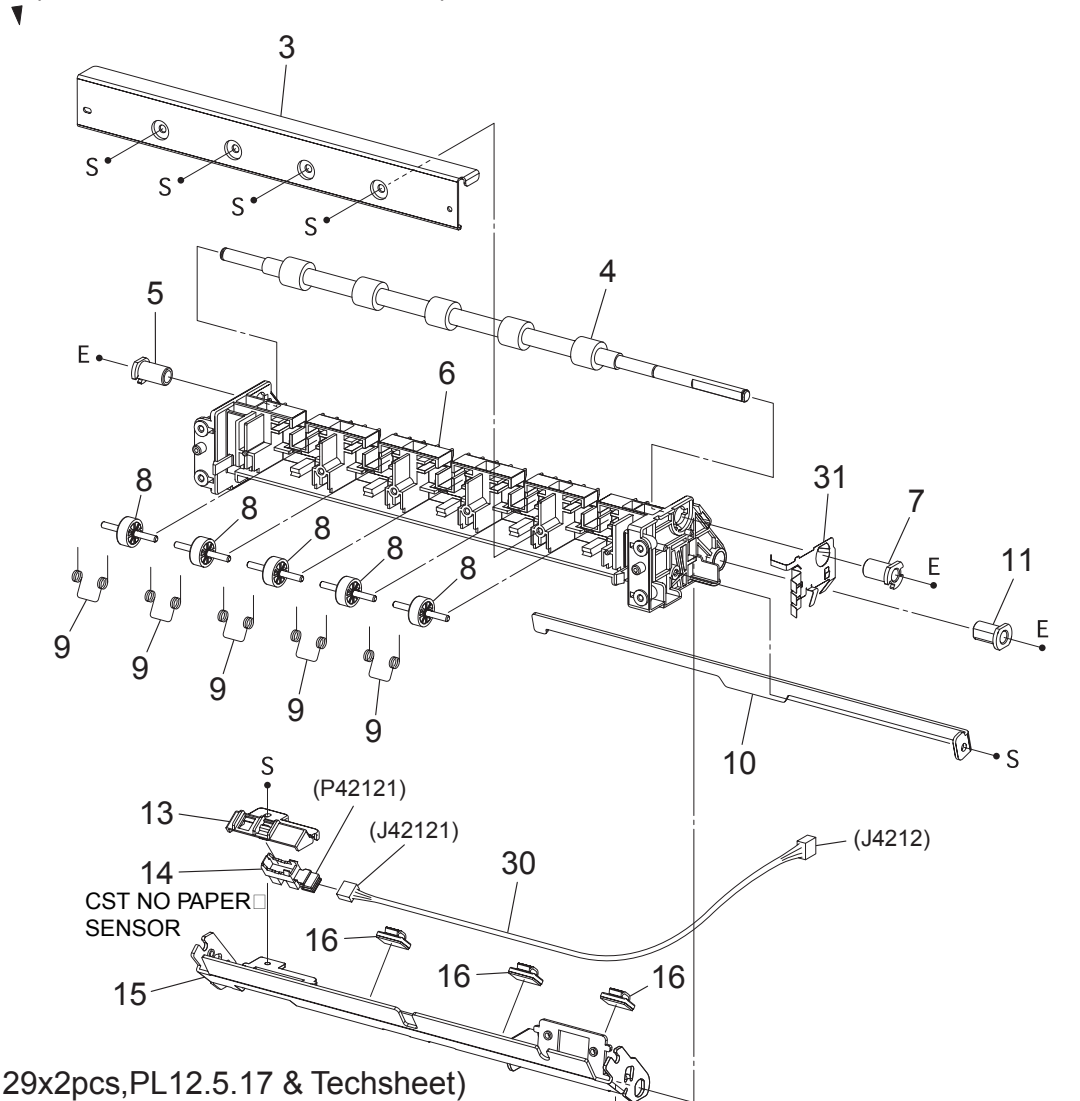

99 (with 29x2pcs, PL12.5.17 & Techsheet)

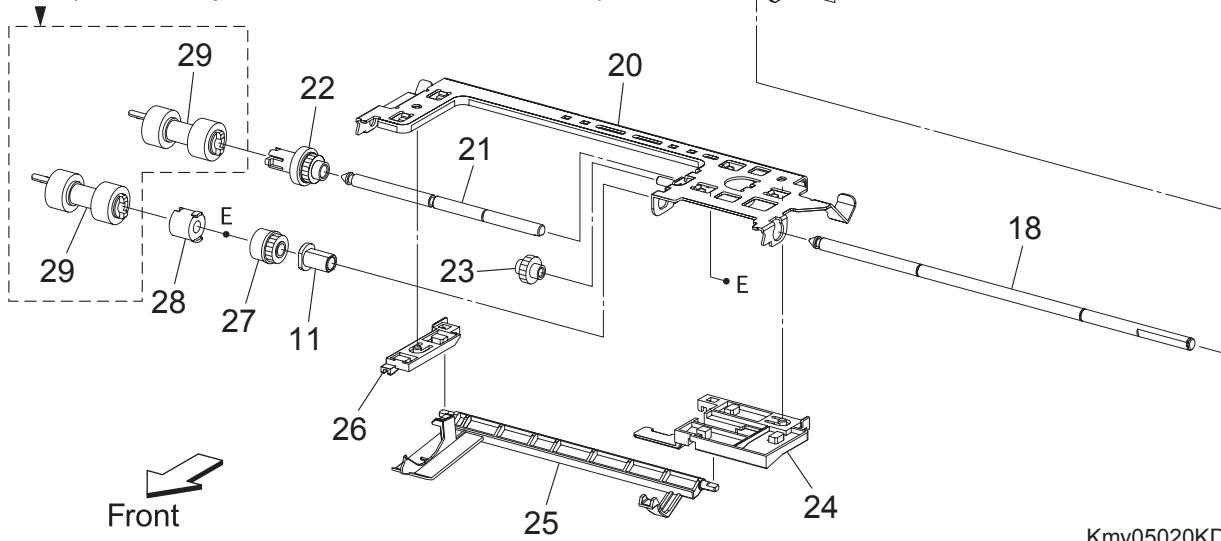

Kmy05020KD

PL12.3 550 Feeder (Option) (3/5) [List] (Reference)

Item	Parts name
1	FDR ASSY OPT (with 3-11,13-16,18,20-29,31)
2	--
3	COVER CHUTE
4	ROLL ASSY TURN
5	BEARING REGI
6	CHUTE FDR OPT
7	BEARING REGI E
8	ROLL PINCH TURN
9	SPRING PINCH TURN
10	CHUTE RETARD BTM OPT
11	BEARING NUDGER
12	--
13	HOLDER NO SNSR
14	SENSOR PHOTO (CST NO PAPER SENSOR)
15	CHUTE ASSY RETARD
16	CLAMP
17	--
18	SHAFT FEED OPT
19	--
20	SUPPORT NUDGER ASSY
21	SHAFT NUDGER
22	ROLL ASSY GEAR NUDGER
23	GEAR IDLER NUDGER
24	HOLDER NO PAPER L A4
25	ACTUATOR NO PAPER A4
26	HOLDER NO PAPER R A4
27	CLUTCH ONEWAY NUDGER
28	CLUTCH ONEWAY FEED
29	ROLL ASSY FEED
30	HARN ASSY C2 NO PAPER (J4212-J42121)
31	PLATE EARTH OPT
99	KIT SEPARATOR and FEED ROLLER (with 29x2pcs, PL12.5.17 & Techsheet) *1

*1 : Periodic Replacing Parts (100KPV)

PL12.4 550 Feeder (Option) (4/5) [Illustration] (Reference)

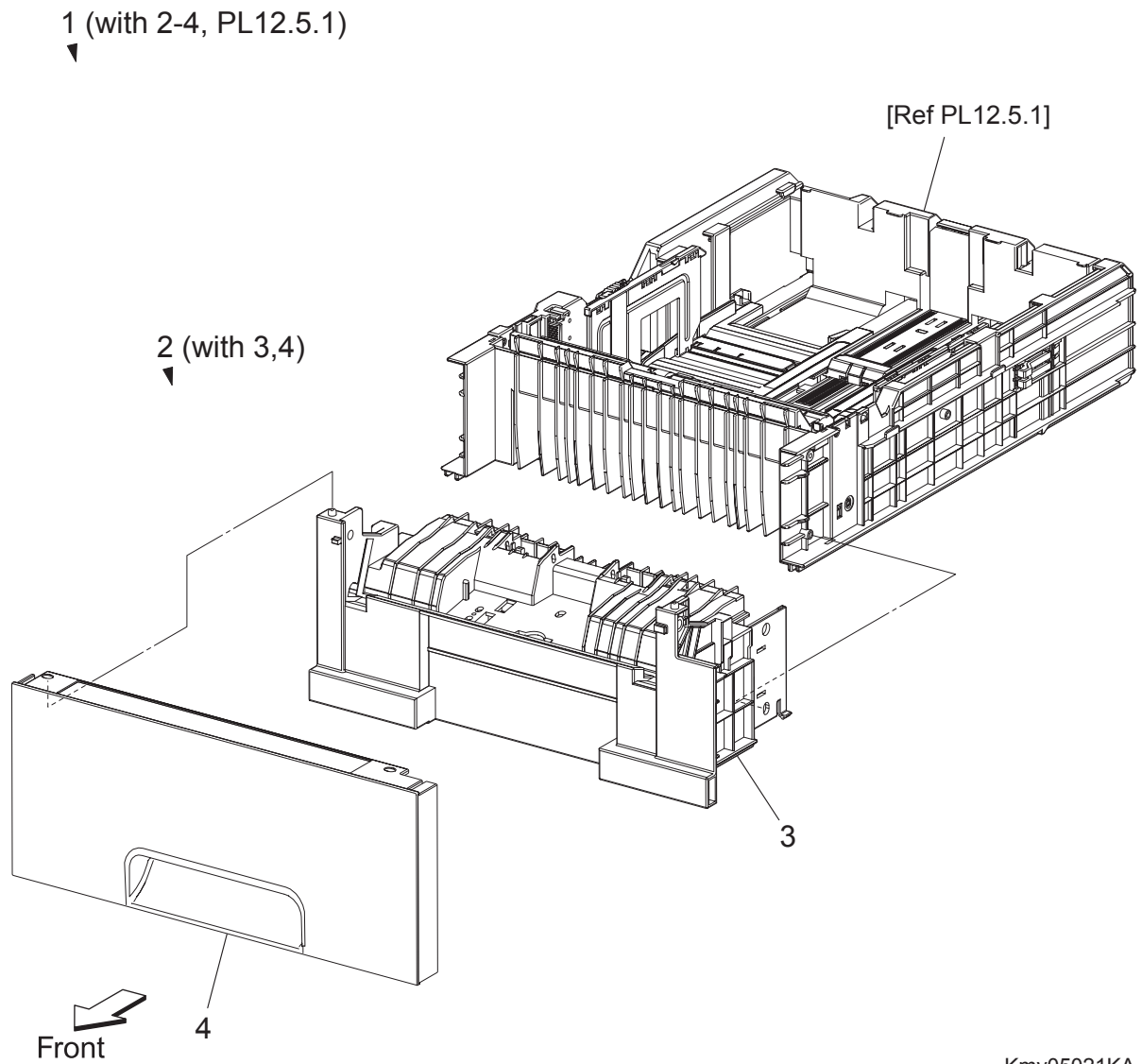

Kmy05021KA

PL12.4 550 Feeder (Option) (4/5) [List] (Reference)

Item	Parts name
1	CASSETTE ASSY 550 OPT (with 2-4, PL12.5.1)
2	CASSETTE ASSY FRONT 550 OPT (with 3,4)
3	HOUSING BASE FR 550
4	HANDLE CST 550 OPT

PL12.5 550 Feeder (Option) (5/5) [List] (Reference)

Item	Parts name
1	CASSETTE ASSY REAR 550 (with 2-34)
2	PLATE ASSY BTM A4
3	STOPPER PB
4	GEAR BTM LOCK ONEWAY
5	SHAFT PB A4
6	GEAR BTM DMP ONEWAY
7	GEAR PB L
8	SPRING BTM UP 550 A4
9	GUIDE ASSY SIDE R 550 A4
10	GUIDE ASSY SIDE L 550 A4
11	GEAR PINION
12	HOLDER ASSY RETARD (with 14-17)
13	CVR RTD CST
14	HOLDER RETARD
15	SHAFT RETARD
16	CLUTCH FRICTION RET
17	SEPARATOR ROLLER
18	SPRING RETARD
19	SWITCH SIZE SET
20	PLATE LOCK CST
21	PLATE GEAR LOCK 550
22	GUIDE ASSY CST END 550
23	ACTUATOR SIZE
24	HSG BASE RE 550
25	ACTUATOR RLS PB
26	SPRING STOPPER GEAR
27	GEAR PB R
28	COVER BTM UP 550
29	RACK BTM LOCK 550
30	SPRING BTM LOCK
31	GEAR BTM LOCK PINION
32	GEAR LEVER BTM LOCK
33	LEVER BTM LOCK
34	GEAR 40 BTM LOCK

PL13.1 Cover (With IIT) (1/2) [Illustration]

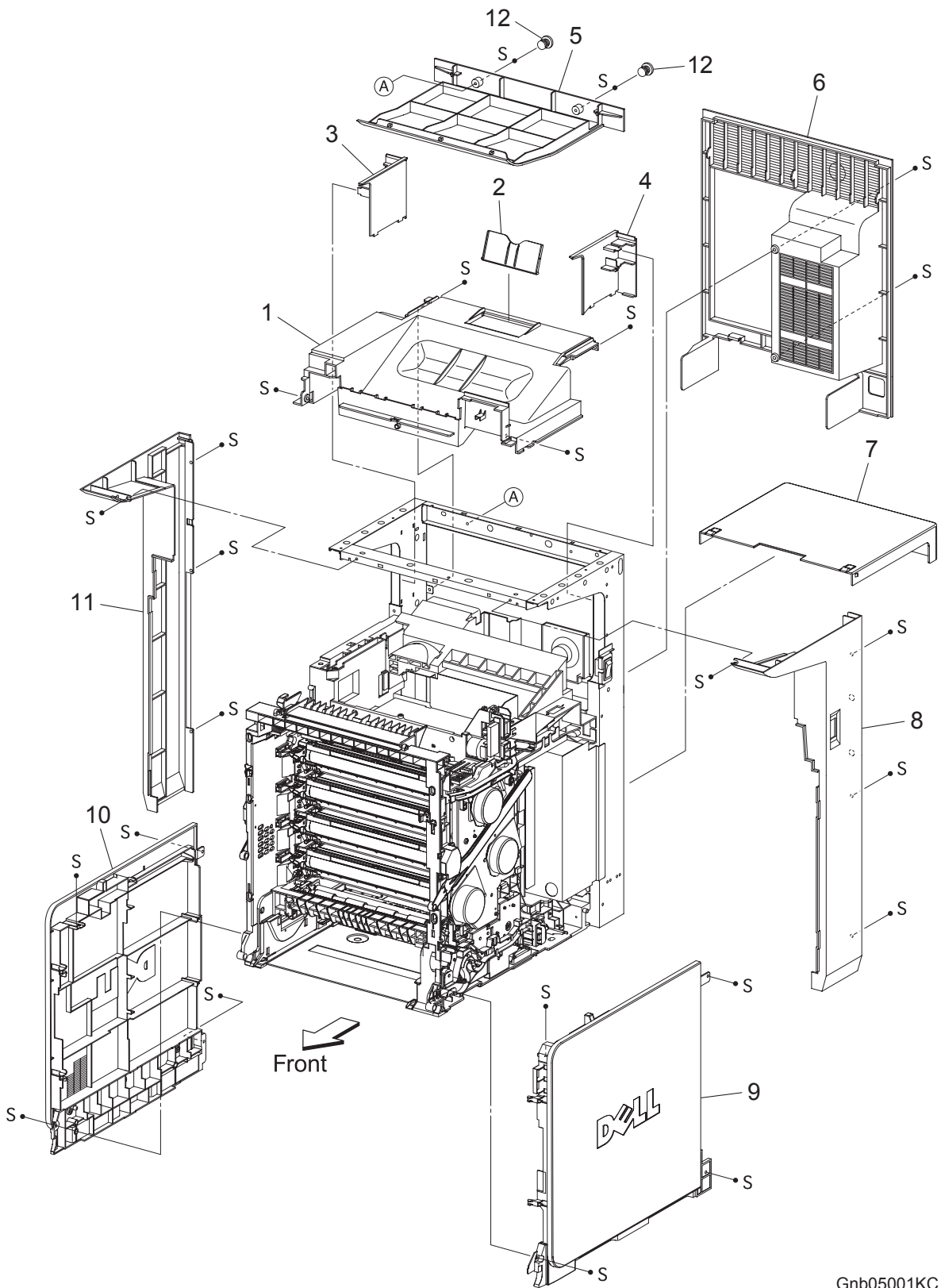

Gnb05001KC

PL13.1 Cover (With IIT) (1/2) [List]

Item	Parts name
1	COVER TOP
2	COVER EXTENSION 2 [Same as PL1.1.3]
3	COVER POLE IN L
4	COVER POLE IN R
5	COVER BOTTOM
6	COVER REAR
7	COVER CST [Same as PL1.1.5]
8	COVER POLE R
9	COVER ASSY R
10	COVER ASSY L
11	COVER POLE L
12	CAP SCREW

PL13.2 Cover (With IIT) (2/2) [Illustration]

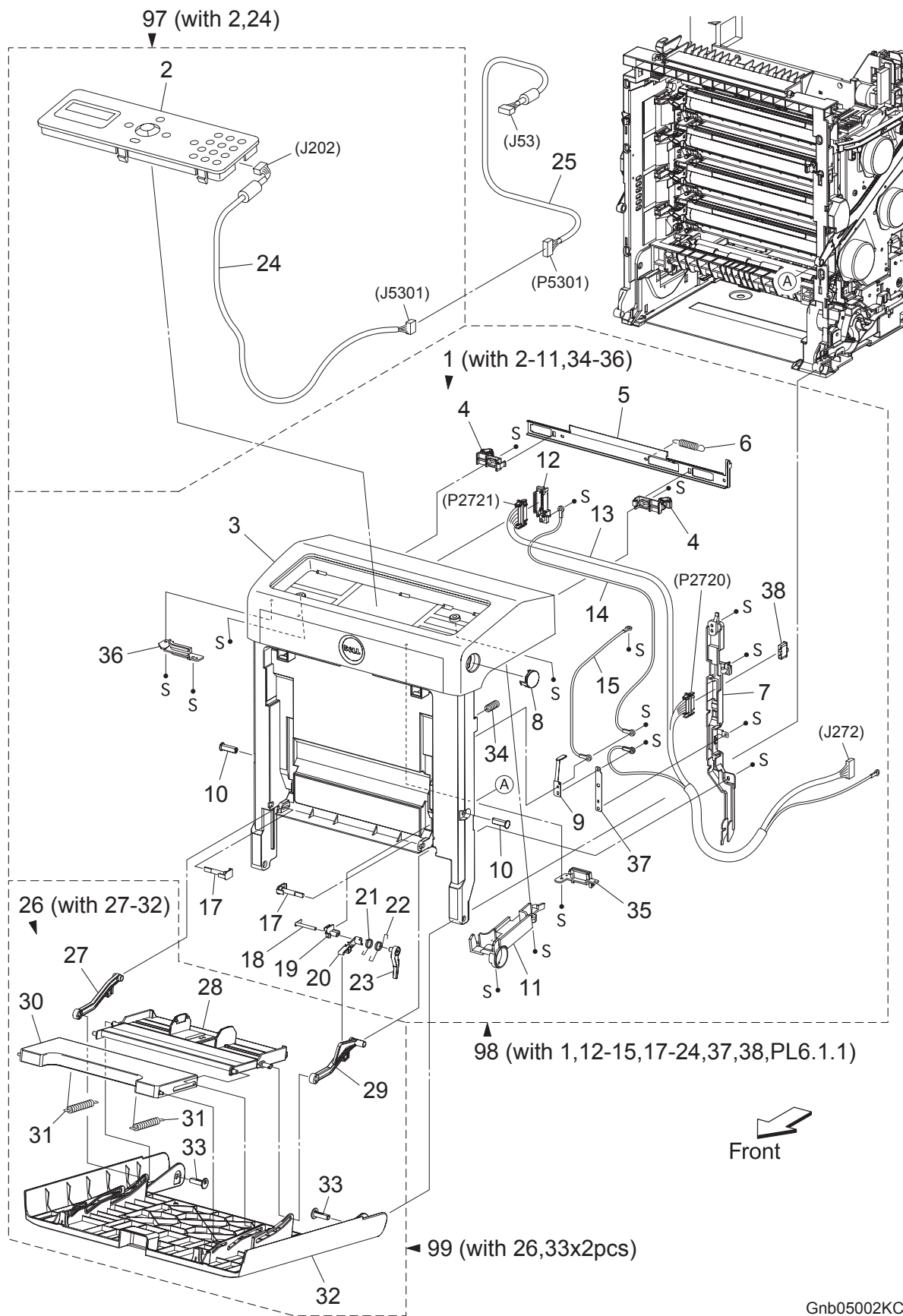

Gnb05002KC

PL13.2 Cover (With IIT) (2/2) [List]

Item	Parts name
1	COVER ASSY FRONT (with 2-11,34-36)
2	CONSOLE PANEL
3	COVER FRONT ASSY
4	LATCH FRONT [Same as PL1.2.4]
5	PLATE LATCH [Same as PL1.2.2]
6	SPRING LATCH [Same as PL1.2.3]
7	COVER HARNESS [Same as PL1.2.5]
8	BUTTON TOP [Same as PL1.2.6]
9	CONTACT FRONT [Same as PL1.2.7]
10	SHAFT PIVOT [Same as PL1.2.8]
11	COVER HARNESS
12	HOLDER DRAWER [Same as PL1.2.14]
13	HARNESS ASSY FRONT COVER (J272-P2720,P2721,T4322-T43221) [Same as PL1.2.11]
14	HARNESS ASSY DRAWER EARTH (T4321-T43210) [Same as PL1.2.13]
15	HARNESS ASSY FRONT COVER EARTH 1 (T4321-T43210) [Same as PL1.2.12]
16	--
17	PIN PIVOT MSI [Same as PL1.2.17]
18	SHAFT LEVER [Same as PL1.2.18]
19	PLATE PIVOT [Same as PL1.2.19]
20	LEVER MSI 1 [Same as PL1.2.20]
21	SPRING LEVER MSI [Same as PL1.2.21]
22	SPRING LEVER LINK [Same as PL1.2.22]
23	LEVER MSI 2 [Same as PL1.2.23]
24	HARNESS ASSY A-OP-OPP (J202-J5301)
25	HARNESS ASSY A-OP-ESS (J53-P5301)
26	COVER ASSY MSI (with 27-32) [Same as PL1.2.24]
27	LINK ASSY MSI L [Same as PL1.2.25]
28	TRAY ASSY MSI BASE [Same as PL1.2.26]
29	LINK ASSY MSI R [Same as PL1.2.27]
30	TRAY MSI [Same as PL1.2.28]
31	SPRING TRAY [Same as PL1.2.35]
32	COVER MSI [Same as PL1.2.29]
33	SHAFT PIVOT MSI [Same as PL1.2.30]
34	SPRING [Same as PL1.2.36]
35	COVER OPP R
36	COVER OPP L
37	PLATE EARTH FC [Same as PL1.2.37]
38	DUP CONNECTOR CAP [Same as PL1.2.38]
97	KIT OPERATOR PANEL (with 2,24)
98	KIT COVER ASSY FRONT (with 1,12-15,17-24,37,38,PL6.1.1)
99	COVER ASSY MSI (with 26,33x2pcs) [Same as PL1.2.99]

PL13.3 Frame & ROS (With IIT) [Illustration]

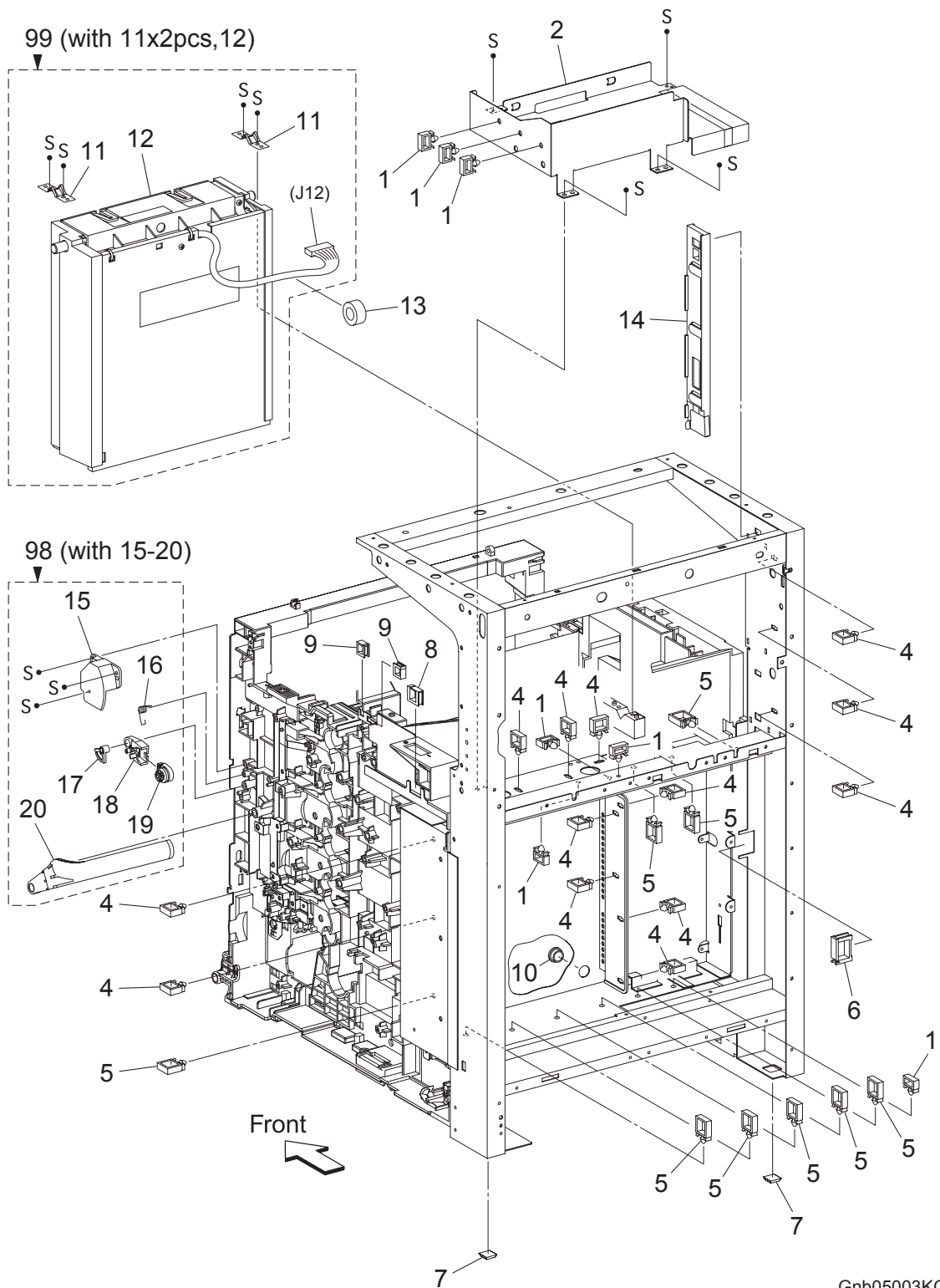

Gnb05003KC

PL13.3 Frame & ROS (With IIT) [List]

Item	Parts name
1	CLAMP RLMS-2V0
2	FRAME ASSY EARTH
3	--
4	CLAMP RLWT-2V0
5	CLAMP RLWC-3SV0
6	CLAMP SADDLE LES-1017
7	FOOT [Same as PL7.1.14]
8	CLAMP SADDLE LES-1010
9	CLAMP SADDLE LES-0505
10	BUSH STB-13
11	SPRING ROS [Same as PL5.1.1]
12	ROS ASSY
13	CORE [Same as PL5.1.22]
14	SPACER ASSY FFC
15	SUPPORT LINK R [Same as PL7.1.12]
16	SPRING SUPPORT [Same as PL7.1.8]
17	LEVER RELEASE [Same as PL7.1.4]
18	HOLDER DAMPER H
19	DAMPER OIL H
20	LINK R [Same as PL7.1.13]
98	KIT LINK ASSY R H (with 15-20)
99	KIT ROS ASSY (with 11 x 2pcs, 12)

PL13.4 Electrical (With IIT) (1/2) [Illustration]

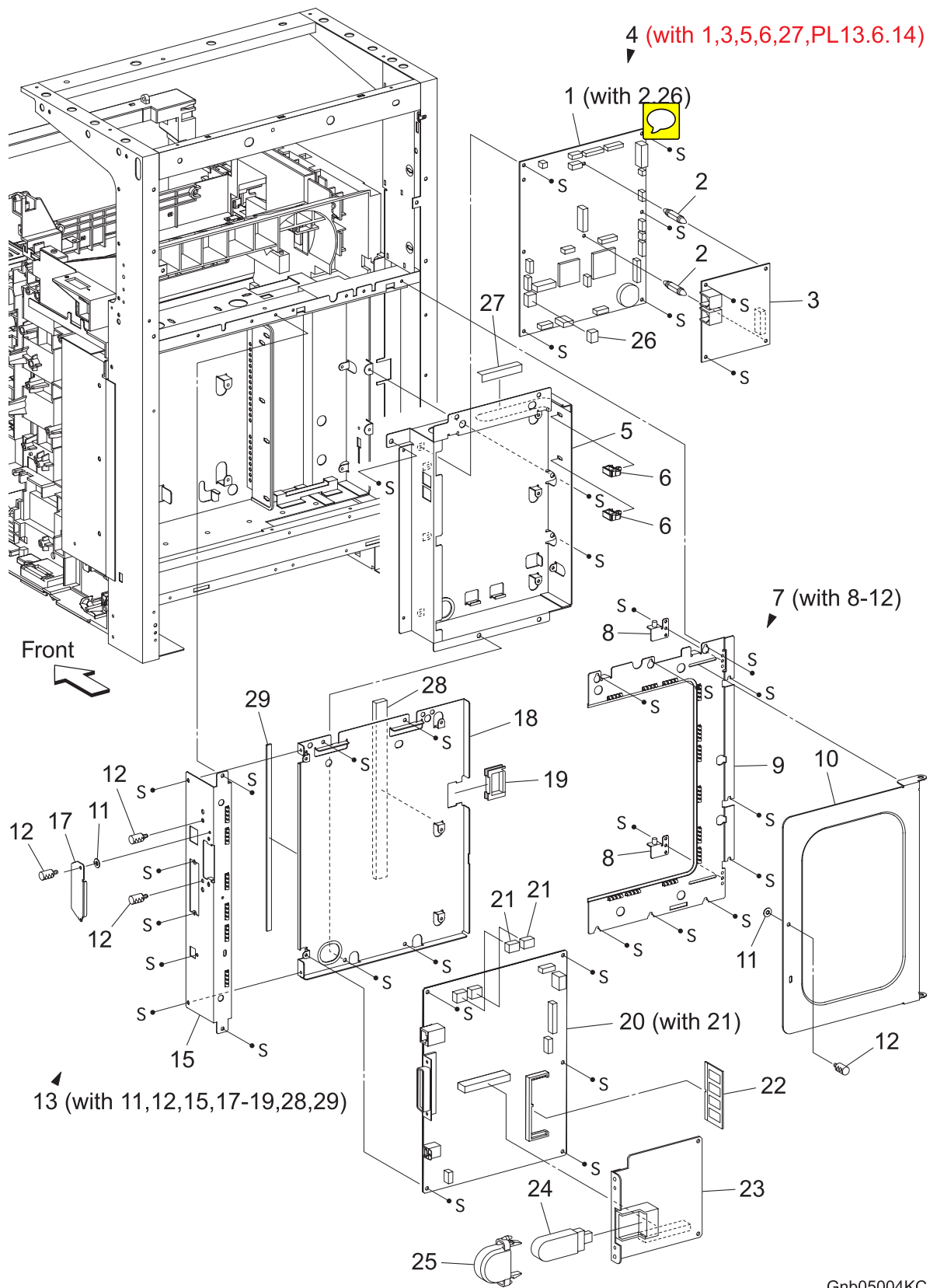

Gnb05004KC

PL13.4 Electrical (With IIT) (1/2) [List]

Item	Parts name
1	PWBA HYUI (with 2,26)
2	SUPPORT FAX
3	PWBA FAX
4	BOX ASSY FAX AIO (with 1,3,5,6,27,PL13.6.14)
5	PLATE ASSY FAX AIO
6	CLAMP RLWT-2V0
7	SHIELD ASSY ESS WINDOW (With 8-12)
8	HINGE ASSY WINDOW
9	PLATE ASSY ESS SUB
10	PLATE WINDOW ESS
11	WASHER [Same as PL9.1.23]
12	SCREW KNURLING [Same as PL9.1.22]
13	BOX ASSY PRT AIO (With 11,12,15,17-19,28,29)
14	--
15	PLATE ASSY PRT AIO
16	--
17	PLATE OPT [Same as PL9.1.29]
18	BOX ESS PRT
19	CLAMP SADDLE LES-1017
20	PWBA ESS (with 21)
21	NVM ROM [Same as PL9.1.35]
22	MEMORY CARD (OPTION) [Same as PL9.1.30]
23	MULTI PROTOCOL CARD (OPTION) [Same as PL9.1.31]
24	WIRELESS PRINTER ADAPTER (Installs to the MULTI PROTOCOL CARD.) (OPTION) [Same as PL9.1.32]
25	COVER USB (OPTION) [Same as PL9.1.34]
26	NVM ROM
27	FILM ASSY INSULATION FFC
28	GASKET SSTG 5-14
29	GASKET SSTG 1-5

PL13.5 Electrical (With IIT) (2/2) [Illustration]

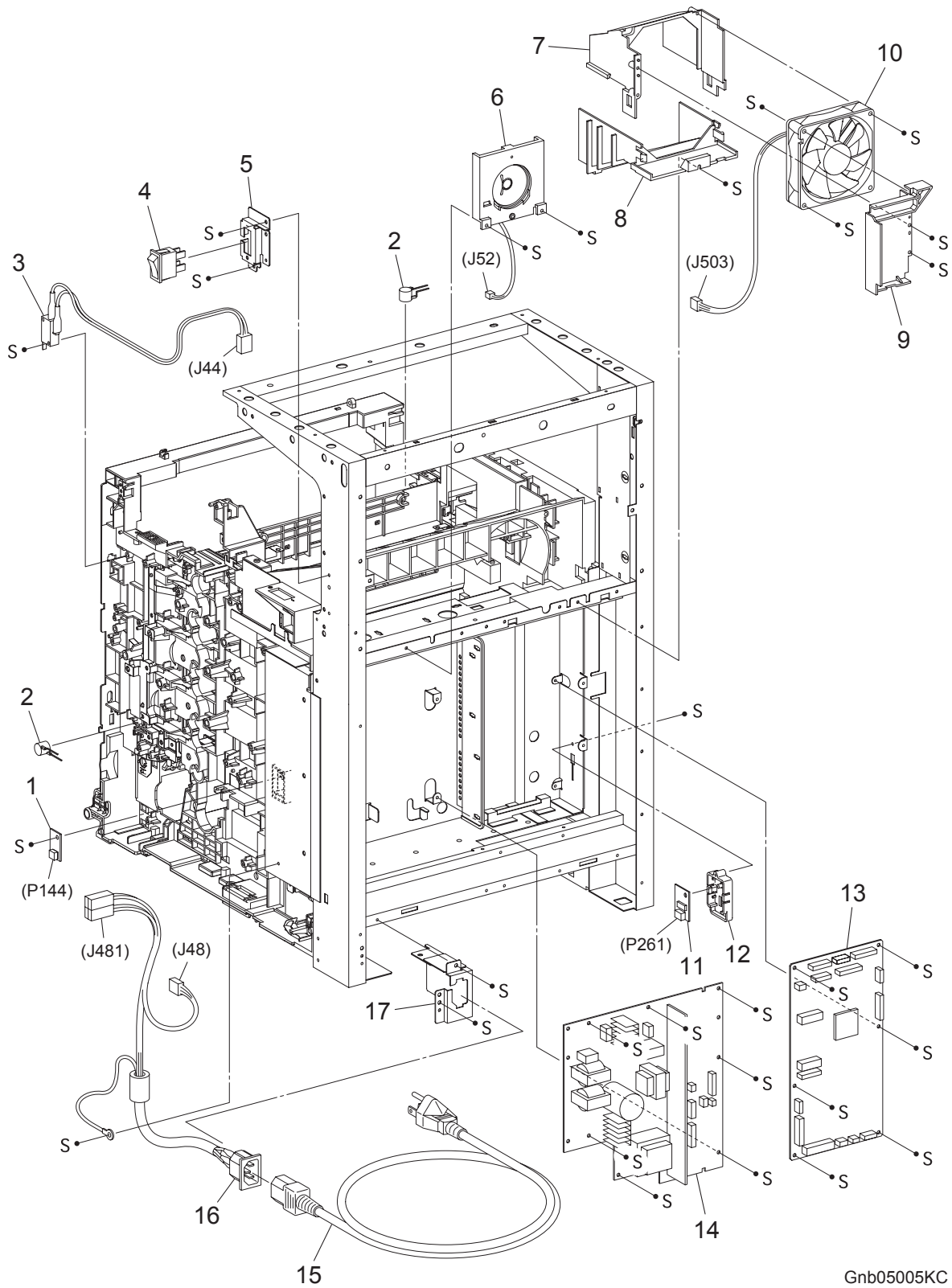

Gnb05005KC

PL13.5 Electrical (With IIT) (2/2) [List]

Item	Parts name
1	PWBA EEPROM(XPRO) [Same as PL9.1.1]
2	VARISTOR [Same as PL9.1.2]
3	HARN ASSY INTERLOCK AIO
4	SWITCH POWER [Same as PL9.1.13]
5	BRACKET MAIN SW
6	SPEAKER ASSY
7	DUCT UPPER
8	DUCT LOWER
9	PLATE DUCT
10	FAN MAIN [Same as PL9.1.10]
11	SENSOR HUM [Same as PL9.1.19]
12	BRACKET SENSOR HUM
13	PWBA MCU [Same as PL9.1.20]
14	LVPS
15	POWER CORD [Same as PL9.1.17]
16	HARN ASSY INLET AIO (J48-J481)
17	BRACKET INLET

PL13.6 Harness (With IIT) [Illustration]

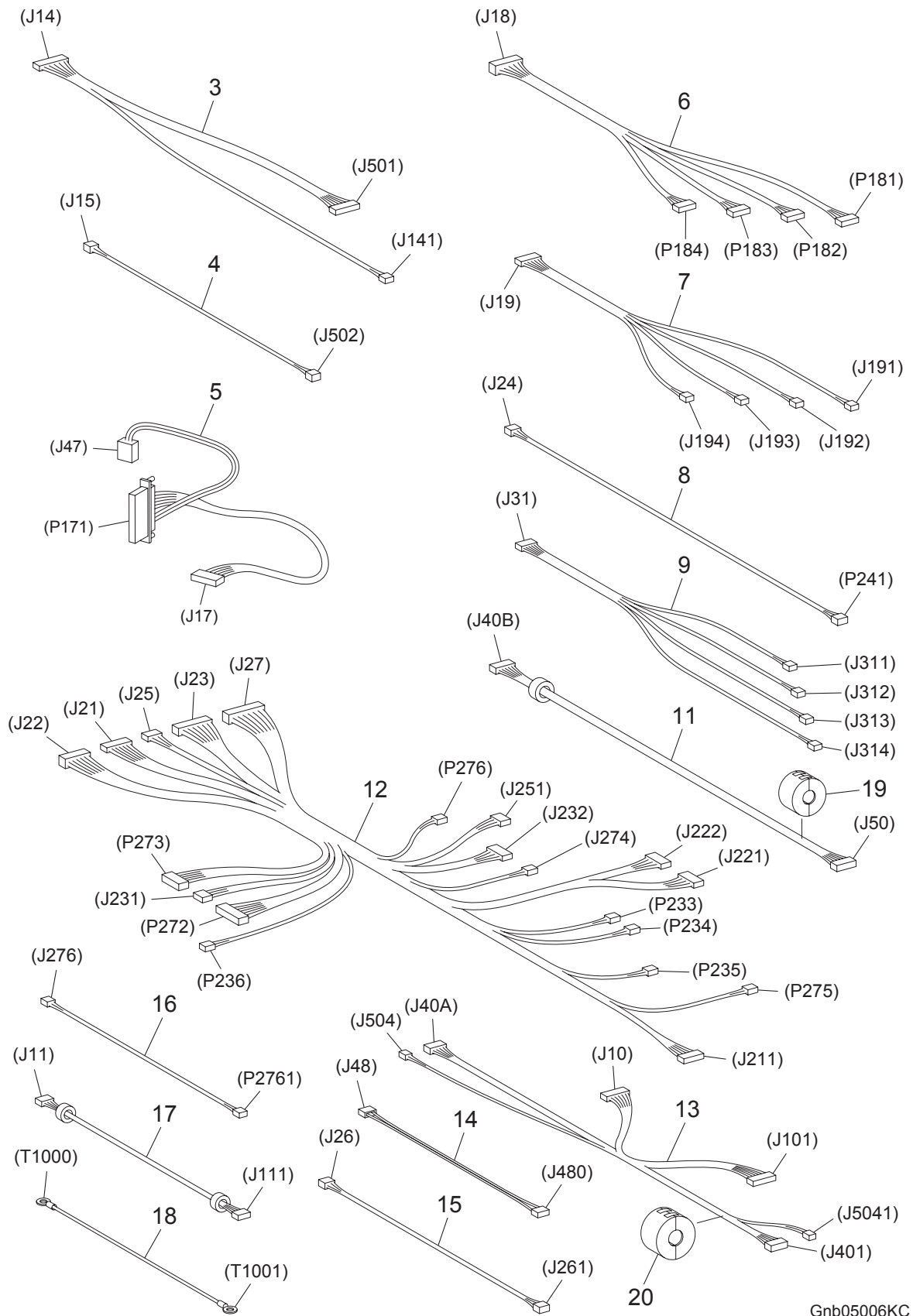

Gnb05006KC

PL13.6 Harness (With IIT) [List]

Item	Parts name
1	--
2	--
3	HARN ASSY LVPS AIO (J14-J141,J501)
4	HARN ASSY 24V AIO (J15-J502)
5	HARN ASSY FUSER AIO (P171-J17,J47)
6	HARN ASSY TNR MOT AIO (J18-P181,P182,P183,P184)
7	HARN ASSY TNR SNR AIO (J19-J191,J192,J193,J194)
8	HARN ASSY OHP AIO (J24-P241)
9	HARN ASSY CRUM AIO (J31-J311,J312,J313,J314)
10	--
11	HARN ASSY ESS POWER AIO (J40B-J50)
12	HARN ASSY R SIDE AIO (J21,J22,J23,J25,J27-J211,J221,J222,J231,J232,P233, P234, P235,P236,J251,P272,P273,J274,P275,P276)
13	HARN ASSY IF AIO (J10,J40A,J504-J101,J401,J5041)
14	HARN ASSY AIO-ESS (J48-J480)
15	HARN ASSY HUM (J26-J261) [Same as PL10.1.4]
16	HARN ASSY EXIT CLT (J276-P2761) [Same as PL10.1.14]
17	HARN ASSY VIDEO AIO (J11-J111)
18	HARN ASSY DRIVE EARTH AIO (T1000-T1001)
19	CORE TFT-081813N
20	CORE TFT-102010N

PL13.7 550 Feeder (Option) (With IIT) [Illustration]

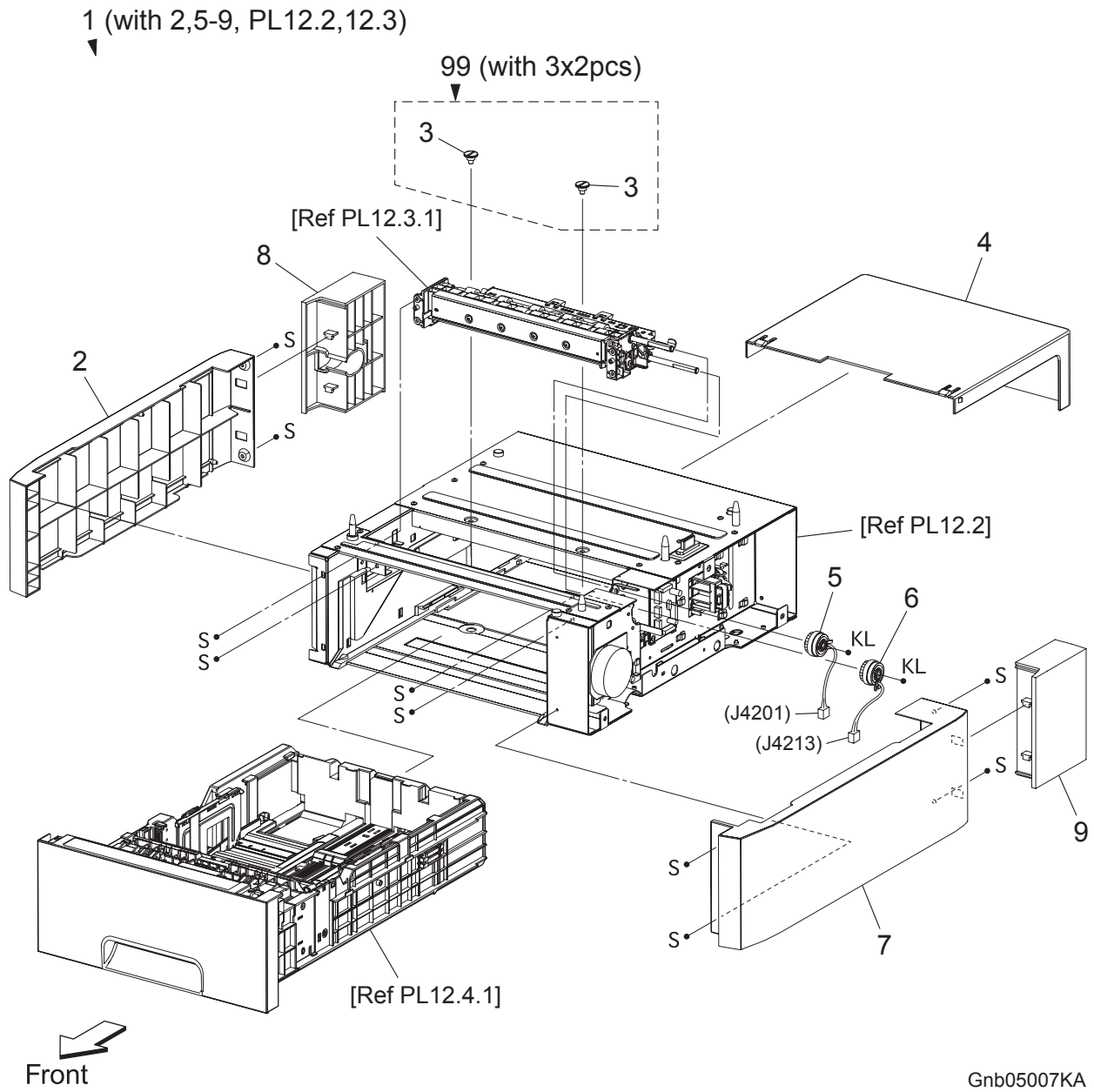

PL13.7 550 Feeder (Option) (With IIT) [List]

- | | |
|----|---|
| 1 | 550 OPTION FEEDER (with 2,5-9, PL12.2,12.3) |
| 2 | COVER LEFT [Same as PL12.1.2] |
| 3 | SCREW JOINT [Same as PL12.1.3] |
| 4 | COVER CST 550 [Same as PL12.1.4] |
| 5 | CLUTCH ASSY PH TURN [Same as PL12.1.5] |
| 6 | CLUTCH ASSY PH FEED [Same as PL12.1.6] |
| 7 | COVER RIGHT [Same as PL12.1.7] |
| 8 | COVER OPT FDR L |
| 9 | COVER OPT FDR R |
| 99 | KIT SCREW JOINT (with 3x2pcs) [Same as PL12.1.99] |

PL13.8 IIT ASSY [List]

Item	Parts name
1	ADF SCANNER ASSY (With 2-10)
2	ADF ASSY (With 3-6,10)
3	ADF FEED ROLLER
4	ADF FEED ROLLER HOLDER
5	ADF SEPARATOR PAD
6	ADF SEPARATOR SPRING
7	SCANNER ASSY
8	PLATE SUB
9	SCREW
10	KIT TRAY MAIN
11	CORE SFT-25SN
12	CORE ASSY FRC27
13	CORE FRC27-12-1.3
14	CORE ASSY SC-18
99	KIT ADF FEED ROLLER (with 3-6 & Techsheet)

Chapter 6 Principle of Operation CONTENTS

1. Telephone System.....	6 - 1
1.1 Converting and Sending Voice in the Form of Electrical Signals.....	6 - 1
1.2 Analog and Digital Signals.....	6 - 3
2. Telephone Call Connection Mechanism.....	6 - 6
2.1 Analog Telephone Network.....	6 - 6
2.2 Telephone Call Connection Mechanism.....	6 - 7
3. Terminology.....	6 - 10
4. FAX System (Overview).....	6 - 11
5. Unit Mechanisms.....	6 - 13
6. FAX Standards (ITU-T Recommendations).....	6 - 16
7. Fault Isolation Procedure for FAX.....	6 - 17
7.1 Fault Occurs.....	6 - 17
7.2 Send Fault.....	6 - 17
7.3 Receive Fault.....	6 - 18
8. Other Problems.....	6 - 19
9. Document Scanning.....	6 - 20
9.1 Document Scanning at Platen (IIT).....	6 - 21
9.2 Document Scanning at ADF.....	6 - 22
9.2.1 Setting a Document.....	6 - 23
9.2.2 Preparation for Feed.....	6 - 23
9.2.3 Prefeed.....	6 - 23
9.2.4 Preregistration.....	6 - 24
9.2.5 Scan Control.....	6 - 24
9.2.6 Simplex Document.....	6 - 25
10. Image Data Flow.....	6 - 26
11. Drive Torque Transfer Scheme.....	6 - 27
11.1 ADF Motor.....	6 - 27
11.2 Gear Layout.....	6 - 28
12. Names and Functions of Components.....	6 - 29
12.1 IIT.....	6 - 29
12.2 ADF.....	6 - 31
13. Control.....	6 - 33
13.1 Document Scanning Steps.....	6 - 33
13.1.1 AGC (Auto Gain Control): White Level Variation Adjustment.....	6 - 33
13.1.2 AOC (Auto Offset Control).....	6 - 33
13.1.3 Shading Compensation.....	6 - 33
13.2 CCD Image Sensor Overview.....	6 - 34
13.3 System Configuration.....	6 - 35

1. Telephone System

1.1 Converting and Sending Voice in the Form of Electrical Signals

The human voice is a sound wave; in other words, air vibrations. Conversation between two people results when such vibrations travel through the air and reach each other's ears. A string telephone transmits the air vibrations generated between two people along a string stretched tight, thus allowing conversation over a distance. In this system, a paper cup at one end of the string receives the air vibrations, which are then transmitted along the string. A paper cup at the other end of the string transmits them back to the air, so that they again become again audible sound waves.

A telephone is a device that replaces the vibrations transmitted by string with electrical signals. The two paper cups correspond to microphone and speaker and the string to the telephone line. Because electrical signals travel over the telephone line at a high speed with minimal attenuation, the telephone enables conversation over great distances.

Voice is changed into electrical signals using electromagnetic induction, a process by which electrical signals are generated by vibrating a coil in a magnetic field. Both the microphone and speaker exploit this process. The microphone transduces sound into electrical signals using electromagnetic induction that occurs at a moving coil coupled to a diaphragm picking up air vibrations.

On the other hand, the speaker functions in the reverse manner, transducing electrical signals back to air vibrations. Therefore, its construction is basically the same as that of a microphone. Electrical signals passing through a coil in the magnetic field vibrate the coil, which in turn vibrates the air to reproduce the voice.

String telephone

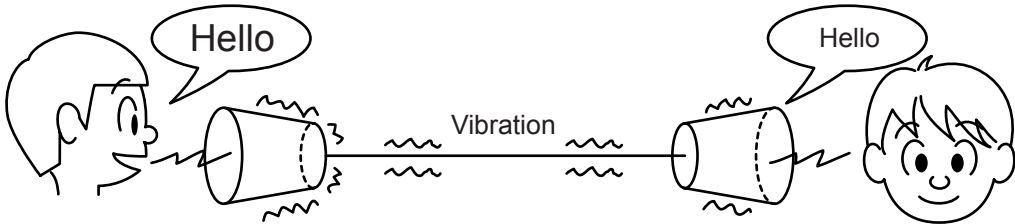

Telephone

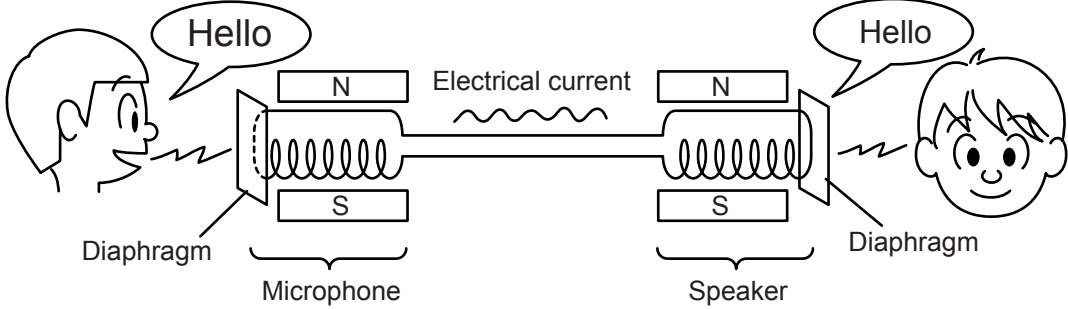

Electromagnetic induction

The diagram shows a coil of wire placed between a North (N) magnet and a South (S) magnet. The coil is connected to a light bulb. Arrows labeled 'a' show the current flow in the coil, and arrows labeled 'b' show the current flow in the wire leading to the light bulb.

a. The coil in the magnetic field is vibrated.
||
The magnetic field around the coil is altered.
↓
b. An electric current (alternating current) is generated in the coil.

Gnb06021KA

These electrical signals are analog signals that fluctuate in response to the volume of the voice.

1.2 Analog and Digital Signals

An electrical signal generated by the telephone's microphone is an analog signal. The waveform of this analog signal fluctuates responsive to the voice volume. When the voice is loud, the amplitude (voltage) increases; when soft, the amplitude decreases. When the voice is high-pitched, the frequency (number of vibrations) increases; when low-pitched, the frequency decreases.

A signal whose values change in a continuous manner with time like this is called an analog signal. In contrast, a digital signal is a set of values that change with time in a discrete instead of continuous manner. In other words, an analog signal is like a hill. A digital signal is like stairs.

A digital signal is a series of values obtained by sampling a continuous analog signal at a certain required rate. For example, when sampling is by time, the rate is once a second, millisecond, etc. Because the sampling reduces the amount of data along the time axis, the converted signal is compressed and smaller in data size. Thus, once digitized, the signal information is thinned out compared to the original analog signal.

Moreover, digital signal transmission is performed by dividing a continuously changing electrical signal according to a certain rate of time, then converting each division to a value of 1 or 0, depending on whether it is greater or less than a specified threshold value. Compared to an analog signal, a digital signal offers precise data exchange because the only change that must be handled is that between 1 (high voltage) and 0 (low voltage) with respect to a standard value (the threshold value).

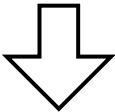
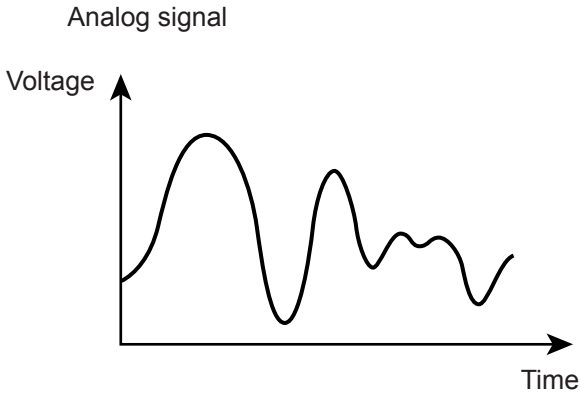

The signal is converted to 1 or 0 depending on whether it is higher or lower than a threshold value. In other words, the waveform is quantified.

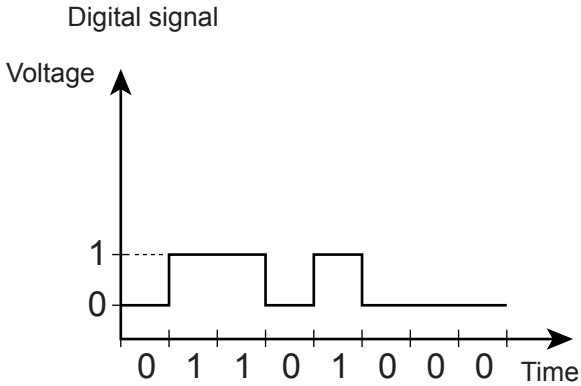
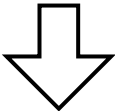
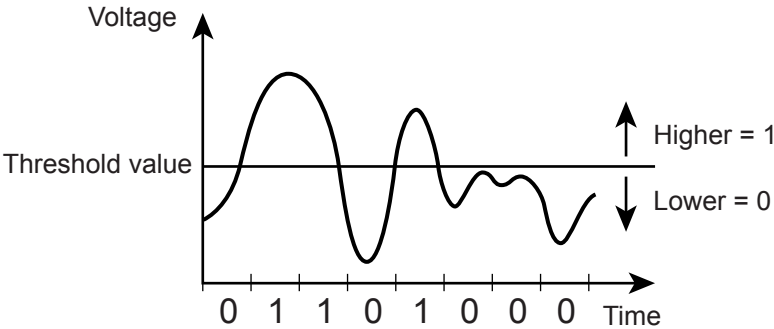

Gnb06022KA

NOTE

The difference between analog and digital signals can be easily understood by comparing analog measuring instruments, such as clocks and scales with their needles and gradations to digital gauges that display results as a value. An analog instrument with a continuously moving needle, can, at least in theory, be read beyond the decimal point to infinitely small divisions (12.47253... g, 35.1864... g, etc.). A digital instrument, however, can only display results to the minimum necessary decimal place (12.5 g, 35.0 g, etc.).

NOTE

Conversion of an analog signal to digital signal is called AD conversion. The reverse is called DA conversion. Image data read by a FAX is a digital signal in which 0s and 1s are assigned according to whether or not there is black in the squares of a paper surface divided into a grid. FAX communications that use an analog telephone network perform DA conversion before transmitting the scanned image from the phone, and AD conversion before printing the received data.

2. Telephone Call Connection Mechanism

2.1 Analog Telephone Network

To make a telephone call, the calling party and called party each must have a telephone set (telephone). These telephones must be connected by a transmission route. The transmission route includes switches located in central offices. The route itself comprises various components such as metallic cable and optical cable. The entire transmission path between the two telephones is called an analog telephone network.

An analog telephone network comprises the following four parts:

■ Analog Telephone Network Configuration

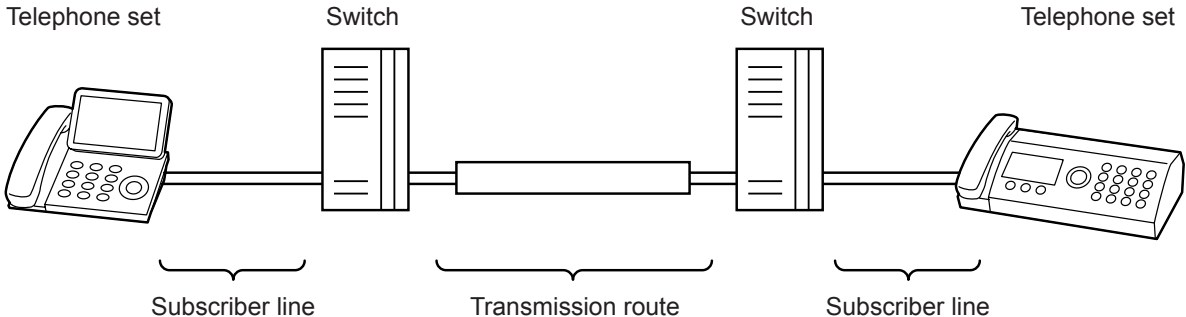

Gnb06023KA

■ Switching Equipment Network

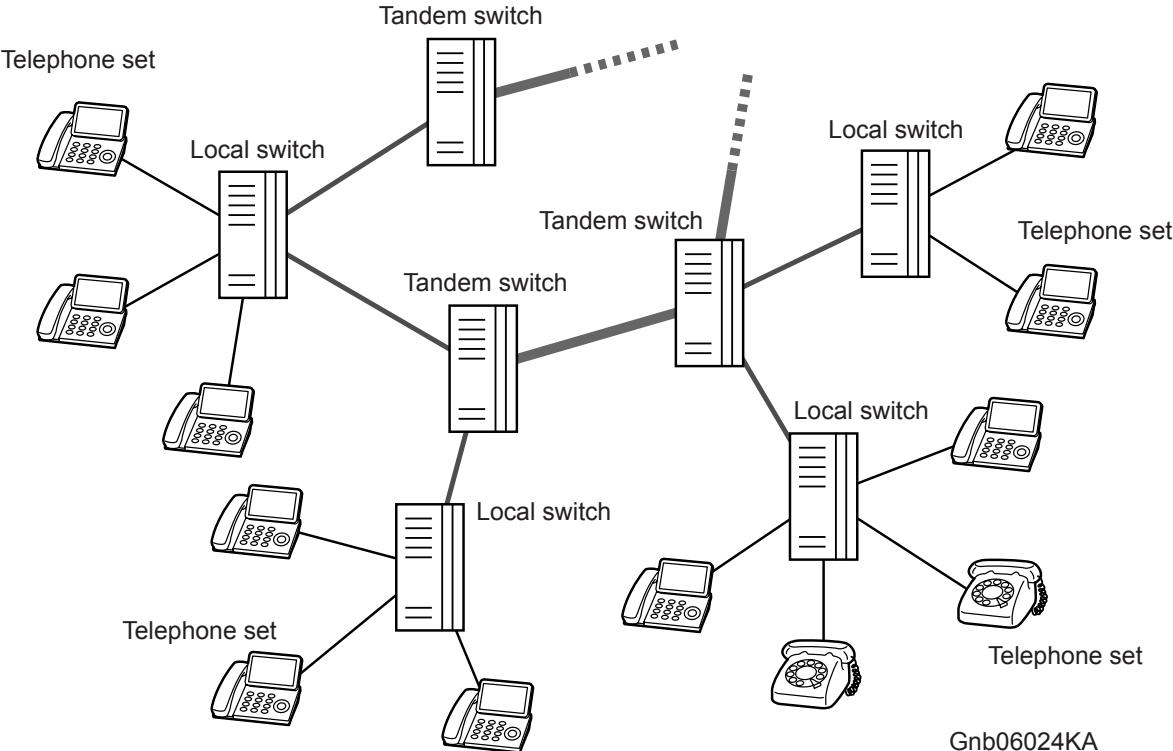

Gnb06024KA

2.2 Telephone Call Connection Mechanism

- 1) When the handset is lifted, the hook switch is activated and a transmission signal (400Hz/48VDC), called a dial tone (DT), is sent from the local switch. The dial tone is audible at the handset speaker, indicating that the calling party can start dialing.
- 2) Entering the telephone number by rotating the dial or pushing the buttons transmits the number to the local switch.

NOTE

There are two types of telephone line corresponding to the two ways of transmitting the phone number. They are known as dial types. Most recent telephones can automatically distinguish the dial type.

One type is "Pulse Dialing (PD)", also called "Dial Pulse (DP)". After the rotary dial on a dial phone is rotated, the dial returns to its original position. While returning, the electric current is interrupted (dividing the signal into pulses) the number of times corresponding to the number dialed. The switch derives the number from the number of pulses. When the pulse repetition rate is ten pulses per second, it is referred to as 10PPS (Pulses Per Second), when twenty, 20PPS.

The other type is a method known as "Tone Dialing (TD)", formally called "Dual-Tone Multi-Frequency (DTMF)". Each button on a push-button phone is assigned a unique pair of frequencies (the "tone"), from which the switch derives the number.

■ Pulse Dialing & Tone Dialing

Pulse dialing

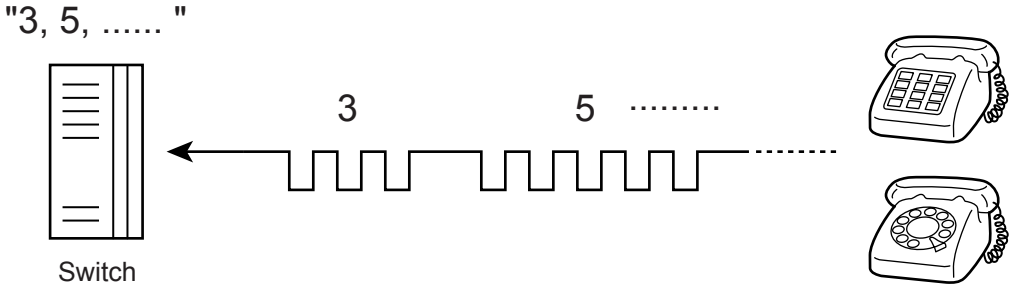

Tone dialing

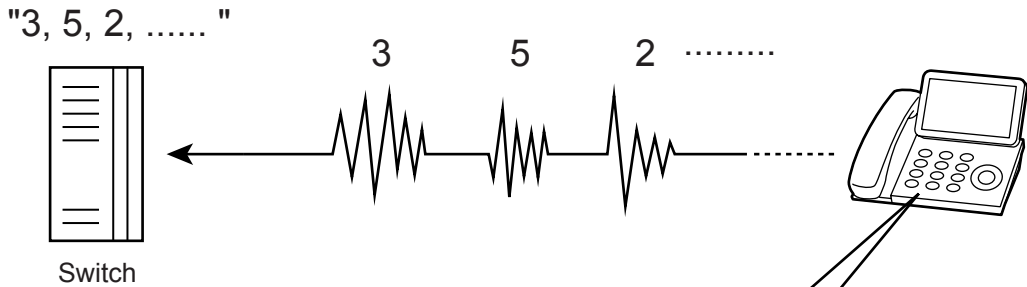

DTMF matrix

1	2	3	697Hz	} Low frequency
4	5	6	770Hz	
7	8	9	852Hz	
*	0	#	941Hz	
1209Hz 1336Hz 1447Hz				} High frequency

Gnb06025KA

- 3) The switch connects lines according to the transmitted number.
- 4) When a connection between local switches is established, the local switch of the called party sends a ringing signal to the telephone of the called party. The telephone that receives the ringing signal emits its ringtone. At the same time, the called party's local switch sends a ring back tone (RBT) to the calling party's telephone to indicate that a connection to the called party has been established.

- 5) When the called party's handset is lifted, activating the hook switch, the local switch on the called party side receives a response signal and stops sending tones to the calling and called parties. This is when a communications path is established between the both parties.

■ Connecting Out-of-Town Calls

a. Lift the handset

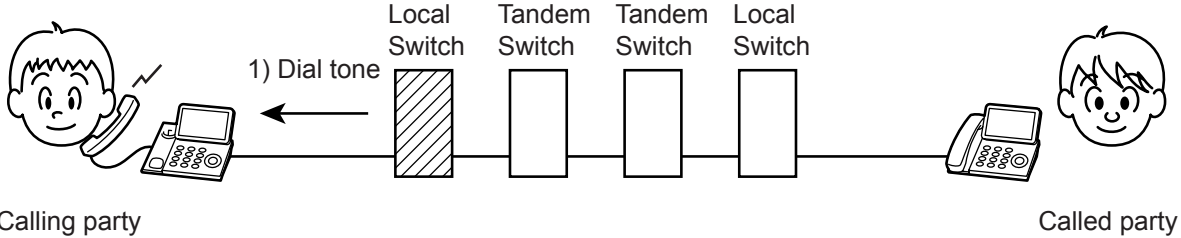

b. Dial the number

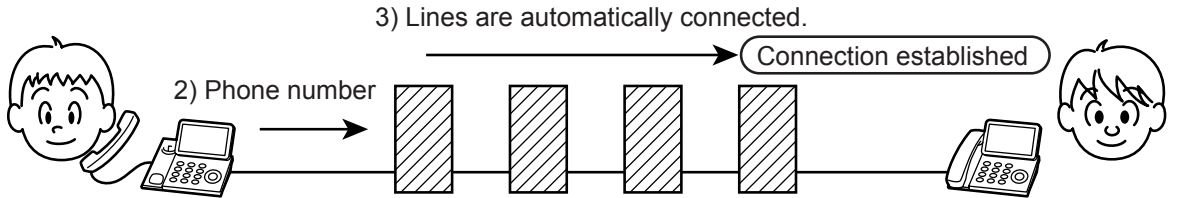

c. Calling

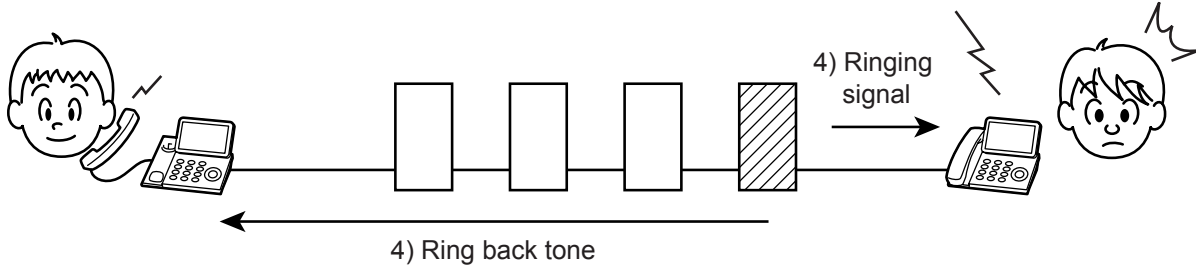

d. Line established

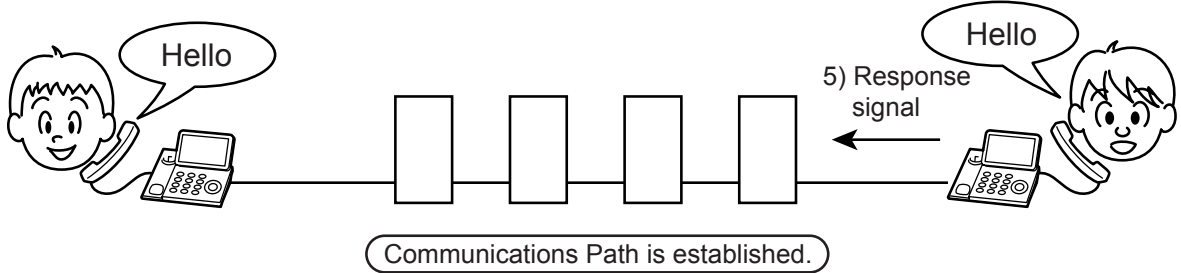

Gnb06026KA

3. Terminology

■ Line Types

- PSTN (Public Switched Telephone Network): Analog telephone network.
- If there is no switch on site, set the line type to PSTN.
- PBX (Private Branch Exchange): On-site switch that connects multiple analog telephones to a single line to establish an in-house phone system.
- If there is a switch on site, set the line type to PBX.

■ Dial Types

- Tone (Push) Dial/Pulse Dial (10PPS)/Pulse Dial (20PPS): See 2.2 Telephone Call Connection Mechanism

■ Other

- Branch Connection: To connect multiple telephones to a single line in parallel. Telephones and FAXes may not function properly in this configuration.

4. FAX System (Overview)

A FAX (abbreviation of facsimile) is a device that sends and receives image data using either an analog or a digital telephone line. The following describes the analog line system (For G3, see 6. FAX Standards).

The three basic units of a FAX are the scanner (for reading the image), the control circuit, and the printer.

The scanner splits the image into a fine grid, then reads the brightness (white/black) of each cell. This operation is called scanning. The white/black information is converted to a digital signal: bright cells become 1, dark cells 0.

The digital signal from a scanned image is subjected to DA conversion (modulation) by the control circuit to enable transmission over an analog telephone line. After conversion, the data is sent as an analog signal. The sound audible during transmission is image data that has become an analog signal, that is, an audio signal.

The analog signal arriving over the telephone line is then subjected to AD conversion (demodulation) by the control circuit of the receiving FAX machine, and restored to a digital signal.

The black/white information obtained from the AD conversion is sent to the printer, where black cells are reproduced on the paper at the positions where they were on the original.

■ FAX System (Overview)

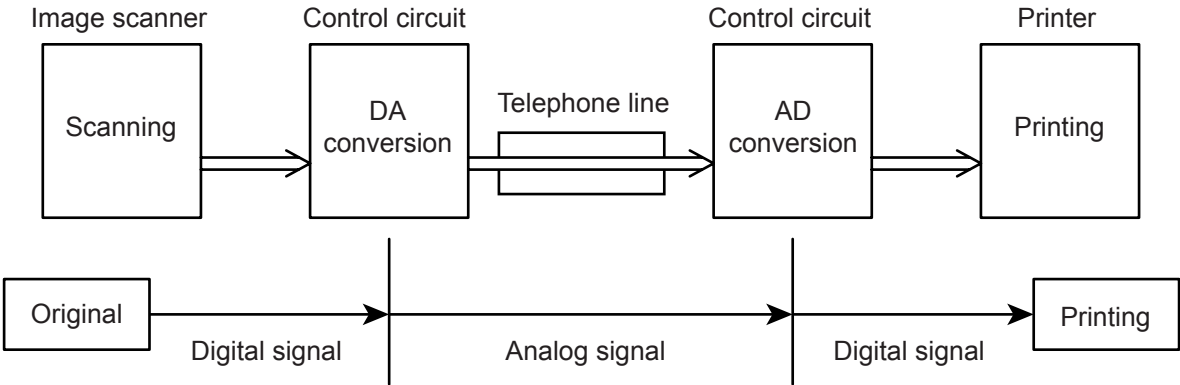

Gnb06027KA

Blank Page

5. Unit Mechanisms

■ Scanner

The scanner consists of a lamp (fluorescent lamp, etc.) that illuminates the original document with uniform light and charged coupled device (CCD) that reads the light reflected from the image.

A CCD is a light-receiving element that produces an electrical signal in response to light. In the case of a FAX, a number of CCDs (e.g. 2048) are arranged in a line.

The white areas of the original document reflect the light from the lamp. The black areas reflect no light. The CCDs read the light reflected from the original, outputting sequentially to the control circuit which areas are white and which black as binary data (1/0 digital data: 1 bit).

NOTE

To scan the original, the CCD device must be shifted a distance of one line after each line is scanned. When the original is scanned on the platen glass (as for a flatbed scanner), the CCD unit is moved with respect to the original. In the case of a FAX equipped with the ADF (Automatic Document Feeder), scanning via the ADF is performed by moving the original with the CCD fixed at one position. This is known as constant velocity transport (CVT).

NOTE

During scanning, the finer the grid into which the original is divided, the greater the scanning precision of the original image. For a G3 FAX (normal mode: G3 Normal), scanning is performed at the resolution of 8 divisions per millimeter (200 dpi) in the horizontal direction and 3.85 divisions per millimeter in the vertical direction. This means that the 200 dpi in-line CCD unit is shifted approximately four times per millimeter in the vertical direction. For an A4 original, the data amounts to approximately two million pixels. In the high-quality mode (G3 Fine), scanning resolution is 8 divisions per millimeter in the horizontal direction and 7.7 divisions per millimeter in the vertical direction, where the data amounts to approximately four million pixels. As resolution increases, the amount of data also increases, lengthening the transmission time.

■ Control Circuit

The control circuit executes scanning of image data by controlling the image scanner. A line of CCDs scans the original image one line at a time. When scanning of one horizontal line is completed, the next line below is scanned. As this continues, the original is scanned from end to end one line at a time and converted to digital data as black-and-white information.

Because this image data is a set of digital signals, it cannot be transmitted using an analog telephone line. It must be subjected to DA conversion (modulation). On the other hand, the receiving FAX machine must perform AD conversion to restore the incoming digital data to analog data.

DA conversion, analog signal transmission, analog signal reception, and AD conversion are all performed by a modem (modulator/demodulator) in the control circuit. A modem consists of a network control unit (NCU) for connecting to the telephone line and an A/D conversion unit for performing DA and AD conversions.

■ FAX System (Detail)

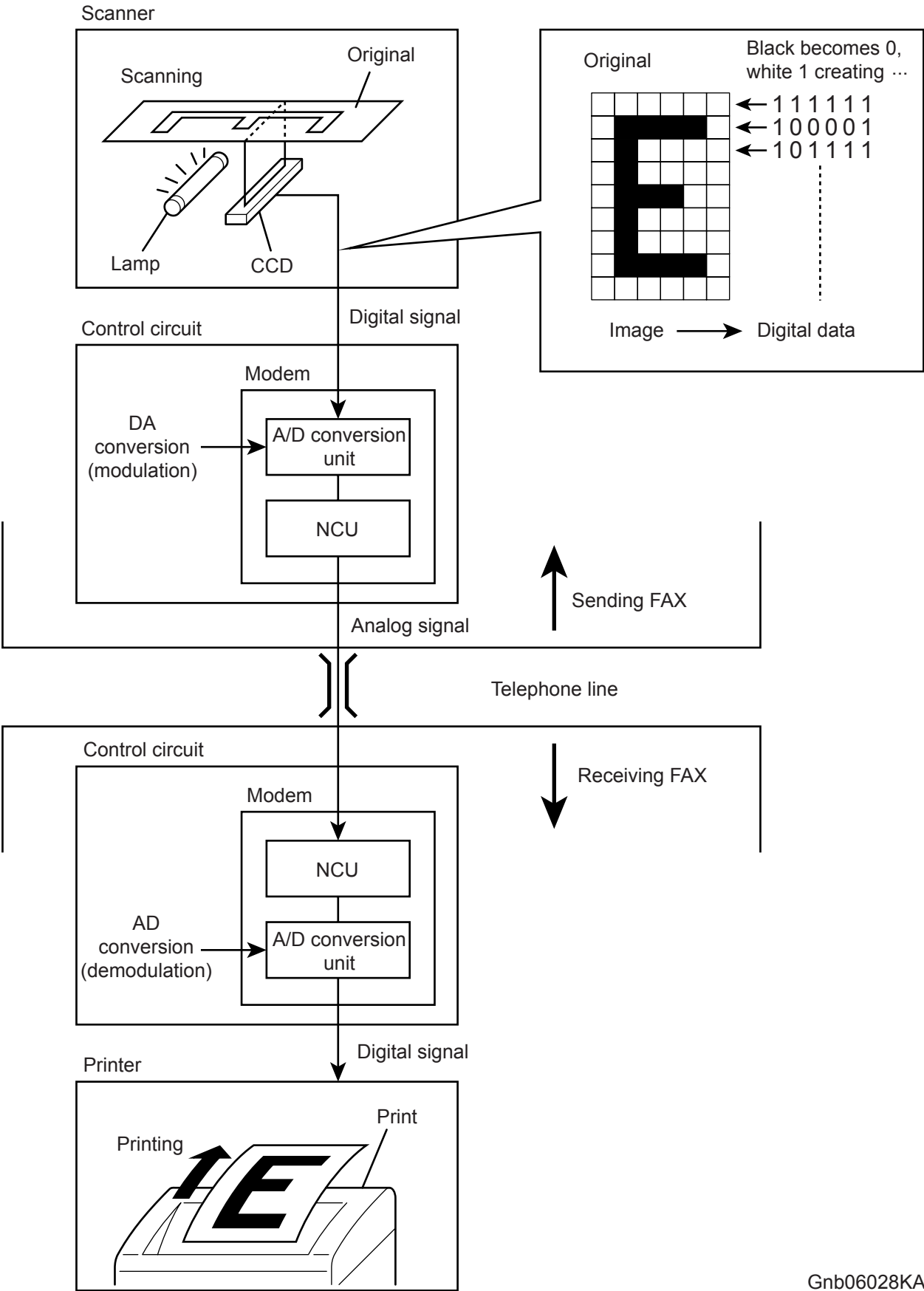

Gnb06028KA

NOTE

After the telephone number is entered, the NCU automatically performs steps 1 and 2 of the line connection procedure described in 2.2 Telephone Call Connection Mechanism.

If on the receiving end, step 6 is automatically performed to answer.

The following is the line connection procedure between two FAXes based on the steps 1 to 5 of 2.2 Telephone Call Connection Mechanism. At the receiving FAX, step 6 is also automatically performed.

- 1) When an AT command (a modem control command) is sent from the control circuit to the modem, the hook switch is activated, and a state is obtained that is identical to that when the handset of a telephone is lifted. A dial tone (400Hz/48VDC) is sent from the local switch. The modem's speaker emits the dial tone as an audible sound.
- 2) After image scanning, the telephone number (a previously stored number, number entered by pressing phone buttons, etc.) is automatically dialed and transmitted to the local switch.
- 3) Steps 3, 4, and 5 for establishing a connection via the switches are identical to those for telephone.
- 6) The receiving party's FAX automatically answers when it receives the call signal, and the hook switch is activated. The local switch on the receiving party side receives a response signal and stops sending tones to the sending and receiving parties, thereby establishing a communications path between the both parties.

In the case of a telephone call, only voice conversion between the two parties follows. For FAX, preparation for delivery of image data is required that includes the following types of exchanges:

- The sending FAX indicates that the transmission is a FAX transmission.
- The receiving FAX indicates that it is ready to receive and also its communications capacity.
- The sending FAX then sends data in accordance with the receiving FAX's communications capacity.

Once mutual preparation is completed, image data sending and receiving is started. Image data is modulated into an analog signal by the A/D converter at the sending FAX, then sent from its NCU. Image data received by the NCU of the receiving FAX is demodulated into a digital signal by its A/D converter and then sent to the control circuit. When image data reception is completed, the FAX automatically disconnects the line (hook is OFF).

In summary, the NCU automatically executes a series of such operations from hook switch ON to hook switch OFF.

NOTE

The control circuit also retains other important functions such as data compression and memory. With data compression, any part of the scanned image data that consists of continuous white or black pixels is encoded into a single element, thus compressing the volume of data.

Memory temporarily stores data during transmission and reception.

■ Printer

The printer prints image data from the control circuit onto the surface of paper. The principle is the same as that of an ordinary printer in that black is applied to specified locations on the paper.

6. FAX Standards (ITU-T Recommendations)

International FAX standards (ITU-T recommendations) include G1 to G4. G1 to G3 use analog telephone networks. G4 uses a digital telephone network (ISDN). G3 is the standard currently in greatest use. FAXes conforming to Super G3, a recently added standard, are equipped with a fast 33.6kps modem and reduce transmission times to about half those of G3 FAXes.

Standard	Year Issued	Minimum Transmission Time for Single-Page A4 Document	Maximum Resolution	Maximum Transmission Speed	Features
Group 1 (G1)	1968	Approx. 6 min.	100 x 100dpi	- (Analog)	First standard. Analog transmission. No band compression technology
Group 2 (G2)	1976	Approx. 3 min.	100 x 100dpi	- (Analog)	Analog transmission. Band compression technology adopted.
Group 3 (G3)	1980	Approx. 1 min.	200 x 200dpi	14.4kbps (Super G3: 33.6kbps)	Connection to analog line using FAX modem. Image data in digital format. Data compression. Most common standard in use.
Group 4 (G4)	1988	Approx. 3 sec.	400 x 400dpi	64kbps (Using ISDN)	Digital transmission. Supported by various digital transmission services. Halftone supported.

7. Fault Isolation Procedure for FAX

Because a FAX is composed of multiple blocks, pinpointing a fault is problematic.

This section describes a simple fault isolation procedure that is based on the contents of 4. FAX System (Overview).

7.1 Fault Occurs

First, try using the copy function. If the copy function's printing results are correct, the probability of a fault in the FAX itself is low. The fault is likely in the telephone line or receiving FAX. If the fault is in the telephone line, first retry sending. If there is no improvement, contact the telephone company. If the copy function's printing results are incorrect, it can be determined if the fault is in the scanner or printer by operating each unit separately via a computer.

7.2 Send Fault

- 1) Problem with printing quality at receiving FAX, such as corrupt image, lines in image, top/bottom cut off.

- a) If copy function is normal

Cause: Degraded telephone line connection caused by noise, etc.; or a fault in receiving FAX's printer.

Corrective Action:

Determine whether fault is in telephone line or at receiving FAX by trying copy function at receiving FAX.

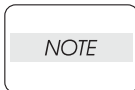

If the telephone line condition is degraded, white horizontal lines, missing rows, and/or cut-off top/bottom may occur.

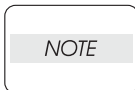

Branch connections or incoming call (call waiting) may also cause image corruption.

- b) If copy function is faulty

Cause: Dirt or fault in scanner.

Corrective Action:

Clean platen glass or repair scanner. If the original is being sent from the ADF, try executing a copy with the original placed on the platen glass. If this solves the problem, the fault is in the ADF.

2) Cannot dial

Cause: Incorrect connection. Incorrect setup of dial type and/or line type.

Corrective Action:

Correct the connection. Reset the dial type and/or line type to correct settings.

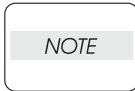

If the telephone line condition is degraded, white horizontal lines, missing rows, and/or cut-off top/bottom may occur.

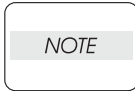

Branch connections or incoming call (call waiting) may also cause image corruption.

7.3 Receive Fault

1) Problem with printing quality, such as corrupt image, lines in image, top/bottom cut off.

a) If copy function is normal

Cause: Degraded telephone line connection caused by noise, etc.; or a fault in sending FAX's scanner.

Corrective Action:

Determine whether fault is in telephone line or at sending FAX by trying copy function at receiving FAX.

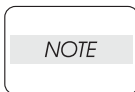

If the telephone line condition is degraded, white horizontal lines, missing rows, and/or cut-off top/bottom may occur.

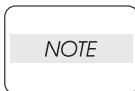

Branch connections or an incoming call (call waiting) may also cause image corruption.

b) If copy function is faulty

Cause: Dirt or fault in printer.

Corrective Action:

Clean all parts of printer or repair printer.

2) Does not emit response signal

Cause: Incorrect connection. Incorrect setup of dial type, line type, and/or reception mode.

Corrective Action:

Correct the connection. Reset the dial type, line type, and/or receive mode to correct settings.

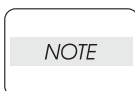

If a call is made to the FAX from a telephone, and the FAX does not emit its ringing sound, a telephone line fault is highly probable.

8. Other Problems

■ Branch Connection (Parallel Connection)

During FAX reception, if the handset of another telephone on a branch connection is lifted, the received image may be corrupted or a transmission error may occur. Branch connection may also interfere with caller identification, call waiting, the receiving operation of connected telephones.

■ Call Waiting

If a call comes in during FAX sending/reception, as with branch connections the image may be corrupted.

■ DSL (Digital Subscriber Line)

DSL, a high-speed digital transmission method using existing telephone lines, has several types. These include ADSL (Asymmetric Digital Subscriber Line) with differing upstream and downstream transmission speeds, SDSL (Symmetric Digital Subscriber Line) with symmetrical upstream and downstream transmission speeds, and VDSL (Very high bit rate Digital Subscriber Line) which features higher speed. However, because the line is used for both voice and data transmission, various problems may occur, such as noise during spoken conversation, low sound volume, and mis-dialing. Replacing the splitter may improve the situation.

■ Noise

If electronic equipment (television, computer, microwave, etc.) or devices equipped with motors are located near a FAX, noise from them may degrade the line condition.

Also, a telephone line, acting as an antenna, may absorb electric waves generated from wireless or broadcasting equipment.

Because FAX data is audio data, the line quality affects the quality/stability of image data as well as that of conversation.

9. Document Scanning

The document scanning section of this machine consists of an Image Input Terminal (ITT), a scanner that reads a single-sheet document placed on the platen glass; and an Auto Document Feeder (ADF) that conveys the pages of a multiple-sheet document.

The optical image reflected from the document reaches the CCD image sensor via the light path shown in the figure below.

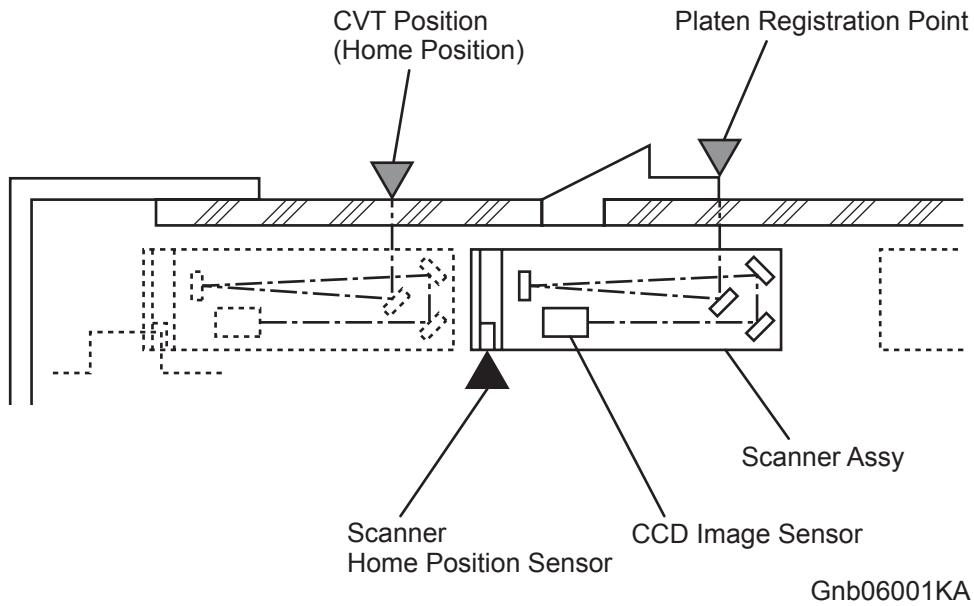

9.1 Document Scanning at Platen (IIT)

Shown below is an operational overview of document scanning at the platen.

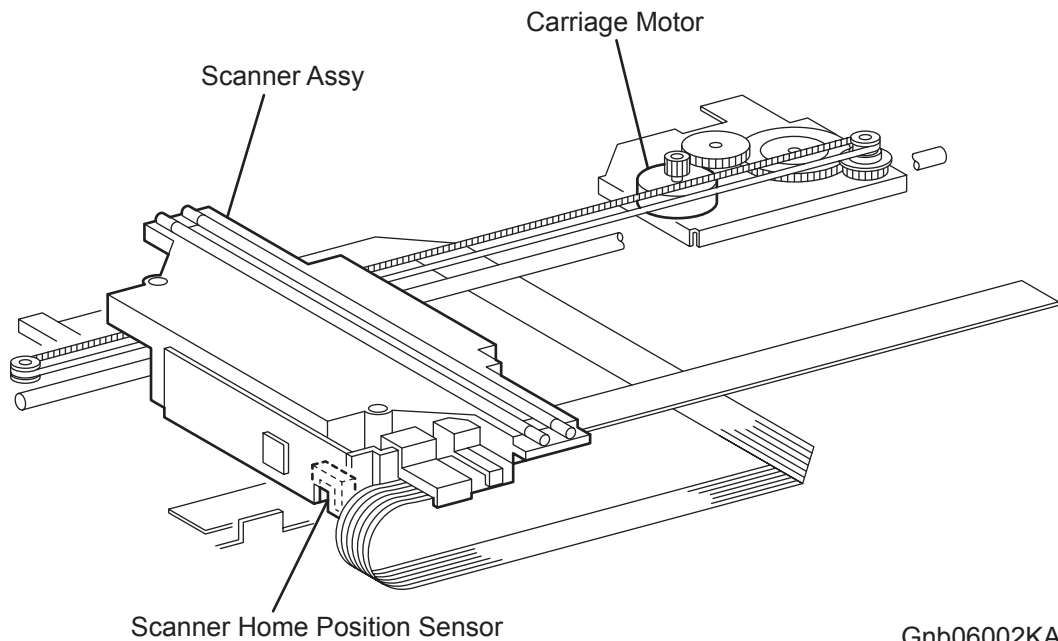

Gnb06002KA

The Scanner ASSY travels to read the document.

The following are installed on the Scanner ASSY: Exposure Lamp that illuminates light onto the document, CCD image sensor that reads light reflected from the document, and the lenses and mirrors comprising the light path for the optical image.

9.2 Document Scanning at ADF

The following describes the document feed path from the ADF.

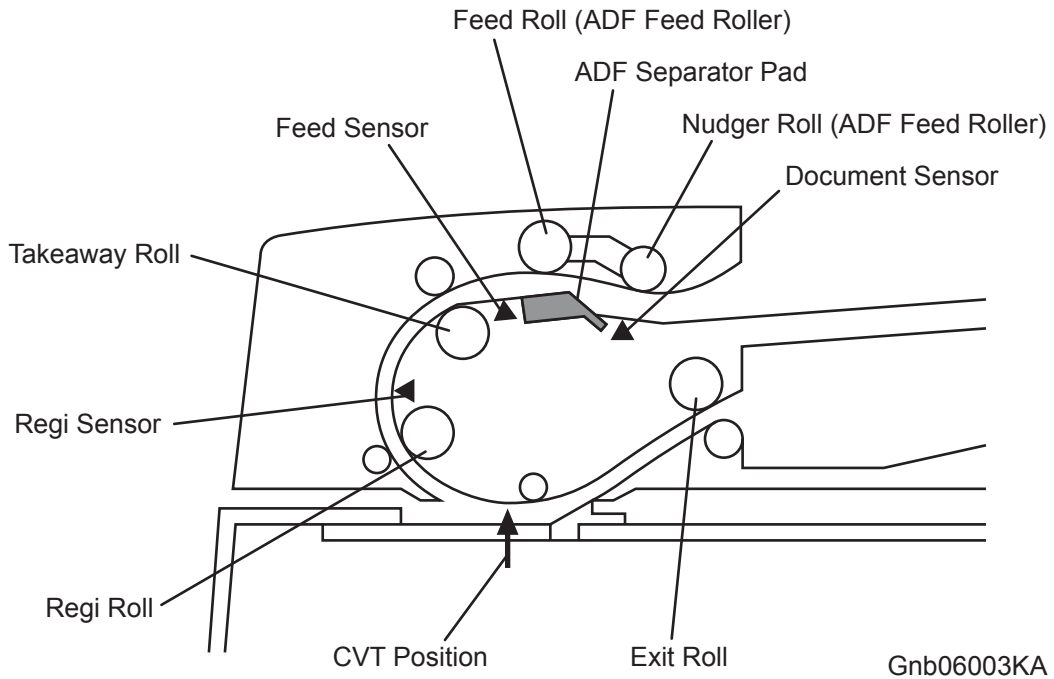

A document sheet set in the document tray is conveyed through the Feed Roll, Takeaway Roll, and Regi Roll. The document image is scanned at the CVT position, and the document sheet is ejected via the Exit Roll.

9.2.1 Setting a Document

When a document is set in the document tray and pushed into the tray until its lead edge stops, an actuator moves to place the ADF document sensor in the unshielded (unblocked) state, indicating detection of the document.

9.2.2 Preparation for Feed

Pressing the Start button with the document set in the tray starts feeding of the document.

First, the Nudger Roll moves down and presses onto the document in the document tray to enable document feed. The Nudger Roll moves down with normal rotation of the ADF Motor. Upon completion of document feed, the ADF Motor reverses rotation to return the Nudger Roll to its normal position.

9.2.3 Prefeed

In the prefeed step, a document sheet is fed from the Feed Roll to the Takeaway Roll.

When the Nudger Roll is pressed down to the document sheet surface, (see "9.2.2 Preparation for Feed"), the ADF Motor rotates to drive the Nudger Roll and Feed Roll. The Nudger Roll feeds the top document sheet in the document tray to the Feed Roll. The Feed Roll, nipped by the ADF Separator Pad, feeds document sheets (coming from the Nudger Roll) one by one. When the Feed Sensor detects a document sheet, the machine recognizes that feed of the first document sheet is complete.

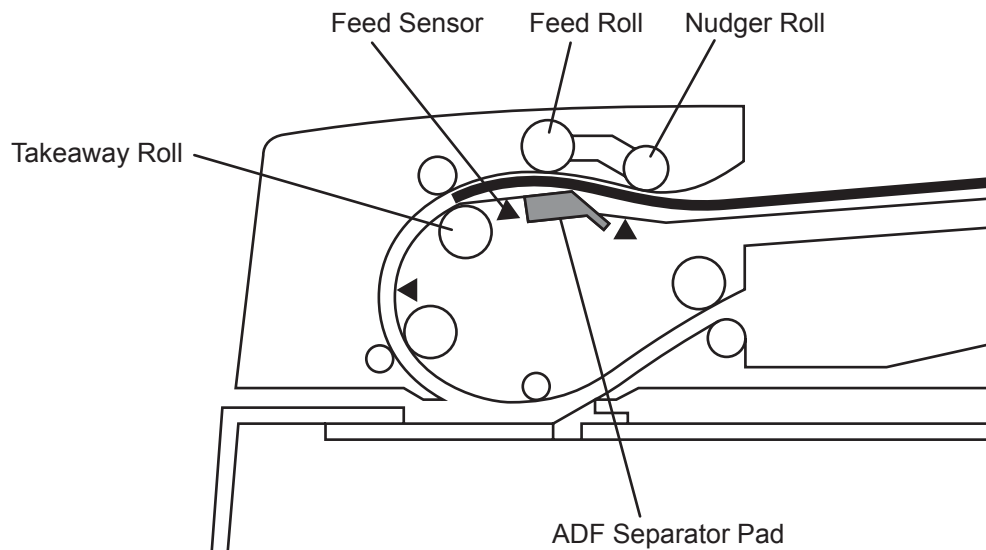

Gnb06004KA

9.2.4 Preregistration

In the preregistration step, the document sheet (fed to the Takeaway Roll in the prefeed step) is fed to the Regi Roll. The lead edge of the document sheet is then fed from the Regi Roll to the scan feed reference position (Wait Position), located upstream from the CVT position, where the document stops. This operation accomplishes registration of the lead edge of the document.

When the document sheet is fed to the Takeaway Roll, the ADF Motor drives the Takeaway Roll. The Takeaway Roll then feeds the document sheet to the Regi Roll. When the Regi Sensor detects the document sheet, the ADF Motor rotates to drive the Regi Roll and Exit Roll. The Regi Roll feeds the document sheet (fed from the Takeaway Roll) to the scan feed reference position.

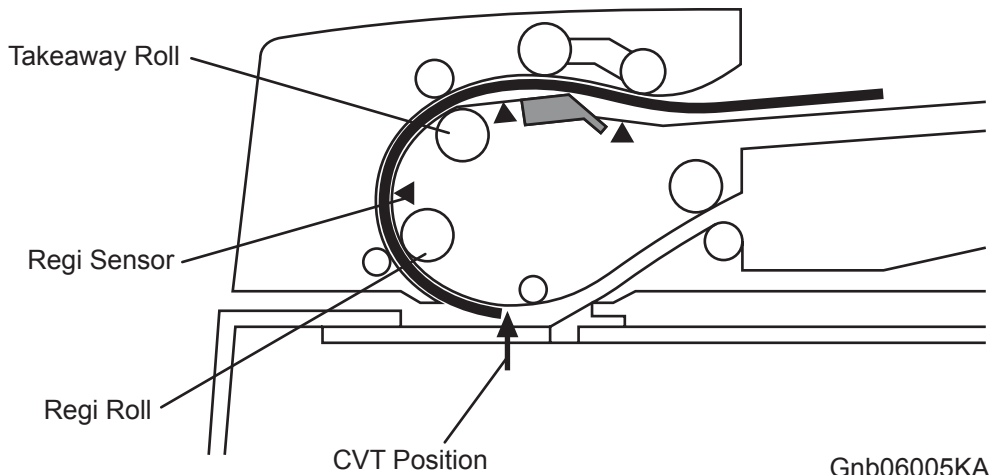

9.2.5 Scan Control

Scanning of the image illuminated with the Exposure Lamp of the Scanner ASSY is controlled by changing the feed speed according to the copy magnification.

When the document sheet passes the CVT position at the specified speed, the images on the document sheet are exposed by scanning with the Exposure Lamp of the Scanner ASSY, and read by the CCD Image Sensor.

9.2.6 Simplex Document

For simplex document sheets, feed is performed in the following sequence:

- 1) The document sheet is fed to the Takeaway Roll. (See "9.2.3 Prefeed.")
- 2) The document is fed to the Regi Roll, and then fed to the scan feed reference position. (See "9.2.4 Preregistration.")
- 3) The document sheet is fed at the feed speed corresponding to the selected magnification, and the image on it is scanned with the Exposure Lamp at the CVT position. (See "9.2.5 Scan Control.")
- 4) As the image is scanned, the document sheet is fed and ejected by the Exit Roll that is driven by the ADF Motor.

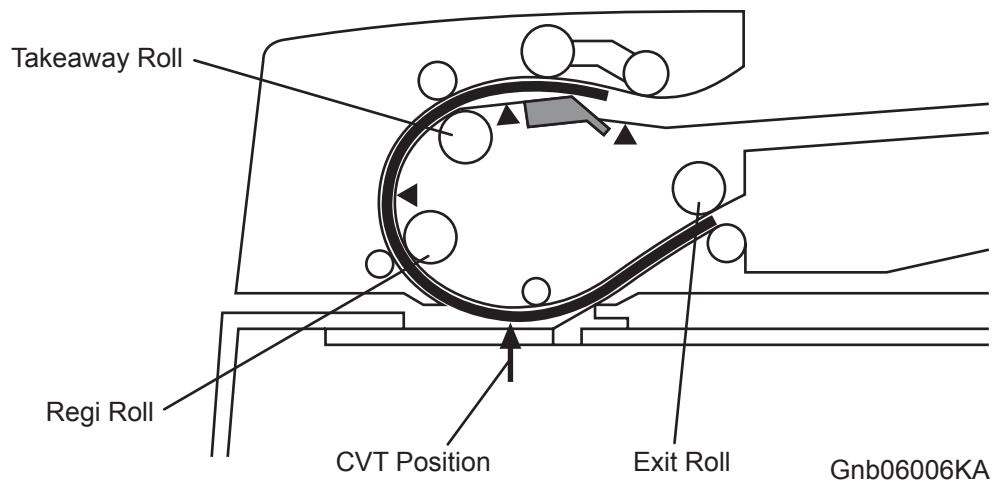

10. Image Data Flow

The image data from the document set on the IIT or ADF goes through the following components before it is printed at the Engine section.

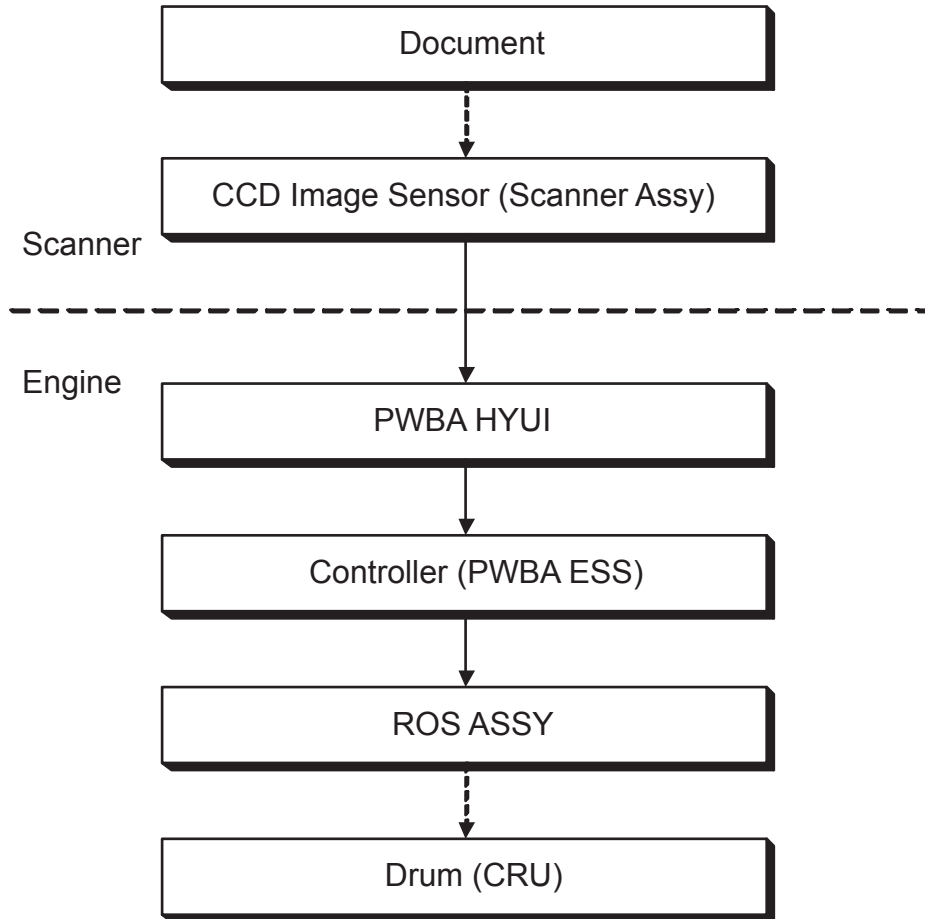

Gnb06007KA

11. Drive Torque Transfer Scheme

11.1 ADF Motor

The torque of the ADF Motor is transferred to each document feeding roll as shown below.

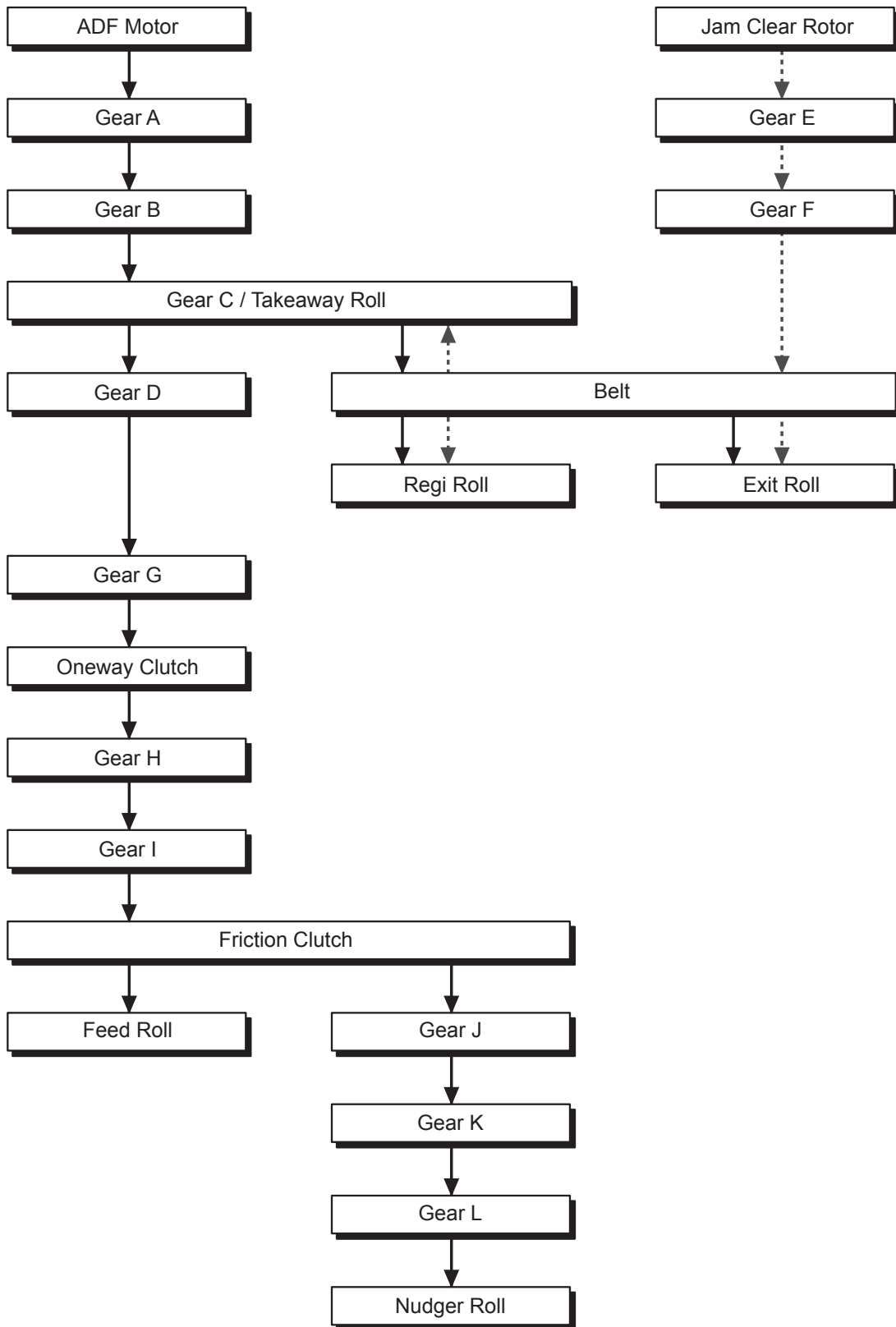

Gnb06012KA

11.2 Gear Layout

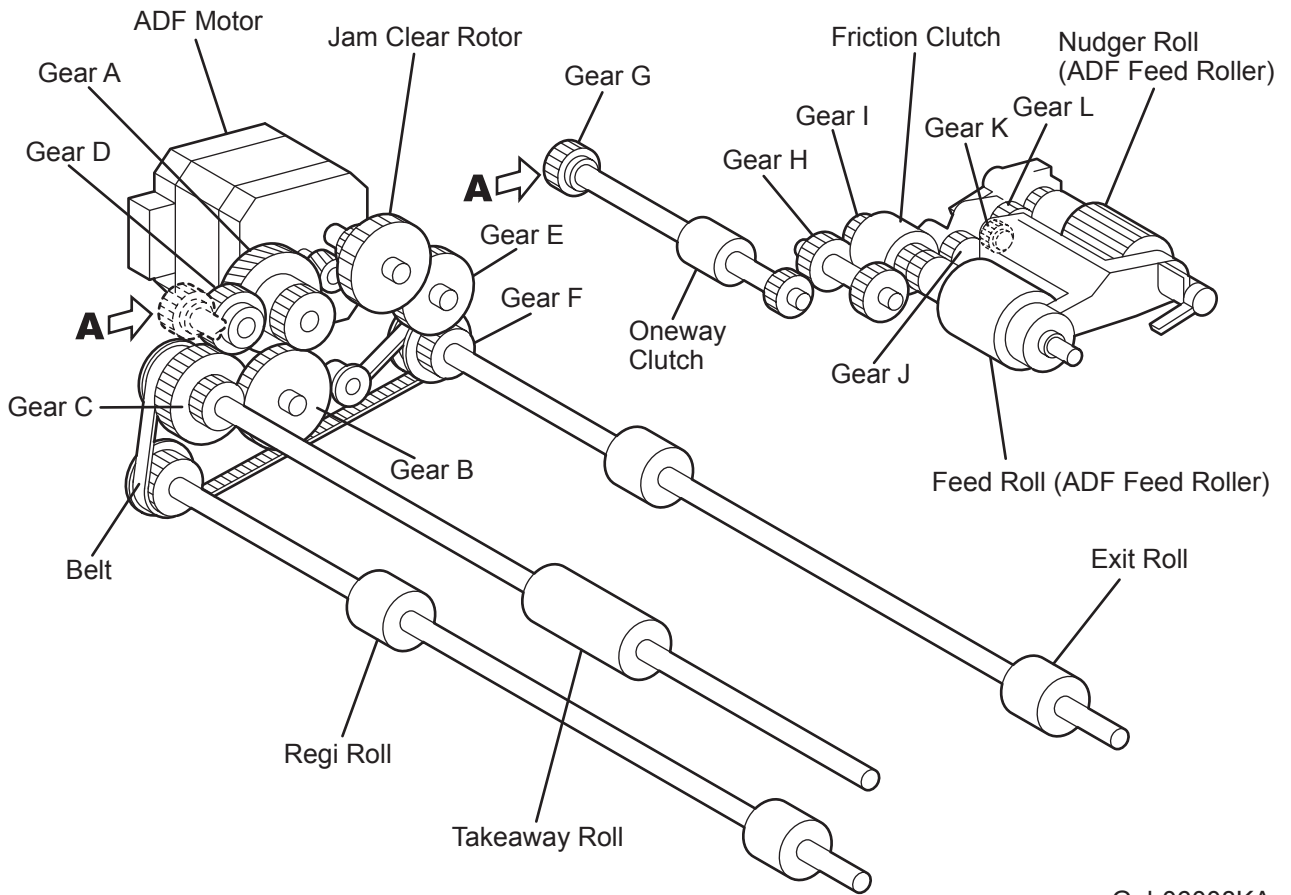

12. Names and Functions of Components

The sections below describe the functions of main components of the scanner.

4.1 IIT

4.2 ADF

12.1 IIT

ADF Open Sensor

A switch that detects whether or not the ADF is open and determines the timing of platen document size detection.

Carriage Motor

A stepping motor that drives the Scanner ASSY.

Scanner Home Position Sensor

A part of the rear section of the Scanner ASSY frame functions as an actuator that shields the Scanner Home Position Sensor, thus detecting the Regi position.

Cold cathode fluorescent lamp (Exposure Lamp)

The lamp that exposes the document.

CCD PWBA

A CCD image sensor that converts optical images into electrical signals.

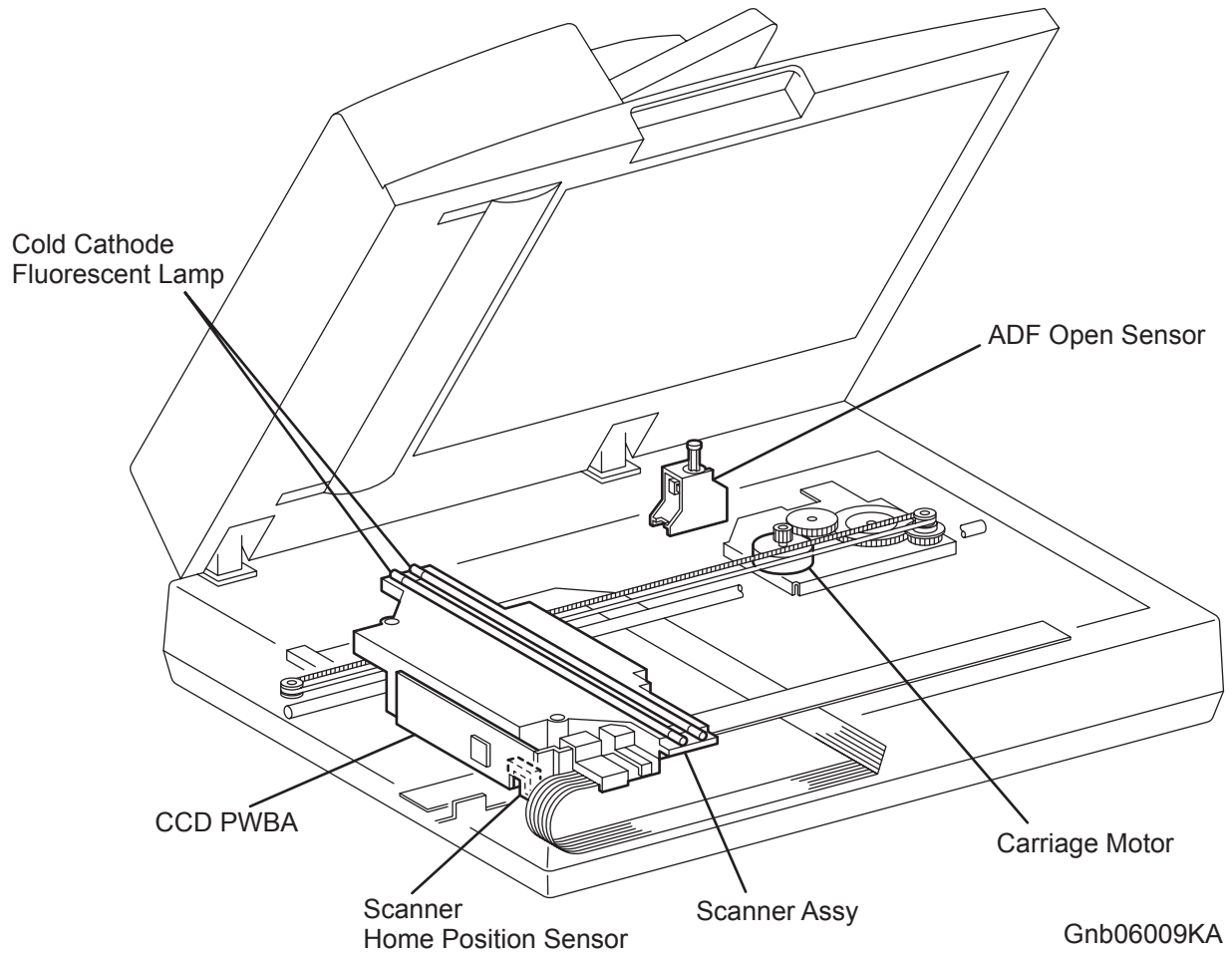

12.2 ADF

Document Sensor

A sensor that detects the presence or absence of a document on the ADF Document Tray.
(Present: Beam is unshielded (unblocked). Absent: Beam is shielded (blocked).)

Cover Open Sensor

A switch that detects whether or not the ADF Top Cover is open.

PWBA ADF

A PWB that controls the sensors and motor in the ADF.

Feed Sensor

The Feed Sensor is installed immediately downstream from the Feed Roll to detect completion of document feed.
(Document present: Shielded (Blocked); Document absent: Unshielded (Unblocked))

Regi Sensor

The Regi Sensor detects that the preceding document sheet is about to leave the Regi Roll, thereby determining that the next document feed can be started.
(Document present: Shielded (Blocked); Document absent: Unshielded (Unblocked))

ADF Motor

The ADF Motor rotates the Nudger Roll, Feed Roll, Takeaway Roll, Regi Roll, and Exit Roll.

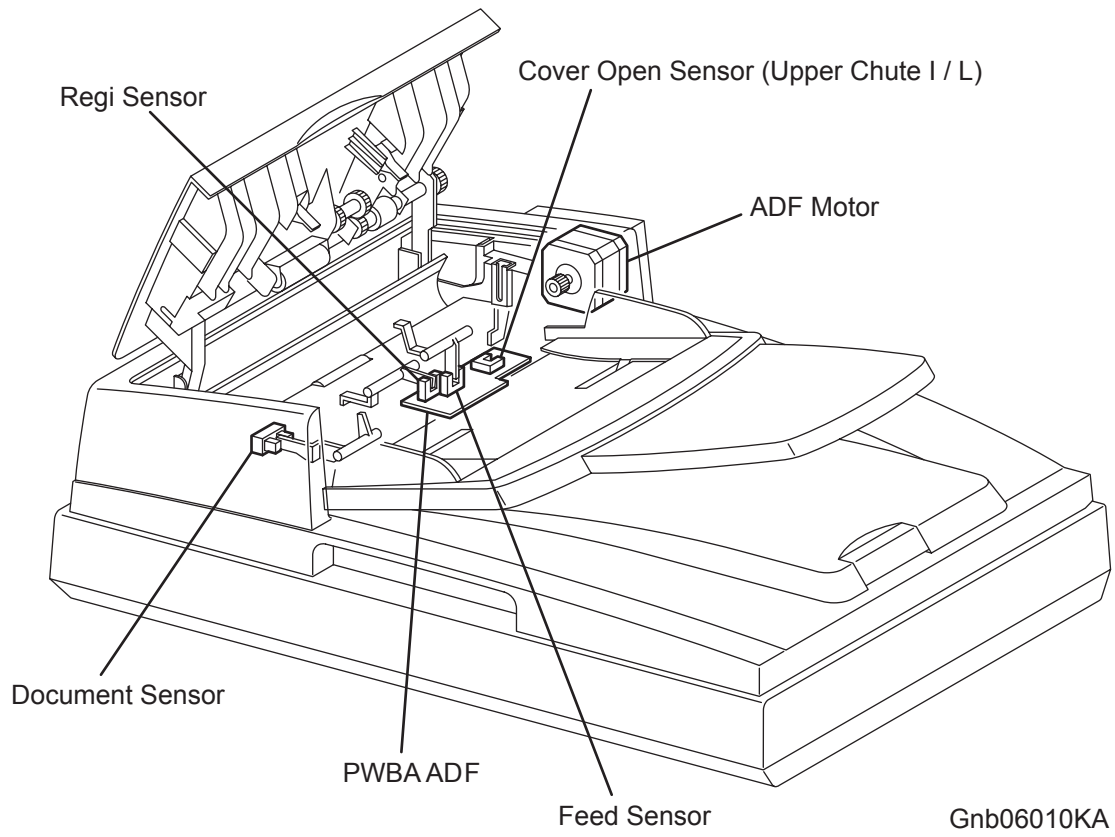

13. Control

13.1 Document Scanning Steps

A CCD Image Sensor is used to read image data from the document. To ensure stabilized image reading, the CCD Image Sensor output is adjusted. Adjustment includes Automatic Gain Control (AGC) and Automatic Offset Control (AOC).

Reference data for adjustment is collected and used to perform compensation on the read image data. Compensation includes shading compensation, white variation compensation, and black variation compensation. These adjustment and compensation steps are described below.

Reference data is obtained by reading image data from a white reference plate via the CCD image sensor.

13.1.1 AGC (Auto Gain Control): White Level Variation Adjustment

During AGC, the Scanner ASSY is moved to the position of the white reference plate, and the Exposure Lamp is illuminated. The light reflected from the white reference plate is read by the CCD Image Sensor as the white reference value, which is used to adjust CCD Image Sensor output.

13.1.2 AOC (Auto Offset Control)

AOC is performed by turning off the Exposure Lamp after AGC. This state is read by the CCD Image Sensor as the black reference value, which is used to adjust CCD Image Sensor output. (The order of AGC and AOC adjustment depends on the model.)

13.1.3 Shading Compensation

Shading compensation compensates for pixel-by-pixel sensitivity variations and the nonuniformity of lamp light in the fast scanning direction. The AGC and AOC adjustment values are used to compensate for the image data read by the CCD Image Sensor.

13.2 CCD Image Sensor Overview

The CCD Image Sensor is a four-color image sensor with three lines for the respective colors R (red), G (green), B (blue), and one line for B/W (black and white).

13.3 System Configuration

The PWBA HYUI controls the FAX, Scanner, and ADF. FAX and copy operations are performed according to data entered at the operation panel.

The following figure shows the system configuration.

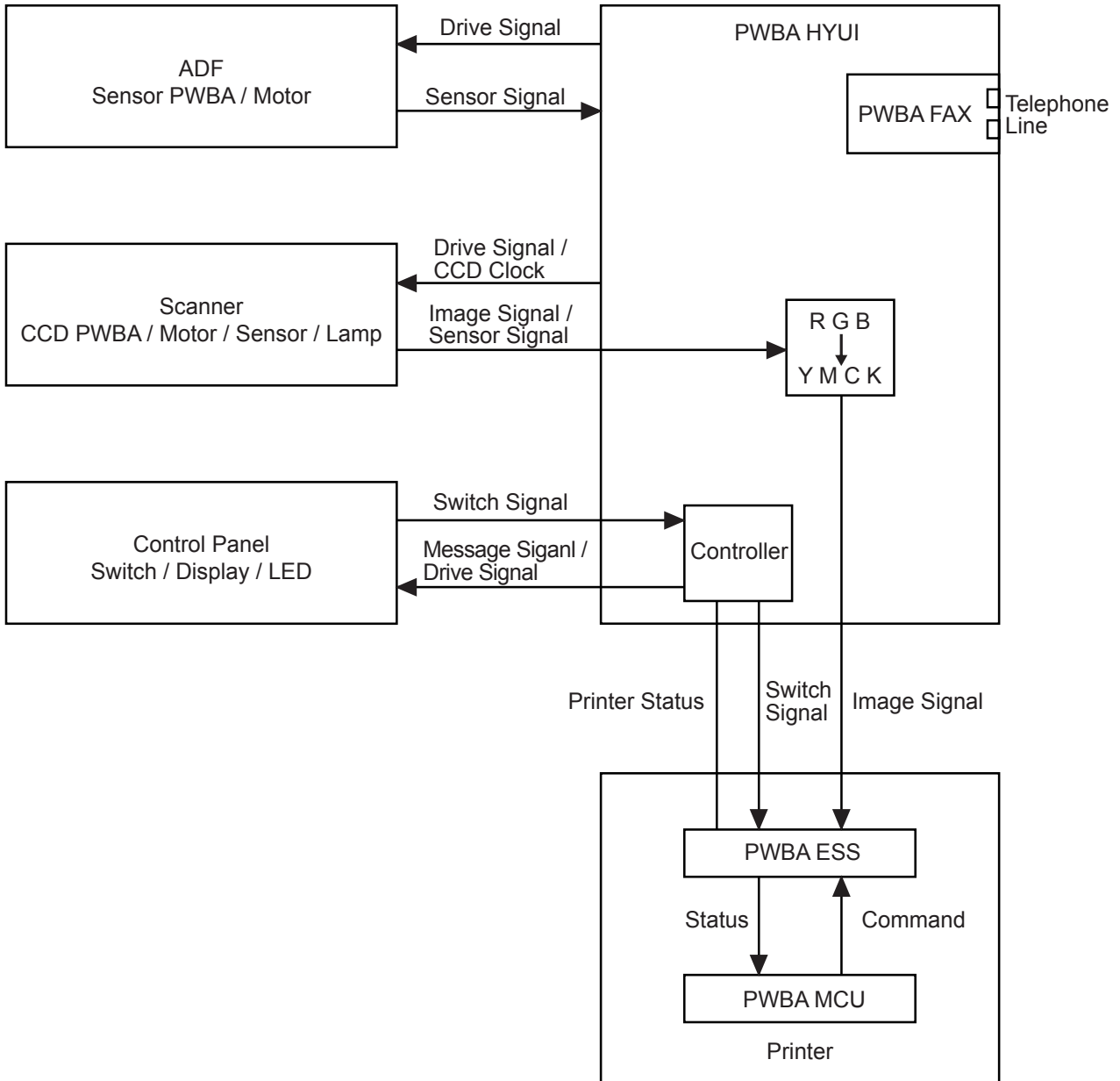

Gnb06011KA

Chapter 7 Wiring Diagrams and Signal Information CONTENTS







1. Connection Wiring Diagram.....	7 - 1
1.1 Symbols in the General Connection Wiring Diagram.....	7 - 1
1.2 General Wiring Diagram	7 - 2
2. Interconnection Wiring Diagram of Parts.....	7 - 3
2.1 Notes on Using the Wiring Diagram between Parts.....	7 - 3
2.2 Configuration of the Interconnection Wiring Diagram of Parts.....	7 - 5
§ 1 DC POWER SUPPLY	7 - 8
§ 2 MSI®I	7 - 10
§ 3 DRIVE	7 - 12
§ 4 FEEDER	7 - 14
§ 5 ROS	7 - 16
§ 6 XEROGRAPHIC	7 - 18
§ 7 HIGH VOLTAGE	7 - 20
§ 8 DEVELOPER	7 - 22
§ 9 FUSER.....	7 - 24
§ 10 CONTROLLER	7 - 26
§ 11 550 FEEDER	7 - 28
§ 12 DUPLEX.....	7 - 30
§ 13 FAX CONTROLLER	7 - 32
§ 14 IMAGING	7 - 34
§ 15 ADF.....	7 - 36

Blank Page

1. Connection Wiring Diagram

1.1 Symbols in the General Connection Wiring Diagram

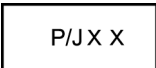
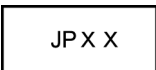
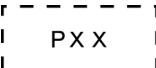
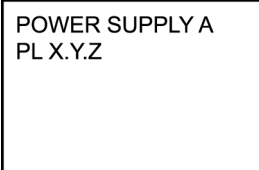
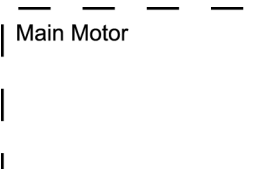
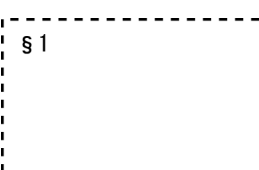
The symbols in the general connection wiring diagram are described below.

Symbol	Description
	Represents an interconnection between parts using wiring harness or wire.
	Represents an interconnection which differs according to the specifications.
	Represents an interconnection between parts using a conductive member such as a plate spring.
	Represents a connection between parts by tightening of a screw.
	Indicates a frame ground.
	Represents a connector. The connector No. is indicated inside the box.
	Represents a connection terminal with a plate spring on the printed circuit board. The connector (terminal) No. is indicated inside the box.
	Represents a connector directly connected to the printed circuit board. The connector No. is indicated inside the box.
	The box containing a part name represents a part. "PL X.Y.Z" indicates the item "Z" of the plate (PL) "X.Y" described in Chapter 5 "Parts List."
	Represents a functional part within a part, and indicates the name of the functional part.
	Represents a section in "2. Interconnection Wiring Diagram of Parts," and indicates its section No.
	Represents a screw for fixing wiring harness and a conductive member such as a plate spring.
	Represents a conductive member such as a plate spring.

1.2 General Wiring Diagram

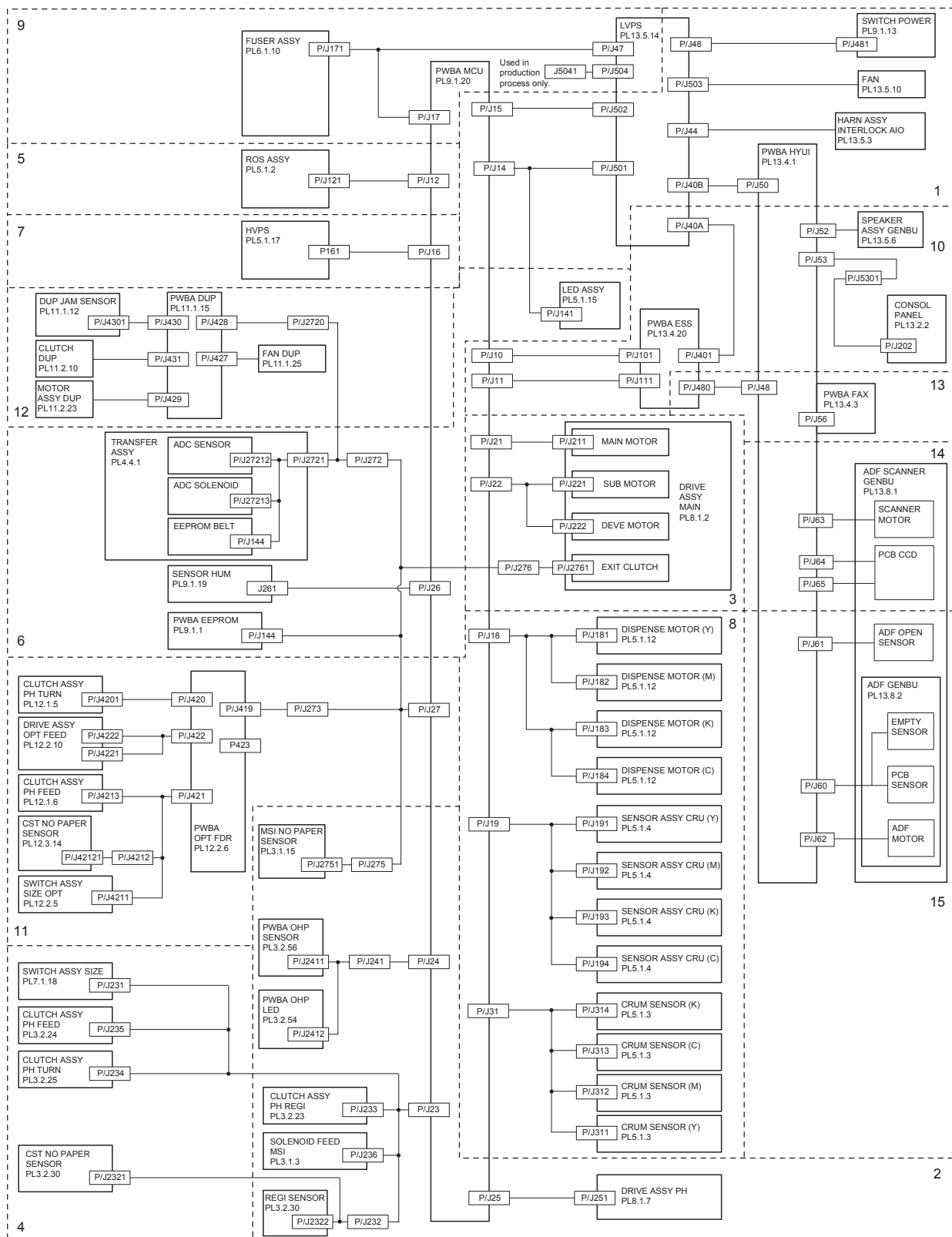





GNB07001KA

2. Interconnection Wiring Diagram of Parts

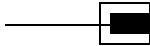
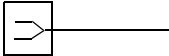
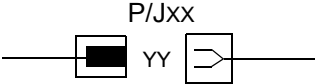
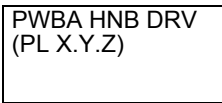
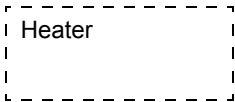
2.1 Notes on Using the Wiring Diagram between Parts

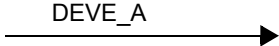
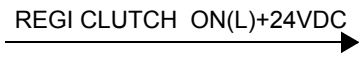
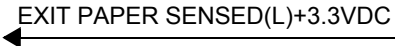
The following describes the legend of the wiring diagrams between parts shown on the following pages.

Symbols	Description
	Denotes a plug.
	Denotes a jack.
	Denotes Pin yy and Jack yy of the connector Pxx and Jxx.
	Denotes the parts. PL X.Y.Z implies the item "Z" of plate (PL) "X.Y" in Chapter 5. Parts List.
	Denotes functional parts attached with functional parts name.
	Denotes the control and its outline in PWB.
	Denotes a connection between parts with harnesses or wires, attached with signal name/contents.
	Denotes the function, and logic value of the signal to operate the function (Low: L, High: H). The given voltage is for signal in high status. The arrow indicates the direction of signal.
	Denotes the function, and logic value of the signal when the function operated (Low: L, High: H). The given voltage is for signal in high status. The arrow indicates the direction of signal.

Symbols	Description
	Denotes a connection between wires.
I/L +24VDC	Denotes DC voltage when the interlock switch in HNB MCU WITH CPU turns on.
+5VDC +3.3VDC	Denotes DC voltage.
SG	Denotes signal ground.
AG	Denotes analog ground.
RTN	Denotes the return.

2.2 Configuration of the Interconnection Wiring Diagram of Parts

The interconnection wiring diagram is divided into 15 sections. § 1 to § 15 indicate details of the interconnections of parts.

§ 1 DC POWER SUPPLY

Connections of LVPS with PWBA MCU.
Connections of MAIN SWITCH with LVPS.
Connections of SIDE FAN with LVPS.
Connections of INTERLOCK SWITCH with LVPS.
Connections of LVPS with PWBA HYUI.

§ 2 MSI & REGI

Connections of DRIVE ASSY PH with PWBA MCU.
Connections of REGI CLUTCH with PWBA MCU.
Connections of MSI FEED SOLENOID with PWBA MCU.
Connections of REGI SENSOR with PWBA MCU.
Connections of OHP TEMP. SENSOR with PWBA MCU.
Connections of OHP LED with PWBA MCU.
Connections of MSI NO PAPER SENSOR with PWBA MCU.

§ 3 DRIVE

Connections of MAIN DRIVE ASSY with PWBA MCU.

§ 4 FEEDER

Connections of NO PAPER SENSOR with PWBA MCU.
Connections of SWITCH ASSY SIZE with PWBA MCU.
Connections of FEED CLUTCH with PWBA MCU.
Connections of TURN CLUTCH with PWBA MCU.

§ 5 ROS

Connections of ROS ASSY with PWBA MCU.

§ 6 XEROGRAPHIC

Connections of ADC SENSOR with PWBA MCU.
Connections of ADC SOLENOID with PWBA MCU.
Connections of EEPROM BELT with PWBA MCU.
Connections of TEMP./HUM. SENSOR with PWBA MCU.
Connections of EEPROM XPRO with PWBA MCU.
Connections of ERASE LAMP with PWBA MCU.

§ 7 HIGH VOLTAGE

Connections of HVPS with PWBA MCU.

§ 8 DEVELOPER

Connections of DISPENSE MOTOR (Y) with PWBA MCU.
Connections of DISPENSE MOTOR (M) with PWBA MCU.
Connections of DISPENSE MOTOR (C) with PWBA MCU.
Connections of DISPENSE MOTOR (K) with PWBA MCU.
Connections of CRU SENSOR (Y) with PWBA MCU.
Connections of CRU SENSOR (M) with PWBA MCU.
Connections of CRU SENSOR (C) with PWBA MCU.
Connections of CRU SENSOR (K) with PWBA MCU.
Connections of CRUM SENSOR (Y) with PWBA MCU.
Connections of CRUM SENSOR (M) with PWBA MCU.
Connections of CRUM SENSOR (C) with PWBA MCU.
Connections of CRUM SENSOR (K) with PWBA MCU.

§ 9 FUSER

Connections of FUSER ASSY with PWBA MCU.
Connections of FUSER ASSY with LVPS.
Connections of PWBA MCU with LVPS.

§ 10 CONTROLLER

Connections of PWBA ESS with PWBA MCU.
Connections of CONSOLE PANEL with PWBA ESS.
Connections of SPEAKER ASSY with PWBA HYUI.

§ 11 550 FEEDER

Connections of PWBA FEEDER with PWBA MCU.
Connections of TURN CLUTCH with PWBA FEEDER.
Connections of FEED MOTOR with PWBA FEEDER.
Connections of FEED CLUTCH with PWBA FEEDER.
Connections of NO PAPER SENSOR with PWBA FEEDER.
Connections of SWITCH ASSY SIZE with PWBA FEEDER.

§ 12 DUPLEX

Connections of PWBA DUP with PWBA MCU.
Connections of DUP JAM SENSOR with PWBA DUP.
Connections of DUP CLUTCH with PWBA DUP.
Connections of DUP MOTOR with PWBA DUP.
Connections of DUP FAN with PWBA DUP.

§ 13 FAX CONTROLLER

Connections of PWBA HYUI with PWBA ESS.
Connections of PWBA FAX with PWBA HYUI.

§ 14 IMAGING

Connections of SCANNER MOTOR with PWBA HYUI.
Connections of PCB CCD with PWBA HYUI.

§ 15 ADF

Connections of ADF OPEN SENSOR with PWBA HYUI.
Connections of EMPTY SENSOR with PWBA HYUI.
Connections of PCB SENSOR with PWBA HYUI.
Connections of ADF MOTOR with PWBA HYUI.

Blank Page

§ 1 DC POWER SUPPLY

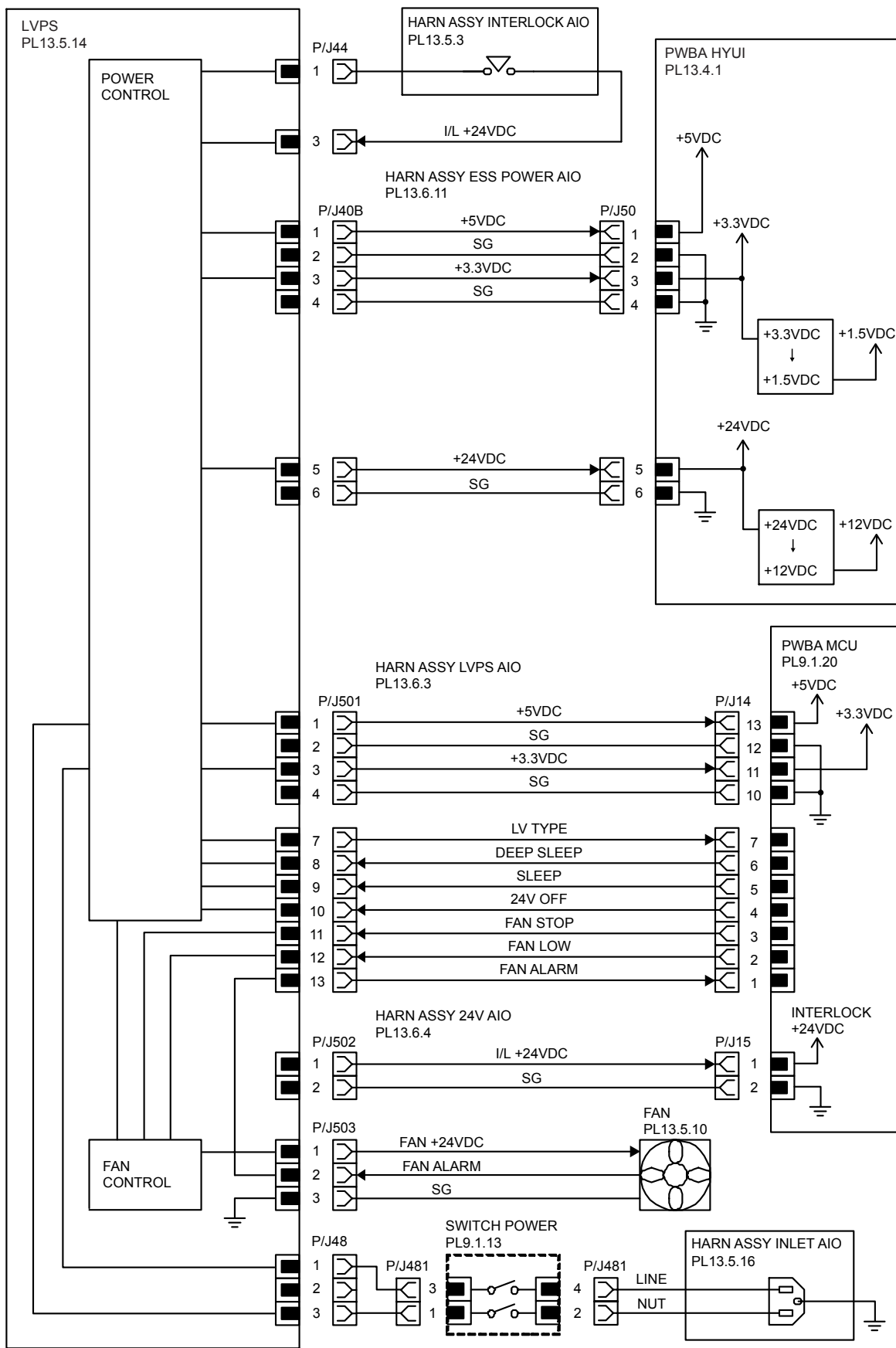

GNB07002KA

Signal line name	Description
LV TYPE DEEP SLEEP SLEEP 24V OFF	Control signal of the LVPS
FAN STOP FAN LOW FAN ALARM	Drive control signal of the SIDE FAN

- LVPS overcurrent protection circuit

This circuit stops all outputs, if the power supply voltage 24VDC, 5VDC, or 3.3VDC is shorted.

The circuit is reset, when after the cause of short was removed, the power is turned off, and then on again after certain time.

- LVPS overvoltage protection circuit

This circuit stops all outputs, if the power supply voltage 24VDC, 5VDC, or 3.3VDC exceeds the specified voltage respectively.

At this time, the operating point is 36VDC or less for 24VDC, 7VDC or less for 5VDC, or 7VDC or less for 3.3VDC.

The circuit is reset, when the power is turned off, and then on again after certain time.

- Sleep mode and deep sleep mode

The output of the following power supply are stopped according to the these signals.

Signal \ Output	+24VDC	+5VDC	+3.3VDC
Sleep	ON	ON	ON
Deep sleep	OFF	ON	ON

§ 2 MSI®I

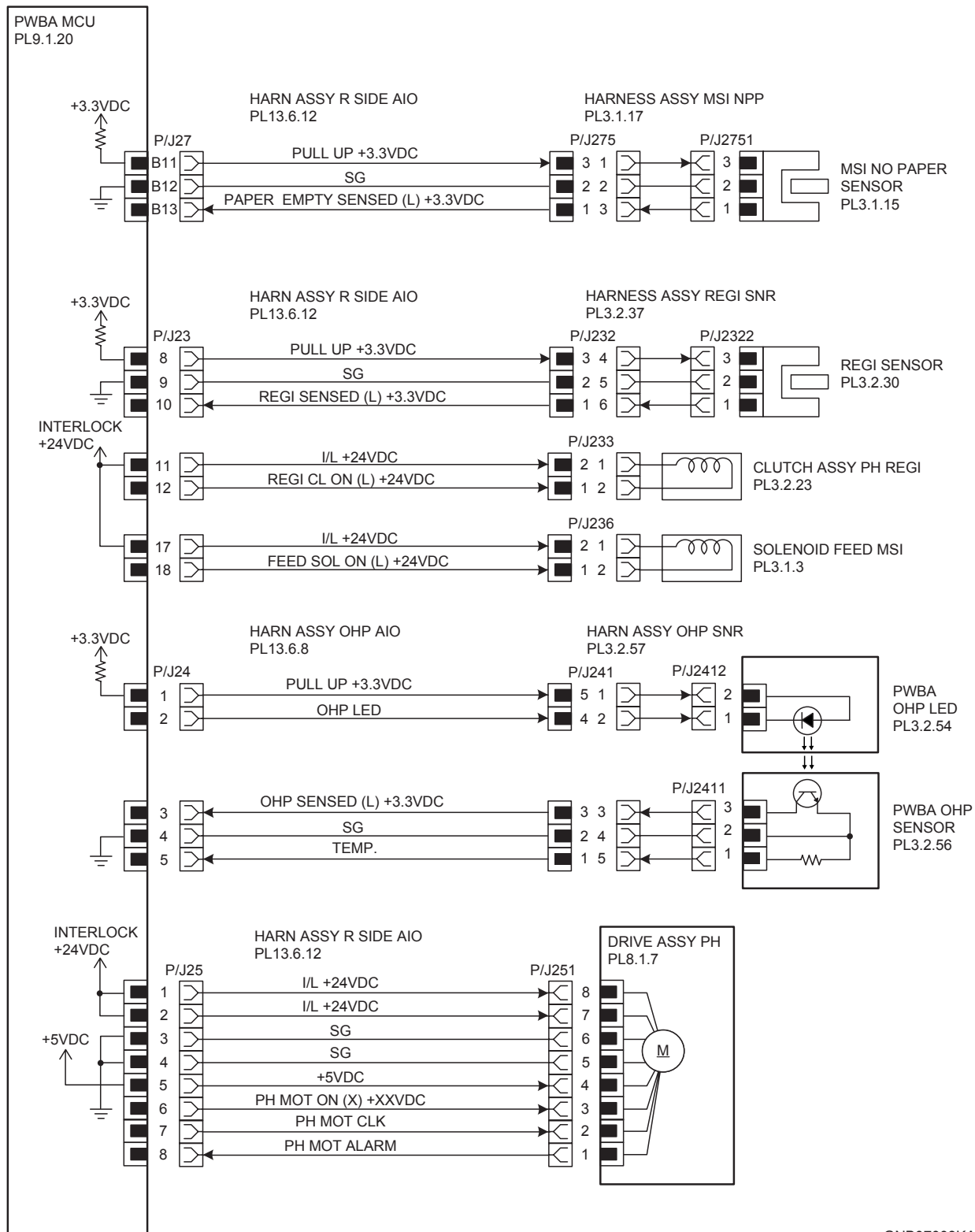

GNB07003KA

Signal line name	Description
PAPER EMPTY SENSED (L) +3.3VDC	Paper detect signal of the MSI by the Sensor Photo (MSI NO PAPER SENSOR)
REGI SENSED (L) +3.3VDC	Paper detect signal of the Regi part by the Sensor Photo (REGI SENSOR)
REGI CL ON (L) +24VDC	ON/OFF signal of the REGI CLUTCH
FEED SOL ON (L) +24VDC	ON/OFF signal of the MSI FEED SOLENOID
OHP LED	ON/OFF signal of the OHP LED
OHP SENSED (L) +3.3VDC	Detect Signal of the transparency sheet by the Sensor Photo (OHP SENSOR)
TEMP.	Data on temperature inside the printer.
PH MOT ON (X) +XXVDC PH MOT CLK PH MOT ALARM	Drive control signal of the DRIVE ASSY PH

§ 3 DRIVE

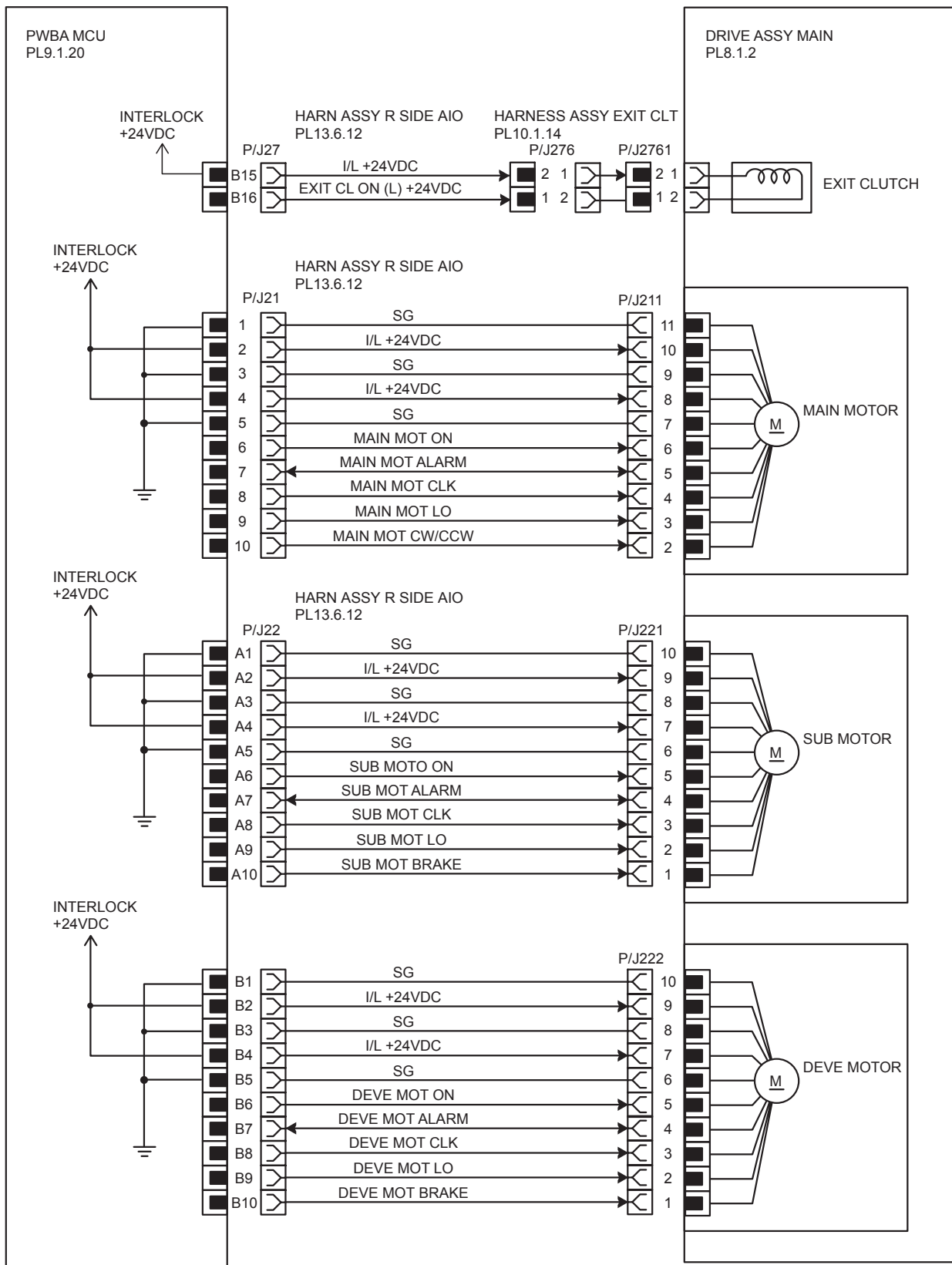

GNB07004KA

Signal line name	Description
MAIN MOT ON MAIN MOT ALARM MAIN MOT CLK MAIN MOT LO MAIN MOT CW/CCW	Drive control signal of the MAIN MOTOR
SUB MOT ON SUB MOT ALARM SUB MOT CLK SUB MOT LO SUB MOT BRAKE	Drive control signal of the SUB MOTOR
DEVE MOT ON DEVE MOT ALARM DEVE MOT CLK DEVE MOT LO DEVE MOT BRAKE	Drive control signal of the DEVE MOTOR
EXIT CL ON (L) +24VDC	ON/OFF signal of the EXIT CLUTCH

§ 4 FEEDER

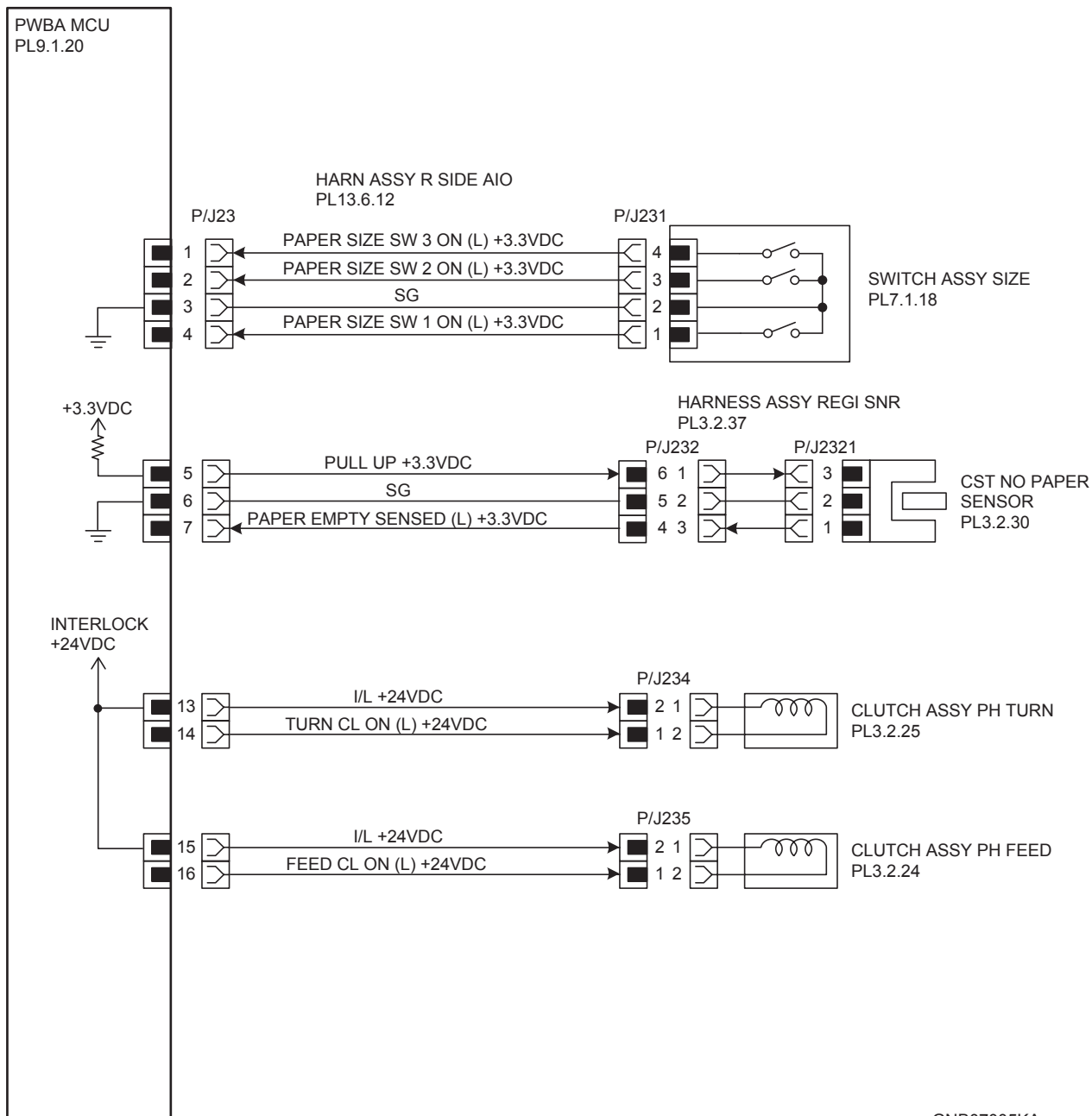

GNB07005KA

Signal line name	Description
PAPER SIZE SW 1 ON (L) +3.3VDC PAPER SIZE SW 2 ON (L) +3.3VDC PAPER SIZE SW 3 ON (L) +3.3VDC	ON/OFF signal of the SWITCH ASSY SIZE
PAPER EMPTY SENSED (L) +3.3VDC	Paper detect signal of the Feeder by the Sensor Photo (NO PAPER SENSOR)
TURN CL ON (L) +24VDC	ON/OFF signal of the TURN CLUTCH
FEED CL ON (L) +24VDC	ON/OFF signal of the FEED CLUTCH

- Outline of SWITCH ASSY SIZE

The paper size is determined by a combination of ON/OFF statuses of the SW 1, SW 2, and SW 3 switches of SWITCH ASSY SIZE.

Paper size	Switches		
	SW 1	SW 2	SW 3
LEGAL 14" (SEF)	ON	ON	ON
LEGAL 13" (SEF)	ON	ON	OFF
EXECUTIVE (SEF)	ON	OFF	ON
B5 (SEF)	ON	OFF	OFF
A4 (SEF)	OFF	ON	ON
LETTER (SEF)	OFF	OFF	ON
A5	OFF	ON	OFF
No cassette	OFF	OFF	OFF

ON : The actuator is pushing the size switch.

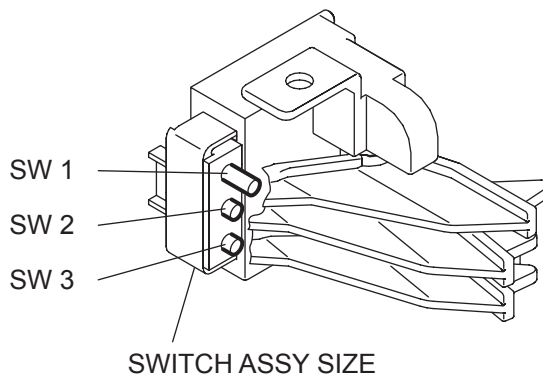

GNB07014KA

§ 5 ROS

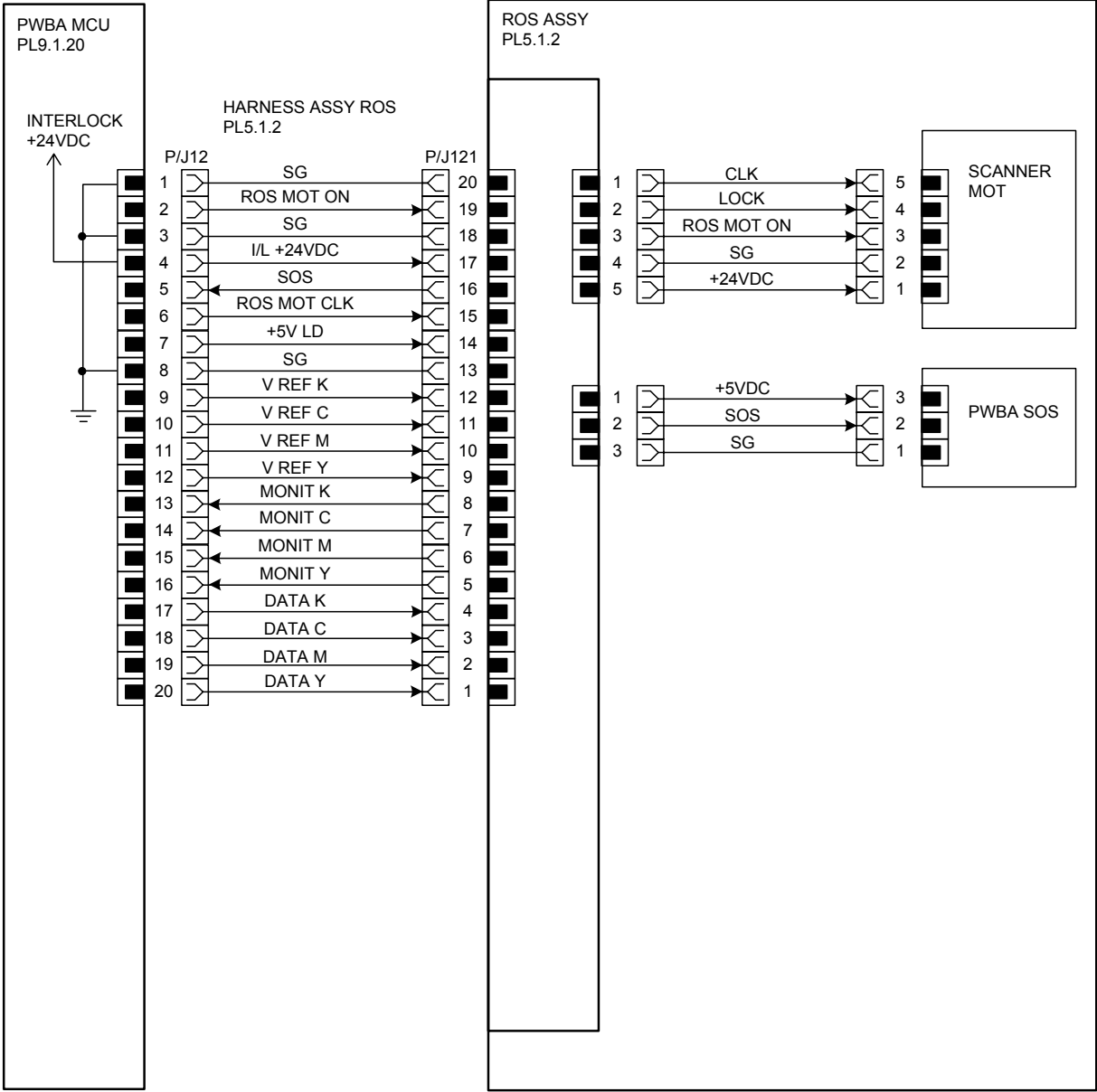

GNB07006KA

Signal line name	Description
ROS MOT ON ROS MOT CLK	Drive control signal of the ROS MOTOR
SOS	Reference signal for scan start of LASER
V REF K V REF C V REF M V REF Y	Emission control signal of the laser diode
MONIT K MONIT C MONIT M MONIT Y	The monitoring voltage of the laser diode
DATA K DATA C DATA M DATA Y	Video signal of the laser diode

§ 6 XEROGRAPHIC

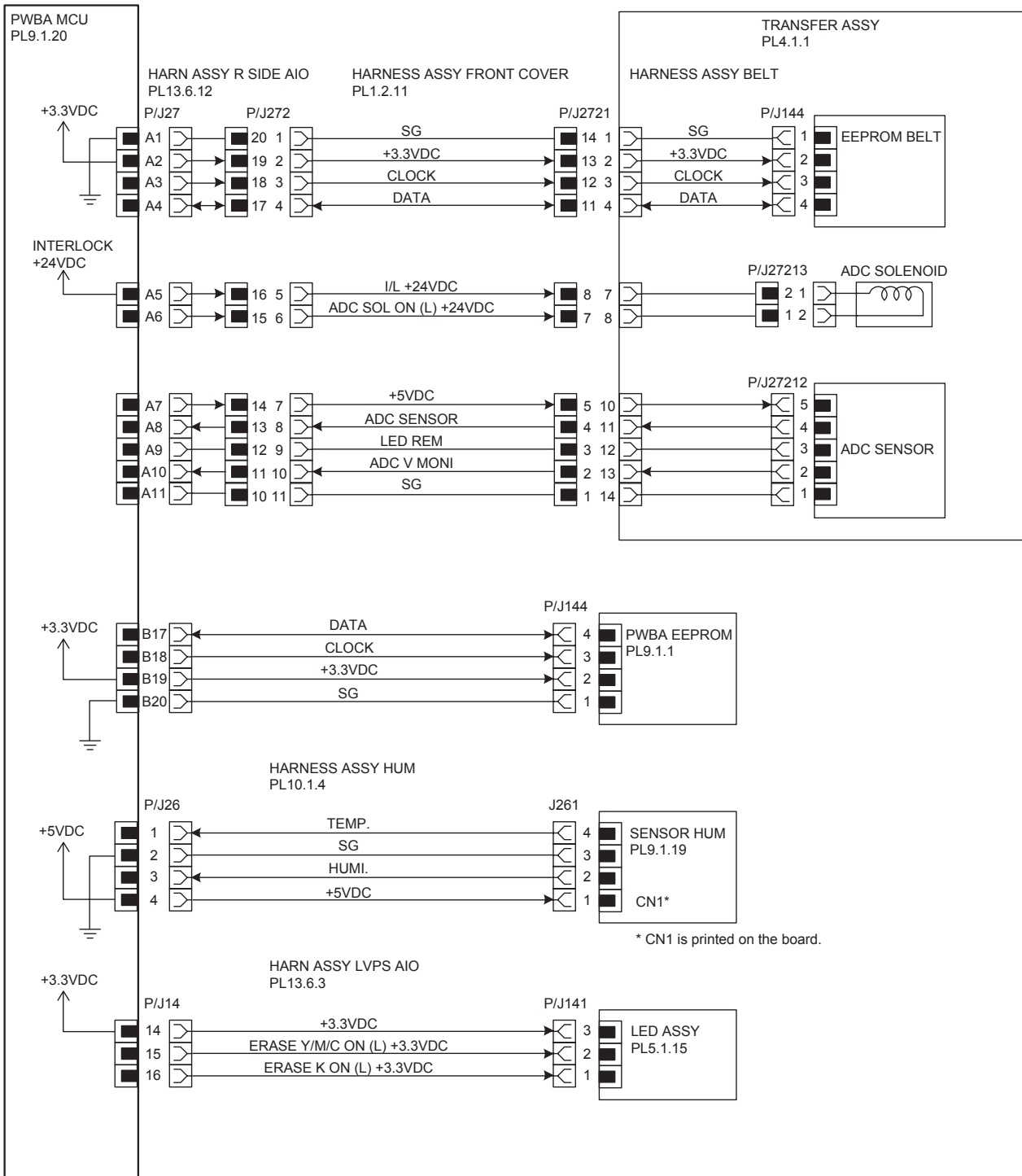

GNB07007KA

Signal line name	Description
CLOCK DATA	Control signal of the EEPROM BELT
ADC SOL ON (L) +24VDC	ON/OFF signal of the ADC SOLENOID
ADC SENSOR	Toner patch density data measured by the ADC SENSOR (Analog value)
LED REM	Remote signal of the LED of ADC SENSOR
ADC V MONI	Control signal of the ADC SENSOR
DATA CLOCK	Control signal of the EEPROM XPRO
TEMP.	Temperature data in the printer by the TEMP./HUM. SENSOR (Analog value)
HUMI.	Humidity data in the printer by the TEMP./HUM. SENSOR (Analog value)
ERASE K ON (L) +3.3VDC ERASE Y/M/C ON (L) +3.3VDC	ON/OFF signal of the ERASE LAMP

§ 7 HIGH VOLTAGE

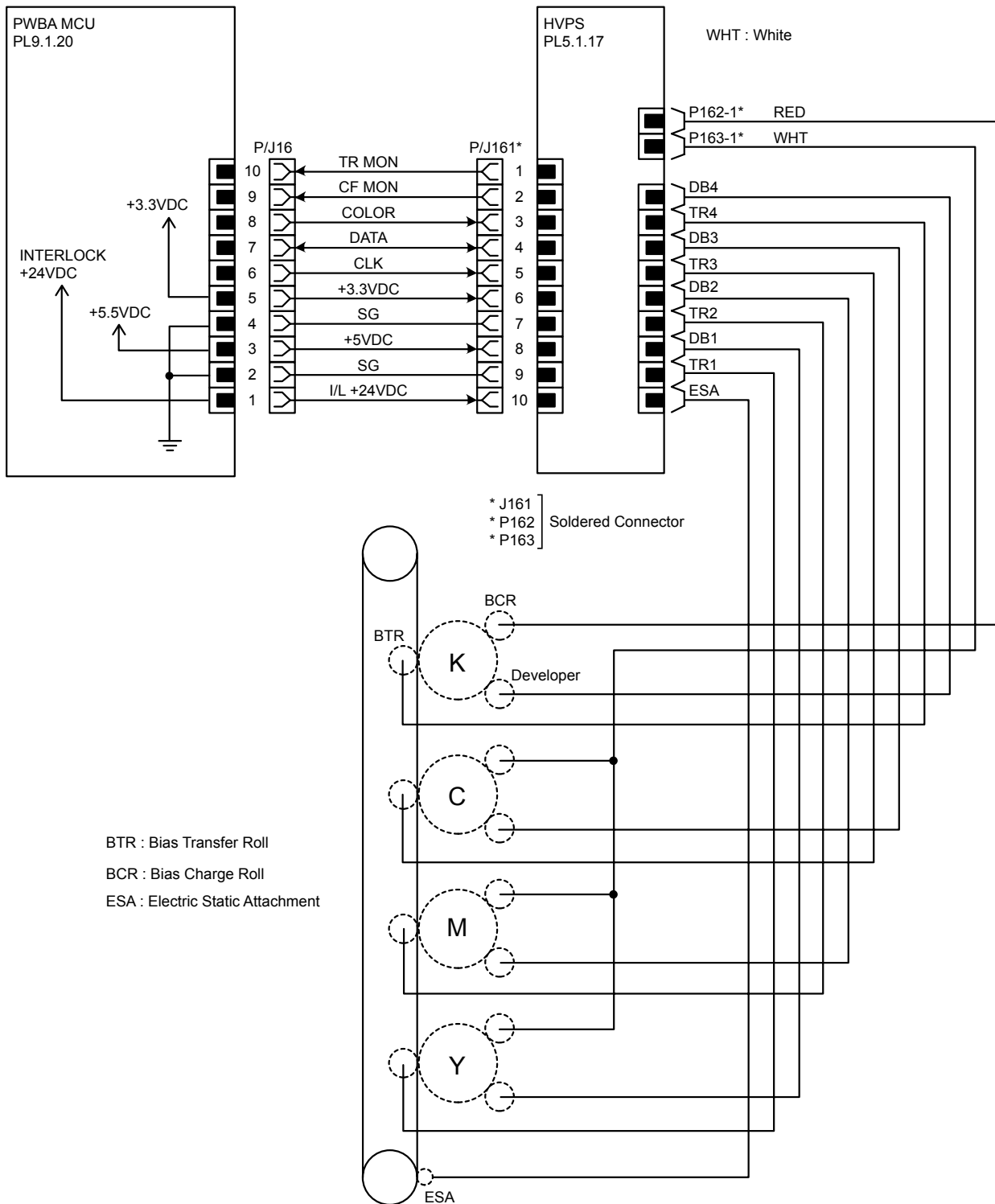

GNB07008KA

Signal line name	Description
TR MON CF MON COLOR DATA CLK	Control signal of the HVPS

§ 8 DEVELOPER

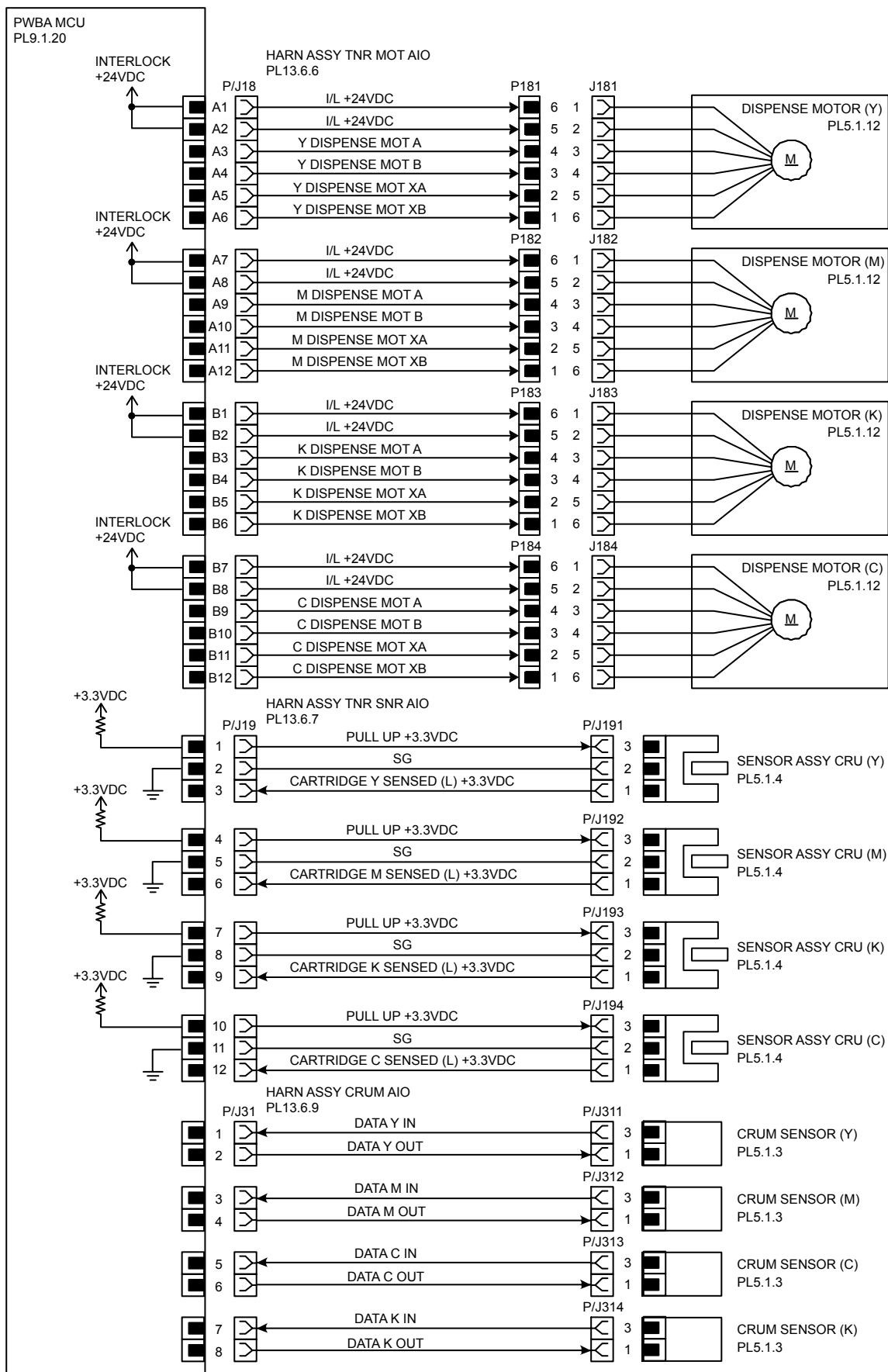

GNB07009KA

Signal line name	Description
Y DISPENSE MOT A Y DISPENSE MOT B Y DISPENSE MOT XA Y DISPENSE MOT XB	Drive control signal of the DISPENSE MOTOR (Y)
M DISPENSE MOT A M DISPENSE MOT B M DISPENSE MOT XA M DISPENSE MOT XB	Drive control signal of the DISPENSE MOTOR (M)
K DISPENSE MOT A K DISPENSE MOT B K DISPENSE MOT XA K DISPENSE MOT XB	Drive control signal of the DISPENSE MOTOR (K)
C DISPENSE MOT A C DISPENSE MOT B C DISPENSE MOT XA C DISPENSE MOT XB	Drive control signal of the DISPENSE MOTOR (C)
CARTRIDGE Y SENSED (L) +3.3VDC	Detection signal of the CRU SENSOR (Y)
CARTRIDGE M SENSED (L) +3.3VDC	Detection signal of the CRU SENSOR (M)
CARTRIDGE K SENSED (L) +3.3VDC	Detection signal of the CRU SENSOR (K)
CARTRIDGE C SENSED (L) +3.3VDC	Detection signal of the CRU SENSOR (C)
DATA Y IN DATA Y OUT	Control signal of the CRUM SENSOR (Y)
DATA M IN DATA M OUT	Control signal of the CRUM SENSOR (M)
DATA C IN DATA C OUT	Control signal of the CRUM SENSOR (C)
DATA K IN DATA K OUT	Control signal of the CRUM SENSOR (K)

§ 9 FUSER

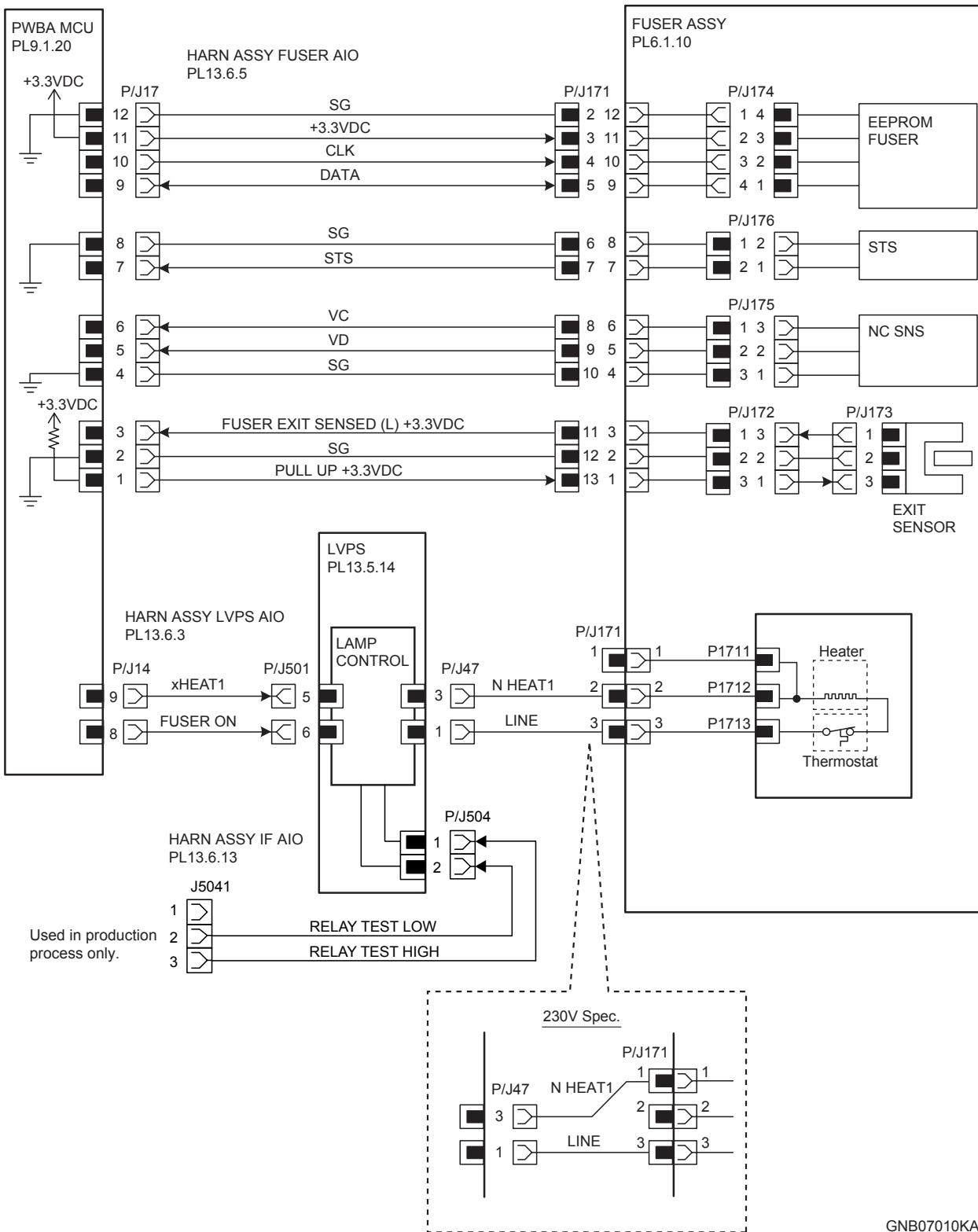

GNB07010KA

Signal line name	Description
CLK DATA	Control signal of the EEPROM FUSER
STS	Heat Roll surface temperature data measured by Temp. Sensor for detecting high temperature (analog value)
VC VD	Temperature data measured by Temp. Sensor for controlling temperature (analog value)
FUSER EXIT SENSED (L) +3.3VDC	Paper detect signal of the Fuser Exit by the Sensor Photo (EXIT SENSOR)
FUSER ON	Lighting signal of Fuser Lamp
RELAY TEST LOW RELAY TEST HIGH	Test signal of the LVPS (Used in production process only)

§ 10 CONTROLLER

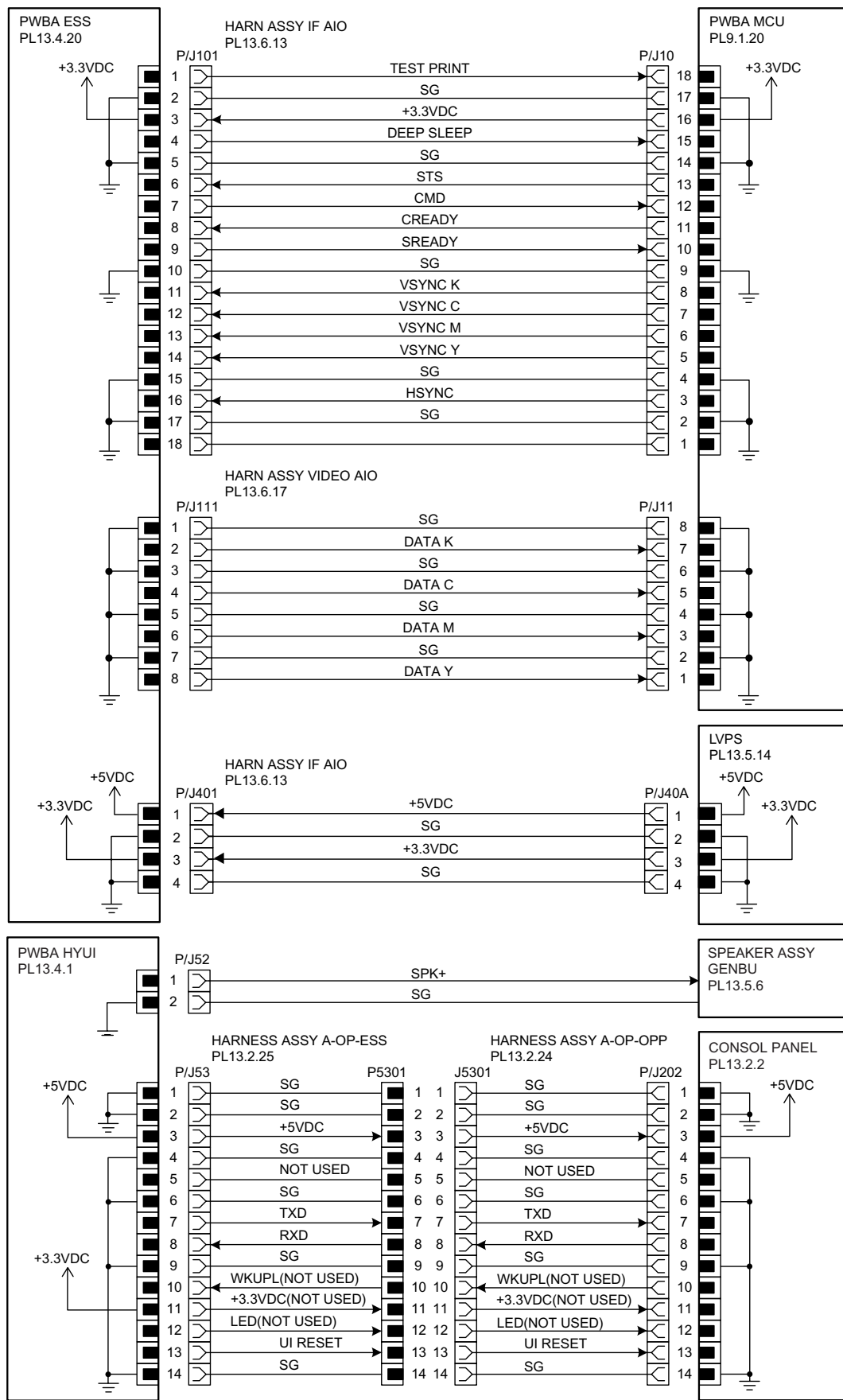

GNB07011KB

Signal line name	Description
TEST PRINT	Control signal for the TEST PRINT mode
DEEP SLEEP	Control signal for the DEEP SLEEP mode
STS	Status signal transmitted fro the PWBA MCU to the PWBA ESS
CMD	Command signal transmitted from the PWBA ESS to the PWBA MCU
CREADY SREADY	Signal for indicating weather or not the printer is ready for receiving command signal
VSYNC K VSYNC C VSYNC M VSYNC Y	Signal for indicating registration position of each of images Y, M, C and K
HSYNC	Signal for data
DATA K DATA C DATA M DATA Y	Video data of four colors
DATA CLK BACK LIGHT BL +5VDC	Control signal of the CONTROL PANEL
SPK+	Control signal of the SPEAKER
TXD RXD	Control signal of the CONSOL PANEL
UI RESET	Reset signal of the CONSOL PANEL

§ 11 550 FEEDER

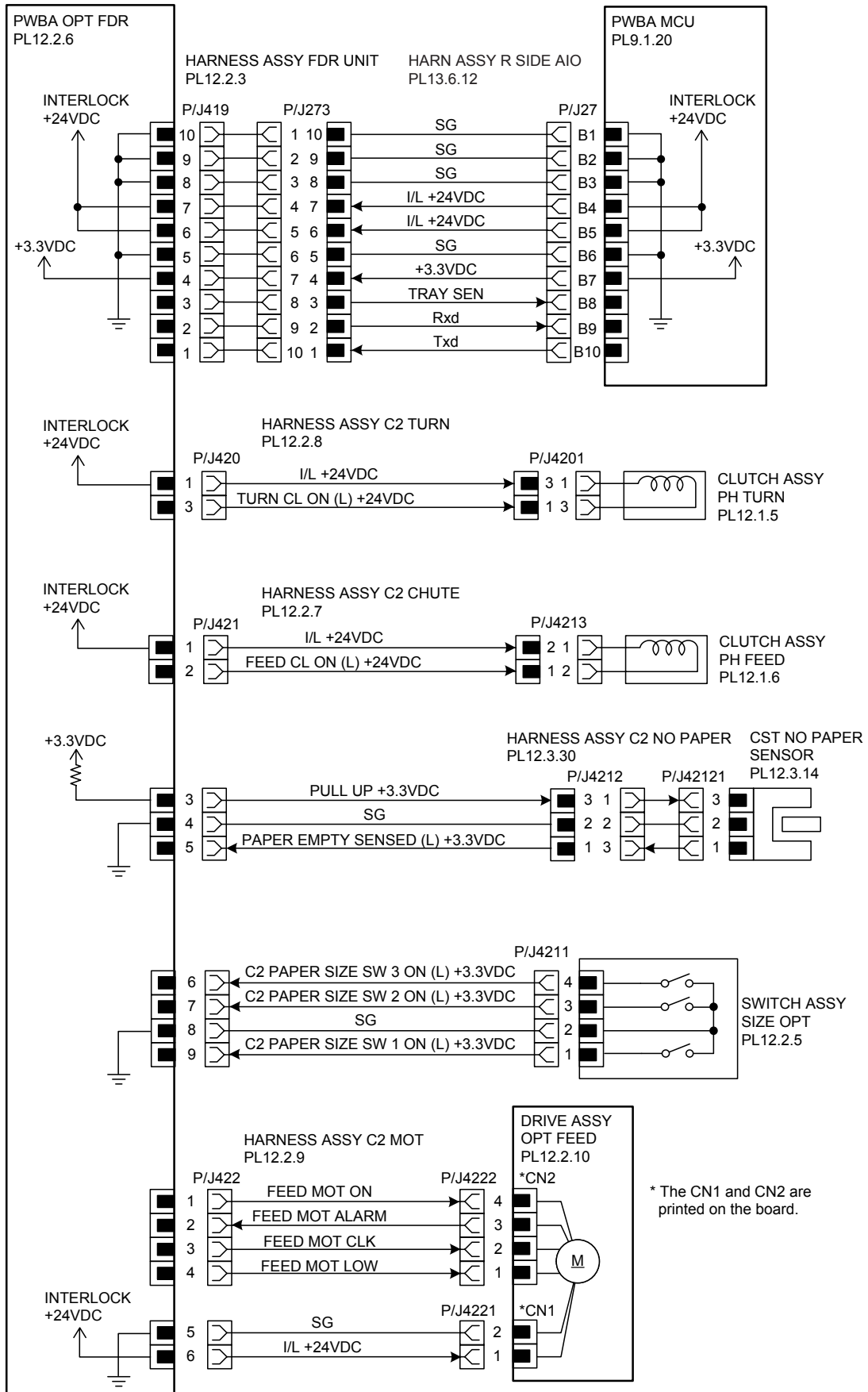

GNB07012KA

Signal line name	Description
TRAY SEN Rxd Txd	Control signal of the PWBA FEEDER
TURN CL ON (L) +24VDC	ON/OFF signal of the TURN CLUTCH
FEED CL ON (L) +24VDC	ON/OFF signal of the FEED CLUTCH
PAPER EMPTY SENSED (L) +3.3VDC	Paper detect signal of the Feeder by the Sensor Photo (NO PAPER SENSOR)
PAPER SIZE SW 1 ON (L) +3.3VDC PAPER SIZE SW 2 ON (L) +3.3VDC PAPER SIZE SW 3 ON (L) +3.3VDC	ON/OFF signal of the SWITCH ASSY SIZE
FEED MOT ON FEED MOT ALARM FEED MOT CLK FEED MOT LOW	Drive control signal of the FEED MOTOR

- Outline of SWITCH ASSY SIZE

The paper size is determined by a combination of ON/OFF statuses of the SW 1, SW 2, and SW 3 switches of SWITCH ASSY SIZE.

Paper size	Switches		
	SW 1	SW 2	SW 3
LEGAL 14" (SEF)	ON	ON	ON
LEGAL 13" (SEF)	ON	ON	OFF
EXECUTIVE (SEF)	ON	OFF	ON
B5 (SEF)	ON	OFF	OFF
A4 (SEF)	OFF	ON	ON
LETTER (SEF)	OFF	OFF	ON
A5	OFF	ON	OFF
No cassette	OFF	OFF	OFF

ON : The actuator is pushing the size switch.

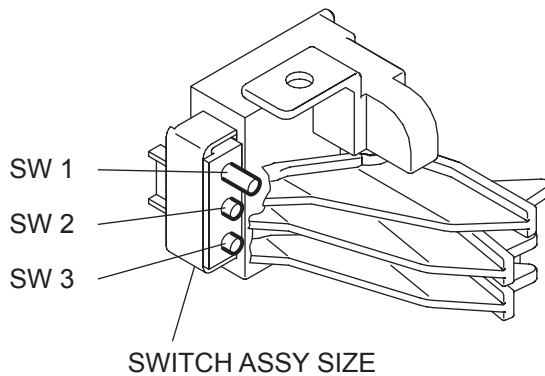

GNB07014KA

§ 12 DUPLEX

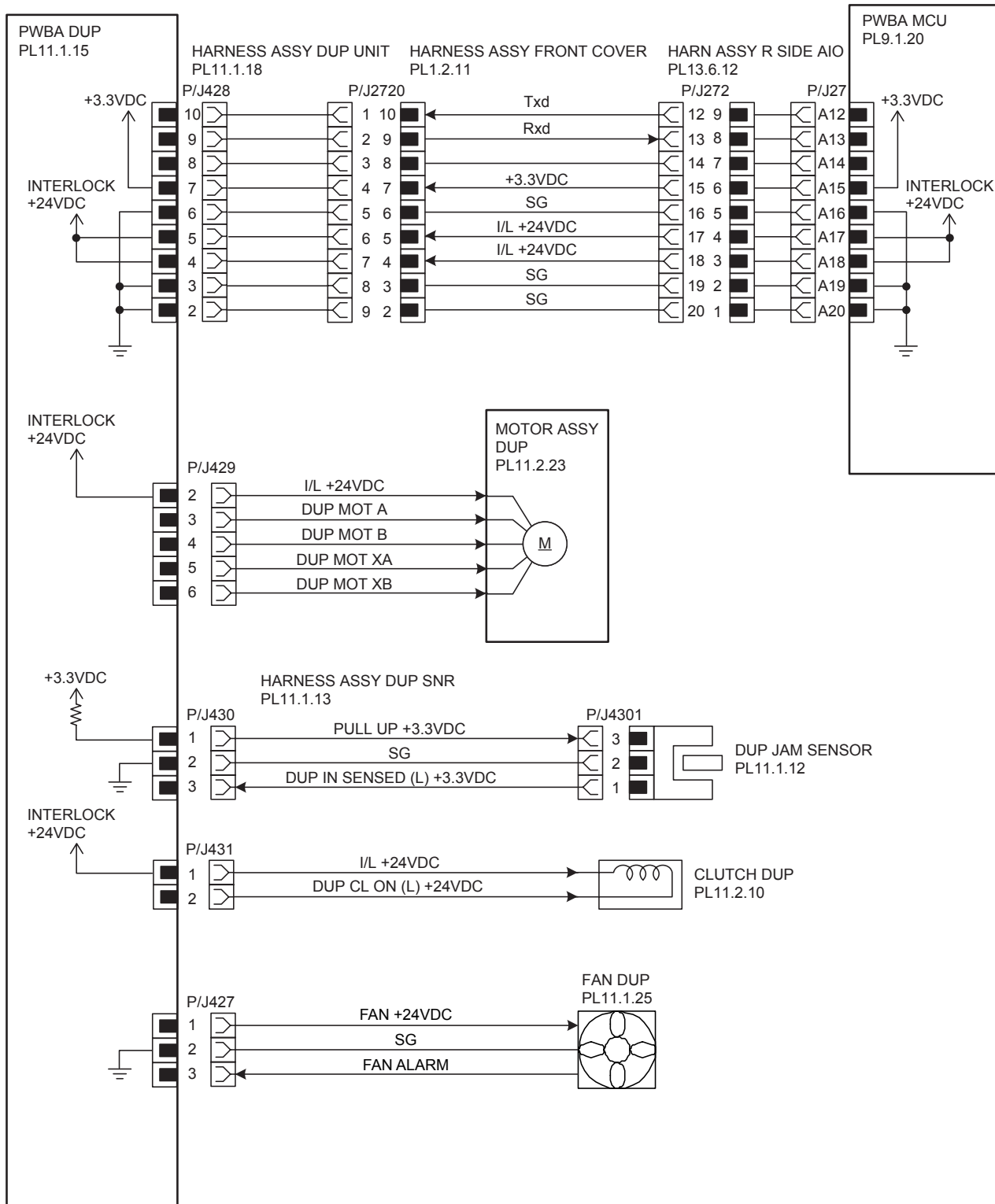

GNB07013KA

Signal line name	Description
Txd Rxd	Control signal of the PWBA DUP
DUP MOT A DUP MOT B DUP MOT XA DUP MOT XB	Drive control signal of the DUP MOTOR
DUP IN SENSED (L) +3.3VDC	Paper detect signal of the Duplex by the Sensor Photo (DUP JAM SENSOR)
DUP CL ON (L) +24VDC	ON/OFF signal of the DUP CLUTCH
FAN +24VDC FAN ALARM	Drive control signal of the DUP FAN

§ 13 FAX CONTROLLER

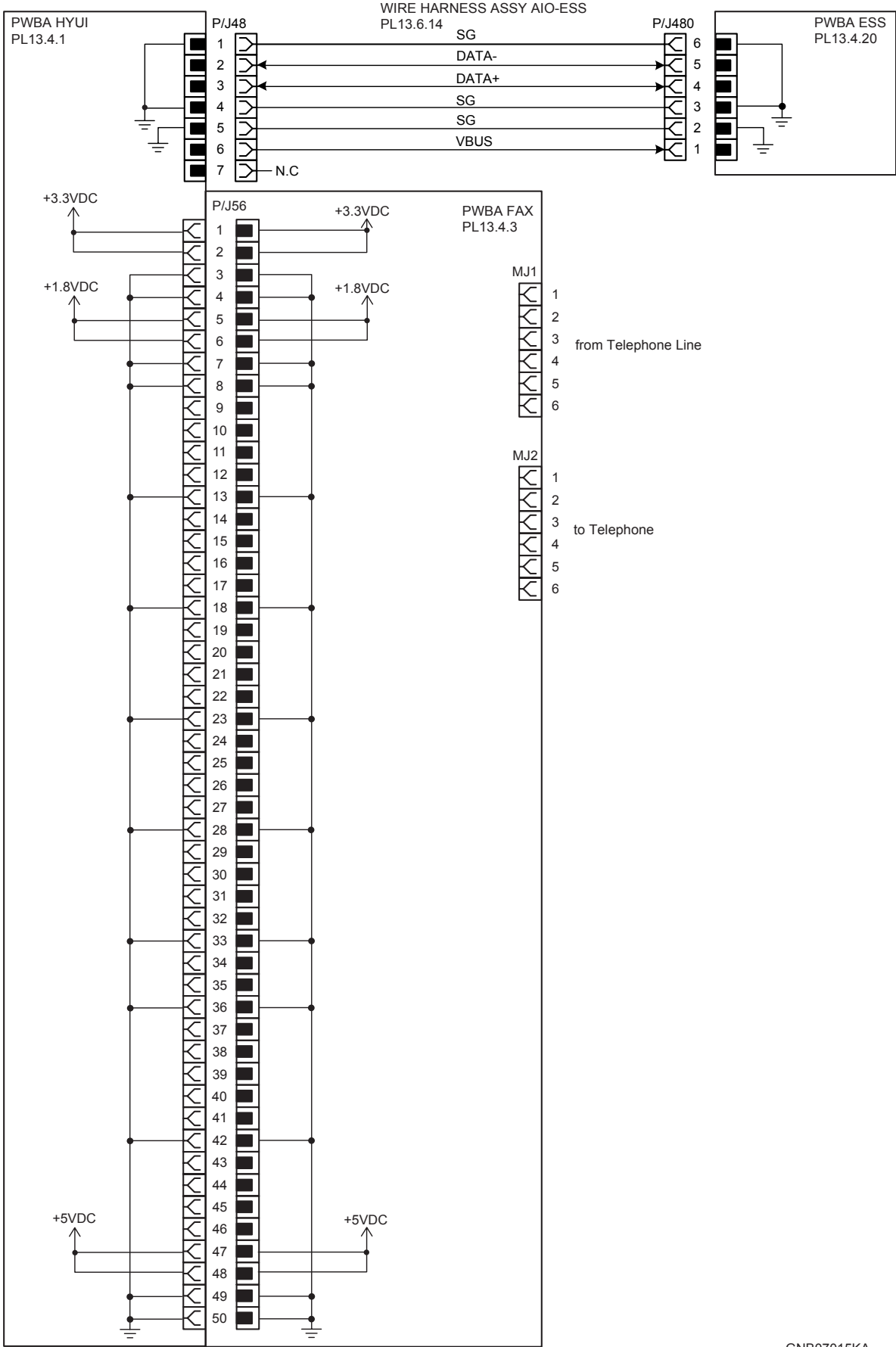

GNB07015KA

Signal line name	Description
DATA+ DATA- VBUS	Control signal of the PWBA ESS

§ 14 IMAGING

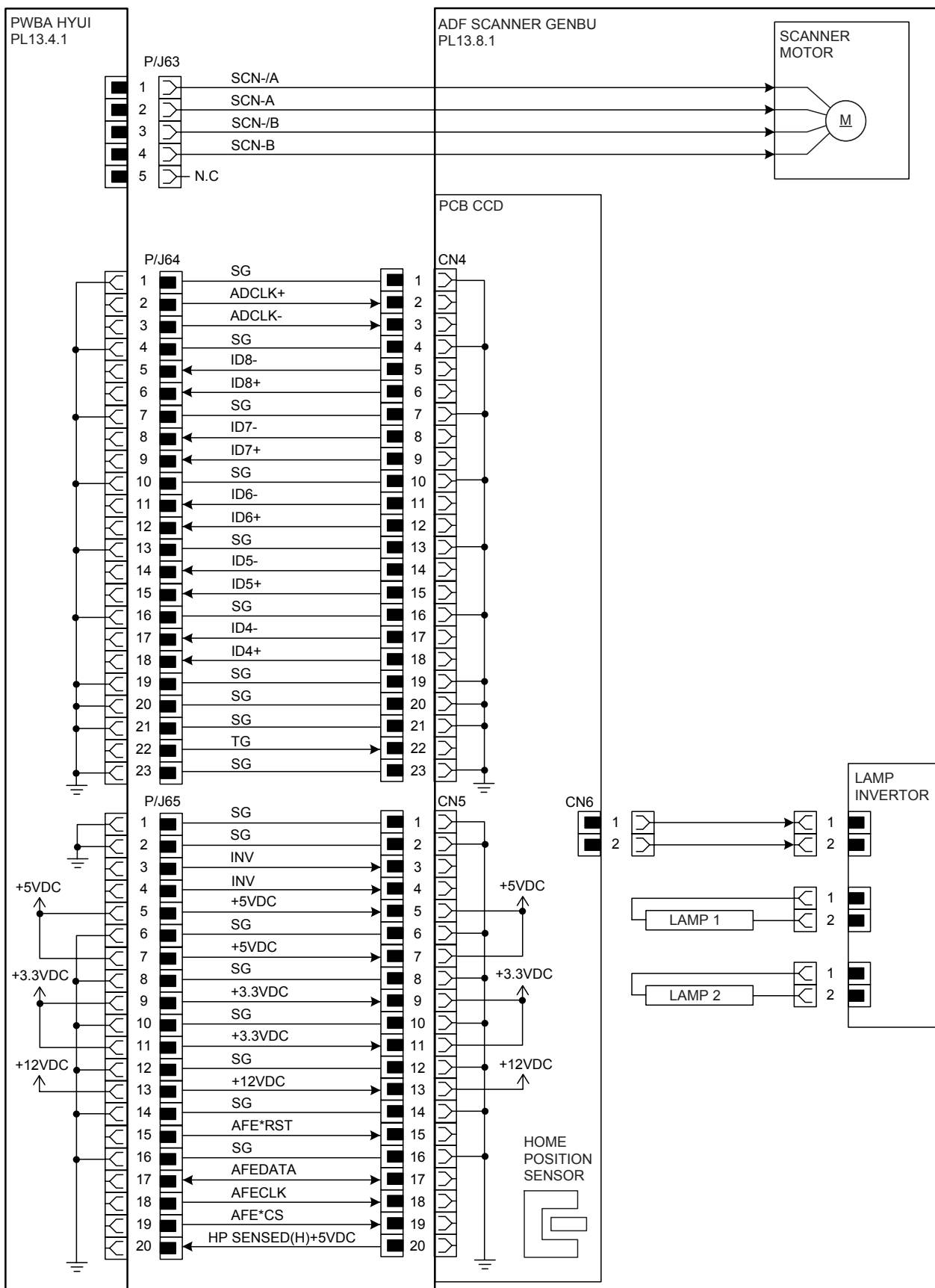

GNB07016KA

Signal line name	Description
SCN-/A SCN-A SCN-/B SCN-B	Drive control signal of the SCANNER MOTOR
ADCLK+ ADCLK- TG	Control signal of the PCB CCD
ID8- ID8+ ID7- ID7+ ID6- ID6+ ID5- ID5+ ID4- ID4+	Image data of the document by the CCD
INV	Control signal of the LAMP INVERTOR
AFE*RST AFEDATA AFECLK AFE*CS	Control signal of the PCB CCD
HP SENSED (H) +5VDC	Home Position signal of the Carriage by the Sensor Photo

§ 15 ADF

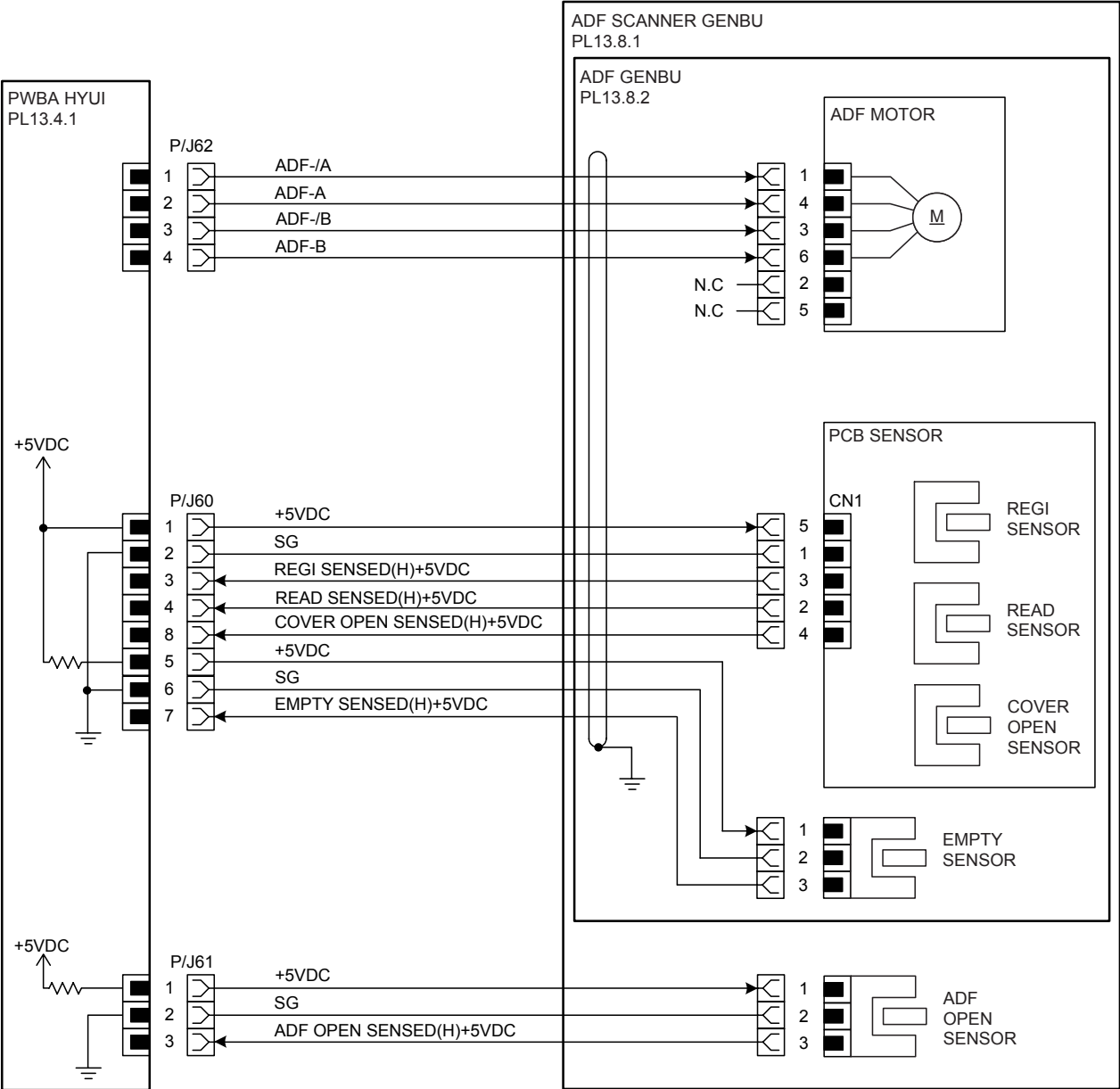

GNB07017KA

Signal line name	Description
ADF-/A ADF-A ADF-/B ADF-B	Drive control signal of the ADF MOTOR
REGI SENSED (H) +5VDC	Document detect signal of the Regi part by the Sensor Photo
READ SENSED (H) +5VDC	Document detect signal of the Read part by the Sensor Photo
COVER OPEN SENSED (H) +5VDC	Cover open signal of the ADF COVER by the Sensor Photo
EMPTY SENSED (H) +5VDC	Document empty signal of the ADF Tray by the Sensor Photo
ADF OPEN SENSED (H) +5VDC	ADF open signal by the Sensor Photo

Chapter 8 Printer Specifications CONTENTS

1. Configuration of Printer.....	8 - 1
1.1 Basic Configuration.....	8 - 1
1.2 Functional Configuration.....	8 - 1
2. Electrical Properties.....	8 - 2
2.1 Power Source.....	8 - 2
2.2 Power Consumption.....	8 - 2
3. Mechanical Properties.....	8 - 3
3.1 Dimensions/Mass of Printer.....	8 - 3
3.2 Dimensions/Mass of Paper Tray.....	8 - 3
3.3 Dimensions/Mass of Duplex.....	8 - 4
3.4 Dimensions/Mass of Consumables and CRUs.....	8 - 5
3.4.1 TRANSFER BELT.....	8 - 5
3.4.2 FUSER CRU.....	8 - 5
3.4.3 Black toner cartridge.....	8 - 5
3.4.4 Yellow toner cartridge.....	8 - 5
3.4.5 Magenta toner cartridge.....	8 - 5
3.4.6 Cyan toner cartridge.....	8 - 6
3.5 Installation Space (min. installation space).....	8 - 6
4. Functions.....	8 - 8
4.1 Recording System.....	8 - 8
4.2 Exposure System.....	8 - 8
4.3 Development System.....	8 - 8
4.4 Fixing System.....	8 - 8
4.5 Resolution.....	8 - 8
4.6 Operation Mode.....	8 - 8
4.7 Warm-up Time.....	8 - 9
4.8 FCOT (First Copy Output Time).....	8 - 9
4.9 Continuous Copying Speed.....	8 - 10
4.10 Input Properties.....	8 - 11
4.10.1 Paper pick-up system.....	8 - 11
4.10.2 Paper pick-up capacity.....	8 - 11
4.11 Output Properties.....	8 - 12
4.11.1 Paper delivery system.....	8 - 12
4.11.2 Paper delivery capacity.....	8 - 12
4.11.3 Delivery paper size/mass.....	8 - 12
4.11.4 Full stack detection.....	8 - 12
4.12 Paper.....	8 - 13
4.12.1 Paper type.....	8 - 13
4.12.2 Paper mass.....	8 - 13
4.12.3 Paper size.....	8 - 13
5. Consumables.....	8 - 14
5.1 Items of Consumables.....	8 - 14
5.2 Consumable Life.....	8 - 14
5.3 Periodic Replacing Parts (Reference).....	8 - 14

Chapter 8 Printer Specifications CONTENTS

6. Operating Environment.....	8 - 16
6.1 Installation Temperature / Humidity	8 - 16
6.2 Installation Altitude	8 - 16
6.3 Installation Horizontality	8 - 16
6.4 Ambient Lighting	8 - 16
6.5 Storage Temperature of a Toner Cartridge.....	8 - 16
7. Safety / Environment Conditions	8 - 17
7.1 Safety Standard	8 - 17
7.2 Laser Safety Standard	8 - 17
7.3 EMI.....	8 - 17
7.4 Noise.....	8 - 17
8. Print image Quality	8 - 18
8.1 Image Quality Guarantee Conditions.....	8 - 18
8.1.1 Environmental conditions.....	8 - 18
8.1.2 Guaranteed paper.....	8 - 18
8.1.3 Paper condition.....	8 - 18
8.1.4 Printer condition.....	8 - 18
8.1.5 Image quality guaranteed area	8 - 18
8.1.6 Criterion	8 - 18
9. Option	8 - 19
9.1 Options to be Installed by Users	8 - 19
10. ESS Specification	8 - 20
10.1 External Interface.....	8 - 20
10.1.1 USB	8 - 20
10.1.2 Ethernet	8 - 20
10.1.3 IEEE1284.....	8 - 20
10.1.4 Wireless	8 - 20
10.1.5 Interface Specification.....	8 - 21
10.2 Network Protocol.....	8 - 21
10.2.1 Printing Protocol.....	8 - 21
10.2.2 Other Protocols.....	8 - 22
10.3 Decomposer.....	8 - 23
10.3.1 PDL/Emulation	8 - 23
10.3.2 Font.....	8 - 23
10.3.3 Form Overlay	8 - 23
10.3.4 Image Area	8 - 23
10.4 Job Control.....	8 - 24
10.4.1 Cancel Print	8 - 24
10.4.2 Job Recovery.....	8 - 24
10.4.3 Job Time Out	8 - 24
10.4.4 Secure Print (/Store Print).....	8 - 24
10.4.5 Proof Print.....	8 - 24
10.4.6 IP Filter.....	8 - 24
10.5 Logging	8 - 25
10.5.1 Job Logging	8 - 25

Chapter 8 Printer Specifications CONTENTS

10.5.2 Error Logging	8 - 25
10.5.3 Billing Count.....	8 - 25
10.6 ID Print.....	8 - 25
10.7 3rd Party Mode	8 - 26
10.8 Utility Print.....	8 - 27
10.8.1 Printer Settings List.....	8 - 27
10.8.2 Panel Settings List Print.....	8 - 27
10.8.3 Font List Print.....	8 - 27
10.8.4 Job Log Print.....	8 - 27
11. IIT (Image Input Terminal) Specifications.....	8 - 28
11.1 Scanner.....	8 - 28
11.1.1 Scanning Method.....	8 - 28
11.1.2 Optical Resolution.....	8 - 28
11.1.3 Fast Scanning Speed.....	8 - 28
11.1.4 Slow Scanning Speed.....	8 - 28
11.1.5 Light Source.....	8 - 28
11.1.6 Maximum Scanning Size	8 - 28
11.1.7 Input Bit Depth	8 - 28
11.2 ADF.....	8 - 29
11.2.1 Document Condition	8 - 29
11.2.2 Document Thickness	8 - 29
11.2.3 Auto Document Size Detection	8 - 29
11.2.4 Document Feed System	8 - 29
11.2.5 ADF Half-Open, Full-Open Angles.....	8 - 29
11.2.6 Document Registration	8 - 29
11.2.7 Capacity.....	8 - 29
12. FAX Specifications	8 - 30
12.1 Communication	8 - 30
12.1.1 Communication Mode.....	8 - 30
12.1.2 Density of Transmitting Pixels.....	8 - 30
12.1.3 Modem Signal Processing	8 - 30
12.1.4 Data Compression, Output Bit Depth.....	8 - 30
12.1.5 Communication Control Procedure.....	8 - 30
12.1.6 Transmission Time.....	8 - 31
12.1.7 Protocol Control Time	8 - 31
12.1.8 Throughput	8 - 31
12.2 Telephone.....	8 - 32
12.2.1 Cable Characteristics.....	8 - 32
12.2.2 Communication Load Characteristics	8 - 32
12.2.3 Incoming Call Level.....	8 - 32

Chapter 8 Printer Specifications CONTENTS

1. Configuration of Printer

1.1 Basic Configuration

The printer has the following basic configurations depending on the destination.

- print engine main unit (MSI and 250 feeder unit as the standard paper feeding)
- consumables (CRU)

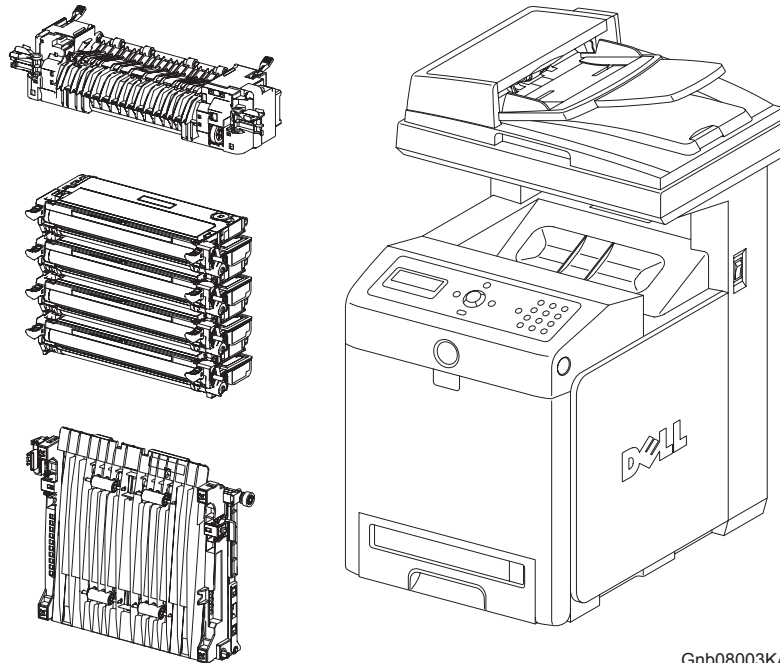

Gnb08003KA

1.2 Functional Configuration

Functional configuration of this printer is shown below.

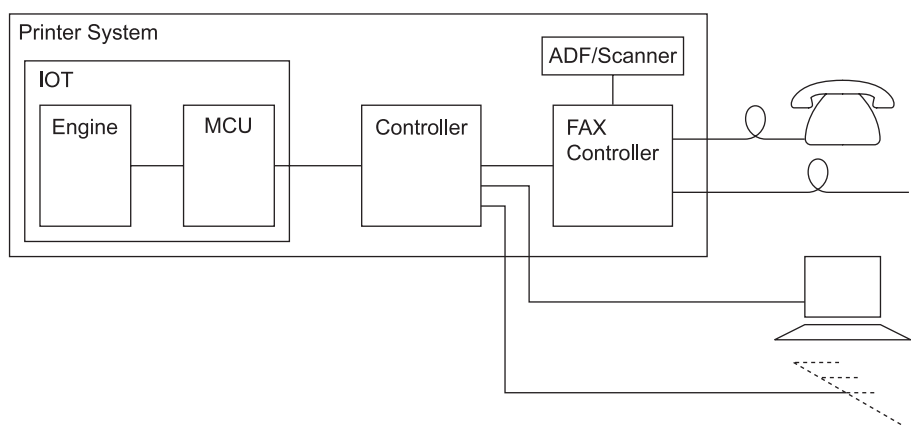

Gnb08004KA

2. Electrical Properties

2.1 Power Source

Two types of power source as follows are available for this printer, which are selected according to the specifications.

110-127V printer: voltage: 110-127VAC $\pm 10\%$ (99 ~ 140V), frequency: 50/60Hz ± 3 Hz

220-240V printer: voltage: 220-240VAC $\pm 10\%$ (198 ~ 264V), frequency: 50/60Hz ± 3 Hz

2.2 Power Consumption

Power consumption in each operation mode at rated voltage input
At standard configuration

Operation mode	Average (Wh/h)
Running mode (F/C)	464 or less
Running mode (B/W)	464 or less
Ready mode	108 or less
Low power mode	35 or less
Deep sleep mode	18 or less

3. Mechanical Properties

3.1 Dimensions/Mass of Printer

Width(mm)	Depth(mm)	Height(mm)	Mass(kg)
460	520	730	36 kg (without CRU) 40 kg (with CRU)

* Including MSI with its cover being closed. And the ejection stacker is also being contained in the main unit.

As regards Depth, 570mm at Legal 14.

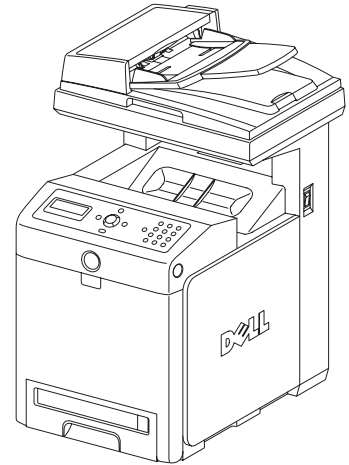

Gnb08005KA

3.2 Dimensions/Mass of Paper Tray

Tray	Width(mm)	Depth(mm)	Height(mm)	Mass(kg)
For 550 sheet	386	506.7	134.4	7.9 or less

(Except COVER OPT FDE L and COVER OPT FDR R)

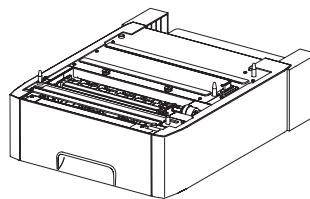

Gnb08006KA

3.3 Dimensions/Mass of Duplex

Width(mm)	Depth(mm)	Height(mm)	Mass(kg)
283	290	134	1.0 or less

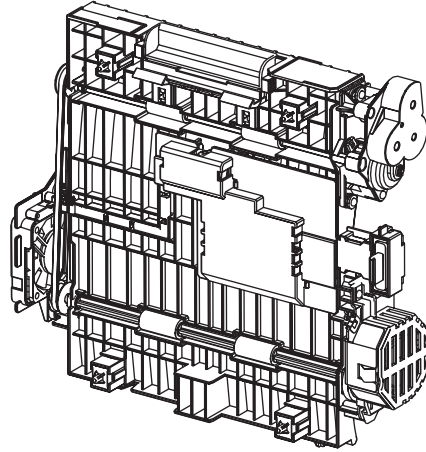

Kmy08007KA

3.4 Dimensions/Mass of Consumables and CRUs

3.4.1 TRANSFER BELT

Width: 275mm
 Depth: 314mm
 Height: 83mm
 Mass: 1.4kg

Reference: *The TRANSFER BELT has CRUM (CRU memory) to record information.*

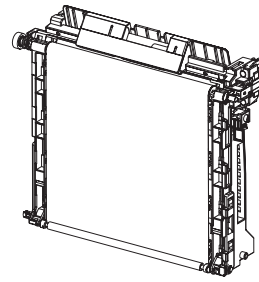

Kmy08008KA

3.4.2 FUSER CRU

Width: 405mm
 Depth: 130mm
 Height: 102mm
 Mass: 1.43kg

Reference: *The FUSER has CRUM (CRU memory) to record information.*

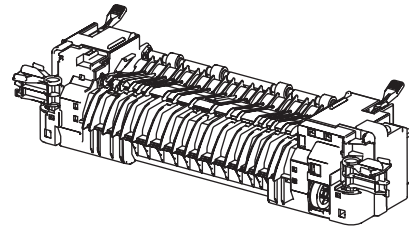

Kmy08009KA

3.4.3 Black toner cartridge

Width: 303.8mm
 Depth: 150mm
 Height: 53.8mm
 Mass: 1.05 (5K)/1.05 (8K) kg

Reference: *The Black toner cartridge has CRUM (CRU memory) to record information.*

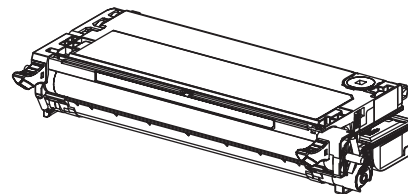

Kmy08010KA

3.4.4 Yellow toner cartridge

Width: 303.8mm
 Depth: 150mm
 Height: 53.8mm
 Mass: 1.05 (4K)/1.05 (8K) kg

Reference: *The Yellow toner cartridge has CRUM (CRU memory) to record information.*

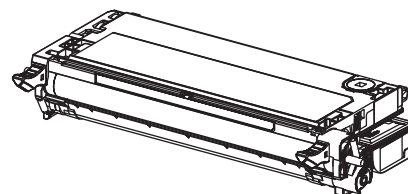

Kmy08010KA

3.4.5 Magenta toner cartridge

Width: 303.8mm
 Depth: 150mm
 Height: 53.8mm
 Mass: 1.05 (4K)/1.05 (8K) kg

Reference: *The Magenta toner cartridge has CRUM (CRU memory) to record information.*

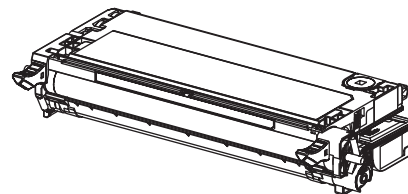

Kmy08010KA

3.4.6 Cyan toner cartridge

Width: 303.8mm

Depth: 150mm

Height: 53.8mm

Mass: 1.05 (4K)/1.05 (8K) kg

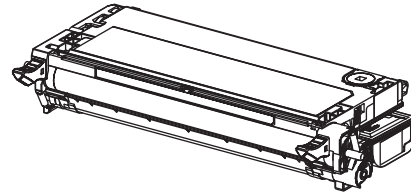

Kmy08010KA

Reference:The Cyan toner cartridge has **CRUM (CRU memory) to record information.**

3.5 Installation Space (min. installation space)

Minimum space as shown below is required to install the printer when it is used for normal objects.
(Space occupied by the operator is not included.)

Top view

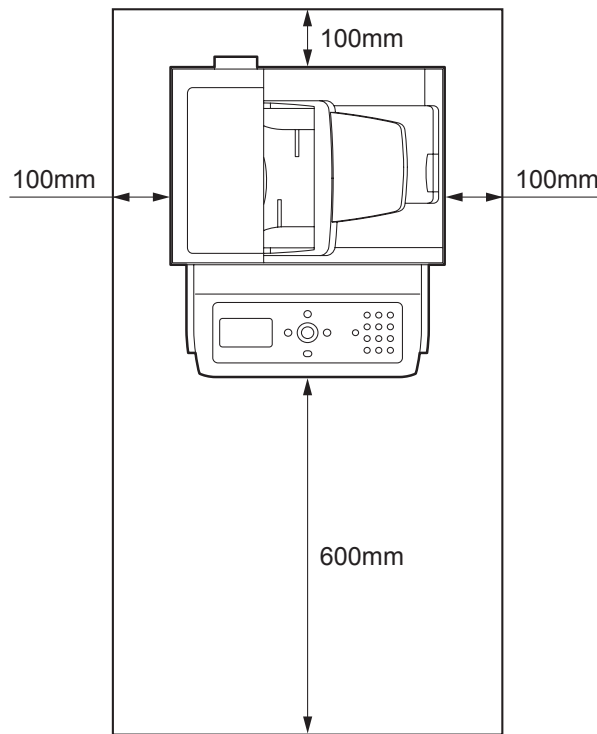

Gnb08011KA

Front view

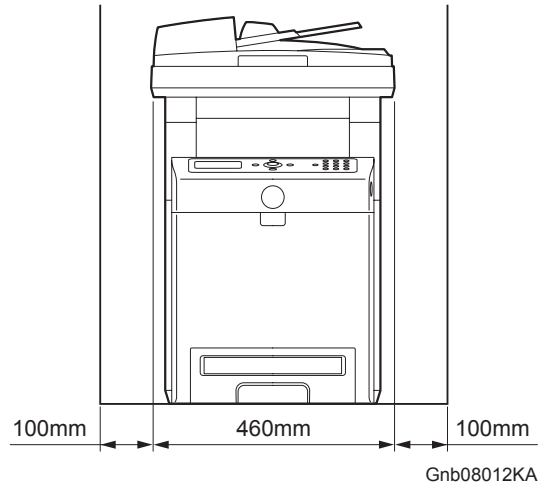

Side view

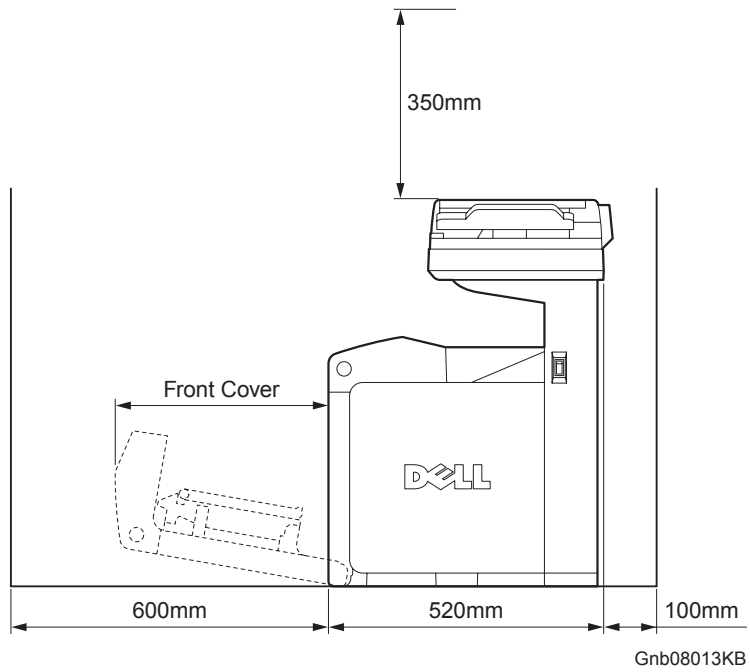

4. Functions

4.1 Recording System

Electro-photographic system employing OPC drum and direct transfer by the transport belt

4.2 Exposure System

Semiconductor four laser beams scanning system

4.3 Development System

Development with dry type 2-component developer

4.4 Fixing System

Thermal fixing system by Free Belt Nip Fusing (FBNF)

4.5 Resolution

- Main scanning direction: by the printer controller
- Sub scanning direction: 600 dots/25.4mm (fixed)

4.6 Operation Mode

The printer can be operated in either of 4 operation modes. The modes are switched over by command from the printer controller or change of printer operation, etc.

Proceeding from power ON, low power mode or sleep mode to standby mode will take place after going through a warm up stage.

- Running mode (Printing)

State in running or recording operation

Fixing system:	Held at operating temperature.
Exposure system:	Operating status
Recording system:	Operating status

- Running mode (Scanning)

Exposure system:	Operating status
------------------	------------------

- Ready mode

Ready state

Fixing system:	Held at ready temperature.
Exposure system:	Stop status
Recording system:	Stop status

- Low power mode

Complete resting state. 35W or less at sleep mode.

18W or less at deep sleep mode.

Fixing system:	Stop status
Exposure system:	Stop status
Recording system:	Stop status

4.7 Warm-up Time

When nominal voltage (115V, 220V) is applied, the printer will proceed to standby mode from POWER-ON within 30 seconds.

Reference: Measured at 22°C, 55% RH, nominal voltage.

4.8 FCOT (First Copy Output Time)

FCOT time of the printer is shown in the table below.

The time required for the first sheet of paper to be delivered after the Copy indication is given is calculated on the following conditions (rounded to one decimal place).

- IOT performance that the controller does not have IOT wait.
- The printer is in the standby mode. (ROS MOTOR OFF, FUSER READY)
- Paper is A4 SEF
- Document on the platen glass.
- Except when process control is operating*1

*1:Process controller operation is process controls such as TC control, electric potential control, cleaning cycle, registration control, and so on. Sometimes, the printer stops feeding papers for a certain period of time while continuous printing for these operations.

- Color mode

B/W:	13 sec. or less
Color:	25 sec. or less

4.9 Continuous Copying Speed

The continuous copying speed is shown in the below. (Same manuscript, after second page)

OS	PDL	Test Chart	Paper Size	Paper Type	Paper Tray	Color/BW	Duplex/Simplex	Average Print Speed
XP	PCL6	J11E	A4/Letter SEF	Plain paper	MPF	Color	Simplex	56 sec. or less
XP	PCL6	J11E	A4/Letter SEF	Plain paper	MPF	BW	Simplex	38 sec. or less
XP	PCL6	J11E	A4/Letter SEF	Plain paper	MPF	Color	Duplex	80 sec. or less
XP	PCL6	J11E	A4/Letter SEF	Plain paper	MPF	BW	Duplex	56 sec. or less
XP	PCL6	J11E	A4/Letter SEF	Plain paper	Tray1	Color	Simplex	56 sec. or less
XP	PCL6	J11E	A4/Letter SEF	Plain paper	Tray1	BW	Simplex	38 sec. or less
XP	PCL6	J11E	A4/Letter SEF	Plain paper	Tray1	Color	Duplex	79 sec. or less
XP	PCL6	J11E	A4/Letter SEF	Plain paper	Tray1	BW	Duplex	56 sec. or less
XP	PCL6	J11E	A4/Letter SEF	Plain paper	Tray2	Color	Simplex	57 sec. or less
XP	PCL6	J11E	A4/Letter SEF	Plain paper	Tray2	BW	Simplex	38.5 sec. or less
XP	PCL6	J11E	A4/Letter SEF	Plain paper	Tray2	Color	Duplex	80 sec. or less
XP	PCL6	J11E	A4/Letter SEF	Plain paper	Tray2	BW	Duplex	57 sec. or less
OSX	PS	J11E	A4/Letter SEF	Plain paper	Tray1	Color	Simplex	435 sec. or less
OSX	PS	J11E	A4/Letter SEF	Plain paper	Tray1	BW	Simplex	355 sec. or less
OSX	PS	J9E	A4/Letter SEF	Plain paper	Tray1	Color	Simplex	77 sec. or less
OSX	PS	J9E	A4/Letter SEF	Plain paper	Tray1	BW	Simplex	71 sec. or less
OSX	PS	J11E	A4/Letter SEF	Plain paper	Tray1	Color	Duplex	442 sec. or less
OSX	PS	J11E	A4/Letter SEF	Plain paper	Tray1	B/W	Duplex	400 sec. or less
OSX	PS	J9E x2	A4/Letter SEF	Plain paper	Tray1	Color	Duplex	151 sec. or less
OSX	PS	J9E x2	A4/Letter SEF	Plain paper	Tray1	BW	Duplex	135 sec. or less

4.10 Input Properties

4.10.1 Paper pick-up system

- Paper pick-up with paper tray
Feeding method of this printer is ARRF method.

- MSI paper pick-up
Feeding method of this printer is S-ARRF method.

- Duplex paper feeder unit
It can be installed as an option, and it enables duplex printing. Selection of Duplex Feeder Unit is designated from the controller.

4.10.2 Paper pick-up capacity

- Paper pick-up with paper tray
 - 550 sheet Paper Tray : 550 sheets or below 59.4mm of standard paper (Option)
 - 250 sheet Paper Tray : 250 sheets or below 27.6mm of standard paper (Standard)

- MSI paper pick-up
150 sheets or below 15mm of standard paper

4.11 Output Properties

4.11.1 Paper delivery system

Paper can be delivered by the following method.

- FACE DOWN delivery

4.11.2 Paper delivery capacity

- FACE DOWN delivery

250 sheets (Letter/A4 standard paper)

4.11.3 Delivery paper size/mass

- FACE DOWN delivery

All paper sizes applicable to this printer

4.11.4 Full stack detection

non

4.12 Paper

4.12.1 Paper type

Paper which can be used with this printer is classified into standard paper, general paper and special paper.

- Standard paper

Using this type of paper is recommended. Reliability, operability and print image quality are the application range of the specifications.

Following paper is the standard paper.

	B/W	F/C
For overseas market	4200DP	X-pressions

- General paper

General paper is plain paper except standard paper and special paper, and its reliability and running performance are within the specification, but the print image quality is out of the specification.

- Special paper

Special paper except for plain paper. Reliability and operability are the applicable range of specifications but the print image quality is out of the applicable range of specifications.

4.12.2 Paper mass

- Paper feed from paper tray

"60 to 216 gsm" (16 lb to 80 lb)

- Paper feed from MSI

"60 to 216 gsm" (16 lb to 80 lb)

4.12.3 Paper size

Paper size which can be set to each paper pick-up unit is shown in the table below.

Cassette	Paper size
550 Sheet Paper Tray	A5, B5 (JIS, IOS), A4, Letter, Executive, Leagal
250 Sheet Paper Tray	A5, B5 (JIS, IOS), A4, Letter, Executive, Leagal
MSI Tray	Minimum size Width 76.2mm (3 in.) × Length 98.4mm (3.87 in.) Maximum size Width 220mm (8.66 in.) × Length 355.6mm (14 in.)

5. Consumables

Consumables are usually replaced by costumers. In the event of recovery of failure attributable to consumables or isolation of failure, you may replace them.

5.1 Items of Consumables

- Black toner cartridge
Cartridge to supply black toner to the development unit.
Black toner cartridge has CRUM (CRU memory) to record information.
- Yellow toner cartridge
Cartridge to supply yellow toner to the development unit.
Yellow toner cartridge has CRUM (CRU memory) to record information.
- Magenta toner cartridge
Cartridge to supply magenta toner to the development unit.
Magenta toner cartridge has CRUM (CRU memory) to record information.
- Cyan toner cartridge
Cartridge to supply cyan toner to the development unit.
Cyan toner cartridge has CRUM (CRU memory) to record information.

5.2 Consumable Life

- Black toner cartridge: 5kPV or 8kPV
- Yellow toner cartridge: 4kPV or 8kPV
- Magenta toner cartridge: 4kPV or 8kPV
- Cyan toner cartridge: 4kPV or 8kPV

5.3 Periodic Replacing Parts (Reference)

- | | |
|--|--------|
| - SEPARATOR and FEED ROLLER (250/550 Feeder) | 100kPV |
| - TRANSFER BELT | 100kPV |
| - FUSER | 100kPV |

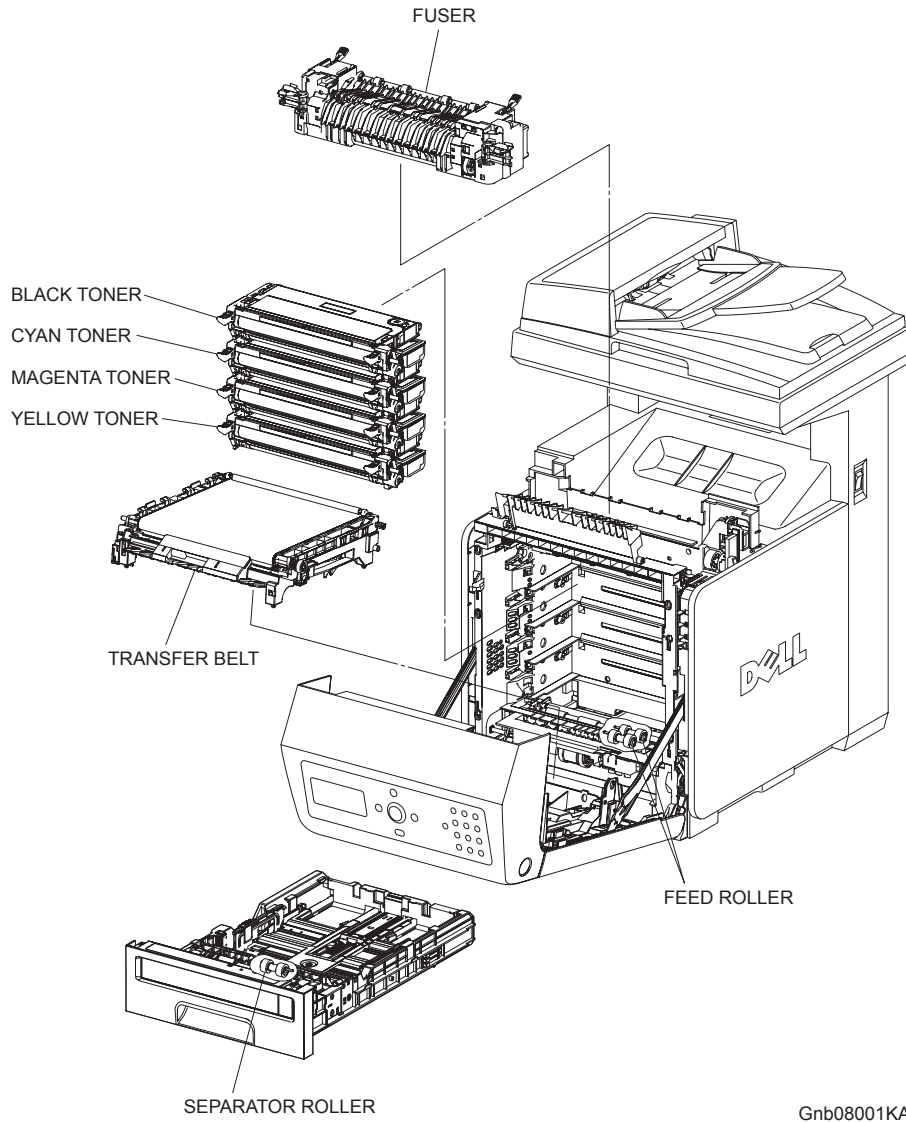

Gnb08001KA

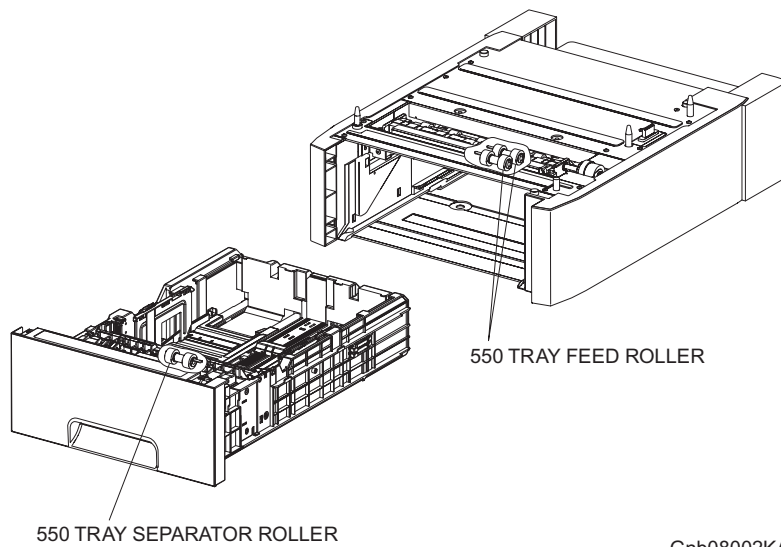

Gnb08002KA

6. Operating Environment

6.1 Installation Temperature / Humidity

Installation temperature and humidity on the condition without condensation is as follows.

At operating: 5-32 °C, 15-85%RH (No condensation)

6.2 Installation Altitude

0 to 3,100m

6.3 Installation Horizontality

Longitudinal levelness of table surface on which the printer is installed: 1 degree or under

Lateral levelness of table surface on which the printer is installed : 1 degree or under

6.4 Ambient Lighting

3000 Lux or less (without no direct sun beams)

6.5 Storage Temperature of a Toner Cartridge

The guaranteed period of the print cartridge before unpacked is as follows:

Normal conditions: 24 months under 0 to 35°C, 15 to 80% RH.

Harsh conditions: Up to one month under -20 to 0°C and 35 to 40°C, 5 to 15% RH and 80 to 95% RH.

The storage altitude shall be 0 to 3500m. Can be extended to 0 to 15000m when shipped by air.

(Provided that the cargo bay is pressurized to 70.9275Kpa or higher.)

7. Safety / Environment Conditions

7.1 Safety Standard

110-127V system

UL60950 3rd Edition

CSA C22.2 No.60950-00

220-240V system

IEC60950 3rd Edition / EN60950 2000

7.2 Laser Safety Standard

110-127V system

FDA21CFR Chapter 1, Subchapter J, Section 1010, 1040

220- 240V system

IEC60825 Class 1 Laser Product

7.3 EMI

110-127V system (US)

FCC Part 15, Subpart B, Class B

220-240V system (EC)

EN55022 (CISPR Publication 22), Class B

7.4 Noise

Noise of printing is as follows.

Noise Printer	Noise Level
Standby	≤ 4.18
Printing	≤ 6.6
Copying	≤ 6.59

8. Print image Quality

8.1 Image Quality Guarantee Conditions

The image quality is specified and guaranteed under the following conditions.

8.1.1 Environmental conditions

Environment condition for evaluating image quality

Temperature: 15-28 °C

Humidity: 20-70%RH

8.1.2 Guaranteed paper

The print image quality specified here is guaranteed with standard paper fed from the paper tray.

Evaluation is performed with the maximum size of each standard paper.

- Xerox C2 paper

8.1.3 Paper condition

The paper used is fresh paper immediately after unpacked.

8.1.4 Printer condition

The print image quality specified in this section is guaranteed with the printer in normal condition.

8.1.5 Image quality guaranteed area

The print image quality specified in this section is guaranteed in the guaranteed image quality area specified in this manual. (Refer to Chapter 1)

8.1.6 Criterion

The print image quality is guaranteed with the Spec. In rate = 90% ($\gamma = 90\%$).

9. Option

9.1 Options to be Installed by Users

Users can install the following units.

- 550 Feeder Unit
- Duplex Unit
- Multi-protocol card
- Expansion memory (256MB/512MB/1024MB)
- Multi-protocol card/Wireless Printer adaptor

10. ESS Specification

10.1 External Interface

10.1.1 USB

Item	Specification
Connector	Type-B x 1
Protocol	USB2.0, HighSpeed
Supported Client	Windows 2000 / XP / x64 XP / Server2003 / x64 Server2003 PC with USB MacOS X PC with USB Linux PC with USB

10.1.2 Ethernet

Item	Specification
Connection	10 Base-T/100 Base-T
Protocol	See "10.2 Network Protocol" for details
Supported Client	Windows NT 4.0/2000/XP/x64XP/Server 2003/x64Server2003, PC Mac OS X PC Linux/Unix PC

10.1.3 IEEE1284

Item	Specification
Connection	Centronics 36pin x 1
Protocol	Standard, Nibble, ECP
Supported Client	Windows NT4.0/2000/XP/x64XP/Server 2003/x64Server2003 PC Linux PC

10.1.4 Wireless

multi-protocol Card is required.

Item	Specification
Connection	802.11b/802.11g
Protocol	See "10.2 Network Protocol" for details
Supported Client	Windows NT4.0/2000/XP/x64XP/Server 2003/x64Server2003, PC Mac OS X PC Linux PC

10.1.5 Interface Specification

Option Configuration	Interface that can be operated				
	USB	IEEE1284	Ethernet		IEEE802.11b/11g (multi-protocol)
			single-protocol	multi-protocol	
Standard	Yes	Yes	Yes	No	No
Standard +MPC	Yes	Yes	No	Yes	No
Standard +MPC +Wireless	Yes	Yes	Yes	No	Yes

*Protocol: See "10.2 Network Protocol" for details

10.2 Network Protocol

10.2.1 Printing Protocol

Protocol	Transport	Maximum Session	Supported Client
LPD	TCP/IP	1	Windows NT 4.0/2000/XP/x64XP/Server 2003/ x64Server2003 Mac OS X Linux ^{*4} Unix ^{*4}
Port9100	TCP/IP	1	Windows NT4.0/2000/XP/x64XP/Server2003/ x64Server2003
IPP ^{*1}	TCP/IP	5	Windows2000/XP/ x64XP/Server2003/x64Server2003, Mac OS X 10.3
SMB ^{*1}	TCP/IP	5	Windows NT4.0/2000/XP/x64XP/Server2003/ x64Server2003
	NetBEUI	5	Windows NT 4.0/2000,
NetWare (P-Server) ^{*1}	NCP/IPX TCP/IP ^{*5}	1	NetWare3.12, 3.2, (NDS unsupported) NetWare4.1, 4.11, 4.2, 5, 6,6.5 ^{*3}
EtherTalk ^{*1}	ATP/DDP	1	Mac OS X
FTP	TCP/IP	1	Windows NT 4.0/2000/XP/x64XP/Server2003/ x64Server2003 Unix (Solaris 9,HP-UX11.i) Linux (RedHat8/9) Mac OS X

*1: Optional multi-protocol processor card is required.

*2: Maximum session is defined as the number of print request acceptable at the same time.

*3: NetWare 6.5 is required to apply support pack 1.1 or later provided by Novell.

*4: Supported if a driver provided by FXPS is used.

*5: Available for versions later than NetWare5.

10.2.2 Other Protocols

Protocol	Transport	Support
SNMP	UDP/IP	[Supported MIB] MIB-II (RFC1213) HostResources MIB (RFC1514) PrinterMIB (RFC1759) XCM12.4
	IPX	
HTTP	TCP/IP	[Client] (Windows NT4.0/2000/XP) Netscape Communicator 7.x or later Internet Explorer 6.0 or later (Mac OS 10.2 or later) Safari 1.0 or later
DHCP	UDP/IP	[Supported OS] Windows NT 4.0 Server, Windows 2000 Server, Windows Server 2003, Windows x64 server 2003, Linux, Unix
BOOTP	UDP/IP	[Supported OS] Windows NT 4.0 Server, Windows 2000 Server, Windows Server 2003, Windows x64 Server 2003, Unix
RARP	TCP/IP	[Supported OS] Unix
AutoIP	TCP/IP	[Software] Installer
WINS* ¹	TCP/IP	[Supported OS] Windows NT 4.0 Server, Windows 2000 Server, Windows Server 2003, Windows x64 Server 2003
SMTP	TCP/IP	E-mail Alert [Supported Mail Server] LotusNotes, MS-Exchange, Eudora
FTP	TCP/IP	Firmware Update
Bonjour(mDNS)* ¹	UDP/IP	[Supported OS] Mac OS 10.2 or later
DDNS* ¹	TCP/IP	[Supported OS] Windows 2000 Server, Windows 2003, Windows x64 Server 2003, Unix

*1: Optional multiprotocol card is required

10.3 Decomposer

10.3.1 PDL/Emulation

Decomposer is still PCL. However printer can accept the job generated only by the own printer driver.

Interface/Protocol	PDL/Emulation		
	PCL5c	PCL6	PS3
USB	Yes	Yes	Yes
1284	Yes	Yes	Yes
Lpd	Yes	Yes	Yes
Port9100	Yes	Yes	Yes
IPP	Yes	Yes	Yes
SMB	Yes	Yes	Yes
NetWare (P-Server)	Yes	Yes	Yes
EtherTalk (A-PAP)	No	No	Yes
FTP	No	No	Yes

Yes: Supported No: Not supported

10.3.2 Font

81 fonts and 36 Symbol Sets for PCL and 136 fonts for PS3 are available as built-in font.

10.3.3 Form Overlay

The function for writing PCL5 forms is supported.

10.3.4 Image Area

Usable Area Size	Maximum : 215.9mm (8.5 in.) x 355.6mm (14 in.)
Unprintable Area	4.1 mm each from four edges (left, right, top and bottom) of paper For DL LEF, 6.1mm from left and right edges, 4.1 mm from top and bottom edges are not printable
Printable Area	Maximum : 207.9mm (8.18 in.) x 347.6mm (13.68 in.)
Print Image Quality Guaranteed Area	Same as Printable Area

10.4 Job Control

10.4.1 Cancel Print

A print job in process can be cancelled at the operation panel.

10.4.2 Job Recovery

When a job fails due to a paper jam, the printer automatically restarts the job after the jammed paper is removed.

10.4.3 Job Time Out

When job transmission is interrupted for a certain period of time (Time can be changed at the operation panel and unlimited time can be selected), the print data is deleted as an error.

10.4.4 Secure Print (/Store Print)

When memory is expanded (256MB or more), the printer holds print data, including a user password (12 digits) specified in the printer driver, user name and document name, in memory. The data is not printed until the same password, user name and document name are specified at the printer UI. The user can select whether the data is cleared or not after being printed. The data remains in the printer as long as it is not cleared. The data on the memory is cleared when the printer is turned off. The user can omit entering a password (This is called Store Print). *This function is not available for MAC OS X 10.2.8.

10.4.5 Proof Print

When memory is expanded (256MB or more) is installed, proof print can be selected only when multiple sets of prints are specified in the printer driver. The printer prints only the first set of the print data including a user name and document name specified in the printer driver. Then the user can select whether the remaining sets are printed or not (the remaining data is cleared) when the same user name and document name are entered at the printer UI. The data remains in the printer as long as it is not cleared. The data on the memory is cleared when the printer is turned off. *This function is not available for MAC OS X 10.2.8 and Linux which use CPUS..

10.4.6 IP Filter

The user can select to accept or reject jobs for the specified IP address. Up to 5 IP addresses can be specified.

IP filter is available only to LPD and Port9100.

10.5 Logging

10.5.1 Job Logging

The printer can retain up to 20 job logs. Job log can be printed instantly according to the user's request or automatically printed when the number of the retained job logs has reached 20. Job log includes the following information:

- Job sent date and time*
- Input interface (USB, Lpd etc.)
- Document name (File name) *
- Output color
- User name/Host name*
- Number of printed pages (Color/B/W)
- Number of printed impressions (Color/B/W)
- Paper size
- Result (Successful, Error, etc.)

*Not displayed for PS.

10.5.2 Error Logging

The printer can retain up to 42 jam errors and up to 42 fatal errors.

The user can print error log by the panel operation.

Jam error log includes the following information:

- TOTAL PV when jam has occurred
- Name of jam

Fatal error log includes the following information:

- TOTAL PV when error has occurred
- Error code

10.5.3 Billing Count

NOTE

- **The same data is stored in two or more addresses in one IC. Datacheck (checksum etc.) is conducted.**

NOTE

- **When ESS is replaced, IC can be transferred. (IC is mounted on socket)**

Counter	Description
Color Print Counter	Count the number of paper printed in color (7 digits)
B/W Print Counter	Count the number of paper printed in B/W (7 digits)
Total Print Counter	Count the total number of paper printed in color and B/W (7 digits)

10.6 ID Print

User name can be printed. The printing position can be selected from upper right, upper left, lower right and lower left (Only for PCL6).

The user selects using the operation panel whether user name is printed or not and where it is printed.

10.7 3rd Party Mode

When life of toner cartridge has ended, the printer stops accepting print request (life of toner cartridge is counted by the counter in CRUM). Taking into consideration that some users use refilled toner cartridges, the printer can accept print request by the user's panel operation even if life of toner cartridge has ended. When the mode has changed so that the printer does not stop even after life of toner cartridge ends, the printer displays a message on the operation panel to inform the user of the mode change. When the printer operates in this mode, print image quality is not guaranteed. Also, remaining toner level is not displayed (as CRUM data can not be guaranteed).

10.8 Utility Print

10.8.1 Printer Settings List

Printer Settings List can be printed according to the user's request.

Printer Settings List is printed in B/W in the automatically selected paper tray.

Printer Settings List includes the following information:

Items on the list are slightly different from below when wireless LAN option is installed.

[Title]

Product name (Logo)

[General]

Printer Name, Service tag, Asset Number, Memory capacity, Printer language, Number of fonts available, PDL name and version, ESS version, IOT version, Boot version, Color print volume, B/W print volume, Default paper size, Default paper type for plain paper, Default paper type for label, Default panel display language

[Network]

MPC version, MAC address, Ethernet Setting (10 or 100base & half or full)

TCP/IP: TCP/IP settings, IP address, Subnet Mask, Gateway Address

IPX/SPX: Frame type, Network address

IP Filter: Address, Mask, Mode

Other supported protocols

[Wireless]

MPC version, MAC address, WirelessSetting*(SSID, Network Type, Encryption, Link Quality, Link Channel)

*Listed when wireless LAN option is installed

[Printer Options]

"Multi-protocol Card" Yes or No (If available, version)

"Available Paper Tray" (Tray 1, Tray 2, MPF)

[Print Volume]

Print volume for each paper size

10.8.2 Panel Settings List Print

Panel Settings List can be printed by the user's operation.

Panel Settings List is printed in B/W on A4 size paper (Letter size paper for the US) in the automatically selected paper tray.

10.8.3 Font List Print

PCL or PS Font List and Color Bar (for color check) can be printed by the user's operation.

Font List is printed in color on A4 size paper (Letter size paper for the US) in the automatically selected paper tray.

10.8.4 Job Log Print

The user can print Job Log by requesting instant print or by setting auto print.

Job Log is printed in B/W on A4 size paper (Letter size paper for the US) in the automatically selected paper tray.

11. IIT (Image Input Terminal) Specifications

11.1 Scanner

11.1.1 Scanning Method

- Platen Mode: The document is scanned directly on the platen glass.
- CVT (Constant Velocity Transport) mode: The document is scanned via the ADF (Auto Document Feeder).

11.1.2 Optical Resolution

- Fast Scanning: 600dpi
- Slow Scanning: 600dpi/300dpi

11.1.3 Fast Scanning Speed

- B/W: 469.8 usec/Line (300dpi)
423 usec/Line (600dpi)
- Color: 939.8 usec/Line (8bit)
1879.6 usec/Line (16bit: including 16bit input -> 8bit output)

11.1.4 Slow Scanning Speed

- B&W 600dpi: 100mm/sec.
- B&W 300dpi: 180mm/sec.
- Color (8bit) 600dpi: 45mm/sec.
- Color (8bit) 300dpi: 90mm/sec.
- Color (8bit) 150dpi: 180mm/sec.
- Color (16bit) 600dpi: 22.5mm/sec.
- Color (16bit) 300dpi: 45mm/sec.
- Color (16bit) 150dpi: 90mm/sec.

11.1.5 Light Source

Cold cathode fluorescent lamp (two tubes)

11.1.6 Maximum Scanning Size

Platen Mode: 215.9mm x 297mm (8.5in. x 11.7in.)
CVT Mode: 215.9mm x 355.6mm (8.5in. x 14in.)

11.1.7 Input Bit Depth

- B&W: 16bit x 2ch. (Odd/Even), 8bit x 2ch. (Odd/Even)
- Color: 16bit x 3ch. (RGB), 8bit x 3ch. (RGB)

11.2 ADF

11.2.1 Document Condition

Sheets without breakage, wrinkles, or folds.

11.2.2 Document Thickness

Unlimited for platen scanning.

11.2.3 Auto Document Size Detection

None

11.2.4 Document Feed System

FRPF: Friction Retard Pad Feeder (Top sheet feeding)

11.2.5 ADF Half-Open, Full-Open Angles

- Full-open: 70 +/- 8 degrees
- Half-open: 10 +/- 5 degrees to 70 +/- 5 degrees
- Self-closing: 10 +/- 5 degrees or less

11.2.6 Document Registration

- ADF Mode: Center Registration
- Platen Mode: Side Registration

11.2.7 Capacity

- 50 sheets. (Plain Paper)

12. FAX Specifications

12.1 Communication

12.1.1 Communication Mode

- Priority 1: ITU-T Super G3
- Priority 2: ITU-T G3 ECM
- Priority 3: ITU-T G3

ITU: International Telecommunication Union

ITU-T: ITU Telecommunication Standardization Sector

ECM: Error Correction Mode

12.1.2 Density of Transmitting Pixels

- B&W (Fast Scan x Slow Scan)

Lines: 16 x 15.4/mm, 8 x 15.4/mm, 8 x 7.71/mm, 8 x 3.85/mm

Pixels: 400 ppi x 400dpi, 300ppi x 300ppi, 200ppi x 200ppi x 200ppi

- Color (Fast Scan x Slow Scan)

200ppi x 200ppi

12.1.3 Modem Signal Processing

The following protocols are supported:

- V. 34 (Max.33.6 kbps)
- V. 17 (14.4/12/9.6/7.2 kbps)
- V. 33 (14.4/12/ kbps) receive only
- V. 29 (9.6/7.2 kbps)
- V. 27ter (4.8/2.4 kbps)

12.1.4 Data Compression, Output Bit Depth

- B&W (1bit): JBIG, MMR, MR, MH
- Color (R, G, B, 8bit): JPEG

12.1.5 Communication Control Procedure

The procedure complies with ITU-T Recommendation T.30

12.1.6 Transmission Time

The time (T_p) to transmit image data in G3 communication is defined in the table below. Resolution is not converted during transmission and density is normal.

Chart / Mode	14.4Kbps (MMR)	28.8Kbps (MMR)	33.6Kbps (JBIG)*1
The Institute of Image Electronics Engineer of Japan No.4 / Super Fine (400dpi)	43 sec. or less	22 sec. or less	17 sec. or less
Fine	22 sec. or less	11 sec. or less	9 sec. or less
Standard	16 sec. or less	8 sec. or less	6 sec. or less
ITU-T No.1 / Super Fine	30 sec. or less	13 sec. or less	10 sec. or less
Fine	13 sec. or less	6 sec. or less	5 sec. or less
Standard	9 sec. or less	5 sec. or less	4 sec. or less
FX English Sales Chart / Standard	6 sec. or less	3 sec. or less	2 sec. or less
FX Japanese Sales Chart / Standard	8 sec. or less	4 sec. or less	3 sec. or less
The Institute of Image Electronics Engineer of Japan No.1 / Standard (Text/Photo)	73 sec. or less	37 sec. or less	20 sec. or less
The Institute of Image Electronics Engineer of Japan No.1 / Standard (Photo)	120 sec. or less	60 sec. or less	20 sec. or less

*1: Reference

12.1.7 Protocol Control Time

When data error is not identified, protocol control time (T_m , T_n , T_u) is as follows:

- V.17, V.29, V.27ter

Mode	Before messages: T_m	Between messages: T_n	After messages: T_u	Total
Standard protocol	16.4 sec. or less	3.2 sec. or less	4.4 sec. or less	24.0 sec. or less

-V.34

Mode	Before messages: T_m	Between messages: T_n	After messages: T_u	Total
Standard protocol	9.9 sec. or less	1.0 sec. or less	0.9 sec. or less	11.8 sec. or less

12.1.8 Throughput

Sending time is calculated in the following formula:

Sending time = Setup time + T_m + (N X T_p) + {(N-1) X T_n } + T_u (sec.)

(N: Send quantity, T_p : Image transmission time)

12.2 Telephone

12.2.1 Cable Characteristics

With pseudo cable of 0 through 15Km, the highest speed is guaranteed for communication with V.17m, V.29, and V.27ter respectively. As for V.34, 33600bps or higher communication speed is guaranteed with 0 through 2Km cable, 31200bps or higher communication speed with 2 through 9Km cable, 19200bps or higher communication speed with 9 through 15km cable.

12.2.2 Communication Load Characteristics

Data error characteristics for noise and cable loss during communication are as follows:

Error rate (Error frequency/Total communication quantity) $\leq 1/500$

12.2.3 Incoming Call Level

Under ideal conditions (flat line, no noise, and no other line stress), normal communication is guaranteed in the range from 0 through 43dBm. As for V.17, V.29, and V.27ter, the highest speed is guaranteed in the range from -6 through -43dBm. As for V.34, 33600bps or higher communication speed shall be guaranteed in the range from -6 through -19dBm, 16800bps or higher communication speed in the range from -19 through -43dBm.

MFG Part Description	MFG P/N	Dell Part Description	DELL PN	CRU or FRU
COVER TOP	802E90341	CVR, TOP, 3115CN	JX636	FRU
COVER POLE IN L	802E90541	CVR, SCANR, INR, LF, 3115CN	NR641	FRU
COVER POLE IN R	802E90561	CVR, SCANR, INR, RT, 3115CN	DT289	FRU
COVER REAR	848E06680	CVR, REAR, 3115CN	UX692	FRU
COVER CST		CVR, TRAY, REAR, 3110/3115CN	NG885	FRU
COVER BOTTOM	848E06670	CVR, BTM, 3115CN	UX742	FRU
COVER R ASSY	802K84870	CVR, RIGHT, 3115CN	NR638	FRU
COVER L ASSY	802K84860	CVR, LEFT, 3115CN	KN332	FRU
COVER POLE R	848E06660	CVR, SCANR, OTR, RT, 3115CN	UX978	FRU
COVER POLE L	848E06650	CVR, SCANR, OTR, LF, 3115CN	JX783	FRU
COVER EXTENSION 2	802E97742	PNL, EXTN, TRAY, PAPER, 3115CN	UX933	CRU
KIT OPERATOR PANEL	604K37800	PNL, OPR, PTR, 3115CN	UX731	FRU
KIT COVER ASSY FRONT	604K37810	CVR, FRONT, 3115CN	DT287	FRU
KIT-COVER ASSY MSI		CVR, MPF, 3110/3115CN	PG783	FRU
CASSETTE ASSY 250		TRAY, PAPER, 250, 3110CN	GG751	CRU
KIT SEPARATOR ROLLER ASSY		RLLR, ASSY, SPRTR, 3110/3115CN	NG884	CRU
KIT SEPARATOR & FEED ROLLER		RLLR, FDR, TRAY, 250, 3110/3115CN	RG399	CRU
KIT SOLENOID FEED MSI		SOL, FEEDER, MPF, 3110/3115CN	RG397	FRU
KIT ROLL ASSY FEED MSI		RLLR, MPF, 3110/3115CN	UG162	CRU
KIT FEEDER ASSY		FDR, ASSY, INTEGRATED, 3110/15CN	NG874	FRU
TRANSFER ASSY(KIT-BELT CRU)		FDR, BTR, XPORT, PAPER, 3110/15, CN	HG432	FRU
SENSOR ASSY CRU		SNSR, ASSY, CTRG, TONER, 3110/15CN	RG394	FRU
DISPENSER ASSY		MOTOR, DSPN, TONER, 3110/3115CN	UG159	FRU
LED ASSY		ASSY, LED, 3110/3115CN	UG158	FRU
HVPS		PWA, PDB, HVPS, 3110/3115CN	TG074	FRU
CARTRIDGE ASSY-5K_K		CTRG, TONR, 5K, BLACK, 3110/3115CN	PF028	CRU
CARTRIDGE ASSY-8K_K		CTRG, TONR, 8K, BLACK, 3110/3115CN	PF030	CRU
CARTRIDGE ASSY-4K_C		CTRG, TONR, 4K, CYAN, 3110/3115CN	RF012	CRU
CARTRIDGE ASSY-8K_C		CTRG, TONR, 8K, CYAN, 3110/3115CN	PF029	CRU
CARTRIDGE ASSY-4K_M		CTRG, TONR, 4K, MGTA, 3110/3115CN	MF790	CRU
CARTRIDGE ASSY-8K_M		CTRG, TONR, 8K, MGTA, 3110/3115CN	RF013	CRU
CARTRIDGE ASSY-4K_Y		CTRG, TONR, 4K, YEL, 3110/3115CN	NF555	CRU
CARTRIDGE ASSY-8K_Y		CTRG, TONR, 8K, YEL, 3110/3115CN	NF556	CRU
KIT ROS ASSY BBR		PRTH, ROS, ASSY, 3115CN	JX767	FRU
FUSER ASSY KMY 100V		ASSY, FUSER, 100V, 3110CN	GG670	CRU
FUSER ASSY KMY 115V		ASSY, FUSER, 110V, 3110/3115CN	FG627	CRU
FUSER ASSY KMY 230V		ASSY, FUSER, 230V, 3110/3115CN	JG336	CRU
MAINTENANCE KIT 100V		KIT, PTR, MAINT, 100V, 100K	TG139	CRU
MAINTENANCE KIT 115V		KIT, PTR, MAINT, 110V, 100K	UG190	CRU
MAINTENANCE KIT 230V		KIT, PTR, MAINT, 220V, 100K	TG142	CRU
CHUTE DUP GATE		CHUTE, GATE, DPLX, 3110/3115CN	RG348	FRU
WHEEL STAR ASSY		RLLR, ASSY, SPUR, 3110/3115CN	DH096	FRU
SWITCH ASSY SIZE		SWT, ASSY, SIZE, 3110/3115CN	PG725	FRU
KIT LINK ASSY L		GDE, ASSY, RT, 3110/3115CN	UG096	FRU
KIT LINK ASSY R		GDE, ASSY, LF, 3110/3115CN	PG731	FRU
KIT FOOT ASSY		FOOT, RBR, 3110/3115CN	TG071	FRU
DRIVE ASSY MAIN		MOTOR, DR, ASSY, PHCN, 3110/15CN	NG741	FRU
DRIVE ASSY PH		MOTOR, DR, ASSY, PROCESS, 3110/115	TG070	FRU
HARN ASSY INTERLOCK AIO	962K45360	SWT, INTERLOCK, 3115CN	NR755	FRU
PSLV AIO 100V	105K22820	PWA, PDB, HV/LVPS, 100V/115V, 3115	DT340	FRU
PSLV AIO 200V	105K22830	PWA, PDB, HV/LVPS, 230V, 3115CN	KN416	FRU
FAN MAIN		FAN, MAIN, 24V, 3110/3115CN	UG084	FRU
SWITCH POWER		SWT, POWER, 3110/3115CN	NG731	FRU
SENSOR HUM		SNSR, HUMIDITY, 3110/3115CN	PG716	FRU
PWBA MCU KMY		CRD, CTL, MCU, 3110/3115, CN	TG065	FRU
PWBA ESS	960K18591	CRD, CTL, I/O, ESS, 3115CN	NR642	FRU
PWBA ESS FAX	604K37830	CRD, CTL, I/O, ESS/FAX, 3115CN	UX752	FRU
PWBA FAX	960K18430	CRD, CTL, I/O, FAX, 3115CN	KN346	FRU
SPEAKER ASSY	604K37840	SPKR, 0.2W, 50MM, 3115CN	NR780	FRU
ADF EXIT TRAY ASSY	604K37850	TRAY, PAPER, ADF, EXIT, 3115CN	NR759	FRU
KIT ADF ROLL & PAD	604K37860	RLLR, ASSY, SPRTR, 3115CN (Roller, separator pad, and spring)	JX768	CRU

MULTI PROTOCOL CARD ZIN		CRD,NTWK,COMM,3110/15/5110CN	JG348	CRU
WIRELESS PRINTER ADAPTER		CRD,WRLES,ANT,COMM, (Installs to Multi Protocol Card includes USB cover)	RD109	CRU
MPC&WIRELESS PRINTER ADAPTER		KIT,ADPT,WRLS,W/NTWK,CRD	JG333	CRU
KIT-DUPLEX MODULE		ASSY,DPLXR,PAPER,3110/3115CN	HG445	CRU
550 FEEDER		FDR,PAPER,550,3110/3115CN	TG147	FRU
COVER CST 550		CVR,REAR,TRAY,550,3110/3115CN	HH956	CRU
KIT SCREW JOINT		SCR,FDR,3110/3115CN	TG064	CRU
CASSETTE ASSY 550		TRAY,PAPER,550,3110/3115,CN	UG197	CRU
550 OPTION FEEDER BARBERA	675K44570	ASSY,FDR,PAPER,550,3115CN	UX932	CRU

Notes

CRU : Customer Replaceable Units - refers to parts that can easily be replaced by the customer without sending an onsite technician.
FRU : Field Replaceable Unit - a part that can be replaced or added by onsite technician.