



Dell 3110cn **Service Manual**

17 Jan 2008

**Information in this document is subject to change without notice.
2010 Dell Inc. All rights reserved.**

Reproduction in any manner whatsoever without the written permission of Dell Inc. is strictly forbidden.
Trademarks used in this text: Dell and the DELL logo are trademarks of Dell Inc.

Other trademarks and trade names may be used in this document to refer to the entities claiming the marks and names of their products. Dell Inc. disclaims any proprietary interest in trademarks and trade names other than its own.

Cautions

Operation contents of this document may be subject to modification without notice.

Dell Inc. will not assume responsibility for accidental or incidental damages resulting from technical or editorial errors or omissions in this manual, the issue of this manual, the execution of descriptions in this manual, or the use of this manual.

This document is protected by copyright. Do not photocopy or duplicate any part of this document in any form without written permission from Dell Inc.

1. About this manual

This manual is a standard service manual of Dell Inc. containing information required for maintenance of this laser printer (standard specifications).

2. Marks giving caution

Maintenance operations requiring special cautions or additional information regarding descriptions in this manual are presented as "Warning," "Caution," or "Note," depending on their nature.



If instructions are not observed, death or serious injury may result.



If instructions are not observed, injuries to workers or physical damage to assets (including this laser printer) may result.

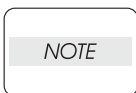

Essentials for procedures, steps, rules, and others.

Reference *Incidental information to descriptions.*

3. Related documents

- Instruction manuals (standard manuals)

Describe the operation and handling of this laser printer.

- Performance specifications

Describe in detail various specifications of this laser printer.

(In the event of a discrepancy between this manual and the performance specifications, the performance specifications take precedence.)

- Spare parts list

Information on maintenance parts (spare parts) for this laser printer.

4. Safety

To prevent possible accidents during maintenance operation, you should observe strictly the "Warning" and "Caution" information in this manual.

Avoid dangerous operations and operations out of the scope of this manual.

Various processes not covered by this manual may be required in actual operations, and should be performed carefully, always giving attention to safety.

4.1 Power source

Keep the power plug disconnected during the maintenance operation to prevent electric shock, burns and other damages.

If the power supply should be kept connected to measure voltage or for other similar reasons, take sufficient care to prevent electric shock, by following the procedures in this manual.



While the printer is on, never touch live parts if not required.



Power is supplied to the power switch / inlet even while the printer is off. Never touch its live components.



Do not touch live parts unless otherwise specified.

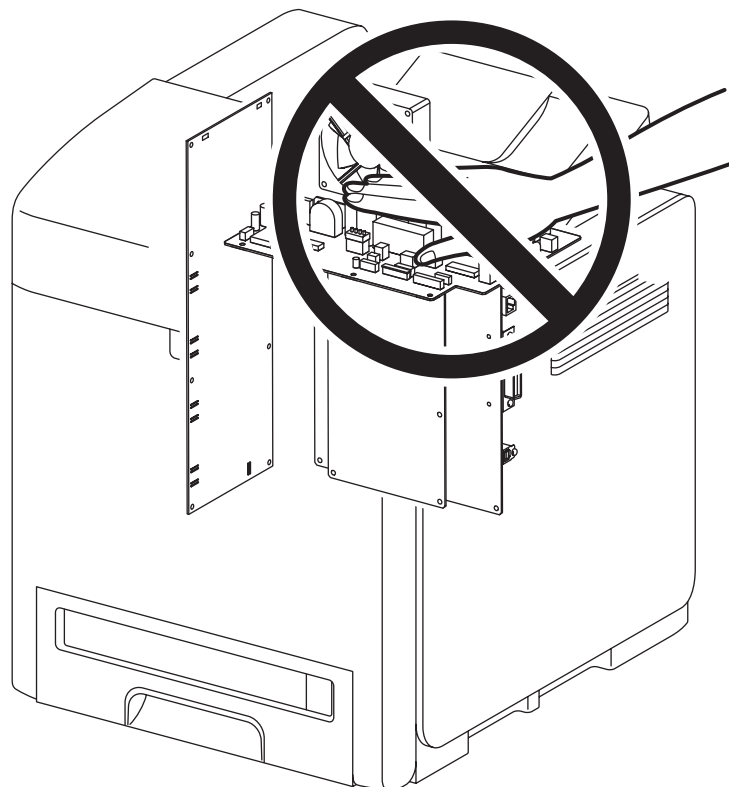

Kmy00002KB

4.2 Driving units

When servicing gears or other driving units, be sure to turn off the power switch and unplug the power cord. Drive them manually when required.



Do not do the print work removing the cover of the printer to confirm the operation of driving part.

4.3 High-temperature units

When servicing high-temperature units (securing unit, etc.), be sure to turn them off to prevent burns, injuries and other troubles. Remove the power plug and start service processes after they have cooled down sufficiently.



Because high-temperature units are still hot after they complete an operation, wait at least 40 minutes before starting maintenance service.

4.4 Laser beams



- *If your eyes are exposed to laser beams, you may lose your eyesight.*
- *Never open the cover if the warning label for laser beams is attached there.*
- *Before disassembling and reassembling this laser printer, be sure to turn it OFF.*
- *When servicing this laser printer while it is running, be sure to follow the procedures specified in this manual.*
- *You should be well aware that the laser beams are capable of injuring you and other people near the printer.*

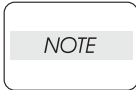

Laser beams have features as follows:

- Frequencies are smaller in width than other beams (sun and electric bulbs) and phases are uniform so that high monochromatic and convergence performance can be obtained and thin beams of light can reach places at a long distance.
- Being highly converged, the laser beams exert a heating action that may be harmful to human body.

Reference: *The laser beams of this laser printer are invisible rays.*

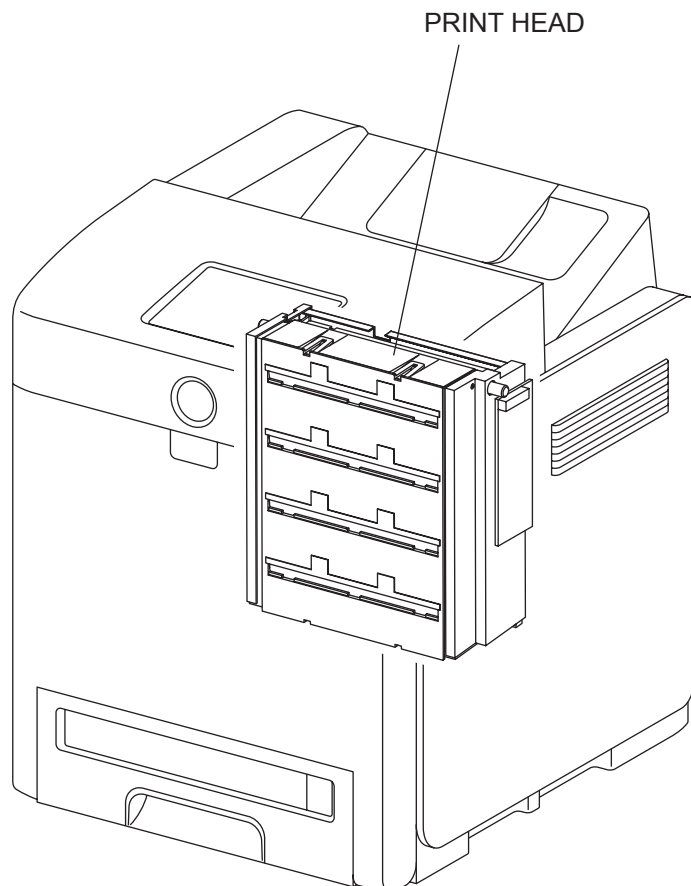

Kmy00003KA

4.5 Warning/caution labels

Warning labels and caution labels are attached to this laser printer to prevent accidents. Check those labels for their peeling or stains when servicing the printer.

4.5.1 Caution label for high-temperature units

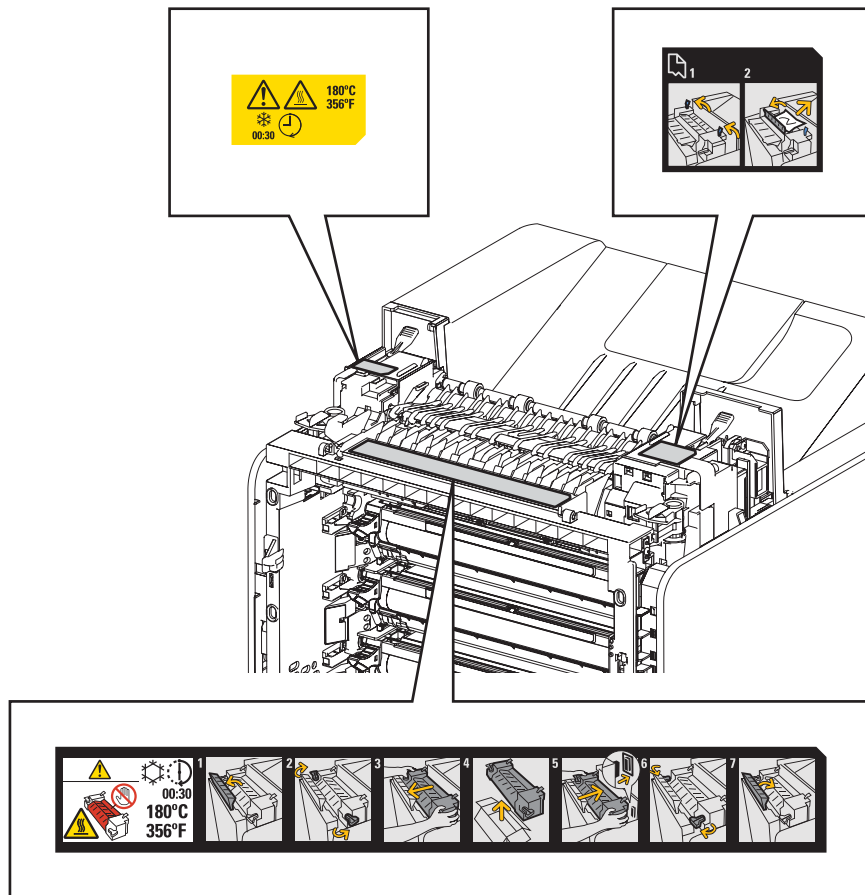

Kmy00004KA

4.5.2 Caution label for toner cartridges

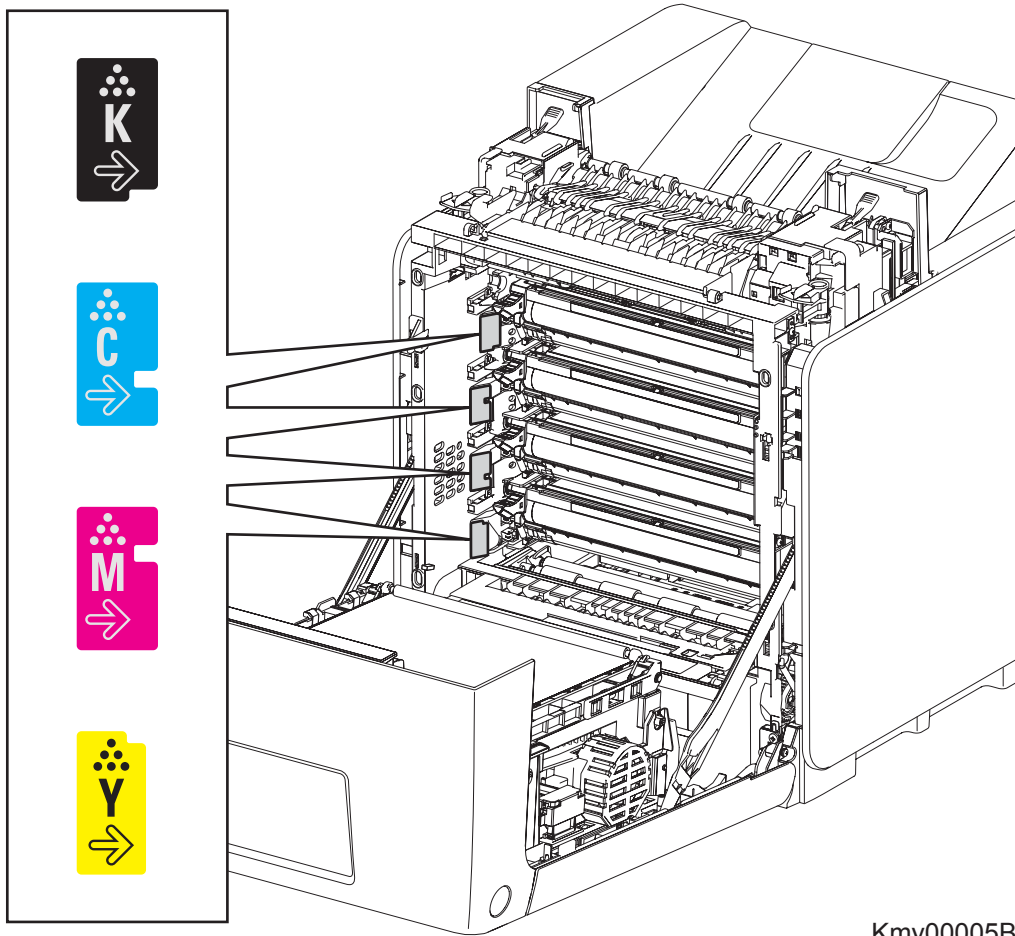

Kmy00005B

Dell® 3110cn Standard Capacity Black Cartridge PF028
 Black Toner Cartridge / Cartucho de toner negro / Cartuccia del toner color Nero
 Tonerkassette schwarz / Cartuchos de toner negro

Order Supplies at: www.dell.com/supplies

Dell is a trademark of Dell Inc. For warranty questions, see the limited warranty statements included with your printer documentation.

Dell® 3110cn Standard Capacity Cyan Cartridge RF012
 Cyan Toner Cartridge / Cartucho de toner cyan / Cartuccia del toner color Ciano
 Tonerkassette cyan / Cartuchos de toner cyan

Order Supplies at: www.dell.com/supplies

Dell is a trademark of Dell Inc. For warranty questions, see the limited warranty statements included with your printer documentation.

Dell® 3110cn Standard Capacity Magenta Cartridge MF790
 Magenta Toner Cartridge / Cartucho de toner magenta / Cartuccia del toner color Magenta
 Tonerkassette magenta / Cartuchos de toner magenta

Order Supplies at: www.dell.com/supplies

Dell is a trademark of Dell Inc. For warranty questions, see the limited warranty statements included with your printer documentation.

Dell® 3110cn Standard Capacity Yellow Cartridge NF555
 Yellow Toner Cartridge / Cartucho de toner jaune / Cartuccia del toner color Giallo
 Tonerkassette gelb / Cartuchos de toner amarillo

Order Supplies at: www.dell.com/supplies

Dell is a trademark of Dell Inc. For warranty questions, see the limited warranty statements included with your printer documentation.

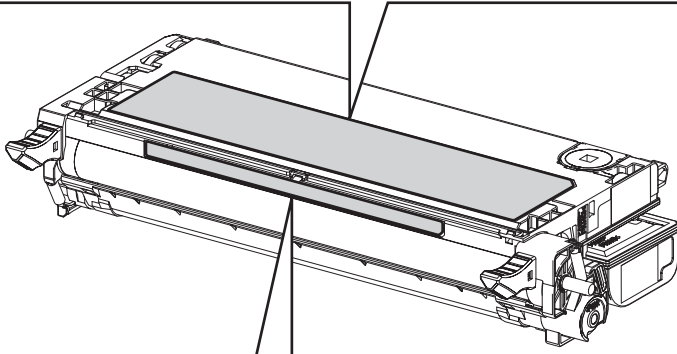

Kmy00006A

4.5.3 Caution label for MPF

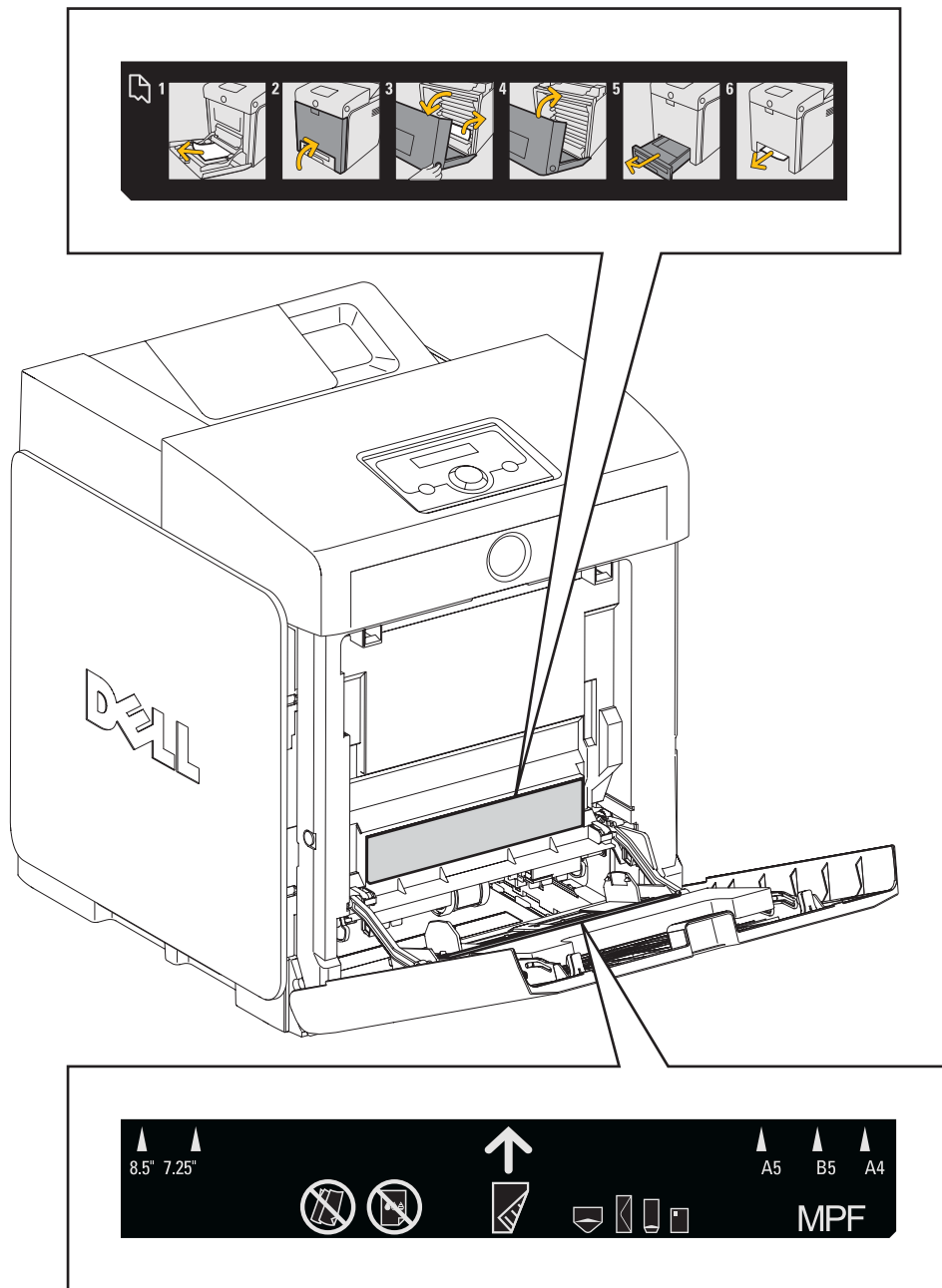

Kmy00008A

4.5.4 Caution label for print head

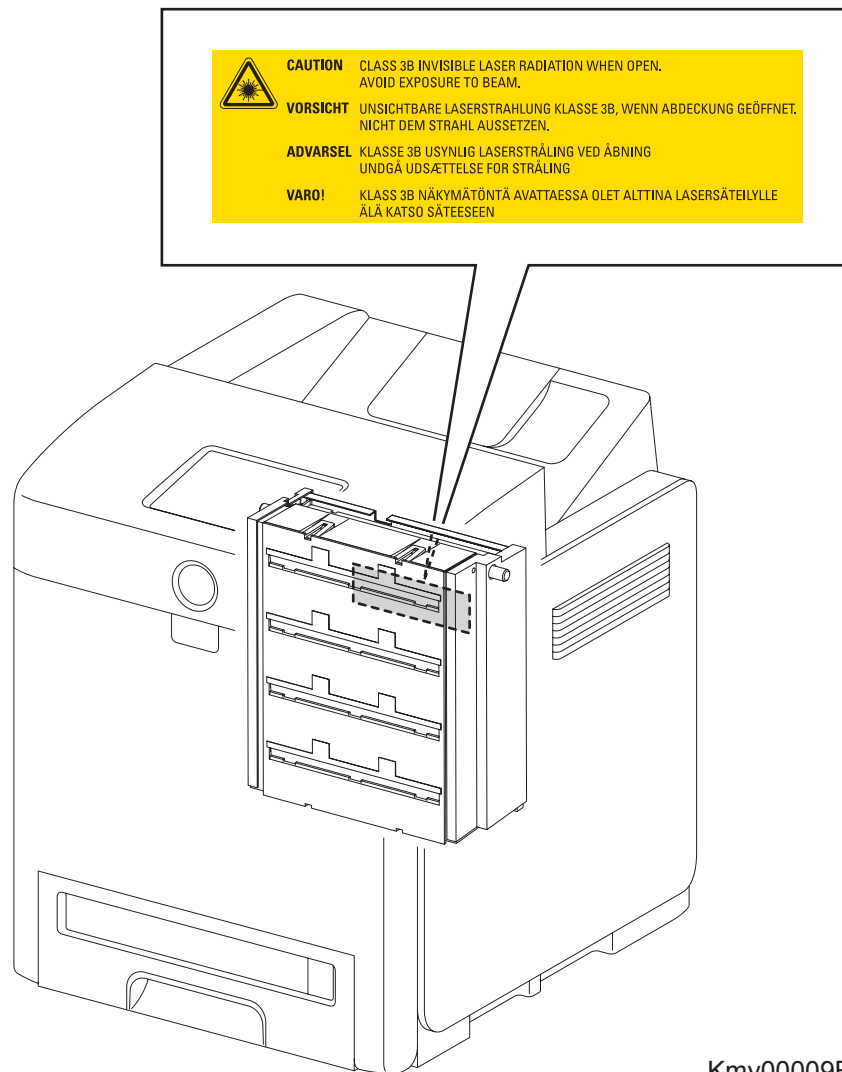

Kmy00009B

4.5.5 Caution label for transfer belt

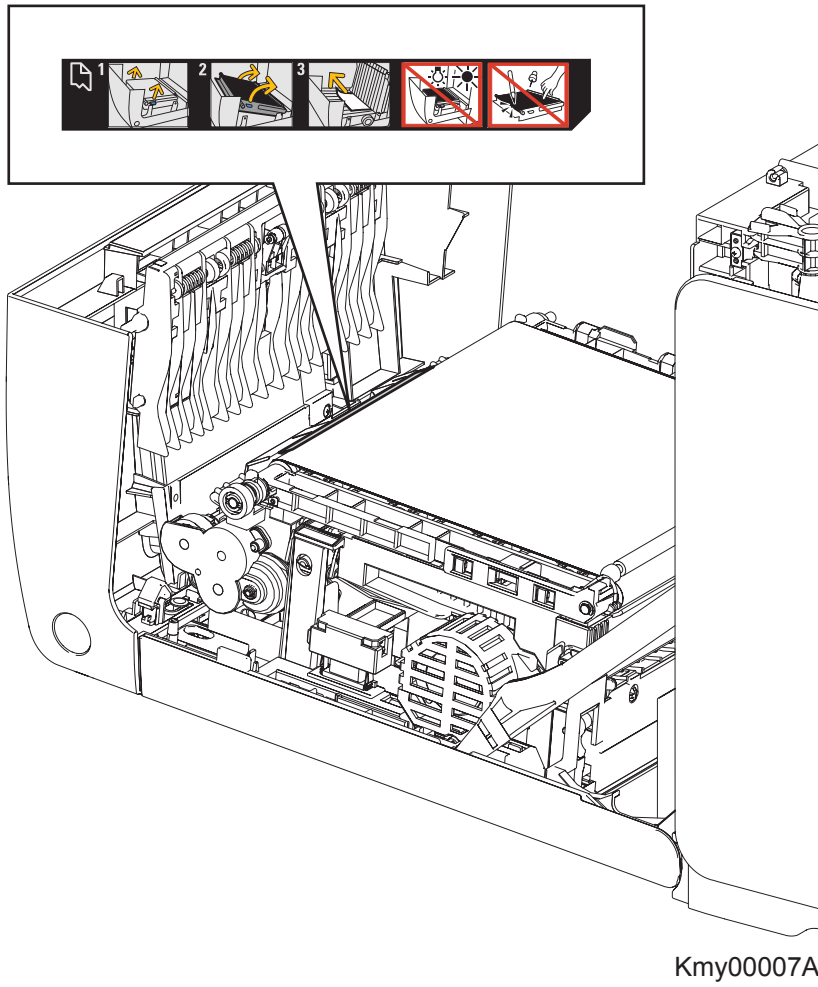

4.5.6 Caution label for duplex

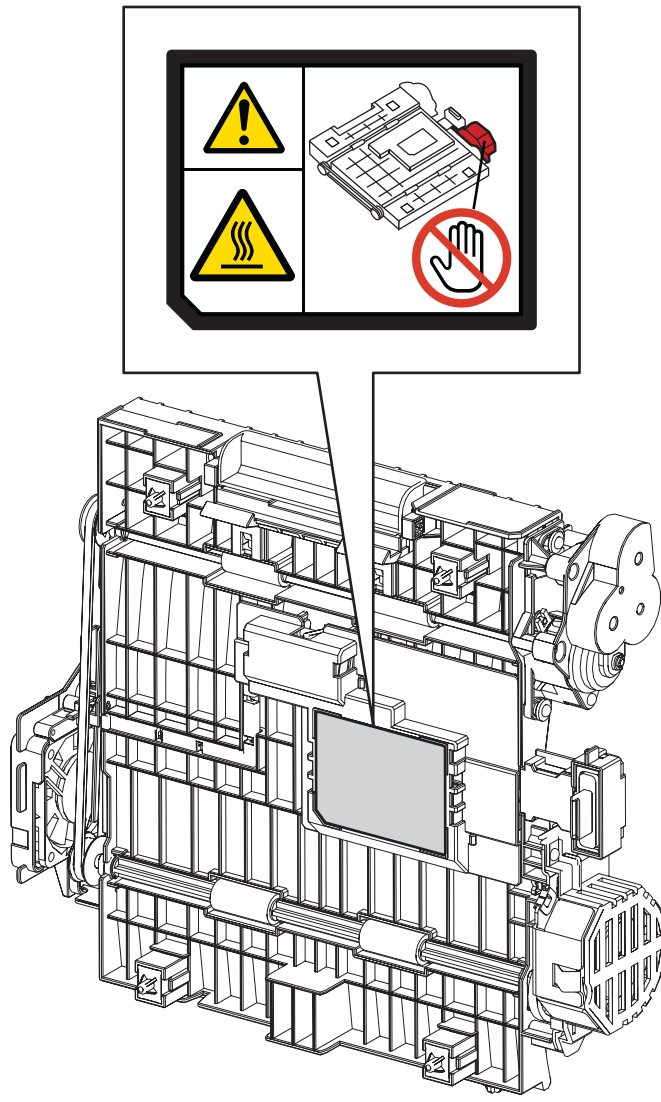

Kmy00011GA

Unpacking the Printer



The printer must be carried horizontally with two or more persons.



Take extreme care to avoid personal injuries.

Check visually the printer for evidence of any damages.
Peel all tapes off the printer.

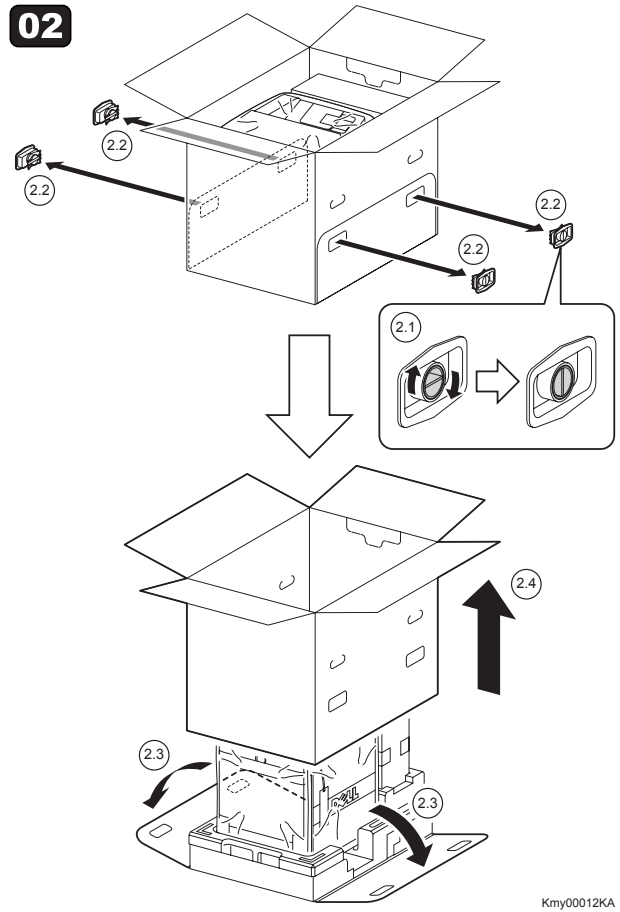
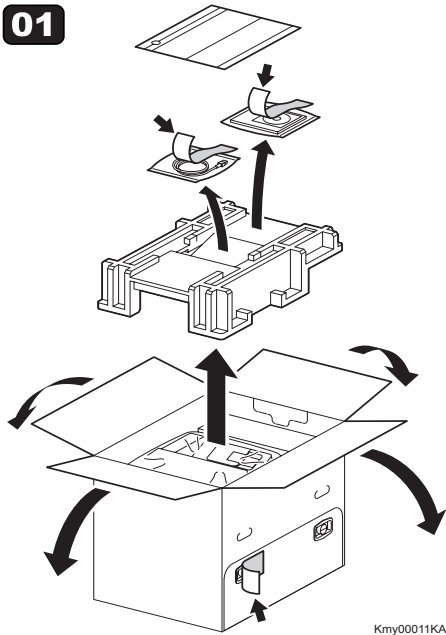

03

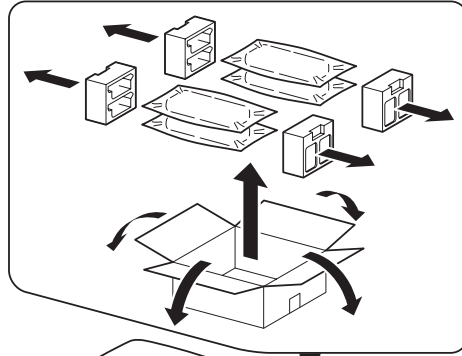

04

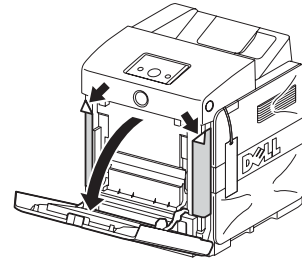
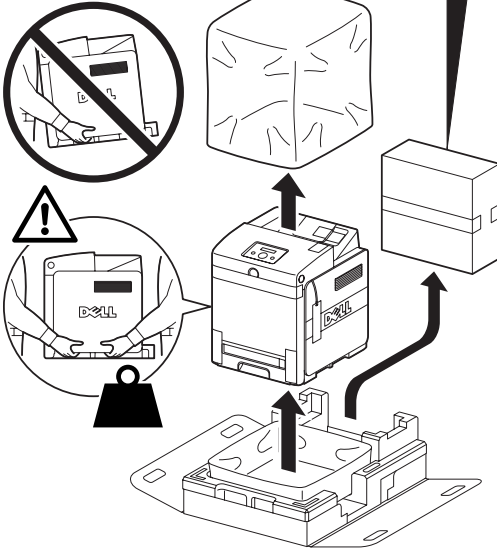
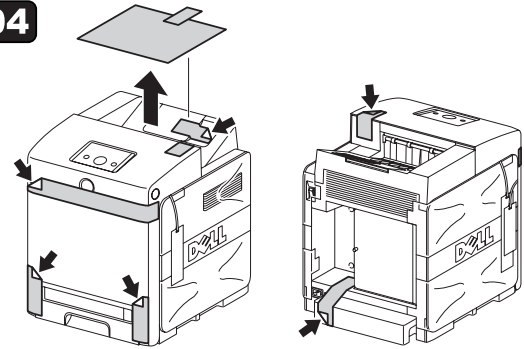

Kmy00014KA

Kmy00013KA

05

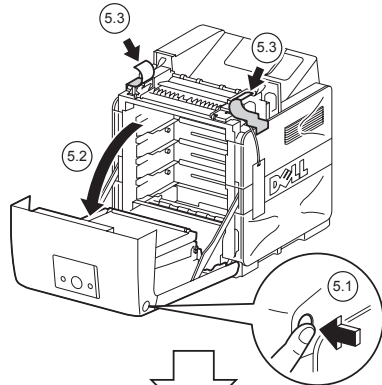

06

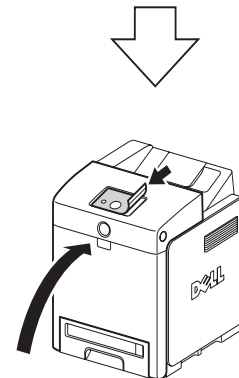
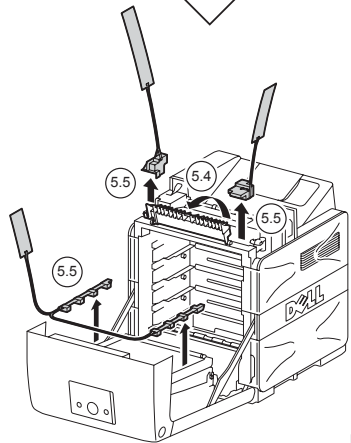
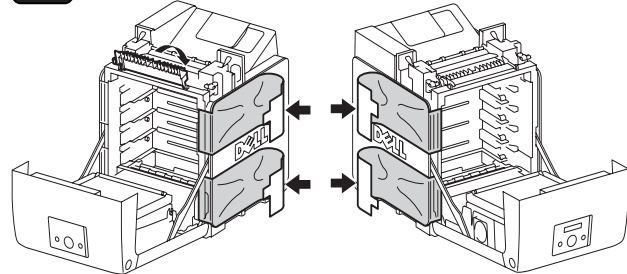

Kmy00016KA

Kmy00015KA

TABLE OF CONTENTS

1. About this manual.....	ii
2. Marks giving caution.....	ii
3. Related documents.....	ii
4. Safety	iii
4.1 Power source	iii
4.2 Driving units	iv
4.3 High-temperature units	iv
4.4 Laser beams	v
4.5 Warning/caution labels.....	vi
4.5.1 Caution label for high-temperature units.....	vi
4.5.2 Caution label for toner cartridges.....	vii
4.5.3 Caution label for MPF	ix
4.5.4 Caution label for print head.....	x
4.5.5 Caution label for transfer belt.....	xi
4.5.6 Caution label for duplex	xii
Unpacking the Printer.....	xiii
Chapter 1 Troubleshooting.....	1 - 1
Chapter 2 Operation of Diagnostic	2 - 1
Chapter 3 Removal and Replacement Procedures	3 - 1
Chapter 4 Plug/Jack(P/J) Connector Locations.....	4 - 1
Chapter 5 Parts List.....	5 - 1
Chapter 6 Principles of Operation	6 - 1
Chapter 7 Wiring Diagrams and Signal Information	7 - 1
Chapter 8 Printer Specifications	8 - 1

Chapter 1 Troubleshooting CONTENTS

1. Progressing with the Troubleshooting.....	1 - 1
1.1 Flow of Troubleshooting	1 - 1
1.2 Confirms Installation Status	1 - 2
1.3 Cautions for Service Operations	1 - 3
1.4 Cautions for FIP Use	1 - 4
1.5 Items To Be Confirmed Before Going To FIP Troubleshooting	1 - 6
2. FIP.....	1 - 11
2.1 FIP	1 - 11
2.2 Flow of FIP	1 - 11
2.3 Status Code List	1 - 12
2.4 LCD Display	1 - 24
3. Error Code FIP	1 - 31
FIP-1. 1 001-360/001-363 Restart Printer	1 - 31
FIP-1. 2 001-361/001-363 Restart Printer	1 - 32
FIP-1. 3 003-341/003-342/003-343/003-344/003-345/003-346/003-347/003-348/003-349/ 003-350 Restart Printer	1 - 33
FIP-1. 4 003-356 Restart Printer	1 - 34
FIP-1. 5 004-310 Restart Printer	1 - 37
FIP-1. 6 004-311 Restart Printer	1 - 38
FIP-1. 7 006-370/006-371/006-372/006-373/006-374/006-375/006-376/006-377/006-378/ 006-379/006-380/006-381/006-382/006-383/006-384 Restart Printer	1 - 39
FIP-1. 8 007-340/007-345/007-346/007-347/007-348/007-355/007-356/007-357/007-358/ 007-359/007-360/007-365/007-366/007-367/007-368/007-370 Restart Printer	1 - 40
FIP-1. 9 007-341/007-345/007-349/007-350/007-351/007-355/007-356/007-357/007-361/ 007-362/007-363/007-365/007-366/007-367/007-369/007-370 Restart Printer	1 - 41
FIP-1. 10 007-342/007-346/007-349/007-352/007-353/007-355/007-358/007-359/007-361/ 007-362/007-364/007-365/007-366/007-368/007-369/007-370 Restart Printer	1 - 42
FIP-1. 11 007-343/007-347/007-350/007-352/007-354/007-356/007-358/007-360/007-361/ 007-363/007-364/007-365/007-367/007-368/007-369/007-370 Restart Printer	1 - 43
FIP-1. 12 007-344/007-348/007-351/007-353/007-354/007-357/007-359/007-360/007-362/ 007-363/007-364/007-366/007-367/007-368/007-369/007-370 Restart Printer	1 - 44
FIP-1. 13 009-360/009-361/009-362/009-363 Restart Printer	1 - 45
FIP-1. 14 009-654 Restart Printer	1 - 46
FIP-1. 15 009-655 Restart Printer	1 - 47
FIP-1. 16 010-317 Insert Fuser	1 - 49
FIP-1. 17 010-351 Replace Fuser/Restart Printer	1 - 50
FIP-1. 18 010-354 Restart Printer	1 - 51
FIP-1. 19 010-377/010-378/010-379/010-380/010-381/010-382/010-383/010-384/ 010-385/010-386/010-387/010-388/010-389/010-390/010-391/010-392/ 010-393/010-394/010-395 Restart Printer	1 - 52
FIP-1. 20 016-300/016-301/016-302/016-310/016-313/016-315/016-317/016-323/016-327/ 016-340/016-344/016-345/016-346/016-347/016-348/016-349 Restart Printer / Erase Flash Err. 016-392 / Write Flash Err. 016-393 / Verify Error 016-394 / PDL Error 016-720	1 - 53
FIP-1. 21 016-316/016-318 Restart Printer	1 - 54

Chapter 1 Troubleshooting CONTENTS

FIP-1. 22	016-330/016-331/016-332/016-333/016-334/016-335/016-336/016-337/016-360 Restart Printer	1 - 55
FIP-1. 23	016-338 Restart Printer	1 - 56
FIP-1. 24	016-350 Restart Printer	1 - 57
FIP-1. 25	016-370 Restart Printer	1 - 58
FIP-1. 26	093-964 CRUM ID	1 - 59
FIP-1. 27	Paper Jam 071-100	1 - 60
FIP-1. 28	Paper Jam 072-100	1 - 63
FIP-1. 29	Paper Jam 075-100	1 - 67
FIP-1. 30	077-900/077-901 Paper Jam	1 - 70
FIP-1. 31	Paper Jam 077-903	1 - 74
FIP-1. 32	Paper Jam 077-907	1 - 75
FIP-1. 33	Load Tray N or MPF 024-910/024-911/024-914	1 - 78
FIP-1. 34	Load Tray N or MPF 024-965/024-966/024-969	1 - 80
FIP-1. 35	CRUM ID 009-367/009-368/009-369/009-370	1 - 83
FIP-1. 36	TapeOn XXX Cart 093-919/093-920/093-921/093-922	1 - 84
FIP-1. 37	Replace Cart. 093-930	1 - 85
FIP-1. 38	Replace Cart. 093-931	1 - 86
FIP-1. 39	Replace Cart. 093-932	1 - 87
FIP-1. 40	Replace Cart. 093-933	1 - 88
FIP-1. 41	Ready to Print 093-423	1 - 89
FIP-1. 42	Ready to Print 093-424	1 - 90
FIP-1. 43	Ready to Print 093-425	1 - 91
FIP-1. 44	Ready to Print 093-426	1 - 92
FIP-1. 45	Insert PrintCart 093-970	1 - 93
FIP-1. 46	Insert PrintCart 093-971	1 - 94
FIP-1. 47	Insert PrintCart 093-972	1 - 95
FIP-1. 48	Insert PrintCart 093-973	1 - 96
FIP-1. 49	CRUM ID 009-371 / Inset Belt Unit 094-910	1 - 97
FIP-1. 50	Ready to Print 094-422	1 - 98
FIP-1. 51	Belt Unit 094-911	1 - 99
FIP-1. 52	010-359 Restart Printer	1 - 100
FIP-1. 53	Ready to Print 010-421	1 - 101
FIP-1. 54	Tray Detached 024-946/024-947 / Load Tray 1 077-912	1 - 102
FIP-1. 55	Close FrontCover 077-300	1 - 104
FIP-1. 56	Invalid ID 016-383 / Range Chk Error 016-384 / Header Error 016-385 / Check Sum Error 016-386 / Format Error 016-387	1 - 105
FIP-1. 57	MPC Error 016-388 / MPC Detached 016-389 / MPC Com. Failed 016-390	1 - 106
FIP-1. 58	Out of Memory 016-700/Disk Full 016-980	1 - 108
FIP-1. 59	Invalid User 016-757 / Disabled Func 016-758 / Reached Limits 016-759	1 - 109
FIP-1. 60	Invalid Job 016-799	1 - 110
FIP-1. 61	Ready to Print 193-700	1 - 111
FIP-1. 62	Over Heat 042-700/Ready to Print 142-700	1 - 112
FIP-1. 63	Electrical Noise	1 - 113
4.	Image Quality Trouble.....	1 - 114

Chapter 1 Troubleshooting CONTENTS

4.1 Entry Chart for Image Quality Troubleshooting	1 - 114
4.2 Items to be Confirmed Before Image Quality Troubleshooting	1 - 117
4.3 Print Image Quality Specification	1 - 119
4.4 Image Quality FIP	1 - 122
FIP-1.P1 Faint print (Low contrast)	1 - 122
FIP-1.P2 Blank print (No print)	1 - 126
FIP-1.P3 Solid black	1 - 131
FIP-1.P4 Vertical blank lines (White stripes in paper transport direction)	1 - 134
FIP-1.P5 Horizontal band cross out (White stripes in the horizontal direction)	1 - 137
FIP-1.P6 Vertical stripes	1 - 141
FIP-1.P7 Horizontal stripes	1 - 145
FIP-1.P8 Partial lack	1 - 148
FIP-1.P9 Spots	1 - 151
FIP-1.P10 Afterimage	1 - 154
FIP-1.P11 Background (Fog)	1 - 156
FIP-1.P12 Skew	1 - 159
FIP-1.P13 Paper damage	1 - 165
FIP-1.P14 No fix	1 - 171
FIP-1.P15 Color Registration (Color Shift)	1 - 172
5. Abnormal Noise Trouble	1 - 176
5.1 Entry Chart for Abnormal Noise Troubleshooting	1 - 176
5.2 Operation Mode Table	1 - 177
FIP-1.N1 When Power is Turned On	1 - 177
FIP-1.N2 During Standby	1 - 182
FIP-1.N3 During Printing	1 - 183
6. Other FIP	1 - 188
FIP-AC	1 - 188
FIP-DC	1 - 190
FIP-Multiple feed	1 - 191

Chapter 1 Troubleshooting CONTENTS

Blank Page

NOTE

Troubleshooting in this manual assumes use of diagnostic operation. However, the troubleshooting allows for the case where the diagnostic operation are not used. You can correct troubles according to these troubleshooting procedures after understanding them well.

1. Progressing with the Troubleshooting

After making sure of actual condition of a trouble, proceed with the troubleshooting process efficiently making use of the Fault Isolation Procedure (FIP), Operation of Diagnostic (Chapter 2), Wiring Diagrams (Chapter 7), and Principles of Operation (Chapter 6).

1.1 Flow of Troubleshooting

Flow of the troubleshooting is as follows:

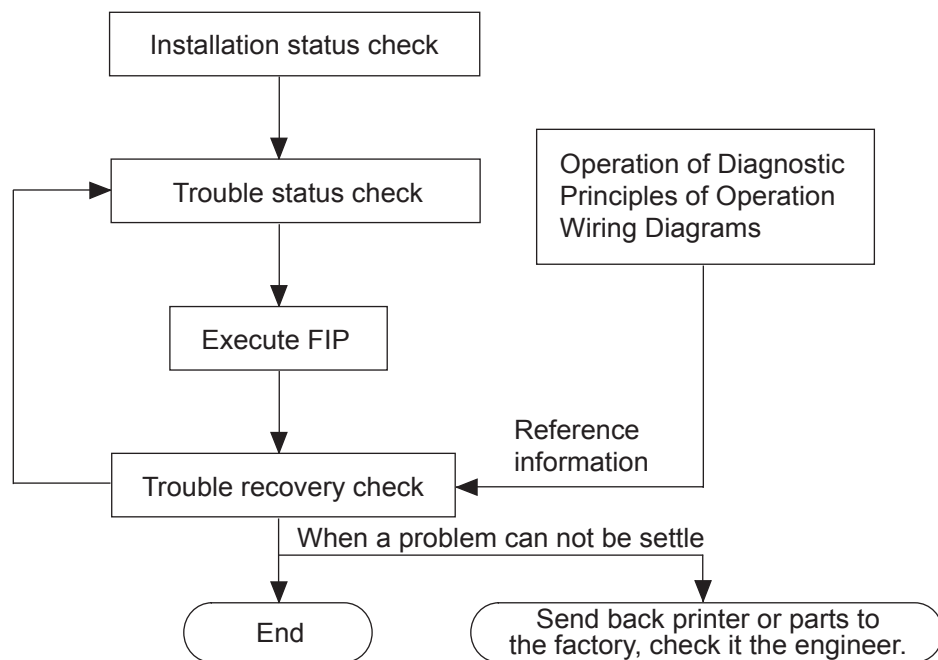

1.2 Confirms Installation Status

Be sure to check the following items before starting the troubleshooting procedures

- 1) Voltage of the power supply is within the specifications (measure the voltage at the electric outlet).
- 2) Power cord is free from breakage, short-circuit, disconnected wire, or incorrect connection in the power cord.
- 3) The laser printer is properly grounded.
- 4) The laser printer is not installed at a place subjected to too high temperature, too high humidity, too low temperature, too low humidity or rapid change of temperature.
- 5) The laser printer is not installed close to water service, humidifier, heat generating unit, or fire, in very dusty place, or a place exposed to air flow from the air conditioning system.
- 6) The laser printer is not installed in a place where volatile gas or inflammable gas is generated.
- 7) The laser printer is not installed under direct sunbeams.
- 8) The laser printer is installed in a well-ventilated place.
- 9) The laser printer is installed on a stout and stable plane.
- 10) Paper used meets specifications (standard paper is recommendable).
- 11) The laser printer is handled properly.
- 12) Parts which should be periodically replaced are replaced each time when specified number of sheets have been printed.

1.3 Cautions for Service Operations

- 1) Be sure to remove the power cord except when it is specifically required.



If the printer is kept ON, never touch the conductive parts while it is not specifically required.

The power switch and inlet are live even while the power supply is cut off. Never touch the live parts.

- 2) When checking some parts with covers removed and with the interlock and safety and power switches ON, remove the connector (P/J601) on the ROS ASSY except when it is specifically required.



When checking some parts with covers removed and with the interlock and safety and power switches ON, laser beams may be irradiated from the ROS ASSY. Since it is dangerous, be sure to remove the connector (P/J151) while it is not required.

- 3) When checking some parts with the Front Cover removed and power ON, be sure to remove the connector (P/J16) on the PWBA MCU while it is not required.



When checking some parts with the Front Cover removed and power ON, high voltage may be applied by the HVPS. Be sure to remove the connector (P/J16) on the PWBA MCU.

When connecting the connector (P/J16) on the PWBA MCU according to the instructions of the FIP, never touch the HVPS and parts of high voltage.

- 4) When using Diag. tools or other tools of high voltage, be sure to keep them covered except when otherwise specified.



When using Diag. Tool or other tools of high voltage, never touch parts of high voltage.

When using Diag. Tool or other tools of high voltage, be sure to follow the procedure of this manual.

- 5) When operating the driving units using the Diag or other tools, be sure to keep them covered unless otherwise specified.



When operating the driving units using the Diag or other tools, never touch the driving units. When operating the driving units using Diag or other tools, be sure to follow the procedures in this manual.

- 6) When touching hot parts, be careful not to get burnt.

- 7) Workers should wear a wrist band or the like to remove static electricity from their body, grounding their body while working.

1.4 Cautions for FIP Use

- 1) It is assumed in the FIP that the printer controller (PWBA ESS) is normally functioning. If any trouble cannot be corrected by troubleshooting, replace the printer controller with a normal one and check for proper operation again.
If the trouble is not still corrected, replace the major parts and then related parts in succession and confirm according to the procedure of the "Check".
- 2) When troubleshooting according to the FIP, normal PWBA MCU, HVPS, LVPS, FUSER ASSY, BELT ASSY and so on may be necessary for isolation of failed parts. Prepare them in advance.
- 3) In the initial check according to the FIP, check only items which can be simply checked.
- 4) In the initial check according to the FIP, check the constitutive parts of the major check parts and related parts, as well as major check parts.
- 5) When working with the printer, be sure to remove the power cord except when required specifically. Never touch live parts if not required, while the power cord is connected.
- 6) Connector condition is denoted as follows:

[P/J12]	Connector (P/J12) is connected.
[P12]	Plug side with the connector (P/J12) removed (except when attached directly to the board).
[J12]	Jack side with the connector (P/J12) removed (except when attached directly to the board).
- 7) [P/J1-2PIN <=> P/J3-4PIN] in the FIP means measurement with the plus side of the measuring instrument connected to [2PIN] of [P/J1] and the minus side to [4PIN] of [P/J3].
- 8) [P/J1<=> P/J2] in the FIP means measurement for all terminals corresponding between [P/J1] and [P/J2] referring to "Wiring Diagrams".
- 9) In [P/J1-2PIN <=> P/J3-4PIN] in the FIP where voltage is measured, [P/J3-4PIN] on the rear minus side is always at the AG (analog ground), SG (signal ground), or RTN (return).
Therefore, after checking of proper conductivity between AGs, SGs, or RTNs respectively, the rear minus side can be connected to the PIN of AG, SG or RTN instead of [P/J3-4PIN].
However, care should be taken not to mistake since [AG], [SG], and [RTN] are not on the same level.
- 10) Measure the voltage of small connectors with the special tool. Handle the tool with care, as the leading edge of the tool is pointed.
- 11) When measuring the voltage, set the BELT ASSY, toner cartridge and paper cassette, close the COVERS and power ON if not required specifically.
- 12) Numerical values in the FIP are only for standard. If numerical values are approximate, they should be considered permissible.

- 13) Parts which are always removed to check as indicated in the FIP and procedures for that purpose are not specifically referred to here. They should be handled carefully.
- 14) "Replacement" in the FIP indicates replacement of parts which are considered to be the source of trouble to be checked after replacing those parts, assemblies containing them (HIGH ASSY).
- 15) The FIP describes the first cassette on the lower part of the printer as "Tray 1," and the second cassette as "Tray 2".
- 16) In the FIP, procedures are differentiated depending on specifications. Correct troubles according to the instructions in the FIP.
- 17) For optional parts, some troubleshooting procedure may follow the manual for those options, of which you should take note.
Keep those manuals for the optional parts when required.

1.5 Items To Be Confirmed Before Going To FIP Troubleshooting

Basic Printer Problems

Some printer problems can be easy to resolve. If a problem occurs with your printer, check each the following:

- 1) If a message is displayed on the LCD of operator panel, see “2.3 Status Code List” or “2.4 LCD Display”.
- 2) The printer power cable is plugged into the printer and a properly grounded electrical outlet.
- 3) The printer power is ON.
- 4) The electrical outlet is not turned off at any switch or breaker.
- 5) Other electrical equipment plugged into the outlet is working.
- 6) All options are properly installed.
- 7) If you have checked all of the above and still have a problem, turn off the printer, wait for 10 seconds, and then turn on the printer. This often solves the problem.

Display Problems

- 1) If the operator panel displays only diamonds or is blank, check and try the action below.
 - a) Turn off the printer, wait for 10 seconds, and turn on the printer.
 - b) Self Test Message appears on the operator panel. When the test is completed, “Ready to Print” is displayed.
- 2) If menu settings changed from the operator panel have no effect, check and try the actions below.

Settings in the software program, the printer driver, or the printer utilities are overriding the settings made on the operator panel.

- a) Change the menu settings from the printer driver, the printer utilities, or the software program instead of the operator panel.
- b) Disable the settings in the printer driver, the printer utilities, or the software program so you can change settings on the operator panel.

Printing Problems

- 1) If a job did not print correct or incorrect characters were printed, check and try the actions below.
 - a) Make sure “Ready to Print” appears on the operator panel before sending a job to print. Press **Menu** to return to “Ready to Print”.
 - b) Make sure print media is loaded in the printer. Press **Menu** to return to “Ready to Print”.
 - c) Verify that you are using the correct printer driver.
 - d) Make sure you are using the correct Ethernet or USB cables and it securely connected at the back of the printer.
 - e) Verify that the correct print media size is selected.
 - f) If using a print spooler, verify that the spooler has not stalled.
 - g) Check the printer interface from the “Configure” menu. Determine the host interface you are using. Print a Panel Setting page to verify that the current interfaces settings are correct.
 - h) Output fonts will not print correctly using the PCL driver in its default mode. To correct this problem, use PostScript driver when using the PCL driver.

- 2) If secure print is not available or not printing, refer to the requirements below.
 - a) Minimum 256 MB is required.
 - b) RAM Disk must be enabled using the operation panel.
 - c) The number of secure print jobs your printer can store is dependent on the job size including number of pages, graphics, color attributes, and the amount of memory installed. To decrease this number, add additional memory.
- 3) If print media misfeeds or multiple feeds occur, check and try the actions below.
 - a) Make sure the print media you are using meets the specifications for your printer. Refer to **Print Media Guidelines** of this section.
 - b) Flex print media before loading it any of the sources.
 - c) Make sure the print media is loaded correctly.
 - d) Make sure the width and length guides on the print media sources are adjusted correctly.
 - e) If the print media are overfilled in sources, reduce the amount of media.
 - f) Load the recommended print side correctly for the type of print media you are using.
 - g) Turn the print media over or around and try printing again to see if feeding improves.
 - h) Check the print media type loaded in the source, and refill only one type of print media, if print media types are mixed.
 - i) Refill a new ream of print media, if some reams are mixed.
 - j) Remove the top and bottom sheets of a ream before loading the print media.
 - k) Load a print media source only when it is empty.
- 4) If envelope misfeeds or multiple feeds occur, check and try the action below.
 - a) Remove the stack of envelopes from the multiple purpose feeder (MPF).
- 5) If page breaks in unexpected places, check and try the action below.
 - a) Check the "Job Timeout" in the Basic Settings menu and increase the setting.
- 6) If a job prints from the wrong source or on the wrong print media, check and try the action below.
 - a) Check the "Paper Size" and "Paper Type" in the Tray Settings menu on the printer operator panel and in the printer driver.
- 7) If print media does not stack neatly in the output tray, check and try the action below.
 - a) Turn the print media stack over in the tray or multipurpose feeder.

Print Media Guidelines

Print media is paper, transparencies, labels, envelopes, coated paper among others. Your printer provides high-quality printing on a variety of print media. Selecting the appropriate print media for your printer helps avoid printing troubles. This section describes how to select print media, how to care for print media, and how to load the print media in the optional 250-sheet tray module or 550-sheet tray module.

Paper

For the best print quality in color, use 75 g/m² (20 lb.) xerographic, grain long paper. For the best print quality in black and white, use 90 g/m² (24 lb.) xerographic, grain long paper. Before buying large quantities of any print media, Dell recommends trying a sample first.

When loading paper, identify the recommended print side on the paper package, and load the paper accordingly. See "Loading Print Media in Optional Trays" and "Loading the Multipurpose Feeder" for detailed loading instructions.

Paper Characteristics

The following paper characteristics affect print quality and reliability. Dell recommends that you follow these guidelines when evaluating new paper stock.

Weight

The tray automatically feeds paper weights from 60 to 216 g/m² (16 to 57.6 lb. bond) grain long. The multipurpose feeder automatically feeds paper weights from 60 to 216 g/m² (16 to 56 lb. bond) grain long. Paper lighter than 60 g/m² (16 lb.) might not be stiff enough to feed properly, and could cause paper jams. For best performance, use 75 g/m² (20 lb. bond) grain long paper.

Curl

Curl is the tendency of print media to curve at its edges. Excessive curl can cause paper feeding problems. Curl usually occurs after the paper passes through the printer, where it is exposed to high temperatures. Storing paper unwrapped in humid conditions, even in the paper tray, can contribute to paper curling prior to printing and cause feeding problems.

Smoothness

The degree of paper smoothness directly affects print quality. If the paper is too rough, the toner does not fuse to the paper properly, resulting in poor print quality. If the paper is too smooth, it can cause paper feeding problems. Smoothness between 150 and 250 Sheffield points produces the best print quality.

Moisture Content

The amount of moisture in the paper affects both print quality and the ability of the printer to feed the paper properly. Leave the paper in its original packaging until you are ready to use it. This limits the exposure of the paper to moisture changes that can degrade its performance.

Grain Direction

Grain refers to the alignment of the paper fibers in a sheet of paper. Grain is either grain long, running the length of the paper, or grain short, running the width of the paper. For 60 to 135 g/m² (16 to 36 lb. bond) paper, grain long fibers are recommended. For papers heavier than 135 g/m² (36 lb. bond), grain short is preferred.

Fiber Content

Most high-quality xerographic paper is made from 100% chemically pulped wood. Paper containing fibers such as cotton possess characteristics that can result in degraded paper handling.

Recommended Paper

To ensure the best print quality and feed reliability, use 75 g/m² (20 lb.) xerographic paper. Business papers designed for general business use also provide acceptable print quality.

Always print several samples before buying large quantities of any type of print media. When choosing any print media, you should consider the weight, fiber content, and color.

The laser printing process heats paper to high temperatures of 225°C (437°F) for Magnetic Ink Character Recognition (MICR) applications, and 205°C (401°F) for non-MICR applications. Only use paper able to withstand these temperatures without discoloring, bleeding, or releasing hazardous emissions. Check with the manufacturer or vendor to determine whether the paper you have chosen is acceptable for laser printers.

Unacceptable Paper

The following paper types are not recommended for use with the printer:

- 1) Chemically treated papers used to make copies without carbon paper, also known as carbonless papers, carbonless copy paper (CCP), or no carbon required (NCR) paper
- 2) Preprinted papers with chemicals that may contaminate the printer
- 3) Preprinted papers that can be affected by the temperature in the printer fuser

- 4) Preprinted papers that require a registration (the precise print location on the page) greater than ± 0.09 in., such as optical character recognition (OCR) forms
In some cases, you can adjust registration with your software program to successfully print on these forms.
- 5) Coated papers (erasable bond), synthetic papers, thermal papers
- 6) Rough-edged, rough or heavily textured surface papers or curled papers
- 7) Recycled papers containing more than 25% post-consumer waste that do not meet DIN 19 309
- 8) Multiple-part forms or documents
- 9) Label paper with Cut

Selecting Paper

Proper paper selection helps prevent jams and ensures trouble-free printing.

To help avoid jams or poor print quality:

1. Always use new, undamaged paper.
2. Before loading the paper, identify the recommended print side of the paper. This information is usually indicated on the paper package.
3. Do not use paper that you have cut or trimmed yourself.
4. Do not mix print media sizes, weights, or types in the same source. This may result in a paper jam.
5. Do not remove trays while a job is printing or Printing is displayed on the operator panel.
6. Make sure the Paper Type and Paper Size settings are correct.
7. Make sure the paper is properly loaded in the tray.
8. Flex paper back and forth, and then fan them. Straighten the edges of the stack on a level surface.
9. When curl is excessive, with plain paper, turn it over and reset it.

Identifying Print Media Sources and Specifications

The following tables provide information on standard and optional print media sources.

Print Media Sizes and Support Y: Yes N: No

	Multipurpose Feeder	250-sheet Tray	Optional 550-sheet Tray
A4	Y	Y	Y
A5	Y	Y	Y
B5	Y	Y	Y
Letter	Y	Y	Y
Folio (8.5 x 13 in.)	Y	Y	Y
Legal (8.5 x 14 in.)	Y	Y	Y
Executive	Y	Y	Y
COM-10 envelope	Y	N	N
Monarch	Y	N	N
C5	Y	N	N
DL	Y	N	N
User-specified print media	Y	N	N
Yokei size 2	Y	N	N
Yokei size 3	Y	N	N
Yokei size 4	Y	N	N
Yochokei size 3	Y	N	N
Chokey size 3	Y	N	N

	Multipurpose Feeder	250-sheet Tray	Optional 550-sheet Tray
Japanese Post Card	Y	N	N

Print Media Supported

Y: Yes N: No

	Multipurpose Feeder	250-sheet Tray	Optional 550-sheet Tray
Plain Paper Light (60-76gsm)	Y	Y	Y
Plain Paper Normal (80gms)	Y	Y	Y
Plain Paper Thick (82-98gms)	Y	Y	Y
Covers Normal (106-163gms)	Y	Y	Y
Covers Thick (164-216gms)	Y	Y	Y
Transparency	Y	N	N
Labels	Y	Y	Y
Coated Normal (106-163gms)	Y	Y	Y
Coated Thick (164-216gms)	Y	Y	Y
Envelope	Y	N	N
Recycled Paper	Y	Y	Y
Japanese Coated Paper	Y	Y	Y
Japanese Post Card	Y	N	N

2. FIP

2.1 FIP

The FIP is the first step for trouble diagnosis. The FIP isolates the presence of various troubles including error codes, and guides the troubleshooting procedure.

2.2 Flow of FIP

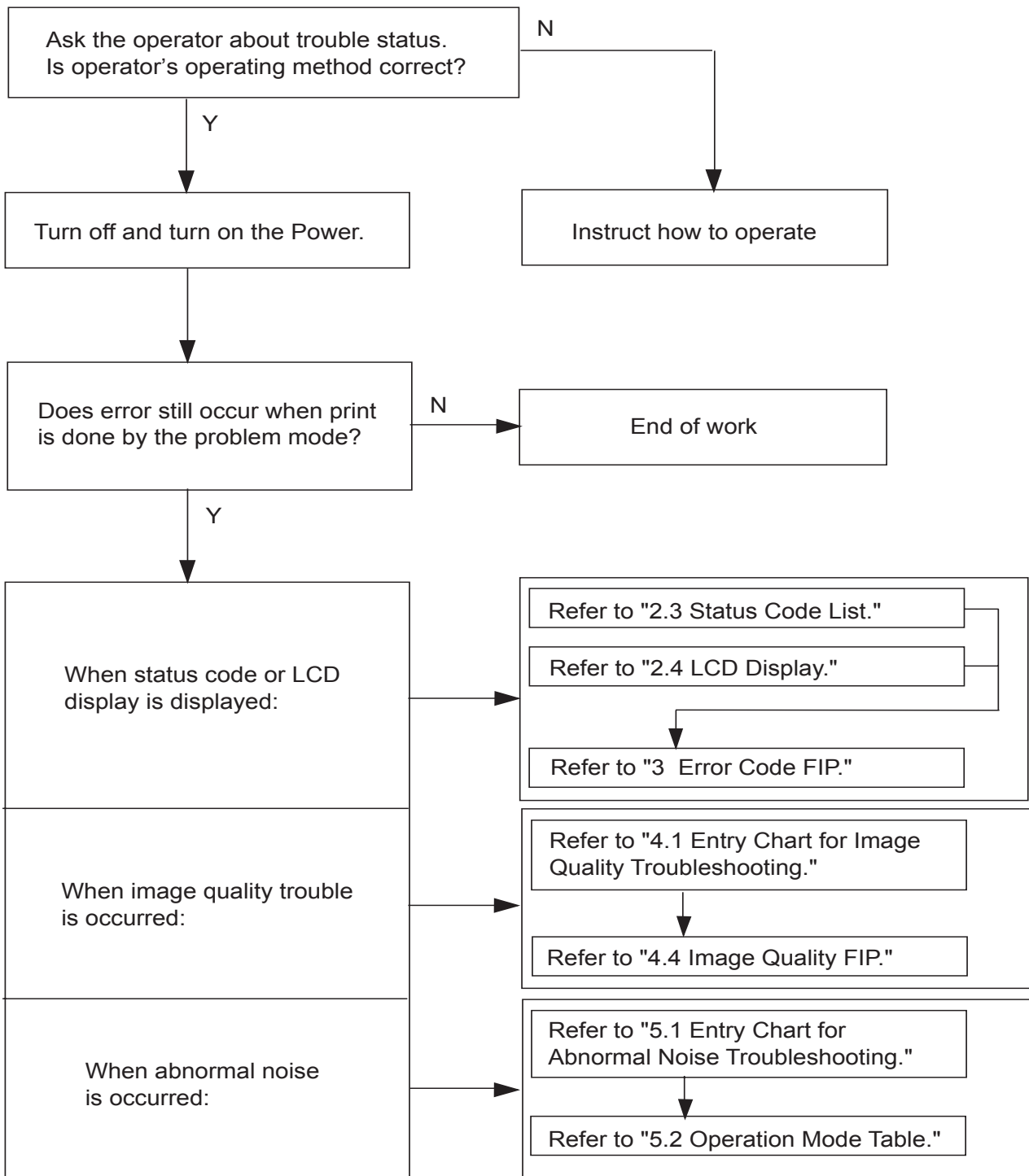

2.3 Status Code List

Error Message	Error Contents	FIP to be referred
001-360 Restart Printer ↕ Flip Contact Support IfMessageReturns	<IOT Fan Motor Failure> MCU detects an error upon receiving error signal from the Rear Fan.	FIP-1. 1
001-361 Restart Printer ↕ Flip Contact Support IfMessageReturns	<IOT Fan Motor Failure> MCU detects an error upon receiving error signal from the Duplex Fan.	FIP-1. 2
001-363 Restart Printer ↕ Flip Contact Support IfMessageReturns	<IOT Fan Motor Failure> MCU detects an error upon receiving error signals from the Duplex and Rear Fans.	FIP-1. 1 FIP-1. 2
003-341 to 347 Restart Printer ↕ Flip Contact Support IfMessageReturns	<IOT Firmware Error> MCU firmware error occurs.	FIP-1. 3
003-348 Restart Printer ↕ Flip Contact Support IfMessageReturns	<IOT NVM illegal data> MCU NVM illegal data.	FIP-1. 3
003-349 Restart Printer ↕ Flip Contact Support IfMessageReturns	<IOT Firmware Error> MCU firmware error occurs.	FIP-1. 3
003-350 Restart Printer ↕ Flip Contact Support IfMessageReturns	<IOT Firmware Error> MCU firmware error occurs.	FIP-1. 3
003-356 Restart Printer ↕ Flip Contact Support IfMessageReturns	<IOT NVRAM Error> The error is detected by MCU NVRAM check.	FIP-1. 4
004-310 Restart Printer ↕ Flip Reseat Feeder Contact Support	<IOT Option Feeder Failure> The error is detected by Option Feeder communication check.	FIP-1. 5
004-311 Restart Printer ↕ Flip Reseat Duplexer Contact Support	<IOT Option Duplexer Failure> The error is detected by Option Duplexer check.	FIP-1. 6

Error Message	Error Contents	FIP to be referred
006-370 Restart Printer ↕ Flip Contact Support IfMessageReturns	<IOT ROS Failure> The rotational error is detected by ROS Motor check.	FIP-1. 7
006-371 Restart Printer ↕ Flip Contact Support IfMessageReturns	<IOT ROS Failure> The interval of SOS signal is longer than the specified value.	FIP-1. 7
006-372 Restart Printer ↕ Flip Contact Support IfMessageReturns	<IOT ROS Failure> The interval of SOS signal is shorter than the specified value	FIP-1. 7
006-373 Restart Printer ↕ Flip Contact Support IfMessageReturns	<IOT ROS Failure> The Laser power is lower than the specified value.	FIP-1. 7
006-374 Restart Printer ↕ Flip Contact Support IfMessageReturns	<IOT ROS Failure> 006-370 and 006-371 errors occurred.	FIP-1. 7
006-375 Restart Printer ↕ Flip Contact Support IfMessageReturns	<IOT ROS Failure> 006-370 and 006-372 errors occurred.	FIP-1. 7
006-376 Restart Printer ↕ Flip Contact Support IfMessageReturns	<IOT ROS Failure> 006-370 and 006-373 errors occurred.	FIP-1. 7
006-377 Restart Printer ↕ Flip Contact Support IfMessageReturns	<IOT ROS Failure> 006-371 and 006-372 errors occurred.	FIP-1. 7
006-378 Restart Printer ↕ Flip Contact Support IfMessageReturns	<IOT ROS Failure> 006-371 and 006-373 errors occurred.	FIP-1. 7
006-379 Restart Printer ↕ Flip Contact Support IfMessageReturns	<IOT ROS Failure> 006-372 and 006-373 errors occurred.	FIP-1. 7

Error Message	Error Contents	FIP to be referred
006-380 Restart Printer ↕ Flip Contact Support IfMessageReturns	<IOT ROS Failure> 006-370, 006-371 and 006-372 errors occurred.	FIP-1. 7
006-381 Restart Printer ↕ Flip Contact Support IfMessageReturns	<IOT ROS Failure> 006-370, 006-371 and 006-373 errors occurred.	FIP-1. 7
006-382 Restart Printer ↕ Flip Contact Support IfMessageReturns	<IOT ROS Failure> 006-370, 006-372 and 006-373 errors occurred.	FIP-1. 7
006-383 Restart Printer ↕ Flip Contact Support IfMessageReturns	<IOT ROS Failure> 006-371, 006-372 and 006-373 errors occurred.	FIP-1. 7
006-384 Restart Printer ↕ Flip Contact Support IfMessageReturns	<IOT ROS Failure> 006-370, 006-371, 006-372 and 006-373 errors occurred.	FIP-1. 7
007-340 Restart Printer ↕ Flip Contact Support IfMessageReturns	<IOT Motor Failure> Main Motor failure is detected.	FIP-1. 8
007-341 Restart Printer ↕ Flip Contact Support IfMessageReturns	<IOT Motor Failure> Sub Motor failure is detected.	FIP-1. 9
007-342 Restart Printer ↕ Flip Contact Support IfMessageReturns	<IOT Motor Failure> DEVE Motor failure is detected.	FIP-1. 10
007-343 Restart Printer ↕ Flip Contact Support IfMessageReturns	<IOT Motor Failure> PH Motor failure is detected.	FIP-1. 11
007-344 Restart Printer ↕ Flip Contact Support IfMessageReturns	<IOT Motor Failure> Option Feeder Motor failure is detected.	FIP-1. 12

Error Message	Error Contents	FIP to be referred
007-345 Restart Printer ↕ Flip Contact Support IfMessageReturns	<IOT Motor Failure> 007-340 and 007-341 errors occurred.	FIP-1. 8 FIP-1. 9
007-346 Restart Printer ↕ Flip Contact Support IfMessageReturns	<IOT Motor Failure> 007-340 and 007-342 errors occurred.	FIP-1. 8 FIP-1. 10
007-347 Restart Printer ↕ Flip Contact Support IfMessageReturns	<IOT Motor Failure> 007-340 and 007-343 errors occurred.	FIP-1. 8 FIP-1. 11
007-348 Restart Printer ↕ Flip Contact Support IfMessageReturns	<IOT Motor Failure> 007-340 and 007-344 errors occurred.	FIP-1. 8 FIP-1. 12
007-349 Restart Printer ↕ Flip Contact Support IfMessageReturns	<IOT Motor Failure> 007-341 and 007-342 errors occurred.	FIP-1. 9 FIP-1. 10
007-350 Restart Printer ↕ Flip Contact Support IfMessageReturns	<IOT Motor Failure> 007-341 and 007-343 errors occurred.	FIP-1. 9 FIP-1. 11
007-351 Restart Printer ↕ Flip Contact Support IfMessageReturns	<IOT Motor Failure> 007-341 and 007-344 errors occurred.	FIP-1. 9 FIP-1. 12
007-352 Restart Printer ↕ Flip Contact Support IfMessageReturns	<IOT Motor Failure> 007-342 and 007-343 errors occurred.	FIP-1. 10 FIP-1. 11
007-353 Restart Printer ↕ Flip Contact Support IfMessageReturns	<IOT Motor Failure> 007-342 and 007-344 errors occurred.	FIP-1. 10 FIP-1. 12
007-354 Restart Printer ↕ Flip Contact Support IfMessageReturns	<IOT Motor Failure> 007-343 and 007-344 errors occurred.	FIP-1. 11 FIP-1. 12

Error Message	Error Contents	FIP to be referred
007-355 Restart Printer ⇕ Flip Contact Support IfMessageReturns	<IOT Motor Failure> 007-340, 007-341 and 007-342 errors occurred.	FIP-1. 8 FIP-1. 9 FIP-1. 10
007-356 Restart Printer ⇕ Flip Contact Support IfMessageReturns	<IOT Motor Failure> 007-340, 007-341 and 007-343 errors occurred.	FIP-1. 8 FIP-1. 9 FIP-1. 11
007-357 Restart Printer ⇕ Flip Contact Support IfMessageReturns	<IOT Motor Failure> 007-340, 007-341 and 007-344 errors occurred.	FIP-1. 8 FIP-1. 9 FIP-1. 12
007-358 Restart Printer ⇕ Flip Contact Support IfMessageReturns	<IOT Motor Failure> 007-340, 007-342 and 007-343 errors occurred.	FIP-1. 8 FIP-1. 10 FIP-1. 11
007-359 Restart Printer ⇕ Flip Contact Support IfMessageReturns	<IOT Motor Failure> 007-340, 007-342 and 007-344 errors occurred.	FIP-1. 8 FIP-1. 10 FIP-1. 12
007-360 Restart Printer ⇕ Flip Contact Support IfMessageReturns	<IOT Motor Failure> 007-340, 007-343 and 007-344 errors occurred.	FIP-1. 8 FIP-1. 11 FIP-1. 12
007-361 Restart Printer ⇕ Flip Contact Support IfMessageReturns	<IOT Motor Failure> 007-341, 007-342 and 007-343 errors occurred.	FIP-1. 9 FIP-1. 10 FIP-1. 11
007-362 Restart Printer ⇕ Flip Contact Support IfMessageReturns	<IOT Motor Failure> 007-341, 007-342 and 007-344 errors occurred.	FIP-1. 9 FIP-1. 10 FIP-1. 12
007-363 Restart Printer ⇕ Flip Contact Support IfMessageReturns	<IOT Motor Failure> 007-341, 007-343 and 007-344 errors occurred.	FIP-1. 9 FIP-1. 11 FIP-1. 12
007-364 Restart Printer ⇕ Flip Contact Support IfMessageReturns	<IOT Motor Failure> 007-342, 007-343 and 007-344 errors occurred.	FIP-1. 10 FIP-1. 11 FIP-1. 12

Error Message	Error Contents	FIP to be referred
007-365 Restart Printer ↕ Flip Contact Support IfMessageReturns	<IOT Motor Failure> 007-340, 007-341, 007-342 and 007-343 errors occurred.	FIP-1. 8 FIP-1. 9 FIP-1. 10 FIP-1. 11
007-366 Restart Printer ↕ Flip Contact Support IfMessageReturns	<IOT Motor Failure> 007-340, 007-341, 007-342 and 007-344 errors occurred.	FIP-1. 8 FIP-1. 9 FIP-1. 10 FIP-1. 12
007-367 Restart Printer ↕ Flip Contact Support IfMessageReturns	<IOT Motor Failure> 007-340, 007-341, 007-343 and 007-344 errors occurred.	FIP-1. 8 FIP-1. 9 FIP-1. 11 FIP-1. 12
007-368 Restart Printer ↕ Flip Contact Support IfMessageReturns	<IOT Motor Failure> 007-340, 007-342, 007-343 and 007-344 errors occurred.	FIP-1. 8 FIP-1. 10 FIP-1. 11 FIP-1. 12
007-369 Restart Printer ↕ Flip Contact Support IfMessageReturns	<IOT Motor Failure> 007-341, 007-342, 007-343 and 007-344 errors occurred.	FIP-1. 9 FIP-1. 10 FIP-1. 11 FIP-1. 12
007-370 Restart Printer ↕ Flip Contact Support IfMessageReturns	<IOT Motor Failure> 007-340, 007-341, 007-342, 007-343 and 007-344 errors occurred.	FIP-1. 8 FIP-1. 9 FIP-1. 10 FIP-1. 11 FIP-1. 12
009-360 Restart Printer ↕ Flip Reseat Y Cart. Contact Support	<IOT (Y) Toner CRUM Error> Yellow Toner CRUM communication error is detected.	FIP-1. 13
009-361 Restart Printer ↕ Flip Reseat M Cart. Contact Support	<IOT (M) Toner CRUM Error> Magenta Toner CRUM communication error is detected.	FIP-1. 13
009-362 Restart Printer ↕ Flip Reseat C Cart. Contact Support	<IOT (C) Toner CRUM Error> Cyan Toner CRUM communication error is detected.	FIP-1. 13
009-363 Restart Printer ↕ Flip Reseat K Cart. Contact Support	<IOT (K) Toner CRUM Error> Black Toner CRUM communication error is detected.	FIP-1. 13

Error Message	Error Contents	FIP to be referred
009-654 Restart Printer ↕ Flip Contact Support IfMessageReturns	<IOT ADC Sensor Error> ADC sensor sensed the high density.	FIP-1. 14
009-655 Restart Printer ↕ Flip Contact Support IfMessageReturns	<IOT ADC Sensor Error> ADC sensor sensed the low density.	FIP-1. 15
010-317 Restart Printer ↕ Flip Reseat Fuser Contact Support	<IOT Fuser Detached> Fuser detached is detected.	FIP-1. 16
010-351 Replace Fuser ↕ Flip Replace Fuser	<IOT Fuser Life Over> The value of Fuser counter has reached the replacement time.	FIP-1. 17
010-354 Restart Printer ↕ Flip Contact Support IfMessageReturns	<IOT environment Sensor Error> Temperature Sensor Error is detected.	FIP-1. 18
010-377 Restart Printer ↕ Flip Reseat Fuser Contact Support	<IOT Fuser Failure> The NC sensor circuit is defective in the MCU. NC: No Contact	FIP-1. 19
010-378 Restart Printer ↕ Flip Reseat Fuser Contact Support	<IOT Fuser Failure> The circuit of the NC sensor is opened. NC: No Contact	FIP-1. 19
010-379 Restart Printer ↕ Flip Reseat Fuser Contact Support	<IOT Fuser Failure> The output value of the NC sensor is the abnormal value. NC: No Contact	FIP-1. 19
010-380 Restart Printer ↕ Flip Reseat Fuser Contact Support	<IOT Fuser Failure> The circuit of the NC sensor is opened. NC: No Contact	FIP-1. 19
010-381 Restart Printer ↕ Flip Reseat Fuser Contact Support	<IOT Fuser Failure> The output value of the NC sensor is the abnormal value. NC: No Contact	FIP-1. 19

Error Message	Error Contents	FIP to be referred
010-382 Restart Printer ↕ Flip Reseat Fuser Contact Support	<IOT Fuser Failure> NC sensor or ST sensor sensed high temp. NC: No contact/ST: Soft Touch	FIP-1. 19
010-383 Restart Printer ↕ Flip Reseat Fuser Contact Support	<IOT Fuser Failure> NC sensor or ST sensor sensed high temp. NC: No contact/ST: Soft Touch	FIP-1. 19
010-384 Restart Printer ↕ Flip Reseat Fuser Contact Support	<IOT Fuser Failure> In the correction of the NC sensor output value, it became the abnormal value. NC: No Contact	FIP-1. 19
010-385 Restart Printer ↕ Flip Reseat Fuser Contact Support	<IOT Fuser Failure> NC sensor sensed high temp. NC: No contact	FIP-1. 19
010-386 Restart Printer ↕ Flip Reseat Fuser Contact Support	<IOT Fuser Failure> The circuit of the ST sensor is opened. ST: Soft Touch	FIP-1. 19
010-387 Restart Printer ↕ Flip Reseat Fuser Contact Support	<IOT Fuser Failure> ST sensor sensed high temp. ST: Soft Touch	FIP-1. 19
010-388 Restart Printer ↕ Flip Reseat Fuser Contact Support	<IOT Fuser Failure> ST sensor sensed low temp. ST: Soft Touch	FIP-1. 19
010-389 Restart Printer ↕ Flip Reseat Fuser Contact Support	<IOT Fuser Failure> NC sensor sensed low temp. NC: No Contact	FIP-1. 19
010-390 Restart Printer ↕ Flip Reseat Fuser Contact Support	<IOT Fuser Failure> Fuser warming up time is longer than the specified value. (at the printing)	FIP-1. 19
010-391 Restart Printer ↕ Flip Reseat Fuser Contact Support	<IOT Fuser Failure> Adjusting time of NC sensor is longer than the specified value.	FIP-1. 19

Error Message	Error Contents	FIP to be referred
010-392 Restart Printer ↕ Flip Reseat Fuser Contact Support	<IOT Fuser Failure> Fuser warming up time is longer than the specified value. (standby)	FIP-1. 19
010-393 Restart Printer ↕ Flip Reseat Fuser Contact Support	<IOT Fuser Failure> ST sensor sensed high temp. and cut off the fuser power. ST: Soft Touch	FIP-1. 19
010-394 Restart Printer ↕ Flip Reseat Fuser Contact Support	<IOT Fuser Failure> NC sensor sensed high temp. and cut off the fuser power. NC: No Contact	FIP-1. 19
010-395 Restart Printer ↕ Flip Reseat Fuser Contact Support	<IOT Fuser Failure> Fuser power is cut off by the errors.	FIP-1. 19
010-396 Restart Printer ↕ Flip Reseat Fuser Contact Support	<IOT Fuser Failure> Fuser power is cut off by the errors.	FIP-1. 19
016-300 Restart Printer ↕ Flip Contact Support IfMessageReturns	<ESS Data Cache Error> CPU data cache error.	FIP-1. 20
016-301 Restart Printer ↕ Flip Contact Support IfMessageReturns	<ESS Instruction Cache Error> CPU instruction cache error.	FIP-1. 20
016-302 Restart Printer ↕ Flip Contact Support IfMessageReturns	<ESS Illegal Exception> CPU illegal exception.	FIP-1. 20
016-310 Restart Printer ↕ Flip Contact Support IfMessageReturns	<ESS FontROM Error (Main)> Checksum error in the built-in font ROM.	FIP-1. 20
016-313 Restart Printer ↕ Flip Contact Support IfMessageReturns	<ESS ASIC Fail> The error is detected by ASIC error.	FIP-1. 20

Error Message	Error Contents	FIP to be referred
016-315 Restart Printer ↕ Flip Contact Support IfMessageReturns	<ESS On Board RAM W/R Check Fail> The error is detected by on board RAM W/R check during initialization.	FIP-1. 20
016-316 Restart Printer ↕ Flip Reseat Memory Contact Support	<ESS DIMM Slot RAM W/R Check Fail> The error is detected by DIMM slot RAM W/R check during initialization.	FIP-1. 21
016-317 Restart Printer ↕ Flip Contact Support IfMessageReturns	<ESS ROM Check (Main) Fail> Checksum error in the main program ROM.	FIP-1. 20
016-318 Restart Printer ↕ Flip Reseat Memory Contact Support	<ESS DIMM Slot RAM Error> The error is detected by DIMM slot check during initialization.	FIP-1. 21
016-323 Restart Printer ↕ Flip Contact Support IfMessageReturns	<ESS NVRAM 1 W/R Check Fail> The fail is detected by NVRAM 1 W/R check during initialization.	FIP-1. 20
016-327 Restart Printer ↕ Flip Contact Support IfMessageReturns	<ESS NVRAM 1 SIZE And ID Check Fail> The error is detected by consistency check between the NVRAM size required by the system and its actual size, and by consistency check of the ID recorded when turning ON the power.	FIP-1. 20
016-330 Restart Printer ↕ Flip Reseat MPC Contact Support	<MPC-ESS Communication Fail> Communication fail between MPC and ESS	FIP-1. 22
016-331 Restart Printer ↕ Flip Reseat MPC Contact Support	<MPC Flash ROM Boot Module Checksum Error> Checksum error in MPC Flash ROM.	FIP-1. 22
016-332 Restart Printer ↕ Flip Reseat MPC Contact Support	<MPC RAM R/W Test Error> The error is detected by MPC RAM R/W check.	FIP-1. 22
016-333 Restart Printer ↕ Flip Reseat MPC Contact Support	<MPC Flash ROM Application Module Checksum Error> Checksum error in the MPC Flash ROM.	FIP-1. 22

Error Message	Error Contents	FIP to be referred
016-334 Restart Printer ↕ Flip Reseat MPC Contact Support	<MPC MAC Address Checksum Error> Checksum error in the MPC MAC address.	FIP-1. 22
016-335 Restart Printer ↕ Flip Reseat MPC Contact Support	<MPC Ethernet BIST parity/RAM R/W Error> The error is detected by MPC Ethernet BIST parity RAM R/W check.	FIP-1. 22
016-336 Restart Printer ↕ Flip Reseat MPC Contact Support	<MPC Internal Loopback Error> The error is detected by Loopback test.	FIP-1. 22
016-337 Restart Printer ↕ Flip Reseat MPC Contact Support	<MPC Fatal Error> The error is detected by MPC check.	FIP-1. 22
016-338 Restart Printer ↕ Flip Reseat Wireless Contact Support	<Wireless Option Error> The error is detected by Wireless option check.	FIP-1. 23
016-340 Restart Printer ↕ Flip Contact Support IfMessageReturns	<ESS Network Communication Fail> Communication error between CPU network and ESS F/W.	FIP-1. 20
016-344 Restart Printer ↕ Flip Contact Support IfMessageReturns	<ESS Network MAC Address Checksum Error> Checksum error in the Network MAC address.	FIP-1. 20
016-345 Restart Printer ↕ Flip Contact Support IfMessageReturns	<ESS Network Ethernet BIST parity/RAM R/W Error> The error is detected by network Ethernet parity RAM R/W check.	FIP-1. 20
016-346 Restart Printer ↕ Flip Contact Support IfMessageReturns	<ESS Network Internal Loopback Error> The error is detected by on board Network Internal Loopback check.	FIP-1. 20
016-347 Restart Printer ↕ Flip Contact Support IfMessageReturns	<ESS Network Fatal Error> The fatal error is detected by On Board Network check.	FIP-1. 20

Error Message	Error Contents	FIP to be referred
016-348 Restart Printer ↕ Flip Reseat MPC Contact Support	<ESS Network OS Error> The error is detected by On Board Network OS.	FIP-1. 20
016-349 Restart Printer ↕ Flip Reseat MPC Contact Support	<ESS Network VxWORKS Error> The error is detected by On Board VxWORKS.	FIP-1. 20
016-350 Restart Printer ↕ Flip Reseat Parallel Contact Support	<IEEE1284 Data Error> The error is detected by IEEE1284 controller.	FIP-1. 24
016-360 Restart Printer ↕ Flip Reseat MPC Contact Support	<ESS PCI Option #0 Fail> Detection error of PCI option 0.	FIP-1. 22
016-370 Restart Printer ↕ Flip Contact Support IfMessageReturns	<MCU-ESS Communication Fail> Communication fail between MCU and ESS.	FIP-1. 25
093-964 Restart Printer ↕ Flip Reseat Fuser Contact Support	<IOT Fuser CRUM ID Error> Fuser CRUM communication error is detected.	FIP-1. 26

2.4 LCD Display

Problem	Error Message	Error Contents	FIP to be referred
Paper Jam	Paper Jam 071-100 ↕ Flip Open Tray1 Remove Paper ↕ Flip Open & close Front Cover	<IOT 250 Feeder Misfeed JAM> The Regi sensor is not turned on within the specified time.	FIP-1. 27
	Paper Jam 072-100 ↕ Flip Open Tray2 Remove Paper ↕ Flip Open & close Front Cover	<IOT Option Feeder Misfeed JAM> The Regi sensor is not turned on within the specified time.	FIP-1. 28
	Paper Jam 075-100 ↕ Flip Check MPF Remove Paper ↕ Flip Open & close Front Cover	<IOT MPF Misfeed JAM> The Regi sensor is not turned on within the specified time.	FIP-1. 29
	Paper Jam 077-900 ↕ Flip Open Front Cover Remove Paper	<IOT Remain Paper JAM> -The remain paper at the Exit Sensor. -The paper does not reach the Exit Sensor within the specified time. -The paper passed Exit Sensor earlier than the specified times.	FIP-1. 30
	Paper Jam 077-901 ↕ Flip Open Front Cover Remove Paper	<IOT Remain Paper JAM> -The remain paper at the Regi Sensor. -The paper does not reach the Exit Sensor within the specified time after the Regi Sensor is ON. -The paper does not pass through the Regi Sensor within the specified time.	FIP-1. 30
	Paper Jam 077-903 ↕ Flip Open Tray1 Remove Paper ↕ Flip Open & close Front Cover	<IOT Feed JAM> The arrival time of the regi sensor is early than the specified time.	FIP-1. 31

Problem	Error Message	Error Contents	FIP to be referred
Paper Jam	Paper Jam 077-907 ⇕ Flip Open Front Cover & Belt Unit ⇕ Flip Remove Paper	<IOT Remain Paper JAM> -The remain paper at the Dup Jam Sensor. -The paper reached Dup Jam Sensor earlier than the specified time. -The paper passed Dup Jam Sensor earlier than the specified time. -The paper does not pass through the Dup Jam Sensor within the specified time. -The paper does not reach the Regi Sensor within the specified time, after the Dup Jam Sensor is ON.	FIP-1. 32
Paper Setting	Load Tray N or MPF 024-910, 024-911, 024-914 ⇕ Flip Load Tray N or MPF XX ⇕ Flip Load Tray N or MPF YY NOTE: 024-910: Tray 1 024-911: Tray 2 024-914: MPF	<IOT Paper Size Mismatch> The paper size mismatch is detected	FIP-1. 33
	Load Tray N or MPF 024-965, 024-966, 024-969 ⇕ Flip Load Tray N or MPF XX ⇕ Flip Load Tray N or MPF YY NOTE: 024-965: Tray 1 024-966: Tray 2 024-969: MPF XX: Paper Size YY: Paper Type	<IOT No Suitable Paper> The specified tray is paper empty, size mismatch or type mismatch.	FIP-1. 34
Toner	CRUM ID 009-367, 009-368, 009-369, 009-370 Reseat XXX Cartridge NOTE: 009-367: Cyan Toner 009-368: Magenta Toner 009-369: Yellow Toner 009-370: Black Toner XXX: Toner color	<IOT Toner Cartridge ID Error> The toner CRUM ID error is detected.	FIP-1. 35

Problem	Error Message	Error Contents	FIP to be referred
Toner	Error XXX Cart 093-919, 093-920, 093-921, 093-922 ⇕ Flip Check XXX Cart Contact Support. NOTE: 093-919: Yellow Toner 093-920: Magenta Toner 093-921: Cyan Toner 093-922: Black Toner XXX: Toner color	<IOT Toner Tape Staying> The toner tape staying is detected. When a new toner cartridge is installed, the ADC sensor checks that the density of the toner patch on the transfer belt does not reach the specified value.	FIP-1. 36
	Replace Cart. 093-930, 093-931, 093-932, 093-933 Replace XXX Cartridge NOTE: 093-930: Yellow Toner 093-931: Magenta Toner 093-932: Cyan Toner 093-933: Black Toner XXX: Toner color	<IOT Toner Cartridge Life Over> The value of toner cartridge counter has reached the replacement time.	FIP-1. 37 Y FIP-1. 38 M FIP-1. 39 C FIP-1. 40 K
	Ready to Print 093-423, 093-424, 093-425, 093-426 ⇕ Flip XXX Cartridge Is close to Life NOTE: 093-423: Yellow Toner 093-424: Magenta Toner 093-425: Cyan Toner 093-426: Black Toner	<IOT Toner Cartridge Near Empty> The value of toner cartridge counter is going to reach the replacement time.	FIP-1. 41 Y FIP-1. 42 M FIP-1. 43 C FIP-1. 44 K
	Insert PrintCart 093-970, 093-971, 093-972, 093-973 ⇕ Flip Insert XXX Cartridge NOTE: 093-970: Yellow Toner 093-971: Magenta Toner 093-972: Cyan Toner 093-973: Black Toner XXX: Toner color	<IOT Toner Cartridge Detached> The yellow, magenta, cyan or black Toner Cartridge detached is detected. The toner cartridge sensor detected the cartridge detached.	FIP-1. 45 Y FIP-1. 46 M FIP-1. 47 C FIP-1. 48 K

Problem	Error Message	Error Contents	FIP to be referred
Belt	CRUM ID 009-371 ↕ Flip Reseat Belt Unit	<IOT Belt Unit CRUM ID Error> The Belt Unit CRUM ID error is detected. The Belt Unit CRUM ID read by the sensor is different from the one that was recorded.	FIP-1. 49
	Ready to Print 094-422 ↕ Flip Belt Unit Is close to ↕ Flip Life	<IOT Belt Unit Life Warning> The Belt Unit Counter is going to reach the replacement time.	FIP-1. 50
	Insert Belt Unit 094-910 ↕ Flip Insert Belt Unit	<IOT Belt Unit Detached> The Belt Unit Detached is detected.	FIP-1. 49
	Belt Unit 094-911 ↕ Flip Replace Belt Unit	<IOT Belt Unit Life Over> The Belt Unit Counter has reached the replacement time.	FIP-1. 51
Fuser	010-351 Restart Printer ↕ Flip Reseat Fuser Contact Support	<IOT Fuser Life Over> The Fuser Counter has reached the replacement time.	FIP-1. 17
	010-359 Restart Printer ↕ Flip Reseat Fuser Contact Support	<IOT Fuser CRUM ID Error> The Fuser CRUM ID error is detected. The Fuser CRUM ID read by the sensor is different from the one that was recorded.	FIP-1. 52
	Ready to Print 010-421 ↕ Flip Replace Fuser Soon	<IOT Fuser Life Warning> The Fuser Counter is going to reach the replacement time.	FIP-1. 53
Tray	Tray Detached 024-946, 024-947 ↕ Flip Push In Tray N NOTE: 024-946: Tray 1 024-947: Tray 2 N: Tray number	<IOT Tray Detached> The paper cassette is detached. The Tray Size Switch detected the no tray.	FIP-1. 54
	Load Tray 1 077-912 ↕ Flip Push In Tray 1	<Upper Cassette Detached> The Tray 1 paper cassette is detached when the tray 2 is specified. The Tray Size Switch detected the no tray.	FIP-1. 54

Problem	Error Message	Error Contents	FIP to be referred
Cover Open	Close FrontCover 077-300 ↕ Flip Front Cover Is Open	<IOT Cover Front Open> The Front Cover is open.	FIP-1. 55
Other	Invalid ID 016-383 ↕ Flip Data Violation Press ✓	<Download Error> The ID of the downloaded file is invalid.	FIP-1. 56
	Range Chk Error 016-384 ↕ Flip Data Violation Press ✓	<Download Error> The address of the write destination is invalid.	FIP-1. 56
	Header Error 016-385 ↕ Flip Data Violation Press ✓	<Download Error> The header information is invalid.	FIP-1. 56
	Check Sum Error 016-386 ↕ Flip Data Violation Press ✓	<Download Error> The checksum is invalid.	FIP-1. 56
	Format Error 016-387 ↕ Flip Data Violation Press ✓	<Download Error> The format is invalid.	FIP-1. 56
	MPC Error 016-388 ↕ Flip Reseat MPC Press ✓	<MPC Download Error> Failed to start MPC download mode at MPC download.	FIP-1. 57
	MPC Detached 016-389 ↕ Flip Reseat MPC Press ✓	<MPC Download Error> MPC Download was attempted without MPC mounted.	FIP-1. 57
	MPC Com. Failed 016-390 ↕ Flip Reseat MPC Press ✓	<MPC Download Error> Communication error occurred between MPC and ESS during download.	FIP-1. 57
	Erase Flash Err. 016-392 ↕ Flip Contact Support IfMessageReturns	<Download Error> An error occurred erasing the Flash.	FIP-1. 20

Problem	Error Message	Error Contents	FIP to be referred
Other	Write Flash Err. 016-393 ↕ Flip Contact Support IfMessageReturns	<Download Error> An error occurred writing the Flash.	FIP-1. 20
	Verify Error 016-394 ↕ Flip Contact Support IfMessageReturns	<Download Error> An error occurred verifying the Flash.	FIP-1. 20
	Out of Memory 016-700 ↕ Flip Job too Large Press ✓	<Memory Over flow> Exceeds the memory capacity.	FIP-1. 58
	Disk Full 016-980 ↕ Flip Job too Large Press ✓	<Memory Over flow> Exceeds the memory capacity.	FIP-1. 58
	PDL Error 016-720 ↕ Flip Data Violation Press ✓	<PDL Error> PDL error occurs. The print data cannot be processed by PDL.	FIP-1. 20
	Invalid User 016-757 ↕ Flip Account Denied Press ✓	<Auditron Error> The user is not registered to any account.	FIP-1. 59
	Disabled Func 016-758 ↕ Flip Denied Col print Press ✓	<Auditron Error> An invalid account was detected.	FIP-1. 59
	Reached Limits 016-759 ↕ Flip Over your limits Press ✓	<Auditron Error> The number of registered users exceeded it's upper limit.	FIP-1. 59
	Invalid Job 016-799 ↕ Flip Data Violation Press ✓	<Job Environment Violation> Detects violation data for the print condition. The print data specifies paper type/size not available for the printer.	FIP-1. 60
	Ready to Print 193-700 ↕ Flip non-DELL Toner Installed	<Custom Toner Mode> The printer is in custom toner mode.	FIP-1. 61

Problem	Error Message	Error Contents	FIP to be referred
Other	Over Heat 042-700 ↕ Flip cooling down Please Wait...	<IOT Over Heat Stop> The temp. sensor in OHP SENSOR sensed high temperature.	FIP-1. 62
	Ready to Print 142-700 ↕ Flip Over Heat Turned Halfmode	<IOT Over Heat Warning> The printing mode becomes half speed mode, by the high temperature. The temp. sensor in OHP SENSOR sensed high temperature.	FIP-1. 62

3. Error Code FIP

FIP-1.1 001-360/001-363 Restart Printer

Possible causative parts:FAN MAIN (PL9.1.10)
LVPS (PL9.1.4)
PWBA MCU (PL9.1.20)

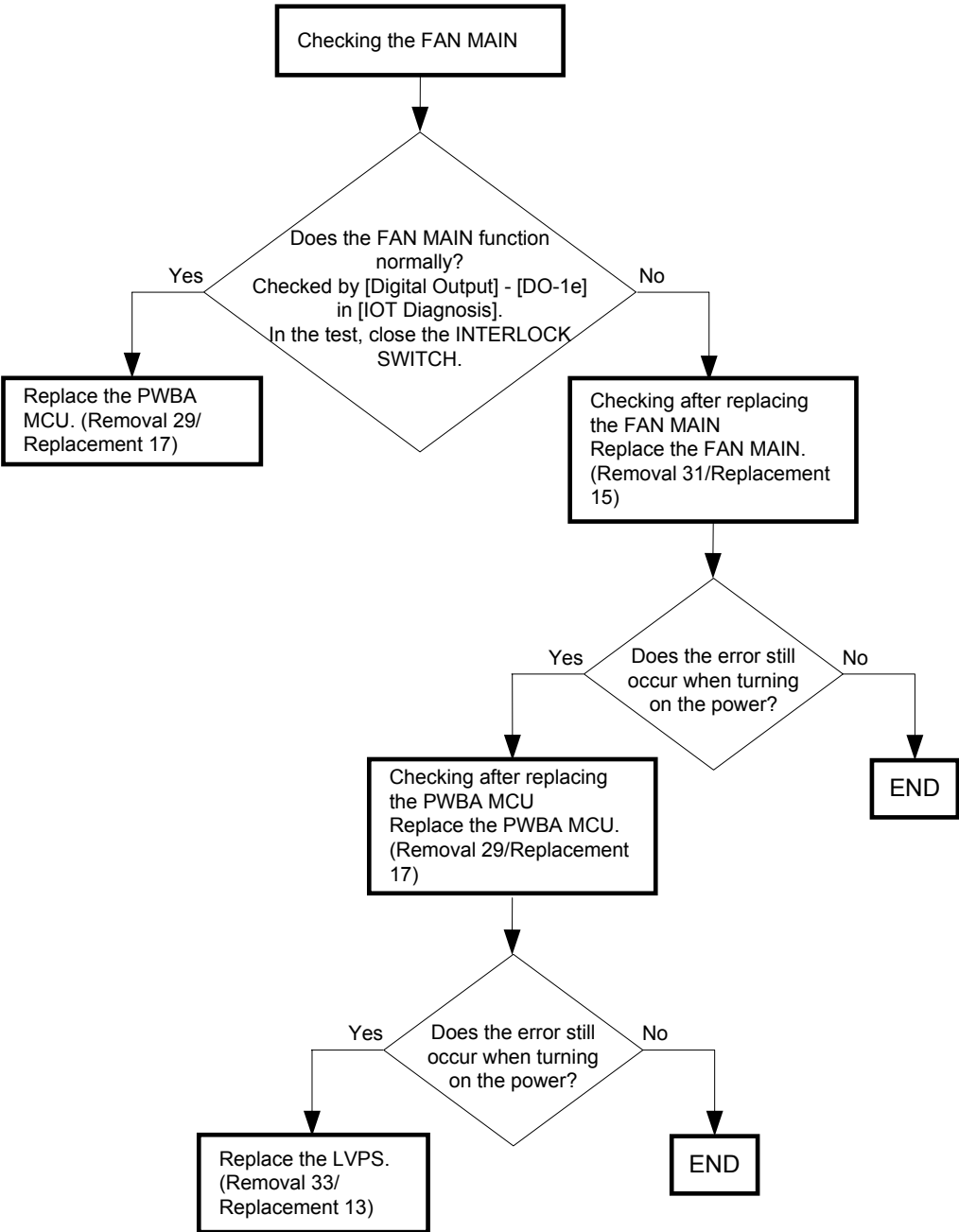

FIP-1.2 001-361/001-363 Restart Printer

Possible causative parts:PWBA MCU (PL9.1.20)
CHUTE ASSY DUP (PL11.1.1)

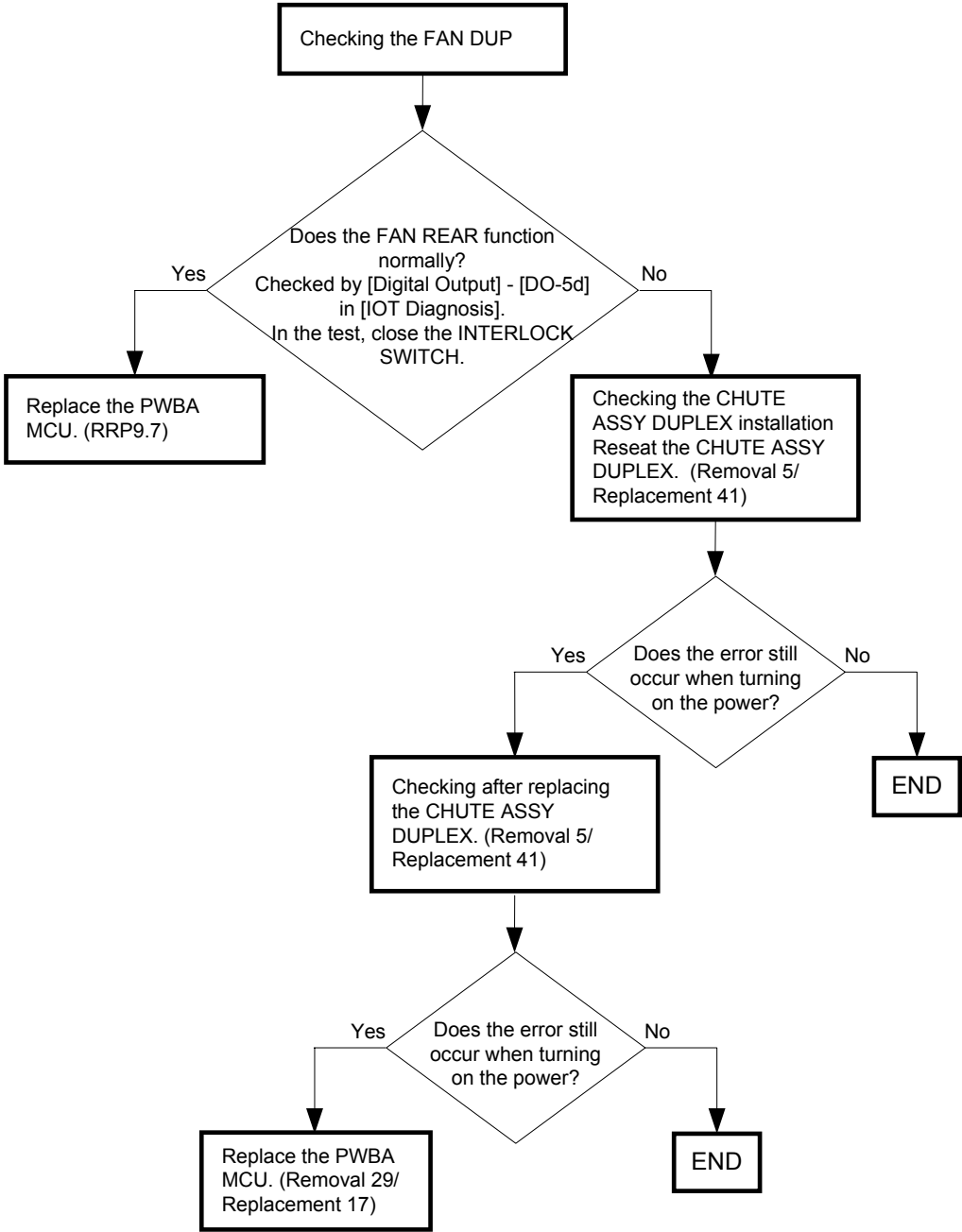

FIP-1. 3 003-341/003-342/003-343/003-344/003-345/003-346/003-347/003-348/003-349/
003-350 Restart Printer

Possible causative parts:PWBA MCU (PL9.1.20)

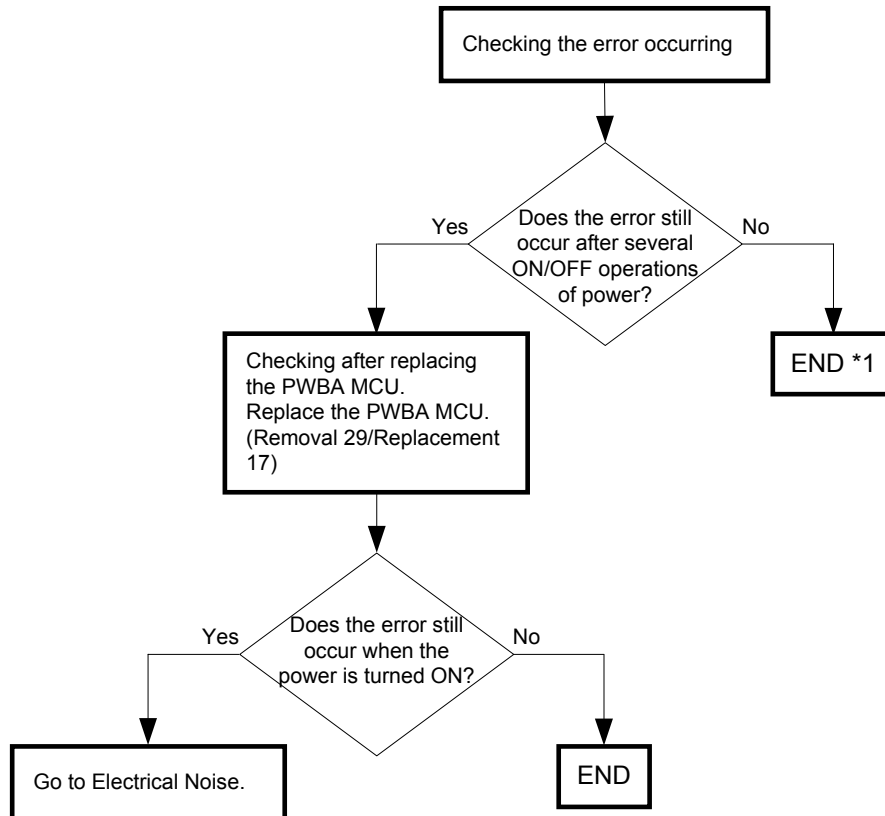

*1: Though some kind of external noise would be possible cause, go to [FIP-1. 59 Electrical Noise] and check, to make sure.

FIP-1.4 003-356 Restart Printer

Possible causative parts:TRANSFER BELT (PL4.1.1)
HVPS (PL5.1.17)
FUSER (PL6.1.10)
PWBA EEPROM (PL9.1.1)
PWBA MCU (PL9.1.20)

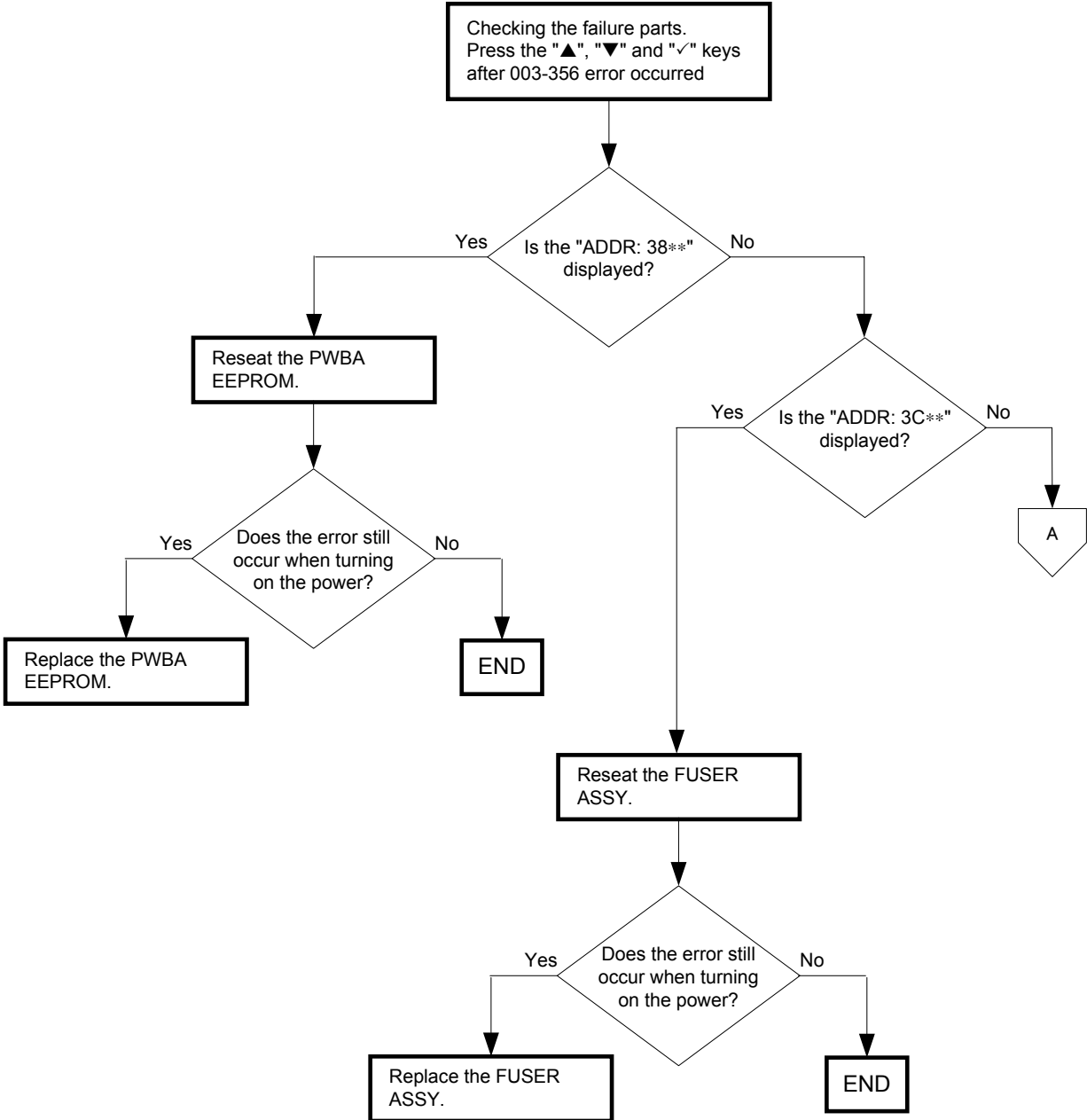

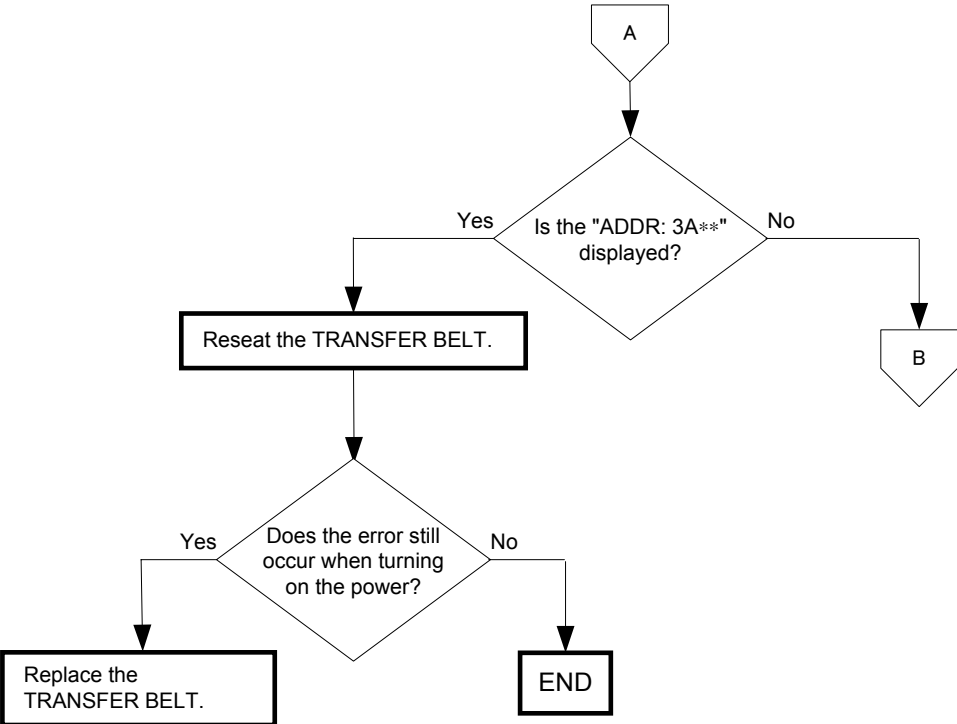

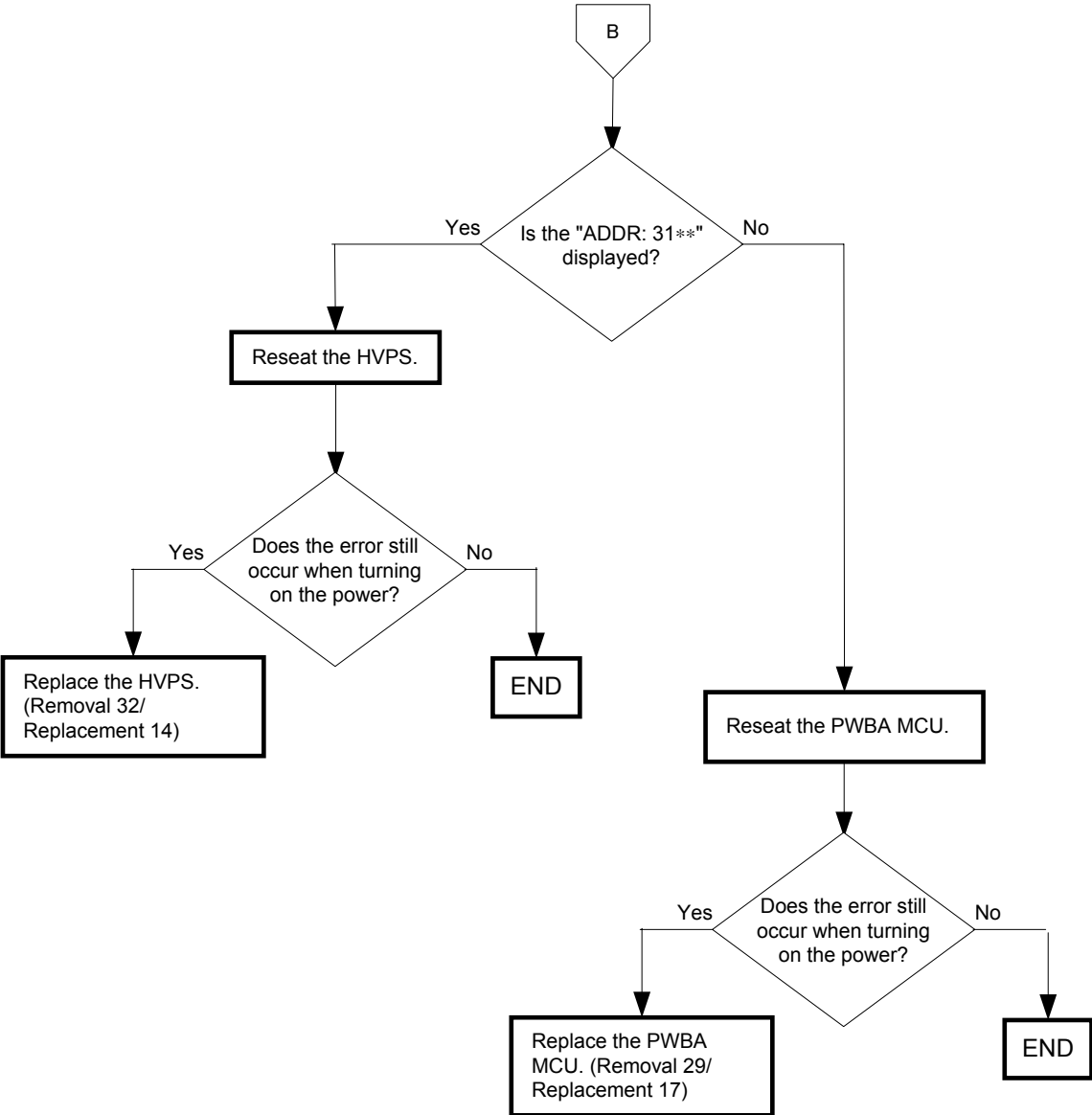

FIP-1.5 004-310 Restart Printer

Possible causative parts:PWBA MCU (PL9.1.14)
OPTION FEEDER ASSY (PL12.1.1)

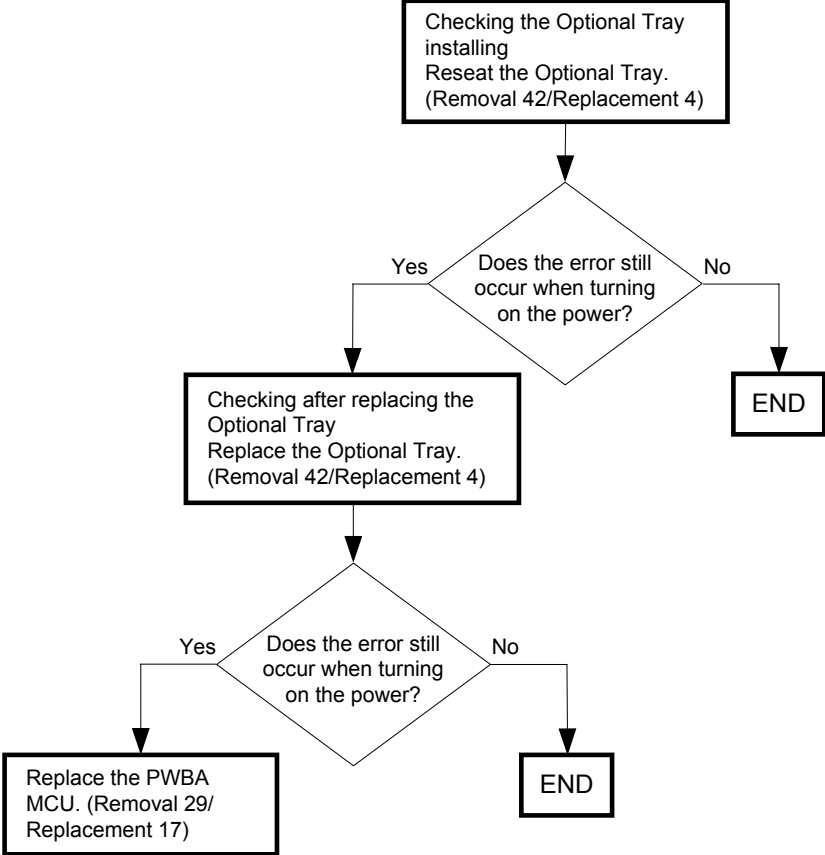

FIP-1.6 004-311 Restart Printer

Possible causative parts:PWBA MCU (PL9.1.20)
DUPLEX ASSY (PL11.1.1)

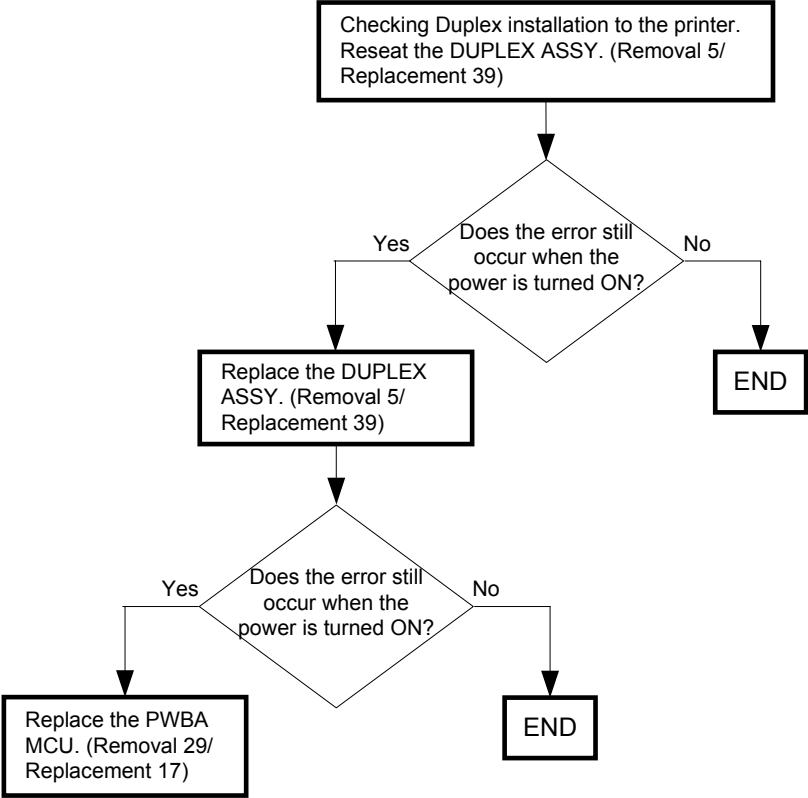

FIP-1.7 006-370/006-371/006-372/006-373/006-374/006-375/006-376/006-377/006-378/
006-379/006-380/006-381/006-382/006-383/006-384 Restart Printer

Possible causative parts:ROS ASSY (PL5.1.2)
PWBA MCU (PL9.1.20)

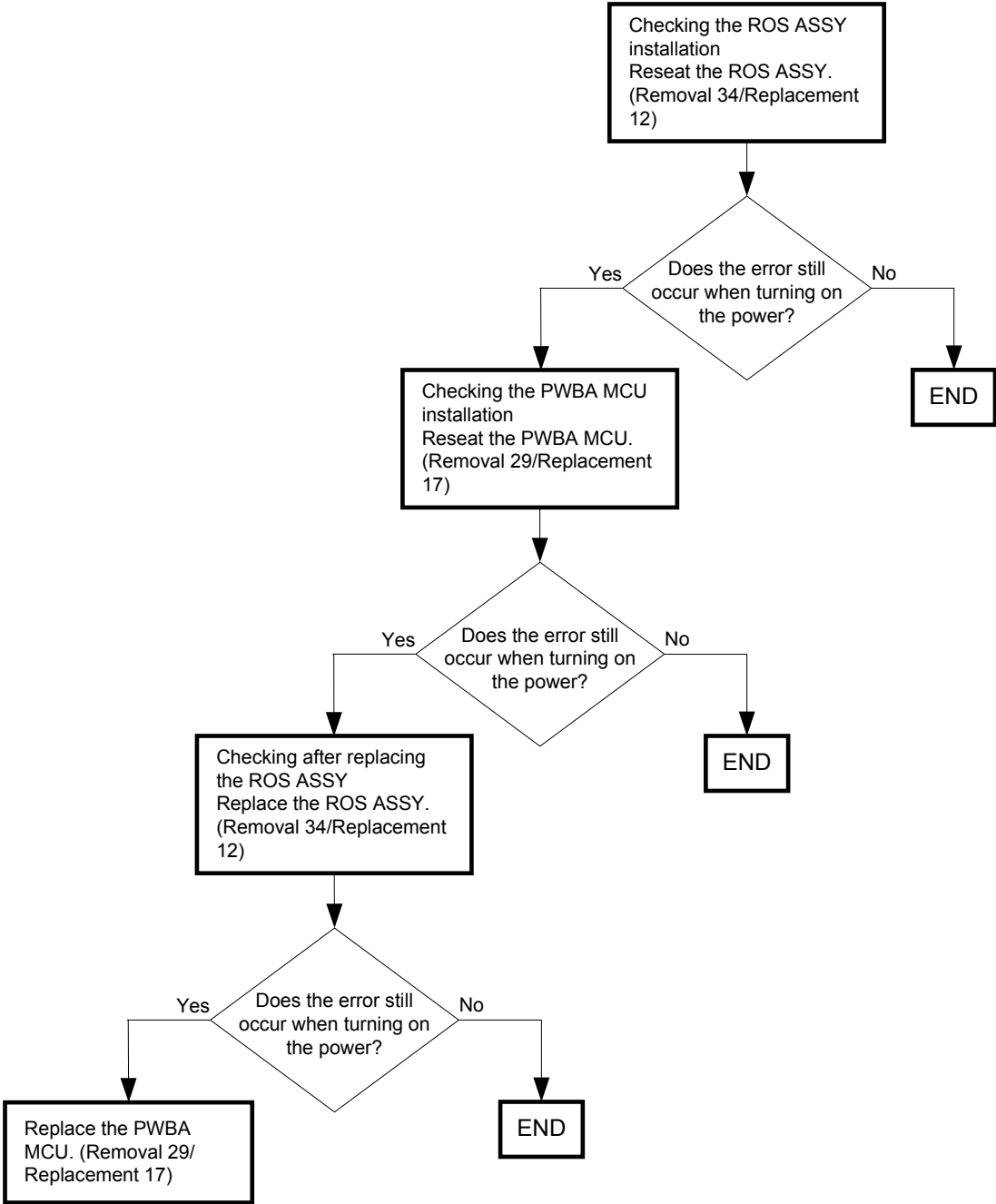

FIP-1.8 007-340/007-345/007-346/007-347/007-348/007-355/007-356/007-357/007-358/
007-359/007-360/007-365/007-366/007-367/007-368/007-370 Restart Printer

Possible causative parts:DRIVE ASSY MAIN (PL8.1.1)
PWBA MCU (PL9.1.20)

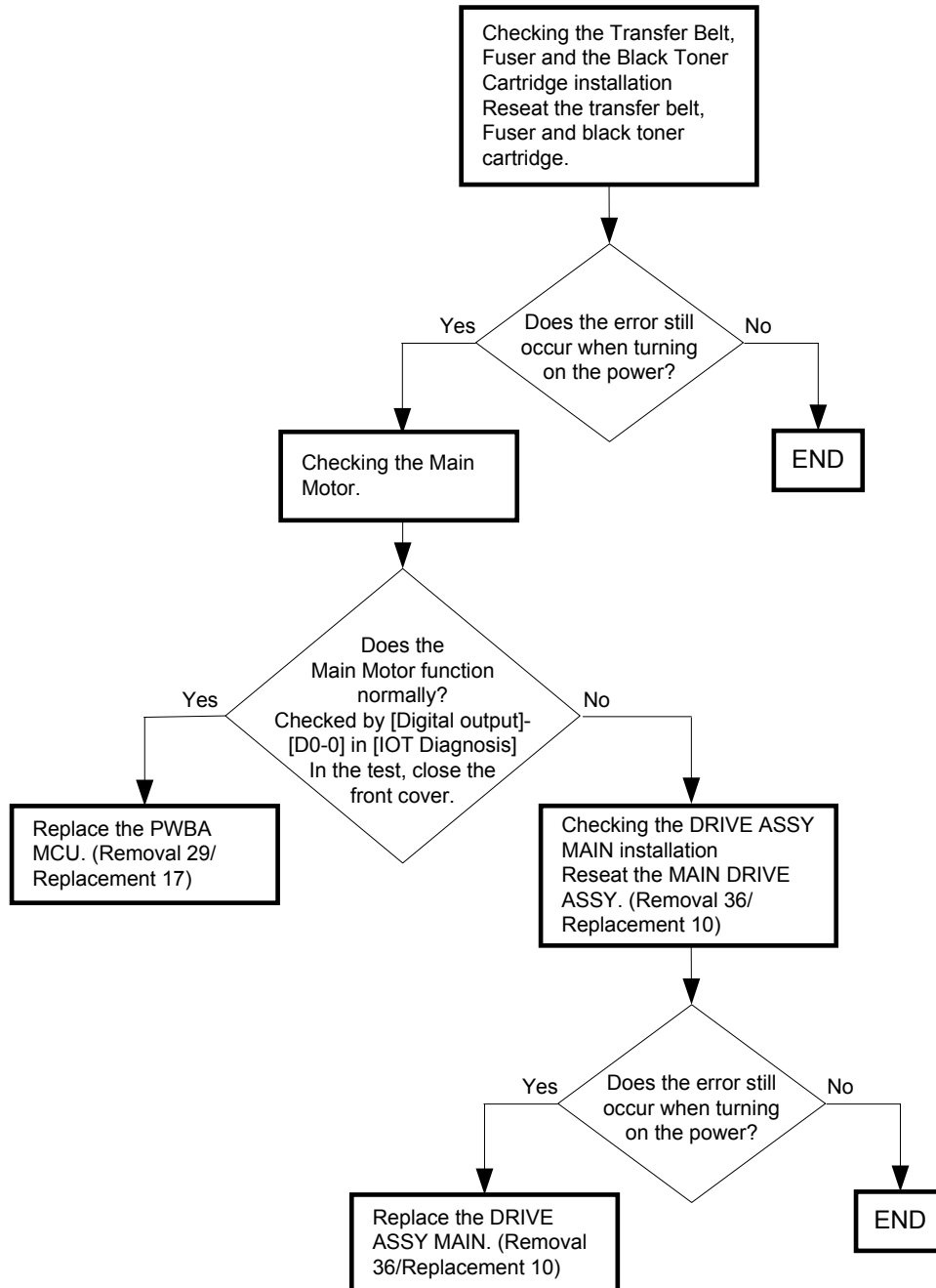

FIP-1.9 007-341/007-345/007-349/007-350/007-351/007-355/007-356/007-357/007-361/
007-362/007-363/007-365/007-366/007-367/007-369/007-370 Restart Printer

Possible causative parts:DRIVE ASSY MAIN (PL8.1.1)
PWBA MCU (PL9.1.20)

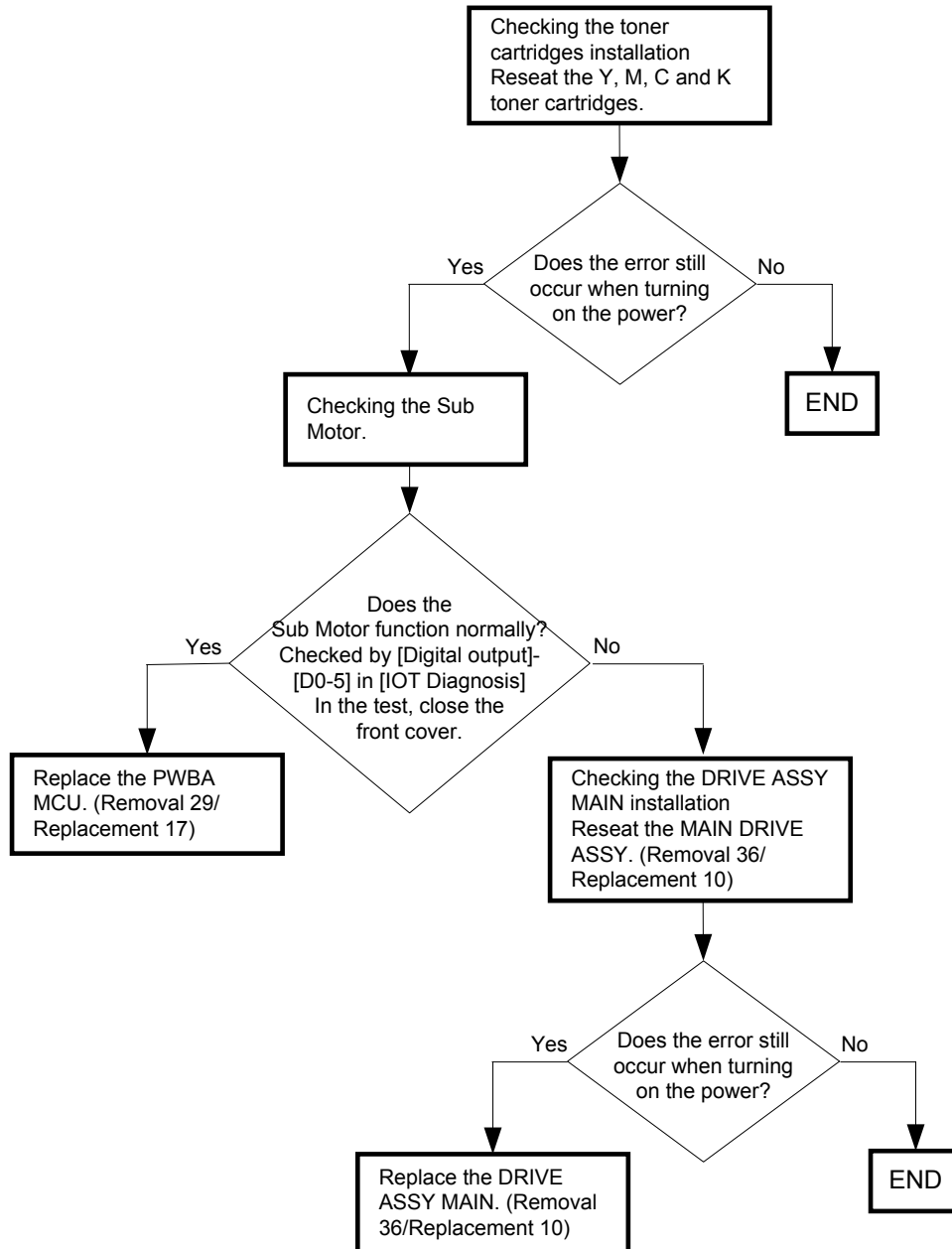

FIP-1. 10 007-342/007-346/007-349/007-352/007-353/007-355/007-358/007-359/
 007-361/007-362/007-364/007-365/007-366/007-368/007-369/007-370 Restart
 Printer

Possible causative parts:DRIVE ASSY MAIN (PL8.1.1)
 PWBA MCU (PL9.1.20)

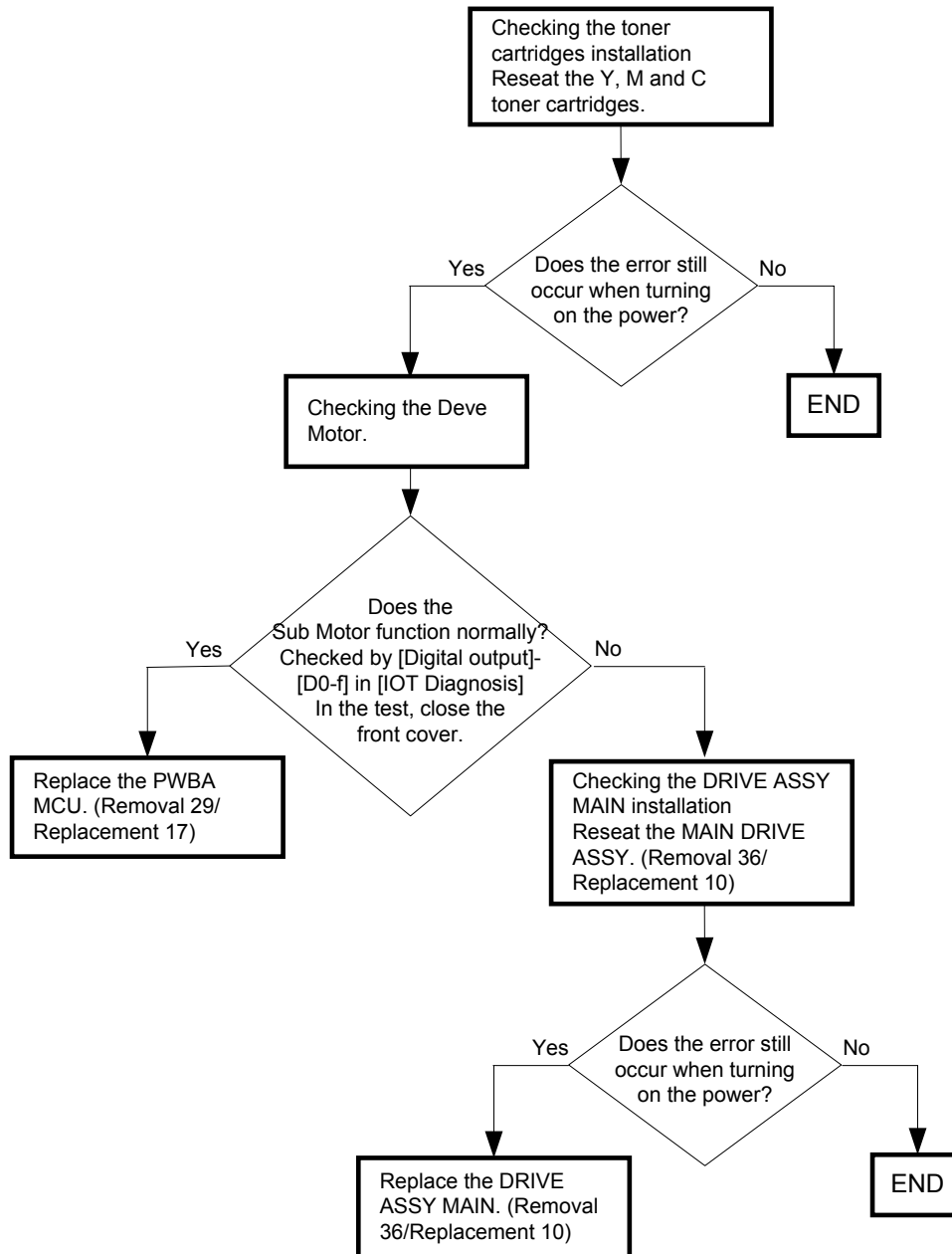

FIP-1. 11 007-343/007-347/007-350/007-352/007-354/007-356/007-358/007-360/
007-361/007-363/007-364/007-365/007-367/007-368/007-369/007-370 Restart
Printer

Possible causative parts:FEEDER ASSY (PL3.2.99)
DRIVE ASSY PH (PL8.1.8)
PWBA MCU (PL9.1.20)

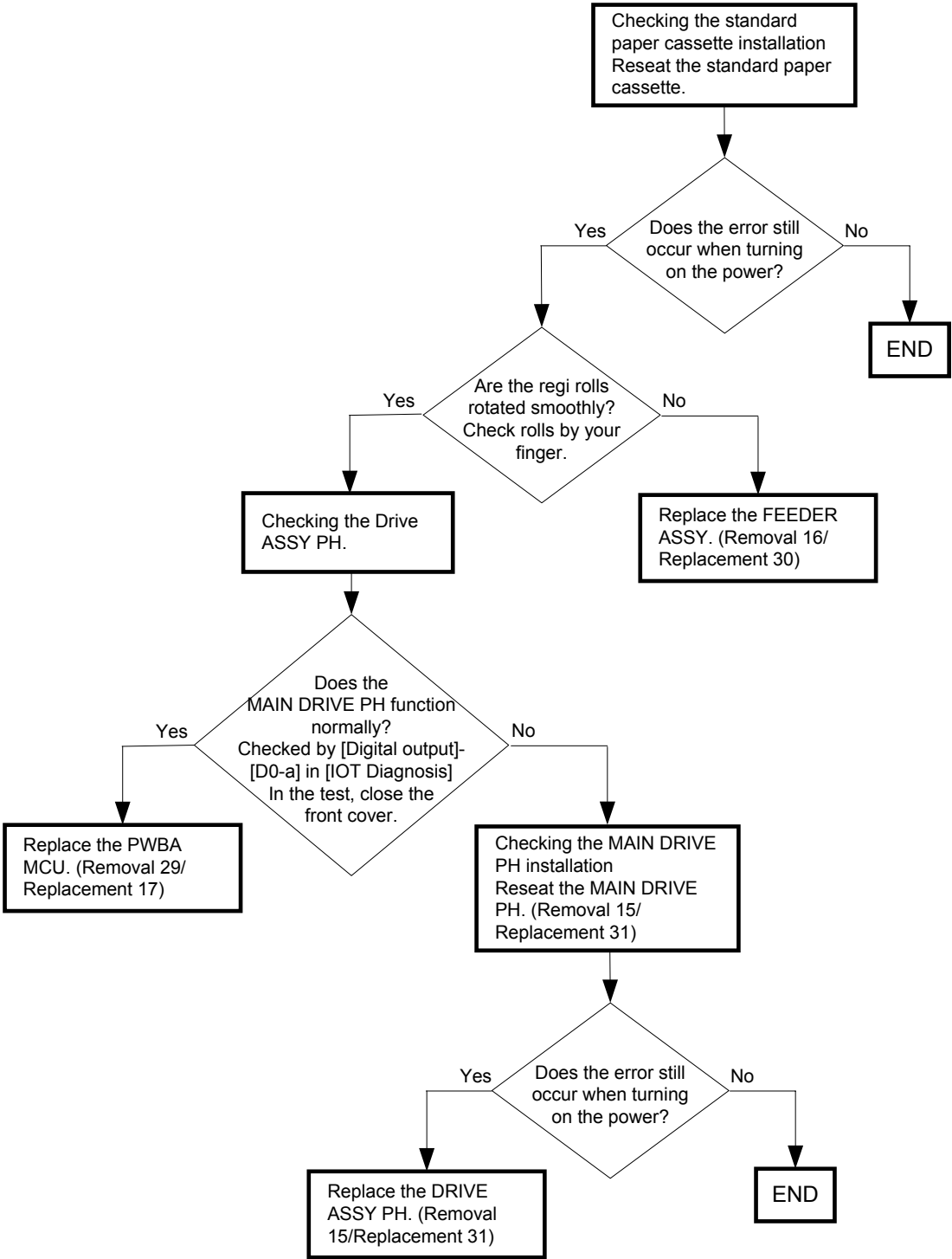

FIP-1. 12 007-344/007-348/007-351/007-353/007-354/007-357/007-359/007-360/
 007-362/007-363/007-364/007-366/007-367/007-368/007-369/007-370 Restart
 Printer

Possible causative parts:PWBA MCU (PL9.1.20)
 550 OPTION FEEDER (PL12.1.1)

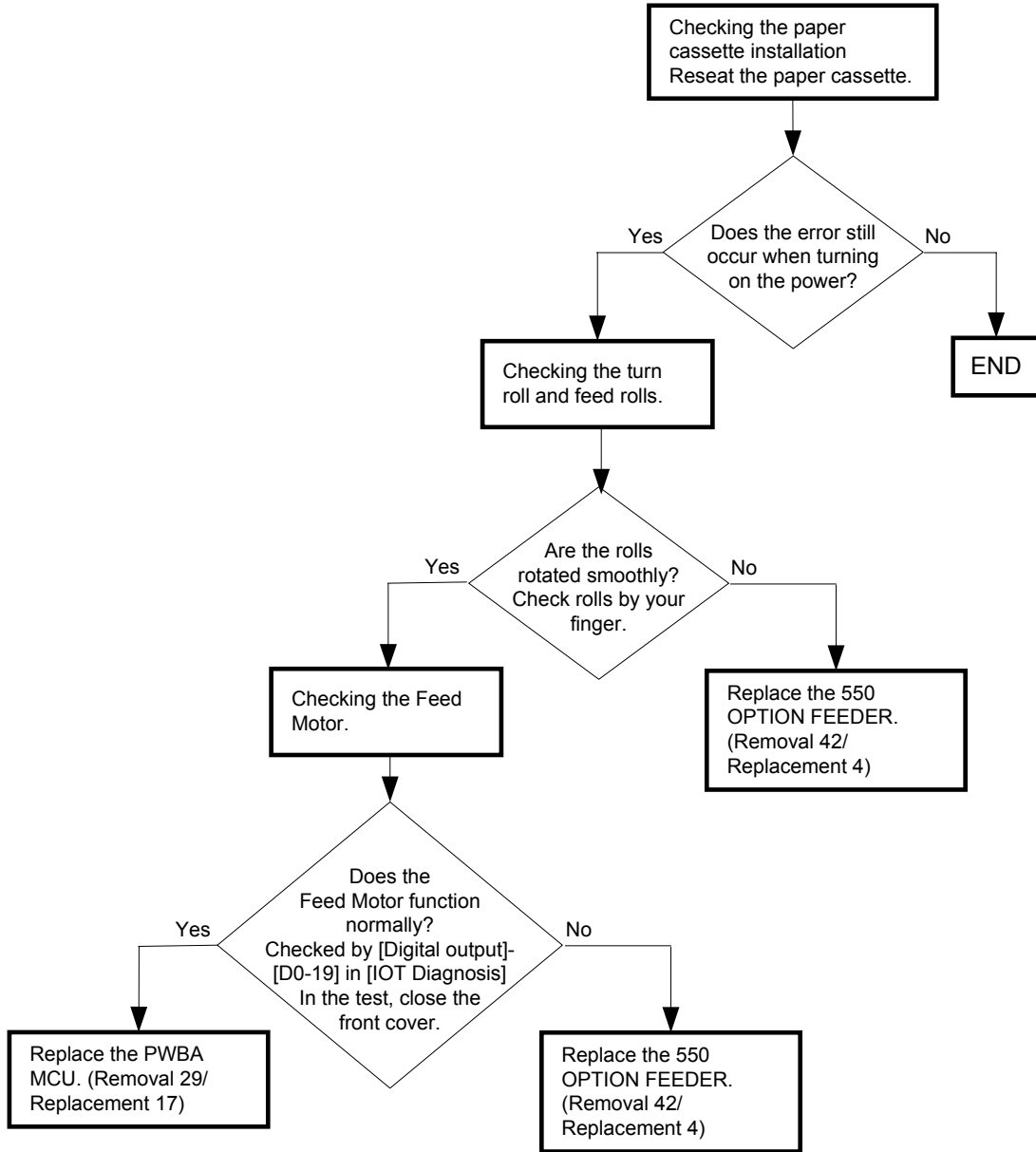

FIP-1. 13 009-360/009-361/009-362/009-363 Restart Printer

Possible causative parts:CONNECTOR CRUM (PL5.1.3)
CARTRIDGE ASSY K (PL5.1.18)
CARTRIDGE ASSY C (PL5.1.19)
CARTRIDGE ASSY M (PL5.1.20)
CARTRIDGE ASSY Y (PL5.1.21)
PWBA MCU (PL9.1.20)

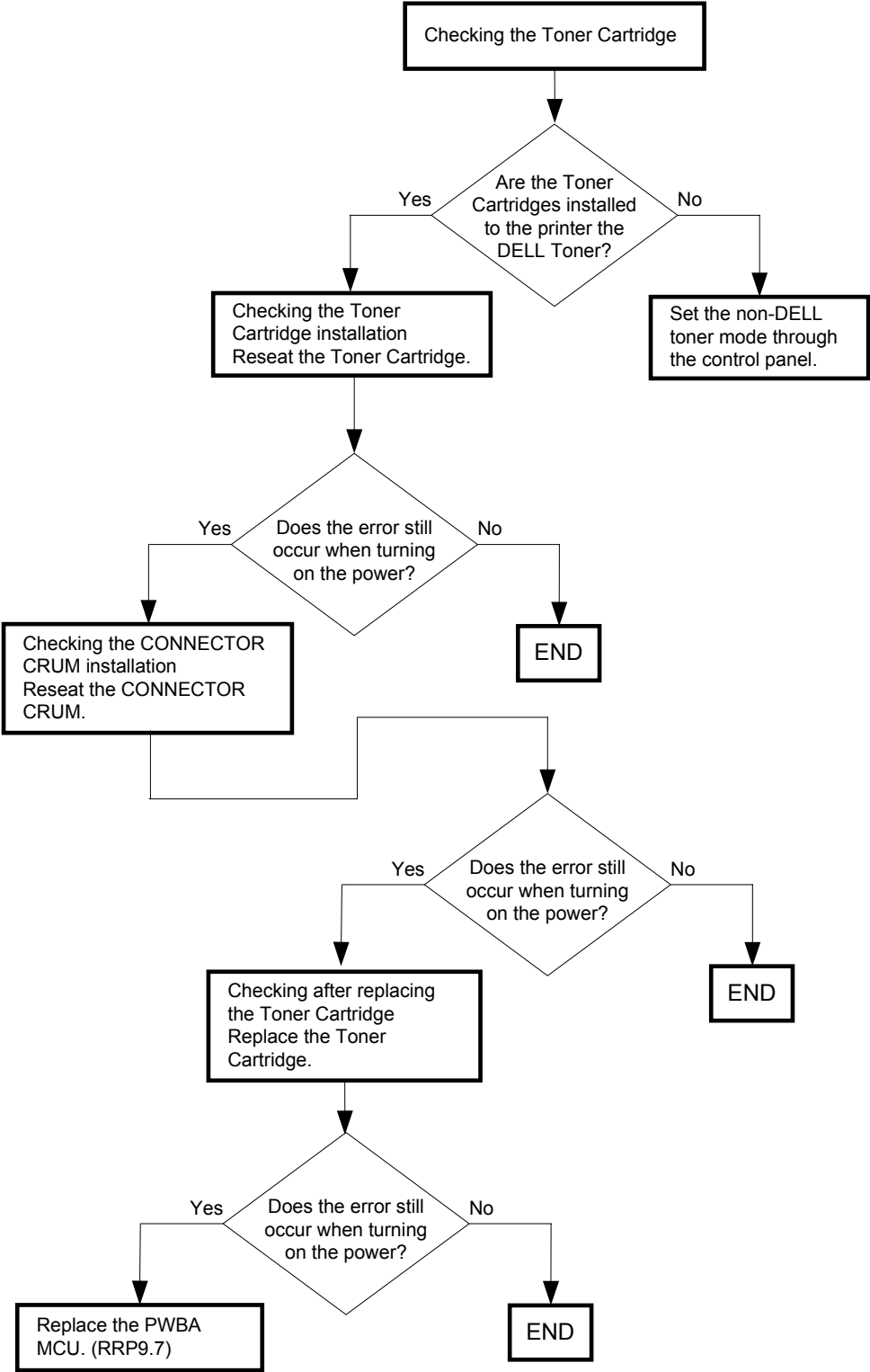

FIP-1. 14 009-654 Restart Printer

Possible causative parts:BELT CRU (PL4.1.1)
CARTRIDGE ASSY (PL5.1.18 (K)/5.1.19 (C)/5.1.20 (M)/5.1.21 (Y))
DRIVE ASSY MAIN (PL8.1.2)
PWBA MCU (PL9.1.20)

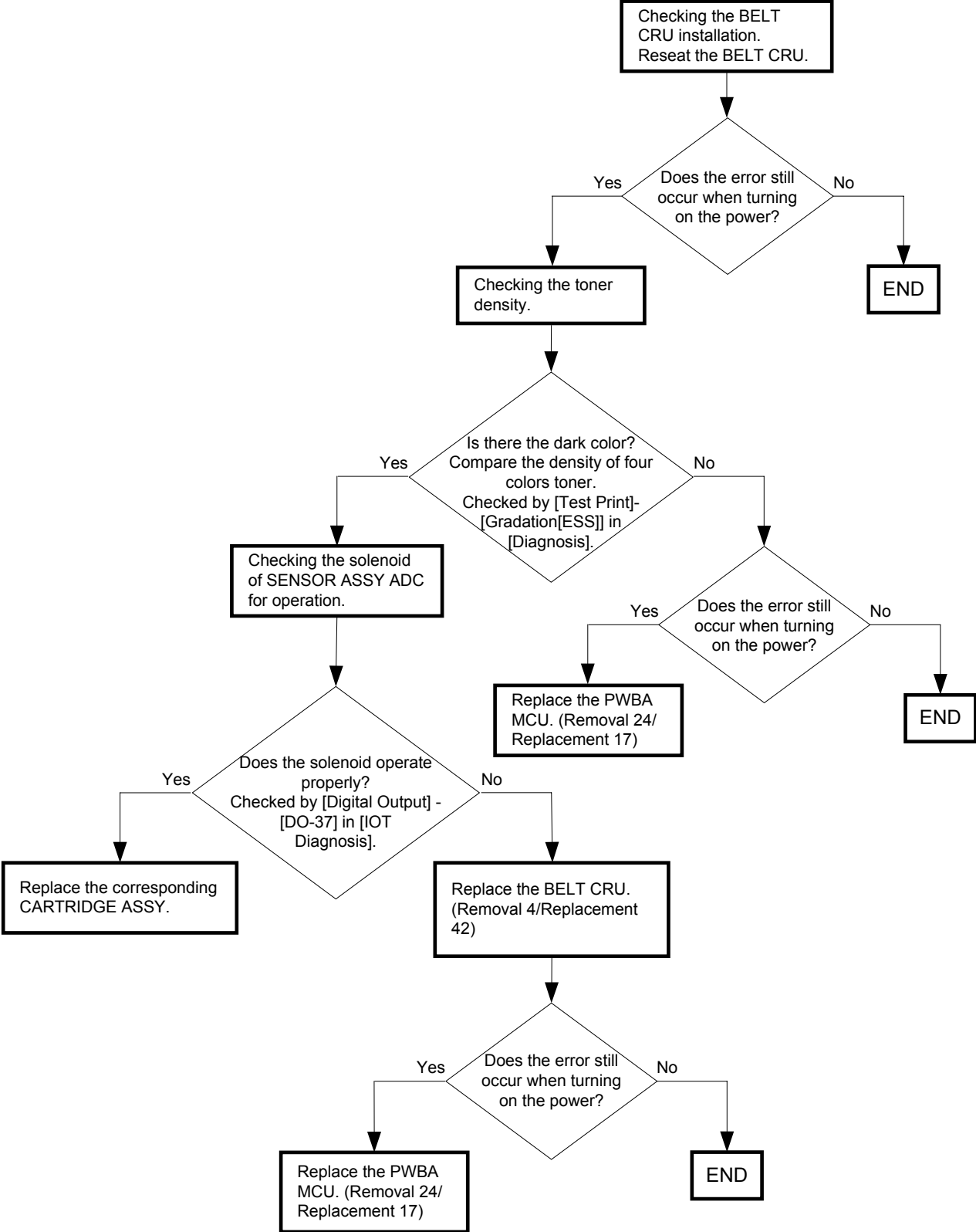

FIP-1. 15 009-655 Restart Printer

Possible causative parts:BELT CRU (PL4.1.1)
ROS ASSY (PL5.1.2)
CARTRIDGE ASSY (PL5.1.18 (K)/5.1.19 (C)/5.1.20 (M)/5.1.21 (Y))
DRIVE ASSY MAIN (PL8.1.2)
PWBA MCU (PL9.1.20)

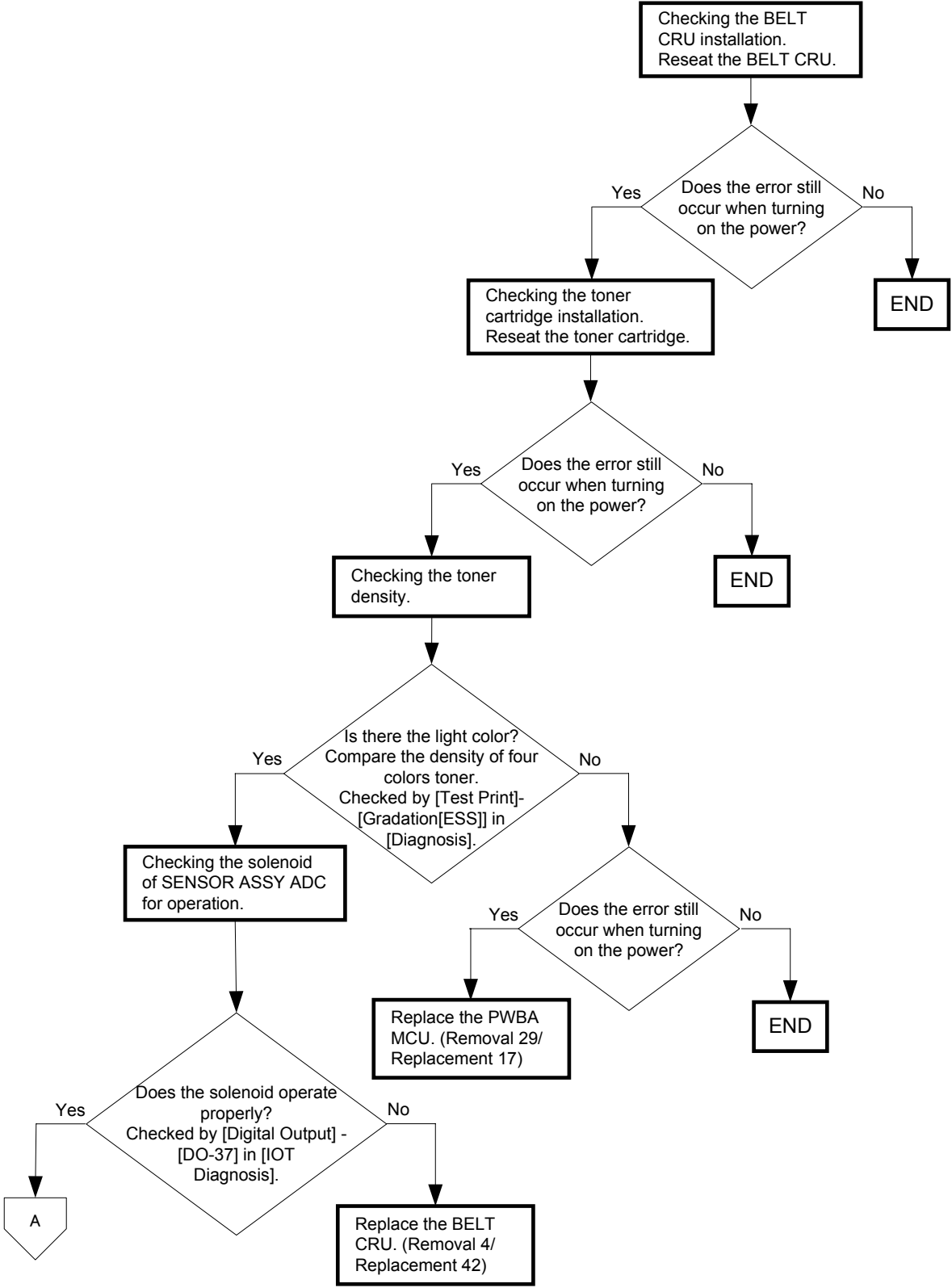

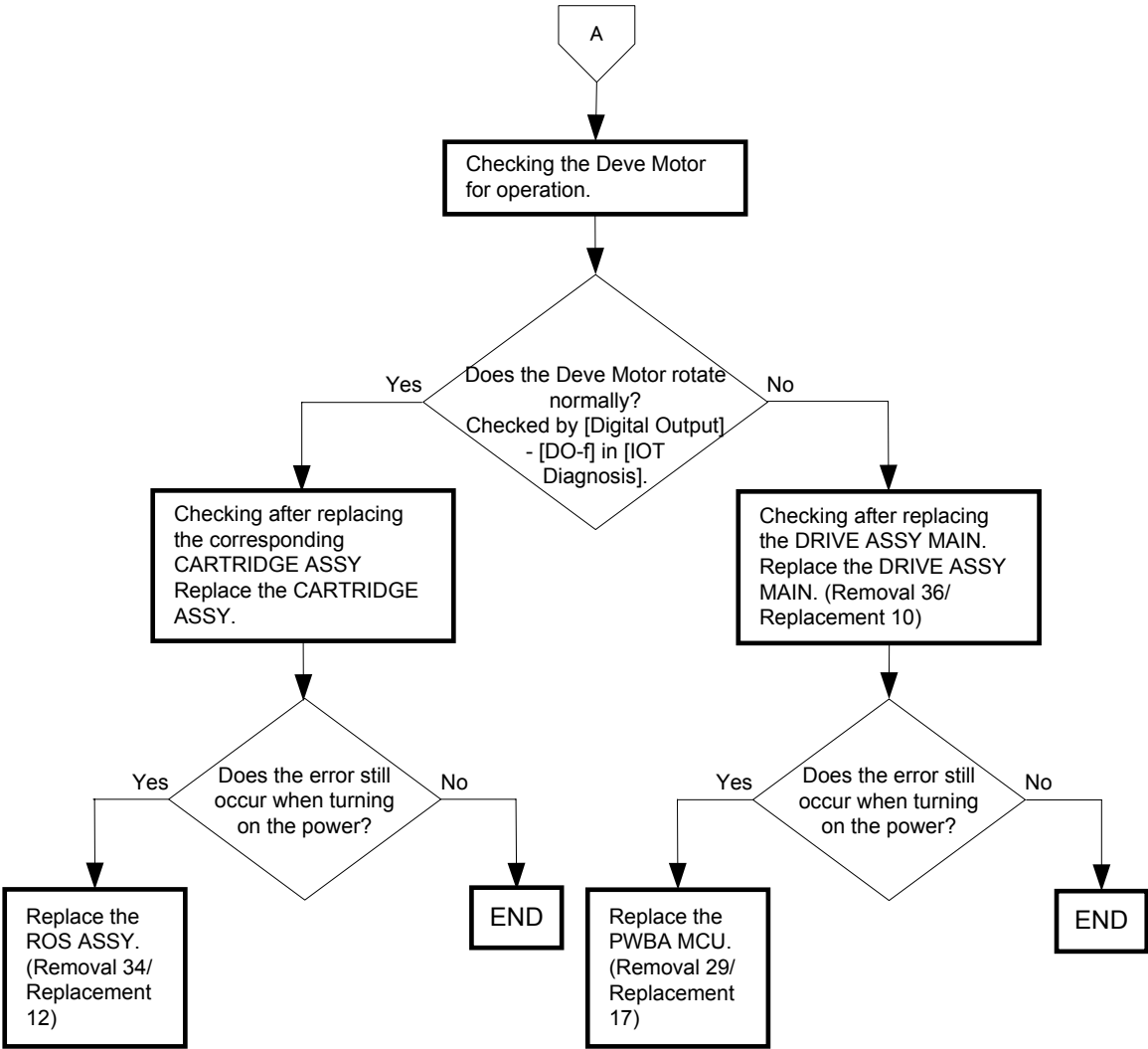

FIP-1. 16 010-317 Insert Fuser

Possible causative parts:FUSER ASSY (PL6.1.10)
PWBA MCU (PL9.1.20)

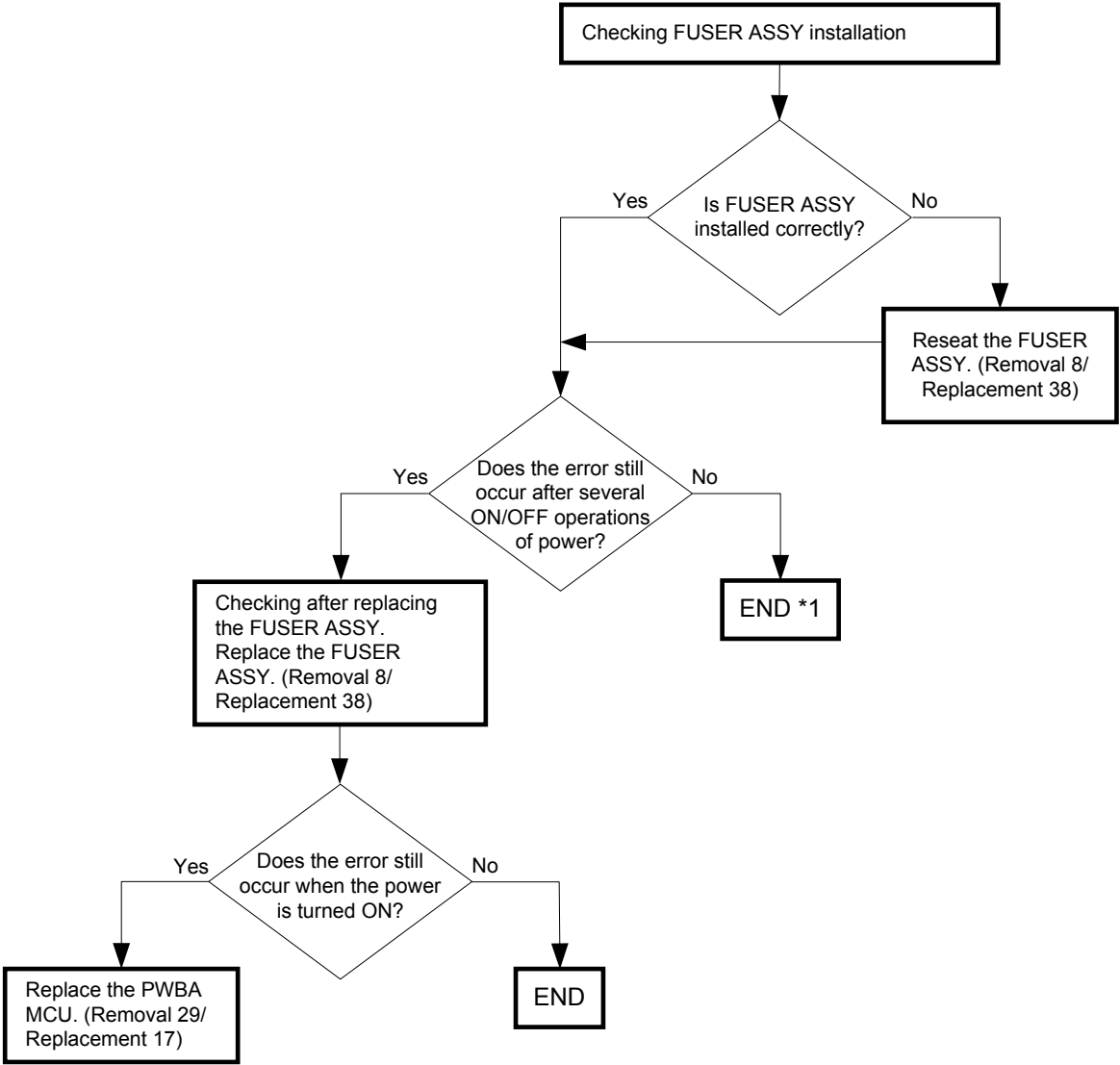

*1: Though some kind of external noise would be possible cause, go to [FIP-1. 63 Electrical Noise] and check, to make sure.

FIP-1. 17 010-351 Replace Fuser/Restart Printer

Possible causative parts:FUSER ASSY (PL6.1.10)
PWBA MCU (PL9.1.20)

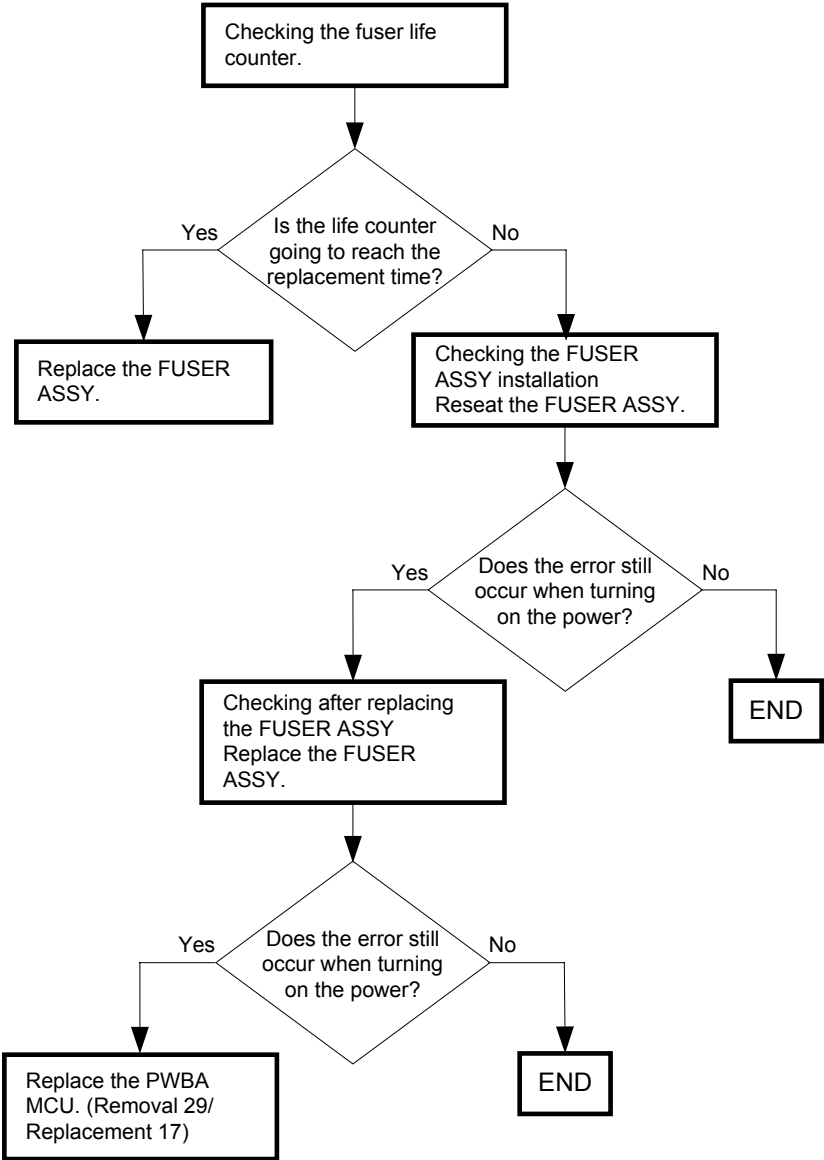

FIP-1. 18 010-354 Restart Printer

Possible causative parts:SENSOR HUM (PL9.1.19)
PWBA MCU (PL9.1.20)

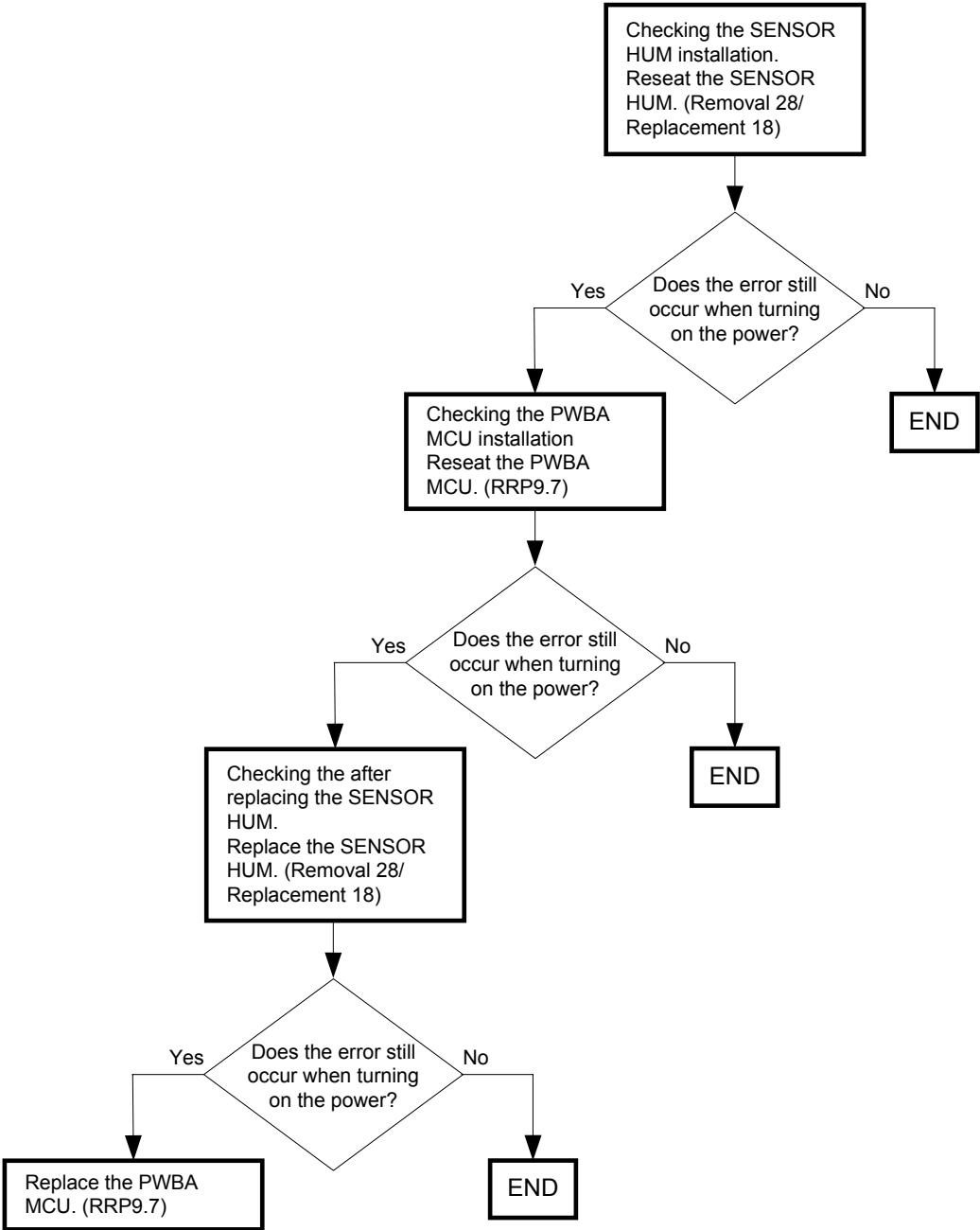

FIP-1. 19 010-377/010-378/010-379/010-380/010-381/010-382/010-383/010-384/
 010-385/010-386/010-387/010-388/010-389/010-390/010-391/010-392/
 010-393/010-394/010-395 Restart Printer

Possible causative parts:FUSER ASSY (PL6.1.10)
 LVPS (PL9.1.4)
 PWBA MCU (PL9.1.206)

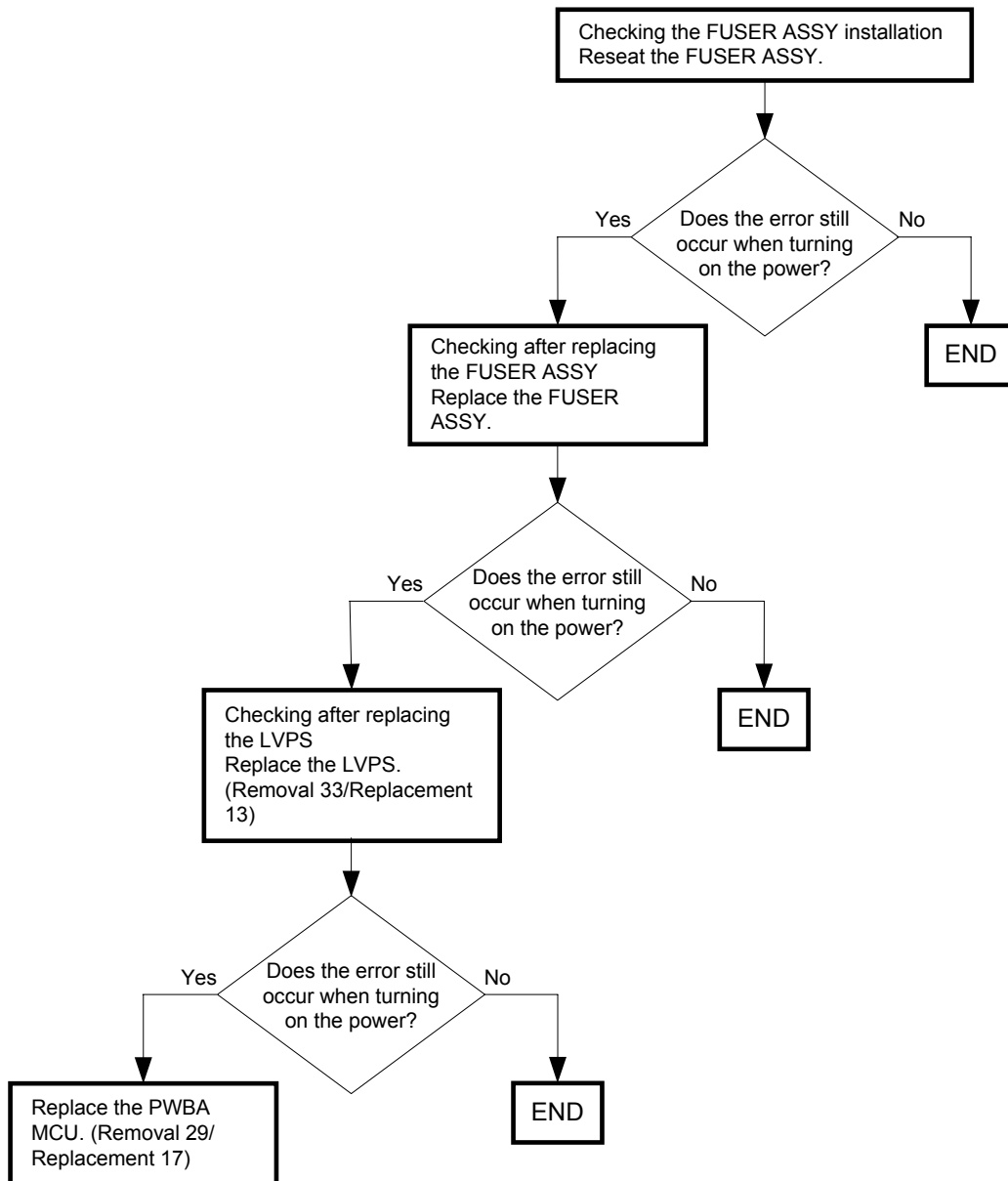

FIP-1. 20 016-300/016-301/016-302/016-310/016-313/016-315/016-317/016-323/
016-327/016-340/016-344/016-345/016-346/016-347/016-348/016-349 Restart
Printer / Erase Flash Err. 016-392 / Write Flash Err. 016-393 / Verify Error
016-394 / PDL Error 016-720

Possible causative parts:PWBA ESS (PL9.1.27)

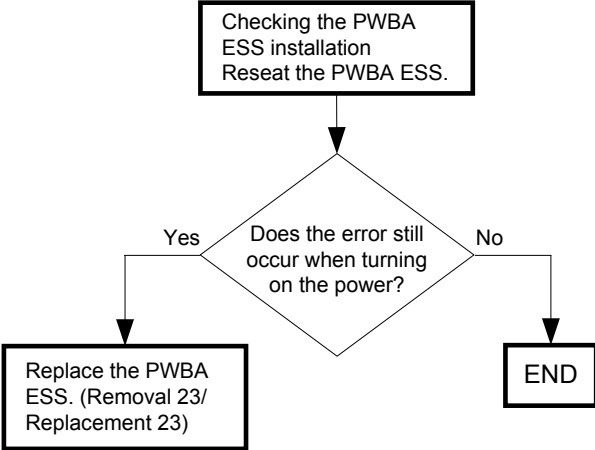

FIP-1. 21 016-316/016-318 Restart Printer

Possible causative parts:Memory Card (option)
PWBA ESS (PL9.1.27)

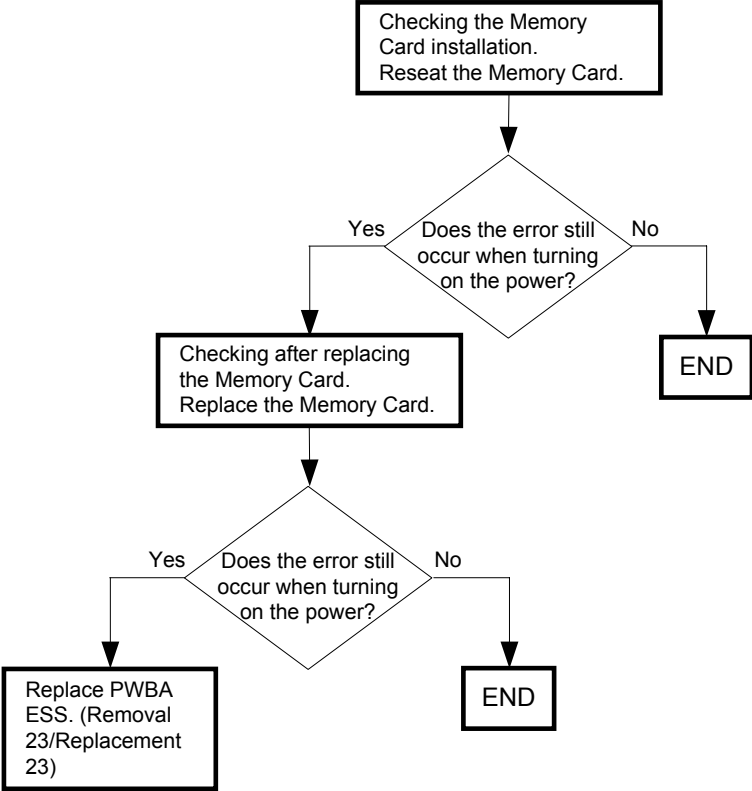

FIP-1.22 016-330/016-331/016-332/016-333/016-334/016-335/016-336/016-337/016-360
Restart Printer

Possible causative parts:Multi Protocol Card (option)
PWBA ESS (PL9.1.27)

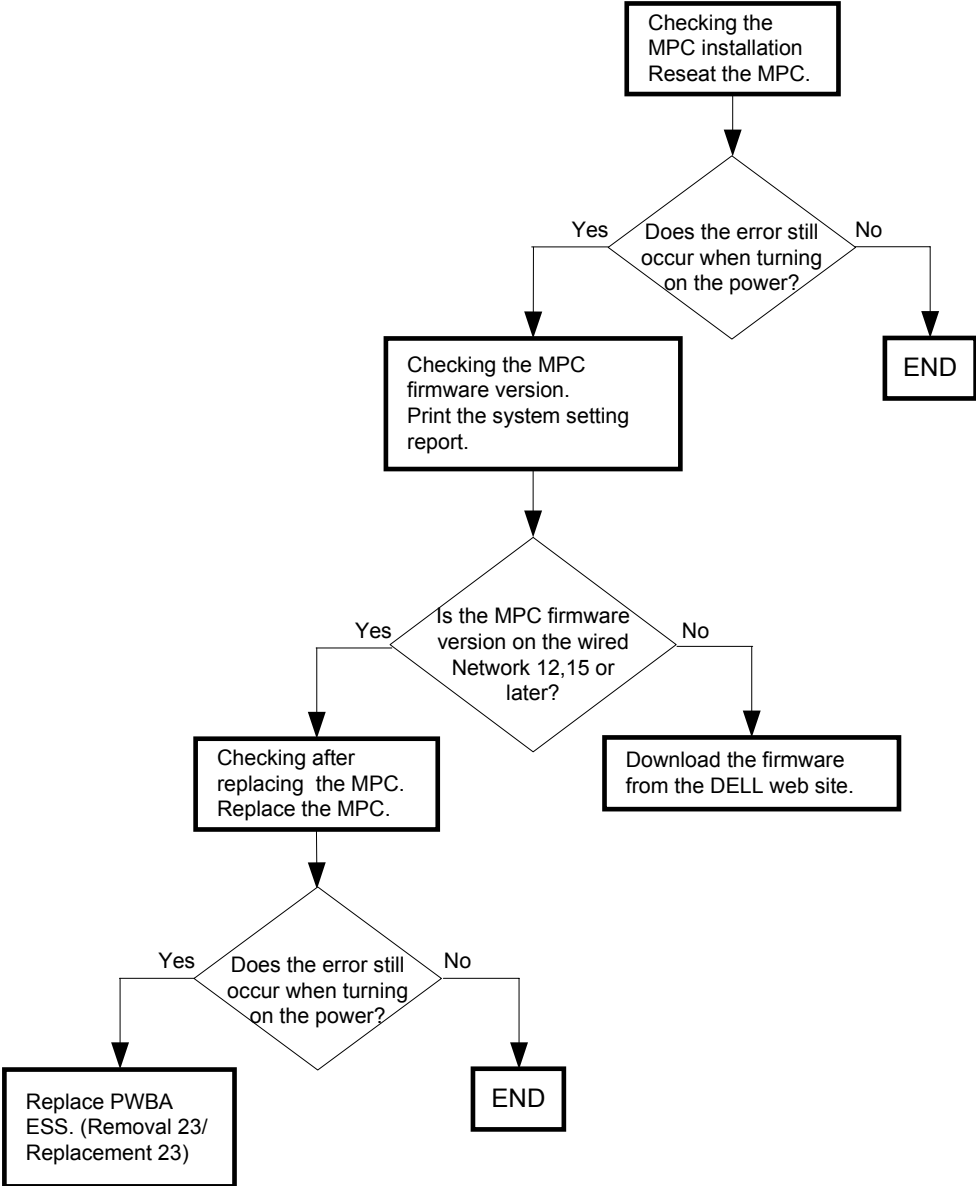

FIP-1. 23 016-338 Restart Printer

Possible causative parts: Option Wireless Printer Adapter
Option MPC Board

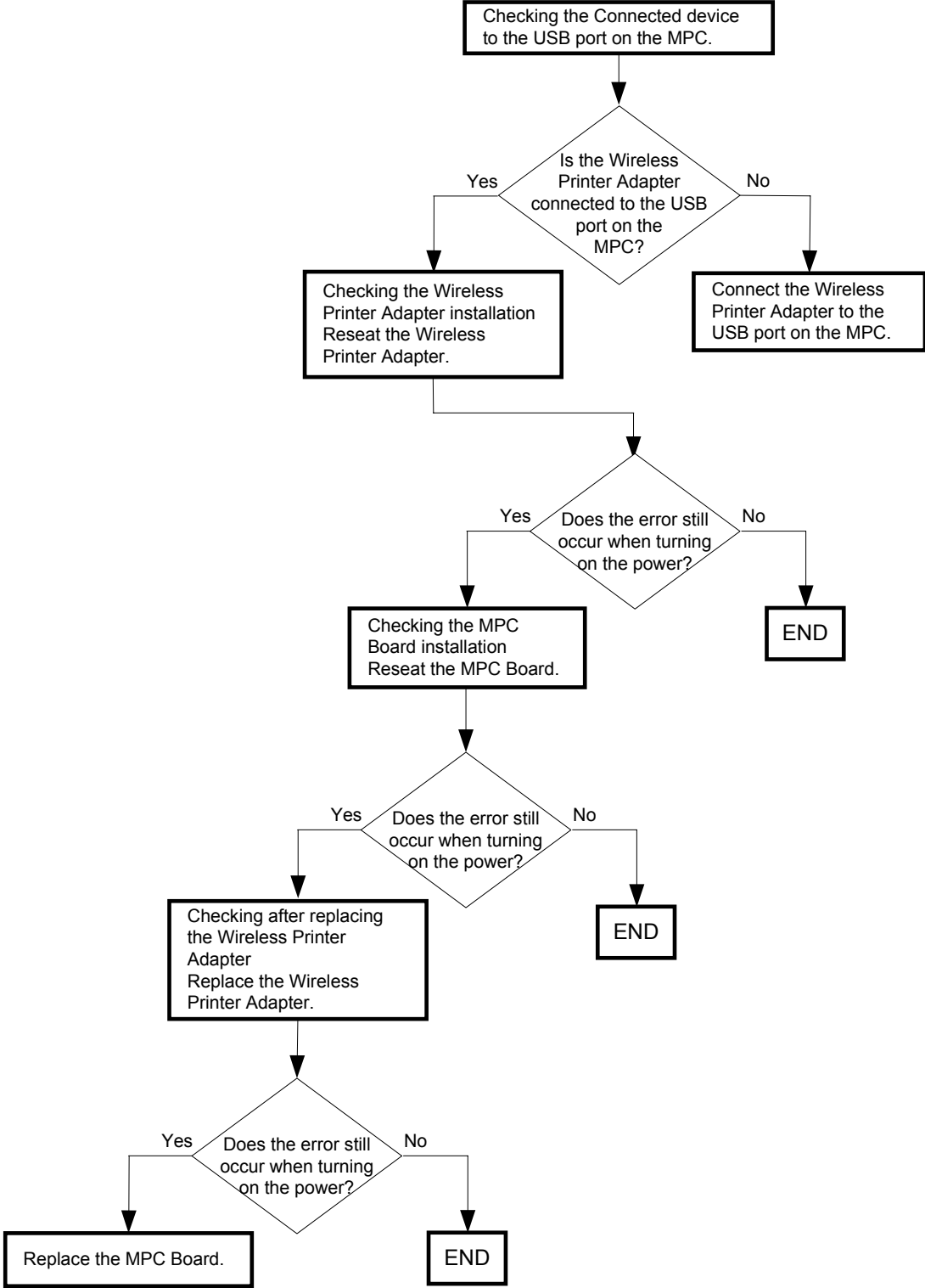

FIP-1. 24 016-350 Restart Printer

Possible causative parts:PWBA ESS (PL9.1.27)
IEEE 1284 Cable

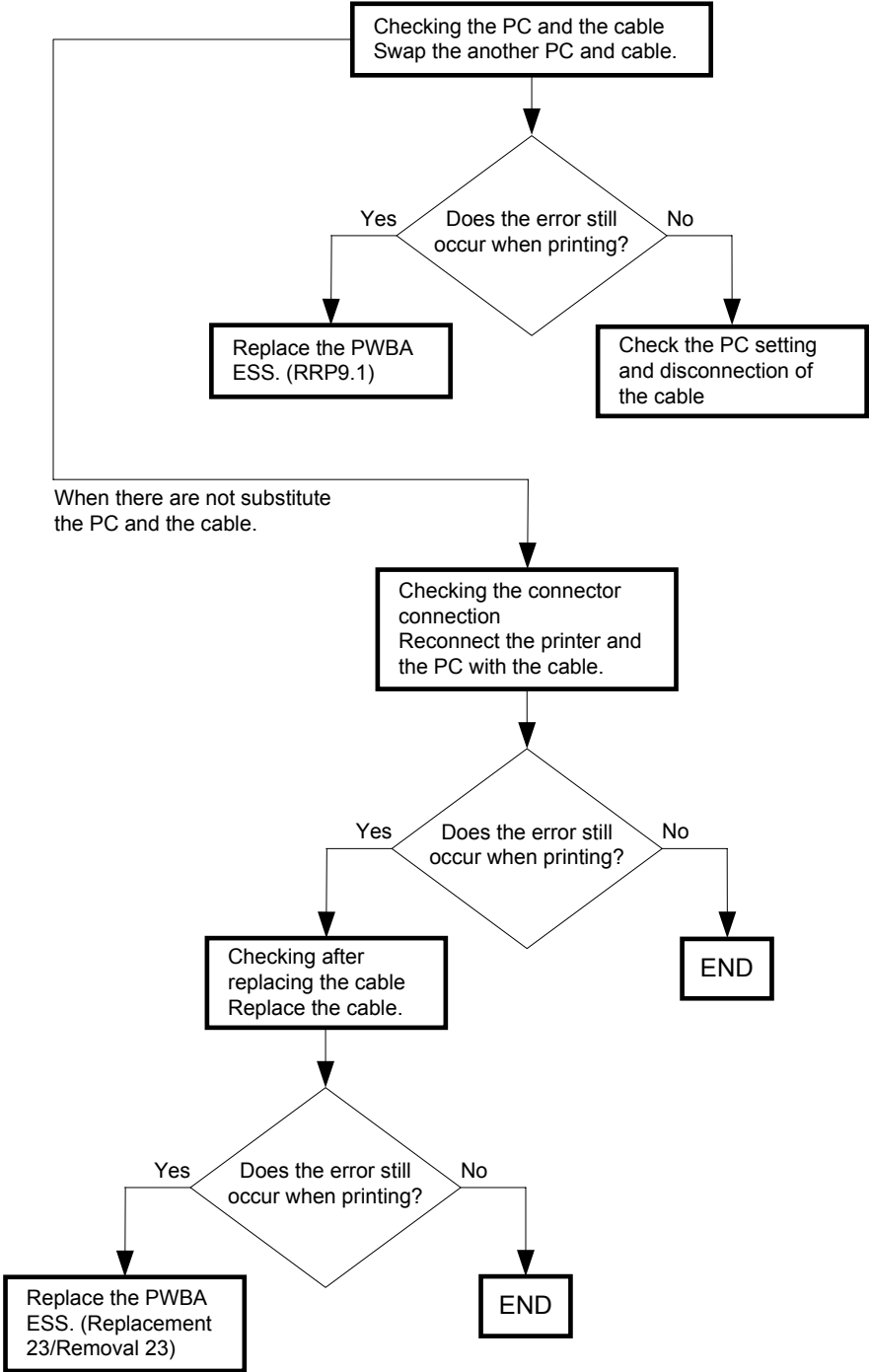

FIP-1. 25 016-370 Restart Printer

Possible causative parts:PWBA MCU (PL9.1.20)
PWBA ESS (PL9.1.23)

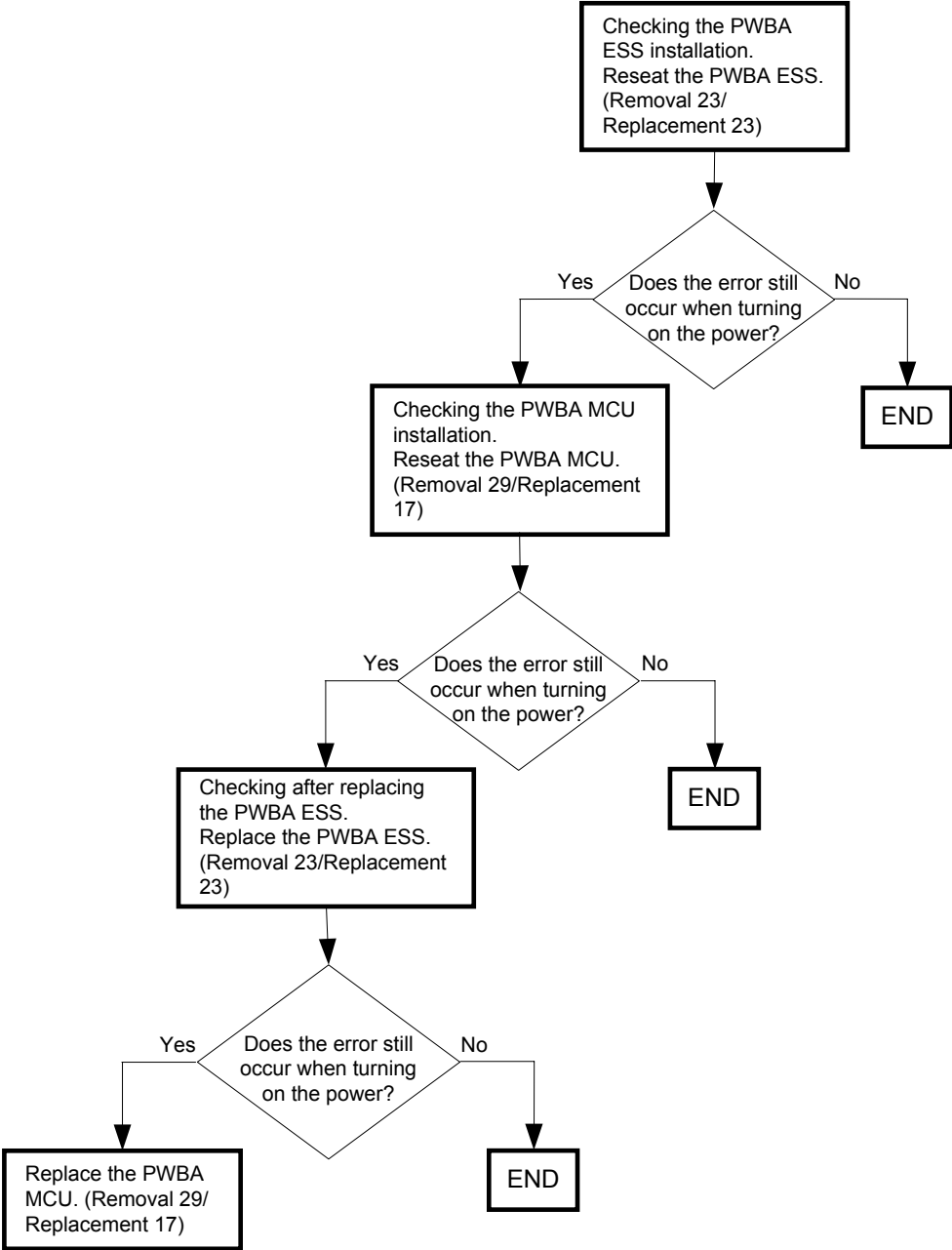

FIP-1. 26 093-964 CRUM ID

Possible causative parts:FUSER ASSY (PL6.1.10)
PWBA MCU (PL9.1.20)

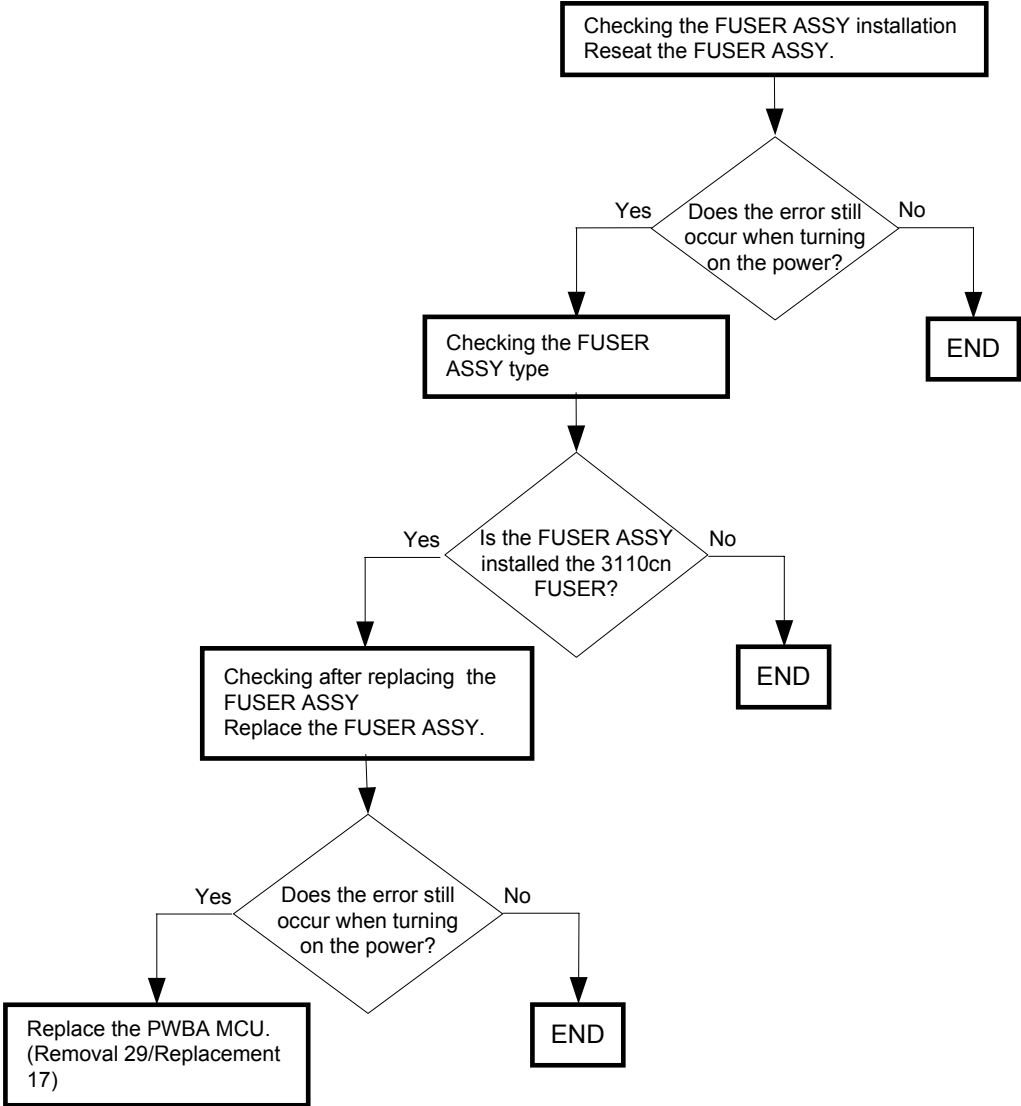

FIP-1. 27 Paper Jam 071-100

Possible causative parts: 250 PAPER CASSETTE ASSY (PL2.2.99)
KIT ROLLER (PL2.2.99)
KIT FEEDER (PL3.2.99)
DRIVE ASSY PH (PL8.1.7)
PWBA MCU (PL9.1.20)

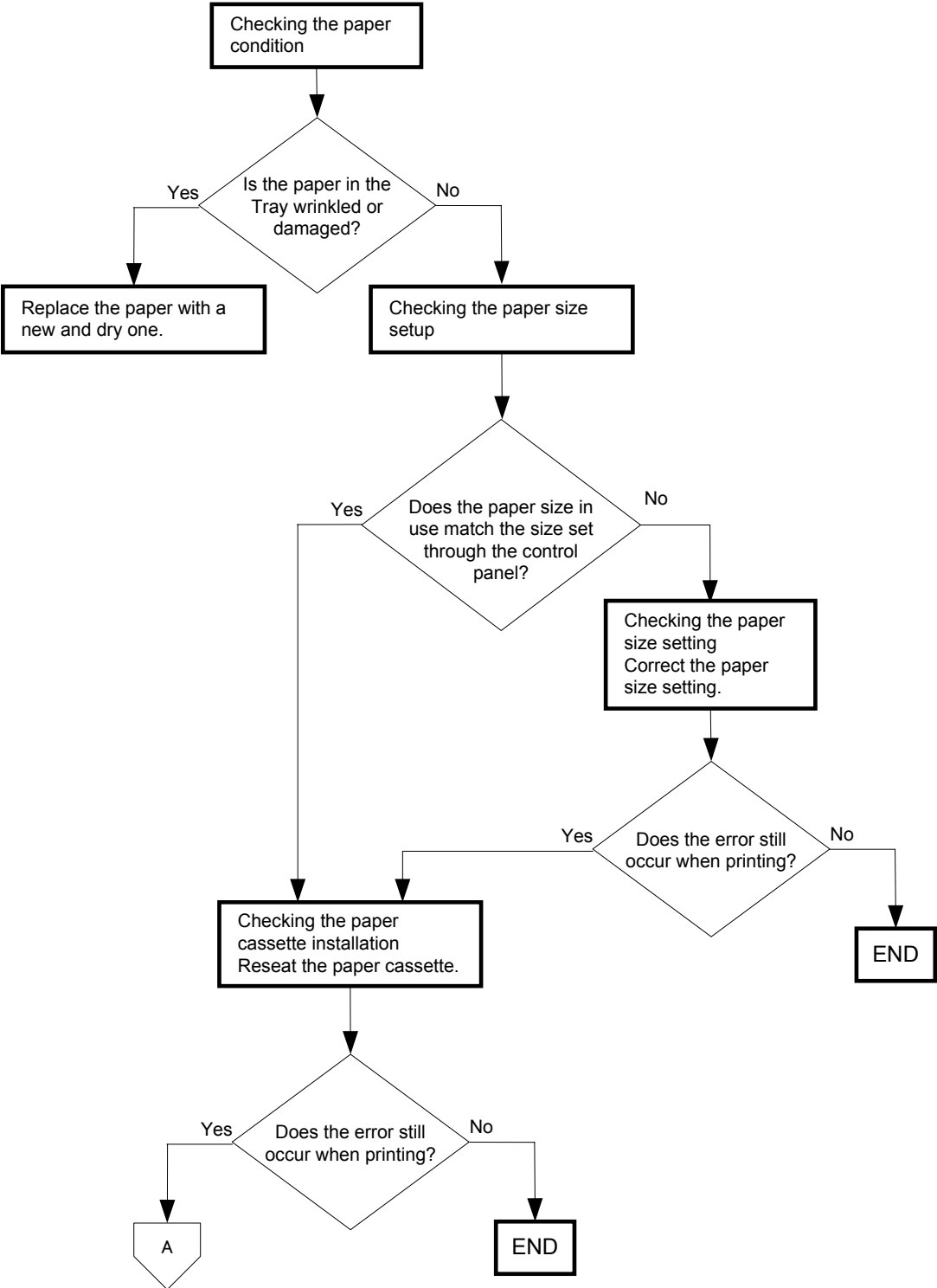

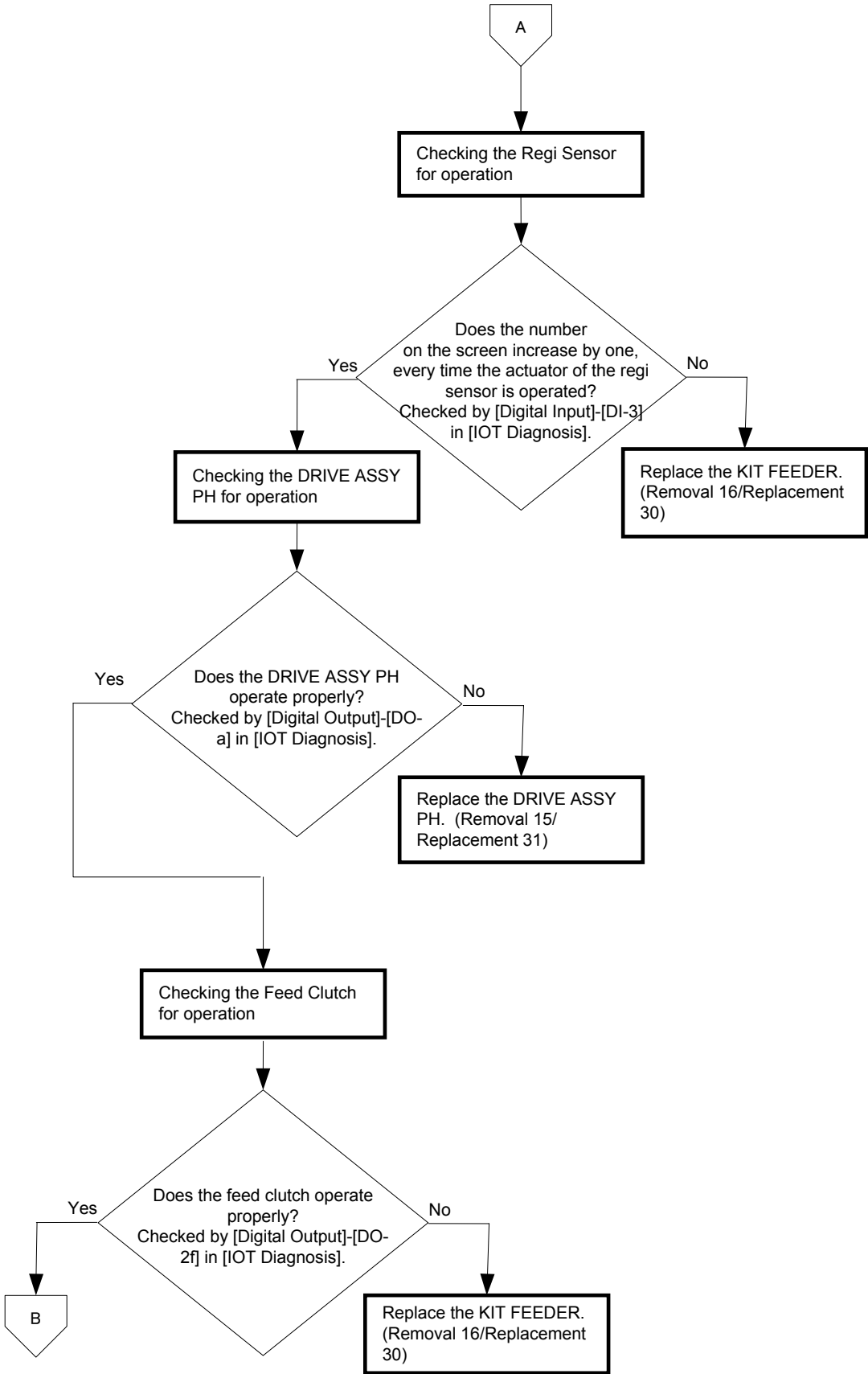

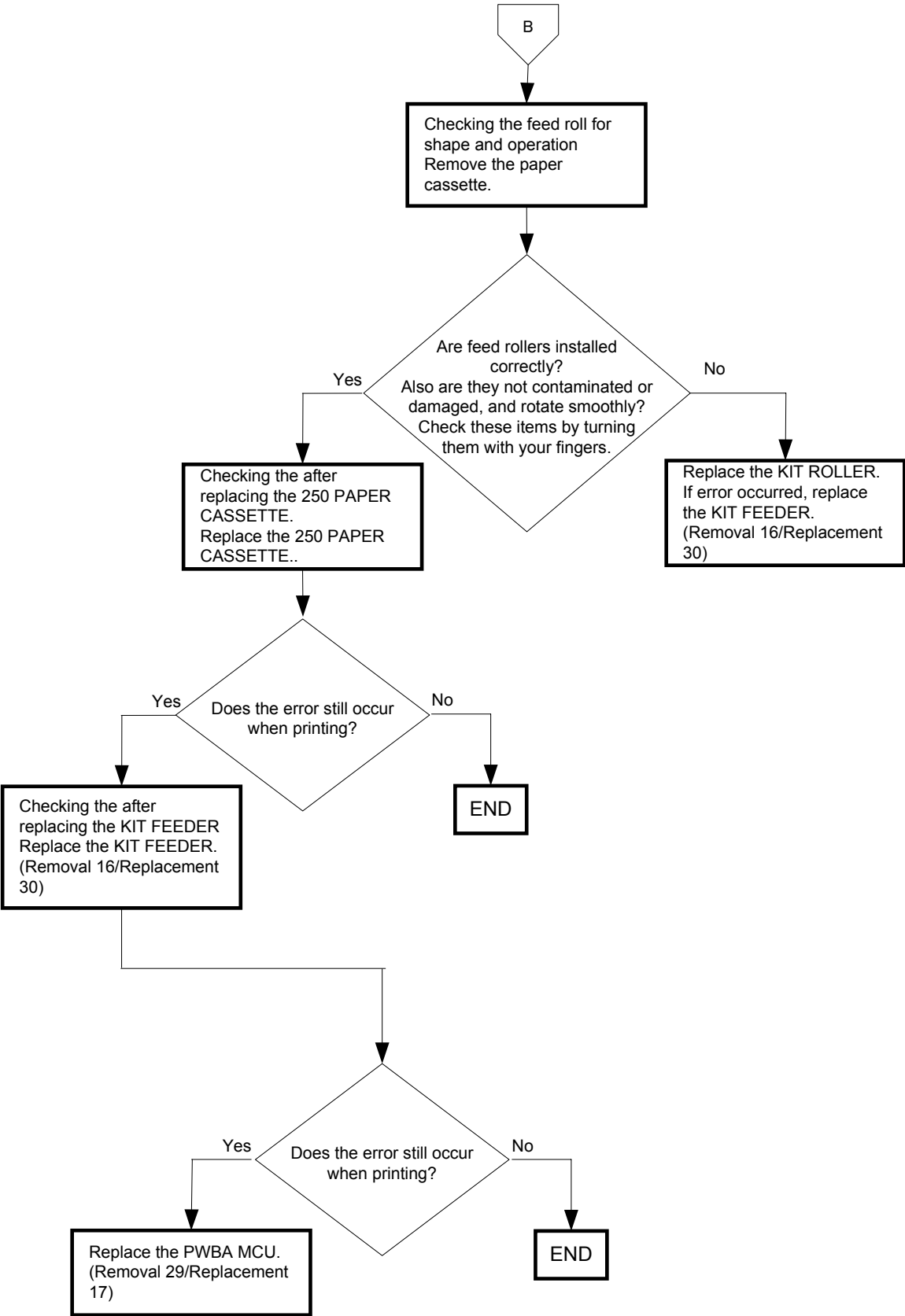

FIP-1. 28 Paper Jam 072-100

Possible causative parts:KIT FEEDER (PL3.2.99)
550 PAPER CASSETTE ASSY (PL12.4.1)
KIT ROLLER (PL12.3.99)
550 OPTION FEEDER (PL12.1.1)
PWBA MCU (PL9.1.20)

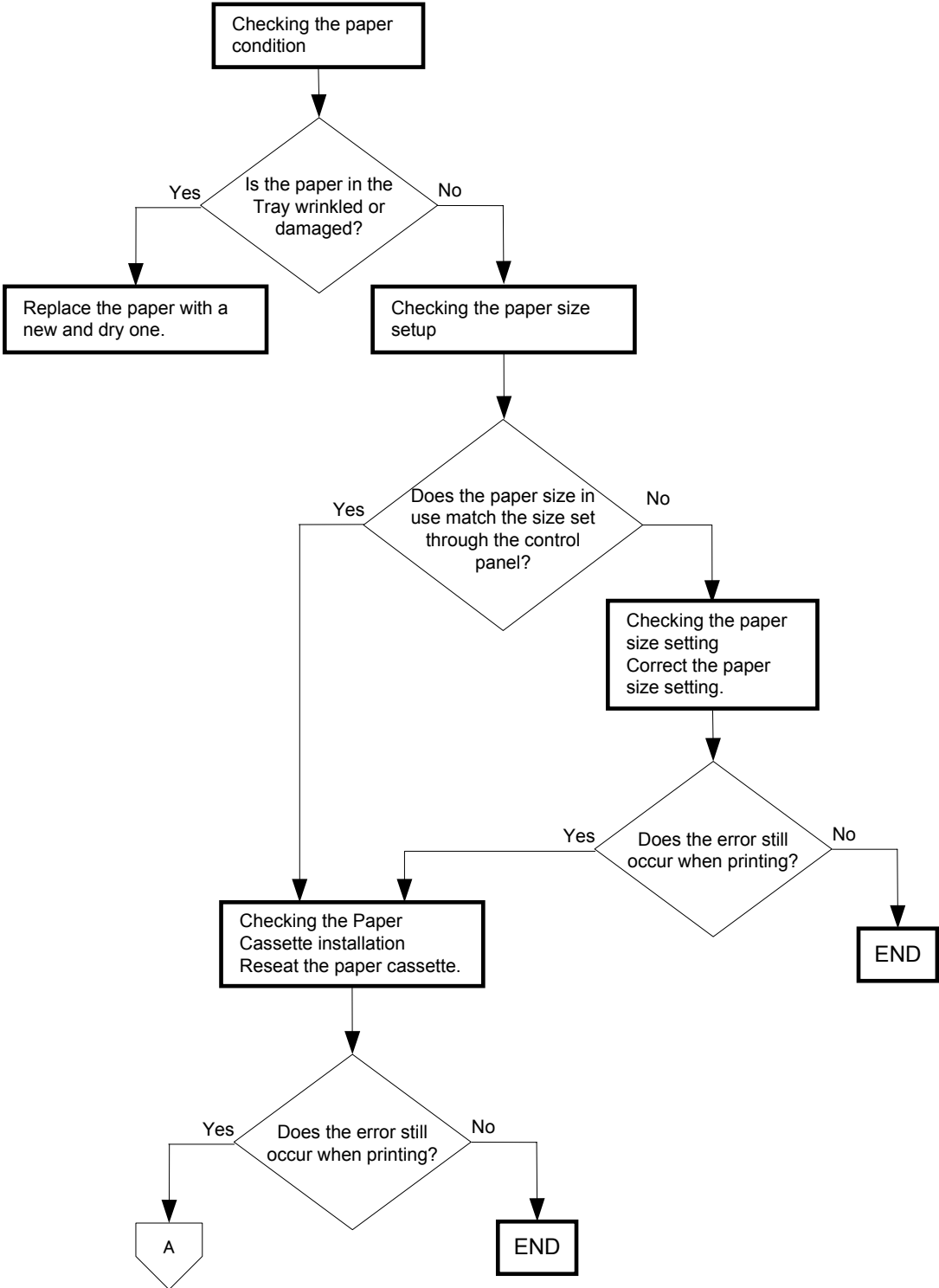

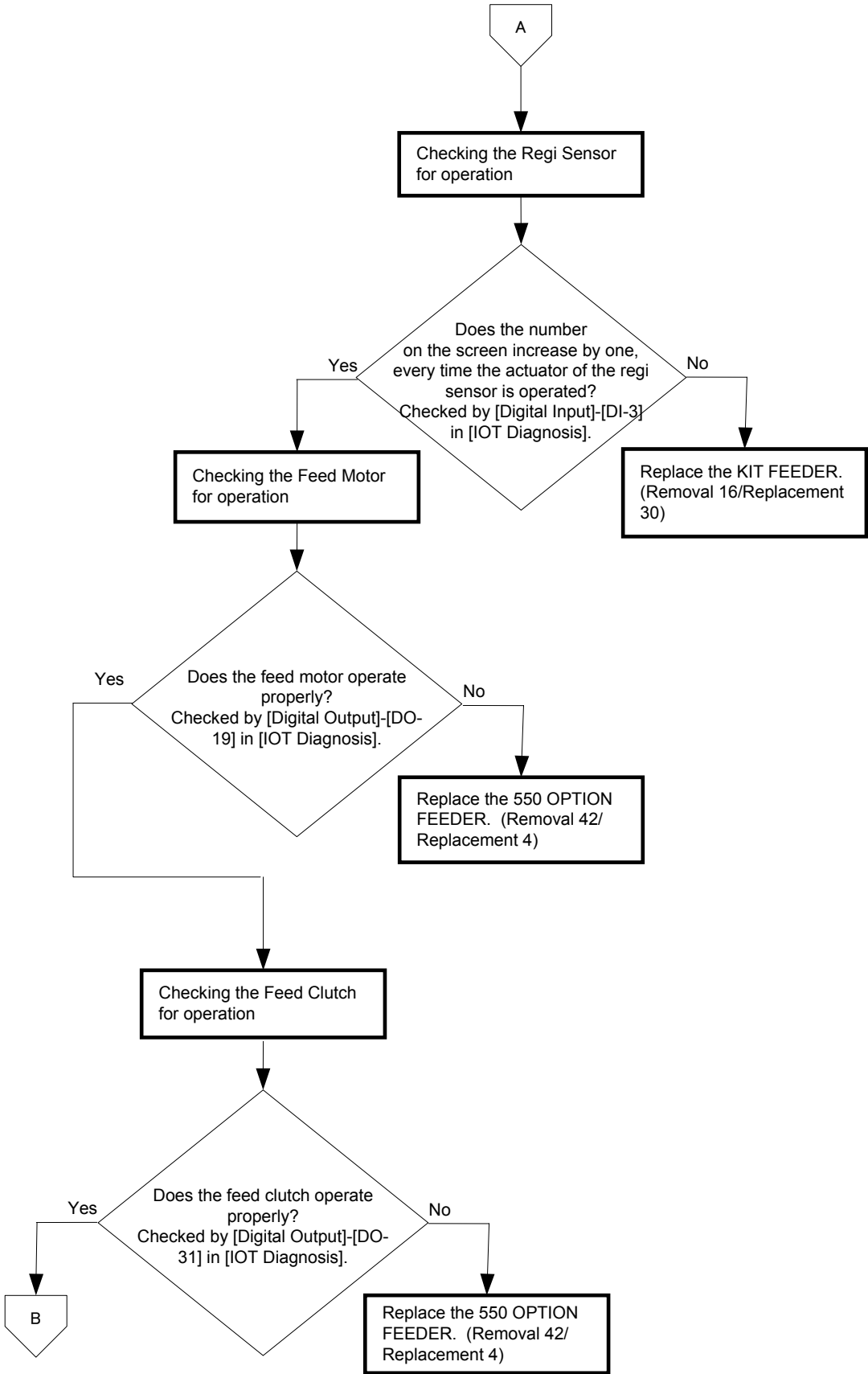

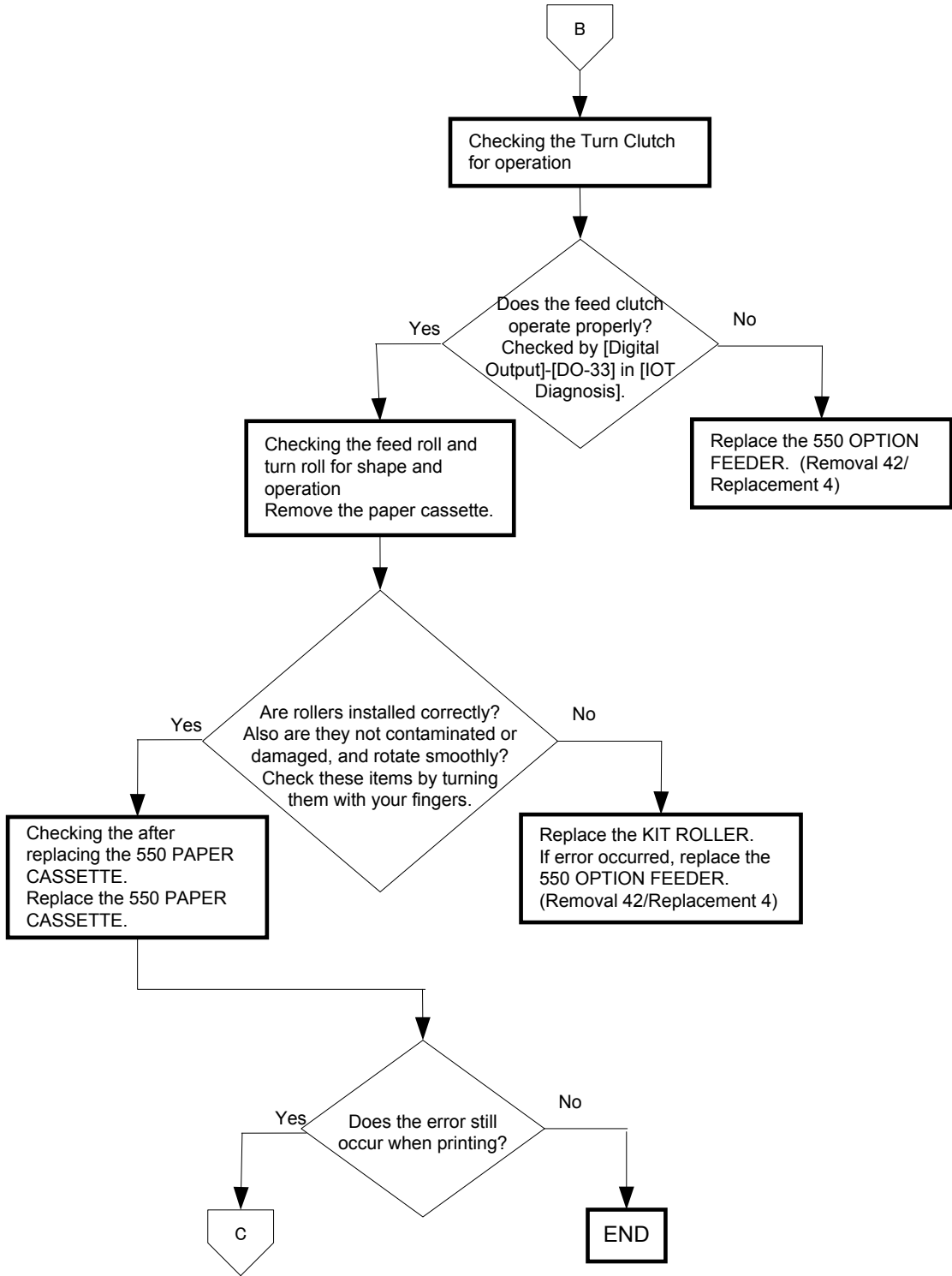

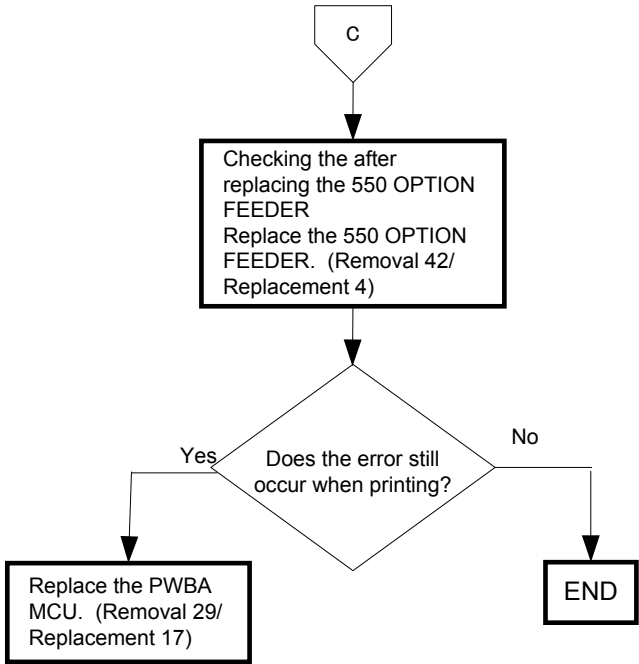

FIP-1. 29 Paper Jam 075-100

Possible causative parts: 250 PAPER CASSETTE ASSY (PL2.2.99)
KIT ROLLER (PL2.2.99)
KIT SOLENOID FEED MSI (PL3.1.98)
KIT FEED ROLL MSI (PL3.1.99)
KIT FEEDER (PL3.2.99)
PWBA MCU (PL9.1.20)

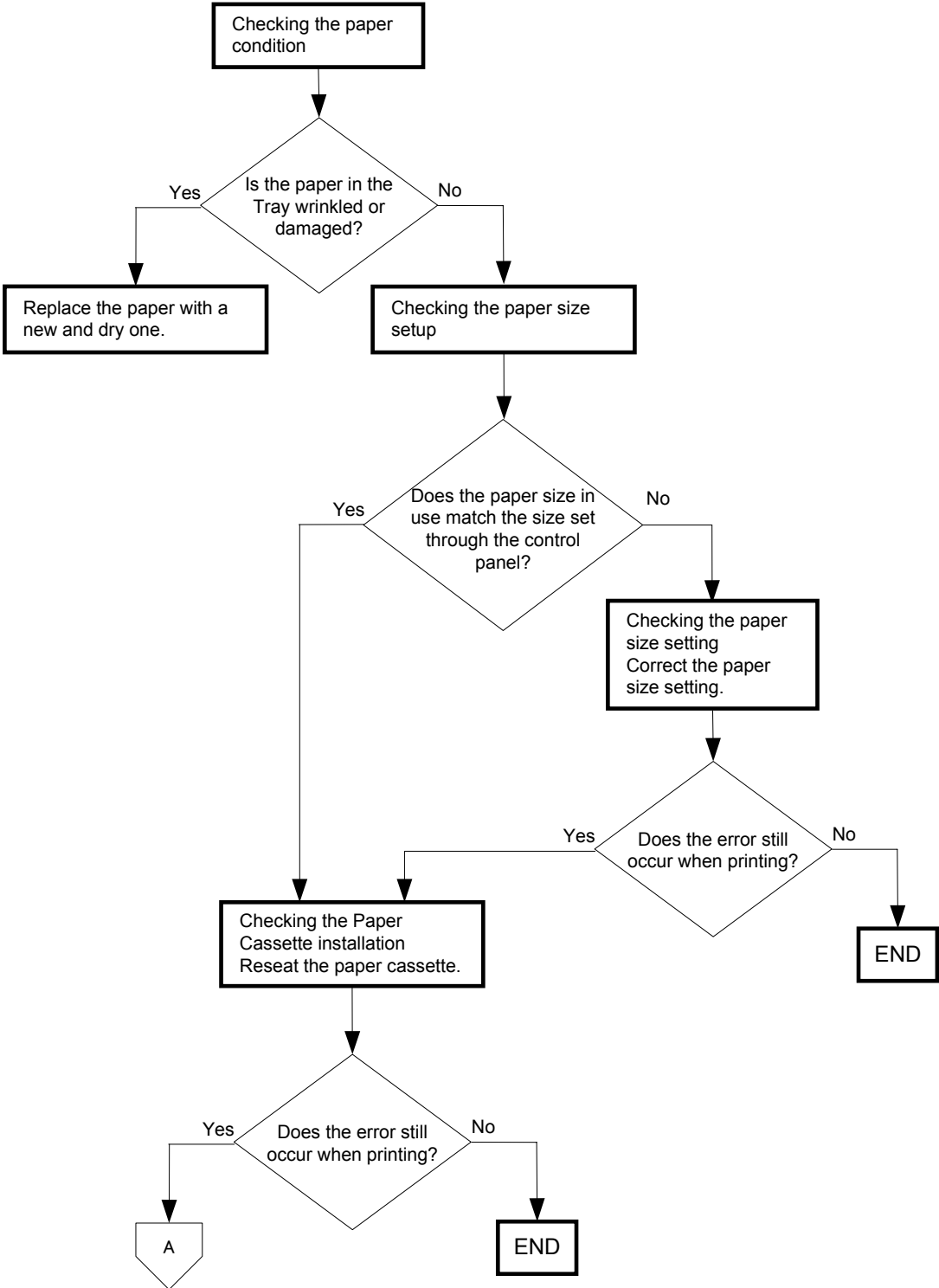

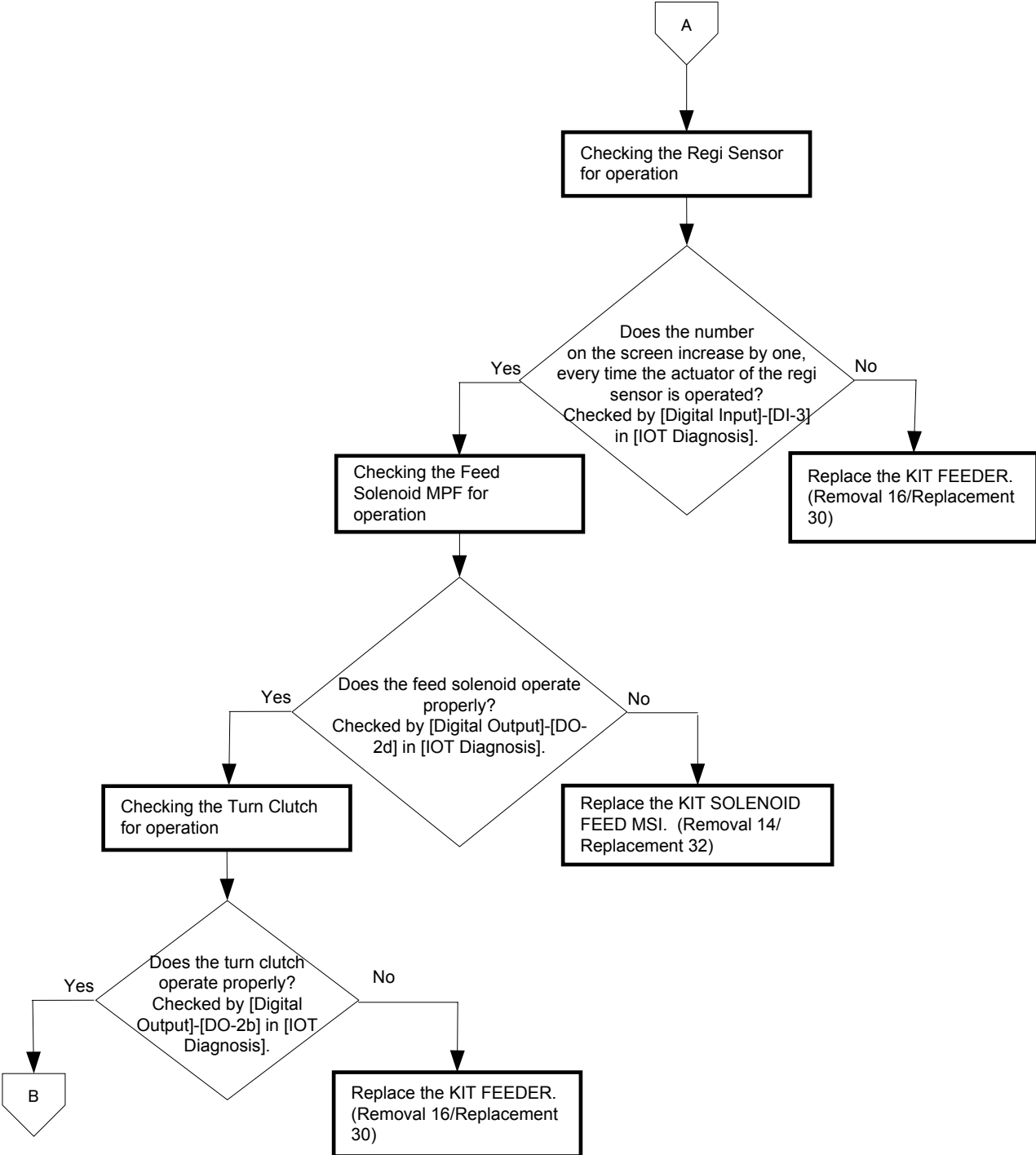

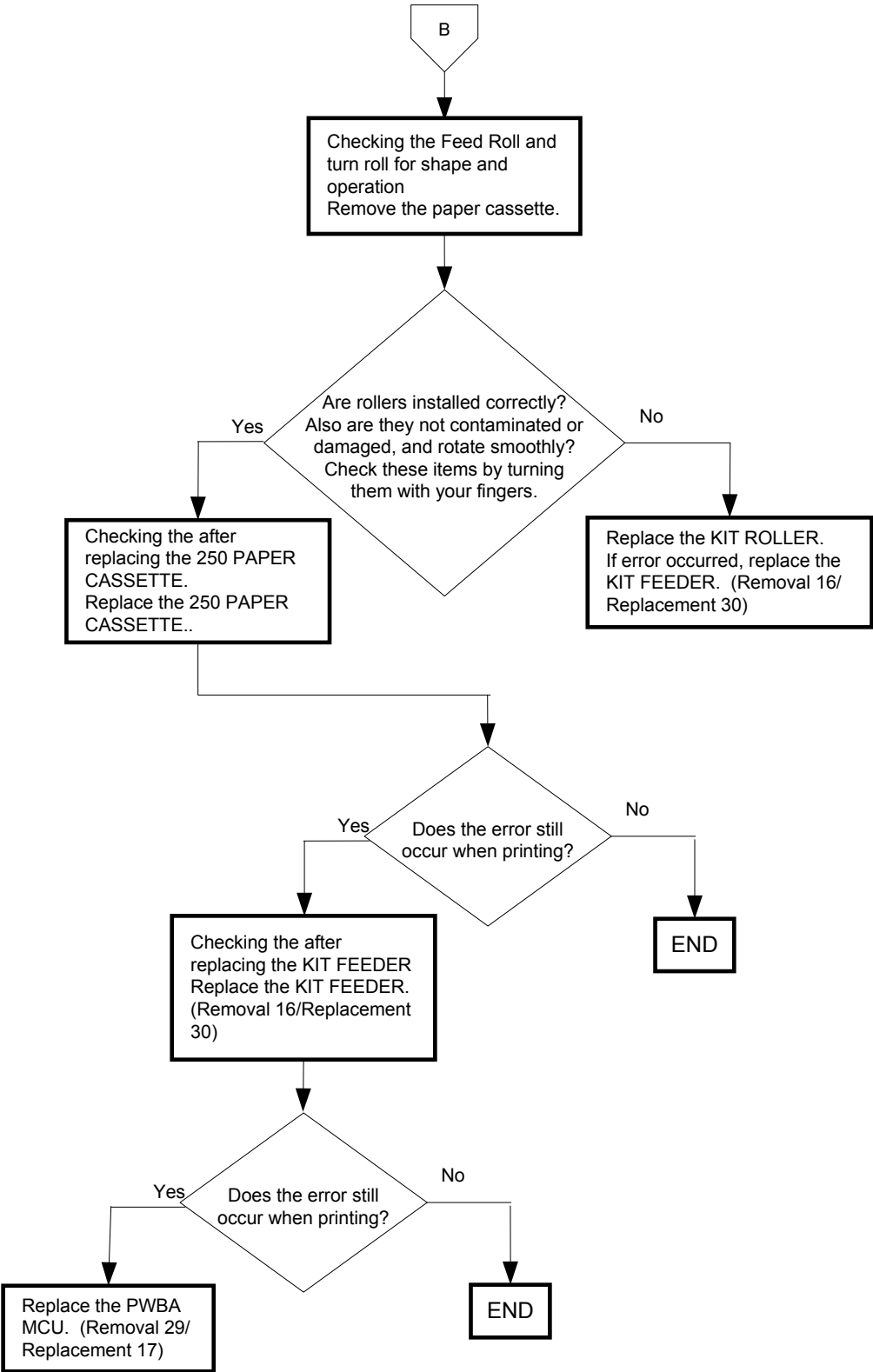

FIP-1. 30 077-900/077-901 Paper Jam

Possible causative parts:KIT FEEDER (PL3.2.99)
FUSER ASSY (PL6.1.10)
DRIVE ASSY MAIN (PL8.1.2)
DRIVE ASSY PH (PL8.1.7)
PWBA MCU (PL9.1.20)

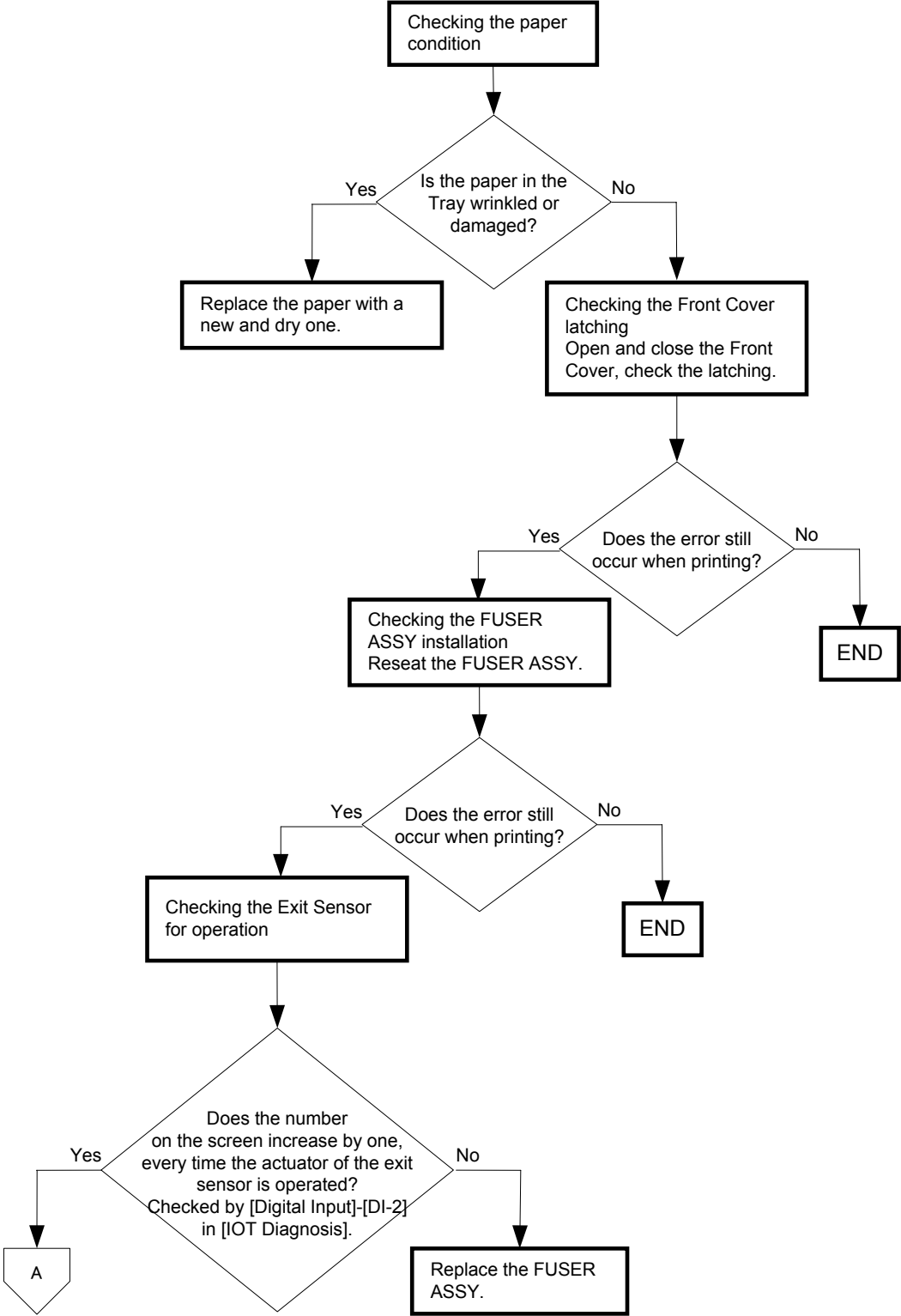

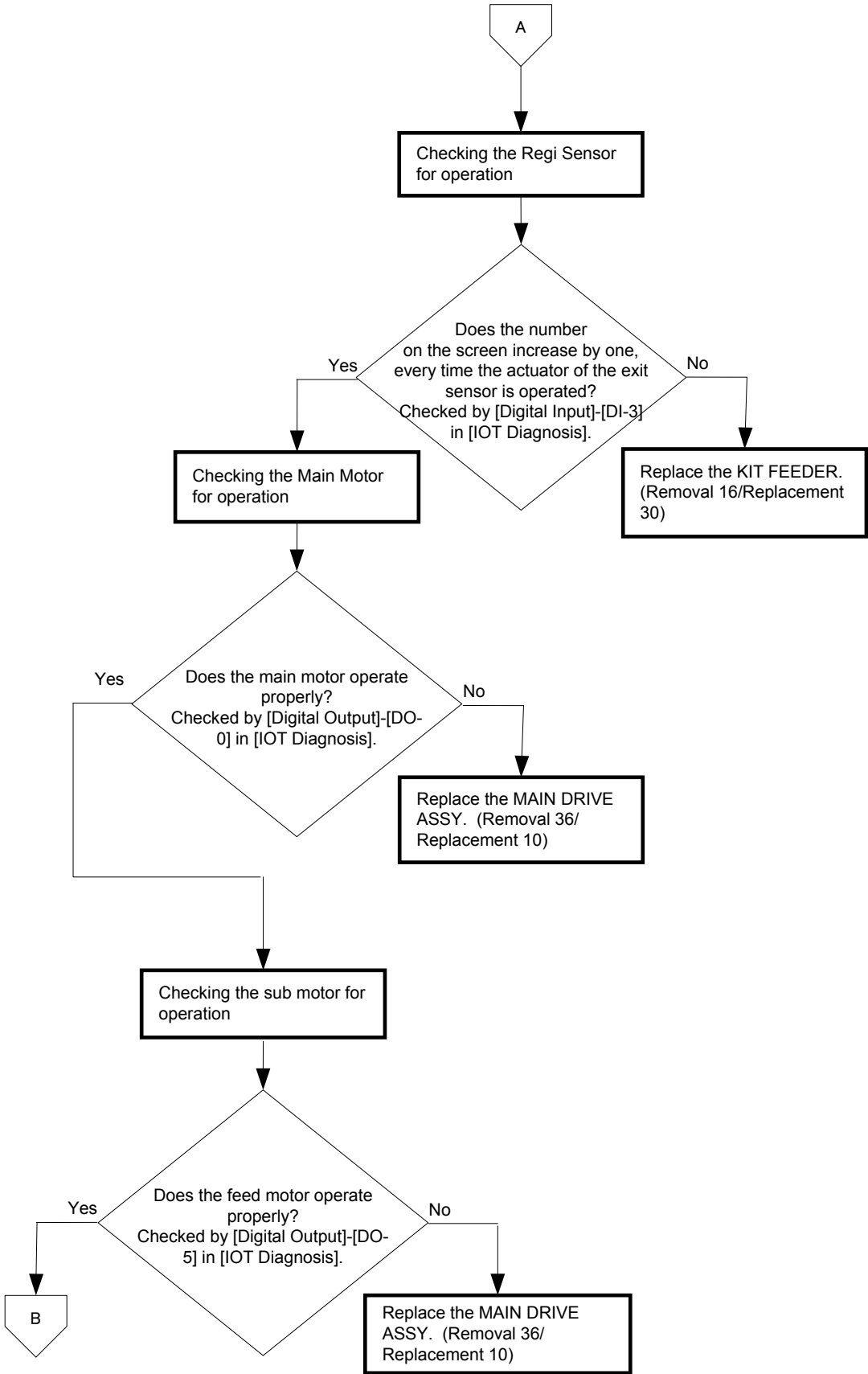

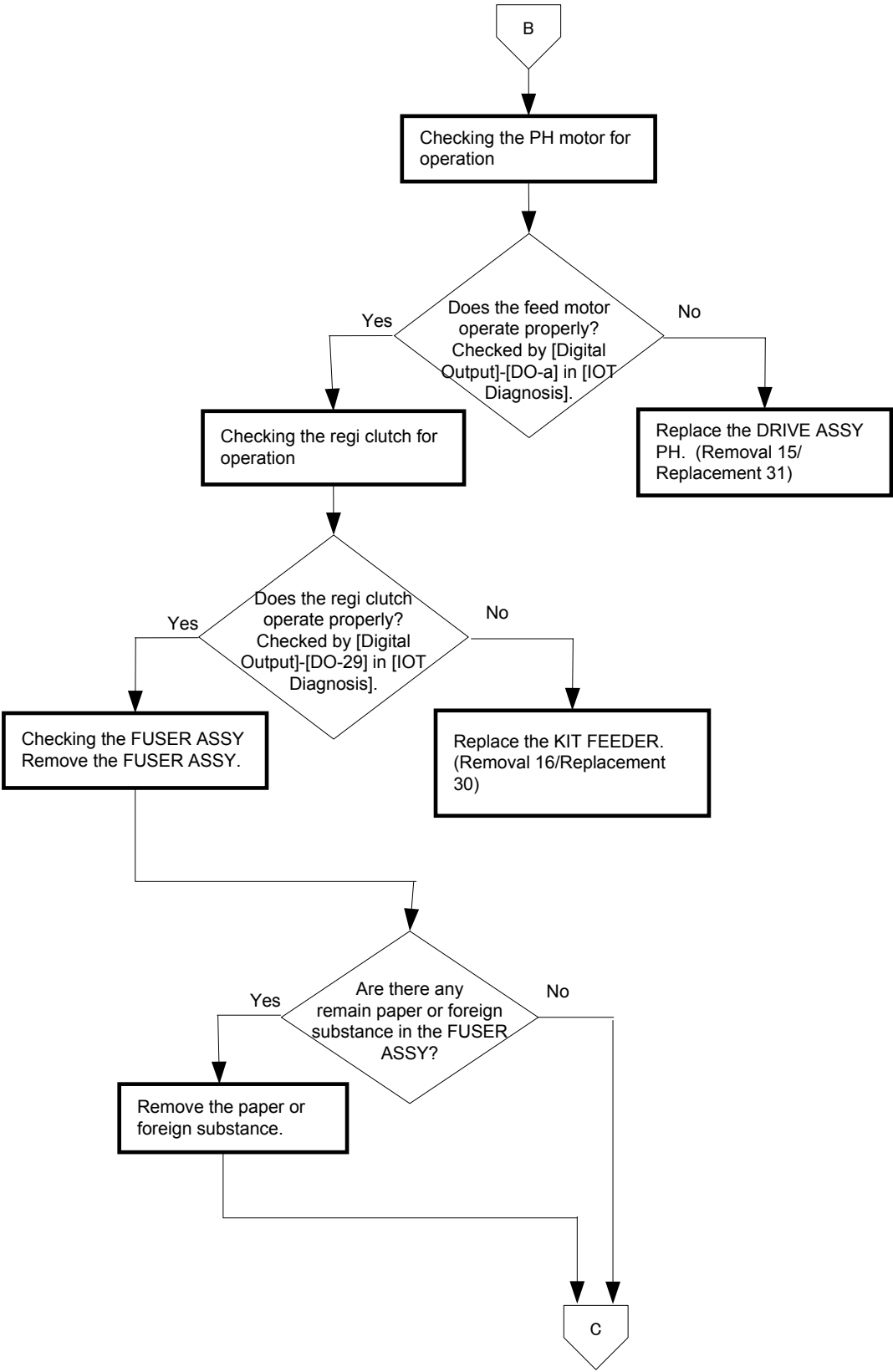

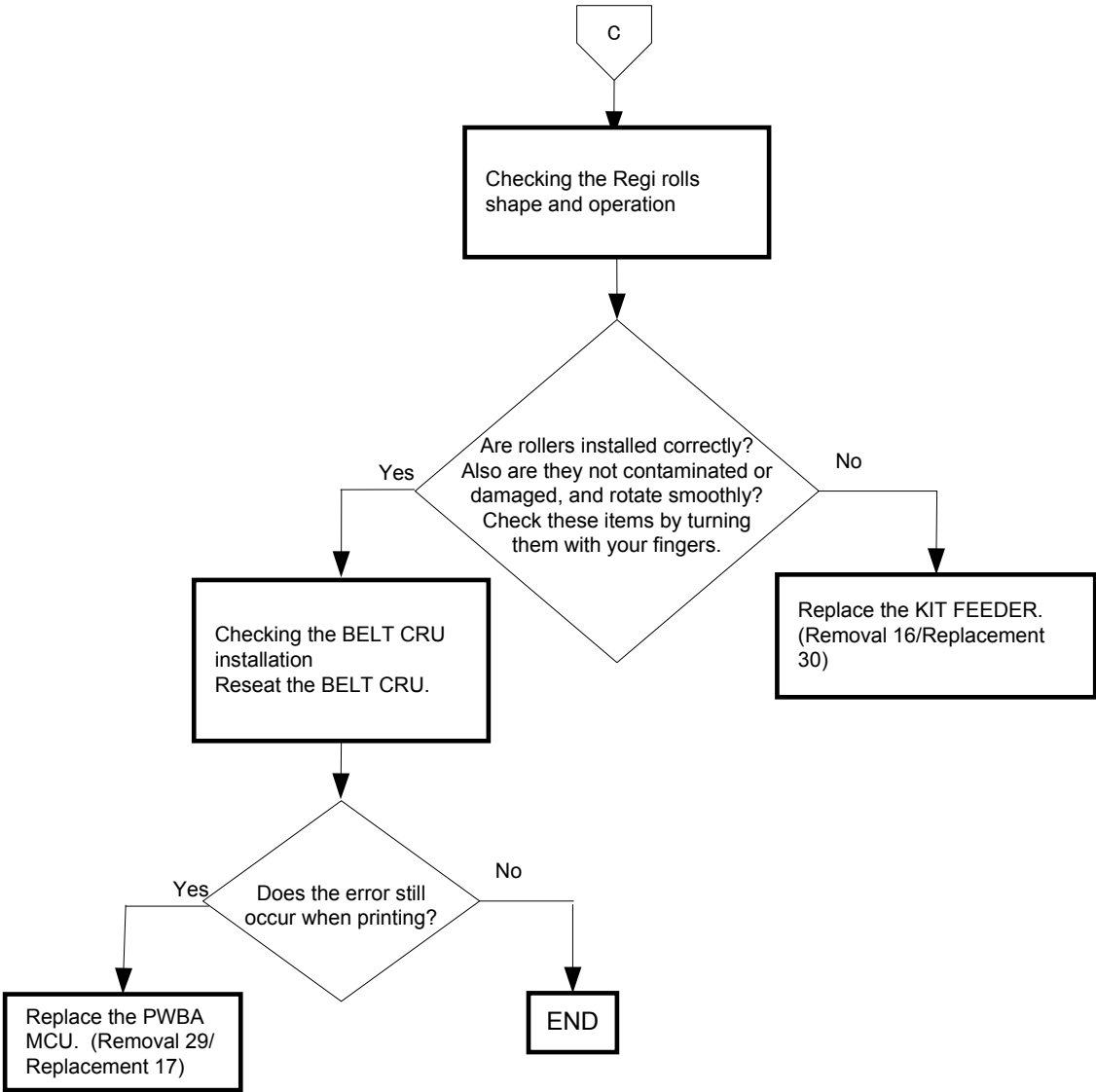

FIP-1. 31 Paper Jam 077-903

Possible causative parts:KIT FEEDER (PL3.2.99)
DRIVE ASSY PH (PL8.1.7)
PWBA MCU (PL9.1.20)

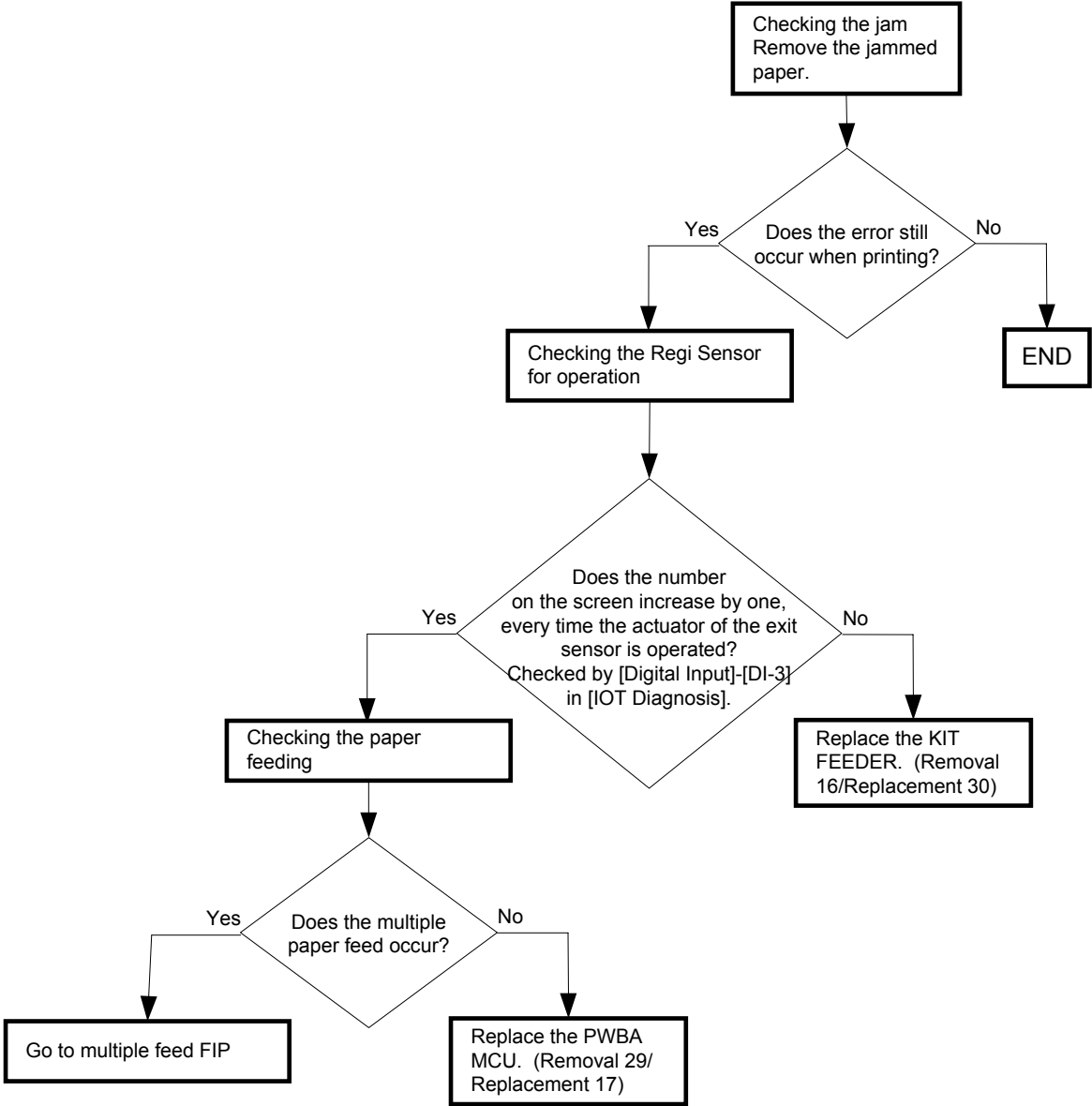

FIP-1. 32 Paper Jam 077-907

- Possible causative parts:KIT COVER ASSY FRONT (PL1.2.98)
- KIT FEEDER (PL3.2.99)
- FUSER ASSY (PL6.1.10)
- CHUTE DUP GATE (PL6.1.13)
- DRIVE ASSY MAIN (PL8.1.2)
- DRIVE ASSY PH (PL8.1.7)
- CHUTE ASSY DUP (PL11.1.1)

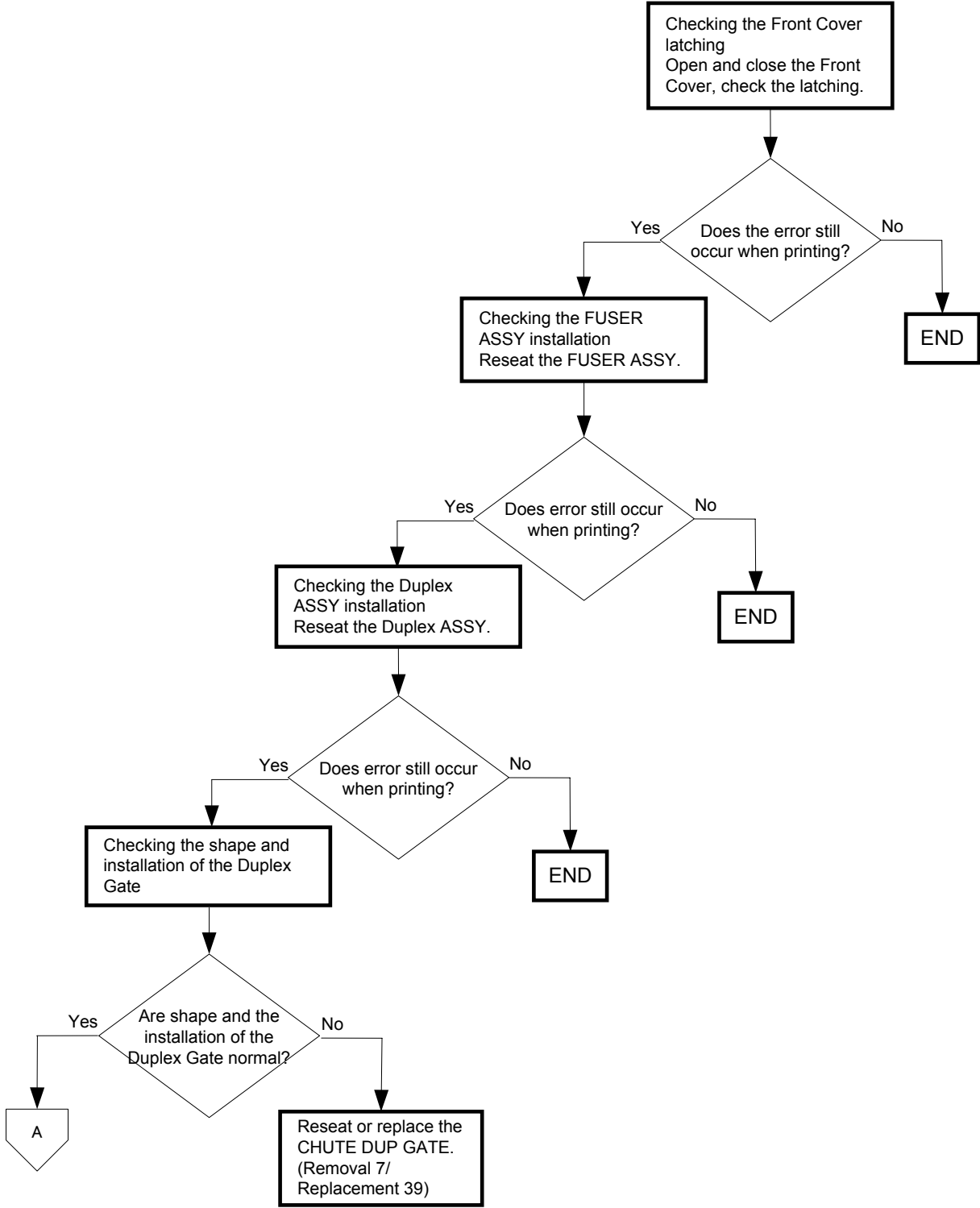

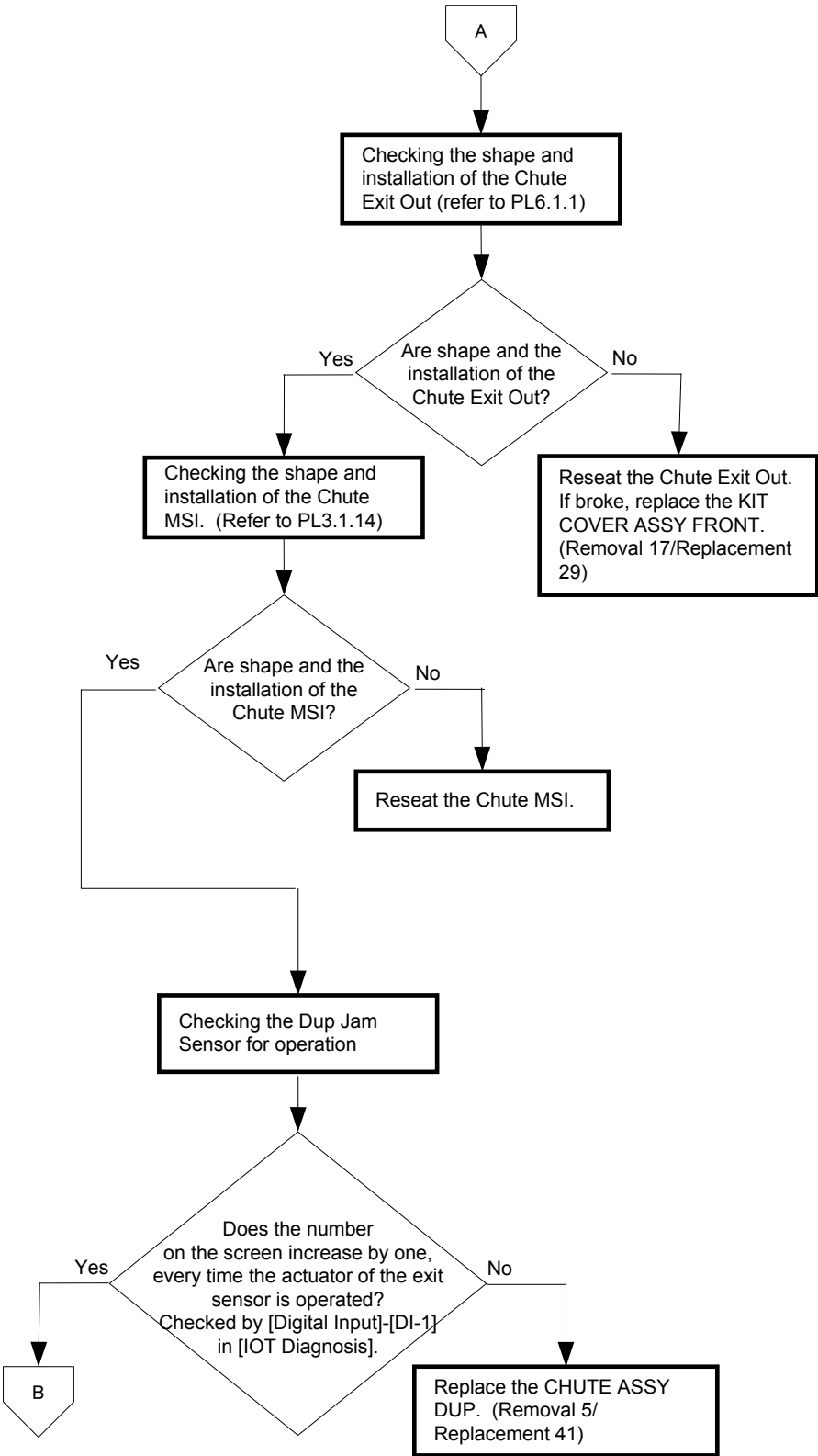

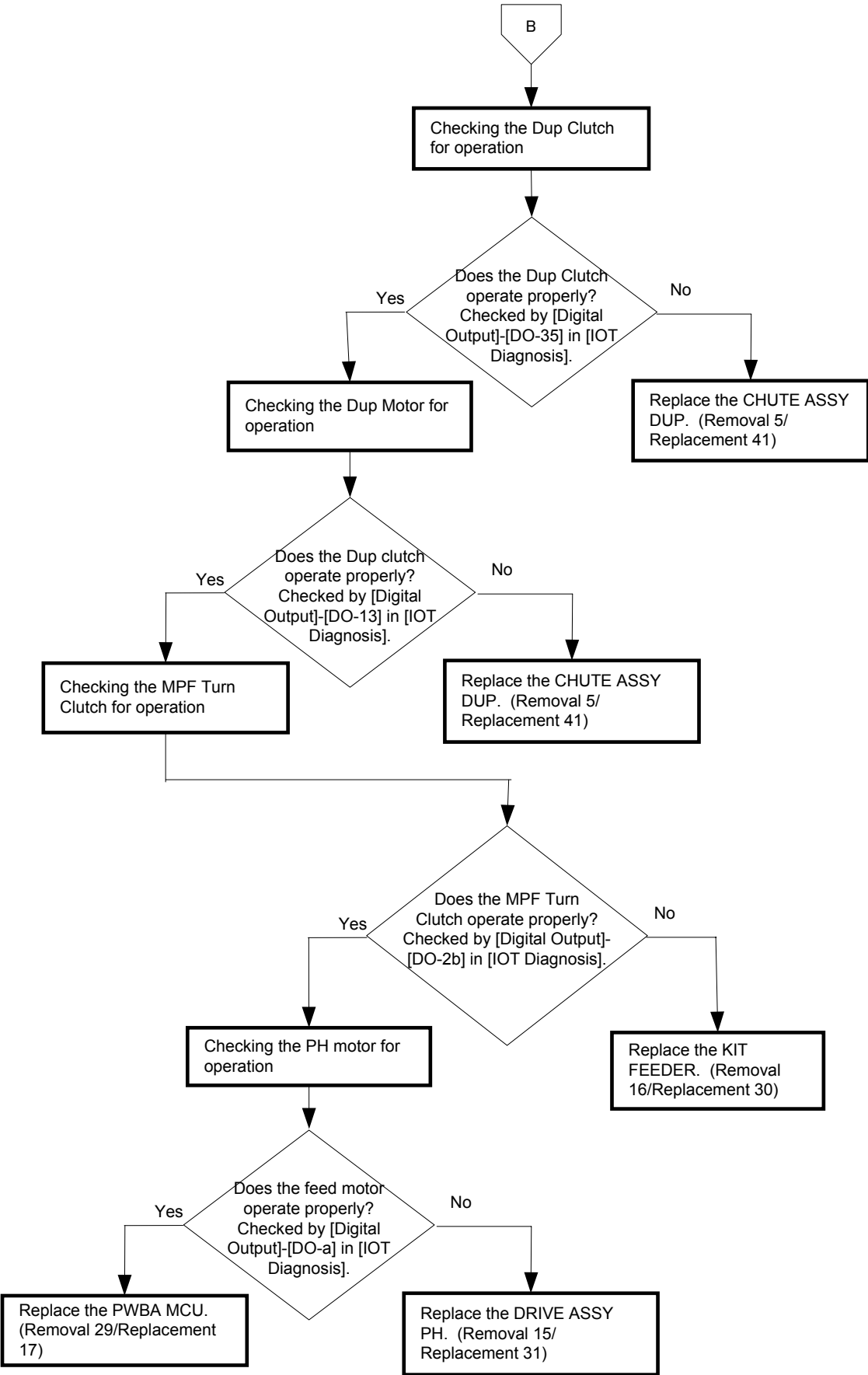

FIP-1. 33 Load Tray N or MPF 024-910/024-911/024-914

Possible causative parts: CASSETTE ASSY 250 (PL2.1.1)
FEEDER ASSY (PL3.2.99)
PWBA MCU (PL9.1.20)
CASSETTE ASSY 500 (PL12.4.1)

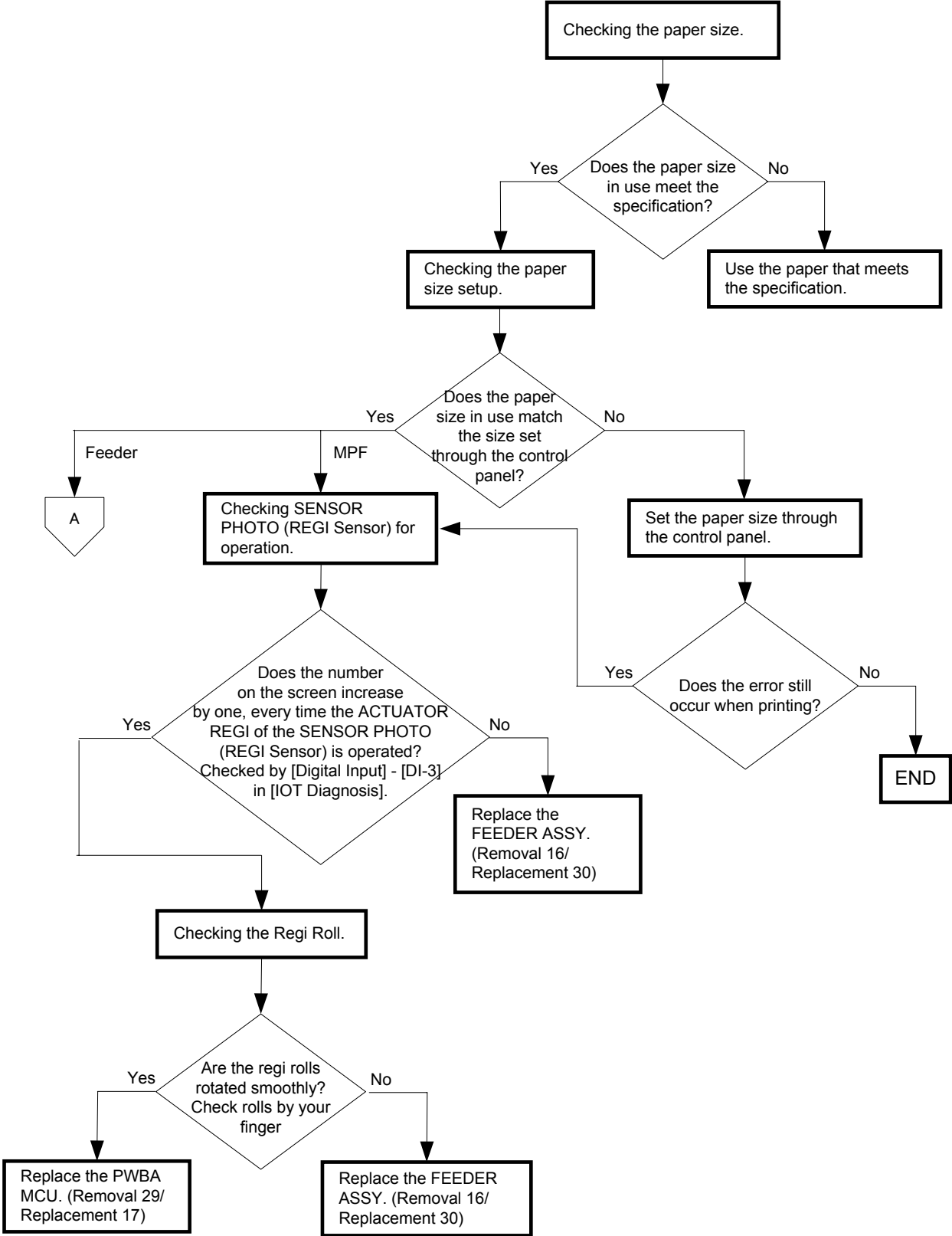

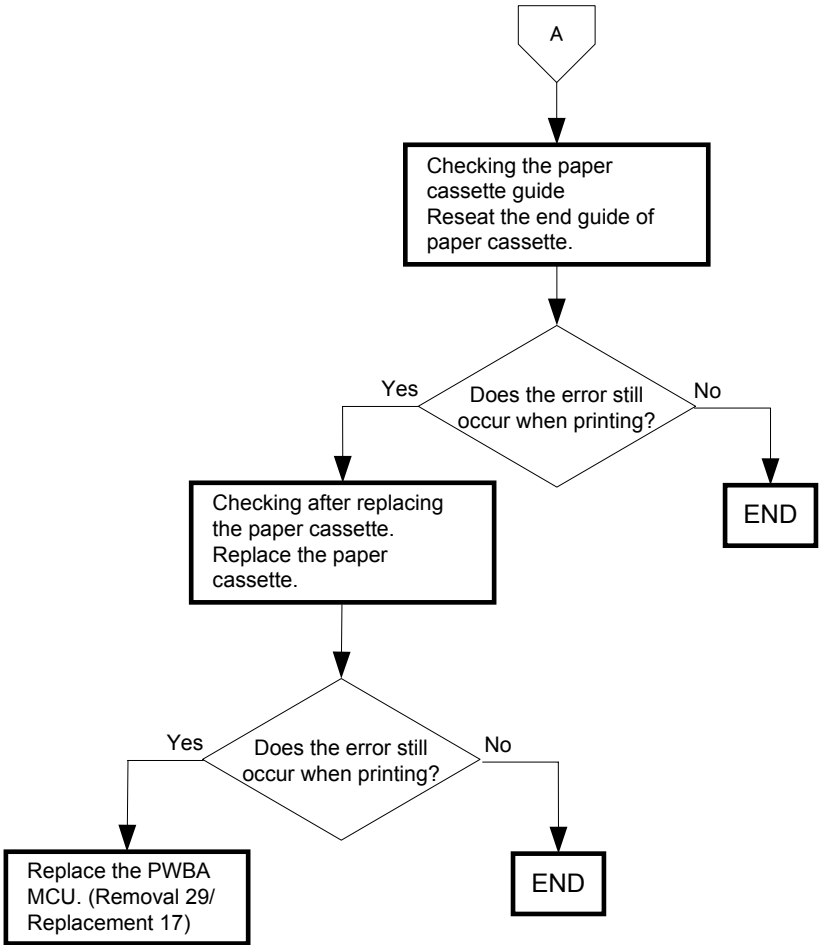

FIP-1. 34 Load Tray N or MPF 024-965/024-966/024-969

Possible causative parts: CASSETTE ASSY 250 (PL2.1.1)
FEEDER ASSY (PL3.2.99)
PWBA MCU (PL9.1.20)
550 OPTION FEEDER (PL12.1.1)

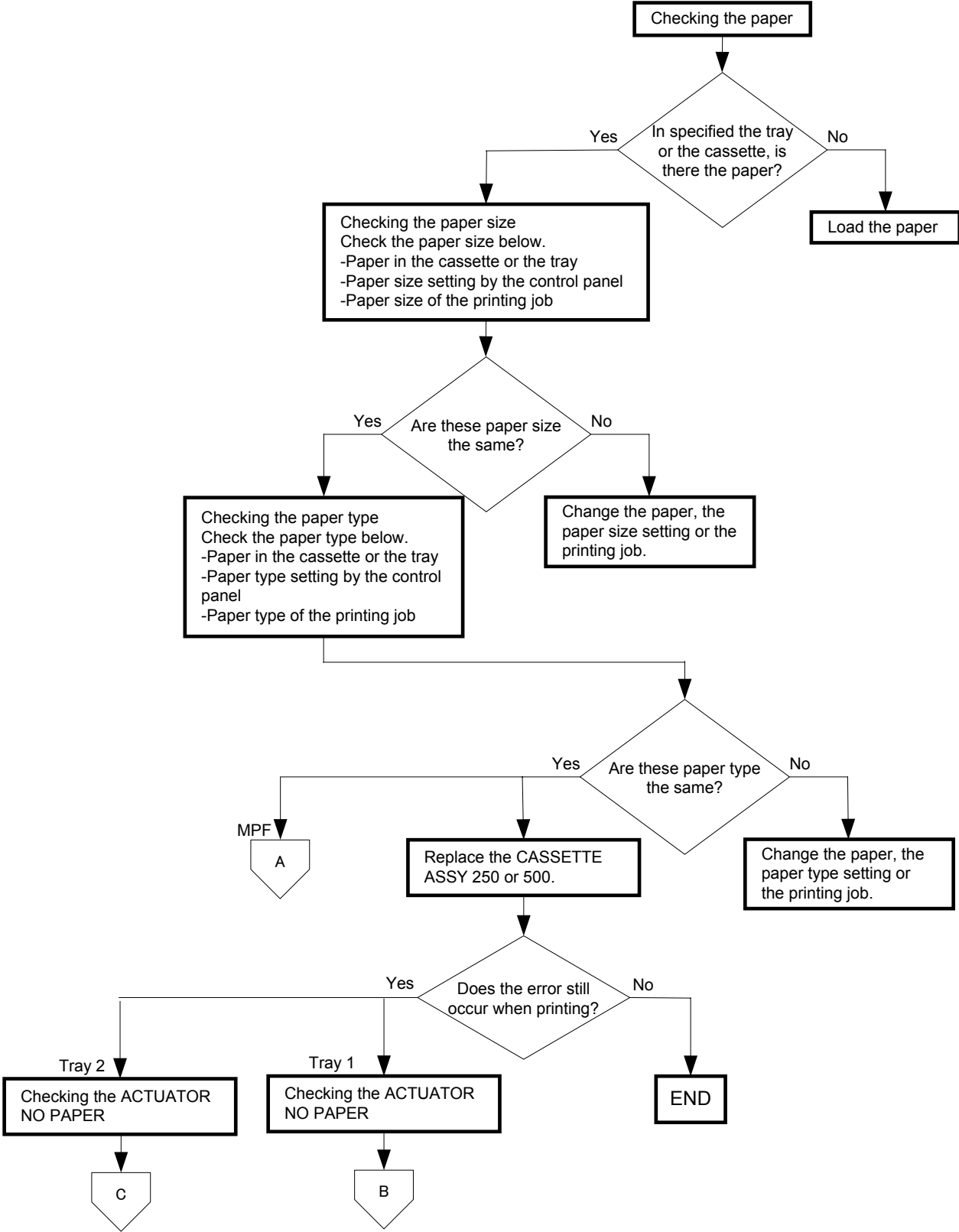

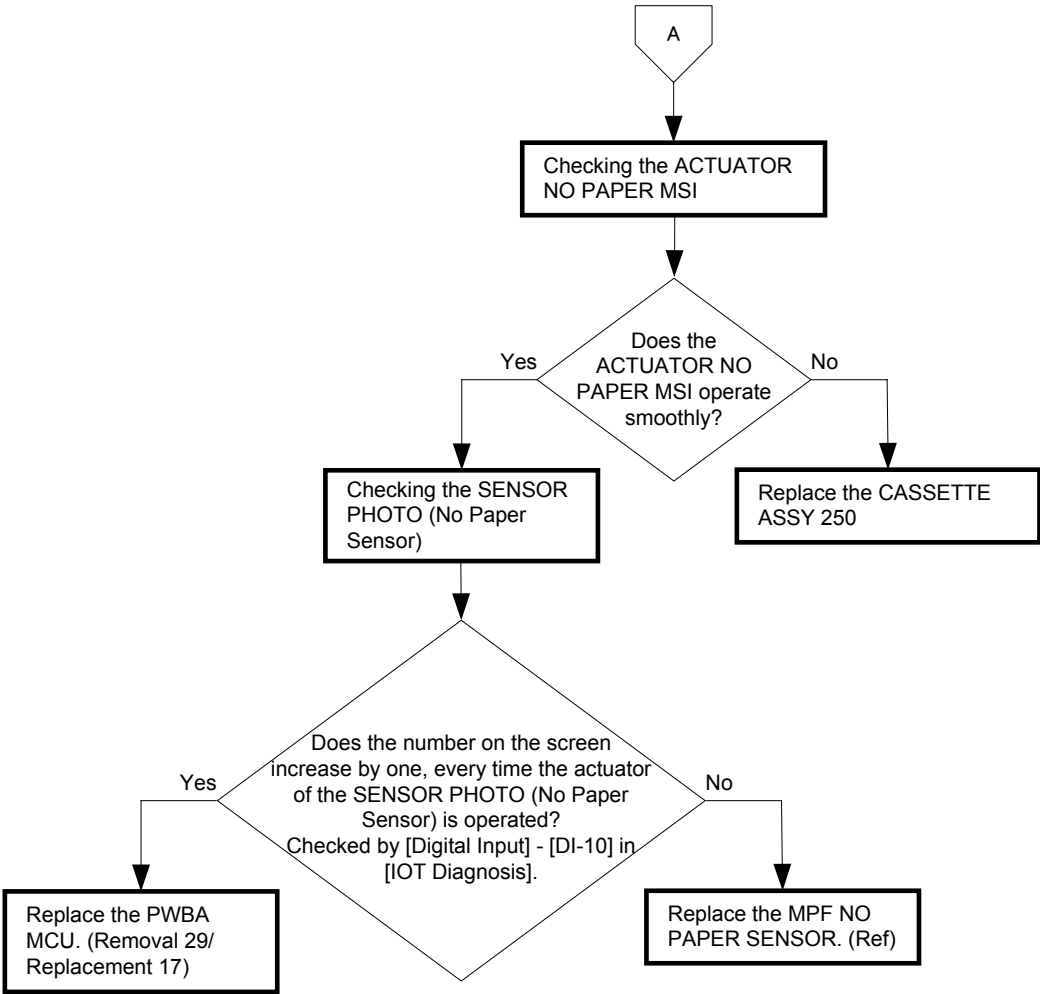

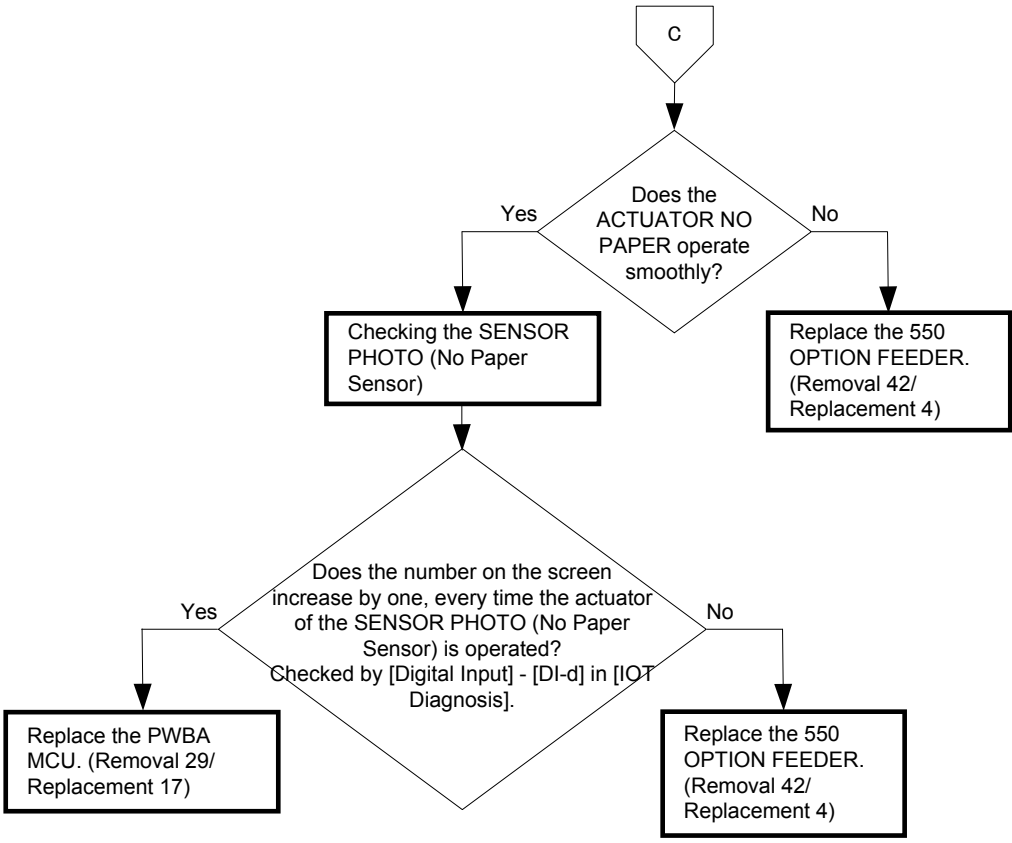
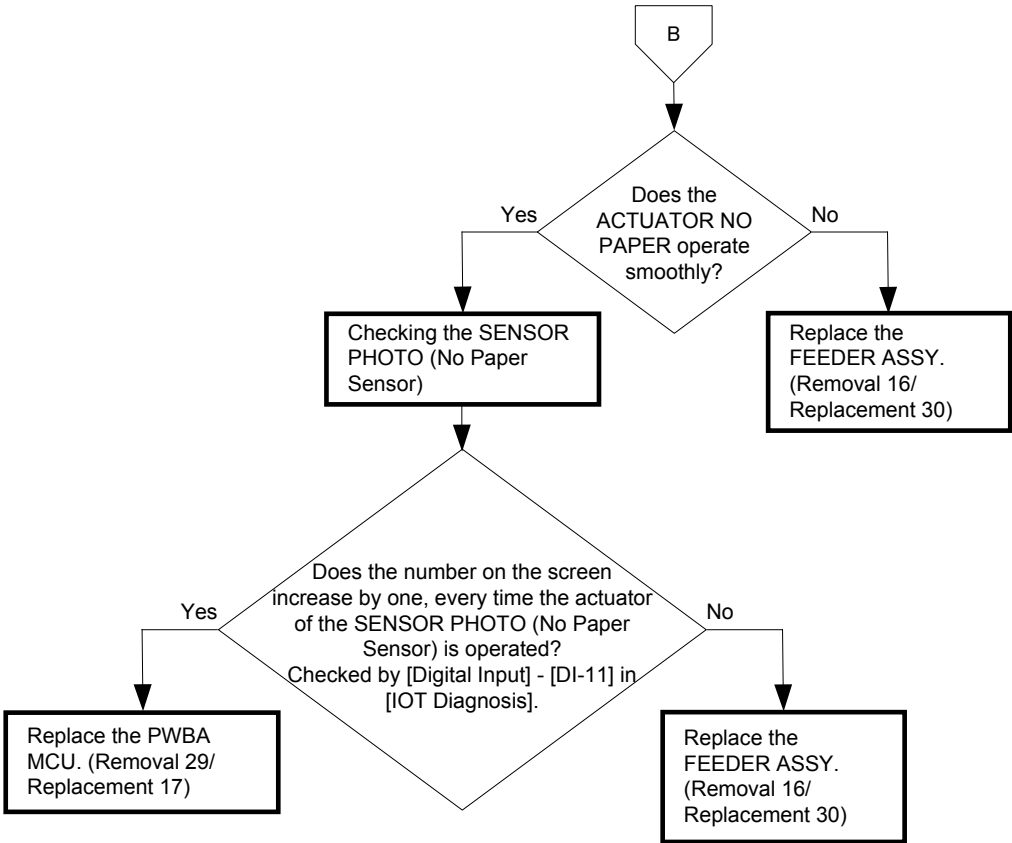

FIP-1. 35 CRUM ID 009-367/009-368/009-369/009-370

Possible causative parts: CARTRIDGE ASSY K (PL5.1.18)
CARTRIDGE ASSY C (PL5.1.19)
CARTRIDGE ASSY M (PL5.1.20)
CARTRIDGE ASSY Y (PL5.1.21)
PWBA MCU (PL9.1.20)

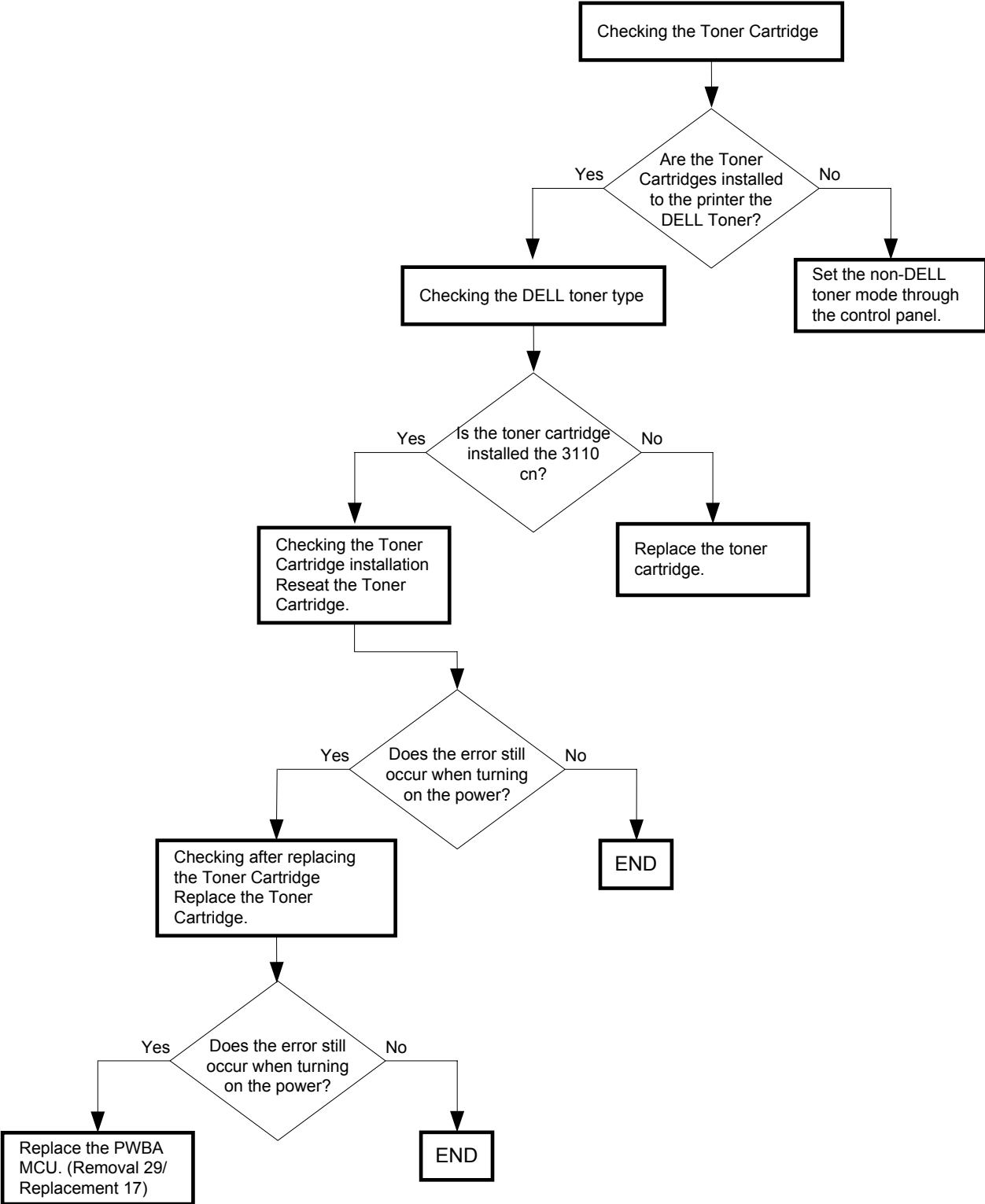

FIP-1. 36 TapeOn XXX Cart 093-919/093-920/093-921/093-922

Possible causative parts: CARTRIDGE ASSY K (PL5.1.18)
CARTRIDGE ASSY C (PL5.1.19)
CARTRIDGE ASSY M (PL5.1.20)
CARTRIDGE ASSY Y (PL5.1.21)

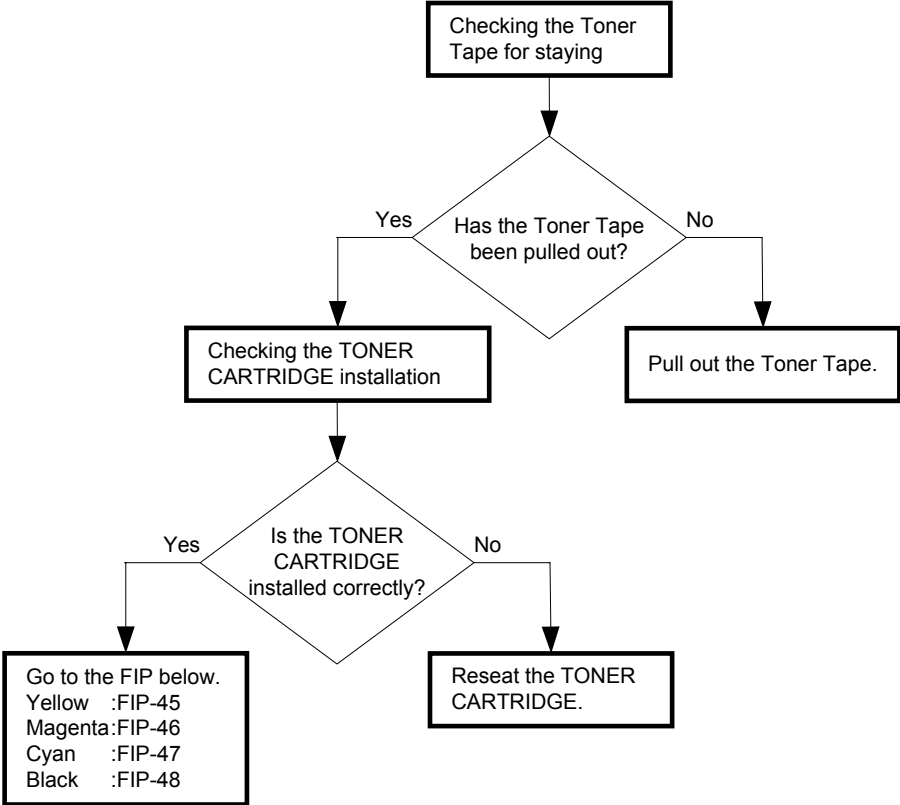

FIP-1. 37 Replace Cart. 093-930

Possible causative parts: CARTRIDGE ASSY Y (PL5.1.21)
PWBA MCU (PL9.1.20)

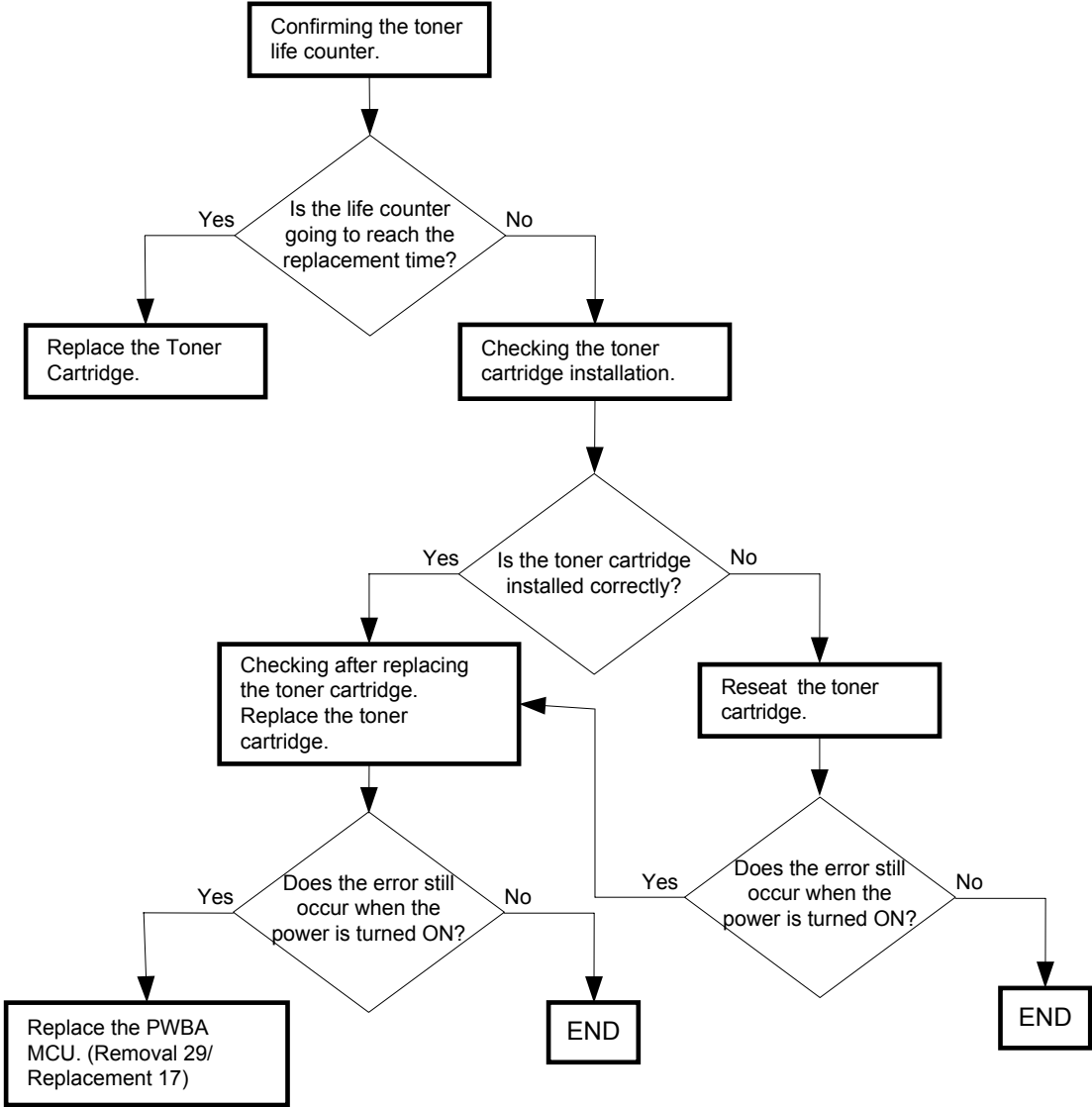

FIP-1. 38 Replace Cart. 093-931

Possible causative parts: CARTRIDGE ASSY M (PL5.1.20)
PWBA MCU (PL9.1.20)

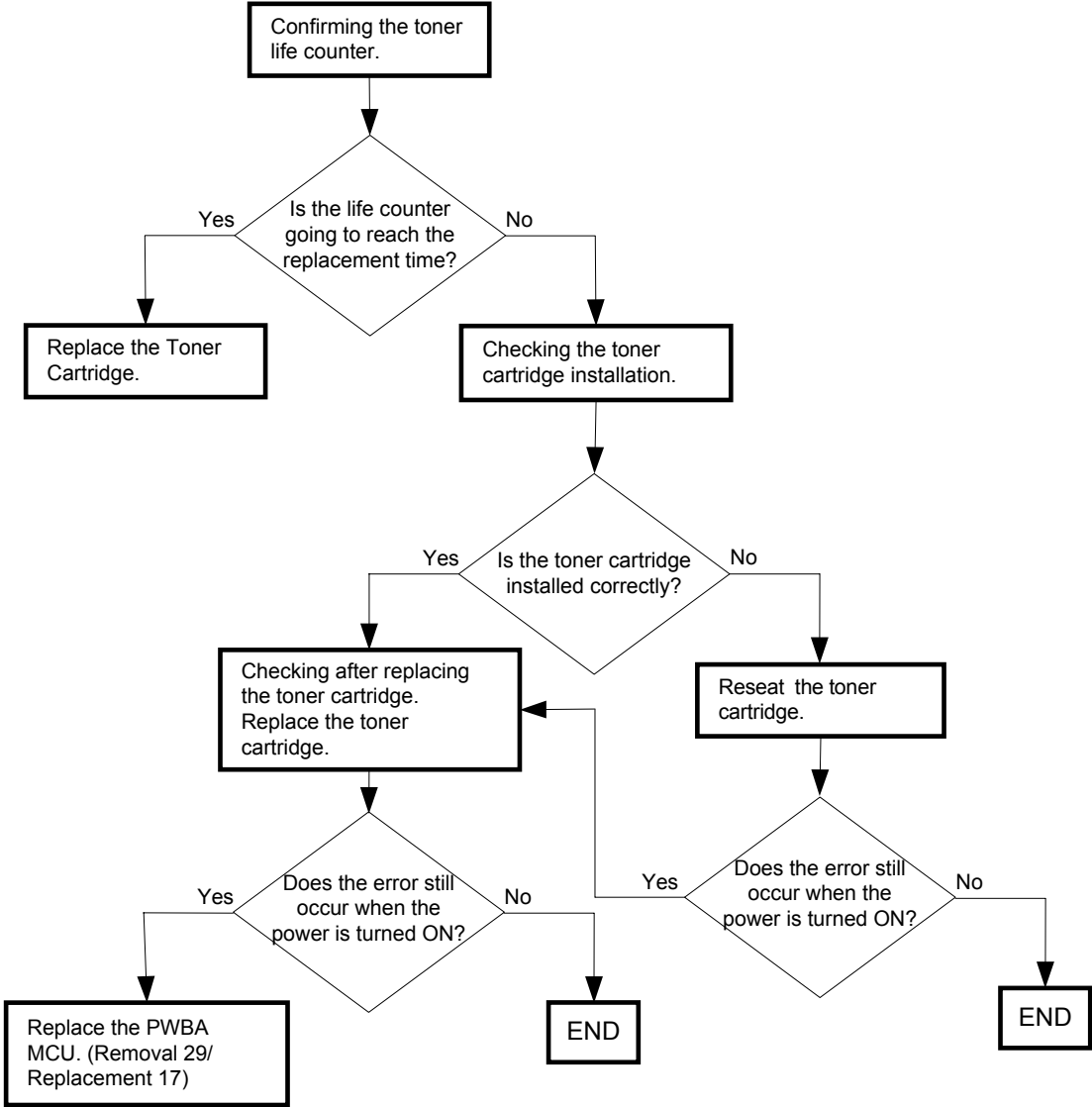

FIP-1. 39 Replace Cart. 093-932

Possible causative parts: CARTRIDGE ASSY C (PL5.1.19)
PWBA MCU (PL9.1.20)

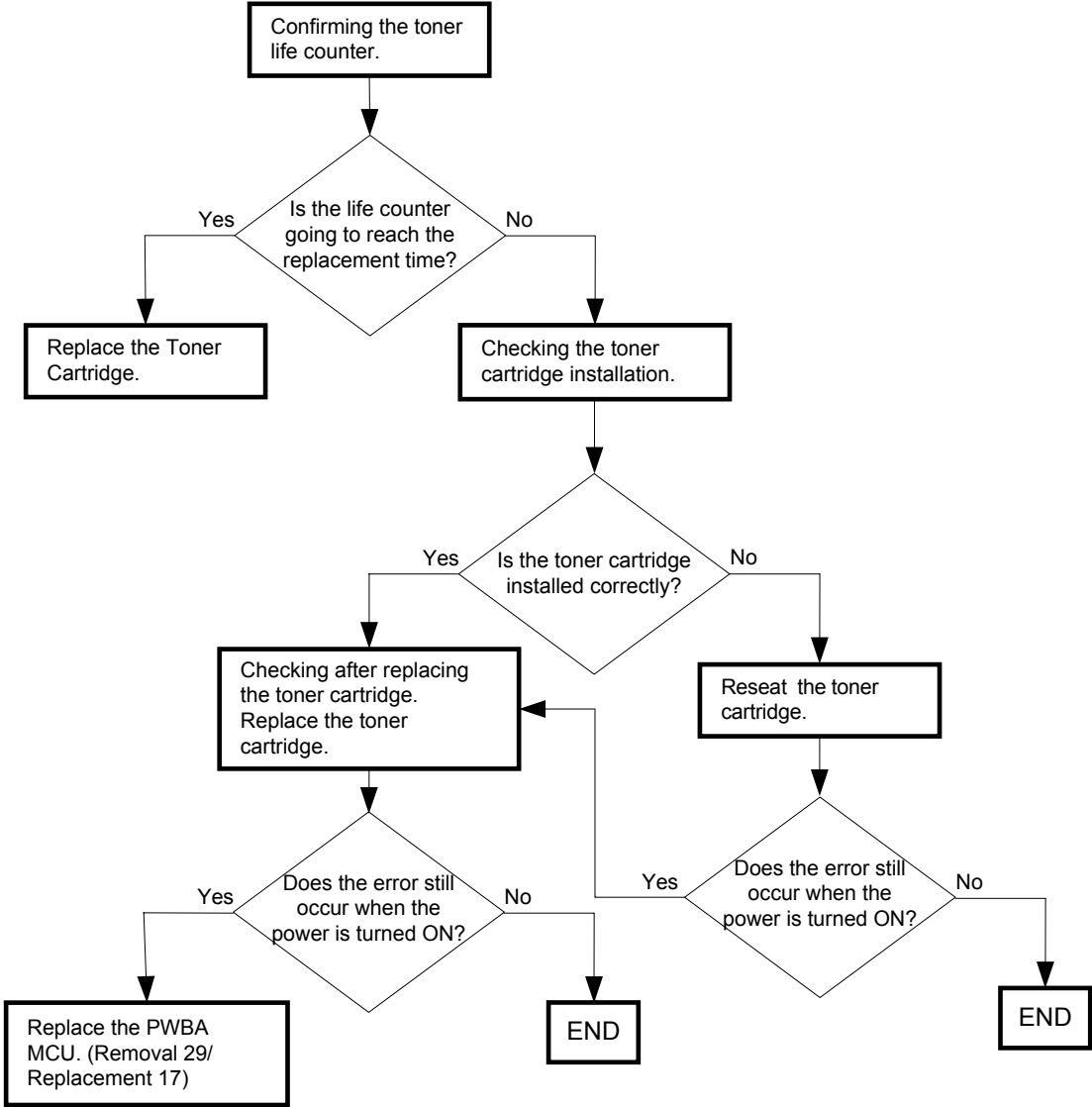

FIP-1. 40 Replace Cart. 093-933

Possible causative parts: CARTRIDGE ASSY K (PL5.1.18)
PWBA MCU (PL9.1.20)

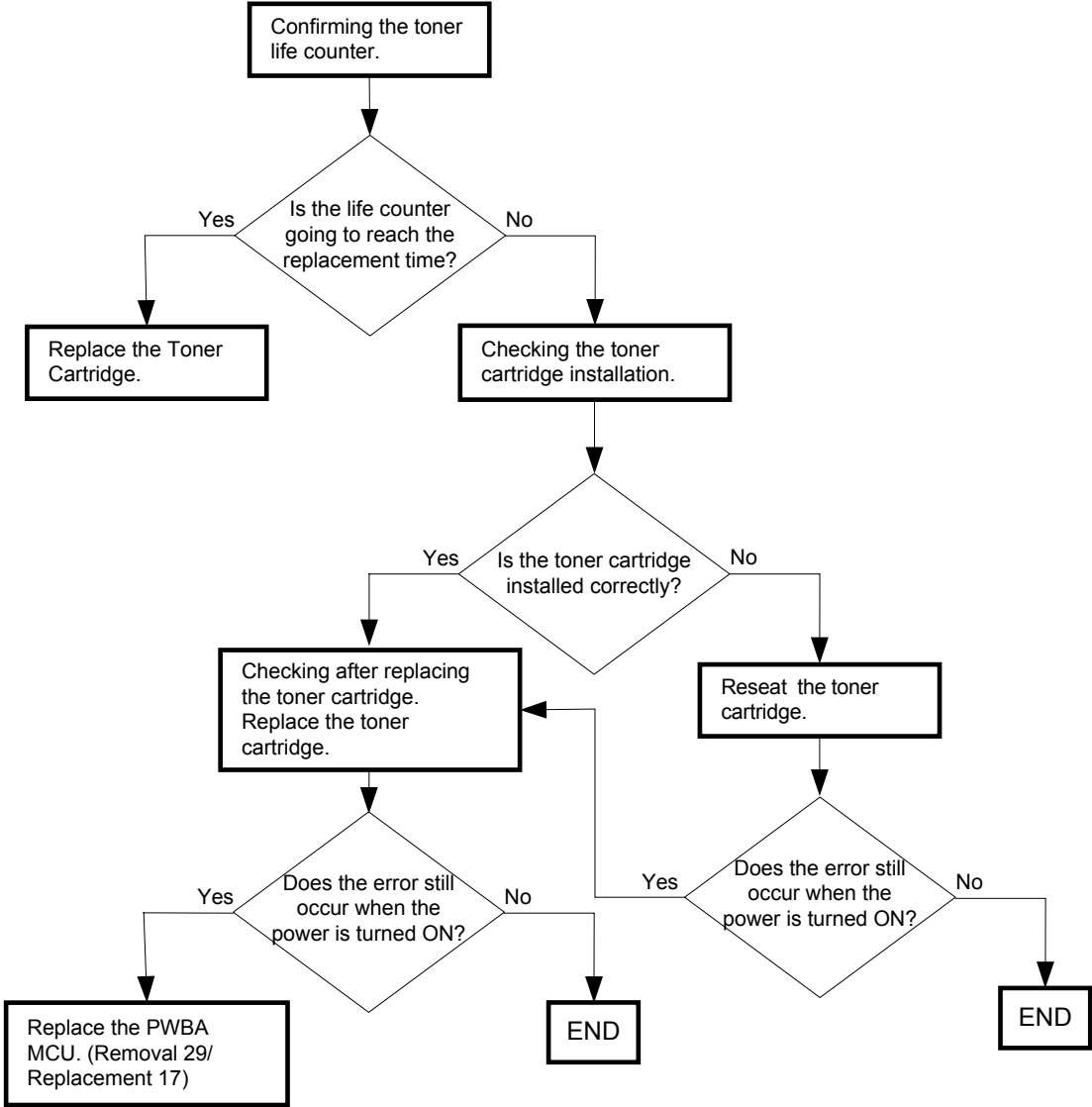

FIP-1. 41 Ready to Print 093-423

Possible causative parts: CARTRIDGE ASSY Y (PL5.1.21)
PWBA MCU (PL9.1.20)

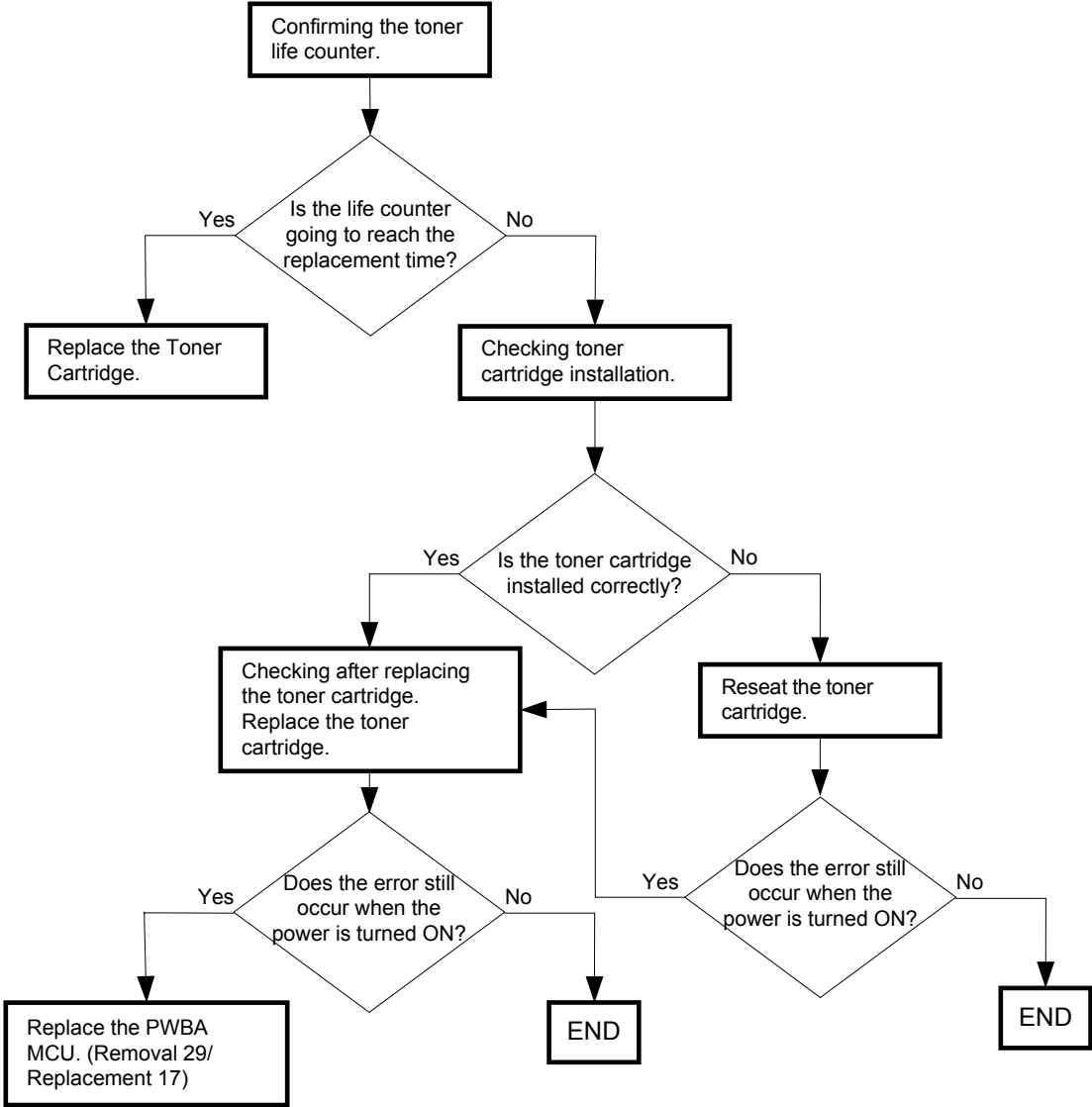

FIP-1. 42 Ready to Print 093-424

Possible causative parts: CARTRIDGE ASSY M (PL5.1.20)
PWBA MCU (PL9.1.20)

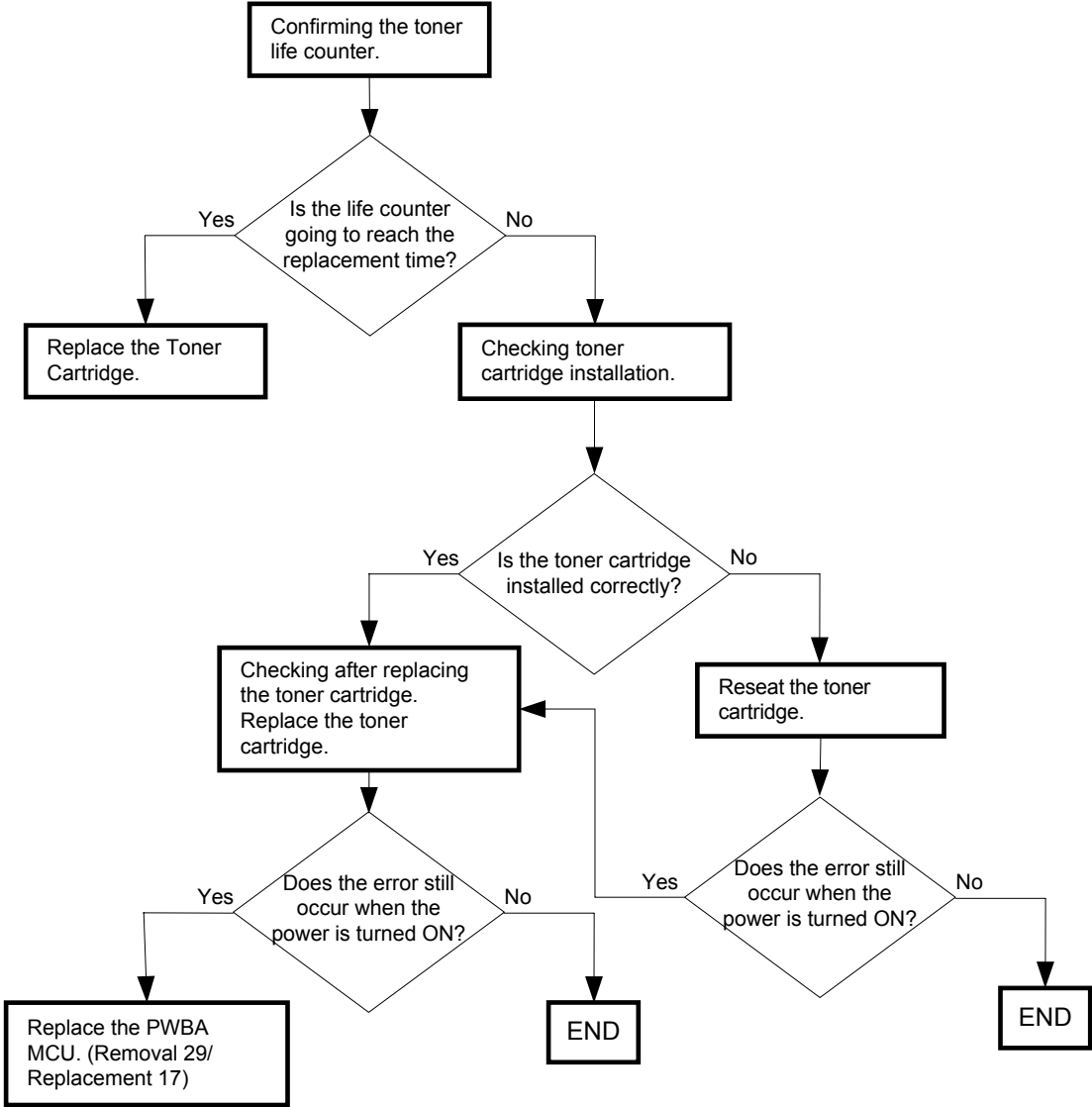

FIP-1. 43 Ready to Print 093-425

Possible causative parts: CARTRIDGE ASSY C (PL5.1.19)
PWBA MCU (PL9.1.20)

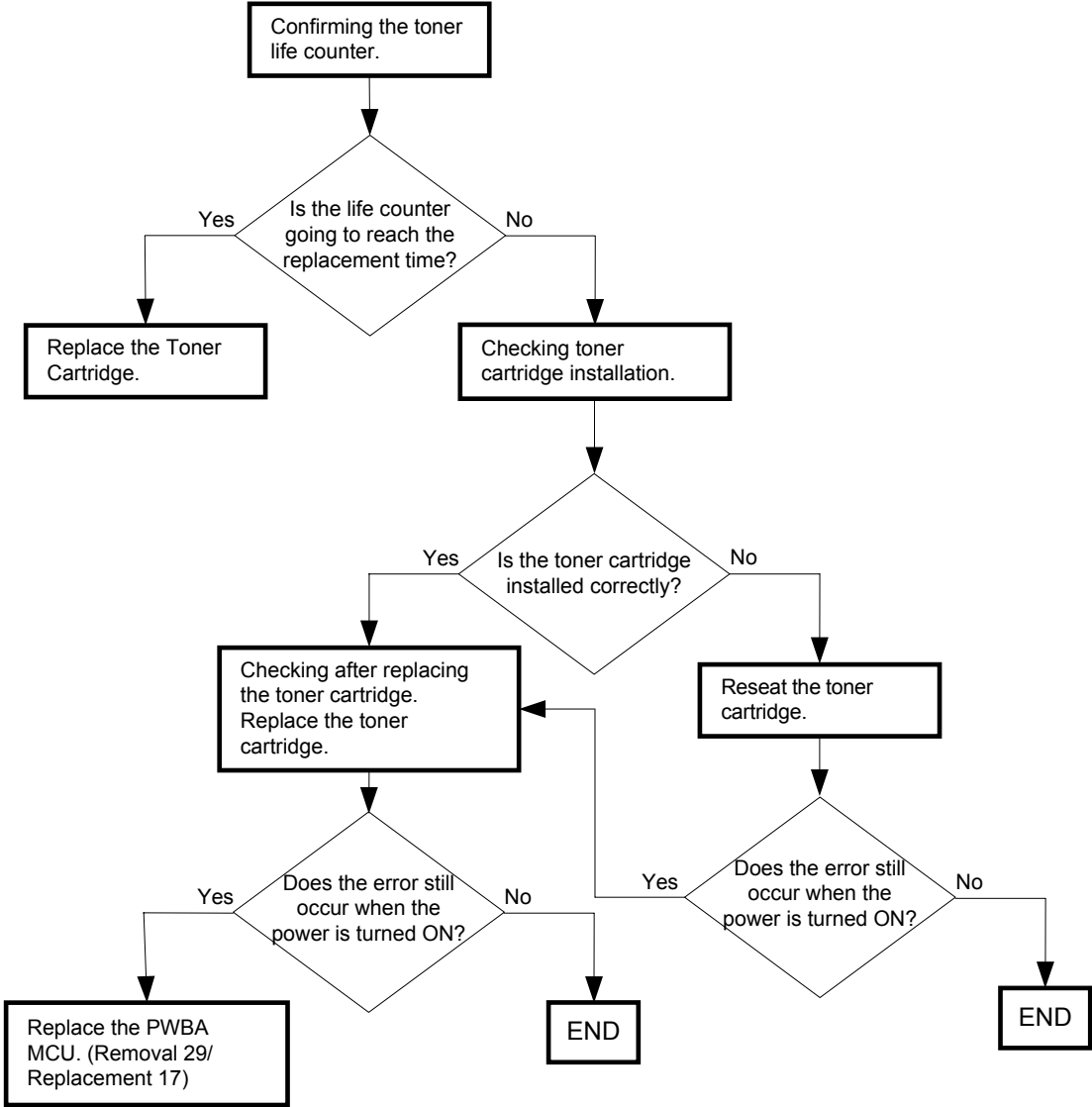

FIP-1. 44 Ready to Print 093-426

Possible causative parts: CARTRIDGE ASSY K (PL5.1.18)
PWBA MCU (PL9.1.20)

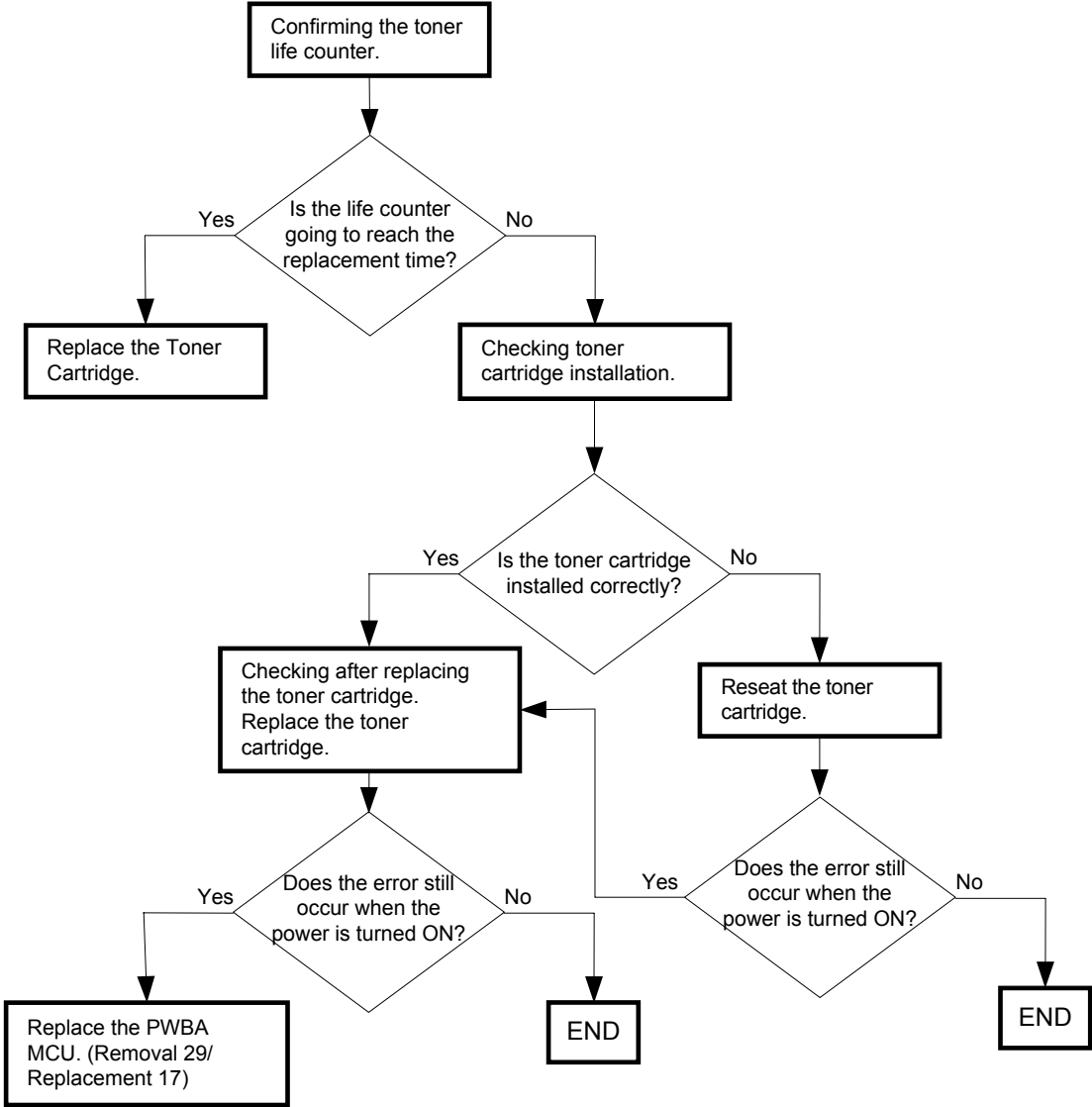

FIP-1. 45 Insert PrintCart 093-970

Possible causative parts: CARTRIDGE ASSY (Y) (PL5.1.21)
SENSOR ASSY CRU (PL5.1.4)
PWBA MCU (PL9.1.20)

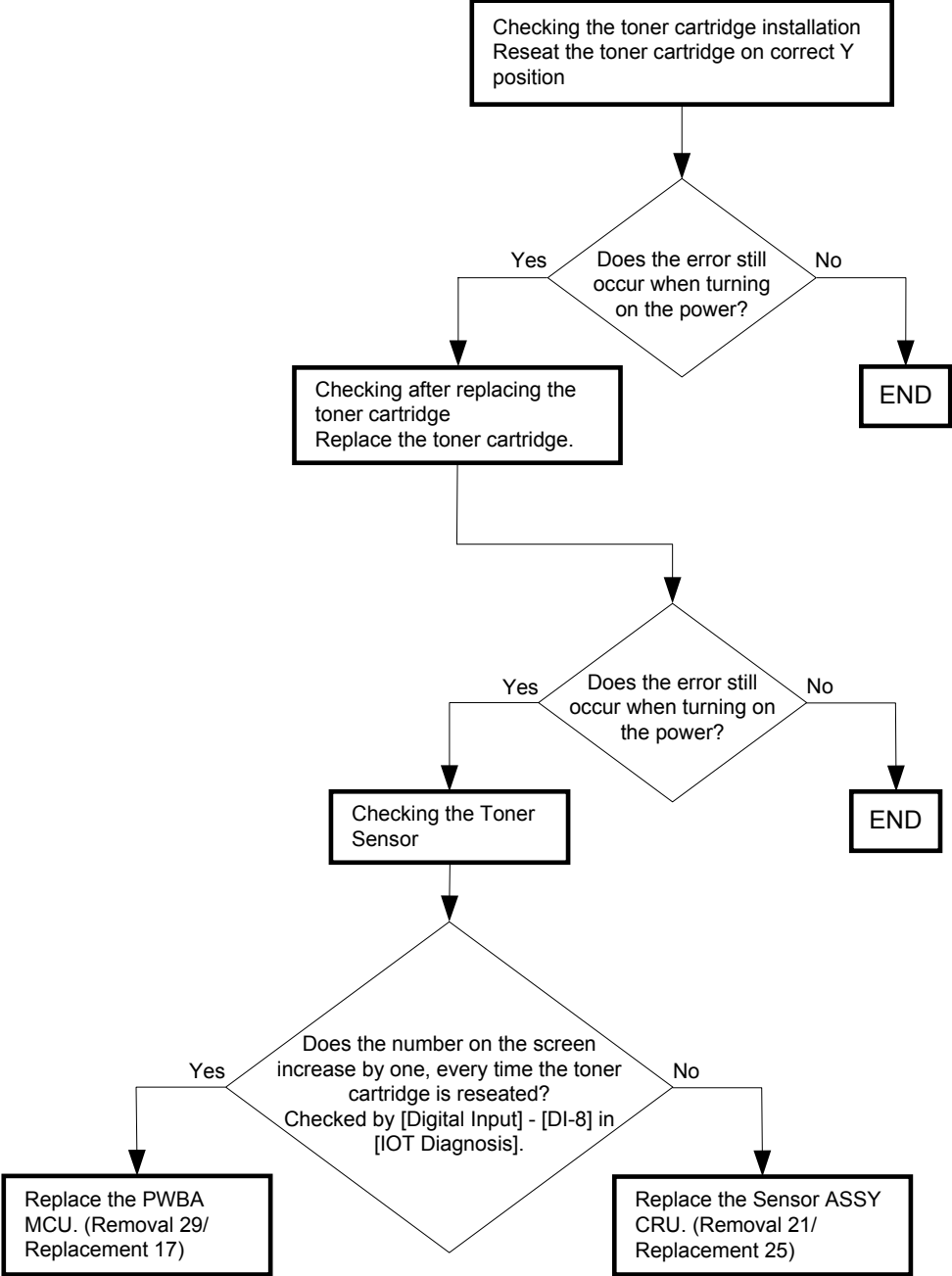

FIP-1. 46 Insert PrintCart 093-971

Possible causative parts: CARTRIDGE ASSY (M) (PL5.1.20)
SENSOR ASSY CRU (PL5.1.4)
PWBA MCU (PL9.1.20)

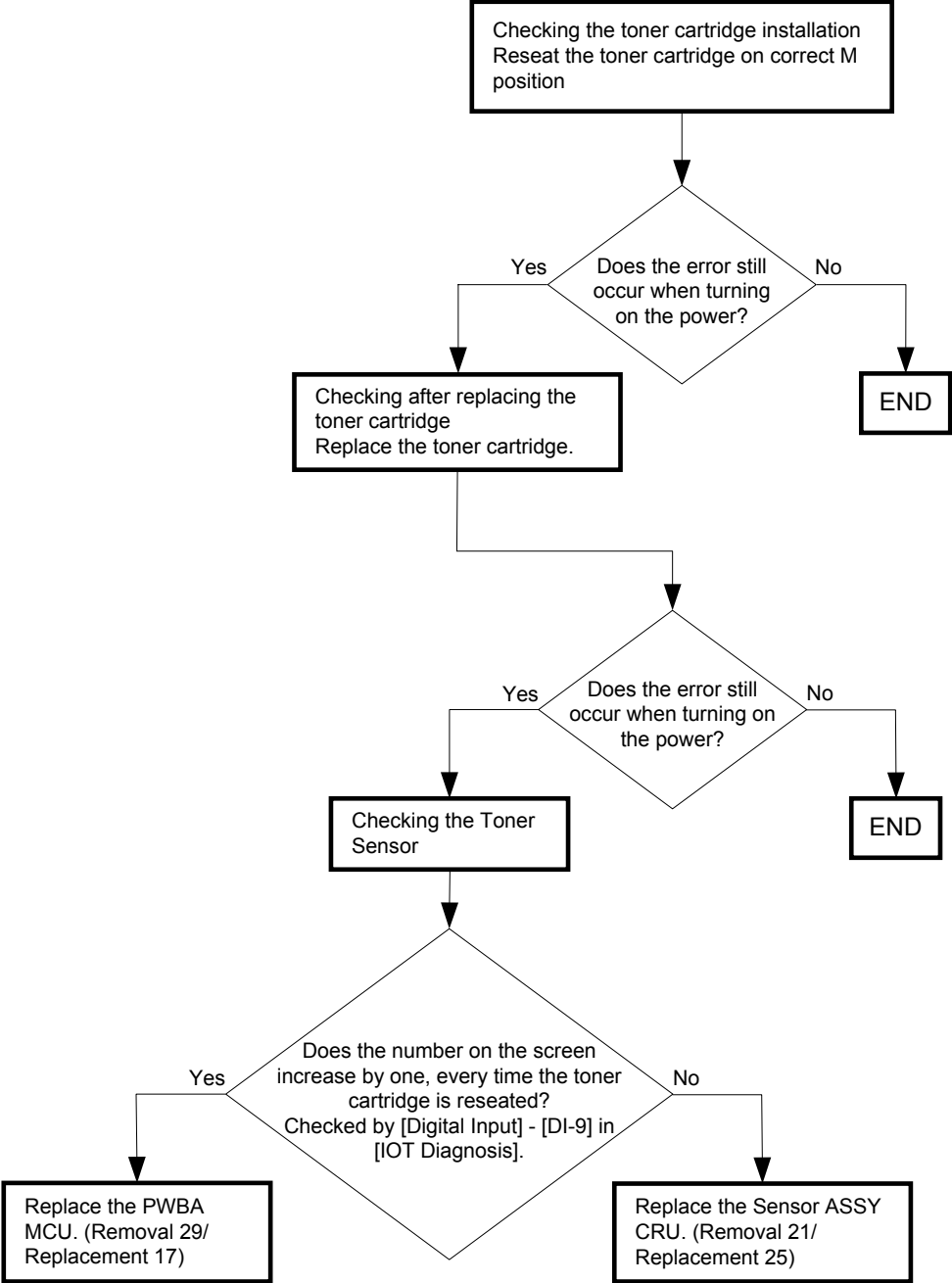

FIP-1. 47 Insert PrintCart 093-972

Possible causative parts: CARTRIDGE ASSY (C) (PL5.1.19)
SENSOR ASSY CRU (PL5.1.4)
PWBA MCU (PL9.1.20)

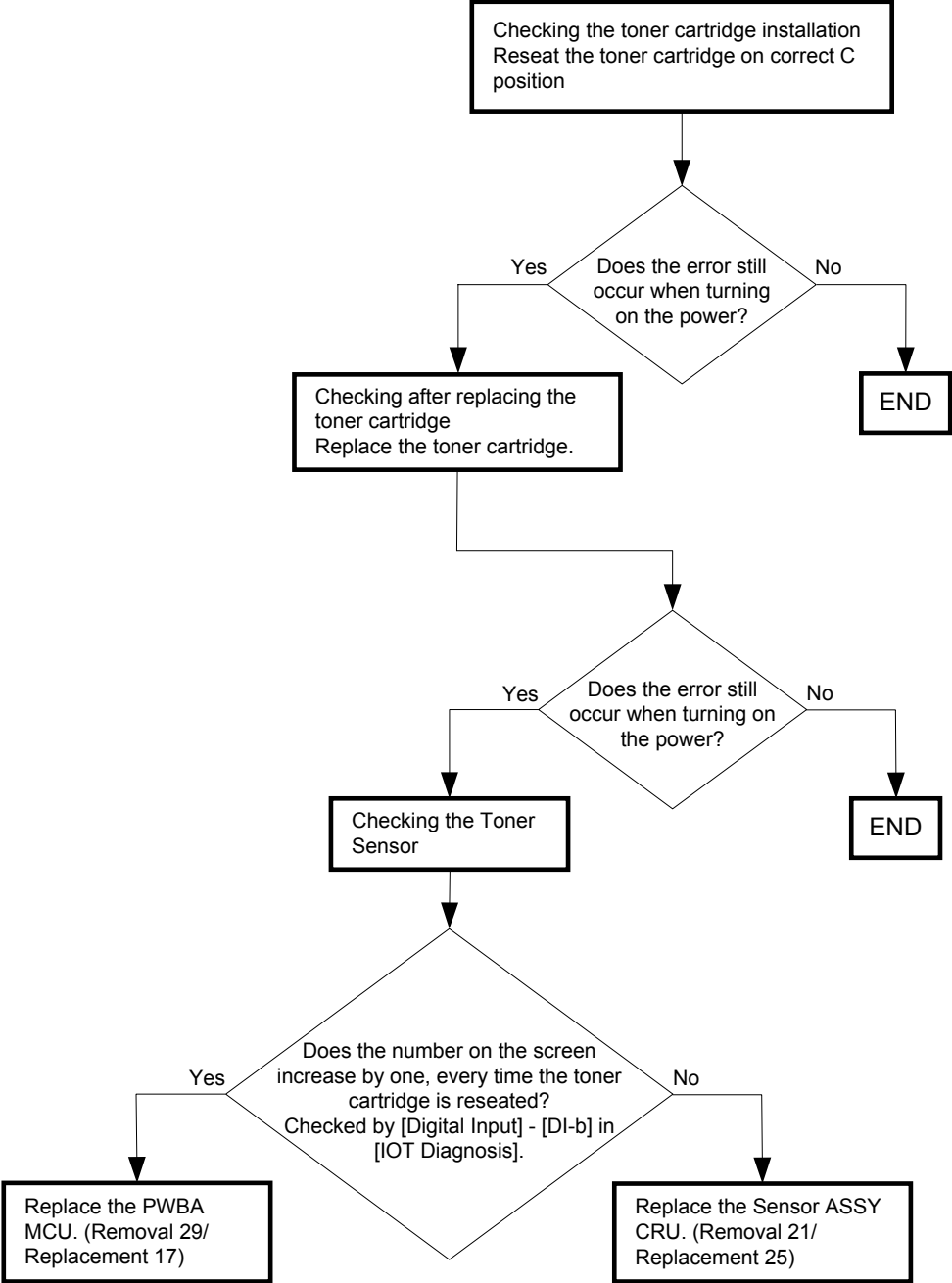

FIP-1. 48 Insert PrintCart 093-973

Possible causative parts: CARTRIDGE ASSY (K) (PL5.1.18)
SENSOR ASSY CRU (PL5.1.4)
PWBA MCU (PL9.1.20)

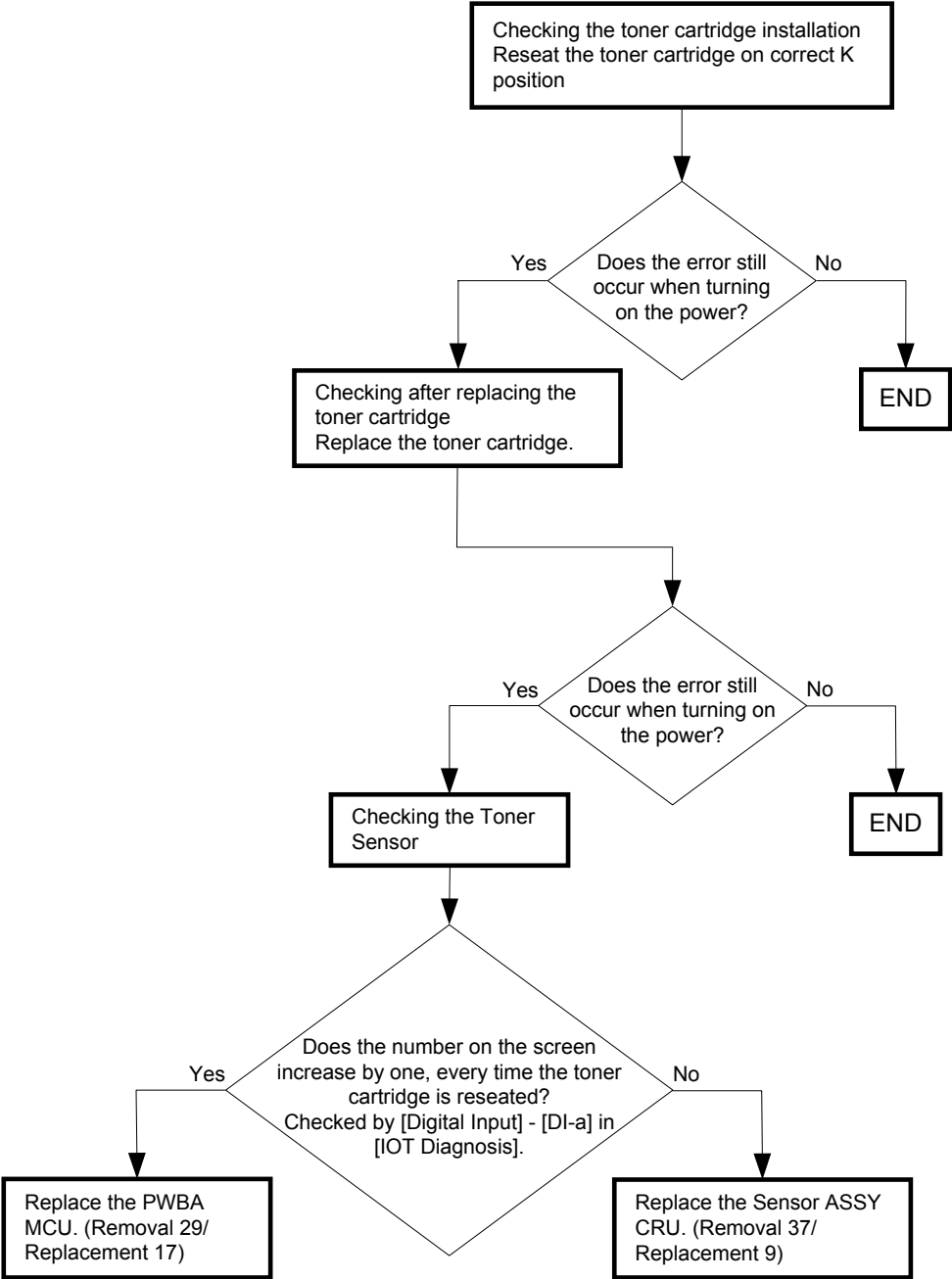

FIP-1. 49 CRUM ID 009-371 / Inset Belt Unit 094-910

Possible causative parts:BELT CRU (PL4.1.1)
PWBA MCU (PL9.1.20)

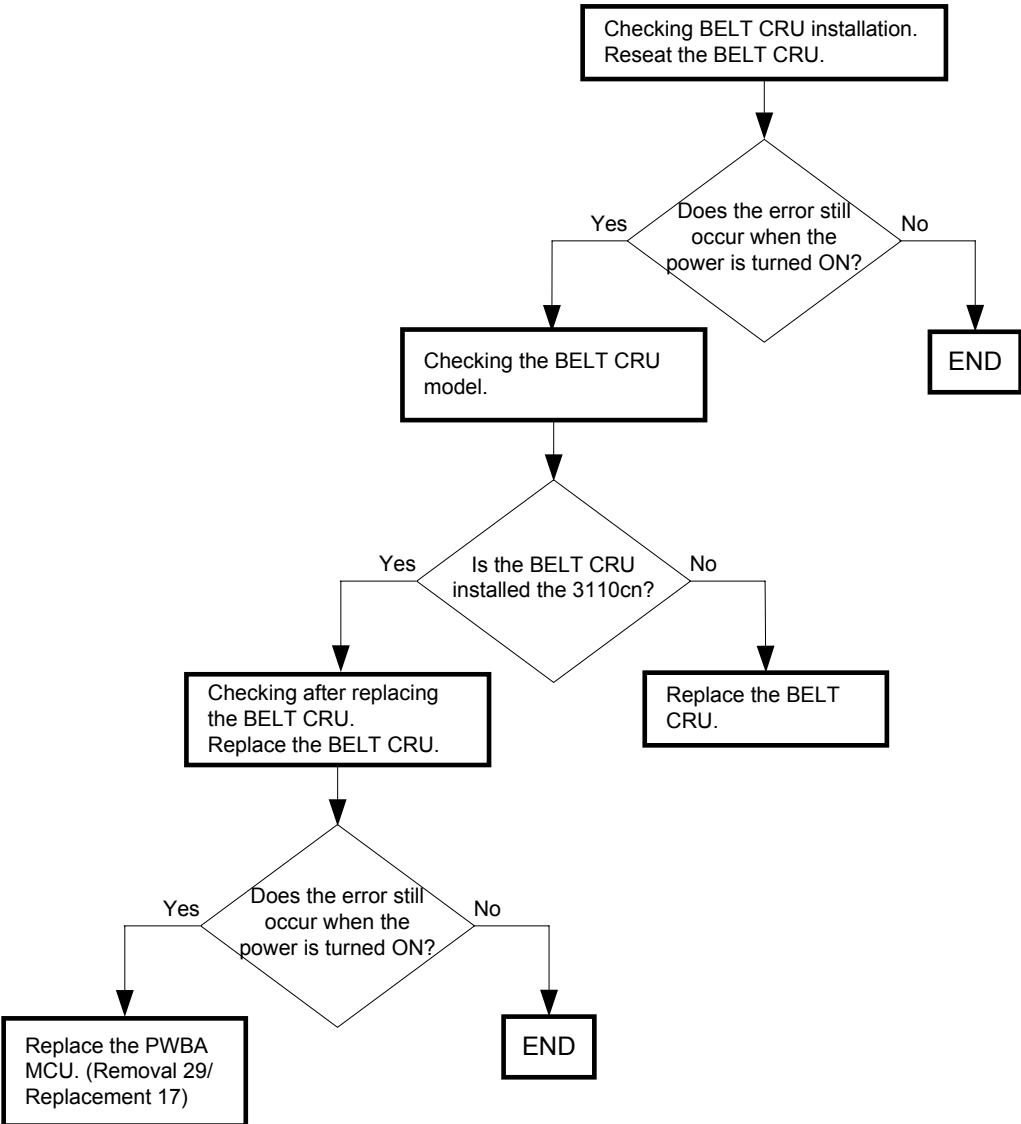

FIP-1. 50 Ready to Print 094-422

Possible causative parts:BELT CRU (PL4.1.1)
PWBA MCU (PL9.1.20)

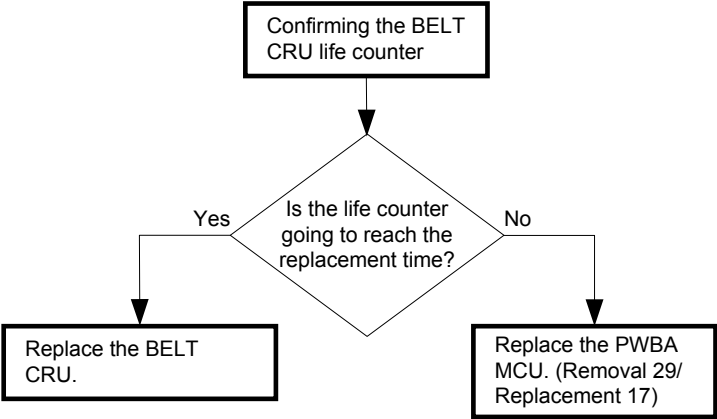

FIP-1. 51 Belt Unit 094-911

Possible causative parts:BELT CRU (PL4.1.1)
PWBA MCU (PL9.1.20)

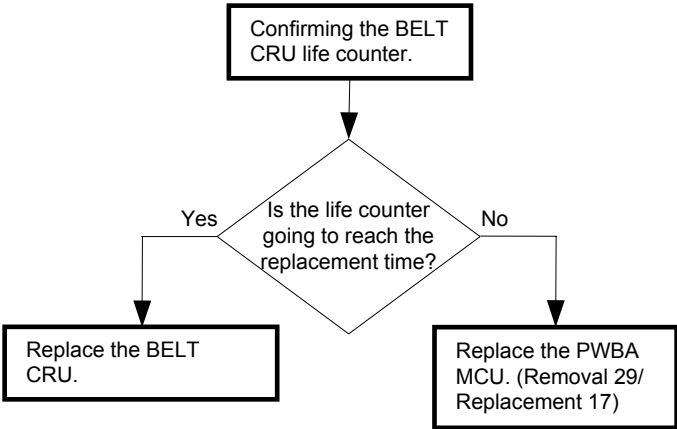

FIP-1. 52 010-359 Restart Printer

Possible causative parts:FUSER ASSY (PL6.1.10)
PWBA MCU (PL9.1.20)

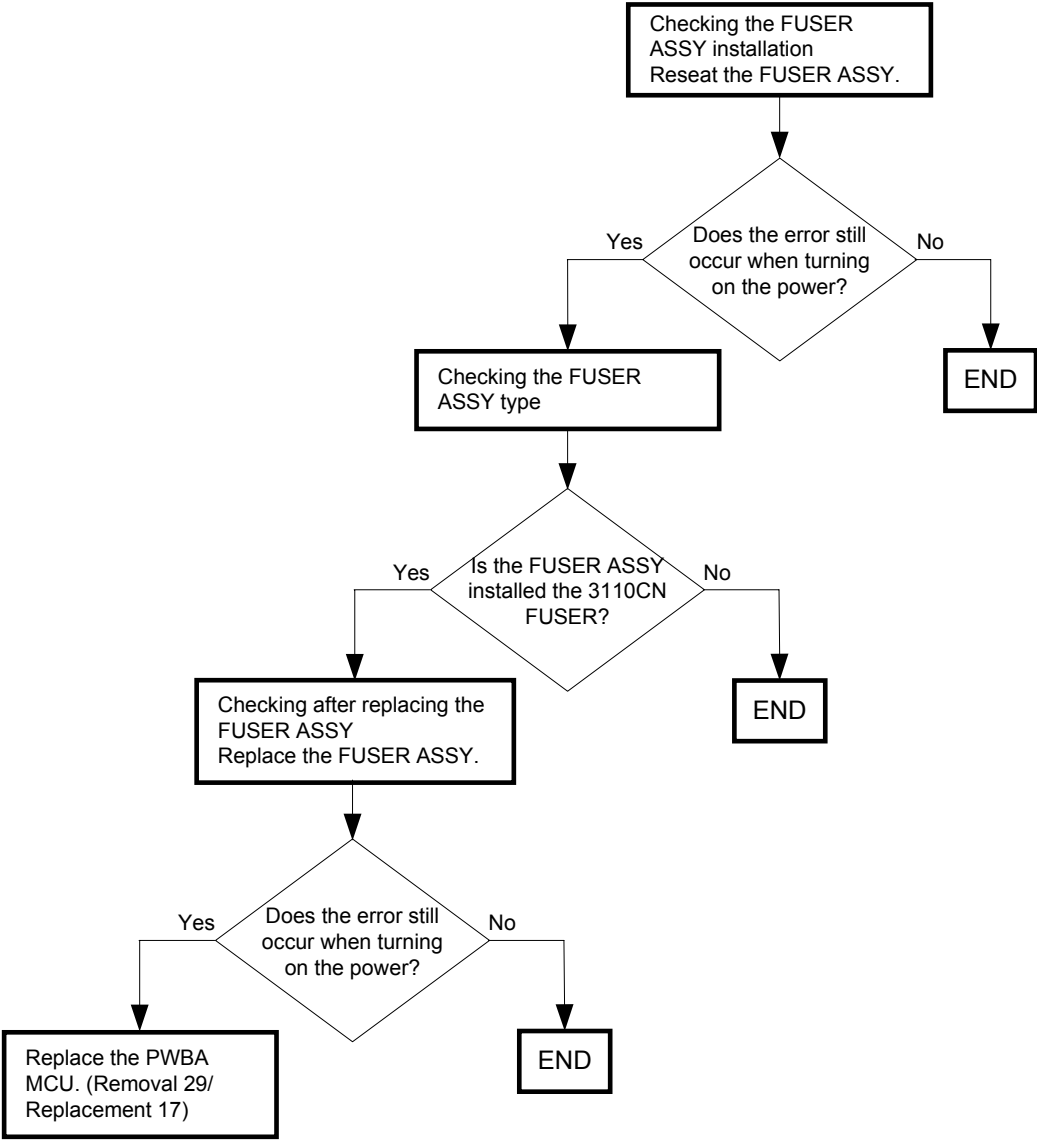

FIP-1. 53 Ready to Print 010-421

Possible causative parts:FUSER ASSY (PL6.1.10)
PWBA MCU (PL9.1.20)

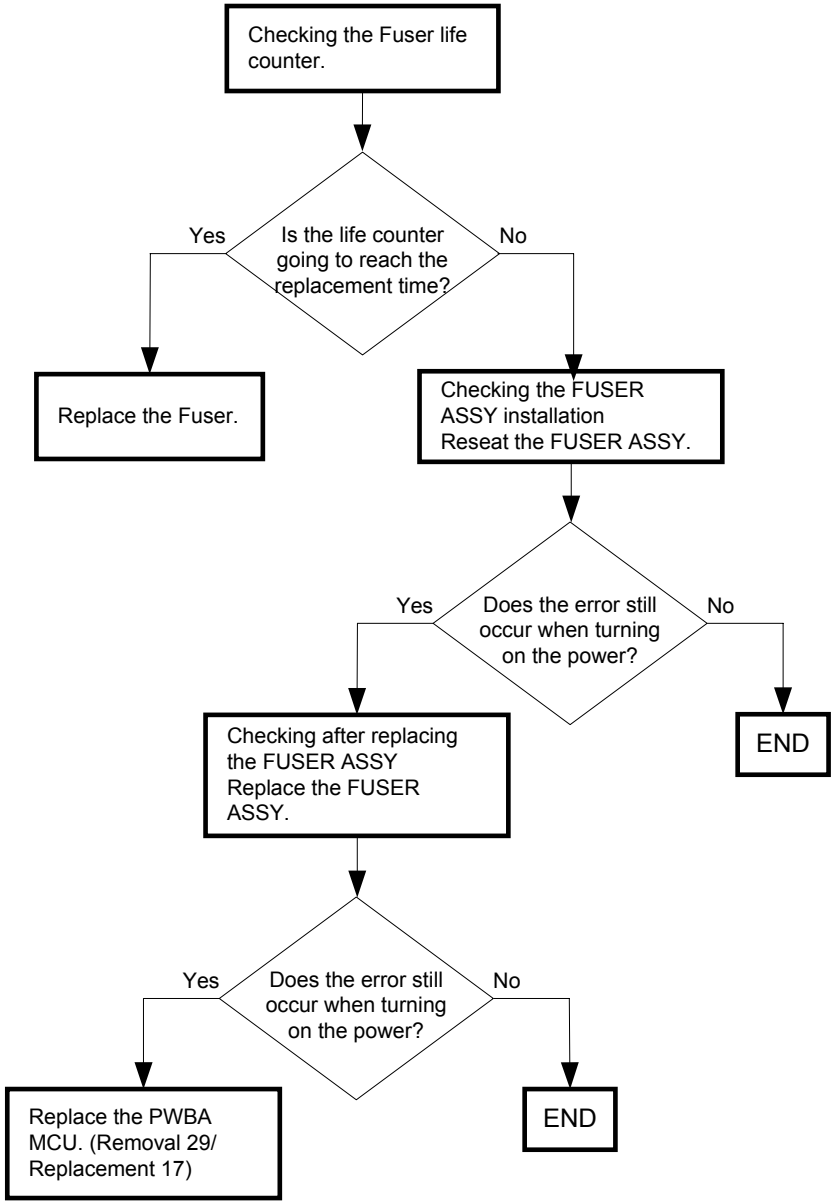

FIP-1. 54 Tray Detached 024-946/024-947 / Load Tray 1 077-912

Possible causative parts: CASSETTE ASSY 250 (PL2.1.1)
SWITCH ASSY SIZE (PL7.1.18)
PWBA MCU (PL9.1.20)
550 OPTION FEEDER (PL12.1.1)
CASSETTE ASSY 550 (PL12.4.1)

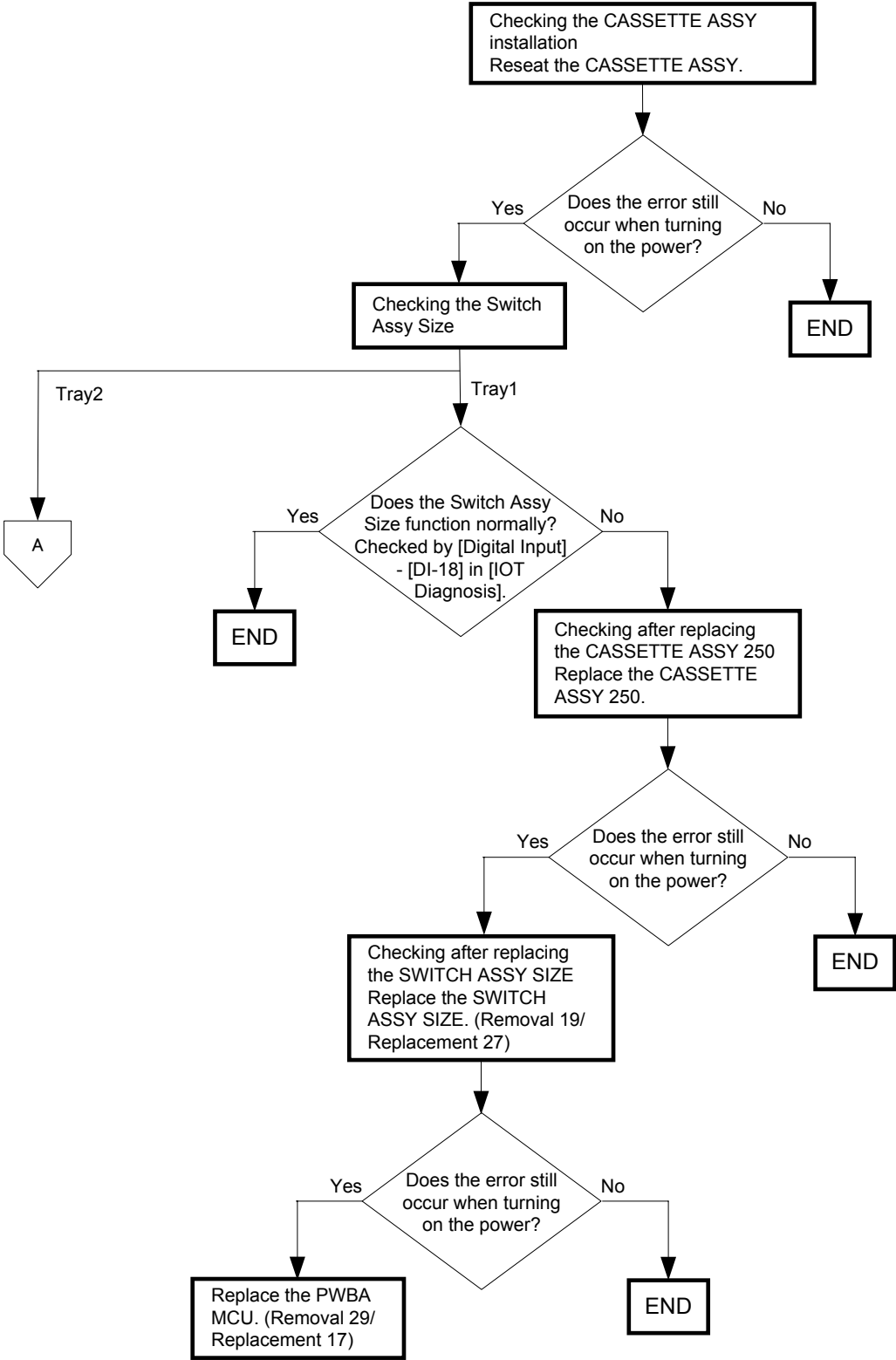

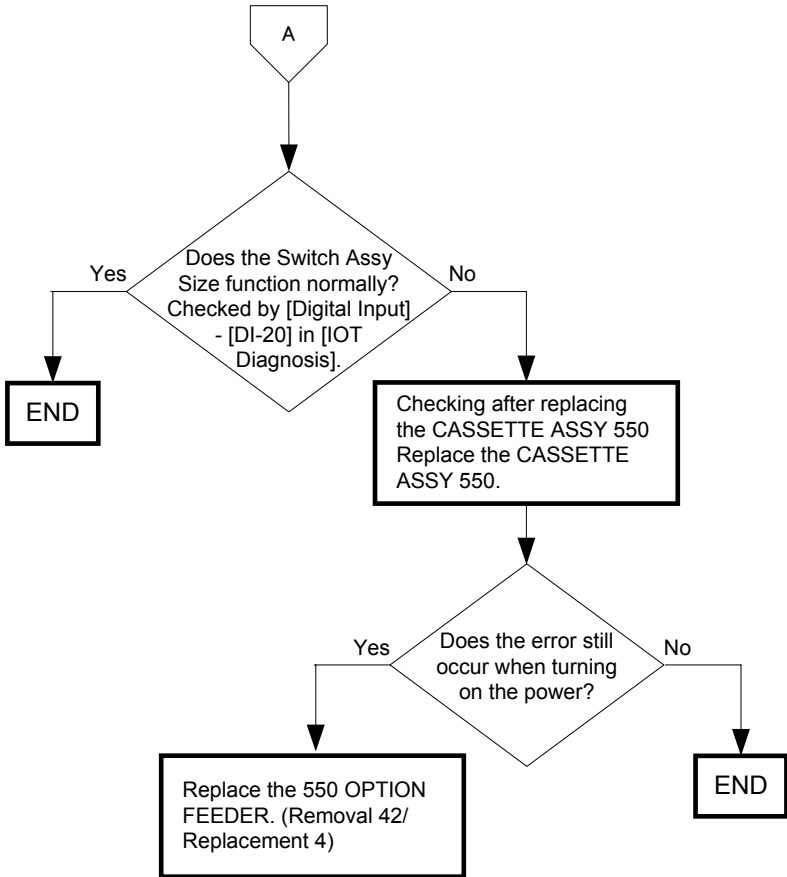

FIP-1. 55 Close FrontCover 077-300

Possible causative parts:COVER ASSY FRONT (PL1.2.98)
HARN ASSY INTERLOCK (PL9.1.3)
LVPS (PL9.1.4)
PWBA MCU (PL9.1.20)

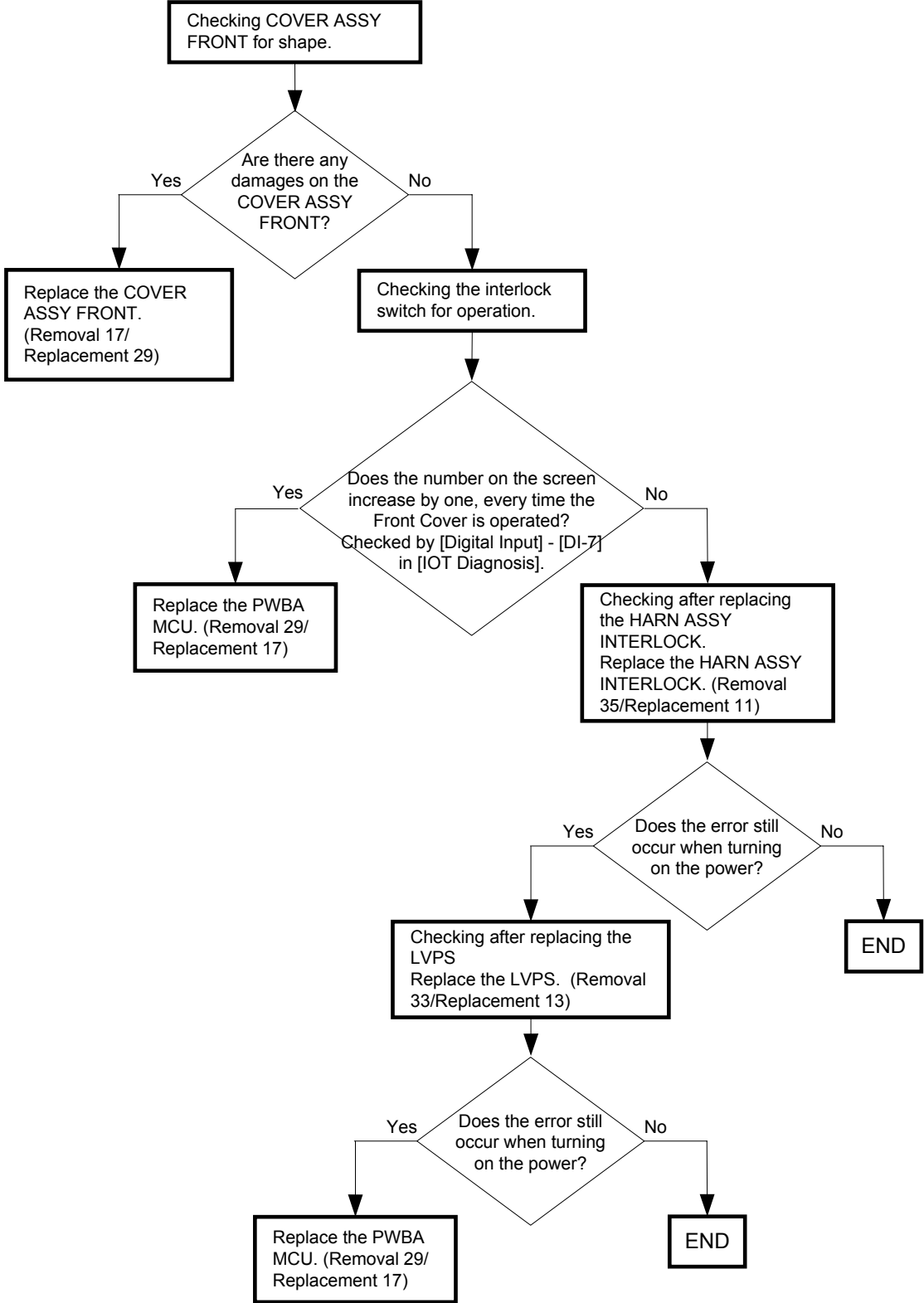

FIP-1. 56 Invalid ID 016-383 / Range Chk Error 016-384 / Header Error 016-385 / Check Sum Error 016-386 / Format Error 016-387

Possible causative parts:PWBA ESS (PL9.1.27)

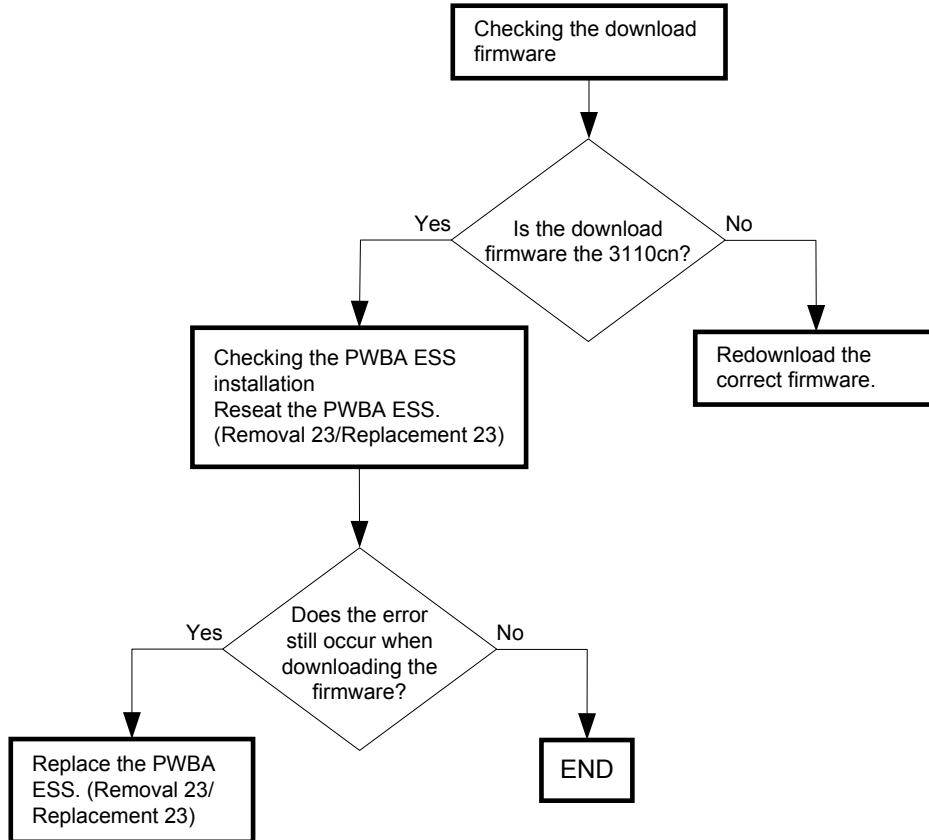

FIP-1. 57 MPC Error 016-388 / MPC Detached 016-389 / MPC Com. Failed 016-390

Possible causative parts:PWBA ESS (PL9.1.27)
MPC (PL9.1.31)

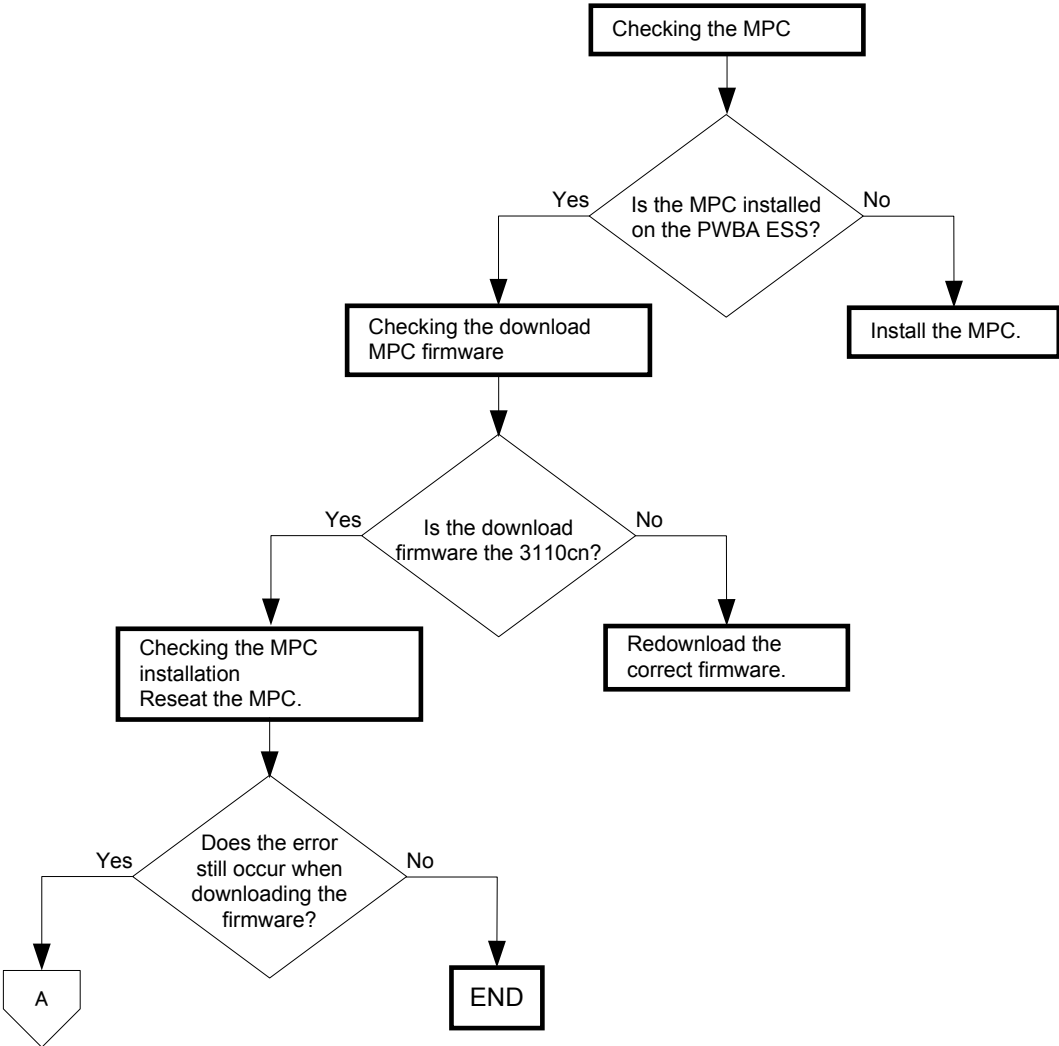

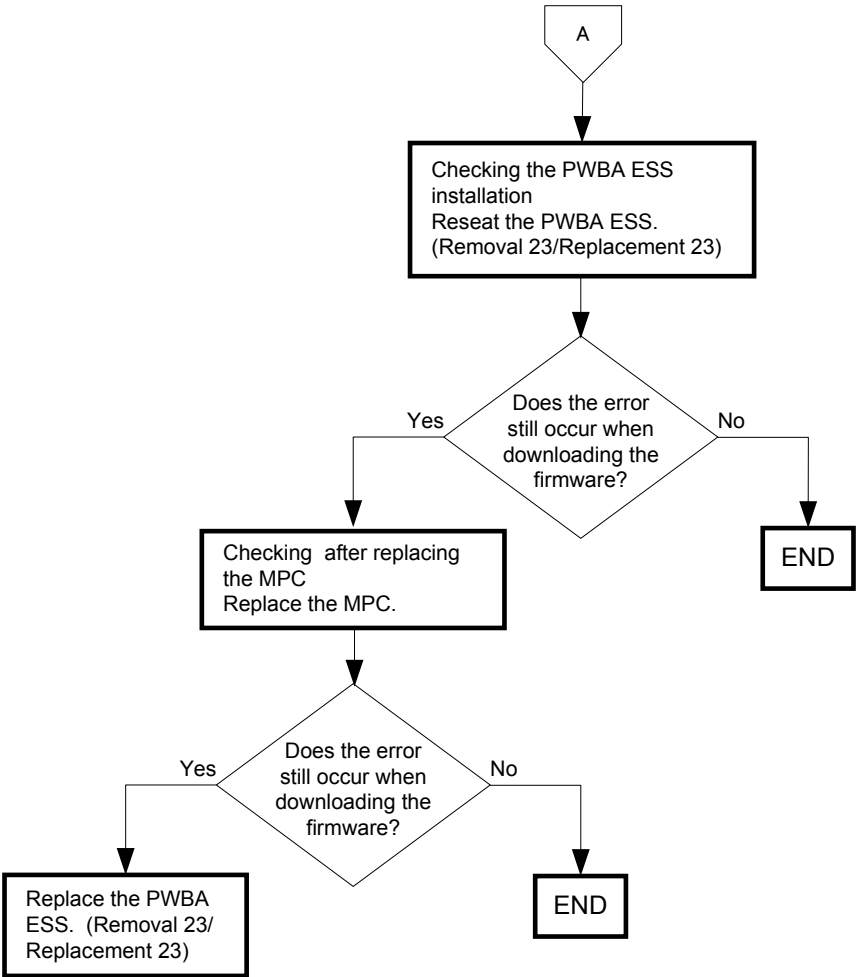

FIP-1. 58 Out of Memory 016-700/Disk Full 016-980

Possible causative parts:PWBA ESS (PL9.1.27)
Memory Card (Option)

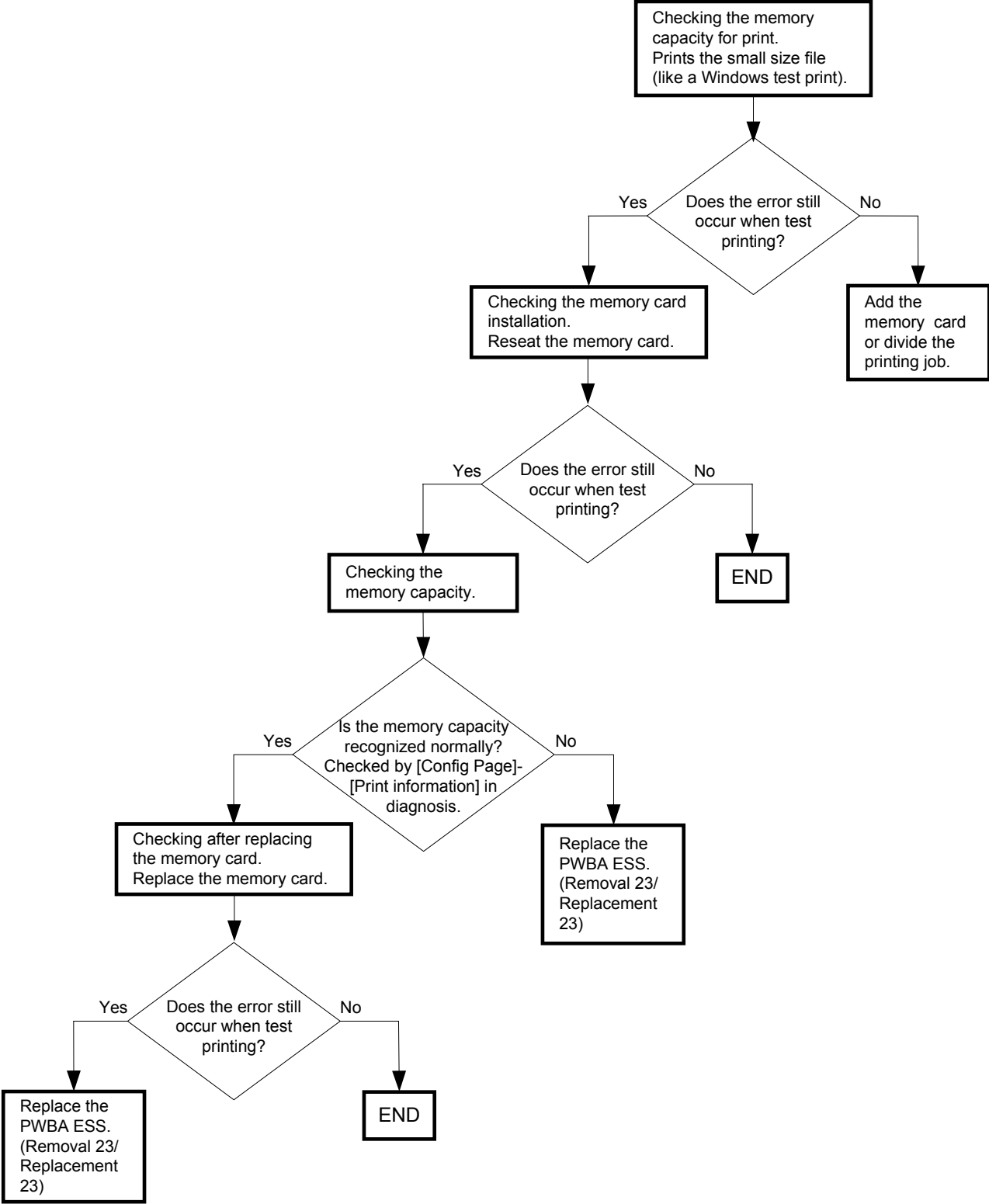

FIP-1. 59 Invalid User 016-757 / Disabled Func 016-758 / Reached Limits 016-759

Possible causative parts:PWBA ESS (PL9.1.27)

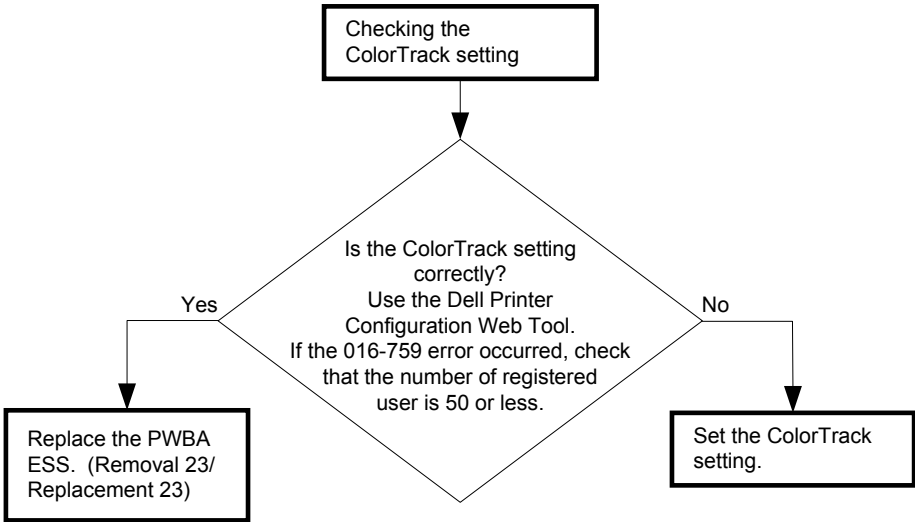

FIP-1. 60 Invalid Job 016-799

Possible causative parts:PWBA ESS (PL9.1.27)

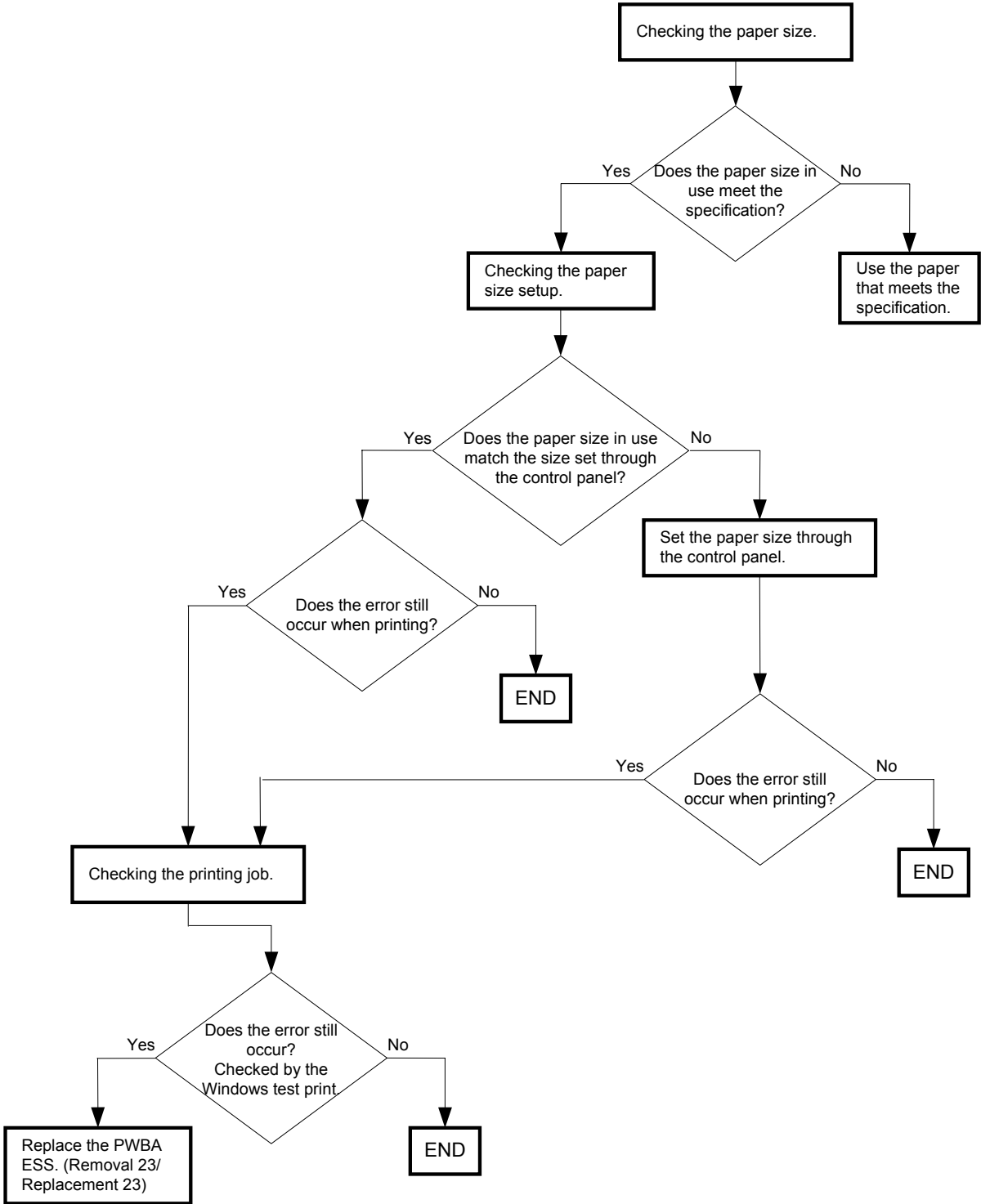

FIP-1. 61 Ready to Print 193-700

Possible causative parts:PWBA ESS (PL9.1.27)

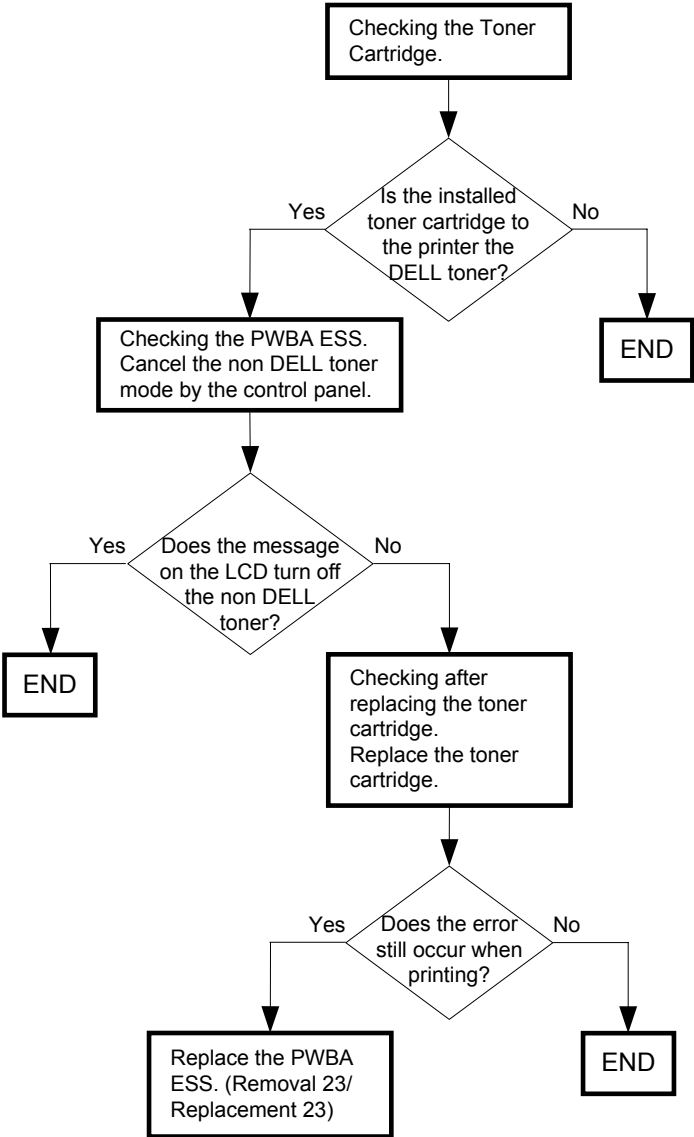

FIP-1. 62 Over Heat 042-700/Ready to Print 142-700

Possible causative parts:KIT FEEDER (PL3.2.99)
PWBA MCU (PL9.1.20)

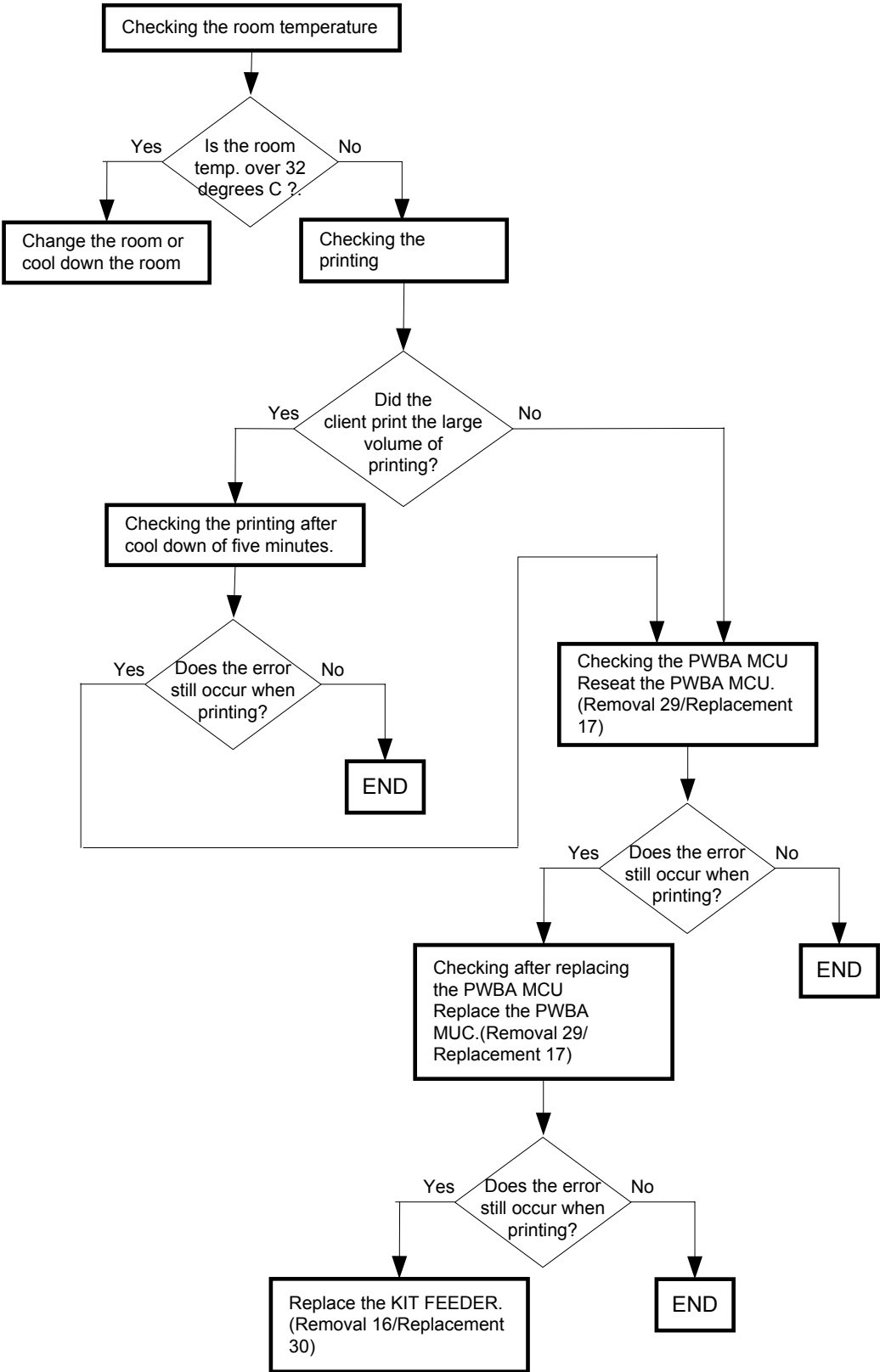

FIP-1. 63 Electrical Noise

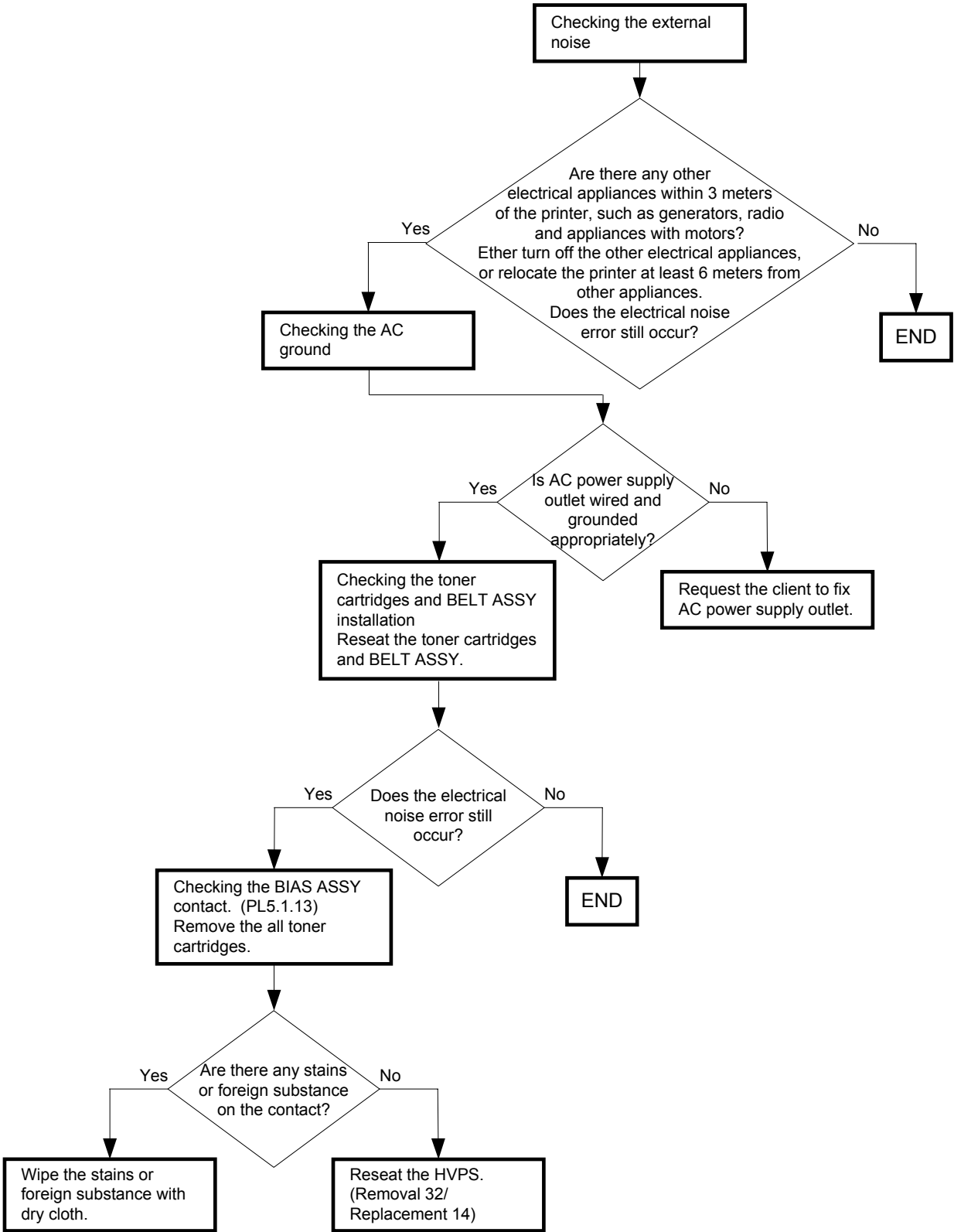

4. Image Quality Trouble

4.1 Entry Chart for Image Quality Troubleshooting

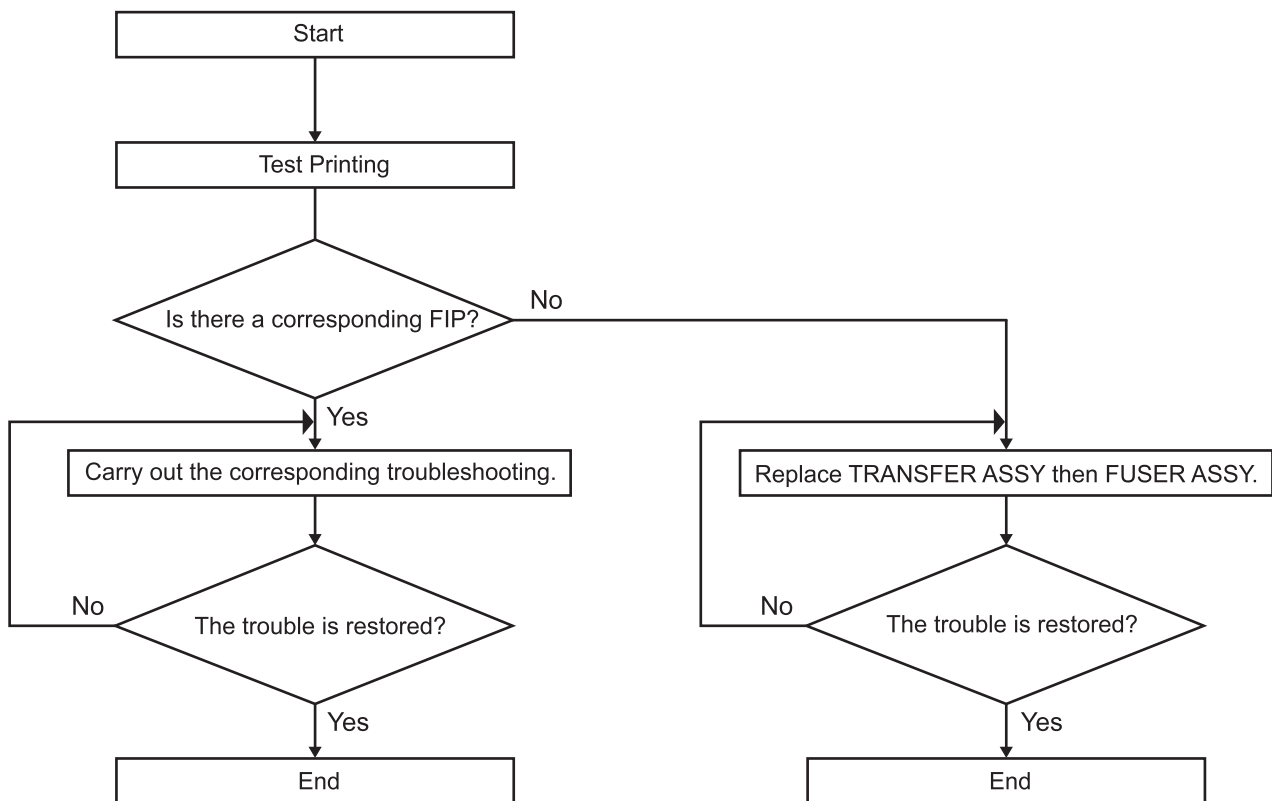

Kmy01003KA

NOTE

It is stated as the Printer Controller is normal. By operating test print with the engine only, if the trouble is on Printer Controller side or the engine side can simply be diagnosed, except those phenomena that are not able to be diagnosed by test print.

- Test print result with the engine only is normal. ---> Malfunction on Printer Controller side

- Test print result with the engine only is also abnormal. ---> Malfunction on the engine side

When it is the case of [Malfunction on Printer Controller side], replace with normal Printer Controller and normal Interface Cable, and check.

When the trouble still occurs after replacement, check the host side, and then operate Troubleshooting efficiently, using the following image quality FIP according to each phenomenon.

When the image quality trouble of print occurs, get a print to judge, understand and treat the trouble substance precisely and appropriately, and then troubleshoot efficiently, using the image quality FIP table according to each phenomenon.

When trouble restoration with image quality FIP is not possible, check again with the image quality FIP, and then replace [ESS and possible causative parts] in order and check, and operate Troubleshooting, using [Chapter 2 Diagnostic].

Image quality FIP states regarding the typical image quality trouble, as follows.

- FIP-1.P1 Faint print (Low contrast)
- FIP-1.P2 Blank print
- FIP-1.P3 Solid black
- FIP-1.P4 Vertical blank lines (White stripes in paper transport direction)
- FIP-1.P5 Horizontal band cross out (White stripes in the horizontal direction)
- FIP-1.P6 Vertical stripes
- FIP-1.P7 Horizontal stripes
- FIP-1.P8 Partial lack
- FIP-1.P9 Spots
- FIP-1.P10 Afterimage
- FIP-1.P11 Background (Fog)
- FIP-1.P12 Skew
- FIP-1.P13 Paper damage
- FIP-1.P14 No fix
- FIP-1.P15 Color Registration (Color Shift)

NOTE

When horizontal lines and/or spot occur periodically, it is possibly caused by the trouble of a particular roll. In this case, measure the trouble interval on the test print, and check the relation to the roll in the table below. The interval does not necessarily match circumference of the roll. The trouble may be solved easily by the check.

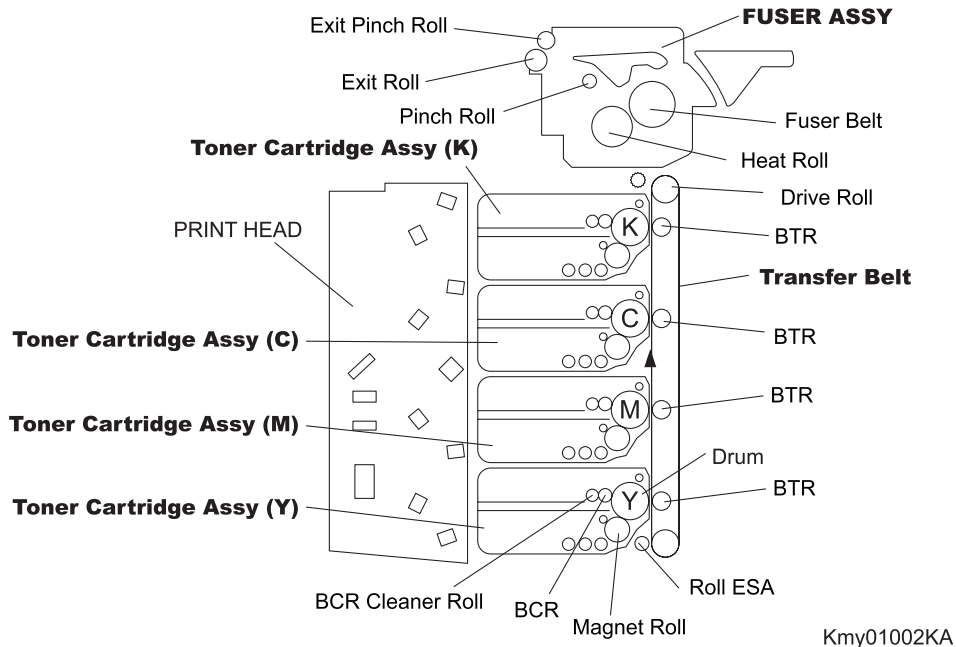

Roll	Parts name	PL No.	Roll diameter (mm)	Interval (mm)
Drum	Toner Cartridge ASSY	PL5.1.18/PL5.1.19/ PL5.1.20/PL5.1.21	24	75.4
BCR	Toner Cartridge ASSY	PL5.1.18/PL5.1.19/ PL5.1.20/PL5.1.21	9	28.8
BCR Cleaner Roll	Toner Cartridge ASSY	PL5.1.18/PL5.1.19/ PL5.1.20/PL5.1.21	8	25.9
Sleeve (K)	Toner Cartridge ASSY	PL5.1.18	16	25.2
Sleeve (Y,M,C)	Toner Cartridge ASSY	PL5.1.19/PL5.1.20/PL5.1.21	16	22.3
1st BTR	Transfer Belt	PL4.1.1	12	37.7
Roll ESA	Transfer Belt	PL4.1.1	9	28.3
Drive Roll	Transfer Belt	PL4.1.1	18.1	56.9
Fuser Roll	FUSER ASSY	PL6.1.10	26.32	82.7
Fuser Belt	FUSER ASSY	PL6.1.10	30	94.2
Pinch Roll	FUSER ASSY	PL6.1.10	6	18.8
Exit Roll	FUSER ASSY	PL6.1.10	13.75	43.2
Exit Pinch Roll	FUSER ASSY	PL6.1.10	10	31.4

4.2 Items to be Confirmed Before Image Quality Troubleshooting

Print Quality Problems

Customers may need your help determining the cause of print quality issues such as streaking, fading, or dropouts. Here are some questions that may help you determine why your customer's printer is not printing optionally. First, confirm the following items to understand customer's operating condition.

1. Does your customer's print media fall within the Printer Media Guidelines? (Go to 1.5 of this chapter and refer to "**Printer Media Guidelines**").
2. Is there enough toner?
3. Has the printer been cleaned recently?

Checking printer condition

Toner

Low toner can cause print quality problems such as fading, streaking, white lines, or dropouts.

Have your customer print a small document from a different application to replicate the problem and verify the amount of toner available for printing. When your customers print a document, the Laser Printer Status Monitor should display a dialog box that estimates the amount of toner left in the cartridge.

If the toner is low, your customers can something extend the cartridge life by removing the cartridge from the 3110cn, gently shaking it from side-to-side, and replacing it (Rocking the toner cartridge from side-to-side loosens toner that may get stuck).

Cleaning

Paper, toner, and dust particles can accumulate inside the 3110cn printer and cause print quality problems, such as smearing or toner specks. Clean inside the 3110cn to prevent these problems.

Prior checks before troubleshooting

Check the following items if any print quality problems occur before going to each troubleshooting.

Those actions may solve problems easily and simply.

If the any problems below have occurred, check and take actions described in each item.

- 1) Color is out of alignment:
 - a) Clean inside of the printer.
 - b) If you install a new black cartridge and a Print Head cleaning has not been done, this problem will happen. Clean inside of the printer.
- 2) Print is too light:
 - a) The toner may be low. Confirm the amount of the toner and change the toner cartridges if necessary.
 - b) Set the **Draft Mode** check box to off in the Advanced in the printer driver.
 - c) If you are printing on an uneven print surface, change the Paper Type settings in the Tray Settings menu.
 - d) Verify that the correct print media is being used.
 - e) The drum cartridge may need to be replaced. Change the drum cartridge.
- 3) Toner smears or print comes off page:
 - a) If you are printing on an uneven print surface, change the Paper Type settings in the Tray Settings menu.
 - b) Verify that the print media is within the printer specifications. (Go to 1.5 of this chapter and refer to "**Printer Media Guidelines**").

- 4) Toner spots appear on the page/printing is blurred:
 - a) Check the toner cartridge to make sure it is installed correctly.
 - b) Change the toner cartridge.
- 5) Entire page is white:
 - a) Make sure the packaging material is removed from the toner cartridge.
 - b) Check the toner cartridge to make sure it is installed correctly.
 - c) The toner may be low. Change the toner cartridge.
- 6) Streaks appear on the page:
 - a) The toner may be low. Change the toner cartridge.
 - b) If you are using preprinted forms, make sure the toner can withstand temperatures of 0°C to 35°C.
- 7) Characters have jagged or uneven edges:
 - a) Change the **Print Mode** in the **Graphics** tab (or **Advanced** dialog box) to **Standard** in the printer driver.
 - b) If you are using downloaded fonts, verify that the fonts are supported by the printer, the host computer, and the software program.
- 8) Part or all of the page prints in black:
 - a) Check the toner cartridge to make sure it is installed correctly.
- 9) The job prints, but the top and side margins are incorrect:
 - a) Make sure the Paper Size setting in the Tray Settings is correct.
 - b) Make sure the margins are set correctly in your software program.
- 10) Printing on both ends of the transparencies is faded:
 - a) This occurs when the printer is operating in a location where relative humidity reaches 85% or more. Adjust the humidity or relocate the printer to an appropriate environment.

4.3 Print Image Quality Specification

Image Quality Guarantee Conditions

The image quality is specified and guaranteed under the following conditions.

1) Environmental Condition

Temperature: 10°C - 32°C

Humidity: 15% RH - 85% RH (85% RH at 28°C)

Note that defect may occur due to condensation after around 30 minutes if the printer is turned on in an critical environment such as 85% at 10°C.

2) Guaranteed Paper

The print image quality specified in this chapter should be guaranteed when the standard paper is fed from the paper tray. The print image quality is evaluated on the maximum size of each standard paper.

Color print quality: X-Pression paper

Black and White quality: 4200 paper

3) Paper condition

The paper used is fresh paper immediately after unpacked, which has been left in the operating environment for 12 hours before unpacking.

4) Printer condition

The print image quality specified in this chapter is guaranteed with the printer in normal condition.

6) Criterion for judgment

The print image quality is guaranteed with Spec. In rate = 95% ($\gamma = 90\%$).

5) For **Color chart**, **Parallelism**, **Perpendicularity**, **Skew**, **Linearity**, **Magnification Error**, **Registration** and **Printed Guaranteed Area**, refer to each chart below.

Chart

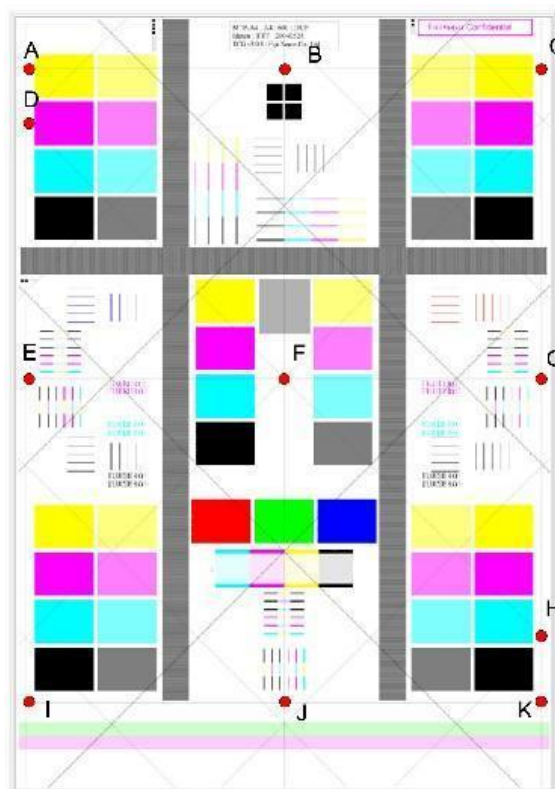

Parallelism

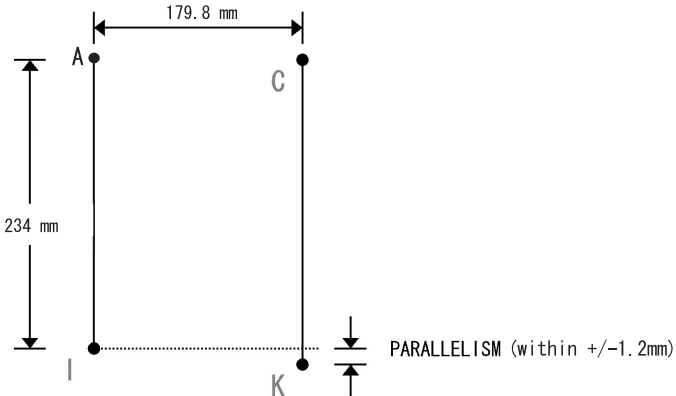

Perpendicularity

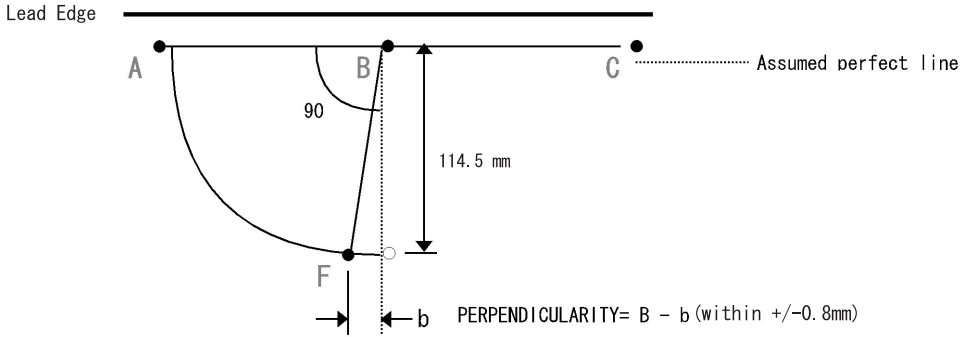

Skew

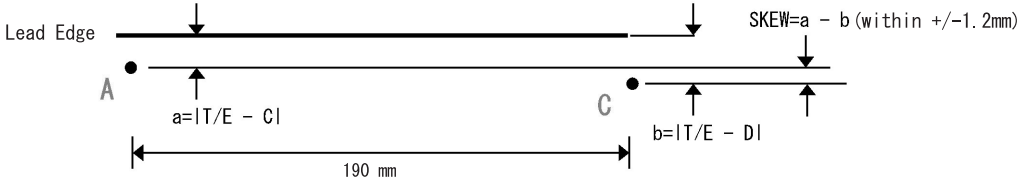

Linearity

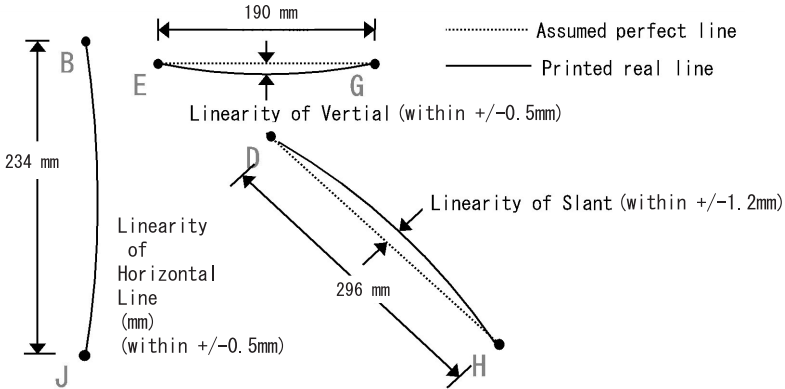

Magnification Error

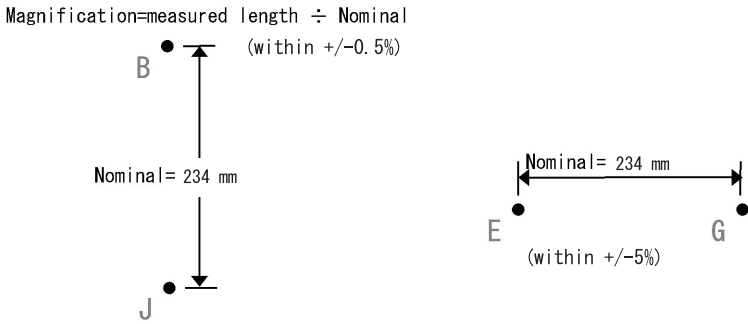

Registration

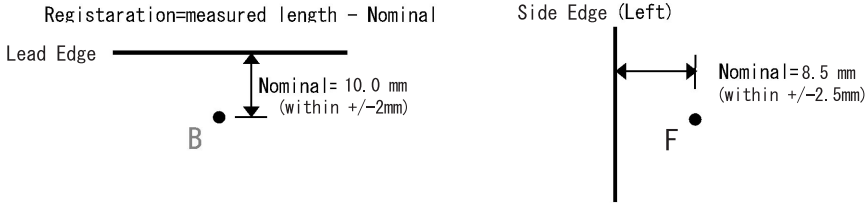

Printed Guaranteed Area

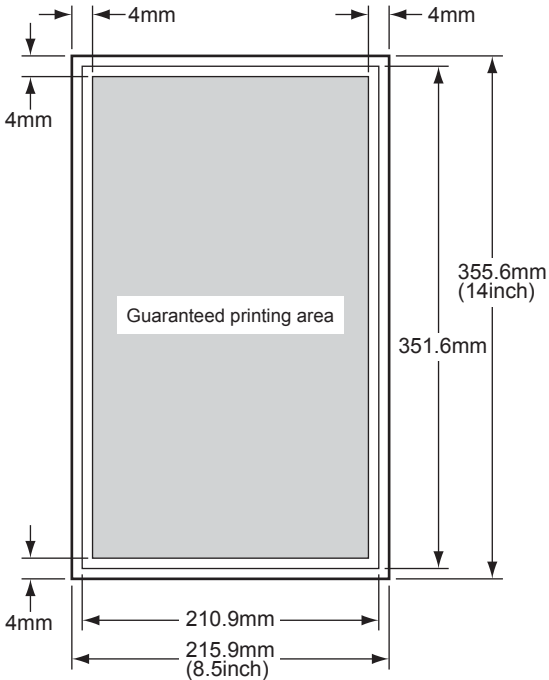

Kmy01001KA

4.4 Image Quality FIP

FIP-1.P1 Faint print (Low contrast)

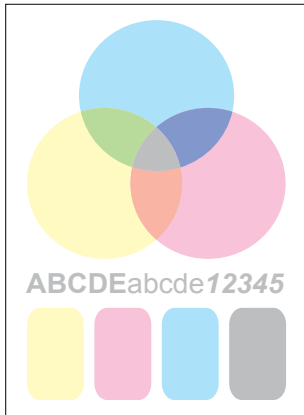
**Trouble substance**

The density of the image is entirely too faint.

Possible causative parts

- TRANSFER ASSY (PL4.1.1)
- DISPENSER ASSY (PL5.1.12)
- CARTRIDGE ASSY (PL5.1.18(K)/PL5.1.19 (C)/PL5.1.20 (M)/PL5.1.21 (Y))
- PWBA MCU (PL9.1.20)

Before commencing troubleshooting, check the paper transfer path. Make sure there is no foreign materials on the transfer path, such as staples, paper clips, scraps of paper and so on.

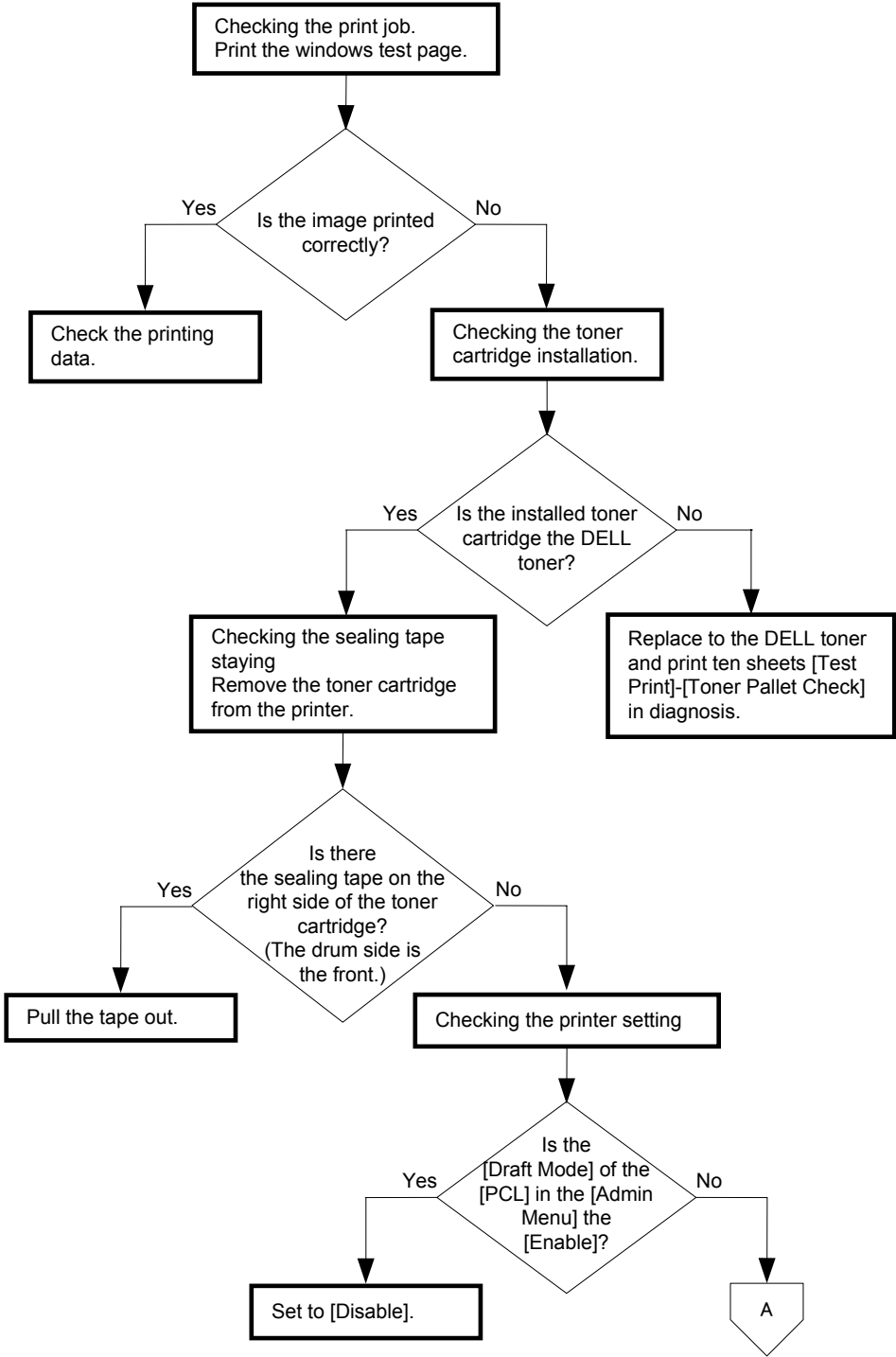

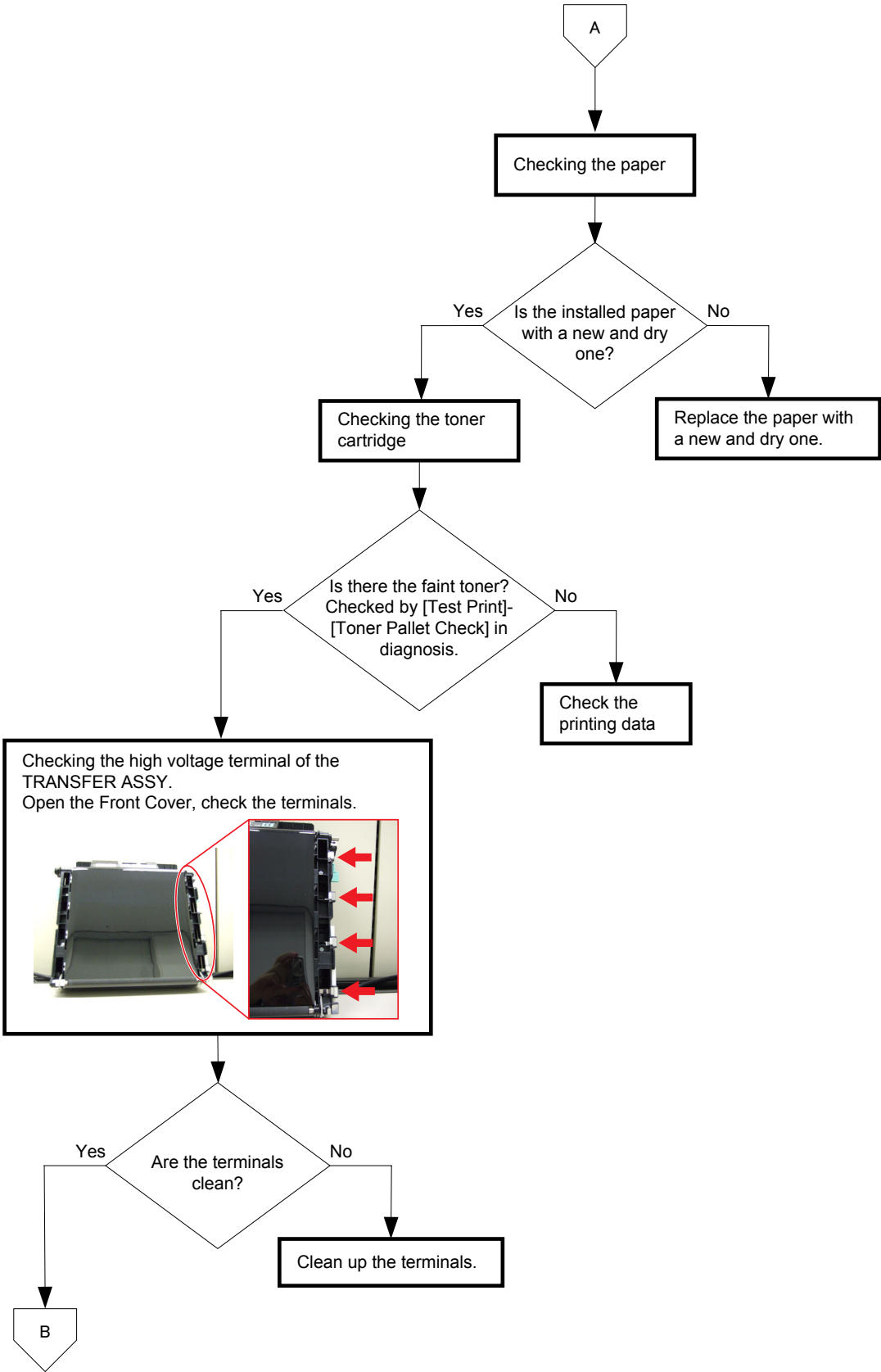

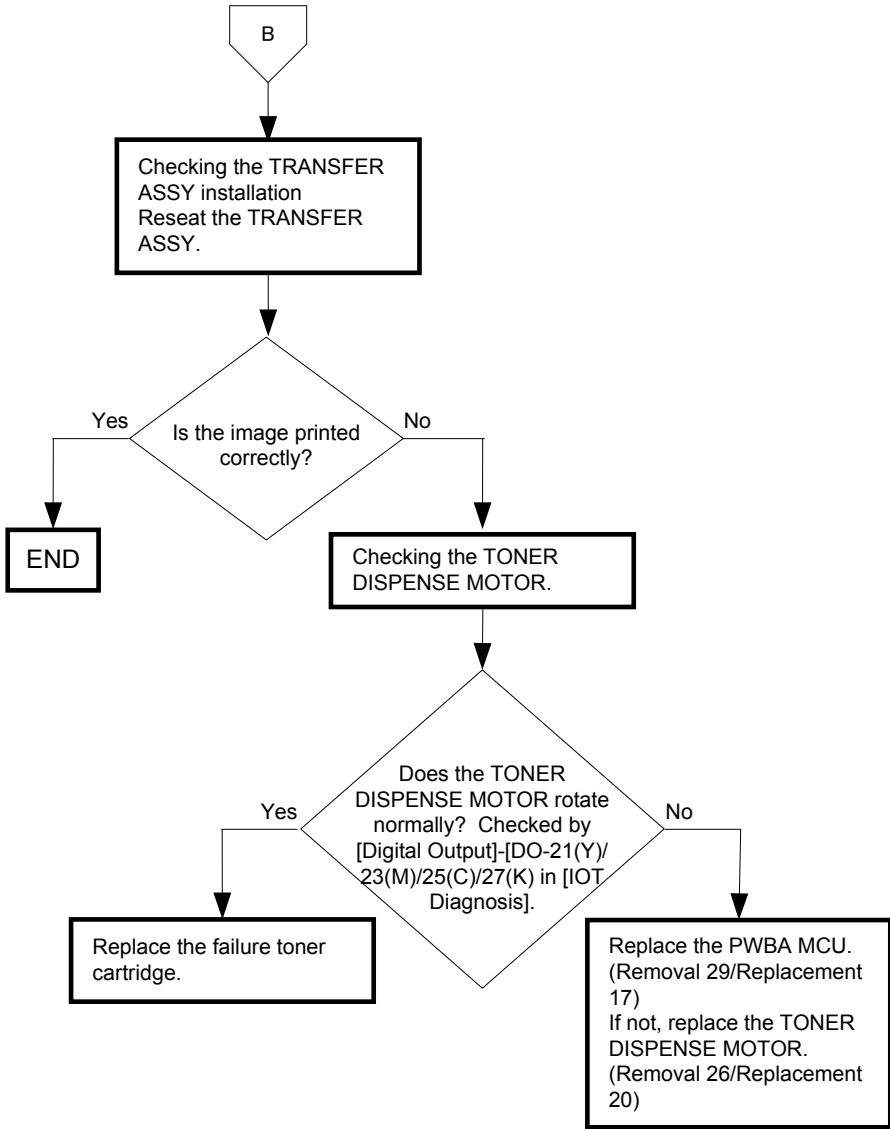

FIP-1.P2 Blank print (No print)

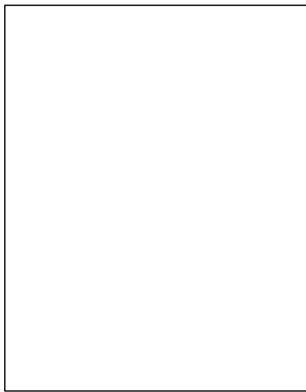

Leg_Sec001_003FA

Trouble substance

The entire paper is printed pure white.

Possible causative parts

- TRANSFER ASSY (PL4.1.1)
- DISPENSER ASSY (PL5.1.12)
- HVPS (PL5.1.17)
- CARTRIDGE ASSY (PL5.1.18(K)/PL5.1.19 (C)/PL5.1.20 (M)/PL5.1.21 (Y))
- KIT ROS ASSY (PL5.1.99)
- PWBA MCU (PL9.1.20)
- PWBA ESS (PL9.1.27)

Before commencing troubleshooting, check the paper transfer path. Make sure there is no foreign materials on the transfer path, such as staples, paper clips, scraps of paper and so on.

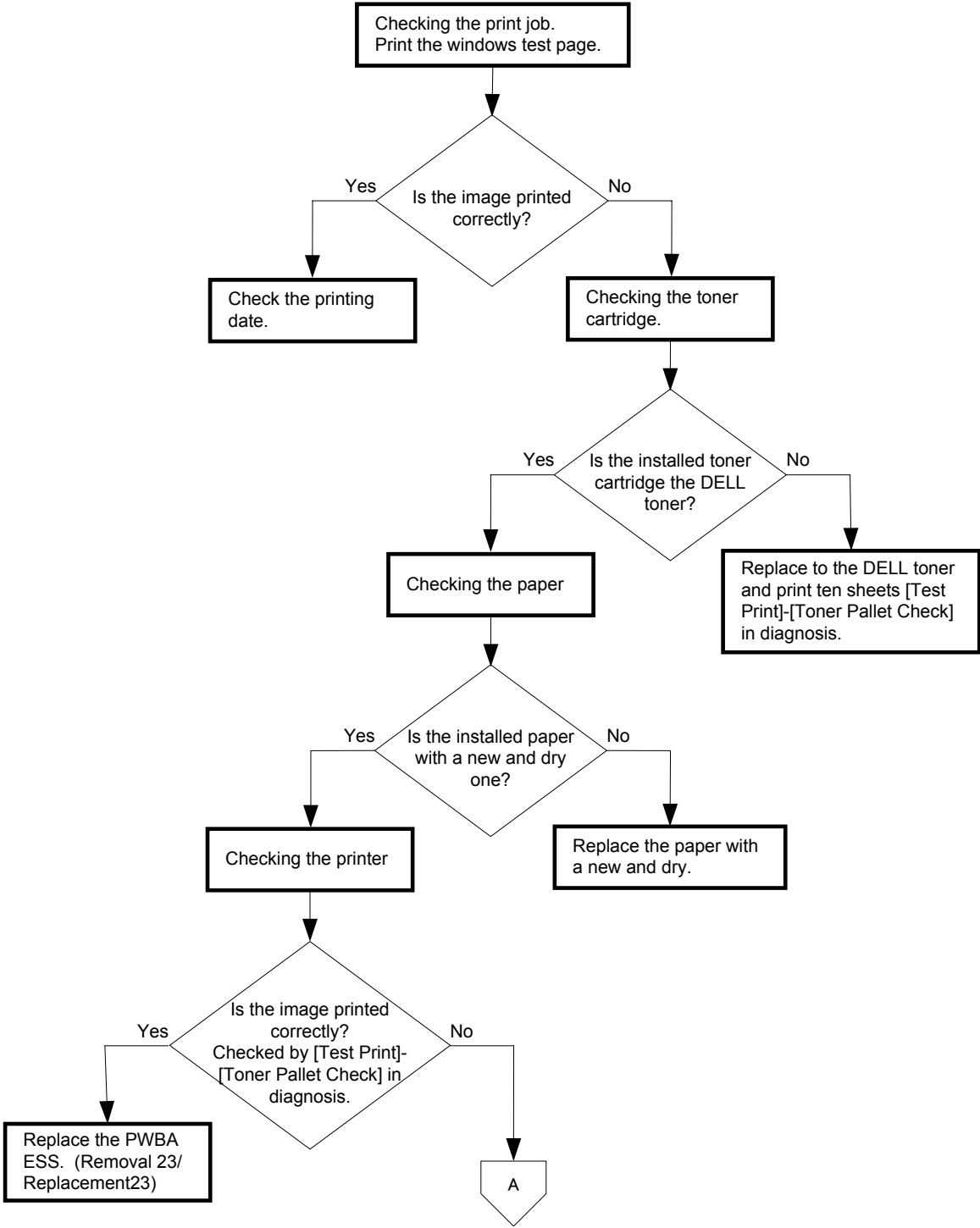

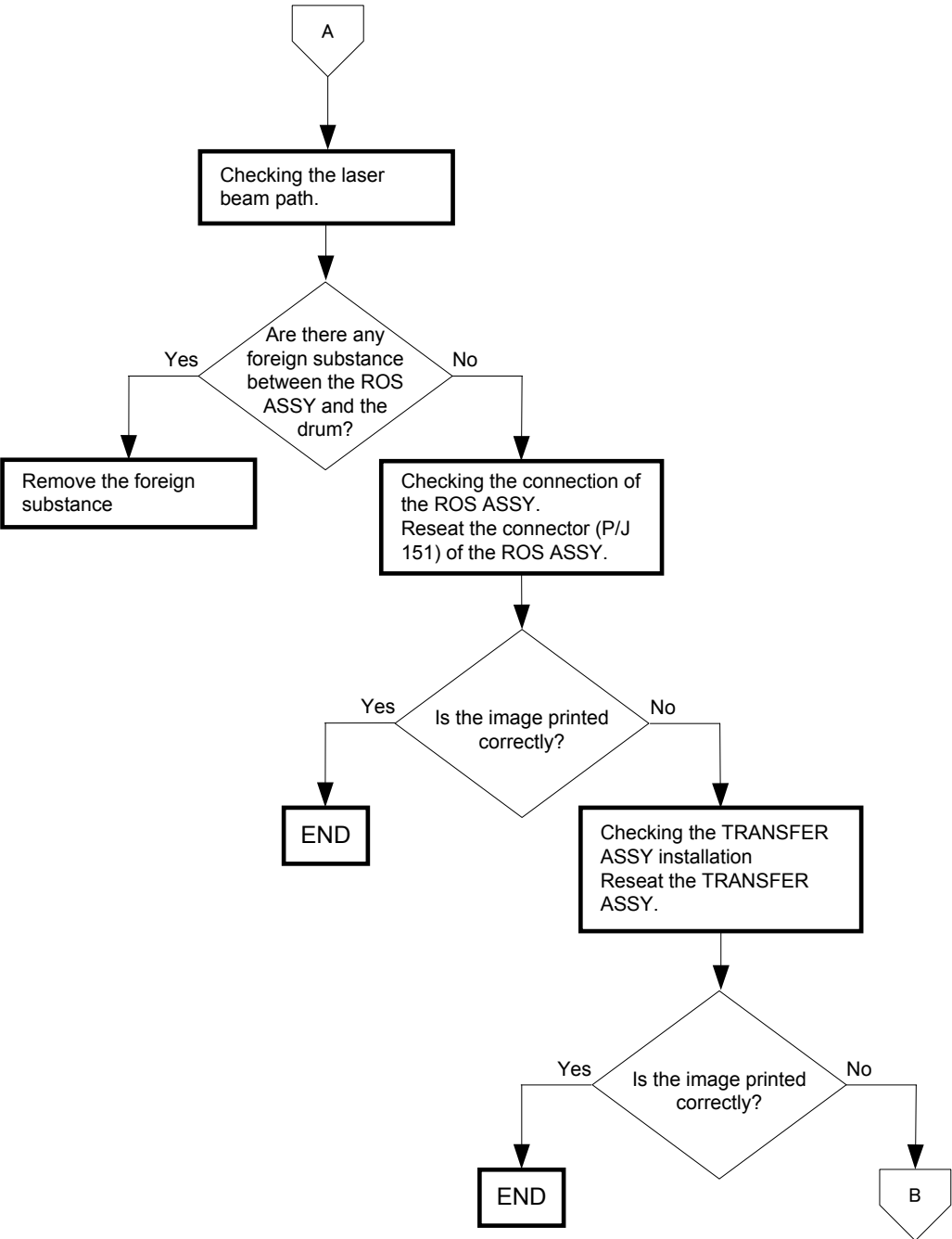

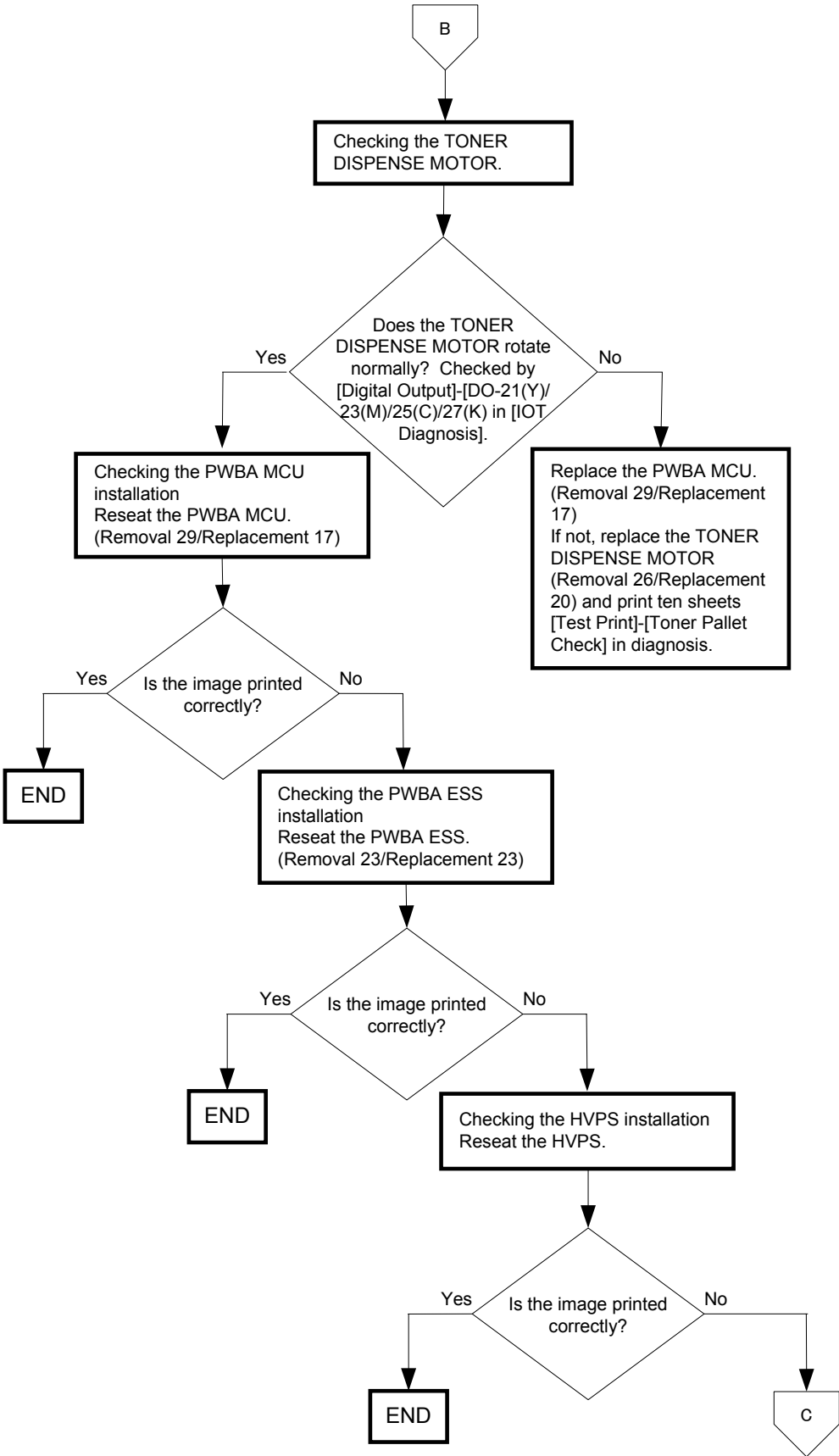

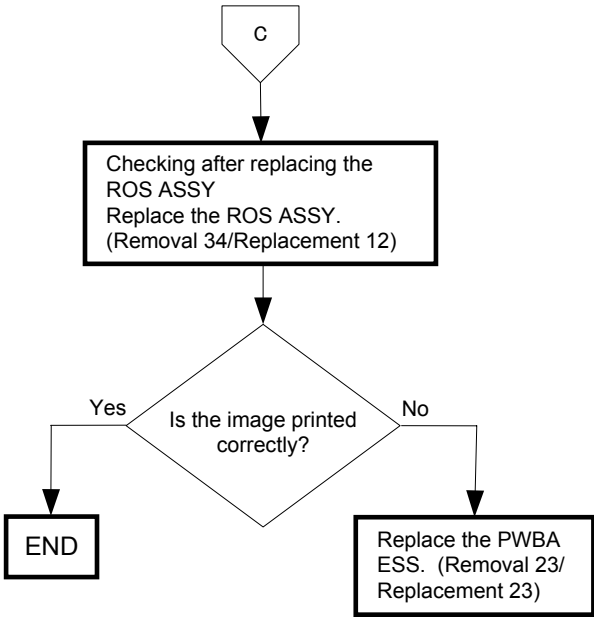

FIP-1.P3 Solid black

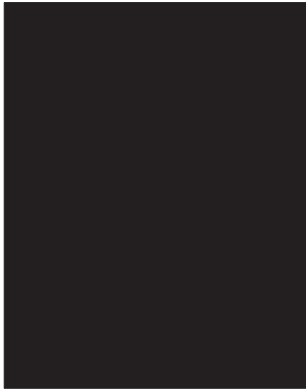

Leg_Sec001_004FA

Trouble substance

The entire paper is printed jet-black.

Possible causative parts

- HVPS (PL5.1.17)
- CARTRIDGE ASSY (PL5.1.18(K)/PL5.1.19(C)/PL5.1.20 (M)/PL5.1.21 (Y))
- KIT ROS ASSY (PL5.1.99)
- PWBA MCU (PL9.1.20)
- PWBA ESS (PL9.1.27)

Before commencing troubleshooting, check the paper transfer path. Make sure there is no foreign materials on the transfer path, such as staples, paper clips, scraps of paper and so on.

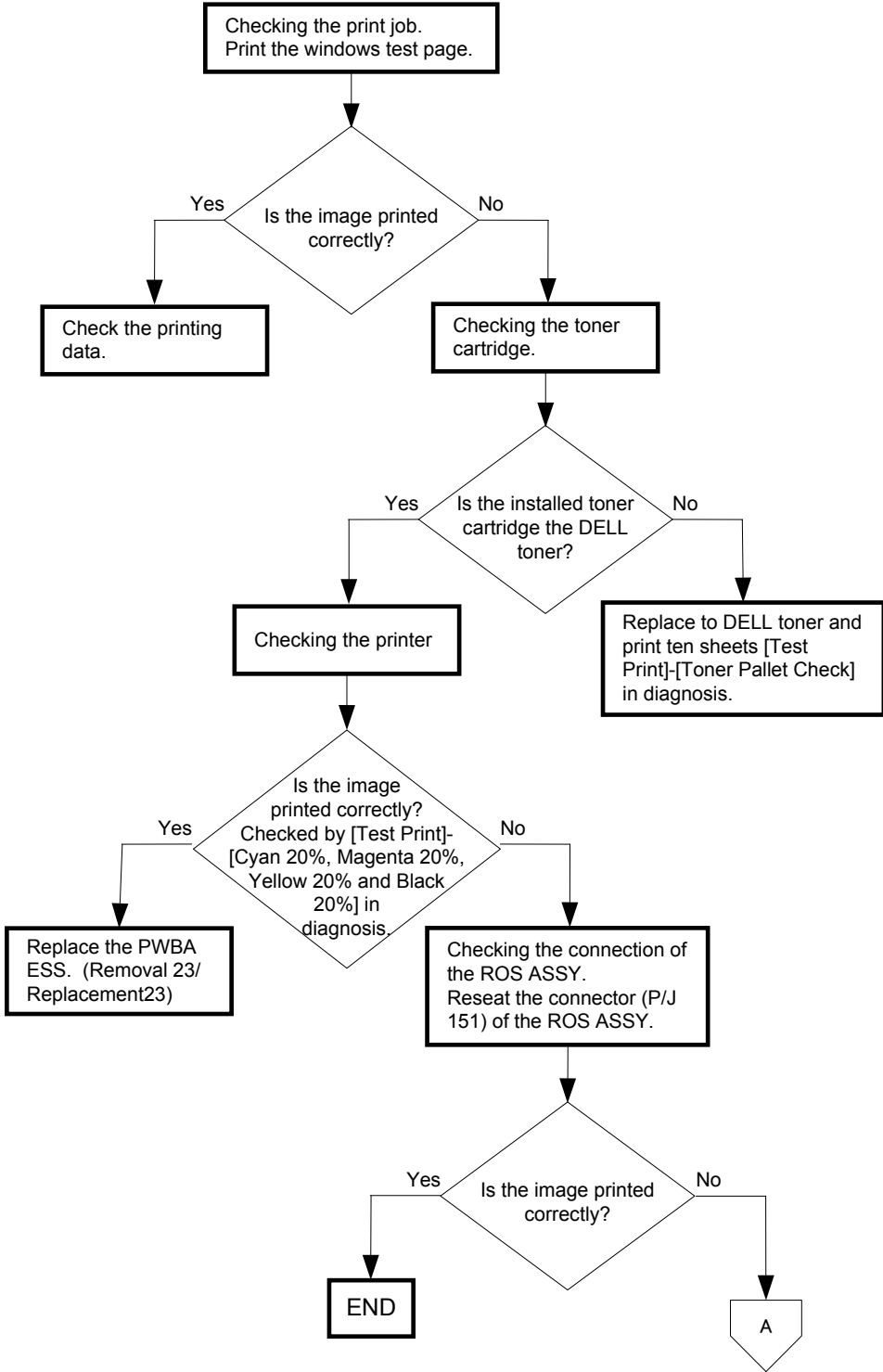

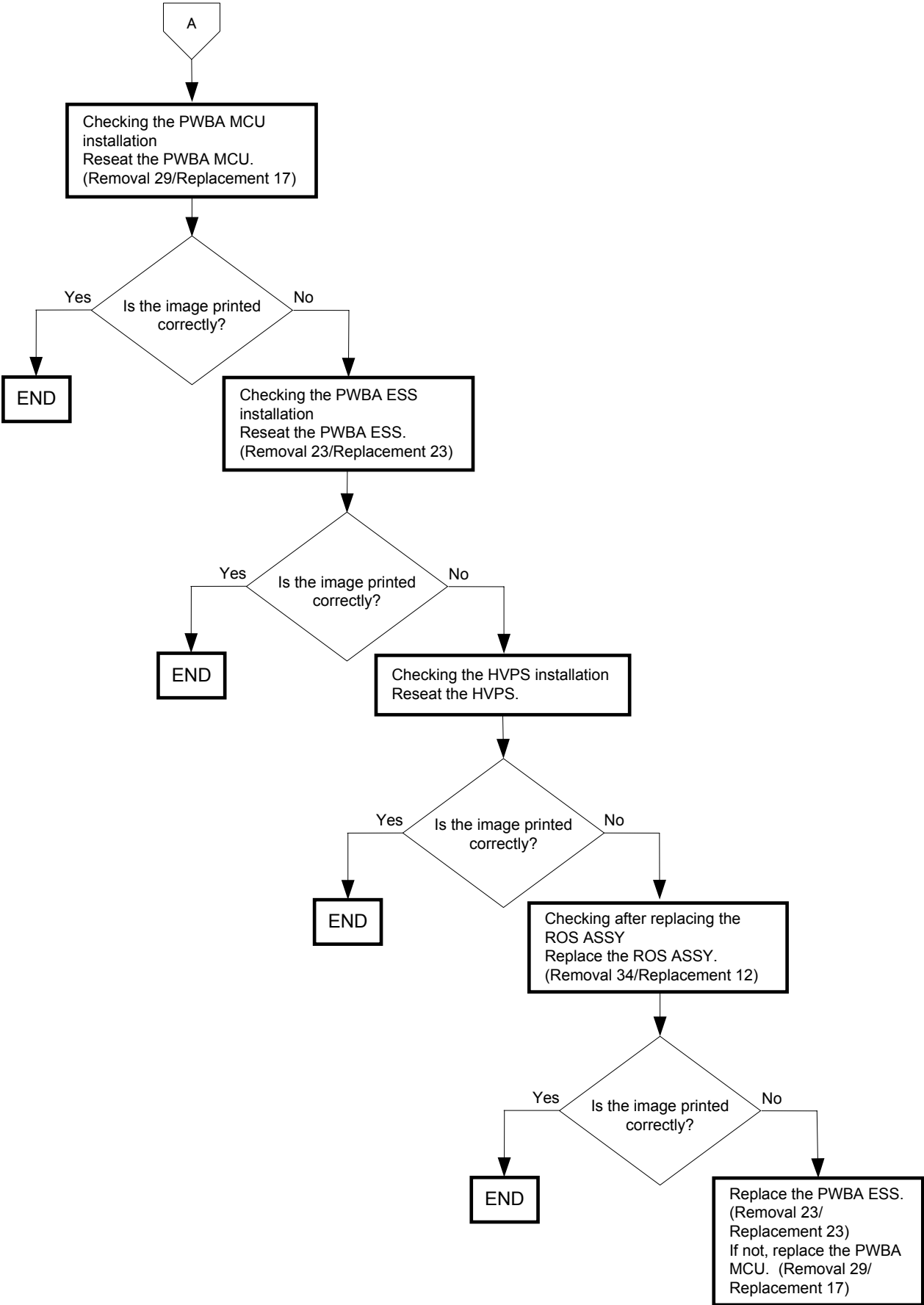

FIP-1.P4 Vertical blank lines (White stripes in paper transport direction)

**Trouble substance**

There are some extremely faint or completely non-printed parts. Those non-printed parts cover a wide area vertically, along the paper feeding direction.

Possible causative parts

- TRANSFER ASSY (PL4.1.1)
- CARTRIDGE ASSY (PL5.1.18(K)/PL5.1.19(C)/PL5.1.20 (M)/PL5.1.21 (Y))
- KIT ROS ASSY (PL5.1.99)
- FUSER ASSY (PL6.1.10)

Before commencing troubleshooting, check the paper transfer path. Make sure there is no foreign materials on the transfer path, such as staples, paper clips, scraps of paper and so on.

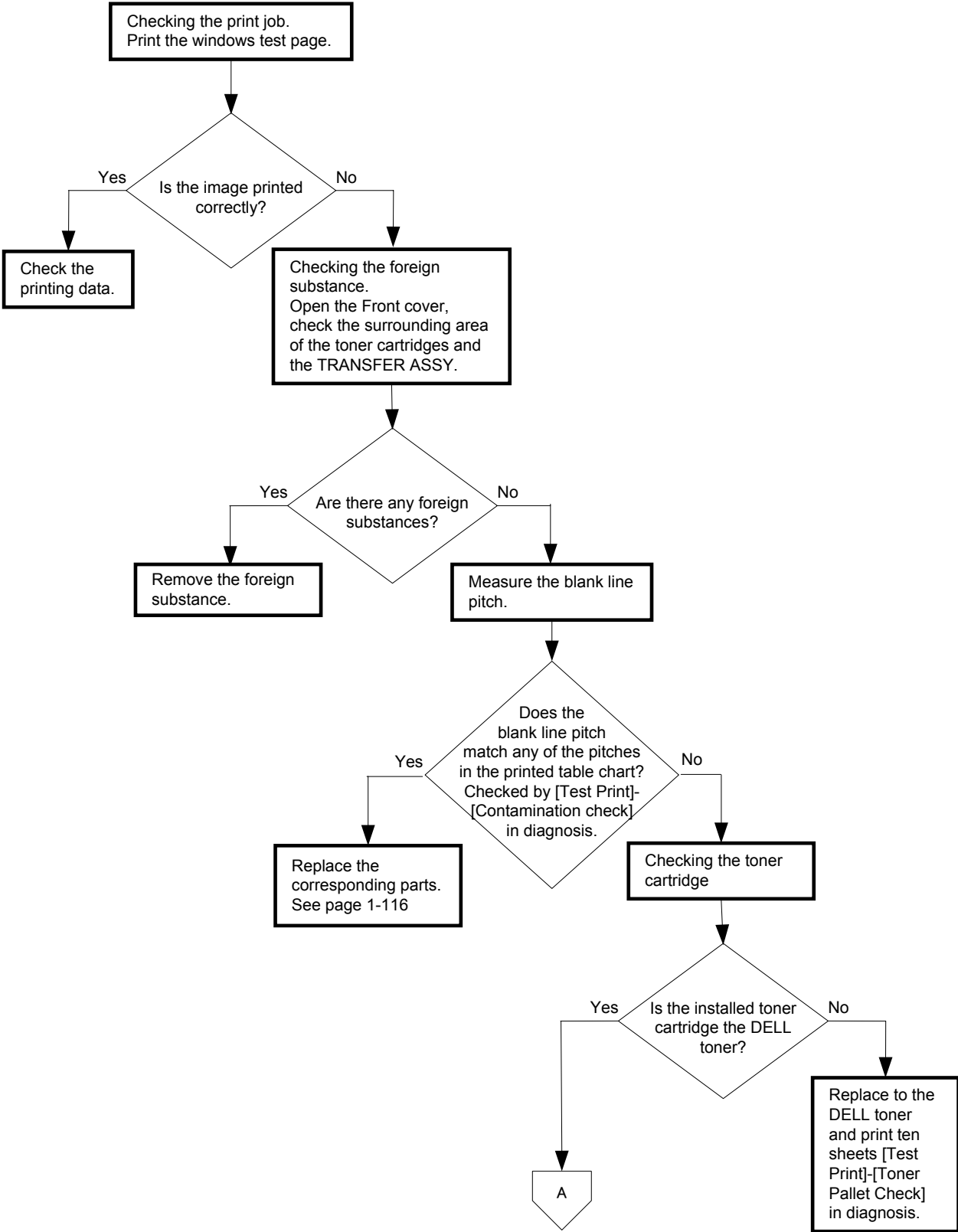

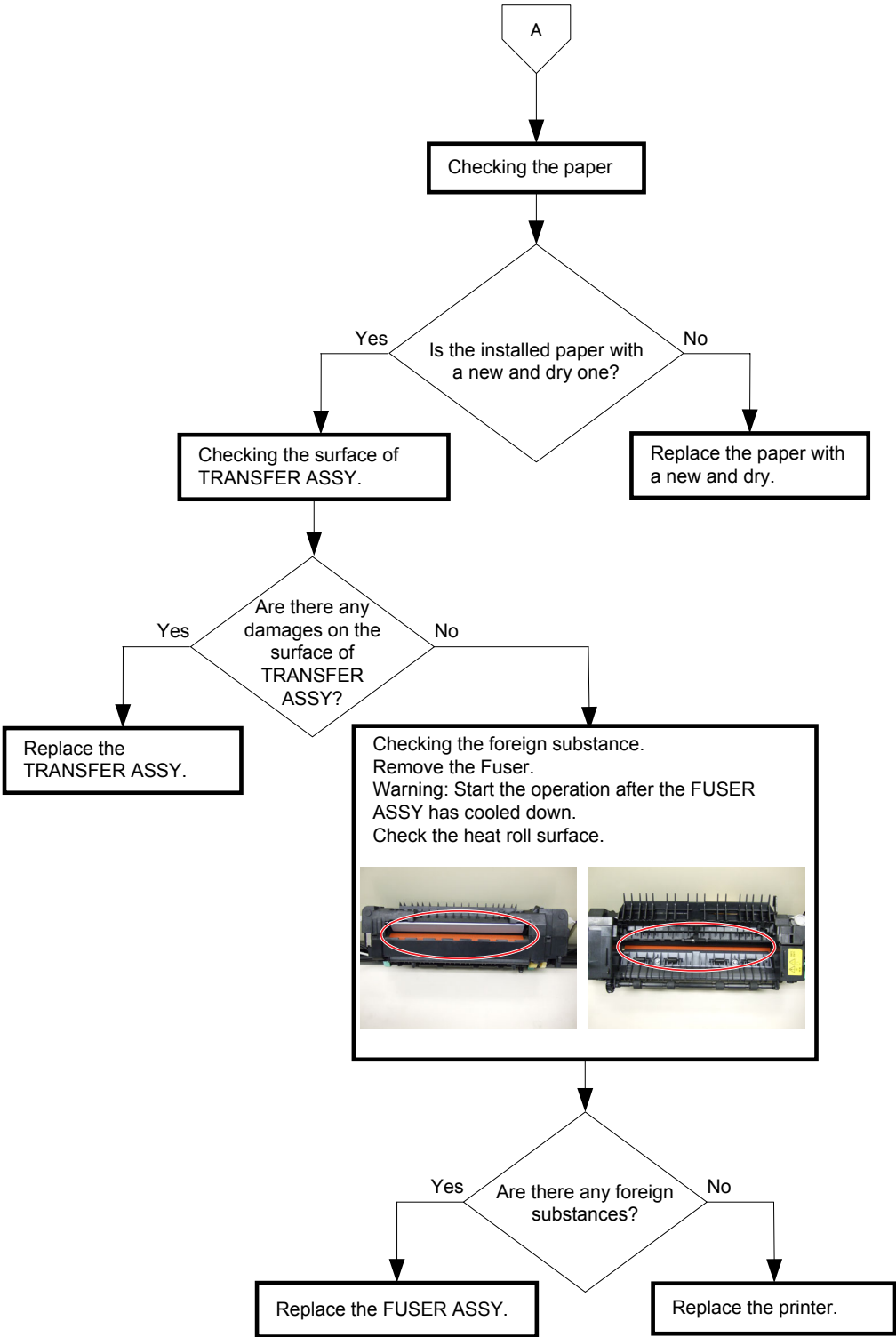

FIP-1.P5 Horizontal band cross out (White stripes in the horizontal direction)

**Trouble substance**

There are some extremely faint or completely non-printed parts. Those non-printed parts cover a wide area horizontally, perpendicular to the paper feeding direction.

Possible causative parts

- TRANSFER ASSY (PL4.1.1)
- CARTRIDGE ASSY (PL5.1.18(K)/PL5.1.19(C)/PL5.1.20 (M)/PL5.1.21 (Y))
- FUSER ASSY (PL6.1.10)

Before commencing troubleshooting, check the paper transfer path. Make sure there is no foreign materials on the transfer path, such as staples, paper clips, scraps of paper and so on.

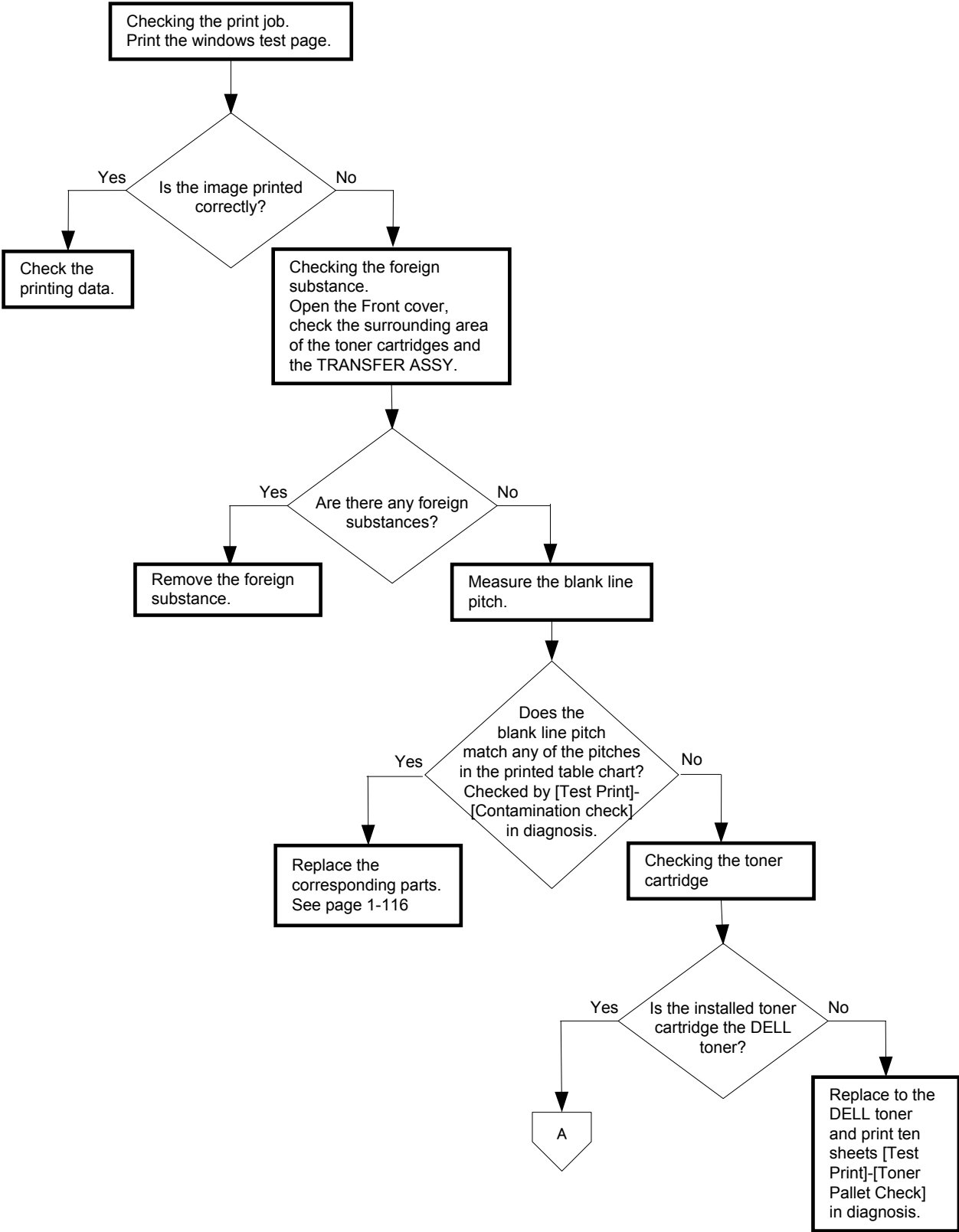

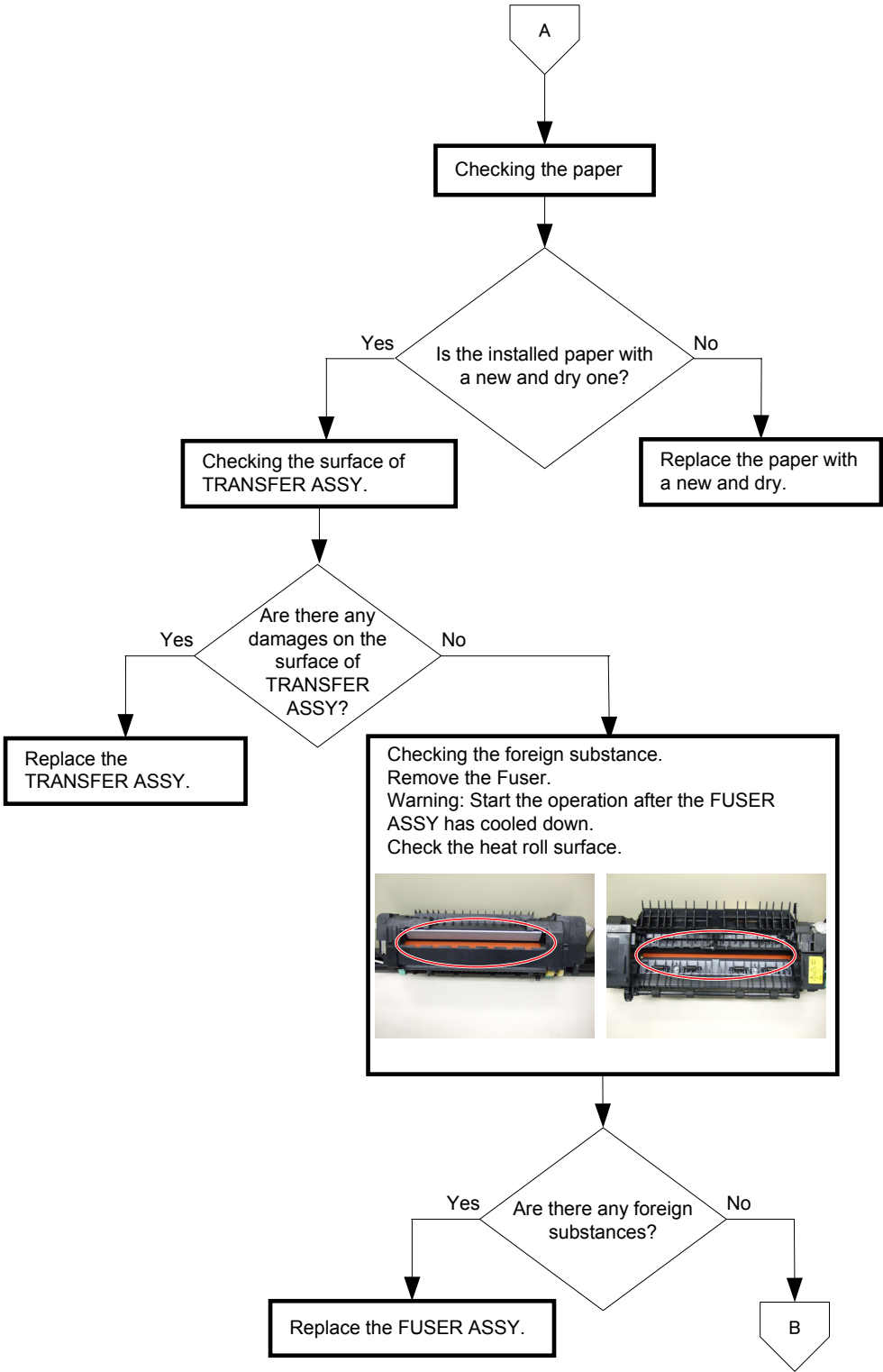

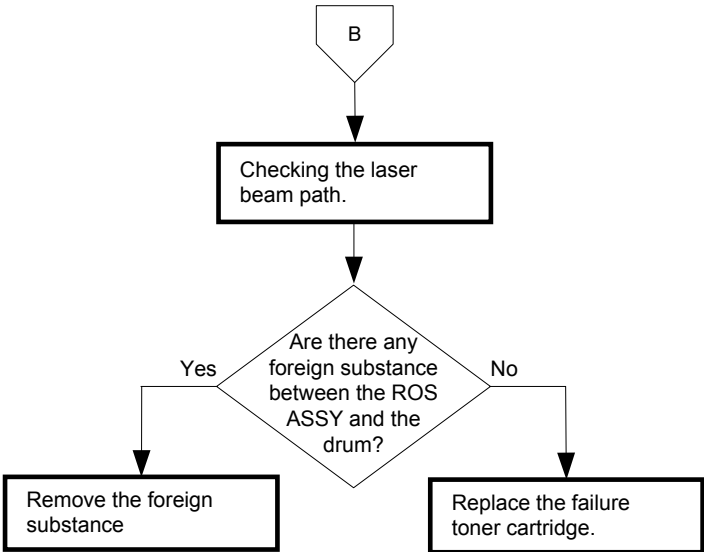

FIP-1.P6 Vertical stripes

**Trouble substance**

There are vertical black stripes along the paper.

Possible causative parts

- TRANSFER ASSY (PL4.1.1)
- CARTRIDGE ASSY (PL5.1.18(K)/PL5.1.19(C)/PL5.1.20 (M)/PL5.1.21 (Y))
- FUSER ASSY (PL6.1.10)

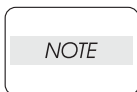

If the stripes at the top or back of the paper, replace the IBT ASSY only.

Before commencing troubleshooting, check the paper transfer path. Make sure there is no foreign materials on the transfer path, such as staples, paper clips, scraps of paper and so on.

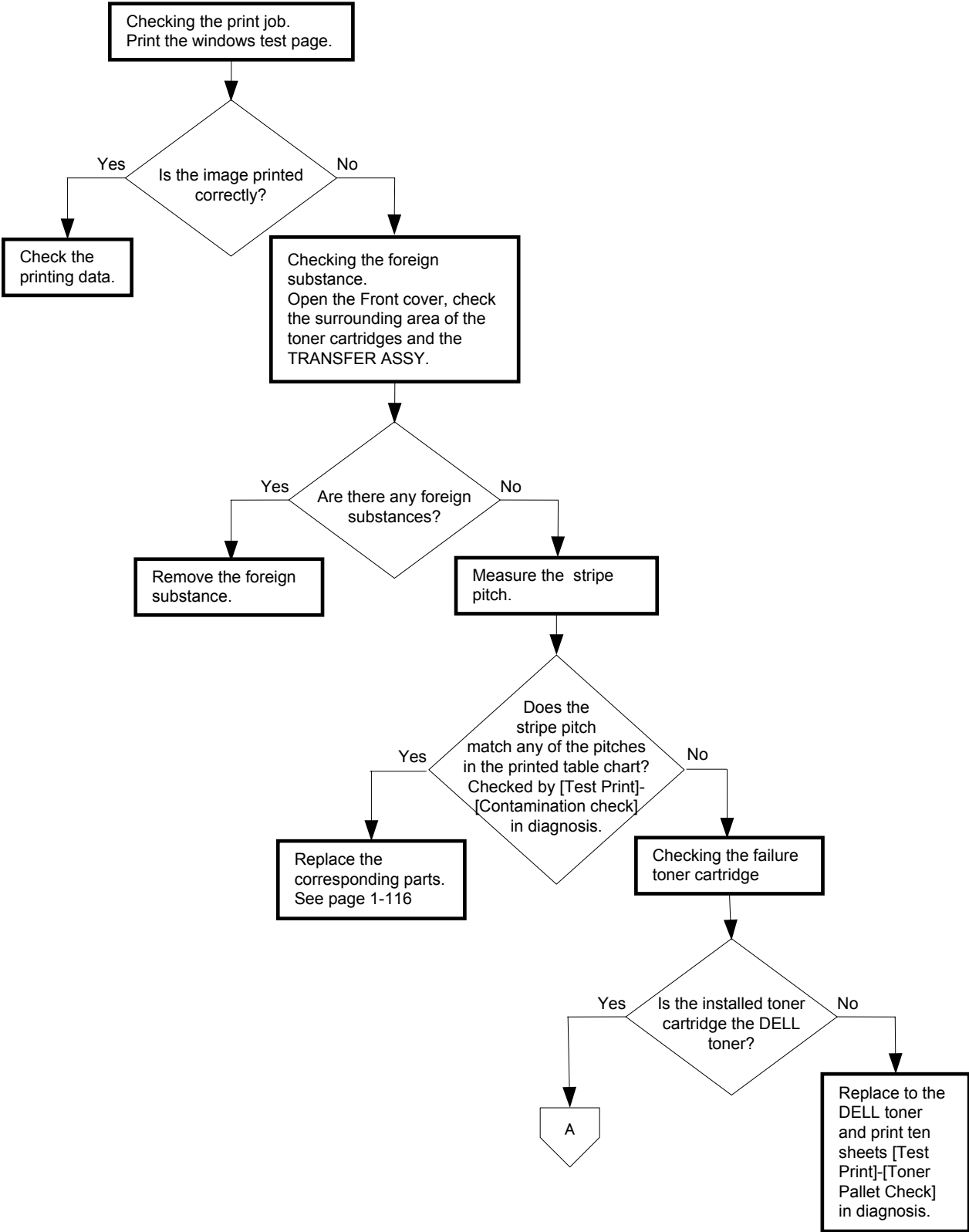

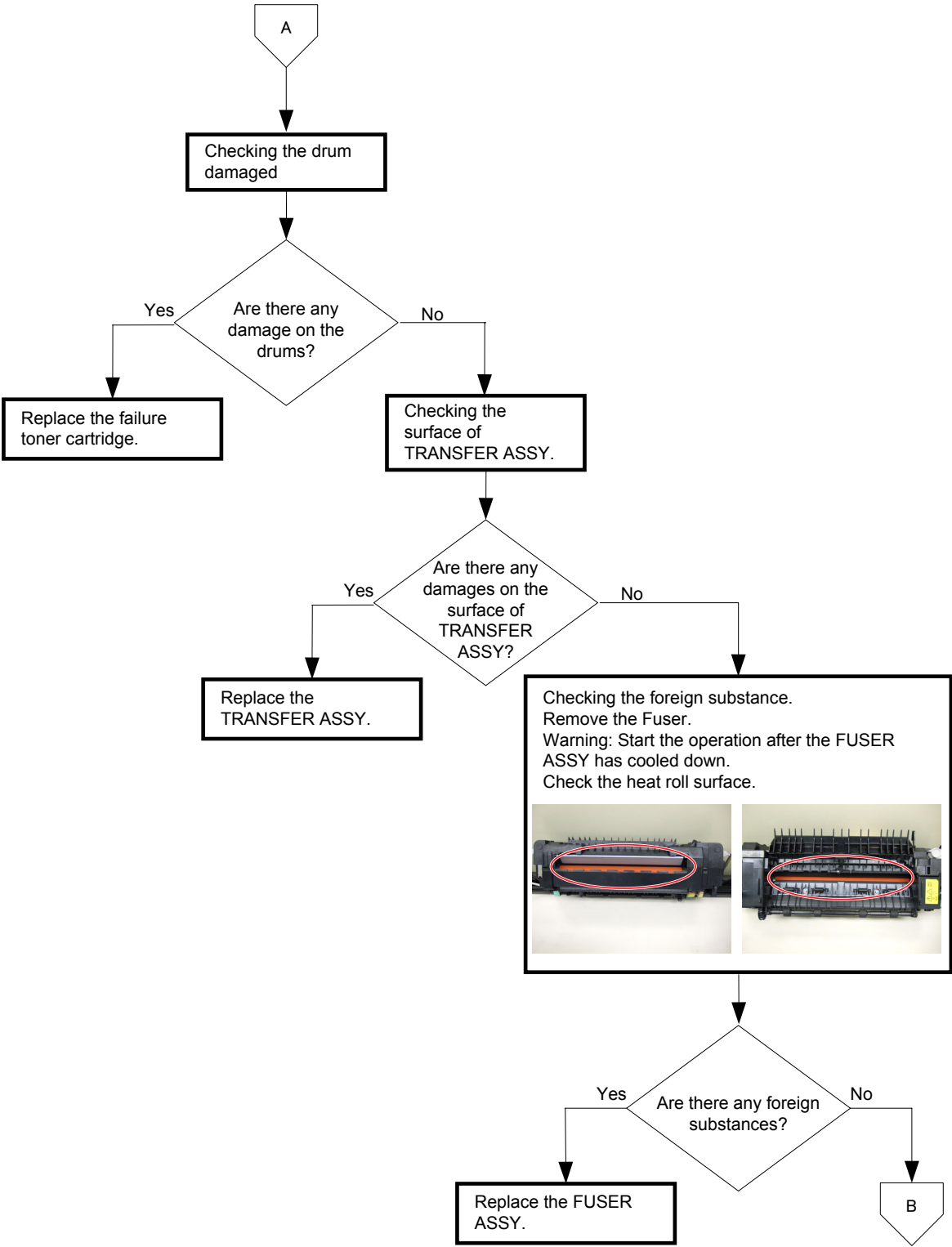

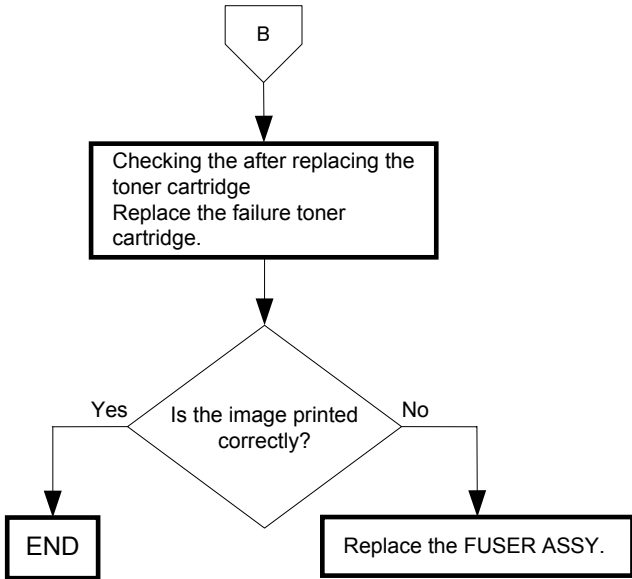

FIP-1.P7 Horizontal stripes

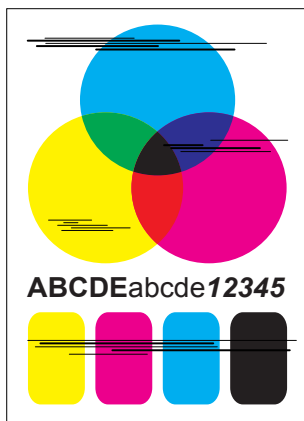
**Trouble substance**

There are horizontal black stripes (perpendicular to the paper path direction) along the paper.

Possible causative parts

- TRANSFER ASSY (PL4.1.1)
- CARTRIDGE ASSY (PL5.1.18(K)/PL5.1.19(C)/PL5.1.20 (M)/PL5.1.21 (Y))
- FUSER ASSY (PL6.1.10)

Before commencing troubleshooting, check the paper transfer path. Make sure there is no foreign materials on the transfer path, such as staples, paper clips, scraps of paper and so on.

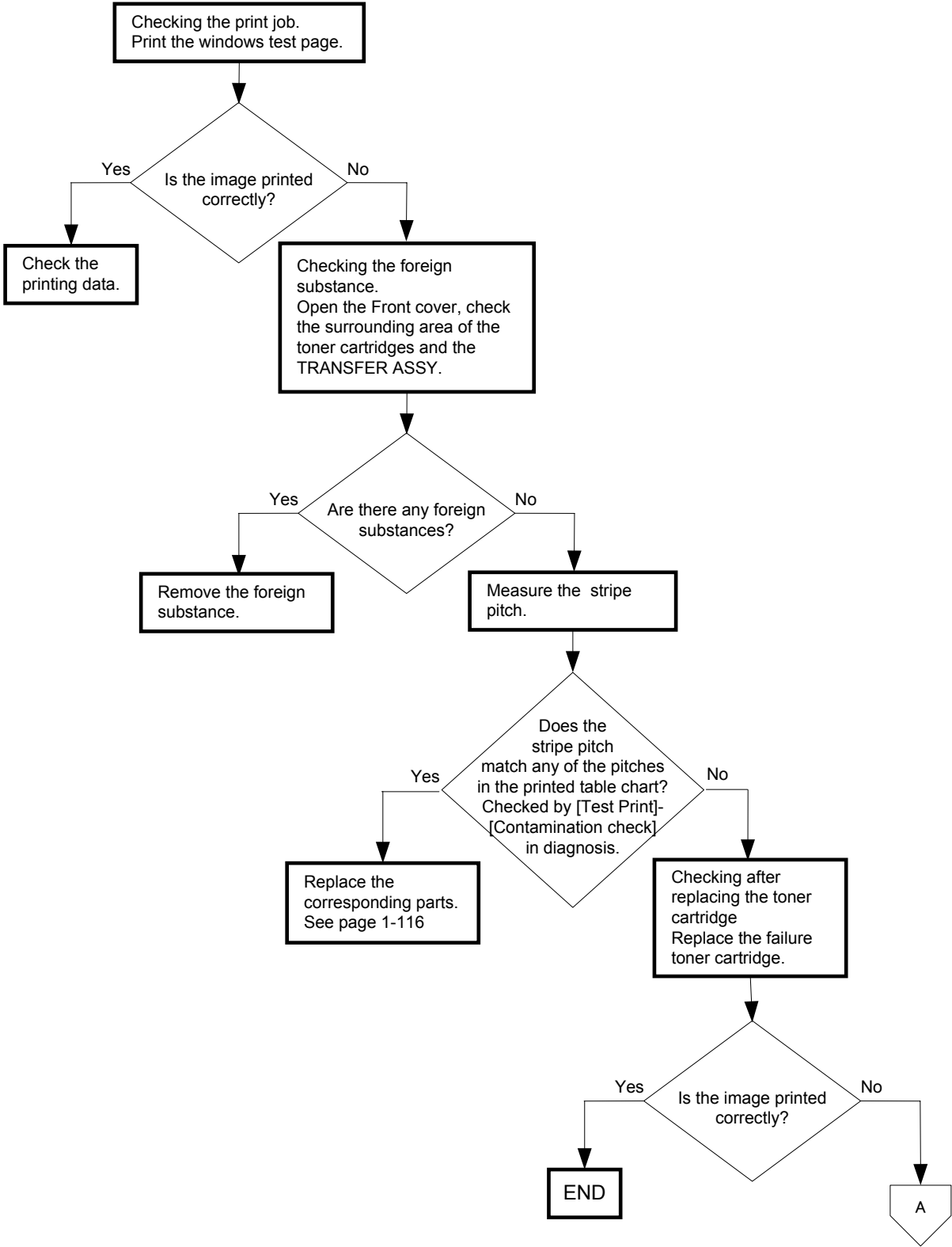

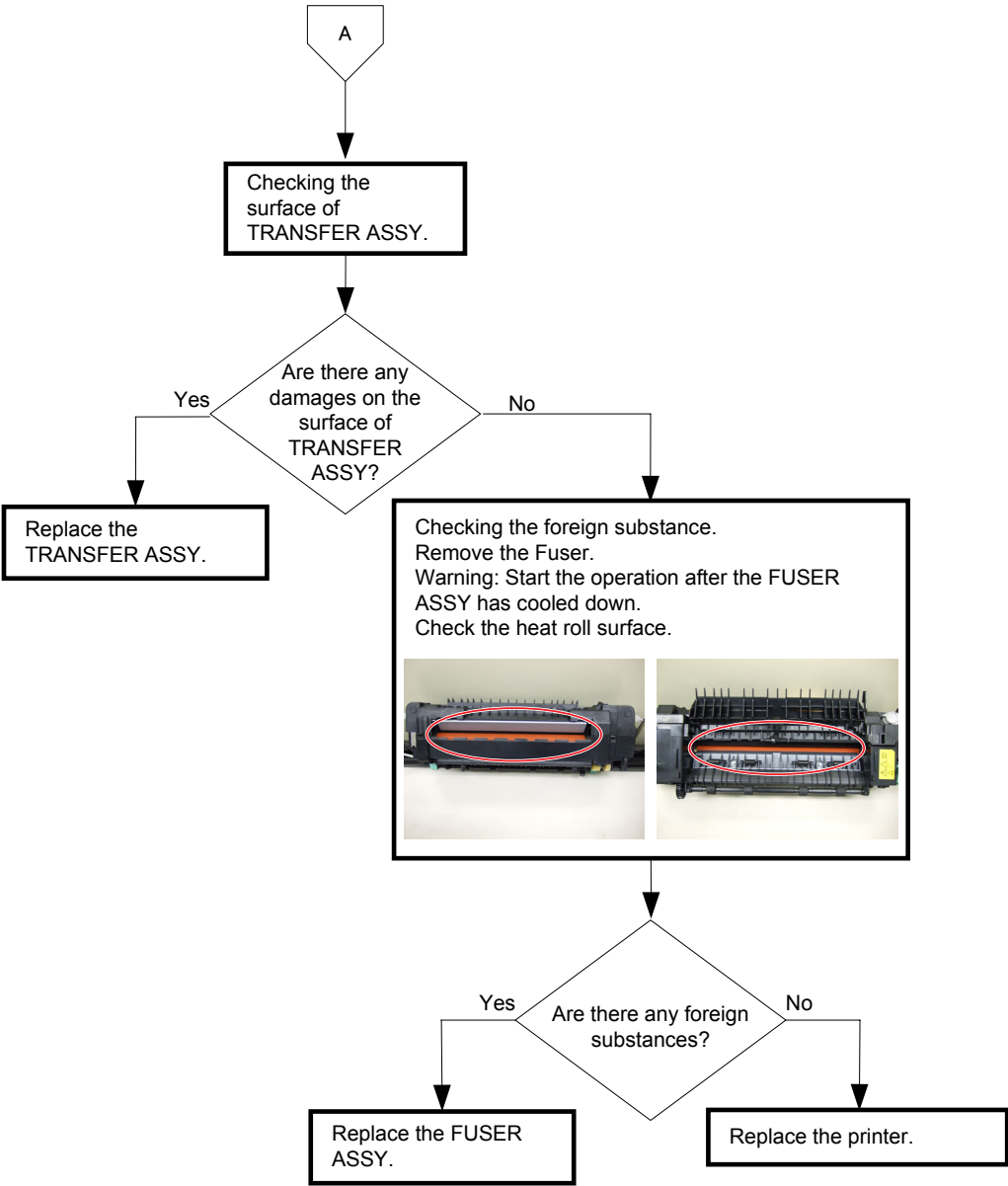

FIP-1.P8 Partial lack

**Trouble substance**

There are some extremely faint or completely missing parts in a limited area on the paper.

Possible causative parts

- TRANSFER ASSY (PL4.1.1)
- CARTRIDGE ASSY (PL5.1.18(K)/PL5.1.19(C)/PL5.1.20 (M)/PL5.1.21 (Y))

Before commencing troubleshooting, check the paper transfer path. Make sure there is no foreign materials on the transfer path, such as staples, paper clips, scraps of paper and so on.

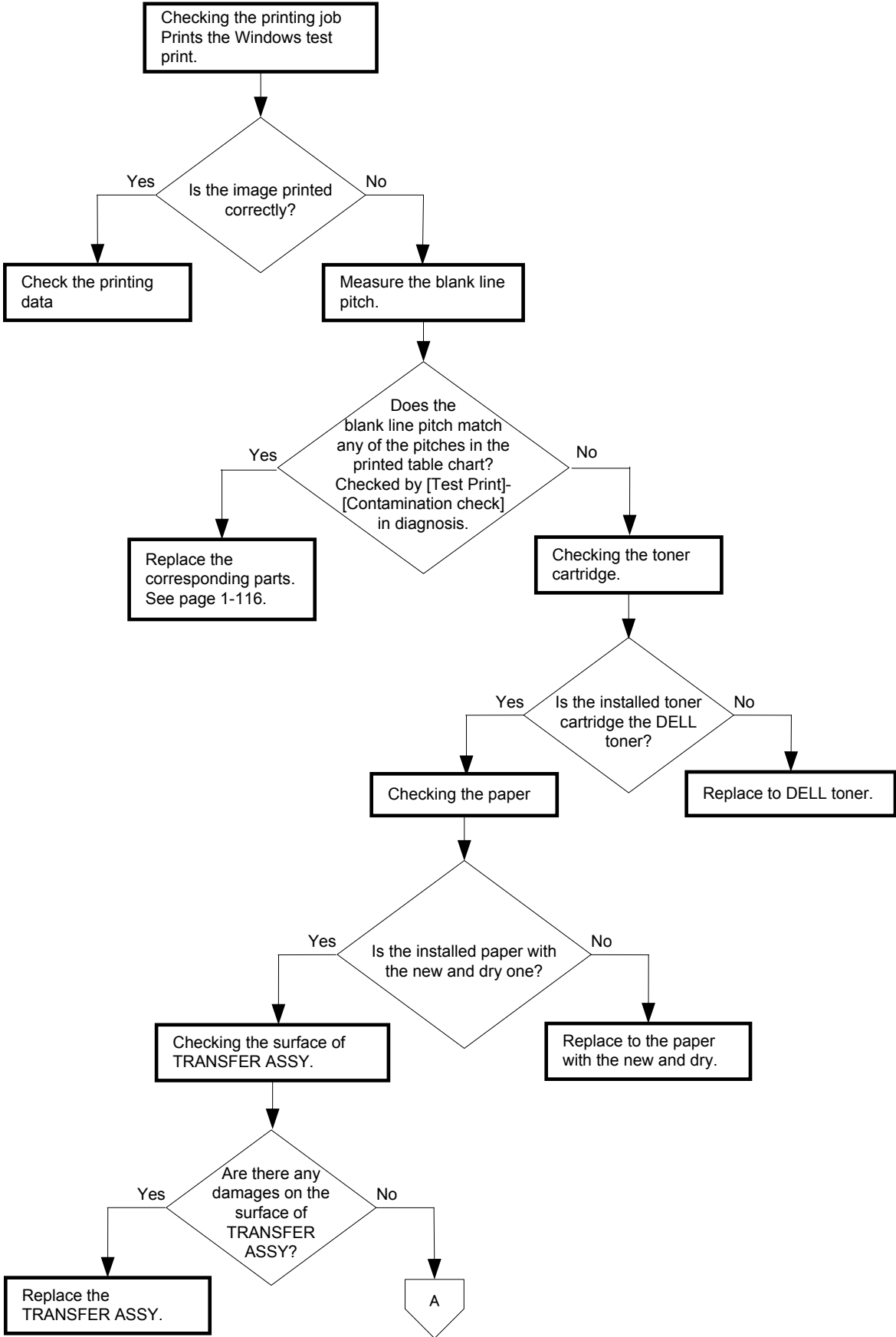

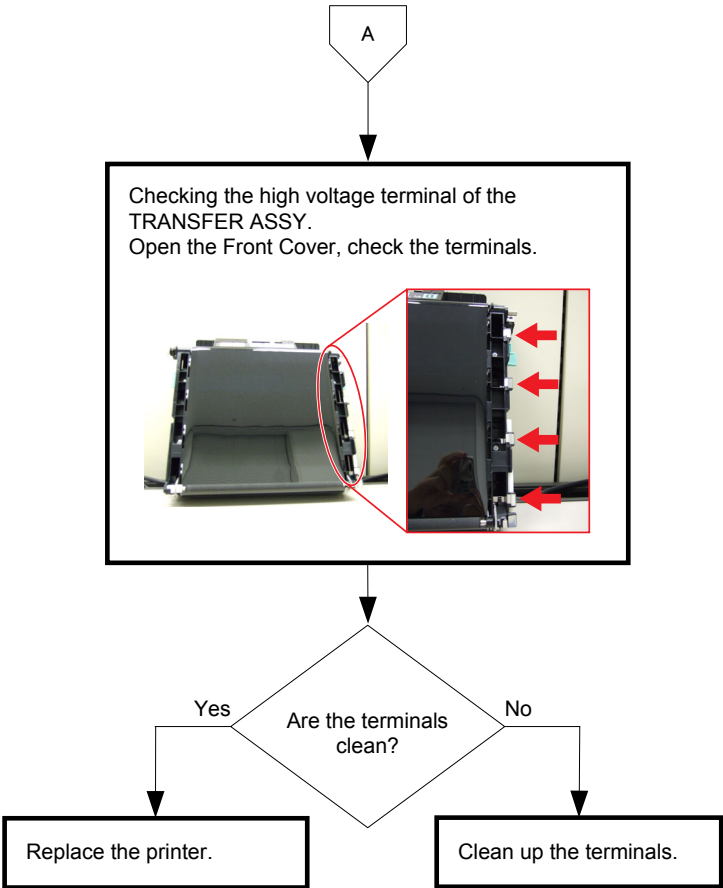

FIP-1.P9 Spots

**Trouble substance**

There are toner spots all over the paper disorderedly.

Possible causative parts

- TRANSFER ASSY (PL4.1.1)
- CARTRIDGE ASSY (PL5.1.18(K)/PL5.1.19(C)/PL5.1.20 (M)/PL5.1.21 (Y))
- FUSER ASSY (PL61.1.10)

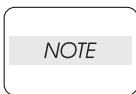

If the toner spot at the top or back of the paper, replace the IBT ASSY only.

Before commencing troubleshooting, check the paper transfer path. Make sure there is no foreign materials on the transfer path, such as staples, paper clips, scraps of paper and so on.

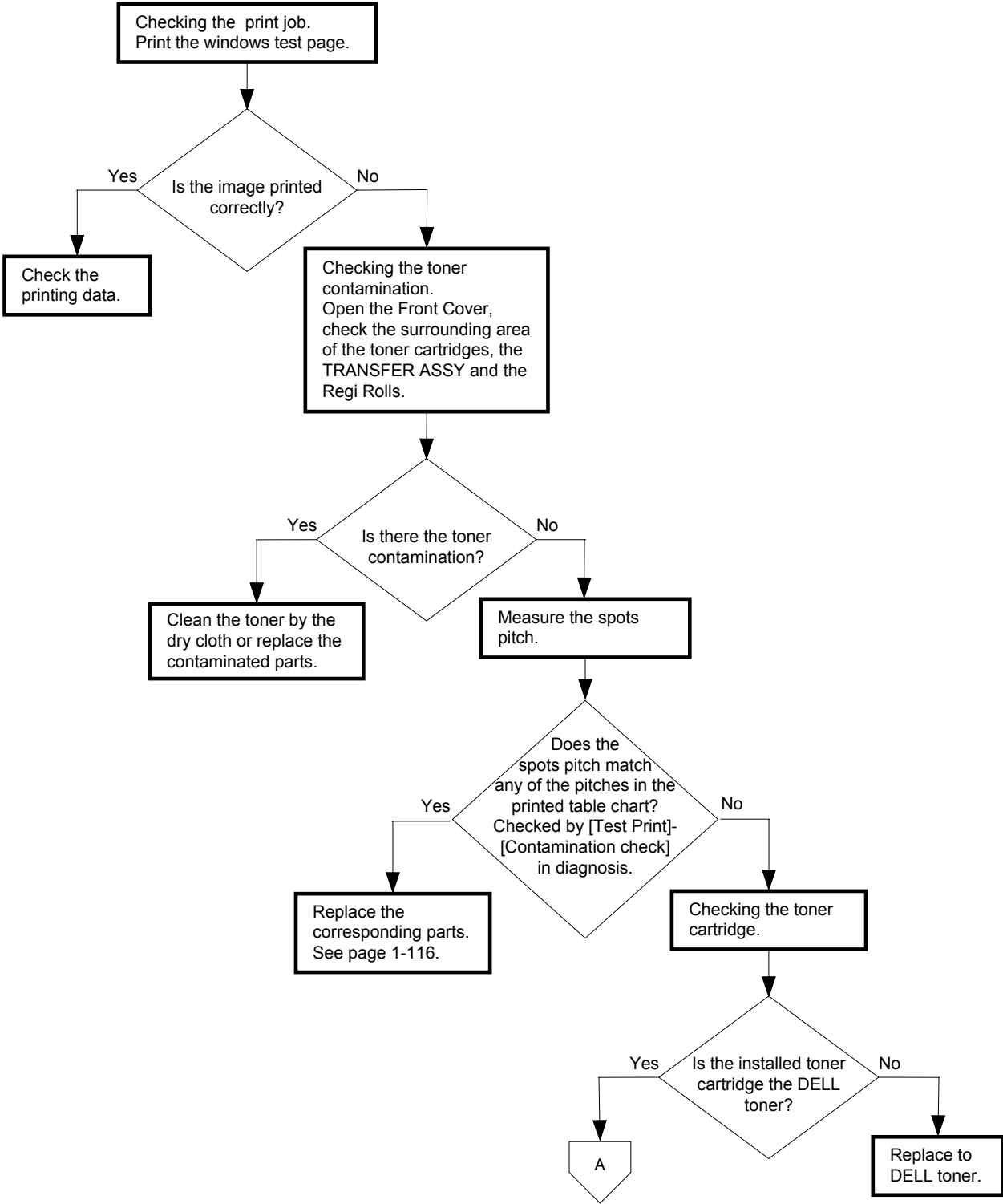

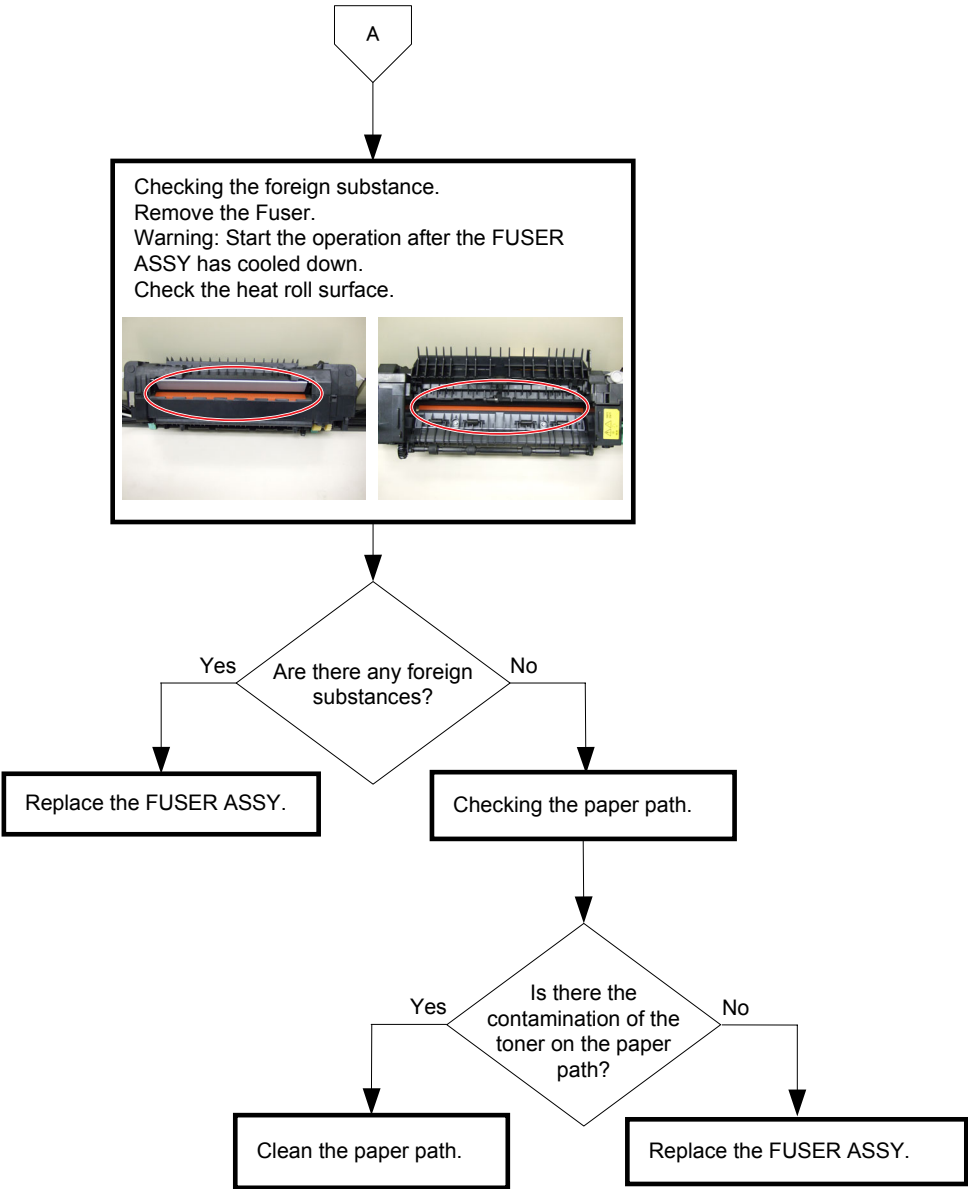

FIP-1.P10 Afterimage

**Trouble substance**

The ghost appears on the paper. The ghost may be the image of the previous page, or a part of the page currently printing.

Possible causative parts

- CARTRIDGE ASSY (PL5.1.18(K)/PL5.1.19(C)/PL5.1.20 (M)/PL5.1.21 (Y))
- FUSER ASSY (PL6.1.10)

Before commencing troubleshooting, check the paper transfer path. Make sure there is no foreign materials on the transfer path, such as staples, paper clips, scraps of paper and so on.

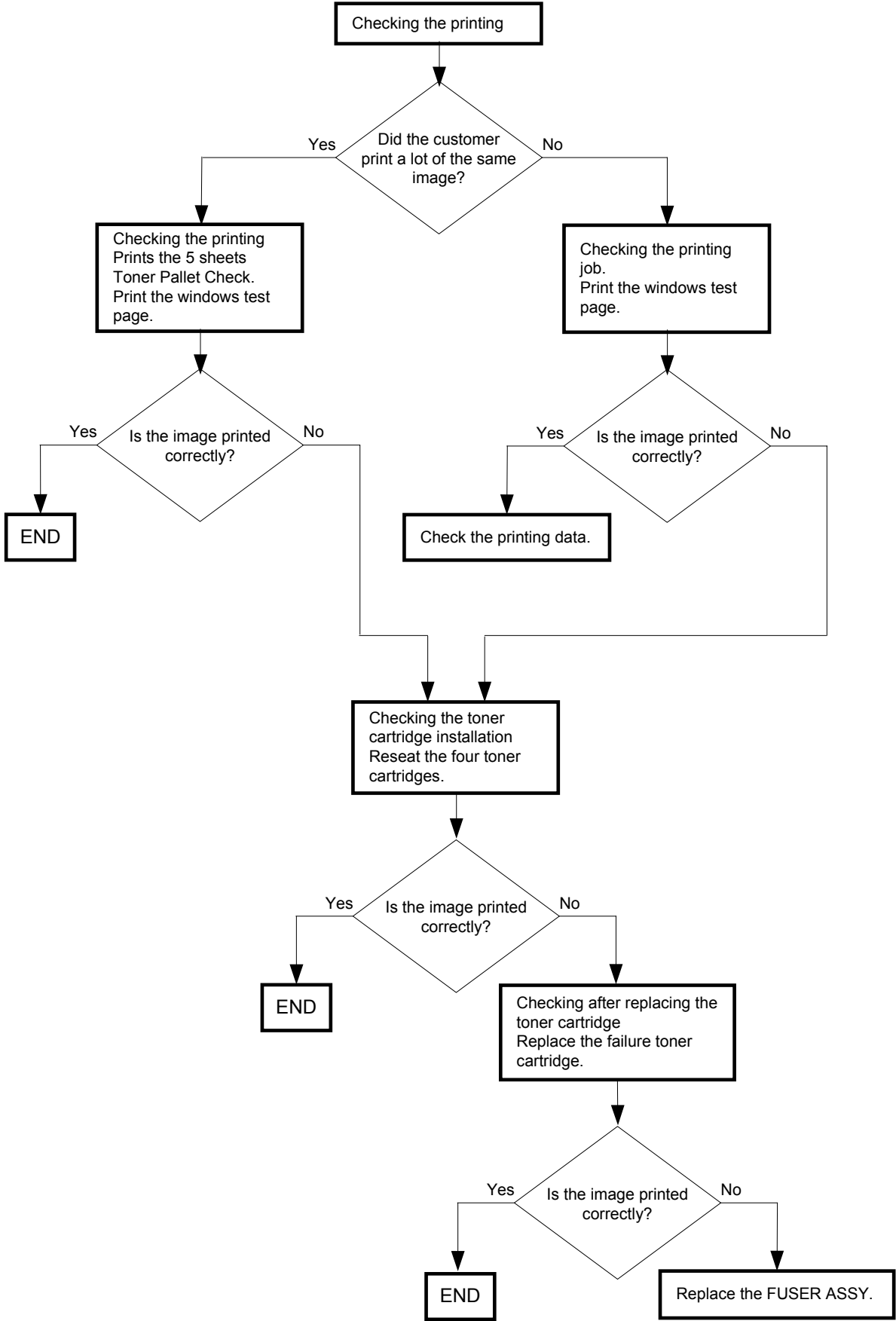

FIP-1.P11 Background (Fog)

**Trouble substance**

There is toner stain all over or a part of the page. The stain appears as very bright color (Y, M, C, K or etc.) stain.

Possible causative parts

- ROS ASSY (PL5.1.2)
- CARTRIDGE ASSY (PL5.1.18(K)/PL5.1.19(C)/PL5.1.20 (M)/PL5.1.21 (Y))

Before commencing troubleshooting, check the paper transfer path. Make sure there is no foreign materials on the transfer path, such as staples, paper clips, scraps of paper and so on.

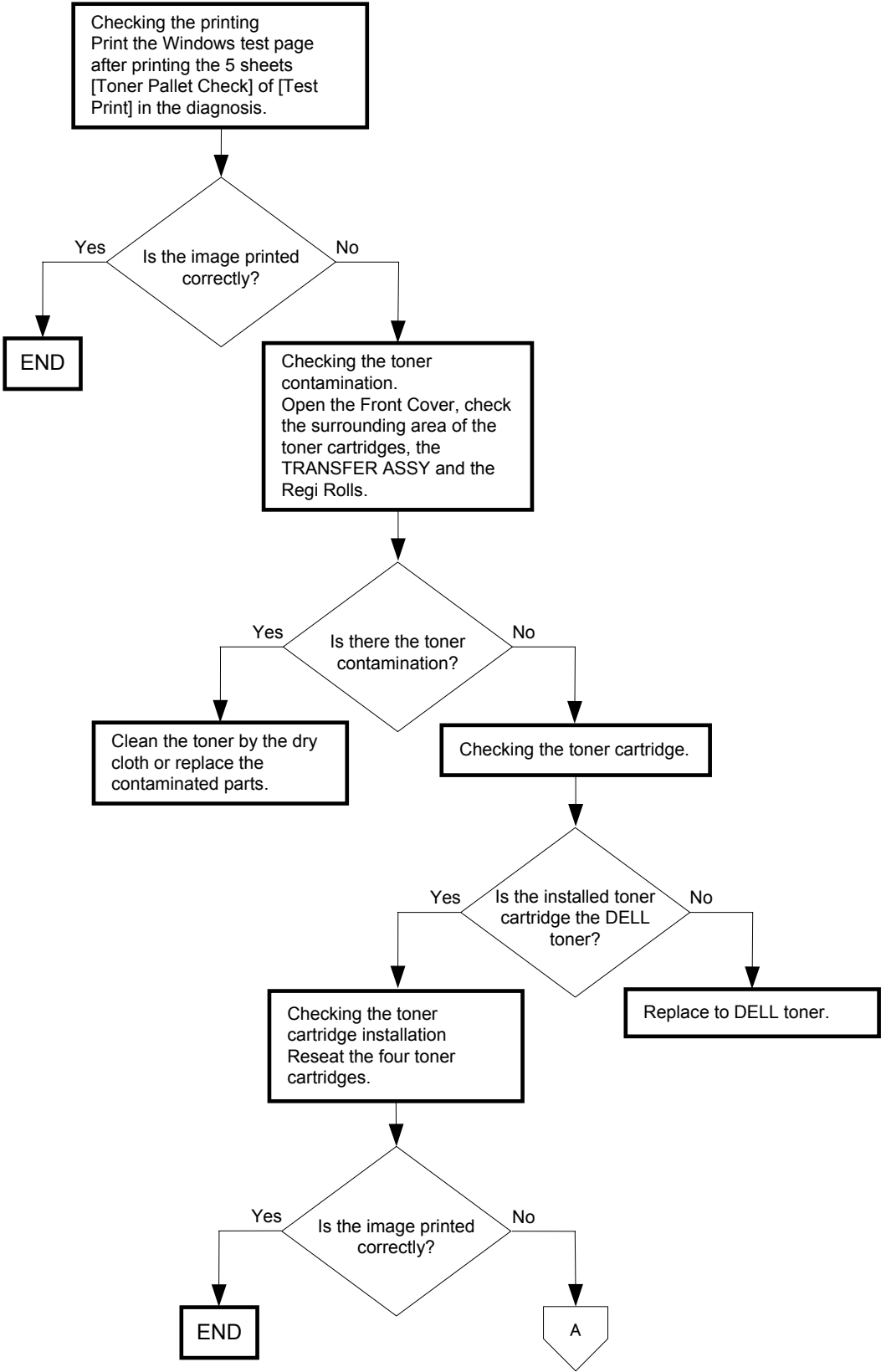

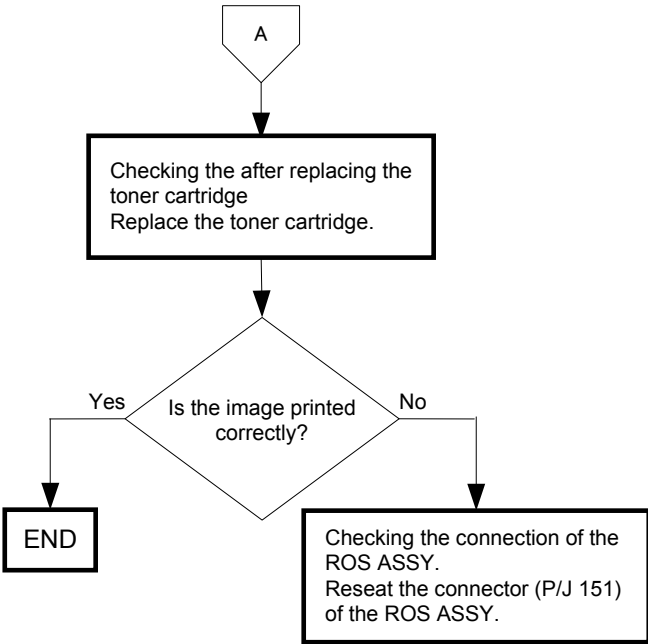

FIP-1.P12 Skew

**Trouble substance**

The printed image is not paralleled with both sides of the paper.

Possible causative parts

- SEPARATOR ROLLER ASSY (PL2.1.3)
- KIT SEPARATOR and FEED ROLLER (PL2.2.99)
- ROLL ASSY FEED MSI (PL3.1.10)
- KIT FEEDER ASSY (PL3.2.99)
- TRANSFER ASSY (PL4.1.1)
- CHUTE ASSY DUP (PL11.1.1)
- KIT SEPARATOR and FEED ROLLER (PL12.3.99)

Before commencing troubleshooting, check the paper transfer path. Make sure there is no foreign materials on the transfer path, such as staples, paper clips, scraps of paper and so on.

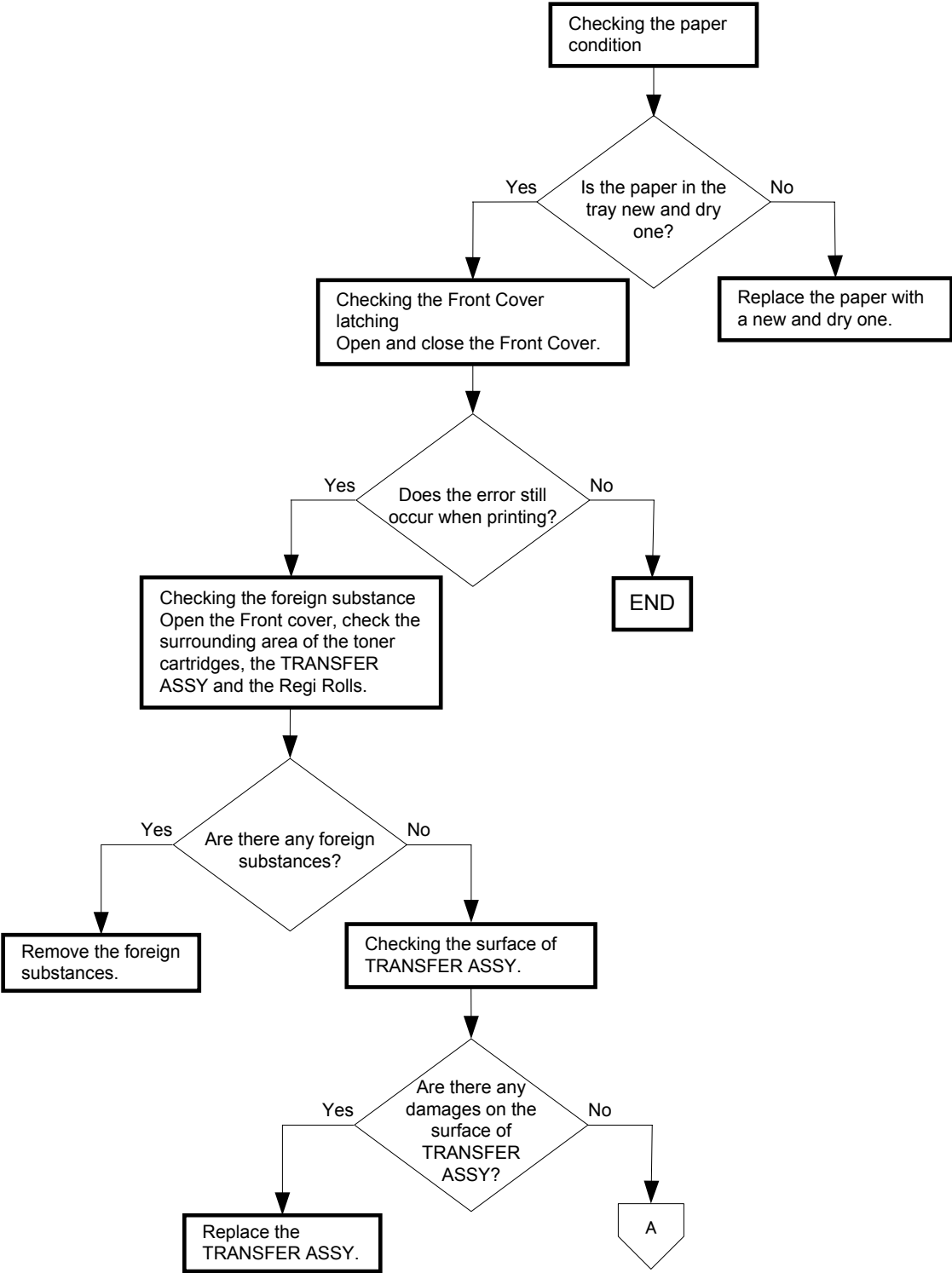

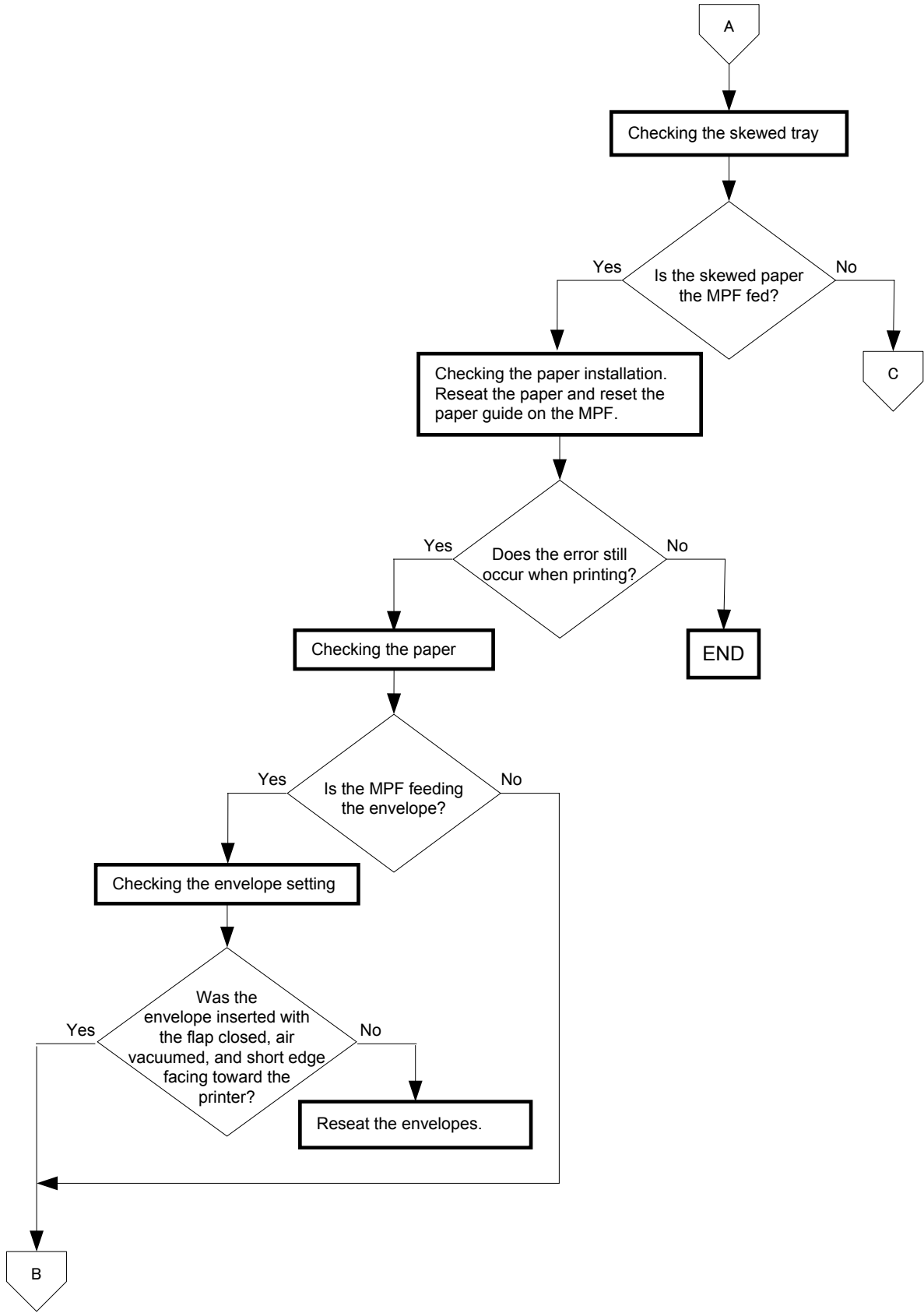

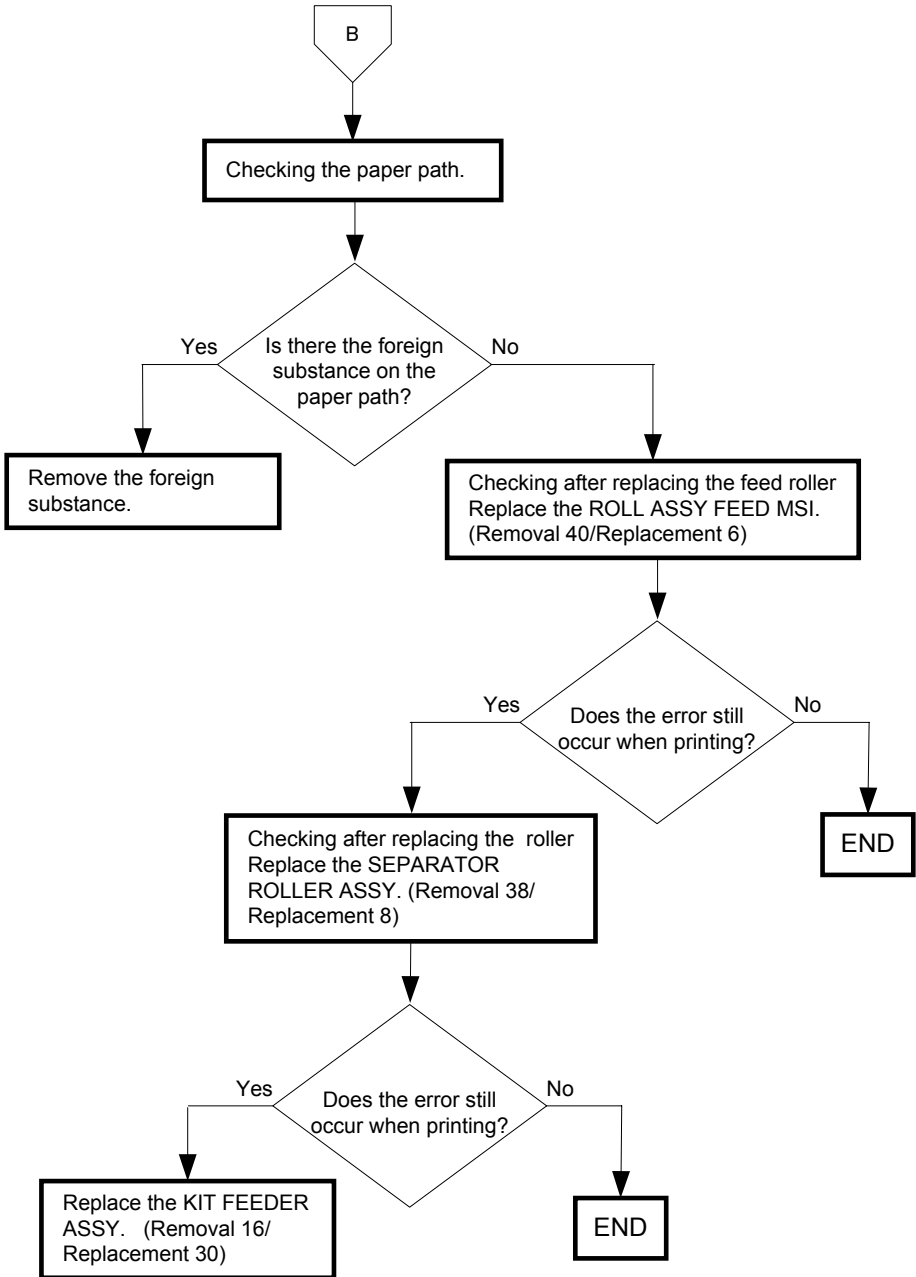

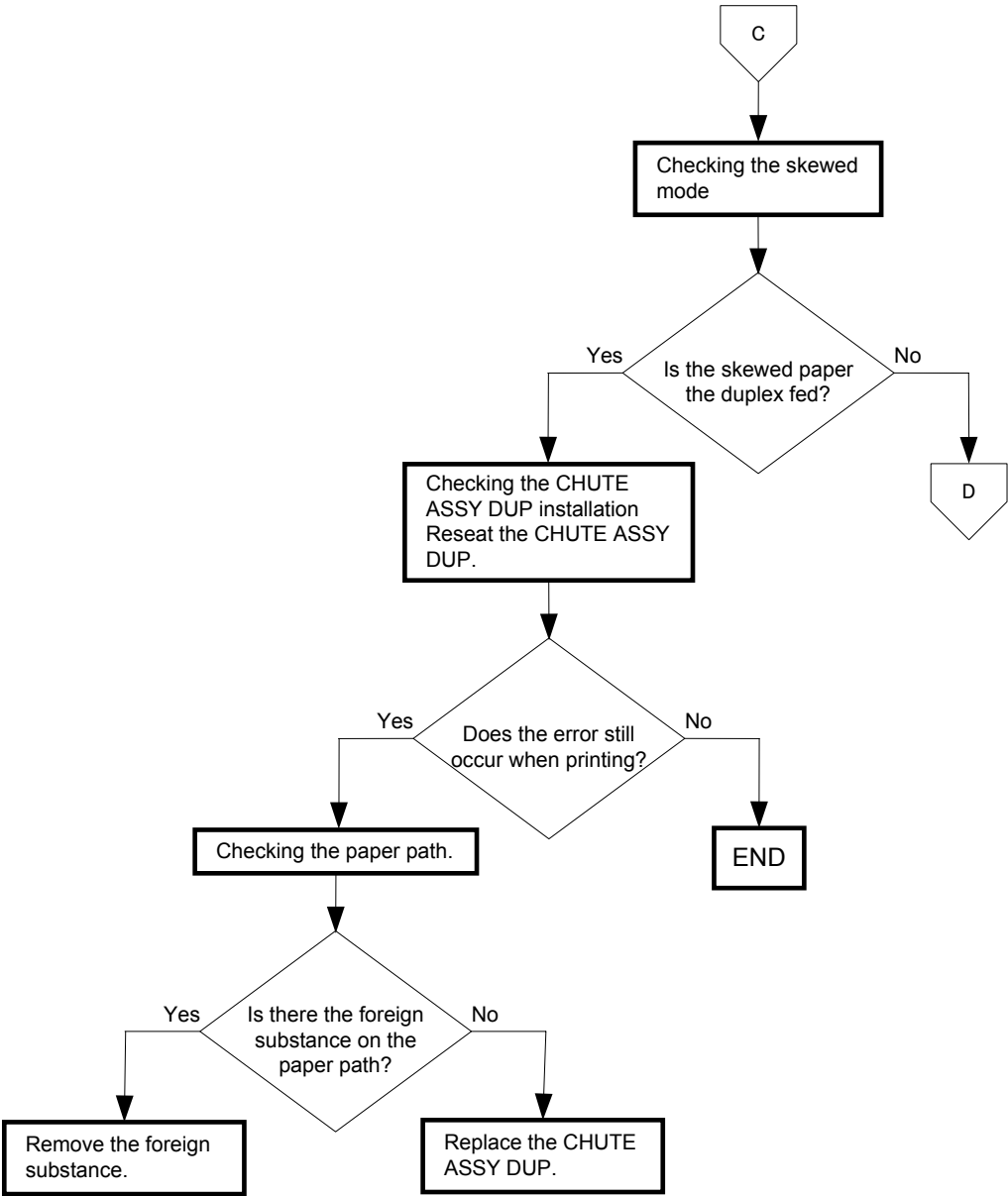

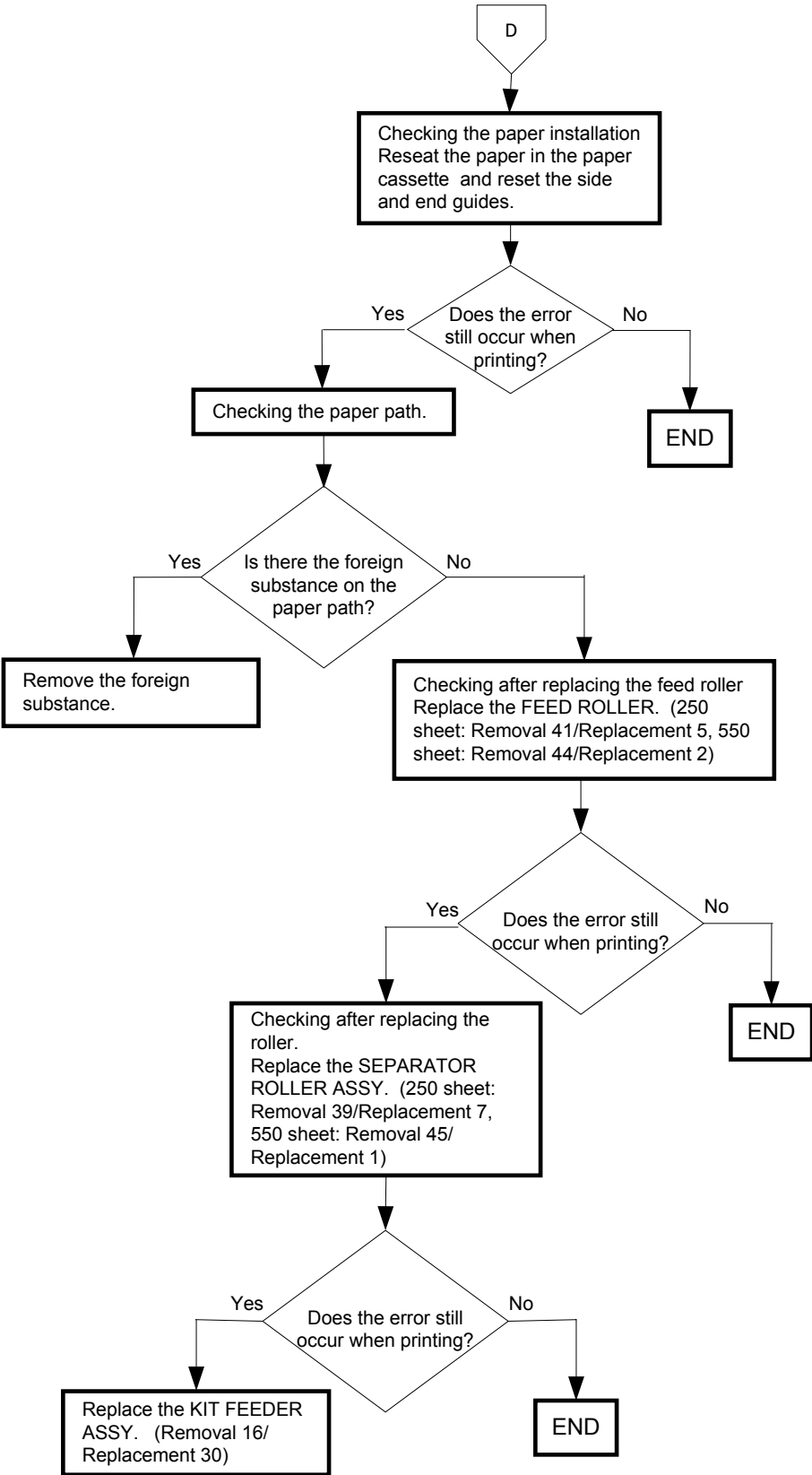

FIP-1.P13 Paper damage

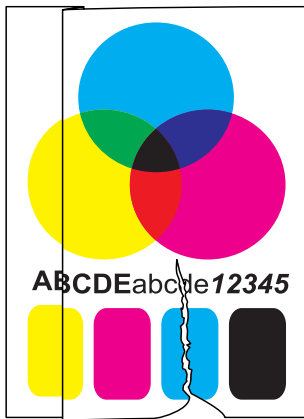
**Trouble substance**

The paper comes out from the printer wrinkled, folded or worn-out.

Possible causative parts

- SEPARATOR ROLLER ASSY (PL2.1.3)
- KIT SEPARATOR and FEED ROLLER (PL2.2.99)
- ROLL ASSY FEED MSI (PL3.1.10)
- TRANSFER ASSY (PL4.1.1)
- FUSER ASSY (PL6.1.10)
- CHUTE ASSY DUP (PL11.1.1)
- KIT SEPARATOR and FEED ROLLER (PL12.3.99)

Before commencing troubleshooting, check the paper transfer path. Make sure there is no foreign materials on the transfer path, such as staples, paper clips, scraps of paper and so on.

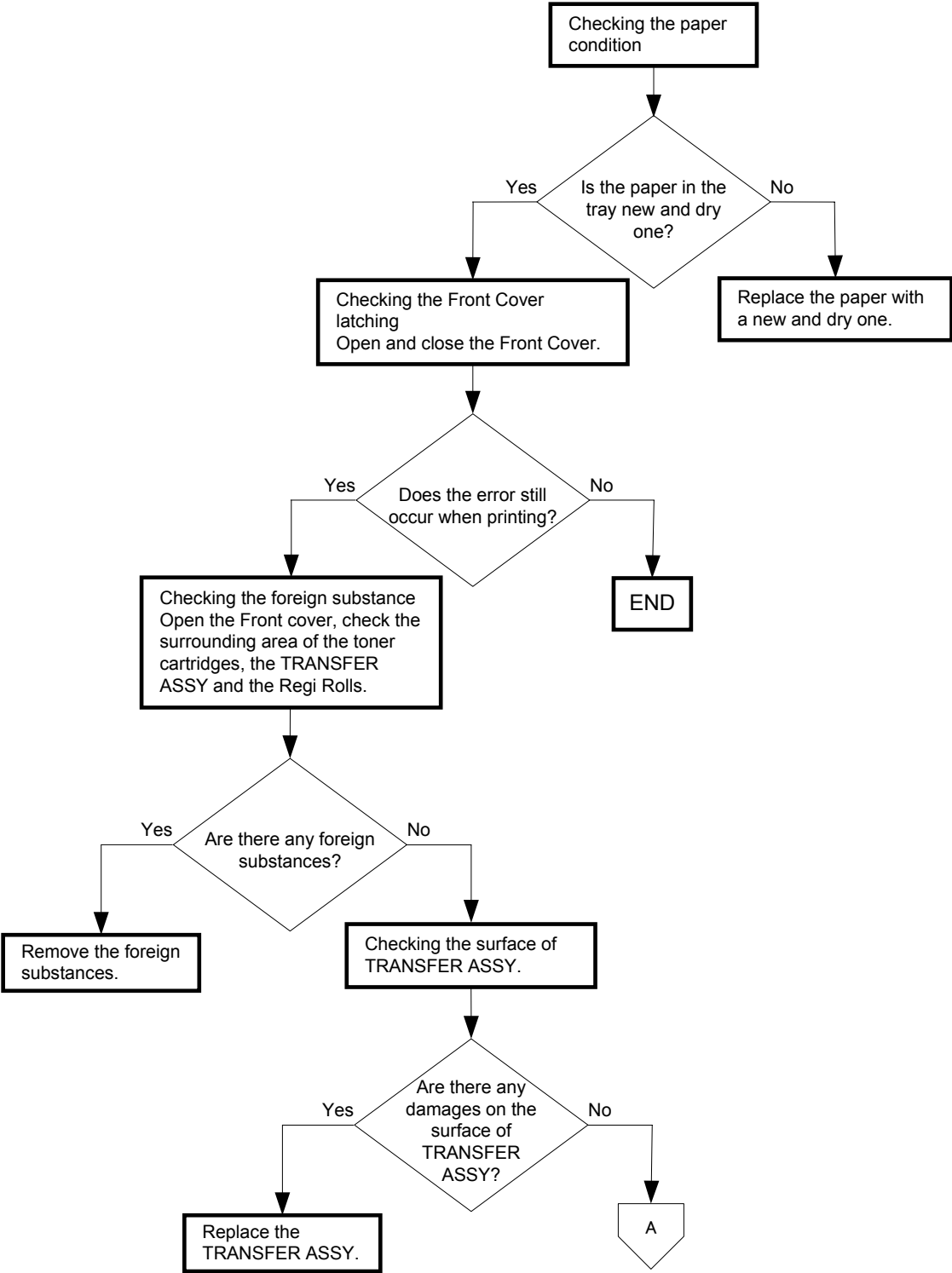

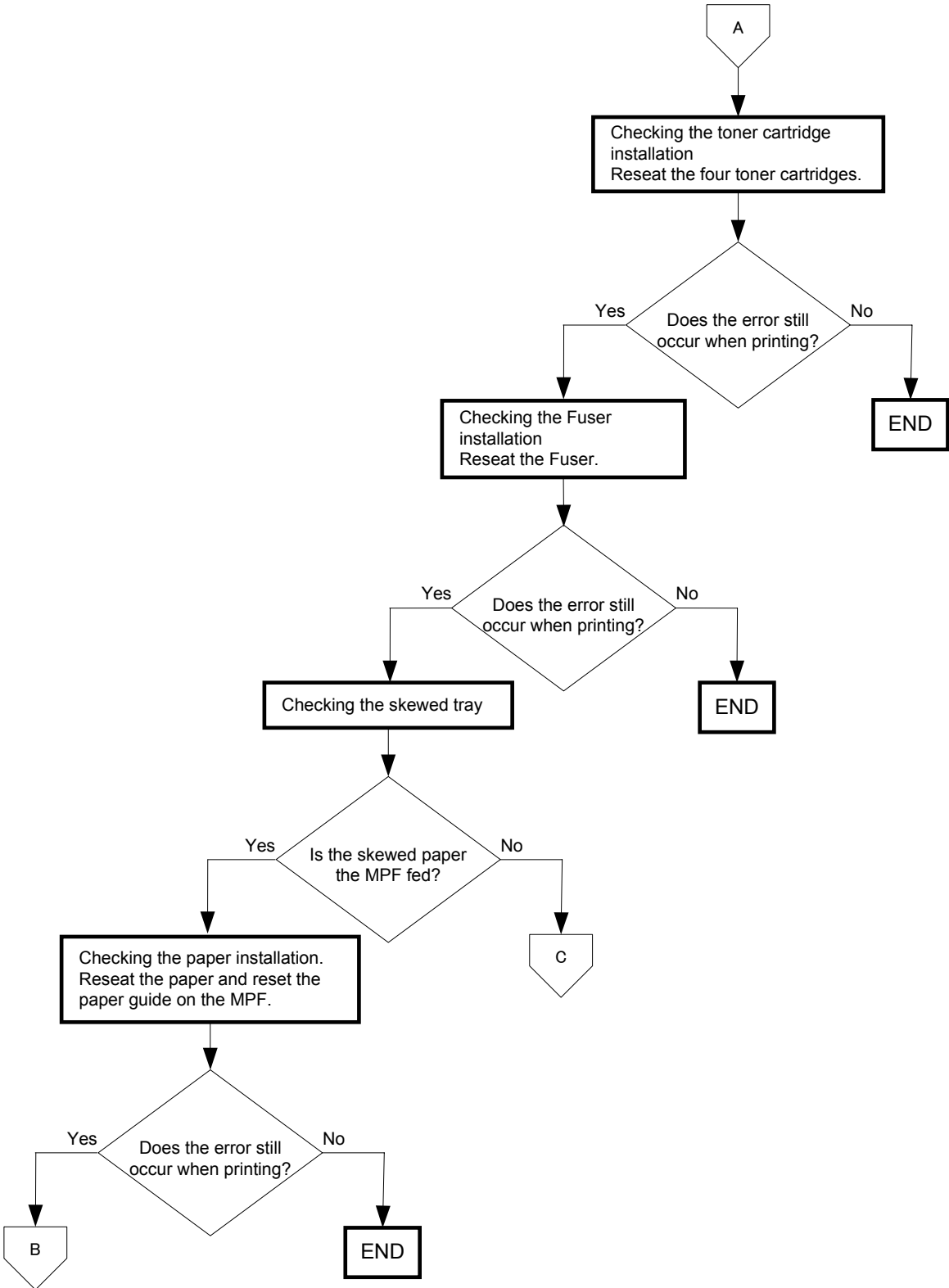

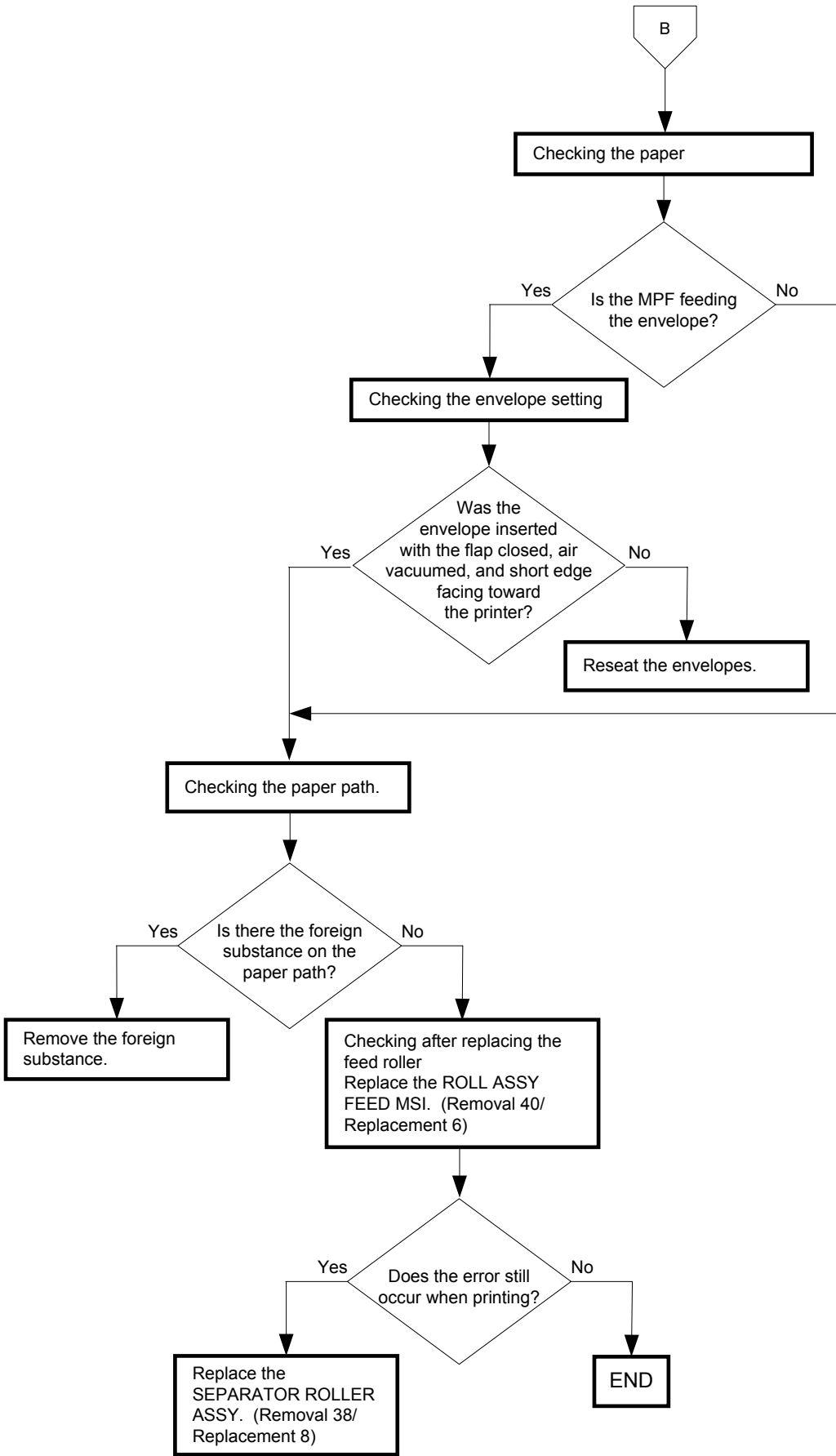

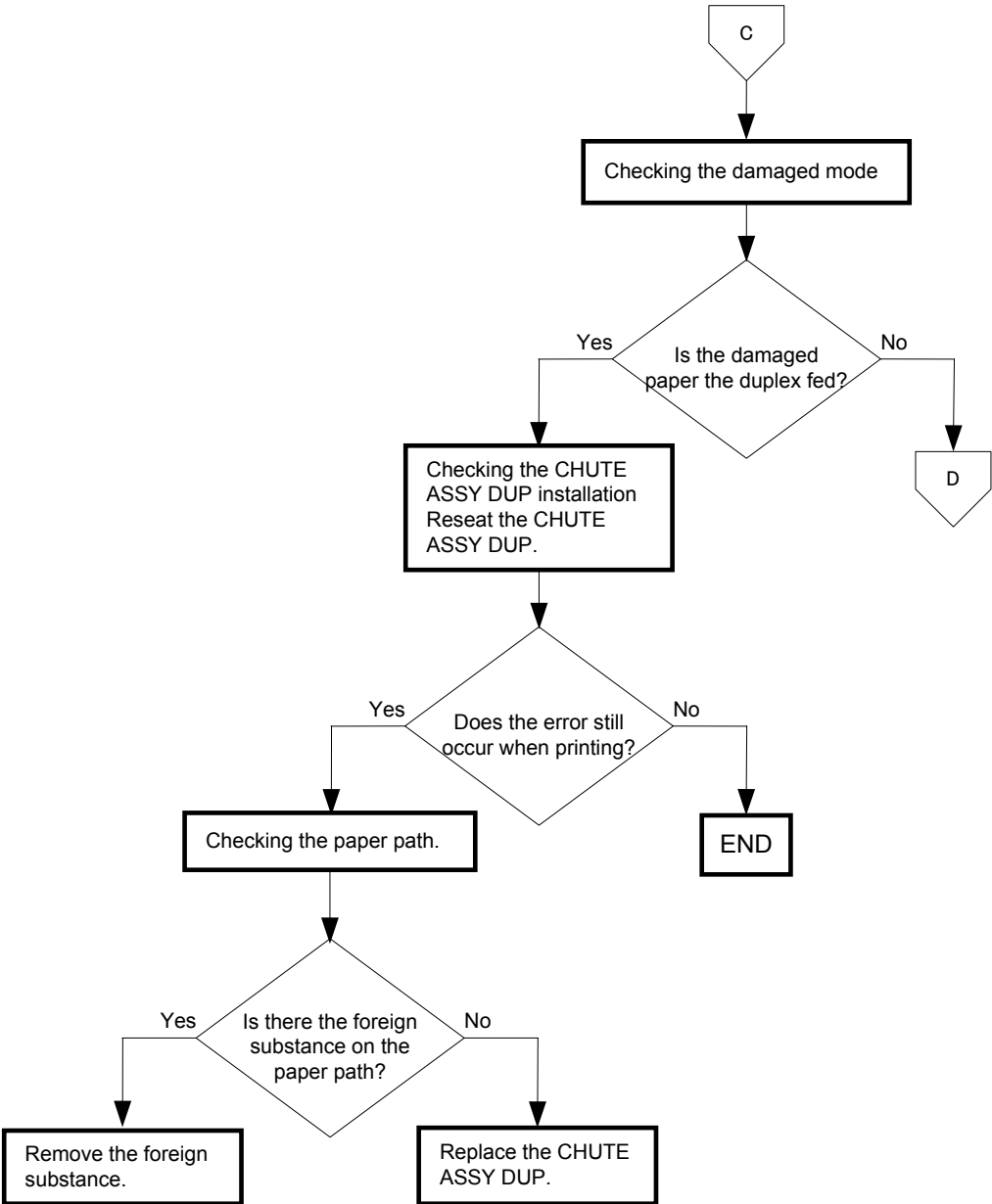

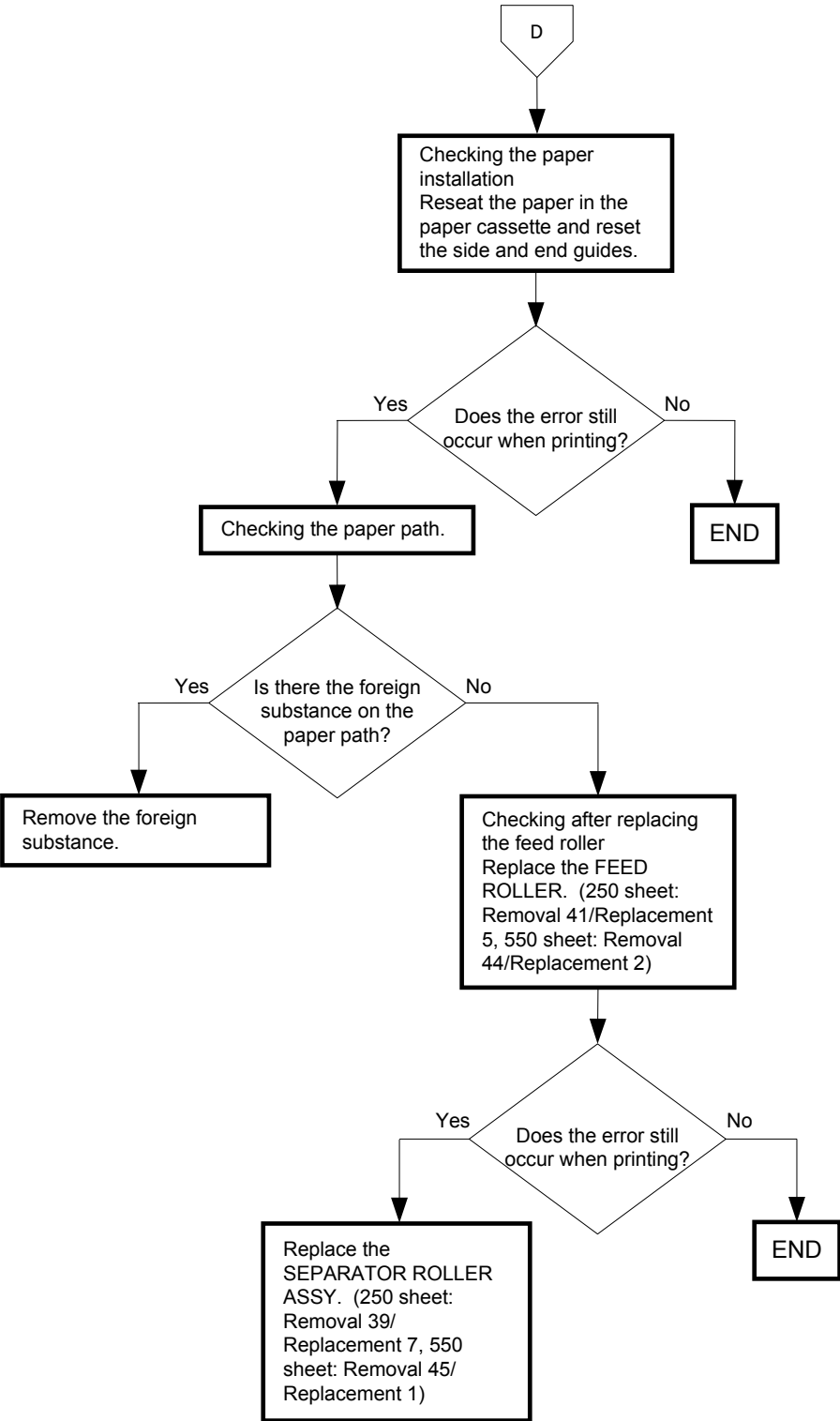

FIP-1.P14 No fix



Trouble substance

The printed image is not fixed on the paper properly. The image easily comes off when rubbed.

Possible causative parts

- CARTRIDGE ASSY (PL5.1.18(K)/PL5.1.19(C)/PL5.1.20 (M)/PL5.1.21 (Y))
- FUSER ASSY (PL6.1.10)

Before commencing troubleshooting, check the paper transfer path. Make sure there is no foreign materials on the transfer path, such as staples, paper clips, scraps of paper and so on.

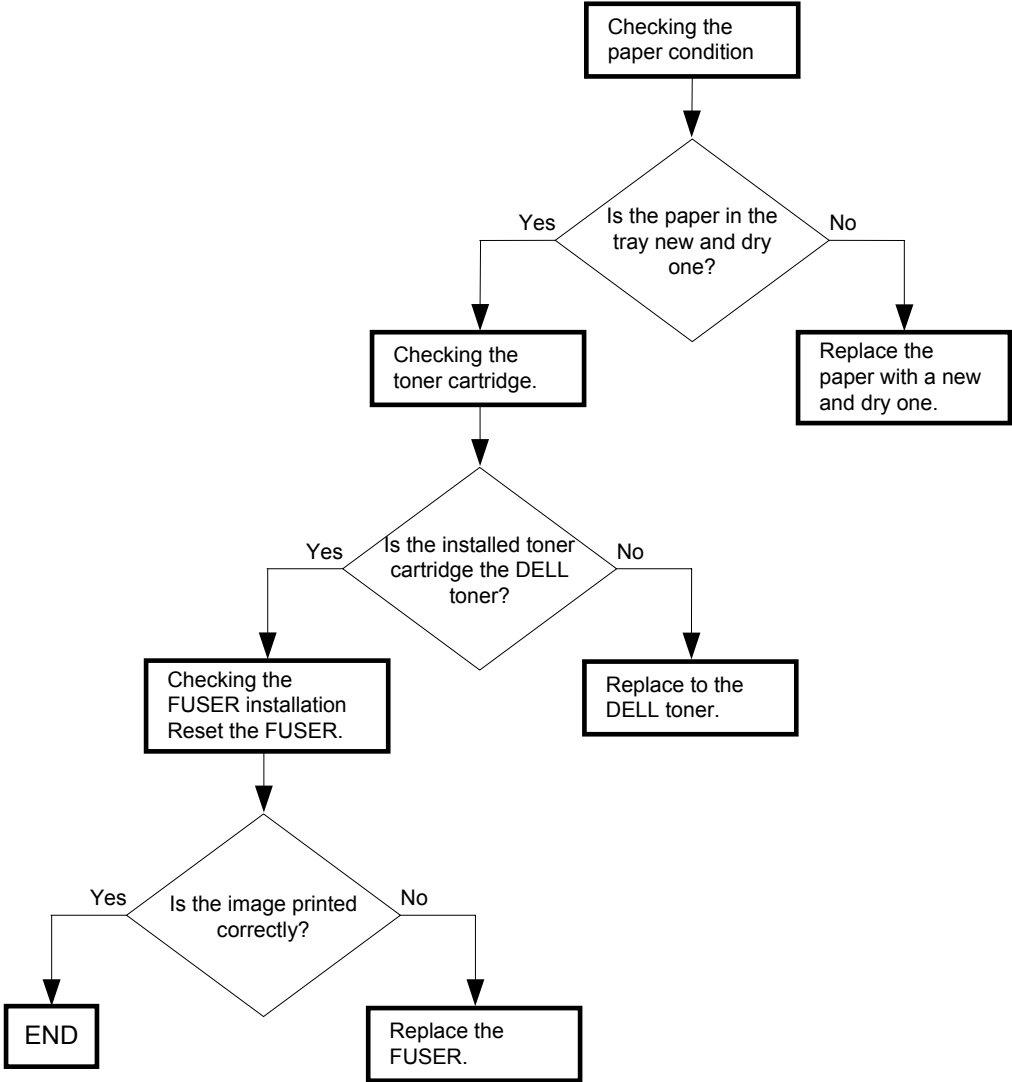

FIP-1.P15 Color Registration (Color Shift)

**Trouble substance**

A yellow or black image printed is not overlapped on a cyan or magenta image correctly.

Possible causative parts

- FEEDER ASSY (PL3.2.1)
- TRANSFER ASSY (PL4.1.1)
- CARTRIDGE ASSY (PL5.1.18(K)/PL5.1.19(C)/PL5.1.20 (M)/PL5.1.21 (Y))
- PWBA MCU (PL9.1.20)

Before commencing troubleshooting, check the paper transfer path. Make sure there is no foreign materials on the transfer path, such as staples, paper clips, scraps of paper and so on.

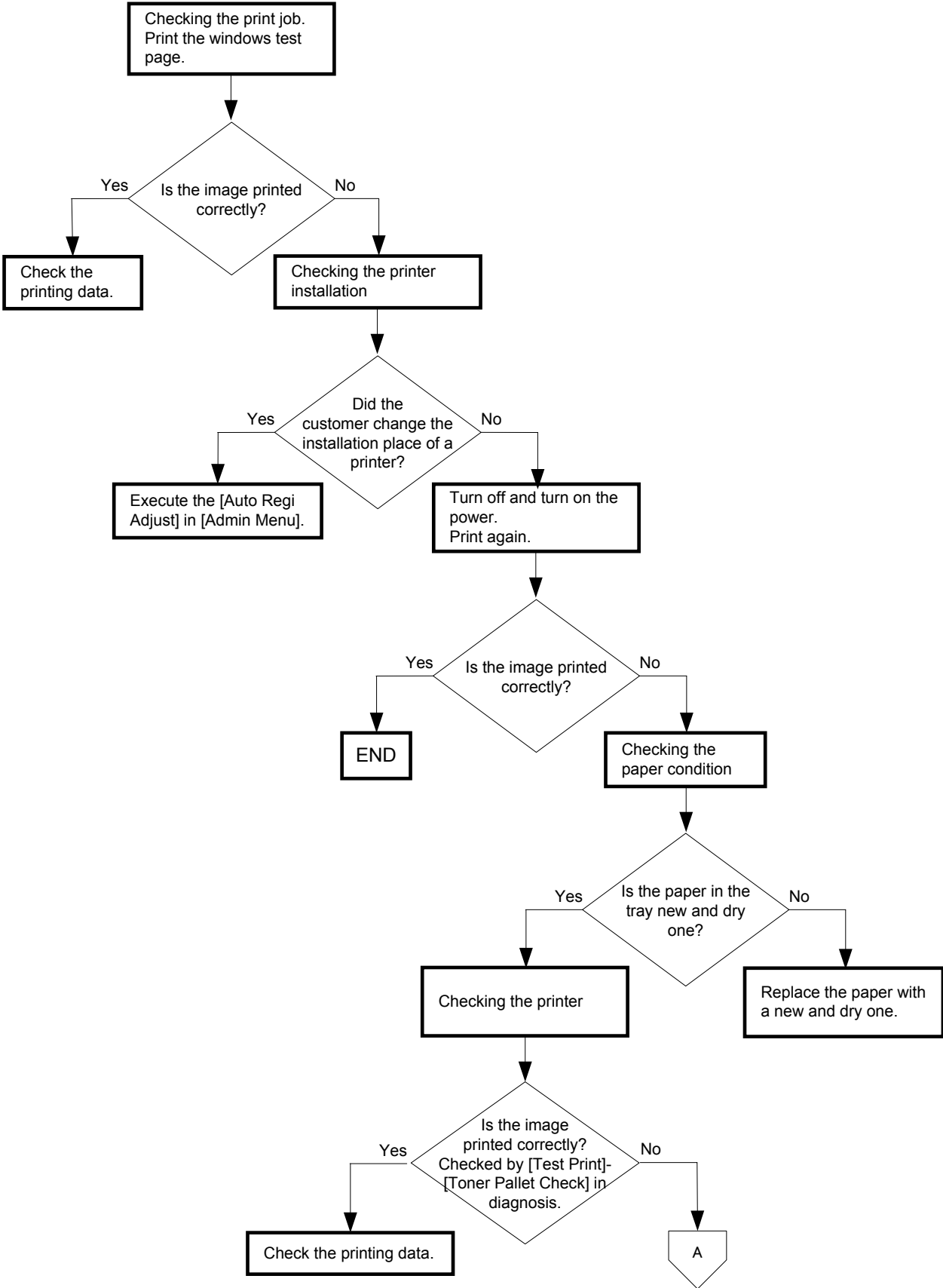

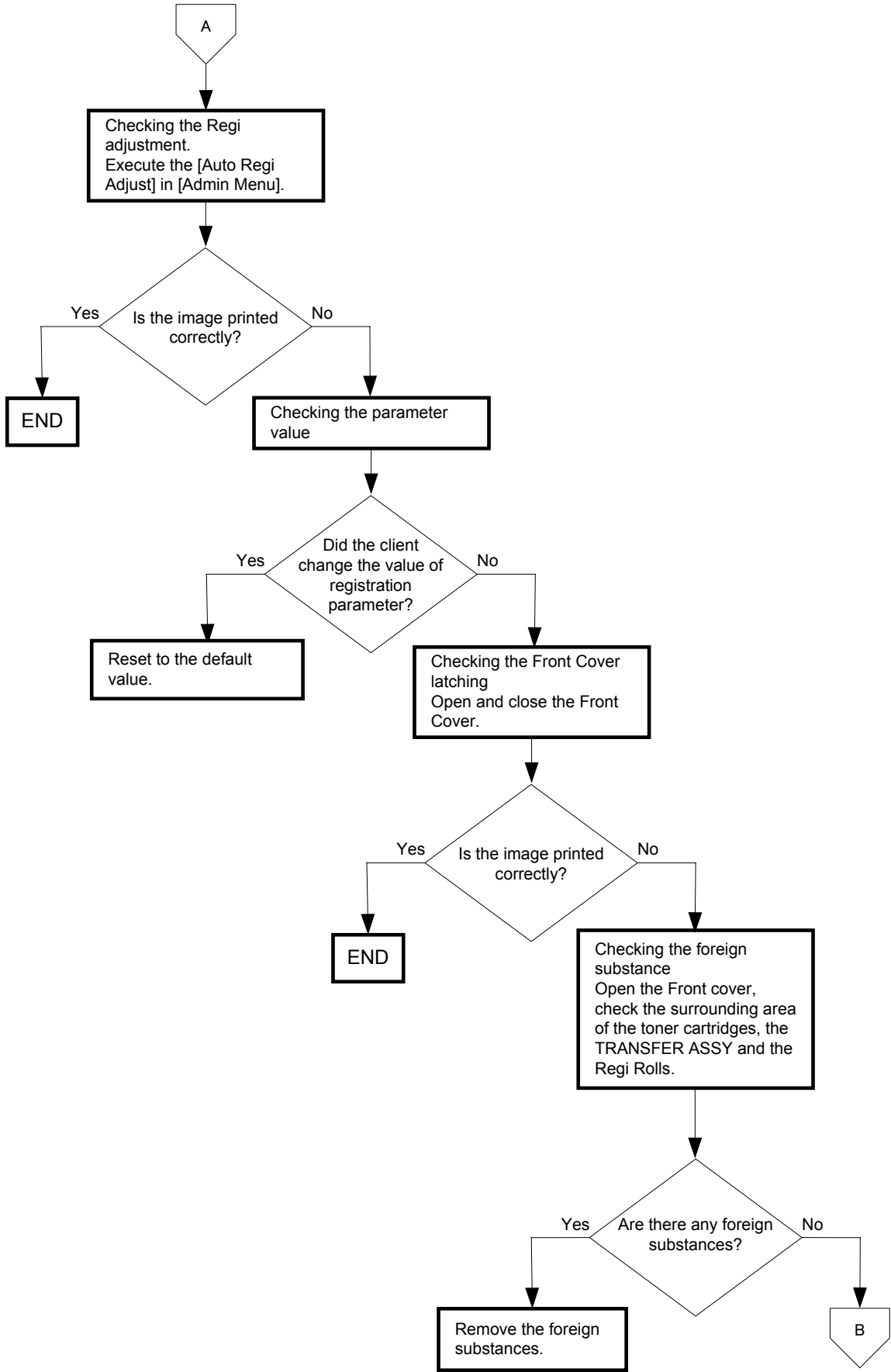

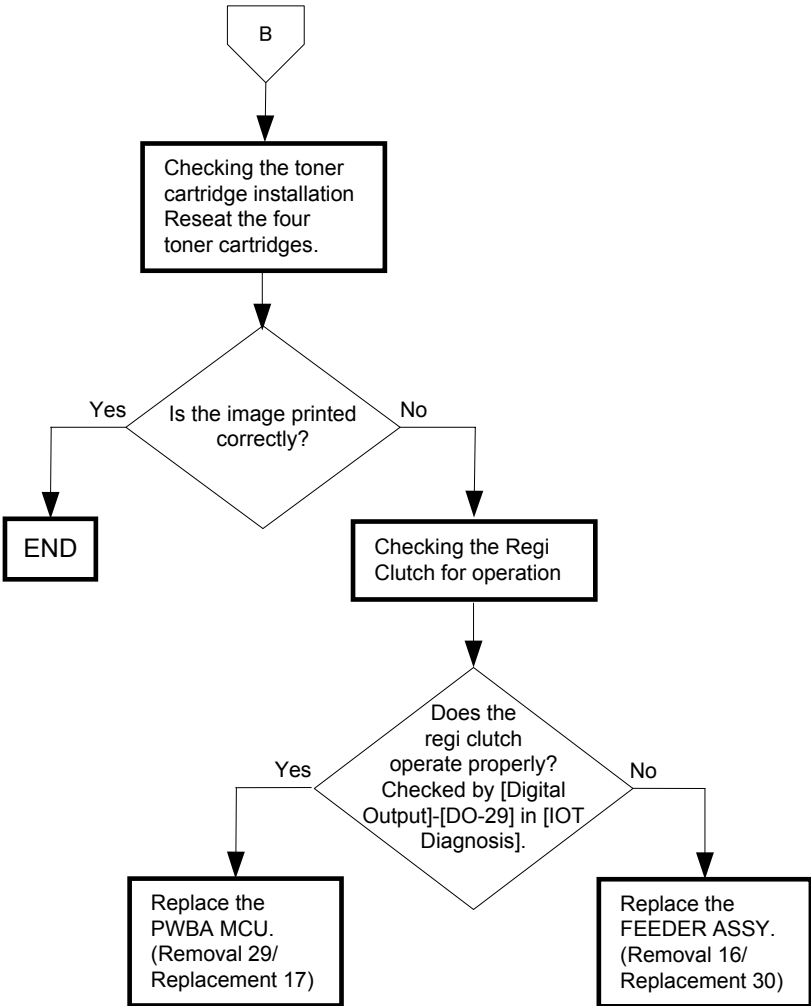

5. Abnormal Noise Trouble

5.1 Entry Chart for Abnormal Noise Troubleshooting

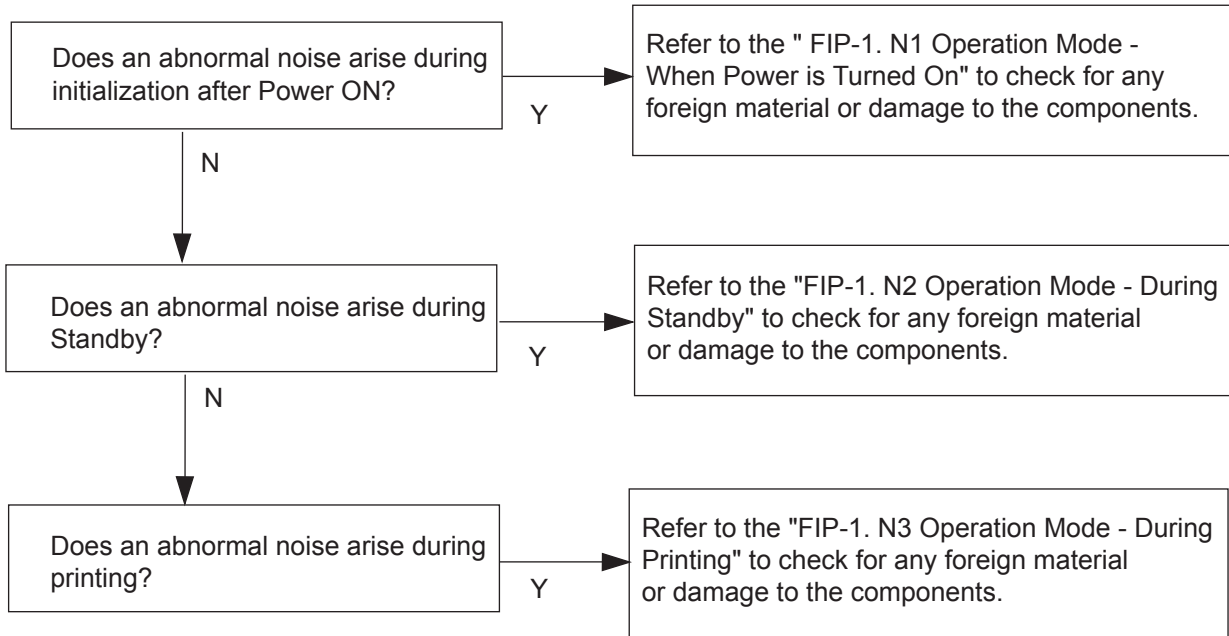

5.2 Operation Mode Table

FIP-1.N1 When Power is Turned On

Possible causative parts:BELT CRU (PL4.1.1)
CARTRIDGE ASSY (PL5.1.18 (K)/PL5.1.19 (C)/PL5.1.20 (M)/PL5.1.21 (Y))
FUSER ASSY (PL6.1.10)
DRIVE ASSY MAIN (PL8.1.2)
DRIVE ASSY PH (PL8.1.7)
500 OPTION FEEDER (PL12.1.1)

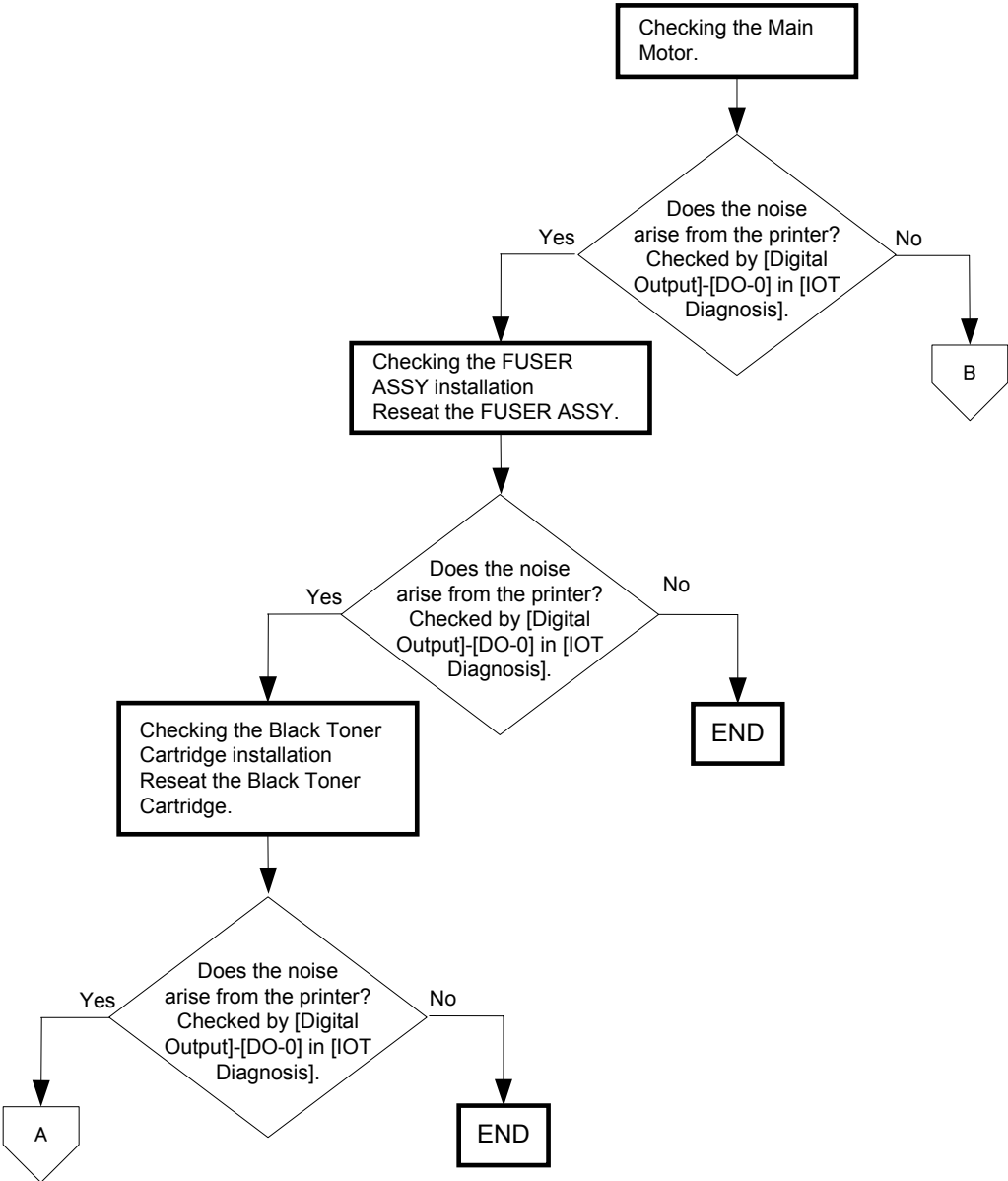

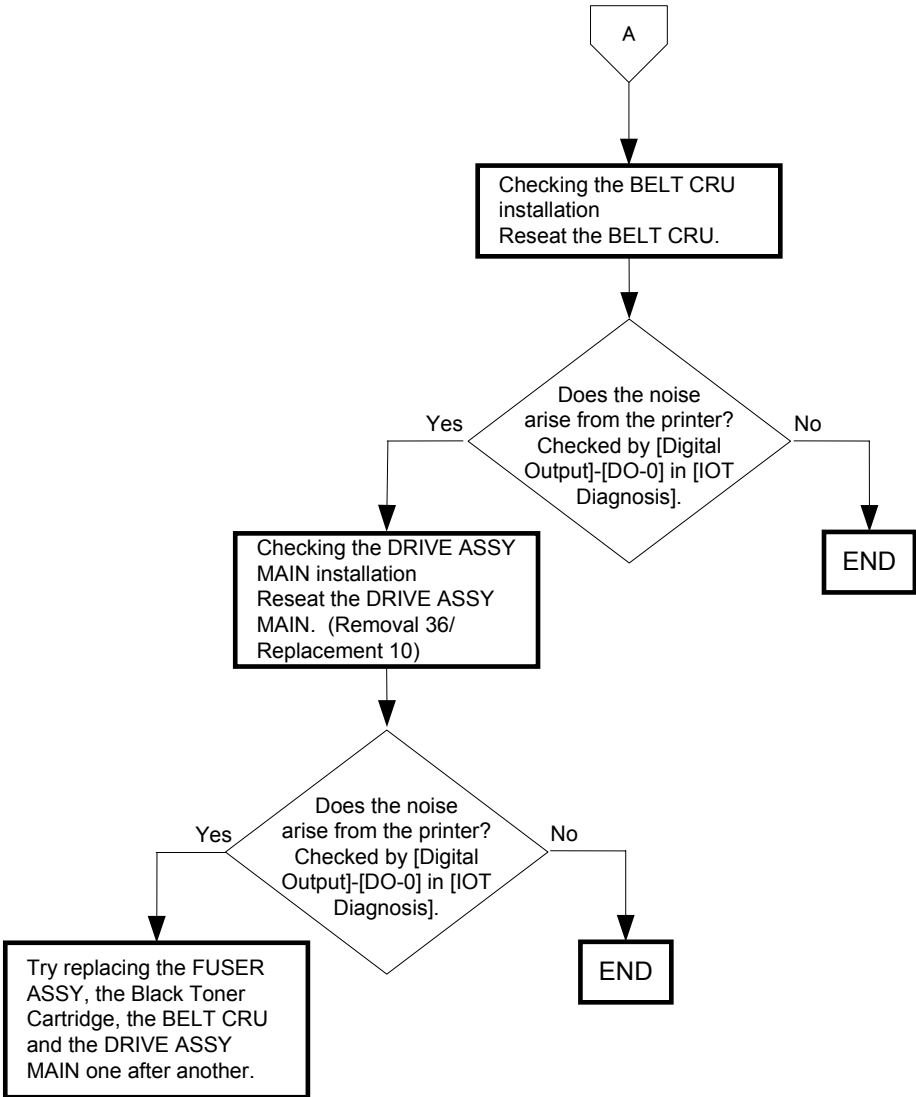

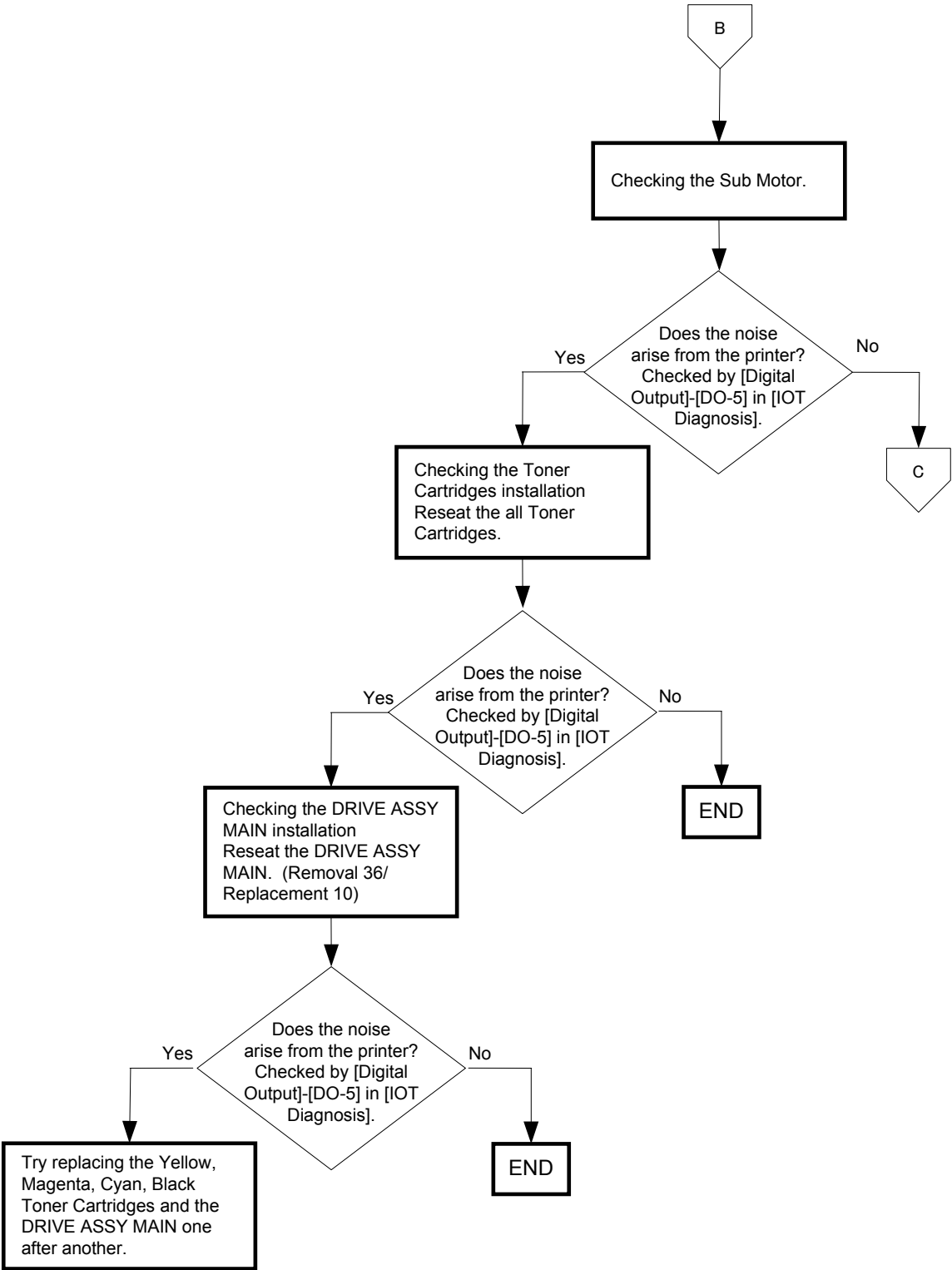

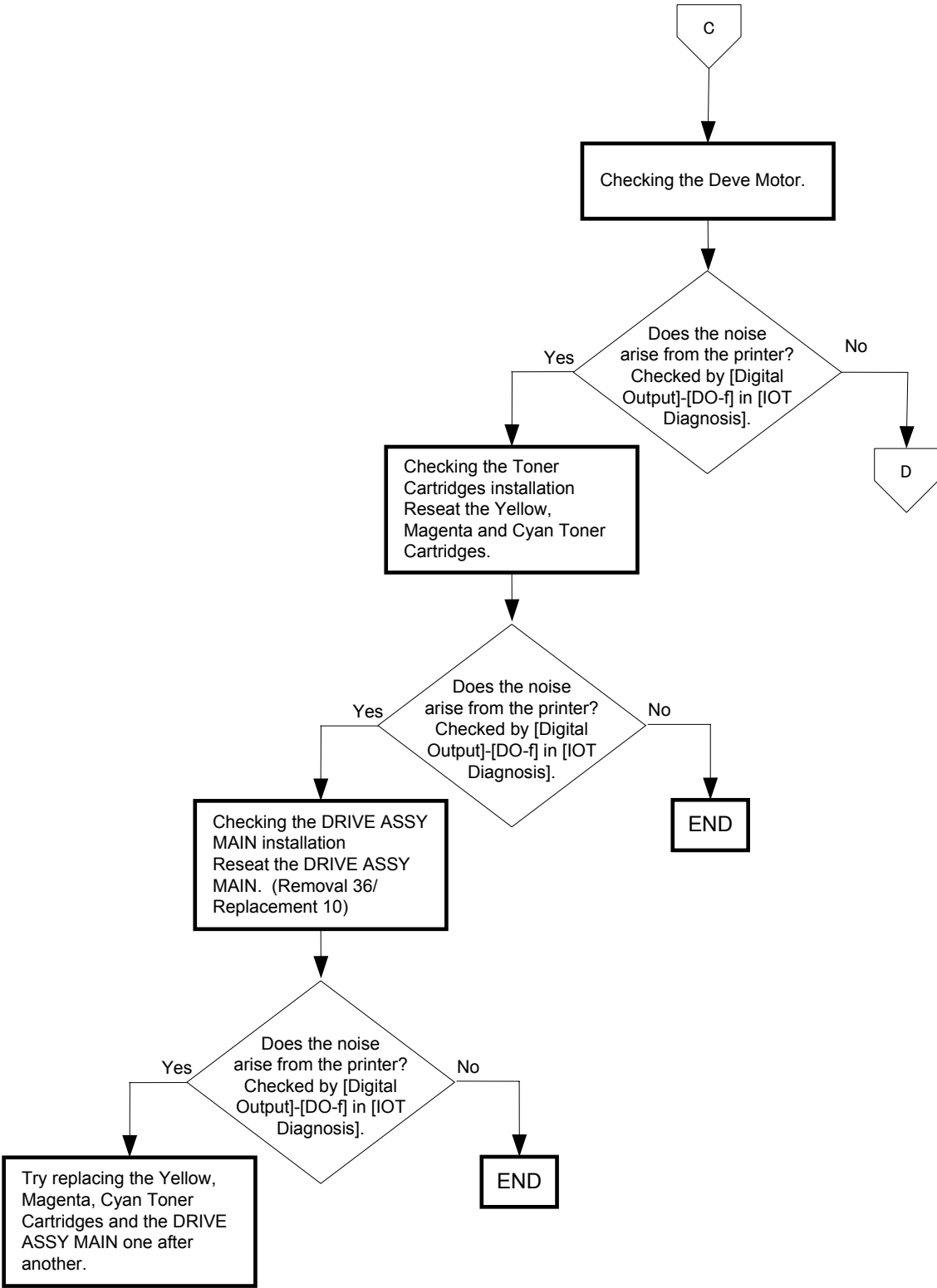

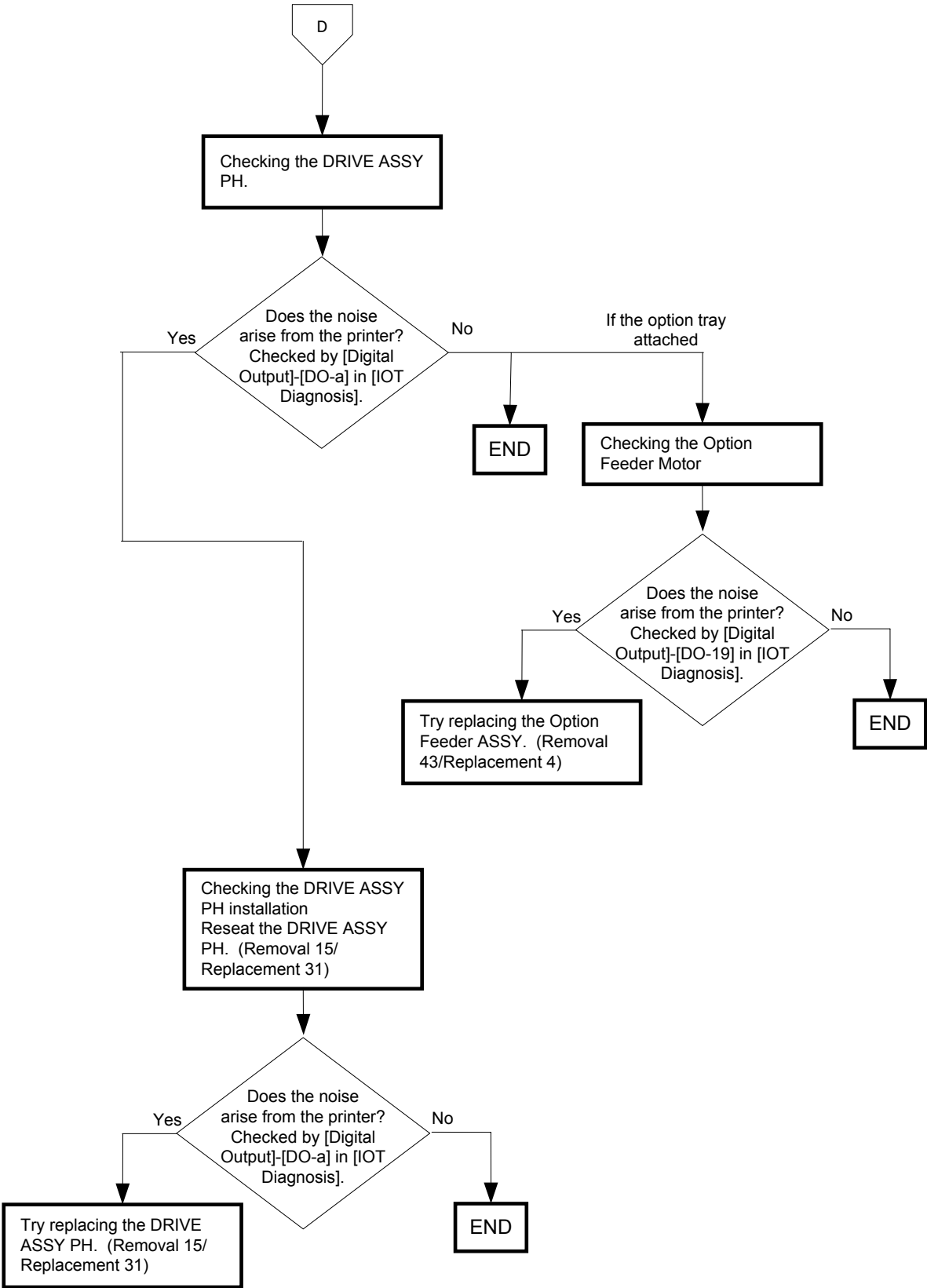

FIP-1.N2 During Standby

Possible causative parts:FAN MAIN (PL9.1.10)
LVPS (PL9.1.6)

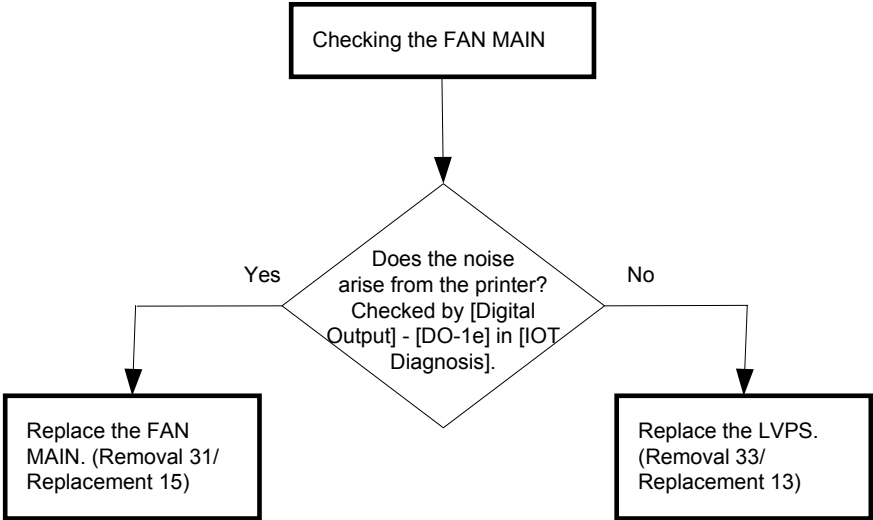

FIP-1.N3 During Printing

Possible causative parts:KIT SEPARATOR ROLLER ASSEMBLY (PL2.1.99)
KIT SEPARATOR AND FEED ROLLER (PL2.2.99)
BELT UNIT (PL4.1.1)
CARTRIDGE ASSY (PL5.1.18/PL5.1.19/PL5.1.20/PL5.1.21)
FUSER ASSY (PL6.1.10)
DRIVE ASSY MAIN (PL8.1.2)
DRIVE ASSY PH (PL8.1.7)
CHUTE ASSY DUP (PL11.1.1)
550 OPTION FEEDER (PL12.1.1)

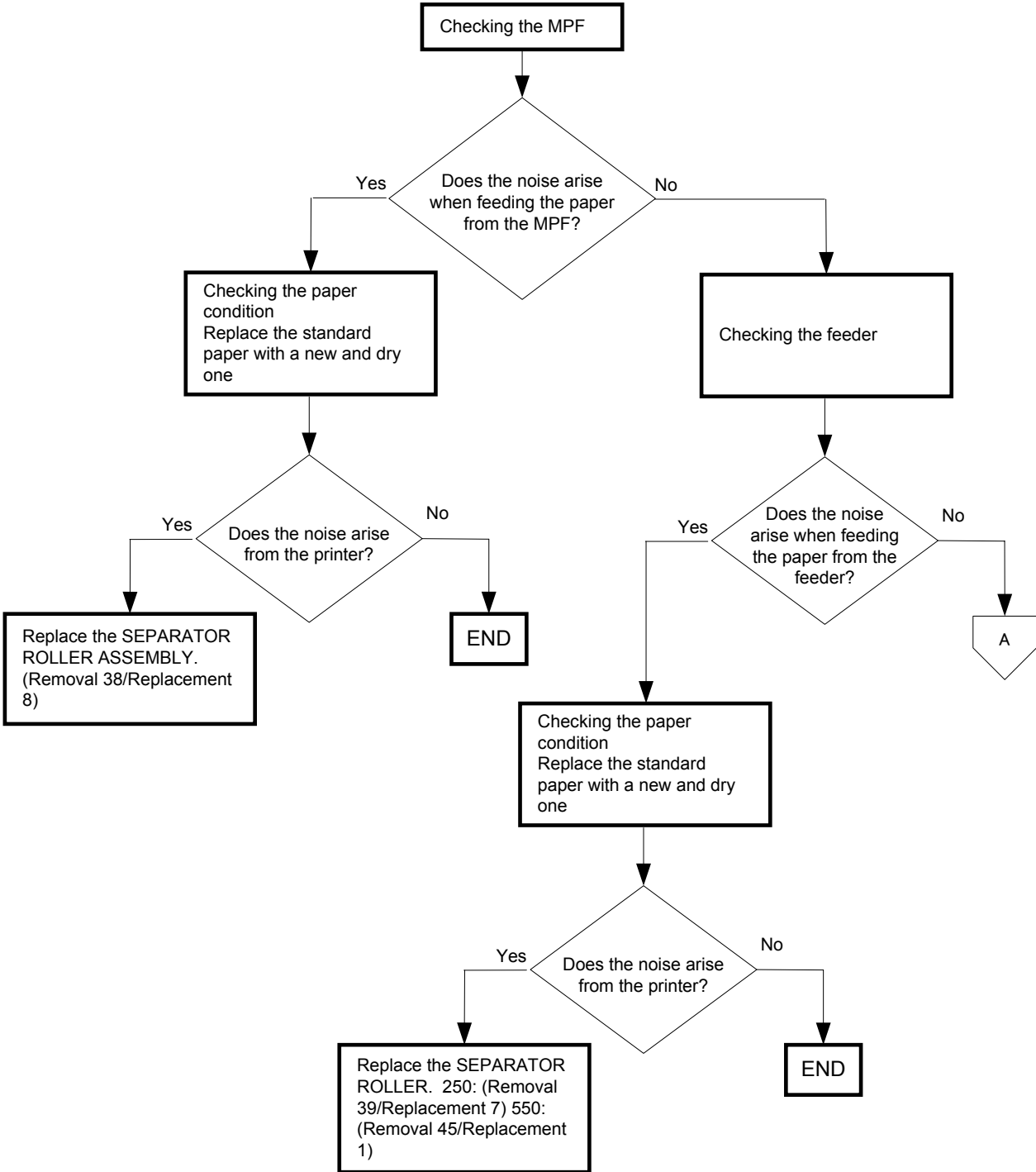

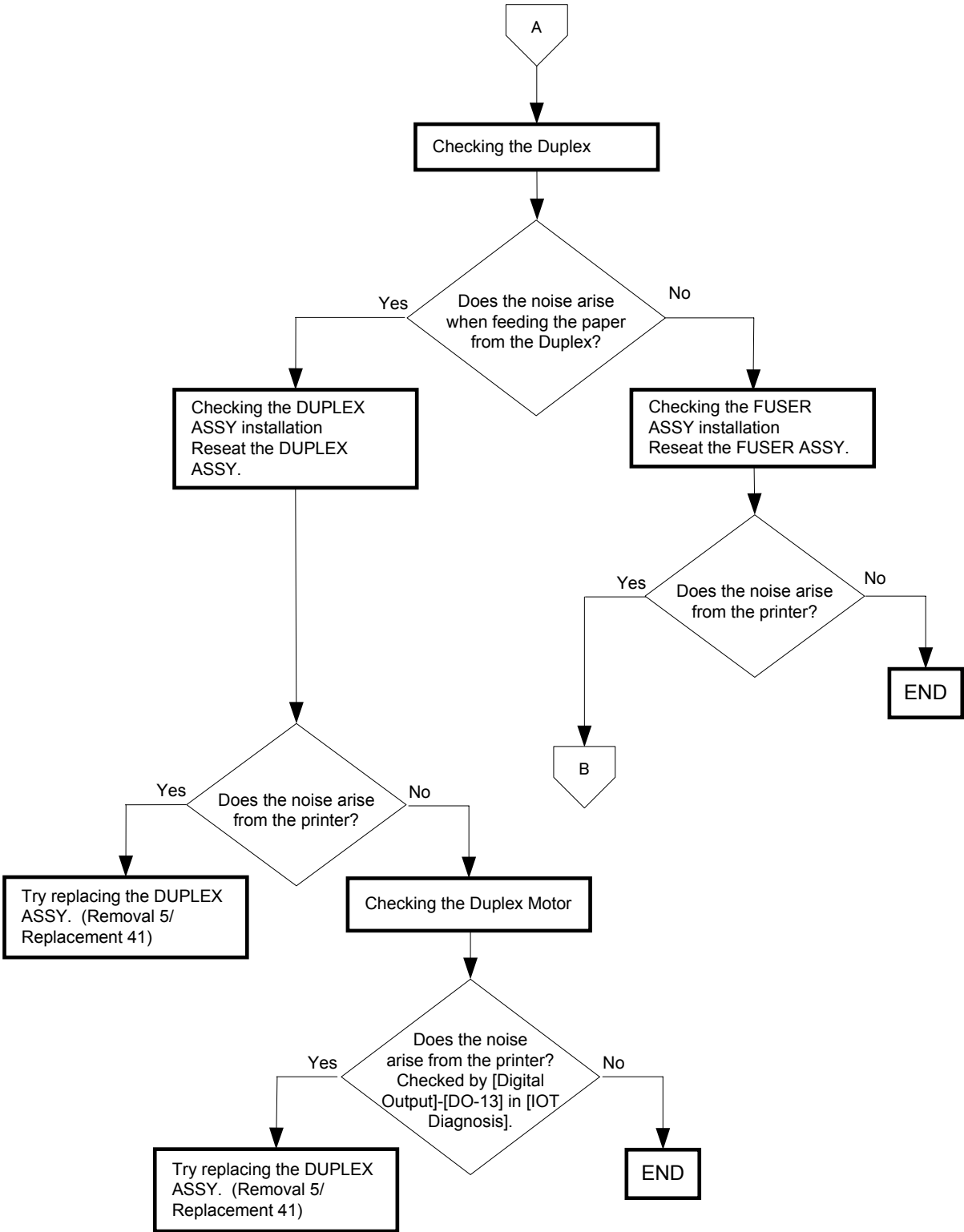

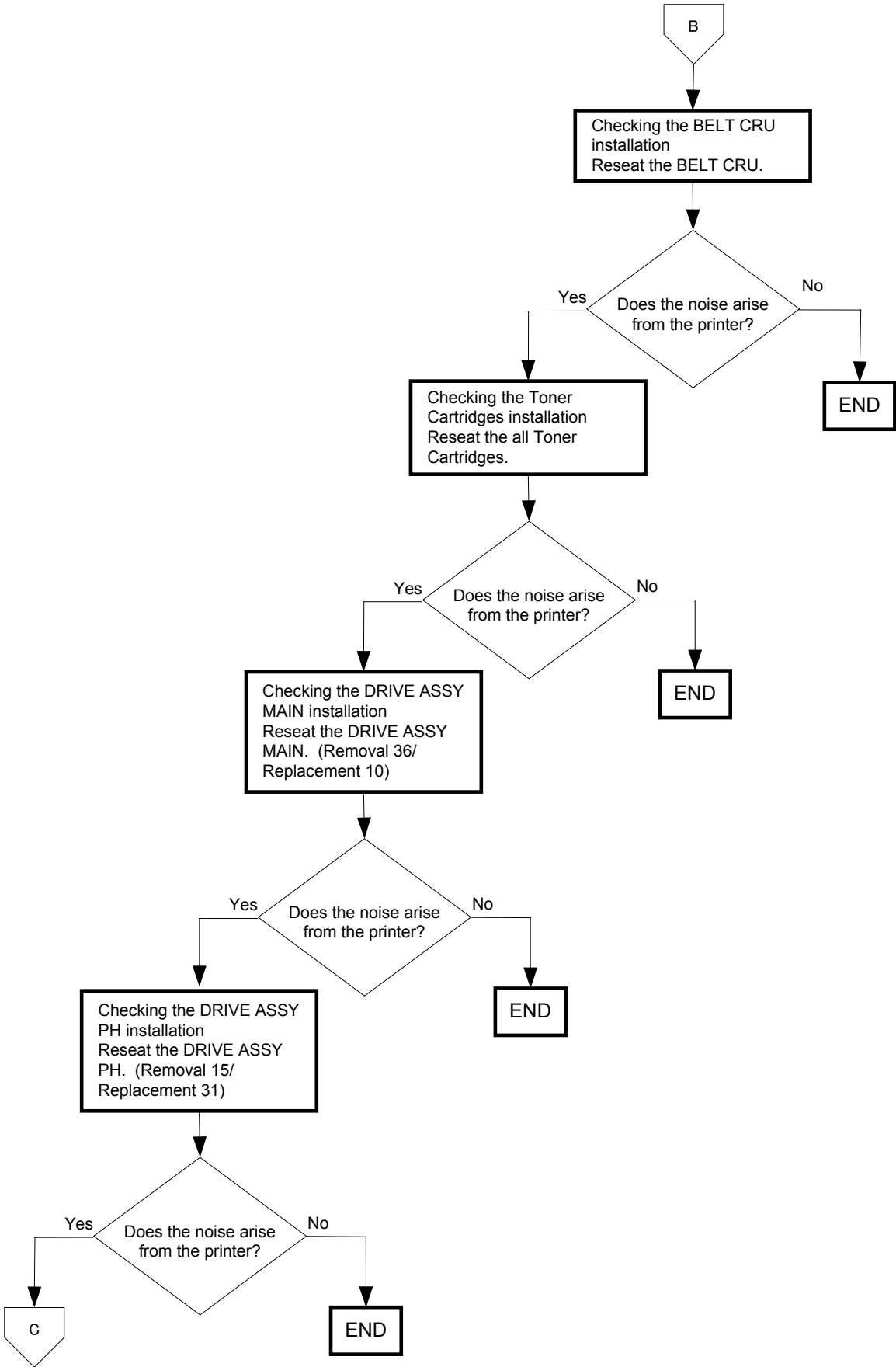

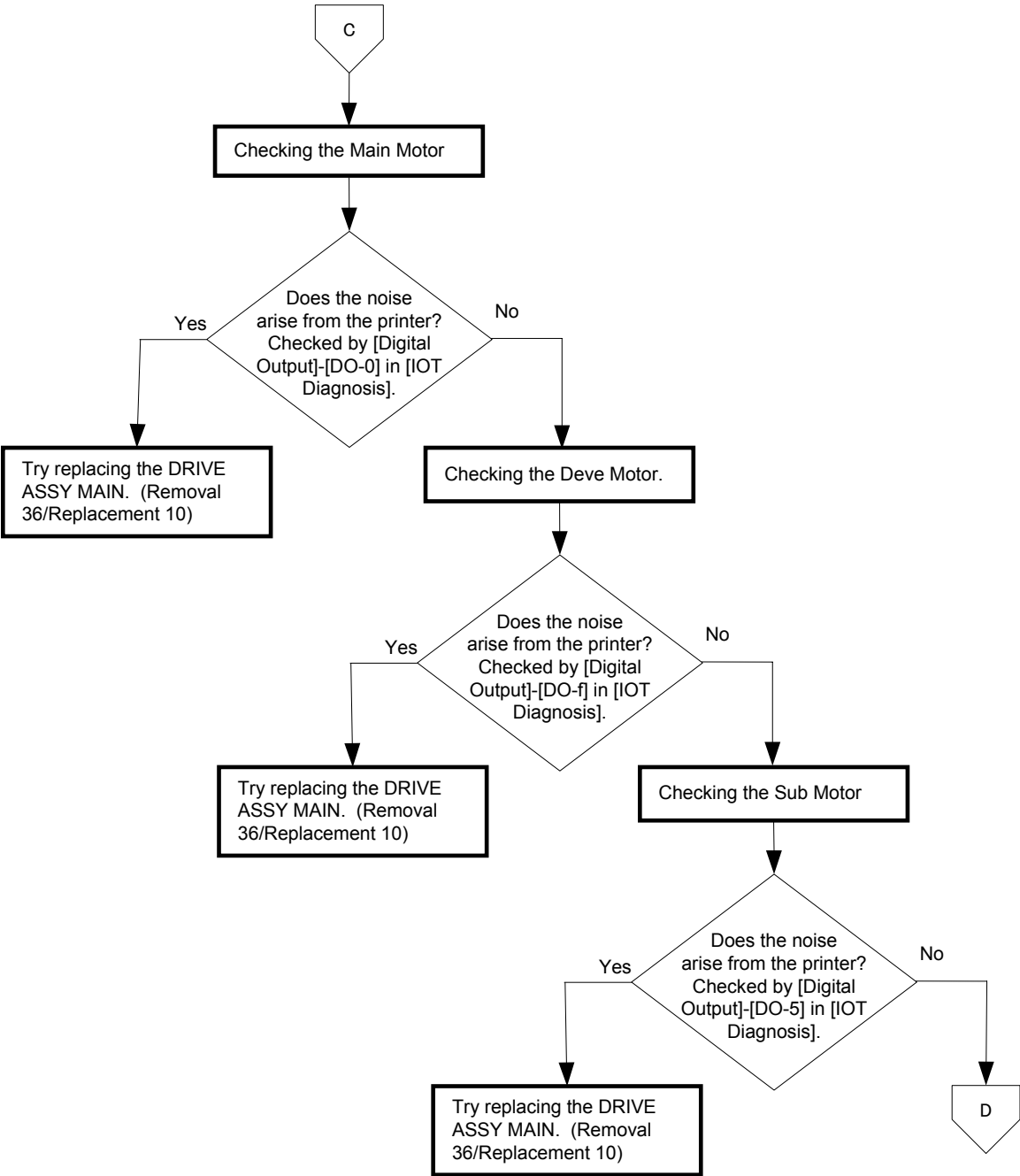

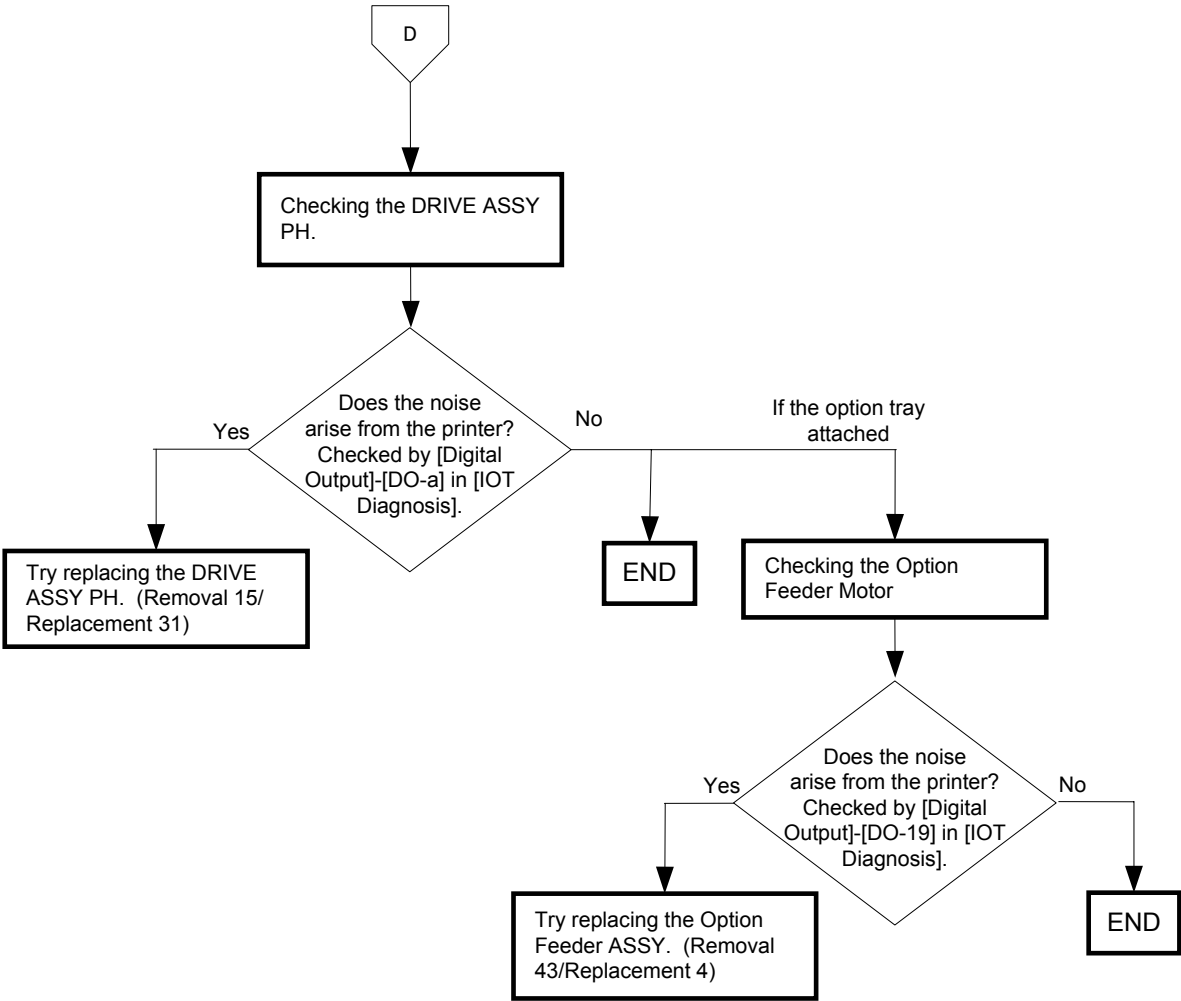

6. Other FIP

Other FIP covers the power supply trouble FIP, except error code FIP, Noise FIP and image quality FIP.

FIP-AC

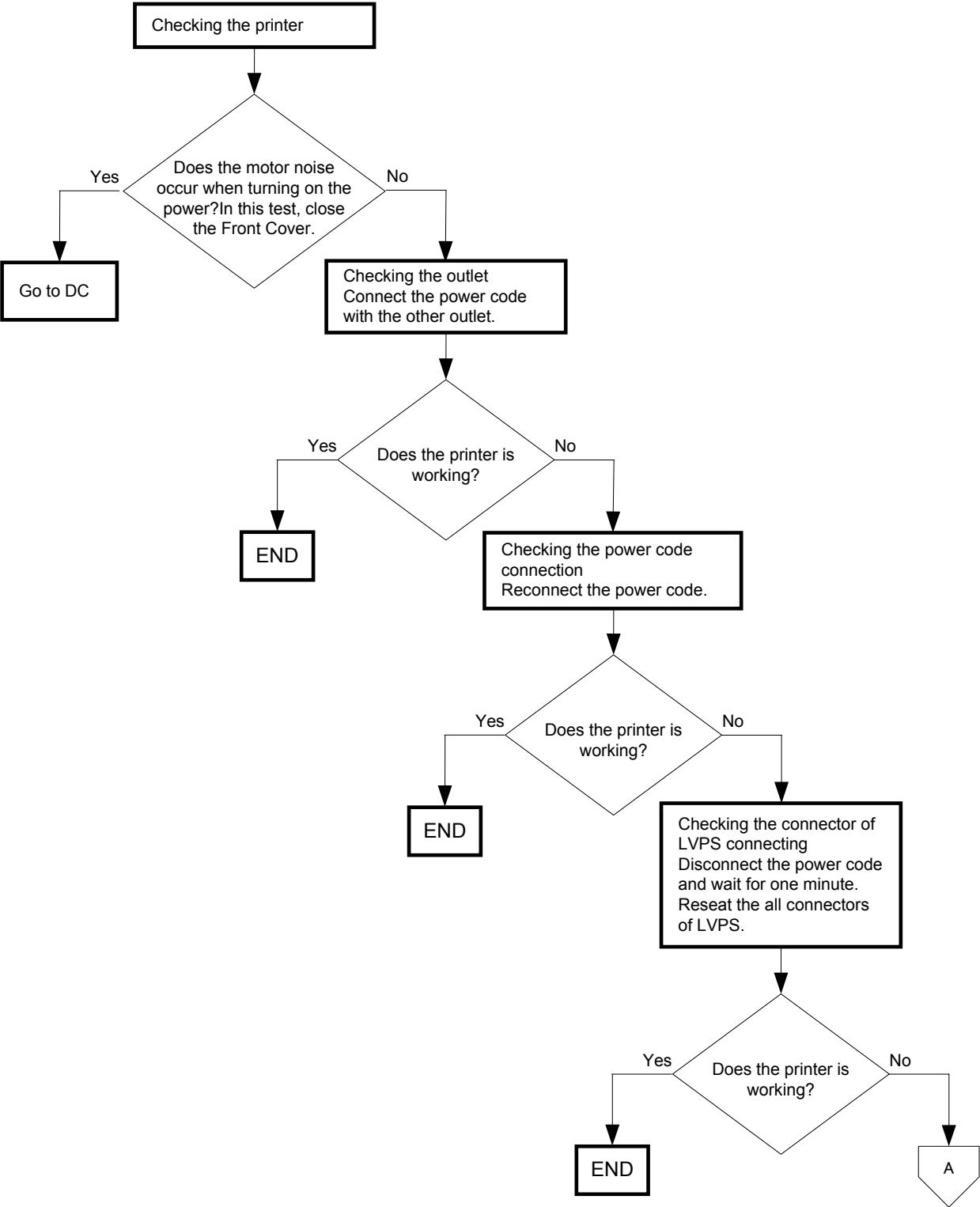

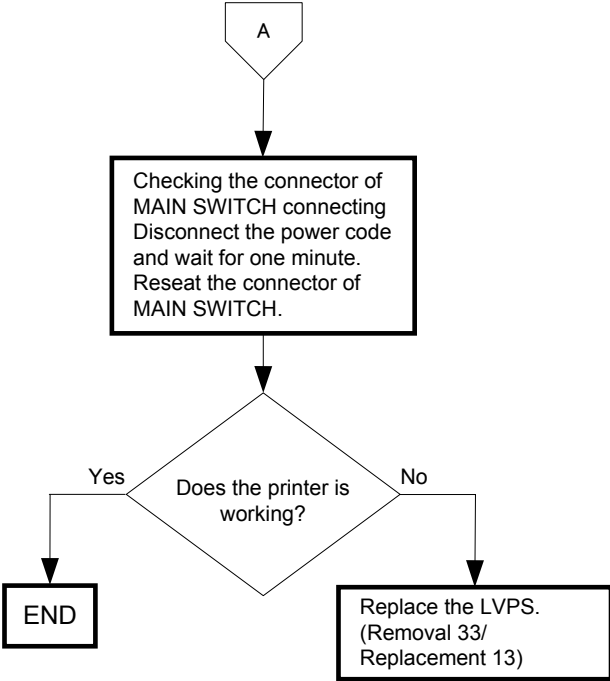

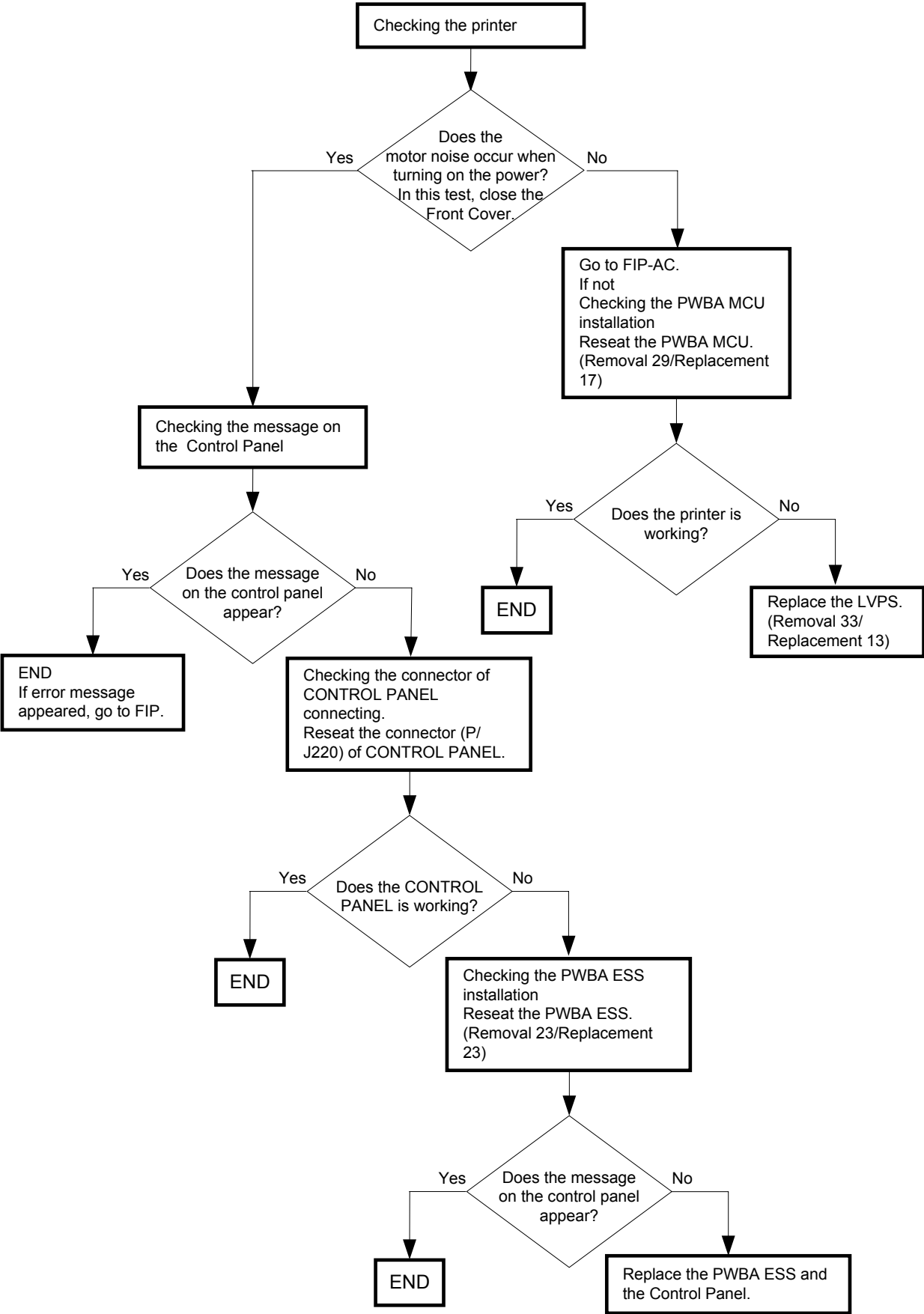

FIP-Multiple feed

Possible causative parts:KIT SEPARATOR ROLLER ASSEMBLY (PL2.1.99)
KIT SEPARATOR AND FEEDER ROLLER (PL2.2.99/PL12.3.99)

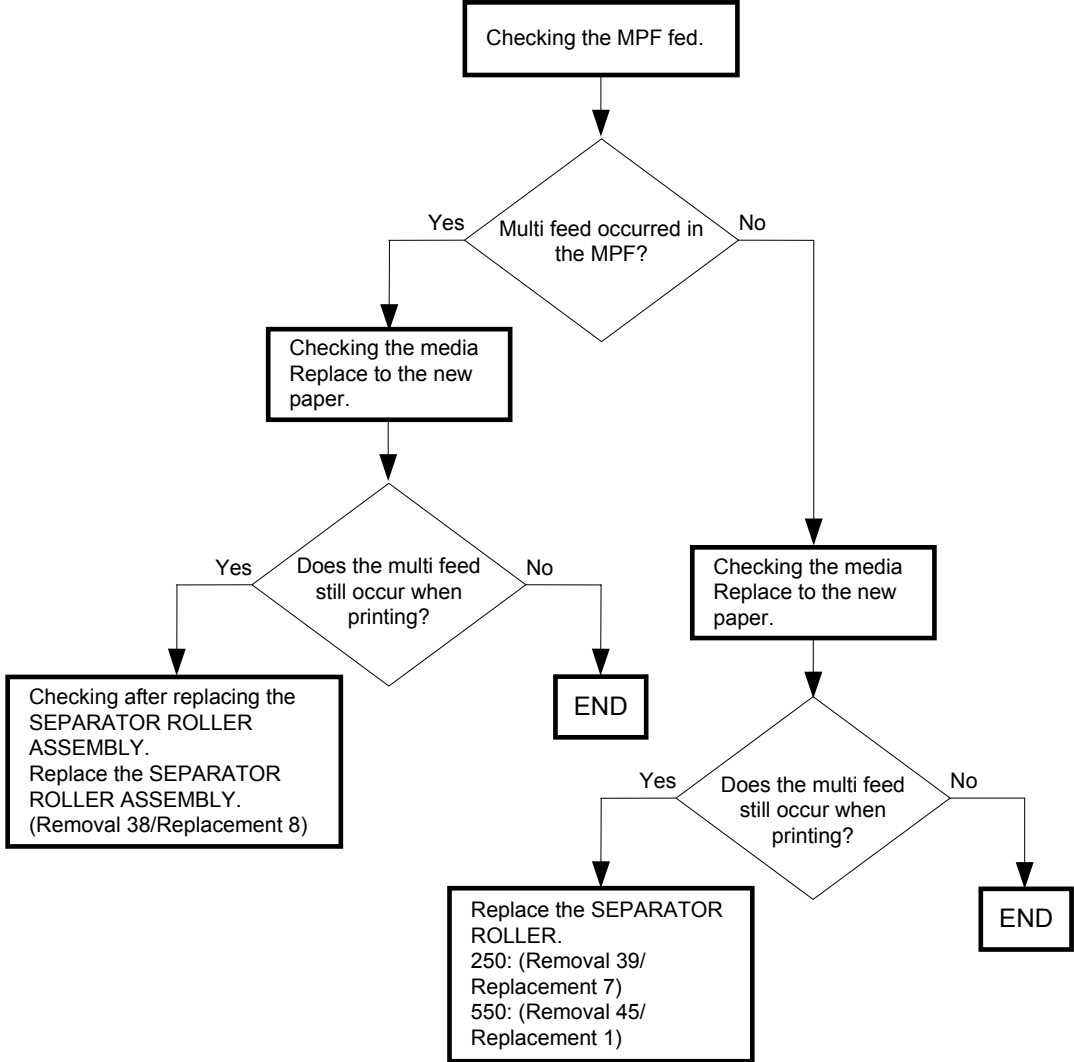

Chapter 2 Operation of Diag. CONTENTS

1. Overview.....	2 - 1
1.1 Position of the Diag. in the Whole System.....	2 - 1
2. Configuration	2 - 2
3. How to use Diag. Customer Mode.....	2 - 3
3.1 Roles of the control panel in Diag.	2 - 3
3.2 Entering diag. Customer mode	2 - 4
3.3 Selecting Diag. item	2 - 4
3.4 Change method parameters value.....	2 - 4
3.5 Executing/Exiting Diag. mode	2 - 4
3.6 Diag. mode menu tree	2 - 5
4. The Kind of Diag. and Contents of a Test	2 - 7
4.1 ESS Diag	2 - 7
4.1.1 Executing ESS diagnosis.....	2 - 7
4.1.2 All Test.....	2 - 7
4.1.3 CodeROM Test.....	2 - 7
4.1.4 FontROM Test	2 - 8
4.1.5 EEPROM Test	2 - 8
4.1.6 DRAM Test	2 - 8
4.1.7 MAC+PHY Test	2 - 9
4.1.8 ASIC Test.....	2 - 9
4.1.9 PANEL Test.....	2 - 9
4.1.10 IOT Test.....	2 - 10
4.2 IOT Diag.....	2 - 11
4.2.1 Digital Input (DI) Test.....	2 - 11
4.2.2 Executing digital input (DI) test	2 - 11
4.2.3 Digital Output (DO) Test	2 - 22
4.2.4 Executing digital output (DO) test	2 - 22
4.3 Print Info.....	2 - 46
4.3.1 Config Page	2 - 46
4.3.2 Print Settings.....	2 - 46
4.4 Complete.....	2 - 46
4.4.1 Complete.....	2 - 46
4.5 Test Print.....	2 - 47
4.5.1 Executing test print	2 - 47
4.5.2 No Image [IOT]	2 - 47
4.5.3 Test Pattern 600[IOT]	2 - 47
4.5.4 Grid2	2 - 48
4.5.5 Cyan 20%	2 - 49
4.5.6 Magenta 20%.....	2 - 49
4.5.7 Yellow 20%	2 - 50
4.5.8 Black 20%	2 - 50
4.5.9 CMY 20%.....	2 - 51
4.5.10 Gradation	2 - 52
4.5.11 Toner Pallet Check	2 - 53
4.5.12 Contamination Check.....	2 - 54

Chapter 2 Operation of Diag. CONTENTS

4.5.13 Parameter Setting	2 - 55
4.5.14 Printing the parameter list	2 - 57

1. Overview

1.1 Position of the Diag. in the Whole System

Major functions of this diag. are as follows:

- ESS diagnosis to locate a chip which causes a problem
- IOT Diag
- Setting of parameters for registration in paper feeding direction and so on.

2. Configuration

The diagnosis provides three modes that have their respective uses (purposes), target operators, and functions.

Shipper Mode:

This mode intends to be used in the production line with the purpose to locate a chip that causes a problem.

Diagnosis time in the mode shall be as short as possible with consideration of production cost.

The mode shifts to the Developer mode (described later) after the ESS Diag.

This mode is protected password.

Customer Mode:

This mode intends to be used by customer who handle problems in field with the purpose to locate a replaceable unit that causes a problem.

Sorting problems on the basis of parts that can be replaced by the customer support center.

This is the base of this mode design, and that is why so many features.

The mode allows the user to execute the ESS diagnosis, test prints, parameter settings and so on through the control panel.

Developer/CE (Customer Engineer) Mode:

This mode is for debugging by developers or CEs. It intends to be partially used in the production line.

The mode allows the user to execute the ESS diagnosis, test prints, parameter settings and so on through the debug terminal.

The functions are activated by commands sent from the serial terminal. Special tool (FX internal debugging terminal) is required to operate Developer mode.

This mode is protected password.

3. How to use Diag. Customer Mode

3.1 Roles of the control panel in Diag.

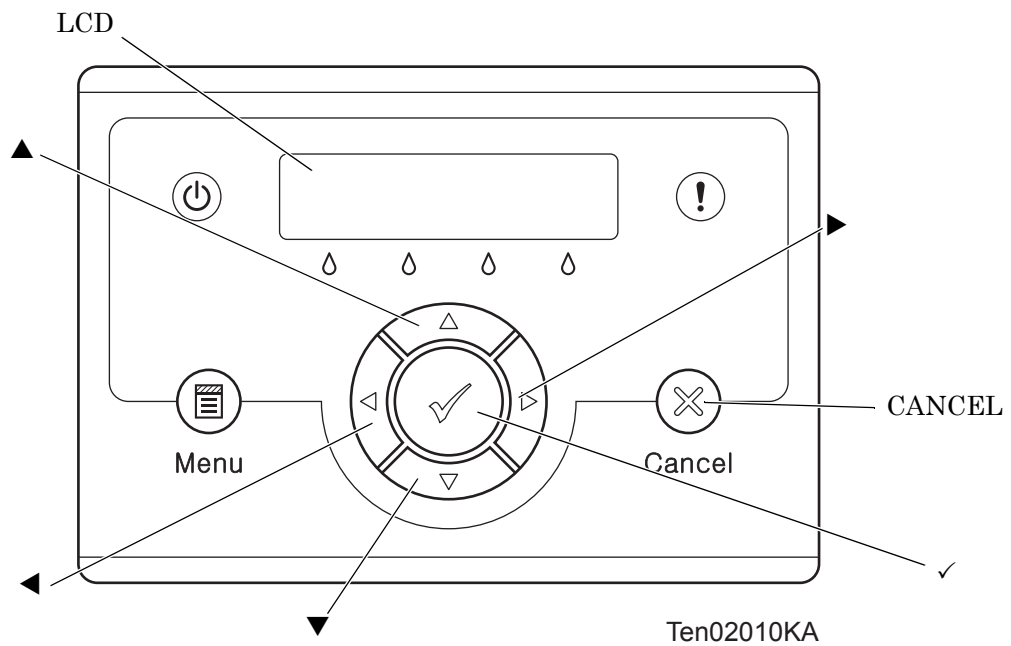

[LCD]:Displaying a diagnosis item and its result

[▲], [▼]:Selecting a diagnosis item/Selecting data at parameter setting

[◀], [▶]:Key moves the cursor to the left/right

[✓]: Determining a diagnosis item/Executing a diagnosis/Determining a parameter at parameter setting

[CANCEL]:Reseting a diagnosis item (Returning to the menu one level higher)
Terminating each digital input/output

3.2 Entering diag. Customer mode

- 1) Turn off the power.
- 2) Turn on the power while holding down “▲” and “▼” keys.
- 3) Release the fingers from these keys when “Diagnosing...” is displayed.
- 4) The “Customer Mode” and “ESS Diag” are displayed. (Entered the Diag. mode.)

3.3 Selecting Diag. item

The diagnosis setting items are configured as menus, which can be operated with the control panel keys. Arrow keys select menu items and “✓” key activates functions.

3.4 Change method parameters value

For parameter setting, pressing “✓” key after selecting an item from the menu displays the current setting value of the item. Then a numeric value selected by “▼” and “▲” keys are written into the NVM by “✓” key.

3.5 Executing/Exiting Diag. mode

The diagnosis can be executed by as follows.

- 1) A test item is displayed. “✓” key fixed the test item.
- 2) The display prompts the user to start the test. Press “✓” key and start the test.

The diagnosis can be stopped by as follows.

- 1) During the diagnosis test, press “CANCEL” key.
- 2) The diagnosis is stopped, and the display indicates the one step higher menu.

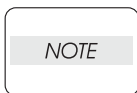

If an error occurs during the diag. sequence, the diagnosis displays the error and stops, leaving the remaining items unperformed.

Pressing “CANCEL” or “✓” key releases the error display, and then the menu items are displayed.

3.6 Diag. mode menu tree

Menu Tree of the Customer Mode is as follows

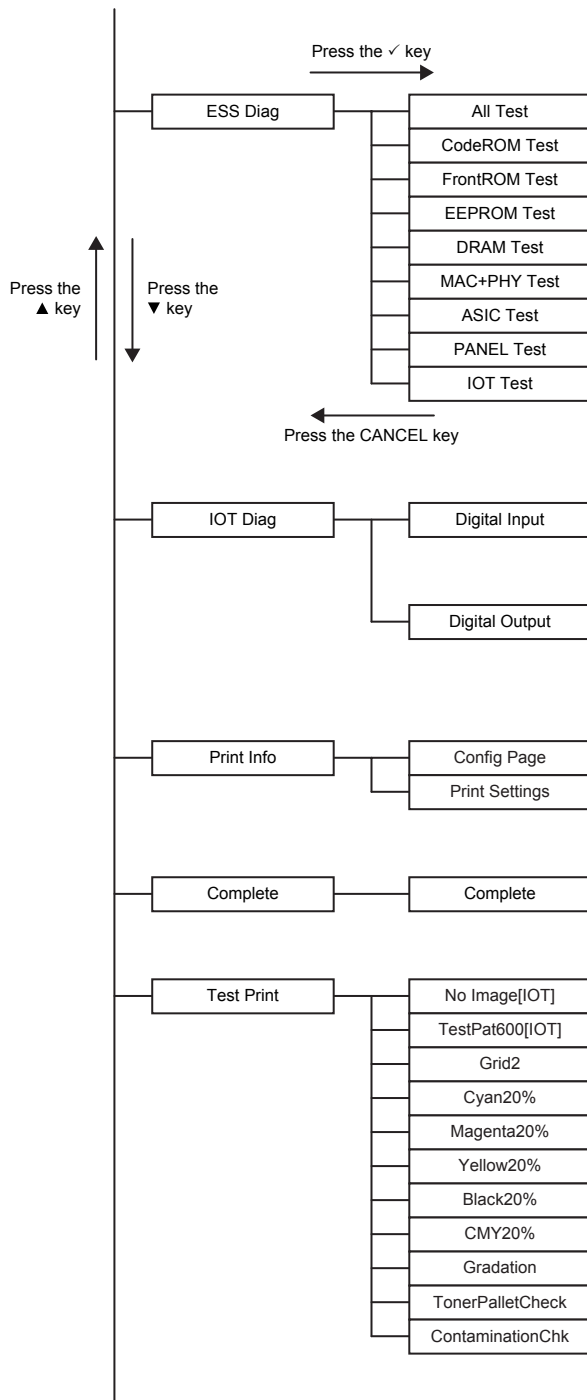

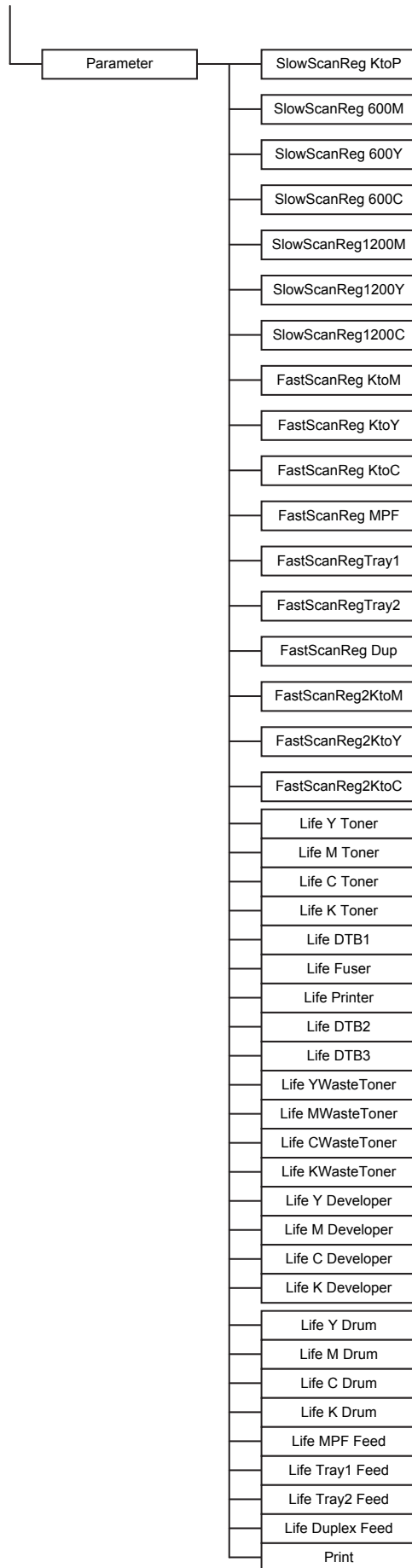

4. The Kind of Diag. and Contents of a Test

4.1 ESS Diag

This section describes how to perform each test of the ESS Diag in detail.

4.1.1 Executing ESS diagnosis

- 1) Turn off the power.
- 2) Turn on the power while holding down “▲” and “▼” keys.
- 3) Release the fingers from these keys when “Diagnosing...” is displayed.
- 4) The “Customer Mode” and “ESS Diag” are displayed. (Entered the Diag. mode.)
- 5) Press “✓” key.
- 6) Press “▲” or “▼” key to select the test item.
- 7) Press “✓” key twice to execute the test.

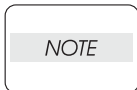

To exit the test or to returning to one step higher menu, press “CANCEL” key.

4.1.2 All Test

This test executes the all tests of the ESS diagnostic except the MAC+PHY test and PANEL test.

Normal	Error
CHECK OK	*** ERROR

***:Displays the test name that became error.

(CodeROM/FontROM/EEPROM/DRAM/ASIC/IOT/HD)

4.1.3 CodeROM Test

Calculates the ROM checksum and compares it with the value stored in the ROM.

Executes this test when the 016-317 error occurred.

Test result: NG (Go to FIP.) OK (Turn off/on the main power.)

This test calculates the checksum of the each ROM, and compares it with the valid checksum value stored in the corresponding chip beforehand. When the checksum is identical to the stored value, this test judges the chip is normal.

Normal	Error
CHECK OK	CodeROM #* ERROR S=xxxx V=yyyy (xxxx:calculated value yyyy:ROM stored value *:0,1)

4.1.4 FontROM Test

Calculates the Font ROM checksum and compares it with the value stored in the FontROM.

Executes this test when the 016-310 error occurred.

Test result: NG (Go to FIP.) OK (Turn off/on the main power.)

This test calculates the checksum of the each FontROM, and compares it with the valid checksum value stored in the corresponding chip beforehand. When the checksum is identical to the stored value, this test judges the chip is normal.

Normal	Error
CHECK OK	FontROM ERROR S=xxxx V=yyyy (xxxx:calculated value yyyy:ROM stored value)

4.1.5 EEPROM Test

Performs write/read/verify on the diag. area of the EEPROM.

Executes this test when the 016-327 and 016-323 errors occurred.

Test result: NG (Go to each FIP.) OK (Turn off/on the main power.)

The test performs read/write/verify of the test patterns (0xff,0xaa, 0x55 and 0x00) on one byte at every 0x400 from the first address of EEPROM.

Normal	Error
CHECK OK	EEPROM ID* ERROR (ID*:1,2)

4.1.6 DRAM Test

Tests OPEN/SHORT with the address line of the DRAM.

Performs write/read/verify on the entire DRAM.

Executes this test when the 016-315, 016-316, 016-318 and 016-332 errors occurred.

Test result: NG (Go to each FIP.) OK (Turn off/on the main power.)

When the optional DRAM SIMM is checked and found, it checks the optional memory area.

First, the test performs read/write/verify of the increment data for the whole tested area by the word. Then, it performs read/write/verify of the test patterns (0xffffffff, 0xaaaaaaaa, 0x55555555, 0x00000000) for the whole tested area by the word.

Normal	Error
CHECK OK	DRAM slot* ERROR (*AF0,1)

4.1.7 MAC+PHY Test

MAC: Media Access Control

PHY: Physical Layer

PHY Internal loopback test

Executes this test when the 016-334, 016-340, 016-344, 016-345 and 016-346 errors occurred.

Test result: NG (Go to each FIP.) OK (Turn off/on the main power.)

PHY Internal loopback test

Normal	Error
CHECK OK	MAC+PHY ERROR

4.1.8 ASIC Test

Register check

Executes this test when the 016-313 error occurred.

Test result: NG (Go to FIP.) OK (Turn off/on the main power.)

ASIC register check.

Normal	Error
CHECK OK	ERROR

4.1.9 PANEL Test

Tests the LED, LCD, and buttons of the control panel.

This test checks input and output of the control panel. When buttons are pressed in the manner shown in the following table, the test displays the corresponding contents on the LED and LCD.

Button	LED	LCD
▲	■ ■	Displays " UP " on the LCD.
▼	■ ■	Displays " DOWN " on the LCD.
◀	■ □	Displays " LEFT " on the LCD.
▶	■ □	Displays " RIGHT " on the LCD.
✓	□ ■	Displays " SET " on the LCD.
MENU	□ ■	Displays " MENU " on the LCD.
CANCEL	□ □	Displays " CANCEL " on the LCD.
▲ ▼ pressed at the same time	- (The test is completed)	Displays " Start " on the LCD.

□□ Indicates left side square is the Ready LED (Green) and right side square is the Alarm LED (Amber). □Not lighting ■Lighting

4.1.10 IOT Test

Communication test with the IOT

Executes this test when the 016-370 error occurred.

Test result: NG (Go to FIP.) OK (Turn off/on the main power.)

This test checks communication with the IOT. Then it reads the status register of the IOT to check whether commands can be exchanged with the IOT.

It sends the following command to read the status register, and checks whether the appropriate response returns.

Read ROM Revision No

Normal	Error
CHECK OK	IOT ERROR

4.2 IOT Diag

4.2.1 Digital Input (DI) Test

This function checks whether the DI components operate normally or not.

The DI test is performed for all the DI components.

Exit operation of the DI test makes the control panel display the Customer diag. function menu.

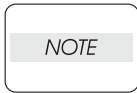

During the DI test, other Customer diag. functions can not be performed simultaneously. Therefore, the printer does not accept any operation except operations for the DI components and exit operation of the DI test.

At the start of the DI test, number “0” is displayed on the control panel. This number is counted up when a DI component is turned on from off, therefore it allows the user to know the component is active.

When a paper jam is occurred, or an error message or code is displayed, execute this test to locate the damaged parts.

The test will execute the DI Test codes of the components that are supposed to be faulty from the error details. (Refer to each FIP on Chapter 1.)

Test result: NG (Go to each FIP or replace the parts.)

OK (Turn off/on the main power.)

4.2.2 Executing digital input (DI) test

- 1) Turn off the power.
- 2) Turn on the power while holding down “▲” and “▼” keys.
- 3) Release the fingers from these keys when “Diagnosing...” is displayed.
- 4) The “Customer Mode” and “ESS Diag” are displayed. (Entered the Diag. mode.)
- 5) Press “▼” to select “IOT Diag”, and then press “✓” key.
- 6) Press “▼” key to select “Digital Input”, and then press “✓” key.
- 7) Press “▲” or “▼” key to select the test item.
- 8) Press “✓” key twice to execute the test.

Parameters for the Digital Input Test are as follows.

Code	Components
DI-1	Dup Jam sensor
DI-2	Exit Sensor
DI-3	Regi Sensor
DI-4	ROS Ready (Not Used)
DI-7	Front Cover Interlock Switch
DI-8	Yellow Toner Cartridge Sensor
DI-9	Magenta Toner Cartridge Sensor
DI-a	Black Toner Cartridge Sensor
DI-b	Cyan Toner Cartridge Sensor
DI-d	Tray 2 No Paper sensor
DI-e	Duplex Fan Alarm (Not Used)
DI-f	Teay 2 Feed Motor Alarm (Not Used)
DI-10	MPF No Paper Sensor
DI-11	Tray 1 No Paper Sensor

Code	Components
DI-12	Main Motor Alarm (Not Used)
DI-13	Sub Motor Alarm (Not Used)
DI-14	OHP Sensor (Not Used)
DI-15	Fan Alarm (Not Used)
DI-16	Feed Drive Alarm (Not Used)
DI-17	Deve Motor Alarm (Not Used)
DI-18	Tray 1 Paper Size Switch
DI-20	Tray 2 Paper Size Switch

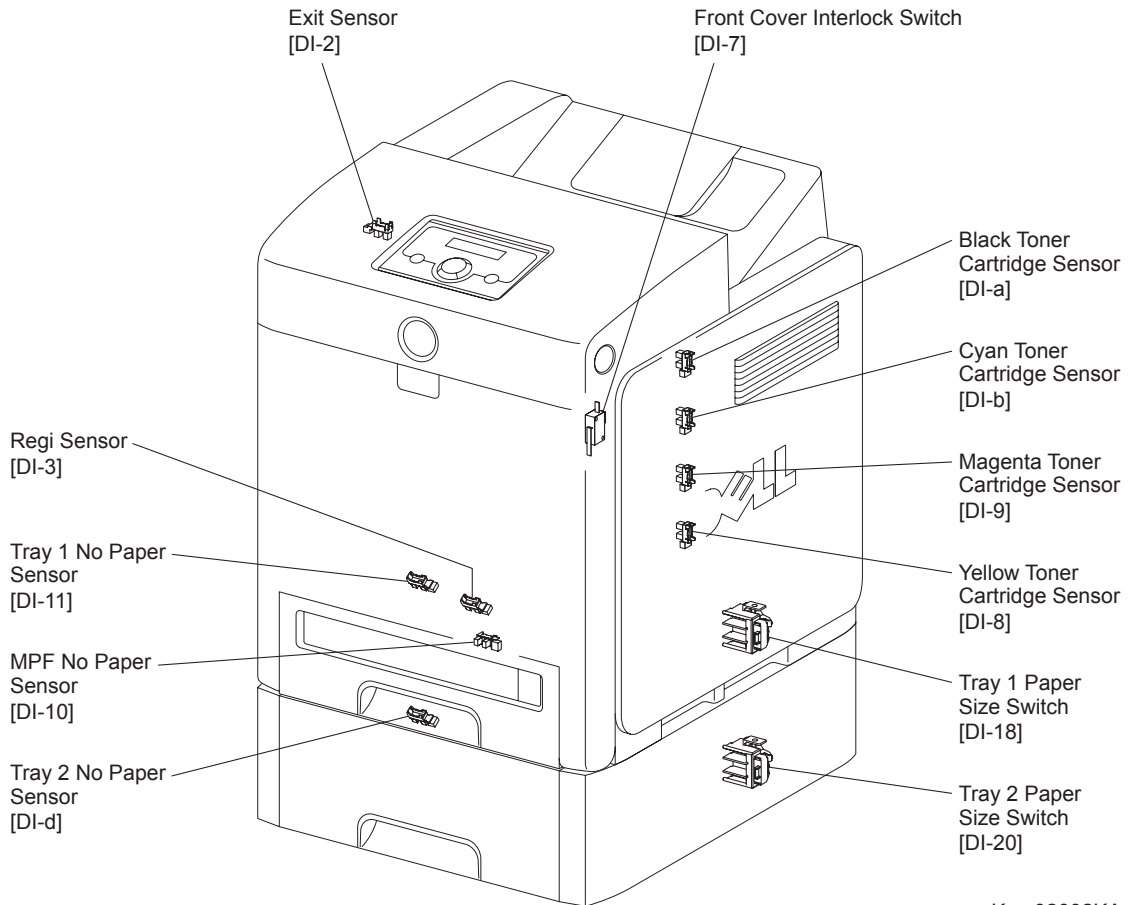

Kmy02002KA

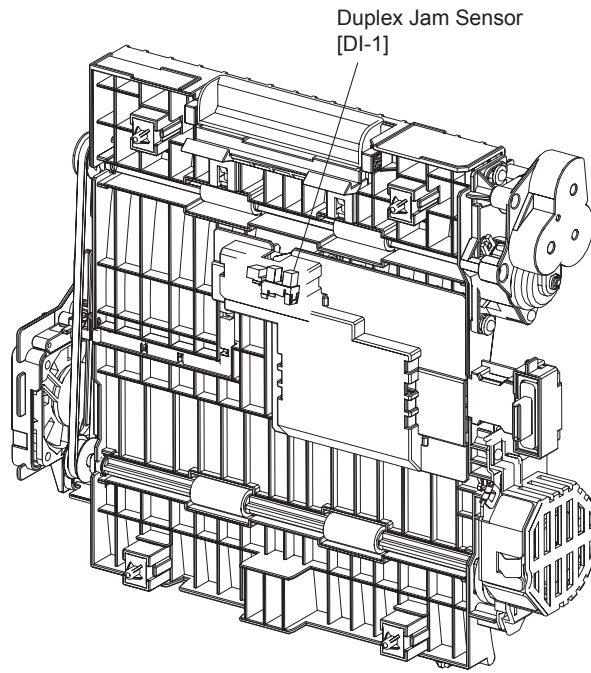

Kmy02042KA

- About Sensor

A transmissive type sensor is composed of the light-emitting side and the light-receiving side that are placed opposite to each other allowing the light to pass from the former to the latter. On the basis of whether or not the light path is blocked due to the actuator, etc., the sensor detects the paper absence/presence or the moving part position such as at the home position or elsewhere.

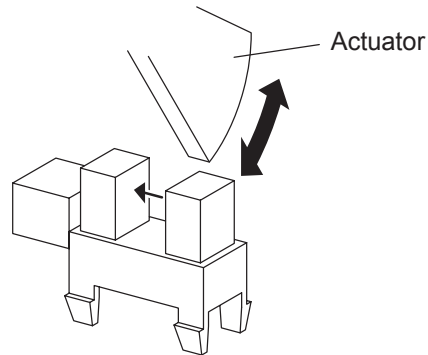

Leg_Sec02_016FA

- About Switch

A micro-switch closes the internal contacts via the button which is pushed down under the provided leaf spring which is held down by the actuator of the cover or door that is being closed. When the door or cover has been opened, the leaf spring returns to its original position and the button is pushed up by the spring in the switch, allowing the internal contacts to open.

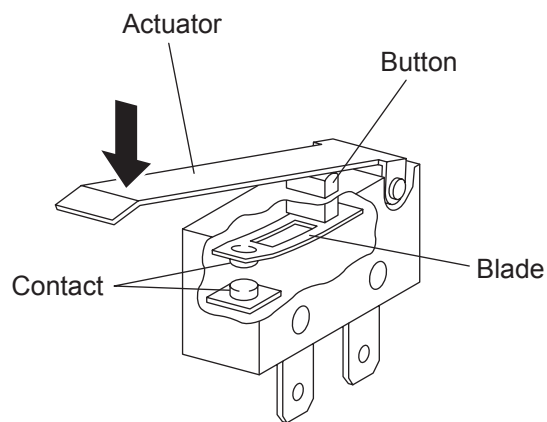

Leg_Sec02_018FA

-Checking the Sensor and Switch

Sensor name (Diag. Code)	Confirmation procedures
Duplex Jam Sensor (DI-1)	<p>NOTE:When performing operation for five minutes or longer with the front cover open, remove all toner cartridges, and cover the drum to avoid exposure to light.</p> <ol style="list-style-type: none"> 1) Turn on the power and enter the Diagnostic Mode. 2) Execute the DI-1. 3) Open the Front Cover. 4) Remove the Transfer Belt. 5) Check the sensor. <div data-bbox="783 539 1265 1294" style="text-align: center;"> <p>The diagram illustrates the sensor's operation. On the left, an 'Actuator' is shown being pressed, with a double-headed arrow indicating its movement. On the right, the 'Operator Panel' displays the 'Digital Input' status. Initially, it shows 'DI-1 L 0'. An arrow labeled 'Normal' points down to a second display showing 'DI-1 L 1'. Below this, a cutaway view of the printer's internal mechanism shows the sensor's location, with a line connecting it to the actuator in the diagram above. The reference code 'Kmy02003KA' is located at the bottom right of the diagram.</p> </div> <ol style="list-style-type: none"> 6) Press the "Cancel" key to stop the test. 7) Replace the Transfer Belt. 8) Close the Front Cover.

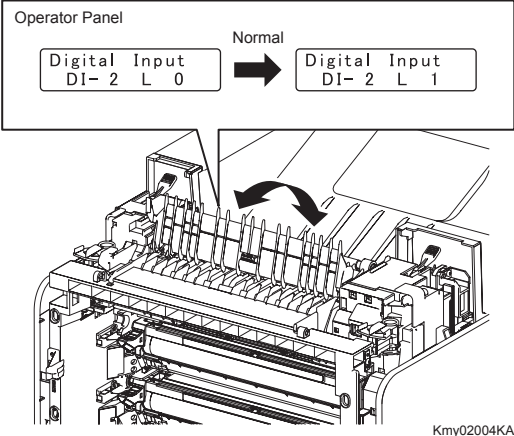
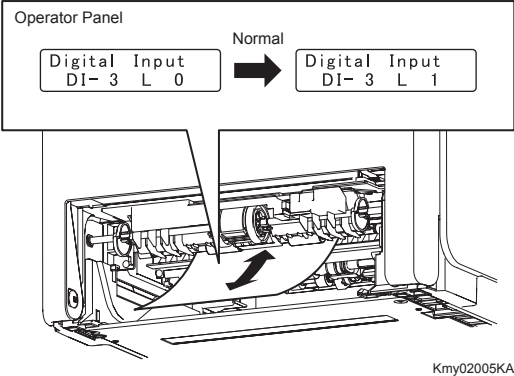
Sensor name (Diag. Code)	Confirmation procedures
Exit Sensor (DI-2)	<p>NOTE: Fuser is very hot, so pay sufficient attention at work to above burns, etc.</p> <ol style="list-style-type: none"> 1) Turn on the power and enter the Diagnostic Mode. 2) Execute the DI-2. 3) Open the Front Cover. 4) Check the sensor. <div data-bbox="767 412 1283 846" style="border: 1px solid black; padding: 5px;"> <p>Operator Panel</p> <div style="display: flex; justify-content: space-around; align-items: center;"> <div style="border: 1px solid black; padding: 2px;">Digital Input DI- 2 L 0</div> <div style="font-size: 2em;">➔</div> <div style="border: 1px solid black; padding: 2px;">Digital Input DI- 2 L 1</div> </div> <p style="text-align: center; margin: 0;">Normal</p>  <p style="text-align: right; font-size: 0.8em;">Kmy02004KA</p> </div> <ol style="list-style-type: none"> 5) Press the "Cancel" key to stop the test. 6) Close the Front Cover.
Regi Sensor (DI-3)	<ol style="list-style-type: none"> 1) Turn on the power and enter the Diagnostic Mode. 2) Execute the DI-3. 3) Remove the 250 paper cassette. 4) Insert the paper into the paper path of the Regi assy. <div data-bbox="767 1099 1283 1473" style="border: 1px solid black; padding: 5px;"> <p>Operator Panel</p> <div style="display: flex; justify-content: space-around; align-items: center;"> <div style="border: 1px solid black; padding: 2px;">Digital Input DI- 3 L 0</div> <div style="font-size: 2em;">➔</div> <div style="border: 1px solid black; padding: 2px;">Digital Input DI- 3 L 1</div> </div> <p style="text-align: center; margin: 0;">Normal</p>  <p style="text-align: right; font-size: 0.8em;">Kmy02005KA</p> </div> <ol style="list-style-type: none"> 5) Press the "Cancel" key to stop the test. 6) Replace the 250 paper cassette.
ROS Ready (DI-4)	Internal signal.

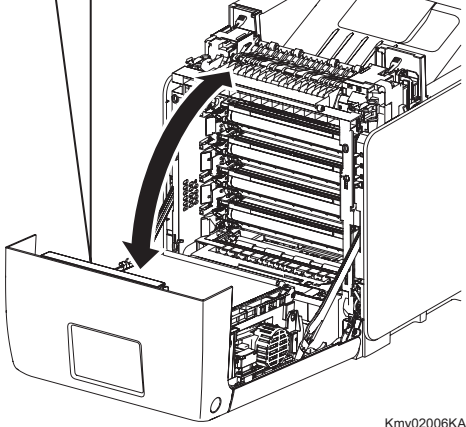
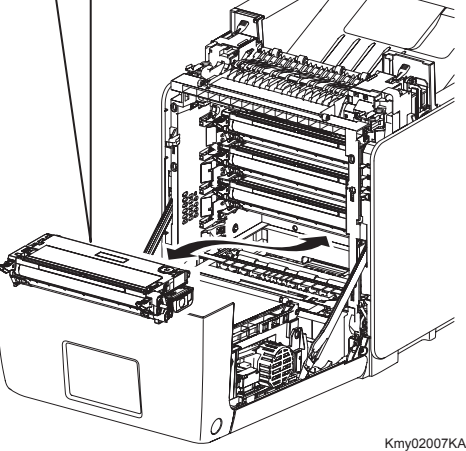
Sensor name (Diag. Code)	Confirmation procedures
<p>Interlock Switch (DI-7)</p>	<ol style="list-style-type: none"> 1) Turn on the power and enter the Diagnostic Mode. 2) Execute the DI-7. 3) Check the Switch <div data-bbox="764 315 1283 875" style="text-align: center;"> <p>Operator Panel</p> <div style="display: flex; justify-content: space-around; align-items: center;"> <div style="border: 1px solid black; padding: 2px;">Digital Input DI- 7 L 0</div> <div style="font-size: 2em;">➔</div> <div style="border: 1px solid black; padding: 2px;">Digital Input DI- 7 L 1</div> </div> <p style="margin-left: 100px;">Normal</p>  <p style="text-align: right; font-size: 0.8em;">Kmy02006KA</p> </div> <ol style="list-style-type: none"> 4) Press the "Cancel" key to stop the test. 5) Close the Front Cover.
<p>Yellow Toner Cartridge (DI-8)</p>	<p>NOTE: When performing operation for five minutes or longer with the front cover open, remove all toner cartridges, and cover the drum to avoid exposure to light.</p> <ol style="list-style-type: none"> 1) Turn on the power and enter the Diagnostic Mode. 2) Execute the DI-8. 3) Open the Front Cover 4) Check the Sensor. <div data-bbox="764 1227 1283 1809" style="text-align: center;"> <p>Operator Panel</p> <div style="display: flex; justify-content: space-around; align-items: center;"> <div style="border: 1px solid black; padding: 2px;">Digital Input DI- 8 L 0</div> <div style="font-size: 2em;">➔</div> <div style="border: 1px solid black; padding: 2px;">Digital Input DI- 8 L 1</div> </div> <p style="margin-left: 100px;">Normal</p>  <p style="text-align: right; font-size: 0.8em;">Kmy02007KA</p> </div> <ol style="list-style-type: none"> 5) Press the "Cancel" key to stop the test. 6) Close the Front Cover.

Sensor name (Diag. Code)	Confirmation procedures
<p>Magenta Toner Cartridge (DI-9)</p>	<p>NOTE: When performing operation for five minutes or longer with the front cover open, remove all toner cartridges, and cover the drum to avoid exposure to light.</p> <ol style="list-style-type: none"> 1) Turn on the power and enter the Diagnostic Mode. 2) Execute the DI-9. 3) Open the Front Cover 4) Check the Sensor. <div data-bbox="766 443 1284 1025" style="text-align: center;"> <p style="text-align: right; font-size: small;">Kmy02008KA</p> </div> <ol style="list-style-type: none"> 5) Press the "Cancel" key to stop the test. 6) Close the Front Cover.
<p>Black Toner Cartridge (DI-a)</p>	<p>NOTE: When performing operation for five minutes or longer with the front cover open, remove all toner cartridges, and cover the drum to avoid exposure to light.</p> <ol style="list-style-type: none"> 1) Turn on the power and enter the Diagnostic Mode. 2) Execute the DI-a. 3) Open the Front Cover 4) Check the Sensor. <div data-bbox="766 1373 1284 1955" style="text-align: center;"> <p style="text-align: right; font-size: small;">Kmy02010KA</p> </div> <ol style="list-style-type: none"> 5) Press the "Cancel" key to stop the test. 6) Close the Front Cover.

Sensor name (Diag. Code)	Confirmation procedures
<p>Cyan Toner Cartridge (DI-b)</p>	<p>NOTE: When performing operation for five minutes or longer with the front cover open, remove all toner cartridges, and cover the drum to avoid exposure to light.</p> <ol style="list-style-type: none"> 1) Turn on the power and enter the Diagnostic Mode. 2) Execute the DI-b. 3) Open the Front Cover 4) Check the Sensor. <div data-bbox="764 443 1283 1025" style="text-align: center;"> <p>Operator Panel</p> <p>Digital Input DI- b L 0 → Normal → Digital Input DI- b L 1</p> <p>Kmy02009KA</p> </div> <ol style="list-style-type: none"> 5) Press the "Cancel" key to stop the test. 6) Close the Front Cover.
<p>Tray 2 No paper Sensor (DI-d)</p>	<p>NOTE: The no paper sensor is in the option feeder.</p> <ol style="list-style-type: none"> 1) Turn on the power and enter the Diagnostic Mode. 2) Execute the DI-d. 3) Remove the Paper Cassete. 4) Check the Sensor. <div data-bbox="783 1308 1267 1912" style="text-align: center;"> <p>Actuator</p> <p>Operator Panel</p> <p>Digital Input DI- d H 0</p> <p>↓ Normal ↓</p> <p>Digital Input DI- d H 1</p> <p>Kmy02011KA</p> </div> <ol style="list-style-type: none"> 5) Press the "Cancel" key to stop the test. 6) Replace the paper cassette.

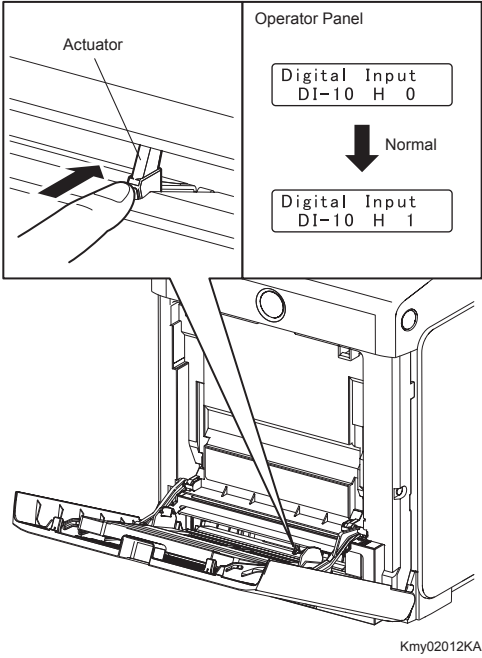
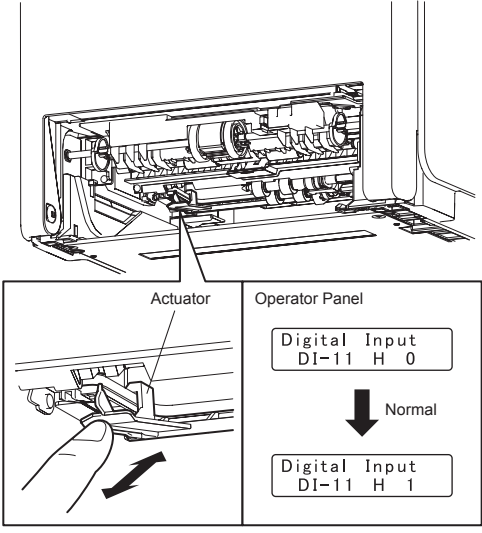
Sensor name (Diag. Code)	Confirmation procedures
Option Tray Feed Motor Alarm (DI-f)	Internal signal.
MPF No Paper Sensor (DI-10)	<p>NOTE: Remove the paper of the MPF before executing the test.</p> <ol style="list-style-type: none"> 1) Turn on the power and enter the Diagnostic Mode. 2) Execute the DI-10. 3) Open the MPF Cover. 4) Check the sensor. <div style="text-align: center;">  <p>The diagram shows a hand operating an actuator on the MPF cover. To the right, the Operator Panel displays 'Digital Input DI-10 H 0' at the top, followed by a downward arrow labeled 'Normal', and 'Digital Input DI-10 H 1' at the bottom. Below this is a detailed view of the MPF mechanism with the actuator highlighted.</p> </div> <p style="text-align: right; font-size: small;">Kmy02012KA</p> <ol style="list-style-type: none"> 5) Press the "Cancel" key to stop the test. 6) Close the MPF Cover.
Tray 1 No paper Sensor (DI-11)	<ol style="list-style-type: none"> 1) Turn on the power and enter the Diagnostic Mode. 2) Execute the DI-11. 3) Remove the paper cassette. 4) Check the sensor. <div style="text-align: center;">  <p>The diagram shows a hand operating an actuator on the paper cassette. To the right, the Operator Panel displays 'Digital Input DI-11 H 0' at the top, followed by a downward arrow labeled 'Normal', and 'Digital Input DI-11 H 1' at the bottom. Below this is a detailed view of the paper cassette mechanism with the actuator highlighted.</p> </div> <p style="text-align: right; font-size: small;">Kmy02013KA</p> <ol style="list-style-type: none"> 5) Press the "Cancel key to stop the test. 6) Replace the paper cassette.
Main Motor Alarm (DI-12)	Internal signal.
Sub Motor Alarm (DI-13)	Internal signal.

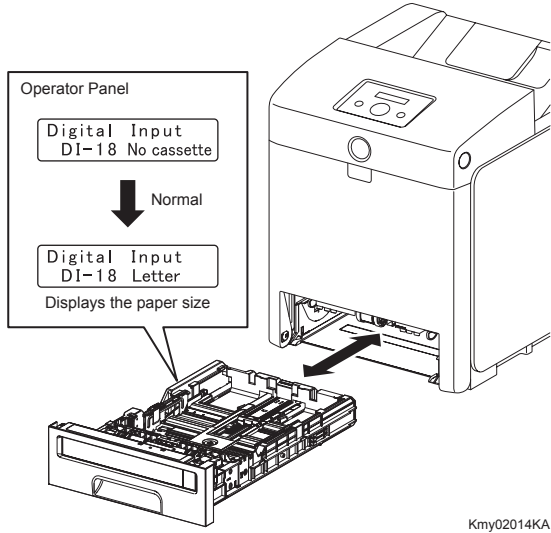
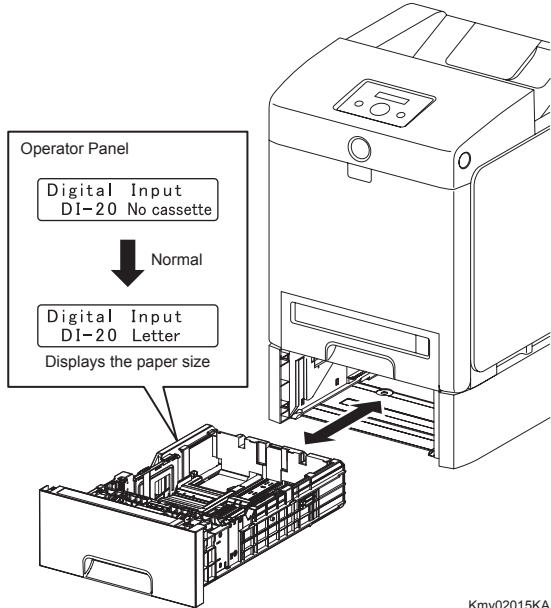
Sensor name (Diag. Code)	Confirmation procedures
OHP Sensor (DI-14)	Not used
FAN Alarm (DI-15)	Internal signal.
PH Motor Alarm (DI-16)	Internal signal.
DEVE Motor Alarm (DI-17)	Internal signal.
Tray 1 Paper Size Switch (DI-18)	<ol style="list-style-type: none"> 1) Turn on the power and enter the Diagnostic Mode. 2) Execute the DI-18. 3) Check the switch.  <p style="text-align: right;">Kmy02014KA</p> <ol style="list-style-type: none"> 4) Press the "Cancel key to stop the test. 5) Replace the paper cassette.
Tray 2 Paper Size Switch (DI-20)	<p>NOTE: The size switch is in the option feeder.</p> <ol style="list-style-type: none"> 1) Turn on the power and enter the Diagnostic Mode. 2) Execute the DI-20. 3) Check the switch.  <p style="text-align: right;">Kmy02015KA</p> <ol style="list-style-type: none"> 4) Press the "Cancel key to stop the test. 5) Replace the paper cassette.

4.2.3 Digital Output (DO) Test

This function checks whether the DO components operate.

When the interlock is opened while the DO test is performed, each component ends to operate.

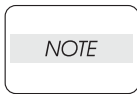

In this Test Mode, each DO component can be turned individually. Therefore it allows the customer to check a component's operation from outside, and judge whether the component is normal or not.

When all the diag. functions are stopped, all the DO components can be turned off.

DO test can make each of the DO components operate simultaneously.

When a paper jam or PQ problem is occurred, or an error message or code is displayed, this test enables to look for the broken or damaged parts.

Test result: NG (Go to each FIP or replace the parts.)

OK (Turn off/on the main power.)

4.2.4 Executing digital output (DO) test

- 1) Turn off the power.
- 2) Turn on the power while holding down “▲” and “▼” keys.
- 3) Release the fingers from these keys when “Diagnosing...” is displayed.
- 4) The “Customer Mode” and “ESS Diag” are displayed. (Entered the Diag. mode.)
- 5) Press “▼” key to select “IOT Diag”, and then press “✓” key.
- 6) Press “▼” key to select “Digital Output”, and then press “✓” key.
- 7) Press “▲” or “▼” key to select test item.
- 8) Press “✓” key to execute the test.

Parameters for the Digital Output Test are as follows.

Code	Components
DO-0,1,2,3	Main Motor
DO-5,6,7,8	Sub Motor
DO-a,b,c,d	Feed Drive
DO-f,10,11	Deve Motor
DO-13,14,16,17	Duplex Motor
DO-19,1a,1b,1c	Teay 2 Feed Motor
DO-1e,1f	Fan
DO-21	Yellow Toner Motor
DO-23	Magenta Toner Motor
DO-25	Cyan Toner Motor
DO-27	Black Toner Motor
DO-29	Regi Clutch
DO-2B	MPF Turn Clutch
DO-2d	MPF Feed Solenoid
DO-2f	Tray 1 Feed Clutch
DO-31	Tray 2 Feed Clutch
DO-33	Tray 2 Turn Clutch
DO-35	Duplex Clutch
DO-37	ADC (CTD) Sensor Solenoid
DO-39	ADC (CTD) Sensor LED

Code	Components
DO-3b	OHP LED (Not Used)
DO-3d	Black Erase Lamp
DO-3f	Yellow, Magenta, Cyan Erase Lamp
DO-5b	Exit Clutch
DO-5d	Duplex Fan

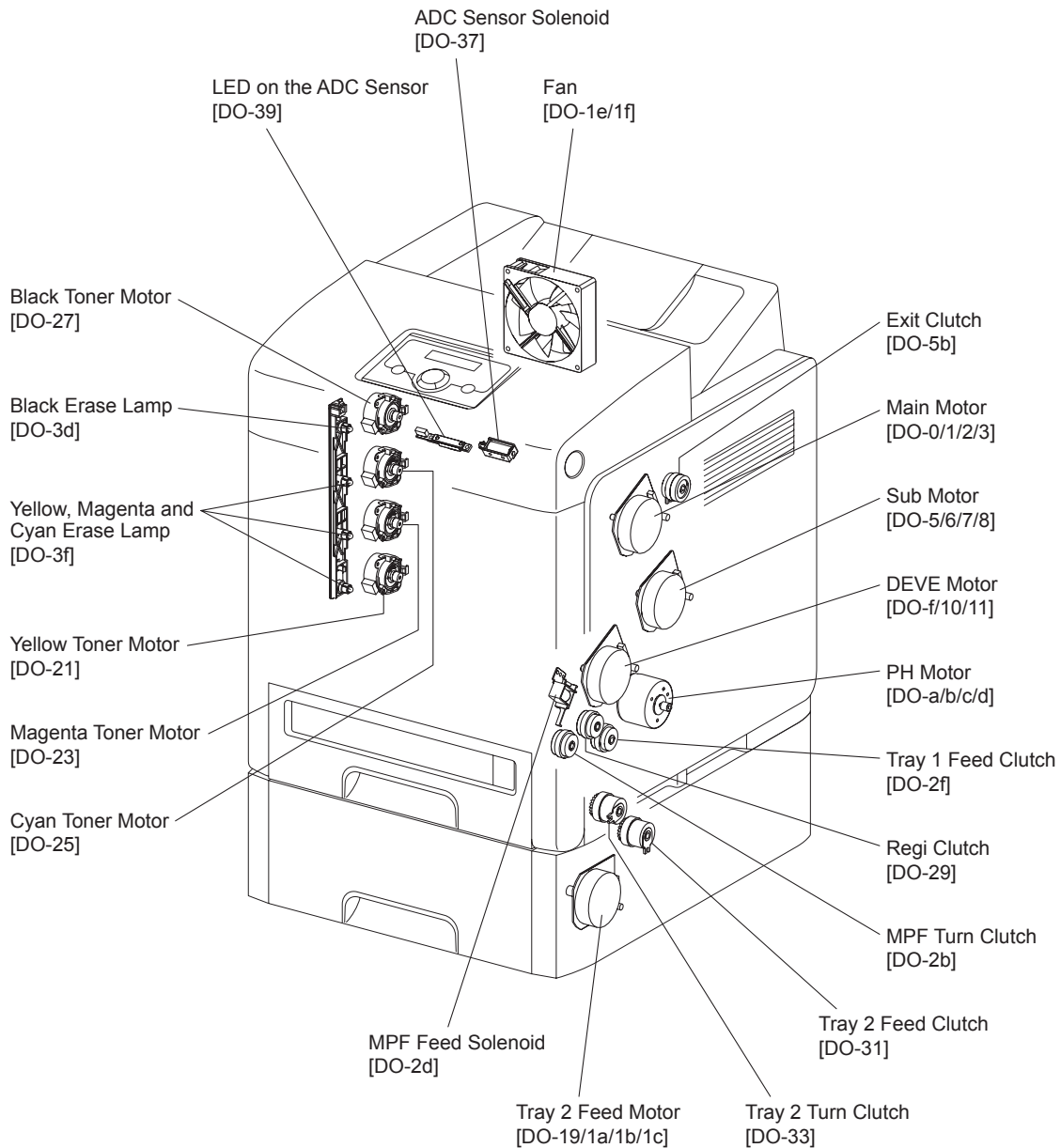

Kmy02016KA

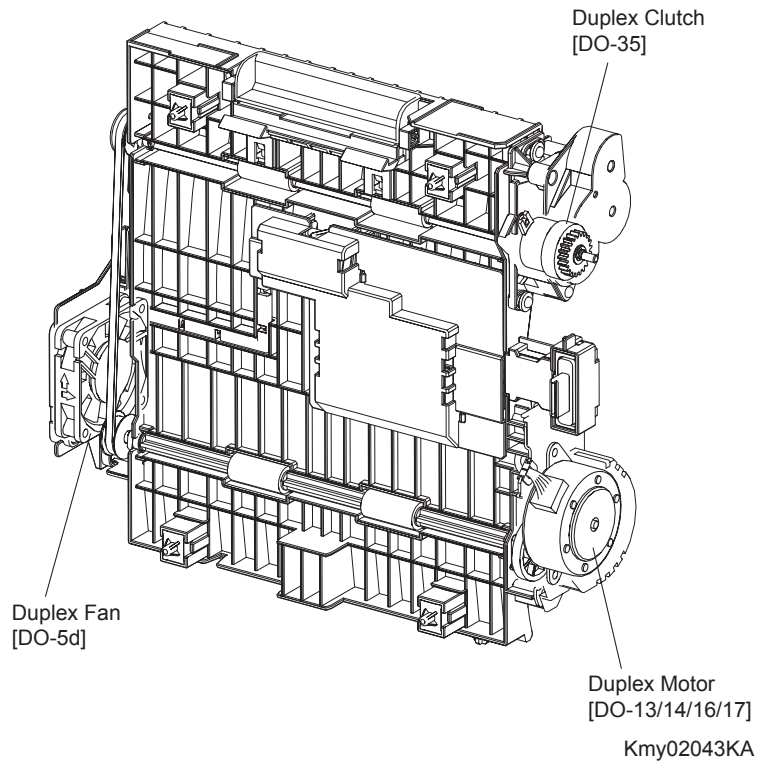

- About Clutch

The electromagnetic clutch in the printer controls the rotation of the roller by transferring or cutting the torque from the motor to the roller.

The electromagnetic clutch becomes an electromagnet by the passage of electric current through the coil inside the case and attracts the armature and gear to the rotating rotor, thereby rotating the gear.

Upon the loss of power to the coil, electromagnetic force is lost and the armature comes off the rotor, and the gear comes to rest.

The clutch makes so soft noises that you must be close the component to audibly confirm the operation of the component.

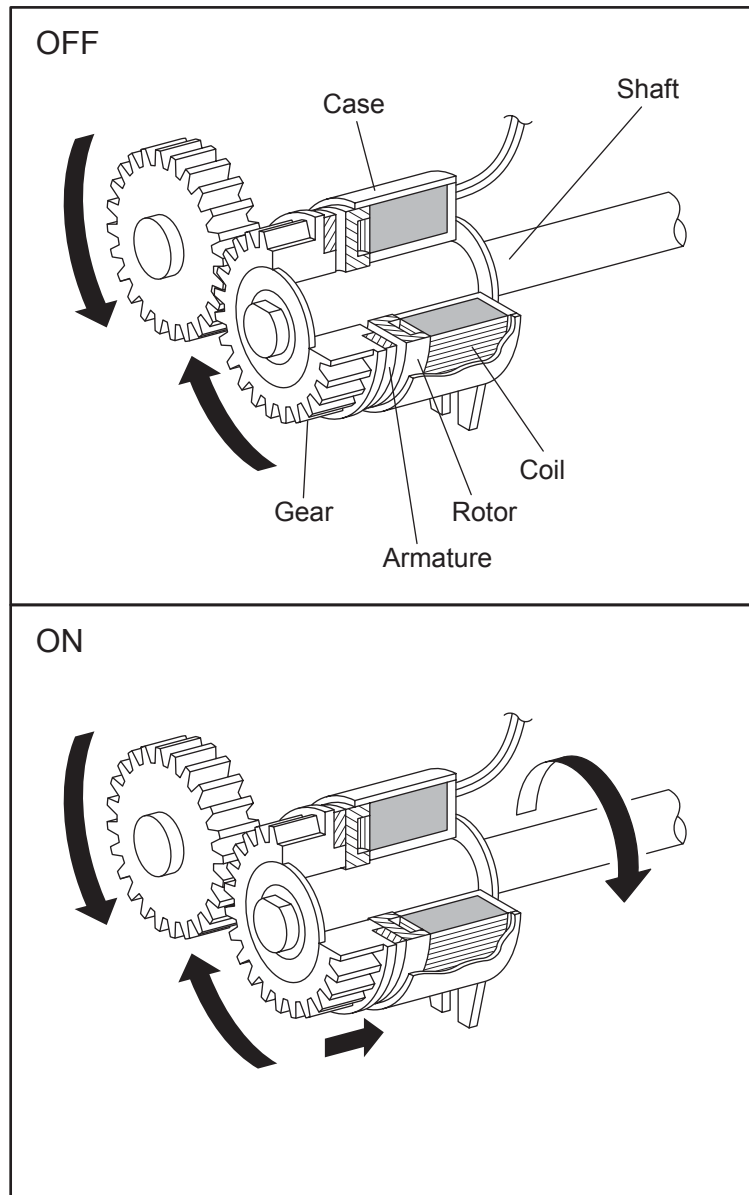

Leg_Sec02_050FA

- About Solenoid

The solenoid in the printer opens/closes the shutter or controls the position of the gear for transferring the torque of the motor to the roller.

A solenoid becomes an electromagnet by the passage of electric current through the coil inside the case and attracts the plunger.

Upon the loss of power to the coil, electromagnetic force is lost and the plunger is returned to its original position by spring action, thereby allowing the shutter to operate or the gear to move to the predefined position.

Unlike a clutch, a solenoid generates a loud operation noise.

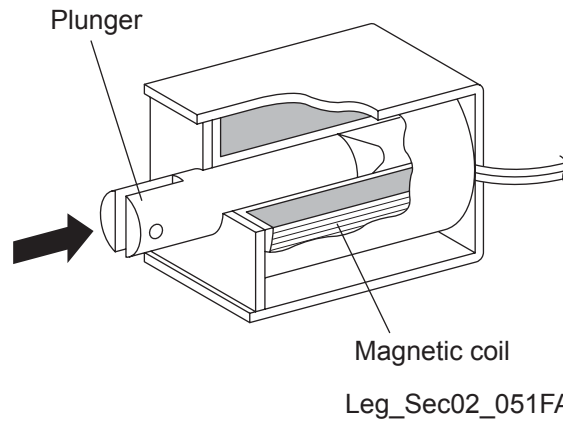

- Checking Motor, Clutch and Solenoid

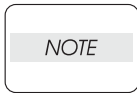

Before executing the DO test, close all covers and doors.

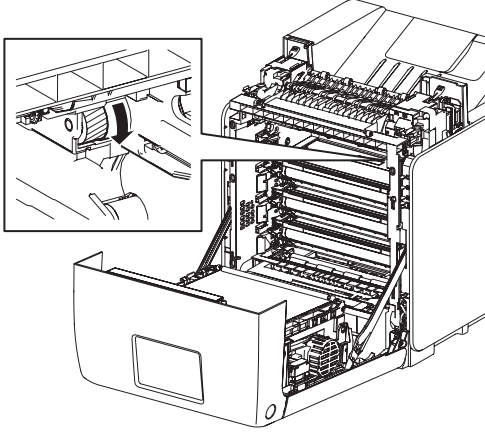
Clutch and Solenoid name (Diag. Code)	Confirmation procedure
<p>Main Motor (DO-0/DO-1/DO-2/DO-3)</p>	<p>NOTE: This procedure is for the technical staff. The customer check are the procedure 1, 5 and 6. The main motor is in the PC/DEVE DRIVE.</p> <p>When performing operation for five minutes or longer with the front cover open, remove all toner cartridges, and cover the drum to avoid exposure to light.</p> <p>The rotational speed of the motor is as follows. DO-3<DO-2<DO-0<DO-1</p> <ol style="list-style-type: none"> 1) Turn on the power and enter the Diagnostic Mode. 2) Open the Front Cover. 3) Remove the black toner cartridge. 4) Cheat the safety Interlock System. 5) Execute the DO-0. (The customer can confirm the motor noise only.)  <p style="text-align: right; font-size: small;">Kmy02017KA</p> <ol style="list-style-type: none"> 6) Press the "Cancel" key to stop test. 7) Remove the cheater and replace the black toner cartridge. 8) Close the Front Cover.

Clutch and Solenoid name (Diag. Code)	Confirmation procedure
Sub Motor (DO-5/DO-6/DO-7/ DO-8)	<p>NOTE: This procedure is for the technical staff. The customer check are the procedure 1, 5 and 6. The sub motor is in the PC/DEVE DRIVE.</p> <p>When performing operation for five minutes or longer with the front cover open, remove all toner cartridges, and cover the drum to avoid exposure to light.</p> <p>The rotational speed of the motor is as follows. DO-8<DO-7<DO-5<DO-6</p> <ol style="list-style-type: none"> 1) Turn on the power and enter the Diagnostic Mode. 2) Open the Front Cover. 3) Remove the all toner cartridges. 4) Cheat the safety Interlock System. 5) Execute the DO-5. (The customer can confirm the motor noise only.) <div data-bbox="746 698 1230 1182" style="text-align: center;"> </div> <p style="text-align: right; font-size: small;">Kmy02018KA</p> <ol style="list-style-type: none"> 6) Press the "Cancel" key to stop test. 7) Remove the cheater and replace the all toner cartridges. 8) Close the Front Cover.

Clutch and Solenoid name (Diag. Code)	Confirmation procedure
PH Motor (DO-a/DO-b/DO-c/ DO-d)	<p>NOTE: This procedure is for the technical staff. The customer check are the procedure 1, 4 and 5. The PH motor is in the FEED DRIVE. When performing operation for five minutes or longer with the front cover open, remove all toner cartridges, and cover the drum to avoid exposure to light.</p> <p>The rotational speed of the motor is as follows. DO-d<DO-c<DO-a<DO-b</p> <ol style="list-style-type: none"> 1) Turn on the power and enter the Diagnostic Mode. 2) Open the Front Cover. 3) Cheat the safety Interlock System. 4) Execute the DO-a. (The customer can confirm the motor noise only.) <div data-bbox="746 636 1225 1077" style="text-align: center;"> </div> <p style="text-align: right; font-size: small;">Kmy02019KA</p> <ol style="list-style-type: none"> 5) Press the "Cancel" key to stop test. 6) Remove the cheater. 7) Close the Front Cover.

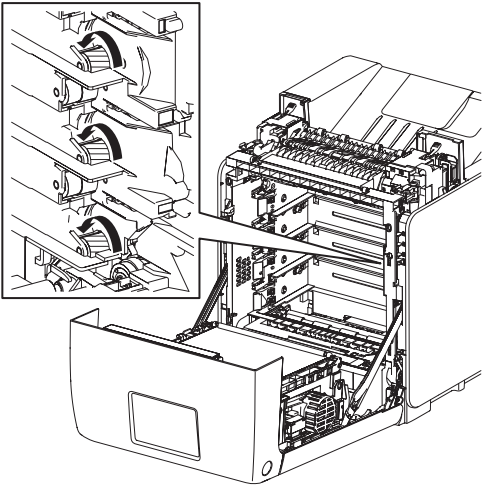
Clutch and Solenoid name (Diag. Code)	Confirmation procedure
<p>DEVE Motor (DO-f/DO-10/ DO-11)</p>	<p>NOTE: This procedure is for the technical staff. The customer check are the procedure 1, 5 and 6. The DEVE motor is in the PC/DEVE DRIVE.</p> <p>When performing operation for five minutes or longer with the front cover open, remove all toner cartridges, and cover the drum to avoid exposure to light.</p> <p>The rotational speed of the motor is as follows. DO-11<DO-10<DO-f</p> <ol style="list-style-type: none"> 1) Turn on the power and enter the Diagnostic Mode. 2) Open the Front Cover. 3) Remove the yellow, magenta and cyan toner cartridges. 4) Cheat the safety Interlock System. 5) Execute the DO-f. (The customer can confirm the motor noise only.)  <p style="text-align: right; font-size: small;">Kmy02020KA</p> <ol style="list-style-type: none"> 6) Press the "Cancel" key to stop test. 7) Remove the cheater and replace the yellow, magenta and cyan toner cartridges. 8) Close the Front Cover.

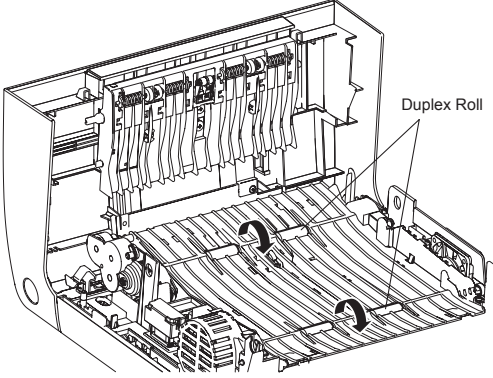
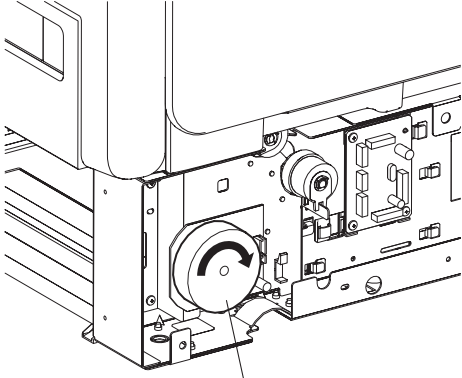
Clutch and Solenoid name (Diag. Code)	Confirmation procedure
<p>DUP Motor (DO-13/DO-14/ DO-16/DO-17)</p>	<p>NOTE: This procedure is for the technical staff. The customer check are the procedure 1, 5 and 6. The DEVE motor is in the DUPLEX MODULE.</p> <p>When performing operation for five minutes or longer with the front cover open, remove all toner cartridges, and cover the drum to avoid exposure to light.</p> <p>The rotational speed of the motor is as follows. DO-17<DO-16<DO-14<DO-13</p> <ol style="list-style-type: none"> 1) Turn on the power and enter the Diagnostic Mode. 2) Open the Front Cover. 3) Cheat the safety Interlock System. 4) Remove the transfer belt. 5) Execute the DO-13. (The customer can confirm the motor noise only.)  <p style="text-align: right; font-size: small;">Kmy02021KA</p> <ol style="list-style-type: none"> 6) Press the "Cancel" key to stop test. 7) Remove the cheater and replace the transfer belt. 8) Close the Front Cover.
<p>Tray 2 Feed Motor (DO-19/ DO-1a/DO-1b/Do-1c)</p>	<p>NOTE: This procedure is for the technical staff. The customer check are the procedure 1, 4 and 5.</p> <p>The rotational speed of the motor is as follows. DO-1c<DO-1b<DO-19<DO-1a</p> <ol style="list-style-type: none"> 1) turn on the power and enter the Diagnostic Mode. 2) Remove the Tray 2 paper cassette. 3) Remove the left side cover of the Tray 2. 4) Execute the DO-19. (The customer can confirm the motor noise only.)  <p style="text-align: right; font-size: small;">Kmy02022KA</p> <ol style="list-style-type: none"> 5) Press the "Cancel" key to stop the test. 6) Replace the left side cover of the Tray 2. 7) Replace the Tray 2 paper cassette.

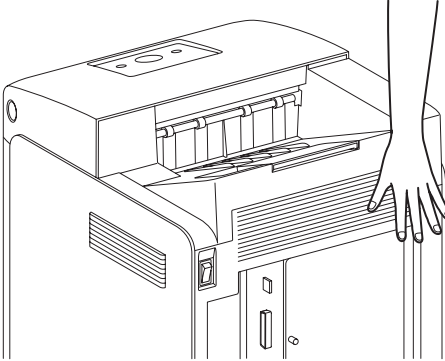
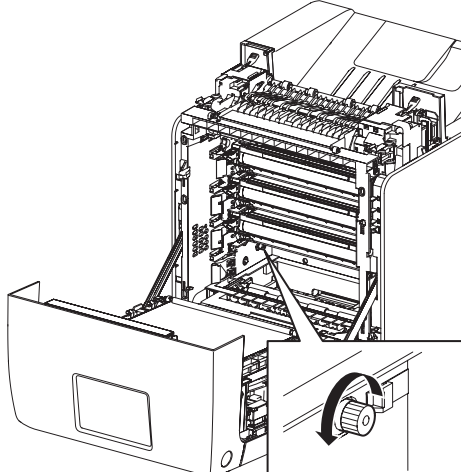
Clutch and Solenoid name (Diag. Code)	Confirmation procedure
Fan (DO-1e/1f)	<p>NOTE: The rotational speed of the fan is as follows. DO-1f<DO-1e</p> <ol style="list-style-type: none"> 1) Turn on the power and enter the Diagnostic Mode. 2) Execute the DO-1e.  <p style="text-align: right; font-size: small;">Kmy02023KA</p> <ol style="list-style-type: none"> 3) Press the "Cancel" key to stop test.
Yellow Toner Motor (DO-21)	<p>NOTE: This procedure is for the technical staff. The customer check are the procedure 1, 5 and 6. When performing operation for five minutes or longer with the front cover open, remove all toner cartridges, and cover the drum to avoid exposure to light.</p> <ol style="list-style-type: none"> 1) Turn on the power and enter the Diagnostic Mode. 2) Open the Front Cover. 3) Cheat the safety Interlock System. 4) Remove the yellow toner cartridge. 5) Execute the DO-21. (The customer can confirm the motor noise only.)  <p style="text-align: right; font-size: small;">Kmy02024KA</p> <ol style="list-style-type: none"> 6) Press the "Cancel" key to stop test. 7) Replace the yellow toner cartridge. 8) Remove the cheater. 9) Close the Front Cover.

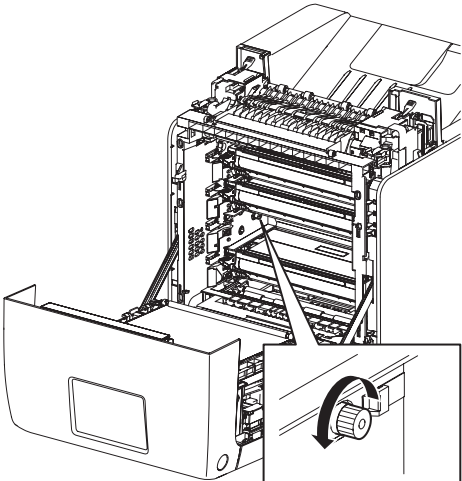
Clutch and Solenoid name (Diag. Code)	Confirmation procedure
Magenta Toner Motor (DO-23)	<p>NOTE: This procedure is for the technical staff. The customer check are the procedure 1, 5 and 6. When performing operation for five minutes or longer with the front cover open, remove all toner cartridges, and cover the drum to avoid exposure to light.</p> <ol style="list-style-type: none"> 1) Turn on the power and enter the Diagnostic Mode. 2) Open the Front Cover. 3) Remove the magenta toner cartridge. 4) Cheat the safety Interlock System. 5) Execute the DO-23. (The customer can confirm the motor noise only.)  <p style="text-align: right; font-size: small;">Kmy02025KA</p> <ol style="list-style-type: none"> 6) Press the "Cancel" key to stop test. 7) Remove the cheater. 8) Replace the magenta toner cartridge. 9) Close the Front Cover.

Clutch and Solenoid name (Diag. Code)	Confirmation procedure
Cyan Toner Motor (DO-25)	<p>NOTE: This procedure is for the technical staff. The customer check are the procedure 1, 5 and 6. When performing operation for five minutes or longer with the front cover open, remove all toner cartridges, and cover the drum to avoid exposure to light.</p> <ol style="list-style-type: none"> 1) Turn on the power and enter the Diagnostic Mode. 2) Open the Front Cover. 3) Remove the cyan toner cartridge. 4) Cheat the safety Interlock System. 5) Execute the DO-25. (The customer can confirm the motor noise only.) <div data-bbox="746 600 1209 1079" style="text-align: center;"> <p style="text-align: right; font-size: small;">Kmy02026KA</p> </div> <ol style="list-style-type: none"> 6) Press the "Cancel" key to stop test. 7) Remove the cheater. 8) Replace the cyan toner cartridge. 9) Close the Front Cover.

Clutch and Solenoid name (Diag. Code)	Confirmation procedure
Black Toner Motor (DO-27)	<p>NOTE: This procedure is for the technical staff. The customer check are the procedure 1, 5 and 6. When performing operation for five minutes or longer with the front cover open, remove all toner cartridges, and cover the drum to avoid exposure to light.</p> <ol style="list-style-type: none"> 1) Turn on the power and enter the Diagnostic Mode. 2) Open the Front Cover. 3) Remove the black toner cartridge. 4) Cheat the safety Interlock System. 5) Execute the DO-27. (The customer can confirm the motor noise only.) <div data-bbox="746 600 1212 1086" style="text-align: center;"> <p style="text-align: right; font-size: small;">Kmy02027KA</p> </div> <ol style="list-style-type: none"> 6) Press the "Cancel" key to stop test. 7) Remove the cheater. 8) Replace the black toner cartridge. 9) Close the Front Cover.

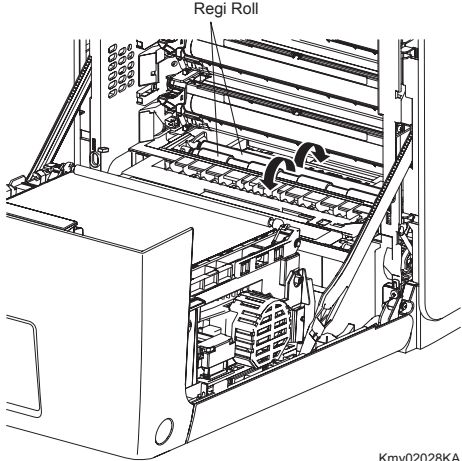
Clutch and Solenoid name (Diag. Code)	Confirmation procedure
Regi Clutch (DO-29)	<p>NOTE: When performing operation for five minutes or longer with the front cover open, remove all toner cartridges, and cover the drum to avoid exposure to light.</p> <ol style="list-style-type: none"> 1) Turn on the power and enter the Diagnostic Mode. 2) Execute the DO-29. Upon hitting the "return" key, the operating noise of the clutch will be heard. 3) Press the "Cancel" key to stop the clutch. <p>Combination test is as follows.</p> <p>NOTE: The regi roll rotates when the DO-a and the DO-29 are executed. This procedure is for the technical staff.</p> <ol style="list-style-type: none"> 1) Turn on the power and enter the Diagnostic Mode. 2) Open the Front Cover. 3) Cheat the safety Interlock System. 4) Execute the DO-a and the DO-29. <div style="text-align: center;">  </div> <ol style="list-style-type: none"> 5) Confirm the Regi Roll rotation. 6) Press the "Cancel" key to stop the clutch. 7) Press the "▼" key to display the DO-a. 8) Press the "Cancel" key to stop the motor. 9) Remove the cheter and close the Front Cover.

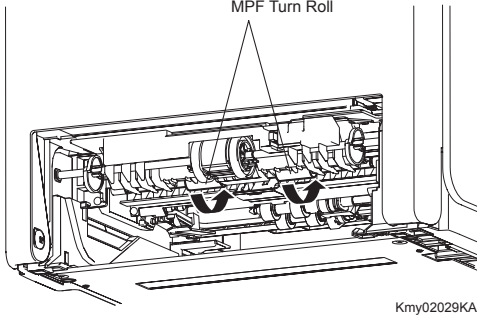
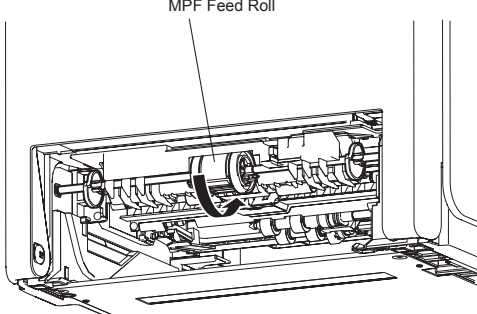
Clutch and Solenoid name (Diag. Code)	Confirmation procedure
MPF Turn Clutch (DO-2b)	<ol style="list-style-type: none"> 1) Turn on the power and enter the Diagnostic Mode. 2) Execute the DO-2b. Upon hitting the "return" key, the operating noise of the clutch will be heard. 3) Press the "Cancel" key to stop the clutch. <p>Combination test is as follows. NOTE: The MPF turn roll rotates when the DO-a and the DO-2b are executed. This procedure is for the technical staff.</p> <ol style="list-style-type: none"> 1) Turn on the power and enter the Diagnostic Mode. 2) Remove the Tray 1 paper cassette. 3) Execute the DO-a and the DO-2b.  <ol style="list-style-type: none"> 4) Confirm the Turn Roll rotation. 5) Press the "Cancel" key to stop the clutch. 6) Press the "▼" key to display the DO-a. 7) Press the "Cancel" key to stop the motor. 8) Replace the Tray 1 paper cassette.
MPF Feed Solenoid (DO-2d)	<ol style="list-style-type: none"> 1) Turn on the power and enter the Diagnostic Mode. 2) Execute the DO-2d. Upon hitting the "return" key, the operating noise of the solenoid will be heard. 3) Press the "Cancel" key to stop the solenoid. <p>Combination test is as follows. NOTE: The MPF feed roll rotates when the DO-a and the DO-2d are executed. This procedure is for the technical staff.</p> <ol style="list-style-type: none"> 1) Turn on the power and enter the Diagnostic Mode. 2) Remove the Tray 1 paper cassette. 3) Execute the DO-a and the DO-2d.  <ol style="list-style-type: none"> 4) Confirm the Feed Roll rotation. 5) Press the "Cancel" key to stop the clutch. 6) Press the "▼" key to display the DO-a. 7) Press the "Cancel" key to stop the motor. 8) Replace the Tray 1 paper cassette.

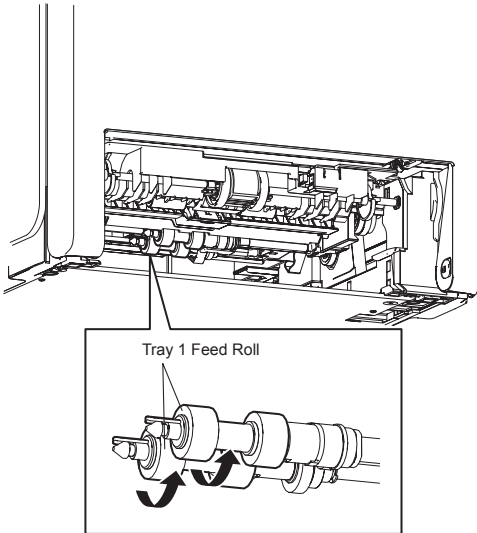
Clutch and Solenoid name (Diag. Code)	Confirmation procedure
Tray 1 Feed Clutch (DO-2f)	<ol style="list-style-type: none"> 1) Turn on the power and enter the Diagnostic Mode. 2) Execute the DO-2f. Upon hitting the "return" key, the operating noise of the clutch will be heard. 3) Press the "Cancel" key to stop the clutch. <p>Combination test is as follows. NOTE: The Tray 1 feed roll rotates when the DO-a and the DO-2f are executed. This procedure is for the technical staff.</p> <ol style="list-style-type: none"> 1) Turn on the power and enter the Diagnostic Mode. 2) Remove the Tray 1 paper cassette. 3) Execute the DO-a and the DO-2f. <div data-bbox="746 600 1225 1131" style="text-align: center;">  <p>The diagram consists of two parts. The upper part is a perspective view of the internal mechanism of the Tray 1 Feed Roll, showing various rollers, gears, and a motor assembly. A callout line points from this view to a more detailed, close-up view of the 'Tray 1 Feed Roll' below. This detailed view shows a cylindrical roll with a central shaft and a curved arrow indicating its rotation direction.</p> </div> <p style="text-align: right; font-size: small;">Kmy02031KA</p> <ol style="list-style-type: none"> 4) Confirm the feed Roll rotation. 5) Press the "Cancel" key to stop the clutch. 6) Press the "▼" key to display the DO-a. 7) Press the "Cancel" key to stop the motor. 8) Replace the Tray 1 paper cassette.

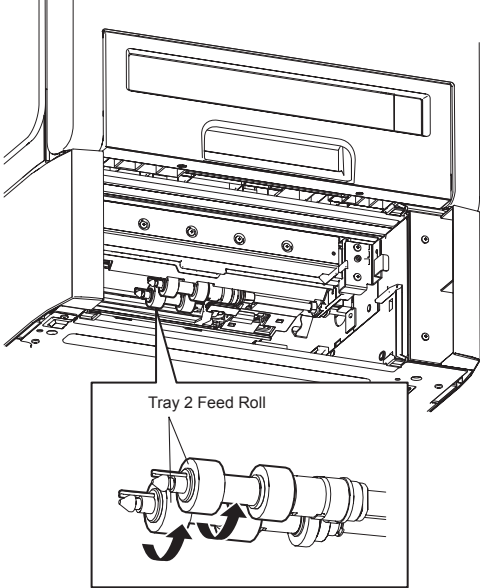
Clutch and Solenoid name (Diag. Code)	Confirmation procedure
Tray 2 Feed Clutch (DO-31)	<ol style="list-style-type: none"> 1) Turn on the power and enter the Diagnostic Mode. 2) Execute the DO-31. Upon hitting the "return" key, the operating noise of the clutch will be heard. 3) Press the "Cancel" key to stop the clutch. <p>Combination test is as follows. NOTE: The Tray 2 feed roll rotates when the DO-19 and the DO-31 are executed. This procedure is for the technical staff.</p> <ol style="list-style-type: none"> 1) Turn on the power and enter the Diagnostic Mode. 2) Remove the Tray 2 paper cassette. 3) Execute the DO-19 and the DO-31. <div style="text-align: center;">  <p style="text-align: center;">Tray 2 Feed Roll</p> <p style="text-align: right; font-size: small;">Kmy02032KA</p> </div> <ol style="list-style-type: none"> 4) Confirm the feed Roll rotation. 5) Press the "Cancel" key to stop the clutch. 6) Press the "▼" key to display the DO-19. 7) Press the "Cancel" key to stop the motor. 8) Replace the Tray 2 paper cassette.

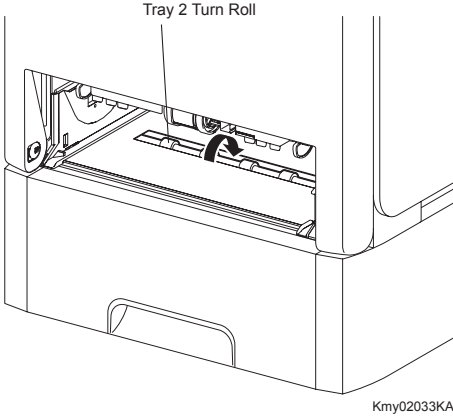
Clutch and Solenoid name (Diag. Code)	Confirmation procedure
Tray 2 Turn Clutch (DO-33)	<ol style="list-style-type: none"> 1) Turn on the power and enter the Diagnostic Mode. 2) Execute the DO-33. Upon hitting the "return" key, the operating noise of the clutch will be heard. 3) Press the "Cancel" key to stop the clutch. <p>Combination test is as follows. NOTE: The Tray 2 turn roll rotates when the DO-19 and the DO-33 are executed. This procedure is for the technical staff.</p> <ol style="list-style-type: none"> 1) Turn on the power and enter the Diagnostic Mode. 2) Remove the Tray 1 paper cassette. 3) Execute the DO-19 and the DO-33. <div style="text-align: center;">  </div> <ol style="list-style-type: none"> 4) Confirm the Turn Roll rotation. 5) Press the "Cancel" key to stop the clutch. 6) Press the "▼" key to display the DO-19. 7) Press the "Cancel" key to stop the motor. 8) Replace the Tray 1 paper cassette.

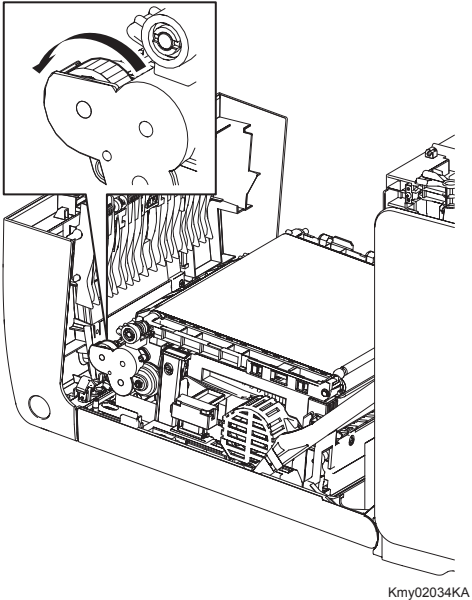
Clutch and Solenoid name (Diag. Code)	Confirmation procedure
Dup Clutch (DO-35)	<ol style="list-style-type: none"> 1) Turn on the power and enter the Diagnostic Mode. 2) Execute the DO-35. Upon hitting the "return" key, the operating noise of the clutch will be heard. 3) Press the "Cancel" key to stop the clutch. <p>Combination test is as follows. NOTE: The duplex gear rotates when the DO-13 and the DO-35 are executed. This procedure is for the technical staff. When performing operation for five minutes or longer with the front cover open, remove all toner cartridges, and cover the drum to avoid exposure to light.</p> <ol style="list-style-type: none"> 1) Turn on the power and enter the Diagnostic Mode. 2) Open the Front Cover. 3) Cheat the safety Interlock System. 4) Execute the DO-13 and the DO-35.  <ol style="list-style-type: none"> 5) Confirm the gear rotation. 6) Press the "Cancel" key to stop the clutch. 7) Press the "▼" key to display the DO-13. 8) Press the "Cancel" key to stop the motor. 9) Remove the cheater and close the Front Cover.

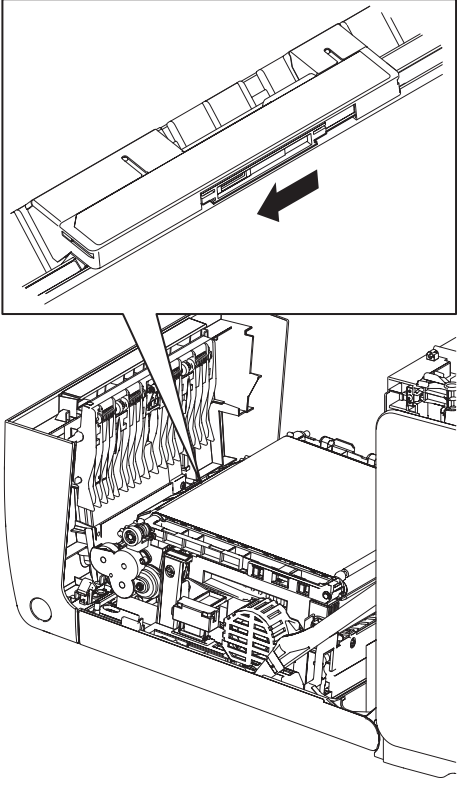
Clutch and Solenoid name (Diag. Code)	Confirmation procedure
ADC Sensor Solenoid (DO-37)	<p>NOTE: This procedure is for the technical staff. The customer check are the procedure 1, 4 and 5. When performing operation for five minutes or longer with the front cover open, remove all toner cartridges, and cover the drum to avoid exposure to light.</p> <ol style="list-style-type: none"> 1) Turn on the power and enter the Diagnostic Mode. 2) Open the Front Cover. 3) Cheat the safety Interlock System. 4) Execute the DO-37. (The customer can confirm the motor noise only.) <div style="text-align: center;">  <p style="text-align: right; font-size: small;">Kmy02035KA</p> </div> <ol style="list-style-type: none"> 5) Press the "Cancel" key to stop the solenoid. 6) Remove the cheater and clode the Front Cover.

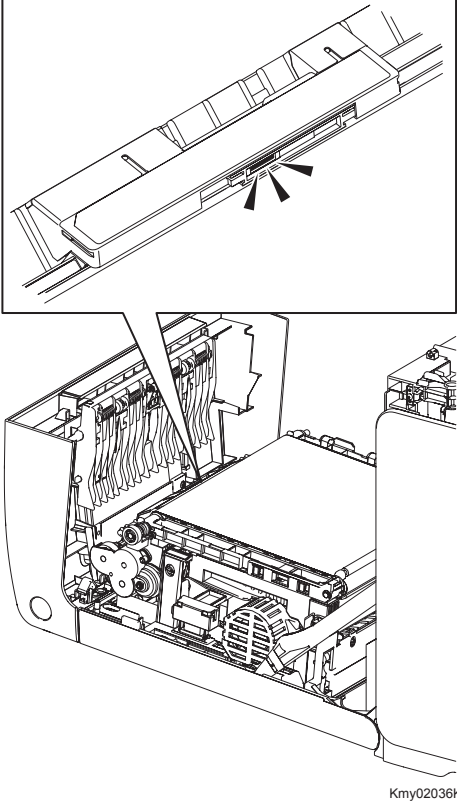
Clutch and Solenoid name (Diag. Code)	Confirmation procedure
ADC Sensor LED (DO-39)	<p>NOTE: This procedure is for the technical staff. When performing operation for five minutes or longer with the front cover open, remove all toner cartridges, and cover the drum to avoid exposure to light.</p> <ol style="list-style-type: none"> 1) Turn on the power and enter the Diagnostic Mode. 2) Open the Front Cover. 3) Cheat the safety Interlock System. 4) Execute the DO-39.  <ol style="list-style-type: none"> 5) Press the "Cancel" key to stop the LED lighting. 6) Remove the cheater and close the Front Cover.
OHP Sensor LED (DO-3b)	Not used

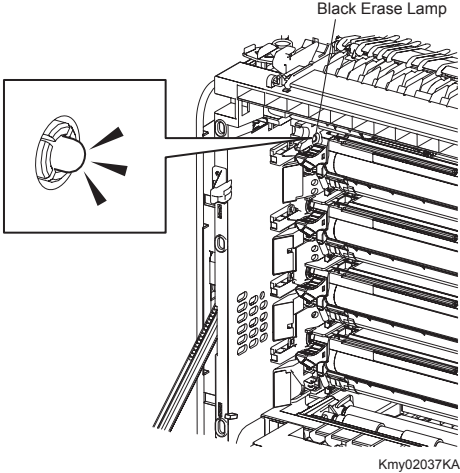
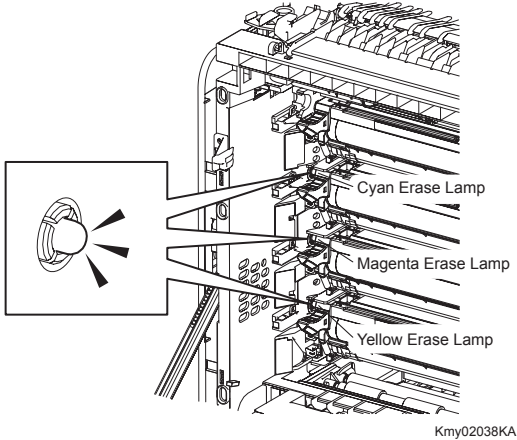
Clutch and Solenoid name (Diag. Code)	Confirmation procedure
<p>Black Drum Erase Lamp (DO-3d)</p>	<p>NOTE: This procedure is for the technical staff. When performing operation for five minutes or longer with the front cover open, remove all toner cartridges, and cover the drum to avoid exposure to light.</p> <ol style="list-style-type: none"> 1) Turn on the power and enter the Diagnostic Mode. 2) Open the Front Cover. 3) Cheat the safety Interlock System. 4) Execute the DO-3d.  <ol style="list-style-type: none"> 5) Press the "Cancel" key to stop the LED lighting. 6) Remove the cheater and clode the Front Cover.
<p>Yellow, Magenta and Cyan Drum Erase Lamp (DO-3f)</p>	<p>NOTE: This procedure is for the technical staff. When performing operation for five minutes or longer with the front cover open, remove all toner cartridges, and cover the drum to avoid exposure to light.</p> <ol style="list-style-type: none"> 1) Turn on the power and enter the Diagnostic Mode. 2) Open the Front Cover. 3) Cheat the safety Interlock System. 4) Execute the DO-3f.  <ol style="list-style-type: none"> 5) Press the "Cancel" key to stop the LED lighting. 6) Remove the cheater and clode the Front Cover.

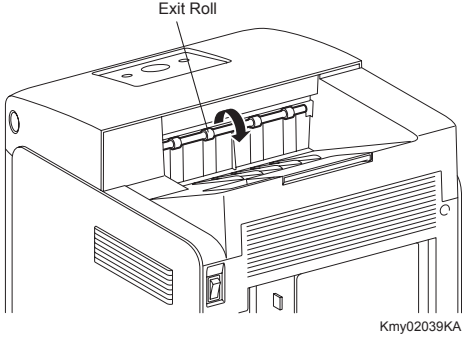
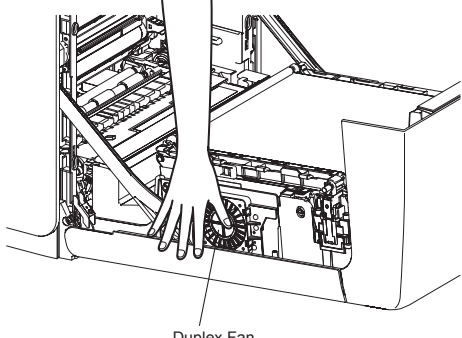
Clutch and Solenoid name (Diag. Code)	Confirmation procedure
Exit Clutch (DO-5b)	<p>1) Turn on the power and enter the Diagnostic Mode.</p> <p>2) Execute the DO-5b. Upon hitting the "return" key, the operating noise of the clutch will be heard.</p> <p>3) Press the "Cancel" key to stop the clutch.</p> <p>Combination test is as follows.</p> <p>NOTE: The exit roll rotates when the DO-0 and the DO-5b are executed. This procedure is for the technical staff.</p> <p>1) Turn on the power and enter the Diagnostic Mode.</p> <p>2) Execute the DO-0 and the DO-5b.</p>  <p>3) Confirm the Exit Roll rotation.</p> <p>4) Press the "Cancel" key to stop the clutch.</p> <p>5) Press the "▼" key to display the DO-0.</p> <p>6) Press the "Cancel" key to stop the motor.</p>
Duplex Fan (DO-5d)	<p>NOTE: This procedure is for the technical staff. The customer check are the procedure 1, 4 and 5.</p> <p>When performing operation for five minutes or longer with the front cover open, remove all toner cartridges, and cover the drum to avoid exposure to light.</p> <p>1) Turn on the power and enter the Diagnostic Mode.</p> <p>2) Open the Front Cover.</p> <p>3) Cheat the safety Interlock System.</p> <p>4) Execute the DO-5d. (The customer can confirm the fan noise only.)</p>  <p>5) Press the "Cancel" key to stop the test.</p> <p>6) Remove the cheater and close the Front Cover.</p>

4.3 Print Info

4.3.1 Config Page

The version of software of IOT and the printer configuration can be confirmed by executing this test.

4.3.2 Print Settings

The service tag, printing count value and error count value can be confirmed by executing this test.

4.4 Complete

4.4.1 Complete

Completes the diagnosis operation and reboot the data.

4.5 Test Print

Print an internal test pattern of the printer. If paper jam or paper empty occurs during the print, the test waits until they are resolved.

4.5.1 Executing test print

- 1) Turn off the power.
- 2) Turn on the power while holding down “▲” and “▼” keys.
- 3) Release the fingers from these keys when “Diagnosing...” is displayed.
- 4) The “Customer Mode” and “ESS Diag” are displayed. (Entered the Diag. mode.)
- 5) Press “▼” key to select “Test Print”, and then press “✓” key.
- 6) Press “▲” or “▼” key to select the test item.
- 7) Press “✓” key twice to execute the test.

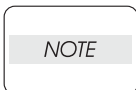

To exit the test or to returning to one step higher menu, press “CANCEL” key.

4.5.2 No Image [IOT]

Prints the blanked paper.

4.5.3 Test Pattern 600[IOT]

Prints the IOT built-in 600dpi pattern.

When the PQ problem occurred, this test enables to identify the problem as the printing process or the PWBA ESS related.

Compare the sample chart with the print.

Check result: NG (Check the printing process.) OK (Check the PWBA ESS related.)

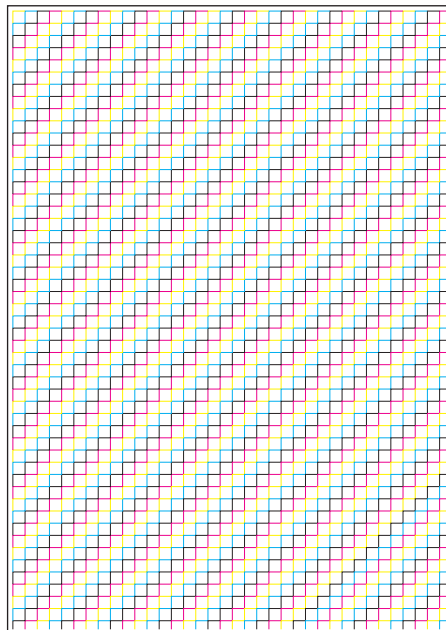

Kmy02001KA

4.5.4 Grid2

Prints the ESS built-in grid pattern.

When the PQ problem occurred, this test enables to identify the problem as printer-related or otherwise.

Compare the sample chart with the print.

Check result: NG (Check the printing process and PWBA ESS-related.) OK (Check the network, cable, PC and so on.)



Leg_Sec02_004FA

4.5.5 Cyan 20%

Outputs cyan 20% paint on the whole area of a A4 paper.

When the PQ problem occurred, this test enables to identify the problem as the cyan toner or another color.

Compare the sample chart with the print.

Check result: NG (Check the cyan toner-related.) OK (Check another toner.)

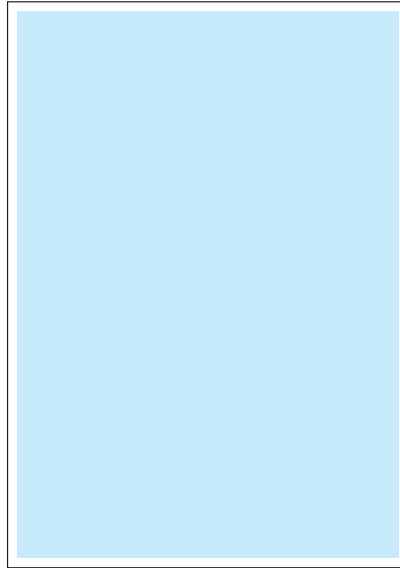

Leg_Sec02_005FA

4.5.6 Magenta 20%

Outputs magenta 20% paint on the whole area of a A4 paper.

When the PQ problem occurred, this test enables to identify the problem as the magenta toner or another color.

Compare the sample chart with the print.

Check result: NG (Check the magenta toner-related.) OK (Check another toner.)

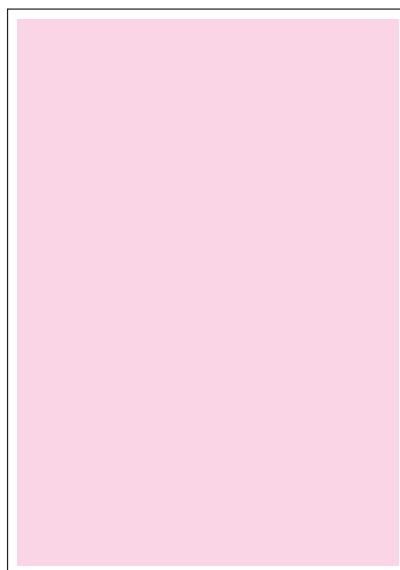

Leg_Sec02_006FA

4.5.7 Yellow 20%

Outputs yellow 20% paint on the whole area of a A4 paper.

When the PQ problem occurred, this test enables to identify the problem as the yellow toner or another color.

Compare the sample chart with the print.

Check result: NG (Check the yellow toner-related.) OK (Check another toner.)

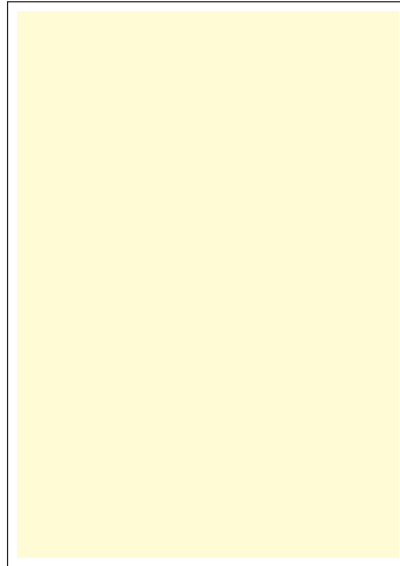

Leg_Sec02_007FA

4.5.8 Black 20%

Outputs black 20% paint on the whole area of a A4 paper.

When the PQ problem occurred, this test enables to identify the problem as the black toner or another color.

Compare the sample chart with the print.

Check result: NG (Check the black toner-related.) OK (Check another toner.)

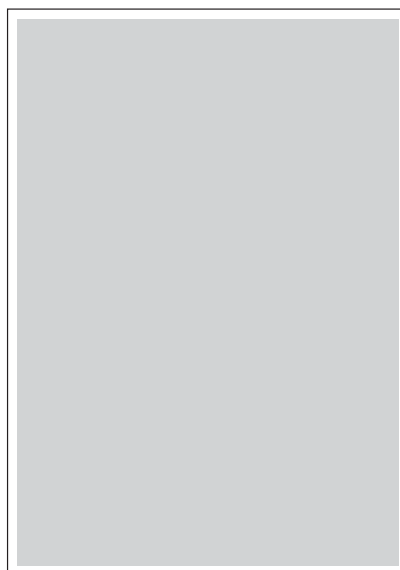

Leg_Sec02_008FA

4.5.9 CMY 20%

Outputs C/M/Y 20% paint on the whole area of a A4 paper.

When the PQ problem occurred, this test enables to identify the problem as the balance of three color toners or otherwise.

Compare the sample chart with the print.

Check result: NG (Check the yellow, magenta or cyan toner-related.) OK (Check black toner.)

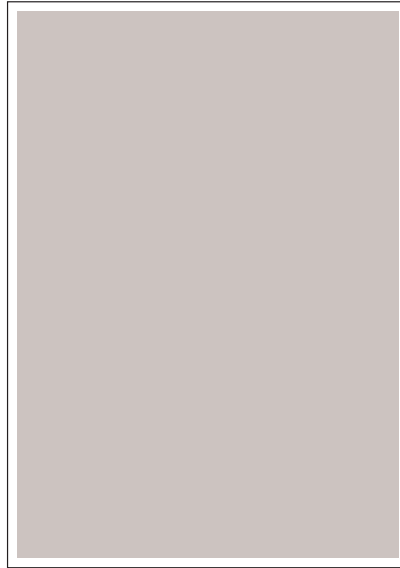

Leg_Sec02_009FA

4.5.10 Gradation

Outputs the tone pattern from 2% to 100% on a A4 paper for each of 4 colors.

When the PQ problem occurred, this test enables to identify the problem as the printing process or PWBA ESS-related.

Compare the sample chart with the print.

Check result: NG (Check the printing process.) OK (Check the PWBA ESS-related.)

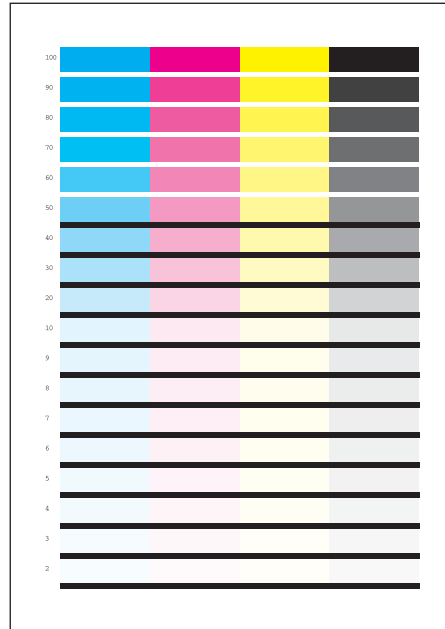

Leg_Sec02_010FA

4.5.11 Toner Pallet Check

Outputs each 100% density color pattern of Y/M/C/K.

When the PQ problem occurred in the picture or photo printing, this test enables to identify the problem as the toner or another.

Compare the sample chart with the print.

Check result: NG (Check the problem toner-related.) OK (Check the print job or print data.)

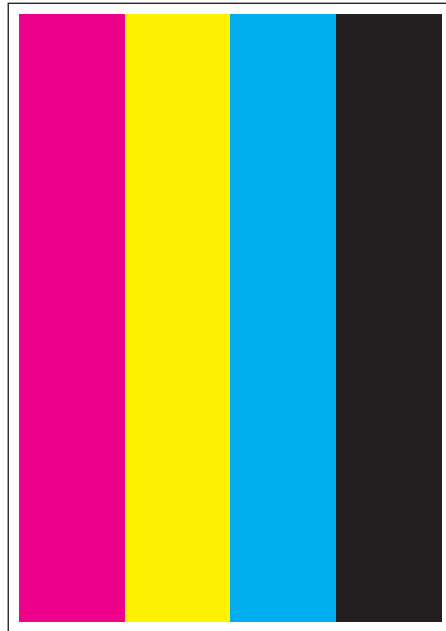

Leg_Sec02_011FA

4.5.12 Contamination Check

Allows you to check the print for any regular lines or toner spots when encountering PQ problems. From the difference in the interval of regular lines or spots, you can determine the parts that have caused the trouble.

Page 1 to 4: Prints the scale patterns in vertical and horizontal directions for evaluating regularity and intervals.

Page 5: Prints the list of intervals by component fault.

Page 1

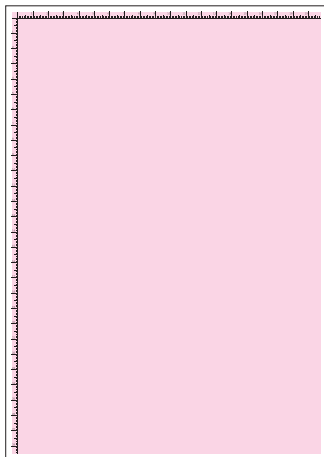

Leg_Sec02_012FA

Page 2

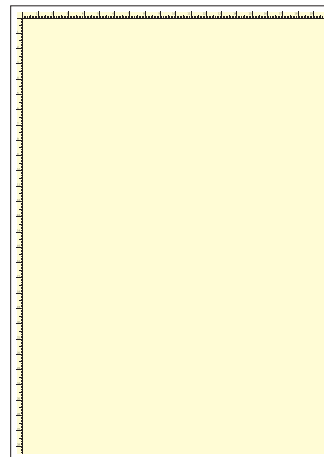

Leg_Sec02_071FA

Page 3

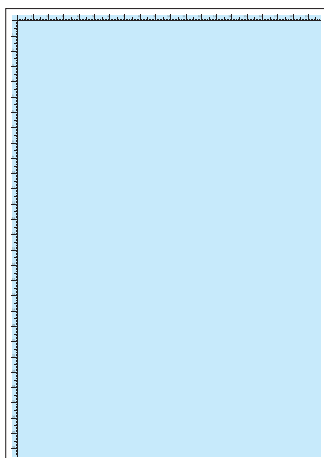

Leg_Sec02_072FA

Page 4

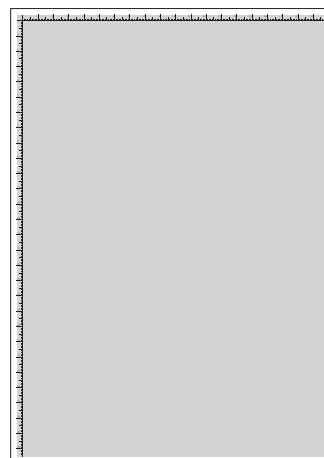

Leg_Sec02_073FA

Page 5

Color Laser 3110cn Components/CRU

Pitch (interval)	Dell Component Name
75.4 mm	Print Cartridge
28.8 mm	Print Cartridge
25.9 mm	Print Cartridge
37.7 mm	Print Cartridge
25.2 mm	Print Cartridge
22.3 mm	Print Cartridge
28.3 mm	Transfer Unit
56.9 mm	Transfer Unit
82.7 mm	Fuser Unit
94.2 mm	Fuser Unit
18.8 mm	Fuser Unit
43.2 mm	Fuser Unit
31.4 mm	Roll Pinch Exit

4.5.13 Parameter Setting

This function reads/writes the following parameters stored in the printer.

Item	Renge	Description
Slow Scan Reg K to P	-128 to 127	Sets the registration in the paper feeding direction.
Slow Scan Reg 600 Y/M/C	-30 to 30	
Slow Scan Reg 1200 Y/M/C	-60 to 60	
First Scan Reg (all items)	-30 to 30	Sets the registration in the scanning direction.
Life Counter	-	Reads the life counter and the printer.

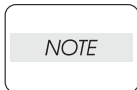

Print the parameter list using the Print function of Parameter Menu in diagnosis before changing the value of the registration.

Parameter	Function	Default	Adjustable range
Slow Scan Reg K to P (Shifts 0.17mm/1count)	Black registration adjustment	--	-128 to 127
Slow Scan Reg 600 M,Y,C (Shifts 0.042mm/1count)	Color registration adjustment (600 and 1200 dpi)	--	-60 to 60
Slow Scan Reg1200 M,Y,C (Shifts 0.021mm/1count)			
Fast Scan Reg K to M, Y or C (Shifts 0.042mm/1count)	Color registration adjustment Calculation of adjustment is shown below. (exp. Yellow)	--	-30 to 30
Fast Scan Reg2 K to M, C or Y (Shifts 0.01mm/1count)	(Value of Fast Scan Reg K to Y + Value of Fast Scan Reg2 K to Y)/4	--	-1 to 2
Fast Scan Reg MPF, Tray1 or Tray2 (Shifts 0.17mm/1count)	Black registration adjustment at side 1 print	--	-30 to 30
Fast Scan Reg Dup (Shifts 0.17mm/1count)	Black registration adjustment at side 2 print	--	-30 to 30

NOTE

The default values are different in each printer.

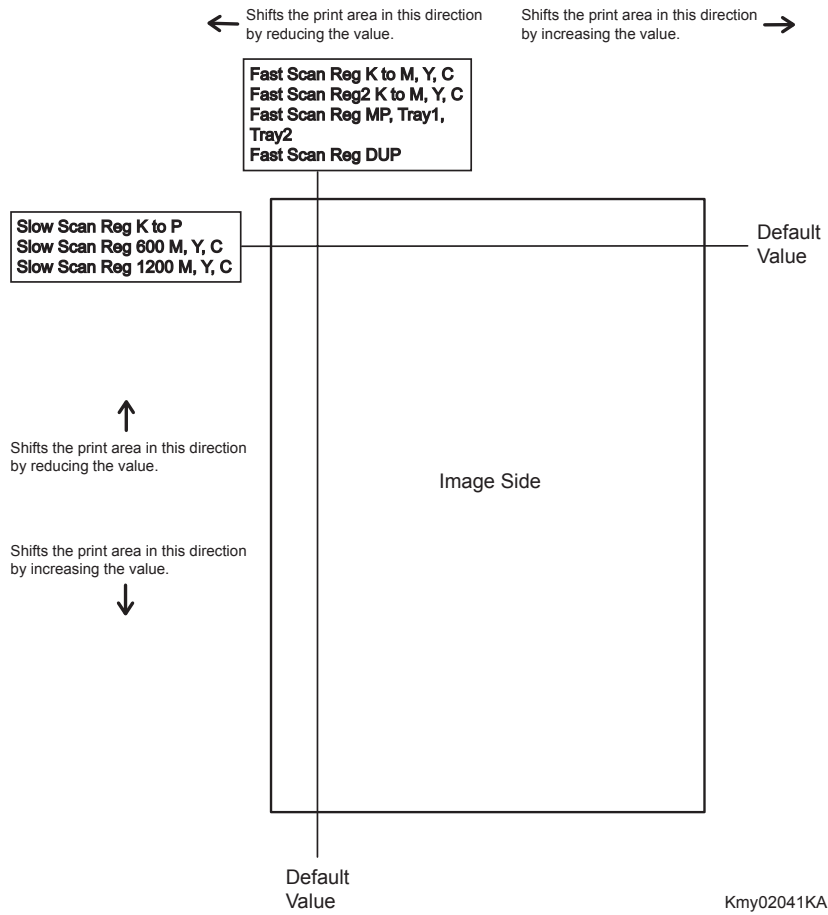

Reference Counter Values

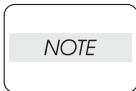

These counter values are reference only. Do not use as the official value.

Counter Name	Value of life warning
Life Y Toner (Dispense time)	-
Life M Toner (Dispense time)	-
Life C Toner (Dispense time)	-
Life K Toner (Dispense time)	-
Life DTB (Transfer Belt) 1 (Paper feeding count)	100000
Life Fuser (Paper feeding count)	100000
Life Printer (Paper feeding count)	-
Life DTB (Transfer Belt) 2 (Waste Toner cleaning count)	200000
Life DTB (Transfer Belt) 3 (Cycle count)	14000000
Life Y Waste Toner (Waste Toner cleaning count)	18000
Life M Waste Toner (Waste Toner cleaning count)	18000
Life C Waste Toner (Waste Toner cleaning count)	18000
Life K Waste Toner (Waste Toner cleaning count)	18000
Life Y Developer (Cycle count)	2500000
Life M Developer (Cycle count)	2500000
Life C Developer (Cycle count)	2500000
Life K Developer (Cycle count)	2500000
Life Y Drum (Cycle count)	3000000
Life M Drum (Cycle count)	3000000
Life C Drum (Cycle count)	3000000
Life K Drum (Cycle count)	3000000
Life MPF Feed	-
Life Tray 1 Feed	-
Life Duplex Feed	-
Print	-

4.5.14 Printing the parameter list

This function prints the parameter values and life counter values stored in the IOT.

Chapter 3 Removal and Replacement Procedures (RRPs) CONTENTS

1. Removal and Replacement Procedures (RRPs)	3 - 1
1.1 Before starting service procedure	3 - 1
1.2 General notes	3 - 3
1.2 Removal Flows	3 - 4
1.2 Replacement Flows	3 - 5
2. Removal Steps	3 - 6
Removal 1 COVER EXTENDER (PL1.1.9).....	3 - 6
Removal 2 MPF COVER (PL1.2.99).....	3 - 7
Removal 3 TRAY REAR COVER (PL1.1.5).....	3 - 8
Removal 4 TRANSFER BELT (PL4.1.1).....	3 - 10
Removal 5 DUPLEX MODULE (PL11.1.1)	3 - 12
Removal 6 TONER CARTRIDGE (K), (C), (M), (Y) (PL5.1.18-21).....	3 - 13
Removal 7 DUPLEX GATE (PL6.1.13).....	3 - 14
Removal 8 FUSER (PL6.1.10).....	3 - 15
Removal 9 SPUR ASSEMBLY (PL7.1.1).....	3 - 16
Removal 10 CHUTE ASSY EXIT OUT (PL6.1.1)	3 - 17
Removal 11 OPERATOR PANEL (PL1.2.97).....	3 - 18
Removal 12 REAR COVER (PL1.1.4)	3 - 22
Removal 13 RIGHT COVER (PL1.1.6).....	3 - 23
Removal 14 MPF FEED SOLENOID (PL3.1.98)	3 - 24
Removal 15 FEED DRIVE ASSEMBLY (PL8.1.7).....	3 - 26
Removal 16 INTEGRATED FEEDER ASSEMBLY (PL3.2.99).....	3 - 30
Removal 17 FRONT COVER (PL1.2.98).....	3 - 34
Removal 18 RIGHT ARM ASSEMBLY(PL7.1.98)	3 - 36
Removal 19 SIZE SWITCH ASSEMBLY (PL7.1.18)	3 - 38
Removal 20 POWER SWITCH (PL9.1.13)	3 - 39
Removal 21 TONER CARTRIDGE SENSOR ASSEMBLY (C), (M), (Y) (PL5.1.4)	3 - 40
Removal 22 LEFT COVER (PL1.1.7)	3 - 41
Removal 23 ELECTRONIC SUB-SYSTEM CONTROL BOARD (PL9.1.27)	3 - 42
Removal 24 LEFT ARM ASSEMBLY(PL7.1.97).....	3 - 44
Removal 25 LED ASSEMBLY (PL5.1.15).....	3 - 46
Removal 26 TONER DISPENSER MOTOR (PL5.1.12)	3 - 48
Removal 27 SHIELD ASSY ESS (REFERENCE ONLY).....	3 - 50
Removal 28 HUMIDITY SENSOR (PL9.1.19)	3 - 51
Removal 29 MACHINE CONTROL UNIT (PL9.1.20)	3 - 52
Removal 30 TOP COVER (PL1.1.1).....	3 - 54
Removal 31 FAN (PL9.1.10).....	3 - 55
Removal 32 HIGH VOLTAGE POWER SUPPLY (PL5.1.17)	3 - 56
Removal 33 LOW VOLTAGE POWER SUPPLY (PL9.1.4).....	3 - 58
Removal 34 PRINT HEAD (PL5.1.99)	3 - 60
Removal 35 INTERLOCK SWITCH (PL9.1.3)	3 - 62
Removal 36 PHOTOCONDUCTOR (PC) / DEVELOPER (DEV) DRIVE (PL8.1.2).....	3 - 64
Removal 37 TONER CARTRIDGE SENSOR ASSEMBLY (K) (PL5.1.4).....	3 - 67
Removal 38 MPF SEPARATOR ROLLER ASSEMBLY (PL2.1.3)	3 - 68
Removal 39 SEPARATOR ROLLER (PL2.2.17) (Same as the FEED ROLLER).....	3 - 69

Chapter 3 Removal and Replacement Procedures (RRPs) CONTENTS

Removal 40 MPF ROLLER (PL3.1.10)	3 - 70
Removal 41 FEED ROLLER (PL3.2.53)	3 - 71
Removal 42 550 SHEET FEEDER ASSEMBLY (PL12.1.1)	3 - 72
Removal 43 550 TRAY REAR COVER (PL12.1.4)	3 - 73
Removal 44 550 TRAY FEED ROLLER (PL12.3.29)	3 - 74
Removal 45 550 TRAY SEPARATOR ROLLER (PL12.5.17) (Same as the 550 TRAY FEED ROLLER). 3-75	
Removal 46 MEMORY CARD (PL9.1.30)	3 - 76
Removal 47 MULTI PROTOCOL CARD (PL9.1.31)	3 - 77
5) 3. Replacement Steps	3 - 78
Replacement 1 550 TRAY SEPARATOR ROLLER (PL12.5.17) (Same as the 550 TRAY FEED ROLLER) 3 - 78	
Replacement 2 550 TRAY FEED ROLLER (PL12.3.29)	3 - 79
Replacement 3 550 TRAY REAR COVER (PL12.1.4)	3 - 80
Replacement 4 550 SHEET FEEDER ASSEMBLY (PL12.1.1)	3 - 81
Replacement 5 FEED ROLLER (PL3.2.53)	3 - 82
Replacement 6 MPF ROLLER (PL3.1.10)	3 - 83
Replacement 7 SEPARATOR ROLLER (PL2.2.17) (Same as the FEED ROLLER)	3 - 84
Replacement 8 MPF SEPARATOR ROLLER ASSEMBLY (PL2.1.3)	3 - 85
Replacement 9 TONER CARTRIDGE SENSOR ASSEMBLY (K) (PL5.1.4)	3 - 86
Replacement 10 PHOTOCOnductor (PC) / DEVELOPER (DEV) DRIVE (PL8.1.2)	3 - 88
Replacement 11 INTERLOCK SWITCH (PL9.1.3)	3 - 90
Replacement 12 PRINT HEAD (PL5.1.99)	3 - 92
Replacement 13 LOW VOLTAGE POWER SUPPLY (PL9.1.4)	3 - 94
Replacement 14 HIGH VOLTAGE POWER SUPPLY (PL5.1.17)	3 - 96
Replacement 15 FAN (PL9.1.10)	3 - 98
Replacement 16 TOP COVER (PL1.1.1)	3 - 99
Replacement 17 MACHINE CONTROL UNIT (PL9.1.20)	3 - 100
Replacement 18 HUMIDITY SENSOR (PL9.1.19)	3 - 102
Replacement 19 SHIELD ASSY ESS (REFERENCE ONLY)	3 - 103
Replacement 20 TONER DISPENSER MOTOR (PL5.1.12)	3 - 104
Replacement 21 LED ASSEMBLY (PL5.1.15)	3 - 106
Replacement 22 LEFT ARM ASSEMBLY(PL7.1.97)	3 - 108
Replacement 23 ELECTRONIC SUB-SYSTEM CONTROL BOARD (PL9.1.27)	3 - 110
Replacement 24 LEFT COVER (PL1.1.7)	3 - 115
Replacement 25 TONER CARTRIDGE SENSOR ASSEMBLY (C), (M), (Y) (PL5.1.4)	3 - 116
Replacement 26 POWER SWITCH (PL9.1.13)	3 - 117
Replacement 27 SIZE SWITCH ASSEMBLY (PL7.1.18)	3 - 118
Replacement 28 RIGHT ARM ASSEMBLY(PL7.1.98)	3 - 120
Replacement 29 FRONT COVER (PL1.2.98)	3 - 122
Replacement 30 INTEGRATED FEEDER ASSEMBLY (PL3.2.99)	3 - 124
Replacement 31 FEED DRIVE ASSEMBLY (PL8.1.7)	3 - 128
Replacement 32 MPF FEED SOLENOID (PL3.1.98)	3 - 132
Replacement 33 RIGHT COVER (PL1.1.6)	3 - 134
Replacement 34 REAR COVER (PL1.1.4)	3 - 135





Chapter 3 Removal and Replacement Procedures (RRPs) CONTENTS

Replacement 35 OPERATOR PANEL (PL1.2.97)	3 - 136
Replacement 36 CHUTE ASSY EXIT OUT (PL6.1.1)	3 - 140
Replacement 37 SPUR ASSEMBLY (PL7.1.1).....	3 - 141
Replacement 38 FUSER (PL6.1.10).....	3 - 142
Replacement 39 DUPLEX GATE (PL6.1.13).....	3 - 143
Replacement 40 TONER CARTRIDGE (K), (C), (M), (Y) (PL5.1.18)	3 - 144
Replacement 41 DUPLEX MODULE (PL11.1.1)	3 - 145
Replacement 42 TRANSFER BELT (PL4.1.1).....	3 - 147
Replacement 43 TRAY REAR COVER (PL1.1.5).....	3 - 149
Replacement 44 MPF COVER (PL1.2.99).....	3 - 150
Replacement 45 COVER EXTENDER (PL1.1.9).....	3 - 152
Replacement 46 MULTI PROTOCOL CARD (PL9.1.31).....	3 - 154
Replacement 47 MEMORY CARD (PL9.1.30).....	3 - 155

1. Removal and Replacement Procedures (RRPs)

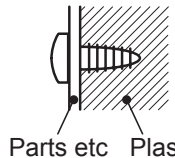
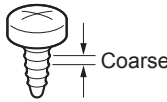
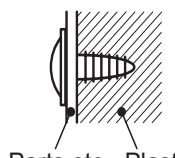
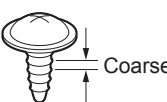
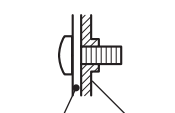
1.1 Before starting service procedure

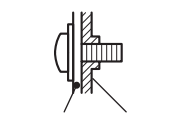
- Start the procedure after turning off the power and removing the power cord from the outlet.
- When performing the service operation around the FUSER ASSY, ensure that FUSER ASSY and its surrounding area have cooled down sufficiently.
- Pay sufficient attention to the parts during the procedure because they may be broken or may not perform their functions properly if unreasonable force is applied.
- Since various types of screws are used, ensure that the right screws are used in their right positions. Use special caution not to confuse the screws for plastic and the ones for sheet metal, because using the wrong type of screw may result in damage to the screw threads or other troubles.

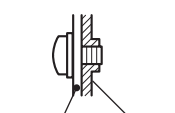
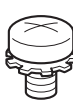
No.	Type	Application	Shape	How to distinguish	Points to be noted	Major application locations
1	Screw for plastic Silver, tap	Plastic  Parts etc Plastic	 Coarse	<ul style="list-style-type: none"> • Silver-colored • Thread is coarser than that of the sheet metal type. • Screw tip is thin. 	Oblique screwing damages the thread because this screw cuts female threads in the base material as it goes in.	
2	Screw for plastic Silver, with flange, tap	Plastic  Parts etc Plastic	 Coarse	<ul style="list-style-type: none"> • Silver-colored • With flange • Thread is coarser than that of the sheet metal type. • Screw tip is thin. 	Oblique screwing damages the thread because this screw cuts female threads in the base material as it goes in.	<ul style="list-style-type: none"> • Chute assy exit out
3	Screw for metal sheet silver	Sheet metal  Parts etc Sheet metal		<ul style="list-style-type: none"> • Silver-colored • Diameter of the thread section is uniform. 		
4	Screw for metal sheet Silver, with flange	Sheet metal  Parts etc Sheet metal		<ul style="list-style-type: none"> • Gold-colored • With flange • Diameter of the thread section is uniform. 		<ul style="list-style-type: none"> • Rear cover
5	Screw for metal sheet Silver, with an external tooth washer	Sheet metal  Parts etc Sheet metal		<ul style="list-style-type: none"> • Silver-colored • Provided with an external tooth washer. • Diameter of the thread section is uniform. 		<ul style="list-style-type: none"> • Mounting positions of the ground wires.

Chapter 3 Removal and Replacement Procedures (RRPs)

- Wear a wristband or the like as far as possible to remove static electricity of the human body.
- Keep the front cover closed. Buzzer goes off when the machine is left powered on with the front cover open for five minutes or longer to prevent the drum deterioration due to exposure to light.
- When removing the toner cartridge in a removal/replacement operation, cover the drum to keep it from being exposed to light.
- Remove PAPER TRAY, TRANSFER BELT, TONER CARTRIDGE, and FUSER, and put them in a place where they do not affect the procedure. (Note that the service procedures can be performed with those parts in place depending on the target section of removal/replacement.)

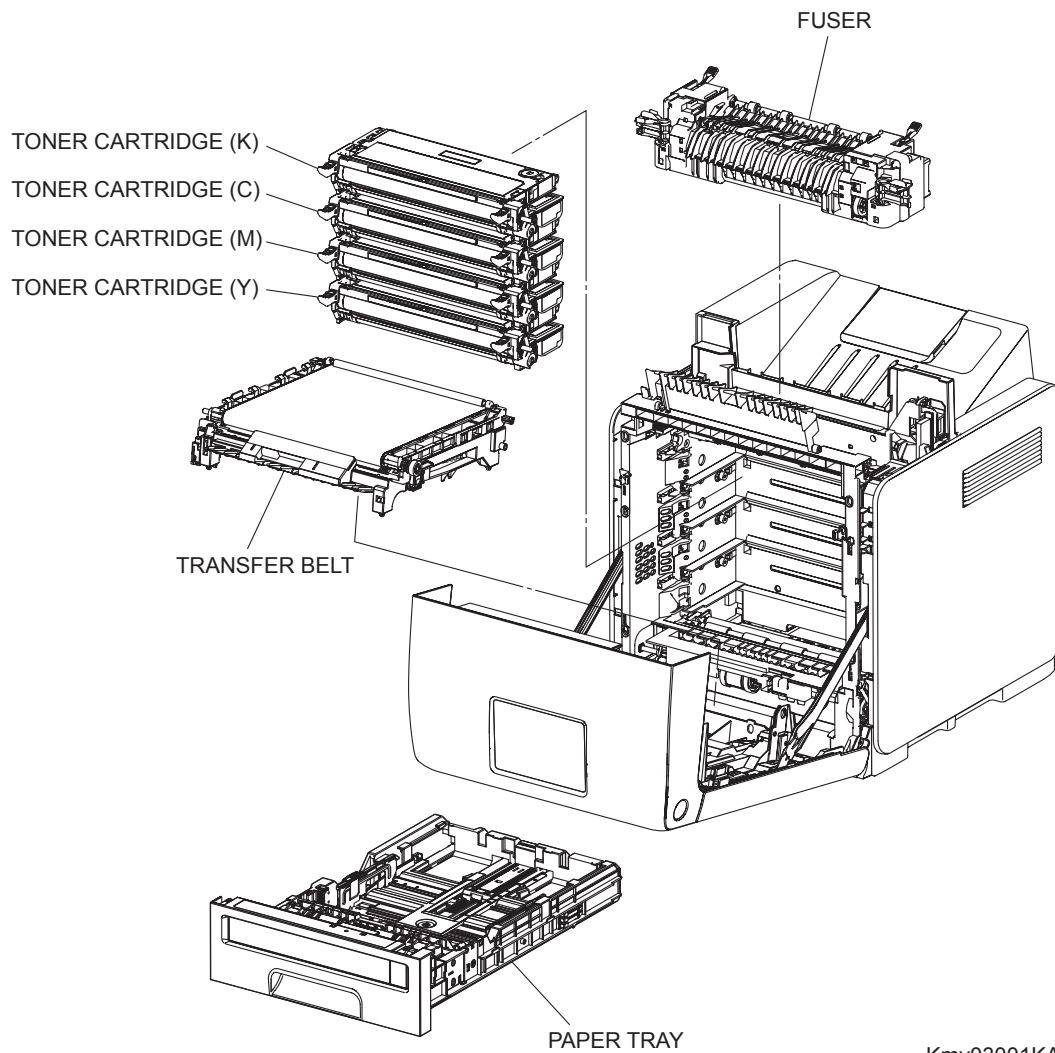

Kmy03001KA

1.2 General notes

- The string “(PL X.Y.Z)” suffixed to the part name in the procedure denotes that the part corresponds to the plate (PL) “X.Y”, item “Z” of [Engineering Parts list], and its shape and fitting position can be checked in [Engineering Parts list].
- Directional descriptions used in the procedures are defined as follows:
 - Front : Direction toward you when facing the front of the printer.
 - Rear : Direction opposite to the front when facing the front of the printer.
 - Left : Left-hand direction when facing the front of the printer.
 - Right : Right-hand direction when facing the front of the printer.

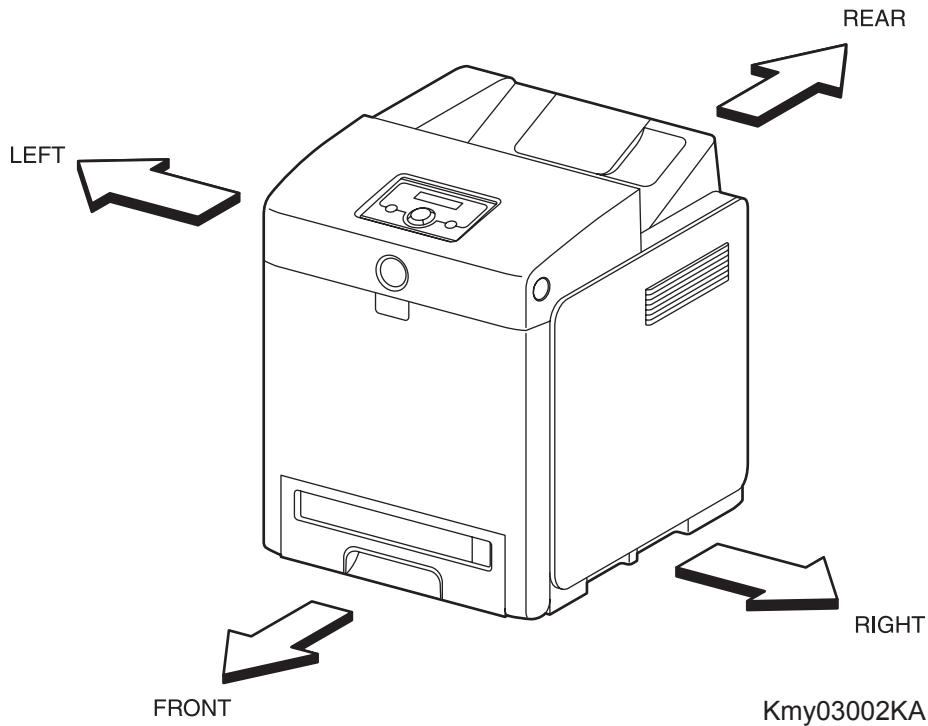

Figure: Definitions of Printer Orientation

- The string “(RRP X.Y)” that appears in or at the end of the procedure denotes that the related service procedure is described in [RRP X.Y].
- Screws shown in the illustrations are to be unscrewed and removed using a Phillips head (cross-slot) screwdriver, unless otherwise specified.
- Black arrows shown in the illustrations denote moving directions. When numbers are assigned to these arrows, they refer to the order in the procedure.
- Refer to [Chapter 4 Plug/Jack (P/J) Connector Locations] for the positions of connectors (P/J).

Removal Flows

The components not connected with arrows in the flow below can be removed independently.

PRINTER Removal FLOW

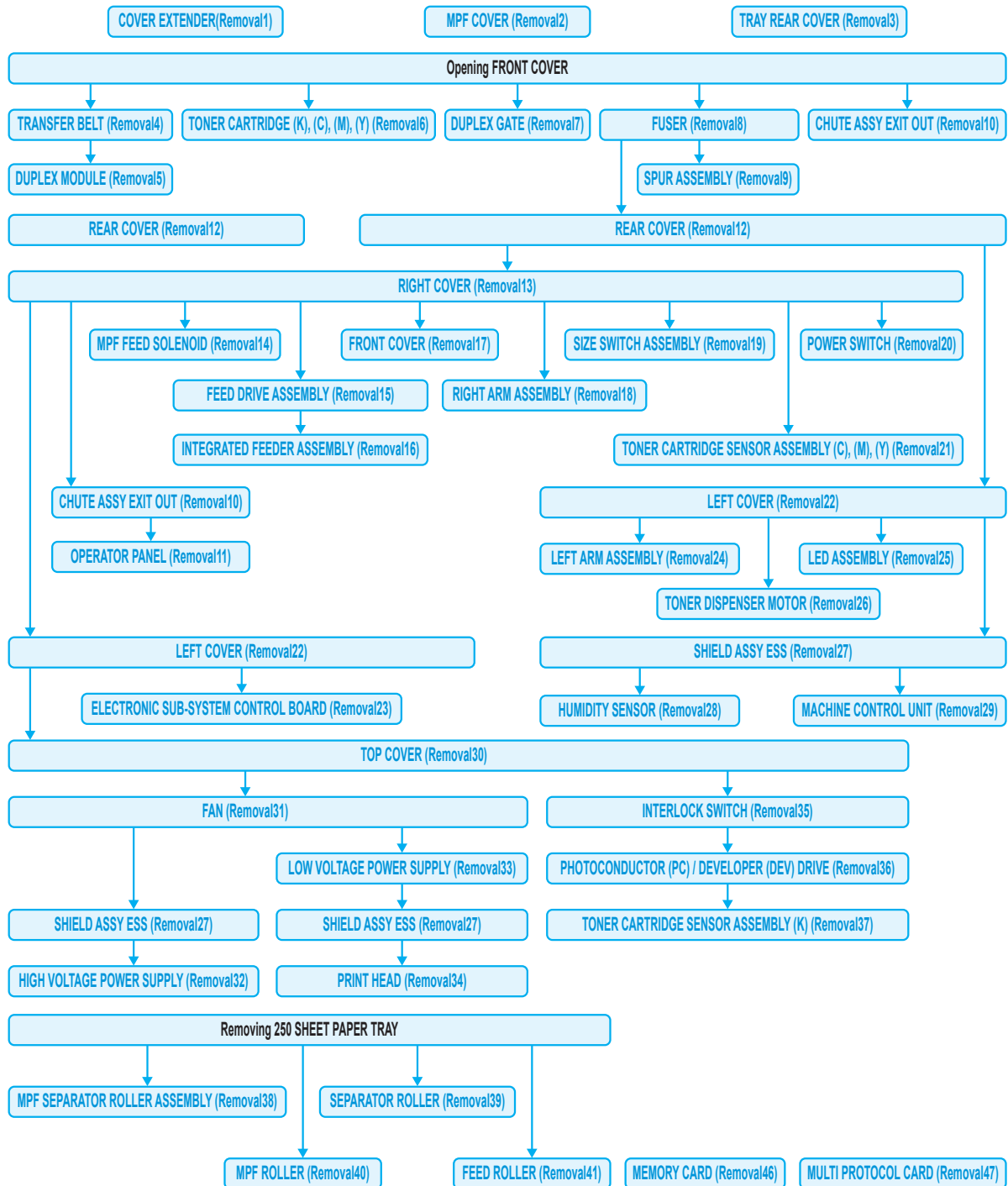

550 SHEET FEEDER ASSEMBLY Removal FLOW

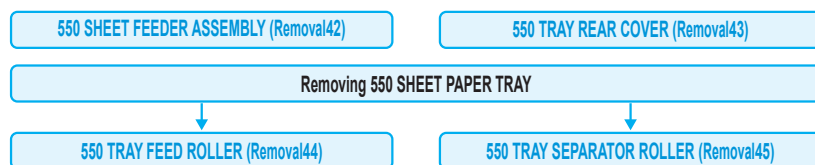

Replacement Flows

The components not connected with arrows in the flow below can be replaced independently. However, the rear cover is an exception when it was removed together with other parts.

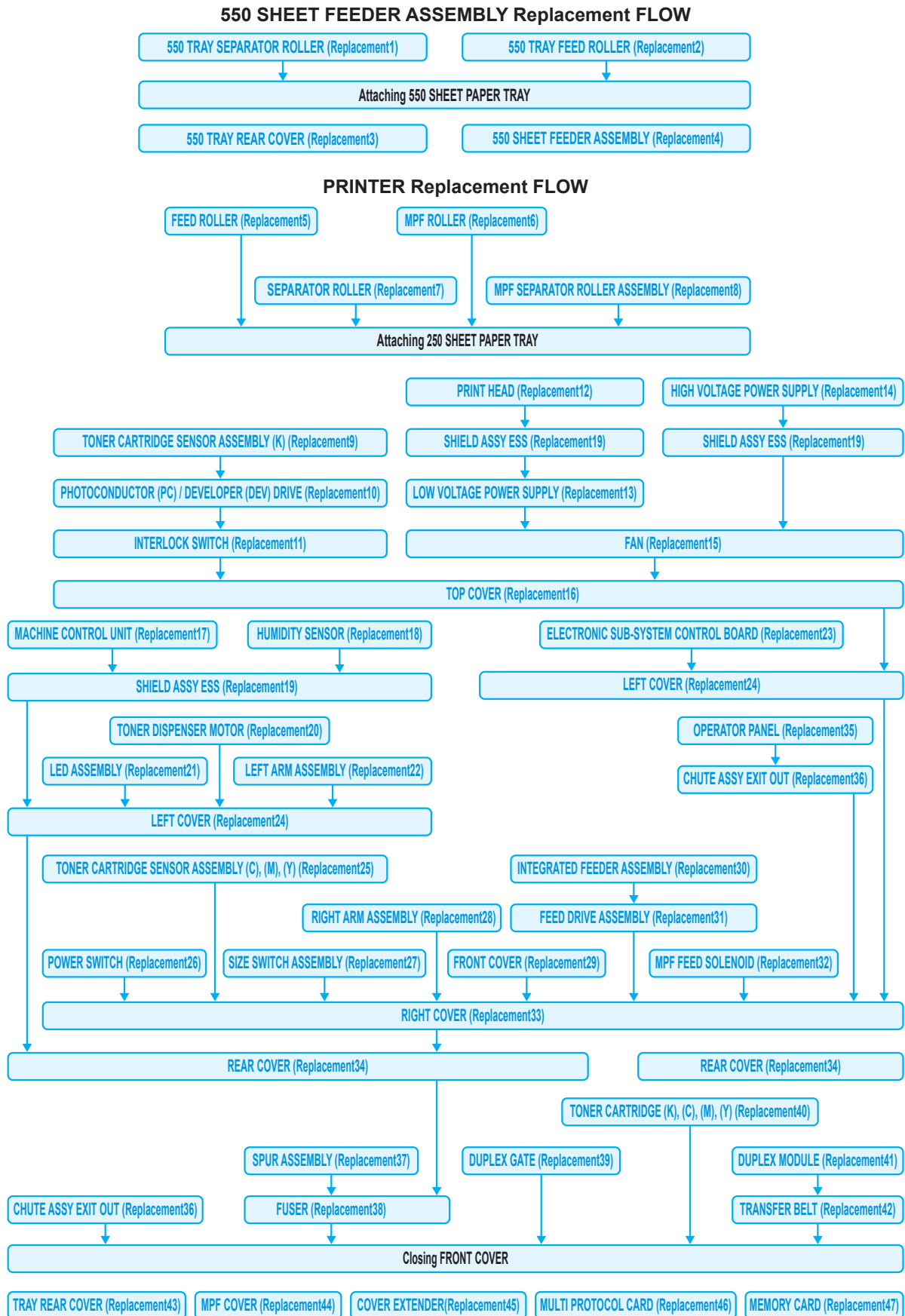

2. Removal Steps

Removal 1 COVER EXTENDER (PL1.1.9)

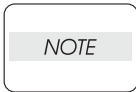

When performing the step described below, take care not to damage the bosses on the COVER EXTENDER.

- 1) Open the COVER EXTENDER (PL1.1.9).

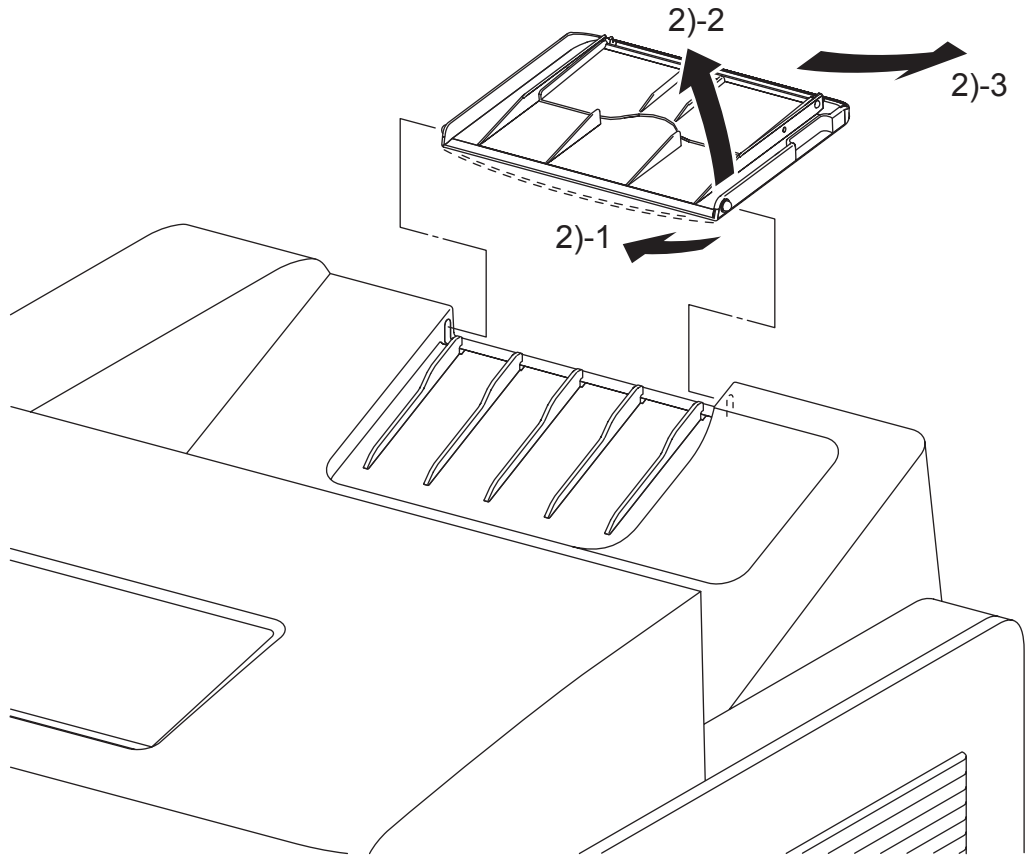

Kmy03003KB

- 2) Remove the COVER EXTENDER (PL1.1.1) by bending it and removing its left and right bosses from the holes on the TOP COVER.

For the replacement procedure of this part, go to:

Replacement 45 COVER EXTENDER (PL1.1.9)

Removal 2 MPF COVER (PL1.2.99)

- 1) Open the MPF COVER (PL1.2.24).

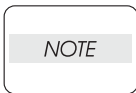

When performing the step described below, take care not to drop or damage the MPF COVER.

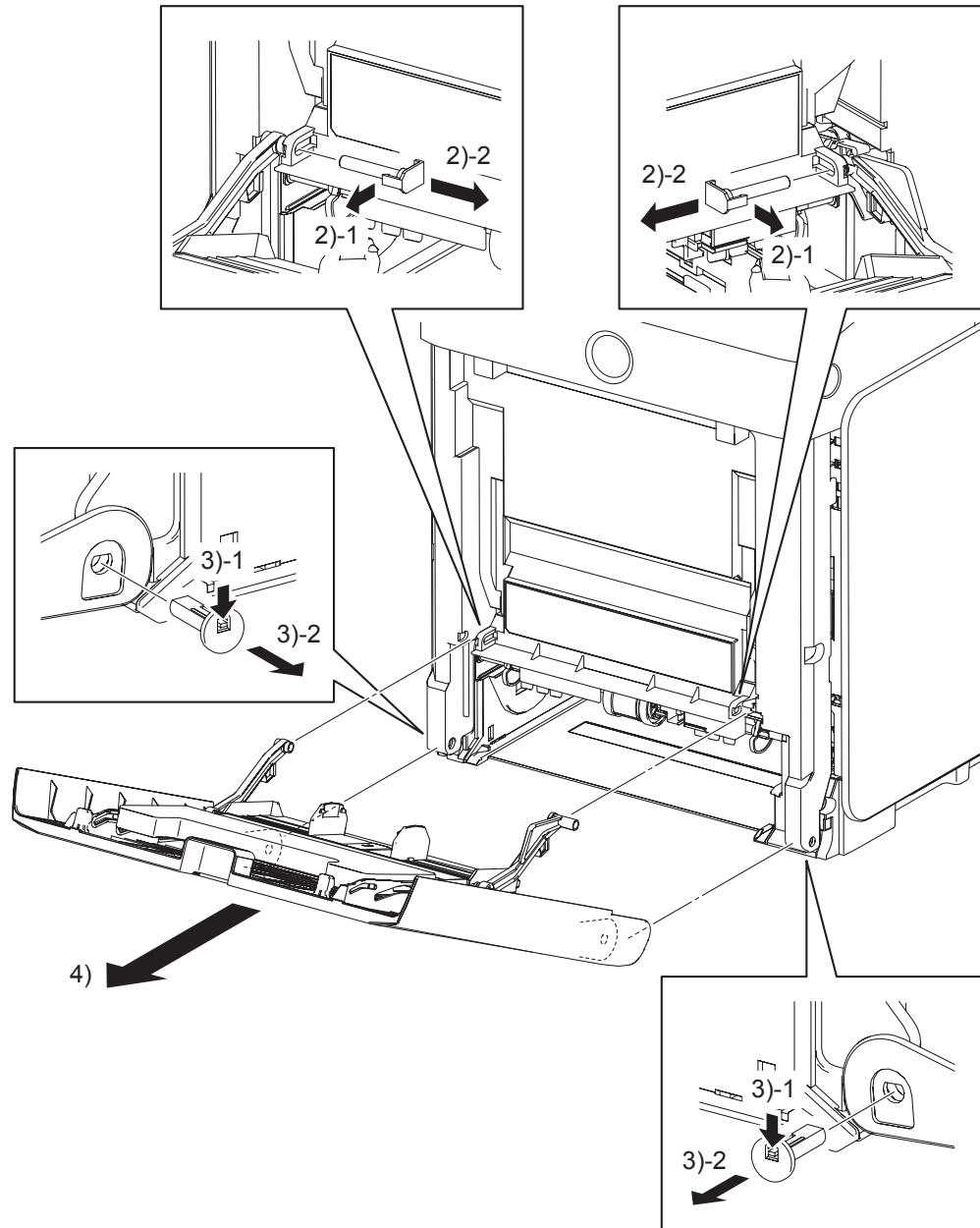

Kmy03004KA

- 2) Release the hooks on the PIN PIVOT MSIs (PL1.2.17) that pivot the LINK ASSY MSIs (pivoted to the TRAY ASSI MSI BASE at the other end) to the FRONT COVER (PL.1.2.1) at the two locations on the left and right, and then pull out the PIN PIVOT MSIs to the inside.
- 3) Release the hooks on the SHAFT PIVOT MSIs (PL1.2.30) that pivot the MPF COVER to the printer at the two locations on the left and right, and then pull out the SHAFT PIVOT MSIs to the inside.
- 4) Remove the MPF COVER from the printer.

Removal 3 TRAY REAR COVER (PL1.1.5)

- 1) Pull the TRAY REAR COVER (PL1.1.5) backward until it stops.

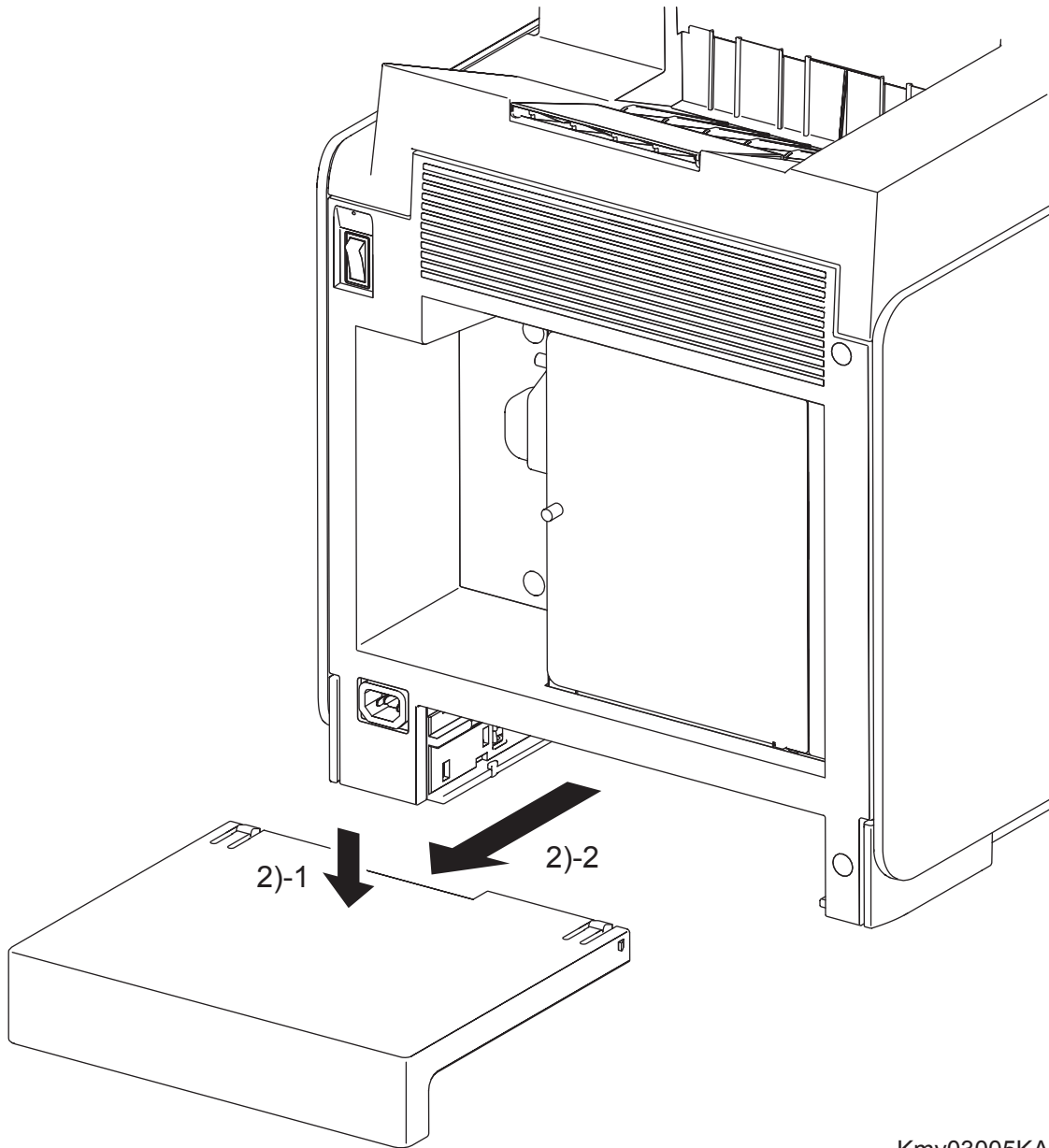

Kmy03005KA

- 2) Release the two hooks by depressing the center of the TRAY REAR COVER, and then remove the TRAY REAR COVER from the printer.

Blank Page

Removal 4 TRANSFER BELT (PL4.1.1)

- 1) Open the FRONT COVER (PL1.2.1).

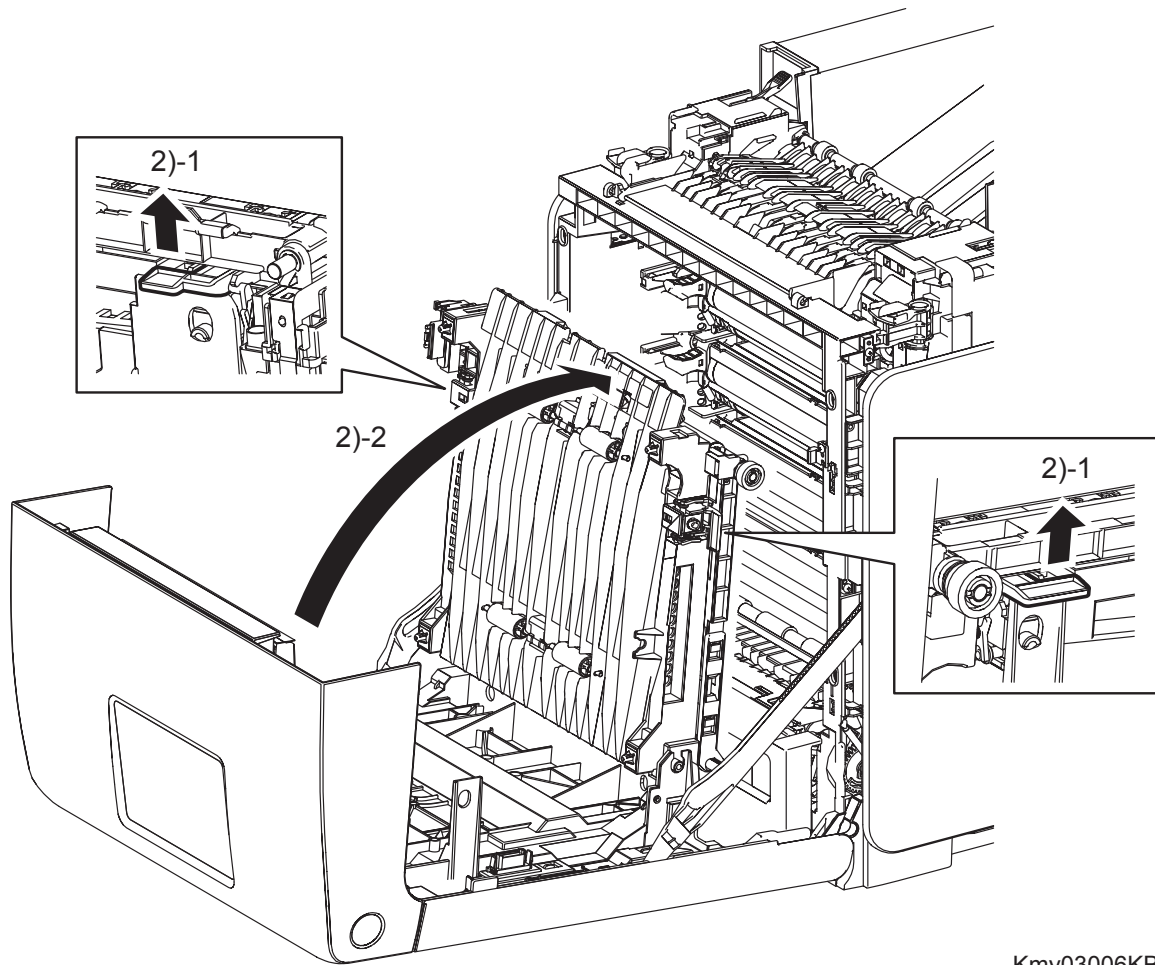

Kmy03006KB

- 2) Release the lock by pulling up the levers on the left and right sides of the TRANSFER BELT (PL4.1.1). Raise the TRANSFER BELT upright.

Continues to the next page.

Removal 4 TRANSFER BELT (PL4.1.1)

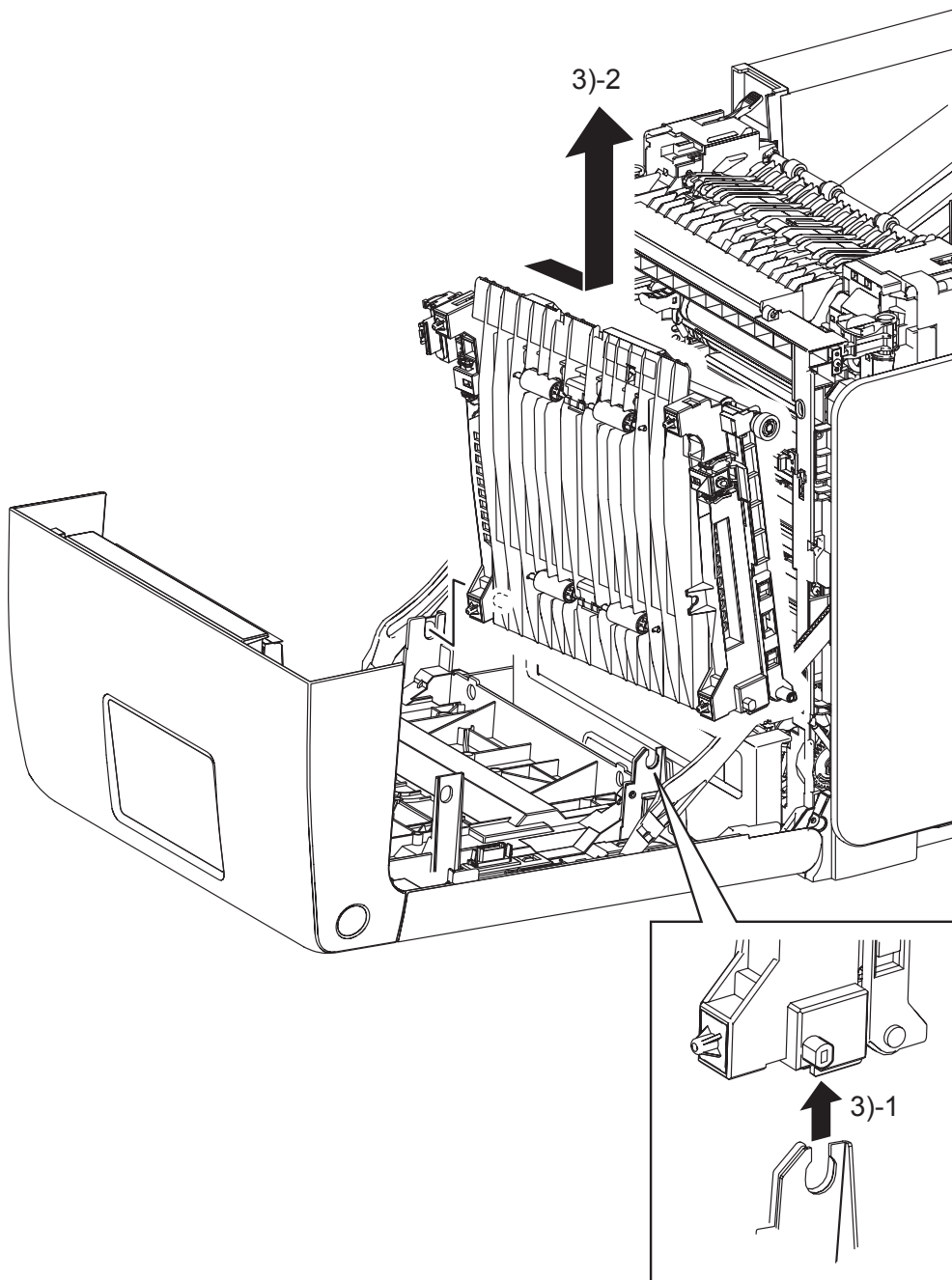

Kmy03007KB

- 3) Remove the TRANSFER BELT by releasing the left side lug on the TRANSFER BELT from the U-shaped notch of the FRONT COVER and pulling out the right side lug on the TRANSFER BELT from the hole on the FRONT COVER.

Go to the next removal step:

Removal 5 DUPLEX MODULE (PL11.1.1)

Removal 5 DUPLEX MODULE (PL11.1.1)

Steps 1 and 2 are for reference. Before removing this component, check that Steps 1 and 2 have been performed.

- 1) Open the FRONT COVER (PL1.2.1).
- 2) Remove the TRANSFER BELT. (Removal 4)

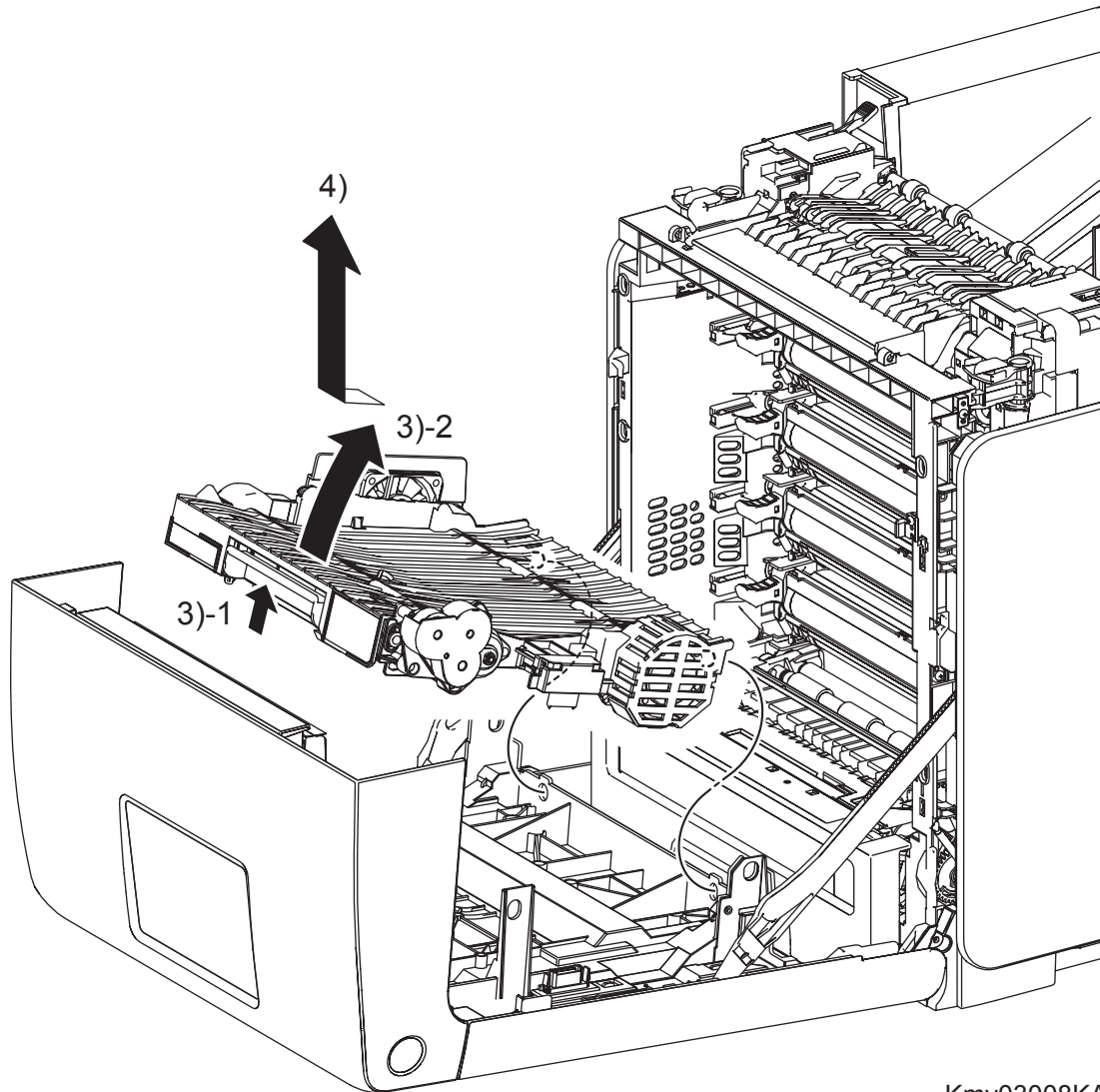

Kmy03008KA

- 3) Release the lock by pulling the lever of the DUPLEX MODULE (PL11.1.1), and then raise the DUPLEX MODULE.
- 4) Release the two bosses on the backside of the DUPLEX MODULE from the holes on the FRONT COVER, and then remove the DUPLEX MODULE.

Removal 6 TONER CARTRIDGE (K), (C), (M), (Y) (PL5.1.18-21)

NOTE

Described below is the removal procedure common among the TONER CARTRIDGES (C), (M), (Y), and (K).

Step 1 is for reference. Before removing this component, check that Step 1 has been performed.

- 1) Open the FRONT COVER (PL1.2.1).

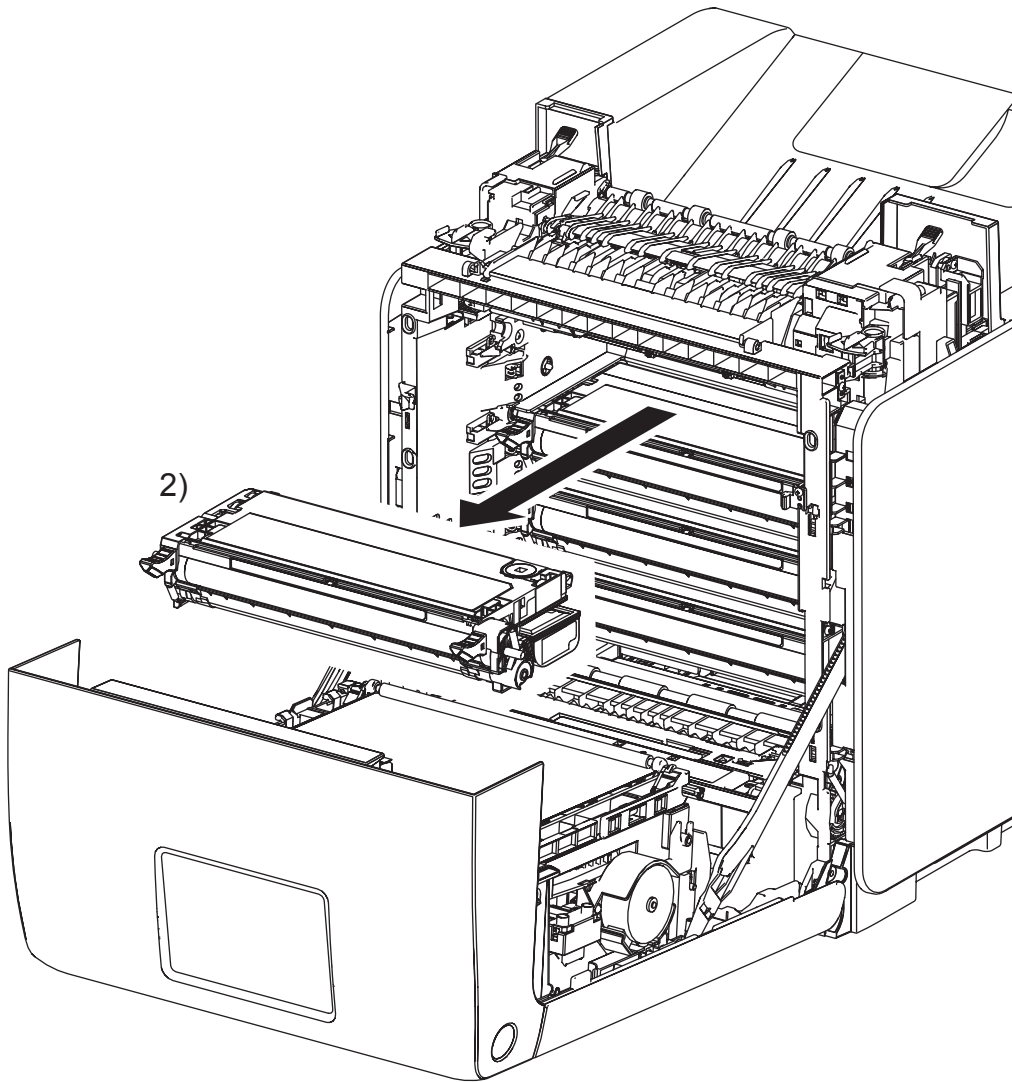

Kmy03009KA

- 2) Remove the TONER CARTRIDGE toward you by pulling it by the left and right handles.

Removal 7 DUPLEX GATE (PL6.1.13)

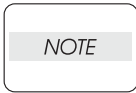

The FUSER part is very hot. Take added care not to get burned when performing the service operation.

- 1) Open the FRONT COVER (PL1.2.1).

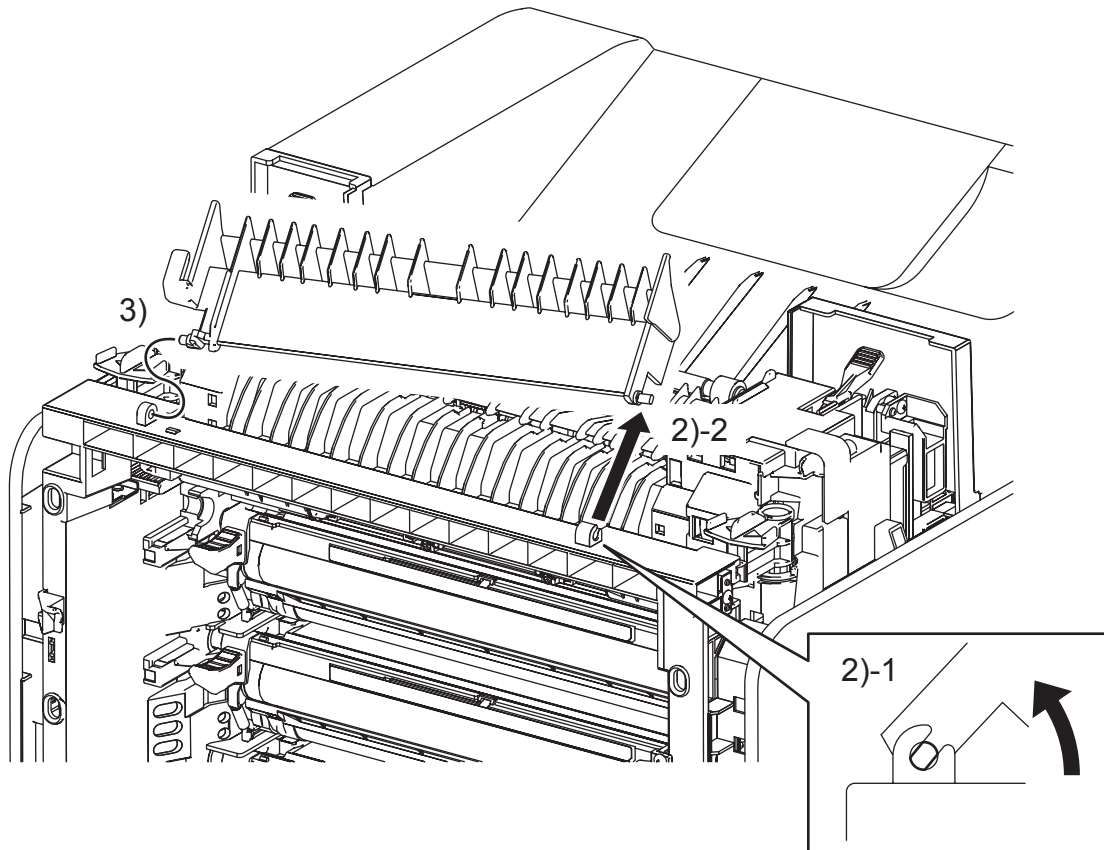

Kmy03010KA

- 2) Open the DUPLEX GATE (PL6.1.13) to about 45 degrees so that the flat faces of the right side pivot of the DUPLEX GATE comes parallel with the U-shaped notch. Pull out the right side pivot of the DUPLEX GATE from the U-shaped notch diagonally backward.
- 3) Pull out the left side pivot of the DUPLEX GATE from the hole on the printer.

Removal 8 FUSER (PL6.1.10)

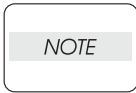

The FUSER part is very hot. Take added care not to get burned when performing the service operation.

- 1) Open the FRONT COVER (PL1.2.1).

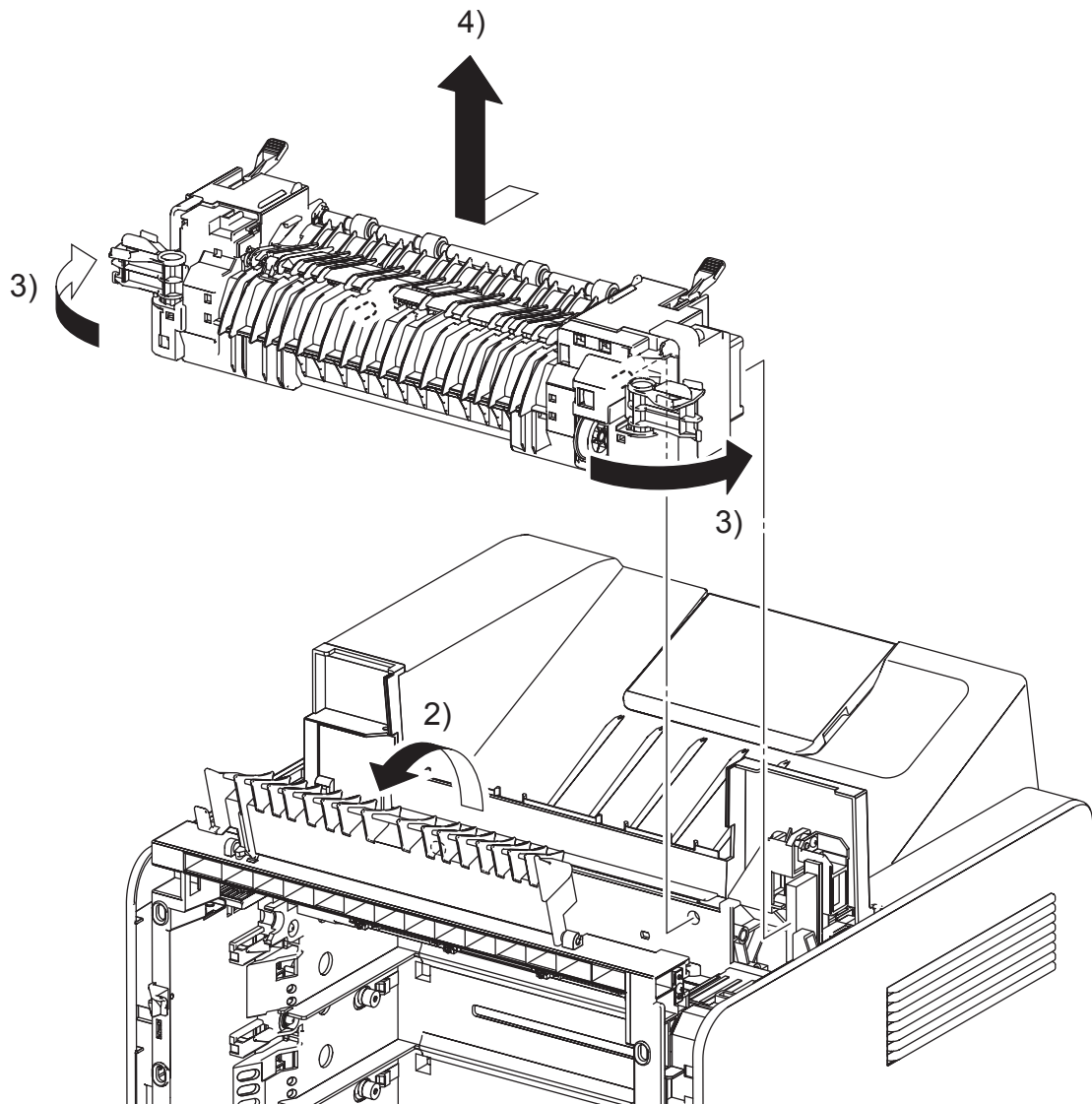

Kmy03011KA

- 2) Open the DUPLEX GATE (PL6.1.13).
- 3) Release the lock by rotating the left and right levers of the FUSER (PL6.1.10) to the outside direction.
- 4) Disengage the bosses and connector of the FUSER by moving the FUSER slightly toward you. Remove the FUSER upward.

Go to the next removal step:

Removal 9 SPUR ASSEMBLY (PL7.1.1)

Removal 9 SPUR ASSEMBLY (PL7.1.1)

NOTE

Described below is the removal procedure common between the left and right sides of the SPUR ASSEMBLY.

Steps 1 and 2 are for reference. Before removing this component, check that Steps 1 and 2 have been performed.

- 1) Open the FRONT COVER (PL1.2.1).
- 2) Remove the FUSER. (Removal 8)

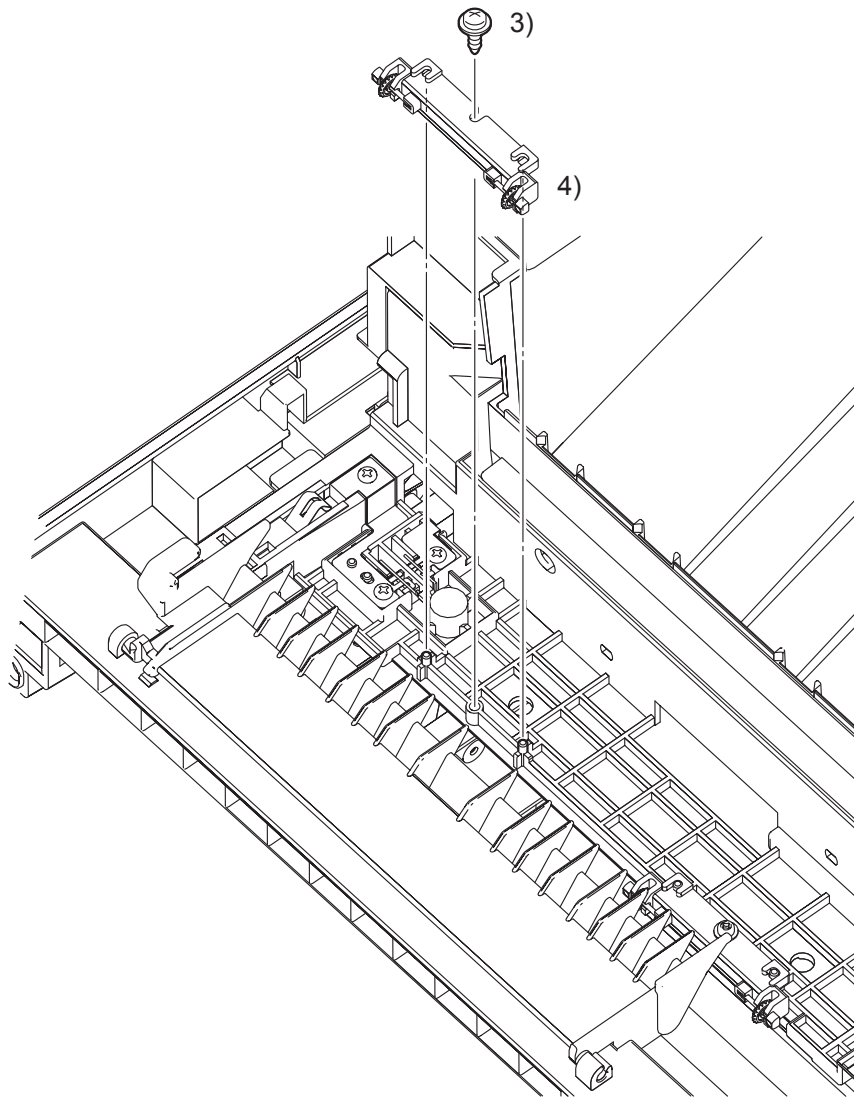

Kmy03012KA

- 3) Remove the one screw (silver, with flange, tap, 8mm) that fixes the SPUR ASSEMBLY to the printer.
- 4) Remove the SPUR ASSEMBLY from the printer.

Removal 10 CHUTE ASSY EXIT OUT (PL6.1.1)

- 1) Open the FRONT COVER (PL1.2.1).

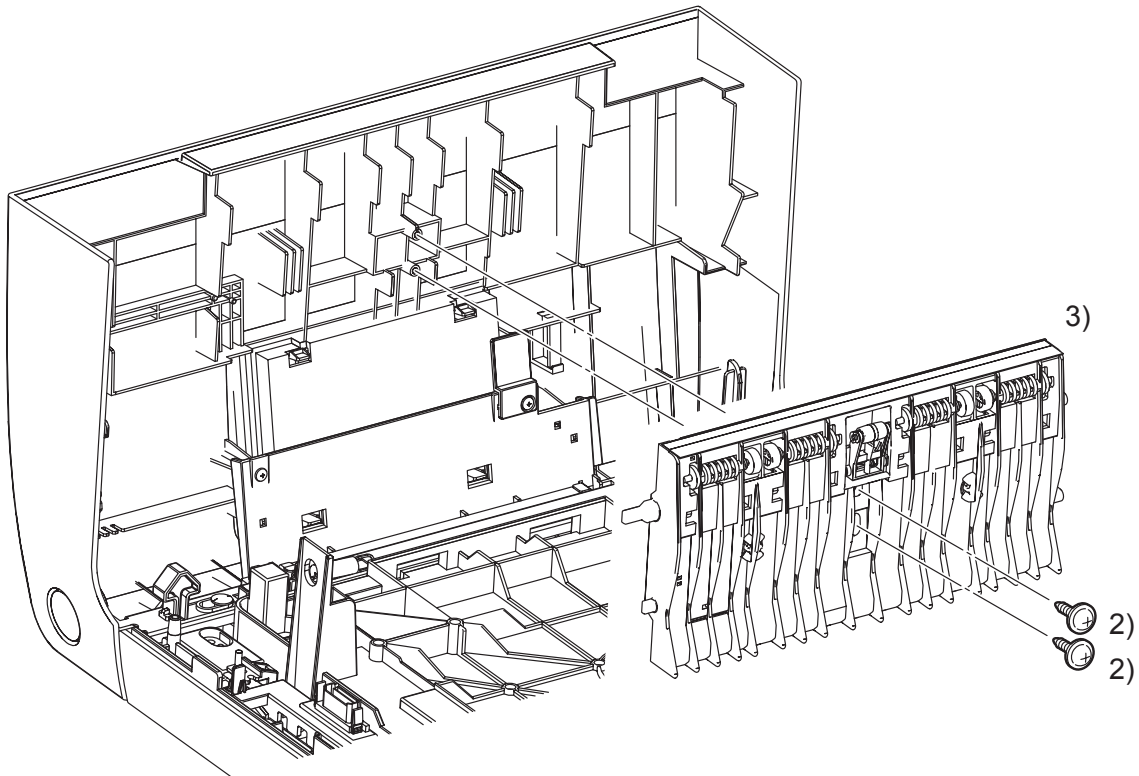

Kmy03013KA

- 2) Remove two screws (silver, with flange, tap, 10mm) that fix the CHUTE ASSY EXIT OUT (PL6.1.1) to the FRONT COVER.
- 3) Remove the CHUTE ASSY EXIT OUT from the FRONT COVER.

Go to the next removal step:

Removal 11 OPERATOR PANEL (PL1.2.97)

Removal 11 OPERATOR PANEL (PL1.2.97)

Steps 1 through 5 are for reference. Before removing this component, check that Steps 1 and 2 have been performed.

When removing the OPERATOR PANEL only, perform Steps 1, 5, 6, 7, 8, and 9.

- 1) Open the FRONT COVER (PL1.2.1).
- 2) Remove the FUSER. (Removal 8)
- 3) Remove the REAR COVER. (Removal 12)
- 4) Remove the RIGHT COVER. (Removal 13)
- 5) Remove the CHUTE ASSY EXIT OUT. (Removal 10)

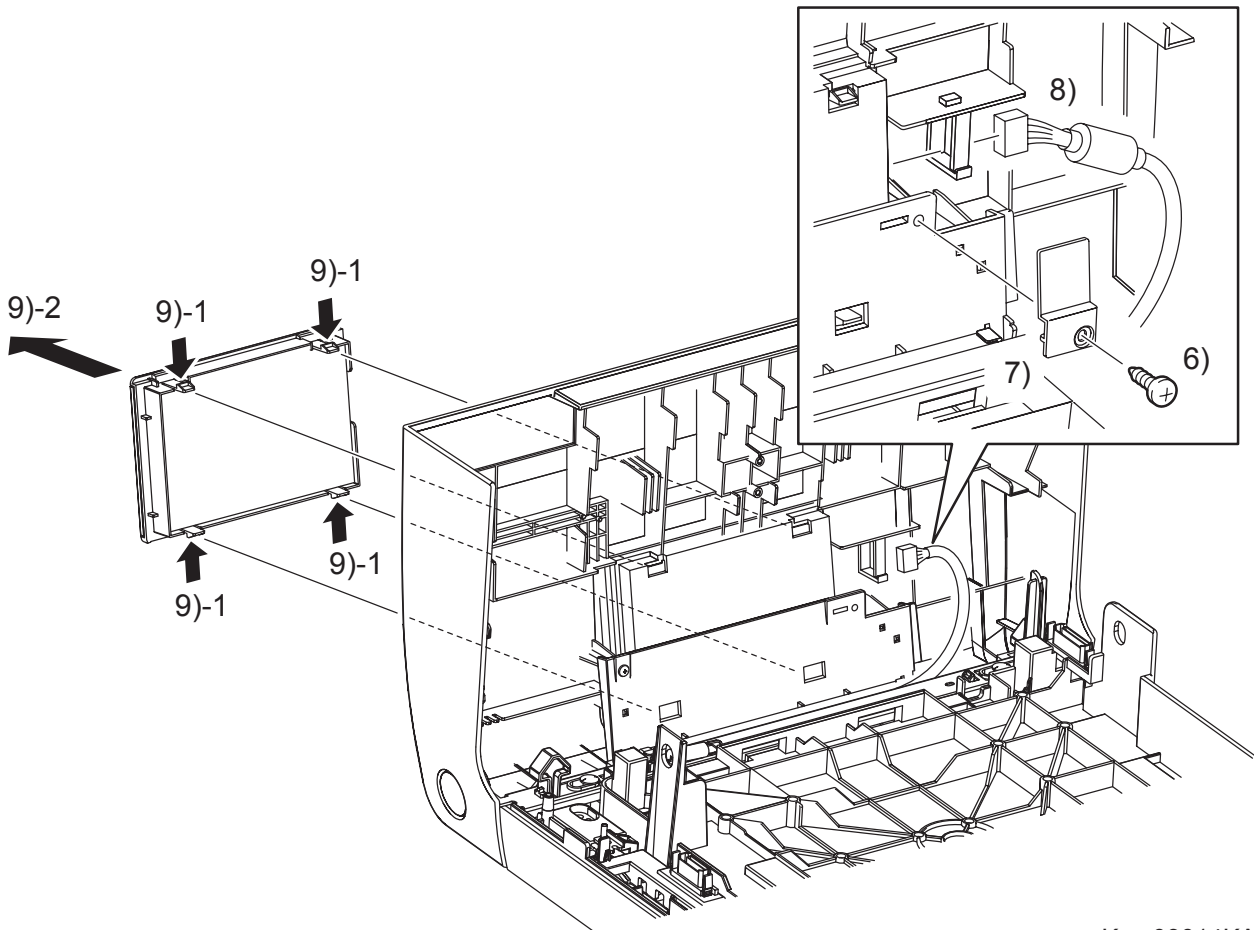

Kmy03014KA

- 6) Remove the one screw (silver, tap, 8mm) that fixes the BRACKET HARNESS (PL1.2.34) to the FRONT COVER.
- 7) Remove the BRACKET HARNESS from the FRONT COVER.
- 8) Release the clamp that fixes the core of the HARNESS ASSY OPEPANE, and then disengage the connector (P/J220) of the OPERATOR PANEL (PL1.2.16).

NOTE

When performing the step described below, take care not to drop or damage the OPERATOR PANEL.

- 9) Remove the OPERATOR PANEL by releasing the four hooks that fix the OPERATOR PANEL to the printer.

Continues to the next page.

Removal 11 OPERATOR PANEL (PL1.2.97)

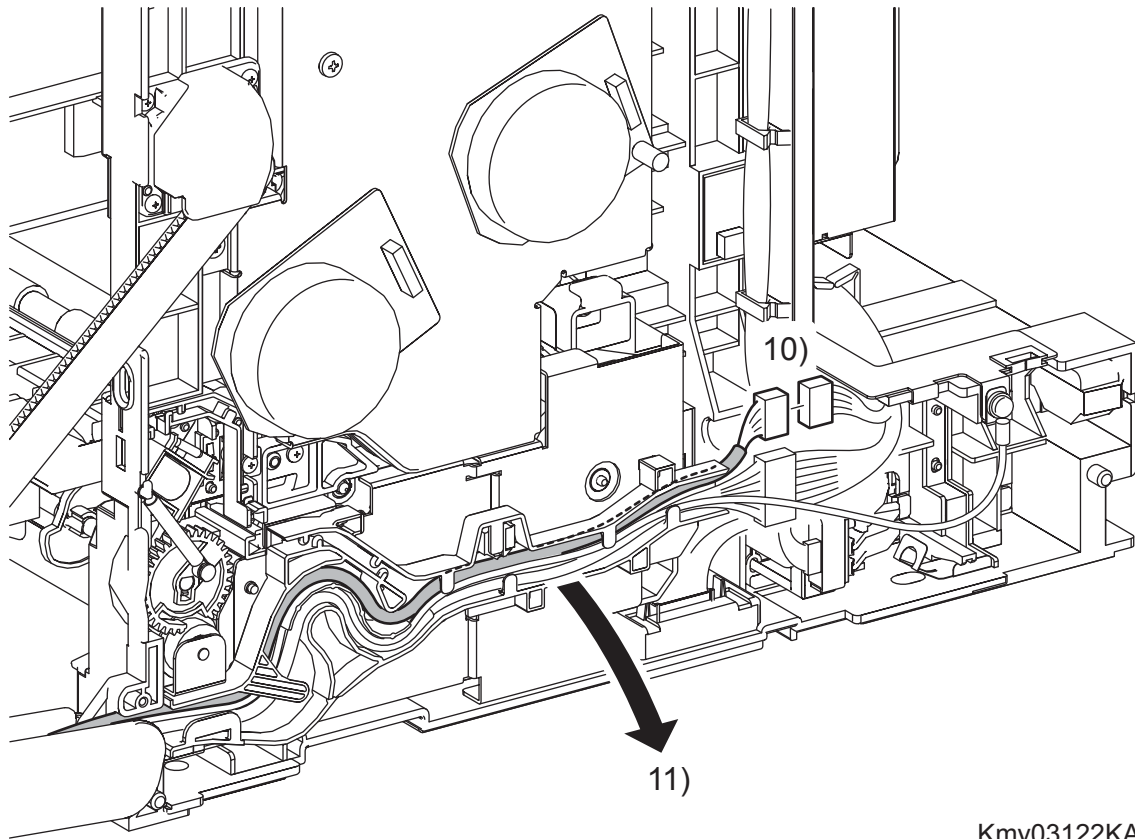

Kmy03122KA

- 10) Disengage the connector (P/J2900) of the HARNESS ASSY OPEPANE (PL1.2.15).
- 11) Release the HARNESS ASSY OPEPANE from the DUCT DRV PH (PL8.1.8).

Continues to the next page.

Removal 11 OPERATOR PANEL (PL1.2.97)

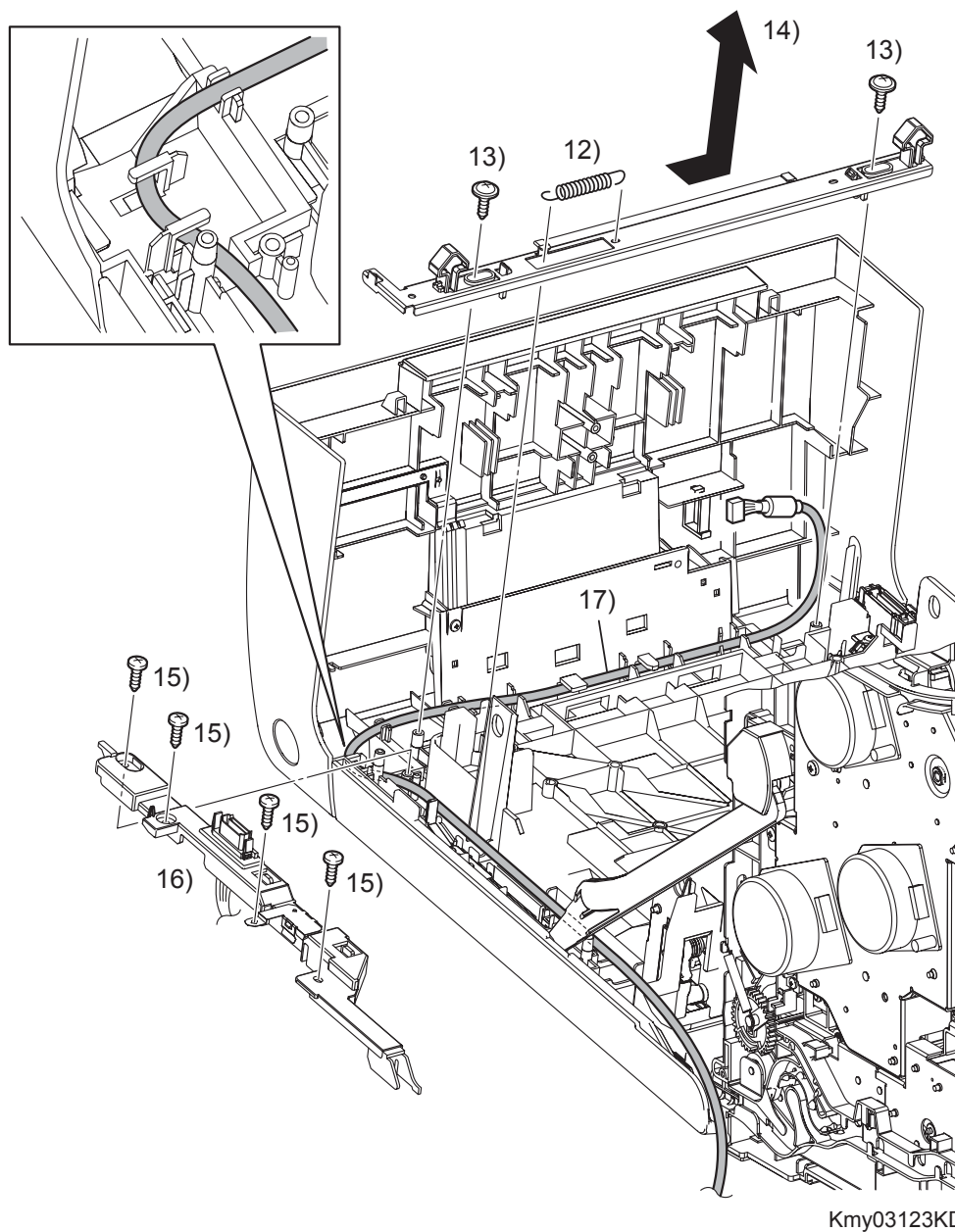

- 12) Remove the SPRING LATCH (PL1.2.3) from the hooks on the PLATE LATCH (PL1.2.2) and the FRONT COVER.
- 13) Remove two screws (silver, with flange, tap, 10mm) that fix the left and right sides of the LATCH FRONT (PL1.24) to the FRONT COVER.
- 14) Slide the PLATE LATCH and LATCH FRONT to the left, and then remove the PLATE LATCH and LATCH FRONT from the FRONT COVER.
- 15) Remove the four screws (silver, tap, 8mm) that fix the COVER HARNESS (PL1.2.5) to the FRONT COVER.

NOTE

Take care not to move the COVER HARNESS away from the FRONT COVER too far because the COVER HARNESS is secured to the HARNESS ASSY FRONT COVER.

- 16) Remove the COVER HARNESS from the FRONT COVER.
- 17) Remove the HARNESS ASSY OPEPANE from the FRONT COVER.

Blank Page

Removal 12 REAR COVER (PL1.1.4)

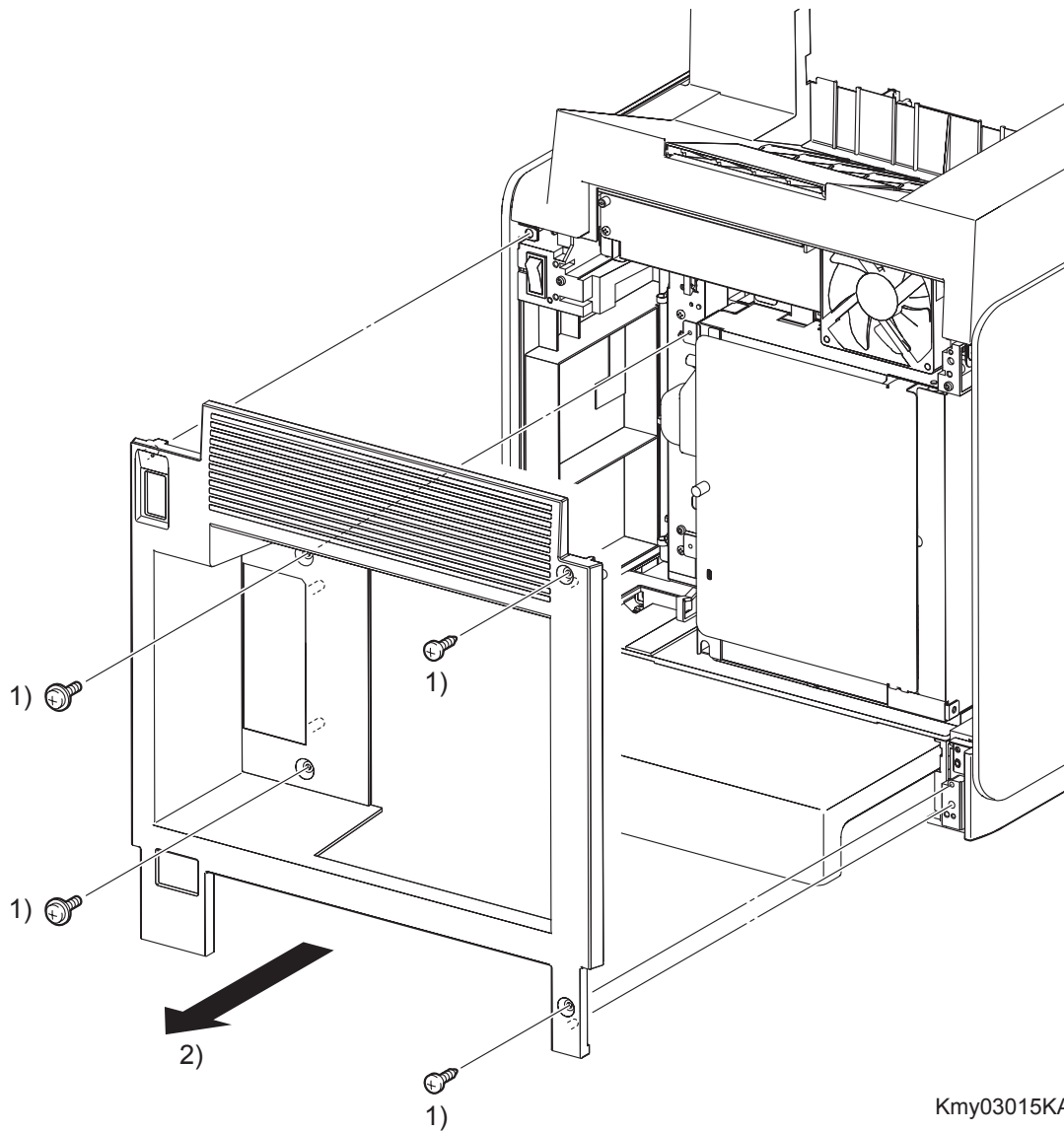

Kmy03015KA

- 1) Remove two screws (silver, tap, 10mm) and two screws (silver, with flange, 8mm) that fix the REAR COVER (PL1.1.4) to the printer
- 2) Remove the REAR COVER from the printer.

Go to the next removal step:

Removal 13 RIGHT COVER (PL1.1.6) or Removal 22 LEFT COVER (PL1.1.7)

Removal 13 RIGHT COVER (PL1.1.6)

Steps 1 through 3 are for reference. Before removing this component, check that Steps 1 through 3 have been performed.

- 1) Open the FRONT COVER (PL1.2.1).
- 2) Remove the FUSER. (Removal 8)
- 3) Remove the REAR COVER. (Removal 12)

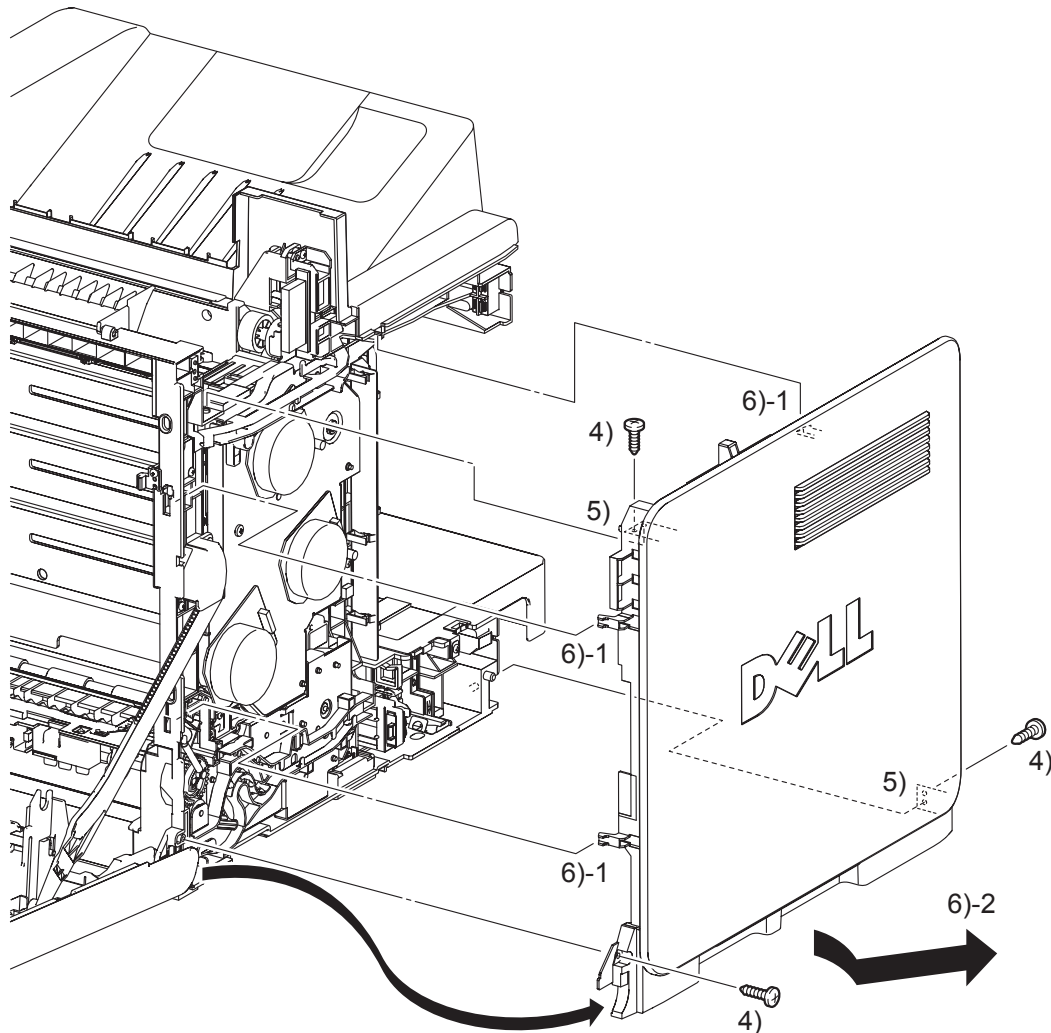

Kmy03016KA

- 4) Remove three screws (silver, tap, 10mm) that fix the RIGHT COVER (PL1.1.6) to the printer.
- 5) Release the two holes on the RIGHT COVER from the bosses on the printer.
- 6) Release the one backside hook and two frontside hooks on the RIGHT COVER, and then remove the RIGHT COVER diagonally backward.

Go to the next removal step:

Removal 14 MPF FEED SOLENOID (PL3.1.98), Removal 15 FEED DRIVE ASSEMBLY (PL8.1.7), Removal 17 FRONT COVER (PL1.2.98), Removal 18 RIGHT ARM ASSEMBLY (PL7.1.98), Removal 19 SIZE SWITCH ASSEMBLY (PL7.1.18), Removal 20 POWER SWITCH (PL9.1.13), Removal 21 TONER CARTRIDGE SENSOR ASSEMBLY (C), (M), (Y) (PL5.1.4) or Removal 22 LEFT COVER (PL1.1.7)

Removal 14 MPF FEED SOLENOID (PL3.1.98)

Steps 1 through 4 are for reference. Before removing this component, check that Steps 1 through 4 have been performed.

- 1) Open the FRONT COVER (PL1.2.1).
- 2) Remove the FUSER. (Removal 8)
- 3) Remove the REAR COVER. (Removal 12)
- 4) Remove the RIGHT COVER. (Removal 13)

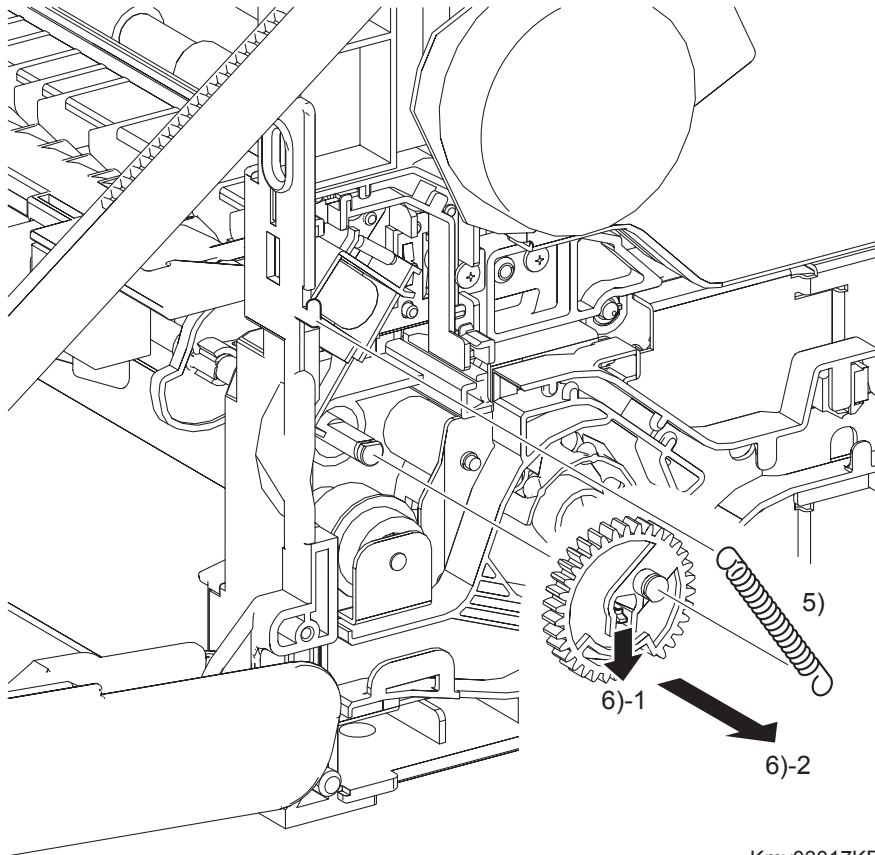

Kmy03017KB

- 5) Remove the SPRING FEED MSI (PL3.1.4) from the printer.
- 6) Remove the GEAR MSI from the SHAFT MSI (PL3.1.12) by releasing the hook on the GEAR MSI (PL3.1.5).

Continues to the next page.

Removal 14 MPF FEED SOLENOID (PL3.1.98)

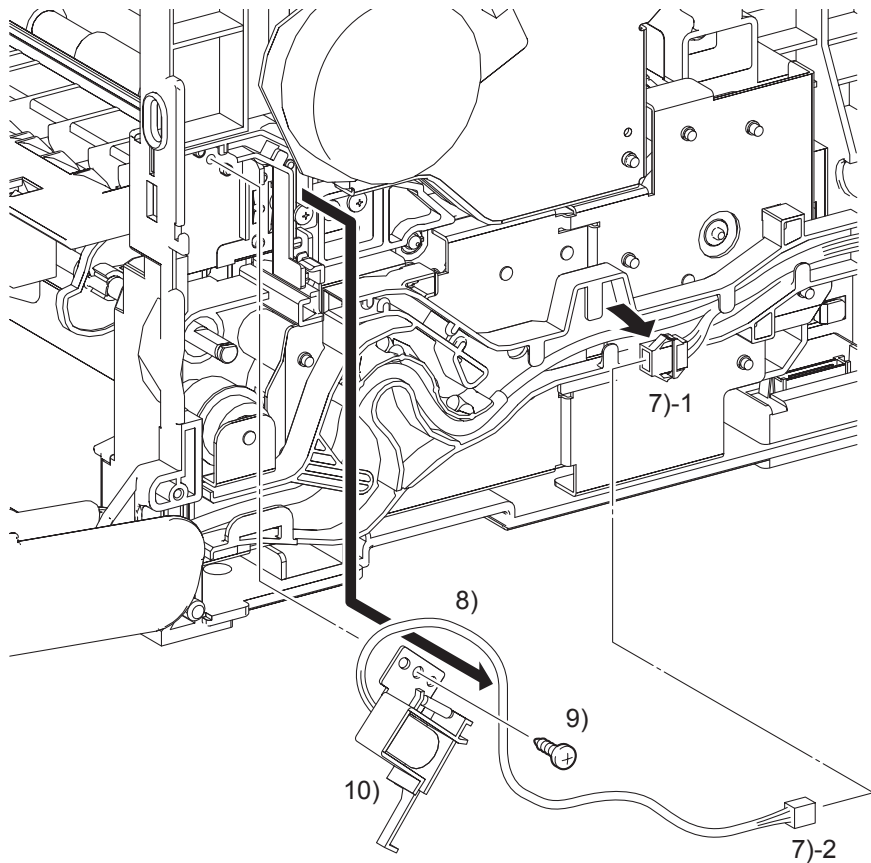

Kmy03018KA

NOTE

When performing the step below, leave the junction connector on the printer side cable.

- 7) Disengage the connector (P/J256) of the MPF FEED SOLENOID (PL3.1.3).
- 8) Remove the harness of the MPF FEED SOLENOID from the DUCT MSI SOL (PL3.1.2) and DUCT DRV PH (PL8.1.8).
- 9) Remove the one screw (silver, tap, 8mm) that fixes the MPF FEED SOLENOID to the printer.
- 10) Remove the MPF FEED SOLENOID from the printer.

Removal 15 FEED DRIVE ASSEMBLY (PL8.1.7)

Steps 1 through 4 are for reference. Before removing this component, check that Steps 1 through 4 have been performed.

- 1) Open the FRONT COVER (PL1.2.1).
- 2) Remove the FUSER. (Removal 8)
- 3) Remove the REAR COVER. (Removal 12)
- 4) Remove the RIGHT COVER. (Removal 13)

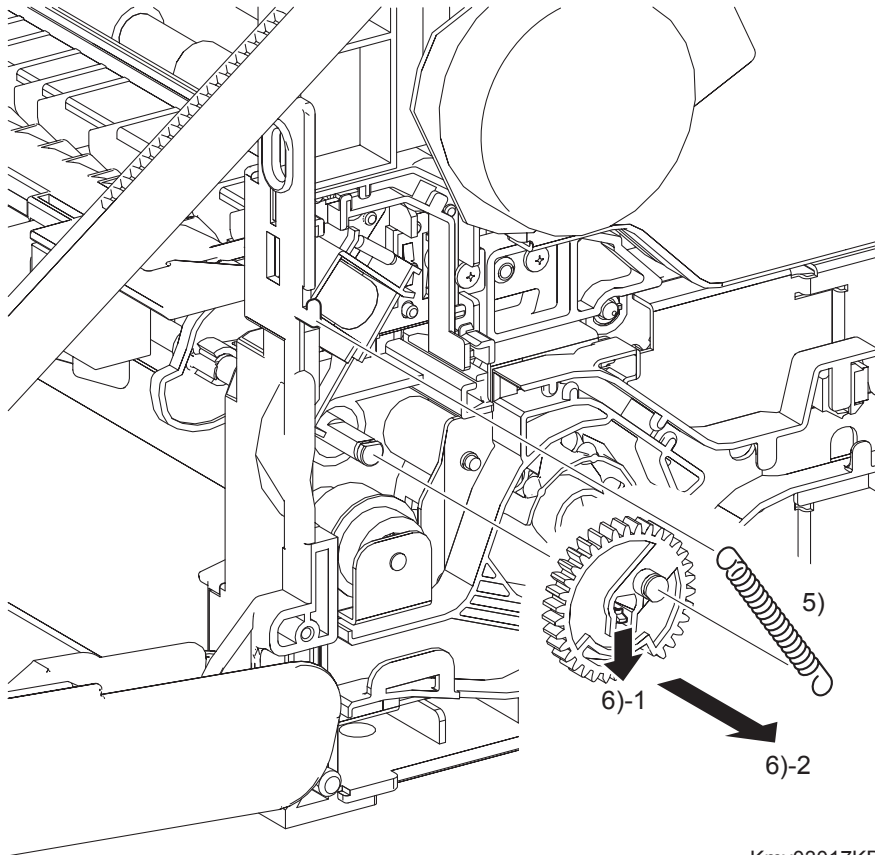

- 5) Remove the SPRING FEED MSI (PL3.1.4) from the printer.
- 6) Remove the GEAR MSI from the SHAFT MSI (PL3.1.12) by releasing the hook on the GEAR MSI (PL3.1.5).
- 7) Remove all the harnesses from the DUCT DRV PH (PL8.1.8).

Continues to the next page.

Removal 15 FEED DRIVE ASSEMBLY (PL8.1.7)

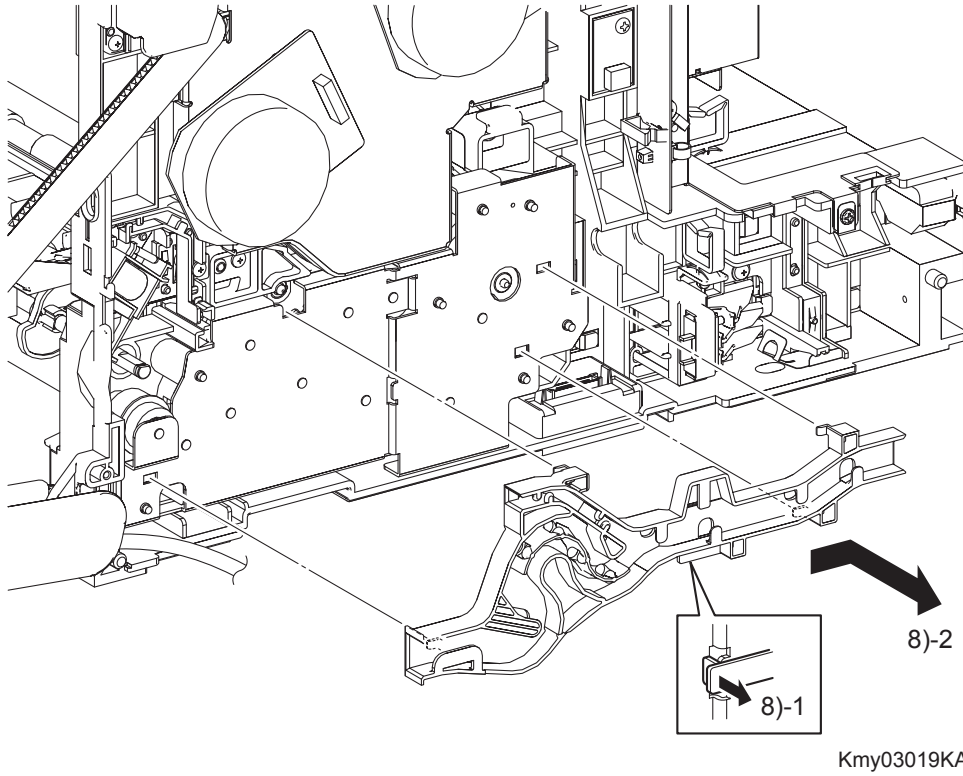

Kmy03019KA

- 8) Remove the DUCT DRV PH from the FEED DRIVE ASSEMBLY (PL8.1.7) by releasing the hook on the DUCT DRV PH and moving it slightly backward.

Continues to the next page.

Removal 15 FEED DRIVE ASSEMBLY (PL8.1.7)

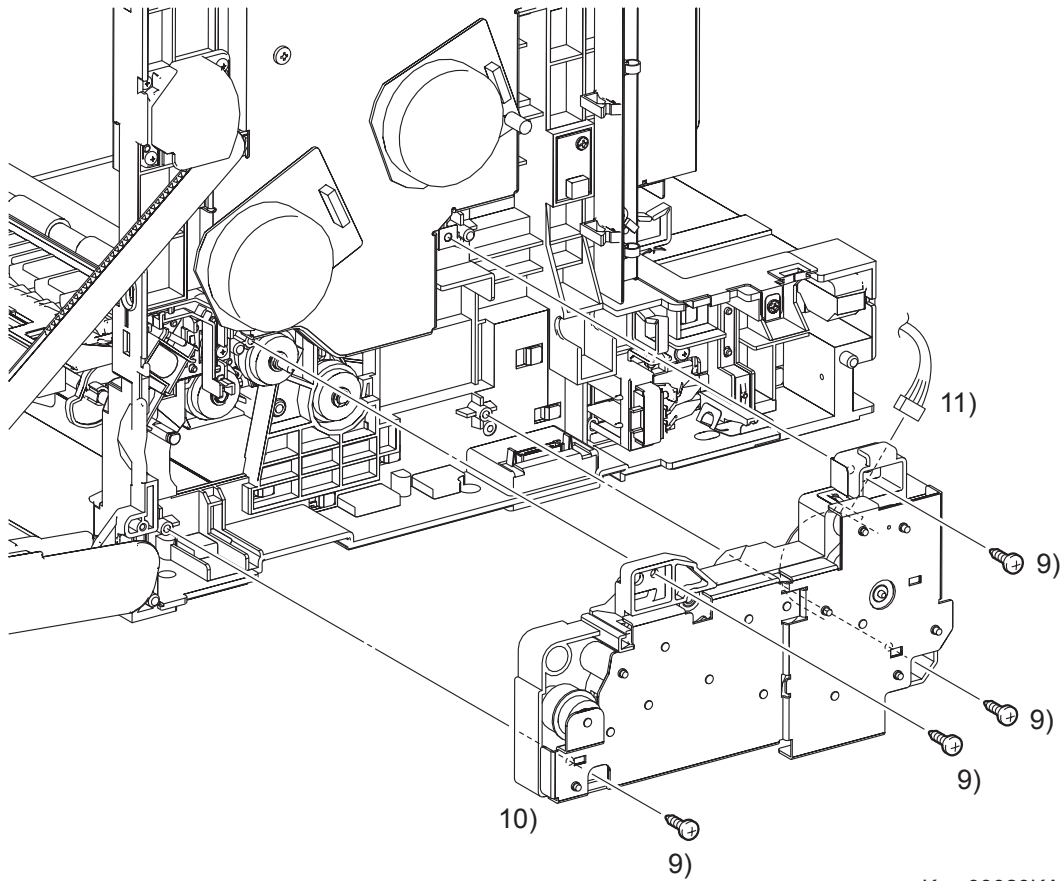

Kmy03020KA

- 9) Remove four screws (silver, tap, 10mm) that fix the FEED DRIVE ASSEMBLY to the printer.

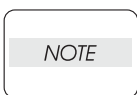

When performing the step described below, take care not to move the FEED DRIVE ASSEMBLY from the printer too far because they are connected with the harness.

- 10) Remove the FEED DRIVE ASSEMBLY from the printer.
 11) Disengage the connector (P/J251) of the FEED DRIVE ASSEMBLY.

Go to the next removal step:

Removal 16 INTEGRATED FEEDER ASSEMBLY (PL3.2.99)

Blank Page

Removal 16 INTEGRATED FEEDER ASSEMBLY (PL3.2.99)

Steps 1 through 5 are for reference. Before removing this component, check that Steps 1 through 5 have been performed.

- 1) Open the FRONT COVER (PL1.2.1).
- 2) Remove the FUSER. (Removal 8)
- 3) Remove the REAR COVER. (Removal 12)
- 4) Remove the RIGHT COVER. (Removal 13)
- 5) Remove the FEED DRIVE ASSEMBLY. (Removal 15)

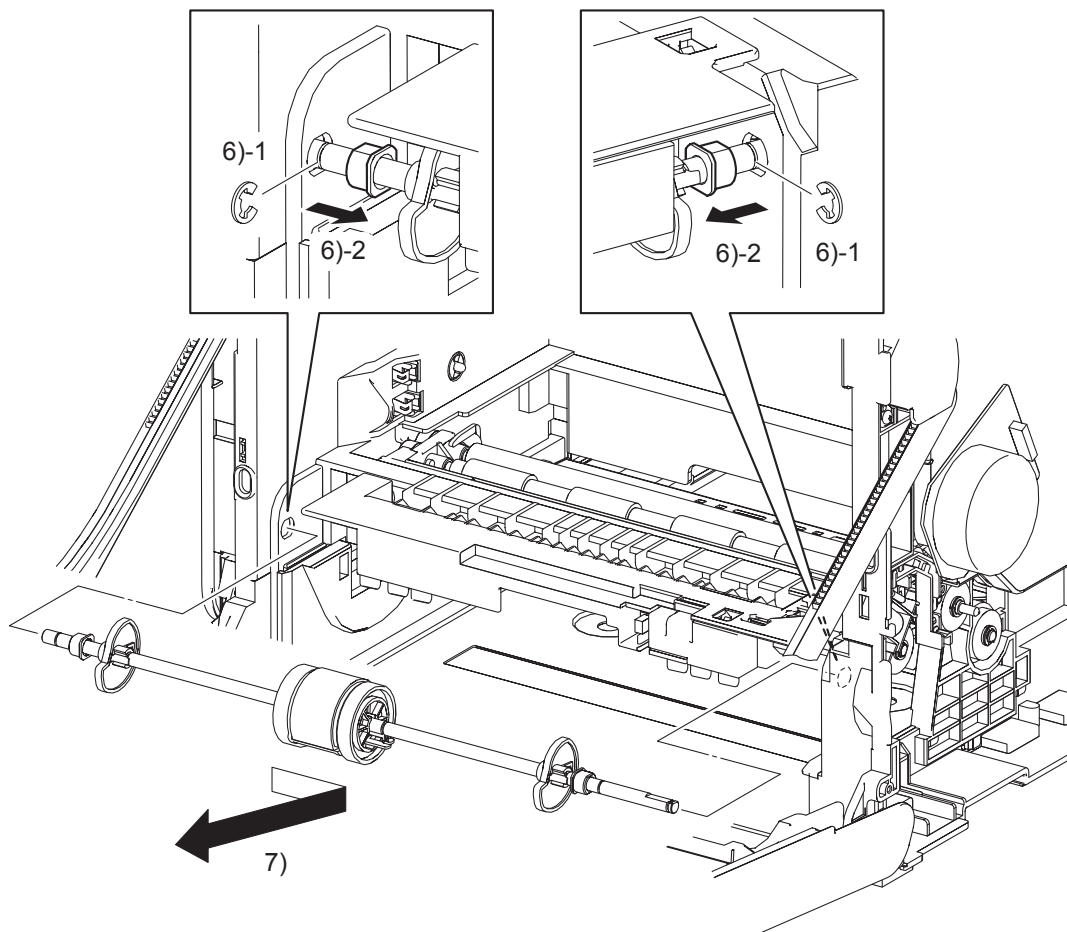

Kmy03021KA

- 6) Remove the e-rings that fix the BEARING on the left and right sides of the ROLL ASSY MSI (PL3.1.8), and then remove the BEARING to the inside.

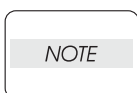

When performing the step described below, take care not to drop and lose the BEARING EARTH (PL3.1.6) and the BEARING (PL3.1.13).

- 7) Remove the ROLL ASSY MSI by sliding it to the right and pulling out its left side shaft from the left side hole on the printer and then pulling it out to the lower left.

Continues to the next page.

Removal 16 INTEGRATED FEEDER ASSEMBLY (PL3.2.99)

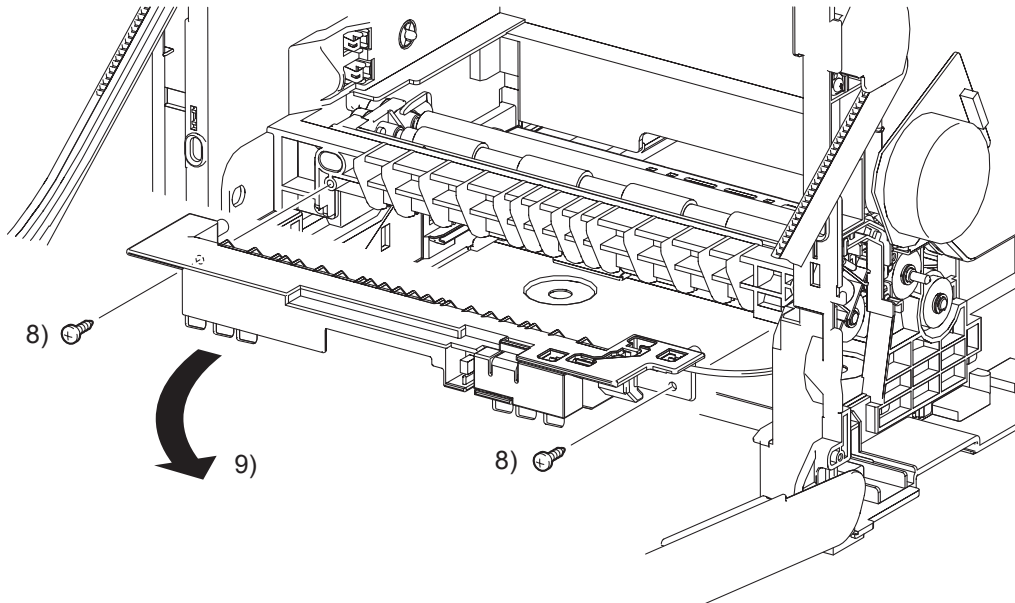

NOTE

When performing the step described below, it is not necessary to remove the SENSOR PHOTO (PL3.1.15) and COVER SNR (PL3.1.16).

- 8) Remove two screws (silver, tap, 10mm) that fix the CHUTE MSI (PL3.1.14) to the printer.

NOTE

When performing the step described below, take care not to move the CHUTE MSI from the printer too far because they are connected with the harness.

- 9) Remove the CHUTE MSI from the printer.

Continues to the next page.

Removal 16 INTEGRATED FEEDER ASSEMBLY (PL3.2.99)

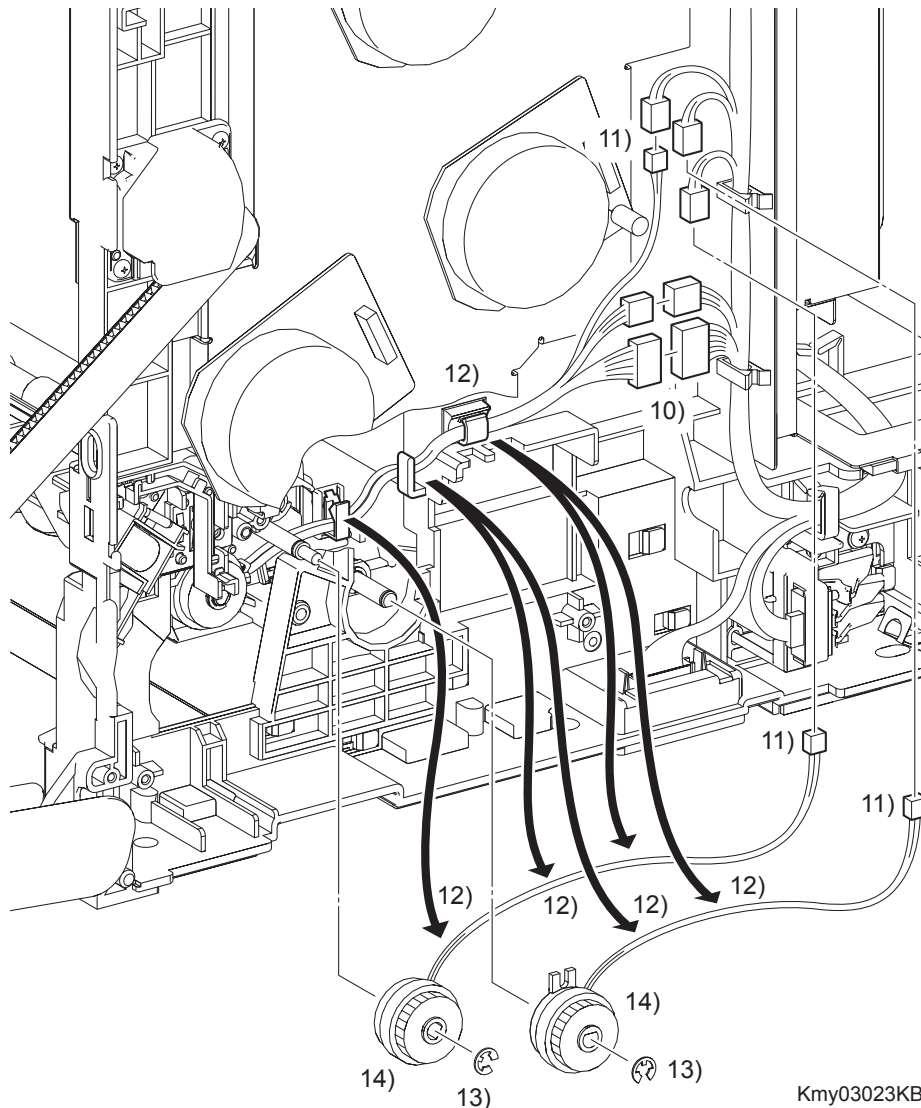

Kmy03023KB

NOTE

When performing the step below, leave the junction connector on the printer side cable.

- 10) Disengage the connectors (P/J232 and P/J241) of the INTEGRATED FEEDER ASSEMBLY (PL3.2.1).
- 11) Disengage the connector (P/J233) of the CLUTCH ASSY PH REGI (PL3.2.23), the connector (P/J235) of the CLUTCH ASSY PH FEED (PL3.2.24), and the connector (P/J234) of the CLUTCH ASSY PH TURN (PL.3.2.25).
- 12) Release the each harness from the clamps on the INTEGRATED FEEDER ASSEMBLY and printer.
- 13) Remove the e-rings that fix the CLUTCH ASSY PH REGI and the CLUTCH ASSY PH FEED to the INTEGRATED FEEDER ASSEMBLY.
- 14) Remove the CLUTCH ASSY PH REGI and the CLUTCH ASSY PH FEED from the INTEGRATED FEEDER ASSEMBLY.

Continues to the next page.

Removal 16 INTEGRATED FEEDER ASSEMBLY (PL3.2.99)

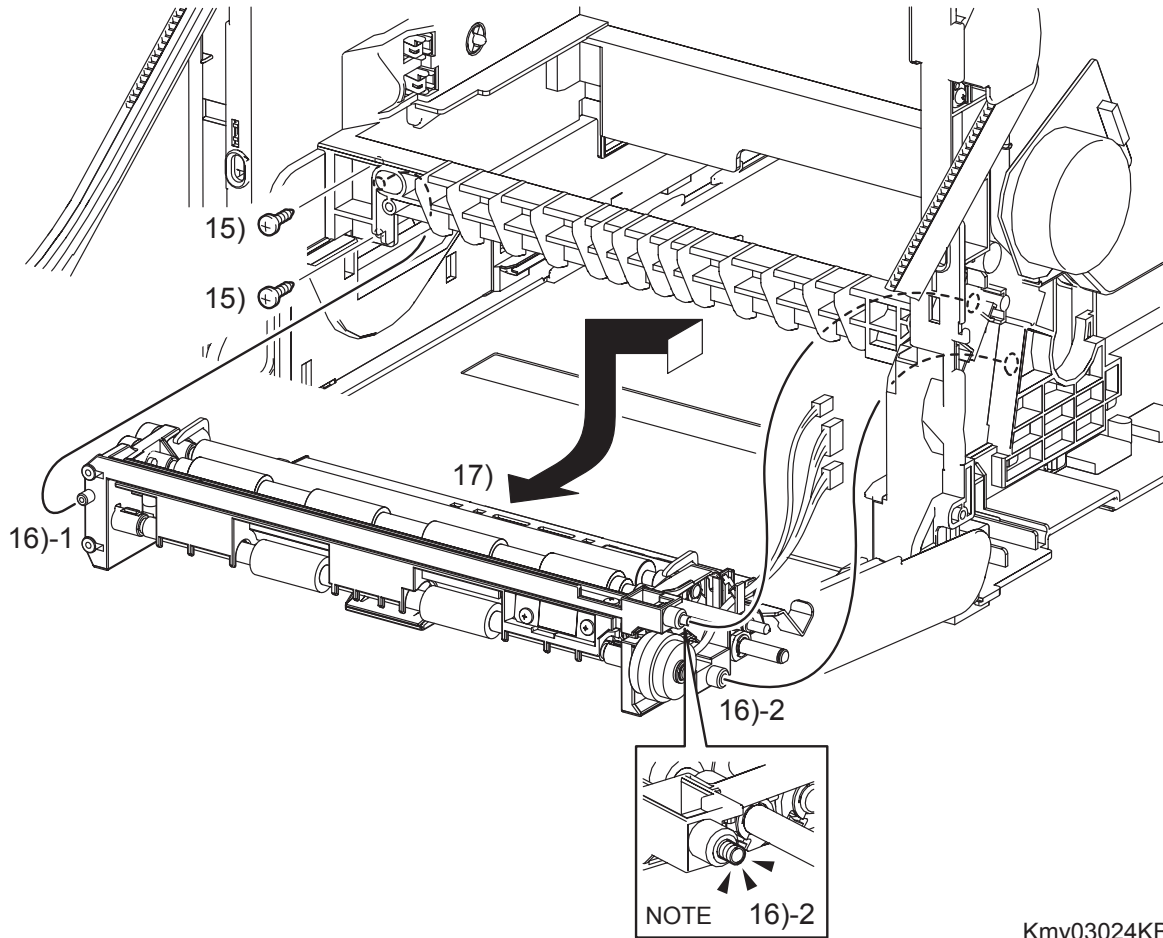

Kmy03024KB

NOTE

When performing the step below, leave the junction connector on the printer side cable.

- 15) Remove two screws (silver, tap, 10mm) that fix the INTEGRATED FEEDER ASSEMBLY to the printer.

NOTE

When performing the step described below, take care not to drop and lose the SPRING EARTH on the right side of the INTEGRATED FEEDER ASSEMBLY.

- 16) Release the left side boss on the INTEGRATED FEEDER ASSEMBLY from the hole on the printer. Move the INTEGRATED FEEDER ASSEMBLY slightly backward to the left and release the two bosses (One is provided with the SPRING EARTH.) on the right side from the hole on the printer.
- 17) Remove the INTEGRATED FEEDER ASSEMBLY from the printer by pulling out its right pivot and clutch from the hole on the printer.

Removal 17 FRONT COVER (PL1.2.98)

NOTE

The procedures described below must be performed with the MPF COVER (PL1.2.24) attached to the FRONT COVER (PL1.2.1).

Steps 1 through 4 are for reference. Before removing this component, check that Steps 1 through 4 have been performed.

- 1) Open the FRONT COVER (PL1.2.1).
- 2) Remove the FUSER. (Removal 8)
- 3) Remove the REAR COVER. (Removal 12)
- 4) Remove the RIGHT COVER. (Removal 13)

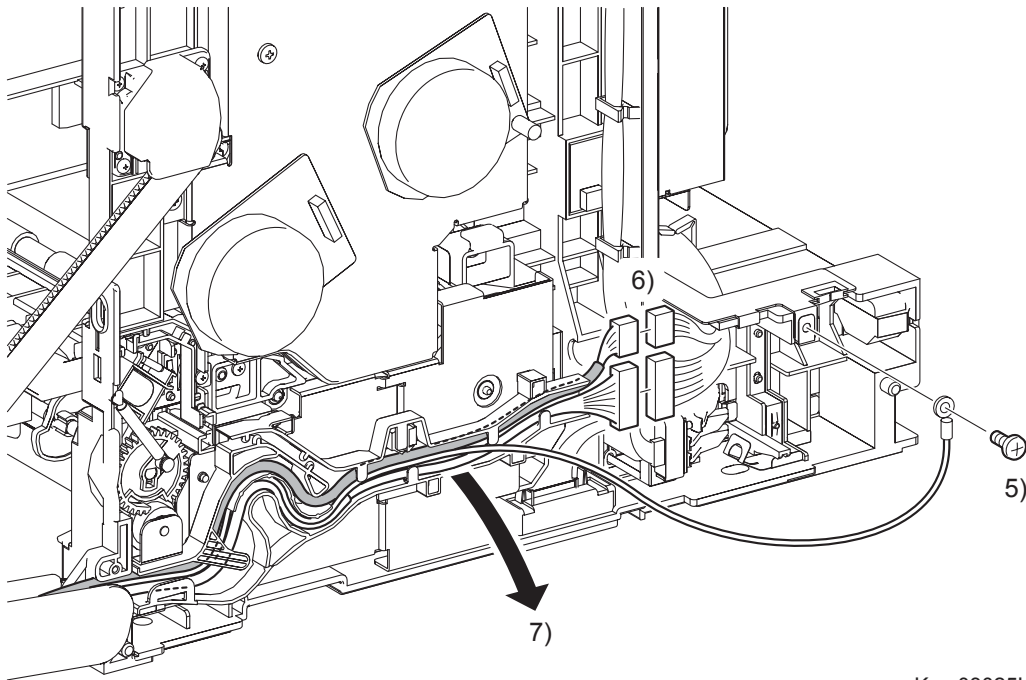

Kmy03025KB

- 5) Remove the one screw (silver, tap, 8mm) that fixes to the printer the ground wire of the HARNESS ASSY FRONT COVER (PL1.2.11).

NOTE

When performing the step below, leave the junction connector on the printer side cable.

- 6) Disengage the connector (P/J2900) of the HARNESS ASSY OPEPANE (PL1.2.15) and the connector (P/J272) of the HARNESS ASSY FRONT COVER.
- 7) Release the HARNESS ASSY OPEPANE and the HARNESS ASSY FRONT COVER from the DUCT DRV PH (PL8.1.8).

Continues to the next page.

Removal 17 FRONT COVER (PL1.2.98)

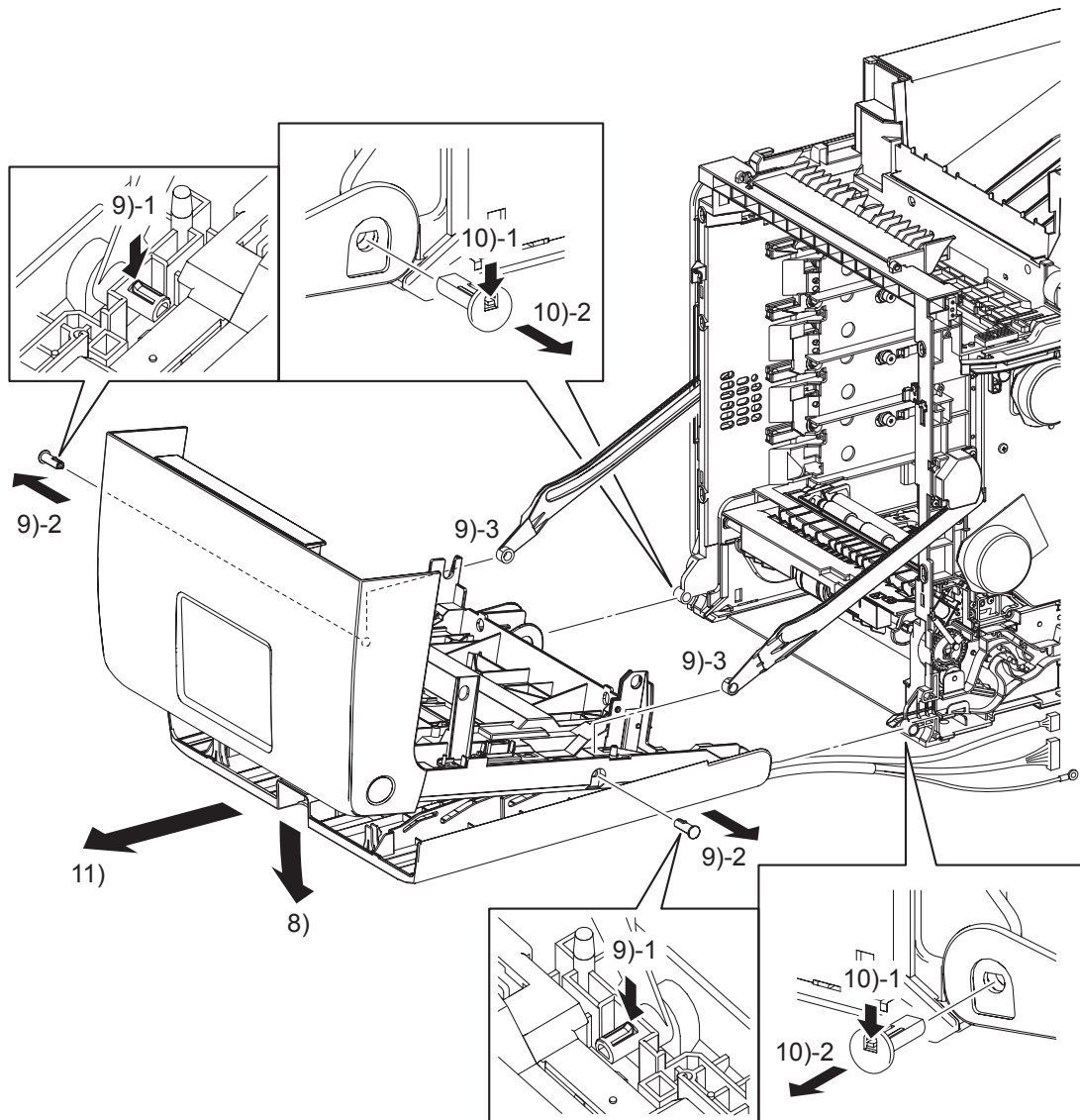

Kmy03026KB

- 8) Open the MPF COVER (PL1.2.24).

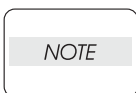

When performing the step described below, take care not to drop and break the FRONT COVER.

- 9) Release the hook of SHAFT PIVOT (PL1.2.8) on the left and right sides of the FRONT COVER, and then pull out the SHAFT PIVOT to the outside while holding the FRONT COVER. Remove the FRONT COVER from the LINK L (PL7.1.3) and LINK R (PL7.1.13) on the printer.
- 10) Release the hook of the SHAFT PIVOT MSI (PL1.2.30) that fixes the left and right sides of the FRONT COVER and the MPF COVER to the printer, and then pull out the SHAFT PIVOT MSI to the inside.
- 11) Remove the FRONT COVER together with the MPF COVER.

Removal 18 RIGHT ARM ASSEMBLY(PL7.1.98)

Steps 1 through 4 are for reference. Before removing this component, check that Steps 1 through 4 have been performed.

- 1) Open the FRONT COVER (PL1.2.1).
- 2) Remove the FUSER. (Removal 8)
- 3) Remove the REAR COVER. (Removal 12)
- 4) Remove the RIGHT COVER. (Removal 13)

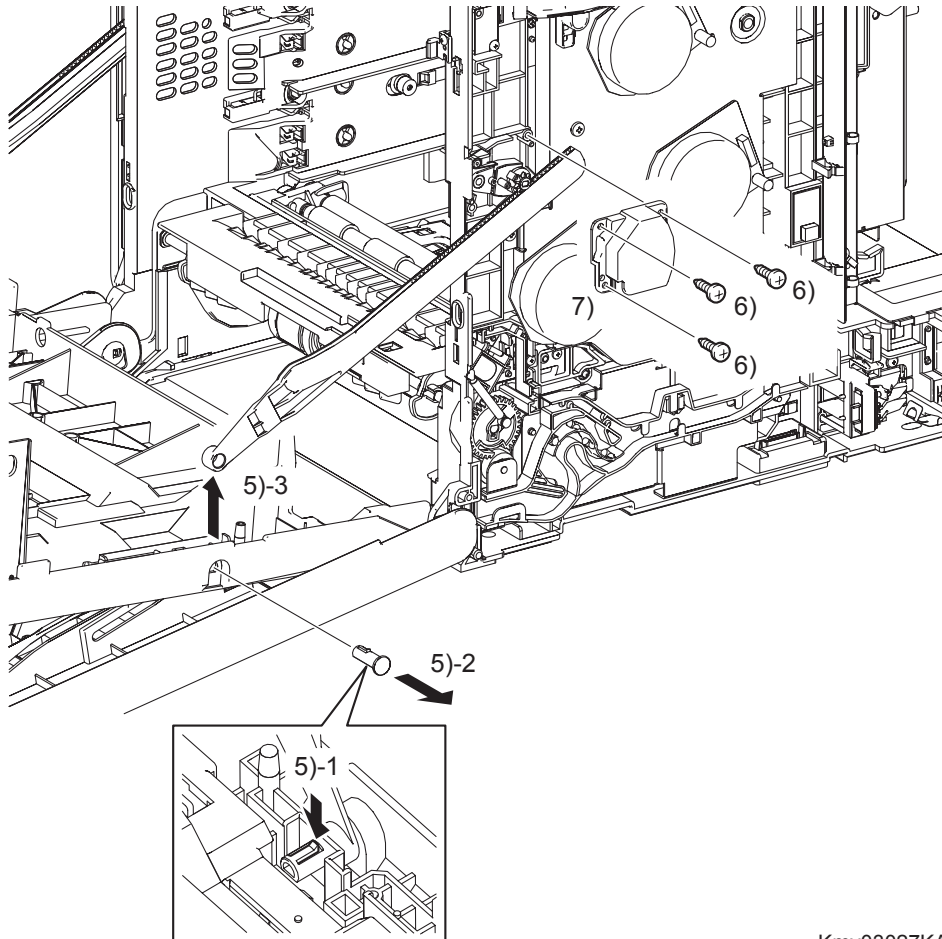

Kmy03027KA

- 5) Release the hook of the SHAFT PIVOT (PL1.2.8) that fixes the LINK R (PL7.1.13) to the FRONT COVER (PL1.2.1), and then pull the SHAFT PIVOT to the outside and remove the LINK R from the FRONT COVER.
- 6) Remove three screws (silver, tap, 8mm) that fix the SUPPORT LINK R (PL7.1.12) to the printer.
- 7) Remove the SUPPORT LINK R from the printer.

Continues to the next page.

Removal 18 RIGHT ARM ASSEMBLY(PL7.1.98)

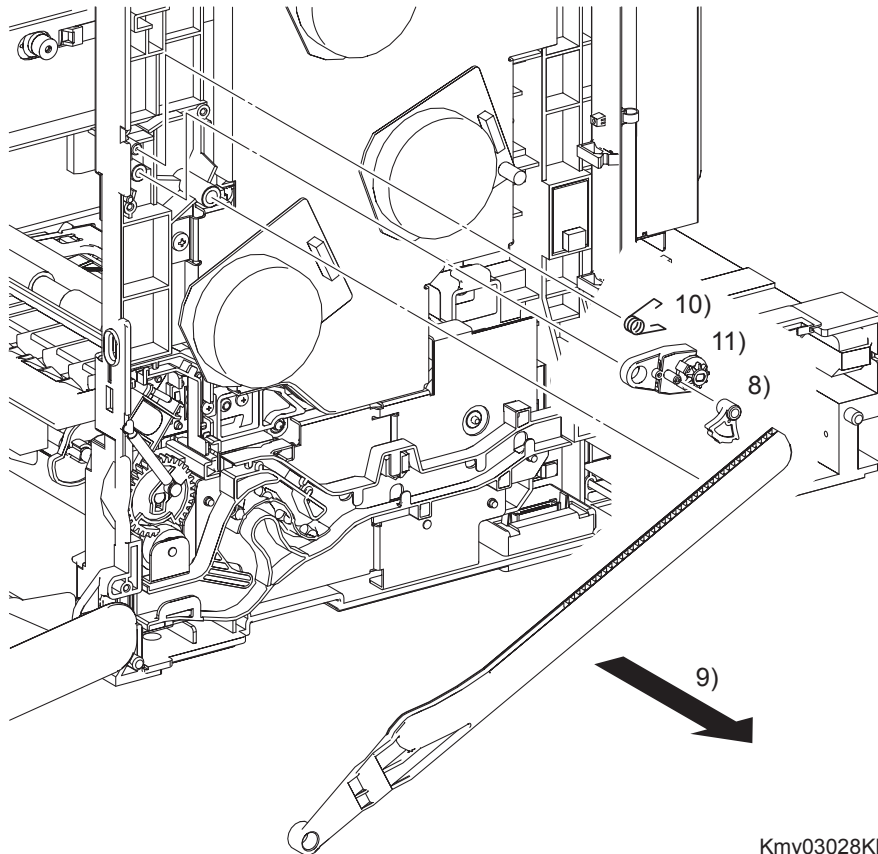

- 8) Remove the LEVER RELEASE (PL7.1.4) from the printer.
- 9) Remove the LINK R from the printer.
- 10) Remove the SPRING SUPPORT (PL7.1.8) from the printer.
- 11) Remove the HOLDER DAMPER (PL7.1.6) from the printer together with the DAMPER OIL (PL7.1.7).

Removal 19 SIZE SWITCH ASSEMBLY (PL7.1.18)

Steps 1 through 4 are for reference. Before removing this component, check that Steps 1 through 4 have been performed.

- 1) Open the FRONT COVER (PL1.2.1).
- 2) Remove the FUSER. (Removal 8)
- 3) Remove the REAR COVER. (Removal 12)
- 4) Remove the RIGHT COVER. (Removal 13)

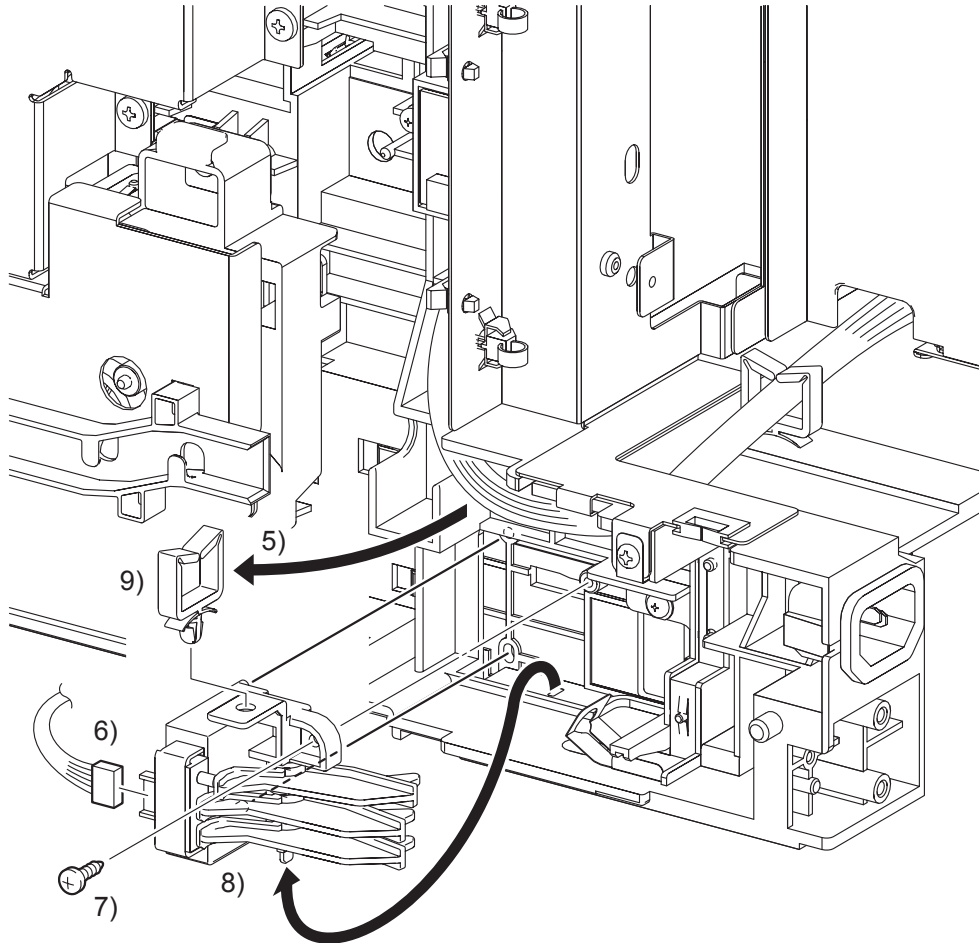

Kmy03029KA

- 5) Release the clamp on the SIZE SWITCH ASSEMBLY (PL7.1.18), and then remove the harness.
- 6) Disengage the connector (P/J231) of the SIZE SWITCH ASSEMBLY.
- 7) Remove the one screw (silver, tap, 10mm) that fixes the SIZE SWITCH ASSEMBLY to the printer.
- 8) Remove the SIZE SWITCH ASSEMBLY by releasing the two bosses and the backside tab of the SIZE SWITCH ASSEMBLY from the holes on the printer.
- 9) Remove the clamp from the SIZE SWITCH ASSEMBLY.

Removal 20 POWER SWITCH (PL9.1.13)

Steps 1 through 4 are for reference. Before removing this component, check that Steps 1 through 4 have been performed.

- 1) Open the FRONT COVER (PL1.2.1).
- 2) Remove the FUSER. (Removal 8)
- 3) Remove the REAR COVER. (Removal 12)
- 4) Remove the RIGHT COVER. (Removal 13)

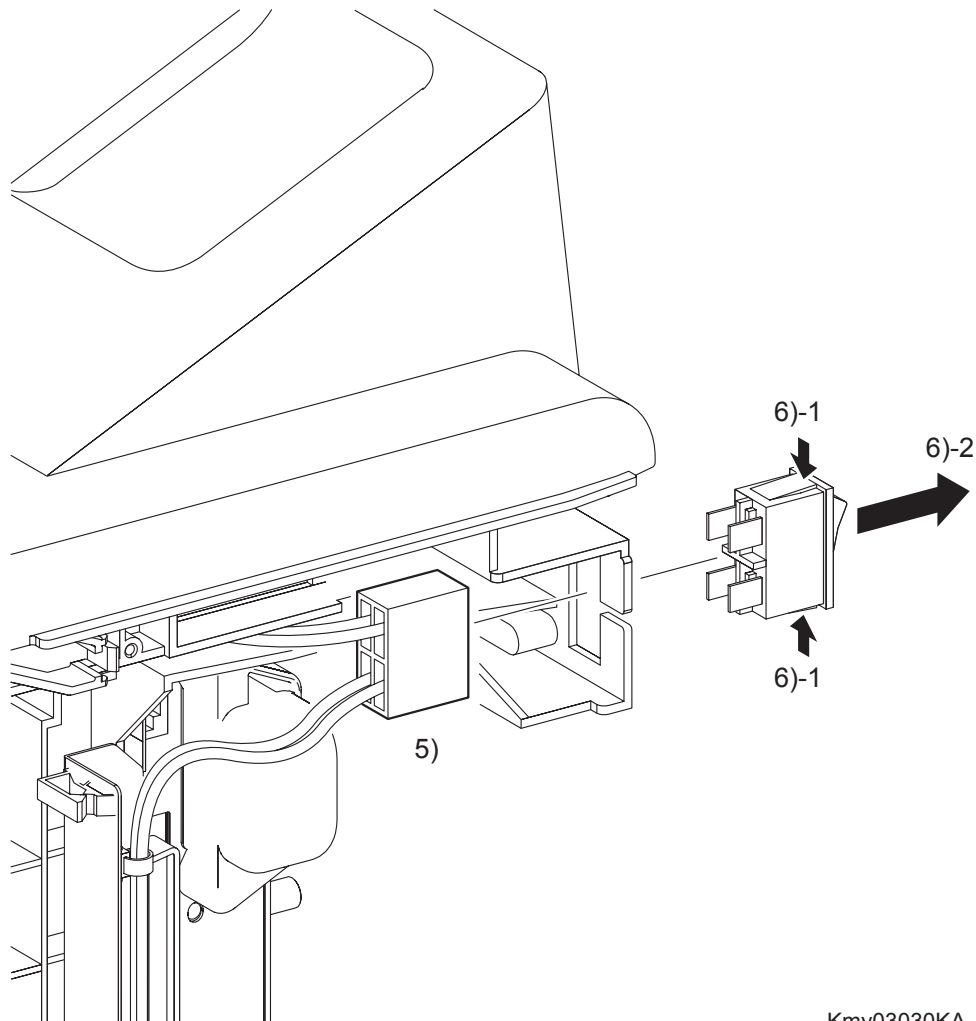

Kmy03030KA

- 5) Disengage the connector (P/J481) of the POWER SWITCH (PL9.1.13).
- 6) Remove the POWER SWITCH by releasing its hook.

Removal 21 TONER CARTRIDGE SENSOR ASSEMBLY (C), (M), (Y) (PL5.1.4)

NOTE

Described below is the removal procedure common among TONER CARTRIDGE SENSOR ASSYs (C), (M), and (Y).

Steps 1 through 4 are for reference. Before removing this component, check that Steps 1 through 4 have been performed.

- 1) Open the FRONT COVER (PL1.2.1).
- 2) Remove the FUSER. (Removal 8)
- 3) Remove the REAR COVER. (Removal 12)
- 4) Remove the RIGHT COVER. (Removal 13)

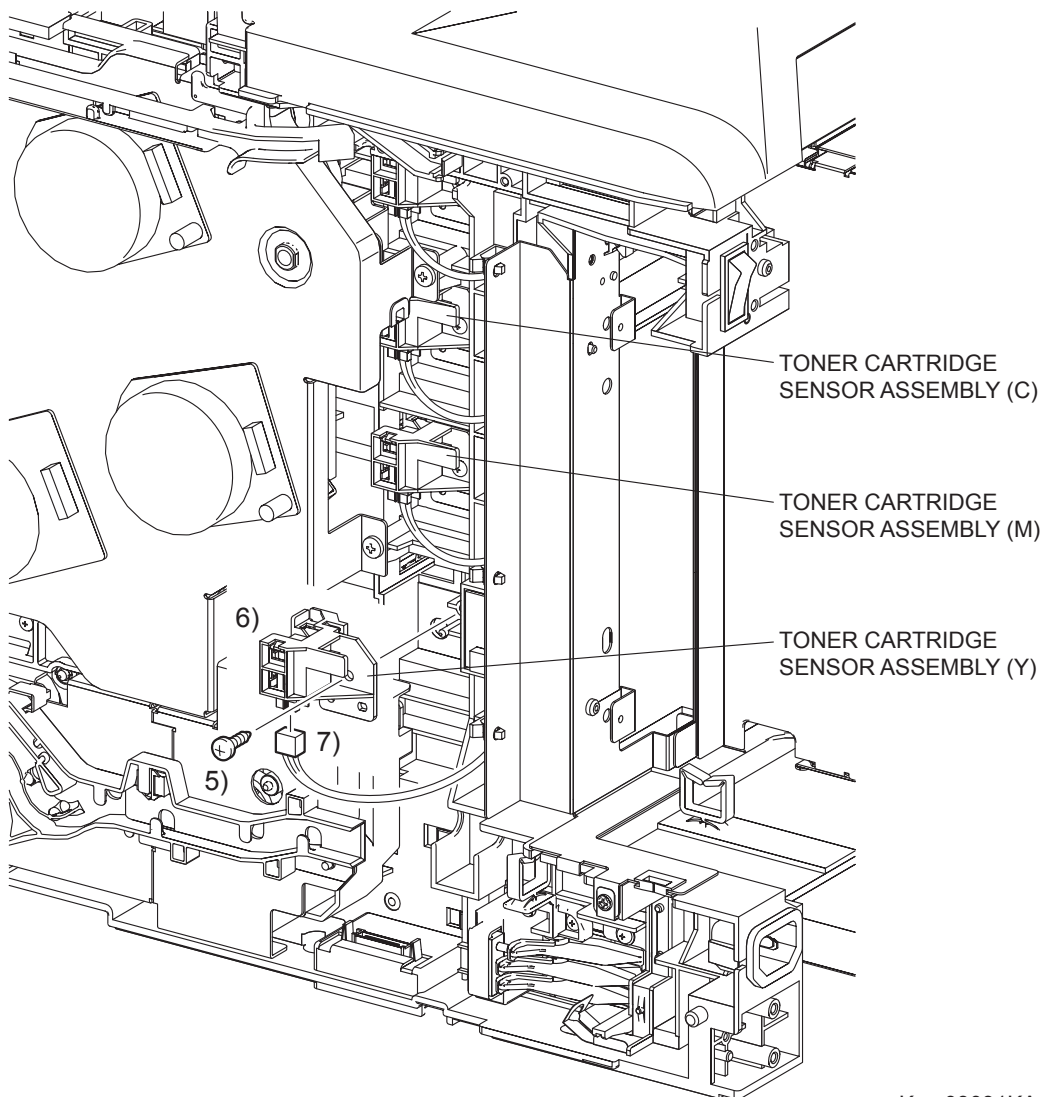

Kmy03031KA

- 5) Remove the one screw (silver, tap, 10mm) that fixes the TONER CARTRIDGE ASSEMBLY (PL5.1.4) to the printer.
- 6) Remove the TONER CARTRIDGE ASSEMBLY from the printer.
- 7) Disconnect the connector of the TONER CARTRIDGE ASSEMBLY.

Removal 22 LEFT COVER (PL1.1.7)

Steps 1 through 3 are for reference. Before removing this component, check that Steps 1 through 3 have been performed.

- 1) Open the FRONT COVER (PL1.2.1).
- 2) Remove the FUSER. (Removal 8)
- 3) Remove the REAR COVER. (Removal 12)

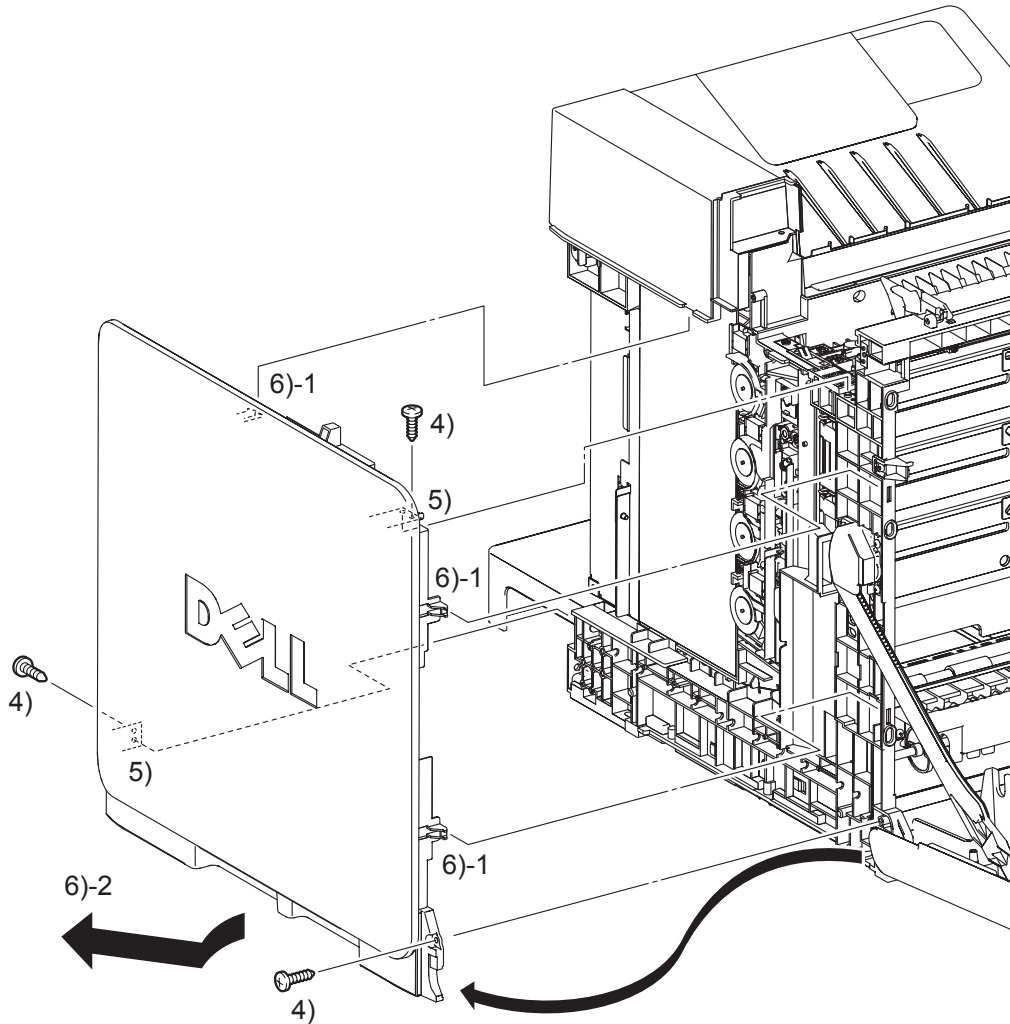

Kmy03032KA

- 4) Remove three screws (silver, tap, 10mm) that fix the LEFT COVER (PL1.1.7) to the printer.
- 5) Release the two holes on the LEFT COVER from the bosses on the printer.
- 6) Release the one backside hook and two front side hooks on the LEFT COVER, and then remove the LEFT COVER from the printer by moving it diagonally backward.

Go to the next removal step:

Removal 23 ELECTRONIC SUB-SYSTEM CONTROL BOARD (PL9.1.27), Removal 24 LEFT ARM ASSEMBLY (PL7.1.97) (PL7.1.97), Removal 25 LED ASSEMBLY (PL5.1.15), Removal 26 TONER DISPENSER MOTOR (PL5.1.12), Removal 27 SHIELD ASSY ESS (REFERENCE ONLY) or Removal 30 TOP COVER (PL1.1.1)

Removal 23 ELECTRONIC SUB-SYSTEM CONTROL BOARD (PL9.1.27)

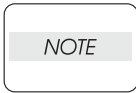

Use a wristband to protect the PWB from electrostatic damage.

Steps 1 through 5 are for reference. Before removing this component, check that Steps 1 through 5 have been performed.

- 1) Open the FRONT COVER (PL1.2.1).
- 2) Remove the FUSER. (Removal 8)
- 3) Remove the REAR COVER. (Removal 12)
- 4) Remove the RIGHT COVER. (Removal 13)
- 5) Remove the LEFT COVER. (Removal 22)

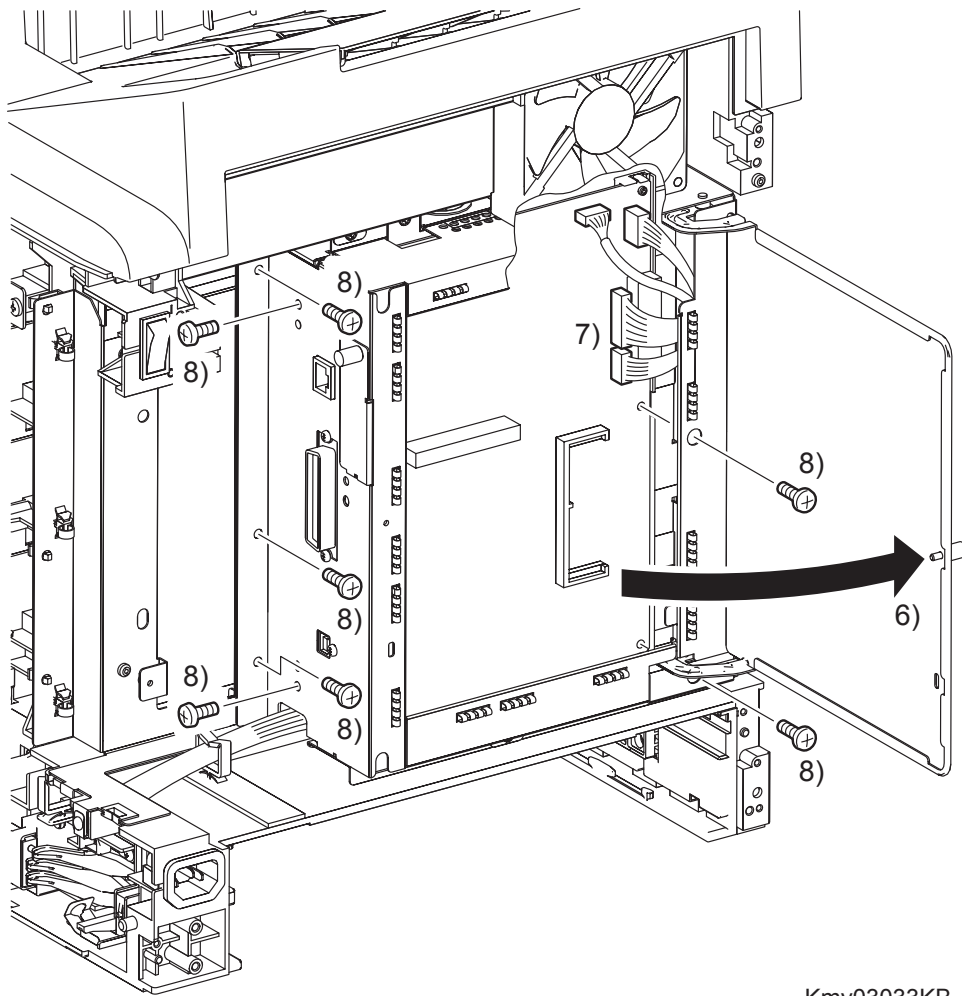

Kmy03033KB

- 6) Loosen the SCREW KNURLING (PL9.1.22) and open the SHIELD WINDOW (PL9.1.21).
- 7) Disengage all the connectors of the ELECTRONIC SUB-SYSTEM CONTROL BOARD (PL9.1.27).
- 8) Remove seven screws (silver, 6mm) that fix the SHIELD ASSY IF (PL9.1.27) to the printer.

Continues to the next page.

Removal 23 ELECTRONIC SUB-SYSTEM CONTROL BOARD (PL9.1.27)

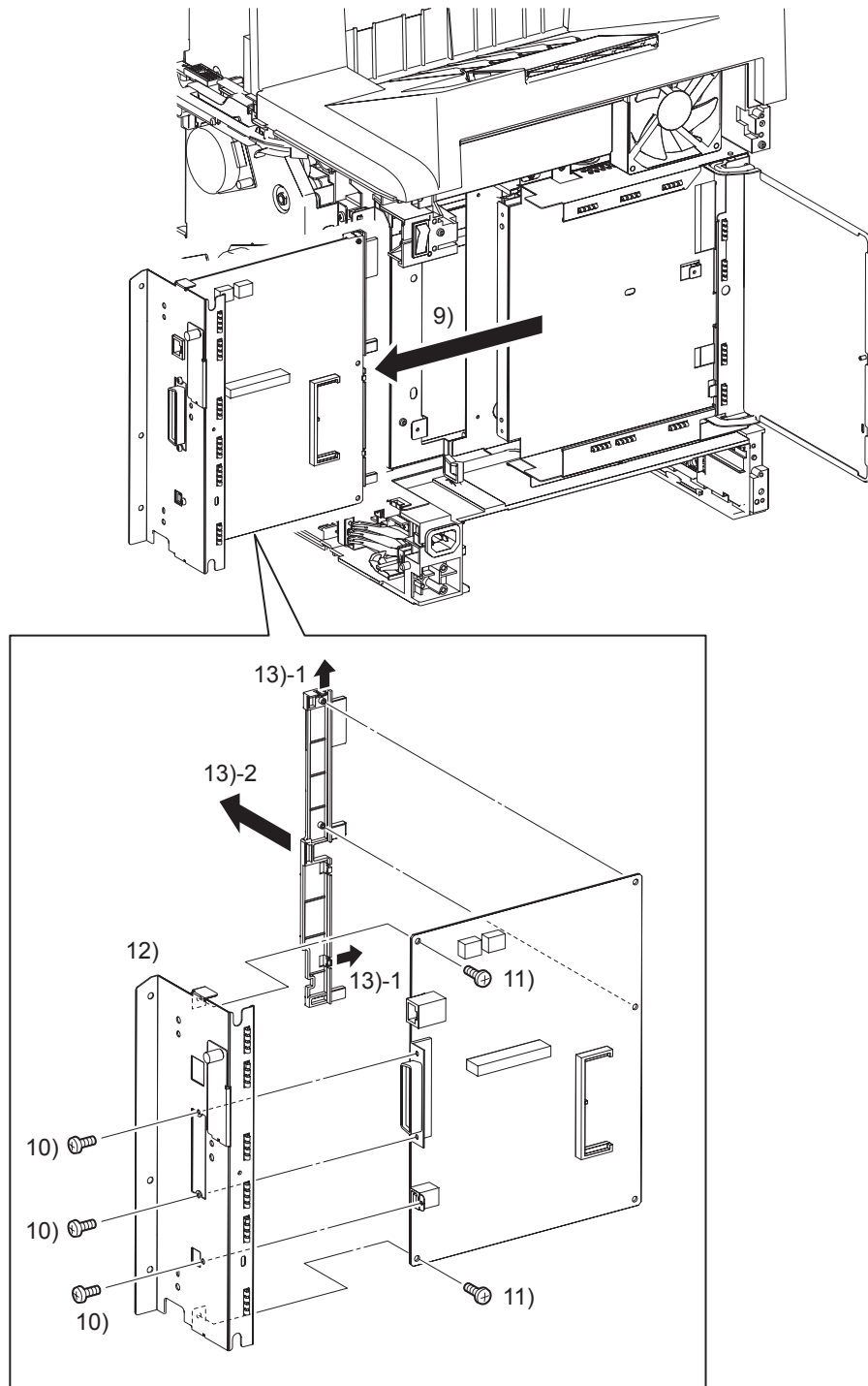

Kmy03034KB

- 9) Remove the SHIELD ASSY IF by pulling it to the arrow direction together with the ELECTRONIC SUB-SYSTEM CONTROL BOARD.
- 10) Remove all the screws that fix the connectors of the ELECTRONIC SUB-SYSTEM CONTROL BOARD to the SHIELD ASSY IF
- 11) Remove two screws (silver, 6mm) that fix the ELECTRONIC SUB-SYSTEM CONTROL BOARD to the SHIELD ASSY IF.
- 12) Remove the ELECTRONIC SUB-SYSTEM CONTROL BOARD from the SHIELD ASSY IF.
- 13) Release the two hooks on the GUIDE ESS, and then remove the GUIDE ESS from the ELECTRONIC SUB-SYSTEM CONTROL BOARD.

Removal 24 LEFT ARM ASSEMBLY(PL7.1.97)

Steps 1 through 4 are for reference. Before removing this component, check that Steps 1 through 4 have been performed.

- 1) Open the FRONT COVER (PL1.2.1).
- 2) Remove the FUSER. (Removal 8)
- 3) Remove the REAR COVER. (Removal 12)
- 4) Remove the LEFT COVER. (Removal 22)

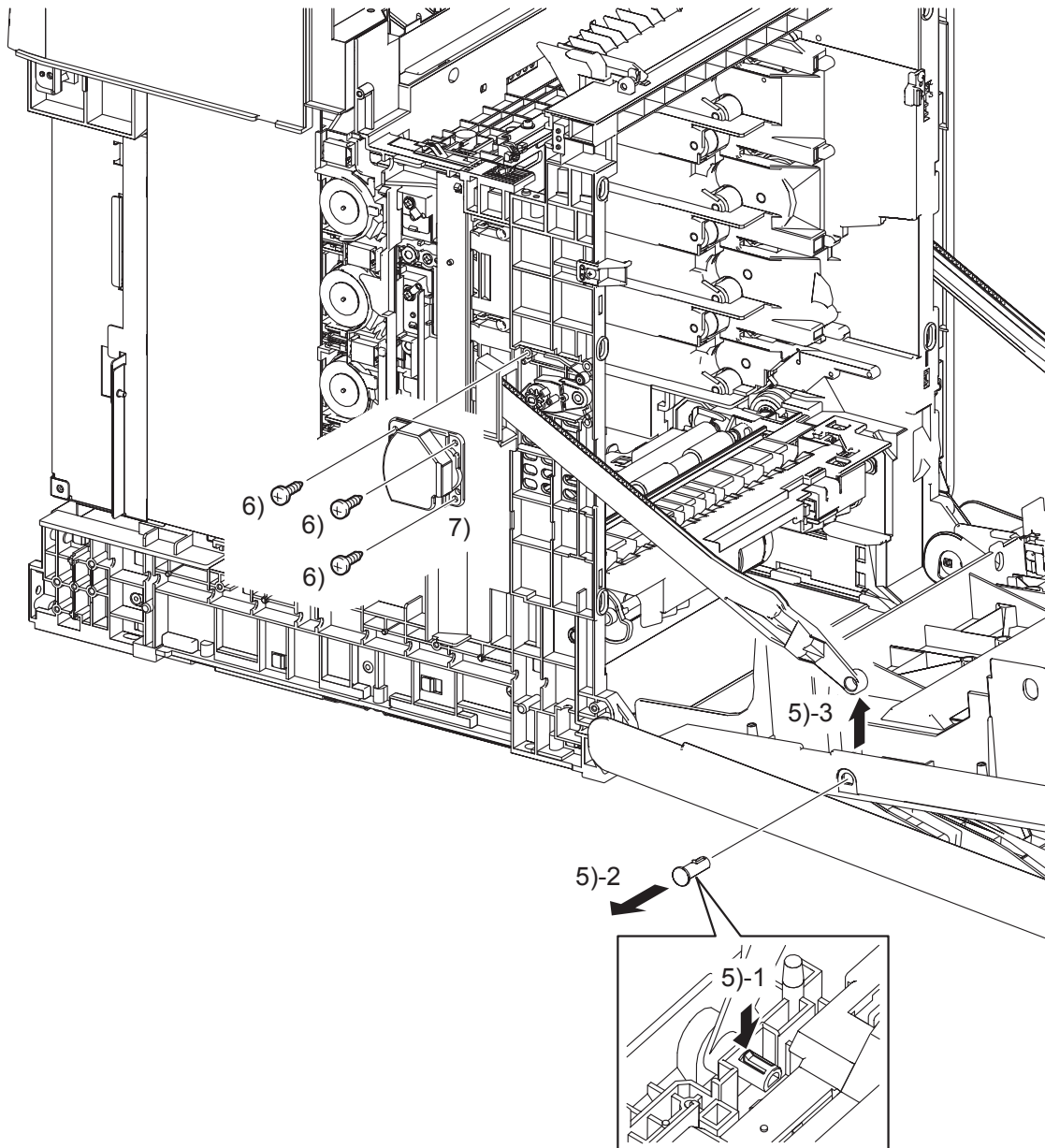

Kmy03035KA

- 5) Release the hook of the SHAFT PIVOT (PL1.2.8) that fixes the LINK L to the FRONT COVER (PL1.2.1), and then remove the LINK L from the FRONT COVER by pulling the SHAFT PIVOT to the outside.
- 6) Remove threescrews (silver, tap, 8mm) that fix the SUPPORT LINK L (PL7.1.2) to the printer.
- 7) Remove the SUPPORT LINK L from the printer.

Continues to the next page.

Removal 24 LEFT ARM ASSEMBLY(PL7.1.97)

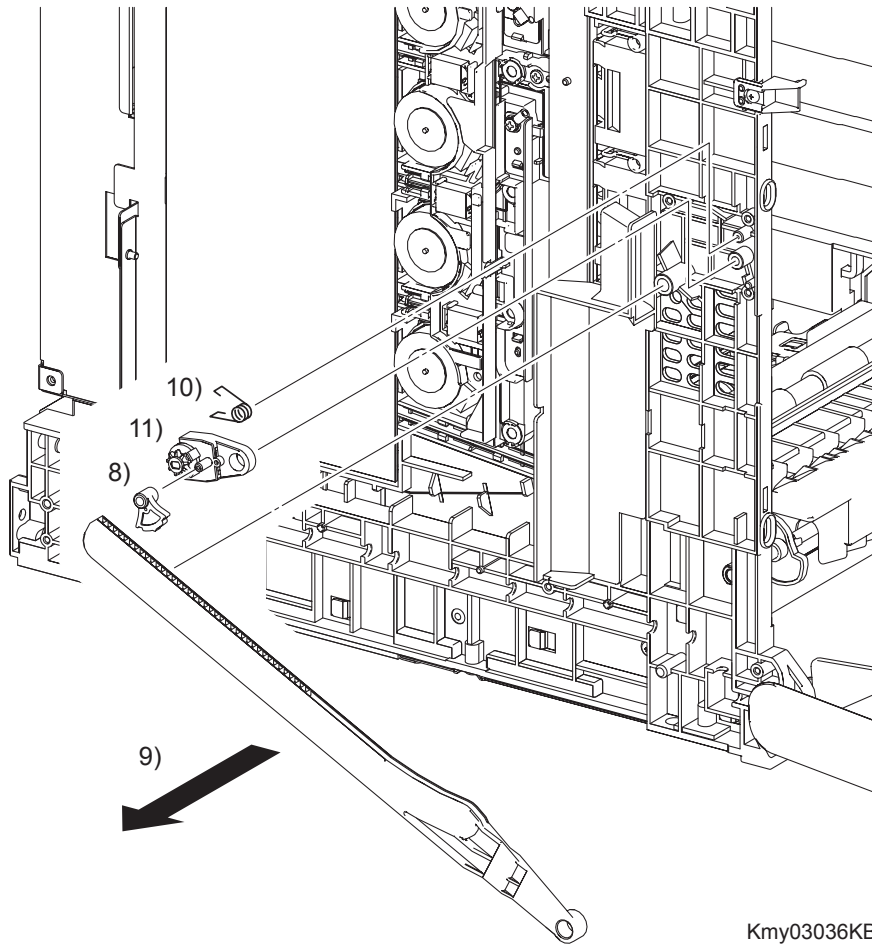

Kmy03036KB

- 8) Remove the LEVER RELEASE (PL7.1.4) from the printer.
- 9) Remove the LINK L from the printer.
- 10) Remove the SPRING SUPPORT (PL7.1.8) from the printer.
- 11) Remove the HOLDER DAMPER (PL7.1.6) from the printer together with the DAMPER OIL (PL7.1.7).

Removal 25 LED ASSEMBLY (PL5.1.15)

Steps 1 through 4 are for reference. Before removing this component, check that Steps 1 through 4 have been performed.

- 1) Open the FRONT COVER (PL1.2.1).
- 2) Remove the FUSER. (Removal 8)
- 3) Remove the REAR COVER. (Removal 12)
- 4) Remove the LEFT COVER. (Removal 22)

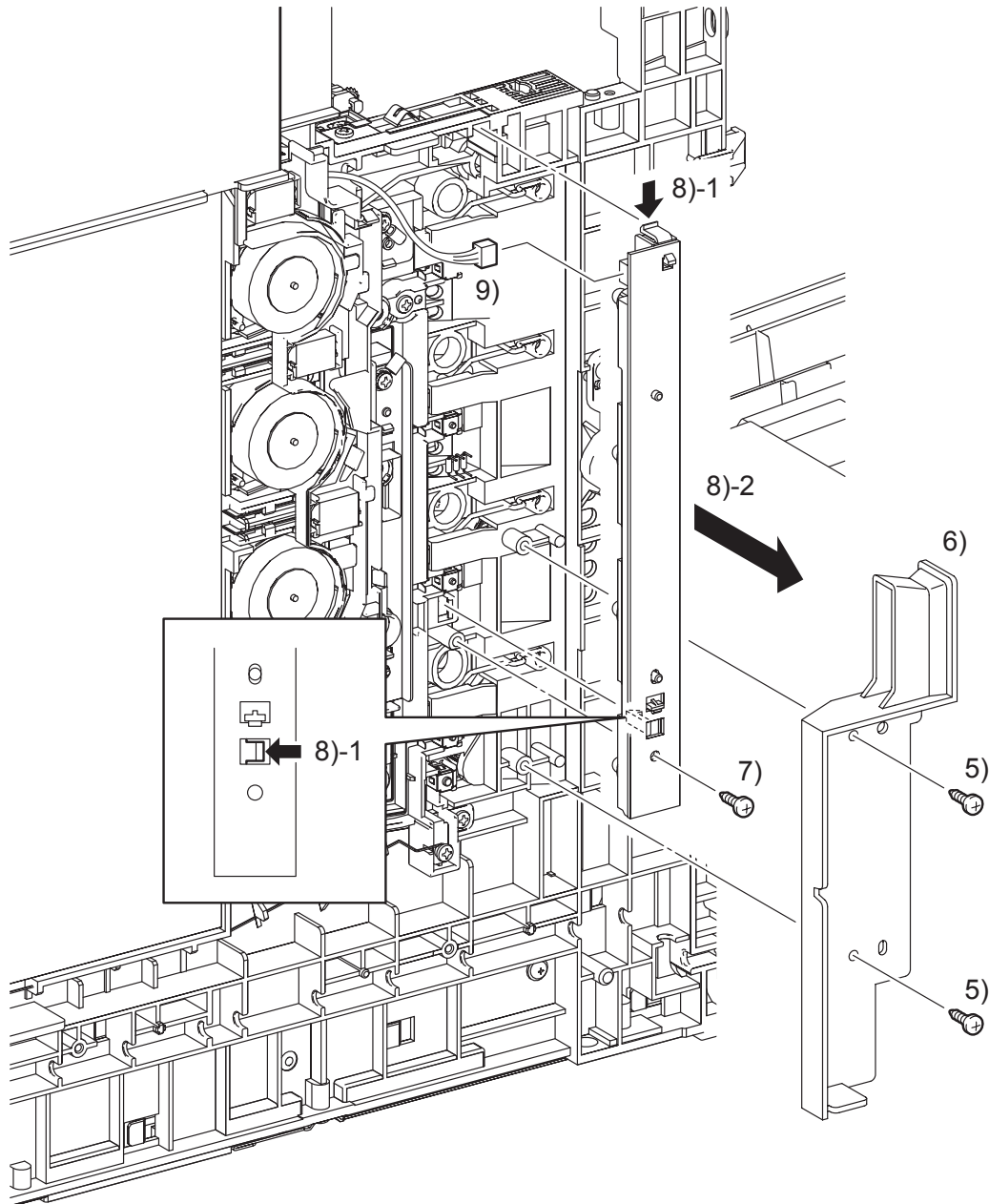

Kmy03037KA

- 5) Remove two screws (silver, tap, 8mm) that fix the DUCT SIDE L (PL7.1.23) to the printer.
- 6) Remove the DUCT SIDE L from the printer.
- 7) Remove one screw (silver, tap, 10mm) that fixes the LED ASSEMBLY (PL5.1.15) to the printer.
- 8) Remove the LED ASSEMBLY from the printer by releasing its two hooks.
- 9) Disengage the connector (P/J141) of the LED ASSEMBLY.

Blank Page

Removal 26 TONER DISPENSER MOTOR (PL5.1.12)

NOTE

Described below is the removal procedure common among the TONER DISPENSER MOTORS (C), (M), (Y), and (K).

Steps 1 through 4 are for reference. Before removing this component, check that Steps 1 through 4 have been performed.

- 1) Open the FRONT COVER (PL1.2.1).
- 2) Remove the FUSER. (Removal 8)
- 3) Remove the REAR COVER. (Removal 12)
- 4) Remove the LEFT COVER. (Removal 22)

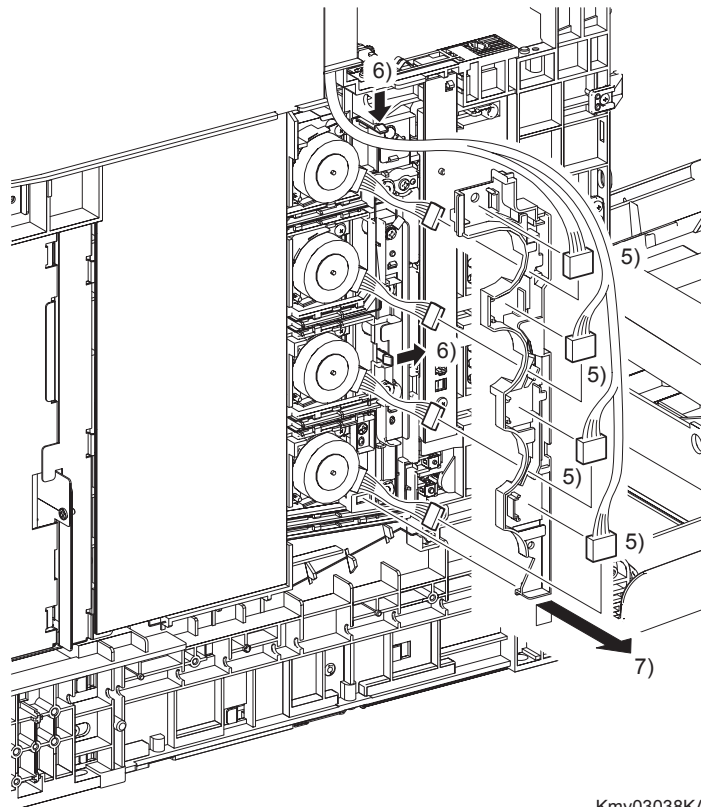

Kmy03038KA

NOTE

When performing the step below, leave the junction connector on the printer side cable.

- 5) Release the four sets of connectors and harness of the TONER DISPENSER (PL5.1.12) from the DUCT HARNESS MOT (PL5.1.16), and disengage the four sets of connectors of the TONER DISPENSER MOTOR.
- 6) Release two hooks that fix the DUCT HARNESS MOT to the printer.
- 7) Release the lug on the DUCT HARNESS MOT from the printer by moving the DUCT HARNESS MOT slightly upward. Pass the four sets connectors of the TONER DISPENSER MOTOR through the hole on the DUCT HARNESS MOT, and then remove the DUCT HARNESS MOT.

Continues to the next page.

Removal 26 TONER DISPENSER MOTOR (PL5.1.12)

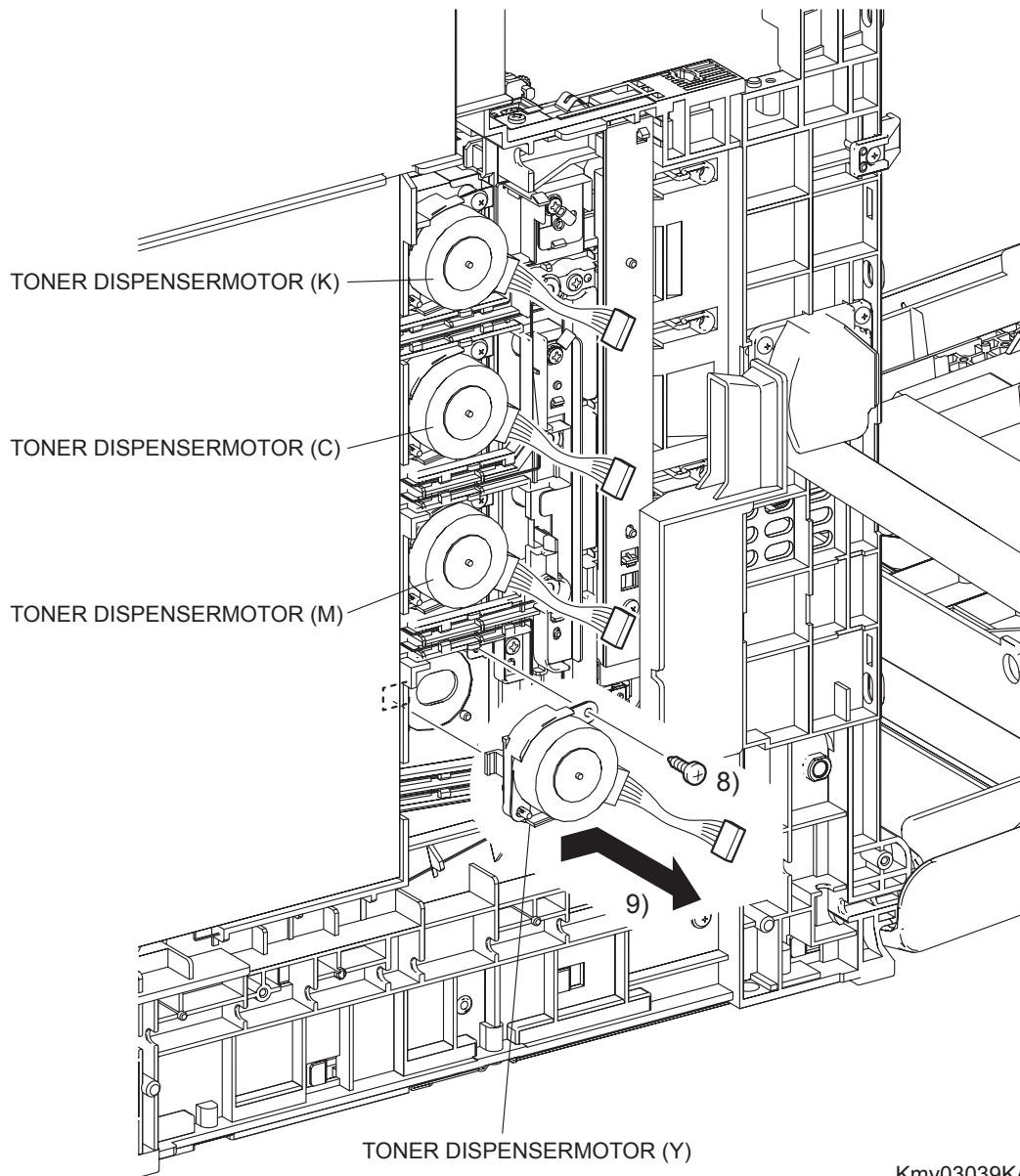

- 8) Remove the one screw (silver, tap, 10mm) that fixes the TONER DISPENSER MOTOR to the printer.
- 9) Release the lug on the TONER DISPENSER MOTOR by moving the TONER DISPENSER MOTOR slightly upward. Remove the TONER DISPENSER MOTOR from the printer.

Removal 27 SHIELD ASSY ESS (REFERENCE ONLY)

Steps 1 through 4 are for reference. Before removing this component, check that Steps 1 through 4 have been performed.

- 1) Open the FRONT COVER (PL1.2.1).
- 2) Remove the FUSER. (Removal 8)
- 3) Remove the REAR COVER. (Removal 12)
- 4) Remove the LEFT COVER. (Removal 22)

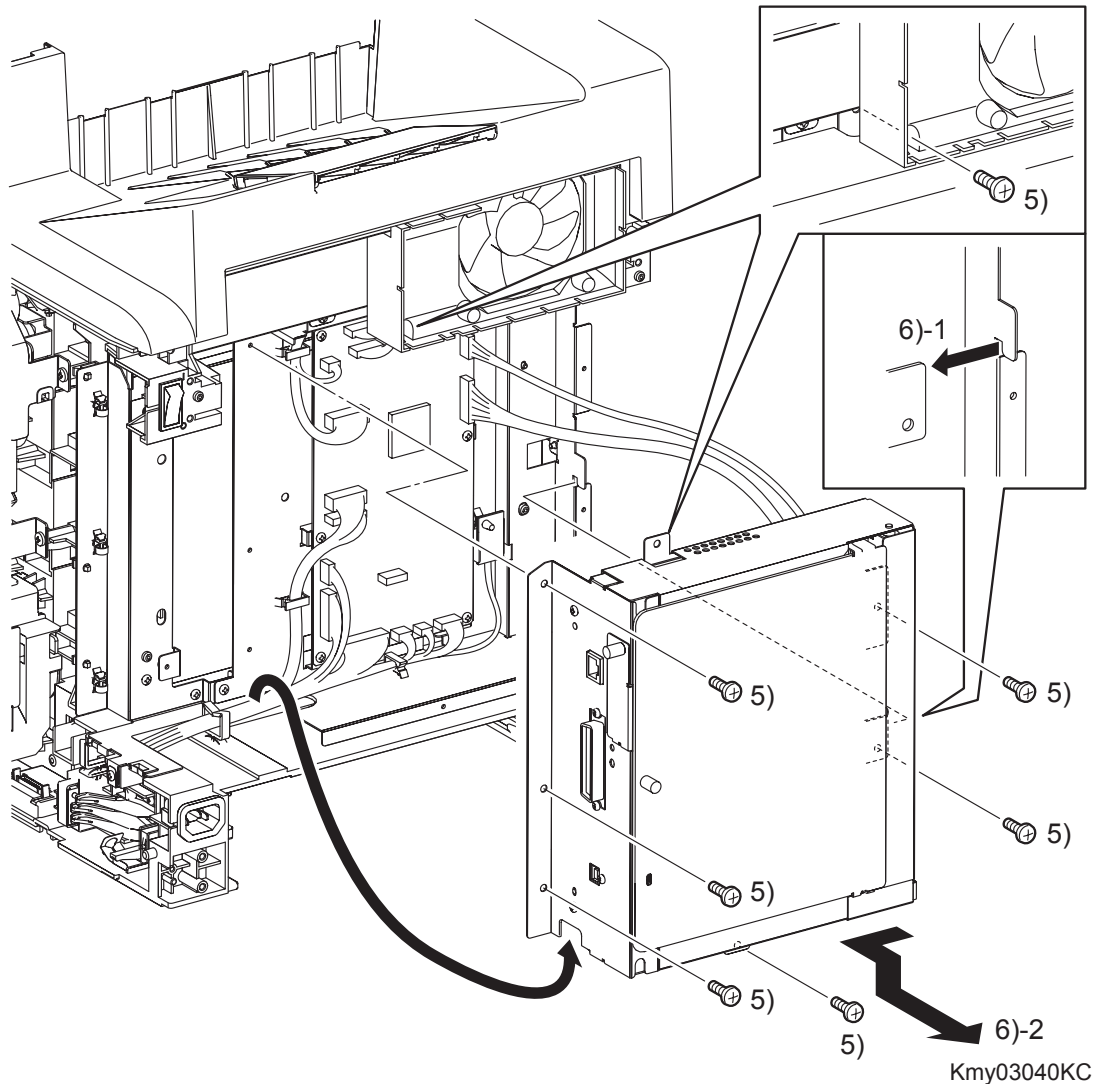

- 5) Remove the seven screws (silver, 6mm) that fix the SHIELD ASSY ESS to the printer.

NOTE

When performing the step described below, take care not to move the SHIELD ASSY ESS from the printer too far because they are connected with the harness.

- 6) Release the lug on the SHIELD ASSY ESS from the notch on the printer by moving the SHIELD ASSY ESS to the arrow direction, and then remove the SHIELD ASSY ESS from the printer.

Go to the next removal step:

Removal 28 HUMIDITY SENSOR (PL9.1.19) or Removal 29 MACHINE CONTROL UNIT (PL9.1.20)

Removal 28 HUMIDITY SENSOR (PL9.1.19)

Steps 1 through 5 are for reference. Before removing this component, check that Steps 1 through 5 have been performed.

- 1) Open the FRONT COVER (PL1.2.1).
- 2) Remove the FUSER. (Removal 8)
- 3) Remove the REAR COVER. (Removal 12)
- 4) Remove the LEFT COVER. (Removal 22)
- 5) Remove the SHIELD ASSY ESS. (Removal 27)

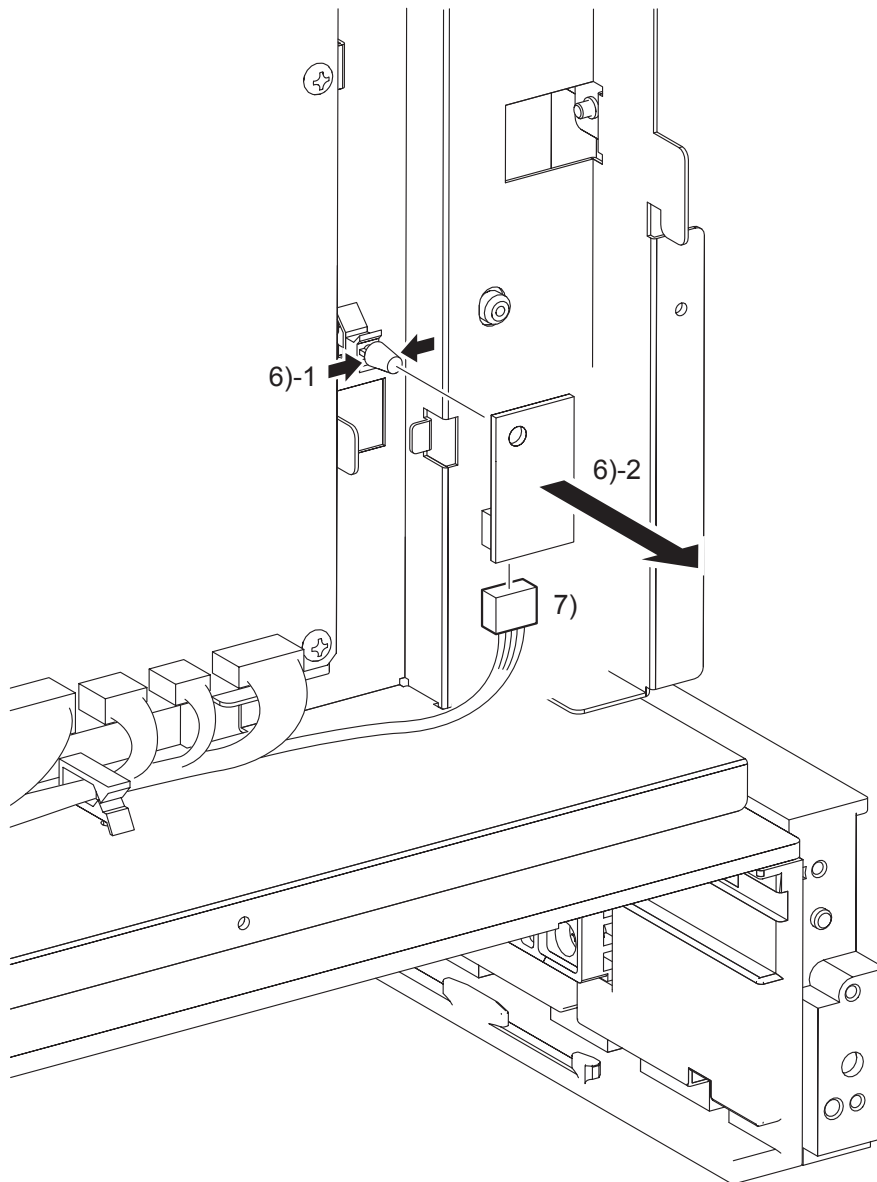

Kmy03041KA

- 6) Release the hook of the SPACER (PL9.1.18), and then remove the HUMIDITY SENSOR from the printer.
- 7) Disengage the connector (P/J261) of the HUMIDITY SENSOR (PL9.1.19).

Removal 29 MACHINE CONTROL UNIT (PL9.1.20)

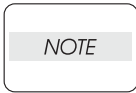

Never fail to perform the diagnostic operation described below. Otherwise the data will be lost in the worst case.

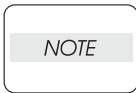

Use a wristband to protect the PWB from electrostatic damage.

- 1) Perform NVM Save to evacuate the MCU data.
- 2) Turn on the power while pressing the ► key, ◀ key, and [MENU] key on the control panel.
- 3) Enter the password, press the ▲ key twice, and press the ✓ key once. The diagnostic screen comes up.
- 4) Press the ▼ key several times until "IOT Diag" is displayed. Press the ✓ key once.
- 5) Press the ▼ key several until "NVM Settings" is displayed. Press the ✓ key once.
- 6) Press the ▼ key several times until "NVM Save" is displayed. Press the ✓ key once.
- 7) Press the ✓ key twice, and NVM Save is performed.
- 8) After NVM Save is complete, press the [CANCEL] key several times until "IOT Diag" is displayed.
- 9) Press the ▼ key several times until "Complete" is displayed.
- 10) Press the ✓ key three times. "Ready to Print" is displayed.
- 11) Turn off the power.
- 12) Remove the POWER CORD from the AC outlet.

Steps 13 through 17 are for reference. Before removing this component, check that Steps 13 through 17 have been performed.

- 13) Remove the FUSER. (Removal 8)
- 14) Remove the REAR COVER. (Removal 12)
- 15) Remove the LEFT COVER. (Removal 22)
- 16) Remove the SHIELD ASSY ESS. (Removal 27)

Continues to the next page.

Removal 29 MACHINE CONTROL UNIT (PL9.1.20)

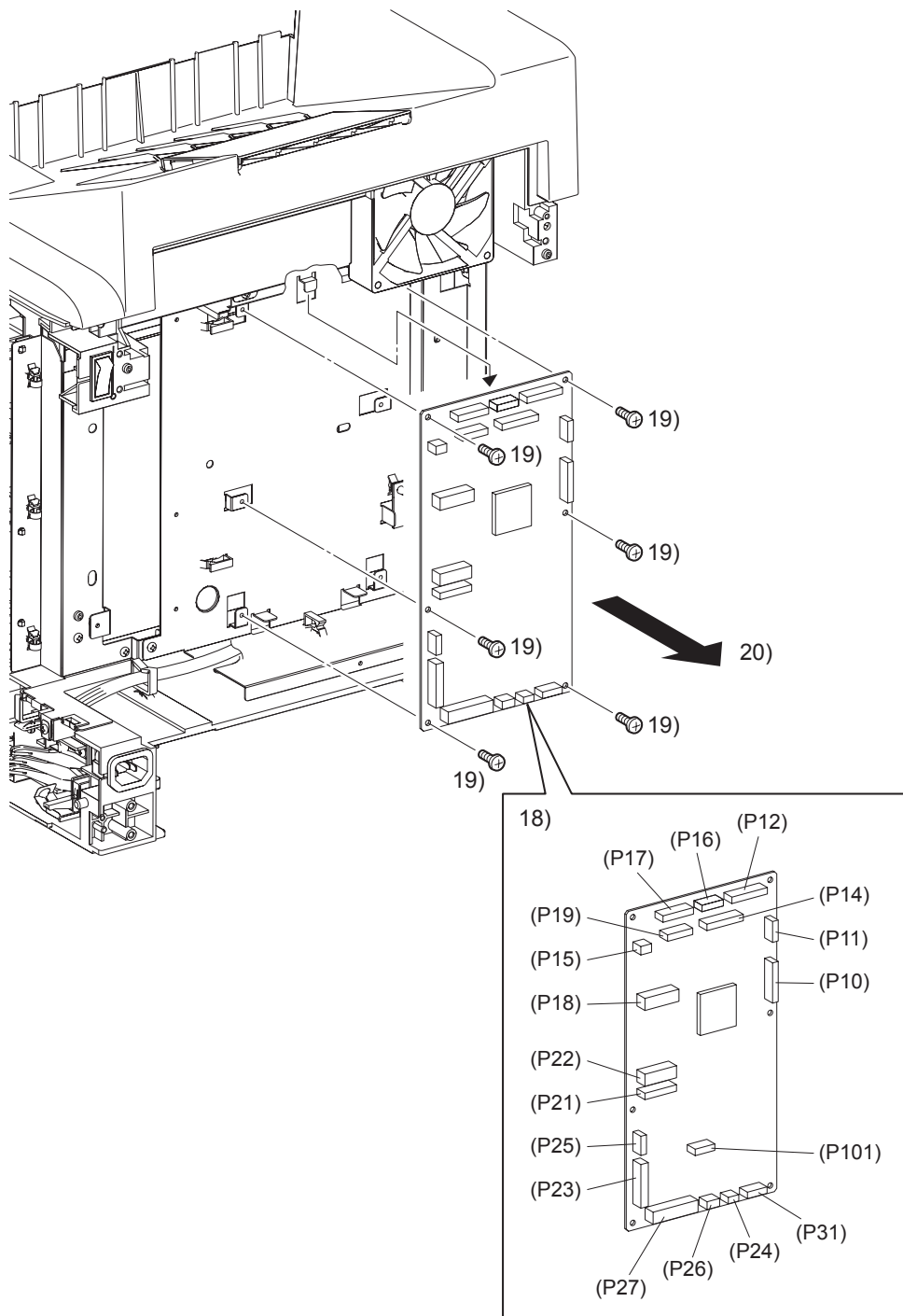

Kmy03042KA

- 17) Disengage all the connectors of the MACHINE CONTROL UNIT (PL9.1.20).
- 18) Remove six screws (silver, 6mm) that fix the MACHINE CONTROL UNIT to the printer.
- 19) Remove the MACHINE CONTROL UNIT from the printer.

Removal 30 TOP COVER (PL1.1.1)

Steps 1 through 5 are for reference. Before removing this component, check that Steps 1 through 5 have been performed.

- 1) Open the FRONT COVER (PL1.2.1).
- 2) Remove the FUSER. (Removal 8)
- 3) Remove the REAR COVER. (Removal 12)
- 4) Remove the RIGHT COVER. (Removal 13)
- 5) Remove the LEFT COVER. (Removal 22)

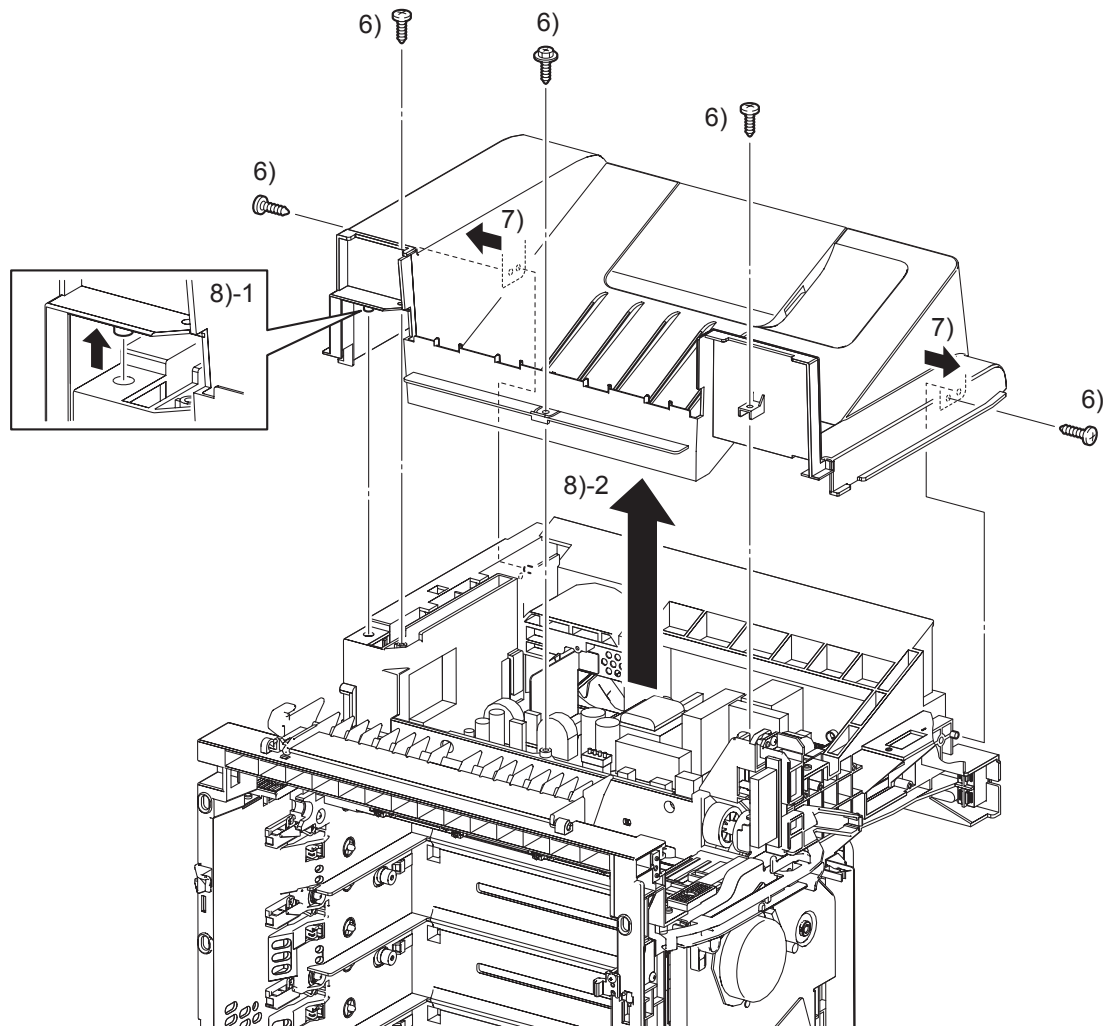

Kmy03043KC

- 6) Remove the four screws (silver, tap, 10mm) and the one screw (silver, with flange, 10mm) that fix the TOP COVER (PL1.1.1) to the printer.
- 7) Disengage the two holes of the TOP COVER from the left and right bosses of the printer.
- 8) Lift up the TOP COVER to disengage the front and left bosses of the TOP COVER from the holes of the printer. Remove it.

Go to the next removal step:

Removal 31 FAN (PL9.1.10) or Removal 35 INTERLOCK SWITCH (PL9.1.3)

Removal 31 FAN (PL9.1.10)

Steps 1 through 6 are for reference. Before removing this component, check that Steps 1 through 6 have been performed.

- 1) Open the FRONT COVER (PL1.2.1).
- 2) Remove the FUSER. (Removal 8)
- 3) Remove the REAR COVER. (Removal 12)
- 4) Remove the RIGHT COVER. (Removal 13)
- 5) Remove the LEFT COVER. (Removal 22)
- 6) Remove the TOP COVER. (Removal 30)

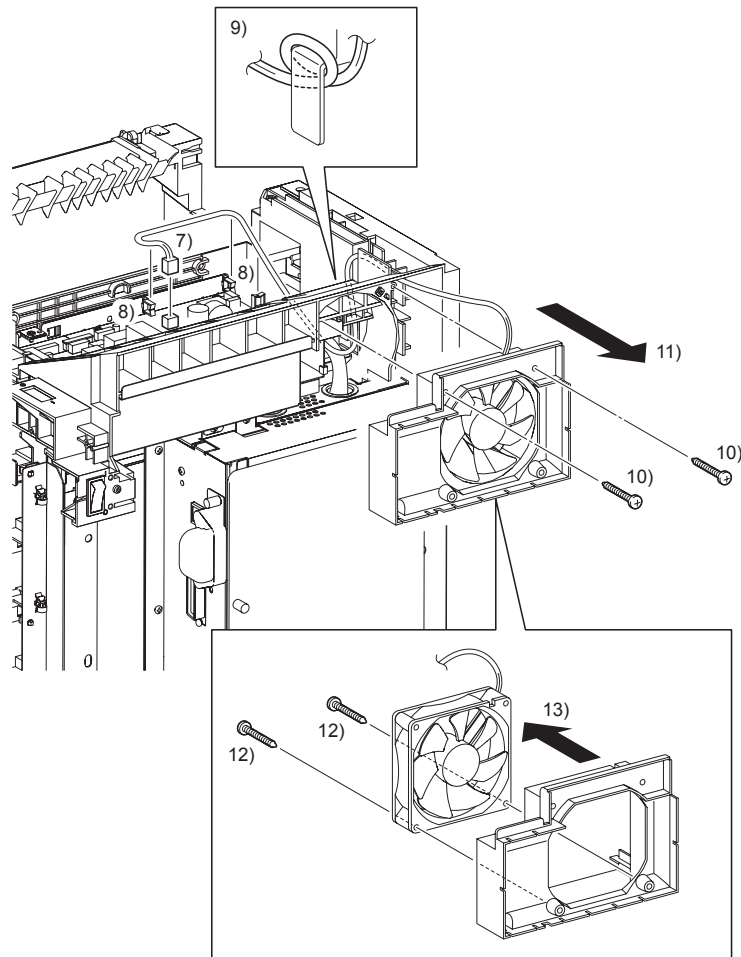

Kmy03044KD

- 7) Disengage the connector (P/J503) of the FAN (PL9.1.10) on the LOW VOLTAGE POWER SUPPLY (PL9.1.4).
- 8) Remove the harness of the FAN by releasing the clamps.
- 9) Release the harness of the FAN from the hook of the printer.
- 10) Remove the two screws (silver, tap, 35mm) that fix the DUCT FAN MAIN (PL9.1.36) and FAN together to the printer.
- 11) Remove from the printer the DUCT FAN MAIN together with the FAN.
- 12) Remove the two screws (silver, tap, 35mm) that fix the FAN to the DUCT FAN MAIN.
- 13) Remove the FAN from the DUCT FAN MAIN.

Go to the next removal steps:

Removal 32 HIGH VOLTAGE POWER SUPPLY (PL5.1.17) or Removal 33 LOW VOLTAGE POWER SUPPLY (PL9.1.4)

Removal 32 HIGH VOLTAGE POWER SUPPLY (PL5.1.17)

Steps 1 through 8 are for reference. Before removing this component, check that Steps 1 through 8 have been performed.

- 1) Open the FRONT COVER (PL1.2.1).
- 2) Remove the FUSER. (Removal 8)
- 3) Remove the REAR COVER. (Removal 12)
- 4) Remove the RIGHT COVER. (Removal 13)
- 5) Remove the LEFT COVER. (Removal 22)
- 6) Remove the TOP COVER. (Removal 30)
- 7) Remove the FAN. (Removal 31)
- 8) Remove the SHIELD ASSY ESS. (Removal 27)

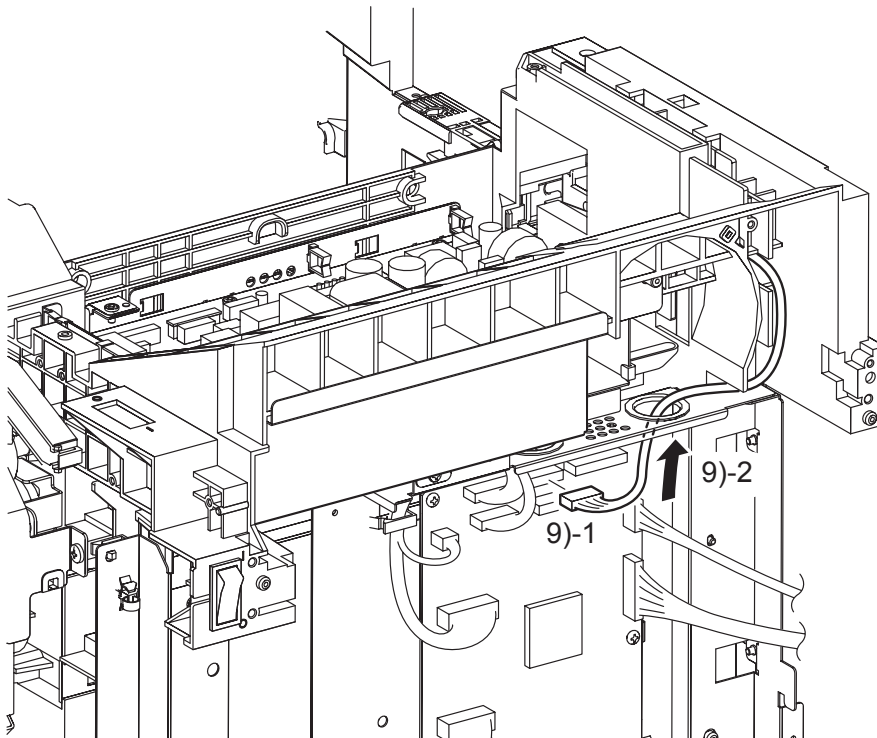

Kmy03045KB

- 9) Disengage the connector (P/J16) of the HIGH VOLTAGE POWER SUPPLY (PL5.1.17) on the MACHINE CONTROL UNIT (PL9.1.20), and then pass the connector through the hole on the SHIELD MCU (PL9.1.11).

Continues to the next page.

Removal 32 HIGH VOLTAGE POWER SUPPLY (PL5.1.17)

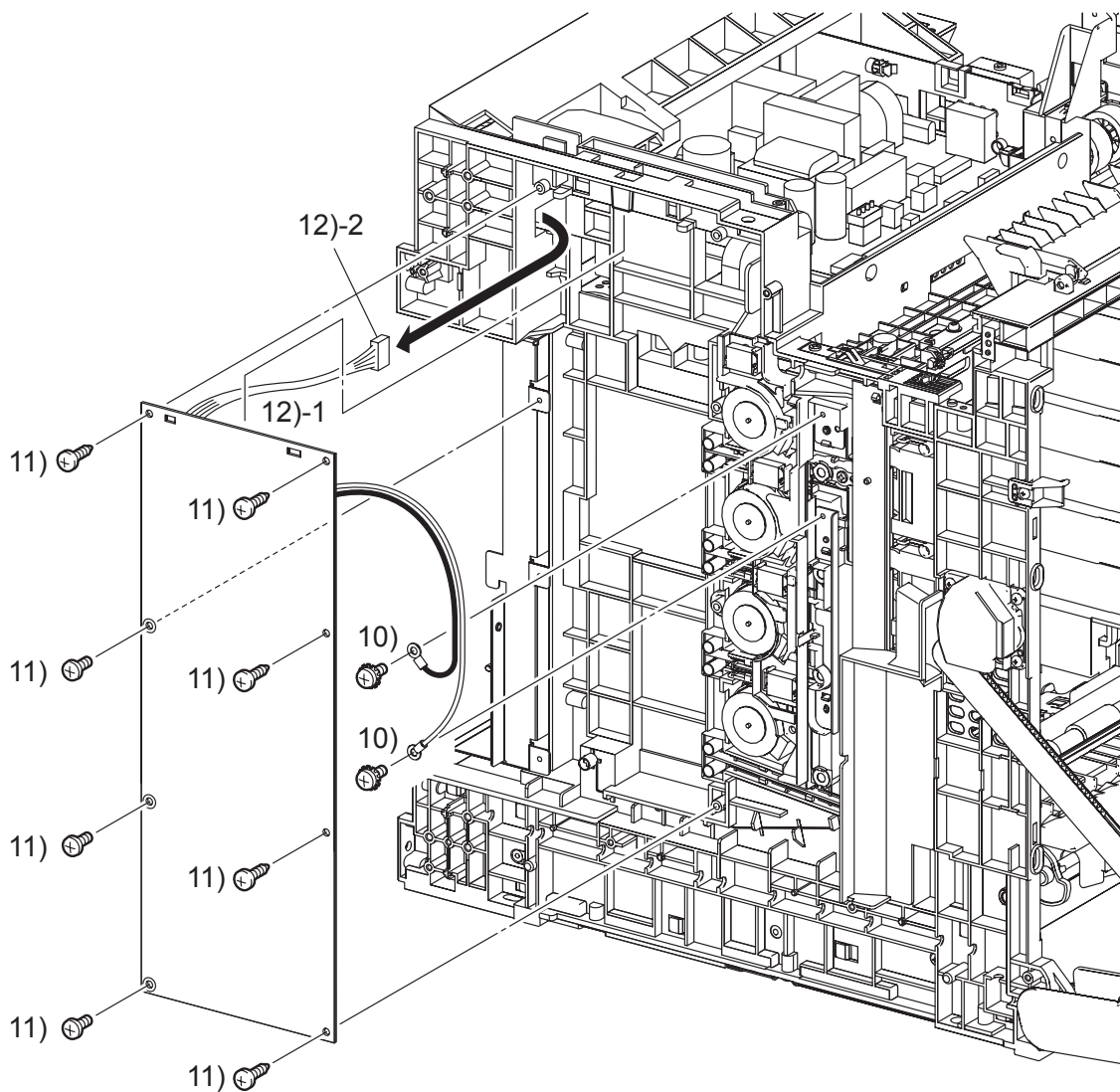

Kmy03046KA

- 10) Remove the two screws (silver, with washer, 6mm) that fix the two harnesses of the HIGH VOLTAGE POWER SUPPLY.
- 11) Remove five screws (silver, tap, 10mm) and threescrews (silver, 6mm) that fix the HIGH VOLTAGE POWER SUPPLY to the printer.
- 12) Remove the HIGH VOLTAGE POWER SUPPLY by releasing the upper part of the HIGH VOLTAGE POWER SUPPLY from the two lugs on the printer. Pull out the connector of the HIGH VOLTAGE POWER SUPPLY from the hole on the printer.

Removal 33 LOW VOLTAGE POWER SUPPLY (PL9.1.4)

Steps 1 through 7 are for reference. Before removing this component, check that Steps 1 through 7 have been performed.

- 1) Open the FRONT COVER (PL1.2.1).
- 2) Remove the FUSER. (Removal 8)
- 3) Remove the REAR COVER. (Removal 12)
- 4) Remove the RIGHT COVER. (Removal 13)
- 5) Remove the LEFT COVER. (Removal 22)
- 6) Remove the TOP COVER. (Removal 30)
- 7) Remove the FAN. (Removal 31)

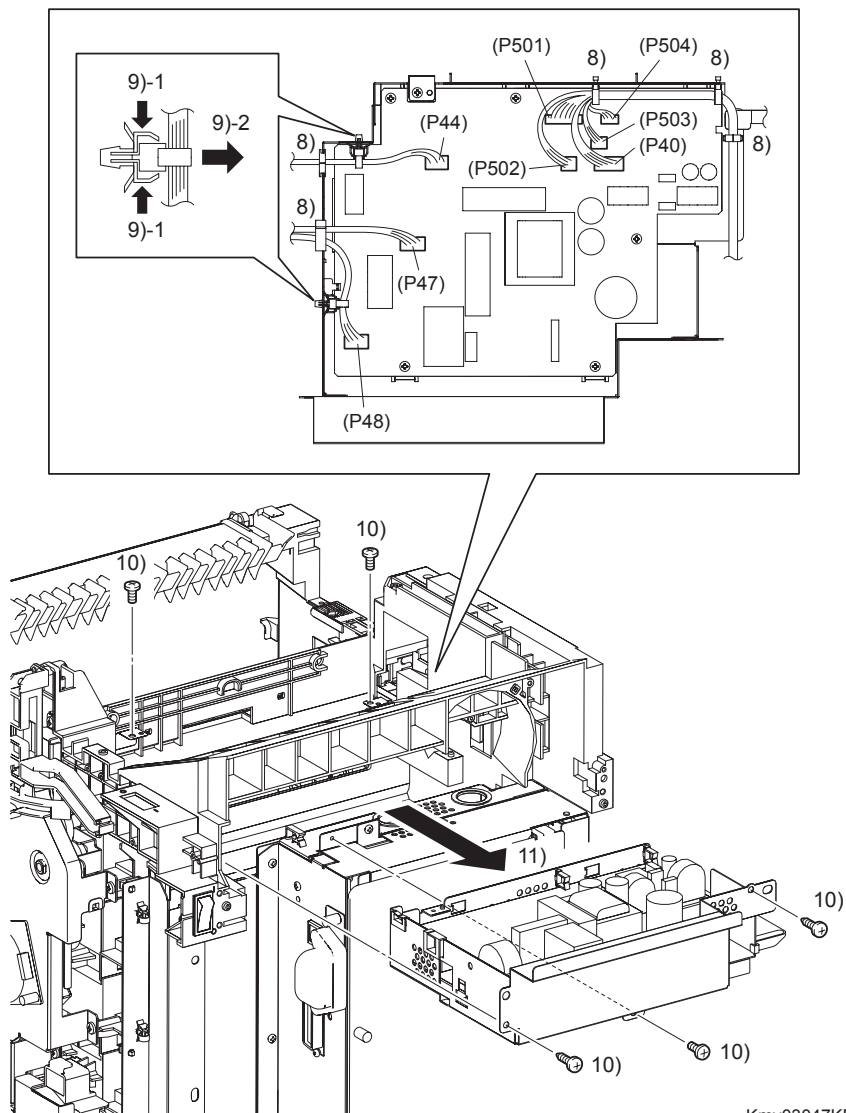

Kmy03047KB

- 8) Disengage all the connectors of the LOW VOLTAGE POWER SUPPLY, and then release the harness from the clamps.
- 9) From the SHIELD LVPS (PL9.1.9), remove the clamp that fixes the harness of the INTER-LOCK SWITCH (PL9.1.3) and the clamp that fixes the harness of the HARNESS ASSY INLET (PL9.1.16).
- 10) Remove two screws (silver, tap, 10mm) and three screws (silver, 6mm) that fix the SHIELD LVPS to the printer.
- 11) Remove the SHIELD LVPS from the printer together with the LOW VOLTAGE POWER SUPPLY.

Continues to the next page.

Removal 33 LOW VOLTAGE POWER SUPPLY (PL9.1.4)

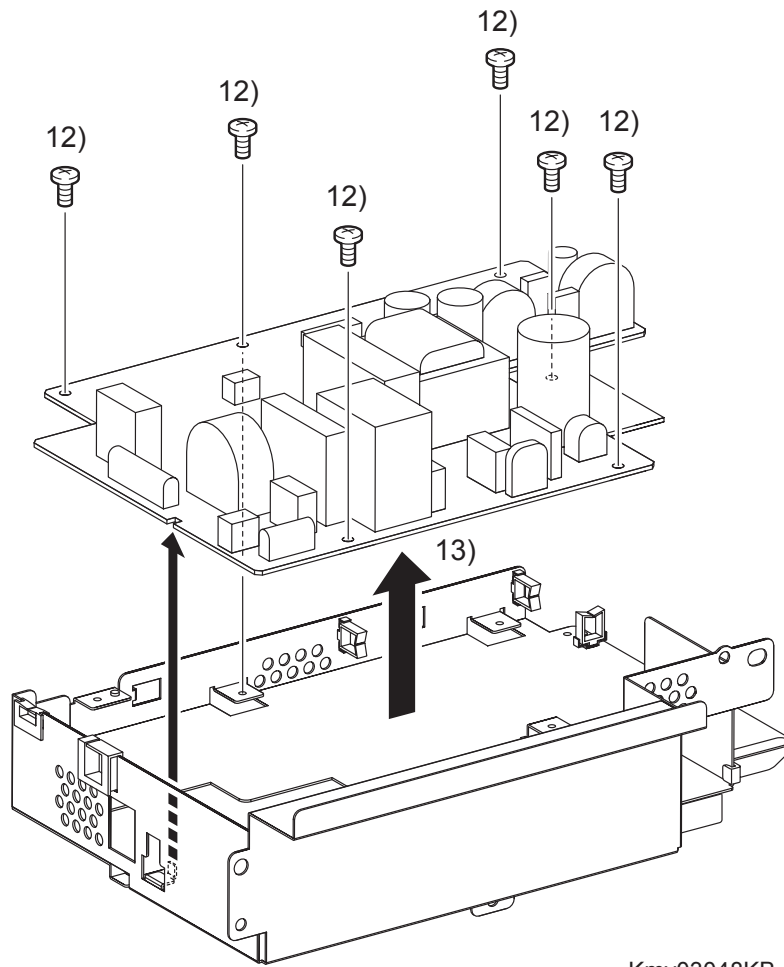

12) Remove six screws (silver, 6mm) that fix the LOW VOLTAGE POWER SUPPLY to the SHIELD LVPS.

13) Remove the LOW VOLTAGE POWER SUPPLY from the SHIELD LVPS.

Go to the next removal step:

Removal 34 PRINT HEAD (PL5.1.99)

Removal 34 PRINT HEAD (PL5.1.99)

Steps 1 through 8 are for reference. Before removing this component, check that Steps 1 through 8 have been performed.

- 1) Open the FRONT COVER (PL1.2.1).
- 2) Remove the FUSER. (Removal 8)
- 3) Remove the REAR COVER. (Removal 12)
- 4) Remove the RIGHT COVER. (Removal 13)
- 5) Remove the LEFT COVER. (Removal 22)
- 6) Remove the TOP COVER. (Removal 30)
- 7) Remove the FAN. (Removal 31)
- 8) Remove the LOW VOLTAGE POWER SUPPLY. (Removal 33)
- 9) Remove the SHIELD ASSY ESS. (Removal 27)

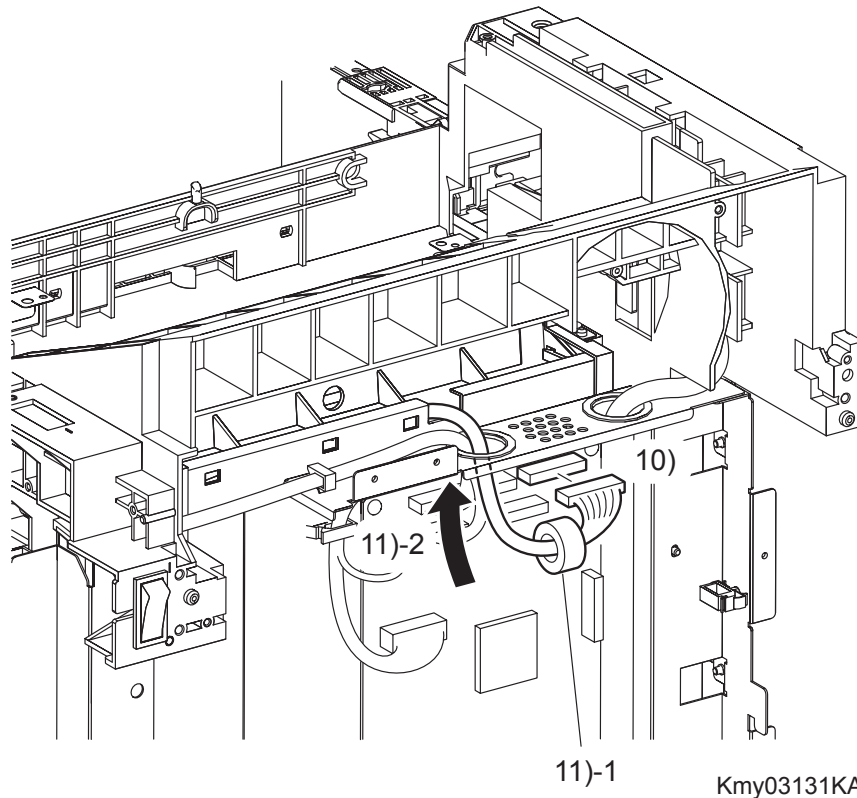

- 10) Disengage the connector (P/J12) of the PRINT HEAD (PL5.1.2) from the MACHINE CONTROL UNIT (PL9.1.20).
- 11) Remove the CORE (PL5.1.22) from the harness of the PRINT HEAD, and then pull out the connector through the hole on the SHIELD MCU (PL9.1.11).

Continues to the next page.

Removal 34 PRINT HEAD (PL5.1.99)

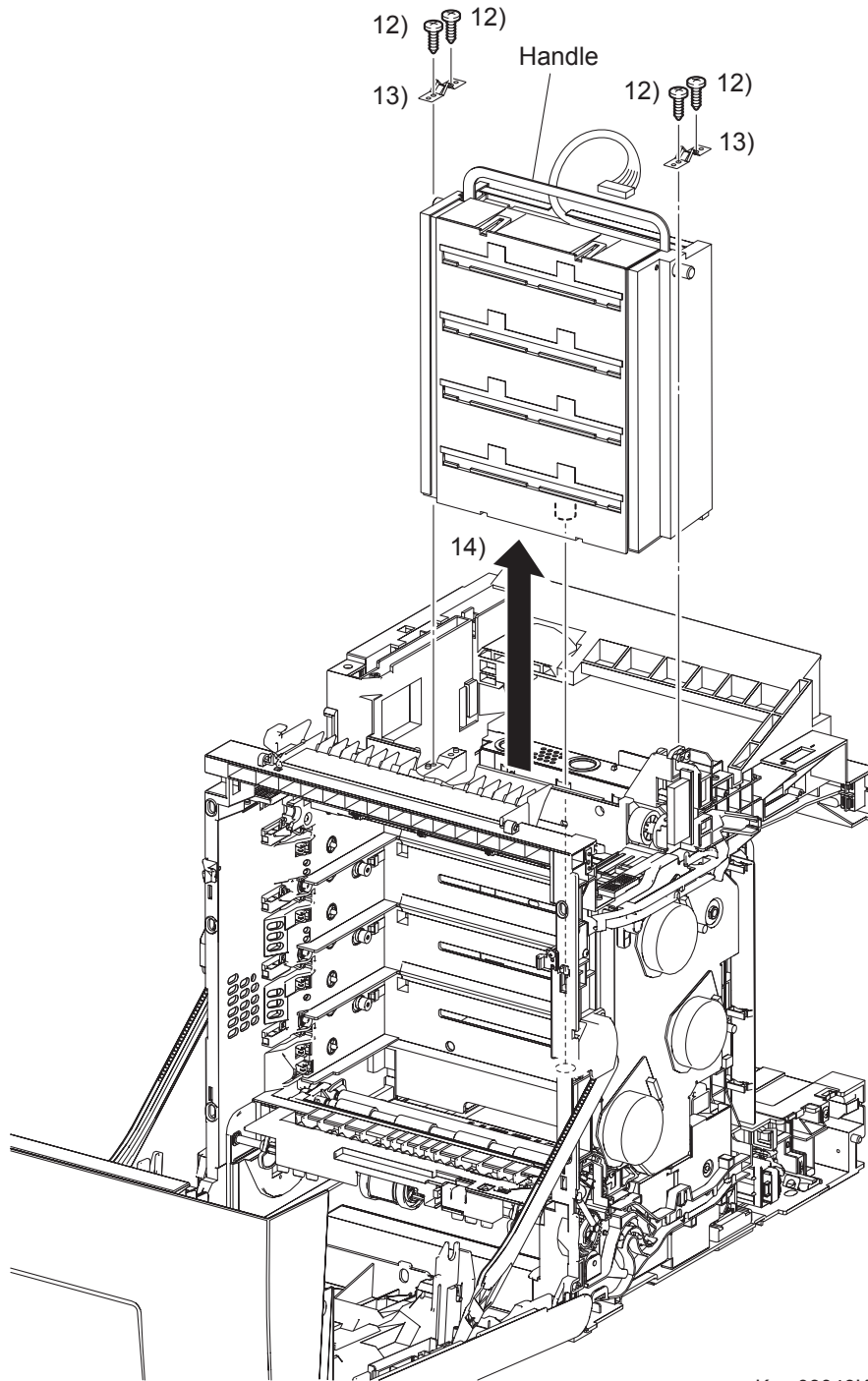

Kmy03049KB

- 12) Remove the four screws (silver, tap, 10mm) that fix the two SPRING ROSs (PL. 5.1.1) to the printer at the left and right sides.
- 13) Remove the left and right SPRING ROSs from the printer.
- 14) Remove the PRINT HEAD from the printer by pulling it up slowly by the handle.

Removal 35 INTERLOCK SWITCH (PL9.1.3)

Steps 1 through 6 are for reference. Before removing this component, check that Steps 1 through 6 have been performed.

- 1) Open the FRONT COVER (PL1.2.1).
- 2) Remove the FUSER. (Removal 8)
- 3) Remove the REAR COVER. (Removal 12)
- 4) Remove the RIGHT COVER. (Removal 13)
- 5) Remove the LEFT COVER. (Removal 22)
- 6) Remove the TOP COVER. (Removal 30)

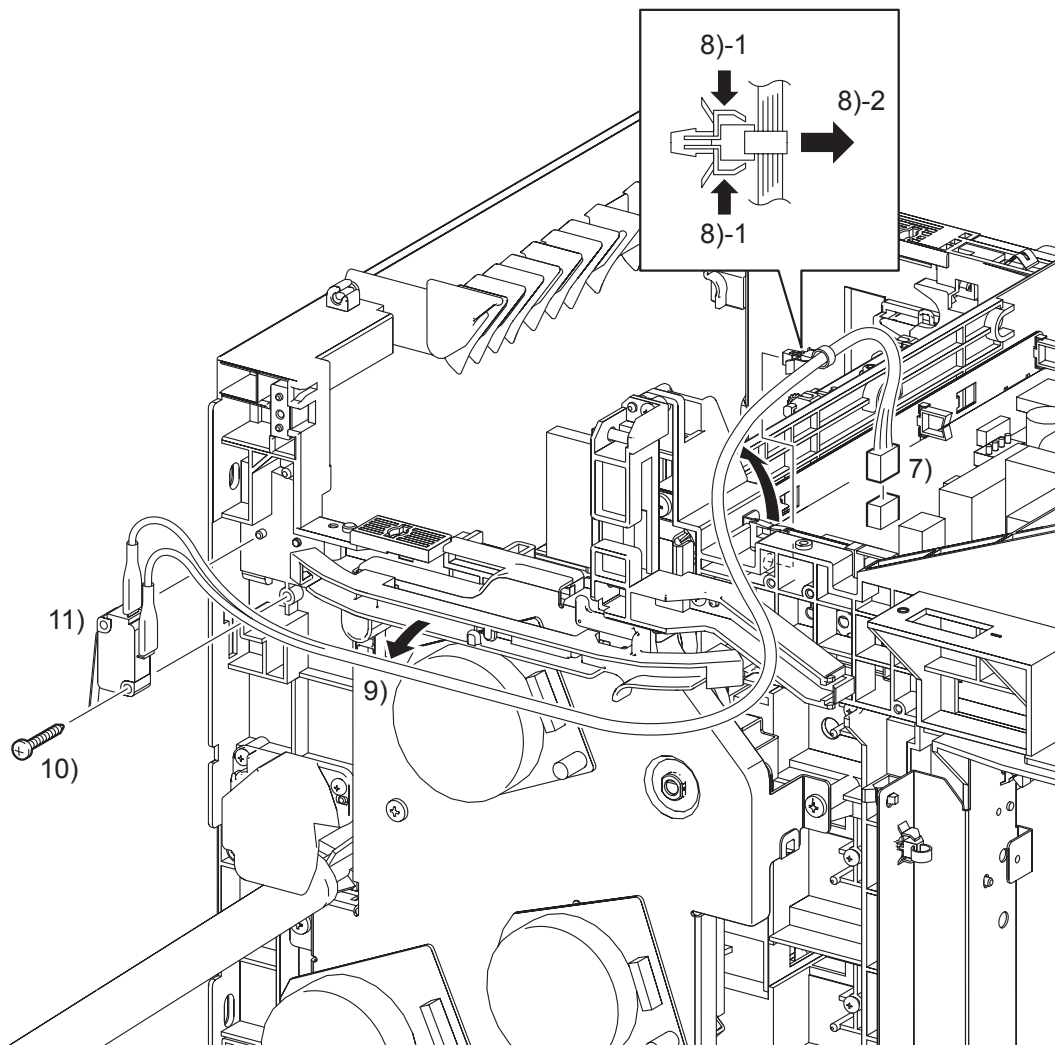

Kmy03050KA

- 7) Disengage the connector (P/J44) of the INTERLOCK SWITCH on the LOW VOLTAGE POWER SUPPLY (PL9.1.4).
- 8) Remove the clamp on the SHIELD LVPS (PL9.1.9) that fix the harness of the INTELOCK SWITCH.
- 9) Remove the harness of the INTERLOCK SWITCH from the DUCT DRV MAIN.
- 10) Remove the one screw (silver, tap, 16mm) that fixes the INTERLOCK SWITCH to the printer.
- 11) Remove the INTERLOCK SWITCH.

Go to the next removal step:

Removal 36 PHOTOCONDUCTOR (PC) / DEVELOPER (DEV) DRIVE (PL8.1.2)

Blank Page

Removal 36 PHOTOCOnductor (PC) / DEVELOPER (DEV) DRIVE (PL8.1.2)

Steps 1 through 7 are for reference. Before removing this component, check that Steps 1 through 7 have been performed.

- 1) Open the FRONT COVER (PL1.2.1).
- 2) Remove the FUSER. (Removal 8)
- 3) Remove the REAR COVER. (Removal 12)
- 4) Remove the RIGHT COVER. (Removal 13)
- 5) Remove the LEFT COVER. (Removal 22)
- 6) Remove the TOP COVER. (Removal 30)

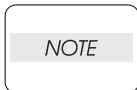

When performing the step described below, it is not necessary to disengage the connector of the INTERLOCK SWITCH.

- 7) Remove the INTERLOCK SWITCH. (Removal 35)

Continues to the next page.

Removal 36 PHOTOCONDUCTOR (PC) / DEVELOPER (DEV) DRIVE (PL8.1.2)

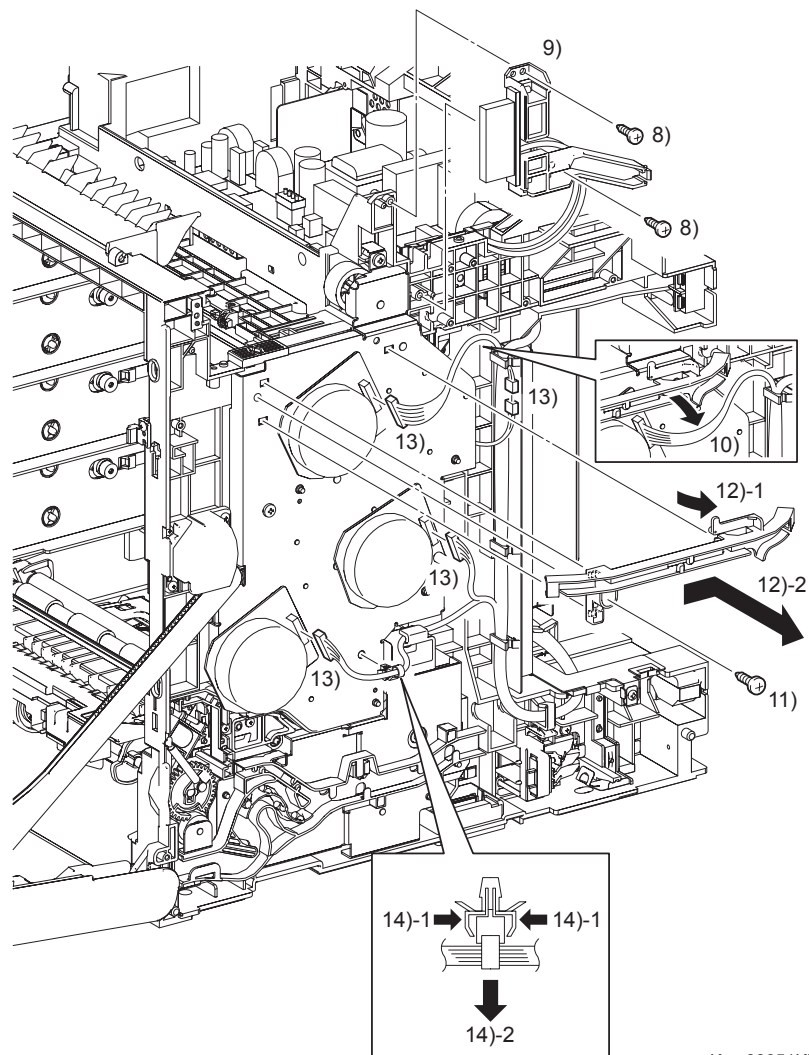

Kmy03051KB

- 8) Remove two screws (silver, tap, 10mm) that fix the BRACKET FUSER (PL6.1.12) to the printer.

NOTE

When performing the step described below, take care not to move the BRACKET FUSER from the printer too far because they are connected with the harness.

- 9) Remove the BRACKET FUSER from the printer.
- 10) Release the harness of the PHOTOCONDUCTOR (PC) / DEVELOPER (DEV) DRIVE (PL8.1.2) from the DUCT DRV MAIN (PL8.1.9).
- 11) Remove the one screw (silver, tap, 10mm) that fixes PHOTOCONDUCTOR (PC) / DEVELOPER (DEV) DRIVE to the printer.
- 12) Remove the DUCT DRV MAIN from the PHOTOCONDUCTOR (PC) / DEVELOPER (DEV) DRIVE by releasing the bosses on the DUCT DRV MAIN and sliding the DUCT DRV MAIN backward.
- 13) Disengage the four connectors (P/J211, P/J221, P/J222, and P/J2761) from the PHOTOCONDUCTOR (PC) / DEVELOPER (DEV) DRIVE.
- 14) Remove the harness from the PHOTOCONDUCTOR (PC) / DEVELOPER (DEV) DRIVE together with the clamp.

Continues to the next page.

Removal 36 PHOTOCONDUCTOR (PC) / DEVELOPER (DEV) DRIVE (PL8.1.2)

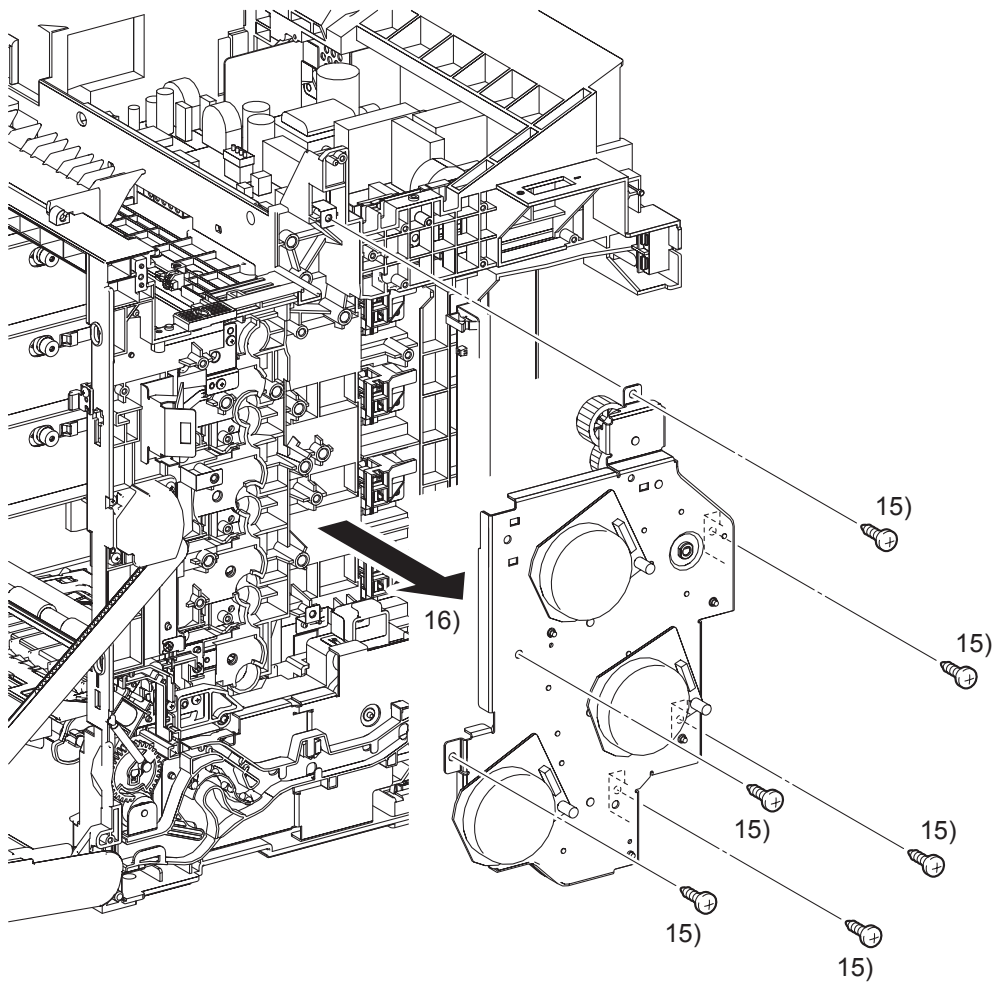

Kmy03052KB

- 15) Remove the six screws (silver, tap, 10mm) that fix the PHOTOCONDUCTOR (PC) / DEVELOPER (DEV) DRIVE to the printer.
- 16) Remove the PHOTOCONDUCTOR (PC) / DEVELOPER (DEV) DRIVE from the printer.

Go to the next removal step:

Removal 37 TONER CARTRIDGE SENSOR ASSEMBLY (K) (PL5.1.4)

Removal 37 TONER CARTRIDGE SENSOR ASSEMBLY (K) (PL5.1.4)

Steps 1 through 8 are for reference. Before removing this component, check that Steps 1 through 8 have been performed.

- 1) Open the FRONT COVER (PL1.2.1).
- 2) Remove the FUSER. (Removal 8)
- 3) Remove the REAR COVER. (Removal 12)
- 4) Remove the RIGHT COVER. (Removal 13)
- 5) Remove the LEFT COVER. (Removal 22)
- 6) Remove the TOP COVER. (Removal 30)
- 7) Remove the INTERLOCK SWITCH. (Removal 35)
- 8) Remove the PHTOTCONDUCTOR (PC) / DEVELOPER (DEV) DRIVE. (RRP8.1)

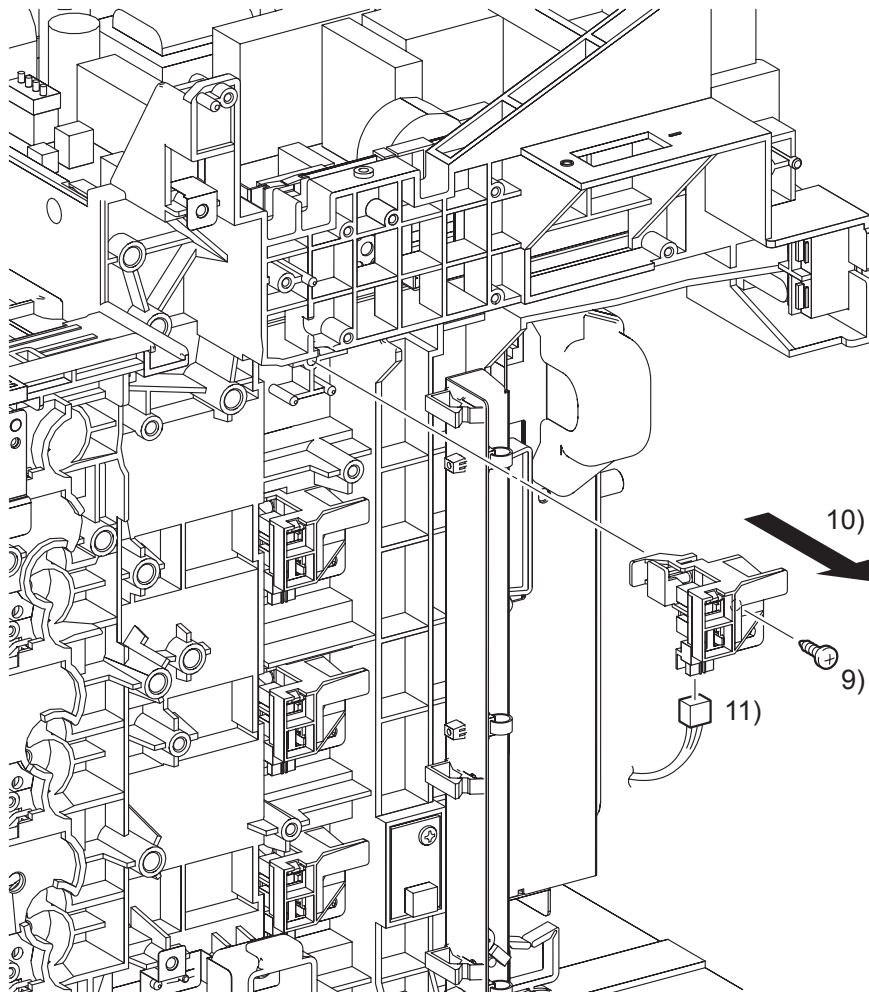

Kmy03053KA

- 9) Remove the one screw (silver, tap, 10mm) that fixes the TONER CARTRIDGE SENSOR ASSEMBLY (K) (PL5.1.4) to the printer.
- 10) Remove the TONER CARTRIDGE SENSOR ASSEMBLY (K) from the printer.
- 11) Disconnect the connector (P/J193) of the TONER CARTRIDGE SENSOR ASSEMBLY (K).

Removal 38 MPF SEPARATOR ROLLER ASSEMBLY (PL2.1.3)

- 1) Remove the 250 SHEET PAPER TRAY (PL2.1.1) from the printer.

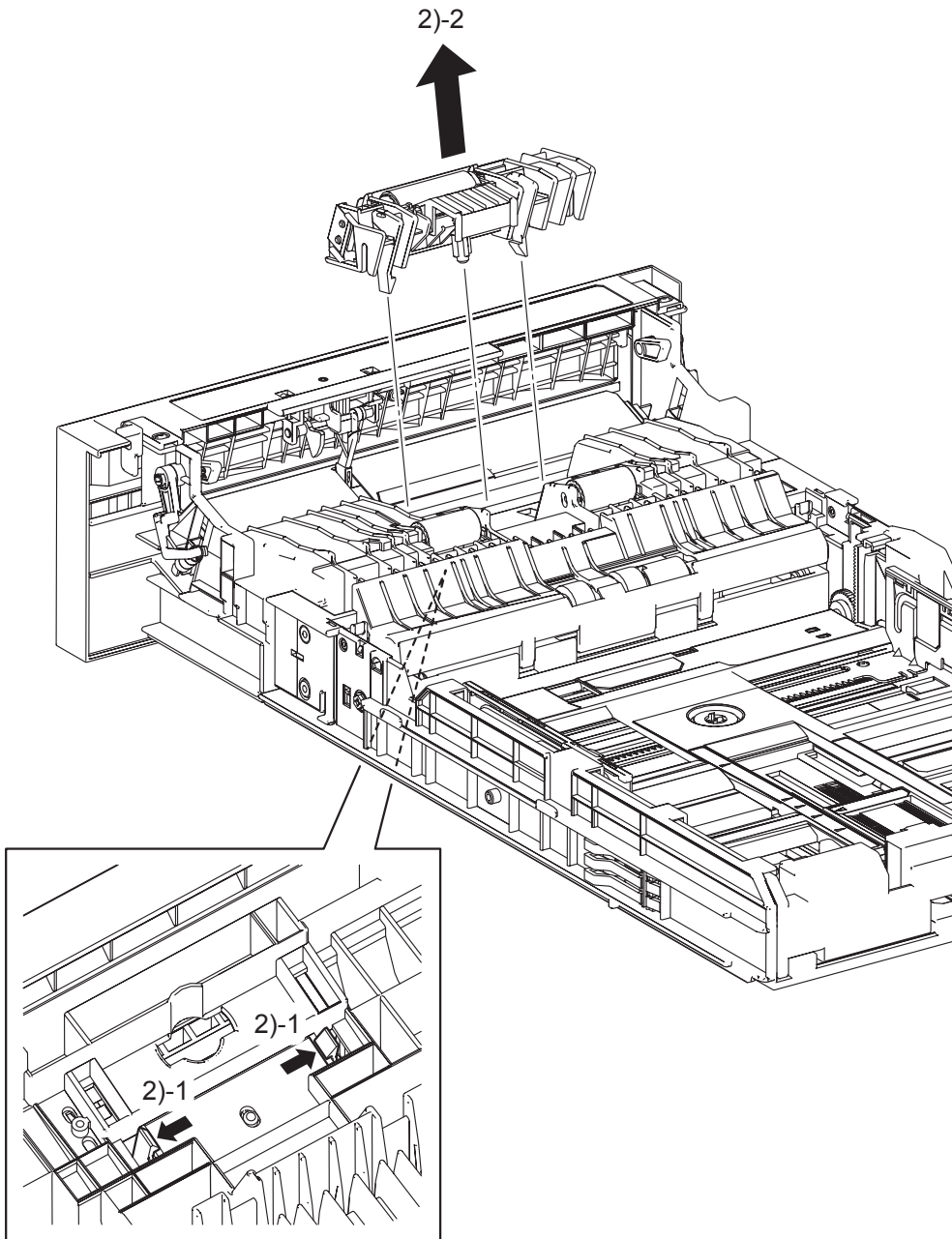

Kmy03054KA

- 2) Release the two backside hooks of the MPF SEPARATOR ROLLER ASSEMBLY (PL2.1.3) and then remove the MPF SEPARATOR ROLLER ASSEMBLY from the 250 SHEET PAPER TRAY.

Removal 39 SEPARATOR ROLLER (PL2.2.17) (Same as the FEED ROLLER)

- 1) Remove the 250 SHEET PAPER TRAY (PL2.1.1) from the printer.

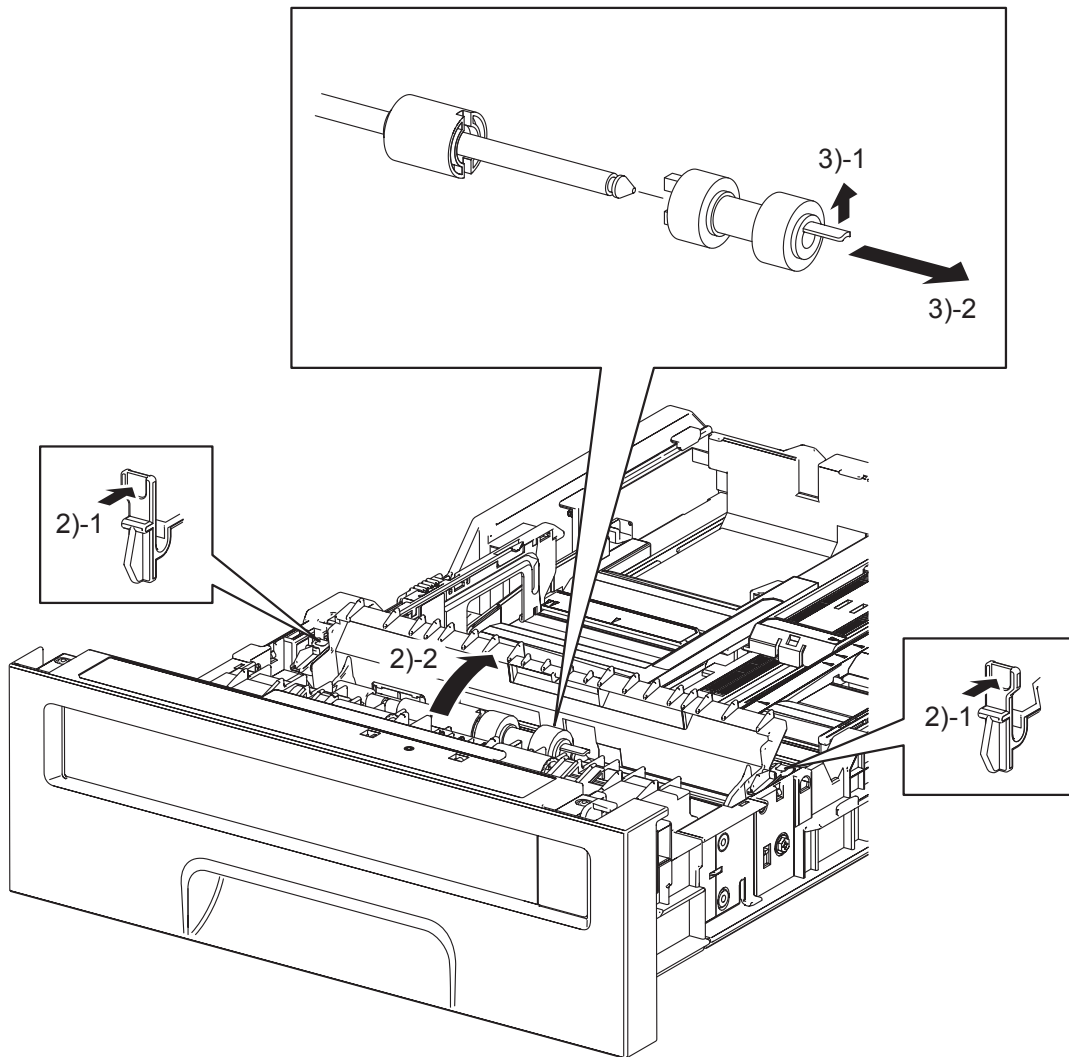

Kmy03055KA

- 2) Release the left and right hooks of the CVR RTD CST (PL2.2.13), and then open the CVR RTD CST.
- 3) Release the hook of the SEPARATOR ROLLER (PL2.2.17), and then remove the SEPARATOR ROLLER from the SHAFT RETARD (PL2.2.15).

Removal 40 MPF ROLLER (PL3.1.10)

- 1) Remove the 250 SHEET PAPER TRAY (PL2.1.1) from the printer.

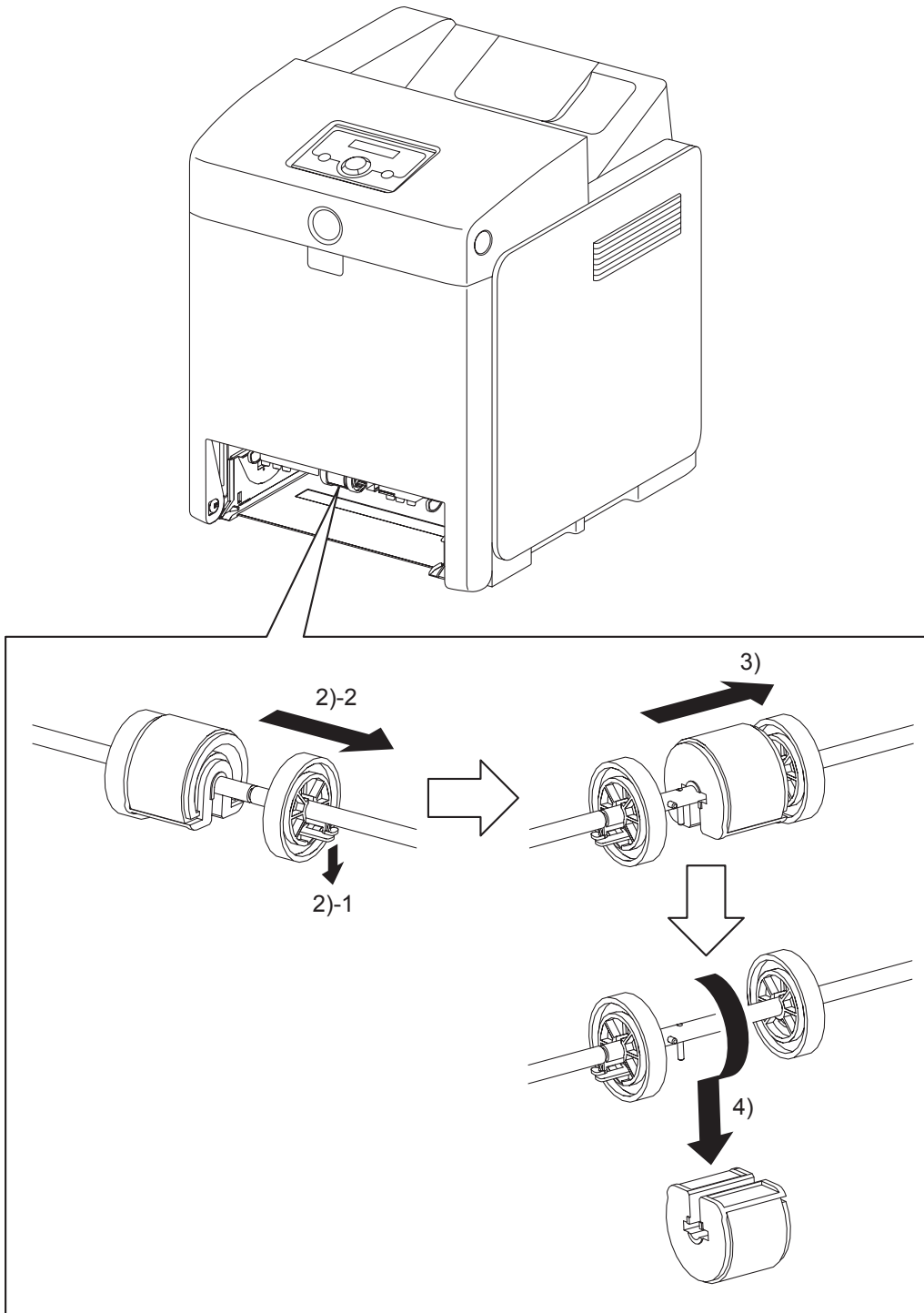

Kmy03056KB

- 2) Release the hook of the ROLL CORE MSI (PL3.1.9) on the right of the MPF ROLLER (PL 3.2.10), and slide the ROLL CORE MSI to the right.
- 3) Release the groove on the MPF ROLLER from the vertical pin mounted on the SHAFT MSI (PL3.1.12) by sliding the MPF ROLLER to the right.
- 4) Remove the MPF ROLLER from the SHAFT MSI by rotating the MPF ROLLER 180 degrees.

Removal 41 FEED ROLLER (PL3.2.53)

- 1) Remove the 250 SHEET PAPER TRAY (PL2.1.1) from the printer.

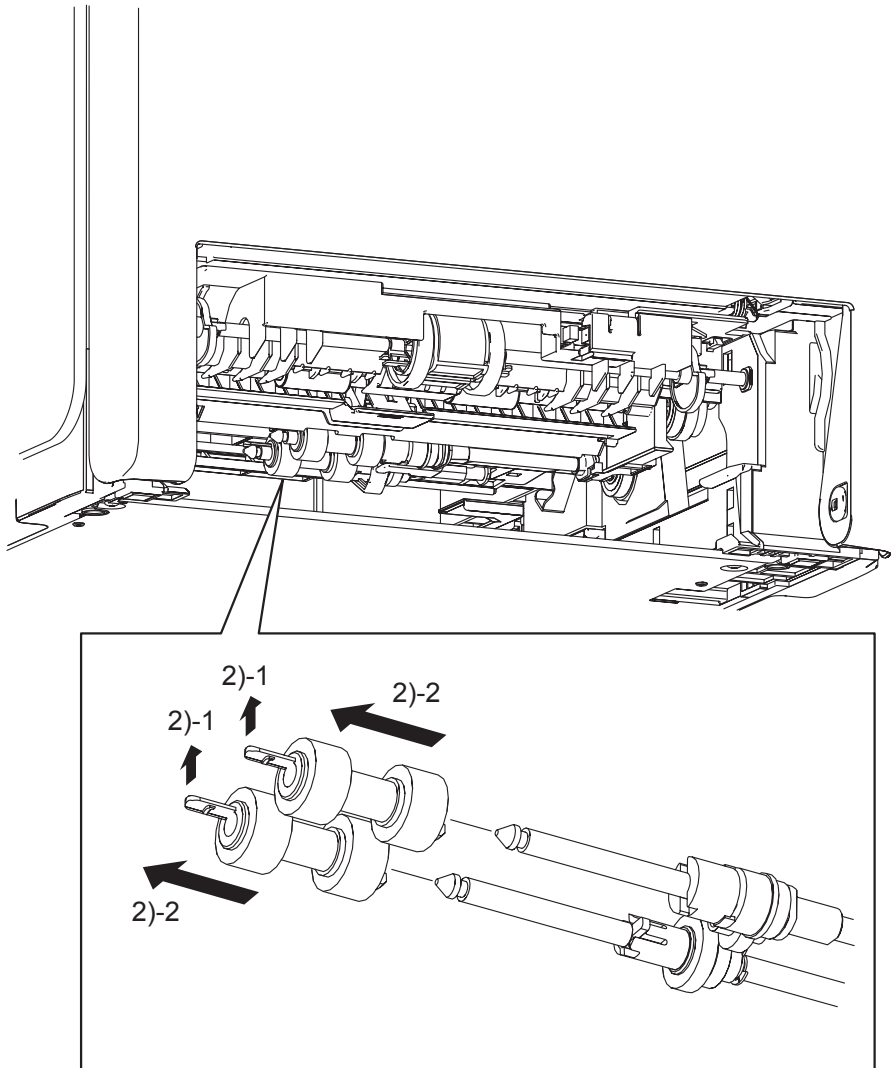

Kmy03057KA

- 2) Release the hooks of the FEED ROLLERS (PL3.2.53) and remove the FEED ROLLERS from the shafts.

Removal 42 550 SHEET FEEDER ASSEMBLY (PL12.1.1)

- 1) Remove the 250 SHEET PAPER TRAY (PL2.1.1) of the printer.

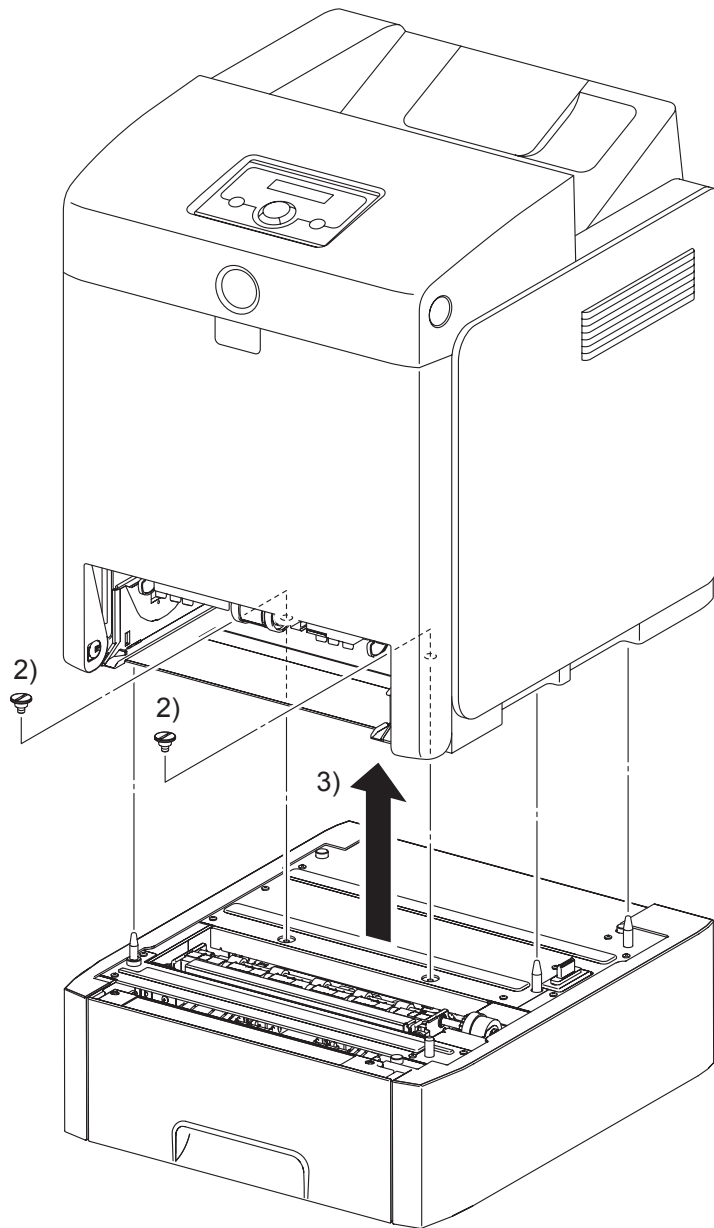

Kmy03058KA

- 2) Remove two FEEDER SCREWS (PL12.1.3) that fix the 550 SHEET FEEDER ASSEMBLY (PL12.1.1) to the printer.

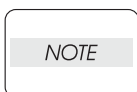

The printer must be lifted by two people.

- 3) Lift up the printer to separate it from the 550 SHEET FEEDER ASSEMBLY.

Removal 43 550 TRAY REAR COVER (PL12.1.4)

- 1) Pull the 550 TRAY REAR COVER backward until it stops

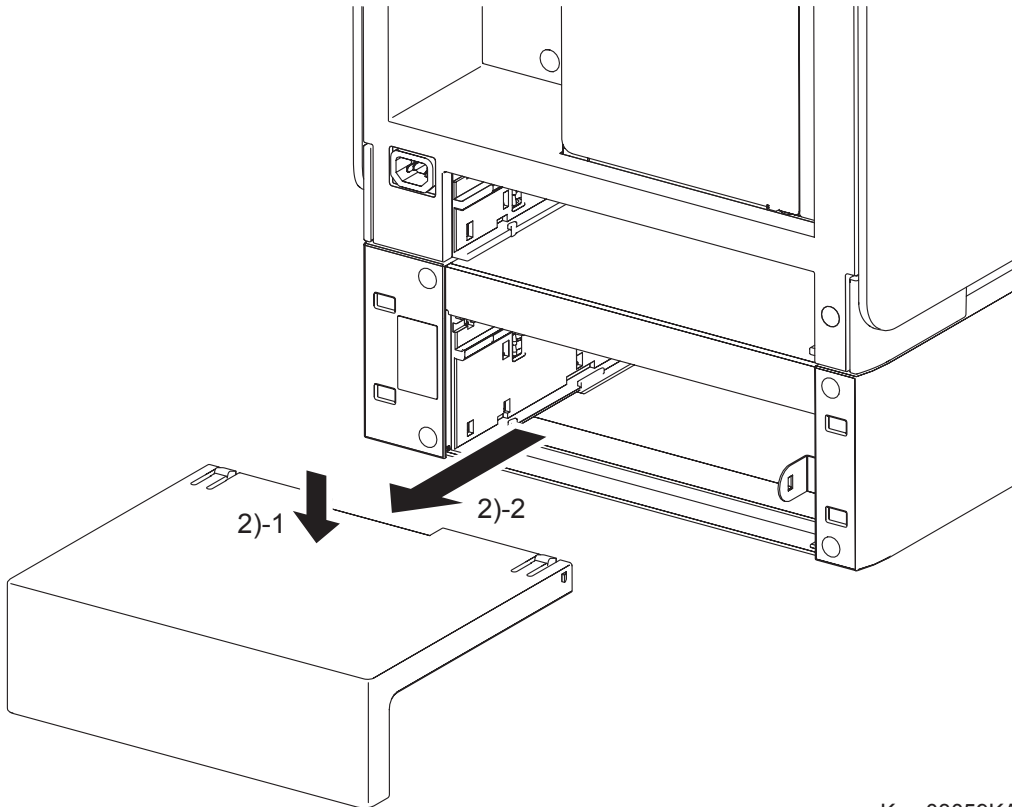

Kmy03059KA

- 2) Release the two hooks by depressing the center of the 550 TRAY REAR COVER, and then remove the 550 TRAY REAR COVER from the 550 SHEET FEEDER ASSEMBLY (PL12.1.1).

Removal 44 550 TRAY FEED ROLLER (PL12.3.29)

- 1) Remove the 550 SHEET PAPER TRAY (PL12.4.1) from the 550 SHEET FEEDER ASSEMBLY (PL12.1.1).

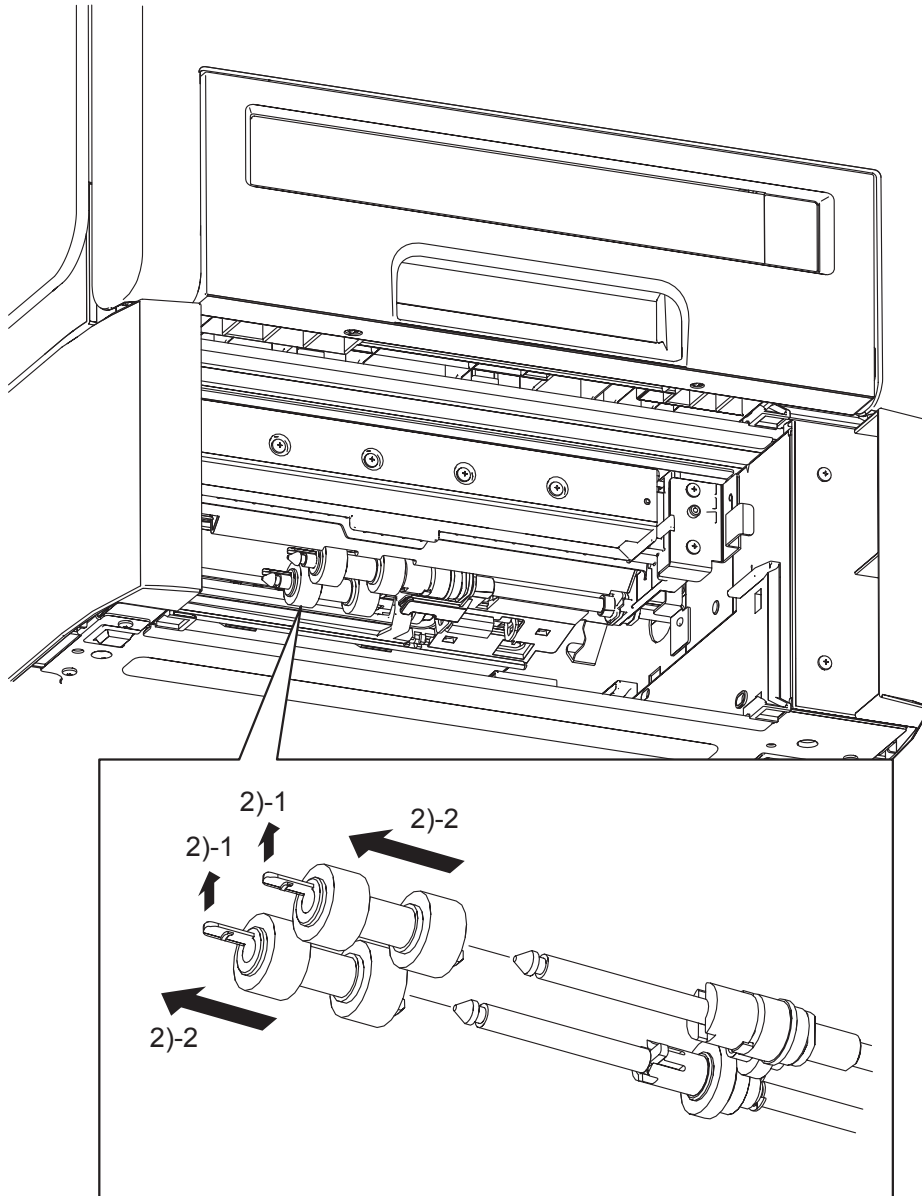

Kmy03060KA

- 2) Release the hooks of the 550 TRAY FEED ROLLERS (PL12.3.29), and then remove the 550 TRAY FEED ROLLERS from the shafts.

Removal 45 550 TRAY SEPARATOR ROLLER (PL12.5.17) (Same as the 550 TRAY FEED ROLLER)

- 1) Remove the 550 SHEET PAPER TRAY (PL12.4.1) from the 550 SHEET FEEDER ASSEMBLY (PL12.1.1).

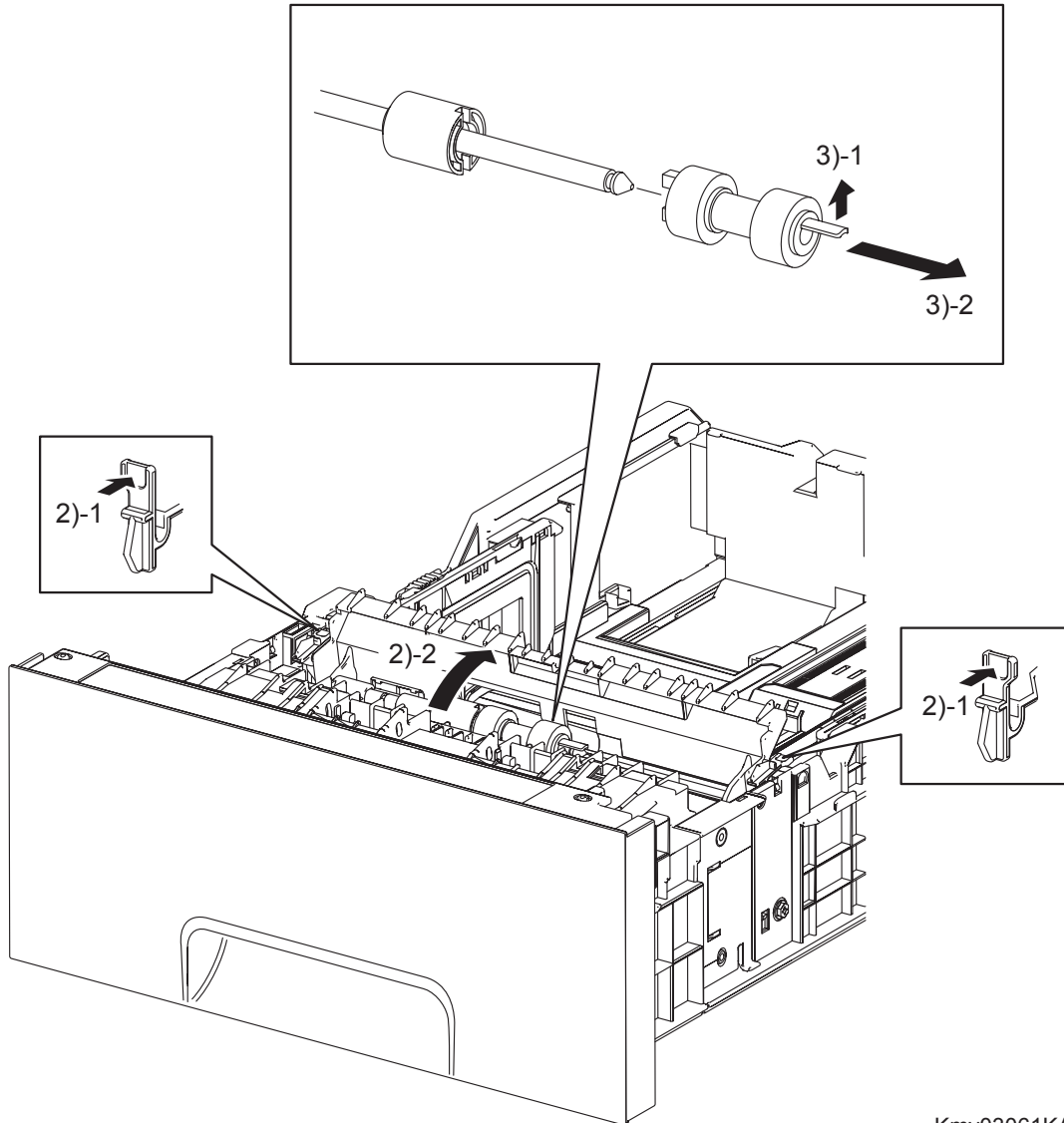

Kmy03061KA

- 2) Release the left and right hooks of the CVR RTD CST (PL12.5.13), and then open the CVR RTD CST.
- 3) Release the hook of the 550 TRAY SEPARATOR ROLLER (PL12.5.17), and then remove the 550 TRAY SEPARATOR ROLLER from the SHAFT RETARD (PL12.5.15).

Removal 46 MEMORY CARD (PL9.1.30)

NOTE

Use a wristband to protect the MEMORY CARD from electrostatic damage.

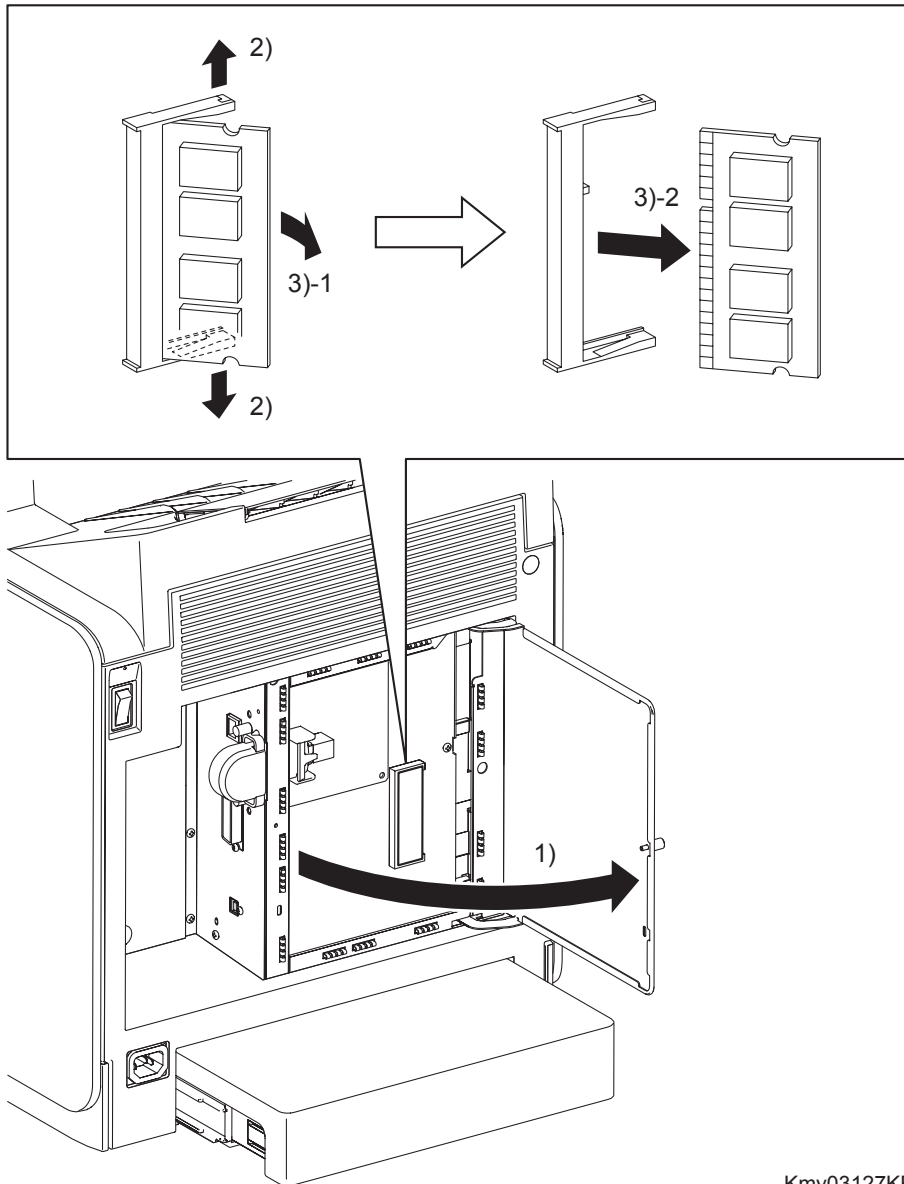

Kmy03127KB

- 1) Loosen the SCREW KNURLING (PL9.1.22), and then open the SHIELD WINDOW (PL9.1.21).
- 2) Gently spread open both the tabs on the socket holding the MEMORY CARD (PL9.1.30) until the MEMORY CARD pops up slightly.
- 3) Remove the MEMORY CARD.

Removal 47 MULTI PROTOCOL CARD (PL9.1.31)

NOTE

Use a wristband to protect the MPC from electrostatic damage.

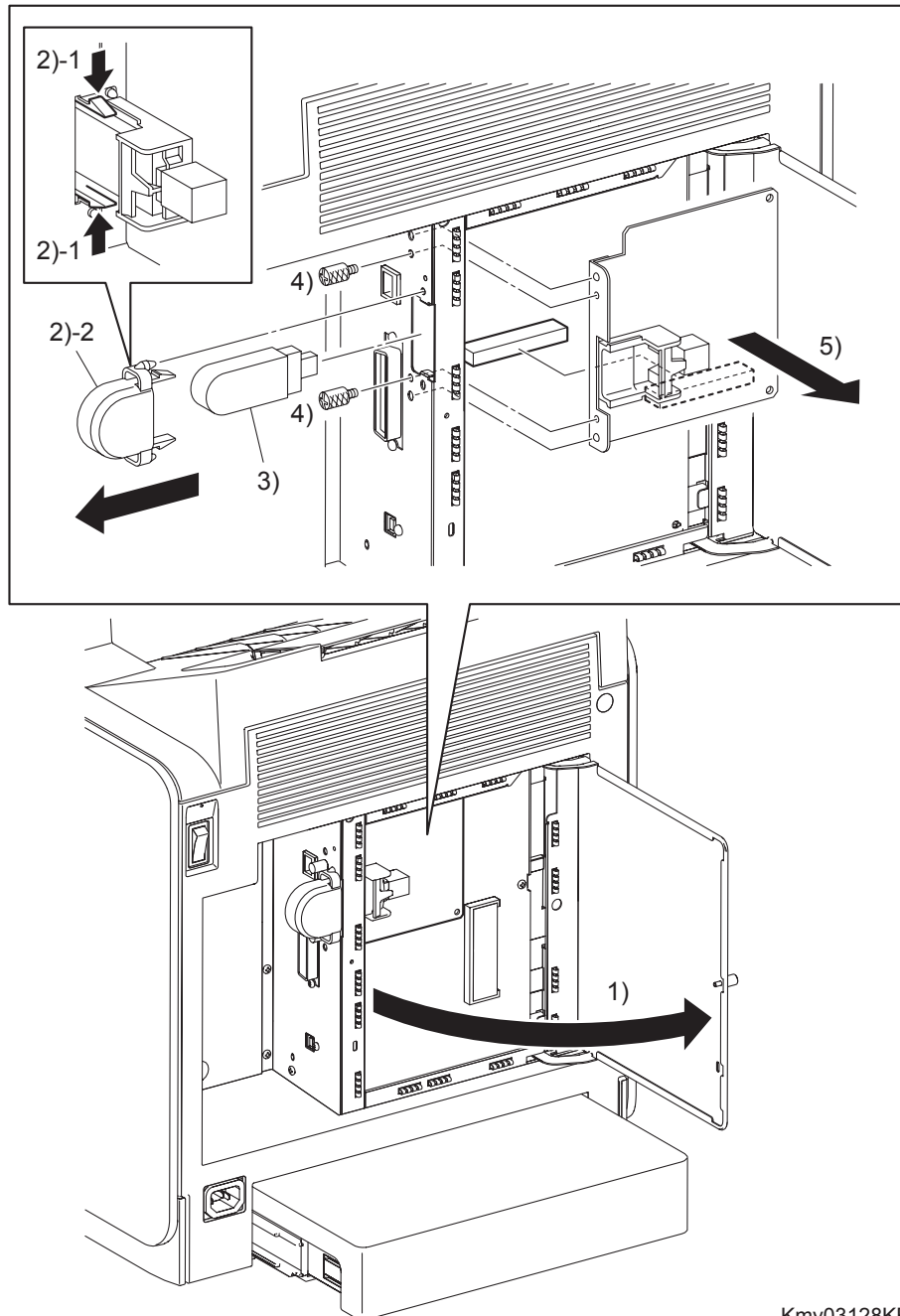

Kmy03128KB

- 1) Loosen the SCREW KNURLING (PL9.1.22), and then open the SHIELD WINDOW (PL9.1.21).
- 2) Remove the COVER USB (PL9.1.34) from the printer by releasing its two hooks.
- 3) Remove the WIRELESS LAN ADAPTER (PL9.1.32) from the MULTI PROTOCOL CARD (PL9.1.31).
- 4) Remove the two SCREW KNURLINGS (PL9.1.22) that fix the MULTI PROTOCOL CARD to the printer.
- 5) Remove the MULTI PROTOCOL CARD from the ELECTRONIC SUB-SYSTEM CONTROL BOARD (PL9.1.27).

3. Replacement Steps

Replacement 1 550 TRAY SEPARATOR ROLLER (PL12.5.17) (Same as the 550 TRAY FEED ROLLER)

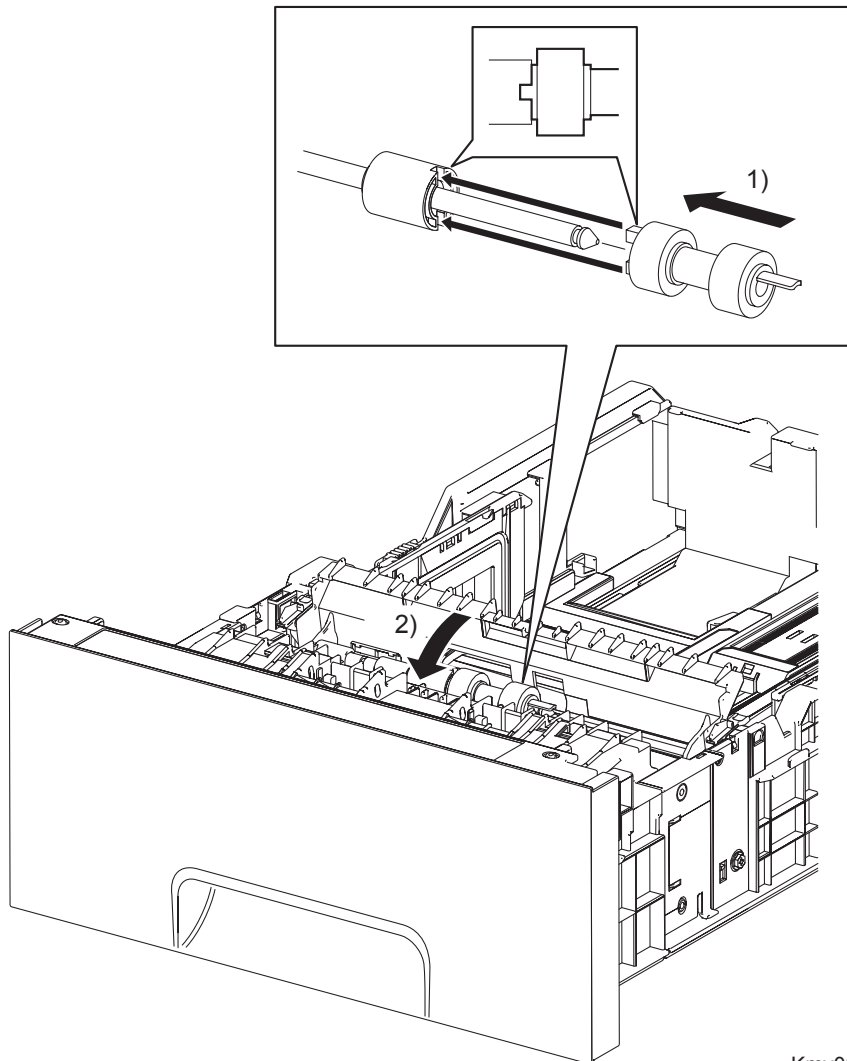

Kmy03121KA

- 1) Slide the 550 TRAY SEPARATOR ROLLER onto the SHAFT RETARD so that the lug on the 550 TRAY SEPARATOR ROLLER is mated with the notch on the CLUTCH FRICTION RET (PL12.5.16). Lock the hook on the other end of the 550 TRAY SEPARATOR ROLLER into the groove on the SHAFT RETARD.
- 2) Close the CVR RTD CST.
- 3) Replace the 550 SHEET PAPER TRAY to the 550 SHEET FEEDER ASSEMBLY.

Replacement 2 550 TRAY FEED ROLLER (PL12.3.29)

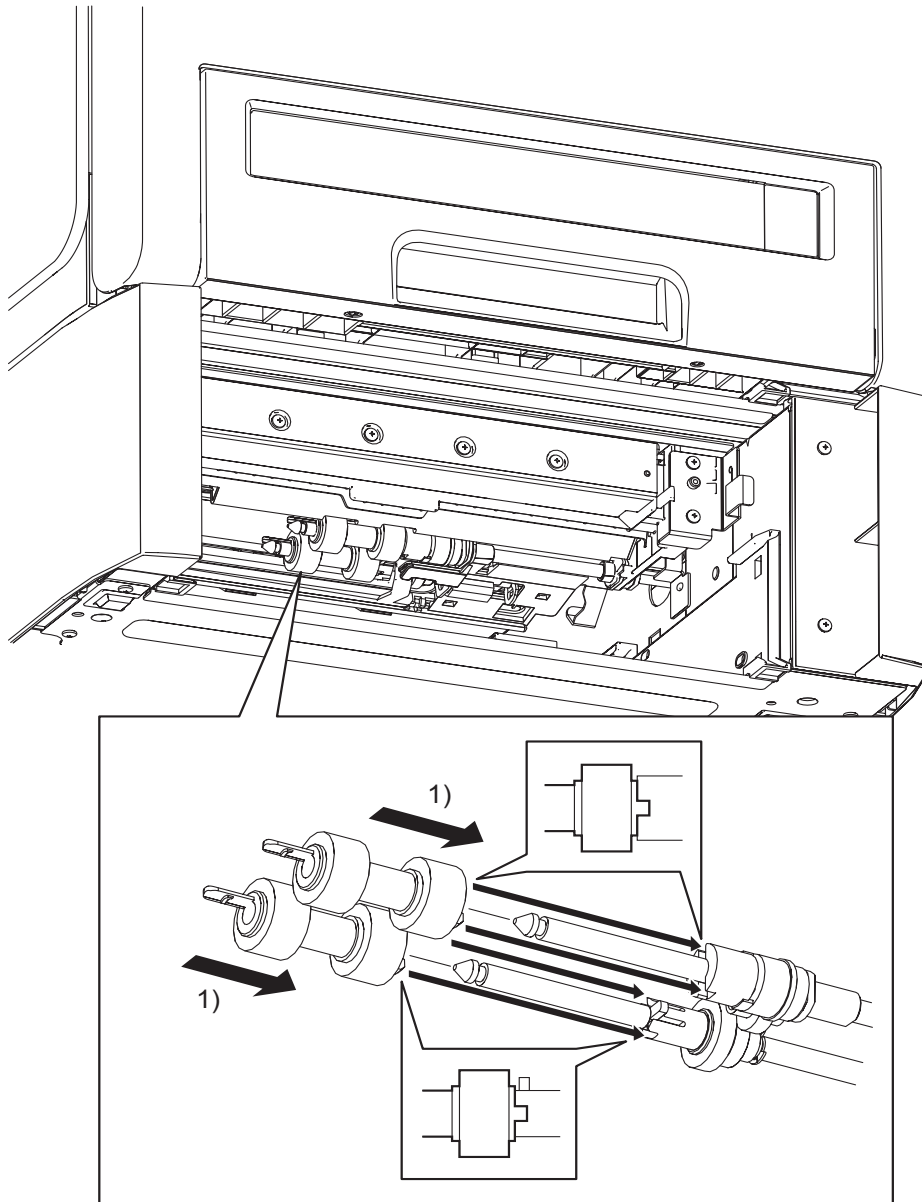

Kmy03120KA

- 1) Slide the 550 TRAY FEED ROLLERS onto the shafts so that the lugs on the 550 TRAY FEED ROLLERS are mated with the notches on the ROLL ASSY GEAR NUDGERS (PL12.3.22) and CLUTCH ONE WAY FEED (PL.1.3.28). Lock the hooks on the other end of the 550 TRAY FEED ROLLERS into the grooves on the shafts.
- 2) Replace the 550 SHEET PAPER TRAY to the 550 SHEET FEEDER ASSEMBLY.

Replacement 3 550 TRAY REAR COVER (PL12.1.4)

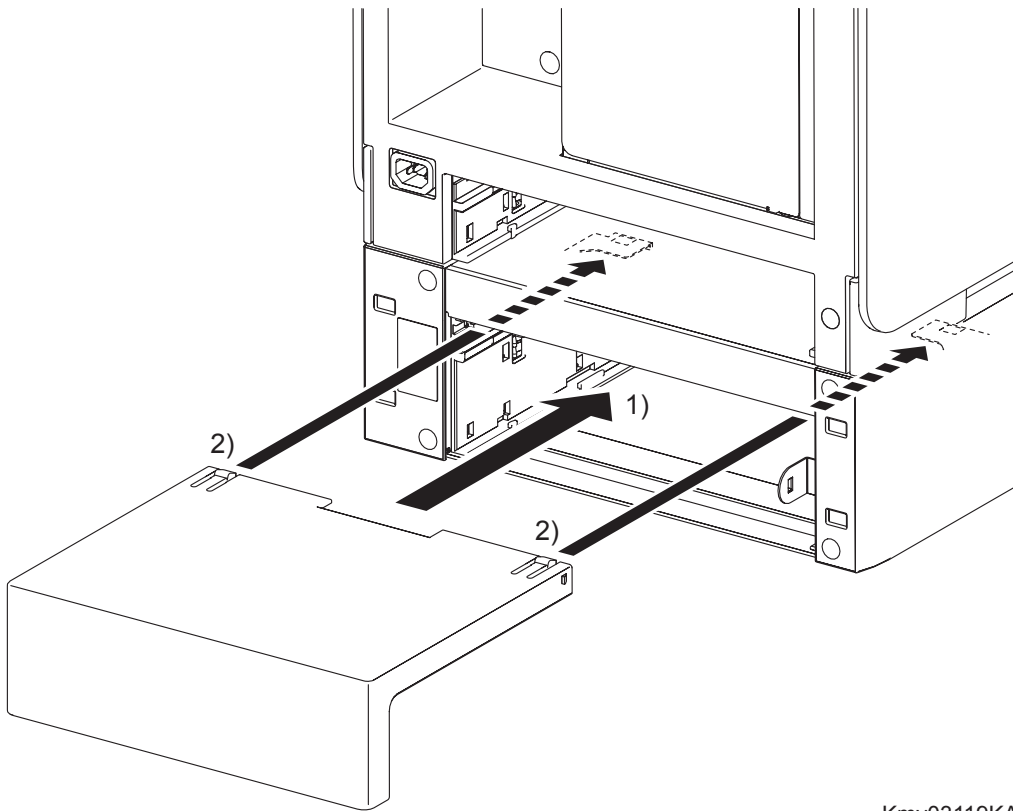

Kmy03119KA

- 1) Insert the 550 TRAY REAR COVER into the 550 SHEET FEEDER ASSEMBLY.
- 2) Push the 550 TRAY REAR COVER frontward until it is locked to the 550 SHEET FEEDER ASSEMBLY at the two hooks on its front edge.

Replacement 4 550 SHEET FEEDER ASSEMBLY (PL12.1.1)

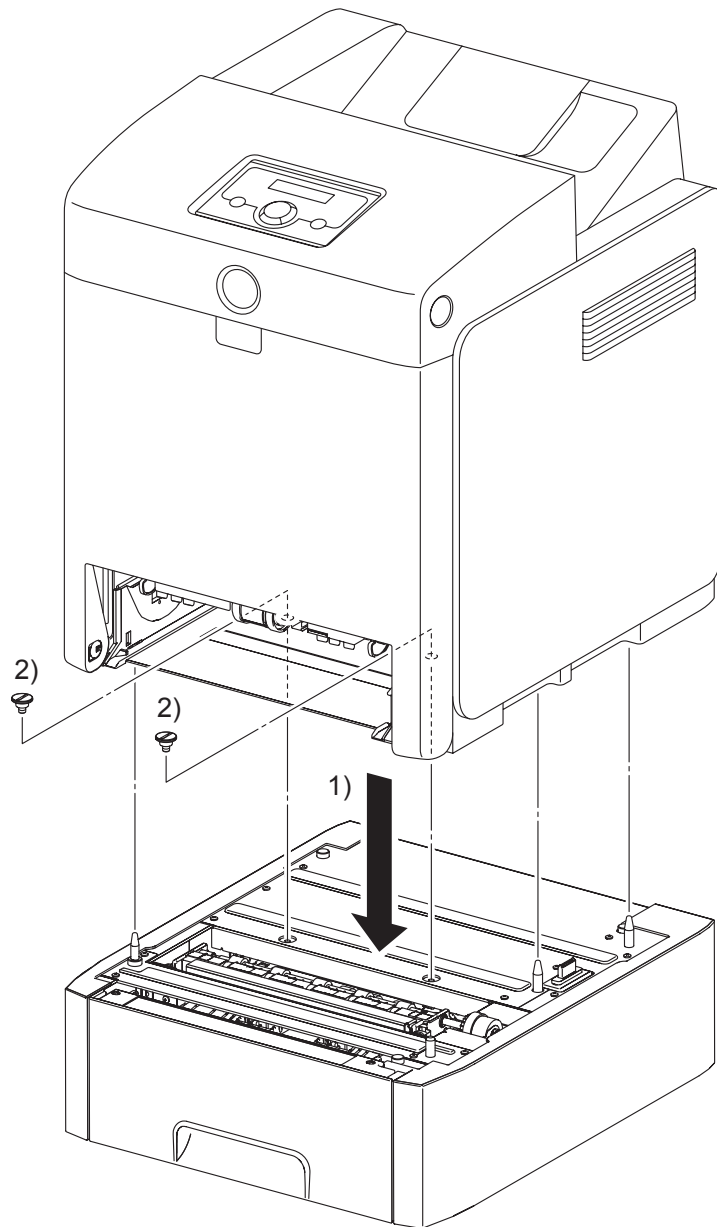

Kmy03118KA

NOTE

The printer must be lifted by two people.

- 1) Place the printer on the 550 SHEET FEEDER ASSEMBLY with the four holes on the bottom of the printer aligned with the studs on the 550 SHEET FEEDER ASSEMBLY.
- 2) Secure the printer to the 550 SHEET FEEDER ASSEMBLY using the two FEEDER SCREWS.
- 3) Replace the 250 SHEET PAPER TRAY to the printer.

Replacement 5 FEED ROLLER (PL3.2.53)

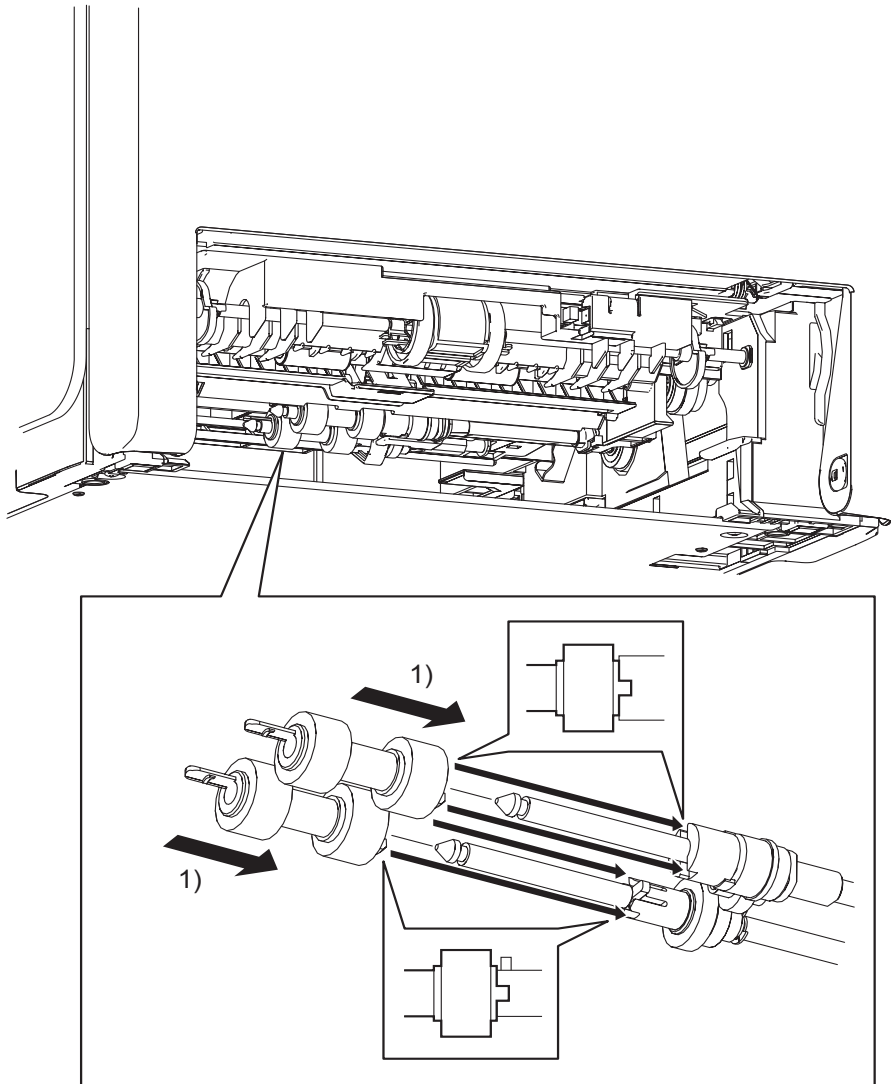

Kmy03117KA

- 1) Slide the FEED ROLLERS onto the shafts so that the lugs on the FEED ROLLERS are mated with the notches on the ROLL ASSY GEAR NUDGER (PL3.2.46) and CLUTCH ONEWAY FEED (PL3.2.52). Lock the hooks on the other end of the FEED ROLLERS into the grooves on the shafts.
- 2) Replace the 250 SHEET PAPER TRAY to the printer.

Replacement 6 MPF ROLLER (PL3.1.10)

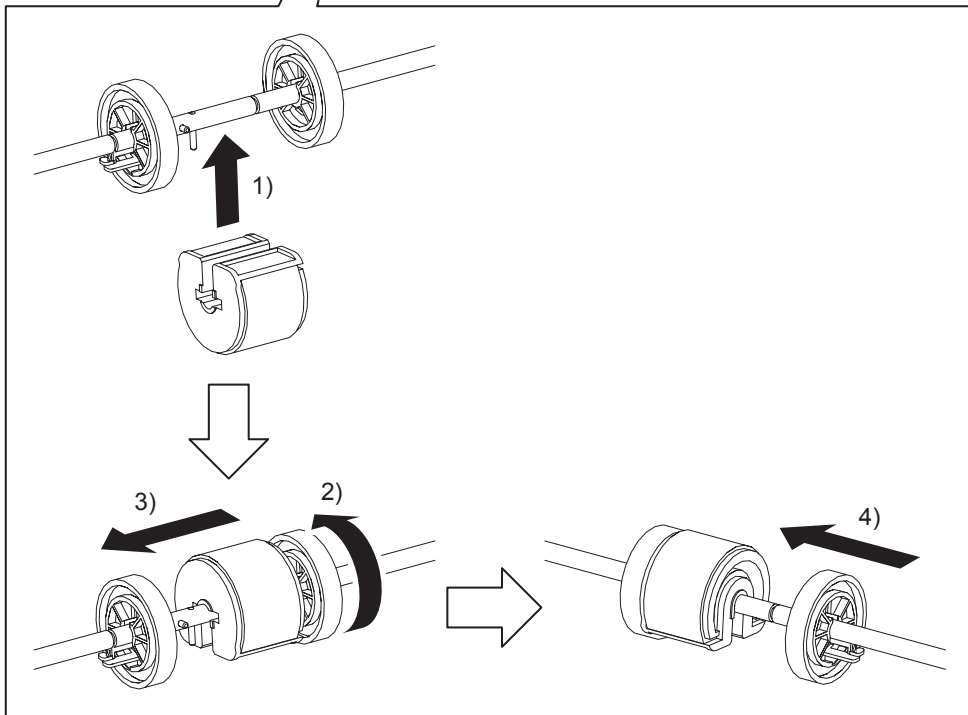
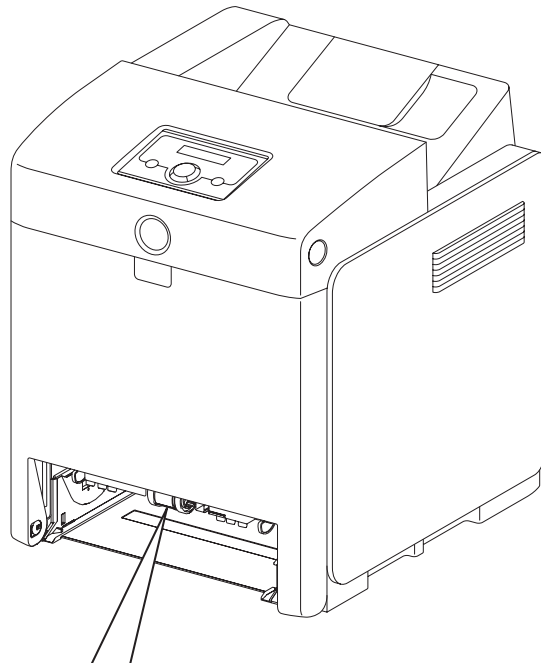

Kmy03116KB

- 1) Fit the MPF ROLLER to the SHAFT MSI with the groove of the MPF ROLLER facing upward.
- 2) Rotate the MPF ROLLER 180 degrees so that the pin on the SHAFT MSI is aligned with the groove on the MPF ROLLER.
- 3) Slide the MPF ROLLER to the right so that the MPF ROLLER covers the pin on the SHAFT MSI.
- 4) Slide the right ROLL CORE MSI to the left. Secure the hook on the ROLL CORE MSI into the groove on the SHAFT MSI.
- 5) Replace the 250 SHEET PAPER TRAY to the printer.

Replacement 7 SEPARATOR ROLLER (PL2.2.17) (Same as the FEED ROLLER)

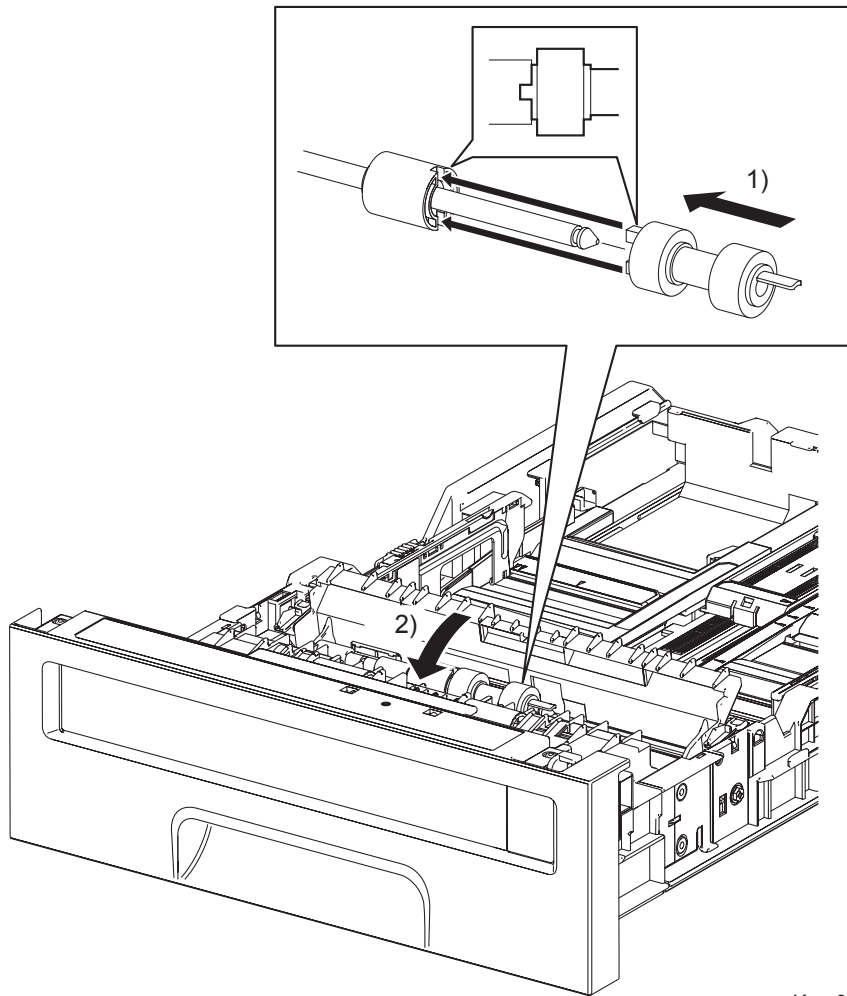

Kmy03115KA

- 1) Slide the SEPARATOR ROLLER onto the SHAFT RETARD so that the lug on the SEPARATOR ROLLER is mated with the notch on the CLUTCH FRICTION RET (PL2.2.16). Secure the hook on the other end of the SEPARATOR ROLLER into the groove on the SHAFT RETARD.
- 2) Close the CVR RTD CST.
- 3) Replace the 250 SHEET PAPER TRAY.

Replacement 8 MPF SEPARATOR ROLLER ASSEMBLY (PL2.1.3)

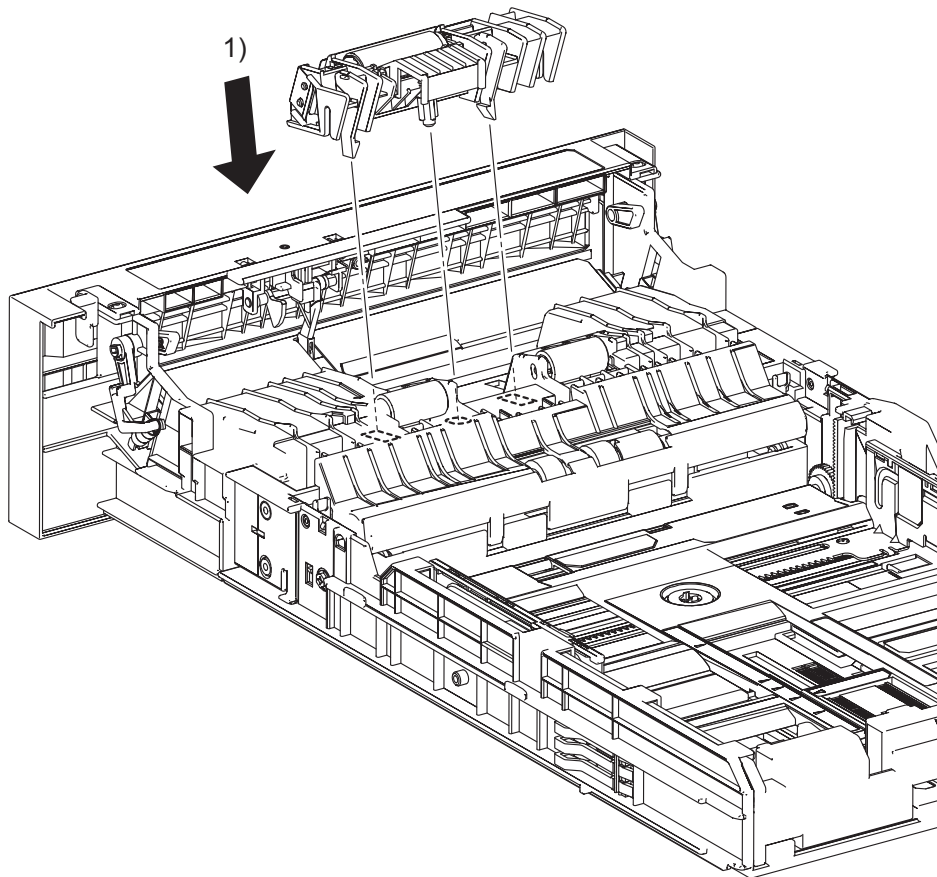

Kmy03114KA

- 1) Replace the MPF SEPARATOR ROLLER ASSEMBLY by mating the bosses of the MPF SEPARATOR ROLLER ASSEMBLY with the holes of the 250 SHEET PAPER TRAY. Secure the MPF SEPARATOR ROLLER ASSEMBLY with the two backside hooks.
- 2) Replace the 250 SHEET PAPER TRAY to the printer.

Replacement 9 TONER CARTRIDGE SENSOR ASSEMBLY (K) (PL5.1.4)

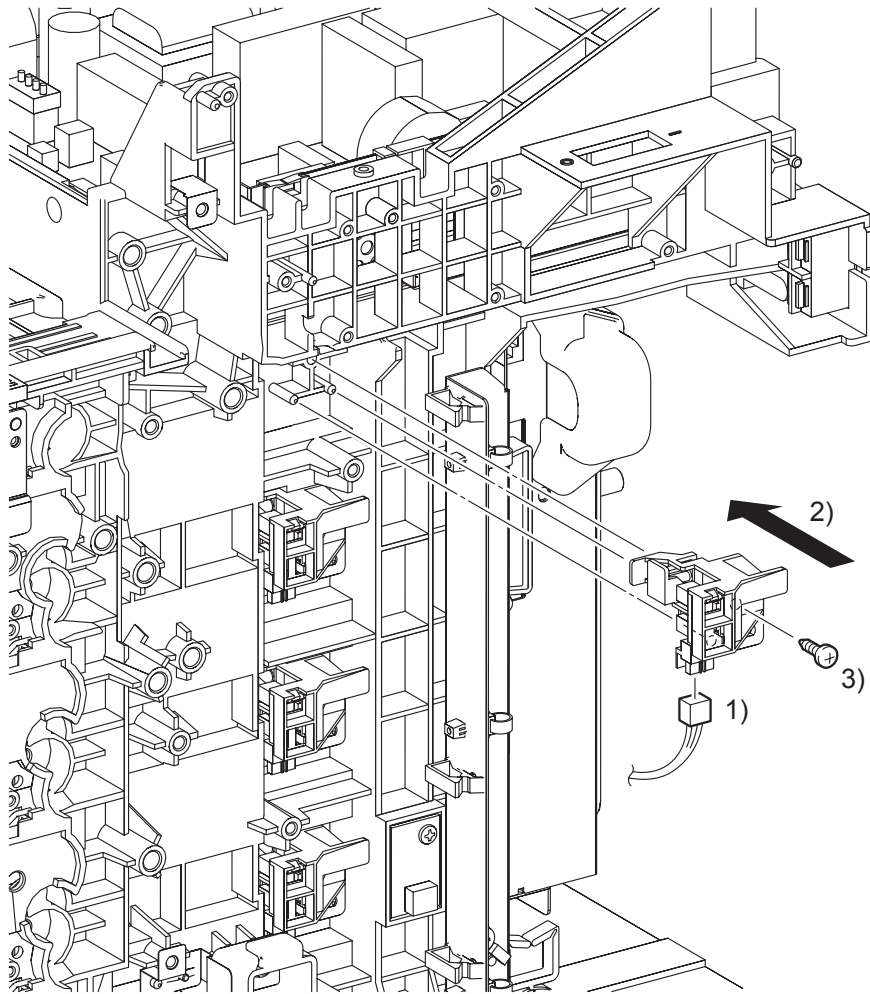

Kmy03113KA

- 1) Engage the connector (P/J193) of the TONER CARTRIDGE SENSOR ASSEMBLY (K).
- 2) Replace the TONER CARTRIDGE SENSOR ASSEMBLY (K) by mating the two holes on the TONER CARTRIDGE SENSOR ASSEMBLY (K) with the bosses on the printer,
- 3) Secure the TONER CARTRIDGE SENSOR ASSEMBLY (K) to the printer using the one screw (silver, tap, 10mm).

Go to the next replacement step:

Replacement 10 PHOTOCOnductor (PC) / DEVELOPER (DEV) DRIVE (PL8.1.2)

Blank Page

Replacement 10 PHOTOCONDUCTOR (PC) / DEVELOPER (DEV) DRIVE (PL8.1.2)

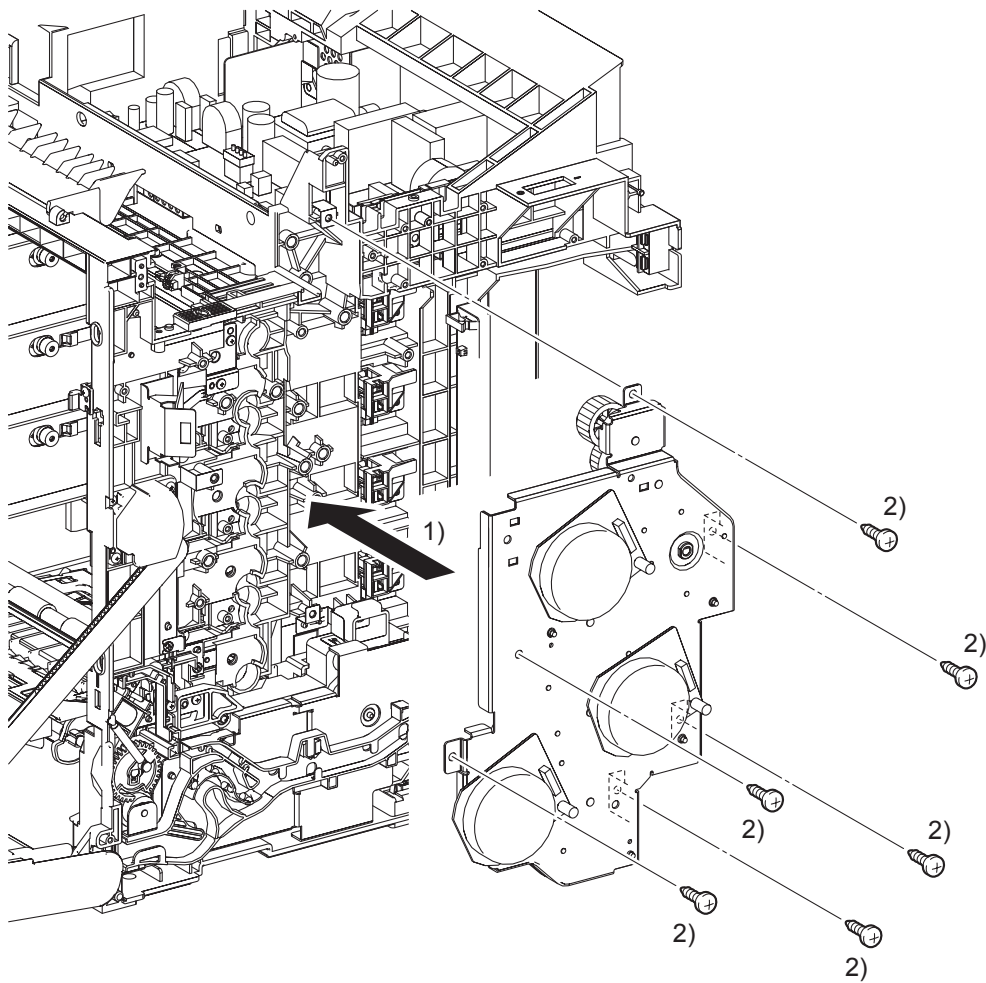

Kmy03111KB

- 1) Replace the PHOTOCONDUCTOR (PC) / DEVELOPER (DEV) DRIVE by aligning the gear of each drive of the PHOTOCONDUCTOR (PC) / DEVELOPER (DEV) DRIVE with the holes on the printer.
- 2) Secure the PHOTOCONDUCTOR (PC) / DEVELOPER (DEV) DRIVE to the printer using the six screws (silver, tap, 10mm).

Continues to the next page.

Replacement 10 PHOTOCONDUCTOR (PC) / DEVELOPER (DEV) DRIVE (PL8.1.2)

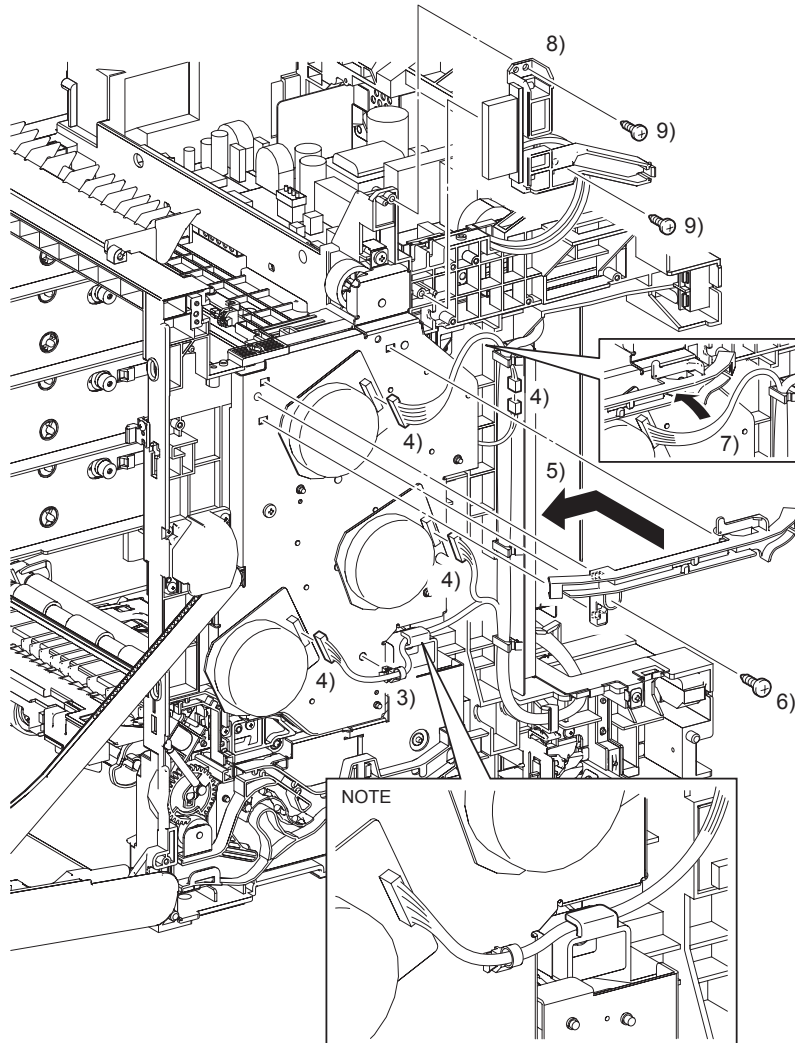

Kmy03112KB

NOTE

When performing the step described below, the harness of the connector to be engaged to the DEVE MOTOR must be routed through the hook above the FEED DRIVE ASSEMBLY (PL8.1.7).

- 3) Replace the clamp and harness together to the PHOTOCONDUCTOR (PC) / DEVELOPER (DEV) DRIVE.
- 4) Engage the connector (P/J211) of the MAIN MOTOR, the connector (P/J221) of the SUB MOTOR, the connector (P/J222) of the DEVE MOTOR, and the connector (P/J2761) of the EXIT CLUTCH in the PHOTOCONDUCTOR (PC) / DEVELOPER (DEV) DRIVE.
- 5) Replace the DUCT DRV MAIN by mating its three hooks into the holes on the PHOTOCONDUCTOR (PC) / DEVELOPER (DEV) DRIVE, and lock the bosses by sliding the DUCT DRV MAIN forward.
- 6) Replace the one remaining screw (silver, tap, 10mm) that fixes the PHOTOCONDUCTOR (PC) / DEVELOPER (DEV) DRIVE to the printer.
- 7) Route the harness of the PHOTOCONDUCTOR (PC) / DEVELOPER (DEV) DRIVE to the DUCT DRV MAIN.
- 8) Replace the BRACKET FUSER by mating its two holes with the bosses on the printer.
- 9) Secure the BRACKET FUSER using the two screws (silver, tap, 10mm).

**Go to the next replacement step:
Replacement 11 INTERLOCK SWITCH (PL9.1.3)**

Replacement 11 INTERLOCK SWITCH (PL9.1.3)

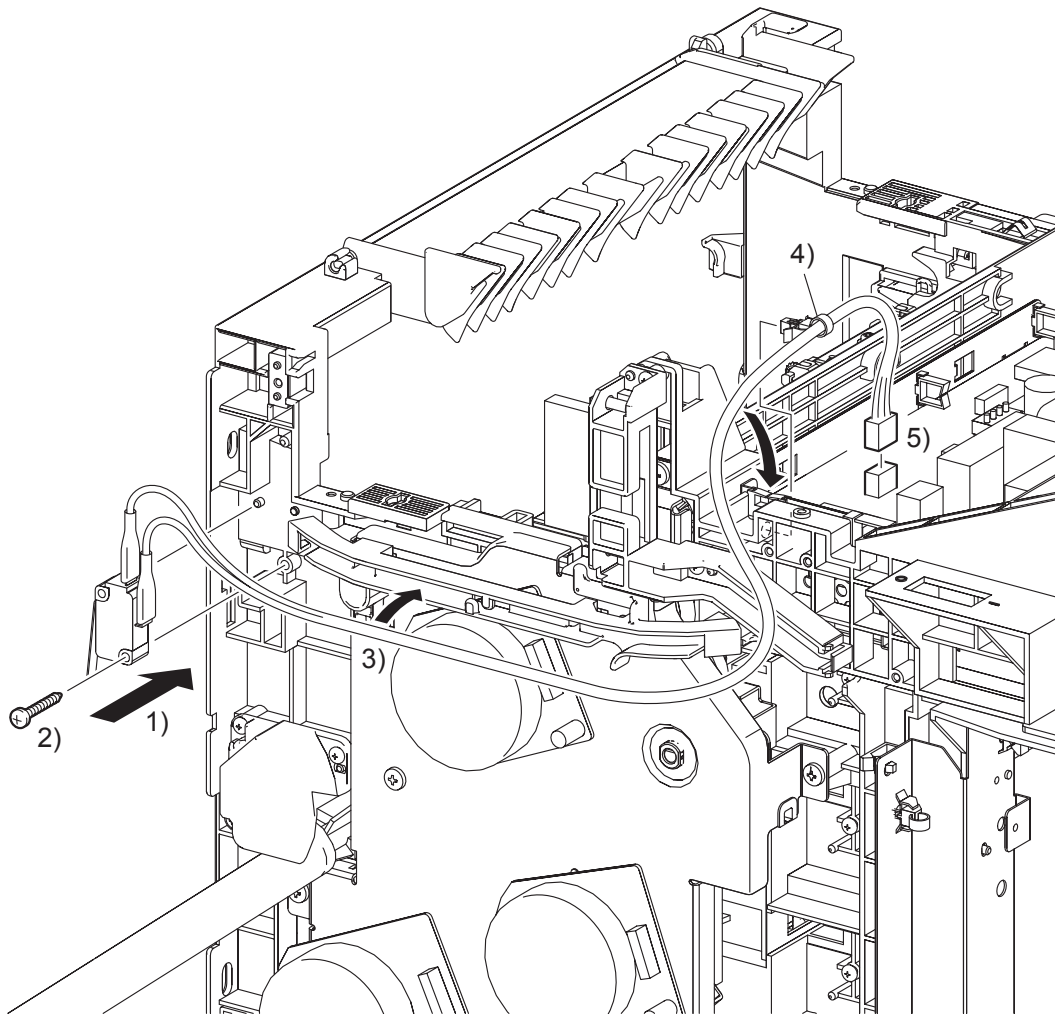

Kmy03110KA

- 1) Replace the INTERLOCK SWITCH by mating the hole on the INTERLOCK SWITCH with the boss on the printer.
- 2) Secure the INTERLOCK SWITCH to the printer using the one screw (silver, tap, 16mm).
- 3) Route the harness of the INTERLOCK SWITCH to the DUCT DRV MAIN.
- 4) Replace the clamp that fixes the harness of the INTERLOCK SWITCH to the SHIELD LVPS.
- 5) Engage the connector (P/J44) of the INTELOCK SWITCH to the LOW VOLTAGE POWER SUPPLY.

Go to the next replacement step:

Replacement 16 TOP COVER (PL1.1.1)

Blank Page

Replacement 12 PRINT HEAD (PL5.1.99)

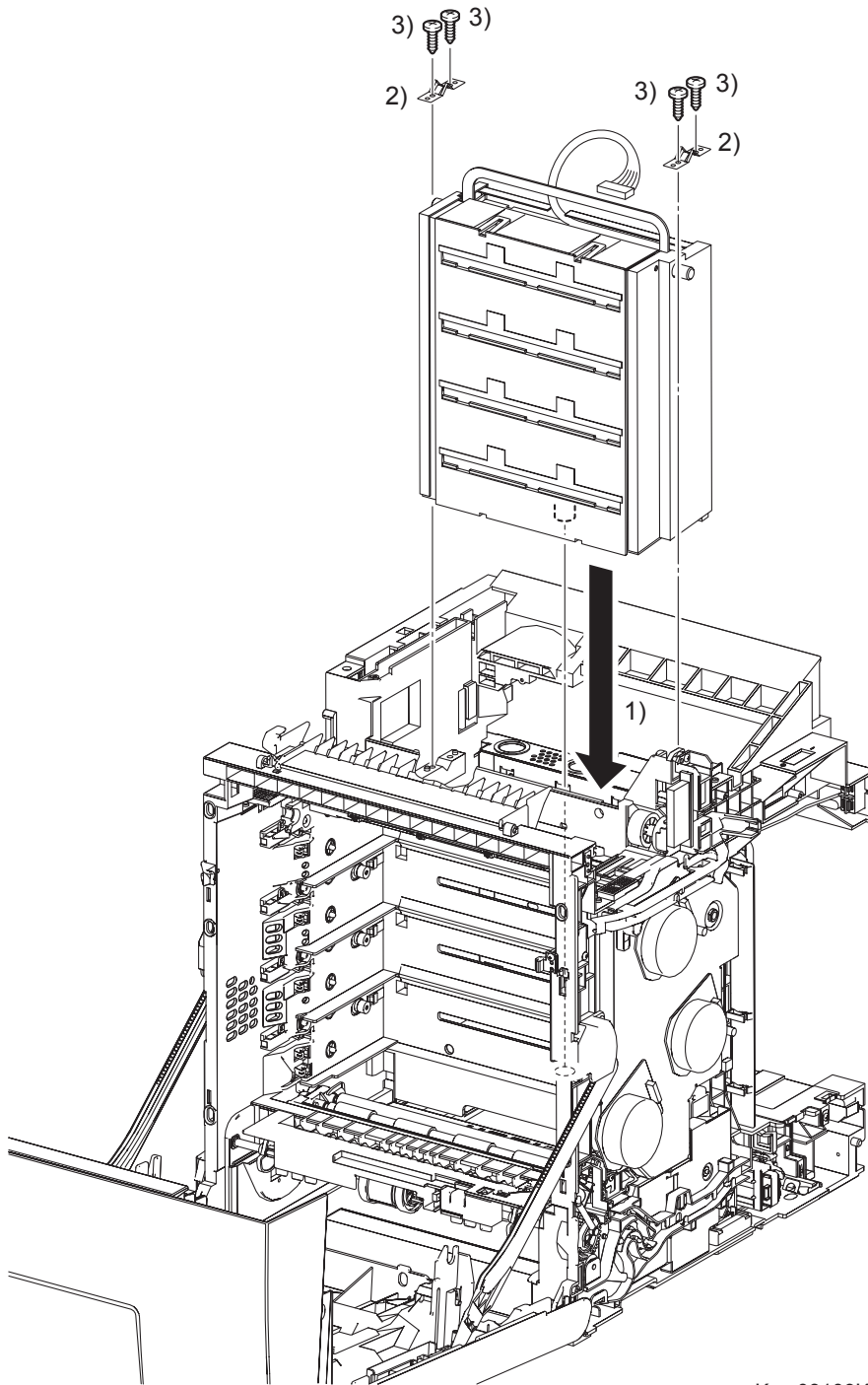

Kmy03109KB

- 1) Insert the PRINT HEAD by mating the backside boss of the PRINT HEAD with the hole on the printer.
- 2) Place the two SPRING ROSs onto the left and right side bosses on the PRINT HEAD so that the holes of SPRING ROSs are mated with the bosses on the printer.
- 3) Secure the SPRING ROSs to the printer using the four screws (silver, tap, 10mm).

Continues to the next page.

Replacement 12 PRINT HEAD (PL5.1.99)

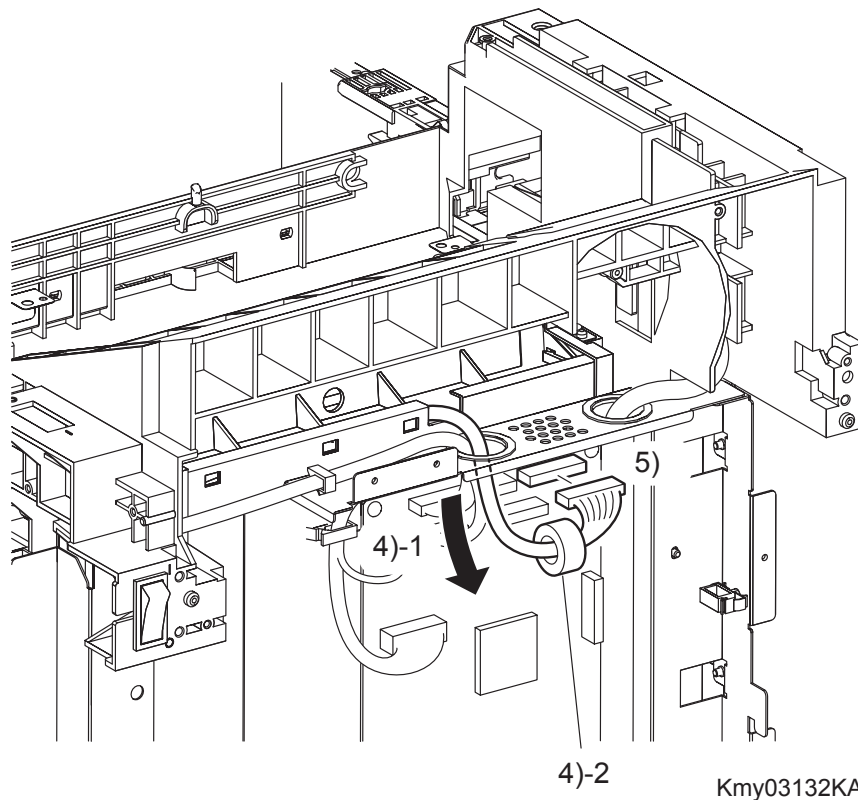

- 4) Pass the connector of the PRINT HEAD through the hole on the SHIELD MCU, and then replace the CORE to the harness of the PRINT HEAD.
- 5) Engage the connector (P/J12) of the PRINT HEAD with the connector on the MACHINE CONTROL UNIT.

Go to the next replacement step:

Replacement 13 LOW VOLTAGE POWER SUPPLY (PL9.1.4)

Replacement 13 LOW VOLTAGE POWER SUPPLY (PL9.1.4)

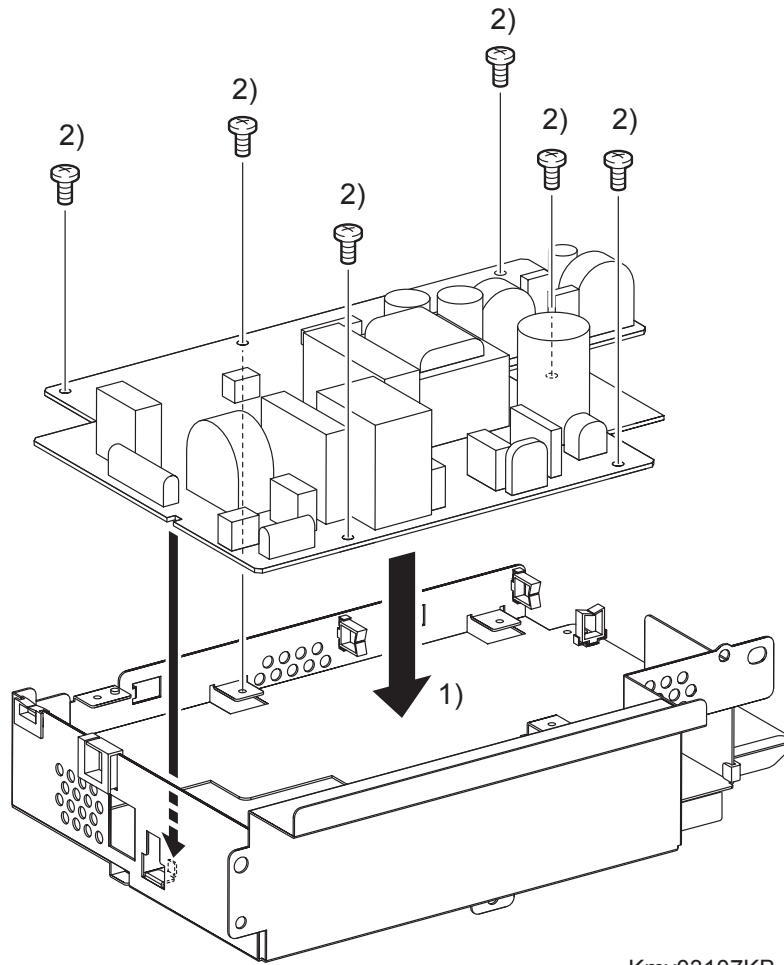

Kmy03107KB

- 1) Replace LOW VOLTAGE POWER SUPPLY to the SHIELD LVPS by mating the notch on the LOW VOLTAGE POWER SUPPLY with the tab on the SHIELD LVPS.
- 2) Secure the LOW VOLTAGE POWE SUPPLY to the SHIELD LVPS using the six screws (silver, 6mm).

Continues to the next page.

Replacement 13 LOW VOLTAGE POWER SUPPLY (PL9.1.4)

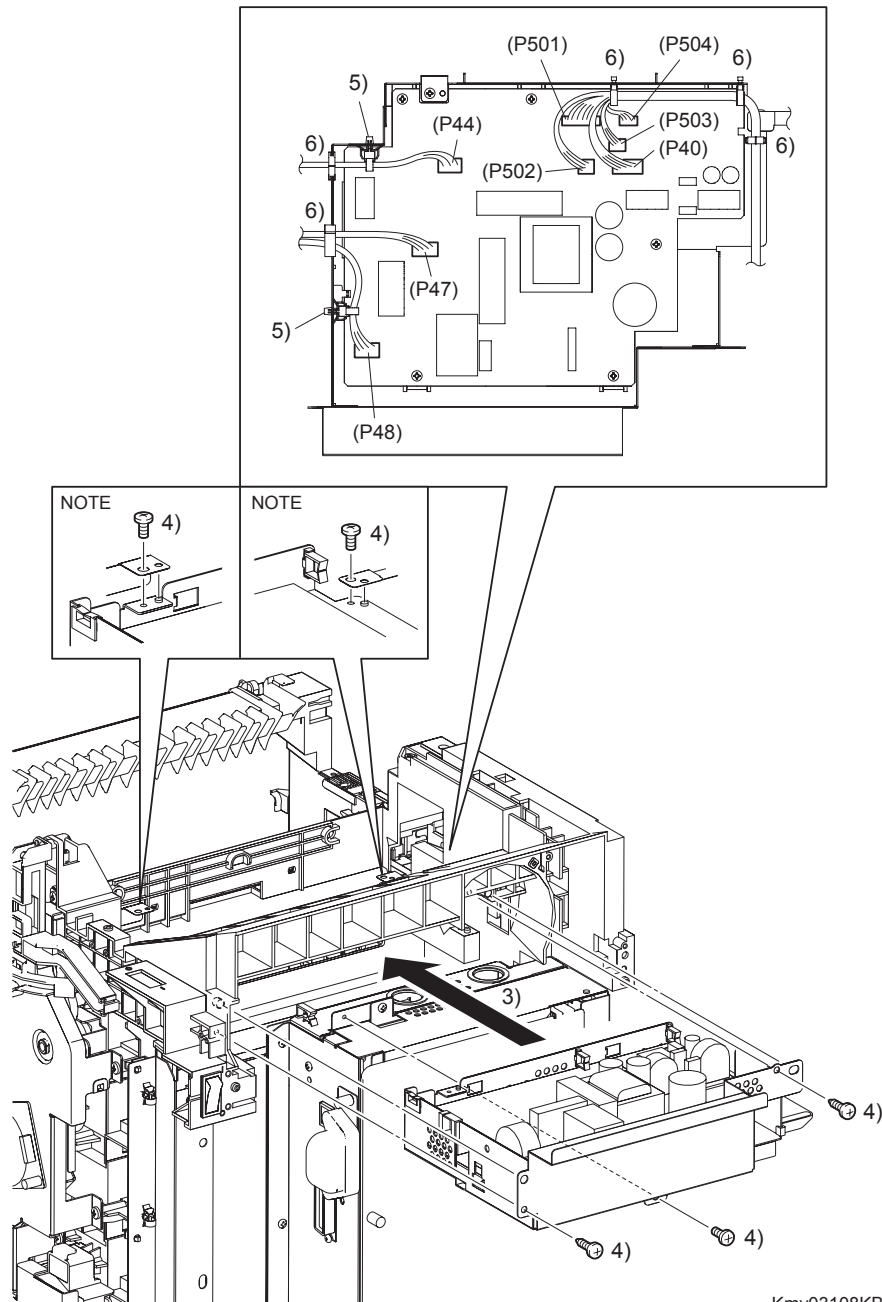

Kmy03108KB

- 3) Replace the SHIELD LVPS and LOW VOLTAGE POWER SUPPLY to the printer by mating the two holes on the SHIELD LVPS with the bosses on the printer.

NOTE

When securing the two positions shown in the figure, make sure that the SHIELD LVPS is under the PLATE EARTH.

- 4) Secure the SHIELD LVPS to the printer using the two screws (silver, tap, 10mm) and the three screws (silver, 6mm).
- 5) Replace the clamps that fix the harness of the INTERLOCK SWITCH and HARN ASSY INLET to the SHIELD LVPS.
- 6) Engage all the connectors of the LOW VOLTAGE POWER SUPPLY, and then secure the harness with the clamps.

**Go to the next replacement step:
Replacement 15 FAN (PL9.1.10)**

Replacement 14 HIGH VOLTAGE POWER SUPPLY (PL5.1.17)

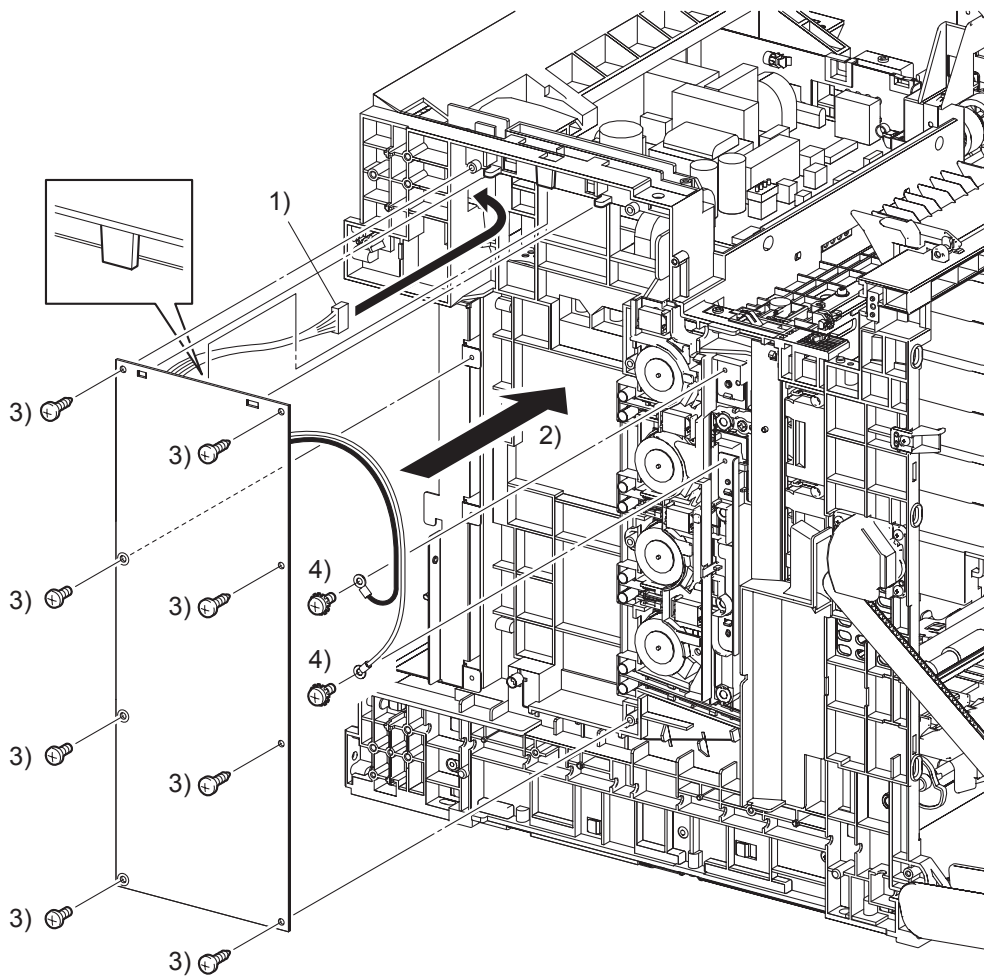

Kmy03105KA

- 1) Pass the connector of the HIGH VOLTAGE POWER SUPPLY through the hole of the printer.
- 2) Replace the HIGH VOLTAGE POWER SUPPLY by mating the two holes on the upper part of the HIGH VOLTAGE POWER SUPPLY with the bosses on the printer and inserting the upper part of the HIGH VOLTAGE POWER SUPPLY into the backside tab on the printer.

NOTE

In the step described below, out of the screw fixing positions of the HIGH VOLTAGE POWER SUPPLY, the three screw fixing positions with white bearing surfaces must be fixed with the 6mm silver screws.

- 3) Secure the HIGH VOLTAGE POWER SUPPLY with the five screws (silver, tap, 10mm) and the three screws (silver, 6mm).

NOTE

When performing the step described below, secure the red harness on the upper side and secure the white harness on the lower side.

- 4) Secure the two harnesses of the HIGH VOLTAGE POWER SUPPLY using the two screws (silver, with washer, 6mm).

Continues to the next page.

Replacement 14 HIGH VOLTAGE POWER SUPPLY (PL5.1.17)

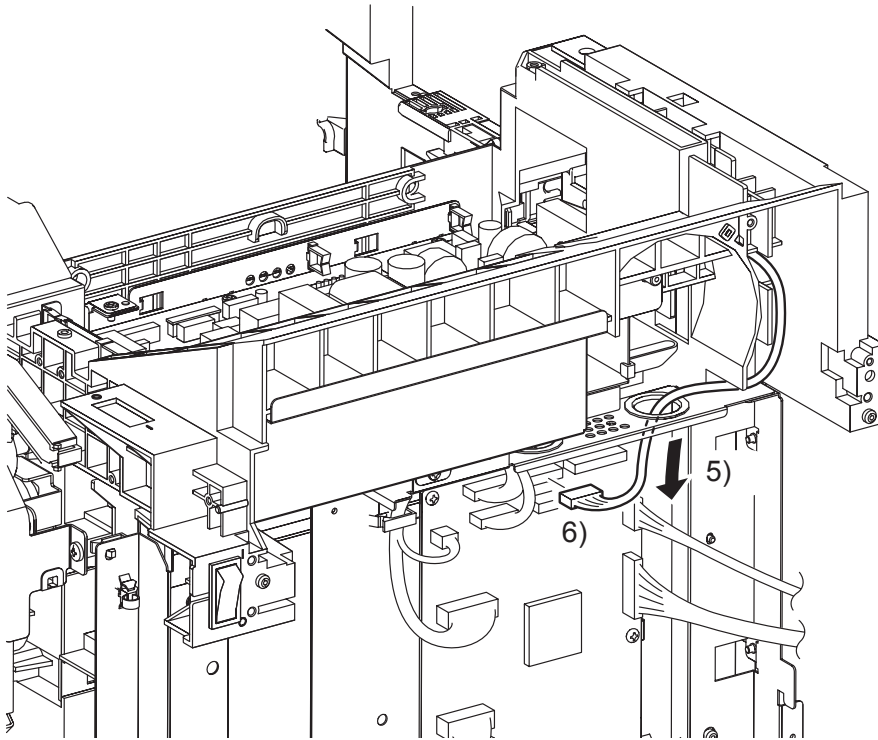

Kmy03106KB

- 5) Route the harness of the HIGH VOLTAGE POWER SUPPLY to the printer and pass the connector into the hole on the SHIELD MCU.
- 6) Engage the connector (J16) of the HIGH VOLTAGE POWER SUPPLY to the connector (P16) of the MACHINE CONTROL UNIT.

**Go to the next replacement step:
Replacement 15 FAN (PL9.1.10)**

Replacement 15 FAN (PL9.1.10)

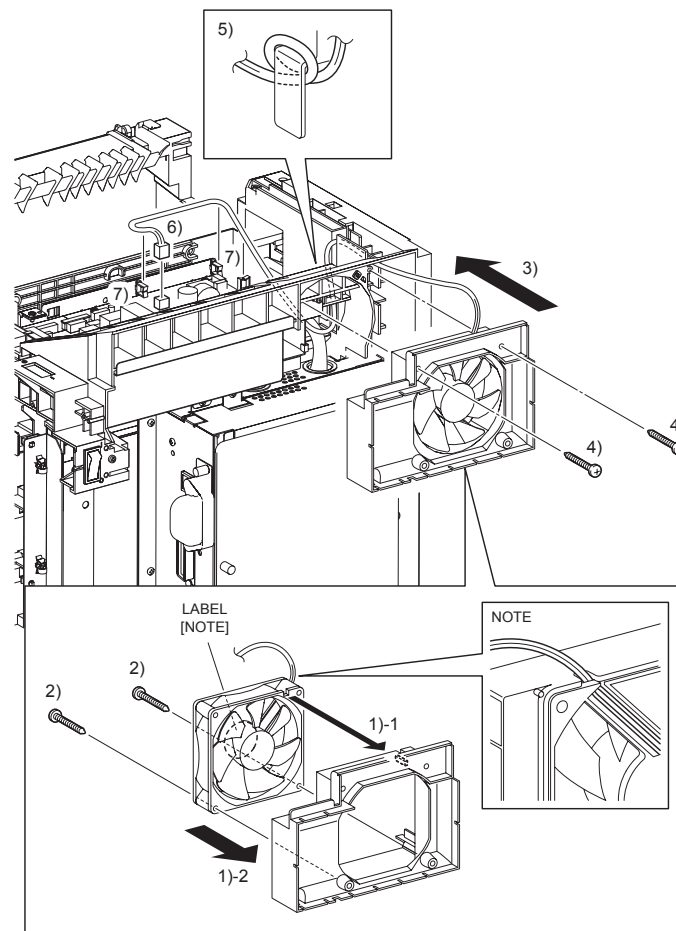

Kmy03104KD

NOTE

When performing the step described below, take care to check the orientation of the FAN. (Attach the FAN so that its labeled surface faces front.)

NOTE

When performing the step described below, route the harness of the FAN through the notch of the DUCT FAN MAIN.

- 1) Mate the notch of the FAN with the rib of the DUCT FAN MAIN and attach the FAN to the DUCT FAN MAIN.
- 2) Secure the FAN to the DUCT FAN MAIN using the two screws (silver, tap, 35mm)
- 3) Route the harness of the FAN into the printer, and replace the DUCT FAN MAIN and FAN together to the printer.
- 4) Secure the DUCT FAN MAIN and FAN together to the printer using the two screws (silver, tap, 35mm).
- 5) Adjust the length of the harness by winding the harness of the FAN to the hook of the printer, and route the harness along the printer.
- 6) Engage the connector (P/J503) of the FAN to the LOW VOLTAGE POWER SUPPLY.
- 7) Secure the harness of the FAN with the clamp.

**Go to the next replacement step:
Replacement 16 TOP COVER (PL1.1.1)**

Replacement 16 TOP COVER (PL1.1.1)

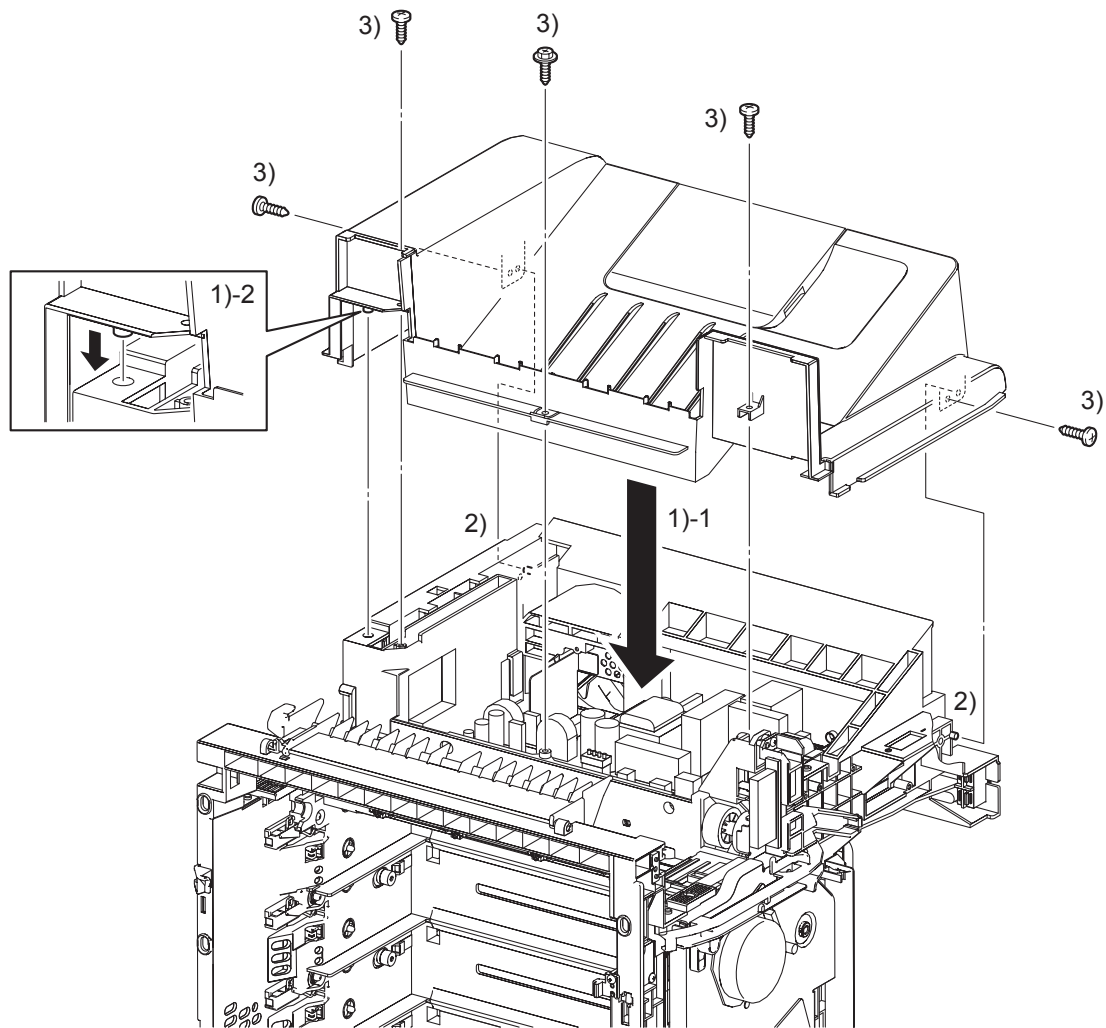

Kmy03103KC

- 1) Mate the left side boss of the TOP COVER with the hole of the printer, set the TOP COVER to the printer.
- 2) Mate the holes of the TOP COVER with the left and right bosses of the printer, attach the TOP COVER.
- 3) Fix the TOP COVER to the printer with the four screws (silver, tap, 10mm) and the one screw (silver, with flange, 10mm).

Go to the next replacement step:

Replacement 24 LEFT COVER (PL1.1.7)

Replacement 17 MACHINE CONTROL UNIT (PL9.1.20)

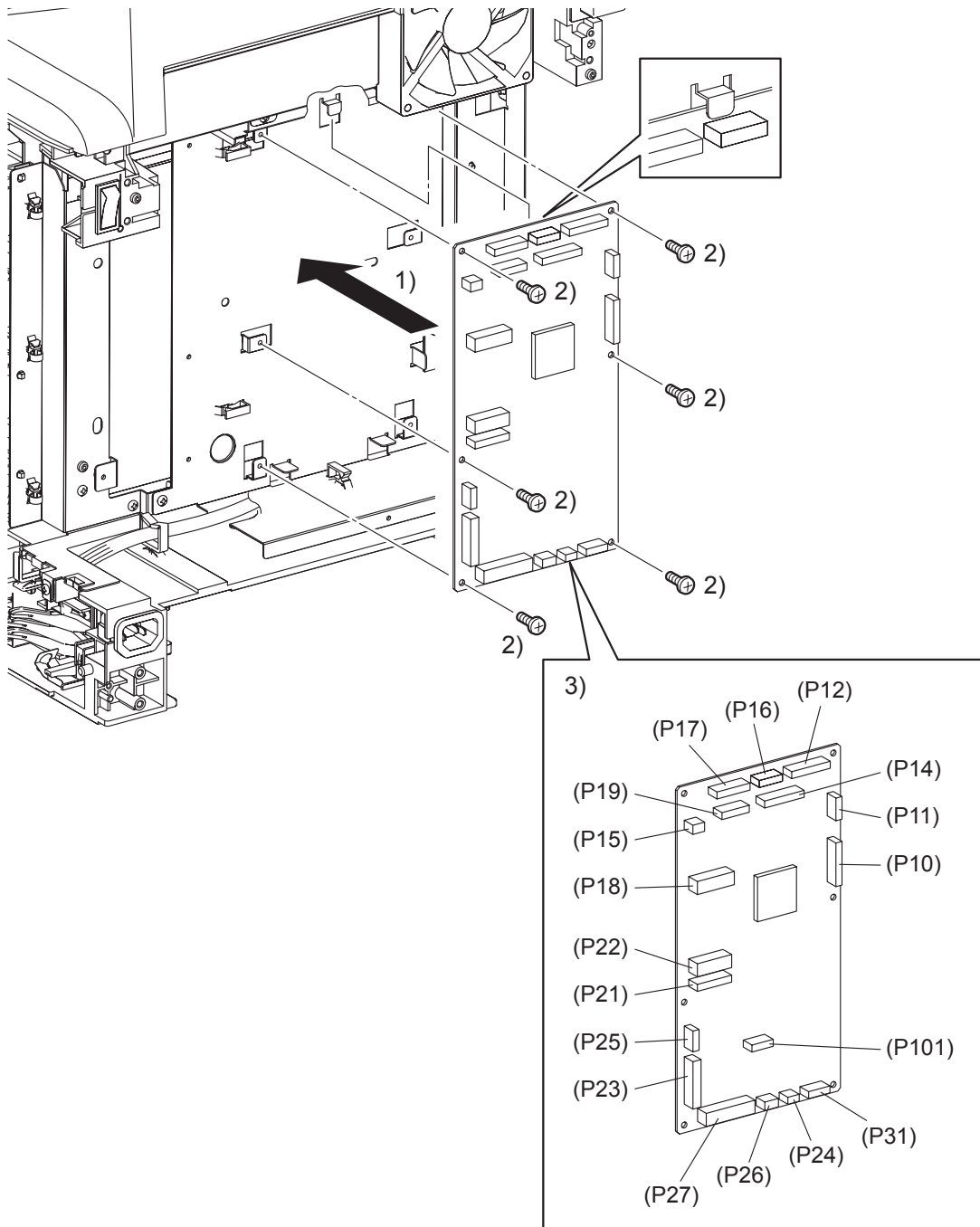

Kmy03102KA

- 1) Replace the MACHINE CONTROL UNIT to the printer.
- 2) Secure the MACHINE CONTROL UNIT using the six screws (silver, 6mm).
- 3) Engage all the connectors of the MACHINE CONTROL UNIT.

Continues to the next page.

Replacement 17 MACHINE CONTROL UNIT (PL9.1.20)

NOTE

When the MACHINE CONTROL UNIT is replaced with a new one, perform the following steps. (After completing all the steps up to Replacement 47.)

- 4) Plug in the power cord to the outlet, and power on the printer.
- 5) Perform the diagnostic operation of NVM Load, and write the data into MCU.
- 6) Turn on the power while pressing the ► key, the ◀ key and the [MENU] key on the control panel.
- 7) Enter the password, push the ▲ key twice and push the ✓ key once. The diagnostic screen comes up.
- 8) Press the ▼ key several times until “IOT Diag” is displayed. Press the ✓ key once.
- 9) Press the ▼ key several times until “NVM Settings” is displayed. Press the ✓ key once.
- 10) Press the ▼ key several times until “NVM Load” is displayed. Press the ✓ key once.
- 11) Press the ✓ key twice, and NVM Load is performed.
- 12) After the NVM Load is complete, press the [CANCEL] key several times until “IOT Diag” is displayed.
- 13) Press the ▼ key several times until “Complete” is displayed.
- 14) Press the ✓ key three times, and “Ready to Print” is displayed.

Go to the next replacement step:

Replacement 19 SHIELD ASSY ESS (REFERENCE ONLY)

Replacement 18 HUMIDITY SENSOR (PL9.1.19)

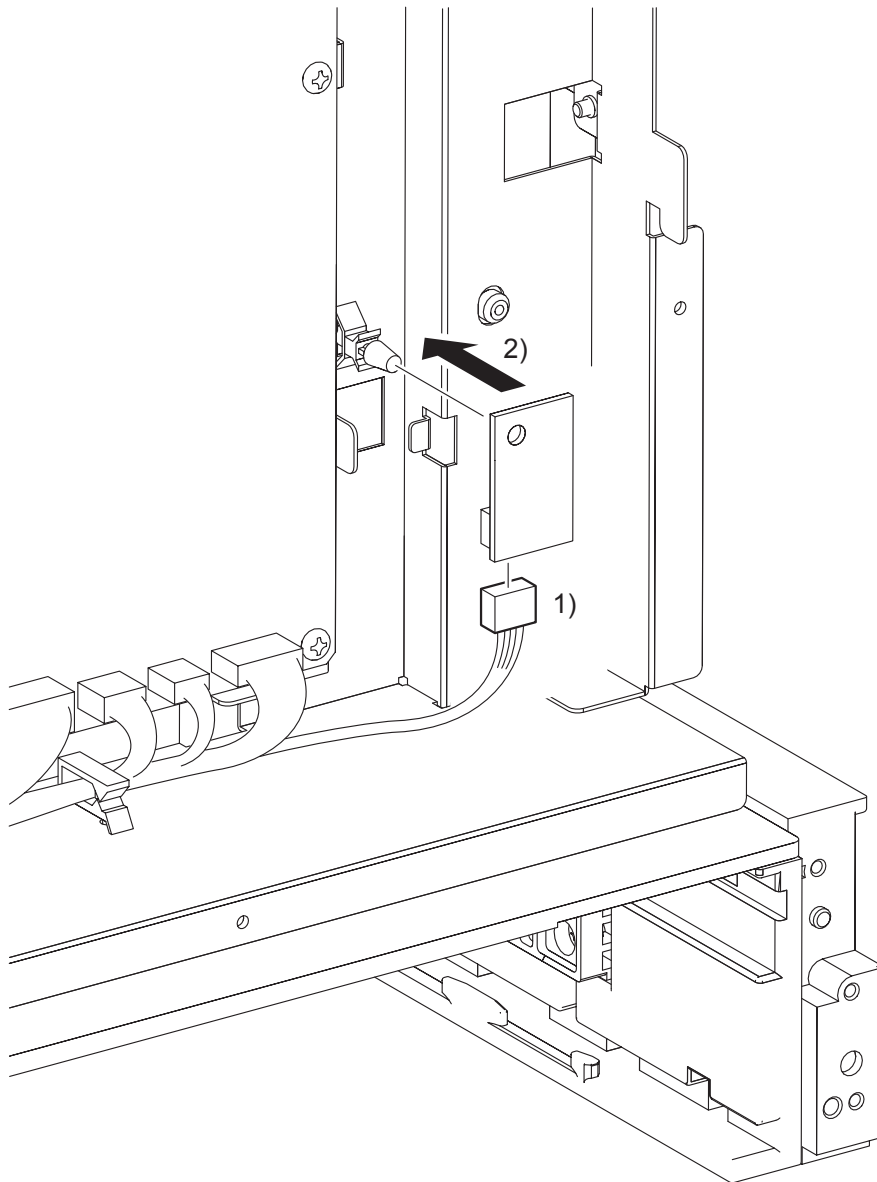

Kmy03101KA

- 1) Engage the connector (P/J261) of the HUMIDITY SENSOR.
- 2) Replace the HUMIDITY SENSOR to the printer, and secure with the hook of the SPACER.

Go to the next replacement step:

Replacement 19 SHIELD ASSY ESS (REFERENCE ONLY)

Replacement 19 SHIELD ASSY ESS (REFERENCE ONLY)

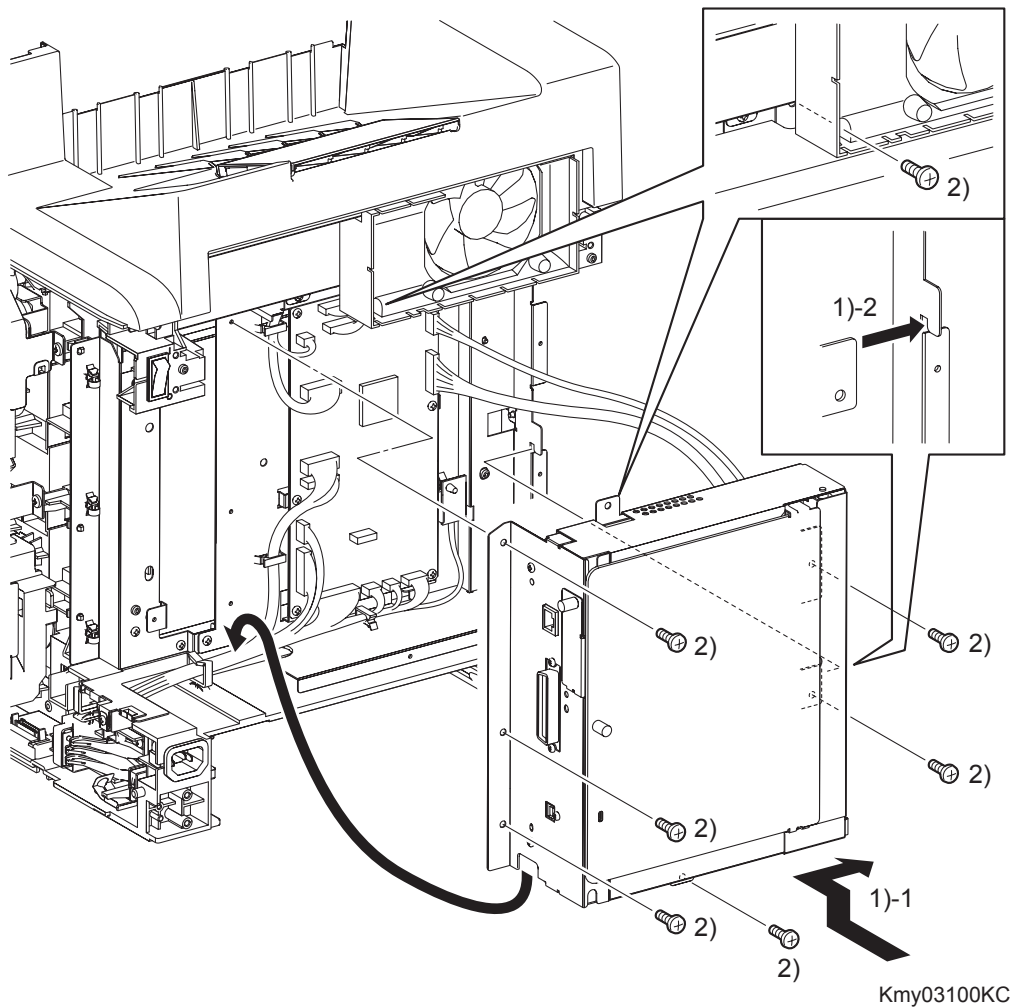

NOTE

When performing the step described below, ensure that the harness will not be caught between the printer and the SHIELD ASSY ESS.

- 1) Replace the SHIELD ASSY ESS by mating the tab of the SHIELD ASSY ESS with the notch on the printer.
- 2) Secure the SHIELD ASSY ESS to the printer using the seven screws (silver, 6mm).

**Go to the next replacement step:
Replacement 24 LEFT COVER (PL1.1.7)**

Replacement 20 TONER DISPENSER MOTOR (PL5.1.12)

NOTE

Described below is the replacement procedure common among TONER DISPENSER MOTORS (C), (M), (Y), and (K).

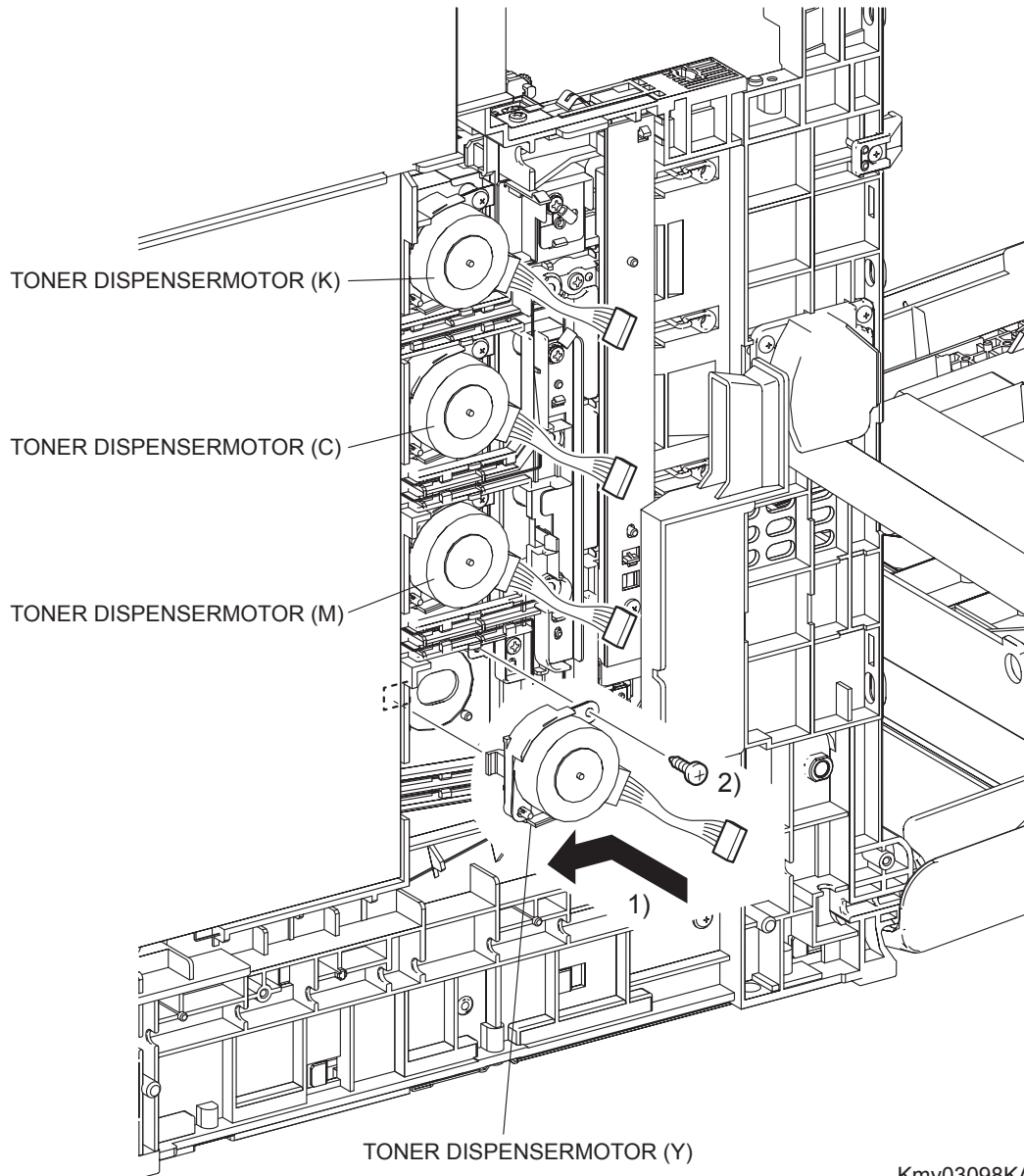

Kmy03098KA

- 1) Replace the TONER DISPENSER MOTOR to the printer by mating the tab of the TONER DISPENSER MOTOR with the hole on the printer and moving it slightly backward.
- 2) Secure the TONER DISPENSER MOTOR to the printer using the one screw (silver, tap, 10mm).

Continues to the next page.

Replacement 20 TONER DISPENSER MOTOR (PL5.1.12)

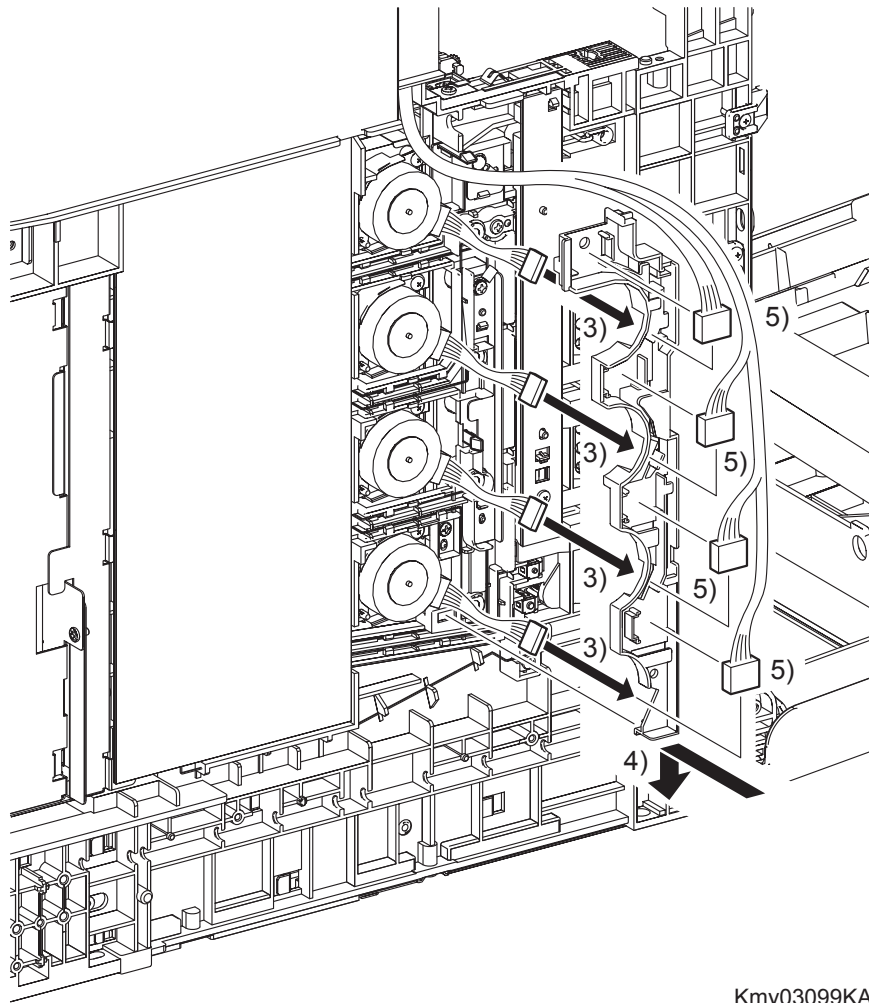

- 3) Pass the four sets of connectors of the TONER DISPENSER MOTOR through the hole of the DUCT HARNESS MOT.
- 4) Mate the tab of the DUCT HARNESS MOT with the hole on the printer, and secure the DUCT HARNESS MOT with the two hooks on the printer.
- 5) Engage the four sets of connectors of the TONER DISPENSER MOTOR and route the harness along the DUCT HARNESS MOT.

**Go to the next replacement step:
Replacement 24 LEFT COVER (PL1.1.7)**

Replacement 21 LED ASSEMBLY (PL5.1.15)

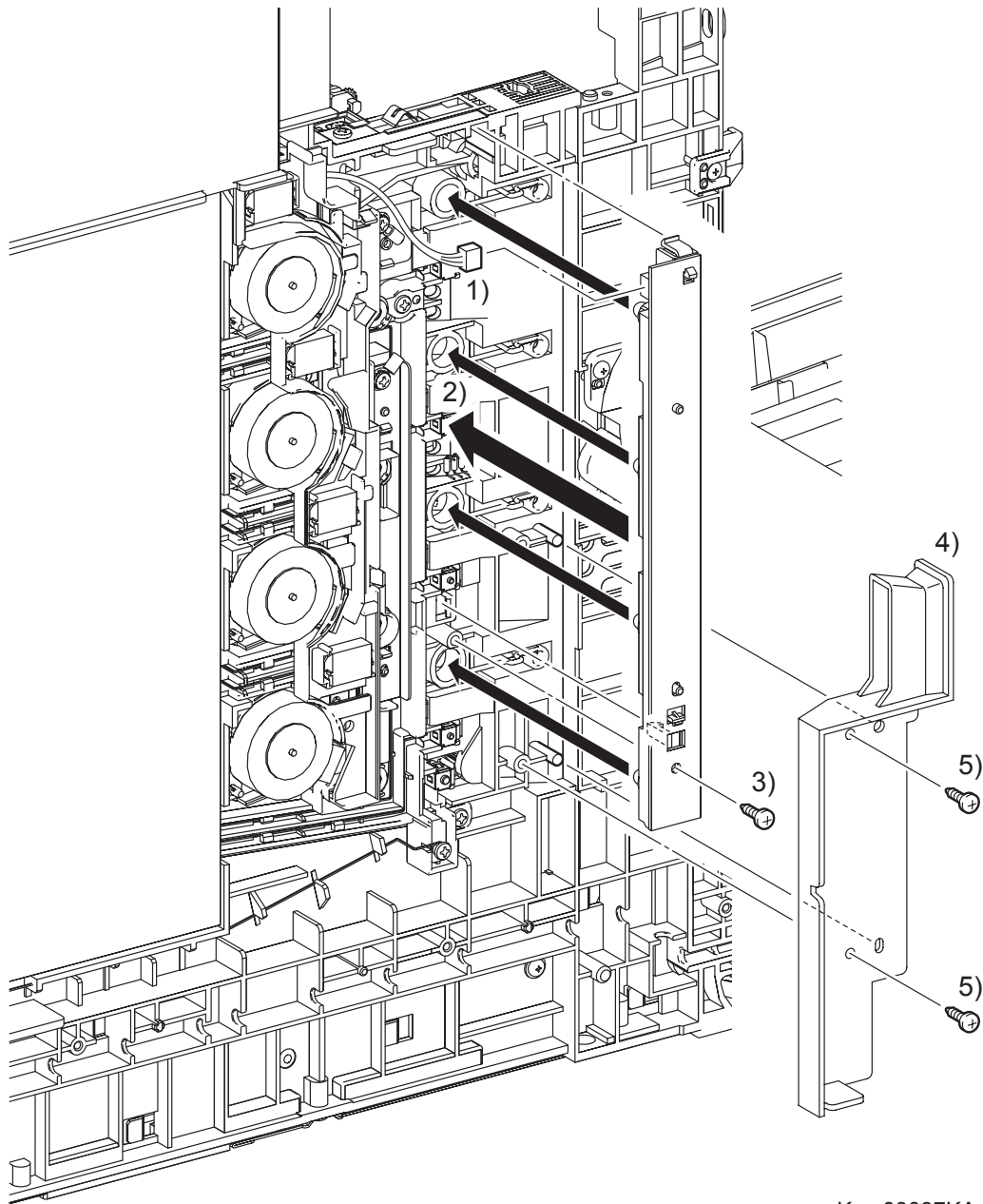

Kmy03097KA

- 1) Engage the connector (P/J141) of the LED ASSEMBLY.
- 2) Mate the four LEDs on the LED ASSEMBLY with the holes on the printer, and then secure the LED ASSEMBLY at the two hooks.
- 3) Fix the LED ASSEMBLY to the printer using the one screw (silver, tap, 10mm).
- 4) Replace the DUCT SIDE L by mating the two holes on the DUCT SIDE L with the bosses on the printer.
- 5) Secure the DUCT SIDE L to the printer using the two screws (silver, tap, 8mm).

Go to the next replacement step:

Replacement 24 LEFT COVER (PL1.1.7)

Blank Page

Replacement 22 LEFT ARM ASSEMBLY(PL7.1.97)

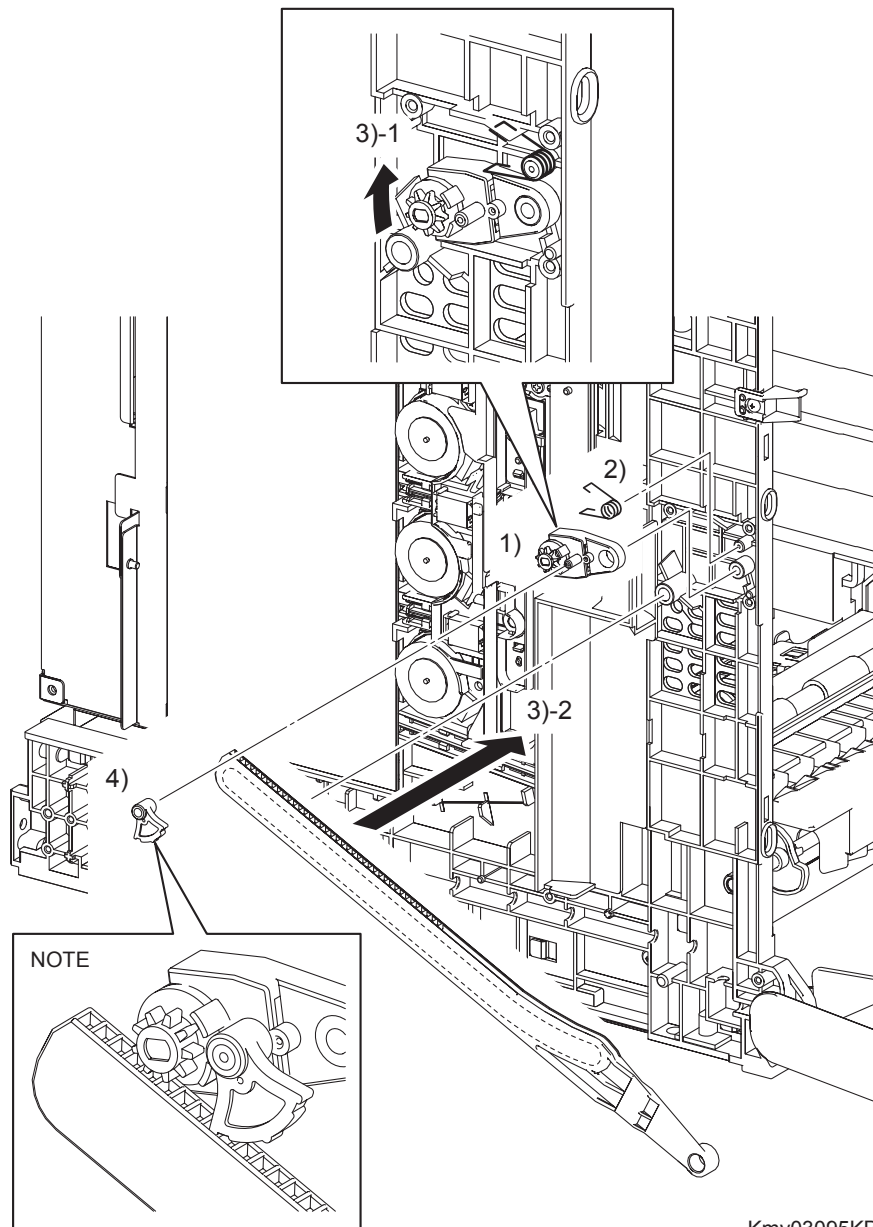

Kmy03095KB

- 1) Replace the HOLDER DAMPER to the printer together with the DAMPER OIL.
- 2) Replace the SPRING SUPPORT to the printer
- 3) Replace the LINK L by mating the backside groove on the LINK L with the boss on the printer and pulling the DAMPER OIL slightly upward.

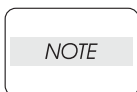

When performing the step described below, pay attention to the orientation of the LEVER RELEASE. Ensure that the longer hollow boss of the LEVER RELEASE faces the HOLDER DAMPER.

- 4) Replace the LEVER RELEASE to the HOLDER DAMPER.

Continues to the next page.

Replacement 22 LEFT ARM ASSEMBLY(PL7.1.97)

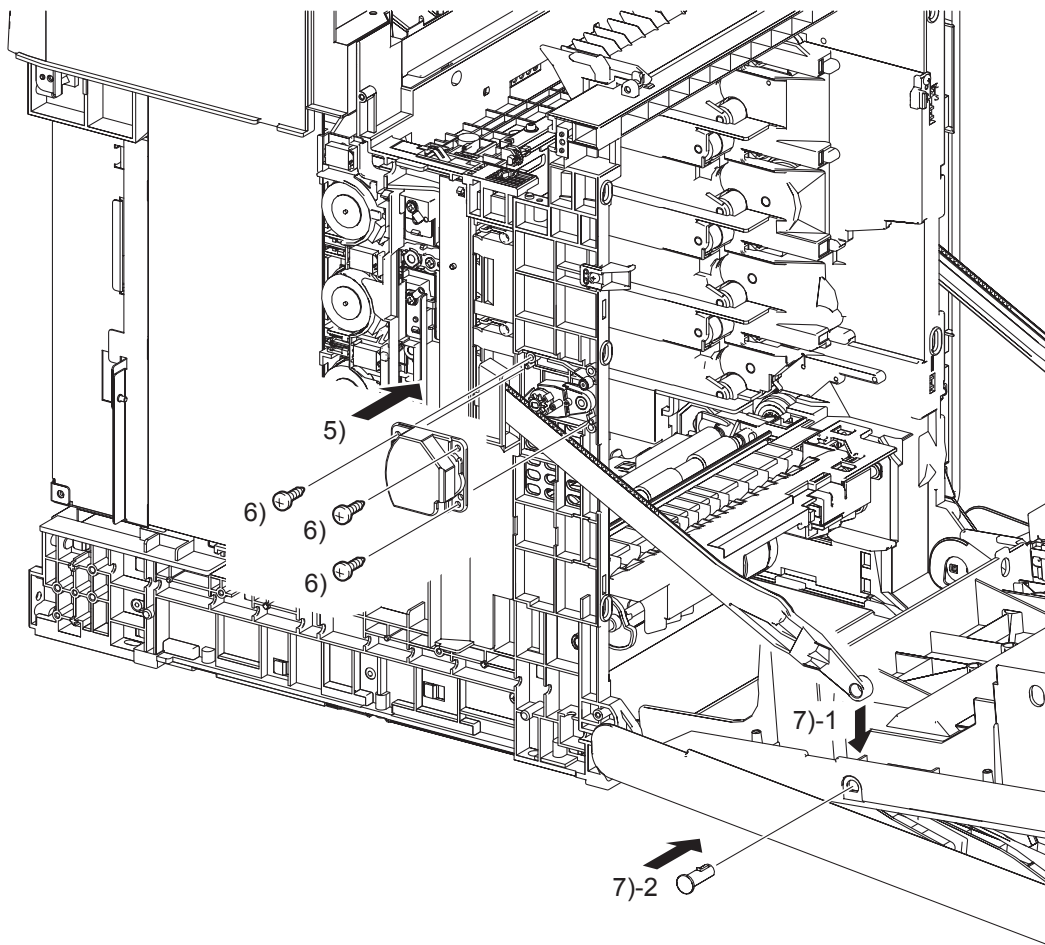

Kmy03096KB

- 5) Replace the SUPPORT LINK L by mating the two holes of the SUPPORT LINK L with the bosses on the printer.
- 6) Secure the SUPPORT LINK L using the three screws (silver, tap, 8mm).
- 7) Mate the fitting hole on the LINK L with the left side fitting hole on the FRONT COVER. Insert the SHAFT PIVOT and secure with the hook.

Go to the next replacement step:

Replacement 24 LEFT COVER (PL1.1.7)

Replacement 23 ELECTRONIC SUB-SYSTEM CONTROL BOARD (PL9.1.27)

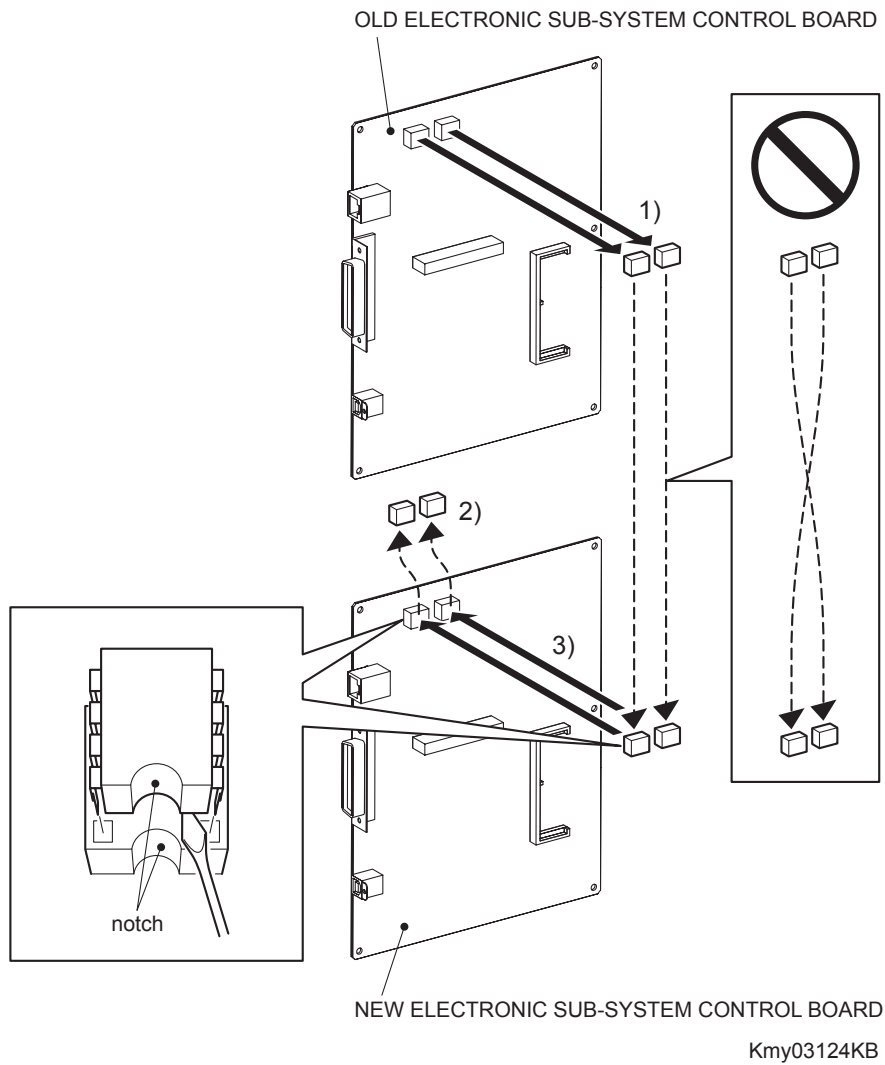

Continues to the next page.

Replacement 23 ELECTRONIC SUB-SYSTEM CONTROL BOARD (PL9.1.27)

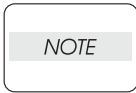

When the ELECTRONIC SUB-SYSTEM CONTROL BOARD is replaced with a new one, the replacement steps 1) to 3) are required. These steps are not required when no replacement is performed.

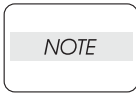

There are two NVM ROMs on the PWB. Do not confuse their fitting positions.

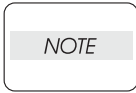

Do not press the PWB when removing the NVM ROM.

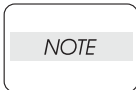

Take care not to bend the terminal section of NVM when performing the step described below.

- 1) Remove the NVM, using a miniature screwdriver or the like, from the IC socket on the old ELECTRONIC SUB-SYSTEM CONTROL BOARD that was removed from the printer.
- 2) Remove the NVM from the IC socket on the new ELECTRONIC SUB-SYSTEM CONTROL BOARD using a miniature screwdriver or the like.

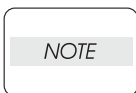

Do not use the NVM removed from the new ELECTRONIC SUB-SYSTEM CONTROL BOARD.

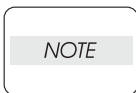

Ensure that the orientation of the NVM is correct when performing the following step.

- 3) Install the NVM that was removed from old ELECTRONIC SUB-SYSTEM CONTROL BOARD on the IC socket of the new ELECTRONIC SUB-SYSTEM CONTROL BOARD with its notch aligned with the notch in the IC socket.

Continues to the next page.

Replacement 23 ELECTRONIC SUB-SYSTEM CONTROL BOARD (PL9.1.27)

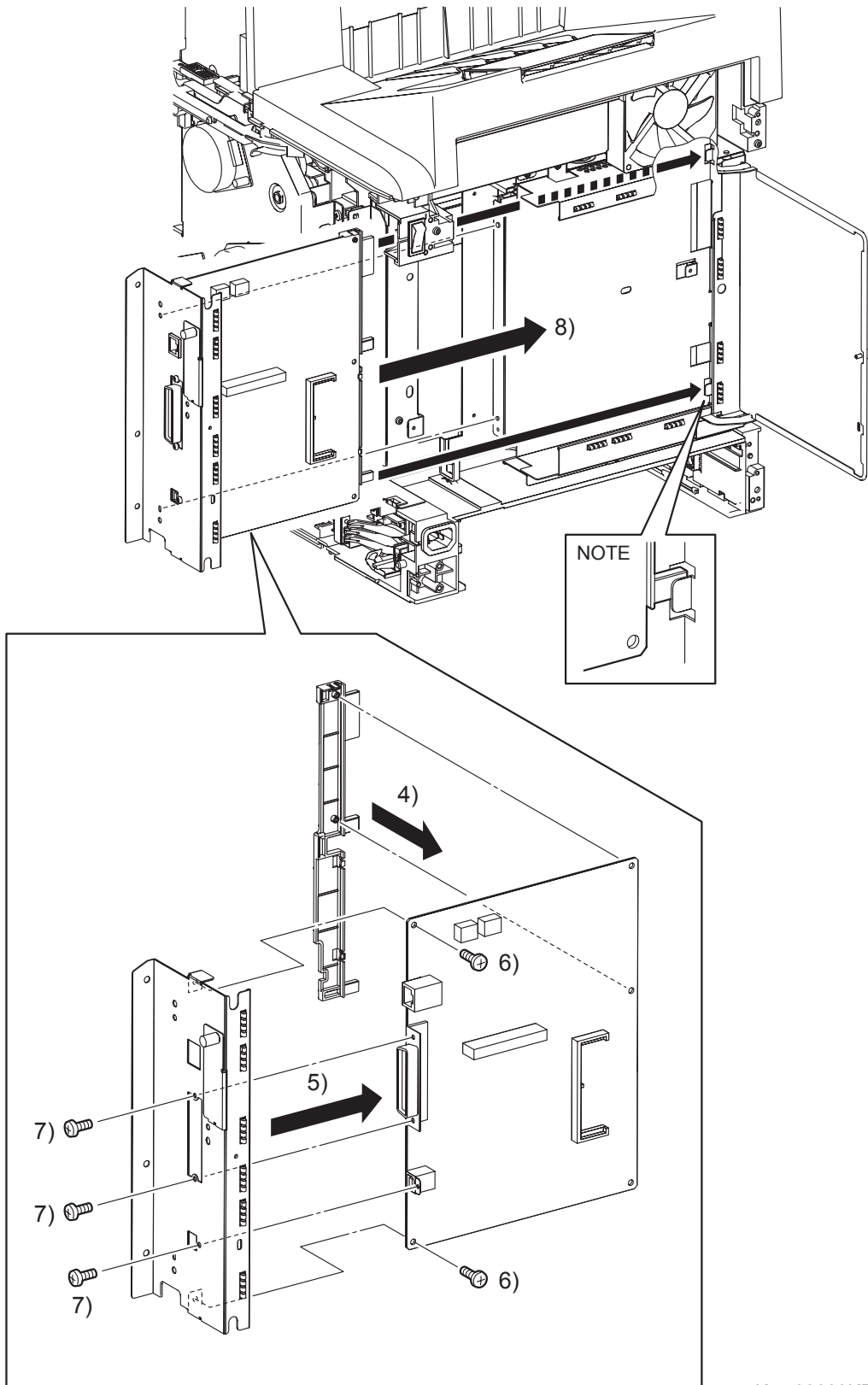

Kmy03093KB

Continues to the next page.

Replacement 23 ELECTRONIC SUB-SYSTEM CONTROL BOARD (PL9.1.27)

- 4) Mate the boss of the GUIDE ESS with the hole of the ELECTRONIC SUB-SYSTEM CONTROL BOARD and secure with the two hooks
- 5) Replace the SHIELD ASSY IF to the ELECTRONIC SUB-SYSTEM CONTROL BOARD.
- 6) Secure the ELECTRONIC SUB-SYSTEM CONTROL BOARD to the SHIELD ASSY IF using the two screws (silver,6mm).
- 7) Secure the SHIELD ASSY IF to the connectors of the ELECTRONIC SUB-SYSTEM CONTROL BOARD with the screws.

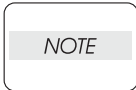

When performing the step described below, ensure that the three tabs of the GUIDE ESS are inserted into the catches on the SHIELD ASSY ESS.

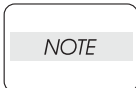

When performing the step described below, ensure that the harness will not be caught between the printer and the SHIELD ASSY IF.

- 8) Replace the SHIELD ASSY IF to the printer together with the ELECTRONIC SUB-SYSTEM CONTROL BOARD by mating the two holes on the SHIELD ASSY IF with the tabs of the printer.

Continues to the next page.

Replacement 23 ELECTRONIC SUB-SYSTEM CONTROL BOARD (PL9.1.27)

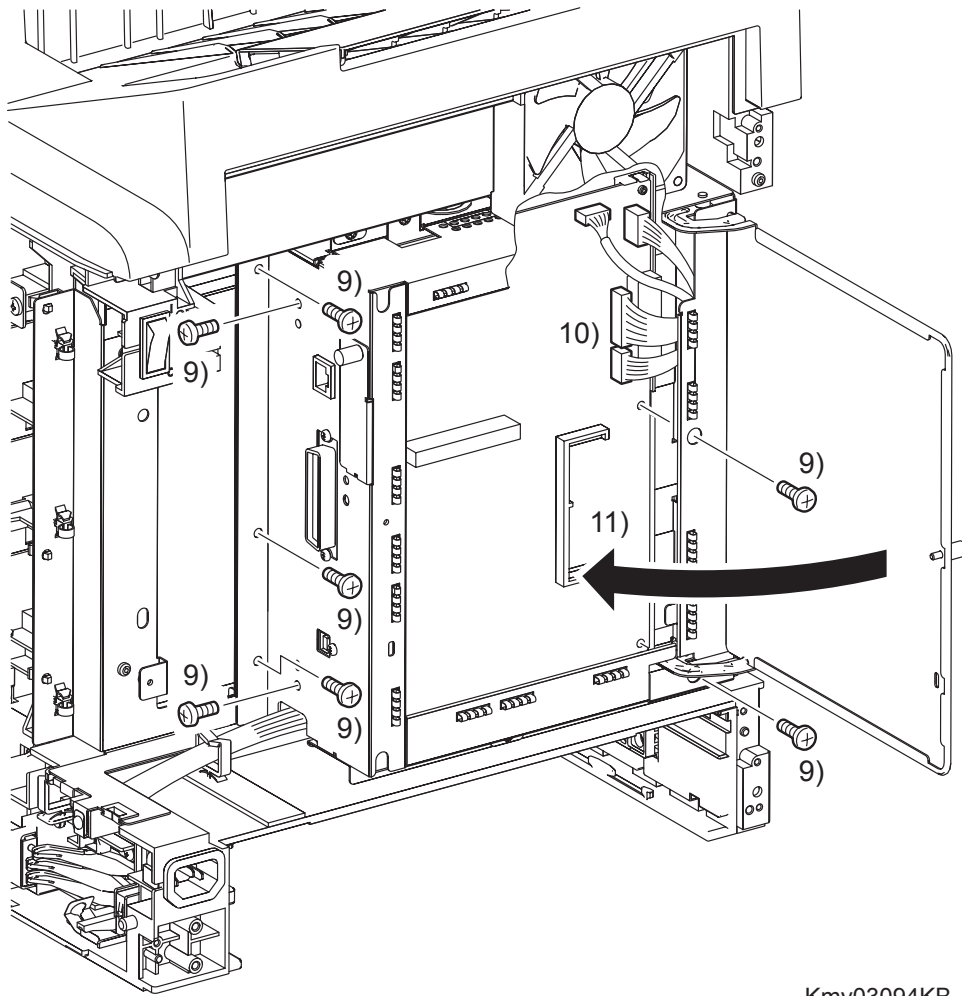

Kmy03094KB

- 9) Secure the SHIELD ASSY IF and ELECTRONIC SUB-SYSTEM CONTROL BOARD to the printer using the seven screws (silver, 6mm).
- 10) Engage all the connectors of the ELECTRONIC SUB-SYSTEM CONTROL BOARD.
- 11) Close the SHIELD WINDOW and secure the SCREW KNURLING.

Go to the next replacement step:

Replacement 24 LEFT COVER (PL1.1.7)

Replacement 24 LEFT COVER (PL1.1.7)

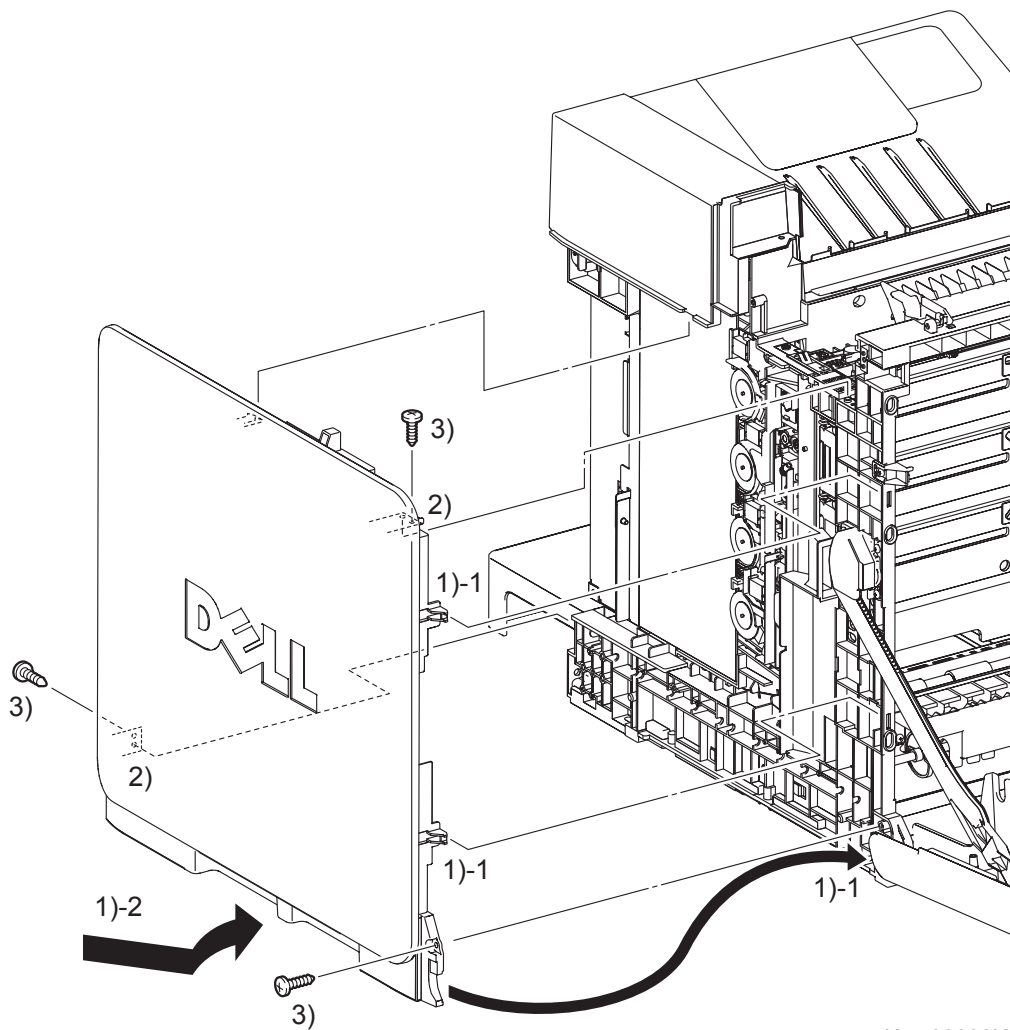

Kmy03092KA

- 1) Insert the front side of the LEFT COVER between the FRONT COVER and the printer, and mate the two front side hooks of the LEFT COVER with the printer.
- 2) Mate the holes on the LEFT COVER with the two bosses on the printer.
- 3) Secure the LEFT COVER to the printer using the three screws (silver, tap, 10mm).

Next Replacement steps.

Replacement 33 RIGHT COVER (PL1.1.6) or Replacement 34 REAR COVER (PL1.1.4)

Replacement 25 TONER CARTRIDGE SENSOR ASSEMBLY (C), (M), (Y) (PL5.1.4)

NOTE

Described below is the replacement procedure common among TONER CARTRIDGE SENSOR ASSYS (C), (M), and (Y).

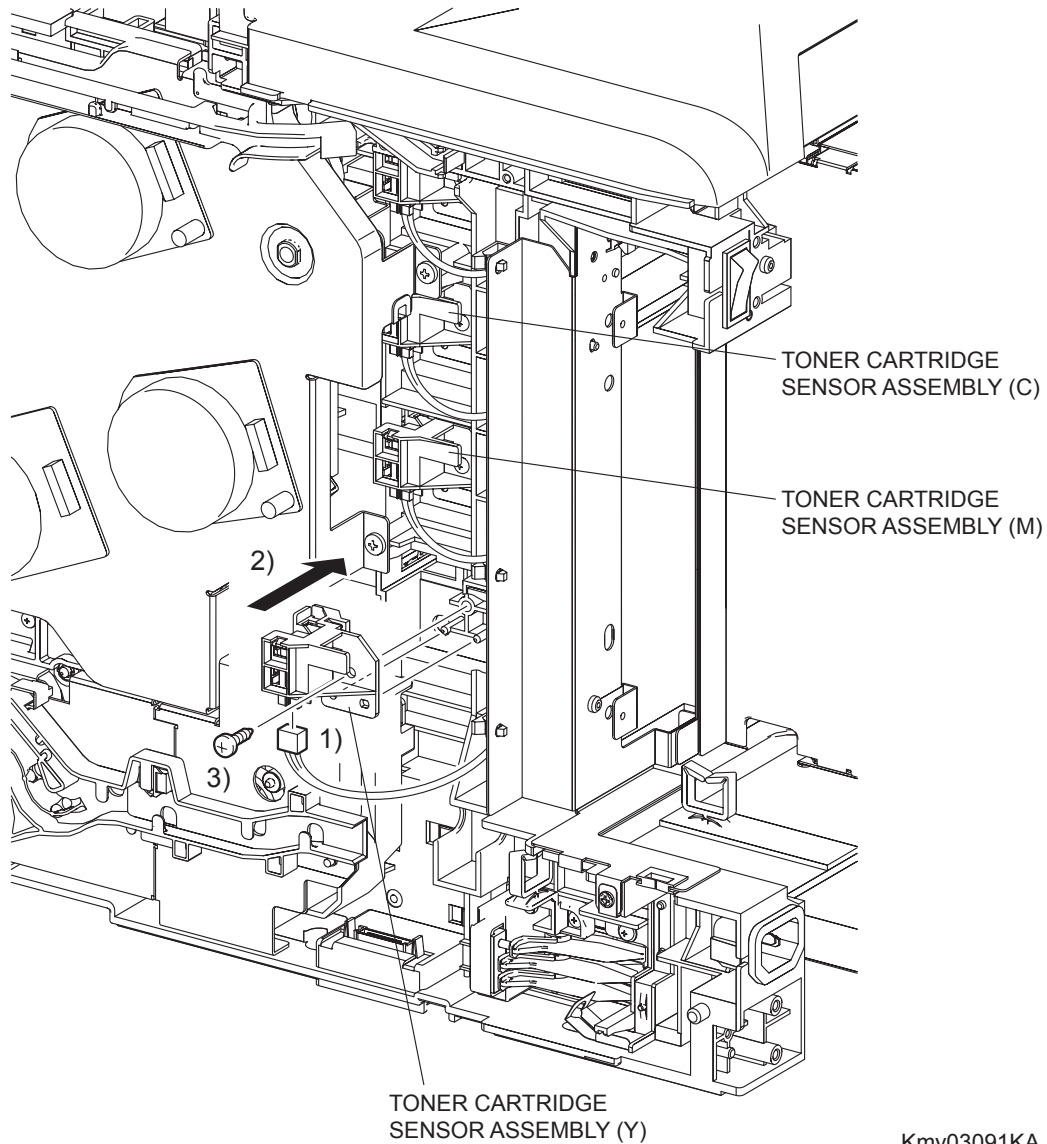

- 1) Engage the connector of the TONER CARTRIDGE SENSOR ASSEMBLY.
- 2) Mate the two holes on the TONER CARTRIDGE SENSOR ASSEMBLY with the bosses on the printer.
- 3) Secure the TONER CARTRIDGE SENSOR ASSEMBLY to the printer using the one screw (silver, tap, 10mm).

**Go to the next replacement step:
Replacement 33 RIGHT COVER (PL1.1.6)**

Replacement 26 POWER SWITCH (PL9.1.13)

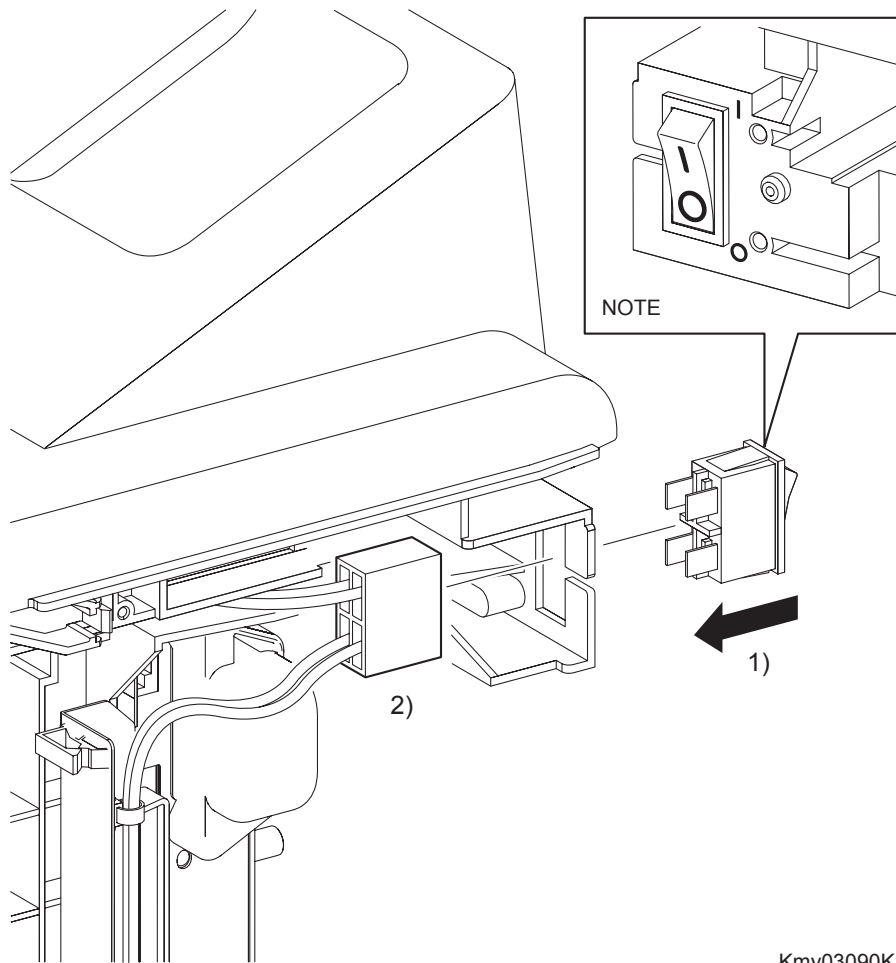

Kmy03090KA

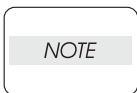

When replacing the POWER SWITCH, match the ON/OFF mark of the POWER SWITCH with the mark on the FRAME.

- 1) Replace the POWER SWITCH to the printer, and secure with the hook.
- 2) Engage the connector (P/J481) of the POWER SWITCH.

Go to the next replacement step:

Replacement 33 RIGHT COVER (PL1.1.6)

Replacement 27 SIZE SWITCH ASSEMBLY (PL7.1.18)

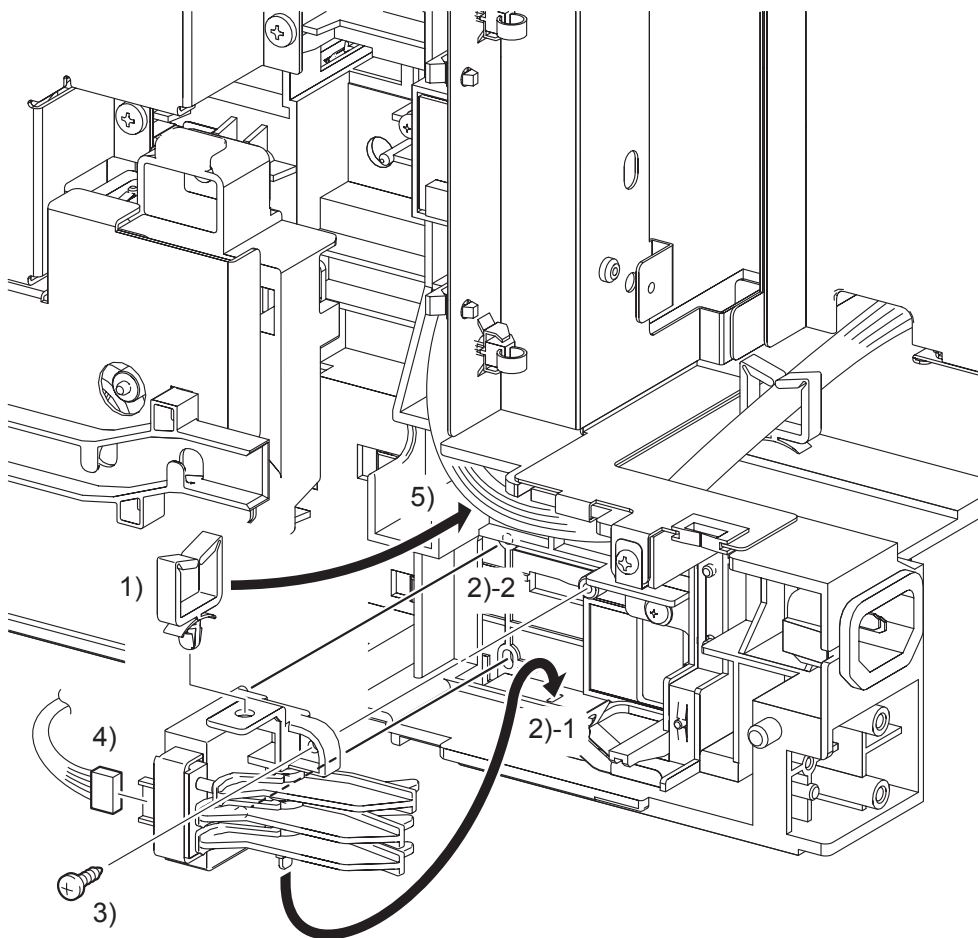

Kmy03089KA

- 1) Replace the clamp to the SIZE SWITCH ASSEMBLY.
- 2) Insert the backside tab of the SIZE SWITCH ASSEMBLY into the hole on the printer and insert the two bosses of the SIZE SWITCH ASSEMBLY into the holes on the printer.
- 3) Secure the SIZE SWITCH ASSEMBLY to the printer using the one screw (silver, tap, 10mm).
- 4) Engage the connector (P/J231) of the SIZE SWITCH ASSEMBLY.
- 5) Secure the harness using the clamp of the SIZE SWITCH ASSEMBLY.

Go to the next replacement step:

Replacement 33 RIGHT COVER (PL1.1.6)

Blank Page

Replacement 28 RIGHT ARM ASSEMBLY(PL7.1.98)

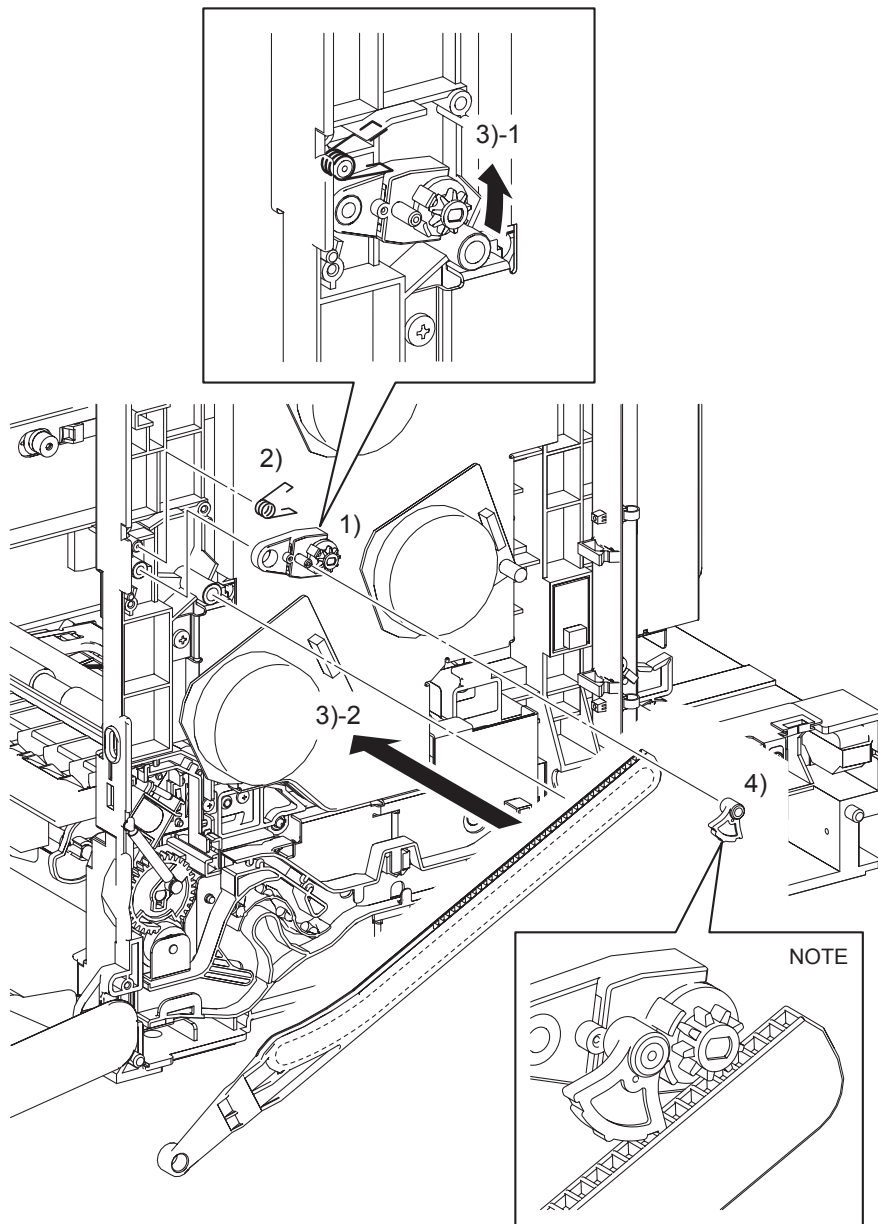

Kmy03087KB

- 1) Replace the HOLDER DAMPER to the printer together with the DAMPER OIL.
- 2) Replace the SPRING SUPPORT to the printer.
- 3) Replace the LINK R by mating the backside groove on the LINK R with the boss on the printer and then pulling the DAMPER OIL slightly upward.

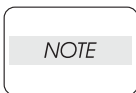

When performing the step described below, pay attention to the orientation of the LEVER RELEASE. Ensure that the longer hollow boss of the LEVER RELEASE faces the HOLDER DAMPER.

- 4) Replace the LEVER RELEASE to the HOLDER DAMPER.

Continues to the next page.

Replacement 28 RIGHT ARM ASSEMBLY(PL7.1.98)

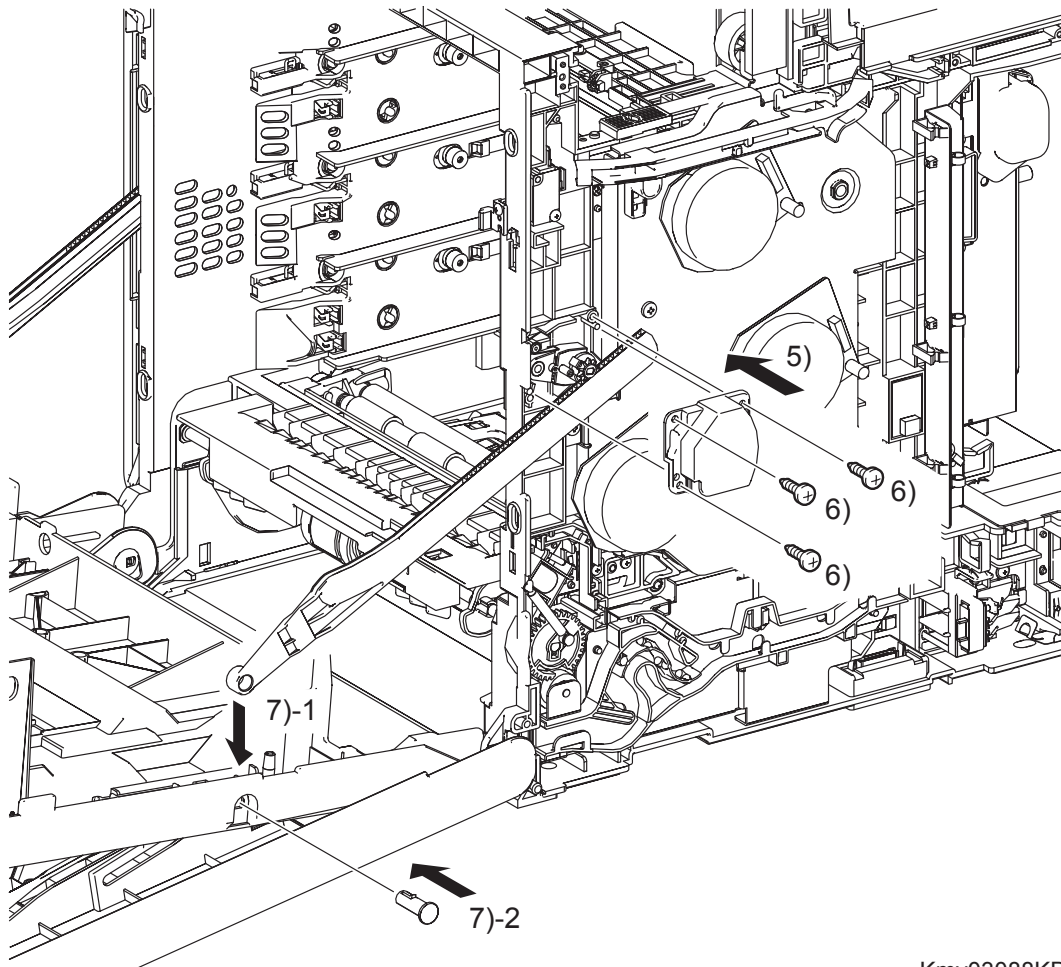

Kmy03088KB

- 5) Replace the SUPPORT LINK R by mating the two holes on the SUPPORT LINK R with the bosses on the printer.
- 6) Secure the SUPPORT LINK R to the printer using the three screws (silver, tap, 8mm).
- 7) Mate the fitting hole on the LINK R with the right side fitting hole on the FRONT COVER. Insert the SHAFT PIVOT and secure using the hook.

**Go to the next replacement step:
Replacement 33 RIGHT COVER (PL1.1.6)**

Replacement 29 FRONT COVER (PL1.2.98)

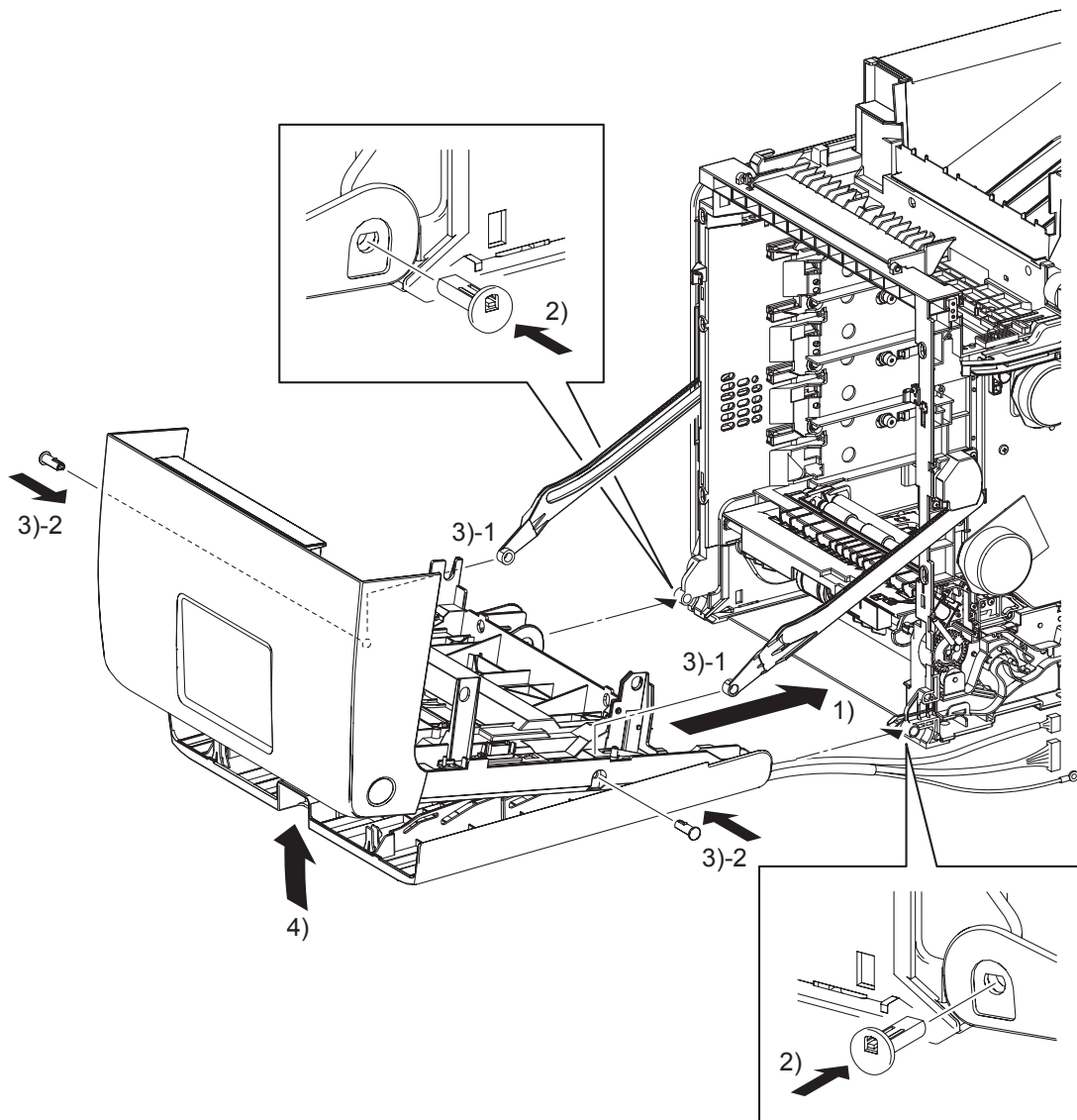

Kmy03085KB

- 1) Align the left and right side holes on the FRONT COVER and MPF COVER to the fitting holes on the printer.
- 2) Insert the SHAFT PIVOT MSIs into the left and right sides fitting holes of the FRONT COVER and the MPF COVER, and then secure the SHAFT PIVOT MSIs with the hooks.
- 3) Align the left and right side fitting holes of the FRONT COVER with the fitting hole of the LINK L and the LINK R, and then insert the SHAFT PIVOTS. Secure the SHAFT PIVOTS with the hooks.
- 4) Close the MPF COVER.

Continues to the next page.

Replacement 29 FRONT COVER (PL1.2.98)

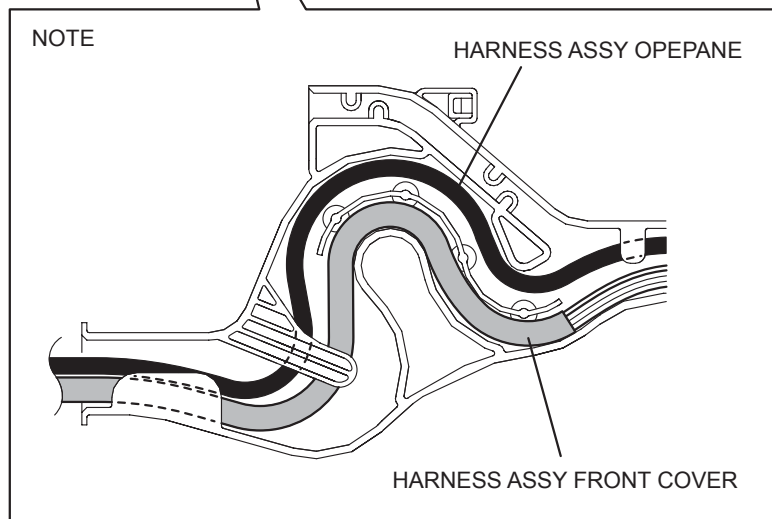
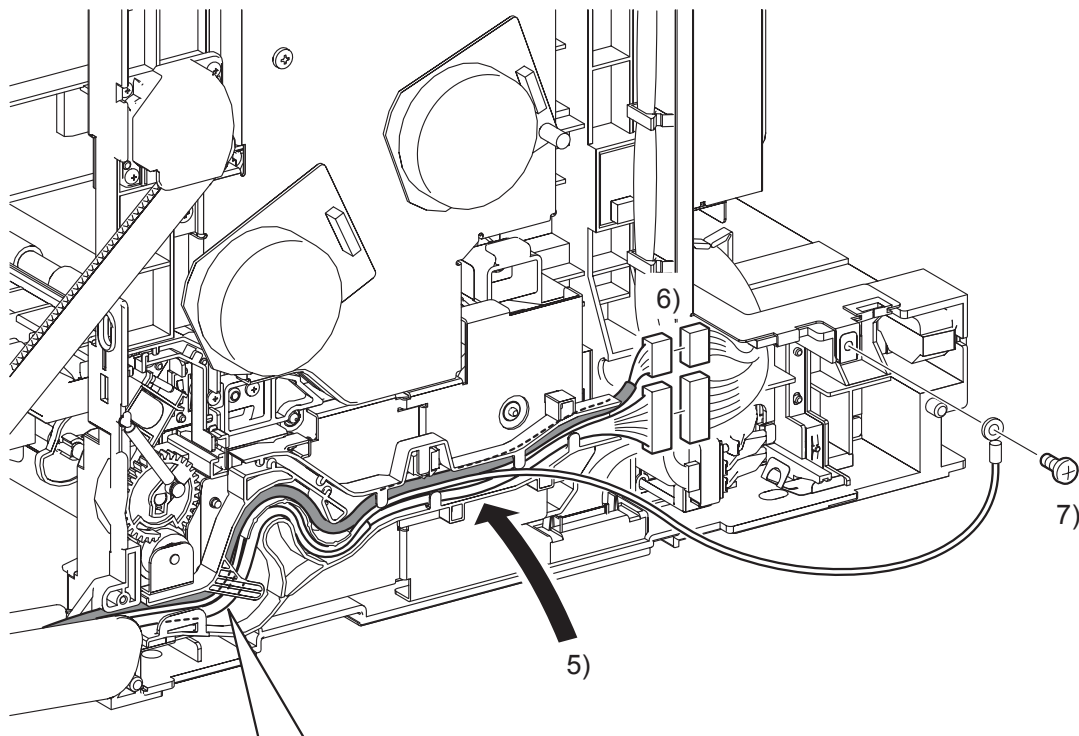

Kmy03086KC

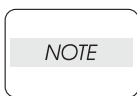

When performing the step below, route the HARNESS ASSY OPEPANE over the HARNESS ASSY FRONT COVER.

- 5) Route the HARNESS ASSY OPEPANE and the HARNESS ASSY FRONT COVER along the DUCT DRV PH.
- 6) Engage the connector (P/J272) of the HARNESS ASSY FRONT COVER and the connector (P/J2900) of the HARNESS ASSY OPEPANE.
- 7) Secure the ground wire of the HARNESS ASSY FRONT COVER to the printer using the one screw (silver, tap, 8mm).

**Go to the next replacement step:
Replacement 33 RIGHT COVER (PL1.1.6)**

Replacement 30 INTEGRATED FEEDER ASSEMBLY (PL3.2.99)

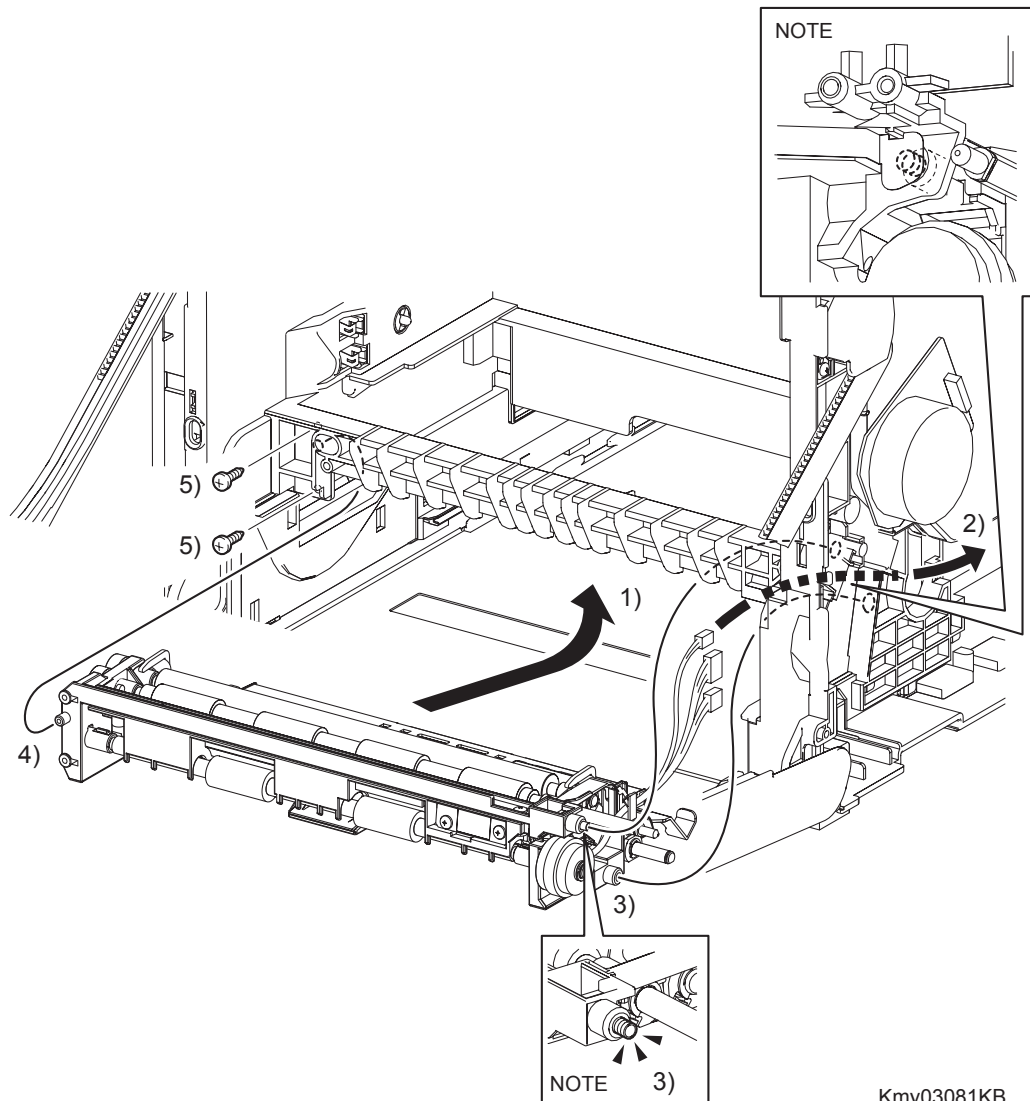

Kmy03081KB

NOTE

When performing the step described below, take care not to drop and lose the SPRING EARTH on the right side of the INTEGRATED FEEDER ASSEMBLY.

NOTE

When performing the step described below, check that the SPRING EARTH on the right side of the INTEGRATED FEEDER ASSEMBLY is in contact with the PLATE EARTH of the printer.

- 1) Insert the INTEGRATED FEEDER ASSEMBLY diagonally into the printer so that the right side of the INTEGRATED FEEDER ASSEMBLY goes in first.
- 2) Route the harness with the two connectors coming from the INTEGRATED FEEDER ASSEMBLY and the connector of the CLUTCH ASSY PH TURN out of the hole on the printer from inside.
- 3) Insert the bearing, the clutch and the two bosses (One is provided with the SPRING EARTH.) on the right side of the INTEGRATED FEEDER ASSEMBLY to the holes on the printer.
- 4) Insert the left side boss of the INTEGRATED FEEDER ASSEMBLY into the hole on the printer.
- 5) Secure the INTEGRATED FEEDER ASSEMBLY to the printer using the two screws (silver, tap, 10mm).

Continues to the next page.

Replacement 30 INTEGRATED FEEDER ASSEMBLY (PL3.2.99)

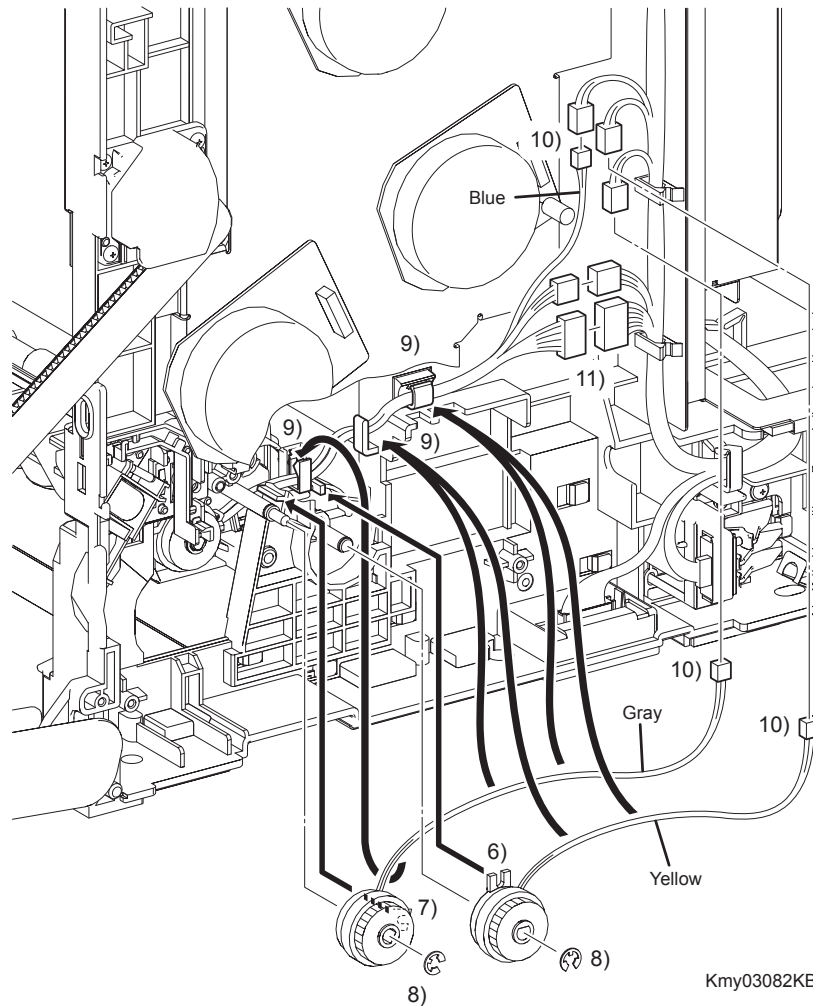
**NOTE**

When replacing the CLUTCH, match the harness color of the CLUTCH with that of the fitting groove of the CLUTCH.

The harness color of the CLUTCH ASSY PH REGI is gray.

The harness color of the CLUTCH ASSY PH FEED is yellow.

The harness color of the CLUTCH ASSY PH TURN is blue.

- 6) Replace the CLUTCH ASSY PH FEED to the INTEGRATED FEEDER ASSEMBLY by mating the fitting groove the CLUTCH ASSY PH FEED with the lug on the INTEGRATED FEEDER ASSEMBLY.
- 7) Replace the CLUTCH ASSY PH REGI to the printer by mating the fitting groove on the CLUTCH ASSY PH REGI with the lug on the printer.
- 8) Replace the CLUTCH ASSY PH REGI and CLUTCH ASSY PH FEED to the INTEGRATED FEEDER ASSEMBLY using the e-rings.
- 9) Route the harnesses along the printer and bind them with the clamps on the INTEGRATED FEEDER ASSEMBLY and the printer.

NOTE

When engaging the connectors of the CLUTCHes, match the color of the CLUTCH harness with that of the harness on the printer side.

- 10) Engage the connector (P/J233) of the CLUTCH ASSY PH REGI, the connector (P/J235) of the CLUTCH ASSY PH FEED, and the connector (P/J234) of the CLUTCH ASSY PH TURN.
- 11) Engage the connectors (P/J232 and P/J241) of the INTEGRATED FEEDER ASSEMBLY.

Continues to the next page.

Replacement 30 INTEGRATED FEEDER ASSEMBLY (PL3.2.99)

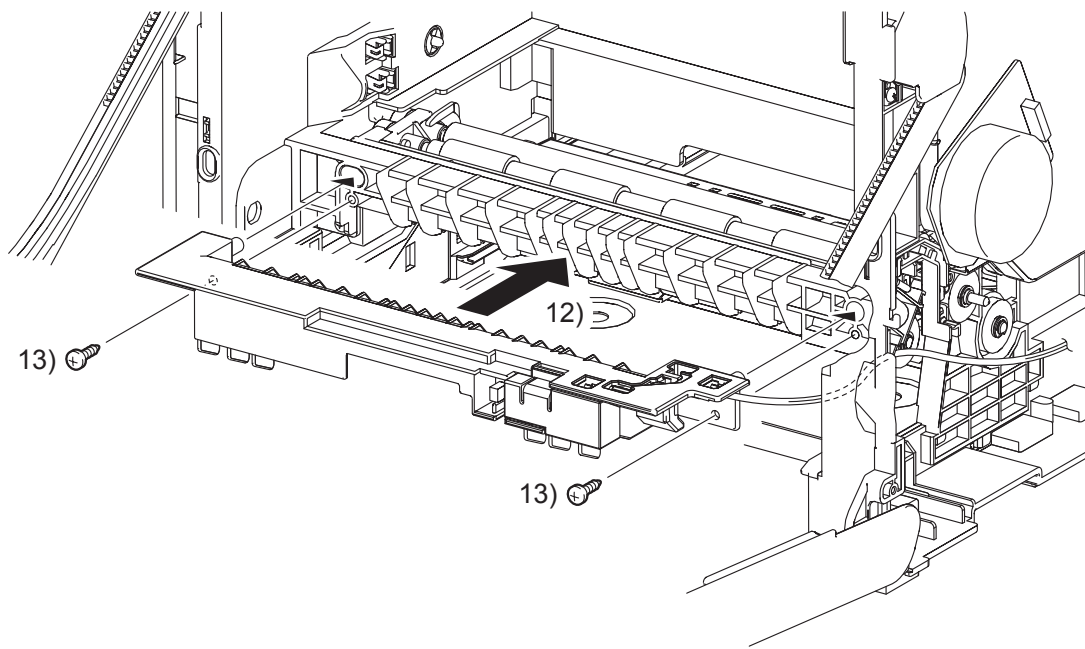

Kmy03083KB

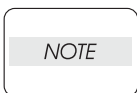

When performing the step described below, ensure that the harness will not be caught between the CHUTE MSI and the printer.

- 12) Replace the CHUTE MSI by mating the two bosses on the CHUTE MSI with the holes on the printer.
- 13) Secure the CHUTE MSI to the printer using the two screws (silver, tap, 10mm).

Continues to the next page.

Replacement 30 INTEGRATED FEEDER ASSEMBLY (PL3.2.99)

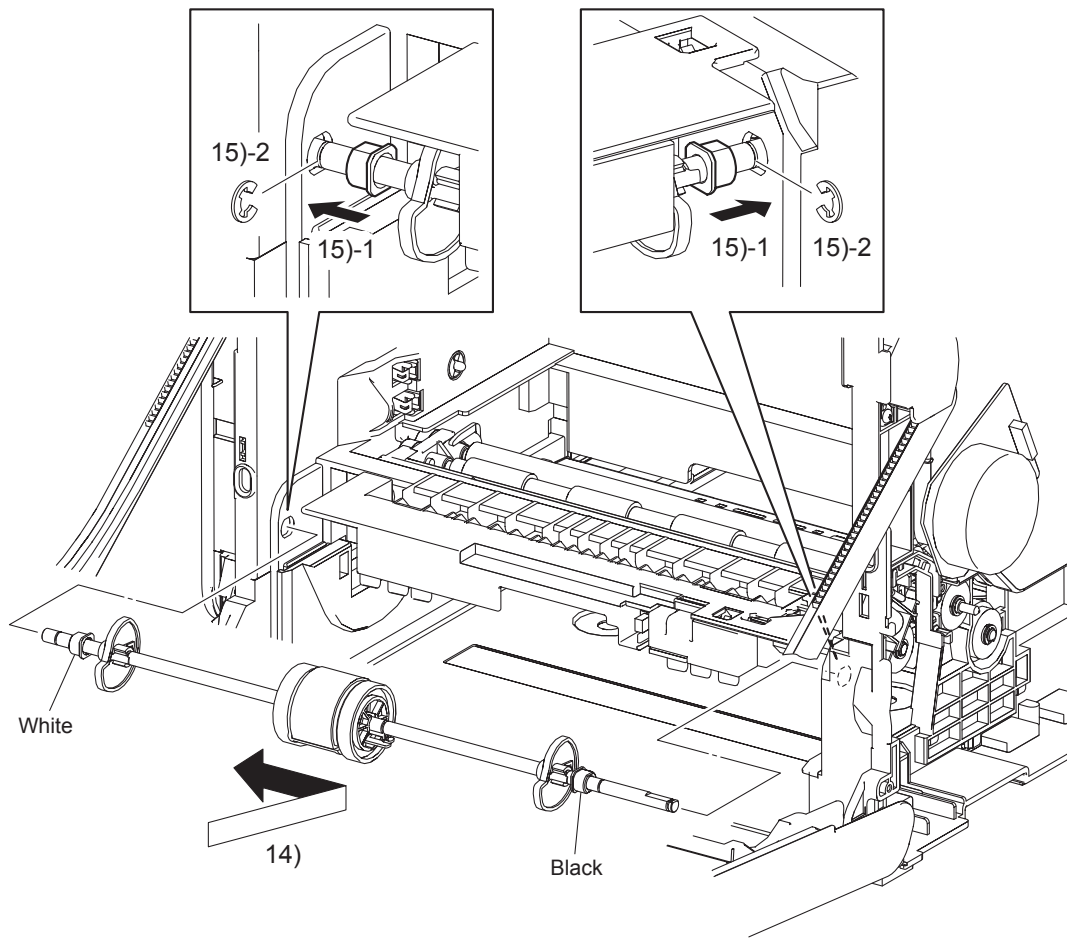

Kmy03084KB

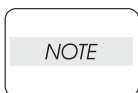

When performing the step described below, ensure that the color of each BEARING is correct.

The color of the right BEARING is black.

The color of the left BEARING is white.

- 14) Replace the ROLL ASSY MSI to the printer by inserting the right and left ends of the ROLL ASSY MSI into the holes on the printer.
- 15) Slide the left and right of the BEARINGS outward into the holes on the printer, and secure using the e-rings.

Go to the next replacement step:

Replacement 31 FEED DRIVE ASSEMBLY (PL8.1.7)

Replacement 31 FEED DRIVE ASSEMBLY (PL8.1.7)

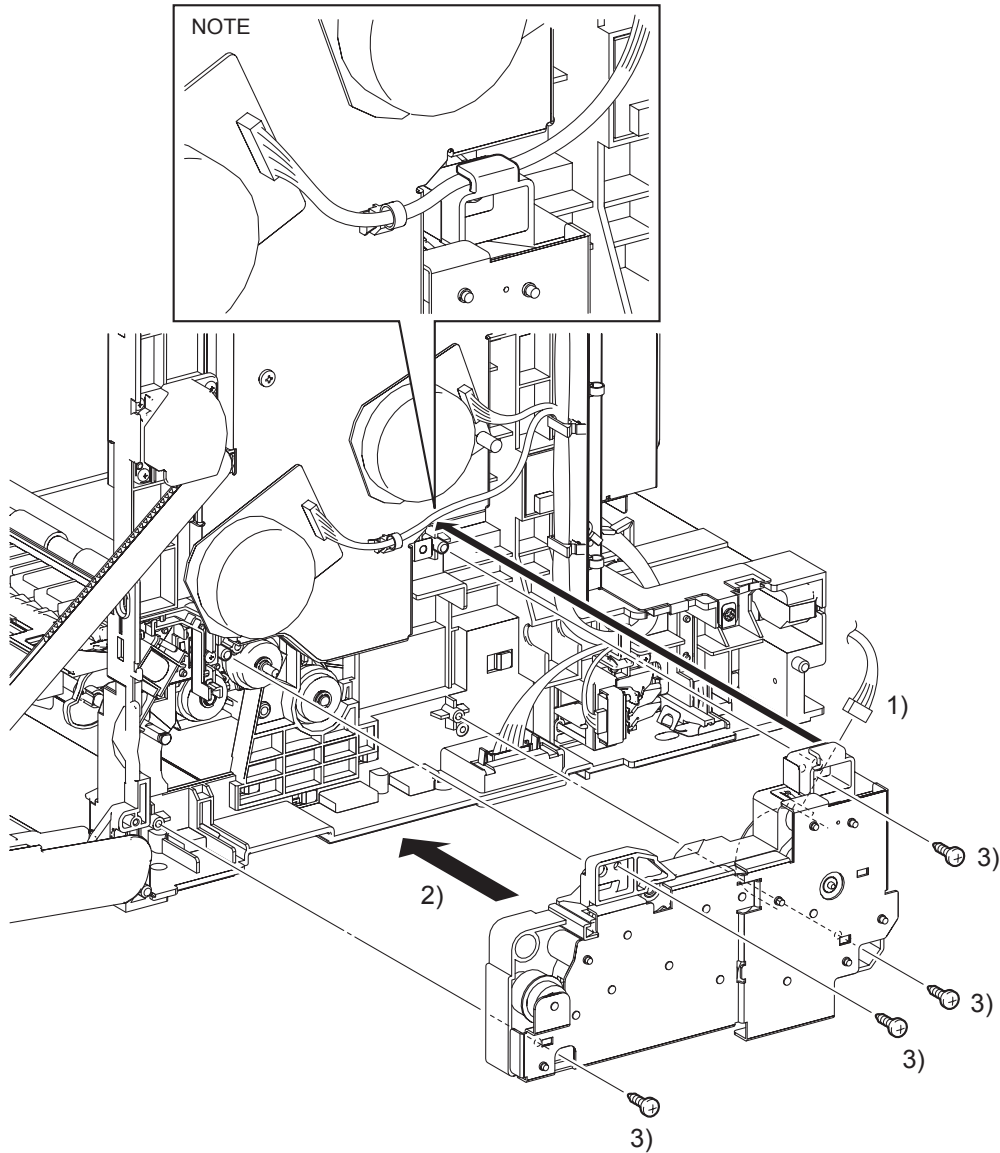

Kmy03078KB

- 1) Engage the connector (P/J251) of the FEED DRIVE ASSEMBLY.

NOTE

When performing the step described below, the harness of the connector to be engaged to the DEVE MOTOR of the PHOTOCOnductor (PC) / DEVELOPER (DEV) DRIVE (PL8.1.2) must be routed through the hook above the FEED DRIVE ASSEMBLY.

- 2) Replace the FEED DRIVE ASSEMBLY by mating the two holes of the FEED DRIVE ASSEMBLY with the bosses on the printer.
- 3) Secure the FEED DRIVE ASSEMBLY to the printer using the four screws (silver, tap, 10mm).

Continues to the next page.

Replacement 31 FEED DRIVE ASSEMBLY (PL8.1.7)

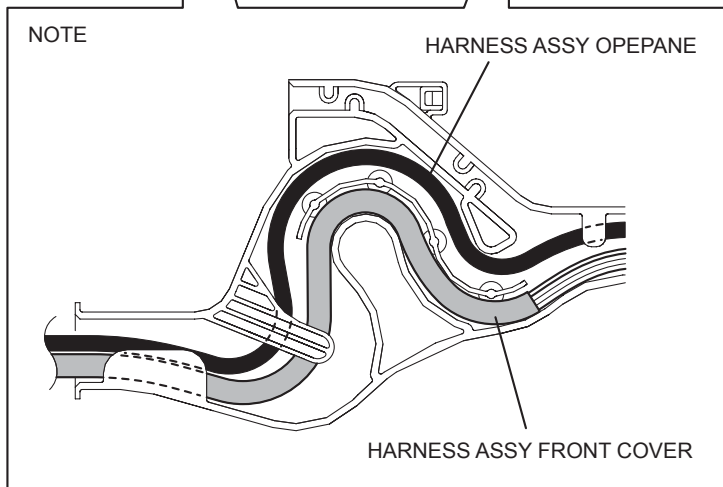
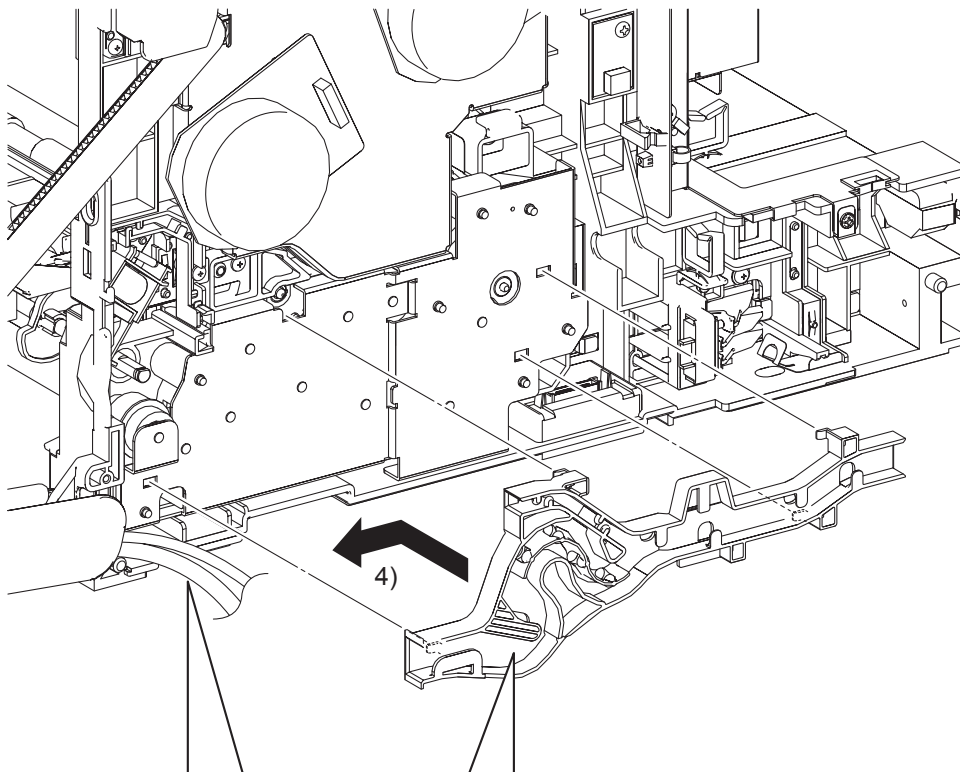

Kmy03079KB

- 4) Mate the four hooks on the DUCT DRV PH with the holes on the FEED DRIVE ASSY. Secure the DUCT DRV PH by moving it frontward allowing the hooks to lock into place.

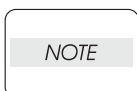

When performing the step below, route the HARNESS ASSY OPEPANE over the HARNESS ASSY FRONT COVER.

- 5) Route all the harnesses along the DUCT DRV PH.

Continues to the next page.

Replacement 31 FEED DRIVE ASSEMBLY (PL8.1.7)

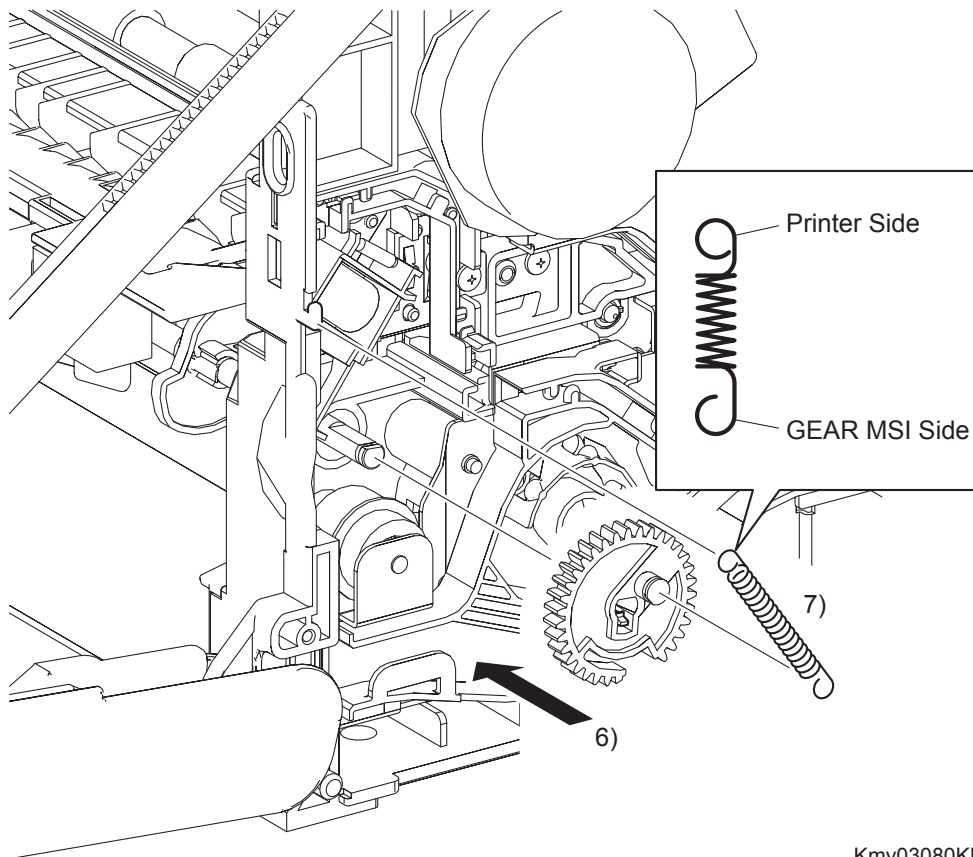

Kmy03080KB

NOTE

When performing the step described below, turn the flat surface of the SHAFT MSI face upward for ease of work.

- 6) Replace the GEAR MSI to the SHAFT MSI and lock the hook of the GEAR MSI into the groove of the SHAFT MSI.

NOTE

When performing the step described below, pay attention to the orientation of the SPRING FEED MSI. Ensure that the longer J-shaped hook of the SPRING FEED MSI is anchored to the GEAR MSI.

- 7) Anchor the SPRING FEED MSI to the GEAR MSI and the printer.

Go to the next replacement step:

Replacement 33 RIGHT COVER (PL1.1.6)

Blank Page

Replacement 32 MPF FEED SOLENOID (PL3.1.98)

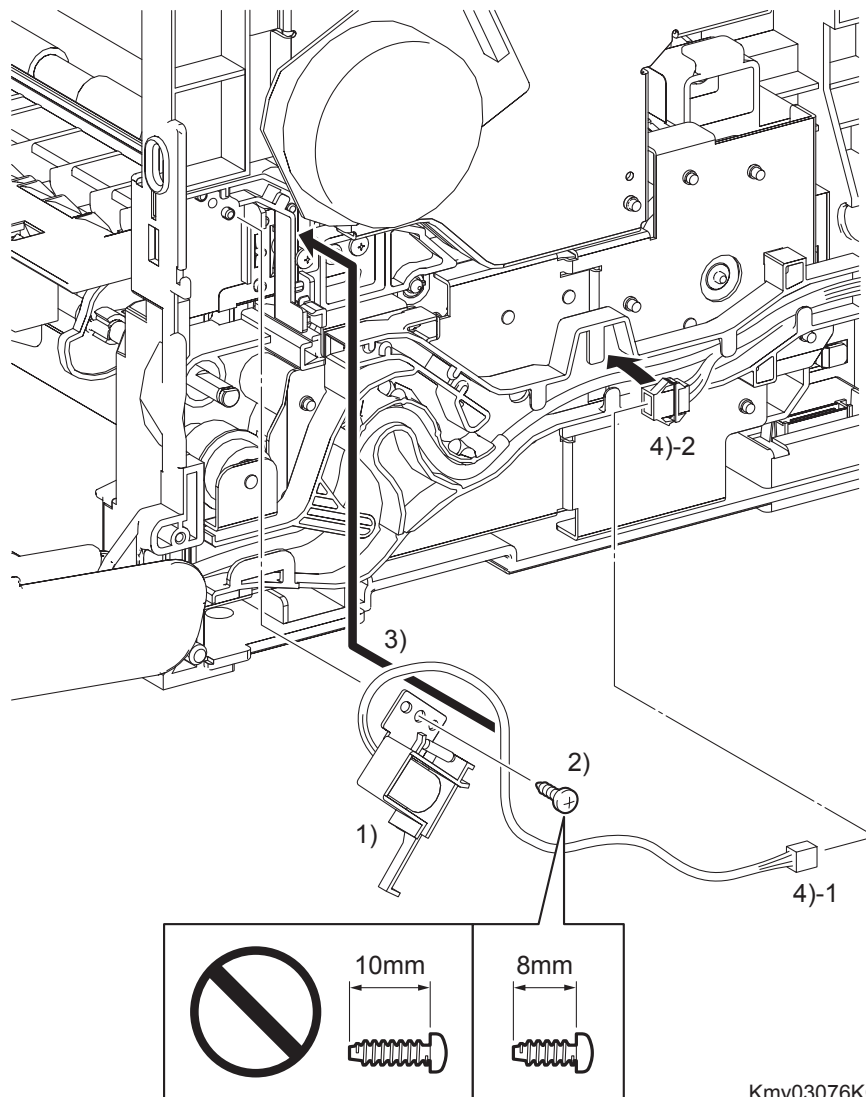

Kmy03076KC

- 1) Replace the MPF FEED SOLENOID to the printer by mating the two holes on the MPF FEED SOLENOID with the bosses on the printer.

NOTE

Ensure that 8mm screws are used to secure the MPF FEED SOLENOID. Use of 10mm screws will damage the frame.

- 2) Secure the MPF FEED SOLENOID to the printer using the one screw (silver, tap, 8mm).
- 3) Route the harness of the MPF FEED SOLENOID to the DUCT MSI SOL and DUCT DRV PH.

NOTE

The harness color of the MPF FEED SOLENOID (gray) does not match that of the printer (yellow).

- 4) Engage the connector (P/J256) of the MPF FEED SOLENOID.

Continues to the next page.

Replacement 32 MPF FEED SOLENOID (PL3.1.98)

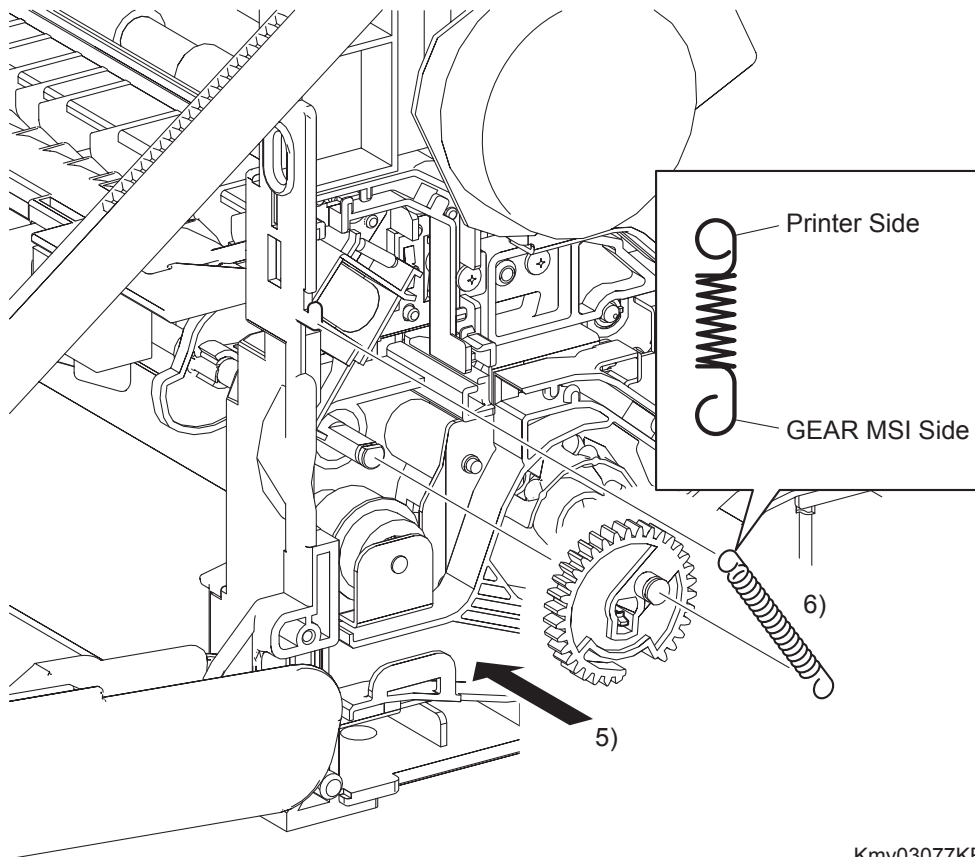

NOTE

When carrying out the work shown below, it is easier to put the D-cut surface of the SHAFT MSI on the top.

- 5) Replace the GEAR MSI to the SHAFT MSI and lock the hook on the GEAR MSI into the groove on the SHAFT MSI.

NOTE

When carrying out the work shown below, pay attention to attach the SPRING FEED MSI in the right direction.

Attach the hyperelliptic side of the SPRING FEED MSI to the GEAR MSI.

- 6) Anchor the SPRING FEED MSI to the printer and GEAR MSI.

Go to the next replacement step:

Replacement 33 RIGHT COVER (PL1.1.6)

Replacement 33 RIGHT COVER (PL1.1.6)

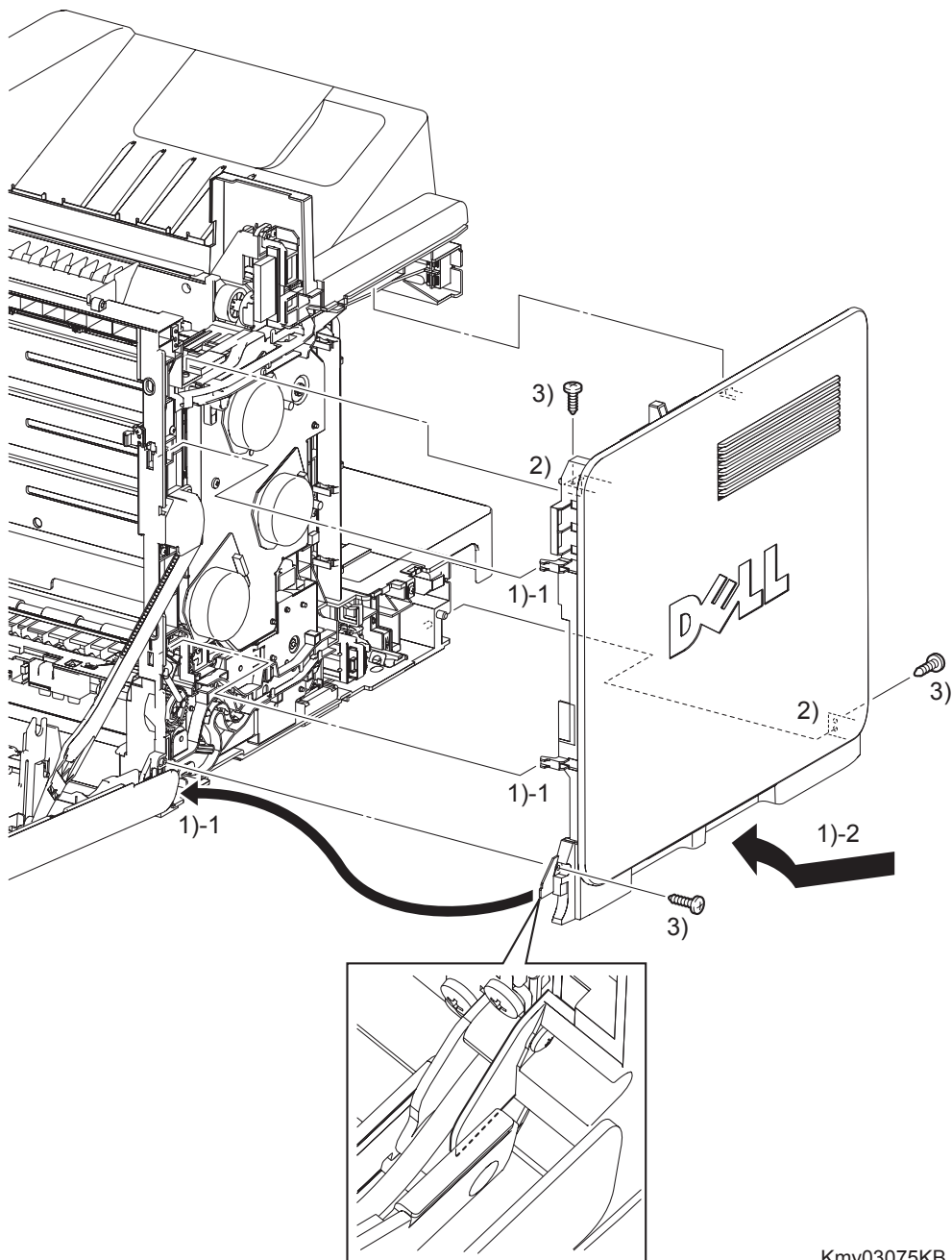

Kmy03075KB

- 1) Insert the front side of the RIGHT COVER between the FRONT COVER and the printer. Mate the two front side hooks of the RIGHT COVER with the holes on the printer.
- 2) Mate the holes of the RIGHT COVER with the two bosses on the printer.
- 3) Secure the RIGHT COVER to the printer using the three screws (silver, tap, 10mm).

Go to the next replacement step:

Replacement 34 REAR COVER (PL1.1.4)

Replacement 34 REAR COVER (PL1.1.4)

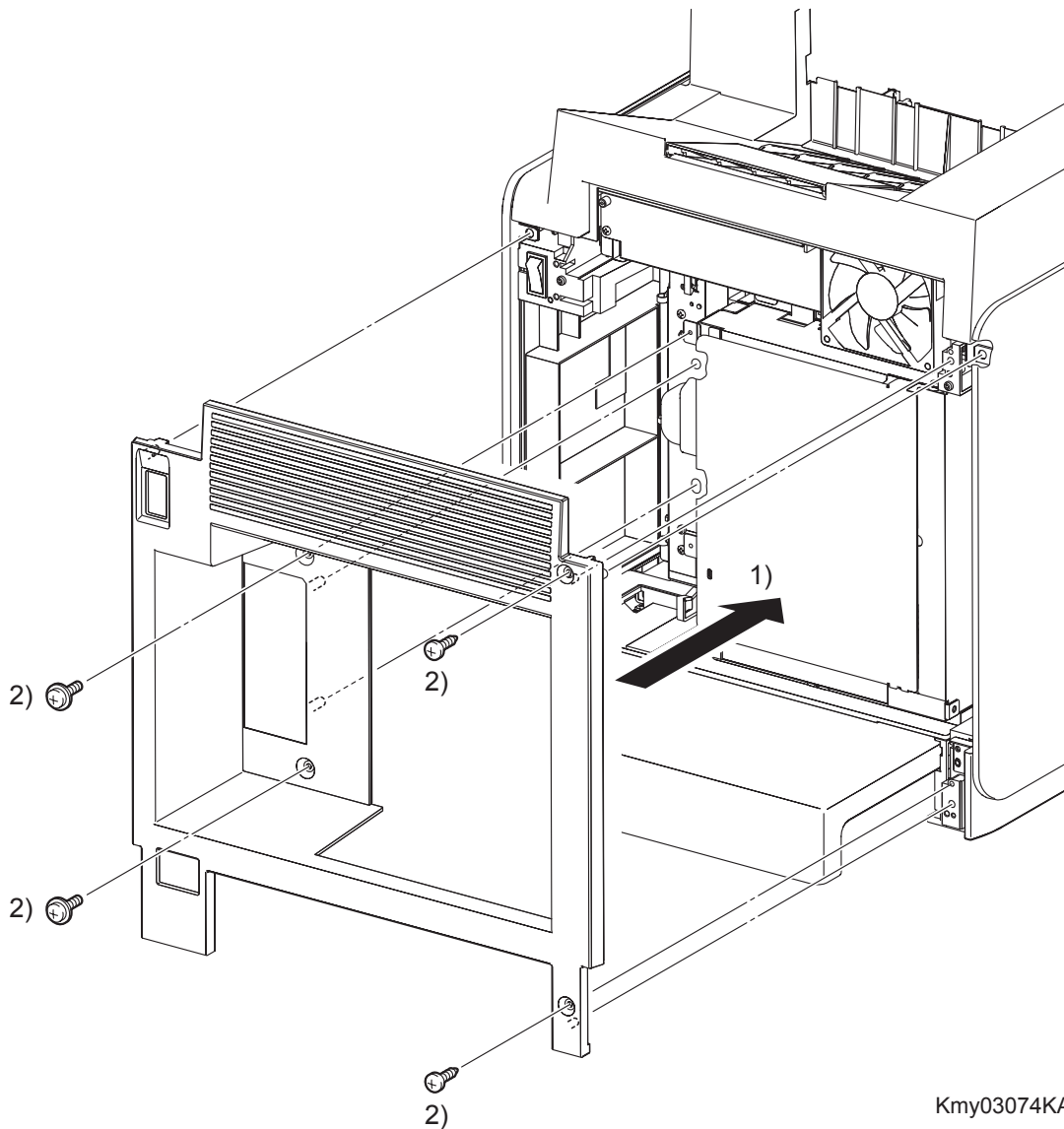

- 1) Replace the REAR COVER by mating the six bosses on the REAR COVER with the holes on the printer, the RIGHT COVER (PL1.1.6), and the LEFT COVER (PL1.1.7).
- 2) Secure the REAR COVER to the printer using the two screws (silver, tap, 10mm) and the two screws (silver, with flange, 8mm).

**Go to the next replacement step:
Replacement 38 FUSER (PL6.1.10)**

Replacement 35 OPERATOR PANEL (PL1.2.97)

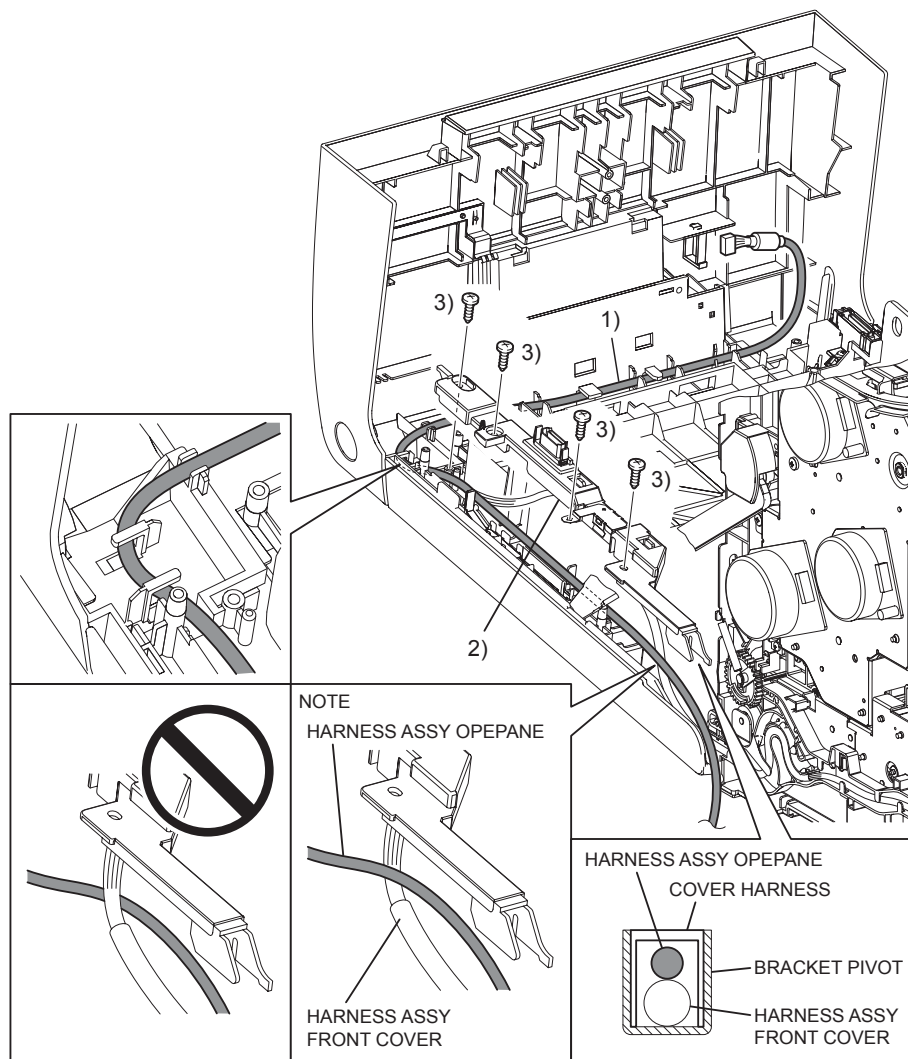

Kmy03125KD

- 1) Route the HARNESS ASSY OPEPANE through the notch on the lib of the FRONT COVER and the hook.

NOTE

When performing the step below, route the HARNESS ASSY OPEPANE so that it crosses the HARNESS ASSY FRONT COVER.

- 2) Replace the COVER HARNESS by mating the hole of the COVER HARNESS with the boss on the FRONT COVER.

NOTE

When performing the step below, check that the HARNESS ASSY OPEPANE is routed over.

- 3) Secure the COVER HARNESS to the FRONT COVER using the four screws (silver, tap, 8mm).

Continues to the next page.

Replacement 35 OPERATOR PANEL (PL1.2.97)

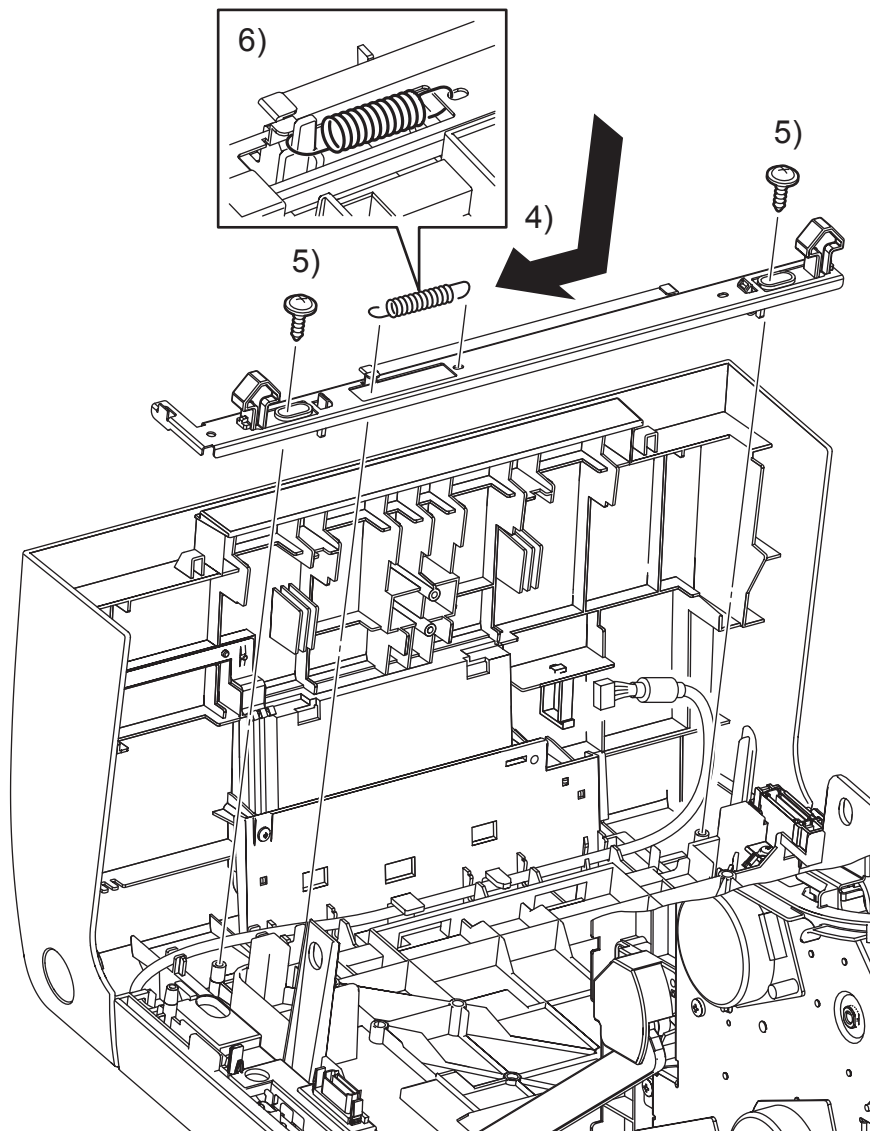

Kmy03133KA

- 4) Replace the LATCH FRONT to the FRONT COVER together with the PLATE LATCH by mating the left and right side slits of the LATCH FRONT with the studs on the FRONT COVER.
- 5) Secure the left and right sides of the LATCH FRONT to the FRONT COVER using the two screws (silver, with flange, tap, 10mm).
- 6) Anchor the SPRING LATCH to the hole on the PLATE LATCH and the peg on the FRONT COVER.

Continues to the next page.

Replacement 35 OPERATOR PANEL (PL1.2.97)

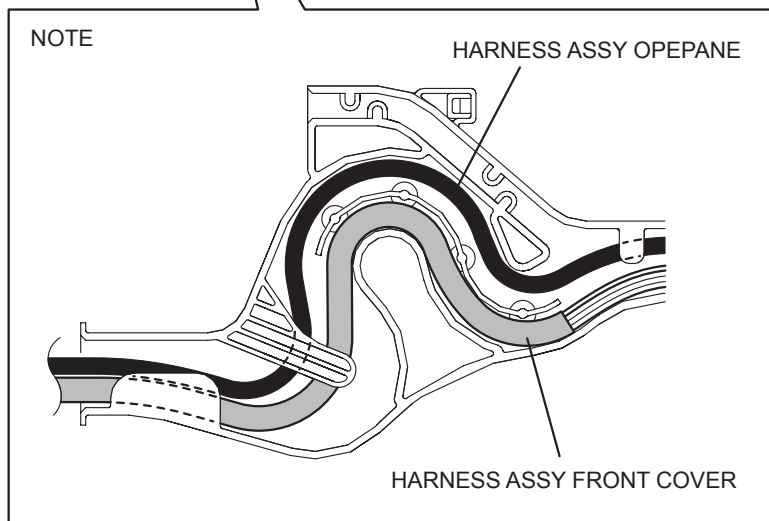
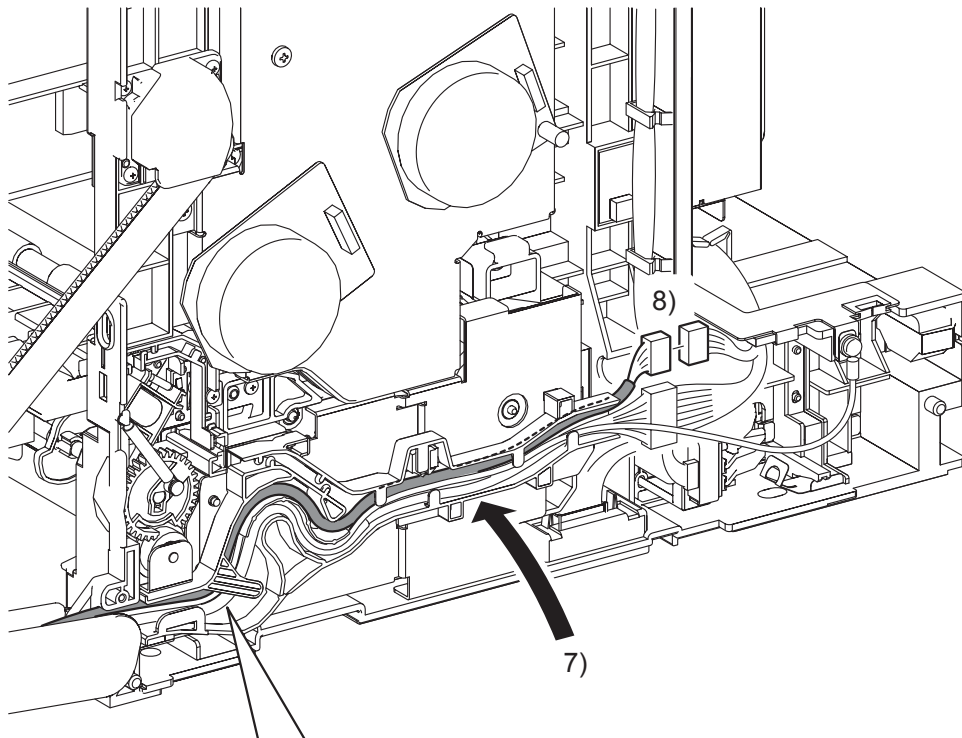

Kmy03126KB

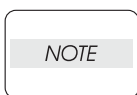

When performing the step below, rote the HARNESS ASSY OPEPANE on the most outward position.

- 7) Route the HARNESS ASSY OPEPANE along the DUCT DRV PH.
- 8) Engage the connector (P/J2900) of the HARNESS ASSY OPEPANE.

Continues to the next page.

Replacement 35 OPERATOR PANEL (PL1.2.97)

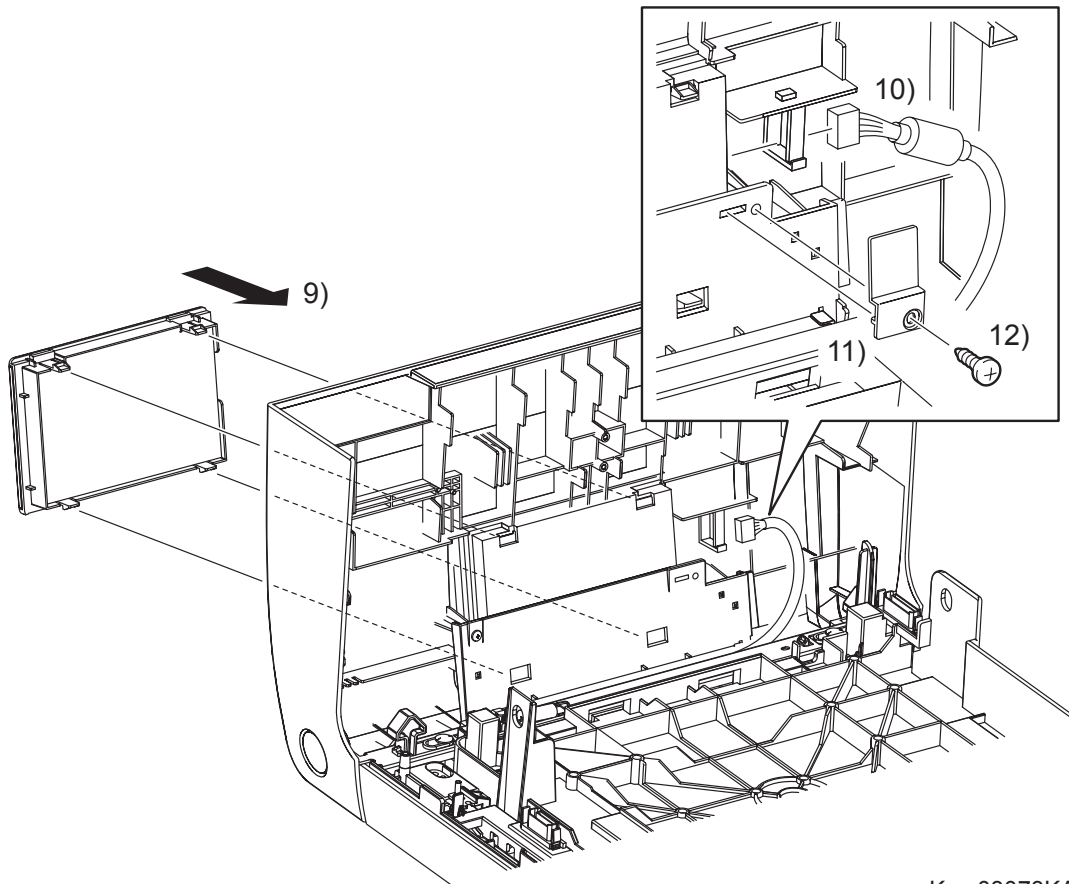

Kmy03073KA

- 9) Replace the OPERATOR PANEL to the FRONT COVER and secure at the four hooks.
- 10) Engage the connector (P/J220) of the OPERATOR PANEL, and then fix the core of the HARNESS ASSY OPEPANE with the clamp.
- 11) Replace the BRACKET HARNESS by mating the lug on the BRACKET HARNESS with the hole of the FRONT COVER,
- 12) Secure the BRACKET HARNESS to the FRONT COVER using the one screw (silver, tap, 8mm).

Go to the next replacement step:

Replacement 36 CHUTE ASSY EXIT OUT (PL6.1.1)

Replacement 36 CHUTE ASSY EXIT OUT (PL6.1.1)

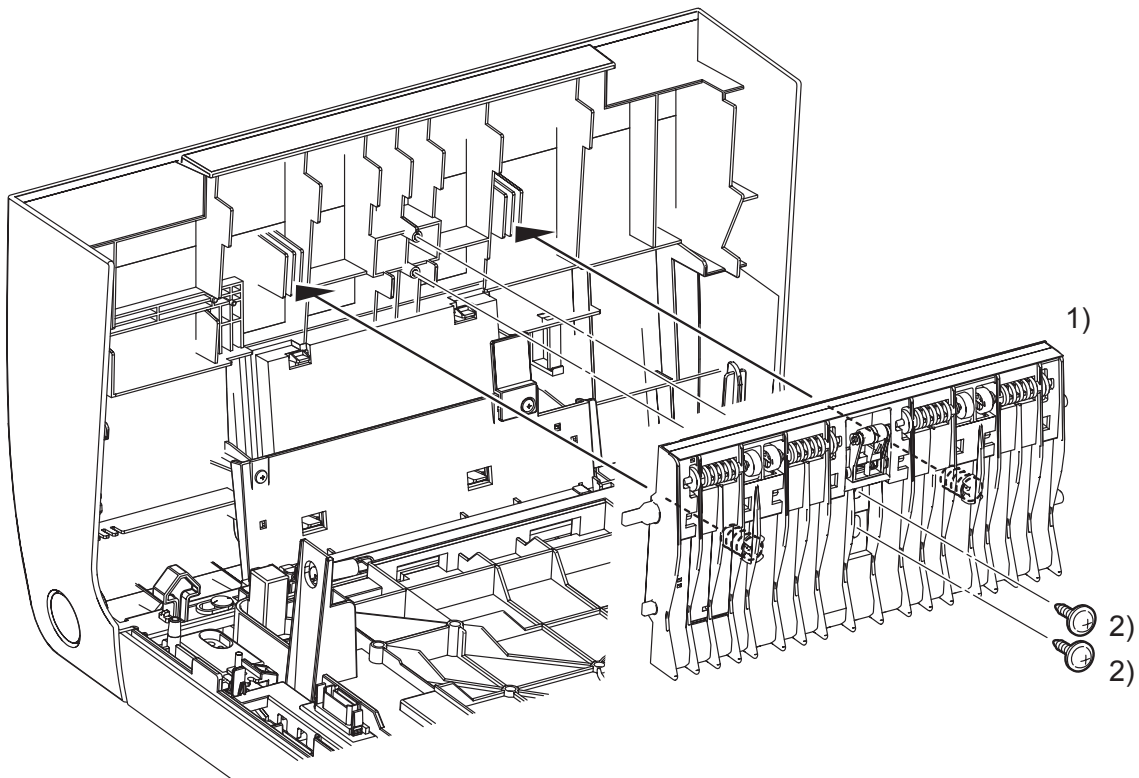

Kmy03072KA

- 1) Replace the CHUTE ASSY EXIT OUT to the FRONT COVER by mating the two springs of the CHUTE ASSY EXIT OUT with the ribs on the FRONT COVER.
- 2) Secure the CHUTE ASSY EXIT OUT to the FRONT COVER using the two screws (silver, with flange, tap, 10mm).
- 3) Close the FRONT COVER.

Replacement 37 SPUR ASSEMBLY (PL7.1.1)

NOTE

Described below is the removal procedure common between the left and right sides of the SPUR ASSEMBLY.

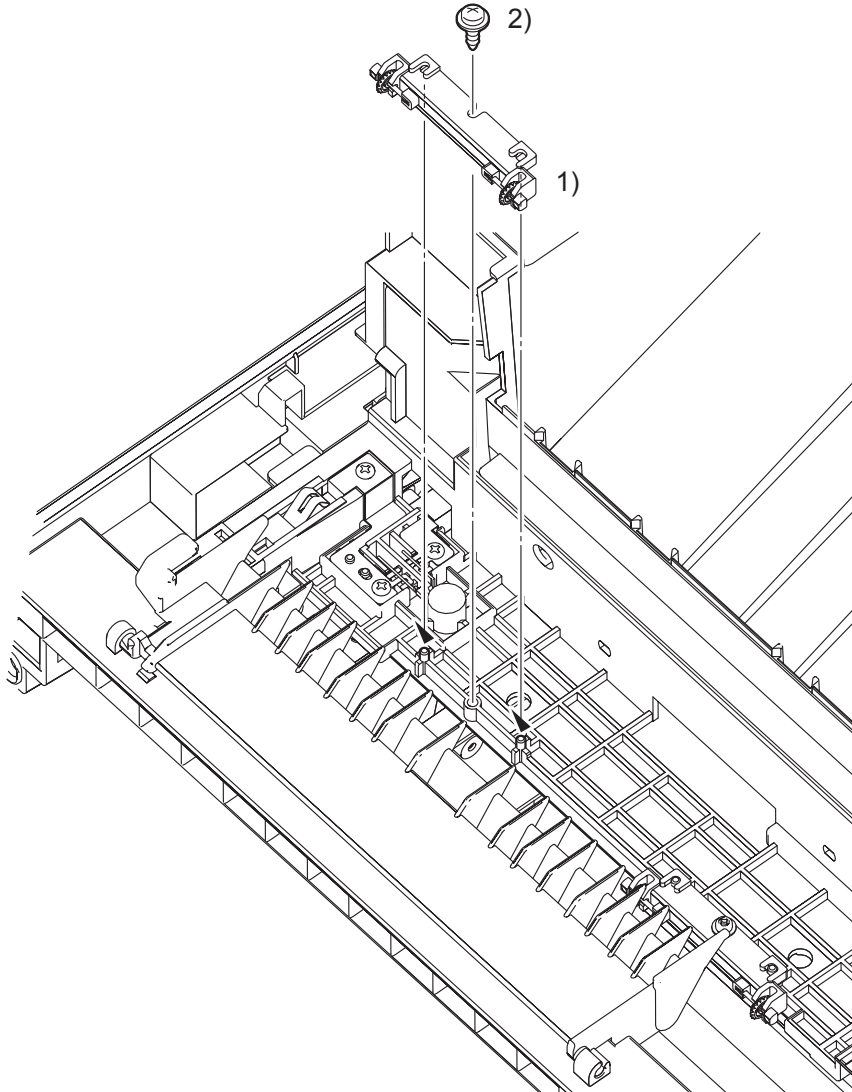

Kmy03071KA

- 1) Replace the SPUR ASSEMBLY to the printer by mating the two holes on the SPUR ASSEMBLY with the bosses on the printer.
- 2) Secure the SPUR ASSEMBLY to the printer with the one screw (silver, with flange, tap, 8mm).

Go to the next replacement step:

Replacement 38 FUSER (PL6.1.10)

Replacement 38 FUSER (PL6.1.10)

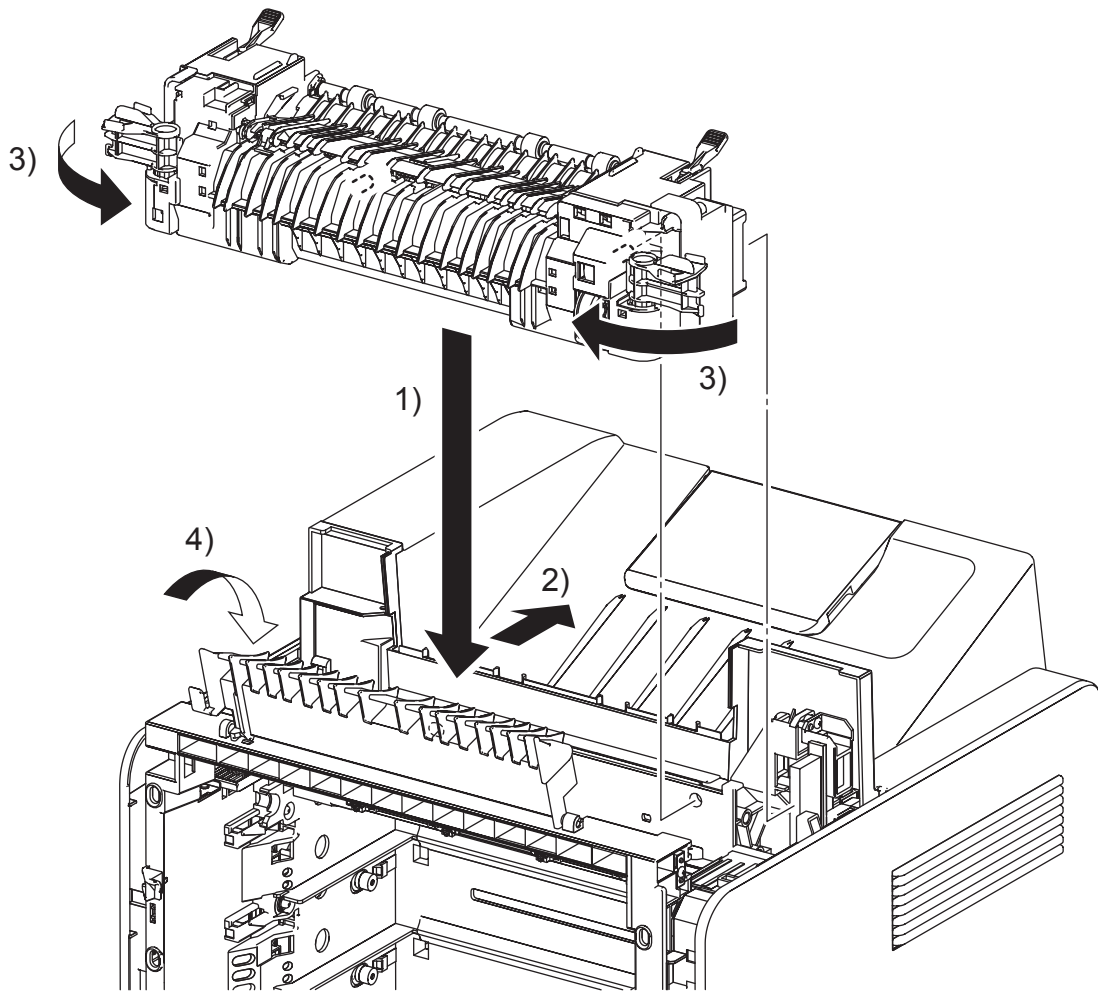

Kmy03070KA

- 1) Put the FUSER on the printer.
- 2) Insert the two rear side bosses of the FUSER into the holes on the printer by moving the FUSER slightly backward.
- 3) Rotate the left and right levers of the FUSER inward.
- 4) Close the DUPLEX GATE.
- 5) Close the FRONT COVER.

Replacement 39 DUPLEX GATE (PL6.1.13)

NOTE

The FUSER part is very hot. Take added care not to get burned when performing the service operation.

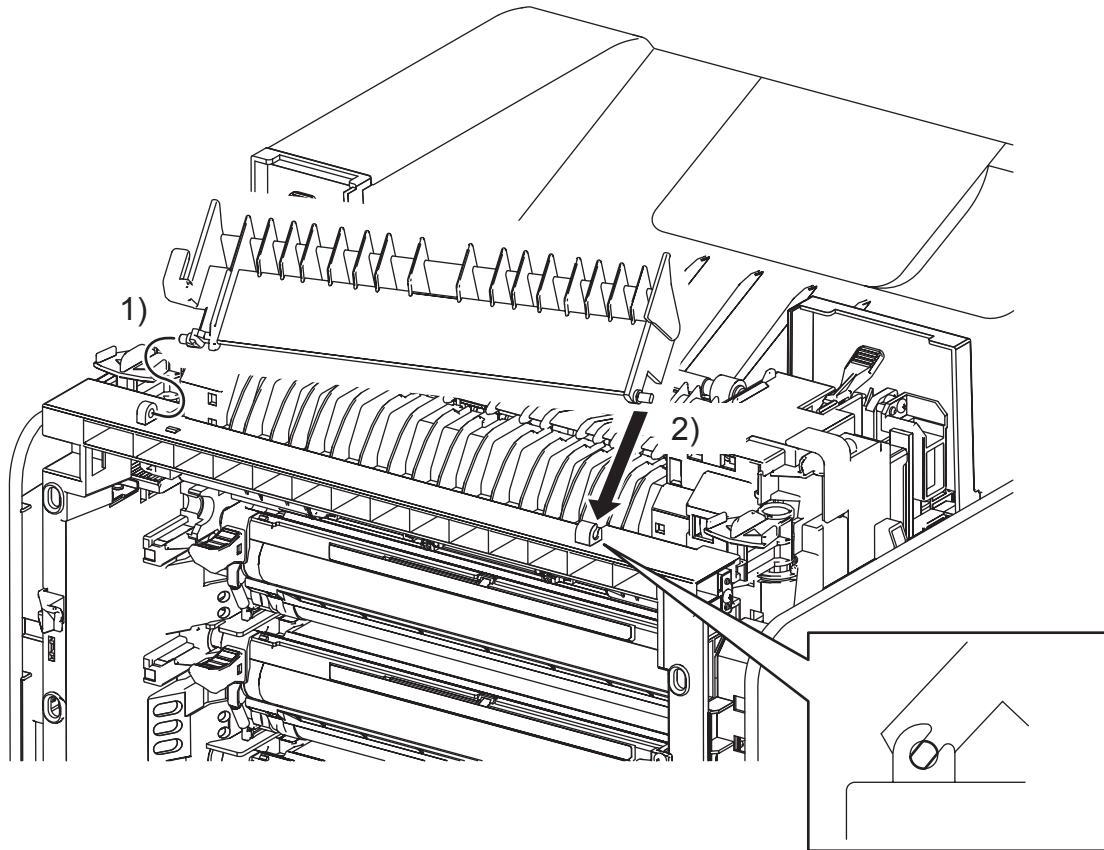

Kmy03069KA

- 1) Insert the left side boss of the DUPLEX GATE with the hole of the printer.
- 2) Open the DUPLEX GATE (PL6.1.13) to about 45 degrees so that the flat faces of the right side pivot of the DUPLEX GATE comes parallel with the U-shaped notch. Push in the right side pivot of the DUPLEX GATE into the U-shaped notch diagonally forward.
- 3) Close the DUPLEX GATE.
- 4) Close the FRONT COVER.

Replacement 40 TONER CARTRIDGE (K), (C), (M), (Y) (PL5.1.18)

NOTE

Described below is the replacement procedure common among TONER CARTRIDGES (C), (M), (Y), and (K).

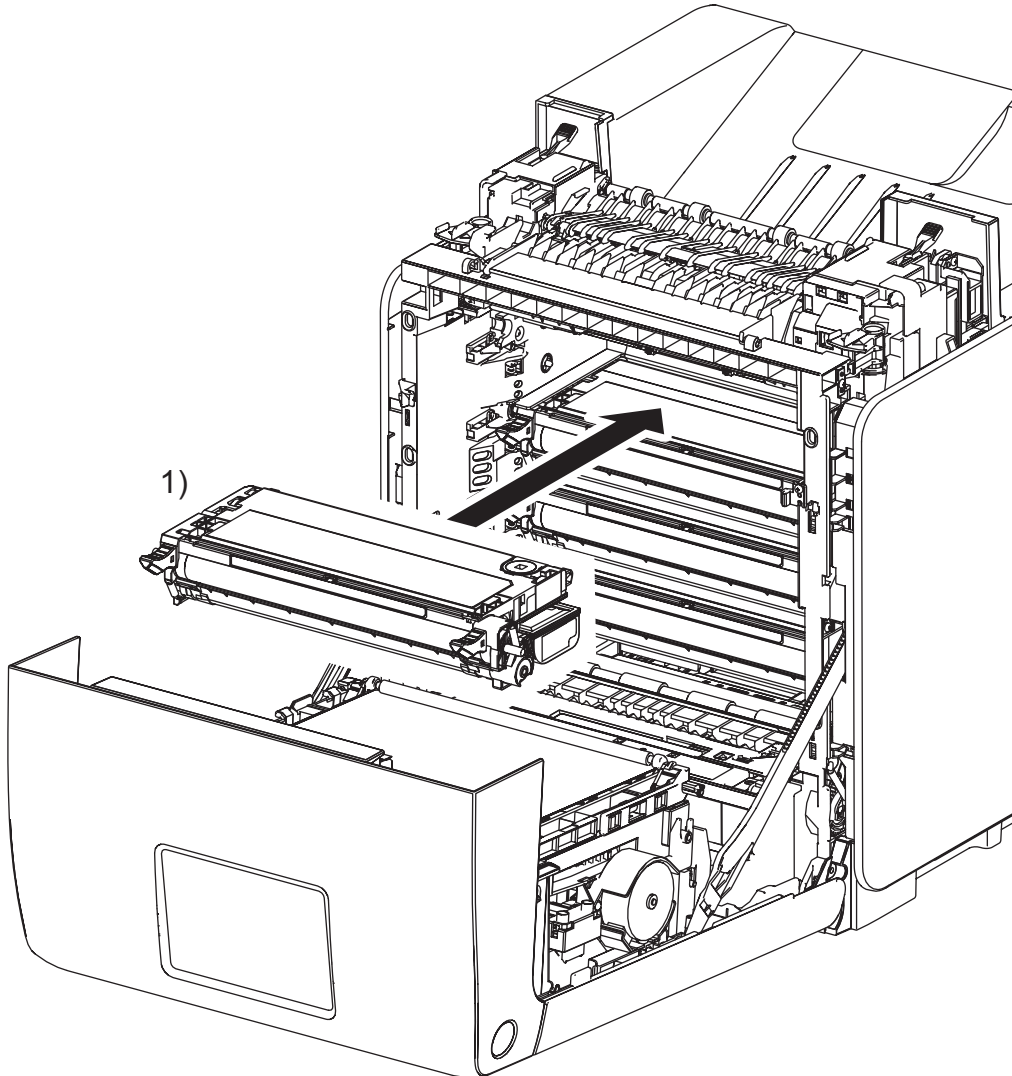

Kmy03068KA

NOTE

If all the TONER CARTRIDGES are removed, attach them in the order of Yellow, Magenta, Cyan, and Black from the bottom.

- 1) Replace the TONER CARTRIDGE inserting it by the left and right handles along the guide on the printer.
- 2) Close the FRONT COVER.

Replacement 41 DUPLEX MODULE (PL11.1.1)

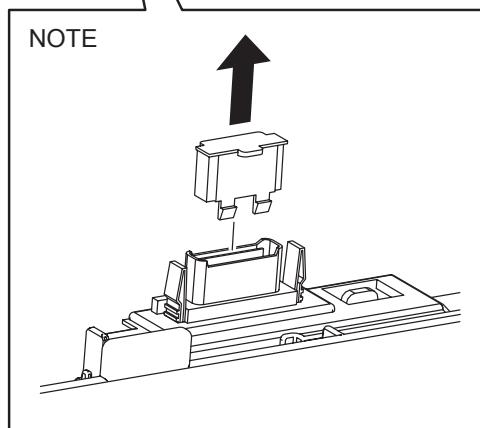
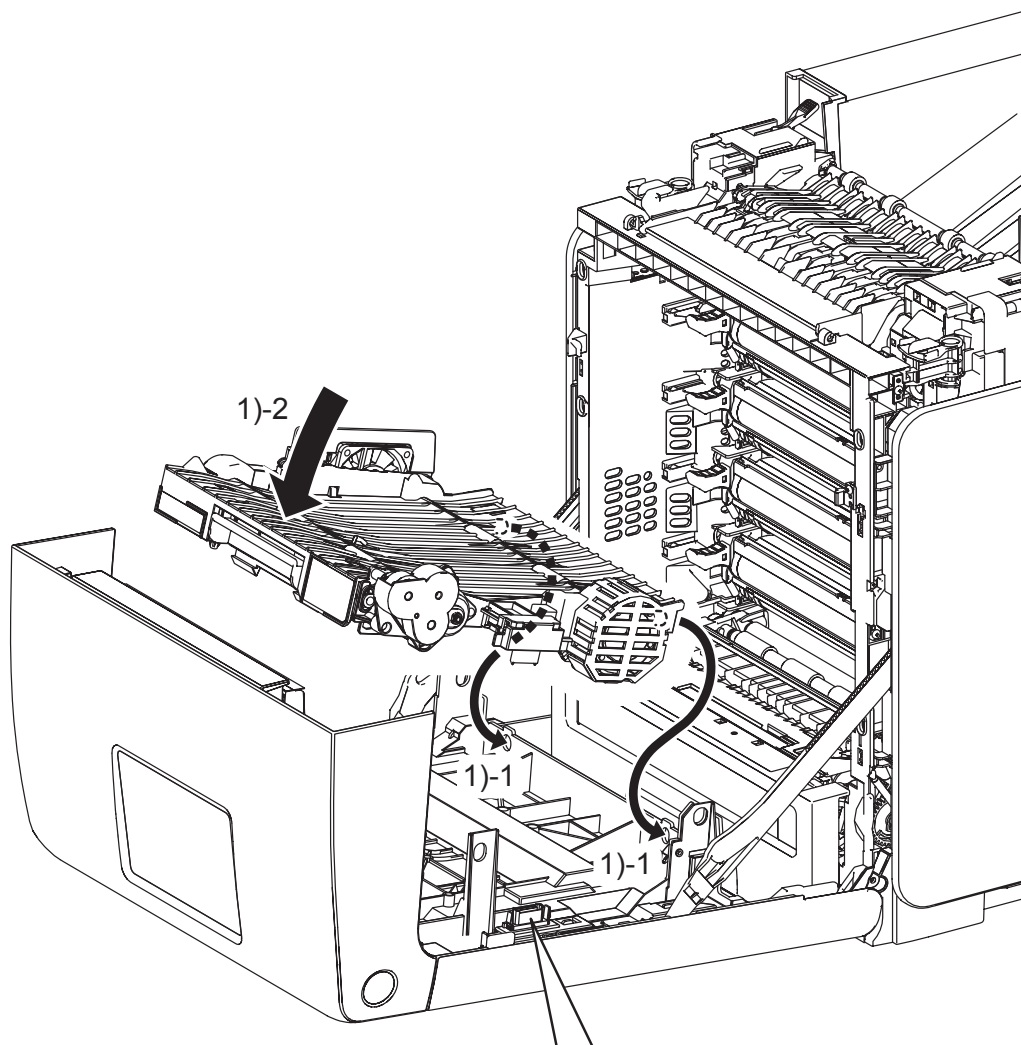

Kmy03067KB

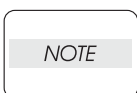

Remove the DUP CONNECTOR CAP (PL1.2.38) of the connector of the FRONT COVER when installing new DUPLEX MODULE.

- 1) Replace the DUPLEX MODULE slowly by mating the two backside bosses of the DUPLEX MODULE with the holes on the FRONT COVER, and then secure with the lever.

**Go to the next replacement step:
Replacement 42 TRANSFER BELT (PL4.1.1)**

Blank Page

Replacement 42 TRANSFER BELT (PL4.1.1)

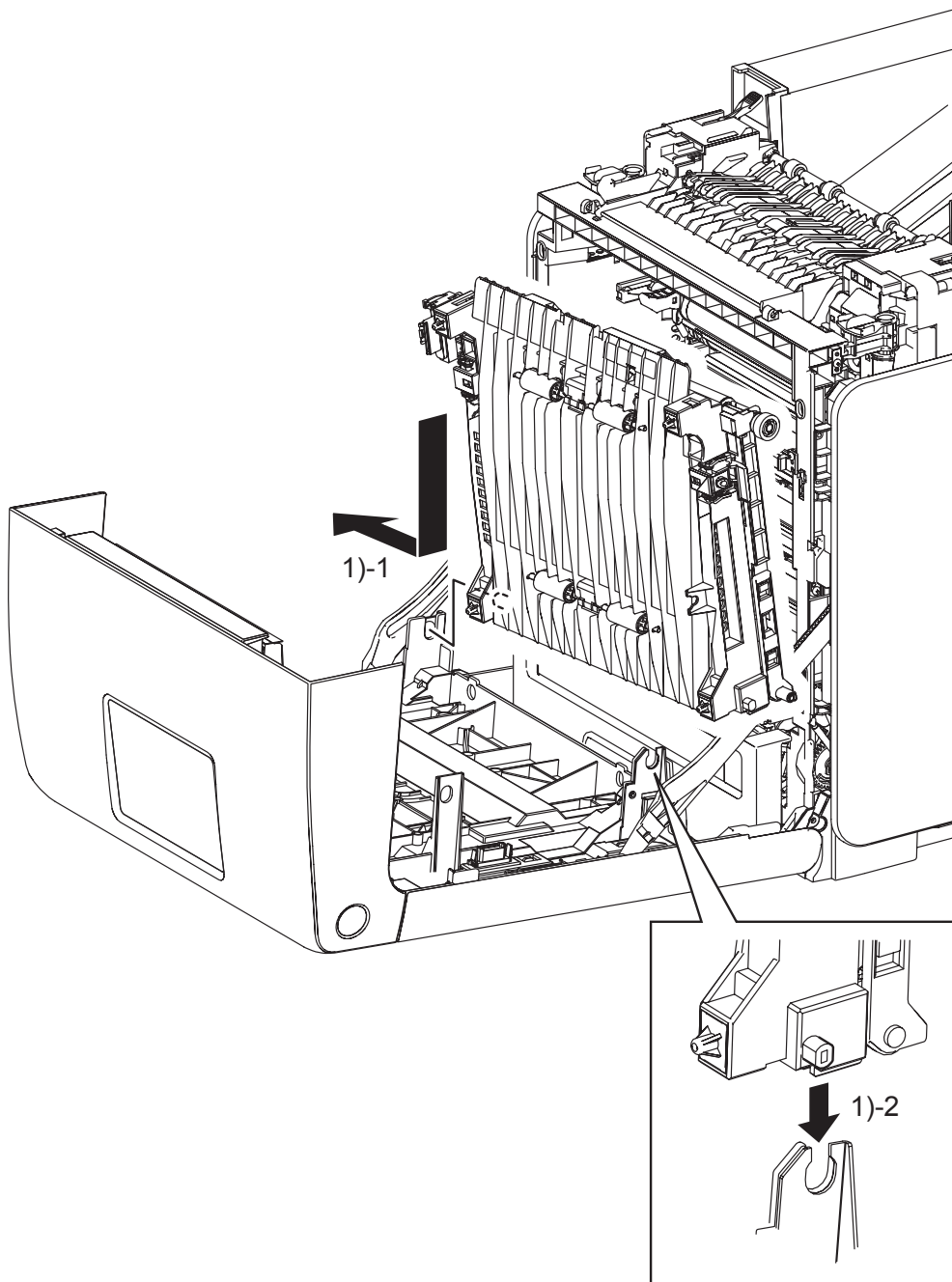

Kmy03065KB

- 1) Replace the TRANSFER BELT by inserting the right side boss on the TRANSFER BELT into the hole on the FRONT COVER and then inserting the left side boss on the TRANSFER BELT into the U-shaped groove on the FRONT COVER.

Continues to the next page.

Replacement 42 TRANSFER BELT (PL4.1.1)

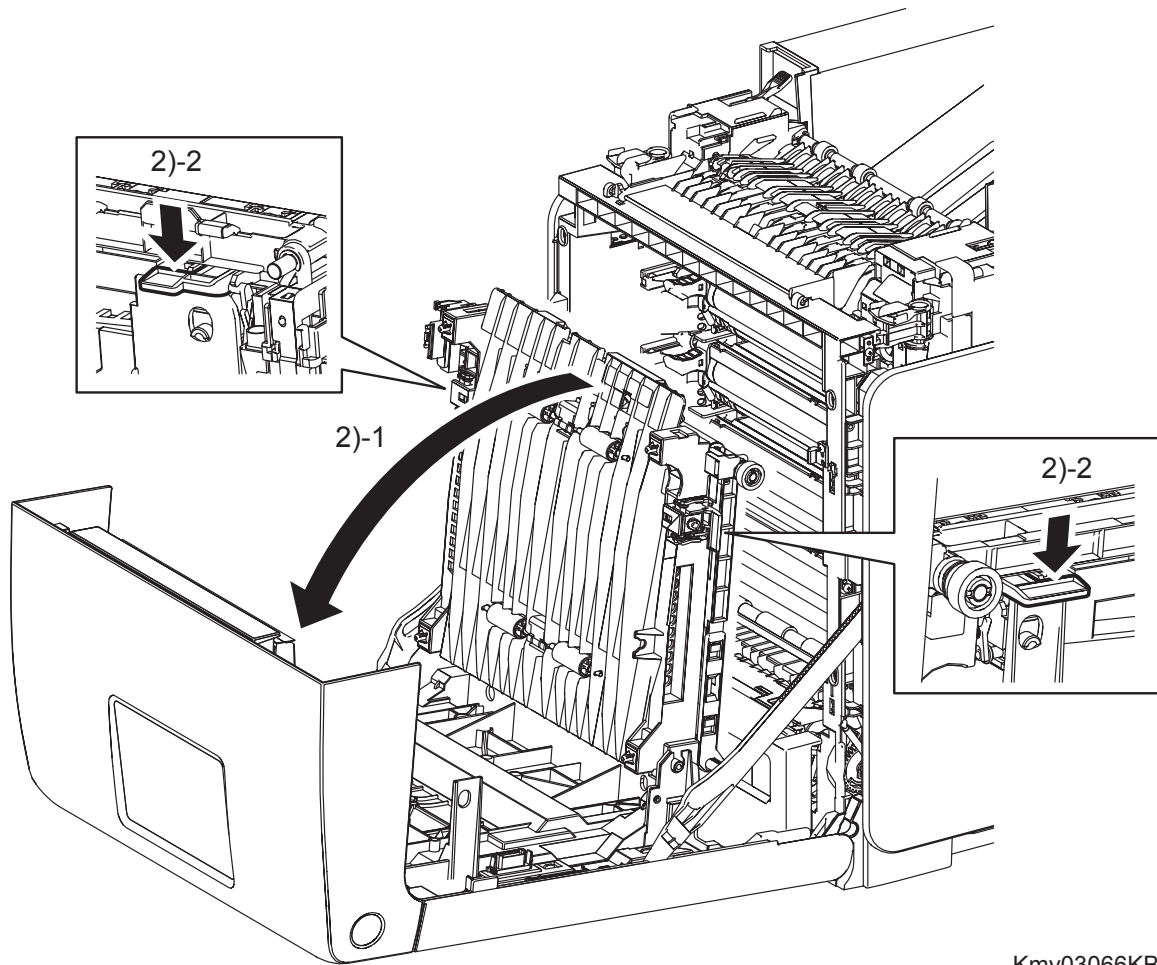

Kmy03066KB

- 2) Tilt the TRANSFER BELT slowly, and then secure with the left and right levers.
- 3) Close the FRONT COVER.

Replacement 43 TRAY REAR COVER (PL1.1.5)

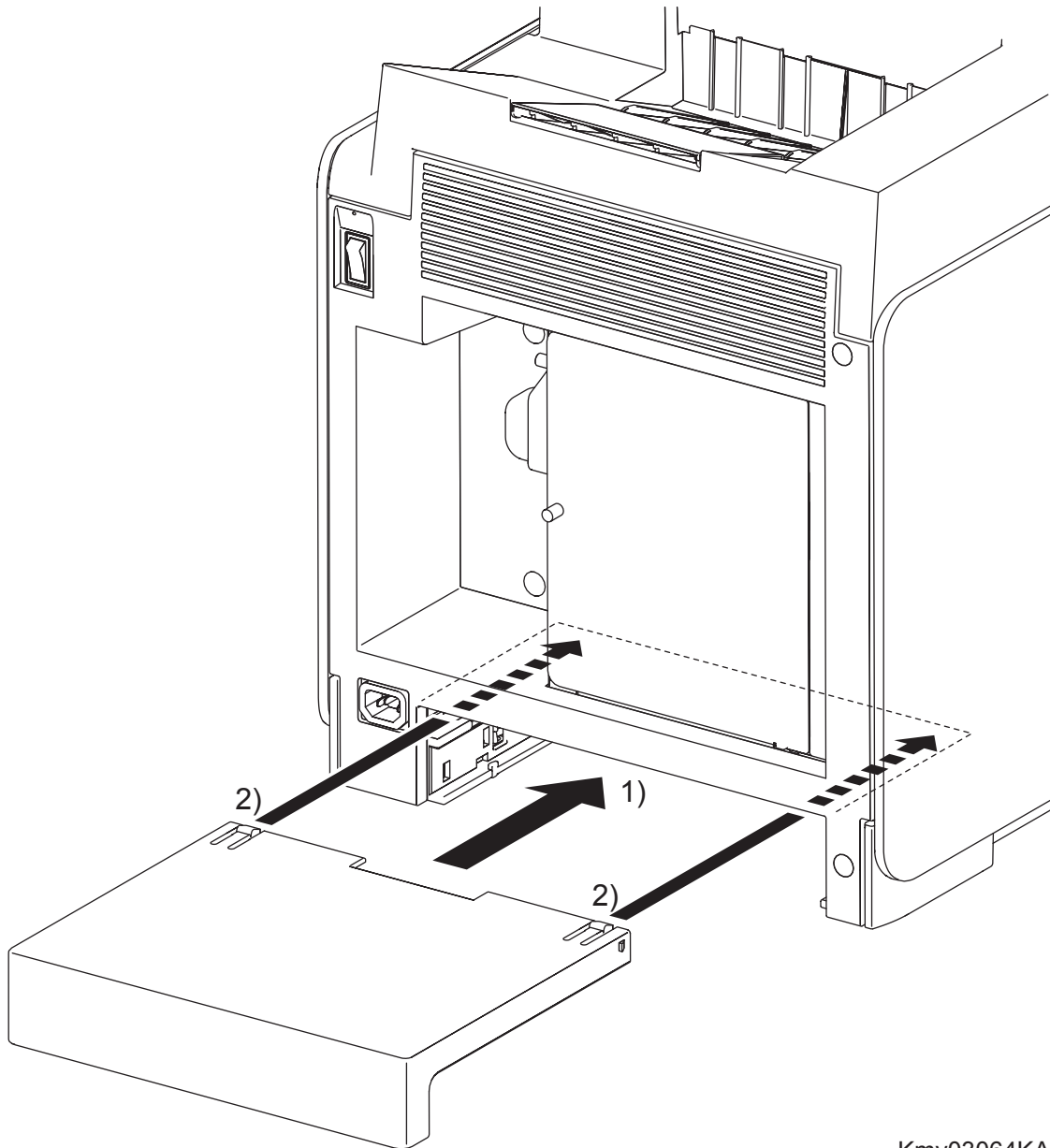

Kmy03064KA

- 1) Insert the TRAY REAR COVER into the printer.
- 2) Secure by locking the two front hooks on TRAY REAR COVER to the printer.

Replacement 44 MPF COVER (PL1.2.99)

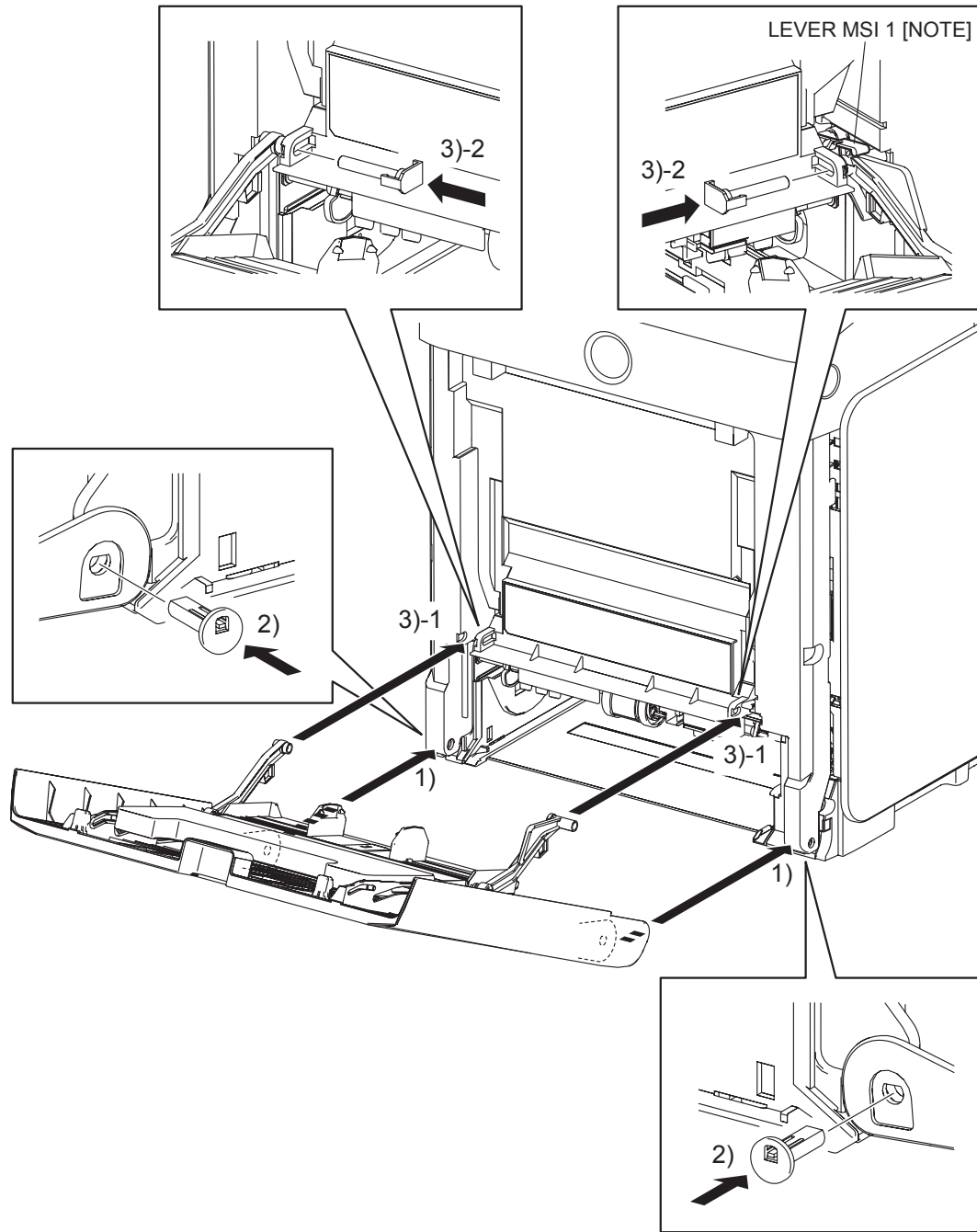

Kmy03063KA

Continues to the next page.

Replacement 44 MPF COVER (PL1.2.99)

- 1) Replace the MPF COVER to the FRONT COVER by mating the left and right side fitting holes on the MPF COVER with the holes on the FRONT COVER.
- 2) Insert the SHAFT PIVOT MSI into the left and right side fitting holes on the MPF COVER, and then secure the SHAFT PIVOT MSI with the hook.

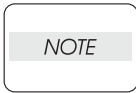

When performing the step described below, make sure that the LEVER MSI 1 is on the LINK ASSY MSI R.

- 3) Mate the LINK ASSY MSIs on the left and right sides of the MPF COVER with the fitting holes on the FRONT COVER. Insert the PIN PIVOT MSI and secure with the hook.
- 4) Close the MPF COVER.

Replacement 45 COVER EXTENDER (PL1.1.9)

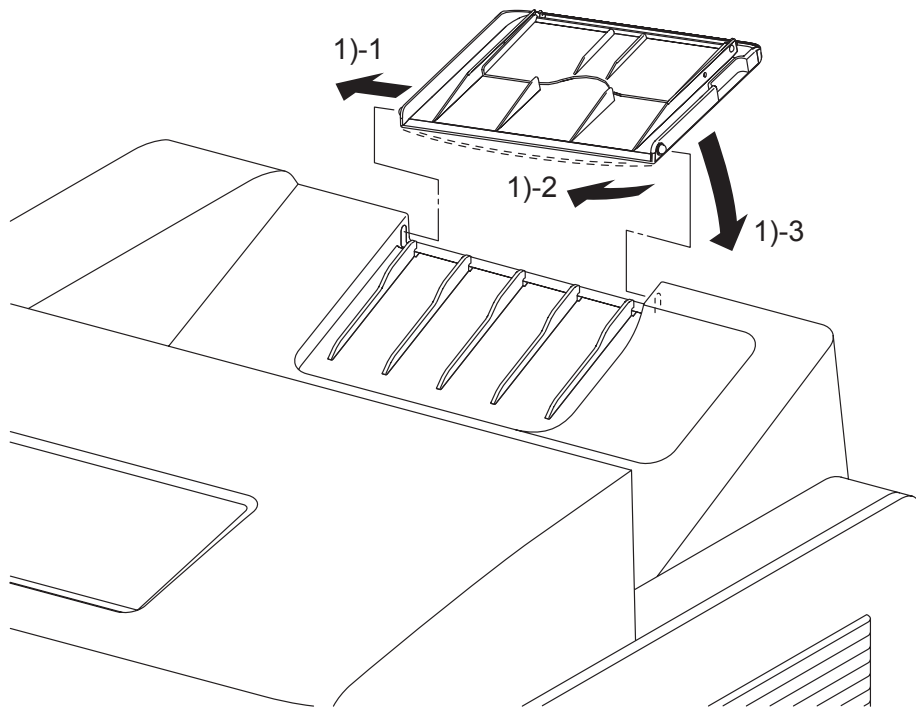

Kmy03062KA

NOTE

When performing the step described below, take care not to damage the boss of the COVER EXTENDER.

- 1) Insert one of the bosses of the COVER EXTENDER, at its open position, into the hole on the TOP COVER, and then bend the COVER EXTENDER to slip the other boss into place.
- 2) Close the COVER EXTENDER.

Blank Page

Replacement 46 MULTI PROTOCOL CARD (PL9.1.31)

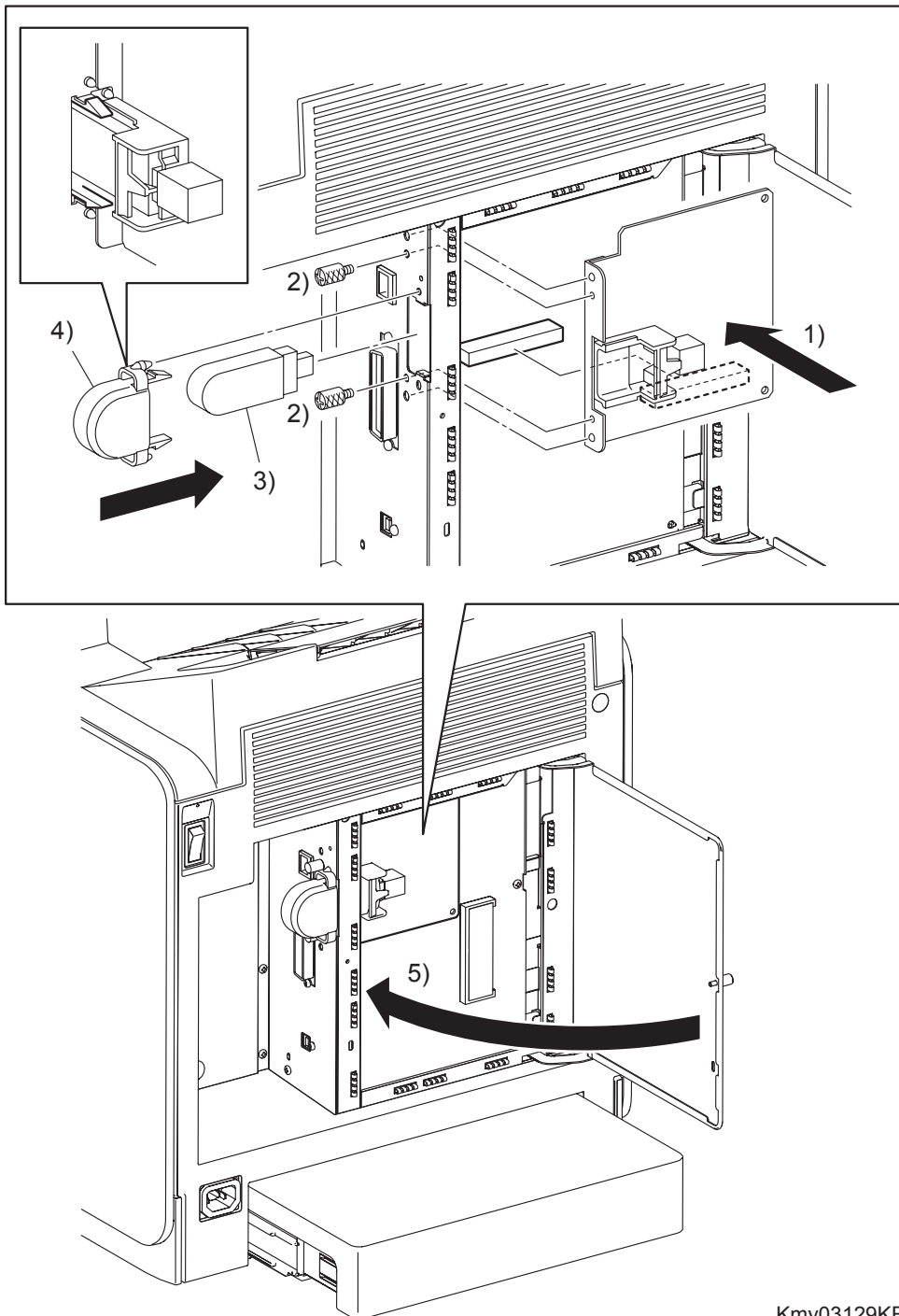

Kmy03129KB

- 1) Mate the two bosses on the MULTI PROTOCOL CARD with the holes on the printer, and then replace the MULTI PROTOCOL CARD to the ELECTRONIC SUB-SYSTEM CONTROL BOARD.
- 2) Secure the MULTI PROTOCOL CARD to the printer using the two SCREW KNURLINGS (PL9.1.22).
- 3) Replace the WIRELESS LAN ADAPTER to the MULTI PROTOCOL CARD.
- 4) Replace the COVER USB to the printer and secure with the hook.
- 5) Close the SHIELD WINDOW and secure the SCREW KNURLING.

Replacement 47 MEMORY CARD (PL9.1.30)

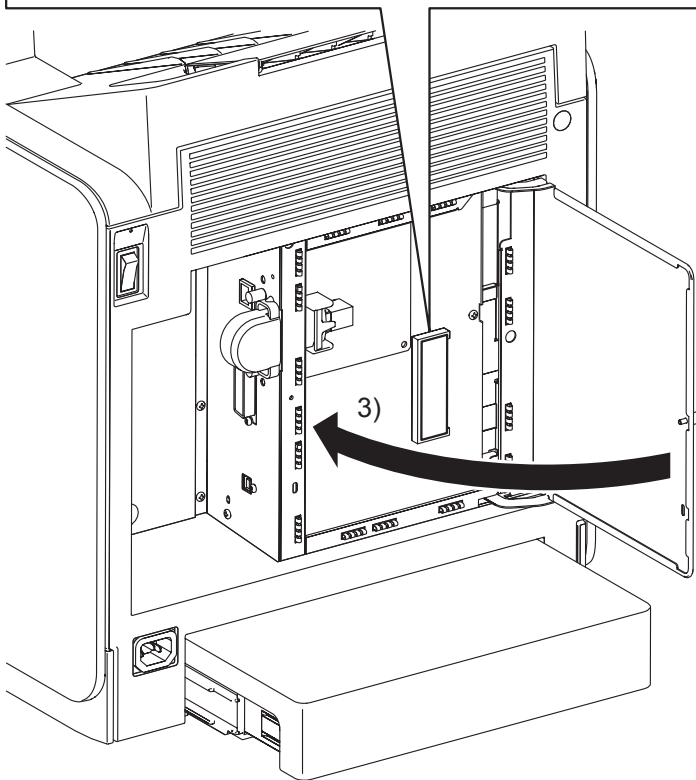
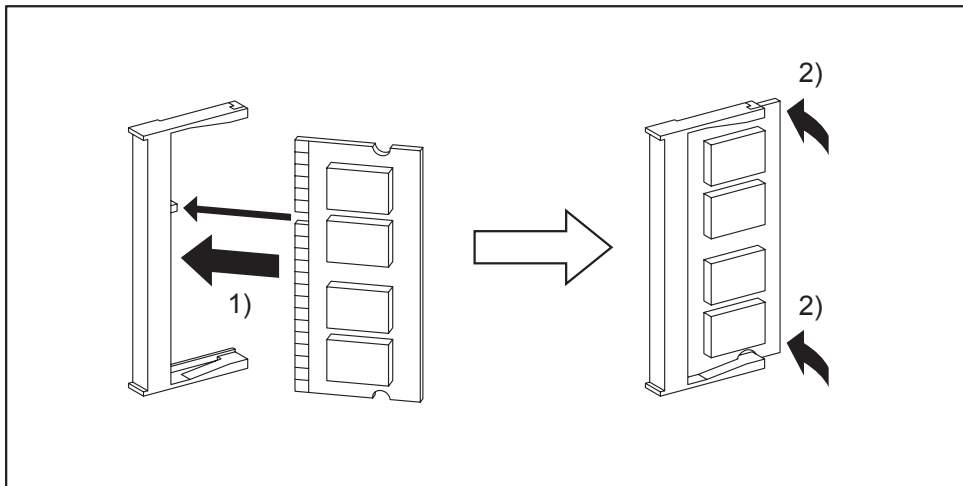

Kmy03130KB

- 1) Fit the MEMORY CARD into the socket by mating the notch of the MEMORY CARD with the lug on the socket.
- 2) Push the MEMORY CARD toward the ELECTRONIC SUB-SYSTEM CONTROL BOARD until it snaps into place.
- 3) Close the SHIELD WINDOW and secure the SCREW KNURLING.

Chapter 4 Plug/Jack(P/J) Connector Locations CONTENTS

1. Connector [P (plug) / J (jack)].....	4 - 1
1.1 List of P/J	4 - 1
1.2 IOT P/J layout diagram	4 - 4
1.3 DUPLEX P/J layout diagram.....	4 - 8
1.4 OPTION FEEDER P/J layout diagram.....	4 - 9

1. Connector [P (plug) / J (jack)]

1.1 List of P/J

IOT

P/J	Coordinates	Remarks
3	F-139	Connects ELECTRONIC SUB-SYSTEM CONTROL BOARD and MULTI PROTOCOL CARD
10	D-157	Connects MACHINE CONTROL UNIT and ESS Harness Assembly
11	D-156	Connects MACHINE CONTROL UNIT and VIDEO Harness Assembly
12	C-156	Connects MACHINE CONTROL UNIT and ROS Harness Assembly
14	C-156	Connects MACHINE CONTROL UNIT and LV TOP Harness Assembly
15	B-157	Connects MACHINE CONTROL UNIT and LV TOP Harness Assembly
16	C-156	Connects MACHINE CONTROL UNIT and HIGH VOLTAGE POWER SUPPLY
17	C-156	Connects MACHINE CONTROL UNIT and FUSER Harness Assembly
18	B-157	Connects MACHINE CONTROL UNIT and LV TOP Harness Assembly
19	B-156	Connects MACHINE CONTROL UNIT and TNR SNR Harness Assembly
21	B-158	Connects MACHINE CONTROL UNIT and R SIDE Harness Assembly
22	B-158	Connects MACHINE CONTROL UNIT and R SIDE Harness Assembly
23	B-159	Connects MACHINE CONTROL UNIT and R SIDE Harness Assembly
24	C-159	Connects MACHINE CONTROL UNIT and OHP Harness Assembly
25	B-158	Connects MACHINE CONTROL UNIT and R SIDE Harness Assembly
26	C-159	Connects MACHINE CONTROL UNIT and HUM Harness Assembly
27	C-159	Connects MACHINE CONTROL UNIT and R SIDE Harness Assembly
29	F-138	Connects ELECTRONIC SUB-SYSTEM CONTROL BOARD and ESS Harness Assembly
31	C-159	Connects MACHINE CONTROL UNIT and CRUM Harness Assembly
40	F-149	Connects LOW VOLTAGE POWER SUPPLY and LV TOP Harness Assembly
44	E-149	Connects LOW VOLTAGE POWER SUPPLY and INTERLOCK SWITCH
47	E-150	Connects LOW VOLTAGE POWER SUPPLY and FUSER Harness Assembly
48	E-150	Connects LOW VOLTAGE POWER SUPPLY and INLET Harness Assembly
101	F-138	Connects ELECTRONIC SUB-SYSTEM CONTROL BOARD and ESS Harness Assembly
101	C-158	Not Connects (Debug only)
111	F-139	Connects ELECTRONIC SUB-SYSTEM CONTROL BOARD and VIDEO Harness Assembly
121	H-122	Connects PRINT HEAD and ROS Harness Assembly
141	I-136	Connects LED ASSEMBLY and LV TOP Harness Assembly
144	D-153	Connects PWBA EEPROM (XPRO) and R SIDE Harness Assembly
144	C-108	Connects PWBA EEPROM (BELT) and BELT Harness Assembly (TRANSFER BELT)
161	G-136	Connects HIGH VOLTAGE POWER SUPPLY and MACHINE CONTROL UNIT
171	H-106	Connects FUSER and FUSER Harness Assembly
181	I-139	Connects TONER DISPENSER (Y) and LV TOP Harness Assembly
182	H-138	Connects TONER DISPENSER (M) and LV TOP Harness Assembly
183	H-136	Connects TONER DISPENSER (K) and LV TOP Harness Assembly
184	H-137	Connects TONER DISPENSER (C) and LV TOP Harness Assembly

P/J	Coordinates	Remarks
191	H-124	Connects TONER CARTRIDGE SENSOR ASSEMBLY (Y) and TNR SNR Harness Assembly
192	H-124	Connects TONER CARTRIDGE SENSOR ASSEMBLY (M) and TNR SNR Harness Assembly
193	H-122	Connects TONER CARTRIDGE SENSOR ASSEMBLY (K) and TNR SNR Harness Assembly
194	H-123	Connects TONER CARTRIDGE SENSOR ASSEMBLY (C) and TNR SNR Harness Assembly
211	H-107	Connects PHOTOCONDUCTOR(PC) / DEVELOPER(DEV) DRIVE (Main Motor) and R SIDE Harness Assembly
220	D-105	Connects OPERATOR PANEL and OPEPANE Harness Assembly
221	H-108	Connects PHOTOCONDUCTOR(PC) / DEVELOPER(DEV) DRIVE (Sub Motor) and R SIDE Harness Assembly
222	G-109	Connects PHOTOCONDUCTOR(PC) / DEVELOPER(DEV) DRIVE (Deve Motor) and R SIDE Harness Assembly
231	I-125	Connects SIZE SWITCH ASSEMBLY and R SIDE Harness Assembly
232	H-125	Connects INTEGRATED FEEDER ASSEMBLY (REGI SNR Harness Assembly) and R SIDE Harness Assembly
233	H-123	Connects INTEGRATED FEEDER ASSEMBLY (REGI Clutch) and R SIDE Harness Assembly
234	I-124	Connects INTEGRATED FEEDER ASSEMBLY (Turn Clutch) and R SIDE Harness Assembly
235	H-123	Connects INTEGRATED FEEDER ASSEMBLY (CST Feed Clutch) and R SIDE Harness Assembly
236	H-111	Connects MPF FEED SOLENOID and R SIDE Harness Assembly
241	I-125	Connects OHP SNR Harness Assembly and OHP Harness Assembly
251	H-110	Connects FEED DRIVE ASSEMBLY (PH Motor) and R SIDE Harness Assembly
261	H-152	Connects HUMIDITY SENSOR and HUM Harness Assembly
272	I-110	Connects FRONT COVER Harness Assembly and R SIDE Harness Assembly
273	H-126	Connects R SIDE Harness Assembly and 550 SHEET FEEDER ASSEMBLY (FDR UNIT Harness Assembly)
275	I-108	Connects MSI NPP Harness Assembly and R SIDE Harness Assembly
276	I-109	Connects EXIT CLT Harness Assembly and R SIDE Harness Assembly
311	G-124	Connects CRUM Sensor (Y) and CRUM Harness Assembly
312	G-123	Connects CRUM Sensor (M) and CRUM Harness Assembly
313	G-122	Connects CRUM Sensor (C) and CRUM Harness Assembly
314	G-122	Connects CRUM Sensor (K) and CRUM Harness Assembly
401	F-138	Connects ELECTRONIC SUB-SYSTEM CONTROL BOARD and LV TOP Harness Assembly
481	E-151	Connects POWER SWITCH and INLET Harness Assembly
501	F-149	Connects LOW VOLTAGE POWER SUPPLY and LV TOP Harness Assembly
502	F-149	Connects LOW VOLTAGE POWER SUPPLY and LV TOP Harness Assembly
503	F-149	Connects LOW VOLTAGE POWER SUPPLY and FAN
504	F-149	Connects LOW VOLTAGE POWER SUPPLY and LV TOP Harness Assembly
2321	D-125	Connects INTEGRATED FEEDER ASSEMBLY (CST No Paper Sensor) and REGI SNR Harness Assembly
2322	E-125	Connects INTEGRATED FEEDER ASSEMBLY (REGI Sensor) and REGI SNR Harness Assembly

P/J	Coordiates	Remarks
2411	F-125	Connects PWBA OHP SNR and OHP SNR Harness Assembly
2412	F-125	Connects PWBA OHP LED and OHP SNR Harness Assembly
2721	B-107	Connects TRANSFER BELT and FRONT COVER Harness Assembly
2751	E-110	Connects MSI No Paper Sensor and MSI NPP Harness Assembly
2761	I-107	Connects PHOTOCONDUCTOR(PC) / DEVELOPER(DEV) DRIVE (Exit Clutch) and EXIT CLT Harness Assembly
2900	I-109	Connects OPEPANE Harness Assembly and ESS Harness Assembly
5041	F-138	Not Connects (Used in production process only)
27212	D-106	Connects ADC Sensor and BELT Harness Assembly (TRANSFER BELT)
27213	D-107	Connects ADC Solenoid and BELT Harness Assembly (TRANSFER BELT)

DUP

P/J	Coordiates	Remarks
1	E-168	Not Connects (Debug only)
427	F-168	Connects PWBA DUP and FAN DUP
428	F-168	Connects PWBA DUP and DUP UNIT Harness Assembly
429	F-169	Connects PWBA DUP and MOTOR ASSY DUP
430	F-168	Connects PWBA DUP and DUP SNR Harness Assembly
431	F-168	Connects PWBA DUP and DUP Clutch
2720	I-169	Connects DUPLEX MODULE (DUP UNIT Harness Assembly) and PRINTER
4301	E-167	Connects DUP Jam Sensor and DUP SNR Harness Assembly

OPT FEEDER

P/J	Coordiates	Remarks
1	G-180	Not Connects (Debug only)
273	H-183	Connects 550 SHEET FEEDER ASSEMBLY (FDR UNIT Harness Assembly) and PRINTER
419	G-180	Connects PWBA OPT FDR and FDR UNIT Harness Assembly
420	G-180	Connects PWBA OPT FDR and C2 TURN Harness Assembly
421	G-179	Connects PWBA OPT FDR and C2 CHUTE Harness Assembly
422	G-179	Connects PWBA OPT FDR and C2 MOT Harness Assembly
423	G-180	Not Connects
4201	H-185	Connects C2 TURN CLUTCH and C2 TURN Harness Assembly
4202	H-185	Not Connects
4211	I-184	Connects SWITCH ASSY SIZE OPT and C2 CHUTE Harness Assembly
4212	H-184	Connects C2 CHUTE Harness Assembly and C2 NO PAPER Harness Assembly
4213	H-185	Connects C2 FEED CLUTCH and C2 CHUTE Harness Assembly
4221	G-185	Connects DRIVE ASSY OPT FDR (OPT FDR Motor) and C2 MOT Harness Assembly
4222	G-185	Connects DRIVE ASSY OPT FDR (OPT FDR Motor) and C2 MOT Harness Assembly
42121	D-183	Connects C2 CST No Paper Sensor and C2 NO PAPER Harness Assembly

1.2 IOT P/J layout diagram

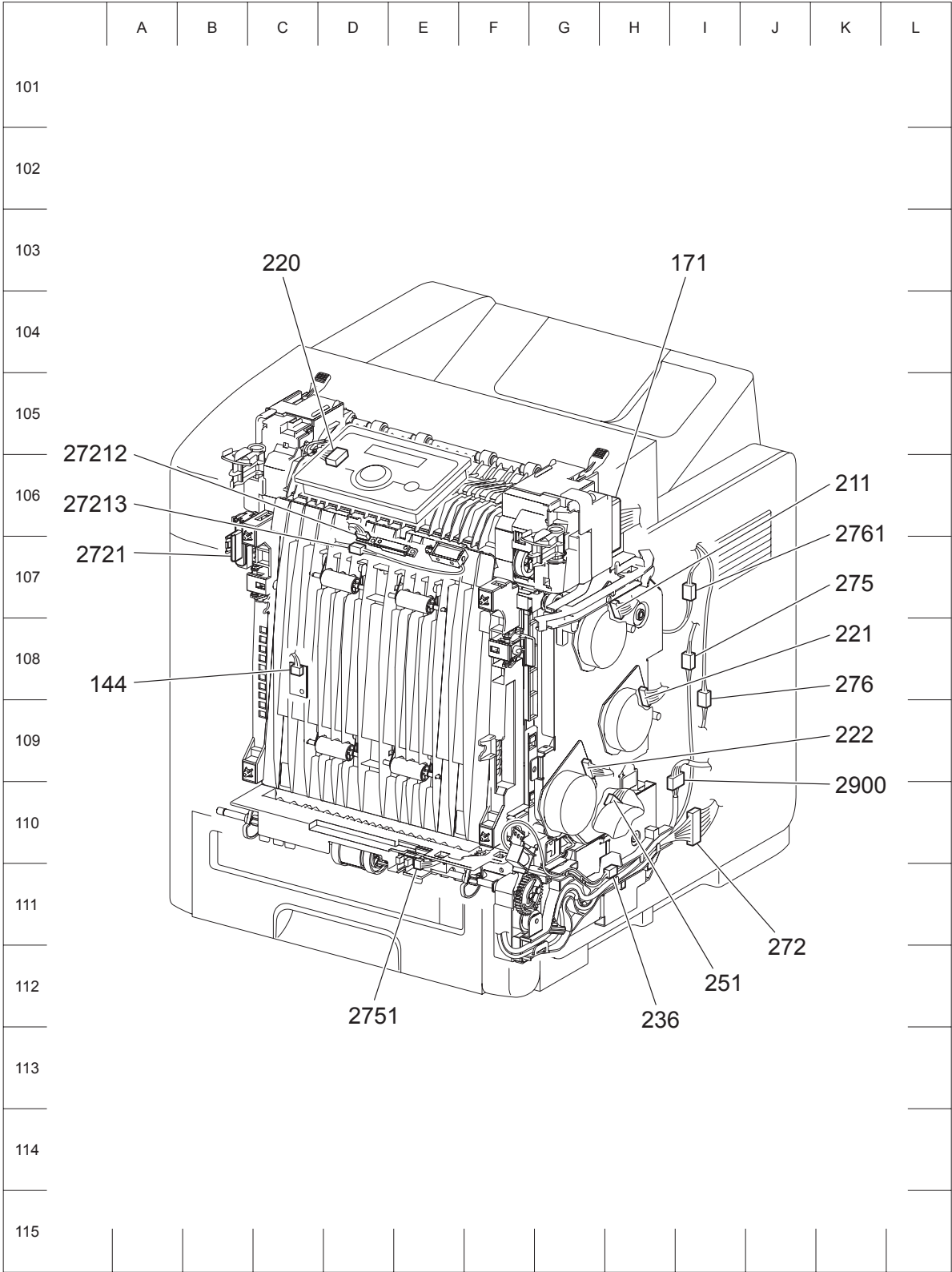

Kmy04001KB

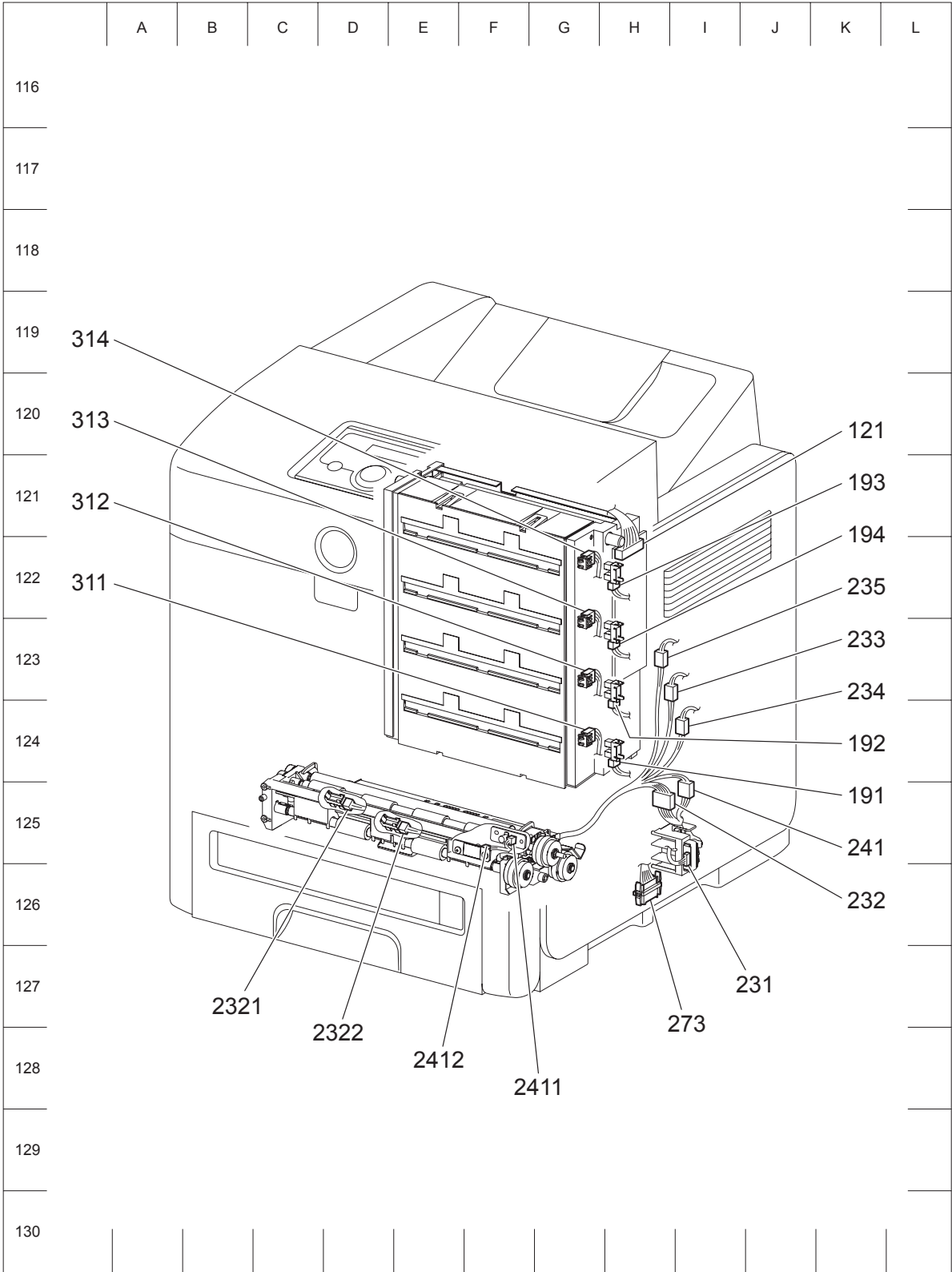

Kmy04002KA

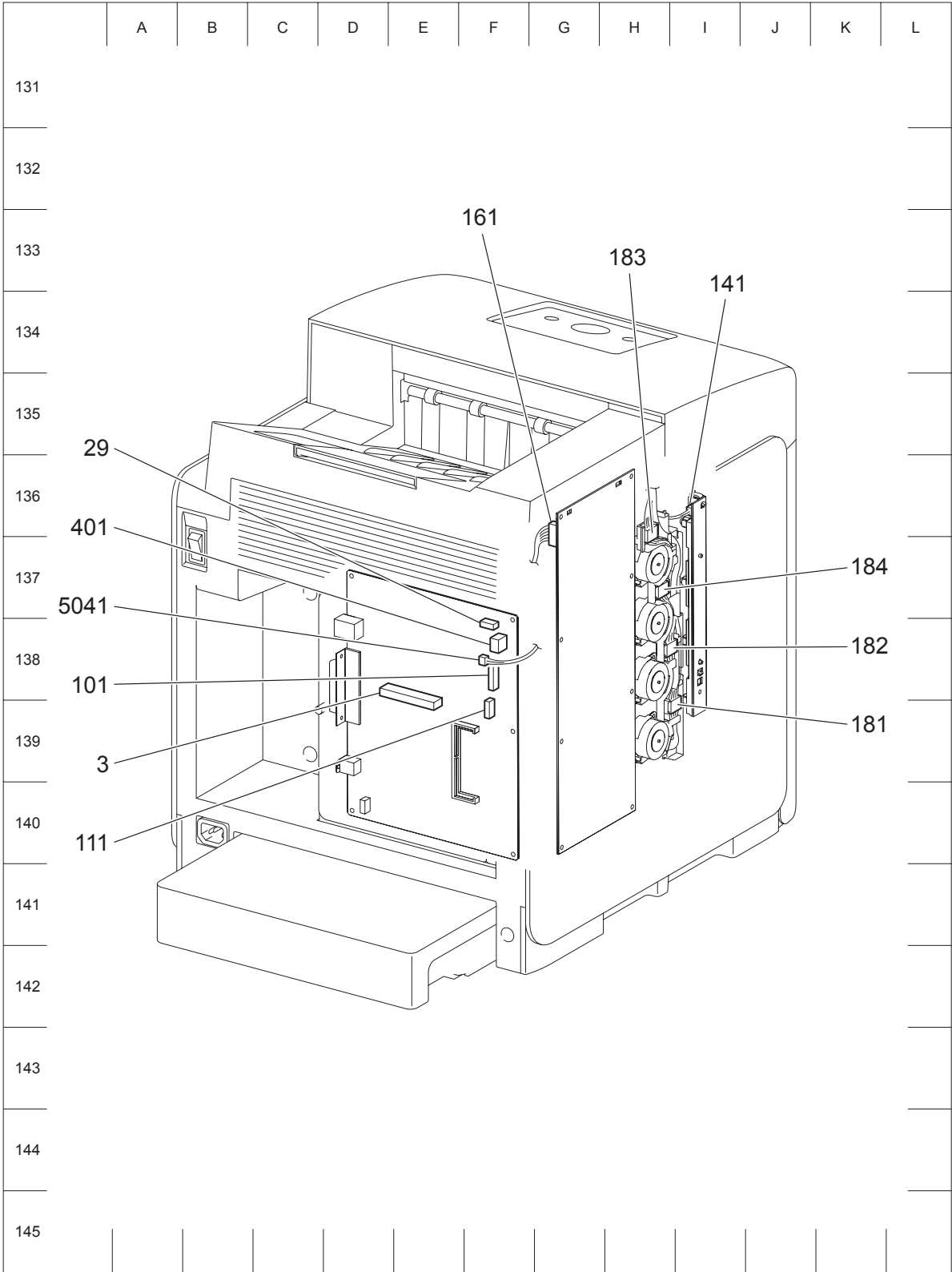

Kmy04003KC

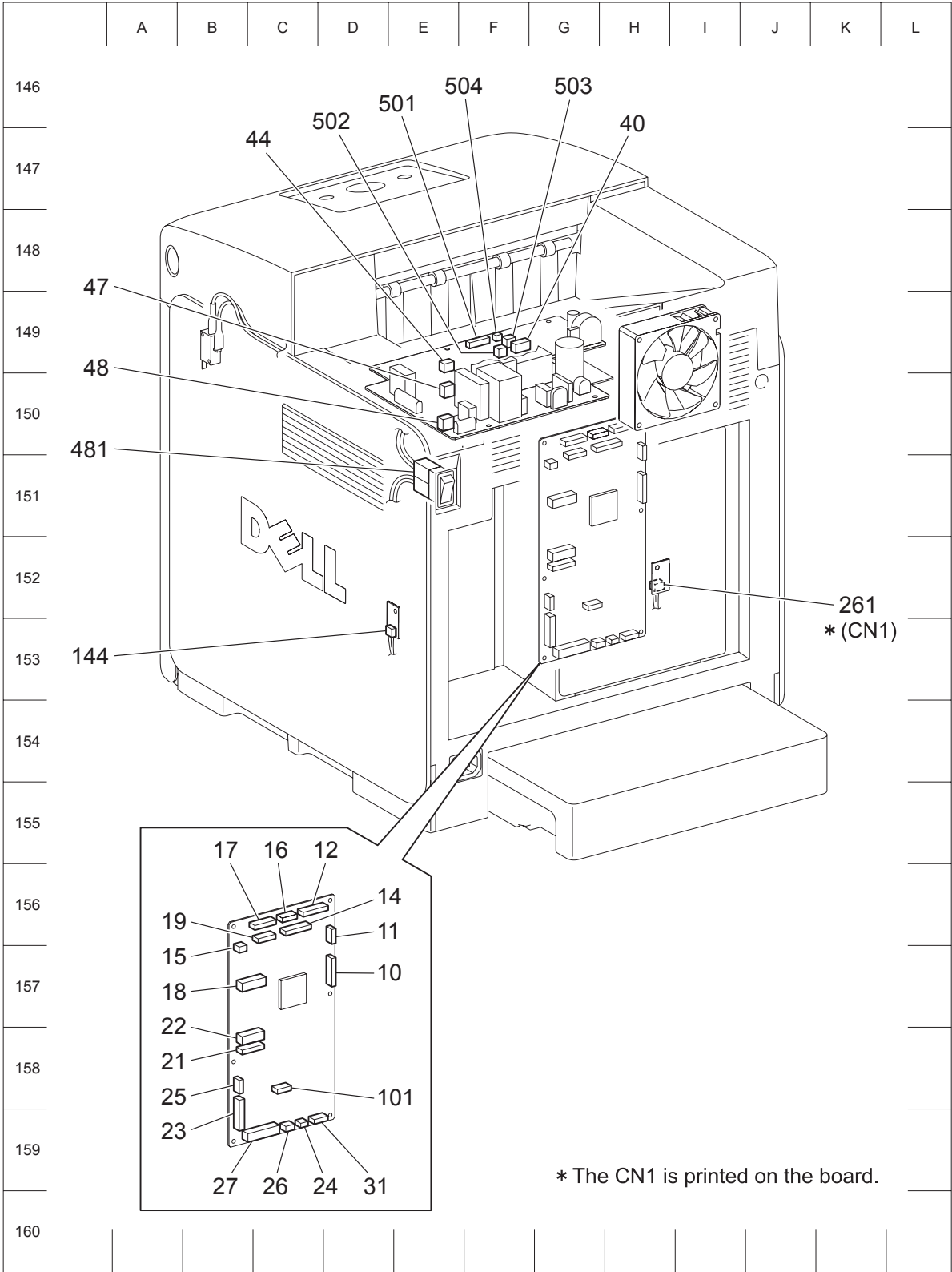

Kmy04004KA

1.3 DUPLEX P/J layout diagram

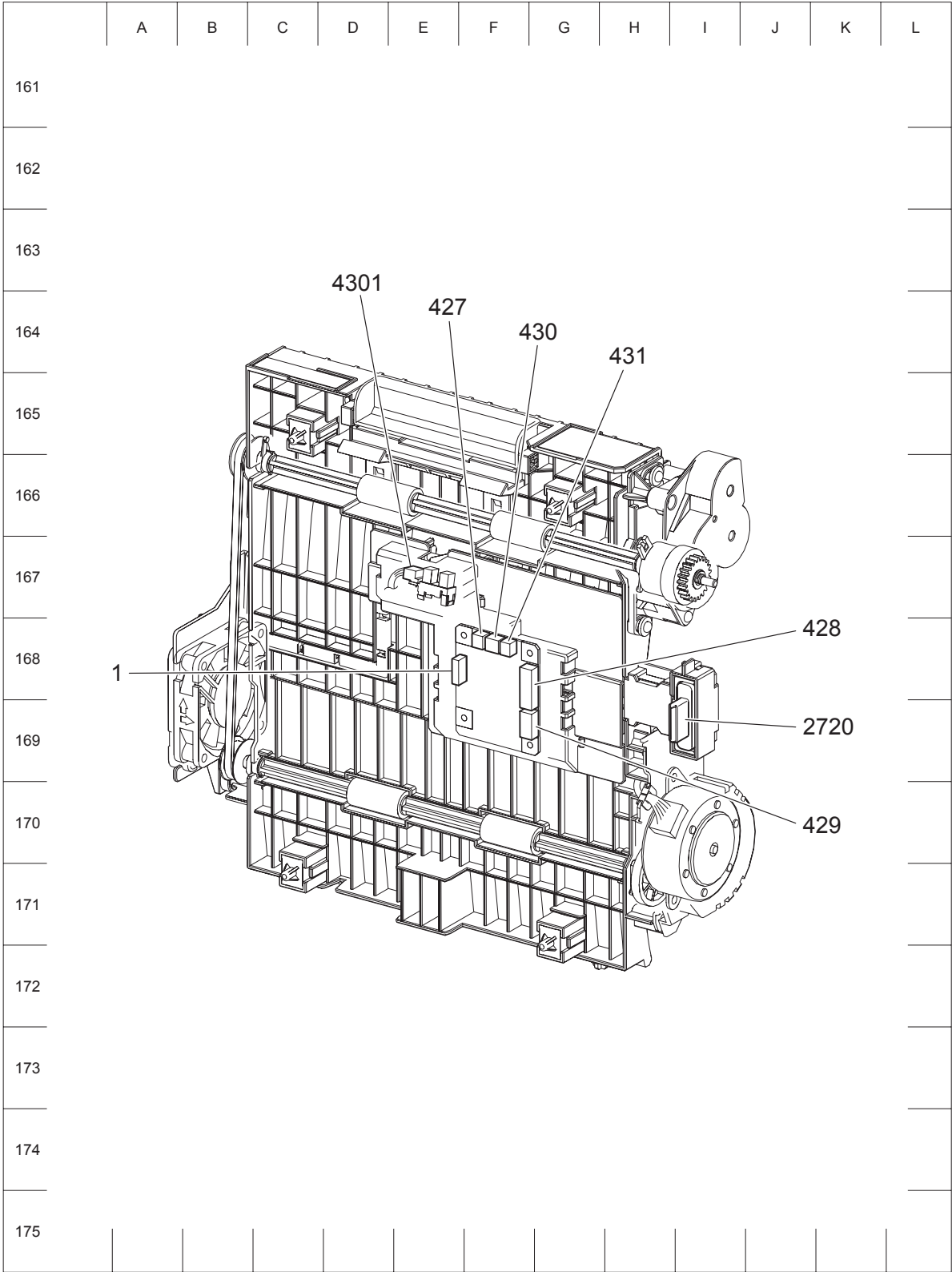

Kmy04005KA

1.4 OPTION FEEDER P/J layout diagram

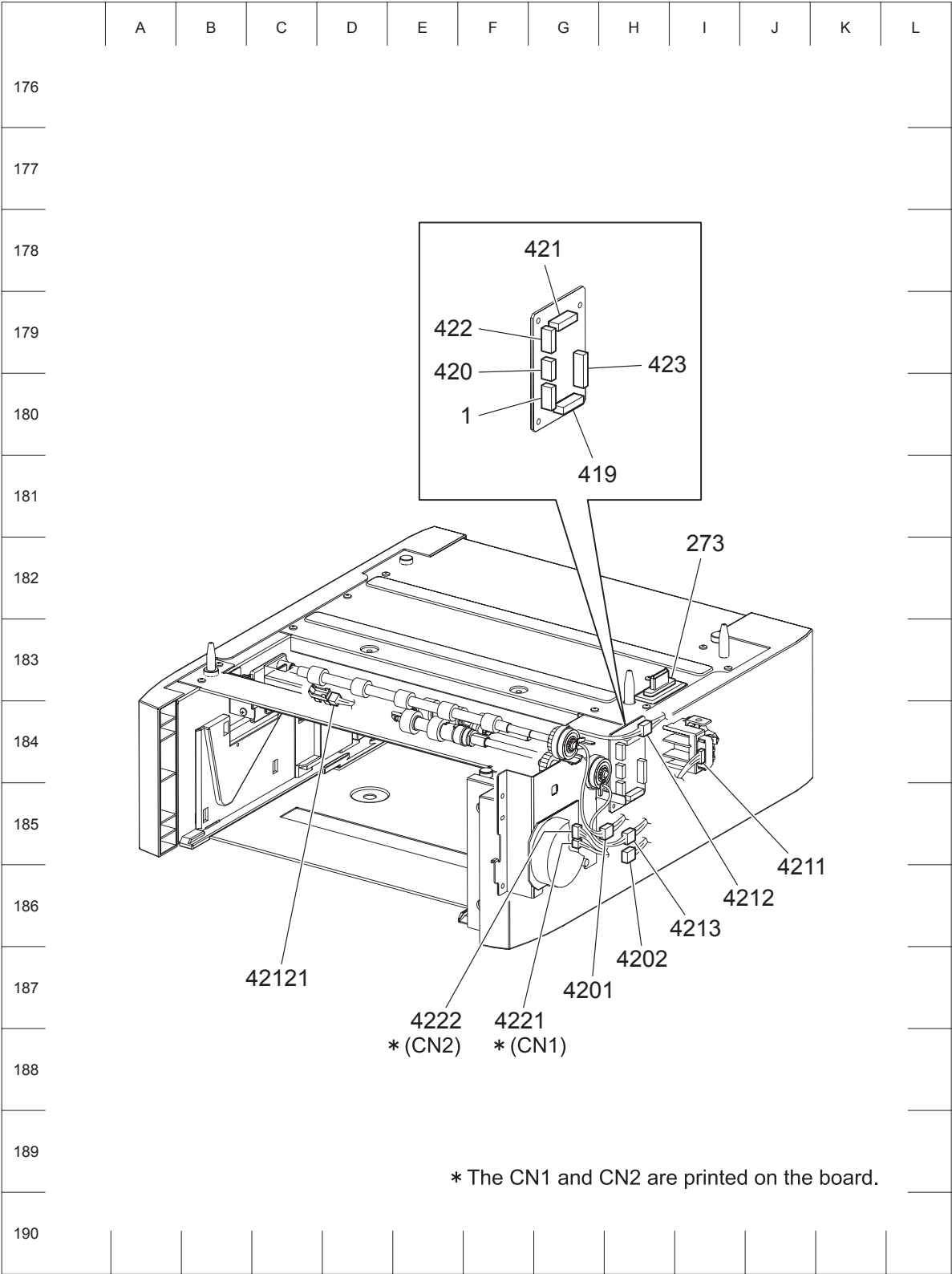

Kmy04006KB

Blank page

Chapter 5 Parts List CONTENTS

1. Parts List.....	5 - 1
1.1 Caution for use of spare parts illustration	5 - 1
1.2 Caution for use of engineering parts list	5 - 1
Customer Replaceable Parts Illustration.....	5 - 2
Engineering parts list	5 - 8
PL1.1 Cover (1/2) [Illustration]	5 - 8
PL1.1 Cover (1/2) [List]	5 - 9
PL1.2 Cover (2/2) [Illustration]	5 - 10
PL1.2 Cover (2/2) [List]	5 - 11
PL2.1 Paper Cassette (1/2) [Illustration]	5 - 12
PL2.1 Paper Cassette (1/2) [List]	5 - 13
PL2.2 Paper Cassette (2/2) [Illustration]	5 - 14
PL2.2 Paper Cassette (2/2) [List]	5 - 15
PL3.1 Paper Feeder (1/2) [Illustration]	5 - 16
PL3.1 Paper Feeder (1/2) [List]	5 - 17
PL3.2 Paper Feeder (2/2) [Illustration]	5 - 18
PL3.2 Paper Feeder (2/2) [List]	5 - 19
PL4.1 Transfer [Illustration]	5 - 20
PL4.1 Transfer [List]	5 - 21
PL5.1 Xerographics [Illustration]	5 - 22
PL5.1 Xerographics [List]	5 - 23
PL6.1 Fuser & Exit [Illustration]	5 - 24
PL6.1 Fuser & Exit [List]	5 - 25
PL7.1 Frame [Illustration]	5 - 26
PL7.1 Frame [List]	5 - 27
PL8.1 Drive [Illustration]	5 - 28
PL8.1 Drive [List]	5 - 29
PL9.1 Electrical [Illustration]	5 - 30
PL9.1 Electrical [List]	5 - 31
PL10.1 Harness [Illustration]	5 - 32
PL10.1 Harness [List]	5 - 33
PL11.1 Duplex (Option) (1/2) [Illustration]	5 - 34
PL11.1 Duplex (Option) (1/2) [List]	5 - 35
PL11.2 Duplex (Option) (2/2) [Illustration]	5 - 36
PL11.2 Duplex (Option) (2/2) [List]	5 - 37
PL12.1 550 Feeder (Option) (1/5) [Illustration]	5 - 38
PL12.1 550 Feeder (Option) (1/5) [List]	5 - 39
PL12.2 550 Feeder (Option) (2/5) [Illustration]	5 - 40
PL12.2 550 Feeder (Option) (2/5) [List]	5 - 41
PL12.3 550 Feeder (Option) (3/5) [Illustration]	5 - 42
PL12.3 550 Feeder (Option) (3/5) [List]	5 - 43
PL12.4 550 Feeder (Option) (4/5) [Illustration]	5 - 44
PL12.4 550 Feeder (Option) (4/5) [List]	5 - 45
PL12.5 550 Feeder (Option) (5/5) [Illustration]	5 - 46
PL12.5 550 Feeder (Option) (5/5) [List]	5 - 47

Chapter 5 Parts List CONTENTS

Blank Page

1. Parts List

1.1 Caution for use of spare parts illustration

- Available spare parts are shown in the illustration by name.
- [Ref PL X.Y.Z] shown below the part name denotes the item is "Z" in the plate "PL X.Y" of the engineering part list.
- For the detailed composition of the KIT parts, check with the engineering part list.

1.2 Caution for use of engineering parts list

- The figures indicating the illustrations are the item No. in the list and present correspondence between the illustrations and parts.
- The notation of PL "X.Y.Z" is composed of the plate (PL), item "X.Y", and parts "Z".
- The alphabet characters in the illustrations represent screws and clips as follows:
"S": screw, "E": E-ring, "KL": KL clip, "C": C-ring, and "N": nut
- "▼" mark in the illustrations are attached to items indicating assembly parts in the illustrations.
- Encircled alphabetical figures in the illustrations indicate interrupted leader lines. Same characters in the illustrations represent lines to be connected.
- The mark "(with 2-5)" attached to assembly parts on the illustrations and lists represents that the items "2, 3, 4, and 5" of that plate are contained and the mark "(with 2-5, PL6.1.1)" represent that the item "2, 3, 4, and 5" of that plate and the item "1" of the plate "6.1" are contained.
- The mark "[Ref PLX.Y.Z]" attached to parts in the illustrations and lists represents that the parts is the same as the parts of the item "Z" of the plate "X.Y".
- The mark "*" attached to parts in the list represents "Note" or "Reference" about that parts is contained in the same page.

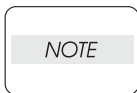

For spare parts, refer to the "Spare parts list" which is issued separately.

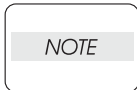

For the connector (P/J), parts such as harness, wire, etc. in the list, refer to "Chapter 7, Electric wiring"

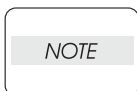

It should be noted that configuration of parts may be different or some parts are not used depending on specifications of OEM.

| Customer Replaceable Parts Illustration

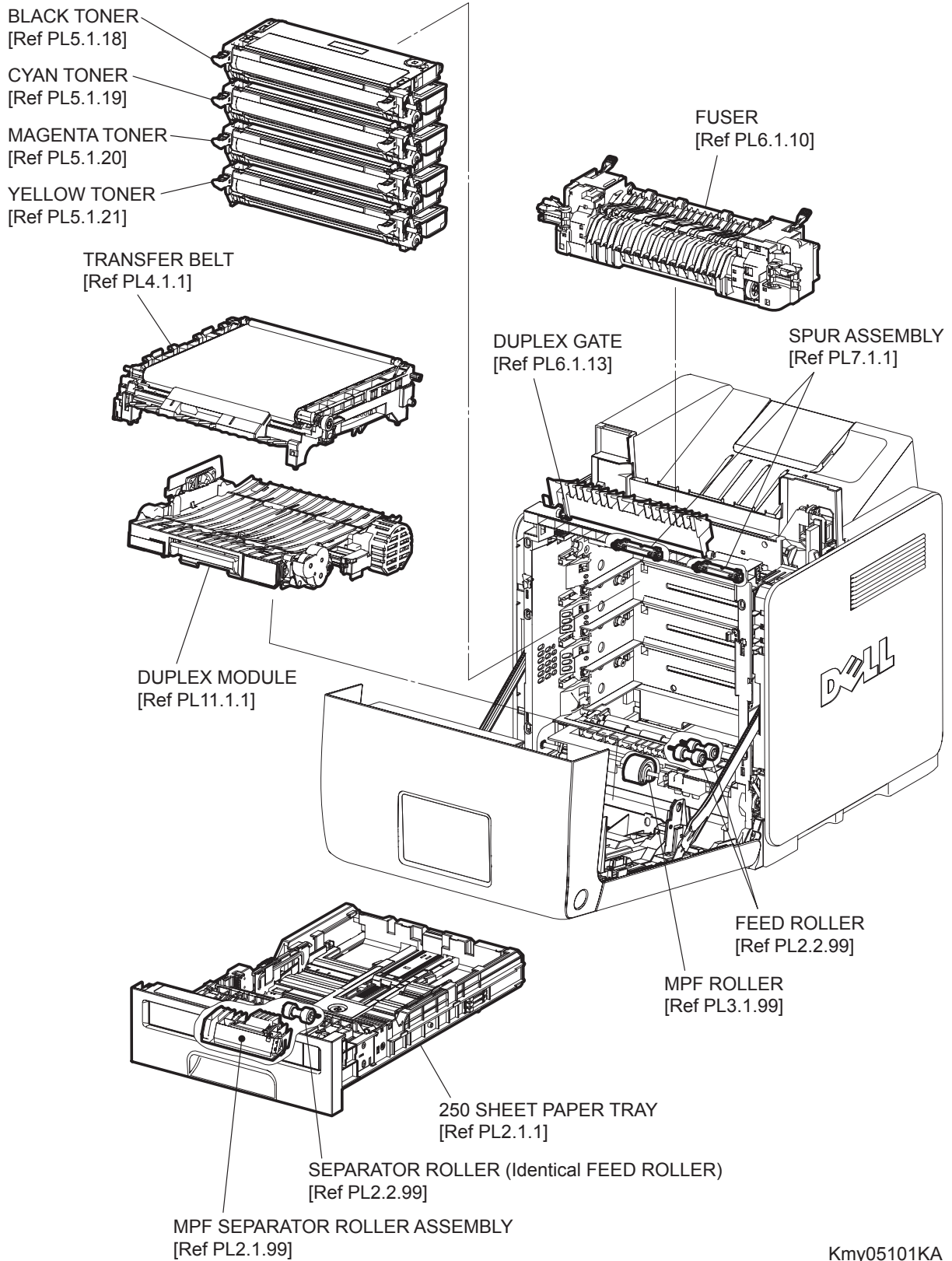

Kmy05101KA

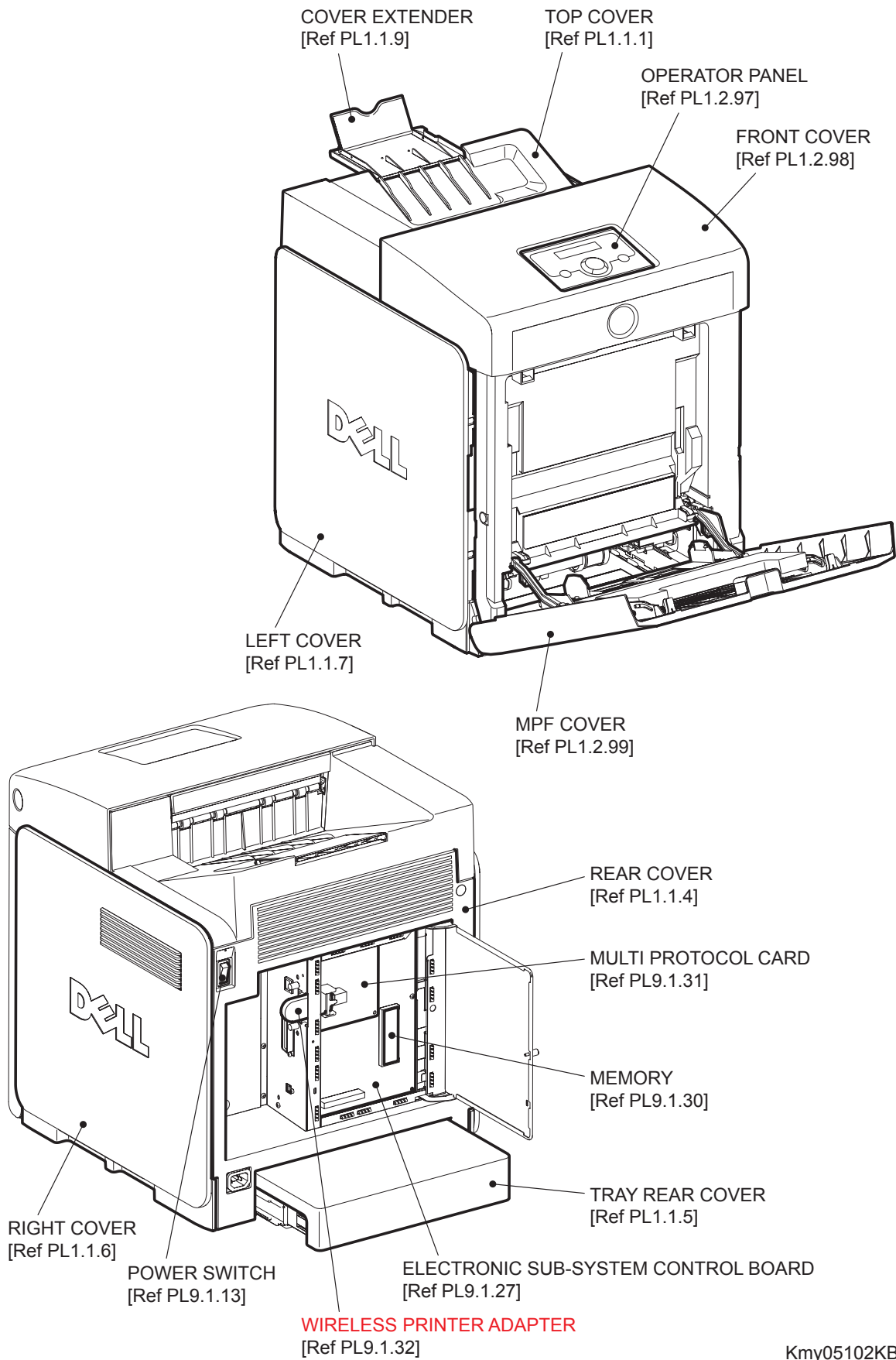

Kmy05102KB

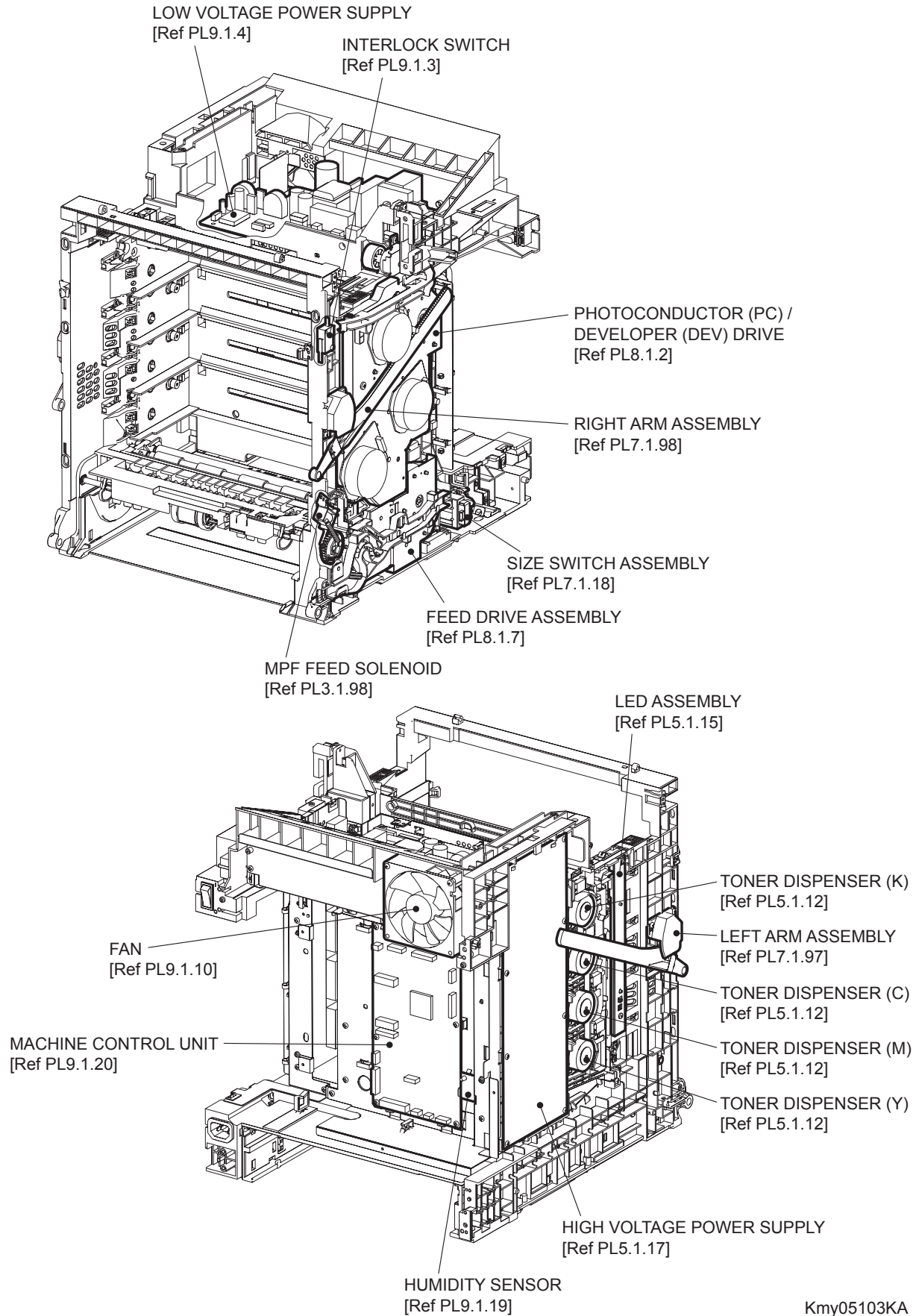

Kmy05103KA

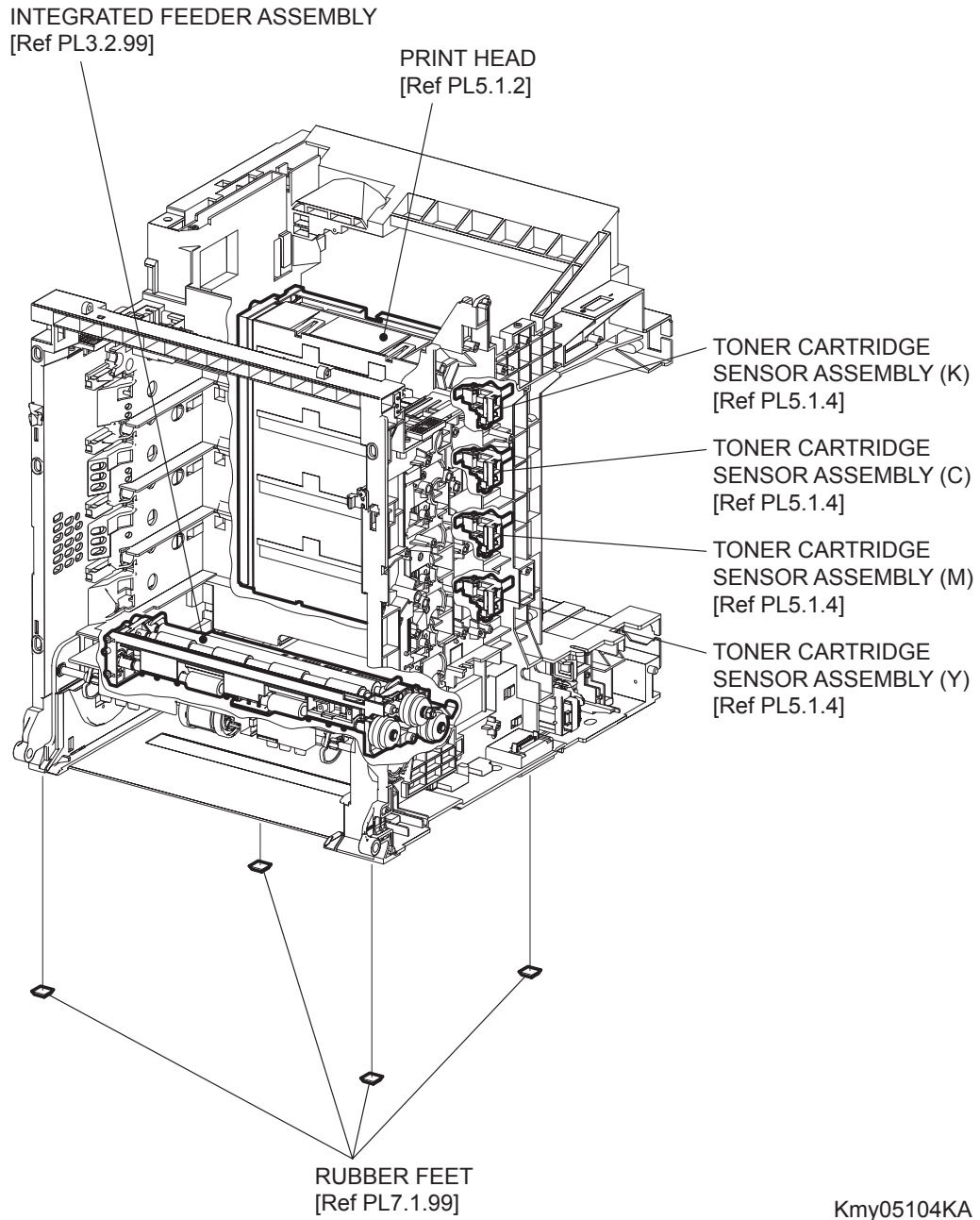

Kmy05104KA

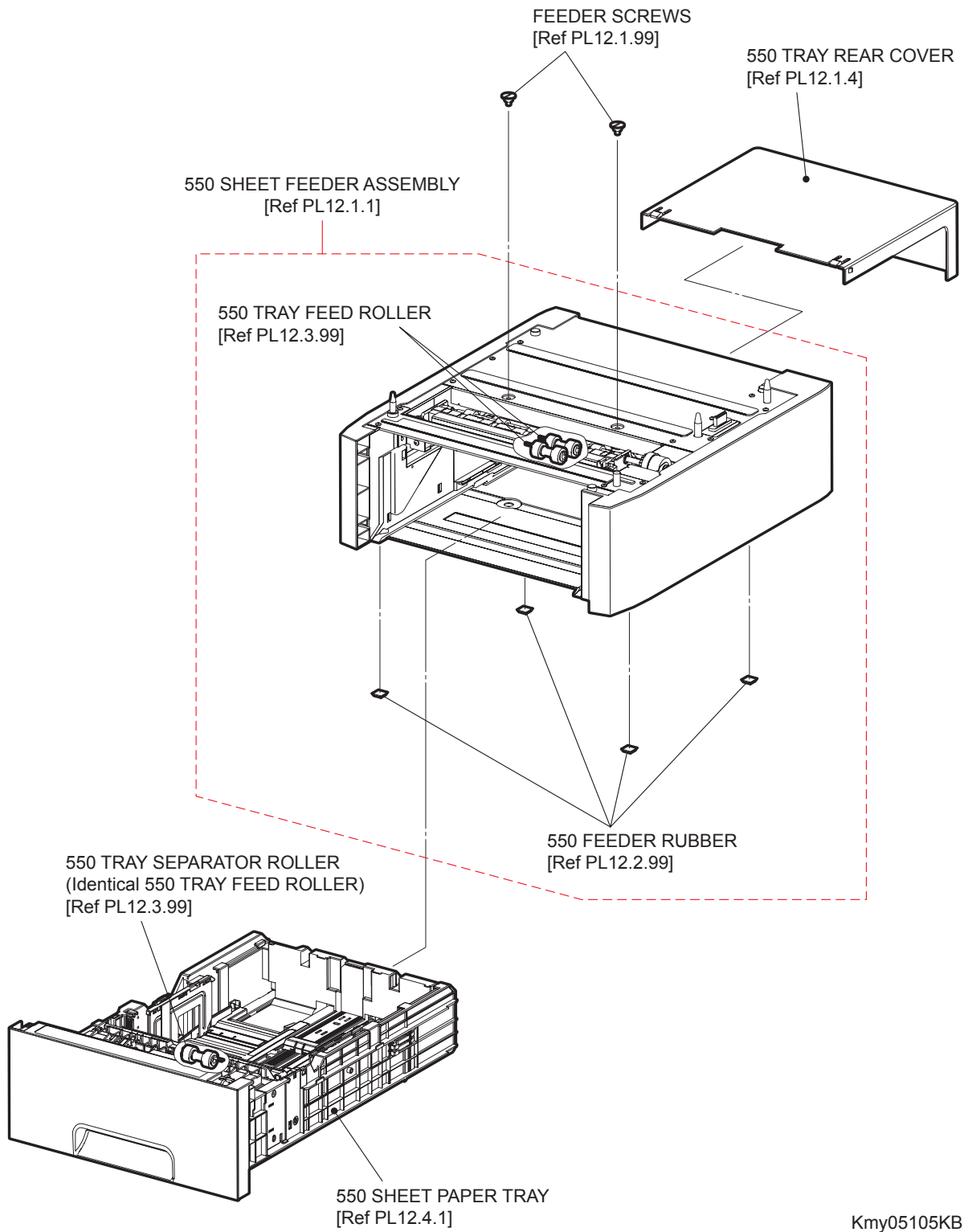

Kmy05105KB

Blank Page

Engineering parts list

PL1.1 Cover (1/2) [Illustration]

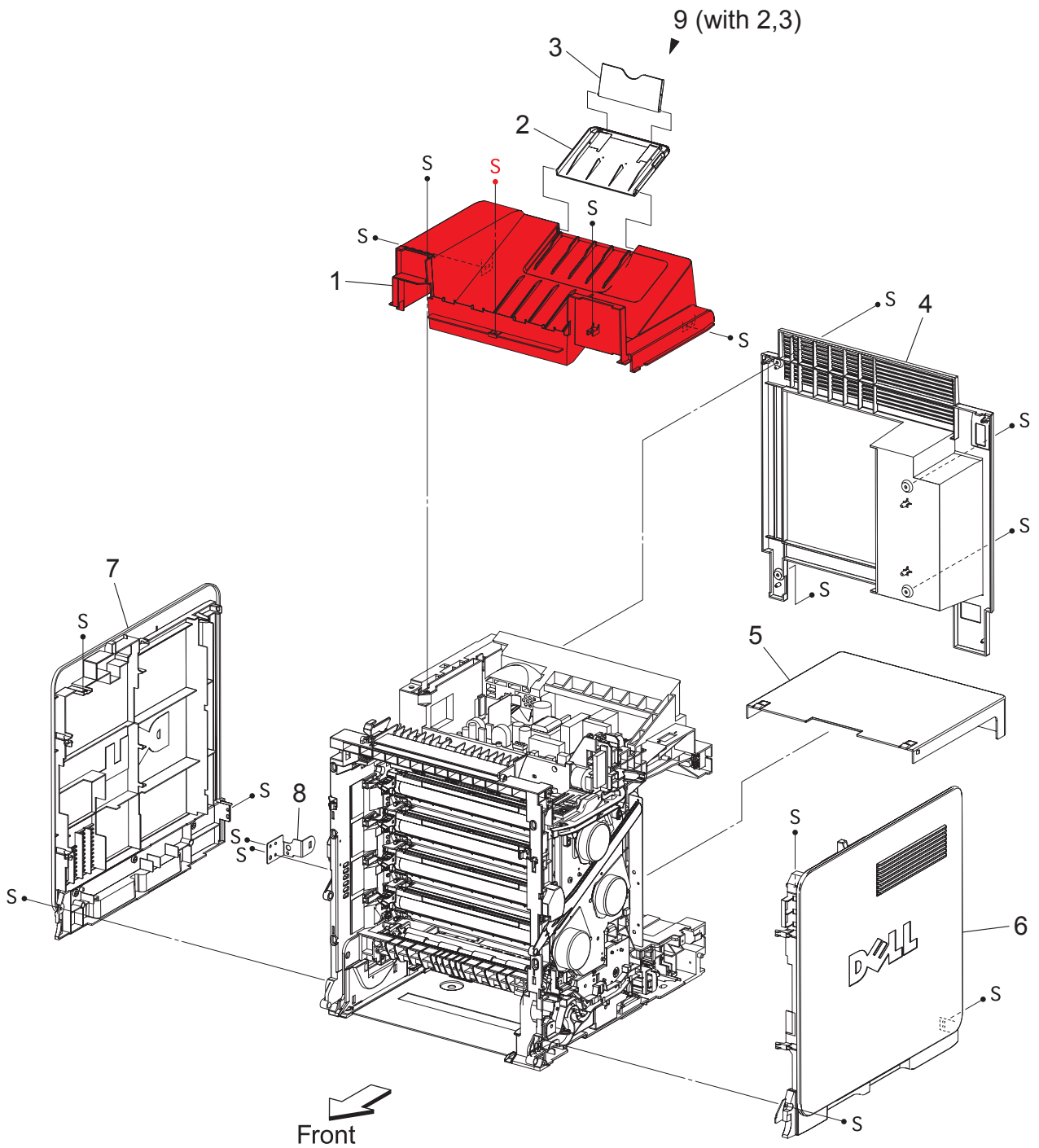

Kmy05001KC

PL1.1 Cover (1/2) [List]

Item	Parts name
1	COVER TOP
2	COVER EXTENTION 1
3	COVER EXTENTION 2
4	COVER REAR
5	COVER CST
6	COVER SIDE R ASSY
7	COVER SIDE L ASSY
8	BRACKET RCB
9	COVER ASSY EXTENDER (with 2,3)

PL1.2 Cover (2/2) [Illustration]

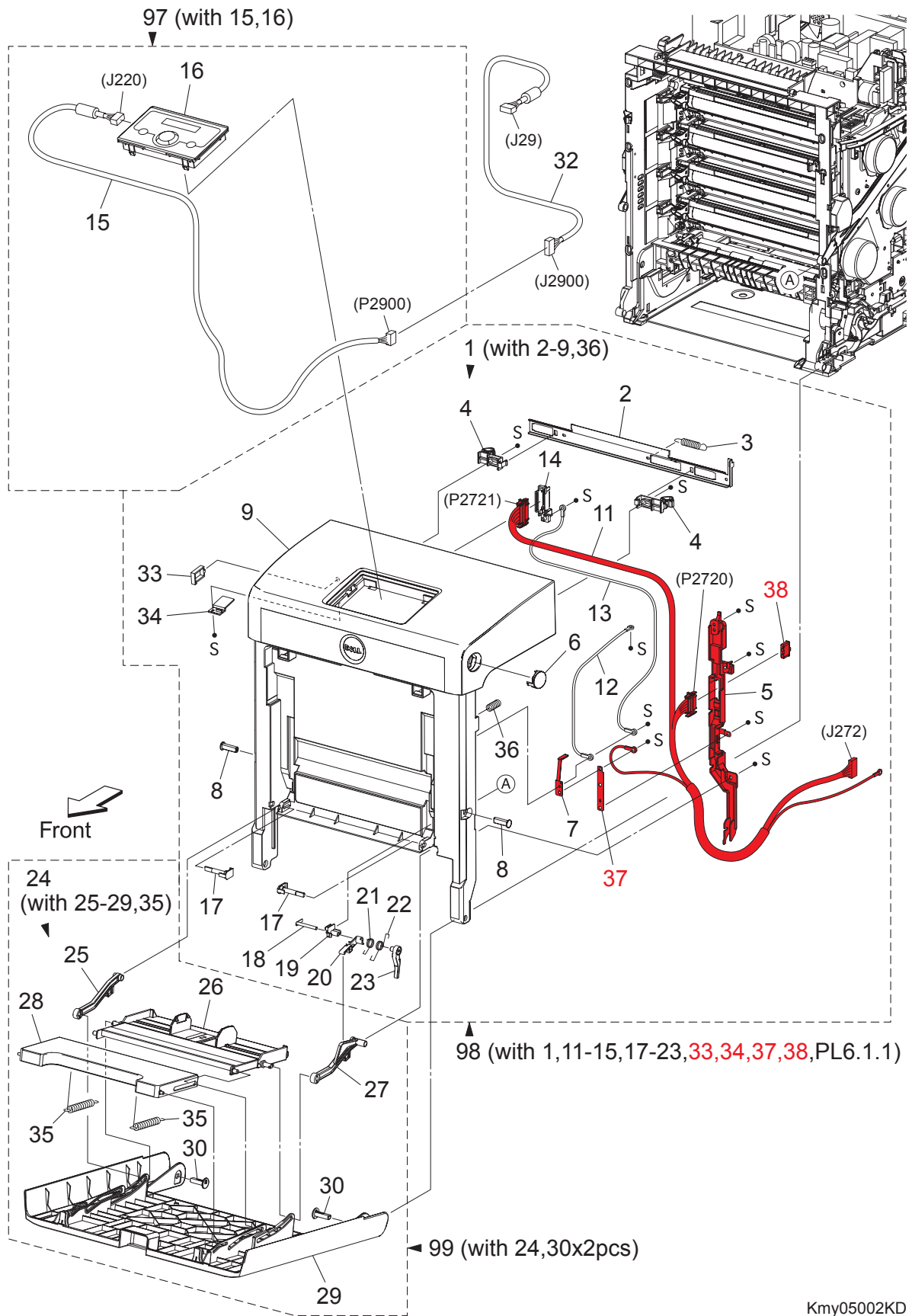

Kmy05002KD

PL1.2 Cover (2/2) [List]

Item	Parts name
1	COVER ASSY FRONT (with 2-9,36)
2	PLATE LATCH
3	SPRING LATCH
4	LATCH FRONT
5	COVER HARNESS
6	BUTTON TOP
7	CONTACT FRONT
8	SHAFT PIVOT
9	COVER FRONT ASSY
10	--
11	HARNESS ASSY FRONT COVER (J272-P2720,P2721,T4322-T43221)
12	HARNESS ASSY FRONT COVER EARTH 1 (T4321-T43210)
13	HARNESS ASSY DRAWER EARTH (T4321-T43210)
14	HOLDER DRAWER
15	HARNESS ASSY OPEPANE (J220-P2900)
16	CONSOLE PANEL
17	PIN PIVOT MSI
18	SHAFT LEVER
19	PLATE PIVOT
20	LEVER MSI 1
21	SPRING LEVER MSI
22	SPRING LEVER LINK
23	LEVER MSI 2
24	COVER ASSY MSI (with 25-29,35)
25	LINK ASSY MSI L
26	TRAY ASSY MSI BASE
27	LINK ASSY MSI R
28	TRAY MSI
29	COVER MSI
30	SHAFT PIVOT MSI
31	--
32	HARNESS ASSY ESS (J29-J2900)
33	CLAMP RLWT-4V0
34	BRACKET HARNESS
35	SPRING TRAY
36	SPRING
37	PLATE EARTH FC
38	DUP CONNECTOR CAP (Remove the connector when installing the Duplex Unit.)
97	KIT OPERATOR PANEL (with 15,16)
98	KIT COVER ASSY FRONT (with 1,11-15,17-23,33,34,37,38,PL6.1.1)
99	KIT COVER ASSY MSI (with 24,30x2pcs)

PL2.1 Paper Cassette (1/2) [Illustration]

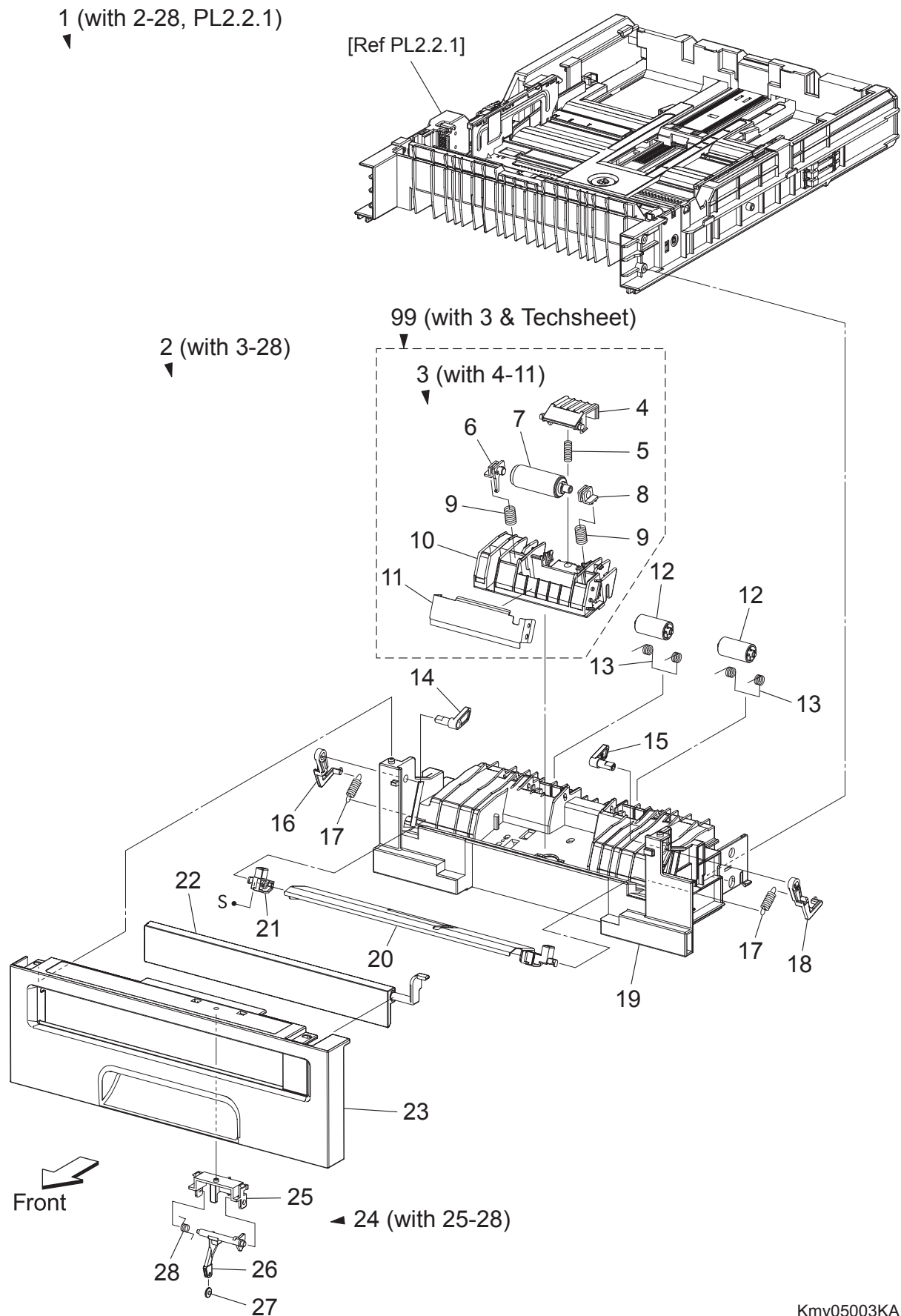

Kmy05003KA

PL2.1 Paper Cassette (1/2) [List]

Item	Parts name
1	CASSETTE ASSY 250 (with 2-28, PL2.2.1)
2	CASSETTE ASSY FRONT (with 3-28)
3	SEPARATOR ROLLER ASSEMBLY (with 4-11)
4	CHUTE RETARD
5	SPRING CHUTE
6	BEARING RETARD L
7	SEPARATOR ROLLER
8	BEARING RETARD R
9	SPRING RETARD 200
10	HOLDER RETARD MSI
11	PLATE ASSY RETARD
12	ROLL PINCH TURN
13	SPRING PINCH TURN
14	FOLLOWER L
15	FOLLOWER R
16	ARM L
17	SPRING NF MSI
18	ARM R
19	HOUSING BASE FR 250
20	PLATE ASSY BOTTOM
21	HOLDER MSI L
22	COVER FRONT MSI
23	HANDLE CST
24	ACTUATOR ASSY MSI (with 25-28)
25	HOLDER ACTUATOR
26	ACTUATOR NO PAPER MSI
27	ROLL ACTUATOR NO PAPER
28	SPRING NO PAPER
99	KIT SEPARATOR ROLLER ASSEMBLY (with 3 & Techsheet)

PL2.2 Paper Cassette (2/2) [Illustration]

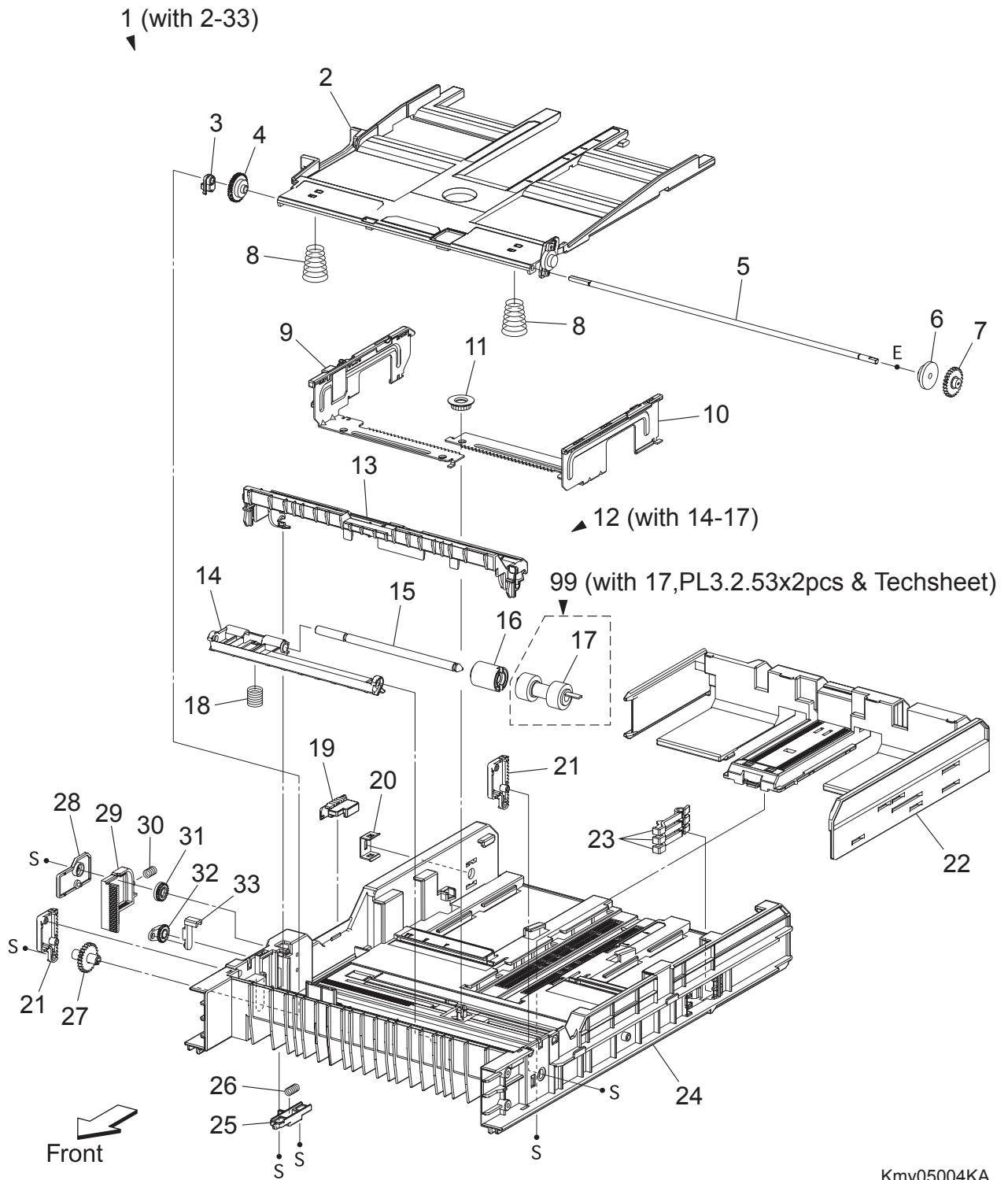

Kmy05004KA

PL2.2 Paper Cassette (2/2) [List]

Item	Parts name
1	CASSETTE ASSY REAR 250 (with 2-33)
2	PLATE ASSY BTM A4
3	STOPPER PB
4	GEAR BTM LOCK ONEWAY
5	SHAFT PB A4
6	GEAR BTM DMP ONEWAY
7	GEAR PB L
8	SPRING BTM UP 250 A4
9	GUIDE ASSY SIDE R 250 A4
10	GUIDE ASSY SIDE L 250 A4
11	GEAR PINION
12	HOLDER ASSY RETARD (with 14-17)
13	CVR RTD CST
14	HOLDER RETARD
15	SHAFT RETARD
16	CLUTCH FRICTION RET
17	SEPARATOR ROLLER
18	SPRING RETARD
19	SWITCH SIZE SET
20	PLATE LOCK CST
21	PLATE GEAR LOCK 250
22	GUIDE ASSY CST END 250
23	ACTUATOR SIZE
24	HSG BASE RE 250
25	ACTUATOR RLS PB
26	SPRING STOPPER GEAR
27	GEAR PB R
28	COVER BTM UP 250
29	RACK BTM LOCK 250
30	SPRING BTM LOCK
31	GEAR BTM LOCK PINION
32	GEAR LEVER BTM LOCK
33	LEVER BTM LOCK
99	KIT SEPARATOR and FEED ROLLER (with 17, PL3.2.53x2pcs & Techsheet) *1

*1 : Periodic Replacing Parts (100KPV)

PL3.1 Paper Feeder (1/2) [Illustration]

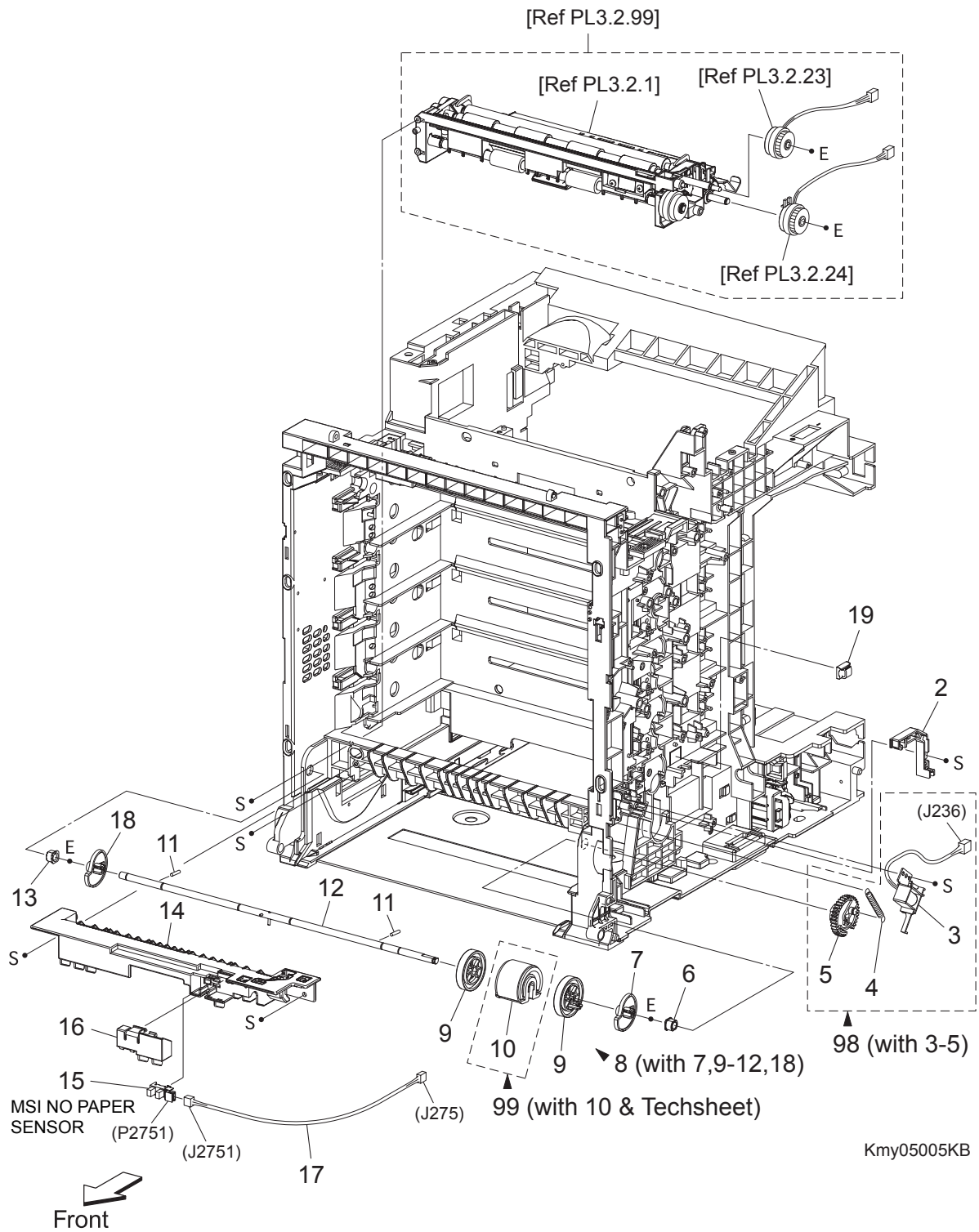

Kmy05005KB

PL3.1 Paper Feeder (1/2) [List]

Item	Parts name
1	--
2	DUCT MSI SOL
3	SOLENOID FEED MSI
4	SPRING FEED MSI
5	GEAR MSI
6	BEARING EARTH
7	CAM MSI R
8	ROLL ASSY MSI (with 7,9-12,18)
9	ROLL CORE MSI
10	ROLL ASSY FEED MSI
11	PIN DOWEL
12	SHAFT MSI
13	BEARING
14	CHUTE MSI
15	SENSOR PHOTO (MSI NO PAPER SENSOR)
16	COVER SNR
17	HARN ASSY MSI NPP (J275-J2751)
18	CAM MSI L
19	CLAMP
98	KIT SOLENOID FEED MSI (with 3-5)
99	KIT ROLL ASSY FEED MSI (with 10 & Techsheet)

PL3.2 Paper Feeder (2/2) [Illustration]

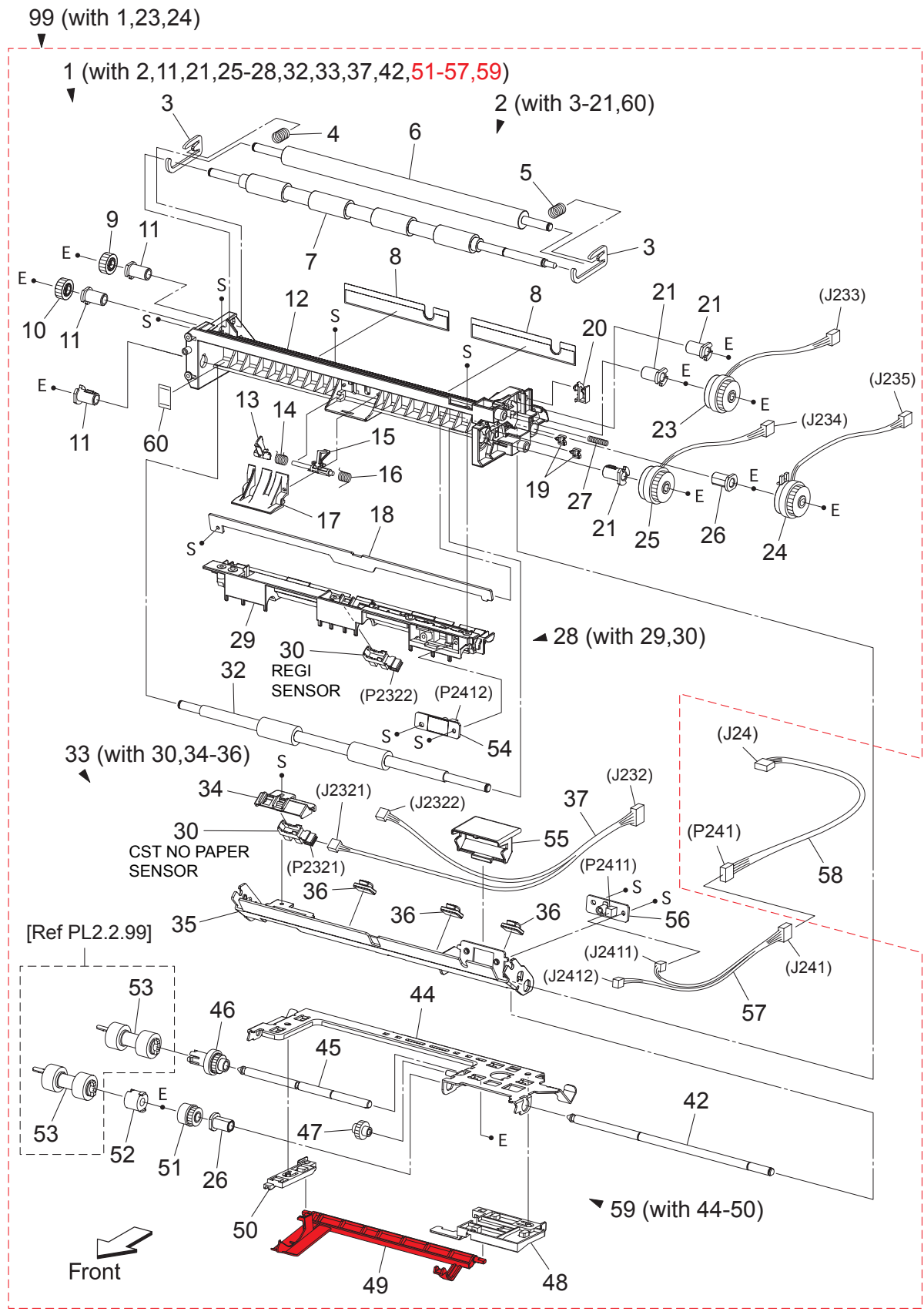

Kmy05006KD

PL3.2 Paper Feeder (2/2) [List]

Item	Parts name
1	FEEDER ASSY (with 2,11,21,25-28,32,33,37,42,51-57,59)
2	CHUTE ASSY REGI (with 3-21,60)
3	BRACKET NIP
4	SPRING REGI L
5	SPRING REGI R
6	ROLL REGI METAL
7	ROLL REGI RUBBER
8	FILM INLET L
9	GEAR REGI METAL
10	GEAR REGI RUBBER
11	BEARING REGI
12	CHUTE REGI
13	ACTUATOR A
14	SPRING REGI SNSR A
15	ACTUATOR B
16	SPRING REGI SNSR B
17	COVER ACTUATOR
18	CHUTE RETARD BTM
19	CLAMP MINI-SADDLE
20	CLAMP
21	BEARING REGI E
22	--
23	CLUTCH ASSY PH REGI
24	CLUTCH ASSY PH FEED
25	CLUTCH ASSY PH TURN
26	BEARING NUDGER
27	SPRING EARTH
28	CHUTE ASSY REGI UPPER (with 29,30)
29	CHUTE REGI UPPER
30	SENSOR PHOTO (REGI SENSOR, CST NO PAPER SENSOR)
31	--
32	ROLL ASSY TURN
33	CHUTE ASSY TOP (with 30,34-36)
34	HOLDER NOSNSR
35	CHUTE ASSY RETARD
36	CLAMP
37	HARN ASSY REGI SNR (J232-J2321,J2322)
38	--
39	--
40	--
41	--
42	SHAFT FEED
43	--
44	SUPPORT NUDGER ASSY
45	SHAFT NUDGER
46	ROLL ASSY GEAR NUDGER
47	GEAR IDLER NUDGER
48	HOLDER NO PAPER L A4
49	ACTUATOR NO PAPER A4
50	HOLDER NO PAPER R A4
51	CLUTCH ONEWAY NUDGER
52	CLUTCH ONEWAY FEED
53	ROLL ASSY FEED
54	PWBA OHP LED
55	COVER OHP SNR
56	PWBA OHP SNR
57	HARN ASSY OHP SNR (J241-J2411,J2412)
58	HARN ASSY OHP (J24-P241)
59	NUDGER ASSY (with 44-50)
60	GUIDE FILM
99	KIT FEEDER ASSY (with 1,23,24)

PL4.1 Transfer [Illustration]

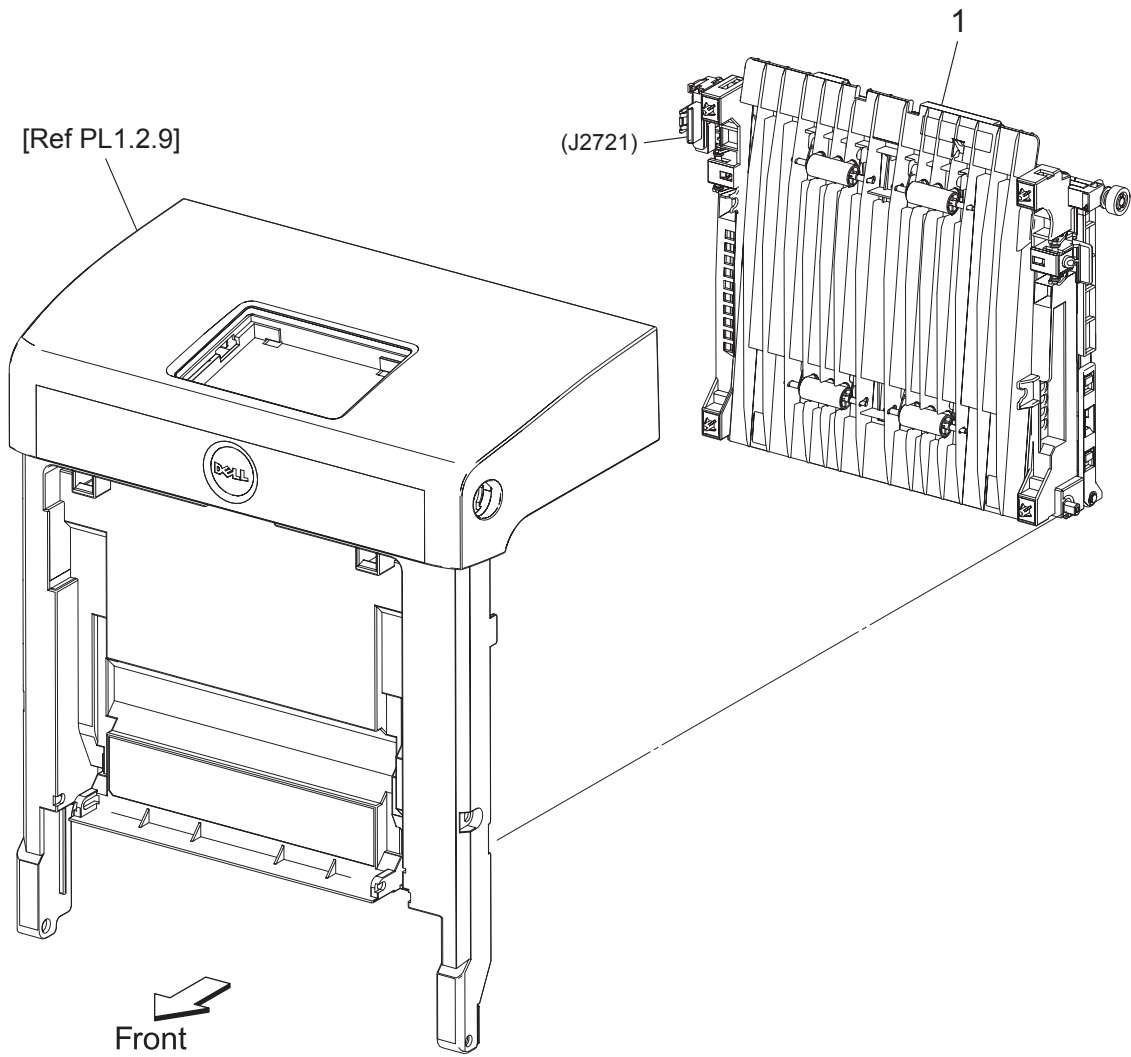

Kmy05007KA

PL4.1 Transfer [List]

Item	Parts name
1	TRANSFER ASSY (KIT BELT CRU) *1
2	--
3	--
4	--
5	--
6	--
7	--

*1 : Periodic Replacing Parts (100KPV)

PL5.1 Xerographics [Illustration]

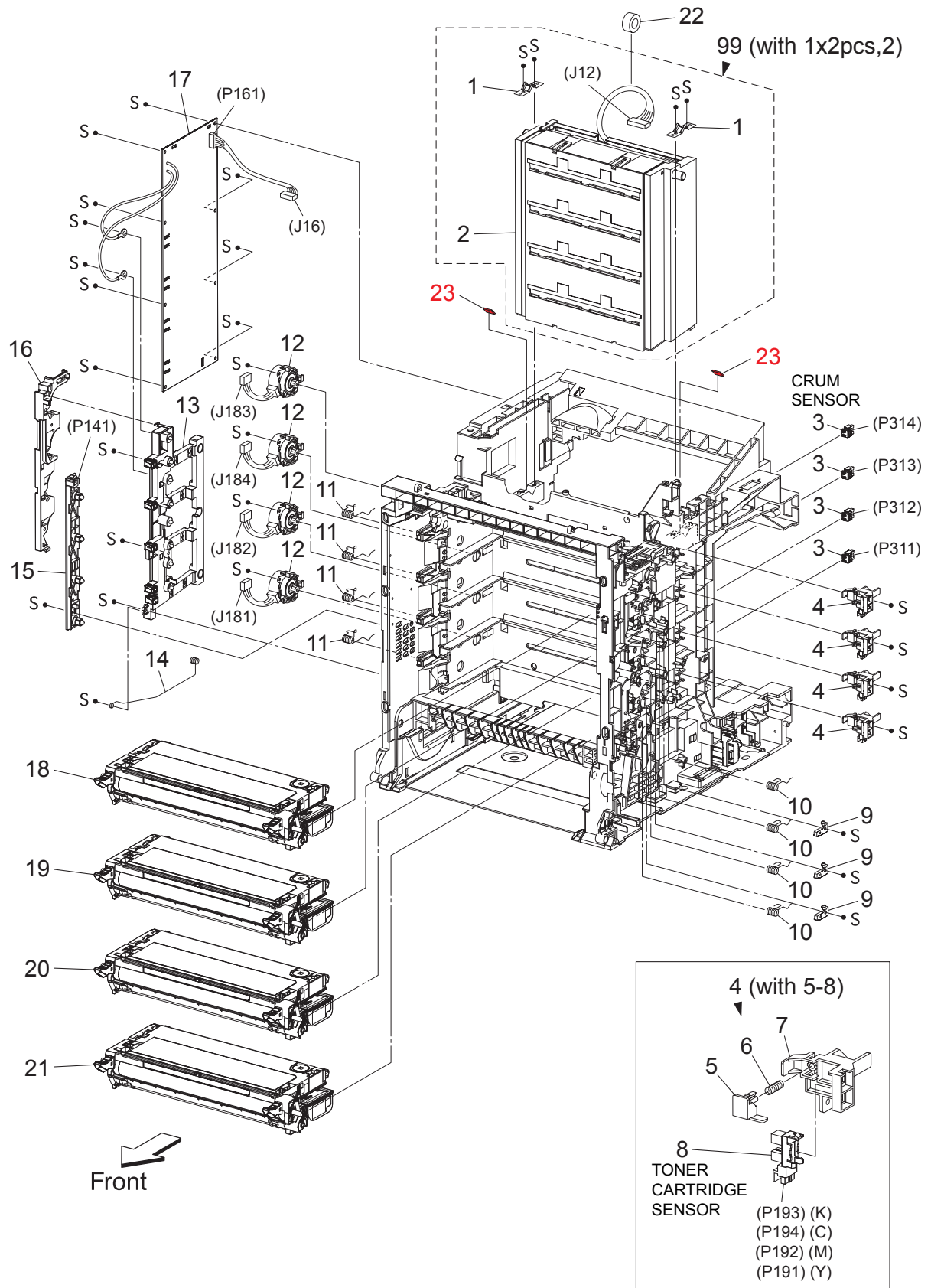

Kmy05010KC

PL5.1 Xerographics [List]

Item	Parts name
1	SPRING ROS
2	ROS ASSY
3	CONNECTOR CRUM
4	SENSOR ASSY CRU (with 5-8)
5	ACTUATOR SENSOR CRU
6	SPRING CRU
7	BRACKET SENSOR CRU
8	SENSOR PHOTO (TONER CARTRIDGE SENSOR)
9	STOPPER SPRING
10	SPRING CRU R
11	SPRING CRU L
12	DISPENSER ASSY
13	BIAS ASSY
14	SPRING ESA ROLL
15	LED ASSY
16	DUCT HARNESS MOT
17	HVPS
18	CARTRIDGE ASSY (K) (with Techsheet) *1
19	CARTRIDGE ASSY (C) (with Techsheet) *2
20	CARTRIDGE ASSY (M) (with Techsheet) *2
21	CARTRIDGE ASSY (Y) (with Techsheet) *2
22	CORE
23	SPACER ROS SHAFT
99	KIT ROS ASSY (with 1x2pcs, 2)

*1 : Periodic Replacing Parts (5KPV/8KPV)

*2 : Periodic Replacing Parts (4KPV/8KPV)

PL6.1 Fuser & Exit [Illustration]

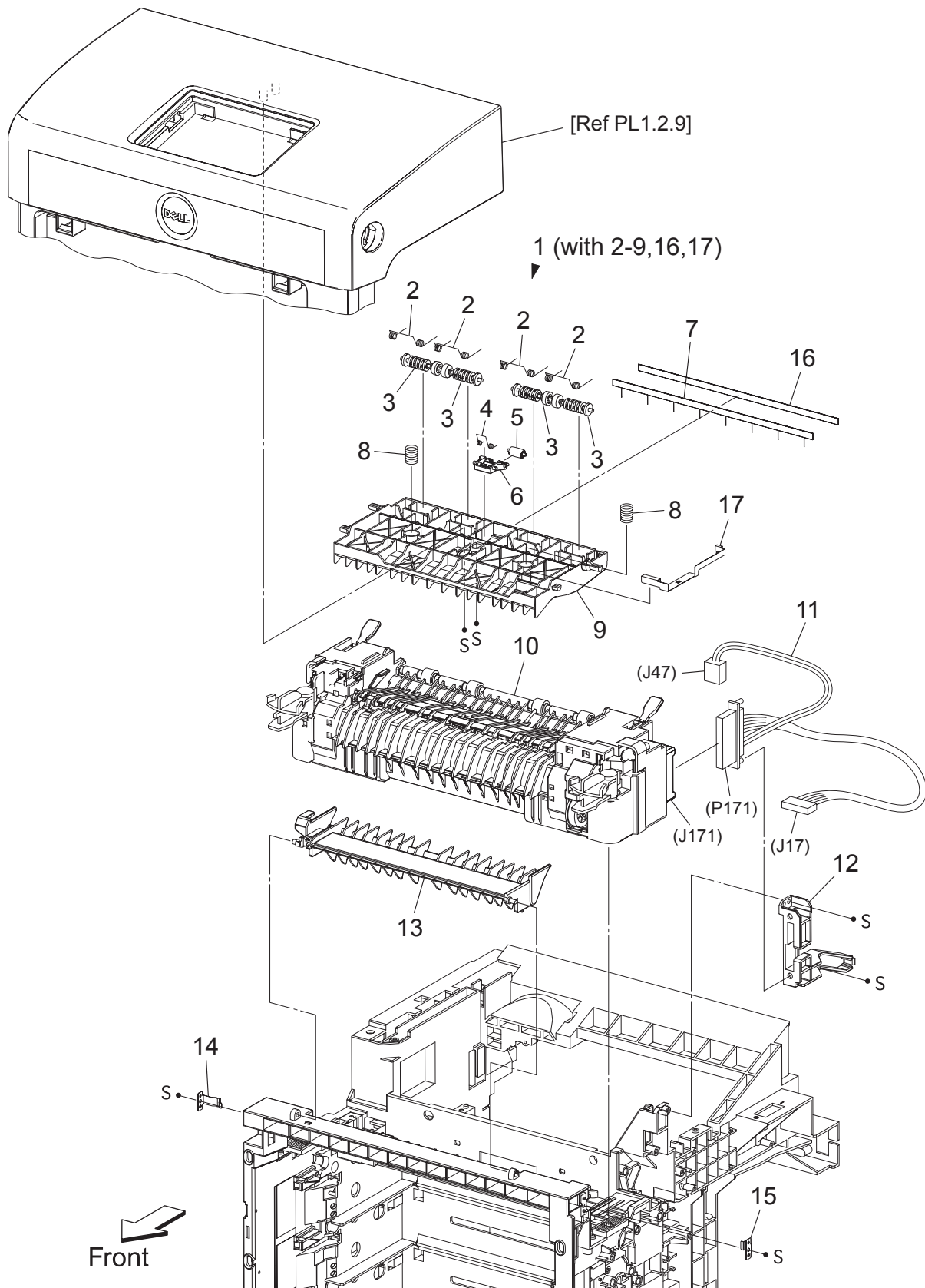

Kmy05011KB

PL6.1 Fuser & Exit [List]

Item	Parts name
1	CHUTE ASSY EXIT OUT (with 2-9,16,17)
2	SPRING PINCH EXIT OUT
3	ROLL PINCH EXIT
4	SPRING CORR
5	ROLL CORRUGATE
6	HOLDER CORR 2
7	ELIMINATOR EXIT1
8	SPRING CHUTE OUT
9	CHUTE EXIT OUT 20
10	FUSER ASSY (with Techsheet) *1
11	HARN ASSY FUSER (P171-J17,J47)
12	BRACKET FUSER
13	CHUTE DUP GATE
14	PLATE LATCH FSR AD
15	PLATE LATCH FSR D
16	TAPE ELIMINATOR
17	PLATE EARTH EXIT

*1 : Periodic Replacing Parts (100KPV)

PL7.1 Frame [Illustration]

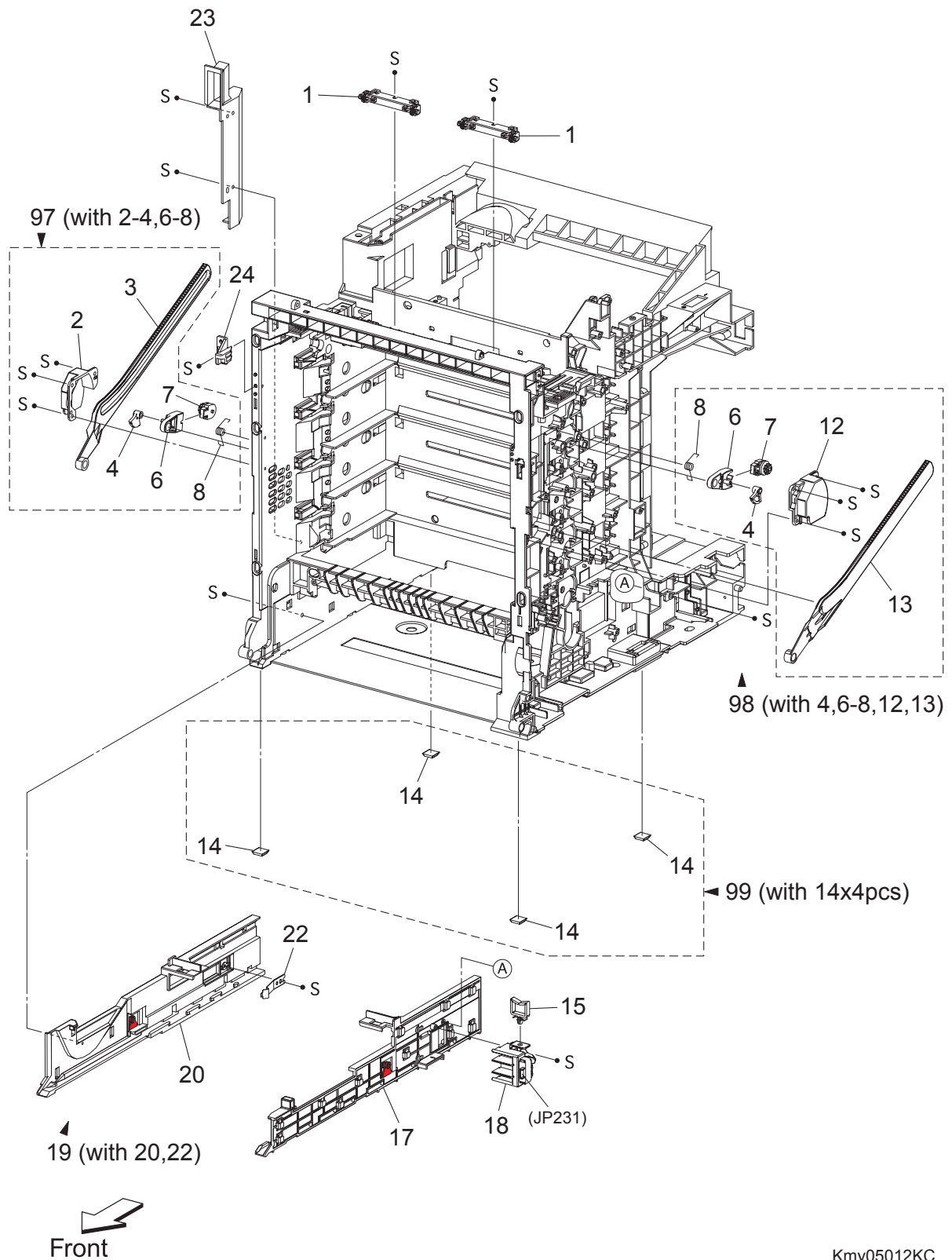

Kmy05012KC

PL7.1 Frame [List]

Item	Parts name
1	WHEEL STAR ASSY
2	SUPPORT LINK L
3	LINK L
4	LEVER RELEASE
5	--
6	HOLDER DAMPER
7	DAMPER OIL
8	SPRING SUPPORT
9	--
10	--
11	--
12	SUPPORT LINK R
13	LINK R
14	FOOT
15	CLAMP WS-2W-V0
16	--
17	GUIDE TRAY R 250
18	SWITCH ASSY SIZE
19	GUIDE CST ASSY L 250 (with 20,22)
20	GUIDE TRAY L 250
21	--
22	SPRING CST LOCK
23	DUCT SIDE L
24	STOPPER FRAME L
97	KIT LINK ASSY L (with 2-4,6-8)
98	KIT LINK ASSY R (with 4,6-8,12,13)
99	KIT FOOT ASSY (with 14x4pcs)

PL8.1 Drive [Illustration]

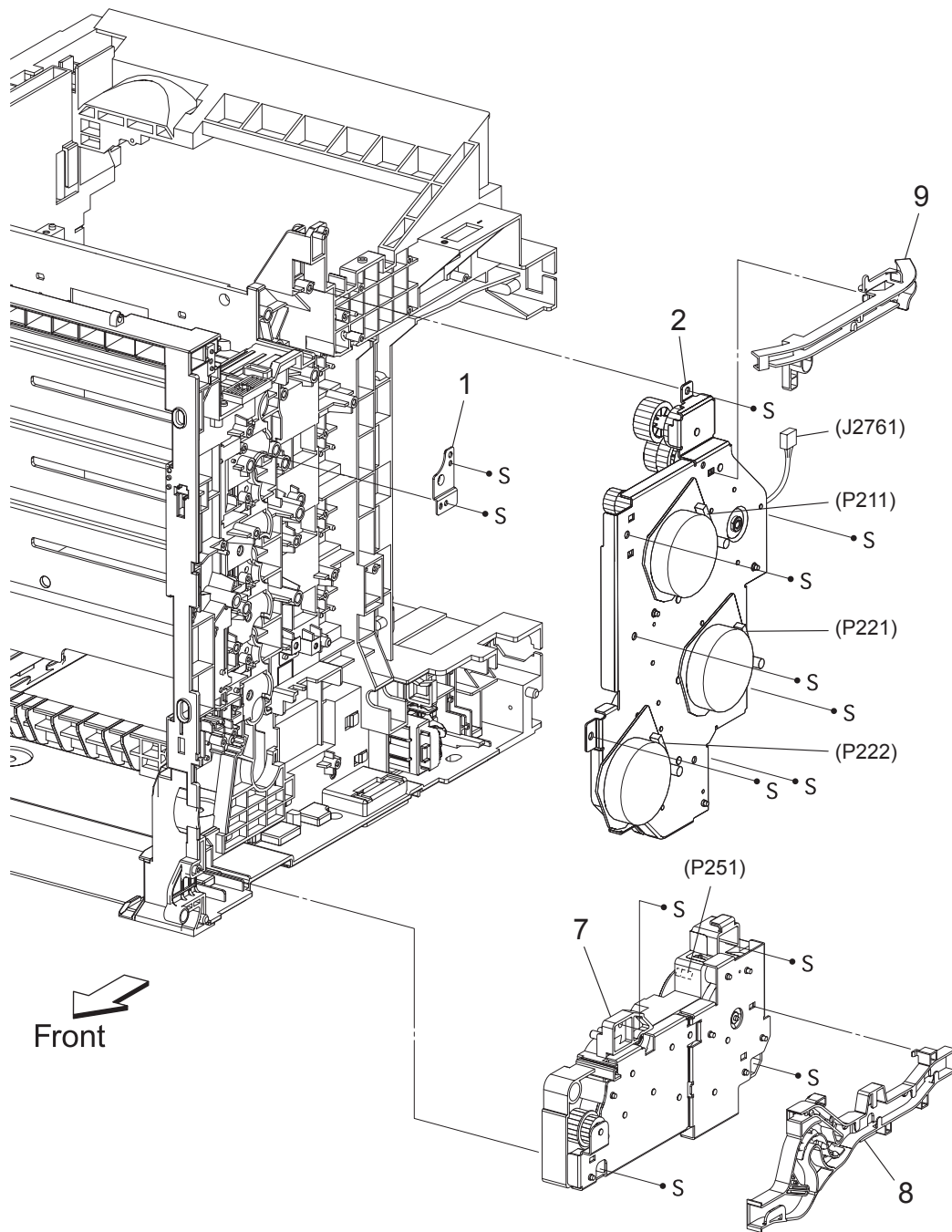

Kmy05013KA

PL8.1 Drive [List]

Item	Parts name
1	BRACKET GEAR T1
2	DRIVE ASSY MAIN
3	--
4	--
5	--
6	--
7	DRIVE ASSY PH
8	DUCT DRV PH
9	DUCT DRV MAIN

PL9.1 Electrical [Illustration]

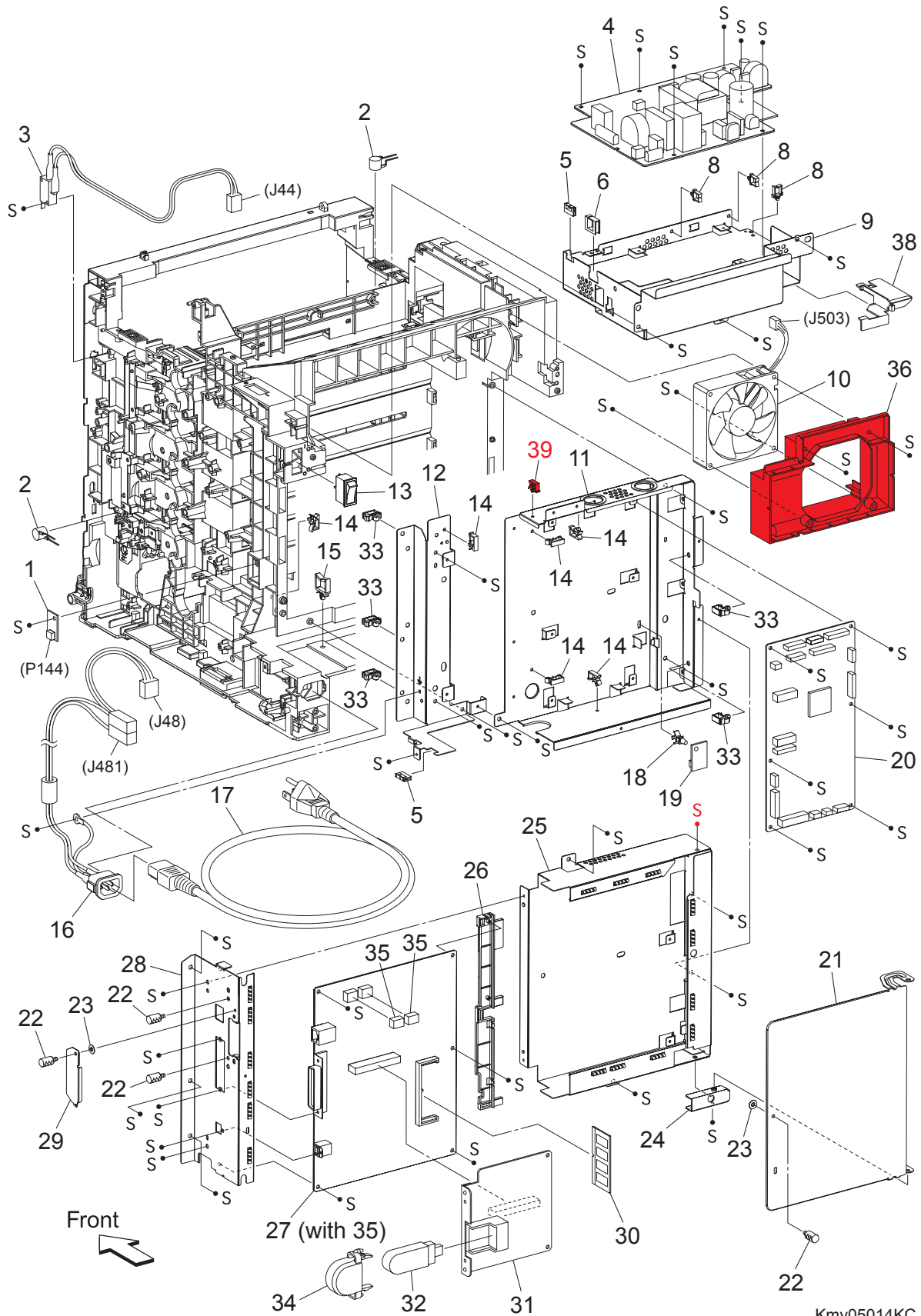

PL9.1 Electrical [List]

Item	Parts name
1	PWBA EEPROM(XPRO)
2	VARISTOR
3	HARN ASSY INTERLOCK
4	LVPS
5	EDGE SADDLE ES-0510
6	EDGE SADDLE LENS-1010
7	--
8	CLAMP RMS-3V0
9	SHIELD LVPS
10	FAN MAIN
11	SHIELD MCU
12	PLATE REAR RH
13	SWITCH POWER
14	CLAMP MST-10V0
15	CLAMP WS-2W-V0
16	HARN ASSY INLET (J48-J481)
17	POWER CORD
18	SPACER RCBT-11S
19	SENSOR HUM
20	PWBA MCU (with Techsheet)
21	SHIELD WINDOW
22	SCREW KNURLING
23	WASHER
24	BRACKET PIVOT
25	SHIELD ASSY ESS
26	GUIDE ESS
27	PWBA ESS (with 35) (with Techsheet)
28	SHIELD ASSY IF
29	PLATE OPT
30	MEMORY CARD (OPTION)
31	MULTI PROTOCOL CARD (OPTION)
32	WIRELESS PRINTER ADAPTER (Installs to the MULTI PROTOCOL CARD.) (OPTION)
33	CLAMP RLWC-1SV0
34	COVER USB (OPTION)
35	NVM ROM
36	DUCT FAN MAIN
37	--
38	DUCT ROS GUARD
39	CLAMP MST-5V0

PL10.1 Harness [Illustration]

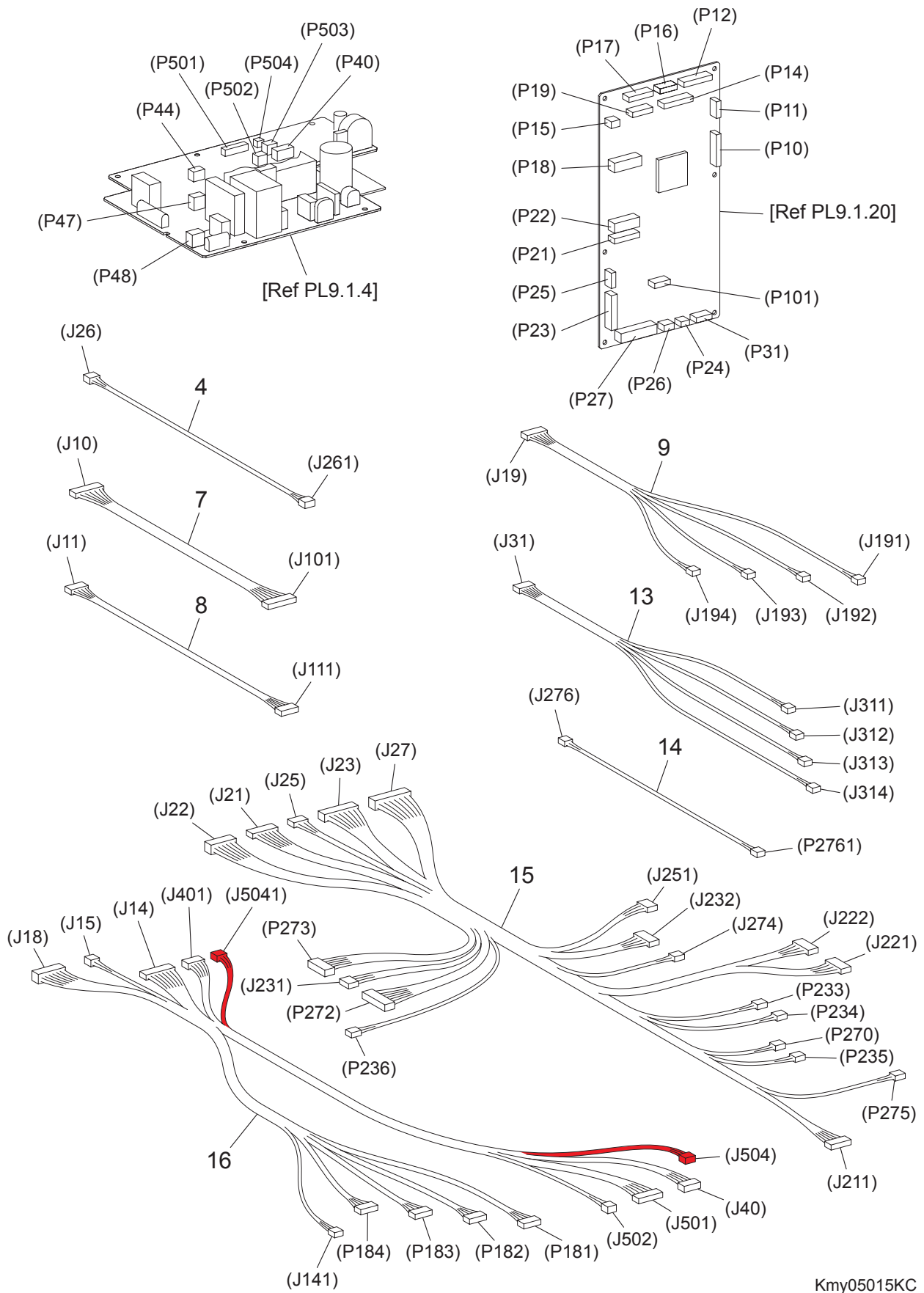

Kmy05015KC

PL10.1 Harness [List]

Item	Parts name
1	--
2	--
3	--
4	HARN ASSY HUM (J26-J261)
5	--
6	--
7	HARN ASSY ESS (J10-J101)
8	HARN ASSY VIDEO (J11-J111)
9	HARN ASSY TNR SNR (J19-J191,J192,J193,J194)
10	--
11	--
12	--
13	HARN ASSY CRUM (J31-J311,J312,J313,J314)
14	HARN ASSY EXIT CLT (J276-P2761)
15	HARN ASSY R SIDE (J21,J22,J23,J25,J27-J211,J221,J222,J231,J232,P233,P234, P235,P236,J251,P272,P273,J274,P275,P276)
16	HARN ASSY LV TOP (J14,J15,J18,J401,J5041-J141,P181,P182,P183,P184,J40,J501, J502,J504)
17	--

PL11.1 Duplex (Option) (1/2) [Illustration]

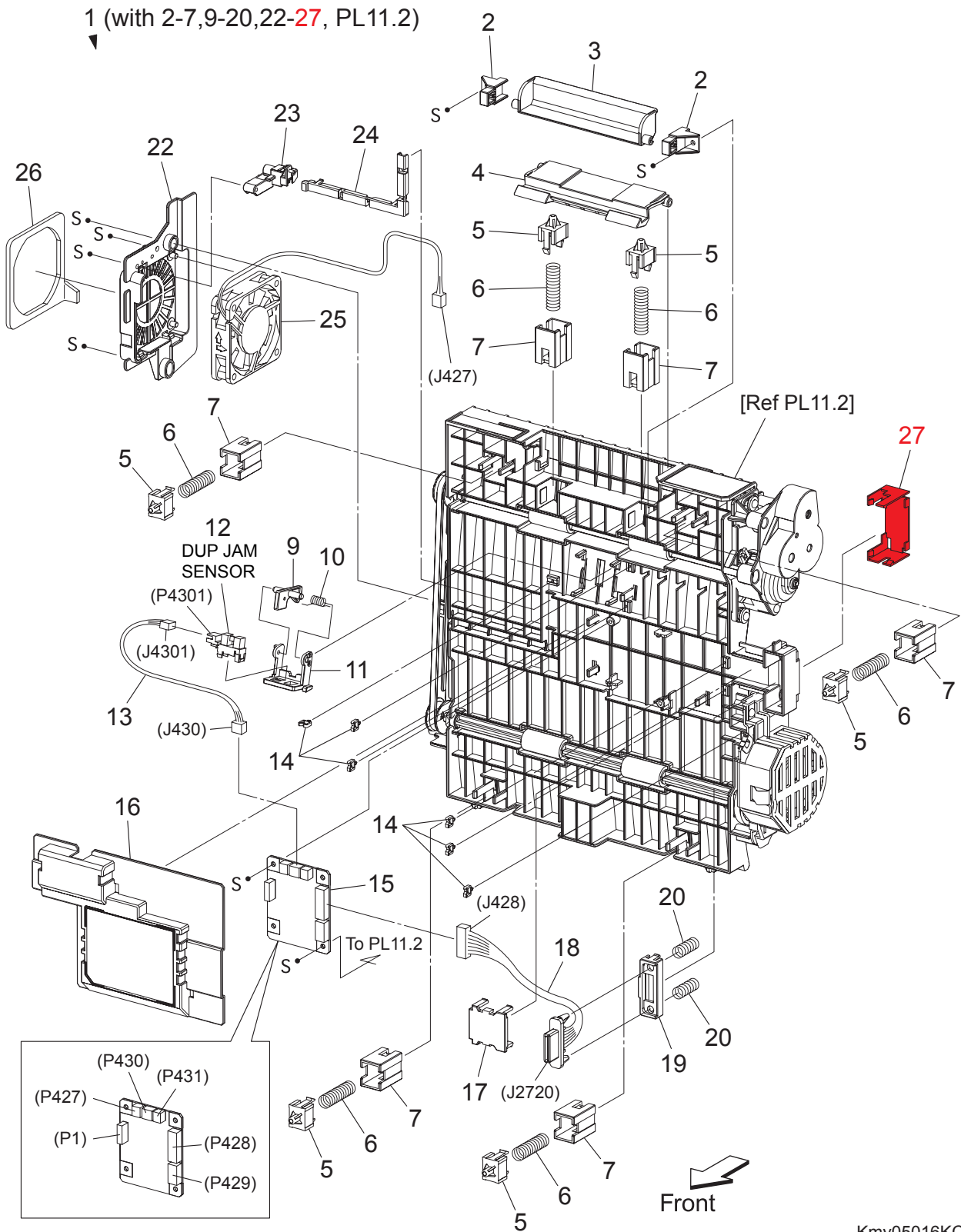

Kmy05016KC

PL11.1 Duplex (Option) (1/2) [List]

Item	Parts name
1	FEEDER ASSY DUP (KIT DUPEX MODULE) (with 2-7,9-20,22-27, PL11.2)
2	STOPPER LATCH DUP
3	HANDLE LATCH DUP
4	LATCH DUP
5	HOLDER MAIN
6	SPRING CHUTE DUP
7	BRACKET HOLDER DUP
8	--
9	ACTUATOR DUP
10	SPRING SENSOR DUP
11	HOLDER SENSOR DUP
12	SENSOR PHOTO (DUP JAM SENSOR)
13	HARN ASSY DUP SNR (J430-J4301)
14	CLAMP MINI
15	PWBA DUP-H
16	COVER PWBA DUP
17	COVER CONNECT DUP
18	HARN ASSY DUP UNIT (J428-J2720)
19	HOLDER CONNECT DUP
20	SPRING CONNECT DUP
21	--
22	BRACKET FAN DUP
23	COVER HARNESS FAN
24	COVER HARNESS CHUTE
25	FAN DUP
26	SEAL DUP
27	COVER CHUTE DUP

PL11.2 Duplex (Option) (2/2) [Illustration]

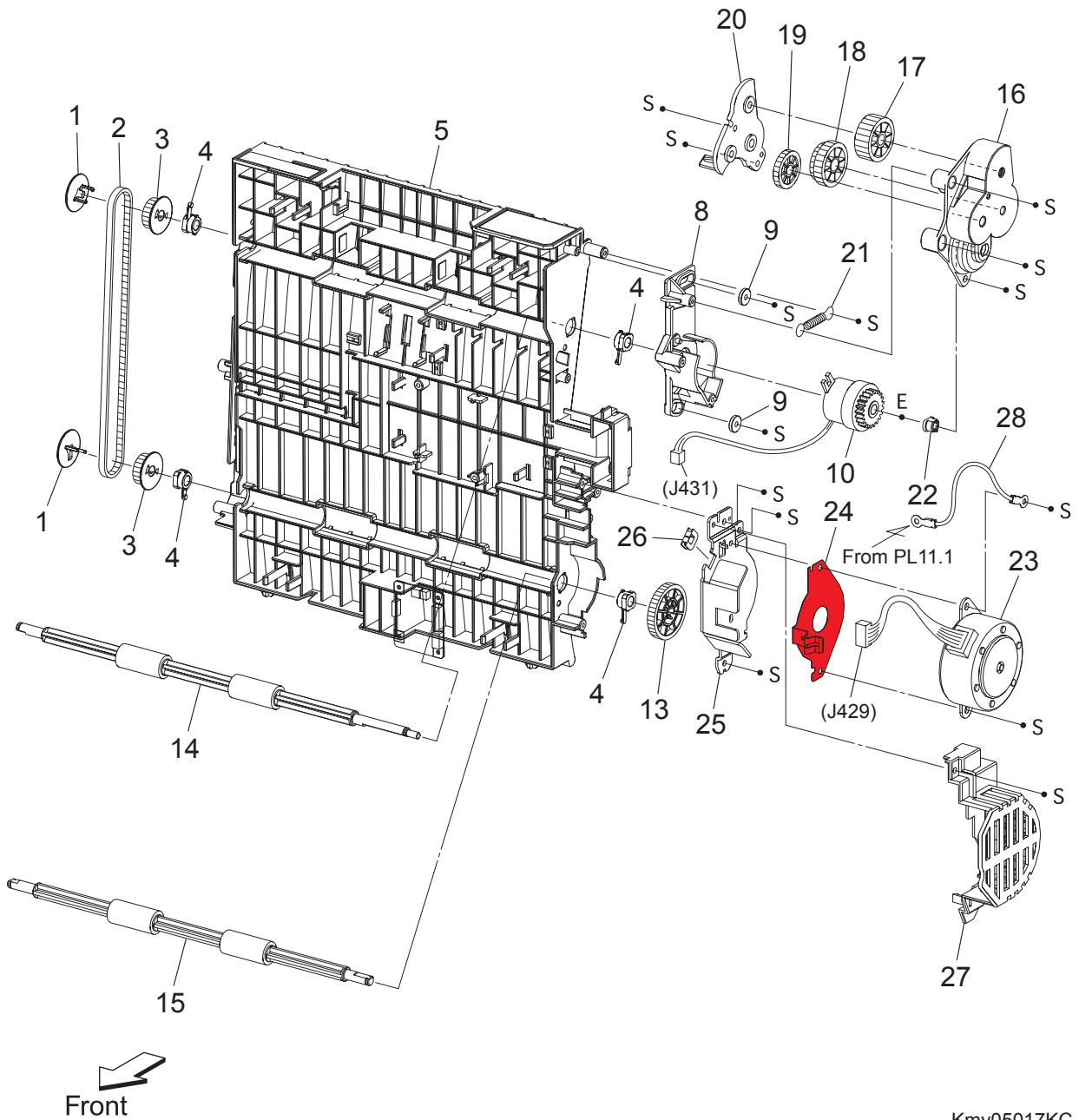

Kmy05017KC

PL11.2 Duplex (Option) (2/2) [List]

Item	Parts name
1	FLANGE PULLEY UP
2	BELT DUP 3M-128Z
3	PULLEY DUP 3M-20T
4	BEARING DUP
5	CHUTE ASSY PH
6	--
7	--
8	BRACKET CLUTCH DUP
9	WASHER DUP CLUTCH
10	CLUTCH DUP
11	--
12	--
13	GEAR DUP 40Z-M0.8
14	ROLL ASSY DUP-1
15	ROLL ASSY DUP-2
16	COVER GEAR DUP
17	GEAR DUP 25Z FUSER
18	GEAR DUP 21Z-25Z
19	GEAR DUP 21Z
20	PLATE GEAR
21	SPRING DUP
22	BEARING
23	MOTOR ASSY DUP
24	PLATE EARTH DUP
25	BRACKET MOTOR DUP
26	BUSH SADDLE
27	COVER DRIVE DUP
28	HARN ASSY DUP EARTH (T432-T4320)

PL12.1 550 Feeder (Option) (1/5) [Illustration]

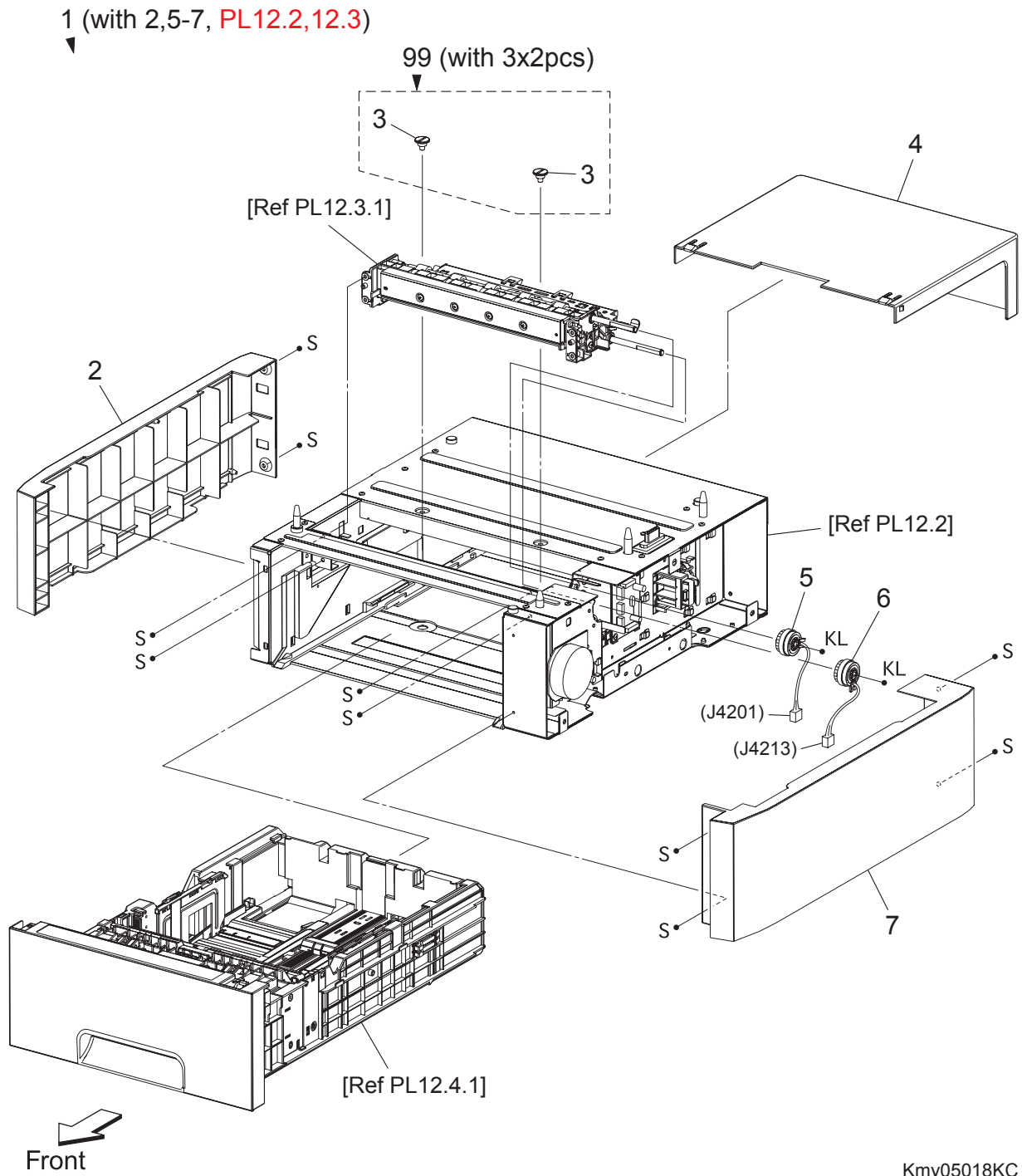

Kmy05018KC

PL12.1 550 Feeder (Option) (1/5) [List]

Item	Parts name
1	550 OPTION FEEDER (with 2,5-7, PL12.2, 12.3)
2	COVER LEFT
3	SCREW JOINT
4	COVER CST 550
5	CLUTCH ASSY TURN OPT
6	CLUTCH ASSY FEED OPT
7	COVER RIGHT
99	KIT SCREW JOINT (with 3x2pcs)

PL12.2 550 Feeder (Option) (2/5) [Illustration]

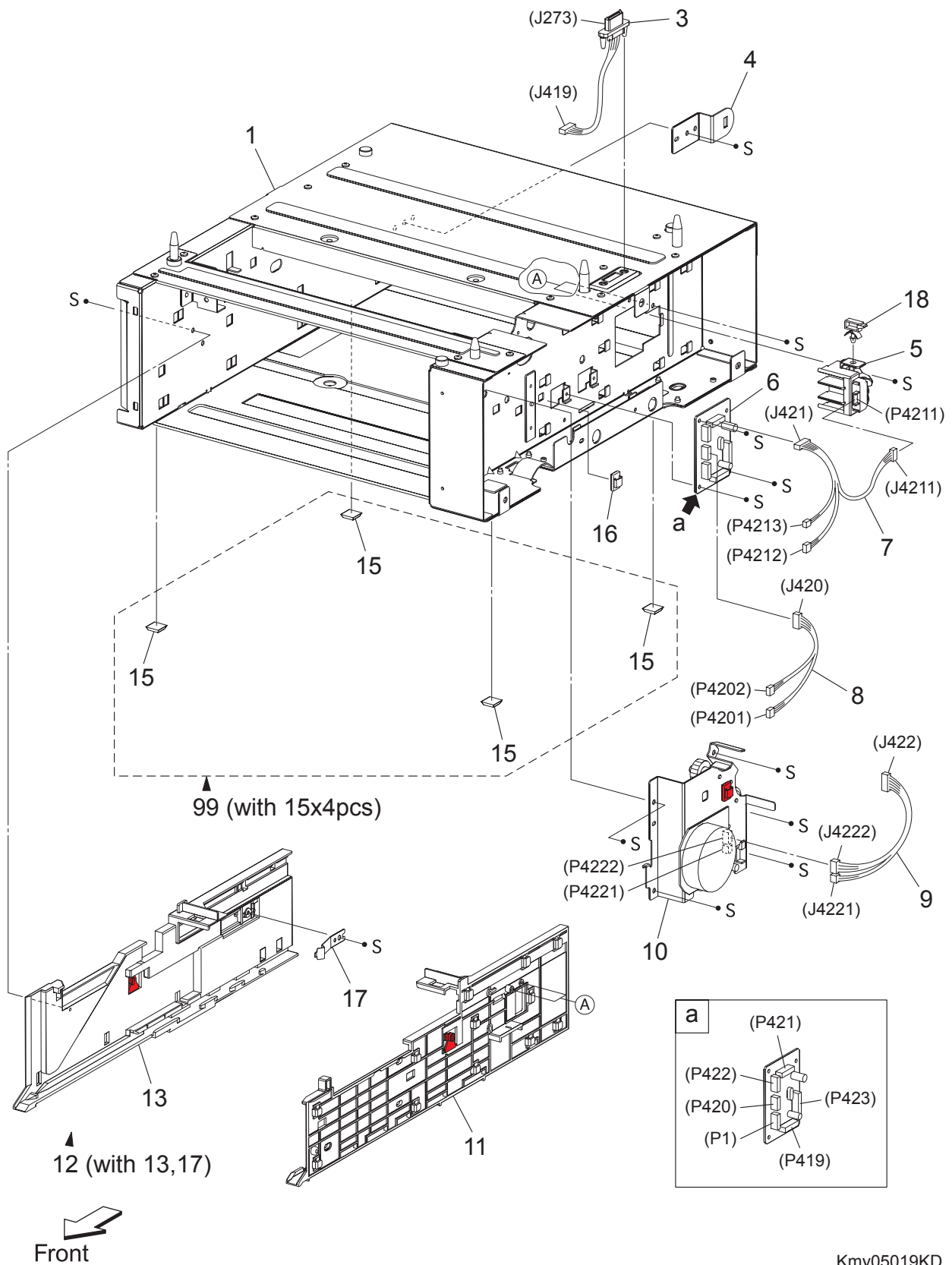

Kmy05019KD

PL12.2 550 Feeder (Option) (2/5) [List]

Item	Parts name
1	FRAME ASSY OPT
2	--
3	HARN ASSY FDR UNIT (J273-J419)
4	BRACKET LOCK
5	SWITCH ASSY SIZE OPT
6	PWBA OPT FDR
7	HARN ASSY C2 CHUTE (J421-J4211,P4212,P4213)
8	HARN ASSY C2 TURN (J420-P4201,P4202)
9	HARN ASSY C2 MOT (J422-J4221,J4222)
10	DRIVE ASSY OPT FDR
11	GUIDE TRAY R 550
12	GUIDE ASSY 550 L (with 13,17)
13	GUIDE TRAY L 550
14	--
15	FOOT
16	CLAMP MINI
17	SPRING CST LOCK
18	CLAMP LOCKING
99	KIT FOOT ASSY (with 15x4pcs)

PL12.3 550 Feeder (Option) (3/5) [Illustration]

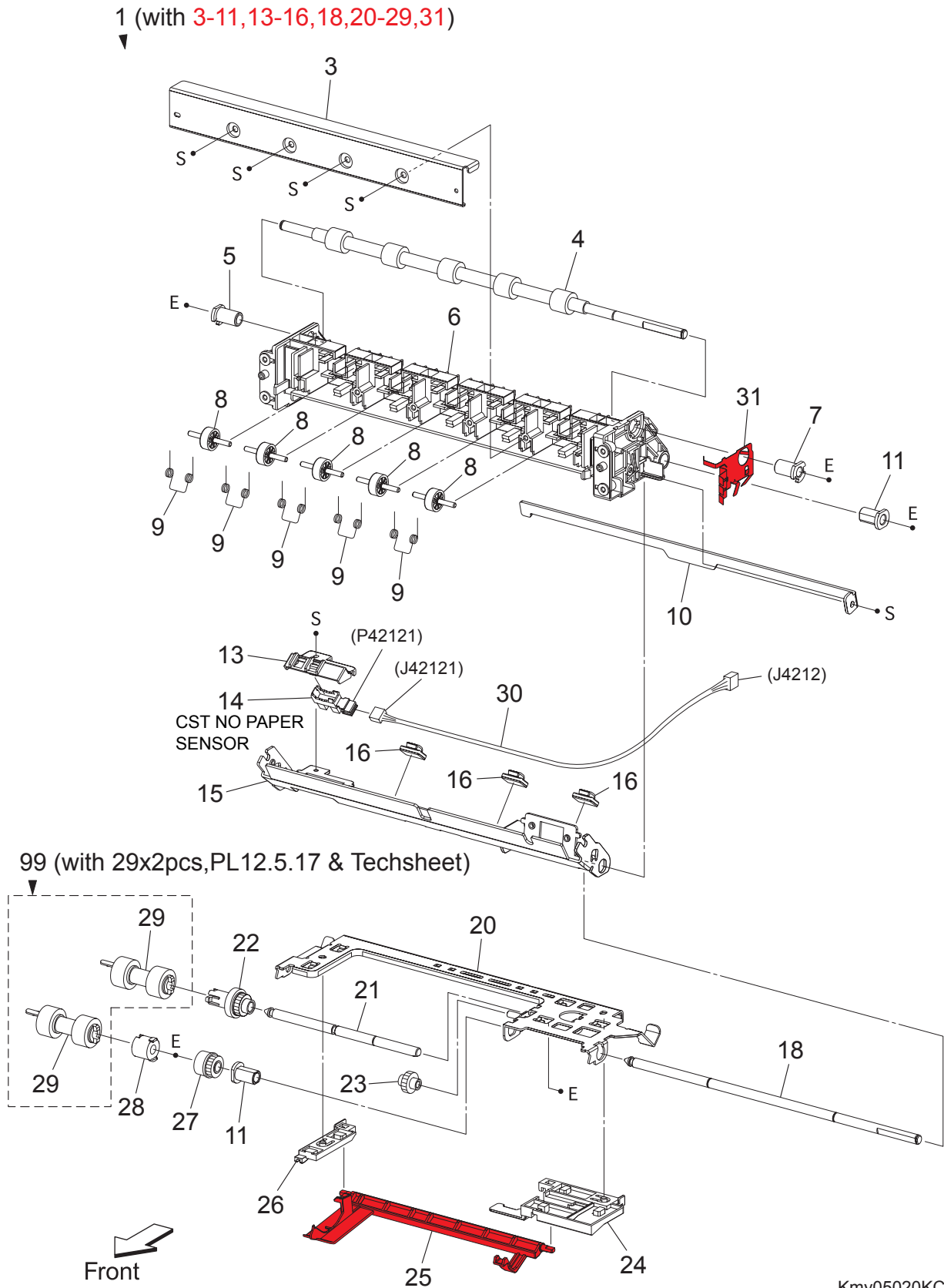

PL12.3 550 Feeder (Option) (3/5) [List]

Item	Parts name
1	FDR ASSY OPT (with 3-11,13-16,18,20-29,31)
2	--
3	COVER CHUTE
4	ROLL ASSY TURN
5	BEARING REGI
6	CHUTE FDR OPT
7	BEARING REGI E
8	ROLL PINCH TURN
9	SPRING PINCH TURN
10	CHUTE RETARD BTM OPT
11	BEARING NUDGER
12	--
13	HOLDER NO SNSR
14	SENSOR PHOTO (CST NO PAPER SENSOR)
15	CHUTE ASSY RETARD
16	CLAMP
17	--
18	SHAFT FEED OPT
19	--
20	SUPPORT NUDGER ASSY
21	SHAFT NUDGER
22	ROLL ASSY GEAR NUDGER
23	GEAR IDLER NUDGER
24	HOLDER NO PAPER L A4
25	ACTUATOR NO PAPER A4
26	HOLDER NO PAPER R A4
27	CLUTCH ONEWAY NUDGER
28	CLUTCH ONEWAY FEED
29	ROLL ASSY FEED
30	HARN ASSY C2 NO PAPER (J4212-J42121)
31	PLATE EARTH OPT
99	KIT SEPARATOR and FEED ROLLER (with 29x2pcs, PL12.5.17 & Techsheet) *1

*1 : Periodic Replacing Parts (100KPV)

PL12.4 550 Feeder (Option) (4/5) [Illustration]

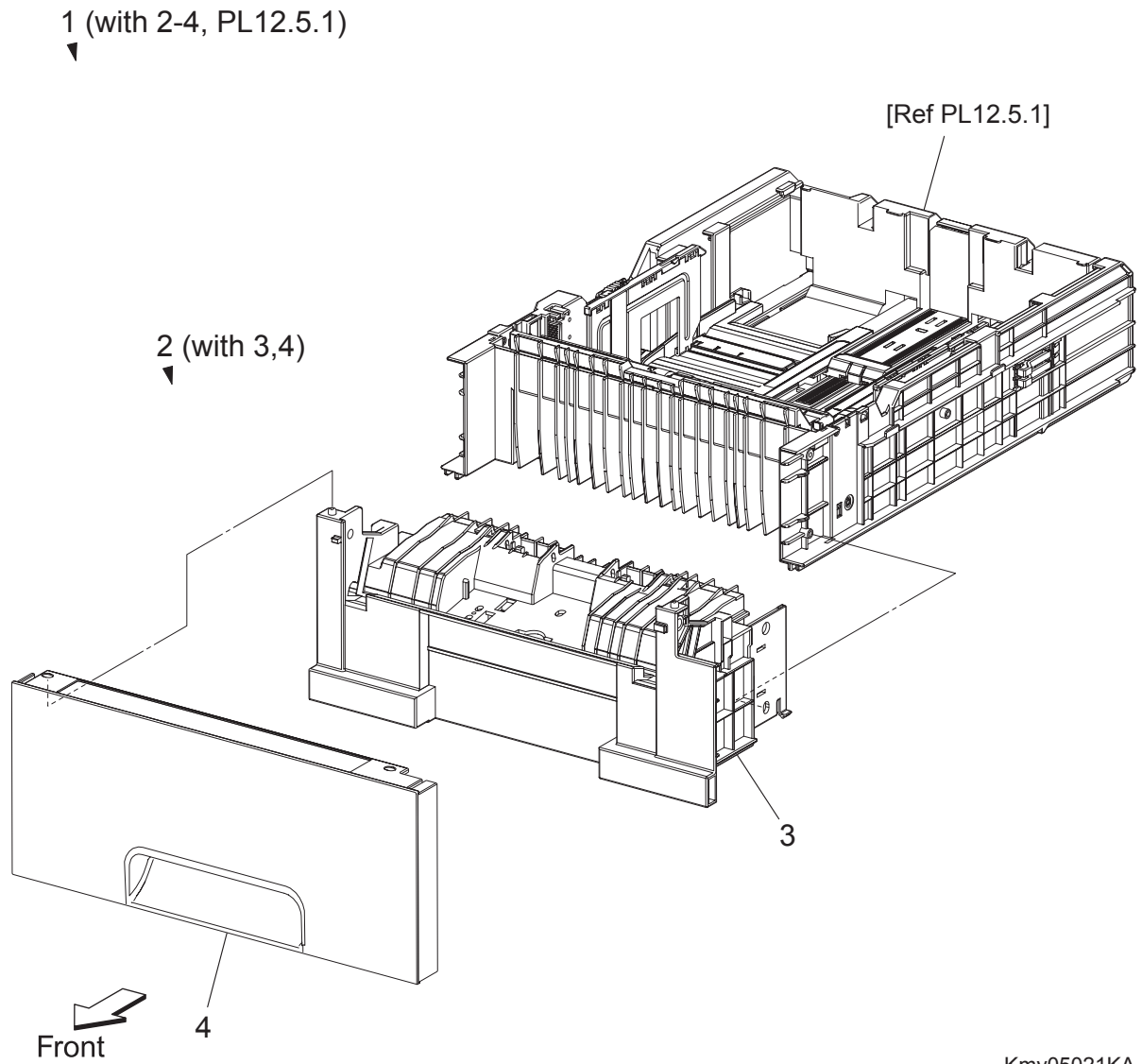

Kmy05021KA

PL12.4 550 Feeder (Option) (4/5) [List]

Item	Parts name
1	CASSETTE ASSY 550 OPT (with 2-4, PL12.5.1)
2	CASSETTE ASSY FRONT 550 OPT (with 3,4)
3	HOUSING BASE FR 550
4	HANDLE CST 550 OPT

PL12.5 550 Feeder (Option) (5/5) [Illustration]

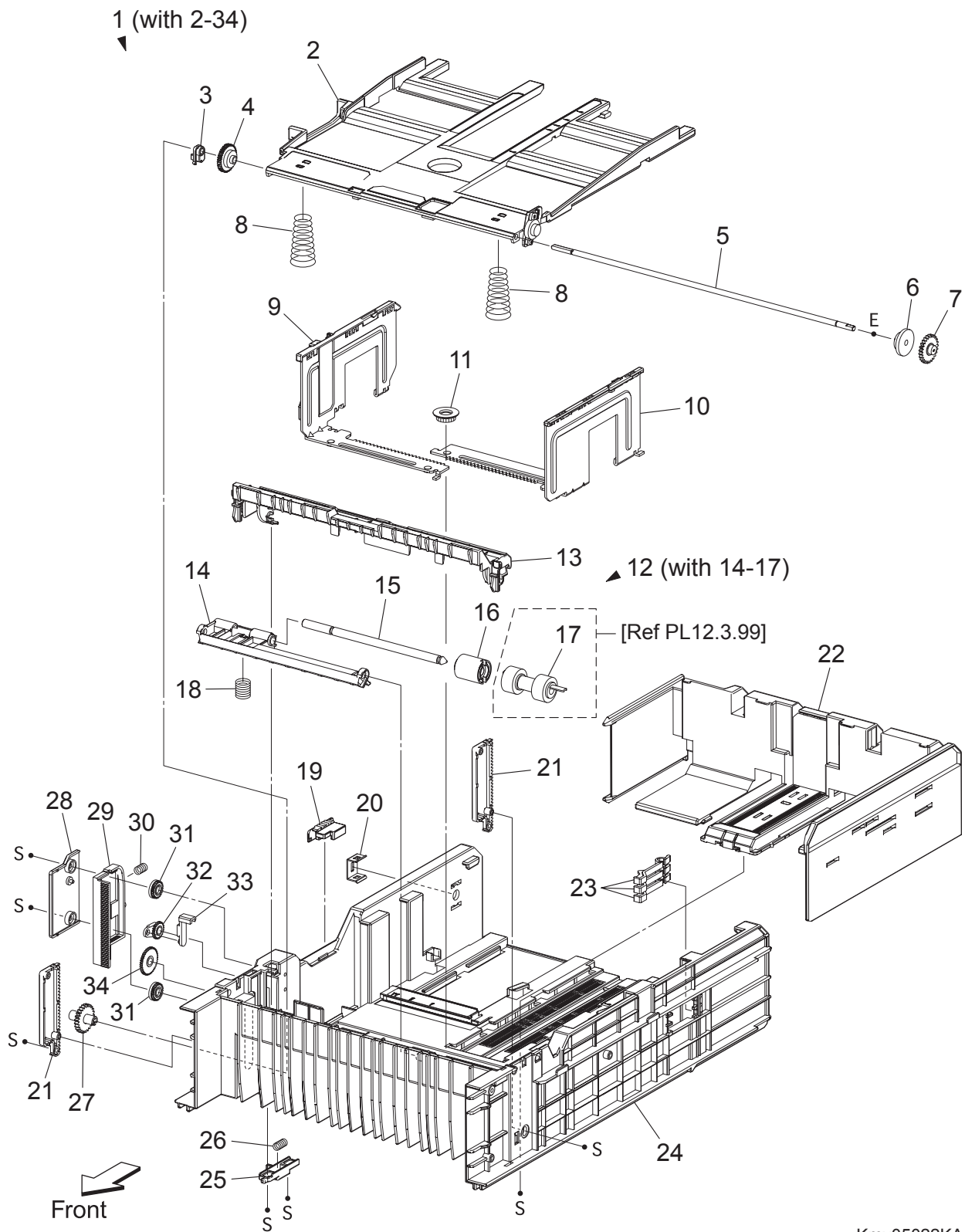

Kmy05022KA

PL12.5 550 Feeder (Option) (5/5) [List]

Item	Parts name
1	CASSETTE ASSY REAR 550 (with 2-34)
2	PLATE ASSY BTM A4
3	STOPPER PB
4	GEAR BTM LOCK ONEWAY
5	SHAFT PB A4
6	GEAR BTM DMP ONEWAY
7	GEAR PB L
8	SPRING BTM UP 550 A4
9	GUIDE ASSY SIDE R 550 A4
10	GUIDE ASSY SIDE L 550 A4
11	GEAR PINION
12	HOLDER ASSY RETARD (with 14-17)
13	CVR RTD CST
14	HOLDER RETARD
15	SHAFT RETARD
16	CLUTCH FRICTION RET
17	SEPARATOR ROLLER
18	SPRING RETARD
19	SWITCH SIZE SET
20	PLATE LOCK CST
21	PLATE GEAR LOCK 550
22	GUIDE ASSY CST END 550
23	ACTUATOR SIZE
24	HSG BASE RE 550
25	ACTUATOR RLS PB
26	SPRING STOPPER GEAR
27	GEAR PB R
28	COVER BTM UP 550
29	RACK BTM LOCK 550
30	SPRING BTM LOCK
31	GEAR BTM LOCK PINION
32	GEAR LEVER BTM LOCK
33	LEVER BTM LOCK
34	GEAR 40 BTM LOCK

Blank Page

Chapter 6 Principles of Operation CONTENTS

1. Printing Process	6 - 1
1.1 Summary of Printing Process	6 - 1
1.2 Schematic Diagram for Printing Processes	6 - 2
1.3 Description of Printing Process Techniques	6 - 3
1.3.1 Charging with electricity	6 - 3
1.3.2 Exposure.....	6 - 4
1.3.3 Development.....	6 - 6
1.3.4 Transfer (Drum -> Paper)	6 - 8
1.3.5 Cleaning (TONER CARTRIDGE).....	6 - 10
1.3.6 Neutralization	6 - 10
1.3.7 Fusing	6 - 12
2. Paper Path.....	6 - 14
2.1 Paper Path	6 - 14
2.2 Layout of Paper Path	6 - 15
3. Functions of Major Functional Components	6 - 16
3.1 Paper Cassette	6 - 16
3.1.1 Major functions.....	6 - 16
3.1.2 Reference diagram	6 - 17
3.1.3 Multiple Sheet Feed Prevention.....	6 - 18
3.1.4 Reference diagram	6 - 18
3.1.5 Bottom Plate Moving.....	6 - 19
3.2 Paper Feeder	6 - 20
3.2.1 Major functions.....	6 - 20
3.2.2 Reference diagram	6 - 21
3.3 MPF & Regi Assy.....	6 - 22
3.3.1 Major functions.....	6 - 22
3.3.2 Reference diagram	6 - 23
3.3.3 Multiple Sheet Feed Prevention.....	6 - 24
3.3.4 Reference diagram	6 - 24
3.3.5 Lead-edge Registration.....	6 - 25
3.3.6 Reference diagram	6 - 25
3.3.7 Paper detection by the Regi Sensor	6 - 26
3.3.8 Reference diagram	6 - 26
3.4 Transfer Belt & Fuser.....	6 - 28
3.4.1 Major functions.....	6 - 28
3.4.2 Reference diagram	6 - 29
3.5 PRINTHEAD	6 - 30
3.5.1 Major functions.....	6 - 30
3.5.2 Reference diagram	6 - 31
3.6 TONER CARTRIDGE	6 - 32
3.6.1 Major functions.....	6 - 32
3.6.2 Reference diagram	6 - 33
3.7 Drive.....	6 - 34
3.7.1 Major functions.....	6 - 34
3.7.2 Reference diagram	6 - 35

Chapter 6 Principles of Operation CONTENTS

3.8 Electrical	6 - 36
3.8.1 Major functions.....	6 - 36
3.8.2 Reference diagram	6 - 37
3.8.3 Data Flow.....	6 - 38
3.9 Duplex.....	6 - 40
3.9.1 Major functions.....	6 - 40
3.9.2 Reference diagram	6 - 41
3.10 550 Paper Feeder	6 - 42
3.10.1 Major functions (Paper Cassette)	6 - 42
3.10.2 Reference diagram	6 - 42
3.10.3 Multiple paper feed prevention.....	6 - 43
3.10.4 Reference diagram	6 - 43
3.10.5 Bottom Plate Moving.....	6 - 44
3.10.6 Major functions (Feeder).....	6 - 46
3.10.7 Reference diagram	6 - 47
4. MODES	6 - 48
4.1 Operation Modes	6 - 48
5. Control	6 - 49
5.1 Control of Paper Size.....	6 - 49
5.2 Selective Control on Paper Cassette	6 - 49
5.3 PRINTHEAD Light Quantity Control	6 - 49
5.4 Process Control	6 - 50
5.4.1 Potential Control	6 - 50
5.4.2 Toner Density Control.....	6 - 51
5.4.3 High Area Coverage Mode	6 - 51
5.4.4 Admix Mode.....	6 - 51
5.4.5 ADC Sensor Adjustment.....	6 - 51
5.5 Color Registration Control.....	6 - 52
5.6 Fuser Control	6 - 53
5.6.1 Fuser temperature control.....	6 - 53
5.6.2 Cool down	6 - 53
5.6.3 Sensor Warm-up.....	6 - 53
6. Drive Transmission Route	6 - 54
6.1 PHOTOCONDUCTOR (PC)/DEVELOPER (DEV) DRIVE.....	6 - 54
6.2 TONER DISPENSER (Y, M, C, K).....	6 - 60
6.3 FEED DRIVE ASSEMBLY	6 - 62
6.4 DRIVE ASSY DUP.....	6 - 64
6.5 DRIVE ASSY OPT FDR.....	6 - 66

1. Printing Process

1.1 Summary of Printing Process

This printer is a "Full-color laser printer" which applies the principle of an electrophotographic recording system. The tandem system comprising the four color TONER CARTRIDGES of yellow, magenta, cyan and black (Y, M, C and K) creates the toner image.

Printing processes of this printer is composed of the basic steps as follows.

- (1) Charge: Drum surface is charged with electricity.
- (2) Exposure: Image unit is exposed to laser beams.
- (3) Development: Image is developed with toner.
- (4) Transfer: Four-color finished toner image on the Drum is transferred onto the paper.
- (5) Cleaning: Remaining toner on the drum is collected.
- (6) Neutralization:..... Electric charge of the paper is eliminated.
- (7) Fusing:..... Toner on the paper is fixed by heat and pressure.
- (8) Cleaning: Remaining toner on the belt is collected.

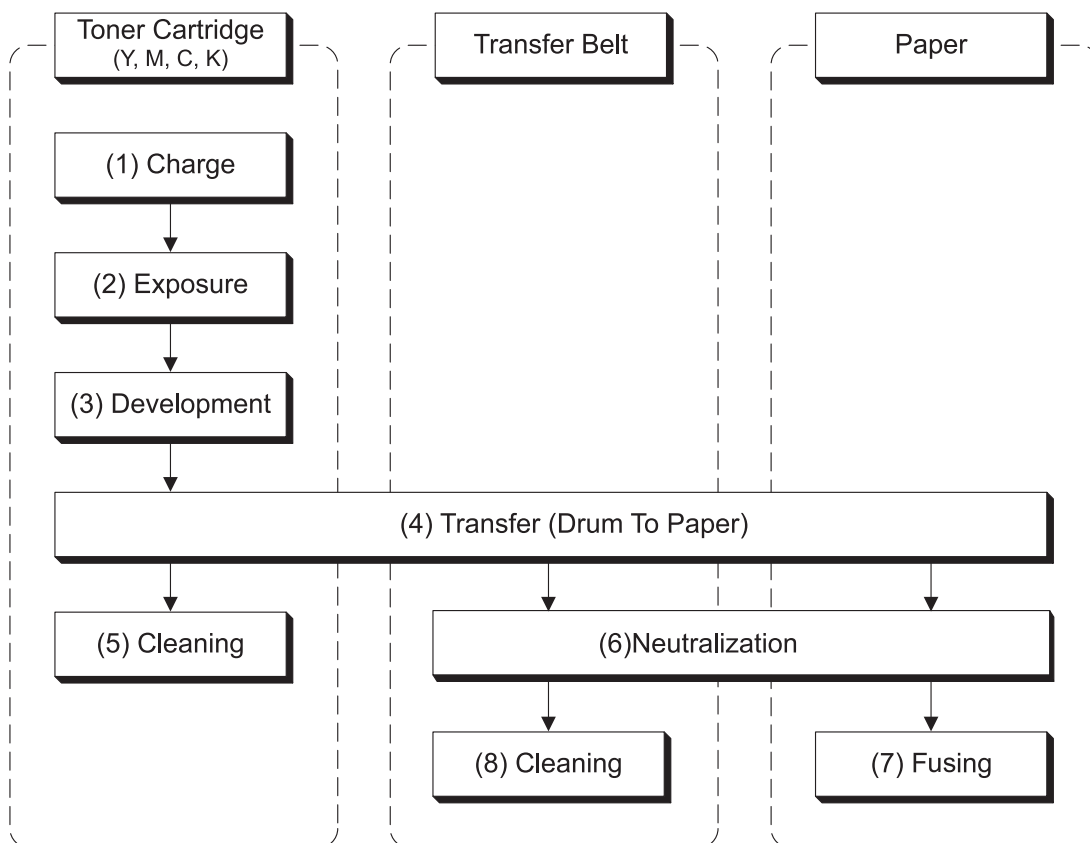

Kmy06001KB

1.2 Schematic Diagram for Printing Processes

Outline of printing processes is shown in the figure below.

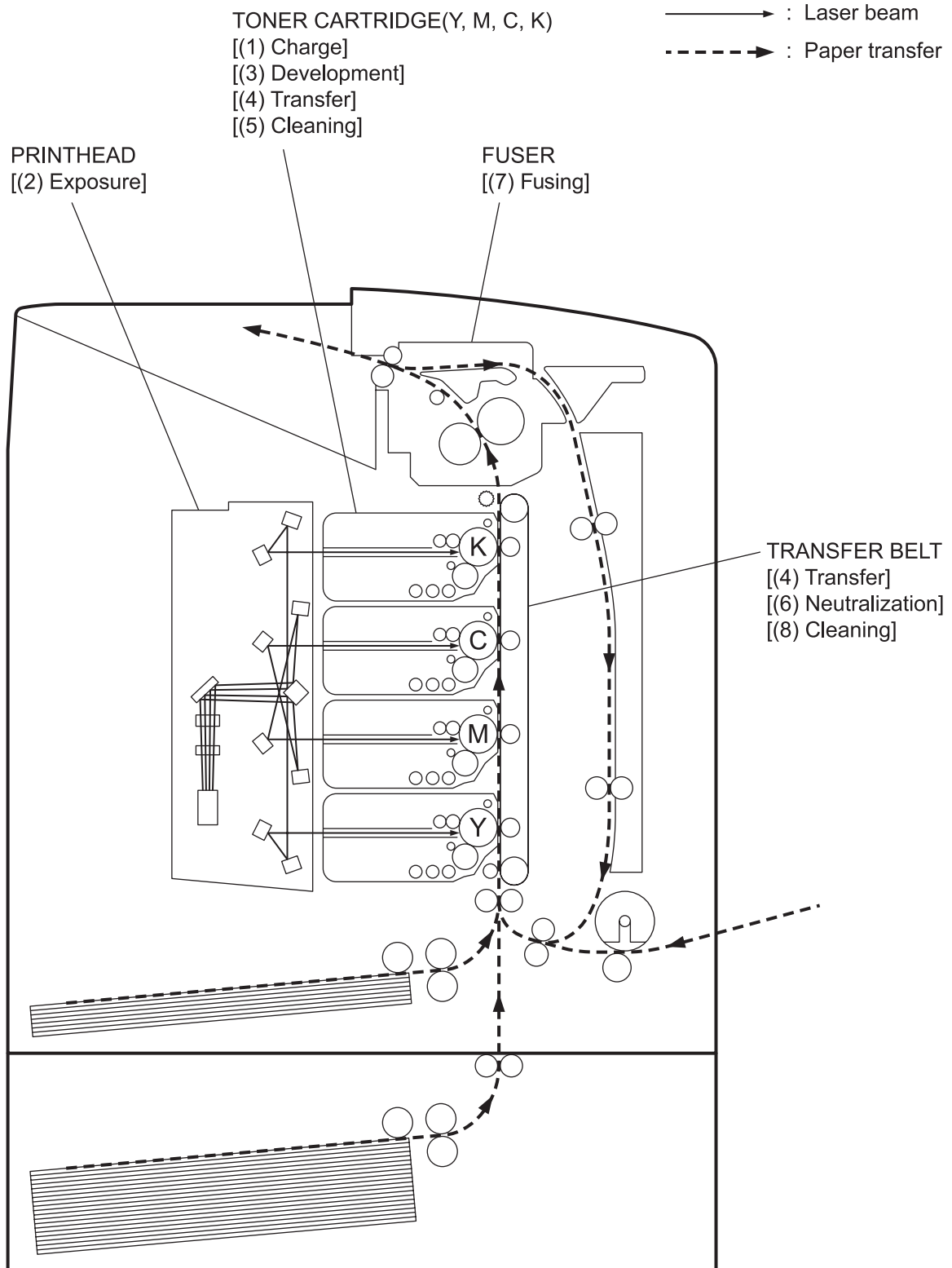

Kmy06002KB

1.3 Description of Printing Process Techniques

1.3.1 Charging with electricity

In the charging process, the drum surface rotating at a constant speed is charged uniformly with negative electricity by the discharge from BCR (Bias Charge Roll).

This process is performed in parallel for yellow, magenta, cyan and black colors.

- The BCR is kept in contact with the drum and rotates following the rotations of the drum. BCR is a conductive roll, receives discharge voltage from the High Voltage Power Supply (HVPS) and discharges a negative DC voltage.
- The drum surface is uniformly and negatively charged with DC bias voltage. The drum surface is a photoreceptor (which is an insulator in the dark and a conductor in the light) and the drum inside is composed of a conductor.
- The Cleaning Roll is a sponge, which contacts with the BCR to catch the toner.

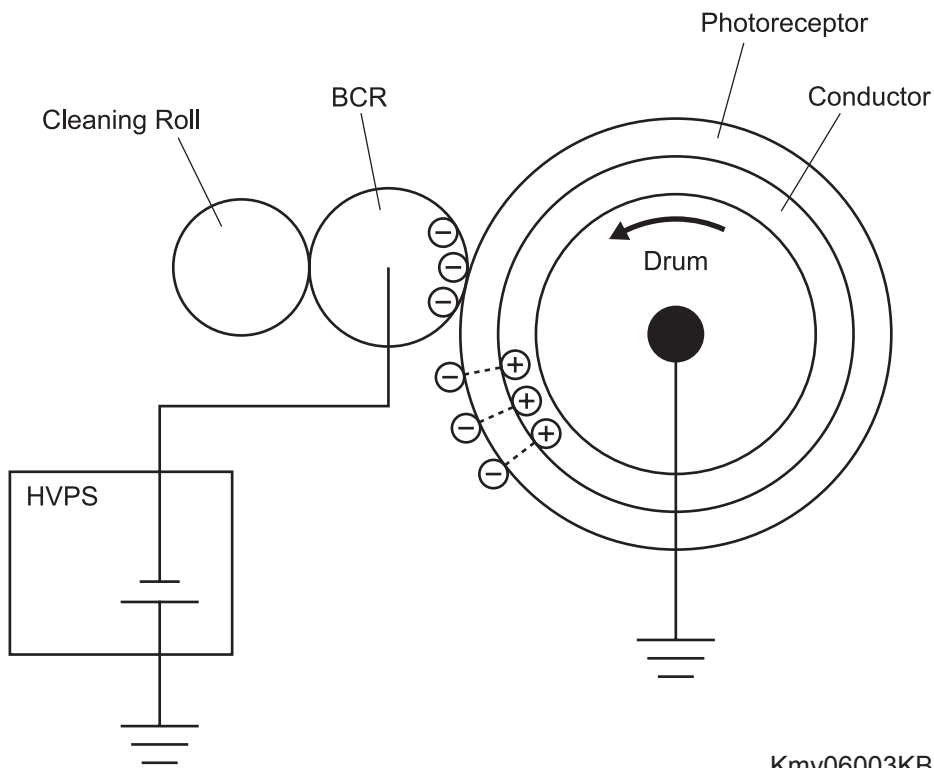

Kmy06003KB

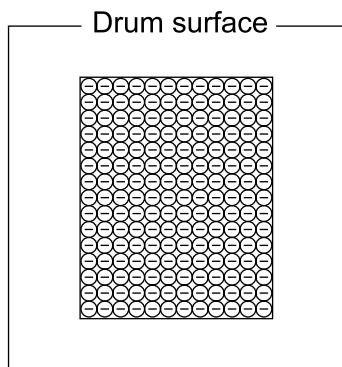

engine principle0005FA

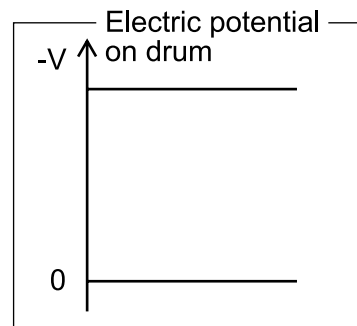

engine principle0006FA

1.3.2 Exposure

In the exposure process, the drum surface charged negatively is scanned by laser beams to form invisible electrostatic latent image on the drum surface.

This process is performed in parallel for yellow, magenta, cyan and black colors.

- Laser beams are emitted from the laser diode in the PRINTHEAD. By the rotating polygon mirror, fixed mirror and lens attached to the Scanner Motor Assy of the PRINTHEAD, the surface of each color drum is scanned from end to end in the axial direction.

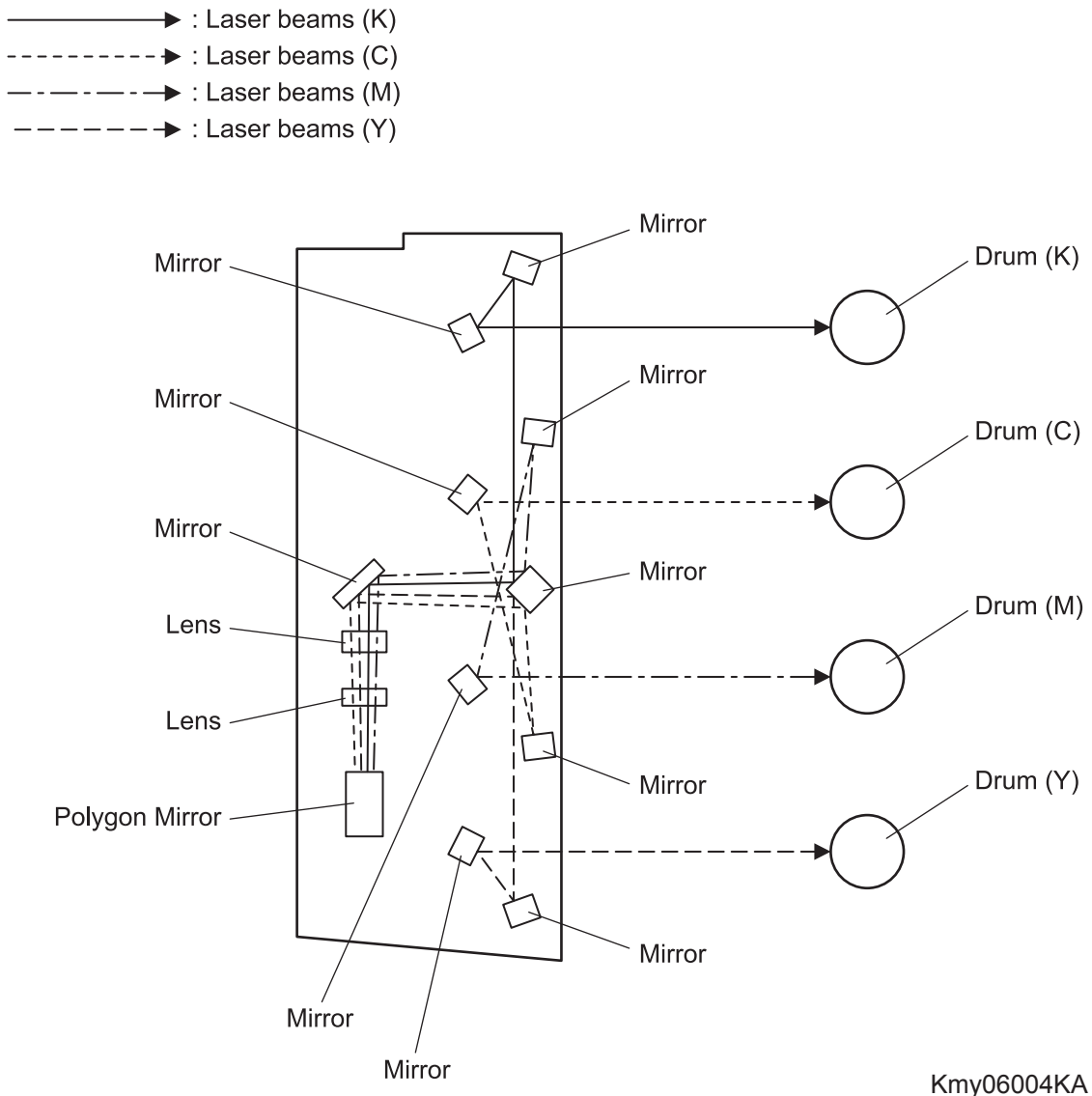

- The laser beam is irradiated according to the printing data (image data) output from the printer controller. The laser beam is output only when printing data is pixels (micro points composing characters or pictures). (The laser diode lights up for parts to be developed by toner, and not for parts that are not to be developed.)

The drum surface irradiated by the laser beam becomes a conductor, and the negative charge on the drum surface flows to the positive side and the charges cancel each other out so that the potential on the drum surface drops. The part on the surface where potential drops becomes the electrostatic latent image.

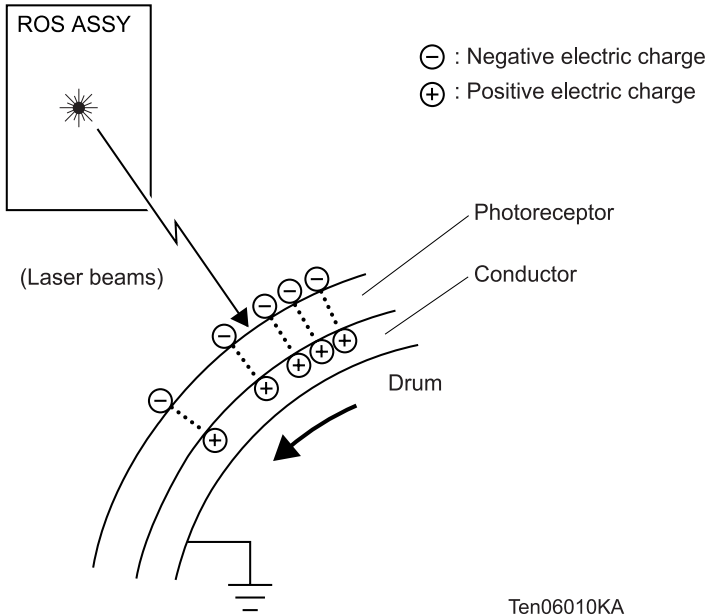

Ten06010KA

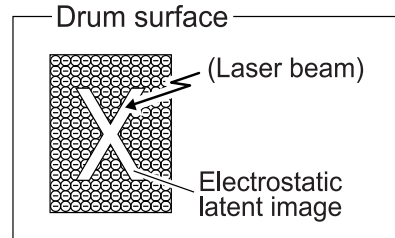

Leg_Sec06_011FA

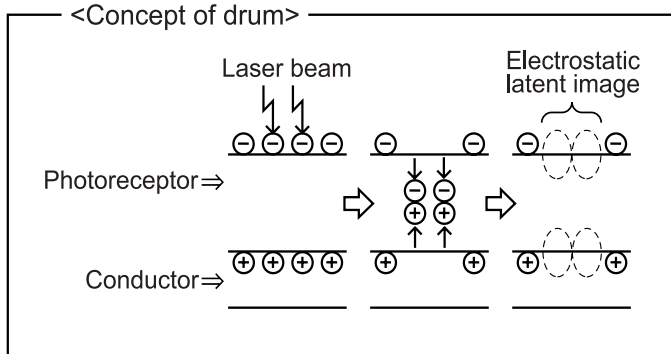

Ten06011KA

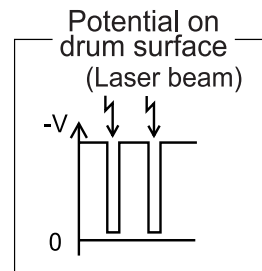

Leg_Sec06_012FA

1.3.3 Development

In the development process, toner is electrically attached to the invisible electrostatic latent image on the drum surface to form visible toner image on the drum.

This process is performed in parallel for yellow, magenta, cyan and black color independently.

- The toner in the toner cartridge part is agitated by the built-in Agitator and fed into the developer part. The Auger is driven by the toner motor and the deve motor in the PHOTOCONDUCTOR (PC)/DEVELOPER (DEV) DRIVE. The amount of toner to be consumed according to the print count is calculated and that amount is fed into the developer. This is called "toner dispensation", which is controlled by two types of control, "PCDC" and "ADC". ([Refer to 5.4.2 Toner Density Control](#))
- The toner fed into the developer part and the carrier in the developer part are agitated by the Auger, and supplied to the Magnet Roll arranged in the vicinity of the drum surface. The toner and carrier are charged by friction due to the agitation (toner in negative, carrier in positive), and they are attracted to one another electrically. As the carrier is a magnetic substance, it is attracted to the Magnet Roll having a magnetic force and a homogeneous layer is formed by the Trimmer Bar.
- The magnet roll is covered by a thin semi-conductive sleeve over the surface. DB (Developing Bias) voltage is supplied to this semiconductor sleeve from the High Voltage Power Supply (HVPS). DB voltage is negative DC voltage combined with AC voltage. The magnet roll is kept at a constant negative voltage against the photoreceptor layer of the drum by DC voltage. Therefore, at the area surface where the negative electric charge on the drum does not decrease, potential is lower than the magnet roll, while the potential is higher than the magnet roll at the area where the negative charge on the drum surface decreases. The AC voltage shakes the developer on the magnet roll surface Stimulating the toner to fly to the drum.
Thus, the toner charged negatively is attracted only to the drum surface area where the negative charge has decreased below that of the magnet roll (electrostatic latent image) and the toner image is formed on the drum.
Once the toner is adhered on the drum, the negative charge of the toner-bearing portion increases, which decreases the potential and the toner-attracting force of that portion.

- ⊖ : Negative electric charge
- ⊕ : Positive electric charge
- : Toner
- : Carrier

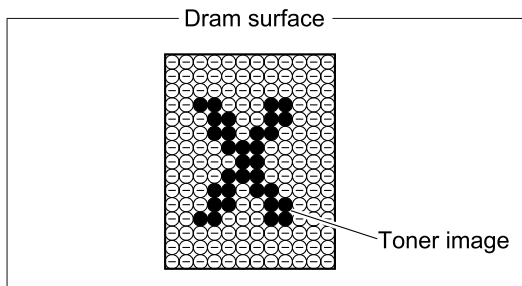
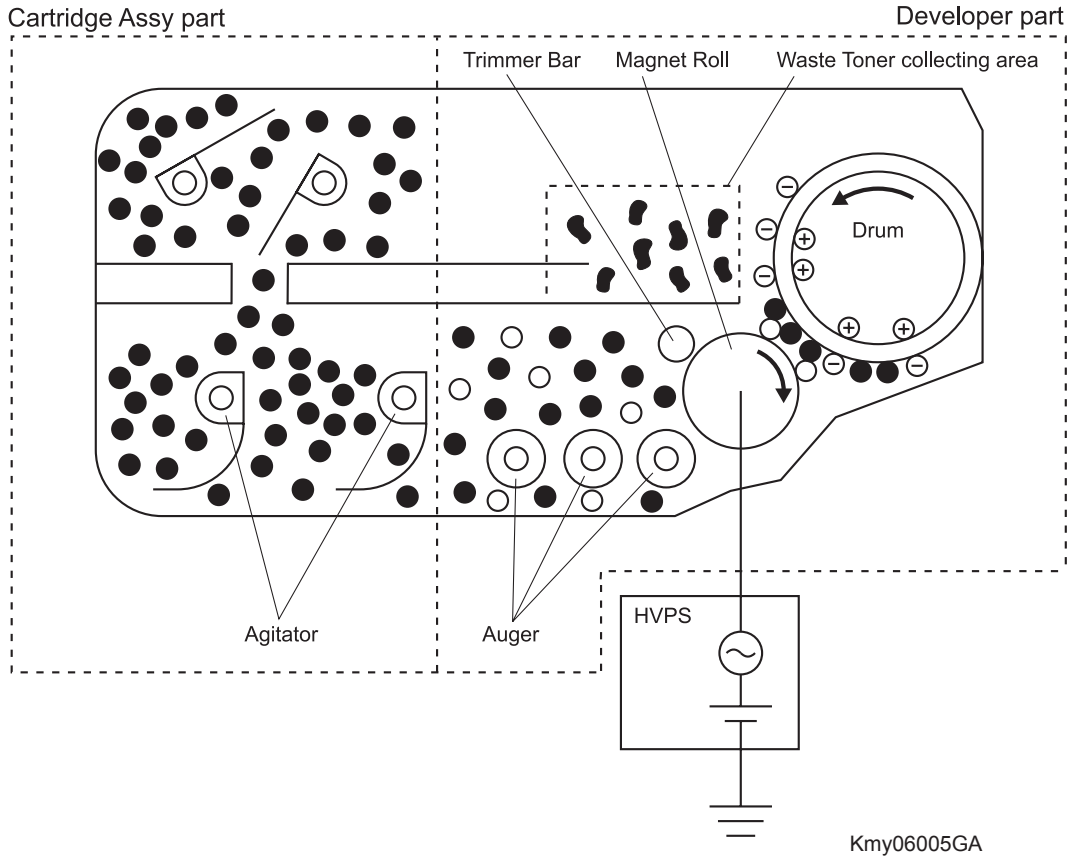

engine principle0013FA

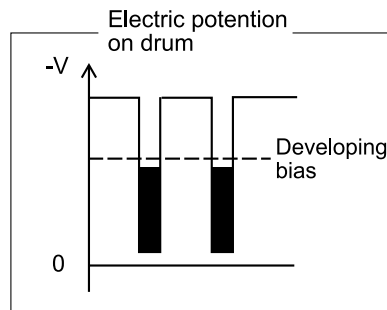

engine principle0014FA

1.3.4 Transfer (Drum -> Paper)

In the transfer process, toner image formed on the drum surface is transferred onto the surface of the paper. The toner is transferred onto the paper in the order of Y, M, C, and K.

- BTR

The BTR (Bias Transfer Roll) is a conductive roll, to which the positive voltage is applied from the High Voltage Power Supply (HVPS). The BTR contacts the rear side of the Belt and applies the positive voltage to the Belt.

- Belt

The Belt is a conductive belt, to which the positive voltage is applied from the BTR. After the negatively charged toner image on the drum surface is drawn by the positive charge on the belt, it is transferred from the drum to the paper. The Belt feeds the paper to the direction of FUSER.

- Roll ESA (Electric Static Attachment)

The Roll ESA is a conductive roll, which receives positive voltage from the High Voltage Power Supply (HVPS) and discharges to the drum to improve the toner transfer efficiency.

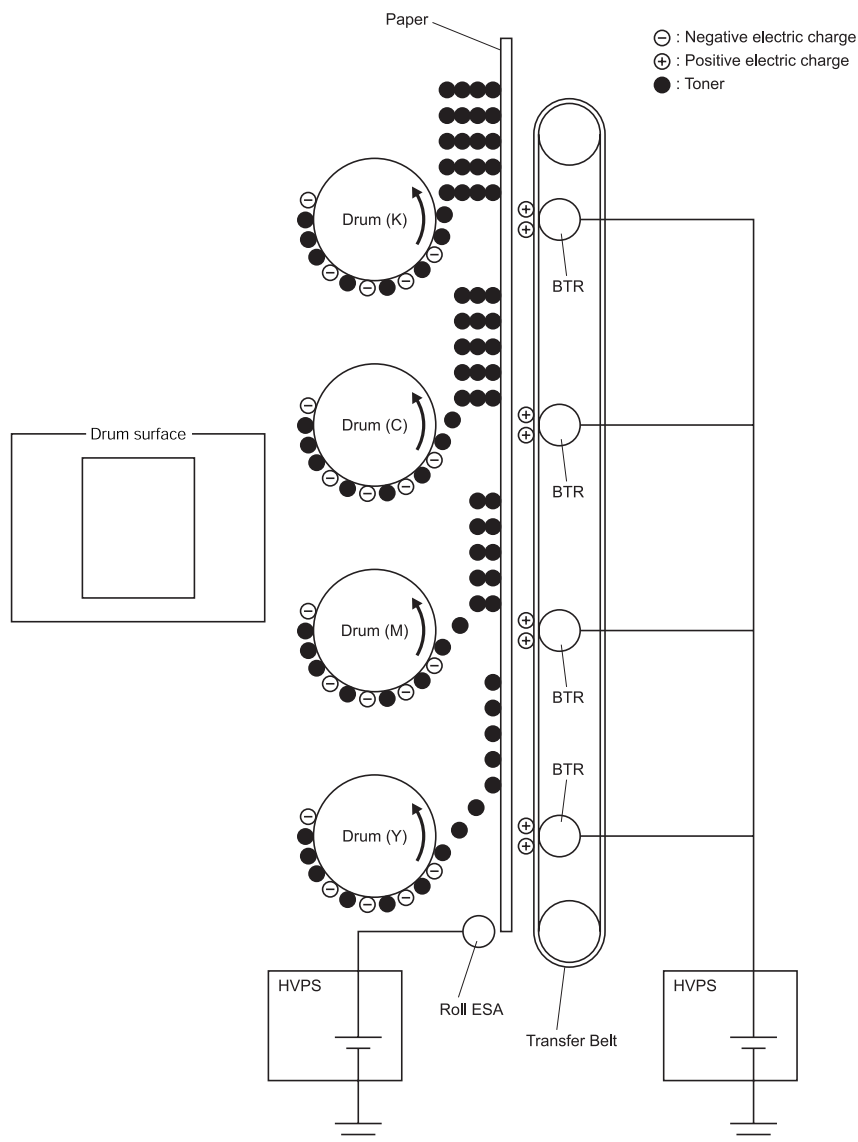

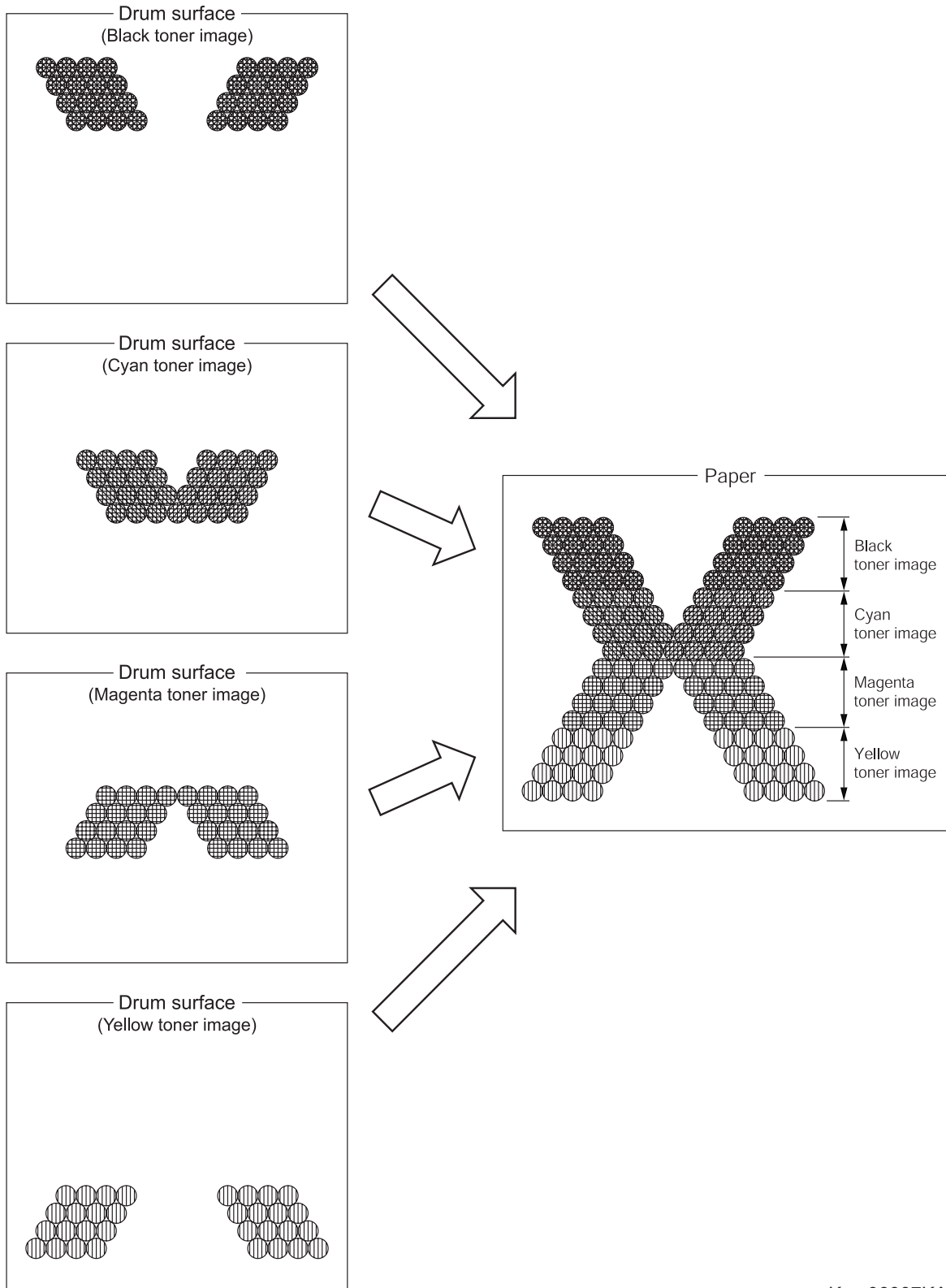

Kmy06007KA

1.3.5 Cleaning (TONER CARTRIDGE)

In the cleaning (TONER CARTRIDGE) process, excess toner is removed from the drum and BCR surfaces, while excess charge is also eliminated from the drum surface.

- Drum cleaning
The cleaning blade contacts the surface of the drum collecting the excess toner by scraping.
- Cleaning Roll
The Cleaning Roll contacts the surface of the BCR collecting the excess toner by scraping.
- Charge cleaning
When the drum is charged by BCR, any excess charge hinders the drum surface from being uniformly charged, which may lead to print quality problems.
The excess charge on the surface of the drum is eliminated by irradiating the light of the Erase Lamp (LED ASSEMBLY).

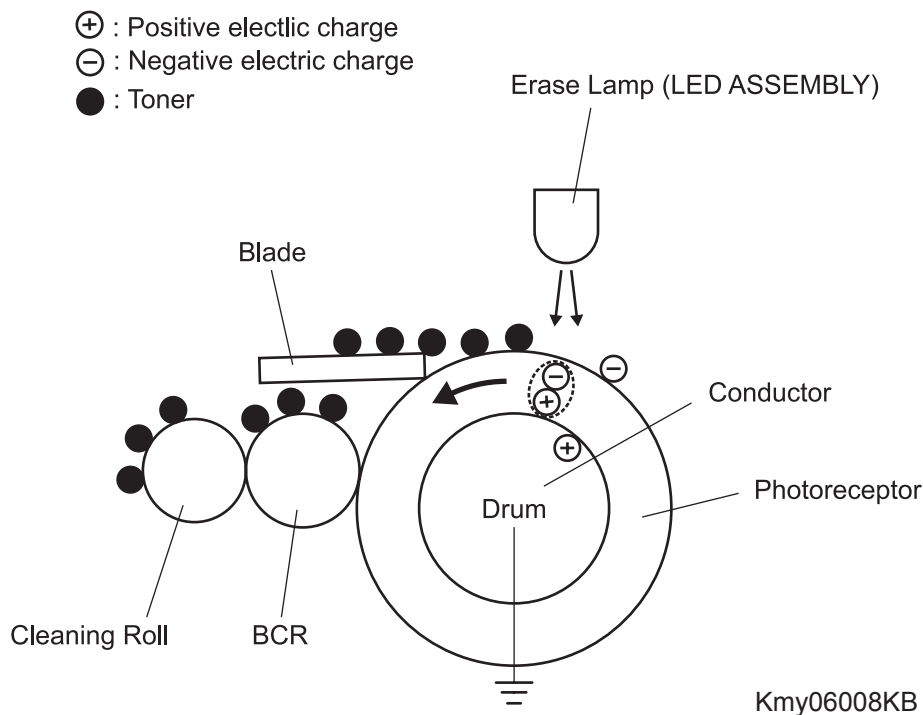

1.3.6 Neutralization

In the Neutralization process, the charge on the paper is neutralized or eliminated by the Detack Saw.

- Detack Saw
The charge is neutralized (removed) because otherwise the toner on the paper will spread over the surrounding metal surfaces.
The Detack Saw is a metal sheet that is held at the ground level. The Detack Saw is installed at several millimeters away from the backside of the belt.

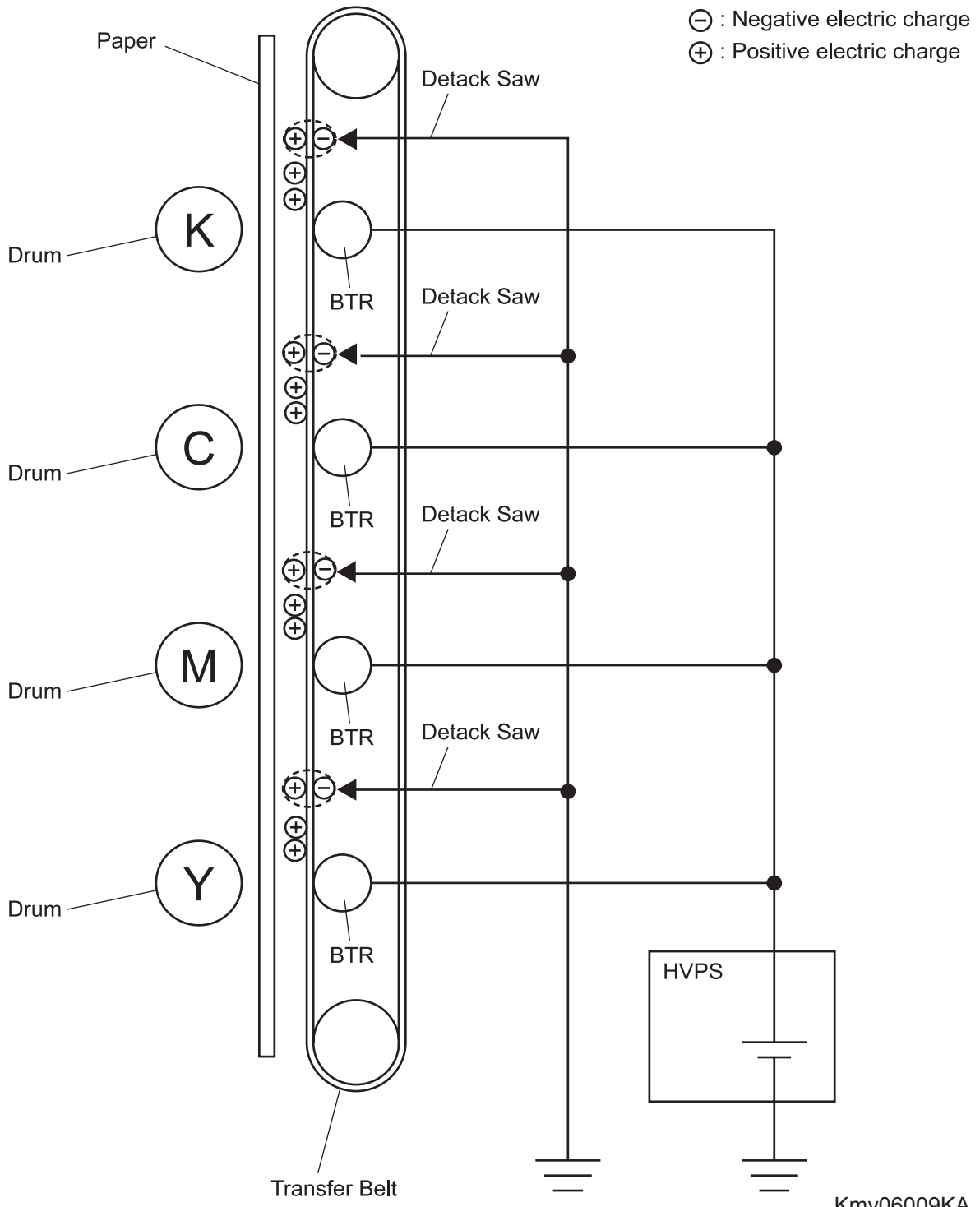

Kmy06009KA

1.3.7 Fusing

In the fusing process, toner is fixed on the paper by heat and pressure.

- Since the finished toner image transferred from the belt can be easily broken by a finger touch, the toner image must be fixed on the paper with the FUSER (fusing unit). The toner particles are melted by the HEAT ROLL heated by the Heater lamp and is deposited on the paper under pressure given by the belt opposed against the heat roll.

Conditions to be met to light up the Heater Lamp

	Warm up	Stand by	Printing
Main Heater Lamp	ON	ON/OFF	ON

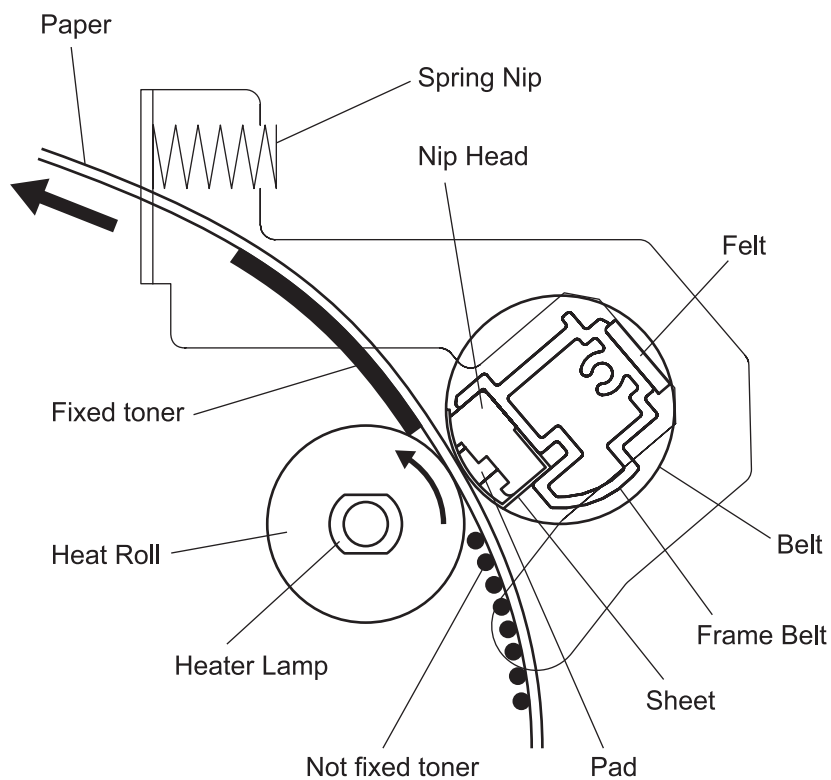

Kmy06010KA

Blank Page

2. Paper Path

2.1 Paper Path

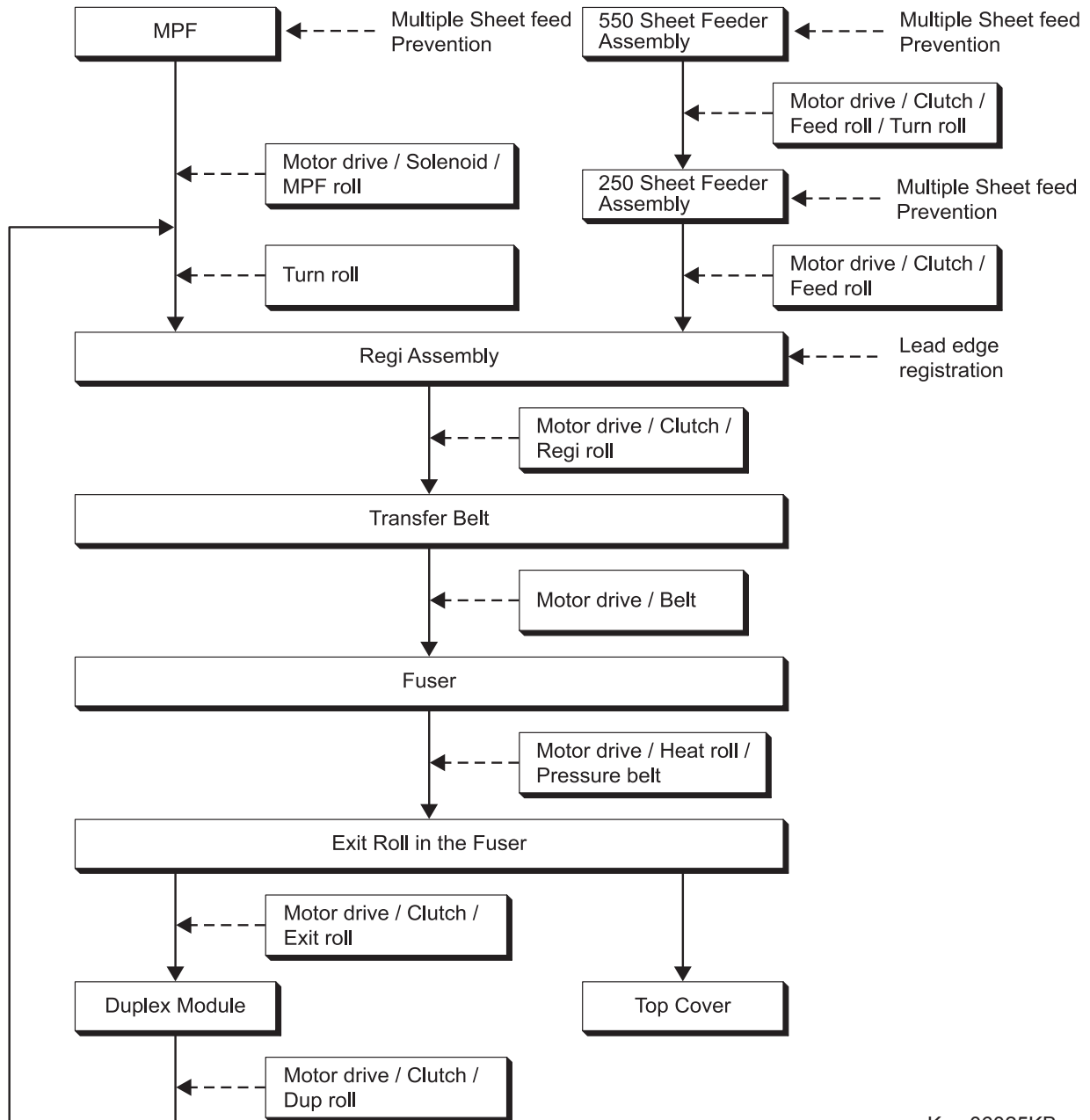

Kmy06025KB

2.2 Layout of Paper Path

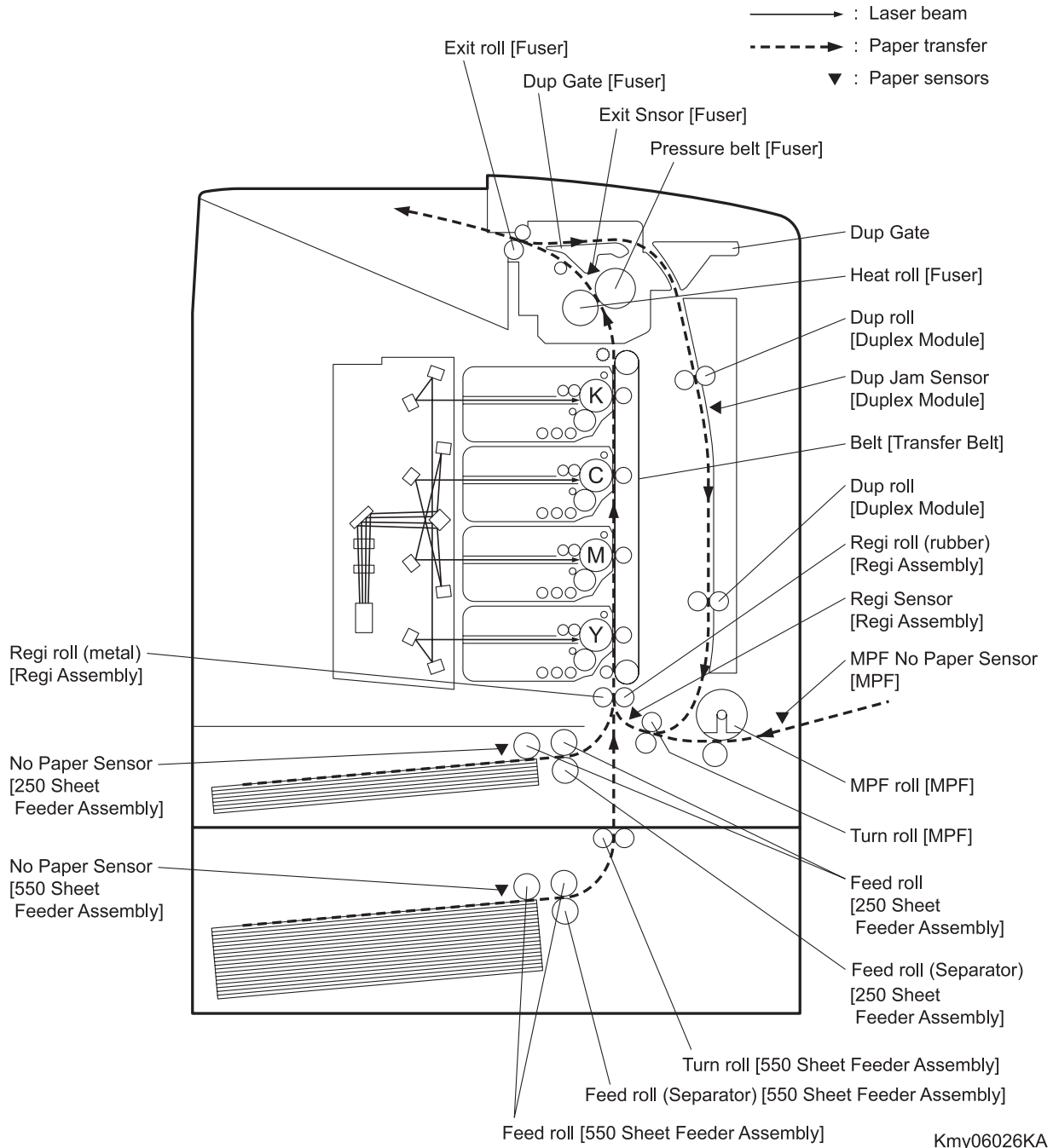

3. Functions of Major Functional Components

Major functional components of the printer are described below with illustrations.

These components are classified into the following blocks based on the configuration of the printer.

- Paper Cassette
- Paper Feeder
- MPF & Regi Assy
- Transfer Belt & Fuser
- PRINTHEAD
- TONER CARTRIDGE
- Drive
- Electrical
- Duplex
- 550 Paper Feeder

3.1 Paper Cassette

3.1.1 Major functions

- Guide Side (R/L)
The Guide Side Assy (R/L) can move at a right angle to the paper transfer direction to align the paper width.

- End Guide
The Guide End Assy can move in the paper transfer direction to determine the paper size. The ON/OFF of SIZE SWITCH ASSEMBLY ([Refer to 5.1 Control of Paper Size](#)) varies according to the Guide End Assy position to detect the paper size.

- FEED ROLLER (SEPARATOR)
The FEED ROLLER (SEPARATOR) and the FEED ROLLER pinch the paper to prevent multiple sheet feed.

- Bottom Plate
Bottom plate is locked to the bottom side when paper cassette is pulled out from the paper feeder and unlocked when paper cassette is installed to the paper feeder. Pushes the paper against the feed roll using a spring tension.

3.1.2 Reference diagram

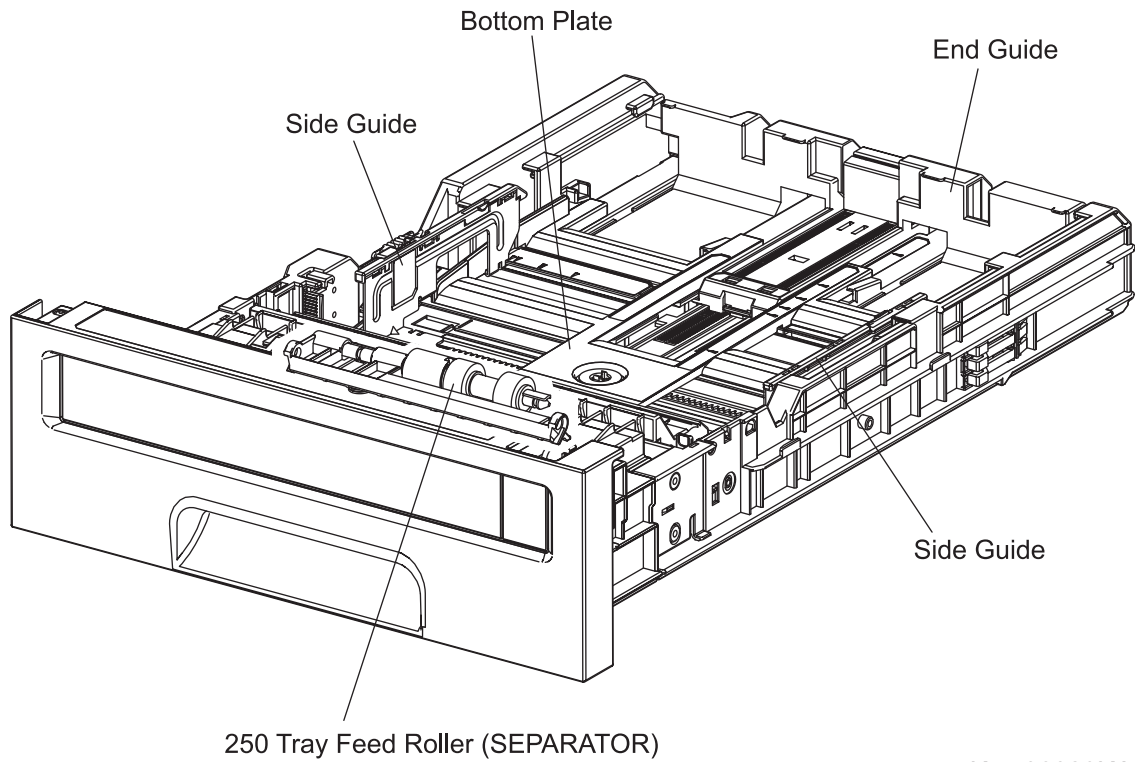

Kmy06029KA

3.1.3 Multiple Sheet Feed Prevention

The sheets set in a tray or cassette are occasionally stuck together along the edges. The stuck sheets cause a multiple sheet feed or a jam. The sheets are fed by the Nudger Roll to a position between the Feed Roll and the Separator Roll. Normally, when only one sheet is fed, both the Feed Roll and Separator Roll rotate to allow the sheet to pass. However, when two sheets are fed concurrently, only the Feed Roll rotates and the Separator Roll is locked thereby allowing the upper sheet to pass by being separated from the lower sheet that is stopped by the friction with the Separator Roll at rest.

The Separator Roll is being pushed toward the Feed Roll by spring pressure, and controlled by the torque limiter (Clutch Assy Friction) with which it is coupled.

3.1.4 Reference diagram

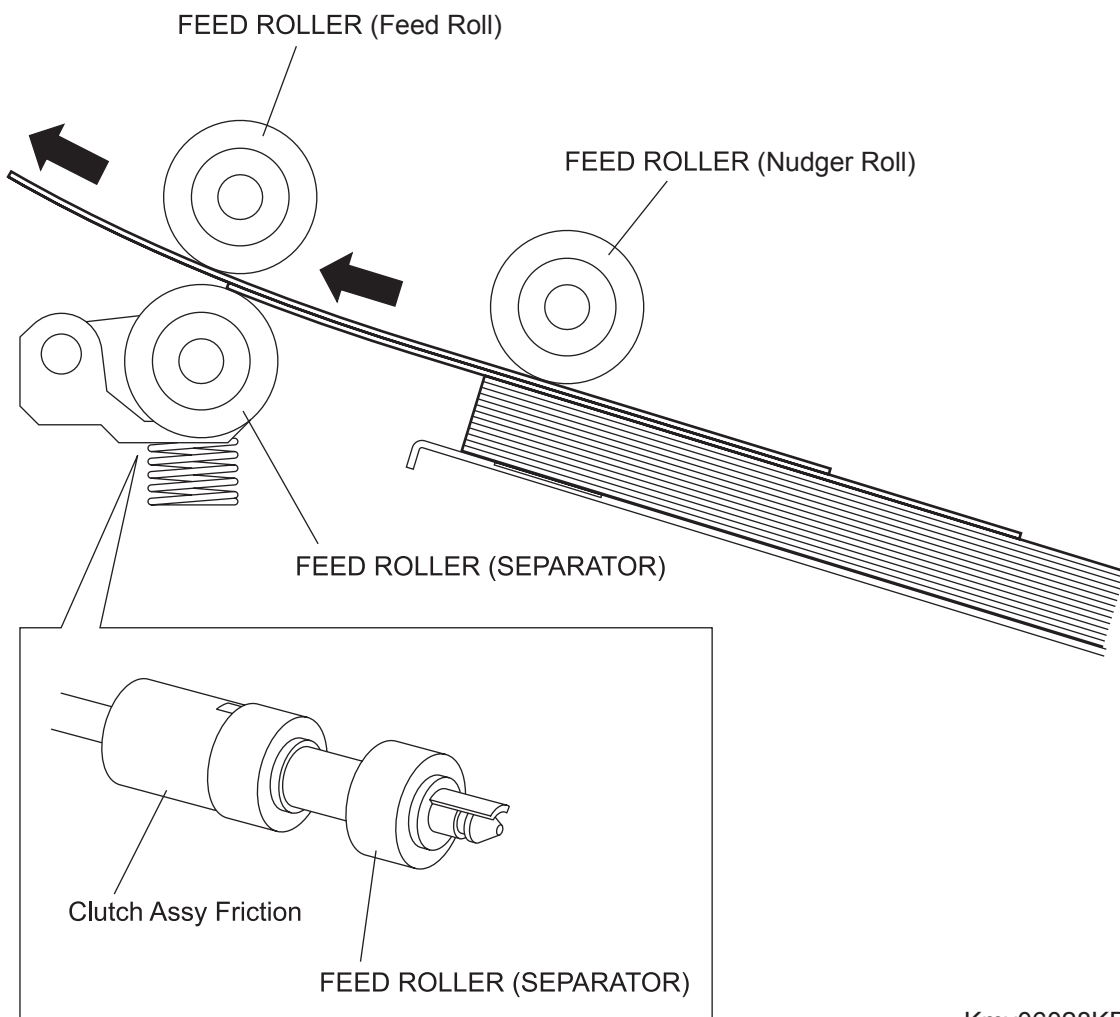

Kmy06028KB

3.1.5 Bottom Plate Moving

Inserting the paper tray into the feeder section unlocks the GEAR BTM LOCK ONEWAY. When the paper tray is pushed in until it stops, the gear teeth of the RACK BTM LOCK and GEAR BTM LOCK ONEWAY are out of engagement allowing the PLATE ASSY BTM to rise by the spring pressure of the SPRING BTM UP.

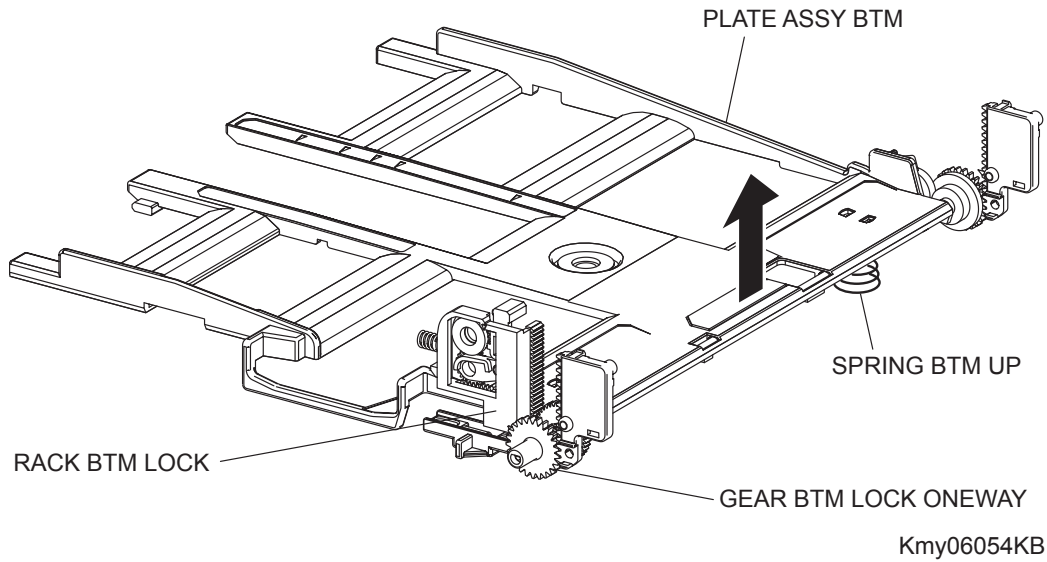

3.2 Paper Feeder

3.2.1 Major functions

- SIZE SWITCH ASSEMBLY

SIZE SWITCH ASSEMBLY detects paper size and the presence/absence of the paper tray.

(Refer to 5.1 Control of Paper Size for the combination of switches.)

The paper size is decided at the position of the END GUIDE.

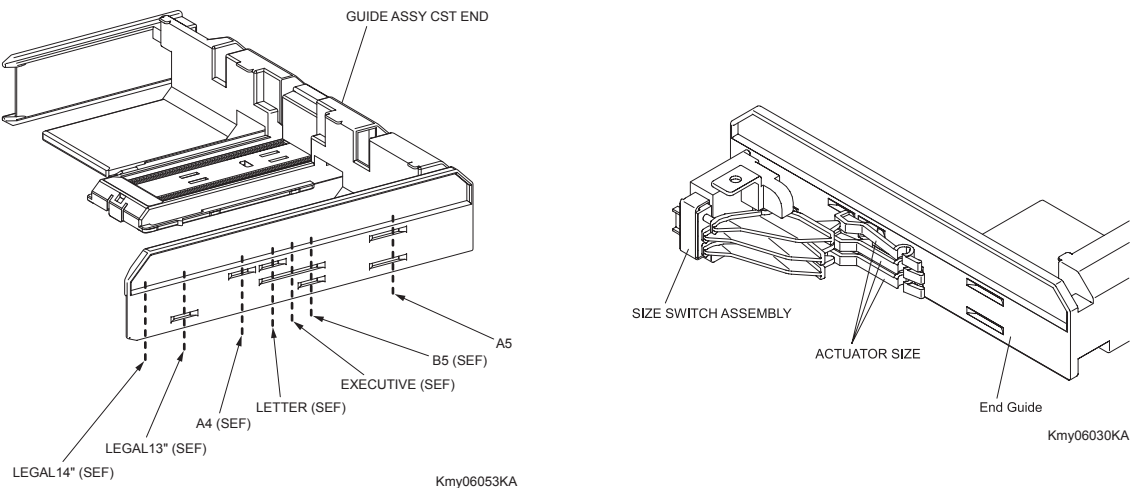

- SENSOR PHOTO (No Paper Sensor)

Detects the presence/absence of paper in the paper tray based on the position of ACTUATOR NO PAPER. (No paper: Sensor beam is intercepted)

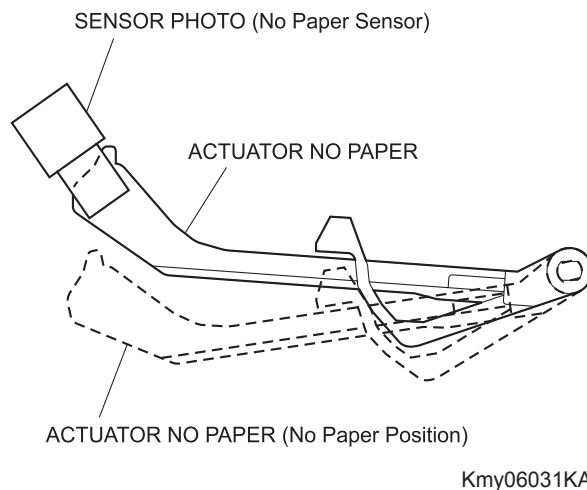

- CLUTCH ASSY FEED

Transmits the drive from the FEED DRIVE ASSEMBLY to FEED ROLLER. (Refer to 6.3 FEED DRIVE ASSEMBLY)

- FEED ROLLER

When the CLUTCH ASSY FEED operates, the FEED ROLLER starts rotating and the FEED ROLLER feeds the paper. (Refer to 6.3 FEED DRIVE ASSEMBLY)

3.2.2 Reference diagram

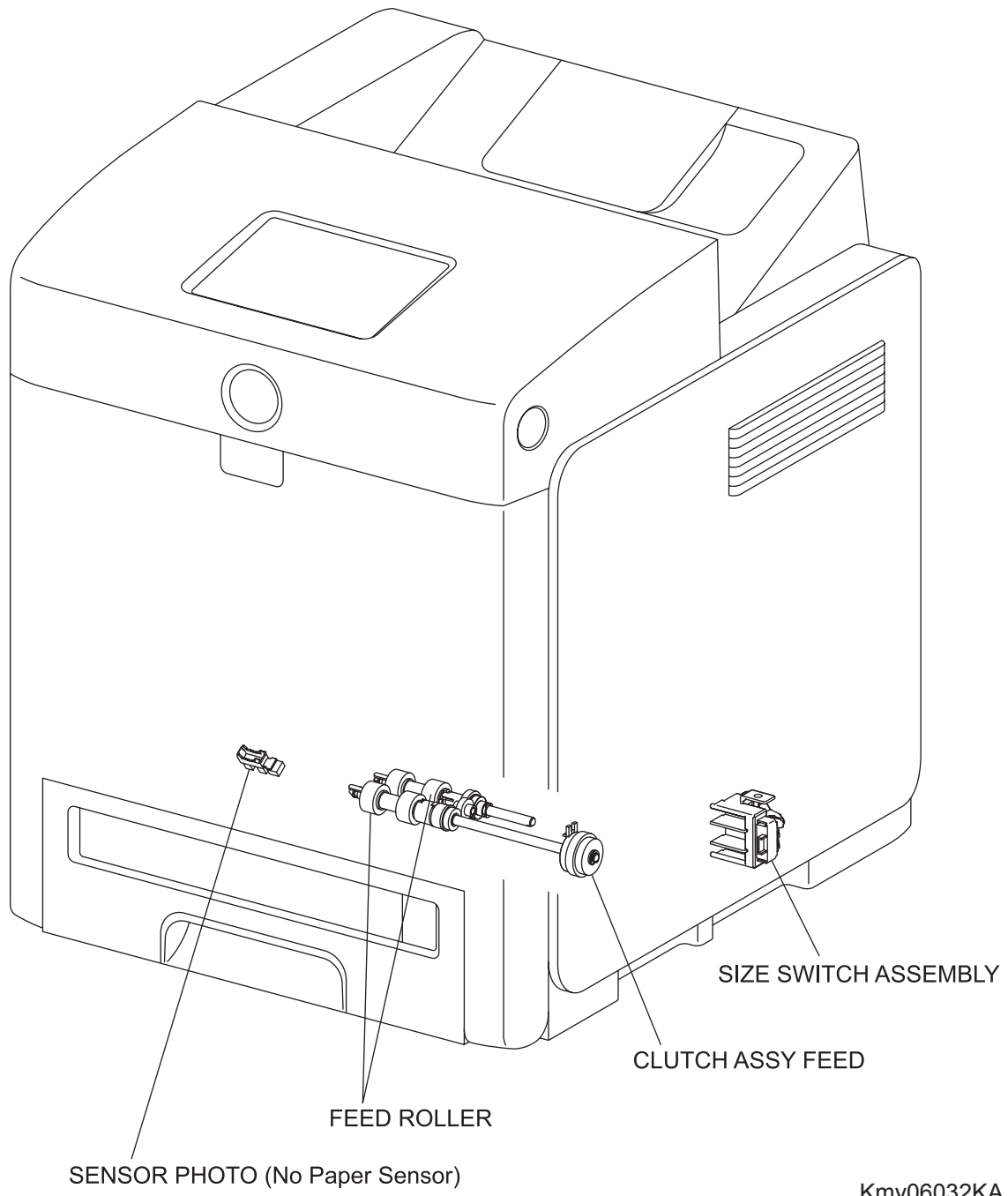

3.3 MPF & Regi Assy

3.3.1 Major functions

- MPF FEED SOLENOID
Controls the drive from the FEED DRIVE ASSEMBLY to the MPF ROLLER. (Refer to 6.3 FEED DRIVE ASSEMBLY)

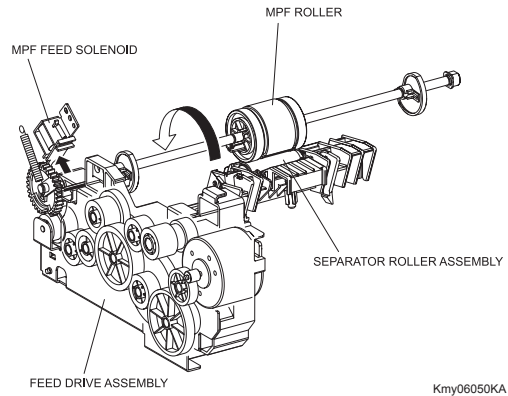

- CLUTCH ASSY TURN
Transmits the drive from the FEED DRIVE ASSEMBLY to the ROLL ASSY TURN. (Refer to 6.3 FEED DRIVE ASSEMBLY)
- ROLL ASSY TURN
The ROLL ASSY TURN is rotated by the drive from the FEED DRIVE ASSEMBLY through the CLUTCH ASSY TURN to feed the paper from the MPF or Duplex to the CHUTE ASSY REGI. (Refer to 6.3 FEED DRIVE ASSEMBLY)
- SENSOR PHOTO (MPF No Paper Sensor)
Detects presence/absence of paper in the MPF tray by the change in actuator position.

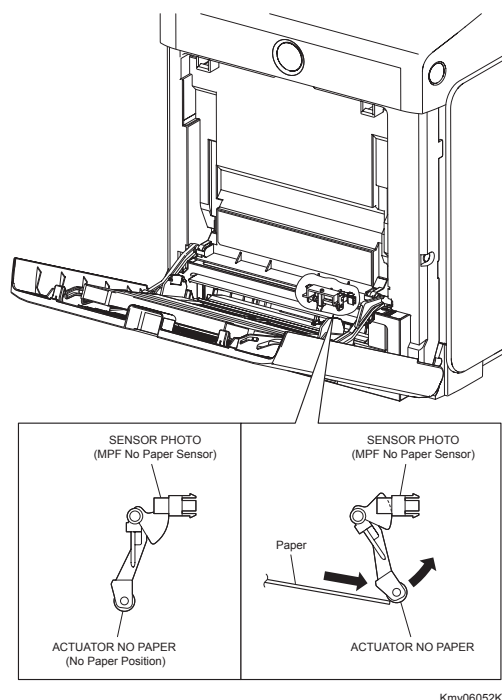

Kmy06052KA

- **SENSOR PHOTO (Regi Sensor)**
 It detects when the paper front end reaches the CHUTE ASSY REGI.
 When the paper feeds from the MPF, Regi Sensor is measuring the paper length (size).
 The ON time of Regi Sensor is converted into the paper length.
 ON: The paper activates the actuator.

- **CLUTCH ASSY REGI**
 CLUTCH ASSY REGI transmits the driving power from the PHOTOCODUCTOR (PC)/
 DEVELOPER (DEV) DRIVE to ROLL REGI RUBBER, and transports the paper from the tray, MPF
 and duplex path toward the toner cartridge direction. (Refer to 6.3 FEED DRIVE ASSEMBLY)
 The timing of sheet feed from the Regi Assy is adjusted by the duration of the CLUTCH ASSY REGI
 operation so that the toner image on the drum can be transferred to the appropriate position on the
 sheet.

3.3.2 Reference diagram

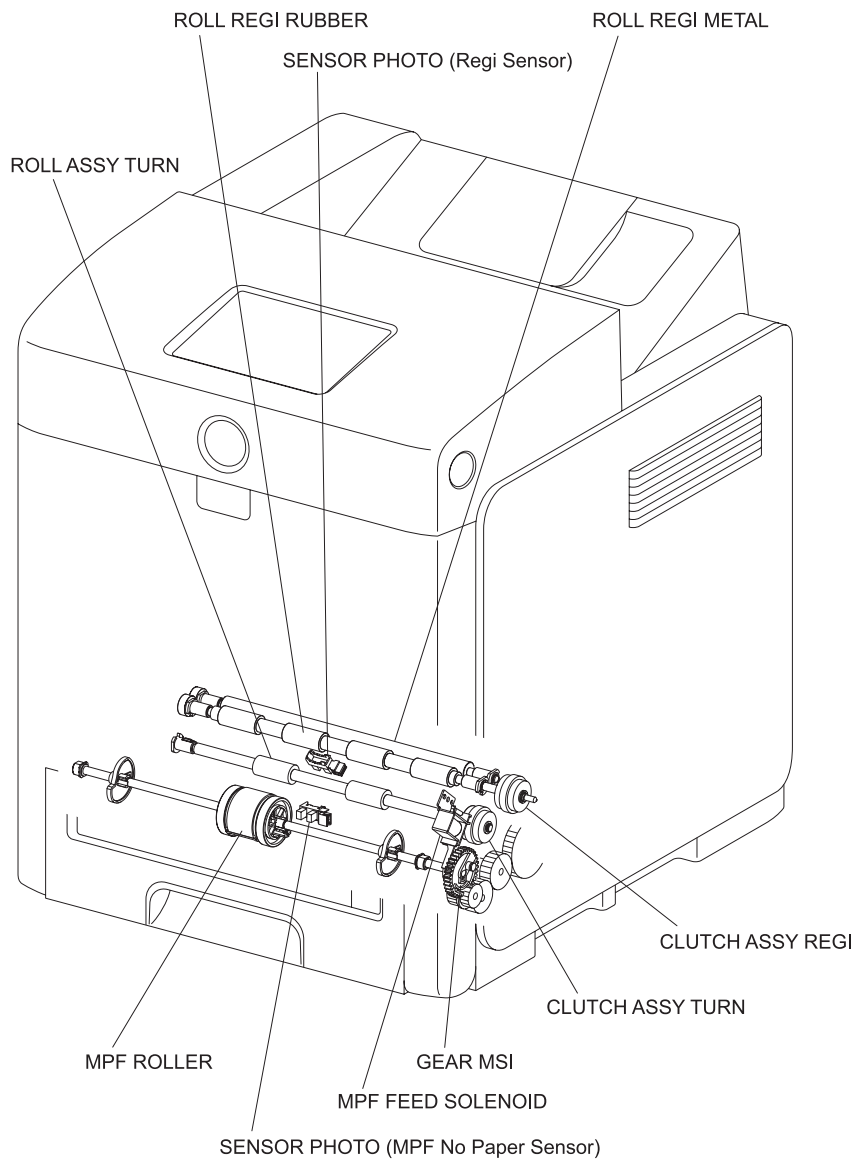

Kmy06033KA

3.3.3 Multiple Sheet Feed Prevention

The sheets set in the MPF are occasionally stuck together at the edges. The stuck sheets cause a multiple sheet feed or a jam. Normally, when only one sheet is fed, both the MPF ROLLER and SEPARATOR ROLLER rotate to allow the sheet to pass. However, when two sheets are fed concurrently, only the MPF ROLLER rotates and the SEPARATOR ROLLER is locked thereby allowing the upper sheet to pass by being separated from the lower sheet that is stopped by the friction with the SEPARATOR ROLLER at rest.

The SEPARATOR ROLLER is being pushed toward the MPF ROLLER by spring pressure, and controlled by the torque limiter with which it is coupled..

3.3.4 Reference diagram

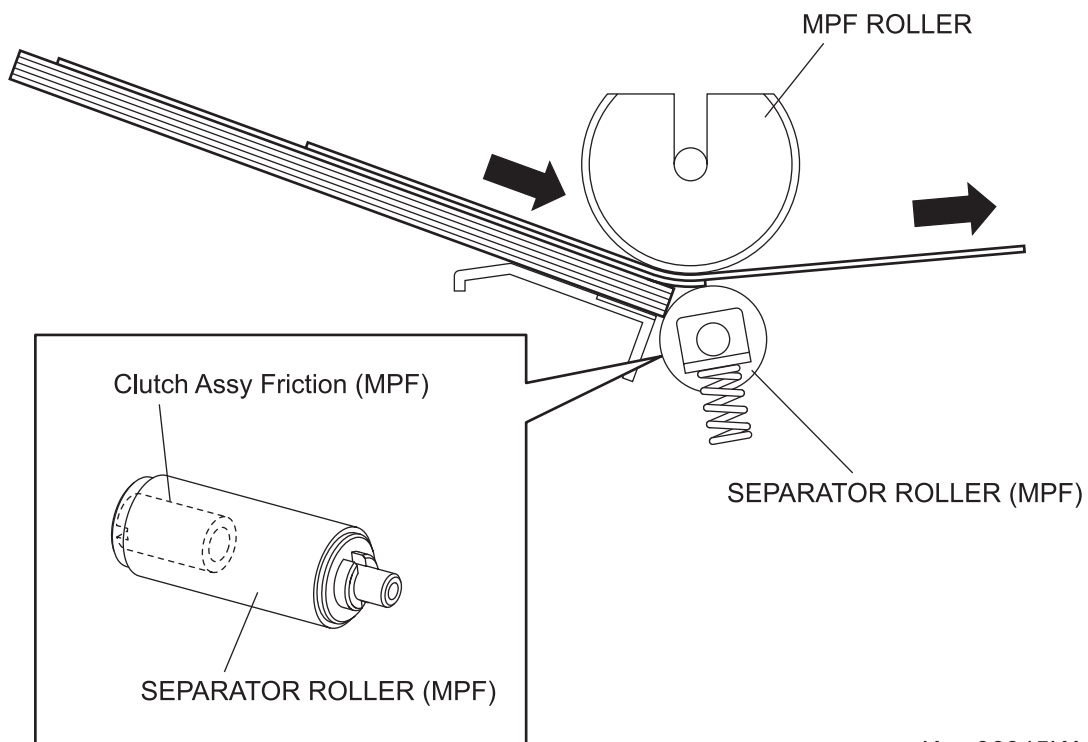

Kmy06045KA

3.3.5 Lead-edge Registration

When a sheet is fed from the MPF or Tray to the toner transfer position, the registration of the sheet may not be correctly maintained due to such troubles as misalignment of lead edges in the tray/cassette. To avoid this trouble, the lead edge position needs to be aligned at the Regi part before the sheet is fed to the toner transfer position.

By thrusting the edge of the sheet coming out of the MPF or Tray against the REGI ROLL that is at rest, the lead edge of the sheet is registered.

3.3.6 Reference diagram

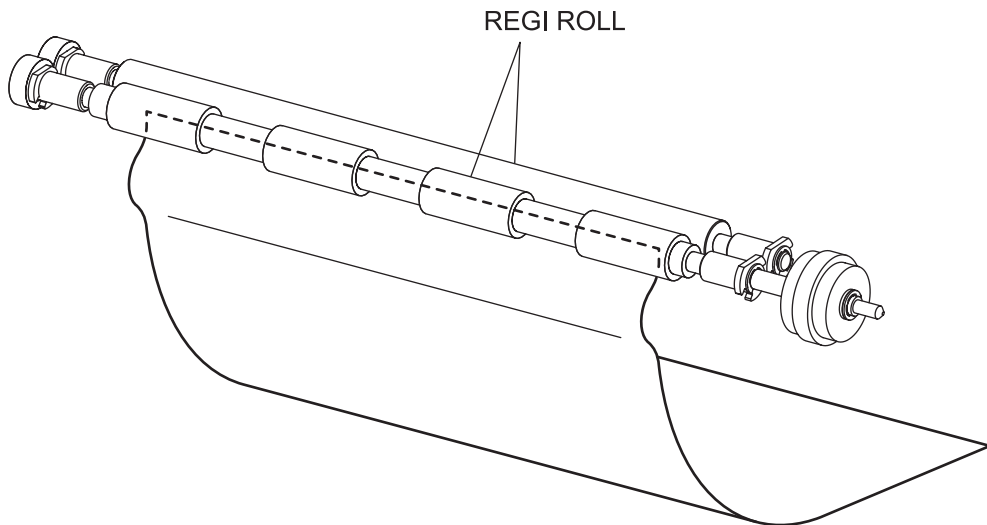

Kmy06034KA

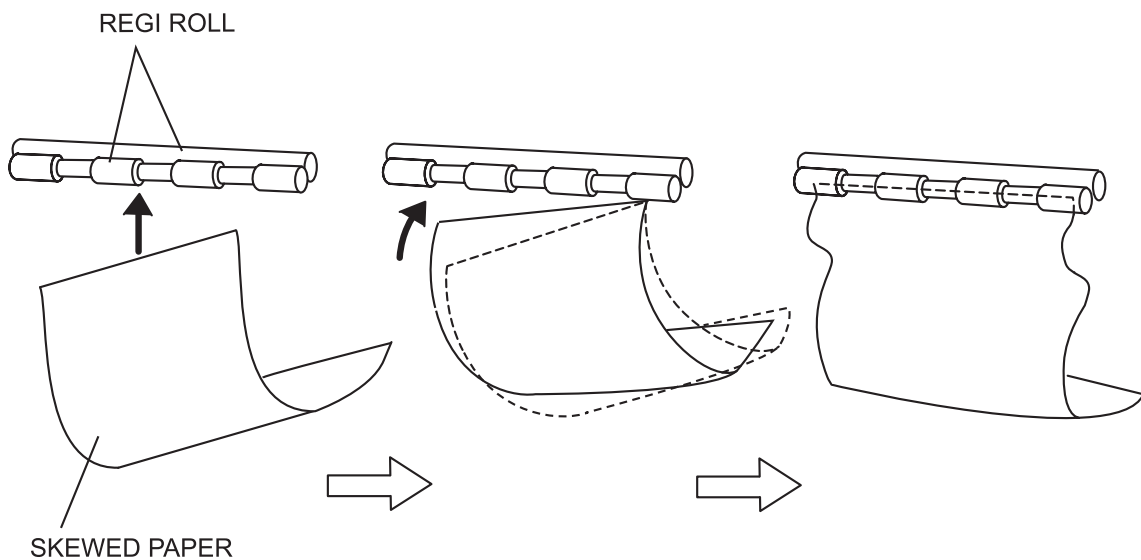

Kmy06049KA

3.3.7 Paper detection by the Regi Sensor

Since the paper path from the MPF/Duplex to the Regi Sensor and that from the Paper Tray to the Regi Sensor are different, the Regi Sensor is provided with the Actuator A and Actuator B.

The Actuator A detects the sheet fed from the MPF/Duplex.

The Actuator B detects the sheet fed from the Paper Tray.

However, the movement of the Actuator A does not affect the Actuator B.

3.3.8 Reference diagram

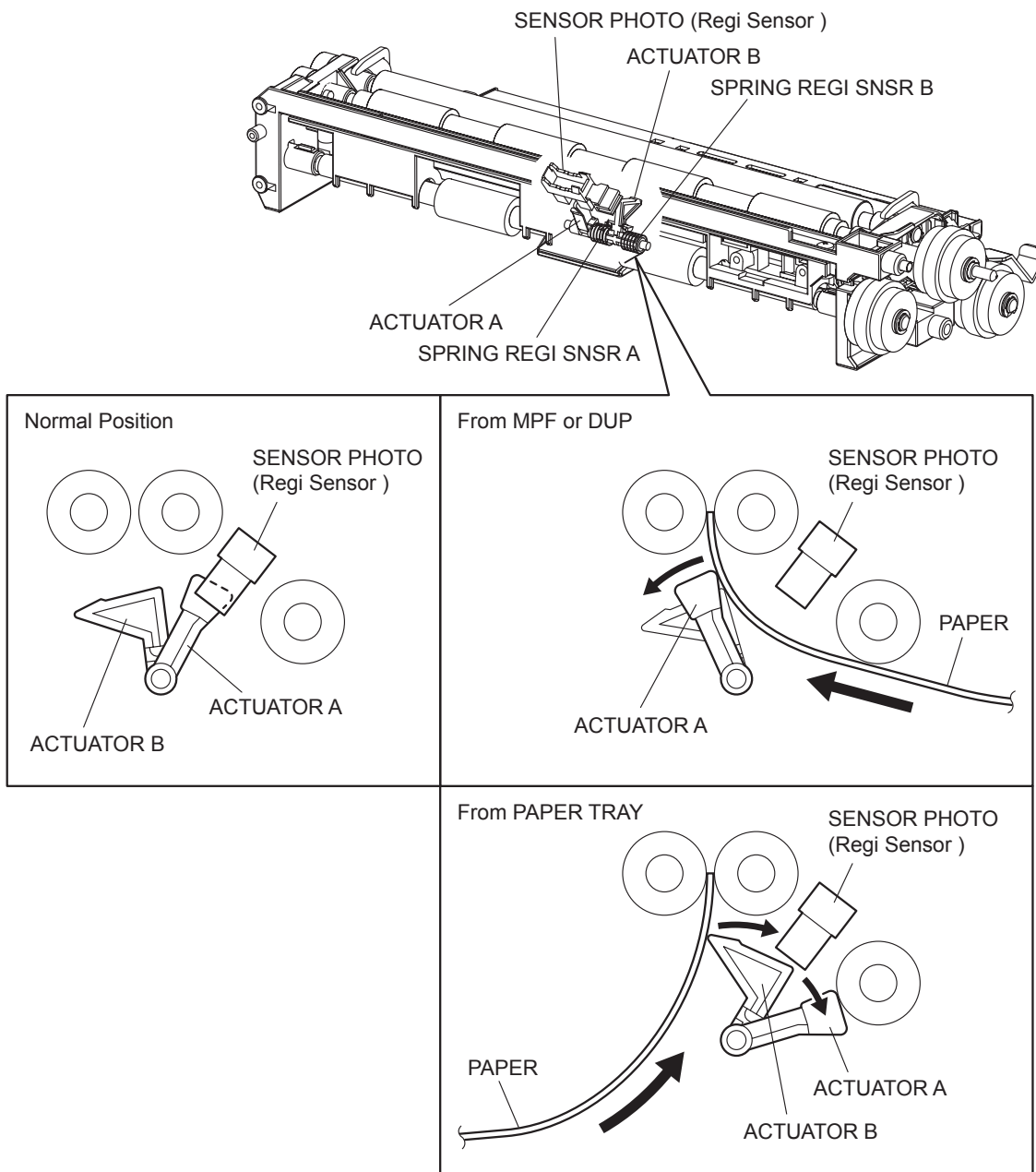

Kmy06057KA

Blank Page

3.4 Transfer Belt & Fuser

3.4.1 Major functions

- FUSER

The FUSER fixes toner which was transferred onto the paper but not fixed by the heat and pressure and feeds paper before and after being fixed.

The FUSER mainly consists of the following parts:

- Heat Roll
- Heater Lamp
- Thermostat
- Temp. Sensor
- Pressure Belt
- Roll Assy Exit
- Exit Sensor

- Exit Sensor

Detects passage of print after fixed based on the change of position of the actuator.

- Transfer Belt

• Belt

Belt feeds the paper to the direction of FUSER

• SENSOR ADC

SENSOR ADC reads the toner patch on the BELT, and converts it to voltage value. Voltage value is used to control the density of toner. (Refer to 5.4.1 Potential Control)

• ADC Solenoid

When turned on, the ADC Solenoid activates the PAD ADC to wipe the ADC Sensor surface clean of contaminants. To activate the PAD ADC, the ADC Solenoid must be turned on for a fixed duration before the ADC Sensor starts reading the toner patches.

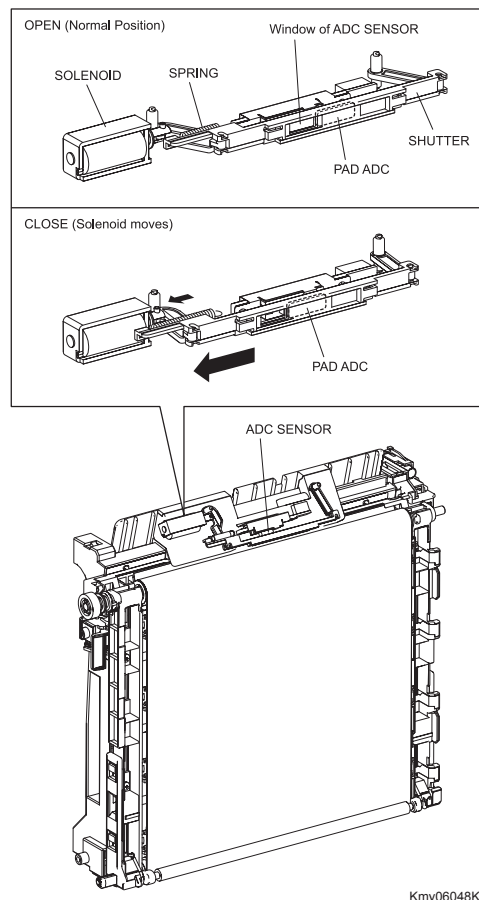

• ROLL ESA (Electric Static Attachment)

ROLL ESA discharges a positive voltage to the paper. The toner transfer efficiency is raised by being positively charged.

3.4.2 Reference diagram

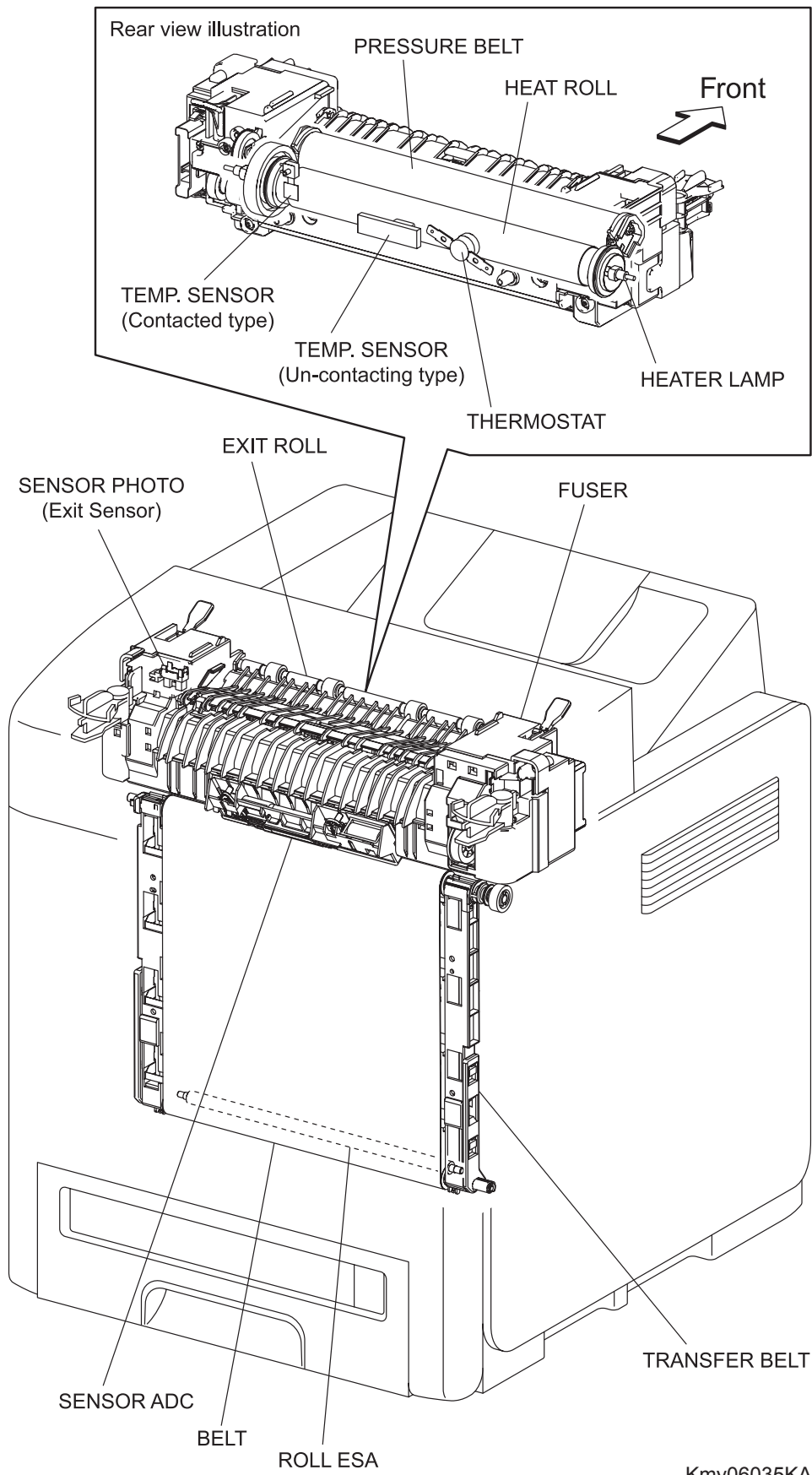

Kmy06035KA

3.5 PRINTHEAD

3.5.1 Major functions

- PRINTHEAD

PRINTHEAD is an exposure unit that generates laser beams to form electrostatic latent image on the drum surface.

In this manual, the PRINTHEAD is referred to as PRINTHEAD.

The PRINTHEAD mainly consists of the following parts:

- LD PWB
- Scanner ASSY
- SOS PWB
- Lens
- Mirror
- Window

* LD PWB

The LD PWB is comprised of four LDs (laser diodes) corresponding to Y, M, C, and K.

Each LD converts the electric signals of incoming image data into laser wave or pulse. In order to stabilize the laser light quantity during formation of an electrostatic latent image, the PWBA LD always monitors the laser light quantity to adjust it to the appropriate level. This is called "APC (auto power control)".

* Scanner Assy

The Scanner Assy is comprised of the Scanner Motor that rotates at a constant speed and the Polygon Mirror that is mounted on the motor shaft.

The laser light output from the LD is irradiated onto the Polygon Mirror via the Mirror.

The Polygon Mirror, provided with six reflecting mirror faces, changes the reflection angle of the laser light as it rotates by the Scanner Motor, thereby allowing the laser light to scan the drum along its axial direction. Scanning is performed using one reflecting mirror face for each line.

* Mirror

* Window

* Lens

The laser light reflected from the Polygon Mirror reaches the drum surface via the Lens, Mirror, and Window. The Lens corrects aberration, the Mirror secures an optical path, and the Window prevents foreign matters from entering the ROS.

* SOS PWB

The SOS sensor on the SOS (start of scan) PWB converts an incoming laser beam, upon detection, to an electric signal as the reference signal for starting scanning and transmits this signal to the PWBA MCU.

The SOS sensor signals are used to synchronize the starting point of the laser-beam scanning with the starting point of the image writing.

3.5.2 Reference diagram

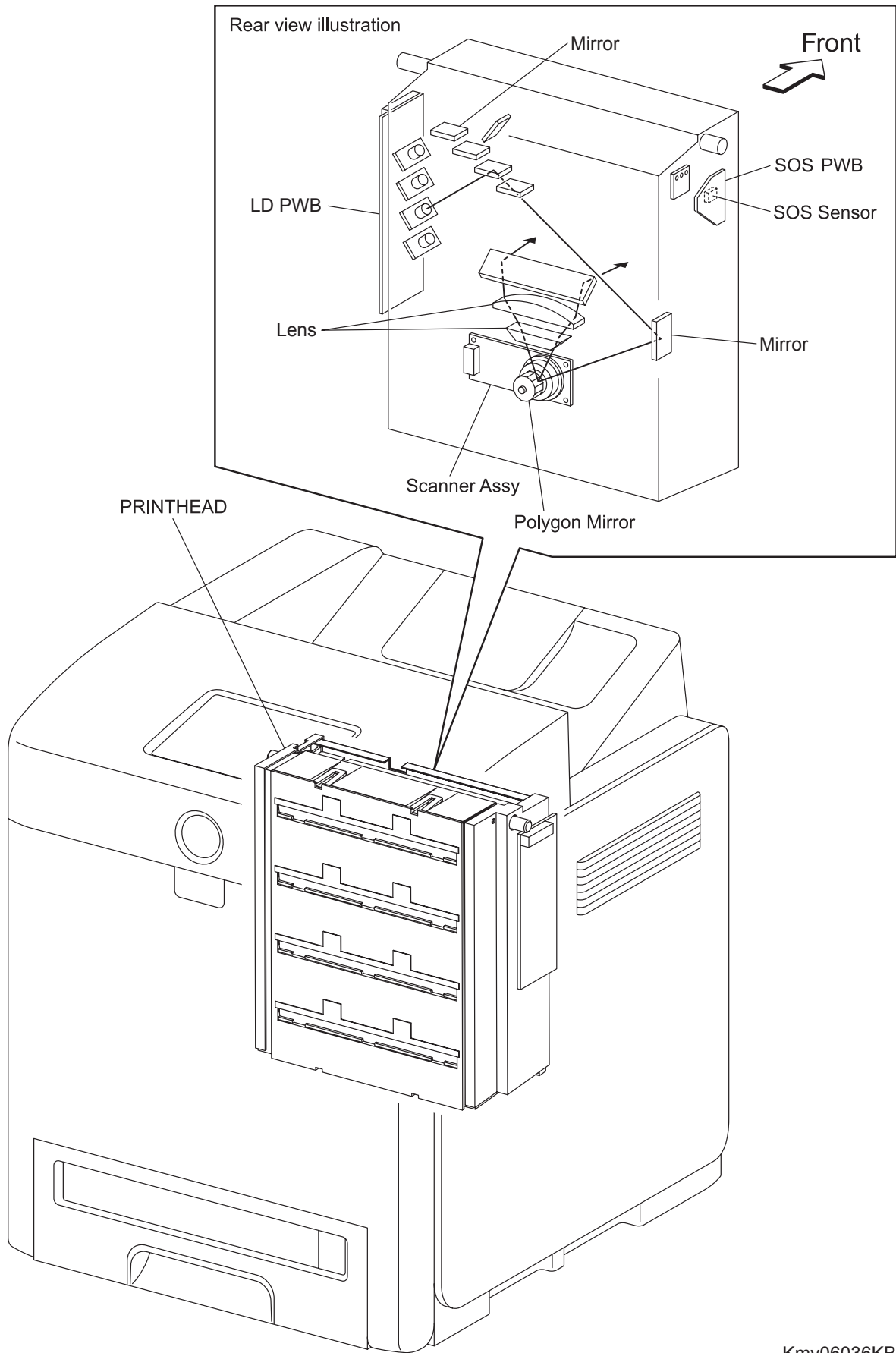

Kmy06036KB

3.6 TONER CARTRIDGE

3.6.1 Major functions

- CRUM (Customer Replaceable Unit Memory) SENSOR
The CRUM SENSOR reads and writes the data of the CRUM.
Printer specific information is stored.

- SENSOR PHOTO (TONER CARTRIDGE Sensor Y/M/C/K)
Detects presence/absence of the TONER CARTRIDGE.

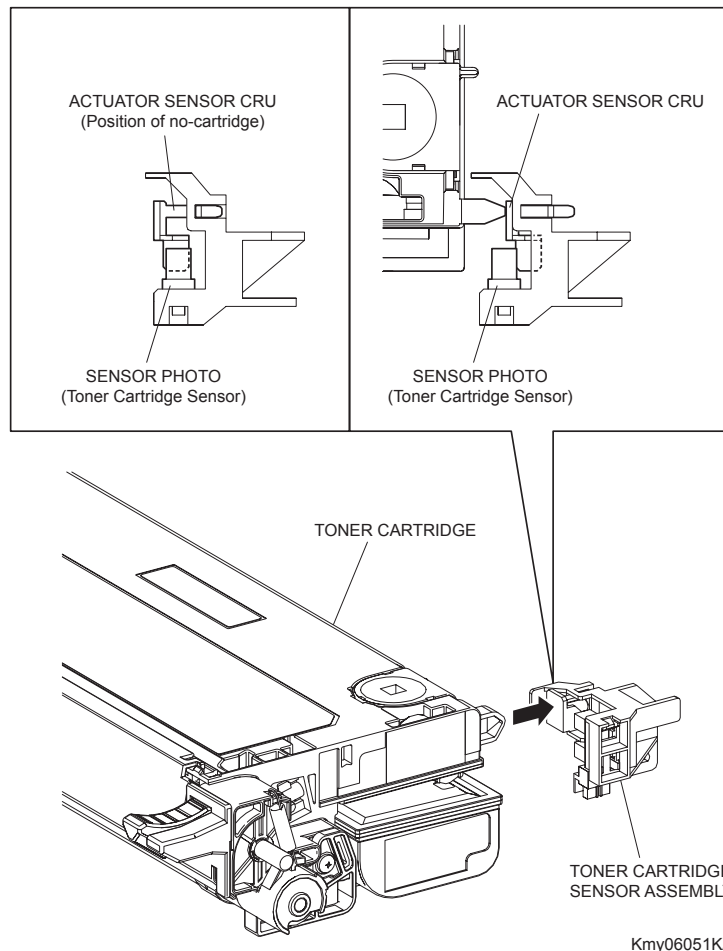

- DISPENSE MOTOR (Y/M/C/K)
The dispense motor supplies the drive to the Agitator and Auger in the TONER CARTRIDGE, and supplies toner to the developer part in the TONER CARTRIDGE.

- TONER CARTRIDGE (Y)
- TONER CARTRIDGE (M)
- TONER CARTRIDGE (C)
- TONER CARTRIDGE (K)
The TONER CARTRIDGE is constituted from the toner cartridge, developer and the drum.

- Erase Lamp (LED ASSEMBLY)
The light of the LED passes through the lens of the TONER CARTRIDGE, and irradiates the drum.
The light of the LED eliminates the charge on the drum.

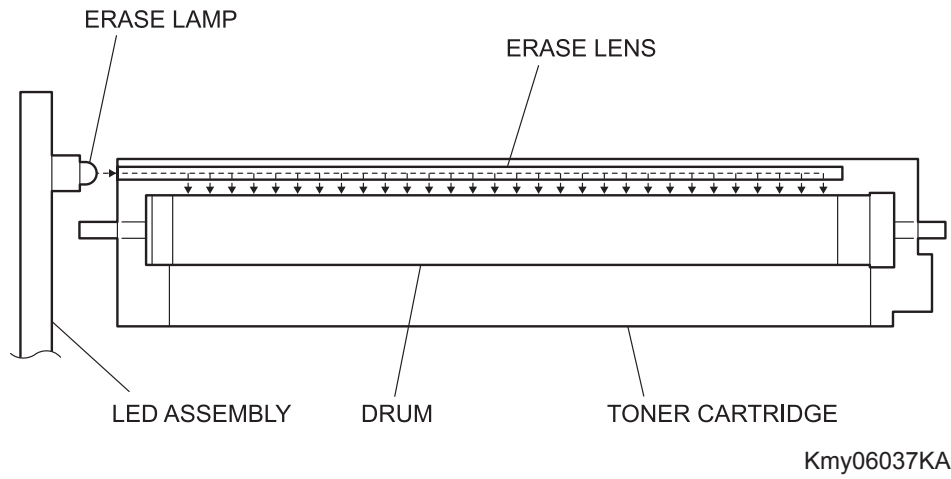

3.6.2 Reference diagram

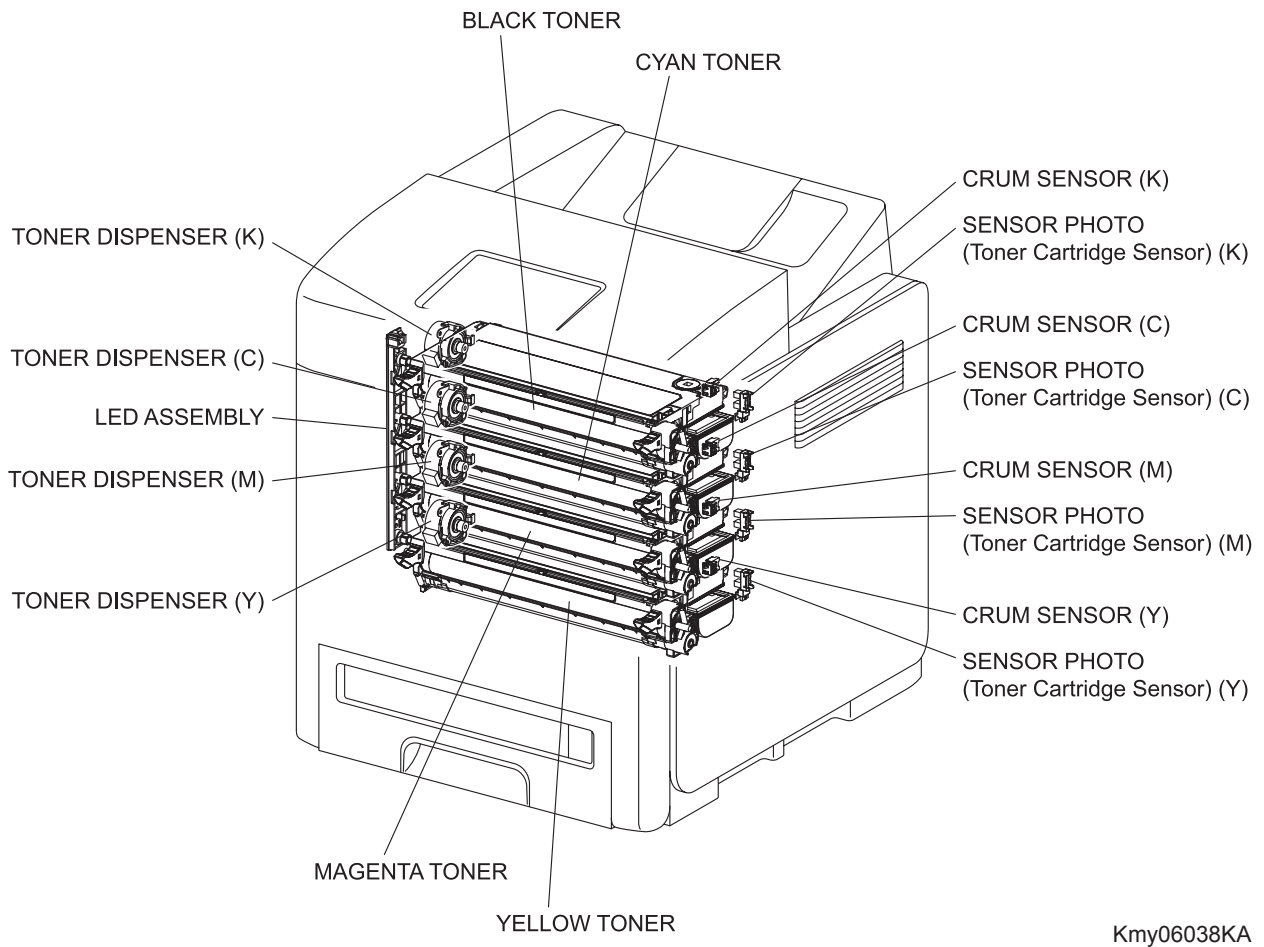

3.7 Drive

3.7.1 Major functions

- PHOTOCONDUCTOR (PC)/DEVELOPER (DEV) DRIVE ([Refer to 6.1 PHOTOCONDUCTOR \(PC\)/DEVELOPER \(DEV\) DRIVE](#))

Supplies the drive to parts as follows.

- Main Motor
 - Black Drum
 - Transfer Belt
 - Fuser

- Sub Motor
 - Yellow, Magenta and Cyan Drum
 - Black Developer

- Deve Motor
 - Yellow, Magenta and Cyan Developer

- Clutch Assy Exit

Transmits the drive from the Main Motor to the Roll Assy Exit in the FUSER.

In the backside printing, the exit clutch stops.

Exit Roll is driven by Duplex Motor. ([Refer to 6.1 PHOTOCONDUCTOR \(PC\)/DEVELOPER \(DEV\) DRIVE \[SIMPLEX MODE\]](#) and [6.4 DRIVE ASSY DUP](#))

- FEED DRIVE ASSEMBLY
 - Standard Cassette
 - MPF
 - Regi Assy

3.7.2 Reference diagram

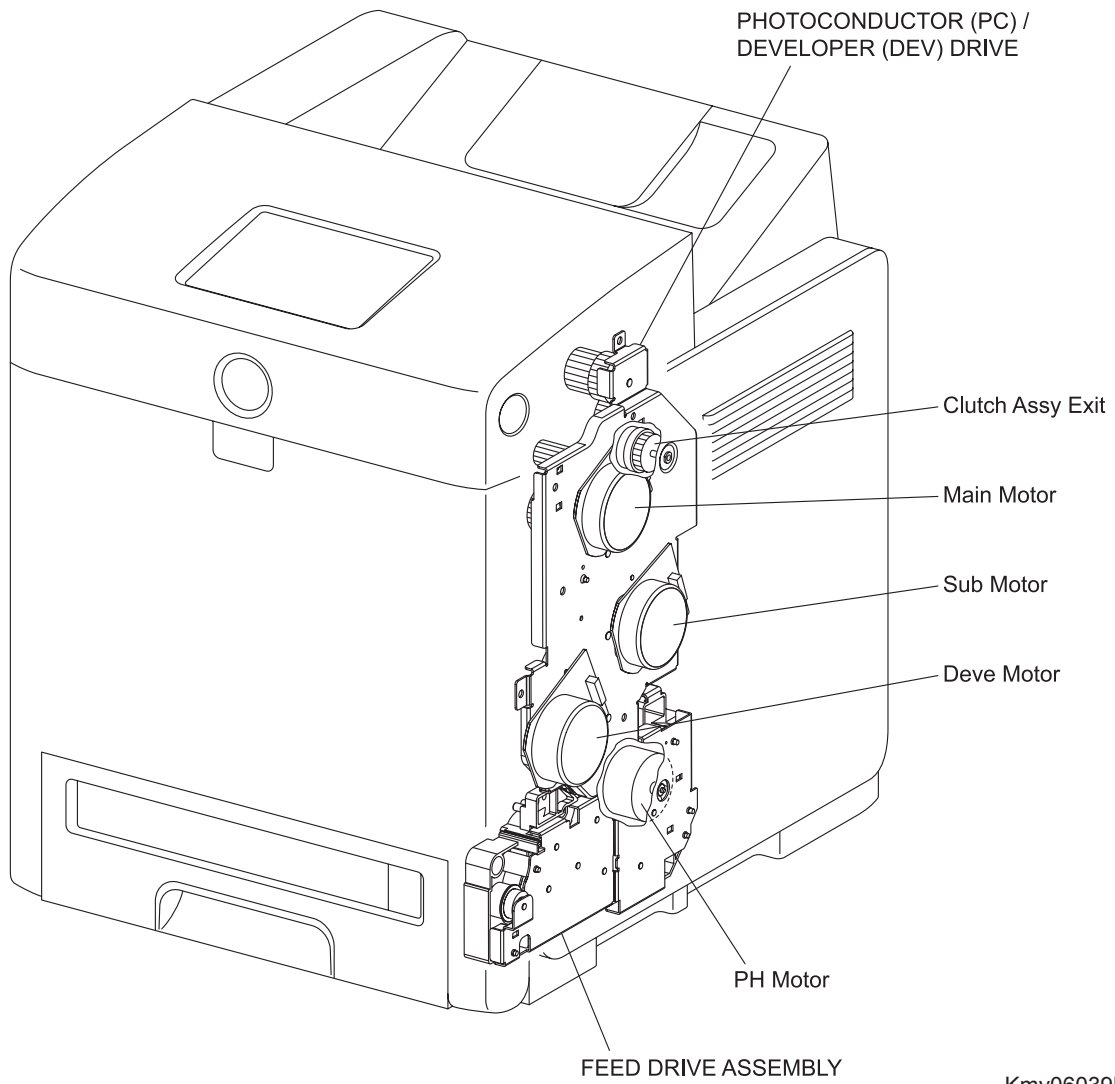

Kmy06039KA

3.8 Electrical

3.8.1 Major functions

- FAN
Dissipates heat out of the printer to prevent the printer from overheating.
- SWITCH
The SWITCH turns ON/OFF the AC power supply of the printer.
- Low Voltage Power Supply (LVPS)
The LVPS is provided in two types, 100/120V and 230V.
Supplies AC power from the power source to the FUSER heater and generates and supplies stable low voltage DC power used for the logic circuit, etc.
LVPS contains control circuit for the heater of the FUSER, in addition to the power circuit.
- Machine Control Unit (MCU)
Controls printing operation based on the communication with the print controller and information from the sensor/switch.
Major functions are as follows:
 - Communication with the ESS.
 - Receive of information from the sensors or switches.
 - Control of Motor in PHOTOCODUCTOR (PC)/DEVELOPER (DEV) DRIVE and FEED DRIVE ASSEMBLY.
 - Distributing low voltage DC power output from LVPS to each component
 - Control of PRINTHEAD
- High Voltage Power Supply (HVPS)
Supplies high voltage to the following parts in the Transfer Belt and TONER CARTRIDGE to perform charging, development, and primary transfer.
 - BCR
 - BTR
 - Developer
 - ESA
- PWBA EEPROM
Information unique to the printer is stored.
- Electronic Sub System (ESS)
The ESS connected to the MCU controls the entire system (Diagnostic, Interface and Image processing).
- HUMIDITY SENSOR
HUMIDITY SENSOR reads the temperature/humidity within the printer and converts the values to voltage values.

- OPERATOR PANEL
OPERATOR PANEL displays the state of the printer using LCD or LED, operates the printer using the switch.
- INTERLOCK SWITCH
INTERLOCK SWITCH is a switch that cuts the +24VDC power supply to the HVPS or Motor, etc. upon the opening of the Front Cover.

3.8.2 Reference diagram

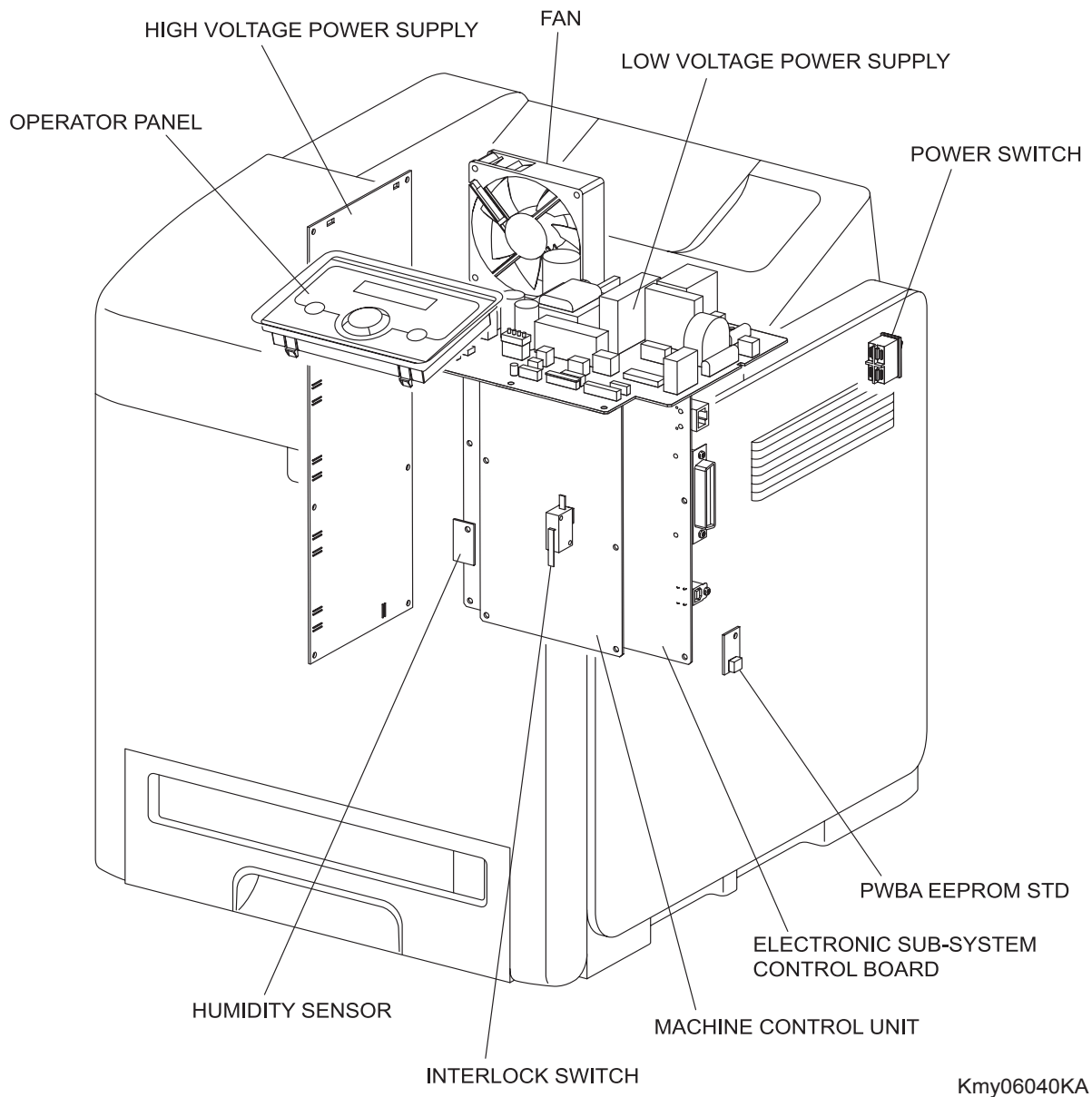

3.8.3 Data Flow

Print data (electric signal) from the printer controller flows as shown below until it is turned into a print.

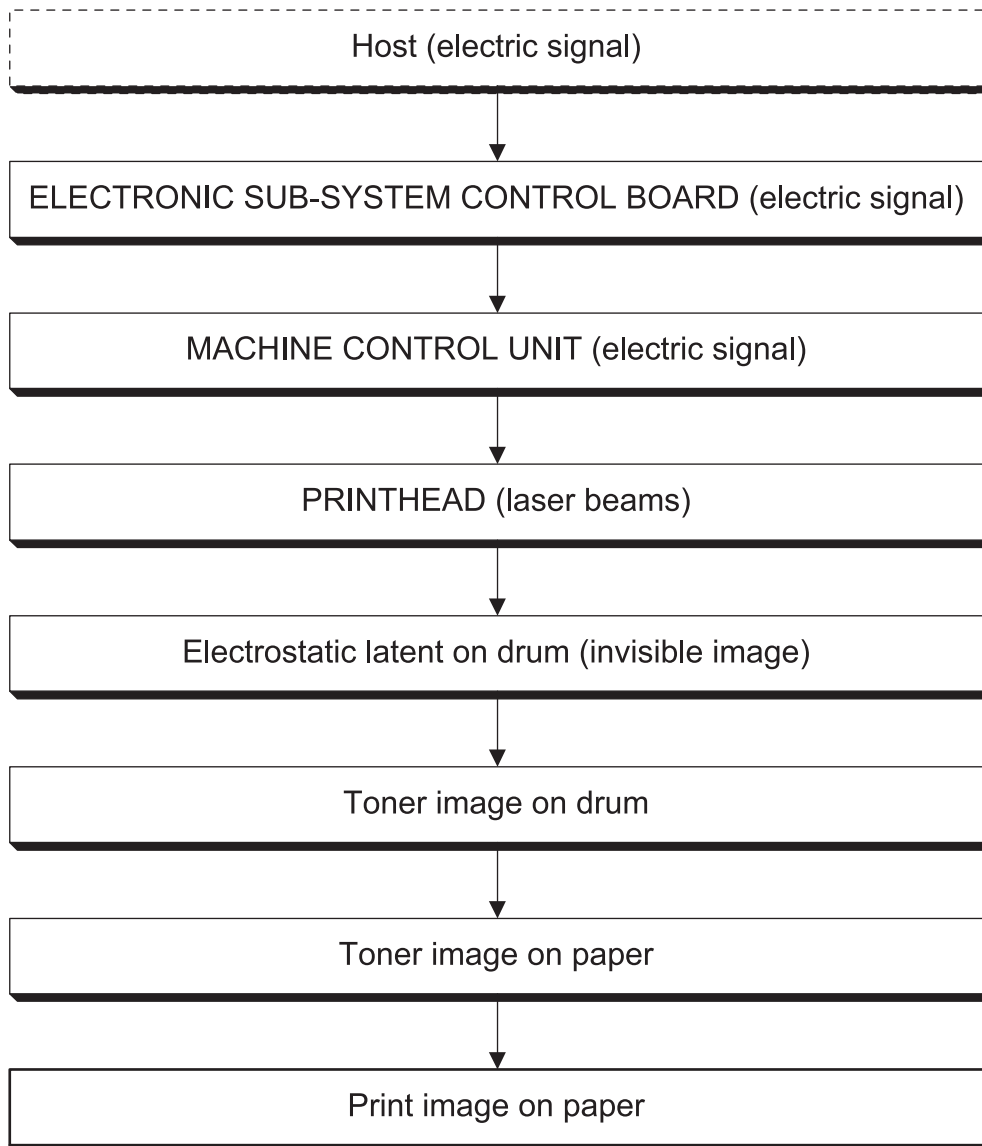

Kmy06011KA

Blank Page

3.9 Duplex

3.9.1 Major functions

- SENSOR PHOTO (DUP Jam Sensor)
The DUP Jam SENSOR detects that the paper is carried to duplex part.

- CLUTCH DUP
Transmits the drive from the MOTOR DUP to Roll Assy Exit in the FUSER.
When the clutch operates, the Roll Assy Exit rotates in the reverse direction.
The clutch is stopped when the paper reached the Duplex.

- DRIVE ASSY DUP
The DRIVE ASSY DUP supplies the driving power to the Lower Roll (ROLL ASSY DUP2), Upper Roll (ROLL ASSY DUP1) and Roll Assy Exit of Fuser. ([Refer to 6.4 DRIVE ASSY DUP](#))

- PWBA DUP
The PWBA DUP controls motor, sensor and clutch.

- FAN DUP
The FAN DUP is cooling inside of printer.

3.9.2 Reference diagram

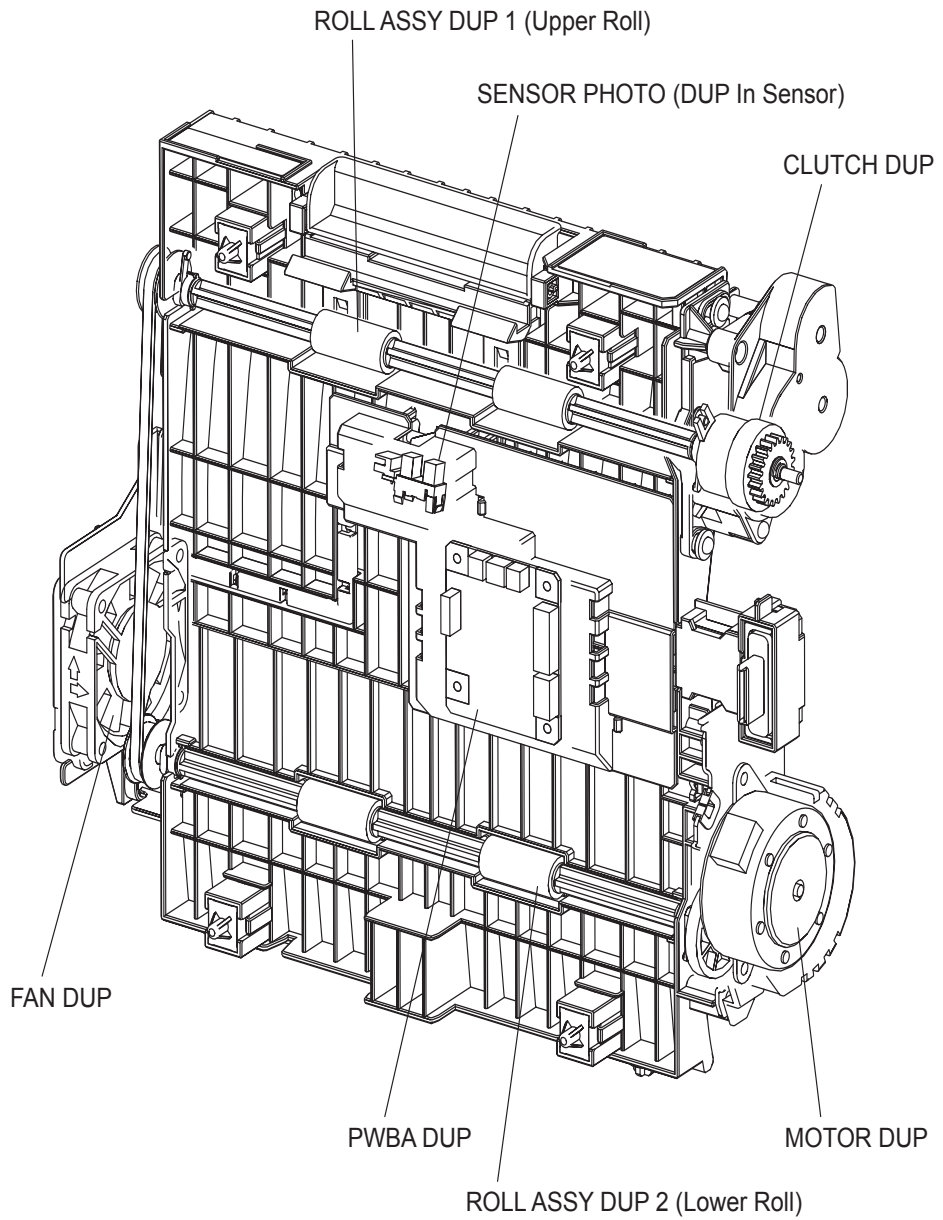

Kmy06041KA

3.10 550 Paper Feeder

3.10.1 Major functions (Paper Cassette)

- Side Guide (R/L)
The Guide Side Assy (R/L) can move at a right angle to the paper transfer direction to align the paper width.
- End Guide
The Guide End Assy can move in the paper transfer direction to determine the paper size. The ON/OFF of SIZE SWITCH ASSEMBLY (Refer to 5.1 Control of Paper Size) varies according to the Guide End Assy position to detect the paper size.
- FEED ROLLER (SEPARATOR)
The FEED ROLLER (SEPARATOR) and the FEED ROLLER (PICK UP ASSY) pinch the paper to feed.
- Bottom Plate
Bottom plate is locked to bottom side when paper cassette is pulled out from the paper feeder and unlocked when the paper cassette is installed to the paper feeder. Pushes the paper against the feed roll using a spring tension.

3.10.2 Reference diagram

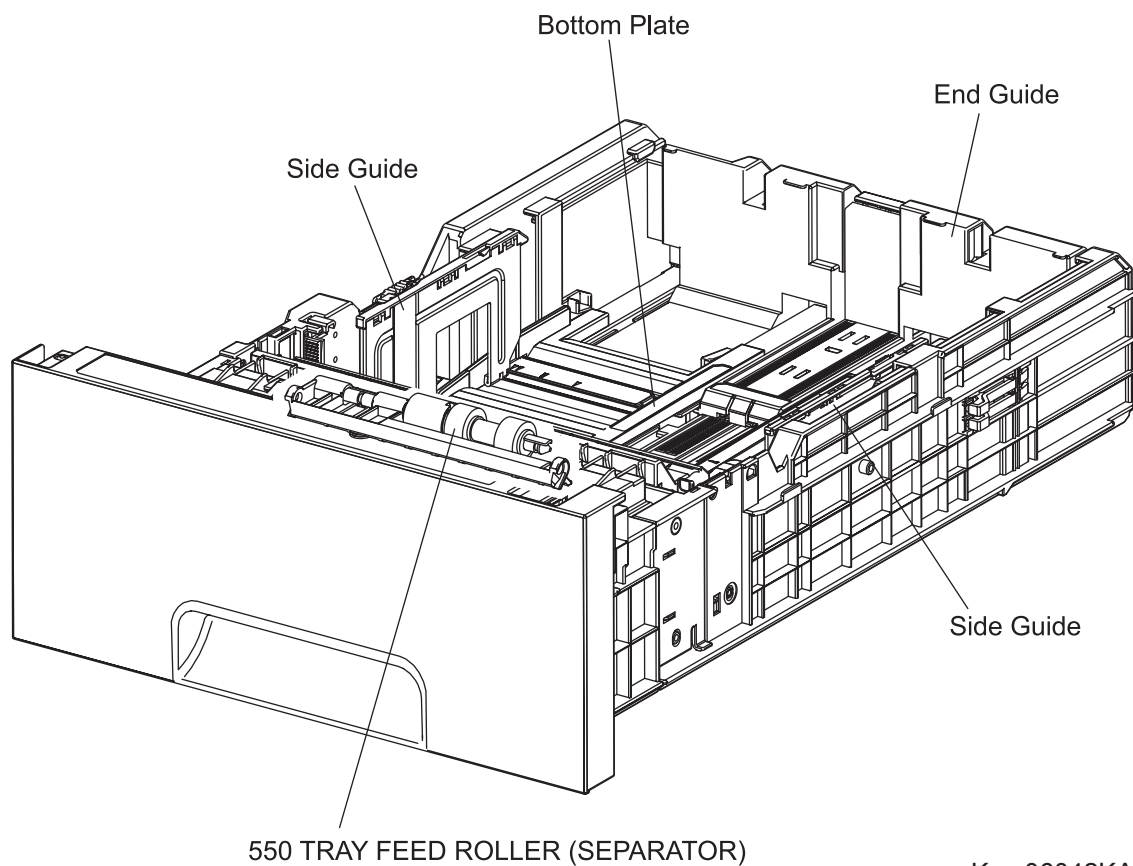

Kmy06042KA

3.10.3 Multiple paper feed prevention

The sheets set in a tray or cassette are occasionally stuck together along the edges. The stuck sheets cause a multiple sheet feed or a jam. The sheets are fed by the Nudger Roll to a position between the Feed Roll and the Separator Roll. Normally, when only one sheet is fed, both the Feed Roll and Separator Roll rotate to allow the sheet to pass. However, when two sheets are fed concurrently, only the Feed Roll rotates and the Separator Roll is locked thereby allowing the upper sheet to pass by being separated from the lower sheet that is stopped by the friction with the Separator Roll at rest.

The Separator Roll is being pushed toward the Feed Roll by spring pressure, and controlled by the torque limiter (Clutch Assy Friction) with which it is coupled.

3.10.4 Reference diagram

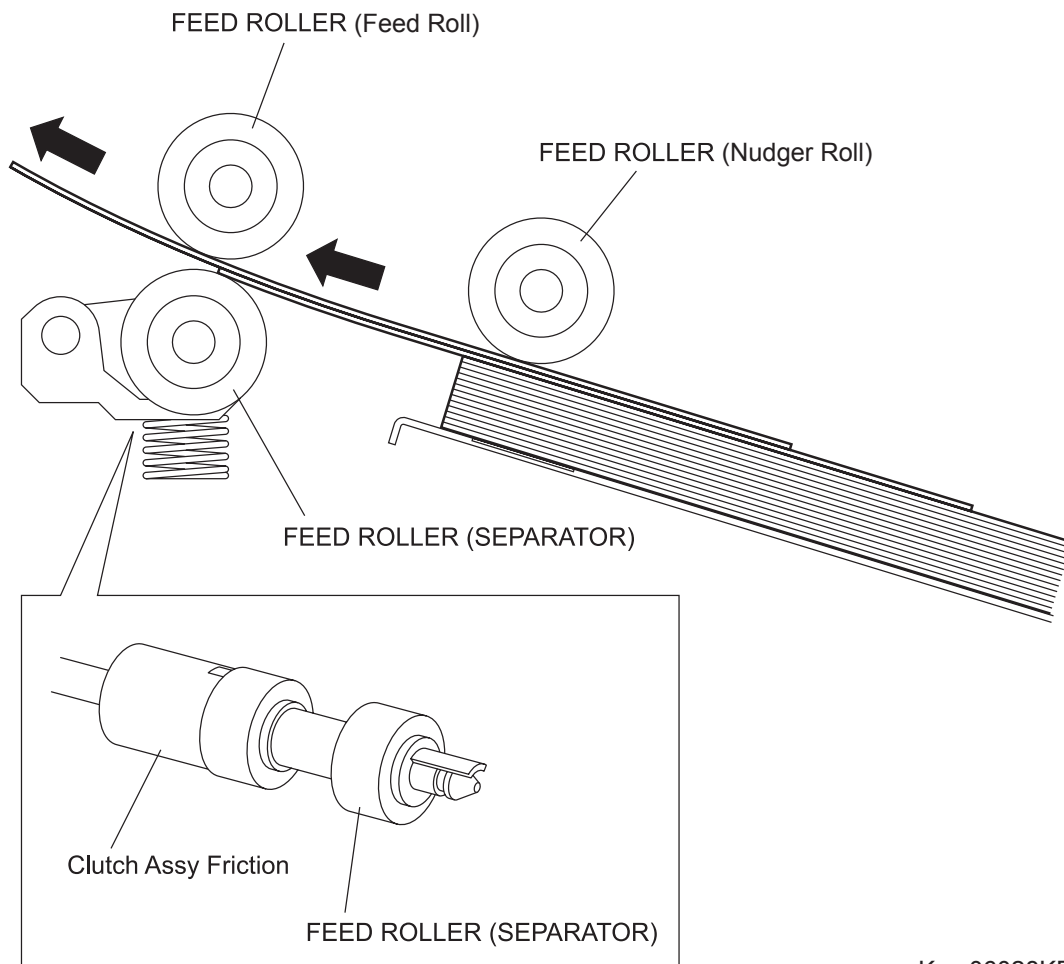

Kmy06028KB

3.10.5 Bottom Plate Moving

Inserting the paper tray into the feeder section unlocks the GEAR BTM LOCK ONEWAY. When the paper tray is pushed in until it stops, the gear teeth of the RACK BTM LOCK and GEAR BTM LOCK ONEWAY are out of engagement allowing the PLATE ASSY BTM to rise by the spring pressure of the SPRING BTM UP.

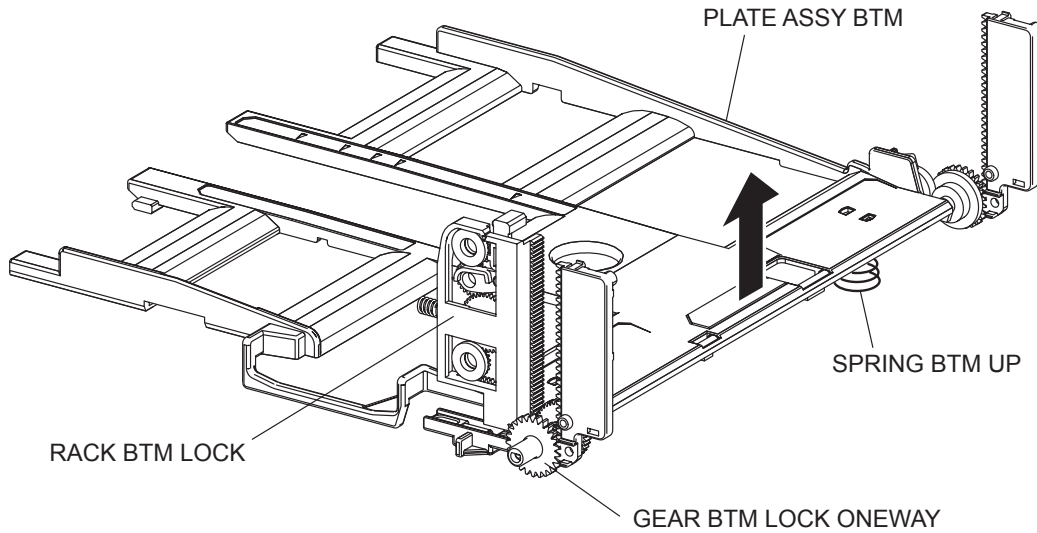

Kmy06023EA

Blank Page

3.10.6 Major functions (Feeder)

- SIZE SWITCH ASSEMBLY

SIZE SWITCH ASSEMBLY detects the paper size and presence/absence of the paper tray.

(Refer to 5.1 Control of Paper Size for the combination of switches.)

The paper size is decided at the position of the END GUIDE.

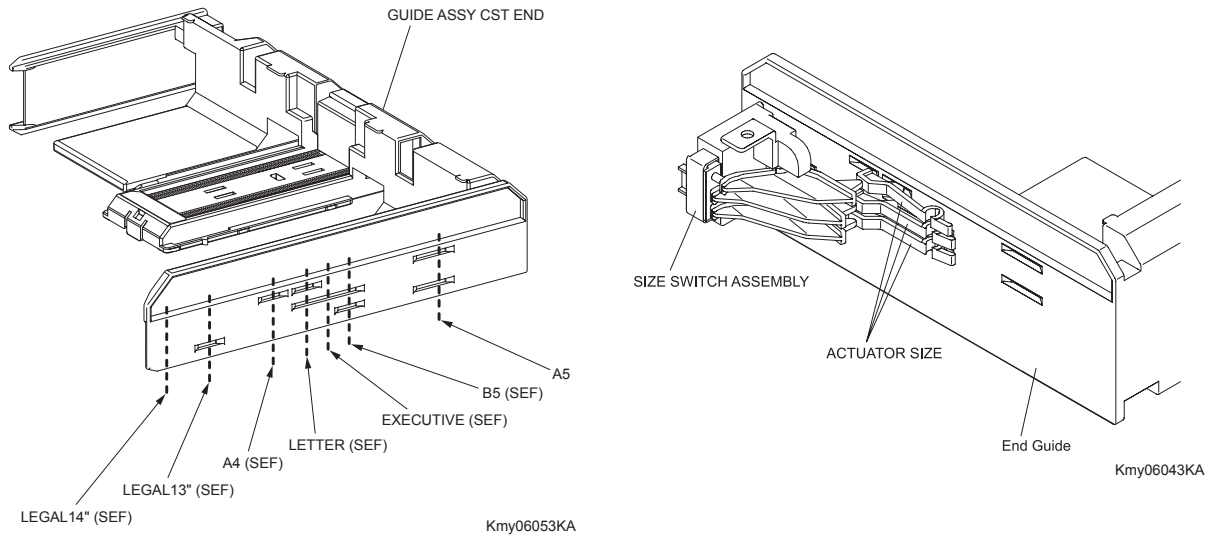

- SENSOR PHOTO (No Paper Sensor)

Detects the presence/absence of paper in the paper tray based on the position of ACTUATOR NO PAPER. (No paper: Sensor beam is intercepted)

- CLUTCH ASSY FEED

Transmits the drive from the DRIVE ASSY OPTION FEEDER to FEED ROLLER. (PICK UP ASSY)
(Refer to 6.5 DRIVE ASSY OPT FDR)

- FEED ROLLER

When the CLUTCH ASSY FEED operates, the FEED ROLLER starts rotating and the FEED ROLLER feeds the paper. (Refer to 6.5 DRIVE ASSY OPT FDR)

- CLUTCH ASSY TURN

Transmits the drive from the DRIVE ASSY OPTION FEEDER to ROLL ASSY TURN.

- ROLL ASSY TURN

The ROLL ASSY TURN rotates by the drive from DRIVE ASSY OPTION FEEDER through the CLUTCH ASSY TURN to feed the paper from the paper tray to the printer.

- DRIVE ASSY OPTION FEEDER

The MOTOR OPTION FEEDER is driving the rolls of the option feeder. (Refer to 6.5 DRIVE ASSY OPT FDR)

- PWBA OPTION FEEDER

The PWBA OPTION FEEDER controls motor, sensor and clutch.

3.10.7 Reference diagram

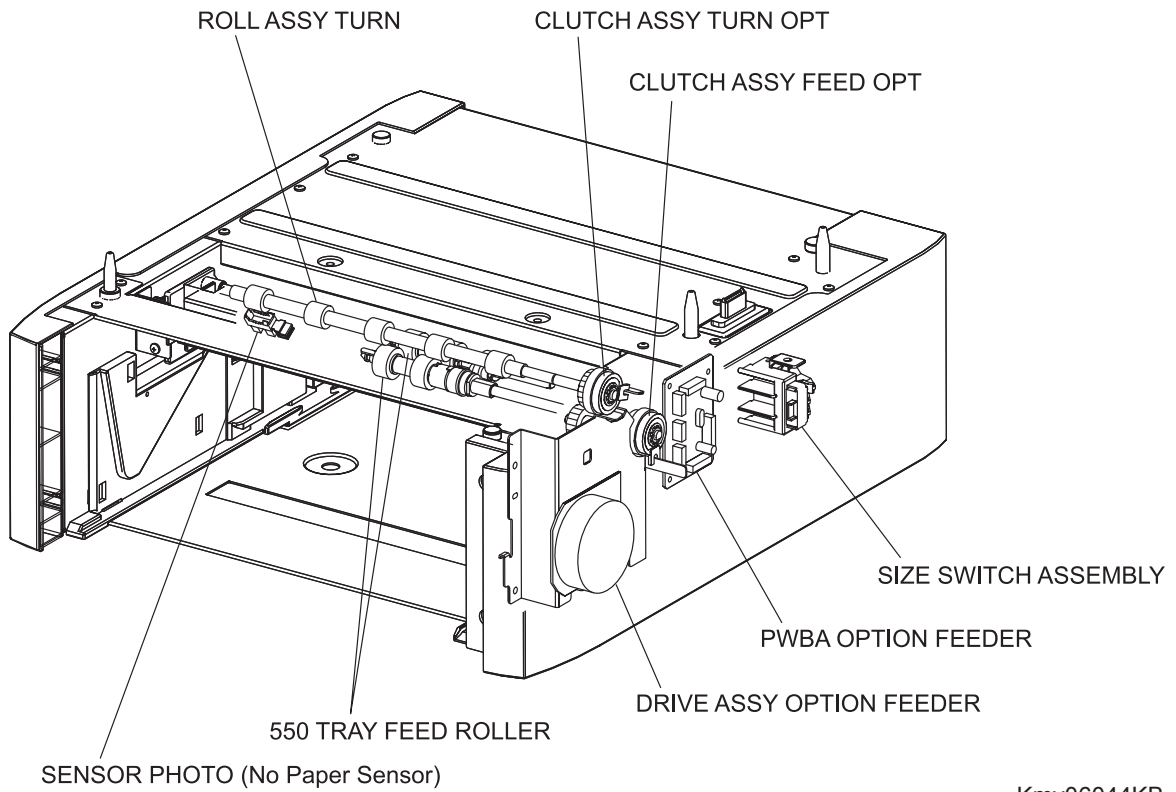

4. MODES

4.1 Operation Modes

For the operation of the printer, the following five modes are provided.

- DIAG TEST mode
The printer is ready for receiving diagnostic commands, or the printer diagnostic function is operating.
- WAIT mode
The printer is under the adjustment of print quality.
- READY mode
The printer is ready for printing.
- PRINTING mode
The printer is under printing.
- ERROR mode
Any error was detected in the printer.
- Initializing mode
New parts have been just set to the printer (initializing with a new Deve Unit).
- Checking Unit mode
Printer is under checking consumable units.

5. Control

5.1 Control of Paper Size

"ON/OFF of Paper Size Switch of SIZE SWITCH ASSEMBLY" and "Diag Tool indication data" are shown in the table below.

NOTE

Paper Size Switches are indicated as SW1, SW2, and SW3 from the above one.

Paper Size	Paper Size Switch			Diag indication data
	SW1	SW2	SW3	
LEGAL14" (SEF)	ON	ON	ON	00
LEGAL13" (SEF)	ON	ON	OFF	01
EXECUTIVE (SEF)	ON	OFF	ON	02
B5 (SEF)	ON	OFF	OFF	03
A4 (SEF)	OFF	ON	ON	04
LETTER (SEF)	OFF	OFF	ON	06
A5	OFF	ON	OFF	05
No cassette	OFF	OFF	OFF	07

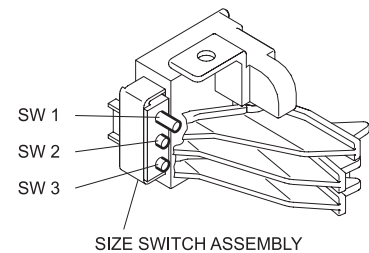

ON: The actuator is pushing the size switch.

5.2 Selective Control on Paper Cassette

The preferred paper cassette selected after powering on can be changed via the printer settings. The default is Tray1 (TBD).

NOTE

The paper feeder by the paper tray under the printer is called "Tray 1", and the optional TRAY is called "Tray 2".

5.3 PRINTHEAD Light Quantity Control

The image data are entered to the laser diodes in the PRINTHEAD as electric signals (data are expressed with high and low voltage values), and the laser diodes convert the image data from electric signals to optical signals (data are expressed with blinking laser beams).

Variations in light quantity of laser beams or variations in optical system (such as lenses) or drum sensitivity cannot attain a proper electrostatic image, therefore, the laser beam light quantity is monitored and controlled by the laser diodes.

The PRINTHEAD in this printer has four laser diodes for yellow, magenta, cyan, and black respectively, and the light quantity is automatically adjusted for each color.

5.4 Process Control

For a stable printing, the parameters related to the image forming must be corrected as necessary. The control of the entire printing process including parameter correction control is called "process control". Mainly, the process control is performed in the following two methods, both of which are performed after every 25 cumulative prints upon termination of a print run or during a continuous run.:

- Potential control
- Toner density control

To supplement these two controls, the following controls are provided:

- High Area Coverage Mode
- Admix Mode

5.4.1 Potential Control

To attain stable printing image density, the drum charging voltage, the developing DC voltage and the PRINT HEAD light amount are adjusted according to the developing capability of each color carrier that varies momentarily. The adjusted drum charging voltage, the developing DC voltage and the PRINT HEAD light amount are fed back to keep the printing image density constant.

The outline of control is as follows.

- 1) The HUMIDITY SENSOR (temperature and humidity sensor) detects the temperature and humidity.
- 2) The patches of respective colors (yellow, magenta, cyan, and black) for the potential control are generated and transferred on the Belt.
- 3) The ADC Sensor (density sensor) detects the density of the patch on Belt.
- 4) The drum charging voltage, the developing DC voltage and the PRINT HEAD light amount are adjusted for each color according to the detected patch density.

5.4.2 Toner Density Control

The toner density must be kept constant to attain stable printing image. The control system for this purpose is called toner density control.

1) PCDC (Pixel Count Dispense Control)

The quantity of the toner to be consumed in the developing process is calculated by counting the video signals entered to the PRINthead. The quantity of the toner to be consumed is calculated by the toner dispensing time. The toner motor is driven based on the calculated toner dispensing time when supplying the toner to the developer.

2) ADC (Auto Density Control)

The patches of respective colors (yellow, magenta, cyan, and black) for the toner density control are generated under specified potential condition, and transferred on the Belt. The ADC Sensor measures this density. The measured value is compared with the reference value. If the toner density is lower, the toner dispense quantity is increased at the next printing, or if the toner density is higher, the toner dispense quantity is reduced at the next printing. The toner dispense quantity is calculated by the toner dispense time. This calculation is made for each color.

5.4.3 High Area Coverage Mode

A continuous printing of any image of area coverage exceeding extra toner dispense capability causes the toner density in the developer to be lowered.

The High Area Coverage Mode postpones the next page feed and dispenses the toner during this time, if the toner dispense time reached the specified value during a continuous printing.

5.4.4 Admix Mode

This mode prevents the toner density from being lowered, whenever the value of the toner density control patch measured by the ADC Sensor falls far below the standard value, by performing extra toner dispensation. If the toner density level cannot be recovered even after this operation, it is judged that the toner has run out.

5.4.5 ADC Sensor Adjustment

The ADC Sensor is a reflection type sensor that irradiates the light from its LED onto the target and detects the reflected light at its photoreceptor and outputs electric signals responsive to the amount of the detected light. To ensure an accurate patch density measurement, the surfaces of the ADC Sensor is cleaned to remove soil due to toner, etc., and the light amount adjustment is made so that the reflected light amount satisfies the prescribed value, when creating the patch for potential control and toner density control.

5.5 Color Registration Control

The printer uses a tandem system where the drums and developers are arranged respectively for each of yellow, magenta, cyan, and black colors. Since the images are formed on the drum of each color to be overlaid one another, a color shift may occur. The color registration control calculates how much the registration is shifted, and adjusts the PRINTHEAD write timing.

The lateral registration control adjusts all of four colors in lateral directions.

The color registration control is made from a change in inside temperature and the print count at the execution of the process control.

The control is outlined below:

- 1) With no toner on the Belt, the output value of ADC Sensor is measured to determine the threshold value.
- 2) The patches for color registration control are generated on the Belt. These patches are composed of 10mm lines of K, C, K, M, K, and Y in this order.

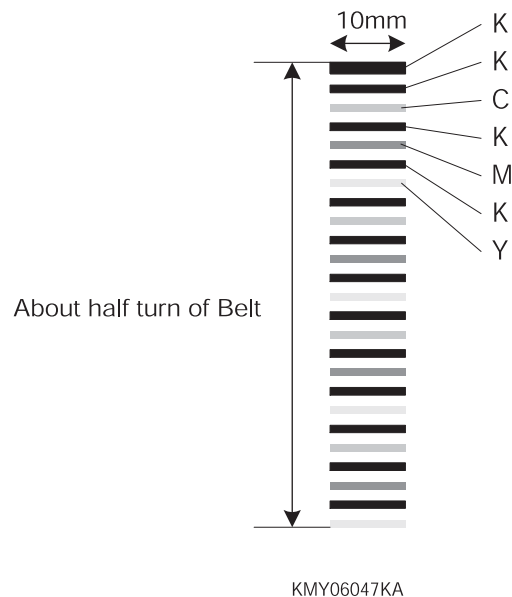

- 3) The density of patches generated by the ADC Sensor is read.
- 4) The shift correction amount is calculated from the threshold value determined in 1) and the patch density measured in 3).
- 5) The PRINTHEAD write timing is changed according to the shift correction amount.

5.6 Fuser Control

5.6.1 Fuser temperature control

As for the fuser temperature control, the target temperature is set, then the Heat Roll surface temperature is controlled so that it can meet the target value by turning on/off the Heater Lamp.

Temperature of individual area of the Heat Roll is detected by the Fuser Non-Contact Sensor (NCS) in the middle of the Heat Roll and the Temp Sensor at the edge of it. When the temperature detected is higher than the target value, the Heater Lamp will be turned OFF. When the temperature is below the target value, the Heater Lamp will be turned ON.

The target temperature setting varies depending on the time of Warm-up, Printing, or Process Control. The target temperature varies according to such environmental factors as the interior temperature detected by the Sensor Hum Temp.

5.6.2 Cooling down

As the printing continues, the temperature distribution in the Heat Roll becomes uneven both in the paper feed and non-paper feed areas. Cooling Down suspends paper feeding for a certain period of time so that the Heat Roll temperature distribution can be uniform.

When the temperature of the Heat Roll edge is high, cooling down is performed to lower the temperature to the target value.

5.6.3 Sensor Warm-up

The Fuser NCS (Non Contact Sensor) at the center of the Heat Roll will lose its accuracy of detecting temperature when the temperature of the Sensor itself is below -5°C . Therefore, the Sensor will be warmed up when the temperature is below -5°C . This action is called Sensor Warm-up.

6. Drive Transmission Route

6.1 PHOTOCONDUCTOR (PC)/DEVELOPER (DEV) DRIVE

Rotation power of the PHOTOCONDUCTOR (PC)/DEVELOPER (DEV) DRIVE is transmitted through the route below.

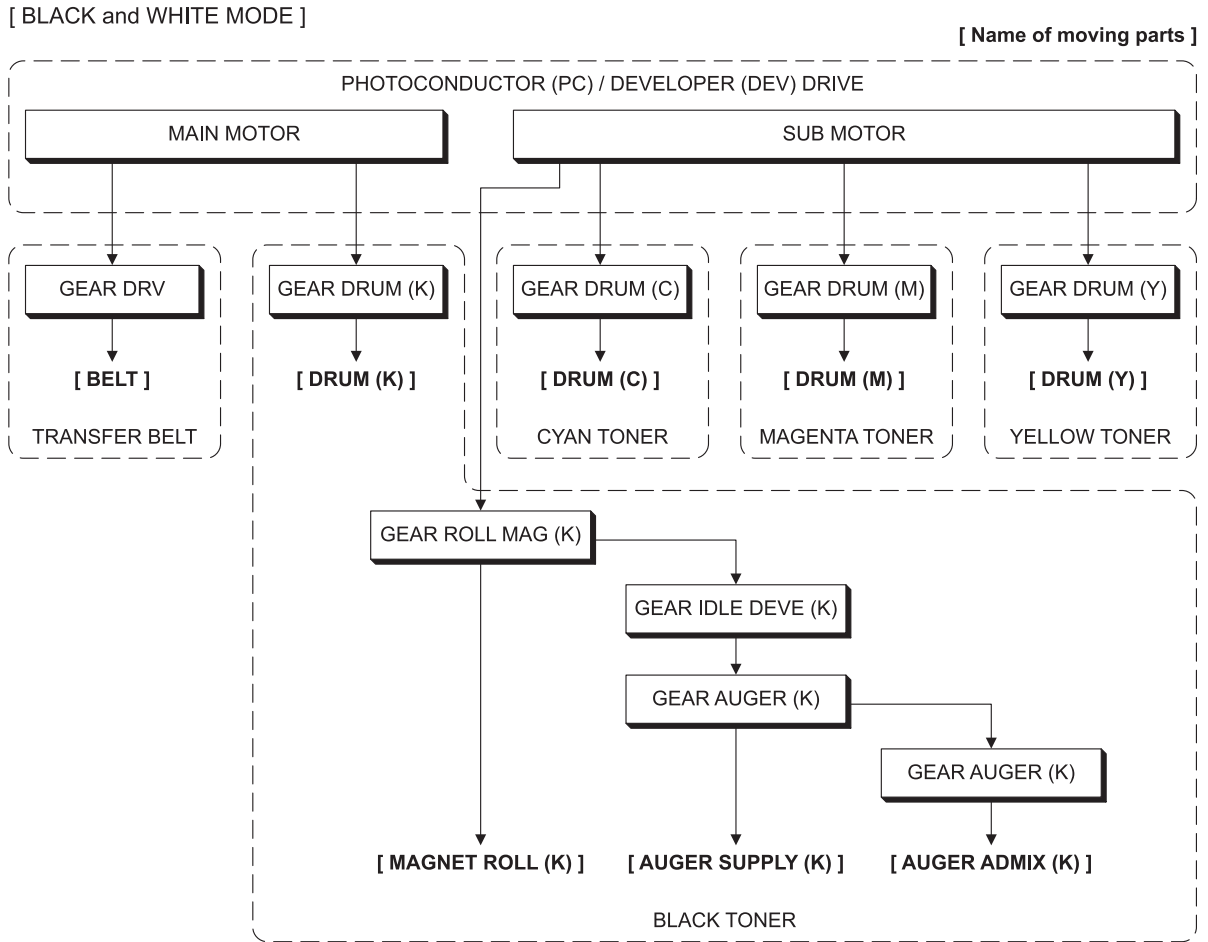

Kmy06012KA

[BLACK and WHITE MODE]

[Name of moving parts]

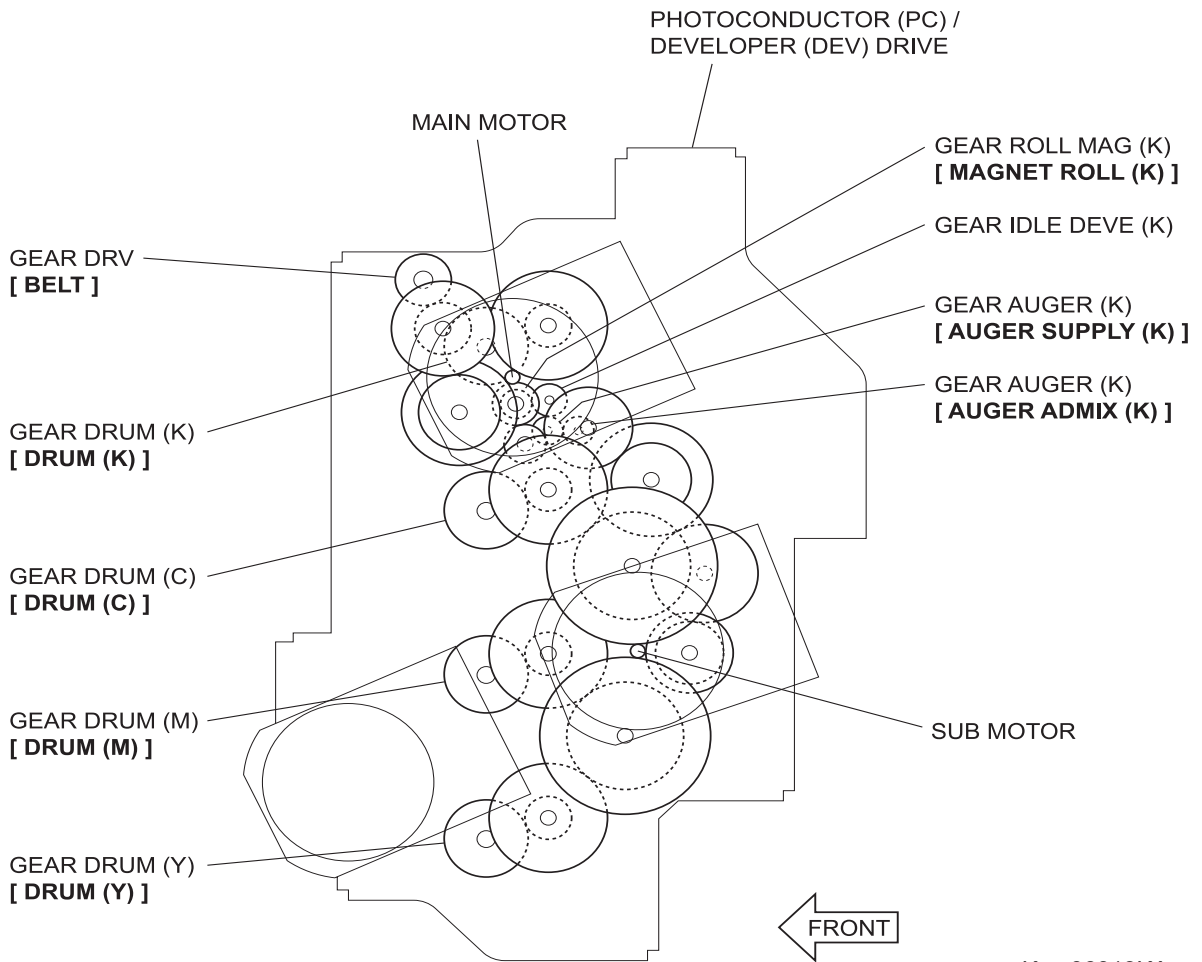

Kmy06013KA

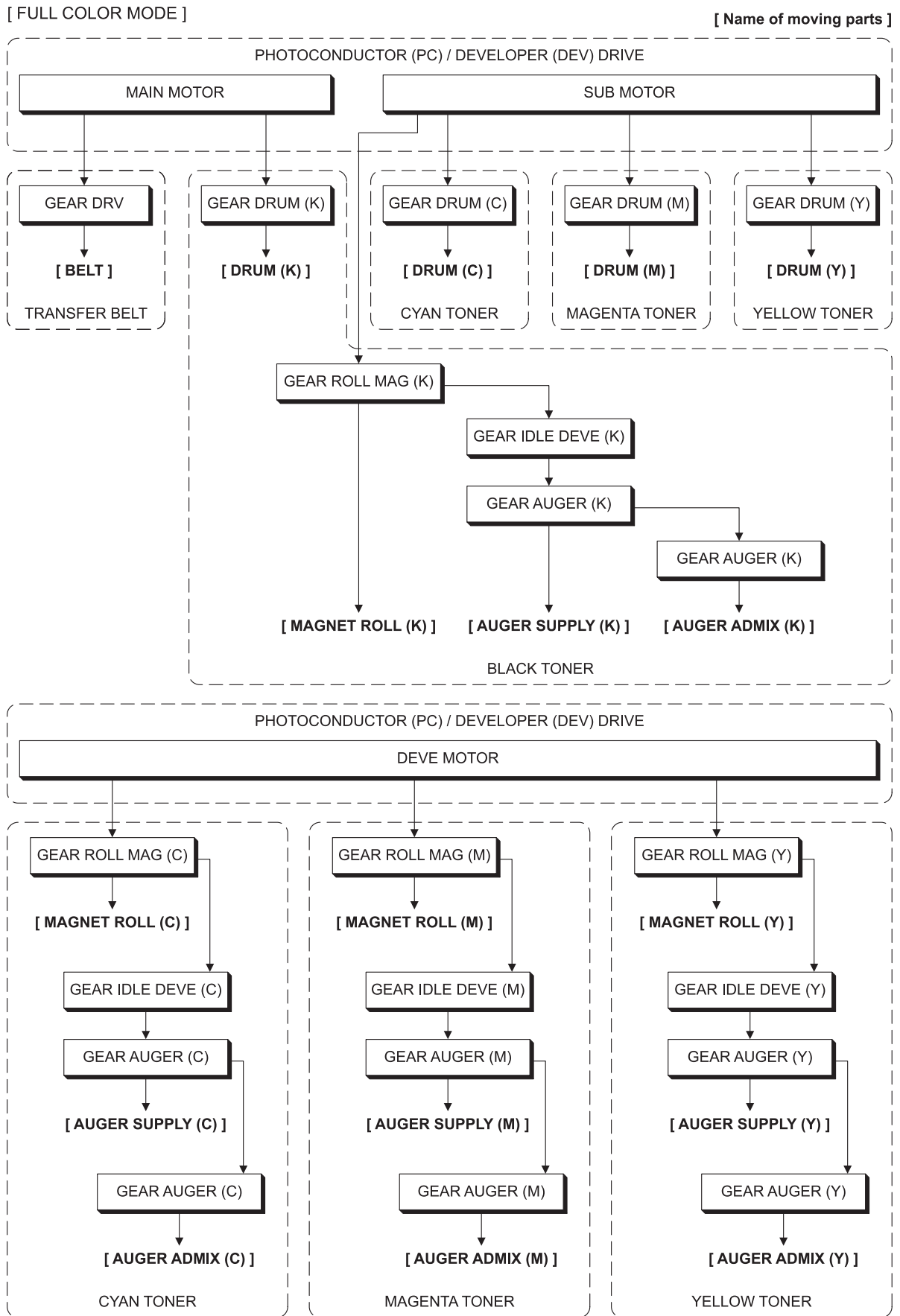

Kmy06014KA

[FULL COLOR MODE]

[Name of moving parts]

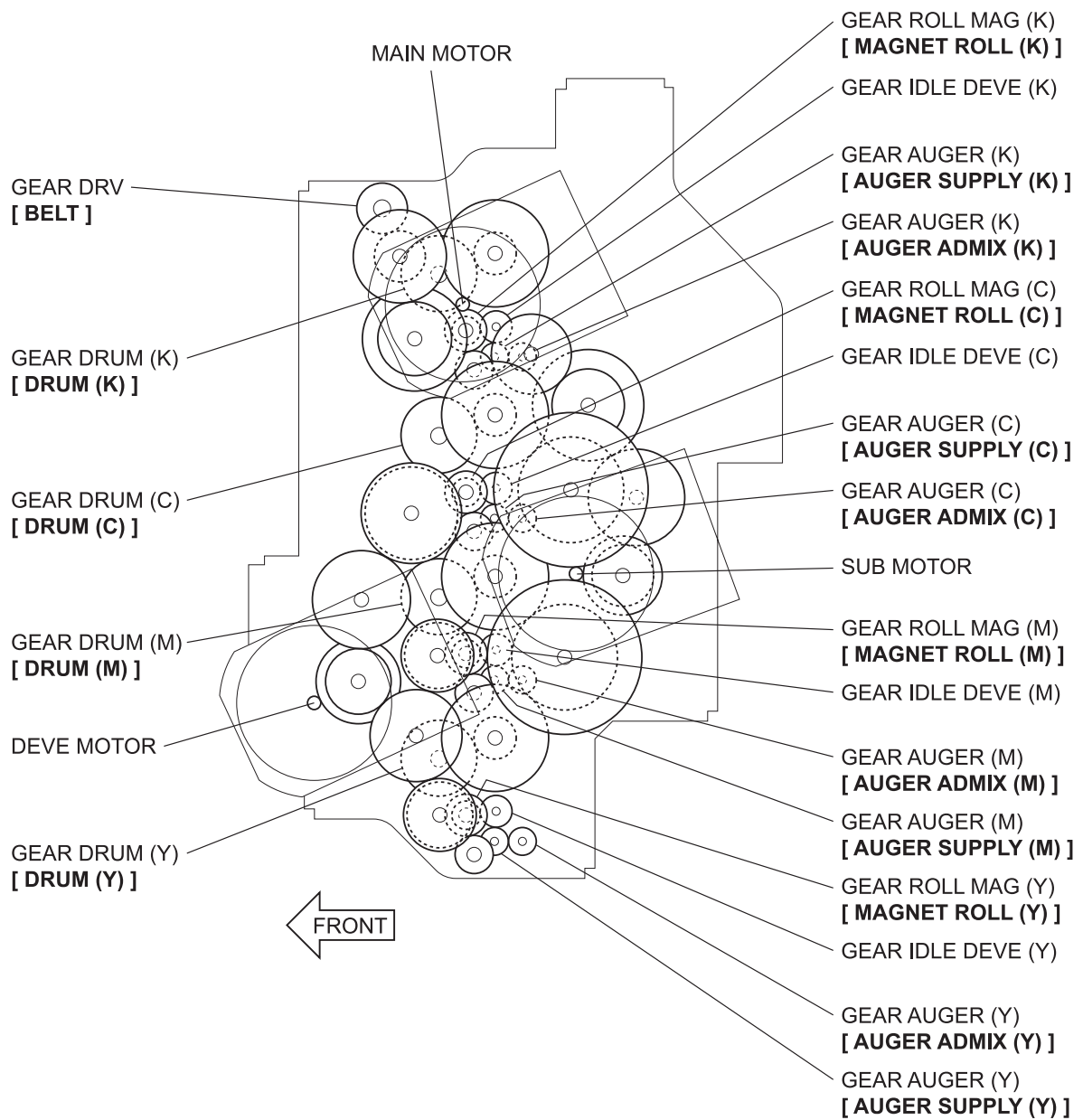

Kmy06015KA

[SIMPLEX MODE]

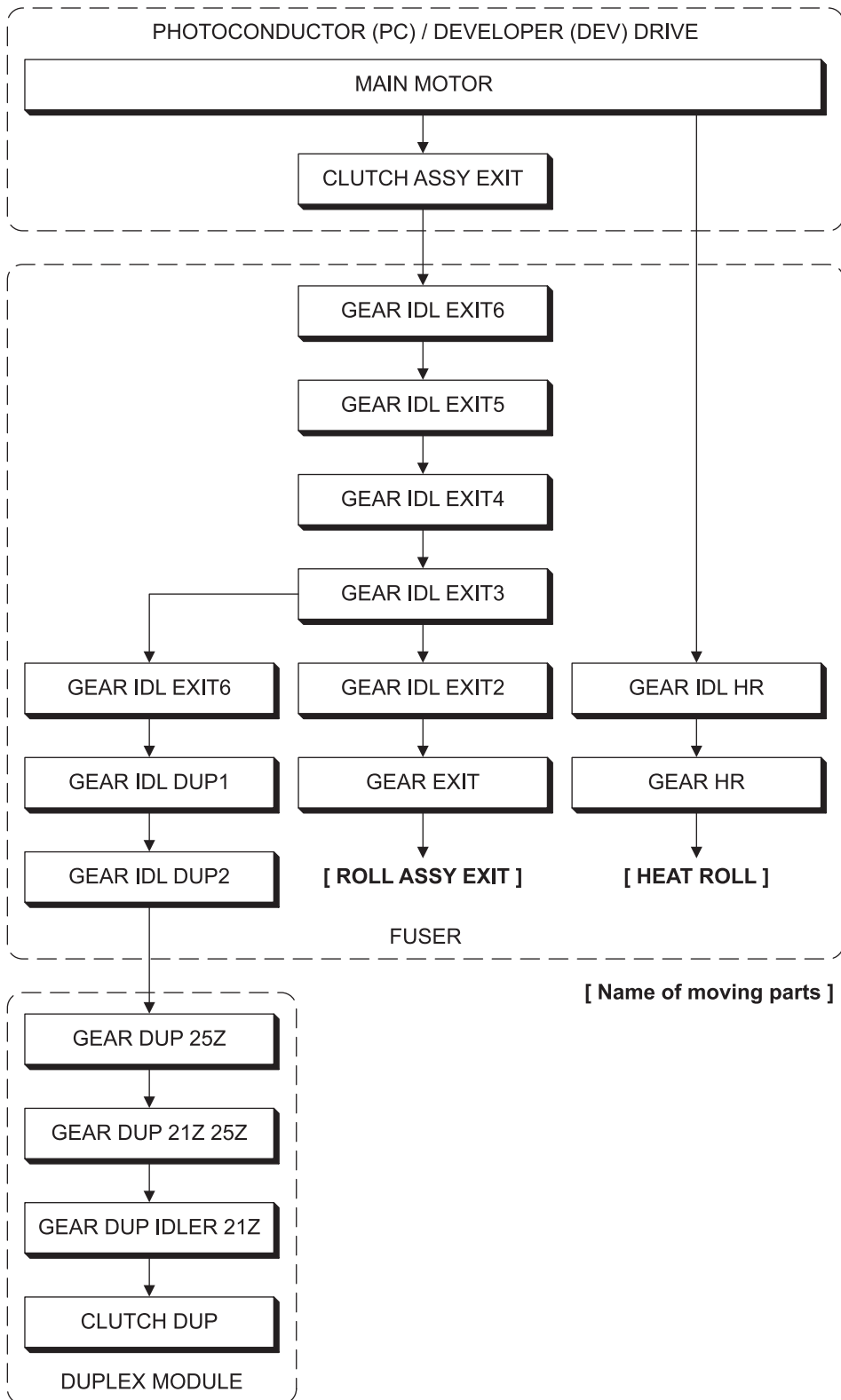

Kmy06016KA

[SIMPEX MODE]

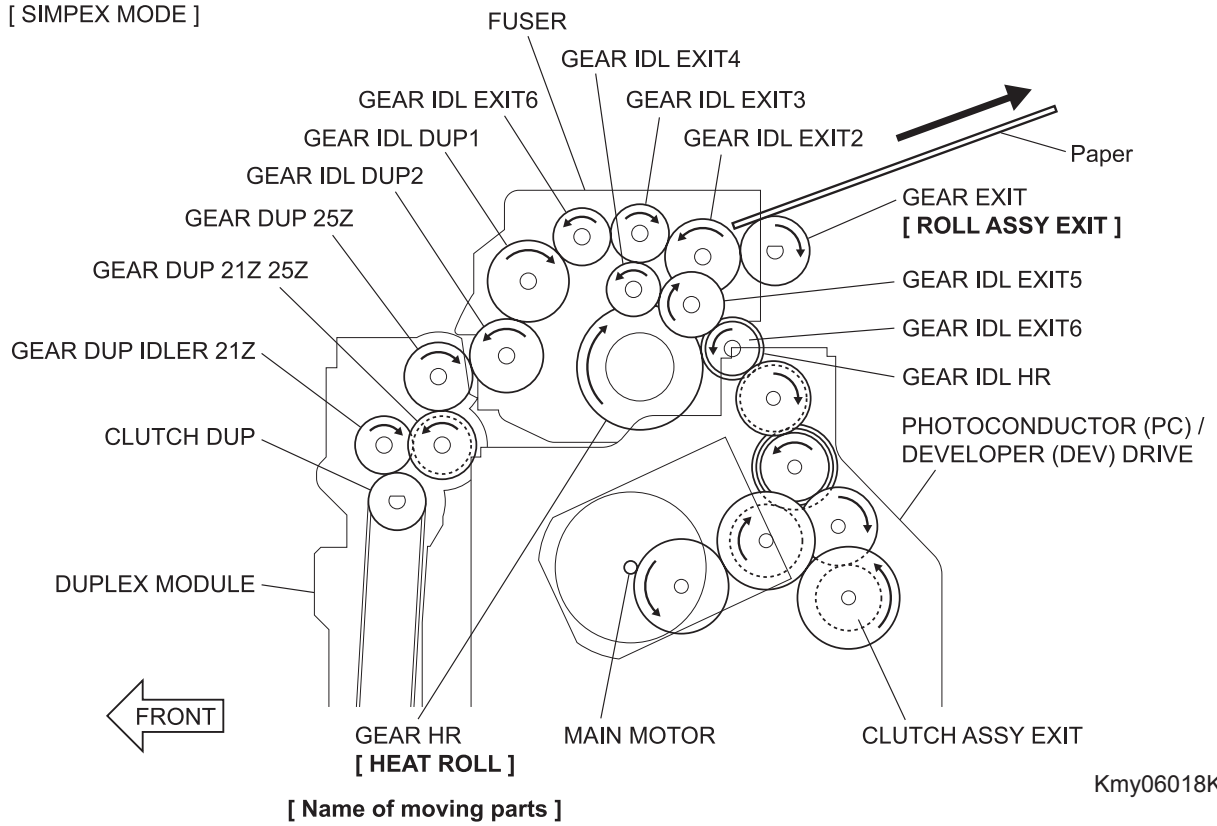

6.2 TONER DISPENSER (Y, M, C, K)

Rotation power of the TONER DISPENSER drives the agitator and the auger in the TONER CARTRIDGE.

The operation is common among the TONER DISPENSER Y, M, C and K.

[TONER CARTRIDGE]

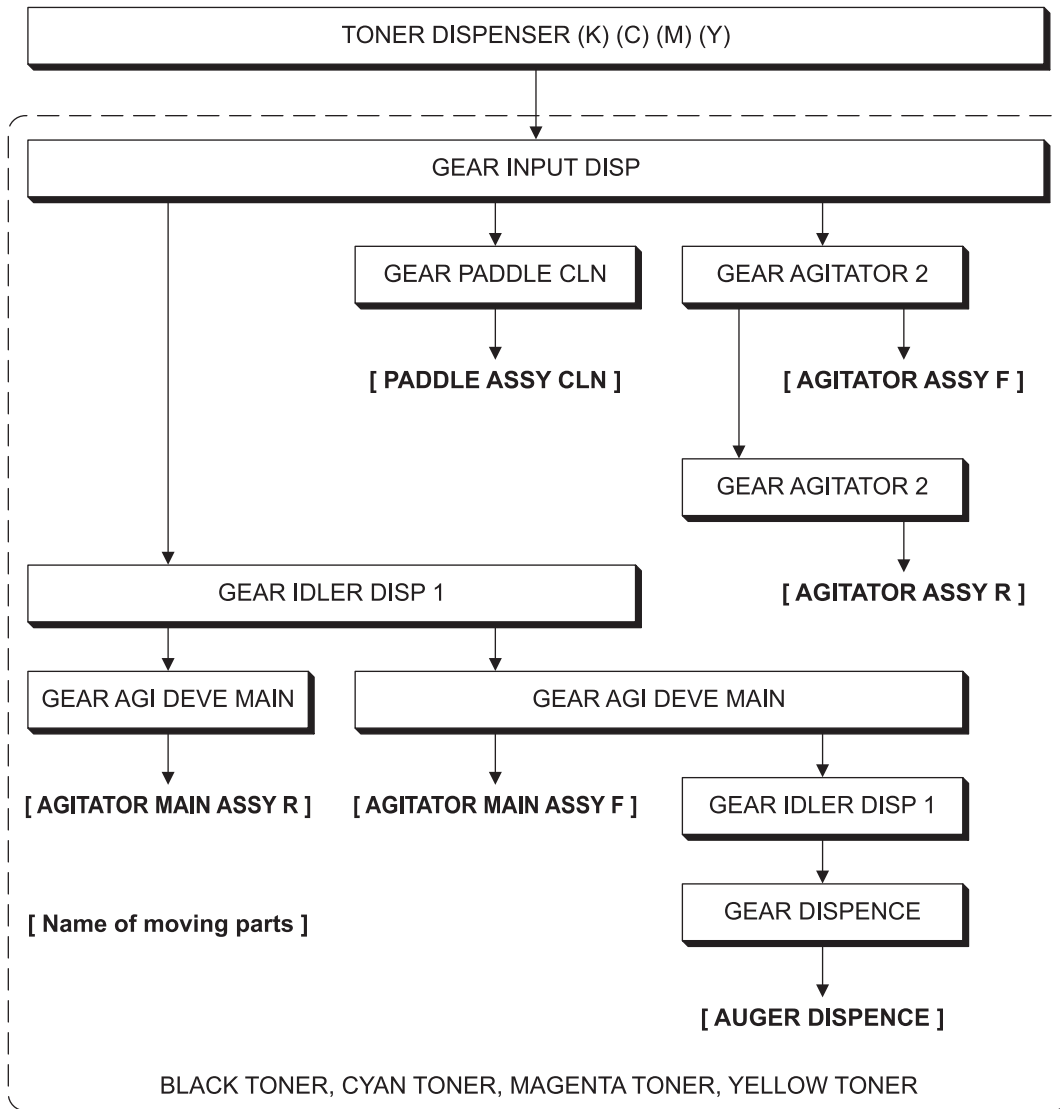

Kmy06021KA

[TONER CARTRIDGE]

GEAR AGITATOR 2
[AGITATOR ASSY R]

GEAR AGITATOR 2
[AGITATOR ASSY F]

TONER DISPENSER (K) (C) (M) (Y)

GEAR PADDLE CLN
[PADDLE ASSY CLN]

[Name of moving parts]

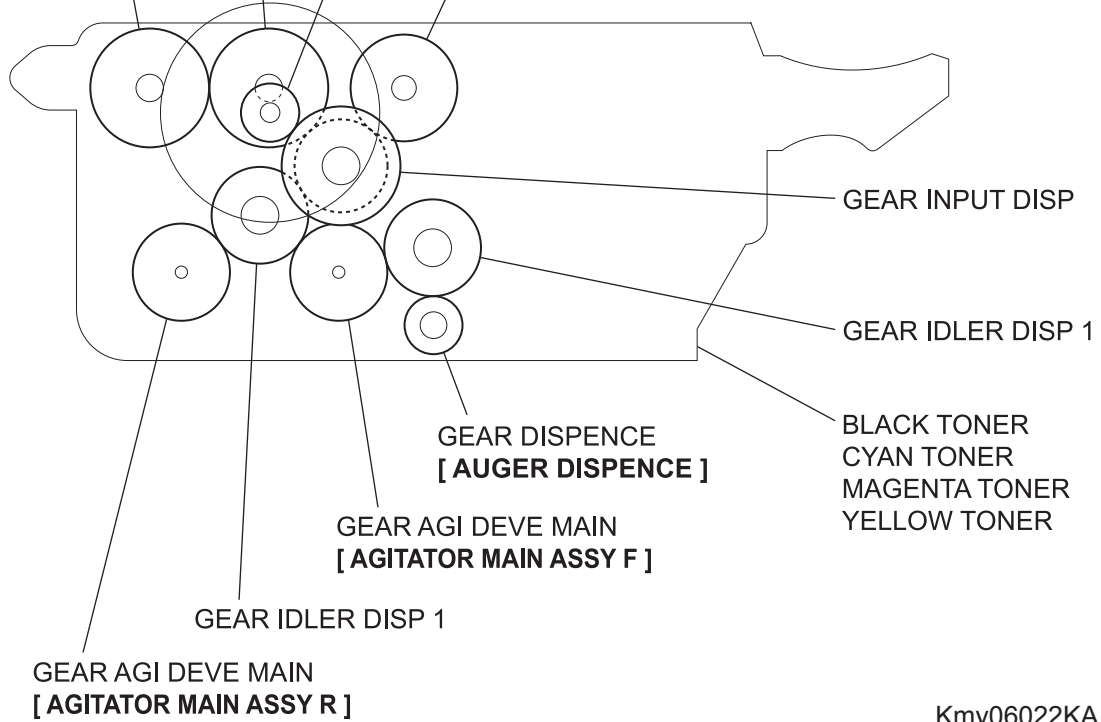

Kmy06022KA

6.3 FEED DRIVE ASSEMBLY

Rotation power of the FEED DRIVE ASSEMBLY is transmitted through the route below.

[PAPER HANDLING]

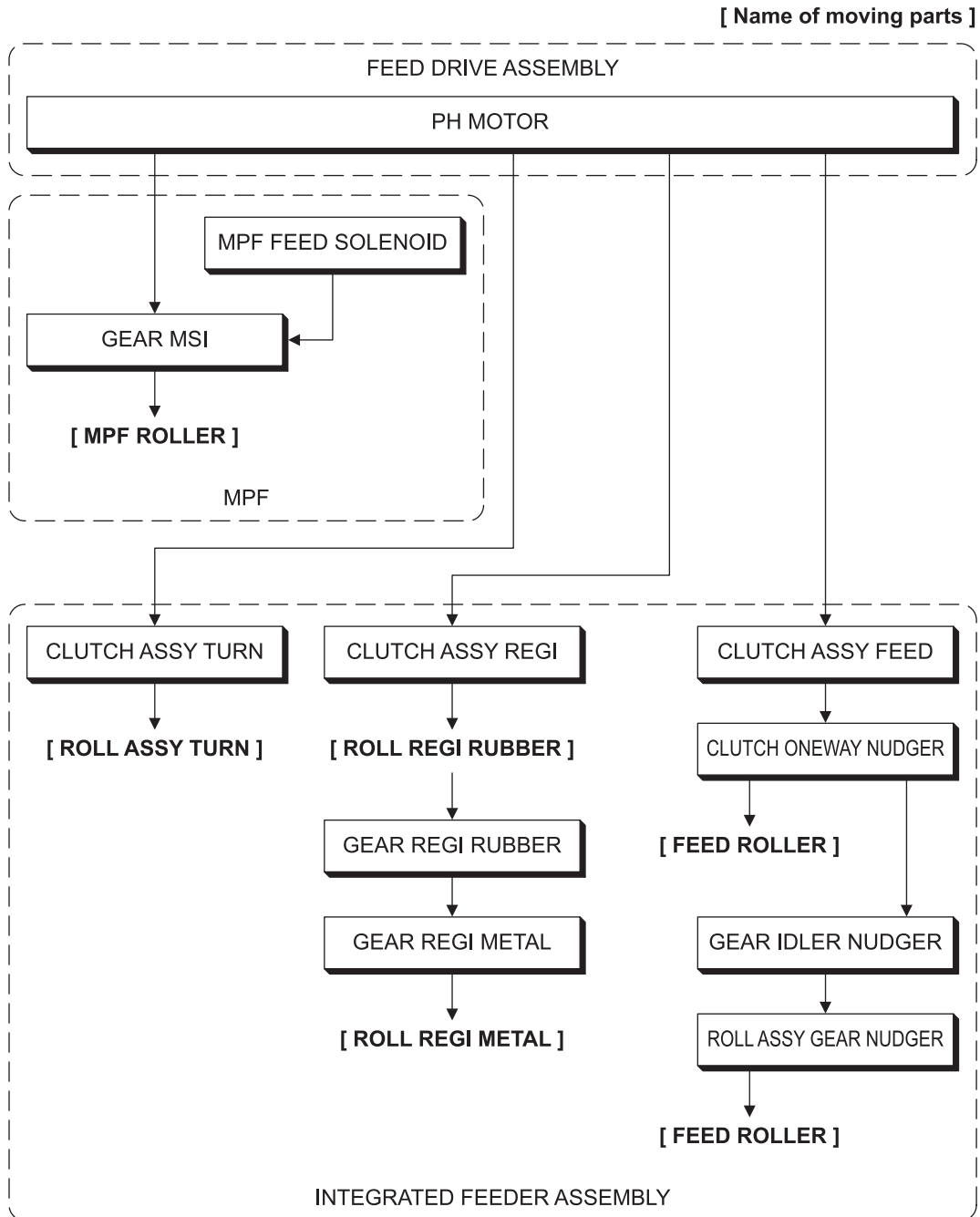

Kmy06019KA

[PAPER HANDLING]

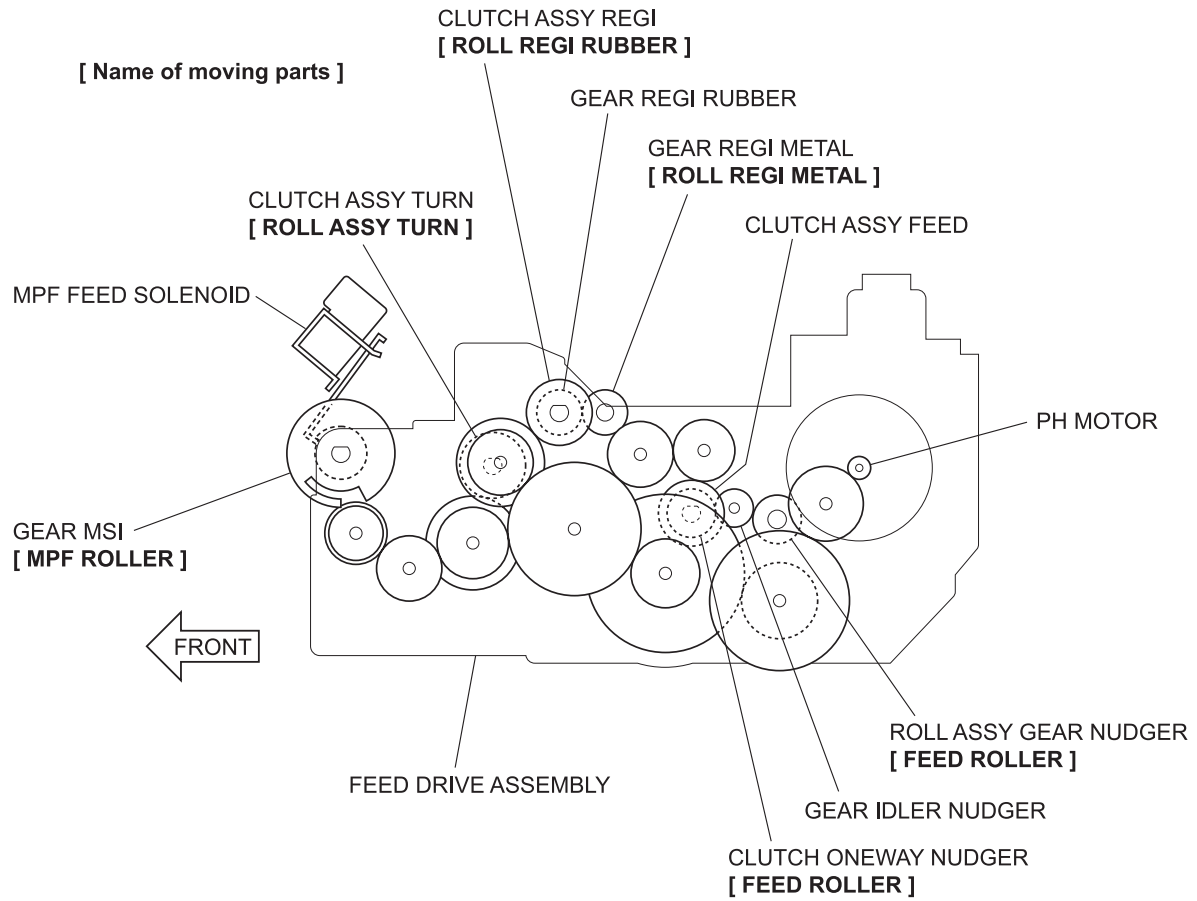

Kmy06020KA

6.4 DRIVE ASSY DUP

Rotation power of the DRIVE ASSY DUP is transmitted through the route below.

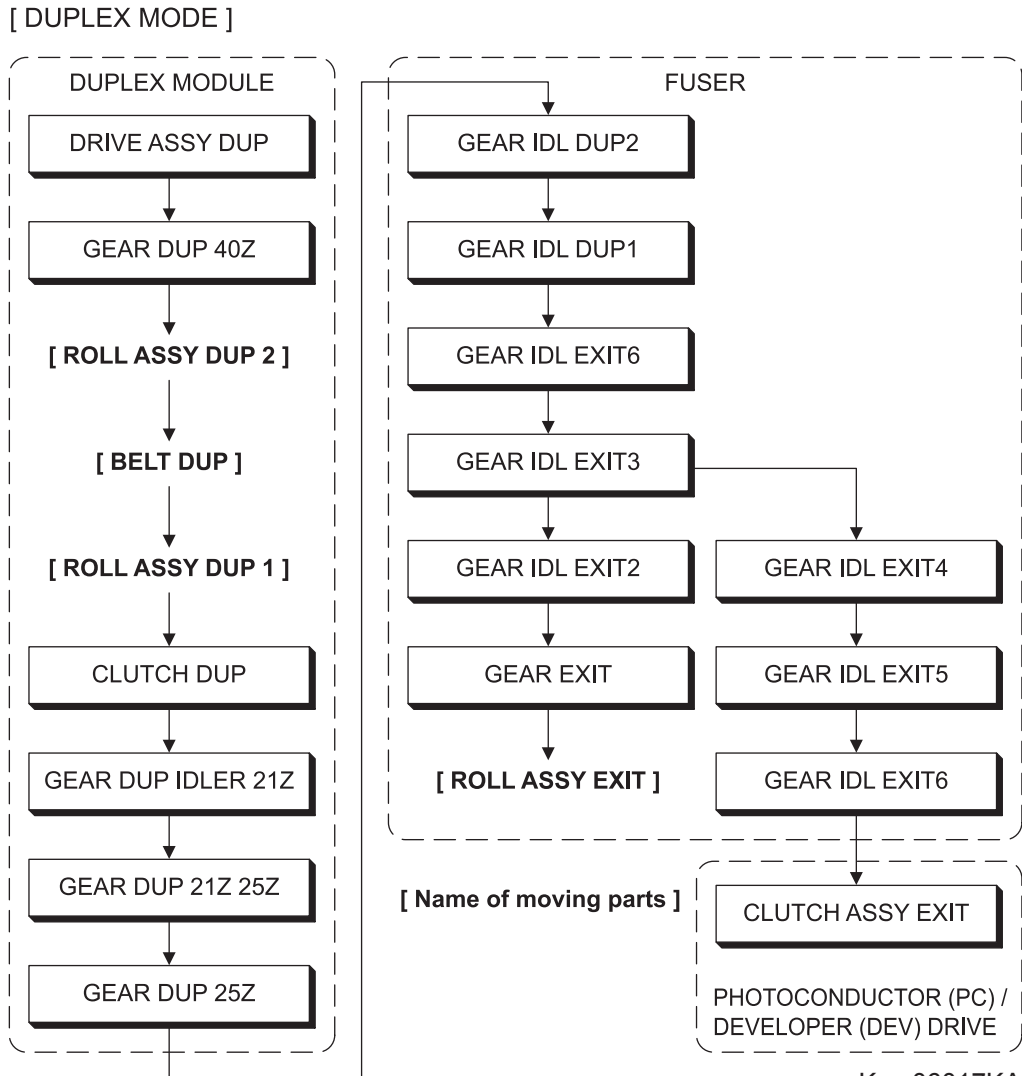

Kmy06017KA

[DUPLEX MODE]

[Name of moving parts]

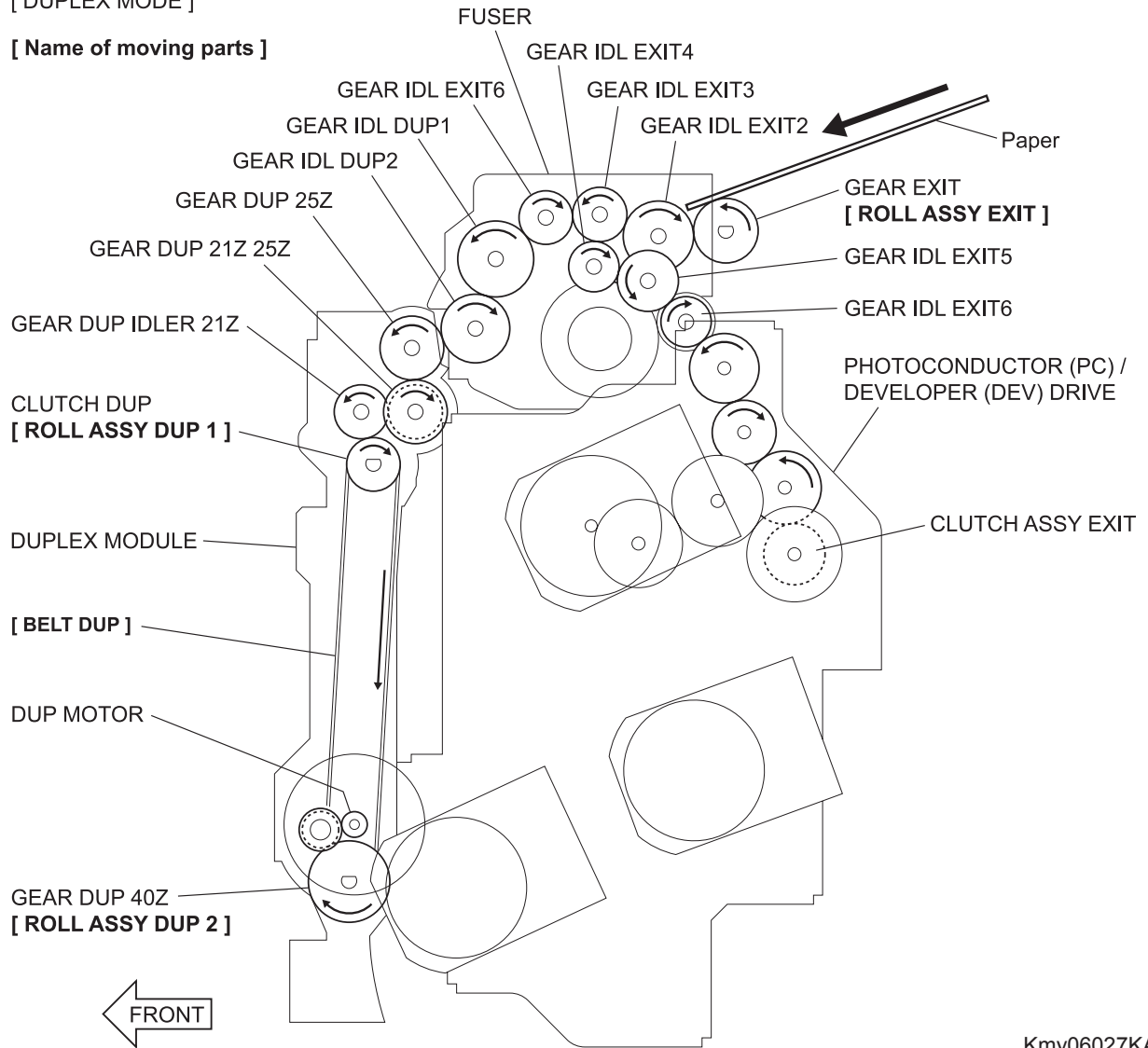

Kmy06027KA

6.5 DRIVE ASSY OPT FDR

Rotation power of the DRIVE ASSY OPT FDR is transmitted through the route below.

[550 OPTION FEEDER]

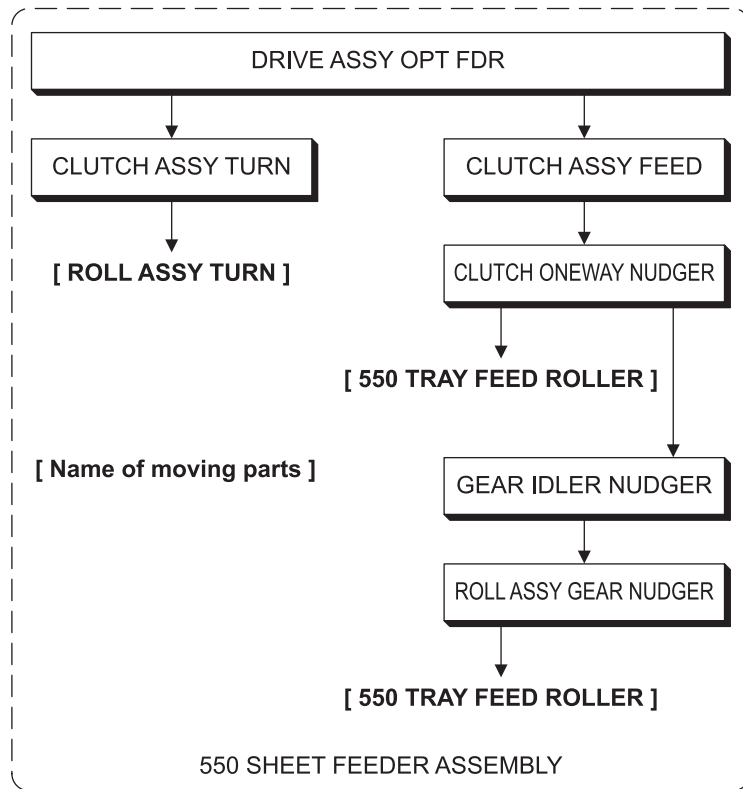

Kmy06023KA

[550 OPTION FEEDER]

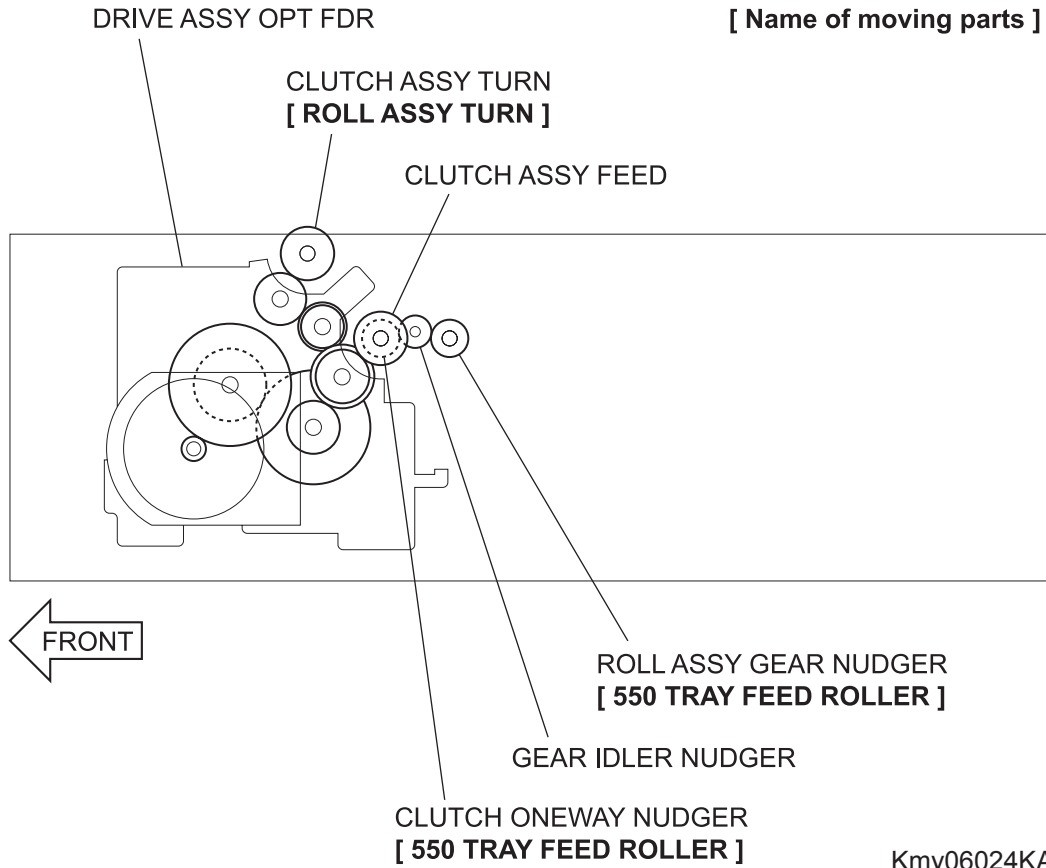

Kmy06024KA

Chapter 7 Wiring Diagrams and Signal Information CONTENTS

1. Connection Wiring Diagram..... 7 - 1

 1.1 Symbols in the General Connection Wiring Diagram..... 7 - 1

 1.2 General Wiring Diagram 7 - 2

2. Interconnection Wiring Diagram of Parts..... 7 - 3

 2.1 Notes on Using the Wiring Diagram between Parts..... 7 - 3

 2.2 Configuration of the Interconnection Wiring Diagram of Parts..... 7 - 5

 § 1 DC POWER SUPPLY 7 - 7

 § 2 MSI®I 7 - 9

 § 3 DRIVE 7 - 11

 § 4 FEEDER 7 - 13

 § 5 ROS 7 - 15

 § 6 XEROGRAPHIC 7 - 17

 § 7 HIGH VOLTAGE 7 - 19

 § 8 DEVELOPER 7 - 21

 § 9 FUSER..... 7 - 23

 § 10 CONTROLLER 7 - 25









 § 11 550 FEEDER 7 - 27

 § 12 DUPLEX..... 7 - 29

1. Connection Wiring Diagram

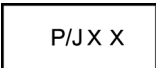
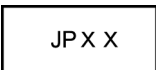
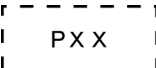
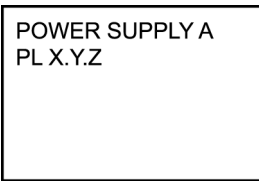
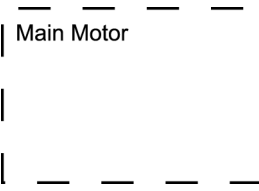
1.1 Symbols in the General Connection Wiring Diagram

The symbols in the general connection wiring diagram are described below.

Symbol	Description
	Represents an interconnection between parts using wiring harness or wire.
	Represents an interconnection which differs according to the specifications.
	Represents an interconnection between parts using a conductive member such as a plate spring.
	Represents a connection between parts by tightening of a screw.
	Indicates a frame ground.
	Represents a connector. The connector No. is indicated inside the box.
	Represents a connection terminal with a plate spring on the printed circuit board. The connector (terminal) No. is indicated inside the box.
	Represents a connector directly connected to the printed circuit board. The connector No. is indicated inside the box.
	The box containing a part name represents a part. "PL X.Y.Z" indicates the item "Z" of the plate (PL) "X.Y" described in Chapter 5 "Parts List."
	Represents a functional part within a part, and indicates the name of the functional part.
	Represents a section in "2. Interconnection Wiring Diagram of Parts," and indicates its section No.
	Represents a screw for fixing wiring harness and a conductive member such as a plate spring.
	Represents a conductive member such as a plate spring.

1.2 General Wiring Diagram

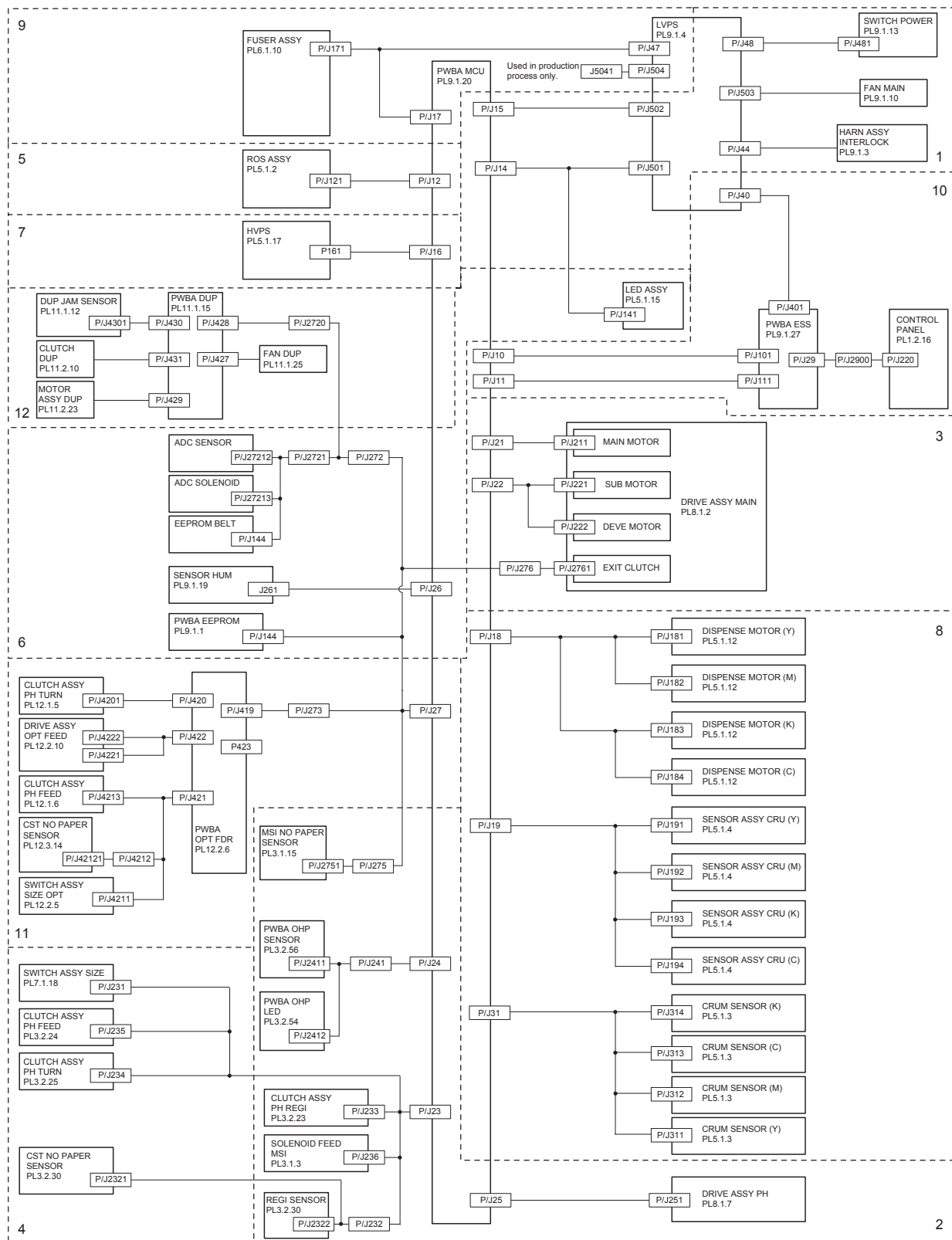



KMY07001KB

2. Interconnection Wiring Diagram of Parts

2.1 Notes on Using the Wiring Diagram between Parts

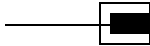
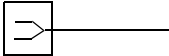
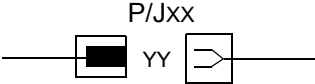
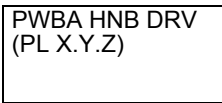
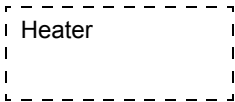
The following describes the legend of the wiring diagrams between parts shown on the following pages.

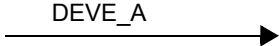
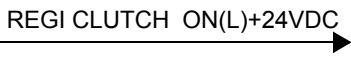
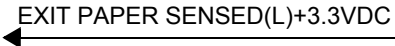
Symbols	Description
	Denotes a plug.
	Denotes a jack.
	Denotes Pin yy and Jack yy of the connector Pxx and Jxx.
	Denotes the parts. PL X.Y.Z implies the item "Z" of plate (PL) "X.Y" in Chapter 5. Parts List.
	Denotes functional parts attached with functional parts name.
	Denotes the control and its outline in PWB.
	Denotes a connection between parts with harnesses or wires, attached with signal name/contents.
	Denotes the function, and logic value of the signal to operate the function (Low: L, High: H). The given voltage is for signal in high status. The arrow indicates the direction of signal.
	Denotes the function, and logic value of the signal when the function operated (Low: L, High: H). The given voltage is for signal in high status. The arrow indicates the direction of signal.

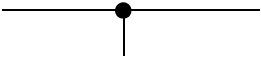
Symbols	Description
	Denotes a connection between wires.
I/L +24VDC	Denotes DC voltage when the interlock switch in HNB MCU WITH CPU turns on.
+5VDC +3.3VDC	Denotes DC voltage.
SG	Denotes signal ground.
AG	Denotes analog ground.
RTN	Denotes the return.

2.2 Configuration of the Interconnection Wiring Diagram of Parts

The interconnection wiring diagram is divided into 12 sections. § 1 to § 12 indicate details of the interconnections of parts.

§ 1 DC POWER SUPPLY

Connections of LVPS with PWBA MCU.
Connections of MAIN SWITCH with LVPS.
Connections of SIDE FAN with LVPS.
Connections of INTERLOCK SWITCH with LVPS.

§ 2 MSI & REGI

Connections of DRIVE ASSY PH with PWBA MCU.
Connections of REGI CLUTCH with PWBA MCU.
Connections of MSI FEED SOLENOID with PWBA MCU.
Connections of REGI SENSOR with PWBA MCU.
Connections of OHP TEMP. SENSOR with PWBA MCU.
Connections of OHP LED with PWBA MCU.
Connections of MSI NO PAPER SENSOR with PWBA MCU.

§ 3 DRIVE

Connections of MAIN DRIVE ASSY with PWBA MCU.

§ 4 FEEDER

Connections of NO PAPER SENSOR with PWBA MCU.
Connections of SWITCH ASSY SIZE with PWBA MCU.
Connections of FEED CLUTCH with PWBA MCU.
Connections of TURN CLUTCH with PWBA MCU.

§ 5 ROS

Connections of ROS ASSY with PWBA MCU.

§ 6 XEROGRAPHIC

Connections of ADC SENSOR with PWBA MCU.
Connections of ADC SOLENOID with PWBA MCU.
Connections of EEPROM BELT with PWBA MCU.
Connections of TEMP./HUM. SENSOR with PWBA MCU.
Connections of EEPROM XPRO with PWBA MCU.
Connections of ERASE LAMP with PWBA MCU.

§ 7 HIGH VOLTAGE

Connections of HVPS with PWBA MCU.

§ 8 DEVELOPER

Connections of DISPENSE MOTOR (Y) with PWBA MCU.
Connections of DISPENSE MOTOR (M) with PWBA MCU.
Connections of DISPENSE MOTOR (C) with PWBA MCU.
Connections of DISPENSE MOTOR (K) with PWBA MCU.
Connections of CRU SENSOR (Y) with PWBA MCU.
Connections of CRU SENSOR (M) with PWBA MCU.
Connections of CRU SENSOR (C) with PWBA MCU.
Connections of CRU SENSOR (K) with PWBA MCU.
Connections of CRUM SENSOR (Y) with PWBA MCU.
Connections of CRUM SENSOR (M) with PWBA MCU.
Connections of CRUM SENSOR (C) with PWBA MCU.
Connections of CRUM SENSOR (K) with PWBA MCU.

§ 9 FUSER

Connections of FUSER ASSY with PWBA MCU.
Connections of FUSER ASSY with LVPS.
Connections of PWBA MCU with LVPS.

§ 10 CONTROLLER

Connections of PWBA ESS with PWBA MCU.
Connections of CONTROL PANEL with PWBA ESS.
Connections of LVPS with PWBA ESS.

§ 11 550 FEEDER

Connections of PWBA FEEDER with PWBA MCU.
Connections of TURN CLUTCH with PWBA FEEDER.
Connections of FEED MOTOR with PWBA FEEDER.
Connections of FEED CLUTCH with PWBA FEEDER.
Connections of NO PAPER SENSOR with PWBA FEEDER.
Connections of SWITCH ASSY SIZE with PWBA FEEDER.

§ 12 DUPLEX

Connections of PWBA DUP with PWBA MCU.
Connections of DUP JAM SENSOR with PWBA DUP.
Connections of DUP CLUTCH with PWBA DUP.
Connections of DUP MOTOR with PWBA DUP.
Connections of DUP FAN with PWBA DUP.

§ 1 DC POWER SUPPLY

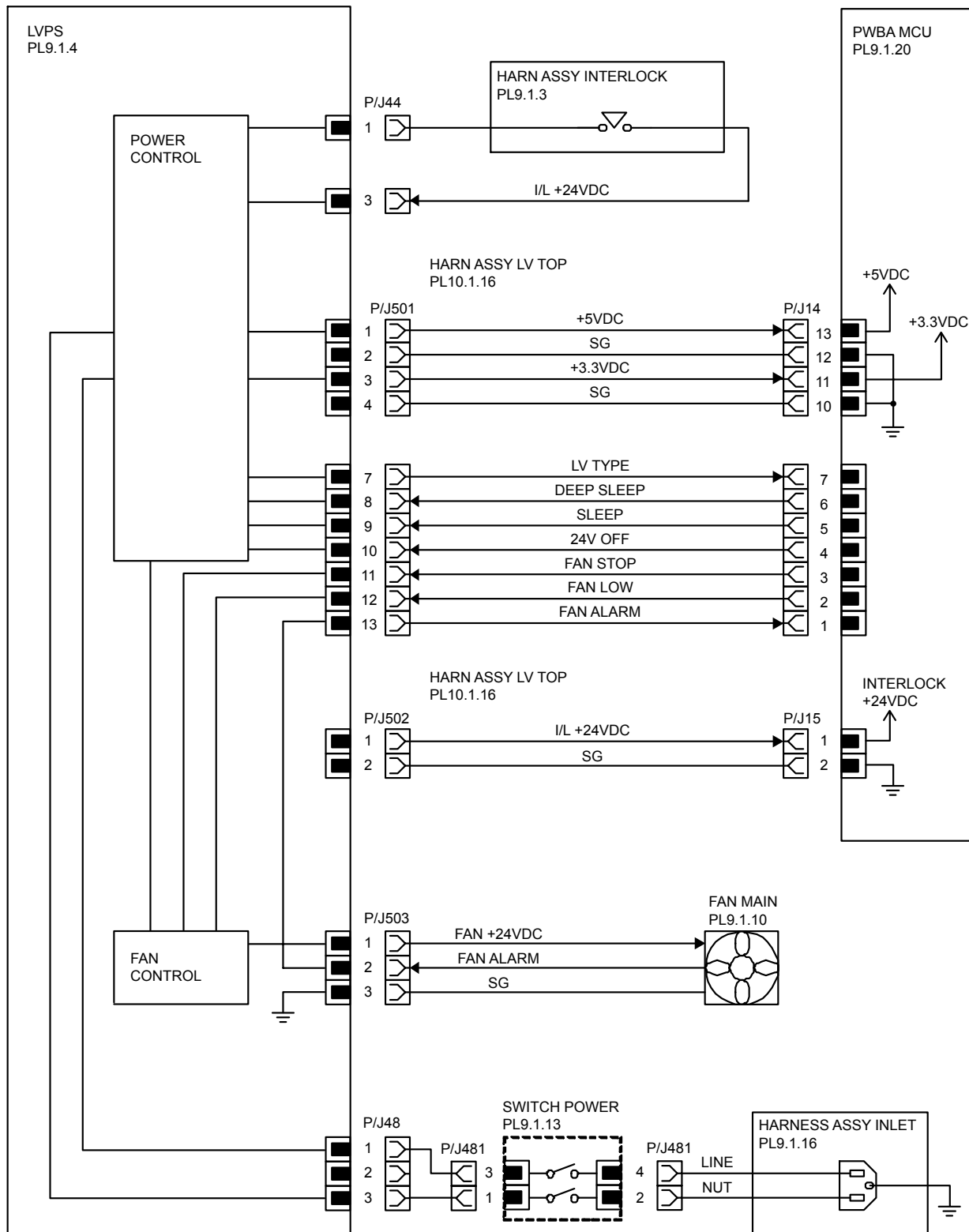

KMY07002KA

Signal line name	Description
LV TYPE DEEP SLEEP SLEEP 24V OFF	Control signal of the LVPS
FAN STOP FAN LOW FAN ALARM	Drive control signal of the SIDE FAN

- LVPS overcurrent protection circuit

This circuit stops all outputs, if the power supply voltage 24VDC, 5VDC, or 3.3VDC is shorted.

The circuit is reset, when after the cause of short was removed, the power is turned off, and then on again after certain time.

- LVPS overvoltage protection circuit

This circuit stops all outputs, if the power supply voltage 24VDC, 5VDC, or 3.3VDC exceeds the specified voltage respectively.

At this time, the operating point is 32VDC(TBD) or less for 24VDC, 7VDC(TBD) or less for 5VDC, or 4.4VDC(TBD) or less for 3.3VDC.

The circuit is reset, when the power is turned off, and then on again after certain time.

- Sleep mode and deep sleep mode

The output of the following power supply are stopped according to the these signals.

Signal \ Output	+24VDC	+5VDC	+3.3VDC
Sleep	OFF	OFF	ON
Deep sleep	OFF	OFF	OFF

§ 2 MSI®I

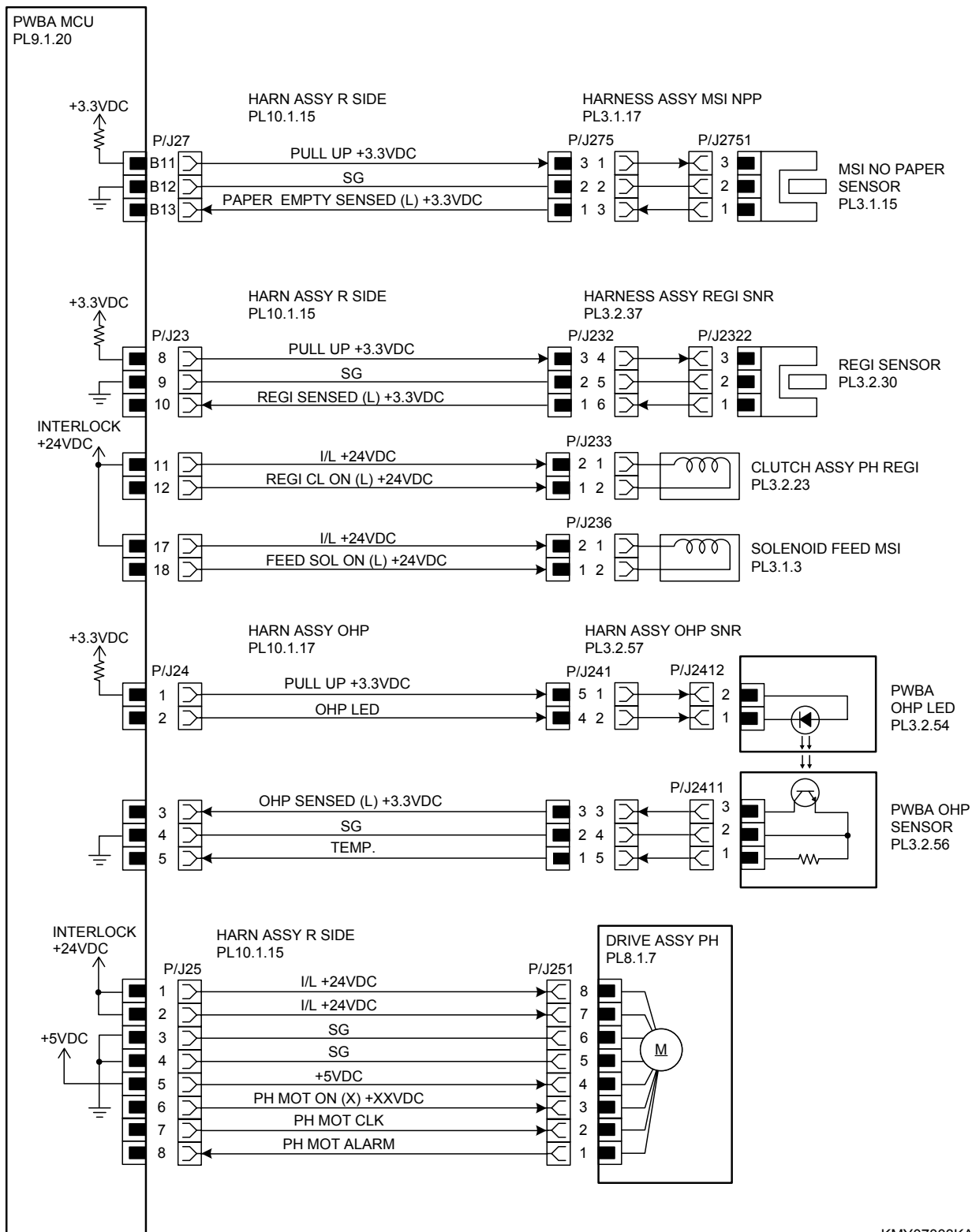

KMY07003KA

Signal line name	Description
PAPER EMPTY SENSED (L) +3.3VDC	Paper detect signal of the MSI by the Sensor Photo (MSI NO PAPER SENSOR)
REGI SENSED (L) +3.3VDC	Paper detect signal of the Regi part by the Sensor Photo (REGI SENSOR)
REGI CL ON (L) +24VDC	ON/OFF signal of the REGI CLUTCH
FEED SOL ON (L) +24VDC	ON/OFF signal of the MSI FEED SOLENOID
OHP LED	ON/OFF signal of the OHP LED
OHP SENSED (L) +3.3VDC	Detect Signal of the transparency sheet by the Sensor Photo (OHP SENSOR)
TEMP.	Data on temperature inside the printer.
PH MOT ON (X) +XXVDC PH MOT CLK PH MOT ALARM	Drive control signal of the DRIVE ASSY PH

§ 3 DRIVE

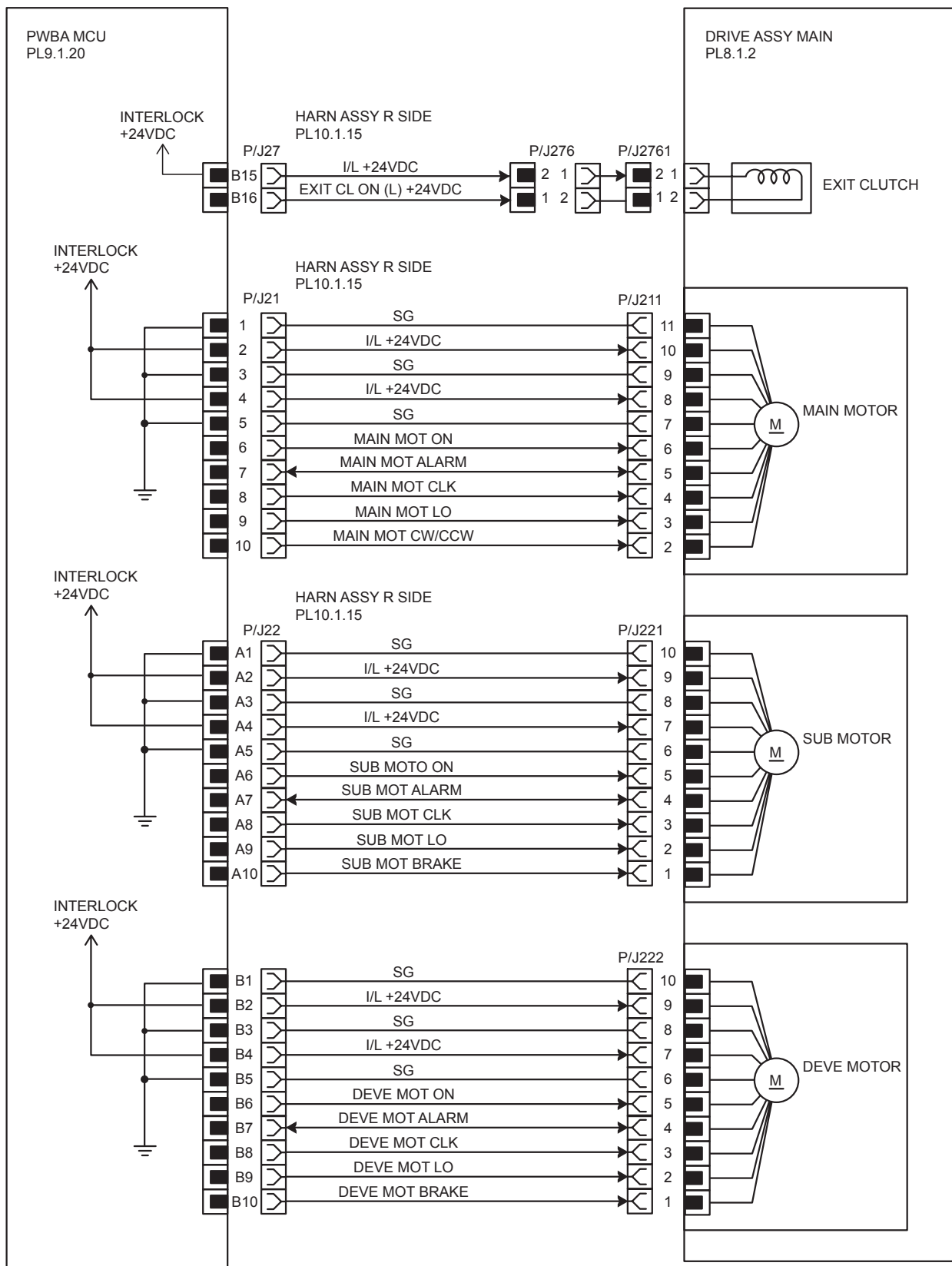

KMY07004KB

Signal line name	Description
MAIN MOT ON MAIN MOT ALARM MAIN MOT CLK MAIN MOT LO MAIN MOT CW/CCW	Drive control signal of the MAIN MOTOR
SUB MOT ON SUB MOT ALARM SUB MOT CLK SUB MOT LO SUB MOT BRAKE	Drive control signal of the SUB MOTOR
DEVE MOT ON DEVE MOT ALARM DEVE MOT CLK DEVE MOT LO DEVE MOT BRAKE	Drive control signal of the DEVE MOTOR
EXIT CL ON (L) +24VDC	ON/OFF signal of the EXIT CLUTCH

§ 4 FEEDER

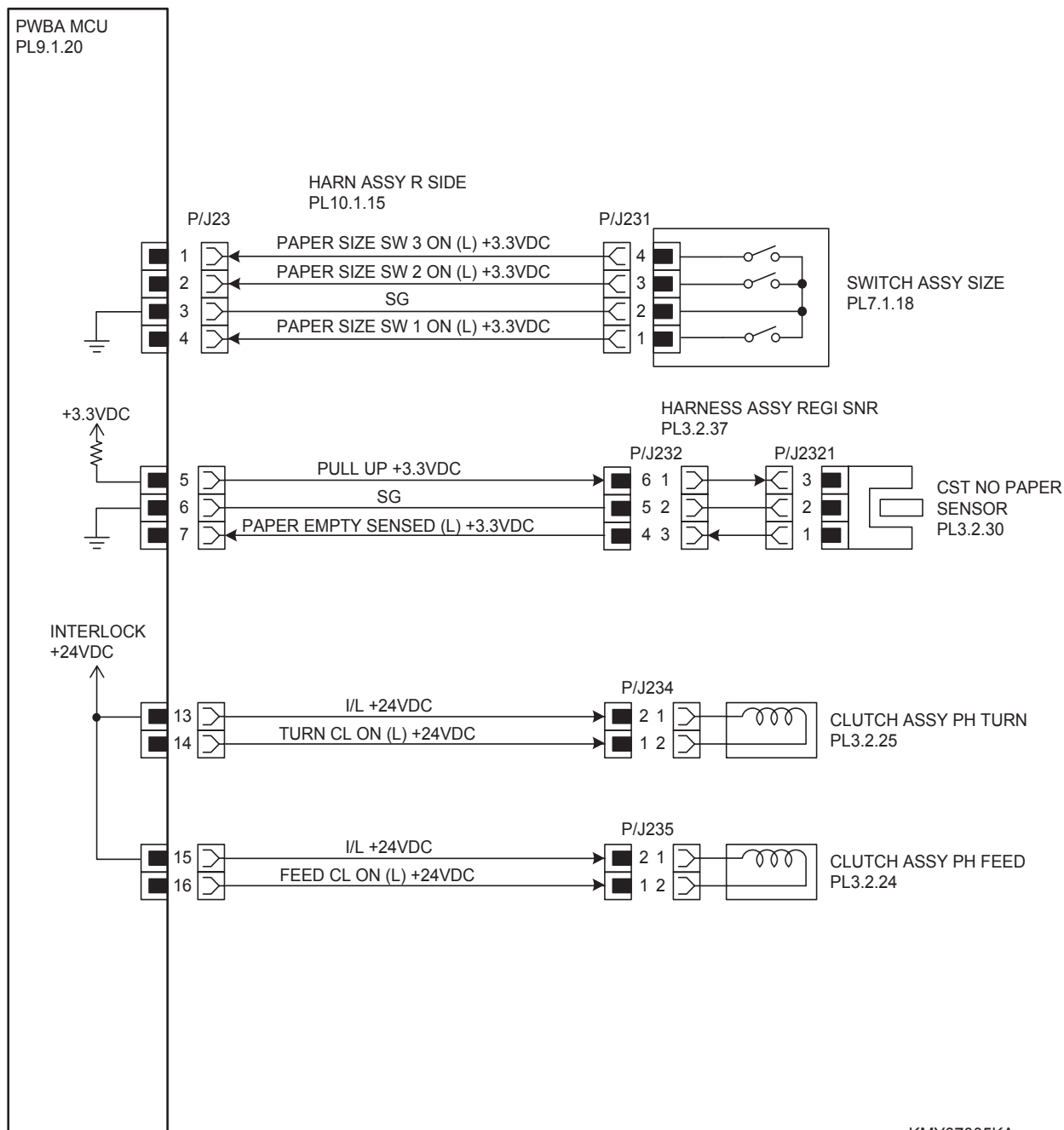

KMY07005KA

Signal line name	Description
PAPER SIZE SW 1 ON (L) +3.3VDC PAPER SIZE SW 2 ON (L) +3.3VDC PAPER SIZE SW 3 ON (L) +3.3VDC	ON/OFF signal of the SWITCH ASSY SIZE
PAPER EMPTY SENSED (L) +3.3VDC	Paper detect signal of the Feeder by the Sensor Photo (NO PAPER SENSOR)
TURN CL ON (L) +24VDC	ON/OFF signal of the TURN CLUTCH
FEED CL ON (L) +24VDC	ON/OFF signal of the FEED CLUTCH

- Outline of SWITCH ASSY SIZE

The paper size is determined by a combination of ON/OFF statuses of the SW 1, SW 2, and SW 3 switches of SWITCH ASSY SIZE.

Paper size	Switches		
	SW 1	SW 2	SW 3
LEGAL 14" (SEF)	ON	ON	ON
LEGAL 13" (SEF)	ON	ON	OFF
EXECUTIVE (SEF)	ON	OFF	ON
B5 (SEF)	ON	OFF	OFF
A4 (SEF)	OFF	ON	ON
LETTER (SEF)	OFF	OFF	ON
A5	OFF	ON	OFF
No cassette	OFF	OFF	OFF

ON : The actuator is pushing the size switch.

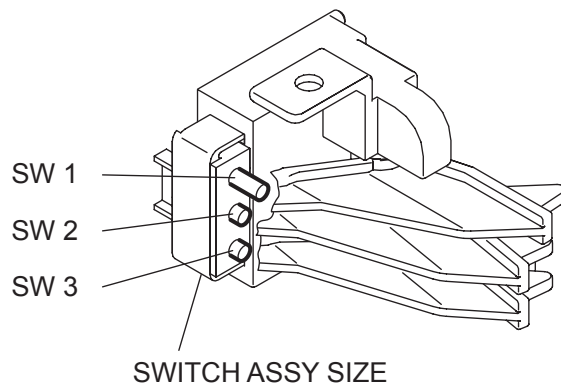

KMY07014KA

§ 5 ROS

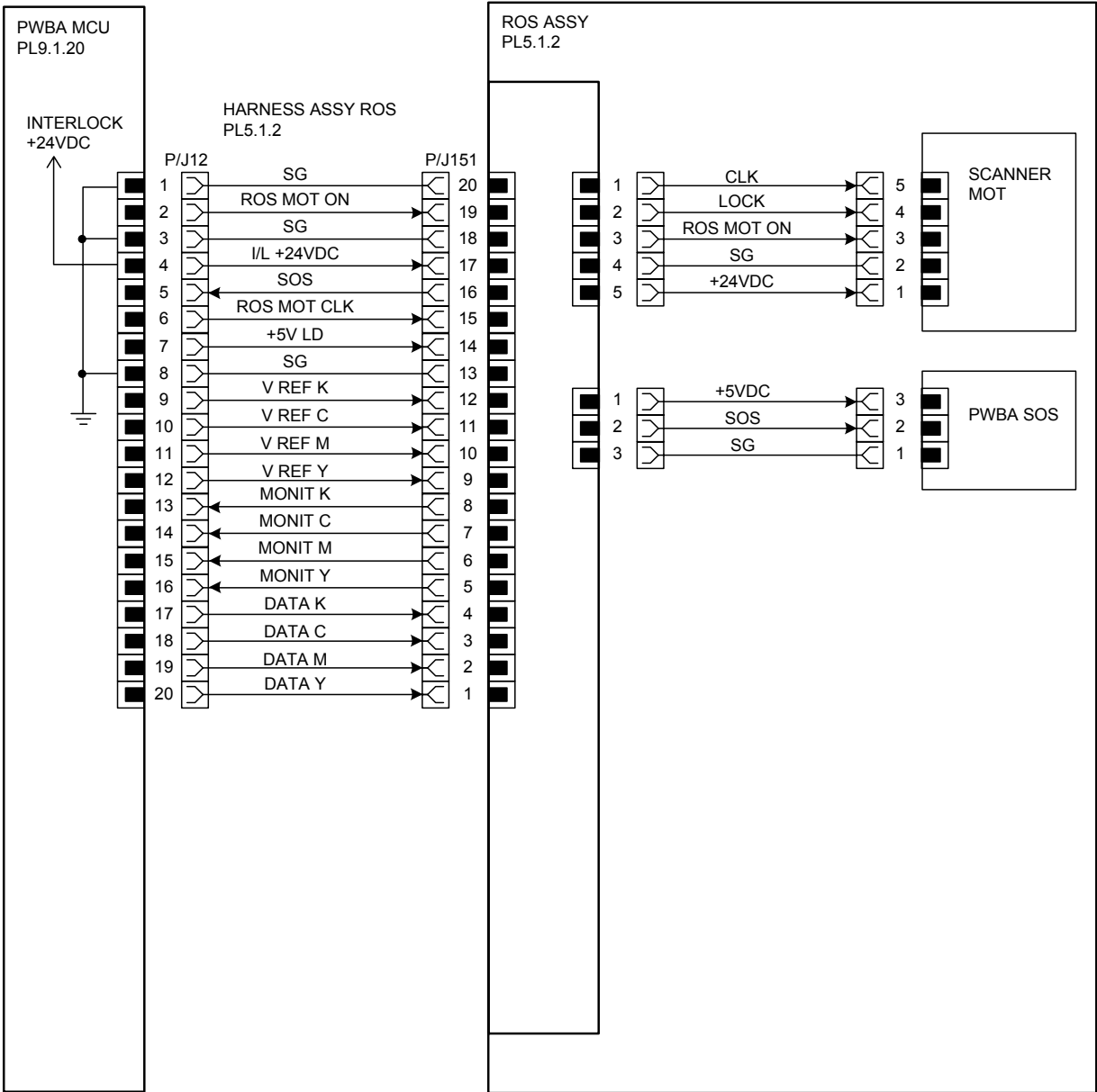

KMY07006KB

Signal line name	Description
ROS MOT ON ROS MOT CLK	Drive control signal of the ROS MOTOR
SOS	Reference signal for scan start of LASER
V REF K V REF C V REF M V REF Y	Emission control signal of the laser diode
MONIT K MONIT C MONIT M MONIT Y	The monitoring voltage of the laser diode
DATA K DATA C DATA M DATA Y	Video signal of the laser diode

§ 6 XEROGRAPHIC

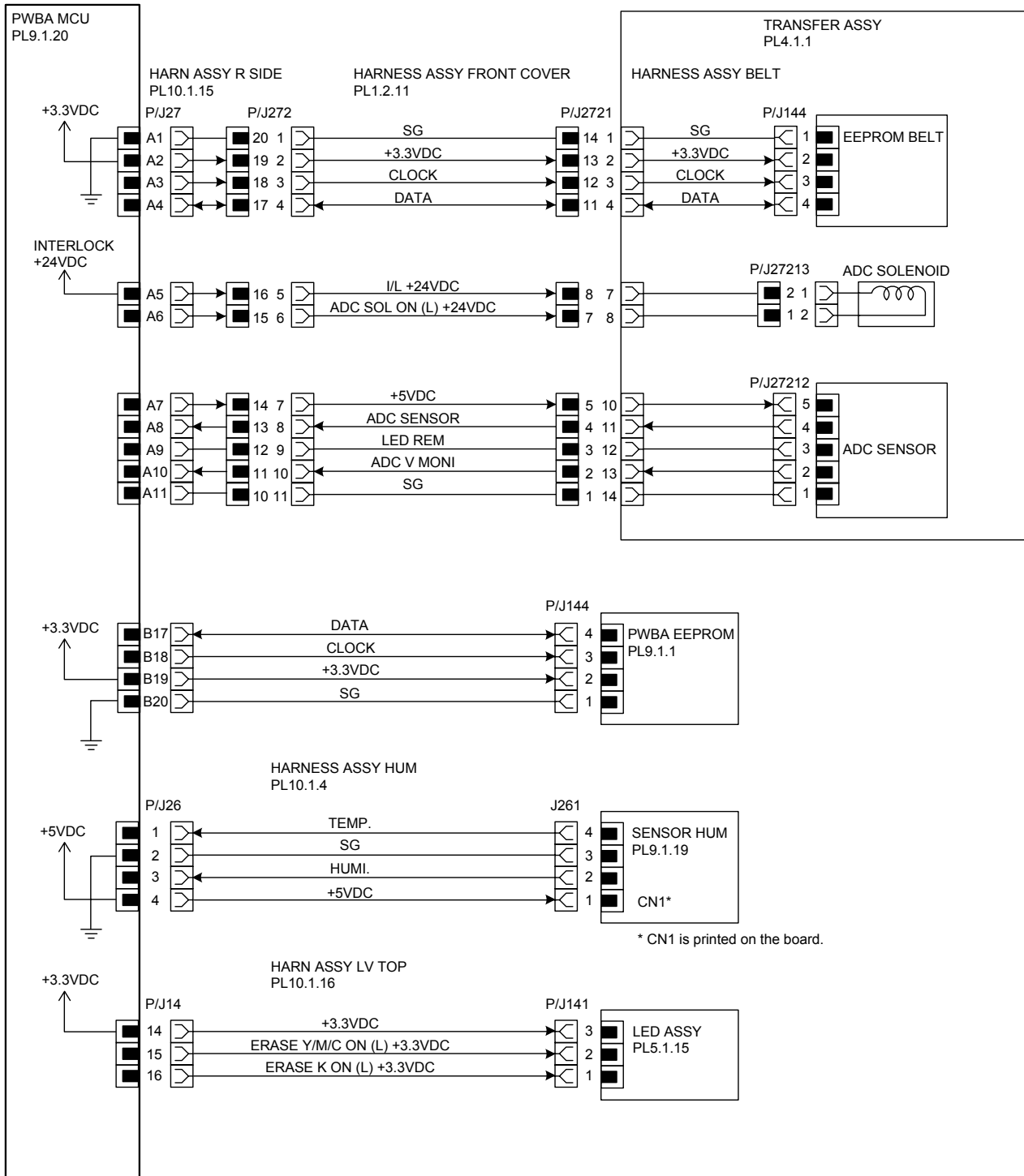

KMY07007KB

Signal line name	Description
CLOCK DATA	Control signal of the EEPROM BELT
ADC SOL ON (L) +24VDC	ON/OFF signal of the ADC SOLENOID
ADC SENSOR	Toner patch density data measured by the ADC SENSOR (Analog value)
LED REM	Remote signal of the LED of ADC SENSOR
ADC V MONI	Control signal of the ADC SENSOR
DATA CLOCK	Control signal of the EEPROM XPRO
TEMP.	Temperature data in the printer by the TEMP./HUM. SENSOR (Analog value)
HUMI.	Humidity data in the printer by the TEMP./HUM. SENSOR (Analog value)
ERASE K ON (L) +3.3VDC ERASE Y/M/C ON (L) +3.3VDC	ON/OFF signal of the ERASE LAMP

§ 7 HIGH VOLTAGE

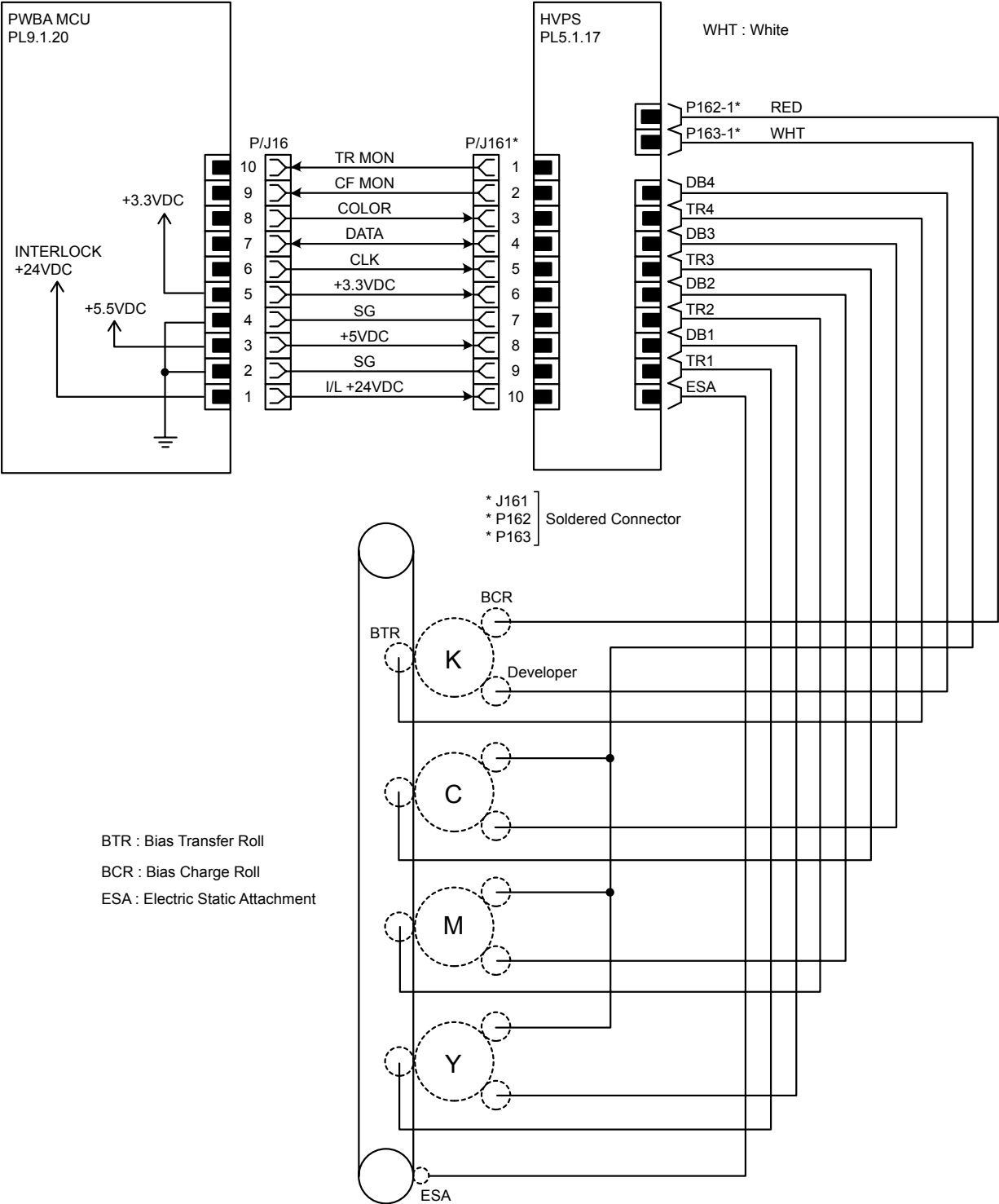

KMY07008KA

Signal line name	Description
TR MON CF MON COLOR DATA CLK	Control signal of the HVPS

§ 8 DEVELOPER

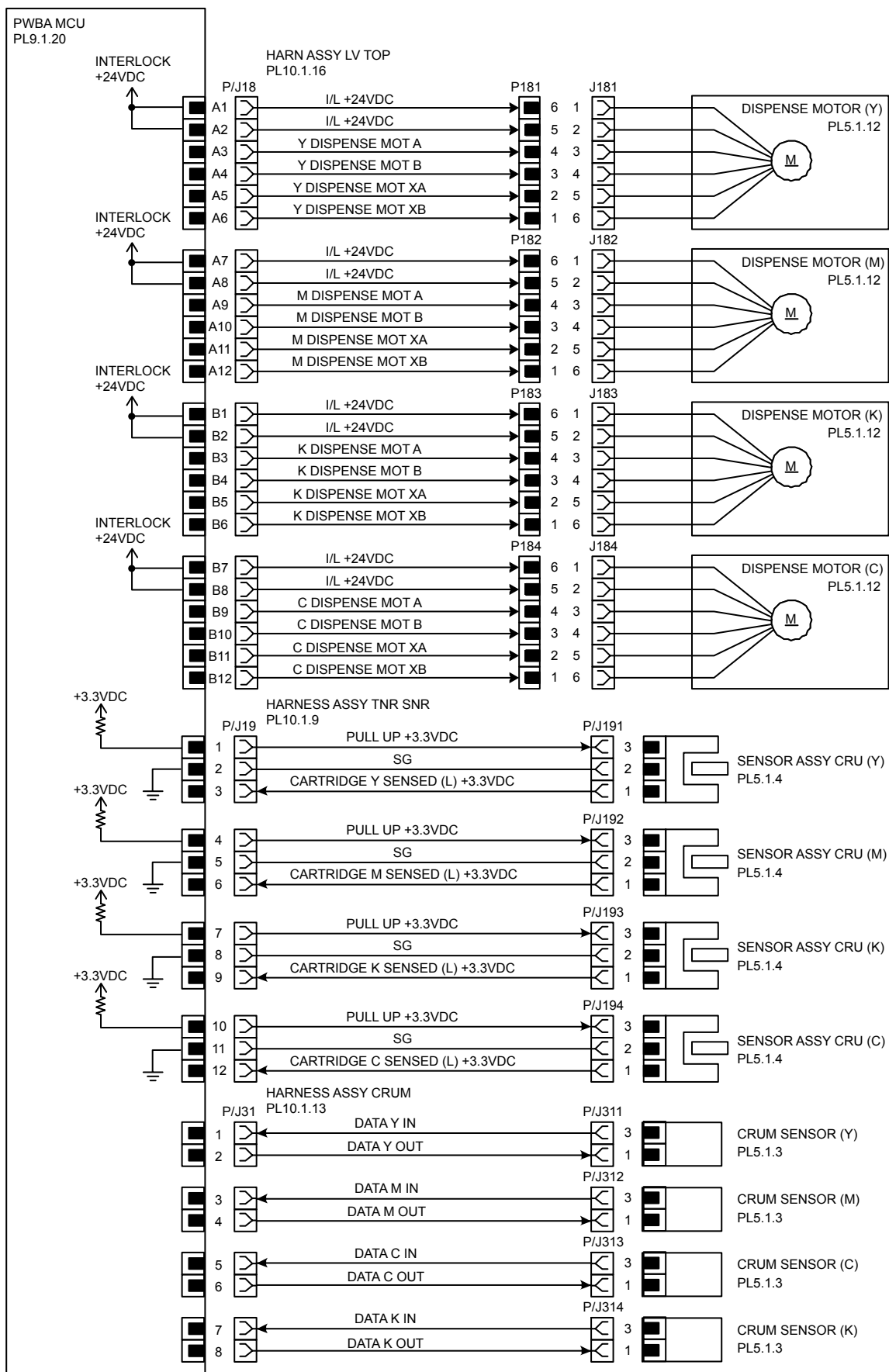

KMY07009KA

Signal line name	Description
Y DISPENSE MOT A Y DISPENSE MOT B Y DISPENSE MOT XA Y DISPENSE MOT XB	Drive control signal of the DISPENSE MOTOR (Y)
M DISPENSE MOT A M DISPENSE MOT B M DISPENSE MOT XA M DISPENSE MOT XB	Drive control signal of the DISPENSE MOTOR (M)
K DISPENSE MOT A K DISPENSE MOT B K DISPENSE MOT XA K DISPENSE MOT XB	Drive control signal of the DISPENSE MOTOR (K)
C DISPENSE MOT A C DISPENSE MOT B C DISPENSE MOT XA C DISPENSE MOT XB	Drive control signal of the DISPENSE MOTOR (C)
CARTRIDGE Y SENSED (L) +3.3VDC	Detection signal of the CRU SENSOR (Y)
CARTRIDGE M SENSED (L) +3.3VDC	Detection signal of the CRU SENSOR (M)
CARTRIDGE K SENSED (L) +3.3VDC	Detection signal of the CRU SENSOR (K)
CARTRIDGE C SENSED (L) +3.3VDC	Detection signal of the CRU SENSOR (C)
DATA Y IN DATA Y OUT	Control signal of the CRUM SENSOR (Y)
DATA M IN DATA M OUT	Control signal of the CRUM SENSOR (M)
DATA C IN DATA C OUT	Control signal of the CRUM SENSOR (C)
DATA K IN DATA K OUT	Control signal of the CRUM SENSOR (K)

§ 9 FUSER

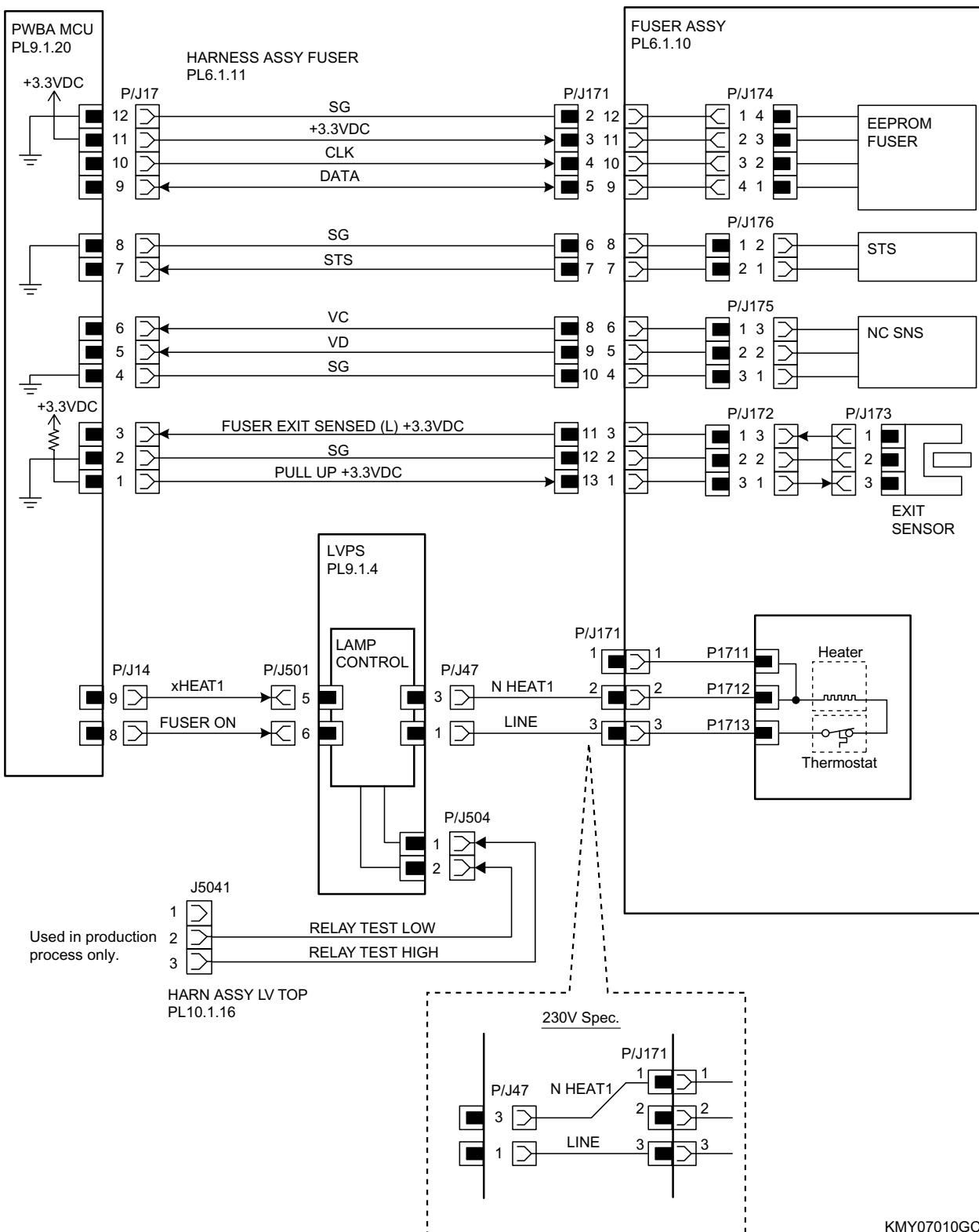

KMY07010GC

Signal line name	Description
CLK DATA	Control signal of the EEPROM FUSER
STS	Heat Roll surface temperature data measured by Temp. Sensor for detecting high temperature (analog value)
VC VD	Temperature data measured by Temp. Sensor for controlling temperature (analog value)
FUSER EXIT SENSED (L) +3.3VDC	Paper detect signal of the Fuser Exit by the Sensor Photo (EXIT SENSOR)
FUSER ON	Lighting signal of Fuser Lamp
RELAY TEST LOW RELAY TEST HIGH	Test signal of the LVPS (Used in production process only)

§ 10 CONTROLLER

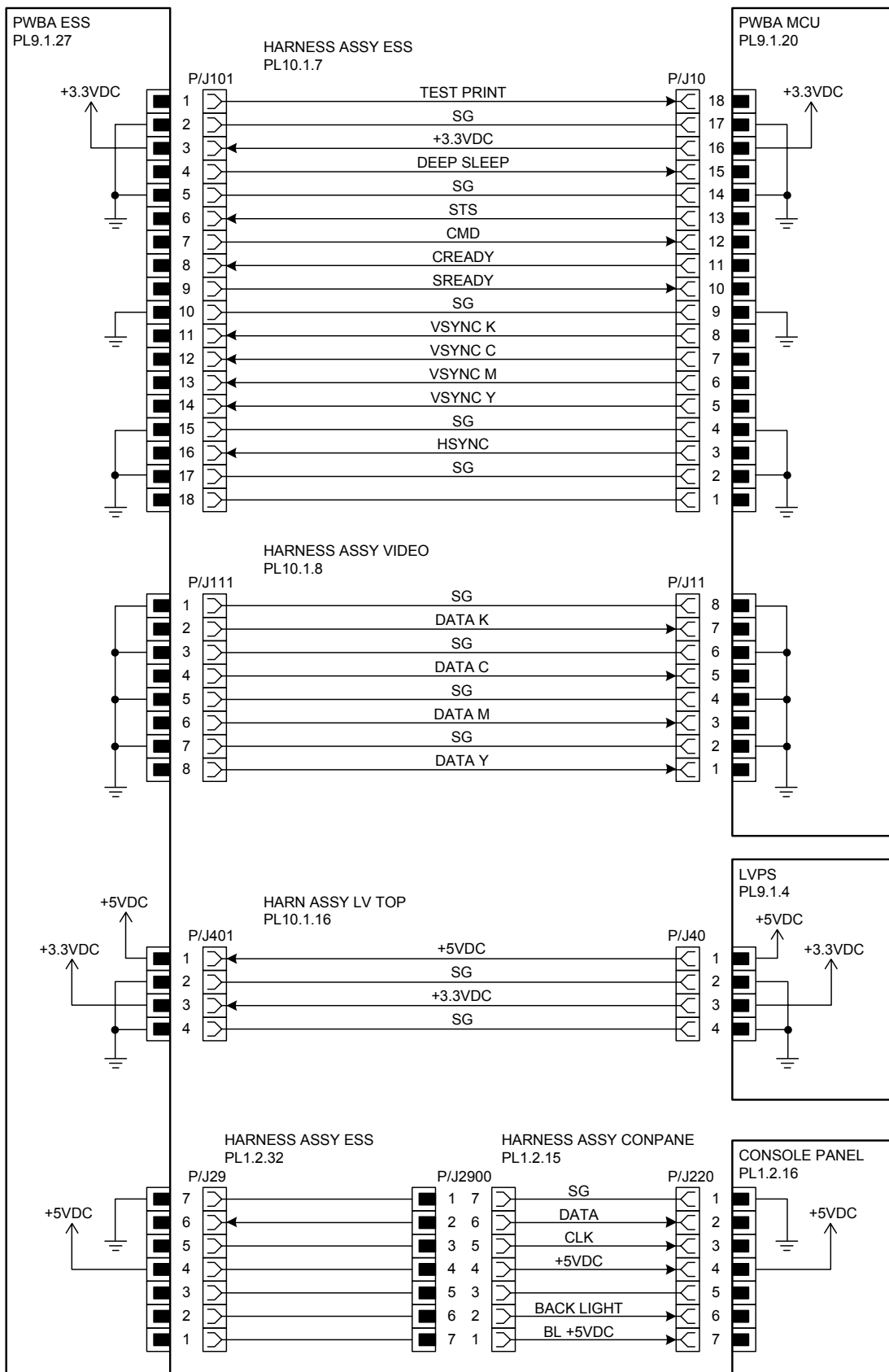

KMY07011KA

Signal line name	Description
TEST PRINT	Control signal for the TEST PRINT mode
DEEP SLEEP	Control signal for the DEEP SLEEP mode
STS	Status signal transmitted fro the PWBA MCU to the PWBA ESS
CMD	Command signal transmitted from the PWBA ESS to the PWBA MCU
CREADY SREADY	Signal for indicating weather or not the printer is ready for receiving command signal
VSYNC K VSYNC C VSYNC M VSYNC Y	Signal for indicating registration position of each of images Y, M, C and K
HSYNC	Signal for data
DATA K DATA C DATA M DATA Y	Video data of four colors
DATA CLK BACK LIGHT BL +5VDC	Control signal of the CONTROL PANEL

§ 11 550 FEEDER

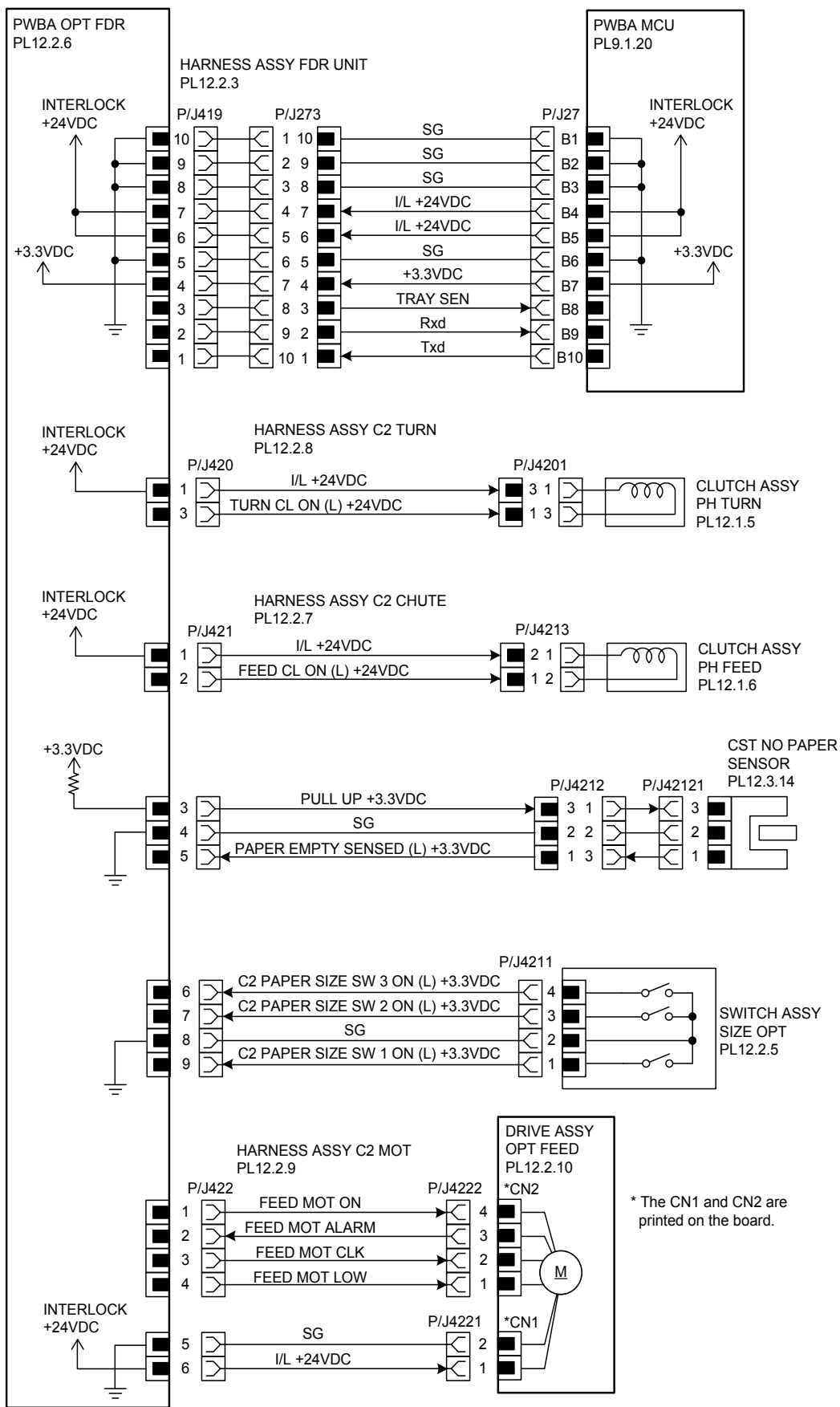

KMY07012KA

Signal line name	Description
TRAY SEN Rxd Txd	Control signal of the PWBA FEEDER
TURN CL ON (L) +24VDC	ON/OFF signal of the TURN CLUTCH
FEED CL ON (L) +24VDC	ON/OFF signal of the FEED CLUTCH
PAPER EMPTY SENSED (L) +3.3VDC	Paper detect signal of the Feeder by the Sensor Photo (NO PAPER SENSOR)
PAPER SIZE SW 1 ON (L) +3.3VDC PAPER SIZE SW 2 ON (L) +3.3VDC PAPER SIZE SW 3 ON (L) +3.3VDC	ON/OFF signal of the SWITCH ASSY SIZE
FEED MOT ON FEED MOT ALARM FEED MOT CLK FEED MOT LOW	Drive control signal of the FEED MOTOR

- Outline of SWITCH ASSY SIZE

The paper size is determined by a combination of ON/OFF statuses of the SW 1, SW 2, and SW 3 switches of SWITCH ASSY SIZE.

Paper size	Switches		
	SW 1	SW 2	SW 3
LEGAL 14" (SEF)	ON	ON	ON
LEGAL 13" (SEF)	ON	ON	OFF
EXECUTIVE (SEF)	ON	OFF	ON
B5 (SEF)	ON	OFF	OFF
A4 (SEF)	OFF	ON	ON
LETTER (SEF)	OFF	OFF	ON
A5	OFF	ON	OFF
No cassette	OFF	OFF	OFF

ON : The actuator is pushing the size switch.

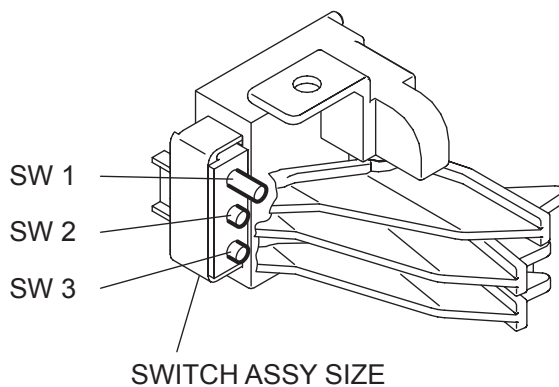

KMY07014KA

§ 12 DUPLEX

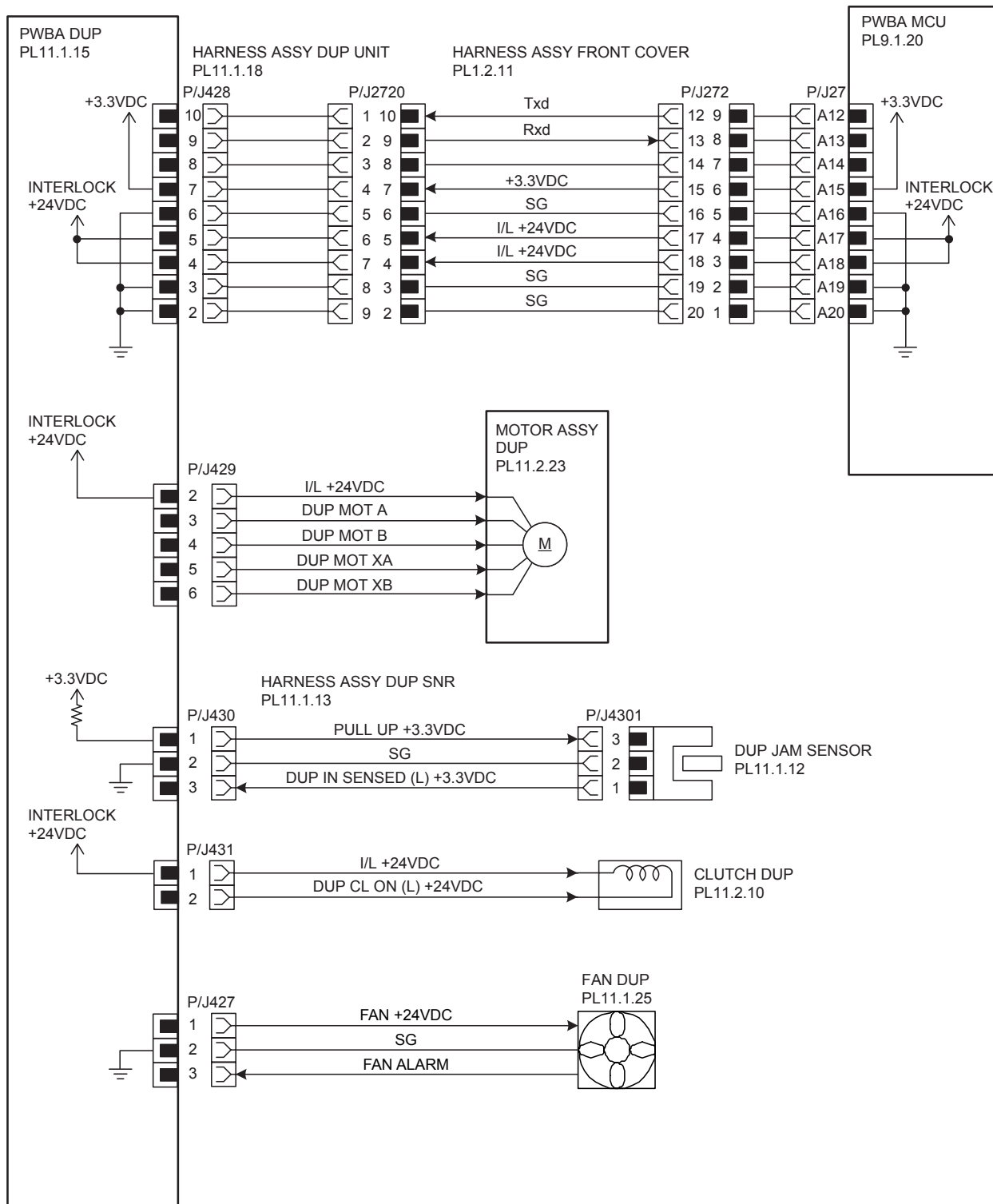

KMY07013KA

Signal line name	Description
Txd Rxd	Control signal of the PWBA DUP
DUP MOT A DUP MOT B DUP MOT XA DUP MOT XB	Drive control signal of the DUP MOTOR
DUP IN SENSED (L) +3.3VDC	Paper detect signal of the Duplex by the Sensor Photo (DUP JAM SENSOR)
DUP CL ON (L) +24VDC	ON/OFF signal of the DUP CLUTCH
FAN +24VDC FAN ALARM	Drive control signal of the DUP FAN

Chapter 8 Printer Specifications CONTENTS

1. Configuration of Printer.....	8 - 1
1.1 Basic Configuration.....	8 - 1
1.2 Functional Configuration.....	8 - 1
2. Electrical Properties.....	8 - 2
2.1 Power Source.....	8 - 2
2.2 Power Consumption.....	8 - 2
3. Mechanical Properties.....	8 - 3
3.1 Dimensions/Mass of Printer.....	8 - 3
3.2 Dimensions/Mass of Paper Tray.....	8 - 3
3.3 Dimensions/Mass of Duplex.....	8 - 4
3.4 Dimensions/Mass of Consumables and CRUs.....	8 - 5
3.4.1 TRANSFER BELT.....	8 - 5
3.4.2 FUSER CRU.....	8 - 5
3.4.3 Black toner cartridge.....	8 - 5
3.4.4 Yellow toner cartridge.....	8 - 5
3.4.5 Magenta toner cartridge.....	8 - 5
3.4.6 Cyan toner cartridge.....	8 - 6
3.5 Installation Space (min. installation space).....	8 - 6
4. Functions.....	8 - 8
4.1 Recording System.....	8 - 8
4.2 Exposure System.....	8 - 8
4.3 Development System.....	8 - 8
4.4 Fixing System.....	8 - 8
4.5 Resolution.....	8 - 8
4.6 Operation Mode.....	8 - 8
4.7 Warm-up Time.....	8 - 9
4.8 FPOT (First Print Output Time).....	8 - 9
4.9 Continuous Printing Speed.....	8 - 10
4.10 Input Properties.....	8 - 11
4.10.1 Paper pick-up system.....	8 - 11
4.10.2 Paper pick-up capacity.....	8 - 11
4.11 Output Properties.....	8 - 12
4.11.1 Paper delivery system.....	8 - 12
4.11.2 Paper delivery capacity.....	8 - 12
4.11.3 Delivery paper size/mass.....	8 - 12
4.11.4 Full stack detection.....	8 - 12
4.12 Paper.....	8 - 13
4.12.1 Paper type.....	8 - 13
4.12.2 Paper mass.....	8 - 13
4.12.3 Paper size.....	8 - 13
5. Consumables.....	8 - 14
5.1 Items of Consumables.....	8 - 14
5.2 Consumable Life.....	8 - 14
5.3 Periodic Replacing Parts (Reference).....	8 - 14

Chapter 8 Printer Specifications CONTENTS

6. Operating Environment.....	8 - 16
6.1 Installation Temperature / Humidity	8 - 16
6.2 Installation Altitude	8 - 16
6.3 Installation Horizontality	8 - 16
6.4 Ambient Lighting	8 - 16
6.5 Storage Temperature of a Toner Cartridge.....	8 - 16
7. Safety / Environment Conditions	8 - 17
7.1 Safety Standard	8 - 17
7.2 Laser Safety Standard	8 - 17
7.3 EMI.....	8 - 17
7.4 Noise.....	8 - 17
8. Print image Quality	8 - 18
8.1 Image Quality Guarantee Conditions.....	8 - 18
8.1.1 Environmental conditions.....	8 - 18
8.1.2 Guaranteed paper.....	8 - 18
8.1.3 Paper condition	8 - 18
8.1.4 Printer condition.....	8 - 18
8.1.5 Image quality guaranteed area	8 - 18
8.1.6 Criterion	8 - 18
9. Option	8 - 19
9.1 Options to be Installed by Users	8 - 19
10. ESS Specification	8 - 20
10.1 External Interface.....	8 - 20
10.1.1 USB	8 - 20
10.1.2 Ethernet	8 - 20
10.1.3 IEEE1284.....	8 - 20
10.1.4 Wireless	8 - 20
10.1.5 Interface Specification.....	8 - 21
10.2 Network Protocol.....	8 - 21
10.2.1 Printing Protocol.....	8 - 21
10.2.2 Other Protocols.....	8 - 22
10.3 Decomposer.....	8 - 23
10.3.1 PDL/Emulation	8 - 23
10.3.2 Font.....	8 - 23
10.3.3 Form Overlay	8 - 23
10.3.4 Image Area	8 - 23
10.4 Job Control.....	8 - 24
10.4.1 Cancel Print	8 - 24
10.4.2 Job Recovery.....	8 - 24
10.4.3 Job Time Out	8 - 24
10.4.4 Secure Print (/Store Print).....	8 - 24
10.4.5 Proof Print.....	8 - 24
10.4.6 IP Filter.....	8 - 24
10.5 Logging	8 - 25
10.5.1 Job Logging	8 - 25

Chapter 8 Printer Specifications CONTENTS

10.5.2 Error Logging	8 - 25
10.5.3 Billing Count.....	8 - 25
10.6 ID Print	8 - 25
10.7 3rd Party Mode	8 - 26
10.8 Utility Print.....	8 - 27
10.8.1 Printer Settings List.....	8 - 27
10.8.2 Panel Settings List Print.....	8 - 27
10.8.3 Font List Print.....	8 - 27
10.8.4 Job Log Print.....	8 - 27

Chapter 8 Printer Specifications CONTENTS

1. Configuration of Printer

1.1 Basic Configuration

The printer has the following basic configurations depending on the destination.

- print engine main unit (MSI and 250 feeder unit as the standard paper feeding)
- consumables (CRU)

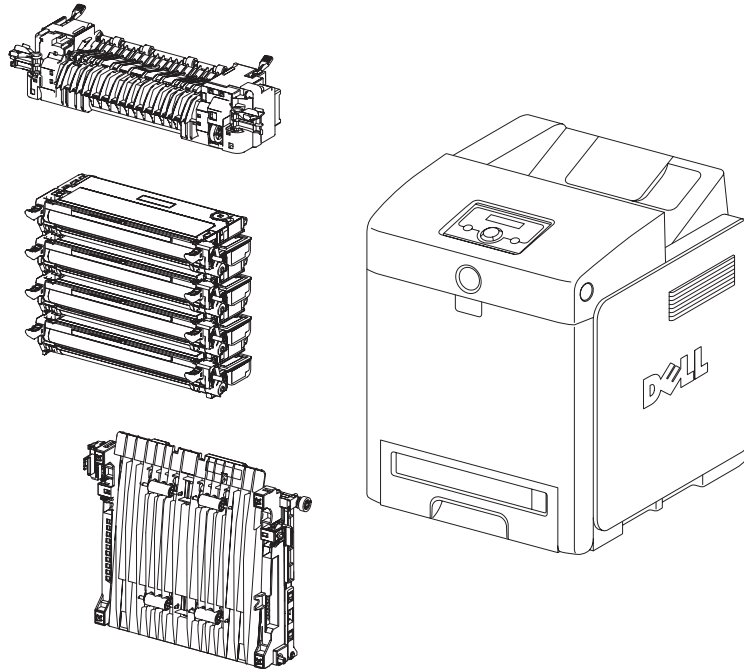

Kmy08003KB

1.2 Functional Configuration

Functional configuration of this printer is shown below.

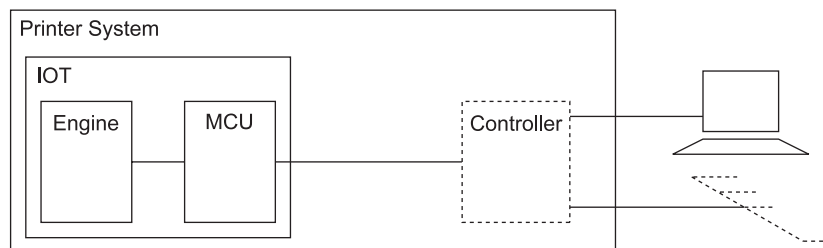

Ten08014KA

2. Electrical Properties

2.1 Power Source

Two types of power source as follows are available for this printer, which are selected according to the specifications.

- 100V/115V printer:..... voltage: 100-127VAC \pm 10% (90 ~ 135V), frequency: 50/60Hz \pm 3Hz
- 220/240V printer: voltage: 220-240VAC \pm 10% (198 ~ 264V), frequency: 50/60Hz \pm 3Hz

2.2 Power Consumption

Power consumption in each operation mode at rated voltage input

Operation mode	Average (Wh/h)
Running mode (F/C)	420 or less
Running mode (B/W)	420 or less
Ready mode	95 or less
Low power mode	9 or less

3. Mechanical Properties

3.1 Dimensions/Mass of Printer

Width(mm)	Depth(mm)	Height(mm)	Mass(kg)
400	485	470	27.2 or less

* Including MSI with its cover being closed. And the ejection stacker is also being contained in the main unit.

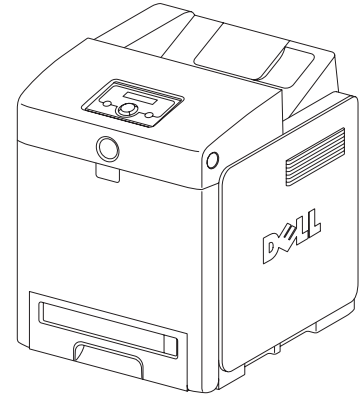

Kmy08005KA

3.2 Dimensions/Mass of Paper Tray

Tray	Width(mm)	Depth(mm)	Height(mm)	Mass(kg)
For 550 sheet	386	506.7	134.4	7.9 or less

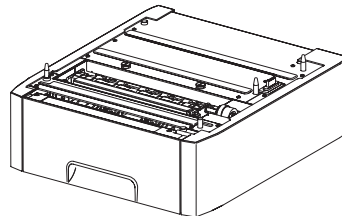

Kmy08006KA

3.3 Dimensions/Mass of Duplex

Width(mm)	Depth(mm)	Height(mm)	Mass(kg)
283	290	134	1.0 or less

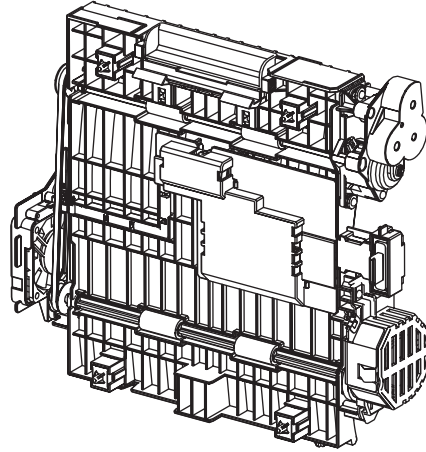

Kmy08007KA

3.4 Dimensions/Mass of Consumables and CRUs

3.4.1 TRANSFER BELT

Width: 275mm
 Depth: 314mm
 Height: 83mm
 Mass: 1.4kg

Reference: *The TRANSFER BELT has CRUM (CRU memory) to record information.*

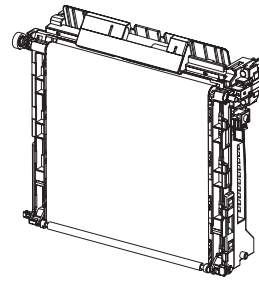

Kmy08008KA

3.4.2 FUSER CRU

Width: 405mm
 Depth: 130mm
 Height: 102mm
 Mass: 1.43kg

Reference: *The FUSER has CRUM (CRU memory) to record information.*

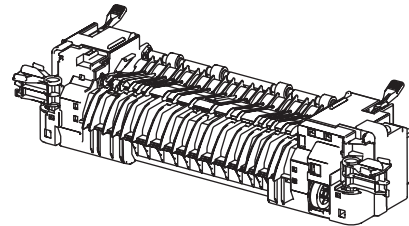

Kmy08009KA

3.4.3 Black toner cartridge

Width: 303.8mm
 Depth: 150mm
 Height: 53.8mm
 Mass: 1.05 (5K)/1.05 (8K) kg

Reference: *The Black toner cartridge has CRUM (CRU memory) to record information.*

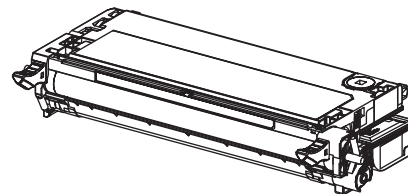

Kmy08010KA

3.4.4 Yellow toner cartridge

Width: 303.8mm
 Depth: 150mm
 Height: 53.8mm
 Mass: 1.05 (4K)/1.05 (8K) kg

Reference: *The Yellow toner cartridge has CRUM (CRU memory) to record information.*

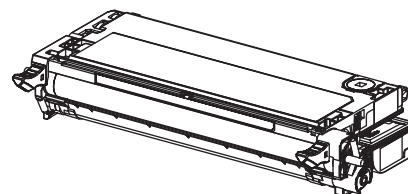

Kmy08010KA

3.4.5 Magenta toner cartridge

Width: 303.8mm
 Depth: 150mm
 Height: 53.8mm
 Mass: 1.05 (4K)/1.05 (8K) kg

Reference: *The Magenta toner cartridge has CRUM (CRU memory) to record information.*

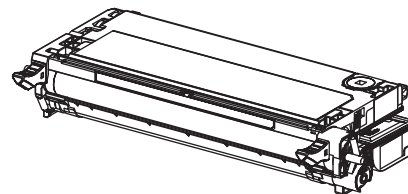

Kmy08010KA

3.4.6 Cyan toner cartridge

Width: 303.8mm

Depth: 150mm

Height: 53.8mm

Mass: 1.05 (4K)/1.05 (8K) kg

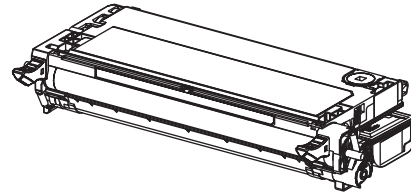

Kmy08010KA

Reference: *The Cyan toner cartridge has CRUM (CRU memory) to record information.*

3.5 Installation Space (min. installation space)

Minimum space as shown below is required to install the printer when it is used for normal objects.
(Space occupied by the operator is not included.)

Top view

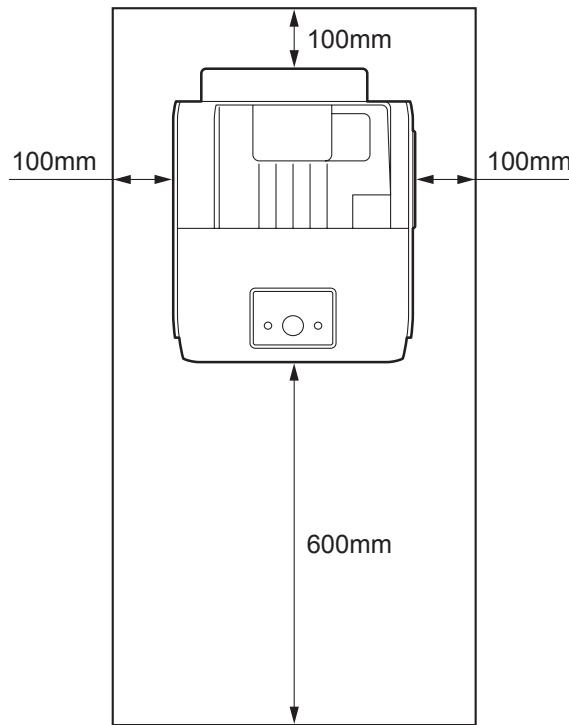

Kmy08011KA

Front view

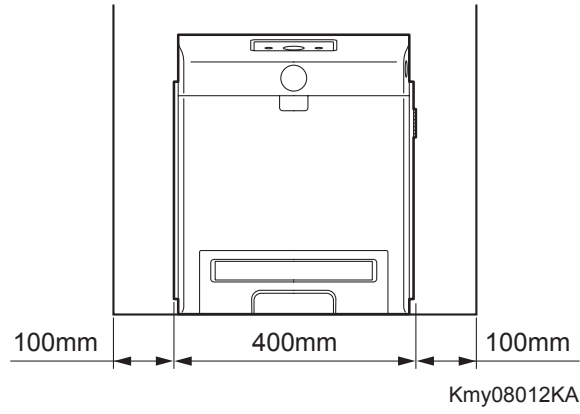

Side view

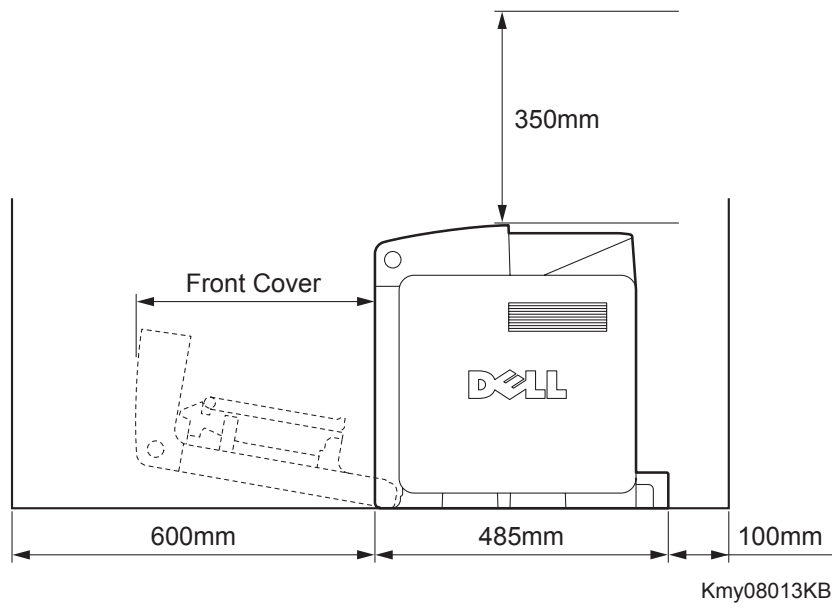

4. Functions

4.1 Recording System

Electro-photographic system employing OPC drum and direct transfer by the transport belt

4.2 Exposure System

Semiconductor four laser beams scanning system

4.3 Development System

Development with dry type 2-component developer

4.4 Fixing System

Thermal fixing system by Free Belt Nip Fusing (FBNF)

4.5 Resolution

- Main scanning direction:by the printer controller
- Sub scanning direction:600 dots/25.4mm (fixed)

4.6 Operation Mode

The printer can be operated in either of 3 operation modes. The modes are switched over by command from the printer controller or change of printer operation, etc. Proceeding from power ON, low power mode or sleep mode to standby mode will take place after going through a warm up stage.

- Running mode

State in running or recording operation

Fixing system:	Held at operating temperature.
Exposure system:	Operating status
Recording system:	Operating status

- Ready mode

Ready state

Fixing system:	Held at ready temperature.
Exposure system:	Stop status
Recording system:	Stop status

- Low power mode

Complete resting state. Compatible to E-Star requirement (30W or less).

Fixing system:	Stop status
Exposure system:	Stop status
Recording system:	Stop status

4.7 Warm-up Time

When nominal voltage (100V, 115V, 220V) is applied, the printer will proceed to standby mode from POWER-ON within 30 seconds.

Reference: Measured at 22°C, 55% RH, nominal voltage.

4.8 FPOT (First Print Output Time)

FPOT time of the printer is shown in the table below.

The time required for the first sheet of paper to be delivered after the PRINT indication is given is calculated on the following conditions (rounded to one decimal place).

- IOT performance that the controller does not have IOT wait.
- The printer is in the standby mode. (ROS MOTOR OFF, FUSER READY)
- Paper is A4 SEF
- Except when process control is operating*1

*1:Process controller operation is process controls such as TC control, electric potential control, cleaning cycle, registration control, and so on. Sometimes, the engine stops feeding papers for a certain period of time while continuous printing for these operations.

Color Mode	Paper Tray	FPOT (Sec.)
B/W	MPF	7.6 sec. or less
	Standard tray	7.5 sec. or less
	Optional 2nd tray	8.1 sec. or less
Color	MPF	8.4 sec. or less
	Standard tray	8.3 sec. or less
	Optional 2nd tray	8.9 sec. or less

4.9 Continuous Printing Speed

The continuous printing speed is shown in the below.

OS	PDL	Test Chart	Paper Size	Paper Type	Paper Tray	Color/BW	Duplex/Simplex	Average Print Speed
XP	PCL6	J11E	A4/Letter SEF	Plain paper	MPF	Color	Simplex	56 sec. or less
XP	PCL6	J11E	A4/Letter SEF	Plain paper	MPF	BW	Simplex	38 sec. or less
XP	PCL6	J11E	A4/Letter SEF	Plain paper	MPF	Color	Duplex	80 sec. or less
XP	PCL6	J11E	A4/Letter SEF	Plain paper	MPF	BW	Duplex	56 sec. or less
XP	PCL6	J11E	A4/Letter SEF	Plain paper	Tray1	Color	Simplex	56 sec. or less
XP	PCL6	J11E	A4/Letter SEF	Plain paper	Tray1	BW	Simplex	38 sec. or less
XP	PCL6	J11E	A4/Letter SEF	Plain paper	Tray1	Color	Duplex	79 sec. or less
XP	PCL6	J11E	A4/Letter SEF	Plain paper	Tray1	BW	Duplex	56 sec. or less
XP	PCL6	J11E	A4/Letter SEF	Plain paper	Tray2	Color	Simplex	57 sec. or less
XP	PCL6	J11E	A4/Letter SEF	Plain paper	Tray2	BW	Simplex	38.5 sec. or less
XP	PCL6	J11E	A4/Letter SEF	Plain paper	Tray2	Color	Duplex	80 sec. or less
XP	PCL6	J11E	A4/Letter SEF	Plain paper	Tray2	BW	Duplex	57 sec. or less
OSX	PS	J11E	A4/Letter SEF	Plain paper	Tray1	Color	Simplex	435 sec. or less
OSX	PS	J11E	A4/Letter SEF	Plain paper	Tray1	BW	Simplex	355 sec. or less
OSX	PS	J9E	A4/Letter SEF	Plain paper	Tray1	Color	Simplex	77 sec. or less
OSX	PS	J9E	A4/Letter SEF	Plain paper	Tray1	BW	Simplex	71 sec. or less
OSX	PS	J11E	A4/Letter SEF	Plain paper	Tray1	Color	Duplex	442 sec. or less
OSX	PS	J11E	A4/Letter SEF	Plain paper	Tray1	B/W	Duplex	400 sec. or less
OSX	PS	J9E x2	A4/Letter SEF	Plain paper	Tray1	Color	Duplex	151 sec. or less
OSX	PS	J9E x2	A4/Letter SEF	Plain paper	Tray1	BW	Duplex	135 sec. or less

4.10 Input Properties

4.10.1 Paper pick-up system

- Paper pick-up with paper tray
Feeding method of this printer is ARRF method.

- MSI paper pick-up
Feeding method of this printer is S-ARRF method.

- Duplex paper feeder unit
It can be installed as an option, and it enables duplex printing. Selection of Duplex Feeder Unit is designated from the controller.

4.10.2 Paper pick-up capacity

- Paper pick-up with paper tray
 - 550 sheet Paper Tray : 550 sheets or below 59.4mm of standard paper
 - 250 sheet Paper Tray : 250 sheets or below 27.6mm of standard paper

- MSI paper pick-up
150 sheets or below 15mm of standard paper

4.11 Output Properties

4.11.1 Paper delivery system

Paper can be delivered by the following method.

- FACE DOWN delivery

4.11.2 Paper delivery capacity

- FACE DOWN delivery

250 sheets (Letter/A4 standard paper)

4.11.3 Delivery paper size/mass

- FACE DOWN delivery

All paper sizes applicable to this printer

4.11.4 Full stack detection

non

4.12 Paper

4.12.1 Paper type

Paper which can be used with this printer is classified into standard paper, general paper and special paper.

- Standard paper

Using this type of paper is recommended. Reliability, operability and print image quality are the application range of the specifications.

Following paper is the standard paper.

	B/W	F/C
For domestic market	P	C2
For overseas market	4200DP	X-pressions

- General paper

General paper is plain paper except standard paper and special paper, and its reliability and running performance are within the specification, but the print image quality is out of the specification.

- Special paper

Special paper except for plain paper. Reliability and operability are the applicable range of specifications but the print image quality is out of the applicable range of specifications.

4.12.2 Paper mass

- Paper feed from paper tray

"60 to 216 gsm" (16 lb to 80 lb)

- Paper feed from MSI

"60 to 216 gsm" (16 lb to 80 lb)

4.12.3 Paper size

Paper size which can be set to each paper pick-up unit is shown in the table below.

Cassette	Paper size
550 Sheet Paper Tray	A5, B5 (JIS, IOS), A4, Letter, Executive, Leagal
250 Sheet Paper Tray	A5, B5 (JIS, IOS), A4, Letter, Executive, Leagal
MSI Tray	Minimum size Width 76.2mm (3 in.) × Length 98.4mm (3.87 in.) Maximum size Width 220mm (8.66 in.) × Length 355.6mm (14 in.)

5. Consumables

Consumables are usually replaced by costumers. In the event of recovery of failure attributable to consumables or isolation of failure, you may replace them.

5.1 Items of Consumables

- Black toner cartridge
Cartridge to supply black toner to the development unit.
Black toner cartridge has CRUM (CRU memory) to record information.
- Yellow toner cartridge
Cartridge to supply yellow toner to the development unit.
Yellow toner cartridge has CRUM (CRU memory) to record information.
- Magenta toner cartridge
Cartridge to supply magenta toner to the development unit.
Magenta toner cartridge has CRUM (CRU memory) to record information.
- Cyan toner cartridge
Cartridge to supply cyan toner to the development unit.
Cyan toner cartridge has CRUM (CRU memory) to record information.

5.2 Consumable Life

- Black toner cartridge: 5kPV or 8kPV
- Yellow toner cartridge: 4kPV or 8kPV
- Magenta toner cartridge: 4kPV or 8kPV
- Cyan toner cartridge: 4kPV or 8kPV

5.3 Periodic Replacing Parts (Reference)

- | | |
|--|--------|
| - SEPARATOR and FEED ROLLER (250/550 Feeder) | 100kPV |
| - TRANSFER BELT | 100kPV |
| - FUSER | 100kPV |

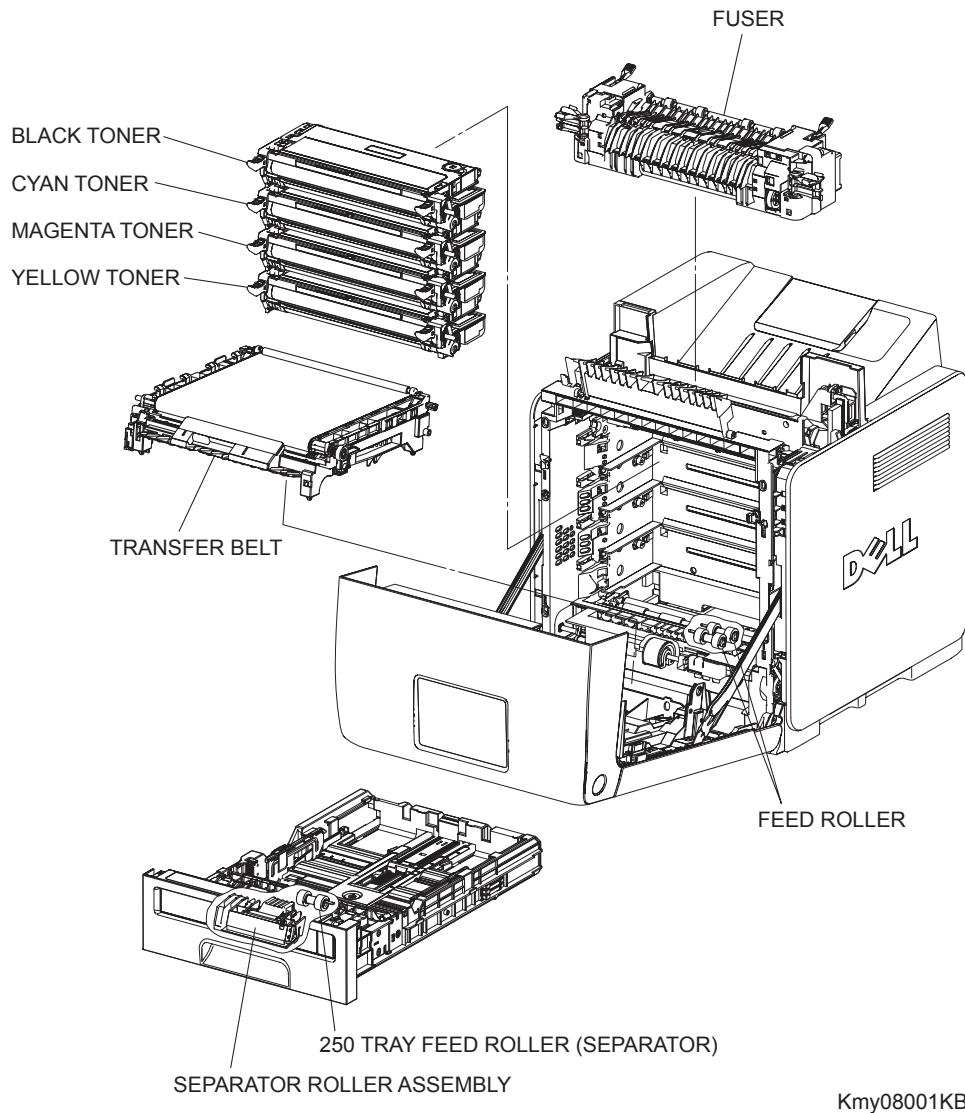

Kmy08001KB

S

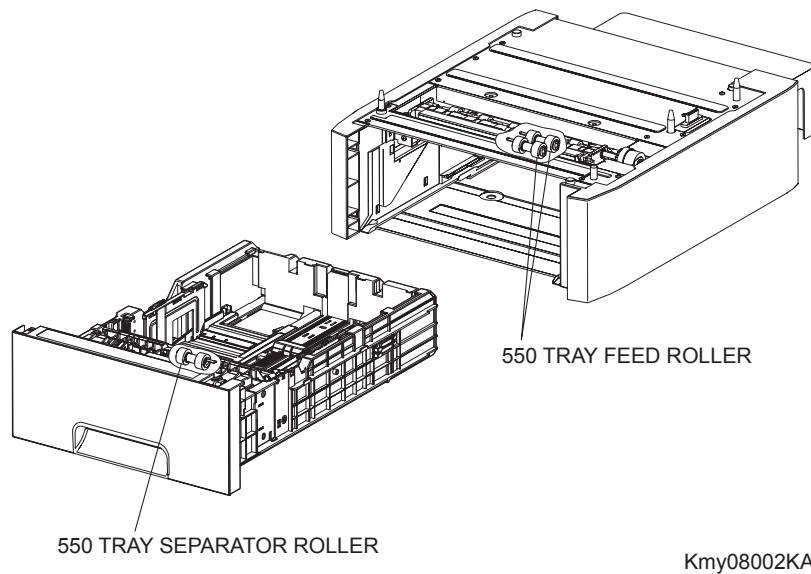

Kmy08002KA

6. Operating Environment

6.1 Installation Temperature / Humidity

Installation temperature and humidity on the condition without condensation is as follows.

At operating: 0-35 °C, 15-85%RH (No condensation)

At standby: minus 20-40 °C, 5-85%RH (No condensation)

6.2 Installation Altitude

0 to 3,100m

6.3 Installation Horizontality

Longitudinal levelness of table surface on which the printer is installed: 1 degree or under

Lateral levelness of table surface on which the printer is installed : 1 degree or under

6.4 Ambient Lighting

3000 Lux or less (without no direct sun beams)

6.5 Storage Temperature of a Toner Cartridge

The guaranteed period of the print cartridge before unpacked is as follows:

Normal conditions: 24 months under 0 to 35°C, 15 to 80% RH.

Harsh conditions: Up to one month under -20 to 0°C and 35 to 40°C, 5 to 15% RH and 80 to 95% RH.

The storage altitude shall be 0 to 3500m. Can be extended to 0 to 15000m when shipped by air.

(Provided that the cargo bay is pressurized to 70.9275Kpa or higher.)

7. Safety / Environment Conditions

7.1 Safety Standard

- 100V / 120V system
UL60950 3rd Edition
CSA C22.2 No.60950-00
- 220V / 240V system
IEC60950 3rd Edition / EN60950 2000

7.2 Laser Safety Standard

- 100V / 120V system
FDA21CFR Chapter 1, Subchapter J, Section 1010, 1040
- 220V / 240V system
IEC60825 Class 1 Laser Product

7.3 EMI

- 120V system (US)
FCC Part 15, Subpart B, Class B
- 220V / 240V system (EC)
EN55022 (CISPR Publication 22), Class B

7.4 Noise

Noise of printing is as follows.

Noise Printer	Sound power level (B)	Impulse Sound Power Level (B)
Standard	≤ 6.3	≤ 6.6
Full option	≤ 6.8	≤ 7.1

8. Print image Quality

8.1 Image Quality Guarantee Conditions

The image quality is specified and guaranteed under the following conditions.

8.1.1 Environmental conditions

Environment condition for evaluating image quality

Temperature: 15-28 °C

Humidity: 20-70%RH

8.1.2 Guaranteed paper

The print image quality specified here is guaranteed with standard paper fed from the paper tray.

Evaluation is performed with the maximum size of each standard paper.

- Xerox 4200DP 2016 letter (Black and White)
- Xerox Digital Color Xpression 24lb letter (Color)

8.1.3 Paper condition

The paper used is fresh paper immediately after unpacked, which has been left in the operating environment for 12 hours before unpacking.

8.1.4 Printer condition

The print image quality specified in this section is guaranteed with the printer in normal condition.

8.1.5 Image quality guaranteed area

The print image quality specified in this section is guaranteed in the guaranteed image quality area specified in this manual. (Refer to Chapter 1)

8.1.6 Criterion

The print image quality is guaranteed with the Spec. In rate = 90% ($\gamma = 90\%$).

9. Option

9.1 Options to be Installed by Users

Users can install the following units.

- 550 Feeder Unit
- Duplex Unit
- Multi-protocol card
- Expansion memory (256MB/512MB/1024MB)
- Wireless Printer adapter (MPC required)

10. ESS Specification

NOTE

In order for the printer to apply to the Windows Vista, it is necessary to download firmware from the DELL website.

10.1 External Interface

10.1.1 USB

Item	Specification
Connector	Type-B x 1
Protocol	USB2.0, HighSpeed
Supported Client	Windows NT 4.0 / 2000 / XP / x64 XP / Server2003 / x64 Server2003 PC with USB MacOS X PC with USB Linux PC with USB

10.1.2 Ethernet

Item	Specification
Connection	10 Base-T/100 Base-TX
Protocol	See "10.2 Network Protocol" for details
Supported Client	Windows NT 4.0/2000/XP/x64XP/Server 2003/x64Server2003, PC Mac OS X PC Linux/Unix PC

10.1.3 IEEE1284

Item	Specification
Connection	Centronics 36pin x 1
Protocol	Standard, Nibble, ECP
Supported Client	Windows NT4.0/2000/XP/x64XP/Server 2003/x64Server2003 PC Linux PC

10.1.4 Wireless

multi-protocol Card is required.

Item	Specification
Connection	802.11b/802.11g
Protocol	See "10.2 Network Protocol" for details
Supported Client	Windows NT4.0/2000/XP/x64XP/Server 2003/x64Server2003, PC Mac OS X PC Linux PC

10.1.5 Interface Specification

Option Configuration	Interface that can be operated				
	USB	IEEE1284	Ethernet		IEEE802.11b/11g (multi-protocol)
			single-protocol	multi-protocol	
Standard	Yes	Yes	Yes	No	No
Standard +MPC	Yes	Yes	No	Yes	No
Standard +MPC +Wireless	Yes	Yes	Yes	No	Yes

*Protocol: See "10.2 Network Protocol" for details

10.2 Network Protocol

10.2.1 Printing Protocol

Protocol	Transport	Maximum Session ^{*2}	Supported Client
LPD	TCP/IP	1	Windows NT 4.0/2000/XP/x64 XP/Server 2003/ x64 Server2003 Mac OSX Linux ^{*4} Unix ^{*4}
Port9100	TCP/IP	1	Windows NT4.0/2000/XP/x64XP/Server2003/ x64Server2003
IPP ^{*1}	TCP/IP	5	Windows NT 4.0/2000/XP/x64XP/Server2003/ x64Server2003, Mac OS 10.3
SMB ^{*1}	TCP/IP	5	Windows NT4.0/2000/XP/x64XP/Server2003/ x64Server2003
	NetBEUI	5	Windows NT 4.0/2000,
NetWare (P-Server) ^{*1}	NCP/IPX TCP/IP ^{*5}	1	NetWare3.12, 3.2, (NDS unsupported) NetWare4.1, 4.11, 4.2, 5, 6,6.5 ^{*3}
EtherTalk ^{*1}	ATP/DDP	1	Mac OSX
FTP	TCP/IP	1	Windows NT 4.0/2000/XP/x64XP/Server2003/ x64Server2003 Mac OSX Linux (Red Hot 8/9) Unix (Solaris 9, HP-UX 11i)

*1: Optional multi-protocol processor card is required

*2: Maximum session is defined as the number of print request acceptable at the same time.

*3: NetWare 6.5 is required to apply support pack 1.1 or later provided by Novell.

*4: Supported if a driver provided by FXPS is used.

*5: Available for versions later than NetWare5

10.2.2 Other Protocols

Protocol	Transport	Support
SNMP	UDP/IP	[Supported MIB] MIB-II (RFC1213) HostResources MIB (RFC1514) PrinterMIB (RFC1759) XCM12.4
	IPX	
HTTP	TCP/IP	[Client] (Windows NT4.0/2000/XP) Netscape Communicator 7.x or later Internet Explorer 6.0 or later Firefox x 1.0.7 (Mac OS 10.2 or later) Safari 1.0 or later
DHCP	UDP/IP	[Supported OS] Windows NT 4.0 Server, Windows 2000 Server, Windows Server 2003, Windows x64 server 2003, Linux, Unix
BOOTP	UDP/IP	[Supported OS] Windows NT 4.0 Server, Windows 2000 Server, Windows Server 2003, Windows x64 Server 2003, Unix
RARP	TCP/IP	[Supported OS] Unix
AutoIP	TCP/IP	[Software] Installer
WINS* ¹	TCP/IP	[Supported OS] Windows NT 4.0 Server, Windows 2000 Server, Windows Server 2003, Windows x64 Server 2003
SMTP	TCP/IP	E-mail Alert [Supported Mail Server] LotusNotes, MS-Exchange, Eudora
FTP	TCP/IP	Firmware Update
Bonjour(mDNS)* ¹	UDP/IP	[Supported OS] Mac OS 10.2 or later
DDNS* ¹	TCP/IP	[Supported OS] Windows 2000 Server, Windows 2003, Windows x64 Server 2003, Unix

*1: Optional multiprotocol card is required

10.3 Decomposer

10.3.1 PDL/Emulation

Decomposer is still PCL. However printer can accept the job generated only by the own printer driver.

Interface/Protocol	PDL/Emulation		
	PCL5c	PCL6	PS3
USB	Yes	Yes	Yes
1284	Yes	Yes	Yes
Lpd	Yes	Yes	Yes
Port9100	Yes	Yes	Yes
IPP	Yes	Yes	Yes
SMB	Yes	Yes	Yes
NetWare (P-Server)	Yes	Yes	Yes
EtherTalk (A-PAP)	No	No	Yes
FTP	No	No	Yes

Yes: Supported No: Not supported

10.3.2 Font

81 fonts and 36 Symbol Sets for PCL and 136 fonts for PS3 are available as built-in font.

10.3.3 Form Overlay

The function for writing PCL5 forms is supported.

10.3.4 Image Area

Usable Area Size	Maximum : 215.9mm (8.5 in.) x 355.6mm (14 in.)
Unprintable Area	4.1 mm each from four edges (left, right, top and bottom) of paper For DL LEF, 6.1mm from left and right edges, 4.1 mm from top and bottom edges are not printable
Printable Area	Maximum : 207.9mm (8.18 in.) x 347.6mm (13.68 in.)
Print Image Quality Guaranteed Area	Same as Printable Area

10.4 Job Control

10.4.1 Cancel Print

A print job in process can be cancelled at the operation panel.

10.4.2 Job Recovery

When a job fails due to a paper jam, the printer automatically restarts the job after the jammed paper is removed.

10.4.3 Job Time Out

When job transmission is interrupted for a certain period of time (Time can be changed at the operation panel and unlimited time can be selected), the print data is deleted as an error.

10.4.4 Secure Print (/Store Print)

When memory is expanded (256MB or more), the printer holds print data, including a user password (12 digits) specified in the printer driver, user name and document name, in memory. The data is not printed until the same password, user name and document name are specified at the printer UI. The user can select whether the data is cleared or not after being printed. The data remains in the printer as long as it is not cleared. The data on the memory is cleared when the printer is turned off. The user can omit entering a password (This is called Store Print). *This function is not available for MAC OS X 10.2.8.

10.4.5 Proof Print

When memory is expanded (256MB or more) is installed, proof print can be selected only when multiple sets of prints are specified in the printer driver. The printer prints only the first set of the print data including a user name and document name specified in the printer driver. Then the user can select whether the remaining sets are printed or not (the remaining data is cleared) when the same user name and document name are entered at the printer UI. The data remains in the printer as long as it is not cleared. The data on the memory is cleared when the printer is turned off. *This function is not available for MAC OS X 10.2.8 and Linux which use CPUS.

10.4.6 IP Filter

The user can select to accept or reject jobs for the specified IP address. Up to 5 IP addresses can be specified.

IP filter is available only to LPD and Port9100.

10.5 Logging

10.5.1 Job Logging

The printer can retain up to 20 job logs. Job log can be printed instantly according to the user's request or automatically printed when the number of the retained job logs has reached 20. Job log includes the following information:

- Job sent date and time*
- Input interface (USB, Lpd etc.)
- Document name (File name) *
- Output color
- User name/Host name*
- Number of printed pages (Color/B/W)
- Number of printed impressions (Color/B/W)
- Paper size
- Result (Successful, Error, etc.)

*Not displayed for PS.

10.5.2 Error Logging

The printer can retain up to 42 jam errors and up to 42 fatal errors.

The user can print error log by the panel operation.

Jam error log includes the following information:

- TOTAL PV when jam has occurred

Fatal error log includes the following information:

- TOTAL PV when error has occurred
- Error code

10.5.3 Billing Count

NOTE

- **The same data is stored in two or more addresses in one IC. Datacheck (checksum etc.) is conducted.**

NOTE

- **When ESS is replaced, IC can be transferred. (IC is mounted on socket)**

Counter	Description
Color Print Counter	Count the number of paper printed in color (7 digits)
B/W Print Counter	Count the number of paper printed in B/W (7 digits)
Total Print Counter	Count the total number of paper printed in color and B/W (7 digits)

10.6 ID Print

User name can be printed. The printing position can be selected from upper right, upper left, lower right and lower left (Only for PCL6).

The user selects using the operation panel whether user name is printed or not and where it is printed.

10.7 3rd Party Mode

When life of toner cartridge has ended, the printer stops accepting print request (life of toner cartridge is counted by the counter in CRUM). Taking into consideration that some users use refilled toner cartridges, the printer can accept print request by the user's panel operation even if life of toner cartridge has ended. When the mode has changed so that the printer does not stop even after life of toner cartridge ends, the printer displays a message on the operation panel to inform the user of the mode change. When the printer operates in this mode, print image quality is not guaranteed. Also, remaining toner level is not displayed (as CRUM data can not be guaranteed).

10.8 Utility Print

10.8.1 Printer Settings List

Printer Settings List can be printed according to the user's request.

Printer Settings List is printed in B/W in the automatically selected paper tray.

Printer Settings List includes the following information:

Items on the list are slightly different from below when wireless LAN option is installed.

[Title]

Product name (Logo)

[General]

Printer Name, Service tag, Asset Number, Memory capacity, Printer language, Number of fonts available, PDL name and version, ESS version, IOT version, Boot version, Color print volume, B/W print volume, Default paper size, Default paper type for plain paper, Default paper type for label, Default panel display language

[Network]

MPC version, MAC address, Ethernet Setting (10 or 100base & half or full)

TCP/IP: TCP/IP settings, IP address, Subnet Mask, Gateway Address

IPX/SPX: Frame type, Network address

IP Filter: Address, Mask, Mode

Other supported protocols

[Wireless]

MPC version, MAC address, WirelessSetting*(SSID, Network Type, Encryption, Link Quality, Link Channel)

*Listed when wireless LAN option is installed

[Printer Options]

"Multi-protocol Card" Yes or No (If available, version)

"Available Paper Tray" (Tray 1, Tray 2, MPF)

[Print Volume]

Print volume for each paper size

10.8.2 Panel Settings List Print

Panel Settings List can be printed by the user's operation.

Panel Settings List is printed in B/W on A4 size paper (Letter size paper for the US) in the automatically selected paper tray.

10.8.3 Font List Print

PCL or PS Font List and Color Bar (for color check) can be printed by the user's operation.

Font List is printed in color on A4 size paper (Letter size paper for the US) in the automatically selected paper tray.

10.8.4 Job Log Print

The user can print Job Log by requesting instant print or by setting auto print.

Job Log is printed in B/W on A4 size paper (Letter size paper for the US) in the automatically selected paper tray.

Dell 3110cn - recommended spare part list

Part #	Dell Part Description	MFG Part Description	CRU or FRU
Accessory			
Part #	Dell Part Description	MFG Part Description	CRU or FRU
DG956	ASSEMBLY, ROLLER, SEPARATOR, TRAY, 3110/15CN	ASSY,RLLR,SPRTR,TRAY,3110/15CN	CRU
JG333	Network Kit (MPC + Wireless Lan Adapter)	KIT,ADPT,NTWK,WRLES,CRD	CRU
JG348	MULTI PROTOCOL CARD	CRD,NTWK,COMM,3110/15/5110CN	CRU
KK877	JAPAN Service Kits - Fuser, Separator Roller & BTR	SVC,ASSY,RLLR,SPRTR,100,31XXCN	CRU
MF790	MAGENTA TONER 4K	CTRG,TONR,4K,MGTA,3110/3115CN	CRU
NF555	YELLOW TONER 4K	CTRG,TONR,4K,YEL,3110/3115CN	CRU
NF556	YELLOW TONER 8K	CTRG,TONR,8K,YEL,3110/3115CN	CRU
PF019	PRINTER FOR SERVICE WHOLE UNIT EXCHANGE 110V AMERICAS 3130CN	PTR,LS,110V,3110CN	CRU
PF028	BLACK TONER 5K	CTRG,TONR,5K,BLACK,3110/3115CN	CRU
PF029	CYAN TONER 8K	CTRG,TONR,8K,CYAN,3110/3115CN	CRU
PF030	BLACK TONER 8K	CTRG,TONR,8K,BLACK,3110/3115CN	CRU
PY018	null	ASSY,BASE,SVC,100V,JPN,3110CN	CRU
RD109	WIRELESS LAN ADAPTER	CRD,WRLES,ANT,COMM	CRU
RF012	CYAN TONER 4K	CTRG,TONR,4K,CYAN,3110/3115CN	CRU
RF013	MAGENTA TONER 8K	CTRG,TONR,8K,MGTA,3110/3115CN	CRU
TG142	EMEA Service kit: Fuser, SepRoller, TransferBelt, 220, 311XCN	KIT,PTR,RLR,FUSER,BTR,EMF,311X	CRU
UG190	DAO Service kit: Fuser, SepRollers, TransferBelt, 110, 311XCN	KIT,PTR,RLR,FUSER,BTR,DAO,311X	CRU
Base Unit			
HF871	TAA, 120V Base Printer 3110	ASSY,BASE,PTR,110V,TAA,3110CN	CRU
HK821	AUSTRALIA SERVICE KIT, Printer Only	ASSY,BASE,SVC,220V,AUS,3110CN	CRU
KK872	DELL AMERICAS ORGANIZATION SERVICE KIT, Printer Only	ASSY,BASE,SVC,110V,DAO,3110CN	CRU
KK874	TRADE AGREEMENT ACT SERVICE KIT, Printer Only	ASSY,BASE,SVC,220V,TAA,3110CN	CRU
MF781	120V Base Printer 3110	ASSY,BASE,PRT,110V,DAO,3110CN	CRU
MK767	SERVICE KIT EUROPE, MIDDLE EAST & AFRICA, Printer Only	ASSY,BASE,SVC,220V,EMEA,3110CN	CRU
N4482	110V Base Printer 3110	ASSY,BASE,PRT,100V,JPN,3110CN	CRU
NF547	240V Base Printer 3110	ASSY,BASE,PRT,220V,EMEA,3110CN	CRU
PF023	240V Base Printer 3110, Asia	ASSY,BASE,PTR,220V,AUS,3110CN	CRU
PY017	TRADE AGREEMENT ACT SERVICE KIT, Printer Only	ASSY,BASE,SVC,110V,TAA,3110CN	CRU
RF007	TAA, 240 Base Printer 3110	ASSY,BASE,PRT,220V,TAA,3110CN	CRU
UT019	DELL AMERICAS ORGANIZATION REFURBISHED SERVICE KIT, Printer Only	BASE,PTR,LS,RFRB,110V,3110CN	CRU
Cables and Cords			
CK548	UNITED KINGDOM POWER CORD	CORD,PWR,250V,10A,2M,C13,UK	CRU
DK166	UNITED STATES POWER CORD	CORD,PWR,125V,13A,2M,C13,US	CRU
UJ859	JAPAN/JAPANESE POWER CORD	CORD,PWR,125V,12A,2.5M,C13,JPN	CRU
UJ860	UNITED KINGDOM POWERCORD	CORD,PWR,250V,10A,2M,C13,UK	CRU
WD420	USB CABLE	CBL,USB,D4B-10,IJ-LJ,LT,BLK	CRU
YJ779	EUROPE/EUROPEAN POWER CORD	CORD,PWR,250V,10A,2M,C13,EUR	CRU
YY498	CABLE, USB, 10FT, PRINTER/PRINTER ACCESSORIES	CBL,USB,10FT,PTR	CRU
Controller Cards			
RG335	LOW VOLTAGE POWER SUPPLY 230V	PWA,PDB,HV/LVPS,230V,3110CN	FRU
TG065	MACHINE CONTROL UNIT	CRD,CTL,MCU,3110/3115,CN	FRU
TG068	LOW VOLTAGE POWER SUPPLY 100V-115V	PWA,PDB,HV/LVPS,100V/115V	FRU
TG074	HIGH VOLTAGE POWER SUPPLY	PWA,PDB,HVPS,3110/3115CN	FRU
UG079	ELECTRONIC SUB-SYSTEM CONTROL BOARD	CRD,CTL,I/O,110,ESS,3110CN	FRU
Documentation			
CN909	KIT, DOCUMENTATON ON FLOPPY DISK, 110, ENGLISH,FRENCH,SPANISH, VSTA, 3110	KIT,DOC/DSK,110,EFS,VSTA,3110	CRU
CN910	KIT, DOCUMENTATON ON FLOPPY DISK, ENG/JPN, VSTA, 3110	KIT,DOC/DSK,ENG/JPN,VSTA,3110	CRU

GG668	KIT DOC 110V US EFS	KIT,DOC/DSK,110V,EFS,3110CN	CRU
HU728	KIT, DOCUMENTATON ON FLOPPY DISK, 220, TRADE AGREEMENT ACT, VSTA, 3110	KIT,DOC/DSK,220,TAA,VSTA,3110	CRU
HU729	KIT, DOCUMENTATON ON FLOPPY DISK, 110, TRADE AGREEMENT ACT, VSTA, 3110	KIT,DOC/DSK,110,TAA,VSTA,3110	CRU
YN420	KIT, DOCUMENTATON ON FLOPPY DISK, ENGLISH,FRENCH,ITALIAN,GERMAN,SPANISH, VSTA, 3110CN	KIT,DOC/DSK,EFIGS,VSTA,3110CN	CRU
YN421	KIT, DOCUMENTATON ON FLOPPY DISK, 220, ENGLAND/ENGLISH, VSTA, 3110	KIT,DOC/DSK,220,ENG,VSTA,3110	CRU
Heatsinks, Fans and Accessories			
UG084	FAN	FAN,MAIN,24V,3110/3115CN	FRU
LCD/Display Assembly Service Kit			
NH713	OPERATOR PANEL JP	PNL,OPR,PTR,JPN,3110CN	FRU
RH412	OPERATOR PANEL EU	PNL,OPR,PTR,EMEA,3110/3115CN	FRU
TG112	OPERATOR PANEL US	PNL,OPR,PTR,3110CN	FRU
Memory			
DK794	512MB Memory, 400MHZ, DDR2	KIT,PTR,MEM,512M,400MHZ,DDR2	CRU
DP904	Memory, 1G, 667MHZ, DDR2. Order SKU Only, P/N= A0743448(for US) or A0616085(for Canada)instead of 5 digit P/N	KIT,PTR,MEM,1G,667MHZ,DDR2	CRU
FK829	256MB Memory, 400MHZ, DDR2	KIT,PTR,MEM,256M,400MHZ,DDR2	CRU
JK997	Memory, 512M, 667MHZ, DDR2. Order SKU Only, P/N= A0743840(for US) or A0616086(for Canada)instead of the 5 digit P/N	KIT,PTR,MEM,512M,667MHZ,DDR2	CRU
PF638	1GB Memory, 400MHZ, DDR2	KIT,PTR,MEM,1G,400MHZ,DDR2	CRU
U565K	Memory, 512MB, DIMM, 51xxcn, 31xxcn, 2130cn	KIT,PTR,MEM,512MB,DIMM	CRU
W270K	Memory, 1GB, DIMM, 51xxcn, 31xxcn, 2130cn	KIT,PTR,MEM,1GB,DIMM	CRU
Miscellaneous Hardware			
DH096	SPUR ASSEMBLY	RLLR,ASSY,SPUR,3110/3115CN	CRU
FG627	FUSER 115V	ASSY,FUSER,110V,3110/3115CN	CRU
GG670	FUSER 100V	ASSY,FUSER,100V,3110/3115CN	CRU
GG751	250 SHEET PAPER TRAY	TRAY,PAPER,250,3110/3115CN	CRU
HG432	TRANSFER BELT	FDR,BTR,XPORT,PAPER,3110/15CN	CRU
HG445	DUPLEX MODULE	ASSY,DPLXR,PAPER,3110/3115CN	CRU
JG336	FUSER 230V	ASSY,FUSER,220V,3110/3115CN	CRU
NG731	POWER SWITCH	SWT,POWER,3110/3115CN	FRU
NG741	PHOTOCONDUCTOR (PC) / DEVELOPER (DEV) DRIVE ASSEMBLY	MOTOR,DR,ASSY,PHCND,3110/15CN	FRU
NG873	PRINthead	PRTH,ROS,ASSY,3110CN	FRU
NG874	INTEGRATED FEEDER ASSEMBLY	FDR,ASSY,INTEGRATED,3110/15CN	FRU
NG884	MPF Separator Roller Assy	RLLR,ASSY,SPRTR,MPF,311XCN	CRU
PG716	HUMIDITY SENSOR	SNSR,HUMIDITY,3110/3115CN	FRU
PG725	SIZE SWITCH ASSEMBLY	SWT,ASSY,SIZE,3110/3115CN	FRU
RG348	DUPLEX GATE	CHUTE,GATE,DPLX,3110/3115CN	CRU
RG394	TONER CARTRIDGE SENSOR ASSEMBLY	SNSR,ASSY,CTRG,TONER,3110/15CN	FRU
RG397	MPF FEED SOLENOID	SOL,FEEDER,MPF,3110/3115CN	FRU
RG399	250 TRAY FEED ROLLER	RLLR,FDR,TRAY,250,3110/3115CN	CRU
TG064	FEEDER SCREWS	SCR,FDR,X2,3110/3115CN	CRU
TG070	FEED DRIVE ASSEMBLY	MOTOR,DR,ASSY,PROCESS,3110/115	FRU
TG071	RUBBER FEET	FOOT,RBR,X4,3110/3115CN	CRU
TG139	100K FUSER SERVICE KIT 100V	KIT,PTR,RLR,FUSER,BTR,JPN,311X	CRU
TG147	550 SHEET FEEDER ASSEMBLY - Housing Only , no Tray	FDR,PAPER,550,3110CN	CRU
UG089	INTERLOCK SWITCH	SWT,INTERLOCK,3110/3115CN	FRU
UG158	LED ASSEMBLY	ASSY,LED,ERASE,3110/3115CN	FRU
UG159	TONER DISPENSER MOTOR	MOTOR,DSPN,TONER,3110/3115CN	FRU
UG162	MPF ROLLER	RLLR,MPF,3110/3115CN	CRU
UG197	550 SHEET PAPER TRAY	TRAY,PAPER,550,3110/3115,CN	CRU
Plastics			
HH956	550 TRAY REAR COVER	CVR,REAR,TRAY,550,3110/3115CN	CRU

NG885	TRAY REAR COVER	CVR,TRAY,REAR,3110/3115CN	CRU
PG731	RIGHT ARM ASSEMBLY	GDE,ASSY,RT,3110CN	FRU
PG783	MPF COVER	CVR,MPF,3110/3115CN	FRU
PG784	RIGHT COVER	CVR,RIGHT,3110CN	FRU
PG785	COVER EXTENDER	PNL,EXTN,TRAY,PAPER,3110CN	CRU
RG402	LEFT COVER	CVR,LEFT,3110CN	FRU
TG114	REAR COVER	CVR,REAR,3110CN	FRU
TG117	TOP COVER	CVR,TOP,3110CN	FRU
UG096	LEFT ARM ASSEMBLY	GDE,ASSY,LF,3110/3115CN	FRU
UG170	FRONT COVER	CVR,FRONT,3110/3115CN	FRU
Software			
FW094	COMPACT DISKETTE, DRIVER, PRINTER/PRINTER ACCESSORIES, VSTA, 3110CN	CDSK,DRV,PTR,VSTA,3110CN	CRU

Notes

CRU : Customer Replaceable Units - refers to parts that can easily be replaced by the customer without sending an onsite technician.

FRU : Field Replaceable Unit - a part that can be replaced or added by onsite technician.