

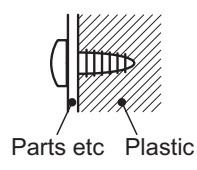

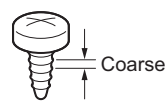
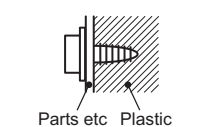
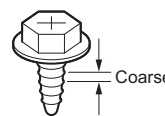
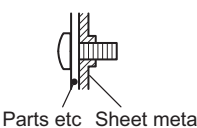

1. Removal and Replacement Procedures (RRPs)

1.1 Before starting service procedure

- Start the procedure after turning off the power and removing the power cord from the outlet.
- When performing the service operation around the FUSER ASSY, ensure that FUSER ASSY and its surrounding area have cooled down sufficiently.
- Pay sufficient attention to the parts during the procedure because they may be broken or may not perform their functions properly if unreasonable force is applied.
- Since various types of screws are used, ensure that the right screws are used in their right positions. Use special caution not to confuse the screws for plastic and the ones for sheet metal, because using the wrong type of screw may result in damage to the screw threads or other troubles.

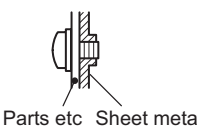
No.	Type	Application	Shape	How to distinguish	Points to be noted	Major application locations
1	Screw for plastic Silver, tap	Plastic  Parts etc Plastic	 Coarse	<ul style="list-style-type: none"> • Silver-colored • Thread is coarser than that of the sheet metal type. • Screw tip is thin. 	Oblique screwing damages the thread because this screw cuts female threads in the base material as it goes in.	-
2	Screw for plastic Silver, tap, with flange	Plastic  Parts etc Plastic	 Coarse	<ul style="list-style-type: none"> • Silver-colored • It has a flange. • Screw thread is coarse comparing to the sheet metal type. • Screw tip is thin. 	As it has a function to cut the thread by itself, if the screw is inserted in an angle and tightened, the screw thread will be damaged.	• FUSER ASSY
3	Screw for metal sheet Silver	Sheet metal  Parts etc Sheet metal		<ul style="list-style-type: none"> • Silver-colored • Diameter of the thread section is uniform. 		-
4	Screw for metal sheet Silver, with an external tooth washer	Sheet metal  Parts etc Sheet metal		<ul style="list-style-type: none"> • Silver-colored • Provided with an external tooth washer. • Diameter of the thread section is uniform. 		• Mounting positions of the ground wires.

Chapter 3 Removal and Replacement Procedures (RRPs)

- Wear a wristband or the like as far as possible to remove static electricity of the human body.
- Keep the front cover closed. Buzzer goes off when the machine is left powered on with the front cover open for five minutes or longer to prevent the drum deterioration due to exposure to light.
- When opening the front door in a removal/replacement operation, cover the drum to keep it from being exposed to light.
- Remove CASSETTE ASSY 250, PHD ASSY, TONER CARTRIDGE and FUSER ASSY, and put them in a place where they do not affect the procedure. (Note that the service procedures can be performed with those parts in place depending on the target section of removal/replacement.)

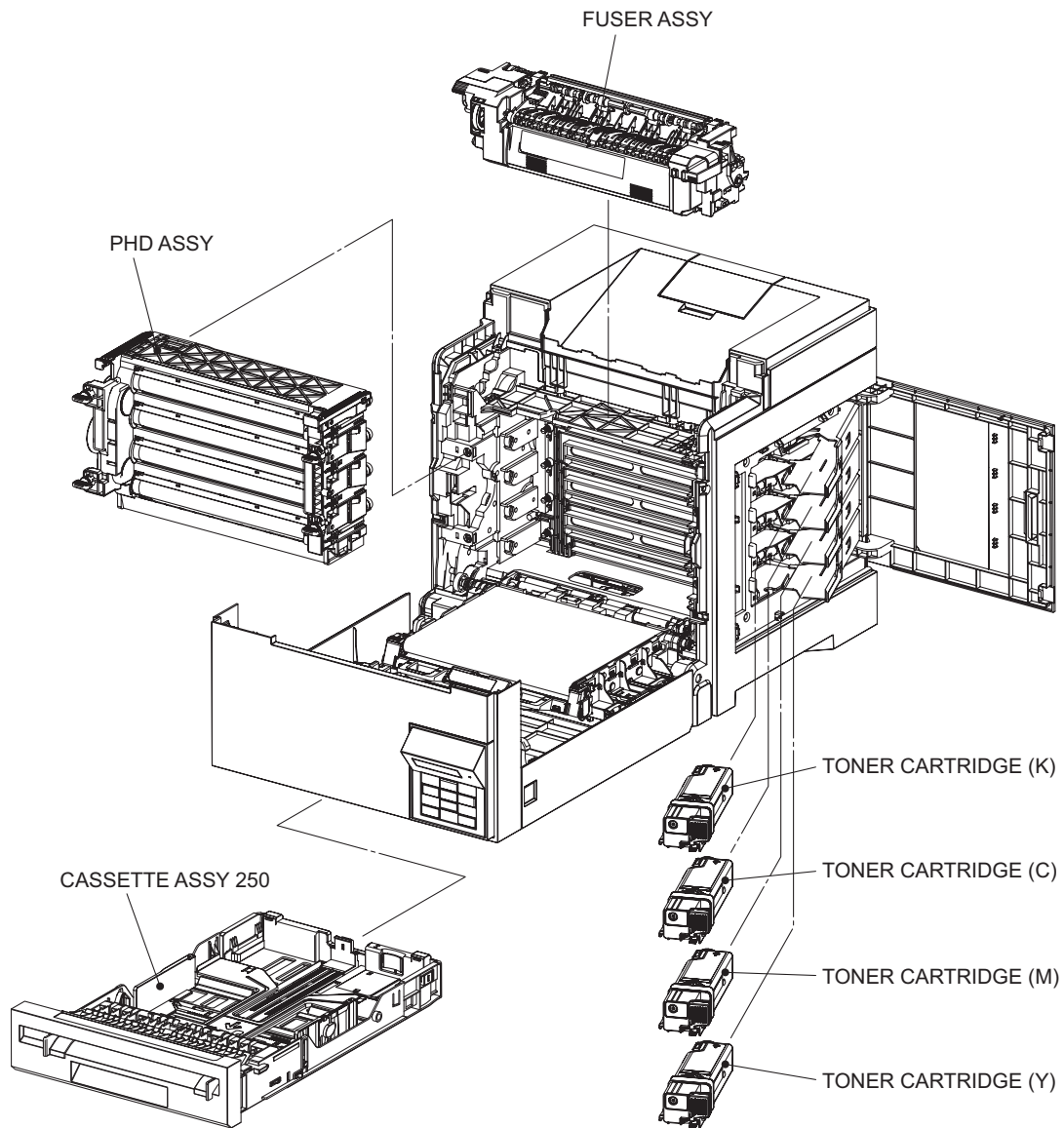

MiS03001KA

1.2 General notes

- The string “(PL X.Y.Z)” suffixed to the part name in the procedure denotes that the part corresponds to the plate (PL) “X.Y”, item “Z” of [Engineering Parts list], and its shape and fitting position can be checked in [Engineering Parts list].
- Directional descriptions used in the procedures are defined as follows:
 - Front : Direction toward you when facing the front of the printer.
 - Rear : Direction opposite to the front when facing the front of the printer.
 - Left : Left-hand direction when facing the front of the printer.
 - Right : Right-hand direction when facing the front of the printer.

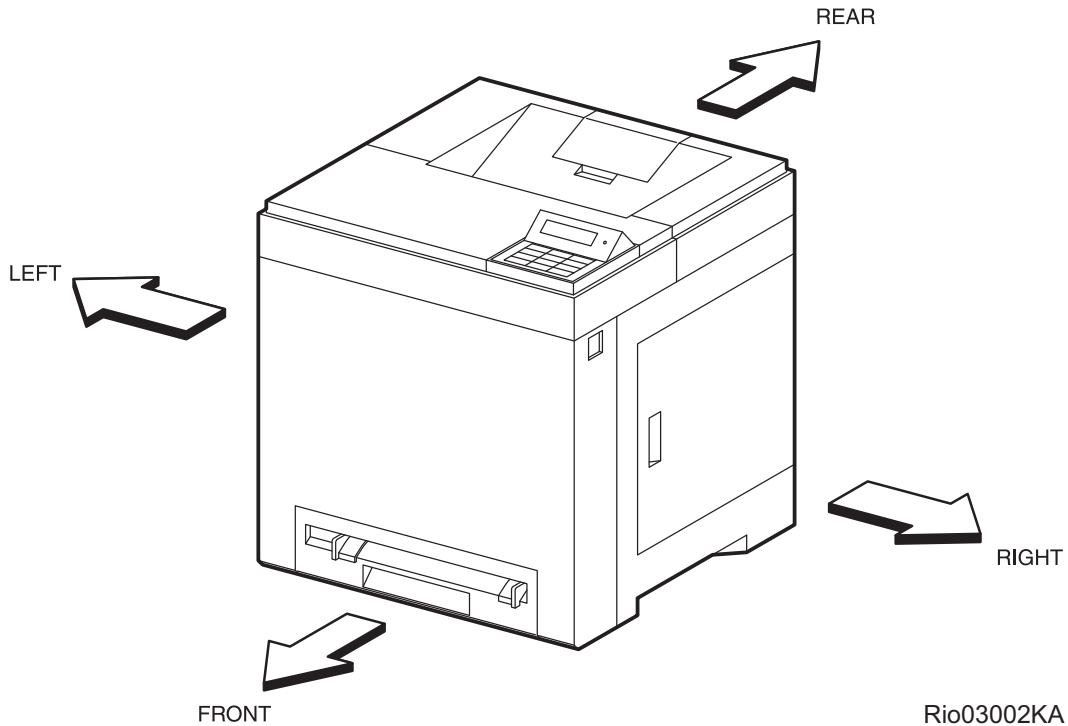

Figure: Definitions of Printer Orientation

- The string “(RRP X.Y)” that appears in or at the end of the procedure denotes that the related service procedure is described in [RRP X.Y].
- Screws shown in the illustrations are to be unscrewed and removed using a Phillips head (cross-slot) screwdriver, unless otherwise specified.
- Black arrows shown in the illustrations denote moving directions. When numbers are assigned to these arrows, they refer to the order in the procedure.
- Refer to [Chapter 4 Plug/Jack (P/J) Connector Locations] for the positions of connectors (P/J).

Removal Flows

The components not connected with arrows in the flow below can be removed independently.

Removal FLOW (Removal 1~45)

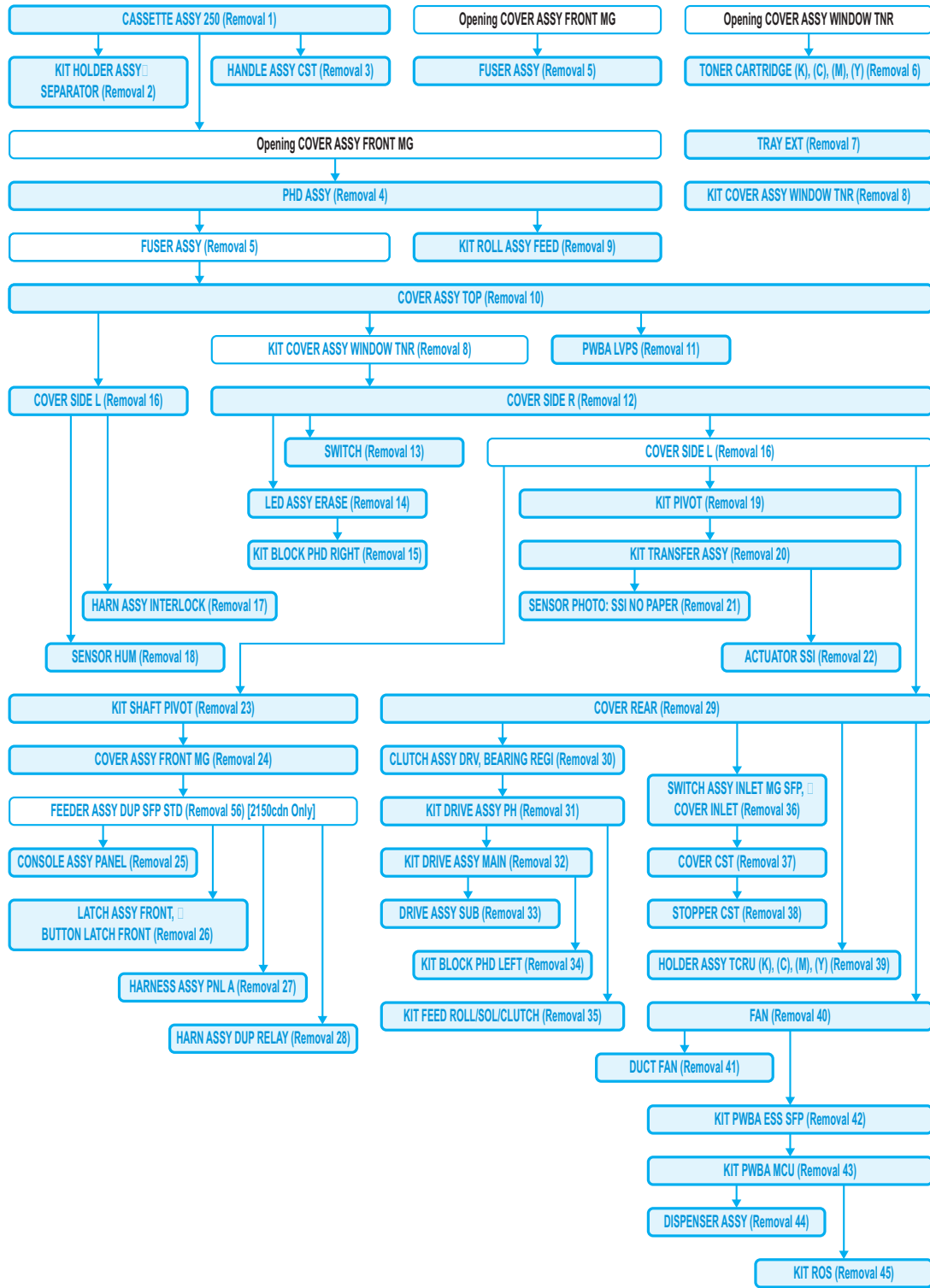

Removal FLOW (Removal 46–59)

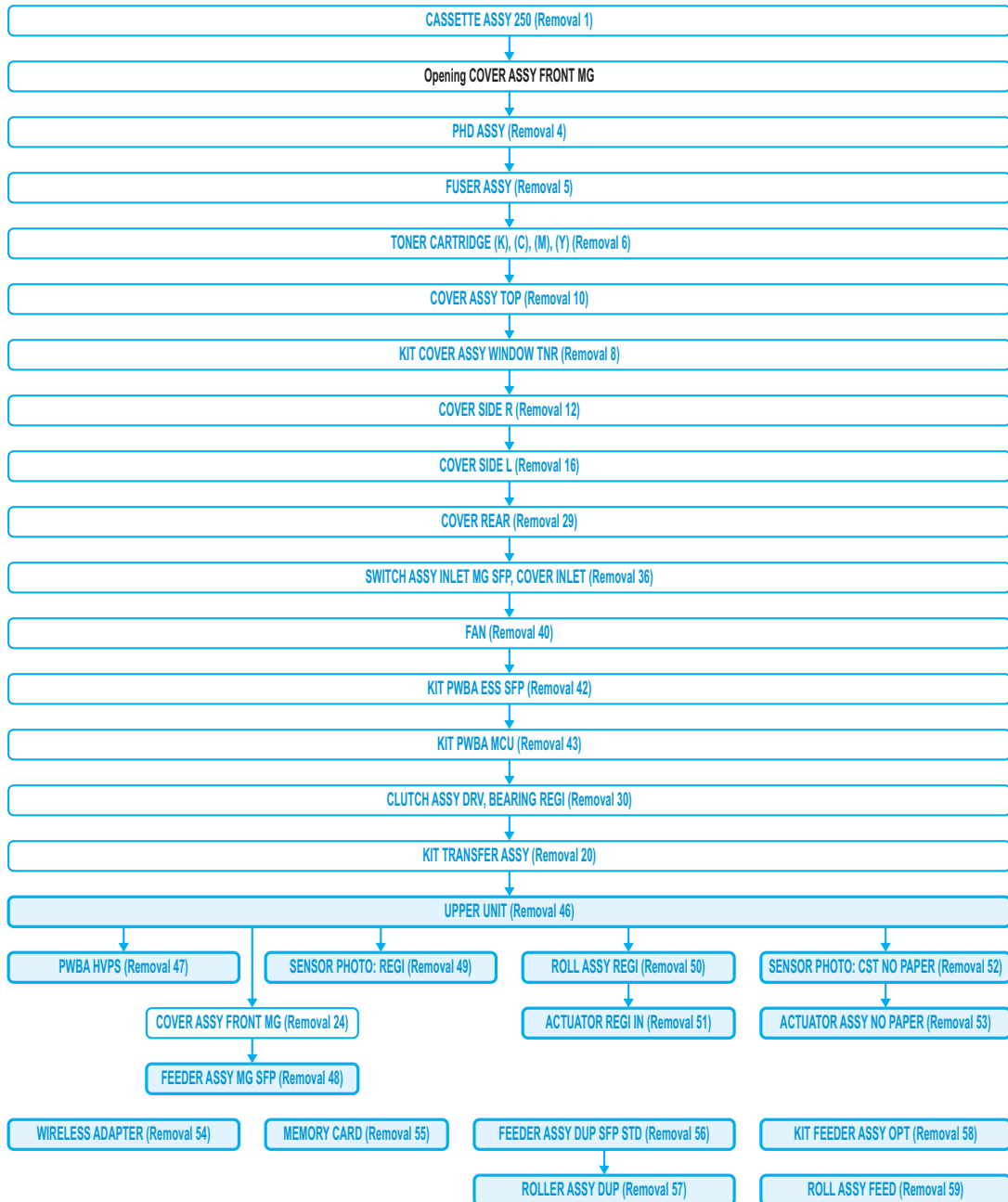

Replacement Flows

The components not connected with arrows in the flow below can be replaced independently. However, the rear cover is an exception when it was removed together with other parts.

Replacement FLOW (Replacement 1~8)

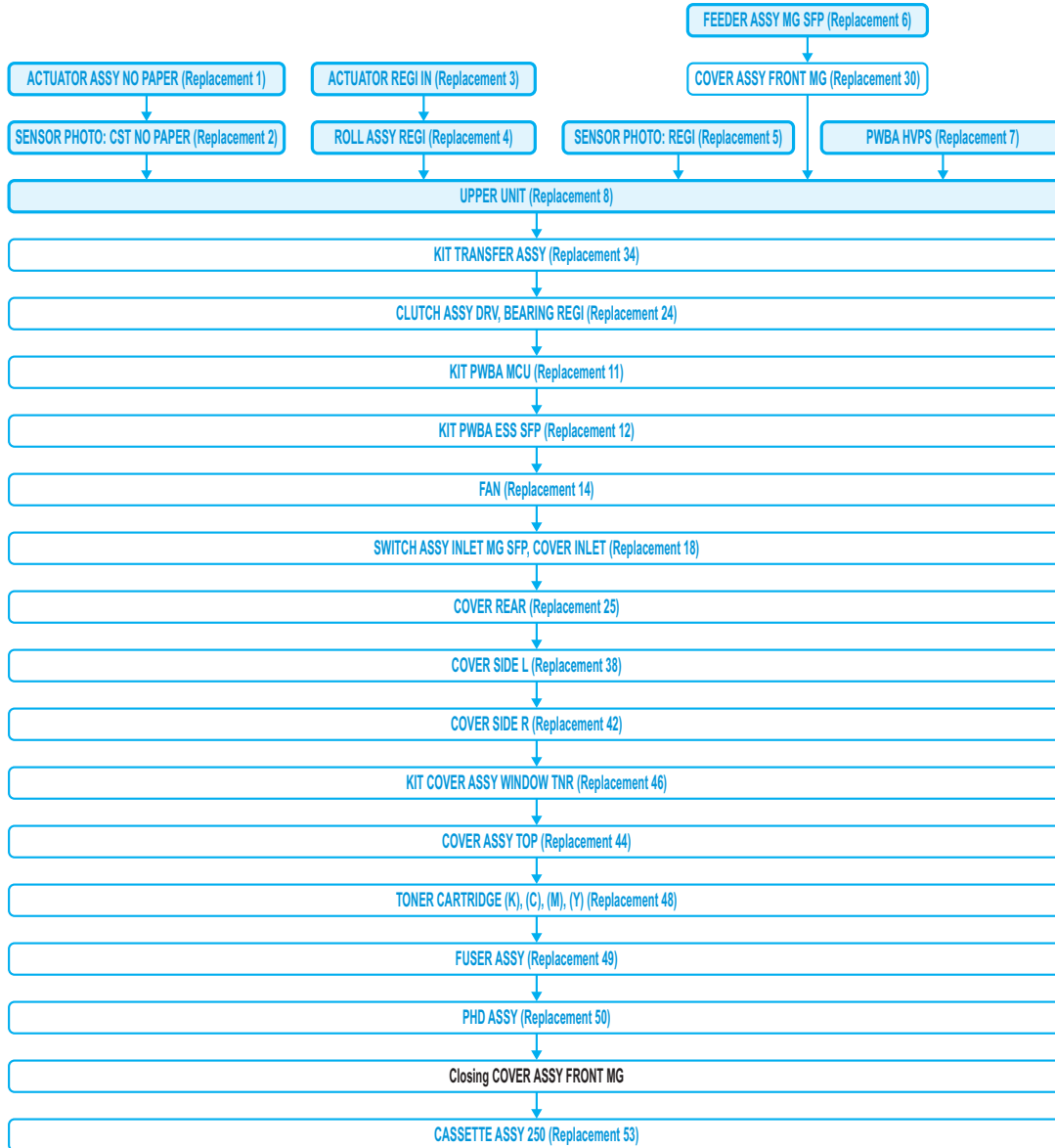

Replacement FLOW (Replacement 9~59)

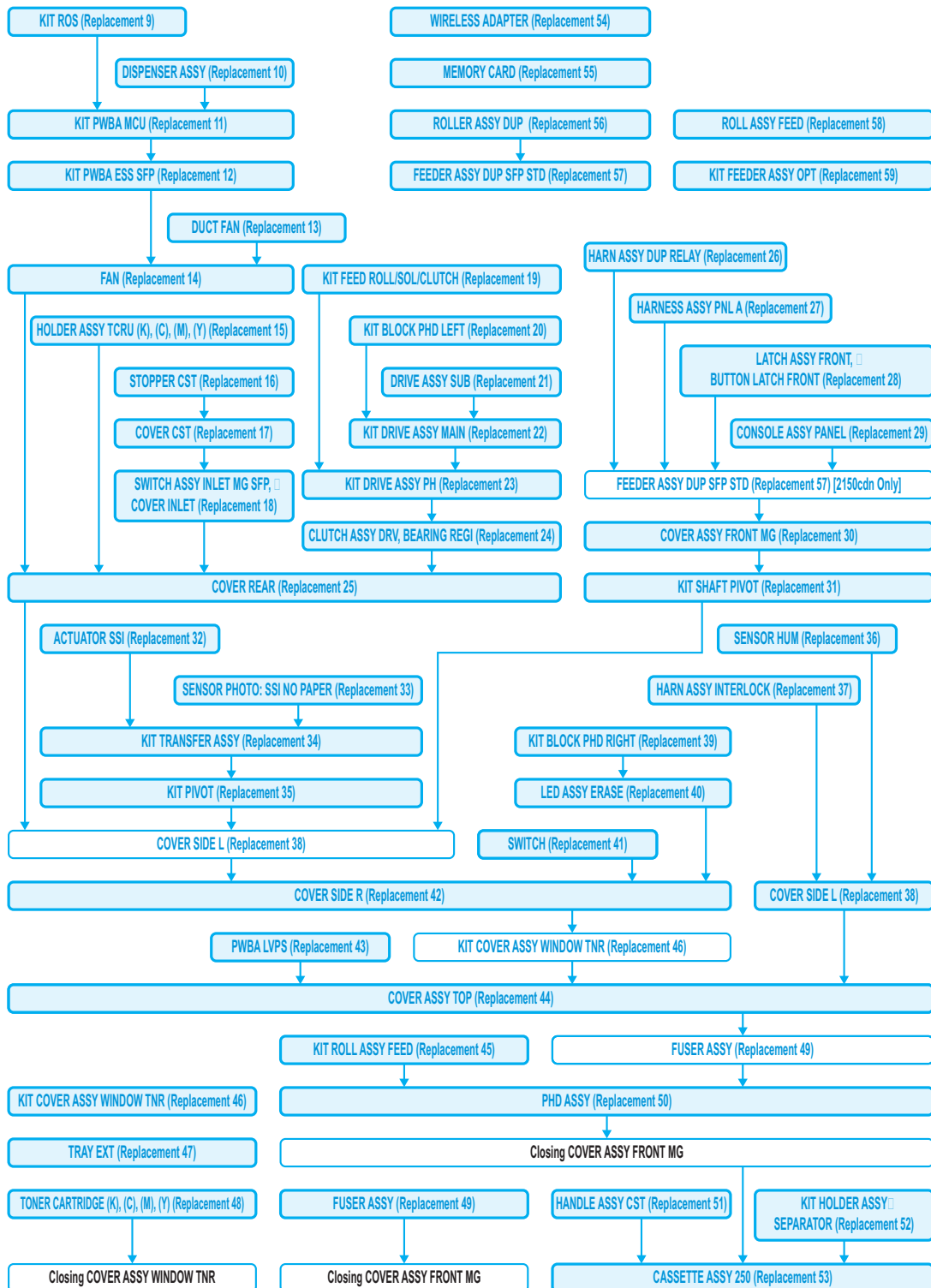

Removal 1 CASSETTE ASSY 250 (PL2.1.1)

1) Pull out the CASSETTE ASSY 250 (PL2.1.1) from the printer.



Removal 2 KIT HOLDER ASSY SEPARATOR (PL2.1.99)

1) Remove the CASSETTE ASSY 250. (Removal 1)

2) Release the two hooks of the HOLDER ASSY SEPARATOR (PL2.1.5).

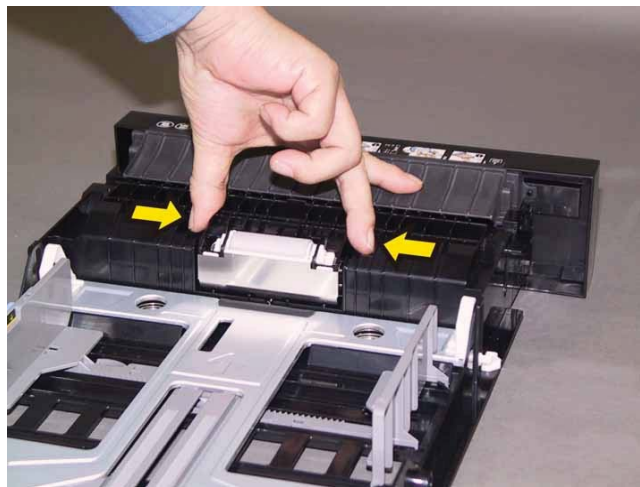

3) Pull up the HOLDER ASSY SEPARATOR to remove the HOLDER ASSY SEPARATOR from the CASSETTE ASSY 250 (PL2.1.1).

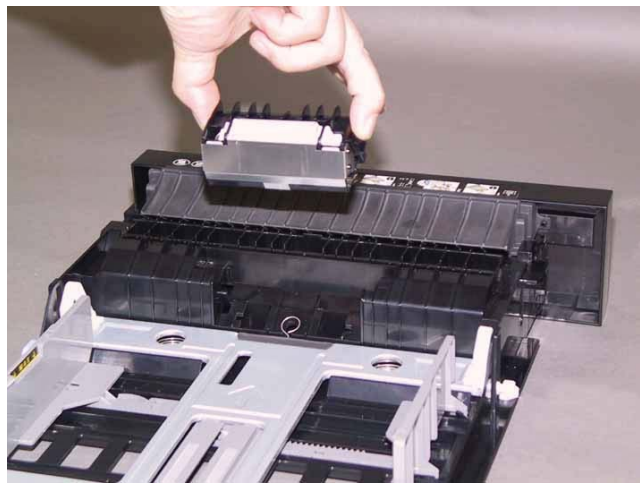

Removal 3 HANDLE ASSY CST (PL2.1.19)

1) Remove the CASSETTE ASSY 250. (Removal 1)

2) Release the left side holes of the HANDLE ASSY CST (PL2.1.19) from the bosses of the CASSETTE ASSY 250 (PL2.1.1), using a miniature screwdriver.

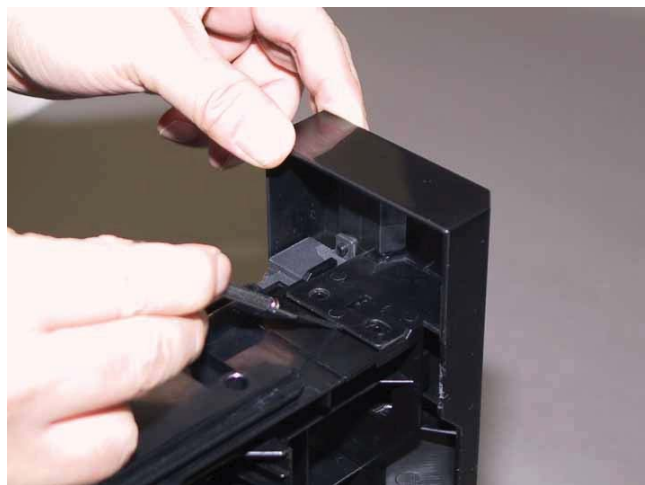

3) Release the right side holes of the HANDLE ASSY CST from the bosses of the CASSETTE ASSY 250, remove the HANDLE ASSY CST.



Removal 4 PHD ASSY (PL4.1.21)

Note: Remove the CASSETTE ASSY 250 before working.

Note: Cover the drum of the PHD ASSY to avoid exposure to light.

1) Remove the CASSETTE ASSY 250. (Removal 1)

2) Open the COVER ASSY FRONT MG (PL1.2.1).

3) Open the TRANSFER ASSY (PL6.1.7).



4) Put the paper on the TRANSFER ASSY to protect the belt.

Note: When carrying out the work this procedure, take care not to cover the left and right of the belt guards with the paper.

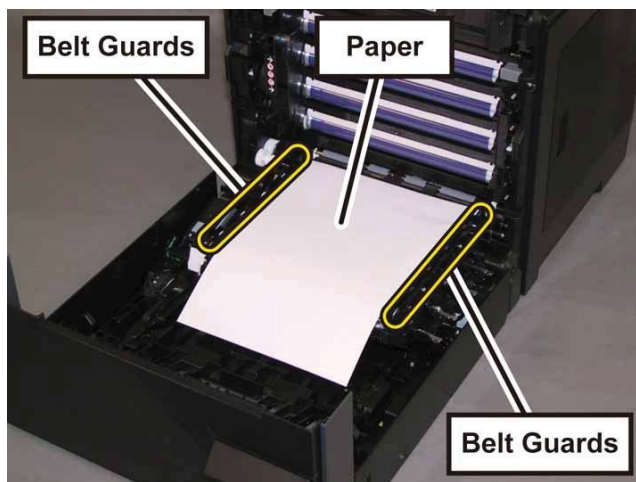

5) Rotate the four stoppers of the PHD ASSY (PL4.1.21) to the counter clock wise direction, to release the lock.



6) Remove the PHD ASSY toward you by pulling it by the left and right handles.



7) Lift up the PHD ASSY from the printer.



Removal 5 FUSER ASSY (PL6.1.1)

1) Open the COVER ASSY FRONT MG (PL1.2.1).

Note: The FUSER part is very hot. Take added care not to get burned when performing the service operation.

2) Open the TRANSFER ASSY (PL6.1.7).



3) Remove the one screw (silver, with flange, tap, 10mm) that fixes the FUSER ASSY (PL6.1.1) to the printer.



4) Pull the LEVER to release the lock.

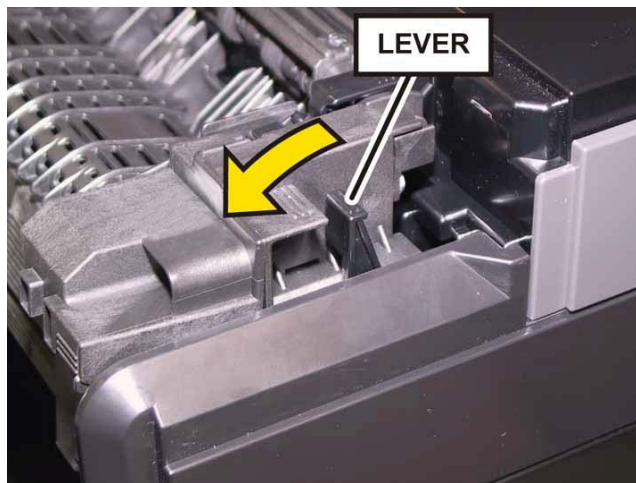

5) Disengage the connector of the FUSER ASSY by pulling the right side of the FUSER ASSY toward you with the LEVER released.



6) Lift up the FUSER ASSY, move the FUSER ASSY to the right side.

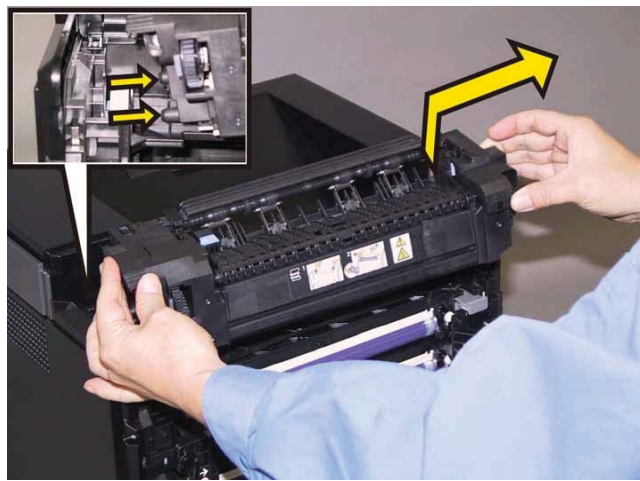

Removal 6 TONER CARTRIDGE (K), (C), (M), (Y) (PL5.1.21~24)

Note: Described below is the removal procedure common among the four TONER CARTRIDGES.

1) Open the COVER ASSY WINDOW TNR (PL1.1.7).

2) Move the handle of the TONER CARTRIDGE to backward, to release the lock.



3) Open the HOLDER ASSY TCRU K (PL5.1.17).



4) Remove the TONER CARTRIDGE from the HOLDER ASSY TCRU.



Removal 7 TRAY EXT (PL1.1.2)

1) Open the TRAY EXT (PL1.1.2).

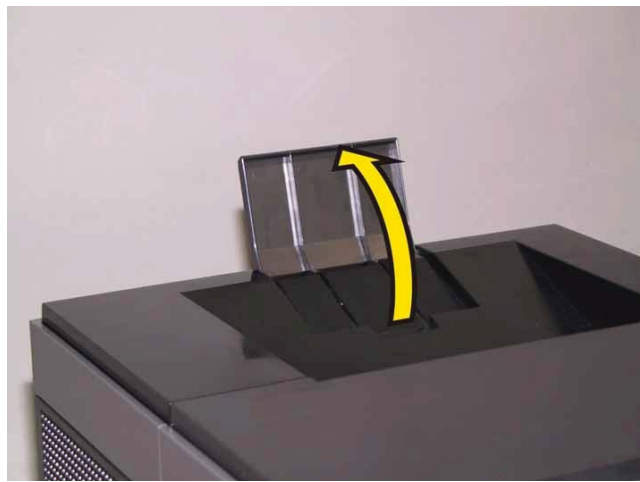

2) Release the boss of the TRAY EXT from the hole of the COVER ASSY TOP (PL1.1.1), using a miniature screwdriver.

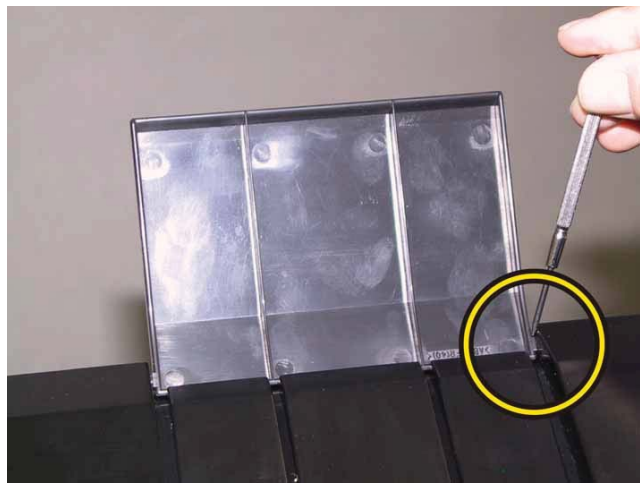

3) Remove the TRAY EXT.

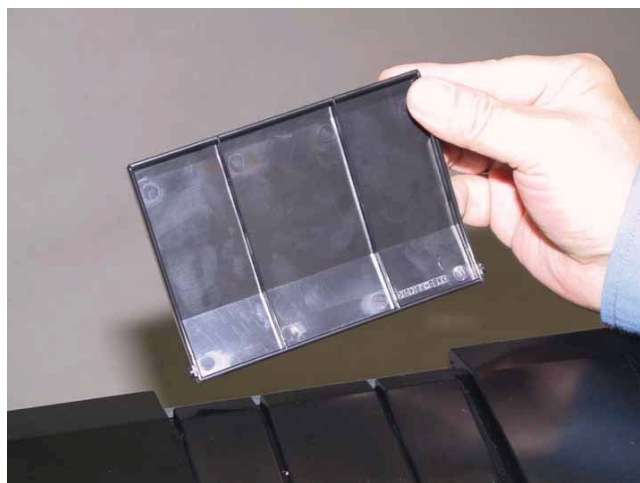

Removal 8 KIT COVER ASSY WINDOW TNR (PL1.1.99)

1) Open the COVER ASSY WINDOW TNR (PL1.1.7).



2) Press the upper hinge of the COVER ASSY WINDOW TNR to release the boss on the hinge from the hole of the printer, move the COVER ASSY WINDOW TNR to arrow direction.



3) Remove the COVER ASSY WINDOW TNR.

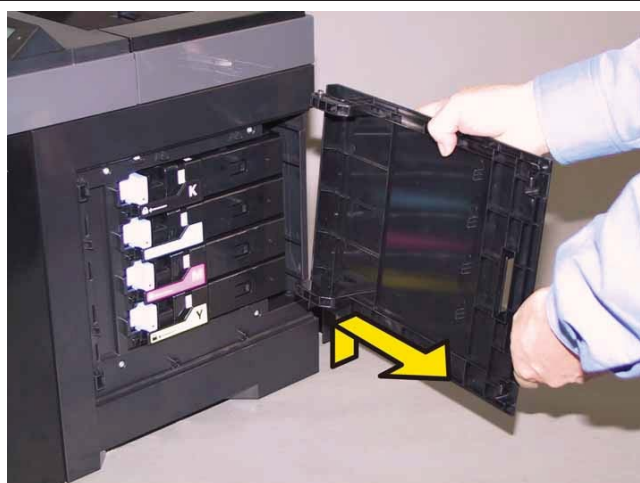

Removal 9 KIT ROLL ASSY FEED (PL3.2.99)

1) Remove the CASSETTE ASSY 250. (Removal 1)

2) Open the COVER ASSY FRONT MG (PL1.2.1).

Note: Cover the drum of the PHD ASSY to avoid exposure to light.

3) Remove the PHD ASSY. (Removal 4)

4) Release the hook of the ROLL CORE MSI (PL3.2.3) on the left of the ROLL ASSY FEED (PL 3.2.4), and move the ROLL CORE MSI to left until it stops.

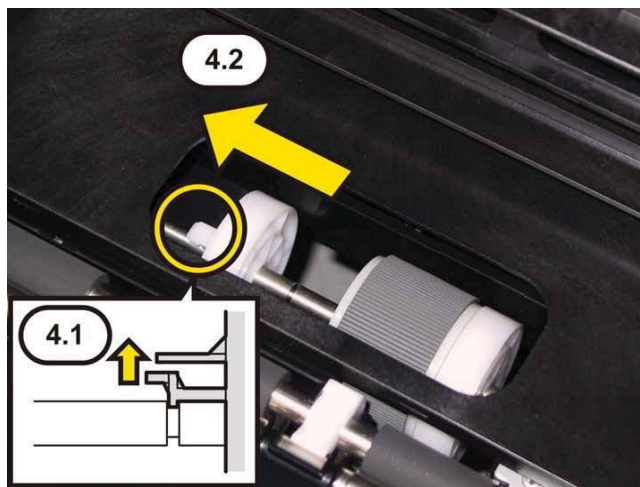

5) Release the groove on the ROLL ASSY FEED from the vertical pin mounted on the SHAFT ASSY FEED (PL3.2.2) by sliding the ROLL ASSY FEED to the left.



6) Close the COVER ASSY FRONT MG.

7) Remove the ROLL ASSY FEED from the SHAFT ASSY FEED by rotating the ROLL ASSY FEED 180 degrees.

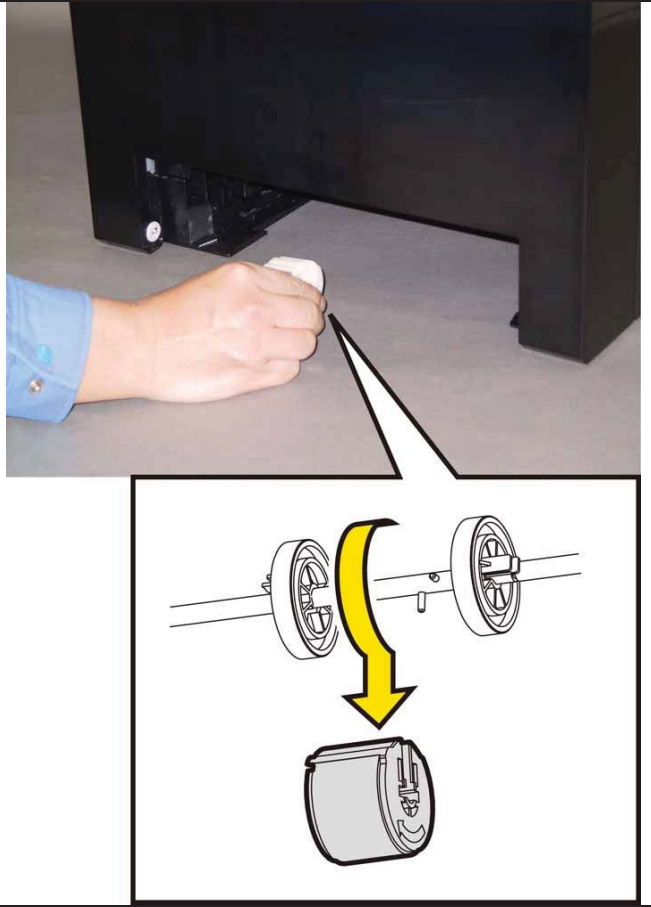

Removal 10 COVER ASSY TOP (PL1.1.1)

- 1) Remove the CASSETTE ASSY 250. (Removal 1)
- 2) Open the COVER ASSY FRONT MG (PL1.2.1).

Note: Cover the drum of the PHD ASSY to avoid exposure to light.

- 3) Remove the PHD ASSY. (Removal 4)

Note: The FUSER part is very hot. Take added care not to get burned when performing the service operation.

- 4) Remove the FUSER ASSY. (Removal 5)

5) Remove the two screws (silver, tap, 8mm) that fix the COVER ASSY TOP (PL1.1.1) to the printer.

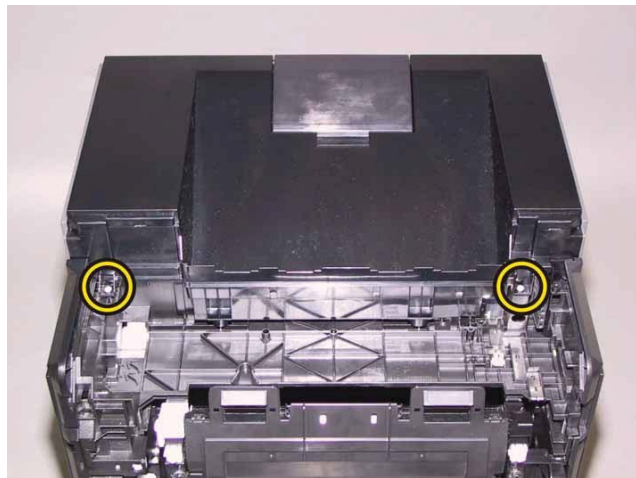

6) Lift up the front side of the COVER ASSY TOP to release the COVER ASSY TOP from the two pegs on the printer.

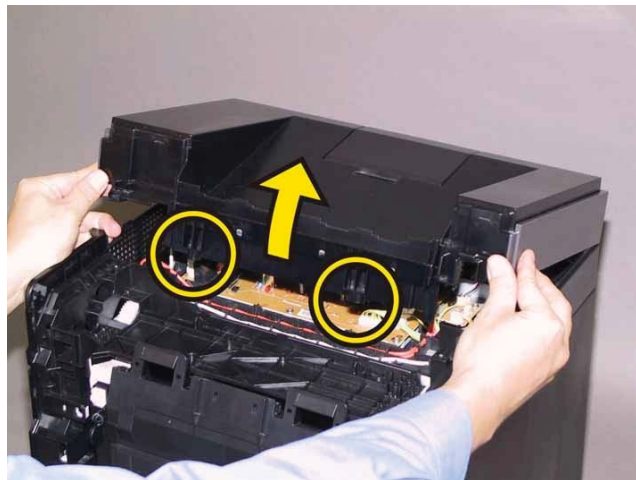

7) Release the inside hooks of the COVER ASSY TOP from the COVER REAR (PL1.1.3), remove the COVER ASSY TOP from the printer.



Removal 11 PWBA LVPS (PL8.2.1)

- 1) Remove the CASSETTE ASSY 250. (Removal 1)
- 2) Open the COVER ASSY FRONT MG (PL1.2.1).

Note: Cover the drum of the PHD ASSY to avoid exposure to light.

- 3) Remove the PHD ASSY. (Removal 4)

Note: The FUSER part is very hot. Take added care not to get burned when performing the service operation.

- 4) Remove the FUSER ASSY. (Removal 5)
- 5) Remove the COVER ASSY TOP. (Removal 10)

- 6) Disengage all the connectors of the PWBA LVPS (PL8.2.1).



- 7) Remove the six screws (silver, 6mm) that fix the PWBA LVPS to the printer.



8) Remove the PWBA LVPS from the printer.

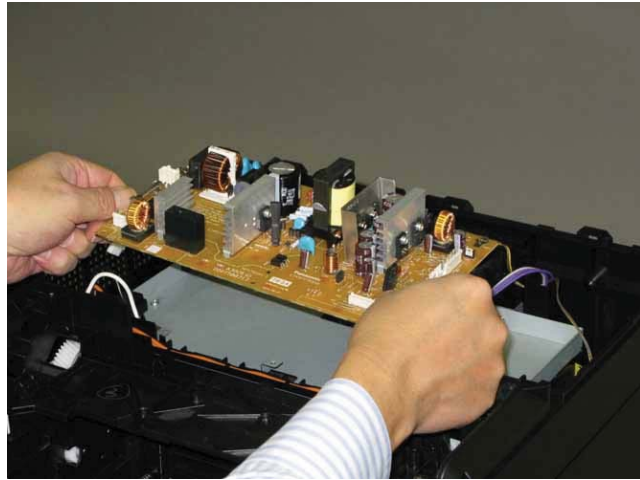

Removal 12 COVER SIDE R (PL1.1.6)

- 1) Remove the CASSETTE ASSY 250. (Removal 1)
- 2) Open the COVER ASSY FRONT MG (PL1.2.1).

Note: Cover the drum of the PHD ASSY to avoid exposure to light.

- 3) Remove the PHD ASSY. (Removal 4)

Note: The FUSER part is very hot. Take added care not to get burned when performing the service operation.

- 4) Remove the FUSER ASSY. (Removal 5)
- 5) Remove the COVER ASSY TOP. (Removal 10)
- 6) Remove the COVER ASSY WINDOW TNR. (Removal 8)

Accesses Position (The 8) show the procedure number.)

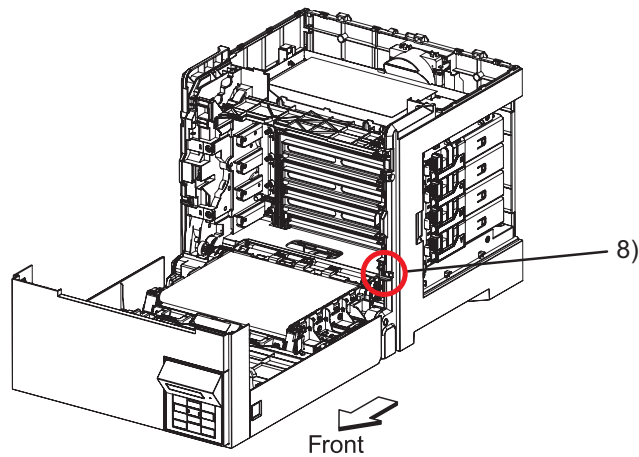

- 7) Remove the six screws (silver, tap, 8mm) that fix the COVER SIDE R (PL1.1.6) to the printer.



8) Release the front hook of the COVER SIDE R.

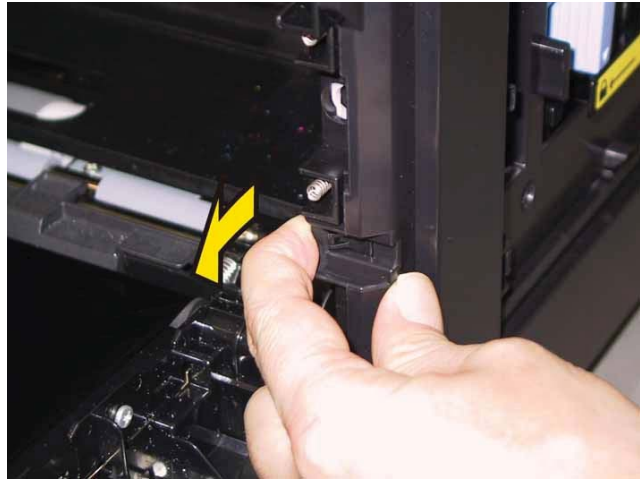

9) Release the inside hooks of the COVER SIDE R from the COVER REAR (PL1.1.3), remove the COVER SIDE R from the printer.

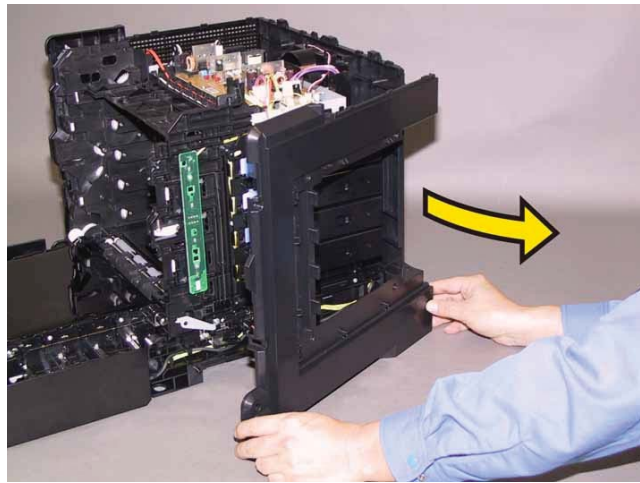

Removal 13 SWITCH (PL5.1.9)

- 1) Remove the CASSETTE ASSY 250. (Removal 1)
- 2) Open the COVER ASSY FRONT MG (PL1.2.1).

Note: Cover the drum of the PHD ASSY to avoid exposure to light.

- 3) Remove the PHD ASSY. (Removal 4)

Note: The FUSER part is very hot. Take added care not to get burned when performing the service operation.

- 4) Remove the FUSER ASSY. (Removal 5)
- 5) Remove the COVER ASSY TOP. (Removal 10)
- 6) Remove the COVER ASSY WINDOW TNR. (Removal 8)
- 7) Remove the COVER SIDE R. (Removal 12)

8) Release the hooks of the SWITCH (PL5.1.9) by using the miniature screwdriver, remove the SWITCH from the printer.

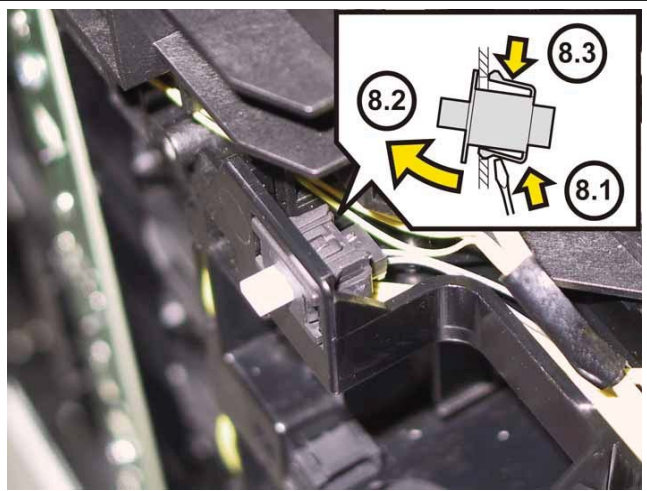

9) Disengage the connector (P/J291) of the SWITCH.



Removal 14 LED ASSY ERASE (PL4.1.8)

- 1) Remove the CASSETTE ASSY 250. (Removal 1)
- 2) Open the COVER ASSY FRONT MG (PL1.2.1).

Note: Cover the drum of the PHD ASSY to avoid exposure to light.

- 3) Remove the PHD ASSY. (Removal 4)

Note: The FUSER part is very hot. Take added care not to get burned when performing the service operation.

- 4) Remove the FUSER ASSY. (Removal 5)
- 5) Remove the COVER ASSY TOP. (Removal 10)
- 6) Remove the COVER ASSY WINDOW TNR. (Removal 8)
- 7) Remove the COVER SIDE R. (Removal 12)

- 8) Remove the two screws (silver, tap, 8mm) that fix the LED ASSY ERASE (PL4.1.8) to the printer.

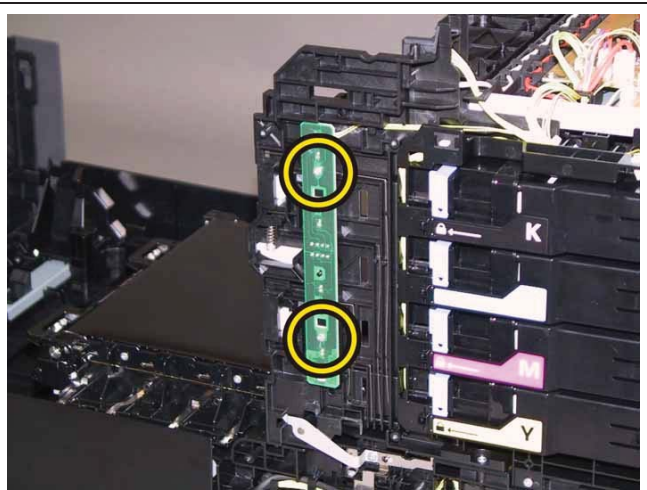

- 9) Remove the LED ASSY ERASE from the printer.



10) Disengage the connector (P/J141) of the LED ASSY ERASE.

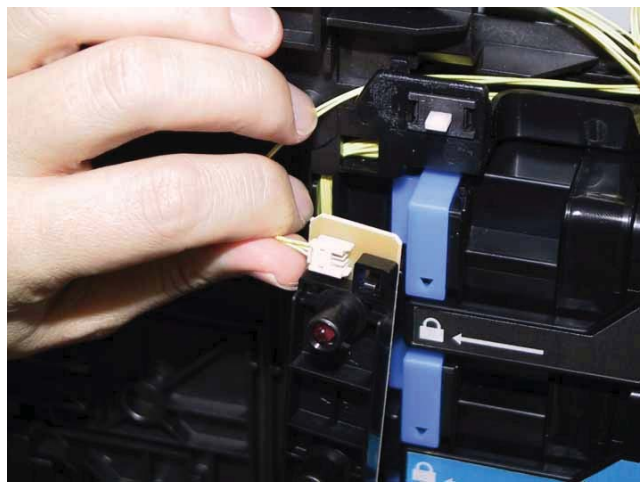

Removal 15 KIT BLOCK PHD RIGHT (PL4.1.97)

- 1) Remove the CASSETTE ASSY 250. (Removal 1)
- 2) Open the COVER ASSY FRONT MG (PL1.2.1).

Note: Cover the drum of the PHD ASSY to avoid exposure to light.

- 3) Remove the PHD ASSY. (Removal 4)

Note: The FUSER part is very hot. Take added care not to get burned when performing the service operation.

- 4) Remove the FUSER ASSY. (Removal 5)
- 5) Remove the COVER ASSY TOP. (Removal 10)
- 6) Remove the COVER ASSY WINDOW TNR. (Removal 8)
- 7) Remove the COVER SIDE R. (Removal 12)
- 8) Remove the LED ASSY ERASE. (Removal 14)

Accesses Position (The 9), 10), 11) and 12) show the procedure number.)

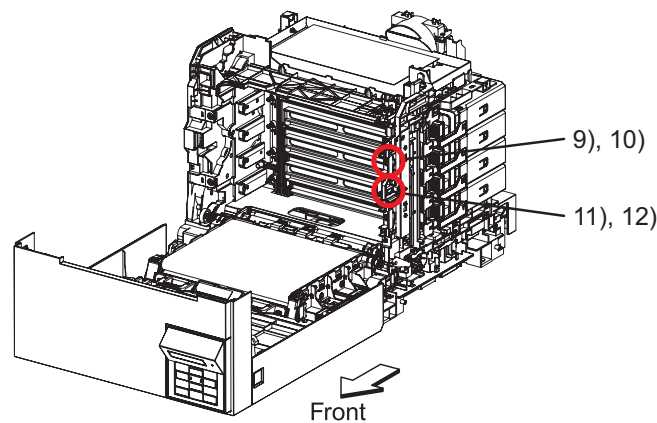

Note: Described below is the removal procedure common among the upper and lower BLOCK STOPPER PHD ADs (PL4.1.7).

- 9) Release the hook of the BLOCK STOPPER PHD AD (PL4.1.7), using a miniature screwdriver.

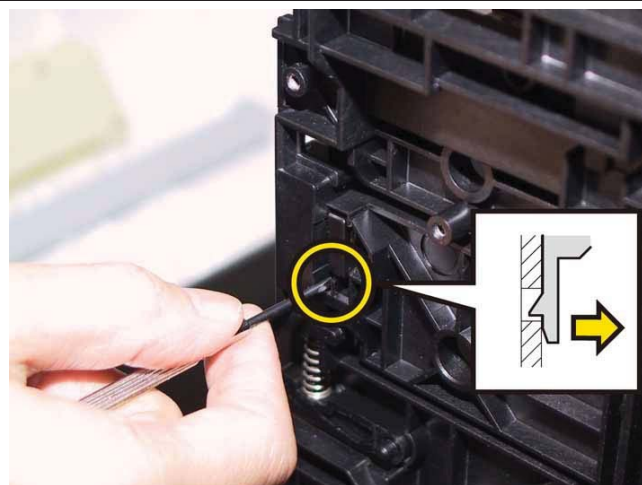

10) Remove the BLOCK STOPPER PHD AD from the printer.

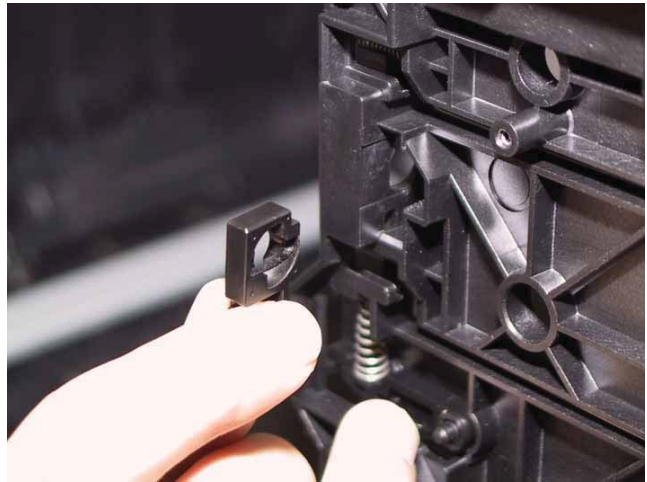

11) Remove the SPRING PHD (PL4.1.4) from the printer.

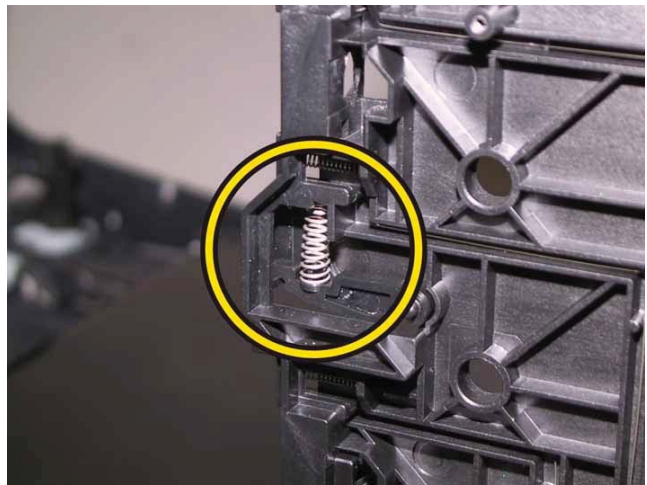

12) Rotate the LEVER PHD (PL4.1.5) slightly, remove the LEVER PHD from the printer.

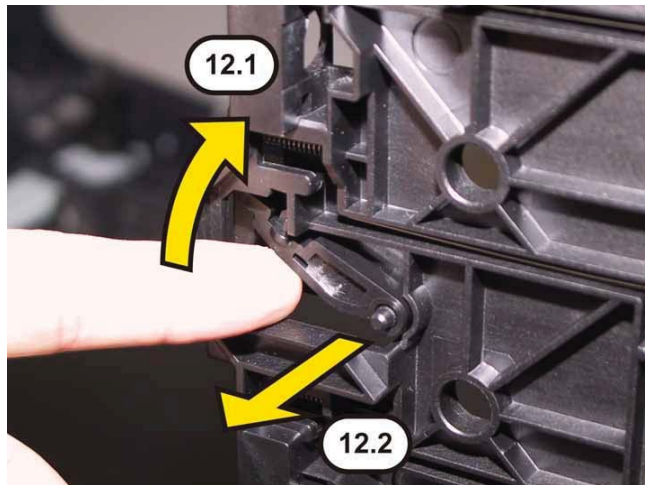

Removal 16 COVER SIDE L (PL1.1.19)

- 1) Remove the CASSETTE ASSY 250. (Removal 1)
- 2) Open the COVER ASSY FRONT MG (PL1.2.1).

Note: Cover the drum of the PHD ASSY to avoid exposure to light.

- 3) Remove the PHD ASSY. (Removal 4)

Note: The FUSER part is very hot. Take added care not to get burned when performing the service operation.

- 4) Remove the FUSER ASSY. (Removal 5)
- 5) Remove the COVER ASSY TOP. (Removal 10)

Accesses Position (The 7) show the procedure number.)

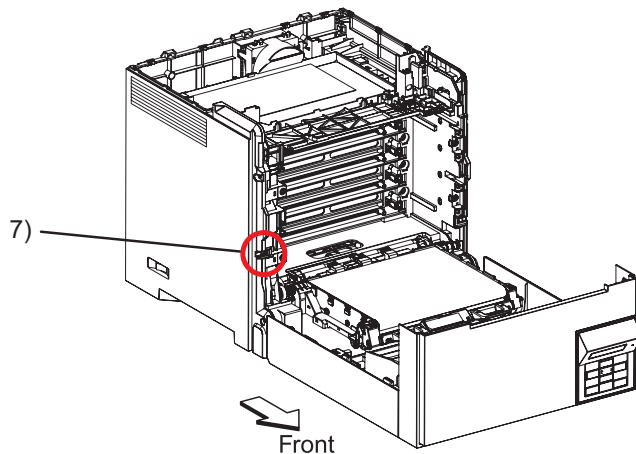

- 6) Remove the two screws (silver, tap, 8mm) that fix the COVER SIDE L (PL1.1.19) to the printer.

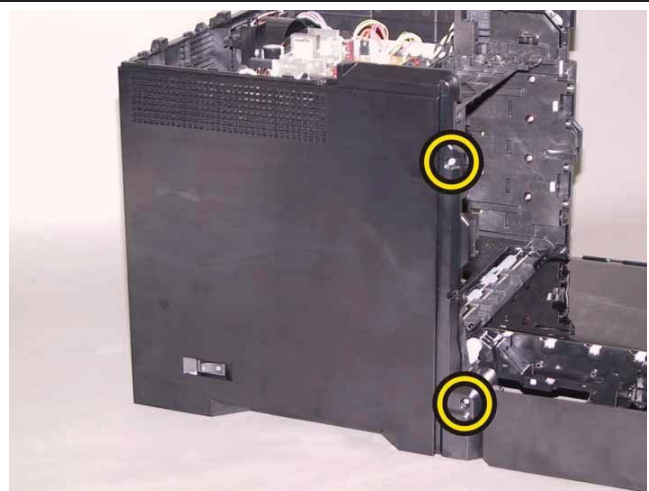

7) Release the front hook of the COVER SIDE L.



8) Release the inside hook of the COVER SIDE L from the COVER REAR (PL1.1.3), remove the COVER SIDE L from the printer.

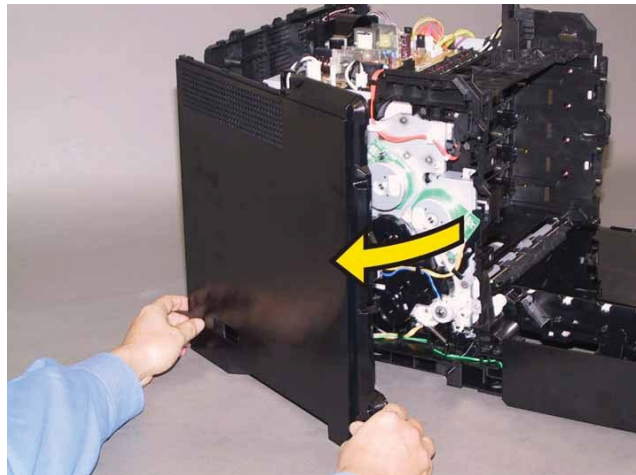

Removal 17 HARN ASSY INTERLOCK (PL8.2.5)

- 1) Remove the CASSETTE ASSY 250. (Removal 1)
- 2) Open the COVER ASSY FRONT MG (PL1.2.1).

Note: Cover the drum of the PHD ASSY to avoid exposure to light.

- 3) Remove the PHD ASSY. (Removal 4)

Note: The FUSER part is very hot. Take added care not to get burned when performing the service operation.

- 4) Remove the FUSER ASSY. (Removal 5)
- 5) Remove the COVER ASSY TOP. (Removal 10)
- 6) Remove the COVER SIDE L. (Removal 16)

Note: Release only the HARN ASSY INTERLOCK from the GUIDE HARNESS FSR to prevent the faulty wiring when it assembles it.

- 7) Disengage the connector (P/J44) of the HARN ASSY INTERLOCK (PL8.2.5) on the PWBA LVPS (PL8.2.1), release the harness of the HARN ASSY INTERLOCK from the GUIDE HARNESS FSR (PL8.2.2).

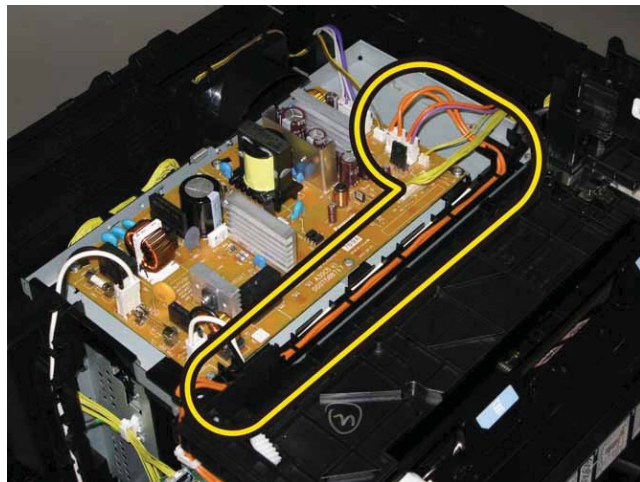

- 8) Release the clamps that fix the harness of the HARN ASSY INTERLOCK, remove the harness.

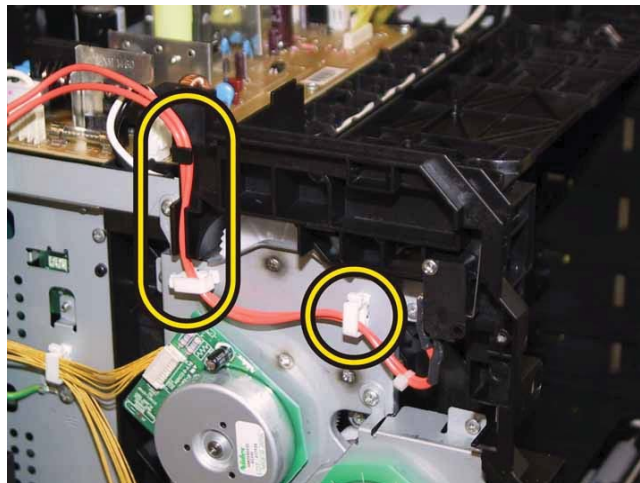

9) Remove the one screw (sliver, tap, 16mm) that fixes the HARN ASSY INTERLOCK to the printer, remove the HARN ASSY INTERLOCK.

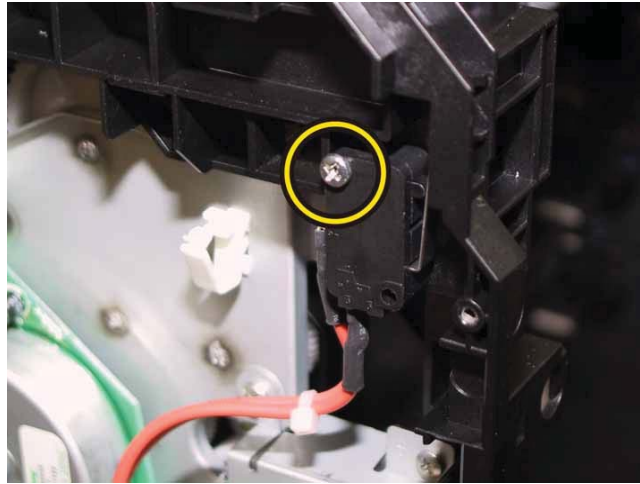

Removal 18 SENSOR HUM (PL8.2.7)

- 1) Remove the CASSETTE ASSY 250. (Removal 1)
- 2) Open the COVER ASSY FRONT MG (PL1.2.1).

Note: Cover the drum of the PHD ASSY to avoid exposure to light.

- 3) Remove the PHD ASSY. (Removal 4)

Note: The FUSER part is very hot. Take added care not to get burned when performing the service operation.

- 4) Remove the FUSER ASSY. (Removal 5)
- 5) Remove the COVER ASSY TOP. (Removal 10)
- 6) Remove the COVER SIDE L. (Removal 16)

7) Remove the one screw (silver, tap, 8mm) that fixes the SENSOR HUM (PL8.2.7) to the printer, remove the SENSOR HUM.

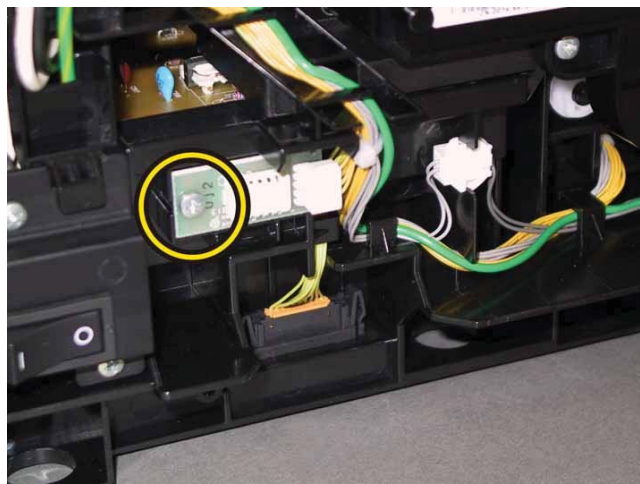

8) Disengage the connector (P/J201) of the SENSOR HUM.

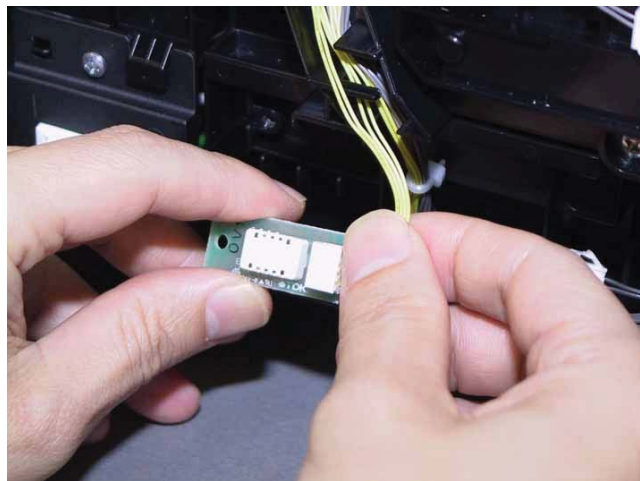

Removal 19 KIT PIVOT (PL6.1.99)

- 1) Remove the CASSETTE ASSY 250. (Removal 1)
- 2) Open the COVER ASSY FRONT MG (PL1.2.1).

Note: Cover the drum of the PHD ASSY to avoid exposure to light.

- 3) Remove the PHD ASSY. (Removal 4)

Note: The FUSER part is very hot. Take added care not to get burned when performing the service operation.

- 4) Remove the FUSER ASSY. (Removal 5)
- 5) Remove the COVER ASSY TOP. (Removal 10)
- 6) Remove the COVER ASSY WINDOW TNR. (Removal 8)
- 7) Remove the COVER SIDE R. (Removal 12)
- 8) Remove the COVER SIDE L. (Removal 16)

Accesses Position (All the numbers show the procedure number.)

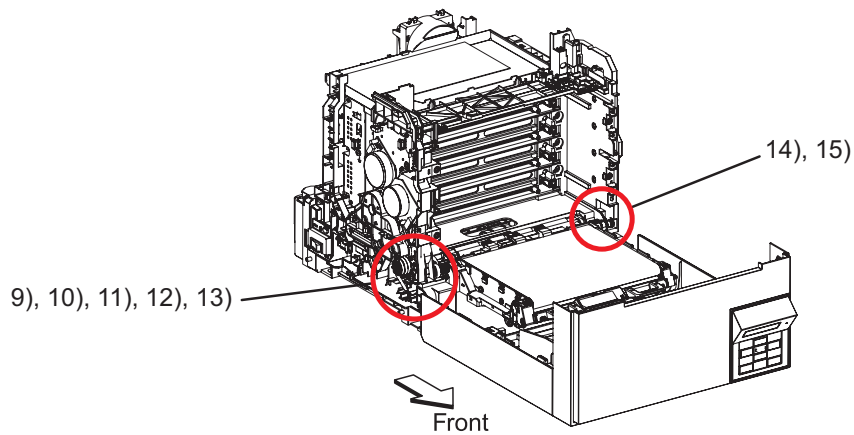

Note: When performing the step described below, it is not necessary to disengage the connector of the CLUTCH ASSY DRV.

- 9) Release the harness of the CLUTCH ASSY DRV (PL3.1.1) from the hook of the DRIVE ASSY PH (PL7.1.4).

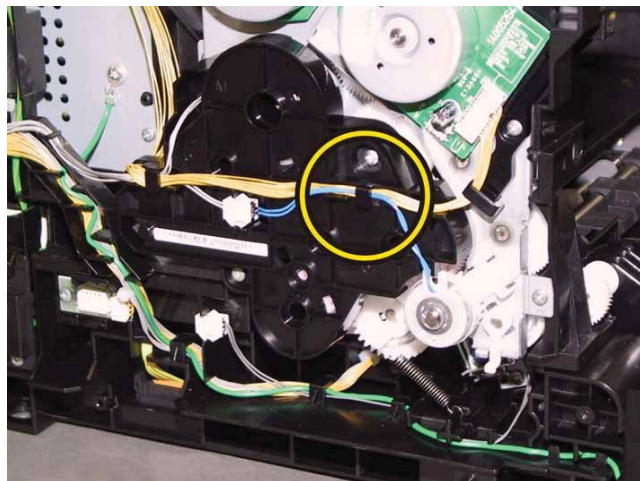

10) Remove the E-ring that fixes the CLUTCH ASSY DRV to the shaft, using a miniature screwdriver, remove the CLUTCH ASSY DRV.

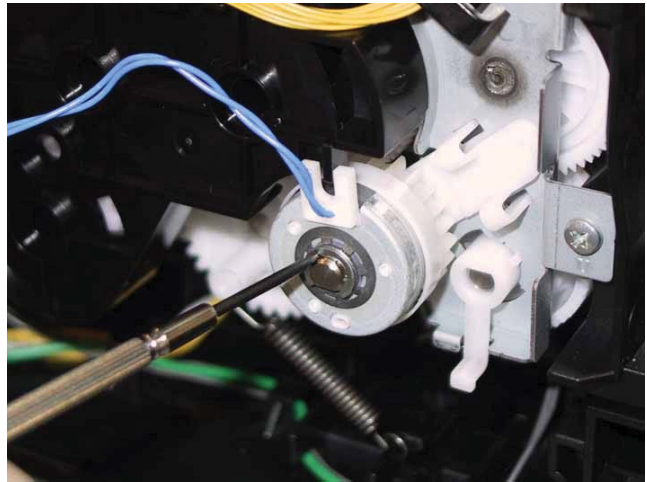

11) Rotate the STOPPER PIVOT (PL6.1.3), mate the tabs of the STOPPER PIVOT with the notches of the DRIVE ASSY MAIN (PL7.1.2).

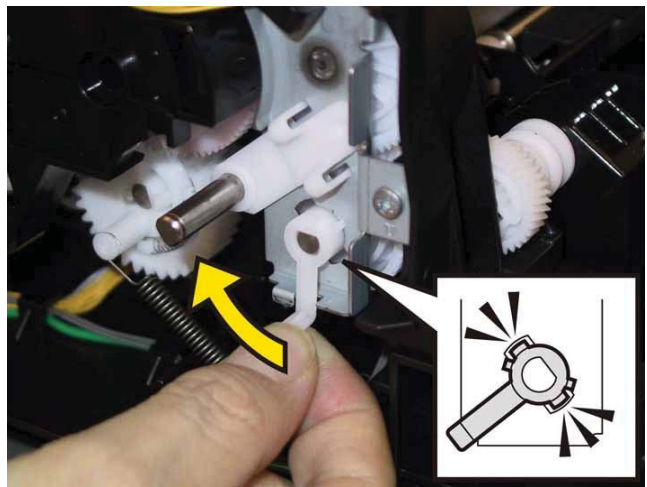

12) Remove the STOPPER PIVOT from the printer.

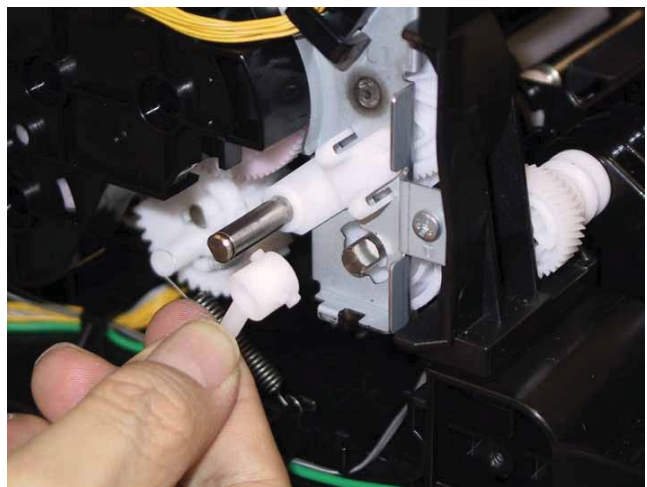

Note: When carrying out the work described next procedure, take care not to drop the GEAR T4.

13) Pull out the PIVOT TRANS L (PL6.1.4), remove the GEAR T4 (PL6.1.5) from the printer.

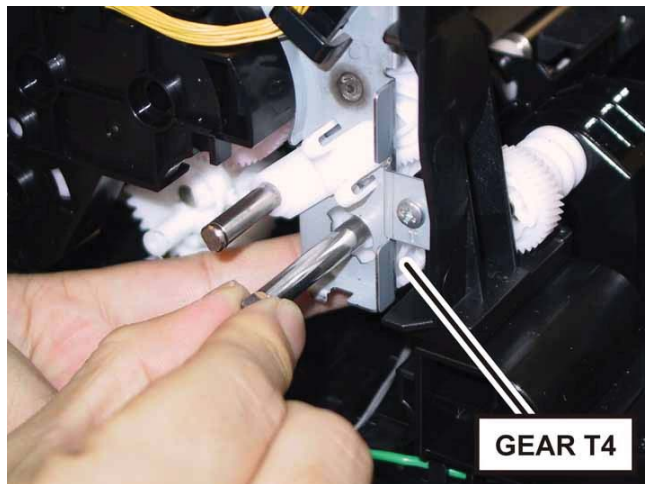

14) Remove the one screw (silver, tap, 8mm) that fixes the SHAFT ASSY PIVOT (PL6.1.6) to the printer.

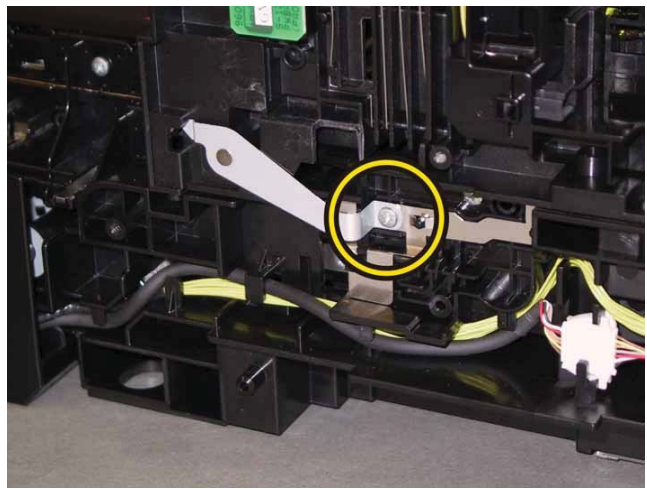

Note: When carrying out the work described next procedure, keep the TRANSFER ASSY slightly lifted for ease of work.

15) Pull out the SHAFT ASSY PIVOT from the printer.



Removal 20 KIT TRANSFER ASSY (PL6.1.98)

- 1) Remove the CASSETTE ASSY 250. (Removal 1)
- 2) Open the COVER ASSY FRONT MG (PL1.2.1).

Note: Cover the drum of the PHD ASSY to avoid exposure to light.

- 3) Remove the PHD ASSY. (Removal 4)

Note: The FUSER part is very hot. Take added care not to get burned when performing the service operation.

- 4) Remove the FUSER ASSY. (Removal 5)
- 5) Remove the COVER ASSY TOP. (Removal 10)
- 6) Remove the COVER ASSY WINDOW TNR. (Removal 8)
- 7) Remove the COVER SIDE R. (Removal 12)
- 8) Remove the COVER SIDE L. (Removal 16)
- 9) Close the TRANSFER ASSY (PL6.1.7).

Note: When carrying out the work described next procedure, take care not to scratch the belt surface of the TRANSFER ASSY.

- 10) Release the hooks of the COVER HARNESS (PL6.1.8), using a miniature screwdriver, and then remove the COVER HARNESS.

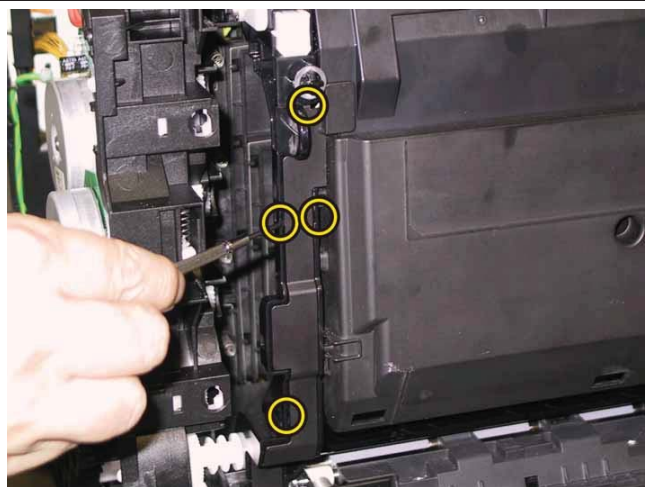

Note: When carrying out the work described below, leave the relay connector on the TRANSFER ASSY harness side.

11) Release the harness from the pegs of the TRANSFER ASSY, disengage the connector (P/J281) of the TRANSFER ASSY.

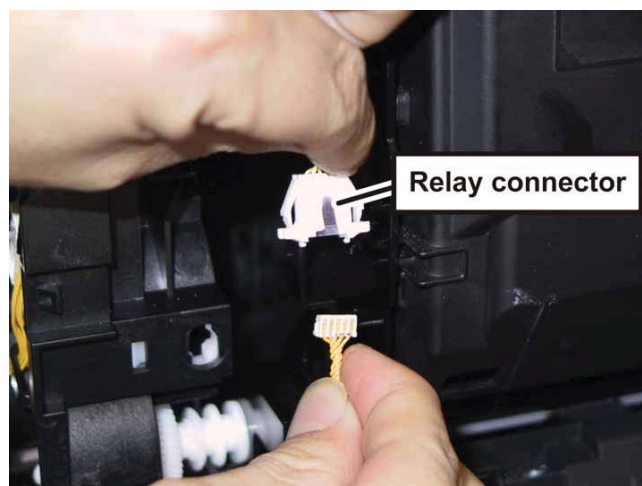

12) Release the harness coming from printer from hook of the TRANSFER ASSY.

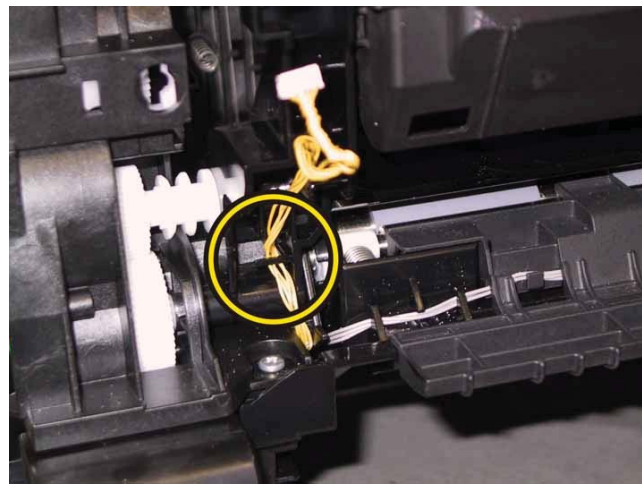

13) Tilt the TRANSFER ASSY slowly.

14) Remove the KIT PIVOT. (Removal 19)

15) Remove the TRANSFER ASSY from the printer.



Removal 21 SENSOR PHOTO: SSI NO PAPER (PL3.2.13)

- 1) Remove the CASSETTE ASSY 250. (Removal 1)
- 2) Open the COVER ASSY FRONT MG (PL1.2.1).

Note: Cover the drum of the PHD ASSY to avoid exposure to light.

- 3) Remove the PHD ASSY. (Removal 4)

Note: The FUSER part is very hot. Take added care not to get burned when performing the service operation.

- 4) Remove the FUSER ASSY. (Removal 5)
- 5) Remove the COVER ASSY TOP. (Removal 10)
- 6) Remove the COVER ASSY WINDOW TNR. (Removal 8)
- 7) Remove the COVER SIDE R. (Removal 12)
- 8) Remove the COVER SIDE L. (Removal 16)
- 9) Remove the KIT TRANSFER ASSY. (Removal 20)

Note: When carrying out the work described next procedure, take care not to move the BRACKET SNS from the printer too far because they are connected with the harness.

10) Remove the two screws (silver, tap, 8mm) that fix the BRACKET SNS (PL3.2.28) to the printer, remove the BRACKET SNS.

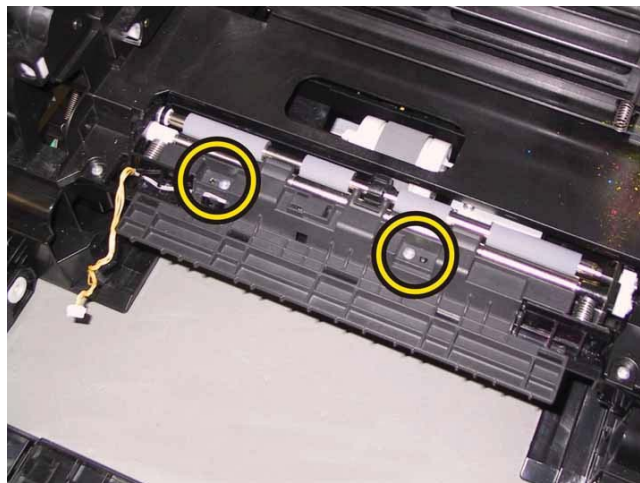

11) Lift the rear part of the BRACKET SNS up to release the two holes of the BRACKET SNS from the bosses of the printer.

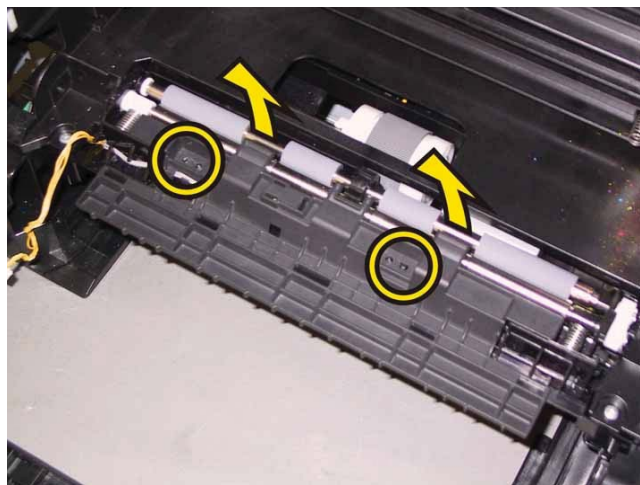

12) Shift the BRACKET SNS to frontward, release the five tabs of the BRACKET SNS from the printer. Remove the BRACKET SNS.

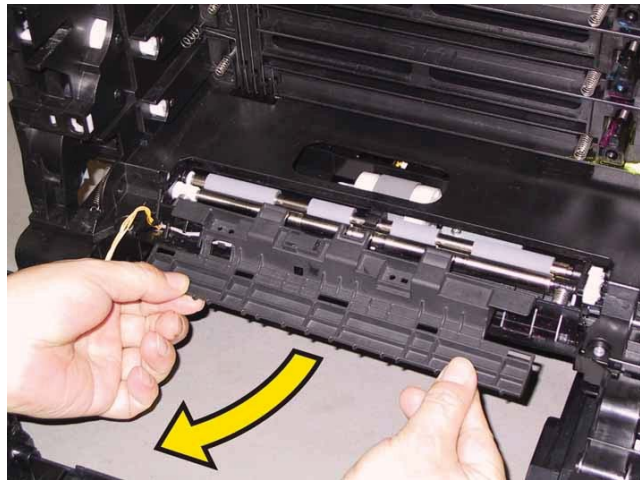

13) Release the three hooks that fix the SENSOR PHOTO: SSI NO PAPER (PL3.2.13) to the BRACKET SNS, and remove the SENSOR PHOTO: SSI NO PAPER.

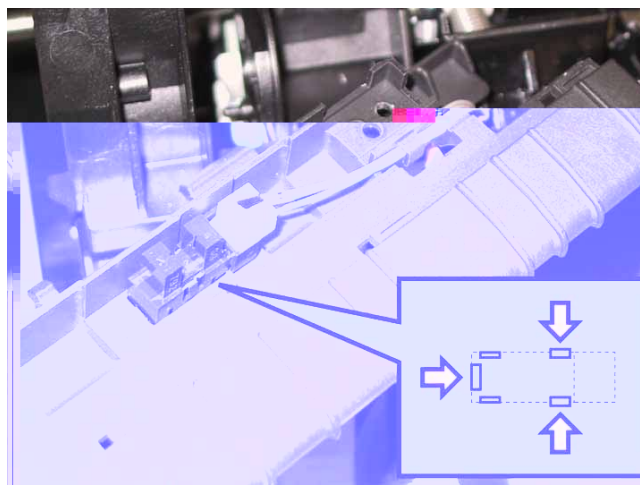

14) Disengage the connector (P/J233) of the SENSOR PHOTO: SSI NO PAPER.

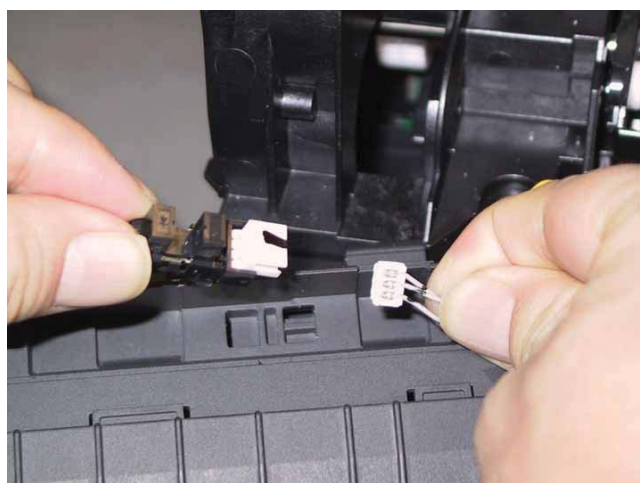

Removal 22 ACTUATOR SSI (PL3.2.14)

- 1) Remove the CASSETTE ASSY 250. (Removal 1)
- 2) Open the COVER ASSY FRONT MG (PL1.2.1).

Note: Cover the drum of the PHD ASSY to avoid exposure to light.

- 3) Remove the PHD ASSY. (Removal 4)

Note: The FUSER part is very hot. Take added care not to get burned when performing the service operation.

- 4) Remove the FUSER ASSY. (Removal 5)
- 5) Remove the COVER ASSY TOP. (Removal 10)
- 6) Remove the COVER ASSY WINDOW TNR. (Removal 8)
- 7) Remove the COVER SIDE R. (Removal 12)
- 8) Remove the COVER SIDE L. (Removal 16)
- 9) Remove the KIT TRANSFER ASSY. (Removal 20)

Note: When carrying out the work described next procedure, take care not to move the BRACKET SNS from the printer too far because they are connected with the harness.

10) Remove the two screws (silver, tap, 8mm) that fix the BRACKET SNS (PL3.2.28) to the printer, remove the BRACKET SNS.

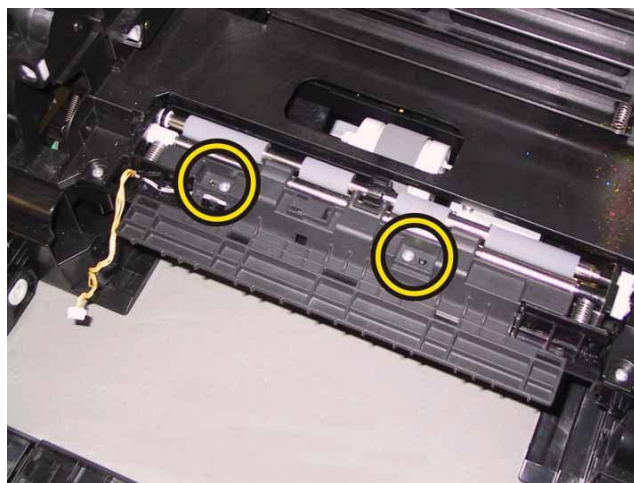

11) Lift the rear part of the BRACKET SNS up to release the two holes of the BRACKET SNS from the bosses of the printer.

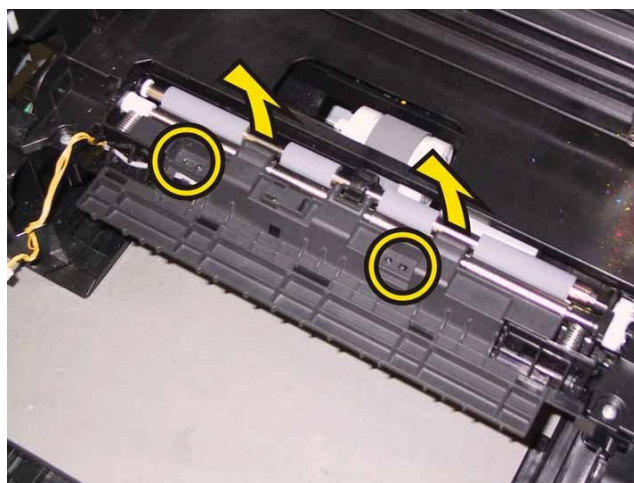

12) Shift the BRACKET SNS to frontward, release the five tabs of the BRACKET SNS from the printer. Remove the BRACKET SNS.

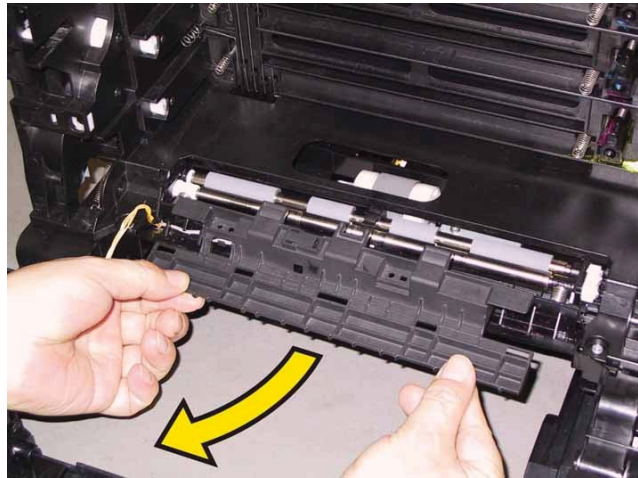

13) Release the left shaft of the ACTUATOR SSI (PL3.2.14) from the hook of the CHUTE UP (PL3.2.26).

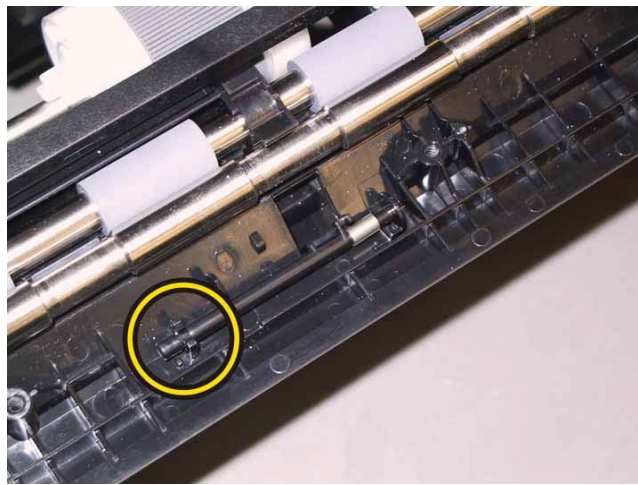

14) Remove the ACTUATOR SSI and the SPRING ACT SSI (PL3.2.15) by releasing the right shaft of the ACTUATOR SSI from the hole of the CHUTE UP.

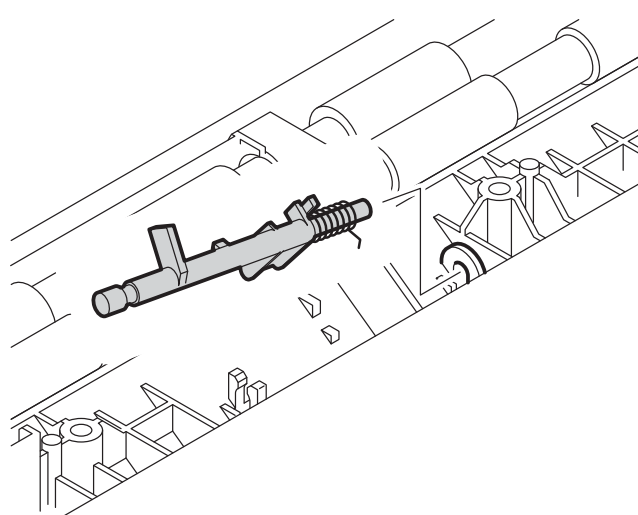

15) Remove the SPRING ACT SSI from the ACTUATOR SSI.

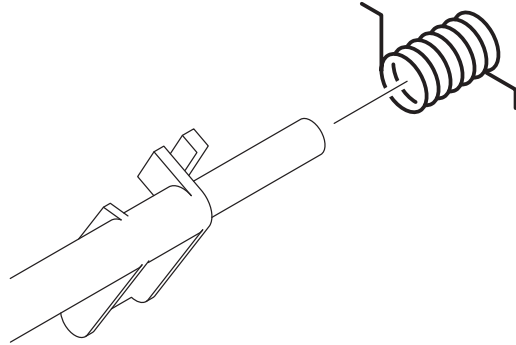

Removal 23 KIT SHAFT PIVOT (PL1.2.98)

Note: Described below is the removal procedure common among the left and right SHAFT PIVOTS (PL1.2.23).

1) Remove the CASSETTE ASSY 250. (Removal 1)

2) Release the hook of the SHAFT PIVOT (PL1.2.23) to pull out the SHAFT PIVOT.

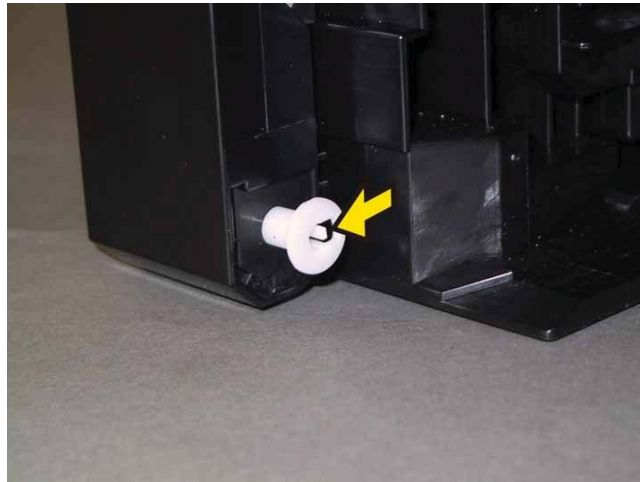

Removal 24 COVER ASSY FRONT MG (PL1.2.1)

- 1) Remove the CASSETTE ASSY 250. (Removal 1)
- 2) Open the COVER ASSY FRONT MG (PL1.2.1).
- 3) Remove the FEEDER ASSY DUP SFP STD. (Removal 56) [2150cdn Only]

Note: Cover the drum of the PHD ASSY to avoid exposure to light.

- 4) Remove the PHD ASSY. (Removal 4)

Note: The FUSER part is very hot. Take added care not to get burned when performing the service operation.

- 5) Remove the FUSER ASSY. (Removal 5)
- 6) Remove the COVER ASSY TOP. (Removal 10)
- 7) Remove the COVER ASSY WINDOW TNR. (Removal 8)
- 8) Remove the COVER SIDE R. (Removal 12)
- 9) Remove the COVER SIDE L. (Removal 16)

Accesses Position (All the numbers show the procedure number.)

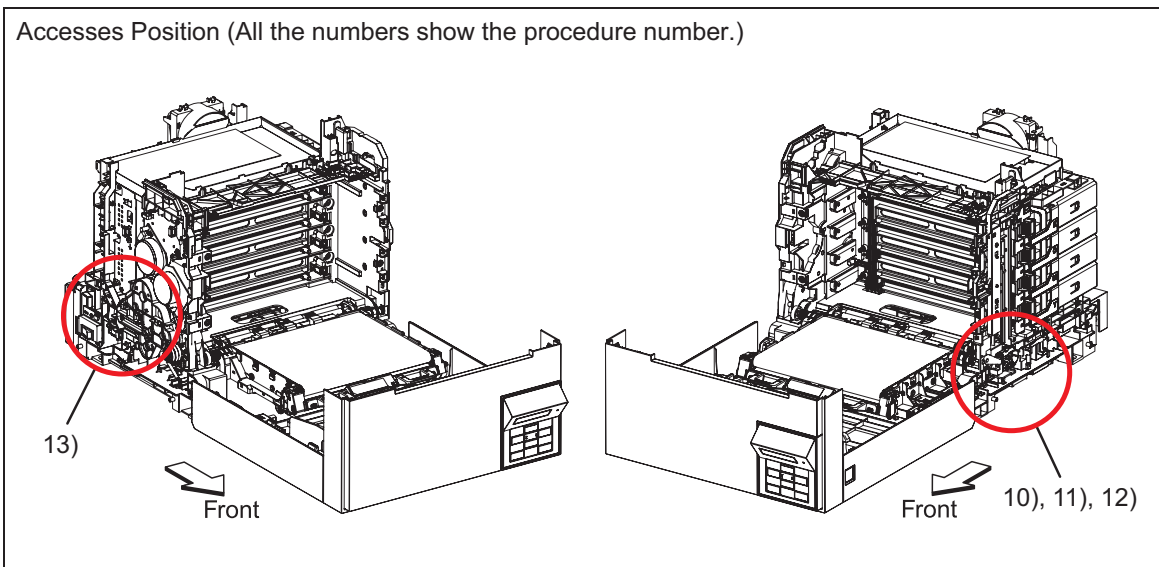

Note: When carrying out the work described next procedure, leave the relay connector on the printer harness side.

10) Release the relay connector from the rib of the printer, disengage the connector (P/J271) of the HARN ASSY DUP RELAY (PL1.2.13).

Note: This step is only 2150cdn.

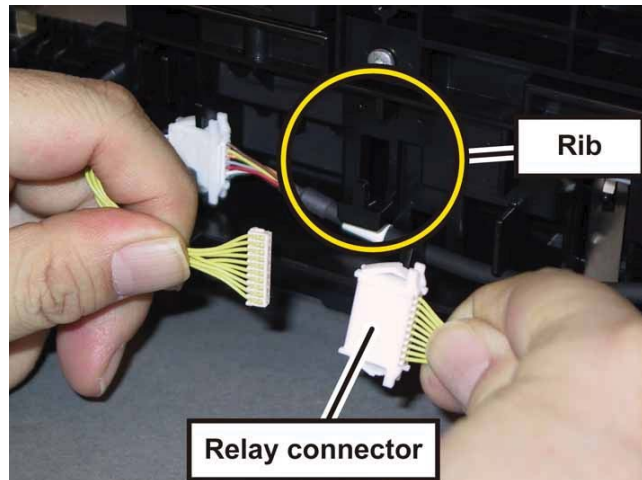

Note: When carrying out the work described below, leave the relay connector on the COVER ASSY FRONT MG side.

11) Release the harness of the HARNESS ASSY PNL A (PL1.1.12) from the rib of the printer, disengage the connector (P/J5301) of the HARNESS ASSY B (PL9.1.12).

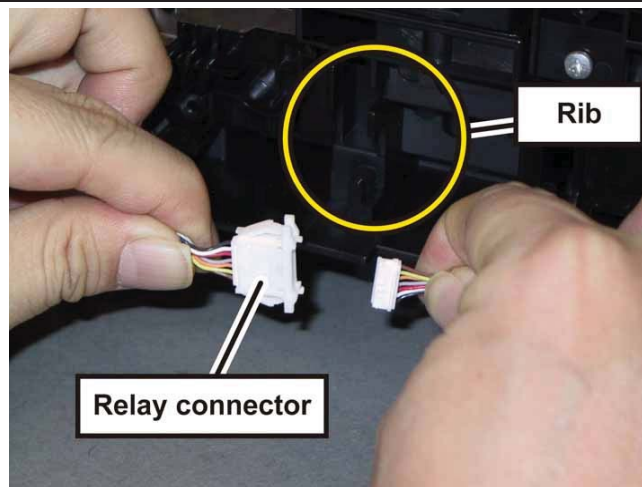

12) Release the HARN ASSY DUP RELAY and the HARNESS ASSY PNL A from the hooks of the printer.

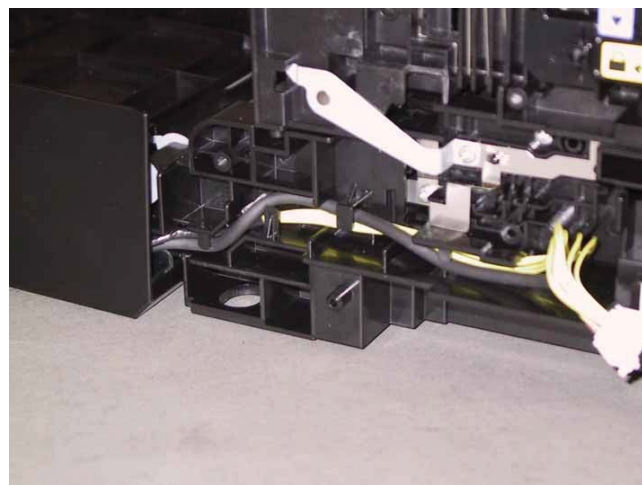

13) Remove the one screw (silver, 6mm) that fixes the grounding terminal of the HARN ASSY GND (PL1.2.22), release the HARN ASSY GND from the GUIDE HARNESS AC (PL8.2.6) and the hooks of the printer.

Note: This step is only 2150cdn.

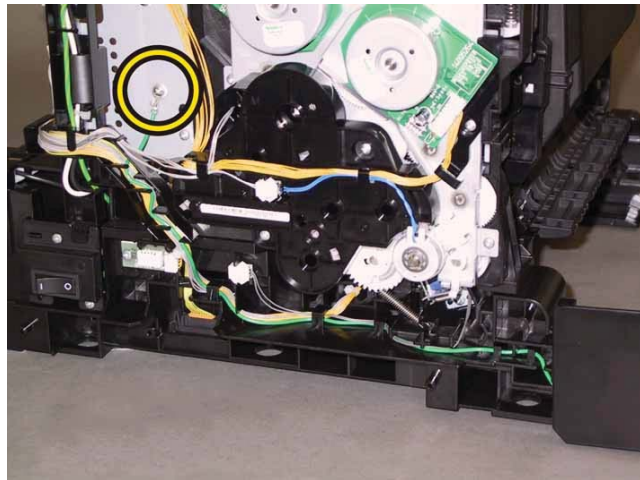

Note: Described below is the removal procedure common among the left and right COVER LINK FRONTS (PL1.2.30).

14) Release the two hooks of the COVER LINK FRONT (PL1.2.30), using a miniature screwdriver.

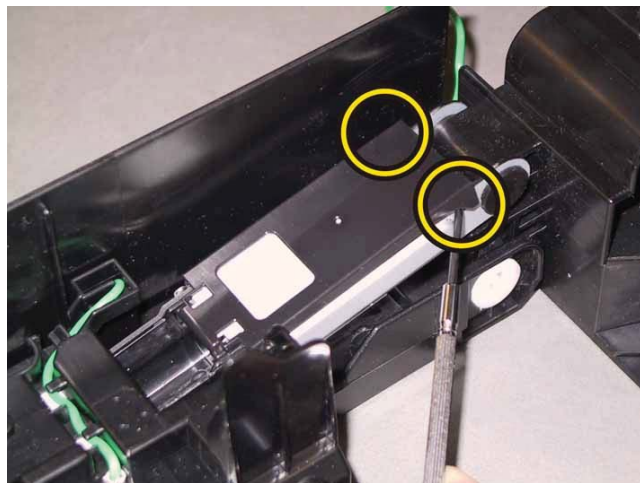

15) Shift the COVER LINK FRONT to front, remove the COVER LINK FRONT from the LINK ASSY FRONT (PL1.2.18).



Note: Described below is the removal procedure common among the left and right SPRING LINK FRONTS (PL1.2.24).

16) Lift the COVER ASSY FRONT MG slightly up to remove the SPRING LINK FRONT (PL1.2.24) from the LINK ASSY FRONT, using a miniature screwdriver.

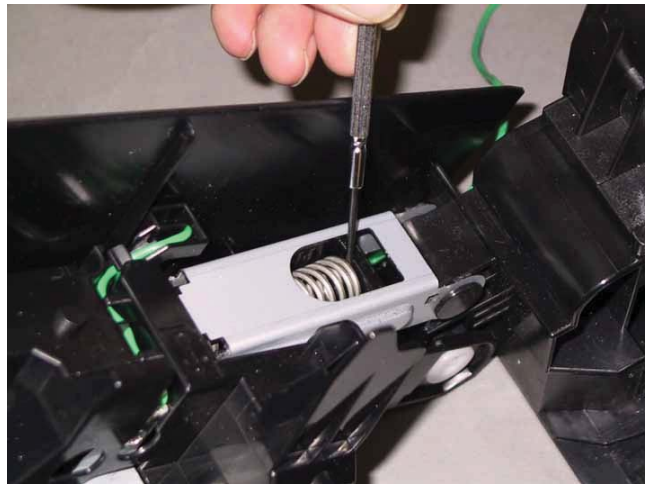

17) Remove the SPRING LINK FRONT from the printer.

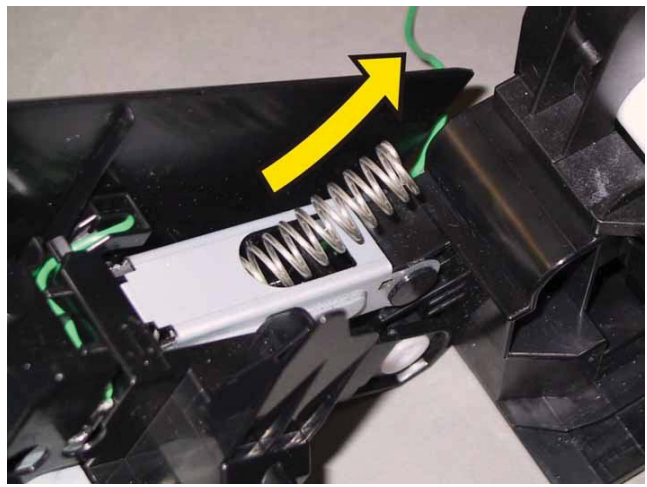

Note: Described below is the removal procedure common among the left and right SHAFT LINK FRONT FDRs (PL1.2.26).

18) Release the hook of the SHAFT LINK FRONT FDR (PL1.2.26) using a miniature screwdriver, to pull out the SHAFT LINK FRONT FDR.

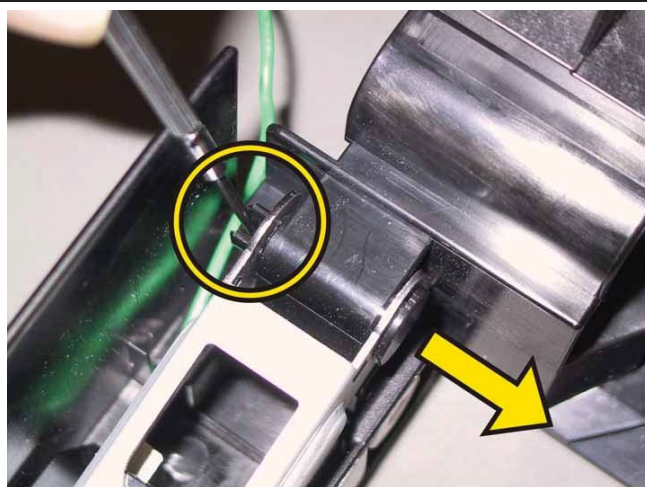

Note: Described below is the removal procedure common among the left and right SHAFT PIVOTS (PL1.2.23).

19) Release the hook of the SHAFT PIVOT (PL1.2.23) to pull out the SHAFT PIVOT.

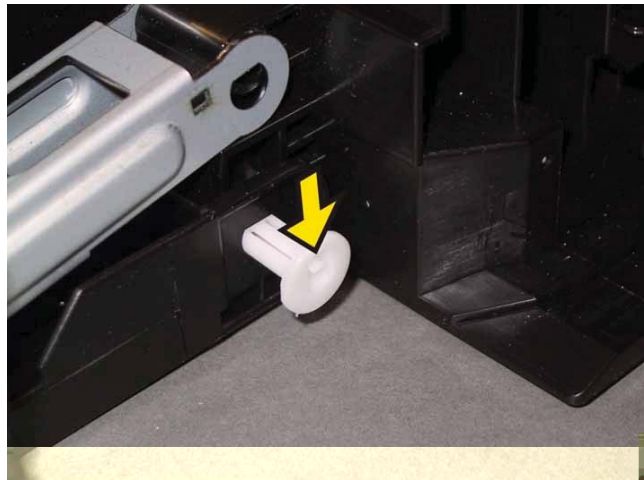

20) Lift the COVER ASSY FRONT MG slightly up to remove the COVER ASSY FRONT MG from the printer.

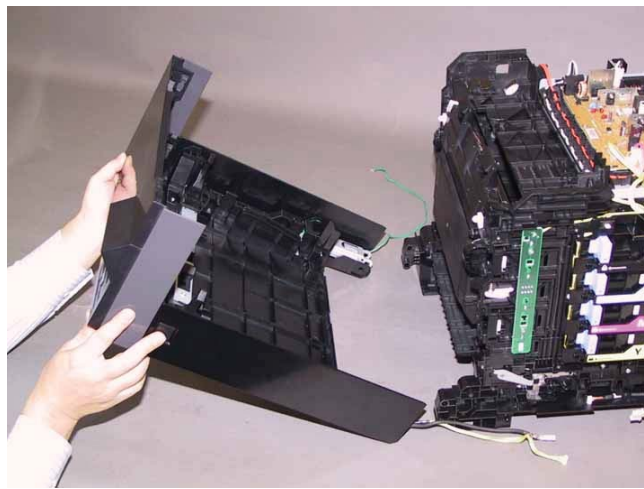

Removal 25 CONSOLE ASSY PANEL (PL1.2.3)

- 1) Remove the CASSETTE ASSY 250. (Removal 1)
- 2) Open the COVER ASSY FRONT MG (PL1.2.1).
- 3) Remove the FEEDER ASSY DUP SFP STD. (Removal 56) [2150cdn Only]

Note: Cover the drum of the PHD ASSY to avoid exposure to light.

- 4) Remove the PHD ASSY. (Removal 4)

Note: The FUSER part is very hot. Take added care not to get burned when performing the service operation.

- 5) Remove the FUSER ASSY. (Removal 5)
- 6) Remove the COVER ASSY TOP. (Removal 10)
- 7) Remove the COVER ASSY WINDOW TNR. (Removal 8)
- 8) Remove the COVER SIDE R. (Removal 12)
- 9) Remove the COVER SIDE L. (Removal 16)
- 10) Remove the COVER ASSY FRONT MG. (Removal 24)

- 11) Release the two hooks of the COVER CONNECTOR (PL1.2.4).

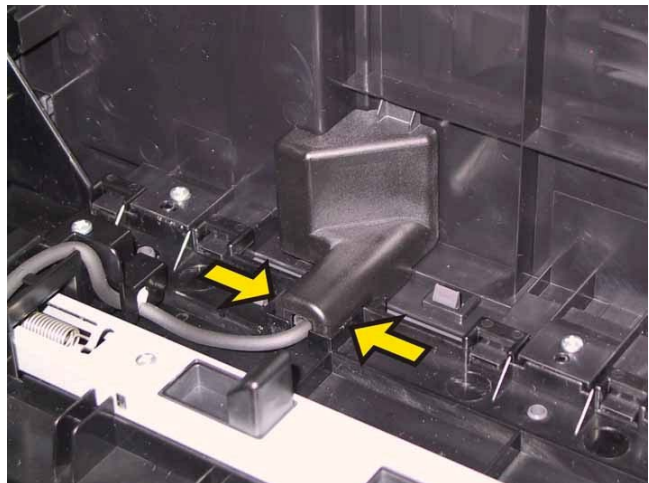

- 12) Remove the COVER CONNECTOR from the COVER ASSY FRONT MG.



13) Disengage the connector (P/J202) of the CONSOLE ASSY PANEL (PL1.2.3).

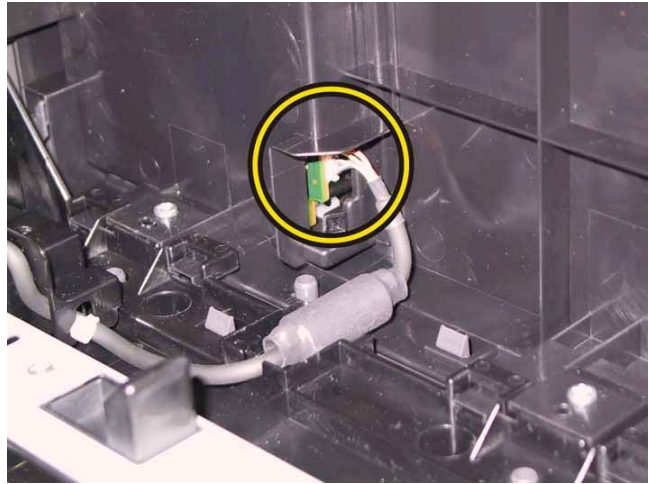

14) Release the four hooks of the COVER FRONT BAND.

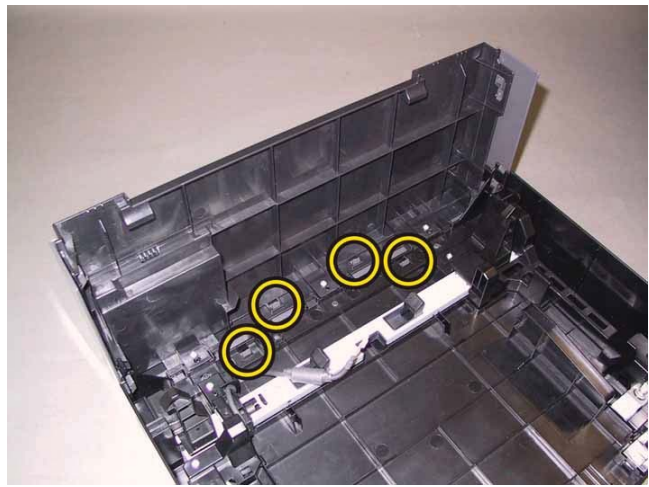

15) Release the left and right hooks of the COVER FRONT BAND.

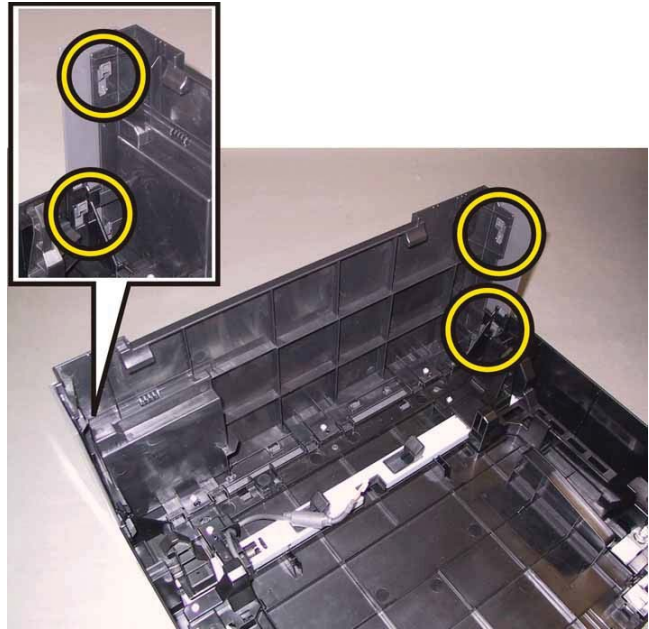

16) Remove the COVER FRONT BAND from the COVER ASSY FRONT MG.

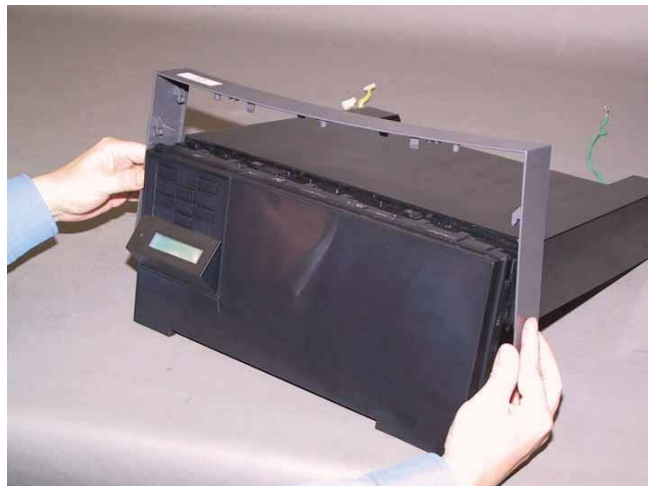

17) Release the two hooks of the CONSOLE ASSY PANEL, using a miniature screwdriver.



18) Release the tab of the CONSOLE ASSY PANEL from the hole of the COVER ASSY FRONT MG, remove the CONSOLE ASSY PANEL.



Removal 26 LATCH ASSY FRONT (PL1.2.5), BUTTON LATCH FRONT (PL1.2.11)

- 1) Remove the CASSETTE ASSY 250. (Removal 1)
- 2) Open the COVER ASSY FRONT MG (PL1.2.1).
- 3) Remove the FEEDER ASSY DUP SFP STD. (Removal 56) [2150cdn Only]

Note: Cover the drum of the PHD ASSY to avoid exposure to light.

- 4) Remove the PHD ASSY. (Removal 4)

Note: The FUSER part is very hot. Take added care not to get burned when performing the service operation.

- 5) Remove the FUSER ASSY. (Removal 5)
- 6) Remove the COVER ASSY TOP. (Removal 10)
- 7) Remove the COVER ASSY WINDOW TNR. (Removal 8)
- 8) Remove the COVER SIDE R. (Removal 12)
- 9) Remove the COVER SIDE L. (Removal 16)
- 10) Remove the COVER ASSY FRONT MG. (Removal 24)

11) Remove the three screws (silver, tap, 8mm) that fix the HOLDER ASSY FRONT R (PL1.2.28) to the COVER ASSY FRONT MG.

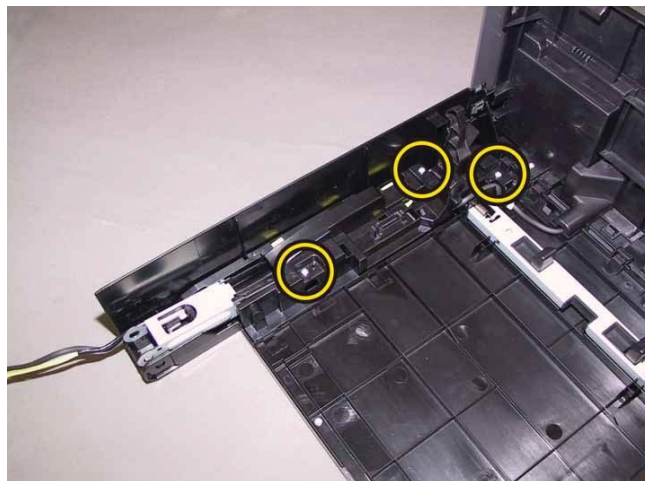

12) Release the one hook of the HOLDER ASSY FRONT R, using a miniature screwdriver.



13) Remove the HOLDER ASSY FRONT R from the COVER ASSY FRONT MG.

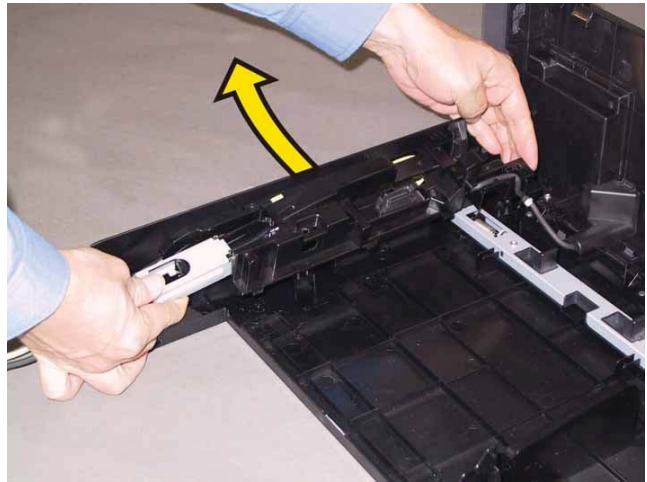

14) Remove the three screws (silver, tap, 8mm) that fix the HOLDER ASSY FRONT L (PL1.2.29) to the COVER ASSY FRONT MG.

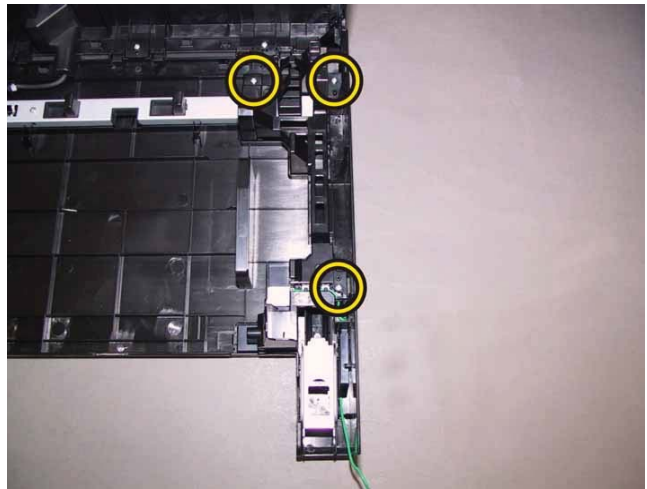

15) Release the two hooks of the HOLDER ASSY FRONT L, using a miniature screwdriver.

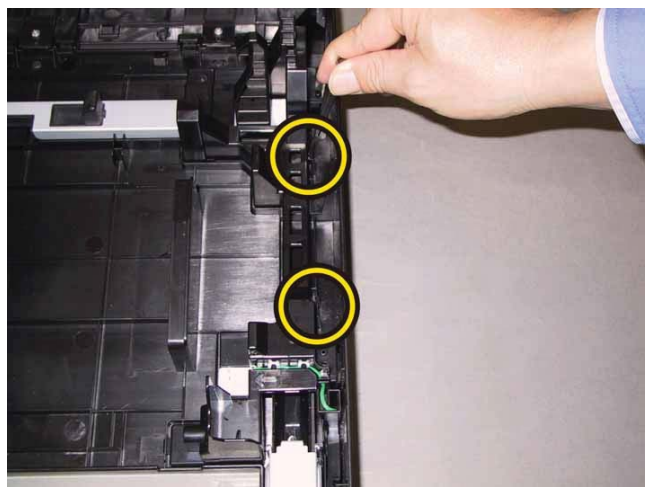

16) Remove the HOLDER ASSY FRONT L from the COVER ASSY FRONT MG.



17) Remove the SPRING LATCH FRONT (PL1.2.10) from the LATCH ASSY FRONT (PL1.2.5).

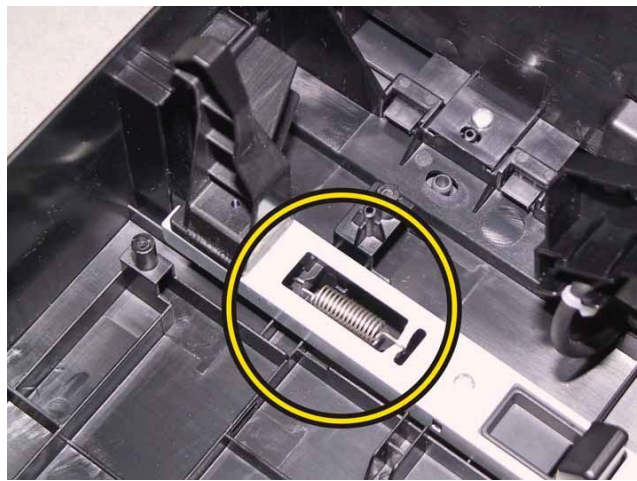

18) Remove the LATCH ASSY FRONT from the COVER ASSY FRONT MG together with the BUTTON LATCH FRONT (PL1.2.11).

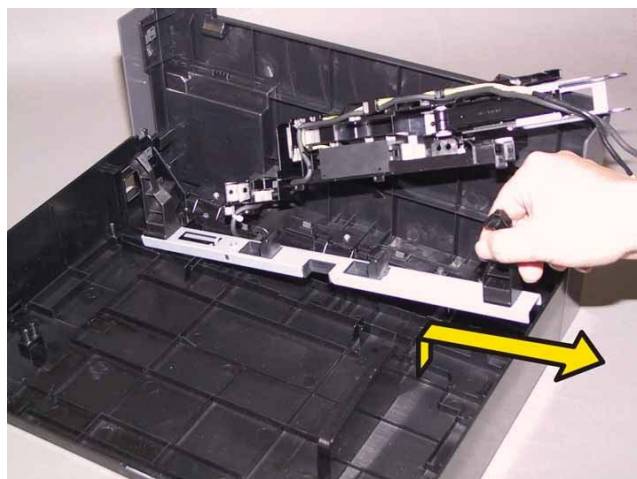

19) Remove the BUTTON LATCH FRONT from the LATCH ASSY FRONT.

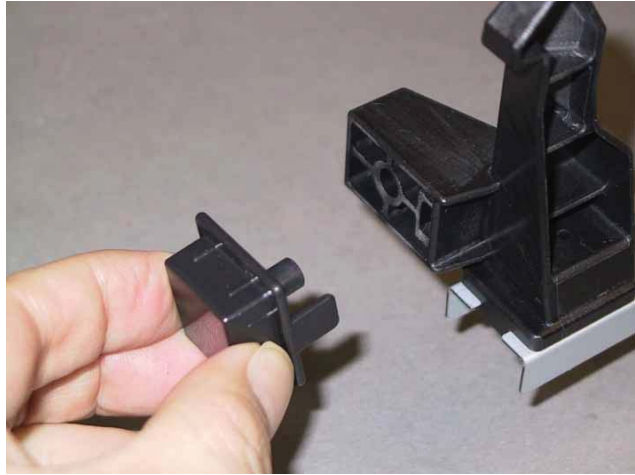

Removal 27 HARNESS ASSY PNL A (PL1.2.12)

- 1) Remove the CASSETTE ASSY 250. (Removal 1)
- 2) Open the COVER ASSY FRONT MG (PL1.2.1).
- 3) Remove the FEEDER ASSY DUP SFP STD. (Removal 56) [2150cdn Only]

Note: Cover the drum of the PHD ASSY to avoid exposure to light.

- 4) Remove the PHD ASSY. (Removal 4)

Note: The FUSER part is very hot. Take added care not to get burned when performing the service operation.

- 5) Remove the FUSER ASSY. (Removal 5)
- 6) Remove the COVER ASSY TOP. (Removal 10)
- 7) Remove the COVER ASSY WINDOW TNR. (Removal 8)
- 8) Remove the COVER SIDE R. (Removal 12)
- 9) Remove the COVER SIDE L. (Removal 16)
- 10) Remove the COVER ASSY FRONT MG. (Removal 24)

- 11) Release the two hooks of the COVER CONNECTOR (PL1.2.4).

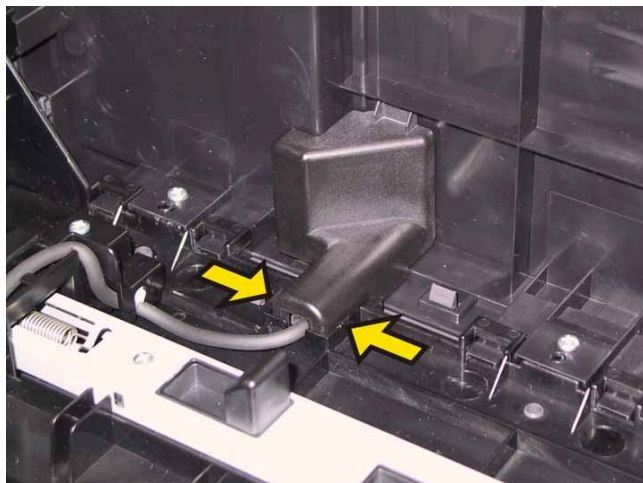

- 12) Remove the COVER CONNECTOR from the COVER ASSY FRONT MG.



13) Disengage the connector (P/J202) of the CONSOLE ASSY PANEL (PL1.2.3).

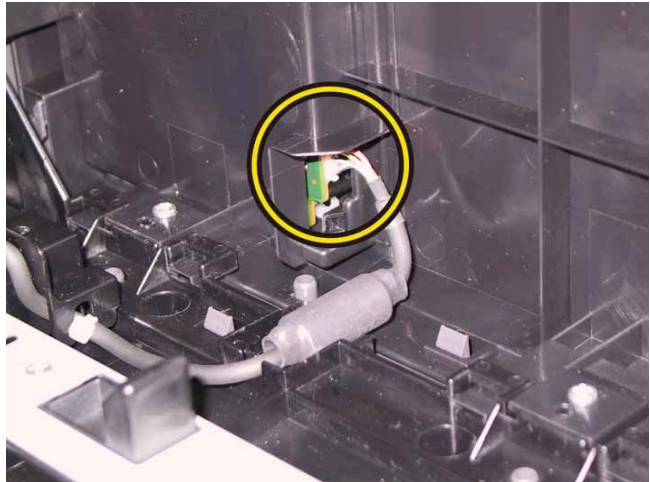

14) Remove the three screws (silver, tap, 8mm) that fix the HOLDER ASSY FRONT R (PL1.2.28) to the COVER ASSY FRONT MG.

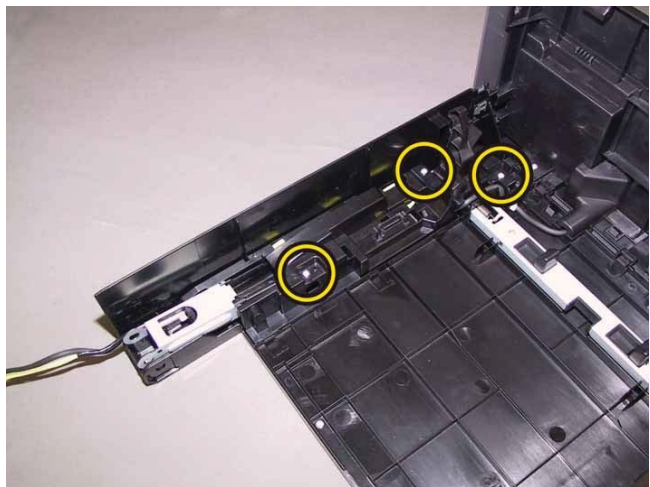

15) Release the one hook of the HOLDER ASSY FRONT R, using a miniature screwdriver.

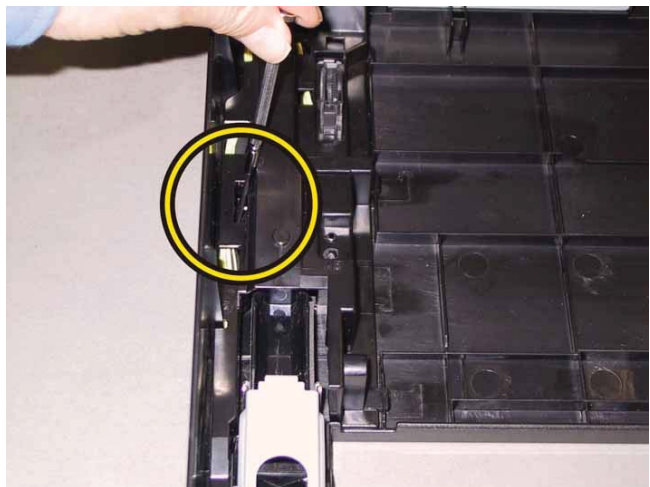

16) Remove the HOLDER ASSY FRONT R from the COVER ASSY FRONT MG.

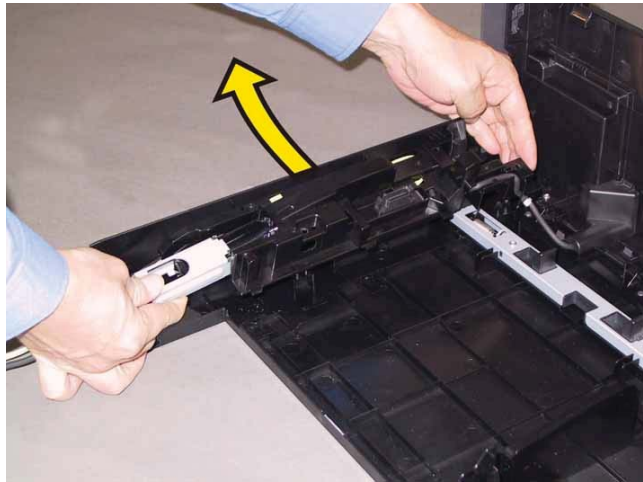

17) Release the HARNESS ASSY PNL A (PL1.2.12) from the hooks of the HOLDER ASSY FRONT R, remove the HARNESS ASSY PNL A.



Removal 28 HARN ASSY DUP RELAY (PL1.2.13) [2150cdn Only]

- 1) Remove the CASSETTE ASSY 250. (Removal 1)
- 2) Open the COVER ASSY FRONT MG (PL1.2.1).
- 3) Remove the FEEDER ASSY DUP SFP STD. (Removal 56) [2150cdn Only]

Note: Cover the drum of the PHD ASSY to avoid exposure to light.

- 4) Remove the PHD ASSY. (Removal 4)

Note: The FUSER part is very hot. Take added care not to get burned when performing the service operation.

- 5) Remove the FUSER ASSY. (Removal 5)
- 6) Remove the COVER ASSY TOP. (Removal 10)
- 7) Remove the COVER ASSY WINDOW TNR. (Removal 8)
- 8) Remove the COVER SIDE R. (Removal 12)
- 9) Remove the COVER SIDE L. (Removal 16)
- 10) Remove the COVER ASSY FRONT MG. (Removal 24)

- 11) Release the two hooks of the COVER CONNECTOR (PL1.2.4).

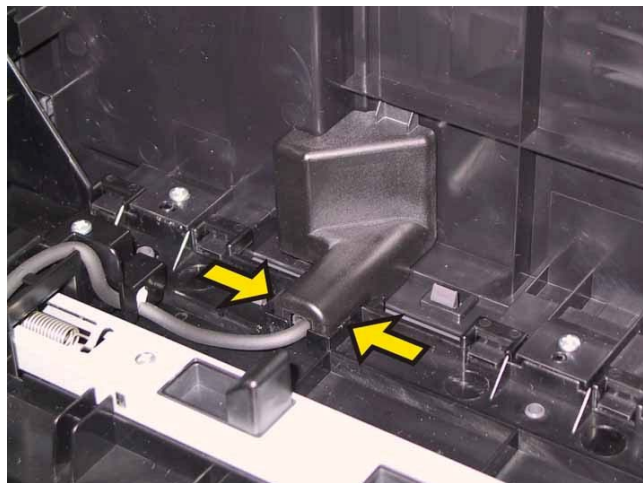

- 12) Remove the COVER CONNECTOR from the COVER ASSY FRONT MG.



13) Disengage the connector (P/J202) of the CONSOLE ASSY PANEL (PL1.2.3).

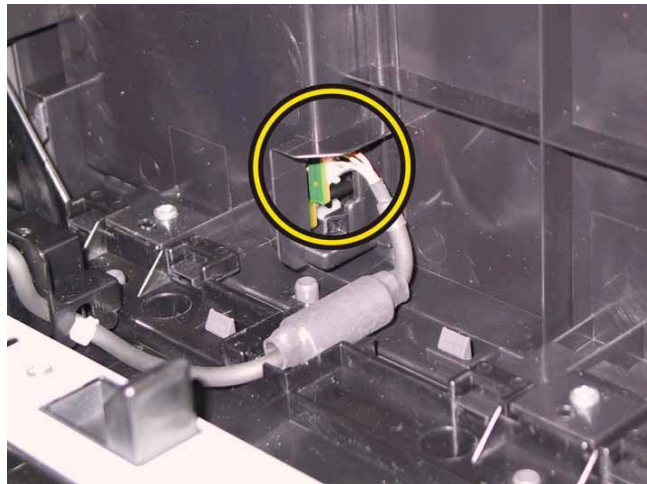

14) Remove the three screws (silver, tap, 8mm) that fix the HOLDER ASSY FRONT R (PL1.2.28) to the COVER ASSY FRONT MG.

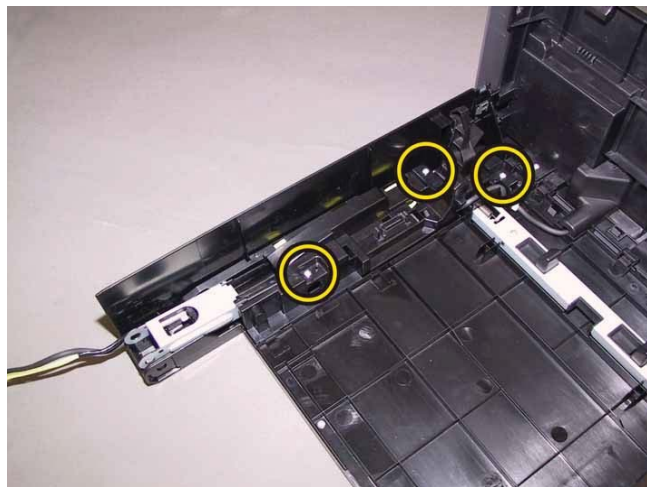

15) Release the one hook of the HOLDER ASSY FRONT R, using a miniature screwdriver.



16) Remove the HOLDER ASSY FRONT R from the COVER ASSY FRONT MG.

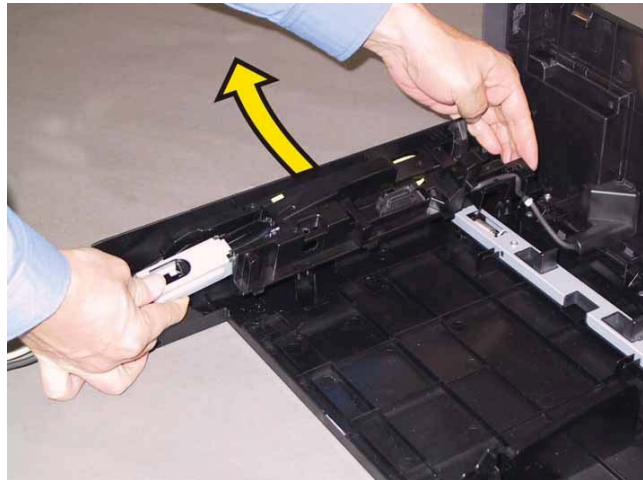

17) Release the two hooks of the COVER DRAWER (PL1.2.4), remove the COVER DRAWER from the HOLDER ASSY FRONT R.

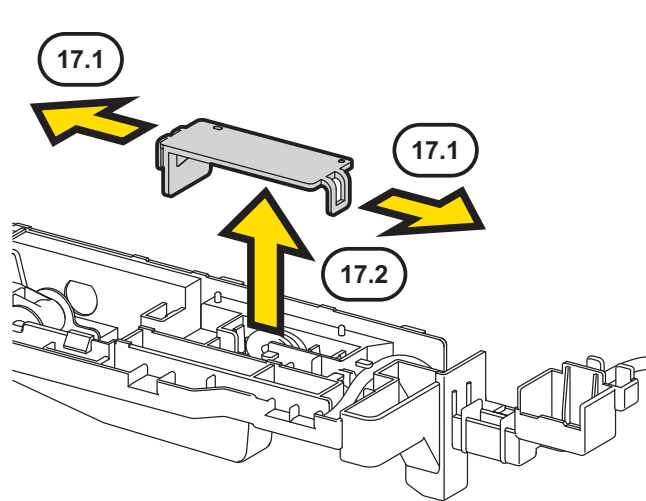

18) Release the harness of the HARN ASSY DUP RELAY (PL1.2.13) from the hooks of the HOLDER ASSY FRONT R.

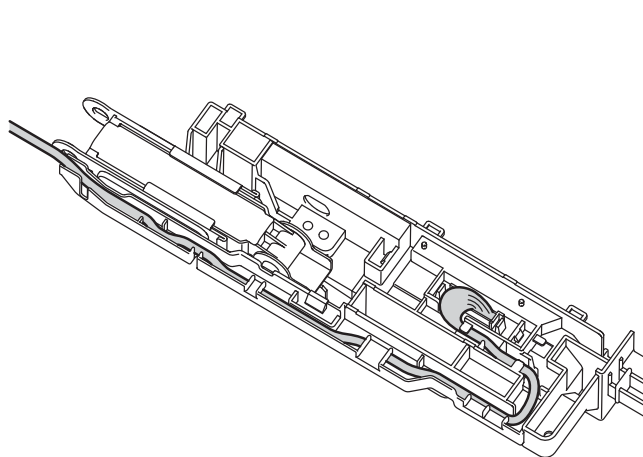

19) Release the two hooks on the connector (P272) of the HARN ASSY DUP RELAY, pull out the harness and connector (J271) through the hole on the HOLDER ASSY FRONT R, and remove the HARN ASSY DUP RELAY.

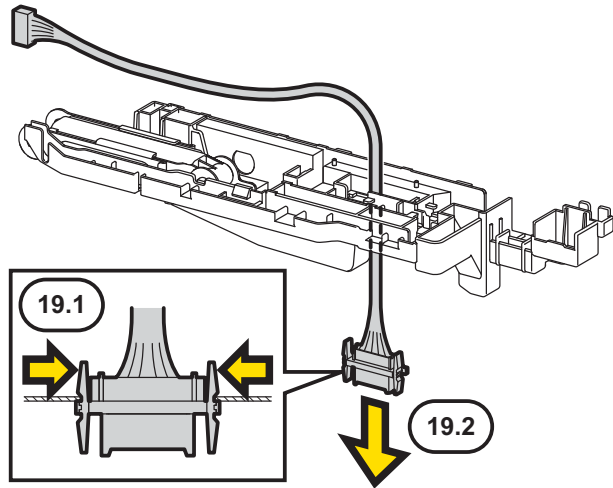

Removal 29 COVER REAR (PL1.1.3)

- 1) Remove the CASSETTE ASSY 250. (Removal 1)
- 2) Open the COVER ASSY FRONT MG (PL1.2.1).

Note: Cover the drum of the PHD ASSY to avoid exposure to light.

- 3) Remove the PHD ASSY. (Removal 4)

Note: The FUSER part is very hot. Take added care not to get burned when performing the service operation.

- 4) Remove the FUSER ASSY. (Removal 5)
- 5) Remove the COVER ASSY TOP. (Removal 10)
- 6) Remove the COVER ASSY WINDOW TNR. (Removal 8)
- 7) Remove the COVER SIDE R. (Removal 12)
- 8) Remove the COVER SIDE L. (Removal 16)

- 9) Remove the two screws (silver, tap, 8mm) that fix the COVER REAR (PL1.1.3) to the printer.



- 10) Remove the COVER REAR from the printer.

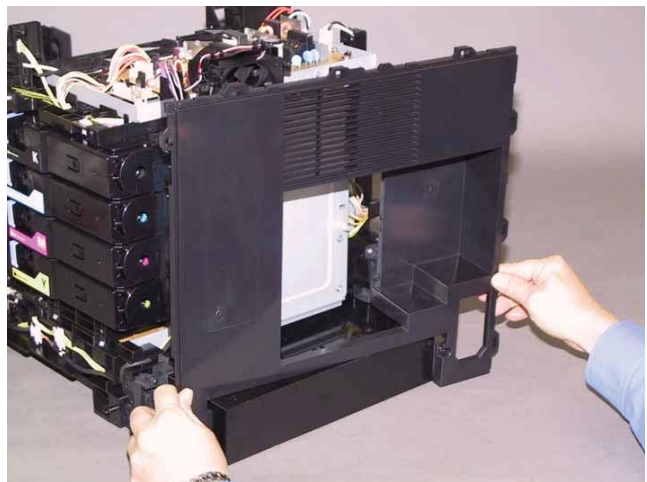

Removal 30 CLUTCH ASSY DRV (PL3.1.1), BEARING REGI (PL3.1.2)

- 1) Remove the CASSETTE ASSY 250. (Removal 1)
- 2) Open the COVER ASSY FRONT MG (PL1.2.1).

Note: Cover the drum of the PHD ASSY to avoid exposure to light.

- 3) Remove the PHD ASSY. (Removal 4)

Note: The FUSER part is very hot. Take added care not to get burned when performing the service operation.

- 4) Remove the FUSER ASSY. (Removal 5)
- 5) Remove the COVER ASSY TOP. (Removal 10)
- 6) Remove the COVER ASSY WINDOW TNR. (Removal 8)
- 7) Remove the COVER SIDE R. (Removal 12)
- 8) Remove the COVER SIDE L. (Removal 16)
- 9) Remove the COVER REAR. (Removal 29)

- 10) Release the harness of the CLUTCH ASSY DRV (PL3.1.1) from the hook of the DRIVE ASSY PH (PL7.1.4).

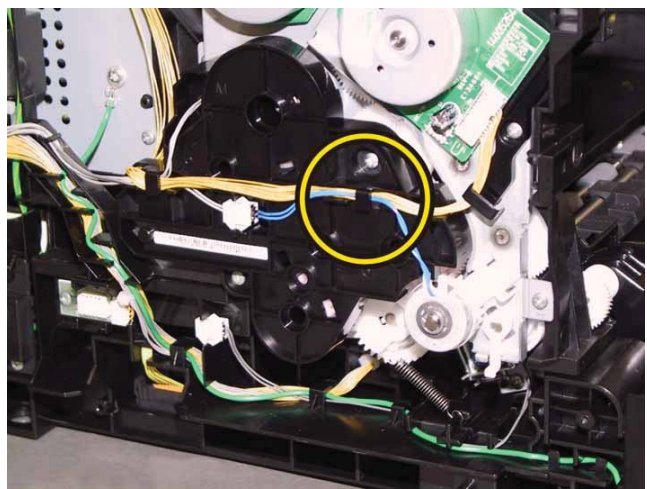

Note: When carrying out the work described below, leave the relay connector on the printer harness side.

- 11) Disengage the connector (P/J262) of the CLUTCH ASSY DRV.

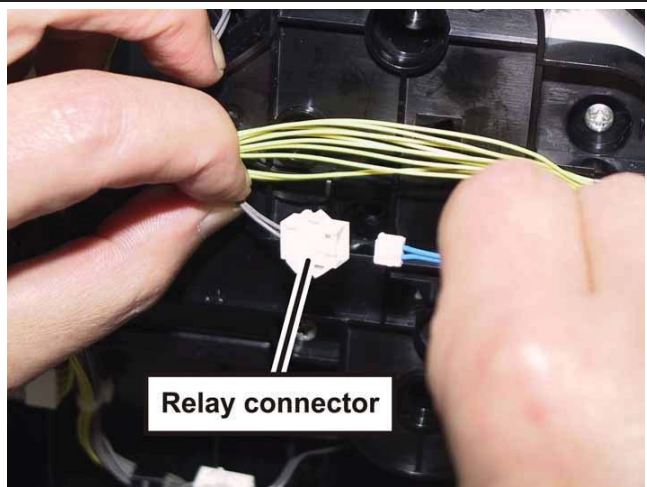

12) Remove the E-ring that fixes the CLUTCH ASSY DRV to the shaft, using a miniature screwdriver, remove the CLUTCH ASSY DRV.

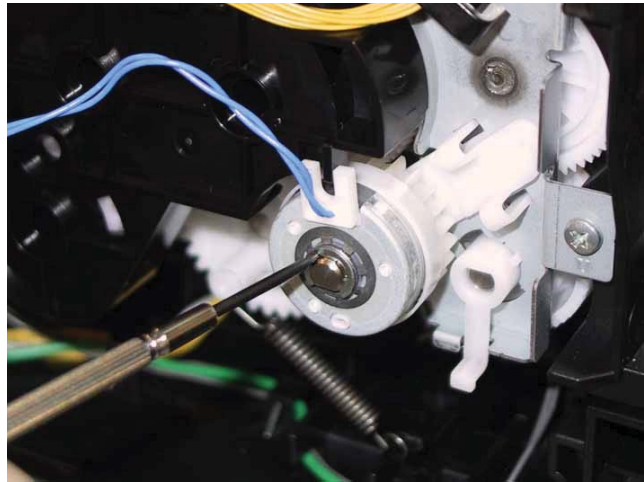

13) Release the two hooks of the BEARING REGI (PL3.1.2), remove the BEARING REGI from the shaft.

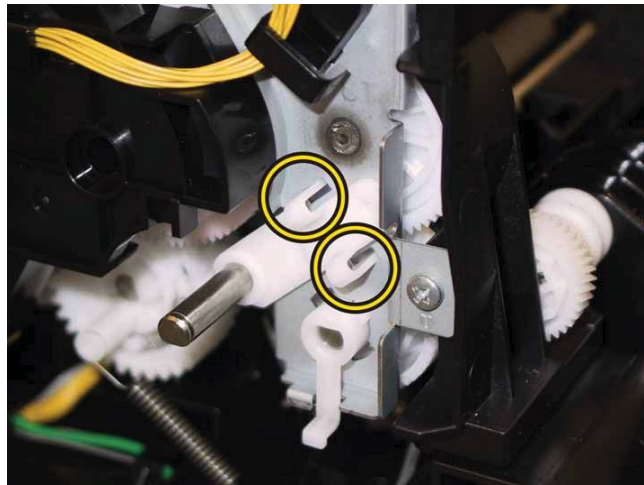

Removal 31 KIT DRIVE ASSY PH (PL7.1.99)

- 1) Remove the CASSETTE ASSY 250. (Removal 1)
- 2) Open the COVER ASSY FRONT MG (PL1.2.1).

Note: Cover the drum of the PHD ASSY to avoid exposure to light.

- 3) Remove the PHD ASSY. (Removal 4)

Note: The FUSER part is very hot. Take added care not to get burned when performing the service operation.

- 4) Remove the FUSER ASSY. (Removal 5)
- 5) Remove the COVER ASSY TOP. (Removal 10)
- 6) Remove the COVER ASSY WINDOW TNR. (Removal 8)
- 7) Remove the COVER SIDE R. (Removal 12)
- 8) Remove the COVER SIDE L. (Removal 16)
- 9) Remove the COVER REAR. (Removal 29)
- 10) Remove the CLUTCH ASSY DRV and BEARING REGI. (Removal 30)

Accesses Position (All the numbers show the procedure number.)

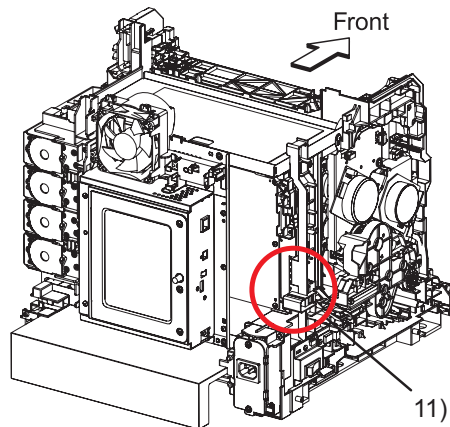

- 11) Disengage the two connectors (P/J24, 26) on the PWBA MCU (PL8.2.13), release the harness from the GUIDE HARNESS AC (PL8.2.6).

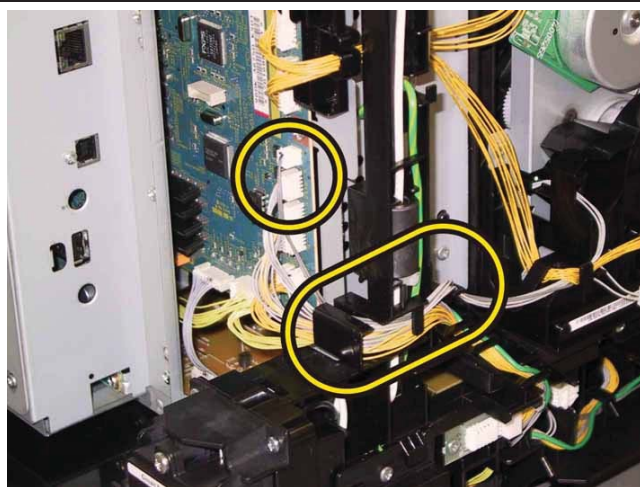

12) Disengage the connector (P/J211) of the DRIVE ASSY MAIN (PL7.1.2), release all the harness from the hooks of the DRIVE ASSY PH.

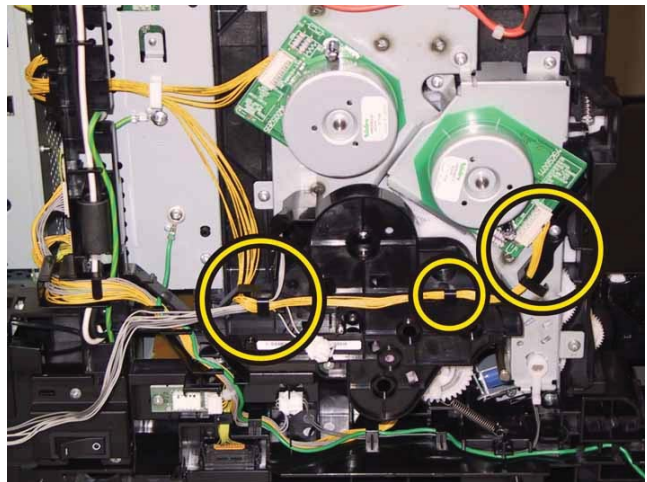

13) Remove the one screw (silver, M4, 6mm), the one screw (silver, M3, 6mm) and the one screw (silver, tap, 8mm) that fix the DRIVE ASSY PH to the printer.

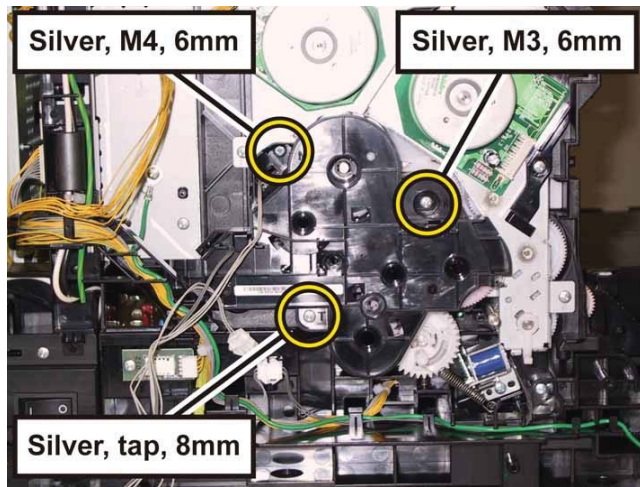

Note: When carrying out the work described next procedure, take care not to drop the coupling gear to inside.

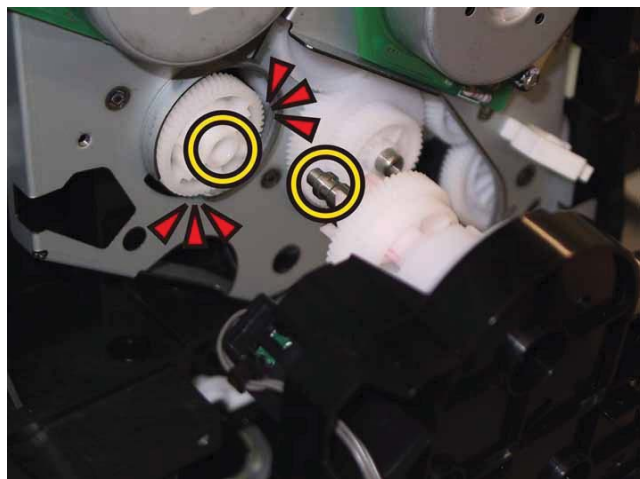

14) Remove the DRIVE ASSY PH from the printer.

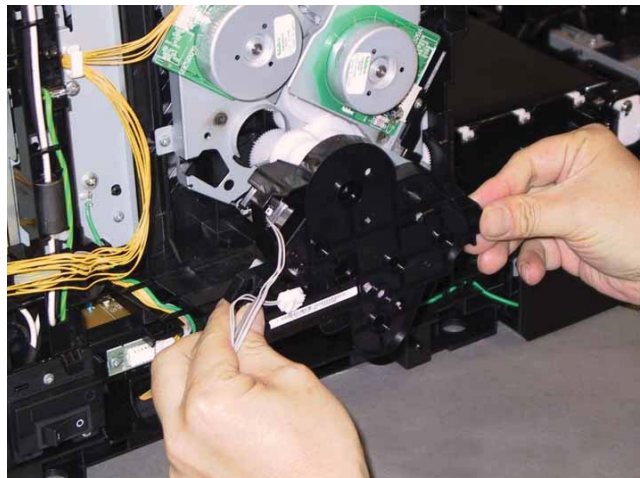

15) Disengage the connector (P/J261) of the color mode sensor on the DRIVE ASSY PH, release the HARN ASSY KSNR REGCL (PL9.1.9) from the hook of the DRIVE ASSY PH.

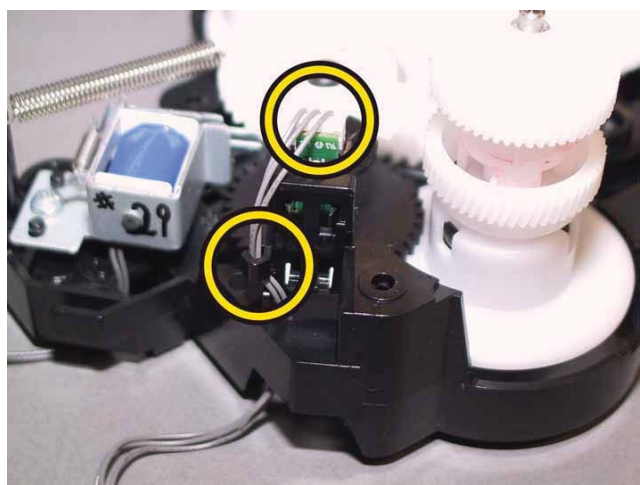

16) Remove the GEAR P2 (PL7.1.3) from the shaft of the DRIVE ASSY SUB (PL7.1.1).



Removal 32 KIT DRIVE ASSY MAIN (PL7.1.98)

- 1) Remove the CASSETTE ASSY 250. (Removal 1)
- 2) Open the COVER ASSY FRONT MG (PL1.2.1).

Note: Cover the drum of the PHD ASSY to avoid exposure to light.

- 3) Remove the PHD ASSY. (Removal 4)

Note: The FUSER part is very hot. Take added care not to get burned when performing the service operation.

- 4) Remove the FUSER ASSY. (Removal 5)
- 5) Remove the COVER ASSY TOP. (Removal 10)
- 6) Remove the COVER ASSY WINDOW TNR. (Removal 8)
- 7) Remove the COVER SIDE R. (Removal 12)
- 8) Remove the COVER SIDE L. (Removal 16)
- 9) Remove the COVER REAR. (Removal 29)
- 10) Remove the CLUTCH ASSY DRV and BEARING REGI. (Removal 30)
- 11) Remove the KIT DRIVE ASSY PH. (Removal 31)

12) Rotate the STOPPER PIVOT (PL6.1.3), mate the tabs of the STOPPER PIVOT with the notches of the DRIVE ASSY MAIN (PL7.1.2).

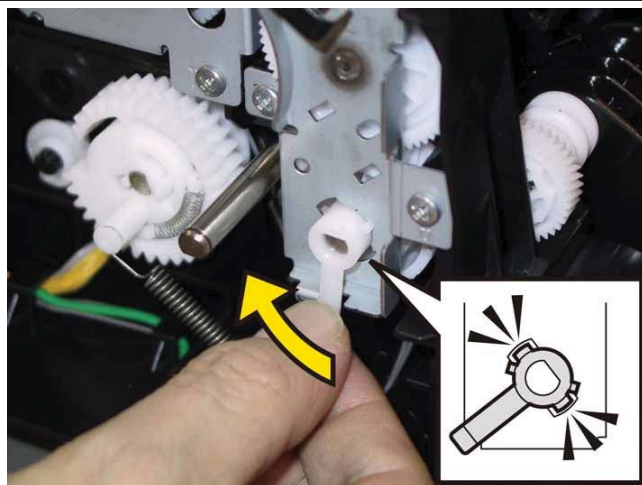

13) Remove the STOPPER PIVOT from the printer.

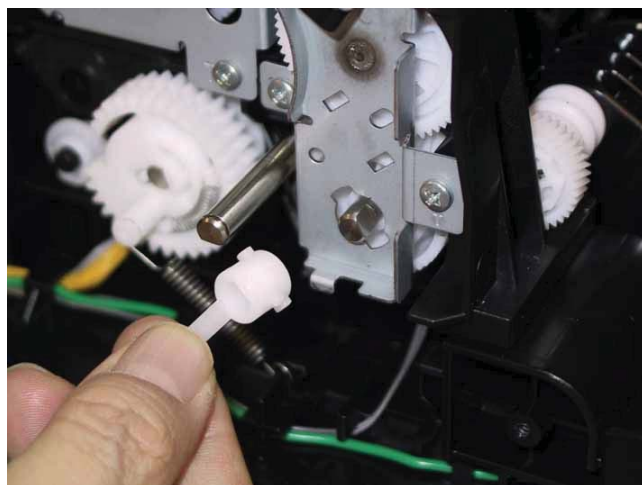

14) Remove the one screw (silver, M4, 6mm) and the five screws (silver, tap, 8mm) that fix the DRIVE ASSY MAIN to the printer.

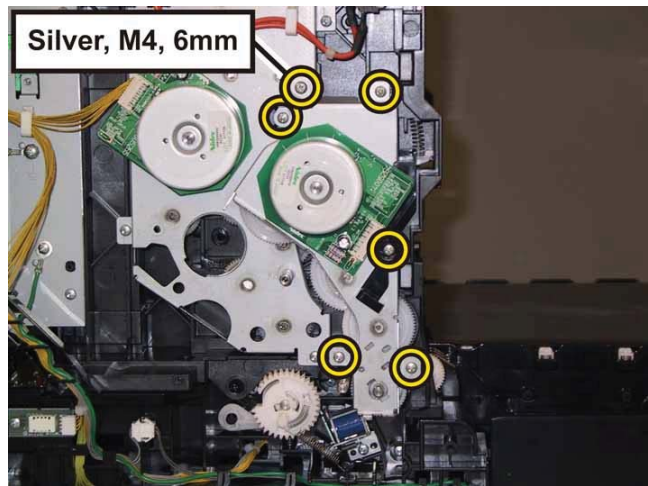

15) Remove the DRIVE ASSY MAIN from the printer.

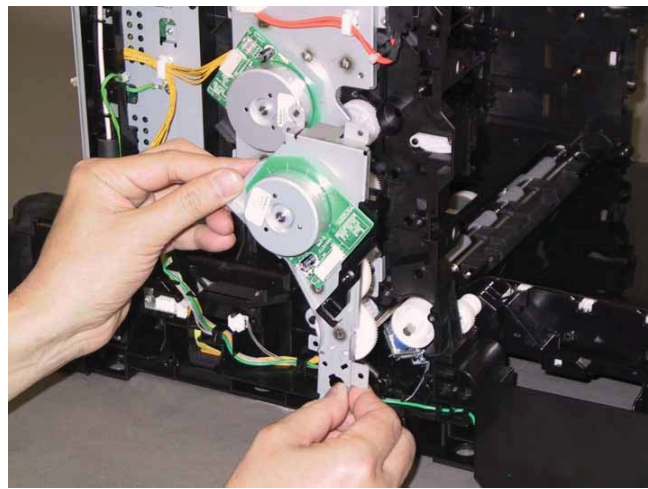

Removal 33 DRIVE ASSY SUB (PL7.1.1)

- 1) Remove the CASSETTE ASSY 250. (Removal 1)
- 2) Open the COVER ASSY FRONT MG (PL1.2.1).

Note: Cover the drum of the PHD ASSY to avoid exposure to light.

- 3) Remove the PHD ASSY. (Removal 4)

Note: The FUSER part is very hot. Take added care not to get burned when performing the service operation.

- 4) Remove the FUSER ASSY. (Removal 5)
- 5) Remove the COVER ASSY TOP. (Removal 10)
- 6) Remove the COVER ASSY WINDOW TNR. (Removal 8)
- 7) Remove the COVER SIDE R. (Removal 12)
- 8) Remove the COVER SIDE L. (Removal 16)
- 9) Remove the COVER REAR. (Removal 29)
- 10) Remove the CLUTCH ASSY DRV and BEARING REGI. (Removal 30)
- 11) Remove the KIT DRIVE ASSY PH. (Removal 31)
- 12) Remove the KIT DRIVE ASSY MAIN. (Removal 32)

Note: When performing the step described below, it is not necessary to disengage the connector of the HARN ASSY INTERLOCK.

- 13) Remove the HARN ASSY INTERLOCK. (Removal 17)

- 14) Disengage the connector (P/J221) of the DRIVE ASSY SUB (PL7.1.1).

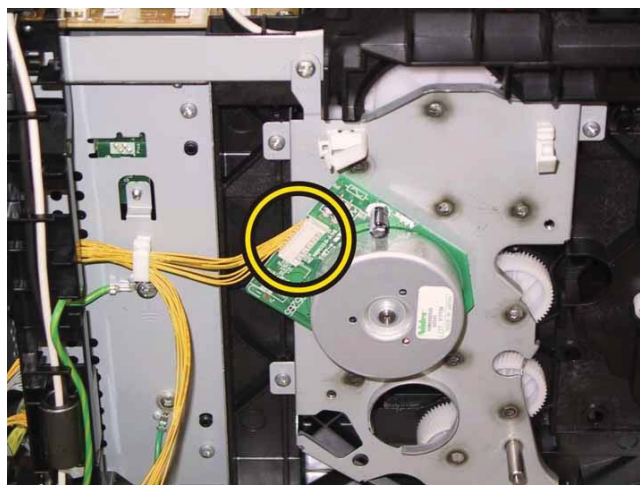

15) Remove the one screw (silver, M4, 6mm) and the four screws (silver, tap, 8mm) that fix the DRIVE ASSY SUB to the printer.

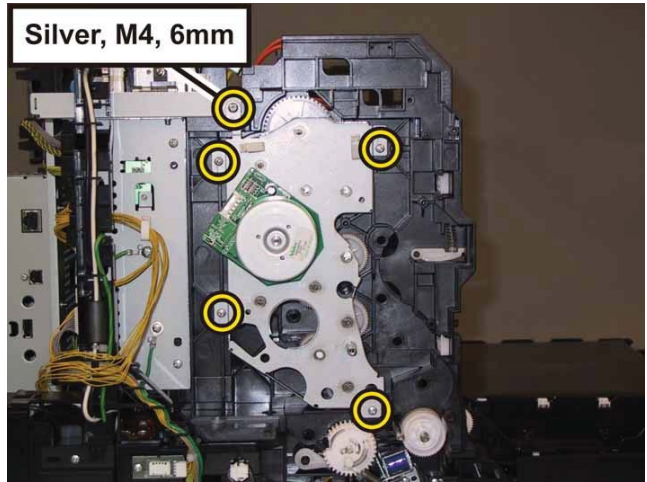

16) Remove the DRIVE ASSY SUB from the printer.

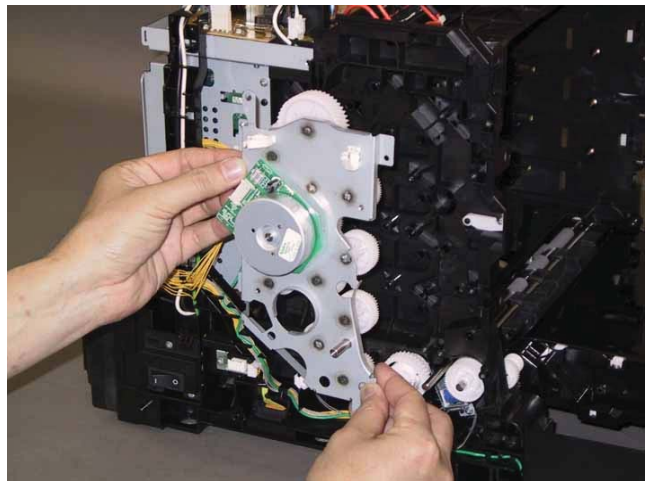

Removal 34 KIT BLOCK PHD LEFT (PL4.1.98)

- 1) Remove the CASSETTE ASSY 250. (Removal 1)
- 2) Open the COVER ASSY FRONT MG (PL1.2.1).

Note: Cover the drum of the PHD ASSY to avoid exposure to light.

- 3) Remove the PHD ASSY. (Removal 4)

Note: The FUSER part is very hot. Take added care not to get burned when performing the service operation.

- 4) Remove the FUSER ASSY. (Removal 5)
- 5) Remove the COVER ASSY TOP. (Removal 10)
- 6) Remove the COVER ASSY WINDOW TNR. (Removal 8)
- 7) Remove the COVER SIDE R. (Removal 12)
- 8) Remove the COVER SIDE L. (Removal 16)
- 9) Remove the COVER REAR. (Removal 29)
- 10) Remove the CLUTCH ASSY DRV and BEARING REGI. (Removal 30)
- 11) Remove the KIT DRIVE ASSY PH. (Removal 31)
- 12) Remove the KIT DRIVE ASSY MAIN. (Removal 32)

Accesses Position (All the numbers show the procedure number.)

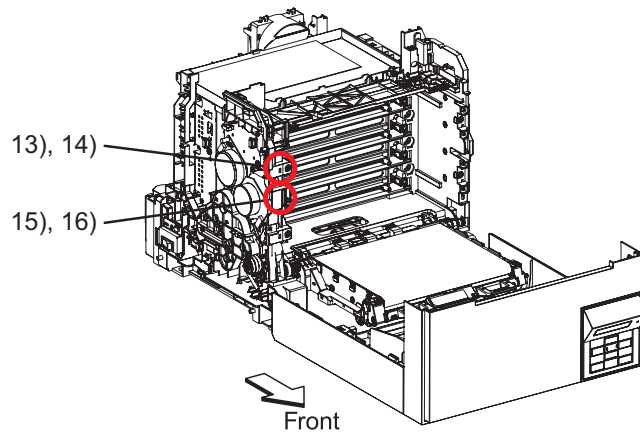

Note: Described next procedure is the removal procedure common among the upper and lower BLOCK STOPPER PDH Ds (PL4.1.7).

13) Release the hook of the BLOCK STOPPER PHD D (PL4.1.6), using a miniature screwdriver.

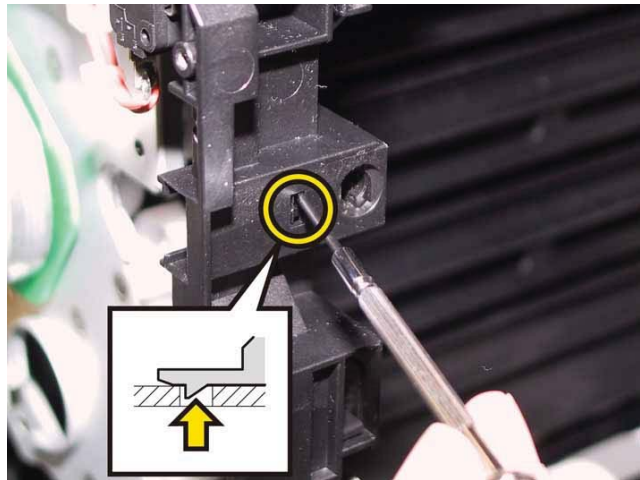

14) Remove the BLOCK STOPPER PHD D from the printer.

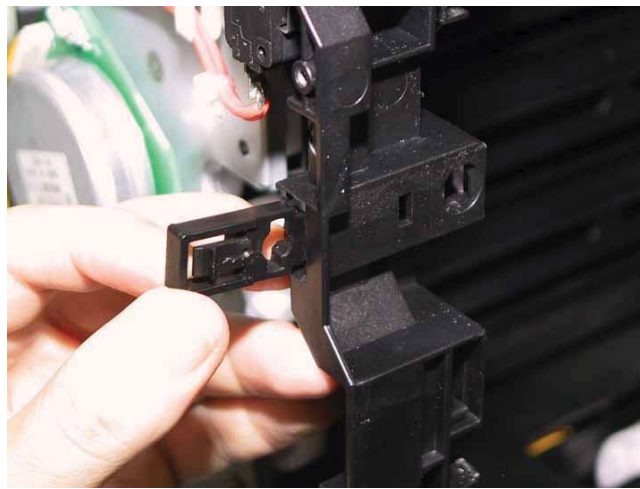

15) Remove the SPRING PHD (PL4.1.4) from the printer.

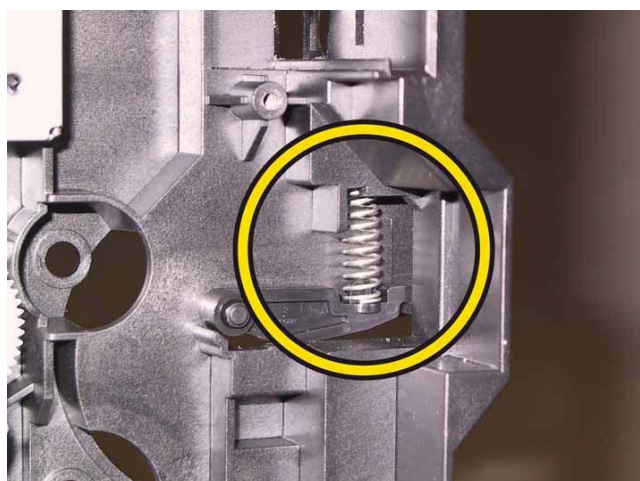

16) Rotate the LEVER PHD (PL4.1.5) slightly, remove the LEVER PHD from the printer.

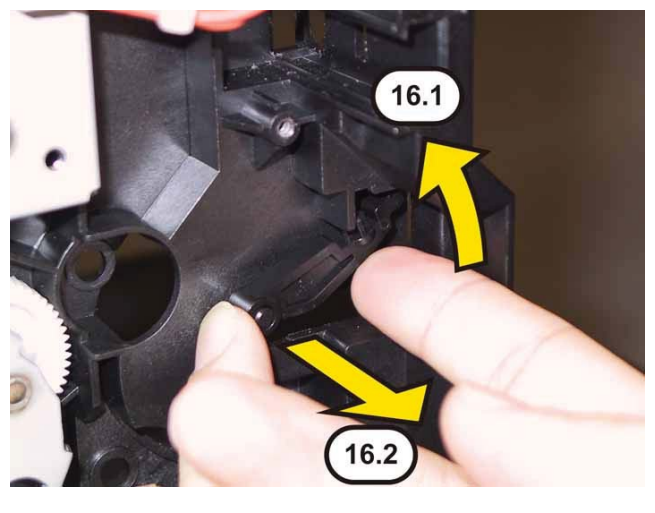

Removal 35 KIT FEED ROLL/SOL/CLUTCH (PL3.1.99)

- 1) Remove the CASSETTE ASSY 250. (Removal 1)
- 2) Open the COVER ASSY FRONT MG (PL1.2.1).

Note: Cover the drum of the PHD ASSY to avoid exposure to light.

- 3) Remove the PHD ASSY. (Removal 4)

Note: The FUSER part is very hot. Take added care not to get burned when performing the service operation.

- 4) Remove the FUSER ASSY. (Removal 5)
- 5) Remove the COVER ASSY TOP. (Removal 10)
- 6) Remove the COVER ASSY WINDOW TNR. (Removal 8)
- 7) Remove the COVER SIDE R. (Removal 12)
- 8) Remove the COVER SIDE L. (Removal 16)
- 9) Remove the COVER REAR. (Removal 29)
- 10) Remove the CLUTCH ASSY DRV and BEARING REGI. (Removal 30)
- 11) Remove the KIT DRIVE ASSY PH. (Removal 31)

12) Release the hook of the ROLL CORE MSI (PL3.2.3) on the left of the ROLL ASSY FEED (PL 3.2.4), and move the ROLL CORE MSI to left until it stops.

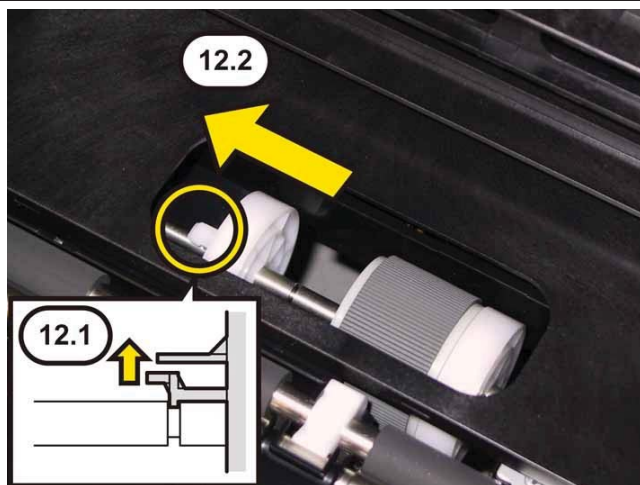

13) Release the groove on the ROLL ASSY FEED from the vertical pin mounted on the SHAFT ASSY FEED (PL3.2.2) by sliding the ROLL ASSY FEED to the left.



- 14) Close the COVER ASSY FRONT MG.

15) Remove the ROLL ASSY FEED from the SHAFT ASSY FEED by rotating the ROLL ASSY FEED 180 degrees.

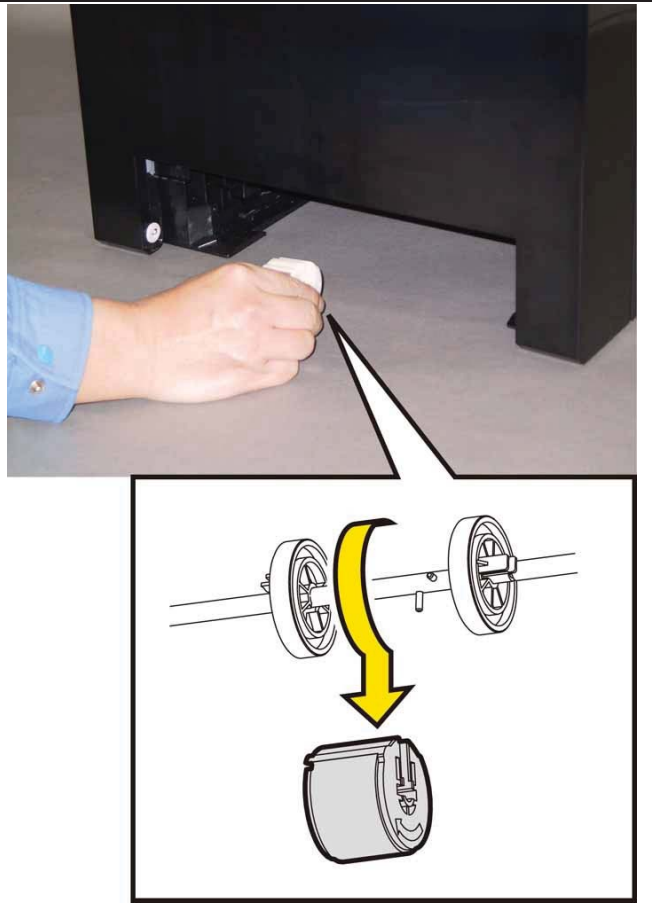

16) Open the COVER ASSY FRONT MG.

17) Remove the SPRING FEED OUT (PL3.1.15) from the printer.

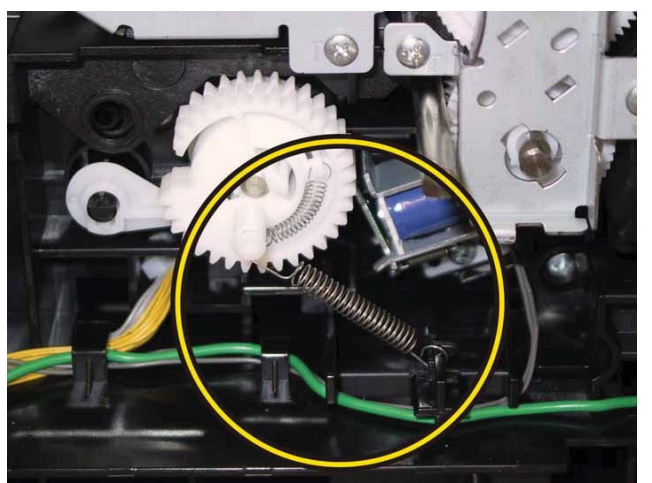

18) Release the hook of the GEAR ASSY FEED (PL3.1.19), remove the GEAR ASSY FEED from the SHAFT ASSY FEED (PL3.2.2).

Note: When carrying out the work this procedure, pushing down the LEVER FEED (PL3.1.13).



19) Release the harness of the SOLENOID FEED MSI (PL3.1.11) from the hooks of the printer.

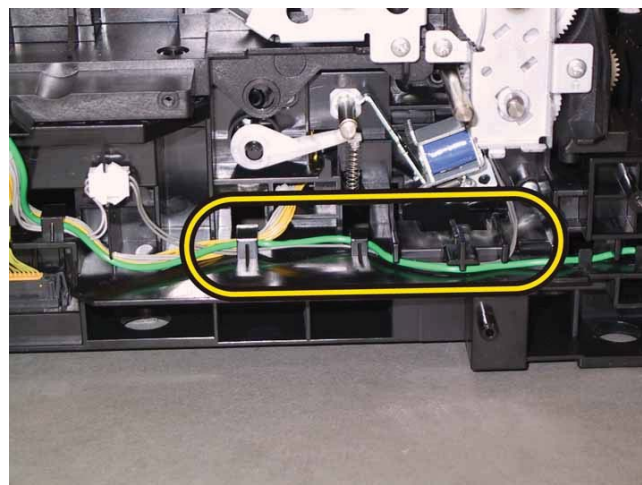

Note: When carrying out the work described next procedure, leave the relay connector on the printer harness side.

20) Release the relay connector from the rib of the printer, disengage the connector (P/J231) of the SOLENOID FEED MSI.

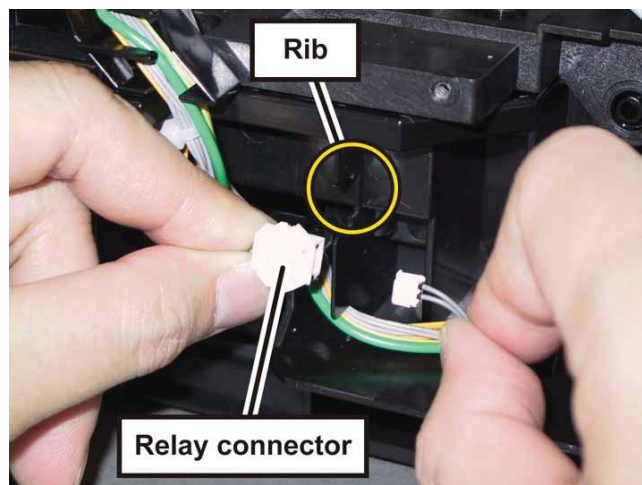

21) Remove the one screw (silver, tap, 8mm) that fixes the SOLENOID FEED MSI to the printer, remove the SOLENOID FEED MSI.

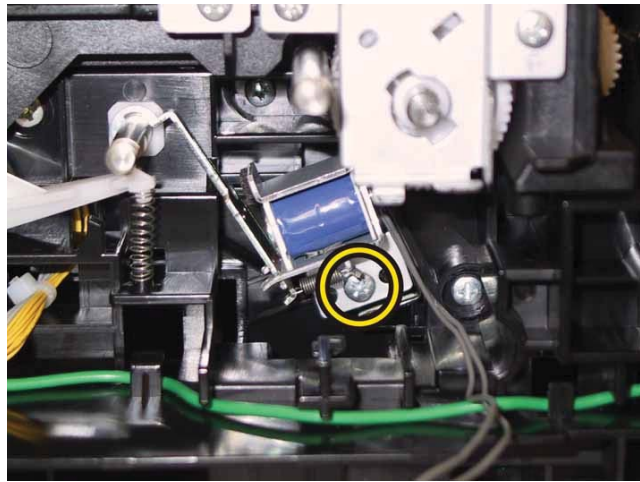

Removal 36 SWITCH ASSY INLET MG SFP (PL8.2.9), COVER INLET (PL8.2.22)

- 1) Remove the CASSETTE ASSY 250. (Removal 1)
- 2) Open the COVER ASSY FRONT MG (PL1.2.1).

Note: Cover the drum of the PHD ASSY to avoid exposure to light.

- 3) Remove the PHD ASSY. (Removal 4)

Note: The FUSER part is very hot. Take added care not to get burned when performing the service operation.

- 4) Remove the FUSER ASSY. (Removal 5)
- 5) Remove the COVER ASSY TOP. (Removal 10)
- 6) Remove the COVER ASSY WINDOW TNR. (Removal 8)
- 7) Remove the COVER SIDE R. (Removal 12)
- 8) Remove the COVER SIDE L. (Removal 16)
- 9) Remove the COVER REAR. (Removal 29)

10) Disengage the five connectors (P/J20, 23, 24, 26 and 28) on the PWBA MCU (PL8.2.13), release the harness from the GUIDE HARNESS AC (PL8.2.6).



11) Disengage the connector (P/J48) of the SWITCH ASSY INLET MG SFP (PL8.2.9) from the PWBA LVPS (PL8.2.1). Remove the one screw (silver, with washer, 6mm) that fixes the grounding terminal of the SWITCH ASSY INLET MG SFP, release the harness of the SWITCH ASSY INLET MG SFP from the GUIDE HARNESS AC.

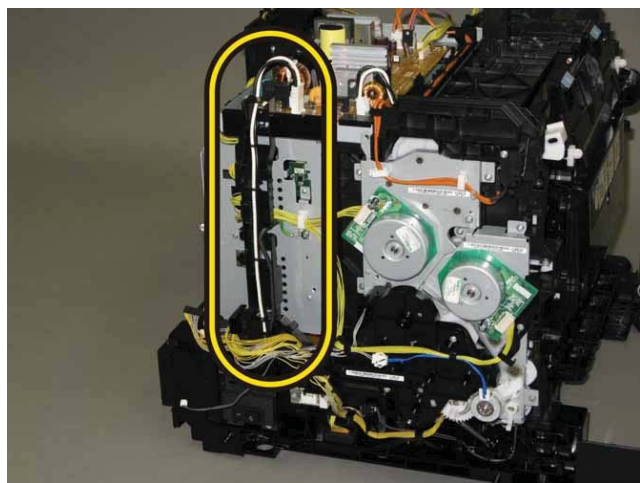

12) Remove the two screws (silver, tap, 8mm) that fix the BRACKET SW (PL8.2.8) to the printer.



Note: The MAIN SWITCH and the printer are connected with the harness, so they should not be far apart when carrying out the work described next procedure.

13) Release the BRAKET SW from the hook together with the MAIN SW.



14) Remove the two screws (silver, tap, 12mm) that fix the COVER INLET (PL8.2.22) to the printer.



15) Release the hooks of the SWITCH POWER, remove the SWITCH POWER of the SWITCH ASSY INLET MG SFP from the BRACKET SW.

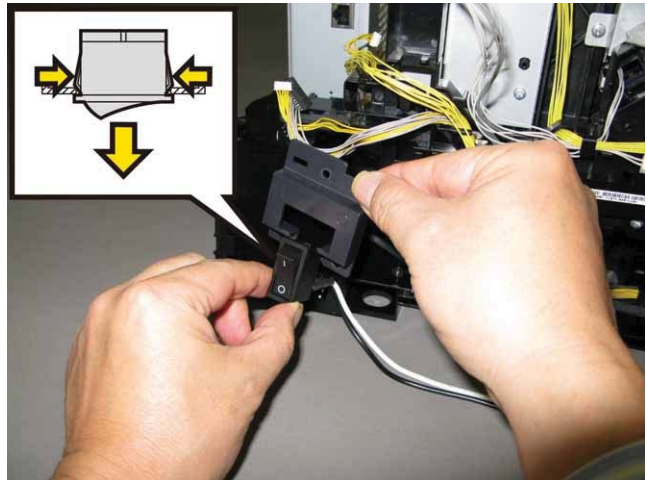

16) Remove the COVER INLET from the printer, pull out the harness and SWITCH POWER through the hole on the printer, and remove the SWITCH ASSY INLET MG SFP from the printer.

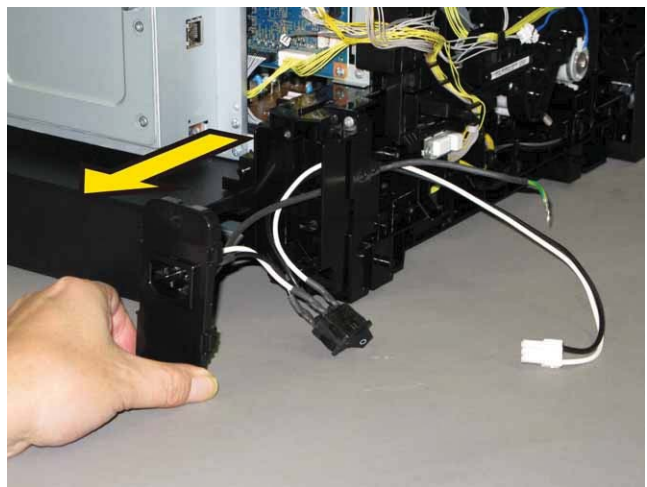

17) Release the hooks of the AC INLET, remove the AC INLET of the SWITCH ASSY INLET MG SFP from the COVER INLET.

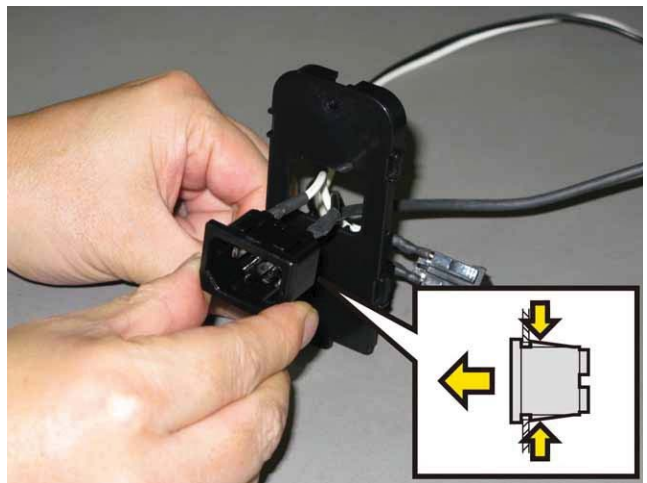

18) Pull out the harness and SWITCH POWER through the hole of the COVER INLET.

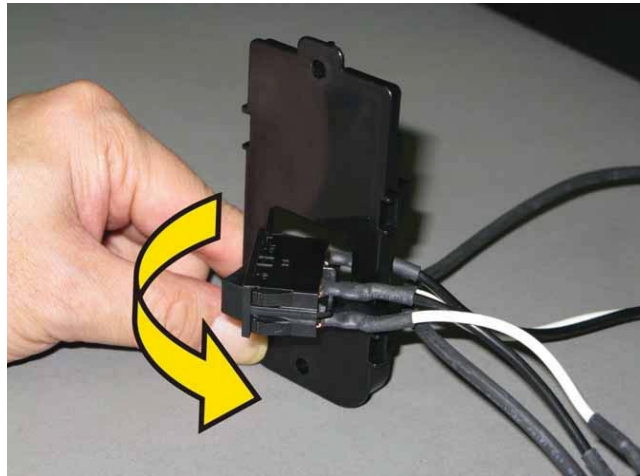

19) Pull out the connector (J48) through the hole of the COVER INLET, and remove the SWITCH ASSY INLET MG SFP from the COVER INLET.

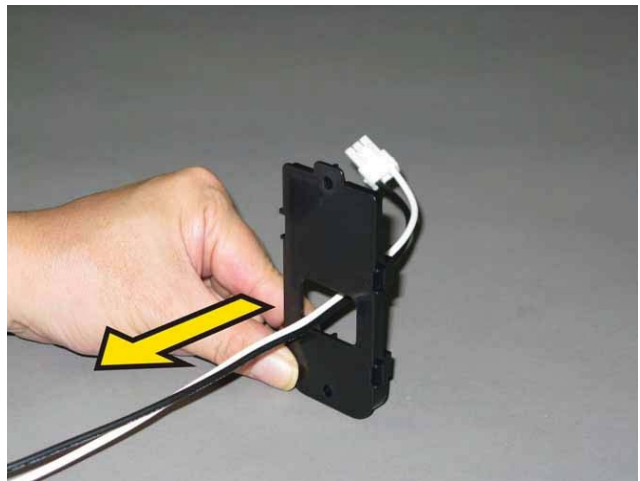

Removal 37 COVER CST (PL3.1.22)

- 1) Remove the CASSETTE ASSY 250. (Removal 1)
- 2) Open the COVER ASSY FRONT MG (PL1.2.1).

Note: Cover the drum of the PHD ASSY to avoid exposure to light.

- 3) Remove the PHD ASSY. (Removal 4)

Note: The FUSER part is very hot. Take added care not to get burned when performing the service operation.

- 4) Remove the FUSER ASSY. (Removal 5)
- 5) Remove the COVER ASSY TOP. (Removal 10)
- 6) Remove the COVER ASSY WINDOW TNR. (Removal 8)
- 7) Remove the COVER SIDE R. (Removal 12)
- 8) Remove the COVER SIDE L. (Removal 16)
- 9) Remove the COVER REAR. (Removal 29)
- 10) Remove the SWITCH ASSY INLET MG SFP, COVER INLET. (Removal 36)

- 11) Remove the two screws (silver, tap, 8mm) that fix the BRACKET GFI (PL3.1.21) to the printer.



- 12) Release the two hooks of the BRACKET GFI, using a miniature screwdriver.

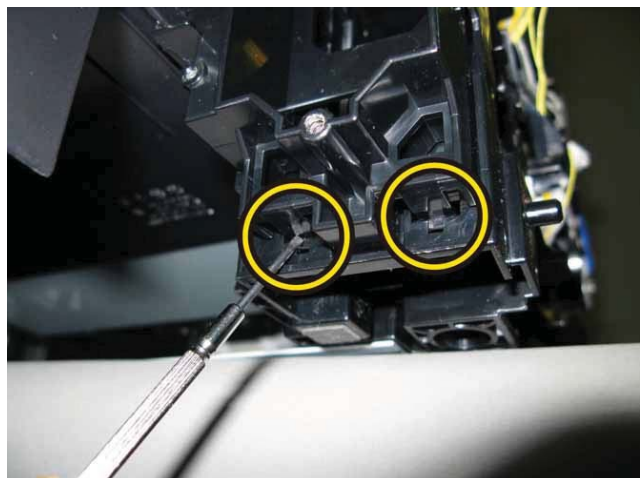

13) Release the tab of the BRACKET GFI from the COVER CST (PL3.1.22), remove the BRACKET GFI from the printer.

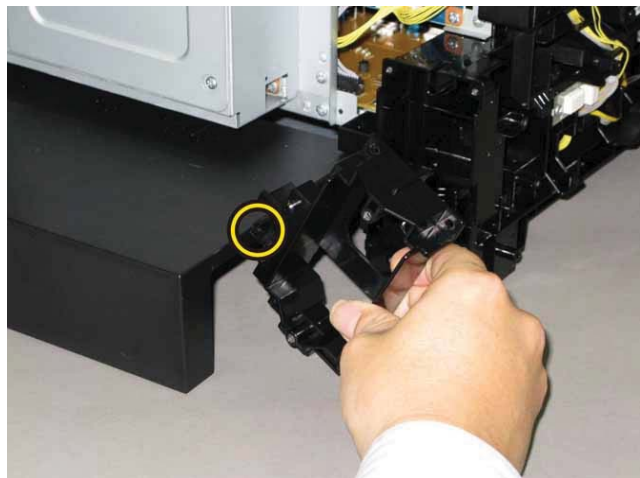

14) Depress the COVER CST to release the hook of the COVER CST. Remove the COVER CST from the printer.

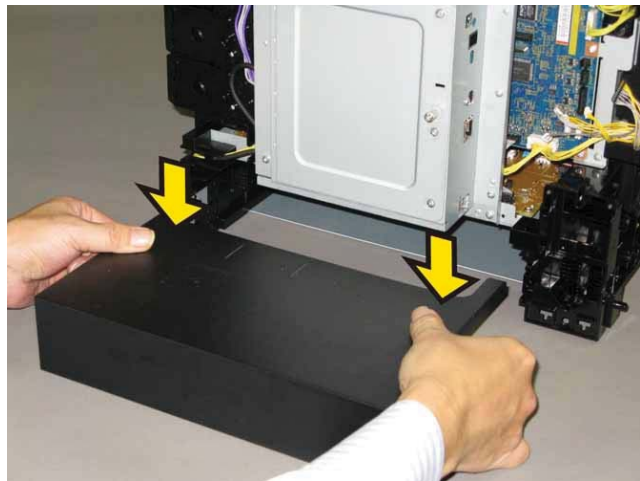

Removal 38 STOPPER CST (PL3.1.10)

- 1) Remove the CASSETTE ASSY 250. (Removal 1)
- 2) Open the COVER ASSY FRONT MG (PL1.2.1).

Note: Cover the drum of the PHD ASSY to avoid exposure to light.

- 3) Remove the PHD ASSY. (Removal 4)

Note: The FUSER part is very hot. Take added care not to get burned when performing the service operation.

- 4) Remove the FUSER ASSY. (Removal 5)
- 5) Remove the COVER ASSY TOP. (Removal 10)
- 6) Remove the COVER ASSY WINDOW TNR. (Removal 8)
- 7) Remove the COVER SIDE R. (Removal 12)
- 8) Remove the COVER SIDE L. (Removal 16)
- 9) Remove the COVER REAR. (Removal 29)
- 10) Remove the SWITCH ASSY INLET MG SFP, COVER INLET. (Removal 36)
- 11) Remove the COVER CST. (Removal 37)

12) Remove the one screw (silver, tap, 8mm) that fixes the STOPPER CST (PL3.1.10) to the printer.

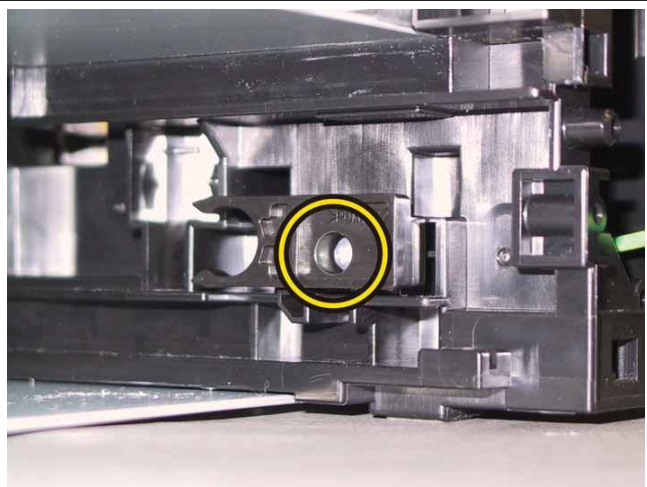

13) Remove the STOPPER CST from the printer.

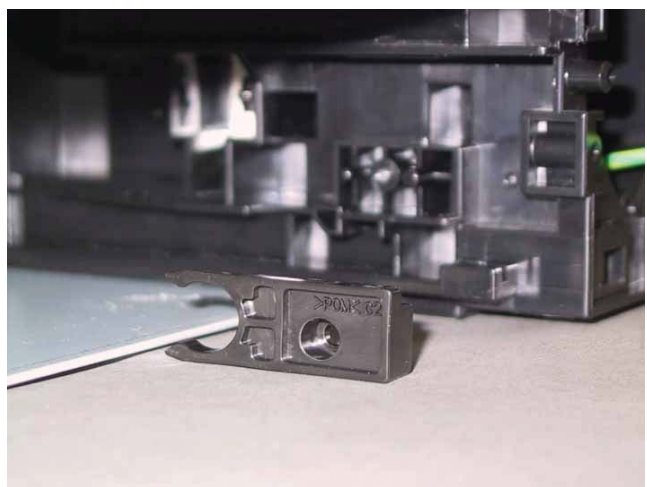

Removal 39 HOLDER ASSY TCRU (K), (C), (M), (Y) (PL5.1.17~20)

- 1) Remove the CASSETTE ASSY 250. (Removal 1)
- 2) Open the COVER ASSY FRONT MG (PL1.2.1).

Note: Cover the drum of the PHD ASSY to avoid exposure to light.

- 3) Remove the PHD ASSY. (Removal 4)

Note: The FUSER part is very hot. Take added care not to get burned when performing the service operation.

- 4) Remove the FUSER ASSY. (Removal 5)
- 5) Remove the COVER ASSY TOP. (Removal 10)
- 6) Remove the COVER ASSY WINDOW TNR. (Removal 8)
- 7) Remove the COVER SIDE R. (Removal 12)
- 8) Remove the COVER SIDE L. (Removal 16)
- 9) Remove the COVER REAR. (Removal 29)

Note: Described below is the removal procedure common among the four HOLDER ASSY TCRU.

10) Press the central part of the HOLDER ASSY TCRU to release the hole of the HOLDER ASSY TCRU from the boss of the FRAME DISP (PL5.1.12). Open the HOLDER ASSY TCRU by 90 degrees.

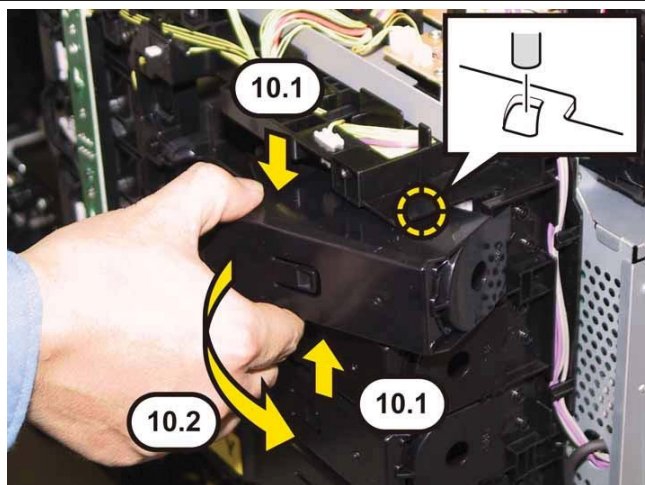

11) Press the boss part of the HOLDER ASSY TCRU, remove the HOLDER ASSY TCRU from the printer.

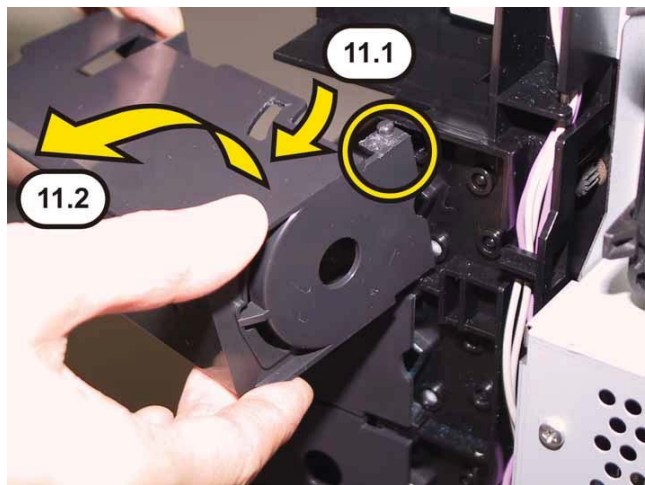

Removal 40 FAN (PL8.1.1)

- 1) Remove the CASSETTE ASSY 250. (Removal 1)
- 2) Open the COVER ASSY FRONT MG (PL1.2.1).

Note: Cover the drum of the PHD ASSY to avoid exposure to light.

- 3) Remove the PHD ASSY. (Removal 4)

Note: The FUSER part is very hot. Take added care not to get burned when performing the service operation.

- 4) Remove the FUSER ASSY. (Removal 5)
- 5) Remove the COVER ASSY TOP. (Removal 10)
- 6) Remove the COVER ASSY WINDOW TNR. (Removal 8)
- 7) Remove the COVER SIDE R. (Removal 12)
- 8) Remove the COVER SIDE L. (Removal 16)
- 9) Remove the COVER REAR. (Removal 29)

10) Disengage the FAN (PL8.1.1) connector (P/J503) on the PWBA LVPS (PL8.2.1), release the harness of the FAN from the hooks of the DUCT FAN (PL8.1.2).



11) Release the four hooks of the DUCT FAN, remove the FAN from the printer.

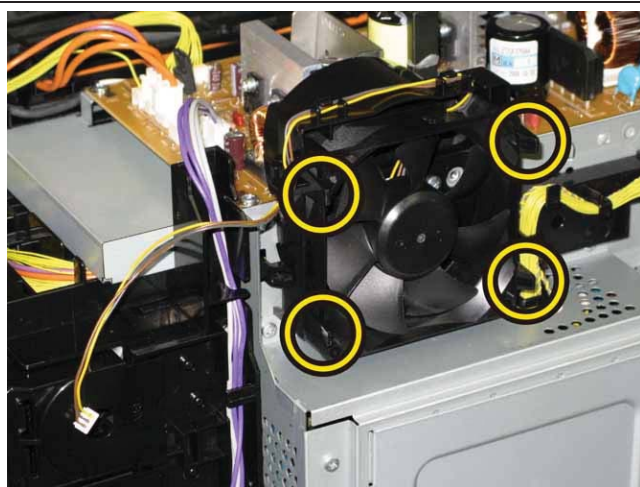

Removal 41 DUCT FAN (PL8.1.2)

- 1) Remove the CASSETTE ASSY 250. (Removal 1)
- 2) Open the COVER ASSY FRONT MG (PL1.2.1).

Note: Cover the drum of the PHD ASSY to avoid exposure to light.

- 3) Remove the PHD ASSY. (Removal 4)

Note: The FUSER part is very hot. Take added care not to get burned when performing the service operation.

- 4) Remove the FUSER ASSY. (Removal 5)
- 5) Remove the COVER ASSY TOP. (Removal 10)
- 6) Remove the COVER ASSY WINDOW TNR. (Removal 8)
- 7) Remove the COVER SIDE R. (Removal 12)
- 8) Remove the COVER SIDE L. (Removal 16)
- 9) Remove the COVER REAR. (Removal 29)
- 10) Remove the FAN. (Removal 40)

- 11) Loosen the SCREW KNURLING (PL8.1.13) and then open the PLATE ESS (PL8.1.12).



- 12) Swing the PLATE ESS to upward slightly, to release the upper tab of the PLATE ESS from the slit of the SHIELD ASSY ESS (PL8.1.3) after releasing the lower tab of the PLATE ESS from the slit of the SHIELD ASSY ESS. Remove the PLATE ESS from the printer.

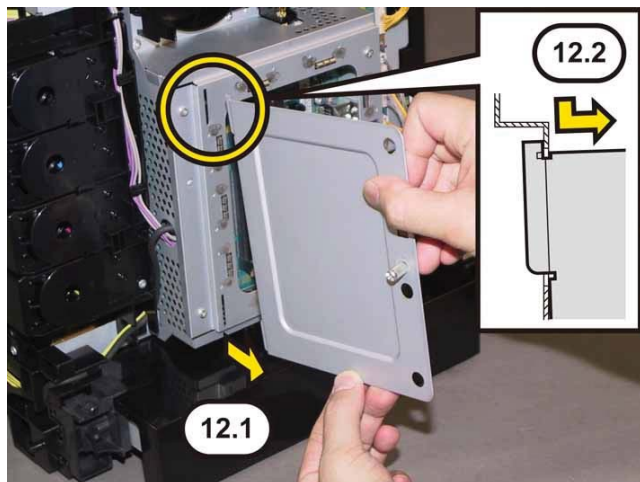

13) Remove the eleven screws (silver, 6mm) that fix the SHIELD ASSY ESS to the printer.

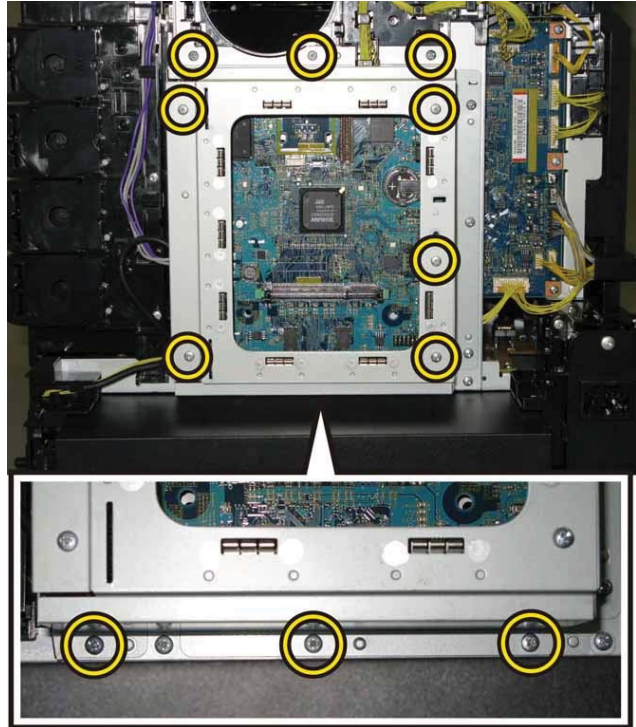

14) Remove the SHIELD ASSY ESS from the printer.

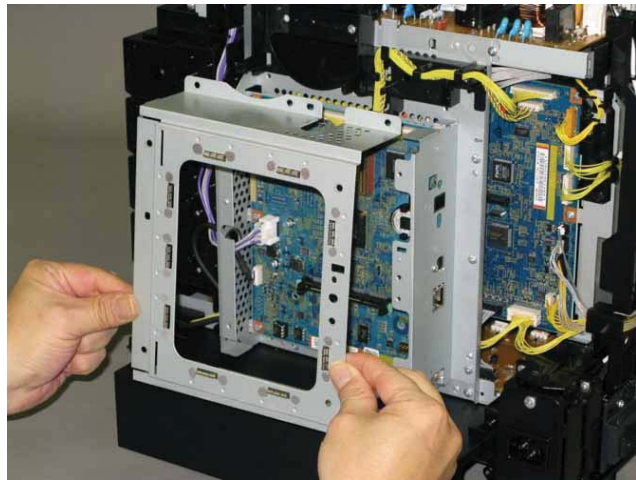

15) Disengage the two connectors (P/J101, 111) on the PWBA ESS SFP (PL8.1.7), release the harness from the hooks of the DUCT FAN (PL8.1.2).



16) Remove the one screw (silver, 6mm) that fixes the DUCT FAN to the printer.

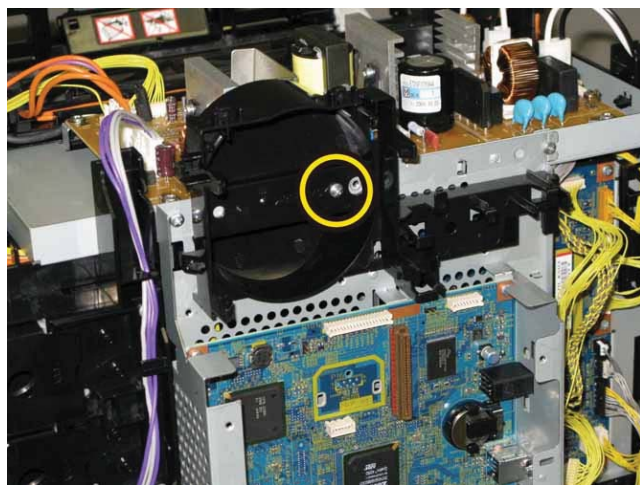

17) Release the two hooks of the DUCT FAN, using a miniature screwdriver, and then remove the DUCT FAN from the printer.

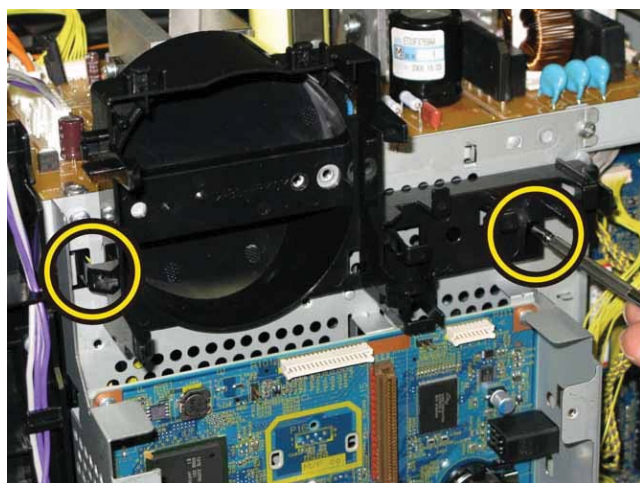

Removal 42 KIT PWBA ESS SFP (PL8.1.99)

Note: Use the wrist strap to protect the PWB from the electrostatic.

- 1) Remove the CASSETTE ASSY 250. (Removal 1)
- 2) Open the COVER ASSY FRONT MG (PL1.2.1).

Note: Cover the drum of the PHD ASSY to avoid exposure to light.

- 3) Remove the PHD ASSY. (Removal 4)

Note: The FUSER part is very hot. Take added care not to get burned when performing the service operation.

- 4) Remove the FUSER ASSY. (Removal 5)
- 5) Remove the COVER ASSY TOP. (Removal 10)
- 6) Remove the COVER ASSY WINDOW TNR. (Removal 8)
- 7) Remove the COVER SIDE R. (Removal 12)
- 8) Remove the COVER SIDE L. (Removal 16)
- 9) Remove the COVER REAR. (Removal 29)
- 10) Remove the FAN. (Removal 40)

11) Loosen the SCREW KNURLING (PL8.1.13) and then open the PLATE ESS (PL8.1.12).



12) Swing the PLATE ESS to upward slightly, to release the upper tab of the PLATE ESS from the slit of the SHIELD ASSY ESS (PL8.1.3) after releasing the lower tab of the PLATE ESS from the slit of the SHIELD ASSY ESS. Remove the PLATE ESS from the printer.

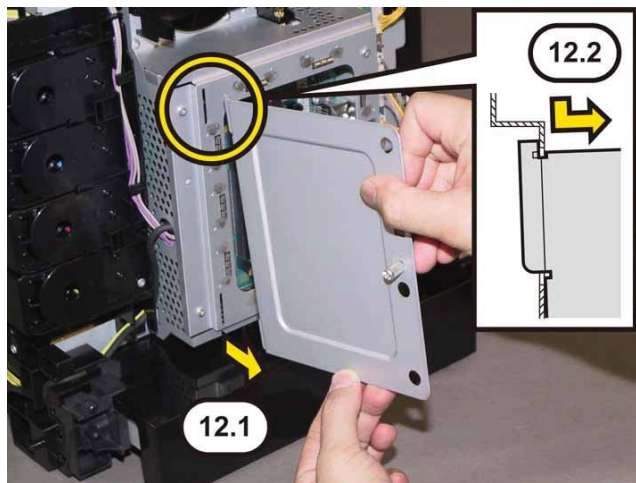

13) Remove the eleven screws (silver, 6mm) that fix the SHIELD ASSY ESS to the printer.



14) Remove the SHIELD ASSY ESS from the printer.



15) Disengage all the connectors of the PWBA ESS SFP (PL8.1.7).



16) Pull out the connector (J401) of the HARN ASSY ESS POWER (PL9.1.10) and the connector (J29) of the HARNESS ASSY B (PL9.1.12) through the hole of the FRAME ESS (PL8.1.5).

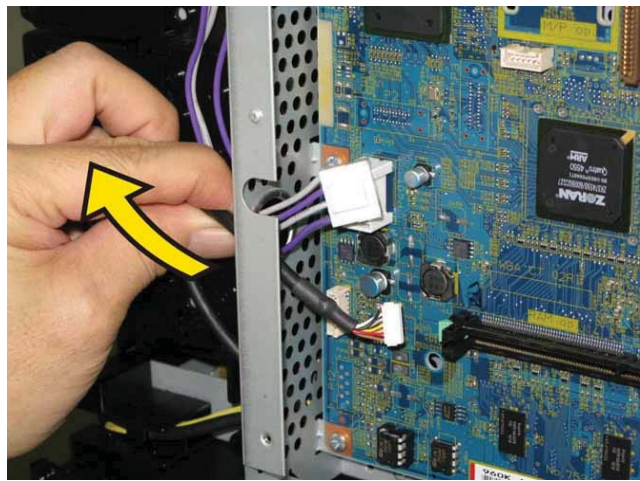

17) Remove the six screws (silver, 6mm) that fix the PWBA ESS SFP and the PLATE IF M (PL8.1.6) to the printer, remove the PWBA ESS SFP from the printer together with the PLATE IF M.



18) Remove the one screw (silver, 4mm) that fixes the USB connector of the PWBA ESS SFP to the PLATE IF M.

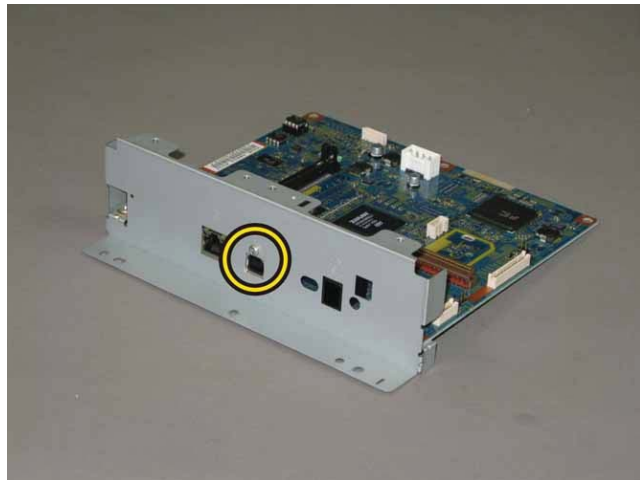

19) Remove the two screws (silver, 6mm) that fix the PWBA ESS SFP to the PLATE IF M, remove the PWBA ESS SFP from the PLATE IF M.



Removal 43 KIT PWBA MCU (PL8.2.99)

Note: Never fail to perform the diagnostic operation. Otherwise the data will be lost in the worst case.

Note: Use the wrist strap to protect the PWB from the electrostatic.

- 1) Perform the NVM Save to evacuate the MCU data.
- 2) Turn on the power while pressing the "▶" key, "◀" key, and [MENU] key on the control panel.
- 3) Enter the password, press the "▲" key twice, and press the " ✓ " key once. The diagnostic screen comes up.
- 4) Press the " ✓ " key once.
- 5) Press the "▼" key several times until "IOT Diag" is displayed. Press the " ✓ " key once.
- 6) Press the "▼" key several times until "NVM Settings" is displayed. Press the " ✓ " key once.
- 7) Press the "▼" key several times until "SaveNVM to ESS" is displayed. Press the " ✓ " key once.
- 8) Press the " ✓ " key once, and NVM Save is performed.
- 9) After NVM Save is complete, press the [CANCEL] key several times until "IOT Diag" is displayed.
- 10) Press the "▼" key several times until "Complete" is displayed.
- 11) Press the " ✓ " key two times. "COPY, SCAN and FAX" are displayed.
- 12) Turn off the power to exit.
- 13) Remove the POWER CORD from outlet.
- 14) Remove the CASSETTE ASSY 250. (Removal 1)
- 15) Open the COVER ASSY FRONT MG (PL1.2.1).

Note: Cover the drum of the PHD ASSY to avoid exposure to light.

- 16) Remove the PHD ASSY. (Removal 4)

Note: The FUSER part is very hot. Take added care not to get burned when performing the service operation.

- 17) Remove the FUSER ASSY. (Removal 5)
- 18) Remove the COVER ASSY WINDOW TNR. (Removal 8)
- 19) Remove the COVER ASSY TOP. (Removal 10)
- 20) Remove the COVER SIDE R. (Removal 12)
- 21) Remove the COVER SIDE L. (Removal 16)
- 22) Remove the COVER REAR. (Removal 29)
- 23) Remove the FAN. (Removal 40)
- 24) Remove the KIT PWBA ESS SFP. (Removal 42)

25) Remove the five screws (silver, 6mm) that fix the FRAME ESS (PL8.1.5) to the printer.

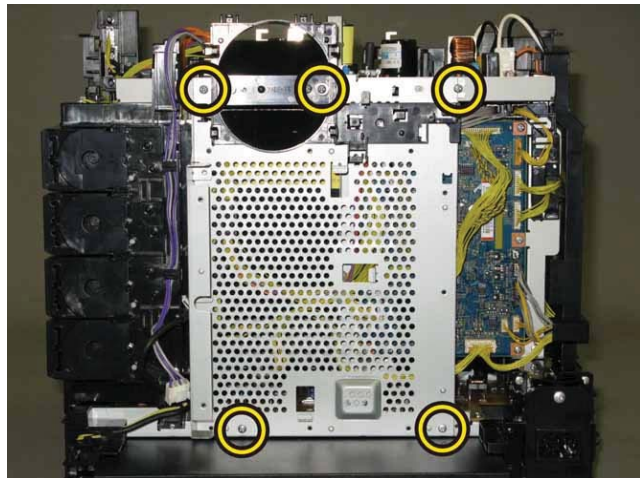

26) Swing the FRAME ESS slightly up and back as if it were hinged at the top.

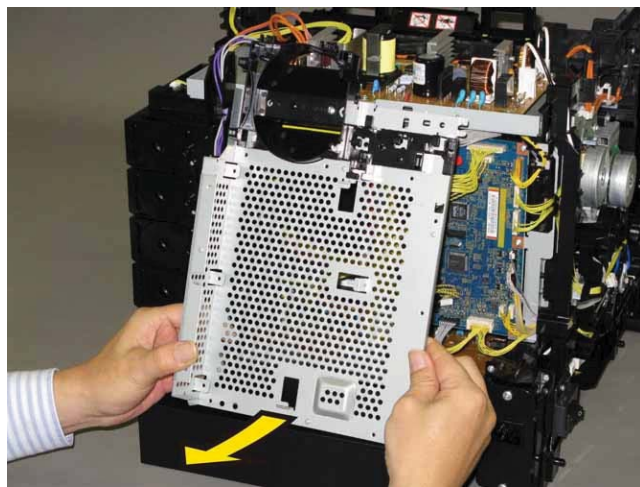

27) Remove the hook of the FRAME ESS from the hook of the FRAME ASSY LVPS (PL8.2.3) by lifting the FRAME ESS slightly. Remove the FRAME ESS from the printer together with the DUCT FAN (PL8.1.2).



28) Disengage all the connectors of the PWBA MCU (PL8.2.13).



29) Remove the six screws (silver, 6mm) that fix the PWBA MCU to the printer.

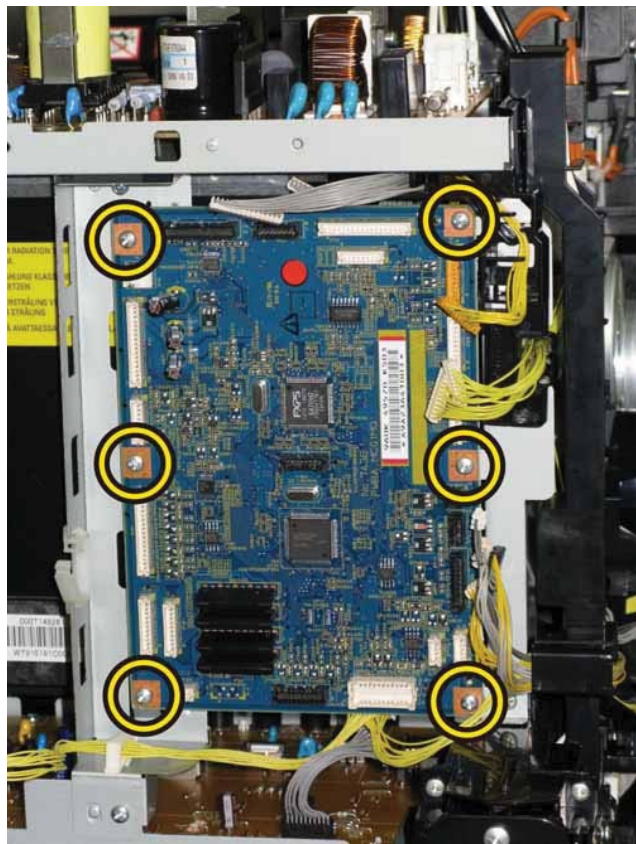

30) Remove the PWBA MCU from the printer.

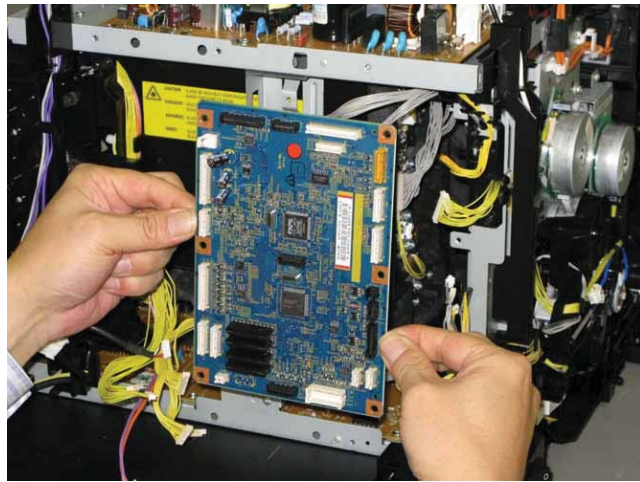

Removal 44 DISPENSER ASSY (PL5.1.1)

- 1) Remove the CASSETTE ASSY 250. (Removal 1)
- 2) Open the COVER ASSY FRONT MG (PL1.2.1).

Note: Cover the drum of the PHD ASSY to avoid exposure to light.

- 3) Remove the PHD ASSY. (Removal 4)

Note: The FUSER part is very hot. Take added care not to get burned when performing the service operation.

- 4) Remove the FUSER ASSY. (Removal 5)
- 5) Remove the TONER CARTRIDGE (K), (C), (M), (Y). (Removal 6)
- 6) Remove the COVER ASSY TOP. (Removal 10)
- 7) Remove the COVER ASSY WINDOW TNR. (Removal 8)
- 8) Remove the COVER SIDE R. (Removal 12)
- 9) Remove the COVER SIDE L. (Removal 16)
- 10) Remove the COVER REAR. (Removal 29)
- 11) Remove the HOLDER ASSY TCRU (K), (C), (M), (Y). (Removal 39)
- 12) Remove the FAN. (Removal 40)
- 13) Remove the KIT PWBA ESS SFP. (Removal 42)
- 14) Remove the KIT PWBA MCU. (Removal 43)
- 15) Remove the PWBA LVPS. (Removal 11)

Accesses Position (All the numbers show the procedure number.)

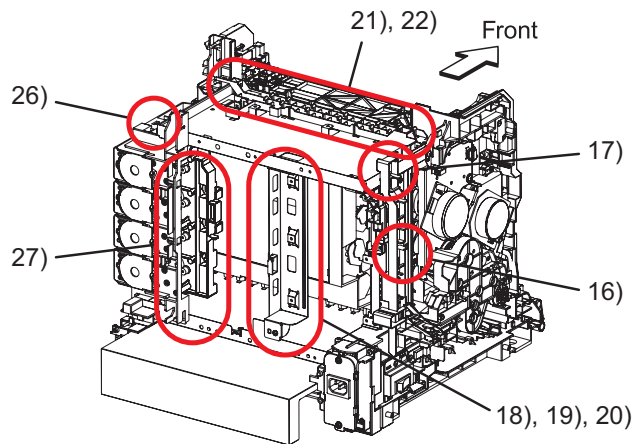

16) Remove the one screw (silver, with washer, 6mm) that fixes the grounding terminal of the SWITCH ASSY INLET MG SFP (PL8.2.9).



Note: The GUIDE HARNESS AC and the printer are connected with the harness, so they should not be far apart when carrying out the work described next procedure.

17) Release the hook of the GUIDE HARNESS AC (PL8.2.6), remove the GUIDE HARNESS AC from the printer.

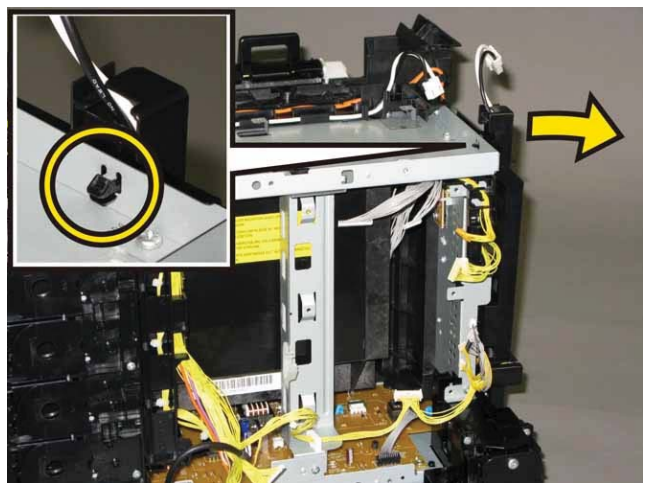

18) Release the harness of the HARN ASSY OPTION (PL3.1.20) from the clamp on the BRACKET MCU R (PL8.2.15).



19) Remove the two screws (silver, 6mm) that fix the BRACKET MCU R to the printer.

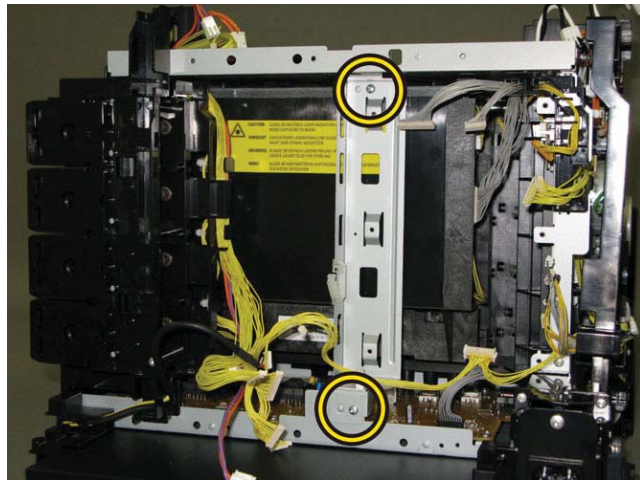

20) Remove the BRACKET MCU R from the printer.



Note: Release only the HARN ASSY INTERLOCK from the GUIDE HARNESS FSR to prevent the faulty wiring when it assembles it.

21) Release the harness of the HARN ASSY INTERLOCK (PL8.2.5) from the GUIDE HARNESS FSR (PL8.2.2).

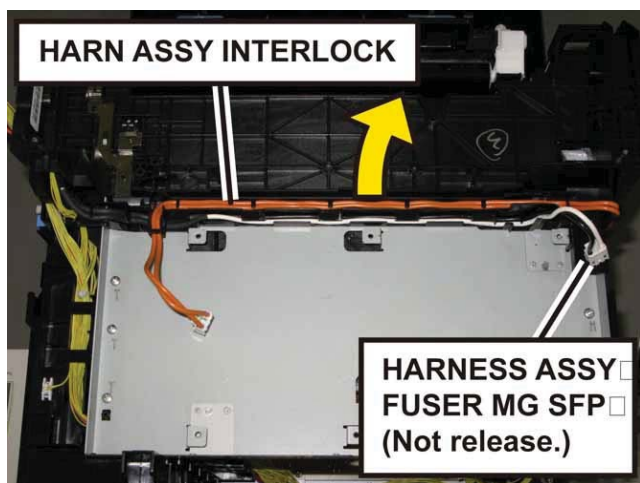

22) Release the hook of the GUIDE HARNESS FSR, to release the boss and tab of the GUIDE HARNESS FSR. Remove the GUIDE HARNESS FSR from the printer.

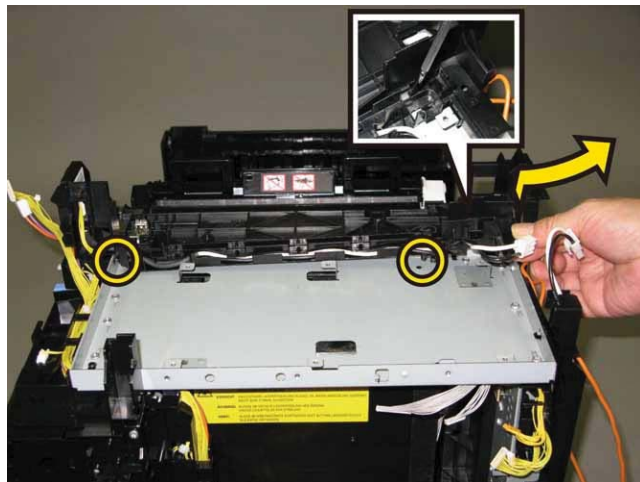

23) Remove two screw (silver, M4, 6mm) and six screws (silver, tap, 8mm) that fix the FRAME ASSY LVPS (PL8.2.3) to the printer.



24) Remove the one screw (silver, M4, 6mm) that fixes the DRIVE ASSY SUB (PL7.1.1) to the FRAME ASSY LVPS.

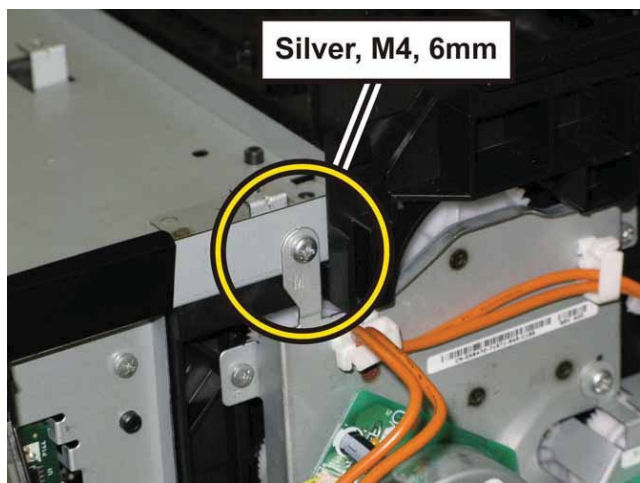

25) Remove the FRAME ASSY LVPS from the printer.



26) Release the hook of the connector (P5041) of the HARNESS ASSY LVPS MAIN MG SFP (PL9.1.3), using pliers, and then remove it from the DISPENSER ASSY (PL5.1.1).

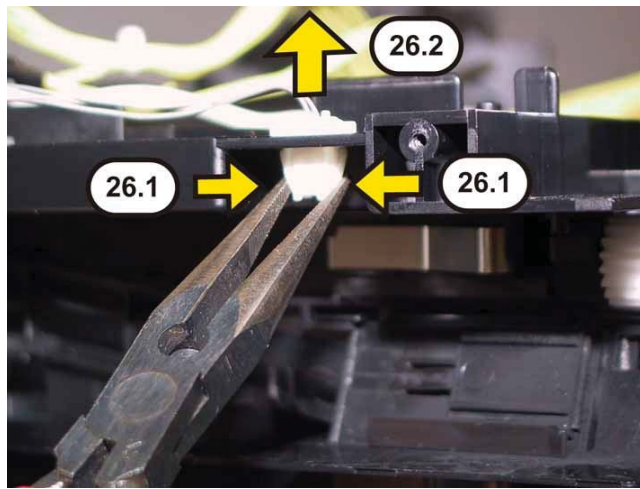

27) Remove the HARNESS ASSY FUSER MG SFP (PL6.1.2), HARNESS ASSY LVPS MAIN MG SFP, HARN ASSY ESS POWER (PL9.1.10), HARNESS ASSY B (PL9.1.12) and HARN ASSY OPTION (PL3.1.20) from the hooks of the DISPENSER ASSY.

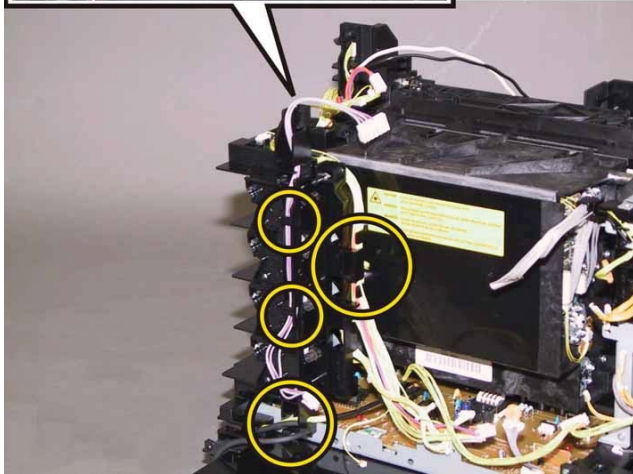
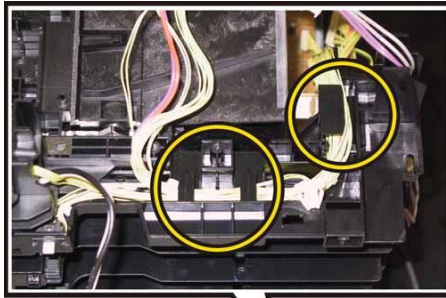

28) Remove the four screws (silver, tap, 8mm) that fix the DISPENSER ASSY to the printer.

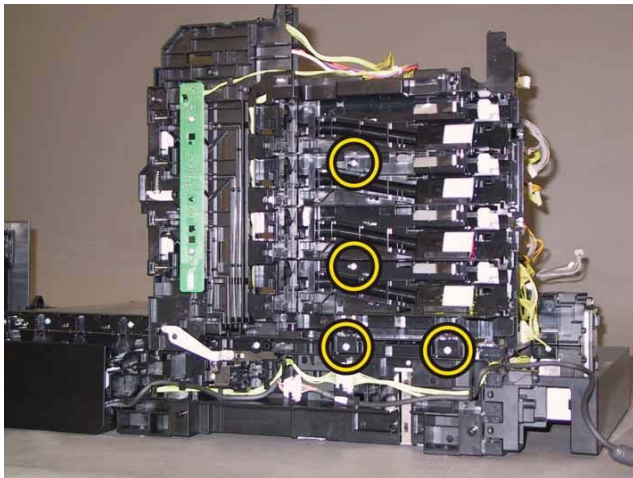

29) Remove the one screw (silver, M4, 6mm) that fixes the rear side of the DISPENSER ASSY to the printer.

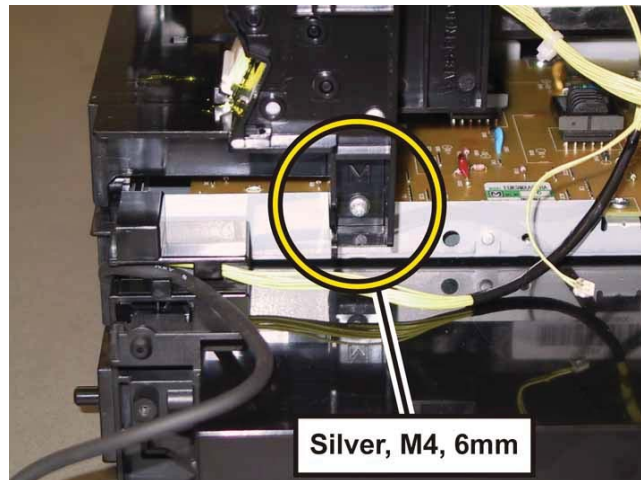

30) Release the hole of the DISPENSER ASSY from the boss of the printer, move the DISPENSER ASSY to backward. Remove the DISPENSER ASSY from the printer.

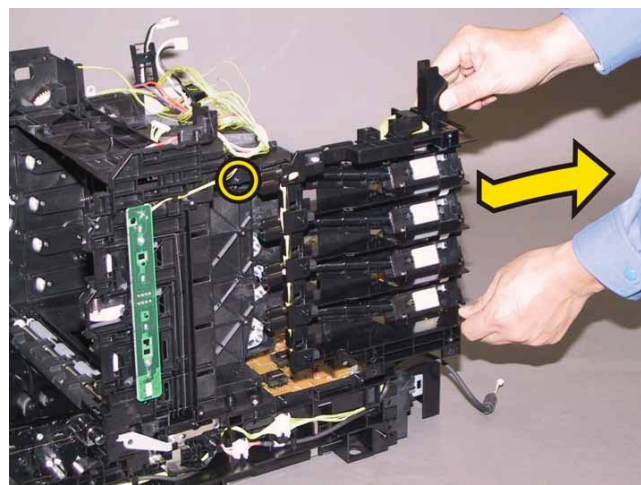

Removal 45 KIT ROS (PL4.1.99)

- 1) Remove the CASSETTE ASSY 250. (Removal 1)
- 2) Open the COVER ASSY FRONT MG (PL1.2.1).

Note: Cover the drum of the PHD ASSY to avoid exposure to light.

- 3) Remove the PHD ASSY. (Removal 4)

Note: The FUSER part is very hot. Take added care not to get burned when performing the service operation.

- 4) Remove the FUSER ASSY. (Removal 5)
- 5) Remove the COVER ASSY TOP. (Removal 10)
- 6) Remove the COVER ASSY WINDOW TNR. (Removal 8)
- 7) Remove the COVER SIDE R. (Removal 12)
- 8) Remove the COVER SIDE L. (Removal 16)
- 9) Remove the COVER REAR. (Removal 29)
- 10) Remove the FAN. (Removal 40)
- 11) Remove the KIT PWBA ESS SFP. (Removal 42)
- 12) Remove the KIT PWBA MCU. (Removal 43)
- 13) Remove the PWBA LVPS. (Removal 11)

Accesses Position (All the numbers show the procedure number.)

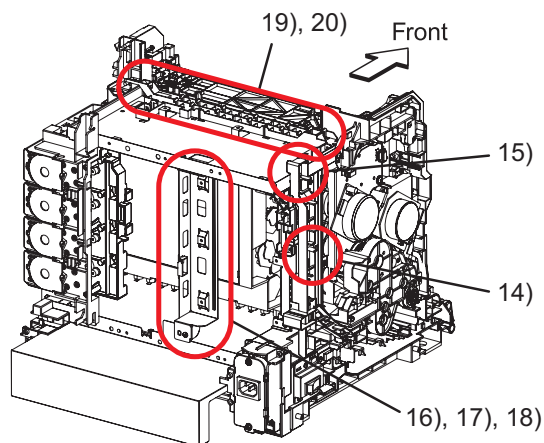

14) Remove the one screw (silver, with washer, 6mm) that fixes the grounding terminal of the SWITCH ASSY INLET MG SFP (PL8.2.9).



Note: The GUIDE HARNESS AC and the printer are connected with the harness, so they should not be far apart when carrying out the work described next procedure.

15) Release the hook of the GUIDE HARNESS AC (PL8.2.6), remove the GUIDE HARNESS AC from the printer.

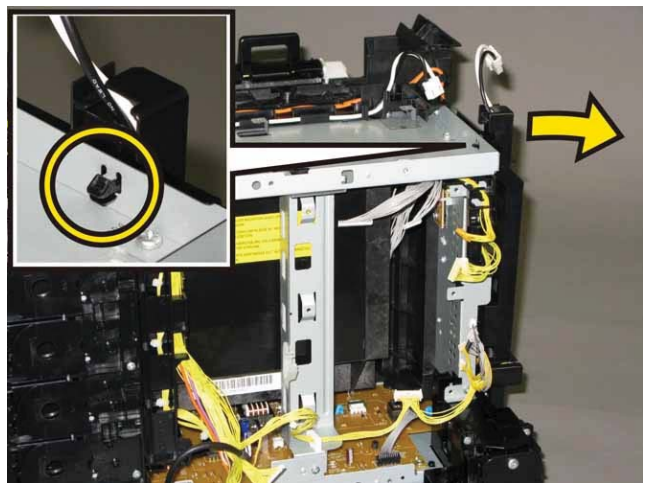

16) Release the harness of the HARN ASSY OPTION (PL3.1.20) from the clamp on the BRACKET MCU R (PL8.2.15).



17) Remove the two screws (silver, 6mm) that fix the BRACKET MCU R to the printer.



18) Remove the BRACKET MCU R from the printer.



Note: Release only the HARN ASSY INTERLOCK from the GUIDE HARNESS FSR to prevent the faulty wiring when it assembles it.

19) Release the harness of the HARN ASSY INTERLOCK (PL8.2.5) from the GUIDE HARNESS FSR (PL8.2.2).

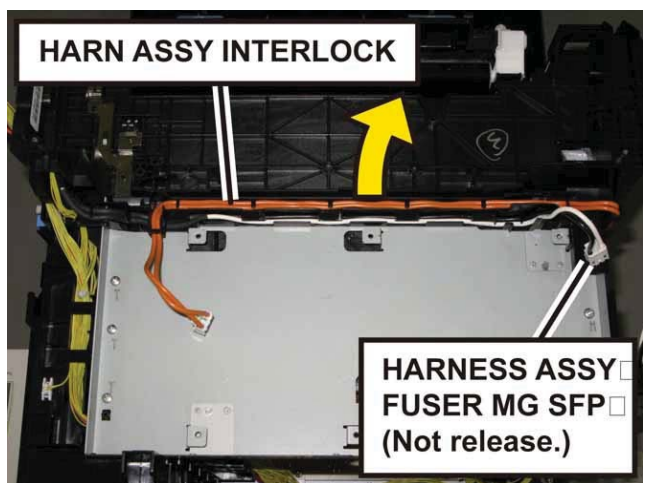

20) Release the hook of the GUIDE HARNESS FSR, to release the boss and tab of the GUIDE HARNESS FSR. Remove the GUIDE HARNESS FSR from the printer.

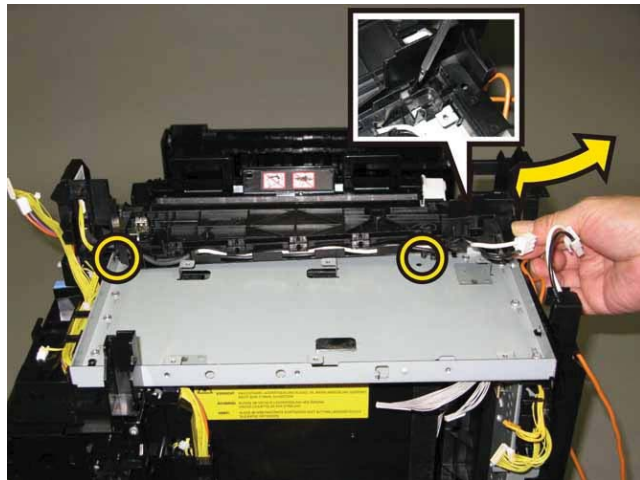

21) Remove two screw (silver, M4, 6mm) and six screws (silver, tap, 8mm) that fix the FRAME ASSY LVPS (PL8.2.3) to the printer.



22) Remove the one screw (silver, M4, 6mm) that fixes the DRIVE ASSY SUB (PL7.1.1) to the FRAME ASSY LVPS.

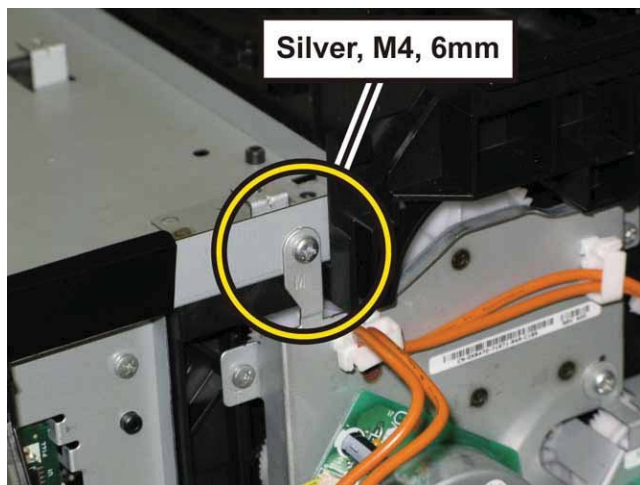

23) Remove the FRAME ASSY LVPS from the printer.

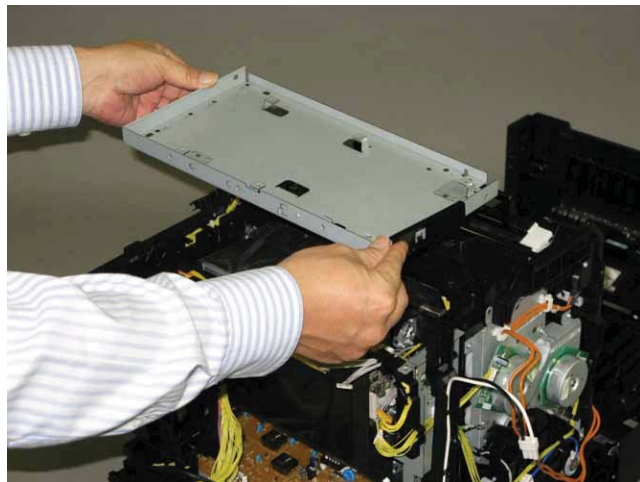

24) Disengage the two connectors (P/J411, 412) of the ROS ASSY (PL4.1.1).

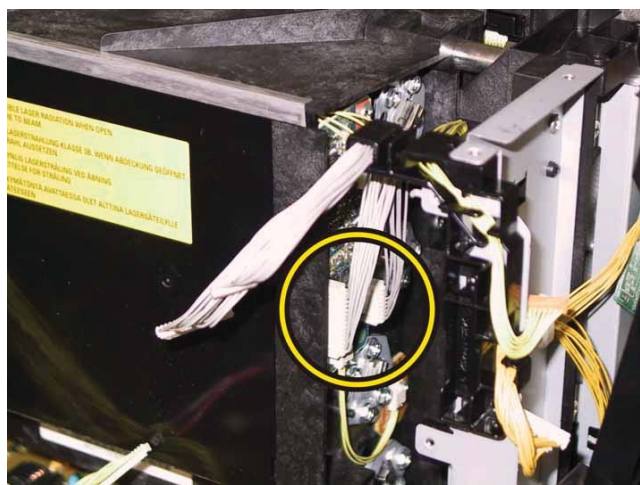

25) Remove the four screws (silver, tap, 8mm) that fix the left and right sides of the SPRING ROSs (PL4.1.2) to the printer. Remove the SPRING ROSs from the printer.

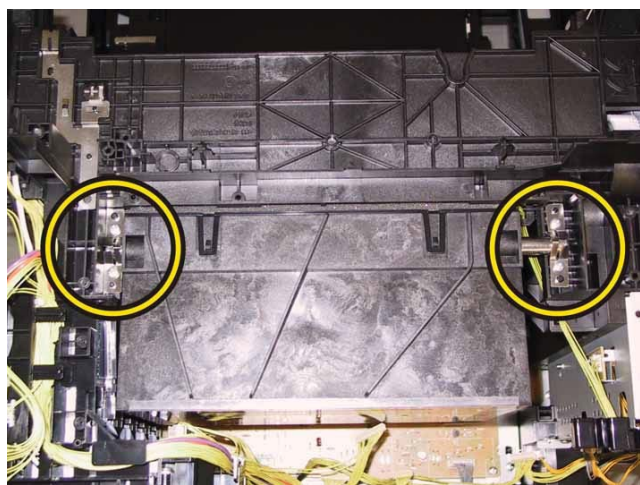

26) Lift up the ROS ASSY slowly from the printer.



Removal 46 UPPER UNIT (Reference only)

- 1) Remove the CASSETTE ASSY 250. (Removal 1)
- 2) Open the COVER ASSY FRONT MG (PL1.2.1).

Note: Cover the drum of the PHD ASSY to avoid exposure to light.

- 3) Remove the PHD ASSY. (Removal 4)

Note: The FUSER part is very hot. Take added care not to get burned when performing the service operation.

- 4) Remove the FUSER ASSY. (Removal 5)
- 5) Remove the TONER CARTRIDGE (K), (C), (M), (Y). (Removal 6)
- 6) Remove the COVER ASSY TOP. (Removal 10)
- 7) Remove the COVER ASSY WINDOW TNR. (Removal 8)
- 8) Remove the COVER SIDE R. (Removal 12)
- 9) Remove the COVER SIDE L. (Removal 16)
- 10) Remove the COVER REAR. (Removal 29)
- 11) Remove the SWITCH ASSY INLET MG SFP, COVER INLET. (Removal 36)
- 12) Remove the FAN. (Removal 40)
- 13) Remove the KIT PWBA ESS SFP. (Removal 42)
- 14) Remove the KIT PWBA MCU. (Removal 43)
- 15) Remove the CLUTCH ASSY DRV and BEARING REGI. (Removal 30)
- 16) Remove the KIT TRANSFER ASSY. (Removal 20)

Accesses Position (All the numbers show the procedure number.)

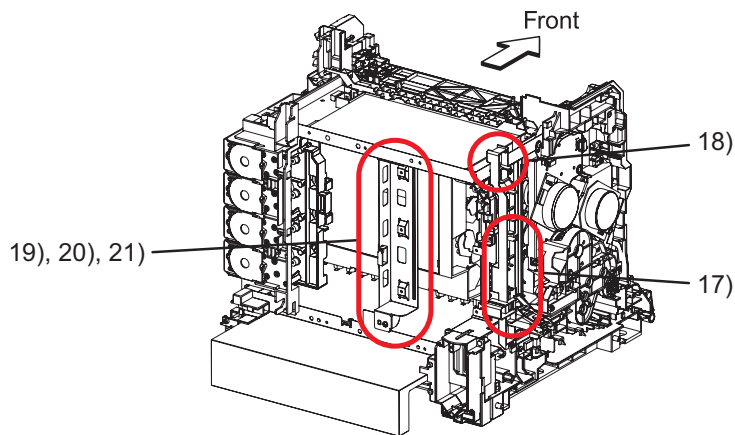

17) Remove the one screw (silver, 6mm) that fixes the grounding terminal of the HARN ASSY GND (PL1.2.22), release the HARN ASSY GND and all the harnesses from the GUIDE HARNESS AC (PL8.2.6).
Note: This step is only 2150cdn.

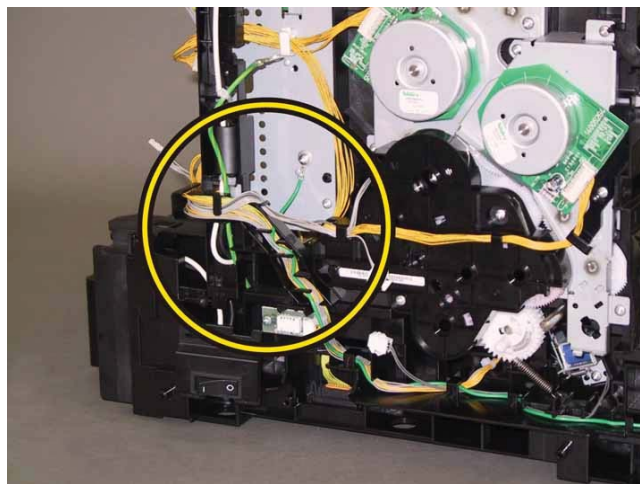

18) Release the hook of the GUIDE HARNESS AC , remove the GUIDE HARNESS AC from the printer

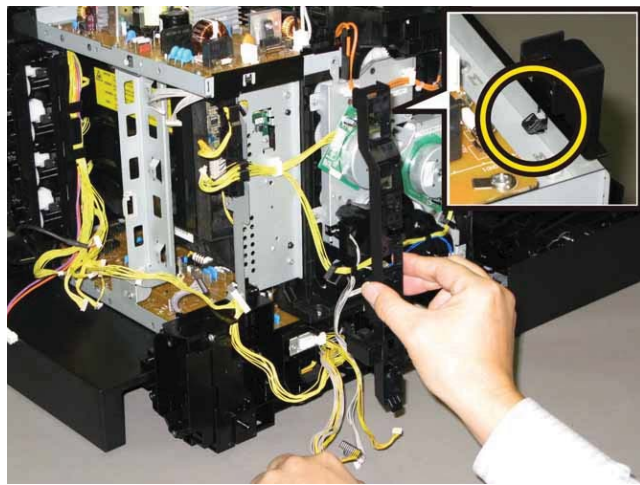

19) Release the harness of the HARN ASSY OPTION (PL3.1.20) from the clamp on the BRACKET MCU R (PL8.2.15).

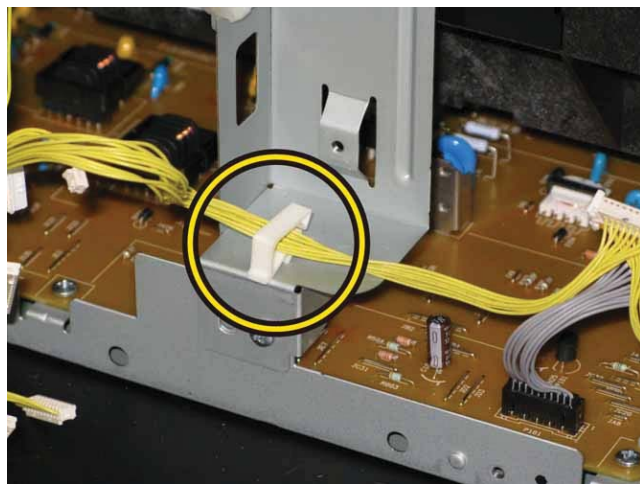

20) Remove the two screws (silver, 6mm) that fix the BRACKET MCU R to the printer.

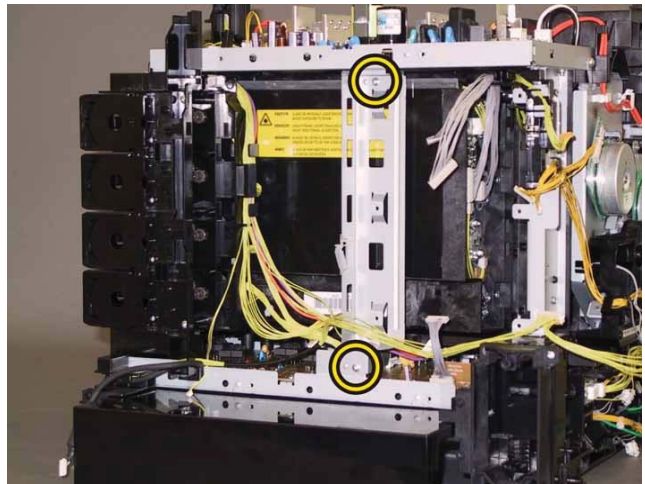

21) Remove the BRACKET MCU R from the printer.

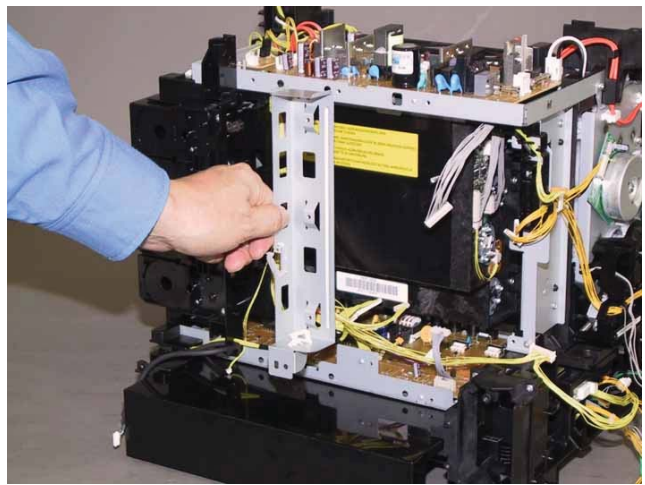

22) Remove the two screws (silver, tap, 8mm) that fix the front side of the printer frame.

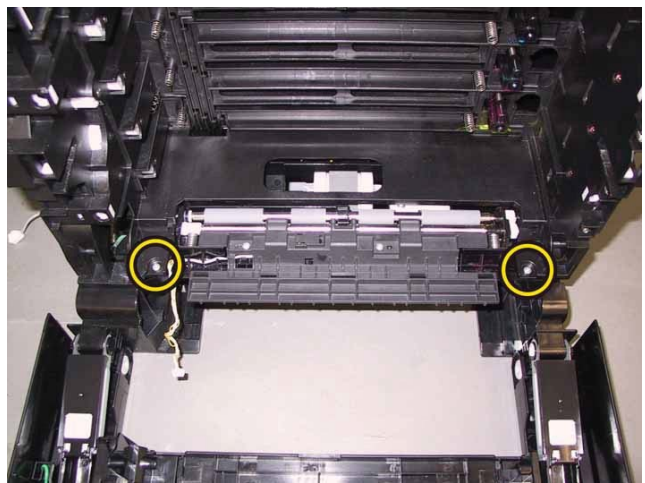

23) Remove the two screws (silver, tap, 8mm) that fix the under part of the DISPENSER ASSY.

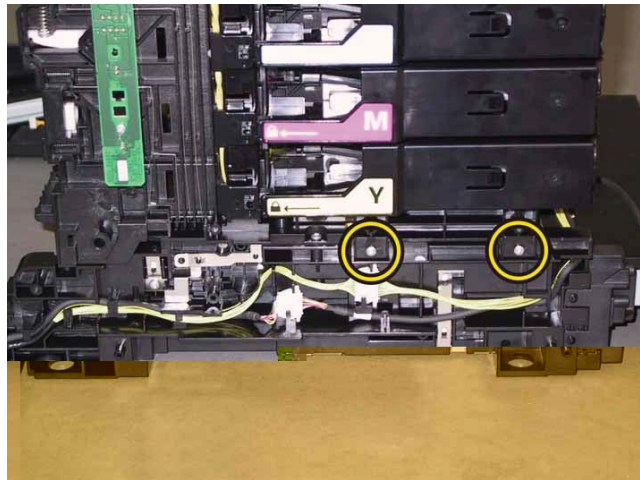

24) Open the HOLDER TCRU (K), (C), (M), and (Y), remove the one screw (silver, tap, 8mm) that fixes the right side of the printer frame.

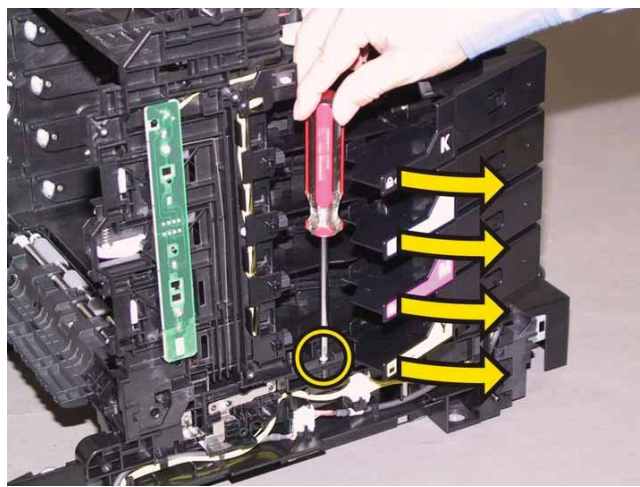

25) Remove the HARNESS ASSY B (PL9.1.12) and HARN ASSY OPTION (PL3.1.20) from the hooks of the DISPENSER ASSY.

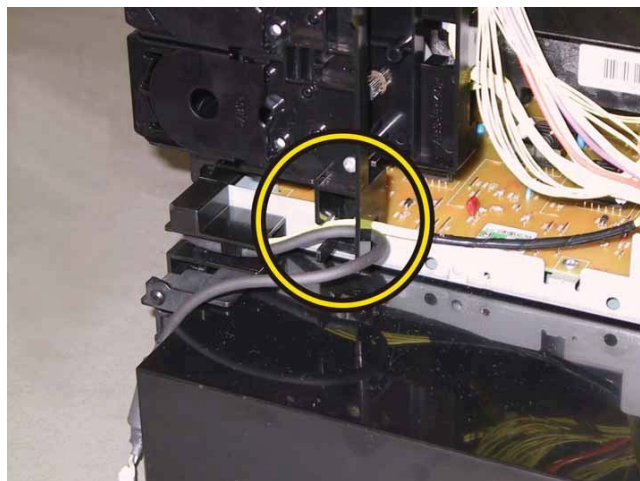

26) Remove the one screw (silver, M4, 6mm) that fixes the rear side of the DISPENSER ASSY and the one screw (silver, tap, 8mm) that fixes the BRACKET MCU L (PL8.2.18).

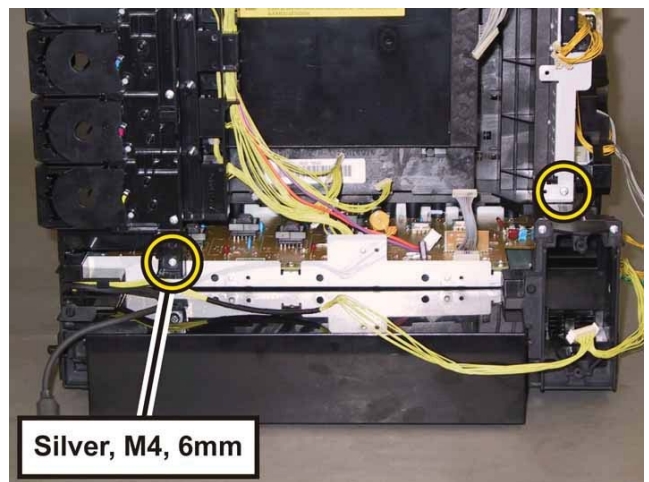

27) Remove the one screw (silver, tap, 8mm) that fixes the left side of the printer frame and the one screw (silver, tap, 8mm) that fixes the BRACKET MCU L.

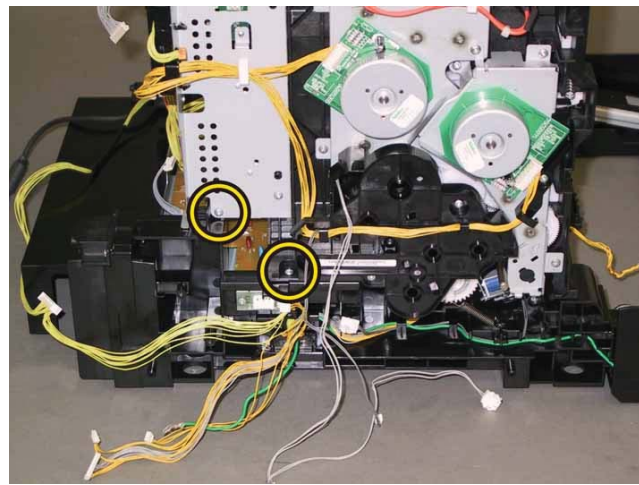

28) Remove the UPPER UNIT.

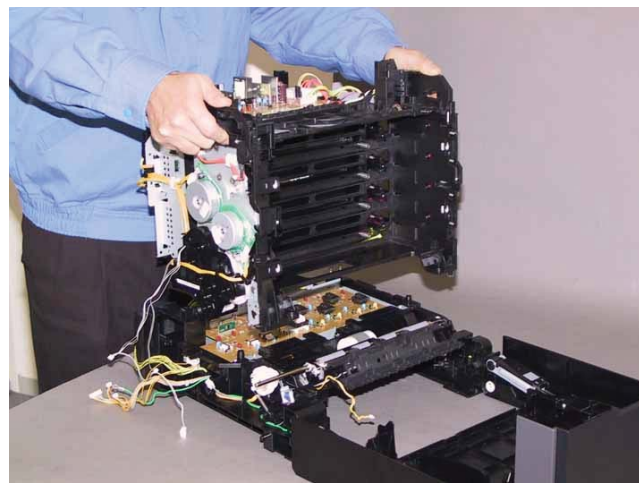

Removal 47 PWBA HVPS (PL4.1.19)

Note: Use the wrist strap to protect the PWB from the electrostatic.

- 1) Remove the CASSETTE ASSY 250. (Removal 1)
- 2) Open the COVER ASSY FRONT MG (PL1.2.1).

Note: Cover the drum of the PHD ASSY to avoid exposure to light.

- 3) Remove the PHD ASSY. (Removal 4)

Note: The FUSER part is very hot. Take added care not to get burned when performing the service operation.

- 4) Remove the FUSER ASSY. (Removal 5)
- 5) Remove the TONER CARTRIDGE (K), (C), (M), (Y). (Removal 6)
- 6) Remove the COVER ASSY TOP. (Removal 10)
- 7) Remove the COVER ASSY WINDOW TNR. (Removal 8)
- 8) Remove the COVER SIDE R. (Removal 12)
- 9) Remove the COVER SIDE L. (Removal 16)
- 10) Remove the COVER REAR. (Removal 29)
- 11) Remove the SWITCH ASSY INLET MG SFP, COVER INLET. (Removal 36)
- 12) Remove the FAN. (Removal 40)
- 13) Remove the KIT PWBA ESS SFP. (Removal 42)
- 14) Remove the KIT PWBA MCU. (Removal 43)
- 15) Remove the CLUTCH ASSY DRV and BEARING REGI. (Removal 30)
- 16) Remove the KIT TRANSFER ASSY. (Removal 20)
- 17) Remove the UPPER UNIT. (Removal 46)

- 18) Remove the HARN ASSY HVPS (PL9.1.5) from the PWBA HVPS (PL4.1.19).

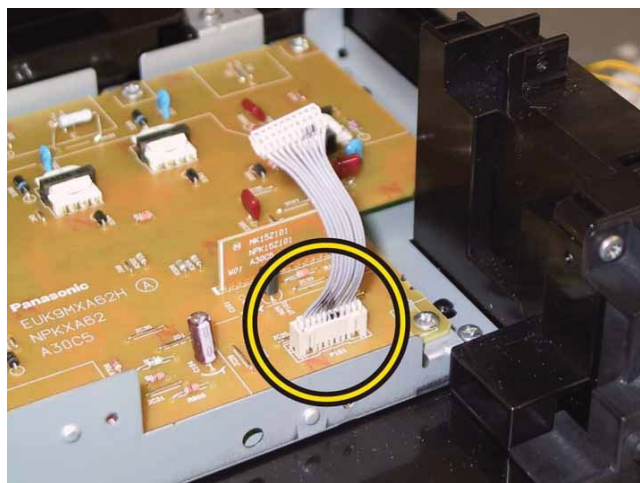

19) Remove the seven screws (silver, 6mm) that fix the PWBA HVPS to the FRAME HVPS (PL4.1.20).

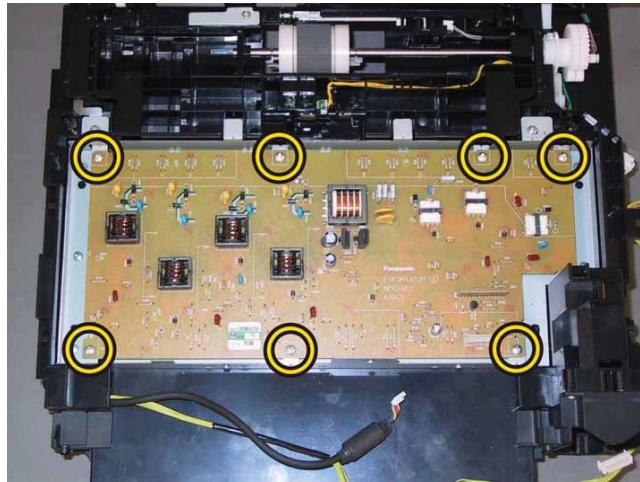

20) Remove the PWBA HVPS from the FRAME HVPS.

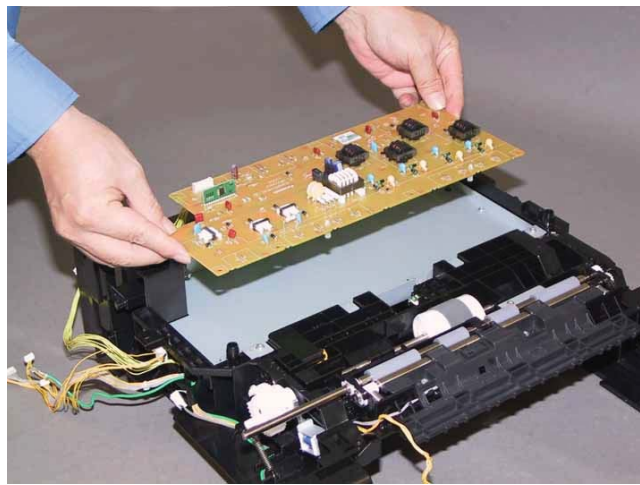

Removal 48 FEEDER ASSY MG SFP (PL3.1.98)

- 1) Remove the CASSETTE ASSY 250. (Removal 1)
- 2) Open the COVER ASSY FRONT MG (PL1.2.1)

Note: Cover the drum of the PHD ASSY to avoid exposure to light.

- 3) Remove the PHD ASSY. (Removal 4)

Note: The FUSER part is very hot. Take added care not to get burned when performing the service operation.

- 4) Remove the FUSER ASSY. (Removal 5)
- 5) Remove the TONER CARTRIDGE (K), (C), (M), (Y). (Removal 6)
- 6) Remove the COVER ASSY WINDOW TNR. (Removal 8)
- 7) Remove the COVER ASSY TOP. (Removal 10)
- 8) Remove the COVER SIDE R. (Removal 12)
- 9) Remove the COVER SIDE L. (Removal 16)
- 10) Remove the COVER REAR. (Removal 29)
- 11) Remove the SWITCH ASSY INLET MG SFP, COVER INLET. (Removal 36)
- 12) Remove the FAN. (Removal 40)
- 13) Remove the KIT PWBA ESS SFP. (Removal 42)
- 14) Remove the KIT PWBA MCU. (Removal 43)
- 15) Remove the CLUTCH ASSY DRV and BEARING REGI. (Removal 30)
- 16) Remove the KIT TRANSFER ASSY. (Removal 20)
- 17) Remove the UPPER UNIT. (Removal 46)
- 18) Remove the COVER ASSY FRONT MG. (Removal 24)

- 19) Remove the eight screws (silver, tap, 8mm) that fix the FRAME HVPS (PL4.1.20) to the FEEDER ASSY MG SFP (PL3.1.98).

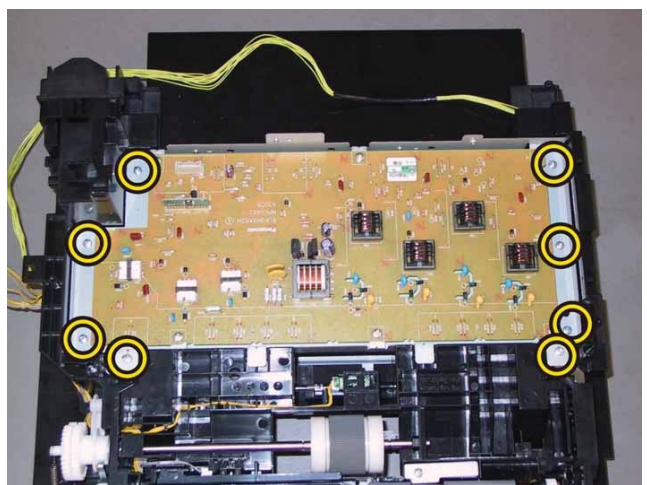

20) Remove the FRAME HVPS from the FEEDER ASSY MG SFP together with the PWBA HVPS (PL4.1.19), remove the FEEDER ASSY.

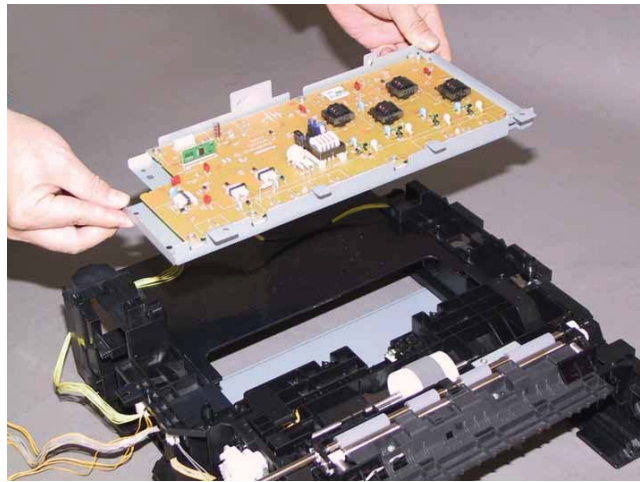

Removal 49 SENSOR PHOTO: REGI (PL3.2.13)

- 1) Remove the CASSETTE ASSY 250. (Removal 1)
- 2) Open the COVER ASSY FRONT MG (PL1.2.1).

Note: Cover the drum of the PHD ASSY to avoid exposure to light.

- 3) Remove the PHD ASSY. (Removal 4)

Note: The FUSER part is very hot. Take added care not to get burned when performing the service operation.

- 4) Remove the FUSER ASSY. (Removal 5)
- 5) Remove the TONER CARTRIDGE (K), (C), (M), (Y). (Removal 6)
- 6) Remove the COVER ASSY TOP. (Removal 10)
- 7) Remove the COVER ASSY WINDOW TNR. (Removal 8)
- 8) Remove the COVER SIDE R. (Removal 12)
- 9) Remove the COVER SIDE L. (Removal 16)
- 10) Remove the COVER REAR. (Removal 29)
- 11) Remove the SWITCH ASSY INLET MG SFP, COVER INLET. (Removal 36)
- 12) Remove the FAN. (Removal 40)
- 13) Remove the KIT PWBA ESS SFP. (Removal 42)
- 14) Remove the KIT PWBA MCU. (Removal 43)
- 15) Remove the CLUTCH ASSY DRV and BEARING REGI. (Removal 30)
- 16) Remove the KIT TRANSFER ASSY. (Removal 20)
- 17) Remove the UPPER UNIT. (Removal 46)

- 18) Release the hook of the ACTUATOR REGI OUT (PL3.2.6), shift the ACTUATOR REGI ROLL M (PL3.2.8) to right side.

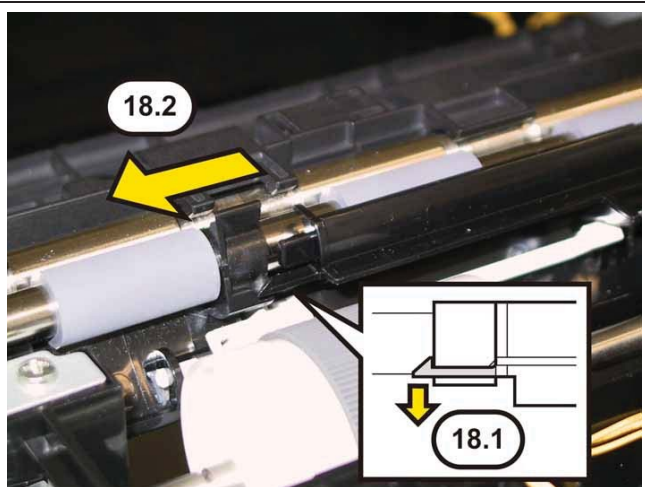

Note: When carrying out the work described next procedure, take care not to drop and lose the SPRING REGI OUT (PL3.2.7).

19) Release the ACTUATOR REGI OUT from the hook on the CHUTE UP (PL3.2.26), open the ACTUATOR REGI OUT.

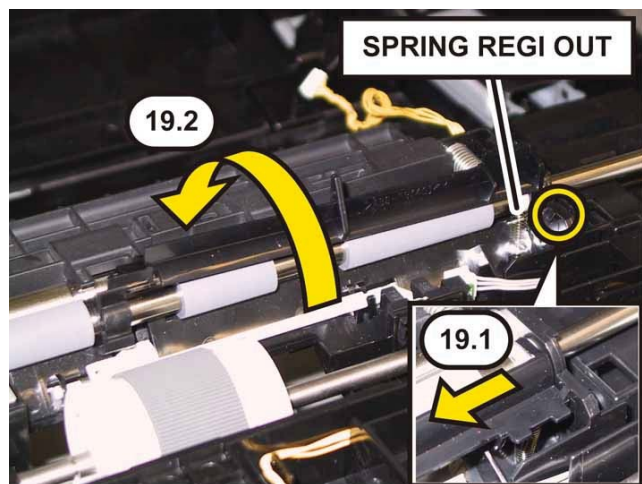

20) Release the three hooks that fix the SENSOR PHOTO: REGI (PL3.2.13) to the FEEDER ASSY MG SFP (PL3.1.98), and remove the SENSOR PHOTO: REGI.
Note: When carrying out the work this procedure, it is easier to push the ACTUATOR.

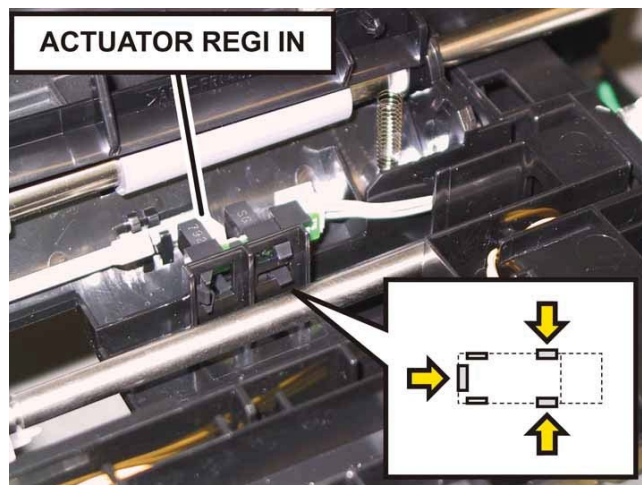

21) Disengage the connector (P/J232) of the SENSOR PHOTO: REGI.



Removal 50 ROLL ASSY REGI (PL3.2.9)

- 1) Remove the CASSETTE ASSY 250. (Removal 1)
- 2) Open the COVER ASSY FRONT MG (PL1.2.1).

Note: Cover the drum of the PHD ASSY to avoid exposure to light.

- 3) Remove the PHD ASSY. (Removal 4)

Note: The FUSER part is very hot. Take added care not to get burned when performing the service operation.

- 4) Remove the FUSER ASSY. (Removal 5)
- 5) Remove the TONER CARTRIDGE (K), (C), (M), (Y). (Removal 6)
- 6) Remove the COVER ASSY TOP. (Removal 10)
- 7) Remove the COVER ASSY WINDOW TNR. (Removal 8)
- 8) Remove the COVER SIDE R. (Removal 12)
- 9) Remove the COVER SIDE L. (Removal 16)
- 10) Remove the COVER REAR. (Removal 29)
- 11) Remove the SWITCH ASSY INLET MG SFP, COVER INLET. (Removal 36)
- 12) Remove the FAN. (Removal 40)
- 13) Remove the KIT PWBA ESS SFP. (Removal 42)
- 14) Remove the KIT PWBA MCU. (Removal 43)
- 15) Remove the CLUTCH ASSY DRV and BEARING REGI. (Removal 30)
- 16) Remove the KIT TRANSFER ASSY. (Removal 20)
- 17) Remove the UPPER UNIT. (Removal 46)

- 18) Release the hook of the ACTUATOR REGI OUT (PL3.2.6), shift the ACTUATOR REGI ROLL M (PL3.2.8) to right side.

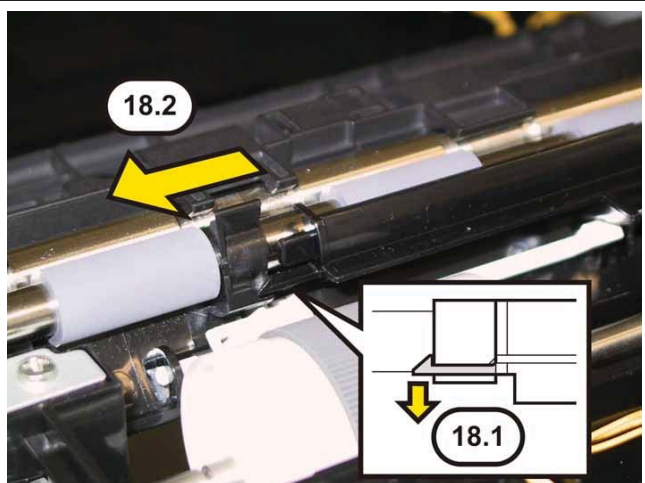

Note: When carrying out the work described next procedure, take care not to drop and lose the SPRING REGI OUT (PL3.2.7).

19) Release the ACTUATOR REGI OUT from the hook on the CHUTE UP (PL3.2.26), open the ACTUATOR REGI OUT.

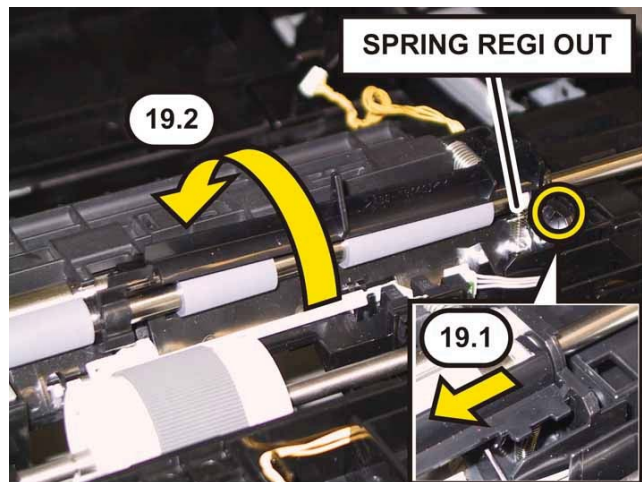

20) Remove the E-ring that fixes the GEAR REGI R (PL3.2.22) to the ROLL ASSY REGI (PL3.2.9), using a miniature screwdriver.

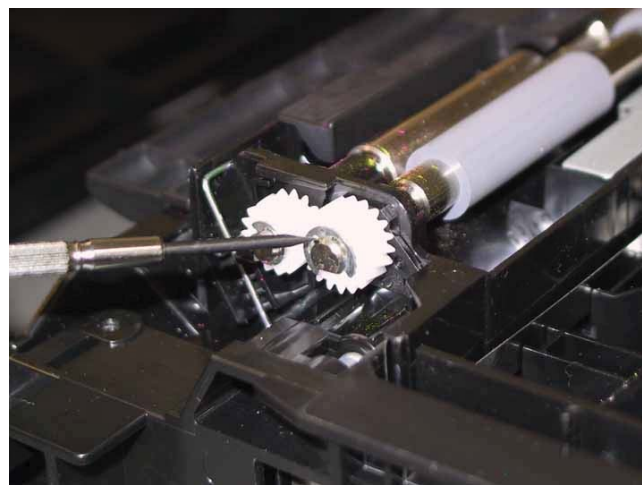

21) Remove the GEAR REGI R from the ROLL ASSY REGI.

Note: When carrying out the work this procedure, it is easier to push the ROLL REGI METAL (PL3.2.10) to frontward.

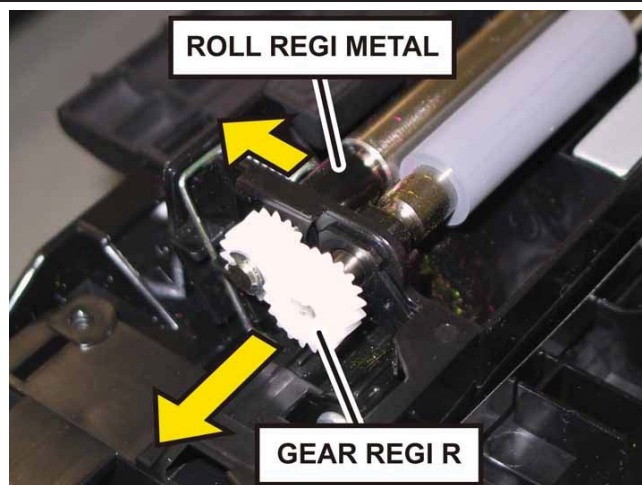

22) Remove the BEARING EARTH REGI (PL3.2.21) from the ROLL ASSY REGI.

Note: When carrying out the work this procedure, it is easier to push the ROLL REGI METAL (PL3.2.10) to frontward.

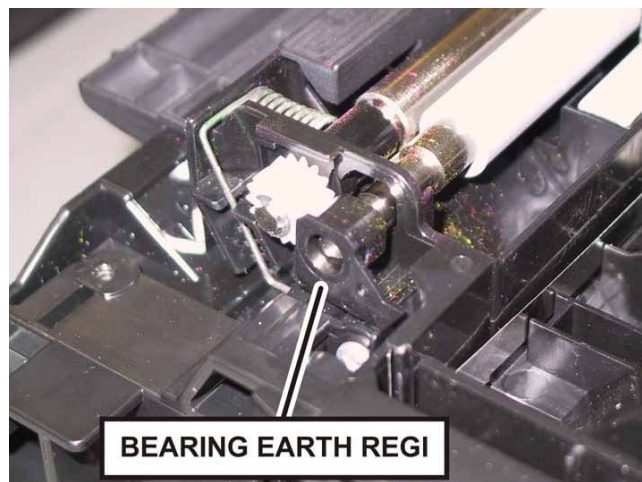

23) Remove the E-ring that fixes the BEARING R (PL3.2.31) to the ROLL ASSY REGI, using a miniature screwdriver.

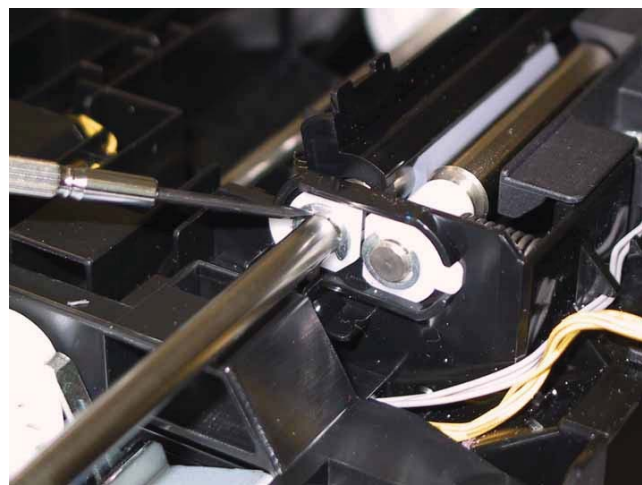

24) Remove the BEARING R from the ROLL ASSY REGI.

Note: When carrying out the work this procedure, it is easier to push the ROLL REGI METAL (PL3.2.10) to frontward.

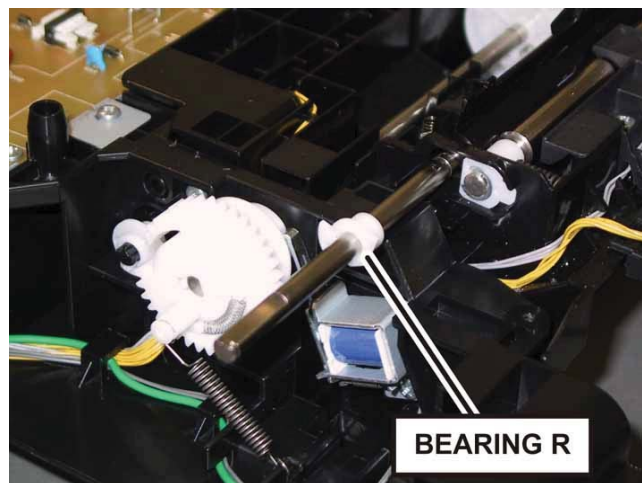

25) Shift the ROLL ASSY REGI to left to remove the right shaft of the ROLL ASSY REGI, remove the ROLL ASSY REGI from the FEEDER ASSY MG SFP (PL3.1.98) together with the ACTUATOR REGI OUT and the ACTUATOR REGI ROLL M.

Note: When carrying out the work this procedure, move the ACTUATOR REGI OUT to right until it stops.

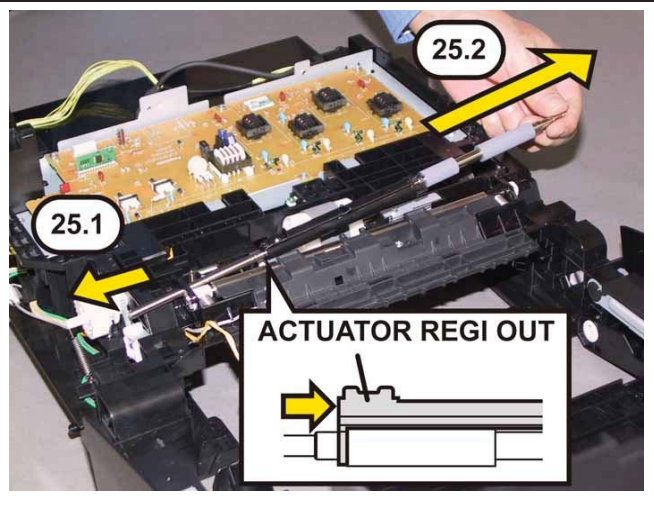

Removal 51 ACTUATOR REGI IN (PL3.2.11)

- 1) Remove the CASSETTE ASSY 250. (Removal 1)
- 2) Open the COVER ASSY FRONT MG (PL1.2.1).

Note: Cover the drum of the PHD ASSY to avoid exposure to light.

- 3) Remove the PHD ASSY. (Removal 4)

Note: The FUSER part is very hot. Take added care not to get burned when performing the service operation.

- 4) Remove the FUSER ASSY. (Removal 5)
- 5) Remove the TONER CARTRIDGE (K), (C), (M), (Y). (Removal 6)
- 6) Remove the COVER ASSY TOP. (Removal 10)
- 7) Remove the COVER ASSY WINDOW TNR. (Removal 8)
- 8) Remove the COVER SIDE R. (Removal 12)
- 9) Remove the COVER SIDE L. (Removal 16)
- 10) Remove the COVER REAR. (Removal 29)
- 11) Remove the SWITCH ASSY INLET MG SFP, COVER INLET. (Removal 36)
- 12) Remove the FAN. (Removal 40)
- 13) Remove the KIT PWBA ESS SFP. (Removal 42)
- 14) Remove the KIT PWBA MCU. (Removal 43)
- 15) Remove the CLUTCH ASSY DRV and BEARING REGI. (Removal 30)
- 16) Remove the KIT TRANSFER ASSY. (Removal 20)
- 17) Remove the UPPER UNIT. (Removal 46)
- 18) Remove the ROLL ASSY REGI. (Removal 50)

19) Release the left shaft of the ACTUATOR REGI IN (PL3.2.11) from the hook of the CHUTE UP (PL3.2.26).

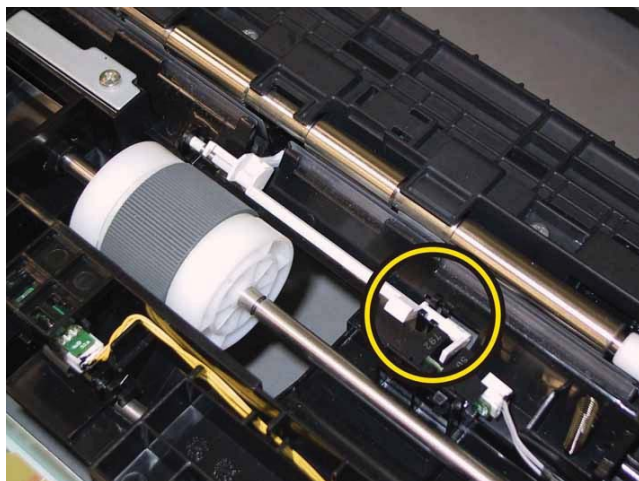

20) Remove the ACTUATOR REGI IN and the SPRING ACT REGI (PL3.2.12) by releasing the right shaft of the ACTUATOR REGI IN from the hole of the CHUTE UP.

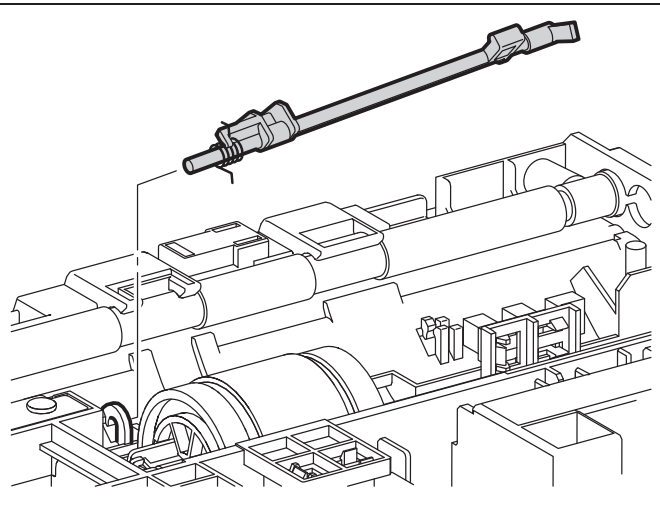

21) Remove the SPRING ACT REGI from the ACTUATOR REGI IN.

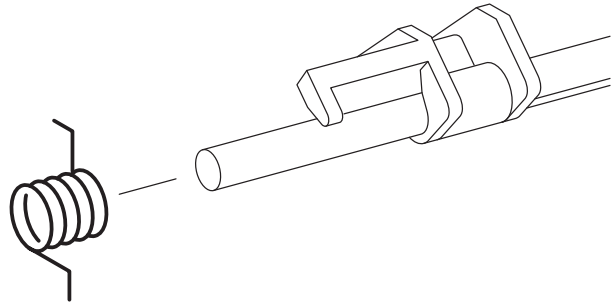

Removal 52 SENSOR PHOTO: CST NO PAPER (PL3.2.13)

- 1) Remove the CASSETTE ASSY 250. (Removal 1)
- 2) Open the COVER ASSY FRONT MG (PL1.2.1).

Note: Cover the drum of the PHD ASSY to avoid exposure to light.

- 3) Remove the PHD ASSY. (Removal 4)

Note: The FUSER part is very hot. Take added care not to get burned when performing the service operation.

- 4) Remove the FUSER ASSY. (Removal 5)
- 5) Remove the TONER CARTRIDGE (K), (C), (M), (Y). (Removal 6)
- 6) Remove the COVER ASSY TOP. (Removal 10)
- 7) Remove the COVER ASSY WINDOW TNR. (Removal 8)
- 8) Remove the COVER SIDE R. (Removal 12)
- 9) Remove the COVER SIDE L. (Removal 16)
- 10) Remove the COVER REAR. (Removal 29)
- 11) Remove the SWITCH ASSY INLET MG SFP, COVER INLET. (Removal 36)
- 12) Remove the FAN. (Removal 40)
- 13) Remove the KIT PWBA ESS SFP. (Removal 42)
- 14) Remove the KIT PWBA MCU. (Removal 43)
- 15) Remove the CLUTCH ASSY DRV and BEARING REGI. (Removal 30)
- 16) Remove the KIT TRANSFER ASSY. (Removal 20)
- 17) Remove the UPPER UNIT. (Removal 46)

- 18) Release the three hooks that fix the SENSOR PHOTO: CST NO PAPER (PL3.2.13) to the FEEDER ASSY MG SFP (PL3.1.98), and remove the SENSOR PHOTO: CST NO PAPER.

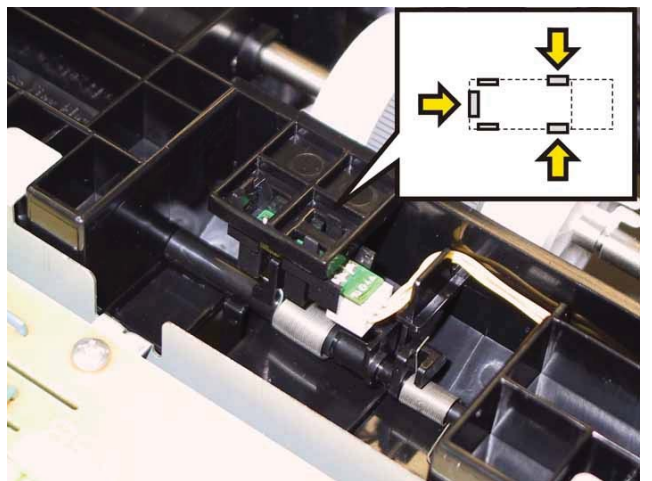

19) Disengage the connector (P/J234) of the SENSOR PHOTO: CST NO PAPER.

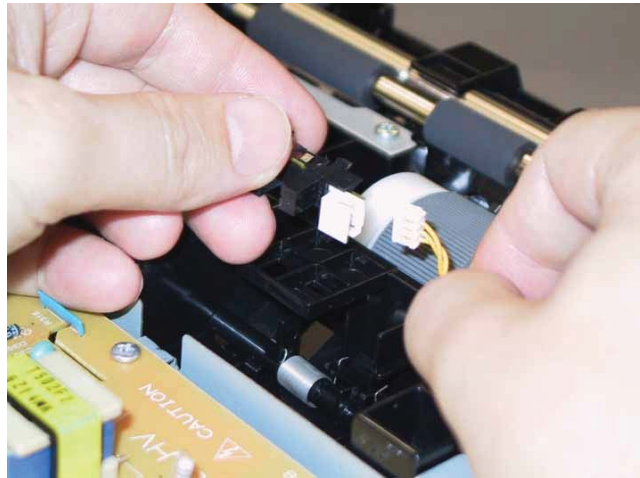

Removal 53 ACTUATOR ASSY NO PAPER (PL3.2.32)

- 1) Remove the CASSETTE ASSY 250. (Removal 1)
- 2) Open the COVER ASSY FRONT MG (PL1.2.1).

Note: Cover the drum of the PHD ASSY to avoid exposure to light.

- 3) Remove the PHD ASSY. (Removal 4)

Note: The FUSER part is very hot. Take added care not to get burned when performing the service operation.

- 4) Remove the FUSER ASSY. (Removal 5)
- 5) Remove the TONER CARTRIDGE (K), (C), (M), (Y). (Removal 6)
- 6) Remove the COVER ASSY TOP. (Removal 10)
- 7) Remove the COVER ASSY WINDOW TNR. (Removal 8)
- 8) Remove the COVER SIDE R. (Removal 12)
- 9) Remove the COVER SIDE L. (Removal 16)
- 10) Remove the COVER REAR. (Removal 29)
- 11) Remove the SWITCH ASSY INLET MG SFP, COVER INLET. (Removal 36)
- 12) Remove the FAN. (Removal 40)
- 13) Remove the KIT PWBA ESS SFP. (Removal 42)
- 14) Remove the KIT PWBA MCU. (Removal 43)
- 15) Remove the CLUTCH ASSY DRV and BEARING REGI. (Removal 30)
- 16) Remove the KIT TRANSFER ASSY. (Removal 20)
- 17) Remove the UPPER UNIT. (Removal 46)
- 18) Remove the SENSOR PHOTO: CST NO PAPER. (Removal 52)

- 19) Release the right shaft of the ACTUATOR ASSY NO PAPER (PL3.2.32) from the hole of the CHUTE UP (PL3.2.26), using a miniature screwdriver.

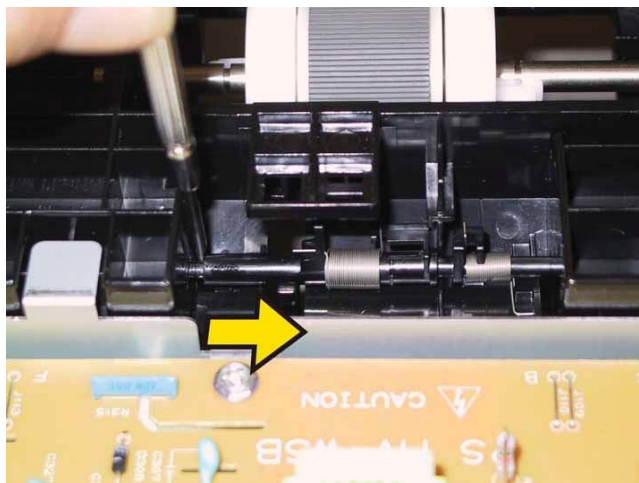

20) Remove the ACTUATOR ASSY NO PAPER and the SPRING STP (PL3.2.16) by releasing the left shaft of the ACTUATOR ASSY NO PAPER from the hole of the CHUTE UP.



21) Remove the SPRING STP from the ACTUATOR ASSY NO PAPER.

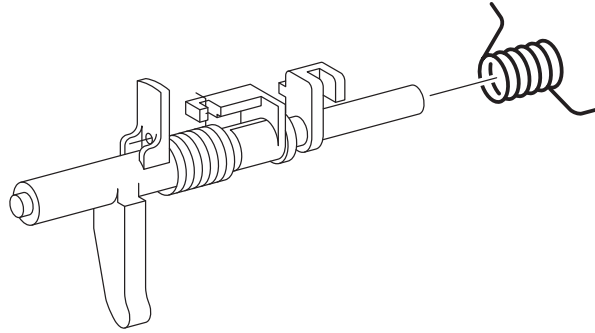

Removal 54 WIRELESS ADAPTER (PL8.1.16)

1) Loosen the SCREW KNURLING (PL8.1.13) and then open the PLATE ESS (PL8.1.12).



2) Release the one hook of the WIRELESS ADAPTER (PL8.1.16).

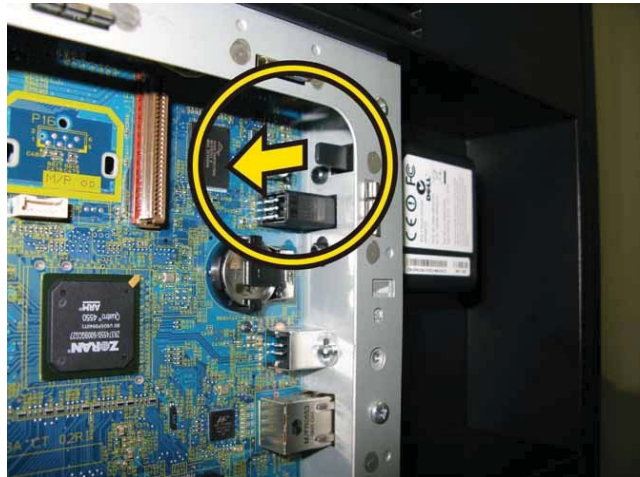

3) Remove the WIRELESS ADAPTER.



Removal 55 MEMORY CARD (PL8.1.15)

Note: Use the wrist strap to protect the PWB from the electrostatic.

1) Loosen the SCREW KNURLING (PL8.1.13) and then open the PLATE ESS (PL8.1.12).



2) Push the release latches of the socket to release the MEMORY CARD (PL8.1.15).



3) Remove the MEMORY CARD.

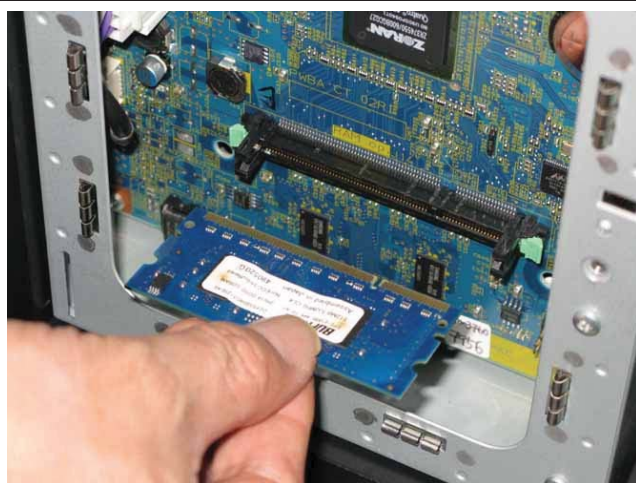

Removal 56 FEEDER ASSY DUP SFP STD (PL11.1.1)

1) Open the COVER ASSY FRONT MG (PL1.2.1).

2) Open the CHUTE DUP IN (PL11.1.2).

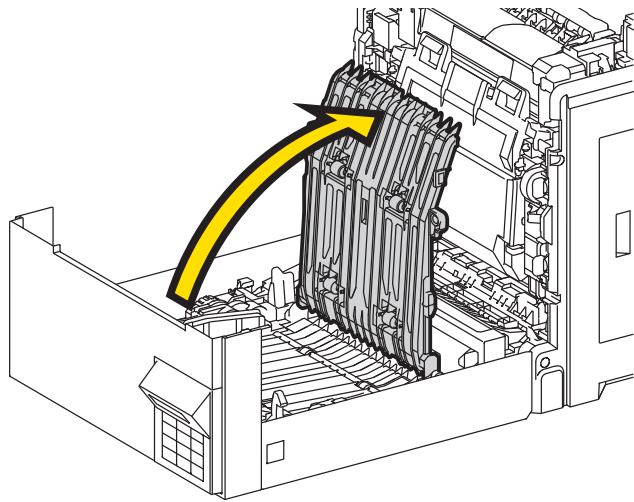

3) Through the hole indicated by the arrow, insert a screwdriver and press the LATCH BUTTON to unlock the FEEDER ASSY DUP SFP STD (PL11.1.1).

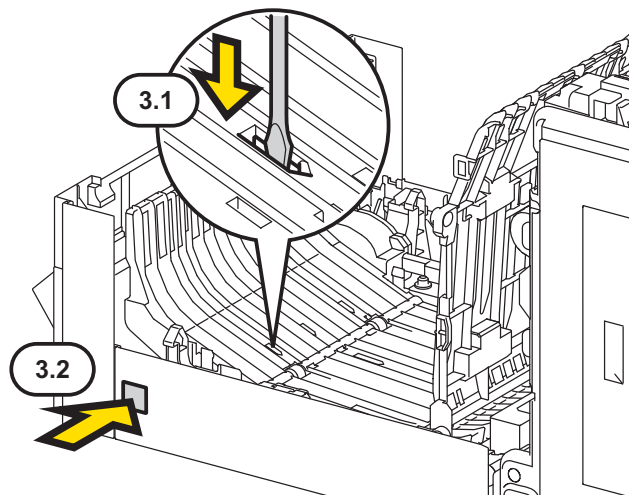

4) Lift up the FEEDER ASSY DUP SFP STD from the printer.

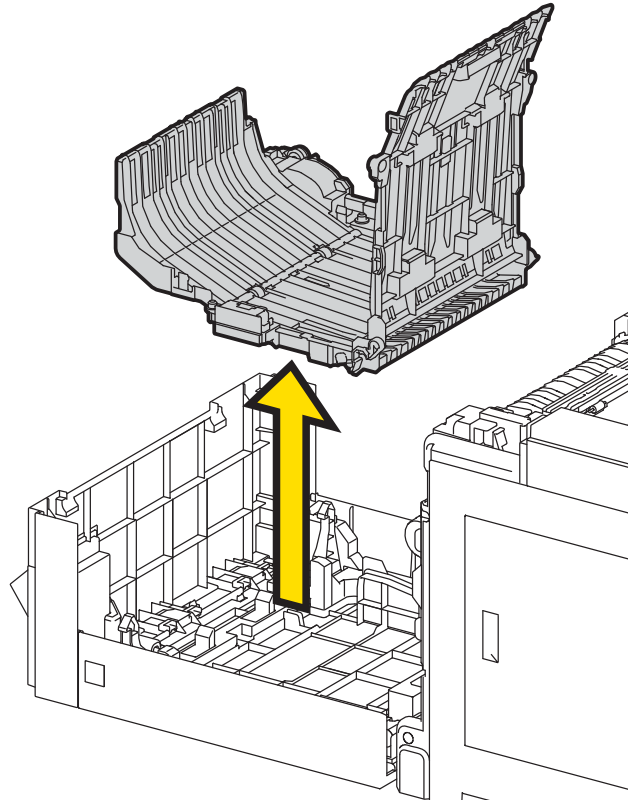

Removal 57 ROLLER ASSY DUP (PL11.2.9)

- 1) Open the COVER ASSY FRONT MG (PL1.2.1).
- 2) Remove the FEEDER ASSY DUP SFP STD. (Removal 56)

3) Release the six hooks that fixes the COVER PWBA DUP (PL11.1.15), remove the COVER PWBA DUP from the FEEDER ASSY DUP SFP STD (PL11.1.1).

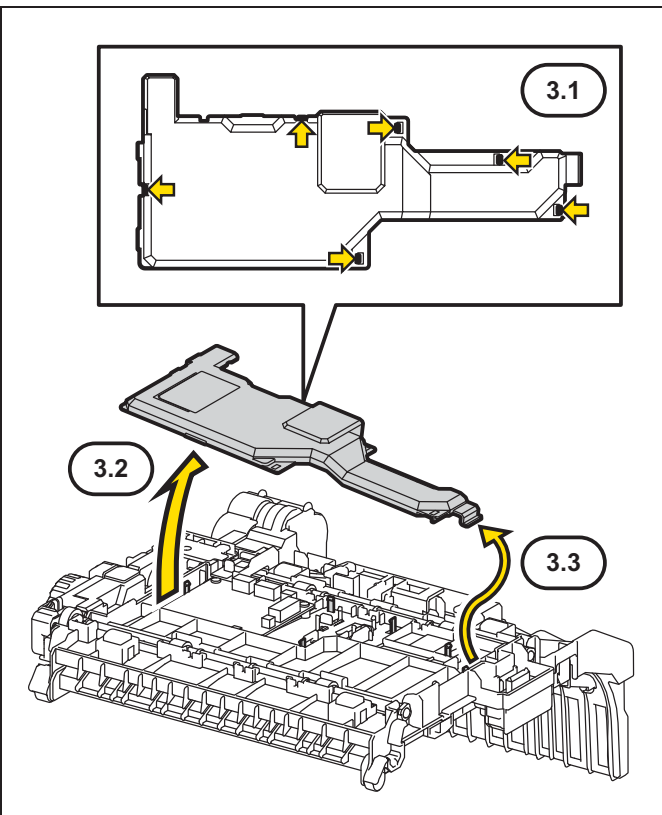

4) Disengage the connector (P/J603) of the DRIVE ASSY DUP (PL11.2.5) on the PWBA DUP (PL11.1.16), release the harness of the DRIVE ASSY DUP from the hooks of the COVER DRIVE DUP (PL11.2.3).

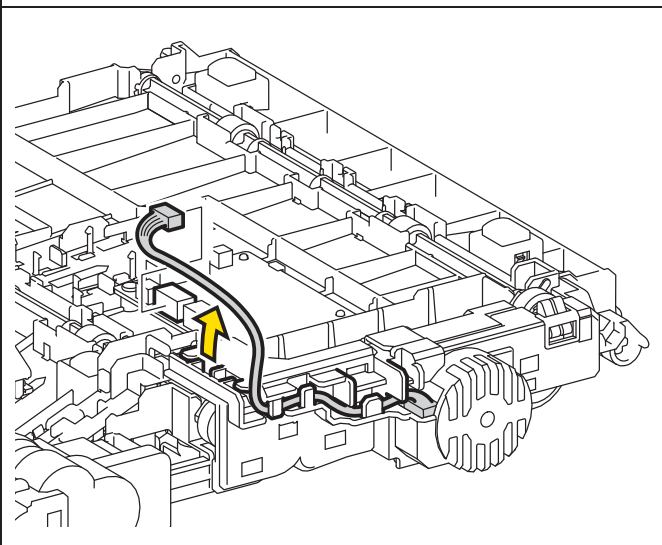

5) Release the five hooks of the COVER DRIVE DUP. Draw out the connector of the DRIVE ASSY DUP from the hole of the COVER DRIVE DUP, and then remove the COVER DRIVE DUP from the FEEDER ASSY DUP SFP STD.

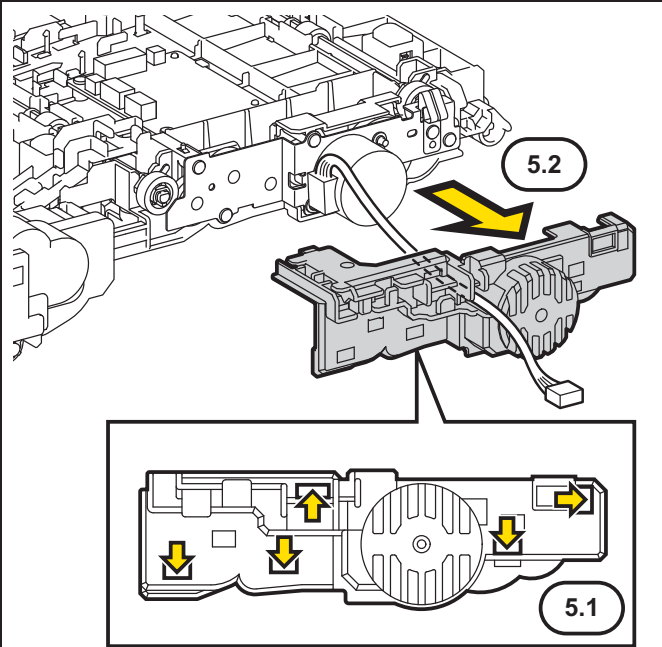

6) Remove the four screws (silver, tap, 8mm) that fix the DRIVE ASSY DUP to the FEEDER ASSY DUP SFP STD, remove the DRIVE ASSY DUP.

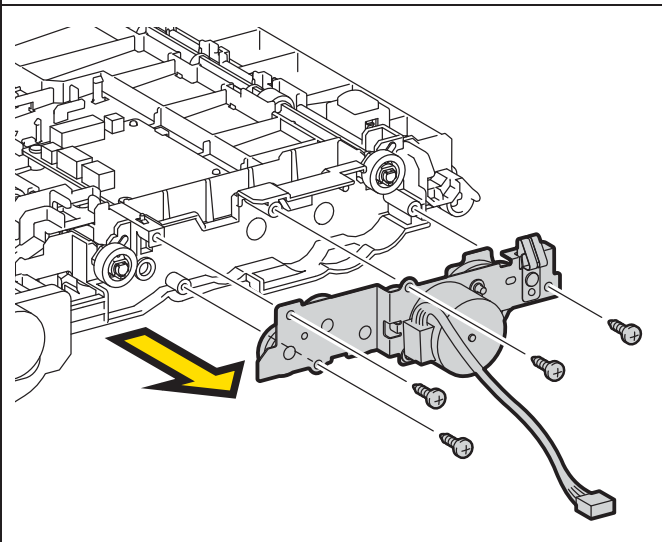

7) Release the hook of the GEAR ROLL DUP (PL11.2.6), remove the GEAR ROLL DUP from the ROLLER ASSY DUP (PL11.2.9).

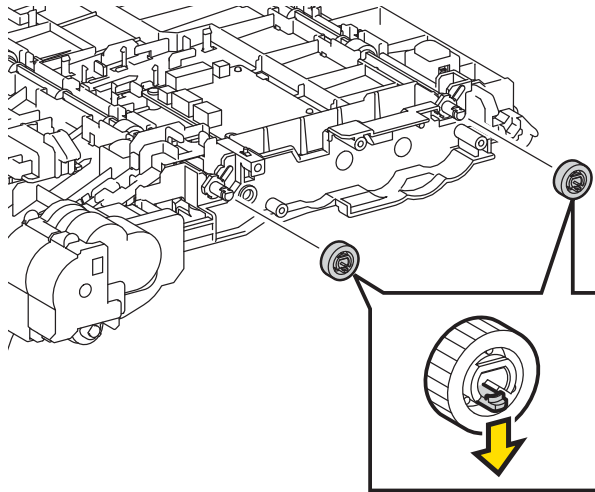

8) Remove the BEARING DUP (PL11.2.7) that fixes the right and left sides of the ROLLER ASSY DUP by rotating in the direction shown by the arrow.

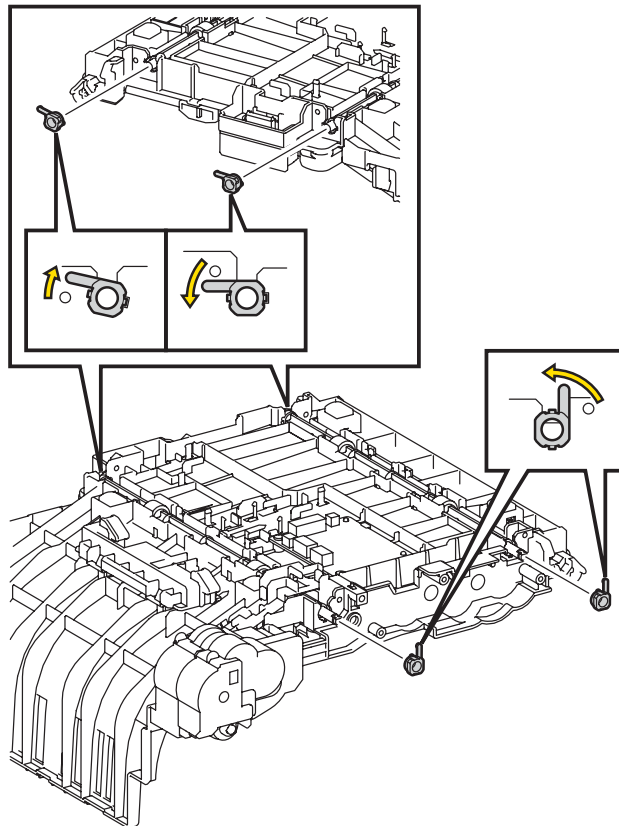

9) Remove the ROLLER ASSY DUP from the FEEDER ASSY DUP SFP STD.

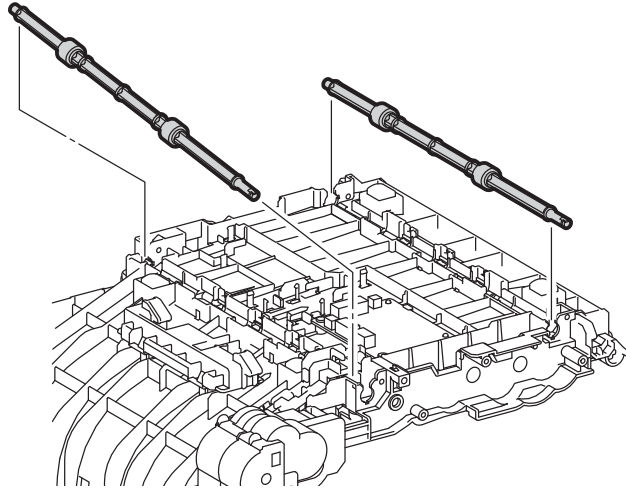

Removal 58 KIT FEEDER ASSY OPT (PL12.1.99)

Note: The printer must be lifted by two people.

1) Remove the CASSETTE ASSY 250. (Removal 1)

2) Remove the CASSETTE ASSY 250 OPT.

3) Remove the two SCREW JOINTs (PL12.1.2) that fix the FEEDER ASSY OPT (PL12.1.3) to the printer.

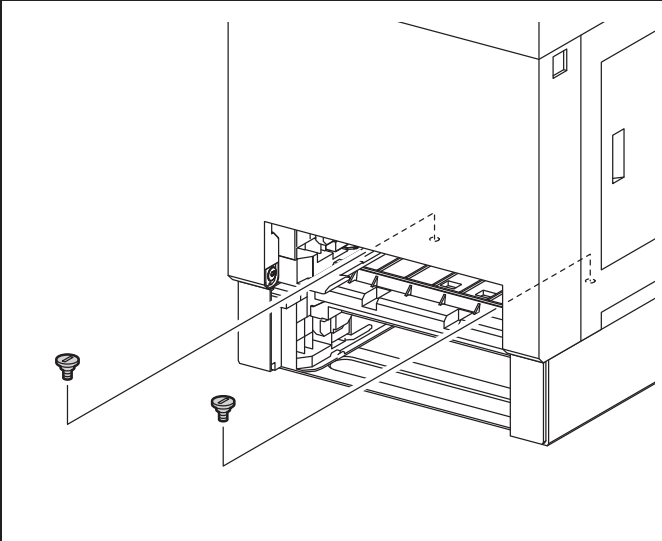

4) Lift up the printer to separate it from the FEEDER ASSY OPT.

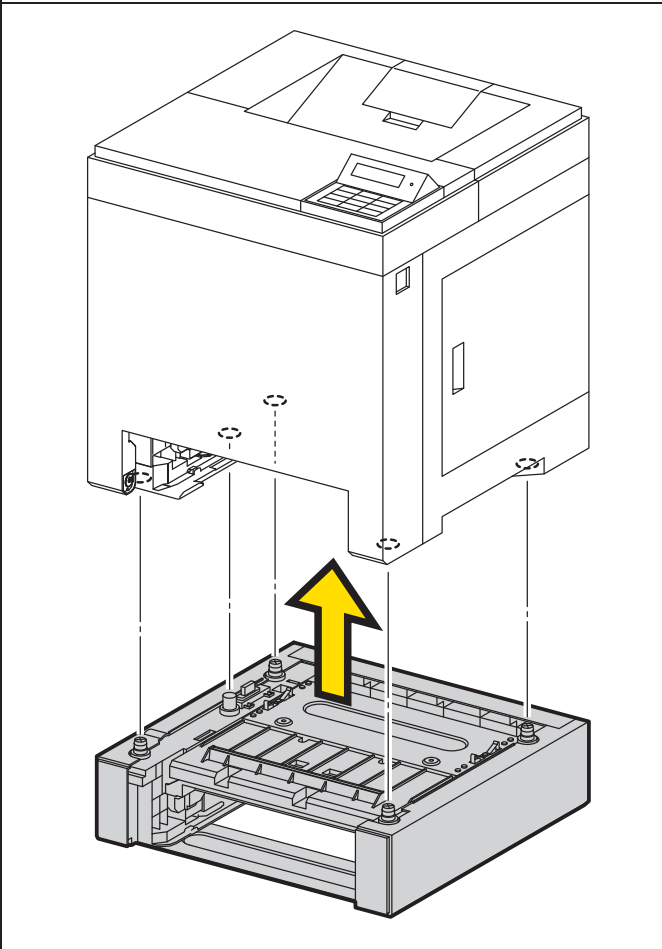

Removal 59 ROLL ASSY FEED (Parts of the FEEDER ASSY OPT) (PL12.4.4)

1) Remove the CASSETTE ASSY 250 OPT.

2) Release the hook of the ROLL CORE MSI (PL12.4.3) on the left of the ROLL ASSY FEED (PL 12.4.4), and move the ROLL CORE MSI to left until it stops.

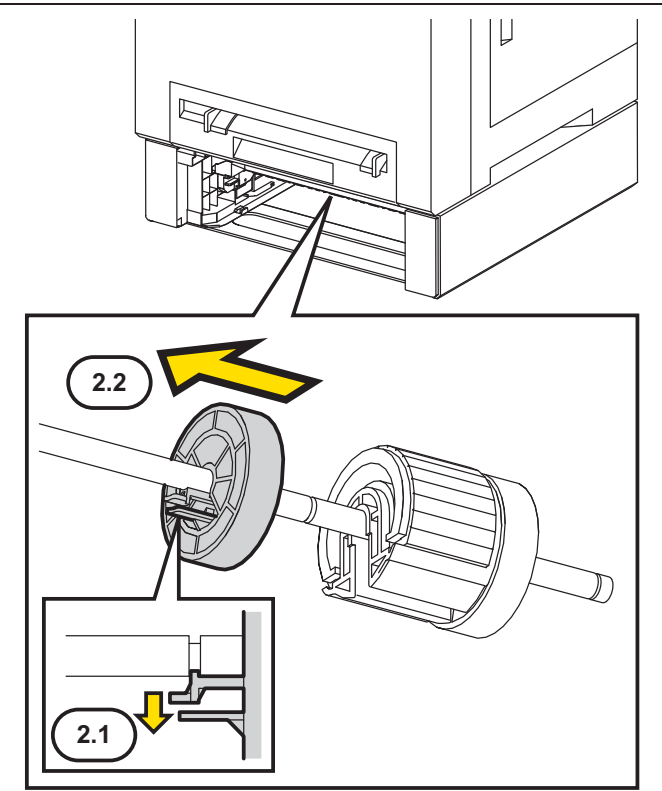

3) Release the groove on the ROLL ASSY FEED from the vertical pin mounted on the SHAFT ASSY FEED (PL12.4.2) by sliding the ROLL ASSY FEED to the left.

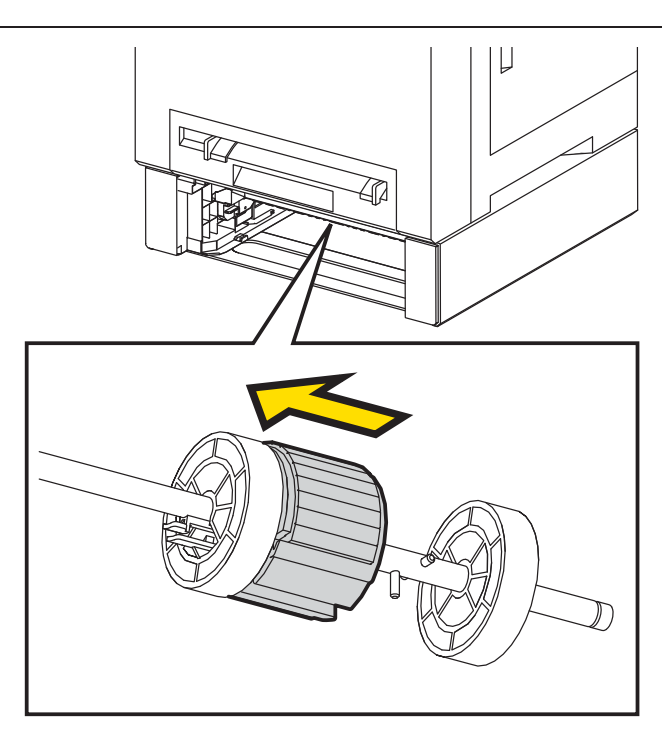

4) Remove the ROLL ASSY FEED from the SHAFT ASSY FEED by rotating the ROLL ASSY FEED 180 degrees.

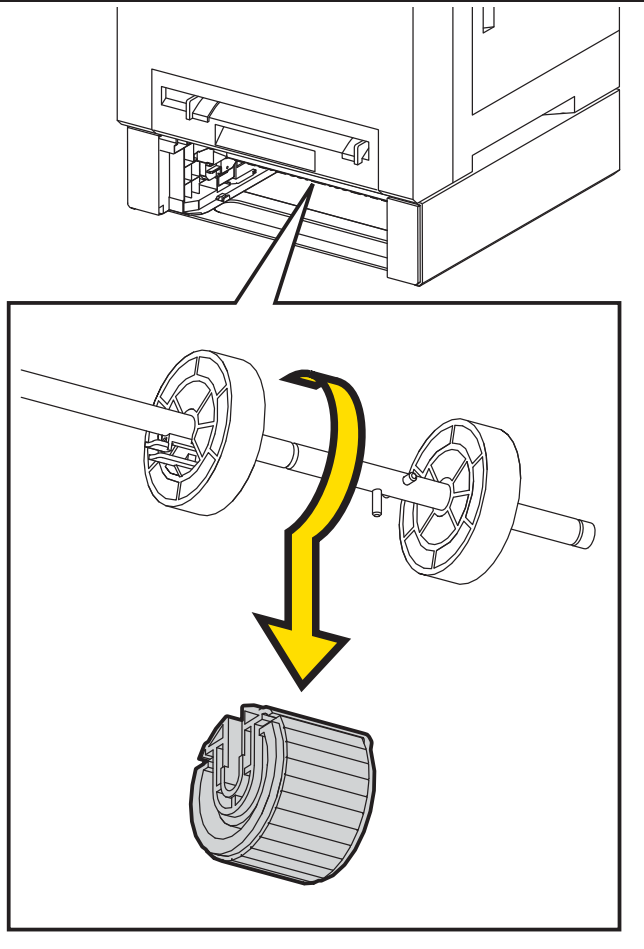

Replacement 1 ACTUATOR ASSY NO PAPER (PL3.2.32)

1) Attach the SPRING STP to the ACTUATOR ASSY NO PAPER.

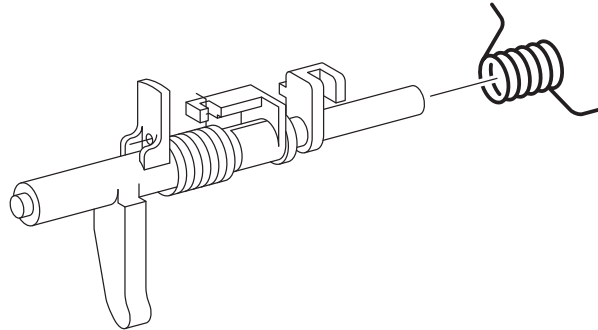

Note: When carrying out the work described next procedure, ensure that the SPRING STP is hung to ACTUATOR NO PAPER and the CHUTE UP correctly.

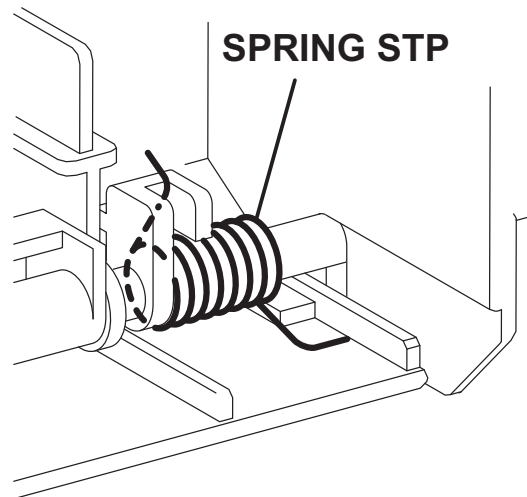

2) Insert the left shaft of the ACTUATOR ASSY NO PAPER into the hole of the CHUTE UP, hang the SPRING STP to the CUHTE UP.

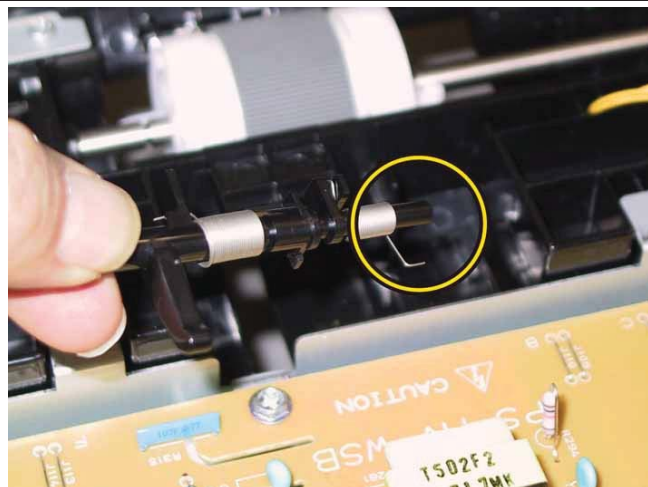

3) Insert the right shaft of the ACTUATOR ASSY NO PAPER into the hole of the CHUTE UP. Attach the ACTUATOR ASSY NO PAPER.

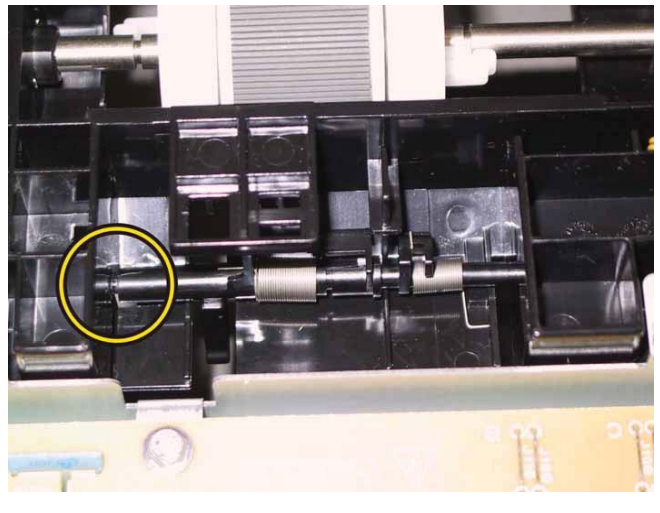

Check the ACTUATOR ASSY NO PAPER movement, after the procedure 3 is completed.

Go to the next replacement step:

Replacement 2 SENSOR PHOTO: CST NO PAPER (PL3.2.13)

Replacement 2 SENSOR PHOTO: CST NO PAPER (PL3.2.13)

1) Engage the connector (P/J234) of the SENSOR PHOTO: CST NO PAPER.



2) Replace the SENSOR PHOTO: CST NO PAPER to the FEEDER ASSY MG SFP V by mating the hook of the SENSOR PHOTO: CST NO PAPER with its mounting position.

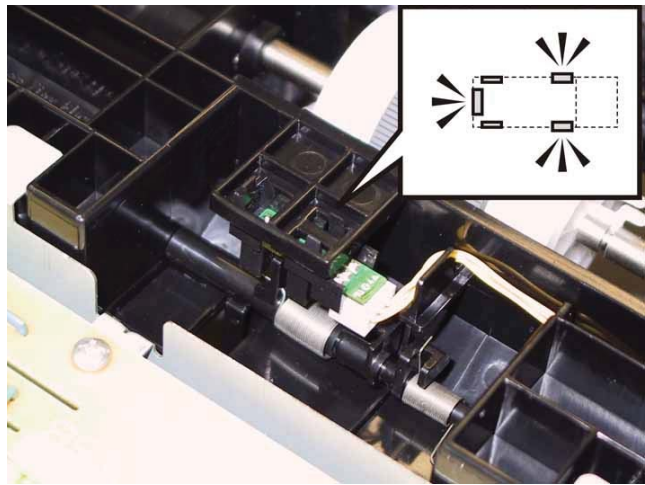

**Go to the next replacement step:
Replacement 8 UPPER UNIT (Reference only)**

Replacement 3 ACTUATOR REGI IN (PL3.2.11)

1) Attach the SPRING ACT REGI to the ACTUATOR REGI IN.

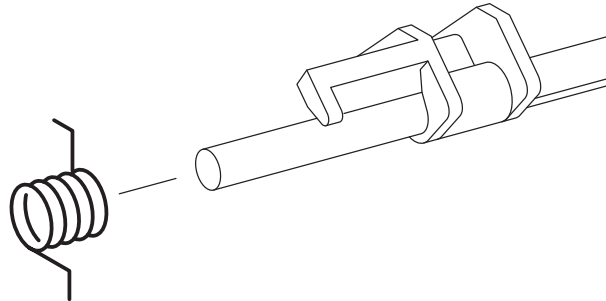

Note: When carrying out the work described next procedure, ensure that the SPRING ACT REGI is hung to ACTUATOR REGI IN and the CHUTE UP correctly.

SPRING ACT REGI

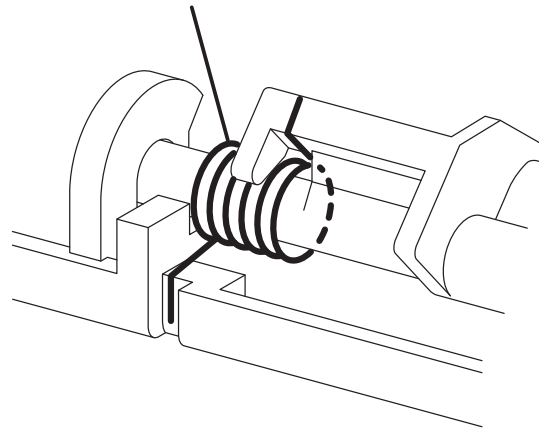

2) Insert the right shaft of the ACTUATOR REGI IN into the hole of the CHUTE UP, hang the SPRING ACT REGI to the CUHTE UP.

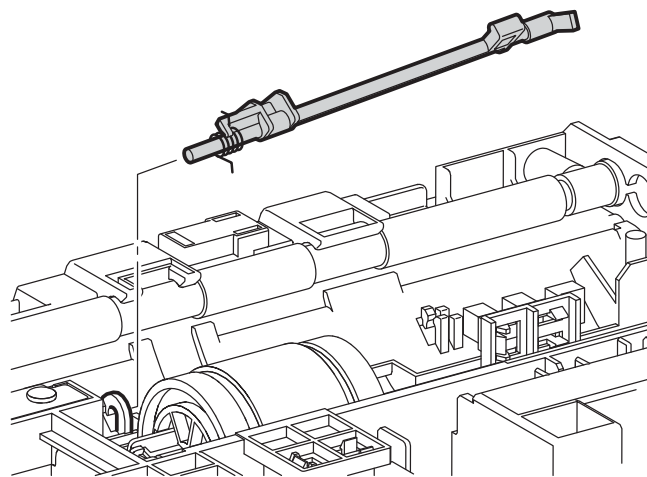

3) Fix the left shaft of the ACTUATOR REGI IN with the hook of the CHUTE UP to attach the ACTUATOR REGI IN.



Check the ACTUATOR REGI IN movement, after the procedure 3 is completed.

Go to the next replacement step:

Replacement 4 ROLL ASSY REGI (PL3.2.9)

Replacement 4 ROLL ASSY REGI (PL3.2.9)

1) After the inserting the left shaft of the ROLL ASSY REGI into the hole of the FEEDER ASSY MG SFP, insert the right shaft of the ROLL ASSY REGI into the hole. Attach the ROLL ASSY REGI together with the ACTUATOR REGI OUT and the ACTUATOR REGI ROLL M.

Note: When carrying out the work this procedure, move the ACTUATOR REGI OUT to right until it stops.

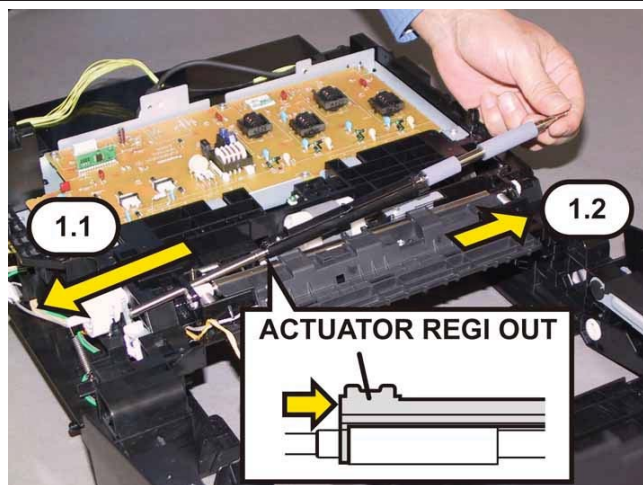

2) Attach the BEARING R to the ROLL ASSY REGI.

Note: When carrying out the work this procedure, it is easier to push the ROLL REGI METAL (PL3.2.10) to frontward.

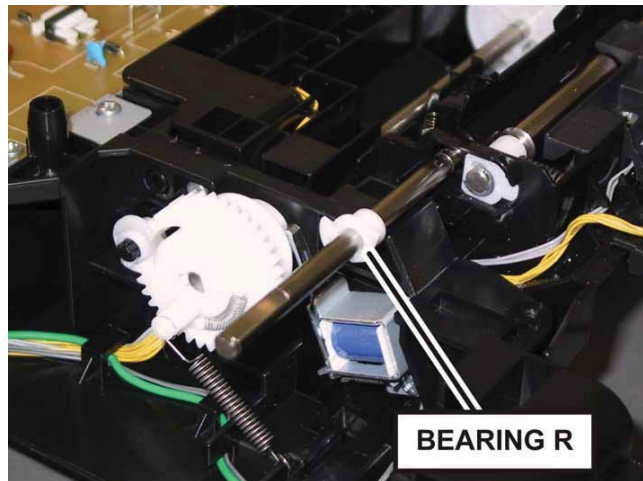

3) Secure the BEARING R to the ROLL ASSY REGI with the E-ring by using the pliers.

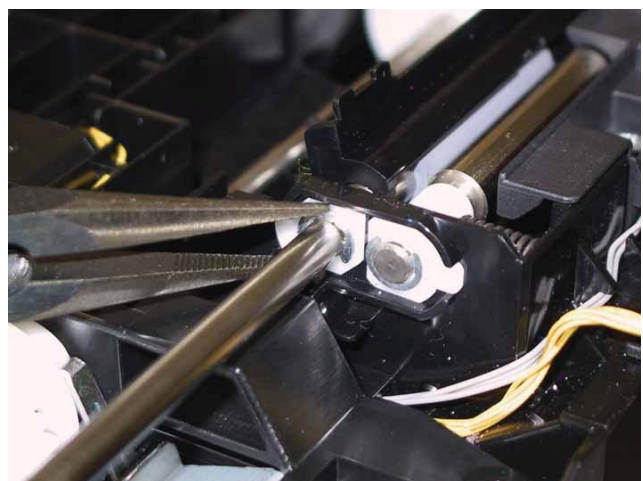

4) Attach the BEARING EARTH REGI to the ROLL ASSY REGI.

Note: When carrying out the work this procedure, it is easier to push the ROLL REGI METAL (PL3.2.10) to forward.

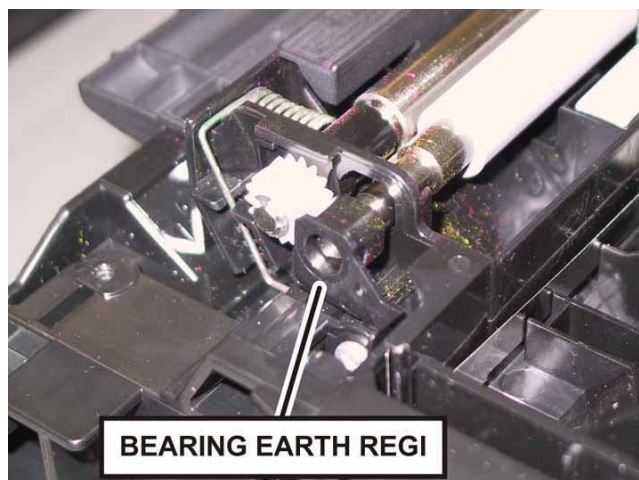

5) Attach the GEAR REGI R to the ROLL ASSY REGI.

Note: When carrying out the work this procedure, it is easier to push the ROLL REGI METAL (PL3.2.10) to forward.

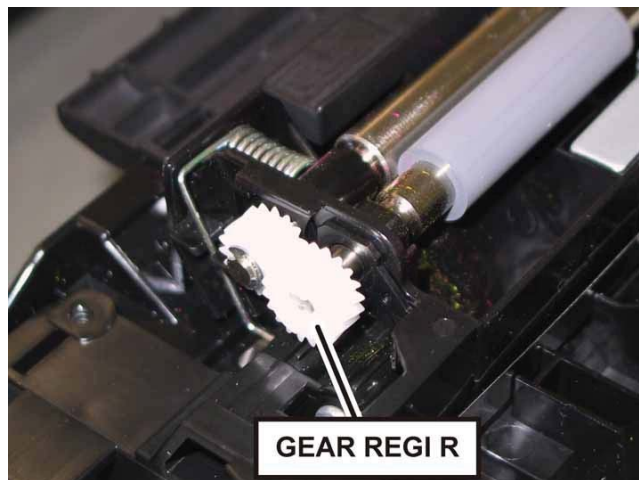

6) Secure the GEAR REGI R to the ROLL ASSY REGI with the E-ring by using the pliers.



7) Close the ACTUATOR REGI OUT by inserting the boss of the ACTUATOR REGI OUT into the SPRING REGI OUT.

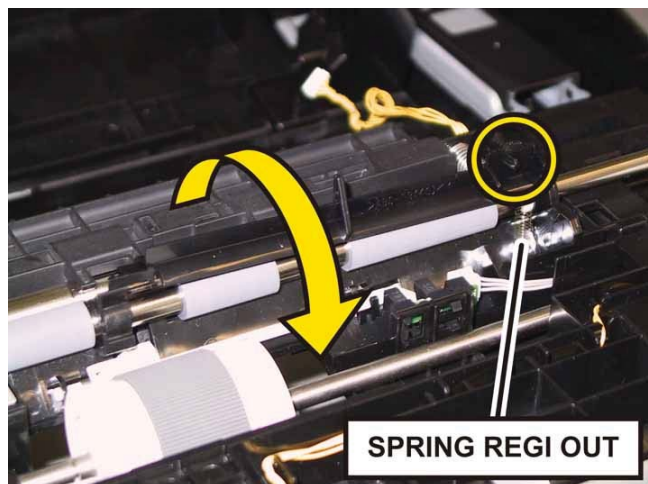

8) Shift the ACTUATOR REGI OUT to left, fix the CHUTE UP using the hook.

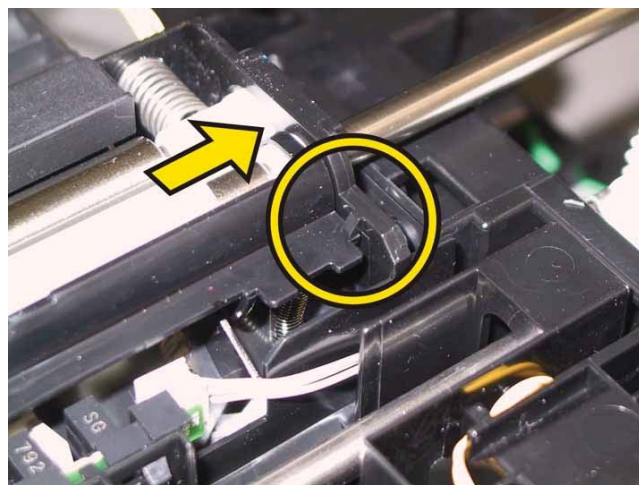

9) Attach the ACTUATOR REGI ROLL M by mating the hole of the ACTUATOR REGI ROLL M with the tab of the ACTUATOR REGI OUT. Fix it using the hook of the ACTUATOR REGI OUT.

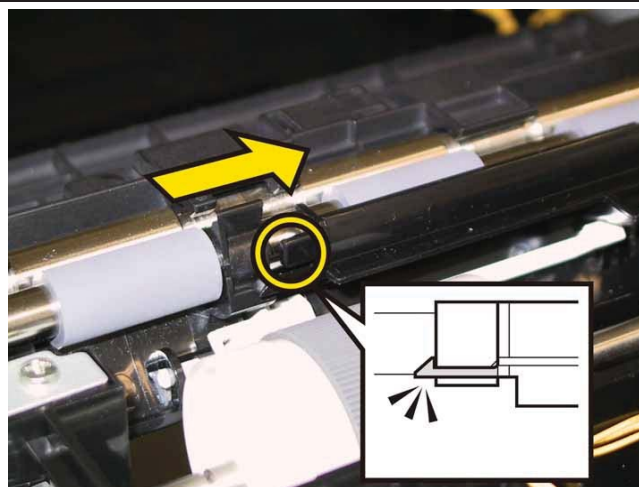

Note: Check the ACTUATOR REGI OUT and the ACTUATOR REGI IN movement, after the procedure 9 is completed.

Go to the next replacement step:

Replacement 8 UPPER UNIT (Reference only)

Replacement 5 SENSOR PHOTO: REGI (PL3.2.13)

1) Engage the connector (P/J232) of the SENSOR PHOTO: REGI.



2) Replace the SENSOR PHOTO: REGI to the FEEDER ASSY MG SFP V by mating the three hooks of the SENSOR PHOTO: REGI.

Note: When carrying out the work this procedure, it is easier to push the ACTUATOR REGI IN (PL3.2.11) to downward.

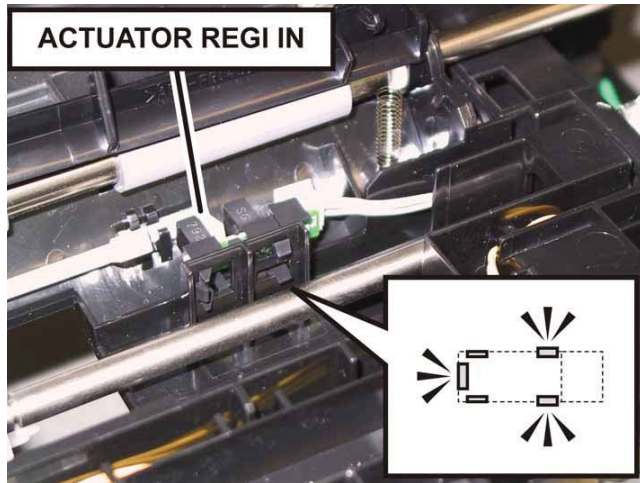

3) Close the ACTUATOR REGI OUT by inserting the boss of the ACTUATOR REGI OUT into the SPRING REGI OUT.

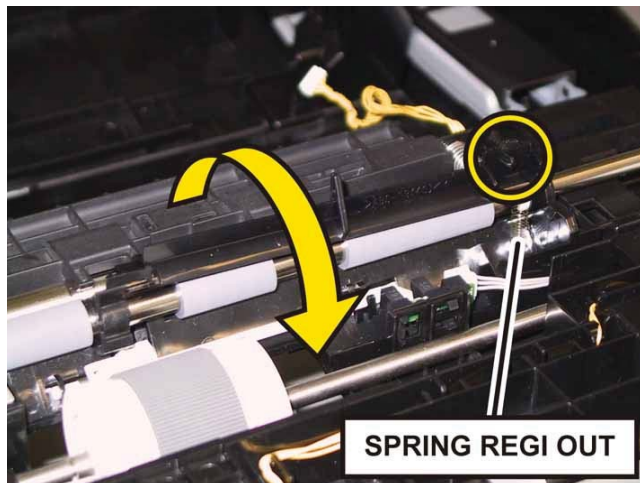

4) Shift the ACTUATOR REGI OUT to left, fix the CHUTE UP using the hook.

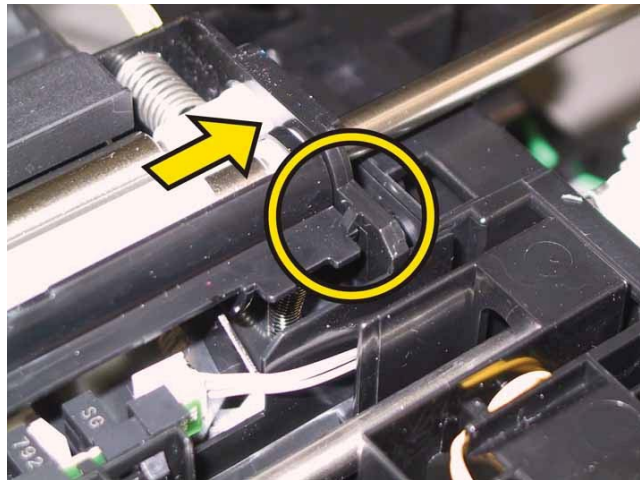

5) Attach the ACTUATOR REGI ROLL M by mating the hole of the ACTUATOR REGI ROLL M with the tab of the ACTUATOR REGI OUT. Fix it using the hook of the ACTUATOR REGI OUT.

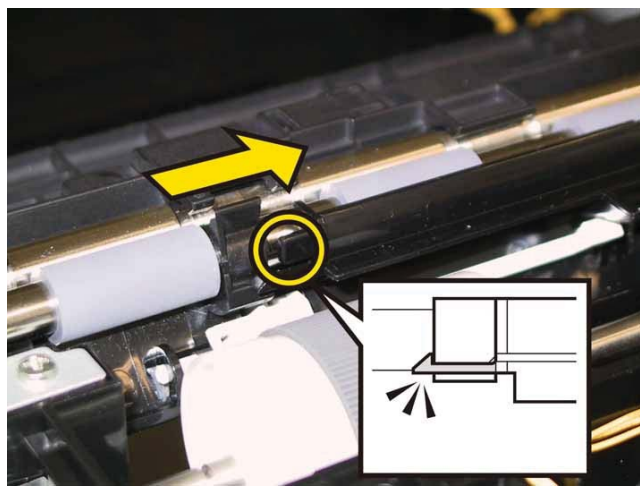

Note: Check the ACTUATOR REGI OUT and the ACTUATOR REGI IN movement, after the procedure 5 is completed.

Go to the next replacement step:

Replacement 8 UPPER UNIT (Reference only)

Replacement 6 FEEDER ASSY MG SFP (PL3.1.98)

1) Mate the four holes of the FRAME HVPS with the bosses of the FEEDER ASSY MG SFP, attach the FRAME HVPS to the FEEDER ASSY MG SFP together with the PWBA HVPS.

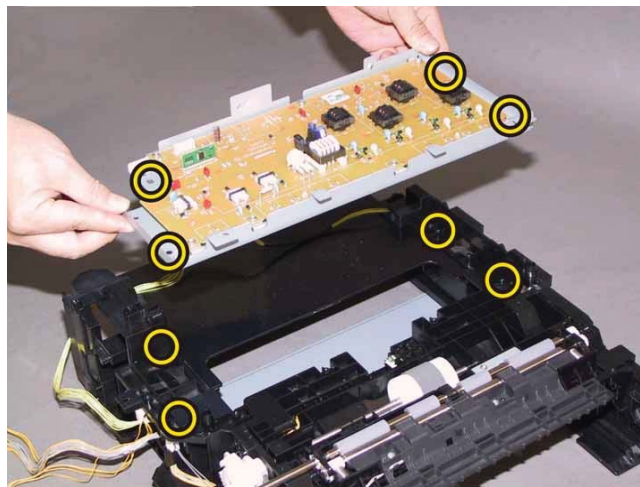

2) Secure the FRAME HVPS to the FEEDER ASSY MG SFP with the eight screws (silver, tap, 8mm).

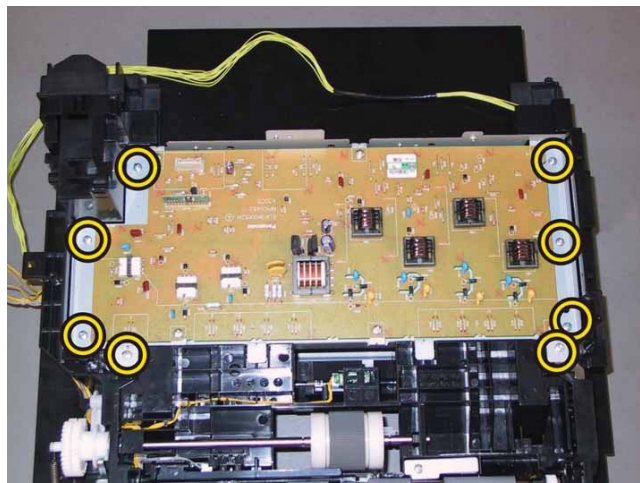

Go to the next replacement step:

Replacement 8 UPPER UNIT (Reference only)

Replacement 7 PWBA HVPS (PL4.1.19)

Note: Use the wrist strap to protect the PWB from the electrostatic.

1) Mate the notch and hole of the PWBA HVPS with the tabs of the FRAME HVPS, attach the PWBA HVPS.

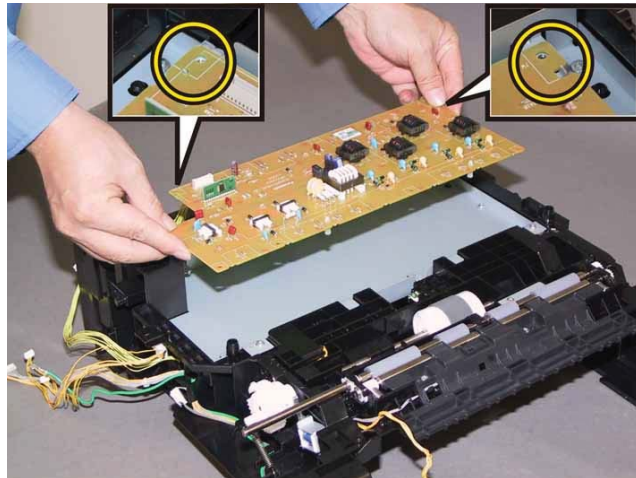

2) Secure the PWBA HVPS to the FRAME HVPS with the seven screws (silver, 6mm).

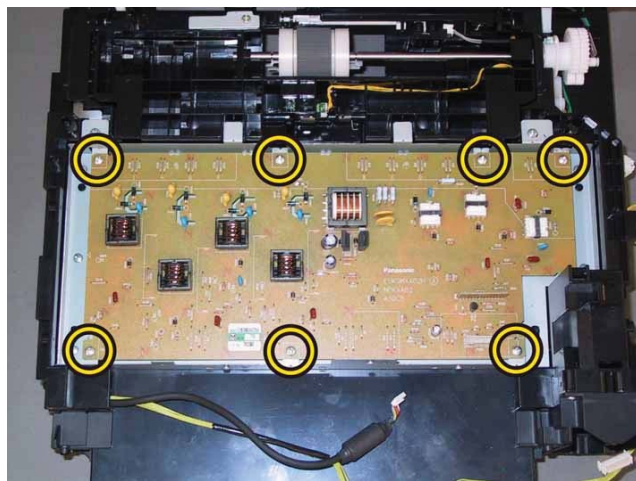

3) Engage the connector (P/J161) of the HARN ASSY HVPS to the PWBAHVPS.

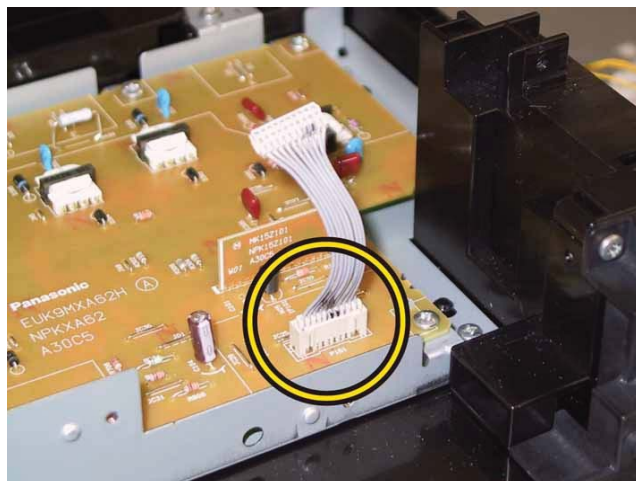

Go to the next replacement step:

Replacement 8 UPPER UNIT (Reference only)

Replacement 8 UPPER UNIT (Reference only)

Accesses Position (All the numbers show the procedure number.)

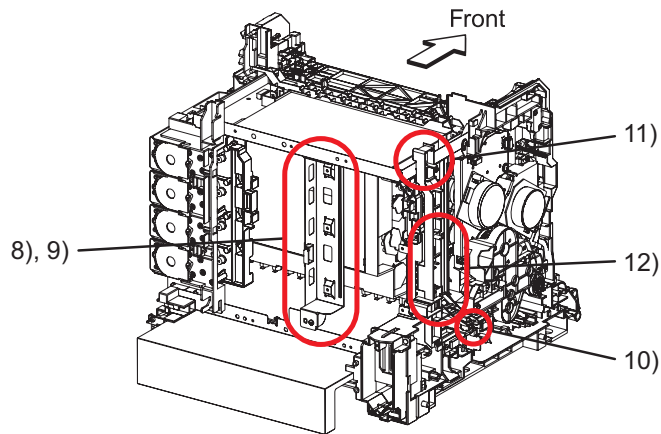

Note: When carrying out the work described next procedure, route the harness of the TRANSFER ASSY through the groove of the UPPER UNIT.

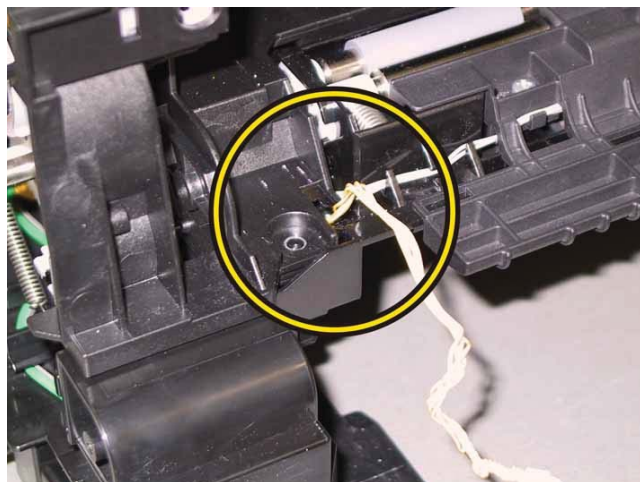

1) Mate the two holes of the UPPER UNIT with the bosses of the FEEDER ASSY MG SFP and attach it.

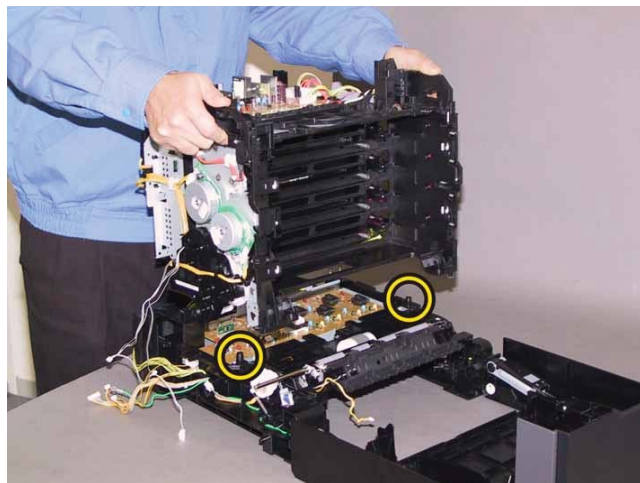

2) Secure the BRACKET MCU L and the left side of the printer frame with the two screws (silver, tap, 8mm).

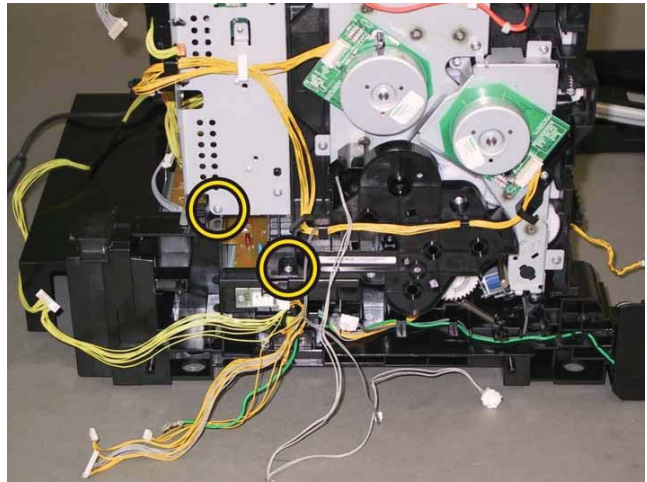

3) Secure the rear side DISPENSER ASSY with the one screw (silver, M4, 6mm) and BRACKET MCU L with the one screw (silver, tap, 8mm).

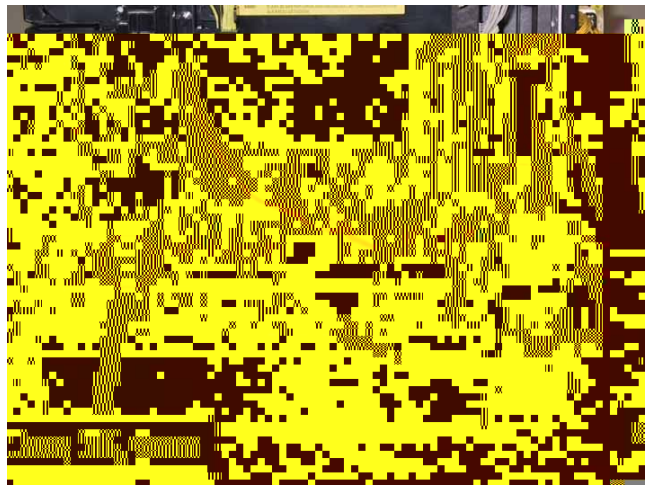

4) Route the HARNESS ASSY B and the HARN ASSY OPTION to the DISPENSER ASSY. Secure the harnesses using the hooks on the DISPENSER ASSY.

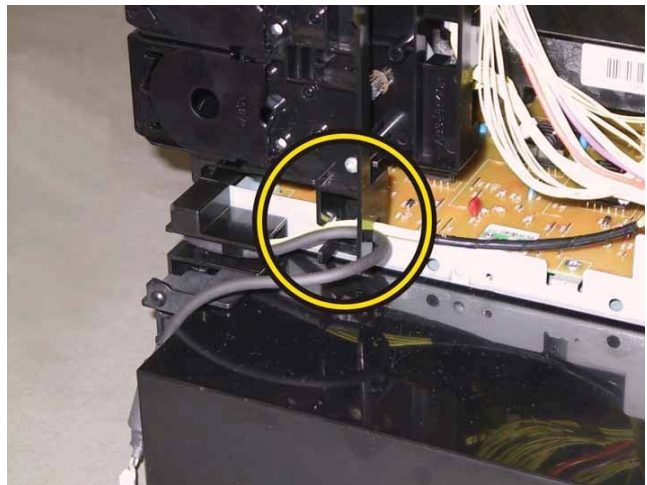

5) Open the HOLDER TCRU (K), (C), (M) and (Y), secure the right side of the printer frame with the one screw (silver, tap, 8mm).

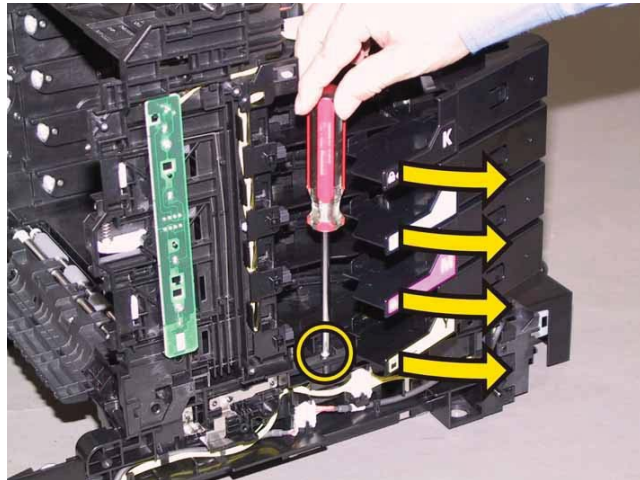

6) Secure the under side of the DISPENSER ASSY with the two screws (silver, tap, 8mm).



7) Secure the front side of the printer frame with the two screws (silver, tap, 8mm).

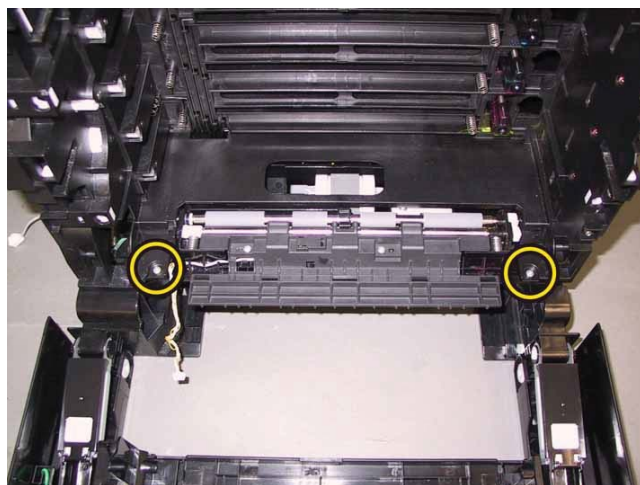

8) Mate the two holes of the BRACKET MCU R with the bosses of the printer, secure it with the two screws (silver, 6mm).

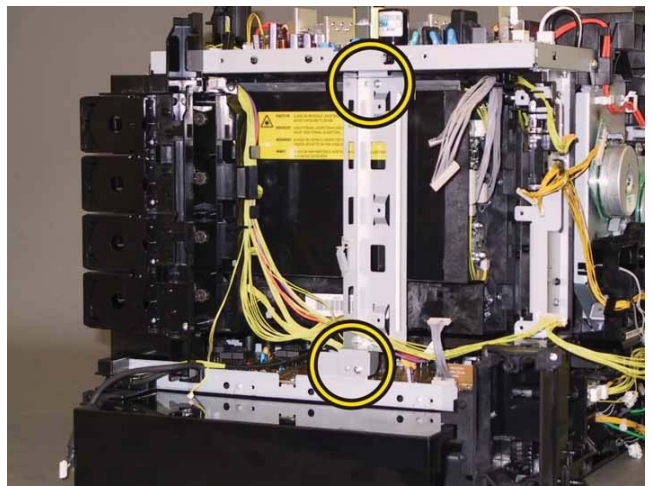

9) Secure the harness of the HARN ASSY OPTION with the clamp on the BRACKET MCU R.

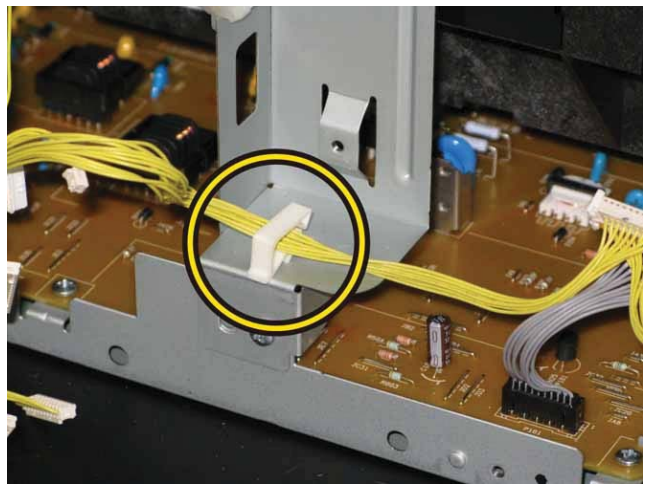

10) Insert the tab on the under side of the GUIDE HARNESS AC into the hole of the printer, attach the GUIDE HARNESS AC to the printer.

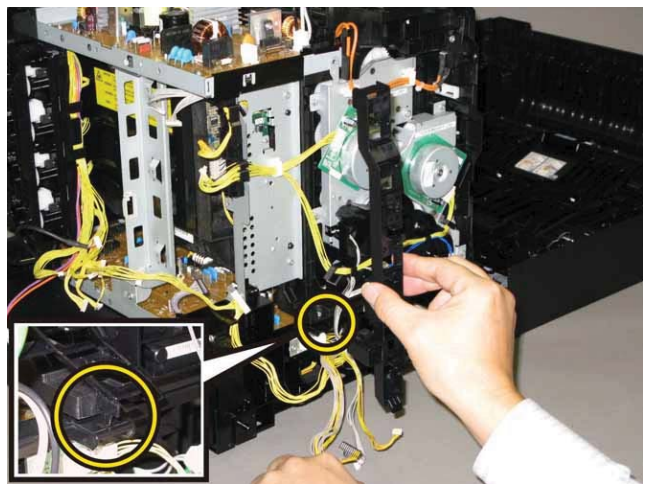

11) Secure the hook of the GUIDE HARNESS AC to the printer.

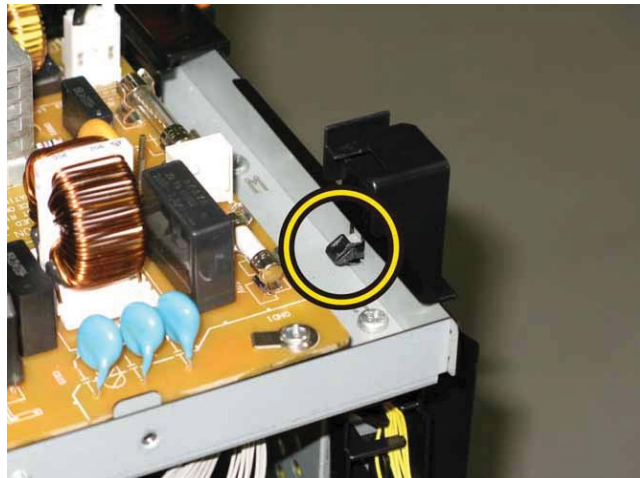

12) Route the HARN ASSY GND and all the harnesses along the GUIDE HARNESS AC, secure the grounding terminal of the HARN ASSY GND with the one screw (silver, 6mm).

Note: This step is only 2150cdn.

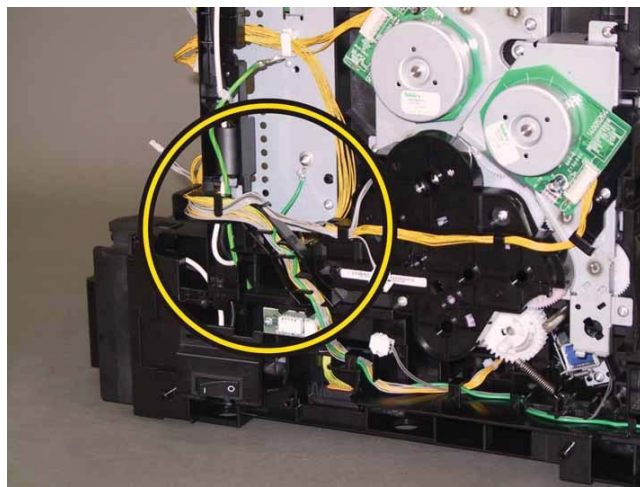

**Go to the next replacement step:
Replacement 34 KIT TRANSFER ASSY**

Replacement 9 KIT ROS (PL4.1.99)

Accesses Position (All the numbers show the procedure number.)

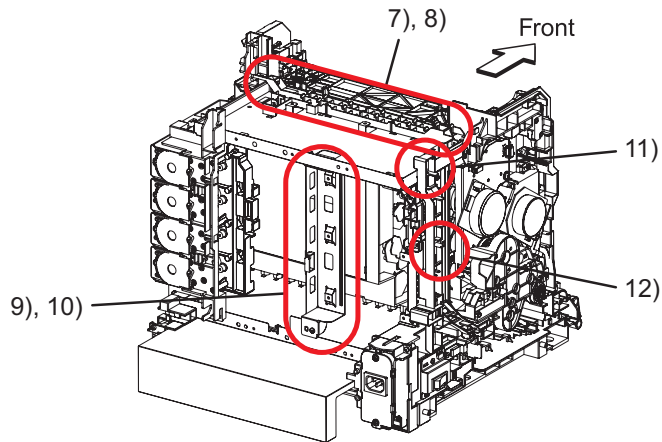

1) Mate the under side boss of the ROS ASSY with the hole of the printer, attach the ROS ASSY.

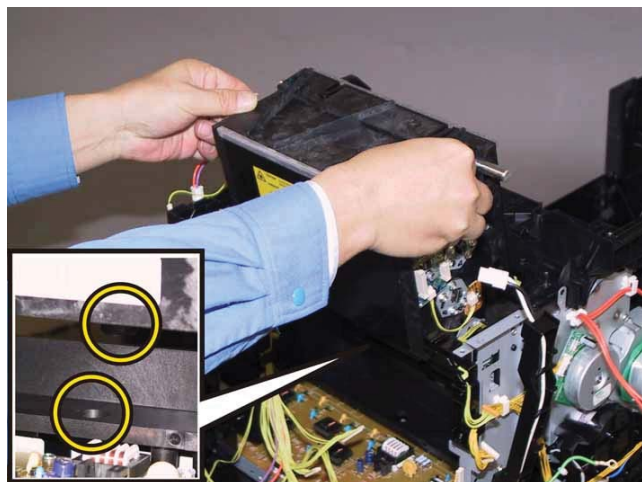

Note: When carrying out the work described next procedure, ensure that the SPRING ROS is oriented to the direction shown in the right.

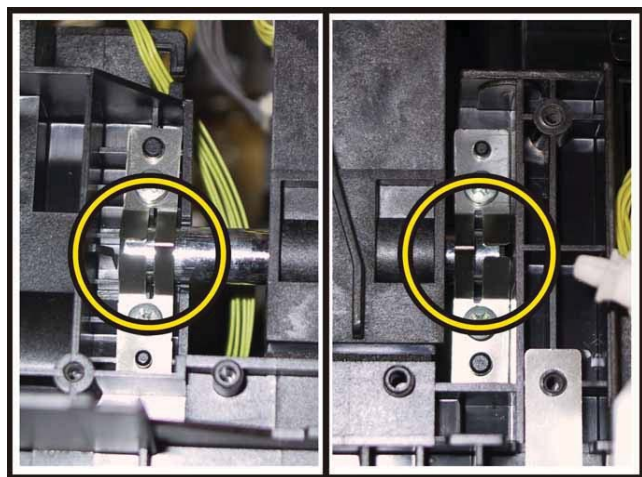

2) Mate the holes of the SPRING ROSSs with the bosses of the printer, secure it with the four screws (silver, tap, 8mm).

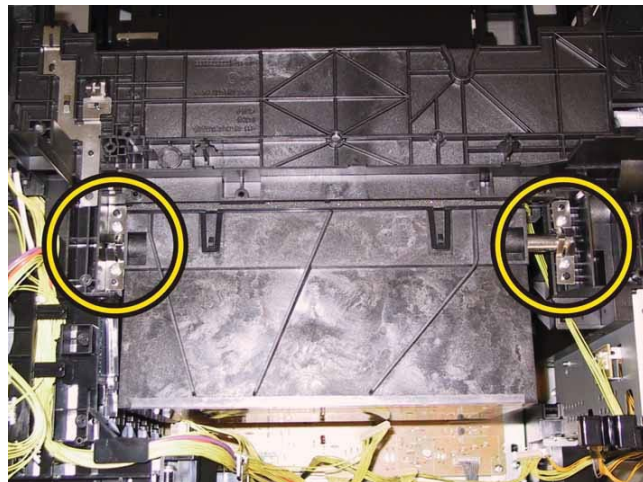

3) Engage the two connectors (P/J411, 412) of the ROS ASSY.

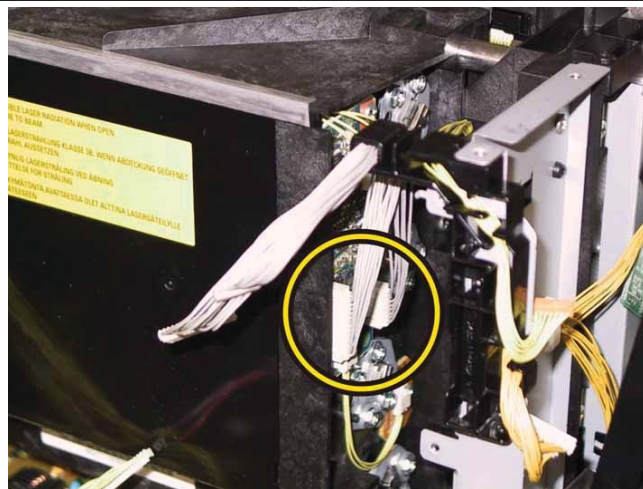

4) Mate the three holes of the FRAME ASSY LVPS with the bosses of the printer, attach the FRAME ASSY LVPS to the printer.



Note: Since two types of screws are used for securing the FRAME ASSY LVPS, ensure that the right screws are used at their right securing positions.

The securing positions for tap screws are marked with [T].

The securing positions for metal screws are marked with [M].

5) Secure the DRIVE ASSY SUB to the FRAME ASSY LVPS with the one screw (silver, M4, 6mm).

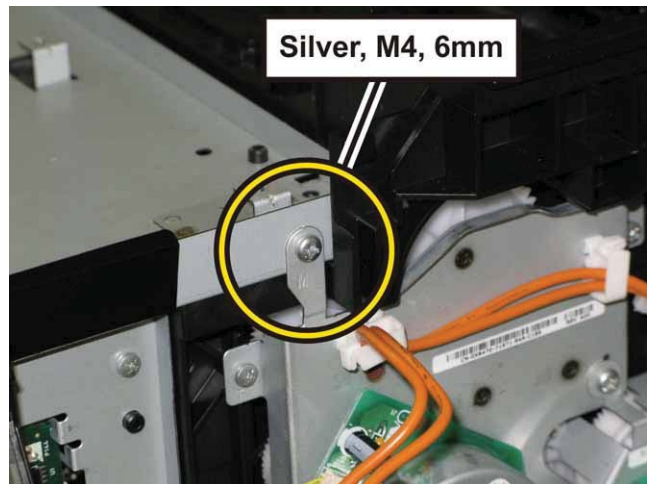

6) Secure the FRAME ASSY LVPS to the printer with the two screws (silver, M4, 6mm) and the six screws (silver, tap, 8mm).



7) Mate the tab and boss of the GUIDE HARNESS FSR with the holes of the FRAME ASSY LVPS, move the GUIDE HARNESS FSR to secure it.

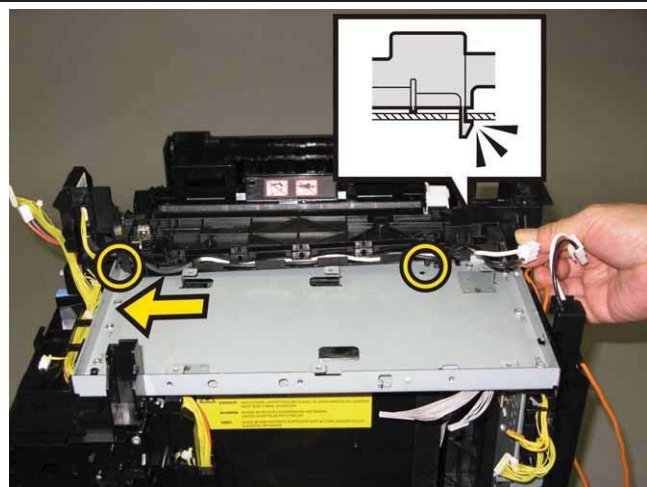

Note: Ensure that the harnesses of the HARN ASSY INTERLOCK and HARNESS ASSY FUSER MG SFP are kept apart so that they do not contact each other.

8) Route the harness of the HARN ASSY INTERLOCK along the GUIDE HARNESS FSR.



9) Mate the two holes of the BRACKET MCU R with the bosses of the printer, secure it with the two screws (silver, 6mm).

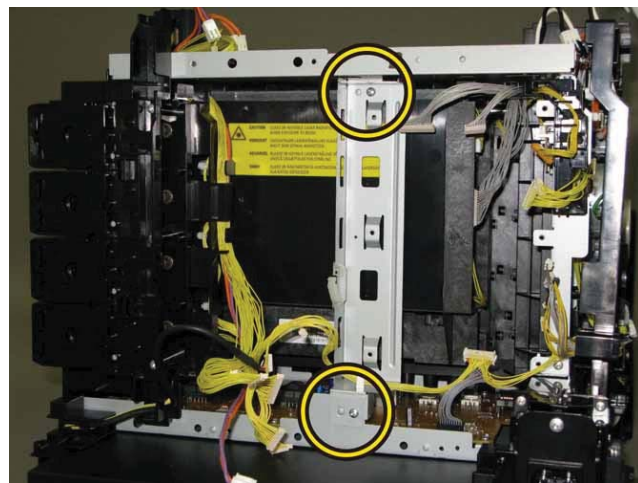

10) Secure the harness of the HARN ASSY OPTION with the clamp on the BRACKET MCU R.

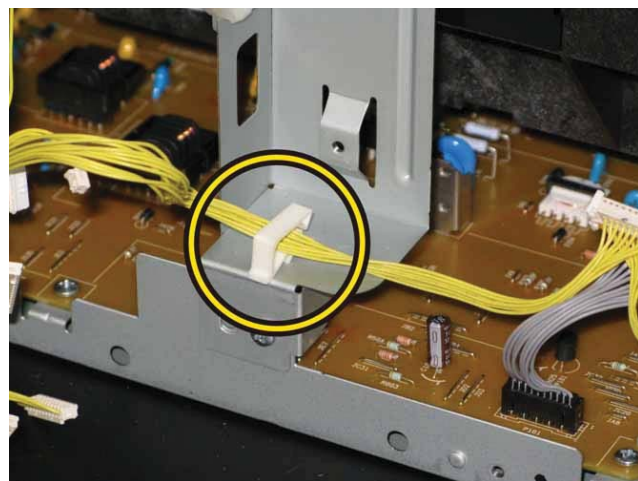

11) Secure the hook of the GUIDE HARNESS AC to the printer.

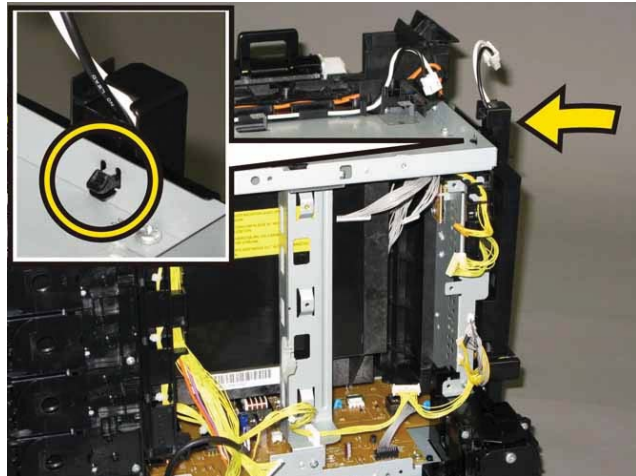

12) Secure the grounding terminal of the SWITCH ASSY INLET MG SFP with the one screw (silver, with washer, 6mm).



**Go to the next replacement step:
Replacement 43 PWBA LVPS (PL8.2.1)**

Replacement 10 DISPENSER ASSY (PL5.1.1)

Accesses Position (All the numbers show the procedure number.)

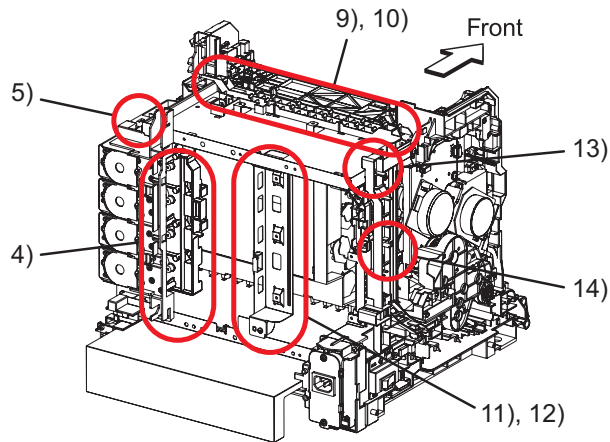

1) Insert the AUGER part of the DISPENSER ASSY into the hole of the printer, mate the hole of the DISPENSER ASSY with the boss of the printer, and then attach the DISPENSER ASSY.

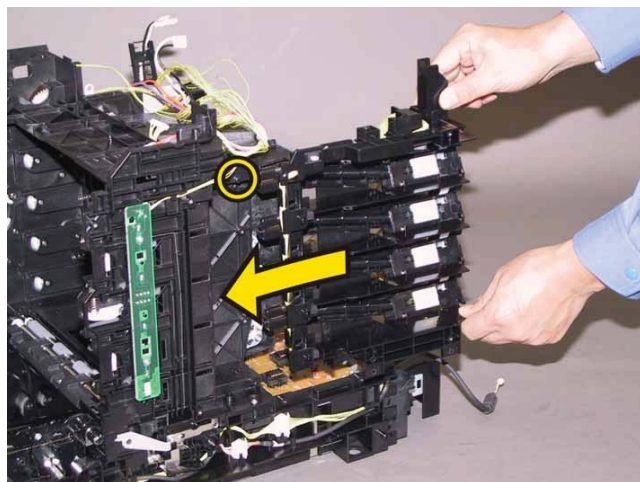

2) Secure the rear side of DISPENSER ASSY to the printer with the one screw (silver, M4, 6mm).

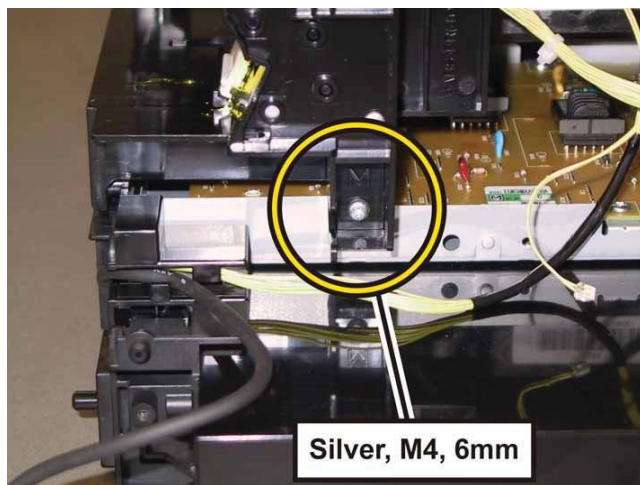

3) Secure the DISPENSER ASSY to the printer with the four screws (silver, tap, 8mm).

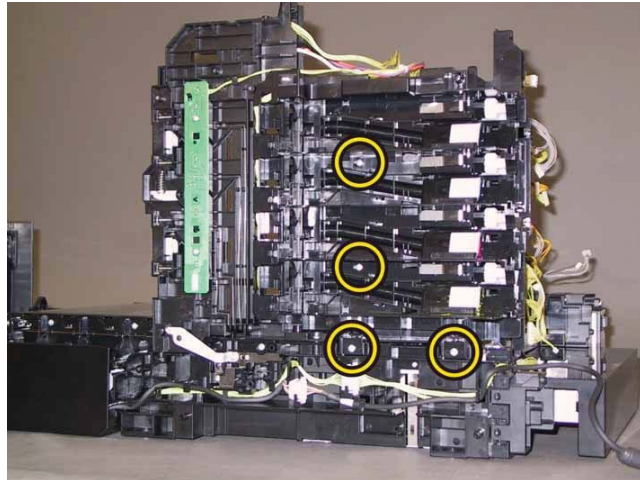

4) Route the HARNESS ASSY FUSER MG SFP, HARNESS ASSY LVPS MAIN MG SFP, HARN ASSY ESS POWER, HARNESS ASSY B and HARN ASSY OPTION through the hooks of the DISPENSER ASSY.

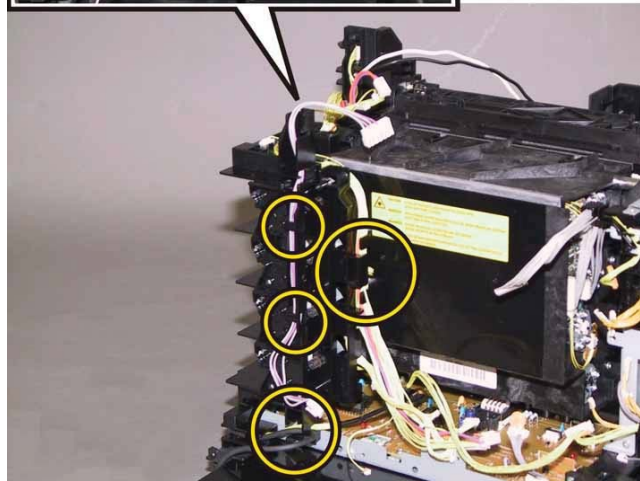
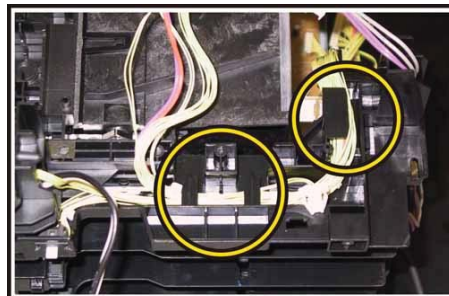

5) Attach the connector (P5041) of the HARNESS ASSY LVPS MAIN MG SFP to the DISPENSER ASSY.

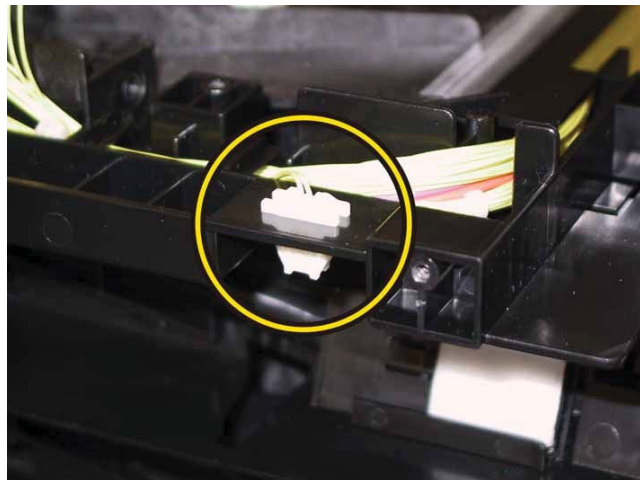

6) Mate the three holes of the FRAME ASSY LVPS with the bosses of the printer, attach the FRAME ASSY LVPS to the printer.



Note: Since two types of screws are used for securing the FRAME ASSY LVPS, ensure that the right screws are used at their right securing positions.

The securing positions for tap screws are marked with [T].

The securing positions for metal screws are marked with [M].

7) Secure the DRIVE ASSY SUB to the FRAME ASSY LVPS with the one screw (silver, M4, 6mm).

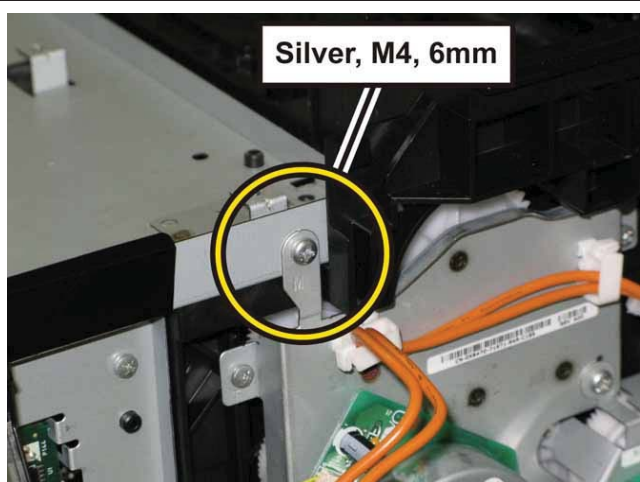

8) Secure the FRAME ASSY LVPS to the printer with the two screws (silver, M4, 6mm) and the six screws (silver, tap, 8mm).



9) Mate the tab and boss of the GUIDE HARNESS FSR with the holes of the FRAME ASSY LVPS, move the GUIDE HARNESS FSR to secure it.

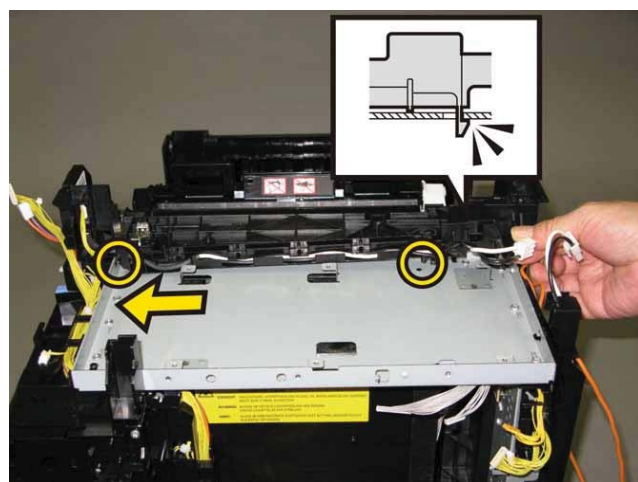

Note: Ensure that the harnesses of the HARN ASSY INTERLOCK and HARNESS ASSY FUSER MG SFP are kept apart so that they do not contact each other.

10) Route the harness of the HARN ASSY INTERLOCK along the GUIDE HARNESS FSR.



11) Mate the two holes of the BRACKET MCU R with the bosses of the printer, secure it with the two screws (silver, 6mm).

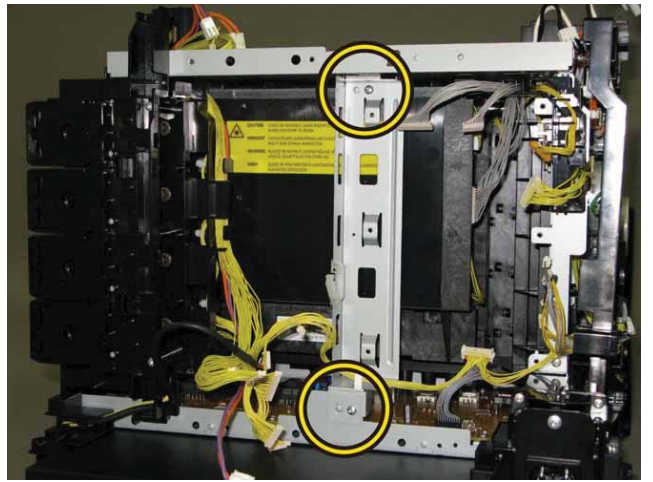

12) Secure the harness of the HARN ASSY OPTION with the clamp on the BRACKET MCU R.



13) Secure the hook of the GUIDE HARNESS AC to the printer.

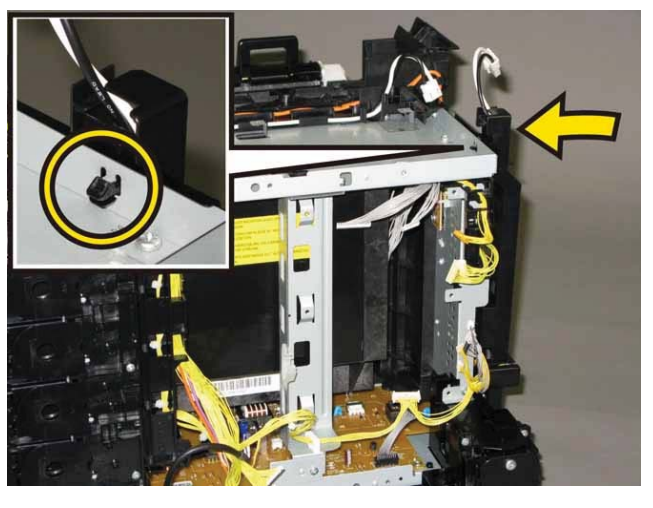

14) Secure the grounding terminal of the SWITCH ASSY INLET MG SFP with the one screw (silver, with washer, 6mm).



**Go to the next replacement step:
Replacement 43 PWBA LVPS (PL8.2.1)**

Replacement 11 KIT PWBA MCU (PL8.2.99)

Note: Use the wrist strap to protect the PWB from the electrostatic.

1) Mate the holes of the PWBA MCU with the tabs of the printer, attach it.

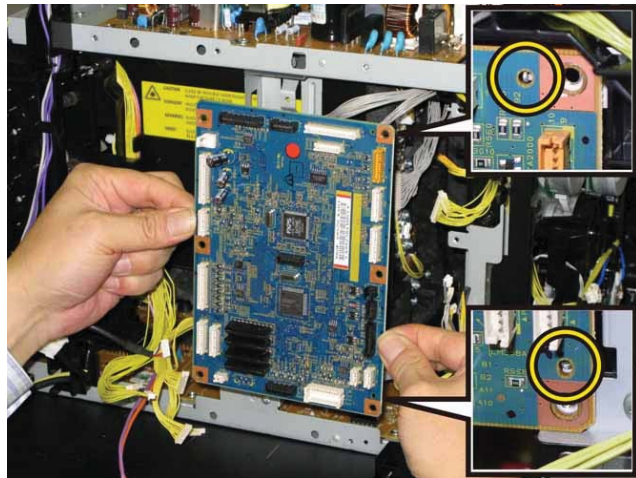

2) Secure the PWBA MCU to the printer with the six screws (silver, 6mm).

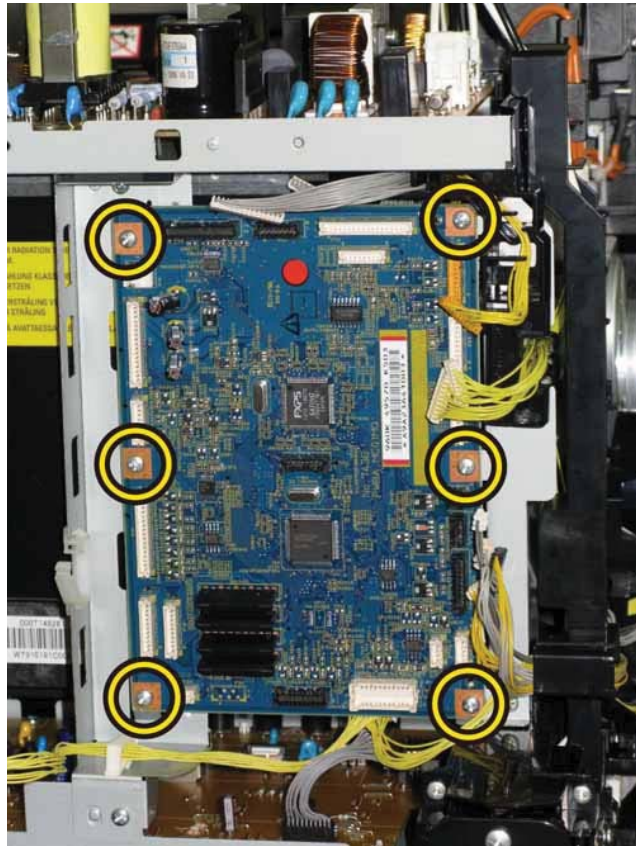

3) Engage all the connectors of the PWBA MCU.



4) Mate the hole of the FRAME ESS with the hook of the FRAME ASSY LVPS.



5) Attach the DUCT FAN to the printer together with the FRAME ESS.

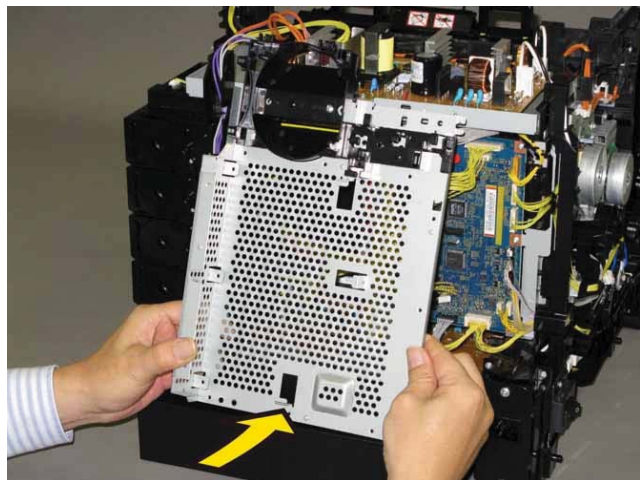

6) Secure the FRAME ESS to the printer with the five screws (silver, 6mm).

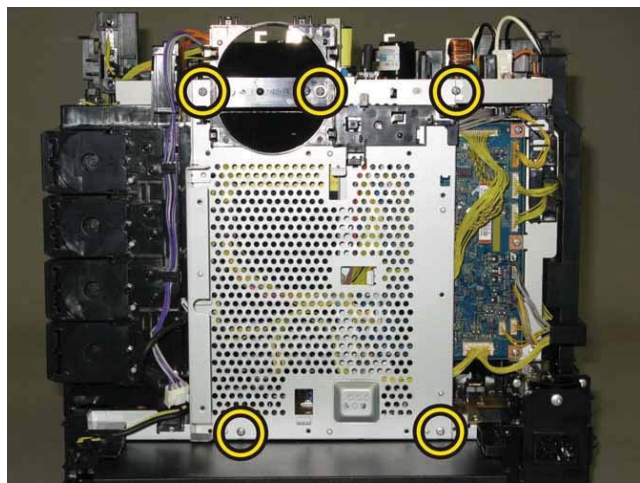

Go to the next replacement step:

Replacement 12 KIT PWBA ESS SFP (PL8.1.99)

Note: When the PWBA MCU is replaced with a new one, perform the following steps.

(After completing all steps up to Replacement 59.)

- 7) Plug in the power cord to the printer.
- 8) Execute diagnostic operation of NVM Load, and write the data into PWBA MCU.
- 9) Turn off the power.
- 10) Perform the diagnostic operation of NVM Load, and write the data into the MCU.
- 11) Turn on the power while pressing the "▶" key, "◀" key, and [MENU] key on the control panel.
- 12) Enter the password, press the "▲" key twice, and press the " ✓ " key once. The diagnostic screen comes up.
- 13) Press the "▼" key several times until "IOT Diag" is displayed. Press the " ✓ " key once.
- 14) Press the "▼" key several times until "NVM Settings" is displayed. Press the " ✓ " key once.
- 15) Press the "▼" key several times until "LoadNVM from ESS" is displayed. Press the " ✓ " key once.
- 16) Press the " ✓ " key once, and NVM Load is performed.

- 17) After NVM Load is complete, press the [CANCEL] key several times until "IOT Diag" is displayed.
- 18) Press the "▼" key several times until "Complete" is displayed.
- 19) Press the " ✓ " key twice. "Ready to Print" is displayed.
- 20) Turn off the power to exit.

Replacement 12 KIT PWBA ESS SFP (PL8.1.99)

Note: Ensure proper electrostatic discharge procedures are followed to prevent damage to the PWBA ESS SFP and options during replacement.

Note: The replacement steps of procedure 1) to 3) are to be required for changing the PWBA ESS SFP. Those steps are not required for only removing it.

Note: There are two ROM chips that must be moved from the original PWBA ESS SFP to the replacement PWBA. Ensure both these chips are installed into the same locations on the replacement PWBA.

Note: Avoid applying excessive pressure when removing and replacing the ROM chips.

Note: Take care not to bend the terminal section of ROM when carrying out the job described below.

1) Remove the ROM, using a miniature screwdriver or the like, from the IC sockets on old PWBA ESS SFP that was removed from the printer.

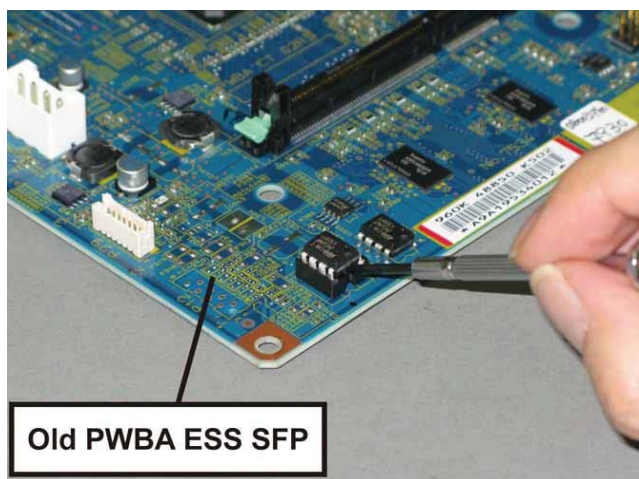

2) Remove the ROM from IC socket on new PWBA ESS SFP using a miniature screwdriver or the like.

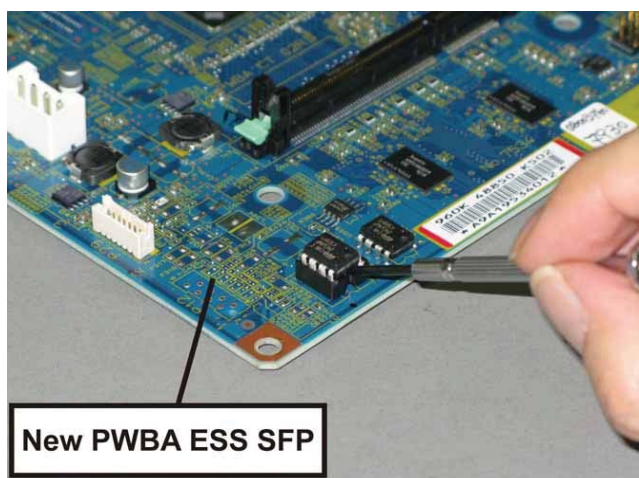

Note: Do not use ROMs removed from new PWBA ESS SFP.

3) Attach the ROM that were removed from old PWBA ESS SFP on IC sockets of new PWBA ESS SFP with its notch aligned with the notch in IC socket.

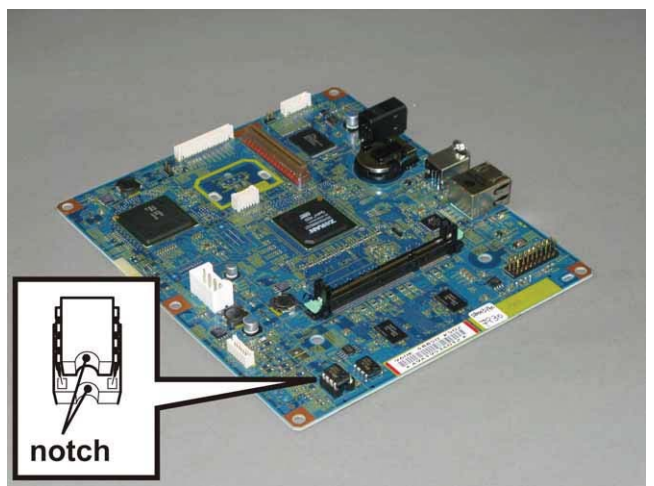

4) Secure the PLATE IF M to the PWBA ESS SFP with the two screws (silver, 6mm).



5) Secure the USB connector of the PWBA ESS SFP to the PLATE IF M with the one screw (silver, 4mm).

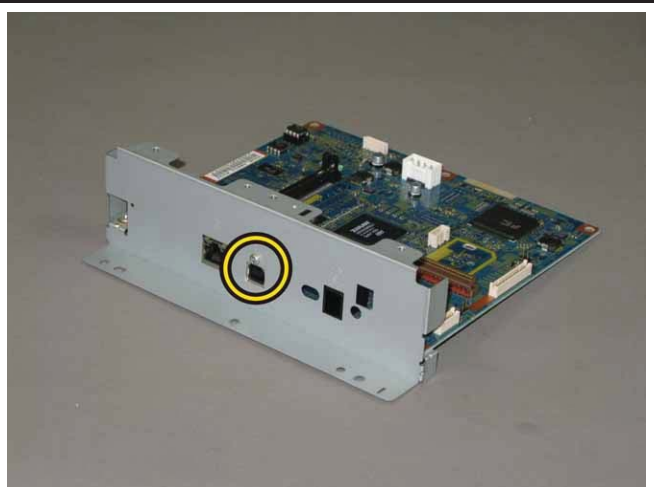

6) Mate the hole of the PLATE IF M with the tab of the printer, attach the PWBA ESS SFP together with the PLATE IF M.



7) Secure the PWBA ESS SFP to the printer with the six screws (silver, 6mm).



8) Insert the connector (J401) of the HARN ASSY ESS POWER and the connector (J29) of the HARNESS ASSY B into the FRAME ESS through the hole.



9) Engage all the connectors of the PWBA ESS SFP.



10) Mate the five bosses of the printer with the holes of the SHIELD ASSY ESS, secure it with the eleven screws (silver, 6mm).

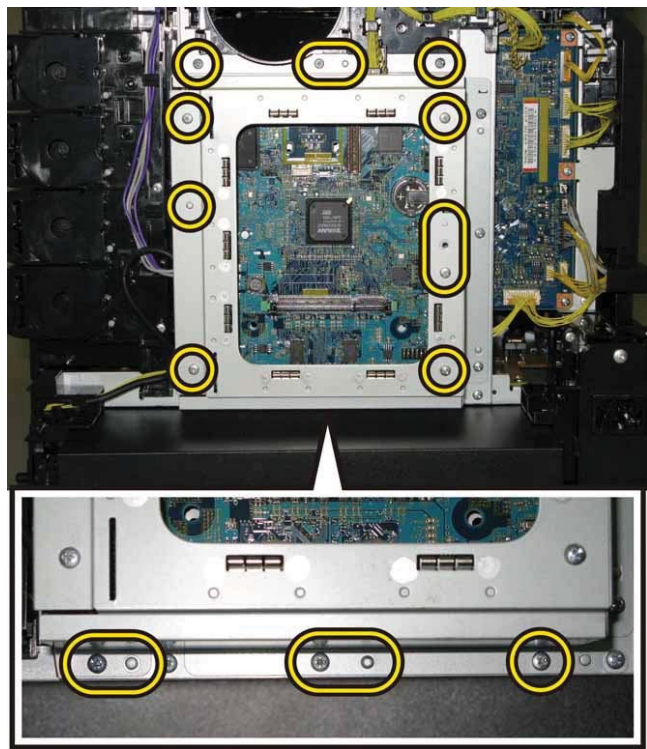

11) Insert the lower tab of the PLATE ESS into the slit of the SHIELD ASSY ESS, after inserting the upper tab of the PLATE ESS into the slit of the SHIELD ASSY ESS.

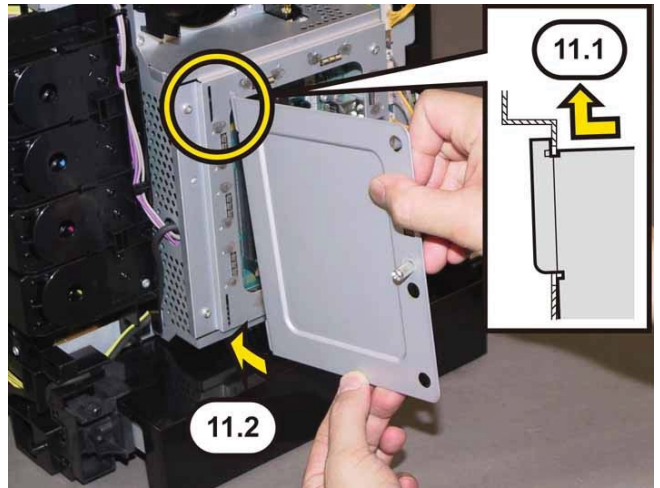

12) Close the PLATE ESS and secure the SCREW KNURLING.



**Go to the next replacement step:
Replacement 14 FAN (PL8.1.1)**

Replacement 13 DUCT FAN (PL8.1.2)

1) Secure the DUCT FAN to the printer with the two hooks.



2) Secure the DUCT FAN to the printer with the one screw (silver, 6mm).

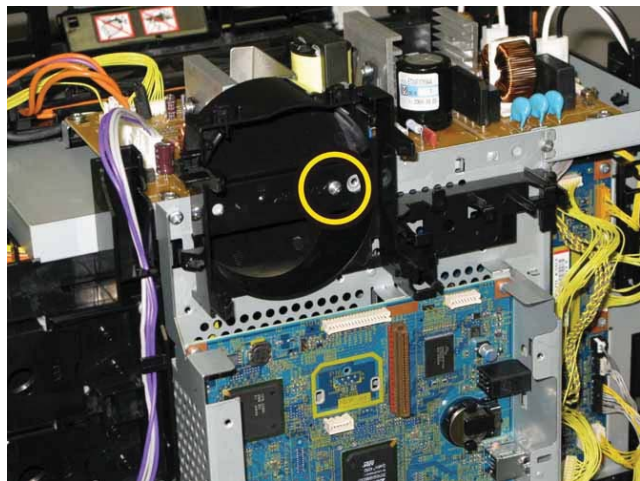

3) Route the HARN ASSY ESS and HARN ASSY ESS VIDEO through the hooks of the DUCT FAN, engage the two connectors (P/J101, 111) on the PWBA ESS SFP.

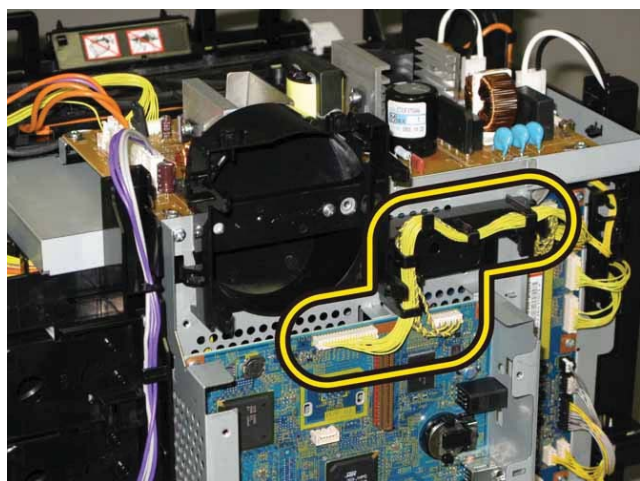

4) Mate the five bosses of the printer with the holes of the SHIELD ASSY ESS, secure it with the eleven screws (silver, 6mm).

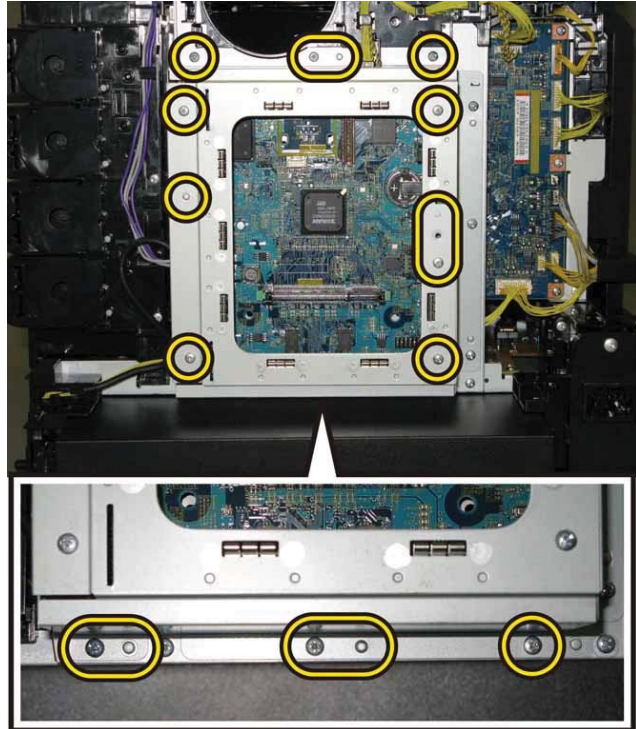

5) Insert the lower tab of the PLATE ESS into the slit of the SHIELD ASSY ESS, after inserting the upper tab of the PLATE ESS into the slit of the SHIELD ASSY ESS.

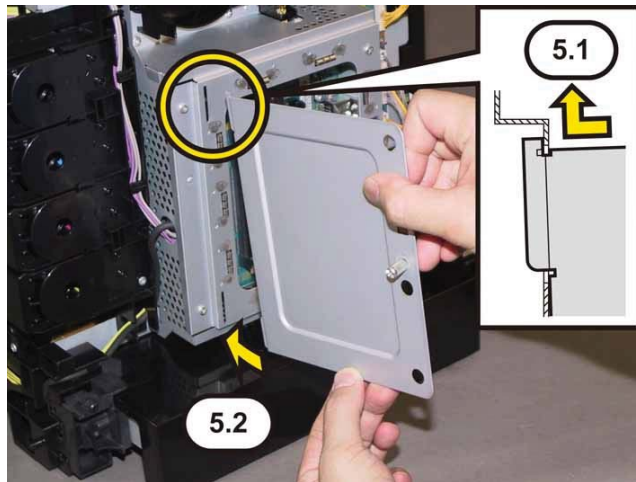

6) Close the PLATE ESS and secure the SCREW KNURLING.



**Go to the next replacement step:
Replacement 14 FAN (PL8.1.1)**

Replacement 14 FAN (PL8.1.1)

Note: When carrying out the work described next procedure, take care to check the orientation of the FAN. (Attach the FAN so that its labeled surface faces front.)

1) Secure the FAN to the DUCT FAN with the four hooks.



2) Route the harness of the FAN through the hooks of the DUCT FAN, engage the connector (P/J503) of the FAN to the PWBA LVPS.



Go to the next replacement step:

Replacement 25 COVER REAR (PL1.1.3)

Replacement 15 HOLDER ASSY TCRU (K), (C), (M), (Y) (PL5.1.17~20)

Note: Described below is the replacement procedure common among the four HOLDER ASSY TCRU.

1) Mate the lower boss of the HOLDER ASSY TCRU with the hole of the FRAME DISP.

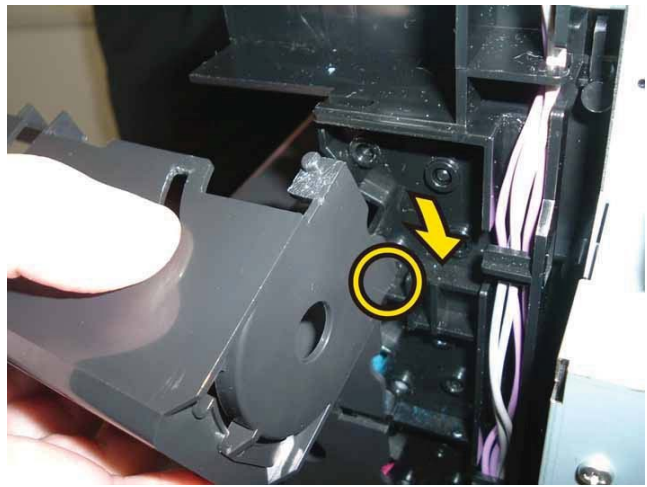

2) Bend the HOLDER ASSY TCRU, mate the upper boss of the HOLDER ASSY TCRU with the hole of the FRAME DISP.

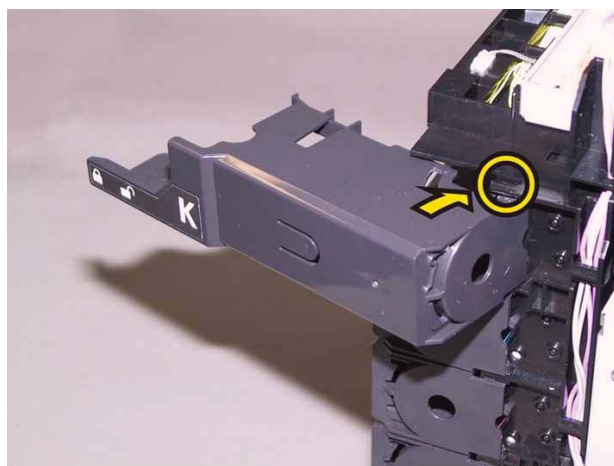

3) Press the central part of the HOLDER ASSY TCRU, mate the hole of the HOLDER ASSY TCRU with the boss of the FRAME DISP.

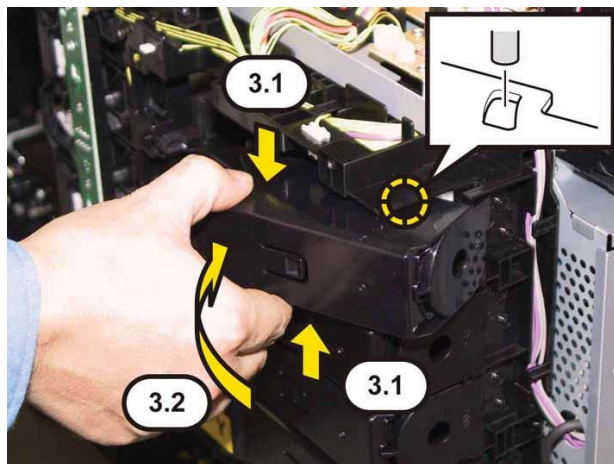

Go to the next replacement step:

Replacement 25 COVER REAR (PL1.1.3)

Replacement 16 STOPPER CST (PL3.1.10)

1) Mate the two holes of the STOPPER CST with the bosses of the printer, attach the STOPPER CST.

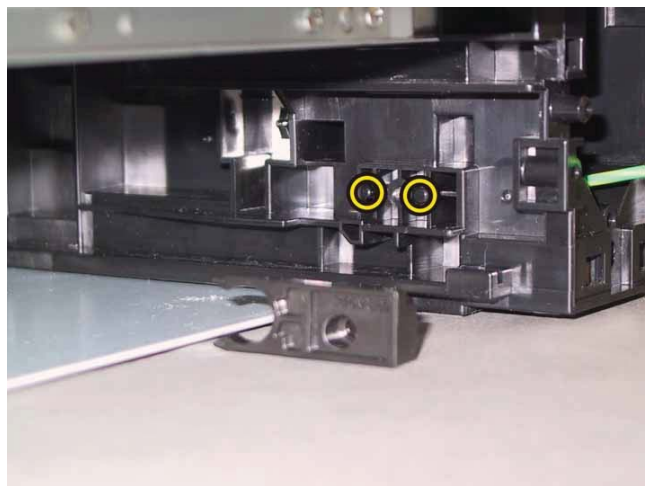

2) Secure the STOPPER CST to the printer with the one screw (silver, tap, 8mm).

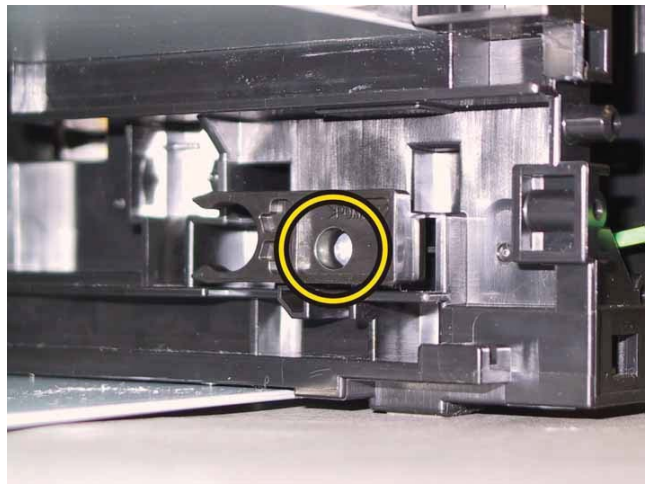

**Go to the next replacement step:
Replacement 17 COVER CST (PL3.1.22)**

Replacement 17 COVER CST (PL3.1.22)

1) Attach the COVER CST to the printer.

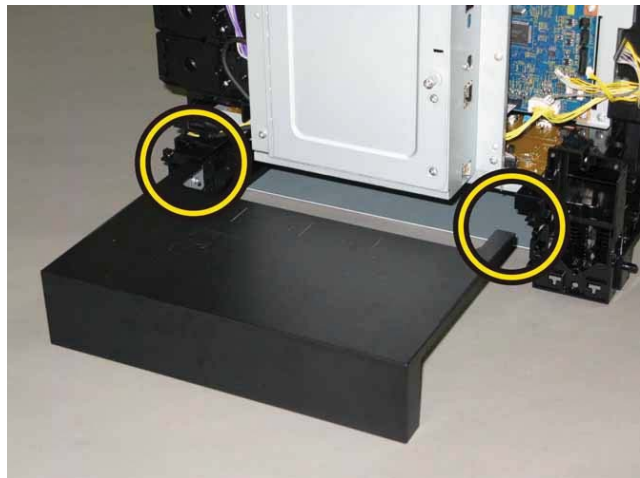

2) Attach the BRACKET GFI to the COVER CST.

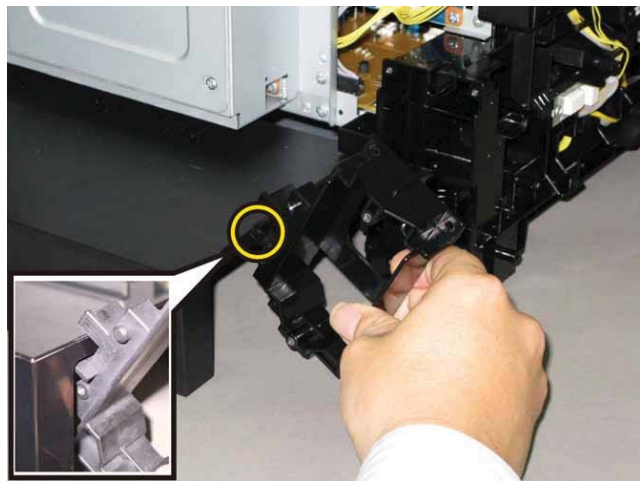

3) Secure the two hooks of the BRACKET GFI to the printer.

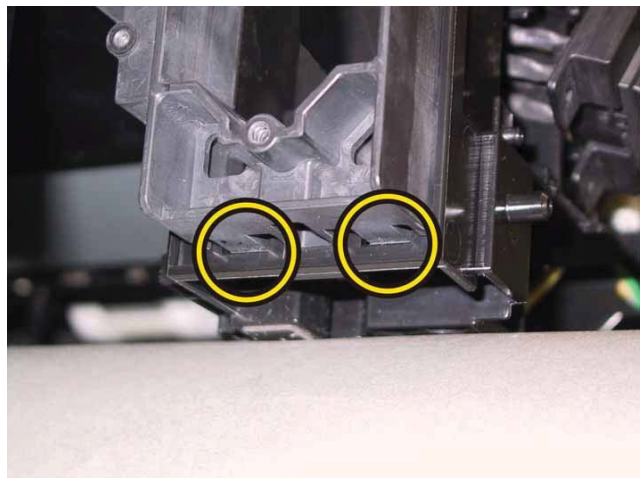

4) Secure the BRACKET GFI to the printer with the two screws (silver, tap, 8mm).



Go to the next replacement step:

Replacement 18 SWITCH ASSY INLET MG SFP (PL8.2.9), COVER INLET (PL8.2.22)

Replacement 18 SWITCH ASSY INLET MG SFP (PL8.2.9), COVER INLET (PL8.2.22)

1) Route the connector (J48) of the SWITCH ASSY INLET MG SFP through the hole of the COVER INLET.

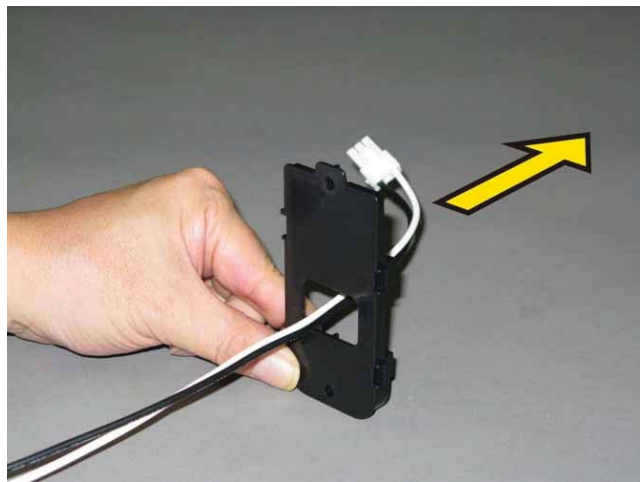

2) Route the harness and SWITCH POWER of the SWITCH ASSY INLET MG SFP through the hole of the COVER INLET.

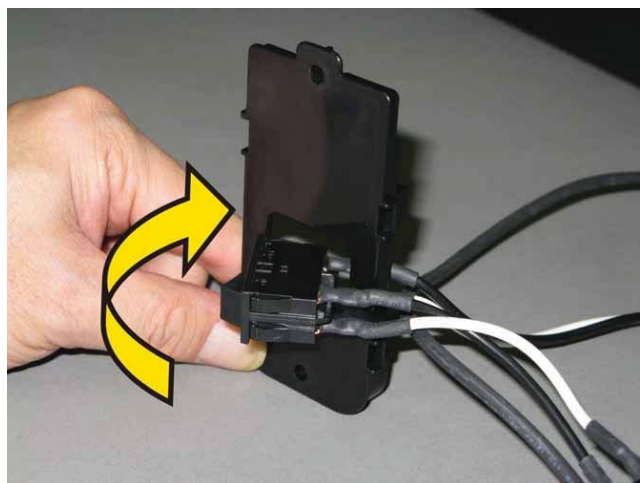

3) Attach the AC INLET of the SWITCH ASSY INLET MG SFP to the COVER INLET, and secure it with the hooks.

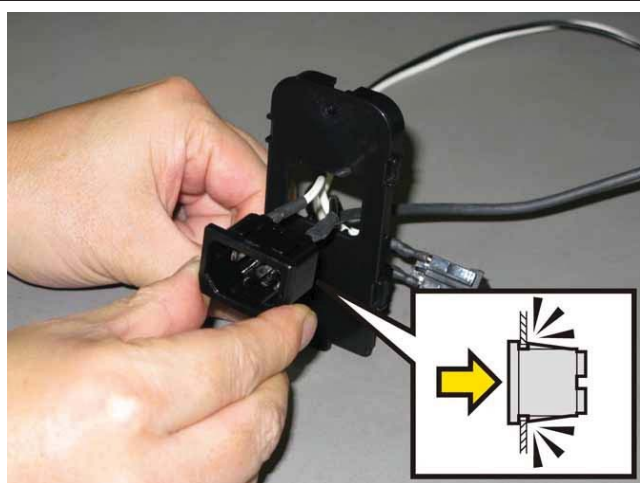

4) Route the harness and SWITCH POWER of the SWITCH ASSY INLET MG SFP through the hole of the printer.



Note: When replacing the SWITCH ASSY INLET MG SFP, match the ON/OFF mark of the SWITCH POWER with the mark on the BRACKET SW.

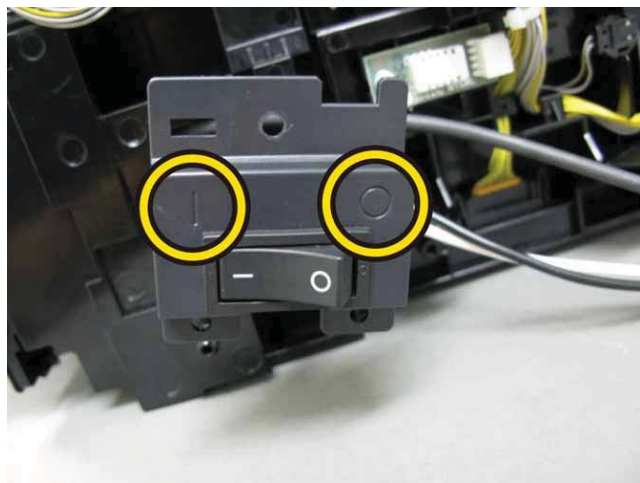

5) Attach the SWITCH POWER of the SWITCH ASSY INLET MG SFP to the BRACKET SW, and secure it with the hooks.

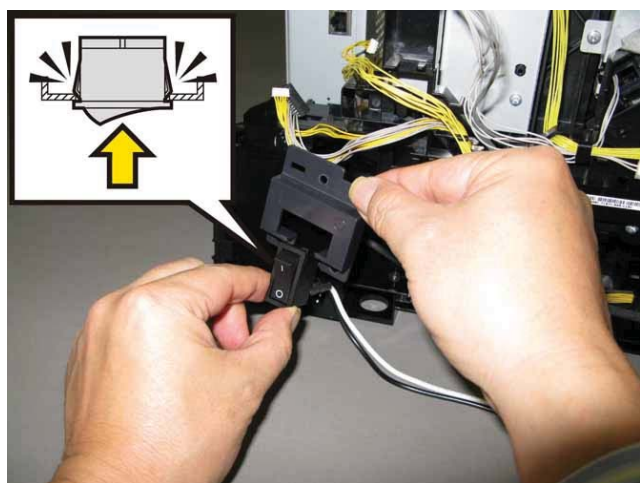

6) Secure the COVER INLET to the printer with the two screws (silver, tap, 12mm).



7) Mate the notch of the BRACKET SW with the hook of the GUIDE HARNESS AC.



8) Mate the holes of the BRACKET SW with the two bosses of the printer, secure the BRACKET SW with the two screws (silver, tap, 8mm).



9) Route the harness of the SWITCH ASSY INLET MG SFP along the GUIDE HARNESS AC, secure the grounding terminal of the SWITCH ASSY INLET MG SFP with the one screw (silver, with washer, 6mm).
Engage the connector (P/J48) of the SWITCH ASSY INLET MG SFP to the PWBA LVPS.

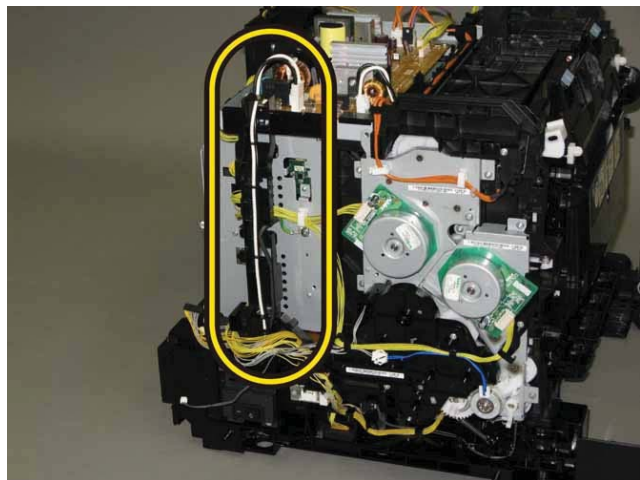

10) Route the harness along the GUIDE HARNESS AC, engage the five connectors (P/J20, 23, 24, 26 and 28) with the PWBA MCU.



**Go to the next replacement step:
Replacement 25 COVER REAR (PL1.1.3)**

Replacement 19 KIT FEED ROLL/SOL/CLUTCH

1) Mate the holes of the SOLENOID FEED MSI with the two bosses of the printer, secure the SOLENOID FEED MSI with the one screw (silver, tap, 8mm).

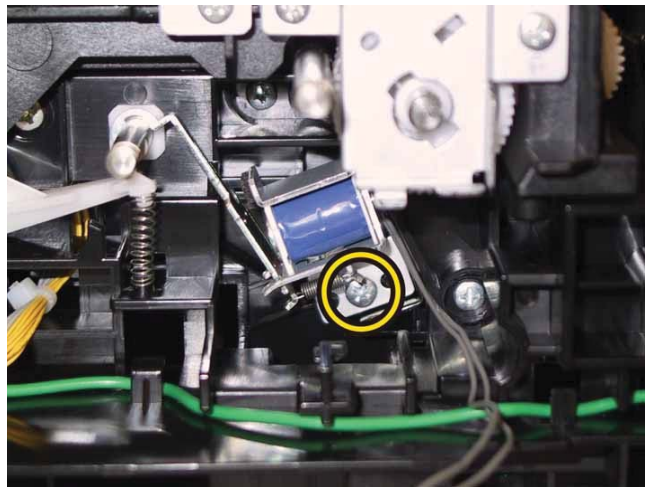

2) Engage the connector (P/J231) of the SOLENOID FEED MSI, secure the relay connector with the rib of the printer.

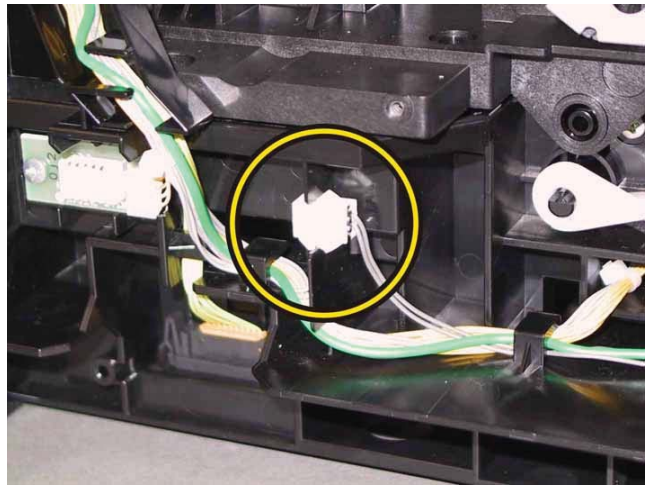

3) Route the harness of the SOLENOID FEED MSI through the hooks of the printer.

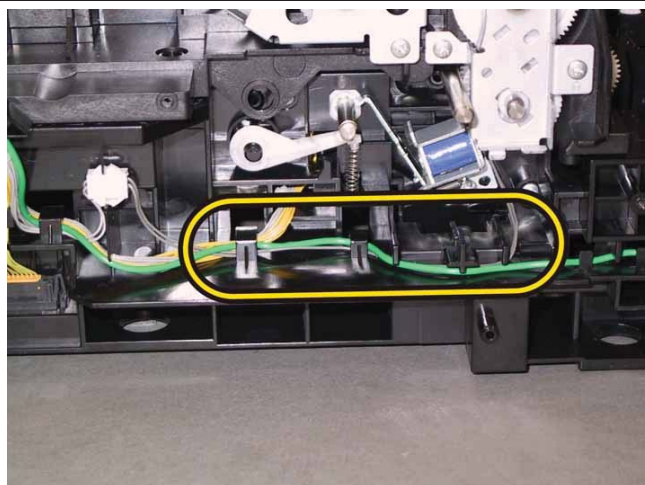

Note: When carrying out the work described next procedure, it is easier to put the D-cut surface of the SHAFT ASSY FEED on the front.

4) Attach the GEAR ASSY FEED to the SHAFT ASSY FEED by pushing down the LEVER FEED, mate the hook of the GEAR ASSY FEED with the groove of the SHAFT ASSY FEED.

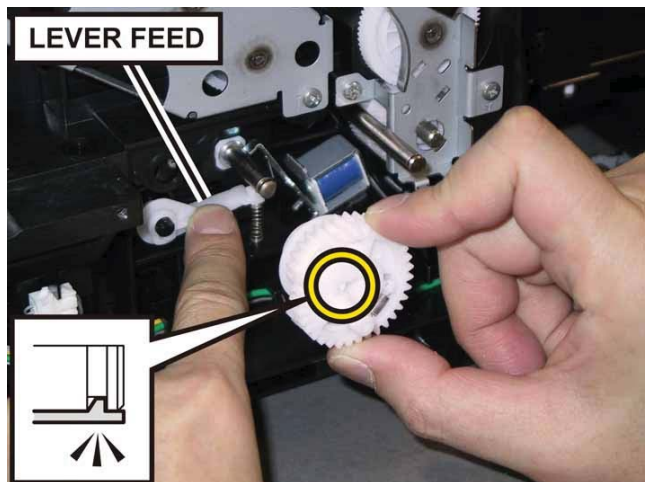

5) Hang the SPRING FEED OUT to the GEAR ASSY FEED and the printer.
Note: Ensure that the SPRING FEED OUT is oriented to the direction shown in the right.

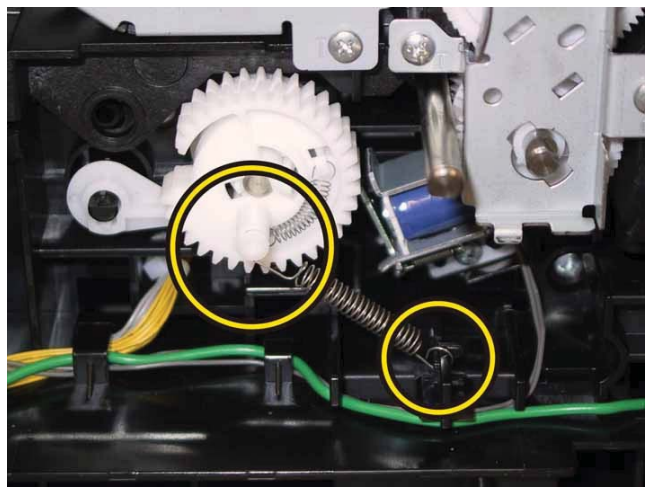

6) Close the COVER ASSY FRONT MG.

7) Fit the ROLL ASSY FEED to the SHAFT ASSY FEED with the groove of the ROLL ASSY FEED facing upward, rotate the ROLL ASSY FEED 180 degrees so that the pin on the SHAFT ASSY FEED is aligned with the groove on the ROLL ASSY FEED.

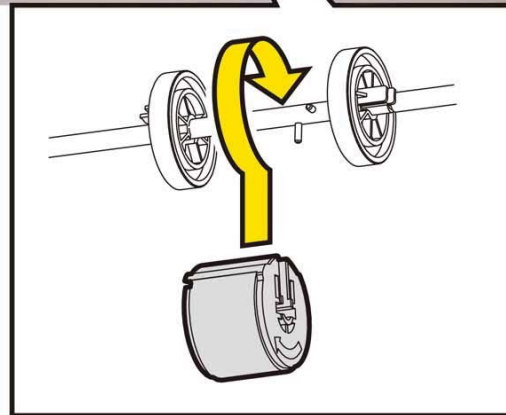
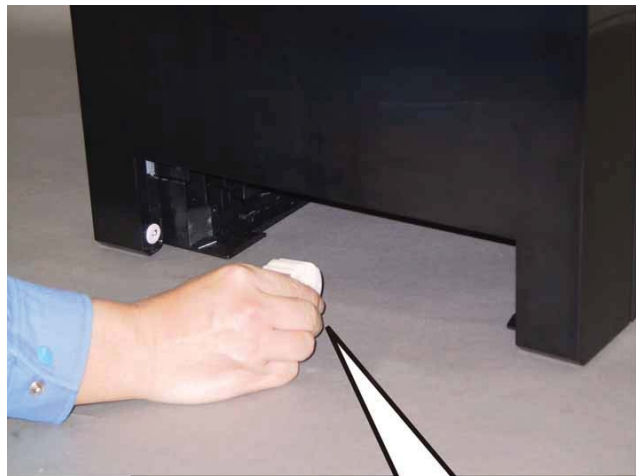

8) Open the COVER ASSY FRONT MG.

9) Move the ROLL ASSY FEED to the right side, put the groove of the ROLL ASSY FEED on the pin of the SHAFT ASSY FEED.



10) Move the ROLL CORE MSI to the right side, to secure the hook of the ROLL CORE MSI with the groove of the SHAFT ASSY FEED.

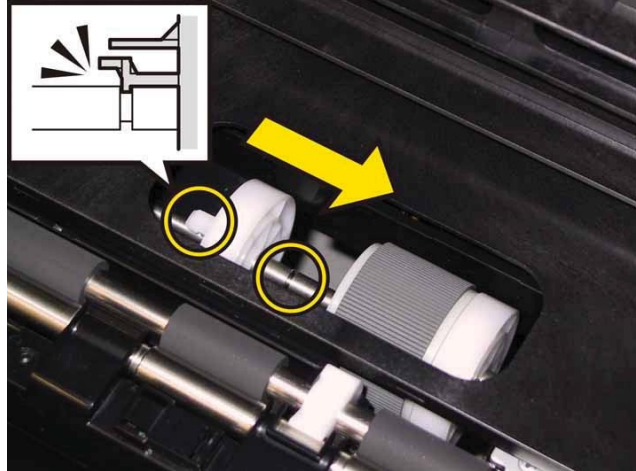

Go to the next replacement step:

Replacement 23 KIT DRIVE ASSY PH (PL7.1.99)

Replacement 20 KIT BLOCK PHD LEFT (PL4.1.98)

Accesses Position (The 1), 2) and 3) show the procedure number.)

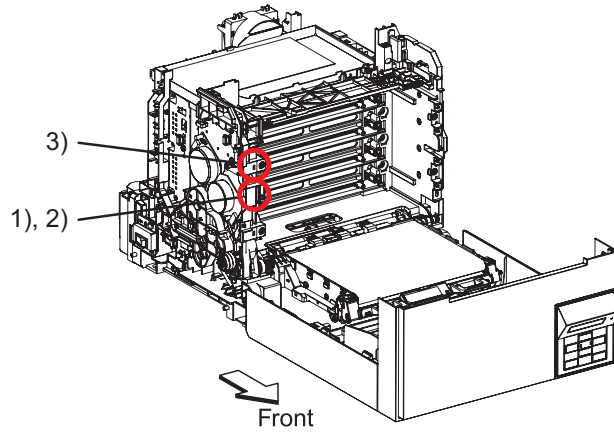

1) Tilt the LEVER PHD slightly, attach the LEVER PHD to the printer.

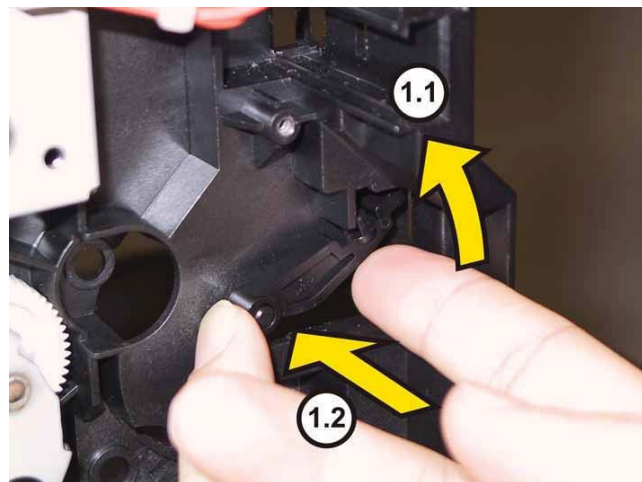

2) Attach the SPRING PHD to the printer.

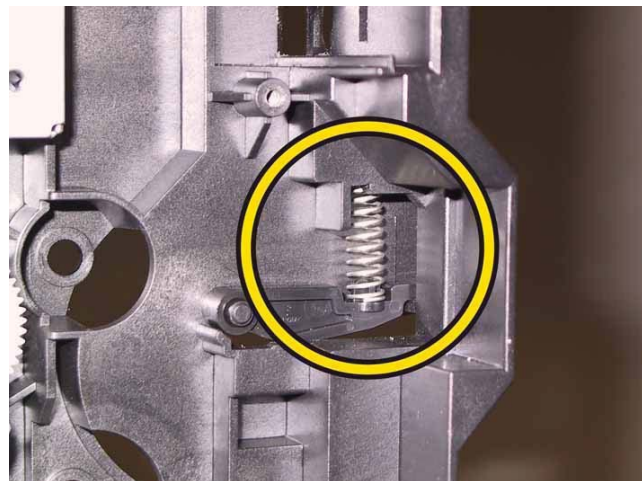

Note: Described below is the replacement procedure common among the upper and lower of the **BLOCK STOPPER PHD Ds**.

3) Push the BLOCK STOPPER PHD D to the printer until it is locked.

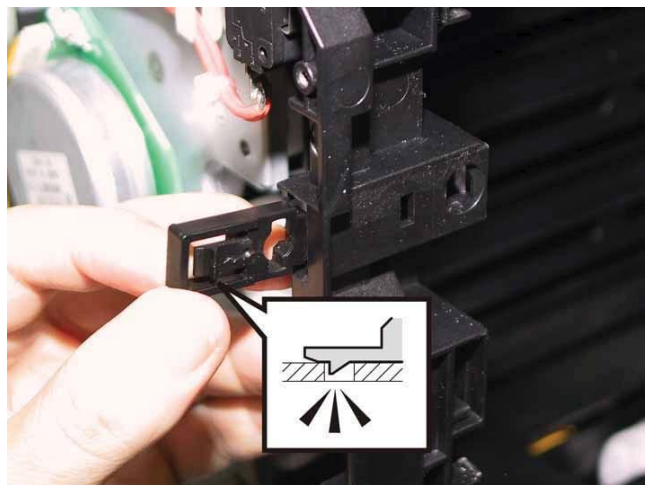

Go to the next replacement step:

Replacement 22 KIT DRIVE ASSY MAIN (PL7.1.98)

Replacement 21 DRIVE ASSY SUB (PL7.1.1)

1) Attach the DRIVE ASSY SUB to the printer.

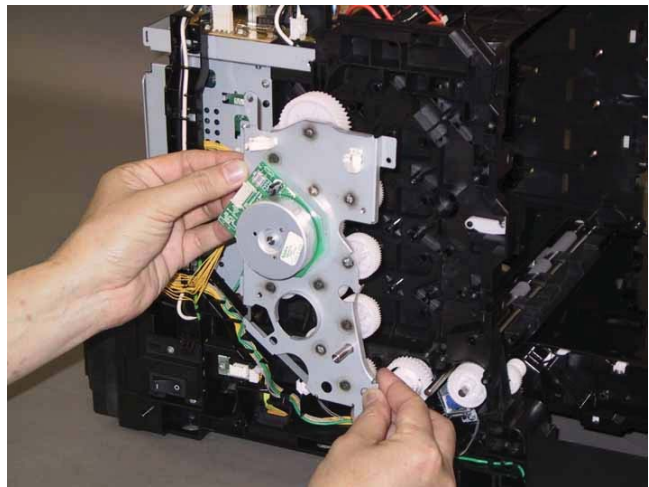

Note: Since two types of screws are used for securing the DRIVE ASSY SUB, ensure that the right screws are used at their right securing positions.

The securing positions for tap screws are marked with [T].

The securing positions for metal screws are marked with [M].

2) Secure the DRIVE ASSY SUB to the printer with the one screw (silver, M4, 6mm) and the four screws (silver, tap, 8mm).

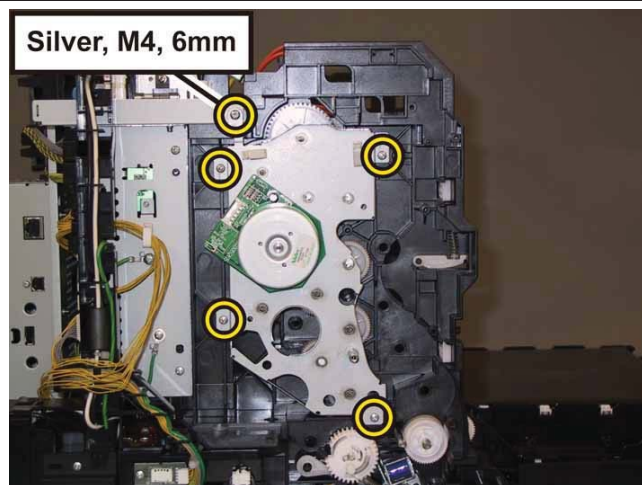

3) Engage the connector (P/J221) of the DRIVE ASSY SUB.

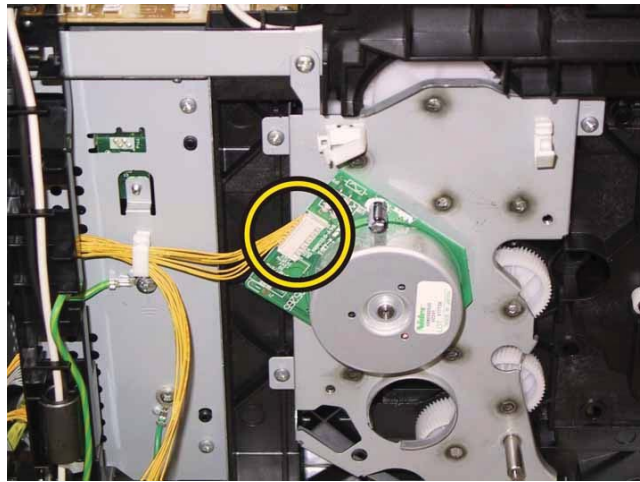

Go to the next replacement step:

Replacement 22 KIT DRIVE ASSY MAIN (PL7.1.98)

Replacement 22 KIT DRIVE ASSY MAIN (PL7.1.98)

1) Attach the DRIVE ASSY MAIN to the printer.

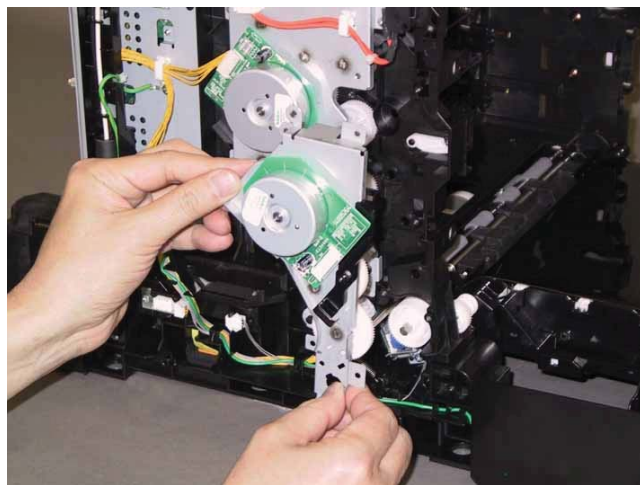

Note: Since two types of screws are used for securing the DRIVE ASSY MAIN, ensure that the right screws are used at their right securing positions.

The securing positions for tap screws are marked with [T].

The securing positions for metal screws are marked with [M].

2) Secure the DRIVE ASSY MAIN to the printer with the one screw (silver, M4, 6mm) and the five screws (silver, tap, 8mm).

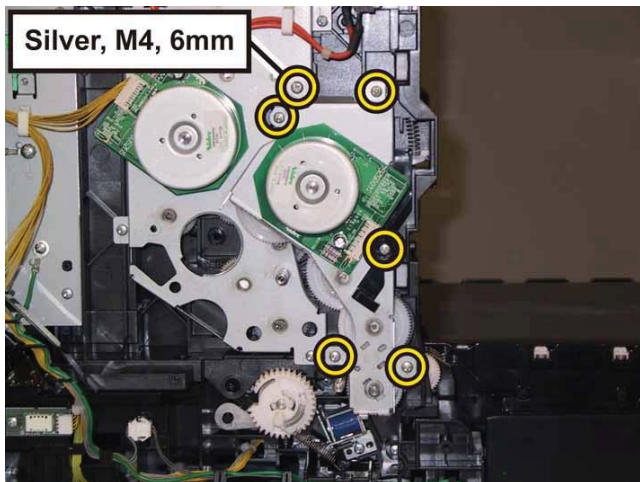

3) Attach the GEAR P2 to the shaft of DRIVE ASSY SUB.

Note: Ensure that the GEAR P2 is oriented to the direction shown in the right.

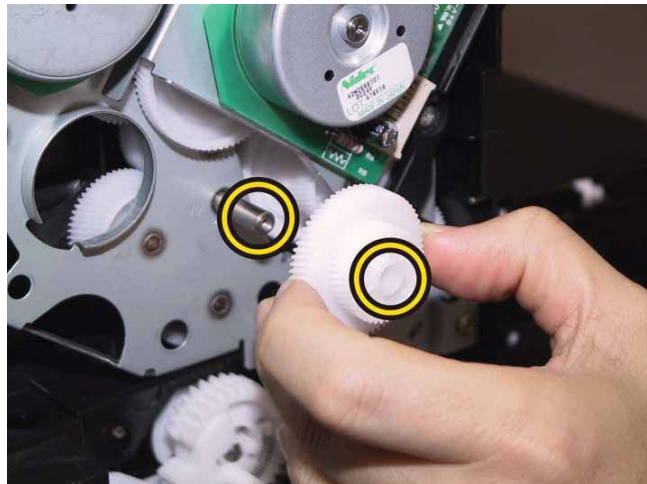

Note: When carrying out the work described next procedure, ensure that the flat face of the PIVOT TRANS L is oriented to the direction shown in the right.

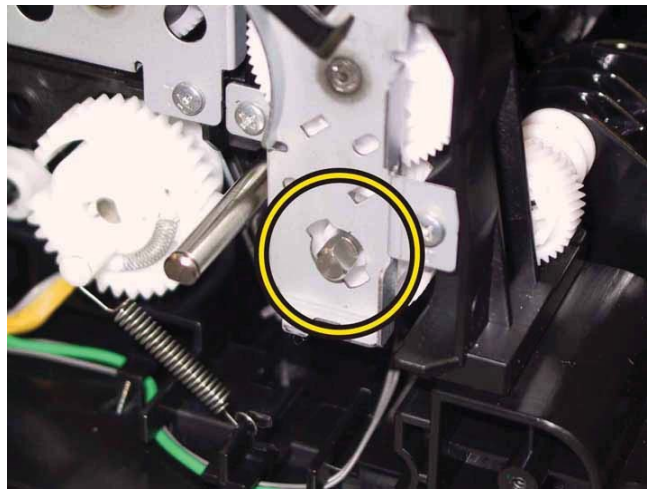

4) Mate the tab of the STOPPER PIVOT with the notch of the DRIVE ASSY MAIN, attach the STOPPER PIVOT to the PIVOT TRANS L.

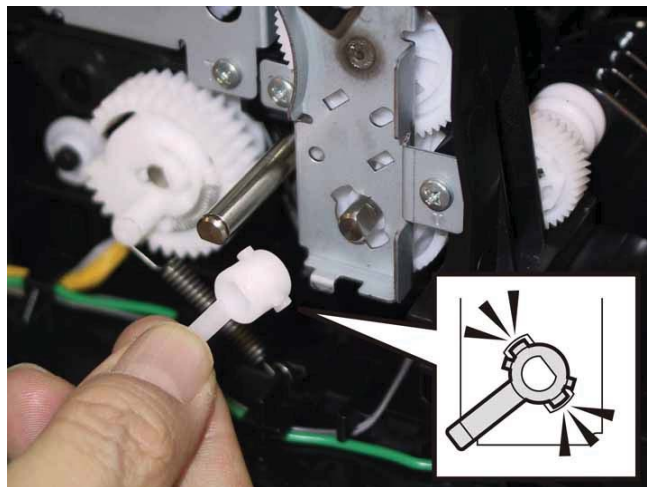

5) Rotate the STOPPER PIVOT to the left, secure the STOPPER PIVOT to the DRIVE ASSY MAIN frame.

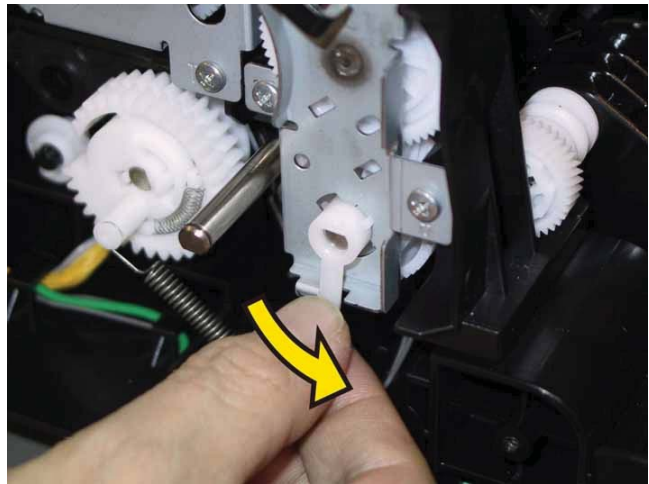

Go to the next replacement step:

Replacement 23 KIT DRIVE ASSY PH (PL7.1.99)

Replacement 23 KIT DRIVE ASSY PH (PL7.1.99)

Accesses Position (All the numbers show the procedure number.)

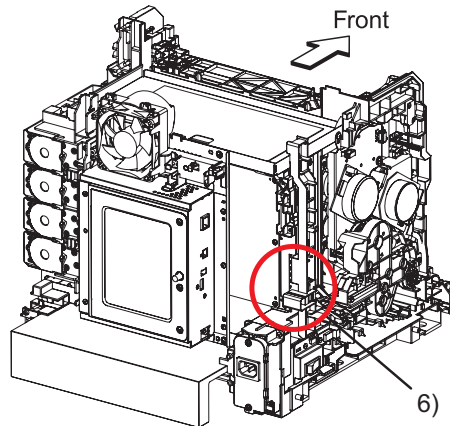

1) Attach the GEAR P2 to the shaft of DRIVE ASSY SUB.

Note: Ensure that the GEAR P2 is oriented to the direction shown in the right.

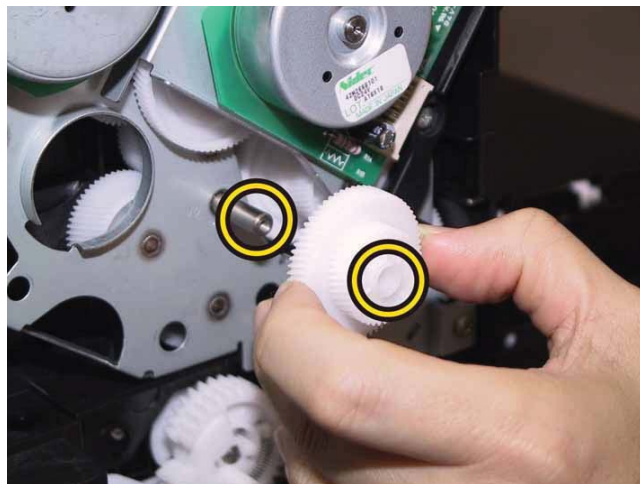

2) Engage the connector (J261) of the HARN ASSY KSNR REGCL with the Color mode switching sensor of the DRIVE ASSY PH, route the HARN ASSY KSNR REGCL through the hook of the DRIVE ASSY PH.

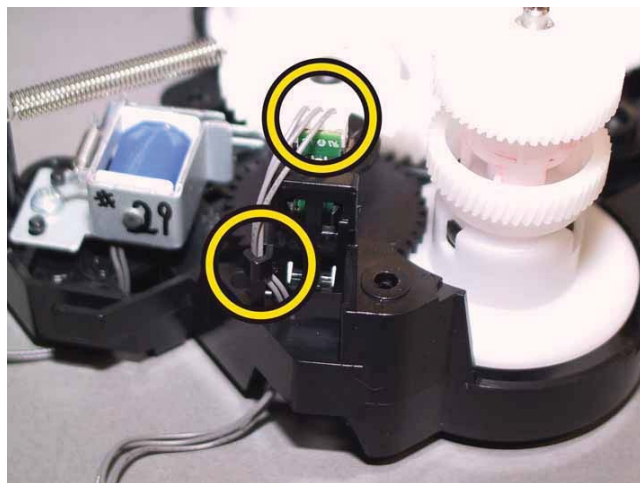

Note: When carrying out the work described next procedure, take care not to drop the coupling gear to inside.

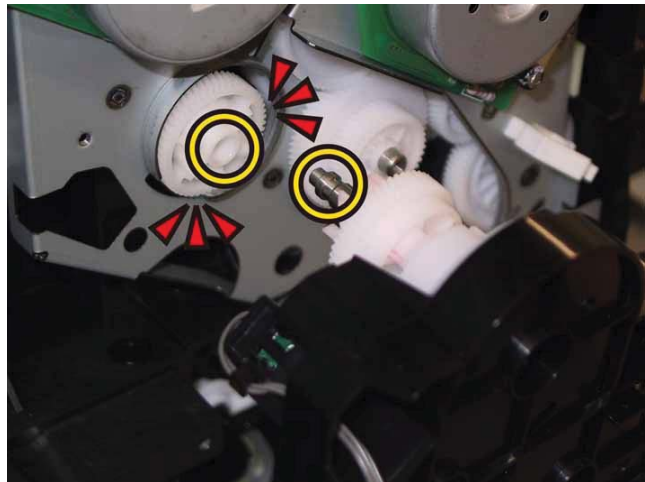

3) Attach the DRIVE ASSY PH to the printer.

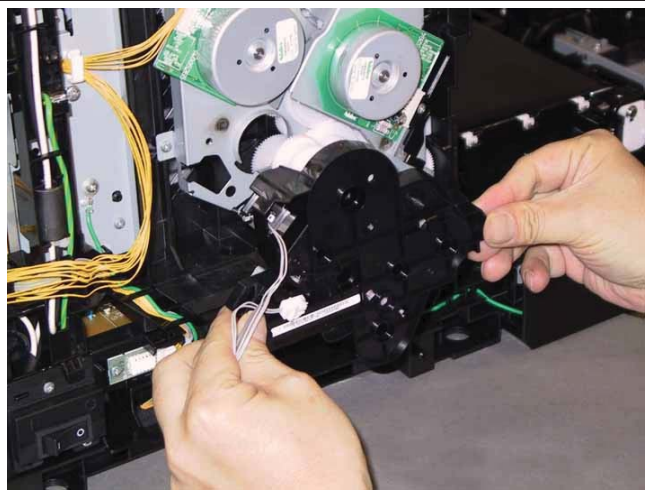

Note: Since three types of screws are used for securing the DRIVE ASSY PH, ensure that the right screws are used at their right securing positions.

The securing positions for tap screws are marked with [T].

The securing positions for metal screws are marked with [M].

4) Secure the DRIVE ASSY PH to the printer with the one screw (silver, M4, 6mm), the one screw (silver, M3, 6mm) and the one screw (silver, tap, 8mm).

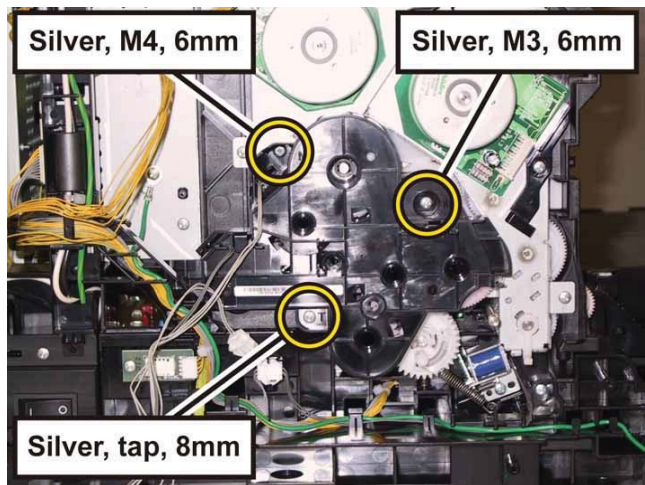

5) Route all the harness through the hooks of the DRIVE ASSY PH, engage the connector (P/J211) of the DRIVE ASSY MAIN.

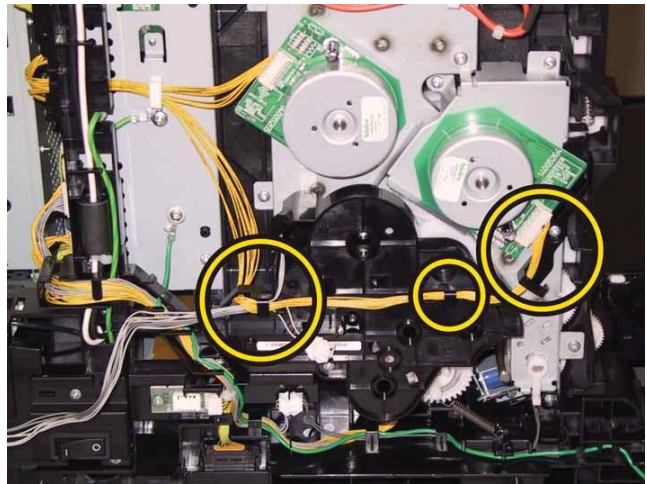

6) Route the harness of the DRIVE ASSY PH and HARN ASSY KSNR REGCL along the GUIDE HARNESS AC, engage the two connectors (P/J24, 26) with the PWBA MCU.

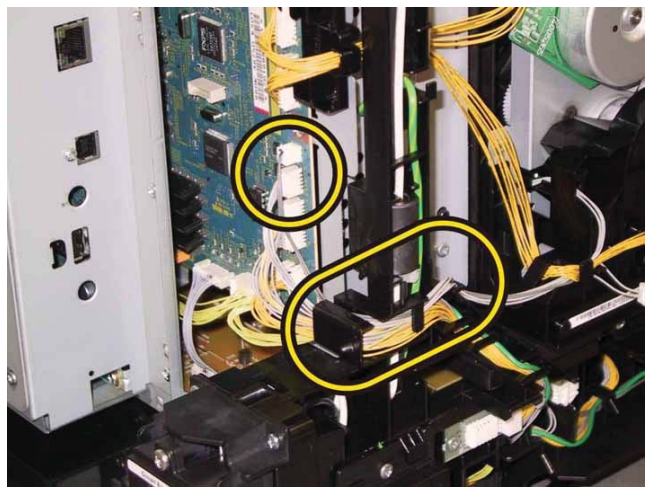

Go to the next replacement step:

Replacement 24 CLUTCH ASSY DRV (PL3.1.1), BEARING REGI (PL3.1.2)

Replacement 24 CLUTCH ASSY DRV (PL3.1.1), BEARING REGI (PL3.1.2)

1) Attach the BEARING REGI to the shaft of the ROLL ASSY REGI, secure the BEARING REGI with the hooks.

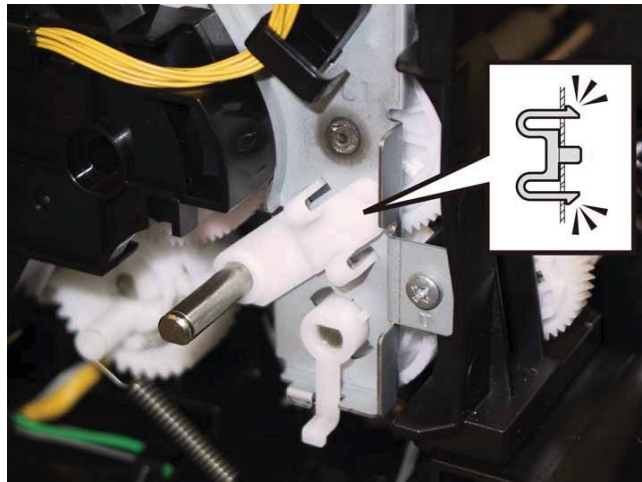

2) Mate the notch of the CLUTCH ASSY DRV with the rib of the DRIVE ASSY PH, secure the CLUTCH ASSY DRV to the ROLL ASSY REGI with the E-ring by using a pliers.

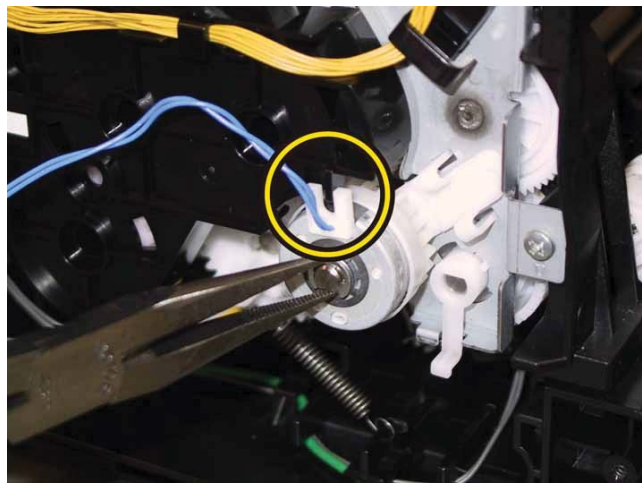

3) Route the harness of the CLUTCH ASSY DRV through the hook of the DRIVE ASSY PH.

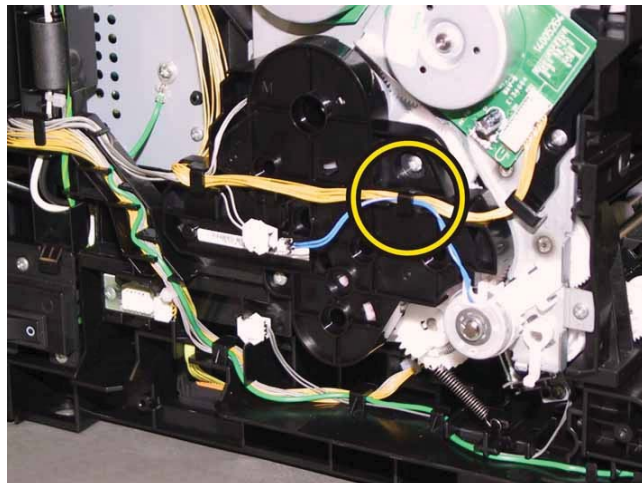

4) Engage the connector (P/J262) of the CLUTCH ASSY DRV, secure the relay connector with the pegs of the DRIVE ASSY PH.

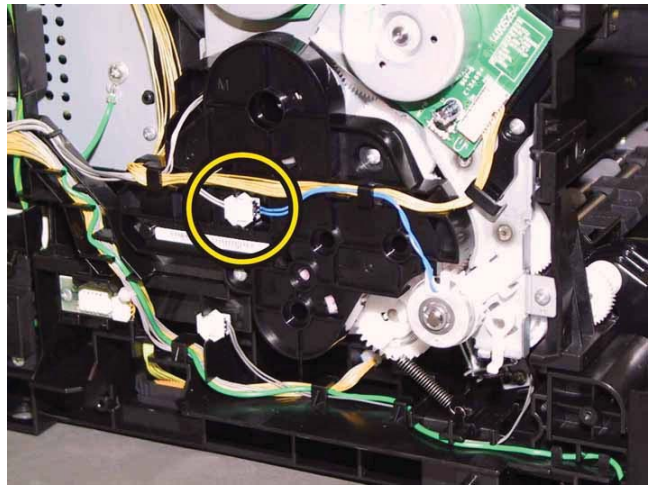

**Go to the next replacement step:
Replacement 25 COVER REAR (PL1.1.3)**

Replacement 25 COVER REAR (PL1.1.3)

1) Attach the COVER REAR to the printer.

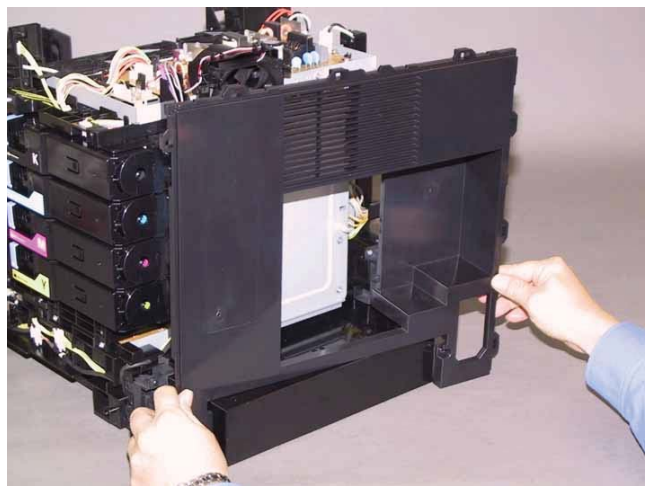

2) Secure the COVER REAR to the printer with the two screws (silver, tap, 8mm).



Go to the next replacement step:

Replacement 38 COVER SIDE L (PL1.1.19)

Replacement 26 HARN ASSY DUP RELAY (PL1.2.13) [2150cdn Only]

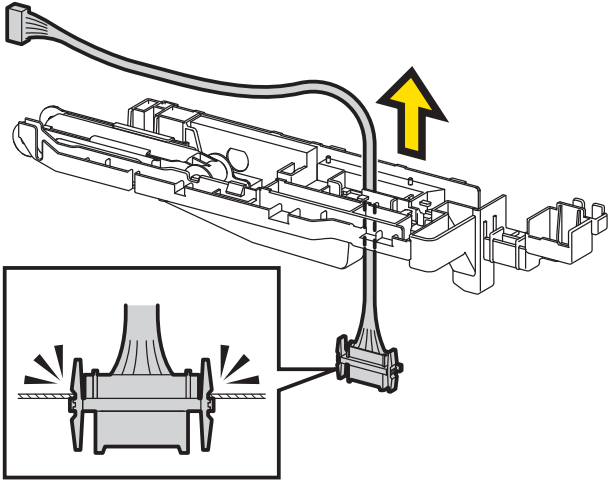
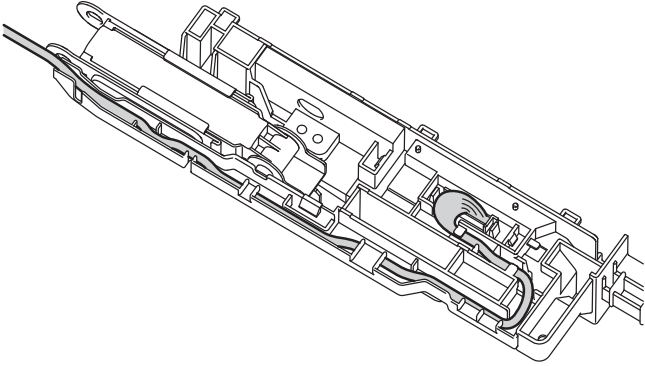
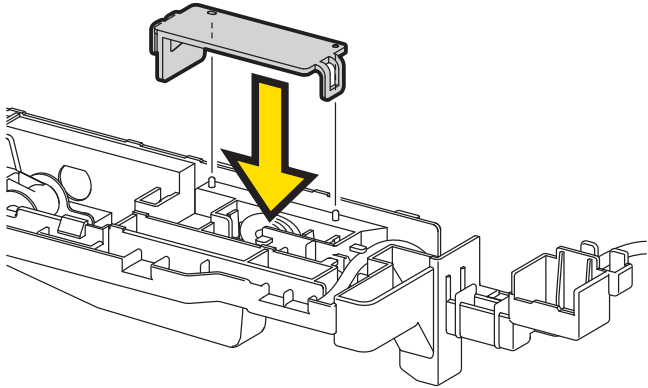
<p>1) Pass the connector (P271) and the harness of the HARN ASSY DUP RELAY through the hole on the HOLDER ASSY FRONT R, and secure the connector (P272) of the HARN ASSY DUP RELAY to the HOLDER ASSY FRONT R with the two hooks.</p>	
<p>2) Route the harness of the HARN ASSY DUP RELAY along the hooks of the HOLDER ASSY FRONT R.</p>	
<p>3) Attach the COVER DRAWER to the HOLDER ASSY FRONT R, secure the COVER DRAWER with the two hooks.</p>	

4) Mate the three tabs of the HOLDER ASSY FRONT R with the hole of the COVER ASSY FRONT MG, attach the HOLDER ASSY FRONT R.

Note: When carrying out the work this procedure, take care not to damage the harness by pinching it between the HOLDER ASSY FRONT R and the COVER ASSY FRONT MG.



5) Secure the one hook of the HOLDER ASSY FRONT R to the COVER ASSY FRONT MG.

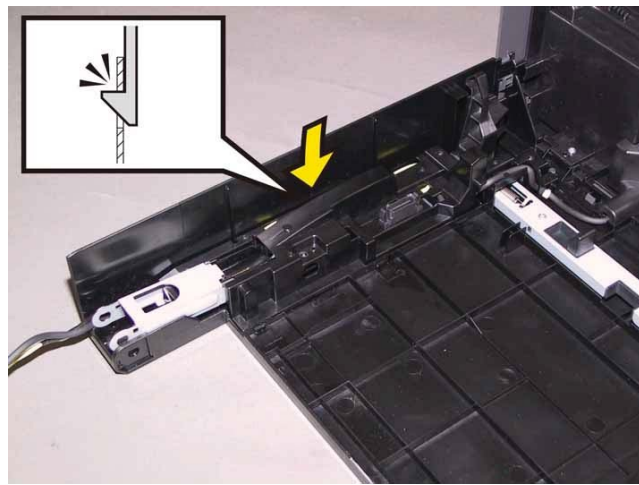

6) Secure the HOLDER ASSY FRONT R to the COVER ASSY FRONT MG with the three screws (silver, tap, 8mm).

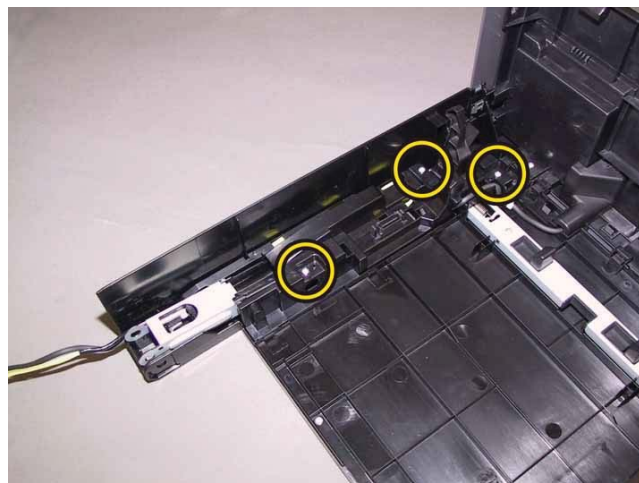

7) Engage the connector (P/J202) of the CONSOLE ASSY PANEL.

Note: When carrying out the work this procedure, route the HARNESS ASSY PNL A so that the core on the HARNESS ASSY PNL A fits into the housing space located on the COVER ASSY FRONT MG.

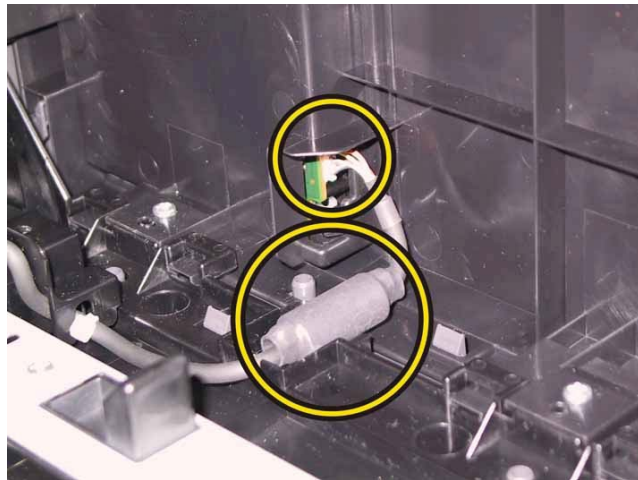

8) Attach the COVER CONNECTOR to the COVER ASSY FRONT MG.



9) Secure the two hooks of the COVER CONNECTOR to the COVER ASSY FRONT MG.

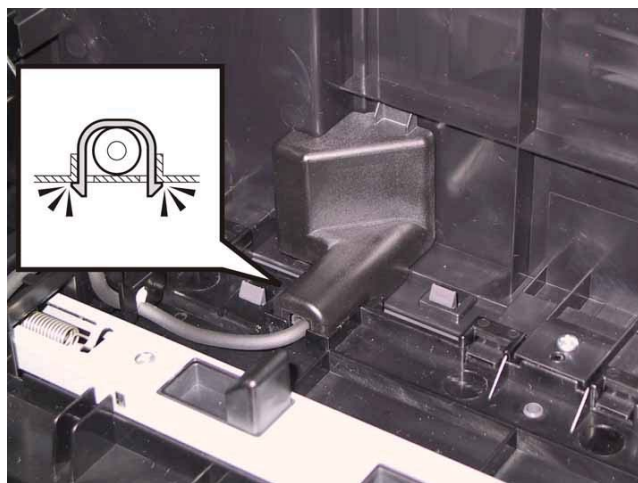

Go to the next replacement step:

Replacement 30 COVER ASSY FRONT MG (PL1.2.1)

Replacement 27 HARNESS ASSY PNL A (PL1.2.12)

1) Route the HARNESS ASSY PNL A through the hooks of the HOLDER ASSY FRONT R.



2) Mate the three tabs of the HOLDER ASSY FRONT R with the hole of the COVER ASSY FRONT MG, attach the HOLDER ASSY FRONT R.

Note: When carrying out the work this procedure, take care not to damage the harness by pinching it between the HOLDER ASSY FRONT R and the COVER ASSY FRONT MG.



3) Secure the one hook of the HOLDER ASSY FRONT R to the COVER ASSY FRONT MG.

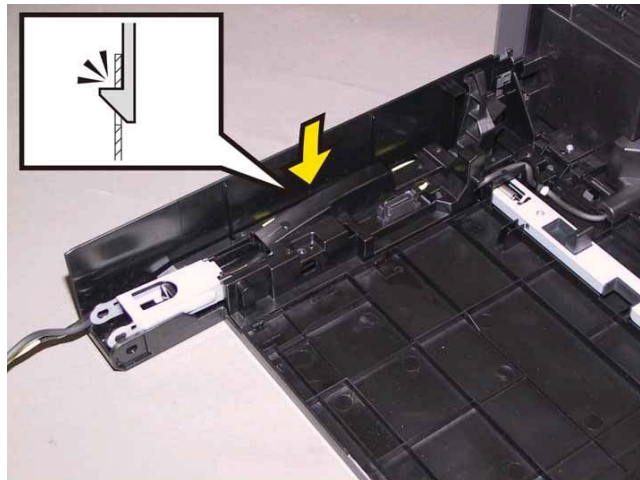

4) Secure the HOLDER ASSY FRONT R to the COVER ASSY FRONT MG with the three screws (silver, tap, 8mm).

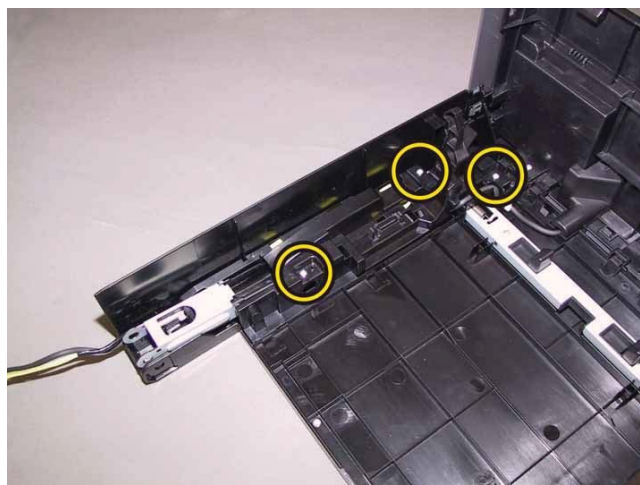

5) Engage the connector (P/J202) of the CONSOLE ASSY PANEL.
Note: When carrying out the work this procedure, route the HARNESS ASSY PNL A so that the core on the HARNESS ASSY PNL A fits into the housing space located on the COVER ASSY FRONT MG.

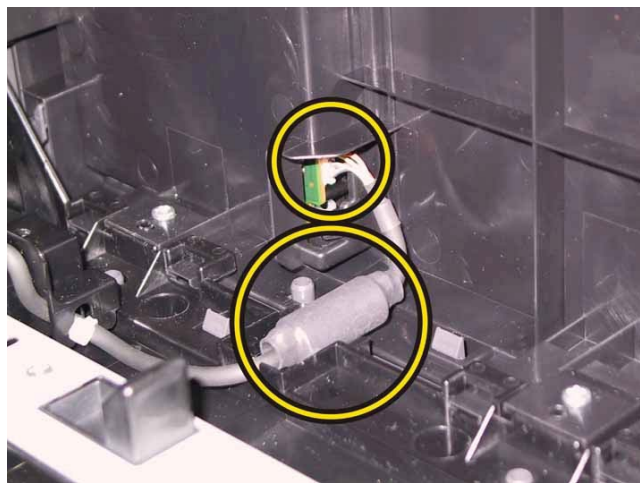

6) Attach the COVER CONNECTOR to the COVER ASSY FRONT MG.



7) Secure the two hooks of the COVER CONNECTOR to the COVER ASSY FRONT MG.

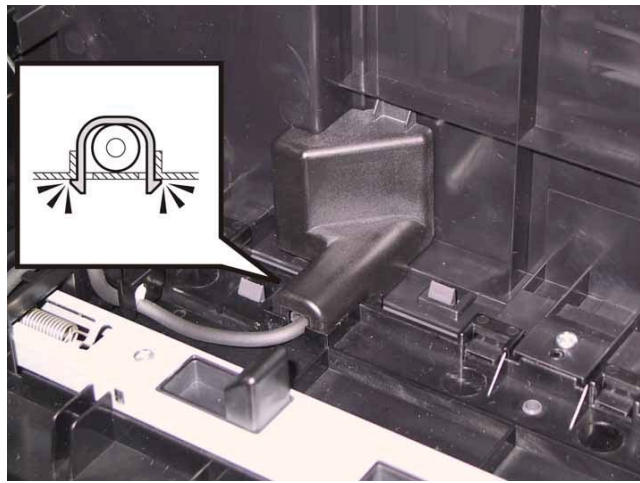

Go to the next replacement step:

Replacement 30 COVER ASSY FRONT MG (PL1.2.1)

Replacement 28 LATCH ASSY FRONT (PL1.2.5), BUTTON LATCH FRONT (PL1.2.11)

1) Mate the boss of the BUTTON LATCH FRONT with the hole of the LATCH ASSY FRONT.

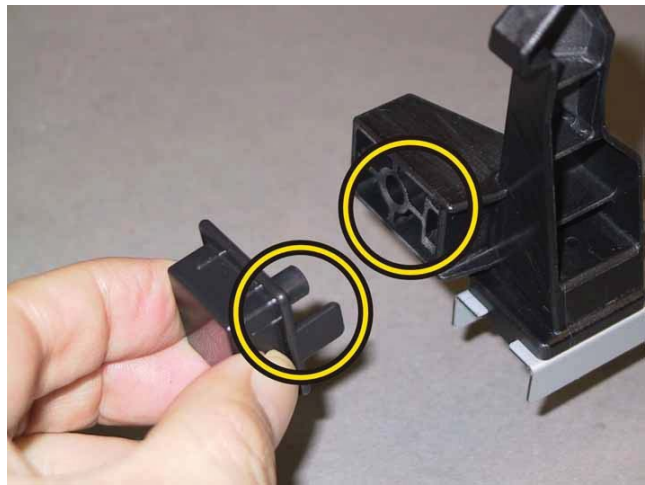

2) Attach the LATCH ASSY FRONT to the COVER ASSY FRONT MG together with the BUTTON LATCH FRONT.



3) Attach the SPRING LATCH FRONT to the LATCH ASSY FRONT.

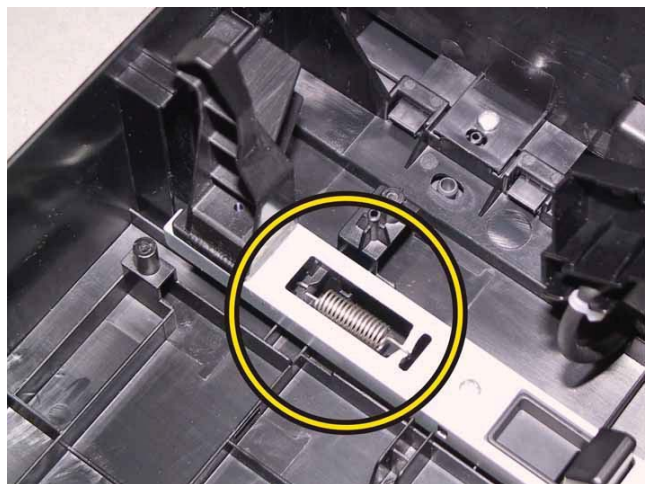

4) Mate the two tabs of the HOLDER ASSY FRONT L with the hole of the COVER ASSY FRONT MG, attach the HOLDER ASSY FRONT L.

Note: When carrying out the work this procedure, take care not to damage the harness by pinching it between the HOLDER ASSY FRONT L and the COVER ASSY FRONT MG.



5) Secure the two hooks of the HOLDER ASSY FRONT L to the COVER ASSY FRONT MG.

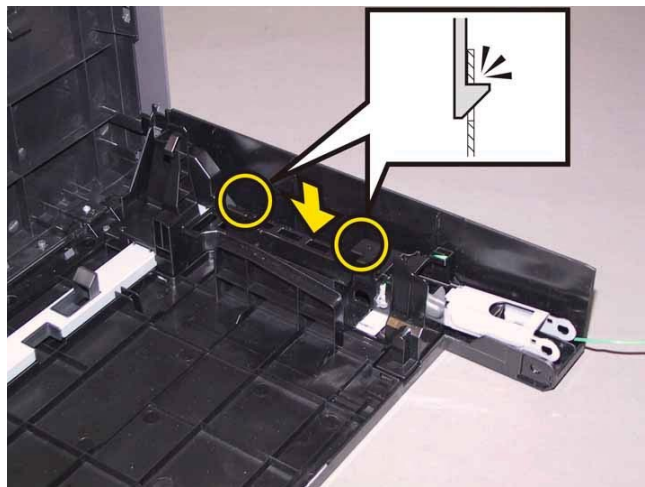

6) Secure the HOLDER ASSY FRONT L to the COVER ASSY FRONT MG with the three screws (silver, tap, 8mm).

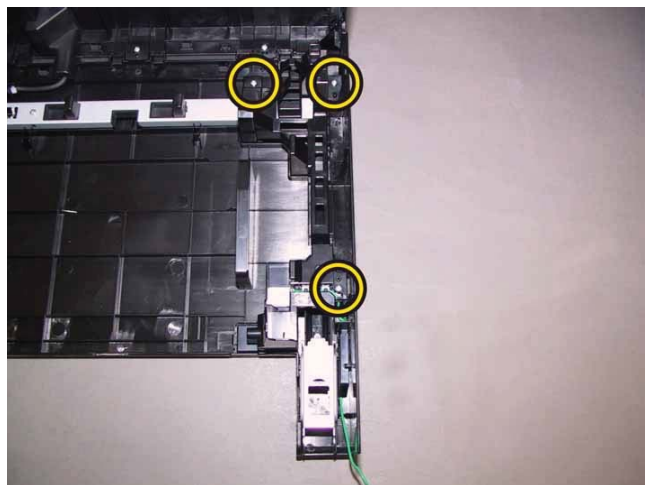

7) Mate the three tabs of the HOLDER ASSY FRONT R with the hole of the COVER ASSY FRONT MG, attach the HOLDER ASSY FRONT R.

Note: When carrying out the work this procedure, take care not to damage the harness by pinching it between the HOLDER ASSY FRONT R and the COVER ASSY FRONT MG.



8) Secure the one hook of the HOLDER ASSY FRONT R to the COVER ASSY FRONT MG.

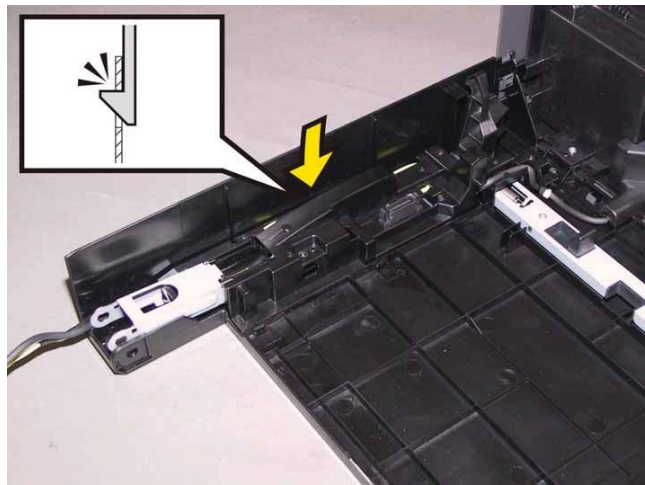

9) Secure the HOLDER ASSY FRONT R to the COVER ASSY FRONT MG with the three screws (silver, tap, 8mm).

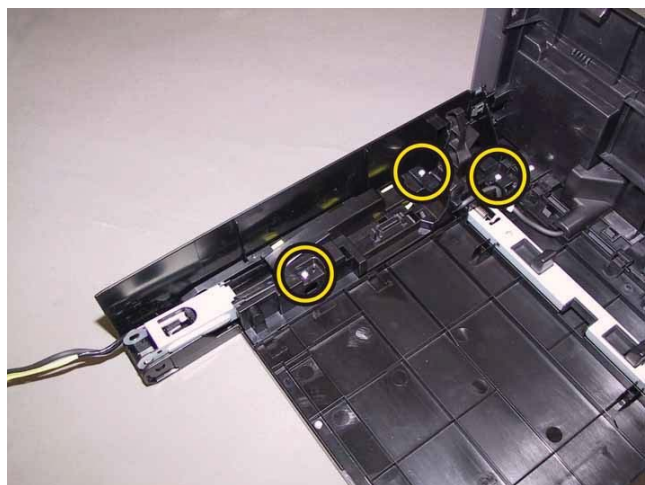

Go to the next replacement step:

Replacement 30 COVER ASSY FRONT MG (PL1.2.1)

Replacement 29 CONSOLE ASSY PANEL (PL1.2.3)

1) Mate the tab of the CONSOLE ASSY PANEL with the holes of the COVER ASSY FRONT MG, attach it.



2) Secure the CONSOLE ASSY PANEL to the COVER ASSY FRONT MG with the two hooks.

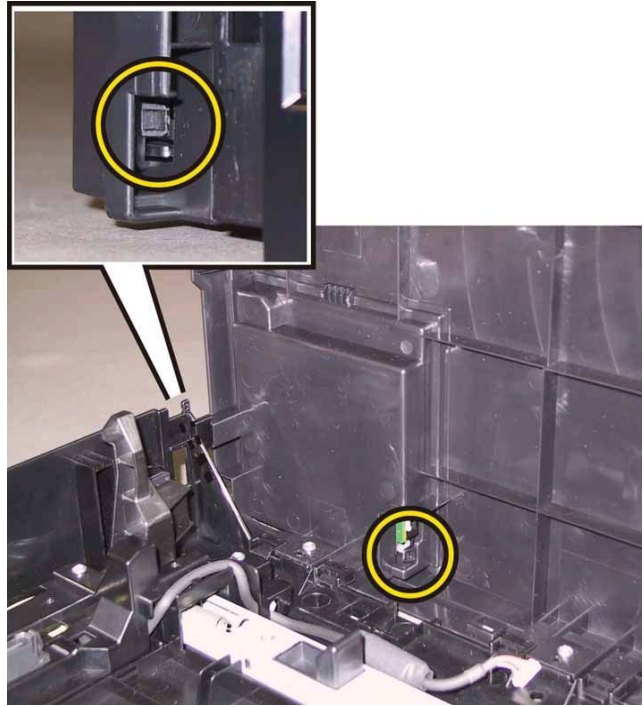

3) Attach the COVER FRONT BAND to the COVER ASSY FRONT MG.

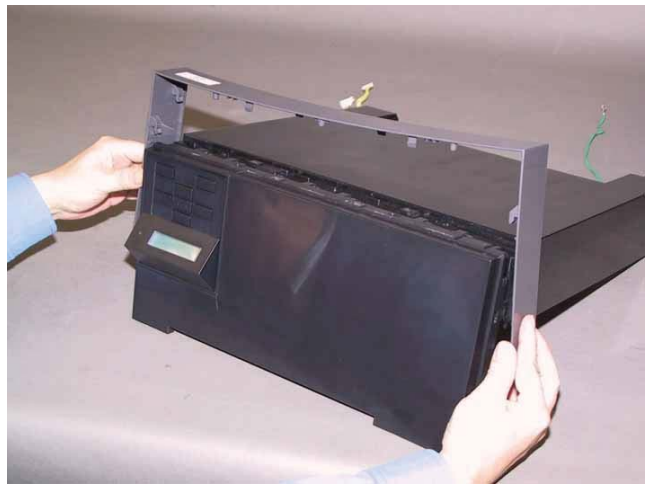

4) Secure the left and right hooks of the COVER FRONT BAND to the COVER ASSY FRONT MG.

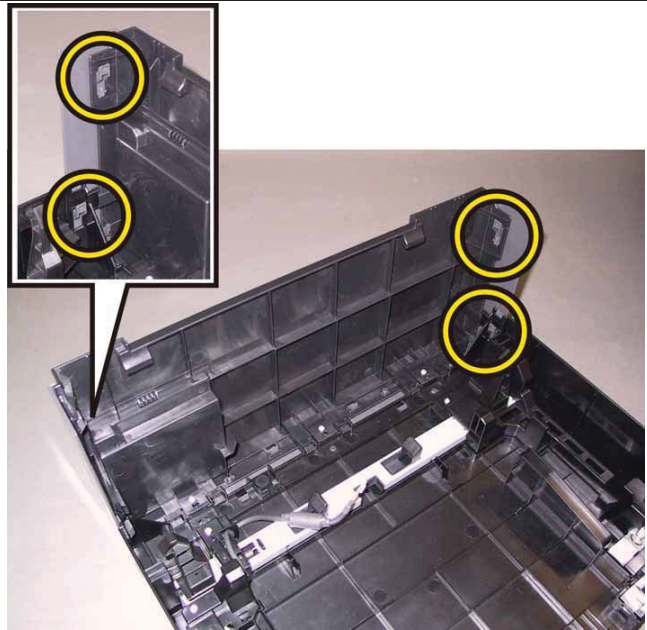

5) Secure the four hooks of the COVER FRONT BAND.

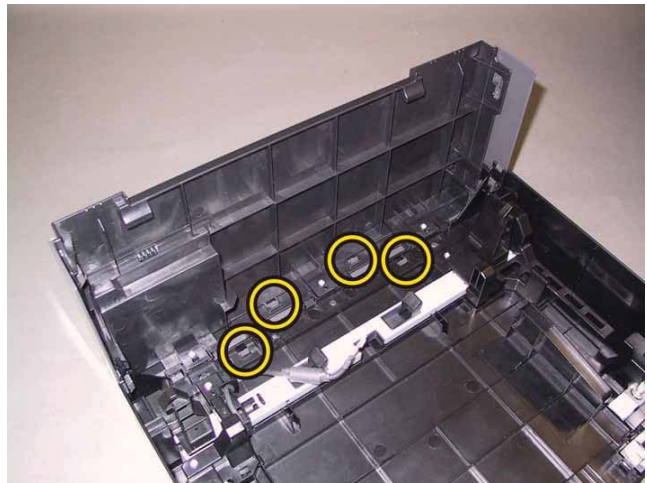

6) Engage the connector (P/J220) of the CONSOLE ASSY PANEL.
Note: When carrying out the work this procedure, route the HARNESS ASSY PNL A so that the core on the HARNESS ASSY PNL A fits into the housing space located on the COVER ASSY FRONT MG.

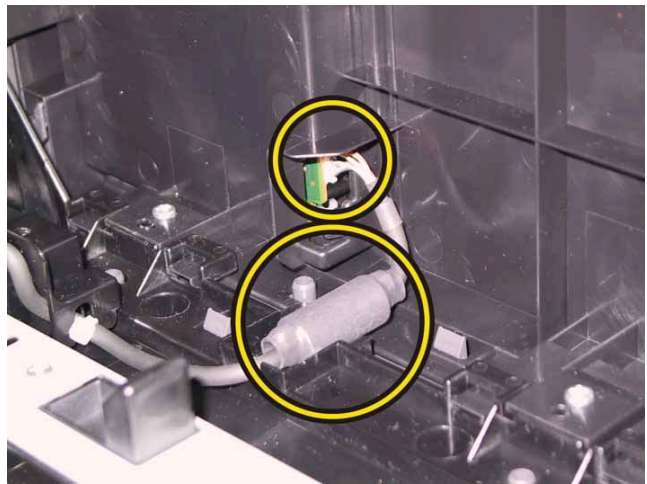

7) Attach the COVER CONNECTOR to the COVER ASSY FRONT MG.



8) Secure the two hooks of the COVER CONNECTOR to the COVER ASSY FRONT MG.

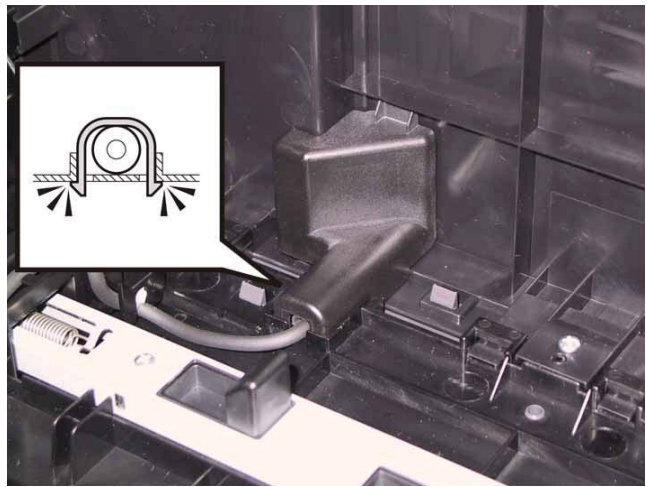

Go to the next replacement step:
Replacement 30 COVER ASSY FRONT MG (PL1.2.1)

Replacement 30 COVER ASSY FRONT MG (PL1.2.1)

Accesses Position (All the numbers show the procedure number.)

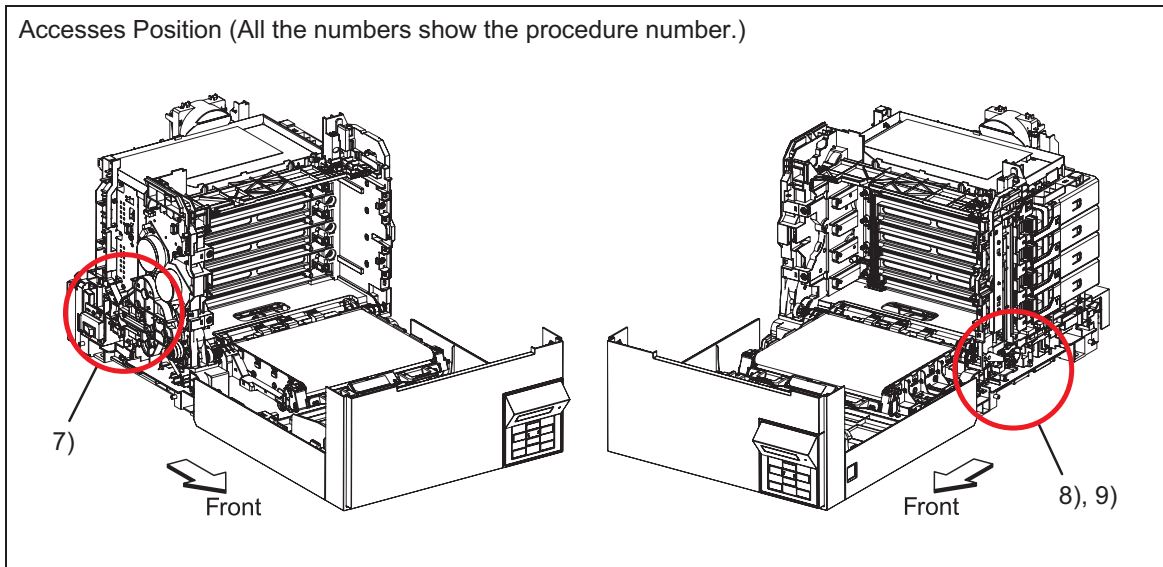

1) Lift the COVER ASSY FRONT MG slightly up to attach it to the printer.

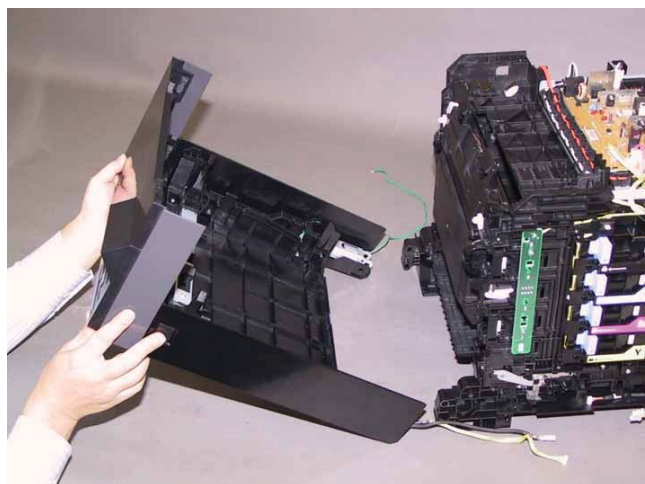

Note: Described below is the replacement procedure common among the left and right sides of the SHAFT PIVOTS (PL1.2.23).

2) Mate the flat face of the SHAFT PIVOT with the hole of the COVER ASSY FRONT MG, push the SHAFT PIVOT until the hook is locked.

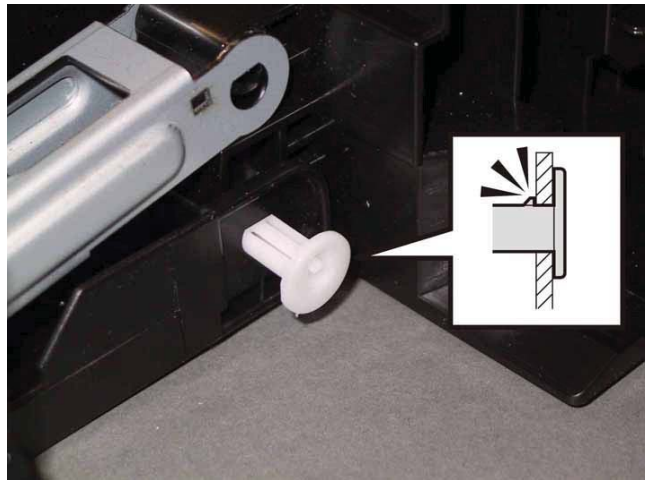

Note: Described below is the replacement procedure common among the left and right sides of the SHAFT LINK FRONT FDRs (PL1.2.26).

3) Mate the flat face of the SHAFT LINK FRONT FDR with the hole of the COVER ASSY FRONT MG, push the SHAFT LINK FRONT FDR until the hook is locked.

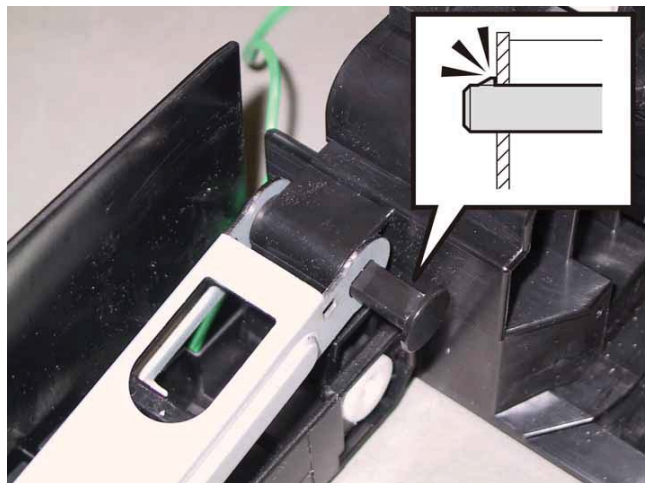

Note: Described below is the replacement procedure common among the left and right SPRING LINK FRONTs (PL1.2.24).

4) Lift the COVER ASSY FRONT MG slightly up to insert the SPRING LINK FRONT into the LINK ASSY FRONT.

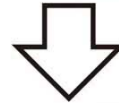
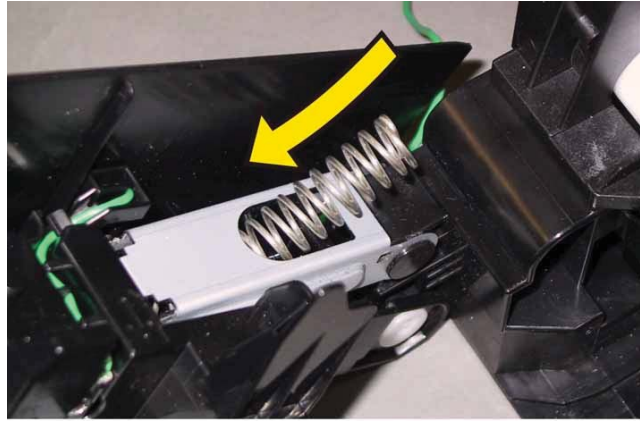

Note: Described below is the replacement procedure common among the left and right COVER LINK FRONTS (PL1.2.30).

5) Attach the COVER LINK FRONT to the LINK ASSY FRONT.

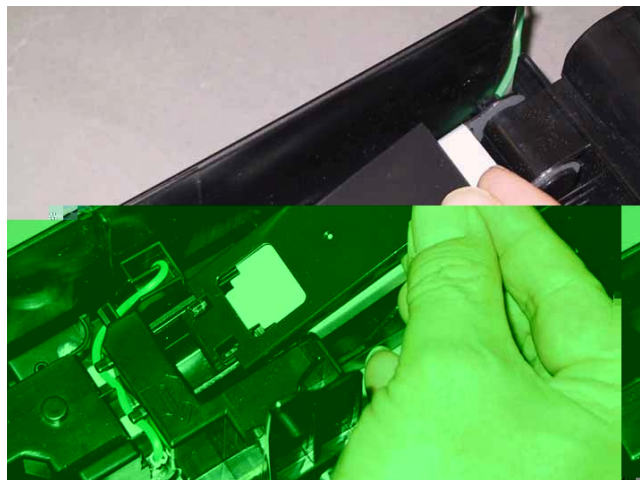

6) Secure the two hooks of the COVER LINK FRONT to the LINK ASSY FRONT.

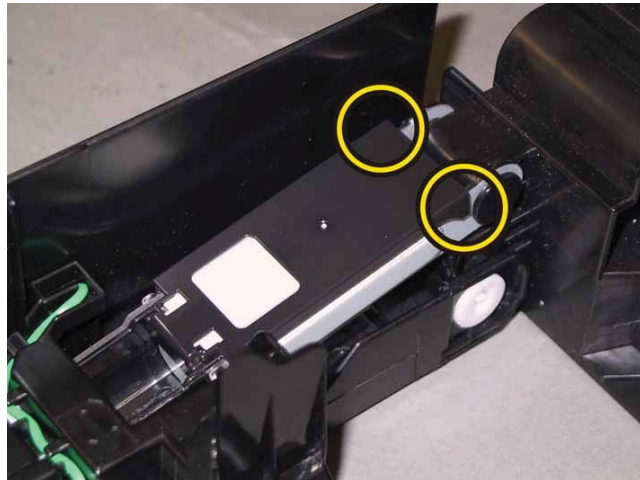

7) Route the HARN ASSY GND along the GUIDE HARNESS AC, secure the grounding terminal of the HARN ASSY GND with the one screw (silver, 6mm).
Note: This step is only 2150cdn.

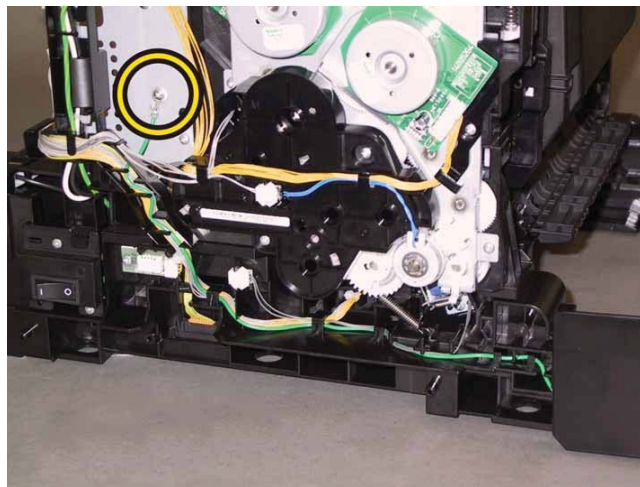

8) Route the HARN ASSY DUP RELAY and the HARNESS ASSY PNL A through the hooks of the printer.

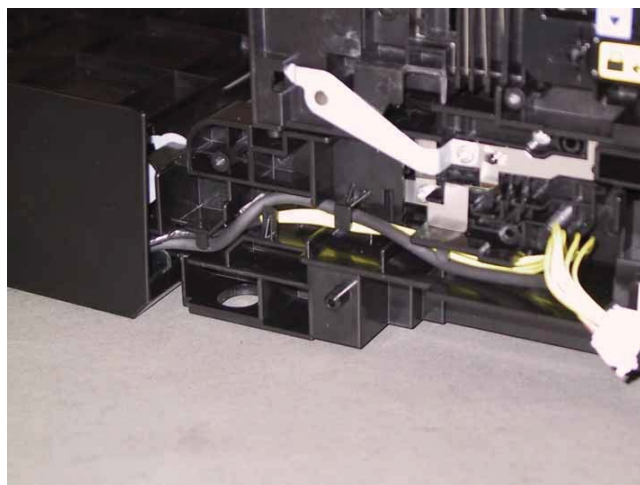

9) Engage the connector (P/J5301) of the HARNESS ASSY PNL A and engage the connector (P/J271) of the HARN ASSY DUP RELAY. Secure the two connectors to the printer.

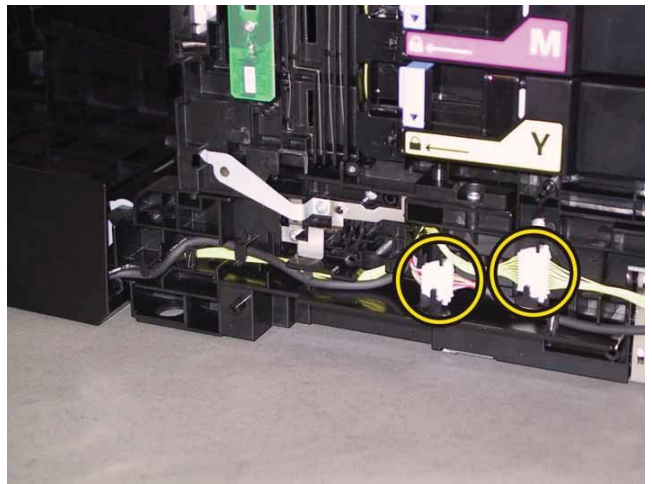

**Go to the next replacement step:
Replacement 38 COVER SIDE L (PL1.1.19)**

Replacement 31 KIT SHAFT PIVOT (PL1.2.98)

Note: Described below is the replacement procedure common among the left and right sides of the SHAFT PIVOTS (PL1.2.23).

1) Mate the flat face of the SHAFT PIVOT with the hole of the COVER ASSY FRONT MG, push the SHAFT PIVOT until the hook is locked.

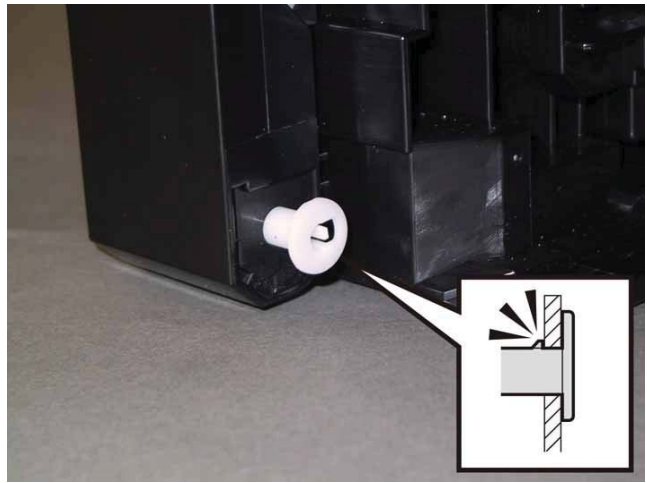

Go to the next replacement step:

Replacement 53 CASSETTE ASSY 250 (PL2.1.1)

Replacement 32 ACTUATOR SSI (PL3.2.14)

1) Attach the SPRING ACT SSI to the ACTUATOR SSI.

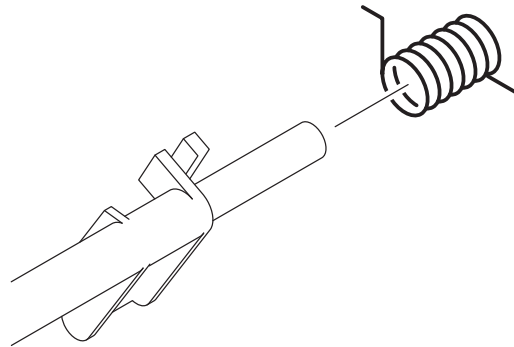

Note: When carrying out the work described next procedure, ensure that the SPRING ACT SSI is hung to ACTUATOR SSI and the CHUTE UP correctly.

SPRING ACT SSI

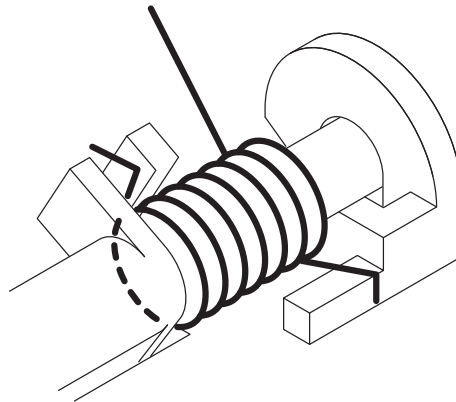

2) Insert the right shaft of the ACTUATOR SSI into the hole of the CHUTE UP, hang the SPRING ACT SSI to the CUHTE UP.

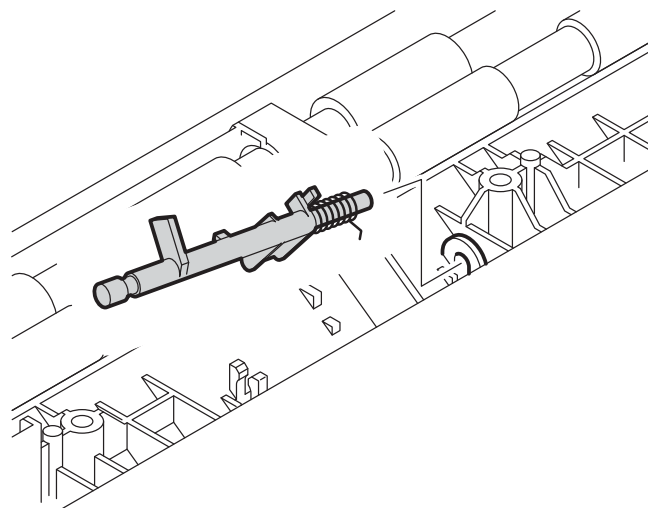

3) Secure the left shaft of the ACTUATOR SSI with the hook of the CHUTE UP, attach the ACTUATOR SSI.

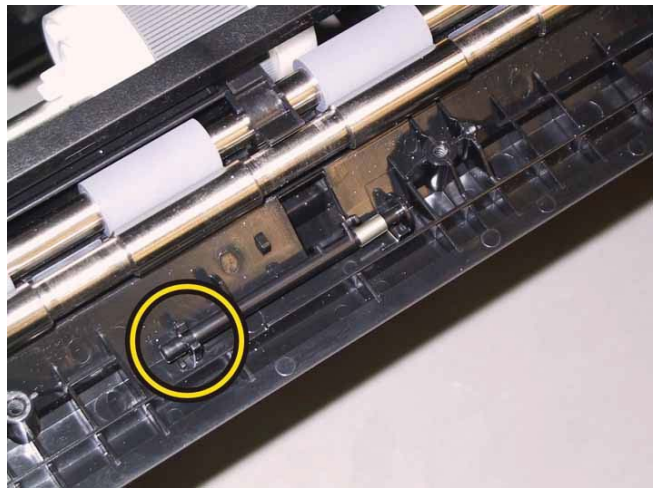

Check the ACTUATOR SSI movement, after the procedure 3 is completed.

4) Mate the five tabs of the BRACKET SNS with the printer.

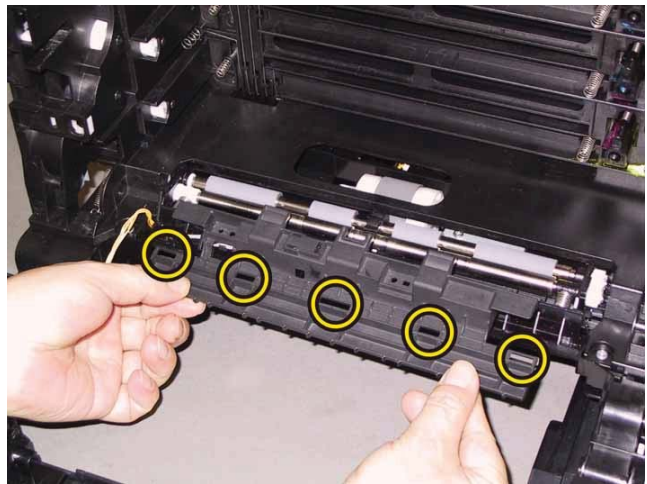

5) Mate the two holes of the BRACKET SNS with the bosses of the printer.

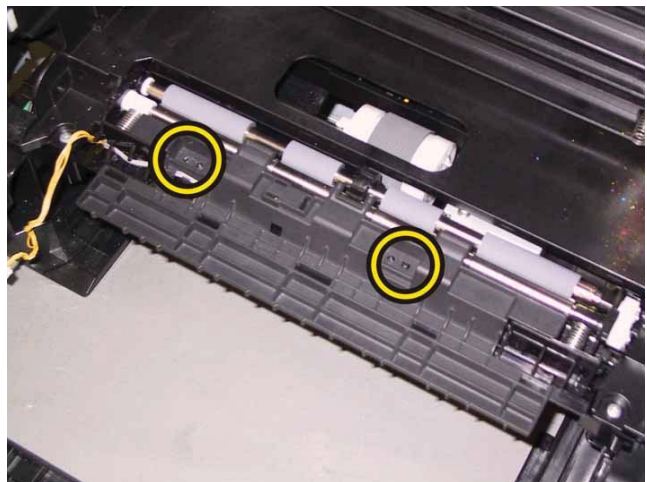

6) Route the harness of the BRACKET SNS through the hooks of the printer.

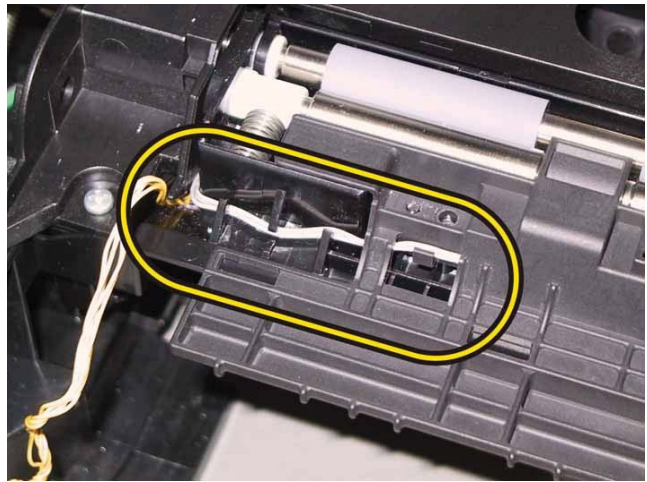

7) Secure the BRACKET SNS to the printer with the two screws (silver, tap, 8mm).

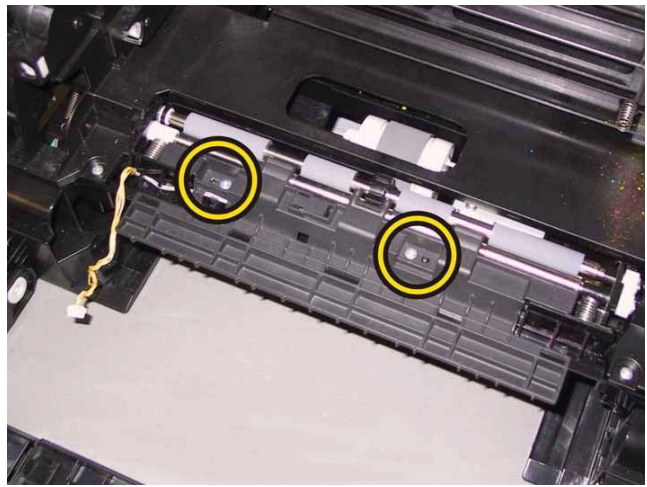

**Go to the next replacement step:
Replacement 34 KIT TRANSFER ASSY (PL6.1.98)**

Replacement 33 SENSOR PHOTO: SSI NO PAPER (PL3.2.13)

1) Engage the connector (P/J233) of the SENSOR PHOTO: SSI NO PAPER.

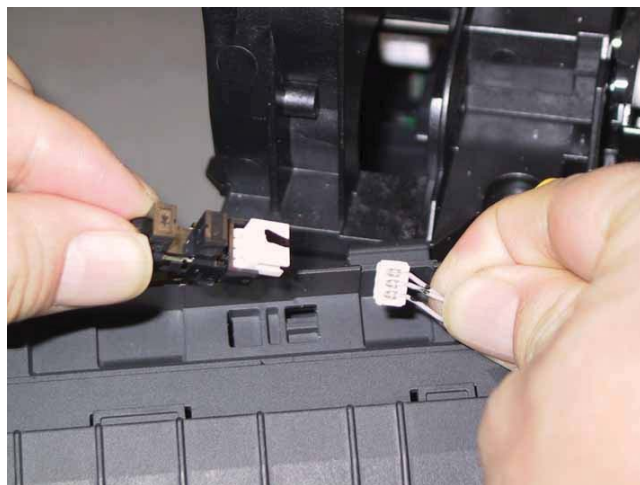

2) Replace the SENSOR PHOTO: SSI NO PAPER to the BRACKET SNS by mating the hook of the SENSOR PHOTO: SSI NO PAPER with its mounting position.

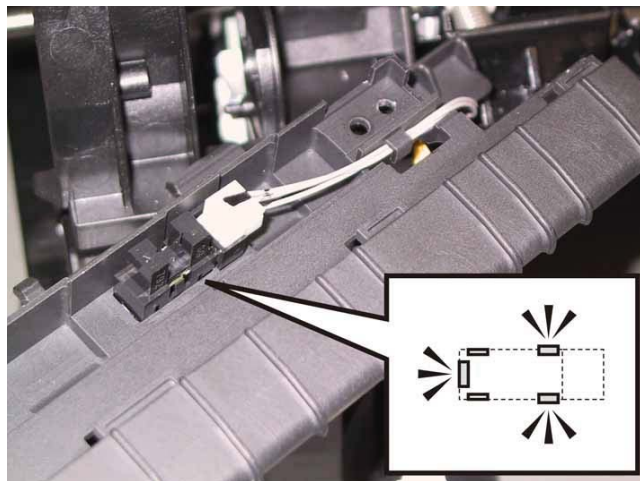

3) Mate the five tabs of the BRACKET SNS with the printer.

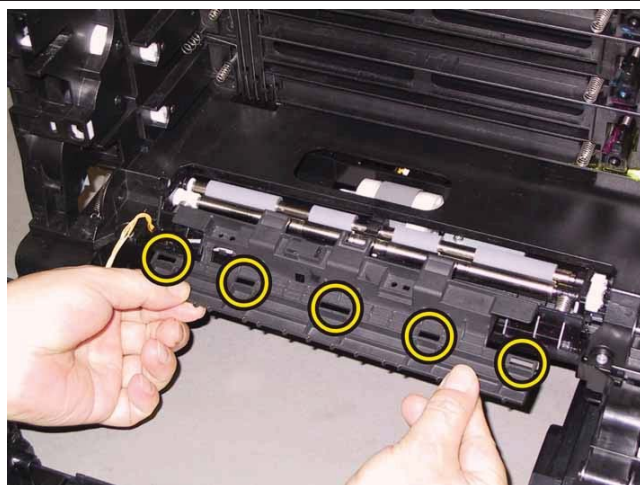

4) Mate the two holes of the BRACKET SNS with the bosses of the printer.

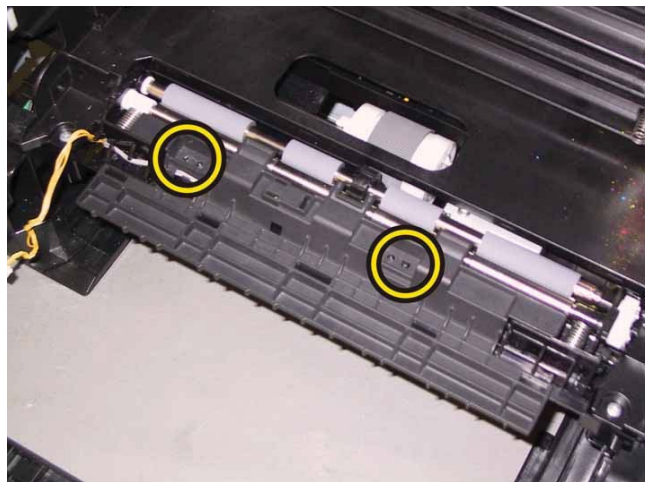

5) Route the harness of the BRACKET SNS through the hooks of the printer.

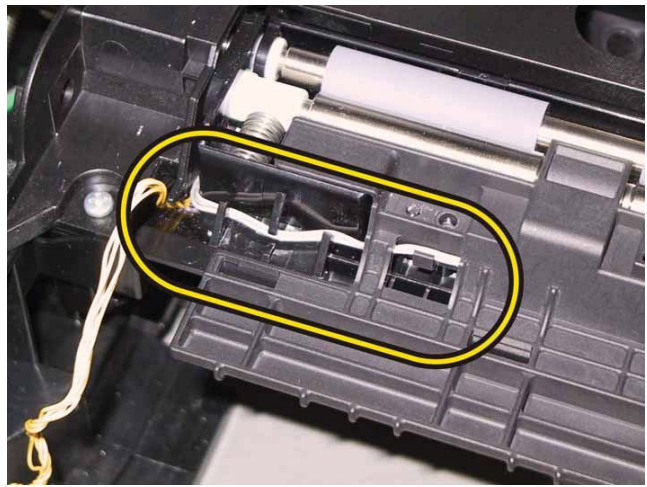

6) Secure the BRACKET SNS to the printer with the two screws (silver, tap, 8mm).

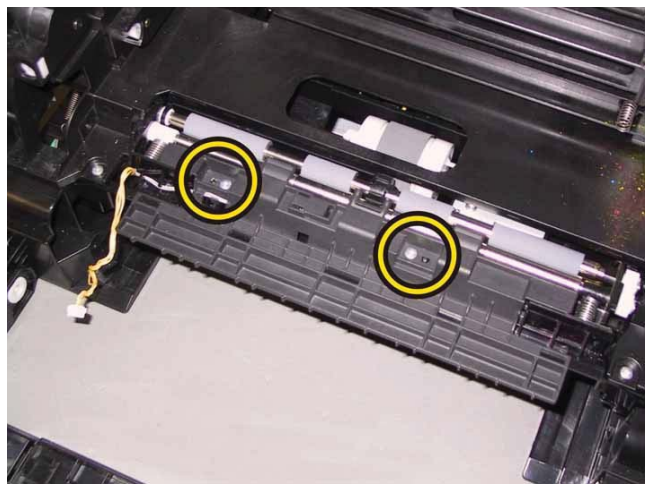

Go to the next replacement step:

Replacement 34 KIT TRANSFER ASSY (PL6.1.98)

Replacement 34 KIT TRANSFER ASSY (PL6.1.98)

1) Attach the TRANSFER ASSY to the printer.

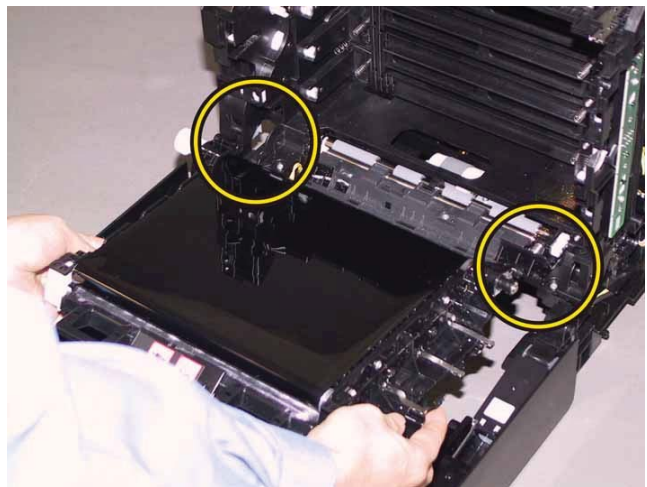

2) Replacement the KIT PIVOT. (Replacement 35)

3) Close the TRANSFER ASSY.

Note: When carrying out the work described next procedure, take care not to scratch the belt surface of the TRANSFER ASSY.

4) Route the harness of the printer through the hooks of the TRANSFER ASSY.

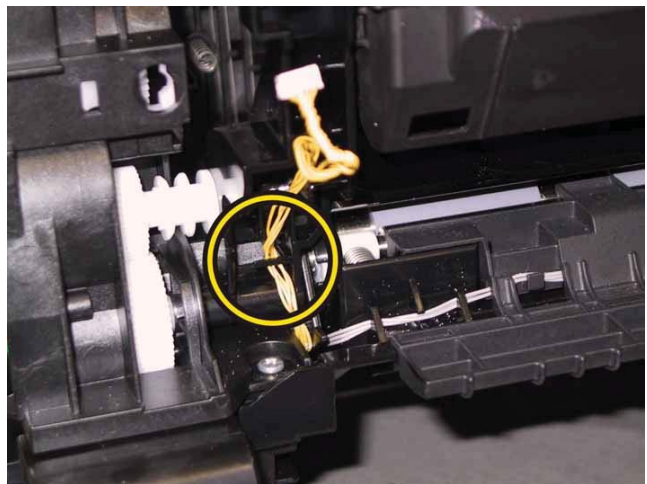

5) Engage the connector (P/J281) of the TRANSFER ASSY, secure the relay connector with the pegs of the TRANSFER ASSY.

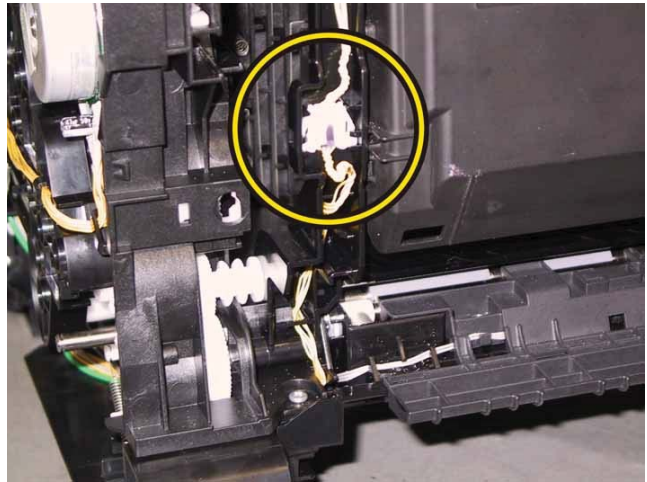

5) Attach the COVER HARNESS to the TRANSFER ASSY.



**Go to the next replacement step:
Replacement 38 COVER SIDE L (PL1.1.19)**

Replacement 35 KIT PIVOT (PL6.1.99)

Accesses Position (All the numbers show the procedure number.)

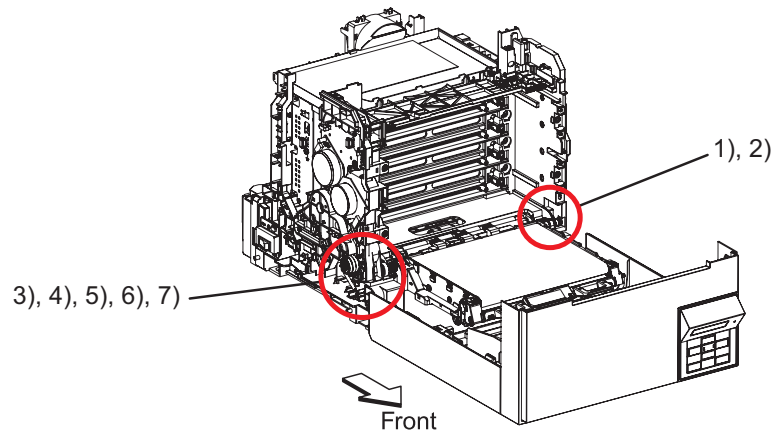

1) Mate the hole of the TRANSFER ASSY with the hole of the printer frame, attach the SHAFT ASSY PIVOT.



2) Secure the SHAFT ASSY PIVOT to the printer with the one screw (silver, tap, 8mm).

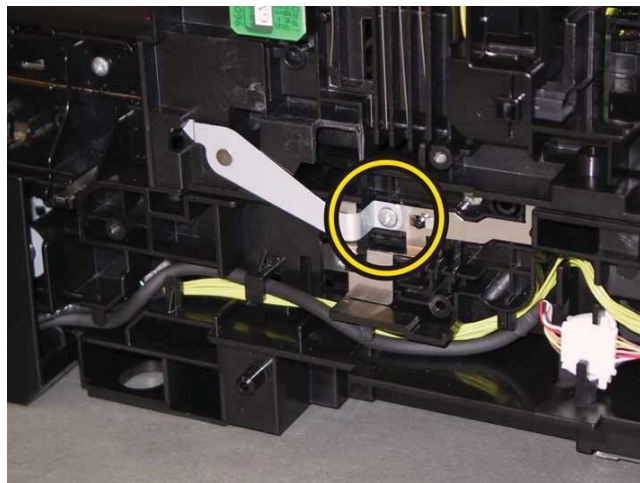

Note: When carrying out the work described next procedure, make sure that the position of the GEAR T4 is correctly.

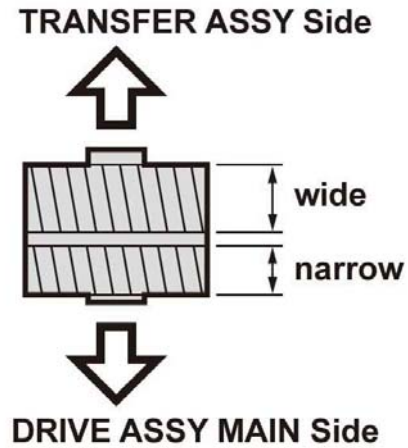

Note: When carrying out the work described next procedure, keep the TRANSFER ASSY slightly lifted for ease of work.

3) Attach the GEAR T4 to the printer, align the holes of the GEAR T4, the printer frame, and the TRANSFER ASSY, and then insert the PIVOT TRANS L.

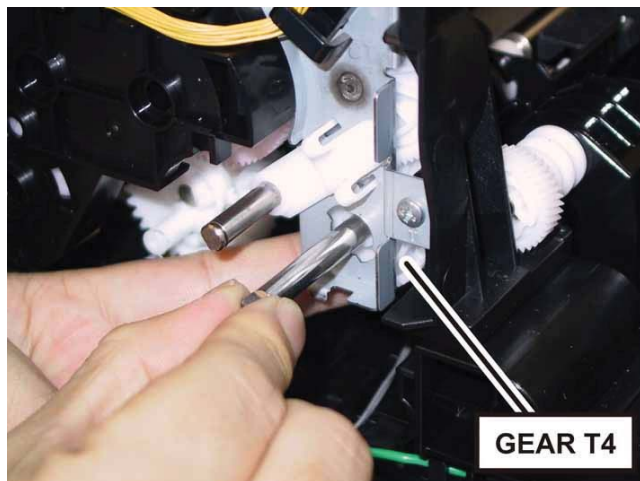

Note: When carrying out the work described next procedure, ensure that the flat face of the PIVOT TRANS L is oriented to the direction shown in the right.



4) Mate the tab of the STOPPER PIVOT with the notch of the DRIVE ASSY MAIN, attach the STOPPER PIVOT to the PIVOT TRANS L.

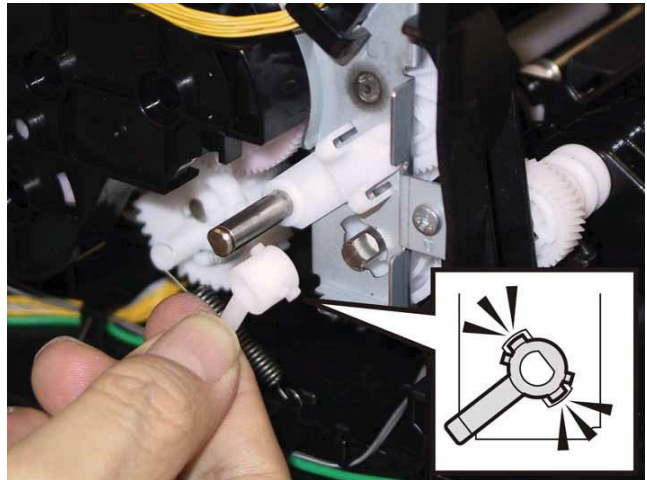

5) Rotate the STOPPER PIVOT to the left, secure the STOPPER PIVOT to the DRIVE ASSY MAIN frame.

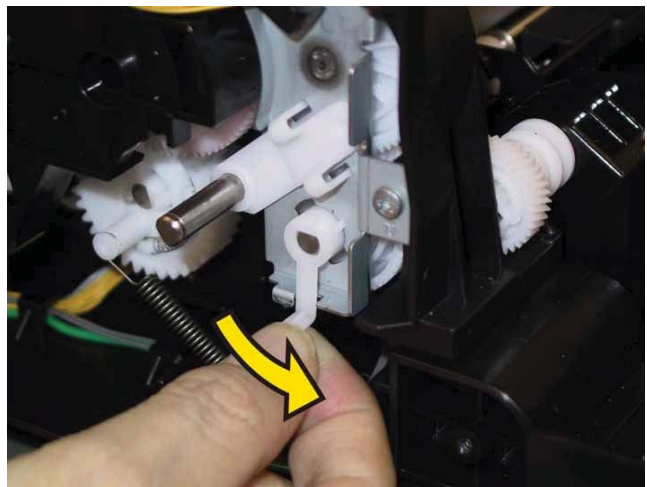

6) Mate the notch of the CLUTCH ASSY DRV with the rib of the DRIVE ASSY PH, secure the CLUTCH ASSY DRV to the ROLL ASSY REG1 with the E-ring by using a pliers.

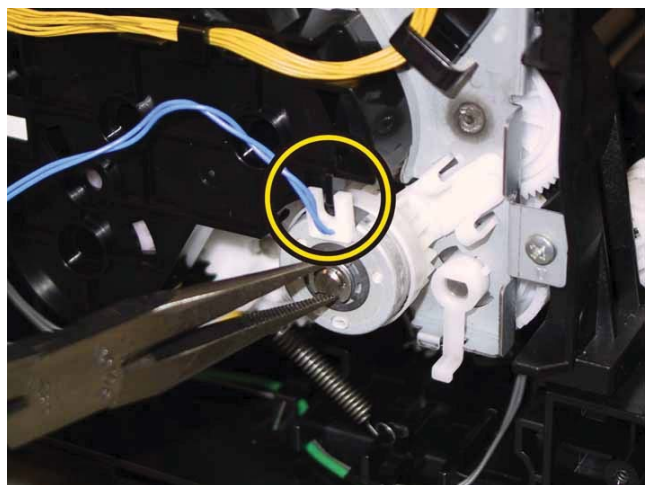

7) Route the harness of the CLUTCH ASSY DRV through the hook of the DRIVE ASSY PH.

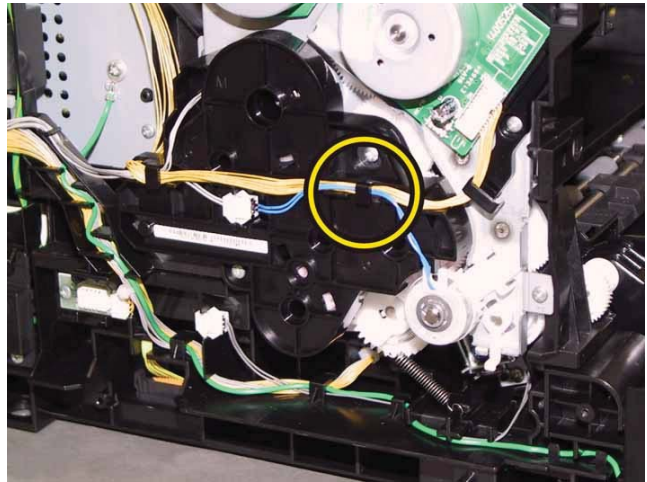

**Go to the next replacement step:
Replacement 38 COVER SIDE L (PL1.1.19)**

Replacement 36 SENSOR HUM (PL8.2.7)

1) Engage the connector (P/J201) of the SENSOR HUM.

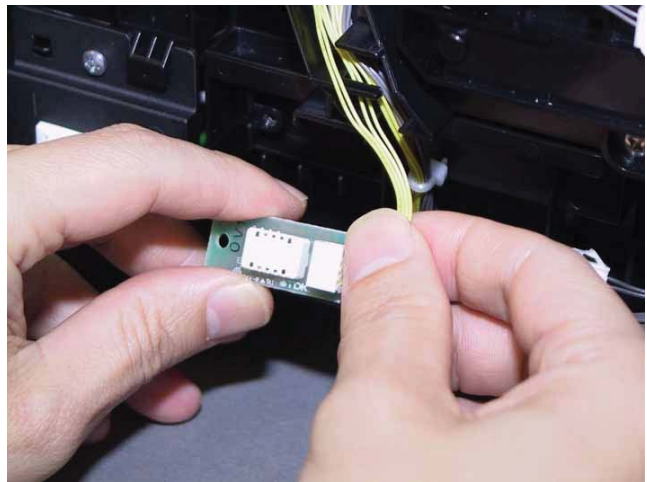

2) Secure the SENSOR HUM to the printer with the one screw (silver, tap, 8mm).

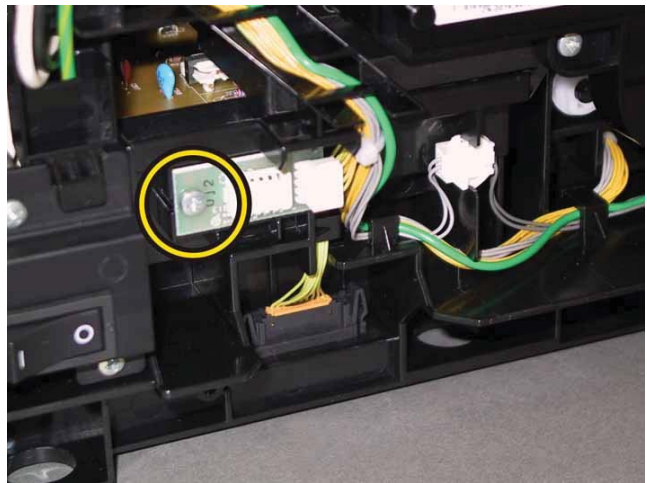

Go to the next replacement step:

Replacement 38 COVER SIDE L (PL1.1.19)

Replacement 37 HARN ASSY INTERLOCK (PL8.2.5)

1) Mate the hole of the switch with the boss of the printer, secure the switch with the one screw (silver, tap, 16mm).

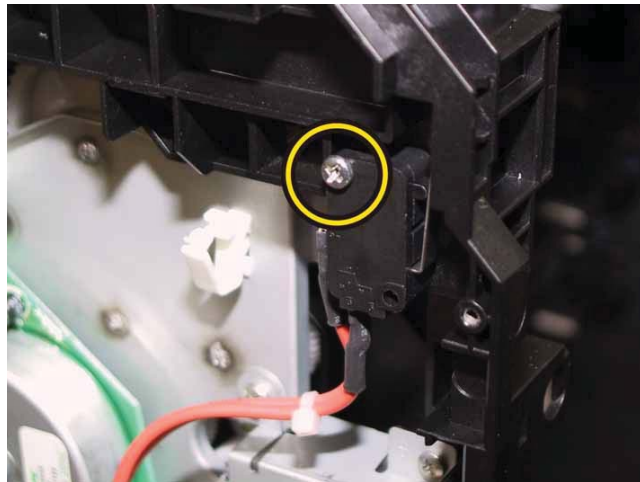

2) Secure the harness of the HARN ASSY INTERLOCK with the clamps.

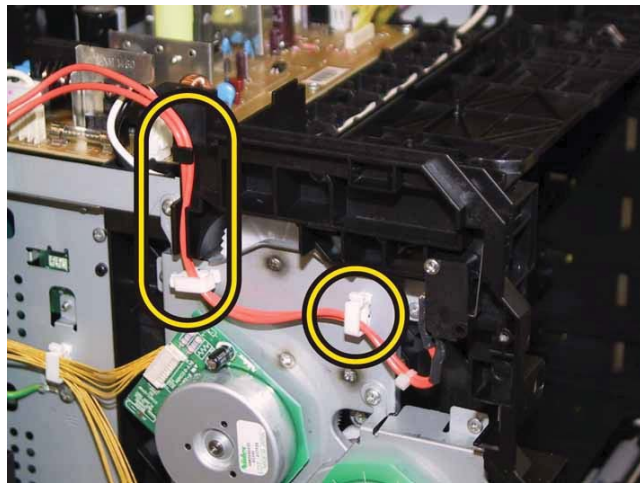

Note: Ensure that the harnesses of the HARN ASSY INTERLOCK and HARNESS ASSY FUSER MG SFP are kept apart so that they do not contact each other.

3) Route the harness of the HARN ASSY INTERLOCK along the GUIDE HARNESS FSR, engage the connector (P/J44) of the HARN ASSY INTERLOCK to the PWBA LVPS.

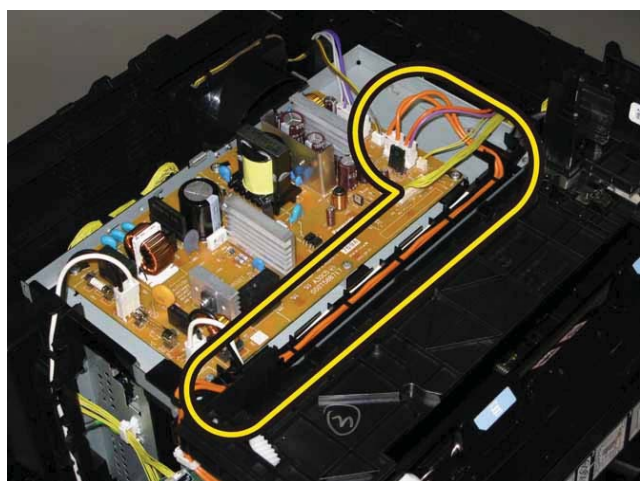

Go to the next replacement step:

Replacement 38 COVER SIDE L (PL1.1.19)

Replacement 38 COVER SIDE L (PL1.1.19)

Accesses Position (The 2) shows the procedure number.)

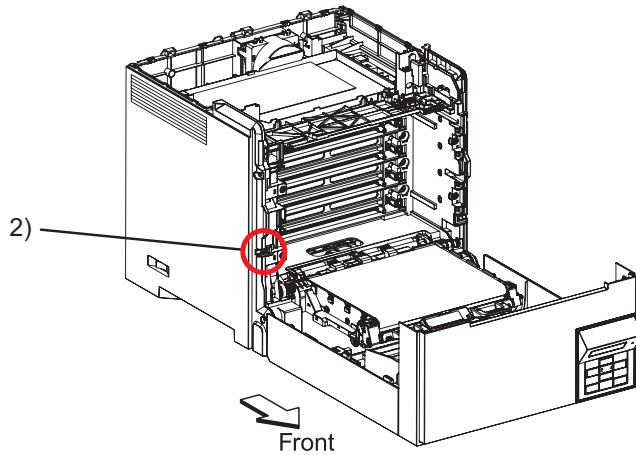

1) Insert the inside hooks of the COVER SIDE L into the hole of the COVER REAR, attach the COVER SIDE L to the printer.



2) Secure the front hook of the COVER SIDE L to the printer.

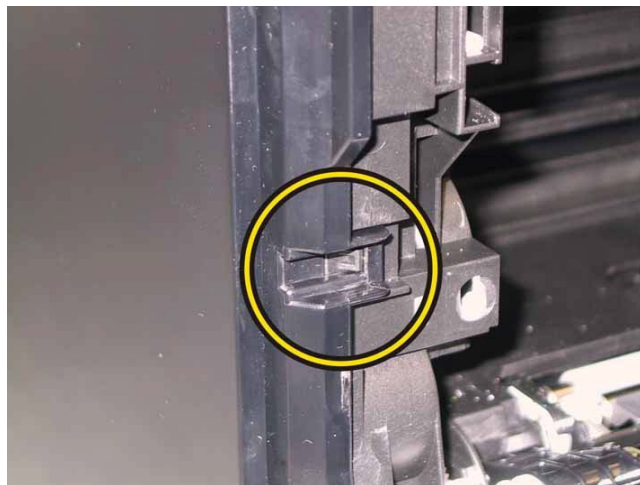

3) Secure the COVER SIDE L to the printer with the two screws (silver, tap, 8mm).

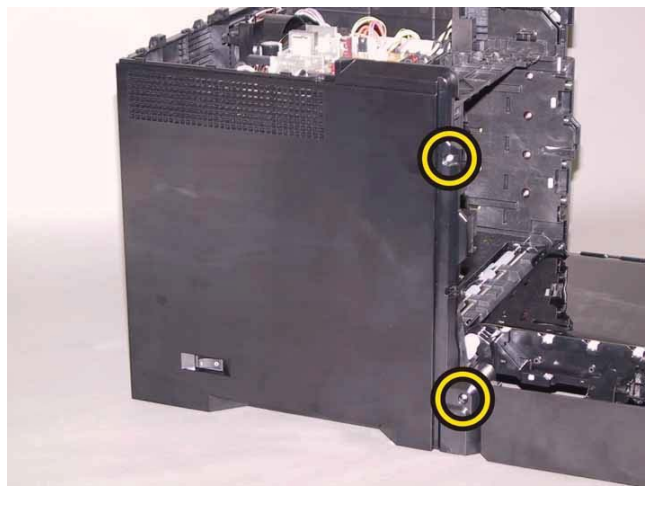

**Go to the next replacement step:
Replacement 44 COVER ASSY TOP (PL1.1.1)**

Replacement 39 KIT BLOCK PHD RIGHT (PL4.1.97)

Accesses Position (The 1), 2) and 3) show the procedure number.)

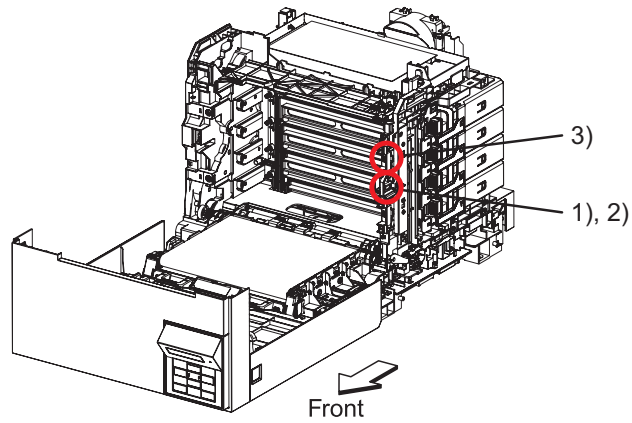

1) Tilt the LEVER PHD slightly, attach the LEVER PHD to the printer.

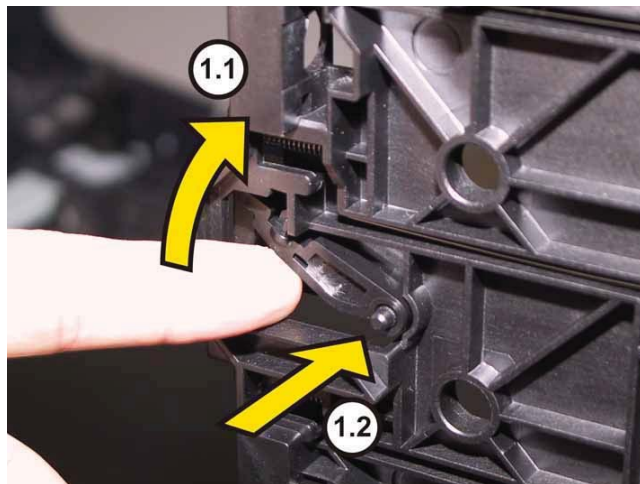

2) Attach the SPRING PHD to the printer.



Note: Described below is the replacement procedure common among the upper and lower of the **BLOCK STOPPER PHD ADs**.

3) Push the BLOCK STOPPER PHD AD to the printer until it is locked.

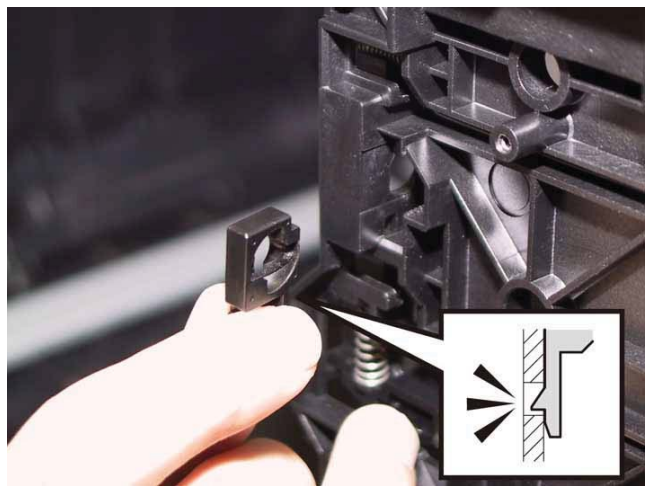

Go to the next replacement step:
Replacement 40 LED ASSY ERASE (PL4.1.8)

Replacement 40 LED ASSY ERASE (PL4.1.8)

1) Engage the connector (P/J141) of the LED ASSY ERASE.

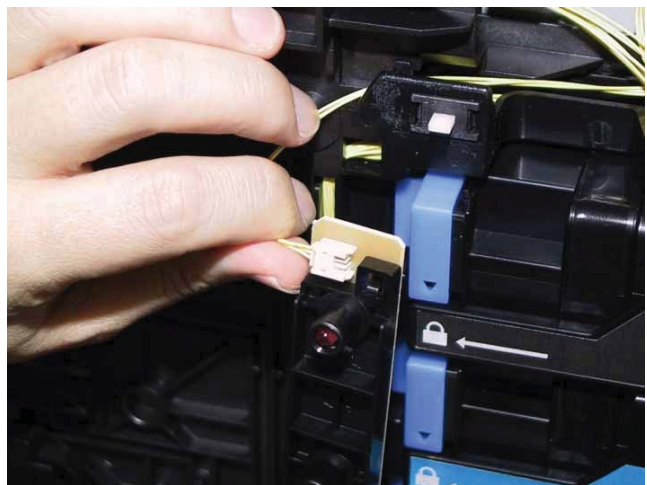

2) Attach the LED ASSY ERASE to the printer.

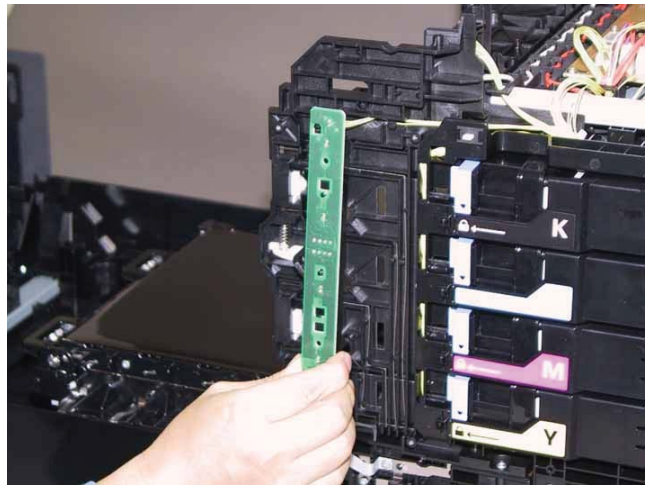

3) Secure the LED ASSY ERASE to the printer with two screws (silver, tap, 8mm).

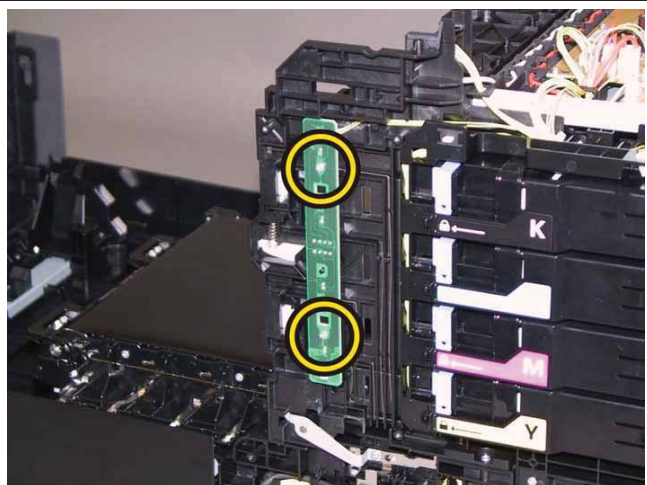

Go to the next replacement step:
Replacement 42 COVER SIDE R (PL1.1.6)

Replacement 41 SWITCH (PL5.1.9)

1) Engage the connector (P/J291) of the SWITCH.



2) Attach the SWITCH to the printer, secure the SWITCH with the two hooks.

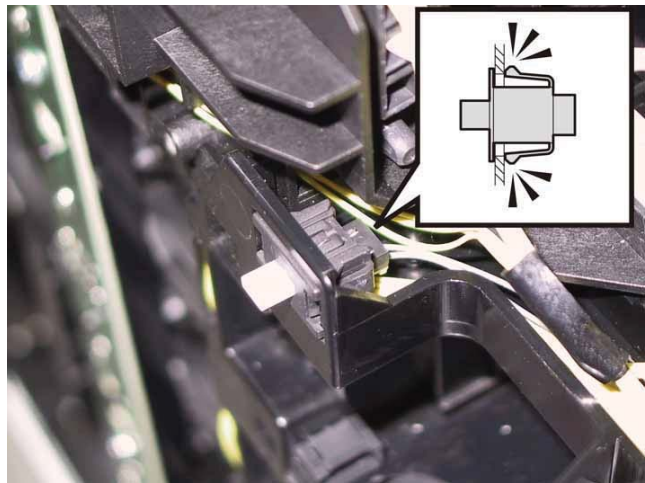

**Go to the next replacement step:
Replacement 42 COVER SIDE R (PL1.1.6)**

Replacement 42 COVER SIDE R (PL1.1.6)

Accesses Position (The 2) shows the procedure number.)

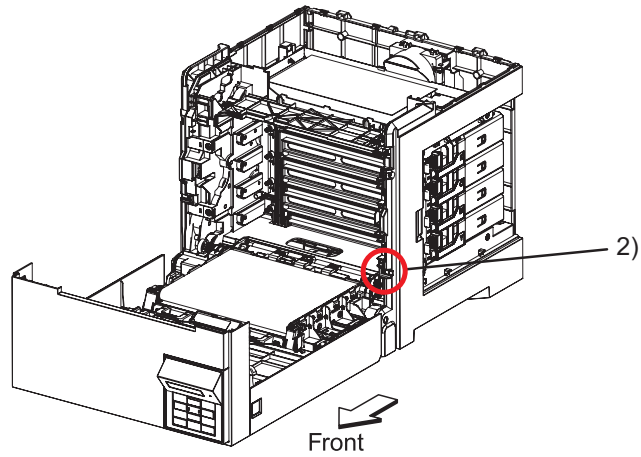

1) Insert the inside hooks of the COVER SIDE R into the hole of the COVER REAR, attach the COVER SIDE R to the printer.

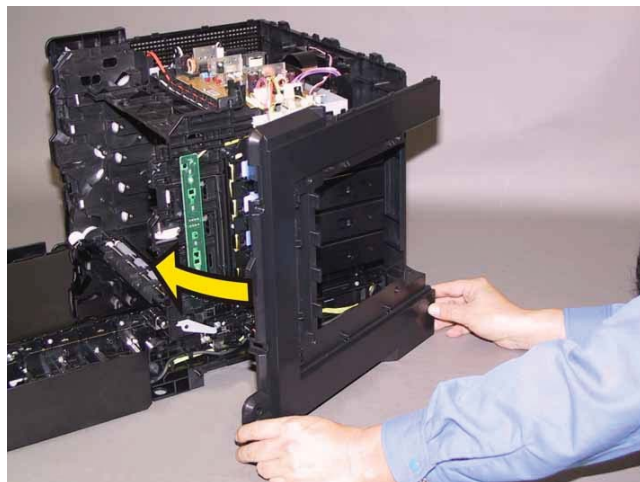

2) Secure the front hook of the COVER SIDE R to the printer.

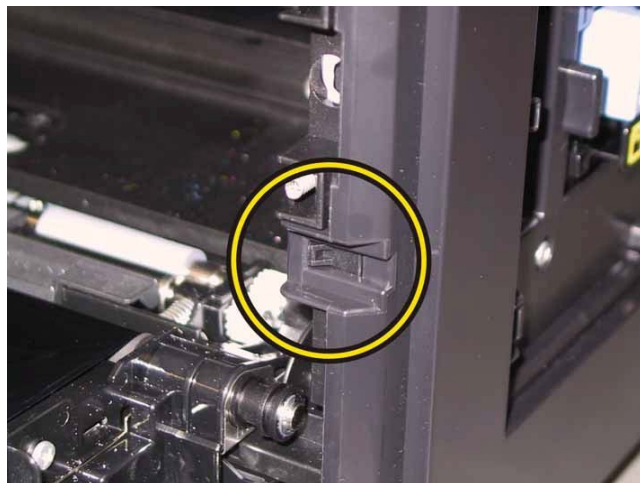

3) Secure the COVER SIDE R to the printer with the six screws (silver, tap, 8mm).



Go to the next replacement step:

Replacement 46 KIT COVER ASSY WINDOW TNR (PL1.1.99)

Replacement 43 PWBA LVPS (PL8.2.1)

1) Attach the PWBA LVPS to the printer.

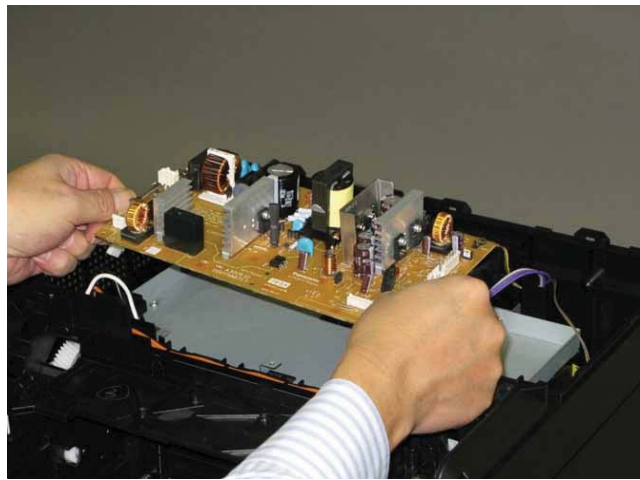

2) Secure the PWBA LVPS to the printer with the six screws (silver, 6mm).



3) Engage all the connectors of the PWBA LVPS.



Go to the next replacement step:

Replacement 44 COVER ASSY TOP (PL1.1.1)

Replacement 44 COVER ASSY TOP (PL1.1.1)

1) Mate the hooks of the COVER TOP with the notch of the COVER REAR.



2) Mate the two holes of the COVER TOP with the pegs of the printer by pulling down the COVER TOP.

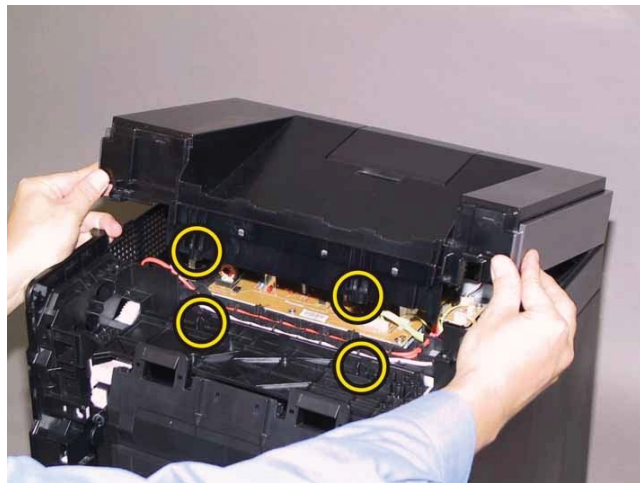

3) Secure the COVER TOP to the printer with the two screws (silver, tap, 8mm).

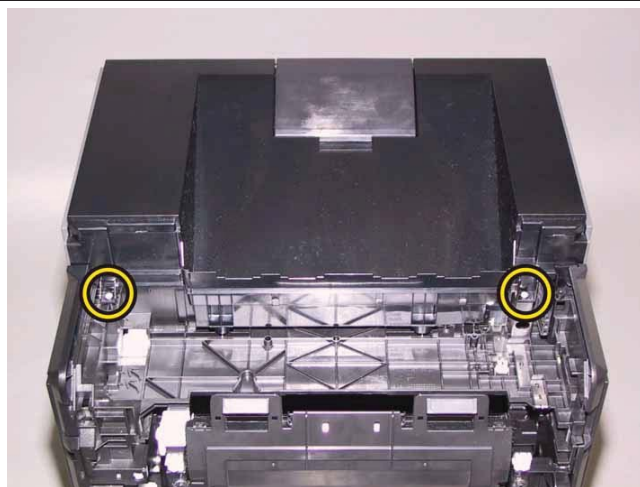

**Go to the next replacement step:
Replacement 49 FUSER ASSY (PL6.1.1)**

Replacement 45 KIT ROLL ASSY FEED (PL3.2.99)

1) Close the COVER ASSY FRONT MG.

2) Fit the ROLL ASSY FEED to the SHAFT ASSY FEED with the groove of the ROLL ASSY FEED facing upward, rotate the ROLL ASSY FEED 180 degrees so that the pin on the SHAFT ASSY FEED is aligned with the groove on the ROLL ASSY FEED.

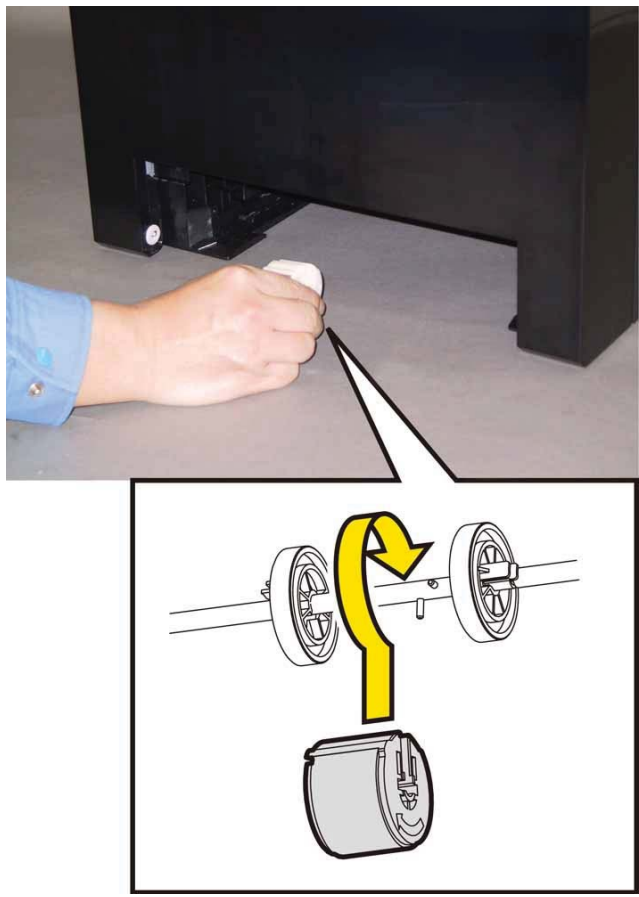

3) Open the COVER ASSY FRONT MG.

4) Move the ROLL ASSY FEED to the right side, put the groove of the ROLL ASSY FEED on the pin of the SHAFT ASSY FEED.

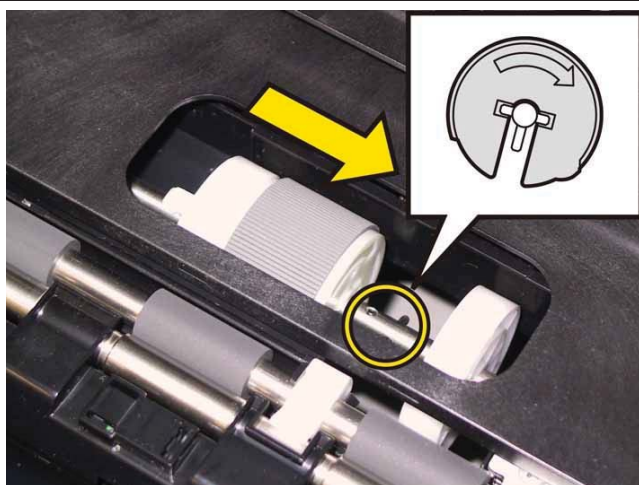

5) Move the ROLL CORE MSI to the right side, to secure the hook of the ROLL CORE MSI with the groove of the SHAFT ASSY FEED.

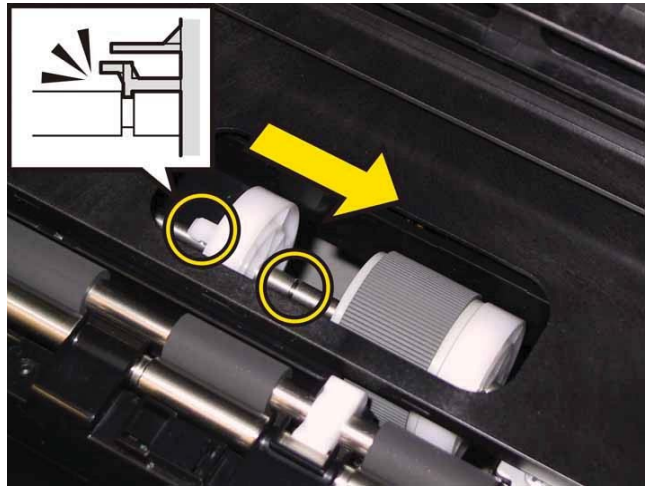

**Go to the next replacement step:
Replacement 50 PHD ASSY (PL4.1.21)**

Replacement 46 KIT COVER ASSY WINDOW TNR (PL1.1.99)

1) Mate the lower boss of the COVER ASSY WINDOW TNR with the hole of the COVER REAR.

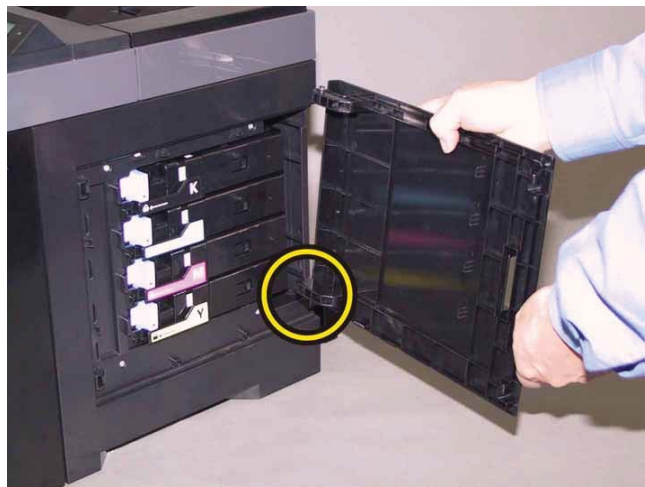

2) Bend the upper hinge of the COVER ASSY WINDOW TNR, mate the upper boss of the COVER ASSY WINDOW TNR with the hole of the COVER REAR. Attach the COVER ASSY WINDOW TNR.



3) Close the COVER ASSY WINDOW TNR.



Replacement 47 TRAY EXT (PL1.1.2)

1) Mate the boss of the TRAY EXT with the hole of the COVER ASSY TOP.

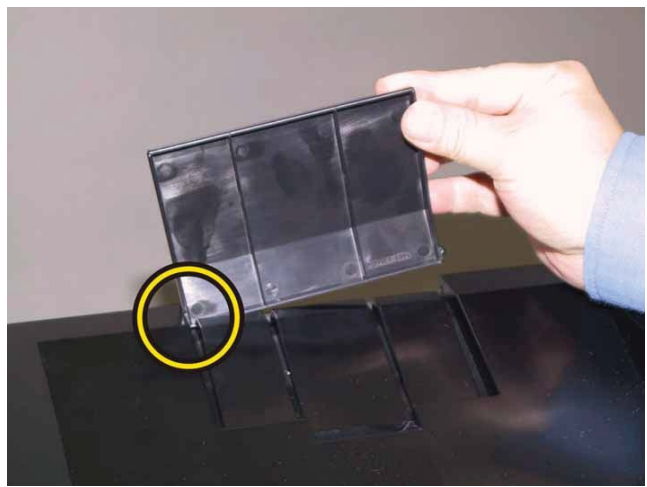

2) Mate the other boss of the TRAY EXT with the hole of the COVER ASSY TOP.

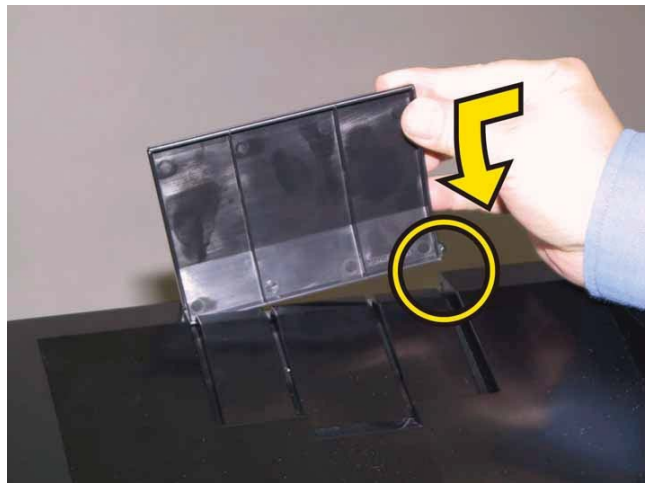

3) Close the TRAY EXT.



Replacement 48 TONER CARTRIDGE (K), (C), (M), (Y) (PL5.1.21~24)

Note: Described below is the replacement procedure common among the four TONER CARTRIDGES.

1) Shake the TONER CARTRIDGE five or six times for the distributing toner evenly.



2) Insert the TONER CARTRIDGE into the HOLDER ASSY TCRU slowly, attach it.



Note: Check that the TONER CARTRIDGE is secured.

3) Close the HOLDER ASSY TCRU.



Note: When performing the step described next procedure, mate the delta mark of the Handle with the lock mark on the cartridge holder.

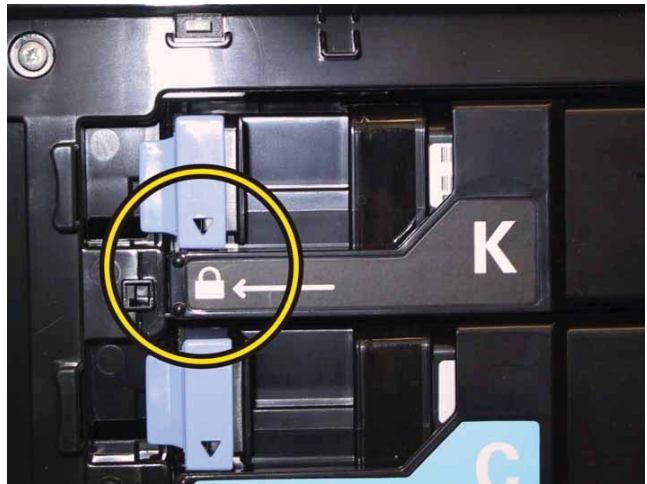

4) Move the handle to the front.



5) Close the COVER ASSY WINDOW TNR.

Replacement 49 FUSER ASSY (PL6.1.1)

1) Insert the two studs of the FUSER ASSY into the holes of the printer.

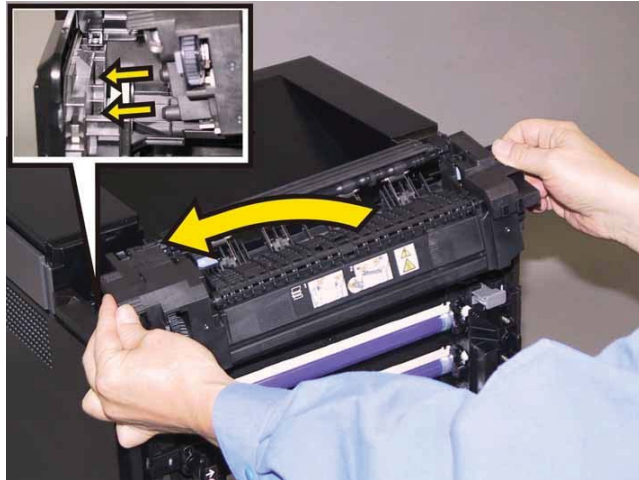

2) Engage the connector (P/J171) of the FUSER ASSY by pushing the FUSER ASSY.



3) Secure the FUSER ASSY to the printer with the one screw (silver, with flange, tap, 10mm).



3) Close the TRANSFER ASSY.

4) Close the COVER ASSY FRONT MG.

Note: When the FUSER ASSY is replaced with a new one, perform the following steps.

- 5) Plug in the power cord to the printer.
- 6) Initialize the Life Counter of the FUSER ASSY.
- 7) Turn off the power.
- 8) Turn on the power while pressing the "▲" key and "▼" key on the control panel.
- 9) Press the "▼" key several times until "Parameter" is displayed. Press the " ✓ " key once.
- 10) Press the "▼" key several times until "Life Fuser Sheet" is displayed. Press the " ✓ " key once.
- 11) Press the "▼" key several times until "Initializing" is displayed. Press the " ✓ " key once.
- 12) Press the " ✓ " key once, and Initializing the Life Counter of the FUSER ASSY is performed.
- 13) Turn off the power to exit.

Replacement 50 PHD ASSY (PL4.1.21)

1) Put the paper on the TRANSFER ASSY (PL6.1.7) to protect the belt.

Note: When carrying out the work this procedure, take care not to cover the left and right of the belt guards with the paper.

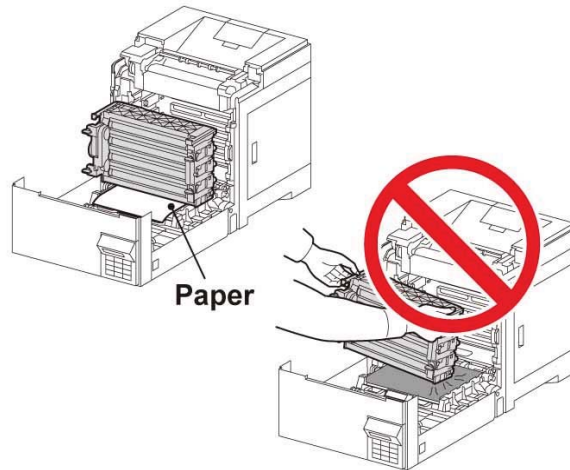

2) Mate the left and right arrows on the Handle of the PHD ASSY with the guides of the printer.



3) Push the PHD ASSY into the printer until it is stopped.



Note: Check that the PHD ASSY is secured.

4) Rotate the four Stoppers of the PHD ASSY to clockwise.

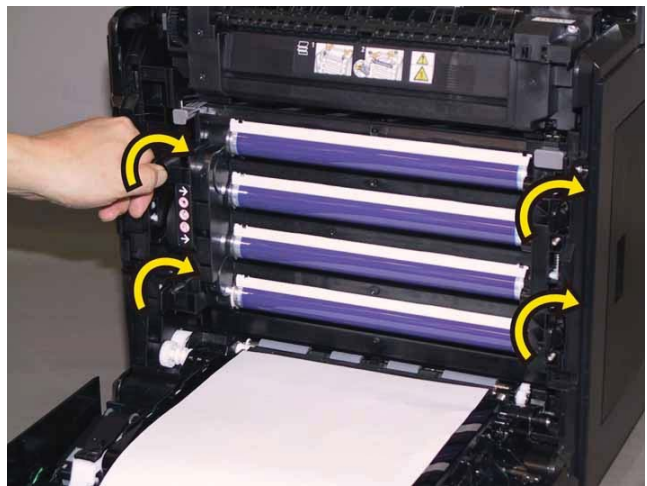

5) Remove the paper from the TRANSFER ASSY.

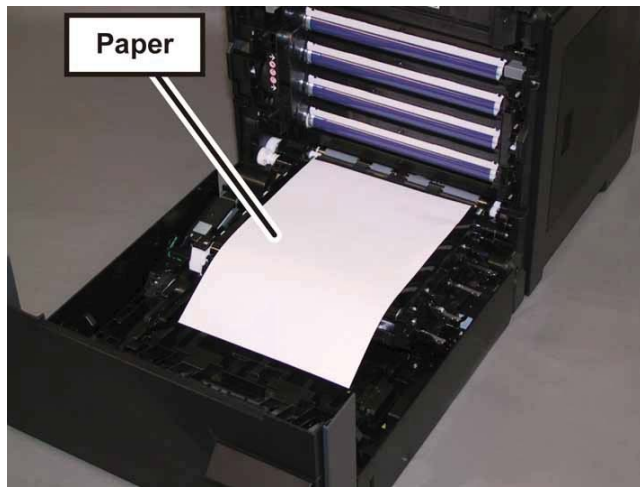

6) Close the TRANSFER ASSY.



7) Close the COVER ASSY FRONT MG.

8) Insert the CASSETTE ASSY 250 into the printer.

Replacement 51 HANDLE ASSY CST (PL2.1.19)

1) Mate the right side holes of the HANDLE ASSY CST with the bosses of the CASSETTE ASSY 250.



2) Mate the left side holes of the HANDLE ASSY CST with the bosses of the CASSETTE ASSY 250, attach the HANDLE ASSY CST.

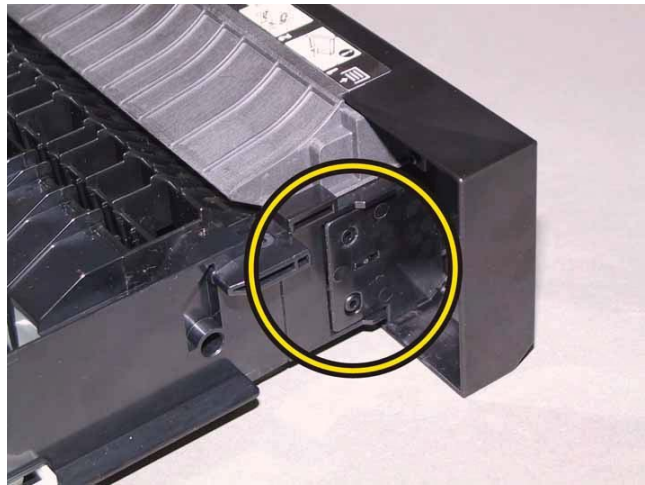

Go to the next replacement step:

Replacement 53 CASSETTE ASSY 250 (PL2.1.1)

Replacement 52 KIT HOLDER ASSY SEPARATOR (PL2.1.99)

1) Mate the under tab of the HOLDER ASSY SEPARATOR with the hole of the CASSETTE ASSY 250.

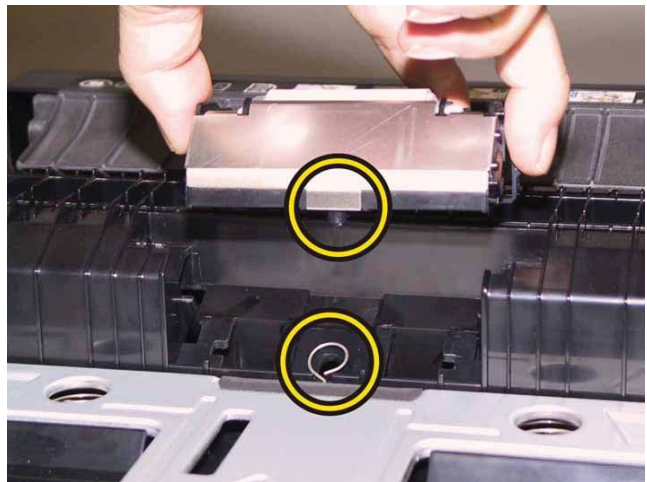

2) Secure the left and right hooks of the HOLDER ASSY SEPARATOR.

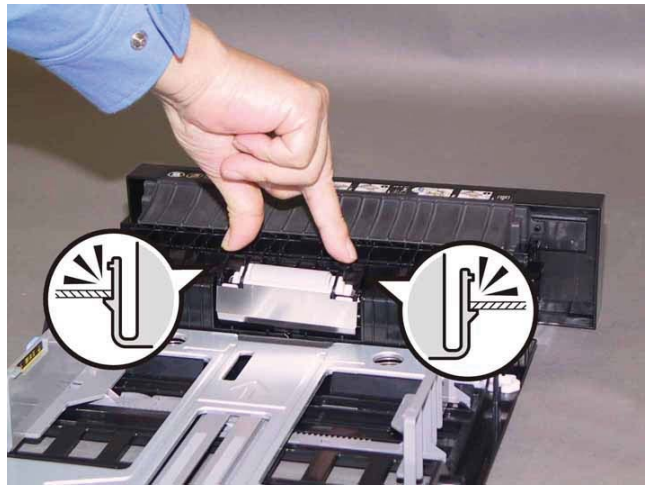

Go to the next replacement step:

Replacement 53 CASSETTE ASSY 250 (PL2.1.1)

Replacement 53 CASSETTE ASSY 250 (PL2.1.1)

1) Insert the CASSETTE ASSY 250 into the printer.

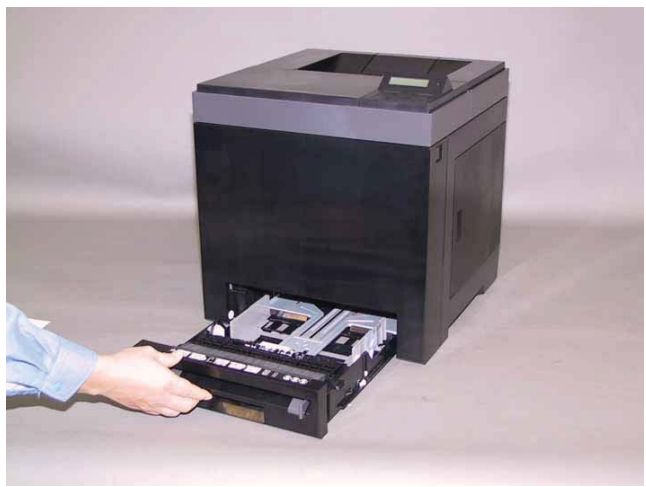

Replacement 54 WIRELESS ADAPTER (PL8.1.16)

1) Attach the WIRELESS ADAPTER to the PWBA ESS SFP and fix it.



Replacement 55 MEMORY CARD (PL8.1.15)

Note: Use the wrist strap to protect the PWB from the electrostatic.

1) Fit the MEMORY CARD into the socket by mating the notch of the MEMORY CARD with the lug on the socket.

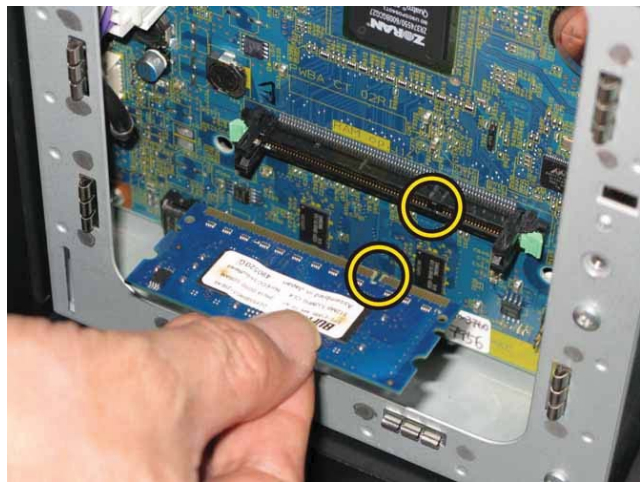

2) Insert the MEMORY CARD to the socket until it locks.



3) Close the PLATE ESS and secure the SCREW KNURLING.



Replacement 56 ROLLER ASSY DUP (PL11.2.9)

1) Attach the ROLLER ASSY DUP to the FEEDER ASSY DUP SFP STD.

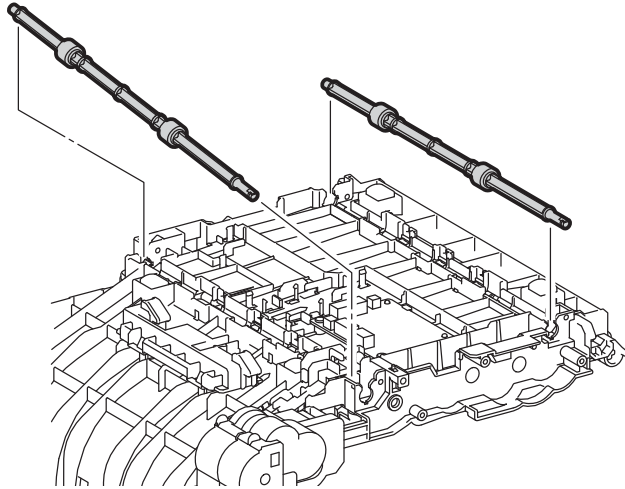

2) Replace the BEARING DUP on both the right and left sides of the ROLLER ASSY DUP by matching the tab of the BEARING DUP with the notch of the FEEDER ASSY DUP SFP STD.
Clamp the BEARING DUP firmly to the FEEDER ASSY DUP SFP STD.

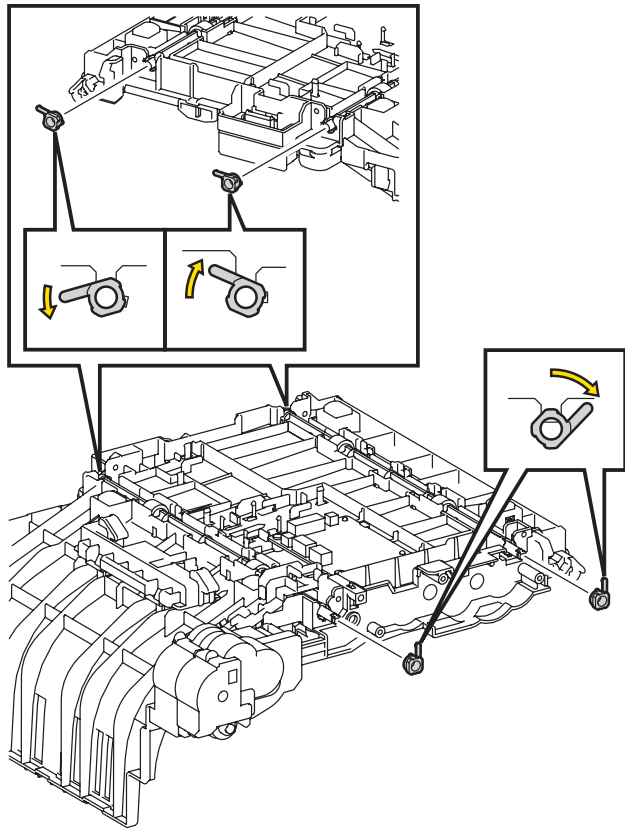

3) Attach the GEAR ROLL DUP to the ROLLER ASSY DUP, mate the hook of the GEAR ROLL DUP with the groove of the FEEDER ASSY DUP SFP STD.

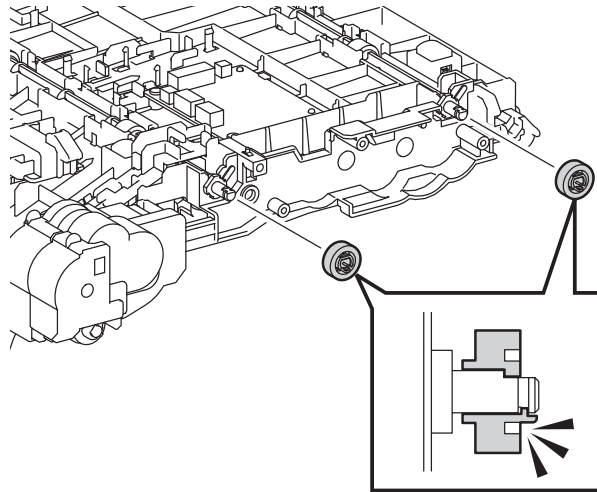

4) Attach the DRIVE ASSY DUP to the FEEDER ASSY DUP SFP STD, secure the DRIVE ASSY DUP with the four screws (silver, tap, 8mm).

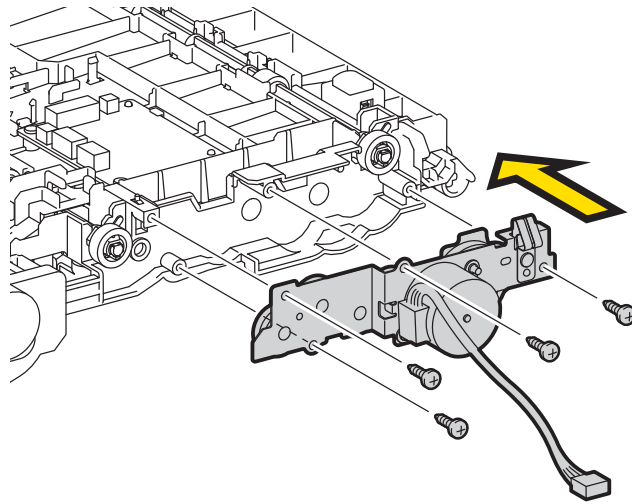

5) Draw the connector of the DRIVE ASSY DUP through the hole of the COVER DRIVE DUP. Then fix the COVER DRIVE DUP to the FEEDER ASSY DUP SFP STD using the five hooks.

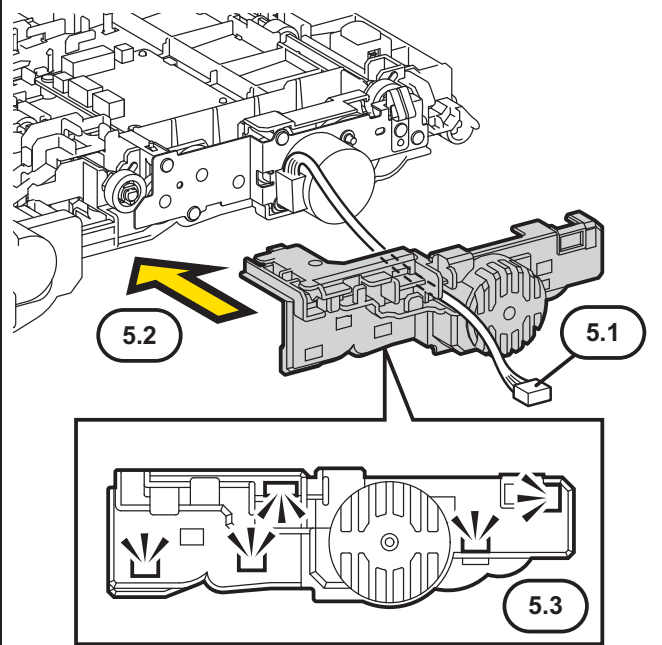

6) Route the harness of the DRIVE ASSY DUP along the hooks of the COVER DRIVE DUP, engage the connector (P/J603) of the DRIVE ASSY DUP to the PWBA DUP.

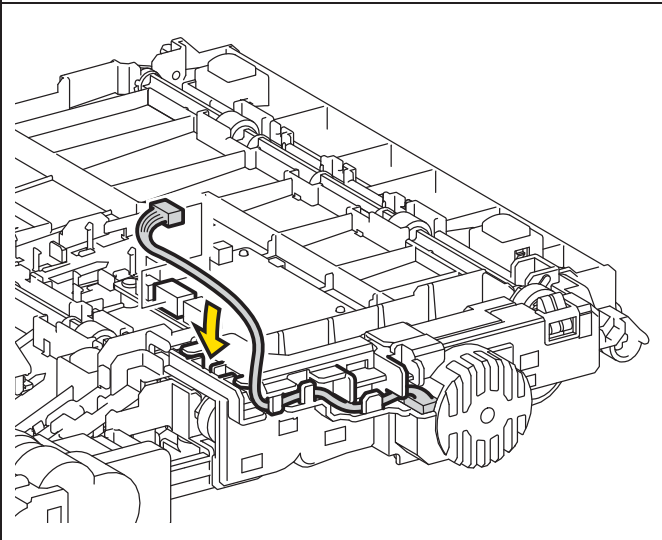

Note: When carrying out the steps described below, insert the right edge of the COVER PWBA DUP into the clearance of the CHUTE DUP FRAME.

7) Attach the COVER PWBA DUP to the FEEDER ASSY DUP SFP STD, secure the COVER PWBA DUP with the six hooks.

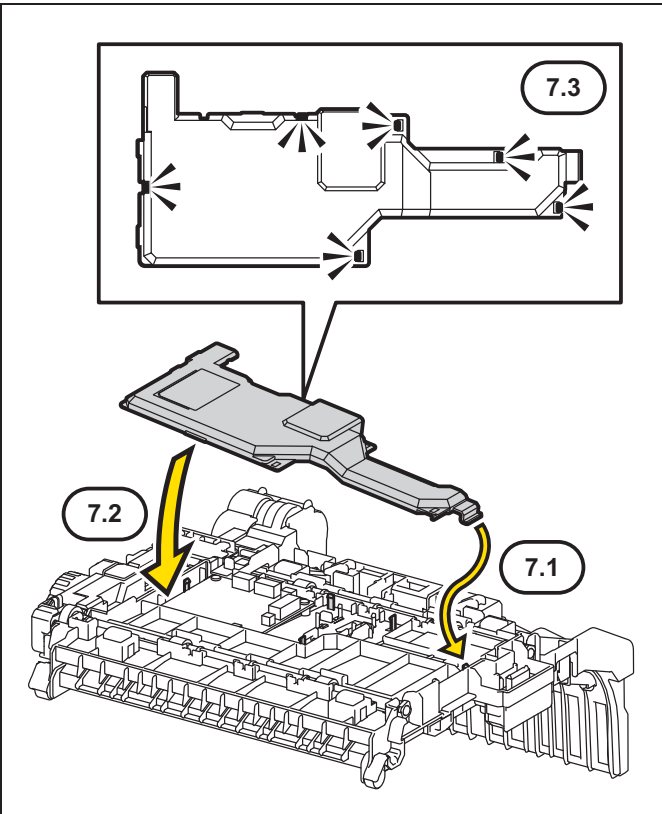

8) Replace the FEEDER ASSY DUP SFP STD. (Replacement 57)

9) Close the COVER ASSY FRONT MG.

Replacement 57 FEEDER ASSY DUP SFP STD (PL11.1.1)

1) Align the arrow on the FEEDER ASSY DUP SFP STD with the one on the COVER ASSY FRONT MG, attach the FEEDER ASSY DUP SFP STD.

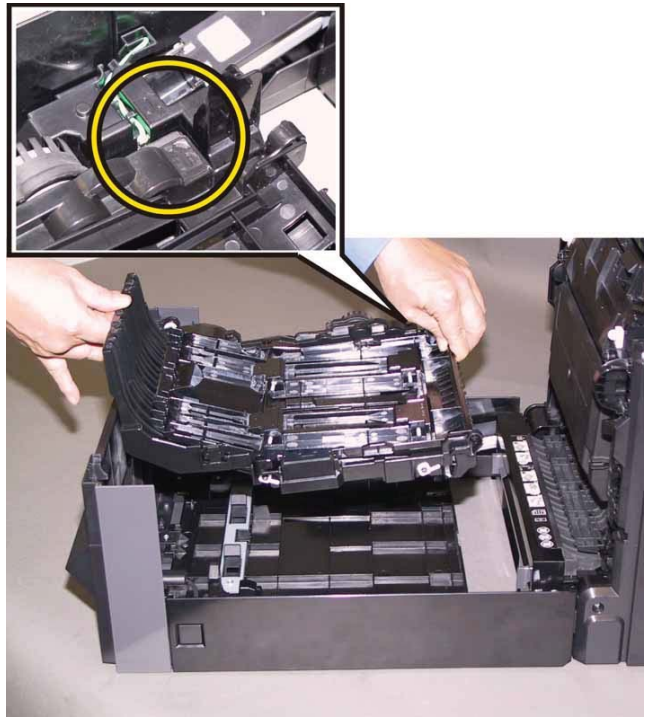

2) Push the FEEDER ASSY DUP SFP STD to secure it.

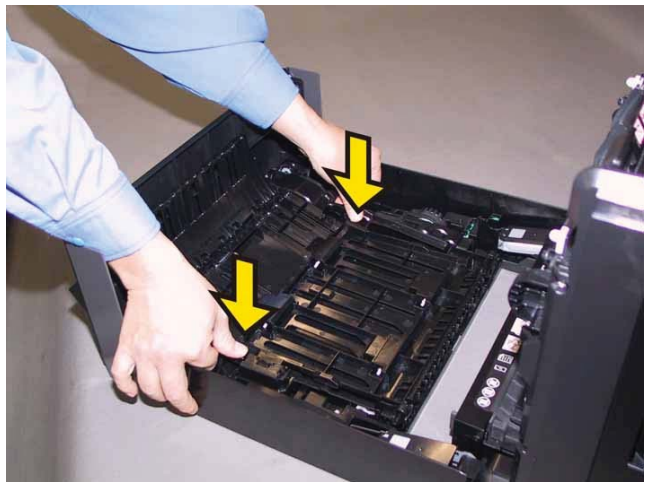

3) Close the COVER ASSY FRONT MG.

Replacement 58 ROLL ASSY FEED (Parts of the FEEDER ASSY OPT) (PL12.4.4)

1) Fit the ROLL ASSY FEED to the SHAFT ASSY FEED with the groove of the ROLL ASSY FEED facing upward, rotate the ROLL ASSY FEED 180 degrees so that the pin on the SHAFT ASSY FEED is aligned with the groove on the ROLL ASSY FEED.

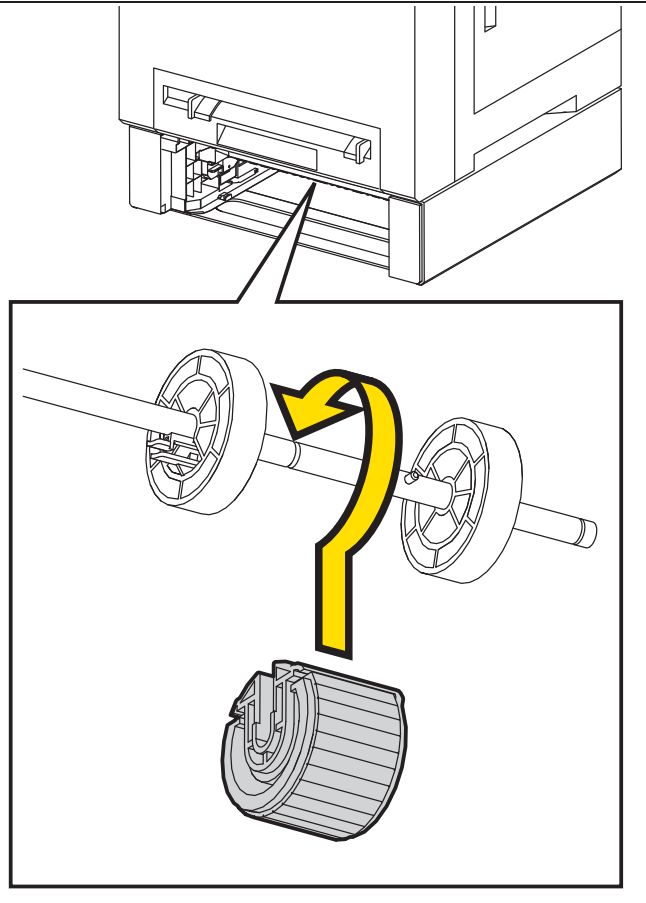

2) Move the ROLL ASSY FEED to the right side, put the groove of the ROLL ASSY FEED on the pin of the SHAFT ASSY FEED.

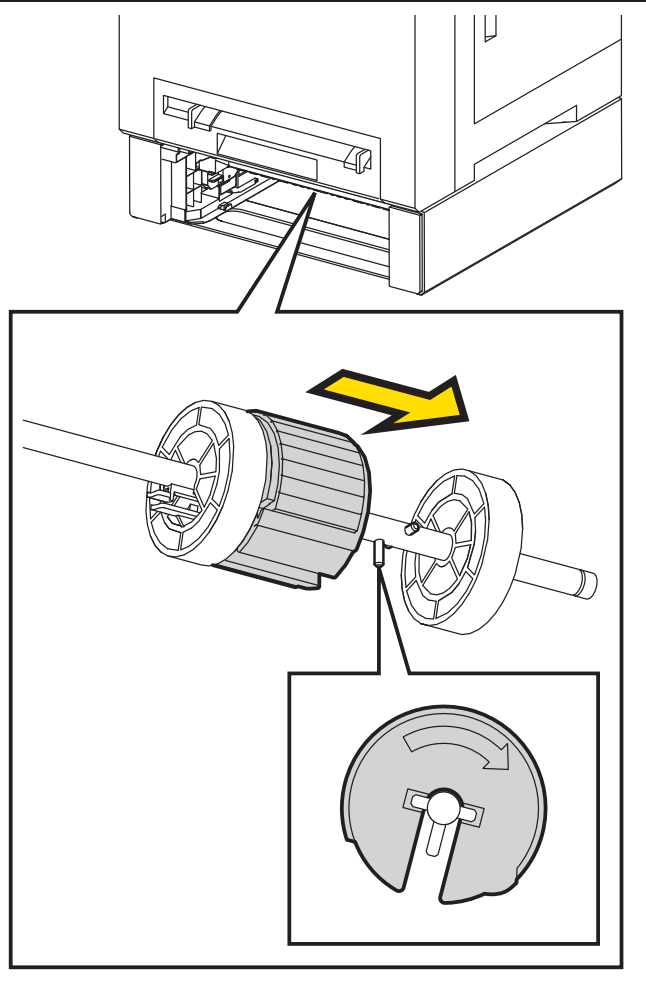

3) Move the ROLL CORE MSI to the right side, to secure the hook of the ROLL CORE MSI with the groove of the SHAFT ASSY FEED.

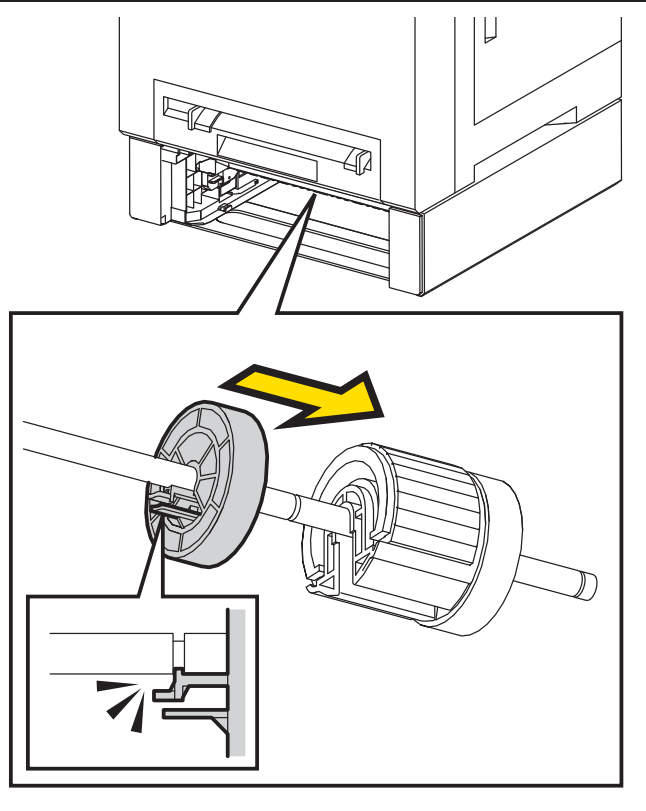

4) Insert the CASSETTE ASSY 250 OPT into the FEEDER ASSY OPT.

Replacement 59 KIT FEEDER ASSY OPT (PL12.1.99)

Note: The printer must be lifted by two people.

1) Place the printer on the FEEDER ASSY OPT with the five holes on the bottom of the printer aligned with the studs on the FEEDER ASSY OPT.

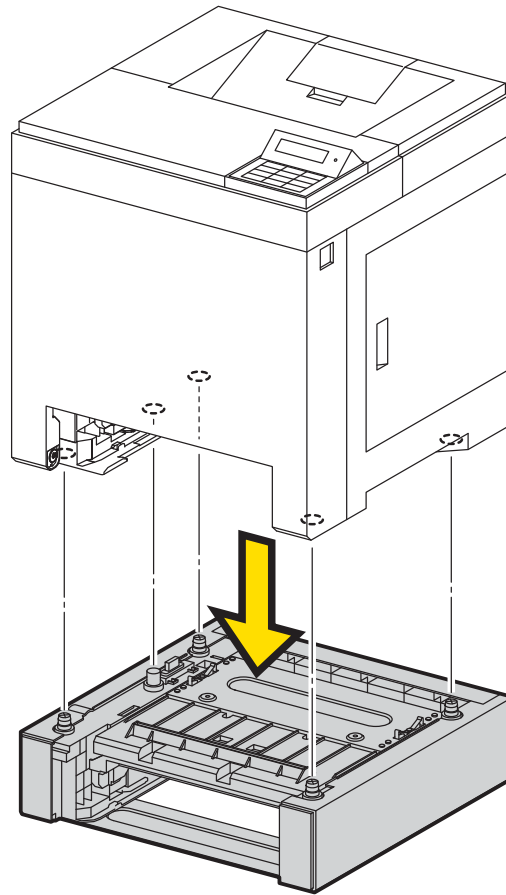

2) Secure the printer to the FEEDER ASSY OPT using the two SCREW JOINTS.

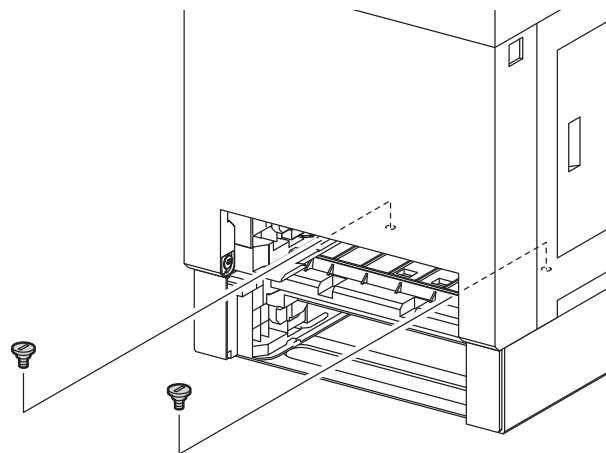

3) Insert the CASSETTE ASSY 250 OPT into the FEEDER ASSY OPT.

4) Insert the CASSETTE ASSY 250 into the printer.