

Chapter 2 Operation of Diag. CONTENTS

1. Overview.....	2 - 1
1.1 Position of the Diag. in the Whole System.....	2 - 1
2. Configuration	2 - 2
3. How to use Diag. Customer Mode.....	2 - 4
3.1 Roles of the control panel in Diag.	2 - 4
3.2 Entering diag. Customer mode	2 - 5
3.3 Selecting Diag. item	2 - 5
3.4 Change method parameters value.....	2 - 5
3.5 Executing/Exiting Diag. mode	2 - 5
3.6 Diag. mode menu tree	2 - 6
4. The Kind of Diag. and Contents of a Test	2 - 8
4.1 IOT Diag.....	2 - 8
4.1.1 Digital Input (DI) Test.....	2 - 8
4.1.2 Executing digital input (DI) test	2 - 8
4.1.3 Digital Output (DO) Test	2 - 16
4.1.4 Executing digital output (DO) test	2 - 16
4.2 Print Info.....	2 - 33
4.2.1 Executing Print Info.....	2 - 33
4.2.2 Config Page	2 - 33
4.2.3 Print Settings.....	2 - 33
4.3 Complete.....	2 - 33
4.3.1 Executing Complete.....	2 - 33
4.3.2 Complete.....	2 - 33
4.4 Installation Set	2 - 34
4.4.1 Executing Installation Set.....	2 - 34
4.5 Test Print.....	2 - 35
4.5.1 Executing test print	2 - 35
4.5.2 No Image IOT	2 - 35
4.5.3 Pattern 600 IOT	2 - 35
4.5.4 Grid 2	2 - 36
4.5.5 Cyan 20%	2 - 37
4.5.6 Magenta 20%.....	2 - 37
4.5.7 Yellow 20%	2 - 38
4.5.8 Black 20%.....	2 - 38
4.5.9 CMY 20%.....	2 - 39
4.5.10 Gradation	2 - 40
4.5.11 Toner Pallet.....	2 - 41
4.5.12 Contamination Check.....	2 - 42
4.5.13 Parameter Setting	2 - 43
4.5.14 Printing the parameter list	2 - 45

Chapter 2 Operation of Diag. CONTENTS

1. Overview

1.1 Position of the Diag. in the Whole System

Major functions of this diag. are as follows:

- IOT Diag
- Setting of parameters for registration in paper feeding direction and so on.

2. Configuration

The diagnosis provides three modes that have their respective uses (purposes), target operators, and functions.

This manual describes the Control Panel Operation of "Customer Mode".

Shippper Mode:

This mode intends to be used in the production line with the purpose to locate a chip that causes a problem.

Diagnosis time in the mode shall be as short as possible with consideration of production cost.

The mode shifts to the Developer mode (described later) after the ESS Diag.

This mode is protected password.

Customer Mode:

This mode intends to be used by customer who handle problems in field with the purpose to locate a replaceable unit that causes a problem.

Sorting problems on the basis of parts that can be replaced by the customer support center.

This is the base of this mode design, and that is why so many features.

The mode allows the user to execute the ESS diagnosis, test prints, parameter settings FAX, Scanner and so on through the control panel.

Developer/CE (Customer Engineer) Mode:

This mode is for debugging by developers or CEs. It intends to be partially used in the production line.

The mode allows the user to execute the ESS diagnosis, test prints, parameter settings and so on through the debug terminal.

The functions are activated by commands sent from the serial terminal. Special tool (FX internal debugging terminal) is required to operate Developer mode.

This mode is protected password.

Blank Page

3. How to use Diag. Customer Mode

3.1 Roles of the control panel in Diag.

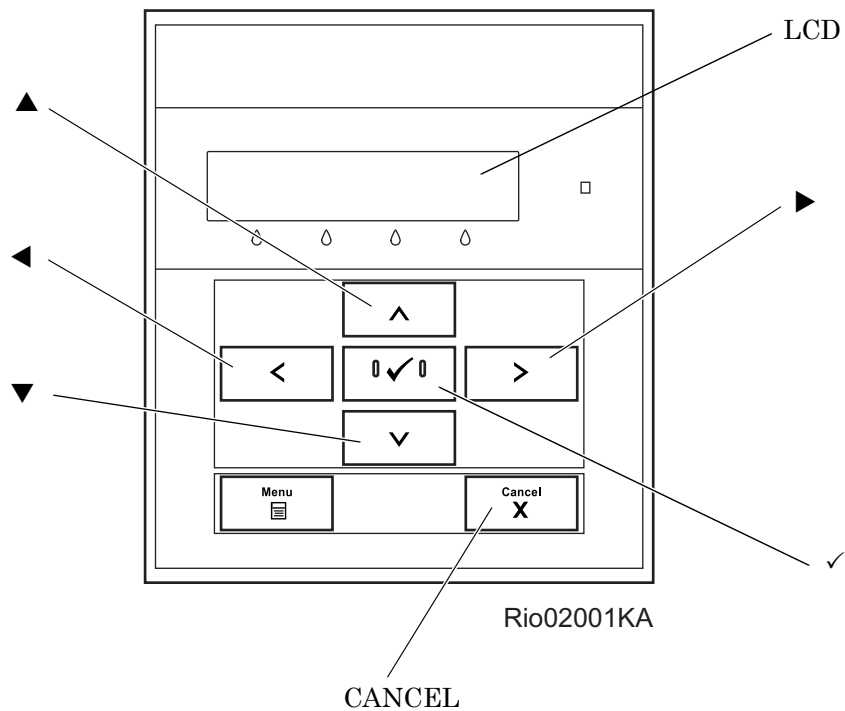

- [LCD]: Displaying a diagnosis item and its result
- [▲], [▼]: Selecting a diagnosis item/Selecting data at parameter setting
- [◀], [▶]: Key moves the cursor to the left/right
- [✓]: Determining a diagnosis item/Executing a diagnosis/Determining a parameter at parameter setting
- [CANCEL]: Resetting a diagnosis item (Returning to the menu one level higher)
Terminating each digital input/output

3.2 Entering diag. Customer mode

- 1) Turn off the power.
- 2) Turn on the power while holding down “▲” and “▼” keys.
- 3) Release the fingers from these keys when “Diagnosing...” is displayed.
- 4) The "Customer Mode" and "IOT Diag" are displayed. (Entered the Diag. mode.)

3.3 Selecting Diag. item

The diagnosis setting items are configured as menus, which can be operated with the control panel keys. Arrow keys select menu items and “✓” key activates functions.

3.4 Change method parameters value

For parameter setting, pressing “✓” key after selecting an item from the menu displays the current setting value of the item. Then a numeric value selected by “▼” and “▲” keys are written into the NVM by “✓” key.

3.5 Executing/Exiting Diag. mode

The diagnosis can be executed by as follows.

- 1) A test item is displayed. “✓” key fixed the test item.
- 2) The display prompts the user to start the test. Press “✓” key and start the test.

The diagnosis can be stopped by as follows.

- 1) During the diagnosis test, press “CANCEL” key.
- 2) The diagnosis is stopped, and the display indicates the one step higher menu.

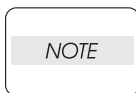

When error occurred during Diag. operations, the display returns to the menu selective state after displaying the error for about three seconds.

3.6 Diag. mode menu tree

Menu Tree of the Customer Mode is as follows

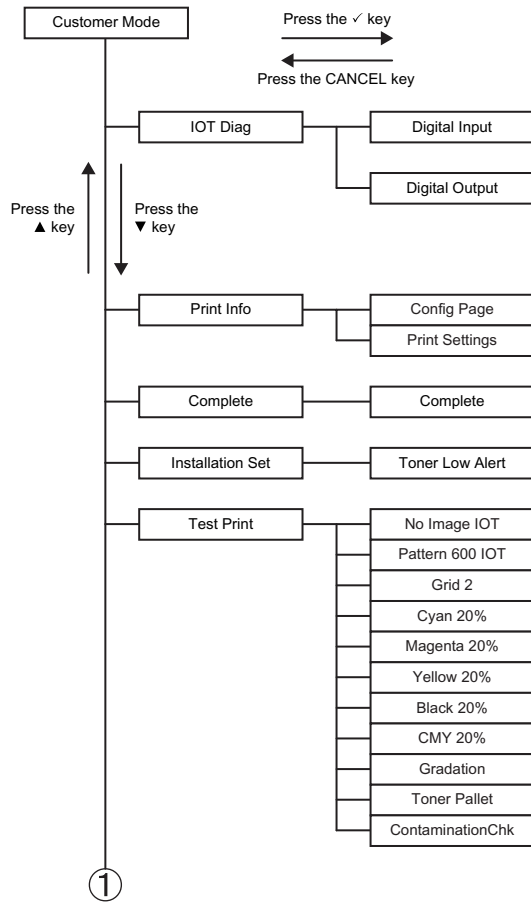

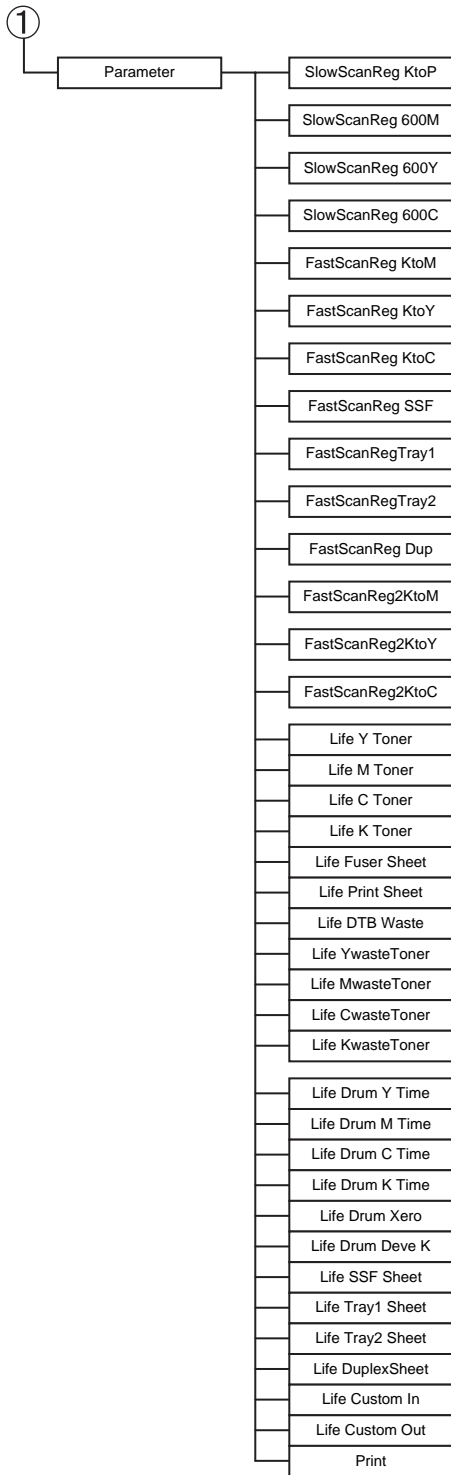

4. The Kind of Diag. and Contents of a Test

4.1 IOT Diag

4.1.1 Digital Input (DI) Test

This function checks whether the DI components operate normally or not.

The DI test is performed for all the DI components.

Exit operation of the DI test makes the control panel display the Customer diag. function menu.

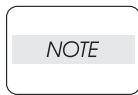

During the DI test, other Customer diag. functions can not be performed simultaneously. Therefore, the printer does not accept any operation except operations for the DI components and exit operation of the DI test.

At the start of the DI test, number “0” is displayed on the control panel. This number is counted up when a DI component is turned on from off, therefore it allows the user to know the component is active.

When a paper jam is occurred, or an error message or code is displayed, execute this test to locate the damaged parts.

The test will execute the DI Test codes of the components that are supposed to be faulty from the error details. (Refer to each FIP on Chapter 1.)

Test result: NG (Go to each FIP or replace the parts.)

OK (Turn off/on the main power.)

4.1.2 Executing digital input (DI) test

- 1) Turn off the power.
- 2) Turn on the power while holding down “▲” and “▼” keys.
- 3) Release the fingers from these keys when “Diagnosing...” is displayed.
- 4) The “Customer Mode” and “IOT Diag” are displayed. (Entered the Diag. mode.)
- 5) Press “✓” key.
- 6) Press “▼” key to select “Digital Input”, and then press “✓” key.
- 7) Press “▲” or “▼” key to select the test item.
- 8) Press “✓” key twice to execute the test.

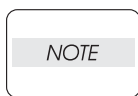

- To exit the test or to return to one step higher menu, press the "CANCEL" key.
- From the menu which performed DI test, to return to one step higher menu, press the "MENU" key.

Parameters for the Digital Input Test are as follows.

Code	Components
DI-0	MPF No Paper Sensor
DI-1	CASSETTE 1 No Paper Sensor
DI-2	Regi Sensor
DI-3	Exit Sensor
DI-4	K Mode Sensor
DI-6	Side Switch
DI-7	Interlock Switch
DI-9	CASSETTE 2 No Paper Sensor
DI-a	CASSETTE 2 Paper Path Sensor

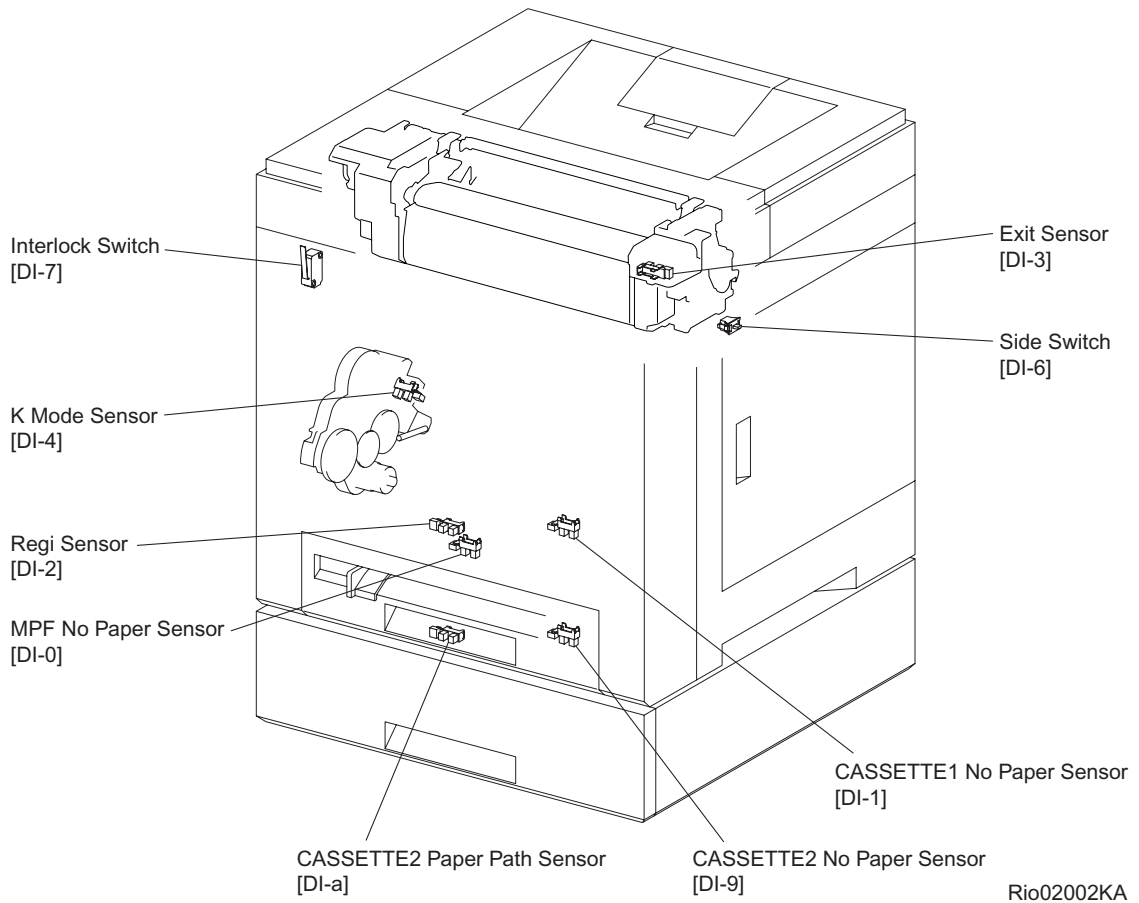

- About Sensor

A transmissive type sensor is composed of the light-emitting side and the light-receiving side that are placed opposite to each other allowing the light to pass from the former to the latter. On the basis of whether or not the light path is blocked due to the actuator, etc., the sensor detects the paper absence/presence or the moving part position such as at the home position or elsewhere.

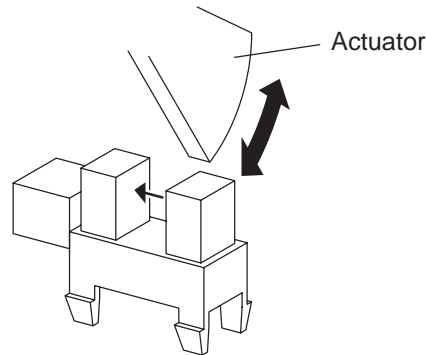

Leg_Sec02_016FA

- About Switch

A micro-switch closes the internal contacts via the button which is pushed down under the provided leaf spring which is held down by the actuator of the cover or door that is being closed. When the door or cover has being opened, the leaf spring returns to its original position and the button is pushed up by the spring in the switch, allowing the internal contacts to open.

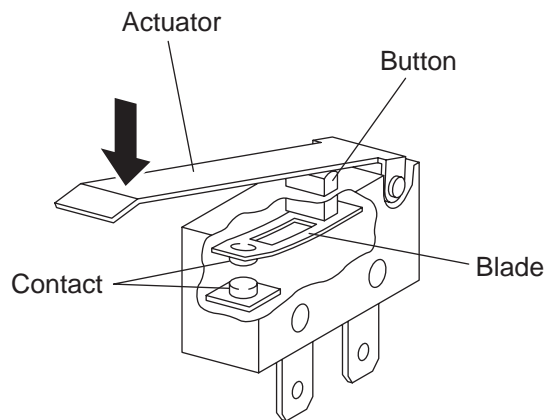

Leg_Sec02_018FA

-Checking the Sensor and Switch

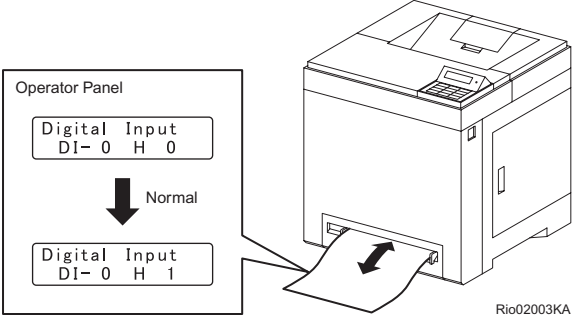
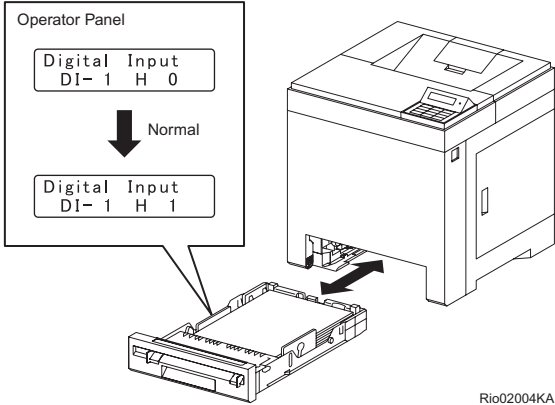
Sensor name (Diag. Code)	Confirmation procedures
<p>MPF No Paper Sensor (DI-0)</p>	<p>NOTE: Remove the paper of the MPF before executing the test.</p> <ol style="list-style-type: none"> 1) Turn on the power and enter the Diagnostic Mode. 2) Execute the DI-0. 3) Check the sensor. <div style="text-align: center;">  <p style="text-align: right; font-size: small;">Rio02003KA</p> </div> <ol style="list-style-type: none"> 4) Press the "Cancel" key to stop the test.
<p>CASSETTE 1 No Paper Sensor (DI-1)</p>	<ol style="list-style-type: none"> 1) Turn on the power and enter the Diagnostic Mode. 2) Execute the DI-1. 3) Remove the paper cassette. 4) Check the sensor. <div style="text-align: center;">  <p style="text-align: right; font-size: small;">Rio02004KA</p> </div> <ol style="list-style-type: none"> 5) Press the "Cancel" key to stop the test. 6) Replace the paper cassette.

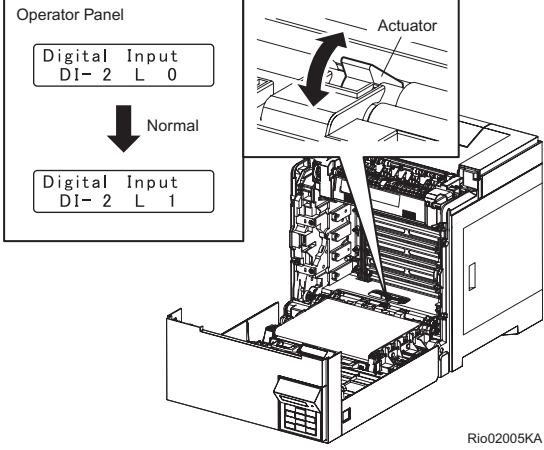
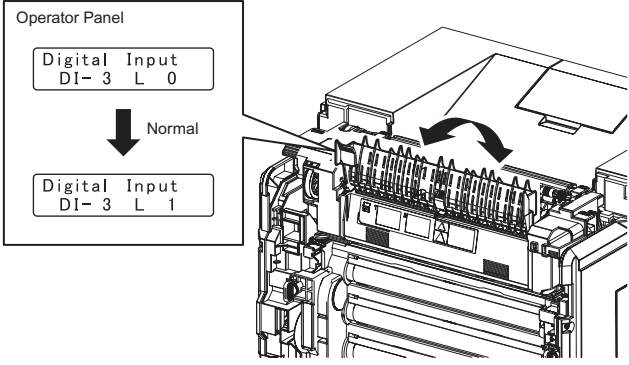
Sensor name (Diag. Code)	Confirmation procedures
<p>Regi Sensor (DI-2)</p>	<ol style="list-style-type: none"> 1) Turn on the power and enter the Diagnostic Mode. 2) Execute the DI-2. 3) Open the Front Cover. 4) Remove the PHD ASSY. 5) Check the sensor by an actuator operation. <div style="text-align: center;">  <p style="text-align: right; font-size: small;">Rio02005KA</p> </div> <ol style="list-style-type: none"> 6) Press the "Cancel" key to stop the test. 7) Replace the PHD ASSY. 8) Close the Front Cover.
<p>Exit Sensor (DI-3)</p>	<p>NOTE: Fuser is very hot, so pay sufficient attention at work to above burns, etc.</p> <ol style="list-style-type: none"> 1) Turn on the power and enter the Diagnostic Mode. 2) Execute the DI-3. 3) Open the Front Cover. 4) Check the sensor. <div style="text-align: center;">  <p style="text-align: right; font-size: small;">Rio02006KA</p> </div> <ol style="list-style-type: none"> 5) Press the "Cancel" key to stop the test. 6) Close the Front Cover.

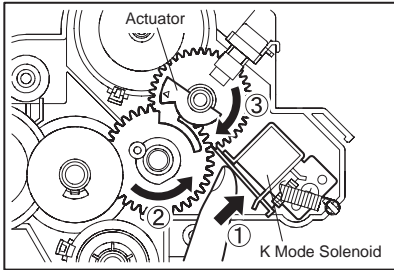
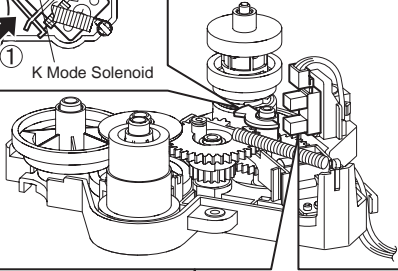
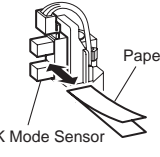
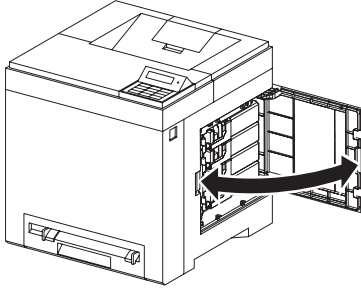
Sensor name (Diag. Code)	Confirmation procedures
<p>K Mode sensor (DI-4) (Color Mode Switching Sensor)</p>	<p>NOTE: These procedures are for the technical staff. When performing operation for five minutes or longer with the front cover open, remove the PHD ASSY, and cover the drum to avoid exposure to light.</p> <ol style="list-style-type: none"> 1) Remove the DRIVE ASSY PH. 2) Cheat the safety Interlock System. 3) Turn on the power and enter the Diagnostic Mode. 4) Execute the DI-4. 5) Check the sensor.   <div style="display: flex; justify-content: space-around;"> <div data-bbox="892 954 1131 1196"> <p>Operator Panel</p> <p>Digital Input DI- 4 L 0</p> <p style="text-align: center;">↓ Normal</p> <p>Digital Input DI- 4 L 1</p> </div> <div data-bbox="1131 954 1339 1196">  <p>Paper</p> <p>K Mode Sensor</p> </div> </div> <p style="text-align: right; font-size: small;">Mnt02007KA</p> <ol style="list-style-type: none"> 6) Press the "Cancel" key to stop the test. 7) Turn off the printer power. 8) Attach the DRIVE ASSY PH.
<p>Side Switch (DI-6)</p>	<ol style="list-style-type: none"> 1) Turn on the power and enter the Diagnostic Mode. 2) Execute the DI-6. 3) Check the Switch.  <div style="display: flex; justify-content: space-around;"> <div data-bbox="1106 1491 1345 1733"> <p>Operator Panel</p> <p>Digital Input DI- 6 L 0</p> <p style="text-align: center;">↓ Normal</p> <p>Digital Input DI- 6 L 1</p> </div> </div> <p style="text-align: right; font-size: small;">Rio02008KA</p> <ol style="list-style-type: none"> 4) Press the "Cancel" key to stop the test. 5) Close the Toner Cover.

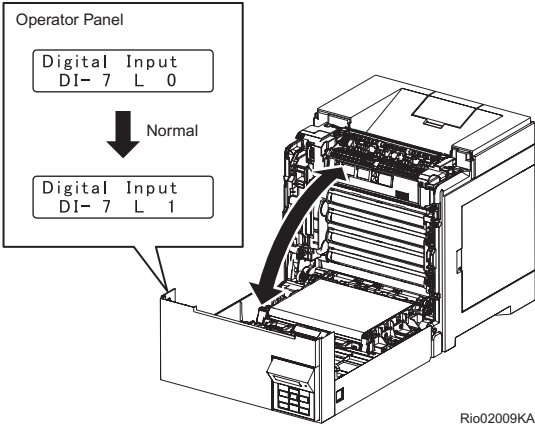
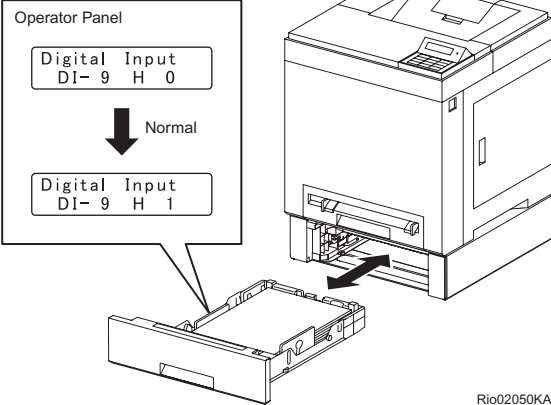
Sensor name (Diag. Code)	Confirmation procedures
Interlock Switch (DI-7)	<ol style="list-style-type: none"> 1) Turn on the power and enter the Diagnostic Mode. 2) Execute the DI-7. 3) Open and close the Front Cover to check the switch.  <ol style="list-style-type: none"> 4) Press the "Cancel" key to stop the test. 5) Close the Front Cover.
CASSETTE 2 No Paper Sensor(DI-9)	<p>NOTE: The No paper sensor is in the option feeder.</p> <ol style="list-style-type: none"> 1) Turn on the power and enter the Diagnostic Mode. 2) Execute the DI-9. 3) Remove the paper cassette. 4) Check the sensor.  <ol style="list-style-type: none"> 5) Press the "Cancel" key to stop the test. 6) Replace the paper cassette.

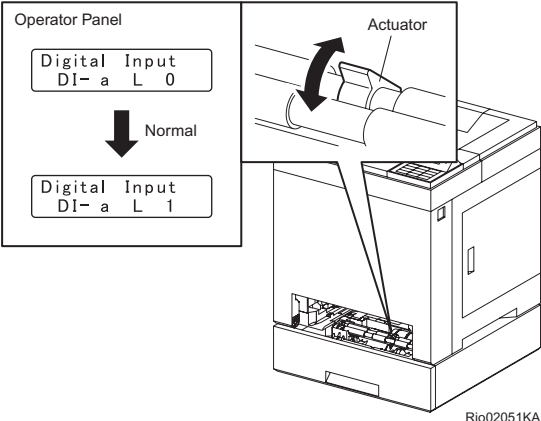
Sensor name (Diag. Code)	Confirmation procedures
CASSETTE 2 Paper Path Sensor(DI-a)	<p>NOTE: These procedures are for the technical staff.</p> <ol style="list-style-type: none"> 1) Remove the COVER CHUTE (PL12.1.5). 2) Turn on the power and enter the Diagnostic Mode. 3) Execute the DI-a. 4) Remove the CASSETTE 1 paper cassette and CASSETTE 2 paper cassette. 5) Check the sensor. <div style="text-align: center;">  <p style="text-align: right; font-size: small;">Rio02051KA</p> </div> <ol style="list-style-type: none"> 6) Press the "Cancel" key to stop the test. 7) Replace the CASSETTE 1 paper cassette and CASSETTE 2 paper cassette. 8) Turn off the power. 9) Replace the COVER CHUTE (PL12.1.5).

4.1.3 Digital Output (DO) Test

This function checks whether the DO components operate.

When the interlock is opened while the DO test is performed, each component ends to operate.

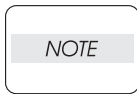

In this Test Mode, each DO component can be turned individually. Therefore it allows the customer to check a component's operation from outside, and judge whether the component is normal or not.

When all the diag. functions are stopped, all the DO components can be turned off. DO test can make each of the DO component's operate simultaneously.

When a paper jam or PQ problem is occurred, or an error message or code is displayed, this test enables to look for the broken or damaged parts.

Test result: NG (Go to each FIP or replace the parts.)

OK (Turn off/on the main power.)

4.1.4 Executing digital output (DO) test

- 1) Turn off the power.
- 2) Turn on the power while holding down “▲” and “▼” keys.
- 3) Release the fingers from these keys when “Diagnosing...” is displayed.
- 4) The “Customer Mode” and “IOT Diag” are displayed. (Entered the Diag. mode.)
- 5) Press “✓” key.
- 6) Press “▼” key to select “Digital Output”, and then press “✓” key.
- 7) Press “▲” or “▼” key to select test item.
- 8) Press “✓” key to execute the test.

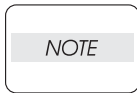

- To exit the test or to return to one step higher menu, press the "CANCEL" key.

- From the menu which performed DO test, to return to one step higher menu, press the "MENU" key.

Parameters for the Digital Output Test are as follows.

Code	Components
DO-0,1,2	Main Motor
DO-5,6,7	Sub Motor
DO-a	K Mode SOLENOID
DO-b ,c	CASSETTE1 FEED SOLENOID (Half / Full Rotation)
DO-d,e,f,10	DUPLEX EXIT MOTOR
DO-12,13,14,15	DUPLEX MOTOR
DO-17,18,19,1a	CASSETTE 2 FEED MOTOR
DO-1e,1f	Fan (HIGH/LOW)
DO-21	Yellow Toner Motor
DO-23	Magenta Toner Motor
DO-25	Cyan Toner Motor
DO-27	Black Toner Motor
DO-29	Regi Clutch
DO-2f	CASSETTE1 FEED SOLENOID (Auto OFF)
DO-31	CASSETTE 2 FEED SOLENOID (Auto OFF)
DO-33	CASSETTE 2 TURN CLUTCH

Code	Components
DO-35	DUPLEX CLUTCH
DO-3d	Black Drum Erase Lamp
DO-3f	Yellow, Magenta and Cyan Drum Erase Lamp

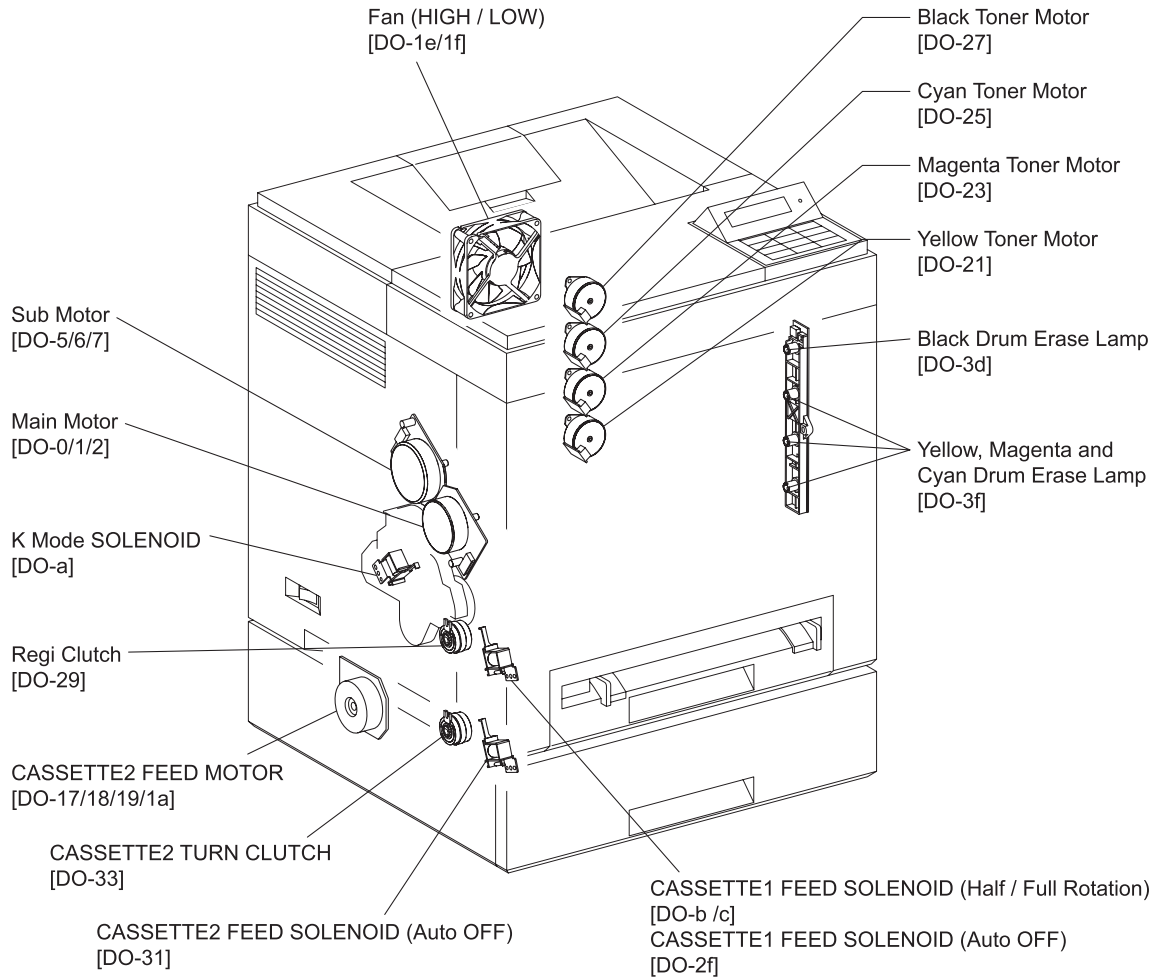

Rio02010KB

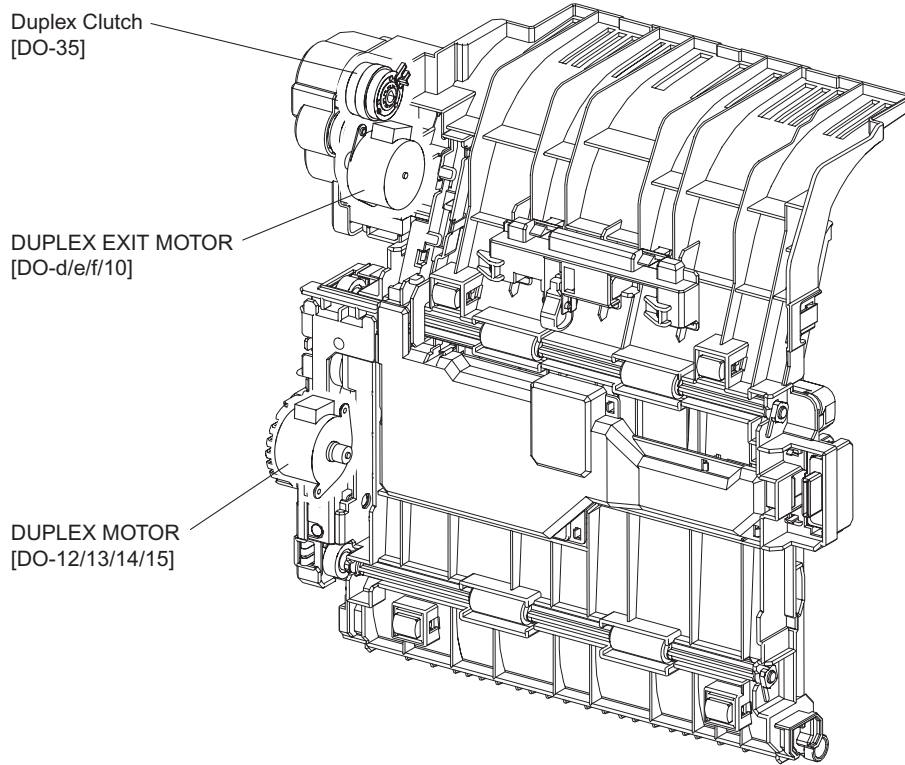

Rio02052KA

- About Clutch

The electromagnetic clutch in the printer controls the rotation of the roller by transferring or cutting the torque from the motor to the roller.

The electromagnetic clutch becomes an electromagnet by the passage of electric current through the coil inside the case and attracts the armature and gear to the rotating rotor, thereby rotating the gear.

Upon the loss of power to the coil, electromagnetic force is lost and the armature comes off the rotor, and the gear comes to rest.

The clutch makes so soft noises that you must be close the component to audibly confirm the operation of the component.

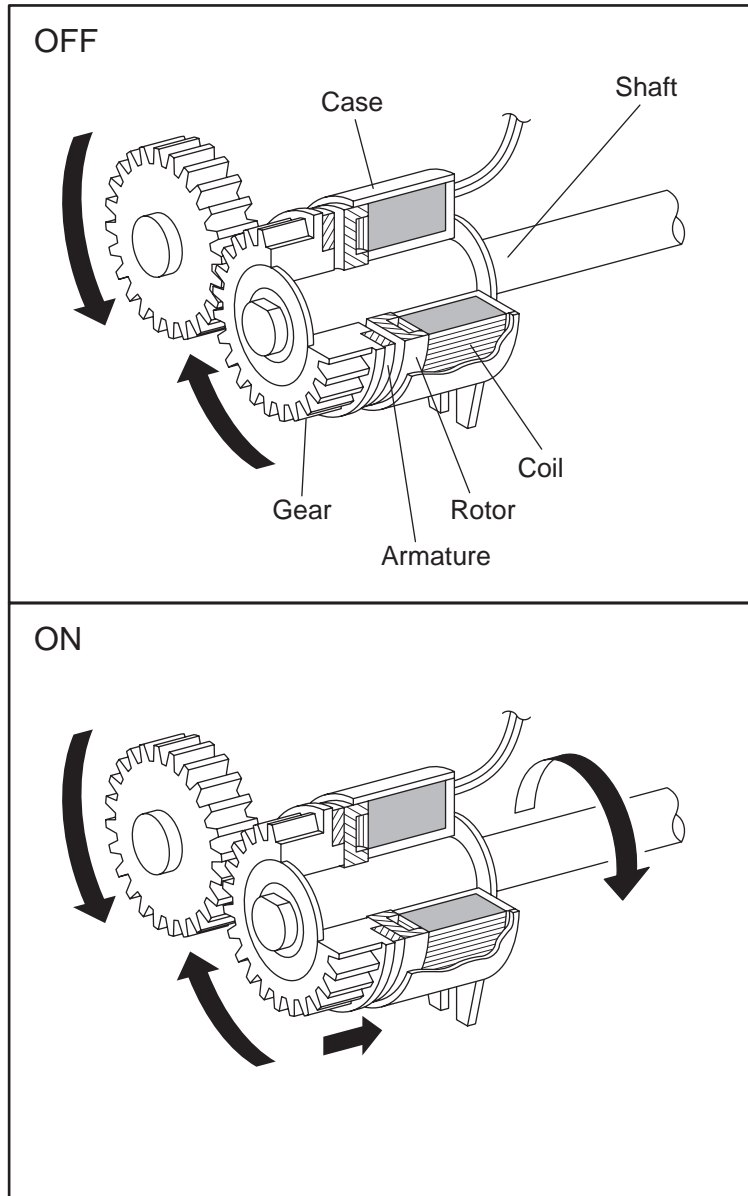

Leg_Sec02_050FA

- About Solenoid

The solenoid in the printer opens/closes the shutter or controls the position of the gear for transferring the torque of the motor to the roller.

A solenoid becomes an electromagnet by the passage of electric current through the coil inside the case and attracts the plunger.

Upon the loss of power to the coil, electromagnetic force is lost and the plunger is returned to its original position by spring action, thereby allowing the shutter to operate or the gear to move to the predefined position.

Unlike a clutch, a solenoid generates a loud operation noise.

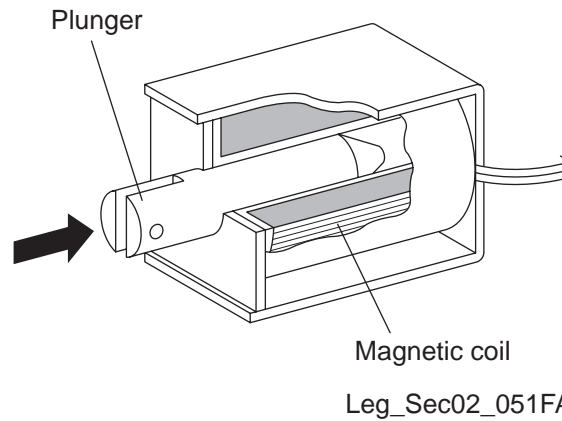

- Checking Motor, Clutch and Solenoid

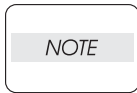

Before executing the DO test, close all covers and doors.

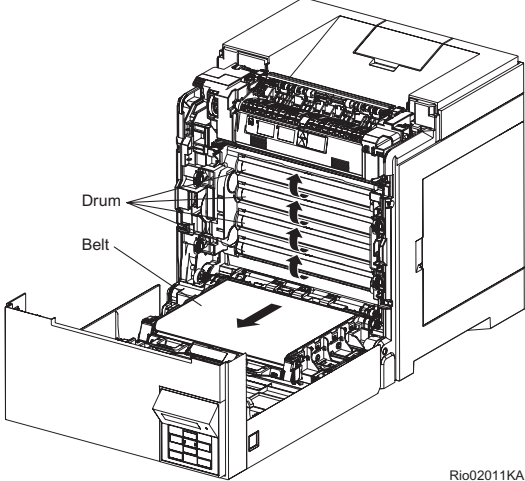
Clutch and Solenoid name (Diag. Code)	Confirmation procedure
<p>Main Motor (DO-0/DO-1/DO-2)</p>	<p>NOTE: These procedures are for the technical staff. The customer check is the procedure 1, 4 and 5. When performing operation for five minutes or longer with the front cover open, remove the PHD ASSY, and cover the drum to avoid exposure to light. The rotational speed of the motor is as follows. DO-2<DO-0<DO-1</p> <ol style="list-style-type: none"> 1) Turn on the power and enter the Diagnostic Mode. 2) Open the Front Cover 3) Cheat the safety Interlock System. 4) Execute the DO-0. (The customer can confirm the motor noise only.)  <p style="text-align: right; font-size: small;">Rio02011KA</p> <ol style="list-style-type: none"> 5) Check the drum rotation. 6) Press the "Cancel" key to stop the test. 7) Remove the cheater and replace the black toner cartridge. 8) Close the Front Cover.

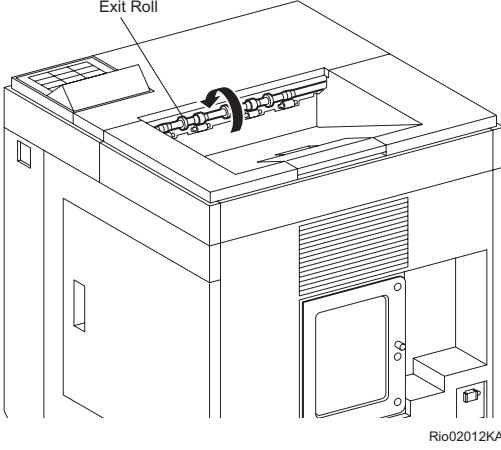
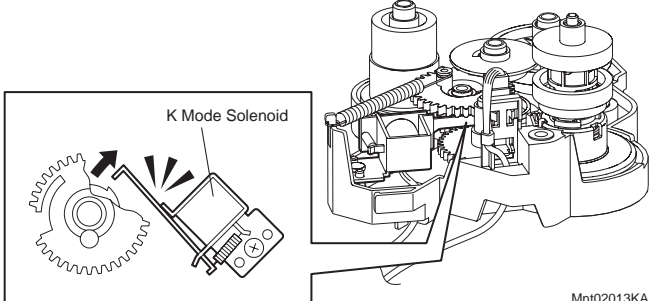
Clutch and Solenoid name (Diag. Code)	Confirmation procedure
Sub Motor (DO-5/DO-6/DO-7)	<p>The rotational speed of the motor is as follows. DO-7<DO-5<DO-6</p> <ol style="list-style-type: none"> 1) Turn on the power and enter the Diagnostic Mode. 2) Execute the DO-5.  <ol style="list-style-type: none"> 3) Check the Exit Roll rotation. 4) Press the "Cancel" key to stop the test.
K Mode SOLENOID (DO-a) (Color Mode Switching Sensor)	<p>NOTE: These procedures are for the technical staff. When performing operation for five minutes or longer with the front cover open, remove the PHD ASSY, and cover the drum to avoid exposure to light.</p> <ol style="list-style-type: none"> 1) Remove the DRIVE ASSY PH. 2) Cheat the safety Interlock System. 3) Turn on the power and enter the Diagnostic Mode. 4) Execute the DO-a.  <ol style="list-style-type: none"> 5) Check the K Mode SOLENOID movement. 6) Press the "Cancel" key to stop the test. 7) Turn off the printer power. 8) Attach the DRIVE ASSY PH. 9) Remove the cheater and turn on the printer power.

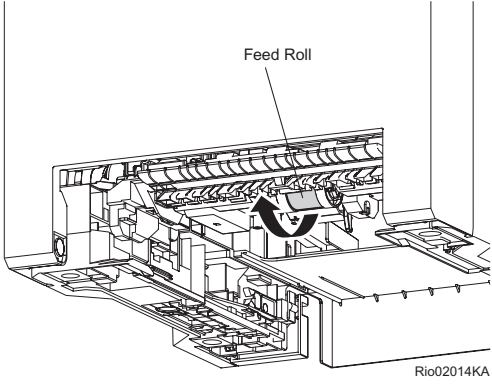
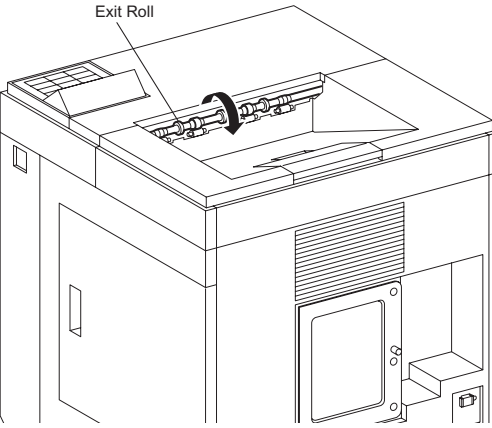
Clutch and Solenoid name (Diag. Code)	Confirmation procedure
<p>CASSETTE1 FEED SOLENOID (Half / Full Rotation) (DO-b ,c)</p>	<ol style="list-style-type: none"> 1) Turn on the power and enter the Diagnostic Mode. 2) Remove the CASSETTE1 paper cassette. 3) Execute the DO-b.  <p style="text-align: right; font-size: small;">Rio02014KA</p> <ol style="list-style-type: none"> 4) Check the Feed Roll rotation. 5) Press the "Cancel" key to stop the test. 6) Replace the paper cassette.
<p>DUPLEX EXIT MOTOR (DO-d,e,f,10)</p>	<p>The rotational speed of the motor is as follows. DO-10<DO-f<DO-e<DO-d</p> <ol style="list-style-type: none"> 1) Turn on the power and enter the Diagnosis Mode. 2) Execute the DO-d.  <p style="text-align: right; font-size: small;">Rio02053KA</p> <ol style="list-style-type: none"> 3) Check the Exit Roll rotation. 4) Press the "Cancel" key to stop the test.

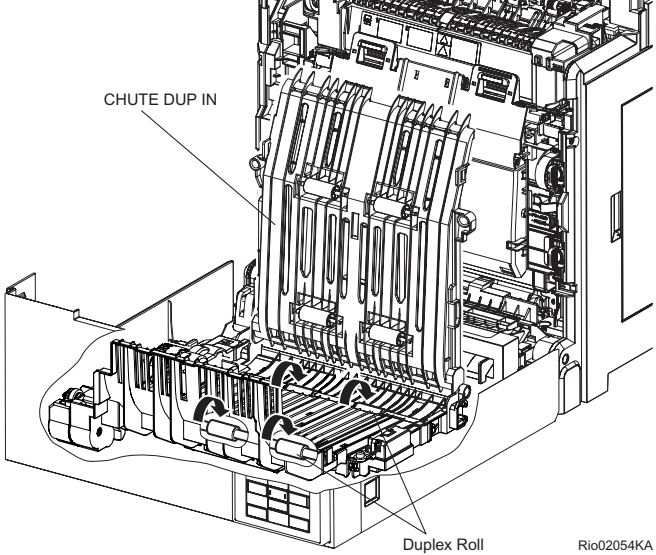
Clutch and Solenoid name (Diag. Code)	Confirmation procedure
<p>DUPLEX MOTOR (DO-12,13,14,15)</p>	<p>NOTE: These procedures are for the technical staff. The customer check is the procedure 1, 4 and 5.</p> <p>When performing operation for five minutes or longer with the front cover open, remove the PHD ASSY, and cover the drum to avoid exposure to light.</p> <p>The rotational speed of the motor is as follows. DO-15<DO-14<DO-13<DO-12</p> <ol style="list-style-type: none"> 1) Turn on the power and enter the Diagnosis Mode. 2) Open the Front Cover and CHUTE DUP IN (PL11.1.2). 3) Cheat the safety Interlock System. 4) Execute the DO-12. (The customer can confirm the motor noise only.)  <ol style="list-style-type: none"> 5) Check the Duplex Roller rotation. 6) Press the "Cancel" key to stop the test. 7) Remove the cheater. 8) Close the CHUTE DUP IN (PL11.1.2) and Front Cover.

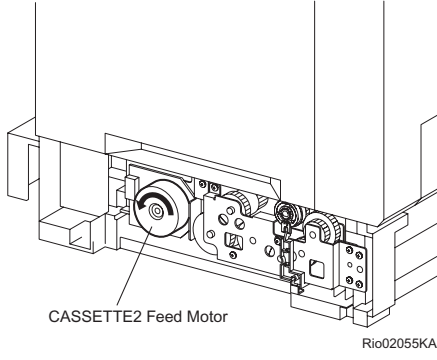
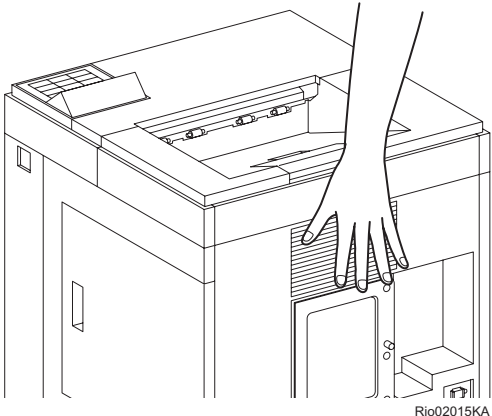
Clutch and Solenoid name (Diag. Code)	Confirmation procedure
<p>CASSETTE 2 FEED MOTOR (DO-17,18,19,1a)</p>	<p>NOTE: This procedure is for the technical staff. The customer check is the procedure 1, 4 and 5. The rotational speed of the motor is as follows. DO-1a<DO-19<DO-18<DO-17</p> <ol style="list-style-type: none"> 1) Turn on the power and enter the Diagnostic Mode. 2) Remove the CASSETTE 2 paper cassette. 3) Remove the COVER REAR OPT (PL12.1.6) and COVER SIDE L OPT (PL12.1.4). 4) Execute the DO-17. (The customer can confirm the motor noise only.)  <ol style="list-style-type: none"> 5) Press the "Cancel" key to stop the test. 6) Replace the COVER REAR OPT (PL12.1.6) and COVER SIDE L OPT (PL12.1.4). 7) Replace the CASSETTE 2 paper cassette.
<p>Fan (HIGH)/ FAN (LOW) (DO-1e ,1f)</p>	<ol style="list-style-type: none"> 1) Turn on the power and enter the Diagnostic Mode. 2) Execute the DO-1e.  <ol style="list-style-type: none"> 3) Check the FAN rotation. 4) Press the "Cancel" key to stop the test.

Clutch and Solenoid name (Diag. Code)	Confirmation procedure
Yellow Toner Motor(DO-21) Magenta Toner Motor (DO-23) Cyan Toner Motor (DO-25) Black Toner Motor (DO-27)	<p>NOTE: These procedures are for the technical staff. Described below is the check procedure common among the four toner motor. Note the operation for the toner in the PHD ASSY spills if the motor is rotated for a long time.</p> <ol style="list-style-type: none"> 1) Turn on the power and enter the Diagnostic Mode. 2) Open the Cover and remove the toner cartridge. 3) Open the toner cartridge holder. 4) Execute the DO-21, DO-23, DO-25 or DO-27. <div data-bbox="639 506 1334 882" style="text-align: center;"> <p style="text-align: right; font-size: small;">Rio02016KA</p> </div> <ol style="list-style-type: none"> 5) Check the TONER MOTER rotation. 6) Press the "Cancel" key to stop the test. 7) Replace the toner cartridge and close the toner cartridge holder. 8) Close the Cover.

Clutch and Solenoid name (Diag. Code)	Confirmation procedure
Regi Clutch (DO-29)	<p>NOTE: When performing operation for five minutes or longer with the front cover open, remove the PHD ASSY , and cover the drum to avoid exposure to light.</p> <ol style="list-style-type: none"> 1) Turn on the power and enter the Diagnostic Mode. 2) Execute the DO-29. Upon hitting the "✓" key, the operating noise of the clutch will be heard. 3) Press the "Cancel" key to stop the clutch. <p>Combination test is as follows.</p> <p>NOTE: The Regi Roll rotates when the DO-0 and the DO-29 are executed. These procedures are for the technical staff.</p> <p>When performing operation for five minutes or longer with the front cover open, remove the PHD ASSY, and cover the drum to avoid exposure to light.</p> <ol style="list-style-type: none"> 1) Turn on the power and enter the Printer Diag. 2) Open the Front Cover. 3) Cheat the safety Interlock System. 4) Execute the DO-0 and the DO-29. <div data-bbox="667 824 1308 1294" style="text-align: center;"> <p style="text-align: right; font-size: small;">Rio02017KA</p> </div> <ol style="list-style-type: none"> 5) Check the Regi Roll rotation. 6) Press the "Cancel" key to stop the test. 7) Press the "▼" key to display the DO-0. 8) Press the "Cancel" key to stop the motor. 9) Remove the cheter and close the Front Cover.

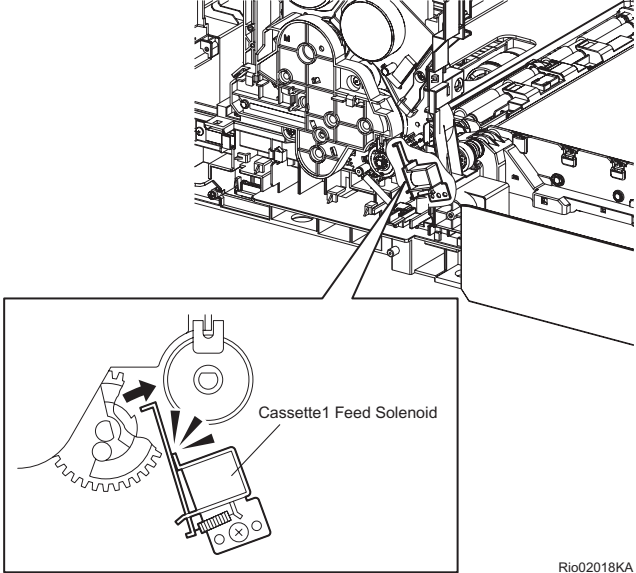
Clutch and Solenoid name (Diag. Code)	Confirmation procedure
<p>CASSETTE1 FEED SOLENOID (Auto OFF) (DO-2f)</p>	<p>NOTE: This test should be carried out in the case where the Feed Roll fails to rotate under the CASSETTE1 FEED SOLENOID (DO-b or DO-c) (Feed Roll Rotation) status.</p> <p>These procedures are for the technical staff. When performing operation for five minutes or longer with the front cover open, remove the PHD ASSY, and cover the drum to avoid exposure to light.</p> <ol style="list-style-type: none"> 1) Remove the COVER ASSY SIDE L. 2) Cheat the safety Interlock System. 3) Turn on the power and enter the Diagnostic Mode. 4) Execute the DO-2f. <div style="text-align: center;">  <p style="text-align: right; margin-right: 50px;">Cassette1 Feed Solenoid</p> <p style="text-align: right; margin-right: 50px;">Rio02018KA</p> </div> <ol style="list-style-type: none"> 5) Check the FEED SOLENOID movement. 6) Press the "Cancel" key to stop the test. 7) Turn off the printer power. 8) Attach the COVER ASSY SIDE L. 9) Remove the cheter and close the Front Cover. 10) Turn on the printer power.

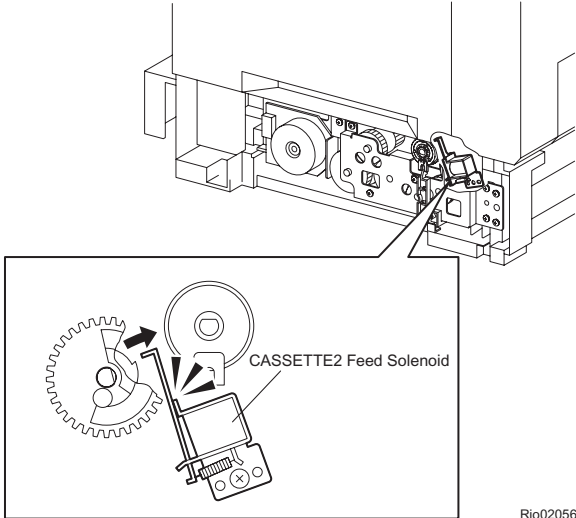
Clutch and Solenoid name (Diag. Code)	Confirmation procedure
<p>CASSETTE 2 FEED SOLENOID(Auto OFF) (DO-31)</p>	<p>NOTE: This procedure is for the technical staff. The customer check is the procedure 1, 3 and 4.</p> <ol style="list-style-type: none"> 1) Turn on the power and enter the Diagnosis Mode. 2) Remove the COVER REAR OPT (PL12.1.6) and COVER SIDE L OPT (PL12.1.4). 3) Execute the DO-31. (The customer can confirm the Solenoid click sound only.) <div style="text-align: center;">  <p style="text-align: right; font-size: small;">Rio02056KA</p> </div> <ol style="list-style-type: none"> 4) Check the FEED SOLENOID movement. 5) Press the "Cancel" key to stop the test. 6) Replace the COVER REAR OPT (PL12.1.6) and COVER SIDE L OPT (PL12.1.4).

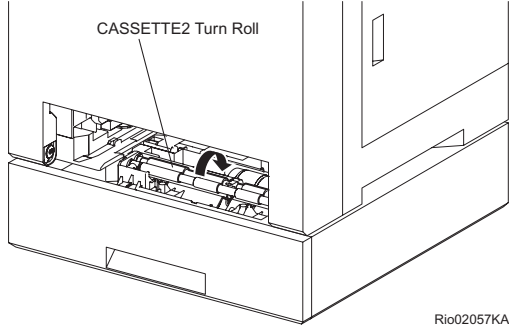
Clutch and Solenoid name (Diag. Code)	Confirmation procedure
CASSETTE 2 TURN CLUTCH (DO-33)	<ol style="list-style-type: none"> 1) Turn on the power and enter the Diagnostic Mode. 2) Execute the DO-33. Upon hitting the "return" key, the operating noise of the clutch will be heard. 3) Press the "Cancel" key to stop the clutch. <p>Combination test is as follows. NOTE: CASSETTE 2 turn roll rotates when the DO-17 and the DO-33 are executed. This procedure is for the technical staff.</p> <ol style="list-style-type: none"> 1) Remove the COVER CHUTE (PL12.1.5). 2) Turn on the power and enter the Diagnostic Mode. 3) Remove the CASSETTE 1 paper cassette and CASSETTE 2 paper cassette. 4) Execute the DO-17 and the DO-33.  <ol style="list-style-type: none"> 5) Confirm the CASSETTE 2 Turn Roll rotation. 6) Press the "Cancel" key to stop the clutch. 7) Press the "▼" key to display the DO-17. 8) Press the "Cancel" key to stop the motor. 9) Replace the CASSETTE 1 paper cassette and CASSETTE 2 paper cassette. 10) Turn off the power. 11) Replace the COVER CHUTE (PL12.1.5).

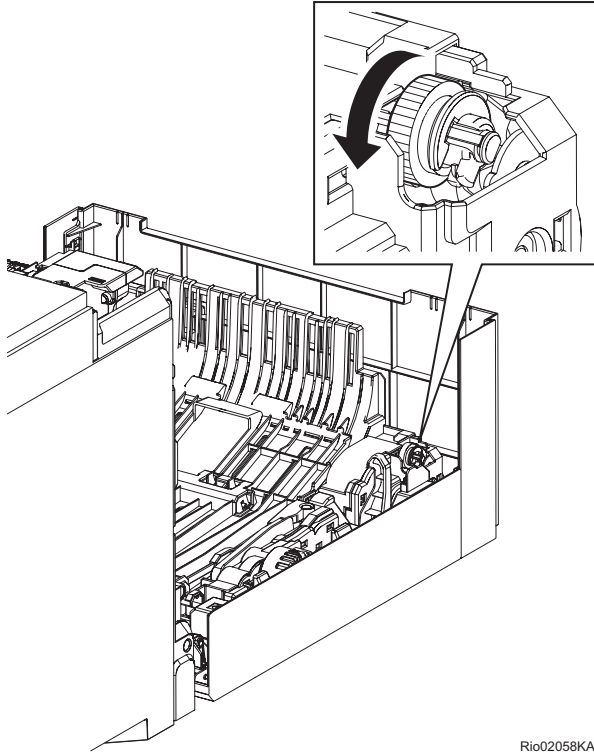
Clutch and Solenoid name (Diag. Code)	Confirmation procedure
Duplex CLUTCH (DO-35)	<ol style="list-style-type: none"> 1) Turn on the power and enter the Diagnostic Mode. 2) Execute the DO-35. Upon hitting the "return" key, the operating noise of the clutch will be heard. 3) Press the "Cancel" key to stop the clutch. <p>Combination test is as follows. NOTE: The duplex gear rotates when the DO-d and the DO-35 are executed. This procedure is for the technical staff. When performing operation for five minutes or longer with the front cover open, remove the PHD ASSY, and cover the drum to avoid exposure to light.</p> <ol style="list-style-type: none"> 1) Turn on the power and enter the Diagnostic Mode. 2) Open the Front Cover. 3) Cheat the safety Interlock System. 4) Execute the DO-d and the DO-35.  <p style="text-align: right; font-size: small;">Rio02058KA</p> <ol style="list-style-type: none"> 5) Confirm the gear rotation. 6) Press the "Cancel" key to stop the clutch. 7) Press the "▼" key to display the DO-d. 8) Press the "Cancel" key to stop the motor. 9) Remove the cheater and close the Front Cover.

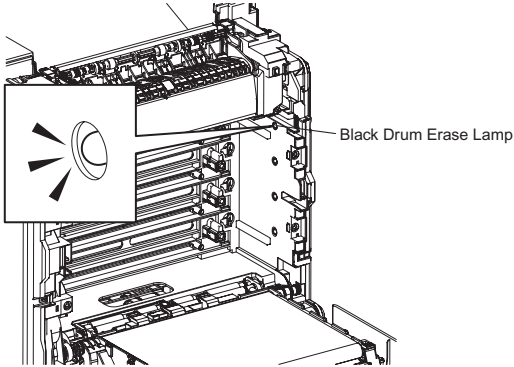
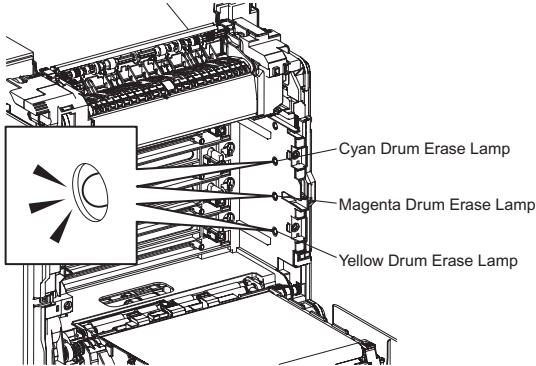
Clutch and Solenoid name (Diag. Code)	Confirmation procedure
<p>Black Drum Erase Lamp (DO-3d)</p>	<p>NOTE: These procedures are for the technical staff.</p> <ol style="list-style-type: none"> 1) Turn on the power and enter the Diagnostic Mode. 2) Open the Front Cover. 3) Remove the PHD ASSY and cover the drum to avoid exposure to light. 4) Cheat the safety Interlock System. 5) Execute the DO-3d.  <p style="text-align: right;">Rio02019KA</p> <ol style="list-style-type: none"> 6) Check the lamp lighting. 7) Press the "Cancel" key to stop the test. 8) Replace the PHD ASSY. 9) Remove the cheter and close the Front Cover.
<p>Yellow, Magenta and Cyan Drum Erase Lamp (DO-3f)</p>	<p>NOTE: These procedures are for the technical staff.</p> <ol style="list-style-type: none"> 1) Turn on the power and enter the Diagnostic Mode. 2) Open the Front Cover. 3) Remove the PHD ASSY and cover the drum to avoid exposure to light. 4) Cheat the safety Interlock System. 5) Execute the DO-3f.  <p style="text-align: right;">Rio02020KA</p> <ol style="list-style-type: none"> 6) Check the lamps lighting. 7) Press the "Cancel" key to stop the test. 8) Replace the PHD ASSY. 9) Remove the cheter and close the Front Cover.

4.2 Print Info

Prints out the detailed printer settings and configuration information.

4.2.1 Executing Print Info

- 1) Turn off the power.
- 2) Turn on the power while holding down “▲” and “▼” keys.
- 3) Release the fingers from these keys when “Diagnosing...” is displayed.
- 4) The “Customer Mode” and “IOT Diag” are displayed. (Entered the Diag. mode.)
- 5) Press “▼” to select “Print Info”, and then press “✓” key.
- 6) Press “▲” and “▼” key to select the item.
- 7) Press “✓” key twice to execute the setting.

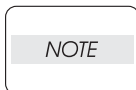

- To exit the test or to return to one step higher menu, press the "CANCEL" key.
- A test is not performed when an obstacle is in IOT.

4.2.2 Config Page

The version of software of IOT and the printer configuration can be confirmed by executing this test.

4.2.3 Print Settings

The service tag, printing count value and error count value can be confirmed by executing this test.

4.3 Complete

Completes the diagnosis operation and reboot the data.

4.3.1 Executing Complete

- 1) Turn off the power.
- 2) Turn on the power while holding down “▲” and “▼” keys.
- 3) Release the fingers from these keys when “Diagnosing...” is displayed.
- 4) The “Customer Mode” and “IOT Diag” are displayed. (Entered the Diag. mode.)
- 5) Press “▼” to select “Complete”, and then press “✓” key.
- 6) Press “✓” key twice to execute the setting.

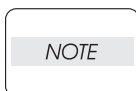

- To exit the test or to return to one step higher menu, press the "CANCEL" key.

4.3.2 Complete

Completes the diagnosis operation and reboot the data.

4.4 Installation Set

Specifies whether or not Alarm display of Toner residual quantity is performed.

4.4.1 Executing Installation Set

- 1) Turn off the power.
- 2) Turn on the power while holding down “▲” and “▼” keys.
- 3) Release the fingers from these keys when “Diagnosing...” is displayed.
- 4) The “Customer Mode” and “IOT Diag” are displayed. (Entered the Diag. mode.)
- 5) Press “▼” to select “Installation Set”, and then press “✓” key.
- 6) Press “▼” key to select the ON or OFF.
- 7) Press “✓” key to execute the setting.

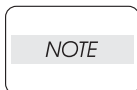

To exit the test or to return to one step higher menu, press the "CANCEL" key.

4.5 Test Print

Print an internal test pattern of the printer. If paper jam or paper empty occurs during the print, the test waits until they are resolved.

4.5.1 Executing test print

- 1) Turn off the power.
- 2) Turn on the power while holding down “▲” and “▼” keys.
- 3) Release the fingers from these keys when “Diagnosing...” is displayed.
- 4) The “Customer Mode” and “IOT Diag” are displayed. (Entered the Diag. mode.)
- 5) Press “▼” key to select “Test Print”, and then press “✓” key.
- 6) Press “▲” or “▼” key to select the test item.
- 7) Press “✓” key twice to execute the test.

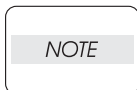

- To exit the test or to return to one step higher menu, press the "CANCEL" key.
- A test is not performed when an obstacle is in IOT.

4.5.2 No Image IOT

Prints the blanked paper.

4.5.3 Pattern 600 IOT

Prints the IOT built-in 600dpi pattern.

When the PQ problem occurred, this test enables to identify the problem as the printing process or the PWBA ESS related.

Compare the sample chart with the print.

Check result: NG (Check the printing process.) OK (Check the PWBA ESS related.)

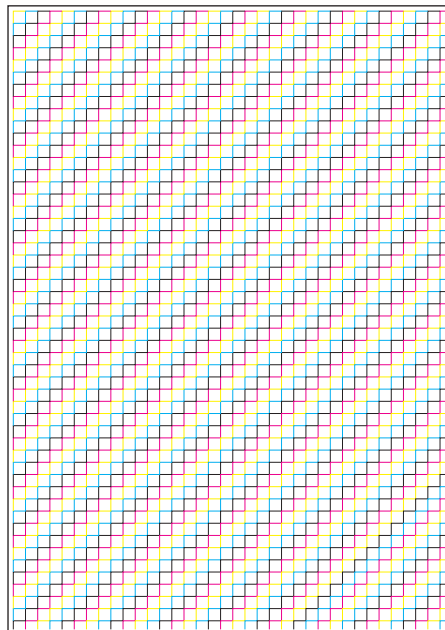

Kmy02001KA

4.5.4 Grid 2

Prints the ESS built-in grid pattern.

When the PQ problem occurred, this test enables to identify the problem as printer-related or otherwise.

Compare the sample chart with the print.

Check result: NG (Check the printing process and PWBA ESS-related.) OK (Check the network, cable, PC and so on.)



Leg_Sec02_004FA

4.5.5 Cyan 20%

Outputs cyan 20% paint on the whole area of a A4 paper.

When the PQ problem occurred, this test enables to identify the problem as the cyan toner or another color.

Compare the sample chart with the print.

Check result: NG (Check the cyan toner-related.) OK (Check another toner.)

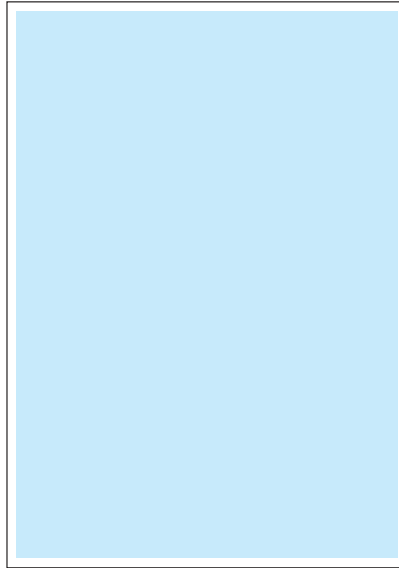

Leg_Sec02_005FA

4.5.6 Magenta 20%

Outputs magenta 20% paint on the whole area of a A4 paper.

When the PQ problem occurred, this test enables to identify the problem as the magenta toner or another color.

Compare the sample chart with the print.

Check result: NG (Check the magenta toner-related.) OK (Check another toner.)

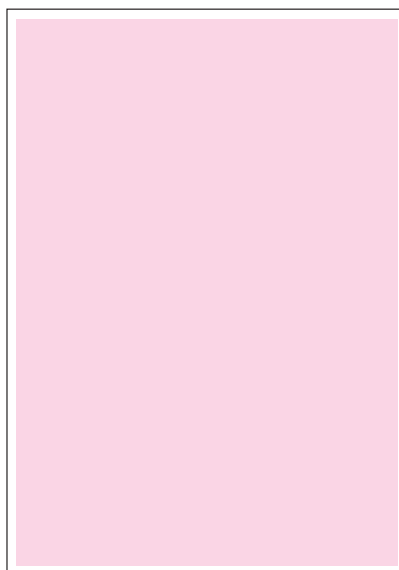

Leg_Sec02_006FA

4.5.7 Yellow 20%

Outputs yellow 20% paint on the whole area of a A4 paper.

When the PQ problem occurred, this test enables to identify the problem as the yellow toner or another color.

Compare the sample chart with the print.

Check result: NG (Check the yellow toner-related.) OK (Check another toner.)

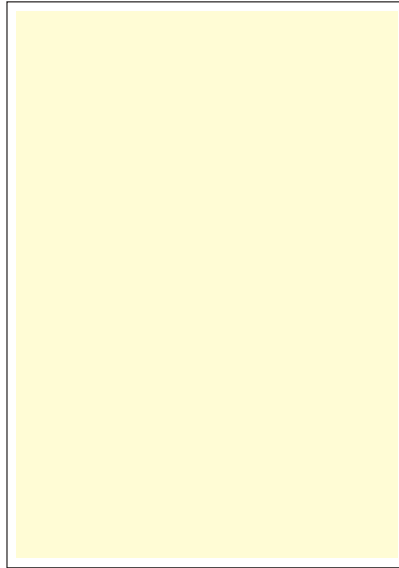

Leg_Sec02_007FA

4.5.8 Black 20%

Outputs black 20% paint on the whole area of a A4 paper.

When the PQ problem occurred, this test enables to identify the problem as the black toner or another color.

Compare the sample chart with the print.

Check result: NG (Check the black toner-related.) OK (Check another toner.)

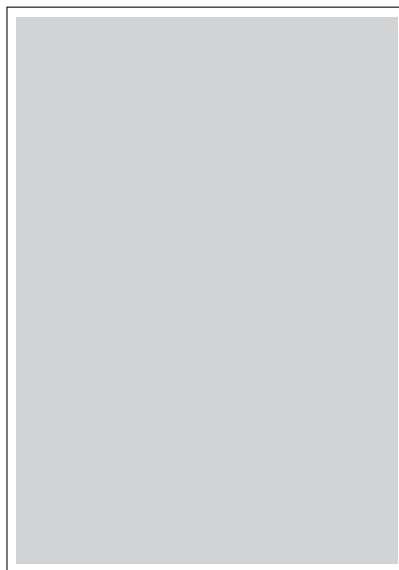

Leg_Sec02_008FA

4.5.9 CMY 20%

Outputs C/M/Y 20% paint on the whole area of a A4 paper.

When the PQ problem occurred, this test enables to identify the problem as the balance of three color toners or otherwise.

Compare the sample chart with the print.

Check result: NG (Check the yellow, magenta or cyan toner-related.) OK (Check black toner.)

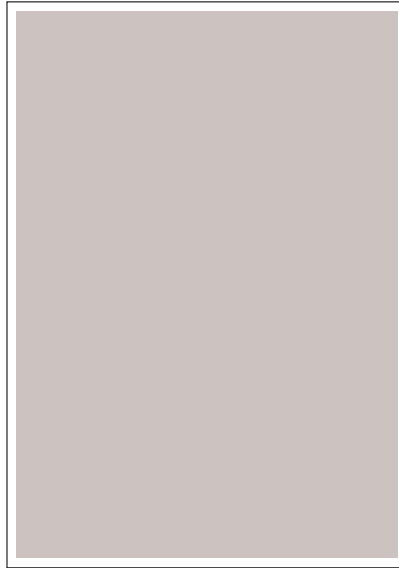

Leg_Sec02_009FA

4.5.10 Gradation

Outputs the tone pattern from 2% to 100% on a A4 paper for each of 4 colors.

When the PQ problem occurred, this test enables to identify the problem as the printing process or PWBA ESS-related.

Compare the sample chart with the print.

Check result: NG (Check the printing process.) OK (Check the PWBA ESS-related.)

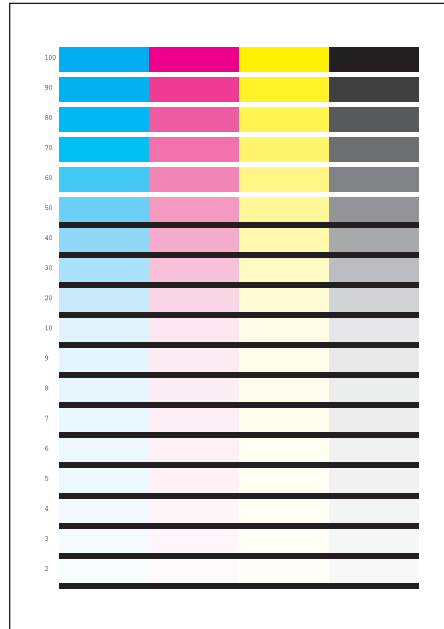

Leg_Sec02_010FA

4.5.11 Toner Pallet

Outputs each 100% density color pattern of Y/M/C/K.

When the PQ problem occurred in the picture or photo printing, this test enables to identify the problem as the toner or another.

Compare the sample chart with the print.

Check result: NG (Check the problem toner-related.) OK (Check the print job or print data.)

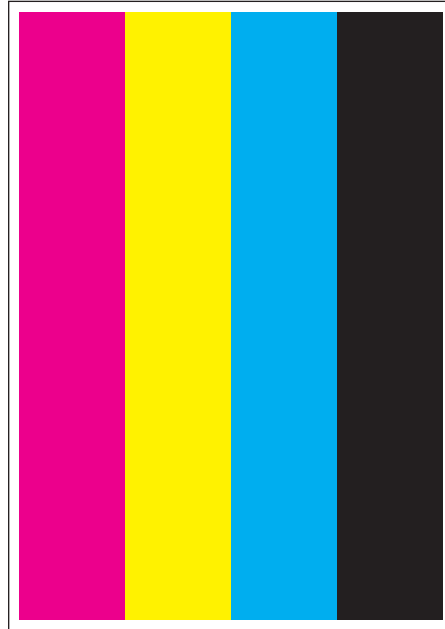

Leg_Sec02_011FA

4.5.12 Contamination Check

Allows you to check the print for any regular lines or toner spots when encountering PQ problems. From the difference in the interval of regular lines or spots, you can determine the parts that have caused the trouble.

Page 1 to 4: Prints the scale patterns in vertical and horizontal directions for evaluating regularity and intervals.

Page 5: Prints the list of intervals by component fault.

Page 1

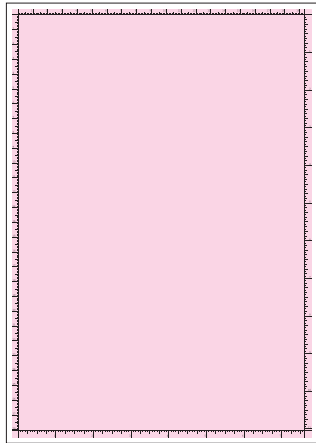

Wsb02028KA

Page 2

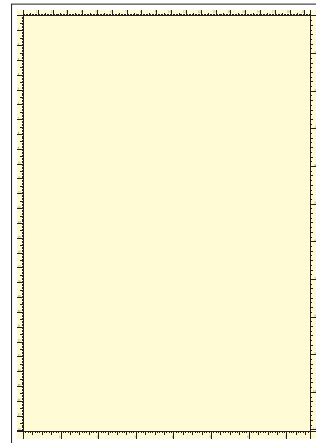

Wsb02027KA

Page 3

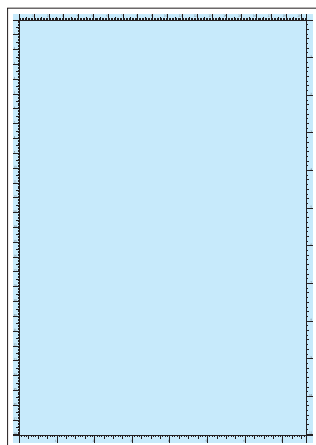

Wsb02029KA

Page 4

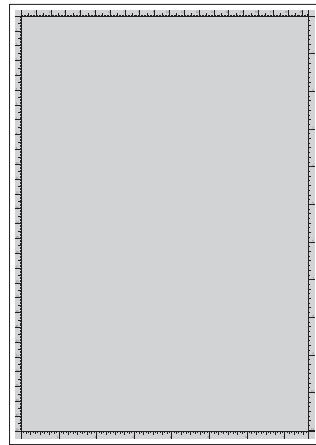

Wsb02030KA

Page 5

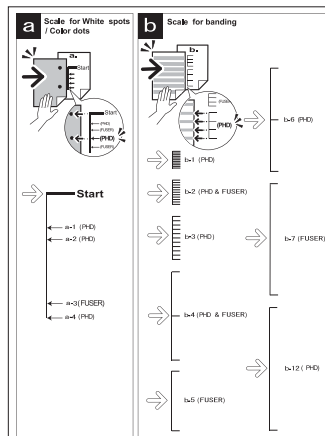

Wsb02025KA

4.5.13 Parameter Setting

This function reads/writes the following parameters stored in the printer.

Item	Range	Description
Slow Scan K to P	-128 to 127	Sets the registration in the paper feeding direction
Slow Scan 600 M,Y,C		
First Scan K to M,Y or C	-128 to 127	Sets the registration in the scanning direction.
First Scan SSF, Tray 1, Tray 2, Dup	-30 to 30	
First Scan 2 K to M,Y or C	-1 to 2	
Life Counter	-	Reads the life counter and the printer.

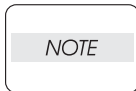

Print the parameter list using the Print function of Parameter Menu in diagnosis before changing the value of the registration.

Parameter	Function	Default	Adjustable range
Slow Scan K to P (Shifts 0.17mm/1count)	Black registration adjustment	--	-128 to 127
Slow Scan 600 M,Y,C (Shifts 0.042mm/1count)	Color registration adjustment (600 dpi)	--	-128 to 127
Fast Scan K to M, Y or C (Shifts 0.042mm/1count)	Color registration adjustment Calculation of adjustment is shown below. (exp. Yellow)	--	-128 to 127
Fast Scan 2 K to M, Y or C (Shifts 0.01mm/1count)	(Value of Fast Scan K to Y + Value of Fast Scan 2 K to Y)/4	--	-1 to 2
First Scan SSF, Tray 1, Tray 2, Dup (Shifts 0.17mm/1count)	Black registration adjustment at side 1 print	--	-30 to 30

NOTE

The default values are different in each printer.

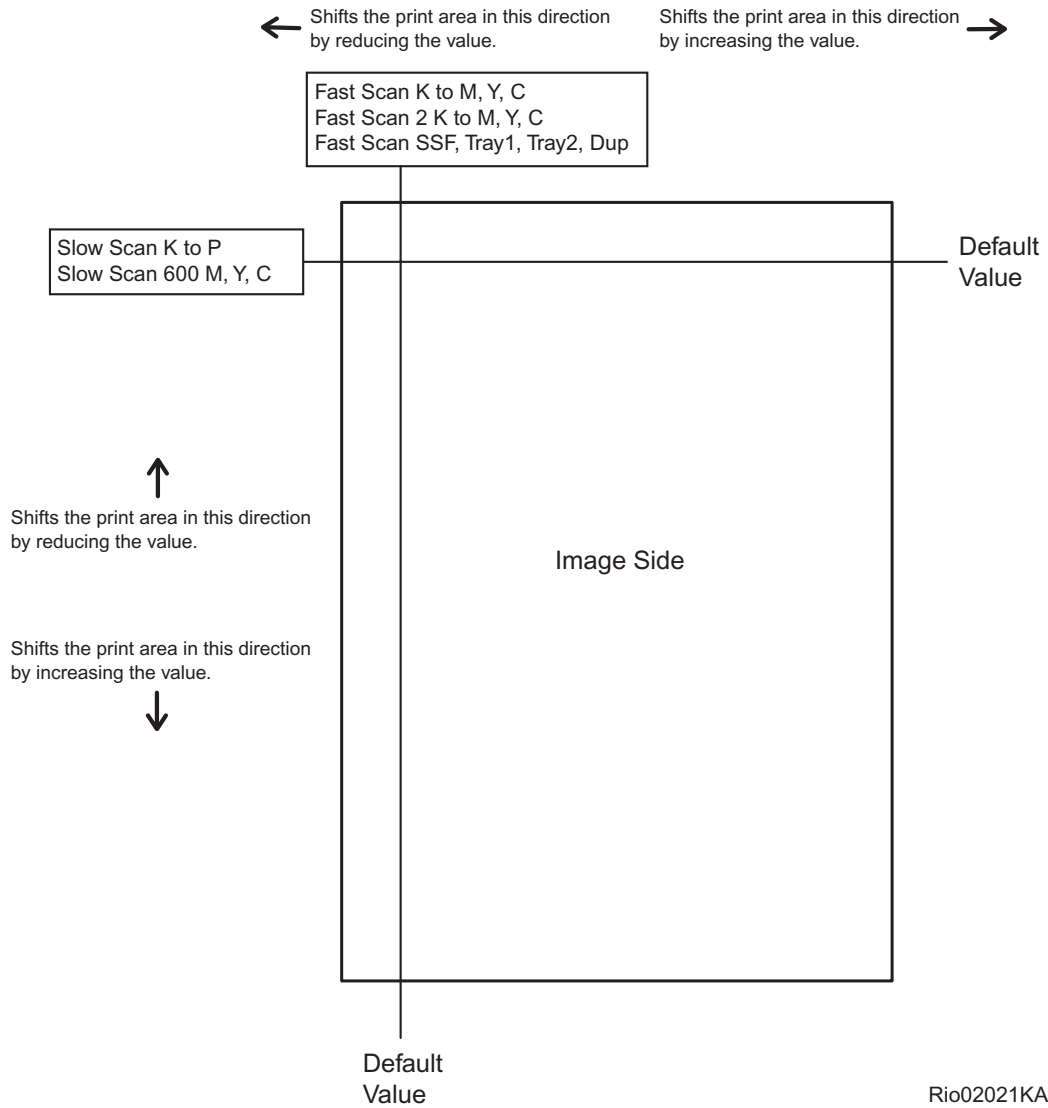

Rio02021KA

Reference Counter Values

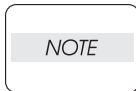

These counter values are reference only. Do not use as the official value.

Counter Name	Value of life warning
Life Y Toner (Dispense time)	-
Life M Toner (Dispense time)	-
Life C Toner (Dispense time)	-
Life K Toner (Dispense time)	-
Life Fuser (Paper feeding count)	100000
Life Printer (Paper feeding count)	-
Life DTB (Transfer Belt) 2 (Waste Toner cleaning count)	200000
Life Y Waste Toner (Waste Toner cleaning count)	18000
Life M Waste Toner (Waste Toner cleaning count)	18000
Life C Waste Toner (Waste Toner cleaning count)	18000
Life K Waste Toner (Waste Toner cleaning count)	18000
Life Y Drum (Cycle count)	3000000
Life M Drum (Cycle count)	3000000
Life C Drum (Cycle count)	3000000
Life K Drum (Cycle count)	3000000
Life Drum Xero	-
Life Drum Deve K	-
Life SSF (MPF) Sheet	-
Life Tray 1 Sheet	-
Life Tray 2 Sheet	-
Life Duplex Sheet	-
Life Custom In	-
Life Custom Out	-
Print	-

4.5.14 Printing the parameter list

This function prints the parameter values and life counter values stored in the IOT.