

# Color imageRUNNER LBP5480

## PARTS CATALOG



# Canon

December 28, 2012  
Rev. 0

[www.Service-Manual.net](http://www.Service-Manual.net)



## **PREFACE**

This Parts Catalog contains listings of parts used

Diagrams are provided with the listings to aid the service technician in identifying clearly, the item to be ordered.

Whenever ordering parts, consult this Parts Catalog for all of the information pertaining to each item. Be sure to include, in the Parts Request, the full item description, the item part number, and the quantity.

***COPYRIGHT (C) 1999 CANON INC.***

Use of this manual should be strictly supervised to avoid disclosure of confidential information.



# Contents

## NUMERICAL INDEX

Color imageRUNNER LBP5480(Numerical Index)..... 1-1

## Color imageRUNNER LBP5480(Parts Catalog)

A1	ASSEMBLY LOCATION DIAGRAM .....	2-1
A2	OPTION PARTS CATALOG LIST .....	2-2
001	ACCESSORIES .....	2-3
100	EXTERNAL PANELS, COVERS, ETC. ....	2-4
101	FRONT DOOR ASS'Y .....	2-6
102	RIGHTDOOR ASS'Y .....	2-7
103	INTERNAL COMPONENTS 1 .....	2-9
104	INTERNAL COMPONENTS 2 .....	2-11
105	INTERNAL COMPONENTS 3 .....	2-14
106	INTERNAL COMPONENTS 4 .....	2-17
107	INTERNAL COMPONENTS 5 .....	2-20
300	CASSETTE ASSEMBLY .....	2-22
310	PAPER PICK-UP ASS'Y .....	2-24
311	MULTI-PURPOSE PICK-UP ASS'Y .....	2-26
810	FIXING ASS'Y .....	2-28
ZZA	MECHANICAL STANDARD PARTS (HOW TO USE) .....	2-29
ZZB	MECHANICAL STANDARD PARTS (SCREWS) .....	2-30
ZZC	MECHANICAL STANDARD PARTS (BOLTS) .....	2-37
ZZD	MECHANICAL STANDARD PARTS (NUTS) .....	2-38
ZZE	MECHANICAL STANDARD PARTS (RETAINING RINGS) .....	2-39



# NUMERICAL INDEX

## Color imageRUNNER LBP5480(Numerical Index)

PARTS NUMBER	FIGURE & KEY NO.	PARTS NUMBER	FIGURE & KEY NO.	PARTS NUMBER	FIGURE & KEY NO.
FC8-9800-000	100 - 15	RC2-4377-000	105 - 26	RC2-5960-000	103 - 16
FC8-9956-000	102 - 1	RC2-4378-000	105 - 24	RC2-5961-020	107 - 15
FE2-1293-000	100 - 1	RC2-4406-000	104 - 26	RC2-5962-000	104 - 18
FE2-1295-000	105 - 31	RC2-4407-030	104 - 25	RC2-5966-000	104 - 16
FE2-1304-000	100 - 2	RC2-4415-000	104 - 23	RC2-5967-000	104 - 17
FE2-1305-000	100 - 3	RC2-4426-000	103 - 20	RC2-5969-000	104 - 19
FE2-1308-000	100 - 4	RC2-4541-000	105 - 1	RC2-5971-000	104 - 6
FE2-1311-000	100 - 5	RC2-4734-000	102 - 3	RC2-5993-000	104 - 7
FE2-1312-000	100 - 6	RC2-4780-000	103 - 21	RC2-6018-000	102 - 7
FE2-1320-000	100 - 16	RC2-4783-000	103 - 15	RC2-9069-000	107 - 10
FE2-1321-000	106 - 28	RC2-4820-000	103 - 10	RC2-9073-000	102 - 5
FE2-1334-000	100 - 8	RC2-4824-000	107 - 2	RC2-9074-000	106 - 15
FE2-1337-000	100 - 9	RC2-4828-000	105 - 6	RC2-9075-000	104 - 8
FE2-1358-000	106 - 29	RC2-4830-000	103 - 9	RC2-9562-000	106 - 19
FE2-1362-000	100 - 10	RC2-4831-000	103 - 8	RC3-1070-000	103 - 5
FE2-2182-000	105 - 12	RC2-4831-000	105 - 16	RC3-1075-000	104 - 24
FE2-2185-000	100 - 7	RC2-4875-000	105 - 2	RC3-1076-000	106 - 5
FK2-9904-000	001 - 2	RC2-4914-000	105 - 5	RC3-1077-000	106 - 8
FK3-1986-000	106 - 32	RC2-4924-000	103 - 31	RC3-1079-000	106 - 9
FK3-3404-000	106 - 27	RC2-5010-000	103 - 7	RC3-1085-000	106 - 12
FK3-3418-000	106 - 31	RC2-5011-000	103 - 4	RC3-1123-000	107 - 24
FK3-3993-000	001 - 1	RC2-5015-000	107 - 4	RC3-1170-000	107 - 3
FM0-1781-000	106 - 24	RC2-5016-000	106 - 18	RC3-1183-000	105 - 40
FM0-2453-000	100 - 11	RC2-5019-000	105 - 8	RC3-1184-000	105 - 41
FM0-2454-000	300 -	RC2-5021-000	106 - 4	RC3-1192-000	103 - 14
FM0-2455-000	101 -	RC2-5044-000	104 - 3	RC3-1205-000	103 - 23
FM0-2456-000	102 -	RC2-5104-000	107 - 9	RC3-1217-000	106 - 13
FM0-2458-000	100 - 12	RC2-5117-000	105 - 15	RC3-1230-000	105 - 3
FM0-2459-000	100 - 13	RC2-5118-000	105 - 14	RC3-1231-000	103 - 2
FM0-2464-000	100 - 14	RC2-5119-000	105 - 13	RC3-1232-000	105 - 4
FM0-3292-000	105 - 37	RC2-5120-000	105 - 9	RC3-1353-000	107 - 27
FM0-3295-000	106 - 33	RC2-5121-000	105 - 11	RK2-2415-000	107 - 25
FM0-3298-000	105 - 32	RC2-5122-000	105 - 27	RK2-2416-000	106 - 6
FM0-3305-000	106 - 20	RC2-5123-000	105 - 10	RK2-2418-000	104 - 30
FM0-3306-000	106 - 25	RC2-5160-000	104 - 9	RK2-3267-000	104 - 27
FM0-3307-000	106 - 26	RC2-5898-000	104 - 2	RK2-3941-000	106 - 16
FM0-3310-000	106 - 21	RC2-5912-000	104 - 12	RK2-3943-000	106 - 7
FM0-3317-000	106 - 30	RC2-5913-000	105 - 17	RL1-1937-000	311 - 2
FM3-8816-000	810 -	RC2-5930-000	106 - 10	RL1-1948-000	106 - 3
FM3-8827-000	103 - 3	RC2-5932-000	104 - 4	RL1-2184-000	311 - 1
FM3-8828-000	103 - 6	RC2-5937-000	103 - 24	RL1-3109-000	103 - 29
FM3-9078-000	105 - 36	RC2-5943-000	106 - 11	RM1-4952-030	105 - 42
FM3-9079-000	105 - 7	RC2-5950-000	103 - 25	RM1-4959-000	102 - 2
NPN	001 -	RC2-5951-000	103 - 26	RM1-4969-000	105 - 44
NPN	100 -	RC2-5954-000	104 - 15	RM1-4970-060	105 - 43
NPN	103 -	RC2-5954-000	105 - 19	RM1-4973-000	107 - 23
NPN	104 -	RC2-5955-000	104 - 14	RM1-4978-000	107 - 20
NPN	105 -	RC2-5956-000	105 - 22	RM1-4983-000	107 - 29
NPN	106 -	RC2-5957-000	105 - 20	RM1-4999-000	104 - 10
NPN	107 -	RC2-5958-000	104 - 13	RM1-5488-000	104 - 11
RC2-3972-000	107 - 16	RC2-5958-000	105 - 21	RM1-5532-000	105 - 39
RC2-3983-030	103 - 19	RC2-5959-000	107 - 18	RM1-5533-000	105 - 45

# NUMERICAL INDEX

## Color imageRUNNER LBP5480(Numerical Index)

PARTS NUMBER	FIGURE & KEY NO.	PARTS NUMBER	FIGURE & KEY NO.	PARTS NUMBER	FIGURE & KEY NO
RM1-5588-000	104 - 28	RU6-2436-000	104 - 5		
RM1-5676-000	104 - 22	RU6-2567-000	103 - 11		
RM1-5696-000	103 - 12	RU6-2568-000	103 - 27		
RM1-5700-000	104 - 29	RU6-2569-000	102 - 6		
RM1-5703-000	105 - 38	RU7-0257-000	105 - 23		
RM1-5704-000	103 - 22	RU7-2192-000	103 - 17		
RM1-5712-000	107 - 11	RU7-2193-000	107 - 17		
RM1-5714-000	106 - 1	VS1-7258-007	107 - 12		
RM1-5730-000	107 - 1	WC4-5171-000	105 - 29		
RM1-5732-000	105 - 30	WG8-5935-000	107 - 13		
RM1-5737-000	106 - 14	WG8-5935-000	310 - 2		
RM1-5740-000	104 - 34	XB4-7401-005	105 - 501		
RM1-5741-000	104 - 35				
RM1-5742-000	103 - 1				
RM1-5746-000	104 - 1				
RM1-5747-000	107 - 31				
RM1-5749-000	104 - 33				
RM1-5752-000	104 - 36				
RM1-7037-000	107 - 30				
RM1-8087-000	106 - 22				
RM1-8088-000	106 - 23				
RM1-8105-000	107 - 8				
RM1-8109-000	107 - 26				
RM1-8112-000	106 - 2				
RM1-8113-000	106 - 17				
RM1-8124-000	311 -				
RM1-8129-000	300 - 1				
RM1-8130-000	310 -				
RM1-8131-000	310 - 1				
RM1-8132-000	105 - 35				
RM1-8133-000	107 - 22				
RM1-8134-050	107 - 21				
RM1-8135-000	107 - 14				
RM1-8136-000	107 - 7				
RM1-8137-000	107 - 5				
RM1-8138-000	103 - 13				
RM1-8140-000	104 - 32				
RM1-8146-000	105 - 33				
RM1-8149-000	104 - 31				
RM1-8161-000	103 - 28				
RM1-8163-000	105 - 34				
RM1-8174-000	107 - 19				
RM1-8176-000	105 - 28				
RM1-9236-000	107 - 28				
RU6-0509-000	102 - 4				
RU6-0536-000	105 - 18				
RU6-2237-000	103 - 18				
RU6-2245-000	103 - 30				
RU6-2268-000	105 - 25				
RU6-2316-000	104 - 21				
RU6-2318-000	104 - 20				
RU6-2405-000	107 - 6				



# Color imageRUNNER LBP5480(Parts Catalog)

Color imageRUNNER LBP5480

120V  
US,CA,LTN

F16-3831-000 MMPA



# Contents

A1	ASSEMBLY LOCATION DIAGRAM .....	2-1
A2	OPTION PARTS CATALOG LIST .....	2-2
001	ACCESSORIES .....	2-3
100	EXTERNAL PANELS, COVERS, ETC. ....	2-4
101	FRONT DOOR ASS'Y .....	2-6
102	RIGHTDOOR ASS'Y .....	2-7
103	INTERNAL COMPONENTS 1 .....	2-9
104	INTERNAL COMPONENTS 2 .....	2-11
105	INTERNAL COMPONENTS 3 .....	2-14
106	INTERNAL COMPONENTS 4 .....	2-17
107	INTERNAL COMPONENTS 5 .....	2-20
300	CASSETTE ASSEMBLY .....	2-22
310	PAPER PICK-UP ASS'Y .....	2-24
311	MULTI-PURPOSE PICK-UP ASS'Y .....	2-26
810	FIXING ASS'Y .....	2-28
ZZA	MECHANICAL STANDARD PARTS (HOW TO USE) .....	2-29
ZZB	MECHANICAL STANDARD PARTS (SCREWS) .....	2-30
ZZC	MECHANICAL STANDARD PARTS (BOLTS) .....	2-37
ZZD	MECHANICAL STANDARD PARTS (NUTS) .....	2-38
ZZE	MECHANICAL STANDARD PARTS (RETAINING RINGS) .....	2-39



# FIGURE A1 ASSEMBLY LOCATION DIAGRAM

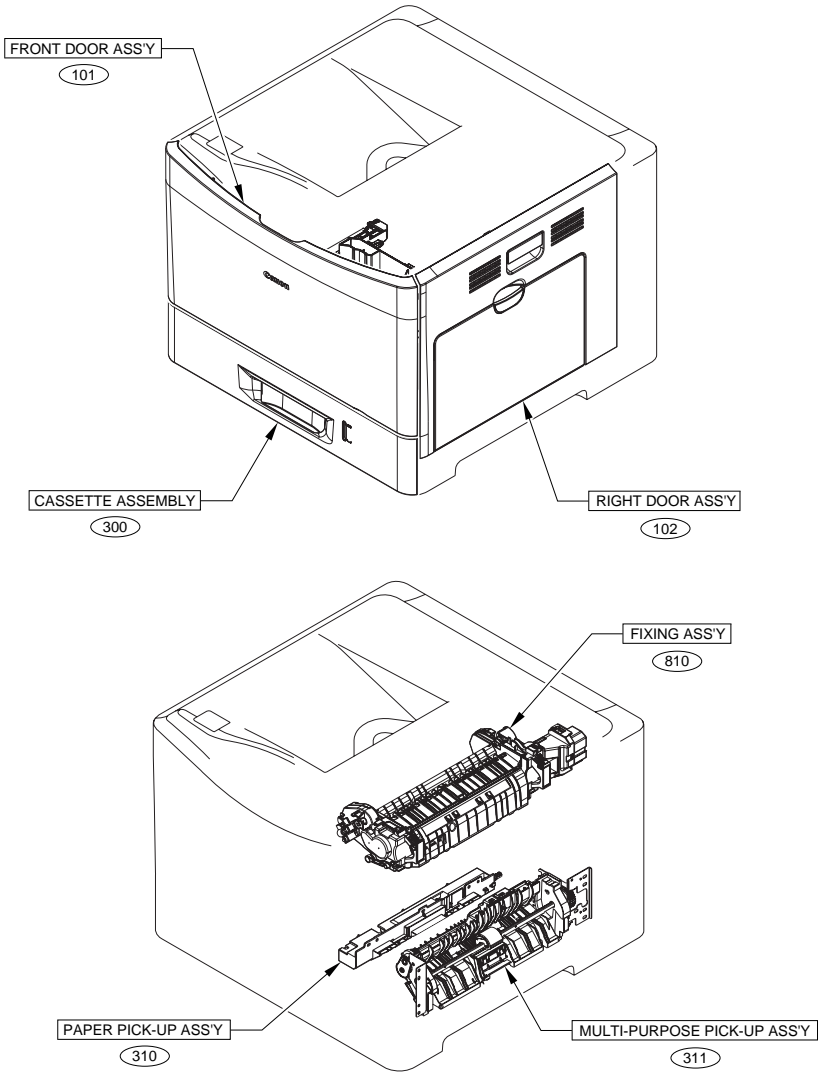

## FIGURE A2 OPTION PARTS CATALOG LIST

This is the table of the machine's options whose parts catalog is issued.  
本機のオプションで、パーツカタログが発行されている機種の一覧である。

No.	Model Name(English)	Model Name(Japanese)
1	Paper Feeder PF-723/723A	(日本仕向けなし)

# FIGURE 001 ACCESSORIES

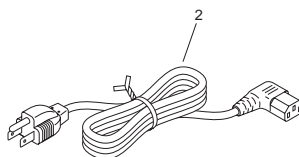
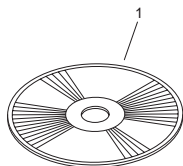

FIGURE & KEY NO.	PARTS NUMBER	RANK	QTY	DESCRIPTION	SERIAL NUMBER/REMARKS	SVC
Fig.001	NPN		RF	ACCESSORIES		
1	FK3-3993-000		1	CD-ROM, USER SOFTWARE		
2	FK2-9904-000		1	CORD, POWER SUPPLY		

# FIGURE 100 EXTERNAL PANELS, COVERS, ETC.

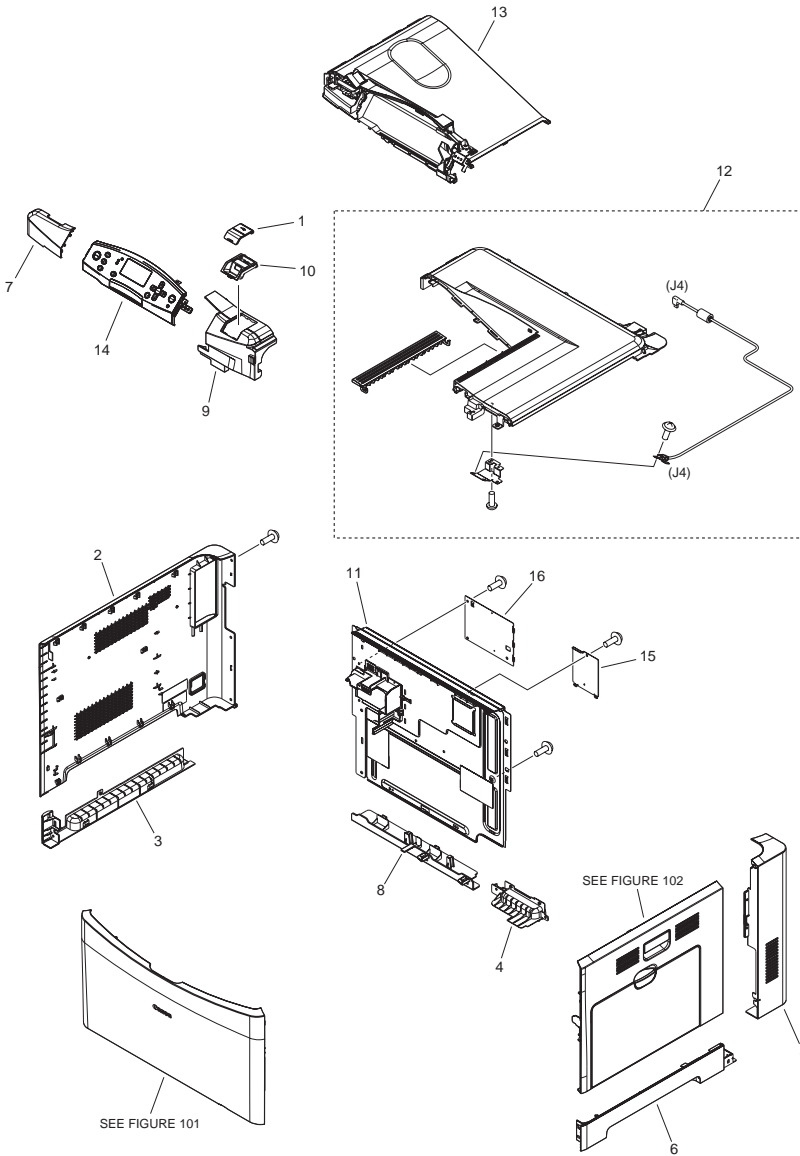



FIGURE & KEY NO.	PARTS NUMBER	R A N K	Q'TY	DESCRIPTION	SERIAL NUMBER/ REMARKS	S V C
Fig.100	NPN		RF	EXTERNAL PANELS, COVERS, ETC.		
1	FE2-1293-000		1	LID, USB		
2	FE2-1304-000		1	COVER, LEFT		
3	FE2-1305-000		1	COVER, LEFT LOWER		
4	FE2-1308-000		1	HANDLE, REAR		
5	FE2-1311-000		1	COVER, REAR RIGHT		
6	FE2-1312-000		1	COVER, RIGHT LOWER		
7	FE2-2185-000		1	COVER, CONTROL PANEL, LEFT		
8	FE2-1334-000		1	COVER, PROTECT., LOWER		
9	FE2-1337-000		1	COVER, CONTROL PANEL, RIGHT		
10	FE2-1362-000		1	COVER, CONTROL PANEL, RIGHT		
11	FM0-2453-000		1	REAR COVER ASSEMBLY		
12	FM0-2458-000		1	UPPERCOVER ASS'Y		
13	FM0-2459-000		1	PAPER DELIVERY TRAY ASS'Y		
14	FM0-2464-000		1	CONTROL PANEL ASS'Y		
15	FC8-9800-000		1	PLATE, SHIELD		
16	FE2-1320-000		1	PLATE, SHIELD R		

# FIGURE 101 FRONT DOOR ASS'Y

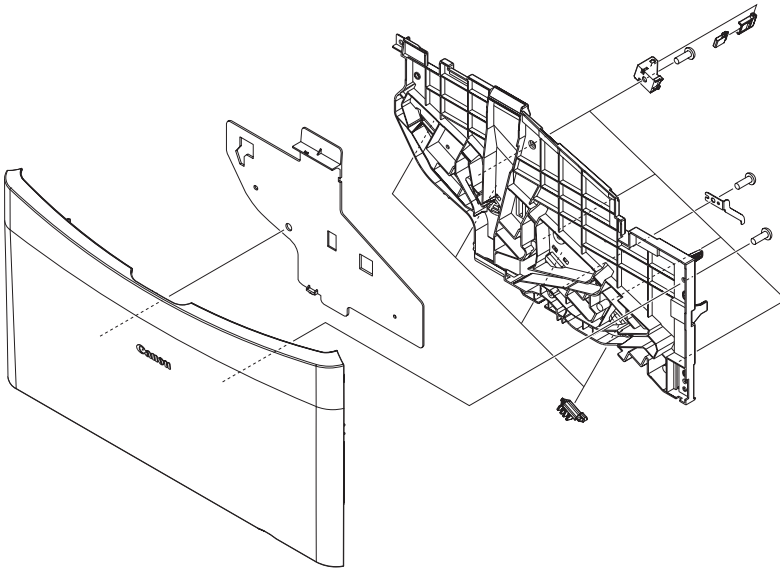
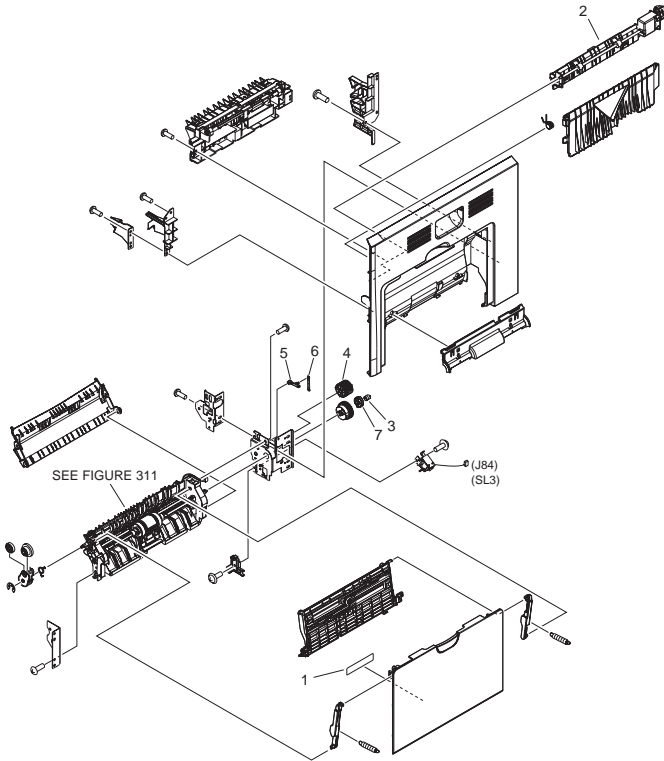

FIGURE & KEY NO.	PARTS NUMBER	RANK	QTY	DESCRIPTION	SERIAL NUMBER/REMARKS	SVC
Fig.101	FM0-2455-000		1	FRONT DOOR ASS'Y		

# FIGURE 102 RIGHTDOOR ASS'Y



NOTE 1 : This assembly includes the assembly shown in Figure 311.  
 NOTE 2 : This assembly does not include the part shown with key No. 1.  
 注 1 : このユニットはFigure 311のユニットを含みます。  
 注 2 : このユニットにKey No. 1の部品は含まれません。

FIGURE & KEY NO.	PARTS NUMBER	RANK	Q'TY	DESCRIPTION	SERIAL NUMBER/REMARKS	SVC
Fig.102	FM0-2456-000		1	RIGHTDOOR ASS'Y	SEE NOTE 1	
1	FC8-9956-000		1	INDEX, FEED TRAY PAPER SIZE	SEE NOTE 2	
2	RM1-4959-000		1	DUPLEXING PAPER FEED ASS'Y		
3	RC2-4734-000		1	SPRING, GROUNDING		
4	RU6-0509-000		1	GEAR, 26T		
5	RC2-9073-000		1	LEVER, STOPPER		
6	RU6-2569-000		1	SPRING, TENSION		
7	RC2-6018-000		1	CAM, STOPPER		

# FIGURE 103 INTERNAL COMPONENTS 1

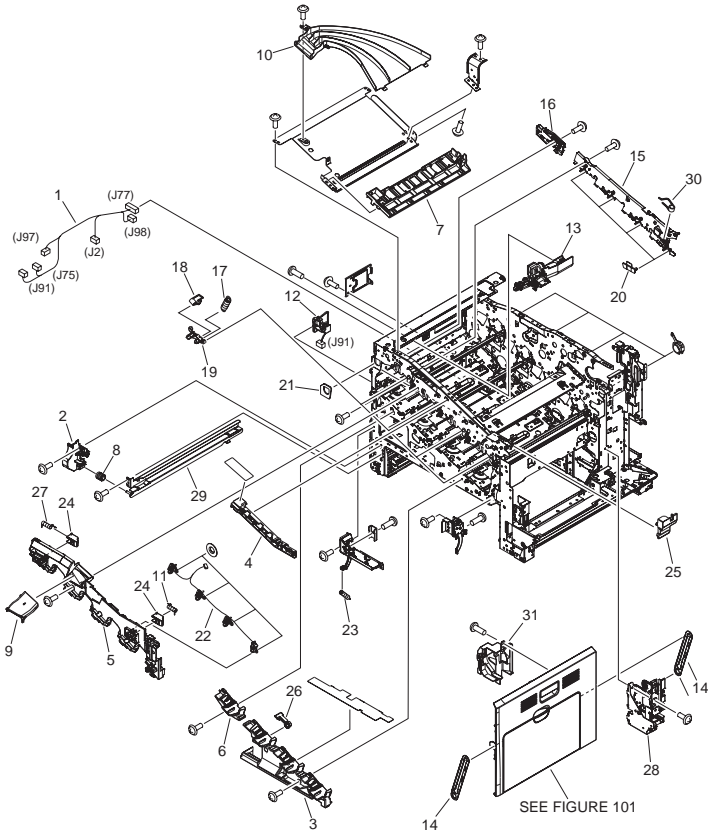

FIGURE & KEY NO.	PARTS NUMBER	R A N K	Q'TY	DESCRIPTION	SERIAL NUMBER/ REMARKS	S V C
Fig.103	NPN		RF	INTERNAL COMPONENTS 1		
1	RM1-5742-000		1	LEFT CABLE ASS'Y		
2	RC3-1231-000		1	HOLDER, CST.POSITIONING,FR.LF.		
3	FM3-8827-000		1	COVER, FRONT INNER, LOWER		
4	RC2-5011-000		1	GUIDE, CABLE, FRONT		
5	RC3-1070-000		1	COVER, FRONT INNER, UPPER		
6	FM3-8828-000		1	COVER, FRONT INNER, LOWER		
7	RC2-5010-000		1	GUIDE, CABLE, UPPER		
8	RC2-4831-000		1	ROLLER, RAIL		
9	RC2-4830-000		1	COVER, FACE-DOWN DUCT		
10	RC2-4820-000		1	DUCT, PAPER DELIVERY		
11	RU6-2567-000		1	SPRING, COMPRESSION		
12	RM1-5696-000		1	WASTE TONER DETECT ASS'Y		
13	RM1-8138-000		1	WASTE TONER DUCT ASS'Y		
14	RC3-1192-000		2	LINK, DOOR STOPPER		
15	RC2-4783-000		1	RAIL, GUIDE, FRONT		
16	RC2-5960-000		1	GUIDE, ROLLER, FRONT		
17	RU7-2192-000		4	SPRING, TENSION		
18	RU6-2237-000		4	SPRING, GROUNDING		
19	RC2-3983-030		4	LEVER, CRG. PRESSURE, FRONT		
20	RC2-4426-000		4	GUIDE, LIGHT		
21	RC2-4780-000		1	SEAL, WASTE TONER BOX		
22	RM1-5704-000		1	FRONT PRE-EXPOSURE PCB ASS'Y		
23	RC3-1205-000		1	SPRING, TENSION		
24	RC2-5937-000		2	LOCK, DOOR		
25	RC2-5950-000		1	COVER, CABLE		
26	RC2-5951-000		1	LEVER, BOX PRESENCE DETECT		
27	RU6-2568-000		1	SPRING, COMPRESSION		
28	RM1-8161-000		1	RIGHT DOOR HINGE REAR ASSY		
29	RL1-3109-000		1	RAIL, CASSETTE, LEFT		
30	RU6-2245-000		1	SPRING, TORSION		
31	RC2-4924-000		1	COVER, RIGHT DOOR GEAR, REAR		

FIGURE 104  
INTERNAL COMPONENTS 2

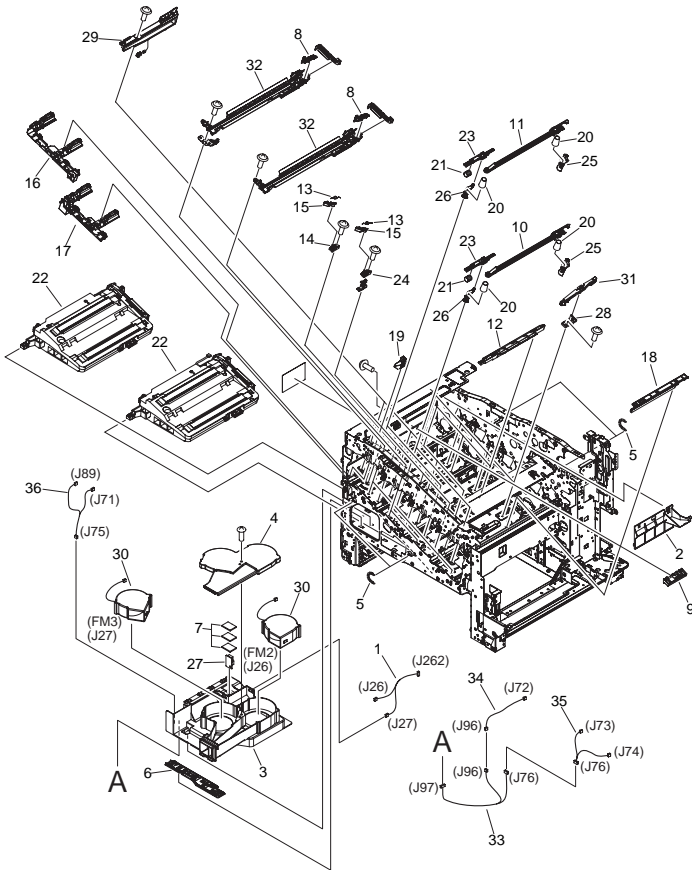

FIGURE & KEY NO.	PARTS NUMBER	R A N K	Q'TY	DESCRIPTION	SERIAL NUMBER/ REMARKS	S V C
Fig.104	NPN		RF	INTERNAL COMPONENTS 2		
1	RM1-5746-000		1	FAN CABLE ASS'Y		
2	RC2-5898-000		1	TRAY, WASTE TONER CATCH		
3	RC2-5044-000		1	HOLDER, CARTRIDGE FAN		
4	RC2-5932-000		1	HOLDER, CARTRIDGE FAN		
5	RU6-2436-000		4	SPRING, TENSION		
6	RC2-5971-000		1	GUIDE, CABLE, LOWER		
7	RC2-5993-000		3	SEAL, CARTRIDGE FAN HOLDER		
8	RC2-9075-000		4	LEVER, ESTRANGEMENT		
9	RC2-5160-000		1	STOPPER, PLATE		
10	RM1-4999-000		2	SHUTTER ASS'Y		
11	RM1-5488-000		2	SHUTTER ASS'Y		
12	RC2-5912-000		3	COVER		
13	RC2-5958-000		3	SPRING, TORSION		
14	RC2-5955-000		1	HOLDER, CRG. LOCK LEVER		
15	RC2-5954-000		3	LEVER, CARTRIDGE LOCK		
16	RC2-5966-000		1	GUIDE, TRANSFER S CABLE, 1		
17	RC2-5967-000		1	GUIDE, TRANSFER S CABLE, 2		
18	RC2-5962-000		1	COVER		
19	RC2-5969-000		1	GUIDE, CARTRIDGE ESTRANGEMENT		
20	RU6-2318-000		8	SPRING, COMPRESSION		
21	RU6-2316-000		4	SPRING, COMPRESSION		
22	RM1-5676-000		2	LASER/SCANNER ASS'Y		
23	RC2-4415-000		4	LEVER, SHUTTER		
24	RC3-1075-000		2	HOLDER, CARTRIDGE LOCK LEVER		
25	RC2-4407-030		4	ARM, SHUTTER, REAR		
26	RC2-4406-000		4	ARM, SHUTTER, FRONT		
27	RK2-3267-000		1	SENSOR UNIT, TMP./HUM. SENSING		
28	RM1-5588-000		4	STAND ASS'Y		
29	RM1-5700-000		4	TONER SENSOR HOLDER ASS'Y		
30	RK2-2418-000		2	FAN	FM2,FM3	
31	RM1-8149-000		4	BASE ASS'Y		



FIGURE & KEY NO.	PARTS NUMBER	R A N K	Q'TY	DESCRIPTION	SERIAL NUMBER/ REMARKS	S V C
32	RM1-8140-000		4	LOWER CRG. GUIDE ASSY		
33	RM1-5749-000		1	CONNECTING CABLE ASS'Y		
34	RM1-5740-000		1	SENSOR CABLE ASS'Y		
35	RM1-5741-000		1	SENSOR CABLE ASS'Y		
36	RM1-5752-000		1	MOTOR/SENSOR CABLE ASS'Y		

# FIGURE 105 INTERNAL COMPONENTS 3

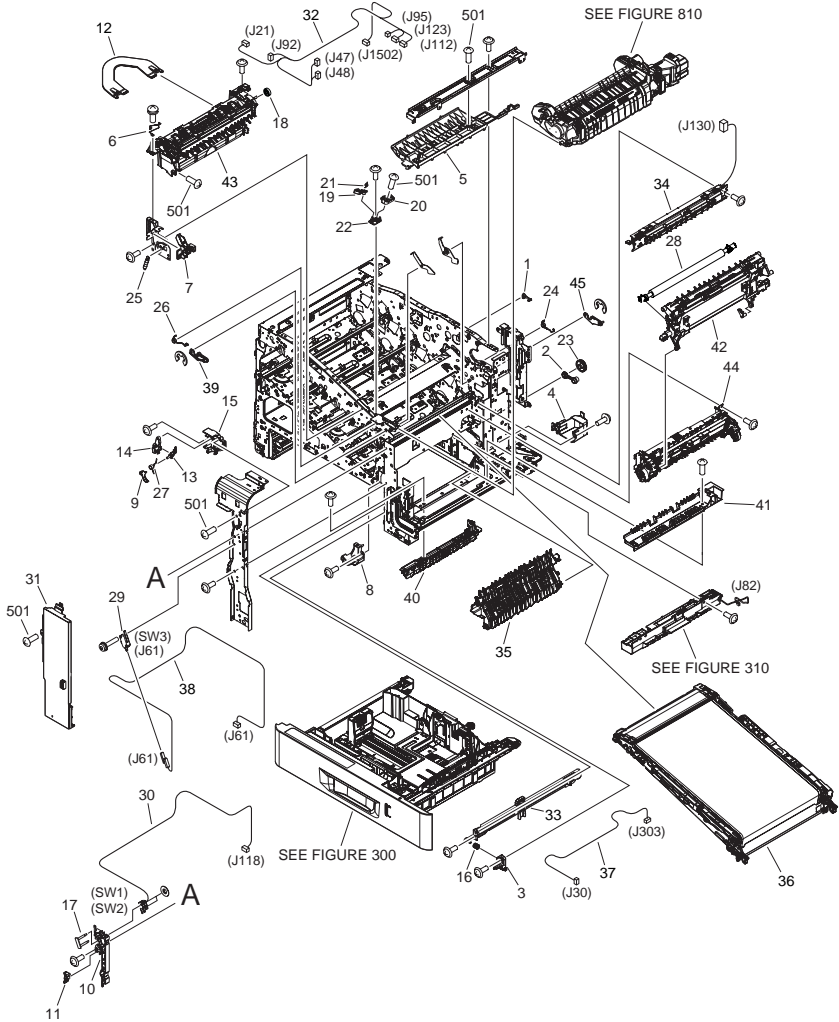

FIGURE & KEY NO.	PARTS NUMBER	R A N K	Q'TY	DESCRIPTION	SERIAL NUMBER/ REMARKS	S V C
Fig.105	NPN		RF	INTERNAL COMPONENTS 3		
1	RC2-4541-000		1	BUSHING		
2	RC2-4875-000		1	BUSHING		
3	RC3-1230-000		1	HOLDER, CST.POSITIONING,FR.RT.		
4	RC3-1232-000		1	HOLDER, CST.POSITIONING,RR.RT.		
5	RC2-4914-000		1	GUIDE, DOOR LATCH, RIGHT		
6	RC2-4828-000		1	WIRE, SENSOR PROTECT		
7	FM3-9079-000		1	SENSOR CABLE GUIDE ASS'Y		
8	RC2-5019-000		1	COVER, INNER, RIGHT LOWER		
9	RC2-5120-000		1	LINK, INTERLOCK		
10	RC2-5123-000		1	MOUNT, INTERLOCK SWITCH		
11	RC2-5121-000		1	ARM, INTERLOCK LINK SWITCH		
12	FE2-2182-000		1	GUIDE, DUPLEXING REVERSE		
13	RC2-5119-000		1	LINK, INTERLOCK		
14	RC2-5118-000		1	LINK, INTERLOCK		
15	RC2-5117-000		1	FRAME, INTERLOCK		
16	RC2-4831-000		1	ROLLER, RAIL		
17	RC2-5913-000		1	SHAFT		
18	RU6-0536-000		1	GEAR, 19T		
19	RC2-5954-000		1	LEVER, CARTRIDGE LOCK		
20	RC2-5957-000		1	HOLDER, CARTRIDGE LOCK LEVER		
21	RC2-5958-000		1	SPRING, TORSION		
22	RC2-5956-000		1	HOLDER, CARTRIDGE LOCK LEVER		
23	RU7-0257-000		1	GEAR, 27T		
24	RC2-4378-000		1	SPRING, TORSION		
25	RU6-2268-000		1	SPRING, TORSION		
26	RC2-4377-000		1	SPRING, TORSION		
27	RC2-5122-000		1	LINK, INTERLOCK		
28	RM1-8176-000		1	2ND TRANSFER ROLLER ASS'Y		
29	WC4-5171-000		1	SWITCH		
30	RM1-5732-000		1	DOOR SWICH ASS'Y		
31	FE2-1295-000		1	COVER, INNER, FRONT		

FIGURE & KEY NO.	PARTS NUMBER	R A N K	Q'TY	DESCRIPTION	SERIAL NUMBER/REMARKS	S V C
32	FM0-3298-000		1	CABLE, FRONT		
33	RM1-8146-000		1	RIGHT CASSETTE RAIL ASS'Y		
34	RM1-8163-000		1	DENSITY DETECT ASS'Y		
35	RM1-8132-000		1	P. PICK-UP LOWER GUIDE ASS'Y		
36	FM3-9078-000		1	INTERMEDIATE TRANS. BELT ASS'Y		
37	FM0-3292-000		1	CABLE, CONTROL PANEL ASS'Y		
38	RM1-5703-000		1	CABLE, INTERLOCK SWITCH		
39	RM1-5532-000		1	FRONT LOCK ARM ASS'Y		
40	RC3-1183-000		1	GUIDE, OPTION ENTRANCE, INNER		
41	RC3-1184-000		1	GUIDE, OPTION ENTRANCE, OUTER		
42	RM1-4952-030		1	SECONDARY TRANSFER ASS'Y		
43	RM1-4970-060		1	PAPER DELIVERY ASS'Y		
44	RM1-4969-000		1	REGISTRATION ASS'Y		
45	RM1-5533-000		1	REAR LOCK ARM ASS'Y		
501	XB4-7401-005		7	SCREW,TAPPING,TRUSS HEAD,M4X10		

# FIGURE 106 INTERNAL COMPONENTS 4

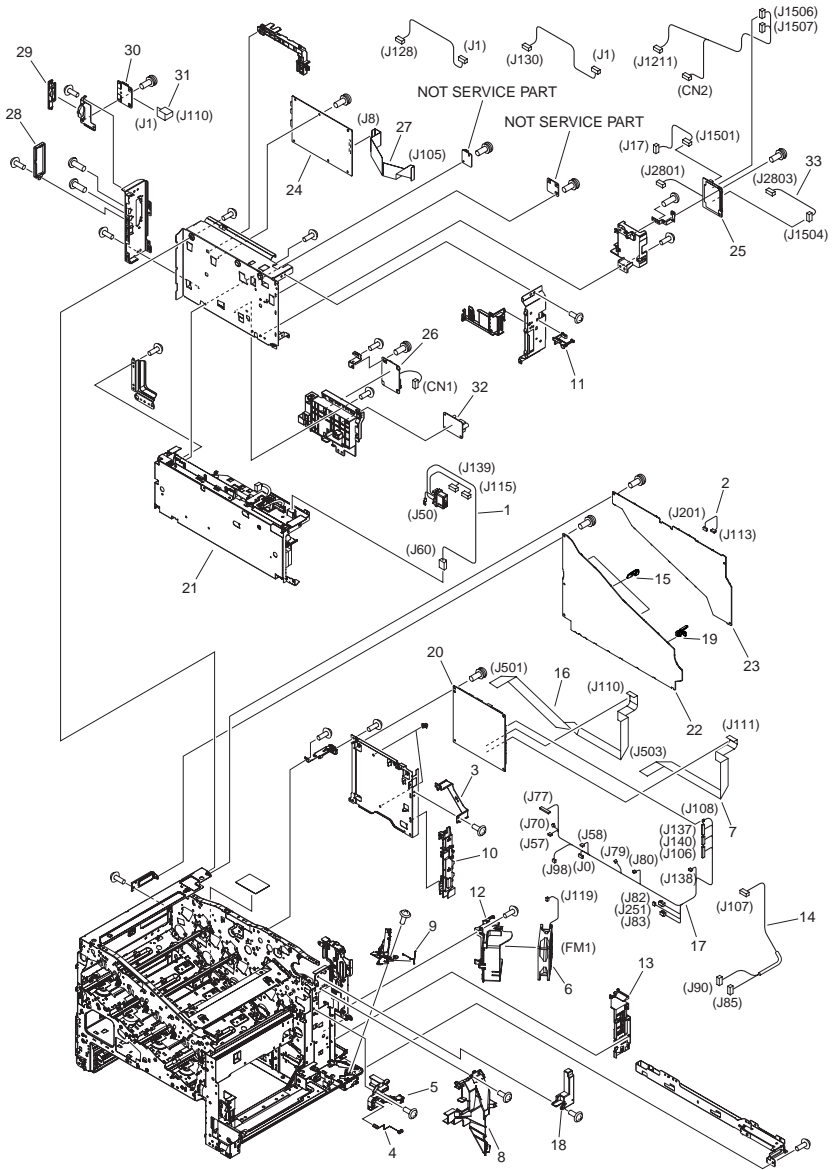

FIGURE & KEY NO.	PARTS NUMBER	R A N K	Q'TY	DESCRIPTION	SERIAL NUMBER/ REMARKS	S V C
Fig.106	NPN		RF	INTERNAL COMPONENTS 4		
1	RM1-5714-000		1	FIXING CONNECTING CABLE ASS'Y		
2	RM1-8112-000		1	CABLE, H.V. POWER SUPPLY		
3	RL1-1948-000		1	PANEL, GUARD		
4	RC2-5021-000		1	SPRING, COMPRESSION		
5	RC3-1076-000		1	HOLDER, 2ND TRANSFER CONTACT		
6	RK2-2416-000		1	FAN		
7	RK2-3943-000		1	CABLE, LASER FLAT, 2		
8	RC3-1077-000		1	DUCT, DUPLEXING FAN		
9	RC3-1079-000		1	SPRING, GROUNDING		
10	RC2-5930-000		1	GUIDE, CABLE		
11	RC2-5943-000		1	ARM, SWITCH		
12	RC3-1085-000		1	HOLDER, DUPLEXING FAN		
13	RC3-1217-000		1	GUIDE, FLEXIBLE FLAT CABLE		
14	RM1-5737-000		1	M.P. SENSOR CABLE ASS'Y		
15	RC2-9074-000		3	SPACER, LOCK		
16	RK2-3941-000		1	CABLE, LASER FLAT, 1		
17	RM1-8113-000		1	CABLE, REAR		
18	RC2-5016-000		1	COVER, CROSSMEMBER, RIGHT REAR		
19	RC2-9562-000		1	SPACER, LOCK		
20	FM0-3305-000		1	DC CONTROLLER PCB ASSEMBLY		
21	FM0-3310-000		1	POWER SUPPLY PCB ASS'Y		
22	RM1-8087-000		1	LW. H.V.POWER SUPPLY PCB ASS'Y		
23	RM1-8088-000		1	UP. H.V.POWER SUPPLY PCB ASS'Y		
24	FM0-1781-000		1	MAIN CONTROLLER PCB ASSEMBLY		
25	FM0-3306-000		1	SLEEP IF PCB ASS'Y		
26	FM0-3307-000		1	RELAY PCB ASS'Y		
27	FK3-3404-000		1	CABLE, DCON FLAT		
28	FE2-1321-000		1	COVER, SD		
29	FE2-1358-000		1	COVER, SD SLOT		
30	FM0-3317-000		1	SDSLOT PCB ASSEMBLY		
31	FK3-3418-000		1	CABLE, DCON FLAT		

FIGURE & KEY NO.	PARTS NUMBER	R A N K	Q'TY	DESCRIPTION	SERIAL NUMBER/ REMARKS	S V C
32	FK3-1986-000		1	A.N. POWER SUPPLY PCB ASSEMBLY		
33	FM0-3295-000		1	CABLE, CONT. POWER		

# FIGURE 107 INTERNAL COMPONENTS 5

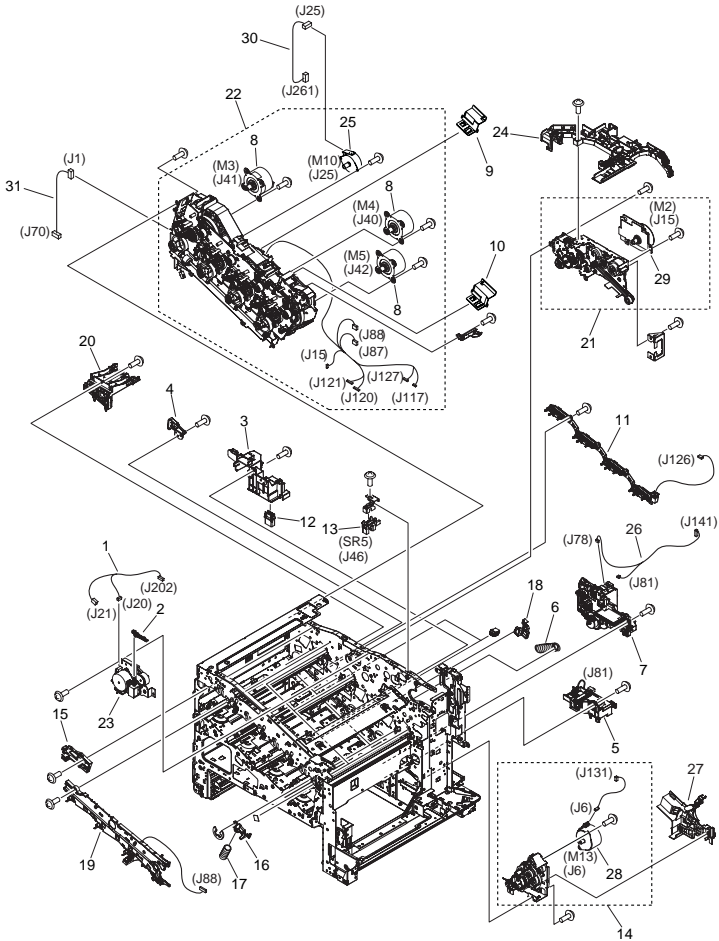



FIGURE & KEY NO.	PARTS NUMBER	R A N K	Q'TY	DESCRIPTION	SERIAL NUMBER/ REMARKS	S V C
Fig.107	NPN		RF	INTERNAL COMPONENTS 5		
1	RM1-5730-000		1	DUPLEXING UNIT CABLE ASS'Y		
2	RC2-4824-000		1	ARM, SOLENOID		
3	RC3-1170-000		1	HOLDER, CST.POSITIONING,RR.LF.		
4	RC2-5015-000		1	STOPPER, SCANNER		
5	RM1-8137-000		1	AUTO CLOSE ASS'Y		
6	RU6-2405-000		1	SPRING, TENSION		
7	RM1-8136-000		1	LIFTER DRIVE ASS'Y		
8	RM1-8105-000		3	MAIN MOTOR ASS'Y	M3,M4,M5	
9	RC2-5104-000		1	GUIDE, CABLE		
10	RC2-9069-000		1	GUIDE, CABLE		
11	RM1-5712-000		1	MEMORY TAG DETECT ASS'Y		
12	VS1-7258-007		1	CONNECTOR, DRAWER		
13	WG8-5935-000		1	PHOTO INTERRUPTER, TLP1243	SR5	
14	RM1-8135-000		1	PAPER PICK-UP DRIVE ASS'Y		
15	RC2-5961-020		1	GUIDE, ROLLER, REAR		
16	RC2-3972-000		4	LEVER, PRESSURE, REAR		
17	RU7-2193-000		4	SPRING, COMPRESSION		
18	RC2-5959-000		1	GUIDE, PRE-EXPOSURE CABLE		
19	RM1-8174-000		1	REAR PRE-EXPOSURE PCB ASS'Y		
20	RM1-4978-000		1	HIGH VOLTAGE HOLDER ASS'Y		
21	RM1-8134-050		1	FIXING DRIVE ASS'Y		
22	RM1-8133-000		1	MAIN DRIVE ASS'Y		
23	RM1-4973-000		1	DUPLEXING DRIVE ASS'Y		
24	RC3-1123-000		1	GUIDE, REAR CABLE, RIGHT		
25	RK2-2415-000		1	MOTOR, STEPPING, DC	M10	
26	RM1-8109-000		1	CABLE, LIFTER MOTOR		
27	RC3-1353-000		1	GUIDE, CABLE		
28	RM1-9236-000		1	PICK-UP MOTOR ASS'Y	M13	
29	RM1-4983-000		1	FIXING MOTOR ASS'Y	M2	
30	RM1-7037-000		1	CABLE, DEVELOP		
31	RM1-5747-000		1	CONNECTING CABLE ASS'Y		

# FIGURE 300 CASSETTE ASSEMBLY

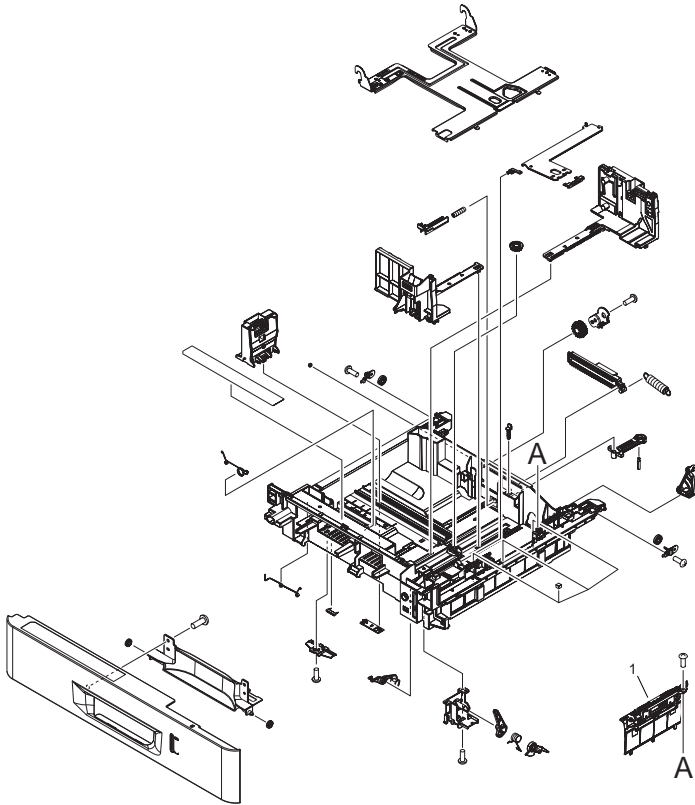

FIGURE & KEY NO.	PARTS NUMBER	RANK	Q'TY	DESCRIPTION	SERIAL NUMBER/REMARKS	SVC
Fig.300	FM0-2454-000		1	CASSETTE ASSEMBLY		
1	RM1-8129-000		1	SEPARATION ROLLER ASS'Y		

# FIGURE 310 PAPER PICK-UP ASS'Y

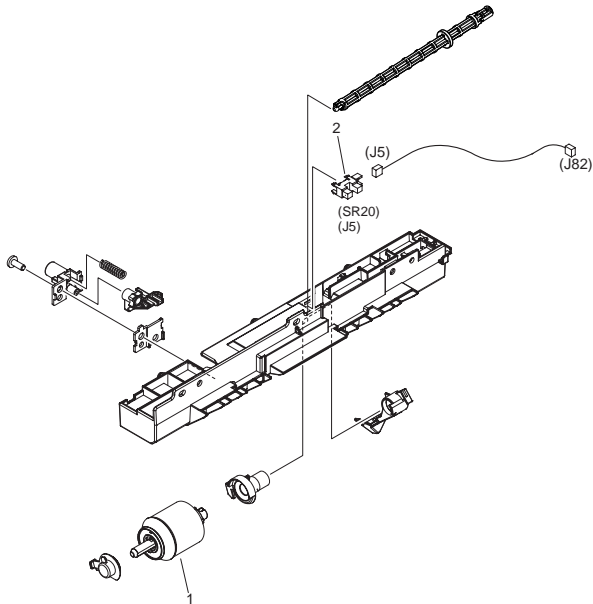

FIGURE & KEY NO.	PARTS NUMBER	RANK	Q'TY	DESCRIPTION	SERIAL NUMBER/REMARKS	SVC
Fig.310	RM1-8130-000		1	PAPER PICK-UP ASS'Y		
1	RM1-8131-000		1	PICK-UP ROLLER ASS'Y		
2	WG8-5935-000		1	PHOTO INTERRUPTER, TLP1243	SR20	

FIGURE 311  
MULTI-PURPOSE PICK-UP ASS'Y

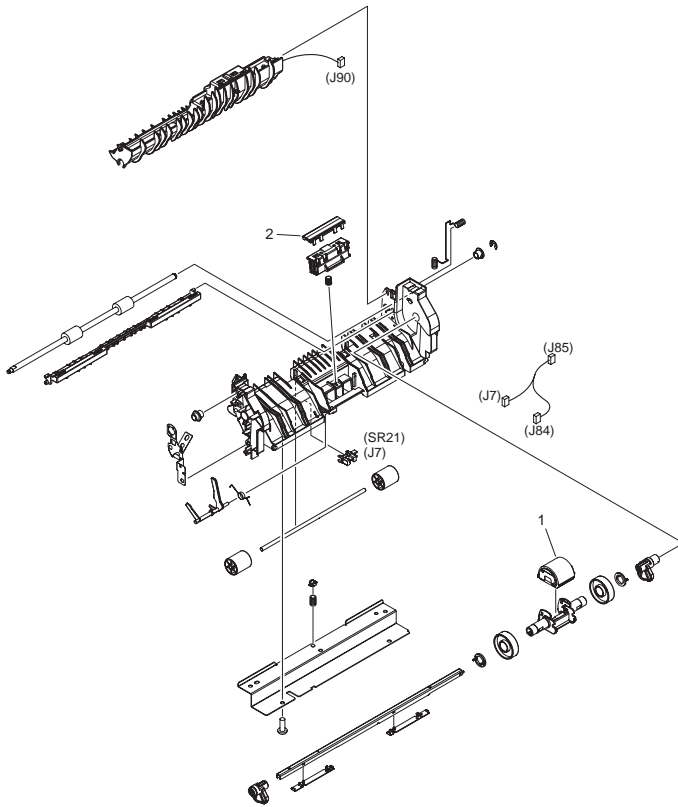

FIGURE & KEY NO.	PARTS NUMBER	RANK	Q'TY	DESCRIPTION	SERIAL NUMBER/REMARKS	SVC
Fig.311	RM1-8124-000		1	MULTI-PURPOSE PICK-UP ASS'Y	SEE NOTE	
1	RL1-2184-000		1	ROLLER, MULTI-PURPOSE PICK-UP		
2	RL1-1937-000		1	PAD, MULTI-PURPOSE SEPARATION		

# FIGURE 810 FIXING ASS'Y

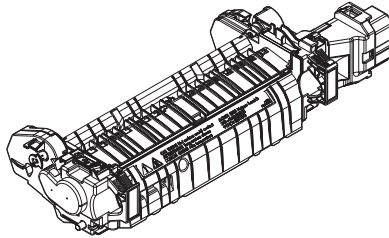

FIGURE & KEY NO.	PARTS NUMBER	RANK	QTY	DESCRIPTION	SERIAL NUMBER/ REMARKS	S V C
Fig.810	FM3-8816-000		1	FIXING ASS'Y		



# FIGURE ZZA

## MECHANICAL STANDARD PARTS (HOW TO USE)

### Mechanical standard parts

#### 機械標準部品

#### About a mechanical standard parts

A Mechanical standard parts is a mechanical part which not parts peculiar to a product. They are parts which are common to a Canon product and are used, such as a screw and a washer. The Fig No. and parts number of the mechanical standard parts are not listed in the product parts catalog. Refer to the parts catalog of mechanical standard parts when checking the parts number for screw or washer etc. and identify them by part shape or size.

#### 機械標準部品とは

機械標準部品とは、製品特有の部品ではなく、ねじやワッシャなどキヤノン製品共通で使用されている機械部品（メカ部品）のことです。  
製品のパーツカタログには、機械標準部品のFig No.や部品番号は記載しておりません。  
ねじや、ワッシャ等の部品番号を調べるときは、機械標準部品のパーツカタログを参照し、部品の形状や大きさから判断し、使用している部品を調べてください。

#### Material and surface treatment of a mechanical standard parts

Material and surface treatment of mechanical standard parts are assigned commonly for each part. Refer to the Table 1 for the parts which material and surface treatment are assigned as numbers.

#### 機械標準部品の材料および表面処理

機械標準部品の材料および表面処理については、各種部品共通で決められています。  
材料および表面処理が番号で決められている部品については、表1を参照してください。

Table 1 Material and Surface treatment  
表1 材料および表面処理

No. 番号	Material 材料	Surface treatment 表面処理	Color 色
1	Stainless steel ステンレス	Stainless steel black coloring (BC4) ステンレス黒着色(BC4)	Black 黒
2		not to be given なし	White 白
3	Brass 黄銅	Regular nickel plating (NL) 普通ニッケルメッキ(NL)	White 白
4		Black nickel plating (BN) 黒色ニッケルメッキ(BN)	Black 黒
5	Steel 鋼	White zinc trivalent chromate treating (ZC3) 白色亜鉛3価クロメート(ZC3)	White 白
6		Regular nickel chromium plating (NC) 普通ニッケルクロムメッキ(NC)	White 白
7		Regular nickel plating (NL) 普通ニッケルメッキ(NL)	White 白
8		Iron and steel phosphating (P1) 鉄鋼磷酸塩処理(P1)	Black 黒
9		Black zinc trivalent chromate treating (BZ3) 黒色亜鉛3価クロメート(BZ3)	Black 黒

# FIGURE ZZB MECHANICAL STANDARD PARTS (SCREWS)

## 1. Screws ねじ

How to read Parts Numbers  
部品番号の見方

Screws  
ねじ

**XB1-2400-609**

Type No.  
類別番号  
Normal designation (d)  
ねじの呼び(d)  
Length (L)  
ねじの長さ(L)  
Material and Surface treatment  
材料および表面処理

XB1-2 expresses Binding head machine screw.  
XB1-2は、バインドねじを表す  
40 expresses M4.0.  
40は、M4.0を表す  
0-60 expresses a length of 6.0mm.  
0-60は、6.0mmの長さを表す  
9 expresses Steel (Black zinc trivalent chromate treating) from Table 1.  
9は、表1より鋼(黒色亜鉛3価クロメート)を表す

### 1-1. Cross Recessed Head Screws for Precision Equipments 精密機器用十字穴付き小ねじ

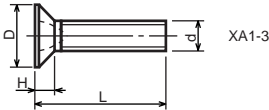
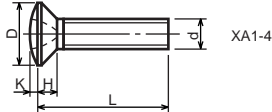
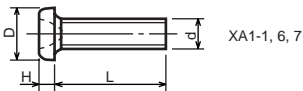

Type No. 類別番号	Type 類別	Head size (mm) 頭部寸法 (mm)							
		M1.4	M1.6	M1.7	M2	M2.5	M2.6		
XA1-1	Pan head Class 1 なべ1種	D	XA1-1	2	2.4	2.5	3	3.8	4
		H	XA1-1	0.5	0.55	0.5	0.6	0.9	0.8
XA1-3	Countersunk head Class 1 さら1種	D	XA1-3	2	2.4	2.5	3	3.8	4
		H	XA1-3	0.48	0.55	0.58	0.73	0.85	0.93
XA1-4	Oval countersunk head Class 1 丸さら1種	D	XA1-4	2	2.4	2.5	3	3.8	4
		H + K	XA1-4	0.68	0.8	0.88	1	1.25	1.3
XA1-6	Pan head Class 3 なべ3種	D	XA1-6	2.5	2.8	3	3.5	4.3	4.5
		H	XA1-6	0.8	0.85	0.9	1	1.3	1.2
XA1-7	Pan head Class 2 なべ2種	D	XA1-7	2.5	2.8	3	3.5	4.3	4.5
		H	XA1-7	0.5	0.55	0.5	0.6	0.9	0.8

1-2. Precision Tapping Screws  
精密用タッピンねじ

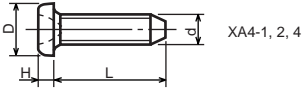

XA4-1, 2, 4

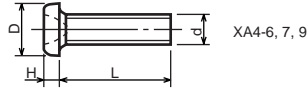

XA4-6, 7, 9

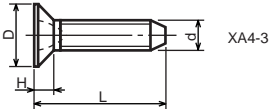

XA4-3

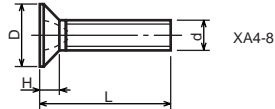

XA4-8

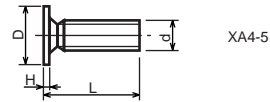

XA4-5

Type No. 類別番号	Type 類別	Head size (mm) 頭部寸法 (mm)						
		M1.4	M1.6	M1.7	M2	M2.5	M2.6	
XA4-1	With tapered end pan head Class 1 絞りなべ1種	D XA4-1	2	2.4	2.5	3	3.8	4
		H XA4-1	0.5	0.55	0.5	0.6	0.9	0.8
XA4-2	With tapered end pan head Class 3 絞りなべ3種	D XA4-2	2.5	2.8	3	3.5	4.3	4.5
		H XA4-2	0.8	0.85	0.9	1	1.3	1.2
XA4-3	With tapered end countersunk head 絞り-さら	D XA4-3	2	2.4	2.5	3	3.8	4
		H XA4-3	0.48	0.55	0.58	0.73	0.85	0.93
XA4-4	With tapered end pan head Class 2 絞りなべ2種	D XA4-4	2.5	2.8	3	3.5	4.3	4.5
		H XA4-4	0.5	0.55	0.5	0.6	0.9	0.8
XA4-5	With parallel end ultra thin head ストレート-超薄頭	D XA4-5	2.5	2.8	3	-	-	-
		H XA4-5	0.2	0.2	0.2	-	-	-
XA4-6	With parallel end pan head Class 1 ストレートなべ1種	D XA4-6	2	2.4	2.5	3	3.8	4
		H XA4-6	0.5	0.55	0.5	0.6	0.9	0.8
XA4-7	With parallel end pan head Class 3 ストレートなべ3種	D XA4-7	2.5	2.8	3	3.5	4.3	4.5
		H XA4-7	0.8	0.85	0.9	1	1.3	1.2
XA4-8	With parallel end countersunk head ストレート-さら	D XA4-8	2	2.4	2.5	3	3.8	4
		H XA4-8	0.48	0.55	0.58	0.73	0.85	0.93
XA4-9	With parallel end pan head Class 2 ストレートなべ2種	D XA4-9	2.5	2.8	3	3.5	4.3	4.5
		H XA4-9	0.5	0.55	0.5	0.6	0.9	0.8

**1-3. Cross Recessed Head Screws**  
 一般用十字穴付き小ねじ

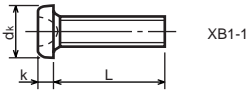

XB1-1

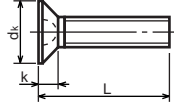

XB1-3

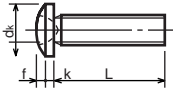

XB1-2

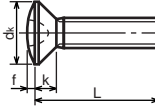

XB1-4

Type No. 類別番号	Type 類別
XB1-1	Pan head なべ
XB1-2	Binding head バインド
XB1-3	Countersunk head さら
XB1-4	Oval countersunk head 丸さら

		Head size (mm) 頭部寸法 (mm)					
		M2	M2.5	M2.6	M3	M4	M5
dk	XB1-1	3.5	4.5	4.5	5.5	7	9
k	XB1-1	1.3	1.7	1.7	2	2.6	3.3
dk	XB1-2	4.3	5.3	5.5	6.3	8.3	10.3
k+f	XB1-2	1.2	1.5	1.6	1.9	2.5	3.1
dk	XB1-3	4	5	-	6	8	10
k	XB1-3	1.2	1.45	-	1.75	2.3	2.8
dk	XB1-4	4	5	-	6	8	10
k+f	XB1-4	1.6	2	-	2.45	3.2	4
Screw part length ねじ部長さ b		8	12	12	12	16	20

1-4. Cross Recessed Head Screws with Captive Washer  
 座金組込み十字穴付き小ねじ

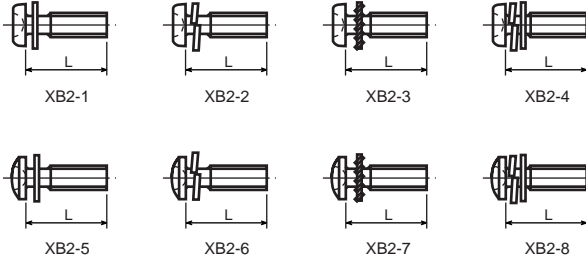

Type No. 類別番号	Type 類別
XB2-1	Pan head + Plain washer (circular bright) なべねじ+平座金
XB2-2	Pan head + Spring washer なべねじ+ばね座金
XB2-3	Pan head + Toothed lock washer なべねじ+歯付座金
XB2-4	Pan head + Spring washer and plain washer (circular bright) なべねじ+(ばね+平)座金
XB2-5	Binding head + Plain washer (circular bright) バインドねじ+平座金
XB2-6	Binding head + Spring washer バインドねじ+ばね座金
XB2-7	Binding head + Toothed lock washer バインドねじ+歯付座金
XB2-8	Binding head + Spring washer and plain washer (circular bright) バインドねじ+(ばね+平)座金

**1-5. Hexagon Head Tapping Screws for Metallic Materials**  
 金属用六角タッピンねじ

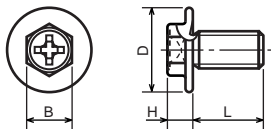

Type No. 類別番号	Type 類別	Head size (mm) 頭部寸法 (mm)	
		M3	M4
XB3-6	For metallic materials 金属用タッピン	D	8 10
		B	5.5 5.5
XB3-7	For metallic materials with clawed 金属用タッピン-つめ付き	H XB3-6	3.1 3.1
		H XB3-7	3.2 3.2

**1-6. Special Tapping Screws**  
 特殊タッピンねじ

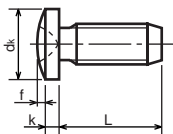

Type No. 類別番号	Type 類別	Head size (mm) 頭部寸法 (mm)	
		M3	M4
XB4-5	Binding head バインド	dk	6.3 8.3
		k	1.3 1.7
		k+f	1.9 2.5

**1-7. General Head Tapping Screws**  
 一般用タッピンねじ

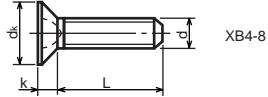
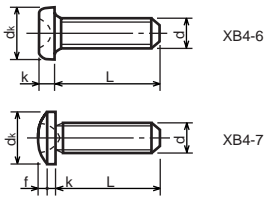

Type No. 類別番号	Type 類別	Head size (mm) 頭部寸法 (mm)						
		M2	M2.5	M2.6	M3	M4	M5	
XB4-6	Pan head なべ	$d_k$ XB4-6	3.5	4.5	4.5	5.5	7	9
		$k$ XB4-6	1.3	1.7	1.7	2	2.6	3.3
XB4-7	Binding head バインド	$d_k$ XB4-7	4.3	5.3	5.5	6.3	8.3	10.3
		$k+f$ XB4-7	1.2	1.5	1.6	1.9	2.5	3.1
XB4-8	Countersunk head さら	$d_k$ XB4-8	4	5	5.2	6	8	10
		$k$ XB4-8	1.2	1.45	1.5	1.75	2.3	2.8

**1-8. Tapping Screws for Metallic Materials**  
 金属用タッピンねじ

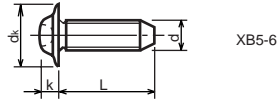
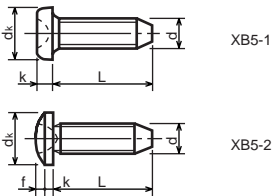

Type No. 類別番号	Type 類別	Head size (mm) 頭部寸法 (mm)					
		M2.5	M2.6	M3	M4	M5	
XB5-1	Pan head なべ	$d_k$ XB5-1	4.5	4.5	5.5	7	9
		$k$ XB5-1	1.7	1.7	2	2.6	3.3
XB5-2	Binding head バインド	$d_k$ XB5-2	5.5	5.5	6.3	8.3	10.3
		$k+f$ XB5-2	1.6	1.6	1.9	2.5	3.1
XB5-6	Flanged pan head つば付きなべ	$d_k$ XB5-6	6.5	6.5	8	10	12
		$k$ XB5-6	2.1	2.1	1.75	3.2	4

**1-9. Hexagon Socket Set Screws**  
六角穴付止めねじ

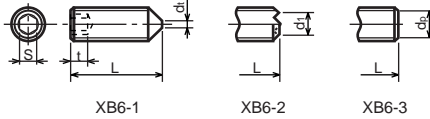

Type No. 類別番号	Type 類別	Head size (mm) 頭部寸法 (mm)							
		M1.6 M1.7	M2	M2.5 M2.6	M3	M5	M5	M6	
XB6-1	Cone point とがり先	S	0.7	0.9	1.3	1.5	2	2.5	3
		t	1.5	1.7	2	2	2.5	3	3.5
		$d_{t \max}$ XB6-1	0.4	0.5	0.65	0.75	1	1.25	1.5
		$d_{t \max}$ XB6-2	-	1.2	1.5	1.7	2.2	2.8	3.3
		$d_{t \min}$ XB6-2	-	1	1.2	1.4	1.9	2.4	2.9
		$d_{p \max}$ XB6-3	0.8	1	1.5	2	2.5	3.5	4
		$d_{p \min}$ XB6-3	0.55	0.75	1.25	1.75	2.25	3.2	3.7

**1-10. Flanged Pan Head Machine Screws**  
つば付きなべ小ねじ

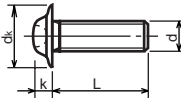

Type No. 類別番号	Type 類別	Head size (mm) 頭部寸法 (mm)					
		M2	M2.5 M2.6	M3	M5	M5	
XB6-7	Flanged pan head つば付きなべ	$d_k$	5	6.5	8	10	12
		k	1.7	2.1	2.5	3.2	4



# FIGURE ZZC MECHANICAL STANDARD PARTS (BOLTS)

## 2. Bolts (Socket head cap screw) ボルト

How to read Parts Numbers  
部品番号の見方

Bolt (Socket head cap screw)  
ボルト

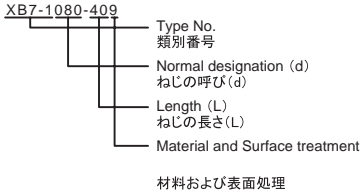

XB7-1 expresses Hexagon socket head cap screws.  
XB7-1は、六角穴付きボルトを表す

080 expresses M8.0.  
080は、M8.0を表す

40 expresses a length of 40mm.  
40は、40mmの長さを表す

9 expresses Steel (Black zinc trivalent chromate  
treating) from Table 1.

9は、表1より鋼(黒色亜鉛3価クロメート)を表す

### 2-1. Hexagon socket head cap screws 六角穴付きボルト

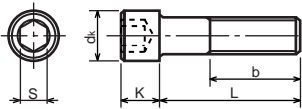

Type No. 類別番号	Type 類別
XB7-1	Hexagon socket head cap screws 六角穴付きボルト

	Head size (mm) 頭部寸法 (mm)						
	M3	M4	M5	M6	M8	M10	M12
S	2.5	3	4	5	6	8	10
$d_k$	5.5	7	8.5	10	13	16	18
K	3	4	5	6	8	10	12
Screw part length $b_{max}$ ねじ部長さ $b_{max}$	18	20	22	24	28	32	36

# FIGURE ZZD MECHANICAL STANDARD PARTS (NUTS)

## 3. Nuts ナット

How to read Parts Numbers  
部品番号の見方

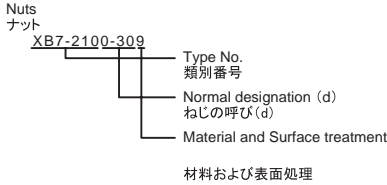

XB7-210 expresses Hexagon nut class 1.  
XB7-210は、六角ナット1種を表す

0-30 expresses M3.0.  
0-30は、M3.0を表す

9 expresses Steel (Black zinc trivalent chromate  
treating) from Table 1.

9は、表1より鋼(黒色亜鉛3価クロメート)を表す

### 3-1. Hexagon Nuts and Hexagon Thin Nuts 六角ナット

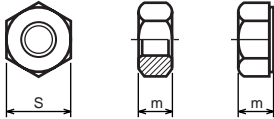

Type No. 類別番号	Type 類別
XB7-210	Hexagon nut Class 1 六角ナット-1種
XB7-220	Hexagon nut Class 3 六角ナット-3種
XB7-230	Hexagon nut Style 1 double chamfered 六角ナット-スタイル1-両面とり
XB7-231	Hexagon nut Style 1 washer faced 六角ナット-スタイル1-座付き
XB7-240	Hexagon nut Style 2 double chamfered 六角ナット-スタイル2-両面とり
XB7-241	Hexagon nut Style 2 washer faced 六角ナット-スタイル2-座付き
XB7-250	Hexagon nut 六角ナット
XB7-260	Hexagon thin nut double chamfered 六角低ナット-両面とり
XB7-270	Hexagon thin nut not chamfered 六角低ナット-面とり無し

	Head size (mm) 頭部寸法 (mm)						
	M2	M2.5	M3	M4	M5	M6	M8
S	4	5	5.5	7	8	10	13
m XB7-210	1.6	2	2.4	3.2	4	5	6.5
m XB7-220	1.2	1.6	1.8	2.4	3.2	3.6	5
m XB7-230, 231	1.6	2	2.4	3.2	4.7	5.2	6.8
m XB7-240, 241	-	-	-	-	5.1	5.7	7.5
m XB7-250	-	-	-	-	5.6	6.1	7.9
m XB7-260	1.2	1.6	1.8	2.2	2.7	3.2	4
m XB7-270	1.2	1.6	1.8	2.2	2.7	3.2	4

# FIGURE ZZE MECHANICAL STANDARD PARTS (RETAINING RINGS)

## 5. Retaining Rings

止め輪

How to read Parts Numbers  
部品番号の見方

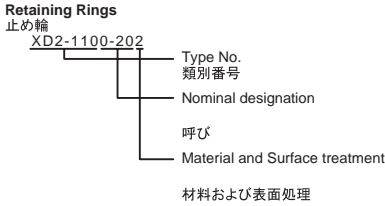

XD2-110 expresses retaining ring-E type (Type1).  
XD2-110は、E形止め輪(1種)を表す

0-20 expresses a 020 of nominal designation.  
(See Table 5)

0-20は、呼び020を表す(表5参照)

2 expresses Stainless steel (Surface treatment is not to be given) from Table 1.

2は、表1よりステンレス(表面処理なし)を表す

### 5-1. Retaining Rings - E type

E形止め輪

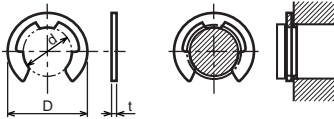

Type No. 類別番号	Type 類別
XD2-110	Retaining ring - E type (Type 1) E形止め輪(1種)
XD2-120	Retaining ring - E type (Type 2) E形止め輪(2種)

Table 5 表5

Type 種類	Nominal designation 呼び	d (mm)	D (mm)	t (mm)
Type 1 1種	007	0.65	2	0.2
	010	0.95	2.8	0.2
	013	1.25	3.3	0.3
	017	1.65	4.2	0.4
	020	1.95	4.6	0.5
	024	2.35	6	0.6
	028	2.74	6.5	0.6
	032	3.14	7.2	0.6
	037	3.64	8	0.7
	040	3.93	10	0.7
	042	4.13	10	0.7
	050	4.93	11	0.7
	058	5.73	12	0.7
	060	5.93	12.7	0.9
	064	6.32	13.5	0.9
	074	7.31	15	0.9
080	7.91	16.5	1	
Type 2 2種	008	0.8	2	0.2
	012	1.2	3	0.3
	015	1.5	4	0.4
	020	2	5	0.4
	025	2.5	6	0.4
	030	3	7	0.6
	040	4	9	0.6
	050	5	11	0.6
	060	6	12	0.8
	070	7	14	0.8
	080	8	16	0.8
	090	9	18	0.8
	100	10	20	1

5-2. Grip Rings  
グリップ止め輪

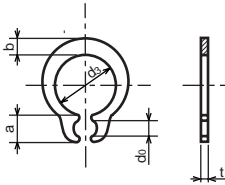

Type No. 類別番号	Type 類別
XD2-210	Grip ring グリップ止め輪

Table 5 表5

Nominal designation 呼び	d <sub>3</sub> (mm)	t (mm)	b (mm)	a (mm)	d <sub>0</sub> (mm)
020	1.9	0.5	1	1.8	0.8
025	2.35	0.5	1.2	1.9	0.9
030	2.85	0.6	1.4	1.9	0.9
035	3.3	0.6	1.6	2	0.9
040	3.8	0.8	1.8	2.8	1.2
045	4.25	0.8	2	2.9	1.3
050	4.75	0.8	2.2	2.9	1.3
060	5.7	1	2.4	3.1	1.4
070	6.7	1	2.7	3.3	1.4
080	7.7	1	3	3.5	1.4
090	8.65	1.2	3.3	4.7	1.5
100	9.65	1.2	3.5	4.7	2

5-3. Toothed Retaining Rings  
歯付き形止め輪

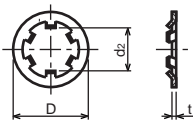

Type No. 類別番号	Type 類別
XD2-230	Toothed retaining ring 歯付き形止め輪

Table 5 表5

Nominal designation 呼び	d <sub>z</sub> (mm)	D (mm)	t (mm)	No of teeth 歯数
015	1.4	5.2	0.25	3
020	1.9	6	0.25	3
024	2.3	6.4	0.25	3
030	2.8	8	0.25	4
040	3.8	9	0.25	4
050	4.8	10	0.25	5
060	5.8	11	0.25	5
080	7.8	13	0.25	5
100	9.8	15.4	0.25	6

### 5-4. Retaining Rings - C Type

C形止め輪

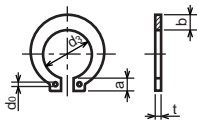

Type No. 類別番号	Type 類別
XD2-310	Retaining ring - C type for shaft C形止め輪 軸用

Table 5 表5

Nominal designation 呼び	d <sub>3</sub> (mm)	t (mm)	b (mm)	a (mm)	d <sub>0</sub> (mm)
010	9.3	1	1.6	3	1.2
012	11.1	1	1.8	3.2	1.5
014	12.9	1	2	3.4	1.7
015	13.8	1	2.1	3.5	1.7
016	14.7	1	2.2	3.6	1.7
017	15.7	1	2.2	3.7	1.7
018	16.5	1.2	2.6	3.8	1.7
020	18.5	1.2	2.7	3.9	2
022	20.5	1.2	2.7	4.1	2
025	23.2	1.2	3.1	4.3	2
028	25.9	1.5	3.1	4.6	2
030	27.9	1.5	3.5	4.8	2
032	29.6	1.5	3.5	5	2.5
035	32.2	1.5	4	5.4	2.5

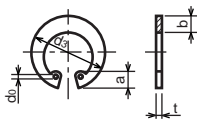

Type No. 類別番号	Type 類別
XD2-320	Retaining ring - C type for hole C形止め輪 穴用

Table 5 表5

Nominal designation 呼び	d <sub>3</sub> (mm)	t (mm)	b (mm)	a (mm)	d <sub>0</sub> (mm)
010	10.7	1	1.8	3.1	1.2
011	11.8	1	1.8	3.2	1.2
012	13	1	1.8	3.3	1.5
014	15.1	1	2	3.6	1.7
016	17.3	1	2	3.7	1.7
018	19.5	1	2.5	4	1.7
019	20.5	1	2.5	4	2
020	21.5	1	2.5	4	2
022	23.5	1	2.5	4.1	2
025	26.9	1.2	3	4.4	2
028	30.1	1.2	3	4.6	2
030	32.1	1.2	3	4.7	2
032	34.4	1.2	3.5	5.2	2.5
035	37.8	1.5	3.5	5.2	2.5
037	39.8	1.5	3.5	5.2	2.5
040	43.5	1.8	4	5.7	2.5
042	45.5	1.8	4	5.8	2.5
045	48.5	1.8	4.5	5.9	2.5
047	50.5	1.8	4.5	6.1	2.5
050	54.2	2	4.5	6.5	2.5
052	56.2	2	5.1	6.5	2.5
055	59.2	2	5.1	6.5	2.5
060	64.2	2	5.1	6.8	2.5
062	66.2	2	5.5	6.9	2.5
068	72.5	2.5	6	7.4	2.5
072	76.5	2.5	6.6	7.4	2.5
075	79.5	2.5	6.6	7.8	2.5
080	85.5	2.5	7	8	2.5
085	90.5	3	7	8	3
090	95.5	3	7.6	8.3	3
095	100.5	3	8	8.5	3



Prepared by  
OIP Business Support Group  
CANON INC.

**Canon**