

PARTS CATALOG

imageRUNNER ADVANCE 715/615/525 series (CEL)

<PREFACE>

This Parts Catalog contains listings of parts used. Diagrams are provided with the listings to aid the service technician in identifying clearly, the item to be ordered.

Whenever ordering parts, consult this Parts Catalog for all of the information pertaining to each item. Be sure to include, in the Parts Request, the full item description, the item part number, and the quantity.

The Canon logo is displayed in a bold, black, sans-serif font. The letter 'C' is significantly larger than the other letters, and the 'o' is stylized with a vertical line through its center.

Index

SNL	Product Code No. /Serial No.
A1D	ASSEMBLY LOCATION DIAGRAM (MODEL WITHOUT FINISHER)
A2	OPTION PARTS CATALOG LIST
001B	ACCESSORIES
100K	EXTERNAL COVERS, PANELS, ETC. (715i)
100L	EXTERNAL COVERS, PANELS, ETC. (615i)
100M	EXTERNAL COVERS, PANELS, ETC. (525i)
101	INTERNAL COMPONENTS 1
102	INTERNAL COMPONENTS 2
103	INTERNAL COMPONENTS 3
104B	INTERNAL COMPONENTS 4 (230V)
105D	INTERNAL COMPONENTS 5 (715i, 615i, 525i)
106B	INTERNAL COMPONENTS 6 (WITHOUT FINISHER model)
130B	FLAT CONTROL PANEL ASSEMBLY
900A	CONTROLLER BOX ASSEMBLY (715 Series)
900B	CONTROLLER BOX ASSEMBLY (615 Series)
900C	CONTROLLER BOX ASSEMBLY (525 Series)
B01	ADF MAINTENANCE KIT
B10B	READER/ADF ASSEMBLY
B11	AUTO DOCUMENT FEEDER ASS'Y SET
B12	PAPER PICK-UP COVER ASS'Y
D10B	READER ASSEMBLY
ZZA	MECHANICAL STANDARD PARTS (HOW TO USE)
ZZB	MECHANICAL STANDARD PARTS (SCREWS)
ZZC	MECHANICAL STANDARD PARTS (BOLTS)
ZZD	MECHANICAL STANDARD PARTS (NUTS)
ZZE	MECHANICAL STANDARD PARTS (RETAINING RINGS)

Figure SNL Product Code No./Serial No.

	Product Code No.	Model Name	Remarks	Serial No.
1	F17-2896-000	imageRUNNER ADVANCE 715i	MODELWITHOUT FINISHER	2CD
2	F17-2894-000	imageRUNNER ADVANCE 615i	MODEL WITHOUT FINISHER	2CF
3	F17-2892-000	imageRUNNER ADVANCE 525i	MODEL WITHOUT FINISHER	2CG

	中オーダー	製品名	備考	シリアル No.
1	F17-2896-000	imageRUNNER ADVANCE 715i	フィニッシャー なしモデル	2CD
2	F17-2894-000	imageRUNNER ADVANCE 615i	フィニッシャー なしモデル	2CF
3	F17-2892-000	imageRUNNER ADVANCE 525i	フィニッシャー なしモデル	2CG

FIGURE & KEY NO.	PART NUMBER	RANK	QTY	DESCRIPTION	SERIAL NUMBER /REMARKS
SNL	NPN		RF	Product Code No./Serial No.	
1	F17-2896-000		1	imageRUNNER ADVANCE 715i	2CD MODEL WITHOUT FINISHER
2	F17-2894-000		1	imageRUNNER ADVANCE 615i	2CF MODEL WITHOUT FINISHER
3	F17-2892-000		1	imageRUNNER ADVANCE 525i	2CG MODEL WITHOUT FINISHER

Figure A1D ASSEMBLY LOCATION DIAGRAM (MODEL WITHOUT FINISHER)

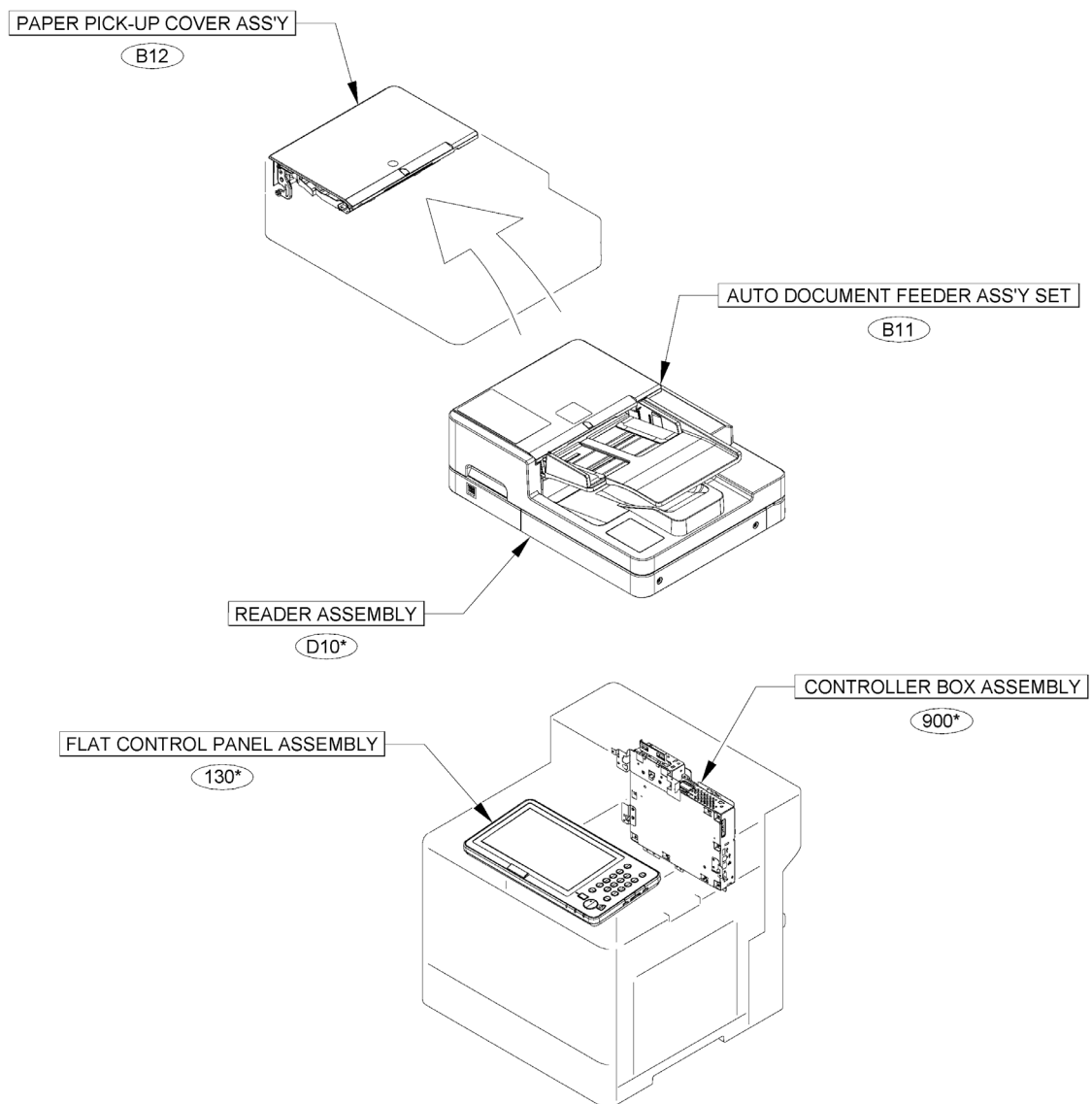

Figure A2 OPTION PARTS CATALOG LIST

This is the table of the machine's options whose parts catalog is issued.
 本機のオプションで、パーツカタログが発行されている機種の一覧である。

No.	Model Name(English)	Model Name(Japanese)
1	ADF Access Handle-A1	(日本仕向けなし)
2	NFC Kit-C1	(日本仕向けなし)
3	Cassette Feeding Unit-AR1/ High Capacity Cassette Feeding Unit-D1	(日本仕向けなし)
4	Cassette Module-AG1/ Envelope Cassette Module-A1	(日本仕向けなし)
5	Copy Card Reader Attachment-B5	(日本仕向けなし)
6	Super G3 FAX Board-AY1	(日本仕向けなし)
7	Copy Control Interface Kit-A1	(日本仕向けなし)
8	IC Card Reader Box-D1	(日本仕向けなし)
9	IC Card Reader Attachment-A1	(日本仕向けなし)
10	Copy Card Reader-F1	(日本仕向けなし)
11	Connection Kit-A1 for Bluetooth LE	(日本仕向けなし)

Figure 001B ACCESSORIES

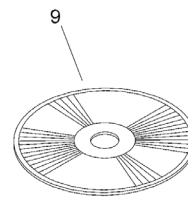
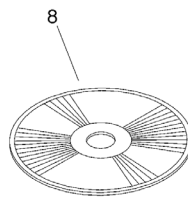
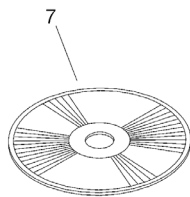
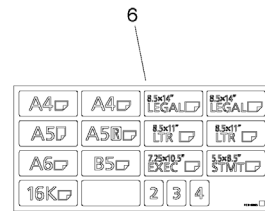
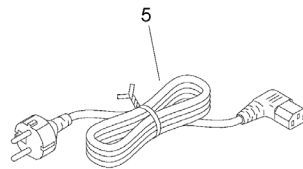
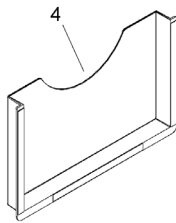
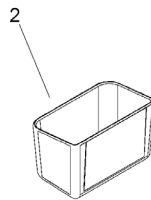
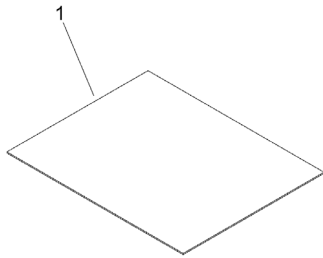

FIGURE & KEY NO.	PART NUMBER	RANK	QTY	DESCRIPTION	SERIAL NUMBER /REMARKS
001B	NPN		RF	ACCESSORIES	
1	FE2-A001-000		1	CLOTH, CLEANING	
2	FE3-9210-000		1	BOX, CLEANING CLOTH STOCK	
3	FE3-4465-000		1	TAPE, DUPLEXING	
4	FE4-3758-000		1	HOLDER, SERVICE BOOK	
5	FK2-9571-000		1	CORD, POWER	
6	FE8-6065-000		1	LABEL, CASSETTE	
7	FK4-6044-000		1	CD-ROM, SOFTWARE FOR UFR II	
8	FK4-6045-000		1	CD-ROM, USER SOFTWARE, PCL	
9	FK4-6046-000		1	CD-ROM, USER SOFTWARE, PS	

Figure 100K EXTERNAL COVERS, PANELS, ETC. (715i)

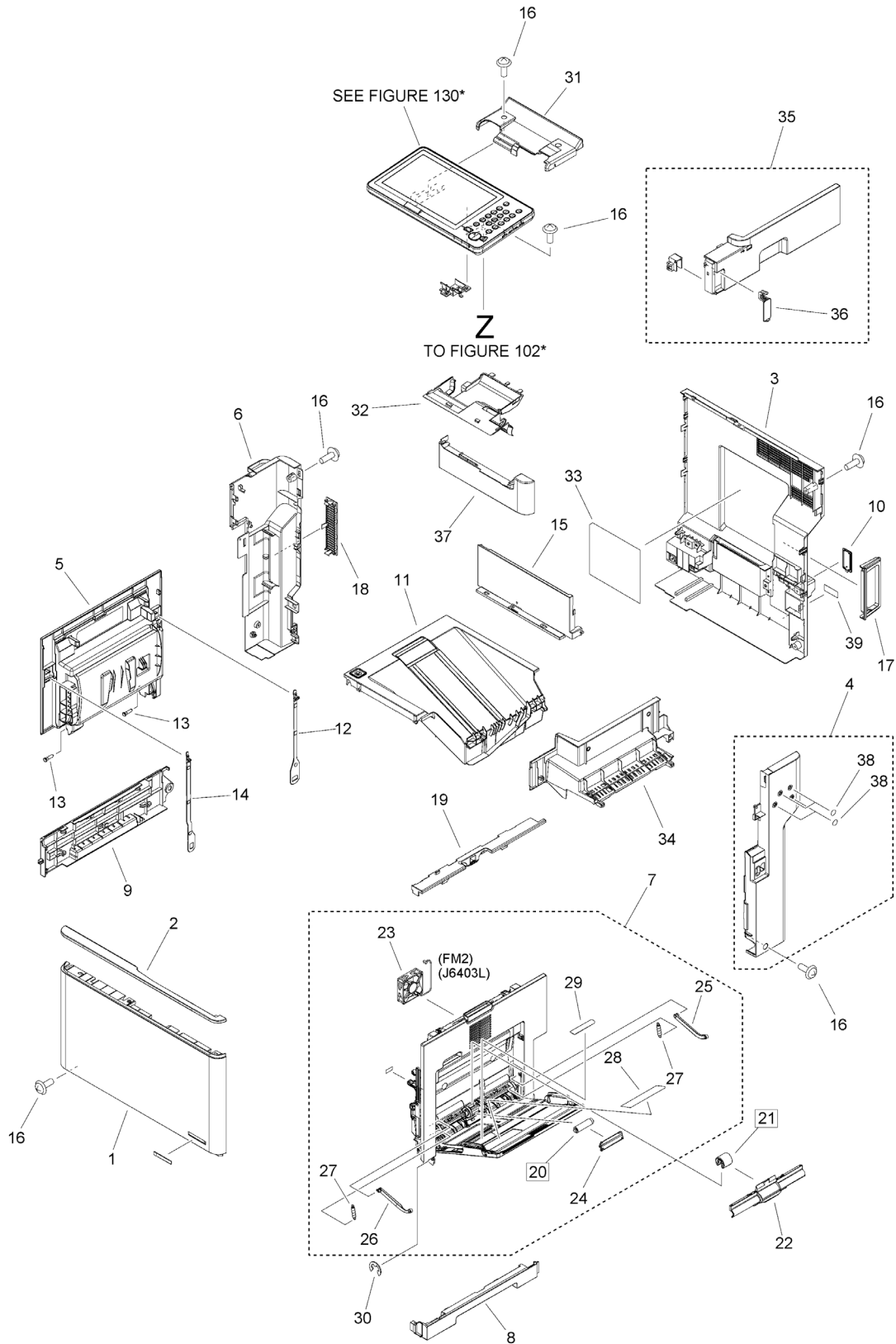

FIGURE & KEY NO.	PART NUMBER	RANK	QTY	DESCRIPTION	SERIAL NUMBER /REMARKS
100K	NPN		RF	EXTERNAL COVERS, PANELS, ETC.	715i
1	FE8-6078-000		1	COVER, FRONT	
2	FE8-6091-000		1	PANEL, FRONT UPPER	
3	FM1-U688-000		1	COVER ASSEMBLY, REAR	
4	FL1-5849-000		1	COVER, INLET	
5	FM1-R109-000		1	CRG. DOOR ASS'Y	
6	FE8-6097-000		1	COVER, LEFT REAR	
7	FM1-R104-000		1	RIGHT DOOR ASS'Y	
8	FE8-6085-000		1	COVER, RIGHT LOWER	
9	FE8-6082-000		1	COVER, LEFT LOWER	
10	FE3-9088-000		1	COVER, FAX CONNECTOR	
11	FM1-R110-000		1	FACE-DOWN TRAY ASS'Y	
12	RC4-8298-000		1	BAND, LEFT, REAR	
13	RC4-8301-000		2	SHAFT, DOOR	
14	RC4-8302-000		1	BAND, LEFT, FRONT	
15	FE8-6079-000		1	COVER, INNER,DELV. REAR	
16	XA9-1671-000		15	SCREW, D, M3X8	
17	FE8-6098-000		1	PANEL, INTERFACE, REAR	
18	FE8-6099-000		1	COVER, DUCT	
19	FE8-6077-000		1	COVER, RIGHT UPPER	
20	RL2-0079-000		1	ROLLER, MULTI-PURPOSE SEP.	[DP]
21	RL2-1566-000		1	ROLLER, MULTI-PURPOSE	[DP]
22	RC4-7318-000		1	MP ROLLER COVER	
23	RK2-8948-000		1	FAN	FM2
24	RC4-0548-000		1	GUIDE, NIP	
25	RC4-0566-000		1	MULTI-PURPOSE ARM, RIGHT	
26	RC4-7316-000		1	MULTI-PURPOSE ARM, LEFT	
27	RU8-2592-000		2	SPRING, TENSION	
28	FE8-6057-000		1	LABEL, MULTI PAPER PICK-UP	
29	FE8-6137-000		1	LABEL, MP SIZE	
30	XD9-0233-010		1	RING, E	
31	FE8-6090-000		1	COVER, CONTROL PANEL, UPPER	
32	FE4-2813-000		1	COVER, CONNECTOR	
33	FL1-5832-000		1	LABEL, SERVICE	
34	FE8-6080-000		1	COVER, INTERFACE, UPPER	
35	FM1-U019-000		1	INTERFACE COVER ASS'Y, RIGHT	
36	FC0-7172-000		1	COVER, MAIN SWITCH	
37	FE8-6081-000		1	COVER, CONTROL PANEL, LOWER	
38	FC6-4513-000		4	SEAL	
39	FE4-1828-020		1	LABEL, GROUNDING CAUTION	

Figure 100L EXTERNAL COVERS, PANELS, ETC. (615i)

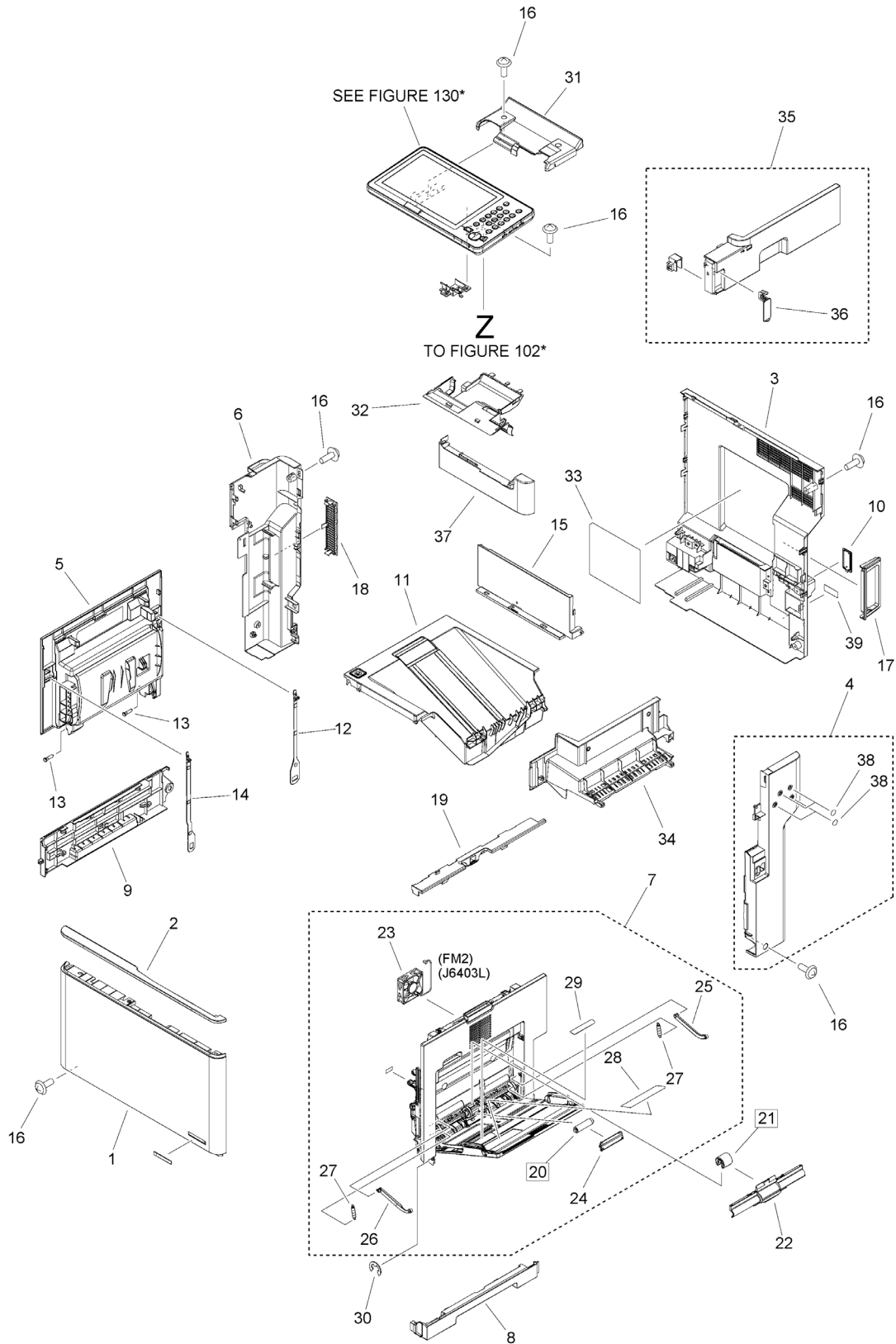

FIGURE & KEY NO.	PART NUMBER	RANK	QTY	DESCRIPTION	SERIAL NUMBER /REMARKS
100L	NPN		RF	EXTERNAL COVERS, PANELS, ETC.	615i
1	FE8-6078-000		1	COVER, FRONT	
2	FE8-6091-000		1	PANEL, FRONT UPPER	
3	FM1-U688-000		1	COVER ASSEMBLY, REAR	
4	FL1-5849-000		1	COVER, INLET	
5	FM1-R109-000		1	CRG. DOOR ASS'Y	
6	FE8-6097-000		1	COVER, LEFT REAR	
7	FM1-R104-000		1	RIGHT DOOR ASS'Y	
8	FE8-6085-000		1	COVER, RIGHT LOWER	
9	FE8-6082-000		1	COVER, LEFT LOWER	
10	FE3-9088-000		1	COVER, FAX CONNECTOR	
11	FM1-R110-000		1	FACE-DOWN TRAY ASS'Y	
12	RC4-8298-000		1	BAND, LEFT, REAR	
13	RC4-8301-000		2	SHAFT, DOOR	
14	RC4-8302-000		1	BAND, LEFT, FRONT	
15	FE8-6079-000		1	COVER, INNER,DELV. REAR	
16	XA9-1671-000		15	SCREW, D, M3X8	
17	FE8-6098-000		1	PANEL, INTERFACE, REAR	
18	FE8-6099-000		1	COVER, DUCT	
19	FE8-6077-000		1	COVER, RIGHT UPPER	
20	RL2-0079-000		1	ROLLER, MULTI-PURPOSE SEP.	[DP]
21	RL2-1566-000		1	ROLLER, MULTI-PURPOSE	[DP]
22	RC4-7318-000		1	MP ROLLER COVER	
23	RK2-8948-000		1	FAN	FM2
24	RC4-0548-000		1	GUIDE, NIP	
25	RC4-0566-000		1	MULTI-PURPOSE ARM, RIGHT	
26	RC4-7316-000		1	MULTI-PURPOSE ARM, LEFT	
27	RU8-2592-000		2	SPRING, TENSION	
28	FE8-6057-000		1	LABEL, MULTI PAPER PICK-UP	
29	FE8-6137-000		1	LABEL, MP SIZE	
30	XD9-0233-010		1	RING, E	
31	FE8-6090-000		1	COVER, CONTROL PANEL, UPPER	
32	FE4-2813-000		1	COVER, CONNECTOR	
33	FL1-5832-000		1	LABEL, SERVICE	
34	FE8-6080-000		1	COVER, INTERFACE, UPPER	
35	FM1-U019-000		1	INTERFACE COVER ASS'Y, RIGHT	
36	FC0-7172-000		1	COVER, MAIN SWITCH	
37	FE8-6081-000		1	COVER, CONTROL PANEL, LOWER	
38	FC6-4513-000		4	SEAL	
39	FE4-1828-020		1	LABEL, GROUNDING CAUTION	

Figure 100M EXTERNAL COVERS, PANELS, ETC. (525i)

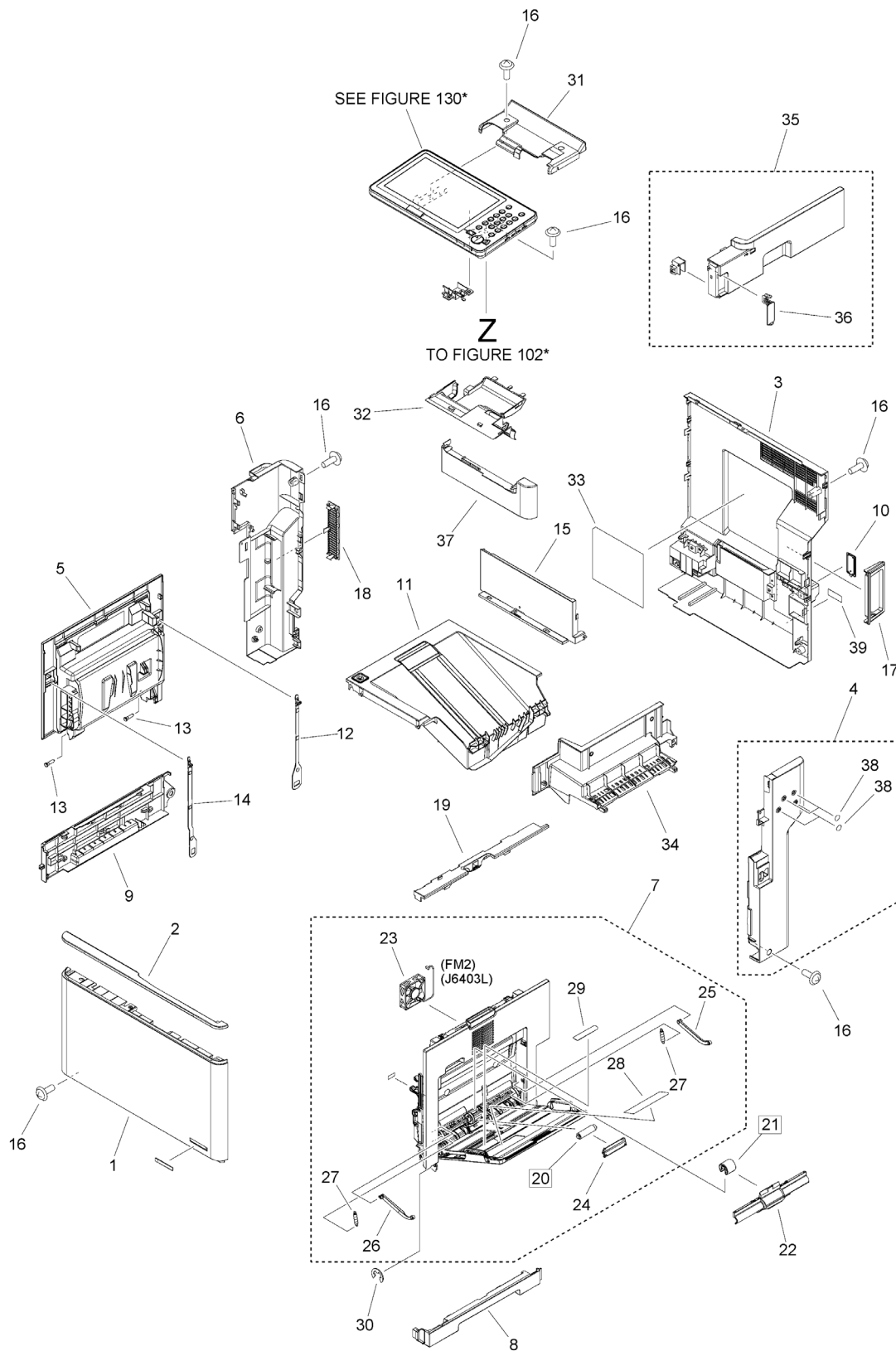

FIGURE & KEY NO.	PART NUMBER	RANK	QTY	DESCRIPTION	SERIAL NUMBER /REMARKS
100M	NPN		RF	EXTERNAL COVERS, PANELS, ETC.	525i
1	FE8-6078-000		1	COVER, FRONT	
2	FE8-6091-000		1	PANEL, FRONT UPPER	
3	FM1-U688-000		1	COVER ASSEMBLY, REAR	
4	FL1-5849-000		1	COVER, INLET	
5	FM1-R109-000		1	CRG. DOOR ASS'Y	
6	FE8-6097-000		1	COVER, LEFT REAR	
7	FM1-R104-000		1	RIGHT DOOR ASS'Y	
8	FE8-6085-000		1	COVER, RIGHT LOWER	
9	FE8-6082-000		1	COVER, LEFT LOWER	
10	FE3-9088-000		1	COVER, FAX CONNECTOR	
11	FM1-R110-000		1	FACE-DOWN TRAY ASS'Y	
12	RC4-8298-000		1	BAND, LEFT, REAR	
13	RC4-8301-000		2	SHAFT, DOOR	
14	RC4-8302-000		1	BAND, LEFT, FRONT	
15	FE8-6079-000		1	COVER, INNER,DELV. REAR	
16	XA9-1671-000		15	SCREW, D, M3X8	
17	FE8-6098-000		1	PANEL, INTERFACE, REAR	
18	FE8-6099-000		1	COVER, DUCT	
19	FE8-6077-000		1	COVER, RIGHT UPPER	
20	RL2-0079-000		1	ROLLER, MULTI-PURPOSE SEP.	[DP]
21	RL2-1566-000		1	ROLLER, MULTI-PURPOSE	[DP]
22	RC4-7318-000		1	MP ROLLER COVER	
23	RK2-8948-000		1	FAN	FM2
24	RC4-0548-000		1	GUIDE, NIP	
25	RC4-0566-000		1	MULTI-PURPOSE ARM, RIGHT	
26	RC4-7316-000		1	MULTI-PURPOSE ARM, LEFT	
27	RU8-2592-000		2	SPRING, TENSION	
28	FE8-6057-000		1	LABEL, MULTI PAPER PICK-UP	
29	FE8-6137-000		1	LABEL, MP SIZE	
30	XD9-0233-010		1	RING, E	
31	FE8-6090-000		1	COVER, CONTROL PANEL, UPPER	
32	FE4-2813-000		1	COVER, CONNECTOR	
33	FL1-5832-000		1	LABEL, SERVICE	
34	FE8-6080-000		1	COVER, INTERFACE, UPPER	
35	FM1-U019-000		1	INTERFACE COVER ASS'Y, RIGHT	
36	FC0-7172-000		1	COVER, MAIN SWITCH	
37	FE8-6081-000		1	COVER, CONTROL PANEL, LOWER	
38	FC6-4513-000		4	SEAL	
39	FE4-1828-020		1	LABEL, GROUNDING CAUTION	

Figure 101 INTERNAL COMPONENTS 1

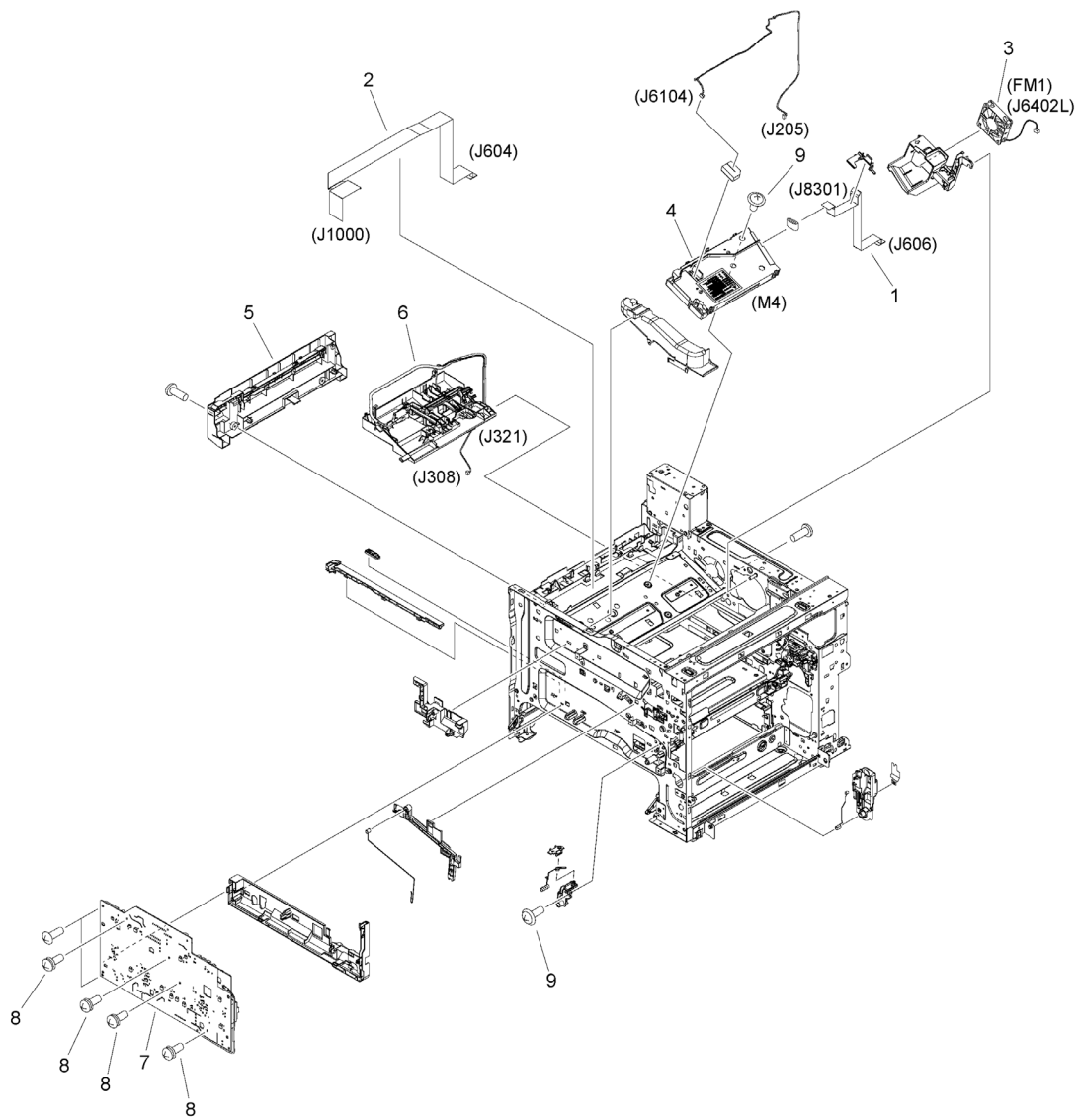

FIGURE & KEY NO.	PART NUMBER	RANK	QTY	DESCRIPTION	SERIAL NUMBER /REMARKS
101	NPN		RF	INTERNAL COMPONENTS 1	
1	RK2-8392-000		1	CABLE, FLAT, LASER	
2	RK2-8394-000		1	CABLE, FLAT, HVT	
3	RK2-8946-000		1	FAN	FM1
4	RM2-0906-000		1	LASER SCANNER ASS'Y	M4
5	RM2-1323-000		1	INNER COVER ASS'Y	
6	RM2-6755-000		1	LASER SHUTTER HOLDER ASS'Y	
7	RM2-9337-000		1	H.V. POWER SUPPLY PCB ASS'Y	
8	XA9-1420-000		4	SCREW, W/WASHER, M3X8	
9	XA9-1671-000		5	SCREW, D, M3X8	

Figure 102 INTERNAL COMPONENTS 2

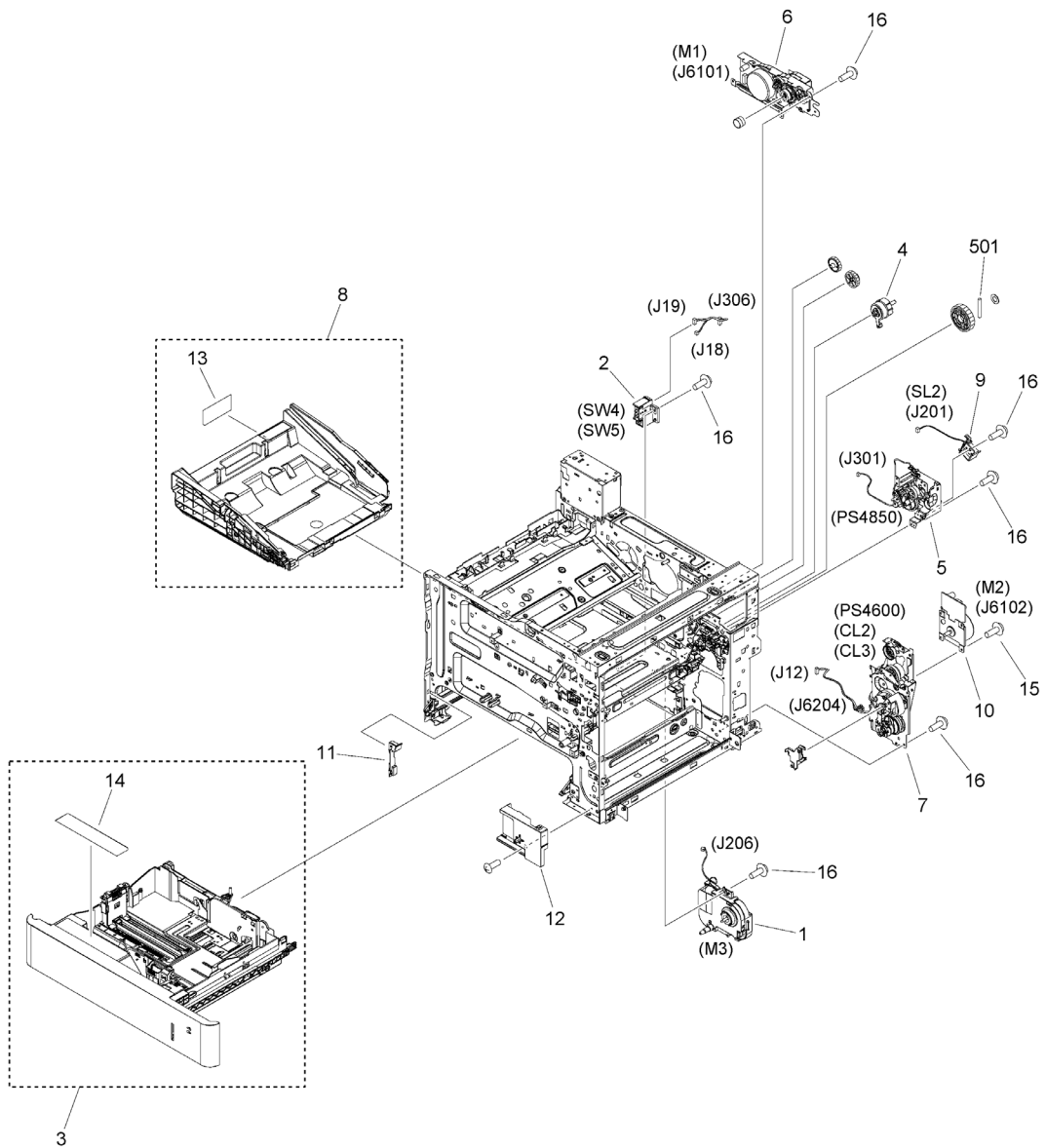

FIGURE & KEY NO.	PART NUMBER	RANK	QTY	DESCRIPTION	SERIAL NUMBER /REMARKS
102	NPN		RF	INTERNAL COMPONENTS 2	
1	RM2-0854-000		1	LIFTER DRIVE ASS'Y	M3
2	RM2-0857-000		1	SIZE DETECT ASS'Y	SW4, SW5
3	FM1-R111-000		1	CASSETTE ASS'Y	
4	RM2-1258-000		1	DEVELOPING GEAR ASS'Y	
5	RM2-1277-000		1	DEVELOPING DRIVE ASS'Y	PS4850
6	RM2-6763-000		1	FIXING DRIVE ASS'Y	M1
7	RM2-6777-000		1	MAIN DRIVE ASS'Y	PS4600, CL2, CL3
8	FM1-R117-000		1	CARTRIDGE TRAY ASS'Y	
9	RM2-9051-000		1	DEV. SOLENOID ASS'Y	SL2
10	RM2-9316-000		1	DRUM MOTOR ASS'Y	M2
11	RC4-8532-000		1	COVER, INNER, LEFT	
12	RC4-8533-000		1	COVER, INNER, RIGHT	
13	FE8-6067-000		1	LABEL, TONER	
14	FE8-6142-000		1	LABEL, CASSETTE OPERATOR	
15	XA9-1503-000		4	SCREW, TAP, M3X6	
16	XA9-1671-000		18	SCREW, D, M3X8	
501	XD3-2300-222		1	PIN, PARALLEL	

Figure 103 INTERNAL COMPONENTS 3

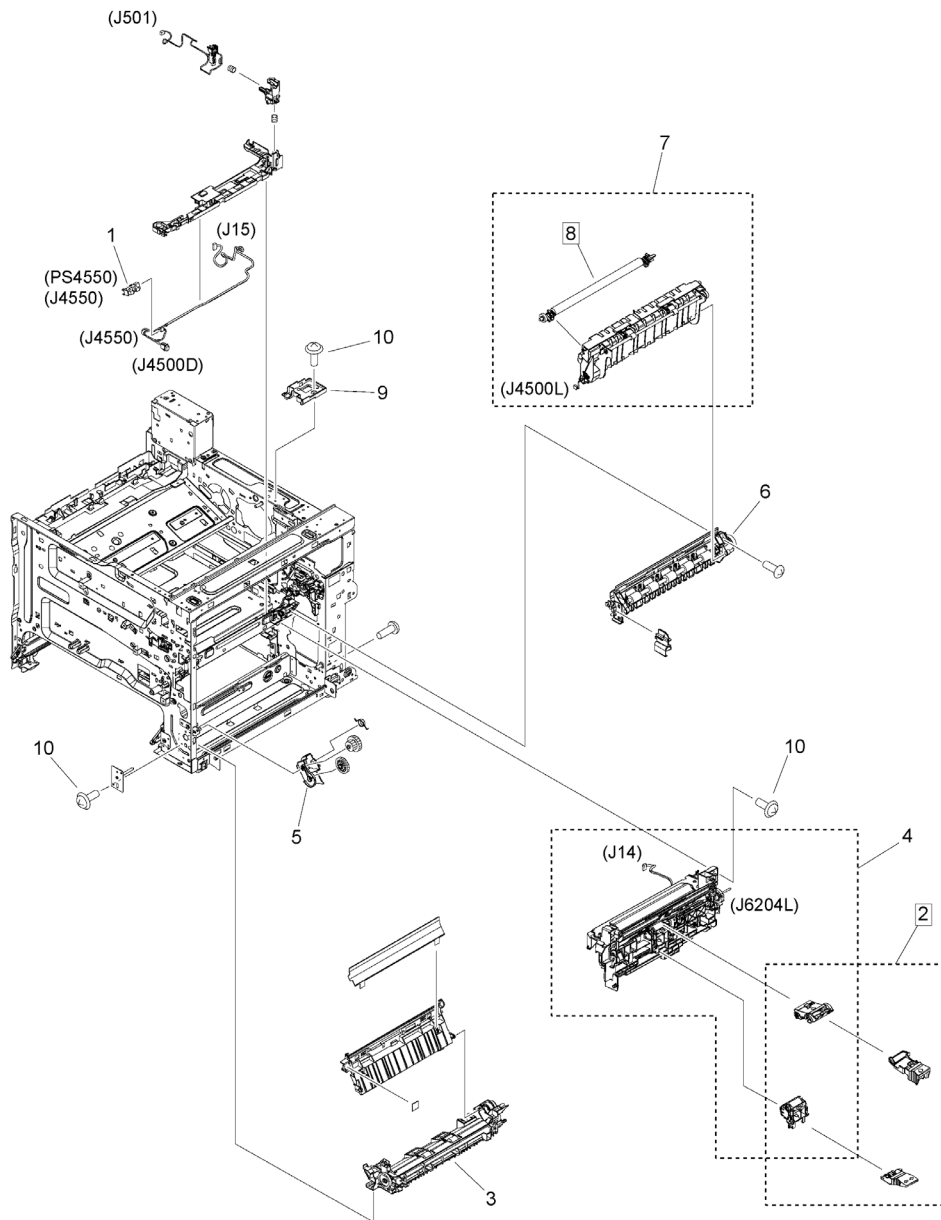

FIGURE & KEY NO.	PART NUMBER	RANK	QTY	DESCRIPTION	SERIAL NUMBER /REMARKS
103	NPN		RF	INTERNAL COMPONENTS 3	
1	WG8-5935-000		1	IC, PHOTO INTERRUPTER	PS4550
2	FM1-U030-000		1	ROLLER KIT, CR-102	FOR NON-TECHNICAL PERSON [DP]
3	RM2-0851-000		1	PAPER FEED FRAME ASS'Y	
4	RM2-6795-000		1	PAPER PICK-UP ASS'Y	
5	RC4-8414-000		1	HOLDER, MULTI-PURPOSE GEAR	
6	FM1-R116-000		1	REGISTRATION ASS'Y	
7	RM2-6776-000		1	TRANSFER ASS'Y	
8	FM1-U032-000		1	TRANSFER ROLLER, TR-102	FOR NON-TECHNICAL PERSON [DP]
9	RM2-1326-000		1	BLANKING COVER ASS'Y	
10	XA9-1671-000		8	SCREW, D, M3X8	

Figure 104B INTERNAL COMPONENTS 4 (230V)

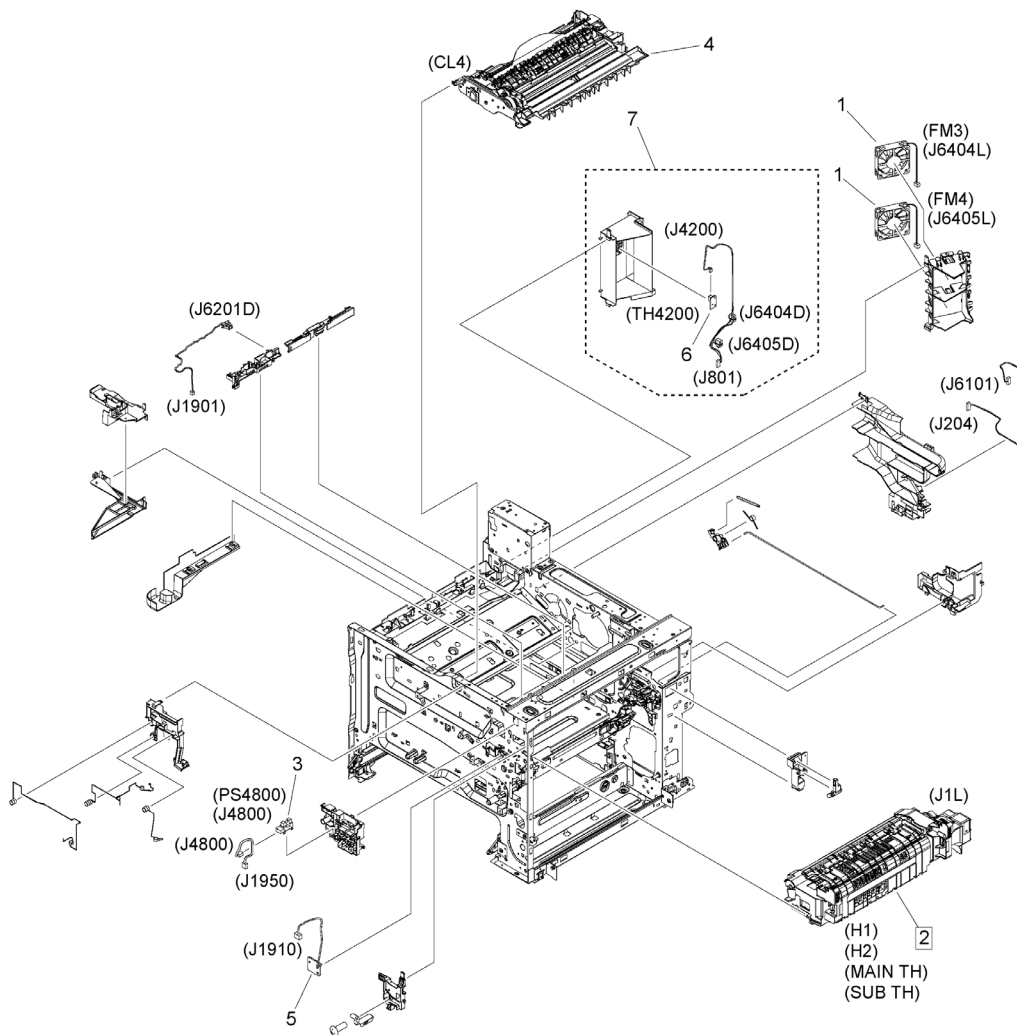

FIGURE & KEY NO.	PART NUMBER	RANK	QTY	DESCRIPTION	SERIAL NUMBER /REMARKS
104B	NPN		RF	INTERNAL COMPONENTS 4	230V
1	RK2-8946-000		2	FAN	FM3, FM4
2	FM1-U028-000		1	FIXING ASSEMBLY, FX-102	H1, H2, MAIN TH, SUB TH FOR NON- TECHNICAL PERSON [DP]
3	WG8-5935-000		1	IC, PHOTO INTERRUPTER	PS4800
4	RM2-6787-000		1	PAPER DELIVERY ASS'Y	CL4
5	RM2-8537-000		1	PRE-EXPOSURE PCB ASS'Y	
6	RM2-9037-000		1	TEMPERATURE SENSOR ASS'Y	TH4200
7	FM1-R115-000		1	AIR INTAKE DUCT ASSEMBLY	

Figure 105D INTERNAL COMPONENTS 5 (715i, 615i, 525i)

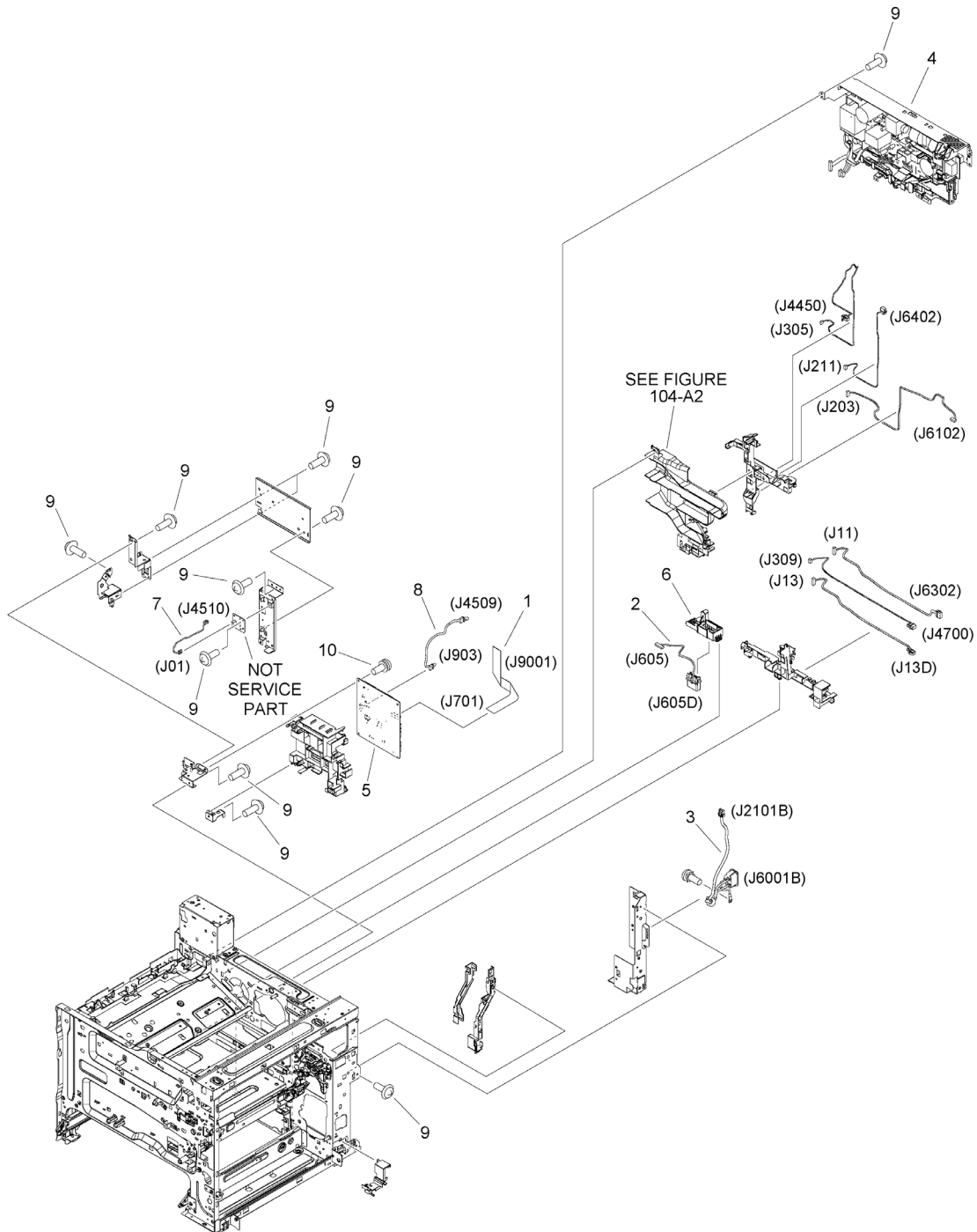

FIGURE & KEY NO.	PART NUMBER	RANK	QTY	DESCRIPTION	SERIAL NUMBER /REMARKS
105D	NPN		RF	INTERNAL COMPONENTS 5	715i, 615i, 525i
1	FK4-5288-000		1	CABLE, FLAT	
2	RM2-8577-000		1	PICK-UP OPTION CABLE ASS'Y	
3	FM2-D958-000		1	INLET CABLE ASS'Y	
4	FM1-R125-000		1	L.V. POWER SUPPLY PCB ASS'Y	
5	FM1-R118-000		1	DC CONTROLLER PCB ASS'Y	
6	RC4-8393-000		1	HOLDER, DRAWER	
7	FM2-D954-000		1	CABLE, SIGNAL	
8	FM2-D951-000		1	CABLE, MAIN CONTROLLER	
9	XA9-1671-000		19	SCREW, D, M3X8	
10	XA9-1420-000		2	SCREW, W/WASHER, M3X8	

Figure 106B INTERNAL COMPONENTS 6 (WITHOUT FINISHER model)

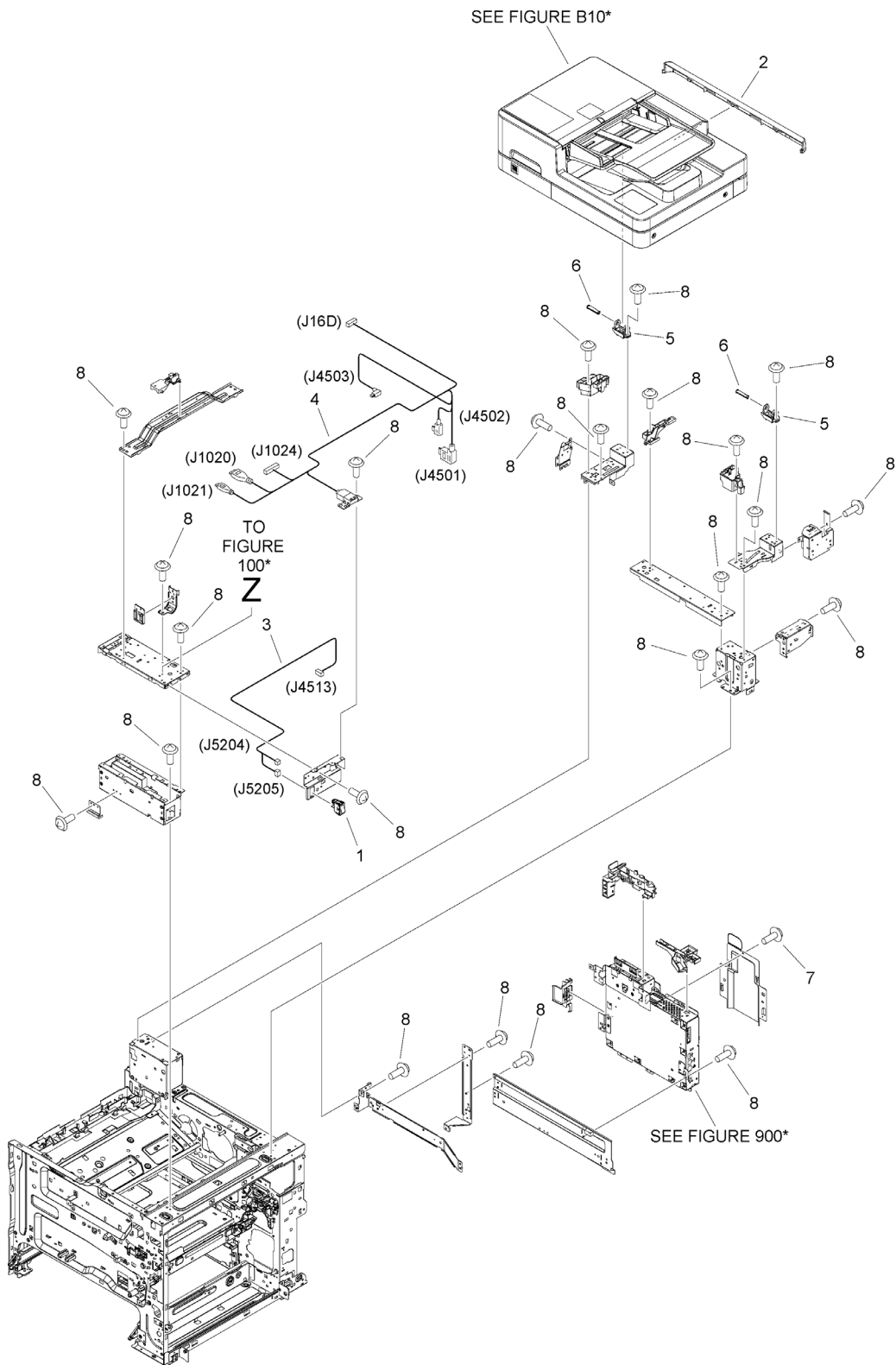

FIGURE & KEY NO.	PART NUMBER	RANK	QTY	DESCRIPTION	SERIAL NUMBER /REMARKS
106B	NPN		RF	INTERNAL COMPONENTS 6	WITHOUT FINISHER model
1	FK3-2835-000		1	SWITCH, MAIN POWER SUPPLY	
2	FE8-2109-000		1	COVER, READER REAR, 2	
3	FM2-D955-000		1	CABLE, MAIN SWITCH	
4	FM2-D963-000		1	UI CABLE UNIT	
5	FE8-2110-000		2	HINGE, READER	
6	FE8-2405-000		2	SHAFT, READER HINGE	
7	XA9-1435-000		1	SCREW, ROUND, M3X6	
8	XA9-1671-000		62	SCREW, D, M3X8	

Figure 130B FLAT CONTROL PANEL ASSEMBLY

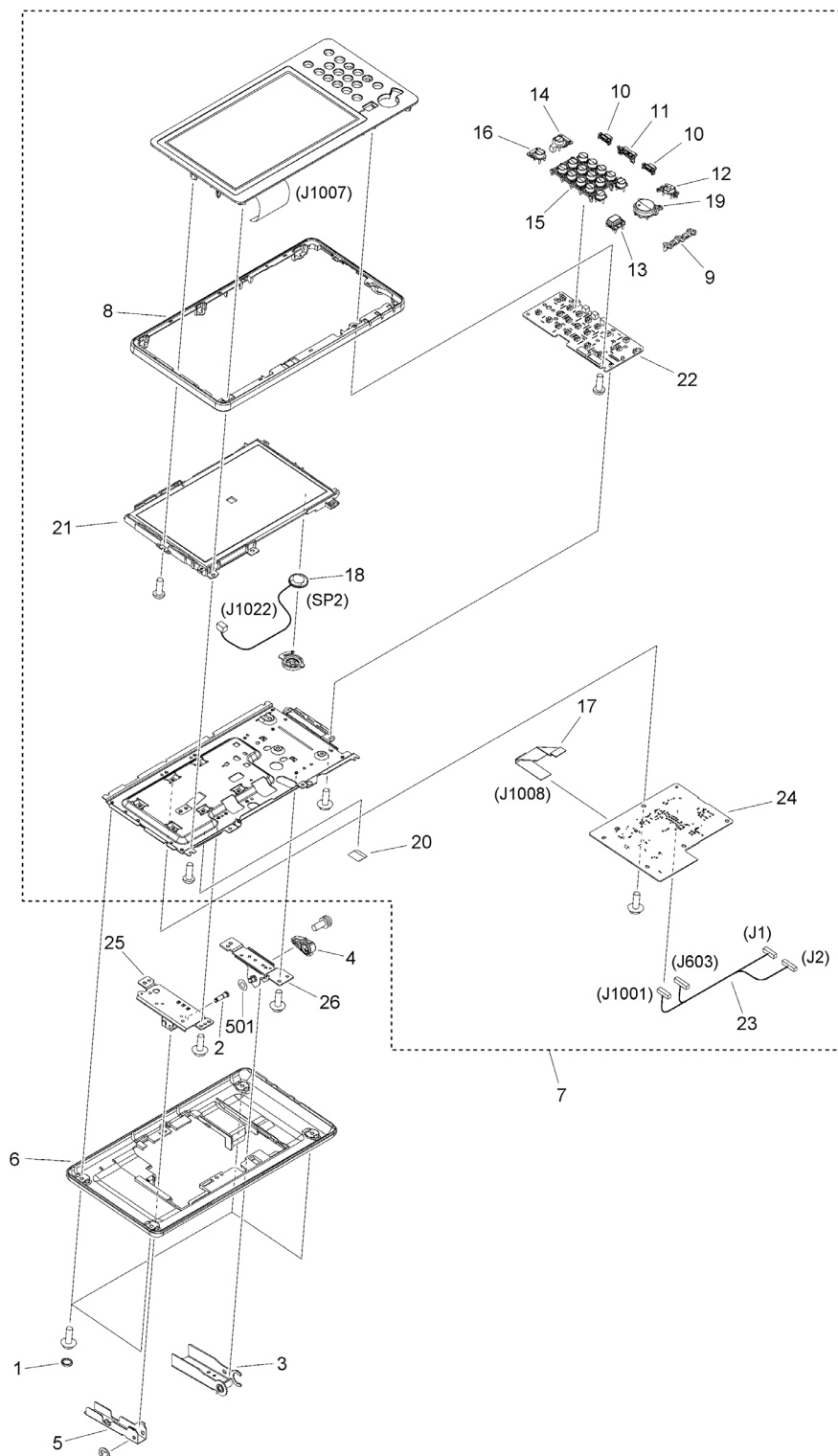

FIGURE & KEY NO.	PART NUMBER	RANK	QTY	DESCRIPTION	SERIAL NUMBER /REMARKS
130B	NPN		RF	FLAT CONTROL PANEL ASSEMBLY	
1	FE3-9169-000		4	CAP	
2	FE4-2501-000		1	HINGE, SHAFT	
3	FL1-6358-000		1	HINGE, RIGHT	
4	FE4-2503-000		1	SUPPORT, HINGE	
5	FL0-4439-000		1	HINGE, LEFT	
6	FE4-2812-000		1	COVER, LOWER	
7	FM1-N430-000		1	FLAT CONTROL PANEL ASSEMBLY	
8	FE4-1774-020		1	COVER, FRAME	
9	FE4-1787-000		1	GUIDE, LAMP LED	
10	FE4-1788-000		2	KEY TOP, SIDE	
11	FE4-1789-000		1	KEY TOP, VOLUME	
12	FE4-5109-000		1	KEY TOP, STOP	
13	FE4-5110-000		1	KEY TOP, RESET	
14	FE4-5111-000		1	KEY TOP, SLEEP	
15	FL1-2178-000		1	KEY TOP, NUMBERS	
16	FE4-5556-000		1	KEY TOP, SETTINGS/REGISTRATION	
17	FK4-2360-000		1	CABLE, FLEXIBLE FLAT	
18	FK4-2365-000		1	SPEAKER	SP2
19	FL0-5116-000		1	KEY TOP, START	
20	FL1-1429-000		1	SHEET	
21	FM1-N440-000		1	LCD HOLDER UNIT	
22	FM1-M929-000		1	KEY TOP PCB ASSEMBLY	
23	FM1-X899-010		1	CABLE, 10 KEY	
24	FM1-X811-000		1	CPU PCB ASSEMBLY	
25	FM1-M730-010		1	HINGE BASE ASSEMBLY, LEFT	
26	FM1-M731-010		1	HINGE BASE ASSEMBLY, RIGHT	
501	XD1-1108-233		1	WASHER	

Figure 900A CONTROLLER BOX ASSEMBLY (715 Series)

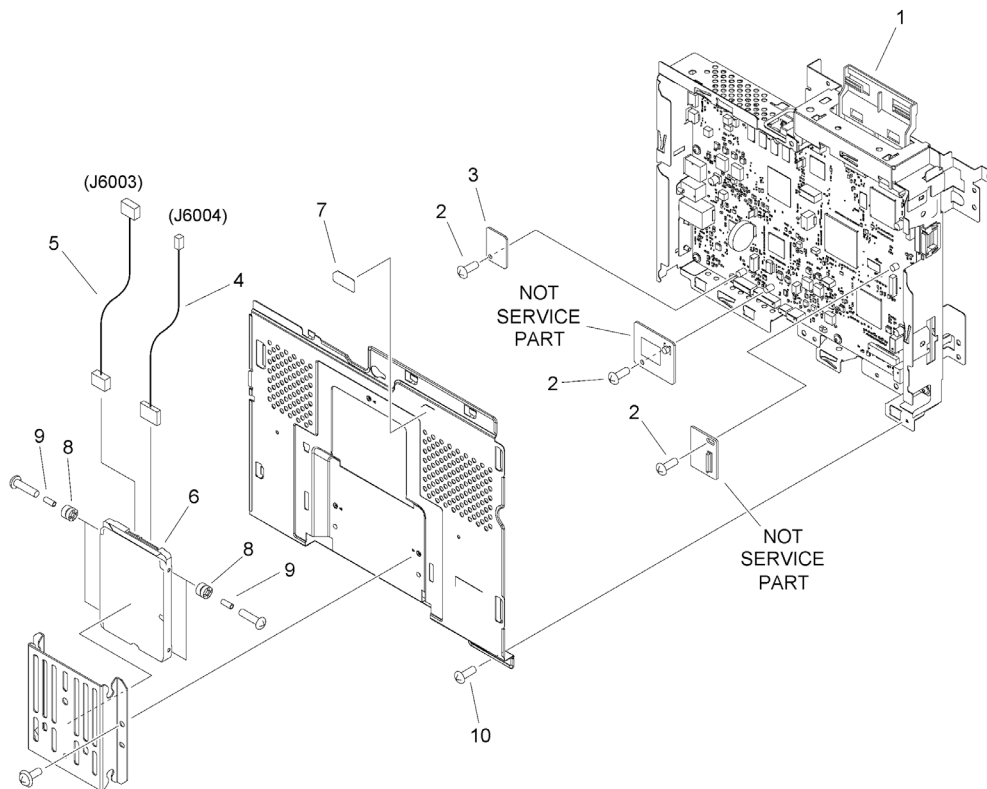

FIGURE & KEY NO.	PART NUMBER	RANK	QTY	DESCRIPTION	SERIAL NUMBER /REMARKS
900A	NPN		RF	CONTROLLER BOX ASSEMBLY	715 Series
1	FM1-U718-000		1	MAIN CONTROLLER PCB ASSEMBLY	
2	XA9-1979-000		3	SCREW, MACH. PAN HEAD, M3X4	
3	FM1-M981-000		1	TPM PCB ASSEMBLY	
4	FK4-3811-000		1	CABLE, SATA POWER	
5	FK4-3810-000		1	CABLE, SATA SIGNAL	
6	FK4-1550-000		1	HARD DISK DRIVE, MQ01ABF032	
7	FU8-8257-000		1	LABEL, CAUTION	
8	XH9-0149-000		4	DAMPER, CUSHION	
9	XZ1-1301-005		4	SPACER	
10	XA9-1435-000		2	SCREW, ROUND, M3X6	

Figure 900B CONTROLLER BOX ASSEMBLY (615 Series)

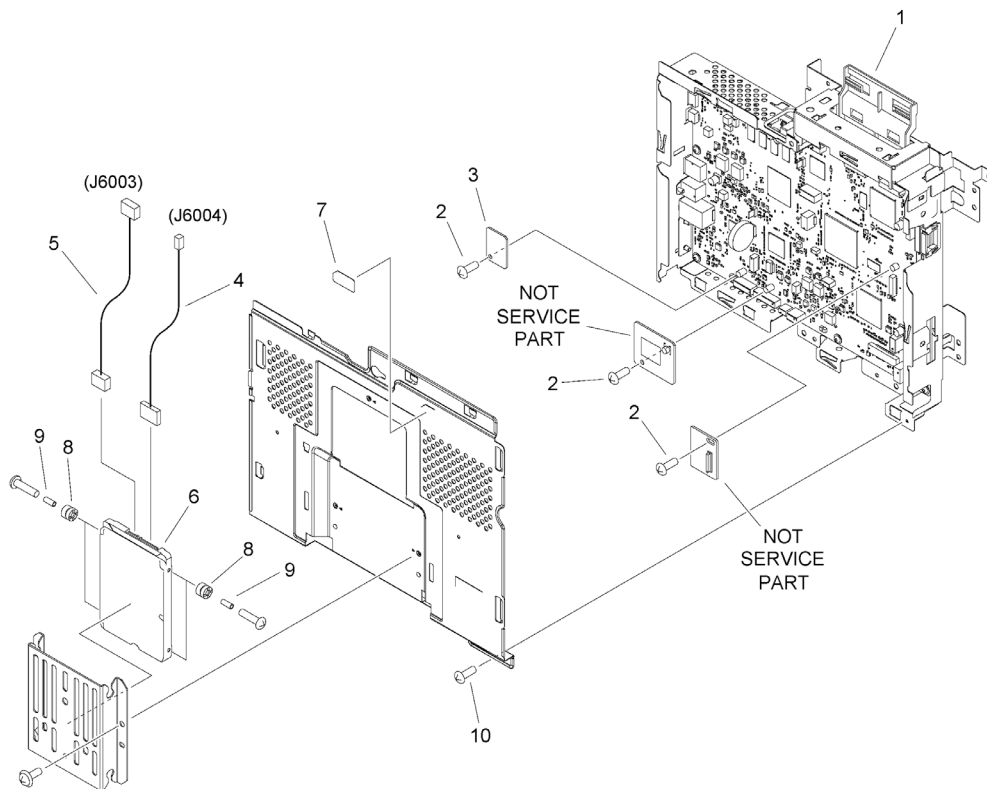

FIGURE & KEY NO.	PART NUMBER	RANK	QTY	DESCRIPTION	SERIAL NUMBER /REMARKS
900B	NPN		RF	CONTROLLER BOX ASSEMBLY	615 Series
1	FM1-U719-000		1	MAIN CONTROLLER PCB ASSEMBLY	
2	XA9-1979-000		3	SCREW, MACH. PAN HEAD, M3X4	
3	FM1-M981-000		1	TPM PCB ASSEMBLY	
4	FK4-3811-000		1	CABLE, SATA POWER	
5	FK4-3810-000		1	CABLE, SATA SIGNAL	
6	FK4-1550-000		1	HARD DISK DRIVE, MQ01ABF032	
7	FU8-8257-000		1	LABEL, CAUTION	
8	XH9-0149-000		4	DAMPER, CUSHION	
9	XZ1-1301-005		4	SPACER	
10	XA9-1435-000		2	SCREW, ROUND, M3X6	

Figure 900C CONTROLLER BOX ASSEMBLY (525 Series)

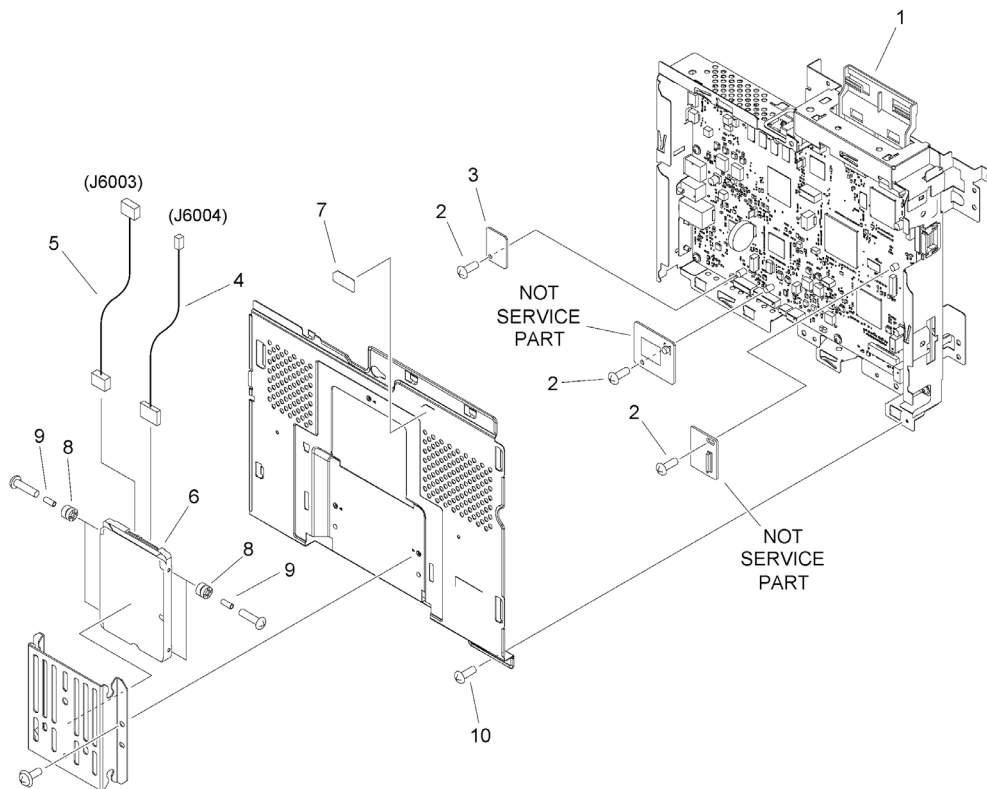

FIGURE & KEY NO.	PART NUMBER	RANK	QTY	DESCRIPTION	SERIAL NUMBER /REMARKS
900C	NPN		RF	CONTROLLER BOX ASSEMBLY	525 Series
1	FM1-U720-000		1	MAIN CONTROLLER PCB ASSEMBLY	
2	XA9-1979-000		3	SCREW, MACH. PAN HEAD, M3X4	
3	FM1-M981-000		1	TPM PCB ASSEMBLY	
4	FK4-3811-000		1	CABLE, SATA POWER	
5	FK4-3810-000		1	CABLE, SATA SIGNAL	
6	FK4-1550-000		1	HARD DISK DRIVE, MQ01ABF032	
7	FU8-8257-000		1	LABEL, CAUTION	
8	XH9-0149-000		4	DAMPER, CUSHION	
9	XZ1-1301-005		4	SPACER	
10	XA9-1435-000		2	SCREW, ROUND, M3X6	

Figure B01 ADF MAINTENANCE KIT

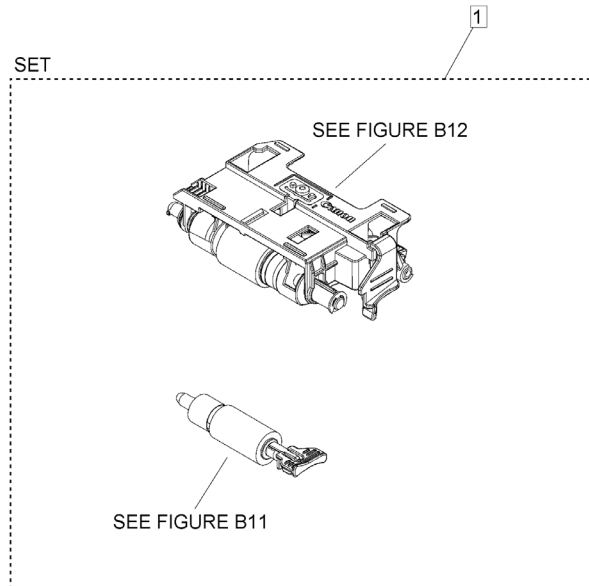

FIGURE & KEY NO.	PART NUMBER	RANK	QTY	DESCRIPTION	SERIAL NUMBER /REMARKS
B01	NPN		RF	ADF MAINTENANCE KIT	
1	FM1-P720-010		1	ADF MAINTENANCE KIT, DR-203	FOR NON-TECHNICAL PERSON [DP]

Figure B10B READER/ADF ASSEMBLY

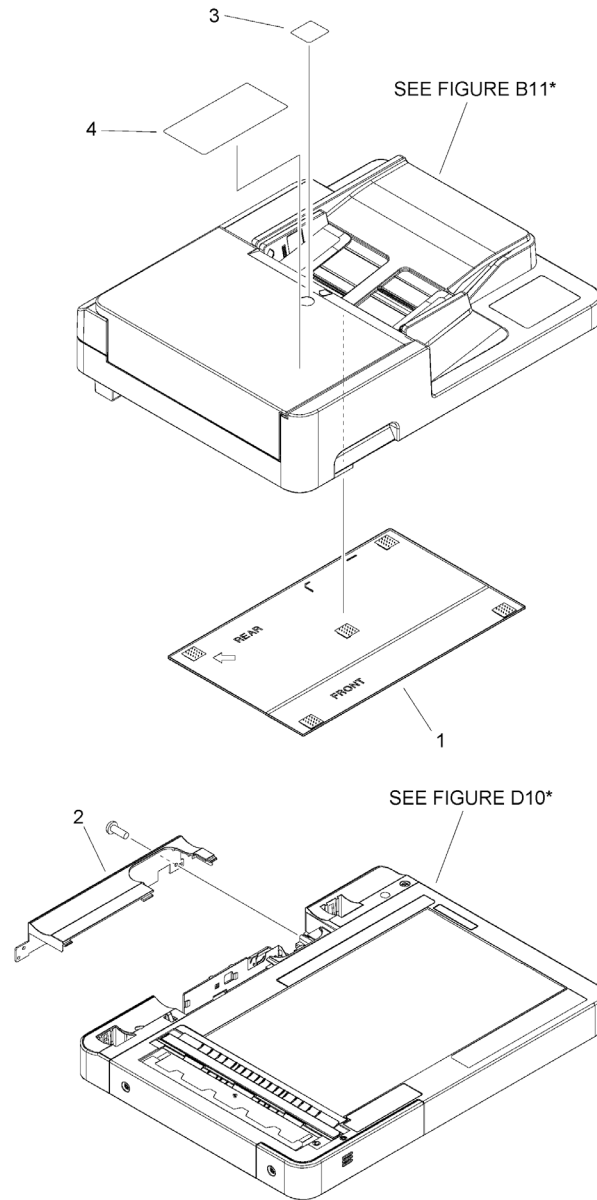

FIGURE & KEY NO.	PART NUMBER	R A N K	QTY	DESCRIPTION	SERIAL NUMBER /REMARKS
B10B	NPN		RF	READER/ADF ASSEMBLY	
1	FL1-0407-000		1	COVER, COPYBOARD	
2	FE8-2099-010		1	COVER, CABLE	
3	FE8-4576-000		1	LABEL, DOCUMENT DIRECTION	
4	FE8-4579-000		1	LABEL,CLEANING/PROHIBITION	

Figure B11 (1/3) AUTO DOCUMENT FEEDER ASS'Y SET

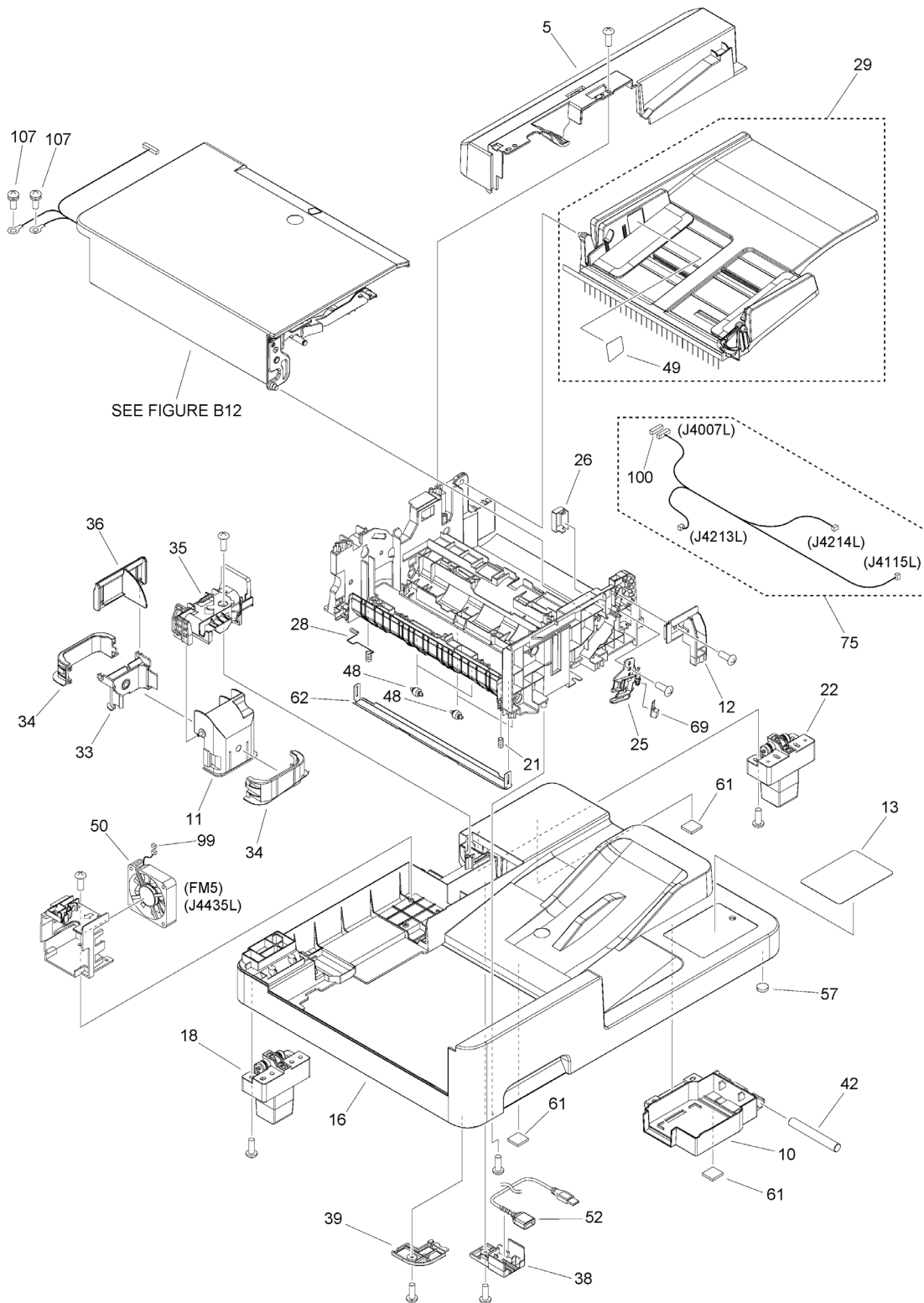

Figure B11 (2/3) AUTO DOCUMENT FEEDER ASS'Y SET

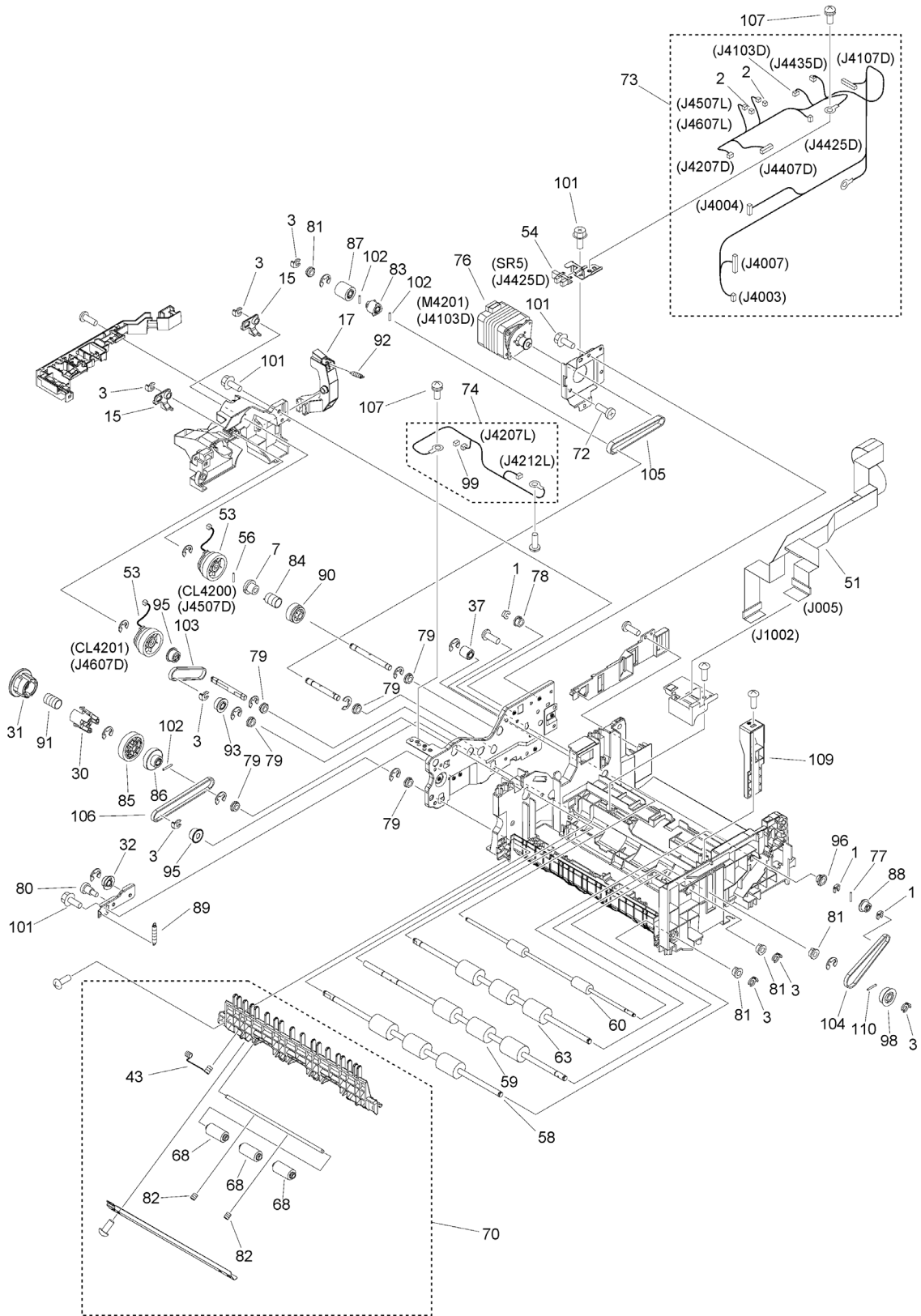

Figure B11 (3/3) AUTO DOCUMENT FEEDER ASS'Y SET

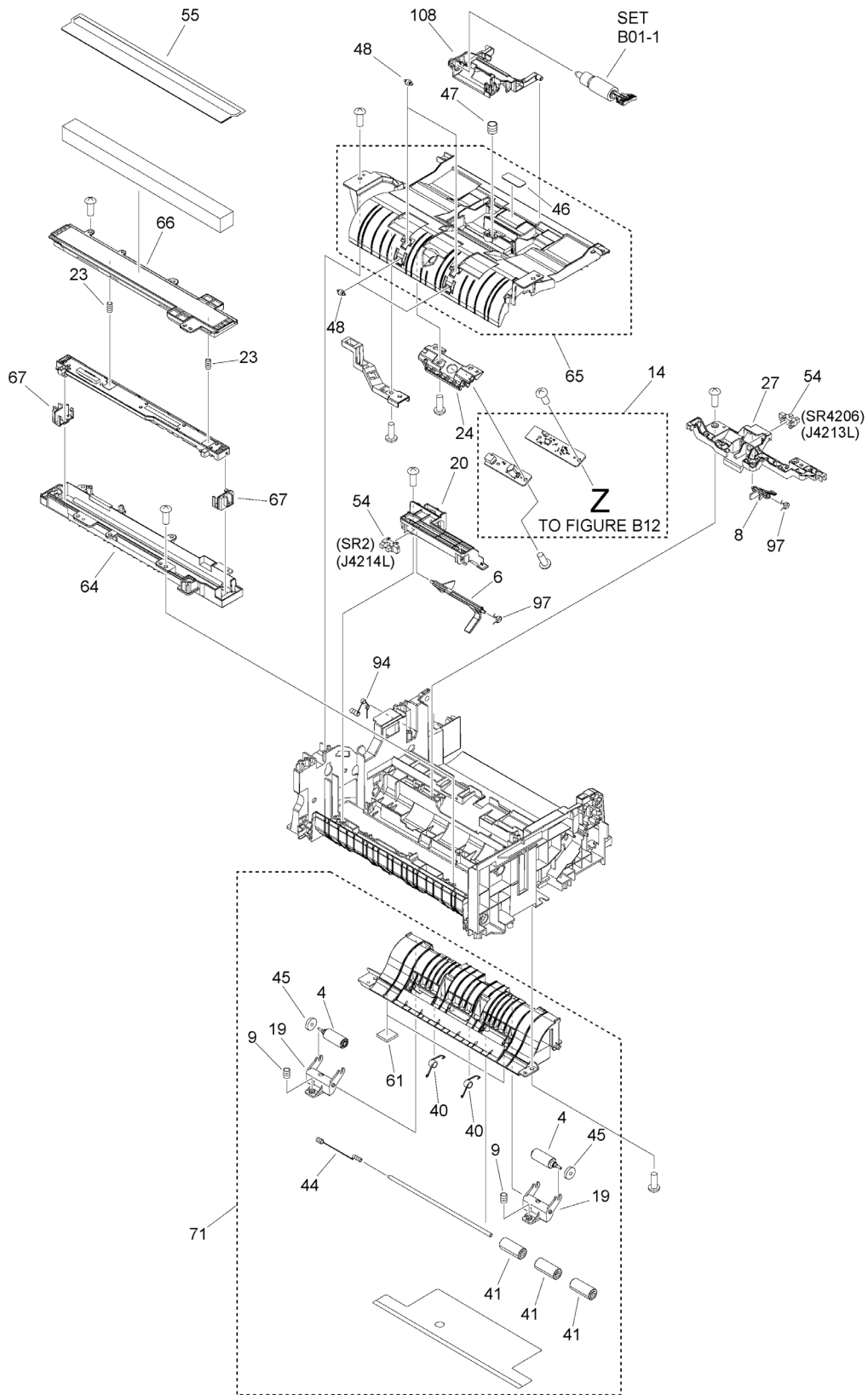

FIGURE & KEY NO.	PART NUMBER	RANK	QTY	DESCRIPTION	SERIAL NUMBER /REMARKS
B11	NPN		RF	AUTO DOCUMENT FEEDER ASS'Y SET	
1	FC0-1271-000		3	CLIP	
2	VS1-7177-002		2	CONNECTOR, SNAP TIGHT, BK	
3	FC5-4424-000		8	CLIP	
4	FC8-6316-010		2	ROLLER, DELIVERY	
5	FE4-5751-000		1	COVER, REAR	
6	FC8-6371-000		1	LEVER, READ SENSOR	
7	FC8-6383-000		1	JOINT, PICK-UP	
8	FE4-5701-000		1	LEVER, PAPER DELIVERY SENSOR	
9	FE4-5712-000		2	SPRING, COMPRESSION	
10	FE4-5735-000		1	COVER, CARD READER	
11	FE4-5746-000		1	GUIDE, CABLE, FRONT	
12	FE4-5761-000		1	ARM, JOINT	
13	FE4-5779-000		1	LABEL	
14	FM1-K086-010		1	DOUBLE FEED DETECTION KIT	
15	FE4-5788-000		2	STOPPER, CLUTCH ROTATION	
16	FE4-5790-000		1	FRAME, BASE	
17	FE4-5796-000		1	LEVER, DRIVE RELEASE	
18	FE8-2341-000		1	HINGE, ADF, LEFT	
19	FE8-1580-000		2	HOLDER, ROLLER	
20	FE8-1582-000		1	HOLDER, SENSOR	
21	FE8-1586-000		1	SPRING, COMPRESSION	
22	FE8-2342-000		1	HINGE, ADF, RIGHT	
23	FE8-1590-000		2	SPRING, COMPRESSION	
24	FE8-1865-000		1	HOLDER, DOUBLE FEED DETECTION	
25	FE8-1882-000		1	HOLDER, LED	
26	FE8-1883-000		1	COVER, LED	
27	FE8-1884-000		1	HOLDER, PAPER DELIVERY SENSOR	
28	FE8-1890-000		1	SPRING, COMPRESSION	
29	FM1-L783-000		1	DOCUMENT TRAY ASSEMBLY	
30	FE8-2329-000		1	COUPLING	
31	FE8-2330-000		1	COUPLING	
32	FE8-2332-000		1	ROLLER, TENSIONER	
33	FE8-2333-000		1	GUIDE, CABLE, REAR	
34	FE8-2334-000		2	GUIDE, CABLE, LOWER	
35	FE8-2335-000		1	GUIDE, CABLE	
36	FE8-2338-000		1	COVER, CABLE	
37	FE8-2339-000		1	ROLLER, TENSIONER	
38	FE8-2355-000		1	COVER, USB	
39	FE8-2356-000		1	COVER, BOTTOM	
40	FE8-2419-000		2	SPRING, TORSION	
41	FC5-4286-000		3	ROLLER, PAPER FEED, 1	
42	FE4-5786-000		1	WEIGHT	
43	FE8-2623-000		1	SPRING, COMPRESSION	

FIGURE & KEY NO.	PART NUMBER	RANK	QTY	DESCRIPTION	SERIAL NUMBER /REMARKS
44	FE8-2624-000		1	SPRING, COMPRESSION	
45	FE8-3710-000		2	DAMPER	
46	FE8-3713-000		1	PAD, PICK-UP	
47	FE8-3716-000		1	SPRING, COMPRESSION	
48	FE8-3973-000		8	ROLLER, PLATEN	
49	FE8-6364-000		1	LABEL, DOCUMENT MAXIMUM LOAD	
50	FK2-0472-010		1	FAN	FM5
51	FK4-3805-000		1	CABLE, FLAT	
52	FK4-3808-000		1	CABLE, USB	
53	FK4-3995-000		2	CLUTCH, ELECTROMAGNETIC	CL4200, CL4201
54	WG8-5935-000		3	IC, PHOTO INTERRUPTER	SR2, SR5, SR4206
55	FL0-5407-000		1	SHEET, WHITE	
56	XD9-0289-000		1	PIN, PARALLEL	
57	FL0-5405-000		1	DAMPER	
58	FL1-0267-000		1	ROLLER, READ, 1	
59	FL1-0268-000		1	ROLLER, READ, 2	
60	FL1-0269-000		1	ROLLER, DELIVERY	
61	FL0-5178-000		5	CUSHION	
62	FL1-0441-000		1	GUIDE, PLATEN	
63	FL1-0740-000		1	ROLLER, REGISTRATION	
64	FL1-1512-000		1	HOLDER, CONTACT IMAGE SENSOR	
65	FL1-1513-010		1	GUIDE, SEPARATION	
66	FL1-2056-000		1	COVER, CONTACT IMAGE SENSOR	
67	FL1-2057-000		2	SPACER CIS ADF FL	RANK B
67	FL1-2174-000		2	SPACER CIS ADF 2 FL	RANK C
67	FL1-2175-000		2	SPACER, CONTACT IMAGE SENSOR	RANK A
68	FL1-3412-000		3	ROLLER, READ	
69	FM0-0294-000		1	EJECT LIGHT LED PCB ASS'Y	
70	FM1-L785-010		1	LEAD 1 OUTER GUIDE ASSEMBLY	
71	FM1-L786-010		1	LEAD 2 OUTER GUIDE ASSEMBLY	
72	XA9-0624-000		2	SCREW,M3X4	
73	FM1-W888-000		1	CABLE, ADF MAIN	
74	FM1-W889-000		1	CABLE, DOUBLE FEED DETECTION	
75	FM1-W892-000		1	CABLE, ADF PASS SENSOR	
76	FM1-W895-000		1	MOTOR ASS'Y	M4201
77	XD9-0352-000		1	PIN	
78	FS1-1528-000		1	BUSHING, PL	
79	FS5-1805-000		6	BUSHING	
80	FS5-9391-000		1	SCREW, STEPPED, M3	
81	FU2-0595-000		4	BUSHING	
82	FU2-1417-000		2	SPRING, COMPRESSION	
83	FU2-1446-000		1	PULLEY, 22T	
84	FU2-1747-000		1	SPRING, CLUTCH	
85	FU2-1749-000		1	GEAR, 38T	

FIGURE & KEY NO.	PART NUMBER	RANK	QTY	DESCRIPTION	SERIAL NUMBER /REMARKS
86	FU2-1750-000		1	PULLEY, 22T	
87	FU2-1751-000		1	GEAR, 18T	
88	FU2-1752-000		1	PULLEY, 18T	
89	FU2-1754-000		1	SPRING, TENSION	
90	FU2-1756-000		1	GEAR, 23T	
91	FU2-1757-000		1	SPRING, COMPRESSION	
92	FU2-1758-000		1	SPRING, TENSION	
93	FU2-1759-000		1	PULLEY, 23T	
94	FU2-1831-000		1	SPRING, TORSION	
95	FU5-3643-000		2	PULLEY, 22T	
96	FU6-1572-000		1	BUSHING	
97	FU7-2658-000		2	SPRING, TORSION	
98	FU8-0240-000		1	PULLEY	
99	VS1-7177-003		2	CONNECTOR, SNAP TIGHT, BK	
100	VS1-7177-008		1	CONNECTOR, SNAP TIGHT, BK	
101	XA9-1386-000		7	SCREW,RS,M3X8	
102	XD9-0333-000		3	PIN, PARALLEL	
103	XF2-1606-940		1	BELT, TIMING	
104	XF2-1608-640		1	BELT, TIMING	
105	XF2-1609-560		1	BELT, TIMING	
106	XF2-1610-640		1	BELT, TIMING	
107	XA9-2003-000		4	SCREW, W/WASHER, M3X6	
108	FE8-2385-000		1	HOLDER, ROLLER	
109	FE8-3531-000		1	HOLDER, CONTACT IMAGE SENSOR	
110	XD9-0290-000		1	PIN, PARALLEL	

Figure B12 PAPER PICK-UP COVER ASS'Y

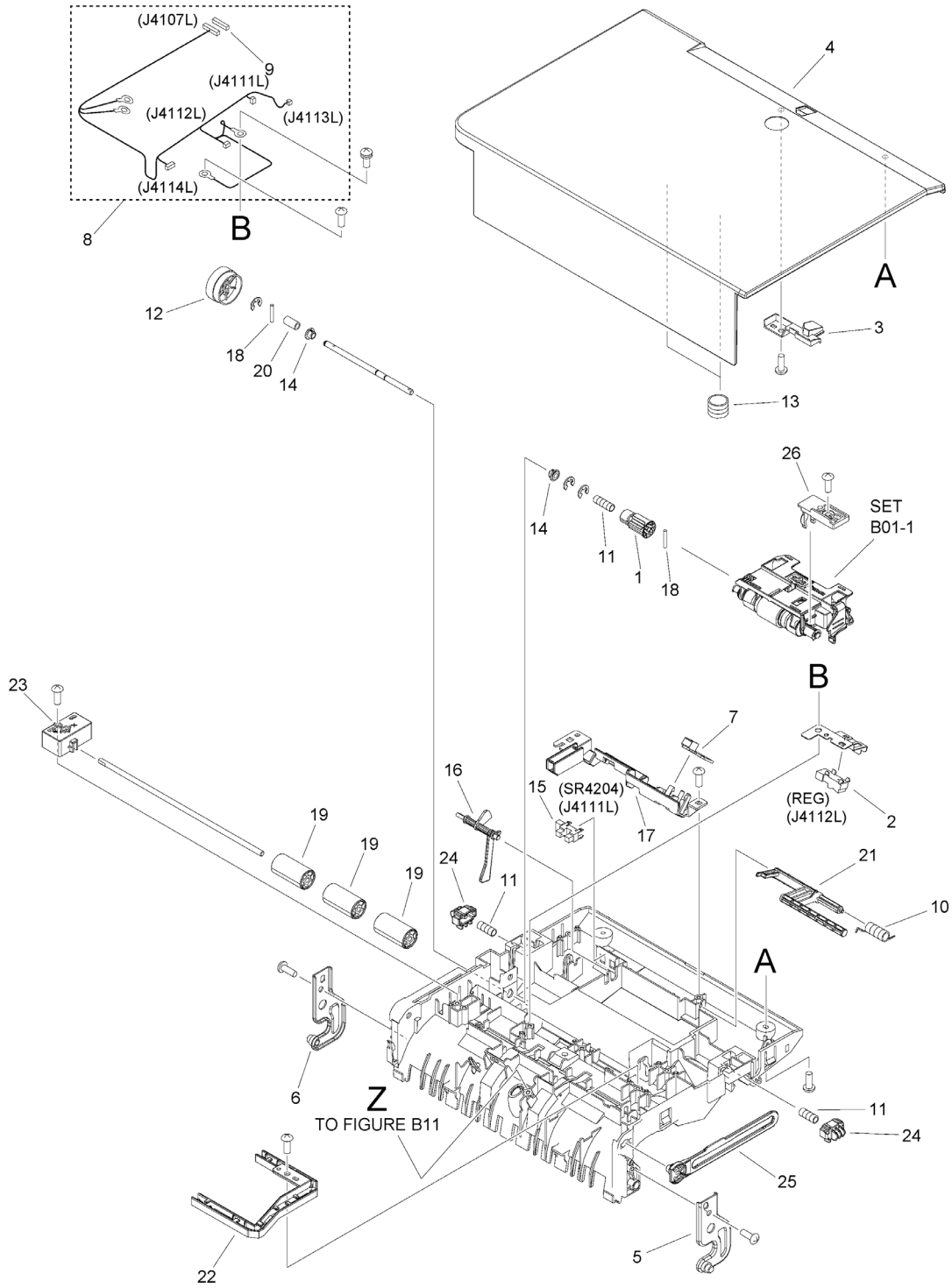

FIGURE & KEY NO.	PART NUMBER	RANK	QTY	DESCRIPTION	SERIAL NUMBER /REMARKS
B12	NPN		RF	PAPER PICK-UP COVER ASS'Y	
1	FE8-2455-000		1	COUPLING	
2	FK2-6470-000		1	PHOTO-SENSOR, KUA0055C	REG
3	FL1-0424-000		1	COVER, LED	
4	FL1-0427-000		1	COVER, PAPER PICK-UP	
5	FL1-0526-000		1	ARM, OPEN/CLOSE COVER, FRONT	
6	FL1-0527-000		1	ARM, OPEN/CLOSE COVER, REAR	
7	FM1-K827-000		1	LED PCB ASSEMBLY	
8	FM1-W890-000		1	CABLE, COVER	
9	VS1-7177-013		1	CONNECTOR, SNAP TIGHT	
10	FU2-1806-000		1	SPRING, TORSION	
11	FU2-1808-000		3	SPRING, COMPRESSION	
12	FU2-1833-000		1	GEAR, 29T	
13	FU2-1807-000		2	SPRING, COMPRESSION	
14	FU6-1572-000		2	BUSHING	
15	WG8-5935-000		1	IC, PHOTO INTERRUPTER	SR4204
16	FE8-2387-000		1	FLAG, SENSOR	
17	FE8-2120-000		1	GUIDE, LED	
18	XD9-0352-000		2	PIN	
19	FC5-4324-000		3	ROLLER, REGISTRATION, 2	
20	FC8-7343-000		1	ROLLER, BELT	
21	FE8-1867-000		1	LEVER, PICK RELEASE	
22	FE8-1868-000		1	GUIDE, GROUNDING	
23	FE8-1869-000		1	HOLDER, REGISTRATION ROLLER	
24	FE8-1870-000		2	LATCH	
25	FE8-1874-000		1	LINK, OPEN/CLOSE	
26	FE8-2386-000		1	HOLDER, PICK	

Figure D10B READER ASSEMBLY

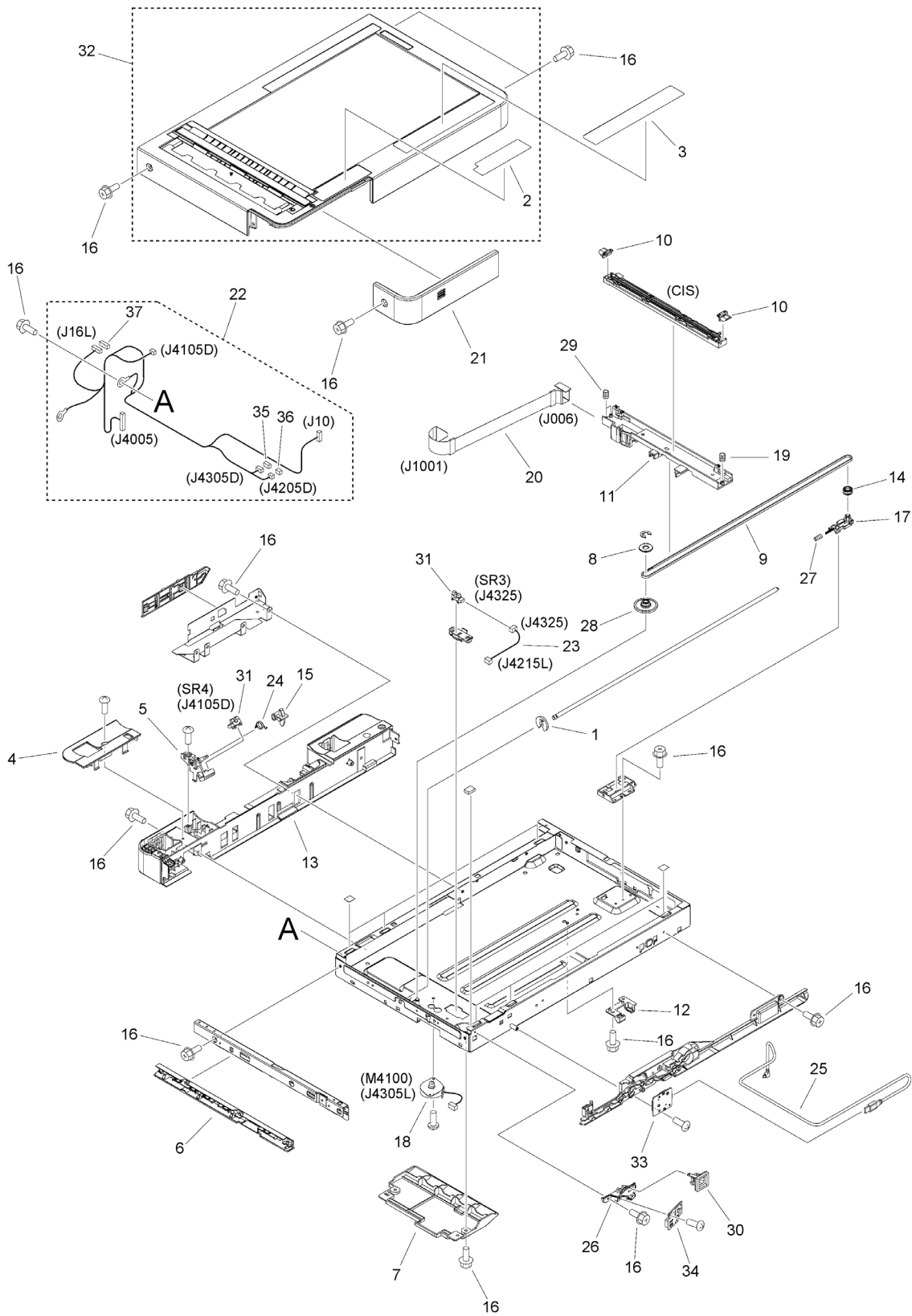

FIGURE & KEY NO.	PART NUMBER	RANK	QTY	DESCRIPTION	SERIAL NUMBER /REMARKS
D10B	NPN		RF	READER ASSEMBLY	
1	FE3-7699-000		1	RING, C,EXTERNAL	
2	FE8-4582-000		1	LABEL, BLACK LINE, CLEANING	
3	FE8-6152-000		1	LABEL, COPY INHIBITED	US English
3	FE8-6154-000		1	LABEL, COPY PROHIBITION	UK English, French, German, Italian
4	FE8-2093-000		1	COVER, READER REAR, UP.	
5	FE8-2094-000		1	HOLDER, OPEN/CLOSE SENSOR	
6	FE8-2011-000		1	GUIDE, CABLE	
7	FE8-2009-000		1	COVER, MOTOR	
8	FC0-5550-000		1	STOPPER, BELT	
9	FE8-2361-000		1	BELT, TIMING, COGGED	
10	FE8-2003-000		2	SPACER CIS RD	RANK B
10	FE8-4730-000		2	SPACER CIS RD 2	RANK C
10	FE8-4731-000		2	SPACER CIS RD 3	RANK A
11	FL1-1521-000		1	HOLDER, CONTACT IMAGE SENSOR	
12	FC0-5557-000		1	BUSHING	
13	FE8-2098-000		1	COVER, READER REAR, 1	
14	FC0-5650-000		1	PULLEY, IDLER	
15	FE8-2095-000		1	FLAG, SENSOR	
16	XA9-1386-000		33	SCREW,RS,M3X8	
17	FC0-5552-000		1	HOLDER, PULLEY, IDLER	
18	FK3-3035-000		1	MOTOR, STEPPING	M4100
19	FU2-1818-000		1	SPRING, COMPRESSION	
20	FK4-3804-000		1	CABLE, FLAT	
21	FE8-2097-000		1	COVER	
22	FM1-W894-000		1	CABLE, READER	
23	FM1-C987-000		1	CABLE, HOME POSITION SENSOR	
24	FE8-2096-000		1	SPRING, TORSION	
25	FK4-3807-000		1	CABLE, USB	
26	FL1-0411-000		1	HOLDER, SENSOR	
27	FU6-2873-000		1	SPRING, COMPRESSION	
28	FU9-0581-000		1	GEAR, 85T/20T	
29	FU2-1817-000		2	SPRING, COMPRESSION	
30	FL1-0415-000		1	MOUNT, SENSOR	
31	WG8-5935-000		2	IC, PHOTO INTERRUPTER	SR3, SR4
32	FM1-M039-000		1	READER COVER UNIT, TOP	
33	FM1-N784-000		1	WIRELESS NETWORK PCB ASSEMBLY	
34	FM1-W896-000		1	INTERFACE SENSOR PCB ASSEMBLY	
35	VS1-7177-004		1	CONNECTOR, SNAP TIGHT, BK	
36	VS1-7207-003		1	CONNECTOR, SNAP TIGHT, BK	
37	VS1-8959-006		1	CONNECTOR, SNAP TIGHT, 6P, W	

Figure ZZA MECHANICAL STANDARD PARTS (HOW TO USE)

Mechanical standard parts 機械標準部品

About a mechanical standard parts

A Mechanical standard parts is a mechanical part which not parts peculiar to a product.
They are parts which are common to a Canon product and are used, such as a screw and a washer.
The Fig No. and parts number of the mechanical standard parts are not listed in the product parts catalog.
Refer to the parts catalog of mechanical standard parts when checking the parts number for screw or washer etc. and identify them by part shape or size.

機械標準部品とは

機械標準部品とは、製品特有の部品ではなく、ねじやワッシャなどキヤノン製品共通で使用されている機械部品（メカ部品）のことです。
製品のパーツカタログには、機械標準部品のFig No.や部品番号は記載していません。
ねじや、ワッシャ等の部品番号を調べるときは、機械標準部品のパーツカタログを参照し、部品の形状や大きさから判断し、使用している部品を調べてください。

Material and surface treatment of a mechanical standard parts

Material and surface treatment of mechanical standard parts are assigned commonly for each part.
Refer to the Table 1 for the parts which material and surface treatment are assigned as numbers.

機械標準部品の材料および表面処理

機械標準部品の材料および表面処理については、各種部品共通で決められています。
材料および表面処理が番号で決められている部品については、表1を参照してください。

Table 1 Material and Surface treatment
表1 材料および表面処理

No. 番号	Material 材料	Surface treatment 表面処理	Color 色
1	Stainless steel ステンレス	Stainless steel black coloring (BC4) ステンレス黒着色(BC4)	Black 黒
2		not to be given なし	White 白
3	Brass 黄銅	Regular nickel plating (NL) 普通ニッケルメッキ(NL)	White 白
4		Black nickel plating (BN) 黒色ニッケルメッキ(BN)	Black 黒
5	Steel 鋼	White zinc trivalent chromate treating (ZC3) 白色亜鉛3価クロメート(ZC3)	White 白
6		Regular nickel chromium plating (NC) 普通ニッケルクロムメッキ(NC)	White 白
7		Regular nickel plating (NL) 普通ニッケルメッキ(NL)	White 白
8		Iron and steel phosphating (P1) 鉄鋼燐酸塩処理(P1)	Black 黒
9		Black zinc trivalent chromate treating (BZ3) 黒色亜鉛3価クロメート(BZ3)	Black 黒

Figure ZZB (1/7)MECHANICAL STANDARD PARTS (SCREWS)

1. Screws
ねじ

How to read Parts Numbers
部品番号の見方

Screws
ねじ

XB1-2400-609

Type No.
類別番号
Normal designation (d)
ねじの呼び (d)
Length (L)
ねじの長さ (L)
Material and Surface treatment
材料および表面処理

XB1-2 expresses Binding head machine screw.
XB1-2は、バインドねじを表す
40 expresses M4.0.
40は、M4.0を表す
0-60 expresses a length of 6.0mm.
0-60は、6.0mmの長さを表す
9 expresses Steel (Black zinc trivalent chromate
treating) from Table 1.
9は、表1より鋼（黒色亜鉛3価クロメート）を表す

1-1. Cross Recessed Head Screws for Precision Equipments
精密機器用十字穴付き小ねじ

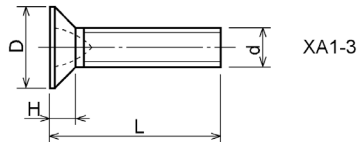
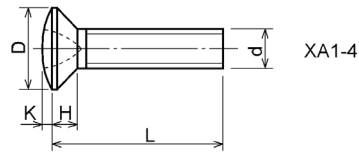
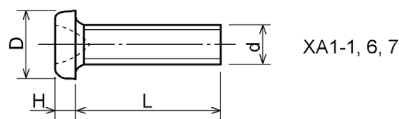

Type No. 類別番号	Type 類別	Head size (mm) 頭部寸法 (mm)						
		M1.4	M1.6	M1.7	M2	M2.5	M2.6	
XA1-1	Pan head Class 1 なべ1種	D	2	2.4	2.5	3	3.8	4
		H	0.5	0.55	0.5	0.6	0.9	0.8
XA1-3	Countersunk head Class 1 さら1種	D	2	2.4	2.5	3	3.8	4
		H	0.48	0.55	0.58	0.73	0.85	0.93
XA1-4	Oval countersunk head Class 1 丸さら1種	D	2	2.4	2.5	3	3.8	4
		H + K	0.68	0.8	0.88	1	1.25	1.3
XA1-6	Pan head Class 3 なべ3種	D	2.5	2.8	3	3.5	4.3	4.5
		H	0.8	0.85	0.9	1	1.3	1.2
XA1-7	Pan head Class 2 なべ2種	D	2.5	2.8	3	3.5	4.3	4.5
		H	0.5	0.55	0.5	0.6	0.9	0.8

Figure ZZB (2/7) MECHANICAL STANDARD PARTS (SCREWS)

1-2. Precision Tapping Screws
精密用タッピンねじ

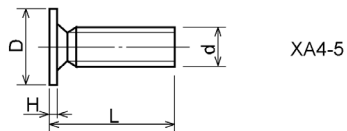
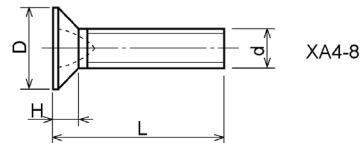
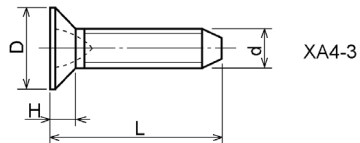
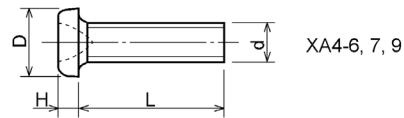
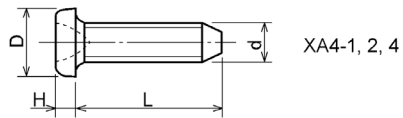

Type No. 類別番号	Type 類別	Head size (mm) 頭部寸法 (mm)						
		M1.4	M1.6	M1.7	M2	M2.5	M2.6	
XA4-1	With tapered end pan head Class 1 絞り-なべ1種	D XA4-1	2	2.4	2.5	3	3.8	4
		H XA4-1	0.5	0.55	0.5	0.6	0.9	0.8
XA4-2	With tapered end pan head Class 3 絞り-なべ3種	D XA4-2	2.5	2.8	3	3.5	4.3	4.5
		H XA4-2	0.8	0.85	0.9	1	1.3	1.2
XA4-3	With tapered end countersunk head 絞り-さら	D XA4-3	2	2.4	2.5	3	3.8	4
		H XA4-3	0.48	0.55	0.58	0.73	0.85	0.93
XA4-4	With tapered end pan head Class 2 絞り-なべ2種	D XA4-4	2.5	2.8	3	3.5	4.3	4.5
		H XA4-4	0.5	0.55	0.5	0.6	0.9	0.8
XA4-5	With parallel end ultra thin head ストレート-超薄頭	D XA4-5	2.5	2.8	3	-	-	-
		H XA4-5	0.2	0.2	0.2	-	-	-
XA4-6	With parallel end pan head Class 1 ストレート-なべ1種	D XA4-6	2	2.4	2.5	3	3.8	4
		H XA4-6	0.5	0.55	0.5	0.6	0.9	0.8
XA4-7	With parallel end pan head Class 3 ストレート-なべ3種	D XA4-7	2.5	2.8	3	3.5	4.3	4.5
		H XA4-7	0.8	0.85	0.9	1	1.3	1.2
XA4-8	With parallel end countersunk head ストレート-さら	D XA4-8	2	2.4	2.5	3	3.8	4
		H XA4-8	0.48	0.55	0.58	0.73	0.85	0.93
XA4-9	With parallel end pan head Class 2 ストレート-なべ2種	D XA4-9	2.5	2.8	3	3.5	4.3	4.5
		H XA4-9	0.5	0.55	0.5	0.6	0.9	0.8

Figure ZZB (3/7)MECHANICAL STANDARD PARTS (SCREWS)

1-3. Cross Recessed Head Screws
一般用十字穴付き小ねじ

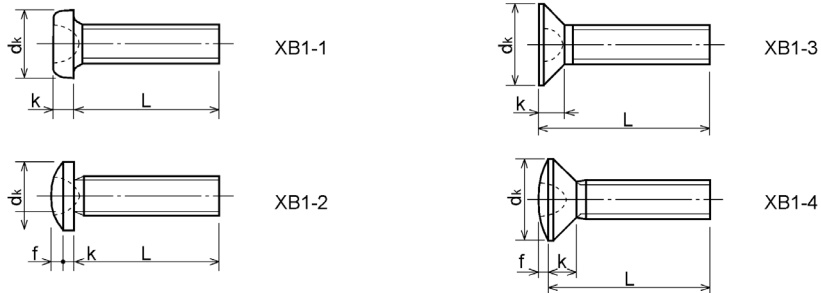

Type No. 類別番号	Type 類別
XB1-1	Pan head なべ
XB1-2	Binding head バインド
XB1-3	Countersunk head さら
XB1-4	Oval countersunk head 丸さら

		Head size (mm) 頭部寸法 (mm)					
		M2	M2.5	M2.6	M3	M4	M5
dk	XB1-1	3.5	4.5	4.5	5.5	7	9
k	XB1-1	1.3	1.7	1.7	2	2.6	3.3
dk	XB1-2	4.3	5.3	5.5	6.3	8.3	10.3
k+f	XB1-2	1.2	1.5	1.6	1.9	2.5	3.1
dk	XB1-3	4	5	-	6	8	10
k	XB1-3	1.2	1.45	-	1.75	2.3	2.8
dk	XB1-4	4	5	-	6	8	10
k+f	XB1-4	1.6	2	-	2.45	3.2	4
Screw part length ねじ部長さ b		8	12	12	12	16	20

Figure ZZB (4/7) MECHANICAL STANDARD PARTS (SCREWS)

1-4. Cross Recessed Head Screws with Captive Washer
座金組み込み十字穴付き小ねじ

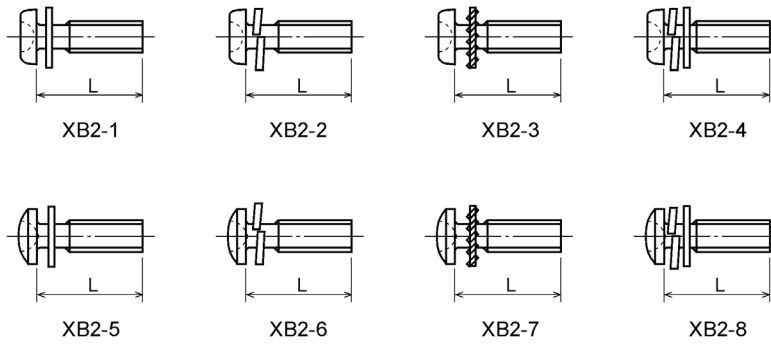

Type No. 類別番号	Type 類別
XB2-1	Pan head + Plain washer (circular bright) なべねじ+平座金
XB2-2	Pan head + Spring washer なべねじ+ばね座金
XB2-3	Pan head + Toothed lock washer なべねじ+歯付座金
XB2-4	Pan head + Spring washer and plain washer (circular bright) なべねじ+(ばね+平)座金
XB2-5	Binding head + Plain washer (circular bright) バインドねじ+平座金
XB2-6	Binding head + Spring washer バインドねじ+ばね座金
XB2-7	Binding head + Toothed lock washer バインドねじ+歯付座金
XB2-8	Binding head + Spring washer and plain washer (circular bright) バインドねじ+(ばね+平)座金

Figure ZZB (5/7) MECHANICAL STANDARD PARTS (SCREWS)

1-5. Hexagon Head Tapping Screws for Matallic Materials
 金属用六角タッピンねじ

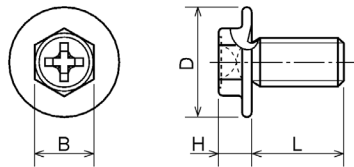

Type No. 類別番号	Type 類別	Head size (mm) 頭部寸法 (mm)		
		M3	M4	
XB3-6	For metallic materials 金属用タッピン	D	8	10
		B	5.5	5.5
XB3-7	For metallic materials with clawed 金属用タッピン-つめ付き	H XB3-6	3.1	3.1
		H XB3-7	3.2	3.2

1-6. Special Tapping Screws
 特殊タッピンねじ

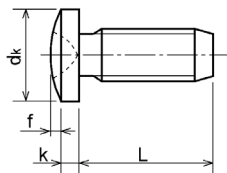

Type No. 類別番号	Type 類別	Head size (mm) 頭部寸法 (mm)		
		M3	M4	
XB4-5	Binding head バインド	dk	6.3	8.3
		k	1.3	1.7
		k+f	1.9	2.5

Figure ZZB (6/7) MECHANICAL STANDARD PARTS (SCREWS)

1-7. General Head Tapping Screws
一般用タッピンねじ

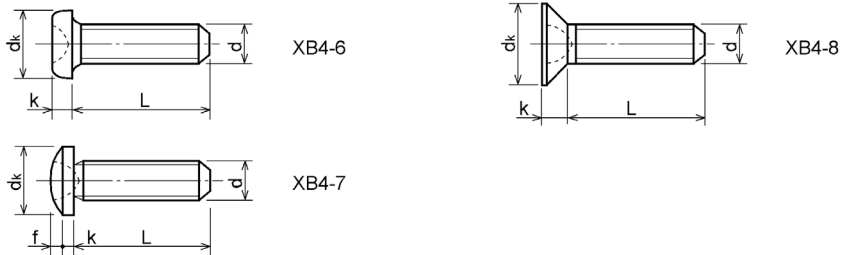

Type No. 類別番号	Type 類別	Head size (mm) 頭部寸法 (mm)						
		M2	M2.5	M2.6	M3	M4	M5	
XB4-6	Pan head なべ	dk	3.5	4.5	4.5	5.5	7	9
		k	1.3	1.7	1.7	2	2.6	3.3
XB4-7	Binding head バインド	dk	4.3	5.3	5.5	6.3	8.3	10.3
		k+f	1.2	1.5	1.6	1.9	2.5	3.1
XB4-8	Countersunk head さら	dk	4	5	5.2	6	8	10
		k	1.2	1.45	1.5	1.75	2.3	2.8

1-8. Tapping Screws for Metallic Materials
金属用タッピンねじ

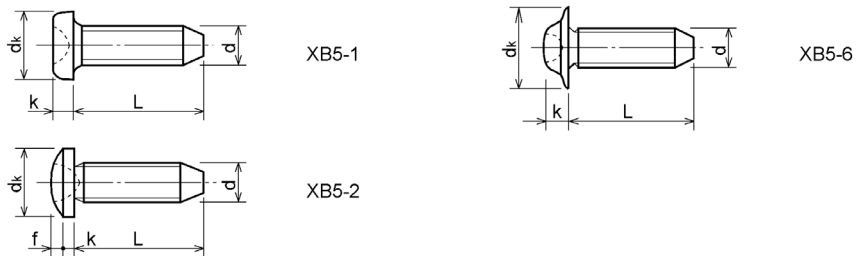

Type No. 類別番号	Type 類別	Head size (mm) 頭部寸法 (mm)					
		M2.5	M2.6	M3	M4	M5	
XB5-1	Pan head なべ	dk	4.5	4.5	5.5	7	9
		k	1.7	1.7	2	2.6	3.3
XB5-2	Binding head バインド	dk	5.5	5.5	6.3	8.3	10.3
		k+f	1.6	1.6	1.9	2.5	3.1
XB5-6	Flanged pan head つば付きなべ	dk	6.5	6.5	8	10	12
		k	2.1	2.1	1.75	3.2	4

Figure ZZB (7/7) MECHANICAL STANDARD PARTS (SCREWS)

1-9. Hexagon Socket Set Screws
六角穴付き止めねじ

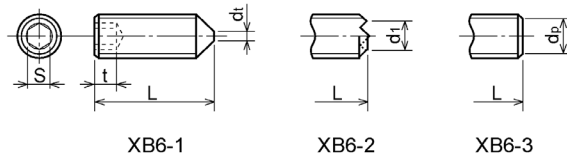

Type No. 類別番号	Type 類別	Head size (mm) 頭部寸法 (mm)						
		M1.6 M1.7	M2	M2.5 M2.6	M3	M5	M5	M6
S		0.7	0.9	1.3	1.5	2	2.5	3
t		1.5	1.7	2	2	2.5	3	3.5
dt max XB6-1		0.4	0.5	0.65	0.75	1	1.25	1.5
d1 max XB6-2		-	1.2	1.5	1.7	2.2	2.8	3.3
d1 min XB6-2		-	1	1.2	1.4	1.9	2.4	2.9
dp max XB6-3		0.8	1	1.5	2	2.5	3.5	4
dp min XB6-3		0.55	0.75	1.25	1.75	2.25	3.2	3.7

1-10. Flanged Pan Head Machine Screws
つば付きなべ小ねじ

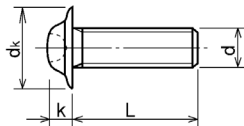

Type No. 類別番号	Type 類別	Head size (mm) 頭部寸法 (mm)				
		M2	M2.5 M2.6	M3	M5	M5
dk		5	6.5	8	10	12
k		1.7	2.1	2.5	3.2	4

Figure ZZC MECHANICAL STANDARD PARTS (BOLTS)

2. Bolts (Socket head cap screw)
ボルト

How to read Parts Numbers
部品番号の見方

Bolt (Socket head cap screw)
ボルト

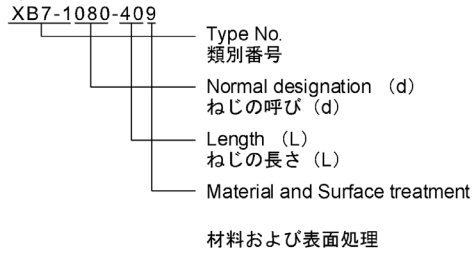

XB7-1 expresses Hexagon socket head cap screws.
XB7-1は、六角穴付きボルトを表す

080 expresses M8.0.
080は、M8.0を表す

40 expresses a length of 40mm.
40は、40mmの長さを表す

9 expresses Steel (Black zinc trivalent chromate treating) from Table 1.
9は、表1より鋼（黒色亜鉛3価クロメート）を表す

2-1. Hexagon socket head cap screws
六角穴付きボルト

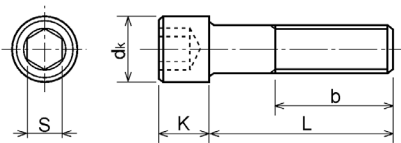

Type No. 類別番号	Type 類別	Head size (mm) 頭部寸法 (mm)						
		M3	M4	M5	M6	M8	M10	M12
S		2.5	3	4	5	6	8	10
dk		5.5	7	8.5	10	13	16	18
K		3	4	5	6	8	10	12
Screw part length ねじ部長さ b_{max}		18	20	22	24	28	32	36

Figure ZZD MECHANICAL STANDARD PARTS (NUTS)

3. Nuts
ナット

How to read Parts Numbers
部品番号の見方

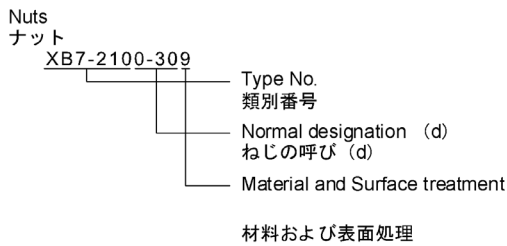

XB7-210 expresses Hexagon nut class 1.
XB7-210は、六角ナット1種を表す

0-30 expresses M3.0.
0-30は、M3.0を表す

9 expresses Steel (Black zinc trivalent chromate
treating) from Table 1.
9は、表1より鋼（黒色亜鉛3価クロメート）を表す

3-1. Hexagon Nuts and Hexagon Thin Nuts
六角ナット

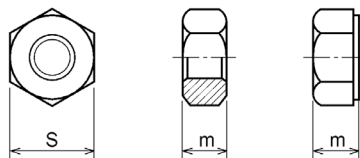

Type No. 類別番号	Type 類別	Head size (mm) 頭部寸法 (mm)						
		M2	M2.5	M3	M4	M5	M6	M8
S		4	5	5.5	7	8	10	13
m XB7-210	Hexagon nut Class 1 六角ナット-1種	1.6	2	2.4	3.2	4	5	6.5
m XB7-220	Hexagon nut Class 3 六角ナット-3種	1.2	1.6	1.8	2.4	3.2	3.6	5
m XB7-230, 231	Hexagon nut Style 1 double chamfered 六角ナット-スタイル1-両面とり	1.6	2	2.4	3.2	4.7	5.2	6.8
m XB7-240, 241	Hexagon nut Style 2 double chamfered 六角ナット-スタイル2-両面とり	-	-	-	-	5.1	5.7	7.5
m XB7-250	Hexagon nut 六角ナット	-	-	-	-	5.6	6.1	7.9
m XB7-260	Hexagon thin nut double chamfered 六角低ナット-両面とり	1.2	1.6	1.8	2.2	2.7	3.2	4
m XB7-270	Hexagon thin nut not chamfered 六角低ナット-面とり無し	1.2	1.6	1.8	2.2	2.7	3.2	4

Figure ZZE (1/3)MECHANICAL STANDARD PARTS (RETAINING RINGS)

5. Retaining Rings
止め輪

How to read Parts Numbers
部品番号の見方

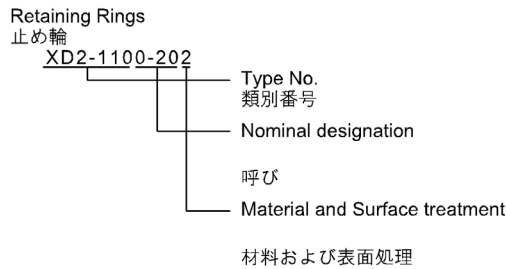

XD2-110 expresses retaining ring-E type (Type1).
XD2-110は、E形止め輪（1種）を表す

0-20 expresses a 020 of nominal designation.
(See Table 5)
0-20は、呼び020を表す（表5参照）

2 expresses Stainless steel (Surface treatment is not to be given) from Table 1.
2は、表1よりステンレス（表面処理なし）を表す

5-1. Retaining Rings - E type
E形止め輪

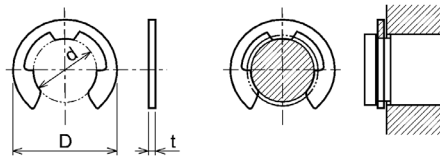

Type No. 類別番号	Type 類別
XD2-110	Retaining ring - E type (Type 1) E形止め輪（1種）
XD2-120	Retaining ring - E type (Type 2) E形止め輪（2種）

Table 5 表5

Type 種類	Nominal designation 呼び	d (mm)	D (mm)	t (mm)
Type 1 1種	007	0.65	2	0.2
	010	0.95	2.8	0.2
	013	1.25	3.3	0.3
	017	1.65	4.2	0.4
	020	1.95	4.6	0.5
	024	2.35	6	0.6
	028	2.74	6.5	0.6
	032	3.14	7.2	0.6
	037	3.64	8	0.7
	040	3.93	10	0.7
	042	4.13	10	0.7
	050	4.93	11	0.7
	058	5.73	12	0.7
	060	5.93	12.7	0.9
Type 2 2種	064	6.32	13.5	0.9
	074	7.31	15	0.9
	080	7.91	16.5	1
	008	0.8	2	0.2
	012	1.2	3	0.3
	015	1.5	4	0.4
	020	2	5	0.4
	025	2.5	6	0.4
	030	3	7	0.6
	040	4	9	0.6
050	5	11	0.6	
060	6	12	0.8	
070	7	14	0.8	
080	8	16	0.8	
090	9	18	0.8	
100	10	20	1	

Figure ZZE (2/3)MECHANICAL STANDARD PARTS (RETAINING RINGS)

5-2. Grip Rings
グリップ止め輪

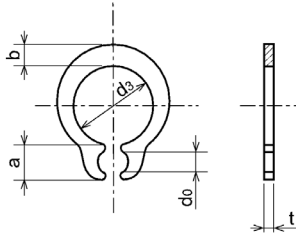

Type No. 類別番号	Type 類別
XD2-210	Grip ring グリップ止め輪

Table 5 表5

Nominal designation 呼び	d ₃ (mm)	t (mm)	b (mm)	a (mm)	d ₀ (mm)
020	1.9	0.5	1	1.8	0.8
025	2.35	0.5	1.2	1.9	0.9
030	2.85	0.6	1.4	1.9	0.9
035	3.3	0.6	1.6	2	0.9
040	3.8	0.8	1.8	2.8	1.2
045	4.25	0.8	2	2.9	1.3
050	4.75	0.8	2.2	2.9	1.3
060	5.7	1	2.4	3.1	1.4
070	6.7	1	2.7	3.3	1.4
080	7.7	1	3	3.5	1.4
090	8.65	1.2	3.3	4.7	1.5
100	9.65	1.2	3.5	4.7	2

5-3. Toothed Retaining Rings
歯付き形止め輪

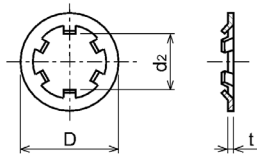

Type No. 類別番号	Type 類別
XD2-230	Toothed retaining ring 歯付き形止め輪

Table 5 表5

Nominal designation 呼び	d ₂ (mm)	D (mm)	t (mm)	No of teeth 歯数
015	1.4	5.2	0.25	3
020	1.9	6	0.25	3
024	2.3	6.4	0.25	3
030	2.8	8	0.25	4
040	3.8	9	0.25	4
050	4.8	10	0.25	5
060	5.8	11	0.25	5
080	7.8	13	0.25	5
100	9.8	15.4	0.25	6

Figure ZZE (3/3)MECHANICAL STANDARD PARTS (RETAINING RINGS)

5-4. Retaining Rings - C Type
C形止め輪

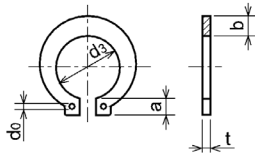

Type No. 類別番号	Type 類別
XD2-310	Retaining ring - C type for shaft C形止め輪 軸用

Table 5 表5

Nominal designation 呼び	ds (mm)	t (mm)	b (mm)	a (mm)	do (mm)
010	9.3	1	1.6	3	1.2
012	11.1	1	1.8	3.2	1.5
014	12.9	1	2	3.4	1.7
015	13.8	1	2.1	3.5	1.7
016	14.7	1	2.2	3.6	1.7
017	15.7	1	2.2	3.7	1.7
018	16.5	1.2	2.6	3.8	1.7
020	18.5	1.2	2.7	3.9	2
022	20.5	1.2	2.7	4.1	2
025	23.2	1.2	3.1	4.3	2
028	25.9	1.5	3.1	4.6	2
030	27.9	1.5	3.5	4.8	2
032	29.6	1.5	3.5	5	2.5
035	32.2	1.5	4	5.4	2.5

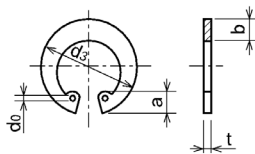

Type No. 類別番号	Type 類別
XD2-320	Retaining ring - C type for hole C形止め輪 穴用

Table 5 表5

Nominal designation 呼び	ds (mm)	t (mm)	b (mm)	a (mm)	do (mm)
010	10.7	1	1.8	3.1	1.2
011	11.8	1	1.8	3.2	1.2
012	13	1	1.8	3.3	1.5
014	15.1	1	2	3.6	1.7
016	17.3	1	2	3.7	1.7
018	19.5	1	2.5	4	1.7
019	20.5	1	2.5	4	2
020	21.5	1	2.5	4	2
022	23.5	1	2.5	4.1	2
025	26.9	1.2	3	4.4	2
028	30.1	1.2	3	4.6	2
030	32.1	1.2	3	4.7	2
032	34.4	1.2	3.5	5.2	2.5
035	37.8	1.5	3.5	5.2	2.5
037	39.8	1.5	3.5	5.2	2.5
040	43.5	1.8	4	5.7	2.5
042	45.5	1.8	4	5.8	2.5
045	48.5	1.8	4.5	5.9	2.5
047	50.5	1.8	4.5	6.1	2.5
050	54.2	2	4.5	6.5	2.5
052	56.2	2	5.1	6.5	2.5
055	59.2	2	5.1	6.5	2.5
060	64.2	2	5.1	6.8	2.5
062	66.2	2	5.5	6.9	2.5
068	72.5	2.5	6	7.4	2.5
072	76.5	2.5	6.6	7.4	2.5
075	79.5	2.5	6.6	7.8	2.5
080	85.5	2.5	7	8	2.5
085	90.5	3	7	8	3
090	95.5	3	7.6	8.3	3
095	100.5	3	8	8.5	3