

PARTS CATALOG

**imageRUNNER ADVANCE
C2030/C2025/C2020 Series**

Canon

Feb 11 2014

PREFACE

This Parts Catalog contains listings of parts used

Diagrams are provided with the listings to aid the service technician in identifying clearly, the item to be ordered.

Whenever ordering parts, consult this Parts Catalog for all of the information pertaining to each item. Be sure to include, in the Parts Request, the full item description, the item part number, and the quantity.

COPYRIGHT (C) 1999 CANON INC.

Use of this manual should be strictly supervised to avoid disclosure of confidential information.

Contents

NUMERICAL INDEX

imageRUNNER ADVANCE C2030/C2025/C2020 Series(Numerical Index)
1-1

imageRUNNER ADVANCE C2030/C2025/C2020 Series(Parts Catalog)

A1	ASSEMBLY LOCATION DIAGRAM	2-1
A2	OPTION PARTS CATALOG LIST	2-4
001	ACCESSORIES	2-5
100	EXTERNAL COVERS, PANELS, ETC.	2-7
101	RIGHT DOOR ASSEMBLY	2-12
102	INTERNAL COMPONENTS 1	2-18
103	INTERNAL COMPONENTS 2	2-21
104	INTERNAL COMPONENTS 3	2-24
105	INTERNAL COMPONENTS 4	2-26
106	INTERNAL COMPONENTS 5	2-28
107	INTERNAL COMPONENTS 6	2-31
108	MACHINE REAR PLATE 1	2-33
109	MACHINE REAR PLATE 2	2-35
130	CONTROL PANEL ASSEMBLY	2-38
140	POWER CORD TERMINAL ASS'Y	2-41
250	MAIN DRIVE ASSEMBLY	2-42
300	CASSETTE ASSEMBLY (UPPER)	2-43
301	CASSETTE ASSEMBLY (LOWER) (EXCEPT 1 CASSETTE MODEL)	2-45
310	PAPER PICK-UP ASSEMBLY (UPPER)	2-48
311	PAPER PICK-UP ASSEMBLY (LOWER) (EXCEPT 1 CASSETTE MODEL)	2-49
312	PAPER PICK-UP DRIVE ASSEMBLY (LOWER) (EXCEPT 1 CASSETTE MODEL)	2-53
350	2ND/3RD PAPER DELIVERY ASS'Y (2/3 DELIVERY MODEL)	2-54
351	2ND/3RD DRIVE FRAME ASSEMBLY (2/3 DELIVERY MODEL)	2-55
352	2ND/3RD DELIVERY GUIDE ASS'Y (2/3 DELIVERY MODEL)	2-57
460	LASER SCANNER UNIT	2-61
530	INTER. TRANSFER BELT ASS'Y	2-62
810	FIXING ASSEMBLY	2-63
900	CONTROLLER BOX ASSEMBLY	2-64
930	MAIN CONTROLLER PCB ASS'Y, 1	2-66
931	MAIN CONTROLLER PCB ASS'Y, 2	2-67

Contents

960	AC DRIVER PCB ASSEMBLY	2-68
980	HIGH VOLTAGE ASSEMBLY	2-69
A01	ADF MOUNTING ASSEMBLY (ADF MODEL)	2-70
A10	ADF MAIN BODY (ADF MODEL)	2-72
A11	BASE ASSEMBLY (ADF MODEL)	2-75
A12	PAPER PICK-UP COVER ASSEMBLY (ADF MODEL)	2-77
A13	DOCUMENT TRAY ASSEMBLY (ADF MODEL)	2-79
A21	ESTRANGEMENT DRIVE ASSEMBLY (ADF MODEL)	2-81
A41	PAPER FEED ASSEMBLY (ADF MODEL)	2-82
D11	READER ASSEMBLY (EXCEPT EUR)	2-87
T20	G3 FAX ASSEMBLY, 1 LINE (G3 FAX MODEL)	2-90
T21	SPEAKER ASSEMBLY (G3 FAX MODEL)	2-92
T22	1 LINE PCB ASSEMBLY (G3 FAX MODEL)	2-93
ZZA	MECHANICAL STANDARD PARTS (HOW TO USE)	2-94
ZZB	MECHANICAL STANDARD PARTS (SCREWS)	2-95
ZZC	MECHANICAL STANDARD PARTS (BOLTS)	2-102
ZZD	MECHANICAL STANDARD PARTS (NUTS)	2-103
ZZE	MECHANICAL STANDARD PARTS (RETAINING RINGS)	2-104

NUMERICAL INDEX

imageRUNNER ADVANCE C2030/C2025/C2020 Series(Numerical Index)

PARTS NUMBER	FIGURE & KEY NO.	PARTS NUMBER	FIGURE & KEY NO.	PARTS NUMBER	FIGURE & KEY NO
FB5-9410-000	A10 - 22	FC5-4285-030	A11 - 1	FC8-4996-000	301 - 18
FB6-3387-000	311 - 2	FC5-4286-000	A11 - 2	FC8-4999-000	107 - 1
FB6-3388-000	311 - 3	FC5-4287-000	A11 - 3	FC8-5164-000	100 - 64
FB6-3389-000	311 - 4	FC5-4323-000	A12 - 1	FC8-5363-000	100 - 2
FB6-3391-000	311 - 5	FC5-4324-000	A12 - 2	FC8-5378-000	100 - 3
FB6-3392-020	311 - 6	FC5-4353-000	A41 - 1	FC8-6163-000	D11 - 29
FB6-3395-000	311 - 7	FC5-4425-000	A11 - 4	FC8-6180-000	D11 - 30
FB6-3396-010	311 - 8	FC5-4425-000	A12 - 3	FC8-6188-010	D11 - 9
FB6-3397-000	311 - 9	FC5-4425-000	A21 - 1	FC8-6311-000	A10 - 4
FB6-3398-000	311 - 10	FC5-4425-000	A41 - 2	FC8-6316-000	A11 - 19
FB6-3402-000	311 - 11	FC6-2784-000	A12 - 14	FC8-6317-000	A11 - 20
FB6-3403-000	311 - 12	FC6-4023-000	102 - 1	FC8-6318-010	A11 - 21
FB6-3404-000	311 - 13	FC6-5022-000	312 - 1	FC8-6319-000	A11 - 6
FB6-3405-000	311 - 14	FC6-5059-000	T21 - 1	FC8-6322-000	A11 - 7
FB6-3413-000	311 - 15	FC6-6661-000	311 - 18	FC8-6330-000	A10 - 5
FB6-4852-000	311 - 16	FC6-7083-000	311 - 19	FC8-6331-000	A11 - 15
FC0-0225-000	100 - 41	FC6-8971-010	A12 - 15	FC8-6332-000	A11 - 16
FC0-0226-000	100 - 41	FC6-8973-000	A11 - 5	FC8-6339-000	A13 - 5
FC0-0598-010	352 - 56	FC6-8973-000	A41 - 3	FC8-6341-000	A13 - 10
FC0-0599-000	109 - 1	FC6-9867-000	311 - 20	FC8-6345-000	A12 - 4
FC0-0618-000	101 - 1	FC7-2362-000	T21 - 2	FC8-6347-010	A12 - 6
FC0-0619-000	101 - 2	FC7-5845-000	311 - 22	FC8-6348-000	A12 - 7
FC0-0620-000	101 - 3	FC7-9381-000	311 - 14	FC8-6351-000	A12 - 16
FC0-0622-000	101 - 4	FC7-9502-000	311 - 19	FC8-6352-010	A12 - 17
FC0-0623-000	101 - 5	FC8-1178-000	311 - 23	FC8-6353-000	A12 - 18
FC0-0624-000	101 - 6	FC8-1202-000	311 - 24	FC8-6355-000	A12 - 19
FC0-0625-000	101 - 7	FC8-1205-000	311 - 21	FC8-6356-000	A12 - 28
FC0-0627-000	101 - 9	FC8-2469-000	301 - 1	FC8-6356-000	A41 - 71
FC0-0628-000	101 - 10	FC8-2470-000	301 - 2	FC8-6357-000	A12 - 29
FC0-0629-000	101 - 11	FC8-2474-000	301 - 3	FC8-6357-000	A41 - 72
FC0-0630-000	101 - 12	FC8-2475-000	301 - 4	FC8-6368-000	A41 - 4
FC0-0636-000	352 - 6	FC8-2670-000	301 - 5	FC8-6371-000	A41 - 6
FC0-2618-000	D11 - 16	FC8-2671-000	301 - 6	FC8-6372-000	A41 - 7
FC0-2633-000	100 - 44	FC8-2672-000	301 - 7	FC8-6373-000	A41 - 31
FC0-2640-000	103 - 23	FC8-3782-000	100 - 63	FC8-6374-000	A41 - 32
FC0-2901-000	100 - 49	FC8-4000-000	100 - 1	FC8-6375-000	A41 - 33
FC0-3637-000	310 - 5	FC8-4137-000	100 - 4	FC8-6376-000	A41 - 34
FC0-3643-000	106 - 18	FC8-4649-000	100 - 32	FC8-6377-000	A41 - 8
FC0-3650-000	351 - 28	FC8-4649-000	106 - 1	FC8-6378-020	A41 - 9
FC0-3651-000	107 - 26	FC8-4749-000	351 - 3	FC8-6379-000	A41 - 10
FC0-3654-000	109 - 23	FC8-4751-000	351 - 4	FC8-6380-000	A41 - 11
FC0-5049-000	900 - 2	FC8-4962-000	301 - 8	FC8-6381-000	A41 - 37
FC0-6693-000	103 - 53	FC8-4966-000	301 - 10	FC8-6382-000	A41 - 12
FC0-6755-000	311 - 1	FC8-4967-000	300 - 1	FC8-6383-000	A41 - 24
FC5-0631-000	100 - 62	FC8-4967-000	301 - 11	FC8-6384-000	A41 - 27
FC5-0987-000	351 - 1	FC8-4970-000	301 - 12	FC8-6385-000	A41 - 13
FC5-0988-000	351 - 2	FC8-4985-000	300 - 2	FC8-6386-000	A41 - 14
FC5-0996-000	352 - 1	FC8-4985-000	301 - 13	FC8-6387-000	A10 - 6
FC5-0997-000	352 - 2	FC8-4989-000	301 - 14	FC8-6388-000	A10 - 7
FC5-1005-000	352 - 3	FC8-4990-000	301 - 15	FC8-6395-000	A41 - 15
FC5-1006-000	352 - 4	FC8-4992-000	301 - 16	FC8-6396-000	A41 - 16
FC5-1010-000	352 - 5	FC8-4993-000	301 - 17	FC8-6397-000	A41 - 17

NUMERICAL INDEX

imageRUNNER ADVANCE C2030/C2025/C2020 Series(Numerical Index)

PARTS NUMBER	FIGURE & KEY NO.	PARTS NUMBER	FIGURE & KEY NO.	PARTS NUMBER	FIGURE & KEY NO
FC8-6398-000	A41 - 35	FC8-8176-000	107 - 2	FC8-8323-000	351 - 7
FC8-6399-000	A41 - 30	FC8-8177-000	107 - 3	FC8-8326-000	351 - 8
FC8-6403-000	A41 - 38	FC8-8180-000	107 - 20	FC8-8327-000	350 - 5
FC8-6404-000	A11 - 8	FC8-8181-010	300 - 4	FC8-8328-000	350 - 1
FC8-6405-000	A10 - 8	FC8-8181-010	301 - 20	FC8-8331-000	352 - 15
FC8-6406-000	A21 - 2	FC8-8182-000	300 - 5	FC8-8332-000	352 - 16
FC8-6407-000	A21 - 3	FC8-8182-000	301 - 21	FC8-8333-000	351 - 9
FC8-6410-010	A12 - 20	FC8-8185-010	107 - 4	FC8-8334-000	351 - 10
FC8-6411-000	A41 - 25	FC8-8186-000	100 - 6	FC8-8338-000	352 - 17
FC8-6412-000	A41 - 28	FC8-8187-000	100 - 7	FC8-8339-000	352 - 18
FC8-6418-000	A41 - 18	FC8-8189-000	100 - 8	FC8-8340-010	352 - 19
FC8-6419-000	A11 - 22	FC8-8190-000	100 - 9	FC8-8341-000	100 - 58
FC8-6420-000	A10 - 9	FC8-8191-000	100 - 10	FC8-8342-000	102 - 8
FC8-6421-000	A41 - 19	FC8-8192-010	100 - 11	FC8-8343-000	102 - 32
FC8-6422-000	A11 - 10	FC8-8193-010	100 - 12	FC8-8344-000	100 - 28
FC8-6423-000	A11 - 11	FC8-8196-000	100 - 13	FC8-8346-000	100 - 29
FC8-7824-000	130 - 1	FC8-8197-000	100 - 14	FC8-8348-000	101 - 15
FC8-7940-000	109 - 2	FC8-8198-000	100 - 15	FC8-8349-000	103 - 51
FC8-7951-000	106 - 2	FC8-8199-000	102 - 31	FC8-8350-000	103 - 52
FC8-7952-000	106 - 3	FC8-8201-000	100 - 16	FC8-8351-000	103 - 5
FC8-7958-000	106 - 5	FC8-8203-000	100 - 17	FC8-8352-000	103 - 6
FC8-7959-000	106 - 7	FC8-8204-000	100 - 18	FC8-8353-000	101 - 88
FC8-7961-000	106 - 36	FC8-8205-000	100 - 19	FC8-8355-000	101 - 16
FC8-7963-000	106 - 8	FC8-8207-010	100 - 20	FC8-8356-010	101 - 17
FC8-7964-000	106 - 10	FC8-8220-000	105 - 10	FC8-8359-000	100 - 30
FC8-7965-000	106 - 12	FC8-8226-000	101 - 13	FC8-8364-000	102 - 9
FC8-7971-000	106 - 4	FC8-8228-000	100 - 54	FC8-8365-000	102 - 10
FC8-7975-000	106 - 9	FC8-8233-000	107 - 6	FC8-8369-000	109 - 4
FC8-7976-000	106 - 11	FC8-8237-000	107 - 25	FC8-8408-000	352 - 20
FC8-7977-000	106 - 13	FC8-8240-000	100 - 55	FC8-8410-000	352 - 21
FC8-7978-000	105 - 1	FC8-8241-000	101 - 14	FC8-8411-000	352 - 22
FC8-7979-000	105 - 2	FC8-8245-000	103 - 49	FC8-8413-000	101 - 18
FC8-7981-000	106 - 14	FC8-8246-000	103 - 4	FC8-8443-000	100 - 21
FC8-7988-000	106 - 15	FC8-8247-000	103 - 50	FC8-8444-000	100 - 5
FC8-7989-000	106 - 6	FC8-8251-000	101 - 86	FC8-8445-000	100 - 31
FC8-7990-000	106 - 16	FC8-8252-000	101 - 87	FC8-8447-000	351 - 11
FC8-7991-000	105 - 3	FC8-8273-000	102 - 6	FC8-8449-000	350 - 2
FC8-7992-000	105 - 4	FC8-8274-000	102 - 7	FC8-8450-000	103 - 54
FC8-7994-000	106 - 17	FC8-8286-000	100 - 22	FC8-8455-010	900 - 1
FC8-8026-000	105 - 5	FC8-8290-000	100 - 23	FC8-8464-000	102 - 11
FC8-8027-000	105 - 6	FC8-8291-000	100 - 24	FC8-8473-000	108 - 29
FC8-8028-000	105 - 7	FC8-8293-000	352 - 7	FC8-8474-000	109 - 5
FC8-8029-000	105 - 15	FC8-8294-000	352 - 32	FC8-8480-000	103 - 7
FC8-8032-000	105 - 8	FC8-8297-000	352 - 8	FC8-8486-000	108 - 1
FC8-8033-000	105 - 9	FC8-8298-000	352 - 9	FC8-8492-000	101 - 19
FC8-8085-000	109 - 3	FC8-8300-000	352 - 10	FC8-8493-000	109 - 6
FC8-8097-000	107 - 29	FC8-8301-000	352 - 11	FC8-8494-000	109 - 7
FC8-8099-000	107 - 30	FC8-8304-000	352 - 12	FC8-8496-000	108 - 2
FC8-8105-000	102 - 2	FC8-8309-000	352 - 13	FC8-8497-000	108 - 3
FC8-8146-000	103 - 1	FC8-8310-000	352 - 55	FC8-8498-010	108 - 4
FC8-8172-000	100 - 65	FC8-8311-000	352 - 14	FC8-8499-000	108 - 5
FC8-8174-000	107 - 5	FC8-8320-000	351 - 6	FC8-8503-010	352 - 23

NUMERICAL INDEX

imageRUNNER ADVANCE C2030/C2025/C2020 Series(Numerical Index)

PARTS NUMBER	FIGURE & KEY NO.	PARTS NUMBER	FIGURE & KEY NO.	PARTS NUMBER	FIGURE & KEY NO
FC8-8512-000	100 - 25	FC9-5282-000	130 - 34	FC9-8612-000	100 - 33
FC8-8513-000	103 - 8	FC9-5283-000	130 - 14	FC9-8615-000	103 - 10
FC8-8514-000	103 - 9	FC9-5284-000	130 - 15	FC9-8619-000	900 - 4
FC8-8515-000	100 - 56	FC9-5290-000	130 - 16	FC9-8621-000	352 - 31
FC8-8516-000	100 - 57	FC9-5303-000	130 - 17	FC9-8645-000	352 - 57
FC8-8524-000	101 - 20	FC9-5304-000	130 - 18	FC9-8646-000	352 - 58
FC8-8530-000	105 - 11	FC9-5306-000	130 - 35	FC9-8649-000	106 - 23
FC8-8538-000	101 - 21	FC9-5683-000	A13 - 3	FC9-8650-000	106 - 25
FC8-8539-000	101 - 22	FC9-5684-000	A13 - 4	FC9-8651-000	106 - 24
FC8-8543-000	100 - 34	FC9-6190-000	A12 - 5	FC9-8652-000	106 - 26
FC8-8544-000	100 - 35	FC9-6192-010	A01 - 3	FC9-9235-000	130 - 5
FC8-8553-000	T20 - 1	FC9-6193-000	A01 - 4	FC9-9237-000	130 - 4
FC8-8582-000	100 - 36	FC9-6232-000	130 - 19	FC9-9238-000	130 - 6
FC8-8590-010	352 - 60	FC9-6233-000	130 - 20	FC9-9239-000	130 - 8
FC8-8591-000	352 - 24	FC9-6235-000	130 - 33	FC9-9240-000	130 - 9
FC8-8594-000	109 - 8	FC9-6236-000	130 - 21	FC9-9433-000	130 - 34
FC8-8596-000	300 - 6	FC9-6237-000	130 - 34	FC9-9434-000	130 - 34
FC8-8597-000	300 - 7	FC9-6238-000	130 - 34	FC9-9435-000	130 - 34
FC8-8606-000	105 - 12	FC9-6239-000	130 - 34	FC9-9436-000	130 - 34
FC8-8615-000	100 - 38	FC9-6240-000	130 - 34	FC9-9437-000	130 - 34
FC8-8616-000	300 - 8	FC9-6241-000	130 - 34	FC9-9438-000	130 - 34
FC8-8617-000	100 - 39	FC9-6242-000	130 - 34	FC9-9439-000	130 - 34
FC8-8621-000	311 - 25	FC9-6243-000	130 - 34	FC9-9440-000	130 - 34
FC8-8622-000	100 - 36	FC9-6244-000	130 - 34	FC9-9442-000	130 - 34
FC8-8623-000	100 - 36	FC9-6245-000	130 - 34	FE2-0329-000	100 - 67
FC8-8625-000	351 - 13	FC9-6246-000	130 - 34	FE2-1821-000	101 - 83
FC8-8626-000	102 - 12	FC9-6247-000	130 - 34	FE2-1822-000	101 - 83
FC8-8627-000	102 - 13	FC9-6249-000	130 - 34	FE2-1823-000	101 - 83
FC8-8628-000	107 - 7	FC9-7253-000	311 - 27	FE2-1824-000	101 - 83
FC8-8631-000	100 - 40	FC9-7284-000	D11 - 10	FE2-1975-000	101 - 48
FC8-8634-000	100 - 59	FC9-7288-010	D11 - 15	FE2-1985-000	105 - 18
FC8-8635-000	100 - 60	FC9-7292-000	D11 - 1	FE2-1989-000	101 - 43
FC8-8636-000	102 - 16	FC9-7294-000	D11 - 28	FE2-1990-000	103 - 24
FC8-8637-000	100 - 27	FC9-7297-000	D11 - 40	FE2-1992-000	101 - 50
FC8-8638-000	100 - 26	FC9-7298-000	D11 - 5	FE2-1993-000	101 - 91
FC8-8643-000	900 - 3	FC9-7299-000	D11 - 14	FE2-1995-000	103 - 32
FC8-8645-000	100 - 43	FC9-7300-000	D11 - 43	FE2-1996-000	101 - 58
FC8-8649-000	130 - 2	FC9-7301-000	D11 - 4	FE2-1999-000	101 - 23
FC8-8650-000	130 - 3	FC9-7308-000	D11 - 27	FE2-2003-000	103 - 19
FC8-8655-000	130 - 7	FC9-7543-000	D11 - 33	FE2-2013-000	104 - 9
FC9-0129-000	301 - 22	FC9-7544-000	D11 - 34	FE2-2016-000	103 - 25
FC9-0130-000	301 - 23	FC9-7550-000	D11 - 6	FE2-2020-000	100 - 71
FC9-0136-000	301 - 25	FC9-7861-000	100 - 41	FE2-2025-000	101 - 42
FC9-0145-000	001 - 1	FC9-7862-000	100 - 41	FE2-2027-000	103 - 31
FC9-4042-000	300 - 9	FC9-7863-000	100 - 41	FE2-2031-000	102 - 33
FC9-4042-000	301 - 26	FC9-8187-000	130 - 22	FE2-2040-000	103 - 20
FC9-4290-010	311 - 26	FC9-8580-000	352 - 25	FE2-2044-000	103 - 21
FC9-4390-000	130 - 10	FC9-8582-000	352 - 54	FE2-2045-000	103 - 22
FC9-4391-000	130 - 11	FC9-8584-000	101 - 84	FE2-2047-000	101 - 44
FC9-4978-000	A41 -	FC9-8585-000	101 - 84	FE2-2048-000	101 - 45
FC9-5278-000	130 - 12	FC9-8588-000	107 - 8	FE2-2049-000	101 - 46
FC9-5279-000	130 - 13	FC9-8606-000	105 - 13	FE2-2050-000	101 - 47

NUMERICAL INDEX

imageRUNNER ADVANCE C2030/C2025/C2020 Series(Numerical Index)

PARTS NUMBER	FIGURE & KEY NO.	PARTS NUMBER	FIGURE & KEY NO.	PARTS NUMBER	FIGURE & KEY NO
FE2-2083-000	101 - 39	FK2-9240-010	900 - 9	FL3-5465-010	D11 - 17
FE2-2084-000	102 - 15	FK2-9242-000	931 - IC	FL3-5538-010	A41 - 43
FE2-2085-000	102 - 34	FK2-9243-000	102 - 23	FL3-6227-000	D11 - 39
FE2-2086-000	102 - 14	FK2-9244-000	930 - 1	FL3-6661-010	311 - 17
FE2-2086-000	351 - 25	FK2-9248-000	900 - 10	FL3-7841-000	102 - 5
FE2-2088-000	101 - 40	FK2-9300-000	001 - 4	FL3-8032-000	311 - 31
FE2-2091-000	109 - 22	FK2-9301-000	001 - 4	FL3-9015-000	001 - 5
FE2-2099-000	103 - 26	FK2-9302-000	001 - 4	FL3-9360-000	104 - 20
FE2-2100-000	103 - 27	FK2-9303-000	001 - 4	FM0-1158-010	109 - 42
FE2-2101-000	103 - 28	FK2-9304-000	001 - 4	FM0-1162-000	310 -
FE2-2102-000	103 - 29	FK2-9305-000	001 - 4	FM0-1163-000	310 - 2
FE2-2103-000	103 - 30	FK2-9464-000	D11 - 23	FM0-4814-000	311 -
FE2-2106-000	100 - 68	FK3-2219-000	900 - 6	FM0-4830-000	311 -
FE2-2110-000	101 - 49	FL0-1354-000	101 - 93	FM0-4833-000	107 - 15
FE2-2111-000	101 - 92	FL0-2029-000	101 - 85	FM1-B281-000	310 - 6
FE2-2115-000	101 - 54	FL2-8280-000	311 - 61	FM1-B289-000	810 - 1
FE2-2116-000	101 - 55	FL2-8282-000	311 - 2	FM1-B290-000	810 - 1
FE2-2117-000	101 - 56	FL2-9472-000	301 - 28	FM1-B291-000	810 - 1
FE2-2118-000	101 - 57	FL2-9933-000	A11 - 12	FM3-4146-010	311 - 32
FE2-2827-000	001 - 6	FL2-9934-010	A11 - 13	FM3-4150-000	311 - 16
FE2-2828-000	001 - 7	FL2-9937-000	A41 - 22	FM3-5580-000	T20 - 2
FE3-4706-000	108 - 26	FL2-9939-000	A41 - 36	FM3-5933-000	107 - 23
FH7-7569-000	D11 - 19	FL2-9945-000	A10 - 12	FM3-6892-010	A12 - 13
FK2-0146-000	140 - 1	FL2-9948-000	A12 - 9	FM3-6893-000	A10 - 26
FK2-0148-000	140 - 1	FL2-9949-000	A41 - 5	FM3-6916-000	A41 - 45
FK2-0149-000	311 - 29	FL3-0626-000	130 - 25	FM3-6930-000	A41 - 73
FK2-0207-000	A21 - 4	FL3-0641-000	352 - 26	FM3-8013-000	104 - 2
FK2-0216-000	A10 - 23	FL3-0701-000	105 - 28	FM3-8014-000	104 - 3
FK2-0360-000	102 - 19	FL3-0777-000	352 - 59	FM3-8018-000	104 - 4
FK2-0408-010	311 - 30	FL3-0778-000	352 - 61	FM3-8021-010	104 - 5
FK2-0428-000	T21 - 3	FL3-0833-000	130 - 26	FM3-8025-000	107 - 9
FK2-2064-000	102 - 21	FL3-1185-000	100 - 45	FM3-8026-010	107 - 10
FK2-2987-000	140 - 1	FL3-1186-000	350 - 3	FM3-8031-000	104 - 6
FK2-3218-000	931 - IC	FL3-2449-000	A13 - 9	FM3-8032-000	104 - 7
FK2-5396-000	T22 - IC	FL3-2450-000	A13 - 1	FM3-8033-000	104 - 8
FK2-6692-000	930 - IC	FL3-2859-000	301 - 30	FM3-8034-010	109 - 9
FK2-6870-000	A41 - 21	FL3-2934-010	A10 - 13	FM3-8035-000	107 - 11
FK2-6871-000	A41 - 39	FL3-2935-000	A10 - 14	FM3-8036-030	101 -
FK2-6873-000	A10 - 11	FL3-2936-000	A11 - 23	FM3-8037-000	101 - 96
FK2-7264-000	102 - 22	FL3-2937-000	A13 - 2	FM3-8038-000	101 - 24
FK2-7367-000	001 - 2	FL3-2939-000	A13 - 11	FM3-8039-000	101 - 89
FK2-7574-000	931 - IC	FL3-2940-000	A12 - 10	FM3-8046-000	300 - 10
FK2-7586-000	312 - 2	FL3-2941-000	A12 - 12	FM3-8047-000	109 - 10
FK2-7835-010	931 - IC	FL3-2942-000	A11 - 14	FM3-8050-010	350 -
FK2-7852-000	931 - IC	FL3-3206-000	D11 - 21	FM3-8051-000	351 -
FK2-8321-000	931 - IC	FL3-3207-000	D11 - 11	FM3-8052-010	352 -
FK2-8341-000	900 - 5	FL3-3591-000	D11 - 20	FM3-8053-000	352 - 27
FK2-8949-000	130 - 23	FL3-3593-000	D11 - 20	FM3-8054-000	352 - 28
FK2-8957-000	130 - 24	FL3-3594-000	D11 - 20	FM3-8056-000	352 - 29
FK2-9199-000	105 - 14	FL3-3691-000	D11 - 7	FM3-8057-000	352 - 30
FK2-9200-000	900 - 7	FL3-3692-000	D11 - 41	FM3-8060-000	352 - 33
FK2-9239-000	900 - 8	FL3-5464-000	D11 - 18	FM3-8062-000	352 - 34

NUMERICAL INDEX

imageRUNNER ADVANCE C2030/C2025/C2020 Series(Numerical Index)

PARTS NUMBER	FIGURE & KEY NO.	PARTS NUMBER	FIGURE & KEY NO.	PARTS NUMBER	FIGURE & KEY NO
FM3-8063-000	352 - 35	FM3-8607-000	107 - 13	FM4-8108-000	107 - 18
FM3-8071-000	103 - 2	FM3-8610-000	109 - 17	FS1-1205-000	311 - 35
FM3-8074-000	460 -	FM3-8622-000	102 - 27	FS5-1943-000	311 - 36
FM3-8077-000	100 - 46	FM3-8623-000	108 - 11	FS5-6945-000	352 - 36
FM3-8078-000	100 - 47	FM3-8624-000	109 - 35	FS7-2788-000	100 - 53
FM3-8079-010	100 - 48	FM3-8626-000	108 - 13	FS7-2800-000	311 - 37
FM3-8083-000	100 - 51	FM3-8636-000	106 - 31	FS7-2801-000	311 - 38
FM3-8084-010	106 - 27	FM3-8639-000	109 - 36	FS7-2803-000	311 - 39
FM3-8085-000	106 - 28	FM3-8644-000	105 - 27	FS7-2859-000	352 - 37
FM3-8108-000	106 - 33	FM3-8647-000	107 - 14	FS9-0203-000	A10 - 1
FM3-8109-000	106 - 34	FM3-8905-010	301 - 31	FS9-0204-000	A41 - 46
FM3-8110-000	106 - 35	FM3-8906-010	301 - 32	FS9-0205-000	A41 - 47
FM3-8111-000	106 - 30	FM3-8907-000	301 - 33	FU0-0043-000	311 - 40
FM3-8117-020	103 - 11	FM3-8912-000	301 - 24	FU0-0178-000	103 - 38
FM3-8137-020	108 - 6	FM3-8913-000	301 - 29	FU0-0179-000	103 - 39
FM3-8138-020	108 - 7	FM4-0783-000	900 - 11	FU0-0180-000	103 - 40
FM3-8142-000	106 - 21	FM4-0788-000	T20 - 3	FU0-0181-000	109 - 30
FM3-8144-010	106 - 22	FM4-0830-000	900 - 12	FU0-0183-000	101 - 74
FM3-8145-000	250 - 1	FM4-0838-010	T22 -	FU0-0198-000	101 - 73
FM3-8149-000	107 - 12	FM4-1198-000	130 - 27	FU3-0282-000	311 - 41
FM3-8150-000	100 - 66	FM4-1201-000	311 - 33	FU3-0283-000	311 - 42
FM3-8151-000	312 -	FM4-1894-000	108 - 12	FU3-0284-000	311 - 43
FM3-8153-000	301 -	FM4-1895-000	102 - 28	FU3-0285-000	312 - 3
FM3-8157-000	109 - 11	FM4-1902-000	109 - 34	FU3-0288-000	311 - 44
FM3-8160-000	109 - 12	FM4-1915-000	109 - 18	FU3-0289-000	311 - 45
FM3-8161-000	109 - 13	FM4-2183-000	130 - 29	FU3-0347-000	311 - 46
FM3-8162-000	109 - 14	FM4-2184-000	130 -	FU3-0349-000	311 - 47
FM3-8163-000	109 - 15	FM4-2185-000	130 - 30	FU3-0350-000	311 - 48
FM3-8166-000	103 - 12	FM4-2430-000	130 - 28	FU3-0352-000	311 - 49
FM3-8167-000	103 - 13	FM4-2431-000	130 - 31	FU5-1035-000	100 - 42
FM3-8172-000	140 -	FM4-2432-000	130 - 32	FU5-1168-000	A11 - 18
FM3-8175-000	980 -	FM4-2458-000	A41 -	FU5-1172-000	A12 - 24
FM3-8176-000	T20 -	FM4-2525-000	311 - 34	FU5-1172-000	A41 - 50
FM3-8177-000	108 - 28	FM4-2667-000	A13 -	FU5-1173-000	A10 - 15
FM3-8178-000	108 - 8	FM4-3023-000	A10 - 21	FU5-1453-000	351 - 15
FM3-8179-010	104 - 10	FM4-3024-000	A13 - 13	FU5-1453-000	352 - 38
FM3-8180-000	960 -	FM4-3138-000	931 -	FU5-1469-000	351 - 16
FM3-8181-000	960 -	FM4-3139-010	930 -	FU5-1469-000	352 - 39
FM3-8182-000	105 - 26	FM4-3140-010	930 -	FU5-1626-000	A12 - 25
FM3-8183-000	104 - 21	FM4-3141-010	930 -	FU5-1626-000	A41 - 51
FM3-8186-000	T21 -	FM4-3338-000	A10 - 17	FU5-1763-000	311 - 50
FM3-8187-000	108 - 9	FM4-3385-010	D11 - 12	FU5-3710-000	D11 - 31
FM3-8189-000	960 -	FM4-3388-000	D11 - 44	FU5-9139-000	A01 - 5
FM3-8190-000	108 - 9	FM4-3390-000	D11 - 45	FU5-9140-000	A01 - 6
FM3-8191-000	140 -	FM4-3392-000	D11 - 2	FU6-0076-000	352 - 40
FM3-8192-000	140 -	FM4-4309-000	A12 -	FU6-0085-000	351 - 17
FM3-8238-000	107 - 28	FM4-4312-010	A41 - 42	FU6-0140-000	351 - 18
FM3-8240-010	530 -	FM4-5644-000	A41 - 20	FU6-1088-000	A41 - 52
FM3-8260-000	100 - 61	FM4-7540-000	D11 - 8	FU6-1089-000	A41 - 53
FM3-8599-000	109 - 16	FM4-7712-000	810 - 2	FU6-1110-000	101 - 68
FM3-8600-000	108 - 10	FM4-7713-000	810 - 2	FU6-1578-000	101 - 69
FM3-8601-000	351 - 14	FM4-7716-000	250 -	FU6-1579-000	101 - 70

NUMERICAL INDEX

imageRUNNER ADVANCE C2030/C2025/C2020 Series(Numerical Index)

PARTS NUMBER	FIGURE & KEY NO.	PARTS NUMBER	FIGURE & KEY NO.	PARTS NUMBER	FIGURE & KEY NO
FU6-1580-000	101 - 71	FU7-2818-000	351 - 22	FU8-0312-000	A41 - 62
FU6-1581-000	101 - 72	FU7-2819-000	101 - 37	FU8-0313-000	A41 - 63
FU6-2684-000	311 - 51	FU7-2820-000	101 - 38	FU8-0314-000	A41 - 64
FU6-2784-000	311 - 52	FU7-2823-000	106 - 29	FU8-0315-000	A41 - 65
FU6-8647-000	107 - 24	FU7-5378-000	311 - 55	FU8-0316-000	A41 - 66
FU7-0445-000	311 - 53	FU7-8079-000	D11 - 38	FU8-0317-000	A41 - 67
FU7-2446-000	351 - 19	FU7-8080-000	D11 - 38	FU8-0318-000	A41 - 68
FU7-2651-000	A10 - 16	FU7-8081-000	D11 - 38	FU8-0319-000	A21 - 6
FU7-2652-000	A11 - 9	FU7-8082-000	D11 - 38	FU8-0320-000	A21 - 7
FU7-2653-000	A11 - 17	FU7-8083-000	D11 - 38	FU8-0396-000	352 - 43
FU7-2654-000	A12 - 26	FU7-8084-000	D11 - 42	FU8-0397-000	352 - 44
FU7-2655-000	A12 - 27	FU7-8085-000	D11 - 42	FU8-0398-000	351 - 23
FU7-2656-000	A12 - 11	FU7-8086-000	D11 - 42	FU8-0403-000	352 - 45
FU7-2657-000	A41 - 44	FU7-8087-000	D11 - 42	FU8-0408-000	351 - 24
FU7-2658-000	A41 - 54	FU7-8142-000	A10 - 2	FU8-0910-000	A13 - 7
FU7-2659-000	A41 - 55	FU7-8223-000	A10 - 24	FU8-2470-000	D11 - 35
FU7-2660-000	A41 - 56	FU7-8225-000	A10 - 2	FU8-2481-000	D11 - 32
FU7-2749-000	106 - 32	FU7-8226-000	A01 - 1	FU8-2497-000	D11 - 26
FU7-2750-000	105 - 16	FU7-8226-000	A10 - 2	FU9-2512-000	104 - 1
FU7-2758-000	107 - 16	FU7-8227-000	D11 - 42	FU9-2514-000	103 - 41
FU7-2759-000	100 - 37	FU7-8232-000	D11 - 42	FU9-2516-000	101 - 77
FU7-2761-000	103 - 14	FU7-8233-000	D11 - 42	FU9-2519-000	101 - 41
FU7-2763-000	105 - 17	FU7-8234-000	D11 - 42	FU9-2521-000	101 - 53
FU7-2764-000	103 - 15	FU7-8442-000	A13 - 6	FU9-2526-000	101 - 75
FU7-2768-000	101 - 25	FU7-8443-000	A13 - 12	FU9-2528-000	101 - 79
FU7-2770-000	351 - 20	FU7-8444-000	A10 - 19	FU9-2529-000	103 - 3
FU7-2772-000	352 - 41	FU7-8446-000	A10 - 19	FU9-2530-000	101 - 78
FU7-2773-000	102 - 30	FU7-8447-000	A10 - 18	HH2-2824-000	001 - 3
FU7-2775-000	103 - 16	FU7-8449-000	A10 - 18	NPN	001 -
FU7-2778-000	102 - 24	FU7-8450-000	A10 - 18	NPN	100 -
FU7-2779-000	109 - 19	FU7-8452-000	A10 - 25	NPN	102 -
FU7-2782-000	101 - 26	FU7-8453-000	A10 - 3	NPN	103 -
FU7-2783-000	352 - 42	FU7-8454-000	A10 - 3	NPN	104 -
FU7-2784-000	351 - 21	FU7-8455-000	A01 - 2	NPN	105 -
FU7-2792-000	101 - 27	FU7-8455-000	A10 - 3	NPN	106 -
FU7-2793-000	109 - 21	FU7-8471-000	100 - 52	NPN	107 -
FU7-2796-000	103 - 17	FU7-8494-000	100 - 50	NPN	108 -
FU7-2797-000	101 - 28	FU7-8521-000	100 - 50	NPN	109 -
FU7-2798-000	101 - 29	FU8-0214-000	311 - 54	NPN	300 -
FU7-2799-000	101 - 30	FU8-0299-000	A12 - 21	NPN	810 -
FU7-2800-000	101 - 31	FU8-0300-000	A12 - 22	NPN	900 -
FU7-2801-000	101 - 32	FU8-0301-000	A12 - 23	NPN	A01 -
FU7-2802-000	103 - 18	FU8-0302-000	A12 - 8	NPN	A10 -
FU7-2803-000	101 - 33	FU8-0303-000	A41 - 57	NPN	A11 -
FU7-2804-000	101 - 34	FU8-0304-000	A41 - 26	NPN	A21 -
FU7-2805-000	101 - 35	FU8-0305-000	A41 - 58	NPN	D11 -
FU7-2809-000	109 - 20	FU8-0306-000	A41 - 40	RC2-6505-000	810 - 6
FU7-2810-000	102 - 25	FU8-0307-000	A41 - 29	RC2-6506-000	810 - 3
FU7-2811-000	102 - 4	FU8-0308-000	A41 - 59	RC2-6598-000	107 - 17
FU7-2812-000	109 - 43	FU8-0309-000	A41 - 60	RC2-6872-000	300 - 11
FU7-2814-000	101 - 36	FU8-0310-000	A41 - 61	RC2-7069-000	101 - 95
FU7-2817-000	102 - 26	FU8-0311-000	A21 - 5	RC2-7271-000	101 - 51

NUMERICAL INDEX

imageRUNNER ADVANCE C2030/C2025/C2020 Series(Numerical Index)

PARTS NUMBER	FIGURE & KEY NO.	PARTS NUMBER	FIGURE & KEY NO.	PARTS NUMBER	FIGURE & KEY NO
RC2-7271-000	352 - 46	VS1-7177-003	104 - 17	XA9-1016-000	107 - 27
RC2-7280-000	101 - 52	VS1-7177-003	105 - 20	XA9-1164-000	A41 - 69
RC2-7282-000	101 - 90	VS1-7177-003	108 - 15	XA9-1415-000	D11 - 13
RK2-2884-000	102 - 20	VS1-7177-003	T20 - 4	XA9-1469-000	D11 - 36
RK2-3298-000	103 - 33	VS1-7177-004	102 - 18	XA9-1523-000	301 - 19
RK2-3298-000	250 - 2	VS1-7177-004	103 - 45	XA9-1561-000	103 - 48
RK2-3298-000	351 - 12	VS1-7177-004	108 - 16	XA9-1567-000	D11 - 3
RL1-2235-000	103 - 34	VS1-7177-004	109 - 38	XA9-1671-000	103 - 47
RL1-2236-000	103 - 35	VS1-7177-004	A21 - 8	XA9-1671-000	104 - 16
RL1-2244-000	101 - 64	VS1-7177-005	105 - 21	XA9-1671-000	107 - 21
RL1-2266-000	103 - 36	VS1-7177-006	105 - 22	XA9-1671-000	108 - 25
RL1-2281-000	100 - 69	VS1-7177-006	108 - 17	XA9-1671-000	109 - 41
RL1-2282-000	100 - 70	VS1-7207-003	101 - 81	XA9-1671-000	351 - 26
RM1-5058-000	109 - 24	VS1-7207-003	104 - 19	XA9-1671-000	352 - 52
RM1-6005-000	109 - 26	VS1-7207-003	108 - 21	XA9-1671-000	T21 - 5
RM1-6015-000	300 - 12	VS1-7207-004	108 - 22	XA9-1833-000	250 - 3
RM1-6034-000	310 - 1	VS1-7207-004	109 - 39	XA9-1979-000	900 - 13
RM1-6035-000	310 - 2	VS1-7207-007	101 - 82	XA9-1980-000	109 - 25
RM1-6041-000	101 - 59	VS1-7207-008	108 - 23	XB4-5301-005	A41 -
RM1-6049-000	101 - 60	VS1-7207-014	108 - 24	XD3-2200-102	A12 - 501
RM1-6050-000	101 - 61	VS1-7207-017	109 - 40	XD3-2200-122	351 - 501
RM1-6074-000	109 - 27	VS1-7207-019	103 - 46	XD3-2200-122	352 - 501
RM1-6106-080	310 -	VS1-7207-019	104 - 18	XD3-2200-122	A11 - 501
RM1-6124-000	101 - 62	VS1-8412-009	108 - 18	XD3-2200-122	A41 - 501
RM1-6150-000	300 - 3	VS1-8412-011	103 - 42	XD9-0136-000	311 - 58
RM1-6151-000	101 - 63	VS1-8412-011	107 - 22	XD9-0136-000	312 - 4
RM1-6163-040	101 - 65	VS1-8412-015	105 - 23	XD9-0136-000	350 - 4
RM1-6789-000	310 - 3	VS1-8412-015	108 - 19	XD9-0136-000	351 - 27
RM1-6790-000	101 - 67	VS1-8412-017	103 - 43	XD9-0136-000	352 - 53
RM1-6857-000	109 - 28	VS1-8412-027	105 - 24	XD9-0136-000	D11 - 37
RM1-7914-070	109 - 33	VS1-8412-029	105 - 25	XD9-0289-000	311 - 60
RM1-7928-000	101 - 66	VS1-8412-031	108 - 20	XF2-1604-940	312 - 5
RM1-8830-000	103 - 37	WE8-5601-000	102 - 17	XF2-1607-640	A21 - 11
RS5-1567-000	352 - 47	WE8-6096-000	T20 - 5	XF2-1607-640	A41 - 70
RU6-0710-000	810 - 4	WE8-6391-000	108 - 27	XF2-4606-740	D11 - 22
RU6-0711-000	810 - 5	WE8-6449-000	104 - 11	XF2-4668-040	D11 - 25
RU6-0852-000	352 - 48	WG8-5696-000	102 - 3	XG9-0820-000	A41 - 23
RU6-0855-000	352 - 49	WG8-5696-000	109 - 29	XH9-0132-000	900 - 14
RU6-2693-000	101 - 76	WG8-5696-000	A13 - 8	XH9-0136-000	107 - 19
VD7-2941-002	960 - 1	WG8-5696-000	A21 - 9		
VD7-2951-502	960 - 2	WG8-5696-000	A41 - 41		
VS1-7177-002	101 - 80	WG8-5776-000	D11 - 24		
VS1-7177-002	105 - 19	WG8-5783-000	351 - 5		
VS1-7177-002	108 - 14	WG8-5783-000	352 - 51		
VS1-7177-002	109 - 37	WG8-5935-000	101 - 8		
VS1-7177-002	311 - 56	WG8-5935-000	109 - 44		
VS1-7177-002	352 - 50	WG8-5935-000	310 - 4		
VS1-7177-002	A10 - 20	WT8-5076-000	T20 - 6		
VS1-7177-002	A41 - 49	XA9-0656-000	311 - 57		
VS1-7177-002	T21 - 4	XA9-0702-000	A41 - 48		
VS1-7177-003	102 - 29	XA9-0732-010	A10 - 10		
VS1-7177-003	103 - 44	XA9-0732-010	A21 - 10		

imageRUNNER ADVANCE C2030/ C2025/C2020 Series(Parts Catalog)

imageRUNNER ADVANCE C2030i

230V EUR F15-5895-000 EZU HDD,2/3 DELIVERY MODEL

imageRUNNER ADVANCE C2030F

100V JP F15-5815-000 EZR HDD,G3 FAX,ADF MODEL

imageRUNNER ADVANCE C2030H

230V
LTN,SG,HK F15-5845-000 EZW HDD MODEL

imageRUNNER ADVANCE C2030L

230V EUR F15-5891-000 EZT

imageRUNNER ADVANCE C2030

120V TW F15-5806-000 GDU HDD,ADF MODEL

100V JP F15-5811-000 EZQ

120V
US,CA,LTN F15-5835-000 EZS HDD,2/3 DELIVERY,ADF
MODEL

120V
GOVERNMENT F15-5836-000 GDV HDD,2/3 DELIVERY,ADF
MODEL

230V CN F15-5846-000 GDS HDD MODEL

230V KR F15-5847-000 GDT

230V AU F15-5865-000 EZX HDD,2/3 DELIVERY,ADF
MODEL

imageRUNNER ADVANCE C2025H

230V LTN,SG,HK	F15-8845-000	GDN	HDD MODEL
---------------------------	---------------------	------------	-----------

imageRUNNER ADVANCE C2025

230V CN	F15-8842-000	GDQ	HDD MODEL
----------------	---------------------	------------	-----------

230V KR	F15-8847-000	GUW	
----------------	---------------------	------------	--

230V EUR	F15-8895-000	KWT	HDD,2/3 DELIVERY MODEL
-----------------	---------------------	------------	------------------------

imageRUNNER ADVANCE C2020i

230V EUR	F15-7795-000	FAK	HDD,2/3 DELIVERY MODEL
-----------------	---------------------	------------	------------------------

imageRUNNER ADVANCE C2020F

100V JP	F15-7715-000	EZZ	HDD,G3 FAX,ADF MODEL
----------------	---------------------	------------	----------------------

imageRUNNER ADVANCE C2020H

230V LTN,SG,HK	F15-7745-000	FAN	HDD MODEL
---------------------------	---------------------	------------	-----------

imageRUNNER ADVANCE C2020L

230V EUR	F15-7791-000	FAJ	
-----------------	---------------------	------------	--

imageRUNNER ADVANCE C2020

120V TW	F15-7705-000	GDY	HDD,ADF MODEL
----------------	---------------------	------------	---------------

100V JP	F15-7711-000	EZY	
----------------	---------------------	------------	--

120V US,CA,LTN	F15-7735-000	FAH	HDD,2/3 DELIVERY,ADF MODEL
---------------------------	---------------------	------------	-------------------------------

120V GOVERNMENT	F15-7736-000	GEB	HDD,2/3 DELIVERY,ADF MODEL
----------------------------	---------------------	------------	-------------------------------

**230V
LTN,SG,HK**

F15-7741-000 FAL

1 CASSETTE MODEL

230V CN

F15-7742-000 GDW

230V KR

F15-7747-000 GDX

230V AU

F15-7765-000 FBD

HDD,2/3 DELIVERY,ADF
MODEL

Contents

A1	ASSEMBLY LOCATION DIAGRAM	2-1
A2	OPTION PARTS CATALOG LIST	2-4
001	ACCESSORIES	2-5
100	EXTERNAL COVERS, PANELS, ETC.	2-7
101	RIGHT DOOR ASSEMBLY	2-12
102	INTERNAL COMPONENTS 1	2-18
103	INTERNAL COMPONENTS 2	2-21
104	INTERNAL COMPONENTS 3	2-24
105	INTERNAL COMPONENTS 4	2-26
106	INTERNAL COMPONENTS 5	2-28
107	INTERNAL COMPONENTS 6	2-31
108	MACHINE REAR PLATE 1	2-33
109	MACHINE REAR PLATE 2	2-35
130	CONTROL PANEL ASSEMBLY	2-38
140	POWER CORD TERMINAL ASS'Y	2-41
250	MAIN DRIVE ASSEMBLY	2-42
300	CASSETTE ASSEMBLY (UPPER)	2-43
301	CASSETTE ASSEMBLY (LOWER) (EXCEPT 1 CASSETTE MODEL)	2-45
310	PAPER PICK-UP ASSEMBLY (UPPER)	2-48
311	PAPER PICK-UP ASSEMBLY (LOWER) (EXCEPT 1 CASSETTE MODEL)	2-49
312	PAPER PICK-UP DRIVE ASSEMBLY (LOWER) (EXCEPT 1 CASSETTE MODEL)2-53	
350	2ND/3RD PAPER DELIVERY ASS'Y (2/3 DELIVERY MODEL)	2-54
351	2ND/3RD DRIVE FRAME ASSEMBLY (2/3 DELIVERY MODEL)	2-55
352	2ND/3RD DELIVERY GUIDE ASS'Y (2/3 DELIVERY MODEL)	2-57
460	LASER SCANNER UNIT	2-61
530	INTER. TRANSFER BELT ASS'Y	2-62
810	FIXING ASSEMBLY	2-63
900	CONTROLLER BOX ASSEMBLY	2-64
930	MAIN CONTROLLER PCB ASS'Y, 1	2-66
931	MAIN CONTROLLER PCB ASS'Y, 2	2-67
960	AC DRIVER PCB ASSEMBLY	2-68
980	HIGH VOLTAGE ASSEMBLY	2-69
A01	ADF MOUNTING ASSEMBLY (ADF MODEL)	2-70
A10	ADF MAIN BODY (ADF MODEL)	2-72
A11	BASE ASSEMBLY (ADF MODEL)	2-75
A12	PAPER PICK-UP COVER ASSEMBLY (ADF MODEL)	2-77
A13	DOCUMENT TRAY ASSEMBLY (ADF MODEL)	2-79
A21	ESTRANGEMENT DRIVE ASSEMBLY (ADF MODEL)	2-81
A41	PAPER FEED ASSEMBLY (ADF MODEL)	2-82
D11	READER ASSEMBLY (EXCEPT EUR)	2-87
T20	G3 FAX ASSEMBLY, 1 LINE (G3 FAX MODEL)	2-90
T21	SPEAKER ASSEMBLY (G3 FAX MODEL)	2-92
T22	1 LINE PCB ASSEMBLY (G3 FAX MODEL)	2-93
ZZA	MECHANICAL STANDARD PARTS (HOW TO USE)	2-94

ZZB	MECHANICAL STANDARD PARTS (SCREWS).....	2-95
ZZC	MECHANICAL STANDARD PARTS (BOLTS).....	2-102
ZZD	MECHANICAL STANDARD PARTS (NUTS).....	2-103
ZZE	MECHANICAL STANDARD PARTS (RETAINING RINGS)	2-104

FIGURE A1 ASSEMBLY LOCATION DIAGRAM

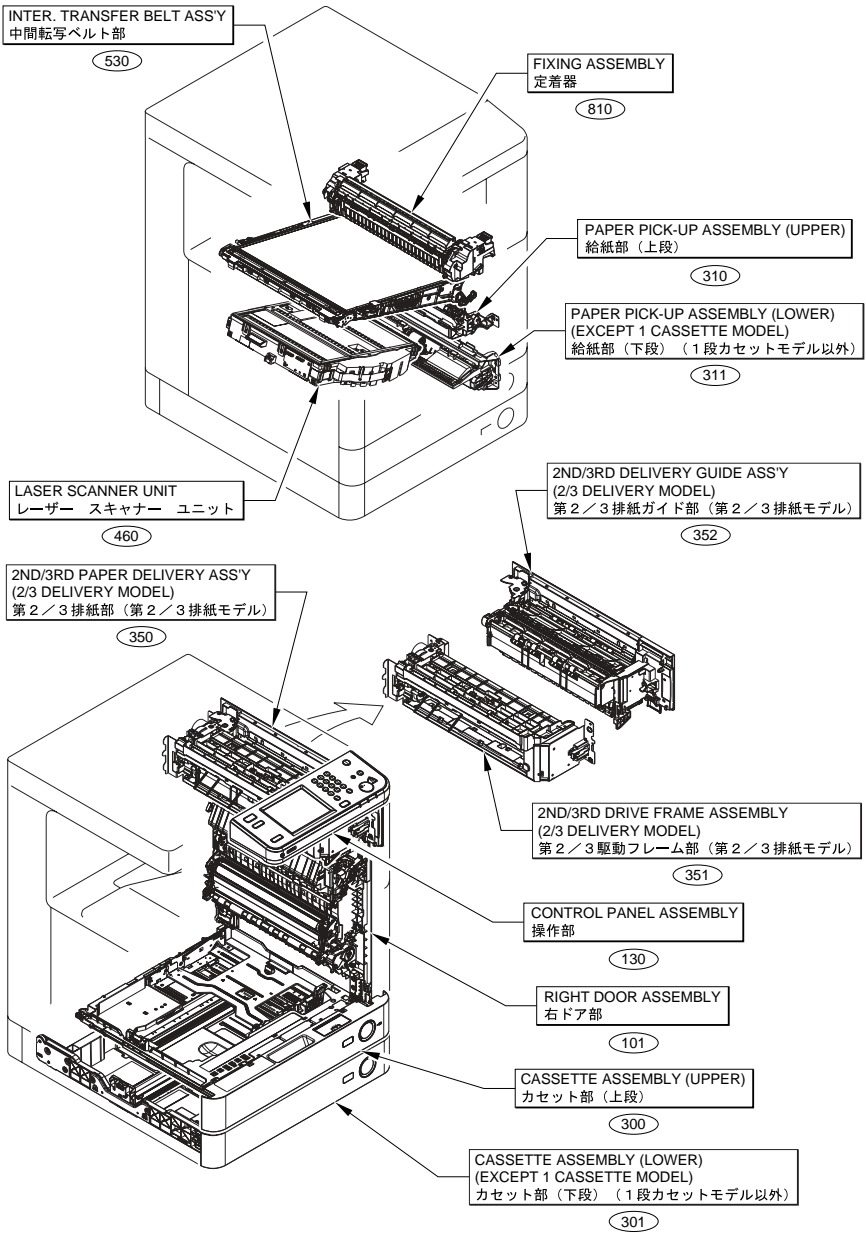

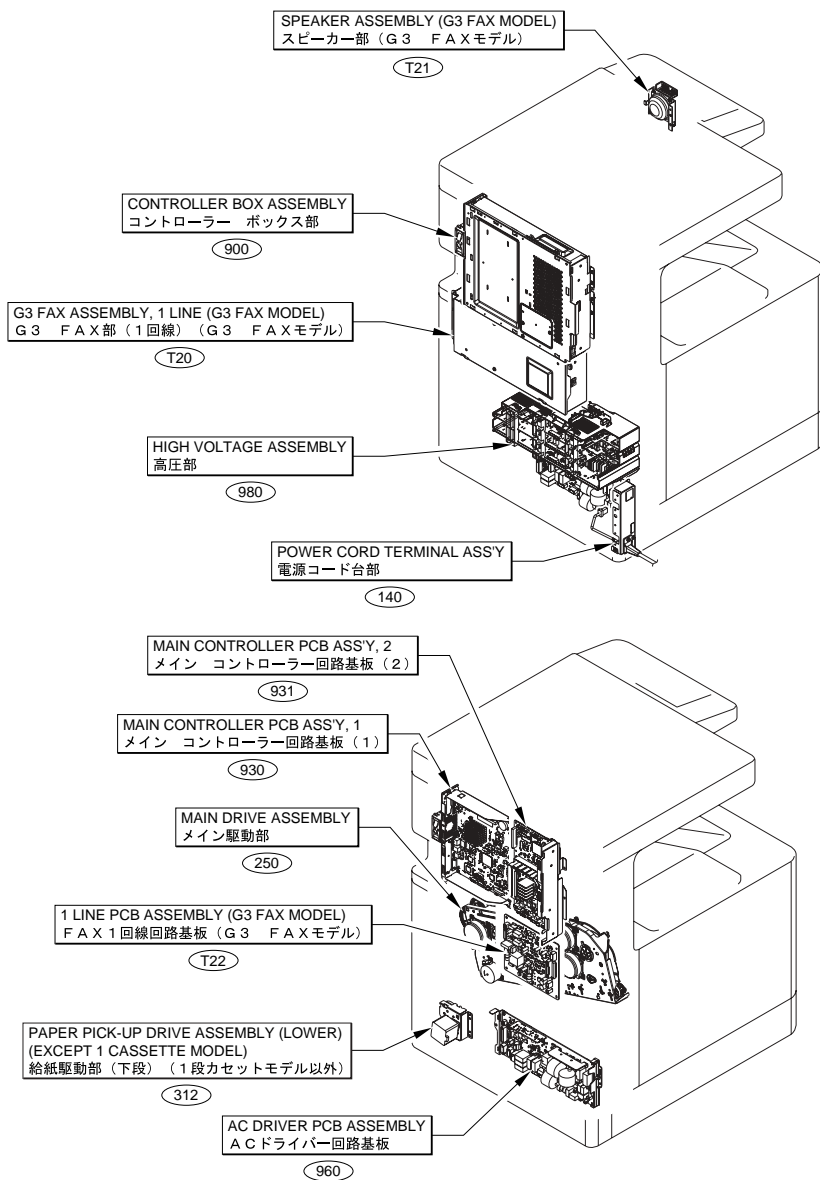

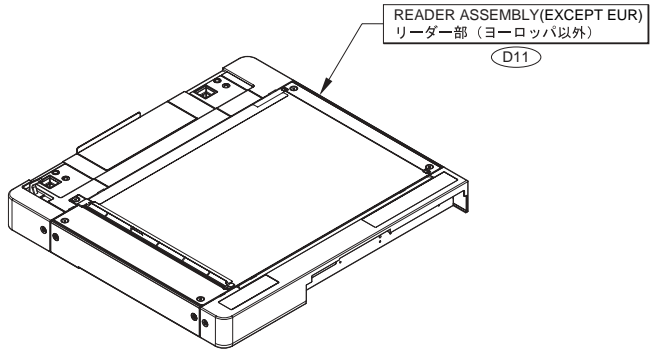

ADF MODEL

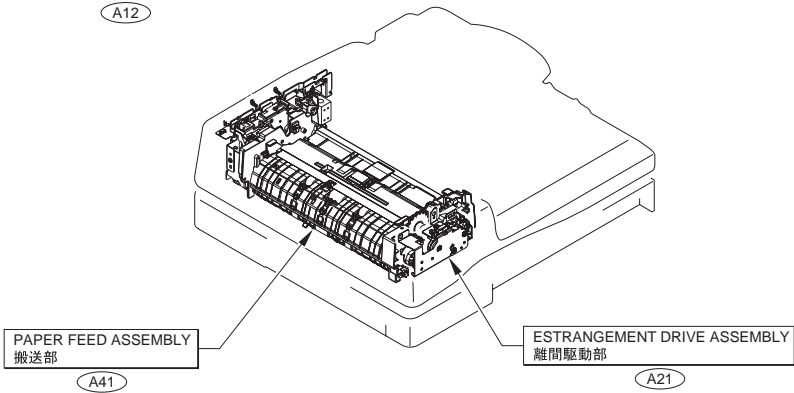
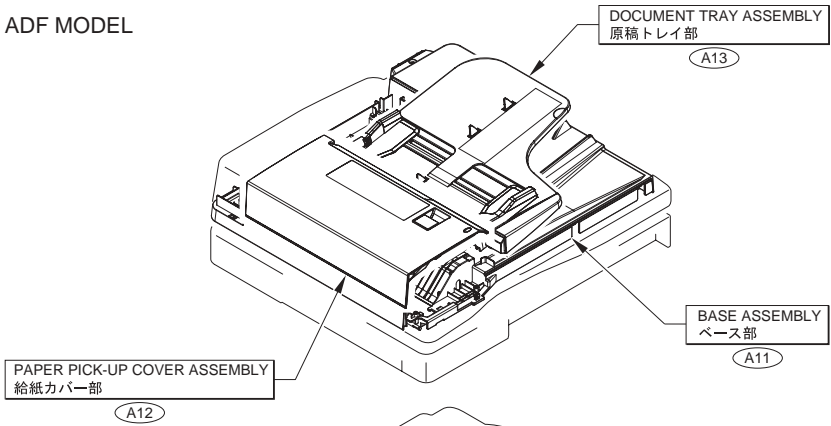

FIGURE A2 OPTION PARTS CATALOG LIST

This is the table of the machine's options whose parts catalog is issued.
本機のオプションで、パーツカタログが発行されている機種の一覧である。

No.	Model Name(English)	Model Name(Japanese)
1	DADF-AC1	DADF-AC1
2	Color Image Reader Unit-D1/D2	(日本仕向けなし)
3	Platen Cover Type R	原稿台カバー タイプR
4	Stamp Unit-B1	スタンプユニット・B1
5	ADF Access Handle-A1	ADFアクセスハンドル・A1
6	Printer Cover-D1/D2	(日本仕向けなし)
7	Cassette Feeding Unit-AF1	2段カセットペディスタル・AF1
8	FL Cassette-AN1	FLカセット・AN1
9	FL Cassette-AM1	FLカセット・AM1
10	Cassette Module-X1	(日本仕向けなし)
11	Envelope Feeder Attachment-D1	(日本仕向けなし)
12	Copy Tray-J1	コピートレイ・J1
13	Inner Finisher-C1	インナーフィニッシャー・C1
14	Inner Finisher Additional Tray-A1	インナーフィニッシャー用追加トレイ・A1
15	Inner 2way Tray-F1	インナー2ウェイトレイ・F1
16	3 Way Unit-C1	拡張挿紙キット・C1
17	Heater Kit-L1	(日本仕向けなし)
18	Reader Heater Unit-H1	(日本仕向けなし)
19	(JAPAN ONLY)	リーダーヒーターキット・B1/B2
20	Cassette Heater Unit-37	(日本仕向けなし)
21	Utility Tray-A2	ユーティリティートレイ・A2
22	Copy Card Reader-F1	コピーカードリーダー・F1
23	CARD READER-C1/D1	カードリーダー・C1/D1
24	Copy Card Reader Attachment-B2/B3	コピーカードリーダー取付けキット・B2/B3
25	(JAPAN ONLY)	iR-ADV C2030セルフ用圧板取付けキット・A1
26	Super G3 FAX Board-AH1/AH2	スーパーG3FAXボード・AH1/AH2
27	Super G3 2nd Line FAX Board-AH1	G3回線増設キット(2回線)・AH1
28	(JAPAN ONLY)	ハンドセット・G2
29	Voice Guidance Kit-F1/F2	(日本仕向けなし)
30	(JAPAN ONLY)	音声操作キット・C2
31	(JAPAN ONLY)	HDDデータ暗号化キット・C3
32	USB Device Port-B1/C1	USBデバイスポート・B1/C1
33	Wireless LAN Board-B1/B2	(日本仕向けなし)
34	2.5inch/80GB HDD-E1/E2	オプションHDD(2.5inch/80GB)・E1/E2
35	Removable HDD Kit-AE1	(日本仕向けなし)
36	Expansion Bus-F1/F2	PCIバス拡張キット・F1/F2
37	IPSec Board-B2	IPSecセキュリティボード・B2
38	Multimedia Reader/Writer-A1/A2	マルチメディアリーダー/ライター・A1/A2
39	(JAPAN ONLY)	モバイル接続キット・A1
40	(JAPAN ONLY)	iR-ADV裸金装置接続キット・A1
41	Serial Interface Kit-K1	シリアルインターフェースキット・K1
42	Copy Control Interface Kit-A1	コントロールインターフェースキット・A1

FIGURE 001 ACCESSORIES

1 CASSETTE MODEL

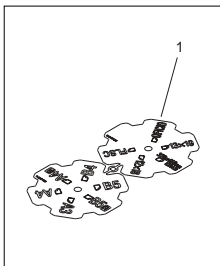

EXCEPT 1 CASSETTE MODEL

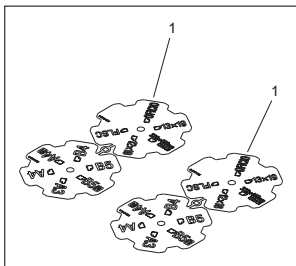

100V

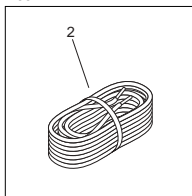

G3 FAX MODEL

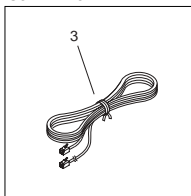

4

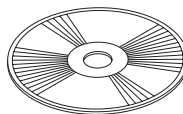

EXCEPT CN,KR

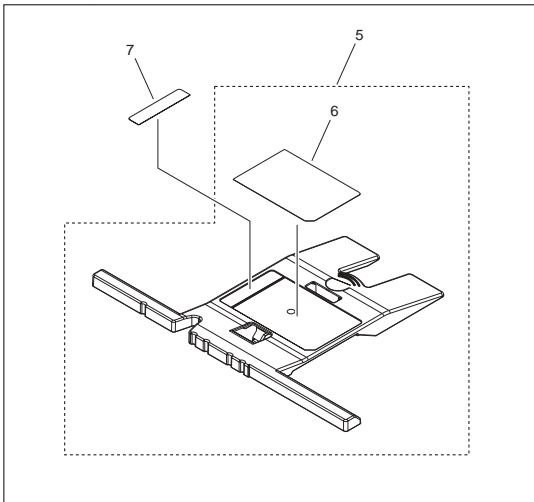
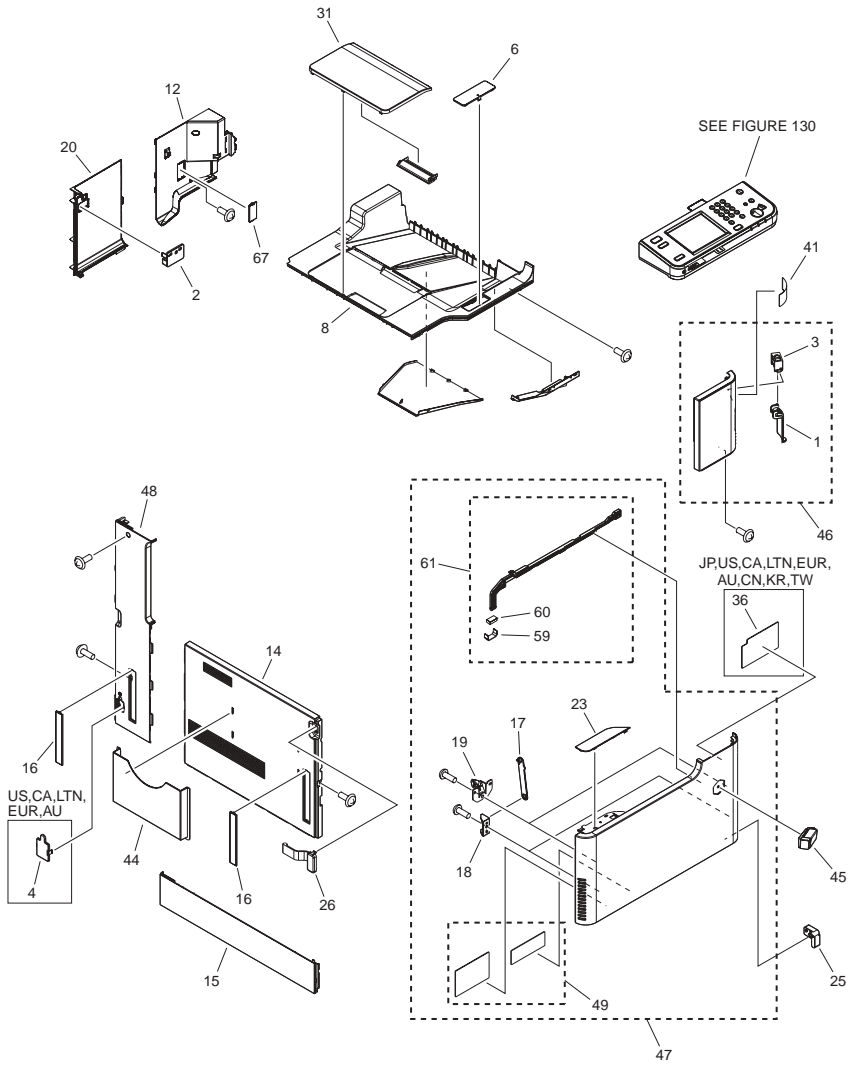

FIGURE & KEY NO.	PARTS NUMBER	RANK	Q'TY	DESCRIPTION	SERIAL NUMBER/REMARKS	SVC
Fig.001	NPN		RF	ACCESSORIES		
1	FC9-0145-000		2	PLATE, SIZE INDICATION		
2	FK2-7367-000		1	CABLE, GROUNDING	100V	
3	HH2-2824-000		1	MODULAR CORD, 2P	G3 FAX MODEL	
4	FK2-9302-000		1	CD-ROM, SOFTWARE FOR UFR II	English	
4	FK2-9300-000		1	CD-ROM, SOFTWARE FOR LIPS LX	Japanese	
4	FK2-9301-000		1	CD-ROM, SOFTWARE FOR FAX DRIVER	Japanese	
4	FK2-9303-000		1	CD-ROM, SOFTWARE FOR UFR II	UK English, French, Italian, German, Spanish	
4	FK2-9304-000		1	CD-ROM, SOFTWARE FOR PCL	UK English, French, Italian, German, Spanish	
4	FK2-9305-000		1	CD-ROM, SOFTWARE FOR UFR II	UK English, Simplified Chinese, Traditional Chinese, Korean	
5	FL3-9015-000		1	BLOCK, PAPER PICK-UP	EXCEPT CN, KR	
6	FE2-2827-000		1	LABEL, INSTRUCTIONS	EXCEPT CN, KR	
7	FE2-2828-000		1	LABEL, PAPER PICK-UP BLOCK	EXCEPT CN, KR	

FIGURE 100 EXTERNAL COVERS, PANELS, ETC.



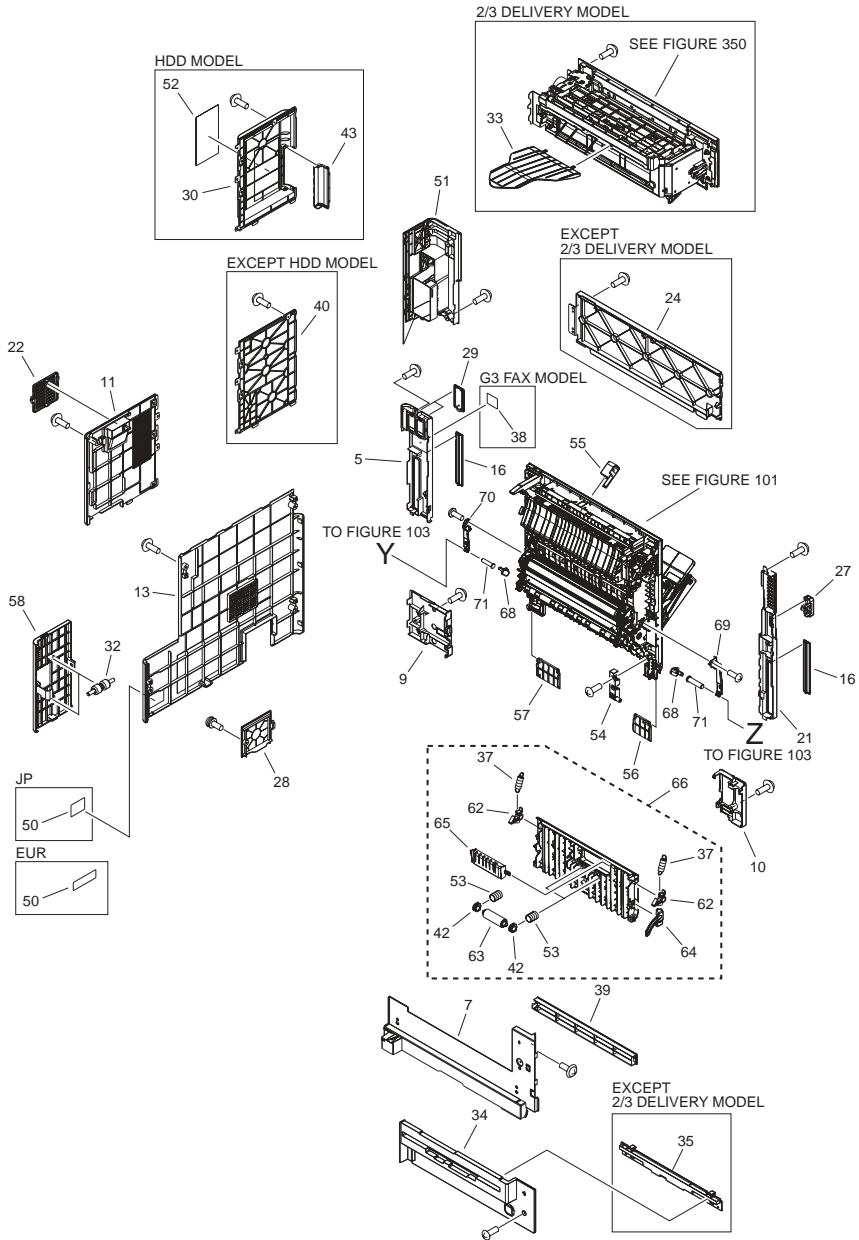
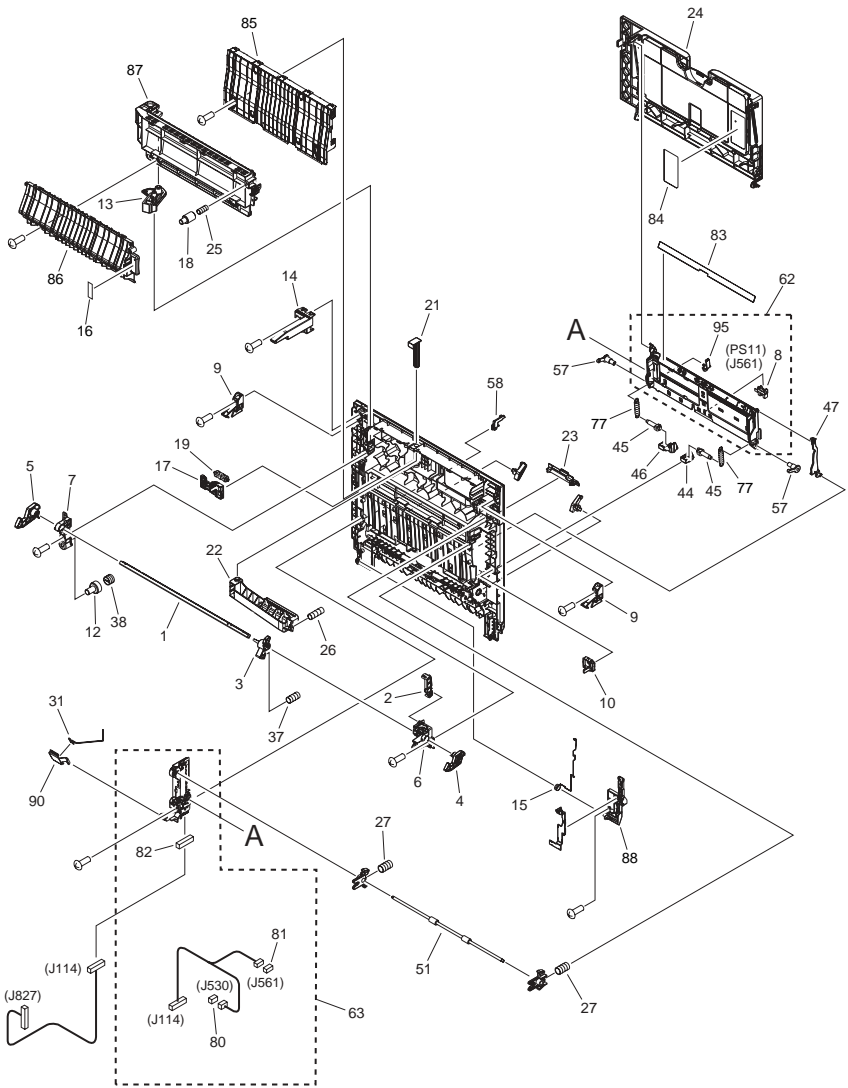

FIGURE & KEY NO.	PARTS NUMBER	RANK	Q'TY	DESCRIPTION	SERIAL NUMBER/REMARKS	SVC
Fig.100	NPN		RF	EXTERNAL COVERS, PANELS, ETC.		
1	FC8-4000-000		1	COVER, MAIN SWITCH		
2	FC8-5363-000		1	PLATE, 2ND DELIV. TRAY SUPPORT		
3	FC8-5378-000		1	MOUNT, SWITCH COVER		
4	FC8-4137-000		1	COVER, ENV. HEATER SWITCH	US,CA,LTN,EUR,AU	
5	FC8-8444-000		1	COVER, RIGHT REAR SUB		
6	FC8-8186-000		1	COVER, INNER SUB, 1		
7	FC8-8187-000		1	COVER, 1ST PAPER DELIVERY		
8	FC8-8189-000		1	TRAY, 1ST PAPER DELIVERY		
9	FC8-8190-000		1	COVER, RIGHT LOWER SUB, 2		
10	FC8-8191-000		1	COVER, RIGHT LOWER SUB, 1		
11	FC8-8192-010		1	COVER, REAR UPPER, 1		
12	FC8-8193-010		1	COVER, INNER REAR, 2		
13	FC8-8196-000		1	COVER, REAR		
14	FC8-8197-000		1	COVER, LEFT FRONT		
15	FC8-8198-000		1	COVER, LEFT LOWER		
16	FC8-8201-000		4	COVER, GRIP		
17	FC8-8203-000		2	ARM, FRONT COVER, B		
18	FC8-8204-000		2	MOUNT, STOPPER ARM		
19	FC8-8205-000		2	HOOK, COVER, FRONT		
20	FC8-8207-010		1	COVER, INNER REAR, 1		
21	FC8-8443-000		1	COVER, RIGHT FRONT SUB		
22	FC8-8286-000		1	COVER, REAR UPPER, 3		
23	FC8-8290-000		1	COVER, INNER SUB, 2		
24	FC8-8291-000		1	COVER, RIGHT UPPER	EXCEPT 2/3 DELIVERY MODEL	
25	FC8-8512-000		1	PLATE, FRONT DOOR FIXED		
26	FC8-8638-000		1	PLATE, STATIC CHARGE, LEFT		
27	FC8-8637-000		1	PLATE, STATIC CHARGE, RIGHT		
28	FC8-8344-000		1	COVER, CONNECTOR, 1		
29	FC8-8346-000		2	COVER, FAX CONNECTOR		
30	FC8-8359-000		1	COVER, HARD DISK DRIVE	HDD MODEL	

FIGURE & KEY NO.	PARTS NUMBER	R A N K	Q'TY	DESCRIPTION	SERIAL NUMBER/ REMARKS	S V C
31	FC8-8445-000		1	COVER, INNER BOTTOM		
32	FC8-4649-000		2	ROLLER, BOTTLE TRAY		
33	FC9-8612-000		1	GUIDE, REVERSE BACK END	2/3 DELIVERY MODEL	
34	FC8-8543-000		1	COVER, 2ND PAPER DELIVERY		
35	FC8-8544-000		1	COVER, REVERSE BLANKING	EXCEPT 2/3 DELIVERY MODEL	
36	FC8-8582-000		1	LABEL, TONER MODEL	JP,AU,CN,KR,TW	
36	FC8-8622-000		1	LABEL, TONER MODEL	LTN,US,CA	
36	FC8-8623-000		1	LABEL, TONER MODEL	EUR	
37	FU7-2759-000		2	SPRING, TENSION		
38	FC8-8615-000		1	LABEL, MODULAR	G3 FAX MODEL	
39	FC8-8617-000		1	COVER, RIGHT LOWER SUB, 3		
40	FC8-8631-000		1	COVER, REAR UPPER, 2	EXCEPT HDD MODEL	
41	FC9-7861-000		1	LABEL, MAIN POWER SUPPLY	JP,TW	
41	FC9-7862-000		1	LABEL, MAIN POWER SUPPLY	US,CA,LTN,AU,SG,HK	
41	FC9-7863-000		1	LABEL, MAIN POWER SUPPLY	EUR	
41	FC0-0225-000		1	LABEL, MAIN POWER SUPPLY	CN	
41	FC0-0226-000		1	LABEL, MAIN POWER SUPPLY	KR	
42	FU5-1035-000		4	BUSHING		
43	FC8-8645-000		1	COVER, SLOT	HDD MODEL	
44	FC0-2633-000		1	HOLDER, SERVICE BOOK		
45	FL3-1185-000		1	EMBLEM		
46	FM3-8077-000		1	FRONT UPPER COVER ASSEMBLY		
47	FM3-8078-000		1	FRONT DOOR ASSEMBLY		
48	FM3-8079-010		1	LEFT REAR COVER ASSEMBLY		
49	FC0-2901-000		1	LABEL, LASER CAUTION		
50	FU7-8494-000		1	LABEL, GROUNDING CAUTION	JP	
50	FU7-8521-000		1	LABEL, GROUNDING CAUTION	EUR	
51	FM3-8083-000		1	RIGHT UPPER SUB COVER ASSEMBLY		
52	FU7-8471-000		1	LABEL, HARD DISK DRIVE CAUTION	HDD MODEL	
53	FS7-2788-000		4	SPRING, COMPRESSION		
54	FC8-8228-000		1	HINGE, RIGHT DOOR, FRONT		

FIGURE & KEY NO.	PARTS NUMBER	R A N K	Q'TY	DESCRIPTION	SERIAL NUMBER/ REMARKS	S V C
55	FC8-8240-000		1	HOLDER, M.P. STOPPER		
56	FC8-8515-000		1	COVER, CASSETTE RIGHT UPPER, 1		
57	FC8-8516-000		1	COVER, CASSETTE RIGHT UPPER, 2		
58	FC8-8341-000		1	COVER, WASTE TONER		
59	FC8-8634-000		1	SHEET, GLASS CLEANING		
60	FC8-8635-000		1	PAD, GLASS CLEANING		
61	FM3-8260-000		1	GLASS CLEANING ARM ASSEMBLY		
62	FC5-0631-000		2	HOOK, RIGHT DOOR		
63	FC8-3782-000		2	ROLLER, PAPER FEED		
64	FC8-5164-000		1	STOPPER, DOOR, RIGHT LOWER		
65	FC8-8172-000		1	HANDLE, DOOR		
66	FM3-8150-000		1	DOOR ASSEMBLY, RIGHT LOWER		
67	FE2-0329-000		1	COVER, REAR RIGHT, SMALL		
68	FE2-2106-000		2	LOCK, DOOR LINK, RIGHT		
69	RL1-2281-000		1	PLATE, RT. DOOR LINK FIXED, FR		
70	RL1-2282-000		1	PLATE, RT. DOOR LINK FIXED, RR		
71	FE2-2020-000		1	SHAFT, RIGHT DOOR LINK		

FIGURE 101 RIGHT DOOR ASSEMBLY



NOTE : This assembly does not include the parts shown with key No. 83 and 84.
 注 : このユニットにKey No. 83, 84の部品は含まれません。

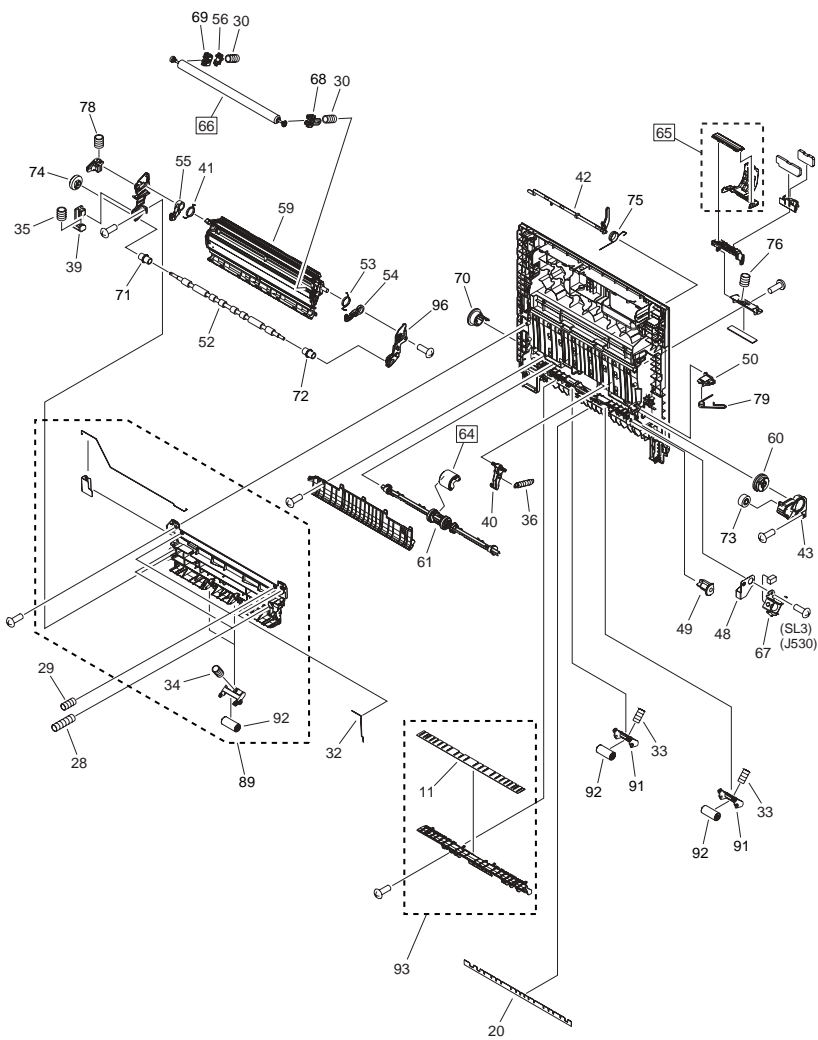

FIGURE & KEY NO.	PARTS NUMBER	R A N K	Q'TY	DESCRIPTION	SERIAL NUMBER/ REMARKS	S V C
Fig.101	FM3-8036-030		1	RIGHT DOOR ASSEMBLY		
1	FC0-0618-000		1	SHAFT		
2	FC0-0619-000		1	LINK, HANDLE		
3	FC0-0620-000		1	LEVER, LINK		
4	FC0-0622-000		1	LATCH, FRONT		
5	FC0-0623-000		1	LATCH, REAR		
6	FC0-0624-000		1	HOLDER, LATCH, FRONT		
7	FC0-0625-000		1	HOLDER, LATCH, REAR		
8	WG8-5935-000		1	IC, PHOTO INTERRUPTER	PS11	
9	FC0-0627-000		2	HOOK		
10	FC0-0628-000		1	LEVER, LOCK		
11	FC0-0629-000		1	SHEET, BASE GUIDE		
12	FC0-0630-000		1	PIN, PRESSURE		
13	FC8-8226-000		1	STOPPER, PAPER DELIVERY GUIDE		
14	FC8-8241-000		1	STOPPER		
15	FC8-8348-000		1	SPRING, GROUNDING		
16	FC8-8355-000		1	LABEL, LASER CAUTION		
17	FC8-8356-010		1	FLAG, OPEN/CLOSE SENSOR		
18	FC8-8413-000		1	PIN, POSITIONING		
19	FC8-8492-000		1	ROLLER, REEL		
20	FC8-8524-000		1	SHEET, NOISE-PROOF		
21	FC8-8538-000		1	SHAFT, HANDLE FIXED		
22	FC8-8539-000		1	HANDLE		
23	FE2-1999-000		1	COVER, PAPER PICK-UP ROLLER		
24	FM3-8038-000		1	MULTI PAPER PICK-UP TRAY ASS'Y		
25	FU7-2768-000		1	SPRING, COMPRESSION		
26	FU7-2782-000		1	SPRING, COMPRESSION		
27	FU7-2792-000		2	SPRING, COMPRESSION		
28	FU7-2797-000		2	SPRING, COMPRESSION		
29	FU7-2798-000		2	SPRING, COMPRESSION		
30	FU7-2799-000		2	SPRING, COMPRESSION		
31	FU7-2800-000		1	SPRING, POWER DISPATCHING		

FIGURE & KEY NO.	PARTS NUMBER	R A N K	Q'TY	DESCRIPTION	SERIAL NUMBER/ REMARKS	S V C
32	FU7-2801-000		1	SPRING, GROUNDING		
33	FU7-2803-000		2	SPRING, COMPRESSION		
34	FU7-2804-000		2	SPRING, COMPRESSION		
35	FU7-2805-000		1	SPRING, COMPRESSION		
36	FU7-2814-000		1	SPRING, TENSION		
37	FU7-2819-000		1	SPRING, COMPRESSION		
38	FU7-2820-000		1	SPRING, COMPRESSION		
39	FE2-2083-000		1	CLAMP, LEVER, REAR		
40	FE2-2088-000		1	STOPPER, PAPER PICK-UP SHAFT		
41	FU9-2519-000		1	SPRING, TORSION		
42	FE2-2025-000		1	FLAG, SENSOR		
43	FE2-1989-000		1	COVER, GEAR		
44	FE2-2047-000		1	HOOK, SPRING, LEFT		
45	FE2-2048-000		2	PIN, SPRING HOOK		
46	FE2-2049-000		1	HOOK, SPRING, RIGHT		
47	FE2-2050-000		1	LINK, M.P. HINGE		
48	FE2-1975-000		1	PLATE, GROUNDING		
49	FE2-2110-000		1	CLIP		
50	FE2-1992-000		1	COVER, GROUNDING		
51	RC2-7271-000		1	ROLLER, DUPLEXING PAPER FEED		
52	RC2-7280-000		1	ROLLER, REG.		
53	FU9-2521-000		1	SPRING, TORSION		
54	FE2-2115-000		1	HOOK, FRONT		
55	FE2-2116-000		1	HOOK, REAR		
56	FE2-2117-000		1	GUIDE, CONDUCTIVE		
57	FE2-2118-000		2	HOOK		
58	FE2-1996-000		1	COVER, CABLE		
59	RM1-6041-000		1	SECONDARY TRANSFER GUIDE ASS'Y		
60	RM1-6049-000		1	M.P. PAPER PICK-UP GEAR ASS'Y		
61	RM1-6050-000		1	M.P. PAPER PICK-UP SHAFT ASS'Y		
62	RM1-6124-000		1	MP LIFTER PLATE ASS'Y		
63	RM1-6151-000		1	DUPLEXING GEAR COVER ASSEMBLY		

FIGURE & KEY NO.	PARTS NUMBER	R A N K	Q'TY	DESCRIPTION	SERIAL NUMBER/REMARKS	S V C
64	RL1-2244-000		1	ROLLER, PAPER PICK-UP	[DP]	
65	RM1-6163-040		1	MULTI-PURPOSE SEP. PAD KIT	[DP]	
66	RM1-7928-000		1	2ND TRANSFER ROLLER ASS'Y	[DP]	
67	RM1-6790-000		1	SOLENOID	SL3	
68	FU6-1110-000		1	BUSHING		
69	FU6-1578-000		1	BUSHING		
70	FU6-1579-000		1	BUSHING		
71	FU6-1580-000		1	BUSHING		
72	FU6-1581-000		1	BUSHING		
73	FU0-0198-000		1	GEAR, 16T		
74	FU0-0183-000		1	GEAR, 21T		
75	FU9-2526-000		1	SPRING, TORSION		
76	RU6-2693-000		1	SPRING, COMPRESSION		
77	FU9-2516-000		2	SPRING, TENSION		
78	FU9-2530-000		1	SPRING, COMPRESSION		
79	FU9-2528-000		1	SPRING, TORSION		
80	VS1-7177-002		1	CONNECTOR, SNAP TIGHT, BK		
81	VS1-7207-003		1	CONNECTOR, SNAP TIGHT, BK		
82	VS1-7207-007		1	CONNECTOR, SNAP TIGHT		
83	FE2-1823-000		1	LABEL, FEED SIZE	SEE NOTE A SIZE	
83	FE2-1821-000		1	LABEL, FEED SIZE	SEE NOTE AB SIZE	
83	FE2-1824-000		1	LABEL, FEED SIZE	SEE NOTE AB/INCH/K SIZE	
83	FE2-1822-000		1	LABEL, FEED SIZE	SEE NOTE INCH SIZE	
84	FC9-8584-000		1	LABEL, PAPER SET INSTRUCTION	SEE NOTE JP,LTN,AU,SG,HK,CN,KR,TW	
84	FC9-8585-000		1	LABEL, PAPER SET INSTRUCTION	SEE NOTE US,CA,LTN,EUR	
85	FL0-2029-000		1	GUIDE, RIGHT DOOR, UPPER		
86	FC8-8251-000		1	GUIDE, PAPER DELIVERY, 1		
87	FC8-8252-000		1	GUIDE, PAPER DELIVERY, 2		
88	FC8-8353-000		1	HINGE, RIGHT DOOR, REAR		
89	FM3-8039-000		1	RIGHT DOOR INNER GUIDE ASS'Y		

FIGURE & KEY NO.	PARTS NUMBER	RANK	Q'TY	DESCRIPTION	SERIAL NUMBER/REMARKS	SVC
90	RC2-7282-000		1	PLATE, POWER DISPATCHING		
91	FE2-1993-000		2	HOLDER, ROLLER		
92	FE2-2111-000		4	ROLLER, PAPER FEED		
93	FL0-1354-000		1	GUIDE, RIGHT DOOR, LOWER		
95	RC2-7069-000		1	PLATE, LINK AUXILIARY		
96	FM3-8037-000		1	RIGHT DOOR INNER GUIDE ASS'Y,2		

FIGURE 102
INTERNAL COMPONENTS 1

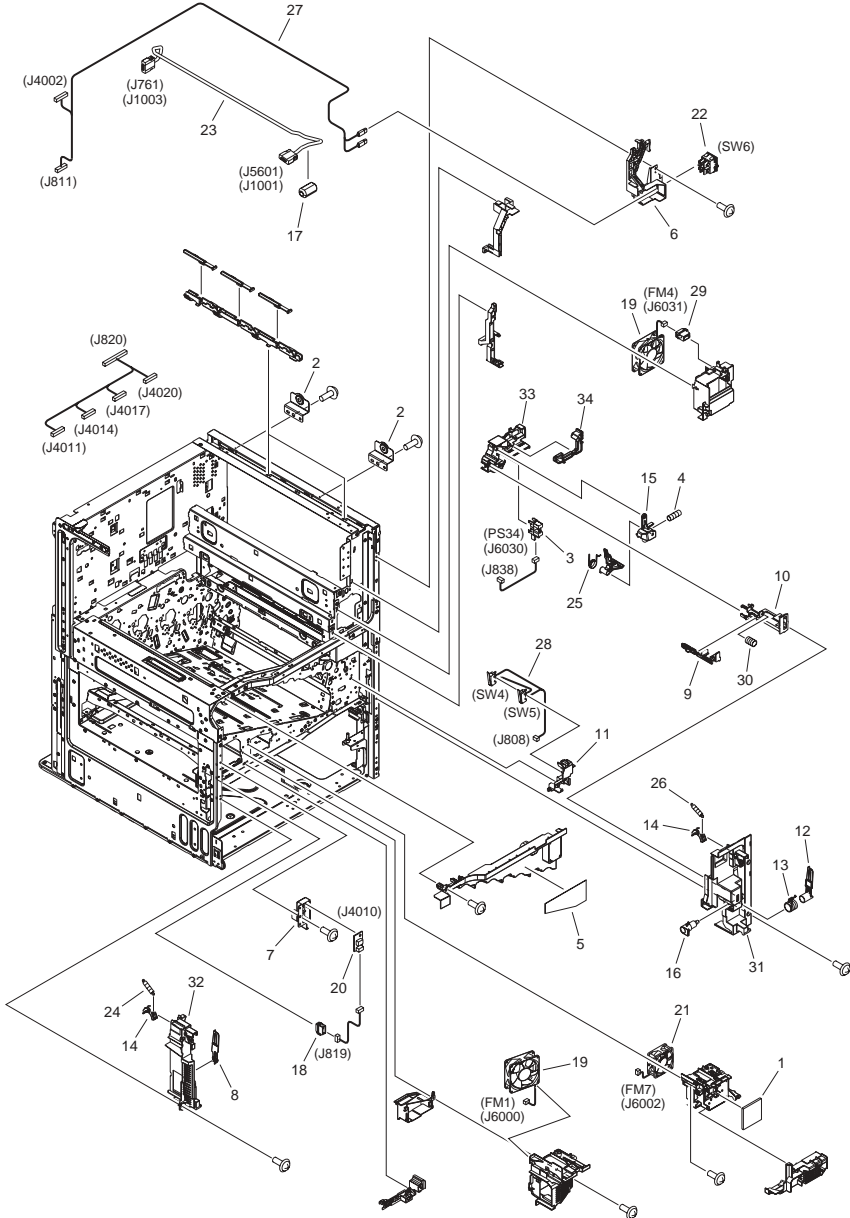

FIGURE & KEY NO.	PARTS NUMBER	R A N K	Q'TY	DESCRIPTION	SERIAL NUMBER/ REMARKS	S V C
Fig.102	NPN		RF	INTERNAL COMPONENTS 1		
1	FC6-4023-000		1	FILTER, AIR		
2	FC8-8105-000		2	PLATE, READER FIXED		
3	WG8-5696-000		1	PHOTO INTERRUPTER, TLP1243	PS34	
4	FU7-2811-000		1	SPRING, COMPRESSION		
5	FL3-7841-000		1	LABEL, SERVICE		
6	FC8-8273-000		1	HOLDER, SWITCH		
7	FC8-8274-000		1	HOLDER, ENVIRONMENT SENSOR		
8	FC8-8342-000		1	ARM, COVER		
9	FC8-8364-000		1	LINK, DOOR, FRONT		
10	FC8-8365-000		1	HOLDER, LINK		
11	FC8-8464-000		1	HOLDER, INTERLOCK SWITCH		
12	FC8-8626-000		1	ARM, COVER		
13	FC8-8627-000		1	SPRING, TORSION		
14	FE2-2086-000		2	LEVER, TOGGLE		
15	FE2-2084-000		1	LEVER, INTERLOCK		
16	FC8-8636-000		1	SHAFT		
17	WE8-5601-000		1	FERRITE CORE		
18	VS1-7177-004		1	CONNECTOR, SNAP TIGHT, BK		
19	FK2-0360-000		2	FAN	FM1,FM4	
20	RK2-2884-000		1	ENVIRONMENT SENSOR PCB ASS'Y		
21	FK2-2064-000		1	FAN	FM7	
22	FK2-7264-000		1	SWITCH, MAIN POWER SUPPLY	SW6	
23	FK2-9243-000		1	CABLE, USER INTERFACE		
24	FU7-2778-000		1	SPRING, TENSION		
25	FU7-2810-000		1	SPRING, TORSION		
26	FU7-2817-000		1	SPRING, TENSION		
27	FM3-8622-000		1	CABLE, SWITCH		
28	FM4-1895-000		1	SWITCH CABLE UNIT, INTERLOCK	SW4,SW5	
29	VS1-7177-003		1	CONNECTOR, SNAP TIGHT, BK		
30	FU7-2773-000		1	SPRING, COMPRESSION		
31	FC8-8199-000		1	COVER, INNER, RIGHT		

FIGURE & KEY NO.	PARTS NUMBER	R A N K	Q'TY	DESCRIPTION	SERIAL NUMBER/ REMARKS	S V C
32	FC8-8343-000		1	COVER, INNER, LEFT		
33	FE2-2031-000		1	HOLDER, INTERLOCK		
34	FE2-2085-000		1	LINK, DOOR INTERLOCK, RIGHT		

FIGURE 103 INTERNAL COMPONENTS 2

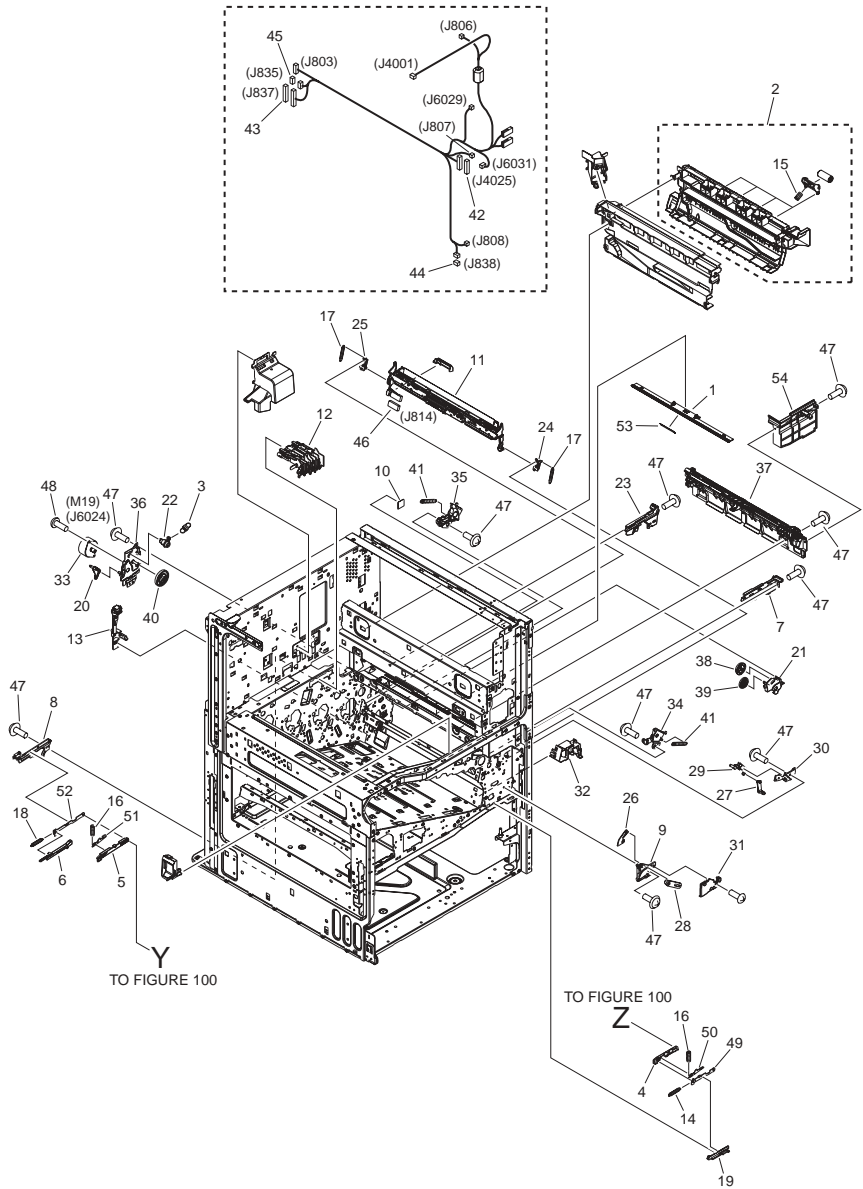

FIGURE & KEY NO.	PARTS NUMBER	R A N K	Q'TY	DESCRIPTION	SERIAL NUMBER/ REMARKS	S V C
Fig.103	NPN		RF	INTERNAL COMPONENTS 2		
1	FC8-8146-000		1	GUIDE, PRE-FIXING		
2	FM3-8071-000		1	DUPLEXING GUIDE ASSEMBLY		
3	FU9-2529-000		1	SPRING, TENSION		
4	FC8-8246-000		1	LINK, RIGHT DOOR, FRONT		
5	FC8-8351-000		1	LINK, RIGHT DOOR		
6	FC8-8352-000		1	ARM, RELEASE		
7	FC8-8480-000		1	RAIL, I.T.B. GUIDE, FRONT, 3		
8	FC8-8513-000		1	RAIL, DOOR LINK		
9	FC8-8514-000		1	GUIDE, ARM		
10	FC9-8615-000		1	LABEL, I.T.B. CAUTION		
11	FM3-8117-020		1	REGISTRATION SENSING ASSEMBLY		
12	FM3-8166-000		1	POWER DISPATCHING ASSY, 1		
13	FM3-8167-000		1	POWER DISPATCHING ASSY, 2		
14	FU7-2761-000		1	SPRING, TENSION		
15	FU7-2764-000		4	SPRING, COMPRESSION		
16	FU7-2775-000		2	SPRING, COMPRESSION		
17	FU7-2796-000		2	SPRING, TENSION		
18	FU7-2802-000		1	SPRING, TENSION		
19	FE2-2003-000		1	RAIL, DOOR LINK, FRONT LOWER		
20	FE2-2040-000		1	LINK,I.T.BELT COUPLING RELEASE		
21	FE2-2044-000		1	COVER, DUPLEXING GEAR		
22	FE2-2045-000		1	HOOK, DUPLEXING SPRING		
23	FC0-2640-000		1	RAIL, I.T.BELT GUIDE		
24	FE2-1990-000		1	SUPPORT, FRAME		
25	FE2-2016-000		1	SUPPORT, FRAME		
26	FE2-2099-000		1	LEVER, PUSH		
27	FE2-2100-000		1	LEVER, LIFT, 1		
28	FE2-2101-000		1	LEVER, LIFT, 2		
29	FE2-2102-000		1	SLIDER, PUSH		
30	FE2-2103-000		1	GUIDE, SLIDE		
31	FE2-2027-000		1	COVER, GUIDE		

FIGURE & KEY NO.	PARTS NUMBER	R A N K	Q'TY	DESCRIPTION	SERIAL NUMBER/ REMARKS	S V C
32	FE2-1995-000		1	DUCT, JOINT	M19	
33	RK2-3298-000		1	MOTOR, STEPPING, DC		
34	RL1-2235-000		1	PLATE, LOCK, FRONT		
35	RL1-2236-000		1	PLATE, 2ND TRNSFR. LOCK		
36	RL1-2266-000		1	PLATE, DUPLEXING DRIVE GEAR		
37	RM1-8830-000		1	PAPER DELIVERY ASSY		
38	FU0-0178-000		1	GEAR, 25T		
39	FU0-0179-000		1	GEAR, 25T		
40	FU0-0180-000		1	GEAR, 74T		
41	FU9-2514-000		2	SPRING, TENSION		
42	VS1-8412-011		1	CONNECTOR, SNAP TIGHT, BL		
43	VS1-8412-017		1	CONNECTOR, SNAP TIGHT, BL		
44	VS1-7177-003		1	CONNECTOR, SNAP TIGHT, BK		
45	VS1-7177-004		1	CONNECTOR, SNAP TIGHT, BK		
46	VS1-7207-019		1	CONNECTOR, SNAP TIGHT, BK		
47	XA9-1671-000		AR	SCREW, D, M3X8		
48	XA9-1561-000		2	SCREW, RS, M3X6		
49	FC8-8245-000		1	PLATE, RIGHT DOOR LINK, FRONT		
50	FC8-8247-000		1	STOPPER, RIGHT DOOR LINK,FRONT		
51	FC8-8349-000		1	STOPPER, RIGHT DOOR LINK, REAR		
52	FC8-8350-000		1	PLATE, RIGHT DOOR LINK, REAR		
53	FC0-6693-000		1	SHEET, PRE-FIXING GUIDE		
54	FC8-8450-000		1	GUIDE, FIXING, FRONT		

FIGURE 104 INTERNAL COMPONENTS 3

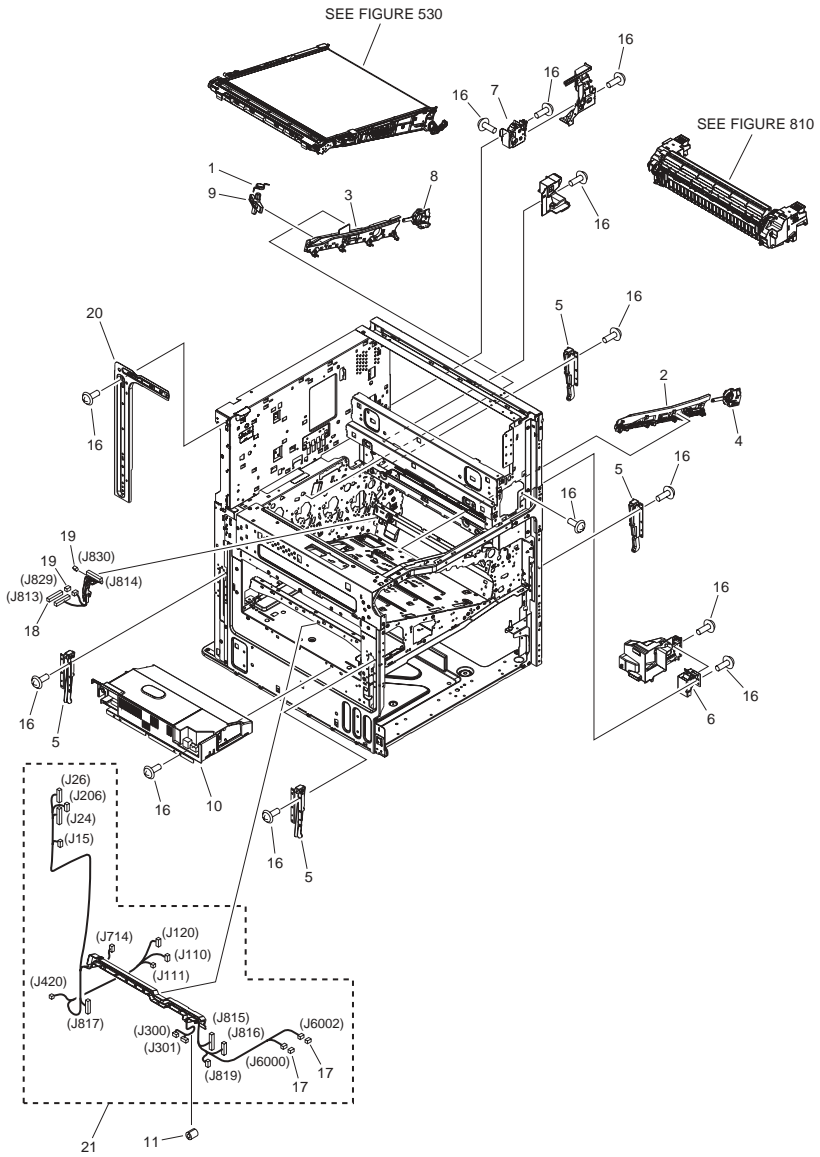

FIGURE & KEY NO.	PARTS NUMBER	R A N K	Q'TY	DESCRIPTION	SERIAL NUMBER/REMARKS	S V C
Fig.104	NPN		RF	INTERNAL COMPONENTS 3		
1	FU9-2512-000		1	SPRING, TORSION		
2	FM3-8013-000		1	ITB GUIDE RAIL ASS'Y, FRONT, 1		
3	FM3-8014-000		1	ITB GUIDE RAIL ASS'Y, REAR, 1		
4	FM3-8018-000		1	I.T.BELT GUIDE RAIL ASS'Y, F		
5	FM3-8021-010		4	HANDLE,MAIN BODY		
6	FM3-8031-000		1	RIGHT DOOR TOGGLE ASS'Y, FRONT		
7	FM3-8032-000		1	RIGHT DOOR TOGGLE ASS'Y, REAR		
8	FM3-8033-000		1	I.T.BELT GUIDE RAIL ASS'Y,REAR		
9	FE2-2013-000		1	LEVER, SWITCHING		
10	FM3-8179-010		1	LOW VOLTAGE POWER SUPPLY ASS'Y		
11	WE8-6449-000		1	CORE, FERRITE		
16	XA9-1671-000		AR	SCREW, D, M3X8		
17	VS1-7177-003		2	CONNECTOR, SNAP TIGHT, BK		
18	VS1-7207-019		1	CONNECTOR, SNAP TIGHT, BK		
19	VS1-7207-003		2	CONNECTOR, SNAP TIGHT, BK		
20	FL3-9360-000		1	PLATE, READER MOUNTING		
21	FM3-8183-000		1	POWER SUPPLY CABLE ASSEMBLY		

FIGURE 105 INTERNAL COMPONENTS 4

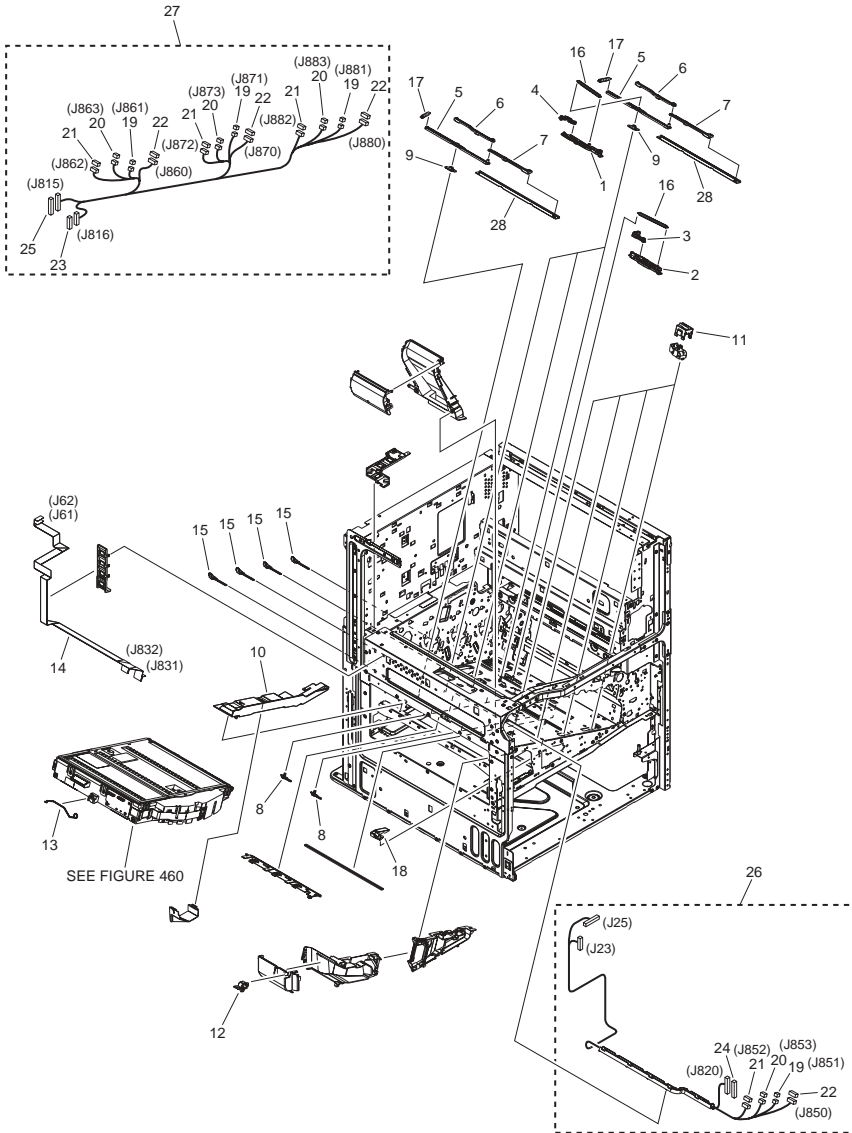

FIGURE & KEY NO.	PARTS NUMBER	R A N K	Q'TY	DESCRIPTION	SERIAL NUMBER/ REMARKS	S V C
Fig.105	NPN		RF	INTERNAL COMPONENTS 4		
1	FC8-7978-000		3	LEVER, TOGGLE, COLOR		
2	FC8-7979-000		1	LEVER, TOGGLE, BLACK		
3	FC8-7991-000		1	LEVER, HOLD, BLACK		
4	FC8-7992-000		3	LEVER, HOLD, COLOR		
5	FC8-8026-000		4	LEVER, SHUTTER, 1		
6	FC8-8027-000		4	LEVER, SHUTTER, 2		
7	FC8-8028-000		4	LEVER, SHUTTER, 3		
8	FC8-8032-000		8	LINK, SHUTTER, 1		
9	FC8-8033-000		4	LINK, SHUTTER, 2		
10	FC8-8220-000		1	GUIDE, CROSSMEMBER, LOWER		
11	FC8-8530-000		4	HOLDER, CONNECTOR		
12	FC8-8606-000		1	GUIDE, FRONT		
13	FC9-8606-000		1	SPRING, RETAINING		
14	FK2-9199-000		1	CABLE, FLEXIBLE FLAT		
15	FC8-8029-000		4	CAP, SHUTTER LEVER		
16	FU7-2750-000		4	SPRING, TENSION		
17	FU7-2763-000		4	SPRING, TENSION		
18	FE2-1985-000		1	GUIDE, 2		
19	VS1-7177-002		4	CONNECTOR, SNAP TIGHT, BK		
20	VS1-7177-003		4	CONNECTOR, SNAP TIGHT, BK		
21	VS1-7177-005		4	CONNECTOR, SNAP TIGHT, BK		
22	VS1-7177-006		4	CONNECTOR, SNAP TIGHT, BK		
23	VS1-8412-015		1	CONNECTOR, SNAP TIGHT, BL		
24	VS1-8412-027		1	CONNECTOR, SNAP TIGHT, BL		
25	VS1-8412-029		1	CONNECTOR, SNAP TIGHT, BL		
26	FM3-8182-000		1	LEFT CABLE ASSEMBLY		
27	FM3-8644-000		1	CABLE, BUFFER CONNECTING		
28	FL3-0701-000		4	SHUTTER, DUST-PROOF		

FIGURE 106 INTERNAL COMPONENTS 5

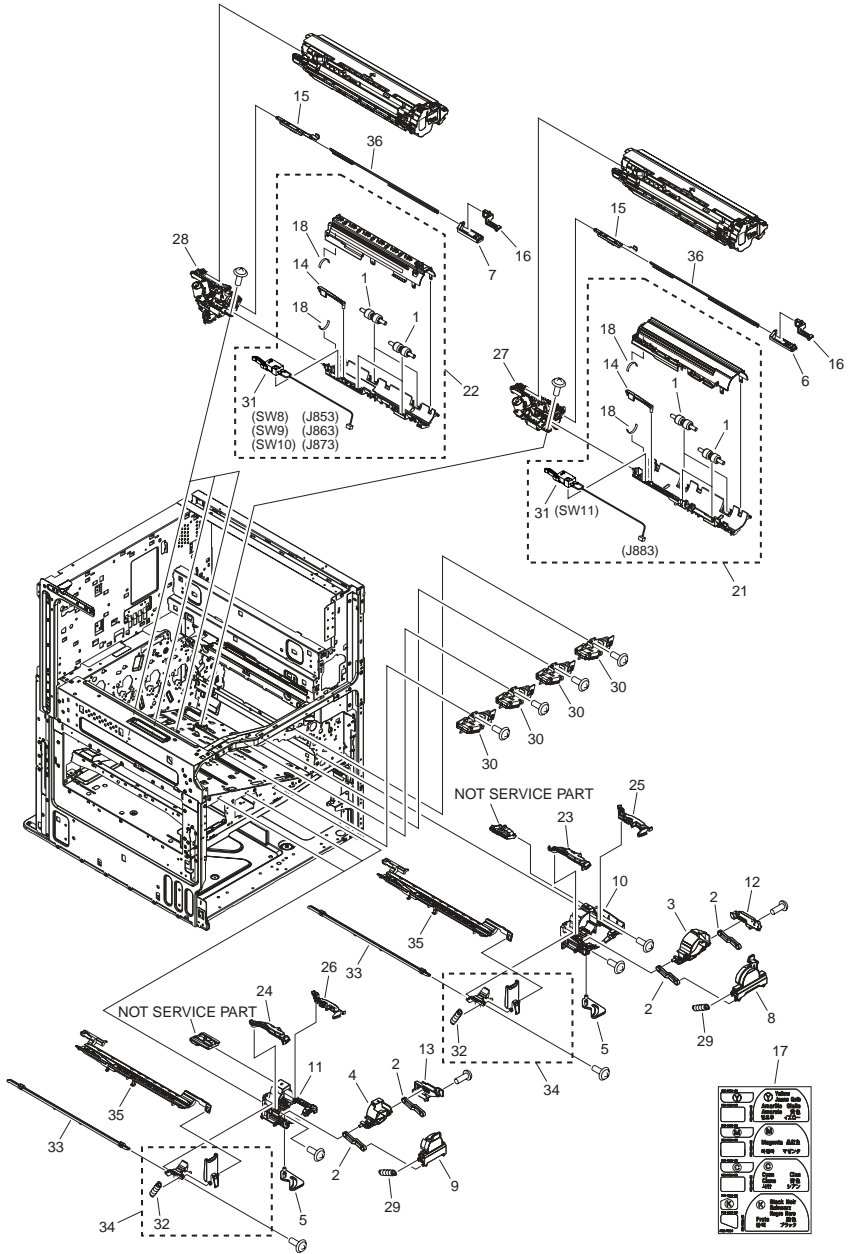

FIGURE & KEY NO.	PARTS NUMBER	R A N K	Q'TY	DESCRIPTION	SERIAL NUMBER/ REMARKS	S V C
Fig.106	NPN		RF	INTERNAL COMPONENTS 5		
1	FC8-4649-000		16	ROLLER, BOTTLE TRAY		
2	FC8-7951-000		8	HINGE		
3	FC8-7952-000		1	COVER, SIDE, BLACK		
4	FC8-7971-000		3	COVER, SIDE, COLOR		
5	FC8-7958-000		4	LEVER, LINK, 1		
6	FC8-7989-000		1	LEVER, LINK, 2, BLACK		
7	FC8-7959-000		3	LEVER, LINK, 2, COLOR		
8	FC8-7963-000		1	COVER, BOTTLE, BLACK		
9	FC8-7975-000		3	COVER, BOTTLE, COLOR		
10	FC8-7964-000		1	GUIDE, BOTTLE INSERT, BLACK		
11	FC8-7976-000		3	GUIDE, BOTTLE INSERT, COLOR		
12	FC8-7965-000		1	PLATE, INSERT GUIDE, BLACK		
13	FC8-7977-000		3	PLATE, INSERT GUIDE, COLOR		
14	FC8-7981-000		4	LEVER, BOTTLE SENSING		
15	FC8-7988-000		4	PLATE, LINK FIXED, 1		
16	FC8-7990-000		4	PLATE, LINK FIXED, 2		
17	FC8-7994-000		1	LABEL, COLOR INDICATION		
18	FC0-3643-000		8	BRUSH, CLEANING		
21	FM3-8142-000		1	BOTTLE BASE ASSEMBLY, BLACK		
22	FM3-8144-010		3	BOTTLE BASE ASSEMBLY, COLOR		
23	FC9-8649-000		1	LEVER, LEFT, BLACK		
24	FC9-8651-000		3	LEVER, LEFT, COLOR		
25	FC9-8650-000		1	LEVER, RIGHT, BLACK		
26	FC9-8652-000		3	LEVER, RIGHT, COLOR		
27	FM3-8084-010		1	TONER FEED ASSEMBLY, BLACK		
28	FM3-8085-000		3	TONER FEED ASSEMBLY, COLOR		
29	FU7-2823-000		4	SPRING, TENSION		
30	FM3-8111-000		4	CONTACT HOLDER UNIT		
31	FM3-8636-000		4	SWITCH CABLE UNIT, BOTTLE	SW8,SW9,SW10,SW11	
32	FU7-2749-000		4	SPRING, TENSION		
33	FM3-8108-000		4	DEVELOPING CROSSMEMBER ASSY		

FIGURE & KEY NO.	PARTS NUMBER	R A N K	Q'TY	DESCRIPTION	SERIAL NUMBER/ REMARKS	S V C
34	FM3-8109-000		4	DEVELOPING DOOR ASSEMBLY		
35	FM3-8110-000		4	RAIL ASSEMBLY		
36	FC8-7961-000		4	PLATE, LINK		

FIGURE 107 INTERNAL COMPONENTS 6

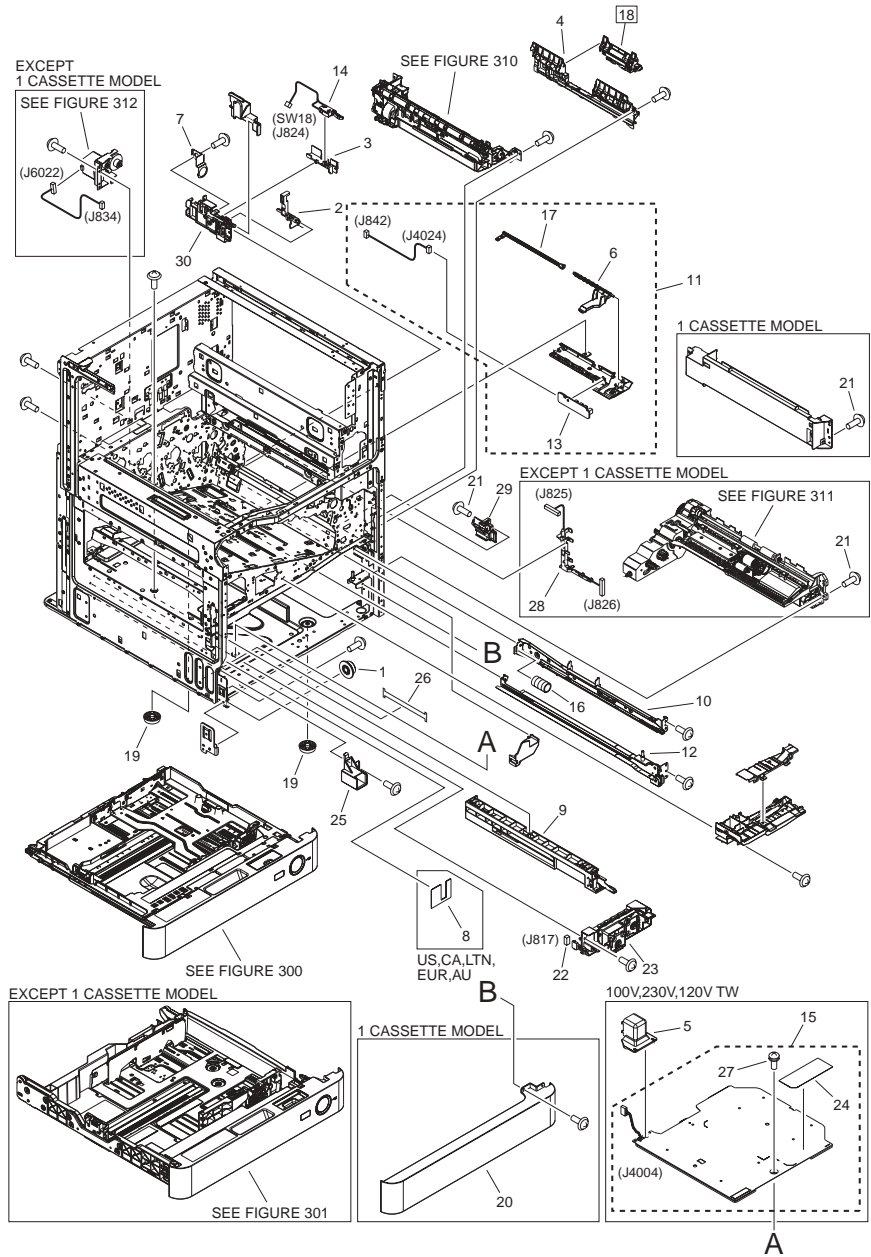

FIGURE & KEY NO.	PARTS NUMBER	R A N K	Q'TY	DESCRIPTION	SERIAL NUMBER/ REMARKS	S V C
Fig.107	NPN		RF	INTERNAL COMPONENTS 6		
1	FC8-4999-000		1	ROLLER, RAIL		
2	FC8-8176-000		1	LEVER, SENSOR		
3	FC8-8177-000		1	HOLDER, SWITCH		
4	FC8-8185-010		1	GUIDE, PAPER FEED		
5	FC8-8174-000		1	COVER, CONNECTOR	100V,230V,120V TW	
6	FC8-8233-000		1	FLAG, PAPER SENSOR		
7	FC8-8628-000		1	SPRING, GROUNDING		
8	FC9-8588-000		1	SEAL, BLANKING	US,CA,LTN,EUR,AU	
9	FM3-8025-000		1	CASSETTE RAIL ASS'Y, LEFT		
10	FM3-8026-010		1	CASSETTE RAIL ASS'Y, RIGHT		
11	FM3-8035-000		1	PHOTO SENSOR ASSEMBLY		
12	FM3-8149-000		1	CASSETTE RAIL ASSEMBLY, RIGHT		
13	FM3-8607-000		1	PHOTO SENSOR ASSEMBLY		
14	FM3-8647-000		1	SWITCH CABLE UNIT, OPEN/CLOSE	SW18	
15	FM0-4833-000		1	CASSETTE HEATER ASSEMBLY	100V,230V,120V TW	
16	FU7-2758-000		1	SPRING, COMPRESSION		
17	RC2-6598-000		1	SHAFT, TRANSMISSION		
18	FM4-8108-000		1	SEPARATION ROLLER ASS'Y	[DP]	
19	XH9-0136-000		2	FOOT, RUBBER		
20	FC8-8180-000		1	COVER, CASSETTE FRONT	1 CASSETTE MODEL	
21	XA9-1671-000		3	SCREW, D, M3X8		
22	VS1-8412-011		1	CONNECTOR, SNAP TIGHT, BL		
23	FM3-5933-000		1	AUTO SIZE DETECT ASSEMBLY		
24	FU6-8647-000		1	LABEL, HIGH TMP. CAUTION	100V,230V,120V TW	
25	FC8-8237-000		1	MOUNT, CASSETTE POSITIONING		
26	FC0-3651-000		1	TAPE, GROUNDING		
27	XA9-1016-000		1	SCREW, W/WASHER, M3X6	100V,230V,120V TW	
28	FM3-8238-000		1	CABLE,PAPER PICK-UP CONNECTING	EXCEPT 1 CASSETTE MODEL	
29	FC8-8097-000		1	GUIDE, RIGHT RAIL, FRONT		
30	FC8-8099-000		1	GUIDE, RIGHT RAIL, REAR		

FIGURE & KEY NO.	PARTS NUMBER	R A N K	Q'TY	DESCRIPTION	SERIAL NUMBER/ REMARKS	S V C
Fig.108	NPN		RF	MACHINE REAR PLATE 1		
1	FC8-8486-000		1	PLATE, READER JOINT	EXCEPT EUR	
2	FC8-8496-000		2	STRAP, WASTE TONER		
3	FC8-8497-000		1	HOLDER, SWITCH, UPPER		
4	FC8-8498-010		1	LEVER, SENSOR		
5	FC8-8499-000		1	HOLDER, SWITCH, LOWER		
6	FM3-8137-020		1	WASTE TONER CASE ASSEMBLY	[DP]	
7	FM3-8138-020		1	WASTE TONER INNER CASE ASS'Y		
8	FM3-8178-000		1	AC CABLE ASSEMBLY		
9	FM3-8187-000		1	ENVIRONMENT HEATER PCB ASS'Y	100V,120V TW	
9	FM3-8190-000		1	ENVIRONMENT HEATER PCB ASS'Y	230V	
10	FM3-8600-000		1	DC CONTROLLER PCB ASSEMBLY		
11	FM3-8623-000		1	CABLE, HEATER		
12	FM4-1894-000		1	CABLE, WASTE TONER SENSING	SW2,SW16	
13	FM3-8626-000		1	SWITCH CABLE UNIT, ENVIRONMENT	SW17 100V,230V,120V TW	
14	VS1-7177-002		3	CONNECTOR, SNAP TIGHT, BK		
15	VS1-7177-003		2	CONNECTOR, SNAP TIGHT, BK		
16	VS1-7177-004		2	CONNECTOR, SNAP TIGHT, BK		
17	VS1-7177-006		1	CONNECTOR, SNAP TIGHT, BK		
18	VS1-8412-009		1	CONNECTOR, SNAP TIGHT, BL		
19	VS1-8412-015		2	CONNECTOR, SNAP TIGHT, BL		
20	VS1-8412-031		1	CONNECTOR, SNAP TIGHT, 31P, BL		
21	VS1-7207-003		4	CONNECTOR, SNAP TIGHT, BK		
22	VS1-7207-004		1	CONNECTOR, SNAP TIGHT, BK		
23	VS1-7207-008		1	CONNECTOR, SNAP TIGHT, BK		
24	VS1-7207-014		1	CONNECTOR, SNAP TIGHT, BK		
25	XA9-1671-000		AR	SCREW, D, M3X8		
26	FE3-4706-000		1	CAP, WASTE TONER CASE		
27	WE8-6391-000		1	CORE, FERRITE		
28	FM3-8177-000		1	MAIN CABLE ASSEMBLY		
29	FC8-8473-000		1	PLATE, FIXED		

FIGURE 109 MACHINE REAR PLATE 2

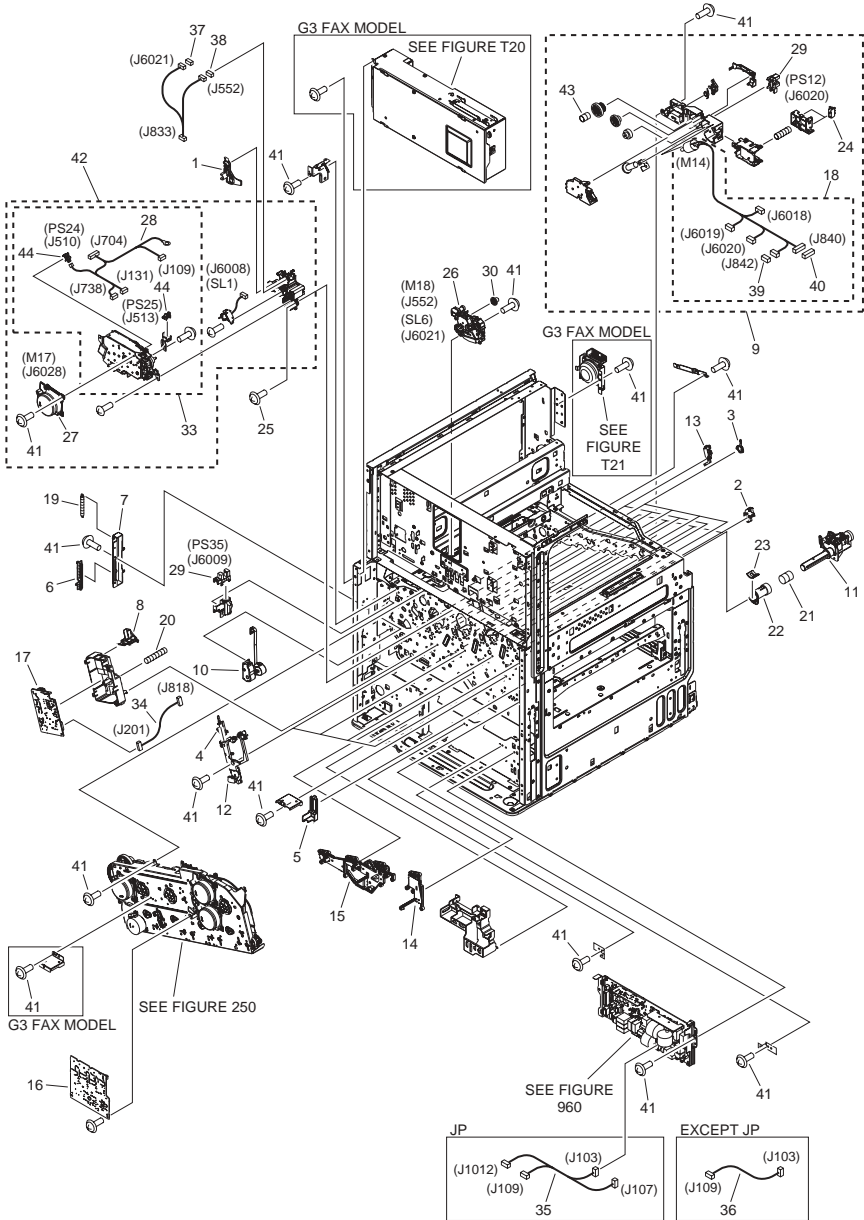
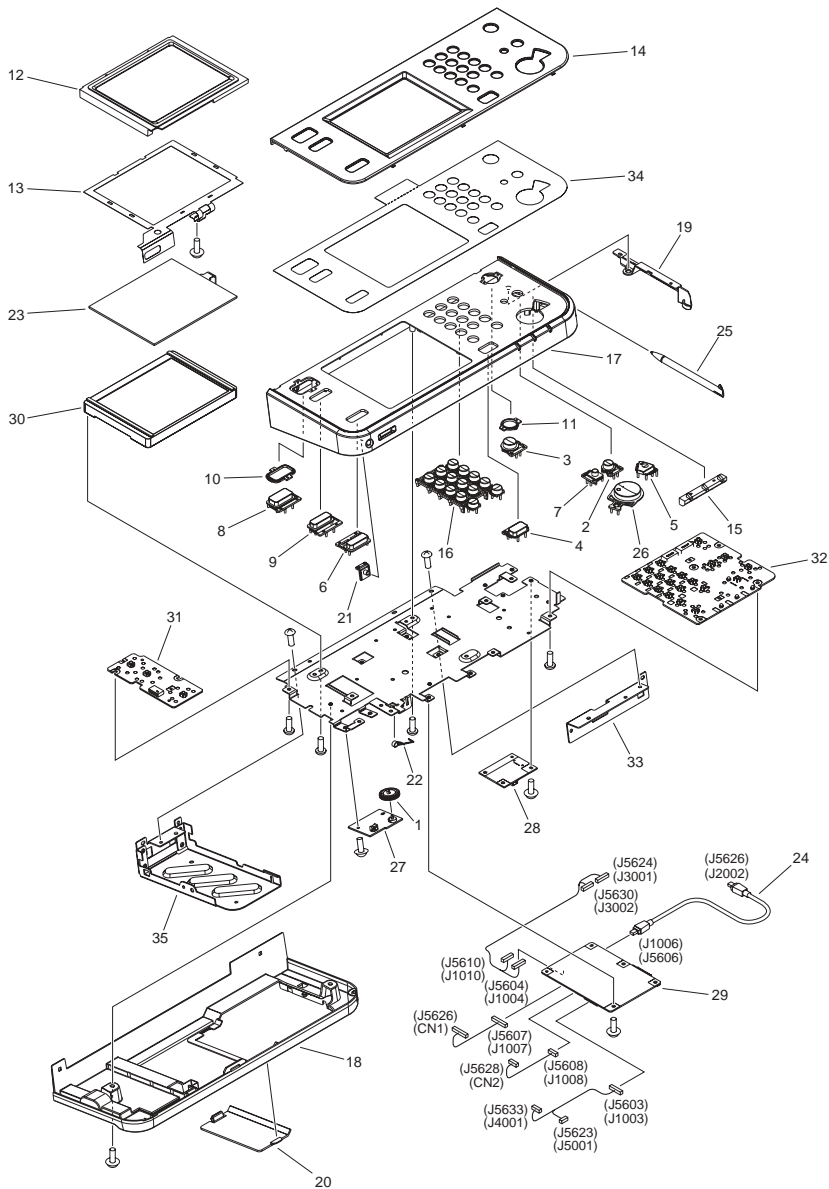

FIGURE & KEY NO.	PARTS NUMBER	RANK	Q'TY	DESCRIPTION	SERIAL NUMBER/REMARKS	SVC
Fig.109	NPN		RF	MACHINE REAR PLATE 2		
1	FC0-0599-000		1	COVER, HIGH VOLTAGE		
2	FC8-7940-000		4	MOUNT, POSITIONING		
3	FC8-8085-000		4	HOLDER, DEVELOPING COUPLING		
4	FC8-8369-000		4	HOLDER, LINK		
5	FC8-8474-000		1	GUARD, EDGE		
6	FC8-8493-000		1	RACK, M.P. STOPPER		
7	FC8-8494-000		1	COVER, RACK		
8	FC8-8594-000		1	MOUNT, HIGH VOLTAGE CASE		
9	FM3-8034-010		1	LIFTER DRIVE ASSEMBLY		
10	FM3-8047-000		1	STOPPER ASSEMBLY		
11	FM3-8157-000		1	WASTE TONER FEED ASSEMBLY		
12	FM3-8160-000		4	HIGH VOLTAGE HOLDER ASS'Y		
13	FM3-8161-000		4	H.V. HOLDER ASS'Y, AUXILIARY		
14	FM3-8162-000		1	H.V. CONTACT GUIDE ASS'Y, Y		
15	FM3-8163-000		1	H.V. CONTACT GUIDE ASS'Y, MCK		
16	FM3-8599-000		1	1ST TRANSFER H.V. PCB ASSEMBLY		
17	FM3-8610-000		1	2ND TRANSFER H.V. PCB ASSEMBLY		
18	FM4-1915-000		1	LIFTER MOTOR UNIT	M14	
19	FU7-2779-000		1	SPRING, TENSION		
20	FU7-2809-000		1	SPRING, COMPRESSION		
21	FU7-2793-000		1	SPRING, COMPRESSION		
22	FE2-2091-000		1	SHUTTER, EXHAUST		
23	FC0-3654-000		1	SEAL, TONER SUPPORTER GUIDE, 1		
24	RM1-5058-000		2	SIZE DETECT SWITCH UNIT		
25	XA9-1980-000		4	SCREW, D, M3X6		
26	RM1-6005-000		1	REVERSE DRIVE ASSEMBLY	M18,SL6	
27	RM1-6074-000		1	FIXING MOTOR ASSEMBLY		
28	RM1-6857-000		1	CABLE, DRAWER		
29	WG8-5696-000		2	PHOTO INTERRUPTER, TLP1243	PS12,PS35	
30	FU0-0181-000		1	GEAR, 18T/29T		
33	RM1-7914-070		1	FIXING GEAR ASS'Y		

FIGURE & KEY NO.	PARTS NUMBER	RANK	Q'TY	DESCRIPTION	SERIAL NUMBER/REMARKS	SVC
34	FM4-1902-000		1	CABLE, 2ND TRANSFER H.V.		
35	FM3-8624-000		1	CABLE, FIXING HEATER	JP	
36	FM3-8639-000		1	CABLE, FIXING HEATER	EXCEPT JP	
37	VS1-7177-002		1	CONNECTOR, SNAP TIGHT, BK		
38	VS1-7177-004		1	CONNECTOR, SNAP TIGHT, BK		
39	VS1-7207-004		1	CONNECTOR, SNAP TIGHT, BK		
40	VS1-7207-017		1	CONNECTOR, SNAP TIGHT, BK		
41	XA9-1671-000		25	SCREW, D, M3X8		
42	FM0-1158-010		1	FIXING DRIVE ASS'Y		
43	FU7-2812-000		1	SPRING, COMPRESSION		
44	WG8-5935-000		2	IC, PHOTO INTERRUPTER	PS24,PS25	

FIGURE 130 CONTROL PANEL ASSEMBLY



NOTE : This assembly does not include the parts shown with key No. 14, 33, 34 and 35.
 注 : このユニットにKey No. 14, 33, 34, 35の部品は含まれません。

FIGURE & KEY NO.	PARTS NUMBER	R A N K	Q'TY	DESCRIPTION	SERIAL NUMBER/ REMARKS	S V C
Fig.130	FM4-2184-000		1	CONTROL PANEL ASSEMBLY	SEE NOTE	
1	FC8-7824-000		1	KEY TOP, BRIGHTNESS ADJUSTMENT		
2	FC8-8649-000		1	KEY TOP, SETTINGS/REGISTRATION		
3	FC8-8650-000		1	KEY TOP, POWER		
4	FC9-9237-000		1	KEY TOP, RESET		
5	FC9-9235-000		1	KEY TOP, STOP		
6	FC9-9238-000		1	KEY TOP, CANCEL		
7	FC8-8655-000		1	KEY TOP, COUNTER CHECK		
8	FC9-9239-000		1	KEY TOP, MAIN MENU		
9	FC9-9240-000		1	KEY TOP, PORTAL		
10	FC9-4390-000		1	COVER, KEY TOP, LEFT		
11	FC9-4391-000		1	COVER, KEY TOP, RIGHT		
12	FC9-5278-000		1	COVER, LIQUID CRYSTAL DISPLAY		
13	FC9-5279-000		1	SHEET, ANTISTATIC		
14	FC9-5283-000		1	COVER, CONTROL PANEL		
15	FC9-5284-000		1	COVER, LAMP		
16	FC9-5290-000		1	KEY TOP, NUMBERS		
17	FC9-5303-000		1	COVER, UPPER		
18	FC9-5304-000		1	COVER, LOWER, 1		
19	FC9-6232-000		1	COVER, PEN		
20	FC9-6233-000		1	COVER, LOWER, 2		
21	FC9-6236-000		1	KEY TOP, VOLUME		
22	FC9-8187-000		1	SPRING, TORSION		
23	FK2-8949-000		1	TOUCH PANEL ASSEMBLY		
24	FK2-8957-000		1	CABLE, USB		
25	FL3-0626-000		1	PEN, TOUCH PANEL		
26	FL3-0833-000		1	KEY TOP, START		
27	FM4-1198-000		1	CONTROL PANEL VOLUME ASSEMBLY		
28	FM4-2430-000		1	CONTROL PANEL HUB ASSEMBLY		
29	FM4-2183-000		1	CPU PCB ASSEMBLY		
30	FM4-2185-000		1	PANEL, LCD		
31	FM4-2431-000		1	SUB KEY PCB ASSEMBLY		

FIGURE & KEY NO.	PARTS NUMBER	R A N K	Q'TY	DESCRIPTION	SERIAL NUMBER/ REMARKS	S V C
32	FM4-2432-000		1	NUMBERS KEY PCB ASSEMBLY		
33	FC9-6235-000		1	PLATE, FIXED, RIGHT	SEE NOTE	
34	FC9-5282-000		1	SHEET, CONTROL PANEL	SEE NOTE EZQ	
34	FC9-6237-000		1	SHEET, CONTROL PANEL	SEE NOTE EZR	
34	FC9-6240-000		1	SHEET, CONTROL PANEL	SEE NOTE EZS,EZX,GDV	
34	FC9-6242-000		1	SHEET, CONTROL PANEL	SEE NOTE EZT	
34	FC9-6243-000		1	SHEET, CONTROL PANEL	SEE NOTE EZU	
34	FC9-6246-000		1	SHEET, CONTROL PANEL	SEE NOTE EZW	
34	FC9-6238-000		1	SHEET, CONTROL PANEL	SEE NOTE EZY	
34	FC9-6239-000		1	SHEET, CONTROL PANEL	SEE NOTE EZZ	
34	FC9-6241-000		1	SHEET, CONTROL PANEL	SEE NOTE FAH,FAL,FBD,GEB	
34	FC9-6244-000		1	SHEET, CONTROL PANEL	SEE NOTE FAJ	
34	FC9-6245-000		1	SHEET, CONTROL PANEL	SEE NOTE FAK	
34	FC9-6249-000		1	SHEET, CONTROL PANEL	SEE NOTE FAN	
34	FC9-6247-000		1	SHEET, CONTROL PANEL	SEE NOTE GDN	
34	FC9-9436-000		1	SHEET, CONTROL PANEL	SEE NOTE GDQ	
34	FC9-9433-000		1	SHEET, CONTROL PANEL	SEE NOTE GDS	
34	FC9-9434-000		1	SHEET, CONTROL PANEL	SEE NOTE GDT	
34	FC9-9435-000		1	SHEET, CONTROL PANEL	SEE NOTE GDU	
34	FC9-9437-000		1	SHEET, CONTROL PANEL	SEE NOTE GDW	
34	FC9-9439-000		1	SHEET, CONTROL PANEL	SEE NOTE GDX	
34	FC9-9440-000		1	SHEET, CONTROL PANEL	SEE NOTE GDY	
34	FC9-9438-000		1	SHEET, CONTROL PANEL	SEE NOTE GUW	
34	FC9-9442-000		1	SHEET, CONTROL PANEL	SEE NOTE KWT	
35	FC9-5306-000		1	PLATE, FIXED, LEFT	SEE NOTE	

FIGURE 140 POWER CORD TERMINAL ASS'Y

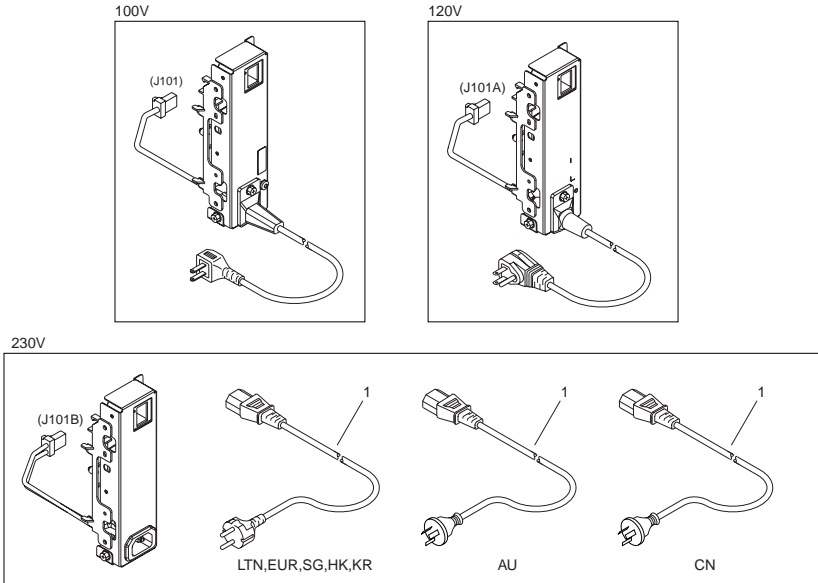

NOTE : This assembly does not include the part shown with key No. 1.
 注 : このユニットにKey No. 1の部品は含まれません。

FIGURE & KEY NO.	PARTS NUMBER	RANK	QTY	DESCRIPTION	SERIAL NUMBER/REMARKS	SVC
Fig.140	FM3-8172-000		1	POWER CORD TERMINAL ASS'Y	100V	
Fig.140	FM3-8191-000		1	POWER CORD TERMINAL ASS'Y	120V	
Fig.140	FM3-8192-000		1	POWER CORD TERMINAL ASS'Y	230V	
1	FK2-0146-000		1	CORD, POWER SUPPLY	SEE NOTE 230V LTN, EUR, SG, HK, KR	
1	FK2-0148-000		1	CORD, POWER SUPPLY	SEE NOTE 230V AU	
1	FK2-2987-000		1	CORD, POWER SUPPLY	SEE NOTE 230V CN	

FIGURE 250 MAIN DRIVE ASSEMBLY

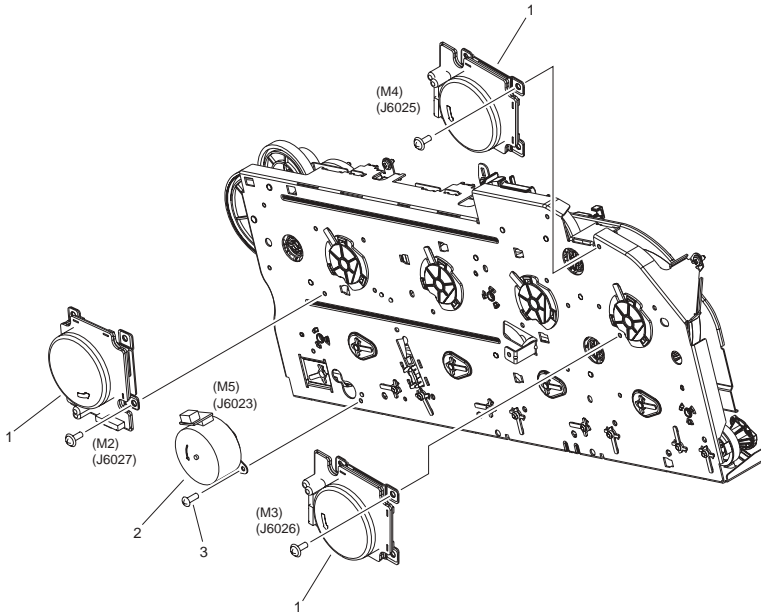

FIGURE & KEY NO.	PARTS NUMBER	RANK	QTY	DESCRIPTION	SERIAL NUMBER/REMARKS	S V C
Fig.250	FM4-7716-000		1	MAIN DRIVE ASSEMBLY		
1	FM3-8145-000		3	MAIN DRIVE MOTOR UNIT	M2,M3,M4	
2	RK2-3298-000		1	MOTOR, STEPPING, DC	M5	
3	XA9-1833-000		2	SCREW, D, M3X6		

FIGURE 300 CASSETTE ASSEMBLY (UPPER)

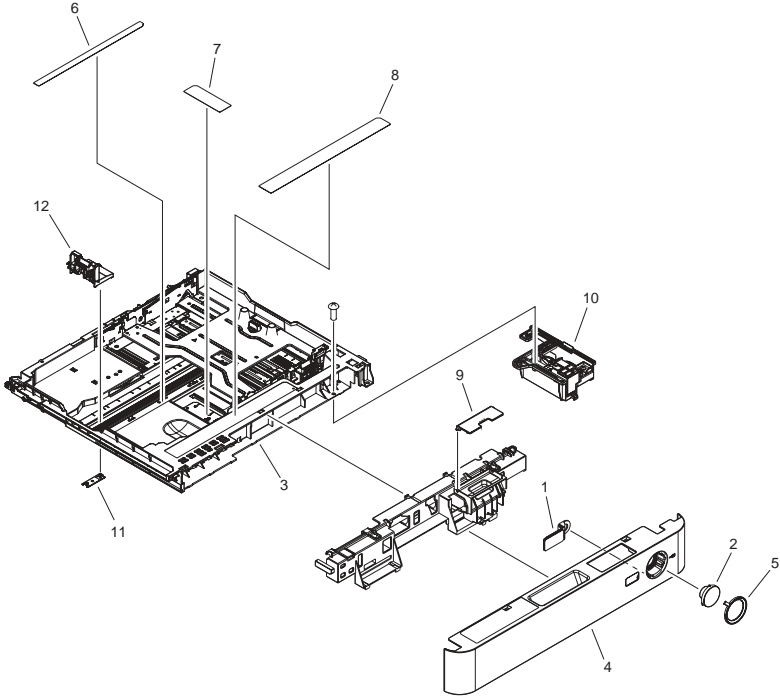

FIGURE & KEY NO.	PARTS NUMBER	R A N K	Q'TY	DESCRIPTION	SERIAL NUMBER/ REMARKS	S V C
Fig.300	NPN		RF	CASSETTE ASSEMBLY	UPPER	
1	FC8-4967-000		1	WINDOW, CST FR. COVER IND.		
2	FC8-4985-000		1	BUTTON, PUSHING		
3	RM1-6150-000		1	CASSETTE ASSEMBLY		
4	FC8-8181-010		1	COVER, CASSETTE FRONT		
5	FC8-8182-000		1	RING, BUTTON		
6	FC8-8596-000		1	LABEL, PAPER SIZE, BACK END		
7	FC8-8597-000		1	LABEL, PAPER SIZE, SIDE		
8	FC8-8616-000		1	LABEL, PAPER PICK-UP OPERATION		
9	FC9-4042-000		1	COVER, SIZEPLATE		
10	FM3-8046-000		1	BUTTON LINK ASSEMBLY		
11	RC2-6872-000		1	PLATE, BACK END LIMIT		
12	RM1-6015-000		1	BACK END LIMIT PLATE ASSEMBLY		

FIGURE 301
CASSETTE ASSEMBLY (LOWER) (EXCEPT 1
CASSETTE MODEL)

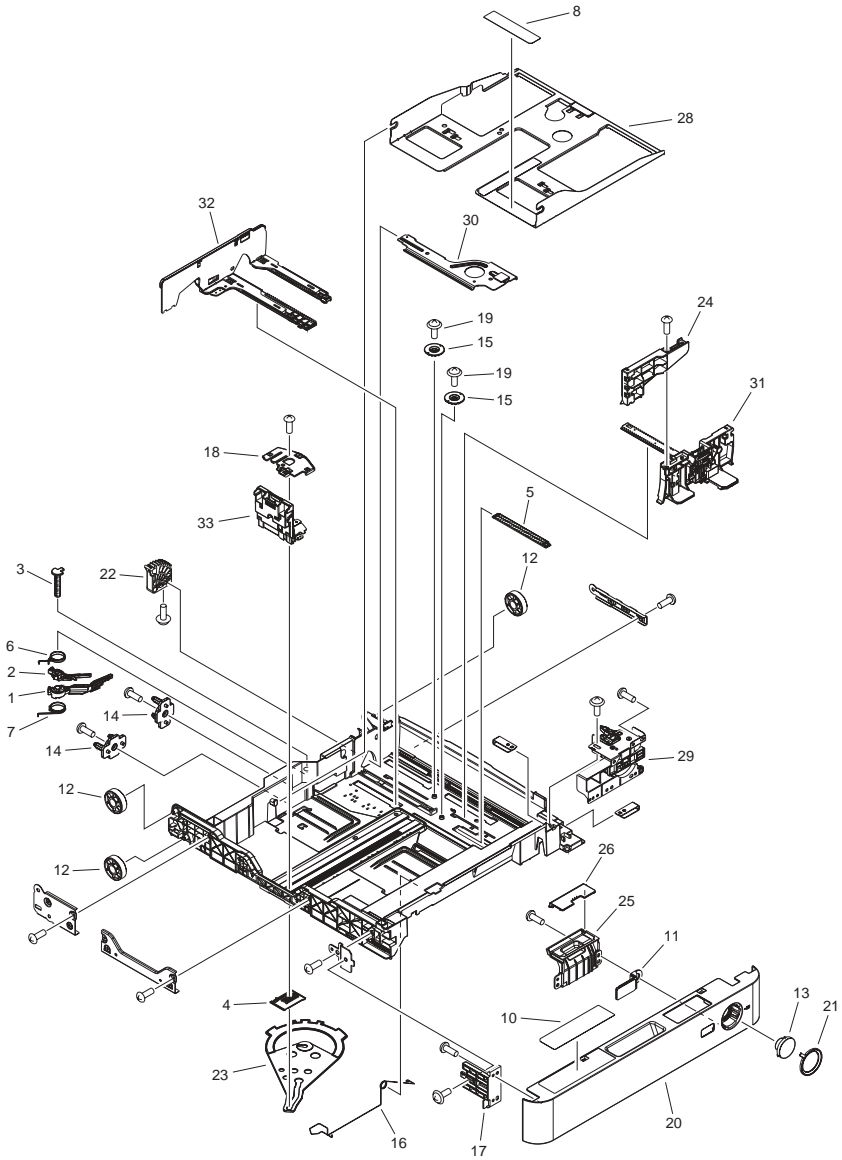
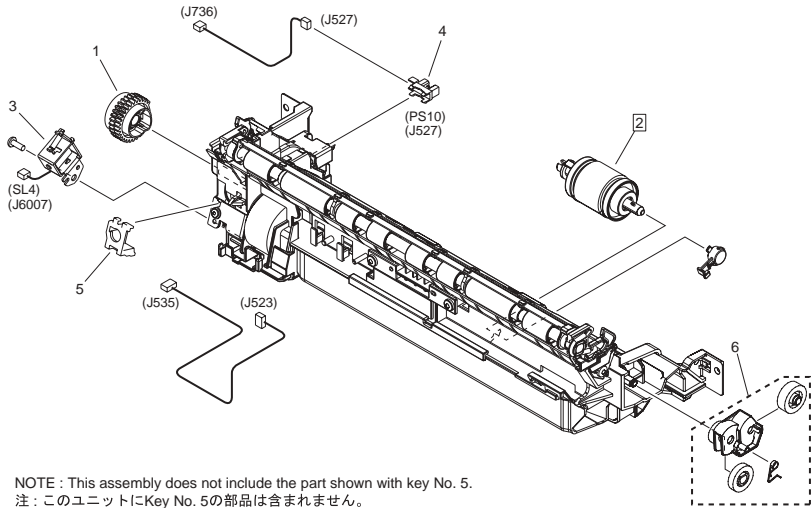

FIGURE & KEY NO.	PARTS NUMBER	R A N K	Q'TY	DESCRIPTION	SERIAL NUMBER/ REMARKS	S V C
Fig.301	FM3-8153-000		1	CASSETTE ASSEMBLY	LOWER EXCEPT 1 CASSETTE MODEL	
1	FC8-2469-000		1	DIAL, DETECT, SMALL		
2	FC8-2470-000		1	DIAL, DETECT, LARGE		
3	FC8-2474-000		1	SHAFT, SUPPORT		
4	FC8-2475-000		1	PLATE, JOINT		
5	FC8-2670-000		1	PLATE, FREE STOP		
6	FC8-2671-000		1	SPRING, TORSION		
7	FC8-2672-000		1	SPRING, TORSION		
8	FC8-4962-000		1	LABEL, SIZE INDEX, SIDE, LARGE		
10	FC8-4966-000		1	LABEL, PAPER PICK-UP OPERATION		
11	FC8-4967-000		1	WINDOW, CST FR. COVER IND.		
12	FC8-4970-000		3	ROLLER, CASSETTE SWING		
13	FC8-4985-000		1	BUTTON, PUSHING		
14	FC8-4989-000		2	PIN, SIZE DETECT POSITIONING		
15	FC8-4990-000		2	GEAR, 14T		
16	FC8-4992-000		1	WIRE,CENTER PLATE GROUNDING,L		
17	FC8-4993-000		1	PLATE, COVER ATTACHMENT, LEFT		
18	FC8-4996-000		1	COVER, TOP		
19	XA9-1523-000		2	SCREW, B, M4X8		
20	FC8-8181-010		1	COVER, CASSETTE FRONT		
21	FC8-8182-000		1	RING, BUTTON		
22	FC9-0129-000		1	GEAR, 9T		
23	FC9-0130-000		1	LINK, BACK END DETECT		
24	FM3-8912-000		1	PAPER SIDE END EXTENSION ASS'Y		
25	FC9-0136-000		1	HOLDER, SIZE INDEX		
26	FC9-4042-000		1	COVER, SIZEPLATE		
28	FL2-9472-000		1	PLATE, CENTER		
29	FM3-8913-000		1	BUTTON LINK ASSEMBLY		
30	FL3-2859-000		1	PLATE, LIFTER		
31	FM3-8905-010		1	SIDE END PLATE ASSEMBLY, FRONT		
32	FM3-8906-010		1	SIDE END PLATE ASSEMBLY, REAR		

FIGURE & KEY NO.	PARTS NUMBER	R A N K	Q'TY	DESCRIPTION	SERIAL NUMBER/ REMARKS	S V C
33	FM3-8907-000		1	BACK END LIMIT PLATE ASSEMBLY		

FIGURE 310 PAPER PICK-UP ASSEMBLY (UPPER)



NOTE : This assembly does not include the part shown with key No. 5.
注 : このユニットにKey No. 5の部品は含まれません。

FIGURE & KEY NO.	PARTS NUMBER	RANK	QTY	DESCRIPTION	SERIAL NUMBER/REMARKS	SVC
Fig.310	FM0-1162-000		1	PAPER PICK-UP ASSEMBLY	CN	
Fig.310	RM1-6106-080		1	PAPER PICK-UP ASSEMBLY	UPPER	
1	RM1-6034-000		1	PAPER PICK-UP GEAR ASSEMBLY		
2	FM0-1163-000		1	PAPER PICK-UP ROLLER ASS'Y	CN [DP]	
2	RM1-6035-000		1	PAPER PICK-UP ROLLER ASS'Y	EXCEPT CN [DP]	
3	RM1-6789-000		1	SOLENOID	SL4	
4	WG8-5935-000		1	IC, PHOTO INTERRUPTER	PS10	
5	FC0-3637-000		1	SPACER	SEE NOTE	
6	FM1-B281-000		1	GEAR HOLDER ASSEMBLY		

FIGURE 311 PAPER PICK-UP ASSEMBLY (LOWER) (EXCEPT 1 CASSETTE MODEL)

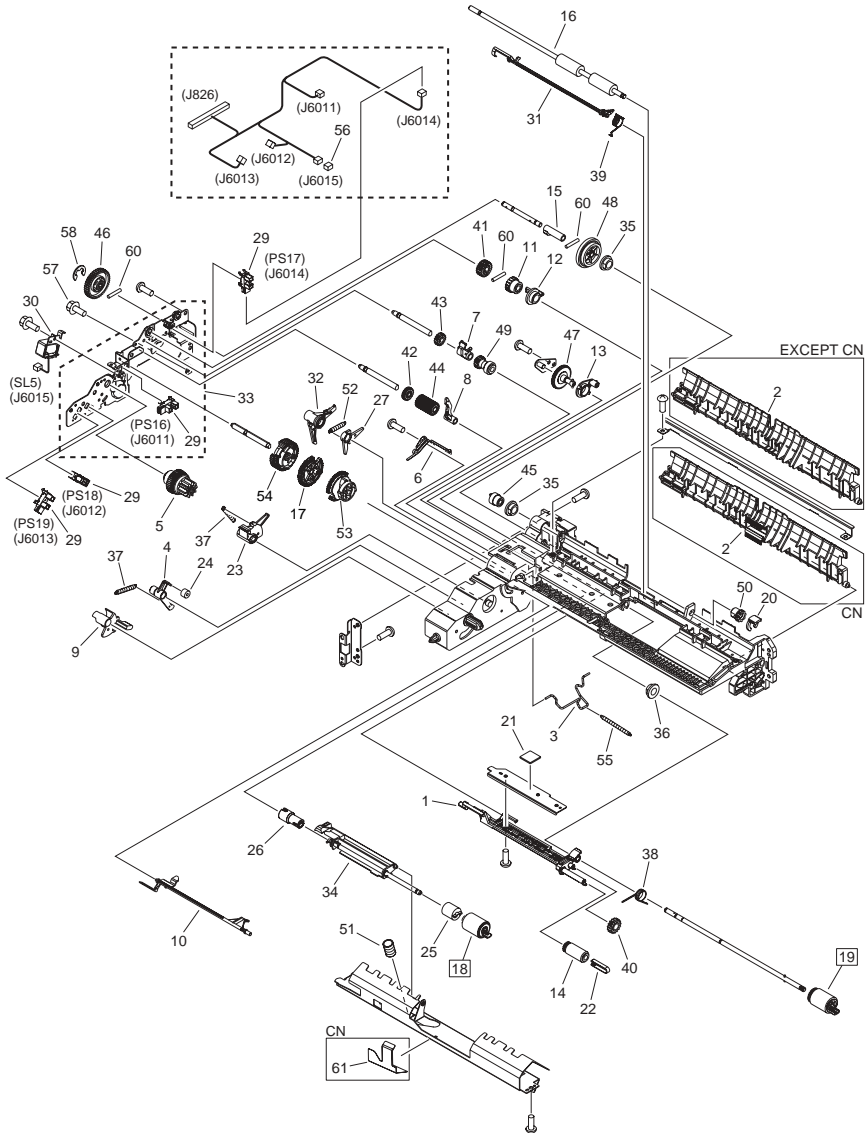

FIGURE & KEY NO.	PARTS NUMBER	R A N K	Q'TY	DESCRIPTION	SERIAL NUMBER/ REMARKS	S V C
Fig.311	FM0-4830-000		1	PAPER PICK-UP ASSEMBLY	LOWER EXCEPT 1 CASSETTE MODEL CN	
Fig.311	FM0-4814-000		1	PAPER PICK-UP ASSEMBLY	LOWER EXCEPT 1 CASSETTE MODEL EXCEPT CN	
1	FC0-6755-000		1	HOLDER, PAPER PICK-UP ROLLER		
2	FL2-8282-000		1	GUIDE, VERTICAL PATH	CN	
2	FB6-3387-000		1	GUIDE, VERTICAL PATH	EXCEPT CN	
3	FB6-3388-000		1	ROD, SEPARATION ROLLER RELEASE		
4	FB6-3389-000		1	CLAW, PICK-UP		
5	FB6-3391-000		1	GEAR, RATCHET		
6	FB6-3392-020		1	SPRING, LEAF		
7	FB6-3395-000		1	ARM, PAPER FEED SHAFT		
8	FB6-3396-010		1	LOCK, PICK-UP		
9	FB6-3397-000		1	FLAG, PAPER SENSOR		
10	FB6-3398-000		1	FLAG, PAPER DETECT SENSOR		
11	FB6-3402-000		1	GEAR, RATCHET		
12	FB6-3403-000		1	COUPLING, FEED SHAFT STOP		
13	FB6-3404-000		1	COUPLING, SEPARATION SHAFT		
14	FC7-9381-000		1	ROLLER, PAPER PICK-UP	CN	
14	FB6-3405-000		1	ROLLER, PAPER PICK-UP	EXCEPT CN	
15	FB6-3413-000		1	COLLAR, PAPER PICK-UP SHAFT		
16	FM3-4150-000		1	ROLLER, VERTICAL PATH	CN	
16	FB6-4852-000		1	ROLLER, VERTICAL PATH	EXCEPT CN	
17	FL3-6661-010		1	GEAR ASSY		
18	FC6-6661-000		1	ROLLER, SEPARATION	[DP]	
19	FC7-9502-000		1	ROLLER, FEED/SEPARATION	CN [DP]	
19	FC6-7083-000		1	ROLLER, FEED/SEPARATION	EXCEPT CN [DP]	
20	FC6-9867-000		1	RING, RETAINING		
21	FC8-1205-000		1	PAD, PAPER PICK-UP HOLDER		
22	FC7-5845-000		1	STOPPER, ROLLER		
23	FC8-1178-000		1	CLAW, PAPER PICK-UP		
24	FC8-1202-000		1	DAMPER		

FIGURE & KEY NO.	PARTS NUMBER	R A N K	Q'TY	DESCRIPTION	SERIAL NUMBER/ REMARKS	S V C
25	FC8-8621-000		1	LIMITER, TORQUE		
26	FC9-4290-010		1	JOINT, RETARD		
27	FC9-7253-000		1	ARM, LIFTING		
29	FK2-0149-000		4	PHOTO-INTERRUPTER, TLP1252(C6)	PS16,PS17,PS18,PS19	
30	FK2-0408-010		1	SOLENOID	SL5	
31	FL3-8032-000		1	FLAG, REGISTRATION SENSOR		
32	FM3-4146-010		1	PICK-UP ARM UNIT		
33	FM4-1201-000		1	PICK-UP DRIVE SIDE PLATE ASS'Y		
34	FM4-2525-000		1	HOLDER, SEPARATION ROLLER		
35	FS1-1205-000		2	BUSHING		
36	FS5-1943-000		1	BUSHING		
37	FS7-2800-000		2	SPRING, TENSION		
38	FS7-2801-000		1	SPRING, TORSION		
39	FS7-2803-000		1	SPRING, TORSION		
40	FU0-0043-000		1	GEAR, 15T		
41	FU3-0282-000		1	GEAR, 21T		
42	FU3-0283-000		1	GEAR, 21T		
43	FU3-0284-000		1	GEAR, 16T		
44	FU3-0288-000		1	GEAR, 21T		
45	FU3-0289-000		1	GEAR, 14T		
46	FU3-0347-000		1	GEAR, 41T		
47	FU3-0349-000		1	GEAR, 41T		
48	FU3-0350-000		1	GEAR, 41T/41T		
49	FU3-0352-000		1	GEAR, 16T/16T		
50	FU5-1763-000		1	BUSHING		
51	FU6-2684-000		1	SPRING, COMPRESSION		
52	FU6-2784-000		1	SPRING, TENSION		
53	FU7-0445-000		1	GEAR, 42T		
54	FU8-0214-000		1	GEAR, 51T		
55	FU7-5378-000		1	SPRING, TENSION		
56	VS1-7177-002		1	CONNECTOR, SNAP TIGHT, BK		
57	XA9-0656-000		1	SCREW,RS,M3X10		

FIGURE & KEY NO.	PARTS NUMBER	R A N K	Q'TY	DESCRIPTION	SERIAL NUMBER/ REMARKS	S V C
58	XD9-0136-000		1	RING, E		
60	XD9-0289-000		3	PIN, PARALLEL		
61	FL2-8280-000		1	GUIDE, ROLLER	CN	

FIGURE 312 PAPER PICK-UP DRIVE ASSEMBLY (LOWER) (EXCEPT 1 CASSETTE MODEL)

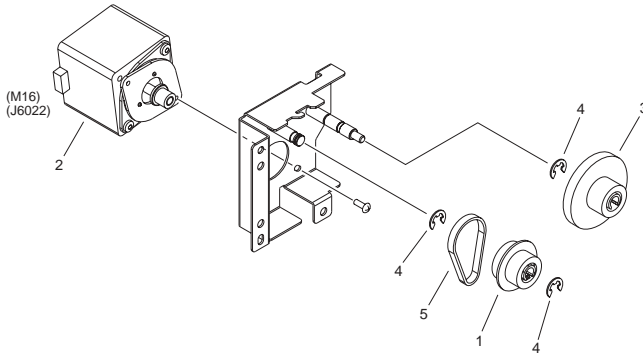
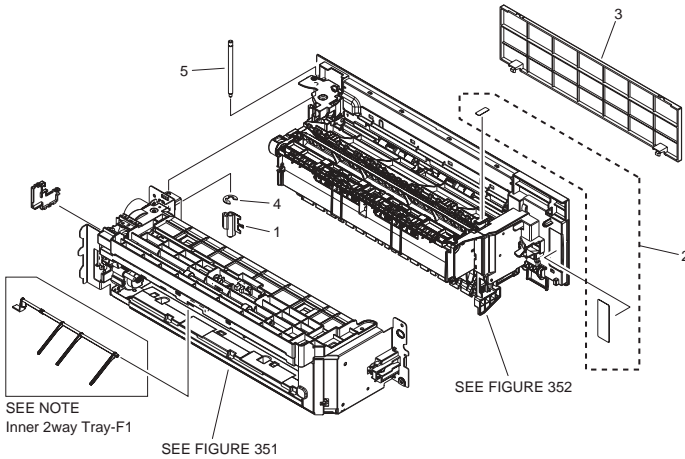

FIGURE & KEY NO.	PARTS NUMBER	RANK	QTY	DESCRIPTION	SERIAL NUMBER/REMARKS	SVC
Fig.312	FM3-8151-000		1	PAPER PICK-UP DRIVE ASSEMBLY	LOWER EXCEPT 1 CASSETTE MODEL	
1	FC6-5022-000		1	PULLEY, 34T		
2	FK2-7586-000		1	MOTOR, STEPPING	M16	
3	FU3-0285-000		1	GEAR, 80T/16T		
4	XD9-0136-000		3	RING, E		
5	XF2-1604-940		1	BELT, TIMING		

FIGURE 350 2ND/3RD PAPER DELIVERY ASS'Y (2/3 DELIVERY MODEL)



NOTE : This assembly includes the assemblies shown in Figure 351 and 352.

NOTE : This assembly does not include the parts shown inside the frame.

注：このユニットはFigure 351, 352のユニットを含みます。

注：このユニットにこの部品は含まれません。

FIGURE & KEY NO.	PARTS NUMBER	RANK	QTY	DESCRIPTION	SERIAL NUMBER/REMARKS	SVC
Fig.350	FM3-8050-010		1	2ND/3RD PAPER DELIVERY ASS'Y	SEE NOTE 2/3 DELIVERY MODEL	
1	FC8-8328-000		1	CAM		
2	FC8-8449-000		1	LABEL, GRIP		
3	FL3-1186-000		1	COVER, THIRD DELIVERY BLANKING		
4	XD9-0136-000		1	RING, E		
5	FC8-8327-000		1	SHAFT		

FIGURE 351 2ND/3RD DRIVE FRAME ASSEMBLY (2/3 DELIVERY MODEL)

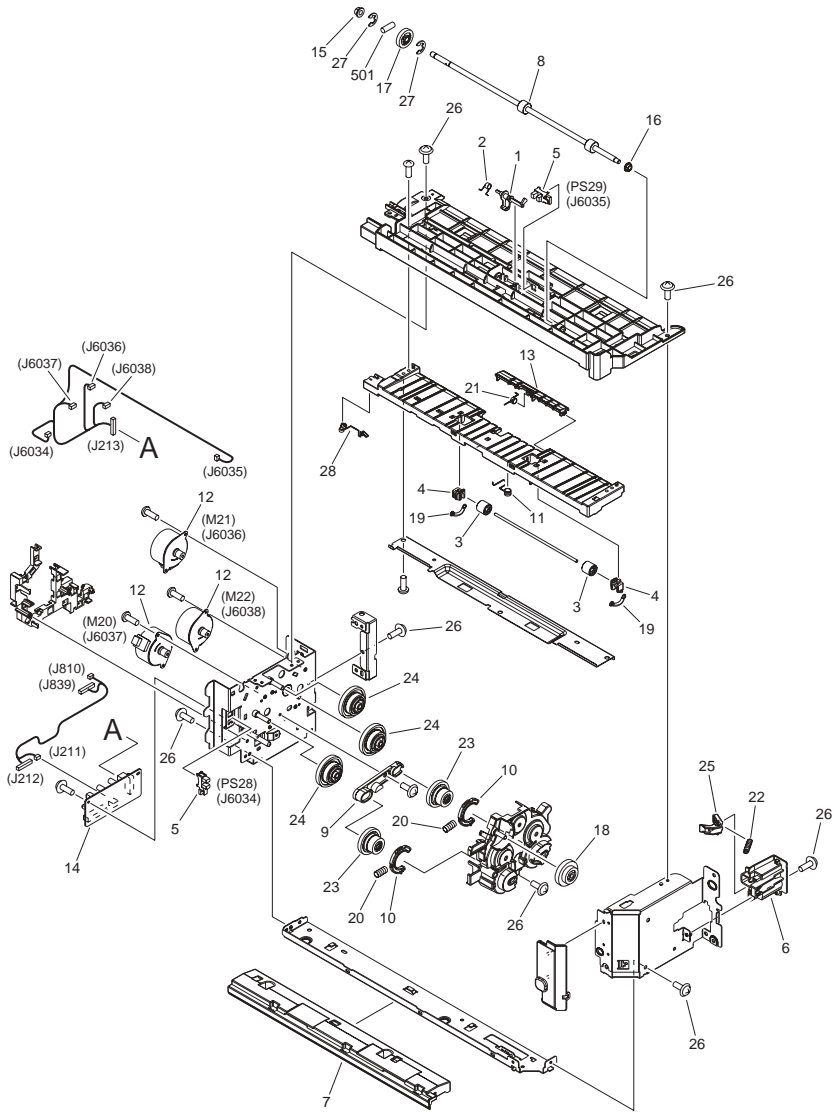

NOTE : This assembly is included in the assembly shown in Figure 350.
 注 : このユニットはFigure 350のユニットに含まれます。

FIGURE & KEY NO.	PARTS NUMBER	R A N K	Q'TY	DESCRIPTION	SERIAL NUMBER/ REMARKS	S V C
Fig.351	FM3-8051-000		1	2ND/3RD DRIVE FRAME ASSEMBLY	SEE NOTE 2/3 DELIVERY MODEL	
1	FC5-0987-000		1	FLAG, REVERSE SENSOR		
2	FC5-0988-000		1	SPRING, TORSION		
3	FC8-4749-000		2	ROLLER, REVERSE		
4	FC8-4751-000		2	BUSHING		
5	WG8-5783-000		2	IC.PHOTO-INTERRUPTER,LG248NL1A	PS28	
6	FC8-8320-000		1	HOLDER, TOGGLE		
7	FC8-8323-000		1	COVER, 2ND/3RD DELIVERY, LOWER		
8	FC8-8326-000		1	ROLLER, REVERSE		
9	FC8-8333-000		1	GUIDE, SWING GEAR		
10	FC8-8334-000		2	CLAMP, SWING GEAR		
11	FC8-8447-000		1	SPRING, GROUNDING		
12	RK2-3298-000		3	MOTOR, STEPPING, DC	M20,M21,M22	
13	FC8-8625-000		1	GUIDE, MOVABLE		
14	FM3-8601-000		1	2ND/3RD DELIVERY PCB ASSEMBLY		
15	FU5-1453-000		1	BUSHING		
16	FU5-1469-000		1	BUSHING, POLYACETAR		
17	FU6-0085-000		1	GEAR, 22T		
18	FU6-0140-000		1	GEAR, 31T/20T		
19	FU7-2446-000		2	SPRING, TENSION		
20	FU7-2770-000		2	SPRING, COMPRESSION		
21	FU7-2784-000		1	SPRING, TORSION		
22	FU7-2818-000		1	SPRING, TENSION		
23	FU8-0398-000		2	GEAR, 32T/19T		
24	FU8-0408-000		3	GEAR, 74T/25T		
25	FE2-2086-000		1	LEVER, TOGGLE		
26	XA9-1671-000		12	SCREW, D, M3X8		
27	XD9-0136-000		2	RING, E		
28	FC0-3650-000		1	SPRING, GROUNDING		
501	XD3-2200-122		1	PIN, DOWEL		

FIGURE 352 2ND/3RD DELIVERY GUIDE ASS'Y (2/3 DELIVERY MODEL)

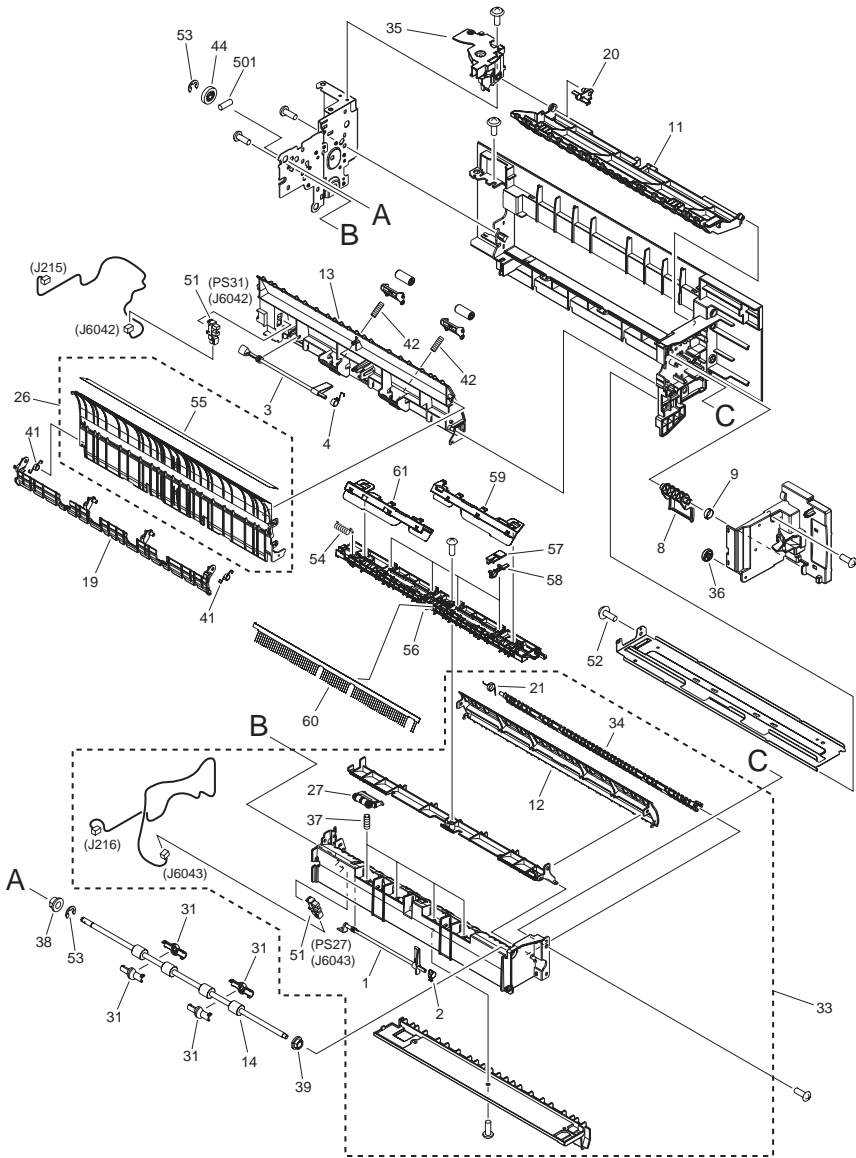

NOTE : This assembly is included in the assembly shown in Figure 350.
 注 : このユニットはFigure 350のユニットに含まれます。

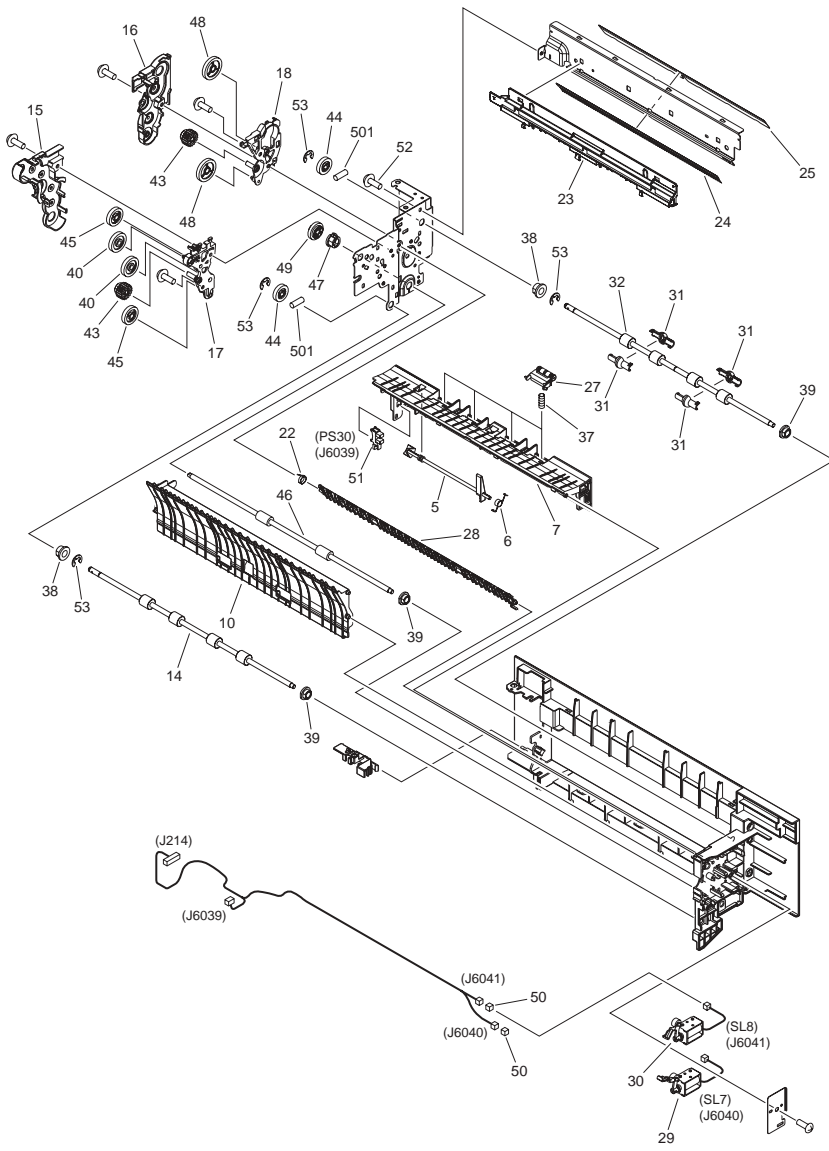

FIGURE & KEY NO.	PARTS NUMBER	R A N K	Q'TY	DESCRIPTION	SERIAL NUMBER/ REMARKS	S V C
Fig.352	FM3-8052-010		1	2ND/3RD DELIVERY GUIDE ASS'Y	SEE NOTE 2/3 DELIVERY MODEL	
1	FC5-0996-000		1	FLAG, 2ND DELIVERY SENSOR		
2	FC5-0997-000		1	SPRING, TORSION		
3	FC5-1005-000		1	FLAG, DUPLEX ENTRANCE SENSOR		
4	FC5-1006-000		1	SPRING, TORSION		
5	FC5-1010-000		1	FLAG, 3RD DELIVERY SENSOR		
6	FC0-0636-000		1	SPRING, TORSION		
7	FC8-8293-000		1	GUIDE, 3RD DELIVERY		
8	FC8-8297-000		1	HANDLE, PAPER DELIVERY DOOR		
9	FC8-8298-000		1	SPRING, TORSION		
10	FC8-8300-000		1	GUIDE, DUPLEX ENTRANCE, 1		
11	FC8-8301-000		1	GUIDE, 3RD DELIVERY, UPPER		
12	FC8-8304-000		1	GUIDE, REVERSE ENTRANCE		
13	FC8-8309-000		1	GUIDE, DUPLEX ENTRANCE, 2		
14	FC8-8311-000		2	ROLLER, 2ND PAPER DELIVERY		
15	FC8-8331-000		1	COVER, 2ND DELIVERY GEAR		
16	FC8-8332-000		1	COVER, 3RD DELIVERY GEAR		
17	FC8-8338-000		1	SUPPORT, 2ND DELIVERY GEAR		
18	FC8-8339-000		1	SUPPORT, 3RD DELIVERY GEAR		
19	FC8-8340-010		1	GUIDE, ENTRANCE, 2		
20	FC8-8408-000		1	GUIDE, SHAFT		
21	FC8-8410-000		1	SPRING, TORSION		
22	FC8-8411-000		1	SPRING, TORSION		
23	FC8-8503-010		1	COVER, 3RD DELIVERY ROLLER		
24	FC8-8591-000		1	ELIMINATOR, STATIC CHARGE		
25	FC9-8580-000		1	SHEET, PAPER DELIVERY		
26	FL3-0641-000		1	GUIDE, ENTRANCE, 1		
27	FM3-8053-000		8	PAPER DELIVERY ROLLER ASSEMBLY		
28	FM3-8054-000		1	3RD DELIVERY FLAPPER ASS'Y		
29	FM3-8056-000		1	2ND FLAPPER SOLENOID ASS'Y	SL7	
30	FM3-8057-000		1	3RD FLAPPER SOLENOID ASS'Y	SL8	

FIGURE & KEY NO.	PARTS NUMBER	R A N K	Q'TY	DESCRIPTION	SERIAL NUMBER/ REMARKS	S V C
31	FC9-8621-000		8	ROLLER, REFORM		
32	FC8-8294-000		1	ROLLER, 3RD PAPER DELIVERY		
33	FM3-8060-000		1	2ND UPPER GUIDE ASSEMBLY		
34	FM3-8062-000		1	PAPER DELIVERY FLAPPER ASS'Y		
35	FM3-8063-000		1	TOGGLE COVER ASSEMBLY		
36	FS5-6945-000		1	COLLAR, REGISTRATION MULTI		
37	FS7-2859-000		8	SPRING, COMPRESSION		
38	FU5-1453-000		3	BUSHING		
39	FU5-1469-000		4	BUSHING, POLYACETAR		
40	FU6-0076-000		2	GEAR, 24T		
41	FU7-2772-000		2	SPRING, TORSION		
42	FU7-2783-000		2	SPRING, COMPRESSION		
43	FU8-0396-000		2	GEAR, 18T		
44	FU8-0397-000		3	GEAR, 20T		
45	FU8-0403-000		2	GEAR, 22T		
46	RC2-7271-000		1	ROLLER, DUPLEXING PAPER FEED		
47	RS5-1567-000		1	BUSHING		
48	RU6-0852-000		2	GEAR, 28T		
49	RU6-0855-000		1	GEAR, 17T		
50	VS1-7177-002		2	CONNECTOR, SNAP TIGHT, BK		
51	WG8-5783-000		3	IC,PHOTO-INTERRUPTER,LG248NL1A	PS27,PS30,PS31	
52	XA9-1671-000		8	SCREW, D, M3X8		
53	XD9-0136-000		6	RING, E		
54	FC9-8582-000		1	SPRING, COMPRESSION		
55	FC8-8310-000		1	SHEET, ENTRANCE GUIDE, 1		
56	FC0-0598-010		1	GUIDE, 2ND DELIVERY ENTRANCE		
57	FC9-8645-000		4	STOPPER, GUIDE, UPPER		
58	FC9-8646-000		4	STOPPER, GUIDE, LOWER		
59	FL3-0777-000		1	SHEET, COMPENSATION, F		
60	FC8-8590-010		1	ELIMINATOR, STATIC CHARGE		
61	FL3-0778-000		1	SHEET, COMPENSATION, R		
501	XD3-2200-122		3	PIN, DOWEL		

FIGURE 460 LASER SCANNER UNIT

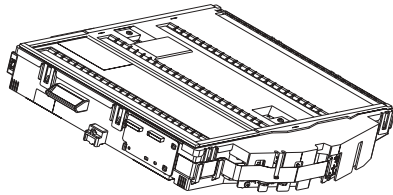

FIGURE & KEY NO.	PARTS NUMBER	R A N K	QTY	DESCRIPTION	SERIAL NUMBER/ REMARKS	S V C
Fig.460	FM3-8074-000		1	LASER SCANNER UNIT		

FIGURE 530
 INTER. TRANSFER BELT ASS'Y

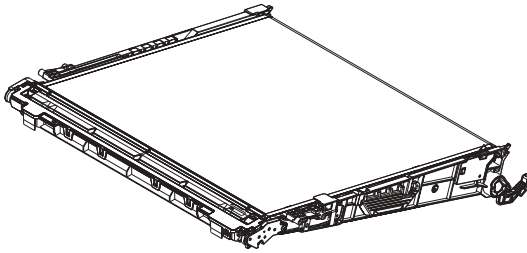

FIGURE & KEY NO.	PARTS NUMBER	RANK	QTY	DESCRIPTION	SERIAL NUMBER/REMARKS	SVC
Fig.530	FM3-8240-010		1	INTER. TRANSFER BELT ASS'Y	[DP]	

FIGURE 810 FIXING ASSEMBLY

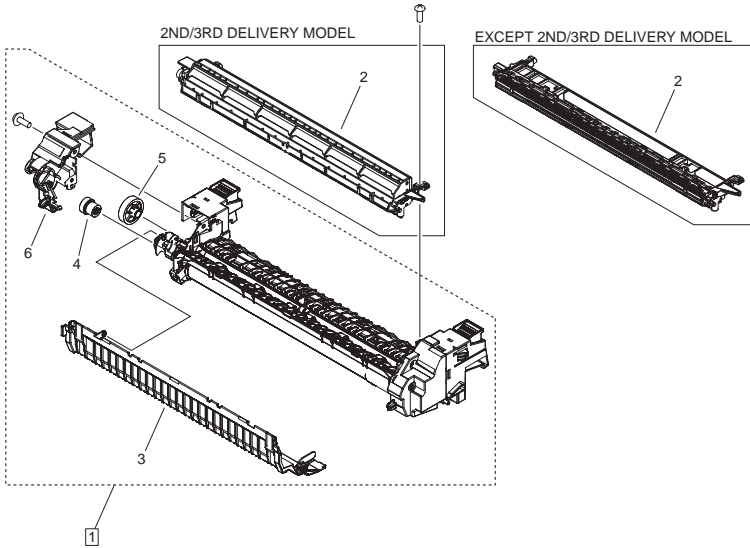

FIGURE & KEY NO.	PARTS NUMBER	R A N K	QTY	DESCRIPTION	SERIAL NUMBER/ REMARKS	S V C
Fig.810	NPN		RF	FIXING ASSEMBLY		
1	FM1-B289-000		1	FIXING ASSEMBLY	100V [DP]	
1	FM1-B290-000		1	FIXING ASSEMBLY	120V [DP]	
1	FM1-B291-000		1	FIXING ASSEMBLY	230V [DP]	
2	FM4-7712-000		1	GUIDE, FIXING DELIVERY, UPPER	2/3 DELIVERY MODEL	
2	FM4-7713-000		1	GUIDE, FIXING DELIVERY, UPPER	EXCEPT 2/3 DELIVERY MODEL	
3	RC2-6506-000		1	COVER, FIXING, LOWER		
4	RU6-0710-000		1	GEAR, 21T/15T		
5	RU6-0711-000		1	GEAR, 35T		
6	RC2-6505-000		1	PANEL, FIXING, REAR		

FIGURE & KEY NO.	PARTS NUMBER	R A N K	Q'TY	DESCRIPTION	SERIAL NUMBER/REMARKS	S V C
Fig.900	NPN		RF	CONTROLLER BOX ASSEMBLY		
1	FC8-8455-010		1	HOLDER, PCB		
2	FC0-5049-000		1	LABEL, MEMORY CAUTION		
3	FC8-8643-000		2	HOLDER, HDD	HDD MODEL	
4	FC9-8619-000		1	GUIDE, CABLE	HDD MODEL	
5	FK2-8341-000		2	DIMM, SMD-E51288HG-6E, SDRAM		
6	FK3-2219-000		1	HDD, MK1676GSX, TOSHIBA	HDD MODEL	
7	FK2-9200-000		1	CABLE, FLAT		
8	FK2-9239-000		1	CABLE, SATA POWER SUPPLY	HDD MODEL	
9	FK2-9240-010		2	CABLE, IP-READER FLAT	EXCEPT EUR	
10	FK2-9248-000		1	CABLE, STANDARD SATA POWER	HDD MODEL	
11	FM4-0783-000		1	TPM PCB ASSEMBLY	EXCEPT CN	
12	FM4-0830-000		1	PCB ASS'Y, DDR-SO-DIMM		
13	XA9-1979-000		4	SCREW, MACH. PAN HEAD, M3X4	HDD MODEL	
14	XH9-0132-000		4	DAMPER, CUSHION	HDD MODEL	

FIGURE 930 MAIN CONTROLLER PCB ASS'Y, 1

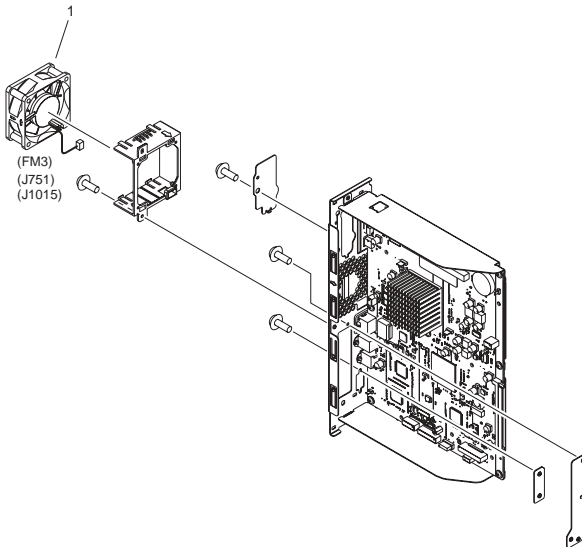

FIGURE & KEY NO.	PARTS NUMBER	RANK	QTY	DESCRIPTION	SERIAL NUMBER/REMARKS	SVC
Fig.930	FM4-3139-010		1	MAIN CONTROLLER PCB ASS'Y, 1	C2020 SERIES	
Fig.930	FM4-3140-010		1	MAIN CONTROLLER PCB ASS'Y, 1	C2025 SERIES	
Fig.930	FM4-3141-010		1	MAIN CONTROLLER PCB ASS'Y, 1	C2030 SERIES	
1	FK2-9244-000		1	FAN	FM3	
IC	FK2-6692-000		1	IC, LE80578EG800C	IC3	

FIGURE 931 MAIN CONTROLLER PCB ASS'Y, 2

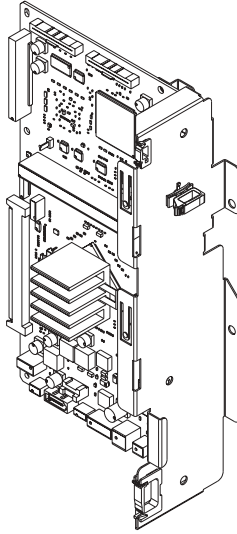

FIGURE & KEY NO.	PARTS NUMBER	RANK	Q'TY	DESCRIPTION	SERIAL NUMBER/REMARKS	SVC
Fig.931	FM4-3138-000		1	MAIN CONTROLLER PCB ASS'Y, 2		
IC	FK2-3218-000		1	IC, MB87L8650, GATE ARRAY	IC24	
IC	FK2-7574-000		1	IC, MB87Q1911, ASIC	IC6	
IC	FK2-7835-010		1	IC, R8A03018ABG U200, ASIC	IC1	
IC	FK2-7852-000		1	IC, T6TH5EFG-0002(0), STANDARD	IC5	
IC	FK2-8321-000		1	IC, MB87S1801	IC7	
IC	FK2-9242-000		1	IC, CLOCK GENERATOR, HYBRID	IC22	

FIGURE 960 AC DRIVER PCB ASSEMBLY

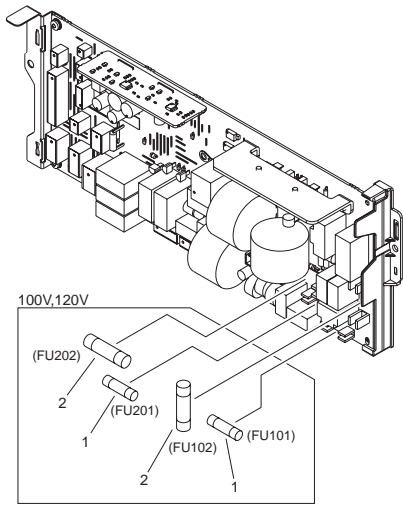

FIGURE & KEY NO.	PARTS NUMBER	RANK	QTY	DESCRIPTION	SERIAL NUMBER/REMARKS	SVC
Fig.960	FM3-8180-000		1	AC DRIVER PCB ASSEMBLY	100V	
Fig.960	FM3-8189-000		1	AC DRIVER PCB ASSEMBLY	120V	
Fig.960	FM3-8181-000		1	AC DRIVER PCB ASSEMBLY	230V	
1	VD7-2941-002		2	FUSE	100V,120V FU101,FU201	
2	VD7-2951-502		2	FUSE	100V,120V FU102,FU202	

FIGURE 980 HIGH VOLTAGE ASSEMBLY

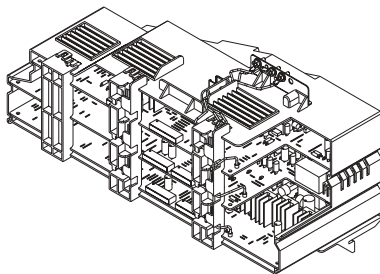

FIGURE & KEY NO.	PARTS NUMBER	RANK	QTY	DESCRIPTION	SERIAL NUMBER/REMARKS	SVC
Fig.980	FM3-8175-000		1	HIGH VOLTAGE PCB ASSEMBLY		

FIGURE A01 ADF MOUNTING ASSEMBLY (ADF MODEL)

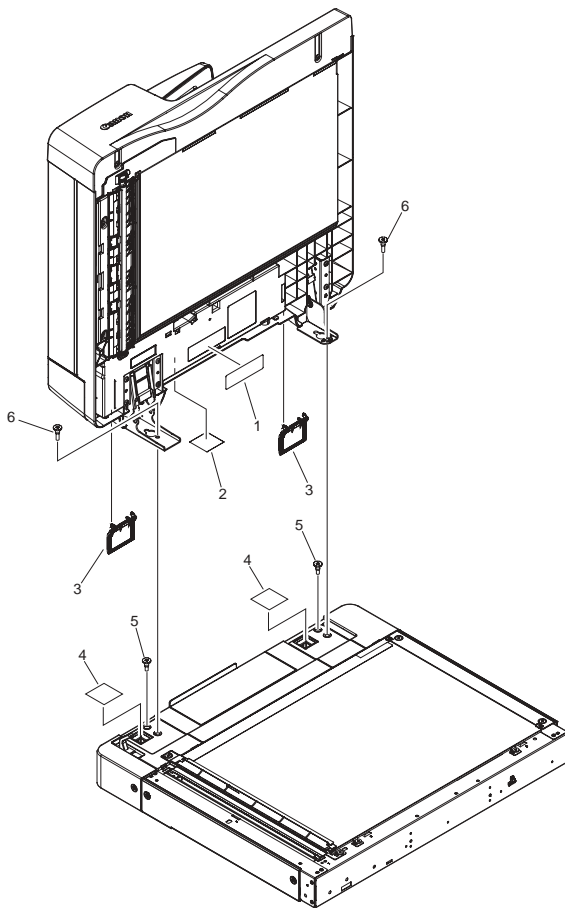

FIGURE & KEY NO.	PARTS NUMBER	RANK	Q'TY	DESCRIPTION	SERIAL NUMBER/REMARKS	SVC
Fig.A01	NPN		RF	ADF MOUNTING ASSEMBLY	ADF MODEL	
1	FU7-8226-000		1	LABEL, HINGE CAUTION	US,CA,LTN	
2	FU7-8455-000		1	LABEL, HINGE CAUTION	US,CA,LTN	
3	FC9-6192-010		2	COVER, HINGE BLANKING		
4	FC9-6193-000		2	SHEET, BLANKING		
5	FU5-9139-000		2	SCREW, STEPPED, M5X6		
6	FU5-9140-000		2	SCREW, STEPPED, M4X10		

FIGURE A10 ADF MAIN BODY (ADF MODEL)

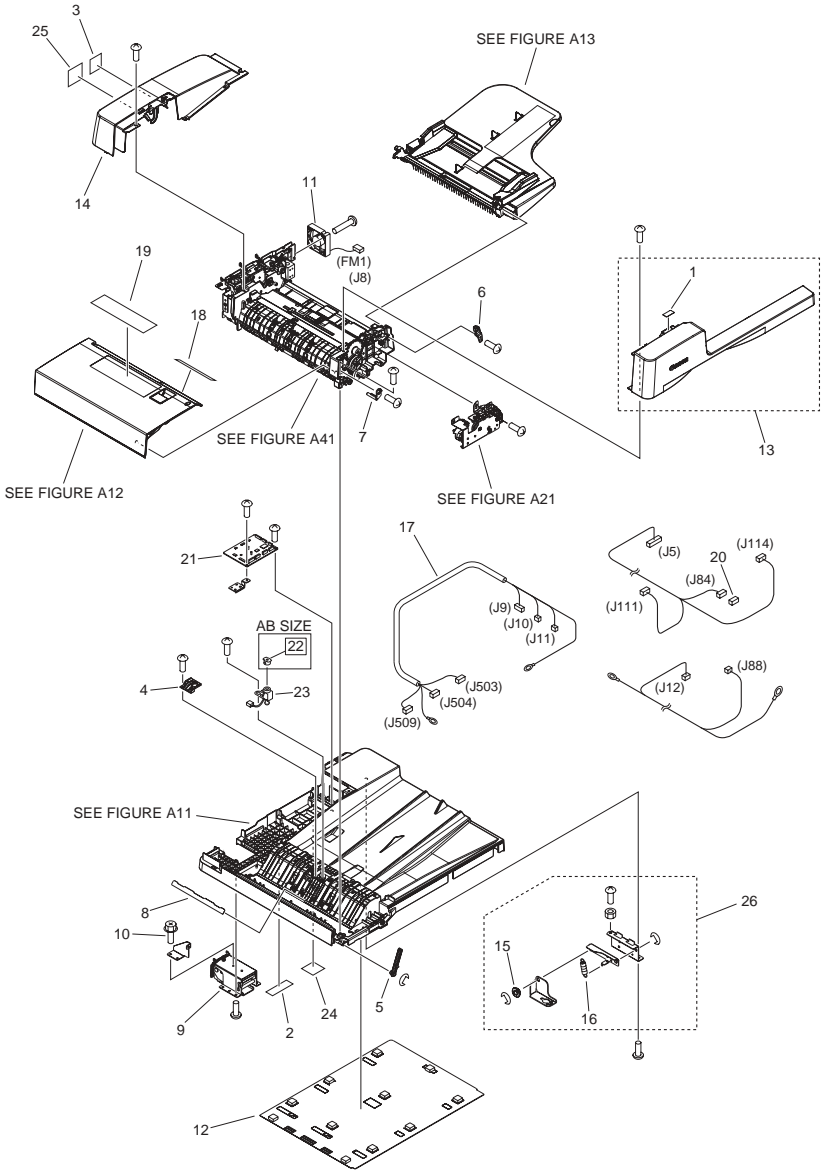

FIGURE & KEY NO.	PARTS NUMBER	R A N K	Q'TY	DESCRIPTION	SERIAL NUMBER/ REMARKS	S V C
Fig.A10	NPN		RF	ADF MAIN BODY	ADF MODEL	
1	FS9-0203-000		1	LABEL, DIAL OPERATION		
2	FU7-8226-000		1	LABEL, HINGE CAUTION	US,CA,LTN	
2	FU7-8142-000		1	LABEL, HINGE CAUTION	Japanese	
2	FU7-8225-000		1	LABEL, HINGE CAUTION	English	
3	FU7-8453-000		1	LABEL, HINGE CAUTION, C	Japanese	
3	FU7-8454-000		1	LABEL, HINGE CAUTION, C	English	
3	FU7-8455-000		1	LABEL, HINGE CAUTION	US,CA,LTN	
4	FC8-6311-000		1	COVER, STAMP		
5	FC8-6330-000		1	LEVER, READ 1 ESTRANGEMENT		
6	FC8-6387-000		1	HOLDER, TRAY SUPPORT		
7	FC8-6388-000		1	HOLDER, FEEDER SHAFT		
8	FC8-6405-000		1	SHEET, READ 2 LEAD		
9	FC8-6420-000		1	HINGE, LEFT		
10	XA9-0732-010		6	SCREW,RS,M4		
11	FK2-6873-000		1	FAN		
12	FL2-9945-000		1	COVER, COPYBOARD		
13	FL3-2934-010		1	COVER, FRONT		
14	FL3-2935-000		1	COVER, REAR		
15	FU5-1173-000		1	BUSHING		
16	FU7-2651-000		1	SPRING, TENSION		
17	FM4-3338-000		1	CABLE, INTERFACE		
18	FU7-8447-000		1	LABEL, DOCUMENT SIZE	AB SIZE	
18	FU7-8449-000		1	LABEL, DOCUMENT SIZE	A/INCH SIZE	
18	FU7-8450-000		1	LABEL, DOCUMENT SIZE	AB/K/INCH SIZE	
19	FU7-8444-000		1	LABEL, PROHIBITION DOCUMENT	Japanese	
19	FU7-8446-000		1	LABEL, PROHIBITION DOCUMENT	EXCEPT Japanese	
20	VS1-7177-002		1	CONNECTOR, SNAP TIGHT, BK		
21	FM4-3023-000		1	ADF PCB ASSEMBLY		
22	FB5-9410-000		1	STAMPER	AB SIZE [DP]	
23	FK2-0216-000		1	SOLENOID		
24	FU7-8223-000		1	LABEL, HINGE CAUTION		

FIGURE & KEY NO.	PARTS NUMBER	R A N K	Q'TY	DESCRIPTION	SERIAL NUMBER/ REMARKS	S V C
25	FU7-8452-000		1	LABEL, HINGE CAUTION		
26	FM3-6893-000		1	RIGHT HINGE ASSEMBLY		

FIGURE A11
BASE ASSEMBLY (ADF MODEL)

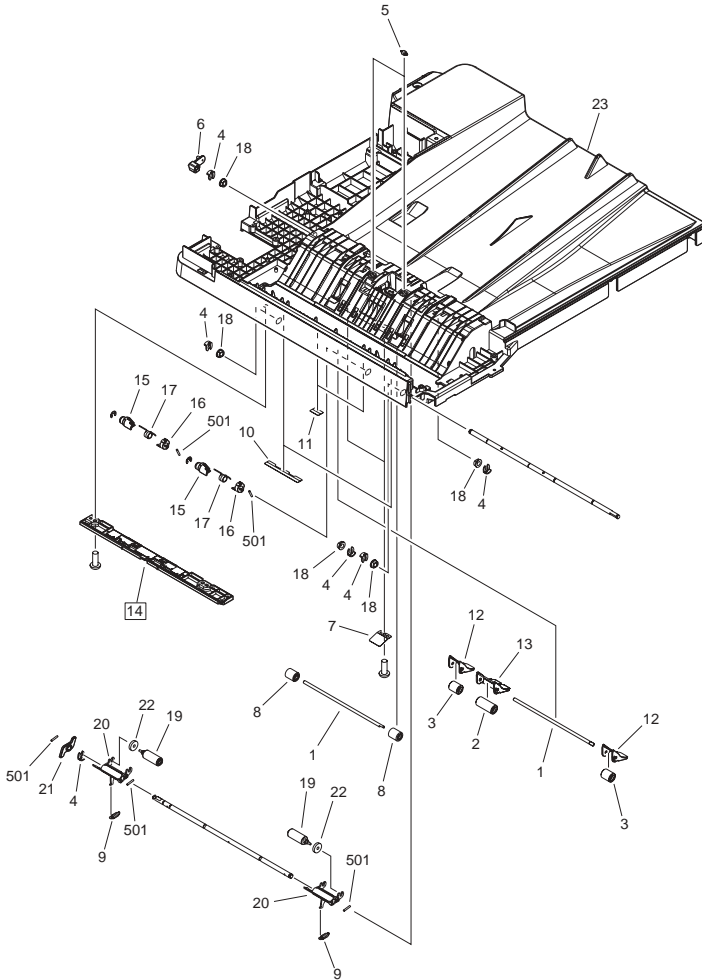

FIGURE & KEY NO.	PARTS NUMBER	R A N K	Q'TY	DESCRIPTION	SERIAL NUMBER/ REMARKS	S V C
Fig.A11	NPN		RF	BASE ASSEMBLY	ADF MODEL	
1	FC5-4285-030		2	SHAFT, PAPER FEED ROLLER		
2	FC5-4286-000		1	ROLLER, PAPER FEED, 1		
3	FC5-4287-000		2	ROLLER, PAPER FEED, 2		
4	FC5-4425-000		6	CLIP		
5	FC6-8973-000		2	ROLLER, PLATEN		
6	FC8-6319-000		1	HOLDER, SOLENOID		
7	FC8-6322-000		2	SPRING, LEAF		
8	FC8-6404-000		2	ROLLER, READ 2 PINCH		
9	FU7-2652-000		2	SPRING, TENSION		
10	FC8-6422-000		2	SHEET, PAPER FEED		
11	FC8-6423-000		2	SHEET, PAPER FEED		
12	FL2-9933-000		2	HOLDER, ROLLER, SMALL		
13	FL2-9934-010		1	HOLDER, ROLLER, LARGE		
14	FL3-2942-000		1	COVER, BASE, LOWER	[DP]	
15	FC8-6331-000		2	LEVER, READ 1 PRESSURE		
16	FC8-6332-000		2	COLLAR, READ 1 PRESSURE		
17	FU7-2653-000		2	SPRING, TORSION		
18	FU5-1168-000		5	BUSHING		
19	FC8-6316-000		2	ROLLER, DELIVERY		
20	FC8-6317-000		2	HOLDER, DELIVERY ROLLER		
21	FC8-6318-010		1	CAM, DELIVERY ESTRANGEMENT		
22	FC8-6419-000		2	DAMPER, DELIVERY		
23	FL3-2936-000		1	FRAME, BASE		
501	XD3-2200-122		5	PIN, DOWEL		

FIGURE A12 PAPER PICK-UP COVER ASSEMBLY (ADF MODEL)

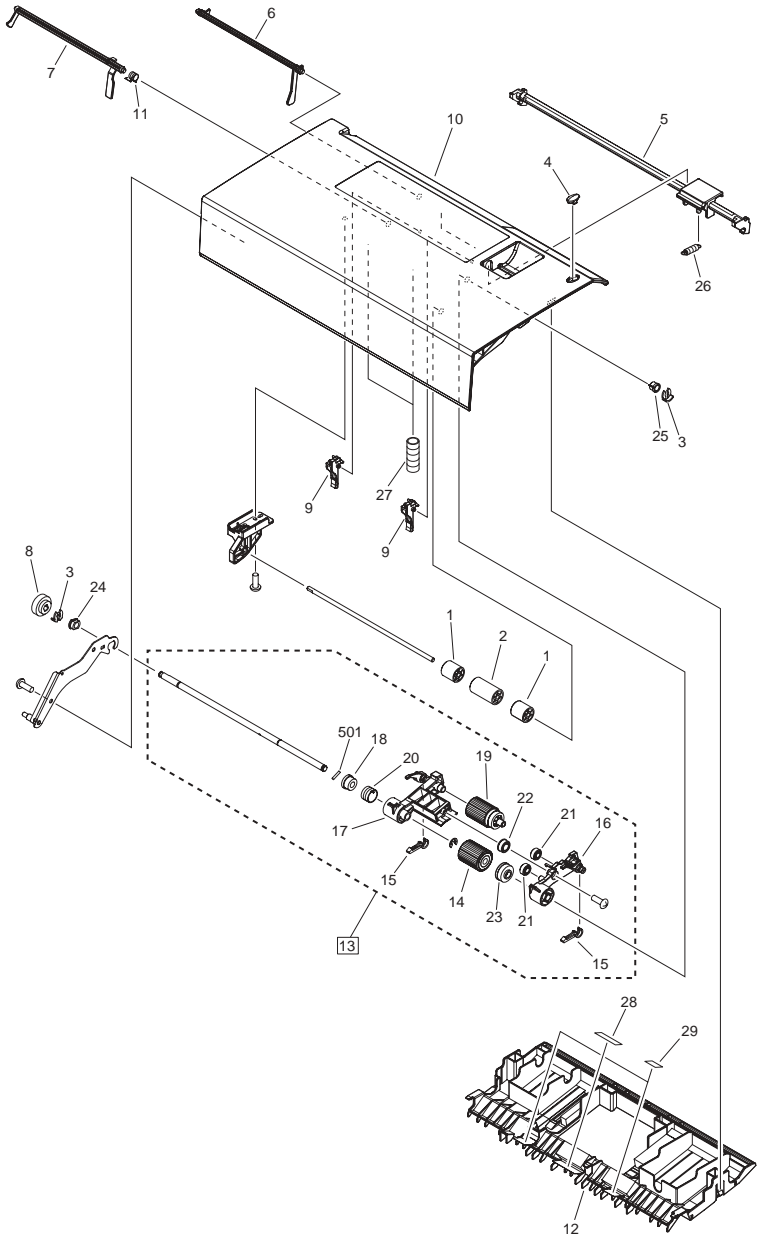

FIGURE & KEY NO.	PARTS NUMBER	R A N K	Q'TY	DESCRIPTION	SERIAL NUMBER/ REMARKS	S V C
Fig.A12	FM4-4309-000		1	PAPER PICK-UP COVER ASSEMBLY	ADF MODEL	
1	FC5-4323-000		2	ROLLER, REGISTRATION, 1		
2	FC5-4324-000		1	ROLLER, REGISTRATION, 2		
3	FC5-4425-000		2	CLIP		
4	FC8-6345-000		1	CASE, LED		
5	FC9-6190-000		1	KNOB, PAPER PICK-UP COVER		
6	FC8-6347-010		1	LEVER, EMPTY SENSOR		
7	FC8-6348-000		1	LEVER, TIMING SENSOR		
8	FU8-0302-000		1	GEAR, 24T		
9	FL2-9948-000		2	SHUTTER		
10	FL3-2940-000		1	COVER, PAPER PICK-UP		
11	FU7-2656-000		1	SPRING, TORSION		
12	FL3-2941-000		1	GUIDE, PAPER PICK-UP, LOWER		
13	FM3-6892-010		1	PAPER PICK-UP ROLLER UNIT	[DP]	
14	FC6-2784-000		1	ROLLER, PAPER SEPARATION		
15	FC6-8971-010		2	LEVER, STOP		
16	FC8-6351-000		1	ARM, PICK, FRONT		
17	FC8-6352-010		1	ARM, PICK, REAR		
18	FC8-6353-000		1	JOINT		
19	FC8-6355-000		1	ROLLER, PICK-UP		
20	FC8-6410-010		2	SPRING, TORSION		
21	FU8-0299-000		2	GEAR, 20T		
22	FU8-0300-000		1	GEAR, 22T		
23	FU8-0301-000		1	GEAR, 33T		
24	FU5-1172-000		1	BUSHING		
25	FU5-1626-000		1	BUSHING		
26	FU7-2654-000		1	SPRING, TENSION		
27	FU7-2655-000		2	SPRING, COMPRESSION		
28	FC8-6356-000		1	SHEET, CLEANING, LARGE		
29	FC8-6357-000		2	SHEET, CLEANING, SMALL		
501	XD3-2200-102		1	PIN, DOWEL		

FIGURE A13 DOCUMENT TRAY ASSEMBLY (ADF MODEL)

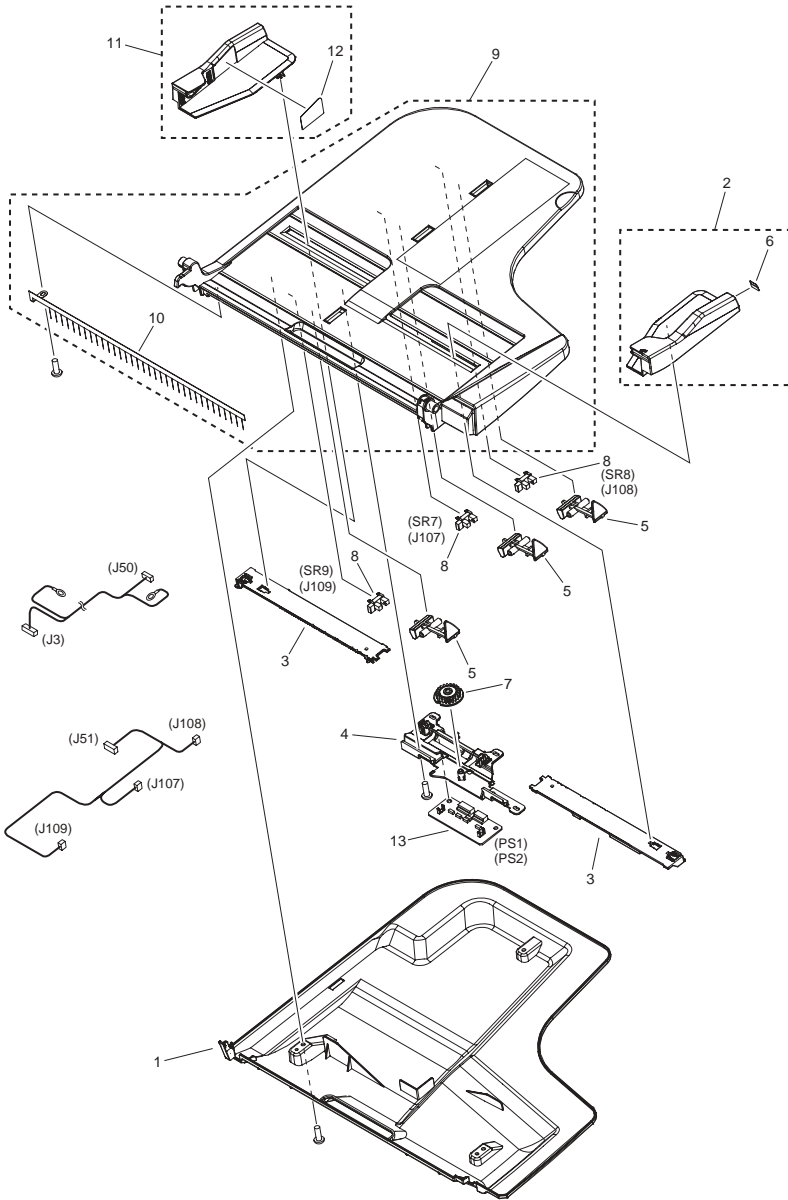

FIGURE & KEY NO.	PARTS NUMBER	R A N K	Q'TY	DESCRIPTION	SERIAL NUMBER/ REMARKS	S V C
Fig.A13	FM4-2667-000		1	DOCUMENT TRAY ASSEMBLY	ADF MODEL	
1	FL3-2450-000		1	COVER, TRAY, LOWER		
2	FL3-2937-000		1	GUIDE, TRAY, FRONT		
3	FC9-5683-000		2	RACK, TRAY		
4	FC9-5684-000		1	HOLDER, TRAY VOLUME		
5	FC8-6339-000		3	LEVER, TRAY SENSOR		
6	FU7-8442-000		1	LABEL, DOCUMENT MAXIMUM LOAD		
7	FU8-0910-000		1	PINION, 22T		
8	WG8-5696-000		3	PHOTO INTERRUPTER, TLP1243		
9	FL3-2449-000		1	TRAY, DOCUMENT		
10	FC8-6341-000		1	ELIMINATOR, STATIC CHARGE		
11	FL3-2939-000		1	GUIDE, TRAY, REAR		
12	FU7-8443-000		1	LABEL, DOCUMENT MAXIMUM LOAD		
13	FM4-3024-000		1	PHOTO SENSOR PCB UNIT, TRAY		

FIGURE A21 ESTRANGEMENT DRIVE ASSEMBLY (ADF MODEL)

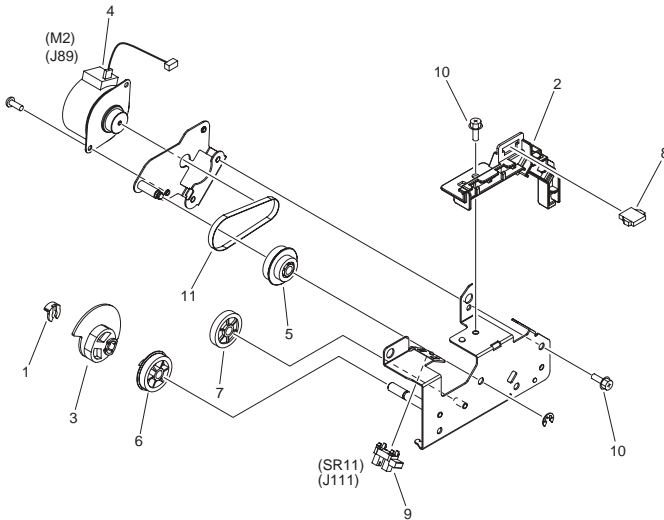

FIGURE & KEY NO.	PARTS NUMBER	RANK	QTY	DESCRIPTION	SERIAL NUMBER/REMARKS	SVC
Fig.A21	NPN		RF	ESTRANGEMENT DRIVE ASSEMBLY	ADF MODEL	
1	FC5-4425-000		1	CLIP		
2	FC8-6406-000		1	DUCT, ESTRANGEMENT HARNESS		
3	FC8-6407-000		1	CAM, ESTRANGEMENT		
4	FK2-0207-000		1	MOTOR, STEPPING, DC		
5	FU8-0311-000		1	GEAR PULLEY, 40T/20T		
6	FU8-0319-000		1	GEAR, 31T		
7	FU8-0320-000		1	GEAR, 30T		
8	VS1-7177-004		1	CONNECTOR, SNAP TIGHT, BK		
9	WG8-5696-000		1	PHOTO INTERRUPTER, TLP1243		
10	XA9-0732-010		3	SCREW,RS,M4		
11	XF2-1607-640		1	BELT, TIMING		

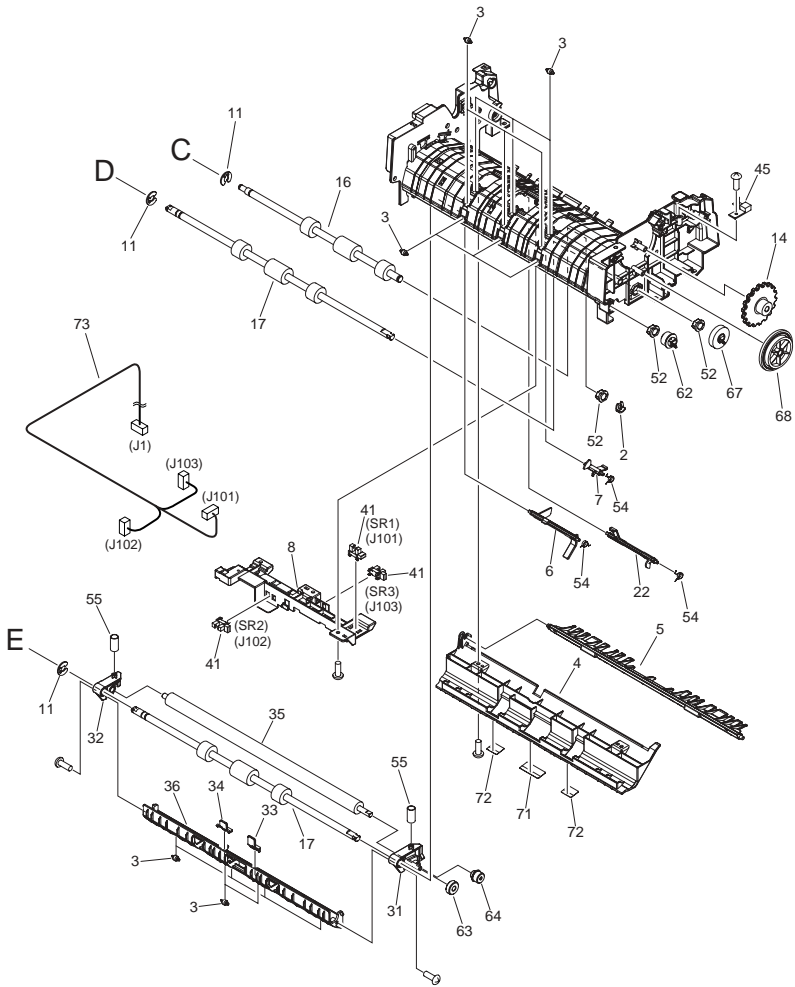

FIGURE & KEY NO.	PARTS NUMBER	R A N K	Q'TY	DESCRIPTION	SERIAL NUMBER/ REMARKS	S V C
Fig.A41	FM4-2458-000		1	PAPER FEED ASSEMBLY	ADF MODEL	
1	FC5-4353-000		1	FLANGE, BELT		
2	FC5-4425-000		9	CLIP		
3	FC6-8973-000		15	ROLLER, PLATEN		
4	FC8-6368-000		1	GUIDE, PLATEN, 2		
5	FL2-9949-000		1	FLAPPER, REVERSE		
6	FC8-6371-000		1	LEVER, READ SENSOR		
7	FC8-6372-000		1	LEVER, PAPER DELIVERY SENSOR		
8	FC8-6377-000		1	HOLDER, SENSOR		
9	FC8-6378-020		1	DUCT, HARNESS		
10	FC8-6379-000		1	FLANGE, PULLEY		
11	FC8-6380-000		3	CLIP		
12	FC8-6382-000		1	ROLLER, BELT TENSION		
13	FC8-6385-000		1	JOINT, DELIVERY GEAR		
14	FC8-6386-000		1	DIAL, JAM		
15	FC8-6395-000		1	ROLLER, DELIVERY		
16	FC8-6396-000		1	ROLLER, REGISTRATION		
17	FC8-6397-000		2	ROLLER, READ		
18	FC8-6418-000		2	JOINT, READ PULLEY		
19	FC8-6421-000		1	BELT, TIMING		
20	FM4-5644-000		1	MOTOR, STEPPING, DC		
21	FK2-6870-000		2	CLUTCH, ELECTROMAGNETIC		
22	FL2-9937-000		1	FLAG, REGISTRATION SENSOR		
23	XG9-0820-000		2	BEARING, BALL, DDLF-1280ZZH		
24	FC8-6383-000		1	JOINT, PICK-UP		
25	FC8-6411-000		1	SPRING, TORSION		
26	FU8-0304-000		1	GEAR, 22T		
27	FC8-6384-000		1	JOINT, REGISTRATION		
28	FC8-6412-000		1	SPRING, TORSION		
29	FU8-0307-000		1	GEAR, 18T		
30	FC8-6399-000		1	ELIMINATOR, STATIC CHARGE		
31	FC8-6373-000		1	ARM, PLATEN, FRONT		

FIGURE & KEY NO.	PARTS NUMBER	R A N K	Q'TY	DESCRIPTION	SERIAL NUMBER/ REMARKS	S V C
32	FC8-6374-000		1	ARM, PLATEN, REAR	[DP]	
33	FC8-6375-000		1	SPACER, READ, FRONT		
34	FC8-6376-000		1	SPACER, READ, REAR		
35	FC8-6398-000		1	ROLLER, WHITE		
36	FL2-9939-000		1	GUIDE, PLATEN, 1		
37	FC8-6381-000		1	LINK, SOLENOID		
38	FC8-6403-000		1	DAMPER, REV. GUIDE RETAINING		
39	FK2-6871-000		1	SOLENOID		
40	FU8-0306-000		1	GEAR, 25T		
41	WG8-5696-000		6	PHOTO INTERRUPTER, TLP1243		
42	FM4-4312-010		1	SEPARATION REVERSE GUIDE ASS'Y		
43	FL3-5538-010		1	PAD, SEPARATION		
44	FU7-2657-000		1	SPRING, COMPRESSION		
45	FM3-6916-000		1	LED PCB UNIT		
46	FS9-0204-000		1	LABEL, JAM CLEARING OPERATION		
47	FS9-0205-000		1	LABEL, GREEN		
48	XA9-0702-000		3	SCREW, WWASHER, M3X6		
49	VS1-7177-002		2	CONNECTOR, SNAP TIGHT, BK		
50	FU5-1172-000		5	BUSHING		
51	FU5-1626-000		1	BUSHING		
52	FU6-1088-000		3	BUSHING		
53	FU6-1089-000		1	BUSHING		
54	FU7-2658-000		3	SPRING, TORSION		
55	FU7-2659-000		2	SPRING, COMPRESSION		
56	FU7-2660-000		2	SPRING, TENSION		
57	FU8-0303-000		1	GEAR PULLEY, 27T/22T		
58	FU8-0305-000		1	GEAR, 18T		
59	FU8-0308-000		1	GEAR, 22T		
60	FU8-0309-000		1	GEAR PULLEY, 36T/54T/28T		
61	FU8-0310-000		2	PULLEY, 36T		
62	FU8-0312-000		1	GEAR, 18T		
63	FU8-0313-000		1	GEAR, 18T		

FIGURE & KEY NO.	PARTS NUMBER	R A N K	Q'TY	DESCRIPTION	SERIAL NUMBER/ REMARKS	S V C
64	FU8-0314-000		1	GEAR, 14T		
65	FU8-0315-000		1	GEAR, 39T		
66	FU8-0316-000		1	GEAR, 21T		
67	FU8-0317-000		1	GEAR, 32T		
68	FU8-0318-000		1	GEAR, 48T/62T		
69	XA9-1164-000		8	SCREW,RS,M3X6.5		
70	XF2-1607-640		2	BELT, TIMING		
71	FC8-6356-000		1	SHEET, CLEANING, LARGE		
72	FC8-6357-000		2	SHEET, CLEANING, SMALL		
73	FM3-6930-000		1	CABLE, PASS SENSOR		
501	XD3-2200-122		2	PIN, DOWEL		
	FC9-4978-000		1	PLATE, REINFORCEMENT		
	XB4-5301-005		2	SCREW,P,M3X10		

FIGURE & KEY NO.	PARTS NUMBER	R A N K	Q'TY	DESCRIPTION	SERIAL NUMBER/ REMARKS	S V C
Fig.D11	NPN		RF	READER ASSEMBLY	EXCEPT EUR	
1	FC9-7292-000		1	ARM, OPEN/CLOSE SENSOR		
2	FM4-3392-000		1	CABLE, CCD		
3	XA9-1567-000		AR	SCREW, RS, M3X8.5		
4	FC9-7301-000		1	COVER, READER SUB, FRONT		
5	FC9-7298-000		1	COVER, PCB		
6	FC9-7550-000		1	COVER, READER SUB, REAR		
7	FL3-3691-000		1	LABEL, SERVICE		
8	FM4-7540-000		1	CARRIAGE ASSEMBLY		
9	FC8-6188-010		1	CASE, OPEN/CLOSE SENSOR		
10	FC9-7284-000		1	CASE, PAPER SIZE SENSOR		
11	FL3-3207-000		1	CCD MIRROR CLEANING UNIT		
12	FM4-3385-010		1	READER CONNECTING PCB ASSEMBLY		
13	XA9-1415-000		10	SCREW, FLAT HEAD, M4		
14	FC9-7299-000		1	COVER, READER, FRONT		
15	FC9-7288-010		2	COVER, GLASS RETAINING	A/B SIZE	
16	FC0-2618-000		1	COVER, GLASS SUPPORT	A/INCH SIZE	
17	FL3-5465-010		1	COVER, HINGE, LEFT	A/B/INCH SIZE	
18	FL3-5464-000		1	COVER, HINGE, RIGHT		
19	FH7-7569-000		2	DOCUMENT SIZE SENSOR UNIT		
20	FL3-3591-000		1	GLASS, COPYBOARD		
20	FL3-3593-000		1	GLASS, COPYBOARD		
20	FL3-3594-000		1	GLASS, COPYBOARD		
21	FL3-3206-000		1	GLASS, READER		
22	XF2-4606-740		1	BELT, TIMING, COGGED		
23	FK2-9464-000		1	MOTOR, STEPPING, DC		
24	WG8-5776-000		3	IC, PHOTO-INTERRUPTER, HYBRID		
25	XF2-4668-040		1	BELT, TIMING		
26	FU8-2497-000		1	SPRING, TORSION		
27	FC9-7308-000		3	PLATE, SHAFT RETAINING		
28	FC9-7294-000		1	COVER, READER, REAR		
29	FC8-6163-000		4	PULLEY		

FIGURE & KEY NO.	PARTS NUMBER	RANK	Q'TY	DESCRIPTION	SERIAL NUMBER/REMARKS	SVC
30	FC8-6180-000		1	PULLEY		
31	FU5-3710-000		1	PULLEY, 24T/41T		
32	FU8-2481-000		1	SPRING, TENSION		
33	FC9-7543-000		1	SHEET, CCD CABLE RETAINING		
34	FC9-7544-000		1	SHEET, CCD CABLE RETAINING		
35	FU8-2470-000		1	SPRING, TENSION		
36	XA9-1469-000		14	SCREW, TP,M3X6		
37	XD9-0136-000		4	RING, E		
38	FU7-8079-000		1	LABEL, CLEANING POSITION	JP	
38	FU7-8080-000		1	LABEL, CLEANING POSITION	US,CA,LTN,AU,SG,HK	
38	FU7-8081-000		1	LABEL, CLEANING POSITION	CN	
38	FU7-8082-000		1	LABEL, CLEANING POSITION	KR	
38	FU7-8083-000		1	LABEL, CLEANING POSITION	TW	
39	FL3-6227-000		1	COVER, READER, LEFT		
40	FC9-7297-000		16	SEAL, BLANKING		
41	FL3-3692-000		1	COVER, READER, RIGHT		
42	FU7-8084-000		1	LABEL, COPY PROHIBITION, JAPAN	Japanese	
42	FU7-8085-000		1	LABEL, COPY INHIBITED	English	
42	FU7-8086-000		1	LABEL, COPY INHIBITED	Canadian French	
42	FU7-8087-000		1	LABEL, COPY INHIBITED	Portuguese	
42	FU7-8227-000		1	LABEL, COPY INHIBITED	Spanish	
42	FU7-8232-000		1	LABEL, COPY INHIBITED	Simplified Chinese	
42	FU7-8233-000		1	LABEL, COPY INHIBITED	Korean	
42	FU7-8234-000		1	LABEL, COPY INHIBITED	Traditional Chinese	
43	FC9-7300-000		2	SEAL, CABLE BLANKING		
44	FM4-3388-000		1	CABLE, COVER OPEN/CLOSE SENSOR		
45	FM4-3390-000		1	CABLE,PAPER SIZE SENSOR	A/B/SIZE, A/B/INCH SIZE	

FIGURE T20 G3 FAX ASSEMBLY, 1 LINE (G3 FAX MODEL)

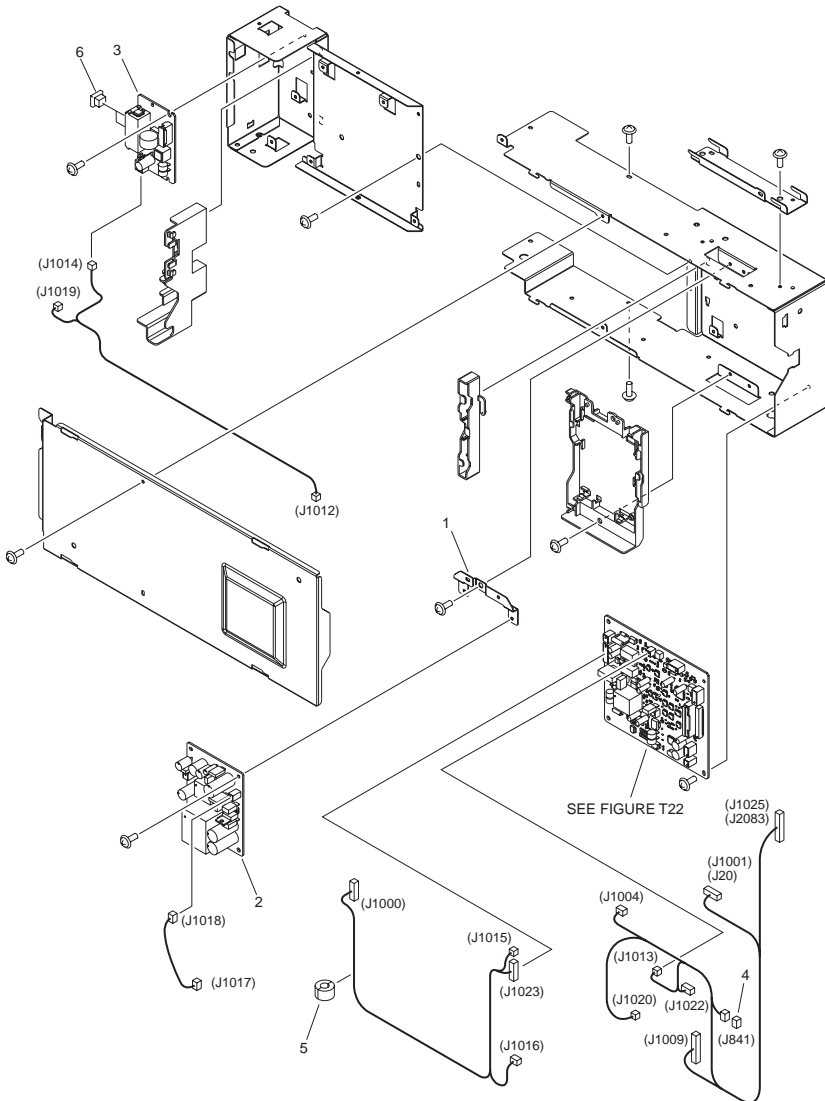

NOTE : This assembly includes the assembly shown in Figure T22.
 注 : このユニットはFigure T22のユニットを含みます。

FIGURE & KEY NO.	PARTS NUMBER	RANK	Q'TY	DESCRIPTION	SERIAL NUMBER/REMARKS	SVC
Fig.T20	FM3-8176-000		1	G3 FAX ASSEMBLY, 1 LINE	SEE NOTE G3 FAX MODEL	
1	FC8-8553-000		1	PLATE, GROUNDING		
2	FM3-5580-000		1	PSEUDO CI2 PCB ASSEMBLY		
3	FM4-0788-000		1	MODULAR PCB ASSEMBLY		
4	VS1-7177-003		1	CONNECTOR, SNAP TIGHT, BK		
5	WE8-6096-000		1	CORE, FERRITE		
6	WT8-5076-000		2	SPACER, MODULAR		

FIGURE T21 SPEAKER ASSEMBLY (G3 FAX MODEL)

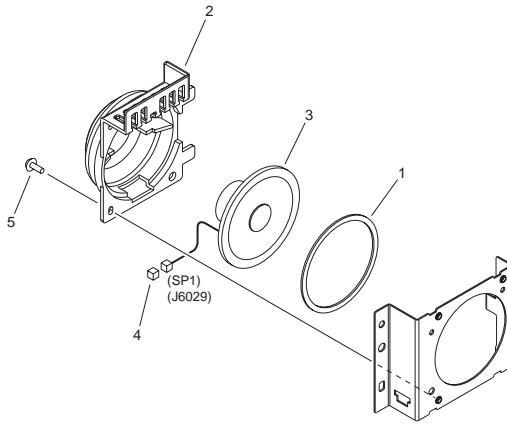
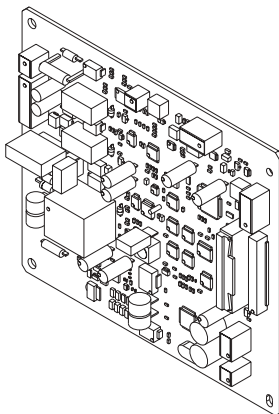

FIGURE & KEY NO.	PARTS NUMBER	RANK	QTY	DESCRIPTION	SERIAL NUMBER/REMARKS	SVC
Fig.T21	FM3-8186-000		1	SPEAKER ASSEMBLY	G3 FAX MODEL	
1	FC6-5059-000		1	DAMPER, RUBBER		
2	FC7-2362-000		1	HOLDER, SPEAKER		
3	FK2-0428-000		1	SPEAKER	SP1	
4	VS1-7177-002		1	CONNECTOR, SNAP TIGHT, BK		
5	XA9-1671-000		3	SCREW, D, M3X8		

FIGURE T22

1 LINE PCB ASSEMBLY (G3 FAX MODEL)



NOTE : This assembly is included in the assembly shown in Figure T20.
 注 : このユニットはFigure T20のユニットに含まれます。

FIGURE & KEY NO.	PARTS NUMBER	RANK	QTY	DESCRIPTION	SERIAL NUMBER/REMARKS	SVC
Fig.T22	FM4-0838-010		1	1 LINE PCB ASSEMBLY	SEE NOTE G3 FAX MODEL	
IC	FK2-5396-000		1	IC, GATE ARRAY	IC7	

FIGURE ZZA

MECHANICAL STANDARD PARTS (HOW TO USE)

Mechanical standard parts

機械標準部品

About a mechanical standard parts

A Mechanical standard parts is a mechanical part which not parts peculiar to a product. They are parts which are common to a Canon product and are used, such as a screw and a washer. The Fig No. and parts number of the mechanical standard parts are not listed in the product parts catalog. Refer to the parts catalog of mechanical standard parts when checking the parts number for screw or washer etc. and identify them by part shape or size.

機械標準部品とは

機械標準部品とは、製品特有の部品ではなく、ねじやワッシャなどキヤノン製品共通で使用されている機械部品（メカ部品）のことです。
製品のパーツカタログには、機械標準部品のFig No.や部品番号は記載しておりません。
ねじや、ワッシャ等の部品番号を調べるときは、機械標準部品のパーツカタログを参照し、部品の形状や大きさから判断し、使用している部品を調べてください。

Material and surface treatment of a mechanical standard parts

Material and surface treatment of mechanical standard parts are assigned commonly for each part. Refer to the Table 1 for the parts which material and surface treatment are assigned as numbers.

機械標準部品の材料および表面処理

機械標準部品の材料および表面処理については、各種部品共通で決められています。
材料および表面処理が番号で決められている部品については、表1を参照してください。

Table 1 Material and Surface treatment

表1 材料および表面処理

No. 番号	Material 材料	Surface treatment 表面処理	Color 色
1	Stainless steel ステンレス	Stainless steel black coloring (BC4) ステンレス黒着色(BC4)	Black 黒
2		not to be given なし	White 白
3	Brass 黄銅	Regular nickel plating (NL) 普通ニッケルメッキ(NL)	White 白
4		Black nickel plating (BN) 黒色ニッケルメッキ(BN)	Black 黒
5	Steel 鋼	White zinc trivalent chromate treating (ZC3) 白色亜鉛3価クロメート(ZC3)	White 白
6		Regular nickel chromium plating (NC) 普通ニッケルクロムメッキ(NC)	White 白
7		Regular nickel plating (NL) 普通ニッケルメッキ(NL)	White 白
8		Iron and steel phosphating (P1) 鉄鋼磷酸塩処理(P1)	Black 黒
9		Black zinc trivalent chromate treating (BZ3) 黒色亜鉛3価クロメート(BZ3)	Black 黒

FIGURE ZZB MECHANICAL STANDARD PARTS (SCREWS)

1. Screws ねじ

How to read Parts Numbers
部品番号の見方

Screws
ねじ

XB1-2400-609

Type No.
類別番号

Normal designation (d)
ねじの呼び(d)

Length (L)
ねじの長さ(L)

Material and Surface treatment
材料および表面処理

XB1-2 expresses Binding head machine screw.
XB1-2は、バインドねじを表す

40 expresses M4.0.
40は、M4.0を表す

0-60 expresses a length of 6.0mm.
0-60は、6.0mmの長さを表す

9 expresses Steel (Black zinc trivalent chromate
treating) from Table 1.

9は、表1より鋼(黒色亜鉛3価クロメート)を表す

1-1. Cross Recessed Head Screws for Precision Equipments

精密機器用十字穴付き小ねじ

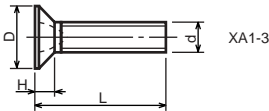
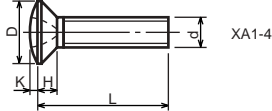
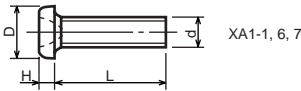

Type No. 類別番号	Type 類別
XA1-1	Pan head Class 1 なべ1種
XA1-3	Countersunk head Class 1 さら1種
XA1-4	Oval countersunk head Class 1 丸さら1種
XA1-6	Pan head Class 3 なべ3種
XA1-7	Pan head Class 2 なべ2種

		Head size (mm) 頭部寸法 (mm)					
		M1.4	M1.6	M1.7	M2	M2.5	M2.6
D	XA1-1	2	2.4	2.5	3	3.8	4
H	XA1-1	0.5	0.55	0.5	0.6	0.9	0.8
D	XA1-3	2	2.4	2.5	3	3.8	4
H	XA1-3	0.48	0.55	0.58	0.73	0.85	0.93
D	XA1-4	2	2.4	2.5	3	3.8	4
H + K	XA1-4	0.68	0.8	0.88	1	1.25	1.3
D	XA1-6	2.5	2.8	3	3.5	4.3	4.5
H	XA1-6	0.8	0.85	0.9	1	1.3	1.2
D	XA1-7	2.5	2.8	3	3.5	4.3	4.5
H	XA1-7	0.5	0.55	0.5	0.6	0.9	0.8

1-2. Precision Tapping Screws
精密用タッピンねじ

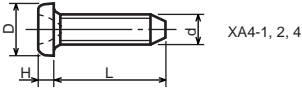

XA4-1, 2, 4

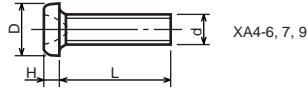

XA4-6, 7, 9

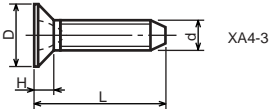

XA4-3

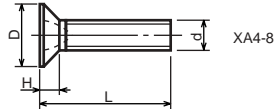

XA4-8

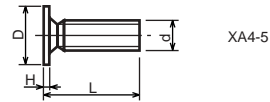

XA4-5

Type No. 類別番号	Type 類別	Head size (mm) 頭部寸法 (mm)						
		M1.4	M1.6	M1.7	M2	M2.5	M2.6	
XA4-1	With tapered end pan head Class 1 絞りなべ1種	D XA4-1	2	2.4	2.5	3	3.8	4
		H XA4-1	0.5	0.55	0.5	0.6	0.9	0.8
XA4-2	With tapered end pan head Class 3 絞りなべ3種	D XA4-2	2.5	2.8	3	3.5	4.3	4.5
		H XA4-2	0.8	0.85	0.9	1	1.3	1.2
XA4-3	With tapered end countersunk head 絞り-さら	D XA4-3	2	2.4	2.5	3	3.8	4
		H XA4-3	0.48	0.55	0.58	0.73	0.85	0.93
XA4-4	With tapered end pan head Class 2 絞りなべ2種	D XA4-4	2.5	2.8	3	3.5	4.3	4.5
		H XA4-4	0.5	0.55	0.5	0.6	0.9	0.8
XA4-5	With parallel end ultra thin head ストレート-超薄頭	D XA4-5	2.5	2.8	3	-	-	-
		H XA4-5	0.2	0.2	0.2	-	-	-
XA4-6	With parallel end pan head Class 1 ストレートなべ1種	D XA4-6	2	2.4	2.5	3	3.8	4
		H XA4-6	0.5	0.55	0.5	0.6	0.9	0.8
XA4-7	With parallel end pan head Class 3 ストレートなべ3種	D XA4-7	2.5	2.8	3	3.5	4.3	4.5
		H XA4-7	0.8	0.85	0.9	1	1.3	1.2
XA4-8	With parallel end countersunk head ストレート-さら	D XA4-8	2	2.4	2.5	3	3.8	4
		H XA4-8	0.48	0.55	0.58	0.73	0.85	0.93
XA4-9	With parallel end pan head Class 2 ストレートなべ2種	D XA4-9	2.5	2.8	3	3.5	4.3	4.5
		H XA4-9	0.5	0.55	0.5	0.6	0.9	0.8

1-3. Cross Recessed Head Screws

一般用十字穴付き小ねじ



XB1-1

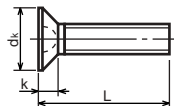

XB1-3

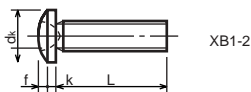

XB1-2

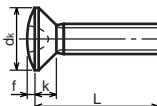

XB1-4

Type No. 類別番号	Type 類別	Head size (mm) 頭部寸法 (mm)						
		M2	M2.5	M2.6	M3	M4	M5	
XB1-1	Pan head なべ	dk XB1-1	3.5	4.5	4.5	5.5	7	9
		k XB1-1	1.3	1.7	1.7	2	2.6	3.3
XB1-2	Binding head バインド	dk XB1-2	4.3	5.3	5.5	6.3	8.3	10.3
		k+f XB1-2	1.2	1.5	1.6	1.9	2.5	3.1
XB1-3	Countersunk head さら	dk XB1-3	4	5	-	6	8	10
		k XB1-3	1.2	1.45	-	1.75	2.3	2.8
XB1-4	Oval countersunk head 丸さら	dk XB1-4	4	5	-	6	8	10
		k+f XB1-4	1.6	2	-	2.45	3.2	4
		Screw part length ねじ部長さ b	8	12	12	12	16	20

1-4. Cross Recessed Head Screws with Captive Washer
座金組み十字穴付き小ねじ

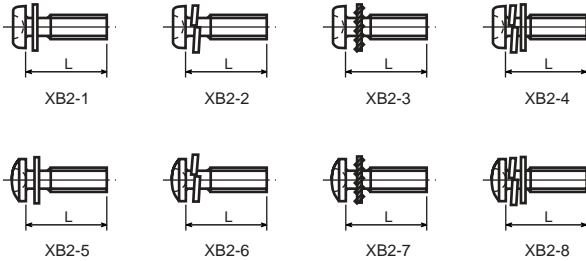

Type No. 類別番号	Type 類別
XB2-1	Pan head + Plain washer (circular bright) なべねじ+平座金
XB2-2	Pan head + Spring washer なべねじ+ばね座金
XB2-3	Pan head + Toothed lock washer なべねじ+歯付座金
XB2-4	Pan head + Spring washer and plain washer (circular bright) なべねじ+(ばね+平)座金
XB2-5	Binding head + Plain washer (circular bright) バインドねじ+平座金
XB2-6	Binding head + Spring washer バインドねじ+ばね座金
XB2-7	Binding head + Toothed lock washer バインドねじ+歯付座金
XB2-8	Binding head + Spring washer and plain washer (circular bright) バインドねじ+(ばね+平)座金

1-5. Hexagon Head Tapping Screws for Metallic Materials
 金属用六角タッピンねじ

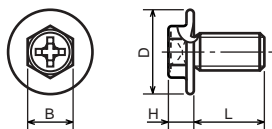

Type No. 類別番号	Type 類別	Head size (mm) 頭部寸法 (mm)	
		M3	M4
XB3-6	For metallic materials 金属用タッピン	D	8 10
		B	5.5 5.5
XB3-7	For metallic materials with clawed 金属用タッピン-つめ付き	H XB3-6	3.1 3.1
		H XB3-7	3.2 3.2

1-6. Special Tapping Screws
 特殊タッピンねじ

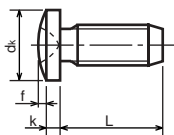

Type No. 類別番号	Type 類別	Head size (mm) 頭部寸法 (mm)	
		M3	M4
XB4-5	Binding head バインド	d _k	6.3 8.3
		k	1.3 1.7
		k+f	1.9 2.5

1-7. General Head Tapping Screws
一般用タッピンねじ

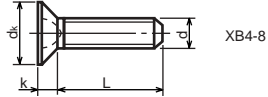
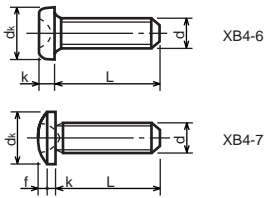

Type No. 類別番号	Type 類別	Head size (mm) 頭部寸法 (mm)						
		M2	M2.5	M2.6	M3	M4	M5	
XB4-6	Pan head なべ	d _k XB4-6	3.5	4.5	4.5	5.5	7	9
		k XB4-6	1.3	1.7	1.7	2	2.6	3.3
XB4-7	Binding head バインド	d _k XB4-7	4.3	5.3	5.5	6.3	8.3	10.3
		k+f XB4-7	1.2	1.5	1.6	1.9	2.5	3.1
XB4-8	Countersunk head さら	d _k XB4-8	4	5	5.2	6	8	10
		k XB4-8	1.2	1.45	1.5	1.75	2.3	2.8

1-8. Tapping Screws for Metallic Materials
金属用タッピンねじ

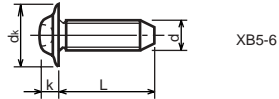
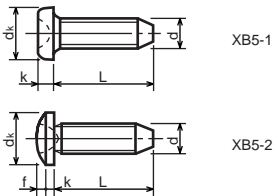

Type No. 類別番号	Type 類別	Head size (mm) 頭部寸法 (mm)					
		M2.5	M2.6	M3	M4	M5	
XB5-1	Pan head なべ	d _k XB5-1	4.5	4.5	5.5	7	9
		k XB5-1	1.7	1.7	2	2.6	3.3
XB5-2	Binding head バインド	d _k XB5-2	5.5	5.5	6.3	8.3	10.3
		k+f XB5-2	1.6	1.6	1.9	2.5	3.1
XB5-6	Flanged pan head つば付きなべ	d _k XB5-6	6.5	6.5	8	10	12
		k XB5-6	2.1	2.1	1.75	3.2	4

1-9. Hexagon Socket Set Screws
六角穴付止めねじ

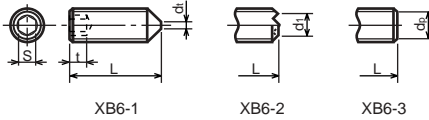

Type No. 類別番号	Type 類別	Head size (mm) 頭部寸法 (mm)							
		M1.6 M1.7	M2	M2.5 M2.6	M3	M5	M5	M6	
XB6-1	Cone point とがり先	S	0.7	0.9	1.3	1.5	2	2.5	3
		t	1.5	1.7	2	2	2.5	3	3.5
		$d_{t \max}$ XB6-1	0.4	0.5	0.65	0.75	1	1.25	1.5
		$d_{l \max}$ XB6-2	-	1.2	1.5	1.7	2.2	2.8	3.3
		$d_{l \min}$ XB6-2	-	1	1.2	1.4	1.9	2.4	2.9
		$d_{p \max}$ XB6-3	0.8	1	1.5	2	2.5	3.5	4
		$d_{p \min}$ XB6-3	0.55	0.75	1.25	1.75	2.25	3.2	3.7

1-10. Flanged Pan Head Machine Screws
つば付きなべ小ねじ

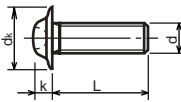

Type No. 類別番号	Type 類別	Head size (mm) 頭部寸法 (mm)					
		M2	M2.5 M2.6	M3	M5	M5	
XB6-7	Flanged pan head つば付きなべ	d_k	5	6.5	8	10	12
		k	1.7	2.1	2.5	3.2	4

FIGURE ZZC MECHANICAL STANDARD PARTS (BOLTS)

2. Bolts (Socket head cap screw)

ボルト

How to read Parts Numbers
部品番号の見方

Bolt (Socket head cap screw)
ボルト

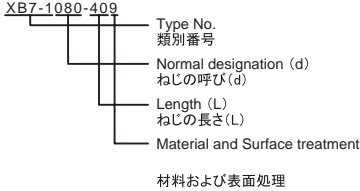

XB7-1 expresses Hexagon socket head cap screws.
XB7-1は、六角穴付きボルトを表す

080 expresses M8.0.
080は、M8.0を表す

40 expresses a length of 40mm.
40は、40mmの長さを表す

9 expresses Steel (Black zinc trivalent chromate treating) from Table 1.
9は、表1より鋼(黒色亜鉛3価クロメート)を表す

2-1. Hexagon socket head cap screws

六角穴付きボルト

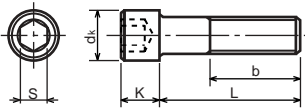

Type No. 類別番号	Type 類別
XB7-1	Hexagon socket head cap screws 六角穴付きボルト

	Head size (mm) 頭部寸法 (mm)						
	M3	M4	M5	M6	M8	M10	M12
S	2.5	3	4	5	6	8	10
d_k	5.5	7	8.5	10	13	16	18
K	3	4	5	6	8	10	12
Screw part length b_{max} ねじ部長さ b_{max}	18	20	22	24	28	32	36

FIGURE ZZD MECHANICAL STANDARD PARTS (NUTS)

3. Nuts ナット

How to read Parts Numbers
部品番号の見方

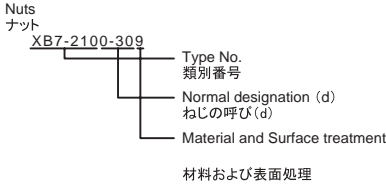

XB7-210 expresses Hexagon nut class 1.
XB7-210は、六角ナット1種を表す

0-30 expresses M3.0.
0-30は、M3.0を表す

9 expresses Steel (Black zinc trivalent chromate treating) from Table 1.
9は、表1より鋼(黒色亜鉛3価クロメート)を表す

3-1. Hexagon Nuts and Hexagon Thin Nuts 六角ナット

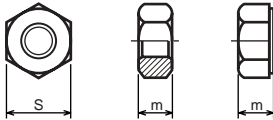

Type No. 類別番号	Type 類別
XB7-210	Hexagon nut Class 1 六角ナット-1種
XB7-220	Hexagon nut Class 3 六角ナット-3種
XB7-230	Hexagon nut Style 1 double chamfered 六角ナット-スタイル1-両面とり
XB7-231	Hexagon nut Style 1 washer faced 六角ナット-スタイル1-座付き
XB7-240	Hexagon nut Style 2 double chamfered 六角ナット-スタイル2-両面とり
XB7-241	Hexagon nut Style 2 washer faced 六角ナット-スタイル2-座付き
XB7-250	Hexagon nut 六角ナット
XB7-260	Hexagon thin nut double chamfered 六角低ナット-両面とり
XB7-270	Hexagon thin nut not chamfered 六角低ナット-面とり無し

	Head size (mm) 頭部寸法 (mm)						
	M2	M2.5	M3	M4	M5	M6	M8
S	4	5	5.5	7	8	10	13
m XB7-210	1.6	2	2.4	3.2	4	5	6.5
m XB7-220	1.2	1.6	1.8	2.4	3.2	3.6	5
m XB7-230, 231	1.6	2	2.4	3.2	4.7	5.2	6.8
m XB7-240, 241	-	-	-	-	5.1	5.7	7.5
m XB7-250	-	-	-	-	5.6	6.1	7.9
m XB7-260	1.2	1.6	1.8	2.2	2.7	3.2	4
m XB7-270	1.2	1.6	1.8	2.2	2.7	3.2	4

FIGURE ZZE MECHANICAL STANDARD PARTS (RETAINING RINGS)

5. Retaining Rings 止め輪

How to read Parts Numbers
部品番号の見方

Retaining Rings 止め輪

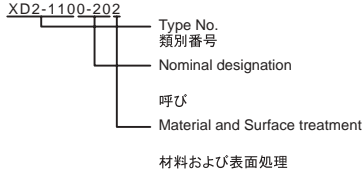

XD2-110 expresses retaining ring-E type (Type1).
XD2-110は、E形止め輪(1種)を表す

0-20 expresses a 020 of nominal designation.
(See Table 5)

0-20は、呼び020を表す(表5参照)

2 expresses Stainless steel (Surface treatment is not to be given) from Table 1.

2は、表1よりステンレス(表面処理なし)を表す

5-1. Retaining Rings - E type E形止め輪

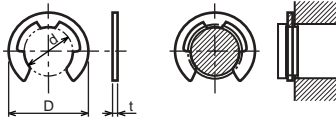

Type No. 類別番号	Type 類別
XD2-110	Retaining ring - E type (Type 1) E形止め輪(1種)
XD2-120	Retaining ring - E type (Type 2) E形止め輪(2種)

Table 5 表5

Type 種類	Nominal designation 呼び	d (mm)	D (mm)	t (mm)
Type 1 1種	007	0.65	2	0.2
	010	0.95	2.8	0.2
	013	1.25	3.3	0.3
	017	1.65	4.2	0.4
	020	1.95	4.6	0.5
	024	2.35	6	0.6
	028	2.74	6.5	0.6
	032	3.14	7.2	0.6
	037	3.64	8	0.7
	040	3.93	10	0.7
	042	4.13	10	0.7
	050	4.93	11	0.7
	058	5.73	12	0.7
	060	5.93	12.7	0.9
	064	6.32	13.5	0.9
	074	7.31	15	0.9
080	7.91	16.5	1	
Type 2 2種	008	0.8	2	0.2
	012	1.2	3	0.3
	015	1.5	4	0.4
	020	2	5	0.4
	025	2.5	6	0.4
	030	3	7	0.6
	040	4	9	0.6
	050	5	11	0.6
	060	6	12	0.8
	070	7	14	0.8
	080	8	16	0.8
	090	9	18	0.8
	100	10	20	1

5-2. Grip Rings
グリップ止め輪

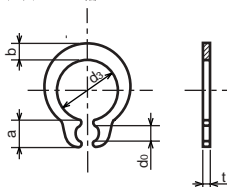

Type No. 類別番号	Type 類別
XD2-210	Grip ring グリップ止め輪

Table 5 表5

Nominal designation 呼び	d_3 (mm)	t (mm)	b (mm)	a (mm)	d_b (mm)
020	1.9	0.5	1	1.8	0.8
025	2.35	0.5	1.2	1.9	0.9
030	2.85	0.6	1.4	1.9	0.9
035	3.3	0.6	1.6	2	0.9
040	3.8	0.8	1.8	2.8	1.2
045	4.25	0.8	2	2.9	1.3
050	4.75	0.8	2.2	2.9	1.3
060	5.7	1	2.4	3.1	1.4
070	6.7	1	2.7	3.3	1.4
080	7.7	1	3	3.5	1.4
090	8.65	1.2	3.3	4.7	1.5
100	9.65	1.2	3.5	4.7	2

5-3. Toothed Retaining Rings
歯付き形止め輪

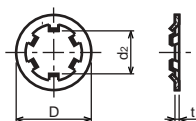

Type No. 類別番号	Type 類別
XD2-230	Toothed retaining ring 歯付き形止め輪

Table 5 表5

Nominal designation 呼び	d_z (mm)	D (mm)	t (mm)	No of teeth 歯数
015	1.4	5.2	0.25	3
020	1.9	6	0.25	3
024	2.3	6.4	0.25	3
030	2.8	8	0.25	4
040	3.8	9	0.25	4
050	4.8	10	0.25	5
060	5.8	11	0.25	5
080	7.8	13	0.25	5
100	9.8	15.4	0.25	6

5-4. Retaining Rings - C Type

C形止め輪

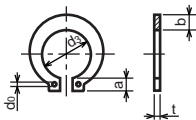

Type No. 類別番号	Type 類別
XD2-310	Retaining ring - C type for shaft C形止め輪 軸用

Table 5 表5

Nominal designation 呼び	d ₃ (mm)	t (mm)	b (mm)	a (mm)	d ₀ (mm)
010	9.3	1	1.6	3	1.2
012	11.1	1	1.8	3.2	1.5
014	12.9	1	2	3.4	1.7
015	13.8	1	2.1	3.5	1.7
016	14.7	1	2.2	3.6	1.7
017	15.7	1	2.2	3.7	1.7
018	16.5	1.2	2.6	3.8	1.7
020	18.5	1.2	2.7	3.9	2
022	20.5	1.2	2.7	4.1	2
025	23.2	1.2	3.1	4.3	2
028	25.9	1.5	3.1	4.6	2
030	27.9	1.5	3.5	4.8	2
032	29.6	1.5	3.5	5	2.5
035	32.2	1.5	4	5.4	2.5

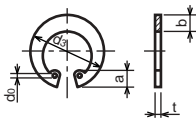

Type No. 類別番号	Type 類別
XD2-320	Retaining ring - C type for hole C形止め輪 穴用

Table 5 表5

Nominal designation 呼び	d ₃ (mm)	t (mm)	b (mm)	a (mm)	d ₀ (mm)
010	10.7	1	1.8	3.1	1.2
011	11.8	1	1.8	3.2	1.2
012	13	1	1.8	3.3	1.5
014	15.1	1	2	3.6	1.7
016	17.3	1	2	3.7	1.7
018	19.5	1	2.5	4	1.7
019	20.5	1	2.5	4	2
020	21.5	1	2.5	4	2
022	23.5	1	2.5	4.1	2
025	26.9	1.2	3	4.4	2
028	30.1	1.2	3	4.6	2
030	32.1	1.2	3	4.7	2
032	34.4	1.2	3.5	5.2	2.5
035	37.8	1.5	3.5	5.2	2.5
037	39.8	1.5	3.5	5.2	2.5
040	43.5	1.8	4	5.7	2.5
042	45.5	1.8	4	5.8	2.5
045	48.5	1.8	4.5	5.9	2.5
047	50.5	1.8	4.5	6.1	2.5
050	54.2	2	4.5	6.5	2.5
052	56.2	2	5.1	6.5	2.5
055	59.2	2	5.1	6.5	2.5
060	64.2	2	5.1	6.8	2.5
062	66.2	2	5.5	6.9	2.5
068	72.5	2.5	6	7.4	2.5
072	76.5	2.5	6.6	7.4	2.5
075	79.5	2.5	6.6	7.8	2.5
080	85.5	2.5	7	8	2.5
085	90.5	3	7	8	3
090	95.5	3	7.6	8.3	3
095	100.5	3	8	8.5	3

Prepared by
OIP Business Support Group
CANON INC.

Canon