

# **imageRUNNER 1750/1740/1730 Series**

# **PARTS CATALOG**



# **Canon**

**March 28, 2012  
Rev. 1**



## **PREFACE**

This Parts Catalog contains listings of parts used

Diagrams are provided with the listings to aid the service technician in identifying clearly, the item to be ordered.

Whenever ordering parts, consult this Parts Catalog for all of the information pertaining to each item. Be sure to include, in the Parts Request, the full item description, the item part number, and the quantity.

***COPYRIGHT (C) 1999 CANON INC.***

Use of this manual should be strictly supervised to avoid disclosure of confidential information.



# Contents

## NUMERICAL INDEX

imageRUNNER1750/1740/1730 Series(Numerical Index)..... 1-1

## imageRUNNER1750/1740/1730 Series(Parts Catalog)

A1	ASSEMBLY LOCATION DIAGRAM .....	2-1
A2	OPTION PARTS CATALOG LIST .....	2-4
001	ACCESSORIES .....	2-5
100	EXTERNAL COVERS, PANELS, ETC. ....	2-7
101	INTERNAL COMPONENTS 1 .....	2-11
102	INTERNAL COMPONENTS 2 .....	2-13
103	INTERNAL COMPONENTS 3 .....	2-15
104	MACHINE REAR PLATE .....	2-17
110	RIGHT DOOR ASSEMBLY .....	2-19
130	CONTROL PANEL ASSEMBLY .....	2-22
250	MAIN DRIVE ASSEMBLY .....	2-24
280	FIXING DRIVE ASS'Y .....	2-26
300	CASSETTE ASSEMBLY .....	2-27
310	PAPER PICK-UP ASSEMBLY .....	2-29
312	MULTI PAPER PICK-UP ASSEMBLY .....	2-31
315	PRE-REGISTRATION GUIDE ASS'Y .....	2-33
320	TRANSFER PAPER FEED ASSEMBLY .....	2-34
350	PAPER DELIVERY REVERSE ASS'Y .....	2-35
400	READER ASSEMBLY .....	2-37
460	LASER SCANNER UNIT .....	2-39
620	HOPPER ASSEMBLY .....	2-40
640	DEVELOPING UNIT .....	2-41
770	WASTE TONER BOX ASSEMBLY .....	2-42
810	FIXING ASSEMBLY .....	2-43
900	CONTROLLER BOX ASSEMBLY .....	2-45
930	MAIN CONTROLLER PCB ASSEMBLY .....	2-46
935	ENGINE CONTROLLER PCB ASS'Y .....	2-47
980	HIGH VOLTAGE PCB ASSEMBLY .....	2-48
A10	INTERNAL COMPONENTS (ADF) .....	2-49
A12	PAPER PICK-UP COVER ASSEMBLY (ADF) .....	2-51
A13	DOCUMENT TRAY ASSEMBLY (ADF) .....	2-52
A30	DRIVE ASSEMBLY (ADF) .....	2-53
A40	PAPER FEED ASSEMBLY (ADF) .....	2-55
T20	FAX ASSEMBLY (FAX model) .....	2-56
ZZA	MECHANICAL STANDARD PARTS (HOW TO USE) .....	2-58

# Contents

ZZB	MECHANICAL STANDARD PARTS (SCREWS) .....	2-59
ZZC	MECHANICAL STANDARD PARTS (BOLTS) .....	2-66
ZZD	MECHANICAL STANDARD PARTS (NUTS) .....	2-67
ZZE	MECHANICAL STANDARD PARTS (RETAINING RINGS)	2-68

# NUMERICAL INDEX

## imageRUNNER1750/1740/1730 Series(Numerical Index)

PARTS NUMBER	FIGURE & KEY NO.	PARTS NUMBER	FIGURE & KEY NO.	PARTS NUMBER	FIGURE & KEY NO
FA8-2446-000	100 - 21	FC0-3273-000	130 - 11	FC0-3989-000	100 - 14
FB6-3405-000	310 - 1	FC0-3274-000	130 - 12	FC0-3990-000	100 - 14
FC0-0829-000	810 - 1	FC0-3275-000	130 - 13	FC0-3991-000	100 - 14
FC0-0830-000	810 - 2	FC0-3278-000	100 - 29	FC0-3993-000	100 - 14
FC0-0868-000	100 - 1	FC0-3283-000	104 - 1	FC0-3994-000	100 - 14
FC0-0883-000	100 - 4	FC0-3300-000	130 - 14	FC0-3997-000	100 - 32
FC0-0884-000	100 - 5	FC0-3305-000	110 - 7	FC0-3998-000	101 - 6
FC0-0913-000	300 - 1	FC0-3309-000	104 - 2	FC0-4005-000	103 - 6
FC0-0922-000	101 - 1	FC0-3350-000	300 - 4	FC0-4012-000	103 - 7
FC0-0945-000	300 - 2	FC0-3351-000	300 - 5	FC0-4029-000	350 - 7
FC0-0967-000	103 - 2	FC0-3381-000	110 - 8	FC0-4033-000	100 - 15
FC0-0969-000	130 - 1	FC0-3392-000	100 - 22	FC0-4034-000	100 - 16
FC0-1003-000	101 - 2	FC0-3394-000	100 - 23	FC0-4038-000	350 - 8
FC0-1005-000	103 - 3	FC0-3395-000	100 - 24	FC0-4054-000	810 - 6
FC0-1010-000	102 - 1	FC0-3396-000	101 - 5	FC0-4061-000	620 - 1
FC0-1013-000	810 - 3	FC0-3398-000	312 - 11	FC0-5104-000	103 - 8
FC0-1021-000	810 - 4	FC0-3399-000	312 - 11	FC0-5105-000	110 - 9
FC0-1022-000	810 - 5	FC0-3400-000	312 - 11	FC0-5110-000	400 - 24
FC0-1045-000	810 - 18	FC0-3401-000	312 - 12	FC0-5113-000	103 - 9
FC0-1076-000	100 - 6	FC0-3403-000	100 - 25	FC0-5123-000	103 - 1
FC0-1077-000	100 - 7	FC0-3404-000	100 - 26	FC0-5254-000	A10 - 6
FC0-1079-000	400 - 1	FC0-3405-000	100 - 26	FC0-6912-000	100 - 23
FC0-1083-000	110 - 1	FC0-3406-000	100 - 26	FC5-1367-000	810 - 19
FC0-1090-000	110 - 2	FC0-3409-000	100 - 30	FC5-4424-000	400 - 5
FC0-1120-000	110 - 3	FC0-3411-000	810 - 15	FC5-4424-000	A30 - 1
FC0-1131-000	103 - 4	FC0-3413-000	810 - 16	FC5-4425-000	A12 - 2
FC0-1133-000	103 - 5	FC0-3414-000	810 - 17	FC5-4697-000	100 - 28
FC0-1143-000	110 - 5	FC0-3418-000	100 - 31	FC6-4391-000	100 - 17
FC0-1144-000	102 - 2	FC0-3419-000	100 - 31	FC6-4511-000	400 - 6
FC0-1155-000	100 - 10	FC0-3425-000	100 - 31	FC6-6661-000	310 - 3
FC0-1156-000	310 - 2	FC0-3426-000	100 - 31	FC6-7083-000	310 - 4
FC0-1159-000	300 - 3	FC0-3427-000	300 - 6	FC6-7598-000	400 - 7
FC0-1179-000	110 - 6	FC0-3428-000	001 - 7	FC6-7604-000	400 - 8
FC0-1184-000	400 - 2	FC0-3429-000	300 - 7	FC6-9867-000	104 - 25
FC0-1188-000	400 - 3	FC0-3430-000	300 - 8	FC6-9867-000	310 - 5
FC0-1191-000	400 - 4	FC0-3431-000	300 - 9	FC7-2975-000	400 - 25
FC0-1193-000	100 - 11	FC0-3433-000	312 - 12	FC7-5845-000	310 - 6
FC0-2970-000	A12 - 1	FC0-3434-000	312 - 12	FC7-9959-000	312 - 3
FC0-2976-000	A10 - 1	FC0-3449-000	A10 - 4	FC7-9960-000	312 - 4
FC0-2978-000	A10 - 2	FC0-3450-000	A10 - 4	FC8-2475-000	300 - 10
FC0-2985-000	A12 - 6	FC0-3451-000	A10 - 5	FC8-4986-000	300 - 11
FC0-3256-000	130 - 22	FC0-3452-000	A10 - 5	FC8-4987-000	300 - 12
FC0-3257-000	130 - 2	FC0-3971-000	100 - 13	FC8-4990-000	300 - 13
FC0-3261-000	130 - 3	FC0-3972-000	100 - 13	FC8-6380-000	103 - 10
FC0-3262-000	130 - 4	FC0-3973-000	100 - 13	FC9-0503-000	101 - 7
FC0-3263-000	130 - 5	FC0-3975-000	100 - 13	FC9-0717-000	110 - 10
FC0-3264-000	130 - 6	FC0-3976-000	100 - 13	FC9-1698-000	101 - 8
FC0-3265-000	130 - 7	FC0-3984-000	100 - 14	FC9-7171-000	300 - 14
FC0-3266-000	130 - 8	FC0-3985-000	100 - 14	FC9-7259-000	300 - 15
FC0-3267-000	130 - 9	FC0-3986-000	100 - 14	FC9-7260-000	300 - 16
FC0-3269-000	130 - 23	FC0-3987-000	100 - 14	FC9-7261-000	300 - 17
FC0-3272-000	130 - 10	FC0-3988-000	100 - 14	FC9-7708-000	101 - 9

# NUMERICAL INDEX

## imageRUNNER1750/1740/1730 Series(Numerical Index)

PARTS NUMBER	FIGURE & KEY NO.	PARTS NUMBER	FIGURE & KEY NO.	PARTS NUMBER	FIGURE & KEY NO
FK2-0408-000	A30 - 2	FL3-5535-000	A10 - 7	FM4-6524-000	102 - 4
FK2-0408-000	A40 - 1	FL3-5542-000	A30 - 5	FM4-6527-000	103 - 15
FK2-1410-000	312 - 5	FL3-5543-000	A30 - 6	FM4-6533-000	300 - 19
FK2-1773-000	935 - IC	FL3-5544-000	A10 - 9	FM4-6534-000	300 - 20
FK2-2530-000	103 - 11	FL3-5556-000	A40 - 3	FM4-6536-000	400 - 14
FK2-2530-000	104 - 3	FL3-5617-000	100 - 18	FM4-6537-000	400 - 15
FK2-3218-000	930 - IC	FL3-5619-000	110 - 12	FM4-6538-000	100 - 27
FK2-4903-000	930 - IC	FL3-5627-000	350 - 2	FM4-6539-000	100 - 27
FK2-5758-000	930 - IC	FL3-5652-000	100 - 3	FM4-6540-000	312 - 6
FK2-6450-000	935 - IC	FL3-5653-000	100 - 2	FM4-6541-000	312 - 7
FK2-6470-000	315 - 1	FL3-5654-000	100 - 9	FM4-6543-000	110 - 4
FK2-6818-000	110 - 11	FL3-5655-000	100 - 8	FM4-6546-000	350 - 3
FK2-6871-000	A40 - 2	FL3-5656-000	100 - 12	FM4-6555-000	310 -
FK2-7852-000	930 - IC	FL3-5659-000	312 - 2	FM4-6558-000	300 -
FK2-8755-000	350 - 1	FL3-5660-000	312 - 1	FM4-6559-000	300 - 21
FK2-9154-000	103 - 12	FL3-7878-000	A10 - 8	FM4-6560-000	300 - 22
FK2-9442-000	T20 - 1	FM0-0098-000	900 - 2	FM4-6564-000	104 - 6
FK3-1408-000	280 - 1	FM0-0099-000	900 - 2	FM4-6566-000	104 - 7
FK3-1416-000	130 - 15	FM0-0139-000	100 - 33	FM4-6568-000	310 - 7
FK3-1417-000	130 - 16	FM0-0629-000	100 - 20	FM4-6571-000	104 - 8
FK3-1418-000	130 - 17	FM0-0630-000	100 - 20	FM4-6572-000	110 - 13
FK3-1443-000	101 - 10	FM0-0631-000	100 - 20	FM4-6573-000	110 - 14
FK3-1444-000	T20 - 2	FM0-0632-000	100 - 20	FM4-6574-000	110 - 15
FK3-1445-000	T20 - 3	FM0-0633-000	100 - 20	FM4-6575-000	110 - 16
FK3-1446-000	900 - 1	FM0-0634-000	100 - 20	FM4-6576-000	110 - 17
FK3-1447-000	400 - 9	FM0-0635-000	100 - 20	FM4-6579-000	103 - 16
FK3-1448-000	400 - 10	FM0-0636-000	100 - 20	FM4-6583-000	810 - 7
FK3-1626-000	104 - 4	FM0-0637-000	100 - 20	FM4-6584-000	810 - 8
FK3-1633-000	A30 - 3	FM0-0638-000	100 - 20	FM4-6590-000	103 - 17
FK3-1634-000	A30 - 4	FM0-0639-000	100 - 20	FM4-7730-000	A30 -
FK3-2091-000	001 - 1	FM0-0640-000	100 - 20	FM4-7732-000	A12 - 4
FK3-2094-000	001 - 1	FM0-1846-000	460 -	FM4-7733-000	A12 -
FK3-2097-000	001 - 2	FM2-4786-000	001 - 6	FM4-7734-000	A13 -
FK3-3006-000	001 - 1	FM4-0040-000	001 - 4	FM4-7735-000	A10 - 10
FK3-3007-000	001 - 1	FM4-6494-000	640 -	FM4-7736-000	A40 -
FL2-3897-000	312 - 8	FM4-6495-000	810 -	FM4-7782-000	101 - 21
FL2-3941-000	400 - 11	FM4-6496-000	312 -	FM4-7810-000	130 - 18
FL3-4856-000	320 - 1	FM4-6497-000	250 -	FM4-7811-000	130 - 19
FL3-4857-000	320 - 2	FM4-6501-000	101 - 11	FM4-7812-000	130 - 20
FL3-4866-000	130 - 21	FM4-6502-000	102 - 3	FM4-7813-000	935 -
FL3-4867-000	130 - 21	FM4-6504-000	280 -	FM4-7814-000	980 - 1
FL3-4868-000	130 - 21	FM4-6505-000	350 -	FM4-7819-000	935 -
FL3-4870-000	130 - 21	FM4-6506-000	620 -	FM4-7826-000	400 - 16
FL3-4871-000	130 - 21	FM4-6507-000	101 - 12	FM4-7836-000	001 - 5
FL3-4874-000	110 - 31	FM4-6509-000	103 - 13	FM4-7989-000	103 - 18
FL3-4875-000	110 - 32	FM4-6511-000	103 - 14	FM4-7990-000	101 - 18
FL3-4878-000	300 - 18	FM4-6514-000	400 - 13	FM4-7991-000	101 - 19
FL3-4881-000	400 - 12	FM4-6515-000	130 -	FM4-7999-000	400 - 17
FL3-4882-000	400 - 12	FM4-6516-000	104 - 5	FM4-8001-000	100 - 19
FL3-4883-000	400 - 12	FM4-6517-000	315 -	FM4-8004-000	103 - 19
FL3-4890-000	312 - 9	FM4-6520-000	320 -	FM4-8011-000	103 - 20
FL3-5532-000	A12 - 3	FM4-6522-000	320 - 3	FM4-8017-000	104 - 9



# NUMERICAL INDEX

## imageRUNNER1750/1740/1730 Series(Numerical Index)

PARTS NUMBER	FIGURE & KEY NO.	PARTS NUMBER	FIGURE & KEY NO.	PARTS NUMBER	FIGURE & KEY NO
FM4-8018-000	102 - 5	FU9-0354-000	A12 - 7	XA9-0702-000	104 - 24
FM4-8027-000	101 - 13	FU9-0358-000	A30 - 9	XA9-0702-000	280 - 2
FM4-8029-000	620 - 2	FU9-0367-000	A30 - 10	XA9-0702-000	810 - 14
FM4-8035-000	770 -	FU9-0401-000	810 - 11	XA9-1016-000	300 - 24
FM4-8040-000	310 - 8	HH2-2824-000	001 - 3	XA9-1523-000	300 - 25
FM4-8050-000	810 -	NPN	001 -	XA9-1567-000	100 - 34
FM4-8051-000	103 - 16	NPN	100 -	XA9-1567-000	101 - 20
FM4-8053-000	130 -	NPN	101 -	XA9-1567-000	102 - 7
FM4-8054-000	130 -	NPN	102 -	XA9-1567-000	103 - 26
FM4-8056-000	130 -	NPN	103 -	XA9-1567-000	104 - 23
FM4-8057-000	130 -	NPN	104 -	XA9-1567-000	310 - 13
FM4-8064-000	102 - 6	NPN	110 -	XA9-1567-000	400 - 21
FM4-8163-000	930 -	NPN	400 -	XD1-4100-402	300 - 501
FM4-8164-000	930 -	NPN	900 -	XD3-2200-222	620 - 501
FM4-8165-000	930 -	NPN	980 -	XF2-1606-040	A30 - 12
FM4-8166-000	T20 - 4	NPN	A10 -	XF2-1606-940	A30 - 13
FM4-8168-000	T20 - 5	NPN	T20 -	XF2-1607-240	250 - 1
FS5-1943-000	310 - 9	VS1-7173-003	104 - 12	XF2-1610-440	104 - 11
FS5-1943-000	350 - 6	VS1-7173-003	110 - 27	XF2-1617-740	110 - 30
FU0-0043-000	310 - 10	VS1-7173-005	104 - 27	XF2-4607-230	400 - 22
FU5-1030-000	103 - 21	VS1-7173-006	103 - 25	XF2-4665-530	400 - 23
FU5-1626-000	A12 - 5	VS1-7173-006	104 - 13		
FU5-1763-000	310 - 11	VS1-7173-009	104 - 14		
FU5-3796-000	110 - 18	VS1-7173-012	104 - 15		
FU6-0934-000	110 - 19	VS1-7177-002	104 - 16		
FU6-2423-000	312 - 10	VS1-7177-002	A10 - 11		
FU6-3074-000	110 - 20	VS1-7177-003	103 - 24		
FU6-8873-000	101 - 14	VS1-7177-003	104 - 17		
FU6-8880-000	101 - 15	VS1-7177-003	110 - 28		
FU7-2192-000	A40 - 4	VS1-7177-006	280 - 3		
FU7-2518-000	300 - 23	VS1-7207-003	A10 - 12		
FU7-2912-000	101 - 16	VS1-7207-004	A10 - 13		
FU7-2996-000	101 - 17	VS1-7207-006	A10 - 14		
FU8-2648-000	103 - 22	VS1-7207-008	A10 - 15		
FU8-2649-000	110 - 21	VS1-7507-002	104 - 18		
FU8-2661-000	103 - 23	VS1-7507-002	A10 - 16		
FU8-2663-000	110 - 22	VS1-8412-015	104 - 19		
FU8-2667-000	104 - 10	VS1-8412-017	104 - 20		
FU8-2669-000	110 - 23	VS1-8412-019	104 - 21		
FU8-2856-000	A10 - 3	VS1-8412-023	104 - 22		
FU8-2953-000	400 - 18	WG8-5836-000	101 - 1		
FU8-2957-000	104 - 26	WG8-5836-000	110 - 29		
FU8-2974-000	A30 - 7	WG8-5836-000	310 - 12		
FU9-0206-000	810 - 9	WG8-5836-000	320 - 4		
FU9-0207-000	810 - 10	WG8-5836-000	350 - 5		
FU9-0209-000	810 - 12	WG8-5836-000	400 - 19		
FU9-0221-000	350 - 4	WG8-5836-000	810 - 13		
FU9-0222-000	110 - 24	WG8-5836-000	A13 - 1		
FU9-0230-000	110 - 25	WG8-5836-000	A30 - 11		
FU9-0231-000	110 - 26	WG8-5836-000	A40 - 5		
FU9-0345-000	A30 - 8	WG8-5928-000	101 - 4		
FU9-0353-000	A30 - 14	XA9-0679-000	400 - 20		



# imageRUNNER1750/1740/1730 Series(Parts Catalog)

## imageRUNNER1750

120V US,CA,LTN	F15-9238-000	HHW	SEND model
230V KR	F15-9277-000	HHV	

## imageRUNNER1750i

230V AU,SG,HK,LTN	F15-9248-000	HJA	SEND model
230V KR	F15-9278-000	HJC	SEND model
230V EUR	F15-9298-000	HHZ	SEND model

## imageRUNNER1750iF

120V US,CA,LTN	F15-9239-000	HJE	FAX/SEND model
-------------------	--------------	-----	----------------

## imageRUNNER1740

120V US,CA,LTN	F15-9235-000	HHJ	
230V KR	F15-9274-000	HHH	

## imageRUNNER1740i

230V TW,HK	F15-9205-000	HHN	SEND model
230V AU,SG,HK,LTN	F15-9245-000	HHL	SEND model
230V KR	F15-9275-000	HHM	SEND model
230V EUR	F15-9295-000	HHK	SEND model

## imageRUNNER1740iF

<b>120V US,CA,LTN</b>	<b>F15-9236-000</b>	<b>HHP</b>	FAX/SEND model
---------------------------	---------------------	------------	----------------

## imageRUNNER1730

<b>120V US,CA,LTN</b>	<b>F15-9232-000</b>	<b>HGX</b>	SEND model
---------------------------	---------------------	------------	------------

<b>230V SG,HK</b>	<b>F15-9241-000</b>	<b>HGU</b>	
-------------------	---------------------	------------	--

<b>230V KR</b>	<b>F15-9271-000</b>	<b>HGW</b>	
----------------	---------------------	------------	--

## imageRUNNER1730i

<b>230V AU,SG,HK,LTN</b>	<b>F15-9242-000</b>	<b>HGZ</b>	SEND model
------------------------------	---------------------	------------	------------

<b>230V KR</b>	<b>F15-9272-000</b>	<b>HHA</b>	SEND model
----------------	---------------------	------------	------------

<b>230V EUR</b>	<b>F15-9292-000</b>	<b>HGY</b>	SEND model
-----------------	---------------------	------------	------------

## imageRUNNER1730iF

<b>120V US,CA,LTN</b>	<b>F15-9233-000</b>	<b>HHC</b>	FAX/SEND model
---------------------------	---------------------	------------	----------------

# Contents

A1	ASSEMBLY LOCATION DIAGRAM .....	2-1
A2	OPTION PARTS CATALOG LIST .....	2-4
001	ACCESSORIES .....	2-5
100	EXTERNAL COVERS, PANELS, ETC. ....	2-7
101	INTERNAL COMPONENTS 1 .....	2-11
102	INTERNAL COMPONENTS 2 .....	2-13
103	INTERNAL COMPONENTS 3 .....	2-15
104	MACHINE REAR PLATE .....	2-17
110	RIGHT DOOR ASSEMBLY .....	2-19
130	CONTROL PANEL ASSEMBLY .....	2-22
250	MAIN DRIVE ASSEMBLY .....	2-24
280	FIXING DRIVE ASS'Y .....	2-26
300	CASSETTE ASSEMBLY .....	2-27
310	PAPER PICK-UP ASSEMBLY .....	2-29
312	MULTI PAPER PICK-UP ASSEMBLY .....	2-31
315	PRE-REGISTRATION GUIDE ASS'Y .....	2-33
320	TRANSFER PAPER FEED ASSEMBLY .....	2-34
350	PAPER DELIVERY REVERSE ASS'Y .....	2-35
400	READER ASSEMBLY .....	2-37
460	LASER SCANNER UNIT .....	2-39
620	HOPPER ASSEMBLY .....	2-40
640	DEVELOPING UNIT .....	2-41
770	WASTE TONER BOX ASSEMBLY .....	2-42
810	FIXING ASSEMBLY .....	2-43
900	CONTROLLER BOX ASSEMBLY .....	2-45
930	MAIN CONTROLLER PCB ASSEMBLY .....	2-46
935	ENGINE CONTROLLER PCB ASS'Y .....	2-47
980	HIGH VOLTAGE PCB ASSEMBLY .....	2-48
A10	INTERNAL COMPONENTS (ADF) .....	2-49
A12	PAPER PICK-UP COVER ASSEMBLY (ADF) .....	2-51
A13	DOCUMENT TRAY ASSEMBLY (ADF) .....	2-52
A30	DRIVE ASSEMBLY (ADF) .....	2-53
A40	PAPER FEED ASSEMBLY (ADF) .....	2-55
T20	FAX ASSEMBLY (FAX model) .....	2-56
ZZA	MECHANICAL STANDARD PARTS (HOW TO USE) .....	2-58
ZZB	MECHANICAL STANDARD PARTS (SCREWS) .....	2-59
ZZC	MECHANICAL STANDARD PARTS (BOLTS) .....	2-66
ZZD	MECHANICAL STANDARD PARTS (NUTS) .....	2-67
ZZE	MECHANICAL STANDARD PARTS (RETAINING RINGS) .....	2-68



# FIGURE A1 ASSEMBLY LOCATION DIAGRAM

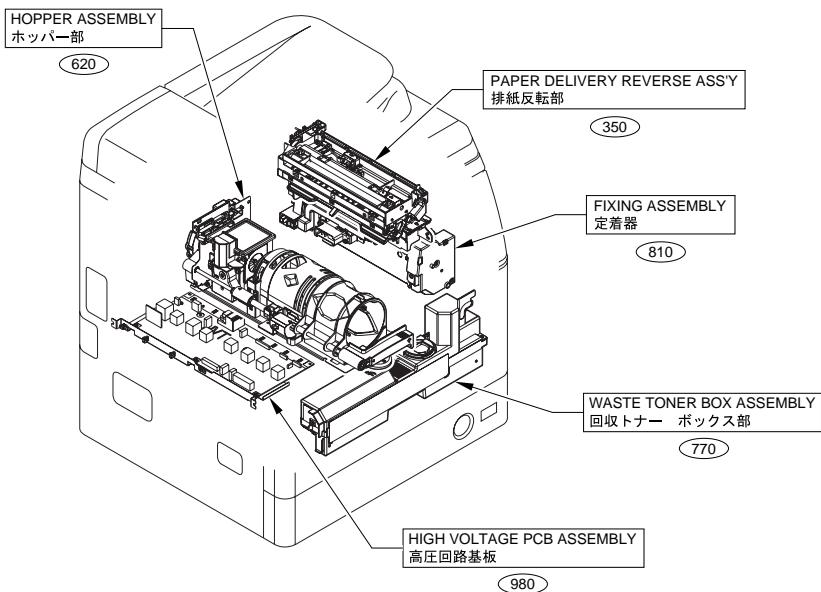
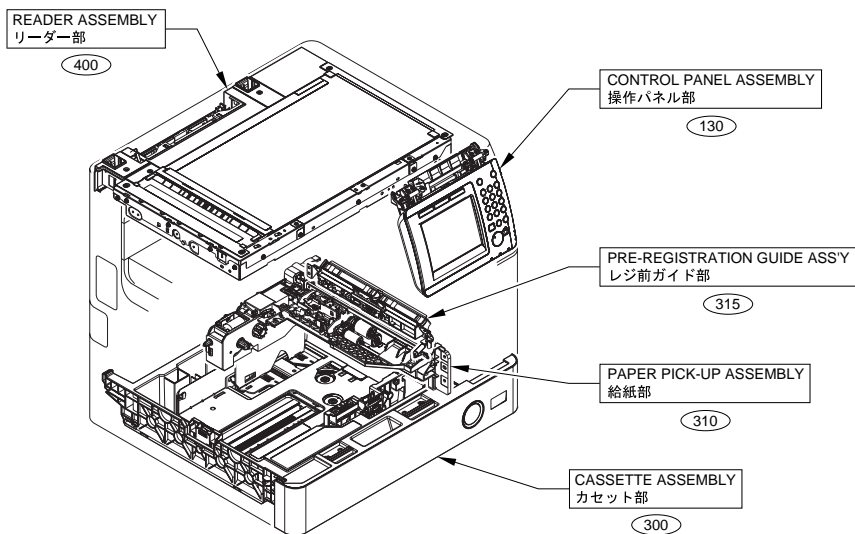

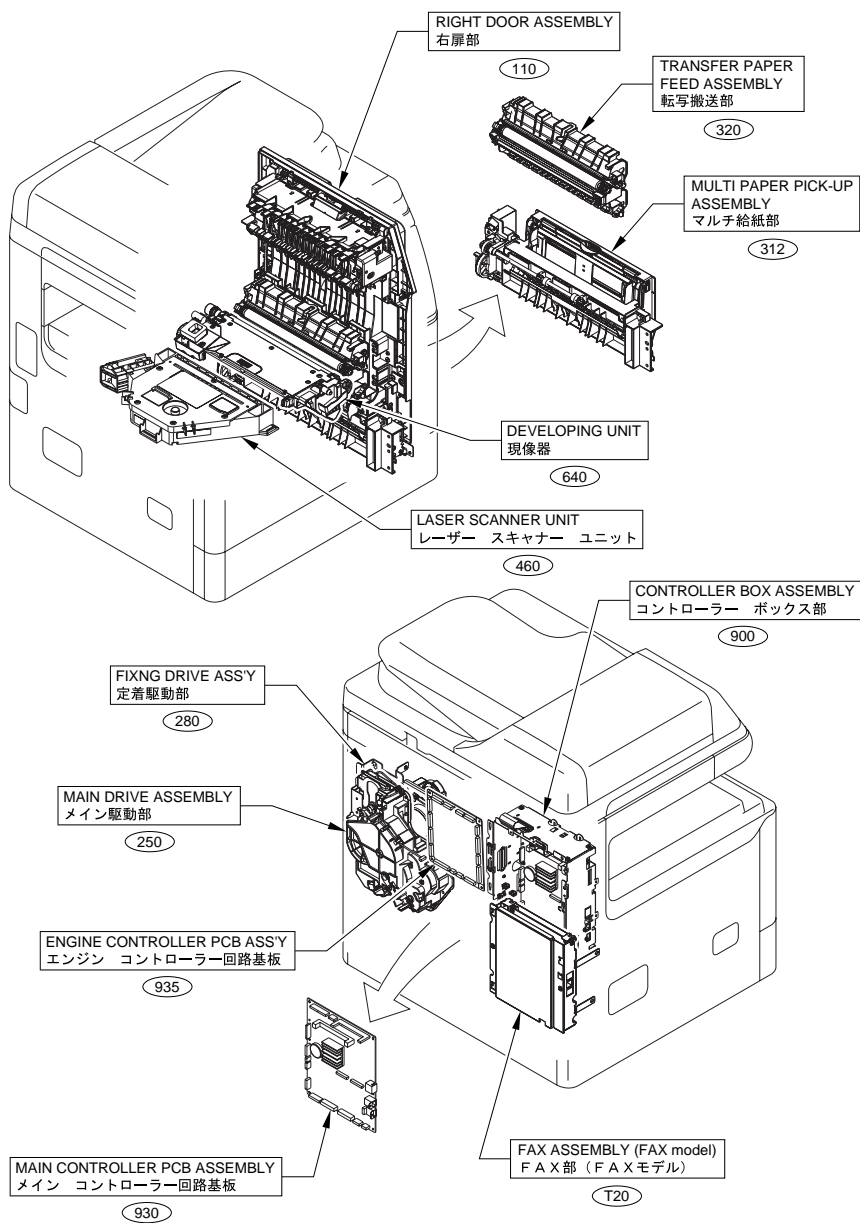



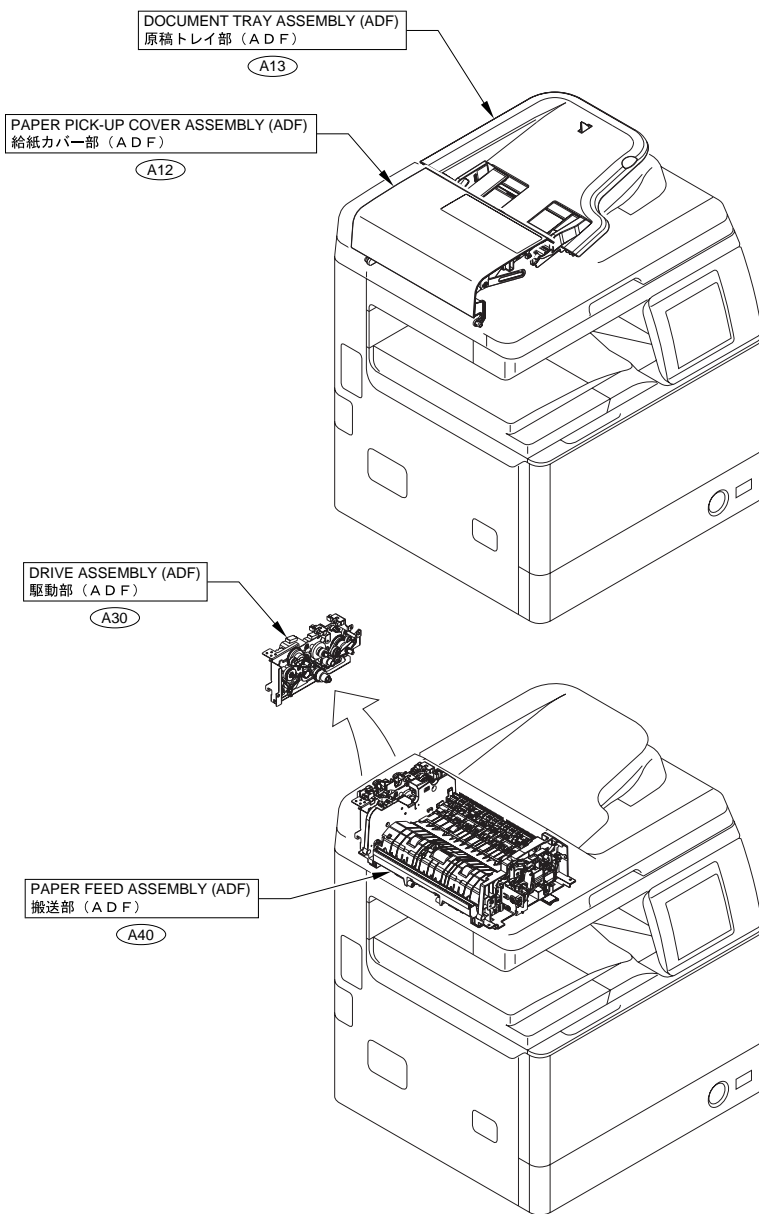

## FIGURE A2 OPTION PARTS CATALOG LIST

This is the table of the machine's options whose parts catalog is issued.  
本機のオプションで、パーツカタログが発行されている機種の一覧である。

No.	Model Name(English)	Model Name(Japanese)
1	ADF Access Handle-A1	(日本仕向けなし)
2	Cassette Module-Y1	(日本仕向けなし)
3	FL Cassette-AP1	(日本仕向けなし)
4	Envelope Cassette-D1	(日本仕向けなし)
5	Staple Finisher-H1	(日本仕向けなし)
6	Drum Heater-D1	(日本仕向けなし)
7	Copy Card Reader Attachment-C1	(日本仕向けなし)
8	Super G3 Fax Board-AJ1	(日本仕向けなし)
9	USB Application 3-Port Interface Kit-B1	(日本仕向けなし)

# FIGURE 001 ACCESSORIES

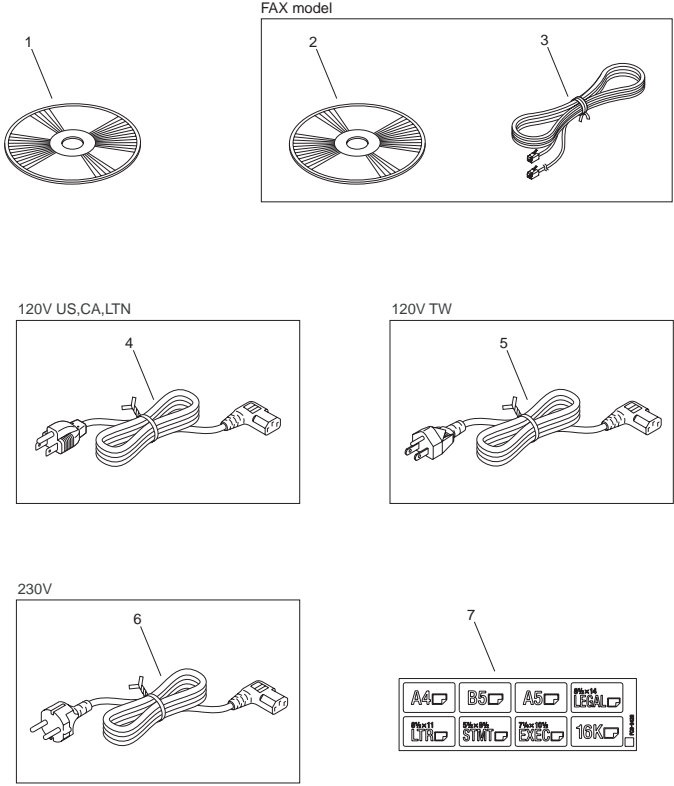

FIGURE & KEY NO.	PARTS NUMBER	R A N K	Q'TY	DESCRIPTION	SERIAL NUMBER/ REMARKS	S V C
Fig.001	NPN		RF	ACCESSORIES		
1	FK3-3006-000		1	CD-ROM, SOFTWARE FOR UFR II LT	English,French,Italian,German,Spanish	
1	FK3-3007-000		1	CD-ROM, SOFTWARE FOR UFR II LT	English,Simplified Chinese,Traditional Chinese,Korean	
1	FK3-2091-000		1	CD-ROM, SOFTWARE FOR PCL	English,French,Italian,German,Spanish	
1	FK3-2094-000		1	CD-ROM, SOFTWARE FOR PS	English,French,Italian,German,Spanish	
2	FK3-2097-000		1	CD-ROM, SOFTWARE FOR FAX	English,French,Italian,German,Spanish	
3	HH2-2824-000		1	MODULAR CORD, 2P	FAX model	
4	FM4-0040-000		1	CORD, POWER	120V US,CA,LTN	
5	FM4-7836-000		1	CORD, POWER	120V TW	
6	FM2-4786-000		1	POWER CORD	230V	
7	FC0-3428-000		1	SHEET, PAPER SIZE		

# FIGURE 100 EXTERNAL COVERS, PANELS, ETC.

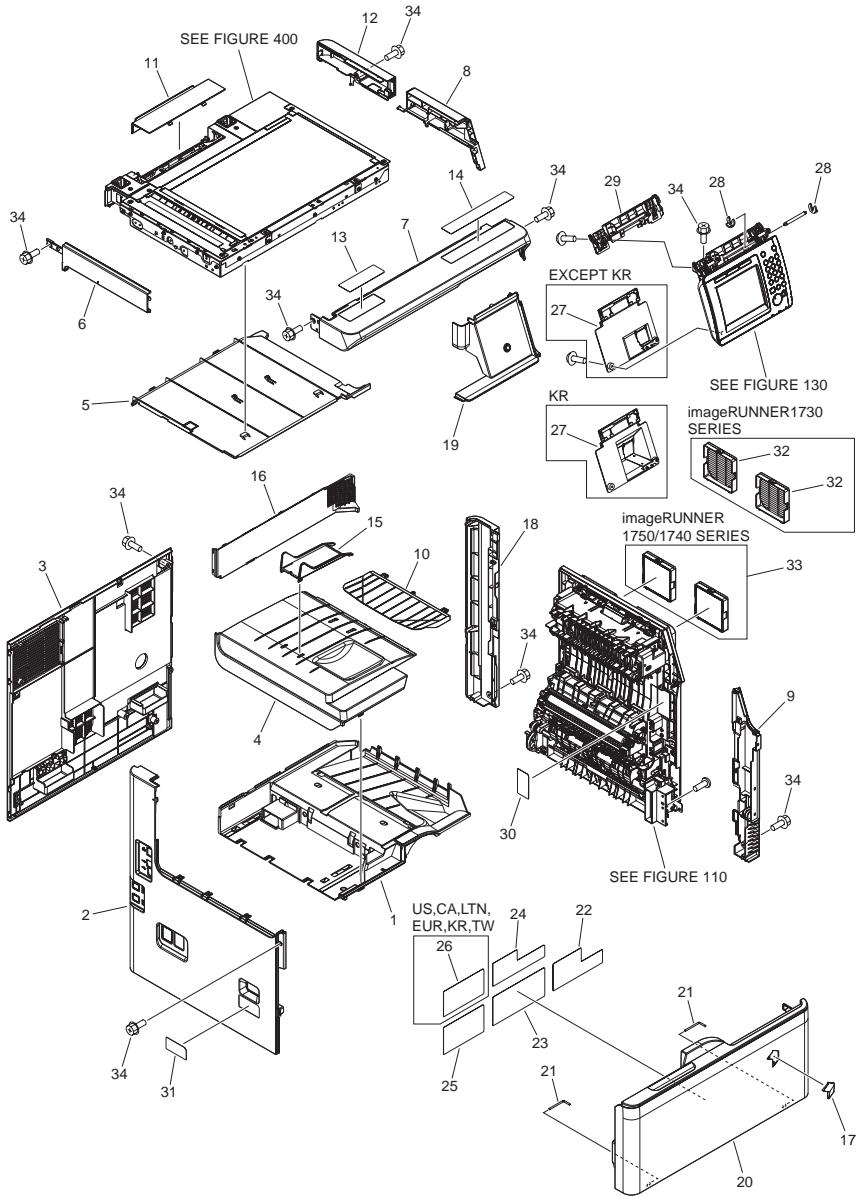

FIGURE & KEY NO.	PARTS NUMBER	R A N K	Q'TY	DESCRIPTION	SERIAL NUMBER/ REMARKS	S V C
Fig.100	NPN		RF	EXTERNAL COVERS, PANELS, ETC.		
1	FC0-0868-000		1	TRAY, PAPER DELIVERY, 1		
2	FL3-5653-000		1	COVER, LEFT		
3	FL3-5652-000		1	COVER, REAR		
4	FC0-0883-000		1	TRAY, PAPER DELIVERY, 2		
5	FC0-0884-000		1	COVER, REEDER, LOWER		
6	FC0-1076-000		1	COVER, READER, LEFT		
7	FC0-1077-000		1	COVER, READER, FRONT		
8	FL3-5655-000		1	COVER, READER, RIGHT		
9	FL3-5654-000		1	COVER, RIGHT FRONT		
10	FC0-1155-000		1	TRAY, REVERSE		
11	FC0-1193-000		1	COVER, READER REAR, 2		
12	FL3-5656-000		1	COVER, READER, RIGHT REAR		
13	FC0-3971-000		1	LABEL, GLASS CLEANING	US,CA,AU,SG,HK,LTN US English	
13	FC0-3972-000		1	LABEL, GLASS CLEANING	US,CA,AU,SG,HK,LTN Canadian French,Spanish,Portuguese	
13	FC0-3973-000		1	LABEL, GLASS CLEANING	EUR	
13	FC0-3975-000		1	LABEL, GLASS CLEANING	KR	
13	FC0-3976-000		1	LABEL, GLASS CLEANING	TW	
14	FC0-3984-000		1	LABEL, COPY INHIBITED	US English	
14	FC0-3985-000		1	LABEL, COPY INHIBITED	Canadian French	
14	FC0-3986-000		1	LABEL, COPY INHIBITED	Portuguese	
14	FC0-3987-000		1	LABEL, COPY INHIBITED	Spanish	
14	FC0-3988-000		1	LABEL, COPY INHIBITED	UK English	
14	FC0-3989-000		1	LABEL, COPY INHIBITED	French	
14	FC0-3990-000		1	LABEL, COPY INHIBITED	German	
14	FC0-3991-000		1	LABEL, COPY INHIBITED	Italian	
14	FC0-3993-000		1	LABEL, COPY INHIBITED	Traditional Chinese	
14	FC0-3994-000		1	LABEL, COPY INHIBITED	Korean	
15	FC0-4033-000		1	RIB, STACK		
16	FC0-4034-000		1	PANEL, INNER		

FIGURE & KEY NO.	PARTS NUMBER	R A N K	Q'TY	DESCRIPTION	SERIAL NUMBER/ REMARKS	S V C
17	FC6-4391-000		1	EMBLEM		
18	FL3-5617-000		1	COVER, RIGHT REAR		
19	FM4-8001-000		1	COVER UNIT, RIGHT FRONT		
20	FM0-0629-000		1	FRONT DOOR ASS'Y	imageRUNNER1750 US,CA,LTN	
20	FM0-0630-000		1	FRONT DOOR ASS'Y	imageRUNNER1750 KR	
20	FM0-0632-000		1	FRONT DOOR ASS'Y	imageRUNNER1750i	
20	FM0-0631-000		1	FRONT DOOR ASS'Y	imageRUNNER1750iF	
20	FM0-0633-000		1	FRONT DOOR ASS'Y	imageRUNNER1740 US,CA,LTN	
20	FM0-0634-000		1	FRONT DOOR ASS'Y	imageRUNNER1740 KR	
20	FM0-0636-000		1	FRONT DOOR ASS'Y	imageRUNNER1740i	
20	FM0-0635-000		1	FRONT DOOR ASS'Y	imageRUNNER1740iF	
20	FM0-0637-000		1	FRONT DOOR ASS'Y	imageRUNNER1730 US,CA,LTN	
20	FM0-0638-000		1	FRONT DOOR ASS'Y	imageRUNNER1730 SG,HK,KR	
20	FM0-0640-000		1	FRONT DOOR ASS'Y	imageRUNNER1730i	
20	FM0-0639-000		1	FRONT DOOR ASS'Y	imageRUNNER1730iF	
21	FA8-2446-000		2	PIN, HINGE		
22	FC0-3392-000		1	LABEL, WASTE TONER EXCHANGE		
23	FC0-3394-000		1	LABEL, DRUM EXCHANGE, 1	US,CA,EUR,AU,SG,HK,L TN	
23	FC0-6912-000		1	LABEL, DRUM EXCHANGE, 1	KR,TW	
24	FC0-3395-000		1	LABEL, DRUM EXCHANGE, 2		
25	FC0-3403-000		1	LABEL, TONER SUPPLY		
26	FC0-3406-000		1	LABEL, TONER	US,CA,LTN	
26	FC0-3405-000		1	LABEL, TONER	EUR	
26	FC0-3404-000		1	LABEL, TONER	KR,TW	
27	FM4-6538-000		1	COVER UNIT, OPERATION, REAR	EXCEPT KR	
27	FM4-6539-000		1	COVER UNIT, OPERATION, REAR	KR	
28	FC5-4697-000		2	RING, RETAINING		
29	FC0-3278-000		1	COVER, FFC		
30	FC0-3409-000		1	LABEL,TRANSFER ROLLER CAUTION		

FIGURE & KEY NO.	PARTS NUMBER	RANK	Q'TY	DESCRIPTION	SERIAL NUMBER/REMARKS	SVC
31	FC0-3419-000		1	LABEL, MAIN POWER	EUR	
31	FC0-3418-000		1	LABEL, MAIN POWER	US,CA,AU,SG,HK,LTN	
31	FC0-3425-000		1	LABEL, MAIN POWER	KR	
31	FC0-3426-000		1	LABEL, MAIN POWER	TW	
32	FC0-3997-000		2	COVER, AIR FILTER	imageRUNNER1730 SERIES	
33	FM0-0139-000		1	FILTER, AIR	imageRUNNER1750/1740 SERIES	
34	XA9-1567-000		AR	SCREW, RS, M3X8.5		



# FIGURE 101 INTERNAL COMPONENTS 1

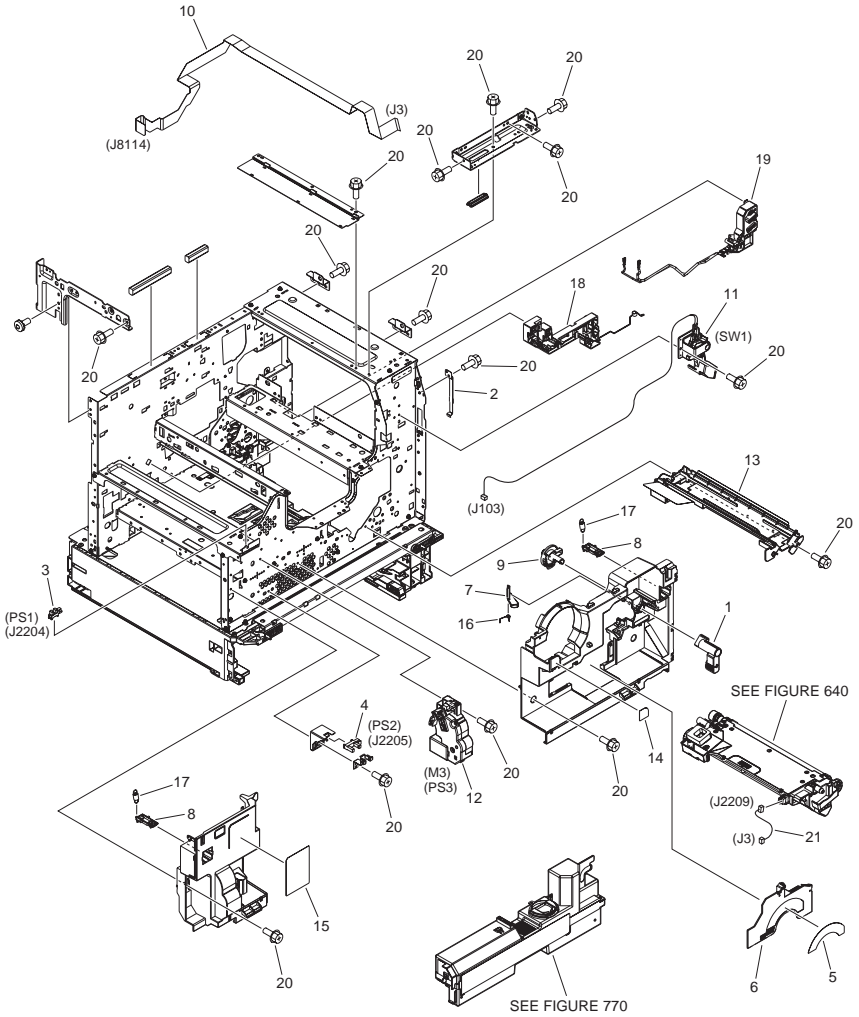

FIGURE & KEY NO.	PARTS NUMBER	R A N K	Q'TY	DESCRIPTION	SERIAL NUMBER/REMARKS	S V C
Fig.101	NPN		RF	INTERNAL COMPONENTS 1		
1	FC0-0922-000		1	LEVER, BOTTLE EXCHANGE		
2	FC0-1003-000		1	SPRING, LEAF		
3	WG8-5836-000		1	IC PHOTOINTERRUPTER, HYBRID	PS1	
4	WG8-5928-000		1	IC, PHOTO INTERRUPTER	PS2	
5	FC0-3396-000		1	LABEL, DEV. PRESSURE LOCK		
6	FC0-3998-000		1	PANEL, DEVELOPING EXCHANGE		
7	FC9-0503-000		1	LEVER, HANDLE LOCK		
8	FC9-1698-000		2	HOOK, FRONT DOOR		
9	FC9-7708-000		1	GEAR, 7T		
10	FK3-1443-000		1	CABLE, PANEL-IP FLAT		
11	FM4-6501-000		1	INTERLOCK UNIT	SW1	
12	FM4-6507-000		1	WASTE TONER DRIVE UNIT	M3,PS3	
13	FM4-8027-000		1	STAY UNIT, DEVELOPING		
14	FU6-8873-000		1	LABEL, LOCK UNLOCK		
15	FU6-8880-000		1	LABEL, LASER CAUTION		
16	FU7-2912-000		1	SPRING, TORSION		
17	FU7-2996-000		2	SPRING, TENSION		
18	FM4-7990-000		1	HV GUIDE UNIT, LOWER		
19	FM4-7991-000		1	HV GUIDE UNIT, RIGHT		
20	XA9-1567-000		AR	SCREW, RS, M3X8.5		
21	FM4-7782-000		1	CABLE, CONNECTING, SENSOR		

# FIGURE 102 INTERNAL COMPONENTS 2

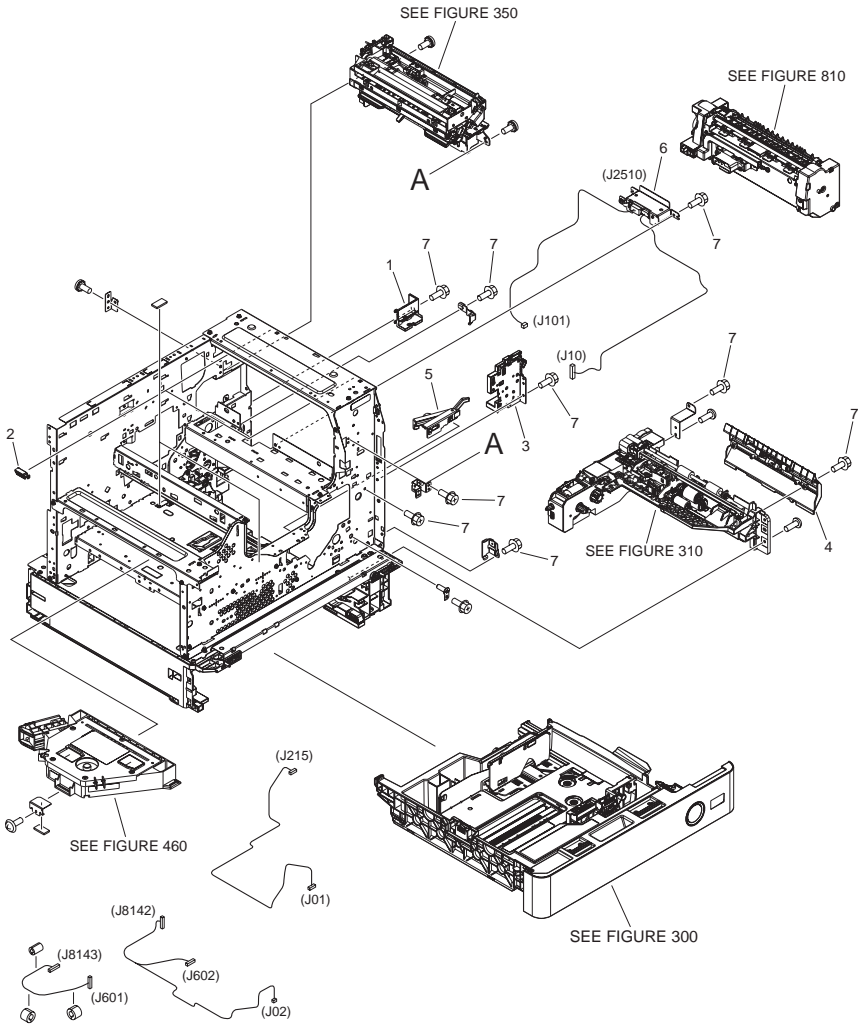

FIGURE & KEY NO.	PARTS NUMBER	RANK	Q'TY	DESCRIPTION	SERIAL NUMBER/REMARKS	SVC
Fig.102	NPN		RF	INTERNAL COMPONENTS 2		
1	FC0-1010-000		1	RAIL, FIXING GUIDE		
2	FC0-1144-000		2	LOCK, RIGHT DOOR		
3	FM4-6502-000		1	RAIL UNIT, FIXING, FRONT		
4	FM4-6524-000		1	VERTICAL PATH GUIDE UNIT		
5	FM4-8018-000		1	LASER SHUTTER UNIT		
6	FM4-8064-000		1	DRAWER CABLE UNIT, FIXING		
7	XA9-1567-000		AR	SCREW, RS, M3X8.5		

# FIGURE 103 INTERNAL COMPONENTS 3

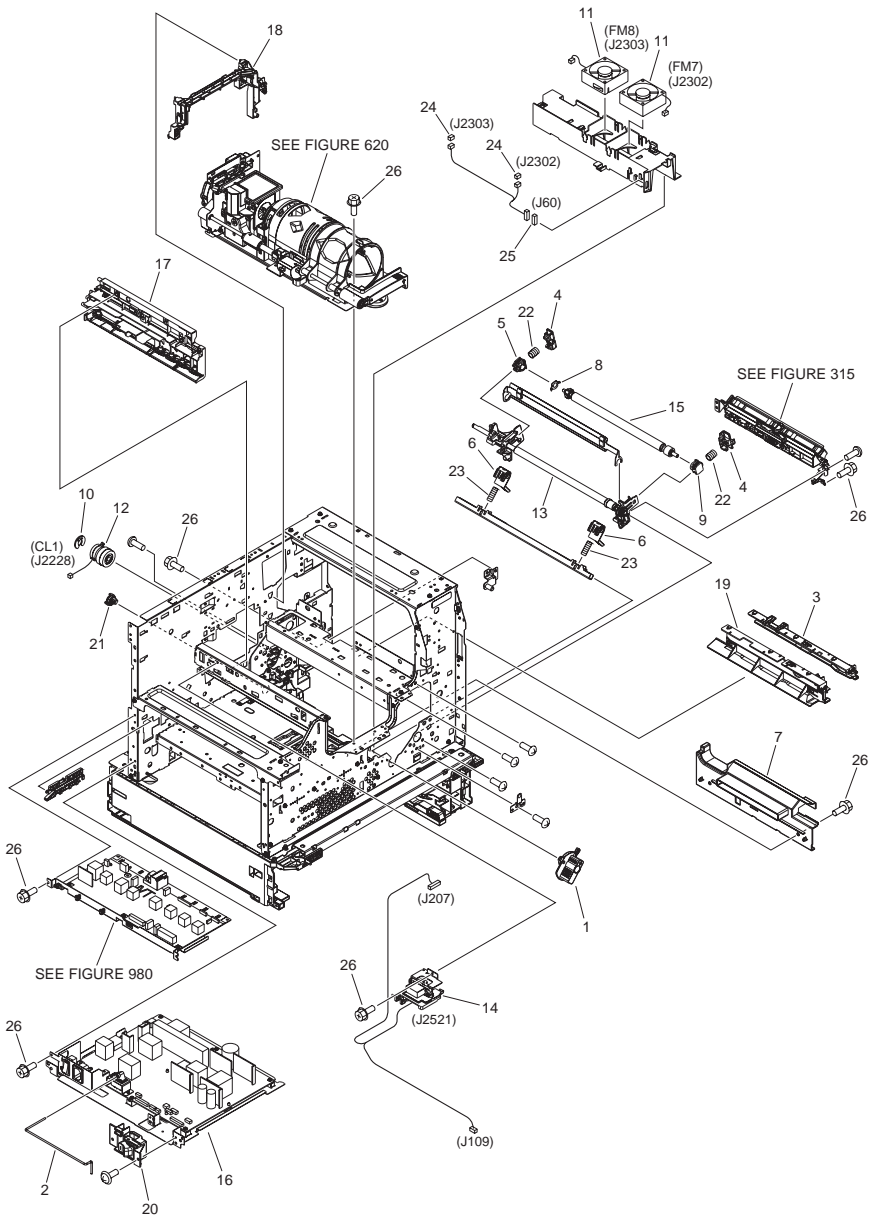

FIGURE & KEY NO.	PARTS NUMBER	RANK	Q'TY	DESCRIPTION	SERIAL NUMBER/REMARKS	SVC
Fig.103	NPN		RF	INTERNAL COMPONENTS 3		
1	FC0-5123-000		1	HANDLE, PRESSURE		
2	FC0-0967-000		1	ROD, JOINT		
3	FC0-1005-000		1	RAIL, CARTRIDGE, RIGHT		
4	FC0-1131-000		2	STOPPER		
5	FC0-1133-000		1	BUSHING		
6	FC0-4005-000		2	CAM, DEVELOPING PRESSURE		
7	FC0-4012-000		1	GUIDE, HOPPER LOWER		
8	FC0-5104-000		1	PLATE, GROUNDING		
9	FC0-5113-000		1	BUSHING		
10	FC8-6380-000		1	CLIP		
11	FK2-2530-000		2	FAN	FM7,FM8	
12	FK2-9154-000		1	CLUTCH	CL1	
13	FM4-6509-000		1	REGISTRATION UNIT		
14	FM4-6511-000		1	DRAWER CABLE UNIT		
15	FM4-6527-000		1	REGISTRATION ROLLER UNIT		
16	FM4-6579-000		1	POWER SUPPLY ASSEMBLY	120V	
16	FM4-8051-000		1	POWER SUPPLY ASSEMBLY	230V	
17	FM4-6590-000		1	HV GUIDE UNIT		
18	FM4-7989-000		1	HV GUIDE UNIT, UPPER		
19	FM4-8004-000		1	RAIL UNIT, CARTRIDGE, LEFT		
20	FM4-8011-000		1	POWER SWITCH UNIT		
21	FU5-1030-000		1	BUSHING		
22	FU8-2648-000		2	SPRING, COMPRESSION		
23	FU8-2661-000		2	SPRING, COMPRESSION		
24	VS1-7177-003		2	CONNECTOR, SNAP TIGHT, BK		
25	VS1-7173-006		1	CONNECTOR, SNAP TIGHT, 6P, W		
26	XA9-1567-000		AR	SCREW, RS, M3X8.5		

# FIGURE 104 MACHINE REAR PLATE

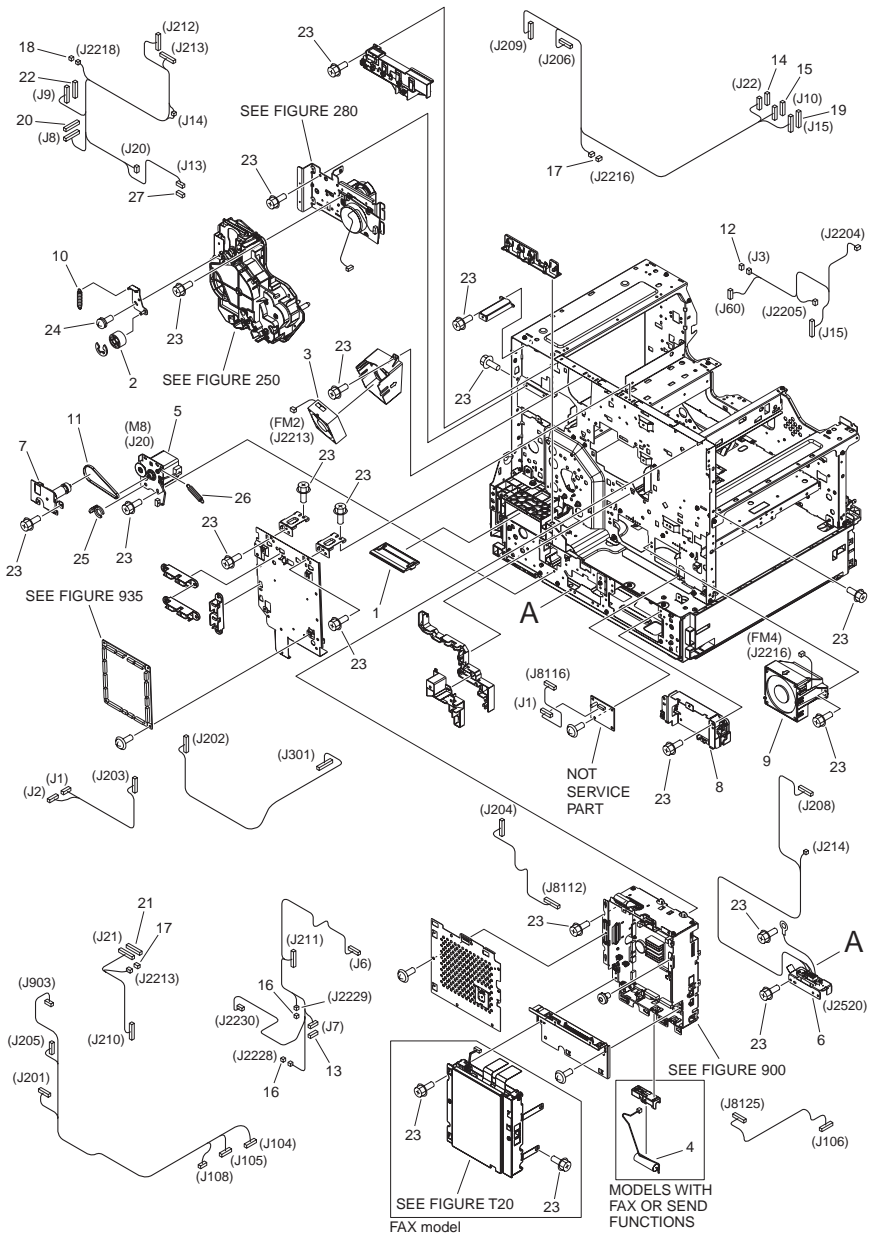

FIGURE & KEY NO.	PARTS NUMBER	R A N K	Q'TY	DESCRIPTION	SERIAL NUMBER/ REMARKS	S V C
Fig.104	NPN		RF	MACHINE REAR PLATE		
1	FC0-3283-000		1	RIB, HANDLE		
2	FC0-3309-000		1	ROLLER, TENSION		
3	FK2-2530-000		1	FAN	FM2	
4	FK3-1626-000		1	BATTERY, NI-MH	MODELS WITH FAX OR SEND FUNCTIONS	
5	FM4-6516-000		1	PAPER PICK-UP MOTOR UNIT	M8	
6	FM4-6564-000		1	DRAWER CABLE UNIT, CASSETTE		
7	FM4-6566-000		1	LINK DRIVE UNIT		
8	FM4-6571-000		1	SIZE DETECT UNIT		
9	FM4-8017-000		1	FAN UNIT	FM4	
10	FU8-2667-000		1	SPRING, TENSION		
11	XF2-1610-440		1	BELT, TIMING, CR		
12	VS1-7173-003		1	CONNECTOR, SNAP TIGHT, 3P, W		
13	VS1-7173-006		1	CONNECTOR, SNAP TIGHT, 6P, W		
14	VS1-7173-009		1	CONNECTOR, SNAP TIGHT, 9P, W		
15	VS1-7173-012		1	CONNECTOR, SNAP TIGHT, 12P, W		
16	VS1-7177-002		2	CONNECTOR, SNAP TIGHT, BK		
17	VS1-7177-003		2	CONNECTOR, SNAP TIGHT, BK		
18	VS1-7507-002		1	CONNECTOR, 2P		
19	VS1-8412-015		1	CONNECTOR, SNAP TIGHT, BL		
20	VS1-8412-017		1	CONNECTOR, SNAP TIGHT, BL		
21	VS1-8412-019		1	CONNECTOR, SNAP TIGHT, BL		
22	VS1-8412-023		1	CONNECTOR, SNAP TIGHT, BL		
23	XA9-1567-000		AR	SCREW, RS, M3X8.5		
24	XA9-0702-000		2	SCREW, W/WASHER, M3X6		
25	FC6-9867-000		1	RING, RETAINING		
26	FU8-2957-000		1	SPRING, TENSION		
27	VS1-7173-005		1	CONNECTOR, SNAP TIGHT		



# FIGURE 110 RIGHT DOOR ASSEMBLY

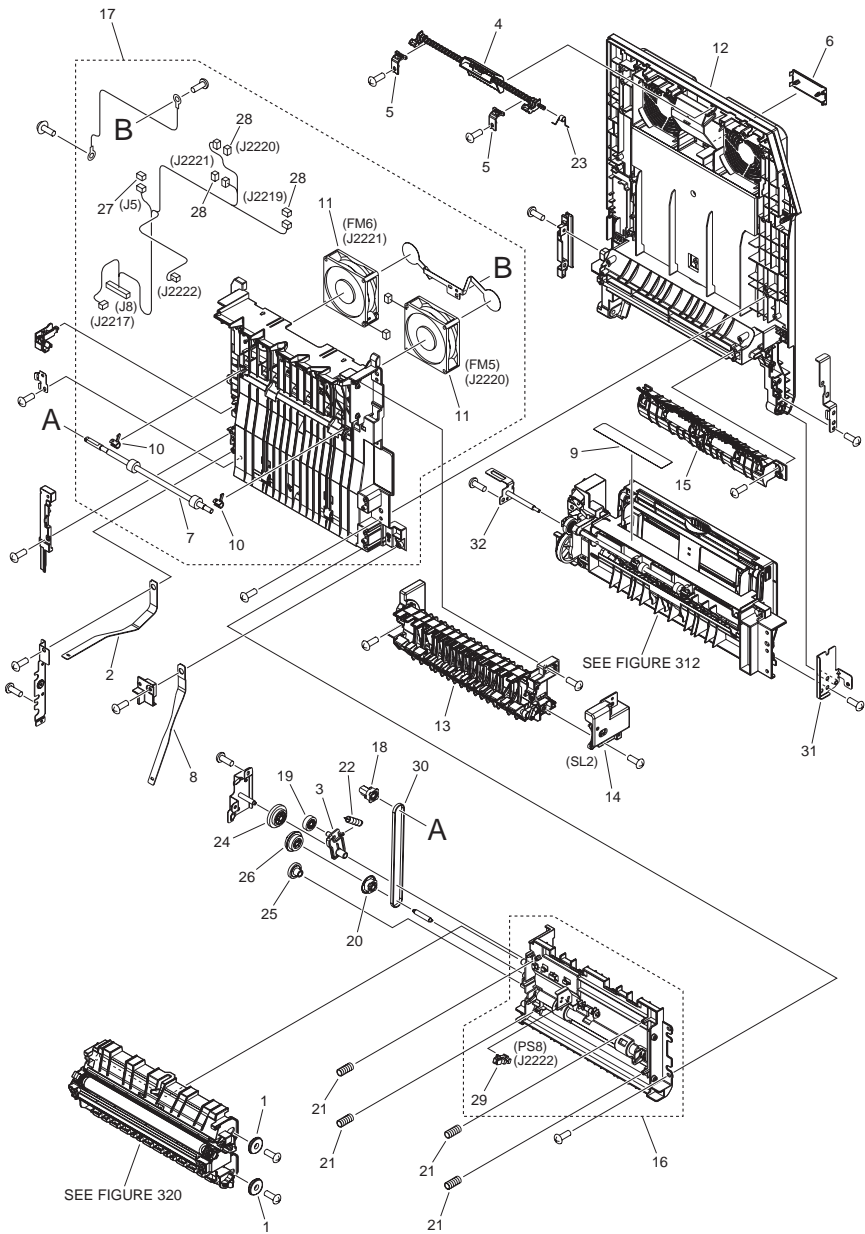

FIGURE & KEY NO.	PARTS NUMBER	RANK	Q'TY	DESCRIPTION	SERIAL NUMBER/REMARKS	SVC
Fig.110	NPN		RF	RIGHT DOOR ASSEMBLY		
1	FC0-1083-000		2	RING		
2	FC0-1090-000		1	BAND, RIGHTDOOR, REAR		
3	FC0-1120-000		1	ARM, GEAR		
4	FM4-6543-000		1	HOOK UNIT, RIGHT DOOR		
5	FC0-1143-000		2	STOPPER, LEVER		
6	FC0-1179-000		1	PLATE, RIGHT DOOR		
7	FC0-3305-000		1	ROLLER		
8	FC0-3381-000		1	BAND, RIGHT DOOR, FRONT		
9	FC0-5105-000		1	LABEL, LEVER		
10	FC9-0717-000		2	BUSHING		
11	FK2-6818-000		2	FAN	FM5,FM6	
12	FL3-5619-000		1	DOOR, RIGHT		
13	FM4-6572-000		1	DUPLEXING PAPER FEED UNIT		
14	FM4-6573-000		1	SOLENOID UNIT	SL2	
15	FM4-6574-000		1	VERTICAL PATH GUIDE UNIT		
16	FM4-6575-000		1	DUPLEXING FEED MOUNT UNIT		
17	FM4-6576-000		1	DUPLEXING ENTRANCE GUIDE ASSY		
18	FU5-3796-000		1	PULLEY, 28T		
19	FU6-0934-000		1	GEAR, 18T		
20	FU6-3074-000		1	PULLEY, 28T		
21	FU8-2649-000		4	SPRING, COMPRESSION		
22	FU8-2663-000		1	SPRING, TENSION		
23	FU8-2669-000		1	SPRING, TORSION		
24	FU9-0222-000		1	GEAR, 31T/22T		
25	FU9-0230-000		1	GEAR, 20 T		
26	FU9-0231-000		1	PULLEY, 28T/GEAR, 20T/26T		
27	VS1-7173-003		1	CONNECTOR, SNAP TIGHT, 3P, W		
28	VS1-7177-003		3	CONNECTOR, SNAP TIGHT, BK		
29	WG8-5836-000		1	IC PHOTOINTERRUPTER, HYBRID	PS8	
30	XF2-1617-740		1	BELT, TIMING		
31	FL3-4874-000		1	HINGE, DOOR, FRONT		

FIGURE & KEY NO.	PARTS NUMBER	R A N K	Q'TY	DESCRIPTION	SERIAL NUMBER/ REMARKS	S V C
32	FL3-4875-000		1	HINGE, DOOR, REAR		

# FIGURE 130 CONTROL PANEL ASSEMBLY

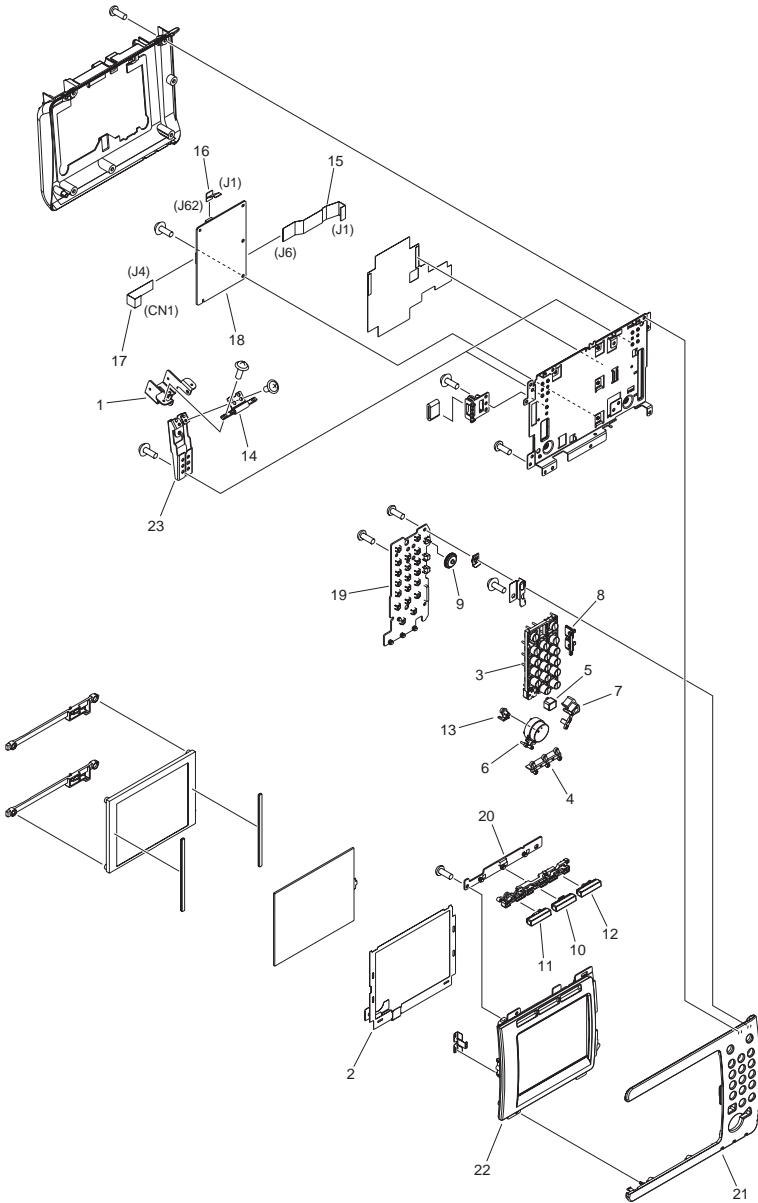

FIGURE & KEY NO.	PARTS NUMBER	R A N K	Q'TY	DESCRIPTION	SERIAL NUMBER/ REMARKS	S V C
Fig.130	FM4-6515-000		1	CONTROL PANEL ASSEMBLY	US,CA,LTN	
Fig.130	FM4-8054-000		1	CONTROL PANEL ASSEMBLY	EUR	
Fig.130	FM4-8053-000		1	CONTROL PANEL ASSEMBLY	AU,SG,HK,LTN	
Fig.130	FM4-8056-000		1	CONTROL PANEL ASSEMBLY	KR	
Fig.130	FM4-8057-000		1	CONTROL PANEL ASSEMBLY	TW	
1	FC0-0969-000		2	HINGE, 1		
2	FC0-3257-000		1	SHEET, TOUCH PANEL		
3	FC0-3261-000		1	KEY TOP, TEN		
4	FC0-3262-000		1	COVER, LED		
5	FC0-3263-000		1	KEY TOP, RESET		
6	FC0-3264-000		1	KEY TOP, START		
7	FC0-3265-000		1	KEY TOP, STOP		
8	FC0-3266-000		1	KEY TOP, VOLUME		
9	FC0-3267-000		1	DIAL, CONTRAST		
10	FC0-3272-000		1	KEY TOP, SYSTEM, 2		
11	FC0-3273-000		1	KEY TOP, SYSTEM, 1		
12	FC0-3274-000		1	KEY TOP, SYSTEM, 3		
13	FC0-3275-000		1	KEY TOP, START, LED		
14	FC0-3300-000		2	HINGE, 2		
15	FK3-1416-000		1	CABLE, CPU-TEN KEY FLAT		
16	FK3-1417-000		1	CABLE, CPU-SYSTEM KEY FLAT		
17	FK3-1418-000		1	CABLE, CPU-LCD FLAT		
18	FM4-7810-000		1	CONTROL PANEL CPU PCB ASS'Y		
19	FM4-7811-000		1	TEN KEY PCB ASS'Y		
20	FM4-7812-000		1	SYSTEM KEY PCB ASS'Y		
21	FL3-4866-000		1	COVER, CONTROL PANEL, FRONT, 1	US,CA,LTN	
21	FL3-4868-000		1	COVER, CONTROL PANEL, FRONT, 1	EUR	
21	FL3-4867-000		1	COVER, CONTROL PANEL, FRONT, 1	AU,SG,HK,LTN	
21	FL3-4870-000		1	COVER, CONTROL PANEL, FRONT, 1	KR	
21	FL3-4871-000		1	COVER, CONTROL PANEL, FRONT, 1	TW	
22	FC0-3256-000		1	COVER, CONTROL PANEL, FRONT, 2		
23	FC0-3269-000		1	PLATE, HINGE		

FIGURE 250  
MAIN DRIVE ASSEMBLY

MAIN DRIVE ASSEMBLY  
メイン駆動部

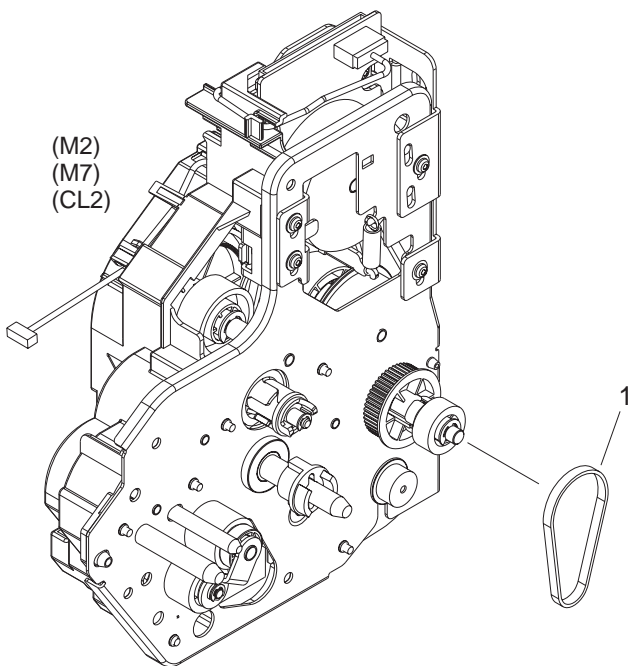

FIGURE & KEY NO.	PARTS NUMBER	R A N K	Q'TY	DESCRIPTION	SERIAL NUMBER/ REMARKS	S V C
Fig.250	FM4-6497-000		1	MAIN DRIVE ASSEMBLY	M2,M7,CL2	
1	XF2-1607-240		1	BELT, TIMING		

# FIGURE 280 FIXNG DRIVE ASS'Y

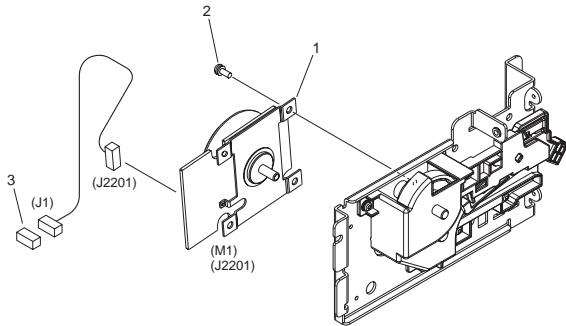

FIGURE & KEY NO.	PARTS NUMBER	RANK	QTY	DESCRIPTION	SERIAL NUMBER/REMARKS	SVC
Fig.280	FM4-6504-000		1	FIXNG DRIVE ASS'Y		
1	FK3-1408-000		1	MOTOR, DC	M1	
2	XA9-0702-000		4	SCREW, WWASHER, M3X6		
3	VS1-7177-006		1	CONNECTOR, SNAP TIGHT, BK		



# FIGURE 300 CASSETTE ASSEMBLY

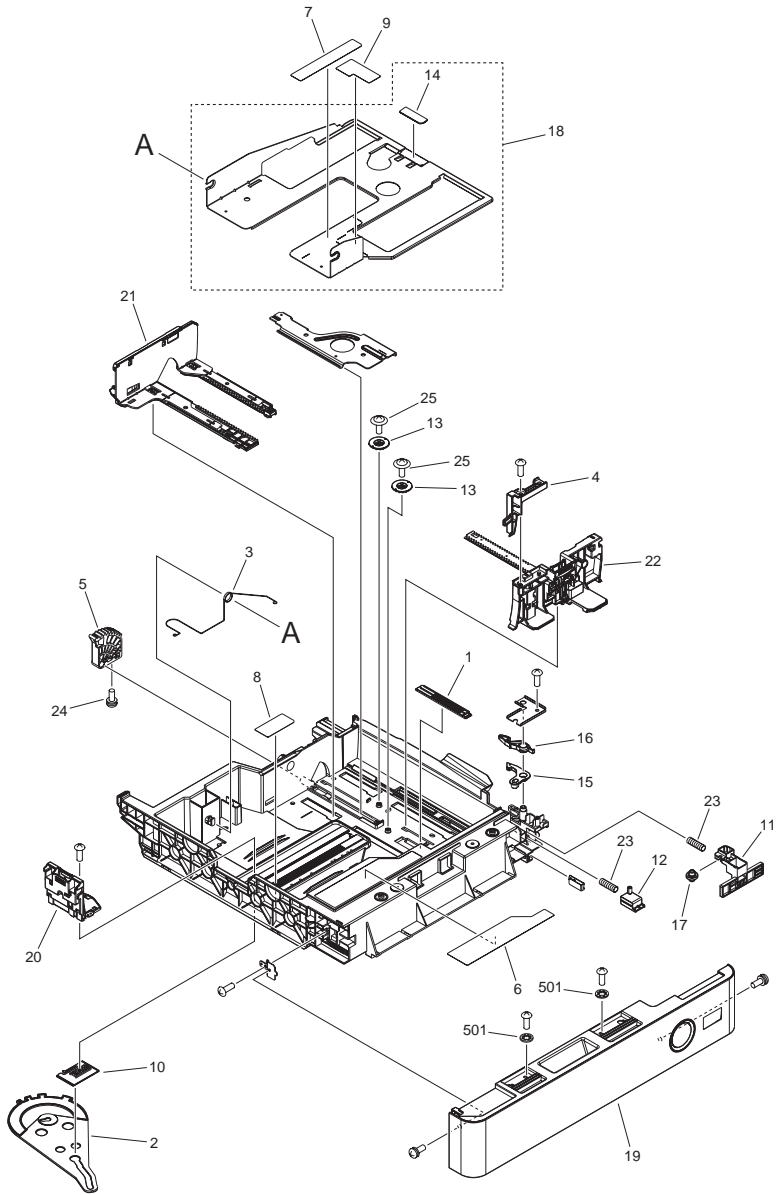

FIGURE & KEY NO.	PARTS NUMBER	R A N K	Q'TY	DESCRIPTION	SERIAL NUMBER/ REMARKS	S V C
Fig.300	FM4-6558-000		1	CASSETTE ASSEMBLY		
1	FC0-0913-000		1	PLATE, FREE STOP		
2	FC0-0945-000		1	LINK, BACK END DETECT		
3	FC0-1159-000		1	SPRING, TORSION		
4	FC0-3350-000		1	PLATE,PAPER SIDE END EXTENSION		
5	FC0-3351-000		1	GEAR, 9T		
6	FC0-3427-000		1	LABEL, PAPER SET		
7	FC0-3429-000		1	LABEL, SIZE INDEX, END, LARGE		
8	FC0-3430-000		1	LABEL, SIZE INDEX, END		
9	FC0-3431-000		1	LABEL, SIZE INDEX, SIDE		
10	FC8-2475-000		1	PLATE, JOINT		
11	FC8-4986-000		1	LINK, BUTTON, UPPER, 2		
12	FC8-4987-000		1	LINK, BUTTON, LOWER		
13	FC8-4990-000		2	GEAR, 14T		
14	FC9-7171-000		1	SHEET, SEPARATION		
15	FC9-7259-000		1	ARM, LOCK, A		
16	FC9-7260-000		1	ARM, LOCK, B		
17	FC9-7261-000		1	ROLLER, LINK		
18	FL3-4878-000		1	PLATE, CENTER		
19	FM4-6533-000		1	CASSETTE FRONT COVER UNIT		
20	FM4-6534-000		1	BACK END LIMIT PLATE UNIT		
21	FM4-6559-000		1	SIDE END PLATE ASSEMBLY, REAR		
22	FM4-6560-000		1	SIDE END PLATE ASSEMBLY, FRONT		
23	FU7-2518-000		2	SPRING, COMPRESSION		
24	XA9-1016-000		1	SCREW W/WASHER, M3X6		
25	XA9-1523-000		2	SCREW, B, M4X8		
501	XD1-4100-402		2	TOOTHED LOCK WASHER(SUS)		

# FIGURE 310 PAPER PICK-UP ASSEMBLY

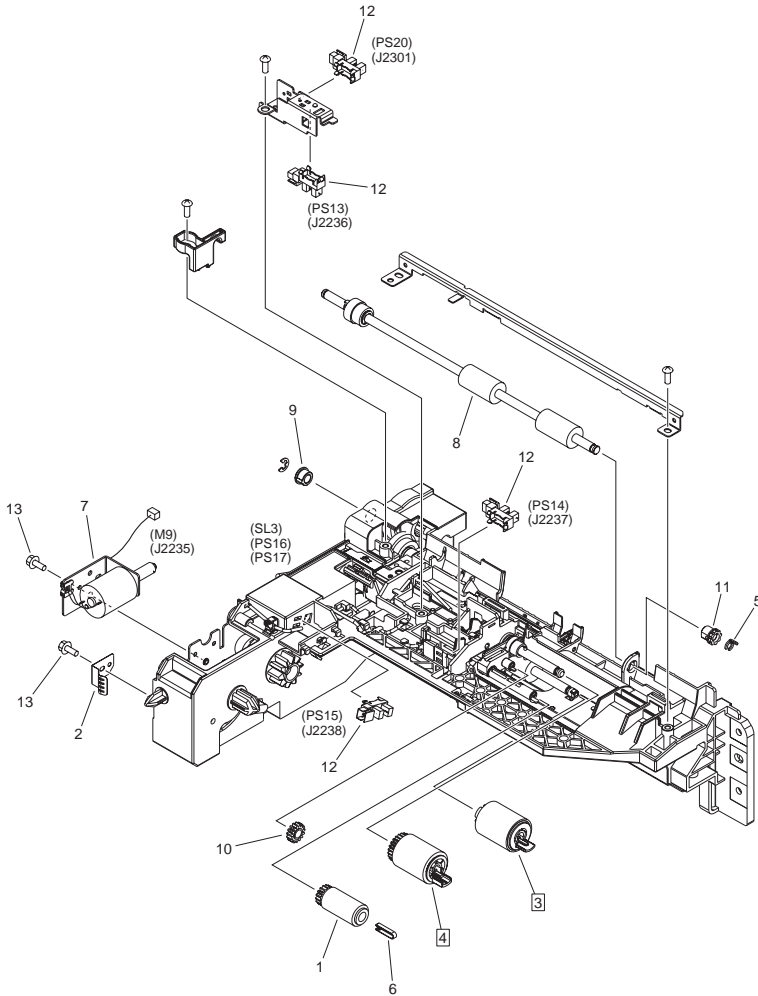
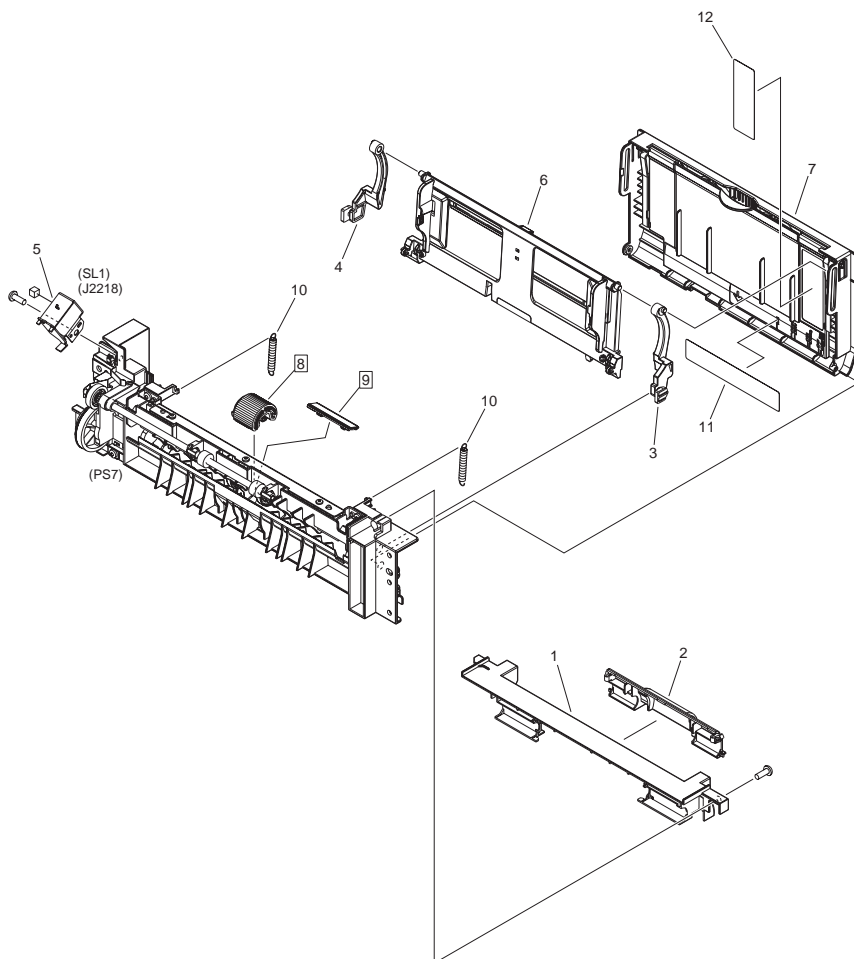

FIGURE & KEY NO.	PARTS NUMBER	R A N K	Q'TY	DESCRIPTION	SERIAL NUMBER/ REMARKS	S V C
Fig.310	FM4-6555-000		1	PAPER PICK-UP ASSEMBLY	SL3,PS16,PS17	
1	FB6-3405-000		1	ROLLER, PAPER PICK-UP		
2	FC0-1156-000		1	PLATE, GROUNDING		
3	FC6-6661-000		1	ROLLER, SEPARATION	[DP]	
4	FC6-7083-000		1	ROLLER, FEED/SEPARATION	[DP]	
5	FC6-9867-000		1	RING, RETAINING		
6	FC7-5845-000		1	STOPPER, ROLLER		
7	FM4-6568-000		1	LIFT MOTOR UNIT	M9	
8	FM4-8040-000		1	VERTICAL PATH ROLLER UNIT		
9	FS5-1943-000		1	BUSHING		
10	FU0-0043-000		1	GEAR, 15T		
11	FU5-1763-000		1	BUSHING		
12	WG8-5836-000		4	IC PHOTOINTERRUPTER, HYBRID	PS13,PS14,PS15,PS20	
13	XA9-1567-000		2	SCREW, RS, M3X8.5		

# FIGURE 312 MULTI PAPER PICK-UP ASSEMBLY



NOTE : This assembly does not include the parts shown with key No. 11 and 12.  
注 : このユニットにKey No. 11, 12の部品は含まれません。

FIGURE & KEY NO.	PARTS NUMBER	R A N K	Q'TY	DESCRIPTION	SERIAL NUMBER/ REMARKS	S V C
Fig.312	FM4-6496-000		1	MULTI PAPER PICK-UP ASSEMBLY	PS7	
1	FL3-5660-000		1	COVER, UPPER		
2	FL3-5659-000		1	COVER, ROLLER		
3	FC7-9959-000		1	HINGE, M.P. PICK UP, LEFT		
4	FC7-9960-000		1	HINGE, M.P. PICK UP, RIGHT		
5	FK2-1410-000		1	SOLENOID	SL1	
6	FM4-6540-000		1	LIFTER PLATE UNIT		
7	FM4-6541-000		1	MULTI TRAY UNIT		
8	FL2-3897-000		1	ROLLER, MP PICK-UP	[DP]	
9	FL3-4890-000		1	PAD, SEPARATION	[DP]	
10	FU6-2423-000		2	SPRING, TENSION		
11	FC0-3399-000		1	LABEL, MULTI TRAY SIZE	SEE NOTE A/INCH SIZE	
11	FC0-3400-000		1	LABEL, MULTI TRAY SIZE	SEE NOTE A SIZE	
11	FC0-3398-000		1	LABEL, MULTI TRAY SIZE	SEE NOTE A/B/INCH/K SIZE	
12	FC0-3433-000		1	LABEL, PAPER SET SIDE	SEE NOTE US,CA,LTN	
12	FC0-3401-000		1	LABEL, PAPER SET SIDE	SEE NOTE EUR	
12	FC0-3434-000		1	LABEL, PAPER SET SIDE	SEE NOTE AU,SG,HK,LTN,KR,TW	

# FIGURE 315 PRE-REGISTRATION GUIDE ASS'Y

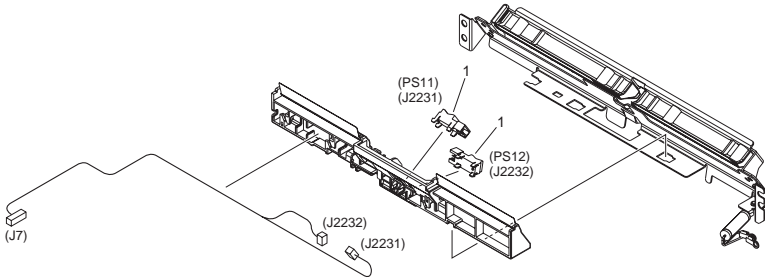

FIGURE & KEY NO.	PARTS NUMBER	RANK	QTY	DESCRIPTION	SERIAL NUMBER/REMARKS	SVC
Fig.315	FM4-6517-000		1	PRE-REGISTRATION GUIDE ASS'Y		
1	FK2-6470-000		2	PHOTO-SENSOR, KUA0055C	PS11,PS12	

# FIGURE 320 TRANSFER PAPER FEED ASSEMBLY

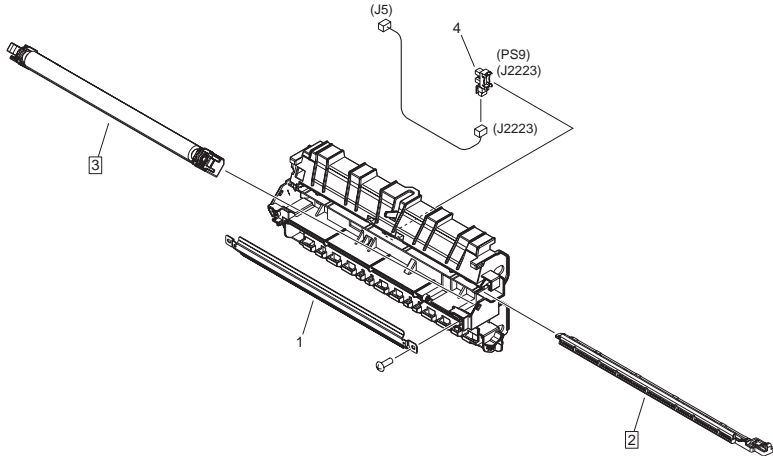

FIGURE & KEY NO.	PARTS NUMBER	RANK	QTY	DESCRIPTION	SERIAL NUMBER/REMARKS	SVC
Fig.320	FM4-6520-000		1	TRANSFER PAPER FEED ASSEMBLY		
1	FL3-4856-000		1	GUIDE, ELIMINATOR		
2	FL3-4857-000		1	HOLDER, ELIMINATOR	[DP]	
3	FM4-6522-000		1	TRANSFER ROLLER UNIT	[DP]	
4	WG8-5836-000		1	IC PHOTOINTERRUPTER, HYBRID	PS9	



# FIGURE 350 PAPER DELIVERY REVERSE ASS'Y

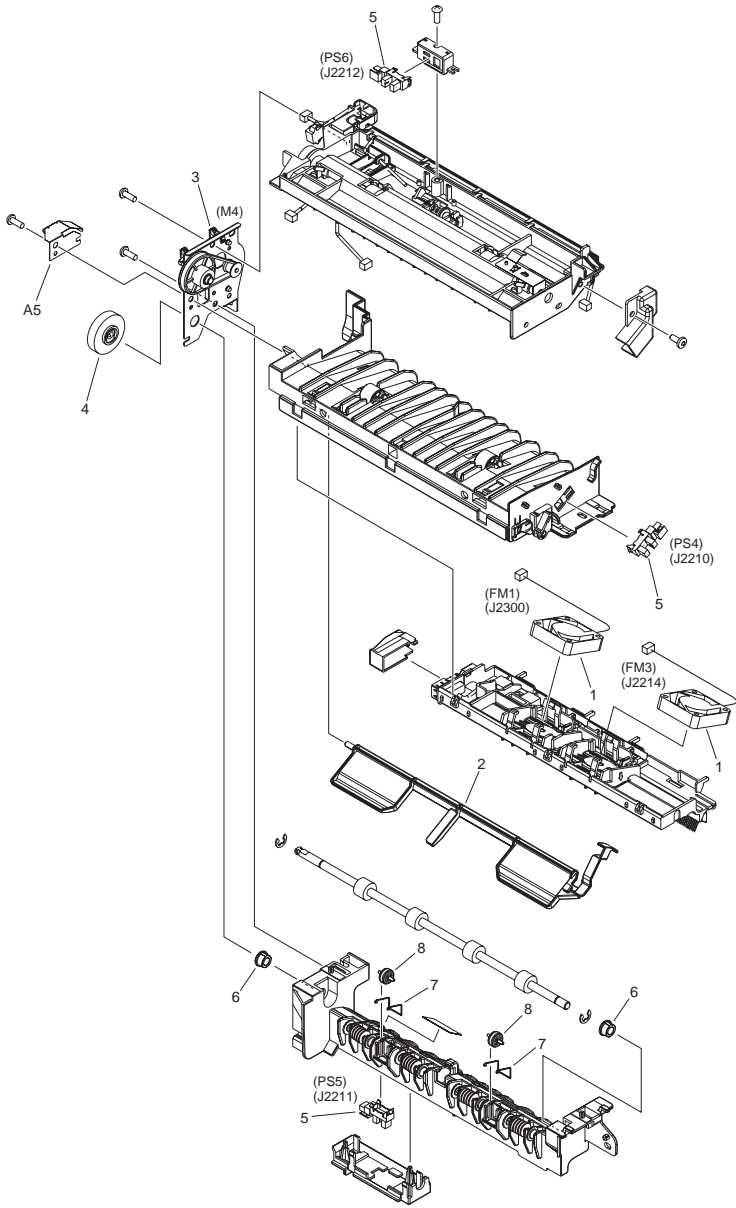

FIGURE & KEY NO.	PARTS NUMBER	RANK	Q'TY	DESCRIPTION	SERIAL NUMBER/REMARKS	SVC
Fig.350	FM4-6505-000		1	PAPER DELIVERY REVERSE ASS'Y		
1	FK2-8755-000		2	FAN	FM1,FM3	
2	FL3-5627-000		1	LEVER, SENSOR		
3	FM4-6546-000		1	REVERSE DRIVE UNIT	M4	
4	FU9-0221-000		1	GEAR, 38T		
5	WG8-5836-000		3	IC PHOTOINTERRUPTER, HYBRID	PS4,PS5,PS6	
6	FS5-1943-000		2	BUSHING		
7	FC0-4029-000		2	SPRING, ROLLER		
8	FC0-4038-000		2	ROLLER		

# FIGURE 400 READER ASSEMBLY

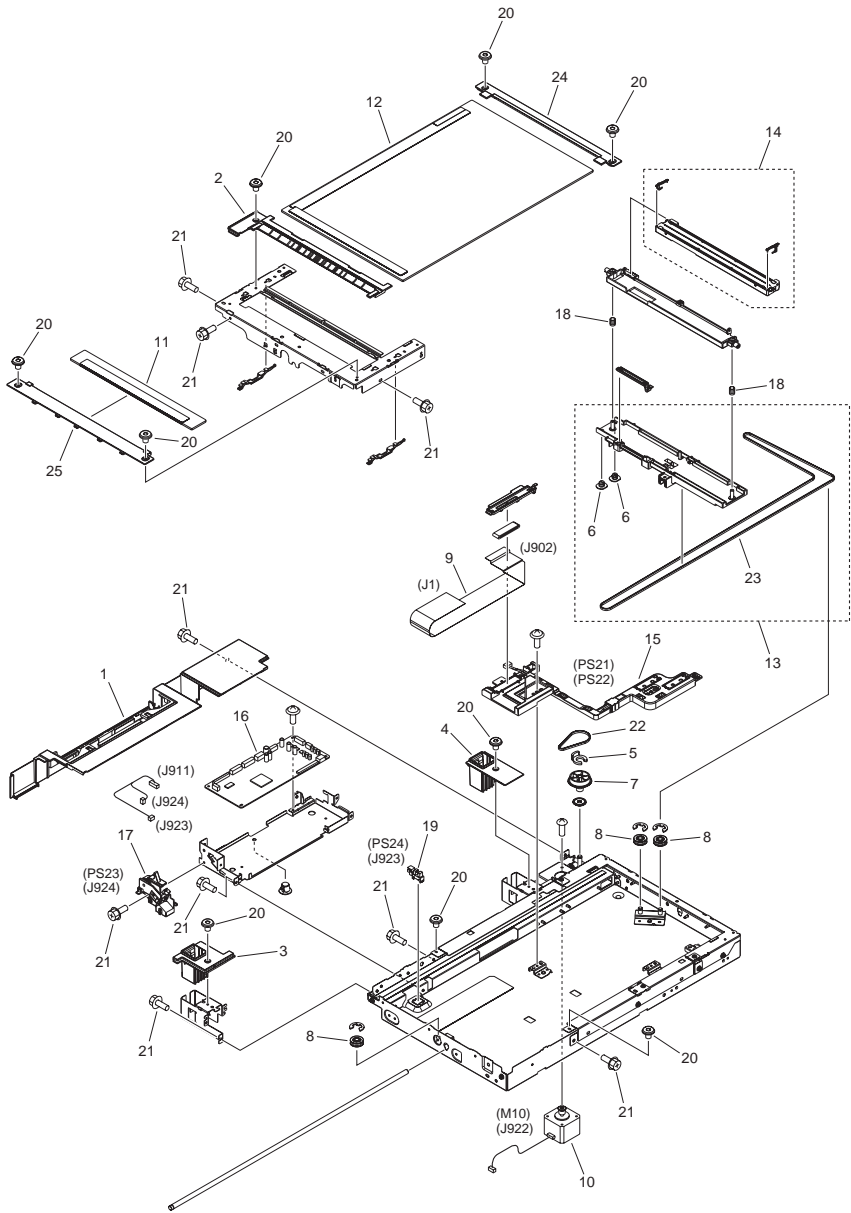

FIGURE & KEY NO.	PARTS NUMBER	R A N K	Q'TY	DESCRIPTION	SERIAL NUMBER/ REMARKS	S V C
Fig.400	NPN		RF	READER ASSEMBLY		
1	FC0-1079-000		1	COVER, READER REAR, 1		
2	FC0-1184-000		1	MOUNT, JUMP		
3	FC0-1188-000		1	COVER, HINGE, LEFT		
4	FC0-1191-000		1	COVER, HINGE, RIGHT		
5	FC5-4424-000		1	CLIP		
6	FC6-4511-000		2	SLIDER		
7	FC6-7598-000		1	PULLEY, 49T/17T		
8	FC6-7604-000		3	PULLEY, DRIVEN		
9	FK3-1447-000		1	CABLE, CIS-READER FLAT		
10	FK3-1448-000		1	MOTOR, STEPPING	M10	
11	FL2-3941-000		1	READER GLASS UNIT		
12	FL3-4881-000		1	GLASS, COPYBOARD	A/INCH SIZE	
12	FL3-4882-000		1	GLASS, COPYBOARD	A SIZE	
12	FL3-4883-000		1	GLASS, COPYBOARD	A/B/INCH/K SIZE	
13	FM4-6514-000		1	CARRIAGE ASS'Y		
14	FM4-6536-000		1	CONTACT IMAGE SENSOR UNIT		
15	FM4-6537-000		1	PAPER SIZE SENSOR UNIT	PS21,PS22	
16	FM4-7826-000		1	READER CONNECTING PCB ASS'Y		
17	FM4-7999-000		1	PHOTO SENSOR UNIT, OPEN/CLOSE	PS23	
18	FU8-2953-000		2	SPRING, COMPRESSION		
19	WG8-5836-000		1	IC PHOTOINTERRUPTER, HYBRID	PS24	
20	XA9-0679-000		9	SCREW, MACH., FLAT HEAD, M3X4		
21	XA9-1567-000		AR	SCREW, RS, M3X8.5		
22	XF2-4607-230		1	BELT, TIMING		
23	XF2-4665-530		1	BELT, TIMING		
24	FC0-5110-000		1	SUPPORT, GLASS, RIGHT		
25	FC7-2975-000		1	SUPPORT, GLASS, LEFT		

# FIGURE 460 LASER SCANNER UNIT

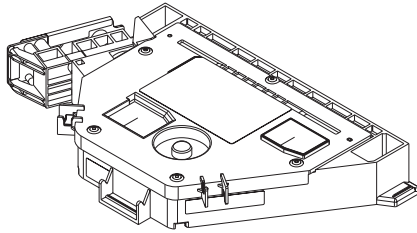

FIGURE & KEY NO.	PARTS NUMBER	RANK	QTY	DESCRIPTION	SERIAL NUMBER/REMARKS	SVC
Fig.460	FM0-1846-000		1	LASER SCANNER UNIT		

# FIGURE 620 HOPPER ASSEMBLY

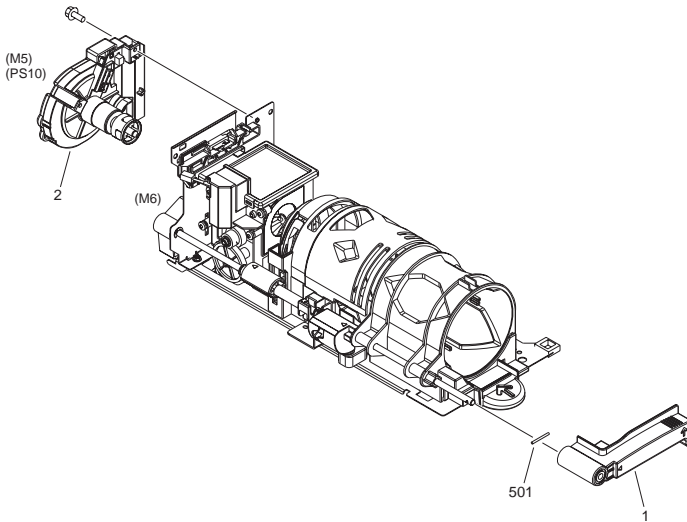

FIGURE & KEY NO.	PARTS NUMBER	RANK	QTY	DESCRIPTION	SERIAL NUMBER/REMARKS	SVC
Fig.620	FM4-6506-000		1	HOPPER ASSEMBLY	M6	
1	FC0-4061-000		1	LEVER, SET		
2	FM4-8029-000		1	BOTTLE DRIVE UNIT	M5,PS10	
501	XD3-2200-222		1	PIN		

# FIGURE 640 DEVELOPING UNIT

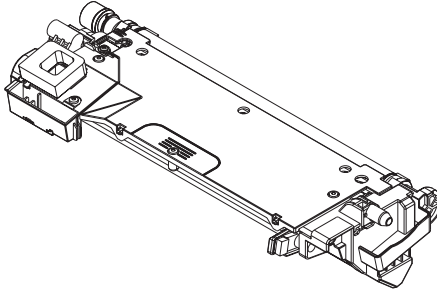

FIGURE & KEY NO.	PARTS NUMBER	RANK	QTY	DESCRIPTION	SERIAL NUMBER/REMARKS	SVC
Fig.640	FM4-6494-000		1	DEVELOPING UNIT		

# FIGURE 770 WASTE TONER BOX ASSEMBLY

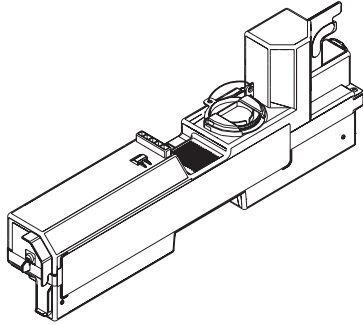

FIGURE & KEY NO.	PARTS NUMBER	RANK	QTY	DESCRIPTION	SERIAL NUMBER/REMARKS	SVC
Fig.770	FM4-8035-000		1	WASTE TONER BOX ASSEMBLY	[DP]	



# FIGURE 810 FIXING ASSEMBLY

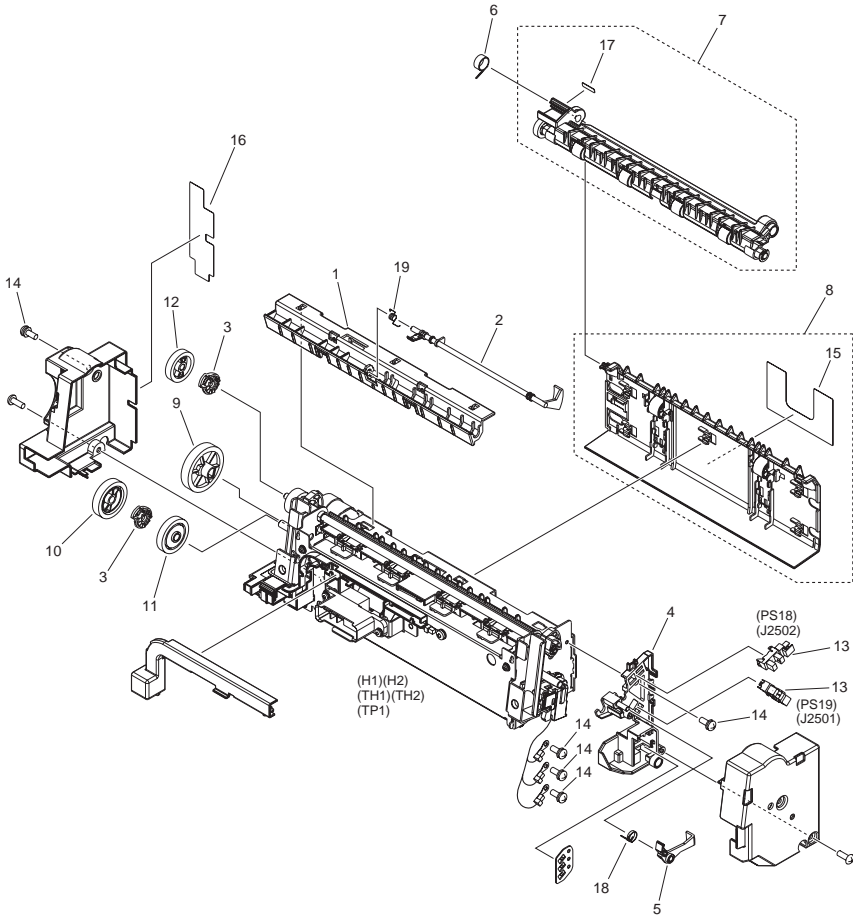

FIGURE & KEY NO.	PARTS NUMBER	R A N K	Q'TY	DESCRIPTION	SERIAL NUMBER/ REMARKS	S V C
Fig.810	FM4-6495-000		1	FIXING ASSEMBLY	120V H1,H2,TH1,TH2,TP1 [DP]	
Fig.810	FM4-8050-000		1	FIXING ASSEMBLY	230V H1,H2,TH1,TH2,TP1 [DP]	
1	FC0-0829-000		1	GUIDE, FIXING, LOWER		
2	FC0-0830-000		1	FLAG, DELIVERY SENSOR		
3	FC0-1013-000		1	CAM		
4	FC0-1021-000		1	GUIDE, FIXING CABLE		
5	FC0-1022-000		1	FLAG, RELEASE SENSOR		
6	FC0-4054-000		1	SPRING, TORSION		
7	FM4-6583-000		1	FIXING DELIVERY LOWER UNIT		
8	FM4-6584-000		1	FIXING DUPLEXING FEED UNIT		
9	FU9-0206-000		1	GEAR, 36T		
10	FU9-0207-000		1	GEAR, 29T		
11	FU9-0401-000		1	GEAR, 27T		
12	FU9-0209-000		1	GEAR, 23T		
13	WG8-5836-000		2	IC PHOTOINTERRUPTER, HYBRID	PS18,PS19	
14	XA9-0702-000		AR	SCREW, WWASHER, M3X6		
15	FC0-3411-000		1	LABEL, HIGH TMP.CAUTION		
16	FC0-3413-000		1	LABEL, FIXING JAM DISPOSE		
17	FC0-3414-000		1	LABEL, GREEN		
18	FC0-1045-000		1	SPRING, TORSION		
19	FC5-1367-000		1	SPRING,SENSOR LEVER		

# FIGURE 900 CONTROLLER BOX ASSEMBLY

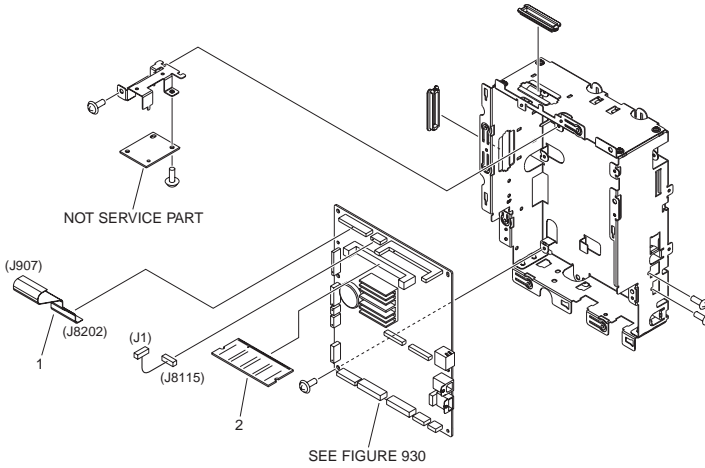

FIGURE & KEY NO.	PARTS NUMBER	RANK	QTY	DESCRIPTION	SERIAL NUMBER/REMARKS	SVC
Fig.900	NPN		RF	CONTROLLER BOX ASSEMBLY		
1	FK3-1446-000		1	CABLE, IP-READER FLAT		
2	FM0-0099-000		1	DIMM PCB ASSEMBLY	MODELS WITH FAX OR SEND FUNCTIONS	
2	FM0-0098-000		1	DIMM PCB ASSEMBLY	MODELS WITHOUT FAX OR SEND FUNCTIONS	

# FIGURE 930 MAIN CONTROLLER PCB ASSEMBLY

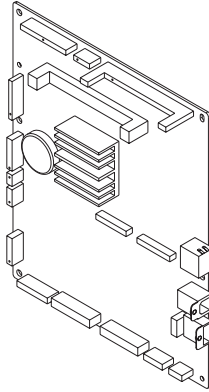

FIGURE & KEY NO.	PARTS NUMBER	RANK	QTY	DESCRIPTION	SERIAL NUMBER/REMARKS	SVC
Fig.930	FM4-8163-000		1	MAIN CONTROLLER PCB ASSEMBLY	imageRUNNER1730	
Fig.930	FM4-8164-000		1	MAIN CONTROLLER PCB ASSEMBLY	imageRUNNER1740	
Fig.930	FM4-8165-000		1	MAIN CONTROLLER PCB ASSEMBLY	imageRUNNER1750	
IC	FK2-3218-000		1	IC, MB87L8650, GATE ARRAY	IC24	
IC	FK2-4903-000		1	IC, MB87S4030, ASIC, FUJITSU	IC5	
IC	FK2-5758-000		1	IC, UPD 808000F1-641-RN4-A	IC32	
IC	FK2-7852-000		1	IC, T6TH5EFG-0002(0), STANDARD	IC28	

# FIGURE 935 ENGINE CONTROLLER PCB ASS'Y

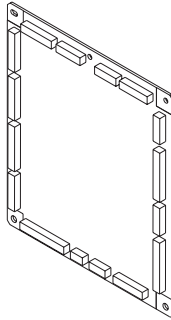

FIGURE & KEY NO.	PARTS NUMBER	RANK	Q'TY	DESCRIPTION	SERIAL NUMBER/REMARKS	SVC
Fig.935	FM4-7813-000		1	ENGINE CONTROLLER PCB ASS'Y	120V	
Fig.935	FM4-7819-000		1	ENGINE CONTROLLER PCB ASS'Y	230V	
IC	FK2-1773-000		1	IC,TC200GO2EFG-1031,GATE ARRAY	IC18	
IC	FK2-6450-000		1	IC, FSA0AC211AA	IC3	

# FIGURE 980 HIGH VOLTAGE PCB ASSEMBLY

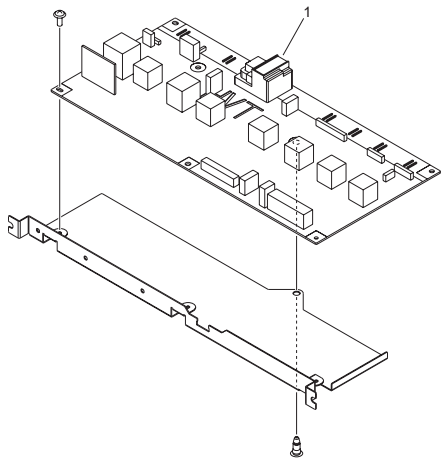

FIGURE & KEY NO.	PARTS NUMBER	RANK	QTY	DESCRIPTION	SERIAL NUMBER/REMARKS	SVC
Fig.980	NPN		RF	HIGH VOLTAGE PCB ASSEMBLY		
1	FM4-7814-000		1	HIGH VOLTAGE PCB ASSEMBLY		

# FIGURE A10 INTERNAL COMPONENTS (ADF)

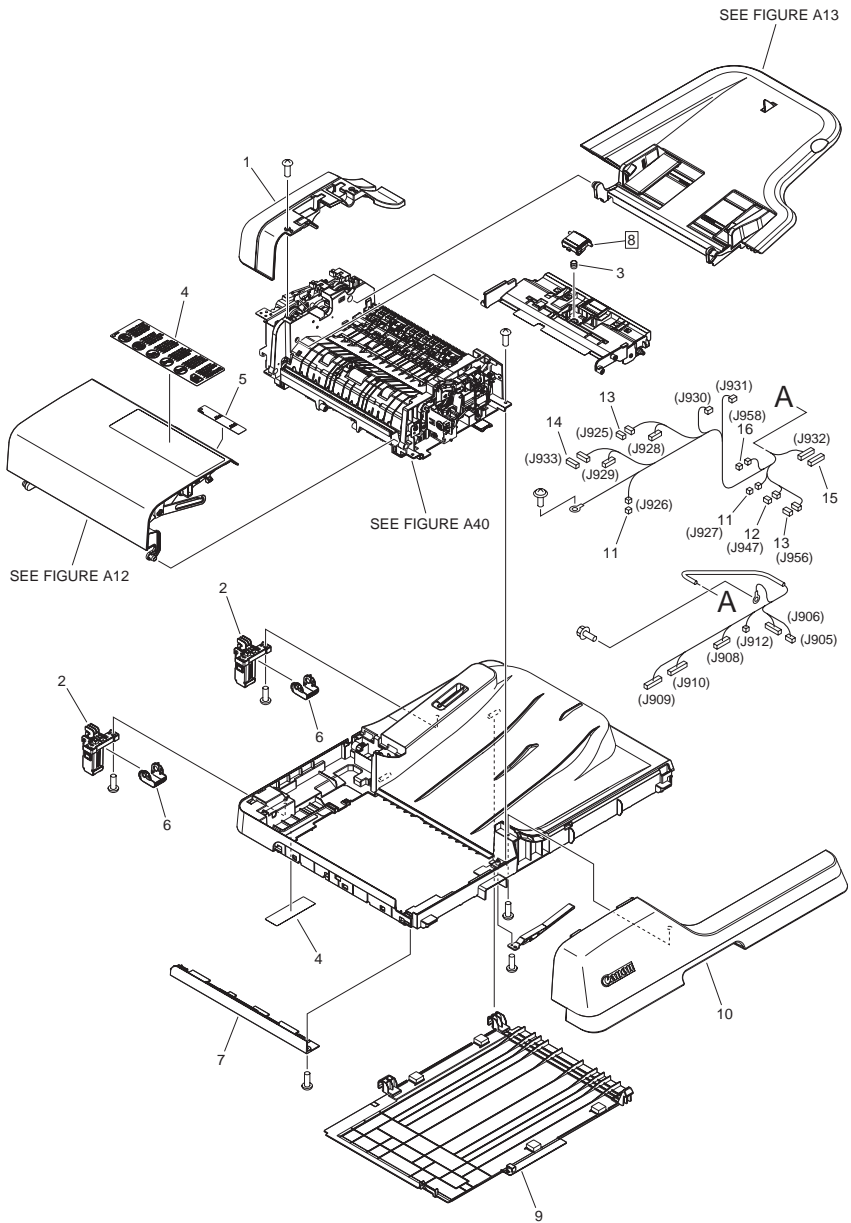

FIGURE & KEY NO.	PARTS NUMBER	R A N K	Q'TY	DESCRIPTION	SERIAL NUMBER/ REMARKS	S V C
Fig.A10	NPN		RF	INTERNAL COMPONENTS	ADF	
1	FC0-2976-000		1	COVER, REAR		
2	FC0-2978-000		2	HINGE		
3	FU8-2856-000		1	SPRING, COMPRESSION		
4	FC0-3449-000		1	LABEL, PROHIBITION DOCUMENT	EUR	
4	FC0-3450-000		1	LABEL, PROHIBITION DOCUMENT	US,CA,AU,SG,HK,LTN,K R,TW	
5	FC0-3451-000		1	LABEL, DOCUMENT SIZE	A SIZE	
5	FC0-3452-000		1	LABEL, DOCUMENT SIZE	A/INCH SIZE	
6	FC0-5254-000		2	SUPPORT, HINGE		
7	FL3-5535-000		1	COVER, LEFT		
8	FL3-7878-000		1	PAD, SEPARATION	[DP]	
9	FL3-5544-000		1	PANEL, COPYBOARD		
10	FM4-7735-000		1	FRONT COVER UNIT		
11	VS1-7177-002		2	CONNECTOR, SNAP TIGHT, BK		
12	VS1-7207-003		1	CONNECTOR, SNAP TIGHT, BK		
13	VS1-7207-004		2	CONNECTOR, SNAP TIGHT, BK		
14	VS1-7207-006		1	CONNECTOR, SNAP TIGHT		
15	VS1-7207-008		1	CONNECTOR, SNAP TIGHT, BK		
16	VS1-7507-002		1	CONNECTOR, 2P		



# FIGURE A12 PAPER PICK-UP COVER ASSEMBLY (ADF)

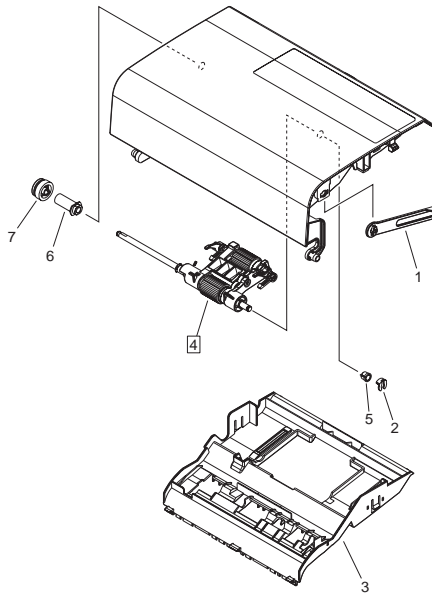

FIGURE & KEY NO.	PARTS NUMBER	RANK	QTY	DESCRIPTION	SERIAL NUMBER/REMARKS	SVC
Fig.A12	FM4-7733-000		1	PAPER PICK-UP COVER ASSEMBLY	ADF	
1	FC0-2970-000		1	LINK, OPEN/CLOSE		
2	FC5-4425-000		1	CLIP		
3	FL3-5532-000		1	GUIDE, PAPER PICK-UP, LOWER		
4	FM4-7732-000		1	PAPER PICK-UP ROLLER UNIT	[DP]	
5	FU5-1626-000		1	BUSHING		
6	FC0-2985-000		1	BUSHING		
7	FU9-0354-000		1	GEAR, 23 T		

# FIGURE A13 DOCUMENT TRAY ASSEMBLY (ADF)

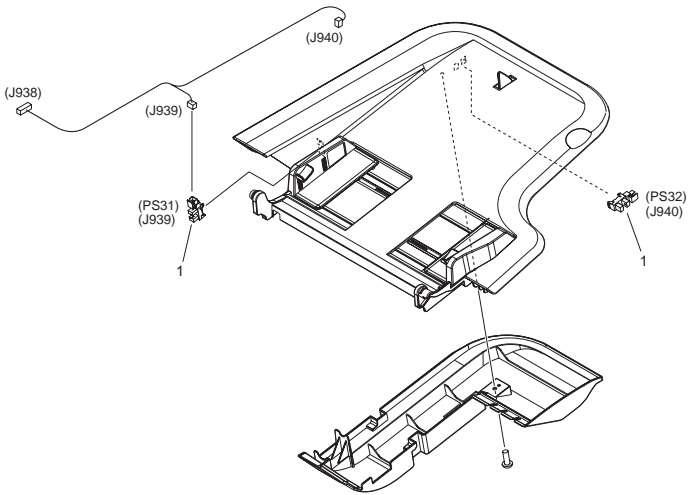
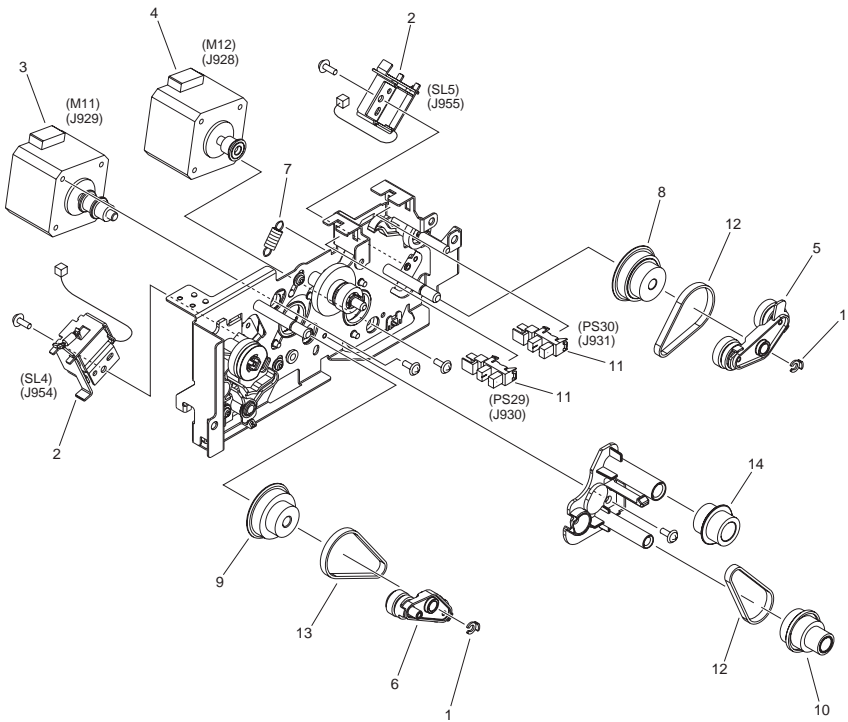

FIGURE & KEY NO.	PARTS NUMBER	RANK	QTY	DESCRIPTION	SERIAL NUMBER/REMARKS	SVC
Fig.A13	FM4-7734-000		1	DOCUMENT TRAY ASSEMBLY	ADF	
1	WG8-5836-000		2	IC PHOTOINTERRUPTER, HYBRID	PS31,PS32	

# FIGURE A30 DRIVE ASSEMBLY (ADF)



NOTE : This assembly is included in the assembly shown in Figure A40.  
 注 : このユニットはFigure A40のユニットに含まれます。

FIGURE & KEY NO.	PARTS NUMBER	R A N K	Q'TY	DESCRIPTION	SERIAL NUMBER/ REMARKS	S V C
Fig.A30	FM4-7730-000		1	DRIVE ASSEMBLY	ADF SEE NOTE	
1	FC5-4424-000		2	CLIP		
2	FK2-0408-000		2	SOLENOID	SL4,SL5	
3	FK3-1633-000		1	MOTOR, STEPPING	M11	
4	FK3-1634-000		1	MOTOR, STEPPING	M12	
5	FL3-5542-000		1	ARM, SWING, FEED		
6	FL3-5543-000		1	ARM, SWING, REGIST		
7	FU8-2974-000		1	SPRING, TENSION		
8	FU9-0345-000		1	PULLEY, 45T/GEAR, 24T		
9	FU9-0358-000		1	PULLEY, 45T/GEAR, 36T		
10	FU9-0367-000		1	PULLEY, 33T/GEAR, 36T/24T		
11	WG8-5836-000		2	IC PHOTOINTERRUPTER, HYBRID	PS29,PS30	
12	XF2-1606-040		2	BELT, TIMING		
13	XF2-1606-940		1	BELT, TIMING		
14	FU9-0353-000		1	GEAR, 20T		

# FIGURE A40 PAPER FEED ASSEMBLY (ADF)

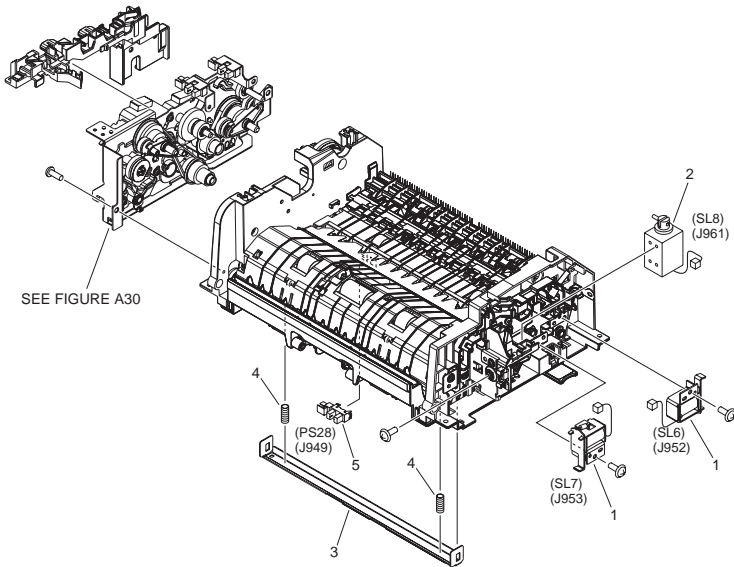

NOTE : This assembly includes the assembly shown in Figure A30.  
注 : このユニットはFigure A30のユニットを含みます。

FIGURE & KEY NO.	PARTS NUMBER	RANK	Q'TY	DESCRIPTION	SERIAL NUMBER/REMARKS	SVC
Fig.A40	FM4-7736-000		1	PAPER FEED ASSEMBLY	ADF SEE NOTE PS25,PS26,PS27	
1	FK2-0408-000		2	SOLENOID	SL6,SL7	
2	FK2-6871-000		1	SOLENOID	SL8	
3	FL3-5556-000		1	STAY, READ		
4	FU7-2192-000		2	SPRING, COMPRESSION		
5	WG8-5836-000		1	IC PHOTOINTERRUPTER, HYBRID	PS28	

# FIGURE T20 FAX ASSEMBLY (FAX model)

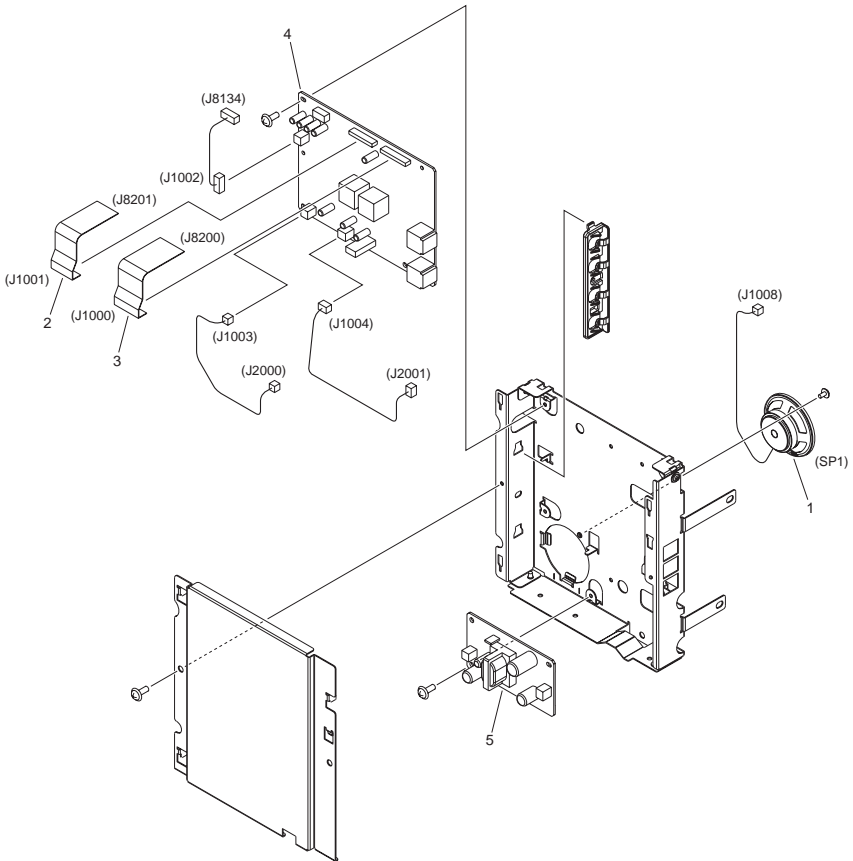

FIGURE & KEY NO.	PARTS NUMBER	RANK	Q'TY	DESCRIPTION	SERIAL NUMBER/REMARKS	SVC
Fig.T20	NPN		RF	FAX ASSEMBLY	FAX model	
1	FK2-9442-000		1	SPEAKER	SP1	
2	FK3-1444-000		1	CABLE, IP-NCU FLAT(21PIN)		
3	FK3-1445-000		1	CABLE, IP-NCU FLAT(24PIN)		
4	FM4-8166-000		1	FAX PCB ASSEMBLY		
5	FM4-8168-000		1	OFFHOOK PCB ASSEMBLY		

# FIGURE ZZA

## MECHANICAL STANDARD PARTS (HOW TO USE)

### Mechanical standard parts

#### 機械標準部品

About a mechanical standard parts

A Mechanical standard parts is a mechanical part which not parts peculiar to a product. They are parts which are common to a Canon product and are used, such as a screw and a washer. The Fig No. and parts number of the mechanical standard parts are not listed in the product parts catalog. Refer to the parts catalog of mechanical standard parts when checking the parts number for screw or washer etc. and identify them by part shape or size.

機械標準部品とは

機械標準部品とは、製品特有の部品ではなく、ねじやワッシャなどキヤノン製品共通で使用されている機械部品（メカ部品）のことです。  
製品のパーツカタログには、機械標準部品のFig No.や部品番号は記載しておりません。  
ねじや、ワッシャ等の部品番号を調べるときは、機械標準部品のパーツカタログを参照し、部品の形状や大きさから判断し、使用している部品を調べてください。

Material and surface treatment of a mechanical standard parts

Material and surface treatment of mechanical standard parts are assigned commonly for each part. Refer to the Table 1 for the parts which material and surface treatment are assigned as numbers.

機械標準部品の材料および表面処理

機械標準部品の材料および表面処理については、各種部品共通で決められています。  
材料および表面処理が番号で決められている部品については、表1を参照してください。

Table 1 Material and Surface treatment

表1 材料および表面処理

No. 番号	Material 材料	Surface treatment 表面処理	Color 色
1	Stainless steel ステンレス	Stainless steel black coloring (BC4) ステンレス黒着色(BC4)	Black 黒
2		not to be given なし	White 白
3	Brass 黄銅	Regular nickel plating (NL) 普通ニッケルメッキ(NL)	White 白
4		Black nickel plating (BN) 黒色ニッケルメッキ(BN)	Black 黒
5	Steel 鋼	White zinc trivalent chromate treating (ZC3) 白色亜鉛3価クロメート(ZC3)	White 白
6		Regular nickel chromium plating (NC) 普通ニッケルクロムメッキ(NC)	White 白
7		Regular nickel plating (NL) 普通ニッケルメッキ(NL)	White 白
8		Iron and steel phosphating (P1) 鉄鋼磷酸塩処理(P1)	Black 黒
9		Black zinc trivalent chromate treating (BZ3) 黒色亜鉛3価クロメート(BZ3)	Black 黒



# FIGURE ZZB MECHANICAL STANDARD PARTS (SCREWS)

## 1. Screws ねじ

How to read Parts Numbers  
部品番号の見方

Screws  
ねじ

XB1-2400-609

Type No.  
類別番号

Normal designation (d)  
ねじの呼び(d)

Length (L)  
ねじの長さ(L)

Material and Surface treatment  
材料および表面処理

XB1-2 expresses Binding head machine screw.  
XB1-2は、バインドねじを表す

40 expresses M4.0.  
40は、M4.0を表す

0-60 expresses a length of 6.0mm.  
0-60は、6.0mmの長さを表す

9 expresses Steel (Black zinc trivalent chromate  
treating) from Table 1.

9は、表1より鋼(黒色亜鉛3価クロメート)を表す

### 1-1. Cross Recessed Head Screws for Precision Equipments

精密機器用十字穴付き小ねじ

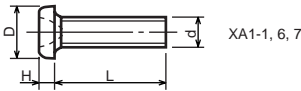

XA1-1, 6, 7

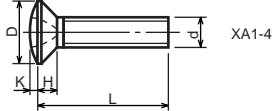

XA1-4

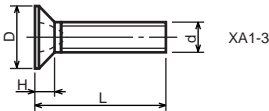

XA1-3

Type No. 類別番号	Type 類別
XA1-1	Pan head Class 1 なべ1種
XA1-3	Countersunk head Class 1 さら1種
XA1-4	Oval countersunk head Class 1 丸さら1種
XA1-6	Pan head Class 3 なべ3種
XA1-7	Pan head Class 2 なべ2種

		Head size (mm) 頭部寸法 (mm)					
		M1.4	M1.6	M1.7	M2	M2.5	M2.6
D	XA1-1	2	2.4	2.5	3	3.8	4
H	XA1-1	0.5	0.55	0.5	0.6	0.9	0.8
D	XA1-3	2	2.4	2.5	3	3.8	4
H	XA1-3	0.48	0.55	0.58	0.73	0.85	0.93
D	XA1-4	2	2.4	2.5	3	3.8	4
H + K	XA1-4	0.68	0.8	0.88	1	1.25	1.3
D	XA1-6	2.5	2.8	3	3.5	4.3	4.5
H	XA1-6	0.8	0.85	0.9	1	1.3	1.2
D	XA1-7	2.5	2.8	3	3.5	4.3	4.5
H	XA1-7	0.5	0.55	0.5	0.6	0.9	0.8

1-2. Precision Tapping Screws  
精密用タッピンねじ

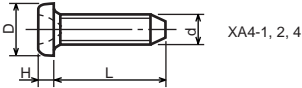

XA4-1, 2, 4

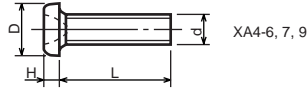

XA4-6, 7, 9

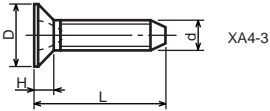

XA4-3

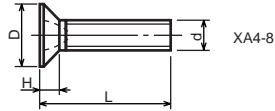

XA4-8

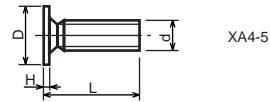

XA4-5

Type No. 類別番号	Type 類別	Head size (mm) 頭部寸法 (mm)						
		M1.4	M1.6	M1.7	M2	M2.5	M2.6	
XA4-1	With tapered end pan head Class 1 絞りなべ1種	D XA4-1	2	2.4	2.5	3	3.8	4
		H XA4-1	0.5	0.55	0.5	0.6	0.9	0.8
XA4-2	With tapered end pan head Class 3 絞りなべ3種	D XA4-2	2.5	2.8	3	3.5	4.3	4.5
		H XA4-2	0.8	0.85	0.9	1	1.3	1.2
XA4-3	With tapered end countersunk head 絞り-さら	D XA4-3	2	2.4	2.5	3	3.8	4
		H XA4-3	0.48	0.55	0.58	0.73	0.85	0.93
XA4-4	With tapered end pan head Class 2 絞りなべ2種	D XA4-4	2.5	2.8	3	3.5	4.3	4.5
		H XA4-4	0.5	0.55	0.5	0.6	0.9	0.8
XA4-5	With parallel end ultra thin head ストレート-超薄頭	D XA4-5	2.5	2.8	3	-	-	-
		H XA4-5	0.2	0.2	0.2	-	-	-
XA4-6	With parallel end pan head Class 1 ストレートなべ1種	D XA4-6	2	2.4	2.5	3	3.8	4
		H XA4-6	0.5	0.55	0.5	0.6	0.9	0.8
XA4-7	With parallel end pan head Class 3 ストレートなべ3種	D XA4-7	2.5	2.8	3	3.5	4.3	4.5
		H XA4-7	0.8	0.85	0.9	1	1.3	1.2
XA4-8	With parallel end countersunk head ストレート-さら	D XA4-8	2	2.4	2.5	3	3.8	4
		H XA4-8	0.48	0.55	0.58	0.73	0.85	0.93
XA4-9	With parallel end pan head Class 2 ストレートなべ2種	D XA4-9	2.5	2.8	3	3.5	4.3	4.5
		H XA4-9	0.5	0.55	0.5	0.6	0.9	0.8

1-3. Cross Recessed Head Screws  
一般用十字穴付き小ねじ

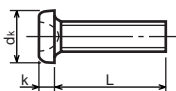

XB1-1

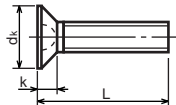

XB1-3

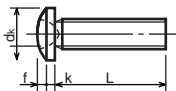

XB1-2

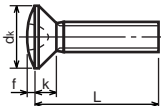

XB1-4

Type No. 類別番号	Type 類別
XB1-1	Pan head なべ
XB1-2	Binding head バインド
XB1-3	Countersunk head さら
XB1-4	Oval countersunk head 丸さら

		Head size (mm) 頭部寸法 (mm)					
		M2	M2.5	M2.6	M3	M4	M5
dk	XB1-1	3.5	4.5	4.5	5.5	7	9
k	XB1-1	1.3	1.7	1.7	2	2.6	3.3
dk	XB1-2	4.3	5.3	5.5	6.3	8.3	10.3
k+f	XB1-2	1.2	1.5	1.6	1.9	2.5	3.1
dk	XB1-3	4	5	-	6	8	10
k	XB1-3	1.2	1.45	-	1.75	2.3	2.8
dk	XB1-4	4	5	-	6	8	10
k+f	XB1-4	1.6	2	-	2.45	3.2	4
Screw part length ねじ部長さ b		8	12	12	12	16	20

1-4. Cross Recessed Head Screws with Captive Washer  
座金組込み十字穴付き小ねじ

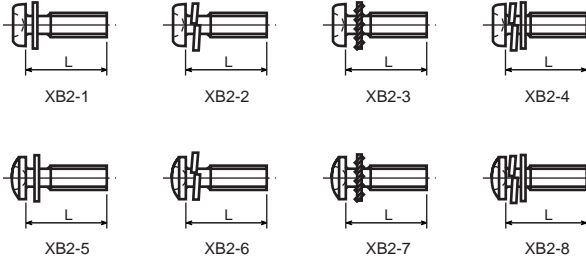

Type No. 類別番号	Type 類別
XB2-1	Pan head + Plain washer (circular bright) なべねじ+平座金
XB2-2	Pan head + Spring washer なべねじ+ばね座金
XB2-3	Pan head + Toothed lock washer なべねじ+歯付座金
XB2-4	Pan head + Spring washer and plain washer (circular bright) なべねじ+(ばね+平)座金
XB2-5	Binding head + Plain washer (circular bright) バインドねじ+平座金
XB2-6	Binding head + Spring washer バインドねじ+ばね座金
XB2-7	Binding head + Toothed lock washer バインドねじ+歯付座金
XB2-8	Binding head + Spring washer and plain washer (circular bright) バインドねじ+(ばね+平)座金

**1-5. Hexagon Head Tapping Screws for Metallic Materials**  
 金属用六角タッピンねじ

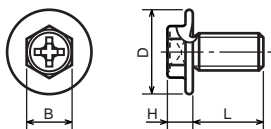

Type No. 類別番号	Type 類別	Head size (mm) 頭部寸法 (mm)	
		M3	M4
XB3-6	For metallic materials 金属用タッピン	D	8 10
		B	5.5 5.5
XB3-7	For metallic materials with clawed 金属用タッピン-つめ付き	H XB3-6	3.1 3.1
		H XB3-7	3.2 3.2

**1-6. Special Tapping Screws**  
 特殊タッピンねじ

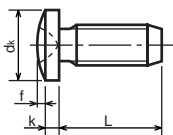

Type No. 類別番号	Type 類別	Head size (mm) 頭部寸法 (mm)	
		M3	M4
XB4-5	Binding head バインド	d <sub>k</sub>	6.3 8.3
		k	1.3 1.7
		k+f	1.9 2.5

1-7. General Head Tapping Screws  
一般用タッピンねじ

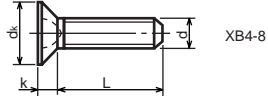
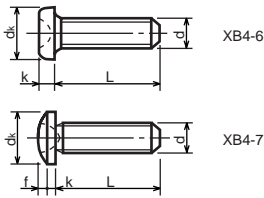

Type No. 類別番号	Type 類別	Head size (mm) 頭部寸法 (mm)						
		M2	M2.5	M2.6	M3	M4	M5	
XB4-6	Pan head なべ	d <sub>k</sub> XB4-6	3.5	4.5	4.5	5.5	7	9
		k XB4-6	1.3	1.7	1.7	2	2.6	3.3
XB4-7	Binding head バインド	d <sub>k</sub> XB4-7	4.3	5.3	5.5	6.3	8.3	10.3
		k+f XB4-7	1.2	1.5	1.6	1.9	2.5	3.1
XB4-8	Countersunk head さら	d <sub>k</sub> XB4-8	4	5	5.2	6	8	10
		k XB4-8	1.2	1.45	1.5	1.75	2.3	2.8

1-8. Tapping Screws for Metallic Materials  
金属用タッピンねじ

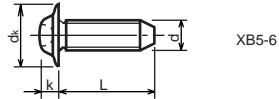
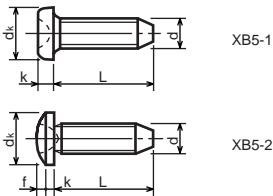

Type No. 類別番号	Type 類別	Head size (mm) 頭部寸法 (mm)					
		M2.5	M2.6	M3	M4	M5	
XB5-1	Pan head なべ	d <sub>k</sub> XB5-1	4.5	4.5	5.5	7	9
		k XB5-1	1.7	1.7	2	2.6	3.3
XB5-2	Binding head バインド	d <sub>k</sub> XB5-2	5.5	5.5	6.3	8.3	10.3
		k+f XB5-2	1.6	1.6	1.9	2.5	3.1
XB5-6	Flanged pan head つば付きなべ	d <sub>k</sub> XB5-6	6.5	6.5	8	10	12
		k XB5-6	2.1	2.1	1.75	3.2	4

**1-9. Hexagon Socket Set Screws**  
六角穴付止めねじ

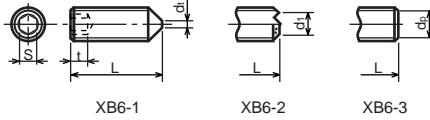

Type No. 類別番号	Type 類別	Head size (mm) 頭部寸法 (mm)							
		M1.6 M1.7	M2	M2.5 M2.6	M3	M5	M5	M6	
XB6-1	Cone point とがり先	S	0.7	0.9	1.3	1.5	2	2.5	3
		t	1.5	1.7	2	2	2.5	3	3.5
		$d_{t \max}$ XB6-1	0.4	0.5	0.65	0.75	1	1.25	1.5
		$d_{t \max}$ XB6-2	-	1.2	1.5	1.7	2.2	2.8	3.3
		$d_{t \min}$ XB6-2	-	1	1.2	1.4	1.9	2.4	2.9
		$d_{p \max}$ XB6-3	0.8	1	1.5	2	2.5	3.5	4
		$d_{p \min}$ XB6-3	0.55	0.75	1.25	1.75	2.25	3.2	3.7

**1-10. Flanged Pan Head Machine Screws**  
つば付きなべ小ねじ

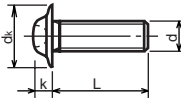

Type No. 類別番号	Type 類別	Head size (mm) 頭部寸法 (mm)					
		M2	M2.5 M2.6	M3	M5	M5	
XB6-7	Flanged pan head つば付きなべ	$d_k$	5	6.5	8	10	12
		k	1.7	2.1	2.5	3.2	4

# FIGURE ZZC MECHANICAL STANDARD PARTS (BOLTS)

## 2. Bolts (Socket head cap screw)

ボルト

How to read Parts Numbers  
部品番号の見方

Bolt (Socket head cap screw)  
ボルト

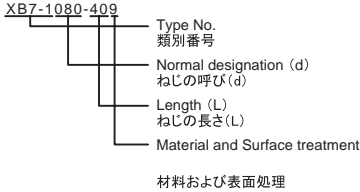

XB7-1 expresses Hexagon socket head cap screws.  
XB7-1は、六角穴付きボルトを表す

080 expresses M8.0.  
080は、M8.0を表す

40 expresses a length of 40mm.  
40は、40mmの長さを表す

9 expresses Steel (Black zinc trivalent chromate treating) from Table 1.  
9は、表1より鋼(黒色亜鉛3価クロメート)を表す

### 2-1. Hexagon socket head cap screws

六角穴付きボルト

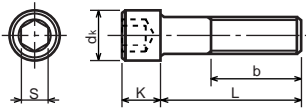

Type No. 類別番号	Type 類別
XB7-1	Hexagon socket head cap screws 六角穴付きボルト

	Head size (mm) 頭部寸法 (mm)						
	M3	M4	M5	M6	M8	M10	M12
S	2.5	3	4	5	6	8	10
$d_k$	5.5	7	8.5	10	13	16	18
K	3	4	5	6	8	10	12
Screw part length $b_{max}$ ねじ部長さ $b_{max}$	18	20	22	24	28	32	36



# FIGURE ZZD MECHANICAL STANDARD PARTS (NUTS)

## 3. Nuts ナット

How to read Parts Numbers  
部品番号の見方

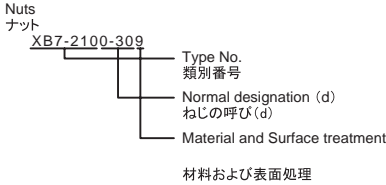

XB7-210 expresses Hexagon nut class 1.  
XB7-210は、六角ナット1種を表す

0-30 expresses M3.0.  
0-30は、M3.0を表す

9 expresses Steel (Black zinc trivalent chromate treating) from Table 1.  
9は、表1より鋼(黒色亜鉛3価クロメート)を表す

### 3-1. Hexagon Nuts and Hexagon Thin Nuts 六角ナット

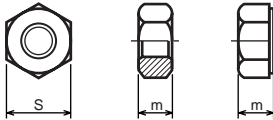

Type No. 類別番号	Type 類別
XB7-210	Hexagon nut Class 1 六角ナット-1種
XB7-220	Hexagon nut Class 3 六角ナット-3種
XB7-230	Hexagon nut Style 1 double chamfered 六角ナット-スタイル1-両面とり
XB7-231	Hexagon nut Style 1 washer faced 六角ナット-スタイル1-座付き
XB7-240	Hexagon nut Style 2 double chamfered 六角ナット-スタイル2-両面とり
XB7-241	Hexagon nut Style 2 washer faced 六角ナット-スタイル2-座付き
XB7-250	Hexagon nut 六角ナット
XB7-260	Hexagon thin nut double chamfered 六角低ナット-両面とり
XB7-270	Hexagon thin nut not chamfered 六角低ナット-面とり無し

	Head size (mm) 頭部寸法 (mm)						
	M2	M2.5	M3	M4	M5	M6	M8
S	4	5	5.5	7	8	10	13
m XB7-210	1.6	2	2.4	3.2	4	5	6.5
m XB7-220	1.2	1.6	1.8	2.4	3.2	3.6	5
m XB7-230, 231	1.6	2	2.4	3.2	4.7	5.2	6.8
m XB7-240, 241	-	-	-	-	5.1	5.7	7.5
m XB7-250	-	-	-	-	5.6	6.1	7.9
m XB7-260	1.2	1.6	1.8	2.2	2.7	3.2	4
m XB7-270	1.2	1.6	1.8	2.2	2.7	3.2	4

# FIGURE ZZE MECHANICAL STANDARD PARTS (RETAINING RINGS)

## 5. Retaining Rings

止め輪

How to read Parts Numbers  
部品番号の見方

### Retaining Rings

止め輪

XD2-1100-202

Type No.  
類別番号

Nominal designation  
呼び

Material and Surface treatment  
材料および表面処理

XD2-110 expresses retaining ring-E type (Type1).  
XD2-110は、E形止め輪(1種)を表す

0-20 expresses a 020 of nominal designation.  
(See Table 5)

0-20は、呼び020を表す(表5参照)

2 expresses Stainless steel (Surface treatment is not to be given) from Table 1.

2は、表1よりステンレス(表面処理なし)を表す

### 5-1. Retaining Rings - E type

E形止め輪

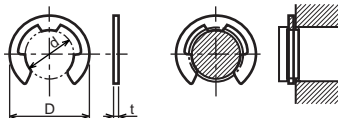

Type No. 類別番号	Type 類別
XD2-110	Retaining ring - E type (Type 1) E形止め輪(1種)
XD2-120	Retaining ring - E type (Type 2) E形止め輪(2種)

Table 5 表5

Type 種類	Nominal designation 呼び	d (mm)	D (mm)	t (mm)
Type 1 1種	007	0.65	2	0.2
	010	0.95	2.8	0.2
	013	1.25	3.3	0.3
	017	1.65	4.2	0.4
	020	1.95	4.6	0.5
	024	2.35	6	0.6
	028	2.74	6.5	0.6
	032	3.14	7.2	0.6
	037	3.64	8	0.7
	040	3.93	10	0.7
	042	4.13	10	0.7
	050	4.93	11	0.7
	058	5.73	12	0.7
	060	5.93	12.7	0.9
	064	6.32	13.5	0.9
	074	7.31	15	0.9
080	7.91	16.5	1	
Type 2 2種	008	0.8	2	0.2
	012	1.2	3	0.3
	015	1.5	4	0.4
	020	2	5	0.4
	025	2.5	6	0.4
	030	3	7	0.6
	040	4	9	0.6
	050	5	11	0.6
	060	6	12	0.8
	070	7	14	0.8
	080	8	16	0.8
	090	9	18	0.8
	100	10	20	1

5-2. Grip Rings  
グリップ止め輪

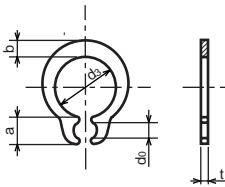

Type No. 類別番号	Type 類別
XD2-210	Grip ring グリップ止め輪

Table 5 表5

Nominal designation 呼び	d <sub>3</sub> (mm)	t (mm)	b (mm)	a (mm)	d <sub>0</sub> (mm)
020	1.9	0.5	1	1.8	0.8
025	2.35	0.5	1.2	1.9	0.9
030	2.85	0.6	1.4	1.9	0.9
035	3.3	0.6	1.6	2	0.9
040	3.8	0.8	1.8	2.8	1.2
045	4.25	0.8	2	2.9	1.3
050	4.75	0.8	2.2	2.9	1.3
060	5.7	1	2.4	3.1	1.4
070	6.7	1	2.7	3.3	1.4
080	7.7	1	3	3.5	1.4
090	8.65	1.2	3.3	4.7	1.5
100	9.65	1.2	3.5	4.7	2

5-3. Toothed Retaining Rings  
歯付き形止め輪

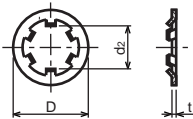

Type No. 類別番号	Type 類別
XD2-230	Toothed retaining ring 歯付き形止め輪

Table 5 表5

Nominal designation 呼び	d <sub>z</sub> (mm)	D (mm)	t (mm)	No of teeth 歯数
015	1.4	5.2	0.25	3
020	1.9	6	0.25	3
024	2.3	6.4	0.25	3
030	2.8	8	0.25	4
040	3.8	9	0.25	4
050	4.8	10	0.25	5
060	5.8	11	0.25	5
080	7.8	13	0.25	5
100	9.8	15.4	0.25	6

### 5-4. Retaining Rings - C Type

C形止め輪

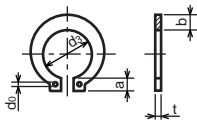

Type No. 類別番号	Type 類別
XD2-310	Retaining ring - C type for shaft C形止め輪 軸用

Table 5 表5

Nominal designation 呼び	d <sub>3</sub> (mm)	t (mm)	b (mm)	a (mm)	d <sub>0</sub> (mm)
010	9.3	1	1.6	3	1.2
012	11.1	1	1.8	3.2	1.5
014	12.9	1	2	3.4	1.7
015	13.8	1	2.1	3.5	1.7
016	14.7	1	2.2	3.6	1.7
017	15.7	1	2.2	3.7	1.7
018	16.5	1.2	2.6	3.8	1.7
020	18.5	1.2	2.7	3.9	2
022	20.5	1.2	2.7	4.1	2
025	23.2	1.2	3.1	4.3	2
028	25.9	1.5	3.1	4.6	2
030	27.9	1.5	3.5	4.8	2
032	29.6	1.5	3.5	5	2.5
035	32.2	1.5	4	5.4	2.5

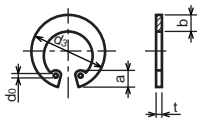

Type No. 類別番号	Type 類別
XD2-320	Retaining ring - C type for hole C形止め輪 穴用

Table 5 表5

Nominal designation 呼び	d <sub>3</sub> (mm)	t (mm)	b (mm)	a (mm)	d <sub>0</sub> (mm)
010	10.7	1	1.8	3.1	1.2
011	11.8	1	1.8	3.2	1.2
012	13	1	1.8	3.3	1.5
014	15.1	1	2	3.6	1.7
016	17.3	1	2	3.7	1.7
018	19.5	1	2.5	4	1.7
019	20.5	1	2.5	4	2
020	21.5	1	2.5	4	2
022	23.5	1	2.5	4.1	2
025	26.9	1.2	3	4.4	2
028	30.1	1.2	3	4.6	2
030	32.1	1.2	3	4.7	2
032	34.4	1.2	3.5	5.2	2.5
035	37.8	1.5	3.5	5.2	2.5
037	39.8	1.5	3.5	5.2	2.5
040	43.5	1.8	4	5.7	2.5
042	45.5	1.8	4	5.8	2.5
045	48.5	1.8	4.5	5.9	2.5
047	50.5	1.8	4.5	6.1	2.5
050	54.2	2	4.5	6.5	2.5
052	56.2	2	5.1	6.5	2.5
055	59.2	2	5.1	6.5	2.5
060	64.2	2	5.1	6.8	2.5
062	66.2	2	5.5	6.9	2.5
068	72.5	2.5	6	7.4	2.5
072	76.5	2.5	6.6	7.4	2.5
075	79.5	2.5	6.6	7.8	2.5
080	85.5	2.5	7	8	2.5
085	90.5	3	7	8	3
090	95.5	3	7.6	8.3	3
095	100.5	3	8	8.5	3

Prepared by  
OIP Business Support Group  
CANON INC.

**Canon**