

# imageRUNNER ADVANCE DX C477iF/C477iFZ

## INSTALLATION MANUAL



# Canon

July 1, 2021  
Rev. 1

# Important Notices

## Application

This manual has been issued by Canon Inc. for qualified persons to learn technical theory, installation, maintenance, and repair of products.

This manual covers all localities where the products are sold. For this reason, there may be information in this manual that does not apply to your locality.

Following "Trademarks" and "Copyright" are not applicable if they are not supported by laws and regulations in the country or region that this document and products are used in.

## Corrections

This manual may contain technical inaccuracies or typographical errors due to improvements or changes in products.

When changes occur in applicable products or in the contents of this manual, Canon will release technical information as the need arises. In the event of major changes in the contents of this manual over a long or short period, Canon will issue a new edition of this manual.

## Trademarks

The Bluetooth word mark and logos are registered trademarks owned by Bluetooth SIG, Inc. and any use of such marks by Canon is under license.

Mopria®, the Mopria® Logo and the Mopria® Alliance logo are registered trademarks and service marks of Mopria Alliance, Inc. in the United States and other countries. Unauthorized use is strictly prohibited.

Apple, AppleTalk, Bonjour, iPad, iPhone, iPod touch, Mac, OS X and Safari are trademarks of Apple Inc.

Microsoft, Windows, Windows Vista, Windows Server, Internet Explorer, Microsoft Edge, Excel and PowerPoint are either registered trademarks or trademarks of Microsoft Corporation in the United States and/or other countries.

Google Cloud Print, Google Chrome and Android are either registered trademarks or trademarks of Google Inc.

OCR Technology by I.R.I.S., copyright 1987-2015, All Rights Reserved.

iHQC™ compression technology by I.R.I.S., copyright 2007-2015, All Rights Reserved.

PDF-iHQC™, XPS-iHQC™ technology by I.R.I.S., copyright 2007-2015, All rights Reserved.

Java is a registered trademark of Oracle and/or its affiliates.

Adobe is a registered trademark of Adobe Systems Incorporated.

Command WorkStation, EFI, Fiery, FreeForm, Spot-On, and WebTools are trademarks of Electronics For Imaging, Inc. and/or its wholly owned subsidiaries in the U.S. and/or certain other countries.

TORX® is a registered trademark of Acument Intellectual Properties, LLC in the United States.

Other product names and other names in this document are generally registered trademarks or trademarks of the companies.

## Copyright

The copyright of this document belongs to Canon Inc. This document may not be copied, reproduced or translated into another language, in whole or in part, without the prior consent of Canon Inc.  
Copyright CANON INC. 2020

## Caution

Use of this manual should be strictly supervised to avoid disclosure of confidential information.

## Symbols

The frequently-performed operations are described with symbols in this procedure.

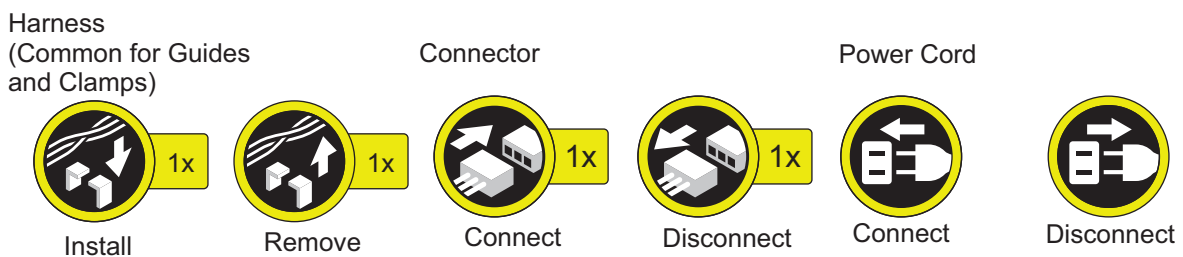
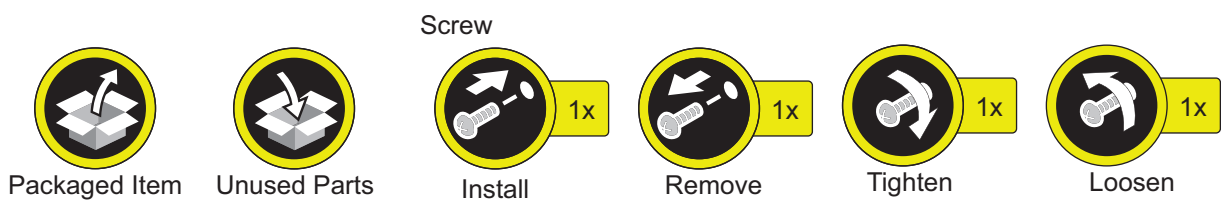

# Contents

<b>Safety Precautions</b> .....	<b>1</b>
Toner Safety.....	2
About Toner.....	2
Handling Adhered Toner.....	2
Points to Note at Installation.....	2
Points to Note Before Servicing.....	2
Essential Items to Be Performed Before Installation.....	2
Points to Note when turning ON/OFF the main power.....	2
illustrations.....	3
<b>1. Product Lineup</b> .....	<b>4</b>
Host Machine Options .....	5
Combination Table of Accessory Installation.....	6
<b>2. Host Machine</b> .....	<b>7</b>
Installation of the Host Machine .....	8
Operation when using uniFLOW Online.....	8
Installing the IC Card Reader.....	8
<b>3. Host Machine Options</b> .....	<b>22</b>
NFC KIT-E1/E2.....	23
Points to Note at Installation.....	23
Installation Outline Drawing.....	23
Checking the Contents .....	23
Installation procedure.....	26
Setting after Installation.....	45
Copy Card Reader-F1/Copy Card Reader Attachment-B5.....	46
Points to Note at Installation.....	46
Checking the Contents.....	46
Installation Outline Drawing.....	48
Installation Procedure.....	49
Checking after Installation.....	68
Copy Control Interface Kit-A1.....	70
Points to Note at Installation.....	70
Checking the Contents.....	70
Installation Outline Drawing.....	70
Installation Procedure.....	71
IC Card Reader Box-D1.....	79
Points to Note at Installation.....	79
Checking the Contents.....	79
Installation Outline Drawing.....	80
Installation Procedure.....	81
Super G3 FAX Board-AT1.....	107
Points to Note at Installation.....	107

Checking the Contents..... 107

Installation Outline Drawin..... 108

Installation Procedure..... 108

Checking the Operation..... 120

Connection Kit-A2/A3 for Bluetooth LE..... 122

    Points to Note at Installation..... 122

    Installation Outline Drawing..... 122

    Checking the Contents..... 122

    Installation Procedure..... 124

    Setting after Installation..... 145

**Revision..... 146**

# Safety Precautions

Toner Safety.....	2
Points to Note at Installation.....	2

## Toner Safety

### About Toner

Toner is a nontoxic matter composed of plastic, iron and a trace of pigments.

#### CAUTION:

Never throw toner in flames to avoid explosion.

### Handling Adhered Toner

- Use dry tissue paper to wipe off toner adhered to skin or clothes and wash in water.
- Never use warm water for cleaning up toner to prevent toner particles from being gelated to soak into fibers permanently.
- Toner particles are reactive with vinyl polymers. Avoid contacting these materials.

## Points to Note at Installation

### Points to Note Before Servicing

- At servicing, be sure to turn OFF the power source according to the specified steps and disconnect the power plug.
- Be sure to disconnect the power plug on a regular basis and remove dust and dirt accumulated around the outlet with dry cloth.

#### CAUTION:

Leaving the power plug connected for a long time in an environment having a lot of dust, moisture, or oily smoke will cause a fire. (Because dust accumulated in the surrounding area will absorb moisture and cause an insulation failure)

- Be careful not to be injured by burrs of edges, sharp corners or protrusions.

#### CAUTION:

Hazardous area such as corners, edges, springs and other sharp sections may be remaining on products. Always be aware of the presence of hazardous area to avoid injury caused by contacting and/or striking those area, by not over-concentrating on service work.

### Essential Items to Be Performed Before Installation

- Turn OFF the main power of the host machine, and disconnect the power plug from the outlet.

#### WARNING:

- If performing work without disconnecting the power plug of the host machine, it may cause electrical shock.
- If disconnecting the power plug without turning OFF the main power, it may cause damage of the machine.

- When turning OFF the main power, follow the below procedure.
  1. Turn OFF the main power switch of the host machine.
  2. The display in the Control Panel and the lamp of the main power are turned off.

### Points to Note when turning ON/OFF the main power

The following message is displayed.

1. When a message prompting to turn OFF and then ON the main power appears, turn OFF and then ON the main power switch.
2. If a message prompting the user to update the version appears, press [Update] to automatically update the version of this equipment.  
If [Skip] is selected, a message prompting the user to update the version will appear every time the host machine is started. In the service mode ( Lv.2 ) shown below, it is possible to set not to display the message.  
COPIER > OPTION > FNC-SW > VER-CHNG

## illustrations

Although pictures or illustrations used for explanation may differ from the actual things, the procedure is the same.





# Product Lineup

Host Machine Options .....5

## Host Machine Options

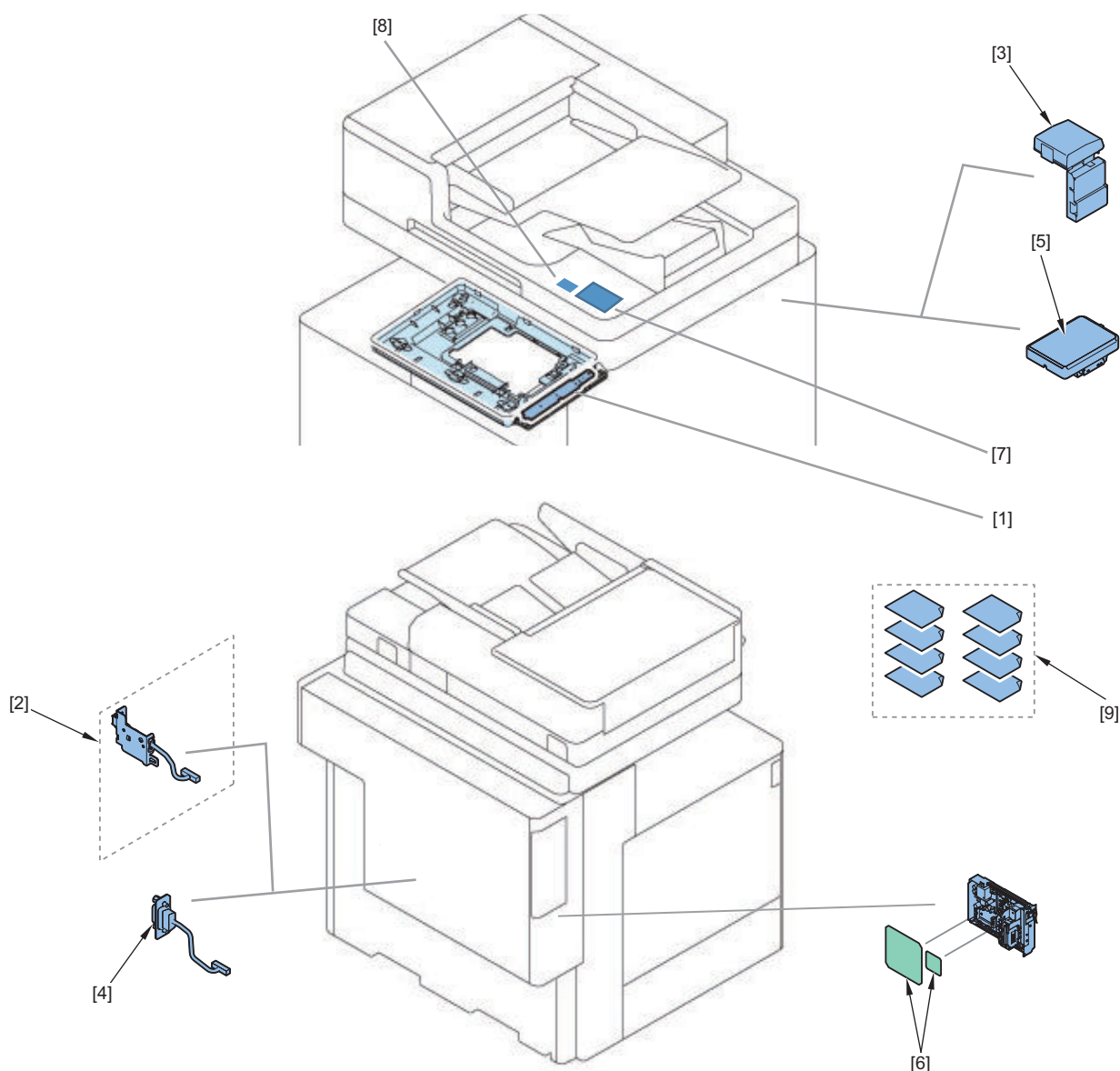

No.	Product name	Condition
1	"NFC KIT-E1/E2" on page 23	
2	"Copy Card Reader-F1/Copy Card Reader Attachment-B5" on page 46	It is required when installing Copy Card Reader-F1.
3	"Copy Card Reader-F1/Copy Card Reader Attachment-B5" on page 46	Copy Card Reader Attachment-B5 is required.
4	" Copy Control Interface Kit-A1" on page 70	
5	"IC Card Reader Box-D1" on page 79	Card Reader (sales company's option) is required.
6	"Super G3 FAX Board-AT1" on page 107	
7	"Installing the IC Card Reader" on page 8	Card Reader (sales company's option) is required.
8	"Connection Kit-A2/A3 for Bluetooth LE" on page 122	

## License Products

At the time of installation, obtain the license number according to the license certificate included. Then, enter the obtained license number from the Control Panel of the machine. The applicable functions are enabled. There is no physically required installation. There is no physically required installation.

No.	Product name	Condition
9	Remote Fax Kit-A1	
-	IP FAX Expansion Kit-B1	
-	PCL International Font Set-A1	
-	Picture Login-A1	
-	Barcode Printing Kit-D1	

## Combination Table of Accessory Installation

### NOTE:

The following table shows the combination of options installed of the host machine. Before installing the following options, refer to the table to check the combination of options.

	NFC Kit	Copy Card Reader/ Copy Card Reader Attachment	Copy Control Interface Kit	IC Card Reader Box	Super G3 FAX Board	IC Card Reader	Connection Kit for Bluetooth LE
NFC Kit	-	Yes	Yes	Yes	Yes	Yes	Yes
Copy Card Reader/ Copy Card Reader Attachment	Yes	-	No	No	Yes	No	Yes
Copy Control Interface Kit	Yes	No	-	Yes	Yes	Yes	Yes
IC Card Reader Box	Yes	No	Yes	-	Yes	No	Yes
Super G3 FAX Board	Yes	Yes	Yes	Yes	-	Yes	Yes
IC Card Reader	Yes	No	Yes	No	Yes	-	Yes
Connection Kit for Bluetooth LE	Yes	Yes	Yes	Yes	Yes	Yes	-

Yes: installation is available No: installation is not available



# Host Machine

Installation of the Host Machine ..... 8

## Installation of the Host Machine

Host Machine can be installed by the user.  
See "Getting Started" for details of the installation procedures.

### Operation when using uniFLOW Online

When using uniFLOW Online\*, follow the setup procedures on the uniFLOW\* Online First Steps Guide ([http://www.nt-ware.com/uFO\\_FS](http://www.nt-ware.com/uFO_FS)).

\* China version of "uniFLOW" is called "mndsFLOW".

### Installing the IC Card Reader

#### Points to Note at Installation

- When installing the IC Card Reader, the IC Card Reader (sales company's option) is required.
- The IC Card Reader and the following options cannot be used together.
  - IC Card Reader Box
  - Copy Card Reader
- When installing the Connection Kit for Bluetooth LE at the same time, install the Connection Kit for Bluetooth LE first.
- The pictures and illustrations used may differ from the actual product, but the procedures are the same.

#### Checking the Contents

**NOTE:**

Use the following parts included with the host machine.

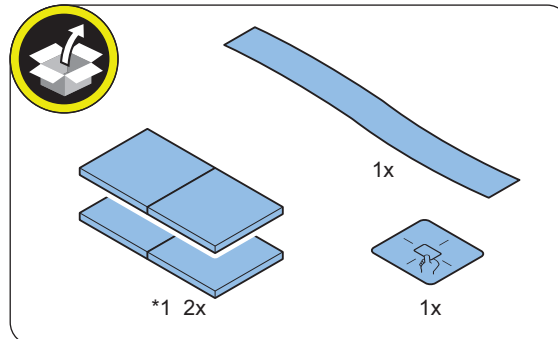

\*1: Use them if necessary when installing the Card Reader.

#### Installation Outline Drawing

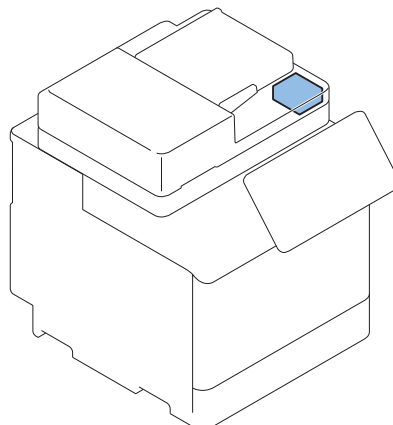

## ■ Installation Procedure

### ● Removing the Covers

□

**1.**

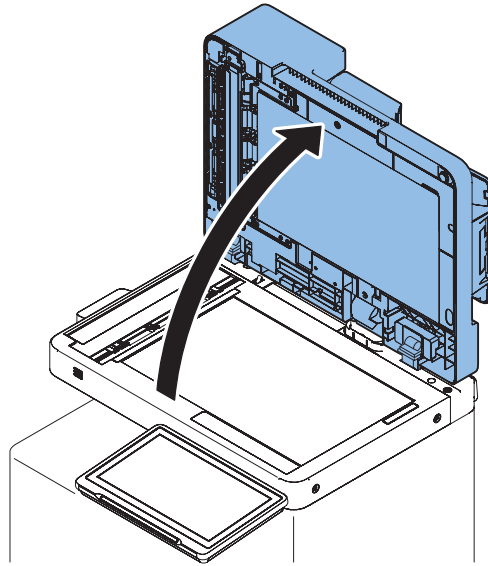

□

**2.**

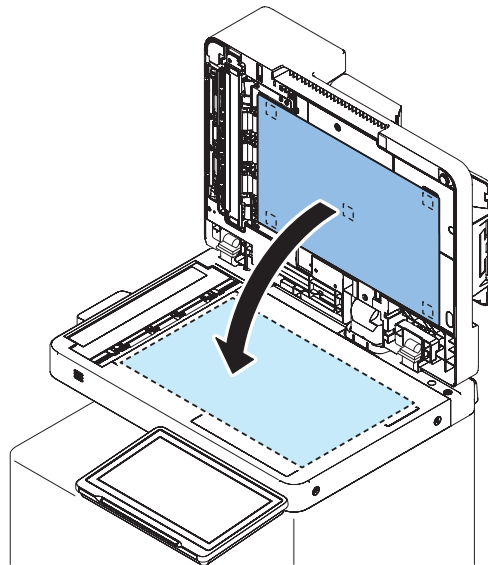

□  
**3.**

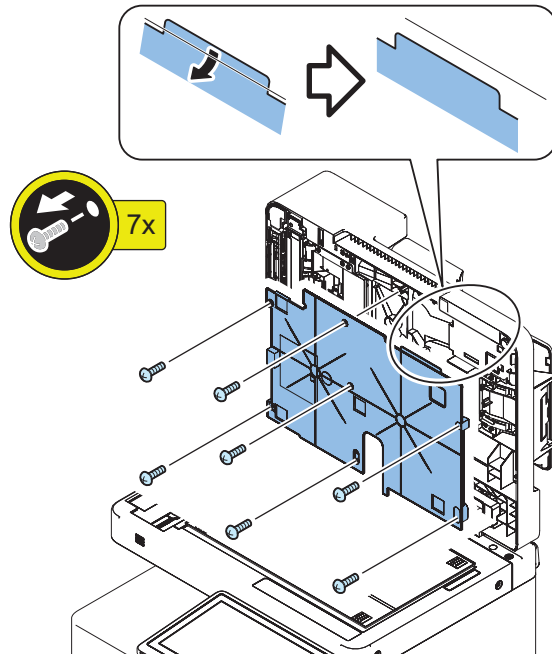

□  
**4.**

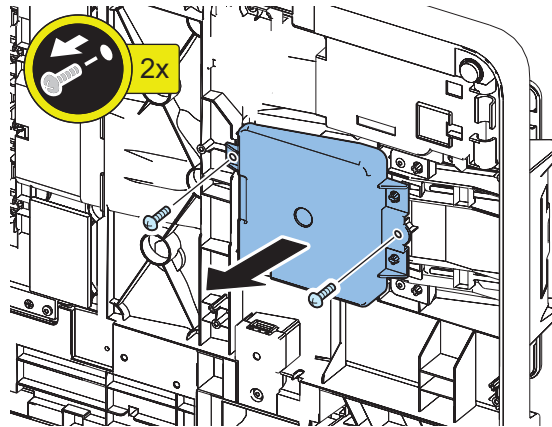

□  
**5.**

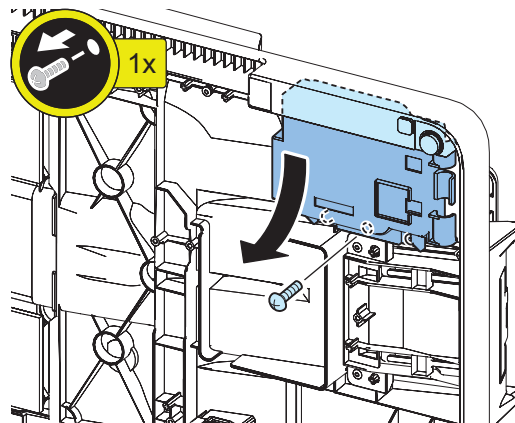

## ● Installing the IC Card Reader

Refer to the table below and install according to the "Reference Procedure" for the IC card reader.

**NOTE:**

The installation procedure depends on the shape of the IC card reader.

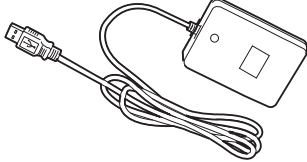
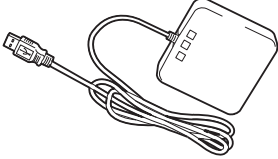
TYPE	Shape of IC card reader	Reference Procedure
1		"Installing the IC Card Reader (For TYPE 1)" on page 11
2		"Installing the IC Card Reader (For TYPE 2)" on page 14

## ● Installing the IC Card Reader (For TYPE 1)

□

**1.**

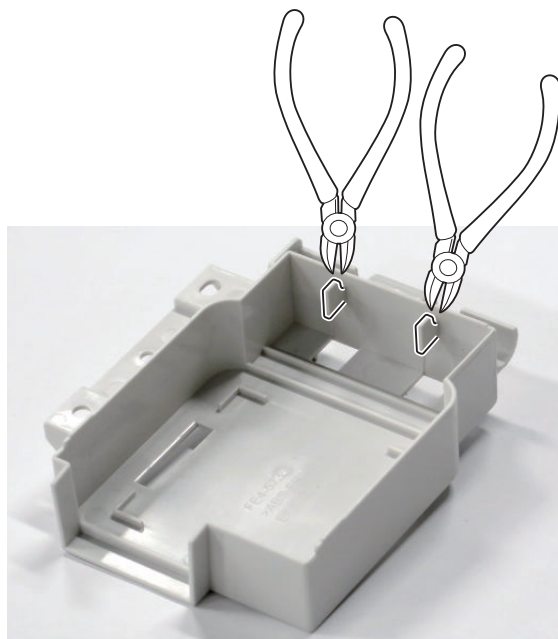



□  
2.

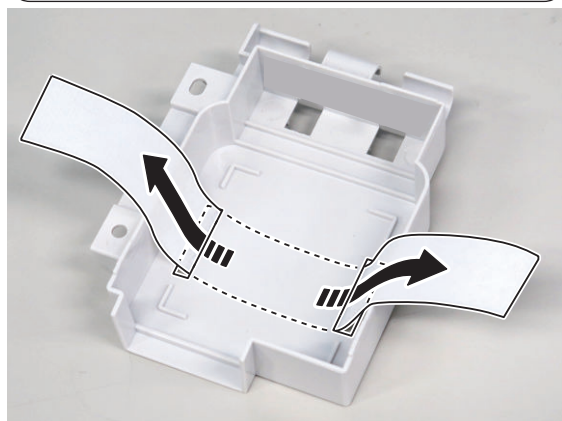
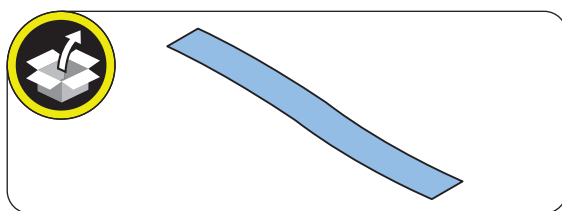

□  
**3.**

**NOTE:**

Be sure to adjust the number of cushions according to the thickness of the Card Reader.

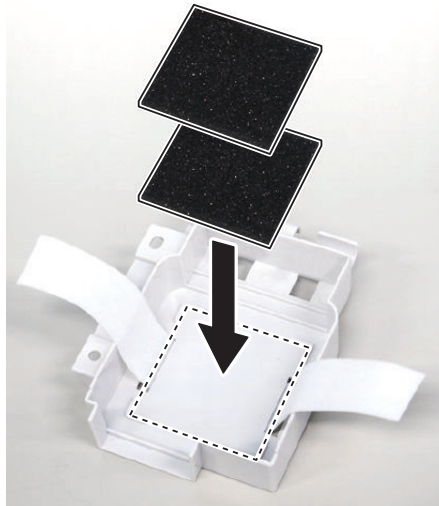
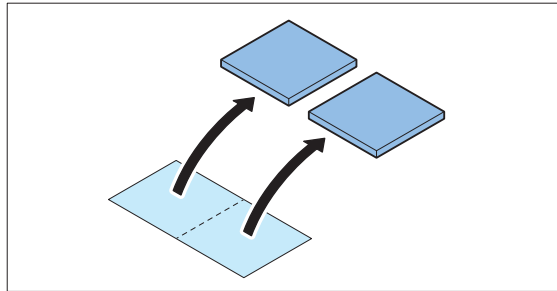
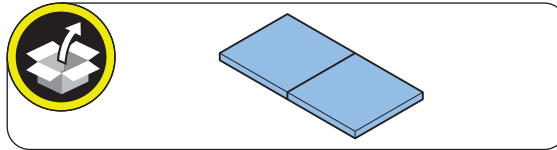

□  
**4.**

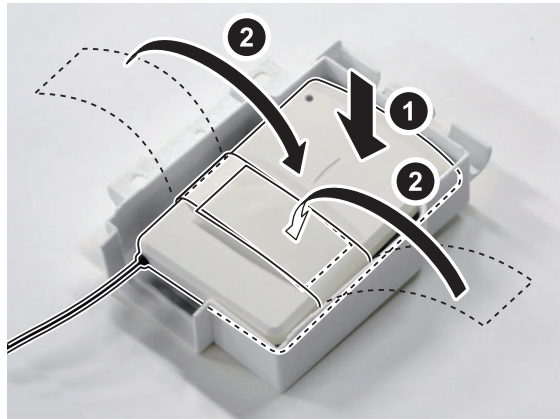

**NOTE:**  
Go to "Subsequent Work". "Subsequent Work " on page 15

• **Installing the IC Card Reader (For TYPE 2)**

□  
**1.**

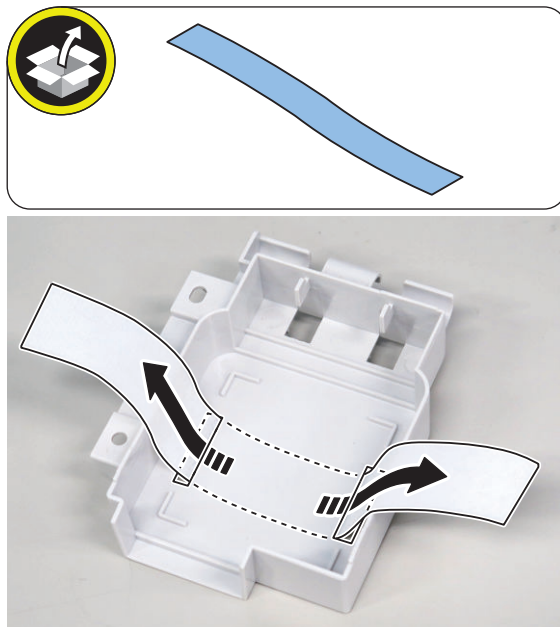

□  
2.

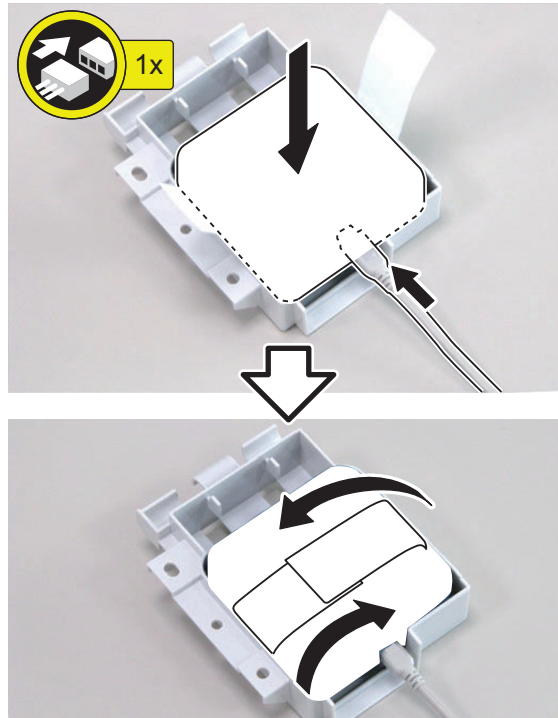

**NOTE:**  
Go to "Subsequent Work". "Subsequent Work" on page 15

• Subsequent Work

□  
1.

**NOTE:**  
Use the screws removed in "Removing the Covers".

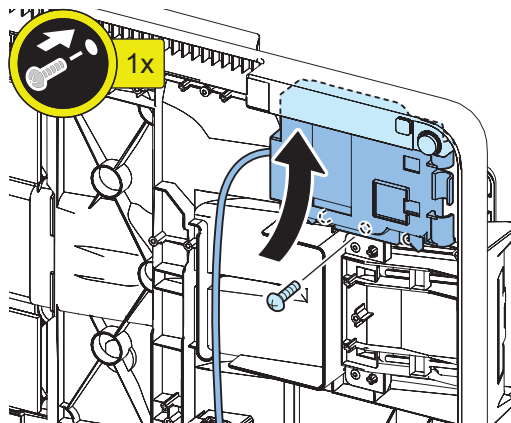

□  
2.

**NOTE:**  
Wind the cable counterclockwise to store it as needed.

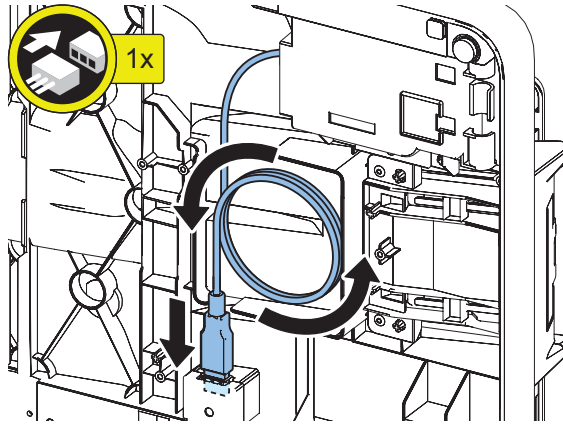

**NOTE:**  
When installing with the Connection Kit for Bluetooth LE at the same time.

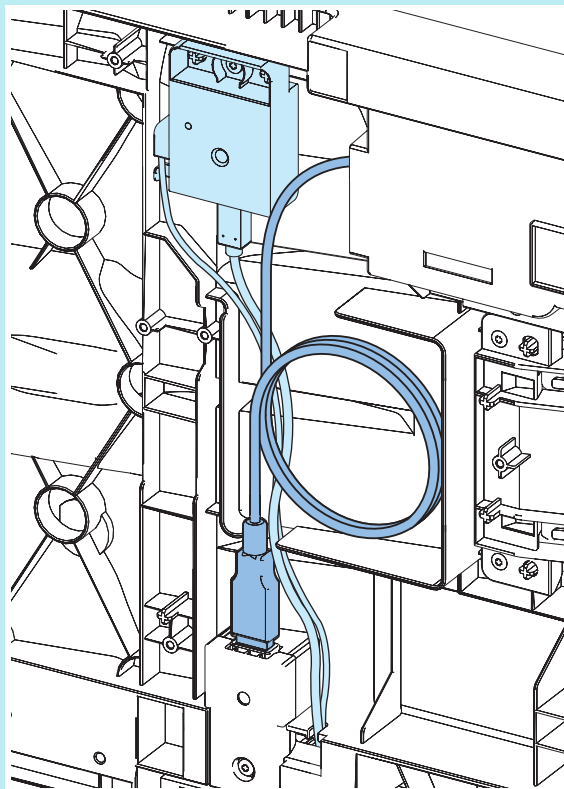

□  
**3.**

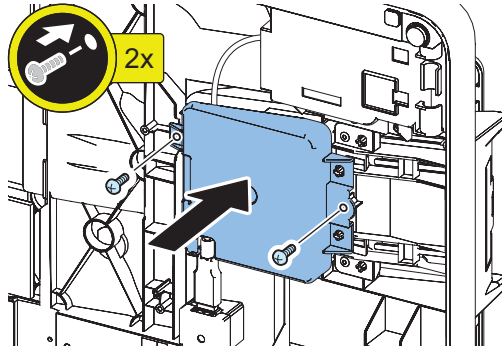

□  
**4.**

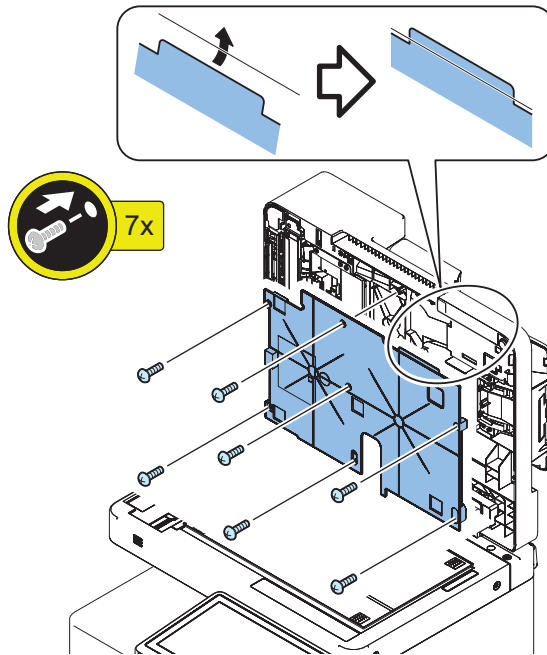

□  
**5.**

**CAUTION:**  
Align the White Plate to the Index.

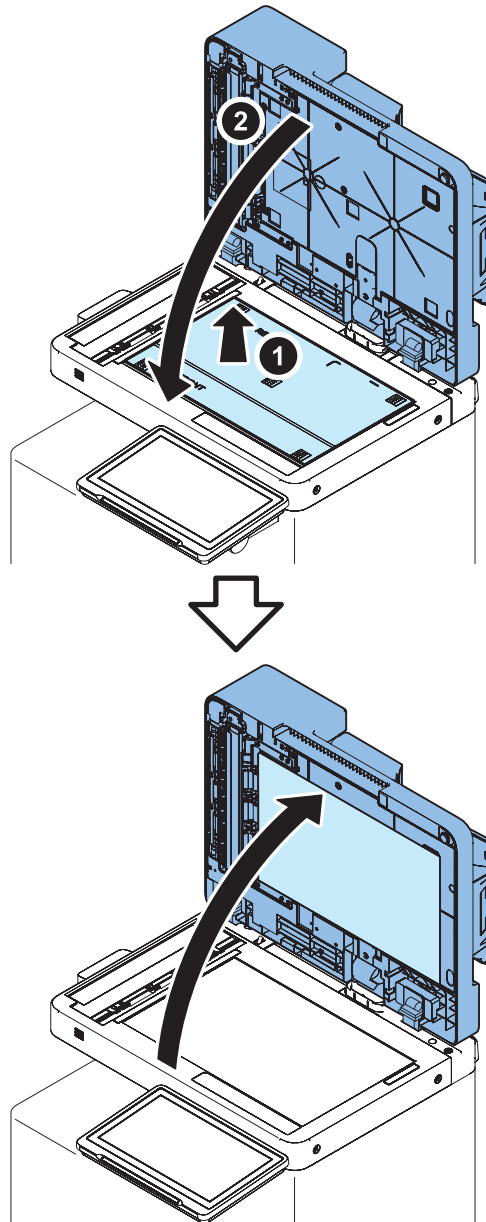
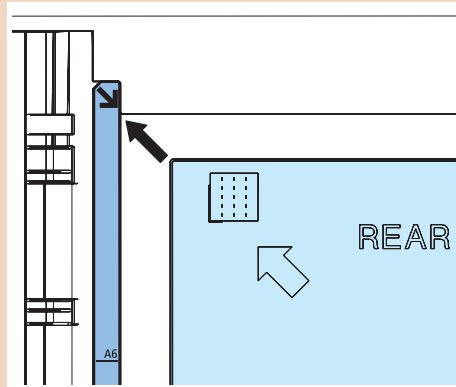

□  
**6.**

**CAUTION:**

If the White Plate is pressed from top to bottom, it is placed on the Index Sheet, so be sure to press it from bottom to top.

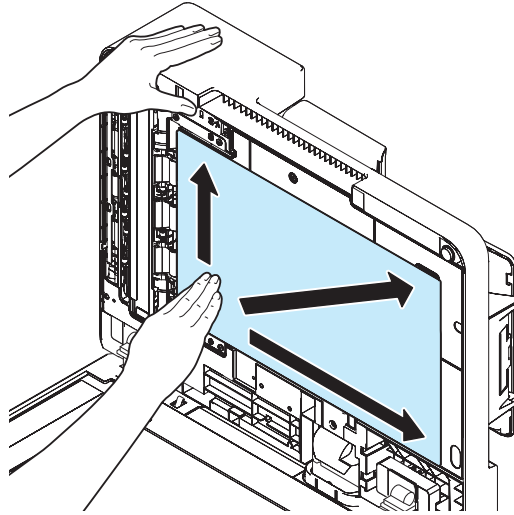



□  
7.

**CAUTION:**

Check that the White Plate is not placed on the Index Sheet with this equipment closed.

- Be sure that there is no gap between the White Plate and the Index Sheet.
- The gap between the White Plate and the Index Sheet must be 0.3 mm or less as a reference.

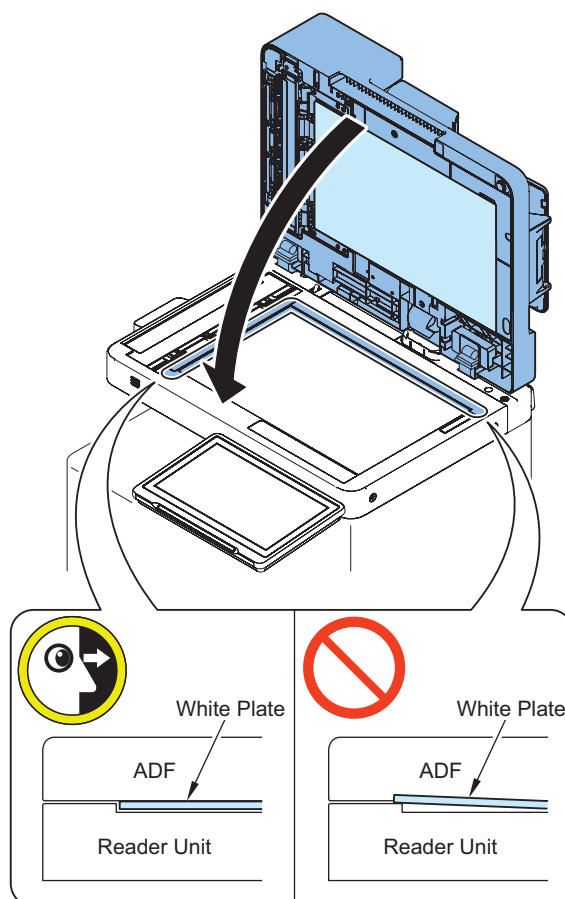

□  
8.

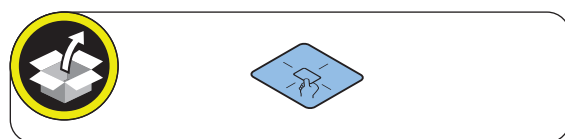



**9.** Connect the power plug of the host machine to the outlet.



**10.** Turn ON the Main Power Supply Switch.



# Host Machine Options

NFC KIT-E1/E2.....	23
Copy Card Reader-F1/Copy Card Reader Attachment-B5.....	46
Copy Control Interface Kit-A1.....	70
IC Card Reader Box-D1.....	79
Super G3 FAX Board-AT1.....	107
Connection Kit-A2/A3 for Bluetooth LE.....	122

## NFC KIT-E1/E2

### Points to Note at Installation

- Do not touch the sensor and PCB components of the Control panel.
- The parts removed in "Removing the Control Panel" will be used in "Installing the Control Panel".

### Installation Outline Drawing

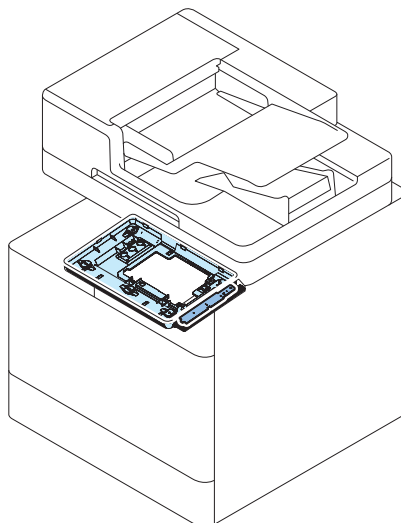

### Checking the Contents

**NOTE:**

The required parts differ depending on the host machine to which this equipment is installed. Use A, B, G, H, I and J for this product.

<NFC KIT-E1>

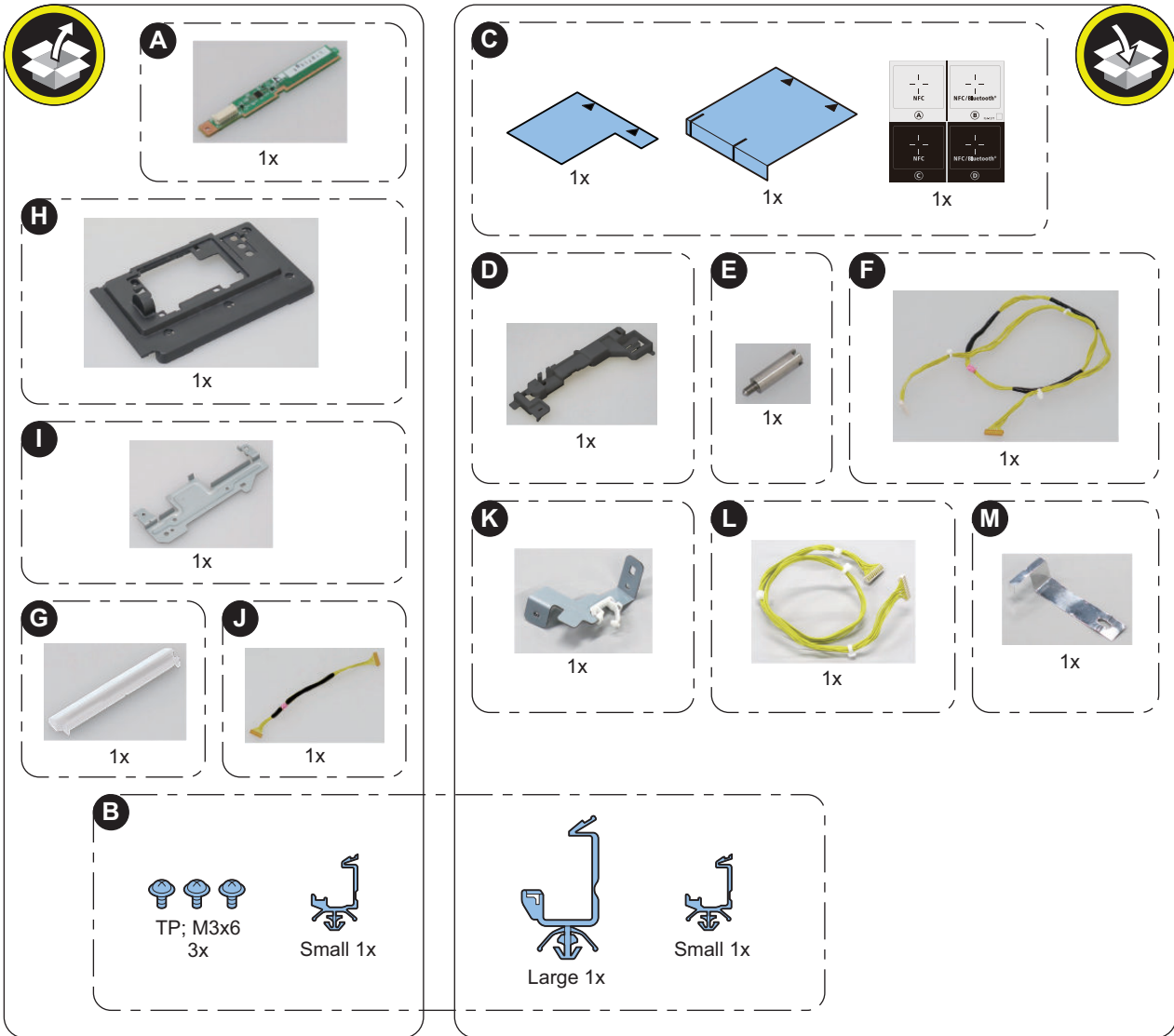

<NFC KIT-E2>

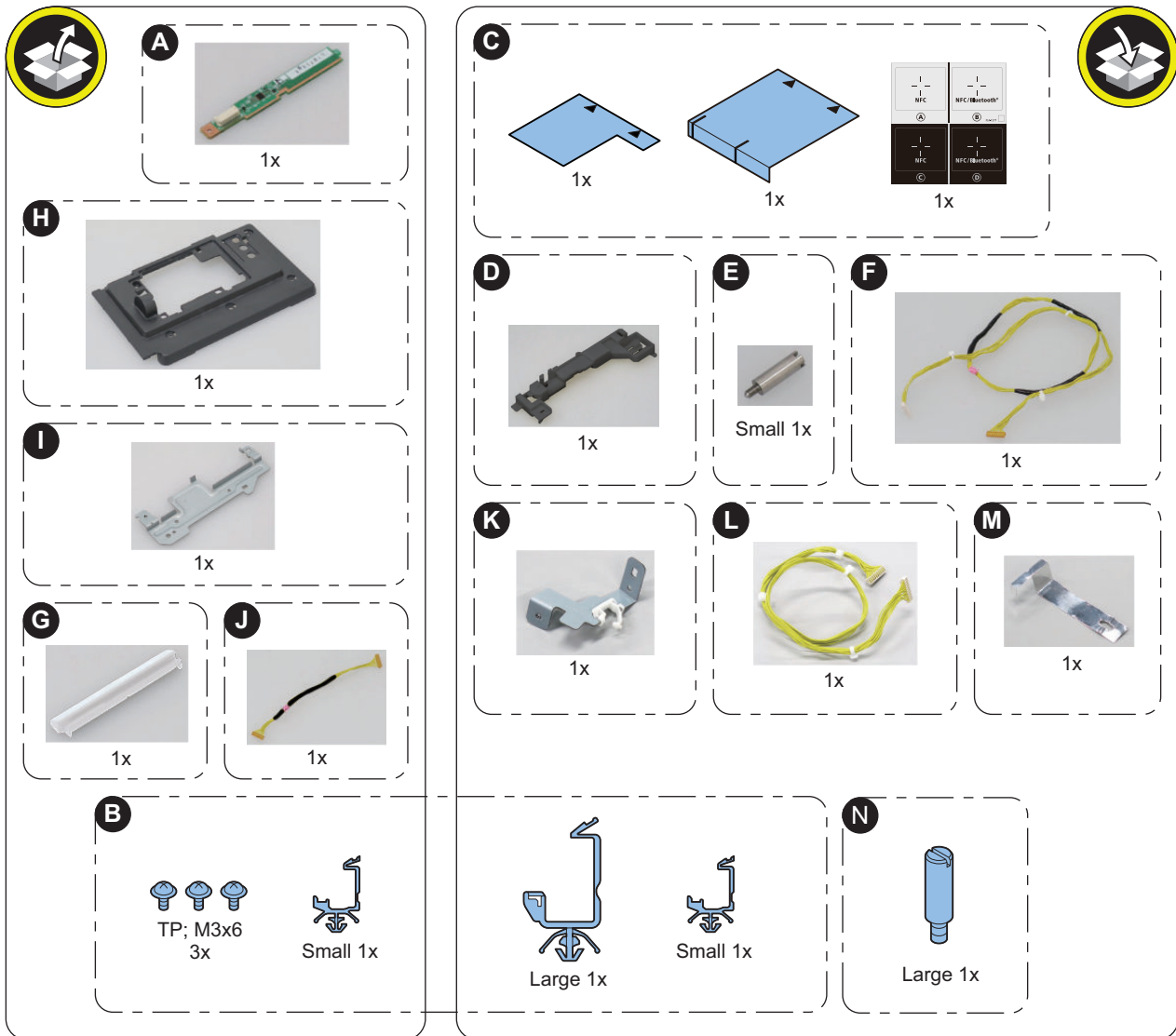

<Others>

- Guides are included

## ● Installation procedure

### ■ Removing the Control Panel

□

1.

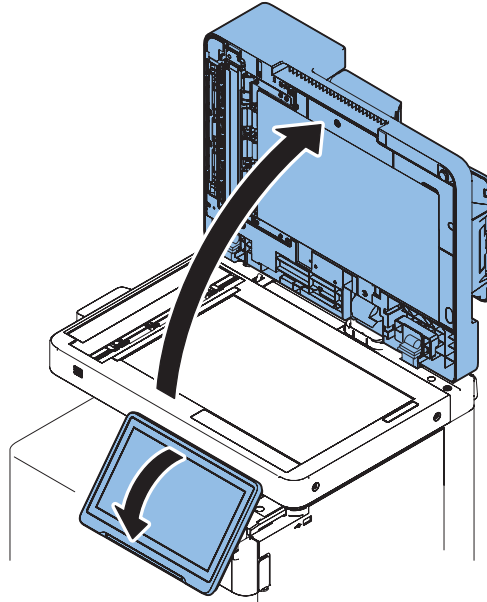

□

2.

**CAUTION:**

Be sure to place 5 or more sheets of paper to prevent damage.

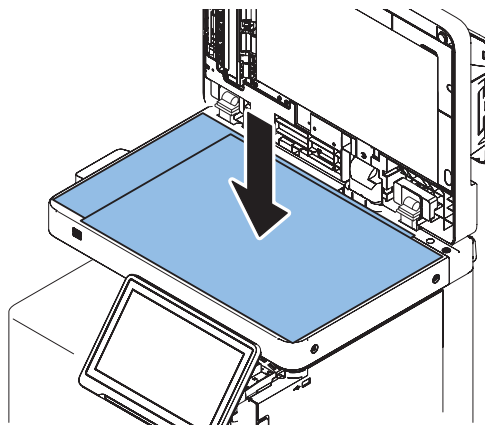

□  
**3.**

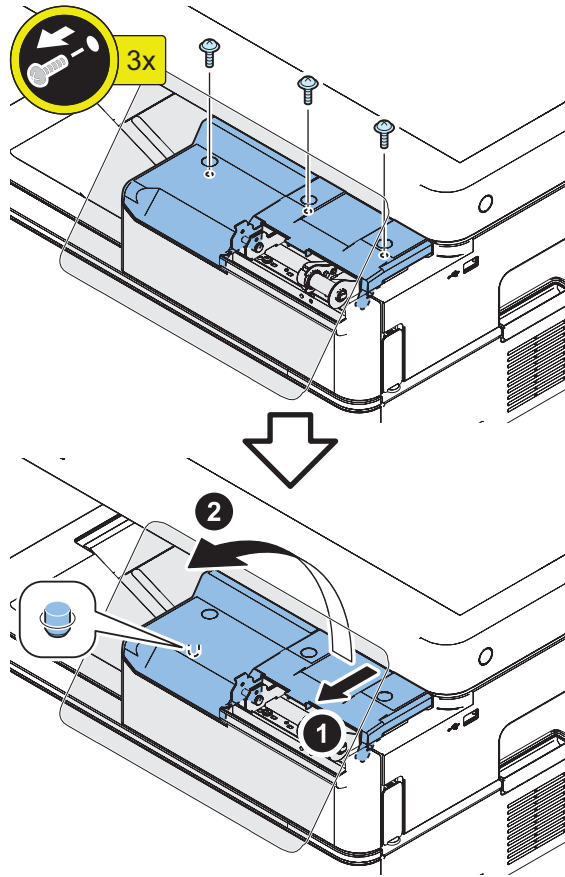

□  
**4.**

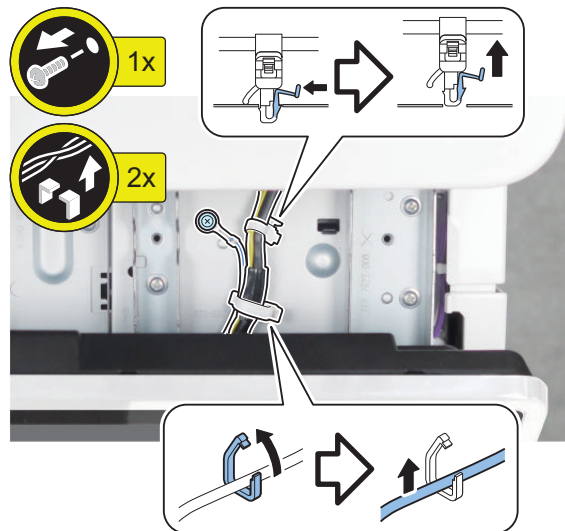



□  
**5.**

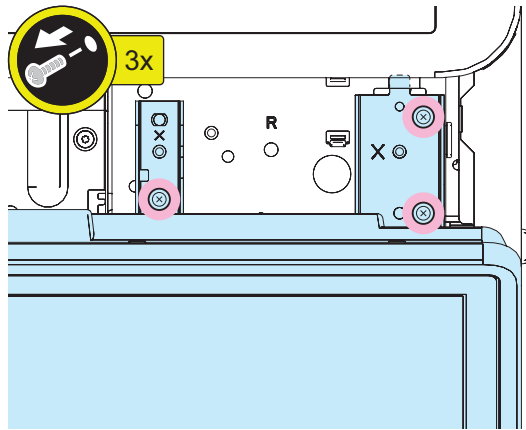

□  
**6.**



□  
7.

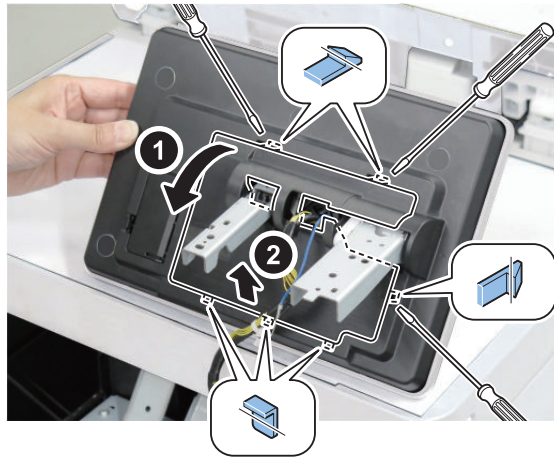

□  
8.

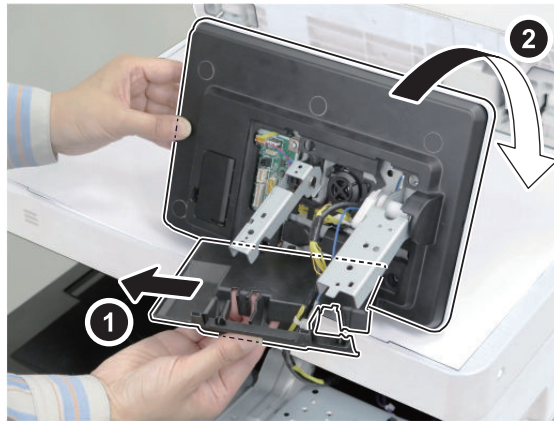

□  
9.

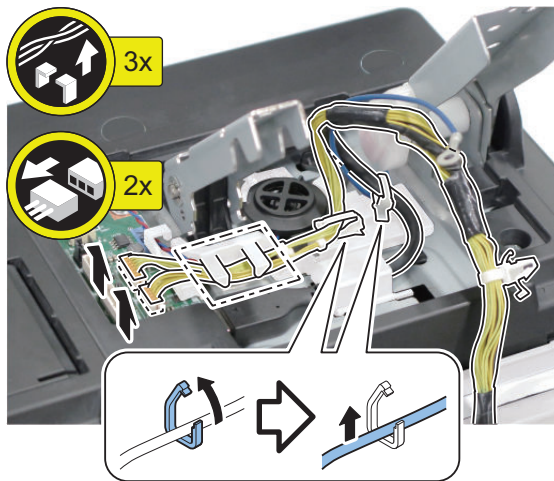

□  
**10.**

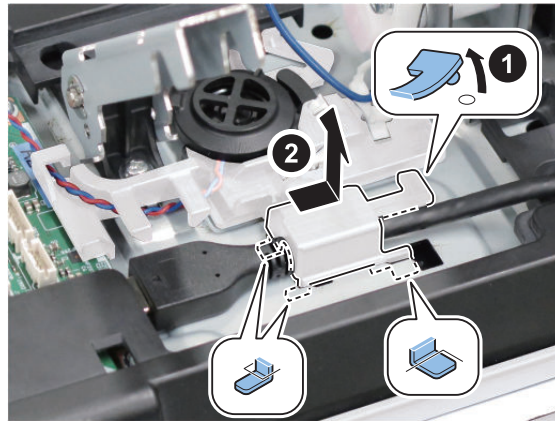

□  
**11.**

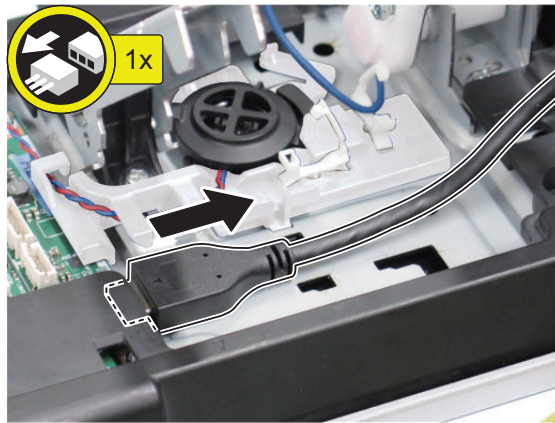

■ **Installing the NFC Kit**

□  
**1.**

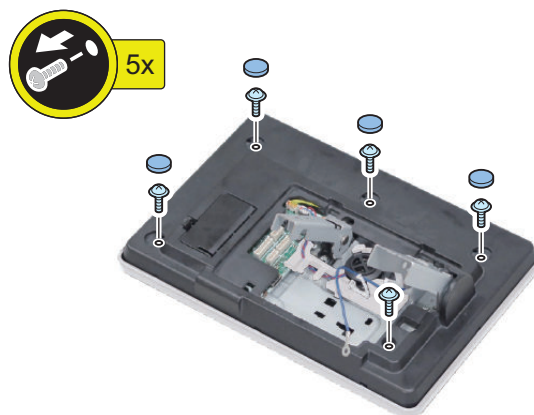

□  
**2.**

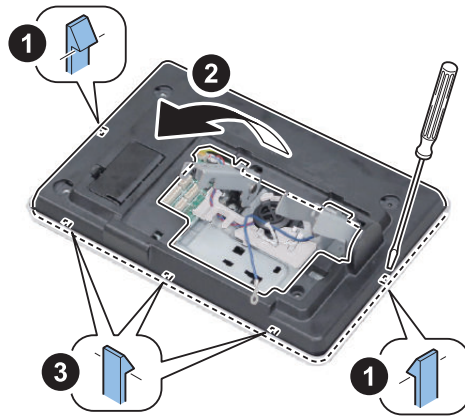

□  
**3.**

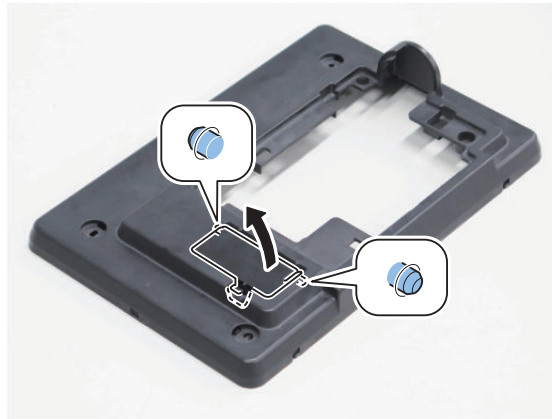

**NOTE:**  
The removed parts will be used in step 8.

□  
4.

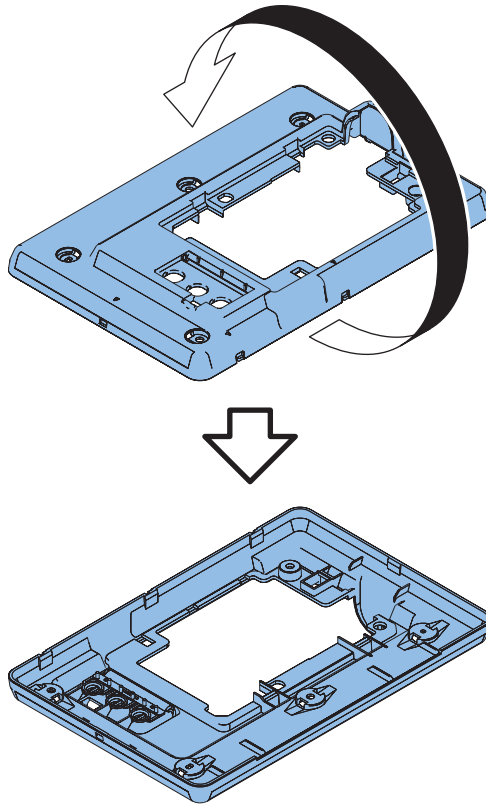

□  
5.

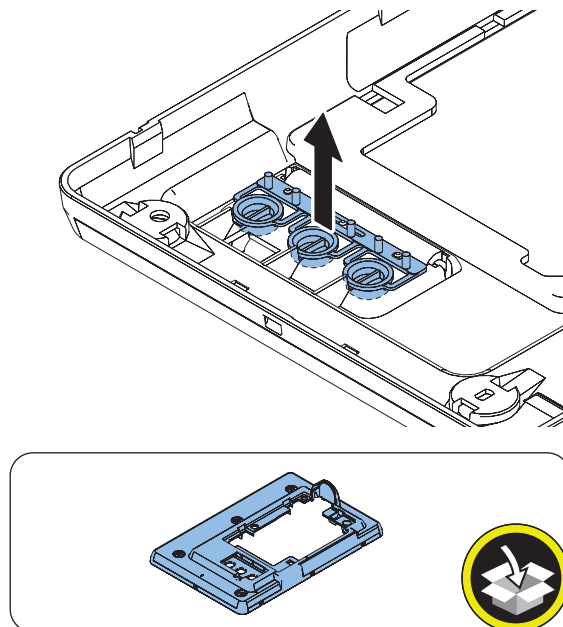

**NOTE:**  
The removed part will be used in the next step.

□  
**6.**

**NOTE:**  
Use the part removed in the previous step.

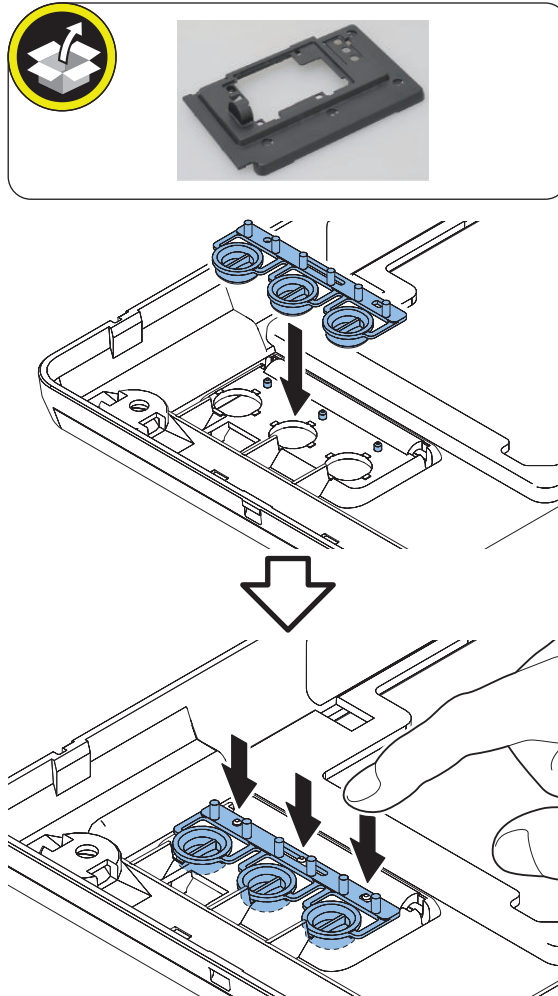

□  
7.

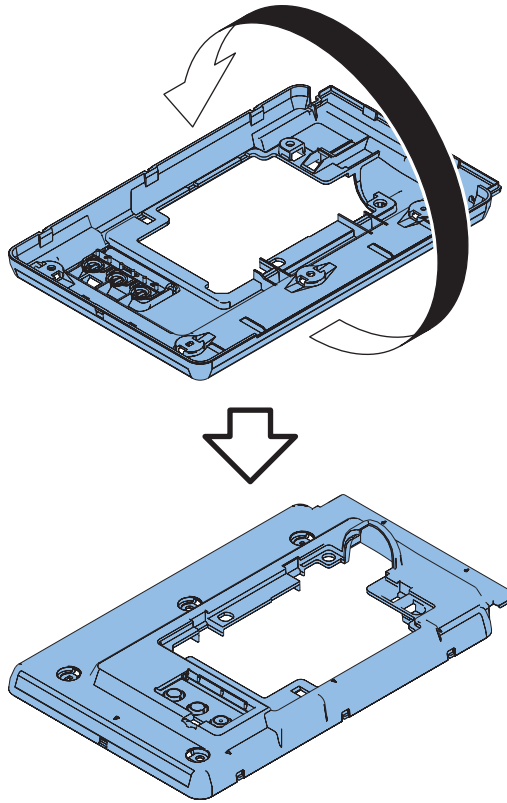

□  
8.

**NOTE:**  
Use the part removed in step 3.

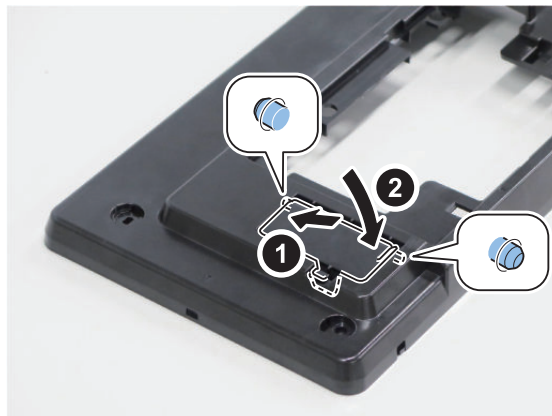

□  
**9.****NOTE:**

Position the NFC Cover by aligning it with the marking line to install.

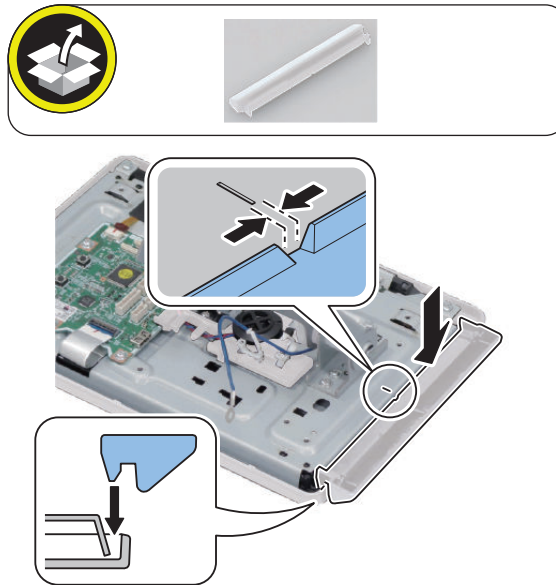
□  
**10.****NOTE:**

Install the cable to the NFC PCB as shown in the figure.

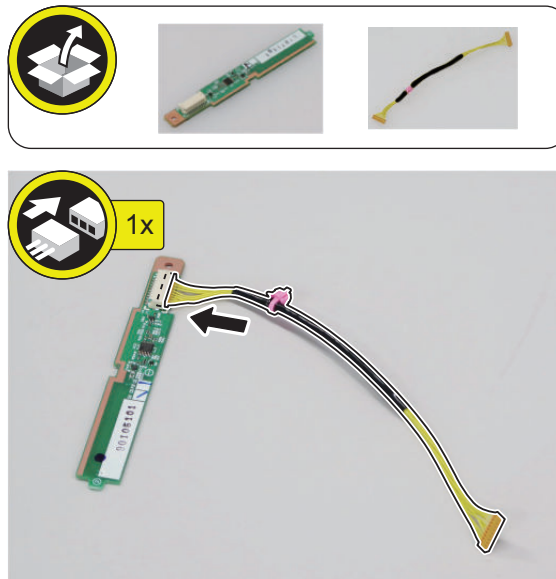



□  
11.

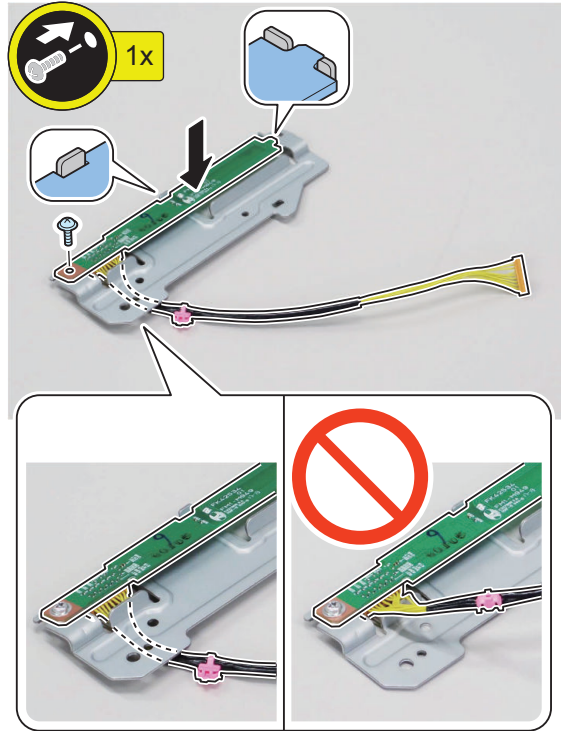
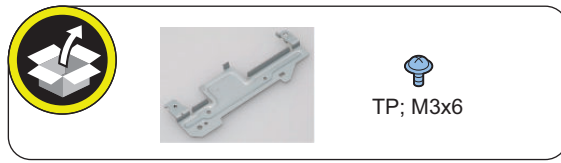

□  
12.

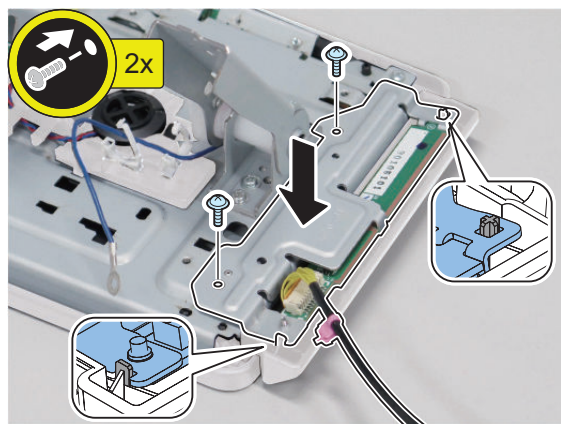
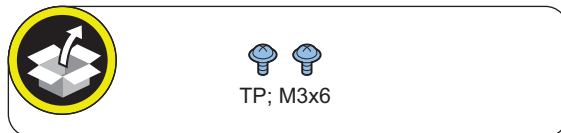

□  
**13.**

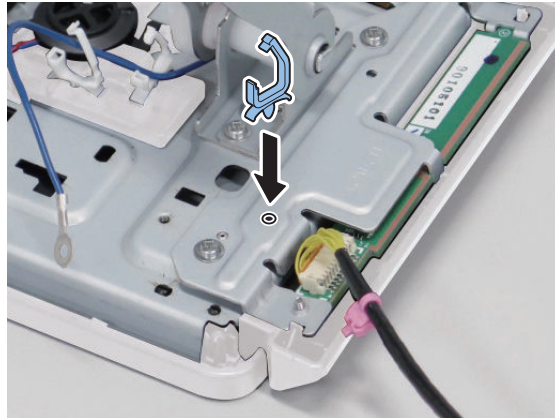

□  
**14.**

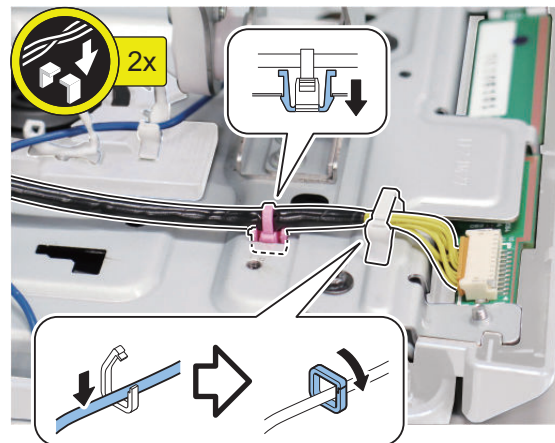

□  
**15.**

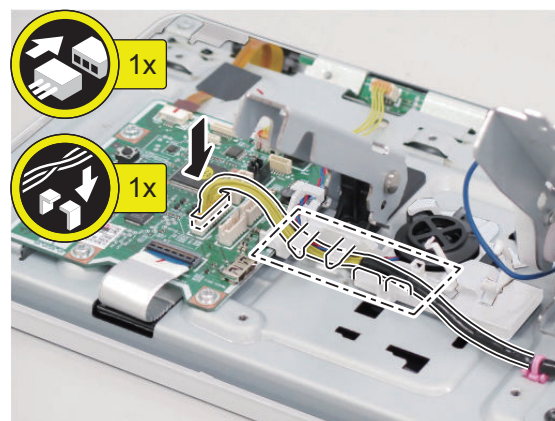

□  
16.

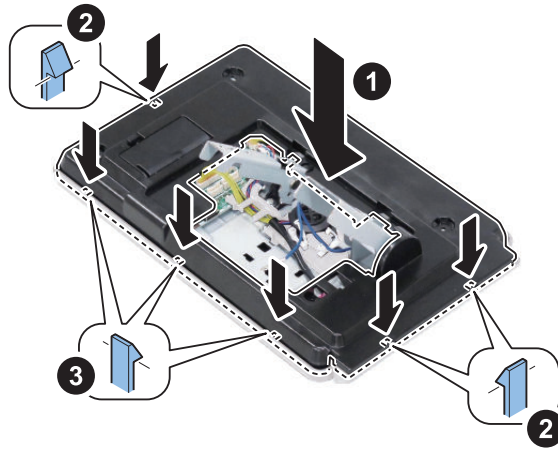

□  
17.

**CAUTION:**  
Be sure to use appropriate type of screws when installing the removed screws.

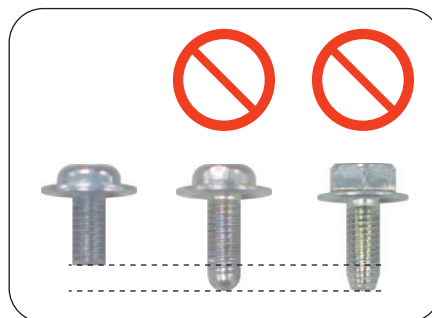
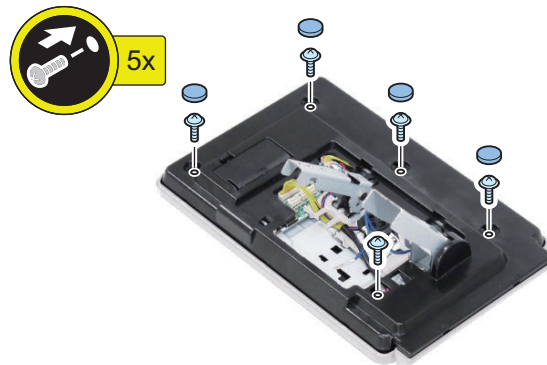

### ■ Installing the Control Panel

□  
**1.**

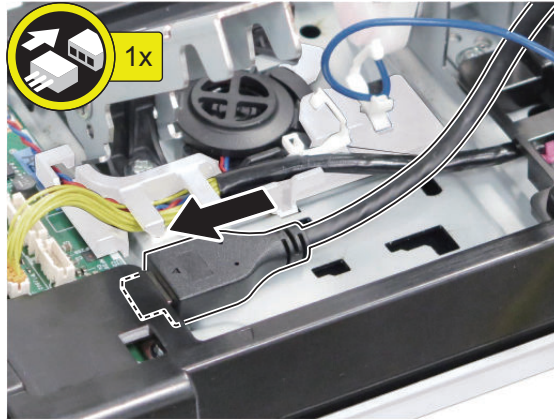

□  
**2.**

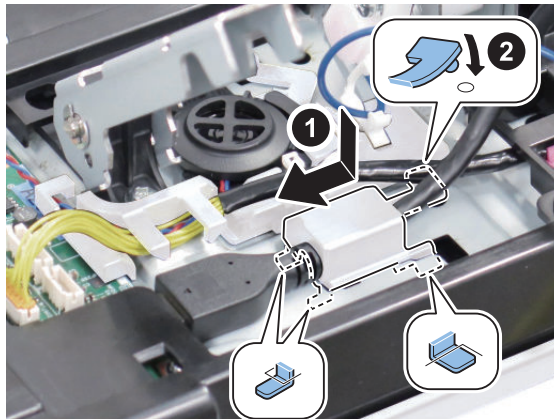

□  
**3.**

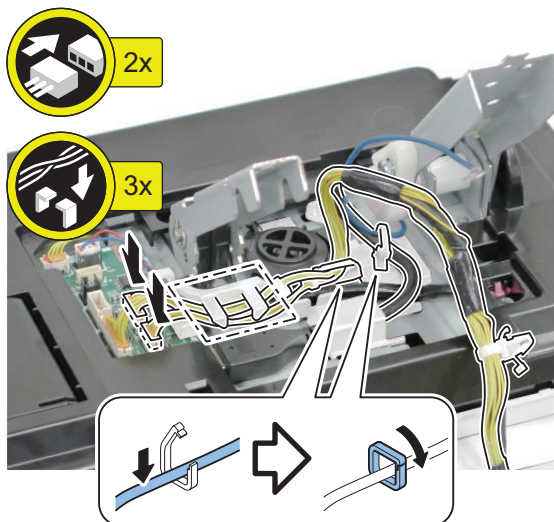

□  
**4.**

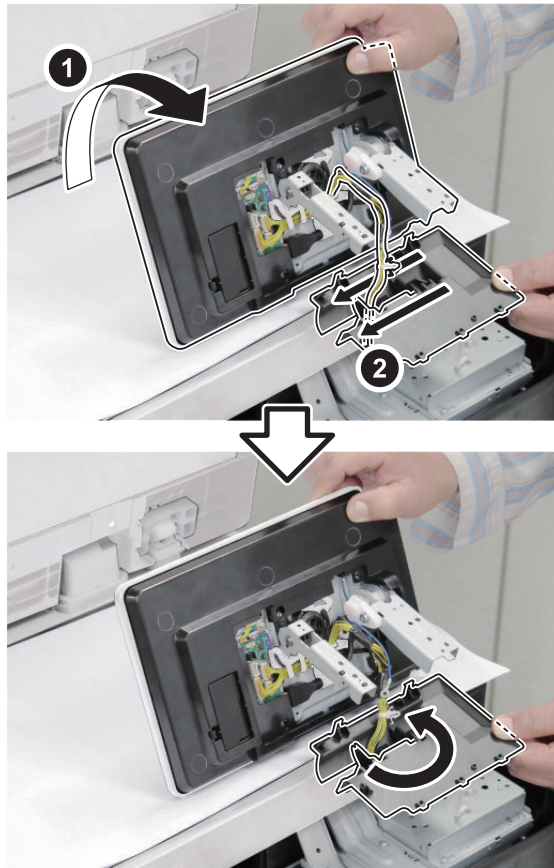

□  
**5.**

**NOTE:**  
Be sure to turn the Cover in the direction of the arrow to install.

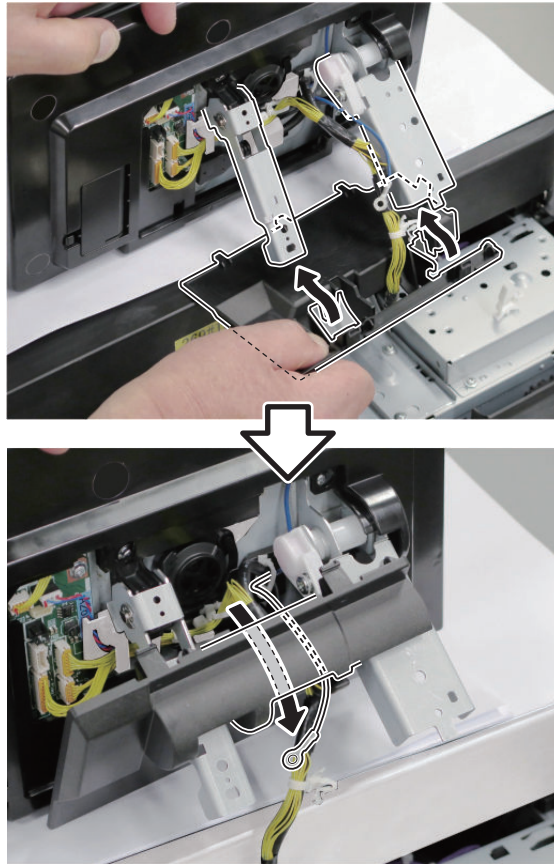

□  
**6.**

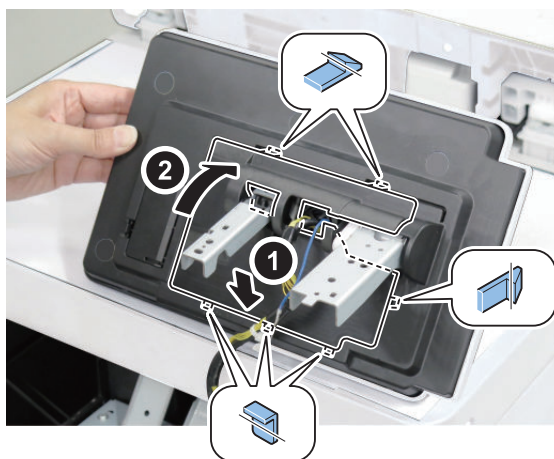

□  
7.



□  
8.

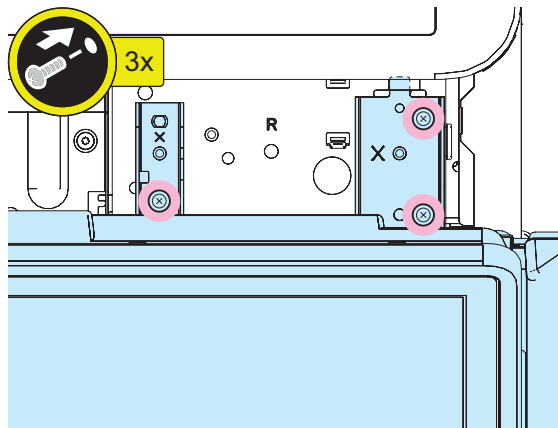

□  
9.**CAUTION:**

Store the excess cable under the Reader.

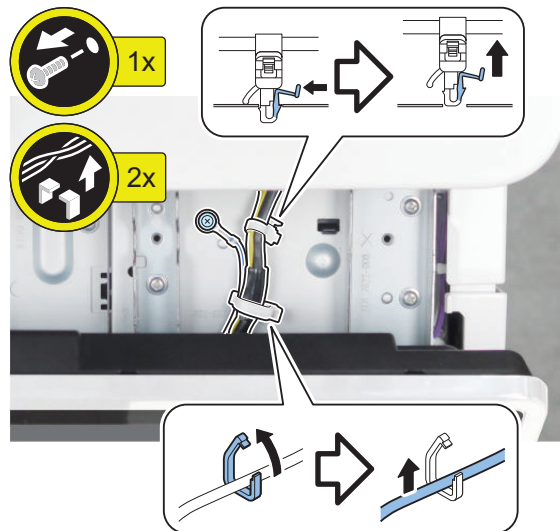
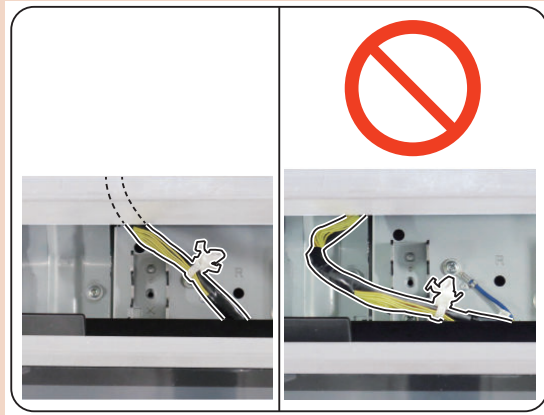



□  
**10.**

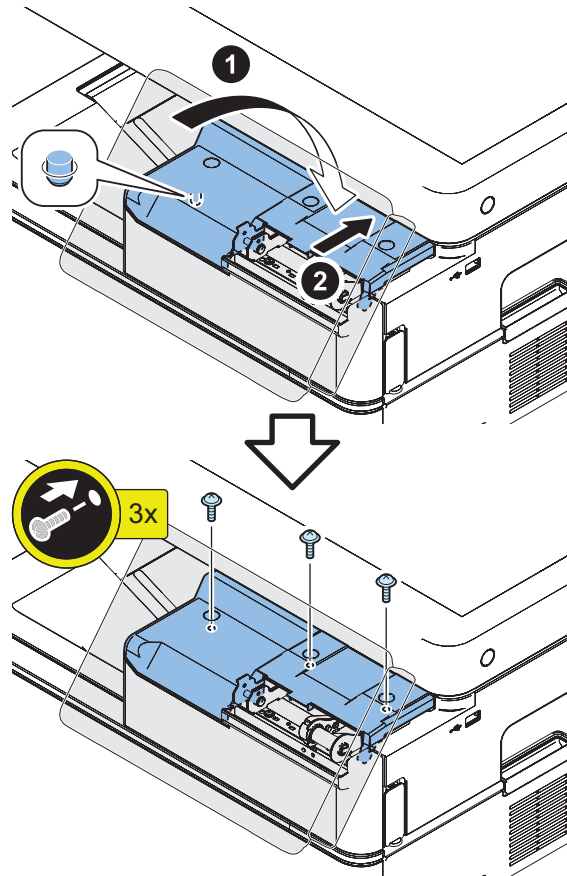

□  
**11.**

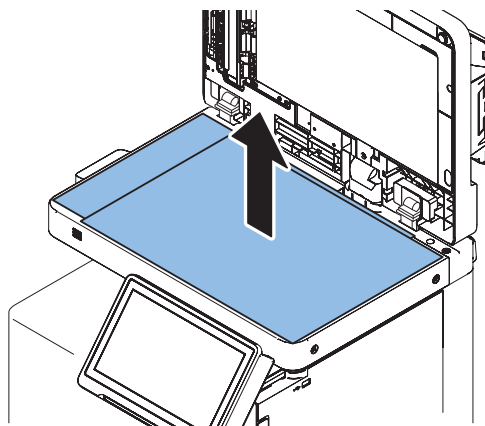

# 12.

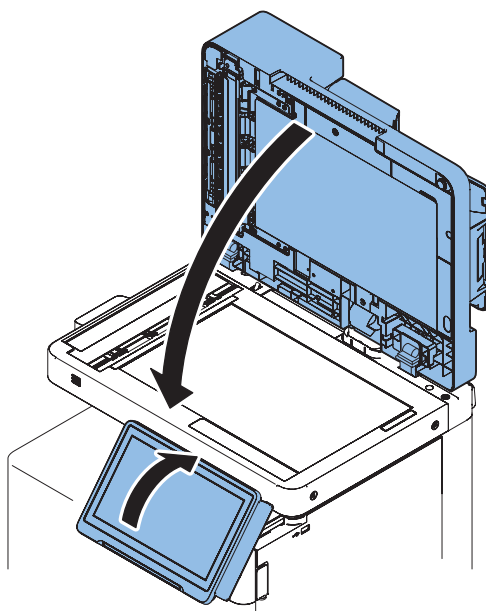

## Setting after Installation



1. Connect the power plug of the host machine to the outlet.
2. Turn ON the main power switch.
3. Enter service mode and set the value to "1".  
COPIER > FUNCTION > INSTALL > NFC-USE

### NOTE:

When [System Manager Information Settings] is set, it is required to log in as a system manager in accordance with instructions of the user administrator.

4. Select [Settings/Registration] > [Management Settings] > [Device Management] > [Use NFC Card Emulation], and set the item to "ON".
5. Turn OFF and then ON the main power switch.
6. When a message prompting the version update is displayed, press [Update] and automatically update the version of this equipment.

### CAUTION:

It may take time to display the update screen. (Approx. 1 to 2 min.) During this time, do not operate the screen.

7. Check the end of the following service mode.  
COPIER > DISPLAY > VERSION > PANEL  
If the end is an even number (e.g. 01.26): NFC is not installed.  
If the end is an odd number (e.g. 01.27): NFC is installed.

## Copy Card Reader-F1/Copy Card Reader Attachment-B5

### Points to Note at Installation

- To install this equipment, the Copy Card Reader Attachment is required.
- Pictures and illustrations used in this procedure are from the model without the Finisher. Procedures that are not separately described are same for the model with the Finisher.
- After installing the Card Reader, enter the card number to be used in the following service mode. Otherwise, the card will not be recognized even if inserting it.  
COPIER > FUNCTION > INSTALL > CARD

### Checking the Contents

< Copy Card Reader-F1 >

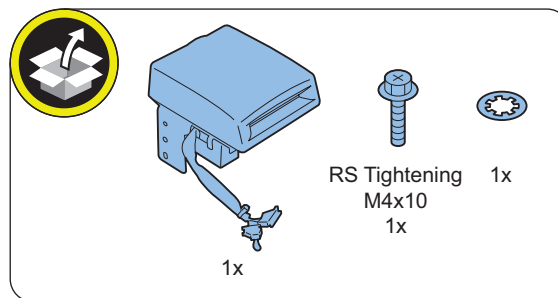

< Copy Card Reader Attachment-B5 >

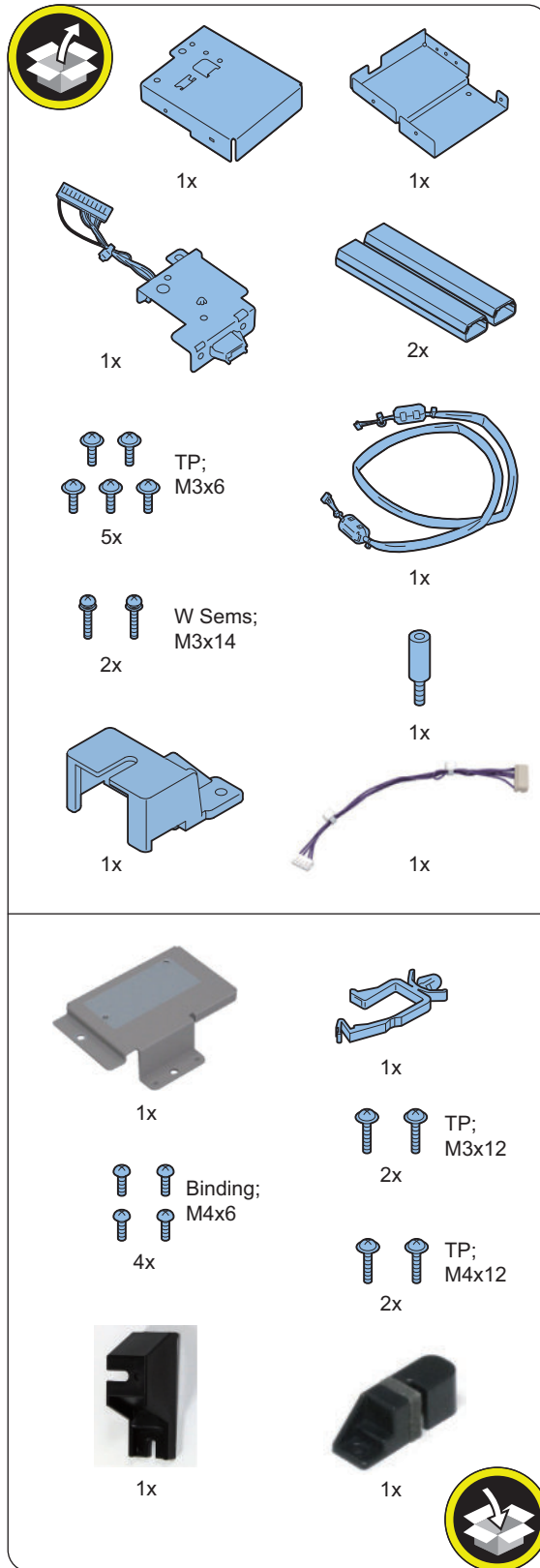

## Installation Outline Drawing

<When the Finisher is not installed>

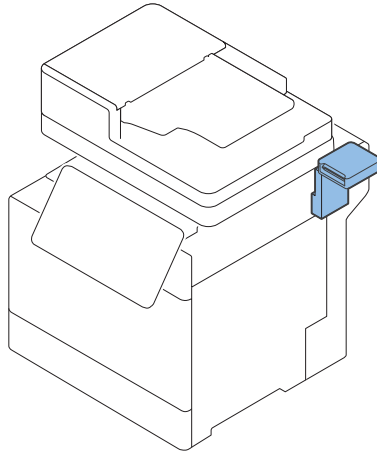

<When the Finisher is installed>

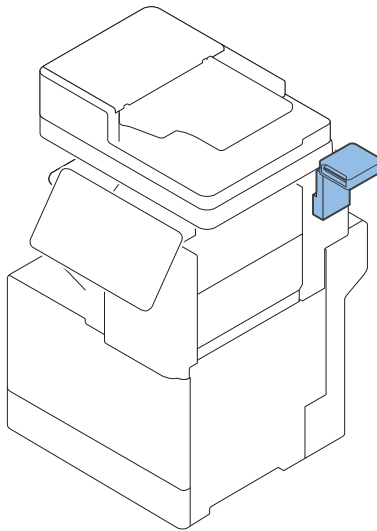

## ● Installation Procedure

### ■ Removing the Covers

□

**1.**

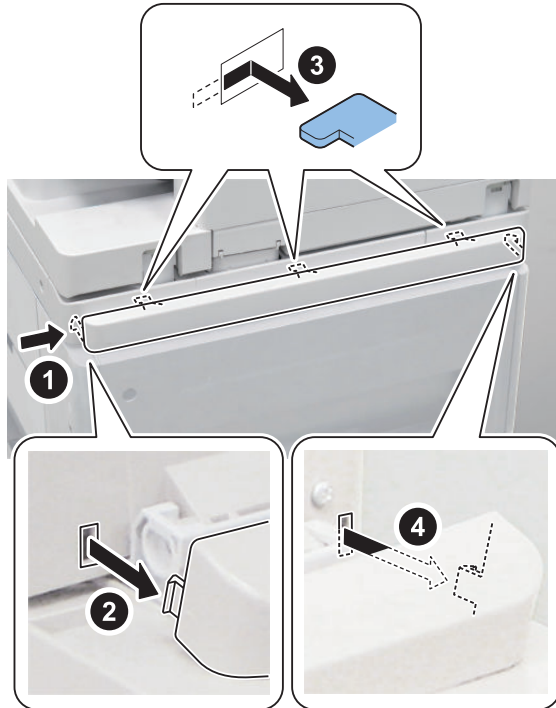

□

**2.** <When the Finisher is installed>

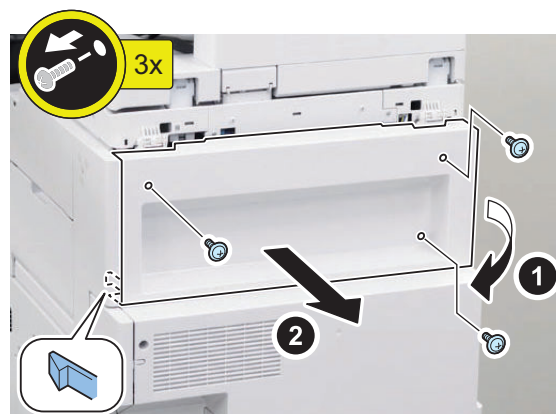

□  
**3.**

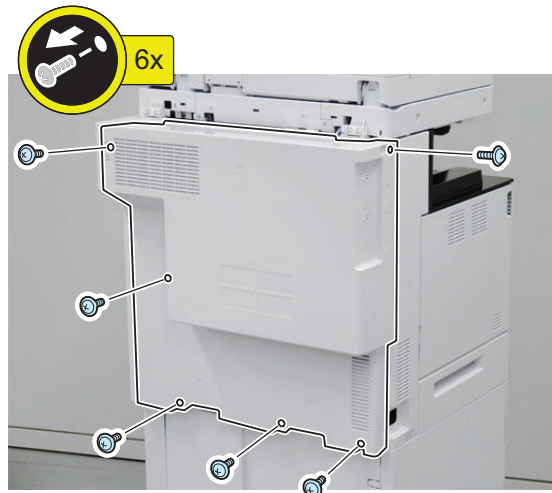

□  
**4.**

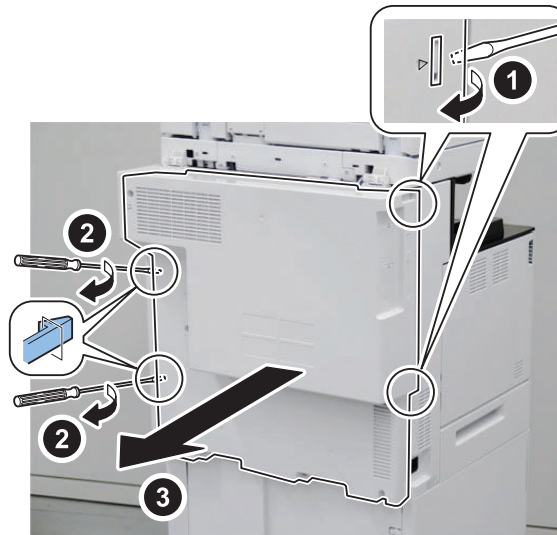

■ **Installing the Card Reader Relay Connector Unit**

□  
**1.**

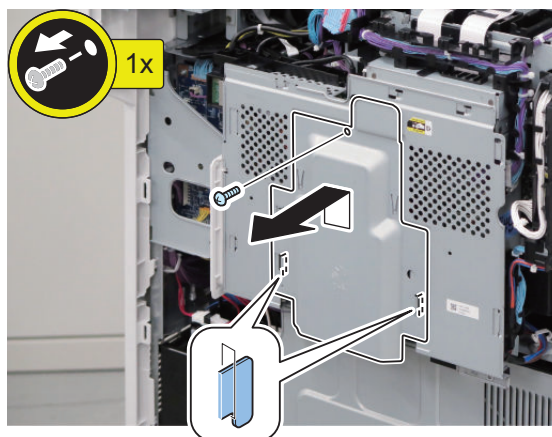

□  
2.

**CAUTION:**  
When handling the hard disc, be careful not to vibrate or drop it.

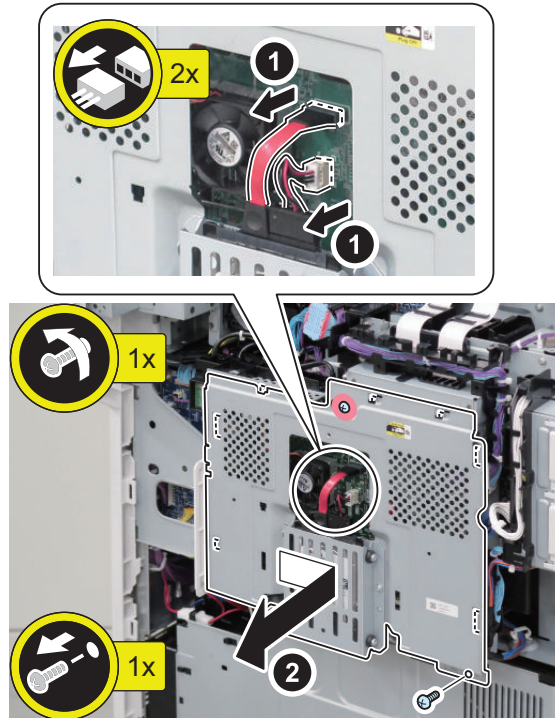

□  
3.

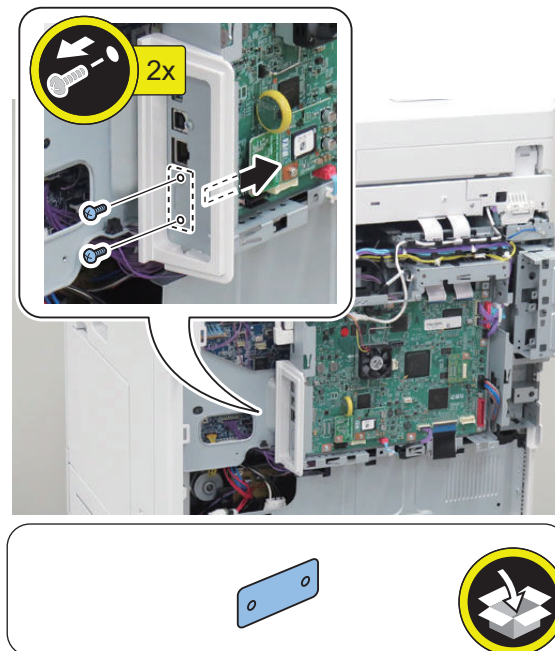

**NOTE:**  
The removed screw will be used in step 8.



□  
4.

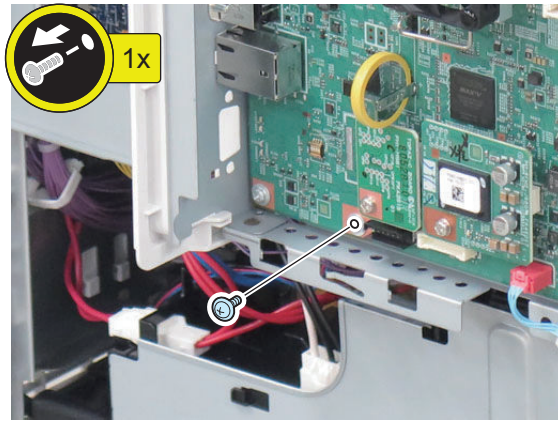

**NOTE:**  
The removed screw will be used in step 8.

□  
5.

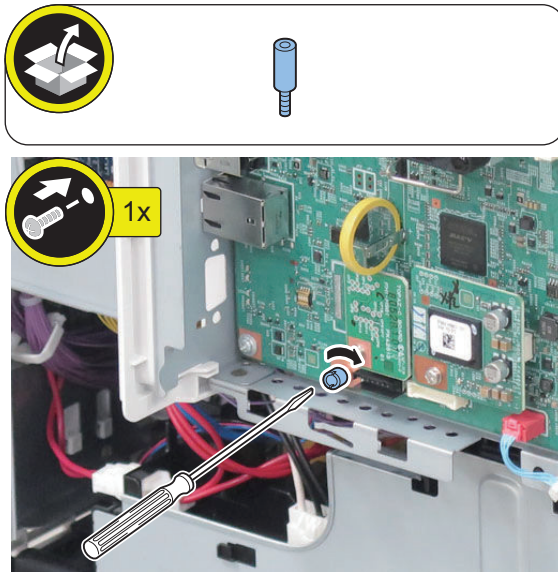

□  
**6.**

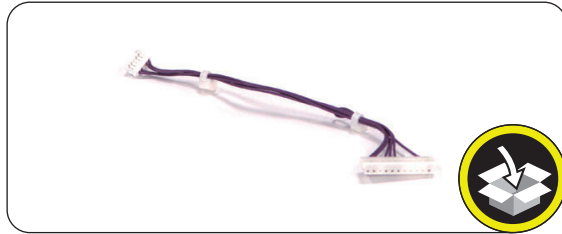
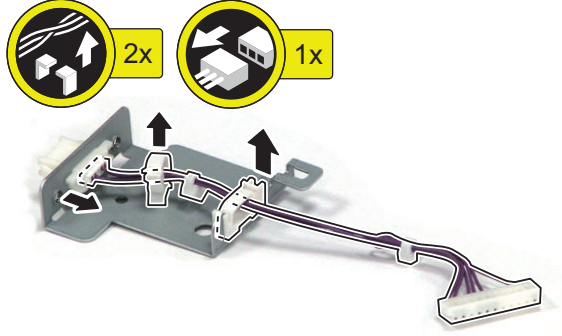
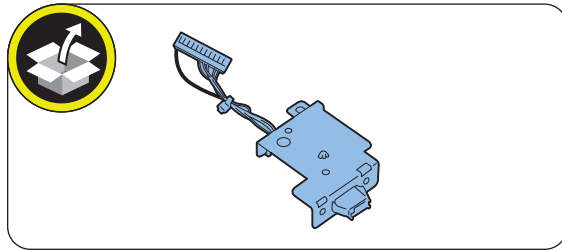

□  
7.

**NOTE:**

Secure the cable to fix the Harness Band as shown in the figure.

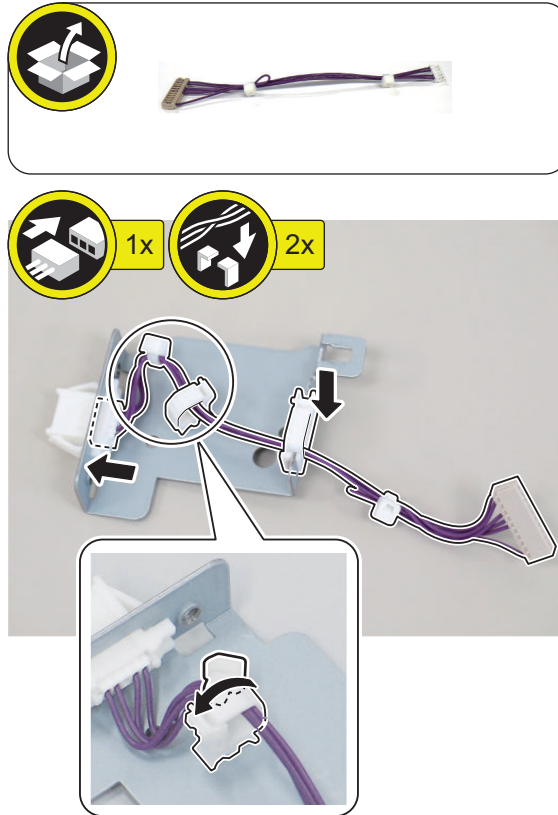

□  
8.

**NOTE:**

Use the screw removed in step 3 and step 4.

**CAUTION:**

Be careful not to let the Relay Cable come in contact with the metal part of the Controller Box. If the Relay Cable come in contact with the metal part of the Controller Box, malfunctions may occur.

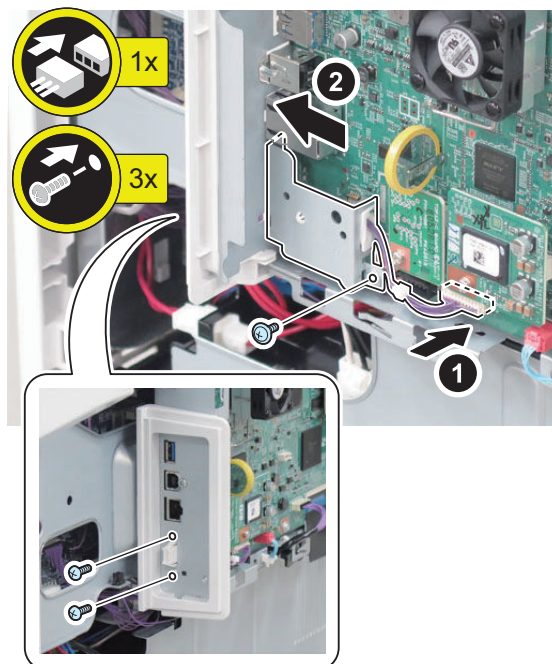
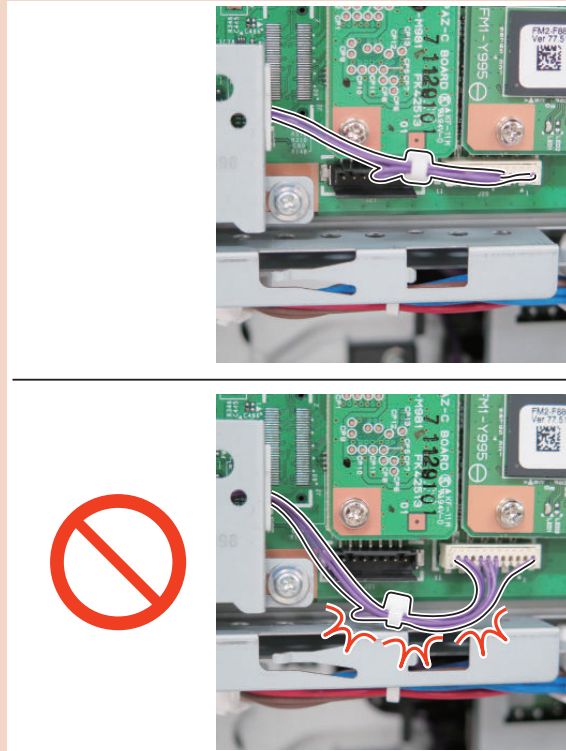

□  
9.**CAUTION:**

When handling the hard disc, be careful not to vibrate or drop it.

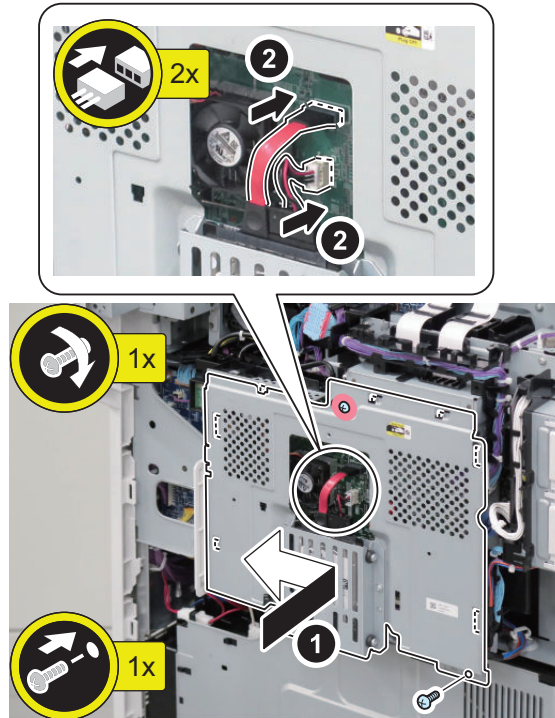
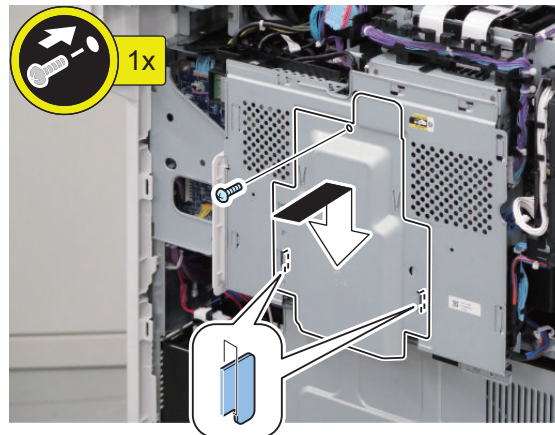
□  
10.

### ■ Installing the Covers

□  
**1.**

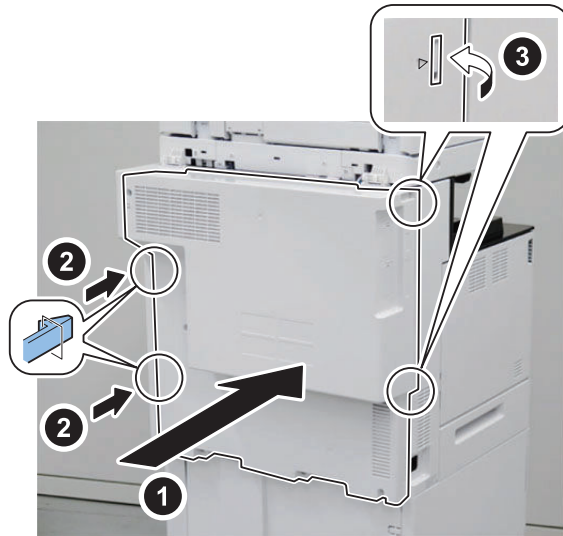

□  
**2.**

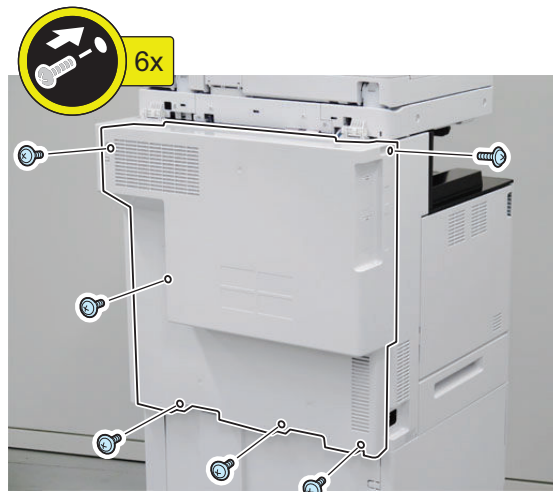

□  
**3.** <When the Finisher is installed>

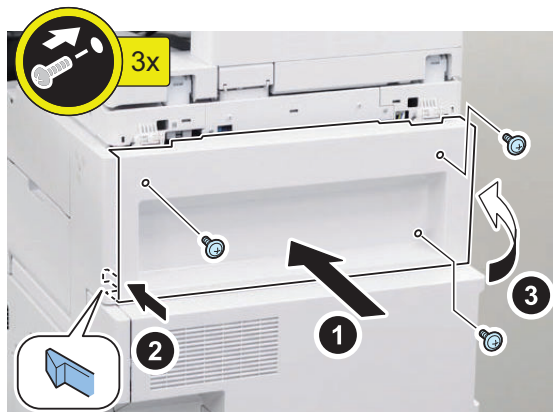

□  
**4.**

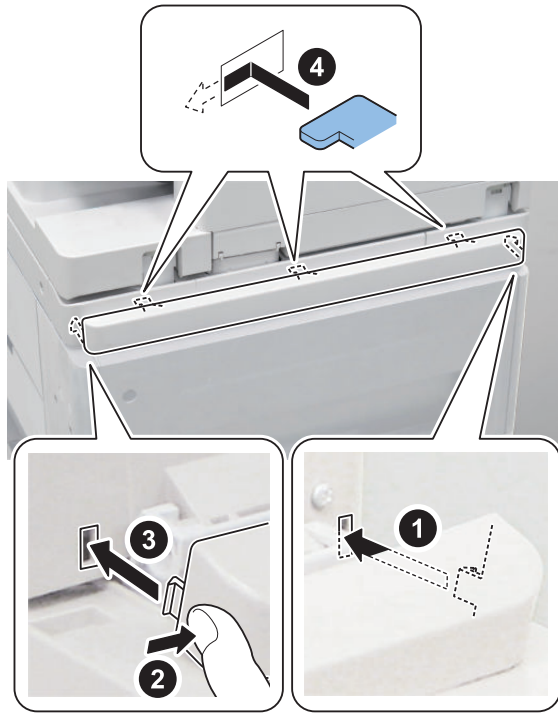

### ■ Installing the Copy Card Reader

□  
**1.**

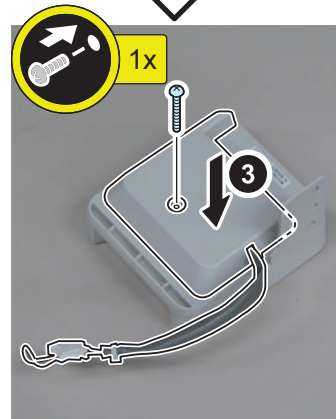
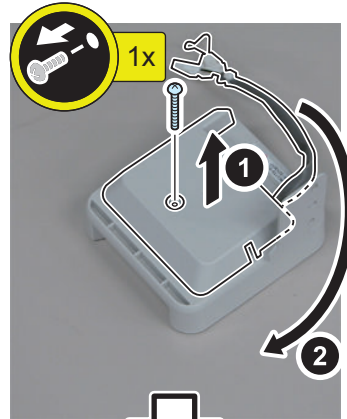

□  
**2.**

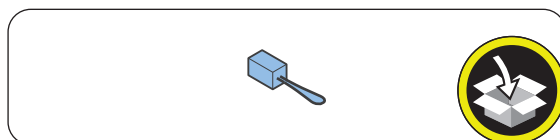
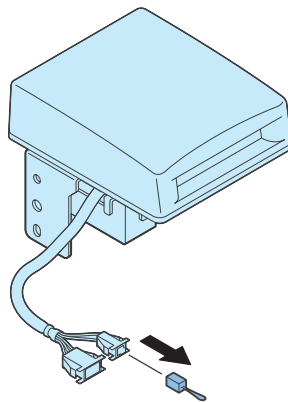



□  
**3.**

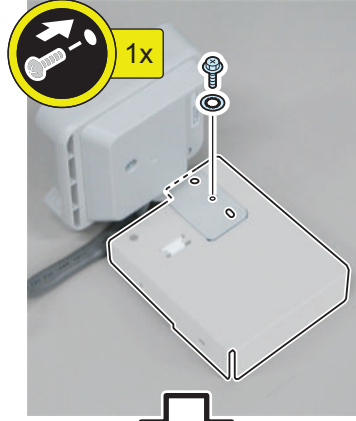
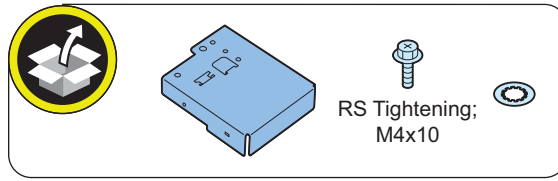

□  
**4.**

**CAUTION:**  
Be sure that the core is inside the Edge Saddle.

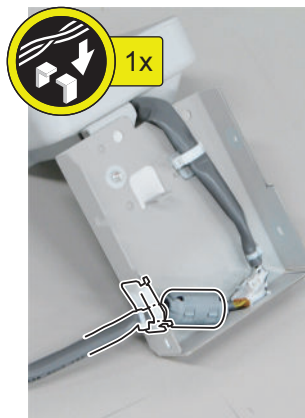
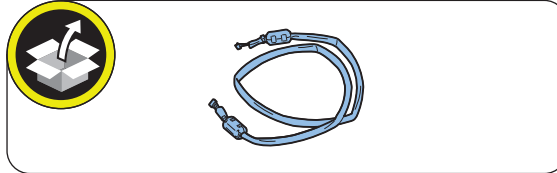

□  
**5.**

<When the Finisher is not installed>

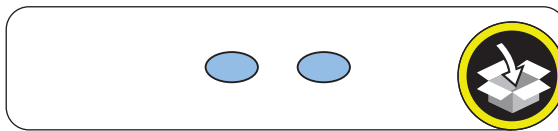

<When the Finisher is installed>

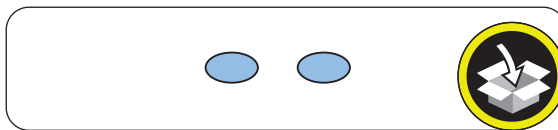

□  
**6.**

<When the Finisher is not installed>

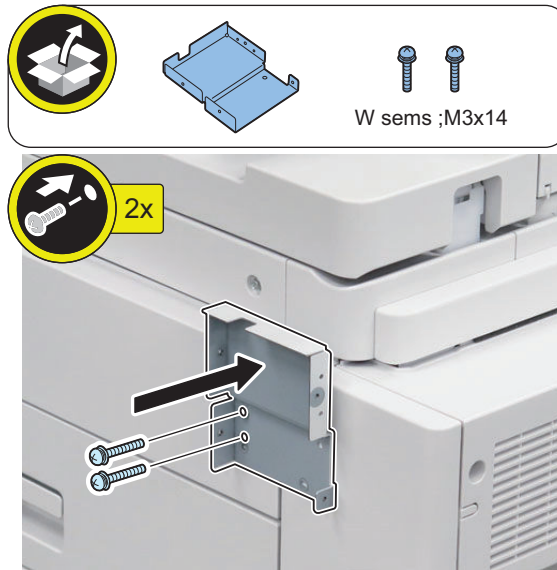

<When the Finisher is installed>

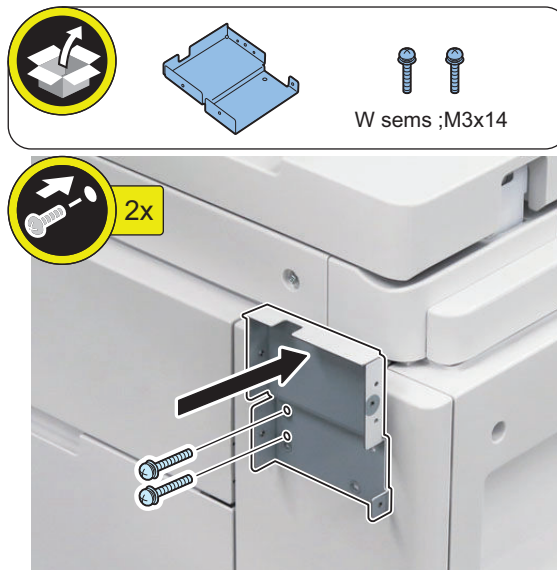

□  
7.

<When the Finisher is not installed>

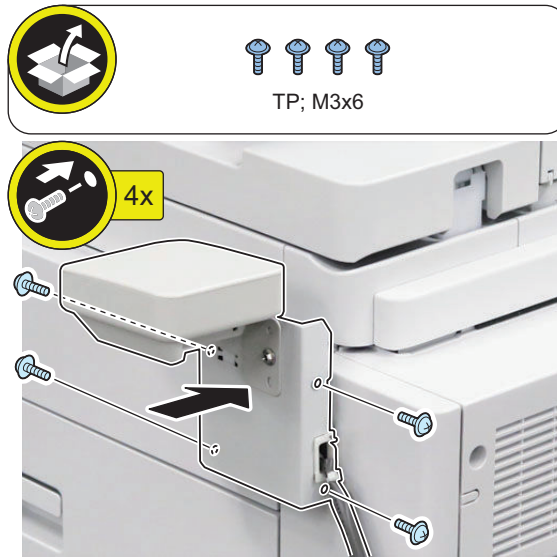

<When the Finisher is installed>

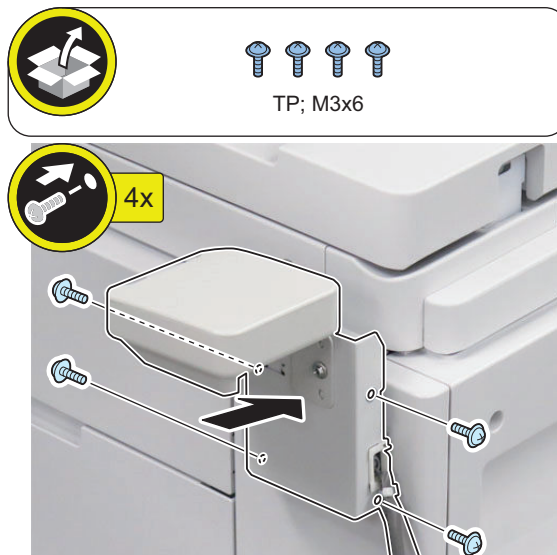

□  
8.**CAUTION:**

To prevent the connector from being disconnected, be sure to place the tie-wrap of the Card Reader External Relay Harness inside of the Connector Cover.

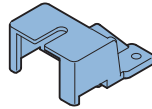
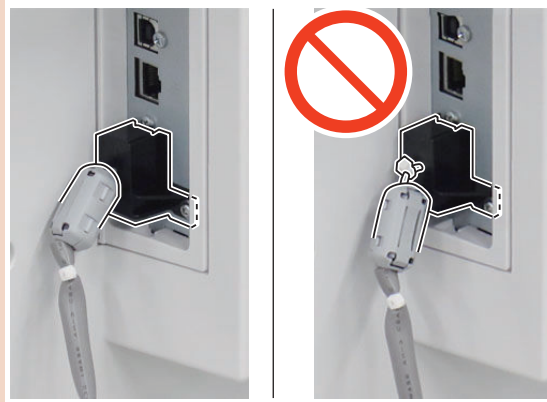

TP; M3x6

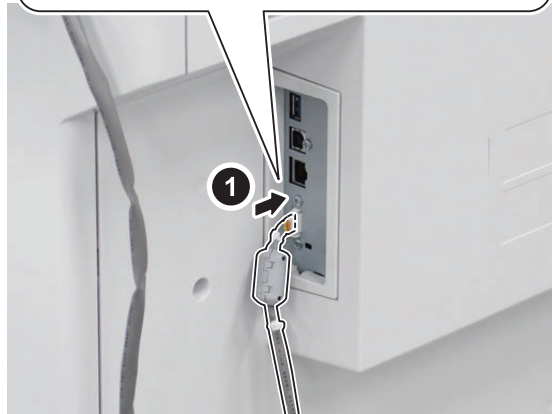
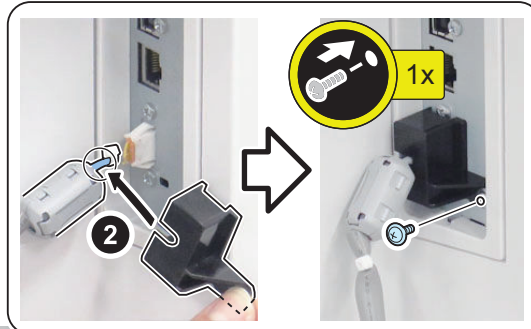

□  
**9.**

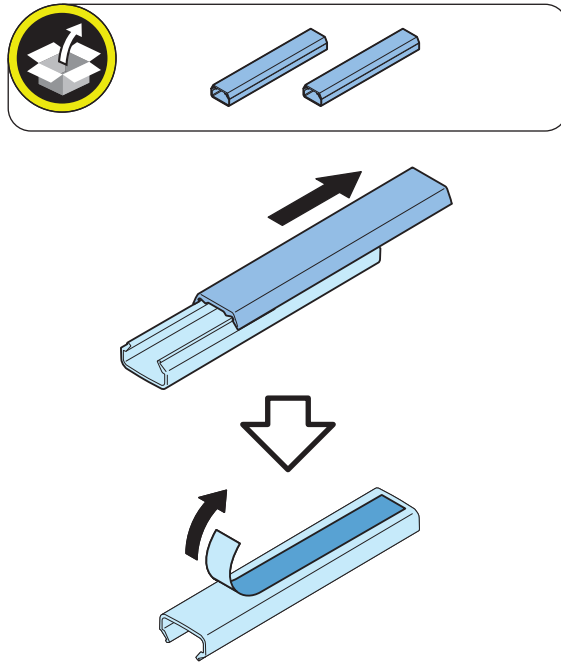

□  
10.**NOTE:**

Attach the cord guides avoiding to overlap the boundary of the cover, ventilation openings and curved surfaces.

<When the Finisher is not installed>

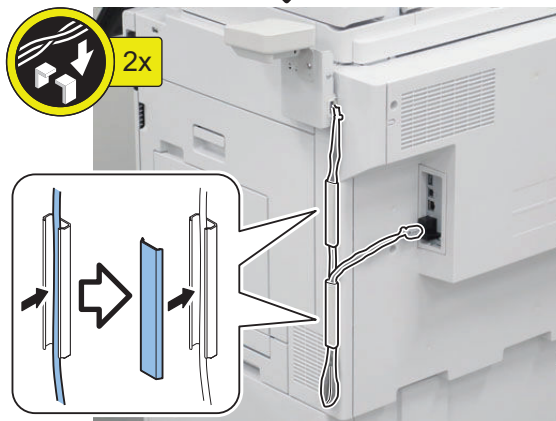
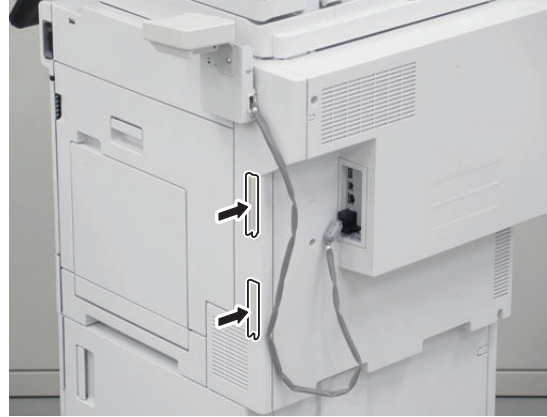



<When the Finisher is installed>

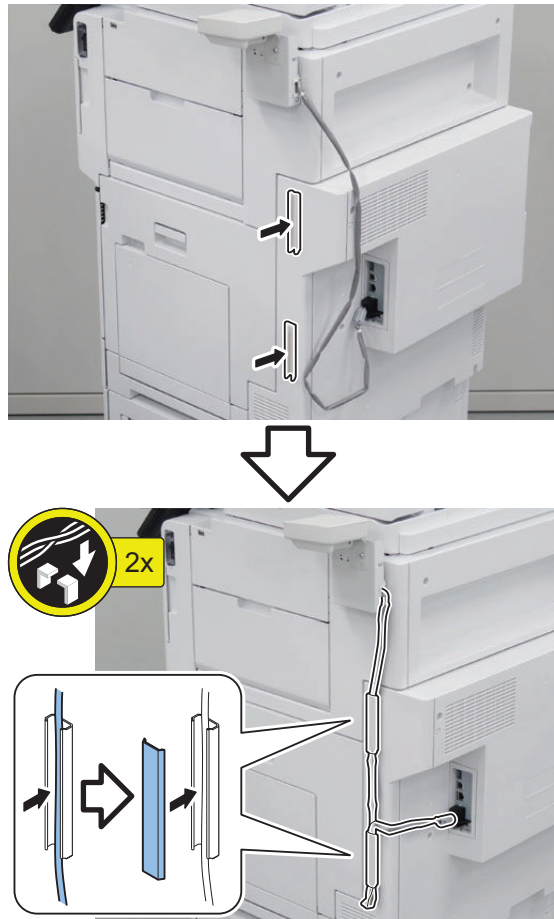

## ● Checking after Installation

- 1. Connect the power plug of the host machine to the power outlet.
  2. Turn the main power switch ON.
  3. Check the model of the Card Reader in service mode. (Default: 0 "Card Reader-F1")  
COPIER > OPTION > ACC > CR-TYPE
- 4. Set the number of card (number of department ID) that can be used with the Card Reader in service mode.(Lv.2).  
COPIER > OPTION > FNC-SW > CARD-RNG
- 5. Use Service Mode to enter the minimum card number to be used by a user (1 to 2001).  
COPIER > FUNCTION > INSTALL > CARD  
Starting from the entered card number, the number of cards set in step 4 can be used.
- 6. Turn OFF and then ON the main power switch to enable the setting values.

7. Insert a card with a card number that has been registered, and check that the machine operates normally.

**NOTE:**

Perform the following operations to change the number of cards (departments) after it has been set. In such a case, counter information for each department is reset.

COPIER > FUNCTION > CLEAR > CARD

- Turn OFF and then ON the main power switch to enable the settings.
- After that, perform from step 3.

## Copy Control Interface Kit-A1

### Points to Note at Installation

Pictures and illustrations used in this procedure are from the model without the Finisher. Procedures that are not separately described are same for the model with the Finisher.

### Checking the Contents

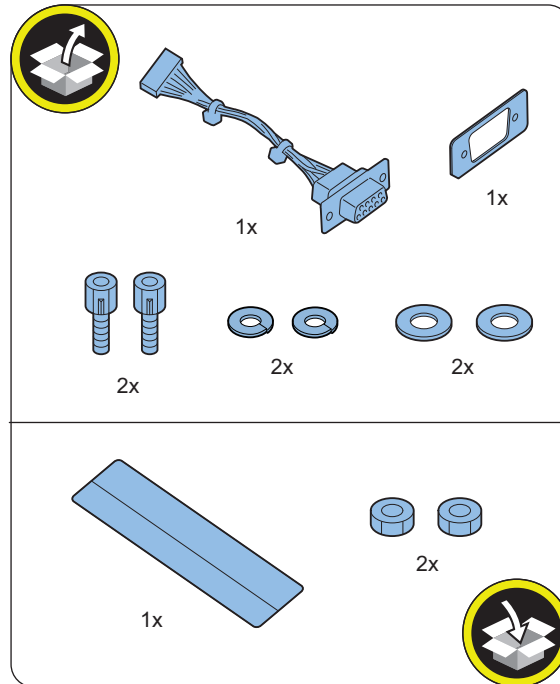

### Installation Outline Drawing

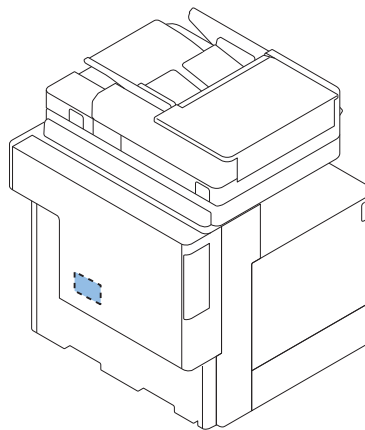

## ● Installation Procedure

### ■ Removing the Covers

□

**1.**

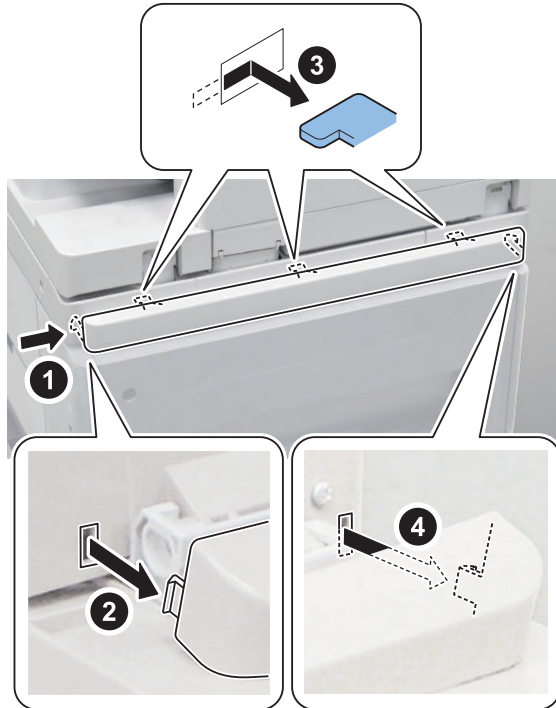

□

**2.** <When the Finisher is installed>

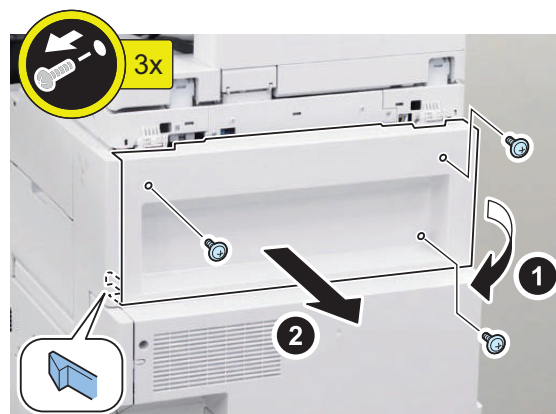

□  
**3.**

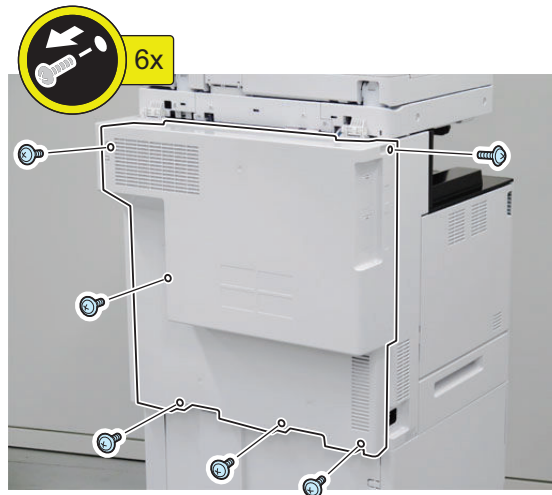

□  
**4.**

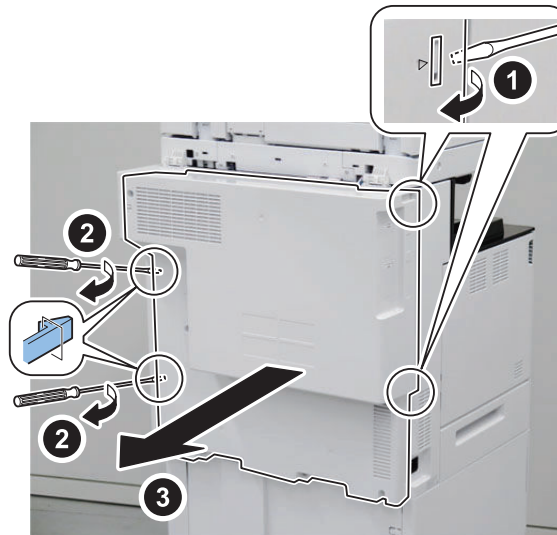

■ **Installing the Copy Control Interface Kit**

□  
**1.**

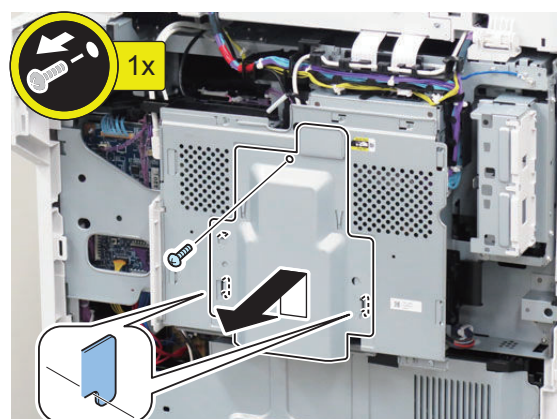

□  
2.

**CAUTION:**

When handling the hard disc, be careful not to vibrate or drop it.

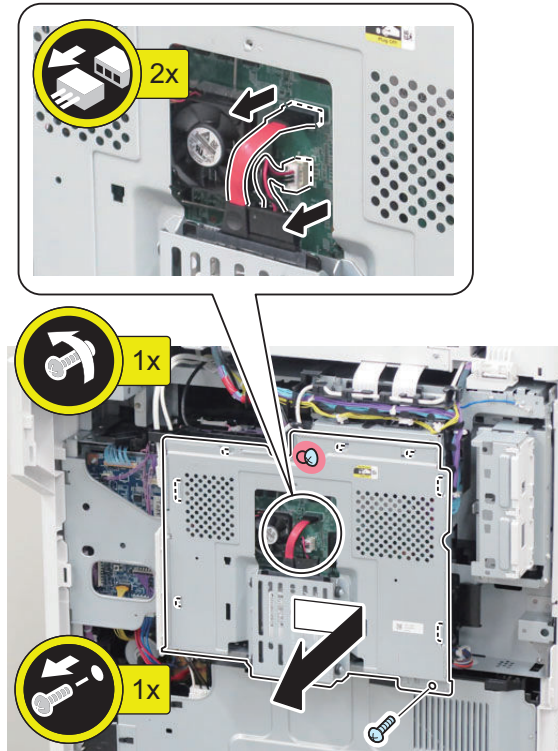

□  
3.

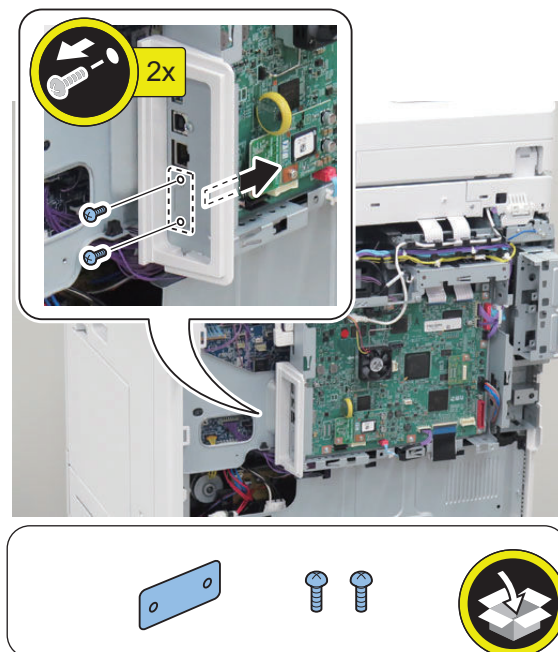

□  
4.**CAUTION:**

Install the extruded side of the D-SUB Support Plate as shown in the figure.

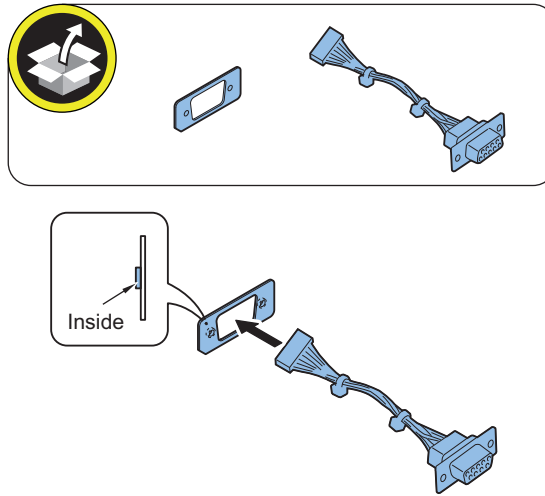

□  
5.

**CAUTION:**

- Be careful not to drop the screws and washers. Dropping a screw or washer may result in damage, so be sure to pick it up.
- Install the CC-VI Cable in the direction shown in the figure.

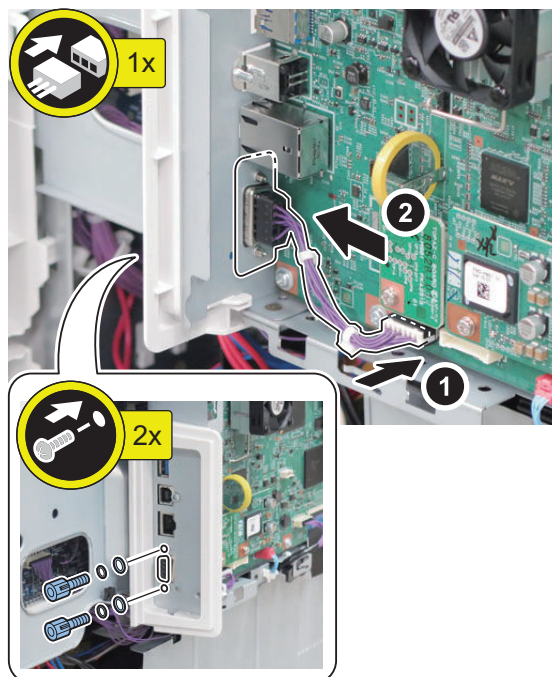
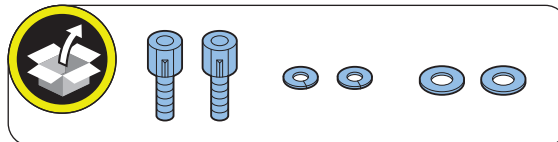
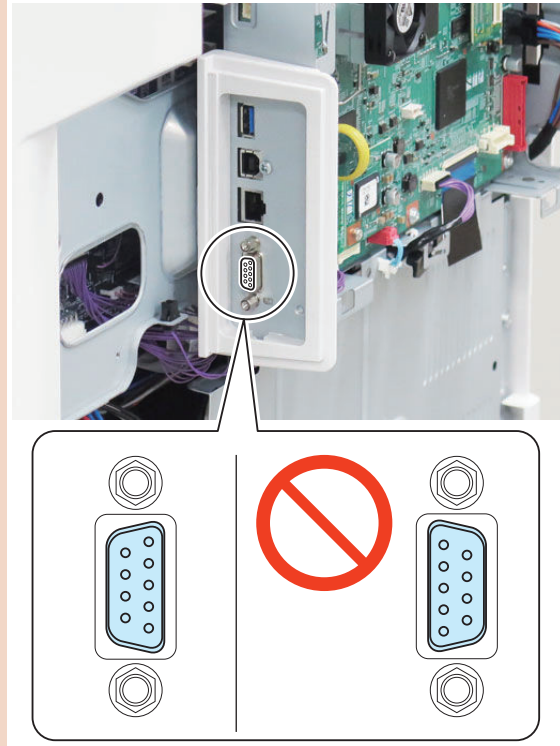



□  
6.**CAUTION:**

When handling the hard disc, be careful not to vibrate or drop it.

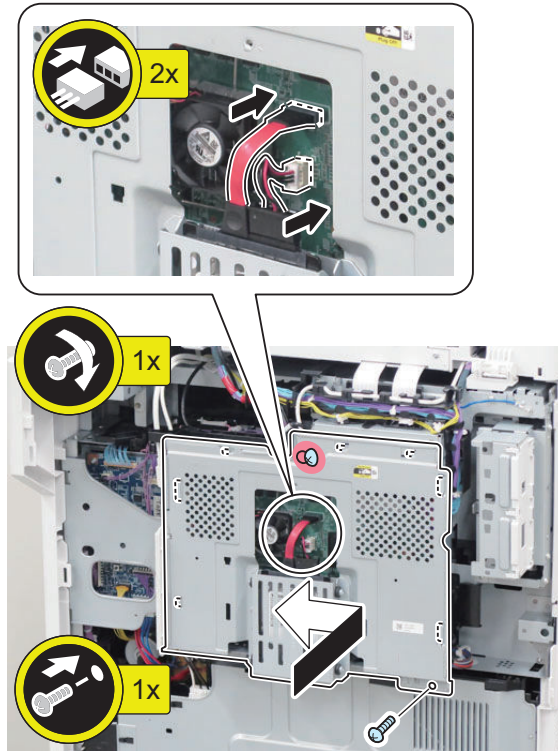
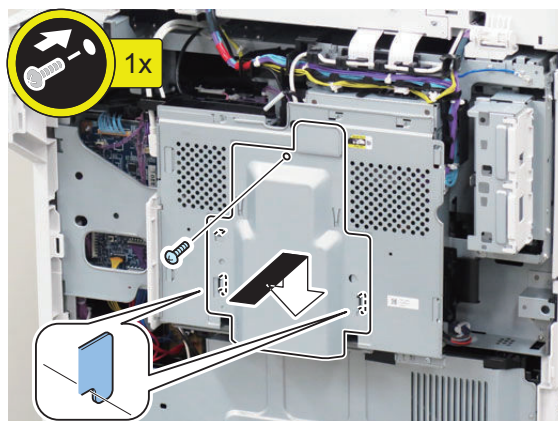
□  
7.

### ■ Installing the Covers

□  
**1.**

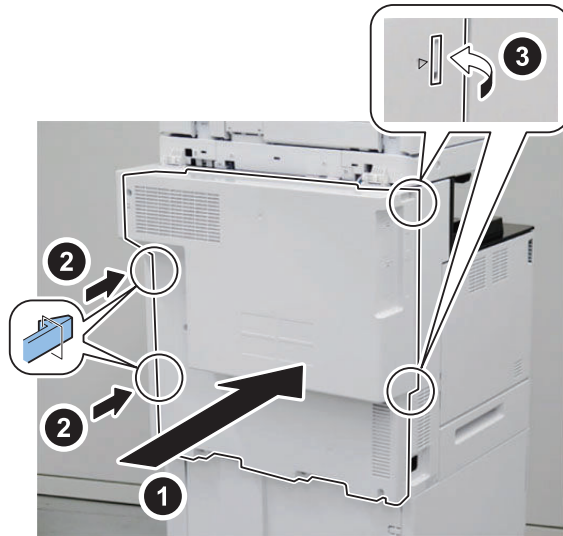

□  
**2.**

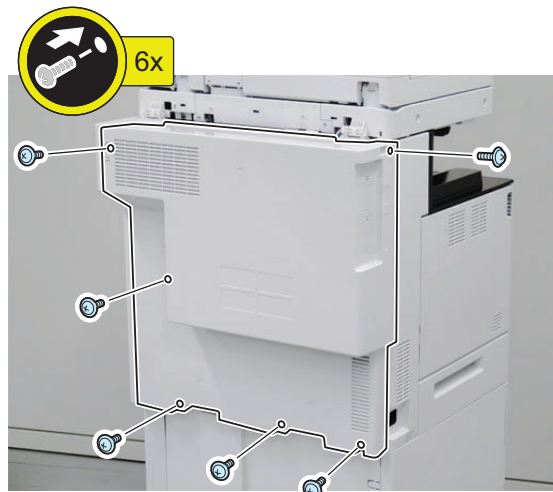

□  
**3.** <When the Finisher is installed>

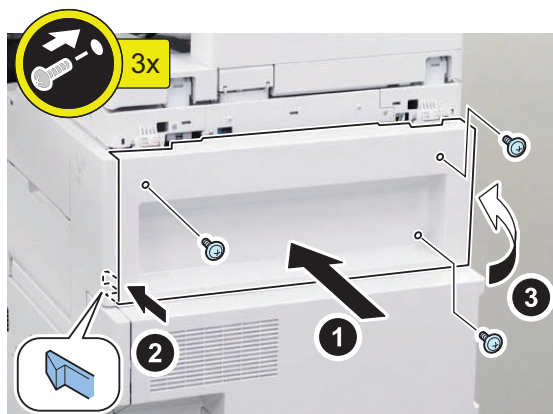

□  
**4.**

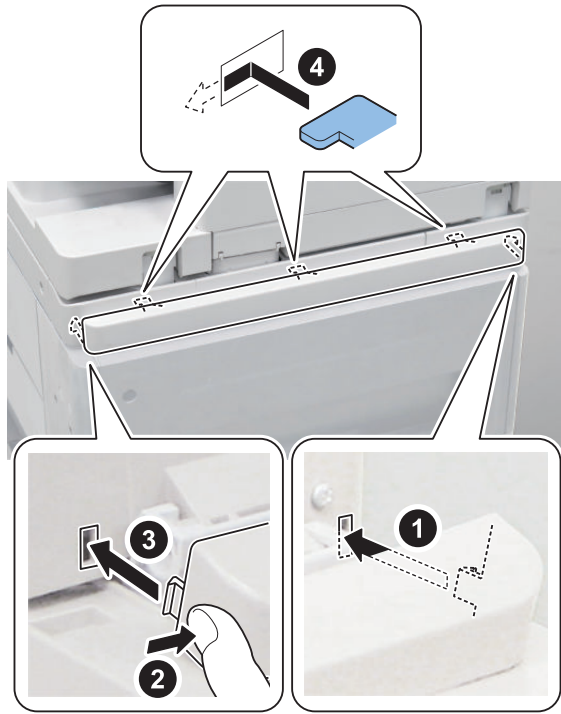

## IC Card Reader Box-D1

### Points to Note at Installation

- When installing this equipment, the IC Card Reader (sales company's option) is required. Use an extension cable for the card reader cable.

### Checking the Contents

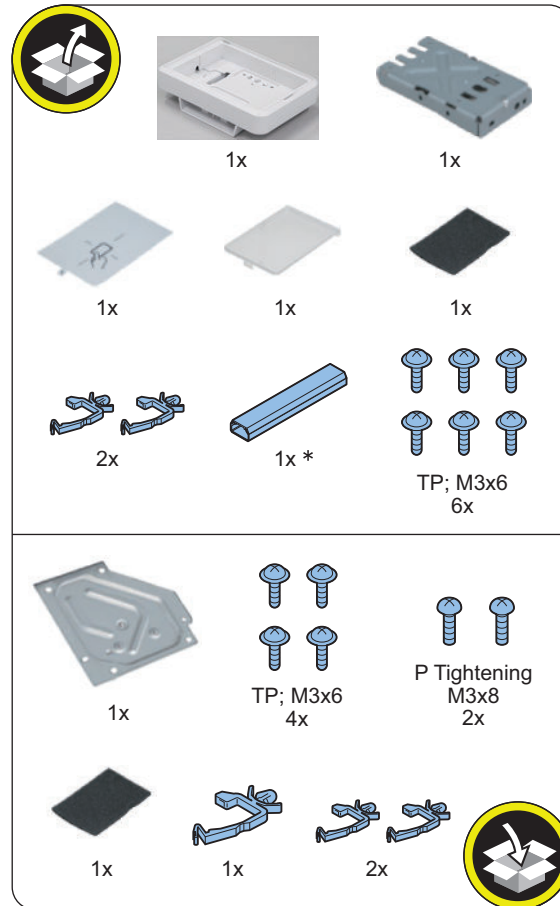

\* This part will be used only for a host machine equipped with the Finisher.

## Installation Outline Drawing

<When the Finisher is not installed>

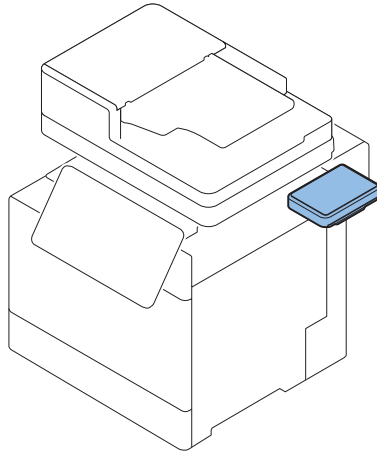

<When the Finisher is installed>

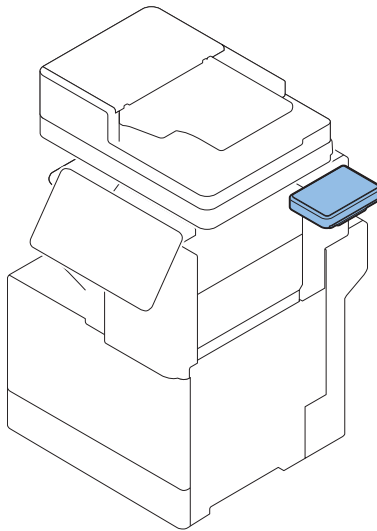

## Installation Procedure

### ■ Preparation



# 1.

**NOTE:**

Remove the claw on Bottom Cover of the IC Card Reader Box Unit by pinching it in the direction of the arrow.

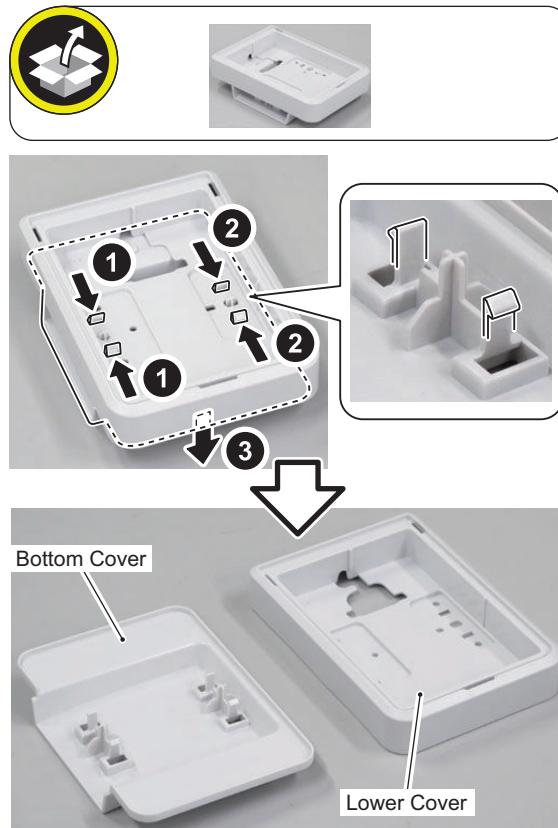

**NOTE:**

The removed Bottom Cover will be used in "Installing the IC Card Reader Box".

□  
2.**CAUTION:**

Do not install the IC Card Reader Support Plate in the opposite direction.

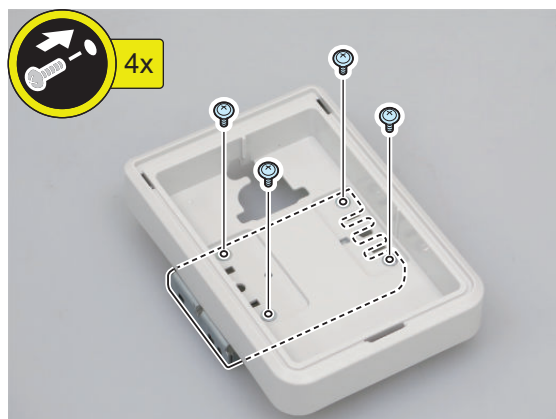
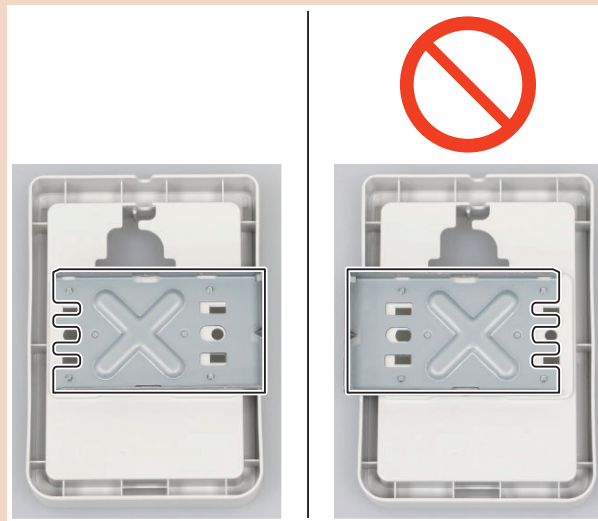

□  
**3.**



■ **Installing the IC Card Reader Box (When the Finisher is not installed)**

□  
**1.**

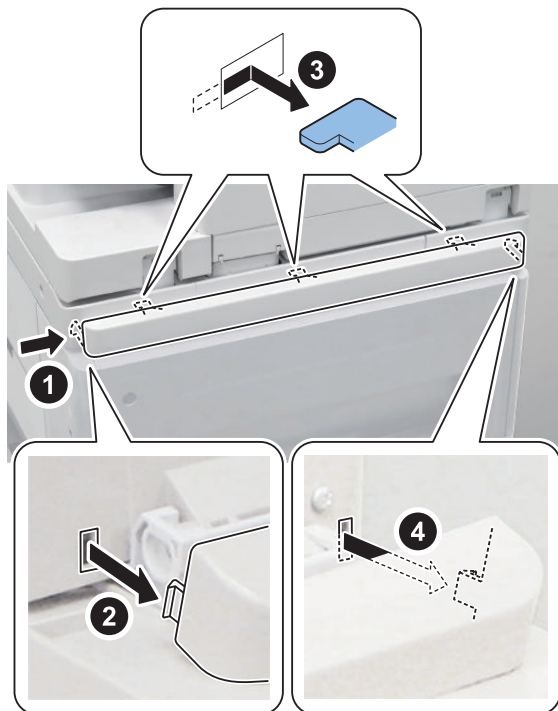



□  
**2.**

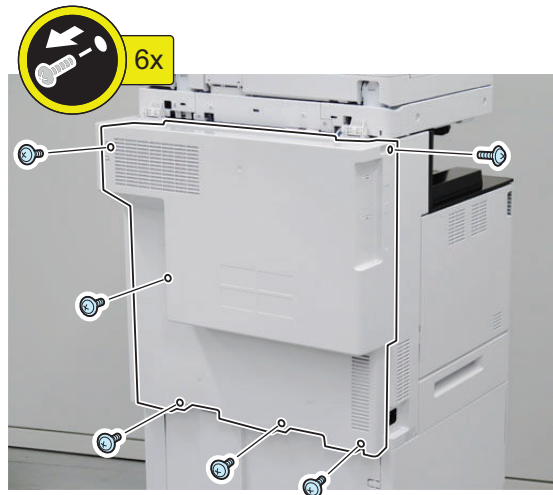

□  
**3.**

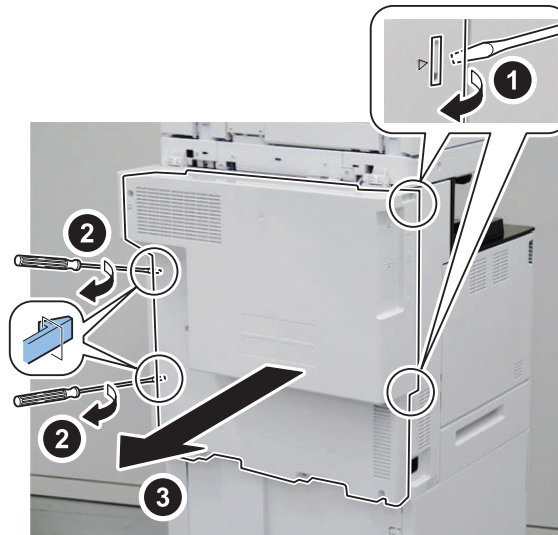

□  
4.

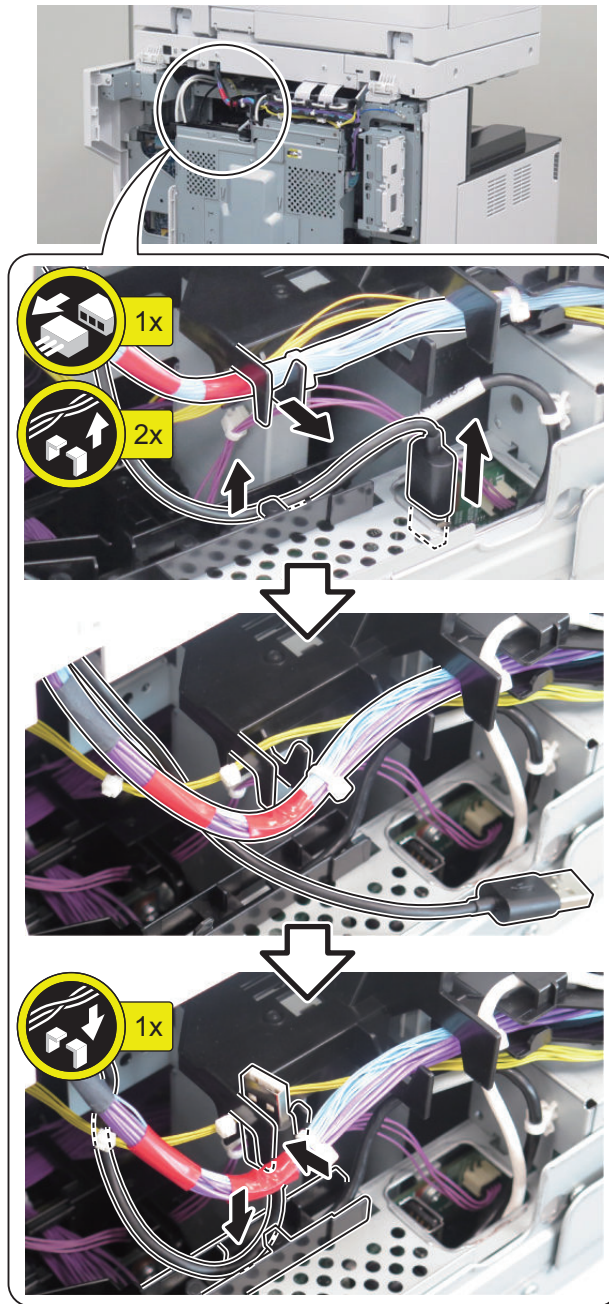

□  
**5.**

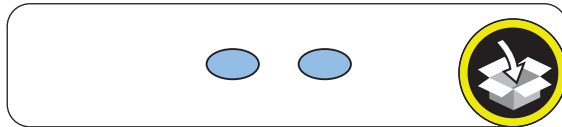

□  
**6.**

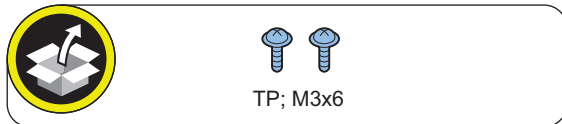

□  
**7.**

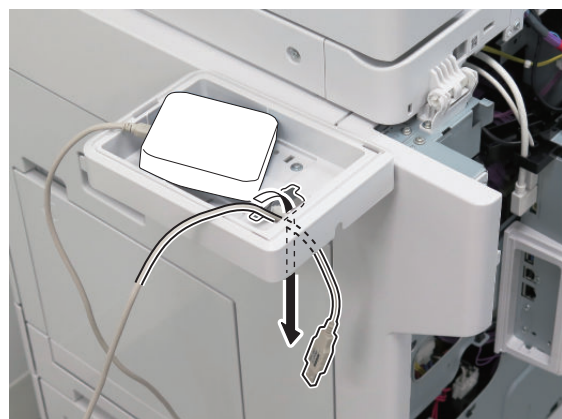

□  
**8.**

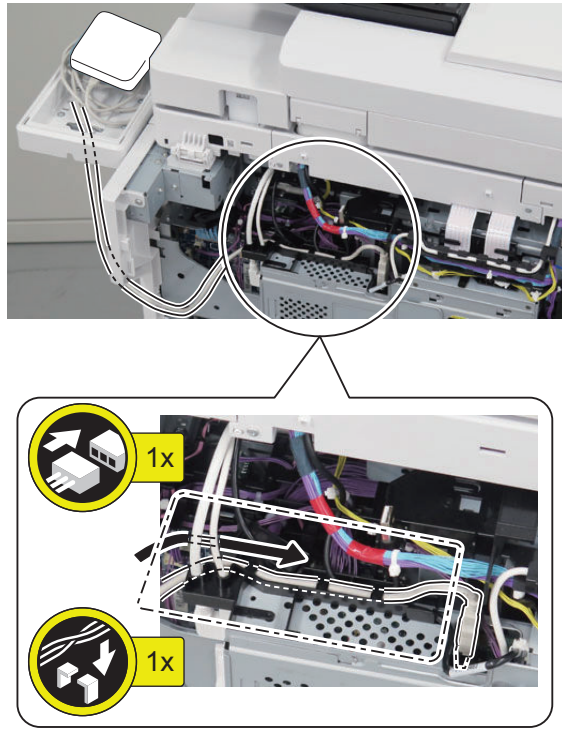

□  
**9.**

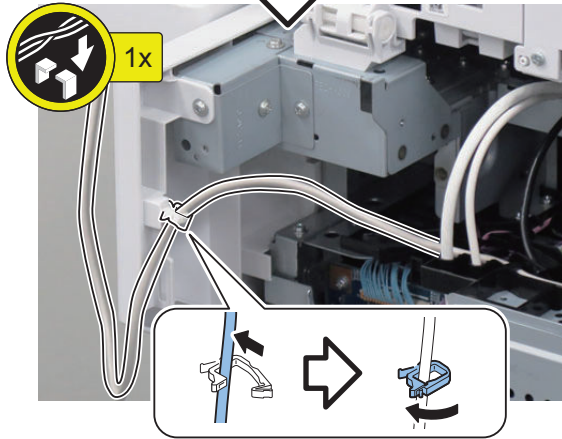
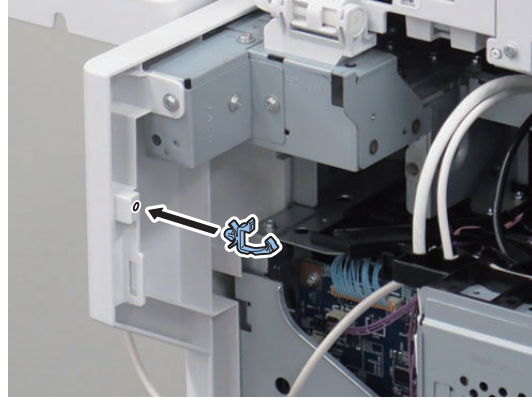
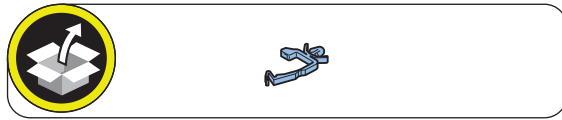

□  
10.

**CAUTION:**  
When cutting off the part, be sure not to make burrs.

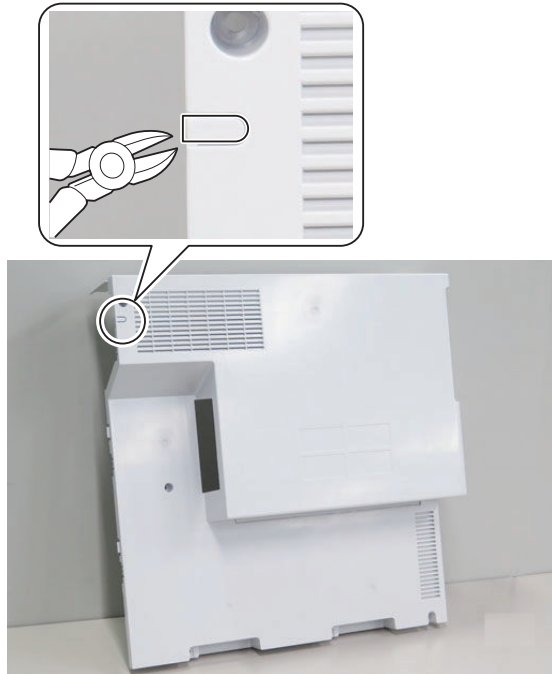

□  
11.

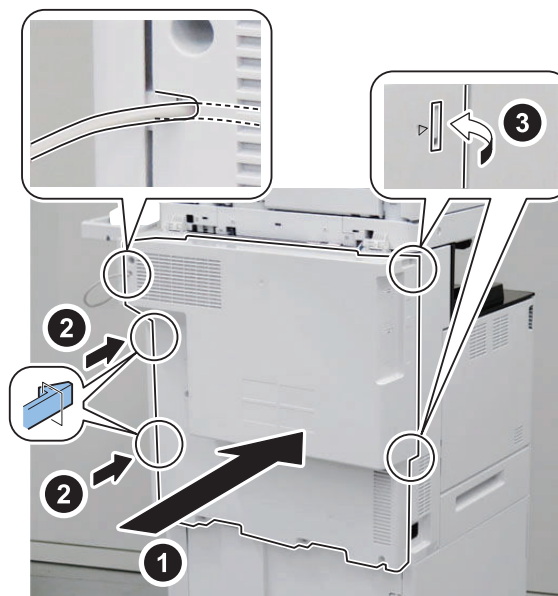

□  
12.



□  
13.

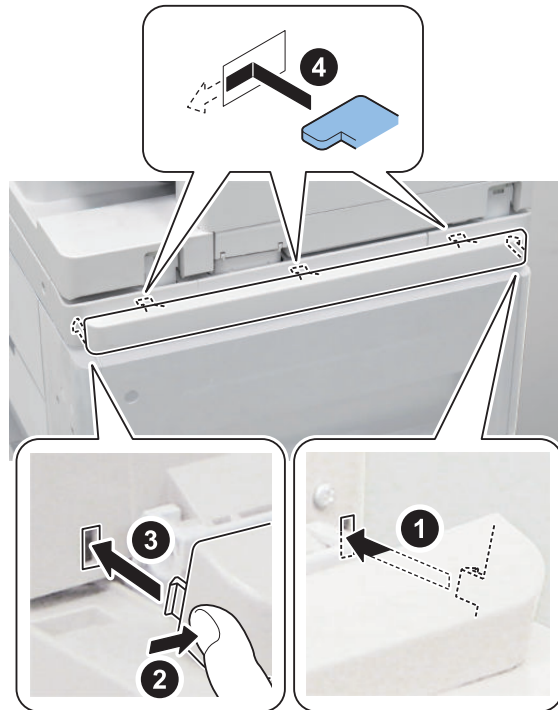

□  
14.

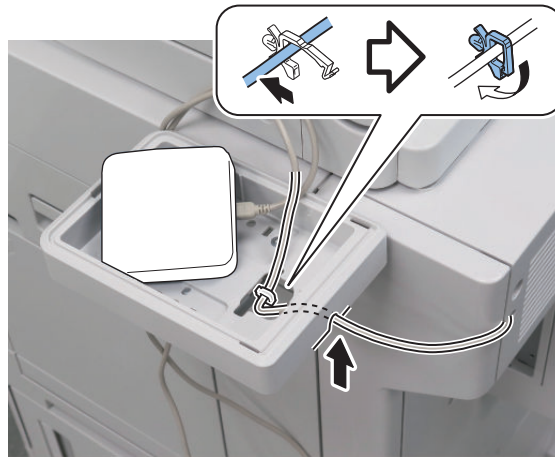

□  
15.

**NOTE:**

Use the Bottom Cover removed in "Preparation".

**CAUTION:**

When installing the Bottom Cover, be careful not to trap cables.

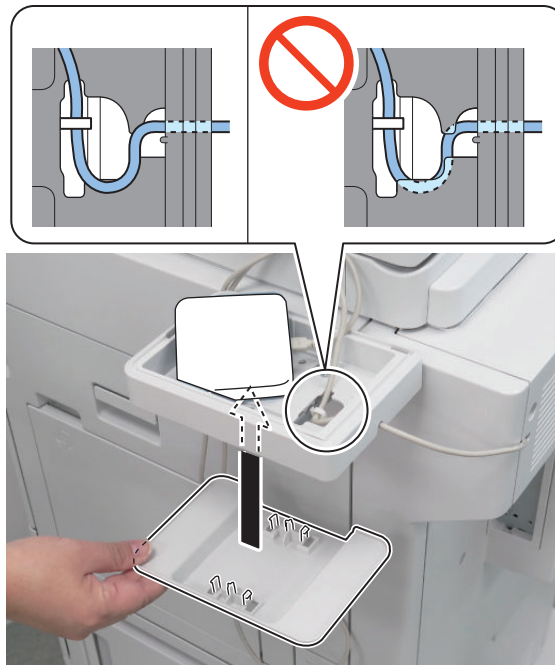



□  
16.



□  
17.

**NOTE:**  
Store the excess cable in the box.

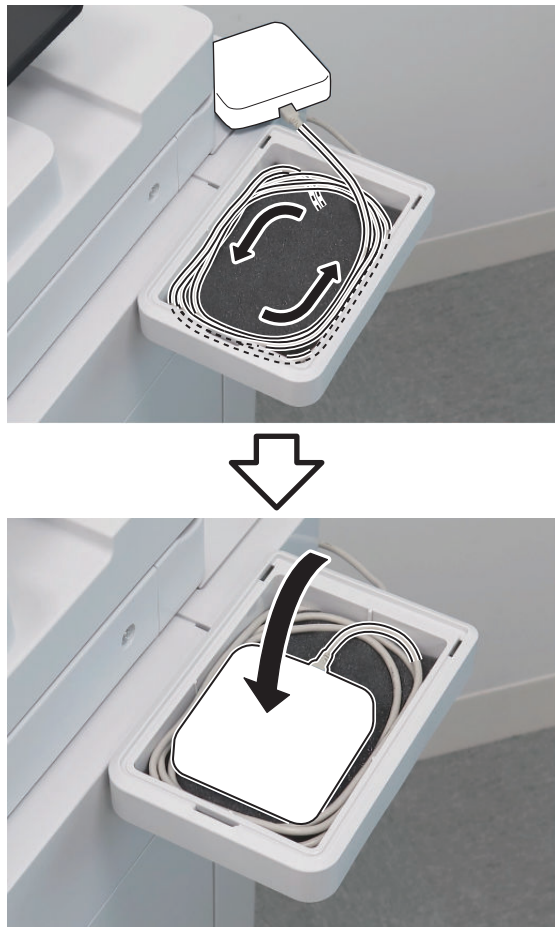

□  
**18.**

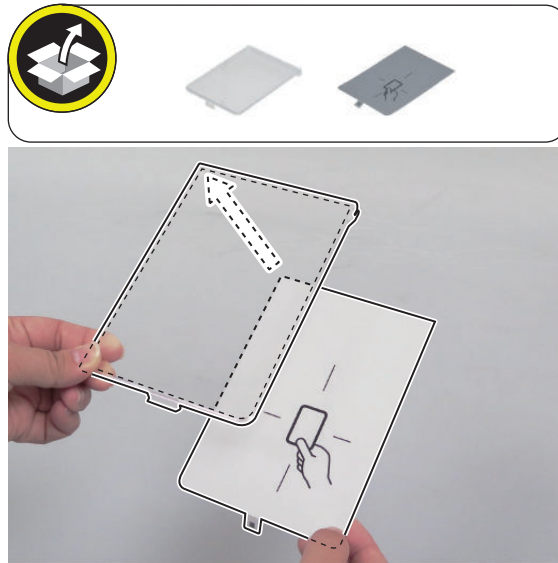

□  
**19.**



□  
**20.** Connect the power plug to the outlet.

**21.** Turn ON the Main Power Switch.

■ Installing the IC Card Reader Box (When the Finisher is Installed)

□  
**1.**

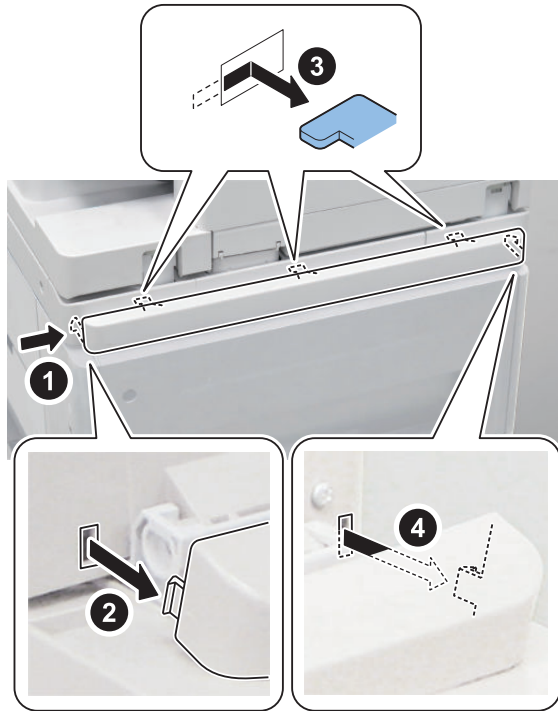

□  
**2.**

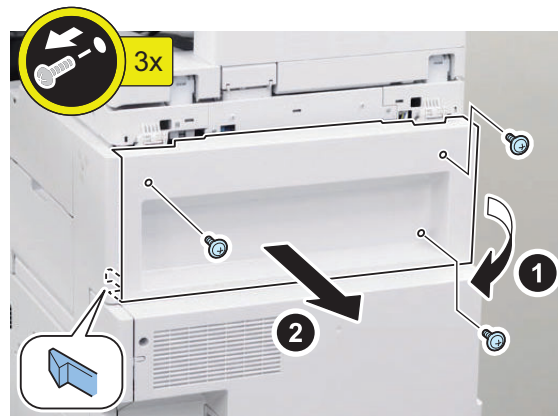

□  
**3.**



□  
**4.**

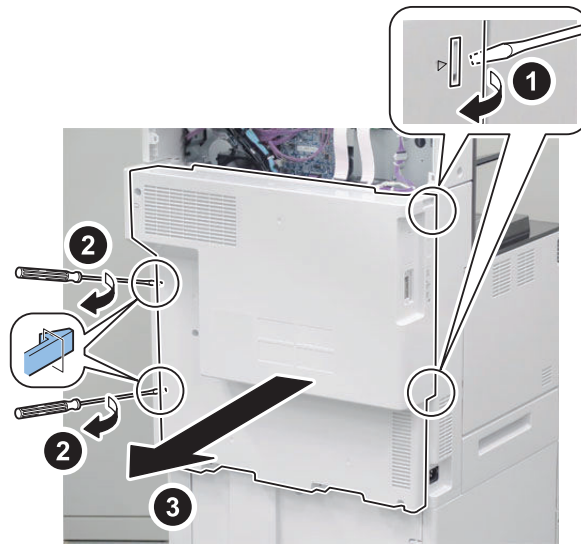

□  
**5.**

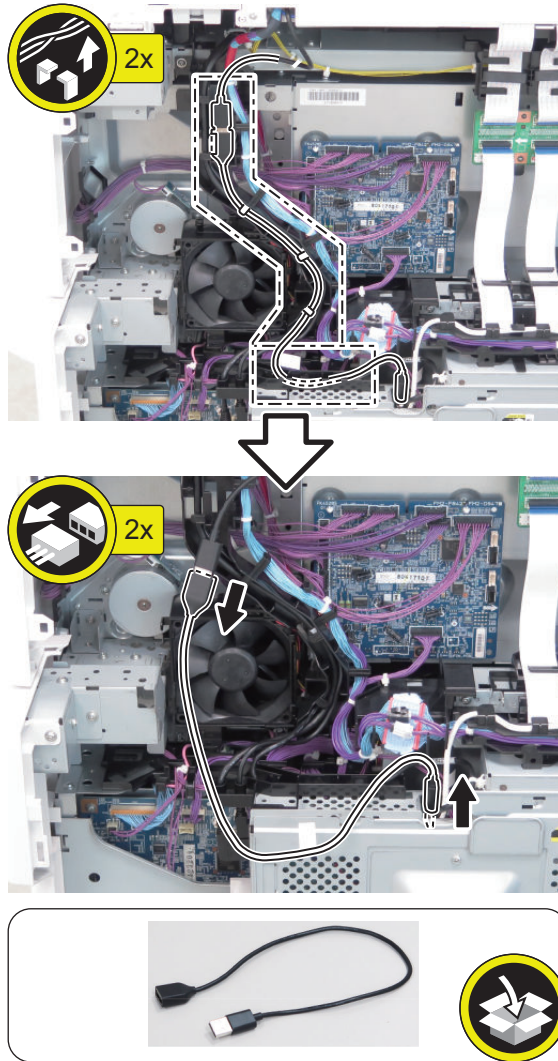

□  
**6.**

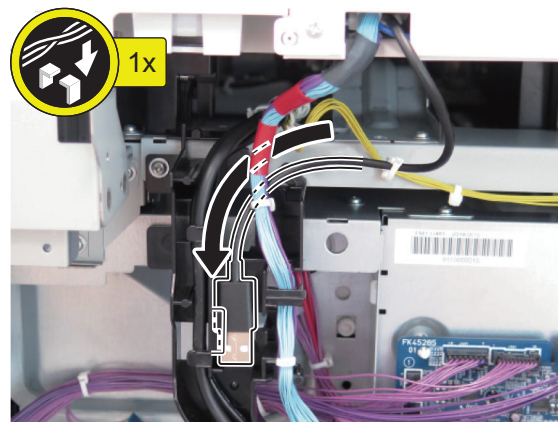

□  
7.

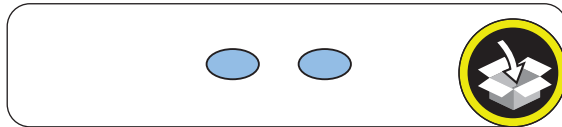
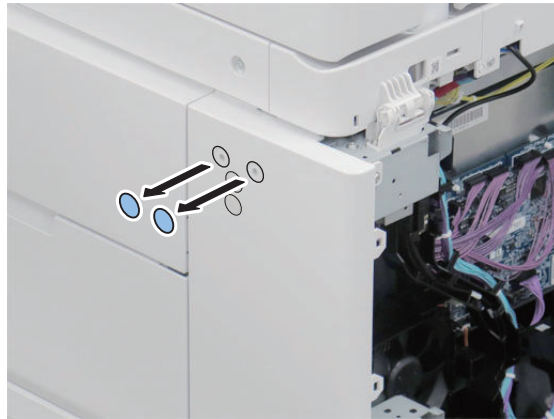

□  
8.

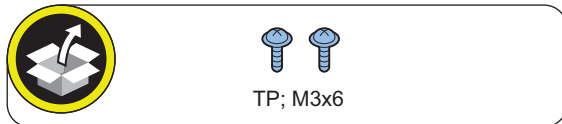

□  
9.



□  
**10.**

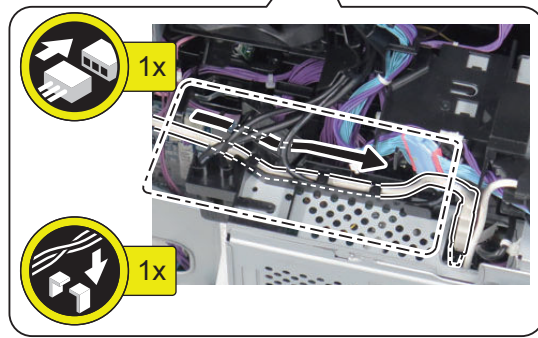
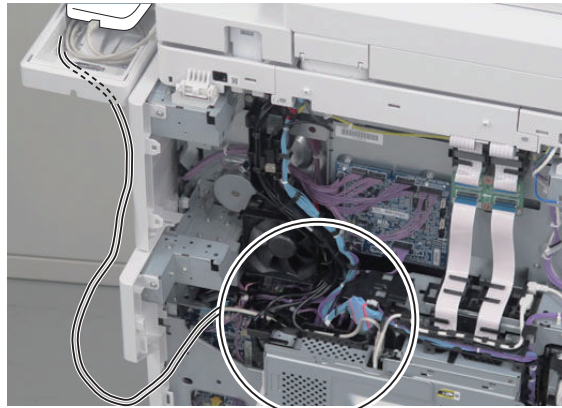

□  
11.

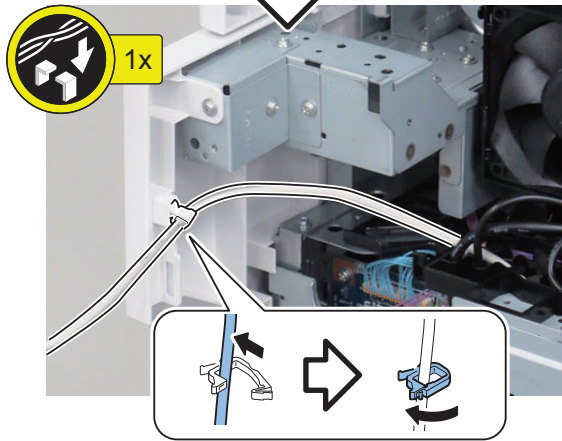
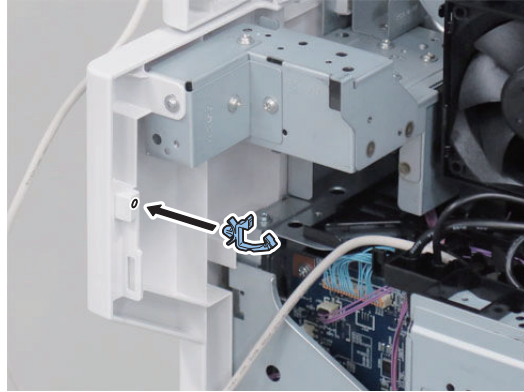
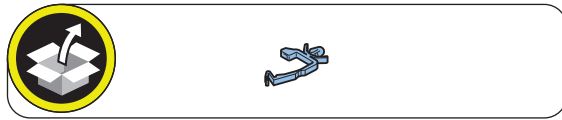



□  
**12.**

**CAUTION:**  
Be sure not to make burrs when cutting the part.

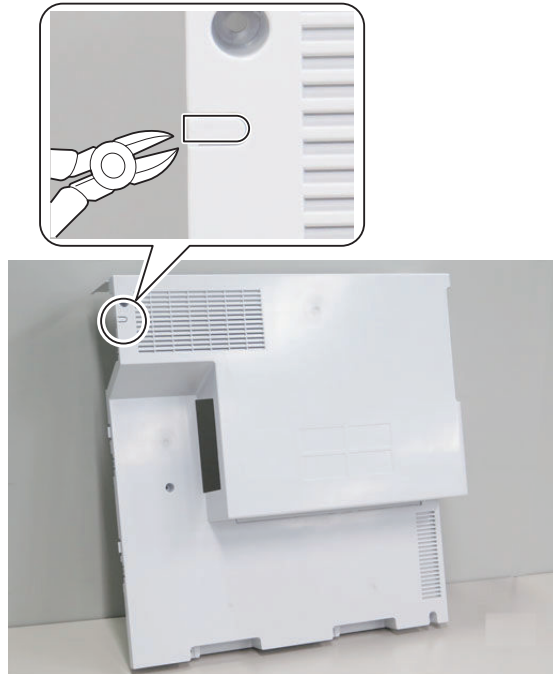
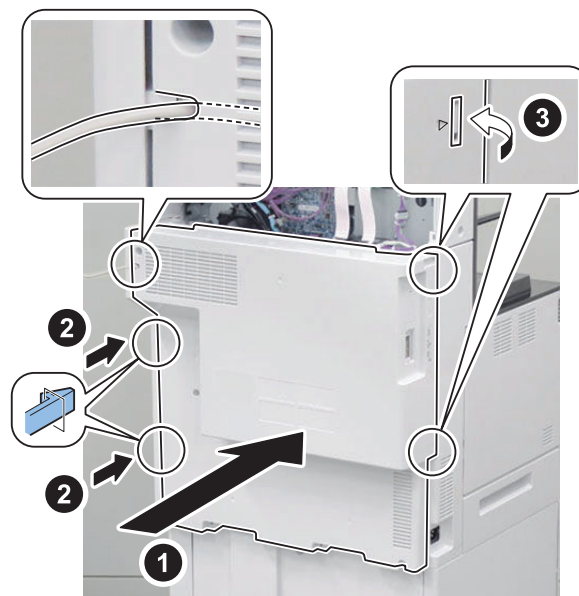
□  
**13.**

□  
**14.**



□  
**15.**

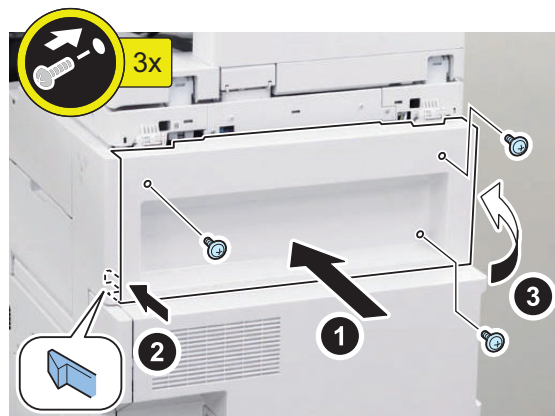

□  
16.

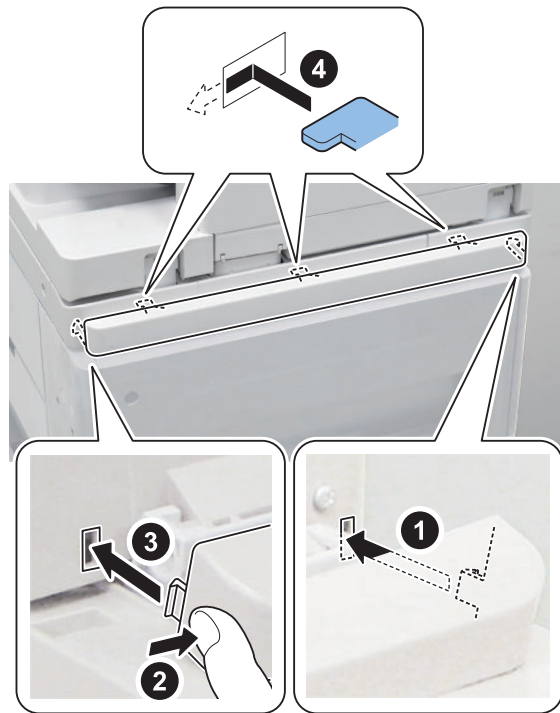

□  
17.

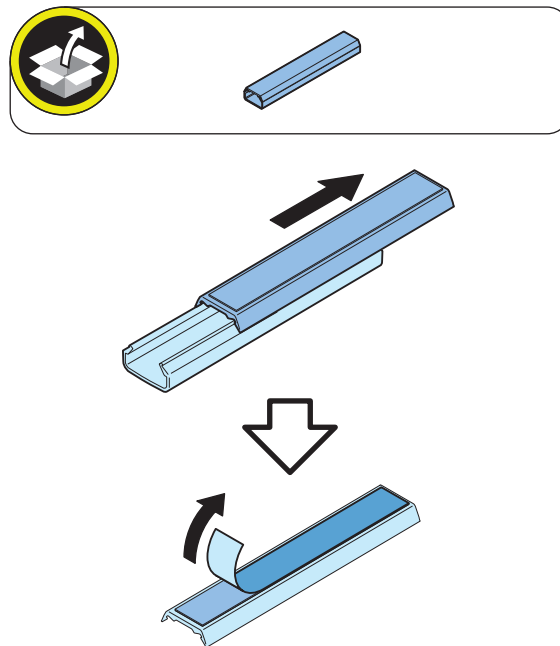

□  
**18.**

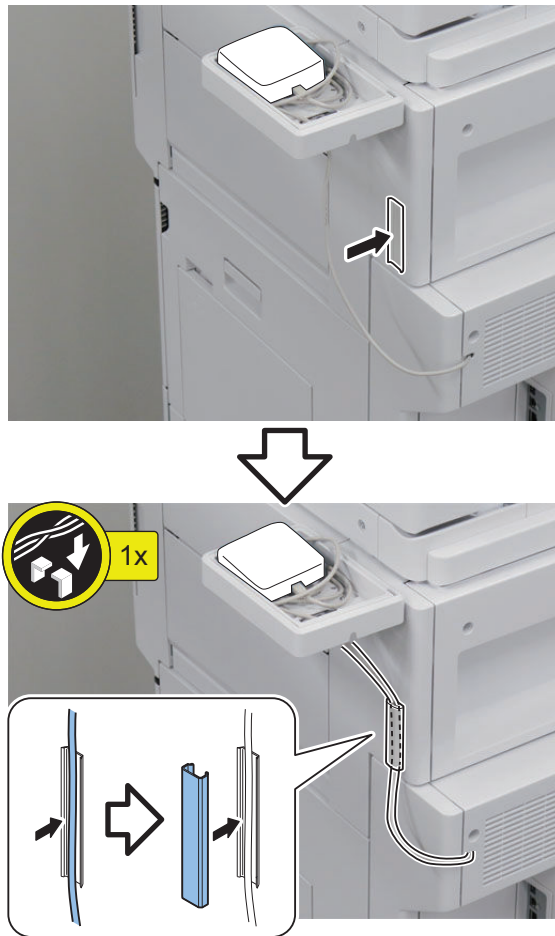

□  
**19.**

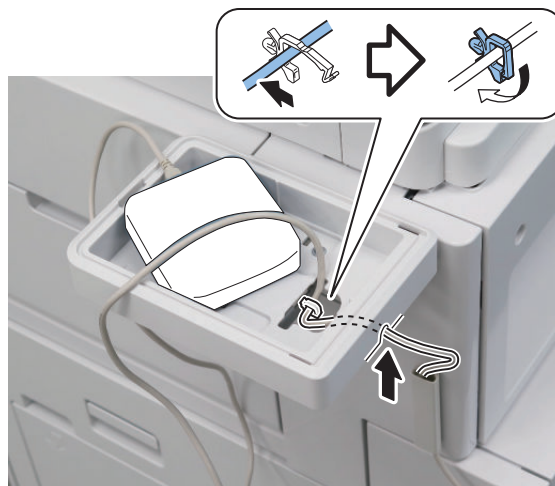

□  
20.**NOTE:**

Use the Bottom Cover that was removed in "Preparation".

**CAUTION:**

When installing the Bottom Cover, be careful not to trap the cable.

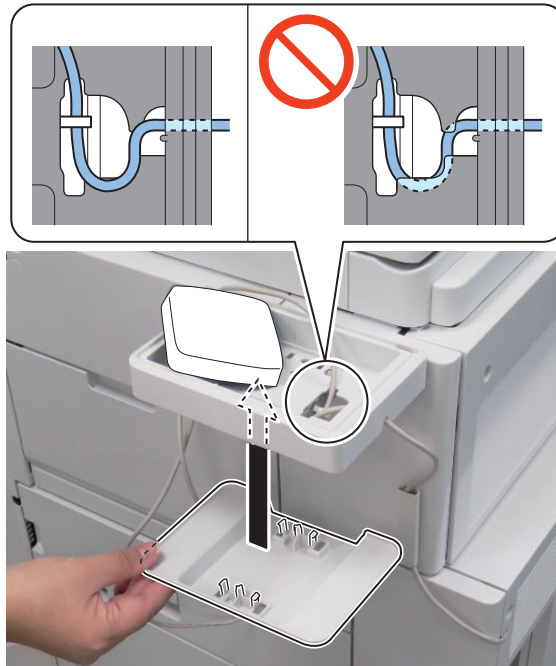
□  
21.

□  
**22.**

**NOTE:**  
Store the excess length of the cable inside the box.



□  
**23.**

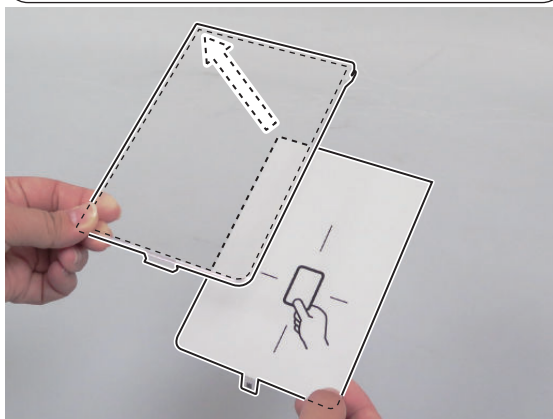

□  
**24.**



□  
**25.** Connect the power plug to the outlet.

**26.** Turn ON the Main Power Switch.

## Super G3 FAX Board-AT1

### Points to Note at Installation

- When installing the Super G3 2nd Line Fax Board and this equipment at the same time, check the parts included in the package, and install them following the Installation Procedure for Super G3 2nd Line Fax Board.
- For "Checking the Operation", refer to this document.

### Checking the Contents

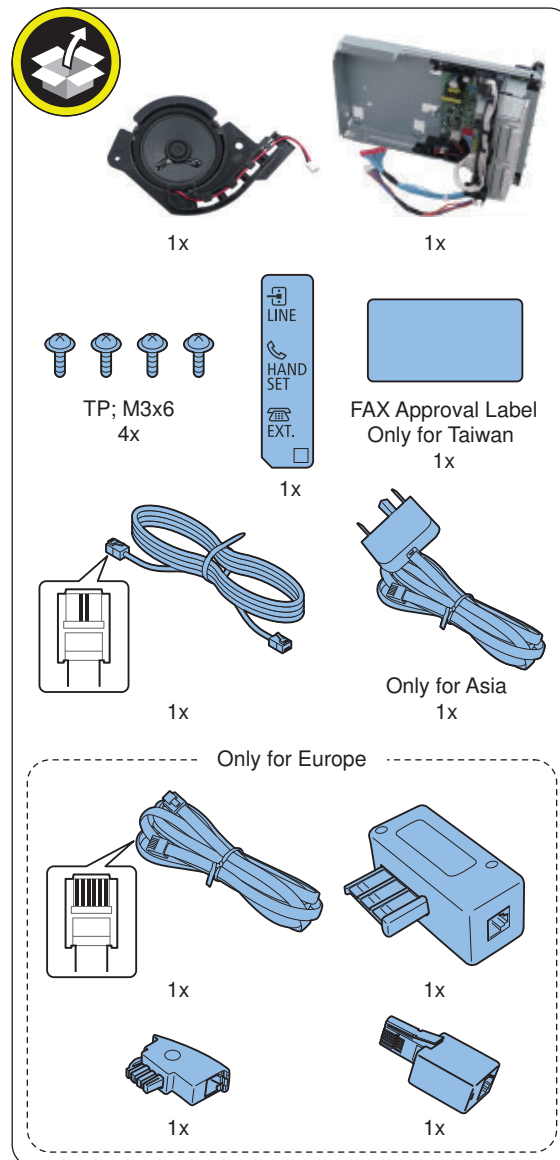

<Others>

- Including guides



## ● Installation Outline Drawin

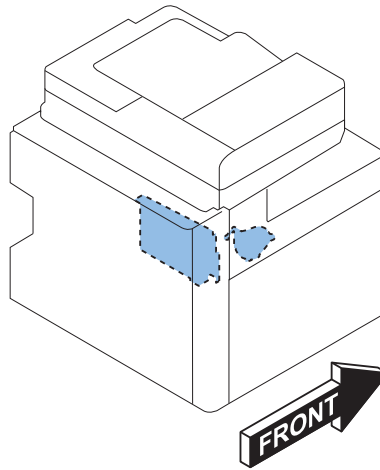

## ● Installation Procedure

### ■ Removing the Covers

□

**1.**

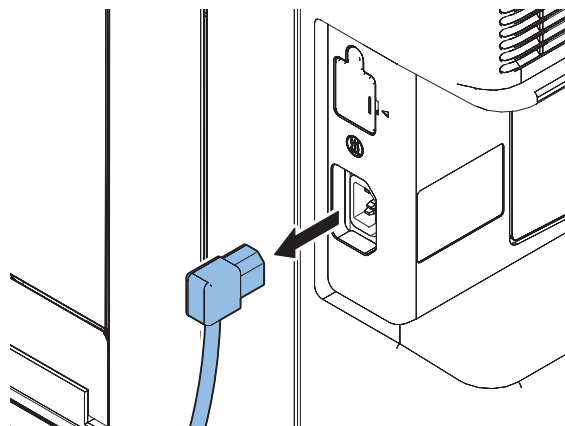

□  
**2.****CAUTION:**

Do not insert a screwdriver into the hole when removing the Small Cover.

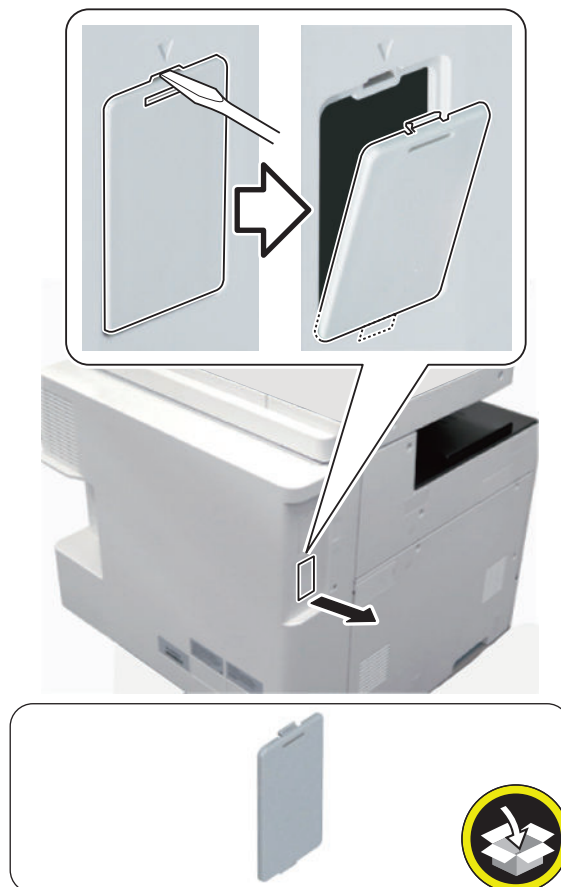
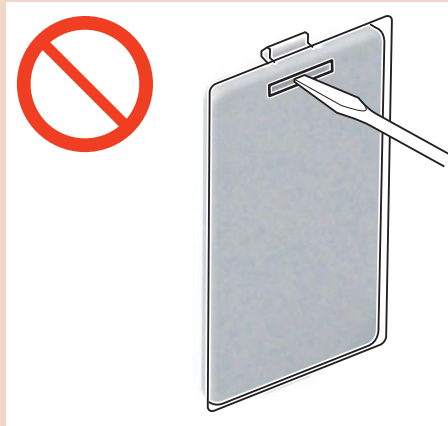

□  
3.

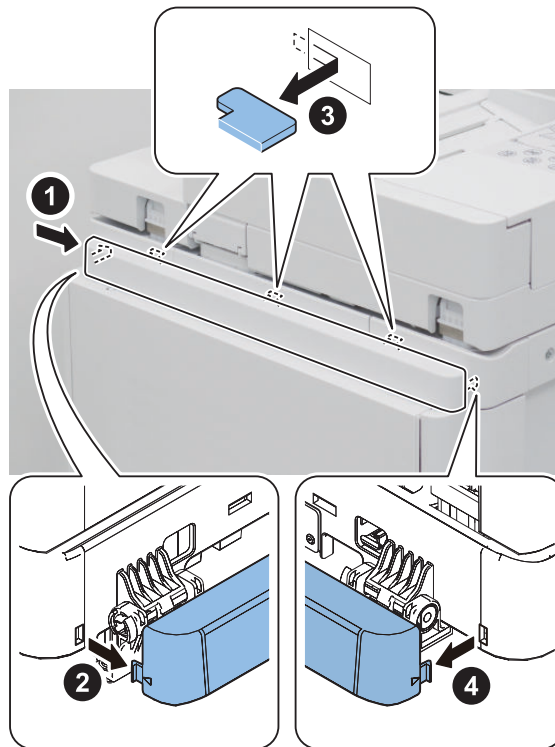
**NOTE:**

When the Cassette Pedestal is not installed, go to step 4.

**NOTE:**

When the Cassette Pedestal is installed, go to step 3. When the Cassette Pedestal is not installed, perform from step 5.

□  
**4.**

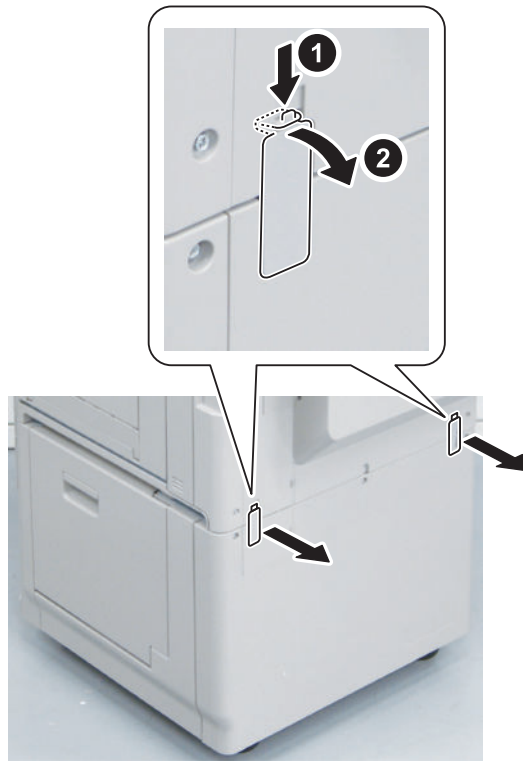

□  
**5.**

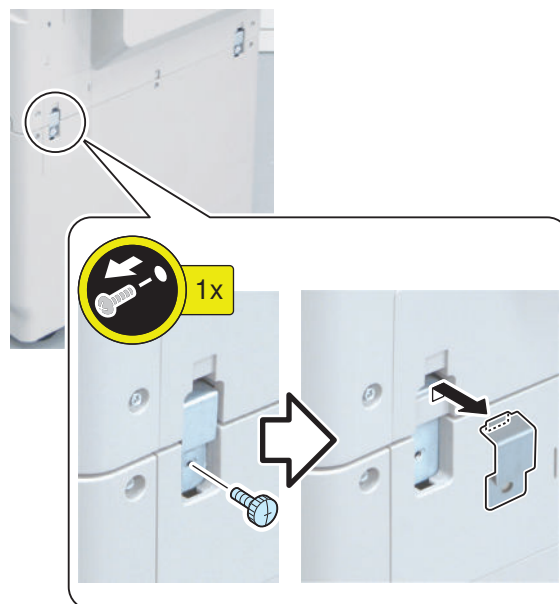

□  
**6.**

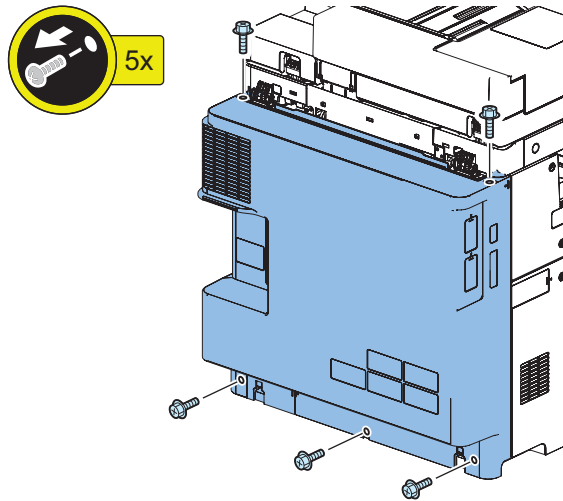

□  
**7.**

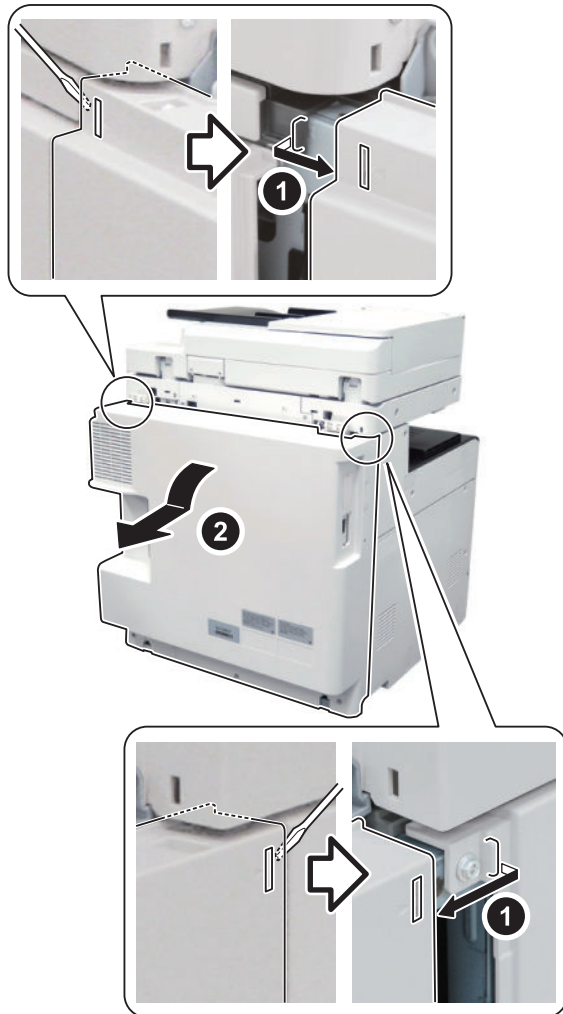

□  
**8.**

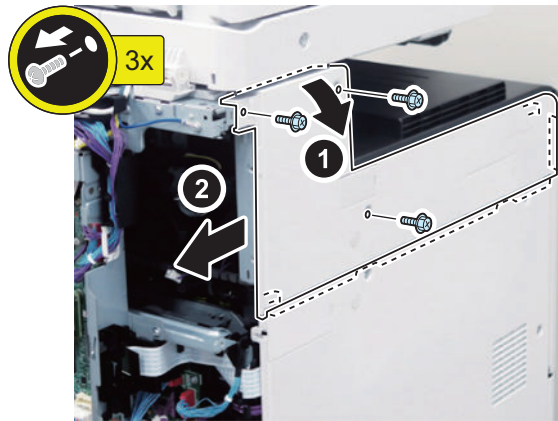

■ **Installing the FAX Unit**

□  
**1.**

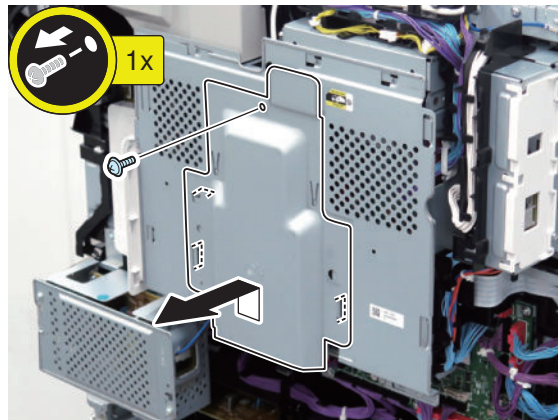

□  
2.**CAUTION:**

When handling the HDD, be careful not to vibrate or drop it.

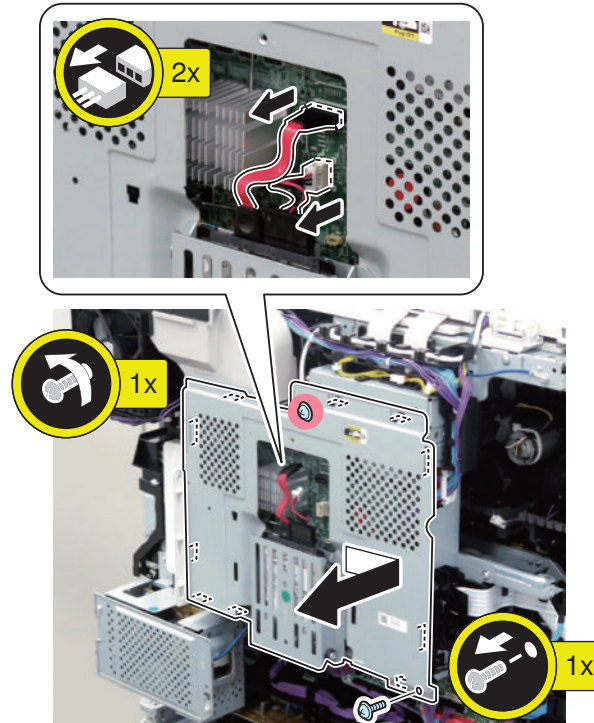

□  
**3.**

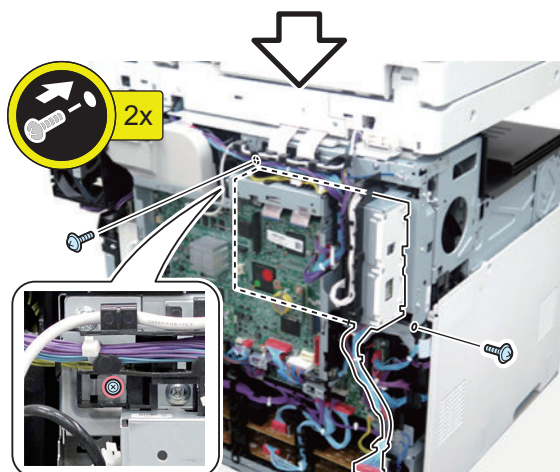
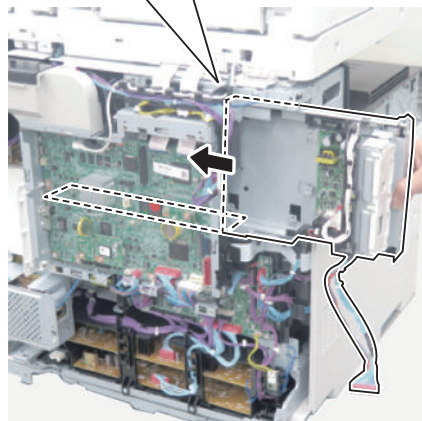
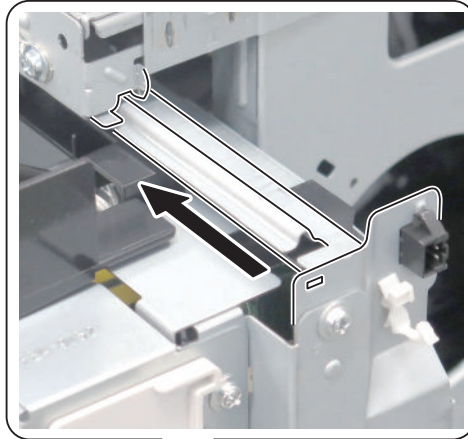
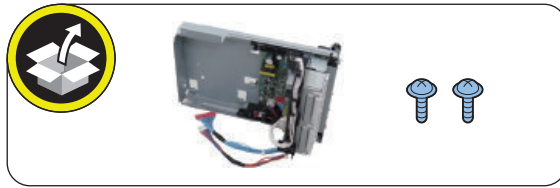



□  
**4.**

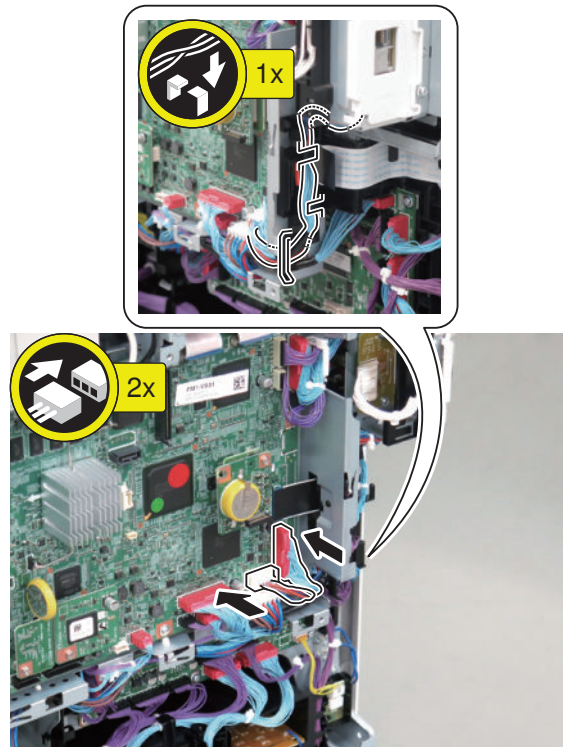

□  
**5.**

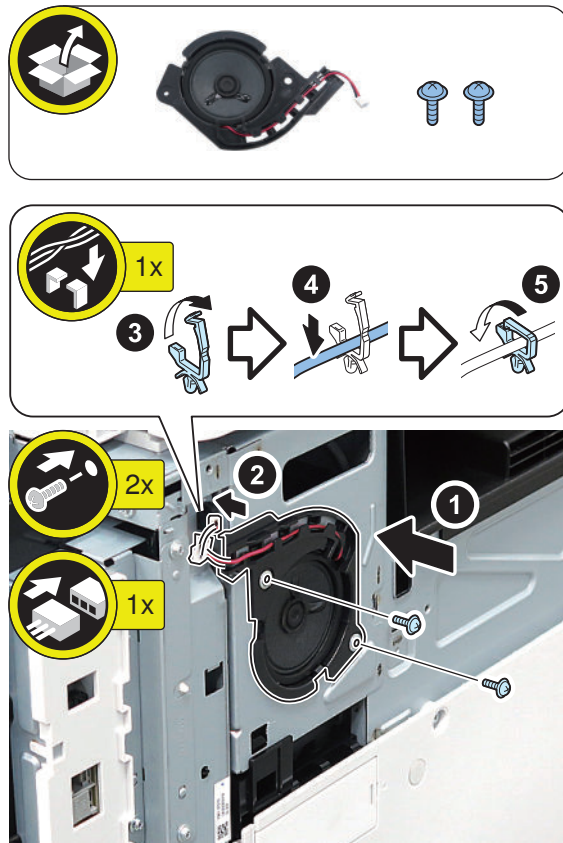

■ Subsequent Work

□  
1.

**NOTE:**  
If the Cassette Pedestal is not installed, skip the following 5 and 6.

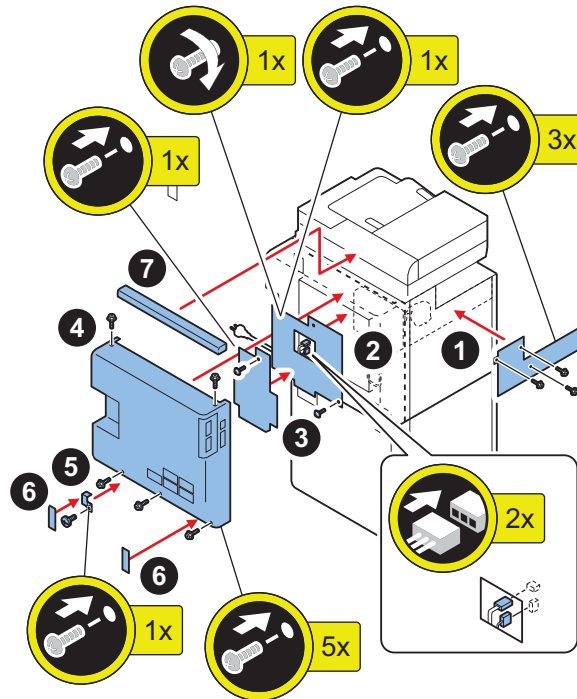

□  
2.

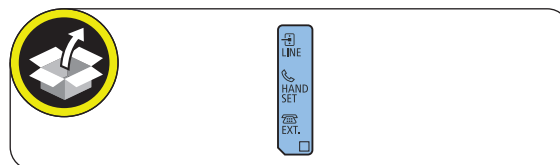

□  
**3.**

**NOTE:**  
This step is only for Taiwan.

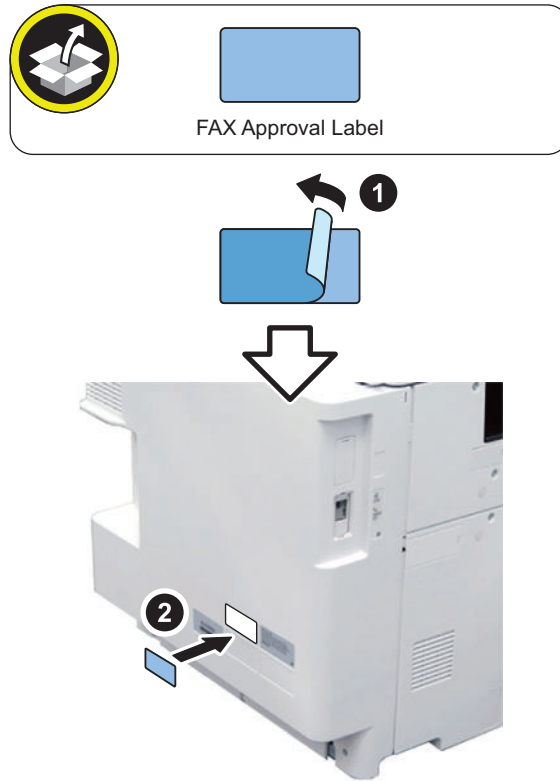

□  
4.**NOTE:**

- This step is only for Europe.
- Do not connect the telephone cord (2 core) to PTT plugs.
- Connect the PTT cable (6 core) to the PTT Plug appropriate for the country/region.

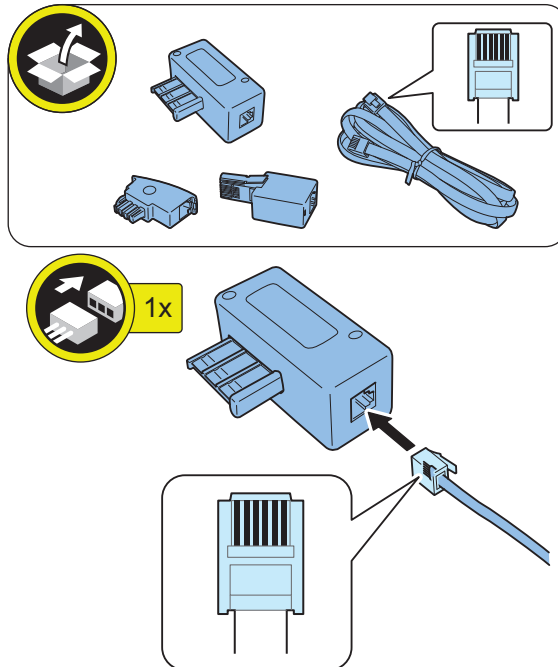
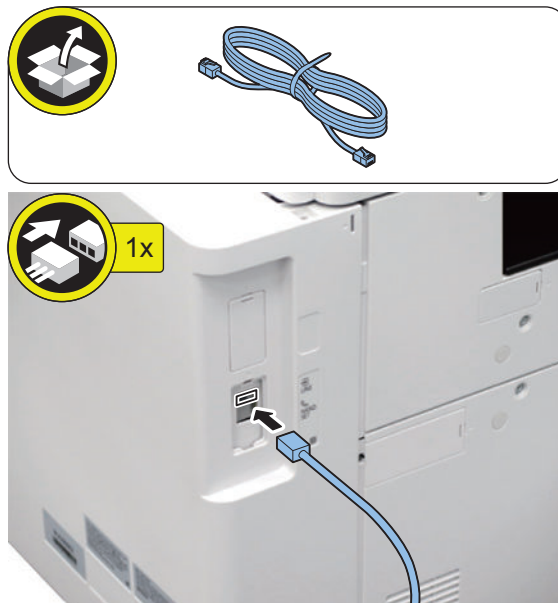
□  
5.

6.

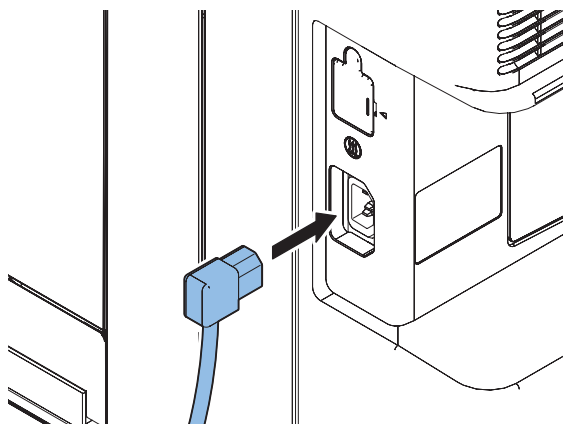

7. Connect the power plug to the outlet.

8. Turn ON the Main Power Supply Switch.

## Checking the Operation

### ■ Type Setting

Select the country/region of the FAX Board in Service Mode: FAX > Type > TYPE

This setting performs the parameter settings to match the communication specification of the country/region.

- 
1. From the following service mode, set the TYPE of country/region to install this machine, and then press OK.  
FAX > TYPE > TYPE
  2. Confirm that service mode parameter below is "0". In the case, parameter is "1", change to "0".  
COPIER > OPTION > DSPLY-SW > SDTM-DSP

#### NOTE:

To change parameter to "0" makes no show below [Settings/Registration > Preferences > Time/Energy Settings > Auto Shutdown Time] and auto shut down is not available.

3. Turn OFF/ON the main power switch to enable this setting.

### ■ Basic Setting

#### NOTE:

- When "System Manager Information Settings" is set, be sure to follow the direction of user administrator in order to log in as an administrator.
- This setting can also be set from the Setup Guide ([Settings/Registration] > [Management Settings] > [License/Other] > [Start Setup Guide]).

In this section, make only minimum settings required for FAX communication.

**1. Set the user telephone number.**

[Settings/Registration] > [Function Settings] > [Send] > [Fax Settings] > [Set Line] > [Line 1] > [Register Unit Telephone Number] > Enter the fax number > [OK]

**2. Set Type of telephone line.**

[Settings/Registration] > [Function Settings] > [Send] > [Fax Settings] > [Set Line] > [Line 1] > [Select Line Type] > Select the line type to connect > [OK]

**3. Turn OFF/ON the main power switch after setting the user telephone numbers and the type of telephone line.****■ FAX Communication Test**

Perform communication test to check if FAX function works correctly.

**1. Switch the control panel display to Send/Fax display.****2. Send the test document from this machine to another machine that can handle the communication test to check that this machine can send the data correctly.****3. Send the test document from the target to this machine to check if the machine can receive the document properly.**

## Connection Kit-A2/A3 for Bluetooth LE

### ● Points to Note at Installation

- When installing the IC Card Reader Installation Kit at the same time, install this equipment first.

### ● Installation Outline Drawing

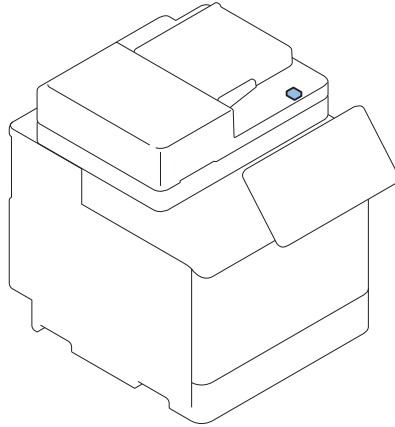

### ● Checking the Contents

**NOTE:**

The required parts differ depending on the host machine to which this equipment is installed.  
Use A, C, D, G and H for this product.

• Connection Kit-A2 for Bluetooth LE

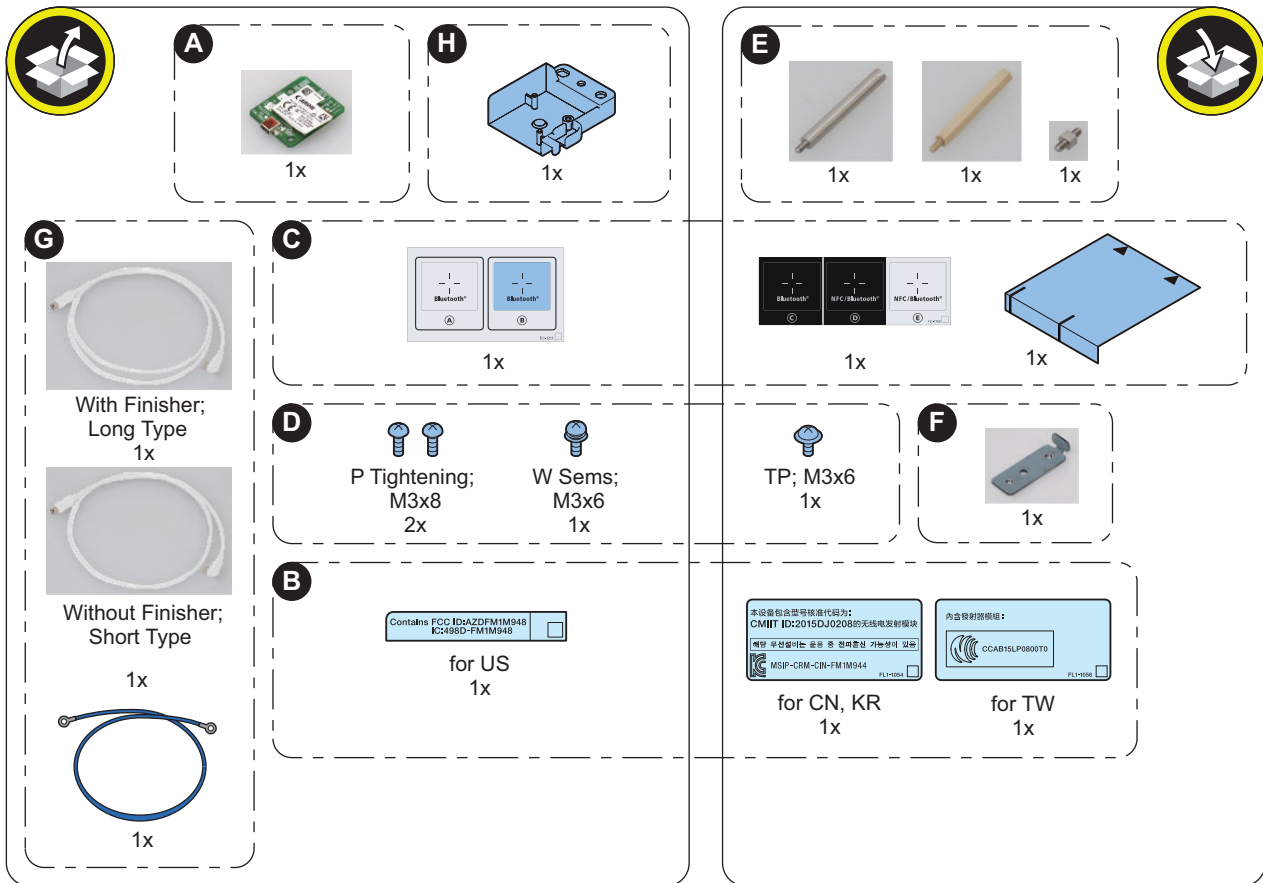

• Connection Kit-A3 for Bluetooth LE

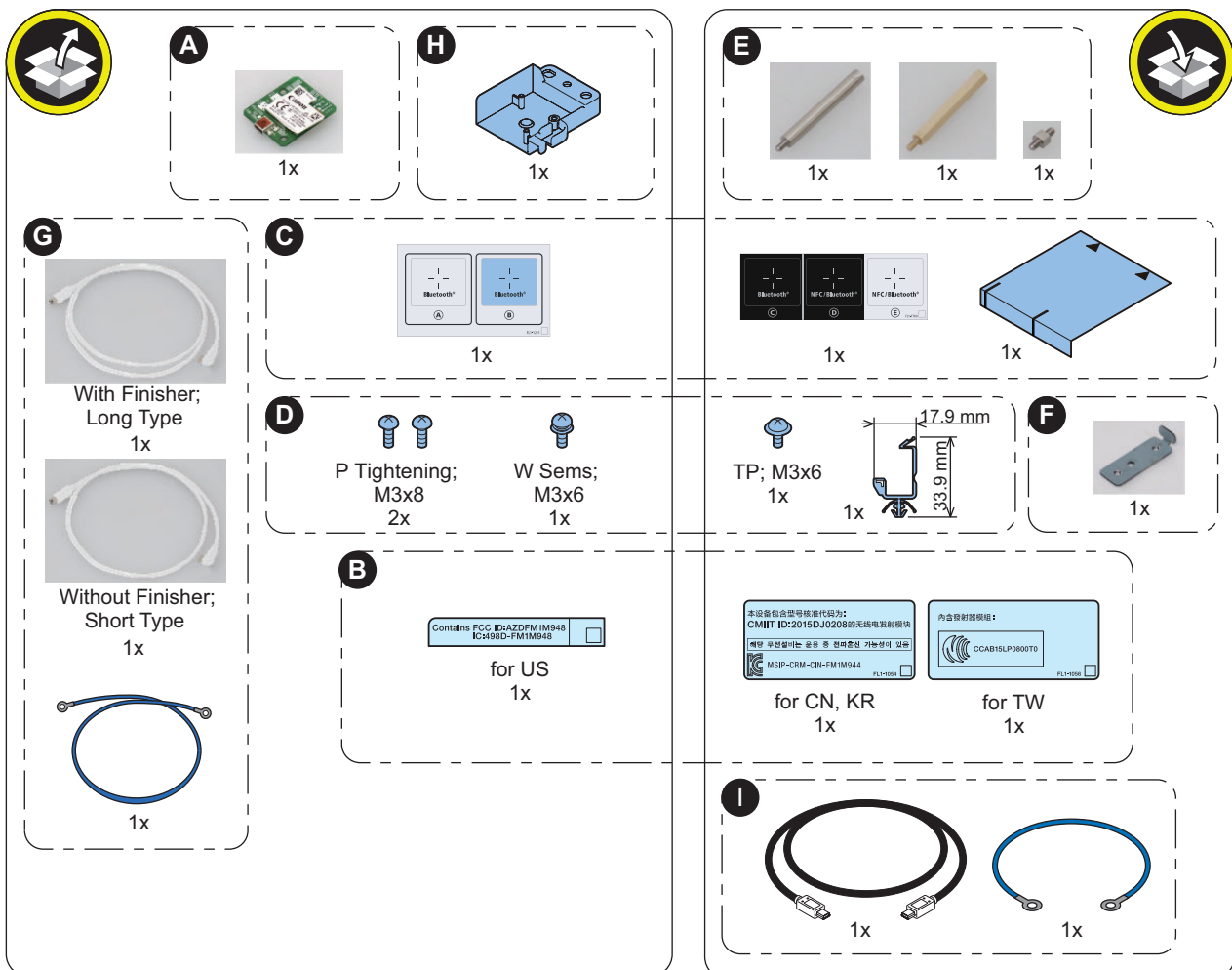



<Others>

- Guides are included

## Installation Procedure

□  
**1.**



□  
**2.**



□  
**3.**

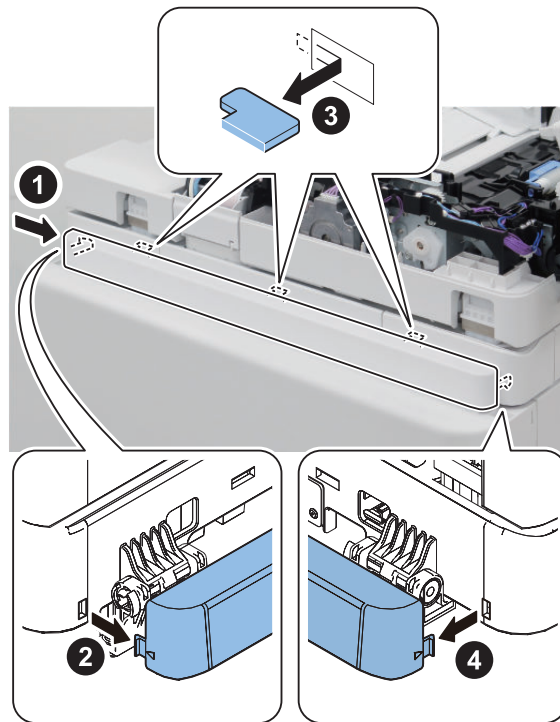

□  
**4.** <When the Finisher is installed>

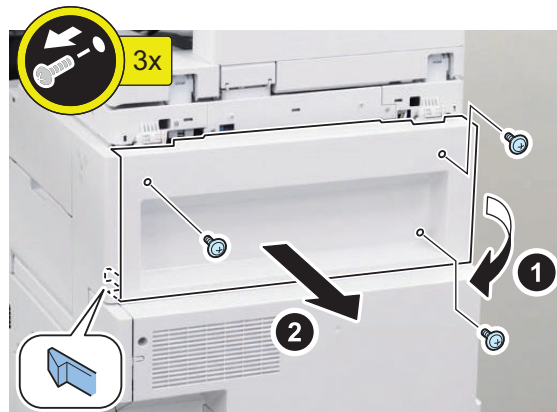

□  
5.



6.

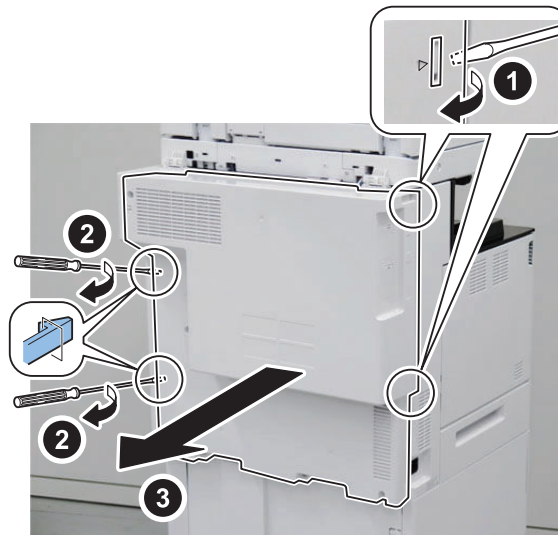

□  
7.

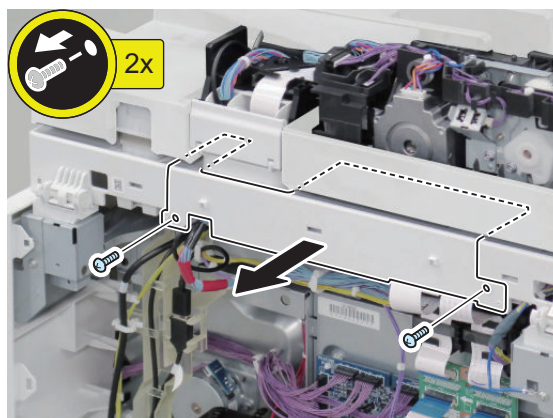

□  
8.

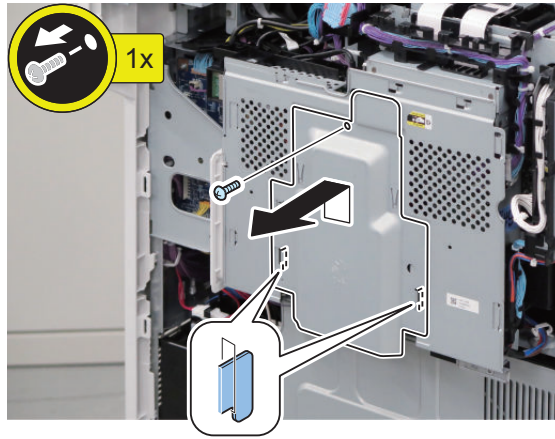

□  
9.

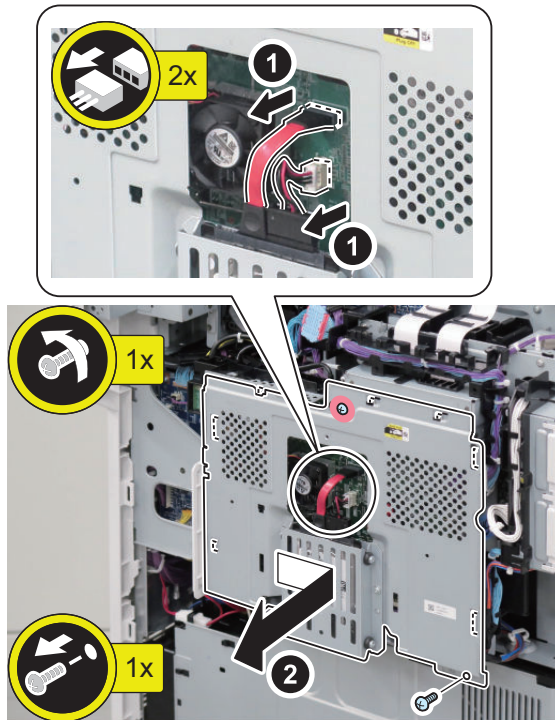

□  
**10.**

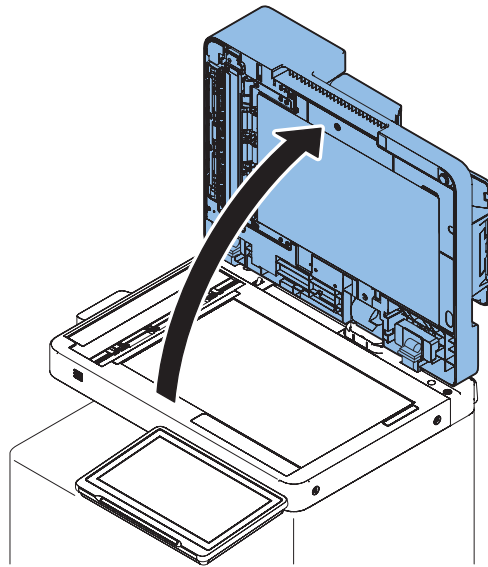

□  
**11.**

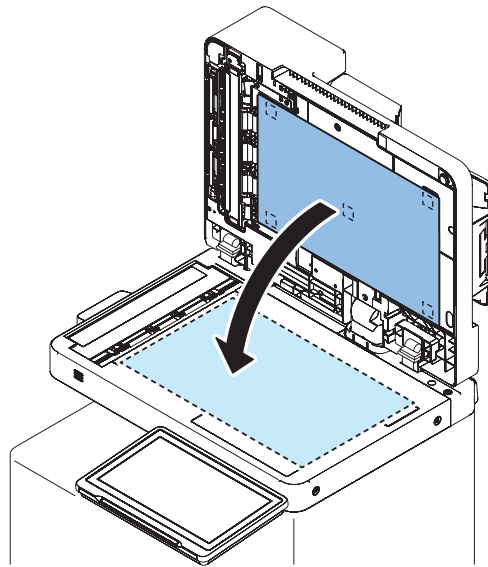

□  
12.

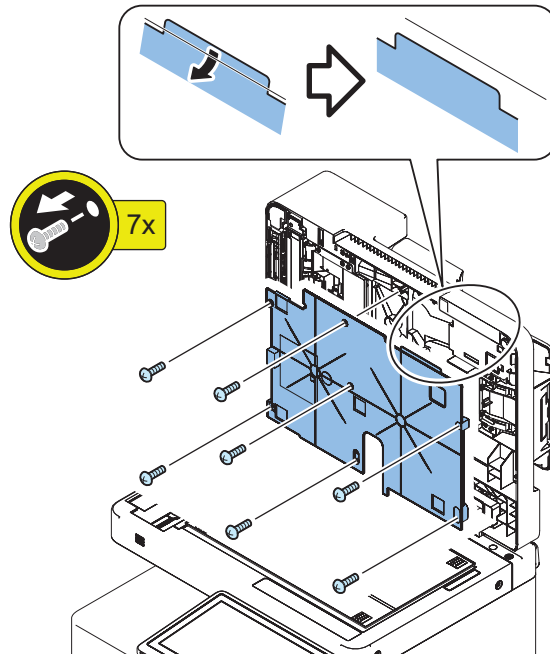

□  
13.

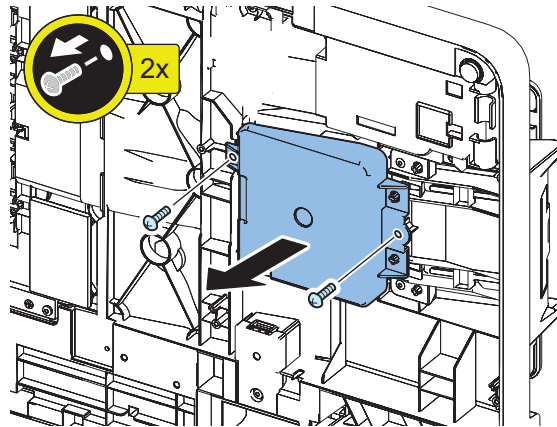

□  
14.

**CAUTION:**  
Be sure to install the Grounding Wire in the correct orientation.

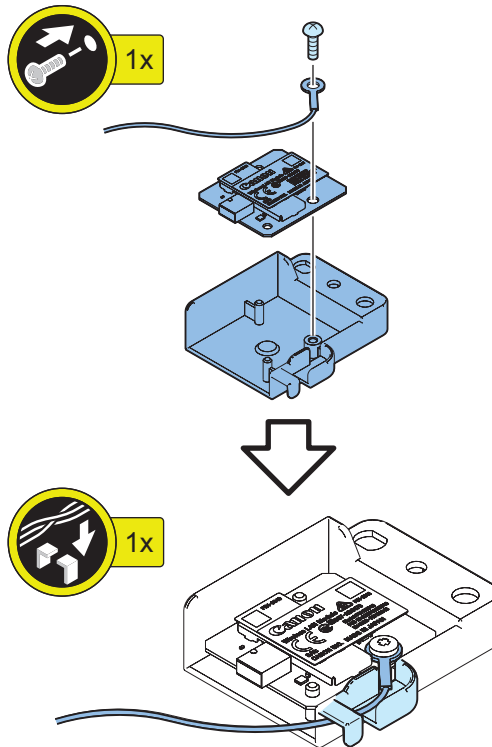
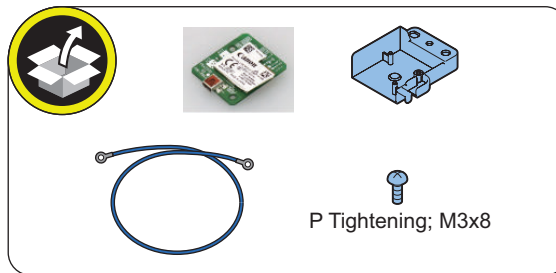
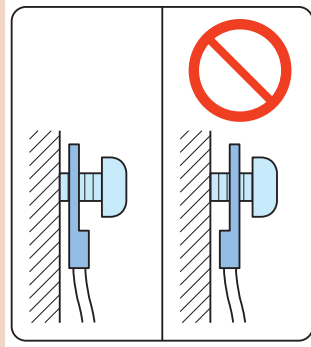

□  
**15.**

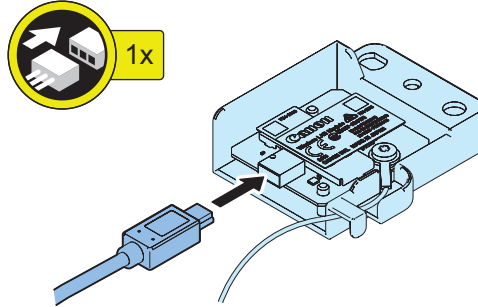
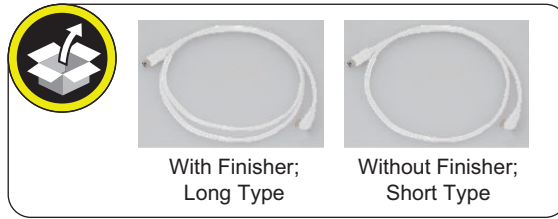

□  
**16.**

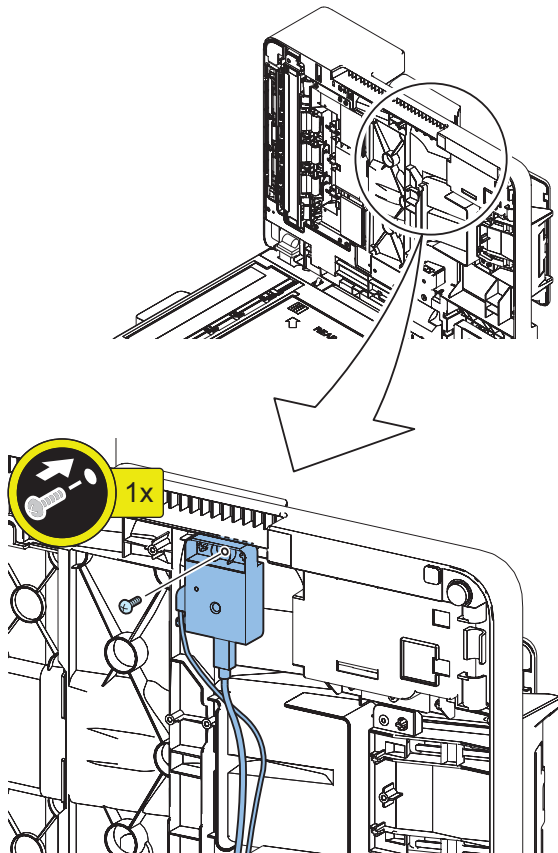
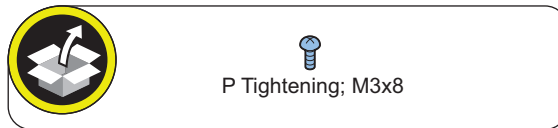



□  
17.

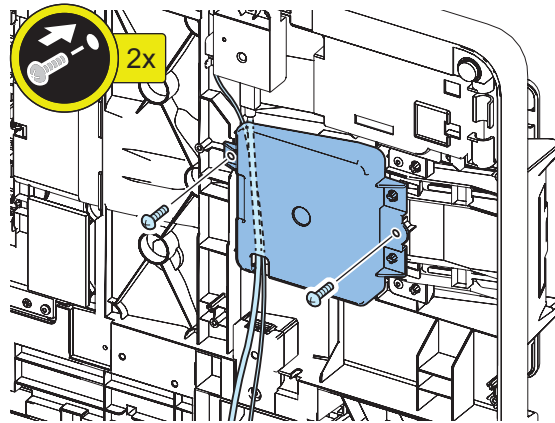

□  
18.

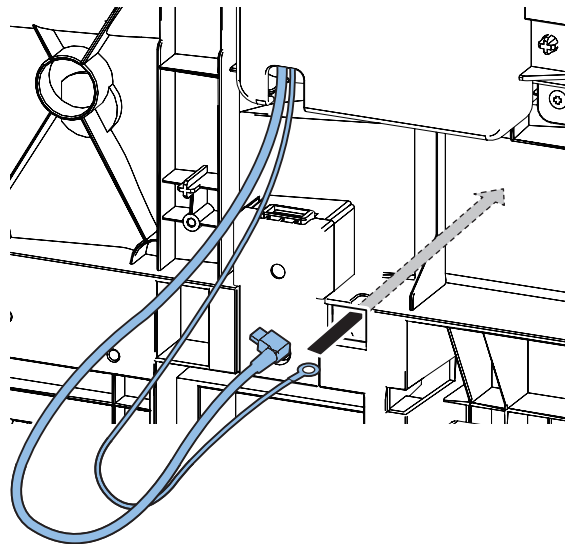

□  
19.

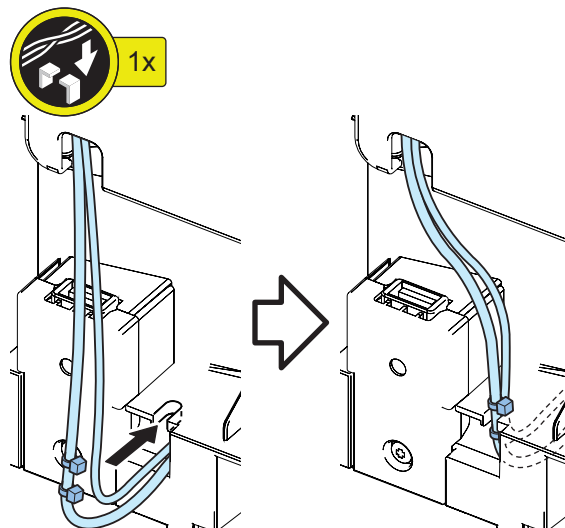

□  
20.

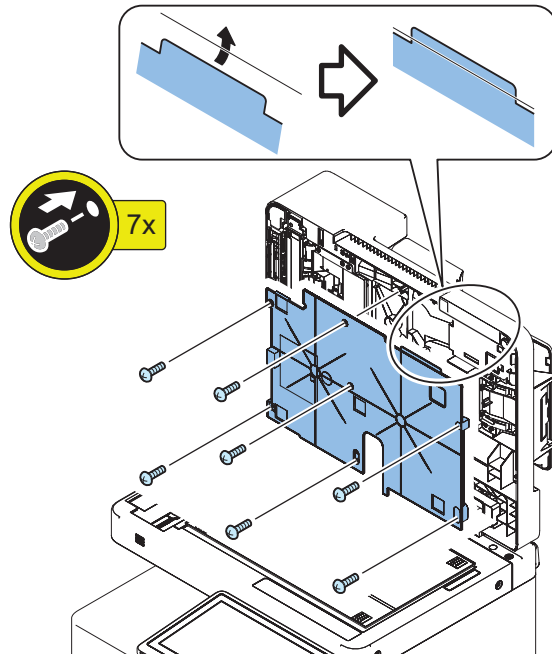

□  
21.**CAUTION:**

Align the White Plate with the Index.

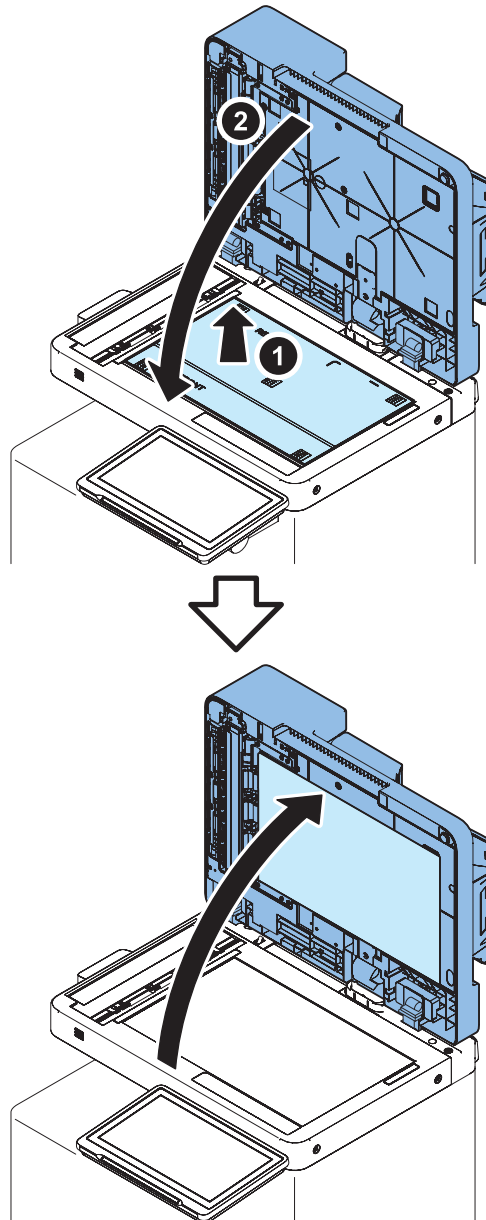
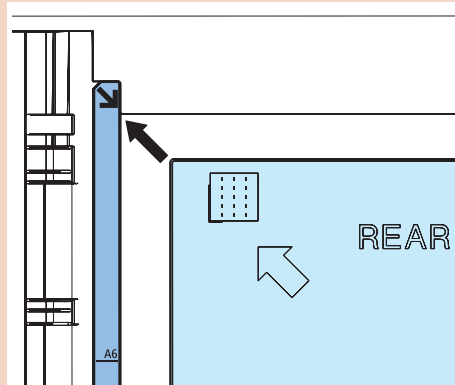

□  
22.

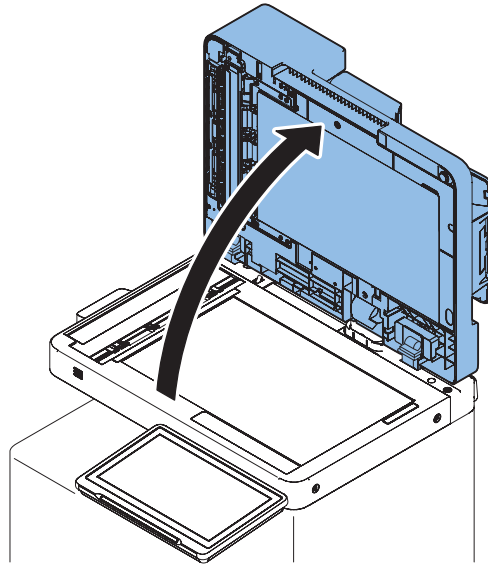

□  
23.

**CAUTION:**

If the White Plate is pressed from top to bottom, it is placed on the Index Sheet, so be sure to press it from bottom to top.

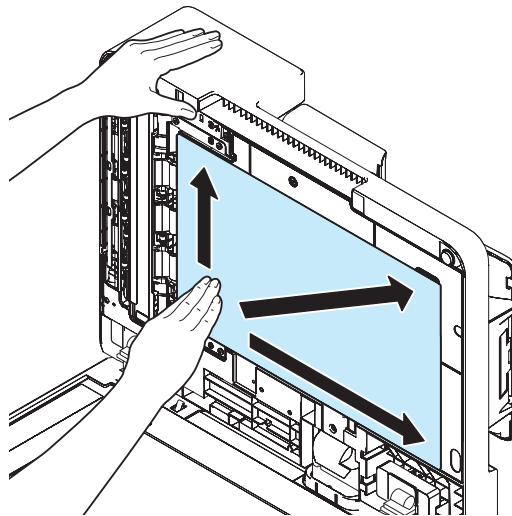

□  
24.**CAUTION:**

Check that the White Plate is not placed on the Index Sheet with this equipment closed.

- Be sure that there is no gap between the White Plate and the Index Sheet.
- The gap between the White Plate and the Index Sheet must be 0.3 mm or less as a reference.

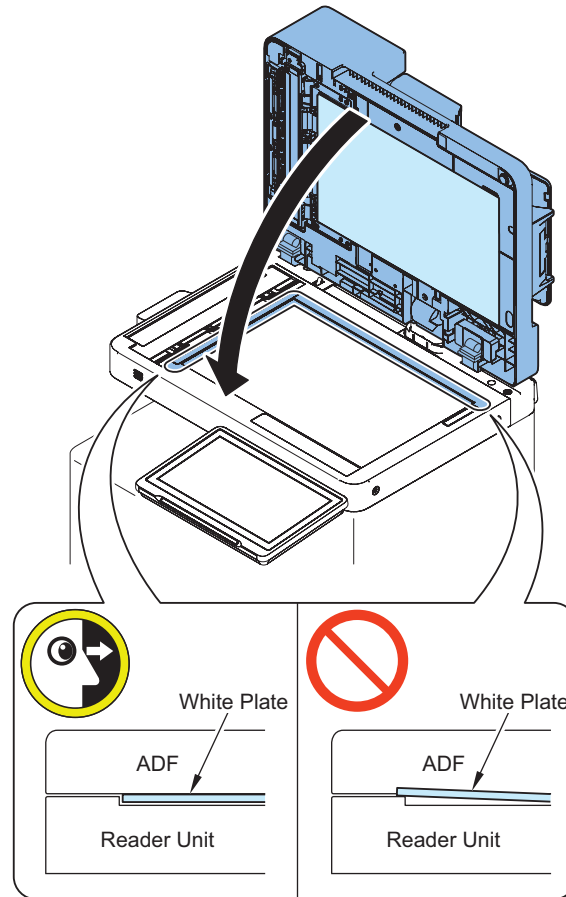

□  
25.

**NOTE:**

Pull out the Grounding Wire that was passed through the hole in step 18, and connect it.

**CAUTION:**

Be sure to install the Grounding Wire in the correct orientation.

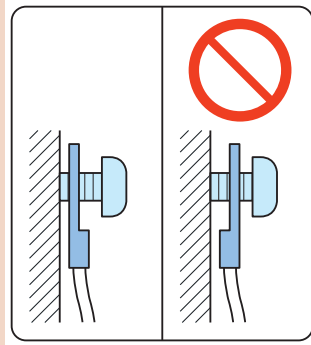

W Sems; M3x6

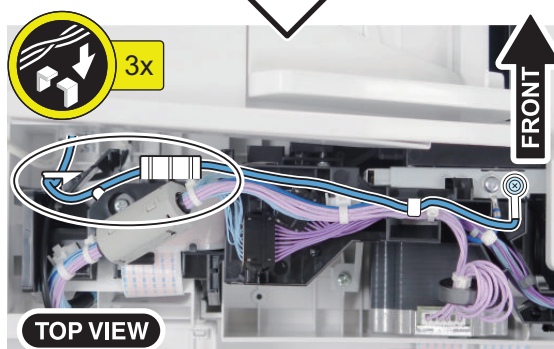
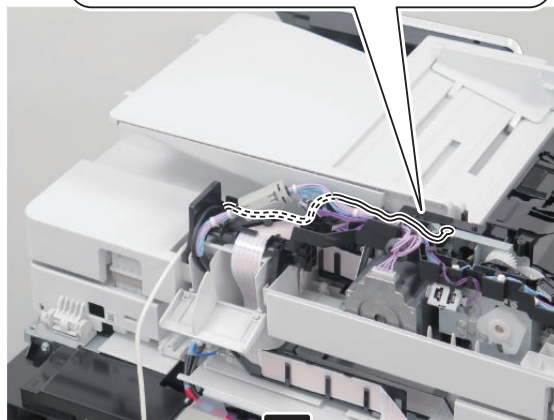
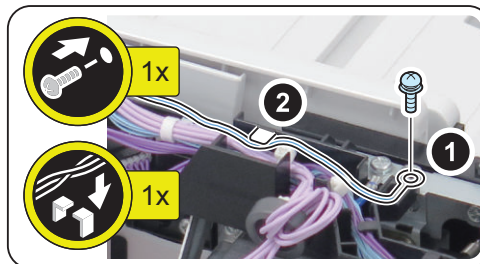

□  
26.**NOTE:**

Pull out the cable that was passed through the hole in step 18.

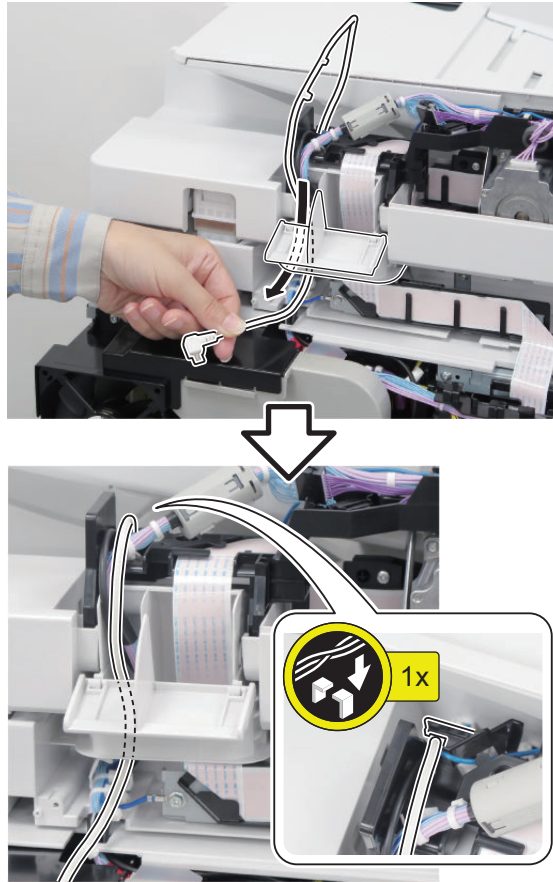

□  
27.

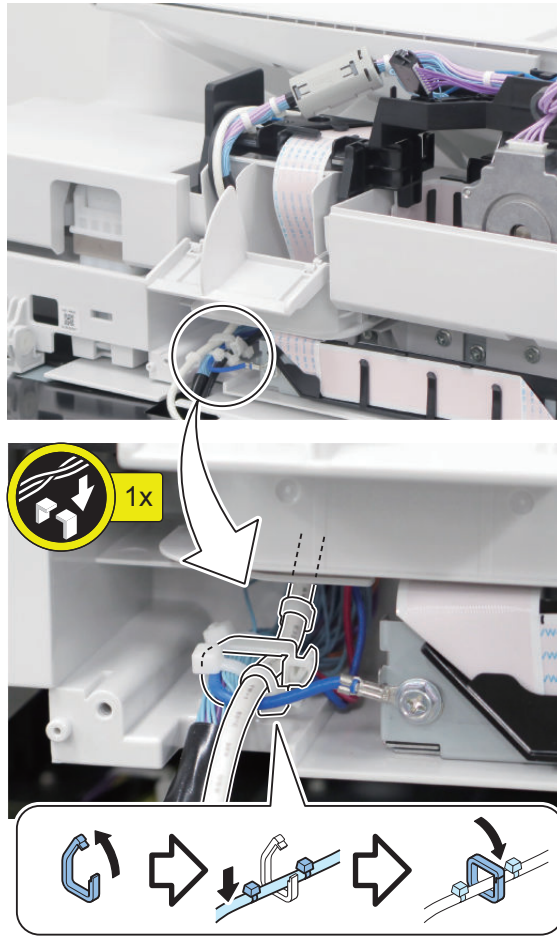

□  
28.

<When the Finisher is not installed>

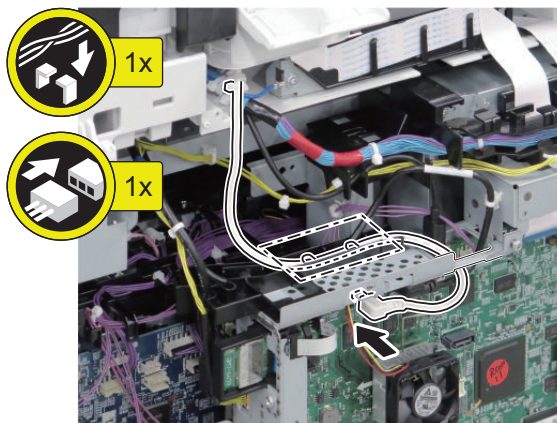



<When the Finisher is installed>

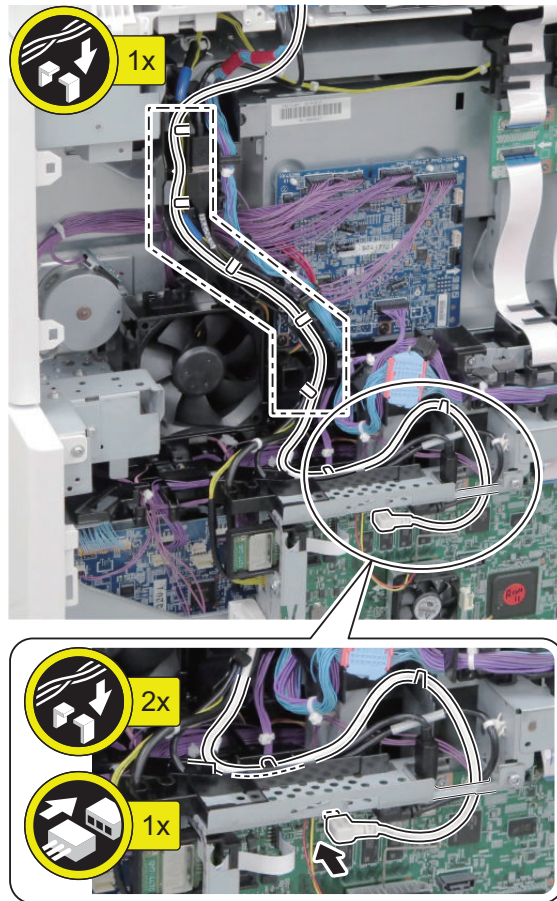

□  
29.

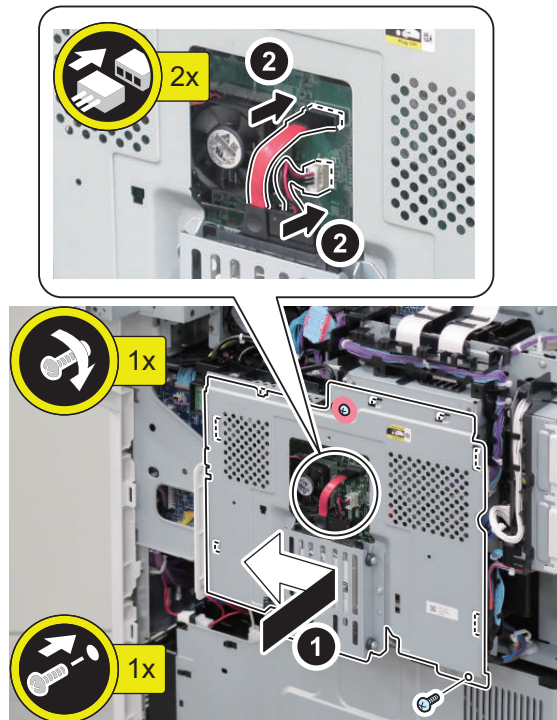

□  
**30.**

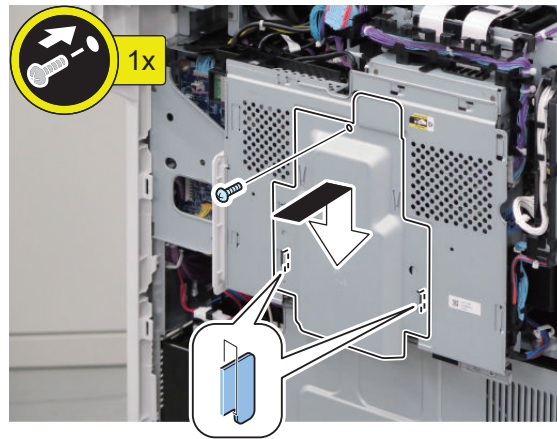

□  
**31.**

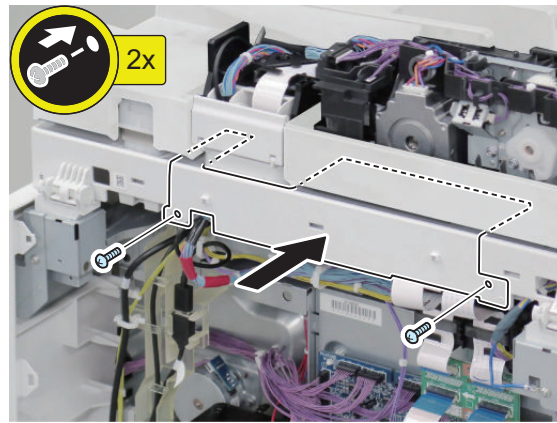

□  
**32.**

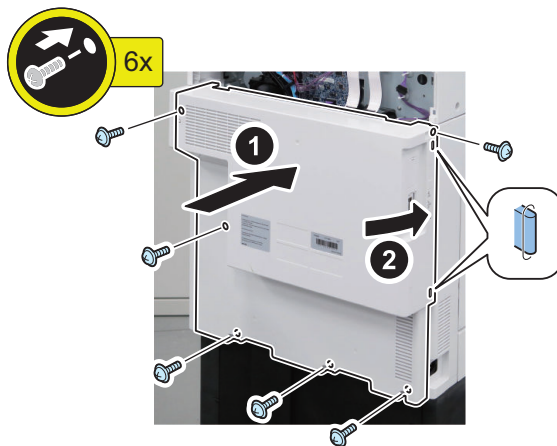

□  
**33.** <When the Finisher is installed>

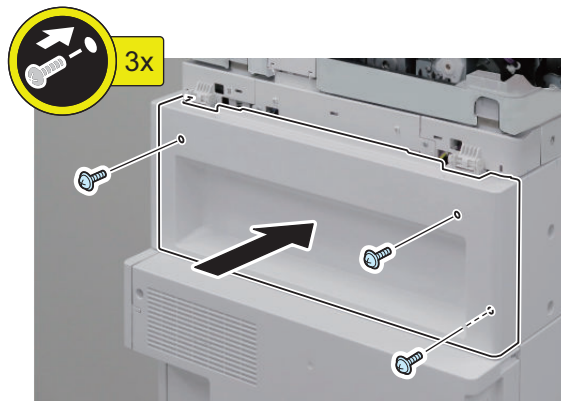

□  
**34.**

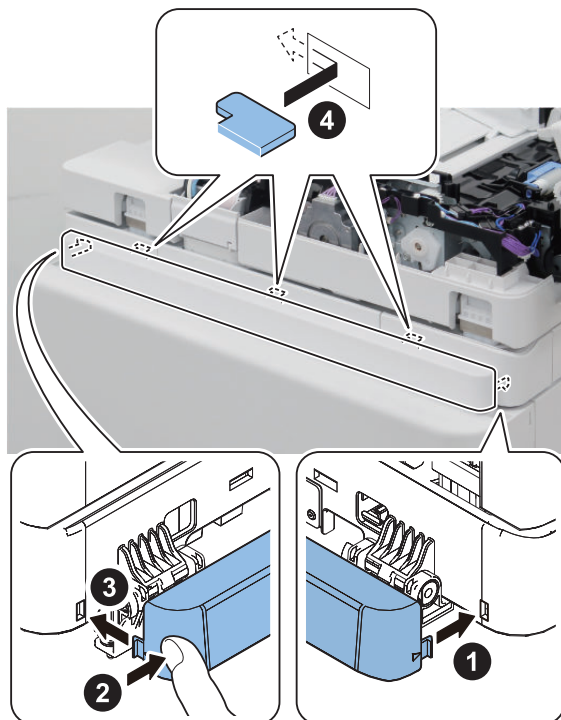

□  
**35.**

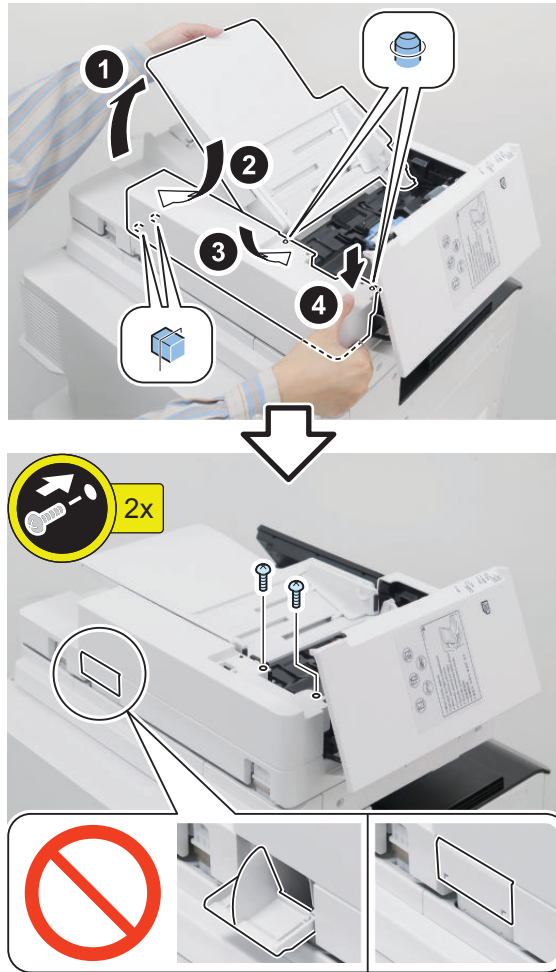

□  
**36.**



□  
37.

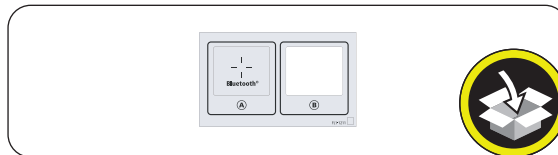
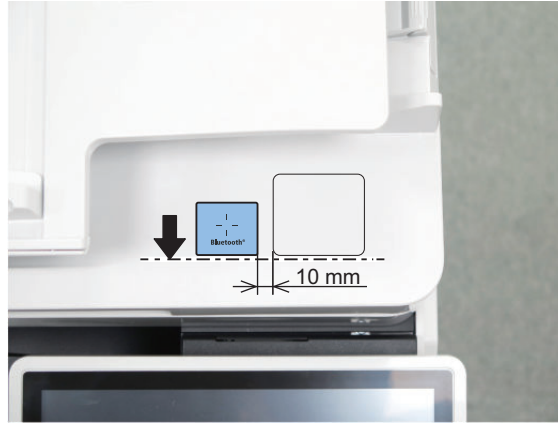
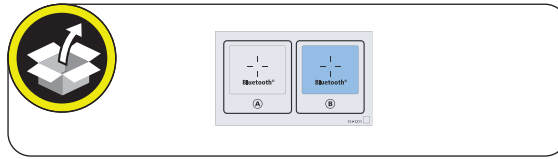

# 38.

**NOTE:**

Affixing the Approval Label is not required in countries/regions other than the following.

**<For US>**

Affix it over the number on the Wireless LAN Approval Label.

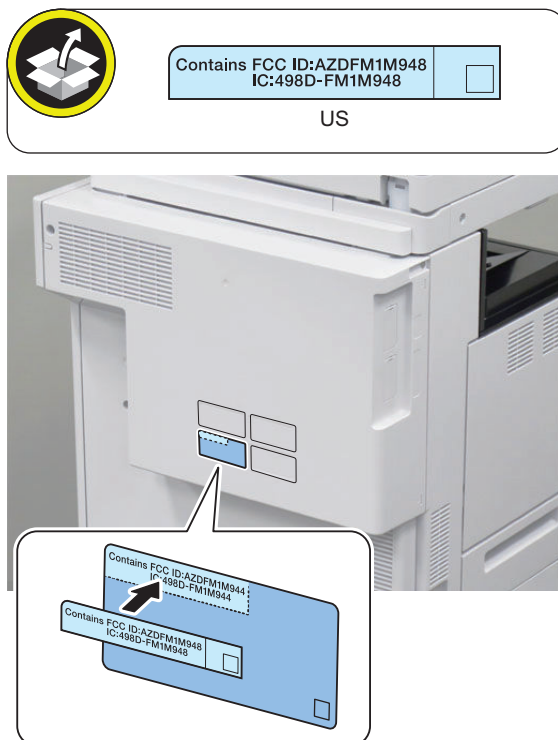

## Setting after Installation

1. Connect the power plug of the host machine to the outlet.
2. Turn ON the main power switch.
3. Enter service mode, and set the value to "1".  
COPIER >FUNCTION > INSTALL > BLE-USE

**NOTE:**

When [System Manager Information Settings] is set, it is required to log in as a system manager in accordance with instructions of the user administrator.

4. Select [Settings/Registration] > [Preferences] > [Network] > [Confirm Network Connection Setting Changes], and set the item [ON].
5. Select [Settings/Registration] > [Preferences] > [Network] > [Bluetooth Settings] > [Use Bluetooth] > [ON].
6. The message "Perform Apply Setting Changes from Settings/Registration" appears at the bottom of the Touch Panel Display.
7. Press [Settings/Registration] > [Apply Setting Changes] > [Yes].

# Revision

Rev.	Product name	Reference	Category	Details	Remarks
1.0	Installation Manual	-	First Edition	-	-