

SERVICE MANUAL

imageRUNNER ADVANCE DX 8705i/8795i/8786i



Canon

June 24, 2021
Rev. 12

Important Notices

Application

This manual has been issued by Canon Inc. for qualified persons to learn technical theory, installation, maintenance, and repair of products.

This manual covers all localities where the products are sold. For this reason, there may be information in this manual that does not apply to your locality.

Following "Trademarks" and "Copyright" are not applicable if they are not supported by laws and regulations in the country or region that this document and products are used in.

Corrections

This manual may contain technical inaccuracies or typographical errors due to improvements or changes in products.

When changes occur in applicable products or in the contents of this manual, Canon will release technical information as the need arises. In the event of major changes in the contents of this manual over a long or short period, Canon will issue a new edition of this manual.

Trademarks

The Bluetooth word mark and logos are registered trademarks owned by Bluetooth SIG, Inc. and any use of such marks by Canon is under license.

Mopria®, the Mopria® Logo and the Mopria® Alliance logo are registered trademarks and service marks of Mopria Alliance, Inc. in the United States and other countries. Unauthorized use is strictly prohibited.

Apple, AppleTalk, Bonjour, iPad, iPhone, iPod touch, Mac, OS X and Safari are trademarks of Apple Inc.

Microsoft, Windows, Windows Vista, Windows Server, Internet Explorer, Microsoft Edge, Excel and PowerPoint are either registered trademarks or trademarks of Microsoft Corporation in the United States and/or other countries.

Google Cloud Print, Google Chrome and Android are either registered trademarks or trademarks of Google Inc.

OCR Technology by I.R.I.S., copyright 1987-2015, All Rights Reserved.

iHQC™ compression technology by I.R.I.S., copyright 2007-2015, All Rights Reserved.

PDF-iHQC™, XPS-iHQC™ technology by I.R.I.S., copyright 2007-2015, All rights Reserved.

Java is a registered trademark of Oracle and/or its affiliates.

Adobe is a registered trademark of Adobe Systems Incorporated.

Command WorkStation, EFI, Fiery, FreeForm, Spot-On, and WebTools are trademarks of Electronics For Imaging, Inc. and/or its wholly owned subsidiaries in the U.S. and/or certain other countries.

TORX® is a registered trademark of Acument Intellectual Properties, LLC in the United States.

Other product names and other names in this document are generally registered trademarks or trademarks of the companies.

Copyright



















The copyright of this document belongs to Canon Inc. This document may not be copied, reproduced or translated into another language, in whole or in part, without the prior consent of Canon Inc.
Copyright CANON INC. 2019



Caution

Use of this manual should be strictly supervised to avoid disclosure of confidential information.



Explanation of Symbols

The following symbols are used throughout this Service Manual.

Symbols	Explanation	Symbols	Explanation
	Check.		Remove the claw.
	Check visually.		Insert the claw.
	Check a sound.		Push the part.
	Disconnect the connector.		Connect the power cable.
	Connect the connector.		Disconnect the power cable.
	Remove the cable/wire from the cable guide or wire saddle.		Turn on the power.
	Install the cable/wire to the cable guide or wire saddle.		Turn off the power.
	Remove the screw.		Loosen the screw.
	Install the screw.		Tighten the screw.

Symbols	Explanation	Symbols	Explanation
	Cleaning is needed.		Measurement is needed.

The following rules apply throughout this Service Manual:

- Each chapter contains sections explaining the purpose of specific functions and the relationship between electrical and mechanical systems with reference to the timing of operation.
In the diagrams,  represents the path of mechanical drive; where a signal name accompanies the symbol, the arrow  indicates the direction of the electric signal.
The expression "turn on the power" means flipping on the power switch, closing the front door, and closing the delivery unit door, which results in supplying the machine with power.
- In the digital circuits, '1' is used to indicate that the voltage level of a given signal is "High", while '0' is used to indicate "Low". (The voltage value, however, differs from circuit to circuit.) In addition, the asterisk (*) as in "DRMD*" indicates that the DRMD signal goes on when '0'.
In practically all cases, the internal mechanisms of a microprocessor cannot be checked in the field. Therefore, the operations of the microprocessors used in the machines are not discussed: they are explained in terms of from sensors to the input of the DC controller PCB and from the output of the DC controller PCB to the loads.

The descriptions in this Service Manual are subject to change without notice for product improvement or other purposes, and major changes will be communicated in the form of Service Information bulletins.

All service persons are expected to have a good understanding of the contents of this Service Manual and all relevant Service Information bulletins and be able to identify and isolate faults in the machine.

Contents

Safety Precautions	1
Laser.....	2
Laser Safety.....	2
Handling of Laser System.....	2
Power Supply / Lithium Battery.....	3
Turn power switch ON.....	3
Power Supply.....	3
Notes When Handling a Lithium Battery.....	3
Toner Safety.....	4
About Toner.....	4
Handling Adhered Toner.....	4
Notes on works.....	4
Points to Note Before Servicing.....	4
Points to Note at Cleaning.....	4
Notes on Assembly/Disassembly.....	5
1. Product Overview	6
Product Lineup.....	7
Host machine.....	7
Pickup/Delivery System Option.....	7
Scanning System Options.....	12
Function Expansion System Options.....	12
Features.....	14
Product Features.....	14
Specifications.....	15
Product Specifications.....	15
Fax Specifications.....	16
Power Supply Specifications.....	16
Weight and Size.....	17
Productivity	17
Paper Type.....	19
External View.....	53
External Cover.....	53
Cross Section View.....	57
Operation.....	59
Power Switch.....	59
Control Panel.....	59
2. Technical Explanation (Device)	61
Basic Configuration.....	62
Functional Configuration.....	62
Original Exposure System (Reader).....	63
Features.....	63
Specifications.....	63

Basic configuration..... 63

Controls..... 67

Original Feed System (Single Pass ADF)..... 76

 Features..... 76

 Specifications..... 76

 Parts Name..... 77

 Basic Configuration..... 78

 ADF Driver PCB..... 82

 Outline of Electric Circuits..... 83

 Scanner Unit..... 84

 Pickup Feed System..... 87

 Power Supply Assembly..... 98

Main Controller..... 99

 Overview..... 99

 Startup Sequence..... 101

 Shutdown Sequence..... 102

 Motion Sensor..... 102

Laser Exposure System..... 103

 Overview..... 103

 Controls..... 105

Image Formation System..... 112

 Overview..... 112

 Controls..... 121

Fixing System..... 162

 Overview..... 162

 Controls..... 166

Pickup/Feed System..... 176

 Overview..... 176

 Controls..... 184

External Auxiliary System..... 212

 Overview..... 212

 Controls..... 214

3. Technical Explanation (System)..... 225

 Overview..... 226

4. Periodical Service..... 227

Periodically Replaced Parts..... 228

 DADF..... 228

 Reader..... 228

 Printer..... 228

 Option..... 229

Consumable Parts..... 230

 DADF..... 230

 Reader..... 230

 Printer..... 231

 Options..... 236

Periodical Maintenance..... 239

 Printer..... 239

DADF.....	239
Options.....	240

5. Parts Replacement and Cleaning..... 242

Preface.....	243
Outline.....	243
Parts List.....	244
List of External / Internal Cover.....	244
List of Main Unit.....	248
Periodic Replacing Parts,Durable Parts,Cleaning Parts.....	251
List of Electrical Parts	262
Original Feed System.....	279
Removing the ADF.....	279
Removing the Sensor Harness Cover.....	282
Removing the ADF Front Cover	283
Removing the ADF Rear Cover.....	284
Removing the Open/Close Cover.....	285
Removing the Lifter Drive Unit.....	287
Removing the Document Tray.....	287
Removing the ADF Scanner Unit.....	288
Removing the Cable Guide Unit.....	290
Removing the Left Hinge.....	292
Removing the Pickup Roller Unit.....	295
Removing the Separation Roller Unit.....	296
Removing the ADF Driver PCB.....	297
Removing the Multi Feed Detect Sensor PCB.....	297
Removing the Pickup Roller Lifting Motor.....	299
Removing the ADF Delivery Motor.....	300
Removing the ADF Pickup Motor Unit.....	300
Removing the ADF Pullout Motor Unit.....	301
Removing the Lead Motor Unit.....	302
Cleaning the Sensor.....	303
Cleaning the Pullout Roller.....	304
Cleaning the Lead Roller 1.....	304
Cleaning the Lead Roller 2.....	307
Cleaning the Paper Back Reading Glass.....	308
Original Exposure System.....	310
Removing the Reader Unit.....	310
Removing the Covers.....	312
Removing the Reader Controller PCB.....	314
Removing the Reader Scanner Unit.....	317
Cleaning the Reader Scanner Unit Scanner Mirror.....	321
Removing the Reader Scanner Motor.....	323
Removing the Copyboard Glass.....	326
Cleaning the Copyboard Glass (Large).....	327
Cleaning the Copyboard Glass (Small).....	328
Controller System.....	330
Removing the HDD.....	330
Removing Main Controller PCB 1.....	333
Removing Main Controller PCB 2.....	335

Removing the Flat Control Panel Unit..... 339

Removing the Control Panel CPU PCB/LCD Unit/LED PCB..... 342

Removing the Upright Control Panel..... 348

Removing the Control Panel CPU PCB (Upright Control Panel)..... 349

Removing the LCD Unit (Upright Control Panel)..... 351

Laser Exposure System..... 355

 Removing the Laser Scanner Unit..... 355

 Cleaning the Dust Collecting Glass..... 360

Image Formation System..... 362

 Removing the Primary Charging Assembly..... 362

 Removing the Primary Charging Wire Cleaner, Cleaner Holder (Right/Left)..... 367

 Replacing the Primary Charging Assembly Grid Wire..... 369

 Replacing the Primary Charging Wire..... 375

 Cleaning the Primary Charging Assembly Grid Wire..... 379

 Removing the Pre-transfer Charging Assembly..... 380

 Removing the Pre-transfer Charging Wire Cleaner, Cleaner Holder..... 382

 Replacing the Pre-transfer Charging Wire..... 386

 Cleaning the Pre-transfer Charging Wire..... 389

 Removing the Process Unit..... 391

 Cleaning the Process Unit..... 393

 Removing the Drum Cleaning Unit..... 394

 Removing the Drum Cleaning Blade..... 396

 Cleaning the Drum Cleaning Unit..... 397

 Replacing the Pre-exposure Plastic Film..... 399

 Removing the Drum Unit..... 400

 Removing the Photosensitive Drum..... 401

 Cleaning Photosensitive Drum..... 407

 Cleaning the Drum edges..... 408

 Removing the Cleaner Separation Claw..... 409

 Removing the Side Seal..... 410

 Removing the Developing Assembly..... 411

 Cleaning the Developing Assembly..... 416

 Removing the ETB Unit..... 418

 Removing the ETB..... 422

 Cleaning the ETB..... 424

 Removing the Transfer Roller..... 425

 Removing the ETB Cleaning Blade..... 427

 Removing the ETB Brush Roller..... 428

 Removing the Waste Toner / Collecting the Waste Toner 431

 Removing the Drum Heater..... 433

 Removing the Primary Charging Shutter Unit..... 434

 Removing the Pre-transfer Charging Assembly Shutter Unit..... 437

 Removing the Patch Sensor..... 441

 Removing the Drum Brush Roller..... 443

 Removing the ETB Drive Unit..... 444

 Removing the Transfer Cleaning Unit..... 447

 Removing the Post-transfer Static Eliminator..... 448

 Removing the Toner Receptacle Tray..... 450

 Removing the Hopper Unit..... 451

 Removing the Buffer Unit..... 459

 Removing the Potential Control PCB Unit..... 464

Removing the Waste Toner Feed Unit.....	467
Removing the Drum Drive Unit.....	472
Removing the Developing Drive Unit.....	475
Fixing System.....	479
Removing the Fixing Assembly.....	479
Cleaning the Fixing Inlet Guide,Fixing Inlet Sensor Flag, Fixing Right Stay, Dowel, Dowel Holder.....	484
Cleaning the Inner Delivery Roller.....	487
Cleaning the Fixing Oil Pan.....	488
Removing the Fixing Cleaning Web.....	488
Cleaning the Fixing Roller Static Eliminator.....	493
Separating the Fixing Upper Unit from the Fixing Lower Unit.....	494
Removing the Fixing Roller, Insulating Bush and Thrust Stopper.....	497
Removing the Pressure Roller.....	500
Removing the Pressure Roller Static Eliminator.....	501
Removing the Main Thermistor.....	503
Removing the Sub Thermistor 1.....	505
Removing the Sub Thermistor 2.....	507
Removing the Upper Separation Claw.....	508
Cleaning the Upper Separation Claw.....	509
Removing the Thermoswitch 2.....	511
Pickup Feed System.....	514
Removing the Left Pickup Deck.....	514
Removing the Left Deck Pickup Roller.....	514
Removing the Left Deck Feed Roller.....	515
Removing the Right Pickup Deck.....	516
Removing the Left Deck Separation Roller/Cleaning the Left Deck Pickup Sensor (PS20).....	517
Removing the Right Deck Pickup Roller.....	518
Removing the Right Deck Feed Roller.....	519
Removing the Right Deck Separation Roller/Cleaning the Right Deck Pickup Sensor (PS19).....	520
Removing the Upper Cassette.....	522
Removing the Upper Cassette Pickup Roller.....	522
Removing the Upper Cassette Feed Roller.....	523
Removing the Upper Cassette Separation Roller/Cleaning the Cassette 3 Pickup Sensor (PS21).....	523
Removing the Lower Cassette.....	525
Removing the Lower Cassette Pickup Roller.....	525
Removing the Lower Cassette Feed Roller.....	526
Removing the Lower Cassette Separation Roller/Cleaning the Cassette 4 Pickup Sensor (PS22).....	526
Removing the Multi-purpose Tray Feed Roller.....	528
Removing the Multi-purpose Tray Separation Roller.....	529
Cleaning the Pickup and Fixing Feed Assembly.....	531
Removing the Left Deck Pickup Unit.....	543
Removing the Right Deck Pickup Unit.....	544
Removing the Cassettes 3 and 4 Pickup Unit.....	546
Removing the Vertical Path Cassette Pickup Drive Unit.....	549
Removing the Registration Unit.....	555
Removing the Left Deck Pickup Drive Unit.....	561
Removing the Main Drive Unit.....	562
Removing the Double Feed Detection Sensor(Reception/Transmission)(Option).....	571
External Auxiliary System.....	574
Removing the Filter (for primary charging).....	574
Removing the Ozone Filter.....	574

Removing the DC Controller PCB.....	575
Removing the Power Supply Assembly.....	579
Removing the Fixing Power Unit.....	581
Removing the Feed Driver PCB.....	583
Removing the CAN Transeiver PCB.....	585
Removing the Upper High Voltage Unit.....	586

6. Adjustment..... 589

Pickup Feed System.....	590
Setting the Deck.....	590
Image Position Adjustment.....	592
Skew Adjustment (at Stream Scanning of Originals).....	600
Workflow1.....	600
Workflow2.....	601
A. Paper Front Skew Correction (Leading Edge, or Both Leading Edge and Trailing Edge).....	602
B. Paper Front Skew Correction (Trailing Edge on the Operator Side).....	602
C. Paper Front Skew Correction (Trailing Edge on the Rear Side / Operator Side / Rear Side).....	603
D. Paper Pack Skew Correction (Operator Side).....	603
E. Paper Back Skew Correction (Trailing Edge on the Operator Side).....	603
F. Paper Back Skew Correction (Trailing Edge on the Rear Side / Operator Side / Rear Side).....	604
G. Edge Margin Adjustment after the Skew Adjustment (at Stream Scanning of the Originals).....	604
Adjusting the Height.....	606
Height Check Sheet Preparation or Creation.....	606
Height Adjustment.....	606
Right Angle Adjustment (Slant Adjustment).....	610
Light intensity adjustment	616
Automatic Adjustment of the Stream Reading Position (Automatic Adjustment of the Reading Position at ADF Reading).....	617
White Level Adjustment	618
Front/Back Side Difference Correction Adjustment.....	619
Automatic Front/Back Side Difference Correction Adjustment.....	619
Manual Front/Back Side Difference Correction Adjustment (Manual Back Side Position Adjustment).....	620
Parallelogram Correction.....	622
Angle Correction (Front / Back).....	623
Image Position Adjustment (at Stream Scanning of Originals).....	624
Creating the Test Charts for Image Position Adjustment.....	624
Side Registration Adjustment.....	625
Leading Edge Margin Adjustment.....	627
Magnification Ratio Adjustment.....	628
Other Adjustments.....	633
Eased Angle Guide (Opening Angle of 90 Degrees)	633
Paper Tray Width Adjustment.....	633
Adjustment of the White Plate	637
Original Feed System.....	641
ADF Scanner Unit.....	641
Pickup Roller Unit.....	641
Separation Roller.....	641
Stamp.....	641
Original Exposure System.....	642

Reader Controller PCB.....	642
Reader Scanner Unit.....	642
Copyboard Glass.....	643
Main Controller.....	644
Hard Disk.....	644
Main controller PCB 1.....	646
Main controller PCB 2.....	646
TPM PCB.....	646
FLASH PCB.....	646
Control Panel Unit.....	647
Laser Exposure System.....	649
Procedure of parts replacement.....	649
Adjustment when Replacing the Parts.....	649
Image Formation System.....	650
Primary Charging Wire.....	650
Primary Charging Assembly.....	650
Pre-transfer Charging Assembly.....	653
Pre-transfer Charging Wire.....	653
Photosensitive Drum.....	653
Drum Side Seals (Front and Rear).....	655
Developing Assembly.....	655
Potential Sensor / Potential Control PCB.....	656
ETB Unit / ETB.....	656
Patch Sensor.....	656
Waste Toner Container.....	656
Fixing System.....	658
Fixing Roller.....	658
External Auxiliary System.....	659
DC Controller PCB.....	659

7. Troubleshooting..... 660

Making Initial Checks.....	661
List of Initial Check Items.....	661
Test Print.....	662
Overview.....	662
How to View the Test Print.....	663
Solid white (TYPE=4).....	664
Halftone (TYPE=5/6/11/12/13/14).....	664
Solid black (TYPE=7).....	665
Horizontal line (TYPE=8/9/10).....	665
Image Faults.....	667
Parts Pitch Related to Periodical Image Failure	667
Image with a line on the trailing edge.....	667
Uneven density correction by 2D shading.....	668
ADF black line.....	671
Bleed-thru/Soil appeared on the back of the paper (Staple Finisher-X1/Booklet Finisher-X1).....	672
White line (foreign matter between Developing Sleeves).....	674
White line (uneven density).....	677
Separation Failure Jam due to Deformation of Separation Claw.....	677

Image error due to soil attached to the Cleaning Brushes for the Duplex Right Roller and the Duplex Outlet Roller.....	678
Uneven density.....	687
Smearred image.....	688
Adjusting the Edge Emphasis Level.....	690
Soil at interval equal to Developing Sleeve circumference.....	691
Image failure due to the temperature rising at the edge of the Fixing Roller (crepe mark).....	692
The output of the image is skewed or misaligned when scanned by ADF.....	693
Feed Faults.....	696
Paper wrinkle.....	696
Other.....	697
Adjusting rotation of the Upright Control Panel Arm.....	697
Remedy to be implemented when the ETB Disengage Member (Transfer Frame Stopper) is left unremoved.....	698
Checking nip width.....	700
ETB Displacement.....	701
Forcible stop of paper feed.....	707
Remedies to be performed when E602-xxxx or E614-xxxx error is displayed.....	709
Debug Log.....	713
Function Overview.....	713
Saving and Collecting Debug Logs.....	716
Service Mode Relating to Debug Logs.....	729
Startup System Failure Diagnosis.....	731
How to See the Startup System Failure Diagnosis.....	731
Startup Failure Analysis Policy.....	731
Flow A: Control Panel LED Check Flow.....	732
Flow B: Controller Self Diagnosis.....	734
Flow C: Power Supply Assembly Check Flow.....	734
Flow C-1: DC Power (12 V) Check Flow.....	736
Flow C-2: All-night Power Supply (5 V) Check Flow.....	738
Reference: Activation Conditions of the Control Panel Backlight.....	740
Controller Self Diagnosis.....	741
Startup Method.....	742
Diagnosis Result.....	742
Limitations.....	745

8. Error/Jam/Alarm..... 746

Outline.....	747
Error code notation.....	747
Location Code.....	747
Pickup Position Code.....	748
Pickup size.....	748
Points to Note When Clearing MN-CON	750
Points to Note When Clearing HDD.....	750
Remedies to be performed when E602-xxxx or E614-xxxx error is displayed.....	750
Error Code.....	754
Error Code Details.....	754
Error Code (FAX).....	977
How to View Fax Error Codes.....	977
User error codes.....	977

Service Error Code.....977

Limited Functions Mode..... 980

 Original Exposure System.....980

Alarm Code..... 981

 Alarm Code Details..... 981

Jam Code..... 1039

 Jam Type.....1039

 Jam screen display specification.....1040

 Main Unit..... 1040

 ADF.....1042

 UniFlow (Advanced Scanning).....1044

 Paper Deck Unit-E1.....1045

 POD Deck Lite-C1.....1046

 Multi Function Professional Puncher-B1.....1047

 Staple Finisher-W1 PRO / Booklet Finisher-W1 PRO.....1050

 Staple Finisher-AC1/Booklet Finisher-AC1.....1052

 Staple Finisher-X1/Booklet Finisher-X1.....1054

 Document Insertion Unit-N1.....1056

 Paper Folding Unit-J1.....1058

 PUNCHER UNIT-A1.....1059

 Booklet Trimmer-F1.....1060

 Jam Code Details.....1060

9. Service Mode..... 1556

Overview..... 1557

 Basic Operations.....1557

 SITUATION Mode.....1560

 Security Support.....1565

 Service Mode Backup.....1569

 Output of Service Print Data.....1569

COPIER (Service mode for printer).....1574

 DISPLAY (State display mode).....1574

 I/O.....1597

 ADJUST (Adjustment mode).....1597

 FUNCTION (Operation / inspection mode).....1635

 OPTION (Specification setting mode).....1675

 TEST (Print test mode).....1796

 COUNTER (Counter mode).....1801

FEEDER (ADF service mode).....1884

 DISPLAY (State display mode).....1884

 ADJUST (Adjustment mode).....1884

 FUNCTION (Operation / inspection mode).....1889

 OPTION (Specification setting mode).....1891

SORTER (Service mode for delivery options).....1893

 ADJUST (Adjustment mode).....1893

 FUNCTION (Operation / inspection mode).....1923

 OPTION (Specification setting mode).....1930

BOARD (Option board setting mode).....1944

 OPTION (Specification setting mode).....1944

FAX (Service Mode for FAX).....1945

Overview.....	1945
Setting of Bit Switch (SSSW).....	1948
Setting of Menu Switch (MENU).....	1959
Setting of Numeric Parameter (NUMERIC Param.).....	1960
Setting of Destination (TYPE).....	1962
Setting of Printer Functions (PRINTER).....	1963
IPFAX Setting.....	1965
Initialization of Set Value (CLEAR).....	1966
Test Mode (TEST).....	1966
Service Report (REPORT).....	1970

10. Installation..... 1974

How to Utilize This Installation Procedure.....	1976
Description on the Parts Included in the Package.....	1976
Symbols.....	1976
Checking before Installation.....	1977
Checking the Power Supply.....	1977
Checking the Installation Environment.....	1977
Points to Note at Installation Work.....	1977
Points to Note When Moving This Host Machine.....	1977
Checking Installation Space.....	1977
Table of Options Combination.....	1978
Order to Install the Host machine and the Options.....	1978
Installation of Host Machine.....	1980
Unpacking.....	1980
Checking the Contents.....	1984
Installation Procedure.....	1985
When Relocating the Machine.....	2022
Points to Note When Relocating the Host Machine.....	2022
Overview.....	2022
Works during Relocation.....	2022
Works after Relocation.....	2029
Printer Cover-H2.....	2031
Points to Note before Installation.....	2031
Checking the Contents.....	2031
Essential Items to Be Performed Before Installation.....	2031
Points to Note When Turning ON/OFF the Main Power.....	2031
Installation Outline Drawing.....	2031
Installation Procedure.....	2032
Operation Check.....	2040
Auto Adjust Gradation.....	2041
NFC Kit-E1/E2.....	2042
Points to Note before Installation.....	2042
Checking the Contents.....	2042
Essential Items to Be Performed Before Installation.....	2042
Points to Note When Turning ON/OFF the Main Power.....	2043
Installation Outline Drawing.....	2043
Installation Procedure.....	2043
Connection Kit-A2/A3 for Bluetooth LE.....	2061
Points to Note before Installation.....	2061

Checking the Contents.....2061

Essential Items to Be Performed Before Installation..... 2061

Points to Note When Turning ON/OFF the Main Power..... 2062

Installation Outline Drawing..... 2062

Installation Procedure..... 2062

Setting after Installation.....2070

Numeric Keypad-A1/A2.....2071

Points to Note before Installation..... 2071

Checking the Contents.....2071

Essential Items to Be Performed Before Installation..... 2071

Points to Note When Turning ON/OFF the Main Power..... 2071

Installation Outline Drawing..... 2071

Installation Procedure..... 2072

Reader Heater-P1.....2077

Points to Note before Installation..... 2077

Checking the Contents.....2077

Essential Items to Be Performed Before Installation..... 2077

Points to Note When Turning ON/OFF the Main Power..... 2077

Installation Outline Drawing..... 2077

Installation Procedure..... 2078

Paper Deck Heater Unit-A1.....2089

Checking the Supplied Parts..... 2089

Essential Items to Be Performed Before Installation..... 2089

Points to Note When Turning ON/OFF the Main Power..... 2089

Installation Procedure..... 2090

Utility Tray-B1.....2097

Points to Note at Installation..... 2097

Checking the Contents.....2097

Installation Outline Drawing..... 2097

Installation Procedure..... 2097

Copy Card Reader-F1.....2101

Points to Note at Installation..... 2101

Essential Items to Be Performed Before Installation..... 2101

Points to Note When Turning ON/OFF the Main Power..... 2101

Installation Outline Drawing..... 2101

Checking the Contents.....2101

Installation Procedure..... 2103

Checking after Installation..... 2110

Serial Interface Kit-K3 / Copy Control Interface Kit-A1.....2111

Points to Note at Installation..... 2111

Checking the Contents.....2111

Essential Items to Be Performed Before Installation..... 2112

Points to Note When Turning ON/OFF the Main Power..... 2112

Installation Outline Drawing..... 2112

Installation Procedure..... 2113

Voice Operation Kit-D1.....2117

Points to Note Before Installation..... 2117

Checking the Contents.....2117

Essential Items to Be Performed Before Installation..... 2118

Points to Note When Turning ON/OFF the Main Power..... 2118

Installation Outline Drawing..... 2118

Installation Procedure.....	2118
Checking after Installation.....	2124
Operation Check.....	2124
Voice Guidance Kit-G1.....	2126
Points to Note at Installation.....	2126
Checking the Contents.....	2126
Essential Items to Be Performed Before Installation.....	2127
Points to Note When Turning ON/OFF the Main Power.....	2127
Installation Outline Drawing.....	2127
Installation Procedure.....	2127
Checking after Installation.....	2132
Operation Check.....	2132
HDD-related Option.....	2133
Pre-checks.....	2133
Removing the HDD Box Unit.....	2133
[TYPE-1] Option HDD (1TB).....	2136
[TYPE-2] Standard HDD + Option HDD (250GB) + HDD Mirroring Kit.....	2139
[TYPE-3] 2 Option HDDs (1TB) + HDD Mirroring Kit.....	2145
Super G3 FAX Board-AS1.....	2153
Product Name.....	2153
Points to Note at Installation.....	2153
Essential Items to Be Performed Before Installation.....	2153
Points to Note When Turning ON/OFF the Main Power.....	2153
Installation Outline Drawing.....	2153
Checking the Contents.....	2154
Installation Procedure.....	2154
Checking the Operation.....	2157
Super G3 FAX Board-AS2.....	2159
Product Name.....	2159
Points to Note at Installation.....	2159
Essential Items to Be Performed Before Installation.....	2159
Points to Note When Turning ON/OFF the Main Power.....	2159
Installation Outline Drawing.....	2159
Checking the Contents.....	2159
Installation Procedure.....	2160
Checking the Operation.....	2162
Super G3 2nd Line Fax Board-AS1.....	2164
Product Name.....	2164
Points to Note at Installation.....	2164
Essential Items to Be Performed Before Installation.....	2164
Points to Note When Turning ON/OFF the Main Power.....	2164
Installation Outline Drawing.....	2164
Checking the Contents.....	2165
Installation Procedure.....	2166
Checking the Operation.....	2174
Super G3 2nd Line Fax Board-AS2.....	2176
Product Name.....	2176
Points to Note at Installation.....	2176
Essential Items to Be Performed Before Installation.....	2176
Points to Note When Turning ON/OFF the Main Power.....	2176
Installation Outline Drawing.....	2176

Checking the Contents.....2177
 Installation Procedure..... 2177
 Checking the Operation..... 2185
Super G3 3rd/4th Line Fax Board-AS1..... 2187
 Product Name..... 2187
 Points to Note at Installation..... 2187
 Essential Items to Be Performed Before Installation..... 2187
 Points to Note When Turning ON/OFF the Main Power..... 2187
 Installation Outline Drawing..... 2187
 Checking the Contents..... 2188
 Installation Procedure..... 2188
 Checking the Operation..... 2192
Super G3 3rd/4th Line Fax Board-AS2..... 2194
 Product Name..... 2194
 Points to Note at Installation..... 2194
 Essential Items to Be Performed Before Installation..... 2194
 Points to Note When Turning ON/OFF the Main Power..... 2194
 Installation Outline Drawing..... 2194
 Checking the Contents..... 2195
 Installation Procedure..... 2195
 Checking the Operation..... 2198

APPENDICES..... 2200

Service Tools..... 2201
 Special Tools..... 2201
 Solvent/Oil List..... 2202
 General Circuit Diagram..... 2203
 Detail of Storage partition..... 2233
 Soft counter specifications..... 2235
 Removal..... 2239
 Overview..... 2239
 Work Procedure..... 2239
 Target PCBs of Automatic Update..... 2242
 List of Service Modes That Can Be Restored..... 2243

Safety Precautions

Laser.....	2
Power Supply / Lithium Battery.....	3
Toner Safety.....	4
Notes on works.....	4

Laser

Laser Safety

Since radiation emitted inside this machine is completely confined with protective housings, external covers and interlock switches, the laser beam cannot escape from the machine during any phase of normal use by users. Therefore, this machine is classified as a Class 1 laser product under the international standard IEC60825-1 that is regarded as safe during normal use.

Handling of Laser System

This machine is classified as a Class 1 laser product. However, inside the machine, Class 3B laser beam is emitted and exposure to the beam may cause eye injuries. Therefore, when servicing on and around the Laser Assembly, be sure to turn OFF the power of the machine before starting the work. If you must service while the power is turned ON, be sure to keep the following in mind.

- Do not use a screwdriver or any tools that reflect laser light.
- Remove watches, rings and any other objects that act as reflectors before starting the work to prevent eye injuries.

The mark or the warning label is affixed to the machine's covers that confine laser beam as shown in the figure. If you must open the cover and disable the interlock switches for servicing, be sure to prevent the eye from exposure.

The following warnings are given to comply with Safety Principles (EN60950-1).

Dieses Gerät ist der Klasse 1 der Laserprodukte zugeordnet. Innerhalb des Geräts wird jedoch ein Laserstrahl der Klasse 3B ausgestrahlt, der Augenschäden verursachen kann, wenn man in diesen Strahl blickt.

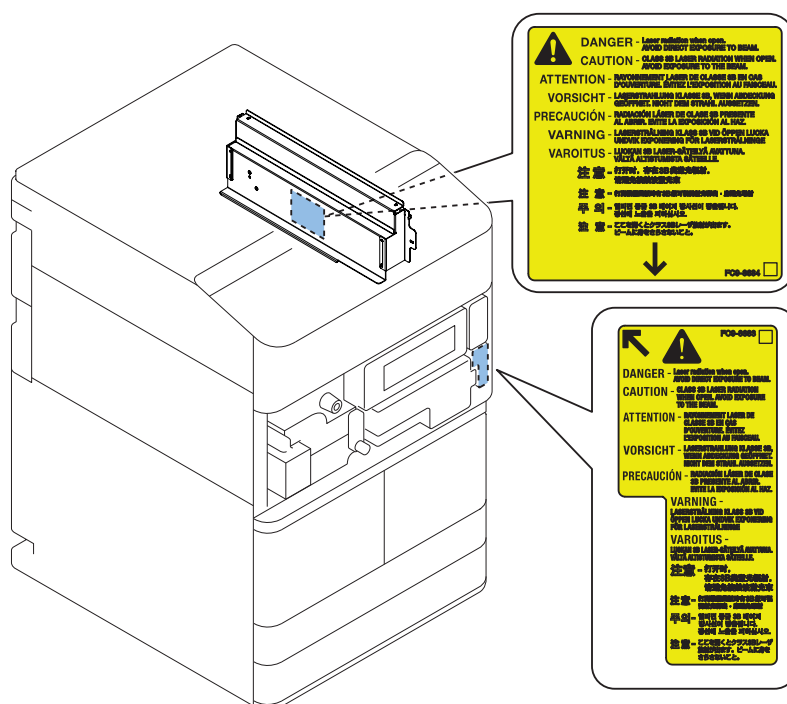
Deshalb sollte bei Servicearbeiten an oder in der Nähe der Laserbaugruppe zuerst die Stromversorgung des Geräts ausgeschaltet werden.

Bei Servicearbeiten, die unbedingt bei eingeschaltetem Gerät durchgeführt werden müssen, auf jeden Fall die folgenden Vorsichtsmaßnahmen beachten.

- Keine Schraubendreher oder ähnliche Werkzeuge verwenden, die Laserlicht reflektieren können.
- Vor Beginn der Arbeit Uhren, Ringe und ähnliche Gegenstände abnehmen, die als Reflektoren fungieren können, um Augenschäden zu verhindern.

An den Abdeckungen des Geräts, die das Austreten des Laserstrahls verhindern, ist das Kennzeichen bzw. der Warnaufkleber angebracht (siehe Abbildung).

Müssen für Servicezwecke die Abdeckung geöffnet und die Verriegelungsschalter deaktiviert werden, besondere Vorsicht walten lassen, damit der Laserstrahl nicht in die Augen gerät.



Power Supply / Lithium Battery

Turn power switch ON

The machine is equipped with 2 power switches: main power switch and control energy saver key.
The machine goes on when the main power switch is turned on (i.e., other than in low power mode, sleep mode).

CAUTION:

Do not turn off the main power switch while the progress bar is indicated, during which access is made to the Storage. If deprived of power, the Storage can suffer a fault (E602).



Power Supply

- As a general rule, do not use extension cords.
If an extension cord must be used, however, use one for local rated voltage and over, untie the cord binding, and insert the power plug completely into the extension cord outlet to ensure a firm connection between the power cord and the extension cord.

⚠ CAUTION:

Do not plug multiple cords together to an extension cord. It may cause a fire or electrical shock.

- The socket-outlet shall be installed near the equipment and shall be easily accessible.

Notes When Handling a Lithium Battery

Dispose of used batteries according to the instructions.

⚠ CAUTION:

Risk of explosion if battery is replaced by an incorrect type.

The following warnings are given to comply with Safety Principles (EN60950-1).

⚠ CAUTION:

Wenn mit dem falschen Typ ausgewechselt, besteht Explosionsgefahr.
Gebrauchte Batterien gemäß der Anleitung beseitigen.

警告

如果更換不正確之電池型式會有爆炸的風險
請依製造商說明書處理用過之電池

Toner Safety

About Toner

Toner is a nontoxic matter composed of plastic, iron and a trace of pigments.

⚠ CAUTION:

Never throw toner in flames to avoid explosion.

Handling Adhered Toner

- Use dry tissue paper to wipe off toner adhered to skin or clothes and wash in water.
- Never use warm water for cleaning up toner to prevent toner particles from being gelated to soak into fibers permanently.
- Toner particles are reactive with vinyl polymers. Avoid contacting these materials.

Notes on works

Points to Note Before Servicing

- At servicing, be sure to turn OFF the power source according to the specified steps and disconnect the power plug.
- Be sure to disconnect the power plug on a regular basis and remove dust and dirt accumulated around the outlet with dry cloth.

⚠ CAUTION:

Leaving the power plug connected for a long time in an environment having a lot of dust, moisture, or oily smoke will cause a fire. (Because dust accumulated in the surrounding area will absorb moisture and cause an insulation failure)

- Be careful not to be injured by burrs of edges, sharp corners or protrusions.

⚠ CAUTION:

Hazardous area such as corners, edges, springs and other sharp sections may be remaining on products. Always be aware of the presence of hazardous area to avoid injury caused by contacting and/or striking those area, by not over-concentrating on service work.

Points to Note at Cleaning

When performing cleaning using organic solvent such as alcohol, be sure to check that the component of solvent is vaporized completely before assembling.

Notes on Assembly/Disassembly

Follow the items below to assemble/disassemble the device.

1. Disconnect the power plug to avoid any potential dangers during assembling/disassembling works.
2. If not specially instructed, reverse the order of disassembly to reinstall.
3. Ensure to use the right screw type (length, diameter, etc.) at the right position when assembling.
4. To keep electric conduction, binding screws with washers are used to attach the grounding wire and the varistor. Ensure to use the right screw type when assembling.
5. Unless it is specially needed, do not operate the device with some parts removed.
6. Never remove the paint-locked screws when disassembling.

⚠ CAUTION:

English

CAUTION

The fuse may be in the neutral, and that the mains shall be disconnected to de-energize the phase conductors.

German

VORSICHT

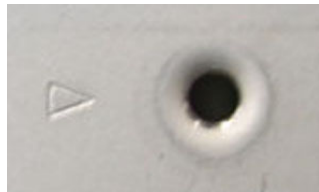
Die Sicherung kann sich im Nulleiter befinden und das Hauptnetz muss abgetrennt werden, um die Phasenleiter stromlos zu machen.

■ Points to Note when Tightening a Screw

When a thin plates is used in some parts for the light weighting purpose, warn the following.

In the case of a screw hole with a triangle mark near it as shown in the figure below, strongly tightening the screw may damage or deform the screw hole.

In the case of a screw hole with a triangle mark, take care not to apply too much force when tightening the screw.



The recommended torque value is shown below as a reference value.

		Type of Screws							
		RS tight		W Sems		Binding		TP	
Fastened member		Metal	Resin	Metal	Resin	Metal	Resin	Metal	Resin
Tightening torque (N*m)	M4	Approx. 1.6	Approx. 1.6	Approx. 1.6	Approx. 0.8	Approx. 1.6	Approx. 0.8	Approx. 1.6	Approx. 0.8
	M3	Approx. 0.8	Approx. 0.8	Approx. 0.6	Approx. 0.6	Approx. 0.6	Approx. 0.6	Approx. 0.6	Approx. 0.6

* For PCB, refer to the tightening torque value of resin (fastened member).

Type of Screws			
RS tight	W Sems	Binding	TP



Product Overview

Product Lineup.....	7
Features.....	14
Specifications.....	15
External View.....	53
Operation.....	59

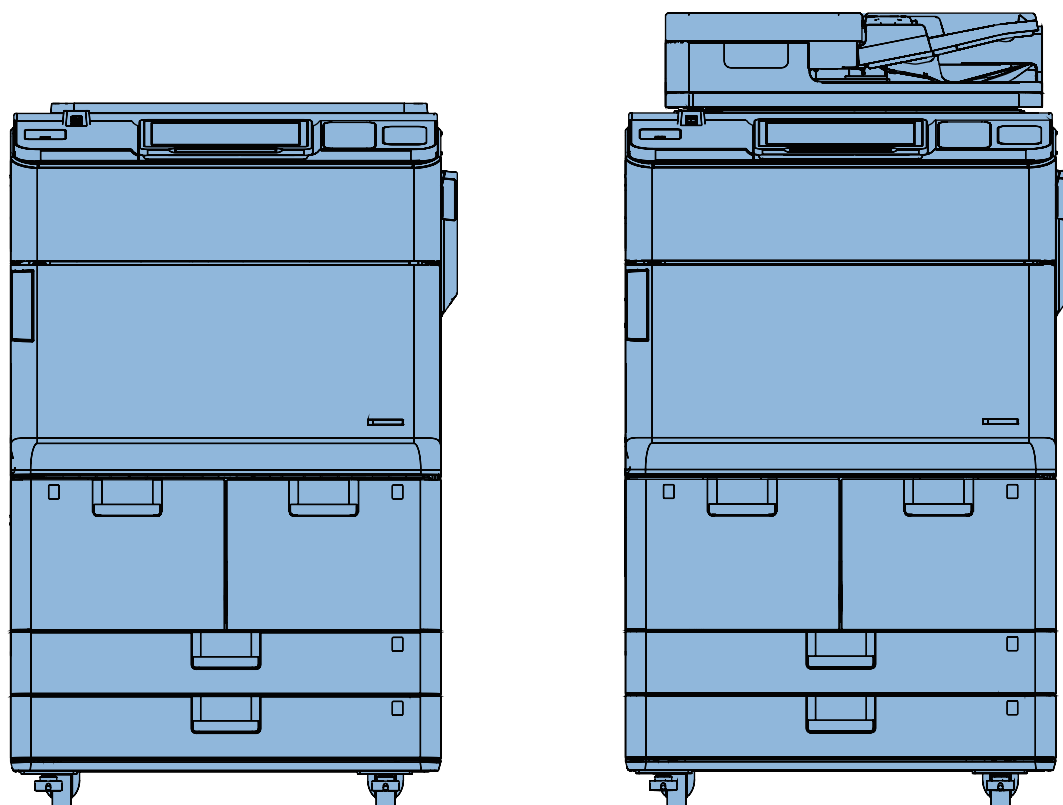
Product Lineup

Host machine

imageRUNNER ADVANCE DX 8705 / 8705B

The underlined numerical value indicates the print speed (ppm: print per minute).

"B" stands for printer model.



	imageRUNNER ADVANCE DX 8705 /8705B		
Machine Configuration	2 models: printer model, model with DADF + Reader		
Print speed*	105 ppm	95 ppm	86 ppm
Control Panel	Flat Control Panel		
HDD	Standard: 320 GB, Maximum: 1 TB		
Communication method with pickup/delivery option	Serial/CAN		Serial/CAN Serial/IPC Serial/UFDI
Pickup/ Delivery System Options	The equipment that can be connected vary according to the communication method.		

*: The speed of the host machine is determined by the license option.

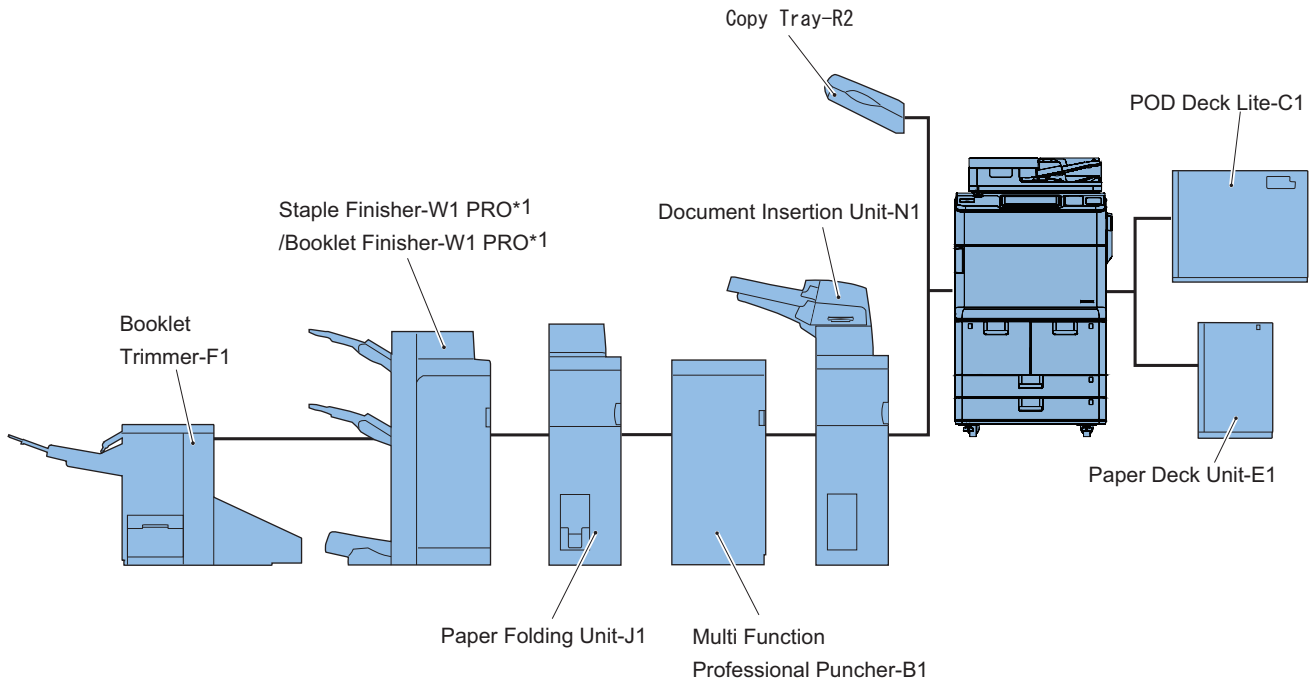
Pickup/Delivery System Option

■ Applicable Option for Each Model

There are 3 main groups of pickup and delivery options, depending on the communication I/F used.

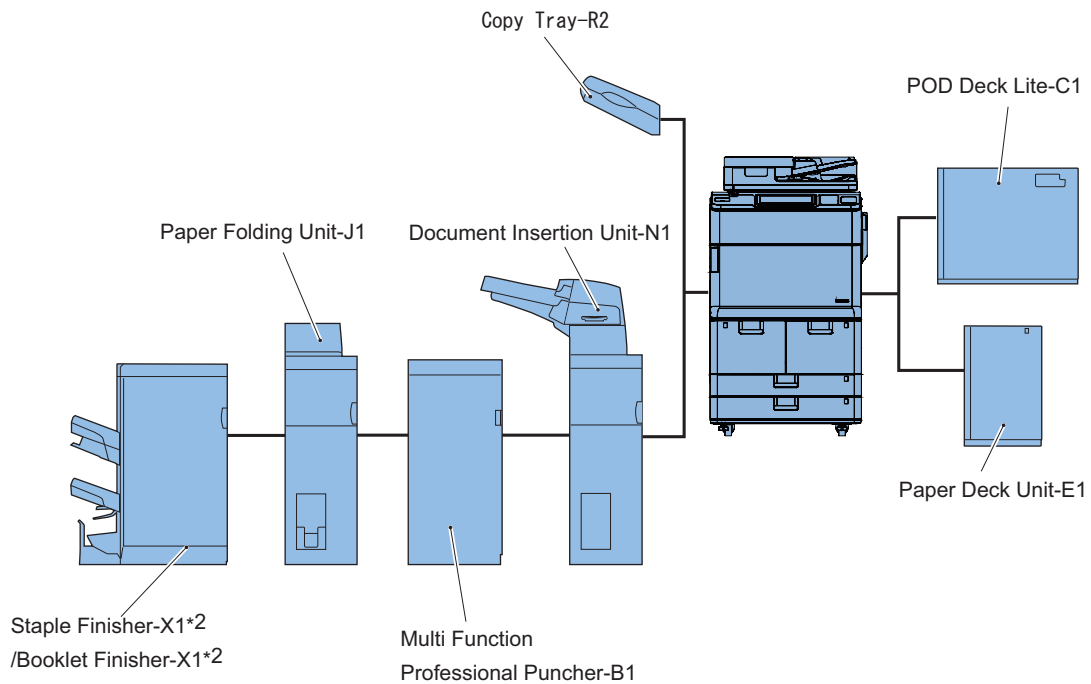
● Combination

A. imageRUNNER ADVANCE DX 8705 / 8795 / 8786 CAN communication option



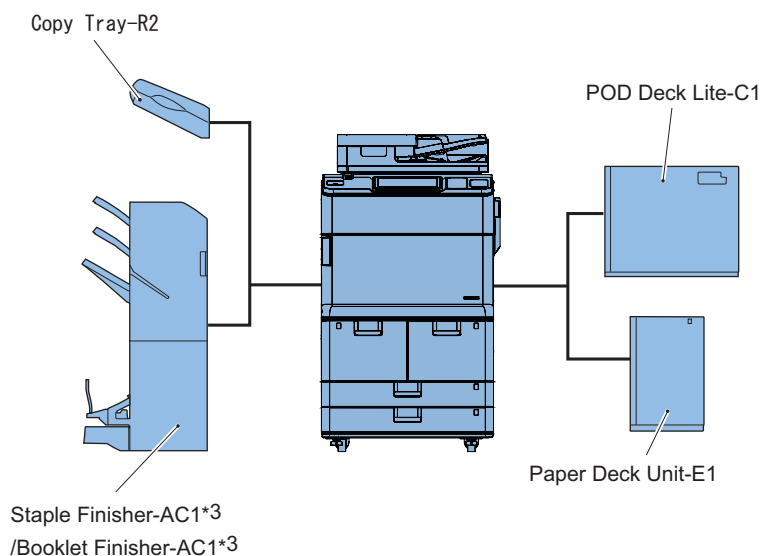
*1: Puncher Unit-BT1 is available as an option.

B. imageRUNNER ADVANCE DX 8705 / 8795 / 8786 IPC communication option



*2: Puncher Unit-BE1 and Inner Booklet Trimmer-A1 are available as an option.

C. imageRUNNER ADVANCE DX 8786 UFDI communication option



*3: 2/3, 2/4, 4 Hole Puncher Unit-A1 are available as an option.

■ Required Options/Conditions for the Pickup/Delivery System

Pickup System Required Options/Conditions

Pickup System Required Options/Conditions

Product name	Required options, conditions, etc.
Paper Deck Unit-E1	Using with POD Deck Lite-C1 is not available. Pickup method: Retard method Pickup capacity: 3,500 sheets (80 g/m ²) Paper type: Thin paper, plain paper, heavy paper, color paper, recycled paper, bond paper, pre-punched paper, letterhead Paper size: A4, B5, LTR Paper weight: 52 to 256 g/m ² Double feed detection: Not available
POD Deck Lite-C1	Using with Paper Deck Unit-E1 is not available. Pickup method: Air separation method Pickup capacity: 3,500 sheets (80 g/m ²) Paper type: Thin paper, plain paper, heavy paper, color paper, recycled paper, pre-punched paper, transparency, labels, tab paper, bond paper, letterhead, postcard Paper size: 13"x19" to A5R Paper weight: 52 to 256 g/m ² Double feed detection: Not available
Tab Feeding Attachment Kit-B1	
Cassette Heater Unit-38	For cassette of main body
Paper Deck Heater Unit-A1	Option for Paper Deck Unit-E1

Delivery System Required Options/Conditions

Delivery System Required Options/Conditions

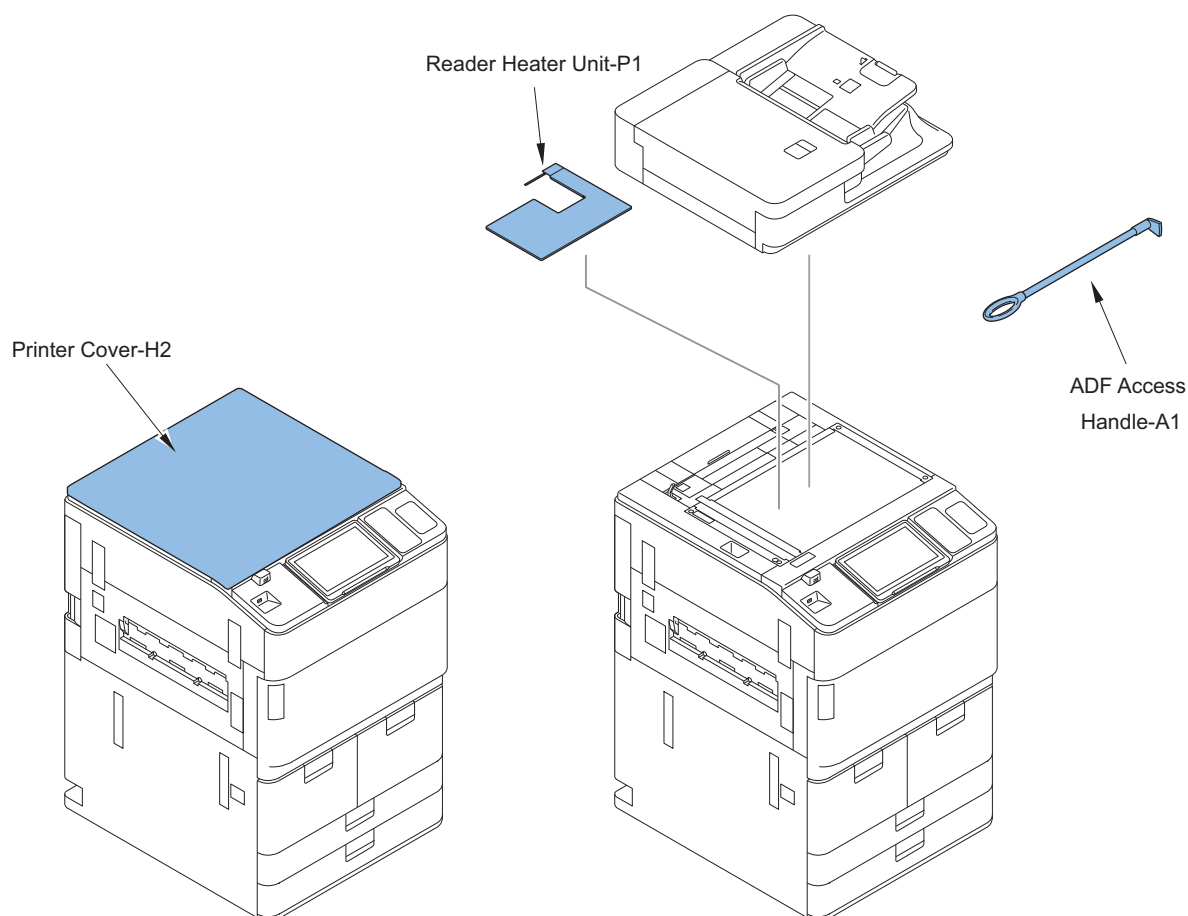
Product name	Required options, conditions, etc.
Copy Tray-R2	Using with delivery-related options is not available. Paper size: Paper available for the host machine Paper weight: 52 to 256 g/m ² Tray capacity: 250 sheets (64 g/m ²)
Document Insertion Unit-N1	Staple Finisher/Booklet Finisher is required at the downstream side. Pickup capacity: Max. 400 sheets (200 sheets each for Upper Tray and Lower Tray (80 g/m ²)) Paper type: Thin paper, plain paper, heavy paper, color paper, recycled paper, pre-punched paper, tab paper, bond paper, letterhead, coated paper Paper size: B5 to 13" x 19" Paper weight: 52 to 256 g/m ²

Product name	Required options, conditions, etc.
Paper Folding Unit-J1	Staple Finisher/Booklet Finisher is required at the downstream side. Folding type: Z-Fold, C-Fold, Half-Fold, Accordion Z-Fold, Double Parallel Fold Paper size: A4R, LTRR (Z-Fold: A3, B4, A4R, LTRR, LGL, 11" x 17") Paper type: Thin paper, plain paper, color paper, recycled paper, bond paper Paper weight: 52 to 105 g/m ² (Double Parallel Fold: 52 to 90 g/m ²)
Multi Function Professional Puncher-B1	Staple Finisher/Booklet Finisher is required at the downstream side.
Staple Finisher-W1 PRO	Using with Booklet Finisher-W1 PRO is not available. Paper weight: 52 to 300 g/m ² Maximum stacking capacity: 5,000 sheets (A4, B5, LTR) The number of sheets to be stitched: Staple: 100 sheets (A4, B5, LTR)
Booklet Finisher-W1 PRO	Using with Staple Finisher-W1 PRO is not available. Paper weight: 52 to 300 g/m ² Maximum stacking capacity: 5,000 sheets (A4, B5, LTR) The number of sheets to be stitched: Staple: 100 sheets (A4, B5, LTR) Saddle Stitch: 25 sheets
Staple Finisher-X1	Using with Booklet Finisher-X1 is not available. Paper weight: 52 to 256 g/m ² Maximum stacking capacity: 4,250 sheets (A4, B5, LTR) The number of sheets to be stitched: Staple: 100 sheets (A4, B5, LTR)
Booklet Finisher-X1	Using with Staple Finisher-X1 is not available. Paper weight: 52 to 256 g/m ² Maximum stacking capacity: 4,250 sheets (A4, B5, LTR) The number of sheets to be stitched: Staple: 100 sheets (A4, B5, LTR) Saddle Stitch: 20 sheets/5 sets (81.4g/m ²)
Staple Finisher-AC1	Using with Booklet Finisher-AC1 is not available. Paper weight: 52 to 256 g/m ² Maximum stacking capacity: 3,500 sheets (A4, B5, LTR) The number of sheets to be stitched: Staple: 65 sheets (A4, B5, LTR) Staple-Free Stapling: 4 sheets (81.4 g/m ²) Manual Staple: 65 sheets (90 g/m ²)
Booklet Finisher-AC1	Using with Staple Finisher-AC1 is not available. Paper weight: 52 to 256 g/m ² Maximum stacking capacity: 3,500 sheets (A4, B5, LTR) The number of sheets to be stitched: Staple: 65 sheets (A4, B5, LTR) Staple-Free Stapling: 4 sheets (81.4 g/m ²) Manual Staple: 65 sheets (90 g/m ²) Saddle Stitch: 20 sheets/10 sets (81.4 g/m ²)
Finisher Jogger Kit-A1	Booklet Finisher-AC1/Staple Finisher-AC1 options
Inner Booklet Trimmer-A1	Booklet Finisher-X1/Staple Finisher-X1 options Paper size: 13" x 19.2" (330.2 x 487.7 mm) to B5 Paper weight: 60 to 256 g/m ²
Puncher Unit-BF1/BG1/BH1	Booklet Finisher-X1/Staple Finisher-X1 options BF1: 2/3 holes BG1: 2/4 holes BH1: 4 holes Paper weight: 52 to 256 g/m ²
Puncher Unit-BS1/BT1/BU1	Booklet Finisher-W1 PRO/Staple Finisher-W1 PRO options BS1: 2/ 3 holes BT1: 2/ 4 holes BU1: 4 holes Paper weight: 52 to 256 g/m ²
2/3, 2/4, 4 Hole Puncher Unit-A1	Booklet Finisher-AC1/Staple Finisher-AC1 options Paper weight: 52 to 256 g/m ²

Product name	Required options, conditions, etc.
Loose Leaf 3-Hole Punch A4/LTR-B1	Multi Function Professional Puncher-B1 options
Loose Leaf 5-Hole Punch LTR-B1	Multi Function Professional Puncher-B1 options
Velo Bind 11-Hole Punch LTR-B1	Multi Function Professional Puncher-B1 options
Plastic Comb 19-Hole Punch LTR-B1	Multi Function Professional Puncher-B1 options
Twin Loop 21-Hole Punch LTR-B1	Multi Function Professional Puncher-B1 options
Twin Loop 32-Hole Punch LTR-B1	Multi Function Professional Puncher-B1 options
Color Coil 44-Hole Punch LTR-B1	Multi Function Professional Puncher-B1 options
Loose Leaf 2/4-Hole(8.0mm) Punch A4-B1	Multi Function Professional Puncher-B1 options
Loose Leaf 2/4-Hole(6.5mm) Punch A4-B1	Multi Function Professional Puncher-B1 options
Plastic Comb 21-Hole Punch A4-B1	Multi Function Professional Puncher-B1 options
Twin Loop 23/21-Hole(Round) Punch A4/LTR-B1	Multi Function Professional Puncher-B1 options
Twin Loop 34/32-Hole(Round) Punch A4/LTR-B1	Multi Function Professional Puncher-B1 options
Twin Loop 23-Hole(Square) Punch A4-B1	Multi Function Professional Puncher-B1 options
Twin Loop 34-Hole(Square) Punch A4-B1	Multi Function Professional Puncher-B1 options
Color Coil 47-Hole Punch A4-B1	Multi Function Professional Puncher-B1 options
High Durability Color Coil 44-Hole Punch LTR-B1	Multi Function Professional Puncher-B1 options
High Durability Loose Leaf 3-Hole Punch LTR-B1	Multi Function Professional Puncher-B1 options
High Durability Plastic Comb 19-Hole Punch LTR-B1	Multi Function Professional Puncher-B1 options
Velo Bind 12-Hole Punch A4-B1	Multi Function Professional Puncher-B1 options
Loose Leaf 4-Hole Punch A4/LTR-B1	Multi Function Professional Puncher-B1 options
MF Professional Puncher Attachment Kit-A1	Multi Function Professional Puncher-B1 options
Staple-N1	Plain Staple Cartridge Option for Booklet Finisher-W1 PRO/X1 and Staple Finisher-W1 PRO/X1
Staple-P1	Saddle Staple Cartridge Option for Booklet Finisher-W1 PRO/X1
Staple Cartridge-X1	Plain Staple Cartridge Option for Booklet Finisher-AC1/Staple Finisher-AC1
Staple Cartridge-Y1	Saddle Staple Cartridge Option for Booklet Finisher-AC1
Booklet Trimmer-F1	Upstream requires Booklet Finisher-W1 PRO
Inserter Option controller Kit-A1	To connect the Document Insertion Unit and Staple Finisher-W1/ Booklet Finisher-W1, the Inserter Option Controller Kit is necessary.

Scanning System Options

Required Options and Conditions



Product name	Required options, conditions, etc.
Reader Heater Unit-P1	Option for Reader Unit
ADF Access Handle-A1	It is the handle to support opening and closing the Feeder.
Printer Cover-H2	It is the cover to be installed at the top of the host machine when using this equipment as a printer model.

Function Expansion System Options

Required options/conditions for hardware products

Product name	Required options, conditions, etc.
Numeric Keypad-A1	No particular options and conditions are required.
Upright Control Panel-J1	No particular options and conditions are required.
NFC Kit-E1	No particular options and conditions are required.
Double Feeding Detection Kit-B1	No particular options and conditions are required.
Utility Tray-B1	Using with Voice Guidance Kit-G1 and Voice Operation Kit-D1 is not available.
Copy Card Reader-F1	Copy Card Reader Attachment-A4 is required. Using with Serial Interface Kit-K3 and Copy Control Interface Kit-A1 is not available.
Copy Card Reader Attachment-A4	Required when Copy Card Reader-F1 is installed.
Card Set-A1 to A6	Copy Card Reader-F1 is required.
Super G3 FAX Board-AS1/AS2	No particular options and conditions are required.
Super G3 2nd Line Fax Board-AS1/AS2	Super G3 FAX Board-AS1/AS2 is required.

Product name	Required options, conditions, etc.
Super G3 3rd/4th Line Fax Board-AS1/AS2	Super G3 FAX Board-AS1/AS2 and Super G3 2nd Line Fax Board-AS1/AS2 is required.
imagePASS-Y3 V1.1	No particular options and conditions are required.
Voice Guidance Kit-G1	Using with Utility Tray-B1 and Voice Operation Kit-D1 is not available.
Voice Operation Kit-D1	Using with Utility Tray-B1 and Voice Guidance Kit-G1 is not available.
Serial Interface Kit-K3	Required when the coin manager is connected. Using with Copy Card Reader-F1 and Copy Control Interface Kit-A1 is not available.
Copy Control Interface Kit-A1	Required when the coin manager is connected. Using with Copy Card Reader-F1 and Serial Interface Kit-K3 is not available.
2.5inch/250GB HDD-N1	This is used when the mirroring function is used with HDD Mirroring Kit-J1.
2.5inch/1TB HDD-P1	This is used when the mirroring function is used with HDD Mirroring Kit-J1.
HDD Mirroring Kit-J1	When performing mirroring, either the Option HDD-N1 (250 GB) or the Option HDD-P1 (1 TB) is required.
Removable HDD Kit-B6	
Connection Kit-A2 for Bluetooth LE	
Power Supply Cable-U1	No particular options and conditions are required.

Required options/conditions for licensed products

At the time of installation, obtain the license number according to the license certificate included and then enter the obtained license number from the Control Panel of the machine. The applicable functions are now enabled.

There is no physical installation work at the time of installation.

Product name	Required options, conditions, etc.
Remote Fax Kit-A1	No particular options and conditions are required.
IP FAX Expansion Kit-B1	Using with Super G3 2nd Line Fax Board-AS1 or Super G3 3rd/4th Line Fax Board-AS1 is not available.
PCL Printer Kit-BD1	No particular options and conditions are required.
PCL International Font Set-A1	No particular options and conditions are required.
PCL Asian Font Set-A1	No particular options and conditions are required.
PCL Printer Kit-CK1	No particular options and conditions are required.
PS Printer Kit-BD1	No particular options and conditions are required.
PS Printer Kit-CK1	No particular options and conditions are required.
Barcode Printing Kit-D1	No particular options and conditions are required.
Universal Send Trace & Smooth PDF Kit-A1	No particular options and conditions are required.
Picture Login-A1	No particular options and conditions are required.
Fiery Compose	No particular options and conditions are required.
Fiery Impose	No particular options and conditions are required.
Fiery Impose and Compose	No particular options and conditions are required.
Fiery imageViewer	No particular options and conditions are required.
iR-ADV Security Kit-AG1 for IEEE 2600 Common Criteria Certification	No particular options and conditions are required.
imageRUNNER ADVANCE 8505 License	Speed License option
imageRUNNER ADVANCE 8595 License	Speed License option
imageRUNNER ADVANCE 8586 License	Speed License option

Features

Product Features

- Hardware keys were changed to software keys for the compact Control Panel with shortened eye-movement distances
- Internal installation of IC Card Reader
- Placement of hardware switches for servicing at the backside of Control Panel
- Feeder with the easy-operable design and newly implemented functions
- Improved image quality adjustment functions
- Improved productivity

Specifications

Product Specifications

Item	Description
Machine installation method	Reader/Printer separated type, console type
Photosensitive medium	84 mm diameter amorphous silicon drum
Exposure method	Laser exposure method
Charging method	Grid charging method
Developing method	Dry, 1-component toner projection
Transfer method	Transfer Roller method
Separation method	Transfer Belt
Pickup method	Right/Left Deck: Separation retard method Cassette 3/4: Separation retard method Multi-purpose Tray: Simple retard method
Cleaning method	Drum: Cleaning Blade ETB: Cleaning Blade + Brush Roller
Fixing method	Heat Roller method
Delivery method	Face-up/Face-down
Toner type	Magnetic negative toner
Toner supply method	Set-on
Toner level detection function	Available
Leading edge image margin	2.5 mm +1.5/-0.5 mm
Left image margin	2.5 mm +/- 1.5 mm
Warm-up time	After Powering ON: 60 sec. or less Returning from the Sleep mode: 60 sec. or less
First copy time	2.7 sec. or less
Image gradations	256 gradations
Print resolution	Max. 1,200 dpi x 1,200 dpi
Maximum image guaranteed area	305.0 x 482.7 mm
Maximum printable area	310.0 x 625.0 mm
Paper Type/Size	"Paper Type" on page 19: Reference
Pickup capacity	Right/Left Deck: 1,500 sheets each (80 g/m ²) Cassette 3/4: 550 sheets each (80 g/m ²) Multi-purpose Tray: 100 sheets (80 g/m ²)
Duplex method	Through path
Memory capacity	For Main Controller 1: Capacity of 2 GB (for controller control) + 1 GB (for image processing)
HDD capacity	Standard: 320 GB, Maximum: 1 TB
Environment temperature/Humidity/Atmosphere range	"10. Installation" on page 1974: Reference
Operation noise	At printing: imageRUNNER ADVANCE DX 8705: 77.9 dB or less imageRUNNER ADVANCE DX 8795: 77.3 dB or less imageRUNNER ADVANCE DX 8786: 75.0 dB or less
Rated power supply	"Power Supply Specifications" on page 16: Reference

Item	Description
Maximum power consumption	120V <ul style="list-style-type: none"> At the time of printing: 2.0 kW or less During sleep mode: 0.9 W or less At main power-off: <ul style="list-style-type: none"> When Quick Startup Settings for Main Power is set to On: 0.5 W or less When Quick Startup Settings for Main Power is set to Off: 0.5 W or less 230V <ul style="list-style-type: none"> At the time of printing: 2.4 kW or less During sleep mode: 0.9 W or less At main power-off: <ul style="list-style-type: none"> When Quick Startup Settings for Main Power is set to On: 0.5 W or less When Quick Startup Settings for Main Power is set to Off: 0.5 W or less
Dimensions/Weight	"Weight and Size" on page 17: Reference

Fax Specifications

Item	Contents
Telephone Line Used *1	Public Switched Telephone Network (PSTN)
Scan Line Density	Normal G3: 8 pels ² / mm x 3.85 line / mm Fine G3: 8 pels ² / mm x 7.7 line / mm Super-Fine G3: 8 pels ² / mm x 15.4 line / mm Ultra-Fine G3: 16 pels ² / mm x 15.4 line / mm
Transmission Speed	Super G3 : 33.6 kbps, G3 : 14.4 kbps
Compression Method	MH, MR, MMR, JBIG
Transmission Type	SuperG3, G3
Sending Original Sizes	<ul style="list-style-type: none"> AB configuration: A3, B4, A4, A4R, B5^{*2}, B5R^{*3}, A5^{*3}, A5R^{*3} Inch configuration: 11" x 17", LGL, LTR, LTRR, STMTR
Receiving Paper Sizes	<ul style="list-style-type: none"> AB configuration: A3, B4, A4, A4R, B5, B5R, A5R Inch configuration: 11" x 17", LGL, LTR, LTRR, STMTR Other: K8, K16
No. of Memory RX Jobs	Up to 320 jobs
Transmission Times	Approximately 2.6 seconds (When sending LTR Canon original paper, Normal 8 pels x 3.85 line/mm ECM (JBIG))

*1 When using an IP telephone service, facsimile communication may not be performed normally via an IP telephone line. It is recommended to use facsimile communication via a general telephone (Public Switched Telephone Network) line.

*2 Pels stands for picture elements (pixels).

*3 Sent as A4.

Power Supply Specifications

Product name	Power supply source (number of cables)	Japan		North America		EUR		Asia		Aus	
		V(V)	I(A)	V(V)	I(A)	V(V)	I(A)	V(V)	I(A)	V(V)	I(A)
imageRUNNER AD-VANCE DX 8705 / 8705B	Power outlet (1)	100	20	110 - 127	16	220 - 240	10	220 - 240	10	220 - 240	10
Paper Deck Unit-E1	Host machine	-	-	-	-	-	-	-	-	-	-
POD Deck Lite-C1	Power outlet (1)	100	2.4	120 - 127	2.2	220 - 240	1.2	220 - 240	1.2	220 - 240	1.2
Document Insertion Unit-N1	Power outlet (1)	100 - 240	1.0	100 - 240	1.0	100 - 240	1.0	100 - 240	1.0	100 - 240	1.0
Paper Folding Unit-J1	Finisher	-	-	-	-	-	-	-	-	-	-
Booklet Finisher-W1	Power outlet (1)	100	10	120 - 127	8	220 - 240	8	220 - 240	8	220 - 240	8
Staple Finisher-W1 PRO	Power outlet (1)	100	10	120 - 127	8	220 - 240	8	220 - 240	8	220 - 240	8

Product name	Power supply source (number of cables)	Japan		North America		EUR		Asia		Aus	
		V(V)	I(A)	V(V)	I(A)	V(V)	I(A)	V(V)	I(A)	V(V)	I(A)
Staple Finisher-X1	Power outlet (1)	100 - 240	2.8	100 - 240	2.8	100 - 240	2.8	100 - 240	2.8	100 - 240	2.8
Booklet Finisher-X1	Power outlet (1)	100 - 240	2.8	100 - 240	2.8	100 - 240	2.8	100 - 240	2.8	100 - 240	2.8
Staple Finisher-AC1	Host machine	-	-	-	-	-	-	-	-	-	-
Booklet Finisher-AC1	Host machine	-	-	-	-	-	-	-	-	-	-
Inner Trimmer-A1	Finisher	-	-	-	-	-	-	-	-	-	-
Puncher Unit-BE1	Finisher	-	-	-	-	-	-	-	-	-	-
Puncher Unit-BT1	Finisher	-	-	-	-	-	-	-	-	-	-
2/4 Hole Puncher Unit-A1	Finisher	-	-	-	-	-	-	-	-	-	-
Booklet Trimmer-F1	Booklet Finisher-W1	-	-	-	-	-	-	-	-	-	-

Weight and Size

Product name		Width (mm)	Depth (mm)	Height (mm)	Weight (kg)
imageRUNNER ADVANCE DX 8705	Without the Upright Control Panel	670	770	1,185	221
	With the Upright Control Panel	1,195	770	1,252	225
imageRUNNER ADVANCE DX 8705B	Without the Upright Control Panel	670	770	1,075	201
	With the Upright Control Panel	1,195	770	1,252	205
Copy Tray-R2		420	382	175	1.1
Paper Deck Unit-E1		363	630	572	34
POD Deck Lite-C1		656	686	574	68
Document Insertion Unit-N1		746	793	1,407	61
Paper Folding Unit-J1		336	793	1,190	71
Booklet Finisher-W1		800	792	1,239	180
Staple Finisher-W1 PRO		800	792	1,239	130
Staple Finisher-X1		654	765	1,040	64
Booklet Finisher-X1		767	765	1,040	110
Staple Finisher-AC1		527	623	1,195	36
Booklet Finisher-AC1		527	623	1,195	60
Inner Trimmer-A1		251	625	403	32
Booklet Trimmer-F1		1933	790	1,040	178
Multi Function Professional Puncher-B1		445	795	1,040	102

Productivity

■ imageRUNNER ADVANCE DX 8705

Unit: images / min.

Paper type	Size	Cassette/Host machine deck		MP Tray		Paper Deck	
		1-sided	2-sided	1-sided	2-sided	1-sided	2-sided
Plain paper	B5/A4/A5R/LTR/STMT/16K	105	105	80	80	105	105
Thin paper							
Recycled paper (52 to 90 g/m2)	A5/A6R	-	-	80	-	-	-
	B5R	88	88	67	67	81	81
	LTRR	81	81	61	61	81	81

Paper type	Size	Cassette/Host machine deck		MP Tray		Paper Deck	
		1-sided	2-sided	1-sided	2-sided	1-sided	2-sided
Plain paper Thin paper Recycled paper (52 to 90 g/m ²)	A4R	76	76	58	58	76	76
	LGL	63	61	48	48	63	61
	B4	62	59	47	47	62	59
	A3	54	54	41	41	54	54
	11 x 17	53	53	40	40	53	53
	SRA3	50	50	38	38	50	50
	12 x 18	49	49	37	37	49	49
	13x19	47	47	35	35	47	47
Heavy paper (91 to 256g/m ²)	B5/A4/A5R/LT R/STMTR/16K	105	105	80	80	105	105
	A5/A6R	-	-	80	-	-	-
	B5R	88	88	67	67	81	88
	LTRR	81	81	61	61	81	81
	A4R	76	76	58	58	76	76
	LGL	63	61	48	48	63	61
	B4	62	59	47	47	62	59
	A3	54	54	41	41	54	54
	11 x 17	53	53	40	40	53	53
	SRA3	50	50	38	38	50	50
	12 x 18	49	49	37	37	49	49
	13x19	47	47	35	35	47	47

■ imageRUNNER ADVANCE DX 8795

Unit: images / min.

Paper type	Size	Cassette/Host machine deck		MP Tray		Paper Deck	
		1-sided	2-sided	1-sided	2-sided	1-sided	2-sided
Plain paper Thin paper Recycled paper (52 to 90 g/m ²)	B5/A4/A5R/LT R/STMTR/16K	95	95	80	80	95	95
	A5/A6R	-	-	80	-	-	-
	B5R	79	79	67	67	73	73
	LTRR	73	73	61	61	73	73
	A4R	69	69	58	58	69	69
	LGL	60	60	48	48	60	60
	B4	59	59	47	47	59	59
	A3	50	50	41	41	50	50
	11 x 17	49	49	40	40	49	49
	SRA3	45	45	38	38	45	45
	12 x 18	44	44	37	37	44	44
	13 x 19	42	42	35	35	42	42
Heavy paper (91 to 256g/m ²)	B5/A4/A5R/LT R/STMTR/16K	95	95	80	80	95	95
	A5/A6R	-	-	80	-	-	-
	B5R	79	79	67	67	73	73
	LTRR	73	73	61	61	73	73
	A4R	69	69	58	58	69	69
	LGL	60	60	48	48	60	60
	B4	59	59	47	47	59	59
	A3	50	50	41	41	50	50
	11 x 17	49	49	40	40	49	49
	SRA3	45	45	38	38	45	45
	12 x 18	44	44	37	37	44	44
	13 x 19	42	42	35	35	42	42

■ imageRUNNER ADVANCE DX 8786

Unit: images / min.

Paper type	Size	Cassette/Host machine deck		MP Tray		Paper Deck	
		1-sided	2-sided	1-sided	2-sided	1-sided	2-sided
Plain paper Thin paper Recycled paper (52 to 90 g/m ²)	B5/A4/A5R/LTR/STMTR/16K	86	86	80	80	86	86
	A5/A6R	-	-	80	-	-	-
	B5R	73	73	67	67	73	73
	LTRR	67	67	61	61	67	67
	A4R	63	63	58	58	63	63
	LGL	57	57	48	48	57	57
	B4	56	56	47	47	56	56
	A3	44	44	41	41	44	44
	11 x 17	43	43	40	40	43	43
	SRA3	40	40	38	38	40	40
	12×18	40	40	37	37	40	40
	13×19	38	38	35	35	38	38
	Heavy paper (91 to 256g/m ²)	B5/A4/A5R/LTR/STMTR/16K	86	86	80	80	86
A5/A6R		-	-	80	-	-	-
B5R		73	73	67	67	73	73
LTRR		67	67	61	61	67	67
A4R		63	63	58	58	63	63
LGL		57	57	48	48	57	57
B4		56	56	47	47	56	56
A3		44	44	41	41	44	44
11 x 17		43	43	40	40	43	43
SRA3		40	40	38	38	40	40
12 x 18		40	40	37	37	40	40
13 x 19		38	38	35	35	38	38

Paper Type

The types of usable papers are shown below.

Paper Types per Pickup Position

Type	Size	Feeding direction (mm)	Width direction (mm)	Pickup position							
				Multi-purpose Tray	Cassette 3	Cassette 4	Right Deck	Left Deck	Paper Deck	POD Deck Lite	Insertion Unit
Thin 1 Thin 2	A3	420	297	Yes	Yes	Yes	No	No	No	Yes	Yes
	B4	364	257	Yes	Yes	Yes	No	No	No	Yes	Yes
	A4R	297	210	Yes	Yes	Yes	No	No	No	Yes	Yes
	A4	210	297	Yes	Yes	Yes	Yes	Yes	Yes	Yes	Yes
	B5R	257	182	Yes	Yes	Yes	No	No	No	Yes	Yes
	B5	182	257	Yes	Yes	Yes	Yes	Yes	Yes	Yes	Yes
	A5	148	210	Yes	No	No	No	No	No	No	No
	A5R	210	148	Yes	Yes	Yes	No	No	No	Yes	No
	A6R	148	105	Yes	No	No	No	No	No	No	No
	11 x 17	431.8	279.4	Yes	Yes	Yes	No	No	No	Yes	Yes
	LGL	355.6	215.9	Yes	Yes	Yes	No	No	No	Yes	Yes
	LTR	215.9	279.4	Yes	Yes	Yes	Yes	Yes	Yes	Yes	Yes
	LTRR	279.4	215.9	Yes	Yes	Yes	No	No	No	Yes	Yes
	STMTR	215.9	139.7	Yes	Yes	Yes	No	No	No	Yes	No

Type	Size	Feeding direction (mm)	Width direction (mm)	Pickup position							
				Multi-purpose Tray	Cassette 3	Cassette 4	Right Deck	Left Deck	Paper Deck	POD Deck Lite	Insertion Unit
Thin 1	SRA3	450	320	Yes	Yes	Yes	No	No	No	Yes	Yes
Thin 2	12 x 18	457.2	304.8	Yes	Yes	Yes	No	No	No	Yes	Yes
	EXEC	184.1	266.7	Yes	Yes	Yes	No	No	No	Yes	Yes
	OFICIO	317.5	215.9	Yes	Yes	Yes	No	No	No	Yes	No
	E-OFI-CIO	320	220	Yes	Yes	Yes	No	No	No	Yes	No
	B-OFI-CIO	355	216	Yes	Yes	Yes	No	No	No	Yes	No
	M-OFI-CIO	341	216	Yes	Yes	Yes	No	No	No	Yes	No
	A-OFI-CIO	340	220	Yes	Yes	Yes	No	No	No	Yes	No
	A-LTR	220	280	Yes	Yes	Yes	No	No	No	Yes	No
	A-LTRR	280	220	Yes	Yes	Yes	No	No	No	Yes	No
	GLTR-R	266.7	203.2	Yes	Yes	Yes	No	No	No	Yes	No
	GLTR	203.2	266.7	Yes	Yes	Yes	No	No	No	Yes	No
	GLGL	330.2	203.2	Yes	Yes	Yes	No	No	No	Yes	No
	AFLS	337	206	Yes	Yes	Yes	No	No	No	Yes	No
	FLS	330.2	215.9	Yes	Yes	Yes	No	No	No	Yes	No
	13 x 19	482.6	330.2	Yes	Yes	Yes	No	No	No	Yes	Yes
	K8	390	270	Yes	Yes	Yes	No	No	No	Yes	Yes
	K16	195	270	Yes	Yes	Yes	No	No	No	Yes	Yes
	K16R	270	195	Yes	Yes	Yes	No	No	No	Yes	No
	F4A	342.9	215.9	Yes	Yes	Yes	No	No	No	Yes	No
	I-LGL	345	215	Yes	Yes	Yes	No	No	No	Yes	No
	Free	182 to 487.7	100 to 330.2	Yes	No	No	No	No	No	No	No
	Free (Long length)	487.8 to 630	100 to 330.2	Yes *1	No	No	No	No	No	No	No
	Custom size 0-1	148 to 181.9	100 to 139.6	Yes	No	No	No	No	No	No	No
	Custom size 0-2	148 to 181.9	139.7 to 330.2	Yes	No	No	No	No	No	No	No
	Custom size 0-3	182 to 487.7	100 to 139.6	Yes	No	No	No	No	No	No	No
	Custom size 1-1	182 to 209.9	139.7 to 181.9	Yes	Yes	Yes	No	No	No	Yes	No
	Custom size 1-2	210 to 279.3	139.7 to 181.9	Yes	Yes	Yes	No	No	No	Yes	No
	Custom size 1-3	279.4 to 431.8	139.7 to 181.9	Yes	Yes	Yes	No	No	No	Yes	No
	Custom size 1-4	431.9 to 457.2	139.7 to 181.9	Yes	Yes	Yes	No	No	No	Yes	No
	Custom size 1-5	457.3 to 487.7	139.7 to 181.9	Yes	Yes	Yes	No	No	No	Yes	No
	Custom size 2-1	182 to 209.9	182 to 209.9	Yes	Yes	Yes	No	No	No	Yes	Yes
	Custom size 2-2	210 to 279.3	182 to 209.9	Yes	Yes	Yes	No	No	No	Yes	Yes
	Custom size 2-3	279.4 to 431.8	182 to 209.9	Yes	Yes	Yes	No	No	No	Yes	Yes
	Custom size 2-4	431.9 to 457.2	182 to 209.9	Yes	Yes	Yes	No	No	No	Yes	Yes

Type	Size	Feeding direction (mm)	Width direction (mm)	Pickup position							
				Multi-purpose Tray	Cassette 3	Cassette 4	Right Deck	Left Deck	Paper Deck	POD Deck Lite	Insertion Unit
Thin 1 Thin 2	Custom size 2-5	457.3 to 487.7	182 to 209.9	Yes	Yes	Yes	No	No	No	Yes	Yes
	Custom size 3-1	182 to 209.9	210 to 297	Yes	Yes	Yes	No	No	No	Yes	Yes
	Custom size 3-2	210 to 279.3	210 to 297	Yes	Yes	Yes	No	No	No	Yes	Yes
	Custom size 3-3	279.4 to 431.8	210 to 297	Yes	Yes	Yes	No	No	No	Yes	Yes
	Custom size 3-4	431.9 to 457.2	210 to 297	Yes	Yes	Yes	No	No	No	Yes	Yes
	Custom size 3-5	457.3 to 487.7	210 to 297	Yes	Yes	Yes	No	No	No	Yes	Yes
	Custom size 4-1	182 to 209.9	297.1 to 304.8	Yes	Yes	Yes	No	No	No	Yes	Yes
	Custom size 4-2	210 to 279.3	297.1 to 304.8	Yes	Yes	Yes	No	No	No	Yes	Yes
	Custom size 4-4	279.4 to 363.9	297.1 to 304.8	Yes	Yes	Yes	No	No	No	Yes	Yes
	Custom size 4-5	364 to 431.8	297.1 to 304.8	Yes	Yes	Yes	No	No	No	Yes	Yes
	Custom size 4-6	431.9 to 457.2	297.1 to 304.8	Yes	Yes	Yes	No	No	No	Yes	Yes
	Custom size 4-7	457.3 to 487.7	297.1 to 304.8	Yes	Yes	Yes	No	No	No	Yes	Yes
	Custom size 5-1	182 to 209.9	304.9 to 320	Yes	Yes	Yes	No	No	No	Yes	Yes
	Custom size 5-2	210 to 279.3	304.9 to 320	Yes	Yes	Yes	No	No	No	Yes	Yes
	Custom size 5-3	279.4 to 363.9	304.9 to 320	Yes	Yes	Yes	No	No	No	Yes	Yes
	Custom size 5-4	364 to 431.8	304.9 to 320	Yes	Yes	Yes	No	No	No	Yes	Yes
	Custom size 5-5	431.9 to 487.7	304.9 to 320	Yes	Yes	Yes	No	No	No	Yes	Yes
	Custom size 6-1	182 to 209.9	320.1 to 330.2	Yes	Yes	Yes	No	No	No	Yes	Yes
	Custom size 6-2	210 to 279.3	320.1 to 330.2	Yes	Yes	Yes	No	No	No	Yes	Yes
	Custom size 6-3	279.4 to 363.9	320.1 to 330.2	Yes	Yes	Yes	No	No	No	Yes	Yes
	Custom size 6-4	364 to 431.8	320.1 to 330.2	Yes	Yes	Yes	No	No	No	Yes	Yes
	Custom size 6-5	431.9 to 487.7	320.1 to 330.2	Yes	Yes	Yes	No	No	No	Yes	Yes
	Custom paper size 7 (long length)	487.8 to 630	100 to 330.2	Yes	No	No	No	No	No	No	No

Type	Size	Feeding direction (mm)	Width direction (mm)	Pickup position							
				Multi-purpose Tray	Cassette 3	Cassette 4	Right Deck	Left Deck	Paper Deck	POD Deck Lite	Insertion Unit
Plain 1	A3	420	297	Yes	Yes	Yes	No	No	No	Yes	Yes
Plain 2 Plain 3	B4	364	257	Yes	Yes	Yes	No	No	No	Yes	Yes

Type	Size	Feeding direction (mm)	Width direction (mm)	Pickup position							
				Multi-purpose Tray	Cassette 3	Cassette 4	Right Deck	Left Deck	Paper Deck	POD Deck Lite	Insertion Unit
Color paper 1 Recycled 1	A4R	297	210	Yes	Yes	Yes	No	No	No	Yes	Yes
	A4	210	297	Yes	Yes	Yes	Yes	Yes	Yes	Yes	Yes
	B5R	257	182	Yes	Yes	Yes	No	No	No	Yes	Yes
	B5	182	257	Yes	Yes	Yes	Yes	Yes	Yes	Yes	Yes
	A5	148	210	Yes	No	No	No	No	No	No	No
	A5R	210	148	Yes	Yes	Yes	No	No	No	Yes	No
	A6R	148	105	Yes	No	No	No	No	No	No	No
	11 x 17	431.8	279.4	Yes	Yes	Yes	No	No	No	Yes	Yes
	LGL	355.6	215.9	Yes	Yes	Yes	No	No	No	Yes	Yes
	LTR	215.9	279.4	Yes	Yes	Yes	Yes	Yes	Yes	Yes	Yes
	LTRR	279.4	215.9	Yes	Yes	Yes	No	No	No	Yes	Yes
	STMTR	215.9	139.7	Yes	Yes	Yes	No	No	No	Yes	No
	SRA3	450	320	Yes	Yes	Yes	No	No	No	Yes	Yes
	12 x 18	457.2	304.8	Yes	Yes	Yes	No	No	No	Yes	Yes
	EXEC	184.1	266.7	Yes	Yes	Yes	No	No	No	Yes	Yes
	OFICIO	317.5	215.9	Yes	Yes	Yes	No	No	No	Yes	No
	E-OFI-CIO	320	220	Yes	Yes	Yes	No	No	No	Yes	No
	B-OFI-CIO	355	216	Yes	Yes	Yes	No	No	No	Yes	No
	M-OFI-CIO	341	216	Yes	Yes	Yes	No	No	No	Yes	No
	A-OFI-CIO	340	220	Yes	Yes	Yes	No	No	No	Yes	No
	A-LTR	220	280	Yes	Yes	Yes	No	No	No	Yes	No
	A-LTRR	280	220	Yes	Yes	Yes	No	No	No	Yes	No
	GLTR-R	266.7	203.2	Yes	Yes	Yes	No	No	No	Yes	No
	GLTR	203.2	266.7	Yes	Yes	Yes	No	No	No	Yes	No
	GLGL	330.2	203.2	Yes	Yes	Yes	No	No	No	Yes	No
	AFLS	337	206	Yes	Yes	Yes	No	No	No	Yes	No
	FLS	330.2	215.9	Yes	Yes	Yes	No	No	No	Yes	No
	13 x 19	482.6	330.2	Yes	Yes	Yes	No	No	No	Yes	Yes
	K8	390	270	Yes	Yes	Yes	No	No	No	Yes	Yes
	K16	195	270	Yes	Yes	Yes	No	No	No	Yes	Yes
	K16R	270	195	Yes	Yes	Yes	No	No	No	Yes	No
	F4A	342.9	215.9	Yes	Yes	Yes	No	No	No	Yes	No
	I-LGL	345	215	Yes	Yes	Yes	No	No	No	Yes	No
Free	182 to 487.7	100 to 330.2	Yes	No	No	No	No	No	No	No	
Free (Long length)	487.8 to 630	100 to 330.2	Yes *1	No	No	No	No	No	No	No	
Custom size 0-1	148 to 181.9	100 to 139.6	Yes	No	No	No	No	No	No	No	
Custom size 0-2	148 to 181.9	139.7 to 330.2	Yes	No	No	No	No	No	No	No	
Custom size 0-3	182 to 487.7	100 to 139.6	Yes	No	No	No	No	No	No	No	
Custom size 1-1	182 to 209.9	139.7 to 181.9	Yes	Yes	Yes	No	No	No	Yes	No	
Custom size 1-2	210 to 279.3	139.7 to 181.9	Yes	Yes	Yes	No	No	No	Yes	No	
Custom size 1-3	279.4 to 431.8	139.7 to 181.9	Yes	Yes	Yes	No	No	No	Yes	No	

Type	Size	Feeding direction (mm)	Width direction (mm)	Pickup position							
				Multi-purpose Tray	Cassette 3	Cassette 4	Right Deck	Left Deck	Paper Deck	POD Deck Lite	Insertion Unit
Custom size 1-4	431.9 to 457.2	139.7 to 181.9	Yes	Yes	Yes	No	No	No	Yes	No	
Custom size 1-5	457.3 to 487.7	139.7 to 181.9	Yes	Yes	Yes	No	No	No	Yes	No	
Custom size 2-1	182 to 209.9	182 to 209.9	Yes	Yes	Yes	No	No	No	Yes	Yes	
Custom size 2-2	210 to 279.3	182 to 209.9	Yes	Yes	Yes	No	No	No	Yes	Yes	
Custom size 2-3	279.4 to 431.8	182 to 209.9	Yes	Yes	Yes	No	No	No	Yes	Yes	
Custom size 2-4	431.9 to 457.2	182 to 209.9	Yes	Yes	Yes	No	No	No	Yes	Yes	
Custom size 2-5	457.3 to 487.7	182 to 209.9	Yes	Yes	Yes	No	No	No	Yes	Yes	
Custom size 3-1	182 to 209.9	210 to 297	Yes	Yes	Yes	No	No	No	Yes	Yes	
Custom size 3-2	210 to 279.3	210 to 297	Yes	Yes	Yes	No	No	No	Yes	Yes	
Custom size 3-3	279.4 to 431.8	210 to 297	Yes	Yes	Yes	No	No	No	Yes	Yes	
Custom size 3-4	431.9 to 457.2	210 to 297	Yes	Yes	Yes	No	No	No	Yes	Yes	
Custom size 3-5	457.3 to 487.7	210 to 297	Yes	Yes	Yes	No	No	No	Yes	Yes	
Custom size 4-1	182 to 209.9	297.1 to 304.8	Yes	Yes	Yes	No	No	No	Yes	Yes	
Custom size 4-2	210 to 279.3	297.1 to 304.8	Yes	Yes	Yes	No	No	No	Yes	Yes	
Custom size 4-4	279.4 to 363.9	297.1 to 304.8	Yes	Yes	Yes	No	No	No	Yes	Yes	
Custom size 4-5	364 to 431.8	297.1 to 304.8	Yes	Yes	Yes	No	No	No	Yes	Yes	
Custom size 4-6	431.9 to 457.2	297.1 to 304.8	Yes	Yes	Yes	No	No	No	Yes	Yes	
Custom size 4-7	457.3 to 487.7	297.1 to 304.8	Yes	Yes	Yes	No	No	No	Yes	Yes	
Custom size 5-1	182 to 209.9	304.9 to 320	Yes	Yes	Yes	No	No	No	Yes	Yes	
Custom size 5-2	210 to 279.3	304.9 to 320	Yes	Yes	Yes	No	No	No	Yes	Yes	
Custom size 5-3	279.4 to 363.9	304.9 to 320	Yes	Yes	Yes	No	No	No	Yes	Yes	
Custom size 5-4	364 to 431.8	304.9 to 320	Yes	Yes	Yes	No	No	No	Yes	Yes	
Custom size 5-5	431.9 to 487.7	304.9 to 320	Yes	Yes	Yes	No	No	No	Yes	Yes	
Custom size 6-1	182 to 209.9	320.1 to 330.2	Yes	Yes	Yes	No	No	No	Yes	Yes	
Custom size 6-2	210 to 279.3	320.1 to 330.2	Yes	Yes	Yes	No	No	No	Yes	Yes	
Custom size 6-3	279.4 to 363.9	320.1 to 330.2	Yes	Yes	Yes	No	No	No	Yes	Yes	
Custom size 6-4	364 to 431.8	320.1 to 330.2	Yes	Yes	Yes	No	No	No	Yes	Yes	
Custom size 6-5	431.9 to 487.7	320.1 to 330.2	Yes	Yes	Yes	No	No	No	Yes	Yes	

Type	Size	Feeding direction (mm)	Width direction (mm)	Pickup position							
				Multi-purpose Tray	Cassette 3	Cassette 4	Right Deck	Left Deck	Paper Deck	POD Deck Lite	Insertion Unit
	Custom paper size 7 (long length)	487.8 to 630	100 to 330.2	Yes	No	No	No	No	No	No	No

Type	Size	Feeding direction (mm)	Width direction (mm)	Pickup position							
				Multi-purpose Tray	Cassette 3	Cassette 4	Right Deck	Left Deck	Paper Deck	POD Deck Lite	Insertion Unit
Heavy 1	A3	420	297	Yes	Yes	Yes	No	No	No	Yes	Yes
Heavy 2	B4	364	257	Yes	Yes	Yes	No	No	No	Yes	Yes
Heavy 3	A4R	297	210	Yes	Yes	Yes	No	No	No	Yes	Yes
	A4	210	297	Yes	Yes	Yes	Yes	Yes	Yes	Yes	Yes
	B5R	257	182	Yes	Yes	Yes	No	No	No	Yes	Yes
	B5	182	257	Yes	Yes	Yes	Yes	Yes	Yes	Yes	Yes
	A5	148	210	Yes	No	No	No	No	No	No	No
	A5R	210	148	Yes	Yes	Yes	No	No	No	Yes	No
	A6R	148	105	Yes	No	No	No	No	No	No	No
	11 x 17	431.8	279.4	Yes	Yes	Yes	No	No	No	Yes	Yes
	LGL	355.6	215.9	Yes	Yes	Yes	No	No	No	Yes	Yes
	LTR	215.9	279.4	Yes	Yes	Yes	Yes	Yes	Yes	Yes	Yes
	LTRR	279.4	215.9	Yes	Yes	Yes	No	No	No	Yes	Yes
	STMTR	215.9	139.7	Yes	Yes	Yes	No	No	No	Yes	No
	SRA3	450	320	Yes	Yes	Yes	No	No	No	Yes	Yes
	12 x 18	457.2	304.8	Yes	Yes	Yes	No	No	No	Yes	Yes
	EXEC	184.1	266.7	Yes	Yes	Yes	No	No	No	Yes	Yes
	OFICIO	317.5	215.9	Yes	Yes	Yes	No	No	No	Yes	No
	E-OFI-CIO	320	220	Yes	Yes	Yes	No	No	No	Yes	No
	B-OFI-CIO	355	216	Yes	Yes	Yes	No	No	No	Yes	No
	M-OFI-CIO	341	216	Yes	Yes	Yes	No	No	No	Yes	No
	A-OFI-CIO	340	220	Yes	Yes	Yes	No	No	No	Yes	No
	A-LTR	220	280	Yes	Yes	Yes	No	No	No	Yes	No
	A-LTRR	280	220	Yes	Yes	Yes	No	No	No	Yes	No
	GLTR-R	266.7	203.2	Yes	Yes	Yes	No	No	No	Yes	No
	GLTR	203.2	266.7	Yes	Yes	Yes	No	No	No	Yes	No
	GLGL	330.2	203.2	Yes	Yes	Yes	No	No	No	Yes	No
	AFLS	337	206	Yes	Yes	Yes	No	No	No	Yes	No
	FLS	330.2	215.9	Yes	Yes	Yes	No	No	No	Yes	No
	13 x 19	482.6	330.2	Yes	Yes	Yes	No	No	No	Yes	Yes
	K8	390	270	Yes	Yes	Yes	No	No	No	Yes	Yes
	K16	195	270	Yes	Yes	Yes	No	No	No	Yes	Yes
	K16R	270	195	Yes	Yes	Yes	No	No	No	Yes	No
	F4A	342.9	215.9	Yes	Yes	Yes	No	No	No	Yes	No
	I-LGL	345	215	Yes	Yes	Yes	No	No	No	Yes	No
	Free	182 to 487.7	100 to 330.2	Yes	No	No	No	No	No	No	No

Type	Size	Feeding direction (mm)	Width direction (mm)	Pickup position								
				Multi-purpose Tray	Cassette 3	Cassette 4	Right Deck	Left Deck	Paper Deck	POD Deck Lite	Insertion Unit	
Heavy 1 Heavy 2 Heavy 3	Free (Long length)	487.8 to 630	100 to 330.2	Yes *1	No	No	No	No	No	No	No	No
	Custom size 0-1	148 to 181.9	100 to 139.6	Yes	No	No	No	No	No	No	No	No
	Custom size 0-2	148 to 181.9	139.7 to 330.2	Yes	No	No	No	No	No	No	No	No
	Custom size 0-3	182 to 487.7	100 to 139.6	Yes	No	No	No	No	No	No	No	No
	Custom size 1-1	182 to 209.9	139.7 to 181.9	Yes	Yes	Yes	No	No	No	No	Yes	No
	Custom size 1-2	210 to 279.3	139.7 to 181.9	Yes	Yes	Yes	No	No	No	No	Yes	No
	Custom size 1-3	279.4 to 431.8	139.7 to 181.9	Yes	Yes	Yes	No	No	No	No	Yes	No
	Custom size 1-4	431.9 to 457.2	139.7 to 181.9	Yes	Yes	Yes	No	No	No	No	Yes	No
	Custom size 1-5	457.3 to 487.7	139.7 to 181.9	Yes	Yes	Yes	No	No	No	No	Yes	No
	Custom size 2-1	182 to 209.9	182 to 209.9	Yes	Yes	Yes	No	No	No	No	Yes	Yes
	Custom size 2-2	210 to 279.3	182 to 209.9	Yes	Yes	Yes	No	No	No	No	Yes	Yes
	Custom size 2-3	279.4 to 431.8	182 to 209.9	Yes	Yes	Yes	No	No	No	No	Yes	Yes
	Custom size 2-4	431.9 to 457.2	182 to 209.9	Yes	Yes	Yes	No	No	No	No	Yes	Yes
	Custom size 2-5	457.3 to 487.7	182 to 209.9	Yes	Yes	Yes	No	No	No	No	Yes	Yes
	Custom size 3-1	182 to 209.9	210 to 297	Yes	Yes	Yes	No	No	No	No	Yes	Yes
	Custom size 3-2	210 to 279.3	210 to 297	Yes	Yes	Yes	No	No	No	No	Yes	Yes
	Custom size 3-3	279.4 to 431.8	210 to 297	Yes	Yes	Yes	No	No	No	No	Yes	Yes
	Custom size 3-4	431.9 to 457.2	210 to 297	Yes	Yes	Yes	No	No	No	No	Yes	Yes
	Custom size 3-5	457.3 to 487.7	210 to 297	Yes	Yes	Yes	No	No	No	No	Yes	Yes
	Custom size 4-1	182 to 209.9	297.1 to 304.8	Yes	Yes	Yes	No	No	No	No	Yes	Yes
	Custom size 4-2	210 to 279.3	297.1 to 304.8	Yes	Yes	Yes	No	No	No	No	Yes	Yes
	Custom size 4-4	279.4 to 363.9	297.1 to 304.8	Yes	Yes	Yes	No	No	No	No	Yes	Yes
	Custom size 4-5	364 to 431.8	297.1 to 304.8	Yes	Yes	Yes	No	No	No	No	Yes	Yes
	Custom size 4-6	431.9 to 457.2	297.1 to 304.8	Yes	Yes	Yes	No	No	No	No	Yes	Yes
	Custom size 4-7	457.3 to 487.7	297.1 to 304.8	Yes	Yes	Yes	No	No	No	No	Yes	Yes
	Custom size 5-1	182 to 209.9	304.9 to 320	Yes	Yes	Yes	No	No	No	No	Yes	Yes
	Custom size 5-2	210 to 279.3	304.9 to 320	Yes	Yes	Yes	No	No	No	No	Yes	Yes
	Custom size 5-3	279.4 to 363.9	304.9 to 320	Yes	Yes	Yes	No	No	No	No	Yes	Yes

Type	Size	Feeding direction (mm)	Width direction (mm)	Pickup position							
				Multi-purpose Tray	Cassette 3	Cassette 4	Right Deck	Left Deck	Paper Deck	POD Deck Lite	Insertion Unit
Heavy 1 Heavy 2 Heavy 3	Custom size 5-4	364 to 431.8	304.9 to 320	Yes	Yes	Yes	No	No	No	Yes	Yes
	Custom size 5-5	431.9 to 487.7	304.9 to 320	Yes	Yes	Yes	No	No	No	Yes	Yes
	Custom size 6-1	182 to 209.9	320.1 to 330.2	Yes	Yes	Yes	No	No	No	Yes	Yes
	Custom size 6-2	210 to 279.3	320.1 to 330.2	Yes	Yes	Yes	No	No	No	Yes	Yes
	Custom size 6-3	279.4 to 363.9	320.1 to 330.2	Yes	Yes	Yes	No	No	No	Yes	Yes
	Custom size 6-4	364 to 431.8	320.1 to 330.2	Yes	Yes	Yes	No	No	No	Yes	Yes
	Custom size 6-5	431.9 to 487.7	320.1 to 330.2	Yes	Yes	Yes	No	No	No	Yes	Yes
	Custom paper size 7 (long length)	487.8 to 630	100 to 330.2	Yes	No	No	No	No	No	No	No

Type	Size	Feeding direction (mm)	Width direction (mm)	Pickup position							
				Multi-purpose Tray	Cassette 3	Cassette 4	Right Deck	Left Deck	Paper Deck	POD Deck Lite	Insertion Unit
Heavy 4 Heavy 5	A3	420	297	Yes	Yes	Yes	No	No	No	Yes	Yes
	B4	364	257	Yes	Yes	Yes	No	No	No	Yes	Yes
	A4R	297	210	Yes	Yes	Yes	No	No	No	Yes	Yes
	A4	210	297	Yes	Yes	Yes	Yes	Yes	Yes	Yes	Yes
	B5R	257	182	Yes	Yes	Yes	No	No	No	Yes	Yes
	B5	182	257	Yes	Yes	Yes	Yes	Yes	Yes	Yes	Yes
	A5	148	210	Yes	No	No	No	No	No	No	No
	A5R	210	148	Yes	Yes	Yes	No	No	No	Yes	No
	A6R	148	105	Yes	No	No	No	No	No	No	No
	11 x 17	431.8	279.4	Yes	Yes	Yes	No	No	No	Yes	Yes
	LGL	355.6	215.9	Yes	Yes	Yes	No	No	No	Yes	Yes
	LTR	215.9	279.4	Yes	Yes	Yes	Yes	Yes	Yes	Yes	Yes
	LTRR	279.4	215.9	Yes	Yes	Yes	No	No	No	Yes	Yes
	STMTR	215.9	139.7	Yes	Yes	Yes	No	No	No	Yes	No
	SRA3	450	320	Yes	Yes	Yes	No	No	No	Yes	Yes
	12 x 18	457.2	304.8	Yes	Yes	Yes	No	No	No	Yes	Yes
	EXEC	184.1	266.7	Yes	Yes	Yes	No	No	No	Yes	Yes
	OFICIO	317.5	215.9	Yes	Yes	Yes	No	No	No	Yes	No
	E-OFI-CIO	320	220	Yes	Yes	Yes	No	No	No	Yes	No
	B-OFI-CIO	355	216	Yes	Yes	Yes	No	No	No	Yes	No
	M-OFI-CIO	341	216	Yes	Yes	Yes	No	No	No	Yes	No
	A-OFI-CIO	340	220	Yes	Yes	Yes	No	No	No	Yes	No
	A-LTR	220	280	Yes	Yes	Yes	No	No	No	Yes	No
	A-LTRR	280	220	Yes	Yes	Yes	No	No	No	Yes	No
GLTR-R	266.7	203.2	Yes	Yes	Yes	No	No	No	Yes	No	
GLTR	203.2	266.7	Yes	Yes	Yes	No	No	No	Yes	No	

Type	Size	Feeding direction (mm)	Width direction (mm)	Pickup position							
				Multi-purpose Tray	Cassette 3	Cassette 4	Right Deck	Left Deck	Paper Deck	POD Deck Lite	Insertion Unit
Heavy 4 Heavy 5	GLGL	330.2	203.2	Yes	Yes	Yes	No	No	No	Yes	No
	AFLS	337	206	Yes	Yes	Yes	No	No	No	Yes	No
	FLS	330.2	215.9	Yes	Yes	Yes	No	No	No	Yes	No
	13 x 19	482.6	330.2	Yes	Yes	Yes	No	No	No	Yes	Yes
	K8	390	270	Yes	Yes	Yes	No	No	No	Yes	Yes
	K16	195	270	Yes	Yes	Yes	No	No	No	Yes	Yes
	K16R	270	195	Yes	Yes	Yes	No	No	No	Yes	No
	F4A	342.9	215.9	Yes	Yes	Yes	No	No	No	Yes	No
	I-LGL	345	215	Yes	Yes	Yes	No	No	No	Yes	No
	Free	182 to 487.7	100 to 330.2	Yes	No	No	No	No	No	No	No
	Free (Long length)	487.8 to 630	100 to 330.2	Yes *1	No	No	No	No	No	No	No
	Custom size 0-1	148 to 181.9	100 to 139.6	Yes	No	No	No	No	No	No	No
	Custom size 0-2	148 to 181.9	139.7 to 330.2	Yes	No	No	No	No	No	No	No
	Custom size 0-3	182 to 487.7	100 to 139.6	Yes	No	No	No	No	No	No	No
	Custom size 1-1	182 to 209.9	139.7 to 181.9	Yes	Yes	Yes	No	No	No	Yes	No
	Custom size 1-2	210 to 279.3	139.7 to 181.9	Yes	Yes	Yes	No	No	No	Yes	No
	Custom size 1-3	279.4 to 431.8	139.7 to 181.9	Yes	Yes	Yes	No	No	No	Yes	No
	Custom size 1-4	431.9 to 457.2	139.7 to 181.9	Yes	Yes	Yes	No	No	No	Yes	No
	Custom size 1-5	457.3 to 487.7	139.7 to 181.9	Yes	Yes	Yes	No	No	No	Yes	No
	Custom size 2-1	182 to 209.9	182 to 209.9	Yes	Yes	Yes	No	No	No	Yes	Yes
	Custom size 2-2	210 to 279.3	182 to 209.9	Yes	Yes	Yes	No	No	No	Yes	Yes
	Custom size 2-3	279.4 to 431.8	182 to 209.9	Yes	Yes	Yes	No	No	No	Yes	Yes
	Custom size 2-4	431.9 to 457.2	182 to 209.9	Yes	Yes	Yes	No	No	No	Yes	Yes
	Custom size 2-5	457.3 to 487.7	182 to 209.9	Yes	Yes	Yes	No	No	No	Yes	Yes
	Custom size 3-1	182 to 209.9	210 to 297	Yes	Yes	Yes	No	No	No	Yes	Yes
	Custom size 3-2	210 to 279.3	210 to 297	Yes	Yes	Yes	No	No	No	Yes	Yes
	Custom size 3-3	279.4 to 431.8	210 to 297	Yes	Yes	Yes	No	No	No	Yes	Yes
	Custom size 3-4	431.9 to 457.2	210 to 297	Yes	Yes	Yes	No	No	No	Yes	Yes
	Custom size 3-5	457.3 to 487.7	210 to 297	Yes	Yes	Yes	No	No	No	Yes	Yes
	Custom size 4-1	182 to 209.9	297.1 to 304.8	Yes	Yes	Yes	No	No	No	Yes	Yes
	Custom size 4-2	210 to 279.3	297.1 to 304.8	Yes	Yes	Yes	No	No	No	Yes	Yes
	Custom size 4-4	279.4 to 363.9	297.1 to 304.8	Yes	Yes	Yes	No	No	No	Yes	Yes

Type	Size	Feeding direction (mm)	Width direction (mm)	Pickup position							
				Multi-purpose Tray	Cassette 3	Cassette 4	Right Deck	Left Deck	Paper Deck	POD Deck Lite	Insertion Unit
Heavy 4 Heavy 5	Custom size 4-5	364 to 431.8	297.1 to 304.8	Yes	Yes	Yes	No	No	No	Yes	Yes
	Custom size 4-6	431.9 to 457.2	297.1 to 304.8	Yes	Yes	Yes	No	No	No	Yes	Yes
	Custom size 4-7	457.3 to 487.7	297.1 to 304.8	Yes	Yes	Yes	No	No	No	Yes	Yes
	Custom size 5-1	182 to 209.9	304.9 to 320	Yes	Yes	Yes	No	No	No	Yes	Yes
	Custom size 5-2	210 to 279.3	304.9 to 320	Yes	Yes	Yes	No	No	No	Yes	Yes
	Custom size 5-3	279.4 to 363.9	304.9 to 320	Yes	Yes	Yes	No	No	No	Yes	Yes
	Custom size 5-4	364 to 431.8	304.9 to 320	Yes	Yes	Yes	No	No	No	Yes	Yes
	Custom size 5-5	431.9 to 487.7	304.9 to 320	Yes	Yes	Yes	No	No	No	Yes	Yes
	Custom size 6-1	182 to 209.9	320.1 to 330.2	Yes	Yes	Yes	No	No	No	Yes	Yes
	Custom size 6-2	210 to 279.3	320.1 to 330.2	Yes	Yes	Yes	No	No	No	Yes	Yes
	Custom size 6-3	279.4 to 363.9	320.1 to 330.2	Yes	Yes	Yes	No	No	No	Yes	Yes
	Custom size 6-4	364 to 431.8	320.1 to 330.2	Yes	Yes	Yes	No	No	No	Yes	Yes
	Custom size 6-5	431.9 to 487.7	320.1 to 330.2	Yes	Yes	Yes	No	No	No	Yes	Yes
	Custom paper size 7 (long length)	487.8 to 630	100 to 330.2	Yes	No	No	No	No	No	No	No

Type	Size	Feeding direction (mm)	Width direction (mm)	Pickup position							
				Multi-purpose Tray	Cassette 3	Cassette 4	Right Deck	Left Deck	Paper Deck	POD Deck Lite	Insertion Unit
Heavy 6	A3	420	297	Yes	No	No	No	No	No	Yes	Yes
	B4	364	257	Yes	No	No	No	No	No	Yes	Yes
	A4R	297	210	Yes	No	No	No	No	No	Yes	Yes
	A4	210	297	Yes	No	No	No	No	Yes	Yes	Yes
	B5R	257	182	Yes	No	No	No	No	No	Yes	Yes
	B5	182	257	Yes	No	No	No	No	Yes	Yes	Yes
	A5	148	210	Yes	No	No	No	No	No	No	No
	A5R	210	148	Yes	No	No	No	No	No	Yes	No
	A6R	148	105	Yes	No	No	No	No	No	No	No
	11 x 17	431.8	279.4	Yes	No	No	No	No	No	Yes	Yes
	LGL	355.6	215.9	Yes	No	No	No	No	No	Yes	Yes
	LTR	215.9	279.4	Yes	No	No	No	No	Yes	Yes	Yes
	LTRR	279.4	215.9	Yes	No	No	No	No	No	Yes	Yes
	STMTR	215.9	139.7	Yes	No	No	No	No	No	Yes	No
	SRA3	450	320	Yes	No	No	No	No	No	Yes	Yes
	12 x 18	457.2	304.8	Yes	No	No	No	No	No	Yes	Yes
EXEC	184.1	266.7	Yes	No	No	No	No	No	Yes	Yes	
OFICIO	317.5	215.9	Yes	No	No	No	No	No	Yes	No	

Type	Size	Feeding direction (mm)	Width direction (mm)	Pickup position								
				Multi-purpose Tray	Cassette 3	Cassette 4	Right Deck	Left Deck	Paper Deck	POD Deck Lite	Insertion Unit	
Heavy 6	E-OFI-CIO	320	220	Yes	No	No	No	No	No	No	Yes	No
	B-OFI-CIO	355	216	Yes	No	No	No	No	No	No	Yes	No
	M-OFI-CIO	341	216	Yes	No	No	No	No	No	No	Yes	No
	A-OFI-CIO	340	220	Yes	No	No	No	No	No	No	Yes	No
	A-LTR	220	280	Yes	No	No	No	No	No	No	Yes	No
	A-LTRR	280	220	Yes	No	No	No	No	No	No	Yes	No
	GLTR-R	266.7	203.2	Yes	No	No	No	No	No	No	Yes	No
	GLTR	203.2	266.7	Yes	No	No	No	No	No	No	Yes	No
	GLGL	330.2	203.2	Yes	No	No	No	No	No	No	Yes	No
	AFLS	337	206	Yes	No	No	No	No	No	No	Yes	No
	FLS	330.2	215.9	Yes	No	No	No	No	No	No	Yes	No
	13 x 19	482.6	330.2	Yes	No	No	No	No	No	No	Yes	Yes
	K8	390	270	Yes	No	No	No	No	No	No	Yes	Yes
	K16	195	270	Yes	No	No	No	No	No	No	Yes	Yes
	K16R	270	195	Yes	No	No	No	No	No	No	Yes	No
	F4A	342.9	215.9	Yes	No	No	No	No	No	No	Yes	No
	I-LGL	345	215	Yes	No	No	No	No	No	No	Yes	No
	Free	182 to 487.7	100 to 330.2	Yes	No	No	No	No	No	No	No	No
	Free (Long length)	487.8 to 630	100 to 330.2	Yes *1	No	No	No	No	No	No	No	No
	Custom size 0-1	148 to 181.9	100 to 139.6	Yes	No	No	No	No	No	No	No	No
	Custom size 0-2	148 to 181.9	139.7 to 330.2	Yes	No	No	No	No	No	No	No	No
	Custom size 0-3	182 to 487.7	100 to 139.6	Yes	No	No	No	No	No	No	No	No
	Custom size 1-1	182 to 209.9	139.7 to 181.9	Yes	No	No	No	No	No	No	Yes	No
	Custom size 1-2	210 to 279.3	139.7 to 181.9	Yes	No	No	No	No	No	No	Yes	No
	Custom size 1-3	279.4 to 431.8	139.7 to 181.9	Yes	No	No	No	No	No	No	Yes	No
	Custom size 1-4	431.9 to 457.2	139.7 to 181.9	Yes	No	No	No	No	No	No	Yes	No
	Custom size 1-5	457.3 to 487.7	139.7 to 181.9	Yes	No	No	No	No	No	No	Yes	No
	Custom size 2-1	182 to 209.9	182 to 209.9	Yes	No	No	No	No	No	No	Yes	Yes
	Custom size 2-2	210 to 279.3	182 to 209.9	Yes	No	No	No	No	No	No	Yes	Yes
	Custom size 2-3	279.4 to 431.8	182 to 209.9	Yes	No	No	No	No	No	No	Yes	Yes
Custom size 2-4	431.9 to 457.2	182 to 209.9	Yes	No	No	No	No	No	No	Yes	Yes	
Custom size 2-5	457.3 to 487.7	182 to 209.9	Yes	No	No	No	No	No	No	Yes	Yes	
Custom size 3-1	182 to 209.9	210 to 297	Yes	No	No	No	No	No	No	Yes	Yes	

Type	Size	Feeding direction (mm)	Width direction (mm)	Pickup position							
				Multi-purpose Tray	Cassette 3	Cassette 4	Right Deck	Left Deck	Paper Deck	POD Deck Lite	Insertion Unit
Heavy 6	Custom size 3-2	210 to 279.3	210 to 297	Yes	No	No	No	No	No	Yes	Yes
	Custom size 3-3	279.4 to 431.8	210 to 297	Yes	No	No	No	No	No	Yes	Yes
	Custom size 3-4	431.9 to 457.2	210 to 297	Yes	No	No	No	No	No	Yes	Yes
	Custom size 3-5	457.3 to 487.7	210 to 297	Yes	No	No	No	No	No	Yes	Yes
	Custom size 4-1	182 to 209.9	297.1 to 304.8	Yes	No	No	No	No	No	Yes	Yes
	Custom size 4-2	210 to 279.3	297.1 to 304.8	Yes	No	No	No	No	No	Yes	Yes
	Custom size 4-4	279.4 to 363.9	297.1 to 304.8	Yes	No	No	No	No	No	Yes	Yes
	Custom size 4-5	364 to 431.8	297.1 to 304.8	Yes	No	No	No	No	No	Yes	Yes
	Custom size 4-6	431.9 to 457.2	297.1 to 304.8	Yes	No	No	No	No	No	Yes	Yes
	Custom size 4-7	457.3 to 487.7	297.1 to 304.8	Yes	No	No	No	No	No	Yes	Yes
	Custom size 5-1	182 to 209.9	304.9 to 320	Yes	No	No	No	No	No	Yes	Yes
	Custom size 5-2	210 to 279.3	304.9 to 320	Yes	No	No	No	No	No	Yes	Yes
	Custom size 5-3	279.4 to 363.9	304.9 to 320	Yes	No	No	No	No	No	Yes	Yes
	Custom size 5-4	364 to 431.8	304.9 to 320	Yes	No	No	No	No	No	Yes	Yes
	Custom size 5-5	431.9 to 487.7	304.9 to 320	Yes	No	No	No	No	No	Yes	Yes
	Custom size 6-1	182 to 209.9	320.1 to 330.2	Yes	No	No	No	No	No	Yes	Yes
	Custom size 6-2	210 to 279.3	320.1 to 330.2	Yes	No	No	No	No	No	Yes	Yes
	Custom size 6-3	279.4 to 363.9	320.1 to 330.2	Yes	No	No	No	No	No	Yes	Yes
	Custom size 6-4	364 to 431.8	320.1 to 330.2	Yes	No	No	No	No	No	Yes	Yes
	Custom size 6-5	431.9 to 487.7	320.1 to 330.2	Yes	No	No	No	No	No	Yes	Yes
Custom paper size 7 (long length)	487.8 to 630	100 to 330.2	Yes	No	No	No	No	No	No	No	

Type	Size	Feeding direction (mm)	Width direction (mm)	Pickup position							
				Multi-purpose Tray	Cassette 3	Cassette 4	Right Deck	Left Deck	Paper Deck	POD Deck Lite	Insertion Unit
1-Sided Coated 1 2-Sided Coated 1	A3	420	297	Yes	No	No	No	No	No	No	Yes
	B4	364	257	Yes	No	No	No	No	No	No	Yes
	A4R	297	210	Yes	No	No	No	No	No	No	Yes
	A4	210	297	Yes	No	No	No	No	No	No	Yes
	B5R	257	182	Yes	No	No	No	No	No	No	Yes
	B5	182	257	Yes	No	No	No	No	No	No	Yes

Type	Size	Feeding direction (mm)	Width direction (mm)	Pickup position							
				Multi-purpose Tray	Cassette 3	Cassette 4	Right Deck	Left Deck	Paper Deck	POD Deck Lite	Insertion Unit
1-Sided Coated 1 2-Sided Coated 1	A5	148	210	No	No	No	No	No	No	No	No
	A5R	210	148	Yes	No	No	No	No	No	No	No
	A6R	148	105	No	No	No	No	No	No	No	No
	11 x 17	431.8	279.4	Yes	No	No	No	No	No	No	Yes
	LGL	355.6	215.9	Yes	No	No	No	No	No	No	Yes
	LTR	215.9	279.4	Yes	No	No	No	No	No	No	Yes
	LTRR	279.4	215.9	Yes	No	No	No	No	No	No	Yes
	STMTR	215.9	139.7	Yes	No	No	No	No	No	No	No
	SRA3	450	320	Yes	No	No	No	No	No	No	Yes
	12 x 18	457.2	304.8	Yes	No	No	No	No	No	No	Yes
	EXEC	184.1	266.7	Yes	No	No	No	No	No	No	Yes
	OFICIO	317.5	215.9	Yes	No	No	No	No	No	No	No
	E-OFI-CIO	320	220	Yes	No	No	No	No	No	No	No
	B-OFI-CIO	355	216	Yes	No	No	No	No	No	No	No
	M-OFI-CIO	341	216	Yes	No	No	No	No	No	No	No
	A-OFI-CIO	340	220	Yes	No	No	No	No	No	No	No
	A-LTR	220	280	Yes	No	No	No	No	No	No	No
	A-LTRR	280	220	Yes	No	No	No	No	No	No	No
	GLTR-R	266.7	203.2	Yes	No	No	No	No	No	No	No
	GLTR	203.2	266.7	Yes	No	No	No	No	No	No	No
	GLGL	330.2	203.2	Yes	No	No	No	No	No	No	No
	AFLS	337	206	Yes	No	No	No	No	No	No	No
	FLS	330.2	215.9	Yes	No	No	No	No	No	No	No
	13 x 19	482.6	330.2	Yes	No	No	No	No	No	No	Yes
	K8	390	270	Yes	No	No	No	No	No	No	Yes
	K16	195	270	Yes	No	No	No	No	No	No	Yes
	K16R	270	195	Yes	No	No	No	No	No	No	No
	F4A	342.9	215.9	Yes	No	No	No	No	No	No	No
	I-LGL	345	215	Yes	No	No	No	No	No	No	No
	Free	182 to 487.7	100 to 330.2	Yes	No	No	No	No	No	No	No
	Free (Long length)	487.8 to 630	100 to 330.2	Yes *1	No	No	No	No	No	No	No
	Custom size 0-1	148 to 181.9	100 to 139.6	No	No	No	No	No	No	No	No
	Custom size 0-2	148 to 181.9	139.7 to 330.2	No	No	No	No	No	No	No	No
Custom size 0-3	182 to 487.7	100 to 139.6	Yes	No	No	No	No	No	No	No	
Custom size 1-1	182 to 209.9	139.7 to 181.9	Yes	No	No	No	No	No	No	No	
Custom size 1-2	210 to 279.3	139.7 to 181.9	Yes	No	No	No	No	No	No	No	
Custom size 1-3	279.4 to 431.8	139.7 to 181.9	Yes	No	No	No	No	No	No	No	
Custom size 1-4	431.9 to 457.2	139.7 to 181.9	Yes	No	No	No	No	No	No	No	
Custom size 1-5	457.3 to 487.7	139.7 to 181.9	Yes	No	No	No	No	No	No	No	

Type	Size	Feeding direction (mm)	Width direction (mm)	Pickup position								
				Multi-purpose Tray	Cassette 3	Cassette 4	Right Deck	Left Deck	Paper Deck	POD Deck Lite	Insertion Unit	
1-Sided Coated 1 2-Sided Coated 1	Custom size 2-1	182 to 209.9	182 to 209.9	Yes	No	No	No	No	No	No	No	Yes
	Custom size 2-2	210 to 279.3	182 to 209.9	Yes	No	No	No	No	No	No	No	Yes
	Custom size 2-3	279.4 to 431.8	182 to 209.9	Yes	No	No	No	No	No	No	No	Yes
	Custom size 2-4	431.9 to 457.2	182 to 209.9	Yes	No	No	No	No	No	No	No	Yes
	Custom size 2-5	457.3 to 487.7	182 to 209.9	Yes	No	No	No	No	No	No	No	Yes
	Custom size 3-1	182 to 209.9	210 to 297	Yes	No	No	No	No	No	No	No	Yes
	Custom size 3-2	210 to 279.3	210 to 297	Yes	No	No	No	No	No	No	No	Yes
	Custom size 3-3	279.4 to 431.8	210 to 297	Yes	No	No	No	No	No	No	No	Yes
	Custom size 3-4	431.9 to 457.2	210 to 297	Yes	No	No	No	No	No	No	No	Yes
	Custom size 3-5	457.3 to 487.7	210 to 297	Yes	No	No	No	No	No	No	No	Yes
	Custom size 4-1	182 to 209.9	297.1 to 304.8	Yes	No	No	No	No	No	No	No	Yes
	Custom size 4-2	210 to 279.3	297.1 to 304.8	Yes	No	No	No	No	No	No	No	Yes
	Custom size 4-4	279.4 to 363.9	297.1 to 304.8	Yes	No	No	No	No	No	No	No	Yes
	Custom size 4-5	364 to 431.8	297.1 to 304.8	Yes	No	No	No	No	No	No	No	Yes
	Custom size 4-6	431.9 to 457.2	297.1 to 304.8	Yes	No	No	No	No	No	No	No	Yes
	Custom size 4-7	457.3 to 487.7	297.1 to 304.8	Yes	No	No	No	No	No	No	No	Yes
	Custom size 5-1	182 to 209.9	304.9 to 320	Yes	No	No	No	No	No	No	No	Yes
	Custom size 5-2	210 to 279.3	304.9 to 320	Yes	No	No	No	No	No	No	No	Yes
	Custom size 5-3	279.4 to 363.9	304.9 to 320	Yes	No	No	No	No	No	No	No	Yes
	Custom size 5-4	364 to 431.8	304.9 to 320	Yes	No	No	No	No	No	No	No	Yes
	Custom size 5-5	431.9 to 487.7	304.9 to 320	Yes	No	No	No	No	No	No	No	Yes
	Custom size 6-1	182 to 209.9	320.1 to 330.2	Yes	No	No	No	No	No	No	No	Yes
	Custom size 6-2	210 to 279.3	320.1 to 330.2	Yes	No	No	No	No	No	No	No	Yes
	Custom size 6-3	279.4 to 363.9	320.1 to 330.2	Yes	No	No	No	No	No	No	No	Yes
	Custom size 6-4	364 to 431.8	320.1 to 330.2	Yes	No	No	No	No	No	No	No	Yes
	Custom size 6-5	431.9 to 487.7	320.1 to 330.2	Yes	No	No	No	No	No	No	No	Yes

Type	Size	Feeding direction (mm)	Width direction (mm)	Pickup position							
				Multi-purpose Tray	Cassette 3	Cassette 4	Right Deck	Left Deck	Paper Deck	POD Deck Lite	Insertion Unit
1-Sided Coated 1 2-Sided Coated 1	Custom paper size 7 (long length)	487.8 to 630	100 to 330.2	Yes	No	No	No	No	No	No	No

Type	Size	Feeding direction (mm)	Width direction (mm)	Pickup position							
				Multi-purpose Tray	Cassette 3	Cassette 4	Right Deck	Left Deck	Paper Deck	POD Deck Lite	Insertion Unit
1-Sided Coated 2	A3	420	297	No	No	No	No	No	No	No	Yes
	B4	364	257	No	No	No	No	No	No	No	Yes
	A4R	297	210	No	No	No	No	No	No	No	Yes
	A4	210	297	No	No	No	No	No	No	No	Yes
	B5R	257	182	No	No	No	No	No	No	No	Yes
	B5	182	257	No	No	No	No	No	No	No	Yes
	A5	148	210	No	No	No	No	No	No	No	No
	A5R	210	148	No	No	No	No	No	No	No	No
	A6R	148	105	No	No	No	No	No	No	No	No
	11 x 17	431.8	279.4	No	No	No	No	No	No	No	Yes
	LGL	355.6	215.9	No	No	No	No	No	No	No	Yes
	LTR	215.9	279.4	No	No	No	No	No	No	No	Yes
	LTRR	279.4	215.9	No	No	No	No	No	No	No	Yes
	STMTR	215.9	139.7	No	No	No	No	No	No	No	No
	SRA3	450	320	No	No	No	No	No	No	No	Yes
	12 x 18	457.2	304.8	No	No	No	No	No	No	No	Yes
	EXEC	184.1	266.7	No	No	No	No	No	No	No	Yes
	OFICIO	317.5	215.9	No	No	No	No	No	No	No	No
	E-OFI-CIO	320	220	No	No	No	No	No	No	No	No
	B-OFI-CIO	355	216	No	No	No	No	No	No	No	No
	M-OFI-CIO	341	216	No	No	No	No	No	No	No	No
	A-OFI-CIO	340	220	No	No	No	No	No	No	No	No
	A-LTR	220	280	No	No	No	No	No	No	No	No
	A-LTRR	280	220	No	No	No	No	No	No	No	No
	GLTR-R	266.7	203.2	No	No	No	No	No	No	No	No
	GLTR	203.2	266.7	No	No	No	No	No	No	No	No
	GLGL	330.2	203.2	No	No	No	No	No	No	No	No
	AFLS	337	206	No	No	No	No	No	No	No	No
	FLS	330.2	215.9	No	No	No	No	No	No	No	No
	13 x 19	482.6	330.2	No	No	No	No	No	No	No	Yes
	K8	390	270	No	No	No	No	No	No	No	Yes
	K16	195	270	No	No	No	No	No	No	No	Yes
	K16R	270	195	No	No	No	No	No	No	No	No
F4A	342.9	215.9	No	No	No	No	No	No	No	No	
I-LGL	345	215	No	No	No	No	No	No	No	No	
Free	182 to 487.7	100 to 330.2	No	No	No	No	No	No	No	No	

Type	Size	Feeding direction (mm)	Width direction (mm)	Pickup position							
				Multi-purpose Tray	Cassette 3	Cassette 4	Right Deck	Left Deck	Paper Deck	POD Deck Lite	Insertion Unit
1-Sided Coated 2	Free (Long length)	487.8 to 630	100 to 330.2	No	No	No	No	No	No	No	No
	Custom size 0-1	148 to 181.9	100 to 139.6	No	No	No	No	No	No	No	No
	Custom size 0-2	148 to 181.9	139.7 to 330.2	No	No	No	No	No	No	No	No
	Custom size 0-3	182 to 487.7	100 to 139.6	No	No	No	No	No	No	No	No
	Custom size 1-1	182 to 209.9	139.7 to 181.9	No	No	No	No	No	No	No	No
	Custom size 1-2	210 to 279.3	139.7 to 181.9	No	No	No	No	No	No	No	No
	Custom size 1-3	279.4 to 431.8	139.7 to 181.9	No	No	No	No	No	No	No	No
	Custom size 1-4	431.9 to 457.2	139.7 to 181.9	No	No	No	No	No	No	No	No
	Custom size 1-5	457.3 to 487.7	139.7 to 181.9	No	No	No	No	No	No	No	No
	Custom size 2-1	182 to 209.9	182 to 209.9	No	No	No	No	No	No	No	Yes
	Custom size 2-2	210 to 279.3	182 to 209.9	No	No	No	No	No	No	No	Yes
	Custom size 2-3	279.4 to 431.8	182 to 209.9	No	No	No	No	No	No	No	Yes
	Custom size 2-4	431.9 to 457.2	182 to 209.9	No	No	No	No	No	No	No	Yes
	Custom size 2-5	457.3 to 487.7	182 to 209.9	No	No	No	No	No	No	No	Yes
	Custom size 3-1	182 to 209.9	210 to 297	No	No	No	No	No	No	No	Yes
	Custom size 3-2	210 to 279.3	210 to 297	No	No	No	No	No	No	No	Yes
	Custom size 3-3	279.4 to 431.8	210 to 297	No	No	No	No	No	No	No	Yes
	Custom size 3-4	431.9 to 457.2	210 to 297	No	No	No	No	No	No	No	Yes
	Custom size 3-5	457.3 to 487.7	210 to 297	No	No	No	No	No	No	No	Yes
	Custom size 4-1	182 to 209.9	297.1 to 304.8	No	No	No	No	No	No	No	Yes
	Custom size 4-2	210 to 279.3	297.1 to 304.8	No	No	No	No	No	No	No	Yes
	Custom size 4-4	279.4 to 363.9	297.1 to 304.8	No	No	No	No	No	No	No	Yes
	Custom size 4-5	364 to 431.8	297.1 to 304.8	No	No	No	No	No	No	No	Yes
	Custom size 4-6	431.9 to 457.2	297.1 to 304.8	No	No	No	No	No	No	No	Yes
	Custom size 4-7	457.3 to 487.7	297.1 to 304.8	No	No	No	No	No	No	No	Yes
	Custom size 5-1	182 to 209.9	304.9 to 320	No	No	No	No	No	No	No	Yes
	Custom size 5-2	210 to 279.3	304.9 to 320	No	No	No	No	No	No	No	Yes
	Custom size 5-3	279.4 to 363.9	304.9 to 320	No	No	No	No	No	No	No	Yes

Type	Size	Feeding direction (mm)	Width direction (mm)	Pickup position							
				Multi-purpose Tray	Cassette 3	Cassette 4	Right Deck	Left Deck	Paper Deck	POD Deck Lite	Insertion Unit
1-Sided Coated 2	Custom size 5-4	364 to 431.8	304.9 to 320	No	No	No	No	No	No	No	Yes
	Custom size 5-5	431.9 to 487.7	304.9 to 320	No	No	No	No	No	No	No	Yes
	Custom size 6-1	182 to 209.9	320.1 to 330.2	No	No	No	No	No	No	No	Yes
	Custom size 6-2	210 to 279.3	320.1 to 330.2	No	No	No	No	No	No	No	Yes
	Custom size 6-3	279.4 to 363.9	320.1 to 330.2	No	No	No	No	No	No	No	Yes
	Custom size 6-4	364 to 431.8	320.1 to 330.2	No	No	No	No	No	No	No	Yes
	Custom size 6-5	431.9 to 487.7	320.1 to 330.2	No	No	No	No	No	No	No	Yes
	Custom paper size 7 (long length)	487.8 to 630	100 to 330.2	No	No	No	No	No	No	No	No

Type	Size	Feeding direction (mm)	Width direction (mm)	Pickup position							
				Multi-purpose Tray	Cassette 3	Cassette 4	Right Deck	Left Deck	Paper Deck	POD Deck Lite	Insertion Unit
1-Sided Coated 3	A3	420	297	No	No	No	No	No	No	No	Yes
	B4	364	257	No	No	No	No	No	No	No	Yes
2-Sided Coated 3	A4R	297	210	No	No	No	No	No	No	No	Yes
	A4	210	297	No	No	No	No	No	No	No	Yes
	B5R	257	182	No	No	No	No	No	No	No	Yes
	B5	182	257	No	No	No	No	No	No	No	Yes
	A5	148	210	No	No	No	No	No	No	No	No
	A5R	210	148	No	No	No	No	No	No	No	No
	A6R	148	105	No	No	No	No	No	No	No	No
	11 x 17	431.8	279.4	No	No	No	No	No	No	No	Yes
	LGL	355.6	215.9	No	No	No	No	No	No	No	Yes
	LTR	215.9	279.4	No	No	No	No	No	No	No	Yes
	LTRR	279.4	215.9	No	No	No	No	No	No	No	Yes
	STMTR	215.9	139.7	No	No	No	No	No	No	No	No
	SRA3	450	320	No	No	No	No	No	No	No	Yes
	12 x 18	457.2	304.8	No	No	No	No	No	No	No	Yes
	EXEC	184.1	266.7	No	No	No	No	No	No	No	Yes
	OFICIO	317.5	215.9	No	No	No	No	No	No	No	No
	E-OFI-CIO	320	220	No	No	No	No	No	No	No	No
	B-OFI-CIO	355	216	No	No	No	No	No	No	No	No
	M-OFI-CIO	341	216	No	No	No	No	No	No	No	No
	A-OFI-CIO	340	220	No	No	No	No	No	No	No	No
A-LTR	220	280	No	No	No	No	No	No	No	No	
A-LTRR	280	220	No	No	No	No	No	No	No	No	
GLTR-R	266.7	203.2	No	No	No	No	No	No	No	No	
GLTR	203.2	266.7	No	No	No	No	No	No	No	No	

Type	Size	Feeding direction (mm)	Width direction (mm)	Pickup position							
				Multi-purpose Tray	Cassette 3	Cassette 4	Right Deck	Left Deck	Paper Deck	POD Deck Lite	Insertion Unit
1-Sided Coated 3	GLGL	330.2	203.2	No	No	No	No	No	No	No	No
	AFLS	337	206	No	No	No	No	No	No	No	No
2-Sided Coated 3	FLS	330.2	215.9	No	No	No	No	No	No	No	No
	13 x 19	482.6	330.2	No	No	No	No	No	No	No	Yes
	K8	390	270	No	No	No	No	No	No	No	Yes
	K16	195	270	No	No	No	No	No	No	No	Yes
	K16R	270	195	No	No	No	No	No	No	No	No
	F4A	342.9	215.9	No	No	No	No	No	No	No	No
	I-LGL	345	215	No	No	No	No	No	No	No	No
	Free	182 to 487.7	100 to 330.2	No	No	No	No	No	No	No	No
	Free (Long length)	487.8 to 630	100 to 330.2	No	No	No	No	No	No	No	No
	Custom size 0-1	148 to 181.9	100 to 139.6	No	No	No	No	No	No	No	No
	Custom size 0-2	148 to 181.9	139.7 to 330.2	No	No	No	No	No	No	No	No
	Custom size 0-3	182 to 487.7	100 to 139.6	No	No	No	No	No	No	No	No
	Custom size 1-1	182 to 209.9	139.7 to 181.9	No	No	No	No	No	No	No	No
	Custom size 1-2	210 to 279.3	139.7 to 181.9	No	No	No	No	No	No	No	No
	Custom size 1-3	279.4 to 431.8	139.7 to 181.9	No	No	No	No	No	No	No	No
	Custom size 1-4	431.9 to 457.2	139.7 to 181.9	No	No	No	No	No	No	No	No
	Custom size 1-5	457.3 to 487.7	139.7 to 181.9	No	No	No	No	No	No	No	No
	Custom size 2-1	182 to 209.9	182 to 209.9	No	No	No	No	No	No	No	Yes
	Custom size 2-2	210 to 279.3	182 to 209.9	No	No	No	No	No	No	No	Yes
	Custom size 2-3	279.4 to 431.8	182 to 209.9	No	No	No	No	No	No	No	Yes
	Custom size 2-4	431.9 to 457.2	182 to 209.9	No	No	No	No	No	No	No	Yes
	Custom size 2-5	457.3 to 487.7	182 to 209.9	No	No	No	No	No	No	No	Yes
	Custom size 3-1	182 to 209.9	210 to 297	No	No	No	No	No	No	No	Yes
	Custom size 3-2	210 to 279.3	210 to 297	No	No	No	No	No	No	No	Yes
	Custom size 3-3	279.4 to 431.8	210 to 297	No	No	No	No	No	No	No	Yes
	Custom size 3-4	431.9 to 457.2	210 to 297	No	No	No	No	No	No	No	Yes
	Custom size 3-5	457.3 to 487.7	210 to 297	No	No	No	No	No	No	No	Yes
	Custom size 4-1	182 to 209.9	297.1 to 304.8	No	No	No	No	No	No	No	Yes
	Custom size 4-2	210 to 279.3	297.1 to 304.8	No	No	No	No	No	No	No	Yes
	Custom size 4-4	279.4 to 363.9	297.1 to 304.8	No	No	No	No	No	No	No	Yes

Type	Size	Feeding direction (mm)	Width direction (mm)	Pickup position								
				Multi-purpose Tray	Cassette 3	Cassette 4	Right Deck	Left Deck	Paper Deck	POD Deck Lite	Insertion Unit	
1-Sided Coated 3 2-Sided Coated 3	Custom size 4-5	364 to 431.8	297.1 to 304.8	No	No	No	No	No	No	No	No	Yes
	Custom size 4-6	431.9 to 457.2	297.1 to 304.8	No	No	No	No	No	No	No	No	Yes
	Custom size 4-7	457.3 to 487.7	297.1 to 304.8	No	No	No	No	No	No	No	No	Yes
	Custom size 5-1	182 to 209.9	304.9 to 320	No	No	No	No	No	No	No	No	Yes
	Custom size 5-2	210 to 279.3	304.9 to 320	No	No	No	No	No	No	No	No	Yes
	Custom size 5-3	279.4 to 363.9	304.9 to 320	No	No	No	No	No	No	No	No	Yes
	Custom size 5-4	364 to 431.8	304.9 to 320	No	No	No	No	No	No	No	No	Yes
	Custom size 5-5	431.9 to 487.7	304.9 to 320	No	No	No	No	No	No	No	No	Yes
	Custom size 6-1	182 to 209.9	320.1 to 330.2	No	No	No	No	No	No	No	No	Yes
	Custom size 6-2	210 to 279.3	320.1 to 330.2	No	No	No	No	No	No	No	No	Yes
	Custom size 6-3	279.4 to 363.9	320.1 to 330.2	No	No	No	No	No	No	No	No	Yes
	Custom size 6-4	364 to 431.8	320.1 to 330.2	No	No	No	No	No	No	No	No	Yes
	Custom size 6-5	431.9 to 487.7	320.1 to 330.2	No	No	No	No	No	No	No	No	Yes
	Custom paper size 7 (long length)	487.8 to 630	100 to 330.2	No	No	No	No	No	No	No	No	No

Type	Size	Feeding direction (mm)	Width direction (mm)	Pickup position								
				Multi-purpose Tray	Cassette 3	Cassette 4	Right Deck	Left Deck	Paper Deck	POD Deck Lite	Insertion Unit	
2-Sided Coated 2	A3	420	297	No	No	No	No	No	No	No	No	Yes
	B4	364	257	No	No	No	No	No	No	No	No	Yes
	A4R	297	210	No	No	No	No	No	No	No	No	Yes
	A4	210	297	No	No	No	No	No	No	No	No	Yes
	B5R	257	182	No	No	No	No	No	No	No	No	Yes
	B5	182	257	No	No	No	No	No	No	No	No	Yes
	A5	148	210	No	No	No	No	No	No	No	No	No
	A5R	210	148	No	No	No	No	No	No	No	No	No
	A6R	148	105	No	No	No	No	No	No	No	No	No
	11 x 17	431.8	279.4	No	No	No	No	No	No	No	No	Yes
	LGL	355.6	215.9	No	No	No	No	No	No	No	No	Yes
	LTR	215.9	279.4	No	No	No	No	No	No	No	No	Yes
	LTRR	279.4	215.9	No	No	No	No	No	No	No	No	Yes
	STMTR	215.9	139.7	No	No	No	No	No	No	No	No	No
	SRA3	450	320	No	No	No	No	No	No	No	No	Yes
	12 x 18	457.2	304.8	No	No	No	No	No	No	No	No	Yes
	EXEC	184.1	266.7	No	No	No	No	No	No	No	No	Yes
OFICIO	317.5	215.9	No	No	No	No	No	No	No	No	No	

Type	Size	Feeding direction (mm)	Width direction (mm)	Pickup position							
				Multi-purpose Tray	Cassette 3	Cassette 4	Right Deck	Left Deck	Paper Deck	POD Deck Lite	Insertion Unit
2-Sided Coated 2	E-OFI-CIO	320	220	No	No	No	No	No	No	No	No
	B-OFI-CIO	355	216	No	No	No	No	No	No	No	No
	M-OFI-CIO	341	216	No	No	No	No	No	No	No	No
	A-OFI-CIO	340	220	No	No	No	No	No	No	No	No
	A-LTR	220	280	No	No	No	No	No	No	No	No
	A-LTRR	280	220	No	No	No	No	No	No	No	No
	GLTR-R	266.7	203.2	No	No	No	No	No	No	No	No
	GLTR	203.2	266.7	No	No	No	No	No	No	No	No
	GLGL	330.2	203.2	No	No	No	No	No	No	No	No
	AFLS	337	206	No	No	No	No	No	No	No	No
	FLS	330.2	215.9	No	No	No	No	No	No	No	No
	13 x 19	482.6	330.2	No	No	No	No	No	No	No	Yes
	K8	390	270	No	No	No	No	No	No	No	Yes
	K16	195	270	No	No	No	No	No	No	No	Yes
	K16R	270	195	No	No	No	No	No	No	No	No
	F4A	342.9	215.9	No	No	No	No	No	No	No	No
	I-LGL	345	215	No	No	No	No	No	No	No	No
	Free	182 to 487.7	100 to 330.2	No	No	No	No	No	No	No	No
	Free (Long length)	487.8 to 630	100 to 330.2	No	No	No	No	No	No	No	No
	Custom size 0-1	148 to 181.9	100 to 139.6	No	No	No	No	No	No	No	No
	Custom size 0-2	148 to 181.9	139.7 to 330.2	No	No	No	No	No	No	No	No
	Custom size 0-3	182 to 487.7	100 to 139.6	No	No	No	No	No	No	No	No
	Custom size 1-1	182 to 209.9	139.7 to 181.9	No	No	No	No	No	No	No	No
	Custom size 1-2	210 to 279.3	139.7 to 181.9	No	No	No	No	No	No	No	No
	Custom size 1-3	279.4 to 431.8	139.7 to 181.9	No	No	No	No	No	No	No	No
	Custom size 1-4	431.9 to 457.2	139.7 to 181.9	No	No	No	No	No	No	No	No
	Custom size 1-5	457.3 to 487.7	139.7 to 181.9	No	No	No	No	No	No	No	No
	Custom size 2-1	182 to 209.9	182 to 209.9	No	No	No	No	No	No	No	Yes
	Custom size 2-2	210 to 279.3	182 to 209.9	No	No	No	No	No	No	No	Yes
	Custom size 2-3	279.4 to 431.8	182 to 209.9	No	No	No	No	No	No	No	Yes
Custom size 2-4	431.9 to 457.2	182 to 209.9	No	No	No	No	No	No	No	Yes	
Custom size 2-5	457.3 to 487.7	182 to 209.9	No	No	No	No	No	No	No	Yes	
Custom size 3-1	182 to 209.9	210 to 297	No	No	No	No	No	No	No	Yes	

Type	Size	Feeding direction (mm)	Width direction (mm)	Pickup position							
				Multi-purpose Tray	Cassette 3	Cassette 4	Right Deck	Left Deck	Paper Deck	POD Deck Lite	Insertion Unit
2-Sided Coated 2	Custom size 3-2	210 to 279.3	210 to 297	No	No	No	No	No	No	No	Yes
	Custom size 3-3	279.4 to 431.8	210 to 297	No	No	No	No	No	No	No	Yes
	Custom size 3-4	431.9 to 457.2	210 to 297	No	No	No	No	No	No	No	Yes
	Custom size 3-5	457.3 to 487.7	210 to 297	No	No	No	No	No	No	No	Yes
	Custom size 4-1	182 to 209.9	297.1 to 304.8	No	No	No	No	No	No	No	Yes
	Custom size 4-2	210 to 279.3	297.1 to 304.8	No	No	No	No	No	No	No	Yes
	Custom size 4-4	279.4 to 363.9	297.1 to 304.8	No	No	No	No	No	No	No	Yes
	Custom size 4-5	364 to 431.8	297.1 to 304.8	No	No	No	No	No	No	No	Yes
	Custom size 4-6	431.9 to 457.2	297.1 to 304.8	No	No	No	No	No	No	No	Yes
	Custom size 4-7	457.3 to 487.7	297.1 to 304.8	No	No	No	No	No	No	No	Yes
	Custom size 5-1	182 to 209.9	304.9 to 320	No	No	No	No	No	No	No	Yes
	Custom size 5-2	210 to 279.3	304.9 to 320	No	No	No	No	No	No	No	Yes
	Custom size 5-3	279.4 to 363.9	304.9 to 320	No	No	No	No	No	No	No	Yes
	Custom size 5-4	364 to 431.8	304.9 to 320	No	No	No	No	No	No	No	Yes
	Custom size 5-5	431.9 to 487.7	304.9 to 320	No	No	No	No	No	No	No	Yes
	Custom size 6-1	182 to 209.9	320.1 to 330.2	No	No	No	No	No	No	No	Yes
	Custom size 6-2	210 to 279.3	320.1 to 330.2	No	No	No	No	No	No	No	Yes
	Custom size 6-3	279.4 to 363.9	320.1 to 330.2	No	No	No	No	No	No	No	Yes
	Custom size 6-4	364 to 431.8	320.1 to 330.2	No	No	No	No	No	No	No	Yes
	Custom size 6-5	431.9 to 487.7	320.1 to 330.2	No	No	No	No	No	No	No	Yes
Custom paper size 7 (long length)	487.8 to 630	100 to 330.2	No	No	No	No	No	No	No	No	

Type	Size	Feeding direction (mm)	Width direction (mm)	Pickup position							
				Multi-purpose Tray	Cassette 3	Cassette 4	Right Deck	Left Deck	Paper Deck	POD Deck Lite	Insertion Unit
Tracing paper	A3	420	297	Yes	No	No	No	No	No	No	Yes
	B4	364	257	Yes	No	No	No	No	No	No	Yes
	A4R	297	210	Yes	No	No	No	No	No	No	Yes
	A4	210	297	Yes	No	No	No	No	No	No	Yes
	B5R	257	182	Yes	No	No	No	No	No	No	Yes
	B5	182	257	Yes	No	No	No	No	No	No	Yes

Type	Size	Feeding direction (mm)	Width direction (mm)	Pickup position							
				Multi-purpose Tray	Cassette 3	Cassette 4	Right Deck	Left Deck	Paper Deck	POD Deck Lite	Insertion Unit
Tracing paper	A5	148	210	Yes	No	No	No	No	No	No	No
	A5R	210	148	Yes	No	No	No	No	No	No	No
	A6R	148	105	Yes	No	No	No	No	No	No	No
	11 x 17	431.8	279.4	Yes	No	No	No	No	No	No	Yes
	LGL	355.6	215.9	Yes	No	No	No	No	No	No	Yes
	LTR	215.9	279.4	Yes	No	No	No	No	No	No	Yes
	LTRR	279.4	215.9	Yes	No	No	No	No	No	No	Yes
	STMTR	215.9	139.7	Yes	No	No	No	No	No	No	No
	SRA3	450	320	Yes	No	No	No	No	No	No	Yes
	12 x 18	457.2	304.8	Yes	No	No	No	No	No	No	Yes
	EXEC	184.1	266.7	Yes	No	No	No	No	No	No	Yes
	OFICIO	317.5	215.9	Yes	No	No	No	No	No	No	No
	E-OFI-CIO	320	220	Yes	No	No	No	No	No	No	No
	B-OFI-CIO	355	216	Yes	No	No	No	No	No	No	No
	M-OFI-CIO	341	216	Yes	No	No	No	No	No	No	No
	A-OFI-CIO	340	220	Yes	No	No	No	No	No	No	No
	A-LTR	220	280	Yes	No	No	No	No	No	No	No
	A-LTRR	280	220	Yes	No	No	No	No	No	No	No
	GLTR-R	266.7	203.2	Yes	No	No	No	No	No	No	No
	GLTR	203.2	266.7	Yes	No	No	No	No	No	No	No
	GLGL	330.2	203.2	Yes	No	No	No	No	No	No	No
	AFLS	337	206	Yes	No	No	No	No	No	No	No
	FLS	330.2	215.9	Yes	No	No	No	No	No	No	No
	13 x 19	482.6	330.2	Yes	No	No	No	No	No	No	Yes
	K8	390	270	Yes	No	No	No	No	No	No	Yes
	K16	195	270	Yes	No	No	No	No	No	No	Yes
	K16R	270	195	Yes	No	No	No	No	No	No	No
	F4A	342.9	215.9	Yes	No	No	No	No	No	No	No
	I-LGL	345	215	Yes	No	No	No	No	No	No	No
	Free	182 to 487.7	100 to 330.2	Yes	No	No	No	No	No	No	No
	Free (Long length)	487.8 to 630	100 to 330.2	Yes *1	No	No	No	No	No	No	No
	Custom size 0-1	148 to 181.9	100 to 139.6	Yes	No	No	No	No	No	No	No
Custom size 0-2	148 to 181.9	139.7 to 330.2	Yes	No	No	No	No	No	No	No	
Custom size 0-3	182 to 487.7	100 to 139.6	Yes	No	No	No	No	No	No	No	
Custom size 1-1	182 to 209.9	139.7 to 181.9	Yes	No	No	No	No	No	No	No	
Custom size 1-2	210 to 279.3	139.7 to 181.9	Yes	No	No	No	No	No	No	No	
Custom size 1-3	279.4 to 431.8	139.7 to 181.9	Yes	No	No	No	No	No	No	No	
Custom size 1-4	431.9 to 457.2	139.7 to 181.9	Yes	No	No	No	No	No	No	No	
Custom size 1-5	457.3 to 487.7	139.7 to 181.9	Yes	No	No	No	No	No	No	No	

Type	Size	Feeding direction (mm)	Width direction (mm)	Pickup position								
				Multi-purpose Tray	Cassette 3	Cassette 4	Right Deck	Left Deck	Paper Deck	POD Deck Lite	Insertion Unit	
Tracing paper	Custom size 2-1	182 to 209.9	182 to 209.9	Yes	No	No	No	No	No	No	No	Yes
	Custom size 2-2	210 to 279.3	182 to 209.9	Yes	No	No	No	No	No	No	No	Yes
	Custom size 2-3	279.4 to 431.8	182 to 209.9	Yes	No	No	No	No	No	No	No	Yes
	Custom size 2-4	431.9 to 457.2	182 to 209.9	Yes	No	No	No	No	No	No	No	Yes
	Custom size 2-5	457.3 to 487.7	182 to 209.9	Yes	No	No	No	No	No	No	No	Yes
	Custom size 3-1	182 to 209.9	210 to 297	Yes	No	No	No	No	No	No	No	Yes
	Custom size 3-2	210 to 279.3	210 to 297	Yes	No	No	No	No	No	No	No	Yes
	Custom size 3-3	279.4 to 431.8	210 to 297	Yes	No	No	No	No	No	No	No	Yes
	Custom size 3-4	431.9 to 457.2	210 to 297	Yes	No	No	No	No	No	No	No	Yes
	Custom size 3-5	457.3 to 487.7	210 to 297	Yes	No	No	No	No	No	No	No	Yes
	Custom size 4-1	182 to 209.9	297.1 to 304.8	Yes	No	No	No	No	No	No	No	Yes
	Custom size 4-2	210 to 279.3	297.1 to 304.8	Yes	No	No	No	No	No	No	No	Yes
	Custom size 4-4	279.4 to 363.9	297.1 to 304.8	Yes	No	No	No	No	No	No	No	Yes
	Custom size 4-5	364 to 431.8	297.1 to 304.8	Yes	No	No	No	No	No	No	No	Yes
	Custom size 4-6	431.9 to 457.2	297.1 to 304.8	Yes	No	No	No	No	No	No	No	Yes
	Custom size 4-7	457.3 to 487.7	297.1 to 304.8	Yes	No	No	No	No	No	No	No	Yes
	Custom size 5-1	182 to 209.9	304.9 to 320	Yes	No	No	No	No	No	No	No	Yes
	Custom size 5-2	210 to 279.3	304.9 to 320	Yes	No	No	No	No	No	No	No	Yes
	Custom size 5-3	279.4 to 363.9	304.9 to 320	Yes	No	No	No	No	No	No	No	Yes
	Custom size 5-4	364 to 431.8	304.9 to 320	Yes	No	No	No	No	No	No	No	Yes
	Custom size 5-5	431.9 to 487.7	304.9 to 320	Yes	No	No	No	No	No	No	No	Yes
	Custom size 6-1	182 to 209.9	320.1 to 330.2	Yes	No	No	No	No	No	No	No	Yes
	Custom size 6-2	210 to 279.3	320.1 to 330.2	Yes	No	No	No	No	No	No	No	Yes
	Custom size 6-3	279.4 to 363.9	320.1 to 330.2	Yes	No	No	No	No	No	No	No	Yes
	Custom size 6-4	364 to 431.8	320.1 to 330.2	Yes	No	No	No	No	No	No	No	Yes
	Custom size 6-5	431.9 to 487.7	320.1 to 330.2	Yes	No	No	No	No	No	No	No	Yes

Type	Size	Feeding direction (mm)	Width direction (mm)	Pickup position							
				Multi-purpose Tray	Cassette 3	Cassette 4	Right Deck	Left Deck	Paper Deck	POD Deck Lite	Insertion Unit
Tracing paper	Custom paper size 7 (long length)	487.8 to 630	100 to 330.2	Yes	No	No	No	No	No	No	No

Type	Size	Feeding direction (mm)	Width direction (mm)	Pickup position								
				Multi-purpose Tray	Cassette 3	Cassette 4	Right Deck	Left Deck	Paper Deck	POD Deck Lite	Insertion Unit	
Clear Film	A3	420	297	Yes *2	No	No	No	No	No	Yes *2	No	
	B4	364	257	Yes *2	No	No	No	No	No	Yes *2	No	
	A4R	297	210	Yes *2	No	No	No	No	No	Yes *2	No	
	A4	210	297	Yes *2	No	No	No	No	No	Yes *2	No	
	B5R	257	182	No	No	No	No	No	No	No	No	
	B5	182	257	No	No	No	No	No	No	No	No	
	A5	148	210	No	No	No	No	No	No	No	No	
	A5R	210	148	No	No	No	No	No	No	No	No	
	A6R	148	105	No	No	No	No	No	No	No	No	
	11 x 17	431.8	279.4	Yes *2	No	No	No	No	No	No	Yes *2	No
	LGL	355.6	215.9	Yes *2	No	No	No	No	No	No	Yes *2	No
	LTR	215.9	279.4	Yes *2	No	No	No	No	No	No	Yes *2	No
	LTRR	279.4	215.9	Yes *2	No	No	No	No	No	No	Yes *2	No
	STMTR	215.9	139.7	No	No	No	No	No	No	No	No	No
	SRA3	450	320	No	No	No	No	No	No	No	No	No
	12 x 18	457.2	304.8	Yes *2	No	No	No	No	No	No	Yes *2	No
	EXEC	184.1	266.7	No	No	No	No	No	No	No	No	No
	OFICIO	317.5	215.9	Yes *2	No	No	No	No	No	No	Yes *2	No
	E-OFI-CIO	320	220	Yes *2	No	No	No	No	No	No	Yes *2	No
	B-OFI-CIO	355	216	Yes *2	No	No	No	No	No	No	Yes *2	No
	M-OFI-CIO	341	216	Yes *2	No	No	No	No	No	No	Yes *2	No
	A-OFI-CIO	340	220	Yes *2	No	No	No	No	No	No	Yes *2	No
	A-LTR	220	280	Yes *2	No	No	No	No	No	No	Yes *2	No
	A-LTRR	280	220	Yes *2	No	No	No	No	No	No	Yes *2	No
	GLTR-R	266.7	203.2	No	No	No	No	No	No	No	No	No
	GLTR	203.2	266.7	No	No	No	No	No	No	No	No	No
	GLGL	330.2	203.2	No	No	No	No	No	No	No	No	No
	AFLS	337	206	No	No	No	No	No	No	No	No	No
	FLS	330.2	215.9	Yes *2	No	No	No	No	No	No	Yes *2	No
	13 x 19	482.6	330.2	No	No	No	No	No	No	No	No	No
	K8	390	270	Yes *2	No	No	No	No	No	No	Yes *2	No
	K16	195	270	No	No	No	No	No	No	No	No	No
K16R	270	195	No	No	No	No	No	No	No	No	No	
F4A	342.9	215.9	Yes *2	No	No	No	No	No	No	Yes *2	No	
I-LGL	345	215	Yes *2	No	No	No	No	No	No	Yes *2	No	
Free	182 to 487.7	100 to 330.2	No	No	No	No	No	No	No	No	No	

Type	Size	Feeding direction (mm)	Width direction (mm)	Pickup position							
				Multi-purpose Tray	Cassette 3	Cassette 4	Right Deck	Left Deck	Paper Deck	POD Deck Lite	Insertion Unit
Clear Film	Free (Long length)	487.8 to 630	100 to 330.2	No	No	No	No	No	No	No	No
	Custom size 0-1	148 to 181.9	100 to 139.6	No	No	No	No	No	No	No	No
	Custom size 0-2	148 to 181.9	139.7 to 330.2	No	No	No	No	No	No	No	No
	Custom size 0-3	182 to 487.7	100 to 139.6	No	No	No	No	No	No	No	No
	Custom size 1-1	182 to 209.9	139.7 to 181.9	No	No	No	No	No	No	No	No
	Custom size 1-2	210 to 279.3	139.7 to 181.9	No	No	No	No	No	No	No	No
	Custom size 1-3	279.4 to 431.8	139.7 to 181.9	No	No	No	No	No	No	No	No
	Custom size 1-4	431.9 to 457.2	139.7 to 181.9	No	No	No	No	No	No	No	No
	Custom size 1-5	457.3 to 487.7	139.7 to 181.9	No	No	No	No	No	No	No	No
	Custom size 2-1	182 to 209.9	182 to 209.9	No	No	No	No	No	No	No	No
	Custom size 2-2	210 to 279.3	182 to 209.9	No	No	No	No	No	No	No	No
	Custom size 2-3	279.4 to 431.8	182 to 209.9	No	No	No	No	No	No	No	No
	Custom size 2-4	431.9 to 457.2	182 to 209.9	No	No	No	No	No	No	No	No
	Custom size 2-5	457.3 to 487.7	182 to 209.9	No	No	No	No	No	No	No	No
	Custom size 3-1	182 to 209.9	210 to 297	No	No	No	No	No	No	No	No
	Custom size 3-2	210 to 279.3	210 to 297	Yes *2	No	No	No	No	No	No	Yes *2
	Custom size 3-3	279.4 to 431.8	210 to 297	Yes *2	No	No	No	No	No	No	Yes *2
	Custom size 3-4	431.9 to 457.2	210 to 297	Yes *2	No	No	No	No	No	No	Yes *2
	Custom size 3-5	457.3 to 487.7	210 to 297	No	No	No	No	No	No	No	No
	Custom size 4-1	182 to 209.9	297.1 to 304.8	No	No	No	No	No	No	No	No
	Custom size 4-2	210 to 279.3	297.1 to 304.8	Yes *2	No	No	No	No	No	No	Yes *2
	Custom size 4-4	279.4 to 363.9	297.1 to 304.8	Yes *2	No	No	No	No	No	No	Yes *2
	Custom size 4-5	364 to 431.8	297.1 to 304.8	Yes *2	No	No	No	No	No	No	Yes *2
	Custom size 4-6	431.9 to 457.2	297.1 to 304.8	Yes *2	No	No	No	No	No	No	Yes *2
	Custom size 4-7	457.3 to 487.7	297.1 to 304.8	No	No	No	No	No	No	No	No
	Custom size 5-1	182 to 209.9	304.9 to 320	No	No	No	No	No	No	No	No
	Custom size 5-2	210 to 279.3	304.9 to 320	No	No	No	No	No	No	No	No
	Custom size 5-3	279.4 to 363.9	304.9 to 320	No	No	No	No	No	No	No	No

Type	Size	Feeding direction (mm)	Width direction (mm)	Pickup position							
				Multi-purpose Tray	Cassette 3	Cassette 4	Right Deck	Left Deck	Paper Deck	POD Deck Lite	Insertion Unit
Clear Film	Custom size 5-4	364 to 431.8	304.9 to 320	No	No	No	No	No	No	No	No
	Custom size 5-5	431.9 to 487.7	304.9 to 320	No	No	No	No	No	No	No	No
	Custom size 6-1	182 to 209.9	320.1 to 330.2	No	No	No	No	No	No	No	No
	Custom size 6-2	210 to 279.3	320.1 to 330.2	No	No	No	No	No	No	No	No
	Custom size 6-3	279.4 to 363.9	320.1 to 330.2	No	No	No	No	No	No	No	No
	Custom size 6-4	364 to 431.8	320.1 to 330.2	No	No	No	No	No	No	No	No
	Custom size 6-5	431.9 to 487.7	320.1 to 330.2	No	No	No	No	No	No	No	No
	Custom paper size 7 (long length)	487.8 to 630	100 to 330.2	No	No	No	No	No	No	No	No

Type	Size	Feeding direction (mm)	Width direction (mm)	Pickup position							
				Multi-purpose Tray	Cassette 3	Cassette 4	Right Deck	Left Deck	Paper Deck	POD Deck Lite	Insertion Unit
Transparency	A4R	297	210	Yes	No	No	No	No	No	Yes	No
	A4	210	297	Yes	No	No	No	No	No	Yes	No
	LTR	215.9	279.4	Yes	No	No	No	No	No	Yes	No
	LTRR	279.4	215.9	Yes	No	No	No	No	No	Yes	No

Type	Size	Feeding direction (mm)	Width direction (mm)	Pickup position							
				Multi-purpose Tray	Cassette 3	Cassette 4	Right Deck	Left Deck	Paper Deck	POD Deck Lite	Insertion Unit
Label 1	A3	420	297	Yes	No	No	No	No	No	Yes	No
	B4	364	257	Yes	No	No	No	No	No	Yes	No
	A4R	297	210	Yes	No	No	No	No	No	Yes	No
	A4	210	297	Yes	No	No	No	No	No	Yes	No
	B5R	257	182	Yes	No	No	No	No	No	Yes	No
	B5	182	257	Yes	No	No	No	No	No	Yes	No
	A5	148	210	No	No	No	No	No	No	No	No
	A5R	210	148	Yes	No	No	No	No	No	Yes	No
	A6R	148	105	No	No	No	No	No	No	No	No
	11 x 17	431.8	279.4	Yes	No	No	No	No	No	Yes	No
	LGL	355.6	215.9	Yes	No	No	No	No	No	Yes	No
	LTR	215.9	279.4	Yes	No	No	No	No	No	Yes	No
	LTRR	279.4	215.9	Yes	No	No	No	No	No	Yes	No
	STMTR	215.9	139.7	Yes	No	No	No	No	No	Yes	No
	SRA3	450	320	Yes	No	No	No	No	No	Yes	No
	12 x 18	457.2	304.8	Yes	No	No	No	No	No	Yes	No
	EXEC	184.1	266.7	Yes	No	No	No	No	No	Yes	No
OFICIO	317.5	215.9	Yes	No	No	No	No	No	Yes	No	
E-OFCIO	320	220	Yes	No	No	No	No	No	Yes	No	

Type	Size	Feeding direction (mm)	Width direction (mm)	Pickup position								
				Multi-purpose Tray	Cassette 3	Cassette 4	Right Deck	Left Deck	Paper Deck	POD Deck Lite	Insertion Unit	
Label 1	B-OFI-CIO	355	216	Yes	No	No	No	No	No	No	Yes	No
	M-OFI-CIO	341	216	Yes	No	No	No	No	No	No	Yes	No
	A-OFI-CIO	340	220	Yes	No	No	No	No	No	No	Yes	No
	A-LTR	220	280	Yes	No	No	No	No	No	No	Yes	No
	A-LTRR	280	220	Yes	No	No	No	No	No	No	Yes	No
	GLTR-R	266.7	203.2	Yes	No	No	No	No	No	No	Yes	No
	GLTR	203.2	266.7	Yes	No	No	No	No	No	No	Yes	No
	GLGL	330.2	203.2	Yes	No	No	No	No	No	No	Yes	No
	AFLS	337	206	Yes	No	No	No	No	No	No	Yes	No
	FLS	330.2	215.9	Yes	No	No	No	No	No	No	Yes	No
	13 x 19	482.6	330.2	Yes	No	No	No	No	No	No	Yes	No
	K8	390	270	Yes	No	No	No	No	No	No	Yes	No
	K16	195	270	Yes	No	No	No	No	No	No	Yes	No
	K16R	270	195	No	No	No	No	No	No	No	Yes	No
	F4A	342.9	215.9	Yes	No	No	No	No	No	No	Yes	No
	I-LGL	345	215	No	No	No	No	No	No	No	Yes	No
	Free	182 to 487.7	100 to 330.2	No	No	No	No	No	No	No	No	No
	Free (Long length)	487.8 to 630	100 to 330.2	No *1	No	No	No	No	No	No	No	No
	Custom size 0-1	148 to 181.9	100 to 139.6	No	No	No	No	No	No	No	No	No
	Custom size 0-2	148 to 181.9	139.7 to 330.2	No	No	No	No	No	No	No	No	No
	Custom size 0-3	182 to 487.7	100 to 139.6	No	No	No	No	No	No	No	No	No
	Custom size 1-1	182 to 209.9	139.7 to 181.9	No	No	No	No	No	No	No	Yes	No
	Custom size 1-2	210 to 279.3	139.7 to 181.9	No	No	No	No	No	No	No	Yes	No
	Custom size 1-3	279.4 to 431.8	139.7 to 181.9	No	No	No	No	No	No	No	Yes	No
	Custom size 1-4	431.9 to 457.2	139.7 to 181.9	No	No	No	No	No	No	No	Yes	No
	Custom size 1-5	457.3 to 487.7	139.7 to 181.9	No	No	No	No	No	No	No	Yes	No
	Custom size 2-1	182 to 209.9	182 to 209.9	No	No	No	No	No	No	No	Yes	No
	Custom size 2-2	210 to 279.3	182 to 209.9	No	No	No	No	No	No	No	Yes	No
	Custom size 2-3	279.4 to 431.8	182 to 209.9	No	No	No	No	No	No	No	Yes	No
	Custom size 2-4	431.9 to 457.2	182 to 209.9	No	No	No	No	No	No	No	Yes	No
Custom size 2-5	457.3 to 487.7	182 to 209.9	No	No	No	No	No	No	No	Yes	No	
Custom size 3-1	182 to 209.9	210 to 297	No	No	No	No	No	No	No	Yes	No	
Custom size 3-2	210 to 279.3	210 to 297	No	No	No	No	No	No	No	Yes	No	

Type	Size	Feeding direction (mm)	Width direction (mm)	Pickup position							
				Multi-purpose Tray	Cassette 3	Cassette 4	Right Deck	Left Deck	Paper Deck	POD Deck Lite	Insertion Unit
Label 1	Custom size 3-3	279.4 to 431.8	210 to 297	No	No	No	No	No	No	Yes	No
	Custom size 3-4	431.9 to 457.2	210 to 297	No	No	No	No	No	No	Yes	No
	Custom size 3-5	457.3 to 487.7	210 to 297	No	No	No	No	No	No	Yes	No
	Custom size 4-1	182 to 209.9	297.1 to 304.8	No	No	No	No	No	No	Yes	No
	Custom size 4-2	210 to 279.3	297.1 to 304.8	No	No	No	No	No	No	Yes	No
	Custom size 4-4	279.4 to 363.9	297.1 to 304.8	No	No	No	No	No	No	Yes	No
	Custom size 4-5	364 to 431.8	297.1 to 304.8	No	No	No	No	No	No	Yes	No
	Custom size 4-6	431.9 to 457.2	297.1 to 304.8	No	No	No	No	No	No	Yes	No
	Custom size 4-7	457.3 to 487.7	297.1 to 304.8	No	No	No	No	No	No	Yes	No
	Custom size 5-1	182 to 209.9	304.9 to 320	No	No	No	No	No	No	Yes	No
	Custom size 5-2	210 to 279.3	304.9 to 320	No	No	No	No	No	No	Yes	No
	Custom size 5-3	279.4 to 363.9	304.9 to 320	No	No	No	No	No	No	Yes	No
	Custom size 5-4	364 to 431.8	304.9 to 320	No	No	No	No	No	No	Yes	No
	Custom size 5-5	431.9 to 487.7	304.9 to 320	No	No	No	No	No	No	Yes	No
	Custom size 6-1	182 to 209.9	320.1 to 330.2	No	No	No	No	No	No	Yes	No
	Custom size 6-2	210 to 279.3	320.1 to 330.2	No	No	No	No	No	No	Yes	No
	Custom size 6-3	279.4 to 363.9	320.1 to 330.2	No	No	No	No	No	No	Yes	No
	Custom size 6-4	364 to 431.8	320.1 to 330.2	No	No	No	No	No	No	Yes	No
	Custom size 6-5	431.9 to 487.7	320.1 to 330.2	No	No	No	No	No	No	Yes	No
	Custom paper size 7 (long length)	487.8 to 630	100 to 330.2	No	No	No	No	No	No	No	No

Type	Size	Feeding direction (mm)	Width direction (mm)	Pickup position							
				Multi-purpose Tray	Cassette 3	Cassette 4	Right Deck	Left Deck	Paper Deck	POD Deck Lite	Insertion Unit
Bond paper 1	A3	420	297	Yes	Yes	Yes	No	No	No	Yes	Yes
	B4	364	257	Yes	Yes	Yes	No	No	No	Yes	Yes
	A4R	297	210	Yes	Yes	Yes	No	No	No	Yes	Yes
	A4	210	297	Yes	Yes	Yes	Yes	Yes	Yes	Yes	Yes
	B5R	257	182	Yes	Yes	Yes	No	No	No	Yes	Yes
	B5	182	257	Yes	Yes	Yes	Yes	Yes	Yes	Yes	Yes
	A5	148	210	Yes	No	No	No	No	No	No	No
	A5R	210	148	Yes	Yes	Yes	No	No	No	Yes	No

Type	Size	Feeding direction (mm)	Width direction (mm)	Pickup position								
				Multi-purpose Tray	Cassette 3	Cassette 4	Right Deck	Left Deck	Paper Deck	POD Deck Lite	Insertion Unit	
Bond paper 1	A6R	148	105	Yes	No	No	No	No	No	No	No	No
	11 x 17	431.8	279.4	Yes	Yes	Yes	No	No	No	No	Yes	Yes
	LGL	355.6	215.9	Yes	Yes	Yes	No	No	No	No	Yes	Yes
	LTR	215.9	279.4	Yes	Yes	Yes	Yes	Yes	Yes	Yes	Yes	Yes
	LTRR	279.4	215.9	Yes	Yes	Yes	No	No	No	No	Yes	Yes
	STMTR	215.9	139.7	Yes	Yes	Yes	No	No	No	No	Yes	No
	SRA3	450	320	Yes	Yes	Yes	No	No	No	No	Yes	Yes
	12 x 18	457.2	304.8	Yes	Yes	Yes	No	No	No	No	Yes	Yes
	EXEC	184.1	266.7	Yes	Yes	Yes	No	No	No	No	Yes	Yes
	OFICIO	317.5	215.9	Yes	Yes	Yes	No	No	No	No	Yes	No
	E-OFFICIO	320	220	Yes	Yes	Yes	No	No	No	No	Yes	No
	B-OFFICIO	355	216	Yes	Yes	Yes	No	No	No	No	Yes	No
	M-OFFICIO	341	216	Yes	Yes	Yes	No	No	No	No	Yes	No
	A-OFFICIO	340	220	Yes	Yes	Yes	No	No	No	No	Yes	No
	A-LTR	220	280	Yes	Yes	Yes	No	No	No	No	Yes	No
	A-LTRR	280	220	Yes	Yes	Yes	No	No	No	No	Yes	No
	GLTR-R	266.7	203.2	Yes	Yes	Yes	No	No	No	No	Yes	No
	GLTR	203.2	266.7	Yes	Yes	Yes	No	No	No	No	Yes	No
	GLGL	330.2	203.2	Yes	Yes	Yes	No	No	No	No	Yes	No
	AFLS	337	206	Yes	Yes	Yes	No	No	No	No	Yes	No
	FLS	330.2	215.9	Yes	Yes	Yes	No	No	No	No	Yes	No
	13 x 19	482.6	330.2	Yes	Yes	Yes	No	No	No	No	Yes	Yes
	K8	390	270	Yes	Yes	Yes	No	No	No	No	Yes	Yes
	K16	195	270	Yes	Yes	Yes	No	No	No	No	Yes	Yes
	K16R	270	195	Yes	Yes	Yes	No	No	No	No	Yes	No
	F4A	342.9	215.9	Yes	Yes	Yes	No	No	No	No	Yes	No
	I-LGL	345	215	Yes	Yes	Yes	No	No	No	No	Yes	No
	Free	182 to 487.7	100 to 330.2	Yes	No	No	No	No	No	No	No	No
	Free (Long length)	487.8 to 630	100 to 330.2	Yes *1	No	No	No	No	No	No	No	No
	Custom size 0-1	148 to 181.9	100 to 139.6	Yes	No	No	No	No	No	No	No	No
Custom size 0-2	148 to 181.9	139.7 to 330.2	Yes	No	No	No	No	No	No	No	No	
Custom size 0-3	182 to 487.7	100 to 139.6	Yes	No	No	No	No	No	No	No	No	
Custom size 1-1	182 to 209.9	139.7 to 181.9	Yes	Yes	Yes	No	No	No	No	Yes	No	
Custom size 1-2	210 to 279.3	139.7 to 181.9	Yes	Yes	Yes	No	No	No	No	Yes	No	
Custom size 1-3	279.4 to 431.8	139.7 to 181.9	Yes	Yes	Yes	No	No	No	No	Yes	No	
Custom size 1-4	431.9 to 457.2	139.7 to 181.9	Yes	Yes	Yes	No	No	No	No	Yes	No	
Custom size 1-5	457.3 to 487.7	139.7 to 181.9	Yes	Yes	Yes	No	No	No	No	Yes	No	
Custom size 2-1	182 to 209.9	182 to 209.9	Yes	Yes	Yes	No	No	No	No	Yes	Yes	

Type	Size	Feeding direction (mm)	Width direction (mm)	Pickup position							
				Multi-purpose Tray	Cassette 3	Cassette 4	Right Deck	Left Deck	Paper Deck	POD Deck Lite	Insertion Unit
Bond paper 1	Custom size 2-2	210 to 279.3	182 to 209.9	Yes	Yes	Yes	No	No	No	Yes	Yes
	Custom size 2-3	279.4 to 431.8	182 to 209.9	Yes	Yes	Yes	No	No	No	Yes	Yes
	Custom size 2-4	431.9 to 457.2	182 to 209.9	Yes	Yes	Yes	No	No	No	Yes	Yes
	Custom size 2-5	457.3 to 487.7	182 to 209.9	Yes	Yes	Yes	No	No	No	Yes	Yes
	Custom size 3-1	182 to 209.9	210 to 297	Yes	Yes	Yes	No	No	No	Yes	Yes
	Custom size 3-2	210 to 279.3	210 to 297	Yes	Yes	Yes	No	No	No	Yes	Yes
	Custom size 3-3	279.4 to 431.8	210 to 297	Yes	Yes	Yes	No	No	No	Yes	Yes
	Custom size 3-4	431.9 to 457.2	210 to 297	Yes	Yes	Yes	No	No	No	Yes	Yes
	Custom size 3-5	457.3 to 487.7	210 to 297	Yes	Yes	Yes	No	No	No	Yes	Yes
	Custom size 4-1	182 to 209.9	297.1 to 304.8	Yes	Yes	Yes	No	No	No	Yes	Yes
	Custom size 4-2	210 to 279.3	297.1 to 304.8	Yes	Yes	Yes	No	No	No	Yes	Yes
	Custom size 4-4	279.4 to 363.9	297.1 to 304.8	Yes	Yes	Yes	No	No	No	Yes	Yes
	Custom size 4-5	364 to 431.8	297.1 to 304.8	Yes	Yes	Yes	No	No	No	Yes	Yes
	Custom size 4-6	431.9 to 457.2	297.1 to 304.8	Yes	Yes	Yes	No	No	No	Yes	Yes
	Custom size 4-7	457.3 to 487.7	297.1 to 304.8	Yes	Yes	Yes	No	No	No	Yes	Yes
	Custom size 5-1	182 to 209.9	304.9 to 320	Yes	Yes	Yes	No	No	No	Yes	Yes
	Custom size 5-2	210 to 279.3	304.9 to 320	Yes	Yes	Yes	No	No	No	Yes	Yes
	Custom size 5-3	279.4 to 363.9	304.9 to 320	Yes	Yes	Yes	No	No	No	Yes	Yes
	Custom size 5-4	364 to 431.8	304.9 to 320	Yes	Yes	Yes	No	No	No	Yes	Yes
	Custom size 5-5	431.9 to 487.7	304.9 to 320	Yes	Yes	Yes	No	No	No	Yes	Yes
	Custom size 6-1	182 to 209.9	320.1 to 330.2	Yes	Yes	Yes	No	No	No	Yes	Yes
	Custom size 6-2	210 to 279.3	320.1 to 330.2	Yes	Yes	Yes	No	No	No	Yes	Yes
	Custom size 6-3	279.4 to 363.9	320.1 to 330.2	Yes	Yes	Yes	No	No	No	Yes	Yes
	Custom size 6-4	364 to 431.8	320.1 to 330.2	Yes	Yes	Yes	No	No	No	Yes	Yes
	Custom size 6-5	431.9 to 487.7	320.1 to 330.2	Yes	Yes	Yes	No	No	No	Yes	Yes
	Custom paper size 7 (long length)	487.8 to 630	100 to 330.2	Yes	No	No	No	No	No	No	No

Type	Size	Feeding direction (mm)	Width direction (mm)	Pickup position							
				Multi-purpose Tray	Cassette 3	Cassette 4	Right Deck	Left Deck	Paper Deck	POD Deck Lite	Insertion Unit
Postcard, 4 on 1 postcard	Postcard	148	100	Yes	No	No	No	No	No	No	No
	Reply Postcard	200	148	Yes	No	No	No	No	No	Yes	No
	4 on 1 postcard	200	296	Yes	No	No	No	No	No	Yes	No

Type	Size	Feeding direction (mm)	Width direction (mm)	Pickup position							
				Multi-purpose Tray	Cassette 3	Cassette 4	Right Deck	Left Deck	Paper Deck	POD Deck Lite	Insertion Unit
Tab 1	A4	210	297	Yes	Yes	Yes	No	No	No	Yes	Yes
	LTR	215.9	279.4	Yes	Yes	Yes	No	No	No	Yes	Yes

Type	Size	Feeding direction (mm)	Width direction (mm)	Pickup position							
				Multi-purpose Tray	Cassette 3	Cassette 4	Right Deck	Left Deck	Paper Deck	POD Deck Lite	Insertion Unit
Pre-Punched 1	A4	210	297	Yes	Yes	Yes	Yes	Yes	Yes	Yes	Yes
	LTR	215.9	279.4	Yes	Yes	Yes	Yes	Yes	Yes	Yes	Yes

Type	Size	Feeding direction (mm)	Width direction (mm)	Pickup position							
				Multi-purpose Tray	Cassette 3	Cassette 4	Right Deck	Left Deck	Paper Deck	POD Deck Lite	Insertion Unit
Letter-head	A3	420	297	Yes	Yes	Yes	No	No	No	Yes	Yes
	B4	364	257	Yes	Yes	Yes	No	No	No	Yes	Yes
	A4R	297	210	Yes	Yes	Yes	No	No	No	Yes	Yes
	A4	210	297	Yes	Yes	Yes	Yes	Yes	Yes	Yes	Yes
	B5R	257	182	Yes	Yes	Yes	No	No	No	Yes	Yes
	B5	182	257	Yes	Yes	Yes	Yes	Yes	Yes	Yes	Yes
	A5	148	210	Yes	No	No	No	No	No	No	No
	A5R	210	148	Yes	Yes	Yes	No	No	No	Yes	No
	A6R	148	105	Yes	No	No	No	No	No	No	No
	11 x 17	431.8	279.4	Yes	Yes	Yes	No	No	No	Yes	Yes
	LGL	355.6	215.9	Yes	Yes	Yes	No	No	No	Yes	Yes
	LTR	215.9	279.4	Yes	Yes	Yes	Yes	Yes	Yes	Yes	Yes
	LTRR	279.4	215.9	Yes	Yes	Yes	No	No	No	Yes	Yes
	STMTR	215.9	139.7	Yes	Yes	Yes	No	No	No	Yes	No
	SRA3	450	320	Yes	Yes	Yes	No	No	No	Yes	Yes
	12 x 18	457.2	304.8	Yes	Yes	Yes	No	No	No	Yes	Yes
	EXEC	184.1	266.7	Yes	Yes	Yes	No	No	No	Yes	Yes
	OFICIO	317.5	215.9	Yes	Yes	Yes	No	No	No	Yes	No
	E-OFI-CIO	320	220	Yes	Yes	Yes	No	No	No	Yes	No
	B-OFI-CIO	355	216	Yes	Yes	Yes	No	No	No	Yes	No
M-OFI-CIO	341	216	Yes	Yes	Yes	No	No	No	Yes	No	
A-OFI-CIO	340	220	Yes	Yes	Yes	No	No	No	Yes	No	
A-LTR	220	280	Yes	Yes	Yes	No	No	No	Yes	No	
A-LTRR	280	220	Yes	Yes	Yes	No	No	No	Yes	No	

Type	Size	Feeding direction (mm)	Width direction (mm)	Pickup position							
				Multi-purpose Tray	Cassette 3	Cassette 4	Right Deck	Left Deck	Paper Deck	POD Deck Lite	Insertion Unit
Letter-head	GLTR-R	266.7	203.2	Yes	Yes	Yes	No	No	No	Yes	No
	GLTR	203.2	266.7	Yes	Yes	Yes	No	No	No	Yes	No
	GLGL	330.2	203.2	Yes	Yes	Yes	No	No	No	Yes	No
	AFLS	337	206	Yes	Yes	Yes	No	No	No	Yes	No
	FLS	330.2	215.9	Yes	Yes	Yes	No	No	No	Yes	No
	13 x 19	482.6	330.2	Yes	Yes	Yes	No	No	No	Yes	Yes
	K8	390	270	Yes	Yes	Yes	No	No	No	Yes	Yes
	K16	195	270	Yes	Yes	Yes	No	No	No	Yes	Yes
	K16R	270	195	Yes	Yes	Yes	No	No	No	Yes	No
	F4A	342.9	215.9	Yes	Yes	Yes	No	No	No	Yes	No
	I-LGL	345	215	Yes	Yes	Yes	No	No	No	Yes	No
	Free	182 to 487.7	100 to 330.2	Yes	No	No	No	No	No	No	No
	Free (Long length)	487.8 to 630	100 to 330.2	Yes *1	No	No	No	No	No	No	No
	Custom size 0-1	148 to 181.9	100 to 139.6	Yes	No	No	No	No	No	No	No
	Custom size 0-2	148 to 181.9	139.7 to 330.2	Yes	No	No	No	No	No	No	No
	Custom size 0-3	182 to 487.7	100 to 139.6	Yes	No	No	No	No	No	No	No
	Custom size 1-1	182 to 209.9	139.7 to 181.9	Yes	Yes	Yes	No	No	No	Yes	No
	Custom size 1-2	210 to 279.3	139.7 to 181.9	Yes	Yes	Yes	No	No	No	Yes	No
	Custom size 1-3	279.4 to 431.8	139.7 to 181.9	Yes	Yes	Yes	No	No	No	Yes	No
	Custom size 1-4	431.9 to 457.2	139.7 to 181.9	Yes	Yes	Yes	No	No	No	Yes	No
	Custom size 1-5	457.3 to 487.7	139.7 to 181.9	Yes	Yes	Yes	No	No	No	Yes	No
	Custom size 2-1	182 to 209.9	182 to 209.9	Yes	Yes	Yes	No	No	No	Yes	Yes
	Custom size 2-2	210 to 279.3	182 to 209.9	Yes	Yes	Yes	No	No	No	Yes	Yes
	Custom size 2-3	279.4 to 431.8	182 to 209.9	Yes	Yes	Yes	No	No	No	Yes	Yes
	Custom size 2-4	431.9 to 457.2	182 to 209.9	Yes	Yes	Yes	No	No	No	Yes	Yes
	Custom size 2-5	457.3 to 487.7	182 to 209.9	Yes	Yes	Yes	No	No	No	Yes	Yes
	Custom size 3-1	182 to 209.9	210 to 297	Yes	Yes	Yes	No	No	No	Yes	Yes
	Custom size 3-2	210 to 279.3	210 to 297	Yes	Yes	Yes	No	No	No	Yes	Yes
	Custom size 3-3	279.4 to 431.8	210 to 297	Yes	Yes	Yes	No	No	No	Yes	Yes
	Custom size 3-4	431.9 to 457.2	210 to 297	Yes	Yes	Yes	No	No	No	Yes	Yes
	Custom size 3-5	457.3 to 487.7	210 to 297	Yes	Yes	Yes	No	No	No	Yes	Yes
	Custom size 4-1	182 to 209.9	297.1 to 304.8	Yes	Yes	Yes	No	No	No	Yes	Yes

Type	Size	Feeding direction (mm)	Width direction (mm)	Pickup position							
				Multi-purpose Tray	Cassette 3	Cassette 4	Right Deck	Left Deck	Paper Deck	POD Deck Lite	Insertion Unit
Letter-head	Custom size 4-2	210 to 279.3	297.1 to 304.8	Yes	Yes	Yes	No	No	No	Yes	Yes
	Custom size 4-4	279.4 to 363.9	297.1 to 304.8	Yes	Yes	Yes	No	No	No	Yes	Yes
	Custom size 4-5	364 to 431.8	297.1 to 304.8	Yes	Yes	Yes	No	No	No	Yes	Yes
	Custom size 4-6	431.9 to 457.2	297.1 to 304.8	Yes	Yes	Yes	No	No	No	Yes	Yes
	Custom size 4-7	457.3 to 487.7	297.1 to 304.8	Yes	Yes	Yes	No	No	No	Yes	Yes
	Custom size 5-1	182 to 209.9	304.9 to 320	Yes	Yes	Yes	No	No	No	Yes	Yes
	Custom size 5-2	210 to 279.3	304.9 to 320	Yes	Yes	Yes	No	No	No	Yes	Yes
	Custom size 5-3	279.4 to 363.9	304.9 to 320	Yes	Yes	Yes	No	No	No	Yes	Yes
	Custom size 5-4	364 to 431.8	304.9 to 320	Yes	Yes	Yes	No	No	No	Yes	Yes
	Custom size 5-5	431.9 to 487.7	304.9 to 320	Yes	Yes	Yes	No	No	No	Yes	Yes
	Custom size 6-1	182 to 209.9	320.1 to 330.2	Yes	Yes	Yes	No	No	No	Yes	Yes
	Custom size 6-2	210 to 279.3	320.1 to 330.2	Yes	Yes	Yes	No	No	No	Yes	Yes
	Custom size 6-3	279.4 to 363.9	320.1 to 330.2	Yes	Yes	Yes	No	No	No	Yes	Yes
	Custom size 6-4	364 to 431.8	320.1 to 330.2	Yes	Yes	Yes	No	No	No	Yes	Yes
	Custom size 6-5	431.9 to 487.7	320.1 to 330.2	Yes	Yes	Yes	No	No	No	Yes	Yes
	Custom paper size 7 (long length)	487.8 to 630	100 to 330.2	Yes	No	No	No	No	No	No	No

*1: It is necessary to set "1" in the following service mode (Lv.2).

COPIER > OPTION > USER > MF-LG-ST

*2: It is necessary to set "1" in the following service mode (Lv.2).

COPIER > OPTION > USER > FLM-DSPL

*3: Envelopes are not supported as a paper type.

Custom size paper

See the table below for the custom paper size.

Size of Custom Size Paper

Size	Feeding direction (mm)	Width direction (mm)
Free	182 to 487.7	100 to 330.2
Free (Long length)	487.8 to 630	100 to 330.2
Custom size 0-1	148 to 181.9	100 to 139.6
Custom size 0-2	148 to 181.9	139.7 to 330.2
Custom size 0-3	182 to 487.7	100 to 139.6
Custom size 1-1	182 to 209.9	139.7 to 181.9
Custom size 1-2	210 to 279.3	139.7 to 181.9
Custom size 1-3	279.4 to 431.8	139.7 to 181.9
Custom size 1-4	431.9 to 457.2	139.7 to 181.9

Size	Feeding direction (mm)	Width direction (mm)
Custom size 1-5	457.3 to 487.7	139.7 to 181.9
Custom size 2-1	182 to 209.9	182 to 209.9
Custom size 2-2	210 to 279.3	182 to 209.9
Custom size 2-3	279.4 to 431.8	182 to 209.9
Custom size 2-4	431.9 to 457.2	182 to 209.9
Custom size 2-5	457.3 to 487.7	182 to 209.9
Custom size 3-1	182 to 209.9	210 to 297
Custom size 3-2	210 to 279.3	210 to 297
Custom size 3-3	279.4 to 431.8	210 to 297
Custom size 3-4	431.9 to 457.2	210 to 297
Custom size 3-5	457.3 to 487.7	210 to 297
Custom size 4-1	182 to 209.9	297.1 to 304.8
Custom size 4-2	210 to 279.3	297.1 to 304.8
Custom size 4-4	279.4 to 363.9	297.1 to 304.8
Custom size 4-5	364 to 431.8	297.1 to 304.8
Custom size 4-6	431.9 to 457.2	297.1 to 304.8
Custom size 4-7	457.3 to 487.7	297.1 to 304.8
Custom size 5-1	182 to 209.9	304.9 to 320
Custom size 5-2	210 to 279.3	304.9 to 320
Custom size 5-3	279.4 to 363.9	304.9 to 320
Custom size 5-4	364 to 431.8	304.9 to 320
Custom size 5-5	431.9 to 487.7	304.9 to 320
Custom size 6-1	182 to 209.9	320.1 to 330.2
Custom size 6-2	210 to 279.3	320.1 to 330.2
Custom size 6-3	279.4 to 363.9	320.1 to 330.2
Custom size 6-4	364 to 431.8	320.1 to 330.2
Custom size 6-5	431.9 to 487.7	320.1 to 330.2
Custom size 7 (long length) *1	487.8 to 630	100 to 330.2

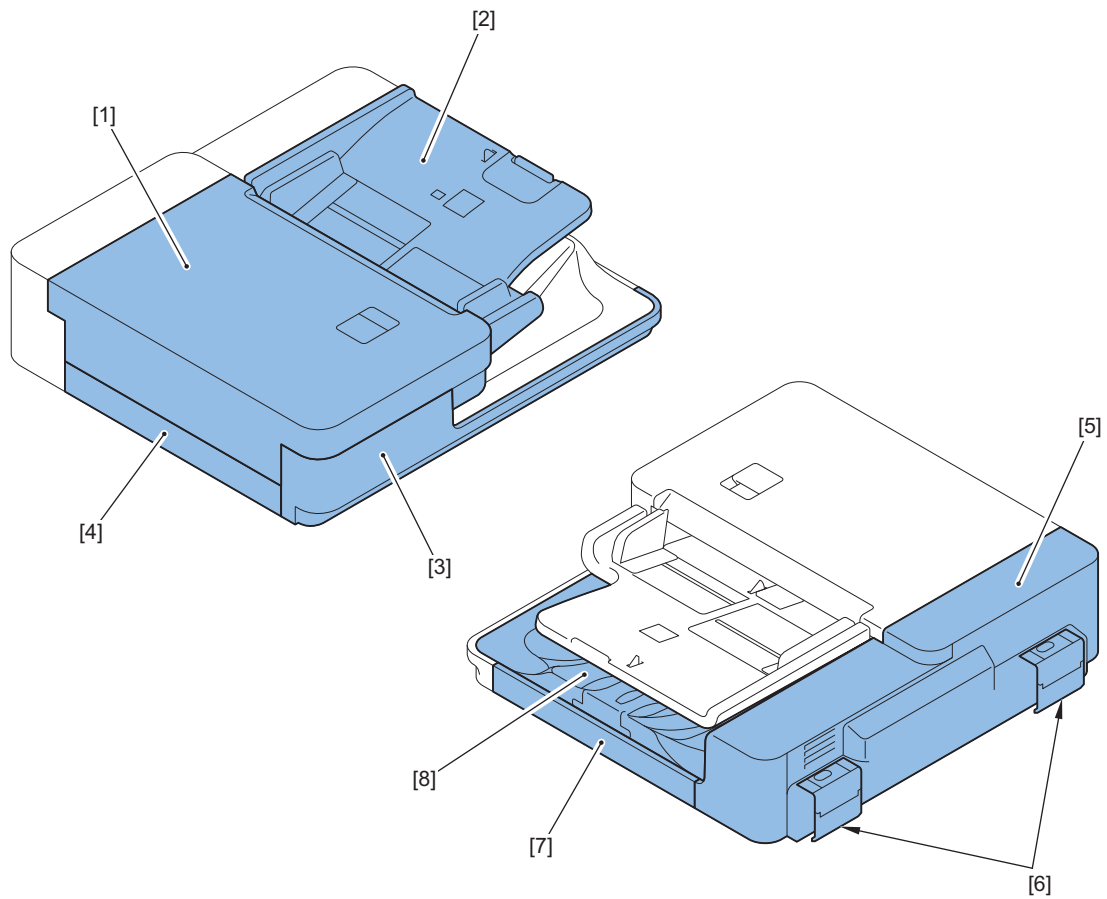
*1: It is necessary to set "1" in the following service mode (Lv.2).

COPIER > OPTION > USER > MF-LG-ST

External View

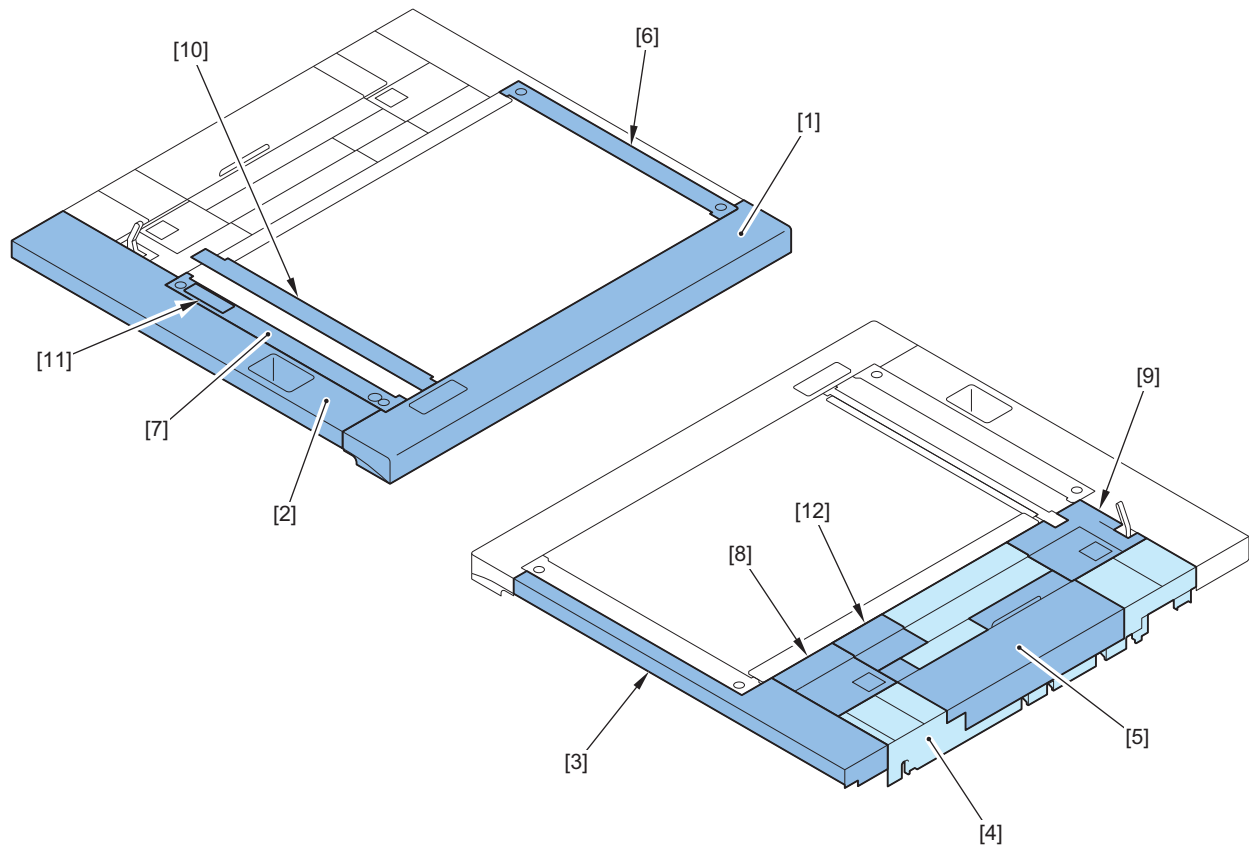
External Cover

ADF



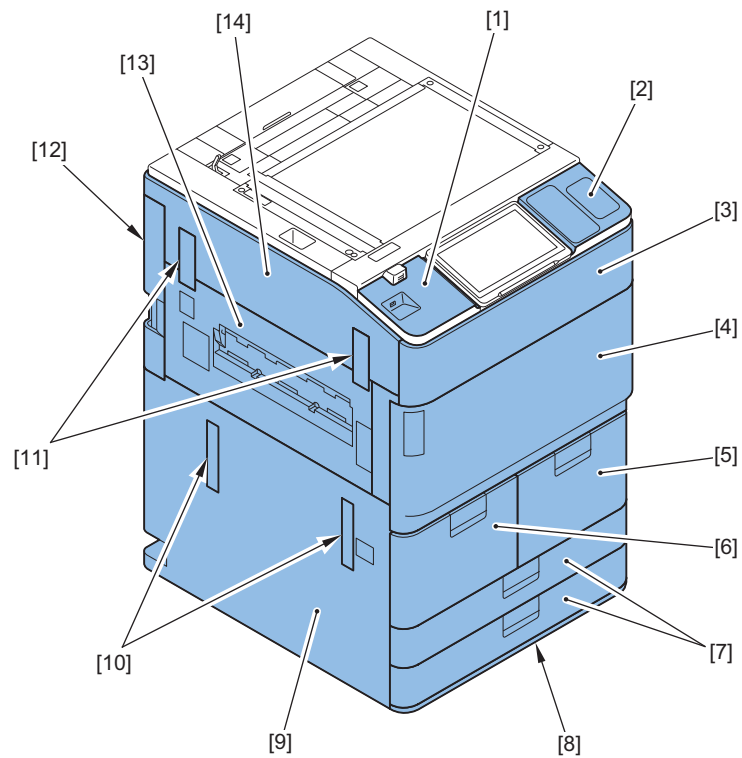
No.	Name	
[1]	Open/Close Cover	
[2]	Document Tray	
[3]	ADF Front Cover	
[4]	ADF Left Lower Cover	
[5]	ADF Rear Cover	
[6]	Hinge Cover	
[7]	ADF Right Cover	
[8]	Delivery Tray	

■ Reader

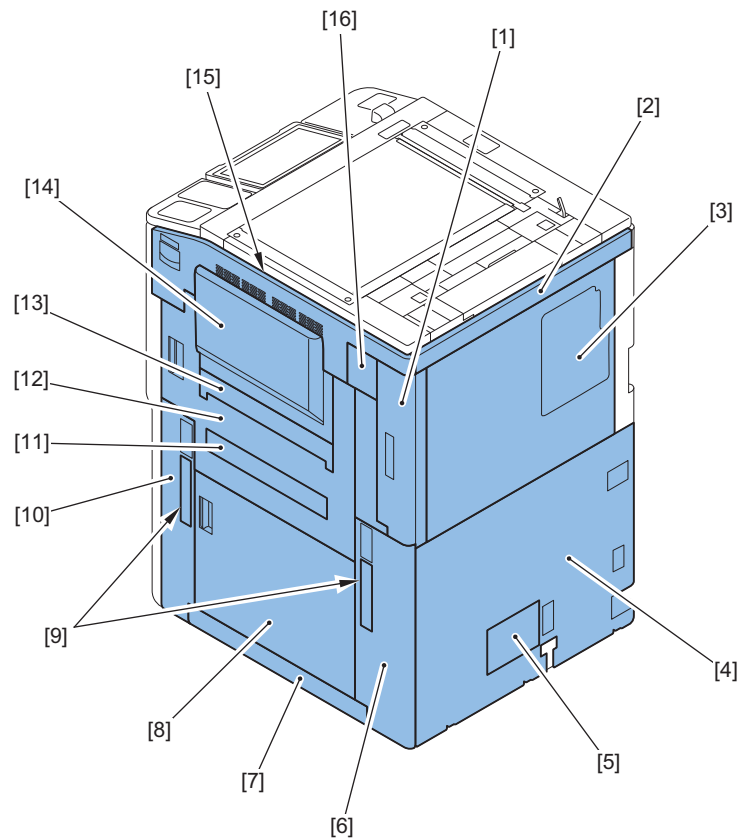


No.	Name	
[1]	Reader Front Cover	
[2]	Reader Left Cover	
[3]	Reader Right Cover	
[4]	Reader Rear Cover	
[5]	Maintenance Cover	
[6]	Glass Retainer Right Cover	
[7]	Glass Retainer Left Cover	
[8]	Right Hinge Lower Cover	
[9]	Left Hinge Lower Cover	
[10]	Jump Guide	
[11]	Left Upper Cover	
[12]	Maintenance Cover (Upper)	

■ Printer

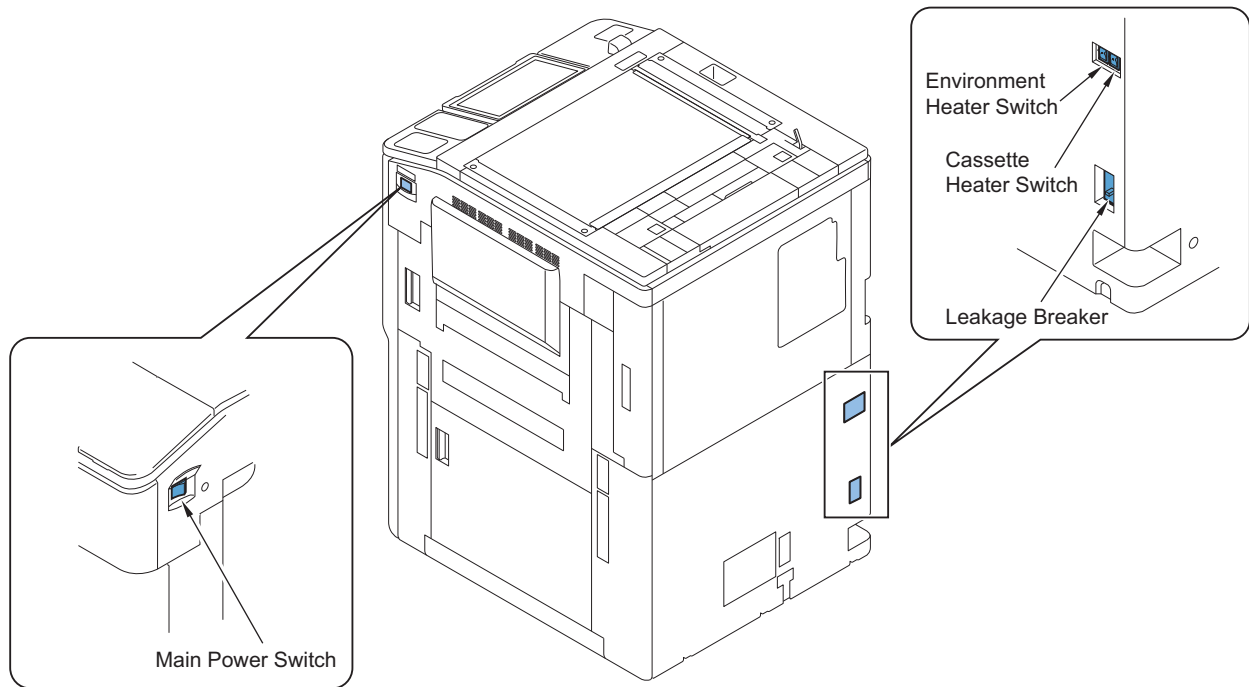


No.	Name	
[1]	Control Panel Left Upper Cover	
[2]	Control Panel Right Upper Cover	
[3]	Toner Replacement Cover	
[4]	Front Cover	
[5]	Deck Right Cover	
[6]	Deck Left Cover	
[7]	Cassette Front Cover	
[8]	Cassette Lower Cover	
[9]	Left Lower Cover	
[10]	Handle Cover	
[11]	Finisher Connector Cover	
[12]	Left Rear Cover	
[13]	Delivery Cover	
[14]	Left Upper Cover	



No.	Name	
[1]	Box Right Cover	
[2]	Box Upper Cover	
[3]	Rear Upper Cover	
[4]	Rear Lower Cover	
[5]	Filter Cover	
[6]	Waste Toner Container Cover	
[7]	Right Lower Middle Cover	
[8]	Vertical Path Cover	
[9]	Handle Cover	
[10]	Right Lower Front Cover	
[11]	Duplex Delivery Cover	
[12]	Right Door	
[13]	Multi-purpose Tray Sub Cover	
[14]	Multi-purpose Tray	
[15]	Right Upper Cover	
[16]	Right Rear Cover	

■ Switches, I/F, Others

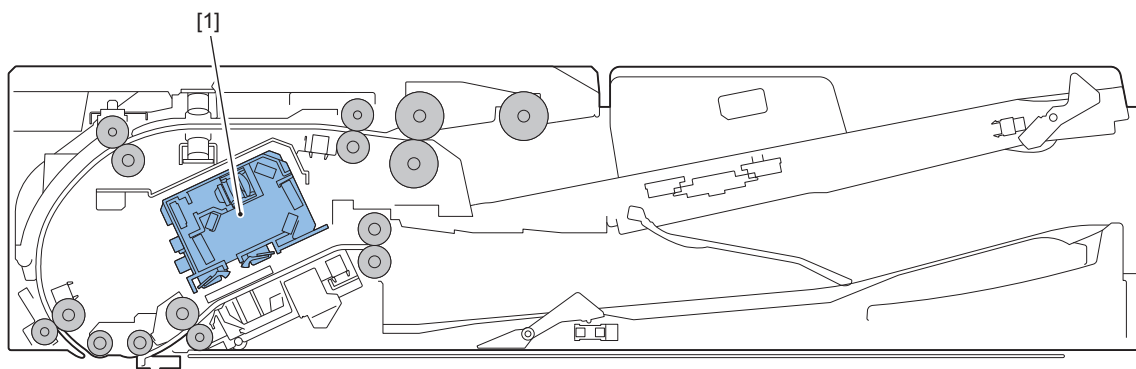


Be sure to perform the following procedure for checking the Leakage Breaker.

1. Turn OFF the main power and check that the Control Panel LED is off.
2. Using a pen point, press the test button of the breaker on the rear side of the host machine.
3. Check that the breaker switch is OFF ("o" side).
4. Return the breaker switch to ON ("I" side).
5. Turn ON the main power.

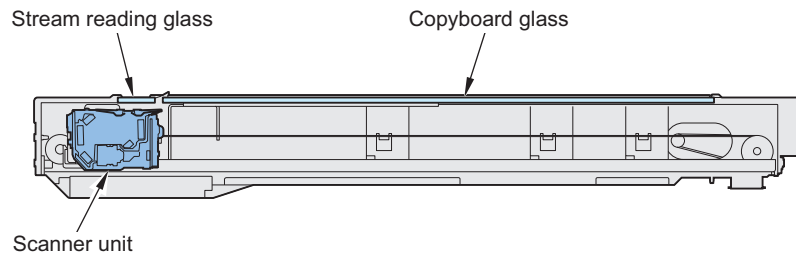
● Cross Section View

■ DADF

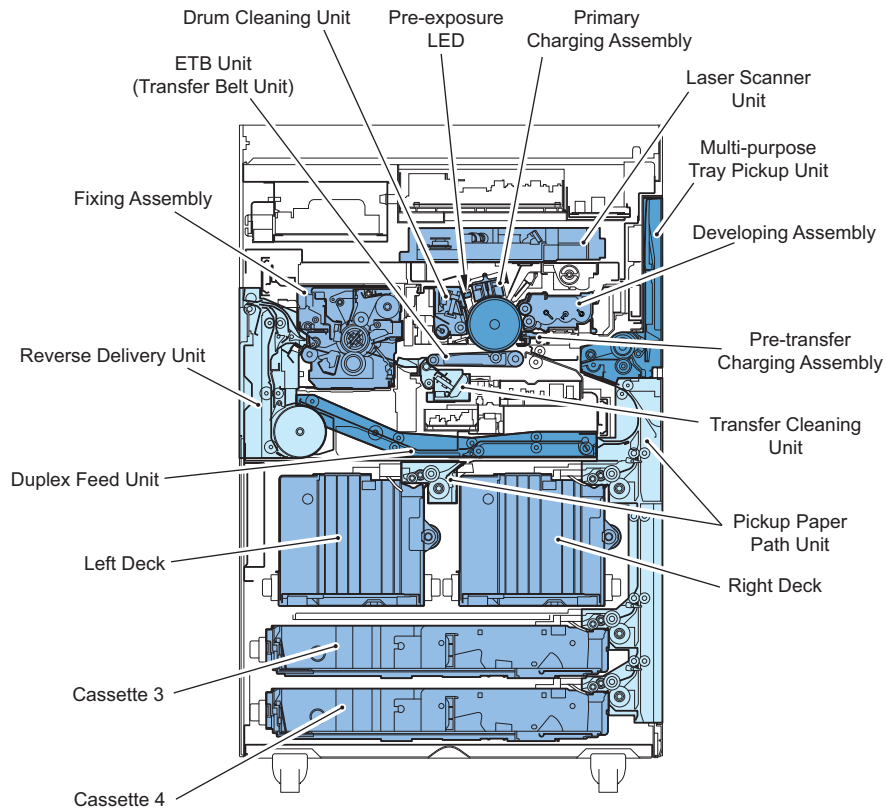


Key No.	Name
[1]	Scanner Unit

■ Reader



■ Printer



Operation

Power Switch

Types of Power Switches

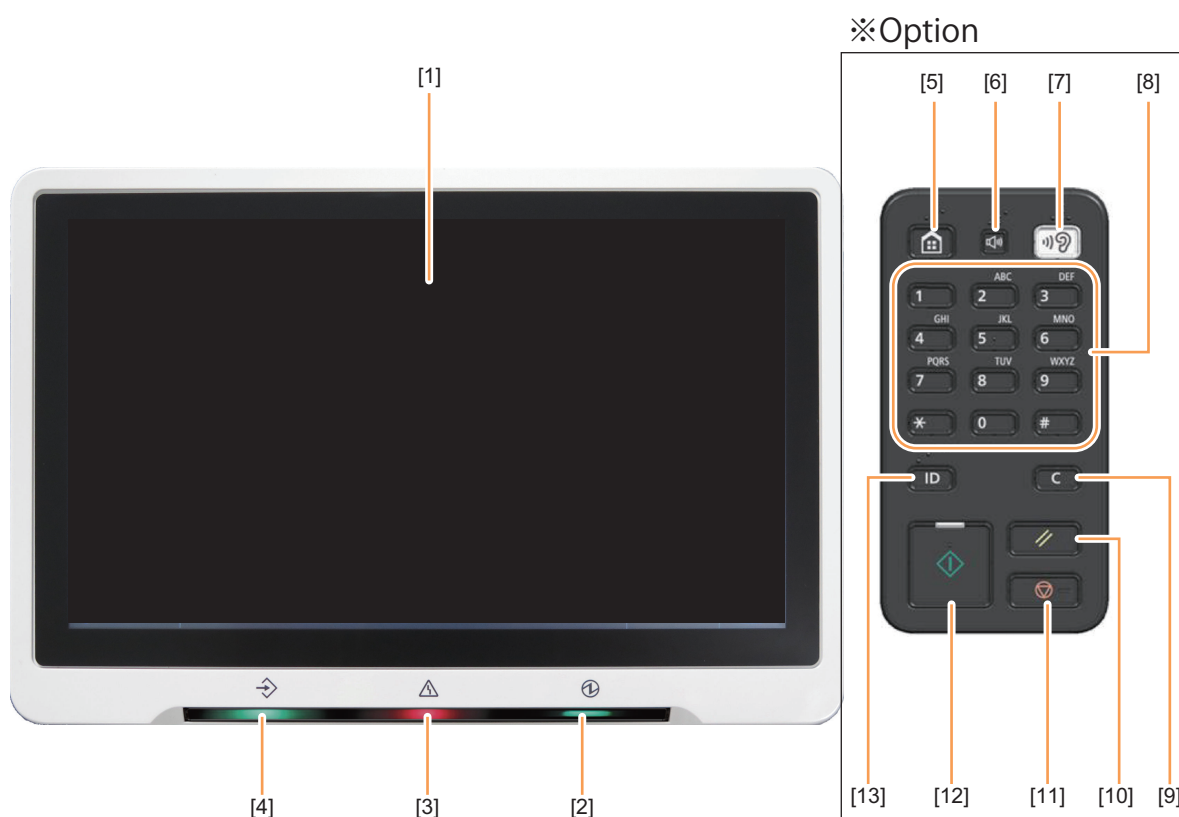
This machine has the Main Power Switch, the Control Panel Power Switch and the Environment Heater Switch. Turning ON the Main Power Switch supplies the power in the usual case (except when the machine is in sleep mode). The Environment Switch supplies or blocks the power to the Drum Heater, the Cassette Heater and the Reader Heater.

Points to Note on Turning ON/OFF the Power Switch

- Do not turn OFF the Main Power Switch while the progress bar (to be displayed when the power is turned ON) is displayed, which indicates access to the HDD.
- Be sure to turn OFF the Main Power Switch to cut the power (there is no need to perform the shutdown sequence which has been performed with the conventional machines).
- After turning OFF the power (after turning OFF the Main Power Switch), do not turn ON the Main Power Switch unless the screen disappears.
- Do not turn OFF the power during downloading.

Control Panel

Control Panel + Numeric Keypad (Option)



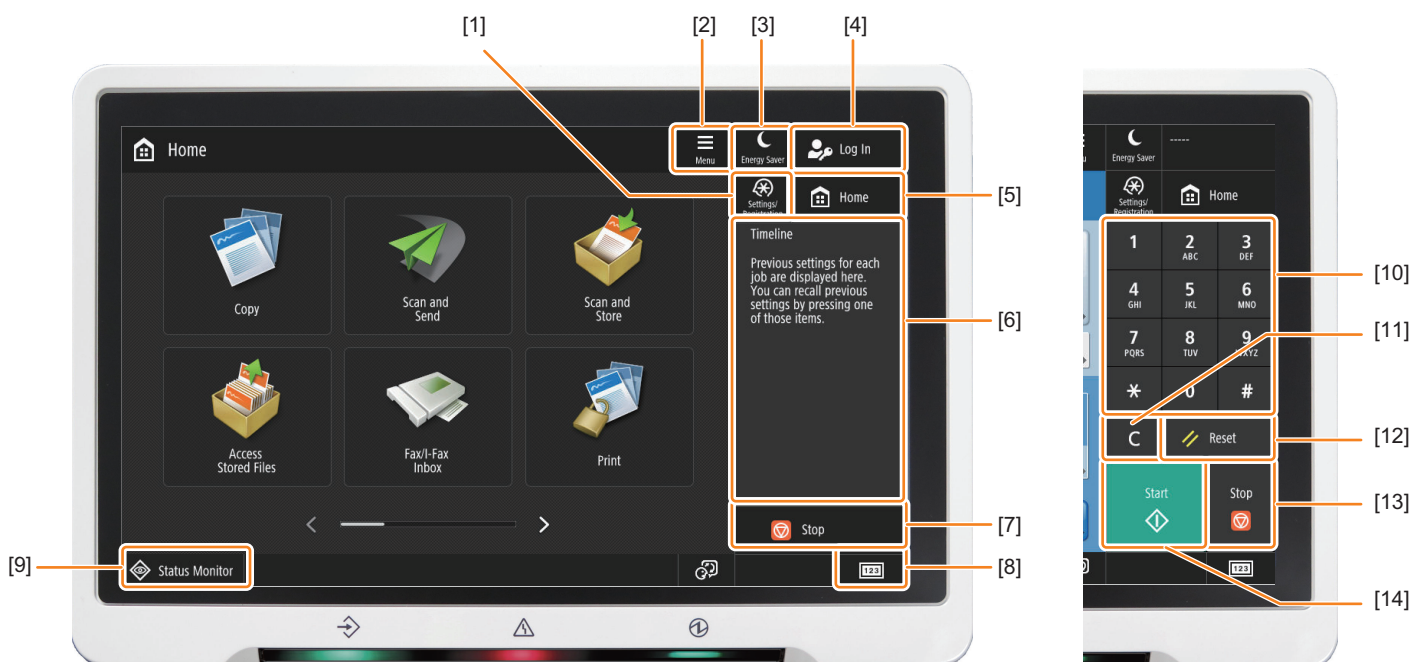
NOTE:

The Numeric Keypad at the right side of above figure is optional.

No.	Name
[1]	Touch Panel Display
[2]	Main Power LED
[3]	Error LED

No.	Name
[4]	Memory LED
[5]	[Home] key
[6]	[Volume Adjustment] key
[7]	[Voice Guide Mode] key
[8]	Numeric key
[9]	[Clear] key
[10]	[Reset] key
[11]	[Stop] key
[12]	[Start] key
[13]	[Authentication] key

■ Main Menu



No.	Name
[1]	Settings/Registration
[2]	Menu
[3]	Energy Saver
[4]	Login
[5]	Home
[6]	Timeline
[7]	Stop
[8]	Counter
[9]	Status Check
[10]	Numeric keys
[11]	Clear
[12]	Reset
[13]	Stop
[14]	Start



2

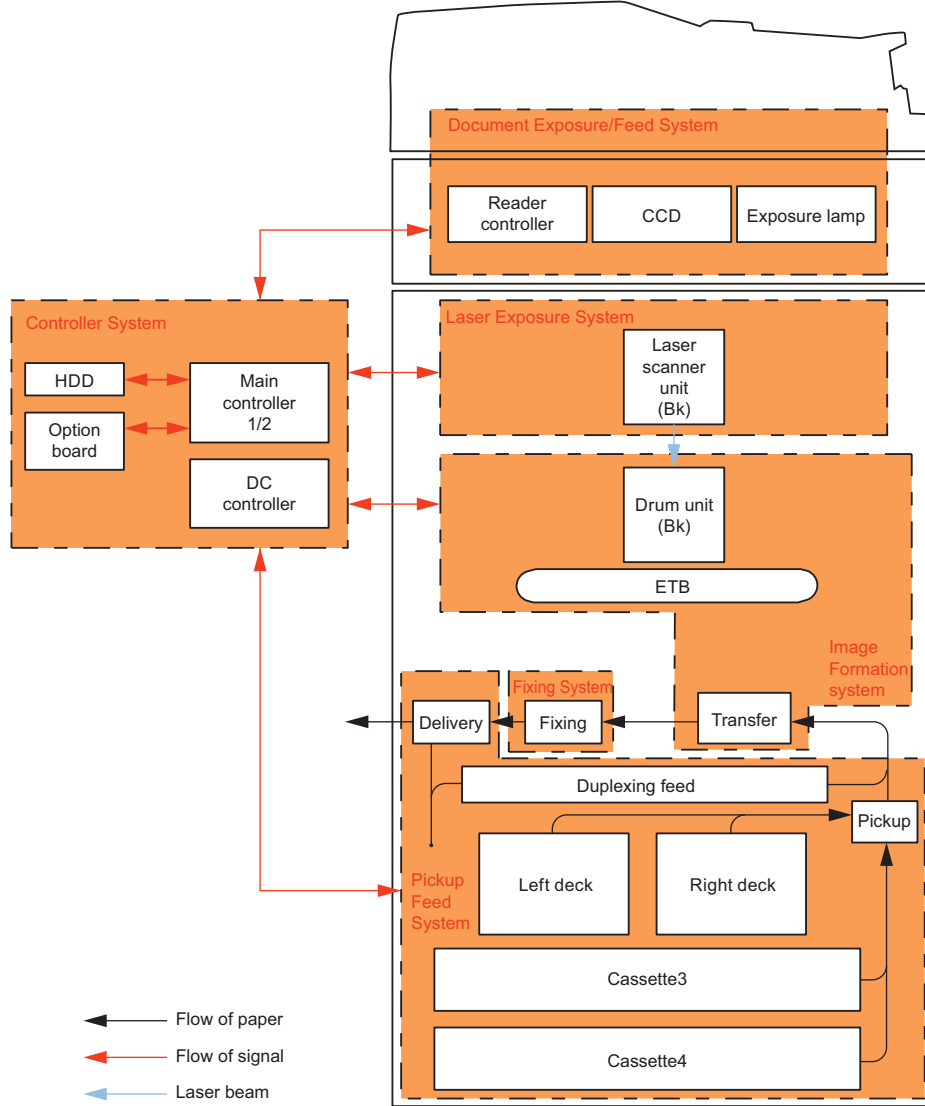
Technical Explanation (Device)

Basic Configuration.....	62
Original Exposure System (Reader)...	63
Original Feed System (Single Pass ADF).....	76
Main Controller.....	99
Laser Exposure System.....	103
Image Formation System.....	112
Fixing System.....	162
Pickup/Feed System.....	176
External Auxiliary System.....	212

Basic Configuration

Functional Configuration

The machine may broadly be divided into the following functional system blocks; document exposure/feed system block, controller system block, laser exposure system block, image formation system block, fixing system block and pickup/feed system block.



Original Exposure System (Reader)

Features

- Double Feed Sensor installed as standard
Double feed detection during paper feed has been realized by the ultrasonic sensor on the feeding path.

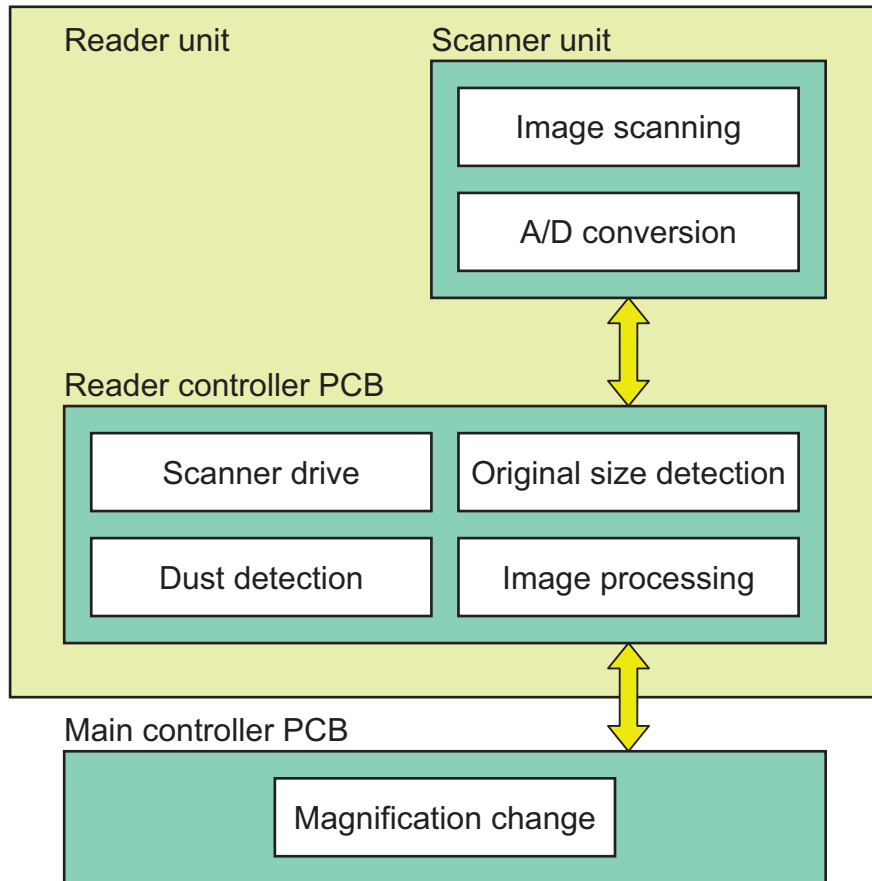
Specifications

Item	Specification/Function	Remark
Photo conductor	White high luminance LED + Reflection Plate	-
Scanning of original	At copyboard reading	Scanning by moving Scanner Unit
	When using the DADF	Stream scanning of the original with the Scanner Unit fixed
Reading resolution	600 dpi x 600 dpi	SEND: 300 x 300 dpi
Number of gradations	256 gradations	-
Carriage position detection	Scanner Unit Home Position Sensor (PS103)	-
Magnification Ratio	25 % to 400 %	Digital magnification
	Horizontal scanning direction	Image processing by the Main Controller PCB
	Vertical scanning direction	Image processing by the Main Controller PCB
Number of lines of the Reading Sensor	4 lines (R, G, B, B/W)	-
Original size detection	At copyboard reading	Horizontal scanning: Detection by the Reading Sensor (Scanner Unit)
		Vertical scanning: Detection by the Reflection Sensor (Original Size Sensor)
	When using the DADF	Horizontal scanning: Detection by original width volume on the DADF/Photo Interrupter
		Horizontal scanning: Detection by the Photo Interrupter on DADF
Maximum original size	At copyboard reading	297 mm x 431.8 mm
	When using the DADF	304.8 mm x 630 mm
Option	Reader Heater	-

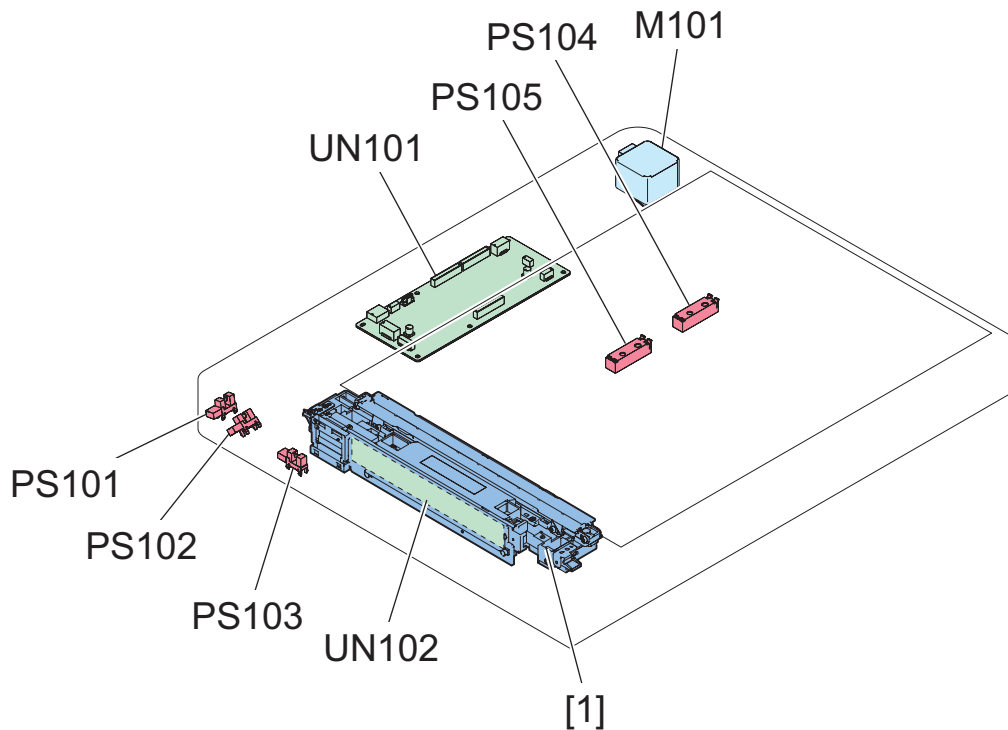
Basic configuration

■ Function configuration

Following is the list of functions.



■ Parts Configuration



Symbol	Name	Function/Specification
M101	Scanner Motor	2-phase Pulse Motor: Pulse control
PS101	DADF Open/Close Sensor 1	DADF open/close detection (at 5 degrees)
PS102	DADF Open/Close Sensor 2	DADF open/close detection (at 15 degrees)
PS103	Scanner Unit Home Position Sensor	Scanner Unit home position detection
PS104	Original Size Sensor 1	Size detection in the vertical scanning direction

Symbol	Name	Function/Specification
PS105 *1	Original Size Sensor 2	Size detection in the vertical scanning direction
UN101	Reader Controller PCB	Overall reader control, digital image processing
UN102	Reader Scanner Unit PCB	Analog image processing
[1]	Scanner Unit	Image reading

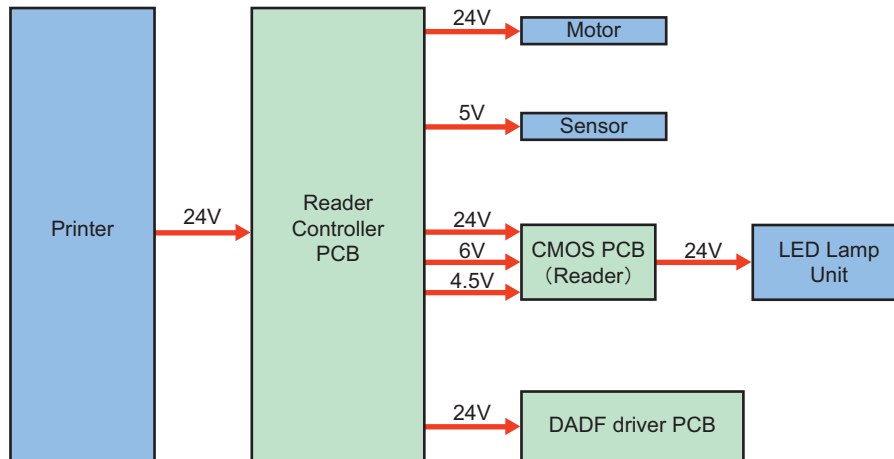
*1 : Use the AB/INCH type sensor option only when connected.

■ Outline of Electric Circuits

This machine is controlled by the Reader Controller PCB.

The Reader Controller PCB also controls DADF Driver PCB and Scanner Unit of DADF.

The relations of the electrical components are shown below.



<Related error codes>

E270-0001: Communication error between the Reader Controller PCB and Reader Scanner Unit(for paper front)

E270-0101: Communication error between the Reader Controller PCB and Reader Scanner Unit(for paper rear)

E280-0001: Communication error between the Reader Controller PCB and Reader Scanner Unit

E280-0002: Communication error between the Reader Controller PCB and Reader Scanner Unit

E280-0004: Communication error between the Reader Controller PCB and Reader Scanner Unit(for paper front)

E280-0104: Communication error between the Reader Controller PCB and Reader Scanner Unit(for paper rear)

E400-0002: Communication error between the Reader Controller PCB and DADF Driver PCB

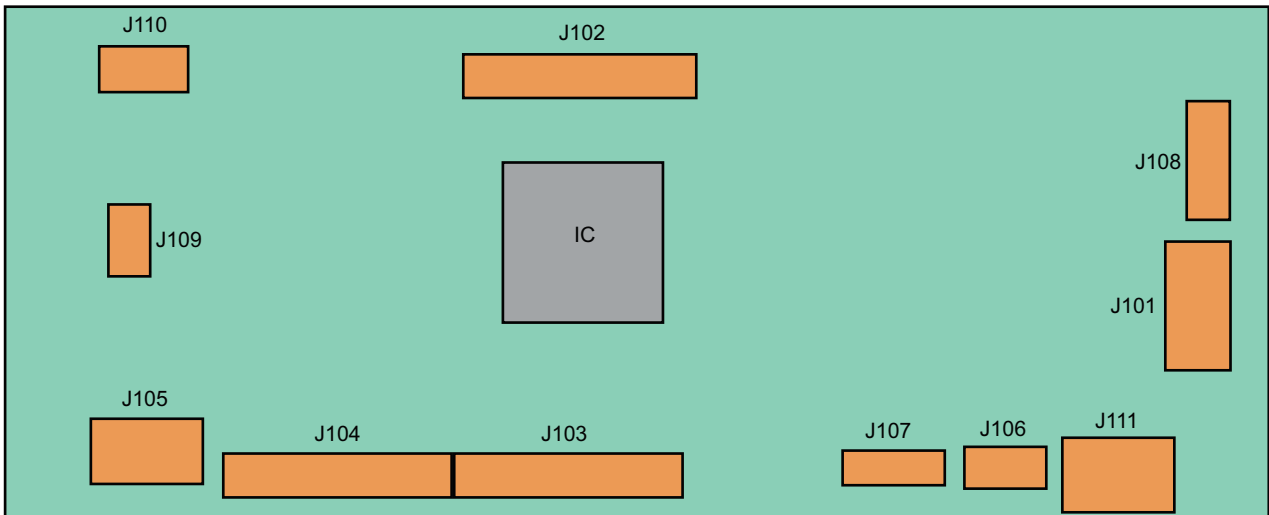
E400-0003: Communication error between the Reader Controller PCB and DADF Driver PCB

E743-0000: Communication error between the Main Controller PCB and Reader Controller PCB

■ Reader Controller PCB

The functional configuration of Reader Controller PCB is shown below.

Jack No.	Connection destination
J101	Host machine (for power supply)
J102	Scanner Unit (Reader)
J103	Scanner Unit (DADF)
J104	DADF Driver PCB (for communication)
J105	DADF Driver PCB (for power supply)
J106	For R&D use
J107	For R&D use
J108	DADF Open/Closed Sensor 1 (PS101) Scanner Unit Home Position Sensor (PS103) DADF Open/Closed Sensor 2 (PS102)
J109	Scanner Motor (M101)
J110	Original Size Sensor 1 (PS104) Original Size Sensor 2 (PS105)
J111	Main Controller PCB (for communication)



■ Scanner Unit

The Scanner Unit consisting of an LED, mirror, lens, and Reading Sensor is used to perform original exposure and reading. Light emitted from LED is reflected by the original and reaches the Reading Sensor through 5 Reflection Mirrors.

a. LED Lamp Unit

The LED Lamp Unit emits light from the 2 LED Lamp PCBs (with 40 LED chips for each PCB). The emitted light exposes the original via the Reflection Plate.

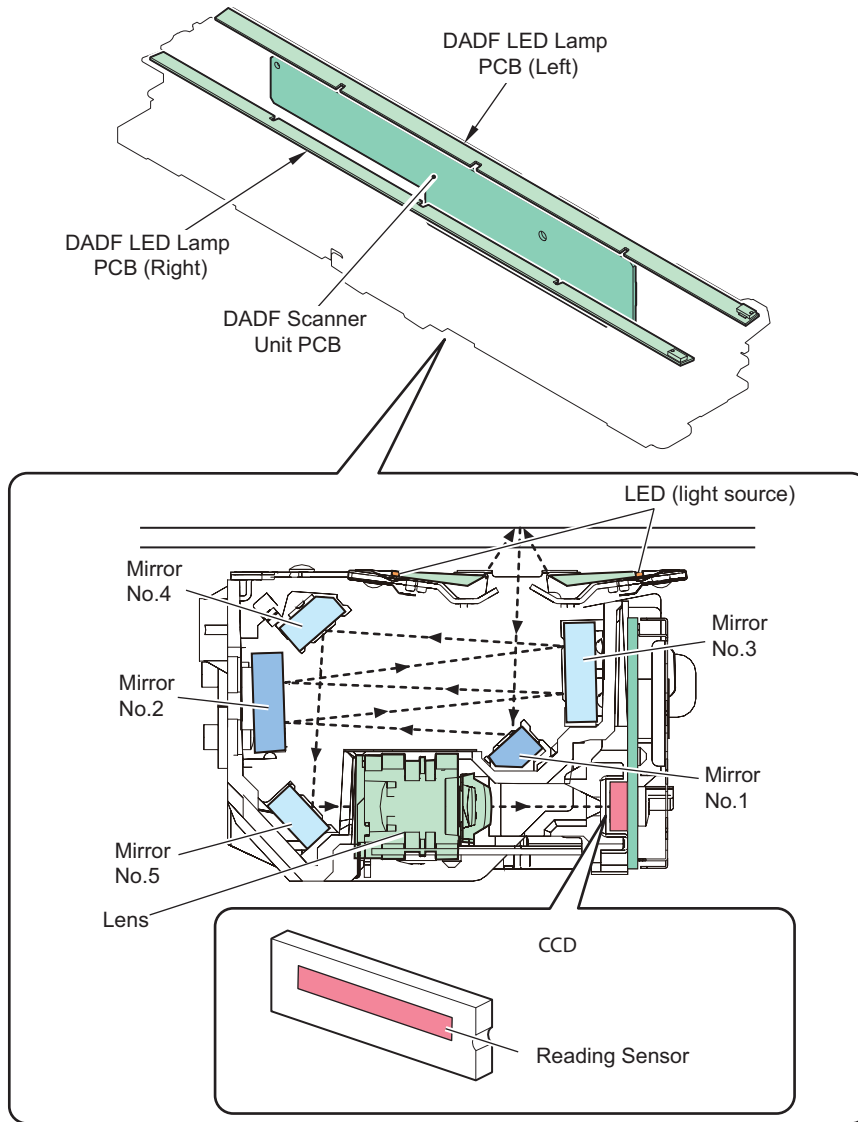
b. Reading Sensor

The Reading Sensor receives the light reflected on the original and reads the image.

<Related error codes>

E302-0001: Error in paper front white shading

E302-0002: Error in paper front black shading

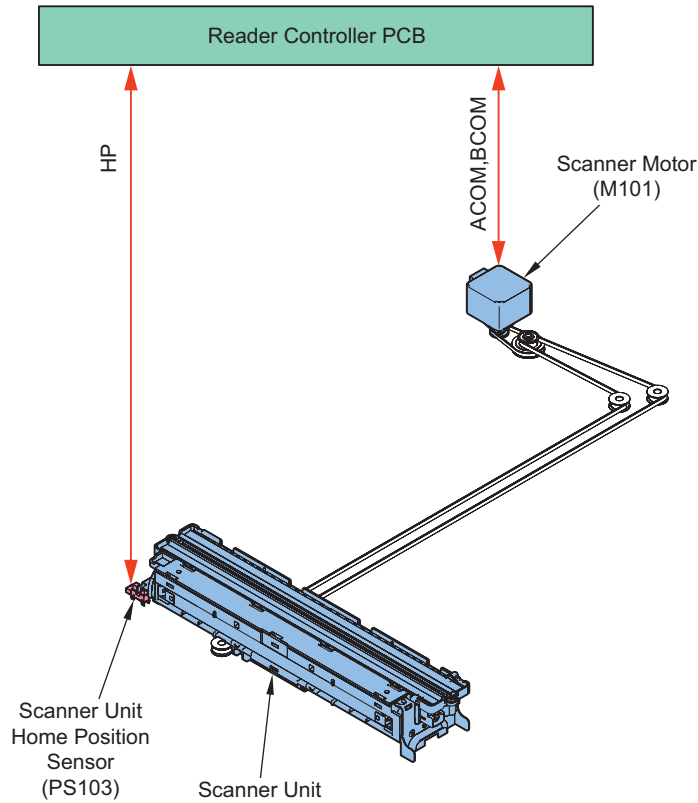


Controls

Scanner drive control

Drive System Configuration

The following shows component parts of scanner drive system.



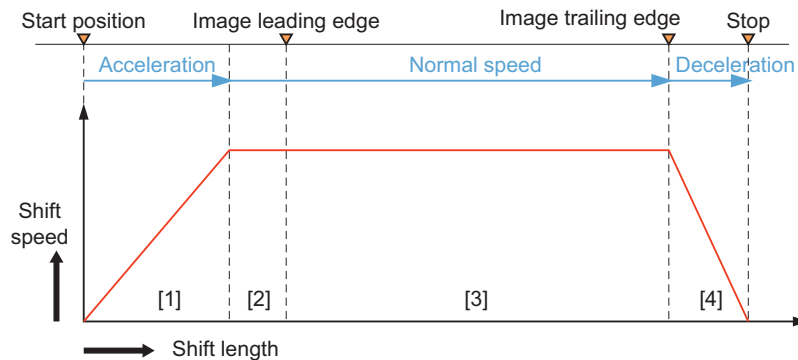
Code	Name	Functions
M101	Scanner Motor	Controls the motor rotation/stop, rotation direction, and rotation speed.
PS103	Scanner Unit Home Position Sensor	Scanner Unit home position detection
-	Scanner Unit	Image reading, analog image processing

• Scanner Motor Control

The following shows the control components for the Scanner Motor control.

The Motor Driver on the Reader Controller PCB controls the rotation/stop, rotation direction, and rotation speed of Scanner Motor based on signals from the CPU.

- Reverse operation after scanning image
After scanning an image, the reverse operation to the shading position of Scanner Unit is controlled at a constant speed regardless of color mode.
- Forward operation when scanning image
When scanning an image, the operation of Scanner Unit is controlled by the following motor control.



- [1] Acceleration Zone: accelerates to suit the selected mode.
- [2] Approach Zone: moves for speed stabilization.
- [3] Image Read Zone: reads the image at a specific speed.
(if black-and-white/SEND mode, twice as fast as in full-color mode.)
- [4] Deceleration Zone: past the image trailing edge, immediately decelerates and stops.

<Related error codes>

E202-0001: Reader Scanner Unit HP error (outward)

E202-0002: Reader Scanner Unit HP error (homeward)
 E202-0003: Reader Scanner Unit HP error (at the start of a job)

<Related service modes>

- Adjustment of the start position (vertical scanning direction) at copyboard reading
 COPIER > ADJUST > ADJ-XY > ADJ-X

■ Original size detection

● Overview

This machine determines the size of an original by the combination of the measurement results of the reflected light at particular points of the Reflection Sensor and Scanner Unit.

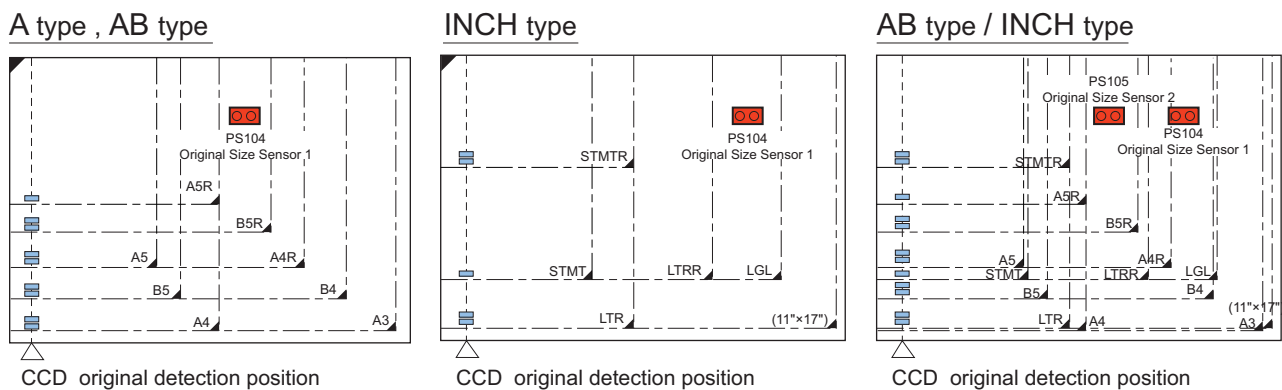
Additionally, measurement is performed for each size to perform accurate detection even if an original is moved when the ADF is closed.

- Horizontal scanning direction: Reading Sensor
- Vertical scanning direction: Reflection Photosensor

● Original Size Detection Position

In horizontal scanning direction, sensor level of each original detection position is measured by moving the Scanner Unit to the detection position shown in the following positions.

The size in the vertical scanning direction is determined by using sensors installed to the following positions.



The sensor that reacts depends on the destination.

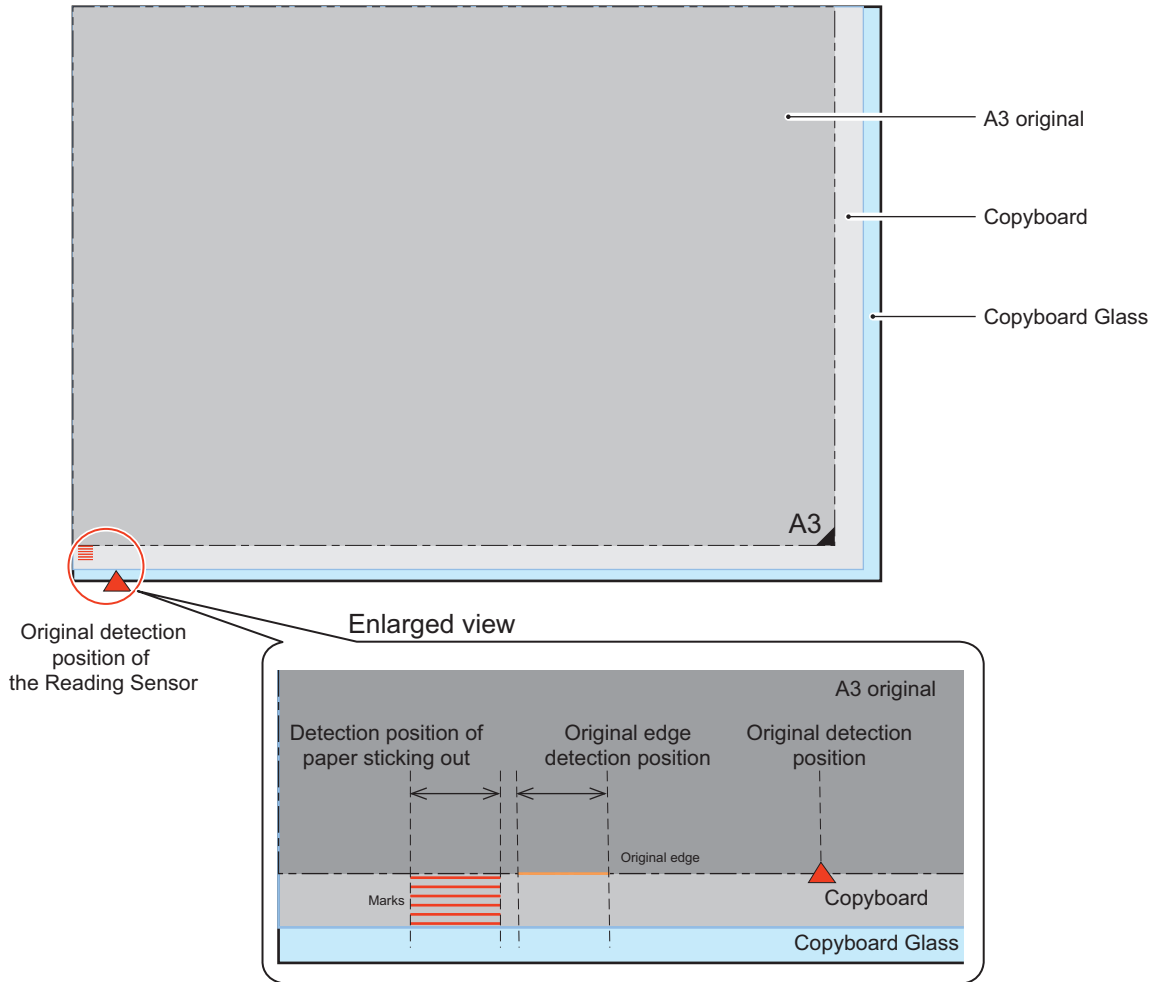
Type	Original pattern	No.
A type	AB or INCH	PS104
AB type	AB or INCH	PS104
INCH type	AB or INCH	PS104
AB/INCH type *1 (Only with sensor option connections)	AB	PS105
	INCH	PS104

*1 : If there is no option connection, the setting is AB or INCH(The presence or absence of option setting depends on the product.).

● Original Protrusion Detection

Marks are inscribed on the Copyboard outside of A3 size. Detection of original edge and detection of marks are successively executed.

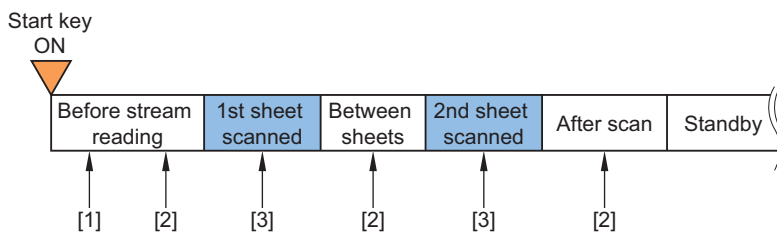
When no mark is detected, the original is identified as "sticking out" and the horizontal scanning direction is set to the maximum size (A3).



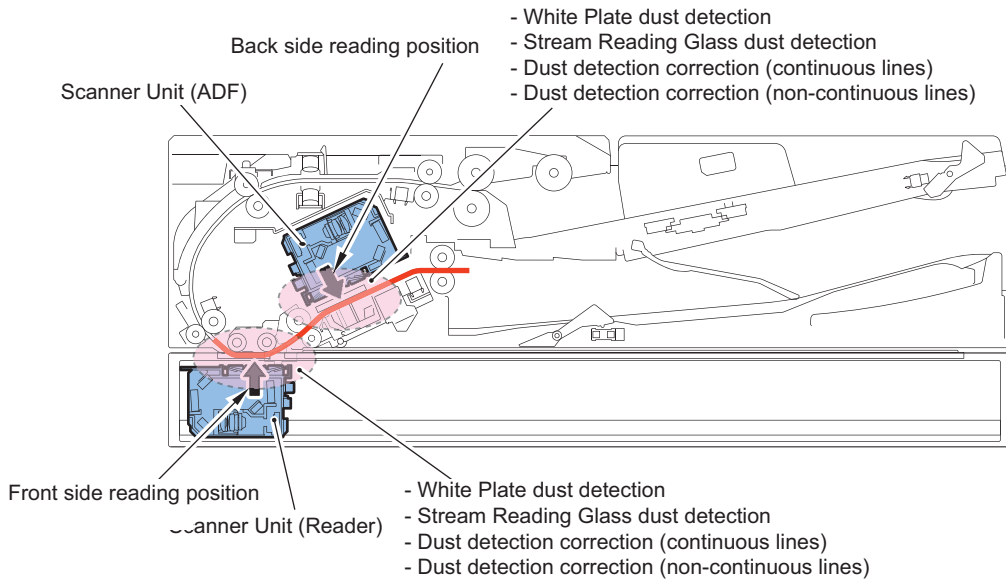
■ Dust detection control

● Overview

Detection timings of this detection are as follows.



No.	Details
[1]	White Plate dust detection control
[2]	Stream Reading Glass/Reading Glass dust detection control, dust detection correction control (continuous lines)
[3]	Dust detection correction control (non-continuous lines)



• White Plate Dust Detection Control

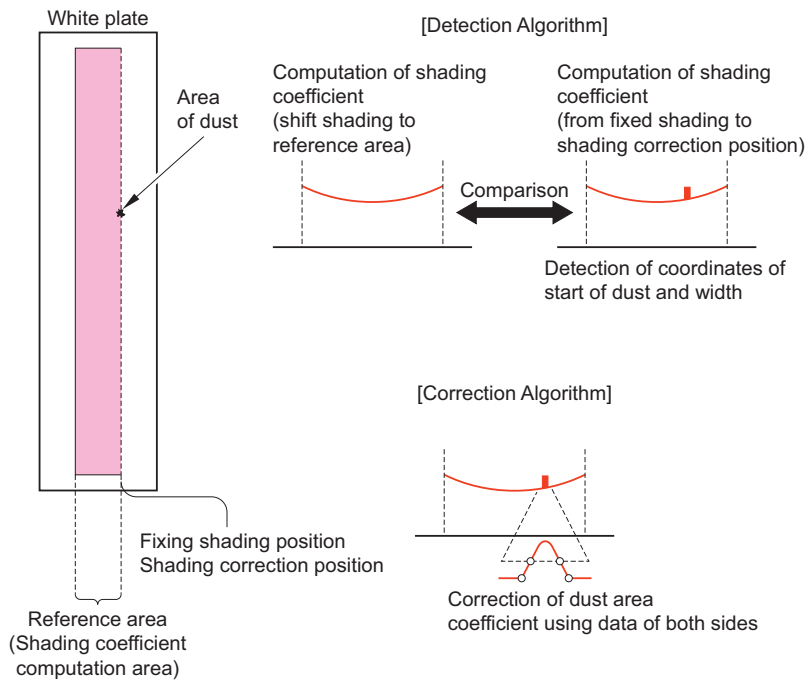
Floating dust inside the Reader may adhere to the White Plate and cause streaks on images. White Plate dust detection and correction are performed to reduce the effect of floating dust.

a. White Plate dust detection

Dust on the White Plate is detected and the coordinate and width of dust is detected by comparing the shading coefficient of shift shading and shading coefficient of fixed shading.

b. White Plate dust correction

When dust is detected by the White Plate dust detection, shading coefficient of dust area is compensated by coefficient on both sides to reduce the effect of dust. The coefficient after compensating is used for the shading correction. When dust is identified by the White Plate dust detection, shading coefficient of dust area that will be used for shading correction is compensated by coefficient on both sides to reduce the effect of dust. The coefficient after compensating is used for the shading correction.



• Guide Plate Dust Detection Control

Dust adhering to the Stream Reading Glass and Guide Plate are identified and continuous lines due to dust adhering to the Stream Reading Glass are corrected.

Dust Detection Control

1. Before the original reaches the Guide Plate, the Guide Plate is scanned and the coordinate and width of dust are detected.
2. When the original reached the Guide Plate, the leading edge of the original is detected.
3. Data scanned before and after the original reached are compared and any data that remained are identified as dust adhering to the Stream Reading Glass and the correction is applied.

Dust Correction Control

When identified as dust adhering to the Stream Reading Glass, data of dust is recorded for each page.

When outputting recorded pages, the image correction is applied and pages are output.

Lines with the maximum width of 20 pixels can be corrected.

Additionally, if non-continuous lines due to floating dust had occurred, they can be corrected by up to 6 pixels.

Related service mode

Adjustment of dust detection level when using DADF (between originals)

- Adjustment of dust detection level when using DADF (between originals)
COPIER > OPTION > IMG-RDR > DFDST-L1
- Adjustment of dust detection level when using DADF (between originals) [back side]
COPIER > OPTION > IMG-RDR > DF2DSTL1

Adjustment of dust detection level (at initial stream reading)

- Adjustment of dust detection level (at initial stream reading) [front side]
COPIER > OPTION > IMG-RDR > DFDST-L2
- Adjustment of dust detection level (at initial stream reading) [back side]
COPIER > OPTION > IMG-RDR > DF2DSTL2

Settings/Registration Menu (Reference information)

- On/Off of line-like soiling removal
[Settings/Registration] > [Function Settings] > [Common] > [Scan Settings] > [Streak Prevention]

■ Blank Paper Detection

This machine can detect blank original included in the data read by stream reading when using the scan function and skip the blank original.

Data read by stream reading is used to perform the blank paper decision by the Image Processing part.

■ Magnification change

● Magnification change in main scanning direction

In main scanning direction at copy, image is always scanned by 100% size at copyboard scanning and DADF scanning, and then magnification is changed at image processing on the main controller block. At image SEND, reading size is changed in the reader controller PCB by the specified resolution and then magnification is changed at image processing on the main controller block.

<Related service mode>

- A fine adjustment of the front side image magnification ratio in horizontal scanning direction at DADF 2-sided reading
FEEDER > ADJUST > ADJMSEN1
- A fine adjustment of the back side image magnification ratio in horizontal scanning direction at DADF 2-sided reading
FEEDER > ADJUST > ADJMSEN2

● Changing the Magnification Ratio in Vertical Scanning Direction

Changing the magnification ratio in the vertical scanning direction when copying is performed by changing the original feed speed, scanning speed, and skipping ratio.

CAUTION:

The output side can expand the vertical scan lines by 200% with the ASIC function so the feed speed does not need to be reduced even when the magnification ratio is 100% or greater.

<Related service modes>

- Fine adjustment of the image magnification ratio in vertical scanning direction at DADF reading [front side]
FEEDER > ADJUST > LA-SPEED

- Fine adjustment of the image magnification ratio in vertical scanning direction at DADF reading [back side]
FEEDER > ADJUST > LA-SPD2

■ Image Processing

The functions of the PCB related to image processing are shown below:

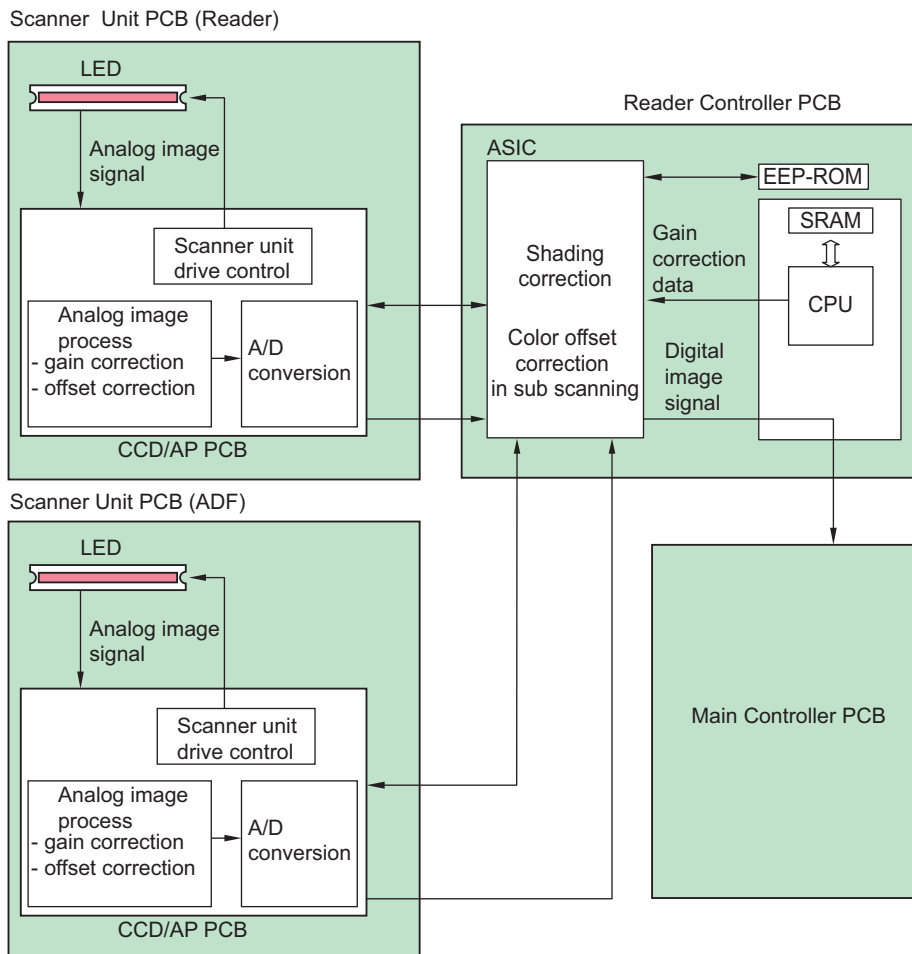
Image processing is performed by the Reader Controller PCB for each line of the images. The main functions are indicated below.

Reader Controller PCB

- Shading correction
- Color displacement correction in vertical scanning direction

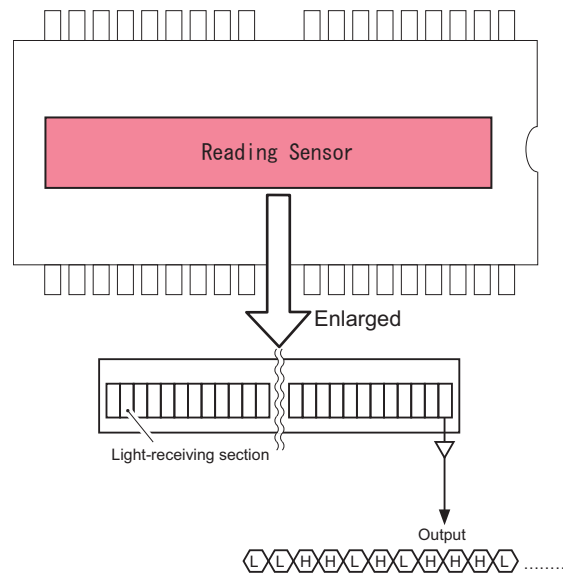
Scanner Unit PCB (in the Scanner Unit)

- Scanner Unit Drive
- Gain correction of the Reading Sensor output, Offset correction



● Scanner Unit Drive

The Reading Sensor included in this equipment is comprised of approx. 7,500 pixels. The signal photoelectrically converted by the light-receiving part is output to the Analog Front-end Circuit on the Scanner Unit PCB.



• Gain correction of the Reading Sensor output, Offset correction

The analog video signal output from the Reading Sensor has its amplification ratio aligned with a fixed value (gain correction) and has its output voltage when there is no incident light aligned with a fixed value (offset correction).

• A/D Conversion for Reading Sensor Output

The corrected analog video signal is converted into the digital signal for each pixel voltage value using an A/D converter.

• Overview of Shading Correction

Even density of an original is even, output of the Reading Sensor may not become even due to the following reasons.

- Variation in sensitivity of pixels of the Reading Sensor
- Variation in lens light intensity
- Difference in the transmission light intensity in the center of the lens and the surrounding area
- Difference in the light intensity in the center of the LED and the surrounding area
- LED deterioration

To correct unevenness of the Reading Sensor output, shading correction is performed.

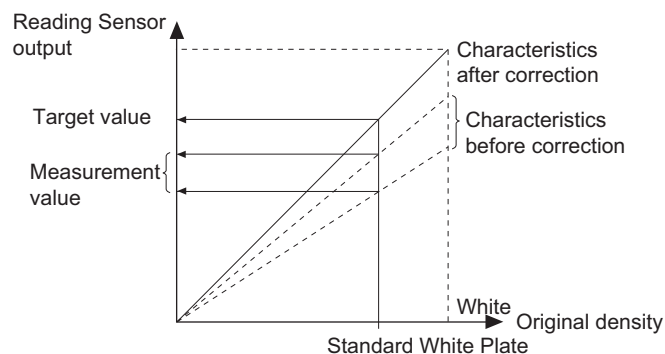
In shading correction, there is a type of shading correction that is executed per job.

• Shading correction

Shading correction is performed for each scanning of original.

With this operation, light of LED Lamp is emitted to the Standard White Plate, and the reflected light is converted into digital data at the analog image processing part of the Scanner Unit PCB. The amount of digitized reflected light is input to the shading correction circuit in the Main Controller PCB as the shading coefficient. In the shading correction circuit, the stored target value and the shading coefficient are compared, and the difference is determined as the shading correction value.

With this shading correction value, variation of pixel of the Reading Sensor of each scan is corrected to make the image density level even.



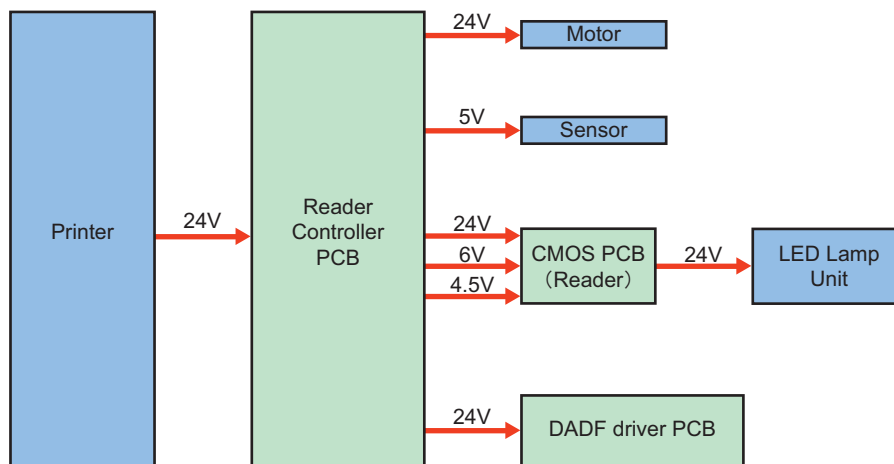
■ Power Supply Assembly

An overview of the power supply is indicated below.

The Reader Controller PCB receives 24 V of power supply.

The 24V power is mainly used for the motor, fan, and the LED Lamp Unit. Additionally, it is supplied to the DADF Driver PCB and Scanner Unit of DADF.

The 5V power is mainly used for the sensors.



<Related error codes>

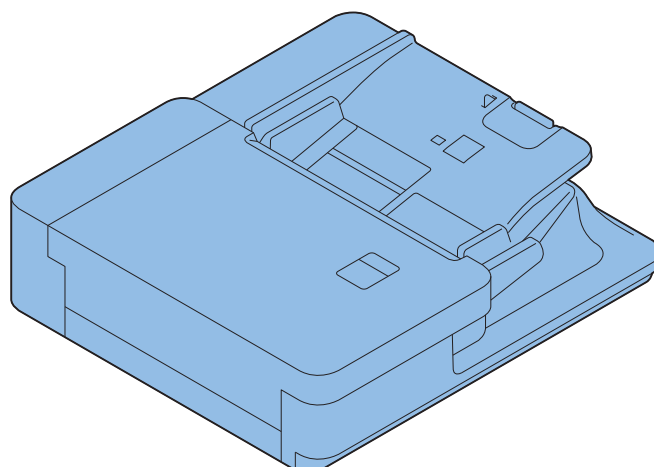
E227-0001: 24V Power Supply error of the Reader Controller PCB

E227-0101: 24V Power Supply error of the DADF Driver PCB

Original Feed System (Single Pass ADF)

Features

- Increased productivity (1-side/2-side): 135 ipm/270 ipm (300 dpi)
- Achieved the reduced operation noise by reducing the registration processing
- Support for Thin / Heavy paper: Supports 38 g/m² paper stack originals and 160 to 220 g/m² paper
- Support for small sized paper: Supports 70 mm x 139.7 mm originals
- Increased tray capacity: 250 sheets (64 g/m²)
- Enhanced measures against lines at stream reading: Surf clear coat glass, image correction improvement
- Improved copyboard original size detection: Modified to no-dazzling method and improved accuracy of folded paper detection
- Abnormal original detection function: Stops feeding when stapled originals (for example) is detected
- Improved operability by location change of the handle



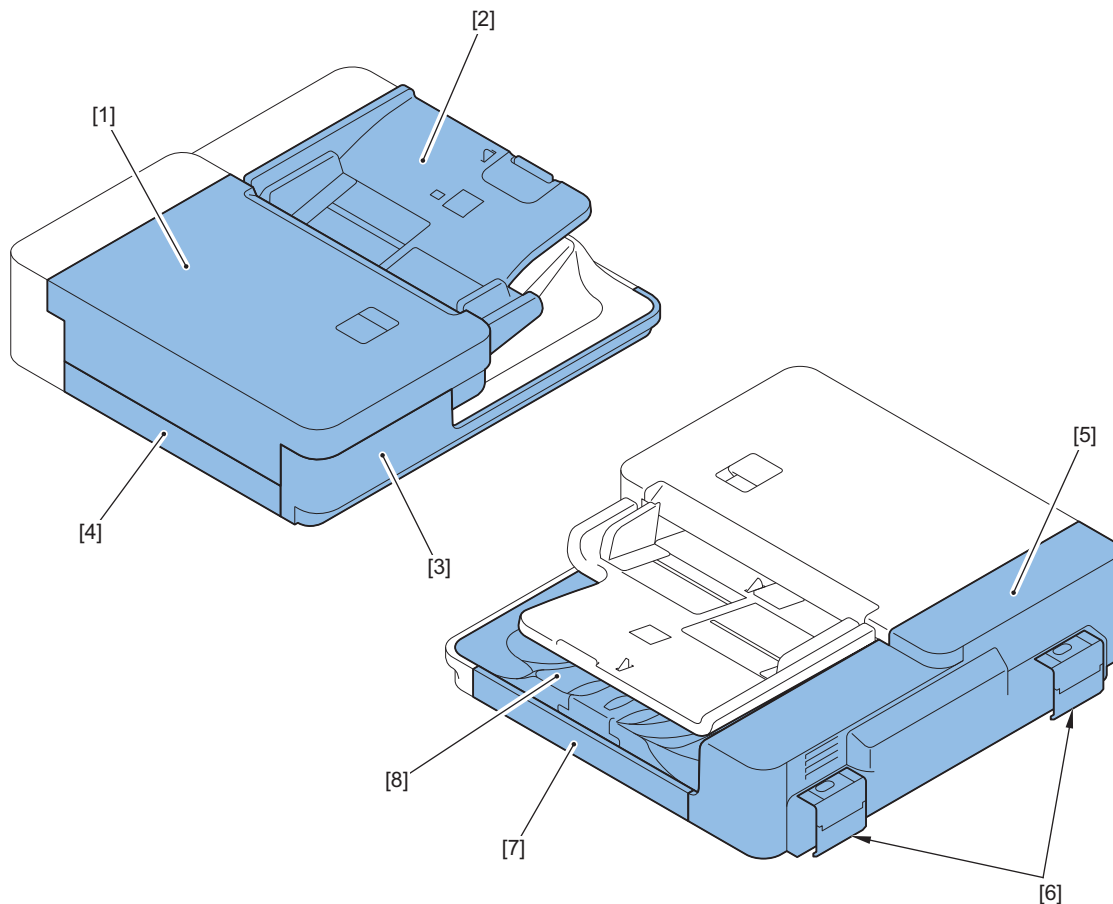
Specifications

Item	Specifications	Remark
Document size	A3R, A4, A4R, A5, A5R, A6R, B4R, B5, B5R, B6R, 11"x17"R, LGLR, LTR, LTRR, STMT, STMT, 8KR, 16K Crosstrack 70.0 mm to 304.8 mm (* 1)(* 2) Intrack 139.7 to 431.8 mm, 431.8 to 990 mm (Long Original) (* 3)	* 1 Max Scanning Width 297 mm * 2 A6R or less(Width):not support automatic paper size sensor. * 3 Intrack range depends on the system function
Paper Material	A/B 38 to 220 g/m ² (* 1)(* 2)(* 3) inch 50 to 220 g/m ² (* 1)(* 3)	* 1 38 to 50 g/m ² :Thin mode, 160 to 220 g/m ² :heavy mode. * 2 A6R or less: 50 to 220 g/m ² * 3 BW/CL mixed original: same as Non mixed BW or CL
Input Capacity	250 sheets (64 g/m ²)(* 1) 200 sheets (75/80 g/m ²)	A6R or less:100 sheets Original feed length more than 432mm :1 sheet. Height22.0mm or less * 1 A6R or less:100 sheets Original feed length more than 432 mm :1 sheet. Height 22.0 mm or less
2-sided single pass ADF	Yes	
Original separation method	Roller separation method	
Mixed Input	Same configuration mode Yes Different configuration mode Yes	

Item	Specifications	Remark
Scan Productivity (* 1)	Platen BW:A4:0.81 sec / LTR:0.83 sec CL:A4:0.81 sec / LTR:0.83 sec ADF 1-sided (Plain mode, Send) BW 135 ipm (A4 / LTR) CL 135 ipm (A4 / LTR) ADF 1-sided (Plain mode, Copy) BW 51 ipm (A4 / LTR) CL 51 ipm (A4 / LTR) ADF 2-sided (Plain mode, Send) BW 270 ipm (A4 / LTR) CL 270 ipm (A4 / LTR) ADF 2-sided (Plain mode, Copy) BW 51 ipm (A4 / LTR) CL 51 ipm (A4 / LTR)	* P/S 260 mm/sec * 1 : The reading speed varies depending on the connected Host machine, so please refer to the specifications of the Host machine.
ADF Durability	2,000K sheets (A4 / LTR) or 5 years	
Power supply	From the Main Unit	
Max. power consumption	Included in the Energy Consumption of main body	

Parts Name

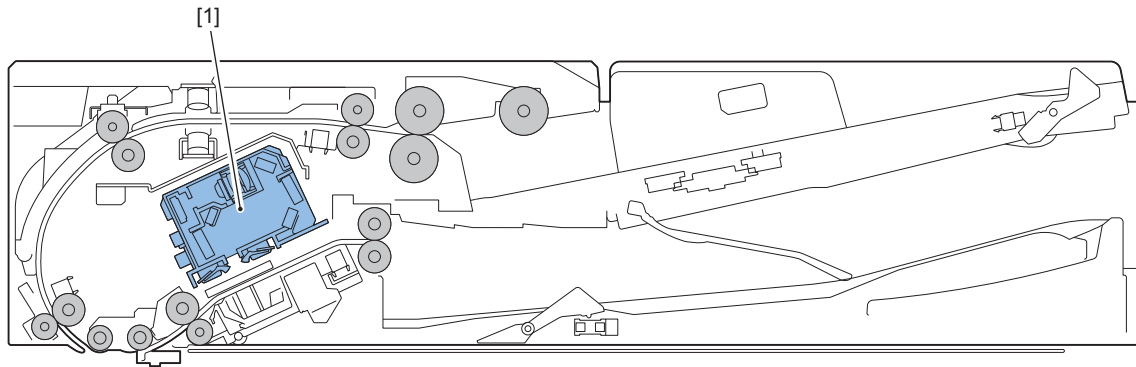
External View



No.	Name
[1]	Open/Close Cover
[2]	Document Tray
[3]	ADF Front Cover

No.	Name
[4]	ADF Left Lower Cover
[5]	ADF Rear Cover
[6]	Hinge Cover
[7]	ADF Right Cover
[8]	Delivery Tray

■ Cross Section View

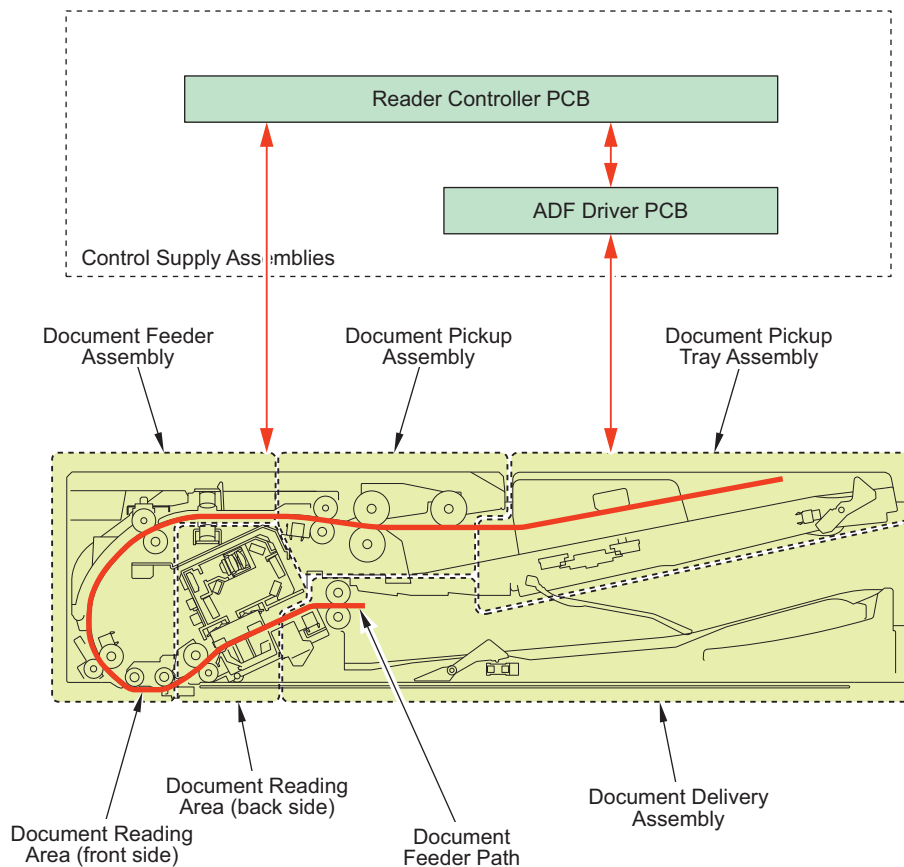


Key No.	Name
[1]	Scanner Unit

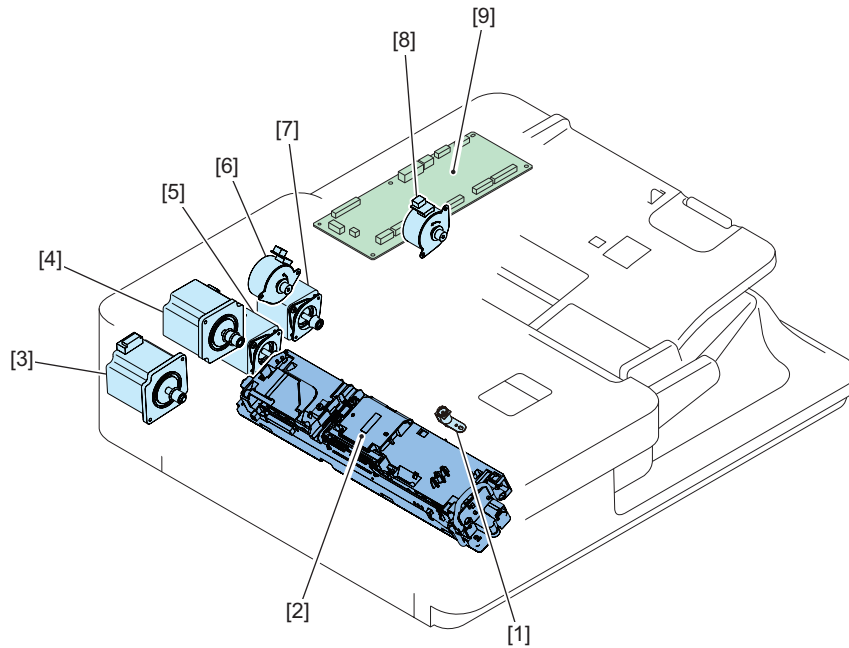
● Basic Configuration

■ Functional Configuration

A list of functions is indicated below.



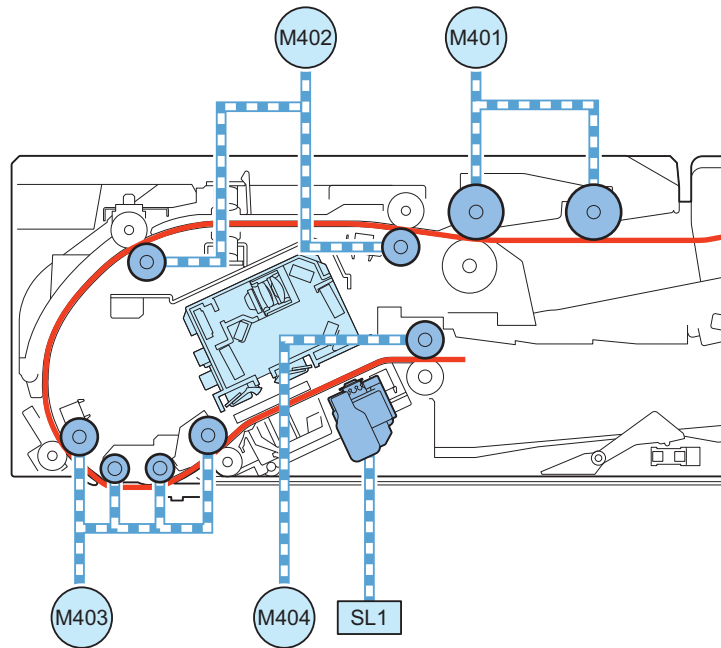
■ Parts Configuration



Key No.	Name	Symbol
[1]	Stamp Solenoid	SL401
[2]	Scanner Unit	-
[3]	Read Motor	M403
[4]	ADF Pull-out Motor	M402
[5]	ADF Delivery Motor	M404
[6]	Pickup Roller Lifting Motor	M405
[7]	ADF Pickup Motor	M401
[8]	Tray Lifting Motor	M406
[9]	ADF Driver PCB	UN_401

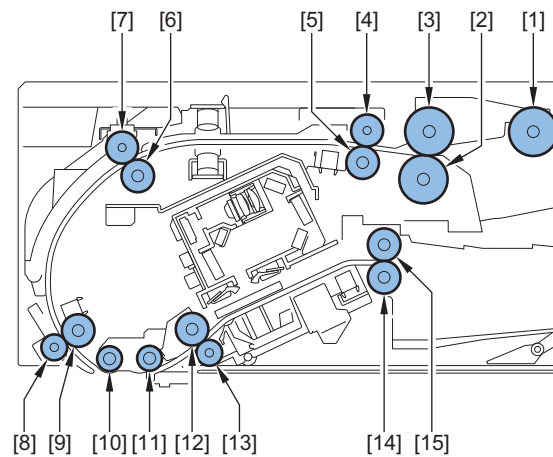
■ Drive Configuration List

This equipment is a document feeder for stream reading only.
 This equipment has 4 motors and a solenoid as drive load.
 It also has a unit for reading originals (for the back side) (Scanner Unit).
 The drive configuration of this equipment is indicated below.



Symbol	Name	Role
M401	Pickup Motor	Drive of Pickup Roller
M402	Pull-out Motor	Drive of Pull-out Roller
M403	Read Motor	Drive of Read Roller
M404	Delivery Motor	Drive of Delivery Motor, Movement of Glass
M405	Pickup Roller Lifting Motor	Drive of Pickup Roller Lifting Roller
M406	Tray Lifting Motor	Drive of Tray Lifting
SL401	Stamp Solenoid	Stamp drive

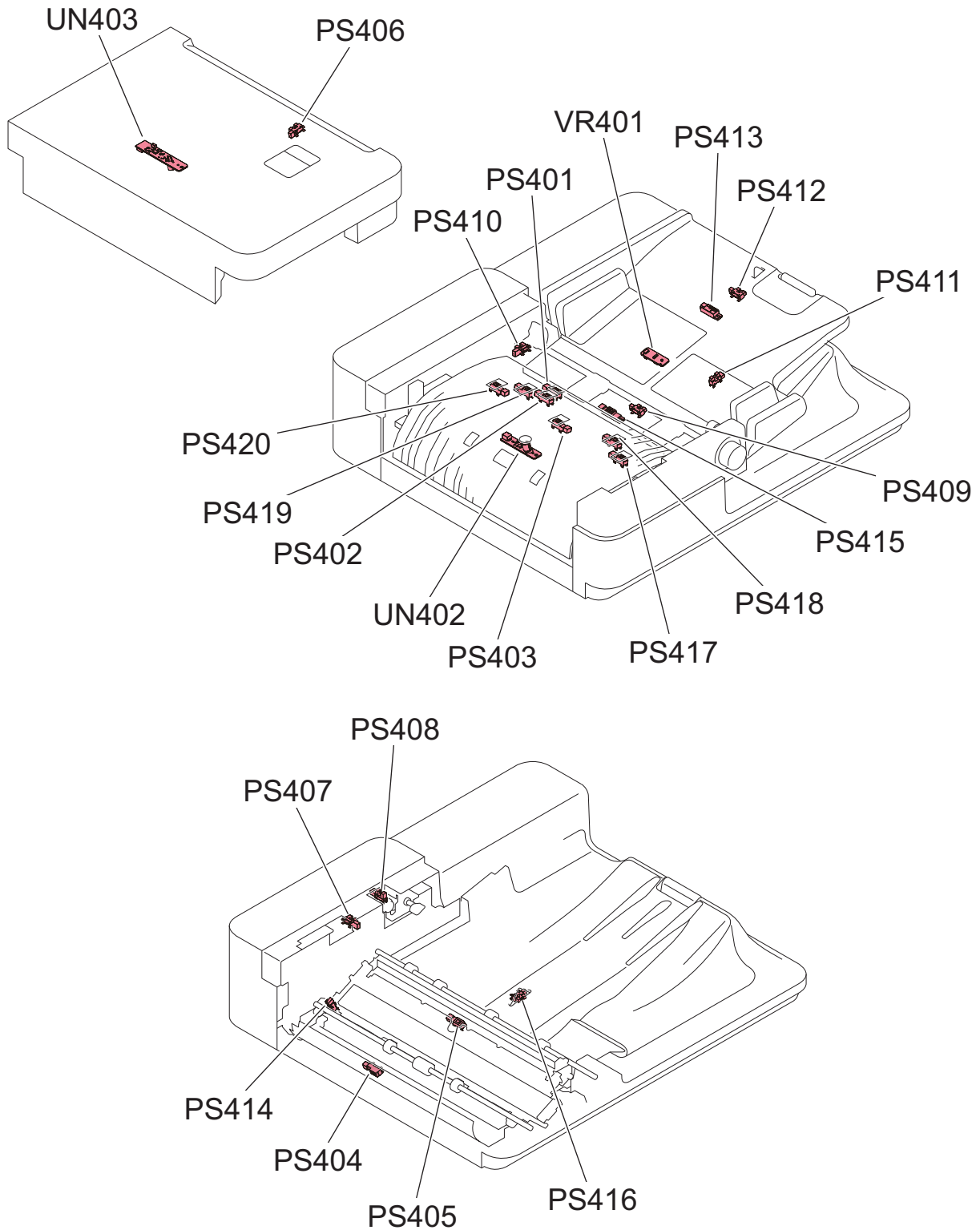
■ List of Rollers



Key No.	Name
[1]	Pickup Roller
[2]	Separation Roller
[3]	Feed Roller
[4]	Pullout Roller
[5]	Pullout Roller
[6]	Pullout Roller
[7]	Pullout Roller
[8]	Lead Roller 1
[9]	Lead Roller 1
[10]	Platen Roller 1

Key No.	Name
[11]	Platen Roller 2
[12]	Lead Roller 2
[13]	Lead Roller 2
[14]	Delivery Roller
[15]	Delivery Roller

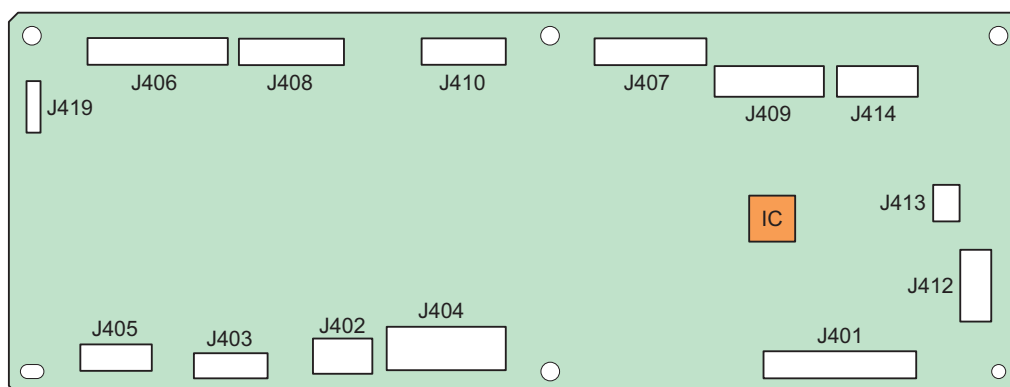
■ List of Sensors



Symbol	Name	Detection description	Jam Detection		
			Delay	Stationary	Others
VR401	Original Width Detection Resistance	Original width length detection	-	-	-
PS401	Pre-separation Sensor	The position of the leading edge of the original immediately before pickup	Applicable	Applicable	Applicable
PS402	Post-separation Sensor	The position of the leading edge of the original immediately after pickup	Applicable	Applicable	Applicable
PS403	Pullout Sensor	The position of the leading edge of the original after pulling out to pickup	Applicable	Applicable	Applicable
PS404	Read Sensor	Image reading start/end timing	Applicable	Applicable	Applicable
PS405	Pre-delivery Sensor	The position of the trailing edge of the original before delivery	Applicable	Applicable	Applicable
PS406	Tray Paper Surface Sensor	Presence of original paper surface on the original pickup tray	-	-	-
PS407	Cover Open/Closed Sensor	Opening/closing of the Feeder Cover	-	-	-
PS408	Pickup Roller Lifting HP Sensor	Home position of the Pickup Roller that rises and lowers	-	-	-
PS409	ADF Sleep Exit Sensor	Presence of original on the Document Pickup Tray	-	-	-
PS410	Tray Lifting HP Sensor	Home position of the tray that rises and lowers	-	-	-
PS411	AB/Inch Identification Sensor	Distinguish between A4R and LTRR, between A5R and STMTR	-	-	-
PS412	LGL Identification Sensor	Distinguish between LTR-R and LGL	-	-	-
PS413	Large Size/ Small Size Sensor	Identify the original warping and bending	-	-	-
PS414	Paper Back Reading Glass HP Sensor	Reading Glass position	-	-	-
PS415	Original Sensor	Presence of original on the Document Pickup Tray	-	-	-
PS416	Delivery Stack Detection Sensor	Capacity of Delivery Tray	-	-	-
PS417	Skew Detection Sensor (Large, Front)	Detect skewing of original by the time difference of detection timing	-	-	-
PS418	Skew Detection Sensor (Small, Front)		-	-	-
PS419	Skew Detection Sensor (Small, Rear)		-	-	-
PS420	Skew Detection Sensor (Large, Rear)		-	-	-
UN402	Double Feed Detection Sensor PCB (Transmission)	Double feed detection (transmission)	-	-	Applicable
UN403	Double Feed Detection Sensor PCB (Reception)	Double feed detection (reception)	-	-	Applicable

ADF Driver PCB

The following shows to which the ADF Driver PCB is connected.

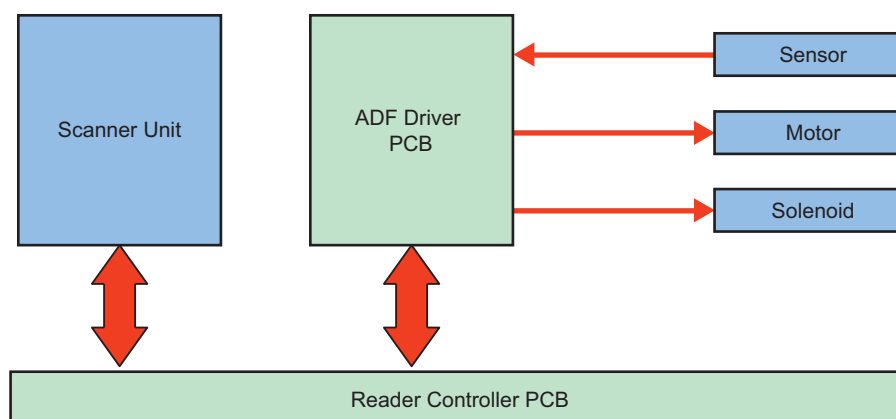


ADF Driver PCB J No.	Connection destination	
	Symbol	Name
J401	-	Reader Controller PCB

ADF Driver PCB J No.	Connection destination	
	Symbol	Name
J402	-	Reader Controller PCB
J403	M401	ADF Pickup Motor
	M404	ADF Delivery Motor
J404	M402	ADF Pull-out Motor
	M403	Read Motor
J405	M405	Pickup Roller Lifting Motor
	M406	Tray Lifting Motor
J406	PS401	Pre-separation Sensor
	PS402	Post-separation Sensor
	PS407	Cover Open/Closed Sensor
	PS408	Pickup Roller Lifting HP Sensor
	PS418	Skew Detection Sensor (Small, Front)
	PS419	Skew Detection Sensor (Small, Rear)
J407	SL401	Stamp Solenoid
	PS404	Lead Sensor
	PS405	Pre-delivery Sensor
	PS414	Paper Back Reading Glass HP Sensor
	PS416	Delivery Stack Detection Sensor
J408	UN402	Post-separation Sensor
	PS403	Pullout Sensor
	PS417	Skew Detection Sensor (Large, Front)
	PS420	Skew Detection Sensor (Large, Rear)
J409	PS409	ADF Sleep Exit Sensor
	PS411	AB/Inch Identification Sensor
	PS412	LGL Identification Sensor
J410	UN403	Double Feed Detection Sensor PCB (Reception)
	PS406	ADF Paper Surface Sensor
	LED401	Original Set LED
J412	PS413	Large Size/ Small Size Sensor
	LED402	Delivery Lighting LED
J413	PS410	Tray Lifting HP Sensor
J414	VR401	Original Width Detection Resistance
	PS415	Original Sensor
J419	-	for R&D

Outline of Electric Circuits

This machine is controlled by the Reader Controller PCB.
The relations of the electrical components are shown below.



Related Error Codes

Communication error between Reader Controller PCB and Scanner Unit

- E270-0001: Communication error between the Reader Controller PCB and Reader Scanner Unit(for paper front)
- E270-0101: Communication error between the Reader Controller PCB and Reader Scanner Unit(for paper rear)
- E280-0001: Communication between the Reader Controller PCB and the Reader Scanner Unit was not completed within the specified period of time.
- E280-0002: Disconnection of FFC between the Reader Controller PCB and the Reader Scanner Unit was detected.
- E280-0101: Communication between the Reader Controller PCB and the DADF Scanner Unit was not completed within the specified period of time.
- E280-0102: Disconnection of FFC between the Reader Controller PCB and the DADF Scanner Unit was detected
- E280-0004: Communication error between the Reader Controller PCB and Reader Scanner Unit(for paper front)
- E280-0104: Communication error between the Reader Controller PCB and Reader Scanner Unit(for paper rear)

Communication error between Reader Controller PCB and DADF

- E400-0001: A communication error between the Reader Controller PCB and the DADF Driver PCB was detected.
- E400-0001: A communication error between the Reader Controller PCB and the DADF Driver PCB was detected.
- E400-0003: Disconnection of the harness between the Reader Controller PCB and the DADF Driver PCB was detected.
- E401-0001: Pickup Roller Unit Lifting HP Sensor error
- E401-0002: Pickup Roller Unit Lifting HP Sensor error
- E407-0001: Lifter Motor error
- E407-0002: Lifter error

ADF Fan error

- E412-0005: Rotation of fan was detected after the stop signal for the DADF Cooling Fan was transmitted.
- E412-0006: Stop of fan was detected after rotation signal for the DADF Cooling Fan was transmitted.

Different DADF model error

- E490-0001: An improper Scanner Unit is installed.
- E490-0101: An improper DADF is installed.

Scanner Unit

■ Configuration of the Scanner Unit

The Scanner Unit has the same mechanism as that of the reader. For details, refer to "Scanner Unit" in "Basic Configuration" in the section "Reader Technology".

Related Error Codes

Shading error

- E302-0001: Error in paper front white shading
- E302-0002: Error in paper front black shading
- E302-0101: Error in paper back white shading
- E302-0102: Error in paper back black shading

Related Alarm Codes

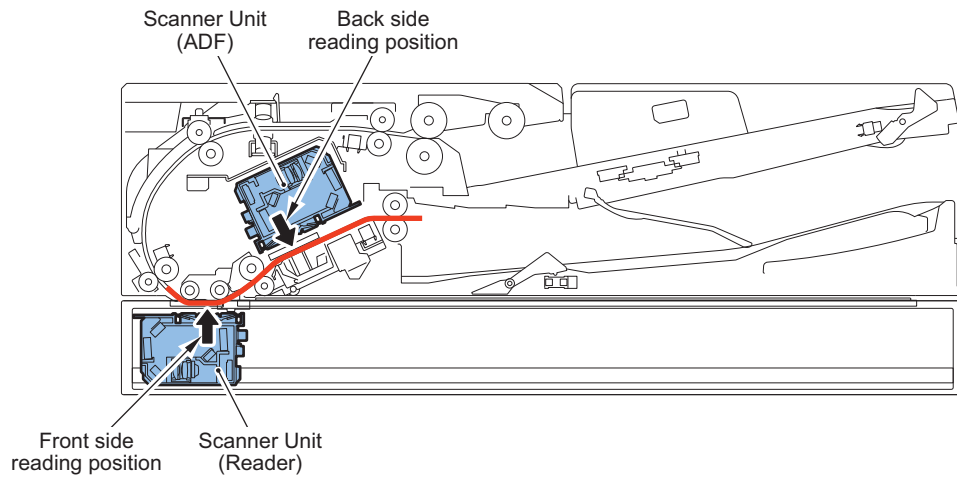
Light intensity error

- 02-0025: Insufficient Scanner Unit (Paper Front) LED light intensity alarm (Some of the LEDs are OFF. Scanning can be continued.)

■ Duplex Reading Control

2-sided originals are read using simultaneous duplex reading.

With one feed, the Scanner Unit of the Reader Unit reads the front side and the Scanner Unit of the ADF reads the back side without reversing the paper.



Related service mode

- Fine adjustment of image ratio in horizontal scanning direction when duplex scanning [paper front]
FEEDER > ADJUST > ADJMSEN1
- Fine adjustment of image ratio in horizontal scanning direction when duplex scanning [back side]
FEEDER > ADJUST > ADJMSEN2

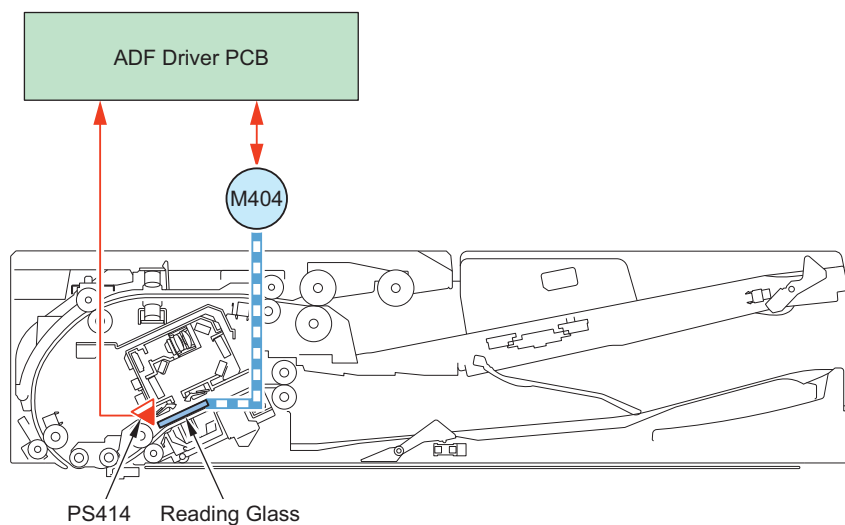
■ Glass Shift Control

This machine has a Reading Glass at the bottom of the Scanner Unit.

This Reading Glass has affixed on it a Standard White Plate used for shading correction and dust detection correction.

The Reader Controller drives the Glass Drive Motor (M404: shared as the Delivery Motor) as needed to move the Reading Glass.

With this, the Reader Controller executes the above-mentioned corrections by comparing the position of the Standard White Plate with the reflection data of the image reading position.



Related Error Codes

Scanner HP error

- E202-0101: DADF Scanner Unit HP error
- E202-0102: DADF Scanner Unit HP error

■ Detecting and Correcting Skew Using Scanned Image

Overview

Images are rotated (skew correction) on the output based on the amount of skew measured during stream reading.

This enables to increase productivity and reduce noise at the same time by eliminating the need for configuration to have a registration mechanism that presses the original document against the roller to make the skew of the leading edge of the original document and the horizontal scanning direction line closer.

Skew Detection

Detects skew by determining it from a scanned image instead of using sensors. It binarizes the scanned image to detect the following three items.

Edge

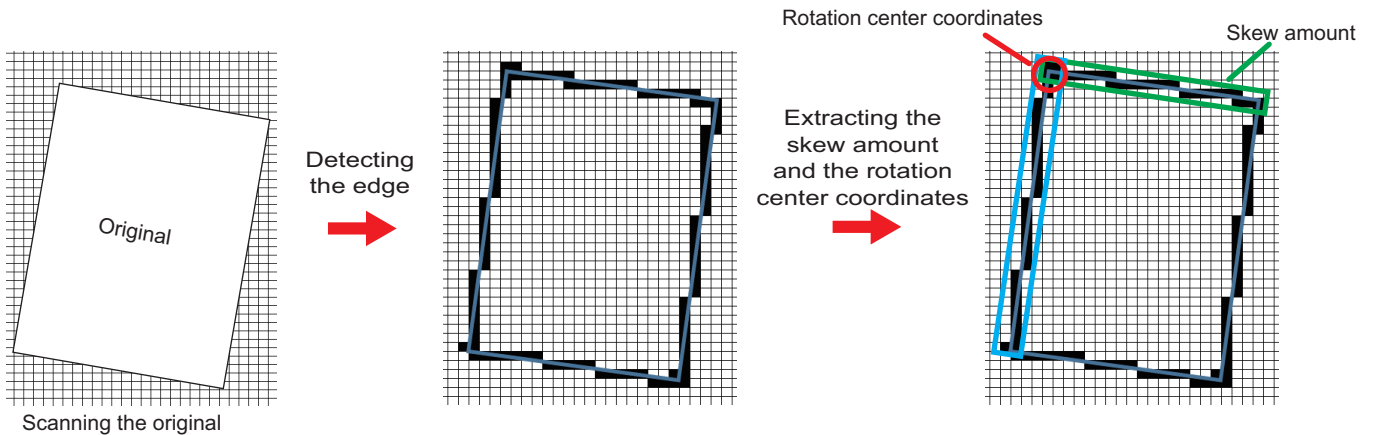
The shadow of the original on the opposed plate is detected as the edge of the original.

Skew amount

Skew amount is detected from the degree of the edge detected.

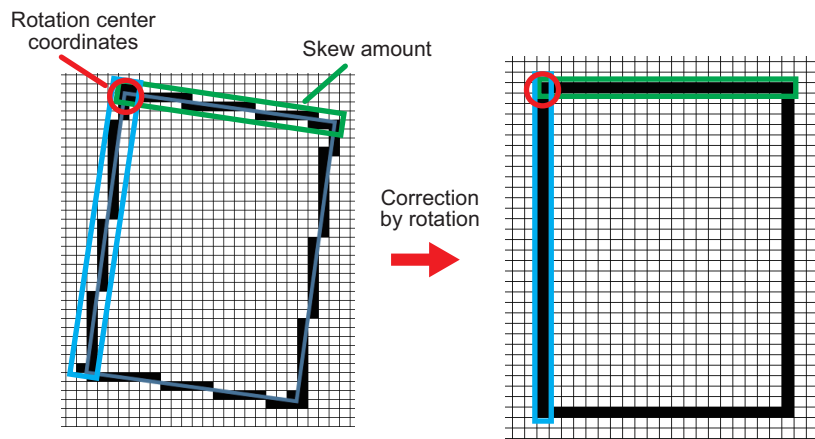
Rotation center coordinates

Rotation center coordinates is detected from the edge and the skew amount.



Skew Correction

Corrects the skew by rotating the image data according to the detected skew amount.



NOTE:

- When the edge of original is damaged or bent, the accurate skew amount may not be detected and the correction function may fail to function.
 - The upper limit value of the cross-feed correction angle varies depending on the document size as shown below. When the cross-feed exceeding the upper limit value of the correction angle is detected, the read image is printed as it is without having the cross-feed correction.
 - Length in vertical scanning direction 250mm or more: 1.5°
 - Length in vertical scanning direction 200mm - 249mm: 2°
 - Length in vertical scanning direction 199mm or less: 3°
- In the mixed mode of the different width original, the cross-feed detection control by the sensor is canceled, and the cross-feed correction is performed up to a maximum of 3.5°.

Correction of the leading edge

Corrects the leading edge of the scanned image after skew correction if the leading edge position of the image is not appropriate.

Correction of the left edge

Corrects the left edge of the scanned image after skew correction if the left edge position of the image is not appropriate.

Angle correction

Corrects rotation angle on the scanned image after skew correction.

Parallelogram correction

Corrects the angle of the image to be 90 degrees by outputting the image while shifting it towards the horizontal scanning direction.

Related Service Mode**ON/OFF of the skew correction function**

- Switching between ON and OFF of the skew correction function at ADF stream reading
FEEDER > OPTION > SKW-SW

Adjustment of leading edge margin of the scanned image for the corrected image

- Adjustment of the leading edge margin of the image at DADF reading [front side]
FEEDER > ADJUST > ADJ-T1
- Adjustment of the leading edge margin of the image at DADF reading [back side]
FEEDER > ADJUST > ADJ-T2

Adjustment of the left edge margin of the scanned image for the corrected image

- Adjustment of the left edge margin of the image at DADF reading [front side]
FEEDER > ADJUST > ADJ-L1
- Adjustment of the left edge margin of the image at DADF reading [back side]
FEEDER > ADJUST > ADJ-L2

Angle correction of the corrected image

- Angle correction at DADF reading [front side]
FEEDER > ADJUST > ADJ-ROT1
- Angle correction at DADF reading [back side]
FEEDER > ADJUST > ADJ-ROT2

Parallelogram correction amount for corrected image

- Parallelogram correction for DADF reading [front side]
FEEDER > ADJUST > ADJ-PAR1
- Parallelogram correction for DADF reading [back side]
FEEDER > ADJUST > ADJ-PAR2

Pickup Feed System

■ Original size detection

Overview

Timing and sensors that perform original size detection for each copy mode are shown below.
For details of detection description, refer to the following chapter.

Timing	Detection direction	Detecting sensor	Copy mode			
			Normal copy (Copy)	Mix of same configuration mode (Copy > Options > Different Size Originals > Same Width)	Mix of different configuration mode (Copy > Options > Different Size Originals > Different Width)	Long original (Copy > Other Functions > Long Original)
Pickup start	Original length detection	LGL Identification Sensor (PS412) Large Size/ Small Size Sensor (PS413)	Detect	-	-	-
	Original width detection	AB Inch Sensor (PS411)	Detect	Detect	-	-

Timing	Detection direction	Detecting sensor	Copy mode			
			Normal copy (Copy)	Mix of same configuration mode (Copy > Options > Different Size Originals > Same Width)	Mix of different configuration mode (Copy > Options > Different Size Originals > Different Width)	Long original (Copy > Other Functions > Long Original)
Pickup start	Original width detection	Original Width Detection Resistance (VR401)	Detect	Detect	Detect	Detect
During feed	Original length detection	Pullout Sensor (PS403)	Detect	Detect	Detect	Detect
	Original width detection	- *	-	-	Detect	-

*: This equipment does not have the Different Width Sensor that the existing machines had. It performs the width detection during feeding by the skew detection function.

NOTE:

Normal, Mix of the same configuration, and Mix of different configurations modes: The measured value is converted to a standard size.

Long original mode (custom size detection): The length of original is detected and the measured value itself is used as the original size.

Tray Size Detection

When the original is placed on the original tray, 3 sensors are used to detect the original size.

AB regions

Width (mm) (Original Width Detection Resistance)	AB/Inch Identification Sensor	Large Size/ Small Size Sensor Large/ Small Sensor	LGL Identification Sensor	Detection size
272 mm or larger	-	ON	ON	A3
	-	OFF	OFF	A4
Larger than 247 mm and 272 mm or smaller	-	ON	ON	B4
	-	OFF	OFF	B5
Larger than 200 mm and 247 mm or smaller	-	ON	ON	A4R
	-	OFF	OFF	A5
Larger than 172 mm and 200 mm or smaller	-	ON	OFF	B5R
Larger than 138.5 mm and 172 mm or smaller	-	OFF	OFF	A5R
Larger than 105 mm and 138.5 mm or smaller	OFF	OFF	OFF	B6R
120 mm or smaller	ON	OFF	OFF	A6R
105 mm or smaller	OFF	OFF	OFF	Narrow width original

AB/K configuration

Width (mm) (Original Width Detection Resistance)	AB/Inch Identification Sensor	Large Size/ Small Size Sensor Large/ Small Sensor	LGL Identification Sensor	Detection size
283 mm or larger	-	ON	ON	A3
	-	OFF	OFF	A4
Larger than 263 mm and 283 mm or smaller	-	ON	ON	K8
	-	OFF	OFF	K16

Width (mm) (Original Width Detection Resistance)	AB/Inch Identification Sensor	Large Size/ Small Size Sensor Large/ Small Sensor	LGL Identification Sensor	Detection size
Larger than 247 mm and 263 mm or smaller	-	ON	ON	B4
	-	OFF	OFF	B5
Larger than 200 mm and 247 mm or smaller	-	ON	OFF	A4R
	-	OFF	OFF	A5
Larger than 172 mm and 200 mm or smaller	-	ON	OFF	B5R
Larger than 138.5 mm and 172 mm or smaller	-	OFF	OFF	A5R
Larger than 105 mm and 138.5 mm or smaller	-	OFF	OFF	B6R
120 mm or smaller	ON	OFF	OFF	A6R
105 mm or smaller	OFF	OFF	OFF	Narrow width original

Inch configuration

Width (mm) (Original Width Detection Resistance)	AB/Inch Identification Sensor	Large Size/ Small Size Sensor Large/ Small Sensor	LGL Identification Sensor	Detection size
289 mm or larger	-	ON	ON	LDR
	-	OFF	OFF	LTR
Larger than 272 mm and 289 mm or smaller	-	ON	ON	LDR
	-	OFF	OFF	LTR
Larger than 247 mm and 272 mm or smaller	-	ON	ON	(LDR)
	-	OFF	OFF	(LTR)
Larger than 200 mm and 247 mm or smaller	-	ON	ON	LGL
	-	ON	OFF	LTRR
	-	OFF	OFF	STMT
Larger than 172 mm and 200 mm or smaller	-	ON	ON	(LGL)
	-	ON	OFF	(LTRR)
	-	OFF	OFF	(STMT)
Larger than 105 mm and 172 mm or smaller	-	OFF	OFF	STMTR
105 mm or smaller	OFF	OFF	OFF	Narrow width original

AB/Inch configuration

Width (mm) (Original Width Detection Resistance)	AB/Inch Identification Sensor	Large Size/ Small Size Sensor Large/ Small Sensor	LGL Identification Sensor	Detection size
289 mm or larger	-	ON	ON	A3
	-	OFF	OFF	A4
Larger than 272 mm and 289 mm or smaller	-	ON	ON	LDR
	-	OFF	OFF	LTR
Larger than 247 mm and 272 mm or smaller	-	ON	ON	B4
	-	OFF	OFF	B5
Larger than 200 mm and 247 mm or smaller	OFF	ON	ON	LGL
	OFF	ON	OFF-	LTRR
	OFF	OFF	OFF	STMT
	ON	ON	OFF	A4R
	ON	OFF	OFF	A5
Larger than 172 mm and 200 mm or smaller	-	ON	OFF	B5R
Larger than 138.5 mm and 172 mm or smaller	OFF	OFF	OFF	A5R
	ON	OFF	OFF	STMTR

Width (mm) (Original Width Detection Resistance)	AB/Inch Identification Sensor	Large Size/ Small Size Sensor Large/ Small Sensor	LGL Identification Sensor	Detection size
Larger than 105 mm and 138.5 mm or smaller	OFF	OFF	OFF	B6R
120 mm or smaller	ON	OFF	OFF	A6R
105 mm or smaller	OFF	OFF	OFF	Narrow width original

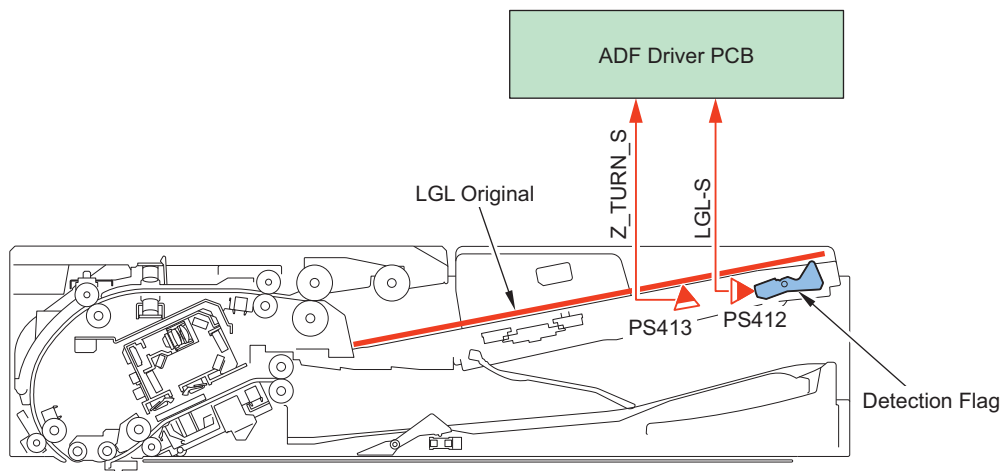
• Detection when Starting Pickup

When starting pickup, the paper size is estimated by the length of feed direction and length of width.

Detection in the Feed Direction

The LGL Identification Sensor (PS412) and Large Size/ Small Size Sensor (PS413) are used to detect the length of original in the feed direction.

When the original is placed on the original pickup tray, the LGL Identification Sensor (PS412) or the Large Size/ Small Size Sensor (PS413) detects the original.

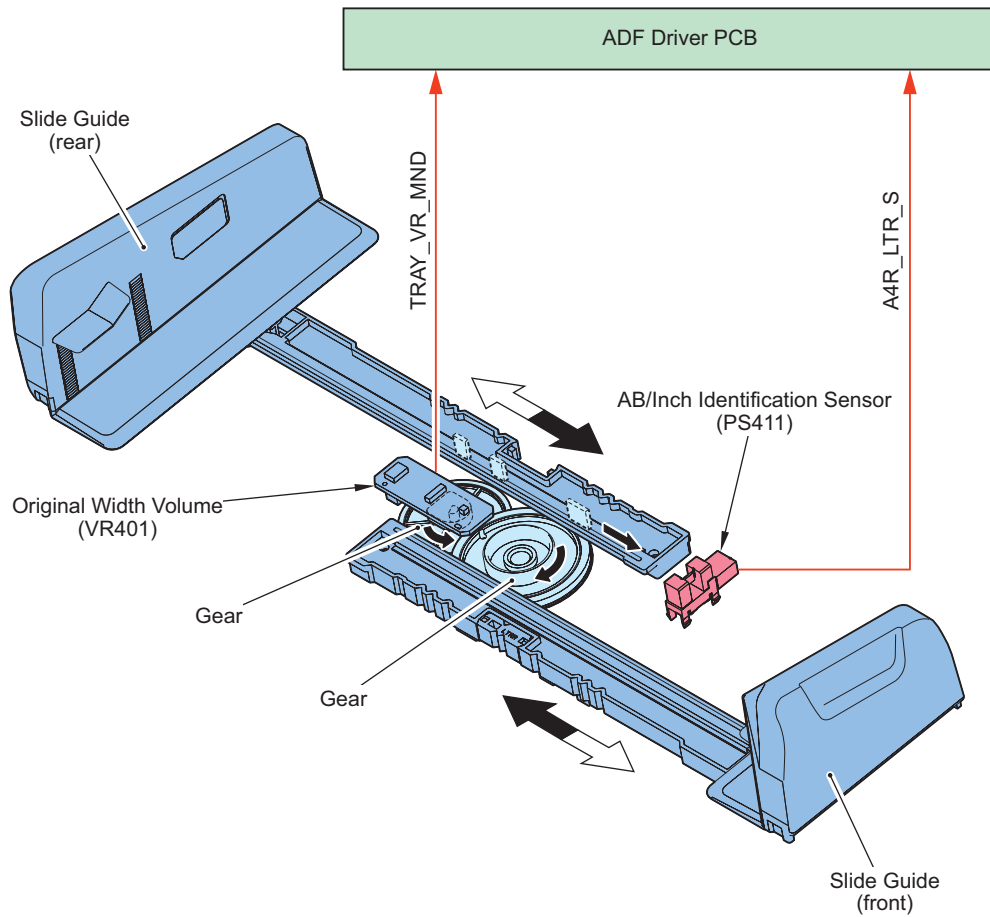


Detection in the Width Direction

The original size in the width direction is detected using the Original Width Detection Resistance (VR401) and AB/Inch Identification Sensor (PS411).

The Original Width Detection Resistance (VR401) is linked to the Slide Guide and its resistance value changes in analog manner. The ADF Driver PCB receives this change in the resistance value as an original size signal, and uses it as the size in the width direction.

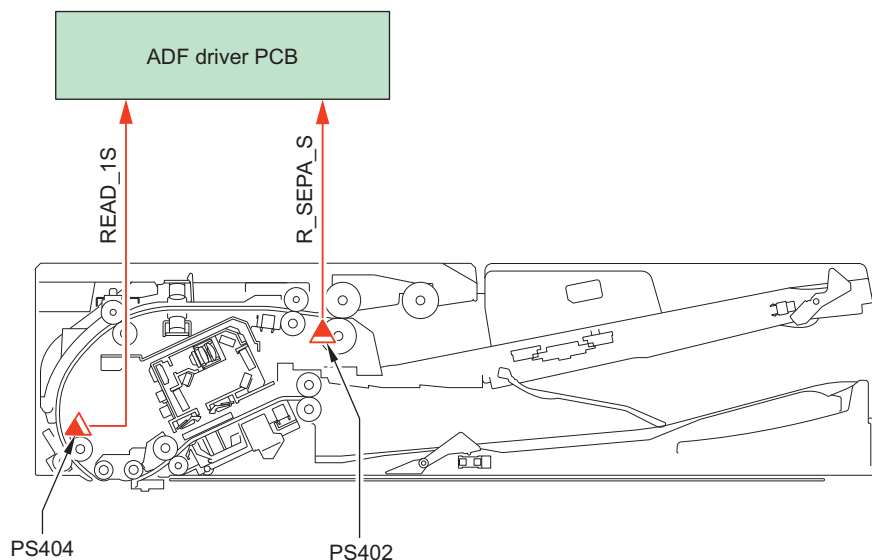
To accurately detect the width of A4R and LTRR, A5R and STMTR, the combination of detection status of AB/Inch Sensor (PS411) and Original Width Detection Resistance (VR401) is used to judge and output the AB/Inch identification detection signal.



• **Detection in the Feed Direction**

Detection in the Feed Direction

Detection signals of the Post-separation Sensor (PS402) and the Lead Sensor (PS404) are used to calculate the original size in the feed direction.



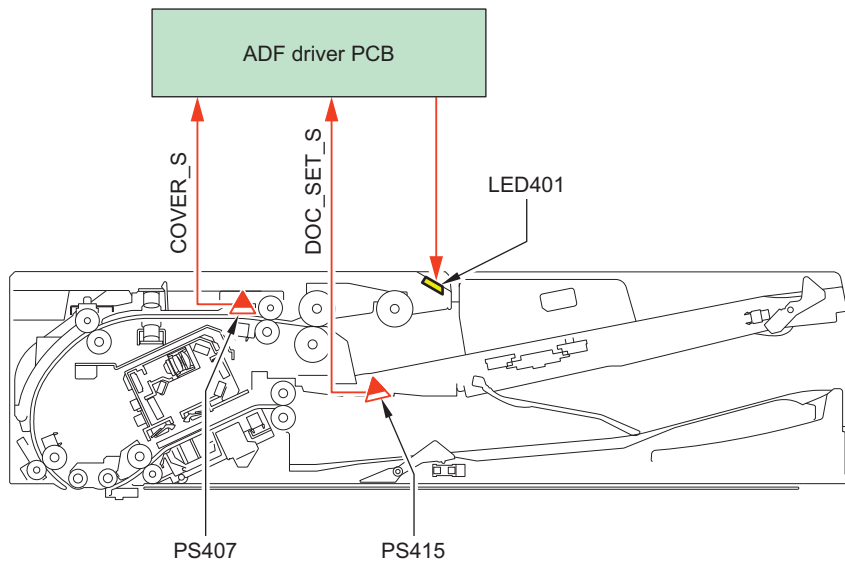
Detection in the Width Direction (only when using the mix of different configurations)

This equipment does not have the Different Width Sensor that the existing machines had. It performs the width detection during feeding by the skew detection function.

■ **Original Detection Control**

When all of following conditions are met, this equipment lights up the Original Set LED (LED401).

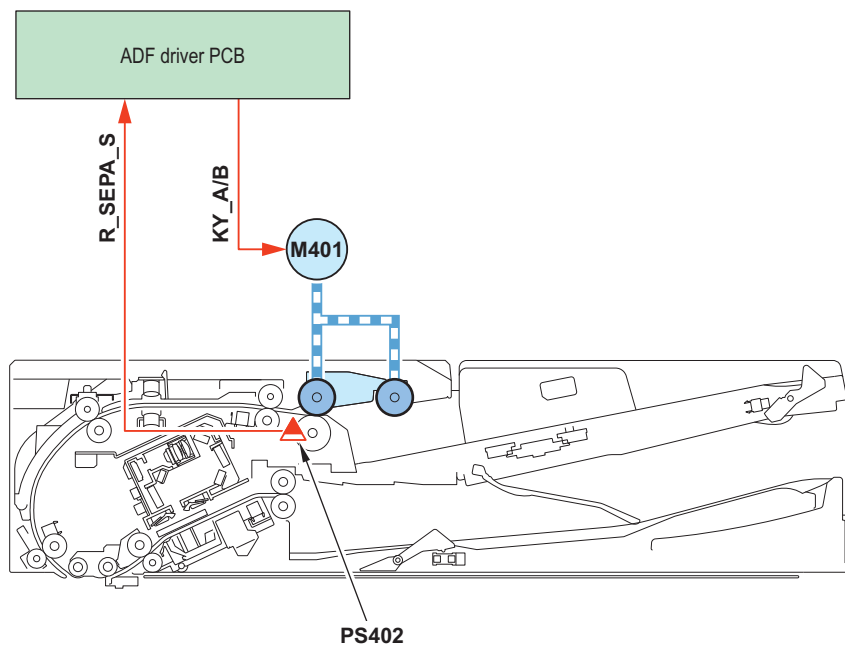
- The Original Sensor (PS415) detects that the original was placed on the original pickup tray and the original detection signal is sent to the ADF Driver PCB
- The Cover Open/Closed Sensor (PS407) detects that the Feeder Cover is closed and sends the feeder cover open/closed detection signal to the ADF Driver PCB



No.	Name
LED401	Original Set LED
PS415	Original Sensor
PS407	Cover Open/Closed Sensor

■ Pickup Operation

The pickup operation is performed by the following rollers and motors driving rollers.



Classification	No.	Name	Description
Roller	-	Pickup Roller	Roller picking up originals
	-	Feed Roller	
	-	Separation Roller	Roller separating originals to prevent double feeding
	-	Pullout Roller	Roller pulling out the picked up original into the machine
	-	Lead Roller	

Classification	No.	Name	Description
Motor	M401	Pickup Motor	Motor driving the A/B Roller
	M402	Pull-out Motor	Motor driving the Pullout Roller
	M405	Pickup Roller Lifting Motor	Motor lifting and lowering the Pickup Roller
	M406	Tray Lifting Motor	Motor lifting and lowering the tray

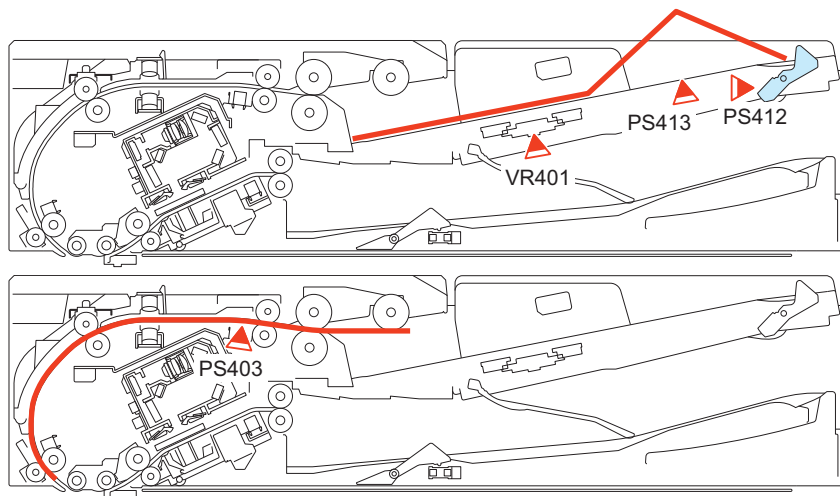
■ Detection of Folded Original

Overview: System Configuration

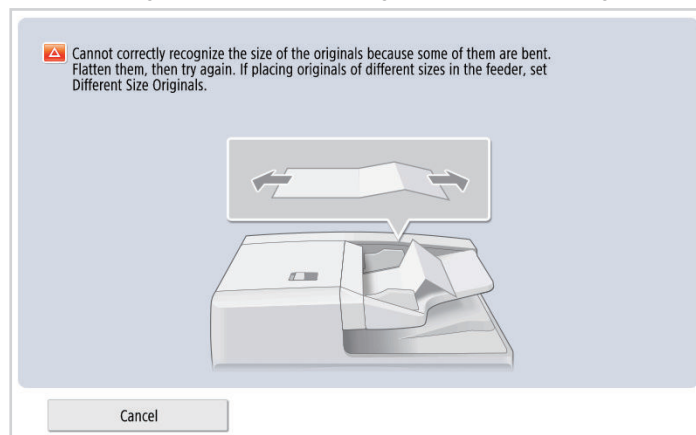
To prevent from a part of the image being lost in case the size of the original is not detected well because of the curl or the bent of the original on the Original Tray.

Detection description

The reading job is stopped when it is determined that a part of the image may be lost due to the fact that the length of the original being fed is longer than the length of the original detected by the sensor (VR401/PS412) on the Original Tray after comparing those lengths.



In case to stop the job, after completing delivery without stopping the delivery, prompt to display the following message on the Control Panel and to straighten the bent originals or to set the Original Sizes mixed original.



Detection condition

The following are the requirements to perform a bend detection.

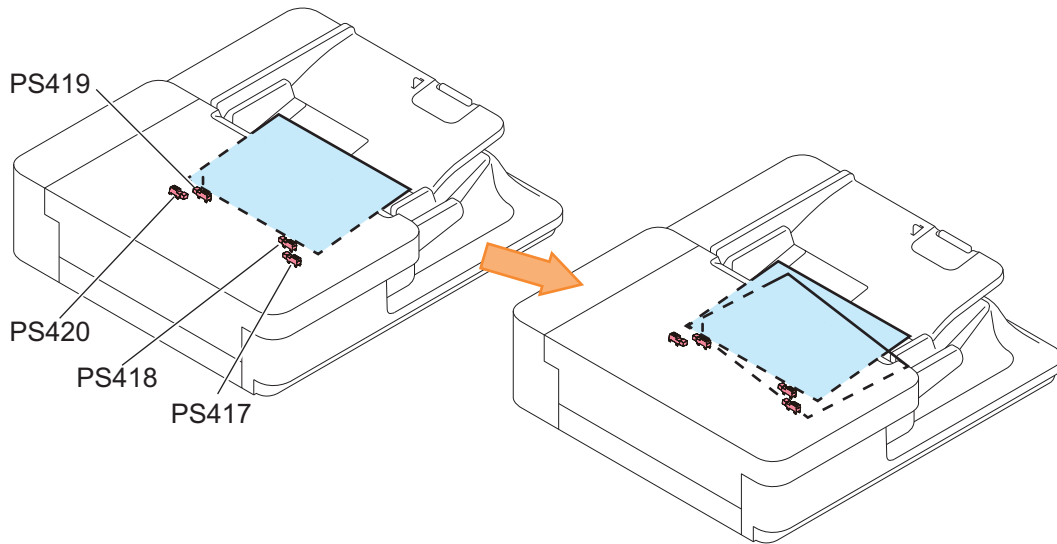
- The original length by vertical scanning on the original tray is smaller than A3.
- Mixed original is not specified
- Long Original is not specified

■ Skew Detection Control

Overview of detection

Skew detection sensors are arranged along the horizontal scanning direction symmetrically with respect to the center line. This function measures the skew amount of originals from the difference of timings in which these sensors are turned ON.

This prevents jams inside the ADF by stopping the feed when a stapled original or an original placed on the Pickup Tray at an angle is picked up.



Symbol	Name:
PS417	Skew Detection Sensor (Large, Front)
PS418	Skew Detection Sensor (Small, Front)
PS419	
PS420	Skew Detection Sensor (Large, Rear)

NOTE:

If the following conditions are met, the skew detection cannot be done.

- The paper width is smaller than the distance between the Skew Staple Detection Sensors (small) (i.e. less than 172 mm).
- Media with different paper widths
- Free Size Original

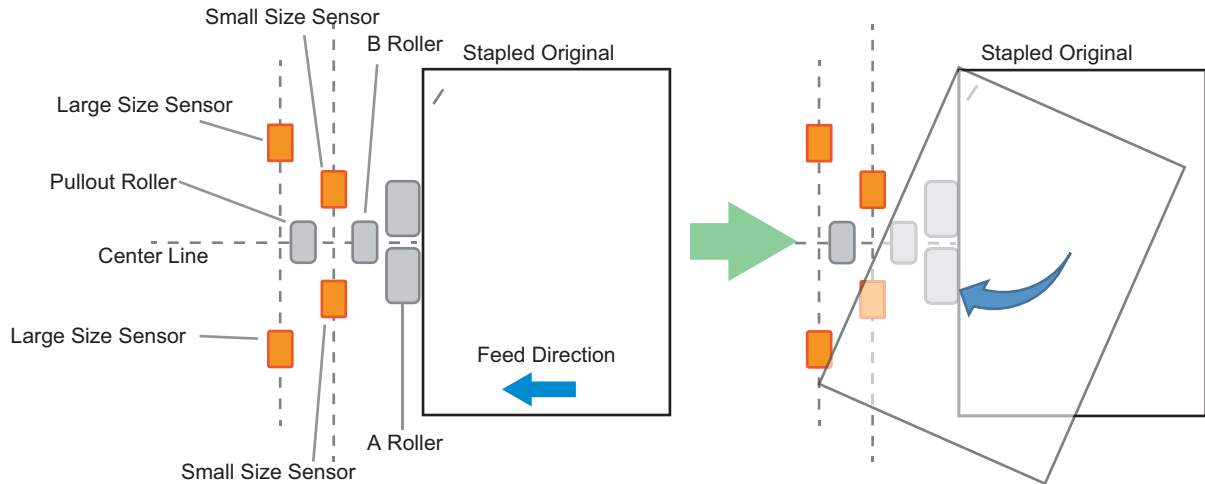
Control Description

The following is an explanation using a case where a stapled original is picked up as an example.

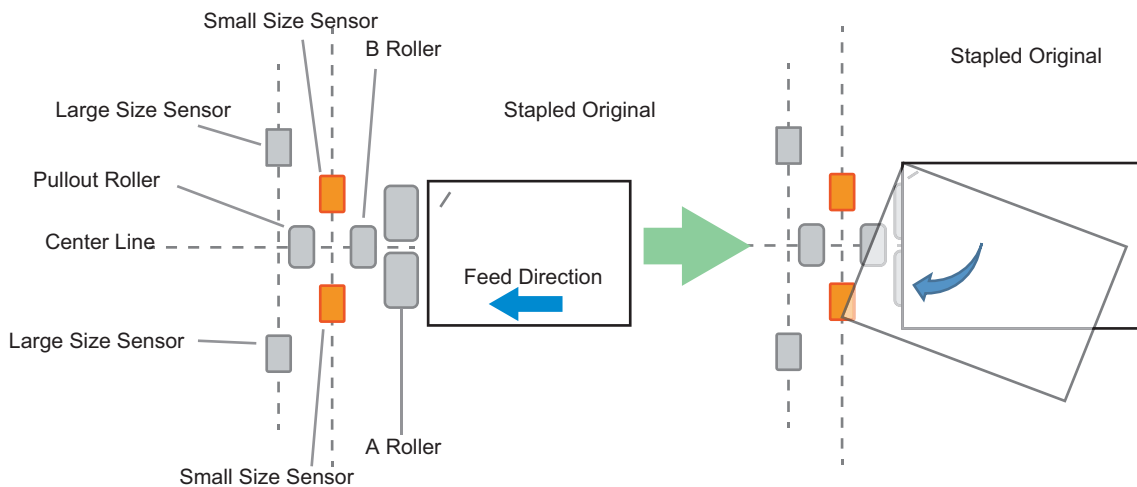
The stapled original has one end stapled and fixed so the non-stapled side is fed first.

As the original is picked up skewed, difference occurs in detection timing with the sensors.

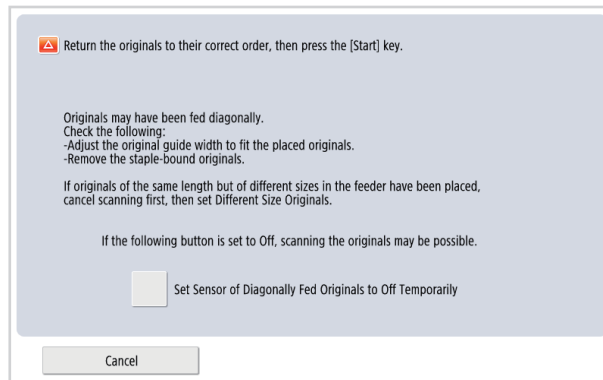
The sensors arranged along the feed path detect the skew from this difference in timings, determine that the original is skewed, and stop the delivery.



For the original width of 247 mm or more



For the original width of 172 mm or more and less than 247 mm



Screen display at the time of detection

Performing this prevents issues (e.g., jams, faulty images) that occurs by feeding skewed originals.

NOTE:

The above screen is displayed when the skew amount is more than approximately +/- 3 degrees.

■ Dust Detection / Correction Control

Dust Detection Control

This equipment detects dust adhered to the Stream Reading Glass that becomes the cause of continuous streak in the vertical scanning direction.

NOTE:

The Stream Reading Glass of this equipment is applied with the coating to prevent adhering of dust so the dust evasion control is not executed.

Dust Correction Control

When dust enters between the Stream Reading Glass and original and continuous streaks occur in the vertical scanning direction of scanned image, the image correction is performed.

Streaks with the width of up to 20 pixels can be corrected.

Additionally, if non-continuous streaks occurred due to floating dust, they can be corrected up to 6 pixels.

Related service mode**Adjustment of the image correction level at stream reading**

- Adjustment of the image correction level at stream reading [front]
COPIER > OPTION > IMG-RDR > DFDST-L1
- ON/OFF of the image correction at stream reading [back] (single pass)
COPIER > OPTION > IMG-RDR > DF2DSTL1

Adjustment of the image correction level at stream reading

- Adjustment of the image detection level at stream reading [front]
COPIER > OPTION > IMG-RDR > DFDST-L2
- Adjustment of the dust detection level at stream reading (back) (single pass)
COPIER > OPTION > IMG-RDR > DF2DSTL2

Settings/Registration Menu (Reference information)

- ON/OFF of streak soiling removal
[Settings/Registration] > [Function Settings] > [Common] > [Scan Settings] > [Streak Prevention]

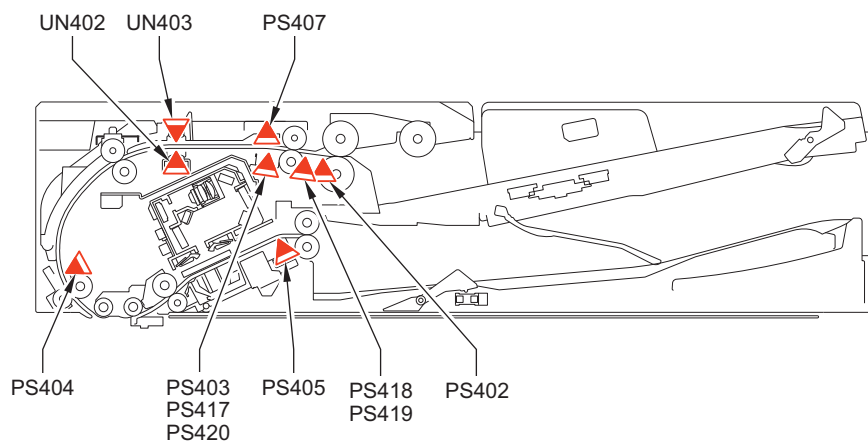
■ Jam Detection

This equipment detects original jam using the sensors shown in the figure below. The occurrence of jam is determined by the presence of an original in the areas of corresponding sensors.

When a jam occurs, the machine stores the information by the code.

This machine's jam code can be checked by printing out a jam error history report from service mode.

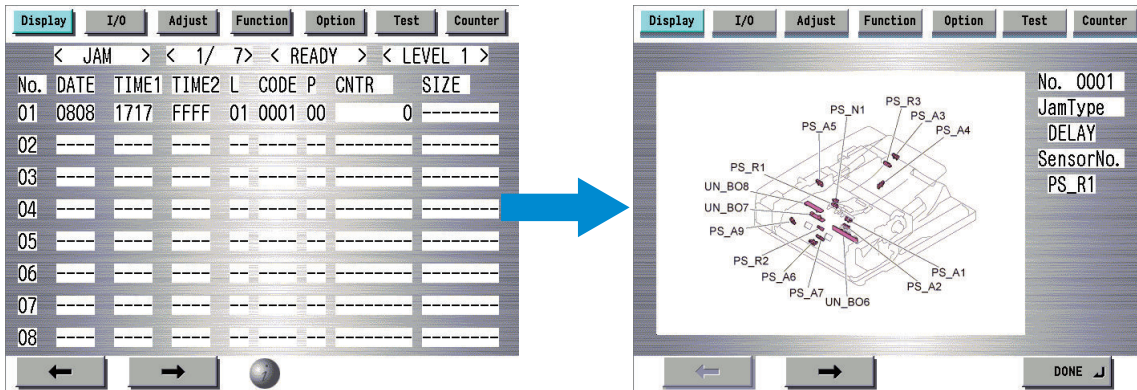
For details of jam, refer to Jam Code List of host machine's manual.

**Sensor Name List**

Symbol	Sensor name
PS402	Post-separation Sensor
PS403	Pullout Sensor
PS404	Lead Sensor
PS405	Pre-delivery Sensor
PS417	Skew Detection Sensor (Large, Front)
PS418	Skew Detection Sensor (Small, Front)
PS419	Skew Detection Sensor (Small, Rear)

Symbol	Sensor name
PS420	Skew Detection Sensor (Large, Rear)
UN402	Double Feed Detection Sensor PCB (Light-emitting)
UN403	Double Feed Detection Sensor PCB (Light-receiving)
PS407	Cover Open/Closed Sensor

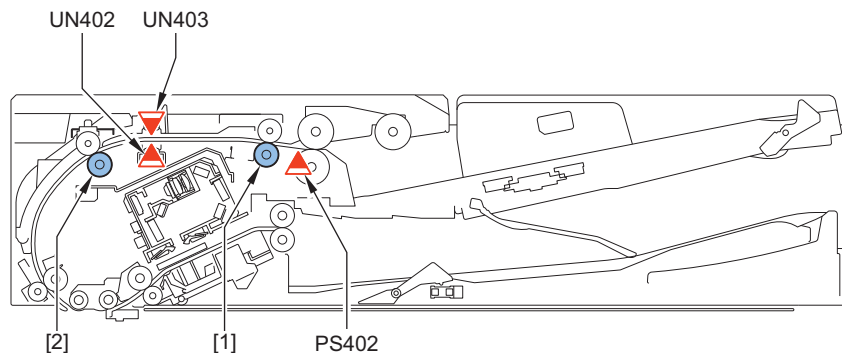
When a jam occurs, the sensor that detected the jam can be checked from the service mode.



■ Double Feed Detection Control

This machine has the Double Feed Sensors PCB (Transmission/Reception) (UN402/UN403) to detect double feeding of paper. The Double Feed Sensor PCBs (Transmission/Reception) (UN_BO7/UN_BO8) using ultrasonic method that are located between the Pullout Roller 1 and Pullout Roller 2 perform double feed detection. Once it is judged that double feed has occurred, the machine stops operation due to a jam.

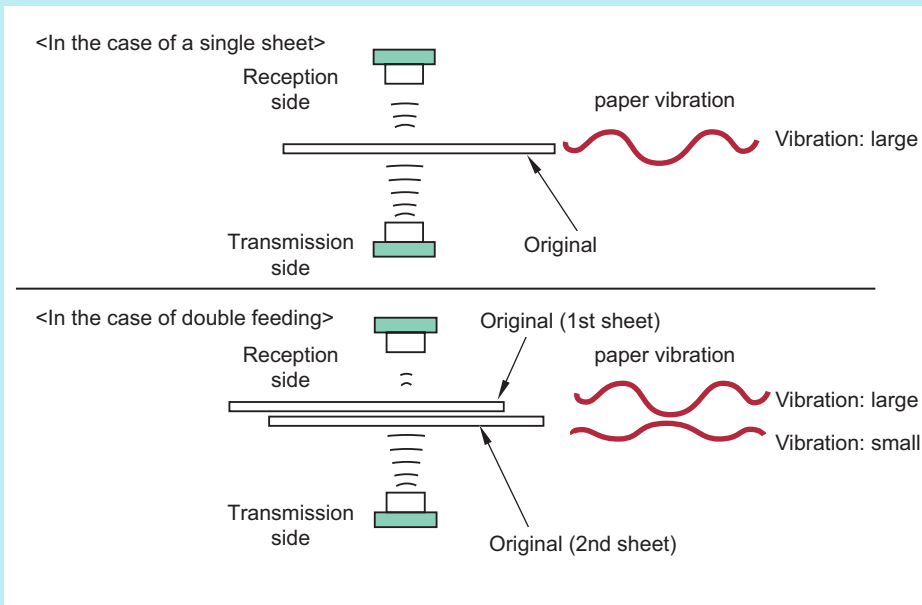
At the start of a job, the sensor level is checked while there is no original, and the threshold value for double feed detection is calculated. During a job, the sensor level is obtained for every detection and this is compared with the threshold value at the job start to judge whether double feed occurs.



No.	Name
[1]	Pullout Roller 1
[2]	Pullout Roller 2
PS402	Post-separation Sensor
UN402	Double Feed Detection Sensor PCB (Transmission)
UN403	Double Feed Detection Sensor PCB (Reception)

NOTE:

The Double Feed Sensor PCB uses an ultrasonic sensor. With the ultrasonic method, the oscillation portion emits ultrasonic wave to the paper surface. In the result, new ultrasonic wave is generated as the paper vibrates, and the reception side reads the ultrasonic wave. A double feed is detected when the oscillation is smaller due to the second sheet of paper.

**Label False Judgment Workaround**

When only a part is detected as double feed, it is judged to have affixed label and the feeding is not stopped. When successively detected as double feed, it is judged that paper is double feeding and the Double Feed Detection Jam is detected.

Related Alarm Code

- 50-0015: Failure of the ADF Double Feed Sensor

Power Supply Assembly

An overview of the power supply is indicated below.

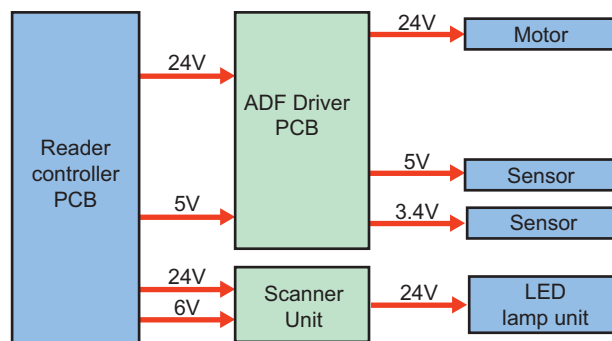
With this equipment, 3 types of power (24V, 6V, and 5V) are received from the Reader Unit.

The 24V power is mainly used for the motor, solenoid, and the Scanner Unit PCB.

The 6V power is mainly used for the Scanner Unit PCB.

The 5V power is mainly used for the sensors.

3.4V power is generated via a converter on the ADF Driver PCB and supplied to the sensors.

**Related Error Codes**

Power supply (24V) error

- Power Supply Error: When the main power is turned ON, the PCB did not detect 24V when the main power was turned ON. E227-0001
- Power Supply error: The DADF Driver PCB did not detect 24V when the main power was turned ON. E227-0101

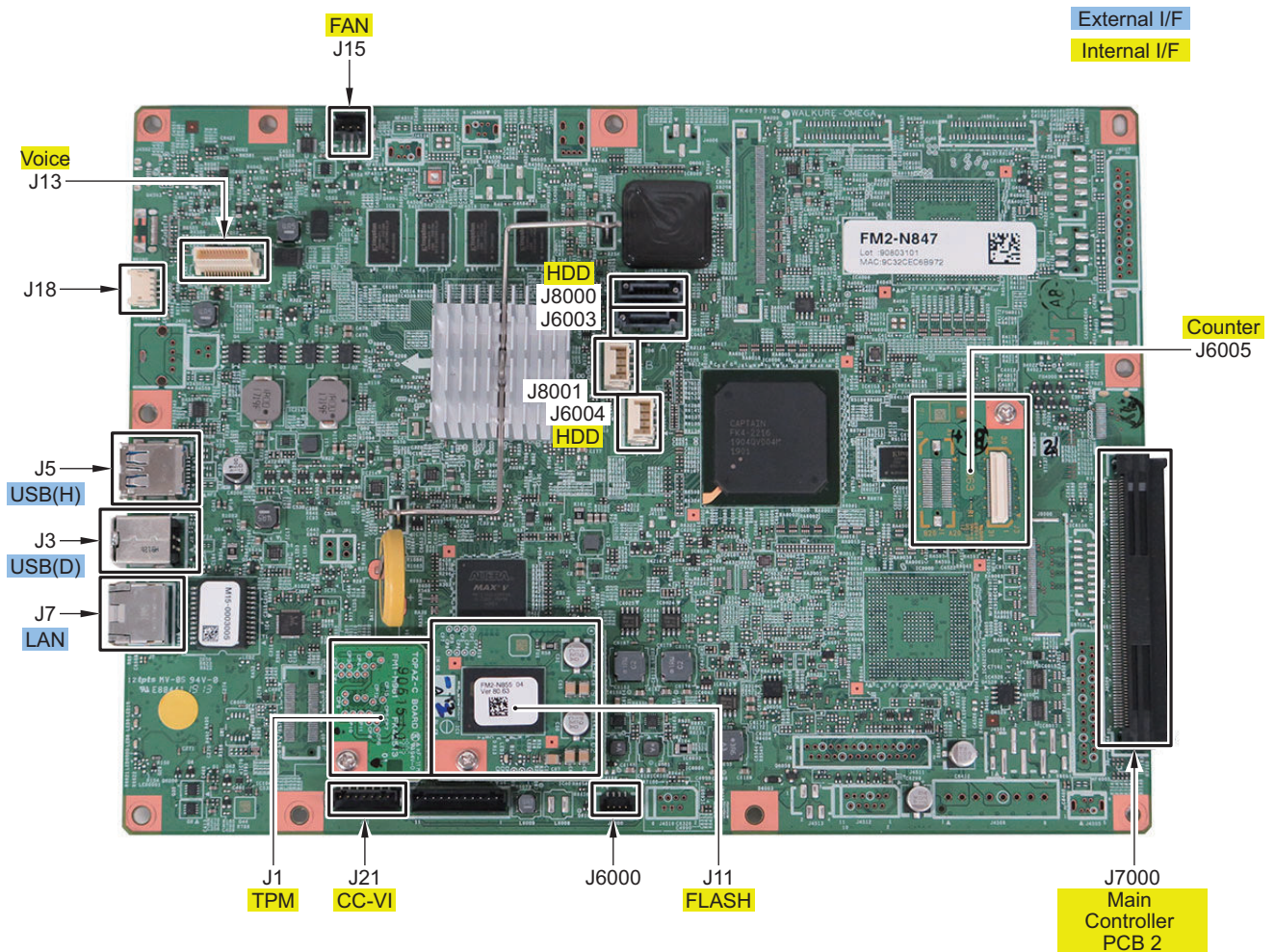
Main Controller

Overview

Configuration/Function

Item	Functions
Main Controller PCB	System Control/Memory Control/Printer Output Image Processing Control, Reader Image Input Processing, Card Reader Connection I/F, Fax Image Processing, USB Extension HUB Connection I/F
RAM	Temporarily storage of image data: Capacity of 2 GB (for controller control) + 1 GB (for image processing)
USB port	USB2.0 Device I/F, USB3.0 Host I/F
HDD	2.5 inch SATA I/F Standard: 250 GB (250 GB usable area), address book, security information (password, certificate), image data, preferences
Flash PCB	Storage of system software: 2 GB
TPM PCB	Generation and storage of the encryption key: Only when Management Settings > Data Management > TPM Settings is "On". Default: OFF)

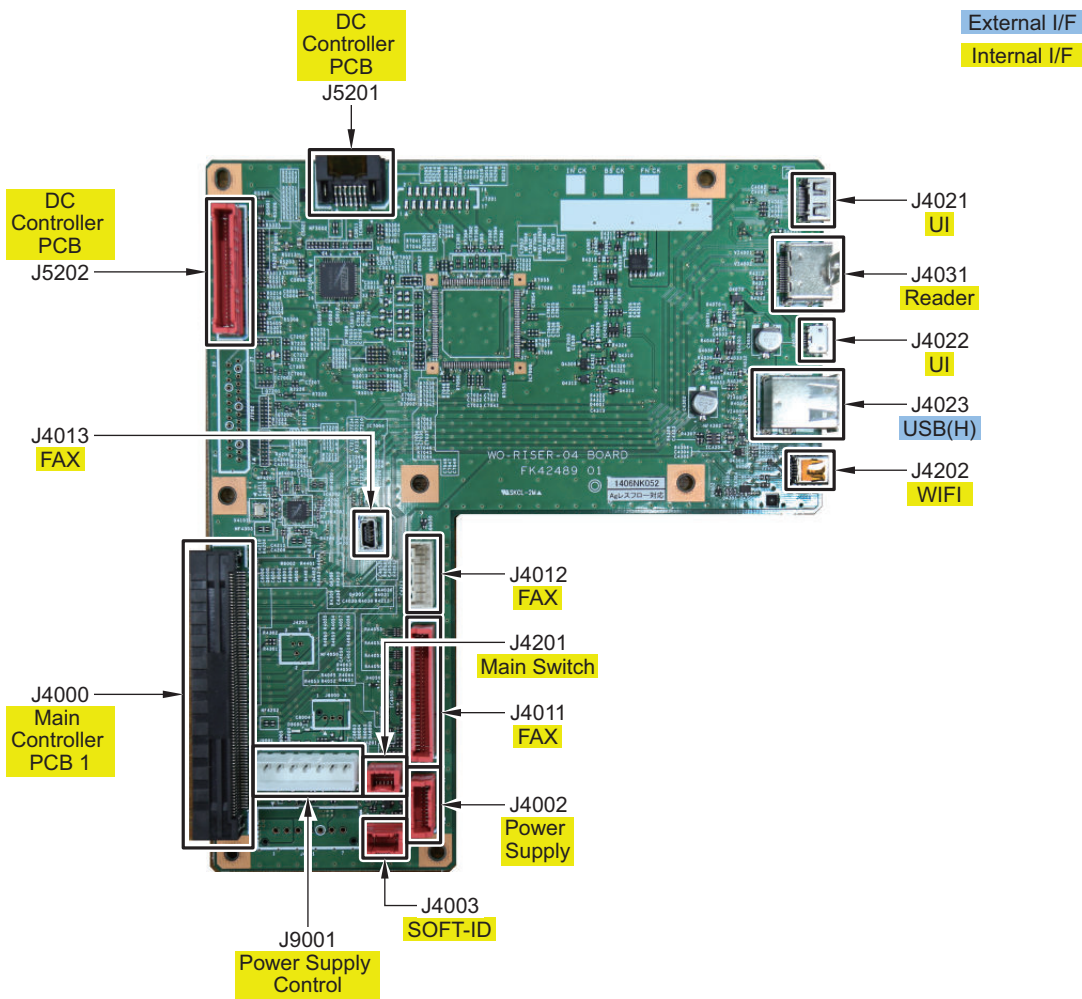
Main Controller PCB 1



No.	Roles and Specifications
J1	TPM PCB
J3	USB I/F (Device)
J5	USB I/F (Host)
J7	LAN I/F
J11	Flash PCB

No.	Roles and Specifications
J13	Voice-Operation Voice-Guidance
J15	Controller Fan
J18	-
J21	Copy Card Reader
J6000	-
J6003 /J6004	Standard hard disk
J6005	Counter PCB
J7000	Main Controller PCB 2
J8000 /J8001	Hard disk for mirroring

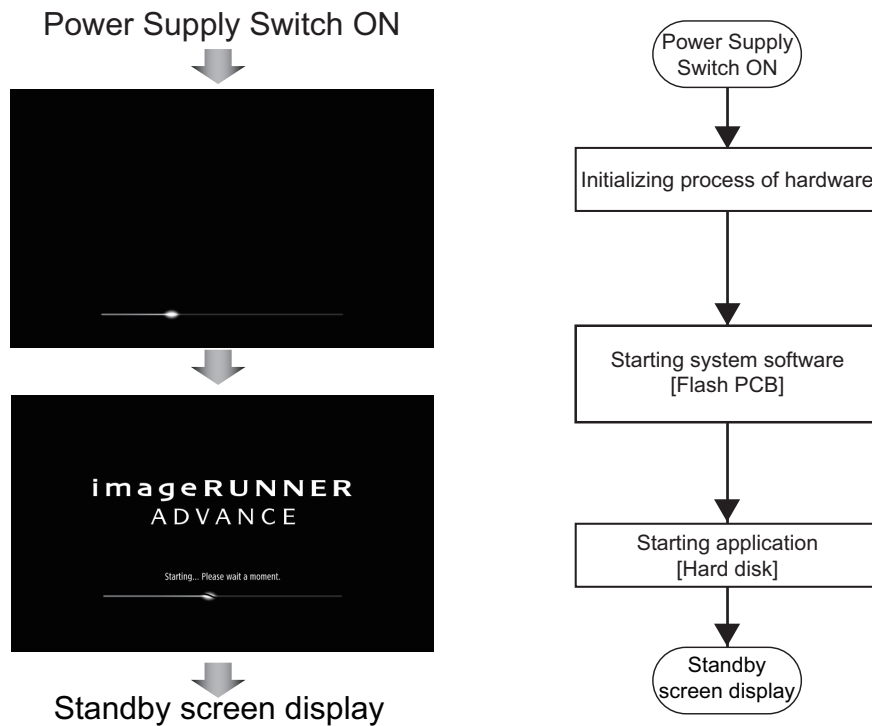
■ Main Controller PCB2



No.	Functions and specifications
J4000	Main Controller PCB1
J4002	Relay PCB
J4003	SOFT-ID PCB
J4011 /4012	Fax (1-Line)
J4013	Fax (2nd/3rd/4th Line)
J4021/J4022	Control Panel I/F
J4023	IC Card Reader (upper port)/USB flash drive for users (lower port)
J4031	Reader
J4201	Main Switch
J4202	WIFI PCB
J5201/5202	DC Controller PCB

No.	Functions and specifications
J9001	Relay PCB

Startup Sequence



Screen sequence and internal processing sequence

NOTE:

To achieve faster startup, the progress bar and the active PCB are not synchronized. For this reason, the progress bar cannot be utilized for troubleshooting. For information about troubleshooting, refer to "Related error codes (major error codes)" shown below.

NOTE:

When system verification* at startup is ON, startup of system software takes more time than when OFF.

*: Settings/Registration (login as an administrator) > [Management Settings] > [Security Settings] > [System verification at startup]
Note that when the machine is recovering from sleep mode or at Quick Startup, system verification is not performed even it is set to ON.

Related error codes (major error codes):

- E602-0001: HDD detection error
- E614-0001: Flash PCB detection error
- E614-0002: Error in file system on the Flash PCB
- E614-4001: Error in file system on the Flash PCB
- E614-4002: Error in file system on the Flash PCB
- E748-2010: Flash PCB error / HDD error

NOTE:

When the following errors occur, the system of the host machine has not been started normally. Therefore the error code is not recorded in the log.

E602-XX01, E614-XX01, E748-2010

Shutdown Sequence

Before shutting down the power supply, it is necessary to perform the HDD completion process (Purpose: to prevent damage on the HDD) and execute the fixing disengagement operation. This sequential process is called "shutdown sequence".

With this machine, the Main Controller PCB detects turning OFF the Main Power Supply Switch, and the shutdown sequence is started and executed automatically.

Note that the maximum shutdown time with this equipment is 90 seconds. (If the maximum of 90 seconds has elapsed, the power supply is turned OFF by the hard timer circuit on the Relay PCB.)

NOTE:

If the power supply is stopped without shutting down the machine, or if the processing to completely delete the hard disk (deletion of the primary file) fails to be completed within the shutdown time (max. 90 sec.), data consistency is checked at startup, during which the progress bar is displayed.

Motion Sensor

Function

Features of the Motion Sensor functions are shown below.

- When the machine detects a person staying in front of it (in the area where the sensor works) for more than a certain period of time, it automatically recovers from sleep mode.
- It judges whether the person is a user or a passerby and controls not to perform recovery triggered by passersby in order to reduce unnecessary power consumption.
- Criteria for judging whether a person is a user or passerby are shown below.
 - If a person approaches the machine from the front, the sensor judges the person as a user and starts recovery from sleep mode quickly.
 - If a person approaches the machine from the side, the sensor judges the person walking fast as a passerby and the person walking slowly as a user.
- The machine may recover from sleep mode in response to the detection of the passerby walking slowly, but the machine shifts to sleep mode again if it is not operated within a specified period of time.

CAUTION:

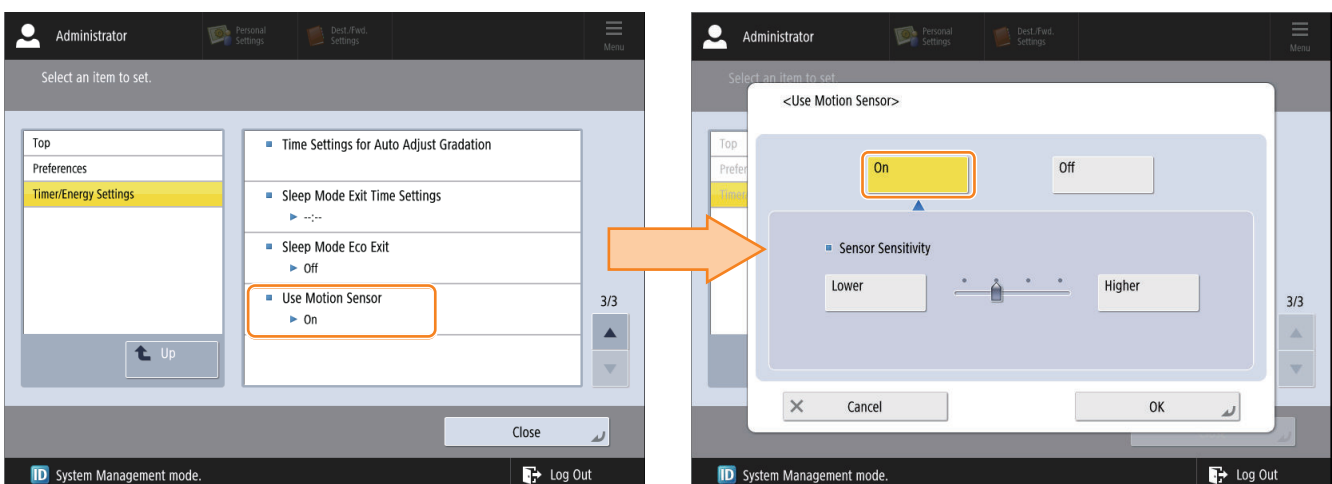
Do not block the opening because the sensor generates ultrasonic waves and detects reflected waves.

Settings/Registration

This function can be set from the following menu.

[Settings/Registration] > [Preferences] > [Timer/Energy Settings] > [Use Motion Sensor]

ON/OFF of this function and the sensor sensitivity can be configured.

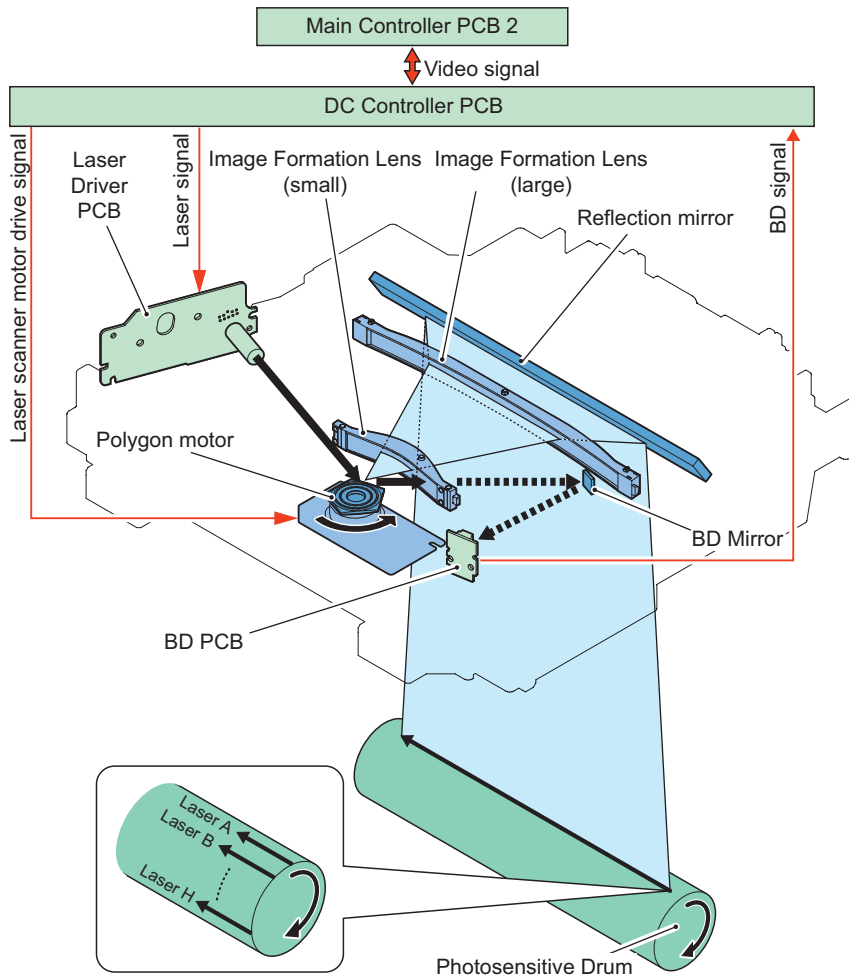


Laser Exposure System

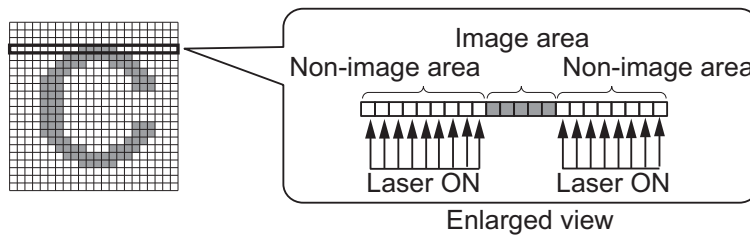
Overview

■ Overview

This machine uses an 8-beam method that enables exposure of 8 beams per scanning direction for high productivity.



Laser is applied to the Non-image image on the positively-charged drum with this machine.



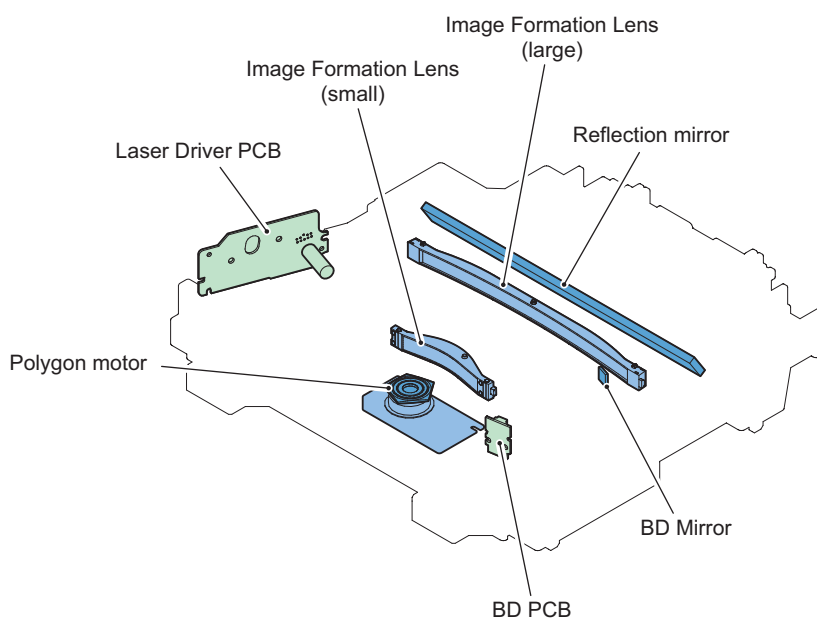
Laser Scanner Unit can be removed from the side of the main body.



■ Specifications

Item		Description
Laser team	Wave length	670nm
	Laser type	Red color laser
	Laser output	7mW(Max)
	Number of laser beams	8 beams
Resolution		1200dpi
Laser scanner motor	Type	Brushless motor
	Number of rotations	35,400rpm(Process speed 500mm/sec)
Number of scanner mirror (polygon) surfaces		5
Controls	Laser ON timing control	Laser ON/OFF control
		Main scanning synchronization control
		Sub scanning synchronization control
	Laser beam intensity control	APC control
	Others	Duplex print magnification correction
Laser scanner motor control		
		Laser shutter control

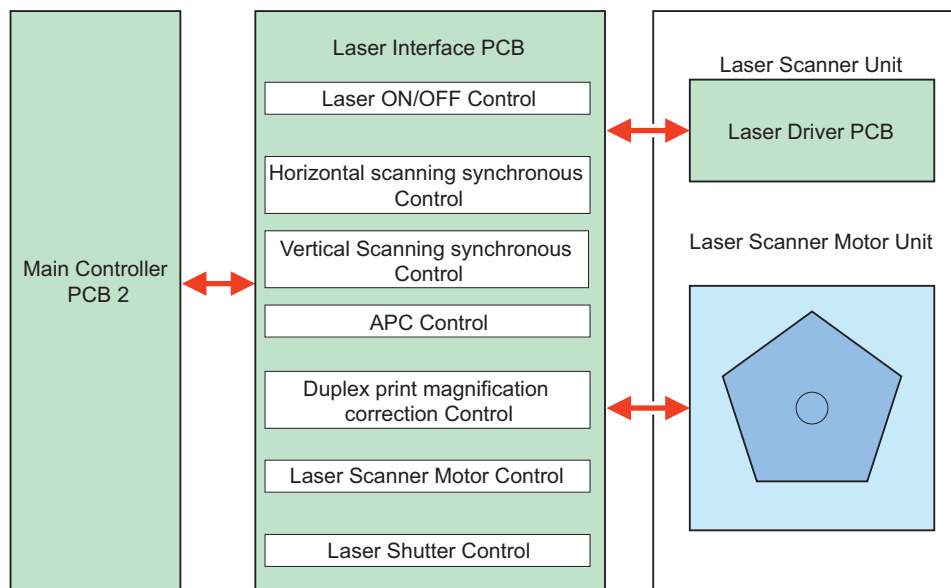
■ Parts Configuration



Name	Role
Laser driver	Laser driver
Polygonal mirror	Perform scanning with a laser beam in the main scanning direction.
Reflection mirror	Reflect a laser team to the drum.
Correction lens	Correct a main-scanning tilt of the laser beam coming from the folding mirror.
Tilt correction motor	Correct a main-scanning tilt by moving the correction lens.
Image Formation Lens (small)	To connect focuses on the Drum to provide an image
Image Formation Lens (Large)	To connect focuses on the Drum to provide an image

Controls

Overview

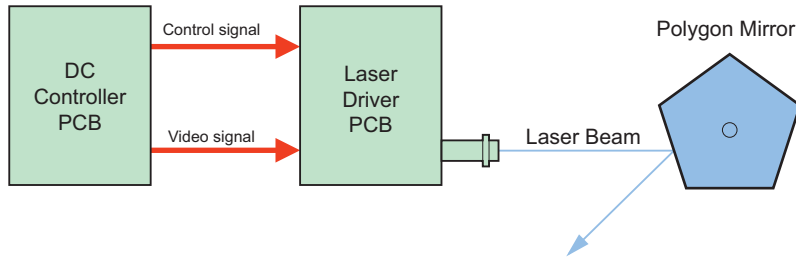


Item		Purpose/Description
Laser ON timing control	Laser ON/OFF control	Turn ON/OFF a laser beam according to the combination of laser control signals.
	Main scanning synchronization control	Performed to adjust the writing position in the main scanning direction.
	Sub scanning synchronization control	Performed to adjust the writing position in the sub scanning direction.
Laser beam intensity control	APC control	1Performed to keep a specified level of laser beam for each line.
Duplex print magnification correction control		To correct image size between the front and the rear when making 2-sided print.
Laser scanner motor control		To be executed to rotate the Polygon Mirror at the specified speed.
Laser shutter control		To prevent exposure of laser light in the machine when the Cover is open.

Laser ON Timing Control

Laser ON/OFF Control

This control is performed to turn ON/OFF a laser beam according to the combination of laser control signals.



<Timing of Execution>

After the power is turned ON

<Details of the Control>

The DC controller switches the mode among four modes (Forcible OFF mode, APC mode, Print mode, Standby mode) according to the laser control signal.

Mode	Laser status	Remarks
Forcible OFF	OFF	Clear the laser beam intensity setting determined by APC.
APC	ON	Adjust the laser beam intensity.
Print mode	OFF/ON	Irradiate a laser beam according to the video signal.
Standby mode	OFF	The main unit is placed in the standby status.

• Main Scanning Synchronization Control

This control is performed to adjust the writing position in the main scanning direction.

<Timing of Execution>

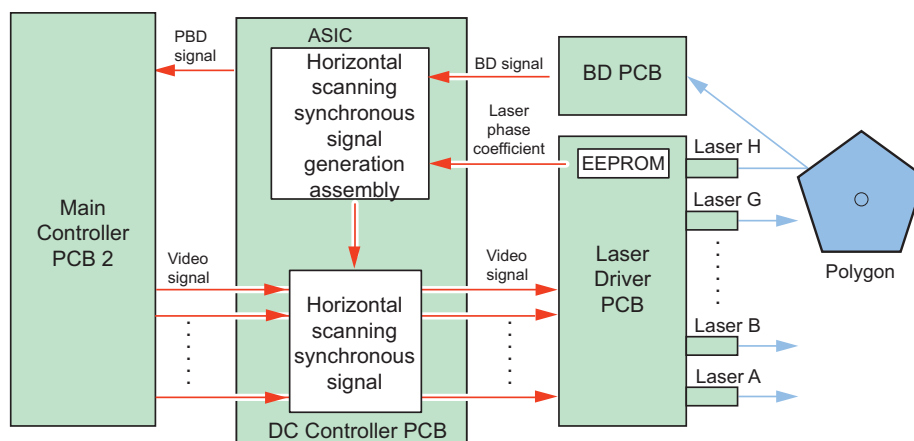
For every eight lines

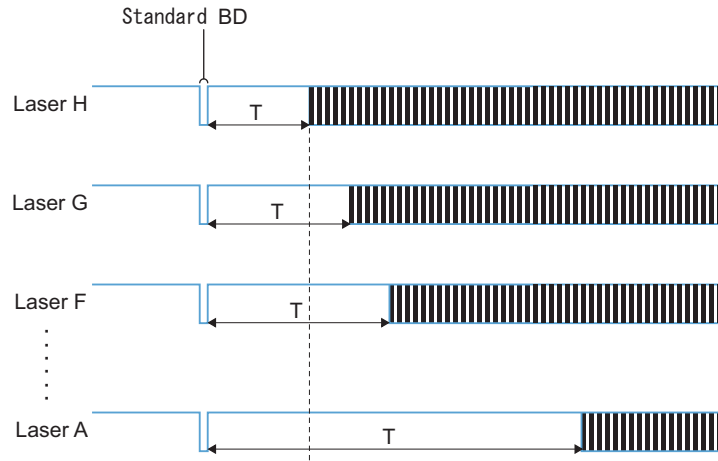
<Details of the Control>

1. The synchronization control in horizontal scanning direction is executed with reference to Laser A.
2. The BD PCB is located on the light path of Laser A laser beam and the laser beam is emitted to the BD PCB.
3. The BD PCB detects laser beam of Laser A and generates BD signal to be sent to the DC Controller PCB.
4. The DC Controller sends the PBD signal to Main Controller PCB 2 according to BD signal.
5. Based on the laser phase coefficient and the BD signal, the DC Controller PCB generates synchronization signal in horizontal scanning direction on an 8 lines basis at the generation area of synchronization signal in horizontal scanning direction.
6. Once the PBD signal is received, Main Controller PCB 2 sends video signal to the DC Controller PCB.
7. The video signal sent from Main Controller PCB 2 is output to the Laser Driver PCB according to the synchronization signal in horizontal scanning direction.

NOTE:

EEPROM on the Laser Driver PCB stores the 8-beam phase displacement coefficient (laser phase coefficient), which is unique to the Laser Scanner Unit, and corrects 8-beam phase difference based on the stored coefficient. When a Laser Scanner Unit is replaced, the DC Controller PCB automatically retrieves the laser phase coefficient of EEPROM.





• Sub Scanning Synchronization Control

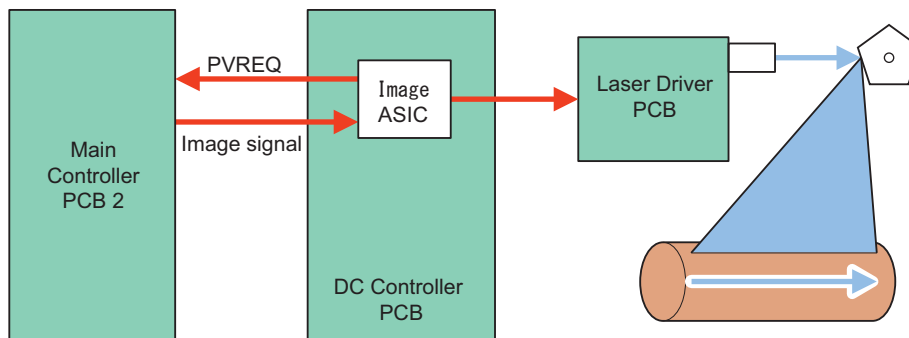
This control is performed to adjust the writing position in the sub scanning direction.

<Execution timing>

When printing is started

<Control Description>

1. The DC Controller PCB generates synchronization signal in vertical scanning direction (PVREQ) and sends to Main Controller PCB 2.
2. Main Controller PCB 2 receives PVREQ (synchronization signal in vertical scanning direction) and sends the video signal to the DC Controller PCB.
3. The DC Controller PCB sends drive signal to the Laser Driver PCB to turn on the laser.



■ Laser Beam Intensity Control

• APC (Auto Power Control) Control

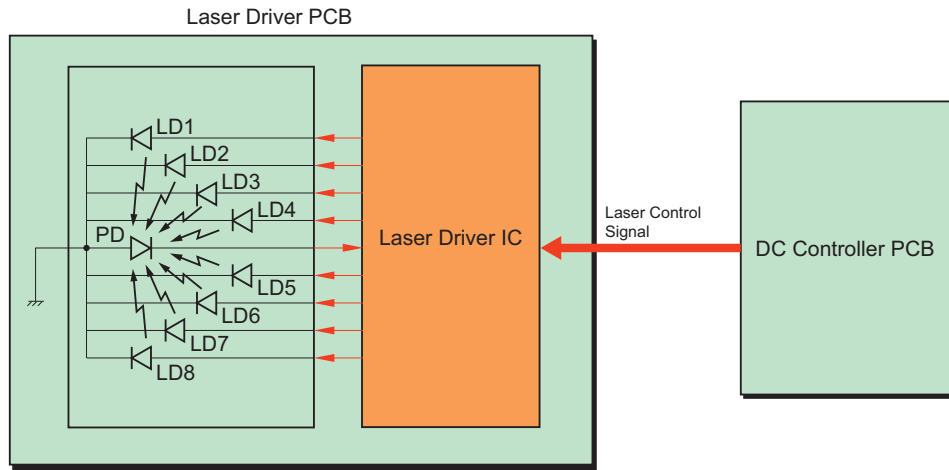
To keep constant laser light intensity per 8 beams (1BD basis)

<Execution timing>

When the laser is scanned (per line)

<Control Description>

1. The DC Controller PCB outputs laser control signal to the Laser Driver IC in the Laser Driver PCB to set in APC mode.
2. The Laser Driver IC is set in APC mode and makes laser diodes (LD1 to LD8) to forcibly emit in series.
3. The Laser Driver IC monitors laser diodes (LD1 to LD8) with the Photo Diode (PD) and adjusts output of laser diode until the laser light intensity reaches a specified level.



■ Duplex print magnification correction

When the paper passes through the fixing area after the image was created on the 1st side of the 2-sided print, the paper temporarily gets shrunk due to the heat. Then, creating the image on the 2nd side causes the 2nd side image extended, which makes the 2nd side image larger than the 1st side image when the paper size returns to the original size after the paper is delivered outside the machine.

<Execution timing>

When the image on the 2nd side of 2-sided print is created

<Control description>

When the 2nd side is printed, the following controls are executed with consideration of paper's shrinkage level.

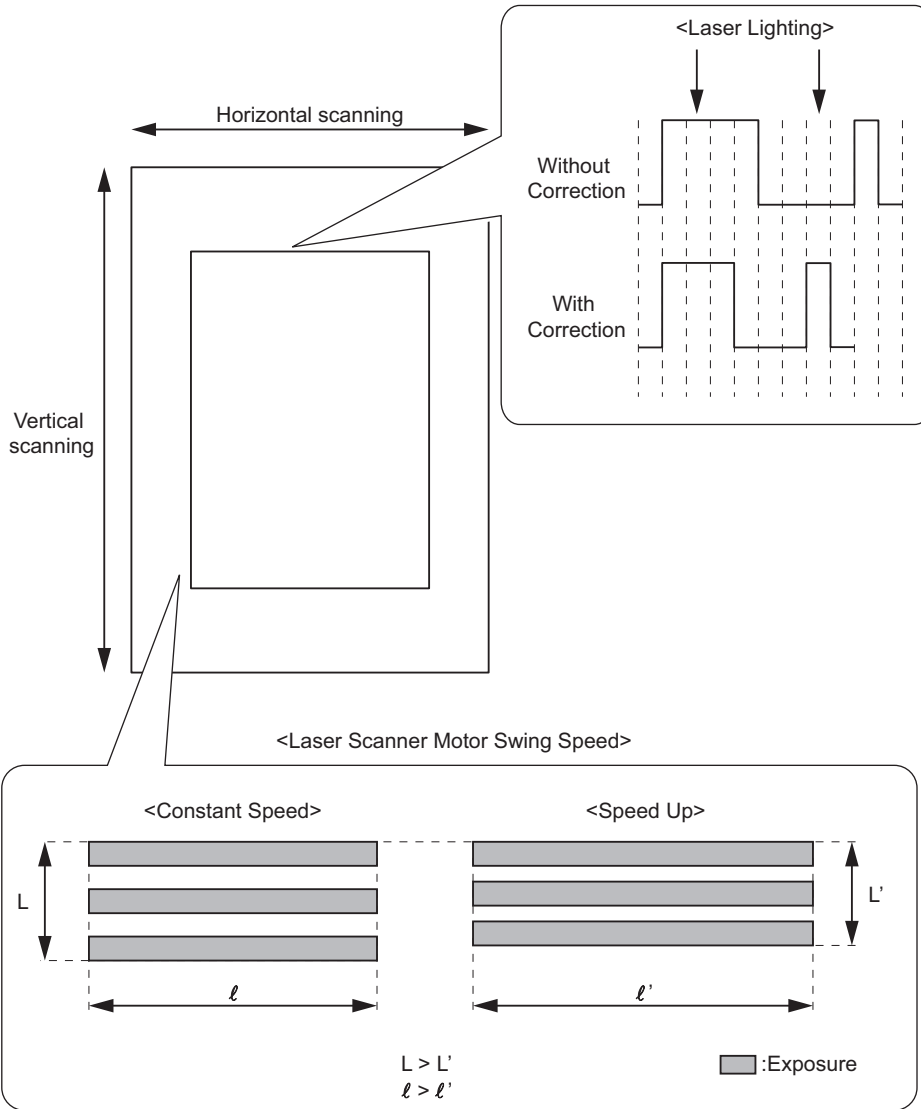
Main scanning direction:

The image in horizontal scanning direction is reduced by skipping the image data.

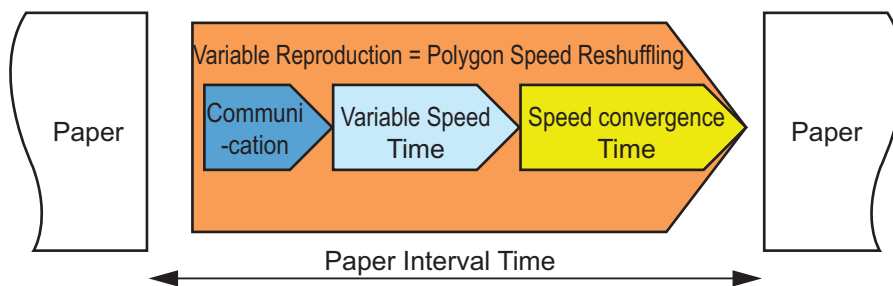
Sub scanning direction:

The image is reduced by increasing rotating speed of the Laser Scanner Motor.

Increasing rotating speed of the Laser Scanner Motor causes an increase of magnification ratio in horizontal scanning direction, and equally effects as skipping of image data.



When magnification is corrected, changing the Polygon Motor speed between sheets might be slower depending on the speed, so productivity might be reduced.



Variable speed Wide	PPM		
	105ppm	95ppm	85ppm
-0.3%	79%	80%	82%
-0.6%	71%	74%	75%
-1.0%	69%	71%	73%

* In the actual use, it is assumed that changing speed over 0.6% is rarely seen.

<Related user mode>

- Settings/Registration > Adjustment/Maintenance > Adjust Image Quality > Fine Adjust Zoom
When copying, a slight difference in size may occur between the size of the original image, and the size of the copied image. In this case, perform a fine adjustment to compensate for this difference.

■ Polygon Motor Control

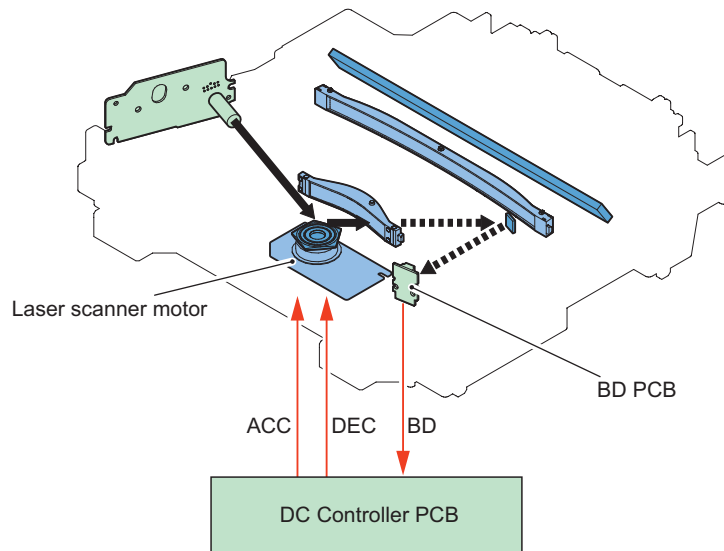
This control is performed to rotate the polygon mirror at a specified speed.

<Execution timing>

When the Laser Scanner Motor is started

<Control description>

1. The DC Controller PCB outputs acceleration signal (ACC) to forcibly rotate the Laser Scanner Motor.
2. The speed detection signals (FG, BD) are detected to be compared with the reference signal generated in the reference signal generation area, so that the acceleration signal (ACC) and the deceleration signal (DEC) are controlled to keep the specified speed.



<Related error code>

- E100: Scanner Motor BD unlock error
- E110: Scanner Motor FG unlock error

■ Laser Shutter Control

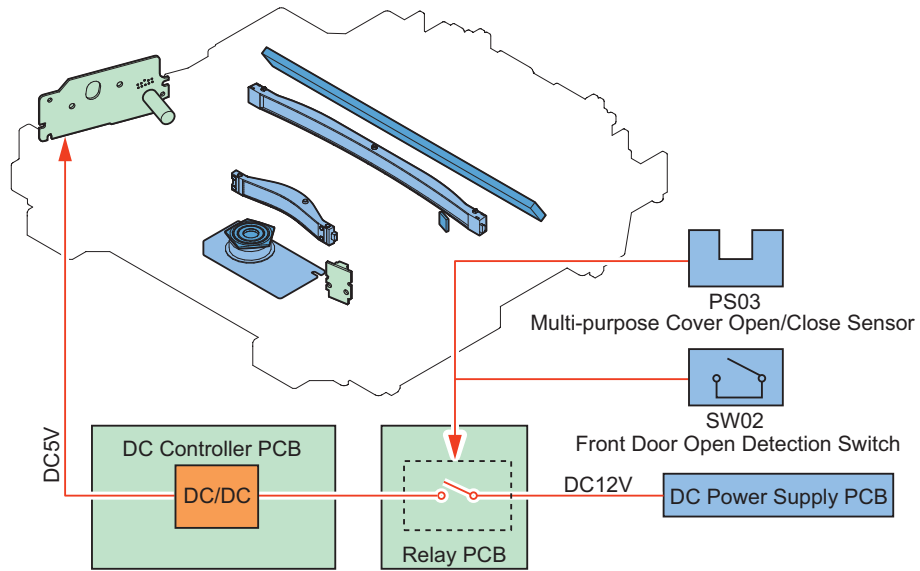
To prevent laser exposure in the machine when the Cover is open

<Execution timing>

When the Front Door or Multi tray Cover opens/closes

<Control description>

When the Front Door or Multi tray Cover opens, the DC Controller PCB stops power supply (DC5V) of the Laser Driver to prevent laser exposure.



NOTE:

This control is executed by the software only and there is no shutter to prevent laser exposure.

Image Formation System

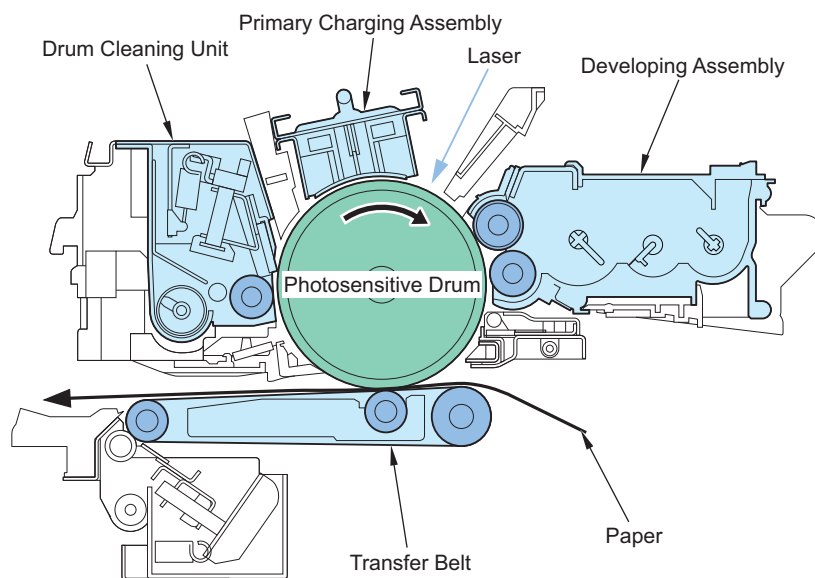
Overview

■ Overview

Toner image is formed by the magnetic, 1-component toner projection developing method in image formation system.

To ensure high quality print, this machine introduces the following new technologies:

- Small-diameter toner
High resolution by fine-grained toner
- Belt transfer method
Improved transfer/feeding performance by the belt feeding
- Twin-developing method
Improving developing efficiency by the 2-time developing. Uneven developing at the first developing is evened out with the second development.
At the second development, if toner is excessively supplied to the drum at the first development, the excessive toner is pulled to the cylinder. If the amount of toner on the drum is not enough, toner shortfall is supplied to the drum from the cylinder.
- Image Stabilization Control
Image density/gradation correction by the D-max control and the D-half control
- The shutter mechanism is added to the Primary Charging Assembly and the Pre-transfer Charging Assembly.
This prevents discharge products from attaching on the Drum, thus prevents image failure just after startup.
- Improved accessibility to the periodically replaced / durable parts provides increased serviceability.



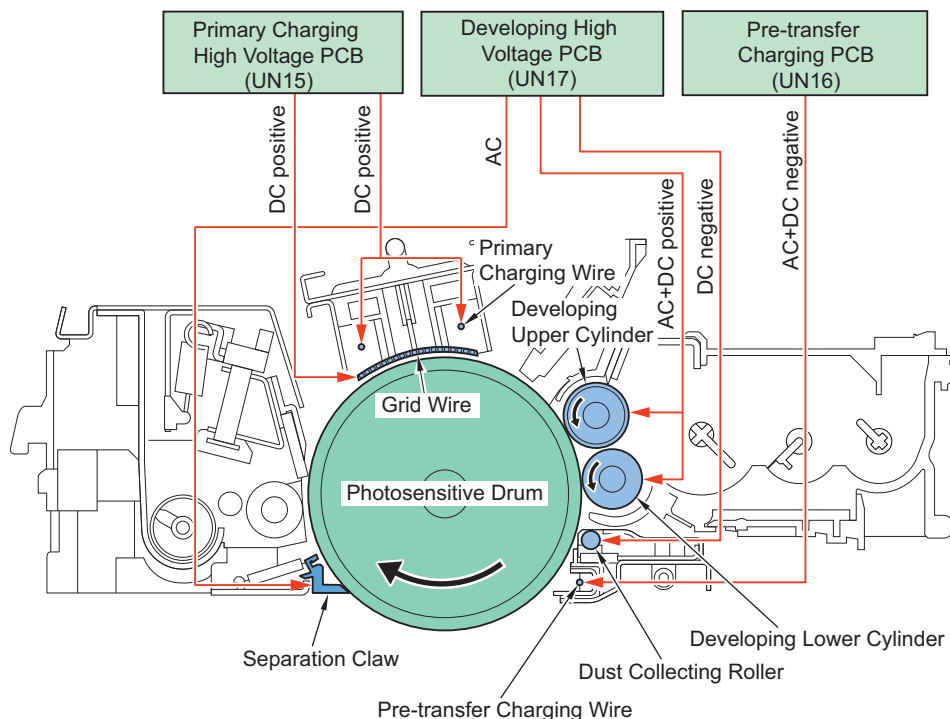
■ Specifications

● Basic Specifications

Item		Function/Method
Photosensitive Drum	Material	A-Si
	Drum diameter	84 mm diameter
	Cleaning	Cleaning Blade
	Process speed	500 mm/sec
	Separation method	Curvature separation + separation claw
	Drum Heater	Yes (42 +/- 2 deg C)
	Drum HP detection	Yes
Developing Assembly	Developing method	Dry, 1-component toner projection method
	Developing Cylinder	iR-ADV 8505/8595/8585 series 2 cylinders (twin-developing method)
		- Developing upper cylinder: 20 mm diameter

Item		Function/Method
Developing Assembly	Developing Cylinder	- Developing lower cylinder: 20 mm diameter
	Toner	Magnetic negative toner
	Toner level detection	Yes (magnetic sensor)
Primary charging	Charging method	Corona charging (2 charging wires + grind wire)
	Cleaning	Cleaning Pad (charging wire)
	Shutter	Yes
Pre-transfer charging	Charging method	Corona charging (1 charging wire)
	Cleaning	Cleaning Pad (charging wire)
	Shutter	Yes
Transfer method		Direct transfer (ETB: Electrostatic Transfer Belt)
ETB Unit	Material	CR rubber + urethane resin
	Circumferential length	298.5 mm
	Cleaning	Brush Roller + Cleaning Blade
	Transfer method	Transfer Roller (sponge roller)
	Separation method	Curvature separation + static eliminator
	Disengagement mechanism	Yes
Waste Toner Container	Capacity	Equivalent to 600,000 sheets (calculation with A4 and 6% image duty)
	Full-level detection	Yes
	Presence/absence detection	Yes
Toner Container	Method	Set-on (manual)
	Presence/absence detection	No
Patch Sensor		Yes

• Charging Specifications



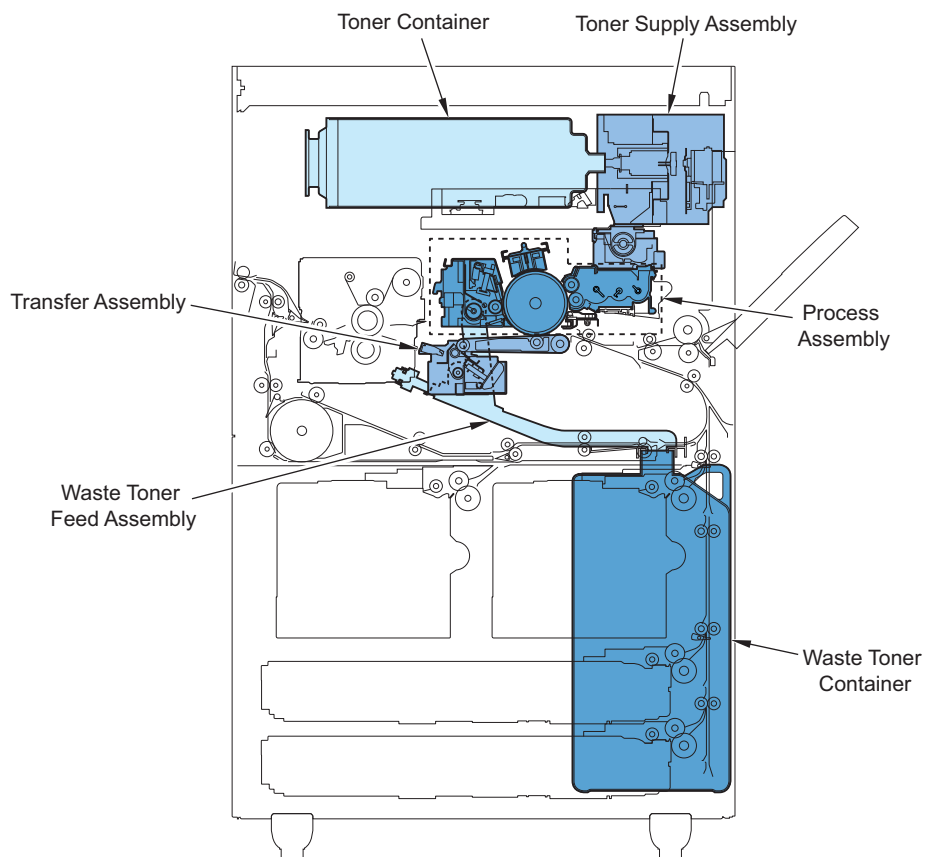
Item		Bias value	Remarks
Primary charging bias	DC bias	6000 to 9000 V	To be specified by the potential control
Grid bias	DC bias	530 to 800 V	To be specified by the estimated life and environment*
Developing bias	AC bias	1500 V	Fixed value (ON/OFF only)

Item		Bias value	Remarks
Developing bias	DC bias	200 to 300 V	To be specified by the D-max control
Dust-collection bias	DC bias	-1000 V	Constant voltage control
Pre-transfer charging bias	AC bias	8300 V	Fixed value (ON/OFF only)
	DC bias	-3500 to 0 V	Constant current control (to be specified by the environment*)
Transfer bias	DC bias	0 to 6500 V	Constant current control (to be specified by the environment*, paper type and print mode)
Separation claw bias	AC bias	690 Vpp	Fixed value (ON/OFF only)

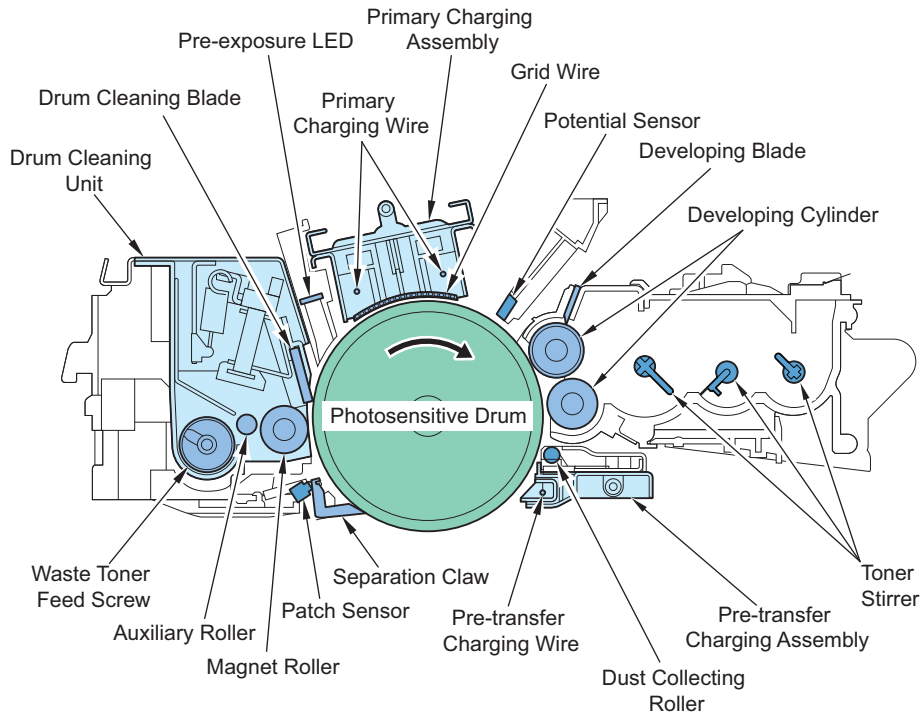
* Detected by the Environment Sensor (THU01)

■ Parts Configuration

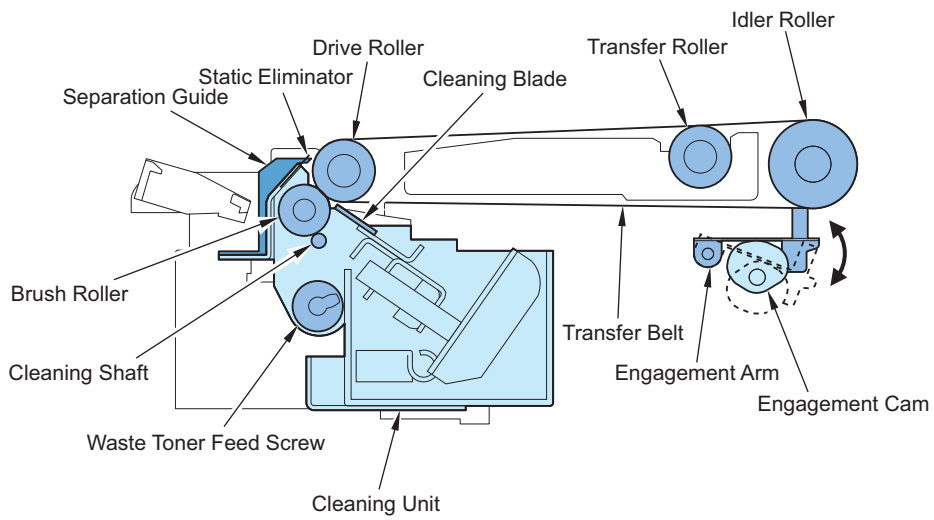
● Entire Configuration



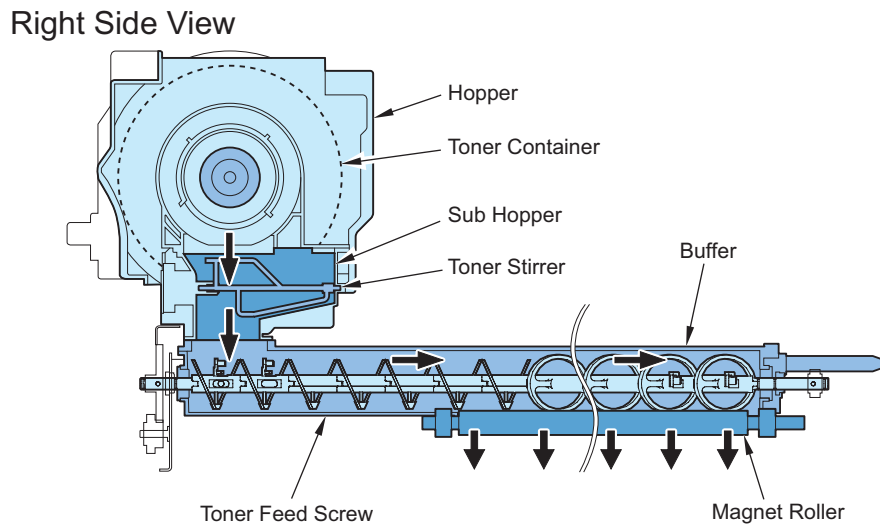
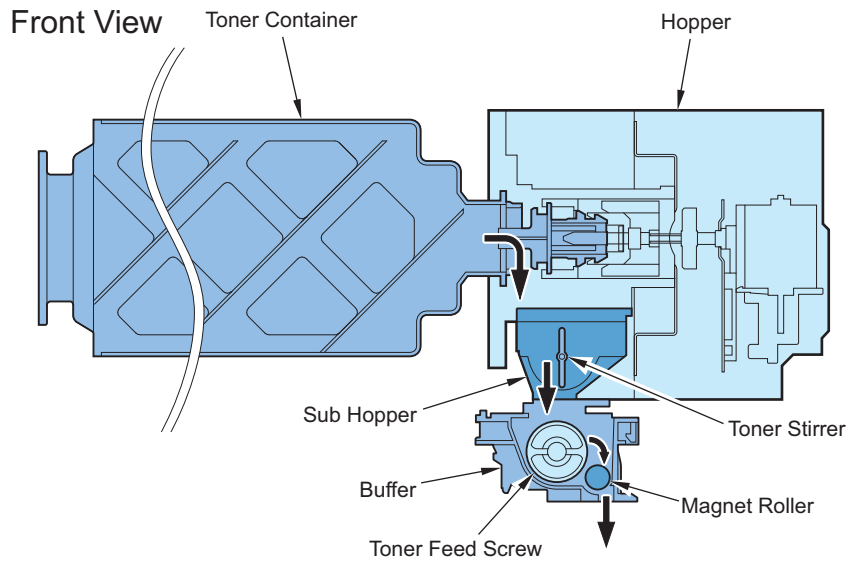
• Process Area



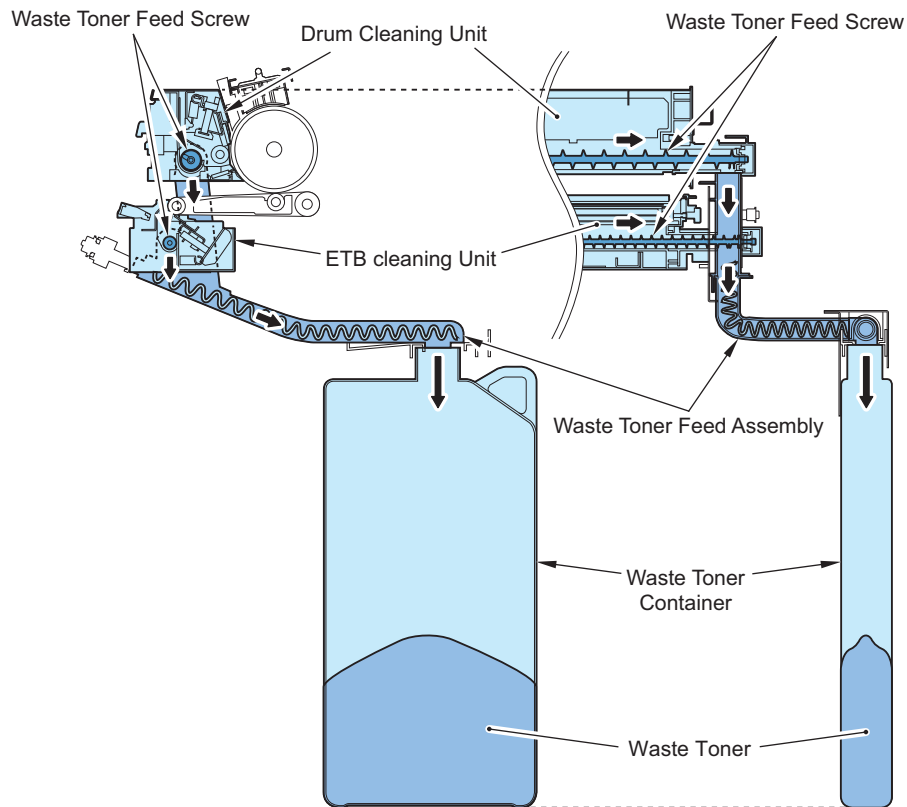
• Transfer Area



• Toner Supply Area

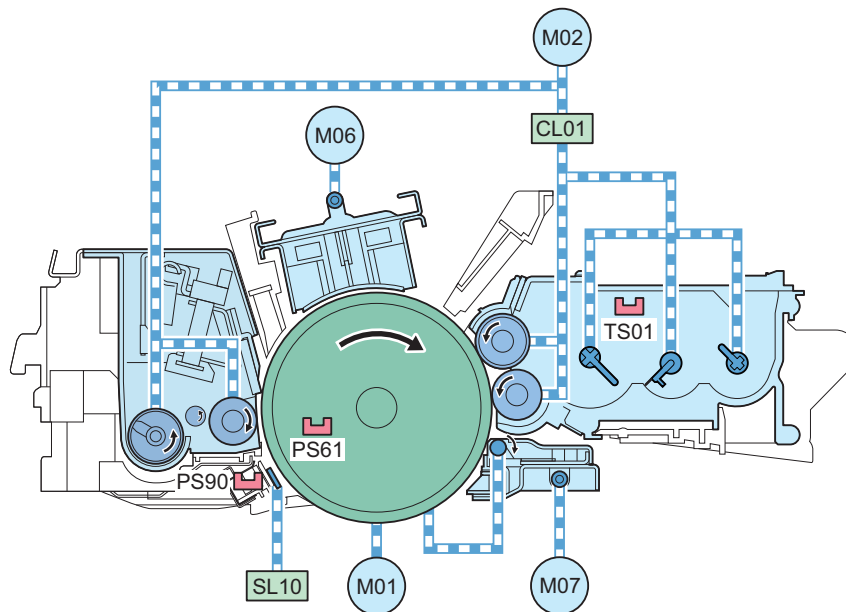


● Waste Toner Feeding Area



■ Drive Configuration

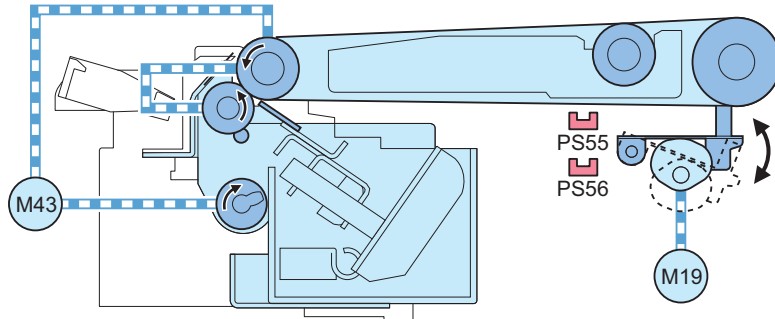
● Process Area



Symbol	Name	Function
M1	Drum Motor	To drive the Photosensitive Drum and the Dust-collection Roller
M2	Main Motor	To drive the Developing Cylinder, the Toner Stirring Plate, the Magnet Roller and the Waste Toner Feed Screw
M6	Primary Charging Wire Cleaning Motor	To drive the Primary Charging Wire Cleaning Pad and the Primary Charging Shutter
M7	Pre-transfer Charging Wire Cleaning Motor	To drive the Pre-transfer Charging Wire Cleaning Pad and the Pre-transfer Charging Shutter
SL10	Patch Sensor Shutter Solenoid	To drive the Patch Sensor Shutter

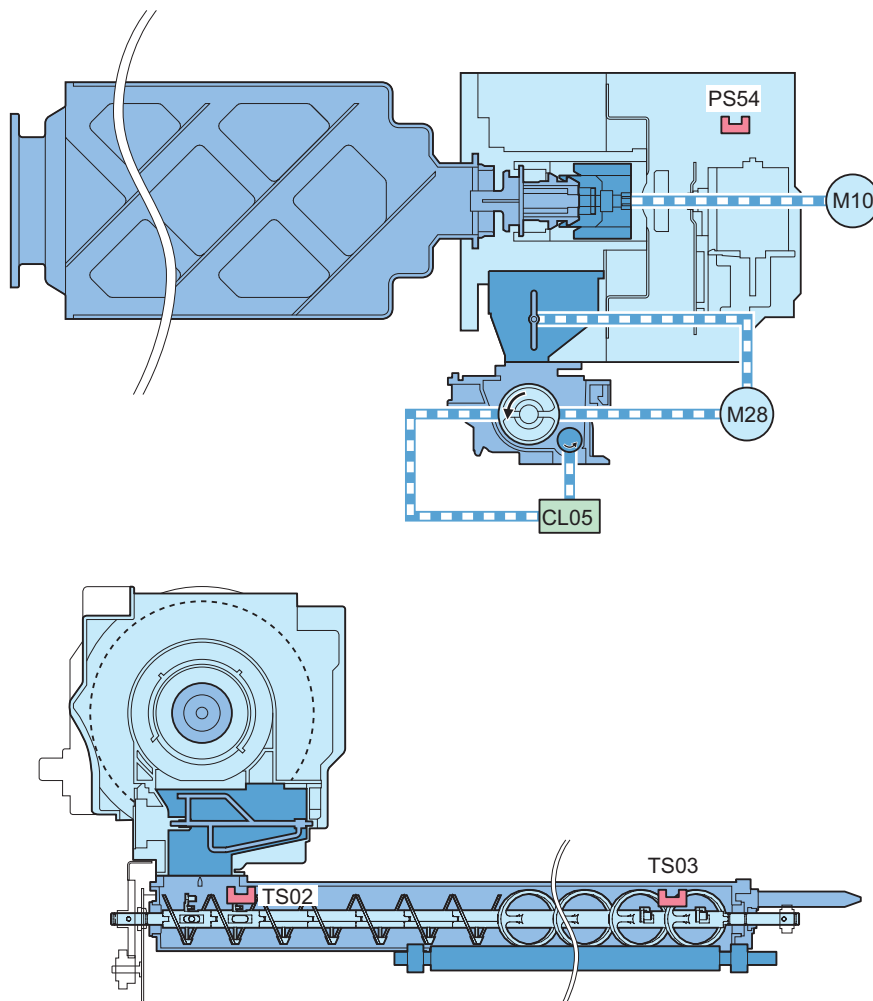
Symbol	Name	Function
CL1	Developing Clutch	To drive the Developing Cylinder and the Toner Stirring Plate
TS1	Developing Toner Sensor	To detect toner level in the Developing Assembly
PS61	Drum Home Position Sensor	To detect home position of the Photosensitive Drum
PS90	Patch Sensor	To detect toner density (image stabilization control)

• Transfer Area



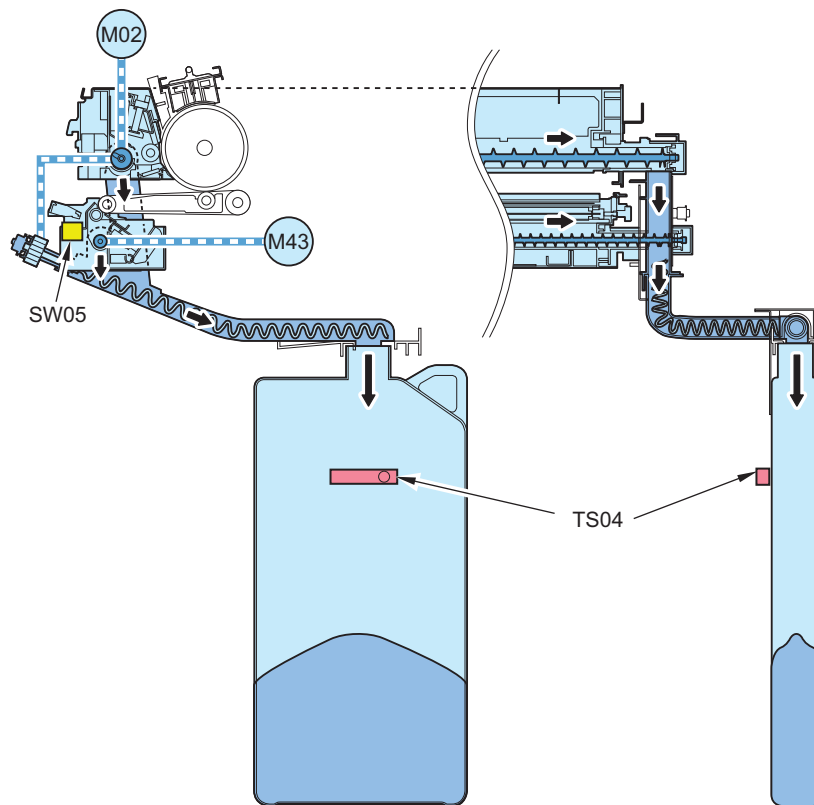
Symbol	Parts name	Function
M19	Duplex Feed Left Motor	To make the ETB Unit (ETB) engaged/disengaged
M43	ETB Motor	To drive the ETB Drive Roller, the Brush Roller and the Waste Toner Feed Screw.
PS55	ETB Engage Sensor	To detect engagement of the.
PS56	ETB Disengage Sensor	To detect disengagement of the ETB (home position).

• Toner Supply Area



Symbol	Parts name	Function
M10	Toner Supply Motor	To drive the Toner Stirring Plate (to supply toner to the Buffer)
M28	Toner Feed Motor	To drive the Toner Feed Screw and the Toner Stirring Plate (to feed toner)
CL05	Magnet Roller Clutch	To drive the Magnet Roller (to supply toner to the Developing Assembly)
TS02	Buffer Toner Sensor 1	To detect toner excess supply* * When toner clusters is supplied from the Sub Hopper, etc.
TS03	Buffer Toner Sensor 2	To detect toner level in the Buffer (to detect absence of toner in the Buffer)
PS54	Toner Exchange Cover Sensor	To detect whether the Toner Exchange Cover is opened/ closed.

● Waste Toner Feeding Area

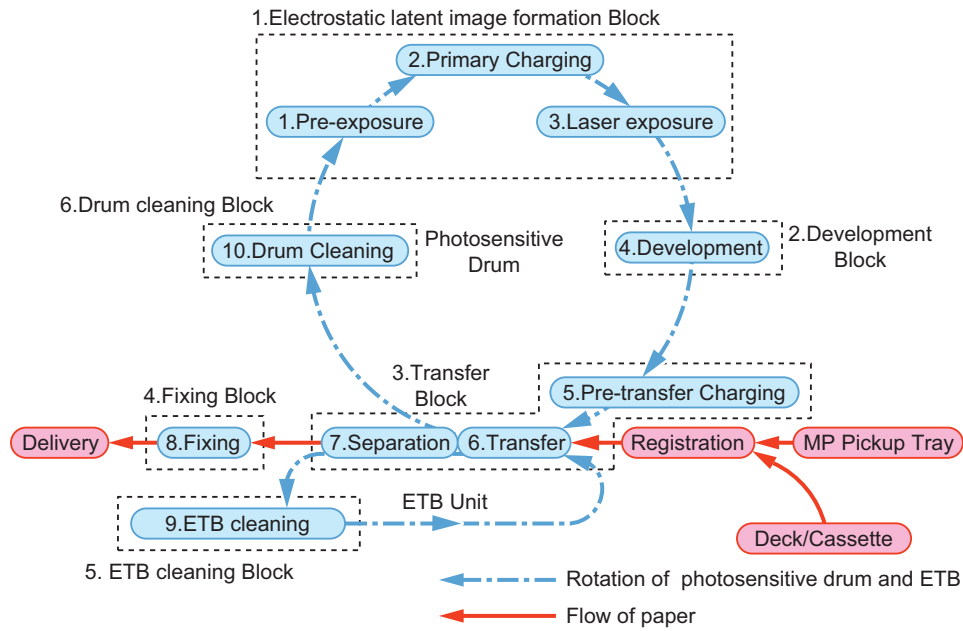


Symbol	Parts name	Function
M02	Developing Motor	To drive the Waste Toner Feed Screw(Drum Cleaning Unit)
M43	ETB Motor	To drive the Waste Toner Feed Screw(ETB Cleaning Unit)
SW5	Waste Toner Lock Detection Switch	To detect lock of the Waste Toner Feed Screw
TS04	Waste Toner Full Sensor	To detect whether the Waste Toner Container is full.

■ Print Process

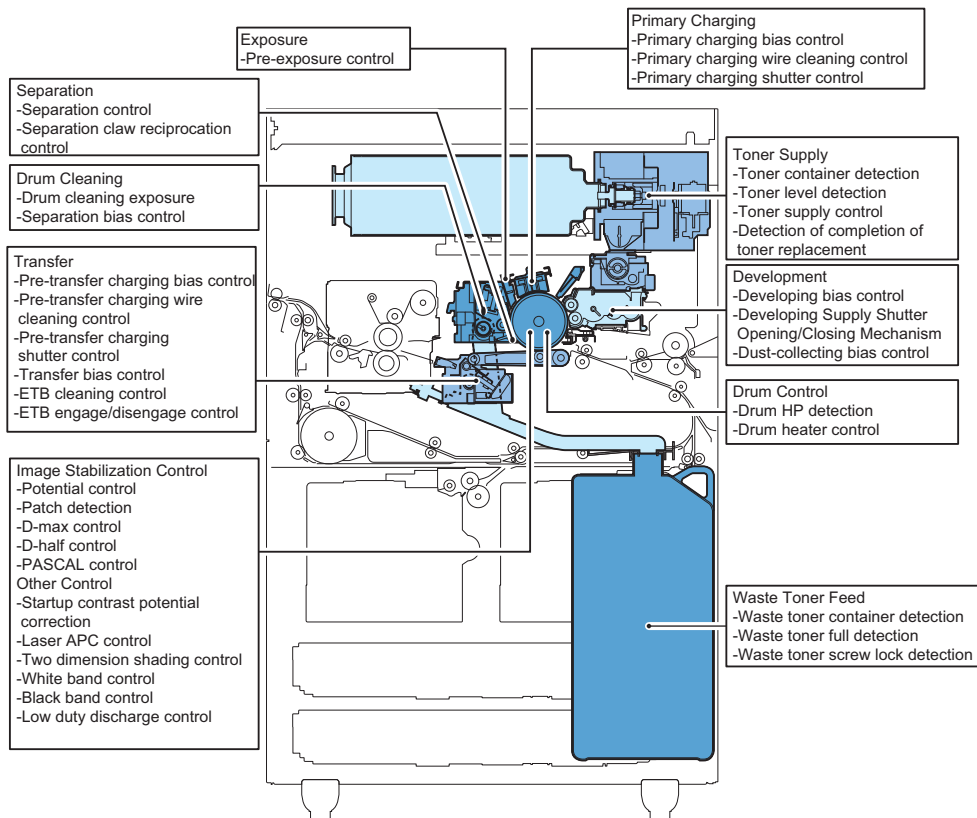
Block	Step	Overview
Static formation block	1	Exposure Light emission from the Pre-exposure LED removes residual potential on the surface of the Photosensitive Drum to prevent density unevenness.
	2	Primary charging The surface of the Photosensitive Drum is charged to make a uniform positive potential. This machine uses the Primary Charging Assembly which indirectly gives potential from the Charging Wire to the Photosensitive Drum.
	3	Laser exposure Emission of the laser beam forms a static latent image on the surface of the Photosensitive Drum. When the laser beam is applied on the surface of the positively charged Photosensitive Drum, the potential at the emitted part is reduced.

Block	Step	Step	Overview
Developing block Transfer block	4	Developing	With the magnetic, 1-component toner projection developing method, toner that has been negatively charged by the Developing Cylinder is attached to the latent image on the surface of the Photosensitive Drum to make it visible.
	5	Pre-transfer charging	Toner on the Photosensitive Drum is made to be a uniform potential.
	6	Transfer	Positive potential is applied to the Transfer Roller so that the toner on the Photosensitive Drum is transferred on a paper.
	7	Separation	With the curvature separation method and the static eliminator, the paper is separated from the Photosensitive Drum and the ETB.
Fixing block	8	Fixing	The toner on the paper is fused on the paper by heat and pressure.
ETB cleaning block	9	ETB cleaning	The Cleaning Blade removes the residual toner attached on the ETB.
Drum cleaning block	10	Drum cleaning	The Cleaning Blade removes the residual toner attached on the Photosensitive Drum.





■ Overview



Control name		Description
Exposure		
	Pre-exposure control	To apply the light of the Pre-exposure LED on the surface of the Photosensitive Drum.
Primary charging		
	Primary charging wire bias control	To apply the positive potential to the Primary Charging Wire and the Grid Wire.
	Primary charging wire cleaning control	To clean the Primary Charging Wire.
	Primary charging shutter control	To prevent image failure caused by ozone generated from the Primary Charging Wire.
Developing		
	Developing bias control	To apply positive potential to the Developing Cylinder so that the toner on the Developing Cylinder is attached on the surface of the Photosensitive Drum.
	Developing Supply Shutter Opening/Closing Mechanism	There are shutters at the Supply Mouths of the Developing Assembly and the Buffer Unit to prevent toner scattering.
	Toner collection sheet bias control	To apply negative potential to the Toner Collection Sheet.
Transfer		
	Pre-transfer charging bias control	To charge toner negatively and evenly to ensure stability of transfer performance.
	Pre-transfer charging wire cleaning control	To clean the Pre-transfer Charging Wire to prevent the Charging Wire failure that is caused by soil of the Pre-transfer Charging Wire.
	Pre-transfer charging shutter control	To prevent image failure caused by ozone generated from the Pretransfer Charging Wire.
	Transfer bias control	To apply positive potential to the Transfer Roller so that the toner on the Photosensitive Drum is transferred on the paper.
	ETB cleaning control	To remove the residual toner on the ETB to prevent image failure that is caused by toner soil on the belt.

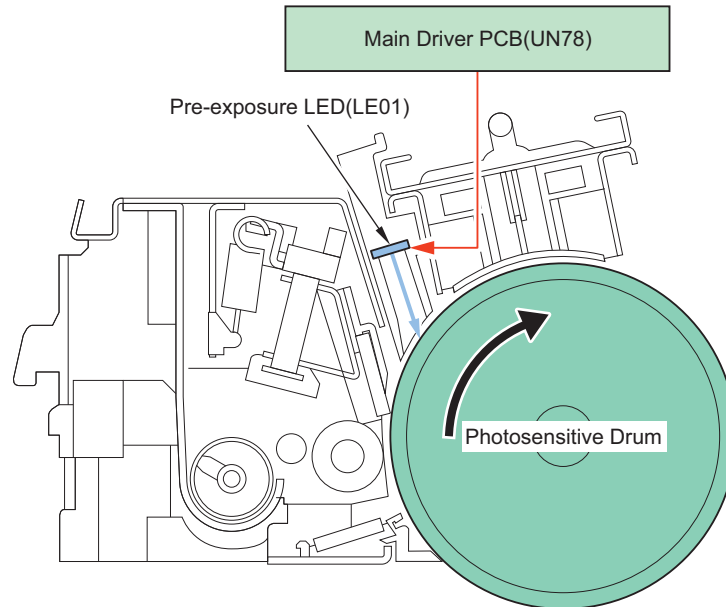
Control name		Description
	ETB engagement/disengagement control	To engage/disengage the ETB with the Photosensitive Drum.
Separation		
	Separation control	To separate paper from the Photosensitive Drum and the ETB.
	Separation Claw Reciprocation Control	By moving the Separation Claw back and forth (reciprocation), scar on the drum caused by the Separation Claw can be prevented.
Drum cleaning		
	Drum cleaning control	To remove residual toner on the Photosensitive Drum.
	Separation bias control	To remove toner attached to the Drum Separation Claw.
Drum control		
	Drum home position detection	To detect home position of the Photosensitive Drum.
	Drum heater control	To keep constant temperature of the Photosensitive Drum.
Toner supply		
	Toner Container Detection	Toner Container detection is not performed with this machine.
	Toner level detection	To detect toner level in the Developing Unit and the Buffer Unit.
	Toner supply control	To supply toner from the Toner Container to the Developing Assembly.
	Toner Replacement Completion Detection	To send a notice of Toner Replacement Completion when Toner Container is replaced.
Waste toner feeding		
	Waste toner container detection	To detect whether the Waste Toner Container is attached to the host machine.
	Waste toner full level detection	To detect whether the Waste Toner Container is full.
	Waste toner screw lock detection	To detect whether the Waste Toner Screw is locked.
Image stabilization control		
	Potential control	To determine primary current (Ip), laser power (Lp) and developing bias (Vdc) according to the deterioration level of the Photosensitive Drum and the environmental change.
	Patch Detection	To detect the patch on the Drum by the Patch Sensor to measure the toner density.
	D-max control	To determine the developing contrast to keep solid density on the image constant.
	D-half control	To determine the gradation adjustment value based on the image density detected by the Patch Sensor.
	PASCAL control	To determine gradation adjustment value based on the image density scanned by the Reader.
Other Control		
	Startup Contrast Potential (Vcont) Correction	To adjust the contrast potential (Vcont) at startup in order to maintain the density consistently.
	Laser APC control	To correct the laser output control value to prevent changes in surface potential by the laser output.
	2D shading control	To correct uneven potential on the Photosensitive Drum by laser exposure.
	White Band Control	To blow off the reversely-charged toner on the Developing Sleeve forcibly to the Drum surface in order to collect the toner into the Drum Cleaning Unit.
	Black Band Control	To supply toner thoroughly to the ends of the Cleaning Blade and prevent the blade from everting by forming the toner band at the Drum ends.
	Low Duty Discharge Control	To forcibly eject toner by forming the toner band at the Drum ends in order to avoid toner deterioration in case low duty images are continuously output.

■ Exposure

● Pre-exposure Control

To prevent uneven density with the print image, residual potential on the Photosensitive Drum is removed before the primary charging.

With the command by the DC Controller PCB, the Pre-exposure LED (LE01) is emitted. By emitting the LED on the Photosensitive Drum, remove residual potential on the drum.



■ Primary Charging

● Primary Charging Bias Control

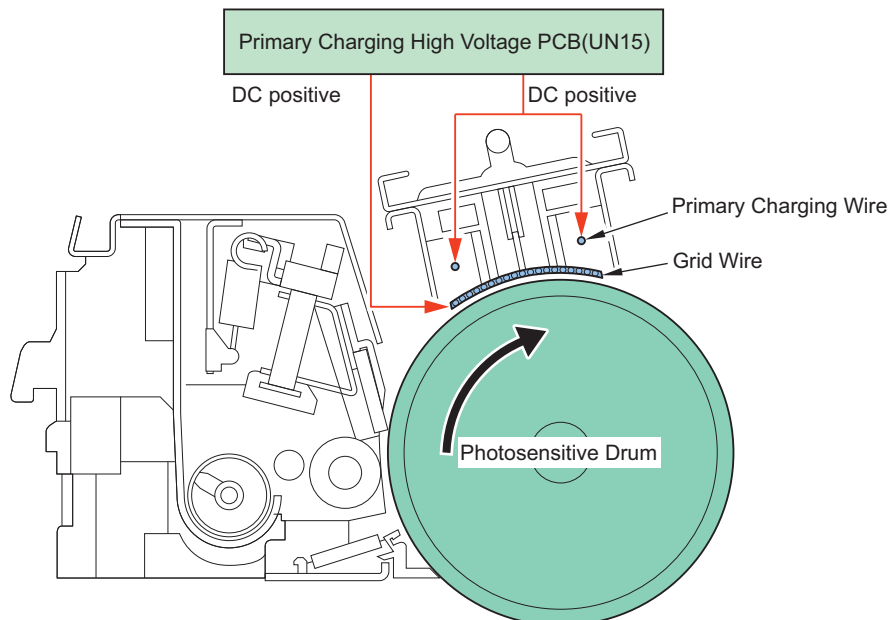
To make the surface of the Photosensitive Drum evenly and positively charged.

The primary charging bias (DC positive), which has been generated by the Primary Charging High Voltage PCB (UN15), is applied to the Primary Charging Wire and the Grid Wire.

- Primary charging DC bias: the bias to be applied to the Primary Charging Wire
- Grid DC bias: the bias to be applied to the Grid Wire

The primary charging bias value is specified by the potential control.

The grid bias is specified based on the estimated life and the environment.



● Primary Charging Wire Cleaning Control

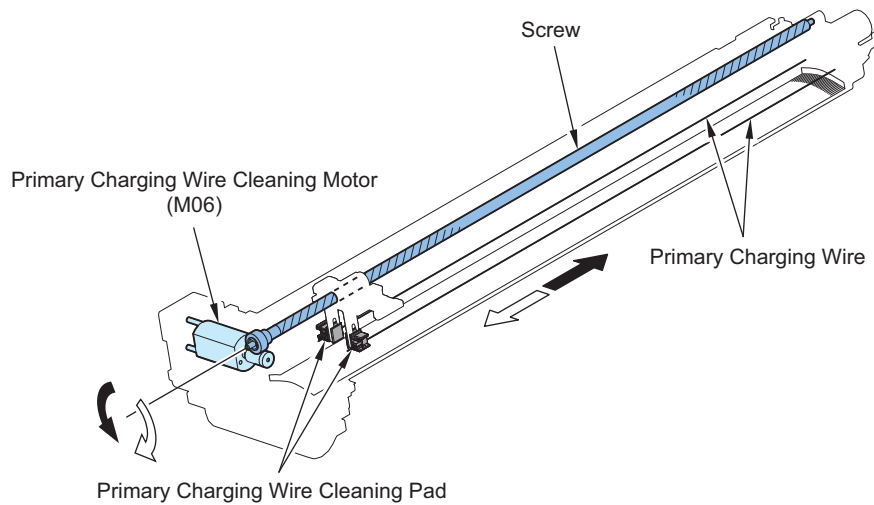
To prevent charging failure caused by soil of the Primary Charging Wire.

<Execution timing>

- Interruption at every 2000 sheets of continuous print (the value can be changed in service mode: 1,000 to 5,000 sheets)
- After last rotation which is performed on the 1500th sheet and later since the last cleaning (1-roundtrip)
- In the case of executing "Clean Wire" in user mode (1-roundtrip)
- In the case of executing the wire cleaning in service mode (1-roundtrip or 5-roundtrip)

<Control description>

The drive of the Primary Charging Wire Cleaning Motor (M06) makes the Cleaner Screw rotate clockwise/counterclockwise, which moves the Cleaning Pad back and forth to clean the Primary Charging Wire. Position detection of the Cleaning Pad is not performed.

**<Related service mode>**

- To clean the Charging Wires of Primary Charging Assembly and Pre-transfer Charging Assembly simultaneously (5-reciprocation).
COPIER > FUNCTION > CLEANING > WIRE-CLN
- To clean the Charging Wires of Primary Charging Assembly and Pre-transfer Charging Assembly simultaneously (1-reciprocation).
COPIER > FUNCTION > CLEANING > WIRE-EX
- To set the offset value of the paper interval for automatic cleaning of the Primary Charging Wire. (Lv.2)
COPIER > OPTION > CLEANING > W-CLN-P

• Primary Charging Shutter Control

To prevent uneven potential on the Photosensitive Drum caused by discharge products (nitrogen oxide) accumulated on the Primary Charging Assembly.

NOTE:

In the environment which moisture content is lower than the one in power saving environment (temperature: 23 deg C, humidity: 70%, moisture content: 15g), set the Drum Heater to OFF in the sleep mode after a specified time passes.

Discharge product (nitrogen compound) which is generated at the Charging Assembly when image is formed is deposited on the Drum when the time passes.

When the Drum Heater is OFF, the discharge product (nitrogen compound) has a chemical reaction with the moisture in the air and generates nitric acid. This nitric acid deteriorates the surface of the Drum and causes the image failure.

<Execution timing>

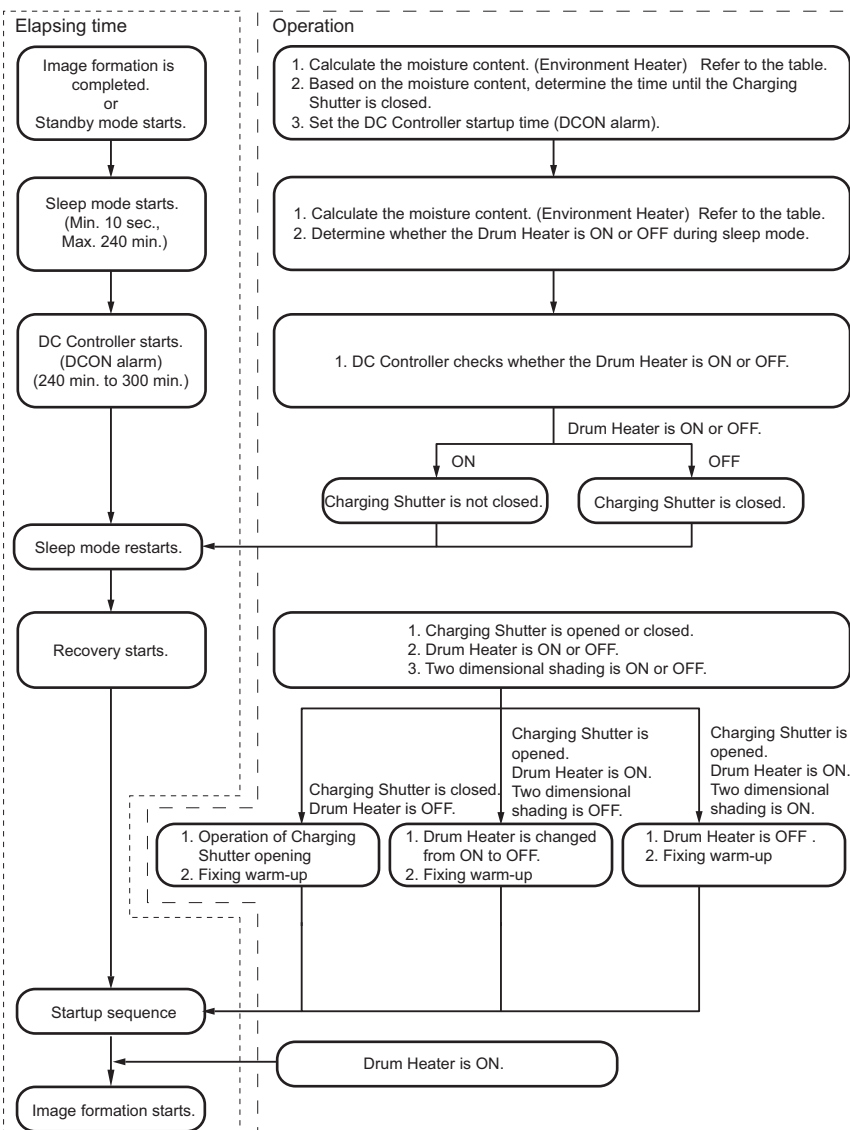
- When the Drum Heater is turned OFF
- During sleep mode

<Execution timing>

- After 4 or 5 hours since the drum was stopped*
 - *The time is determined by the environment (moisture content) when the drum operation was stopped.
- The timing for closing the Primary/Pre-transfer Charging Shutter can be set in the following service mode.
 COPIER > OPTION > IMG-DEV > PRI-SHUT

Environment	Moisture content	Temperature/Humidity	Drum Heater	Time
1	to 0.86	23 deg C 5%	OFF	300min.
2	to 1.73	23 deg C 10%	OFF	285min.
3	to 5.8	23 deg C 30%	OFF	270min.
4	to 8.9	23 deg C 50%	OFF	255min.
Energy save	to 12.41	22 deg C 75%	OFF	240 min.
5	to 15	23 deg C 70%	ON	Not close
6	to 18	27 deg C 80%	ON	Not close
7	to 21.6	30 deg C 80%	ON	Not close

Shutter Open/Close Operation Sequence

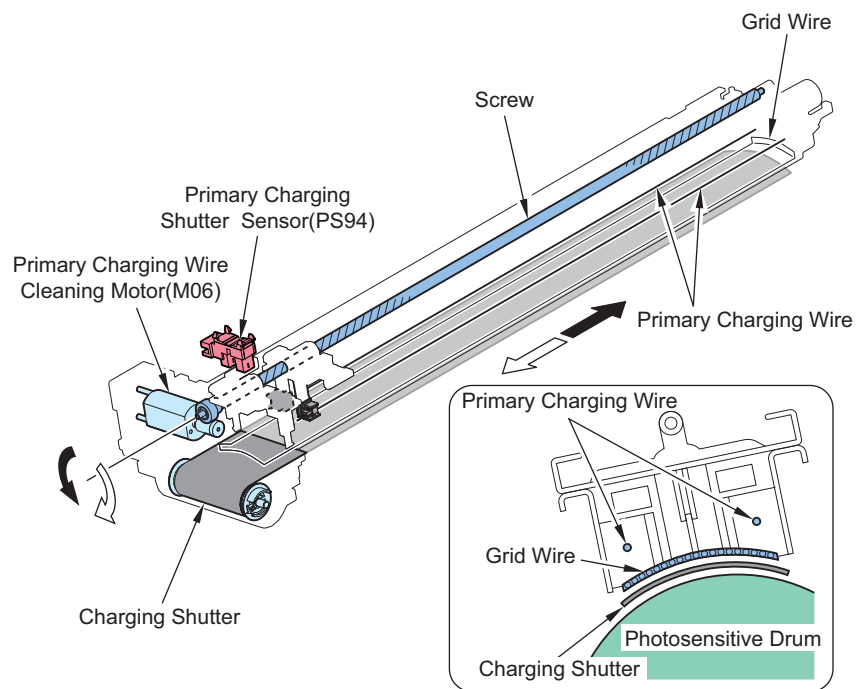


<Control description>

The shutter is open or closed by the cleaning mechanism of the Primary Charging Wire. The Primary Charging Shutter is made of fiber and usually taken up by the bobbin. The drive of the Primary Charging Wire Cleaning Motor (M06) moves the Cleaning Pad to the rear and the shutter taken up by the bobbin becomes extended to make the Shutter closed.

Because the Shutter comes between the Grid Wire and the Photosensitive Drum, discharge products from the Primary Charging Assembly do not reach the Photosensitive Drum.

The Primary Charging Shutter Sensor (PS94) detects opening/close of the shutter.



<Related error code>

E060-0001: Primary Charging Shutter HP open error

E060-0002: Primary Charging Shutter HP close error

■ Developing

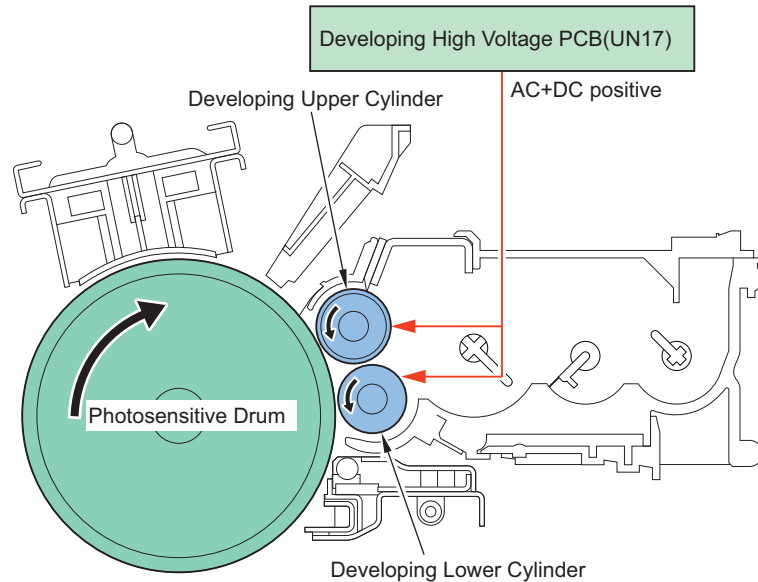
● Developing Bias Control

To form a toner image on the Photosensitive Drum by charging toner on the Developing Cylinder.

<Control description>

The developing bias (AC, DC positive), which has been generated on the Develop High Voltage PCB (UN17), is applied to the Developing Cylinder.

- Developing DC bias
 - The bias to generate potential difference with the Photosensitive Drum.
 - The bias value is determined based on the D-max control.
- Developing AC bias
 - The bias to improve image quality.
 - The bias value is fixed.

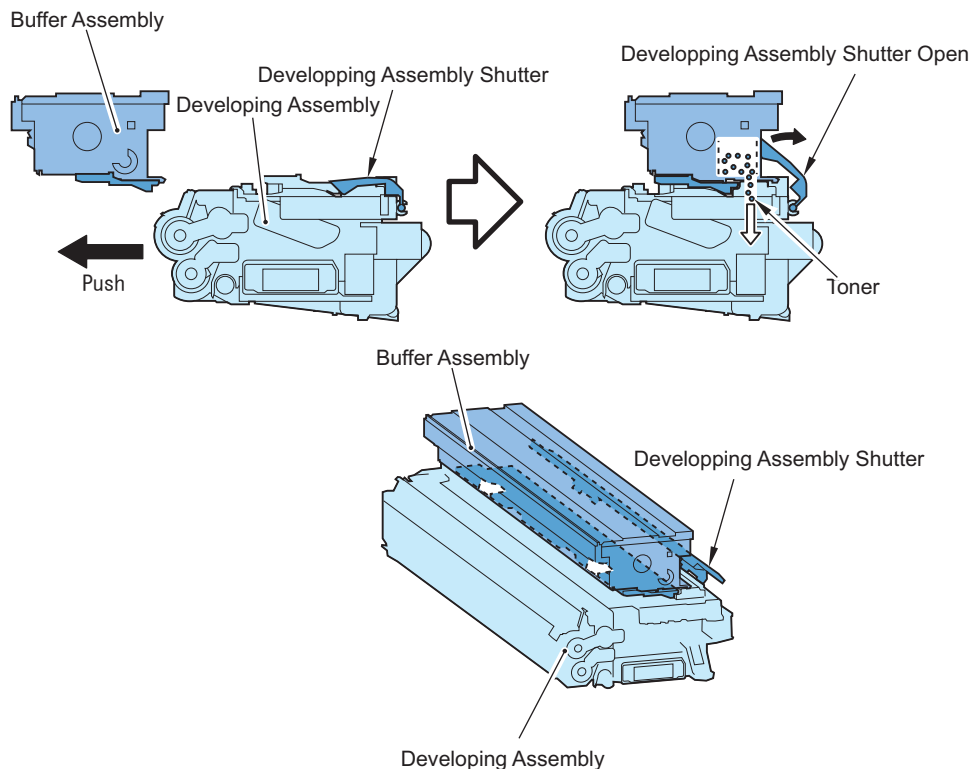


• Developing Supply Shutter Opening/Closing Mechanism

There are shutters at the Supply Mouths of the Developing Assembly and the Buffer Unit to prevent toner scattering. The Developing Shutter and Buffer Shutter is opened/closed in conjunction with push-in and pull-out of the Developing Assembly.

<Opening and Closing Operations of the Developing Shutter>

By pushing the Developing Assembly in the main body, the Developing Shutter comes in contact with the Buffer Unit. By pushing the assembly in farther, the Developing Shutter opens along the side of the Buffer Unit. By pulling the Developing Assembly out from the main body, the Developing Shutter closes by its own weight so the Supply Mouth is closed.



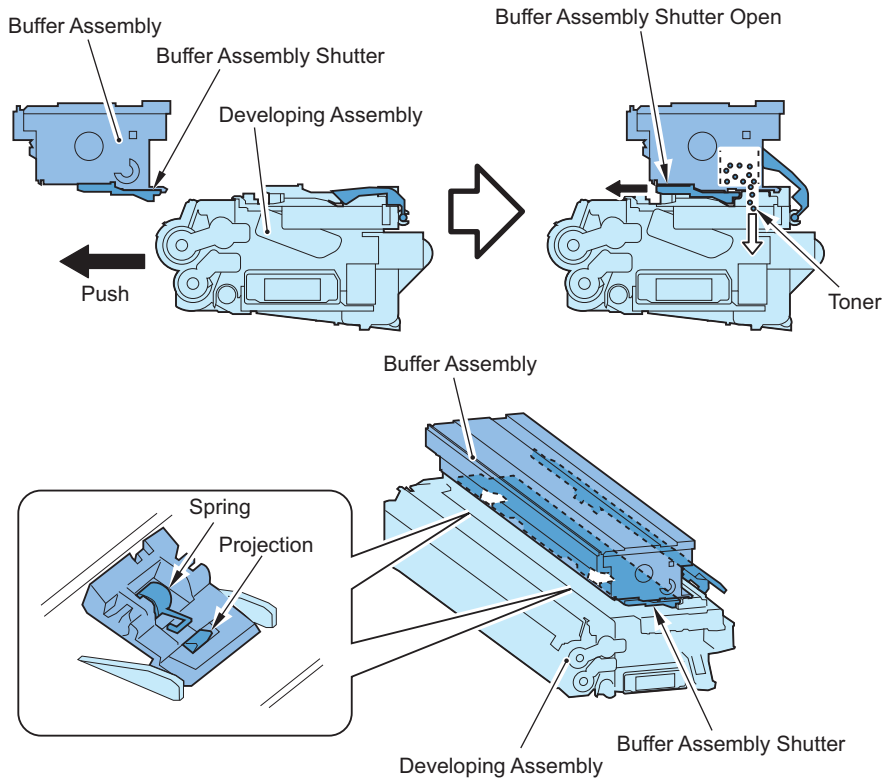
<Opening and Closing Operations of the Buffer Shutter>

By pushing the Developing Assembly in the main body, edge of the Supply Mouth on the assembly hits to leading edge of the Buffer Shutter.

By pushing the assembly in farther, the Buffer Shutter moves to the rear so the Supply Mouth is opened.

The Shutter Arm goes down by spring pressure, and it interlocks with the protrusion on the Developing Shutter.

By pulling the Developing Assembly out, the Shutter Arm is pushed by the protrusion on the Developing Shutter, so the Buffer Shutter is closed followed by the Supply Mouth. The Shutter Arm lifts up by hitting to the bottom of the Hopper.



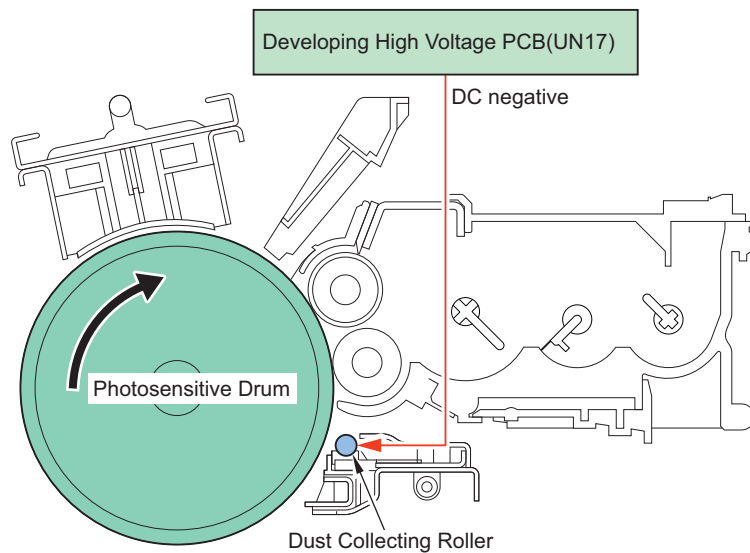
• Dust-collection Bias Control

To collect toner which floats over the Photosensitive Drum during developing process.

<Control description>

The dust-collection bias (DC negative), which has been generated on the Develop High Voltage PCB (UN17), is applied to the Dust-collection Roller.

The bias value is fixed.

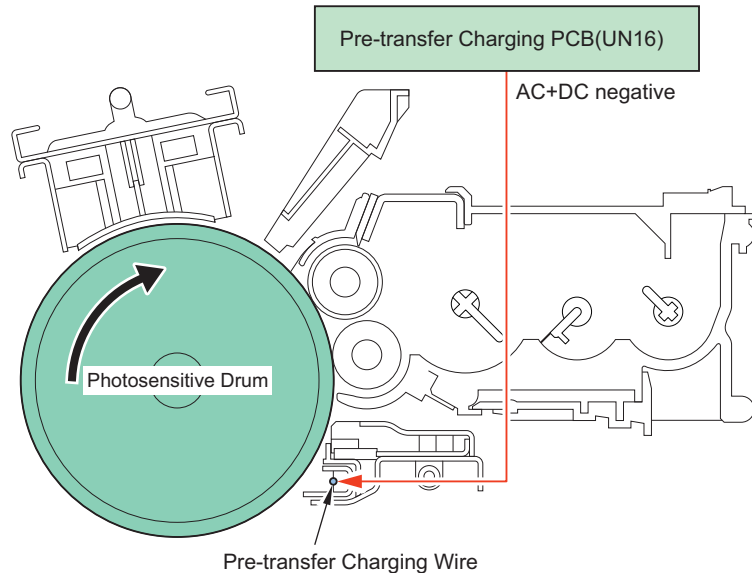


■ Transfer

• Pre-transfer Charging Bias Control

To make the charging amount of toner on the Photosensitive Drum appropriate to improve transfer performance.

The pre-transfer charging bias (AC + DC negative), which has been generated on the Pretransfer Charging PCB (UN16), is applied to the Pre-transfer Charging Wire.



• Pre-transfer Charging Wire Cleaning Control

To prevent charging failure caused by soil of the Pre-transfer Charging Wire.

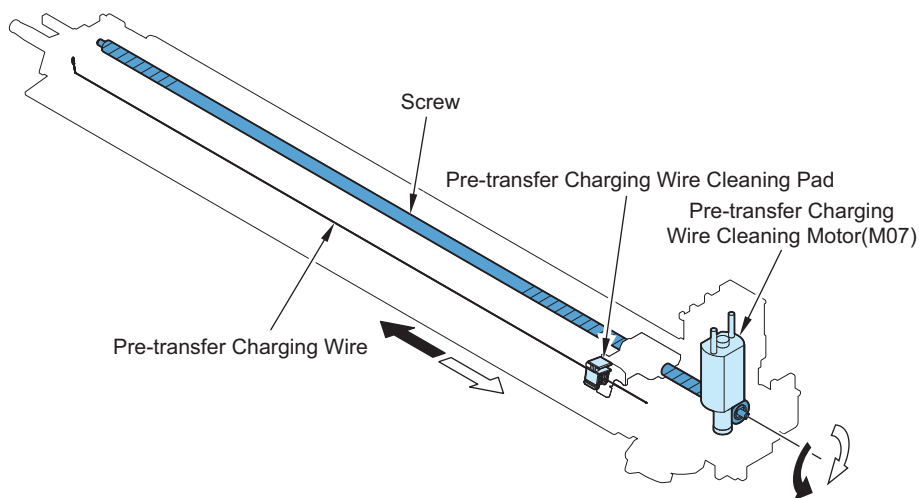
<Execution timing>

To be executed together with the primary charging wire cleaning control at the same time.

<Control description>

The drive of the Pre-Transfer Charging Wire Cleaning Motor (M7) makes the Cleaner Screw rotate clockwise/counterclockwise, which moves the Cleaning Pad back and forth to clean the Pre-transfer Charging Wire.

The Pre-transfer Charging Shutter Position Sensor () detects position of the Cleaning Pad.



<Related service mode>

- To clean the Charging Wires of Primary Charging Assembly and Pre-transfer Charging Assembly simultaneously (5-reciprocation).
COPIER > FUNCTION > CLEANING > WIRE-CLN
- To clean the Charging Wires of Primary Charging Assembly and Pre-transfer Charging Assembly simultaneously (1-reciprocation).
COPIER > FUNCTION > CLEANING > WIRE-EX
- To set the offset value of the paper interval for automatic cleaning of the Primary Charging Wire. (Lv.2)
COPIER > OPTION > CLEANING > W-CLN-P

• Pre-transfer Charging Shutter Control

To prevent uneven potential on the Photosensitive Drum caused by discharge products (nitrogen oxide) accumulated on the Pre-transfer Charging Assembly.

<Execution timing>

- To be executed together with the Pre-transfer charging wire cleaning control at the same time.

<Control description>

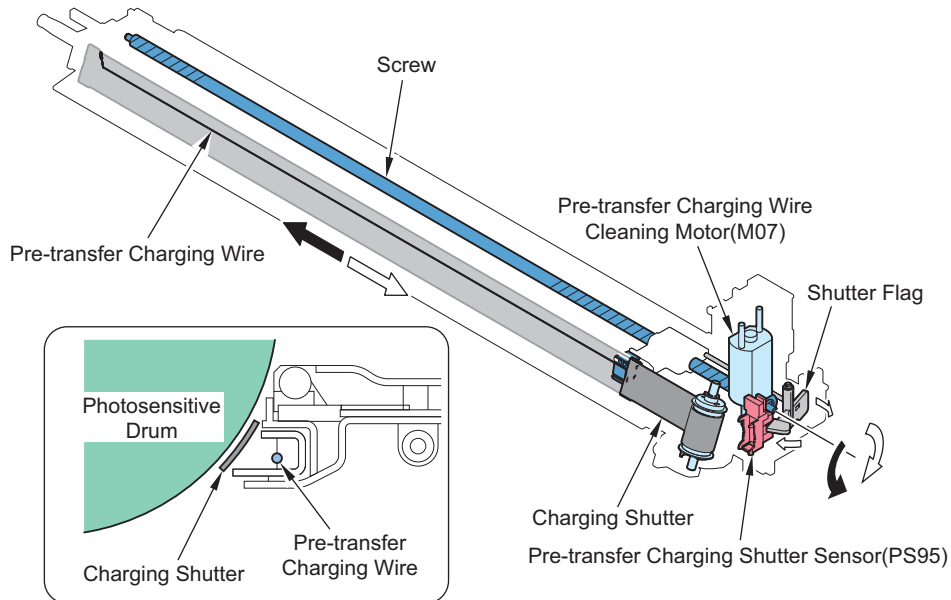
The shutter is opened or closed by the cleaning mechanism of the Pre-transfer Charging Wire.

The Pre-transfer Charging Shutter is made of fiber and usually taken up by the bobbin.

The drive of the Pre-transfer Charging Wire Cleaning Motor (M07) moves the Cleaning Pad to the rear and the shutter taken up by the bobbin becomes extended to make the Shutter closed.

Because the Shutter comes between the Pre-transfer Charging Wire and the Photosensitive Drum, discharge products from the Primary Charging Assembly do not reach the Photosensitive Drum.

The Pre-transfer Charging Shutter Position Sensor (PS95) detects opening/close of the shutter.

**• Transfer Bias Control**

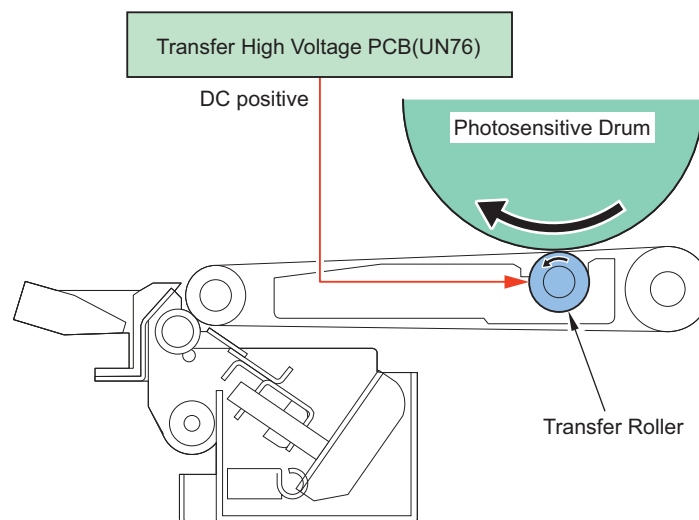
To transfer toner on the Photosensitive Drum to a paper.

The transfer bias (DC positive), which has been generated on the Transfer High Voltage PCB (UN76), is applied to the Transfer Roller.

Following shows the 3 types of transfer bias:

- Print bias: the bias to be applied during printing
- Paper leading edge weak bias: the bias to be applied to the leading edge of the paper (to prevent failure in paper separation)
- Paper interval bias: the bias to be applied between sheets

The bias value is determined by the environment, the paper type and the mode table.

**<Related service mode>**

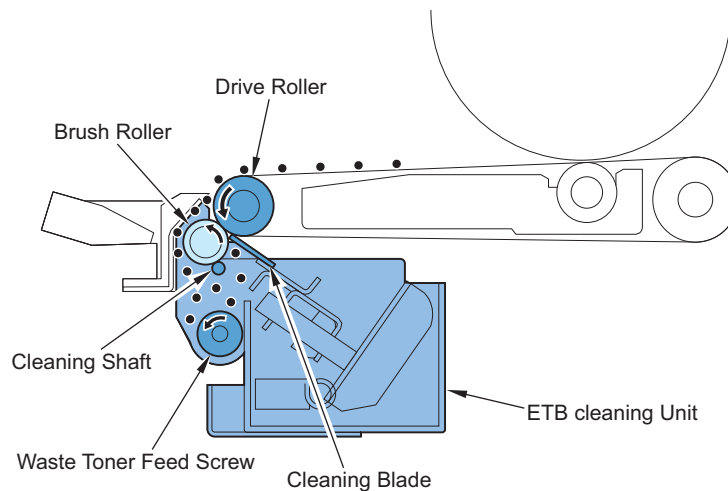
- To adjust the offset value of the target current of the Transfer Roller (Lv.2)
COPIER > ADJUST > HV-TR > TR-OFS1 to 6
- To adjust the leading edge transfer target current and the offset value of leading edge transfer bias output timing (Lv.2)
COPIER > ADJUST > HV-TR > TR-L-OF1 to 6
- To adjust the offset value of the pre-transfer charging current (Lv.2)
COPIER > ADJUST > HV-TR > P-TR-OF1 to 6
- To set the paper type which the target current of the Transfer Roller is adjusted. (Lv.2)
COPIER > ADJUST > HV-TR > TR-SP1 to 2
- To set the paper type which the leading edge transfer target current and the leading edge transfer bias output timing are adjusted. (Lv.2)
COPIER > ADJUST > HV-TR > TR-L-SP1 to 2
- To set the paper type which the pre-transfer charging current is adjusted. (Lv.2)
COPIER > ADJUST > HV-TR > P-TR-SP1 to 2

• ETB Cleaning Control

To prevent image failure caused by toner soil on the ETB, the residual toner on the Transfer Belt is removed.

<Control description>

1. The Brush Roller collects toner on the ETB.
2. The Cleaning Shaft scrapes toner on the Brush Roller.
3. The ETB Cleaning Blade scrapes toner on the ETB.
4. The scraped toner is fed to the Waste Toner Container.



<Related service mode>

- To execute three idle rotations of the ETB and clean the ETB.
COPIER > FUNCTION > CLEANING > TBLT-CLN
- To set the number of times to apply cleaning bias at the time of ETB cleaning.
COPIER > OPTION > IMG-DEV > TBLTTMS
- To set the timing to execute ETB cleaning control.
COPIER > OPTION > IMG-DEV > TBLTCLSW
- To set the transfer current value to apply cleaning bias(+) at the time of ETB cleaning.
COPIER > OPTION > IMG-DEV > TBLTBIS+
- To set the transfer current value to apply cleaning bias (-) at the time of ETB cleaning.
COPIER > OPTION > IMG-DEV > TBLTBIS-

• ETB Engagement/Disengagement Control

To prevent image failure caused by toner soil on the ETB, the ETB is engaged or disengaged with the Photosensitive Drum.

<Execution timing>

- To make the belt engaged: during printing
- To make the belt disengaged: any timing other than the above

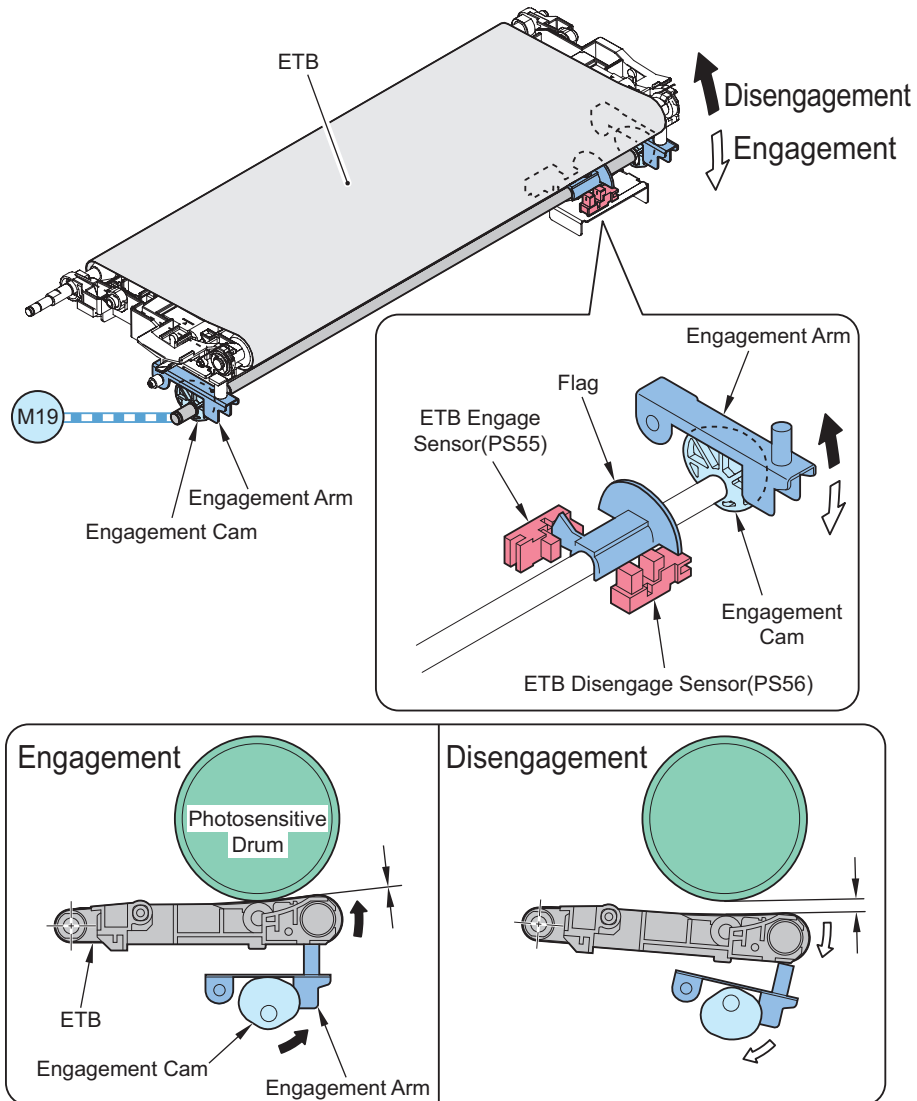
<Control description>

1. Reverse rotation of the Duplex Feed Left Motor (M19) makes the Disengagement Cam rotate.

2. Rotation of the Disengagement Cam moves the Disengagement Arm up and down to make the ETB engaged/disengaged with the Photosensitive Drum.
3. Following 2 sensors detect position of the Transfer Belt.
 - ETB Engage Sensor (PS55): to detect engagement of the ETB.
 - ETB Disengage Sensor (PS56): to detect disengagement (home position) of the ETB.

<Related error code>

- E017-0001: ETB disengagement error
 E017-0002: ETB engagement error
 E017-0003: ETB HP error

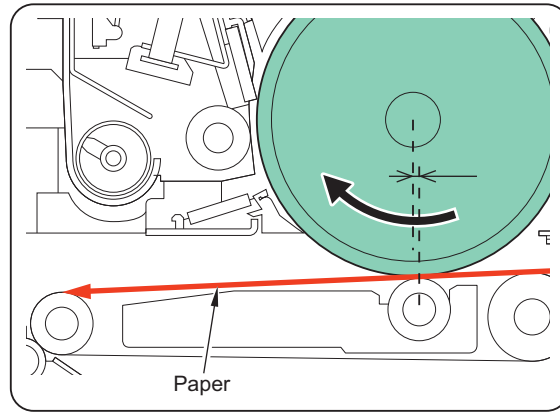


■ **Separation**

● **Separation Control**

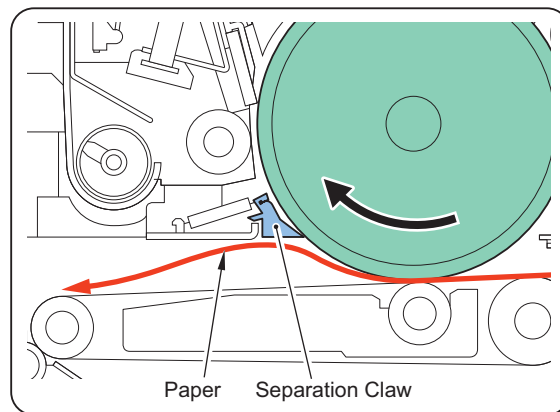
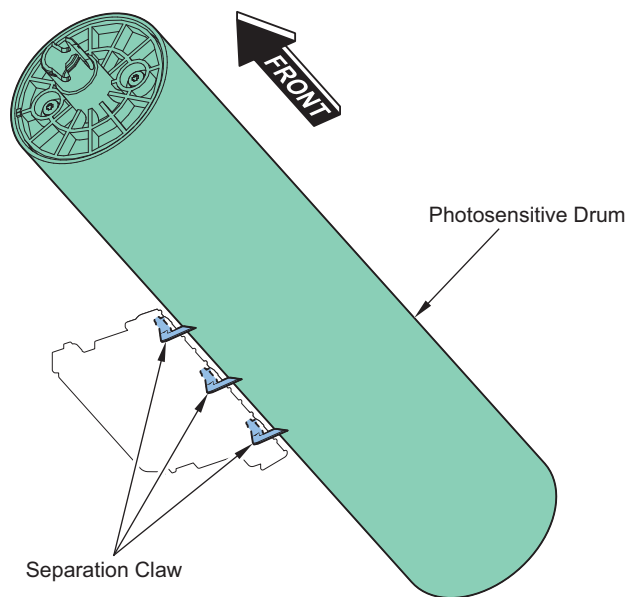
<Separation from the Drum>

Separation is performed using the curvature separation method.



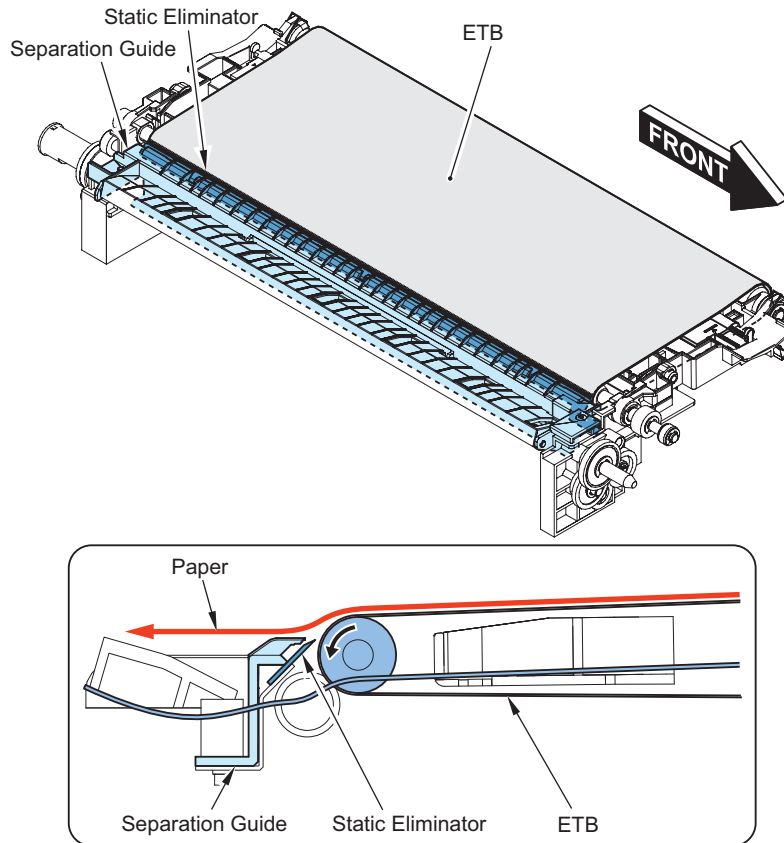
NOTE:

The Separation Claw separates sheets before entering the Drum Cleaning Unit. This effectively avoids failure in paper feed (double feed, etc.)



<Separation from the ETB>

Separation is performed using the curvature separation method and the Static Eliminator. There is no bias for separation.



• Separation Claw Reciprocation Control

By moving the Separation Claw back and forth (reciprocation), scar on the drum caused by the Separation Claw can be prevented.

<Execution Timing>

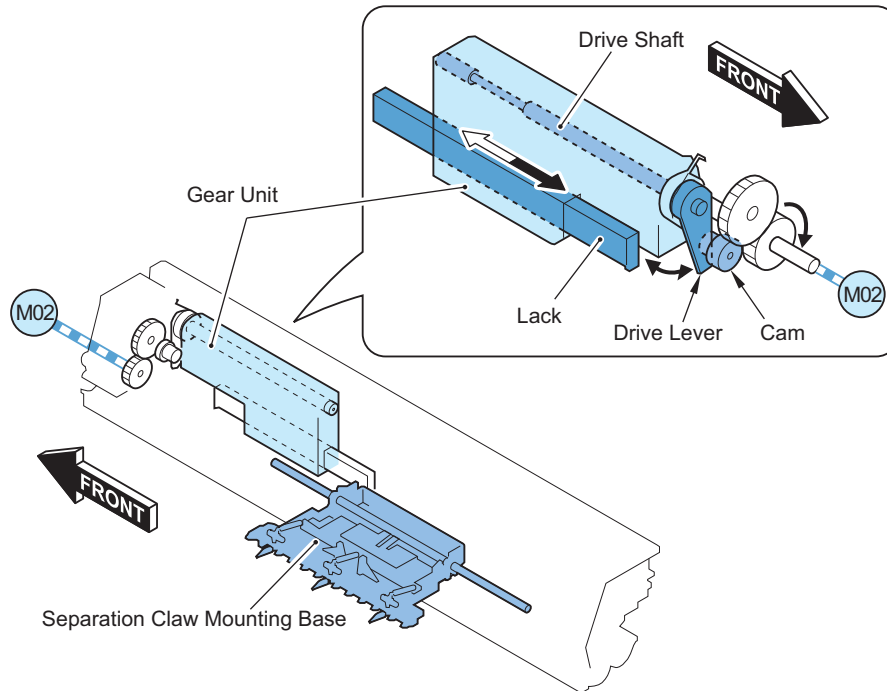
During printing (while the Developing Motor is driving)

<Control Description>

Making the Separation Claw move back and forth by transmitting the rotation force of the Developing Motor Drive via the cam and Gear Unit.

Reciprocation width: +/-25mm

1. The drive of the Developing Motor (M02) makes the cam rotate.
2. The Drive Lever moves in a pendulum motion by the rotation of the cam, which make the Drive Shaft rotates. (With the one-way bearing, the Drive Shaft rotates in only one direction.)
3. Making the Lack move back and forth by transmitting the rotating motion of the Drive Shaft via the Gear Unit. The Separation Mounting Base linked with the Lack moves back and forth.



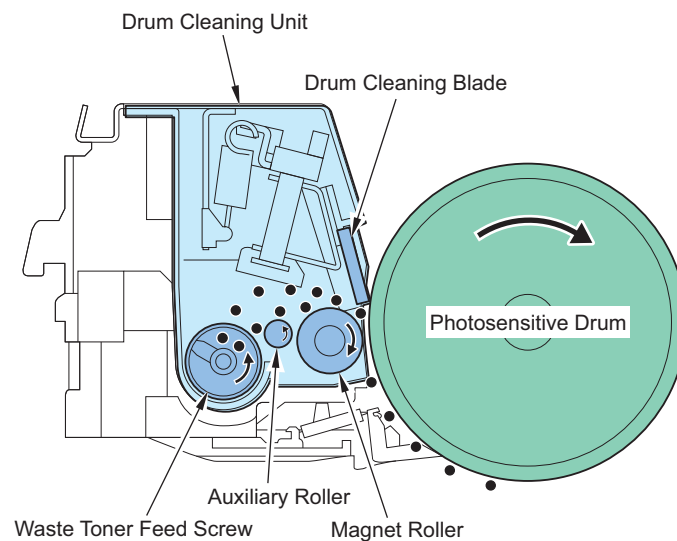
■ Drum Cleaning

● Drum Cleaning Control

The blade, which is in contact with the Drum, removes residual toner and paper dust on the Photosensitive Drum.

<Control description>

1. The drive of the Developing Motor (M02) makes the Magnet Roller rotate.
2. The Magnet Roller forms a thin toner coating layer on the surface of the Photosensitive Drum.
3. The Drum Cleaning Blade scrapes residual toner on the surface of the Drum.
4. The Toner Collection Feeding Screw feeds the scraped waste toner to the Waste Toner Container.



● Separation Bias Control

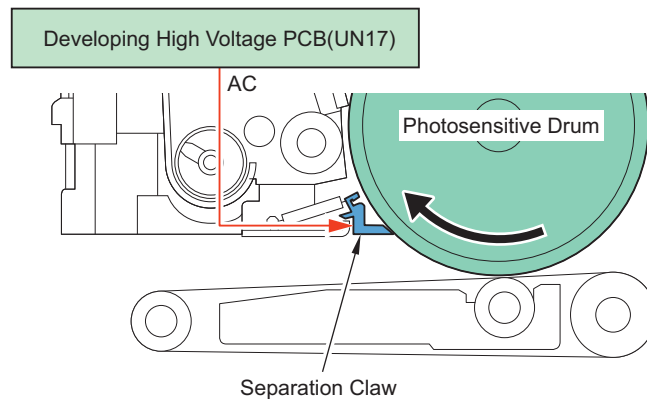
To prevent image soil caused by toner accumulated on the Drum Separation Claw, this control prevents attachment of toner on the Photosensitive Drum with the Drum Separation Claw.

<Execution timing>

When the developing bias is applied

<Control description>

The separation claw bias (AC), which has been generated on the Develop High Voltage PCB (UN17), is applied to the Separation Claw so that vibration is given to the Separation Claw to prevent toner attachment. The bias value is fixed.



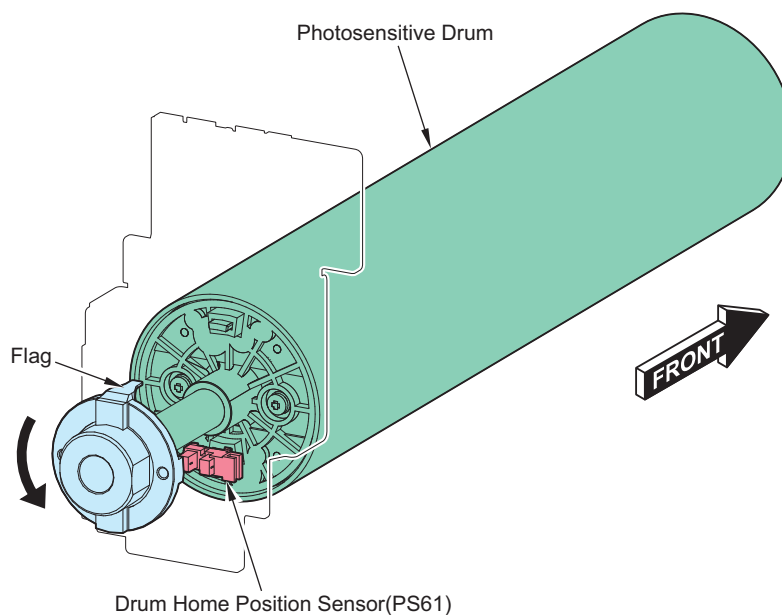
■ Drum-related Issues

● Drum HP Detection

To detect home position of the Photosensitive Drum.

There is a flag for HP detection on the shaft of the Photosensitive Drum. Once the Photosensitive Drum starts rotating, the flag passes through the Drum HP Sensor (PS61) and the home position of the Photosensitive Drum is detected.

This control is used during the D-max control, the D-half control and the 2D shading control.

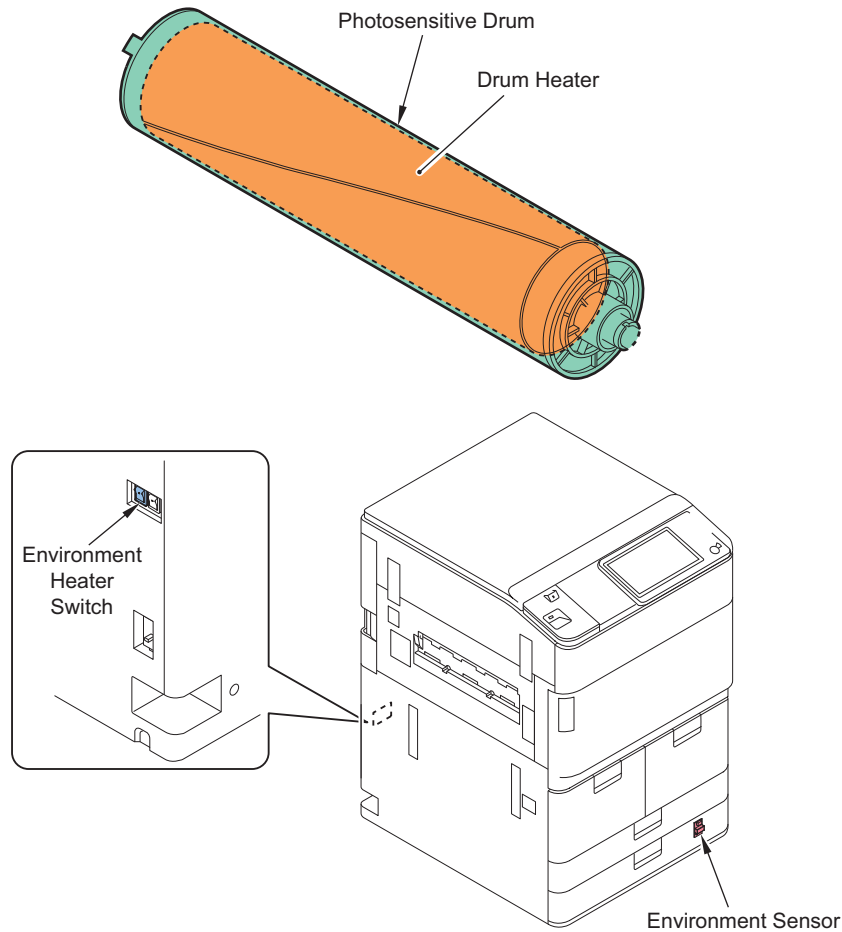


● Drum Heater Control

To make potential characteristic for charging or exposure stable by keeping the specified temperature of the Photosensitive Drum. The Drum Heater is the flat heater located inside the Photosensitive Drum to keep moisture content on the surface of the Photosensitive Drum constant by turning ON the heater.

NOTE:

Temperature of the drum is detected by the Thermistor in the Drum Control PCB, and is controlled by turning ON/OFF the Drum Heater to make it 42 deg C.



<Operating condition>

Operating condition of the heater differs according to the status of the Environment Switch and the host machine.

A. In the case of normal image mode*1 (DRM-H-SW: "2")

<Environment Heater Switch: OFF>

Mode		Main Power OFF		sleep mode		WarmUp (Recovery)		Standby/Energy Saver		Copy/Print	
Switch	Main SW	OFF		ON							
	Cassette Heater SW	OFF	ON	OFF	ON	OFF	ON	OFF	ON	OFF	ON
Heater	Drum	OFF	OFF	OFF	OFF	ON*3	ON*3	ON	ON	ON	ON
	Cassette	OFF	OFF	OFF	OFF	OFF	ON	OFF	ON	OFF	ON
	Reader	OFF	OFF	OFF	OFF	OFF	OFF	OFF	OFF	OFF	OFF

<Environment Heater Switch: ON>

Mode		Main Power OFF		sleep mode		WarmUp (Recovery)		Standby/Energy Saver		Copy/Print	
Switch	Main SW	OFF		ON							
	Cassette Heater SW	OFF	ON	OFF	ON	OFF	ON	OFF	ON	OFF	ON
Heater	Drum	OFF	OFF	OFF	OFF	ON*3	ON*3	ON	ON	ON	ON
	Cassette	OFF	ON	OFF	ON	OFF	ON	OFF	ON	OFF	ON
	Reader	ON	ON	ON	ON	ON	OFF	OFF	OFF	OFF	OFF

B. In the case of image priority mode*1 (DRM-H-SW: "1")

<Environment Heater Switch: OFF>

Mode		Main Power OFF		sleep mode		WarmUp (Recovery)		Standby/Energy Saver		Copy/Print	
Switch	Main SW	OFF		ON							
	Cassette Heater SW	OFF	ON	OFF	ON	OFF	ON	OFF	ON	OFF	ON
Heater	Drum	OFF	OFF	OFF	OFF	ON*3	ON*3	ON	ON	ON	ON
	Cassette	OFF	OFF	OFF	OFF	OFF	ON	OFF	ON	OFF	ON
	Reader	OFF	OFF	OFF	OFF	OFF	OFF	OFF	OFF	OFF	OFF

<Environment Heater Switch: ON>

Mode		Main Power OFF		sleep mode		WarmUp (Recovery)		Standby/Energy Saver		Copy/Print	
Switch	Main SW	OFF		ON							
	Cassette Heater SW	OFF	ON	OFF	ON	OFF	ON	OFF	ON	OFF	ON
Heater	Drum	ON	ON	ON	ON	ON*3	ON*3	ON	ON	ON	ON
	Cassette	OFF	ON	OFF	ON	OFF	ON	OFF	ON	OFF	ON
	Reader	ON	ON	ON	ON	ON	OFF	OFF	OFF	OFF	OFF

*1: ON/OFF can be switched in the following service mode (Lv. 2).

COPIER > OPTION > IMG-MCON > DRM-H-SW

*2: When 1 or 2 is set in the following service mode, the Drum Heater is turned ON.

COPIER > OPTION > IMG-LSR > 2D-SHADE

*3: OFF when the detected temperature of the Environment Sensor is 15 deg C or higher.

• Drum Unit Life Detection

Purpose

To display the LIFE and Remaining Days of the Drum Unit (photosensitive drum) to notify the replacement timing. The LIFE and the Remaining Days can be checked in the service modes below.

Consumption rate check

Service Mode:

COPIER > COUNTER > LIFE > PT-DRM

Control description

1. This calculates the drum life from the drum rotation time and the application time of primary charging DC bias.
2. The calculated drum life value is added to the counter value stored in the drum memory.
3. The remaining days are calculated by the calculated life with the consideration for the usage conditions.

Item	Advance Notice Alarm	Replacement display	Replacement completion
Alarm code name	Drum Unit prior notification alarm *1	-	Drum Unit replacement completion alarm
Alarm Code	40-0073	-	43-0073
Message	-	Insert the drum cartridge.	
Host machine operation after displaying the message		Continuous printing is available	
Detection timing	When the consumption rate of Drum Unit *2 reaches the setting value *1 of service mode	7 days after sending the Advance Notice Alarm (default value) *1	When clearing the life value
Detected to (location)	DC controller PCB		
Alarm log display	ALARM-3 *3	-	ALARM-3

*1. The display/hide and display timing settings for prior notification alarm can be changed from the following service mode items.
COPIER > OPTION > PM-DLV-M > PT-DRM

*2. The consumption rate of Drum Unit can be checked from the following service mode.
COPIER > COUNTER > LIFE > PT-DRM

*3. The next prior notification alarm is not sent from sending the previous prior notification alarm and then sending the replacement completion alarm.

Service Mode

- Drum Unit (Bk): Life VL/No. of days
COPIER > COUNTER > LIFE > PT-DRM
- Set Drum-U(Bk) prior alarm notice timing
COPIER > OPTION > PM-DLV-D > PT-DRM

Alarm Code

- Drum Unit prior notification alarm
40-0073
- Drum Unit replacement completion alarm
43-0073

■ Toner Supply Area

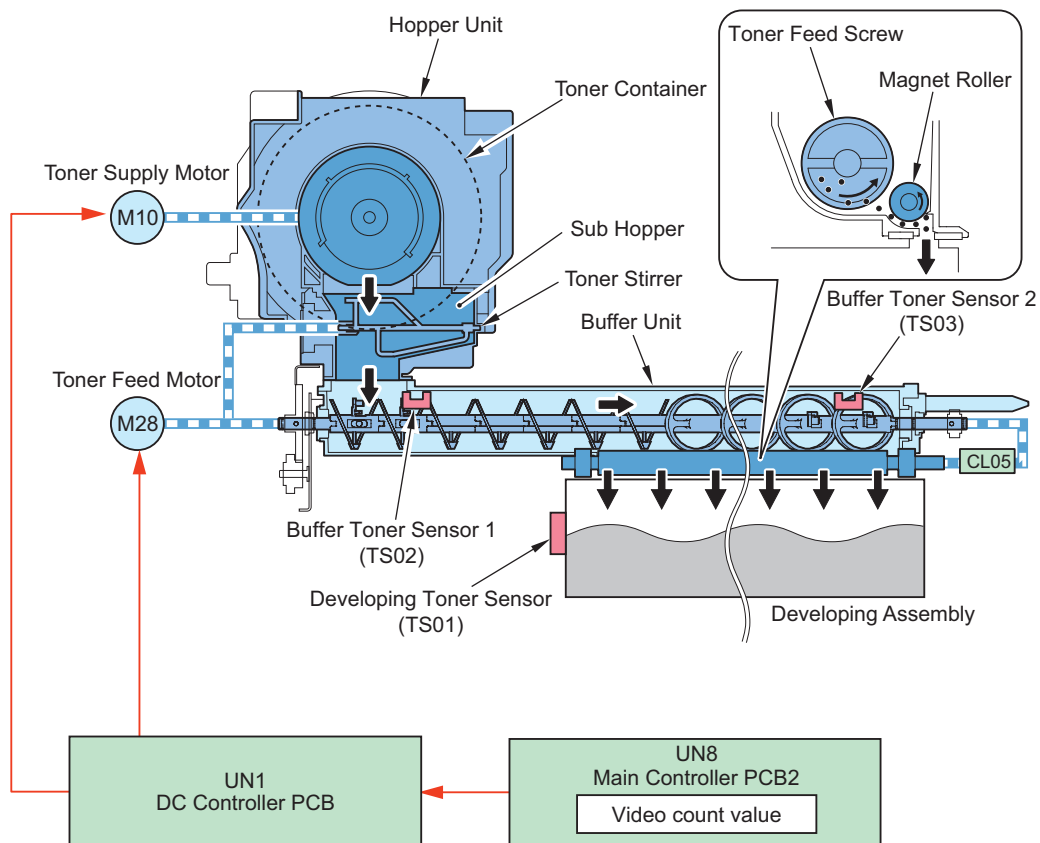
● Toner Container Detection

Toner Container detection is not performed with this machine.

● Toner Supply Control

To supply toner in the Toner Container to the Developing Assembly.

The Magnet Roller helps toner supplied to the Developing Assembly uniformly in the longitudinal direction to form an even toner layer in the Developing Cylinder.



Title	Description	Supply timing	Operation of the host machine
Supply to the Hopper	Toner in the Toner Container is supplied to the Buffer Unit.	When both the Buffer Toner Sensor 1 (TS02) and the Buffer Toner Sensor 2 (TS03) detect absence of toner, the Toner Supply Motor (M10) is driven. When the Buffer Toner Sensor 1 (TS02) or the Buffer Toner Sensor 2 (TS03) detects presence of toner, the Toner Supply Motor (M10) is stopped. When the Buffer Toner Sensor 2 (TS03) detects absence of toner, the Toner Supply Motor (M10) is driven. When the Buffer Toner Sensor 1 (TS02) detects presence of toner, the Toner Supply Motor (M10) is stopped whereas the Toner Feed Motor (M28) is driven.	

Title	Description	Supply timing	Operation of the host machine
Supply to the Developing Assembly	Developer in the Buffer Unit is supplied to the Developing Assembly.	When the Developing Toner Sensor (TS01) detects absence of toner	Drive the Toner Feed Motor (M28) and turn ON the Magnet Roller Clutch (CL05). Drive the Toner Feed Motor (M28) and connect the Magnet Roller Clutch (CL05). Toner is supplied intermittently until the Developing Toner Sensor (TS01) detects presence of toner. The supply amount is determined based on the output value of the video count of the image (image duty).

NOTE:

The Buffer Toner Sensor1 (TS02) detects amount of toner around the Buffer Inlet. If toner is supplied excessively from the Sub Hopper to the Buffer Unit (if there are toner clusters), toner in the Buffer may overflow.

If the Buffer Toner Sensor1 (TS02) detects presence of toner, regardless of presence/absence detection of toner by the Buffer Toner Sensor2 (TS03), the Toner Supply Motor (M10) is stopped so that toner supply to the Buffer is stopped to prevent toner leak.

<Related service mode>

- Toner supply to the Developing Assembly
COPIER > FUNCTION > INSTALL > TONER-S

<Related error code>

E020-0000: Developing Assembly toner absence error

E020-0001: Error in Developing Toner Sensor (TS01) connection detection

E020-0002: Error in Buffer Toner Sensor 1 (TS02) connection detection

E020-0003: Error in Buffer Toner Sensor 2 (TS03) connection detection

E020-0004: Error in Magnet Roller Clutch connection detection

E020-0020: Error in Developing Toner Sensor Cleaning Scraper displacement (absence of toner)

E020-0021: Error in Developing Toner Sensor Cleaning Scraper displacement (presence of toner)

• Toner Level Detection

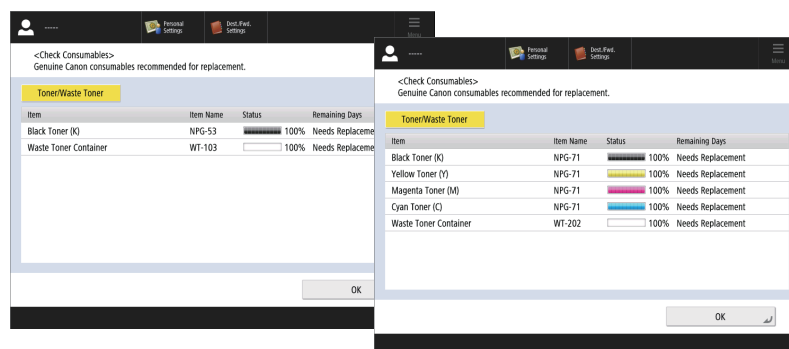
Purpose

To display the life/remaining days to notify the Toner Container replacement timing.

The life and remaining days can be seen in the following menu or service mode and whether to display/hide can be specified in the following service mode.

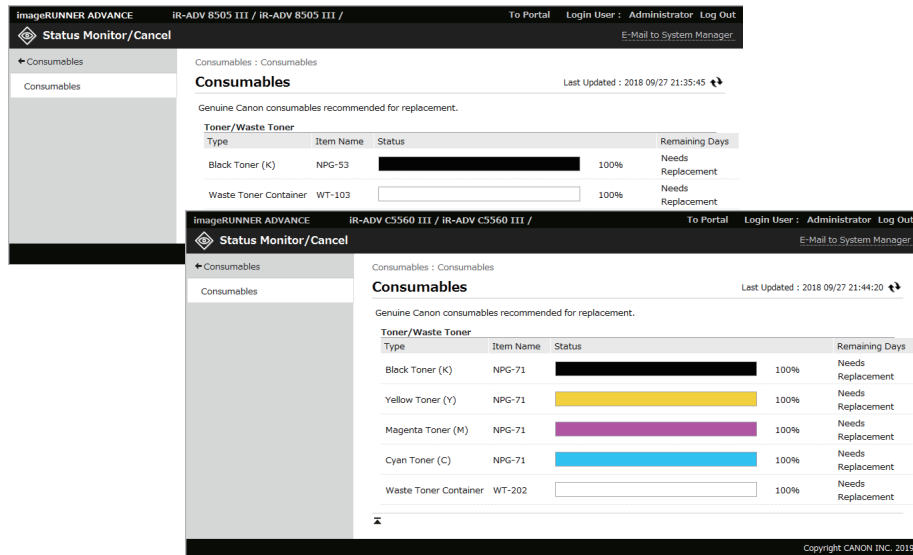
Consumption confirmation

Control Panel : Status Monitor > Consumables / Others > Check Consumables



Control Panel display example




Remote UI : Status Monitor / Cancel > Consumables



Remote UI display example

Service Mode :

COPIER > COUNTER > LIFE > TONER-K

Status name	Low remaining toner in container		Toner Container Empty	Toner Container / Buffer Empty
Toner Status	 Toner Container: Low toner remaining Buffer: 100%		 Toner Container: 0% Buffer: 100%	 Toner Container: 0% Buffer: 0%
Alarm code name	Toner prior notification alarm *1 *4	Toner low alarm *5	Toner Bottle empty alarm	-
Alarm codes	10-0020	10-0001	10-404	None
Message	None	Toner is low. Replacement is not yet needed. *2	Replace the toner cartridge. (Replacement not yet needed.)	Replace the toner cartridge. (Job is stopped.)
Host machine operation after the message is displayed	Replacement not yet needed.			Host machine is stopped.
Detection timing	Depends on the service mode setting *1	Depends on the service mode setting *3	When the Buffer Toner Sensor 2 (TS03) detects absence of toner even after performing a toner supply operation	After approx. 900 sheets have been printed by starting the toner supply count since an empty toner warning *6
Detected to (location)	Toner supply count		Buffer Toner Sensor 2 (TS03)	Toner supply count
Alarm log storage location	ALARM-2	-	ALARM-2	-
Whether the Toner Container can be removed	Not Available *7		Available	

*1 : The detection timing can be changed in the following service modes (setting of the Toner advance notice alarm notification timing). The alarm can also be set to be disabled.

- COPIER > OPTION > PM-DLV-D > TONER-K

*2 : Whether to display this message can be changed in the following service mode (setting of the ON/OFF of toner preparation message).

- COPIER > OPTION > PM-PRE-M > TONER-K

*3 : The detection timing can be changed in the following service modes (setting of the days left before the Toner Preparation Warning).

- COPIER > OPTION > PM-MSG-D > TONER-K

*4 : After an advance notice alarm is sent, the next advance notice alarm will not be sent until the replacement completion alarm is sent.

*5 : The message is generated by UGW and displayed on the UGW portal screen. This is not displayed on this machine.

*6 : The exact number of printed sheets differs depending on the usage environment/usage conditions.

Service Mode

To display the life value and the number of days left of Toner (Bk).

COPIER > COUNTER > LIFE > TONER-K

Display/hide Toner (Bk) preparation warning

COPIER > OPTION > PM-PRM > TONER-K

Set Toner (Bk) prior alarm notice timing

COPIER > OPTION > PM-DLV-D > TONER-K

Set number of days left before Toner (Bk) preparation warning

COPIER > OPTION > PM-MSG-D > TONER-K

Display/hide of Toner Container counter

COPIER > OPTION > USER > TNRB-SW

Alarm code

Toner Low (Black) alarm

10-0001

Toner (Bk) prior notification alarm

10-0020

Toner (Bk) empty alarm

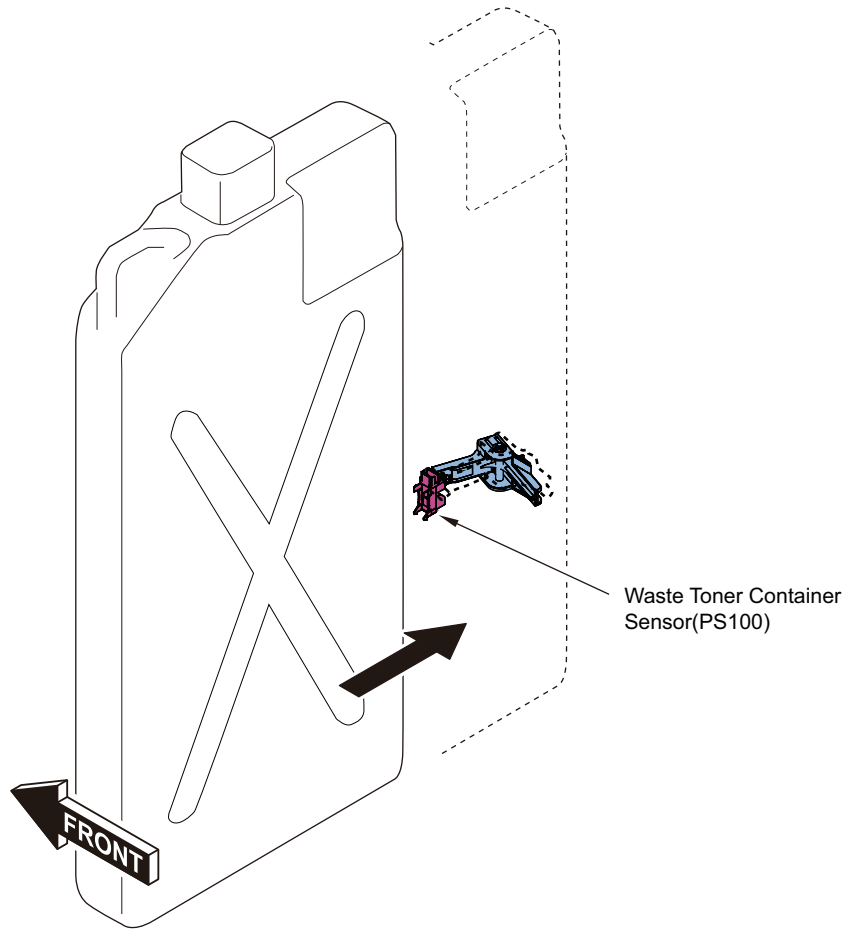
10-0404

■ Waste Toner Feed Unit

● Waste Toner Container Detection

Presence of the Waste Toner Container is detected by the Waste Toner Container Sensor (PS100).

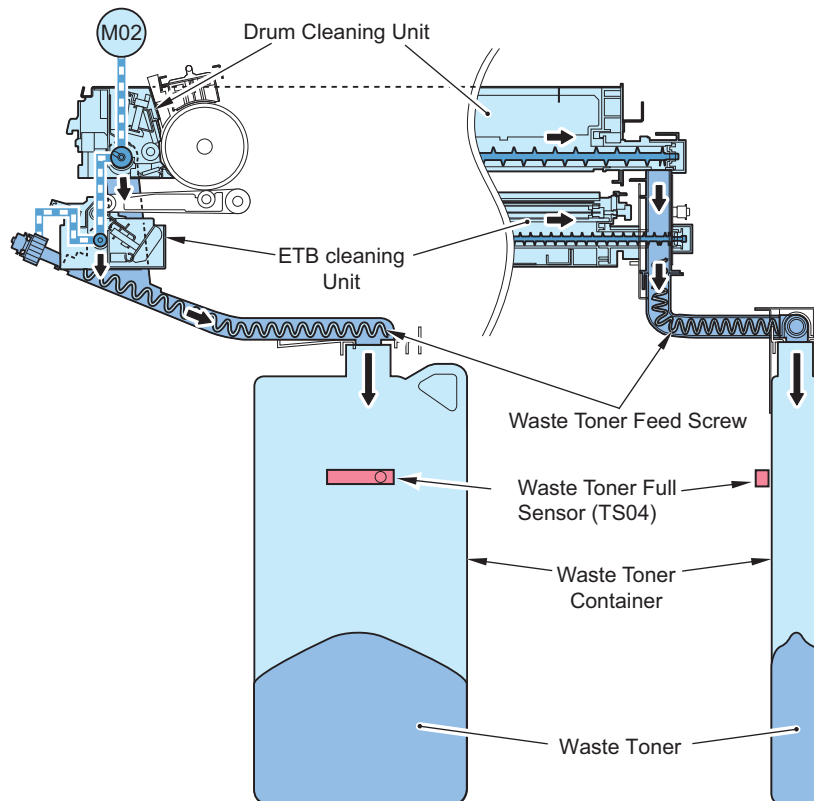
The Waste Toner Container Sensor (PS100) is turned ON when the Waste Toner Container is pushed into the host machine.



• **Waste Toner Feed Assembly**

Overview

Waste toner occurring in the Drum Cleaning Unit and ETB Cleaning Unit are fed to the Waste Toner Container.



Control description

This machine performs the following controls.

- "Black band control" to maintain the drum cleaning performance
- "Low duty ejection control" to maintain the density stability when continuously outputting low duty images

Therefore the criterion of the full Waste Toner Container varies according to the environment and the image duty as shown in the following table.

Temperature/ Humidity	Moisture con- tent	Image duty (%)					
		0 to less than 1.0	1.0 to less than 2.0	2.0 to less than 3.0	3.0 to less than 4.0	4.0 to less than 5.0	5.0 to 6.0
23 deg C / 5%	0.86	250,000 pages	1,000,000 pages		800,000 pages	700,000 pages	600,000 pages
23 deg C / 10%	1.73						
23 deg C / 30%	5.8						
23 deg C / 50%	8.9						
27 deg C / 70%	15	100,000 pages	250,000 pages	600,000 pages			500,000 pages
28 deg C / 75%	18		120,000 pages	150,000 pages	300,000 pages	500,000 pages	
30 deg C / 80%	21.6		100,000 pages		150,000 pages	200,000 pages	

The Drive Gear escapes when a certain load is applied to the Waste Toner Feeding Screw and an error is displayed after the Host Machine has been stopped.

Error Code

Waste Toner Lock detection error

- 013-0001: At power-on
- 013-0002: While the Developing Assembly is driven

Service Mode

Low duty ejection threshold value setting

COPIER > OPTION > BODY > IMG-DEV > LWDTYADJ

ON/OFF of low duty ejection

COPIER > OPTION > BODY > IMG-DEV > LWDTY-SW

• Waste Toner Full Level Detection

Purpose

The life/remaining days are detected to notify the Waste Toner Container replacement timing. Life and remaining days of Waste Toner Container can be checked by the following menu and service mode.

Consumption rate check

- Menu (Control Panel): Status Monitor/Cancel > Consumables > Check Item Number
- Menu (Remote UI): Status Monitor/Cancel > Consumables
- Service Mode: COPIER > COUNTER > LIFE

Waste Toner Container status notification

Detection description	Waste Toner Container advance notice alarm *1	Waste Toner Container preparation alarm *2	Waste Toner Container full level	Waste Toner Container replacement completion alarm
Detection timing	The number of remaining days before the Waste Toner Container becomes full has reached the setting value. *1	The number of remaining days before the Waste Toner Container becomes full has reached the setting value. *3	When 100,000 pages in terms of video counter (5.0 to 6.0% duty) have been printed from the Waste Toner Container preparation alarm	When the Waste Toner Sensor PCB (UN75) detected absence of Waste Toner while "preparation warning" or "full" is detected. *4
Detected to (location)	Waste Toner Full Sensor (TS04)	Waste Toner Full Sensor (TS04)	Waste toner counter	Waste Toner Full Sensor (TS04)
Message	-	Prepare a new Waste Toner Container. (Printing can be continued.)	When service replacement is set: "The waste toner container is full. (Call service representative.)" When user replacement is set, "Replace the waste toner container." (Host machine is stopped.) *5	-
Host machine operation after displaying the message	Continuous printing is available		Host machine is stopped.	Continuous printing is available
Alarm Code	11-0010	-	11-0001	11-0100

Alarm Code**Waste Toner Container full level**

11-0001

Waste Toner Container preparation warning

11-0010

Waste Toner Container replacement completion alarm

11-0100

Waste Toner Container high consumption alarm

11-F010

Service Mode**Display/Hide the Waste Toner Container Preparation Warning**

COPIER > OPTION > PM-PRE-M > WST-TNR

Set days left before the Waste Toner Container Preparation Warning

COPIER > OPTION > PM-MSG-D > WST-TNR

*1. The notification timing and display/hide for the Waste Toner Container Advance Notice Alarm can be set by the following service mode.

COPIER > OPTION > PM-DLV-D > WST-TNR

*2. Whether to display/hide the Waste Toner Container preparation warning can be specified in the following service mode.

COPIER > OPTION > PM-PRE-M > WST-TNR

*3. The remaining days to display the Waste Toner Container Preparation Warning message can be set by the following service mode.

COPIER > OPTION > PM-MSG-D > WST-TNR

*4. The parts counter is automatically cleared; however, it is not cleared at replacement while "preparation warning" or "full" is not detected or at replacement when the power is OFF. In that case, the following service mode can be executed to manually clear.

COPIER > COUNTER > DRBL-1 > WST-TNR

Note that to manually clear, all following conditions must be fulfilled.

- A Waste Toner Container is available
- The sensor is not detecting waste toner full.

*5. Whether to display the replacement procedure on the Control Panel when the Waste Toner Container is full is set in the following service mode.

COPIER > OPTION > USER > W-TN-DSP

Set the Waste Toner Container prior notification alarm timing

COPIER > OPTION > PM-DLV-D > WST-TNR

Check High Consumption Alarm Send Status

COPIER > DISPLAY > MISC > STC-REC

● Waste Toner Feed Screw Lock Detection

To detect lock state of the Waste Toner Feed Screw.

The drive by the Developing Motor (M02) is transmitted to the Screw Gear, which makes the Waste Toner Screw rotate. When this Screw Gear becomes unable to rotate, it slides sideways by the transmitted drive force.

The Screw Gear fails to rotate once the Waste Toner Screw is locked; therefore, the transmitted drive force makes the Screw Gear slide sideways. The Waste Toner Lock Detection Switch (SW05) is placed by the side of the Screw Gear and SW05 is pressed when the Screw Gear is moved. With this mechanism, it is detected that the Waste Toner Screw is locked.

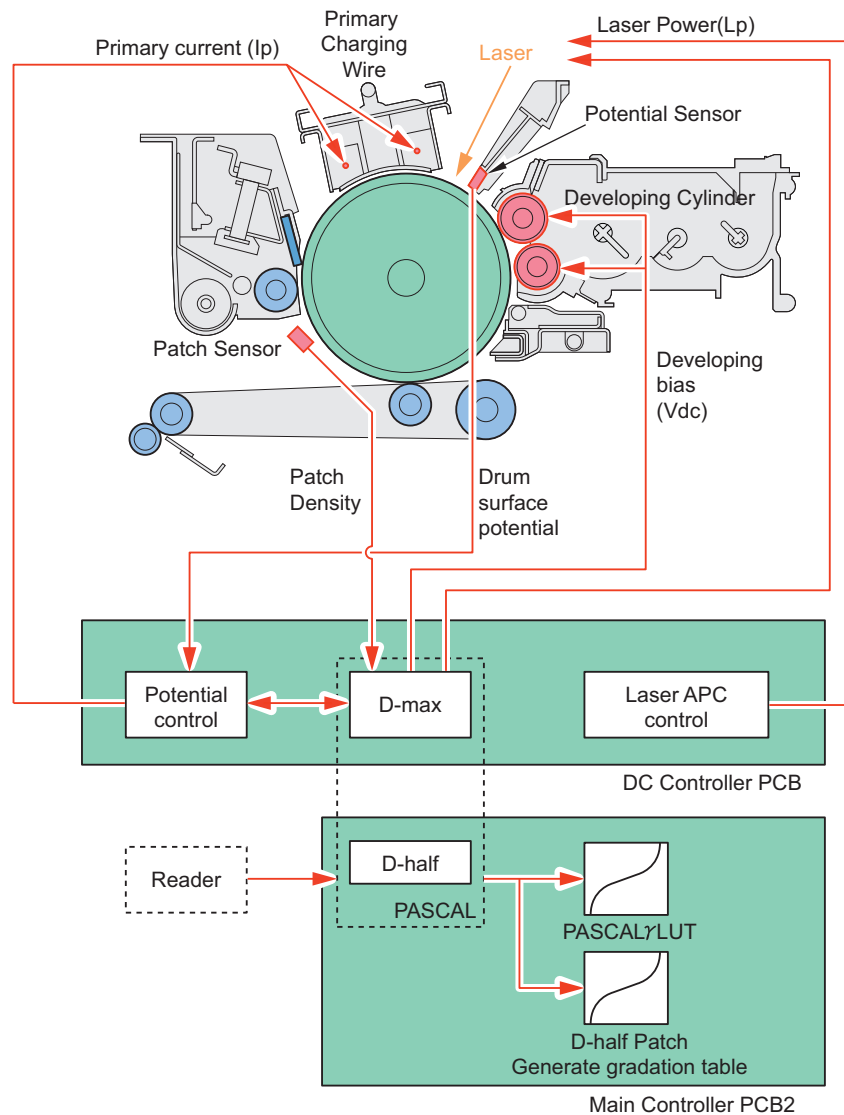
<Related error code>

E013-0001 Error in Waste Toner Lock Detection Connector disconnection

E013-0002 Error in Waste Toner Feed Screw Lock detection

■ Image Stabilization Control**● Overview**

This control prevents image failure due to change of the environment or deterioration of the Photosensitive Drum to ensure stabilized print.



● Execution Timing

Execution items for image stabilization control differ according to the environment and condition of image formation parts. Following shows the control items at each sequence.

*: 70 deg C or lower in the fixing temperature, **: 60 sec.70 deg C or lower in the fixing temperature, ***: Fixing temperature remaining high at power OFF/ON

Control	Standard duration (second) Approx.	Timing												
		Warm-up rotation					Initial rotation	Paper interval	Interruption		Last rotation	Arbitrary		
		At startup *	Normal startup **	Power OFF/ON ***	Door open	Jam recovery						Forcible interruption at 2,000 sheets	Low duty ejection	Normal
Full Potential Control	8	Yes	-	-	-	-	-	(Yes) * 2	-	(Yes) * 3	-	(Yes) * 1	Yes	Yes
	Remarks	*1 Operation Criteria - Last rotation after the first job right after startup first time for the day takes 10 minutes or longer - Last rotation after processing 1,500 sheets or more following the last potential control execution - Last rotation after the first job following 90 minutes or more elapsed from the last potential control execution *2 Operation Criteria - Every initial rotation for the job that start within 10 minutes after density judgment at normal startup mode (60 seconds startup) - Initial rotation for the first job that starts after more than 10 minutes have passed from density judgment at normal startup mode (60 seconds startup) *3 Operation Criteria Forcible interruption when the accumulated value of the paper interval VL correction value exceeds 10V within 10 minutes after density judgment at normal startup mode (60 seconds startup)												
APC Correction at Paper Interval	0.2	-	-	-	-	-	-	-	Yes*5	-	-	-	-	-
	Remarks	*5 At every 20-sheet interval												
APC Control at Warm-up Rotation	2	-	-	-	-	-	-	(Yes) * 6	-	-	-	-	-	-
	Remarks	*6 Operation Criteria - Initial rotation after the first job following 60 minutes or more elapsed from the last job completion												
APC Correction at Last Rotation	2	-	-	-	-	-	-	-	-	-	-	(Yes) * 7	-	-
	Remarks	*7 Operation Criteria - Last rotation after the first job following 30 minutes or more elapsed from the last job completion												
Drum Idle Rotation at First in the Day	60	Yes	-	-	-	-	-	-	-	-	-	-	-	-
	Remarks													
Charging Wire Cleaning	120	-	-	-	-	-	-	-	-	(Yes) * 8	-	(Yes) * 8	-	-
	Remarks	*8 Operation Criteria - Last rotation after 1,500 sheets or more processed following the last Charging Wire cleaning execution - Forcibly interruption at 2,000 sheets or more processed following the last Charging Wire cleaning execution												

Control	Standard duration (second) Approx.	Timing												
		Warm-up rotation					Initial rotation	Paper interval	Interruption		Last rotation	Arbitrary		
		At startup *	Normal start-up **	Power OFF/ON ***	Door open	Jam recovery			Forcible interruption at 2,000 sheets	Low duty ejection	Normal	PAS-CAL (Full correction)	PAS-CAL (Quick correction)	
D-max Control* (including the Drum background correction)	20	(Yes) * 9	(Yes) * 9	-	-	-	-	-	-	-	-	(Yes) * 9	Yes	Yes
Remarks	*9 Perform this control together at the time of potential control. - When specified by service technician (user) at startup (in 2-dimensional shading) - At last rotation after 6,000 sheets or more processed following the last D-max control execution													
D-half Control* (including the Drum background correction)	18	(Yes) * 10	(Yes) * 10	-	-	-	-	-	-	-	-	(Yes) * 10	Yes	Yes
Remarks	*10 Operation Criteria (performed together at the time of potential control / D-max control) - When specified via service technician (user) at startup (in 2-dimensional shading mode) - At last rotation after 6,000 sheets or more processed following the last D-max control execution													
LED Intensity Correction / Drum background correction	3.5	Yes	Yes	-	Yes	Yes	-	-	-	-	-	-	-	-
Remarks														
Idle Rotation at First in the Day	15 to 30	Yes	Yes	Yes	Yes	Yes	-	-	-	-	-	-	-	-
Remarks	To stabilize toner toribology after long idle time													
Low Duty Ejection	-	-	-	-	-	-	-	-	-	-	Yes	Yes	-	-
Remarks	To prevent toner deterioration during continuous Low DUTY image printing													
White Band Control	* 11	-	-	-	-	-	-	-	-	-	-	Yes	-	-
Remarks	*11 When the predefined sheets were printed													
Idle Rotation at First in the Day (H/H environment)	15 (30)	(Yes) * 12	Yes	-	-	-	-	-	-	-	-	-	-	-
Remarks	*12 Only when the environment is in high temperature/humidity													
Contrast Potential Correction	1	-	Yes	-	-	-	-	-	-	-	-	-	-	-

Control	Standard duration (second) Approx.	Timing												
		Warm-up rotation					Initial rotation	Paper interval	Interruption		Last rotation	Arbitrary		
		At startup *	Normal startup **	Power OFF/ON ***	Door open	Jam recovery			Forcible interruption at 2,000 sheets	Low duty ejection	Normal	PAS-CAL (Full correction)	PAS-CAL (Quick correction)	
tion at Startup	Remarks													
Disengagement of Transfer Unit	Description	1	Yes	Yes	Yes	Yes	Yes	Yes	-	Yes	Yes	Yes	Yes	Yes
	Remarks	At jam recovery/after patch generation/at job completion												
Weak Bias Control at Leading Edge	Description		-	-	-	-	-	Yes	Yes	-	-	-	-	-
	Remarks													

• Potential Control

Perform the following controls according to the deterioration level of the Photosensitive Drum and the environmental change.

- VD control
The primary current value (Ip) is determined to become the target dark area potential (VD).
- VL control
The laser power (LP) is determined to become the target bright area potential (VL).
- Vdc control
Developing bias (Vdc) is determined by adding the "fogging removal potential (Vback)" (based on the environment) to the bright area potential (VL).

Execution timing

- Initial rotation except the following environment after Power-On first time for the day (the fixing roller is 70 deg C or less.)
Environment: The room temperature is less than 17 deg C, the moisture content is 13 g or more.
- Initial rotation After Power-On at the 2D shading ON
- Every initial rotation for the job that start within 10 minutes after density judgment at normal startup mode (60 seconds startup)
- Forcible interruption when the accumulated value of the paper interval VL correction value exceeds 10V within 10 minutes after density judgment at normal startup mode (60 seconds startup).
- Last rotation after processing 1,500 sheets or more following the last potential control execution
- Last rotation after the first job right after startup first time for the day takes 10 minutes or long
- Last rotation after the first job following 90 minutes or more elapsed from the last potential control execution

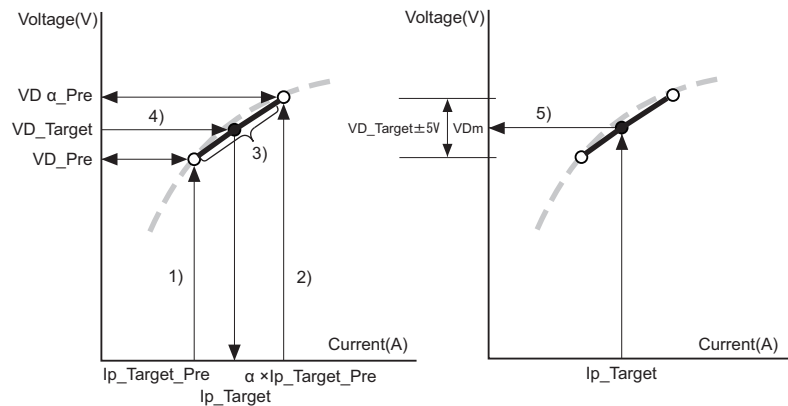
NOTE:

At normal startup mode (60 sec. startup), simple potential control is executed to shorten the startup time.

<Control description>

1. VD control

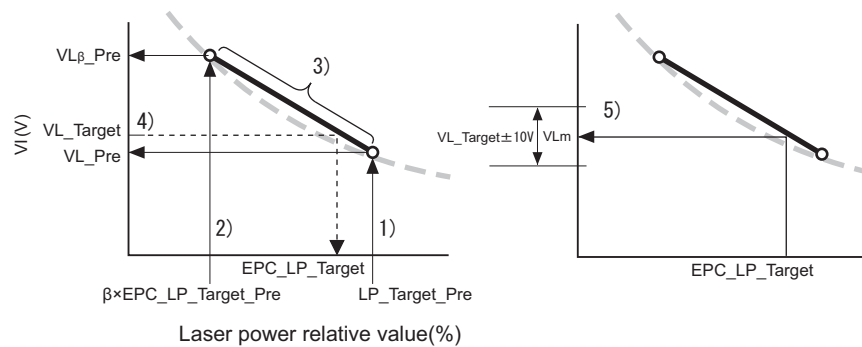
1. The primary current ($I_{p_Target_Pre}$), which has been determined in the last potential control*1, is applied and the Potential Sensor measures drum surface potential (VD_Pre).
*1: At the time of installation, the primary current adjusted in the factory is applied.
2. The drum surface potential (VD_Pre) and the target potential (VD_Target) are compared to apply the primary current ($\alpha \times I_{p_Target_Pre}$), which makes the target potential (VD_Target) to be in range between the drum surface potential (VD_Pre) and the drum surface potential (VD_{α_Pre}), and then the drum surface potential (VD_{α_Pre}) at that moment is read.
3. The 2 points of measured dark area potentials are connected with a straight line to calculate dark area potential characteristics.
4. Based on the obtained dark area potential characteristics, the primary current (I_{p_Target}) is calculated, which can obtain the target potential (VD_Target).
5. The calculated primary current is applied and this operation is repeated until the drum surface potential (VD_m) is within the range of the target potential $\pm 5V$. Potential measurement is executed up to 8 times and correction is executed up to 8 times.



[When the drum surface potential (VD_m) is not as follows: $-5V \leq \text{target potential} \leq +5V$]
Potential control error (VD) "E061-0101" occurs.

2. VL control

1. The laser power (LP_Target_Pre), which has been determined in the last bright area potential control *1 is applied and the Potential Sensor measures the drum surface potential (VL_Pre).
*1: At the time of installation, the primary current adjusted in the factory is applied.
2. The drum surface potential (VL_Pre) and the target potential (VL_Target) are compared to apply the primary current ($\beta \times \text{EPC_LP_Target_Pre}$), which makes the target potential (VL_Target) to be in range between the drum surface potential (VL_Pre) and the drum surface potential (VL β _Pre), and then the drum surface potential (VL β _Pre) at that moment is read.
3. The 2 points of measured bright area potentials are connected with a straight line to calculate the bright area potential characteristics.
4. Based on the obtained bright area potential characteristics, the laser power (EPC_LP_Target) is calculated, which can obtain the target potential (VL_Target).
5. The Drum is exposed with the calculated laser power and this operation is repeated until the drum surface potential (VLm) is within the range of the target potential +/- 10V. Potential measurement is executed up to 8 times and correction is executed up to 8 times.



[When the drum surface potential is not as follows: $-10V \leq \text{target potential} \leq +10V$]

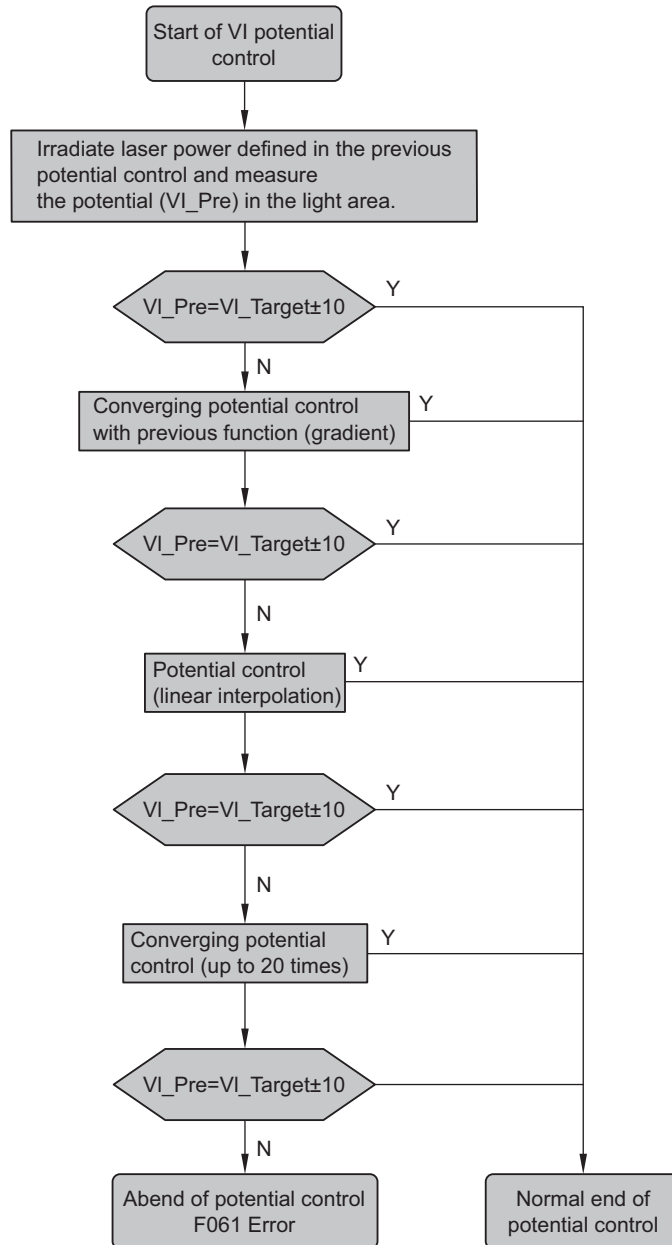
- When the drum surface potential is as follows: $-10V > \text{target potential} > -30V$ or $+10V < \text{target potential} < +30V$
The laser power (LP) when the previous potential control was succeeded (within +/- 10V target potential) is applied.
Refer to the alarm code "32-0002" for the processing when the image is influenced.
- When the target potential is as follows: $\text{target potential} \leq -30V$ or $\text{target potential} \geq +30V$
Potential control error (VL) "E061-0001" occurs.

NOTE:

With this machine, laser APC control is executed to correct the bright area potential between sheets and jobs (see Auxiliary Control > Laser APC Control)

Lp is actually calculated by the laser power (LP) and the bright area potential characteristics that were obtained in the last VL control because executing VL control each time takes time.

When the bright area potential measured value fails to be within the range of the target potential +/- 10V, follow the workflow as described below to obtain bright area potential characteristics by the foregoing VL control to calculate LP.



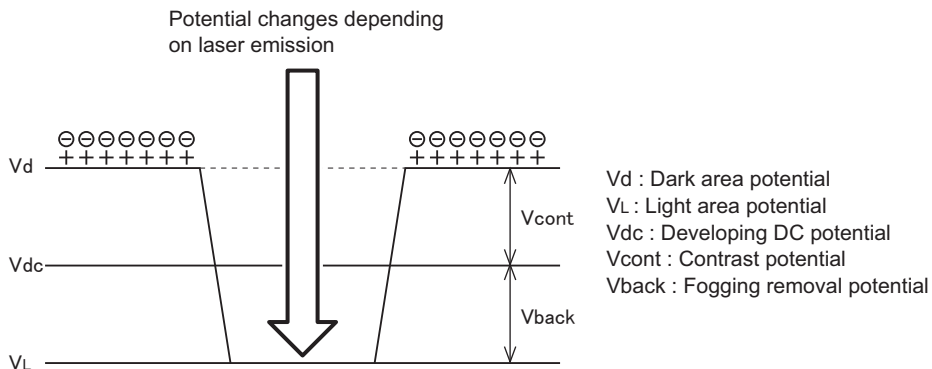
3. Determination of developing bias (Vdc)

Developing bias is determined by adding the Vback value (based on the environment table) to VL (bright area potential) determined in the foregoing control.

Developing bias (Vdc) = VL+Vback

VL: measured bright area potential determined by the potential control

Vback: the potential to remove foggy image that was determined in the environment table



NOTE:

This machine executes D-max control; therefore, density correction value (offset) calculated in the D-max control is also reflected when the developing bias (Vdc) is calculated.

Developing bias (Vdc) = VL + Vback + DeltaVoffset

Deltaoffset: density correction value determined by D-max control

<Related error code>

E061-0001: error in potential control (VL)

E061-0101: error in potential control (VD)

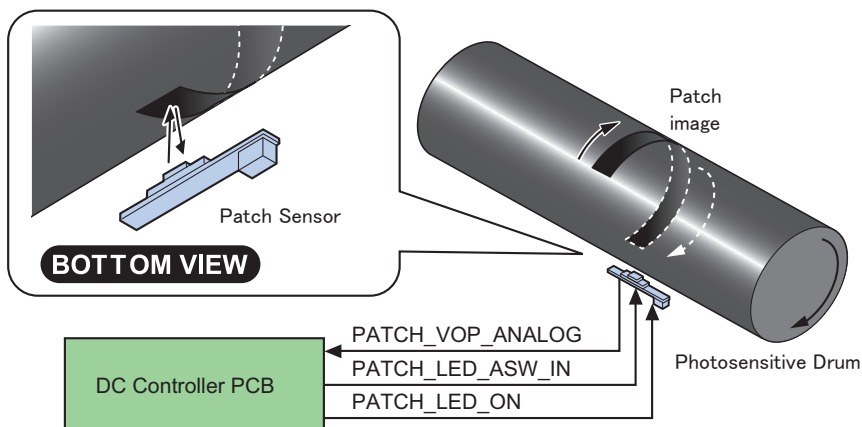
• Patch Detection

Toner density is detected by detection of the patch created on the Drum with the Patch Sensor.

Parts configuration

The Patch Sensor consists of the light-emitting part (LED) and the light-receiving part.

- Light-emitting part (LED): to emit light to the patch image (PATCH_VOP_ANALOG signal)
- Reflected light detection part: to receive light reflected from patch image (PATCH_LED_ASW_IN signal)



Operation description

1. LED light intensity correction

Reflected light is detected by the Patch Sensor by changing LED light intensity (input voltage) (6 points) while rotating the Drum to calculate LED light intensity characteristics.

LED light intensity (input voltage) is calculated by the LED light intensity characteristics, which become the target reflected light intensity.

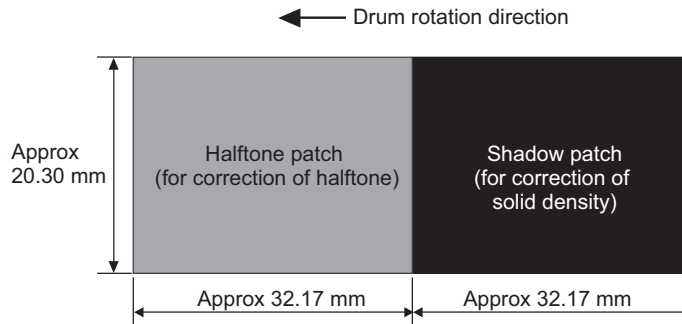
2. Drum base correction

LED is emitted with the light intensity (input voltage) determined by the LED light intensity correction to measure reflected light intensity for a rotation of the Drum. Using the Drum HP Sensor as a reference, the reflected light intensity and the position on the Drum are saved in the memory on the DC Controller PCB. The patch density is calculated with this drum base correction value.

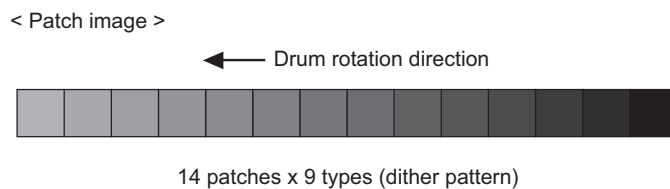
3. A patch pattern is created on the DC Controller PCB to form the patch pattern on the Drum.

The patch pattern differs according to the control to be executed (D-max control/D-half control).

<Patch image at D-max control>



<Patch image at D-half control>



• D-max Control

This control determines developing contrast to keep a constant solid image density.

Execution timing

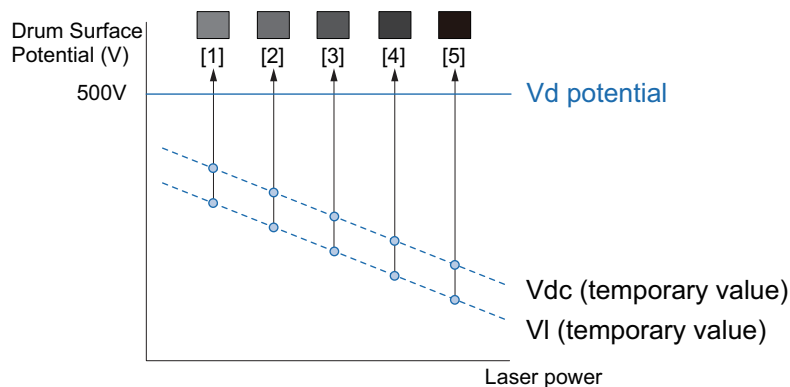
- At the low temperature startup mode (The temperature is less than 20 deg C.)
- At the high temperature startup mode (The temperature is 20 deg C or more and the moisture content is more than 13 g.)
- Last rotation after 6,000 sheets (or more) have been passed through since execution of the last D-max control.
- When service mode is executed
COPIER > FUNCTION > MISC-P > DMAX-N

Control description

D-max control is always executed together with potential control. Following shows a series of workflow.

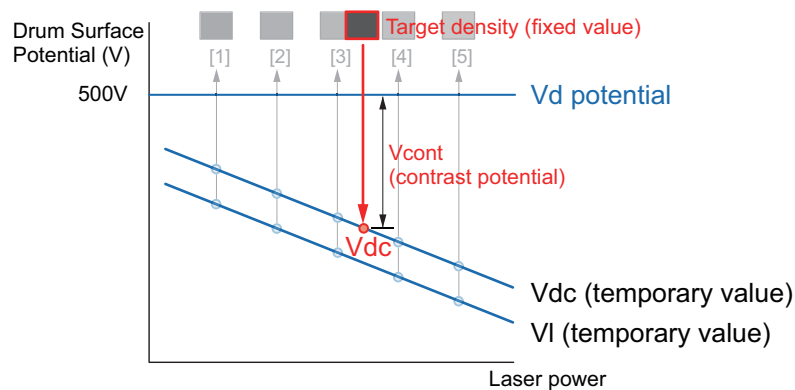
1. Determination of the primary current (See "Full Potential Control > VD control".)
2. Patch image formation

While the calculated primary current is applied, contrast potential (Vcont) (actually the laser power (Lp) and the developing bias (Vdc)) is applied to form 5 stages of D-max patches (values +/- 25 and +/- 50 with the D-max environment table value as the center value) on the Drum

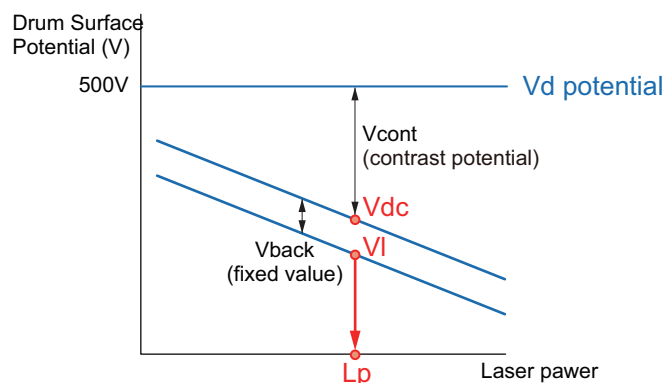


3. Determination of contrast potential (V_{cont})

Patch image density is read by the Patch Sensor to determine the contrast potential (V_{cont}) (that becomes the target density) using the obtained density characteristics.

4. Determination of developing DC (V_{dc}) and bright area potential (V_L)

V_{dc} and V_L are determined from the V_{cont} value and the V_{back} value (to be determined by the environment. Fixed values)

5. Determination of laser power (L_p) (See "Full Potential Control > V_L control".)

V_L control is executed to calculate L_p that can obtain V_L

<Related service mode>

- To set ON/OFF of D-max control for plain paper group.
COPIER > OPTION > FNC-SW > DMAX-SW
- To execute D-max control for plain paper group manually.
COPIER > FUNCTION > MISC-P > DMAX-N

● D-half Control

This control determines gradation correction value based on the image density detected by the Patch Sensor.

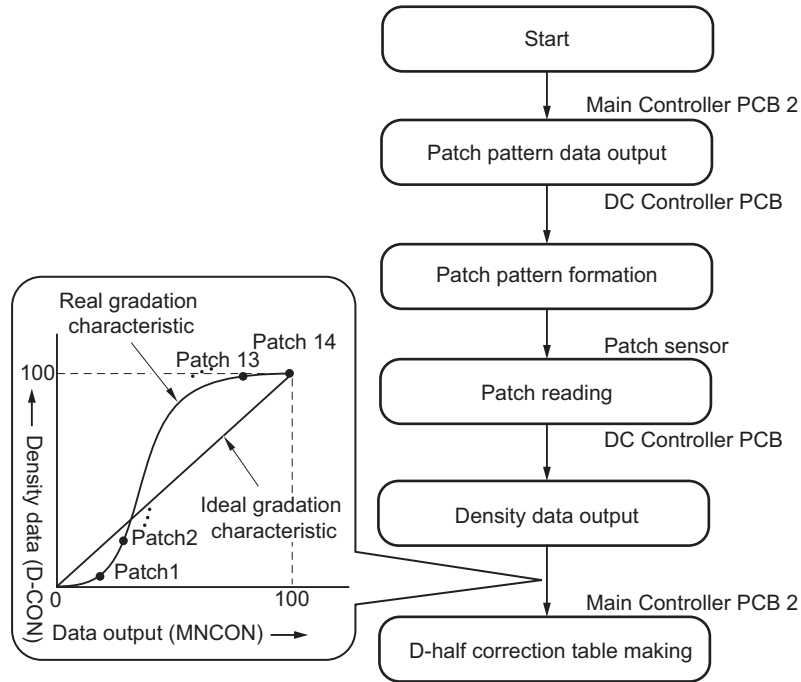
<Execution timing>

- At the low temperature startup mode (The temperature is less than 20 deg C.)
- At the high temperature startup mode (The temperature is 20 deg C or more and the moisture content is more than 13 g.)
- Last rotation after 6,000 sheets (or more) have been passed through since execution of the last D-half control.
- When PASCAL (Settings/Registration > Adjustment/Maintenance > Adjust Image Quality > Auto Adjust Gradation > Full Adjust/Quick Adjust) is executed.

<Control description>

- Based on the gradation data sent from the Main Controller, patch images (up to 9 patterns) are formed on the Drum.
- Patch density is detected to feed the value back to the Main Controller.
- The Main Controller corrects the gradation data (LUT table)*1.

*1: Gradation data (LUT table) is generated when executing Full Adjust: Auto Adjust Gradation > Full Adjust.



• PASCAL Control

This control stabilizes gradation density characteristics on the image.

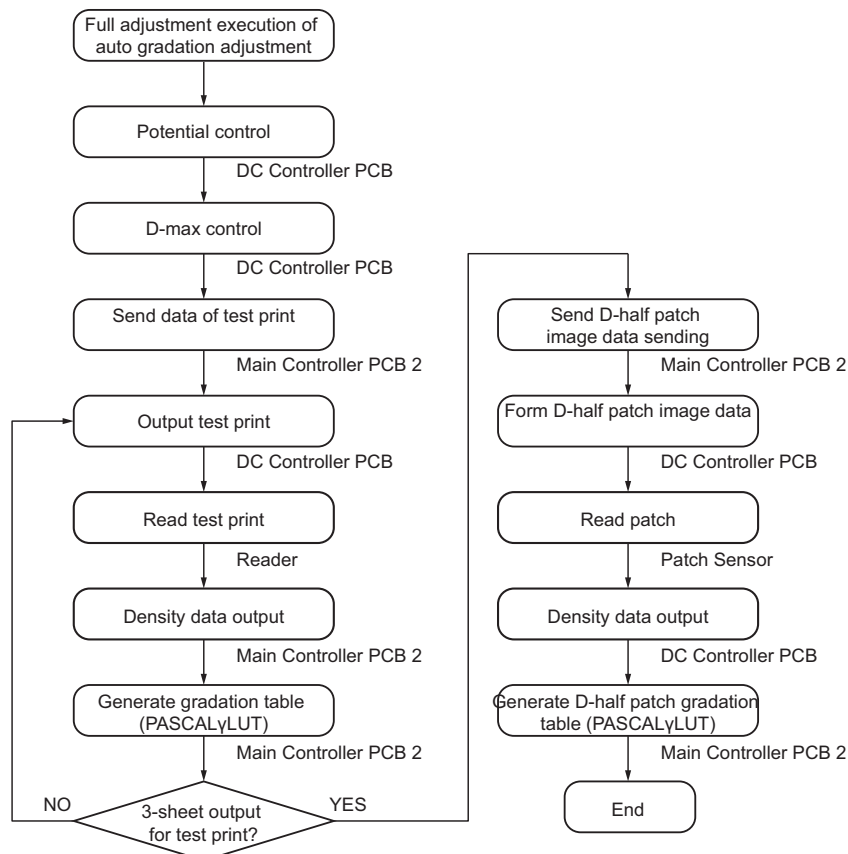
This control is executed when the following is selected in user mode: Auto Adjust Gradation > Full Adjust Patch pattern on the test print is scanned by the Reader to create a gradation table (PASCALyLUT).

Then, a D-half patch gradation table is created to be used as the target in D-half control.

The foregoing table corrects image gradation characteristics caused by change of environment and deterioration of the Photosensitive Drum.

Execution timing

During execution of Full Adjust: User mode > Settings/Registration > Adjustment/Maintenance > Adjust Image Quality > Auto Adjust Gradation > Full Adjust



NOTE:

Since Inbox images are binary, gradation adjustment cannot be performed after being stored in Inbox. Gradation adjustment is performed on the rasterized data before they are stored in Inbox.

When the stored image is output after a long time, gradation adjustment is not performed on the basis of the environment at the time of output, so appropriate printing results may not be able to be obtained.

If the environment changes with time, it is advisable to store the data into Inbox just before output.

■ Other Control

● Startup Contrast Potential (Vcont) Correction

Contrast potential (Vcont) is corrected to keep a constant density and prevent light image caused by reduced toner charging amount in an energy-saving environment.

NOTE:

Temperature in the Developing Assembly is reduced because the Drum Heater is turned OFF at sleep state in an energy-saving environment. This operation increases moisture content in the Developing Assembly and reduces toner charging amount.

Execution timing

At the time of the normal startup mode (in the case that the two dimension shading control is OFF)

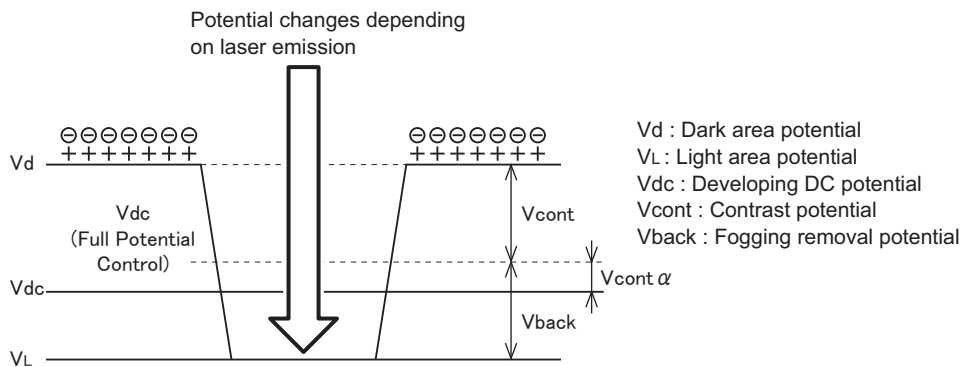
NOTE:

This control is not executed when the two dimension shading control is ON because the Drum Heater is turned ON.

Control description

- At the time of normal image formation, contrast potential (Vcont α) based on the environment table is added to the developing bias (Vdc (full potential control value)) determined by the full potential control to correct developing bias.

$$Vdc = Vdc \text{ (potential control value)} - Vcont\alpha$$
- The corrected contrast potential (Vcont) is reset (making Vcont α 0) when the next full potential correction is executed.



● Laser APC Control

This control corrects laser output control value to prevent change of surface potential by laser output.

Correction type

- Between-sheet APC control: to keep constant bright area potential (VL) without reducing productivity during continuous jobs.
- Initial rotation APC to determine VL according to the laser and drum temperature characteristics.
- Last rotation APC control: to determine VL according to the laser and drum temperature characteristics.

Execution timing

- Between-sheet APC control: at every paper interval of a job.
- Initial rotation APC control: to be executed during initial rotation of the first job after the machine has been left unattached for 60 minutes or more since execution of the last job.
- Last rotation APC control: to be executed during last rotation of the first job after the machine has been left unattached for 30 minutes or more since execution of the last job.

Control description

A. Between-sheet APC control

- Bright area potential is measured at every sheet interval by the Potential Sensor.
- Average sheet interval VL_ave of the measured paper interval VL potential (for 20 sheet intervals) is calculated.
- Laser power correction value is determined by the difference between the measured potential VL (measured at the time of potential control) and the average paper interval VL_ave in addition to the last bright area potential characteristics (gradient (γ)).

Correction formula

$$LP_after = LP_before - (VL - VL_ave) \times \gamma$$

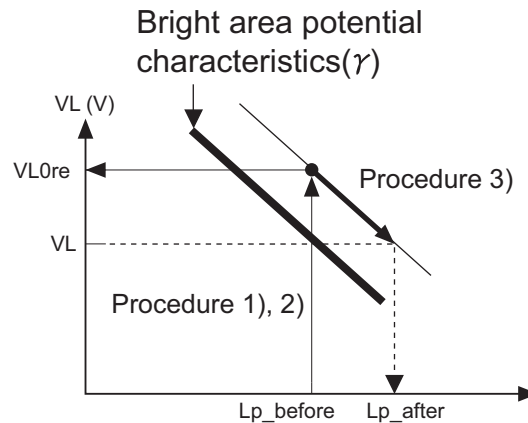
LP_after: laser power after correction

LP_before: laser power before correction

VL: measured VL determined at the time of potential control

VL_ave: average paper interval VL_ave

γ: gradient (control coefficient): gradient reciprocal of LP_VL straight line in the range including VL target



B. Initial rotation APC control

- Bright area potential VL is measured during initial rotation to correct laser power. The primary current value and developing bias value are fi
- Correction is executed by following the same way as between-sheet APC control.

C. Last rotation APC control

This correction follows the same way as initial rotation APC control

• Two Dimension Shading Control

Uneven potential on the Photosensitive Drum is corrected by laser exposure.

Execution timing

At the time of laser exposure (only when the two dimension shading control is ON. Default: OFF)

Control description

- Potential data on the Drum surface is saved in EEPROM on the DC Controller PCB in the format supporting two-dimension coordinate (measured when the Drum was manufactured).
- When the power is turned ON, EEPROM data is compared to RAM data. If there is any difference in the data, the EEPROM data is stored in the backup RAM.

NOTE:

Whether the control is enabled can be checked with COPIER>DISPLAY>2D-SHD>2DSTS.

If 0 is displayed, check DRM-LOT number. When 0 is displayed, it means that the drum has not been registered; thus, execute FUNCTION/2D-SHADE/2D-READ to register the drum.

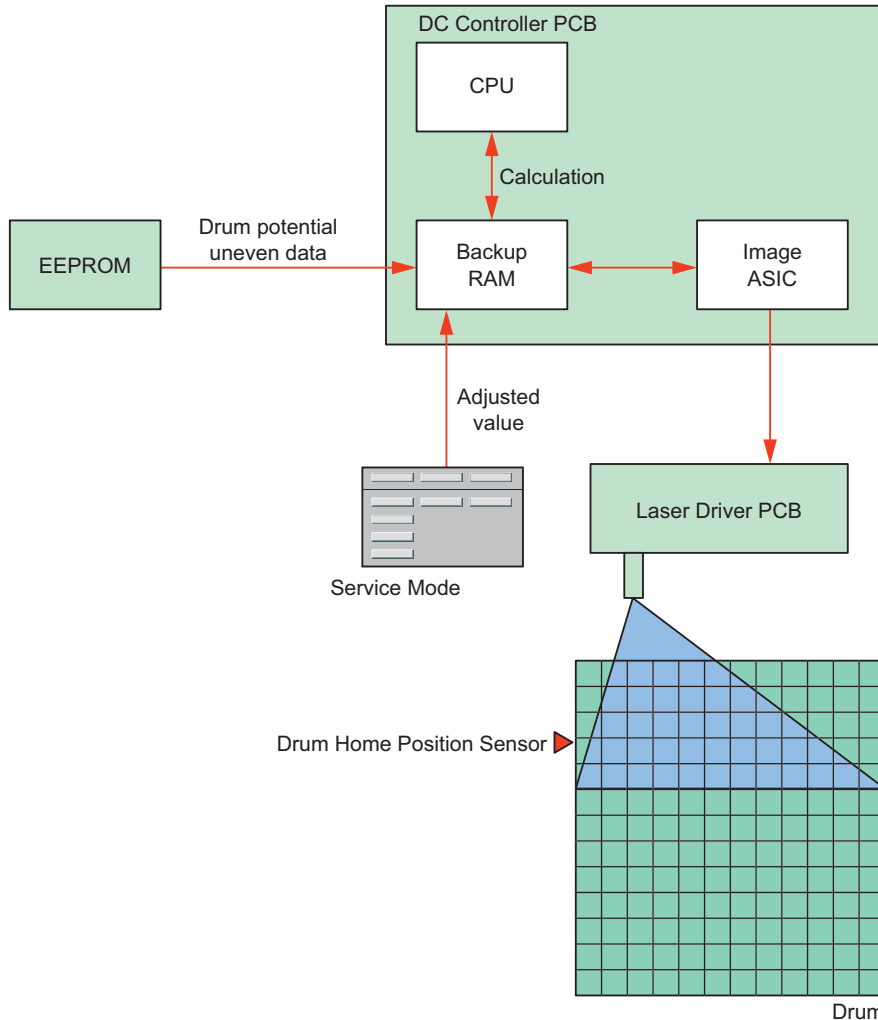
- Potential data on the Drum surface is sent to the image ASIC and the image data is synchronized with the Drum home position, and then the uneven potential data is converted into light intensity to be sent to the Laser Driver PCB.
- The Laser Driver PCB is exposed to remove uneven potential on the Drum.

NOTE:

For Drum provided as a service part, EEPROM which stores potential unevenness data is included. Therefore, the EEPROM needs to be replaced when the Drum is replaced.

As the life of the Drum advances, uneven density can occur when the halftone image is output despite correction of the drum uneven potential. In such a case, uneven density can be corrected by specifying a particular position in service mode. See Troubleshooting for procedure.

FCOT (First Copy Time) is reduced to detect home position of the Drum by turning ON the two dimension shading.

**<Related service mode>**

- Display of 2D shading ON/OFF (Lv.2)
COPIER > DISPLAY > 2D-SHADE > 2D-ST5
- Display of Drum Lot number
COPIER > DISPLAY > 2D-SHADE > DRM-LOT
- Display of checksum calculation result (Lv.2)
COPIER > DISPLAY > 2D-SHADE > CHK-SUM
- 2D shading horizontal scan correction
COPIER > FUNCTION > 2D-SHADE > M-LINE1, M-LINE2
- 2D shading pattern output
COPIER > FUNCTION > 2D-SHADE > SHD-P1 to 3
- Read 2D shading ROM
COPIER > FUNCTION > 2D-SHADE > 2D-READ

• White Band Control

Oppositely-charged toner on the Developing Sleeve is forcibly applied on the Drum and collected by the Cleaning Unit.

NOTE:

Large-grained toner is less likely to be charged compared to small-grained toner and can be positively charged (opposite charging) in rare cases. Such oppositely-charged toner fails to be developed but remains on the Developing Sleeve, which causes image failure.

Execution timing

Last rotation after every job

Control description

Developing bias V_{dc} is increased once the image trailing edge passes through the developing position. V_{back} is increased and the oppositely-charged toner on the Developing Cylinder is moved onto the Drum.

<Related service mode>

- Reverse toner forcible eject: blank band (Lv.2)
COPIER > FUNCTION > MISC-P > WB
- Setting of blank band ejection time (Lv.2)
COPIER > ADJUST > MISC> TBSIS-WB

• Black Band Control

This control maintains the cleaning performance by providing sufficient amount of toner to the edge of the Cleaning Blade.

NOTE:

Friction coefficient between the Blade and the Drum is increased unless sufficient amount of toner is applied on the Drum Cleaning Blade, which causes ride-up of the Blade. Although toner is properly applied to the center of the Blade by normal cleaning operation, toner is supplied insufficiently to the edge of the Blade.

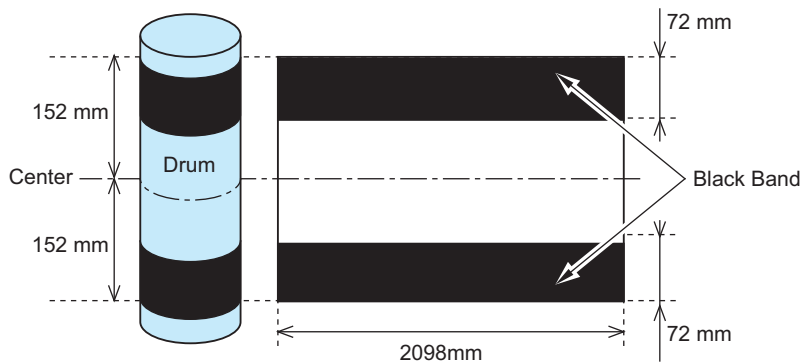
Execution timing

- Last rotation after the specified number of sheets*1 has been fed since execution of the last black band control.
 - Paper interval after the specified number of sheets*1 has been fed since execution of the last black band control.
- *1: This value can be changed in service mode.

Timing	Moisture content	Interval (sheets)
Last rotation	12g or more	1,500
Paper interval		2,000

Control description

1. Black band described below is created on the Drum.
2. Black band is scraped by the Drum Cleaning Blade and toner is properly applied on the Cleaning Blade at that moment.
3. This control turns off the transfer high voltage and makes the Transfer Belt disengaged so that image is not applied on the Transfer Belt.



<Related service mode>

- To set the paper interval to output black band for preventing flip of the Cleaning Blade.
COPIER > OPTION > IMG-DEV > BB-CNT

- Set black band length for cleaning
COPIER > OPTION > CLEANING > CLN-ADJ
- ON/OFF of cleaning black band sequence
COPIER > OPTION > CLEANING > CLN-SW
- Toner forcible eject (black band)
COPIER > FUNCTION > MISC-P > BB

• Low Duty Discharge Control

In the case of continuous output of low duty image, this control consumes toner at non-image area to maintain the density stability.

Execution timing

While the video count for every page is accumulated, in the case that the average image duty is less than the threshold*1, the ongoing job is interrupted at the time of last rotation of a job or the ongoing job is interrupting in the middle of the job to discharge the toner according to the average image duty.

*1: Threshold is determined by the following environment table. The value can be changed in service mode

Moisture content	Temperature/Humidity	Threshold
0.86	23deg C/5%	0.8%
1.73	23deg C/10%	0.8%
5.8	23deg C/30%	0.8%
8.9	23deg C/50%	0.8%
15	23deg C/70%	1.6%
18	28deg C/80%	1.6%
21.6	30deg C/80%	1.6%

Control description

1. Video count on every page is retrieved.
2. The obtained video count is converted into A4 size and the value is accumulated.
3. Once the accumulated value reaches the threshold, the following patch is created on the Drum to discharge deteriorated toner.

<Related service mode>

- ON/OFF of low duty ejection
COPIER > OPTION > IMG-DEV > LWDTY-SW
- Set low duty ejection threshold value
COPIER > OPTION > IMG-DEV > LWDTYADJ

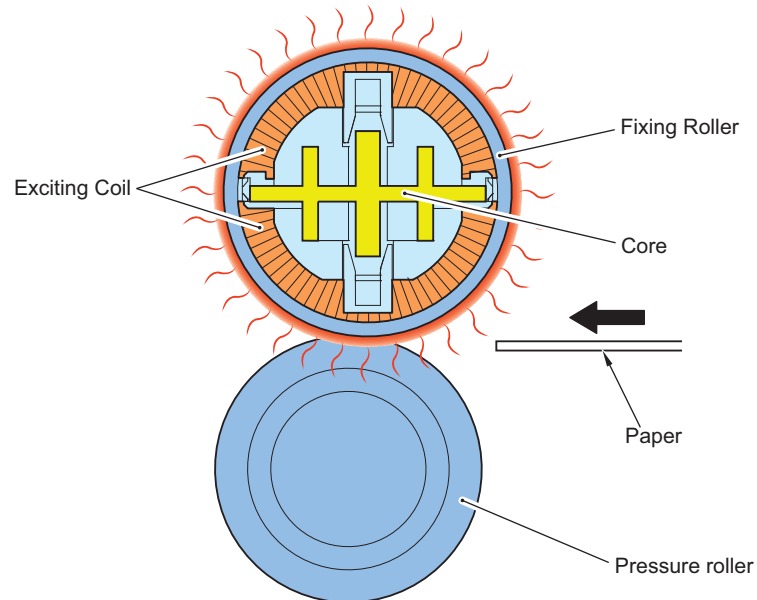
Fixing System

Overview

Characteristics

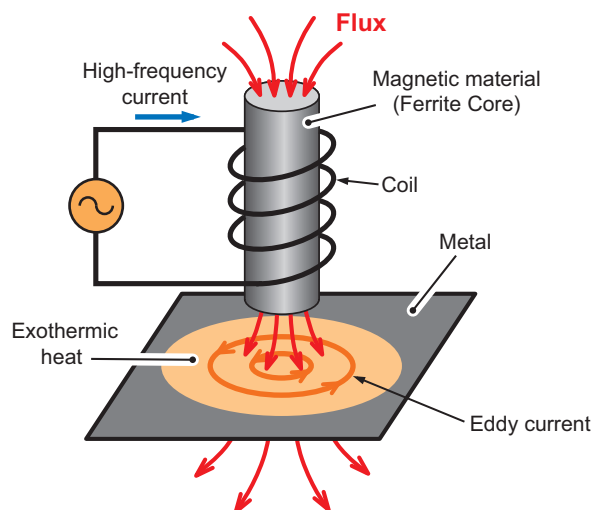
1. Whole-circumference IH heating method

This machine uses the IH heating method to heat the whole circumference of the Fixing Roller. This method enables to shorten the warm-up time and high-speed printing.



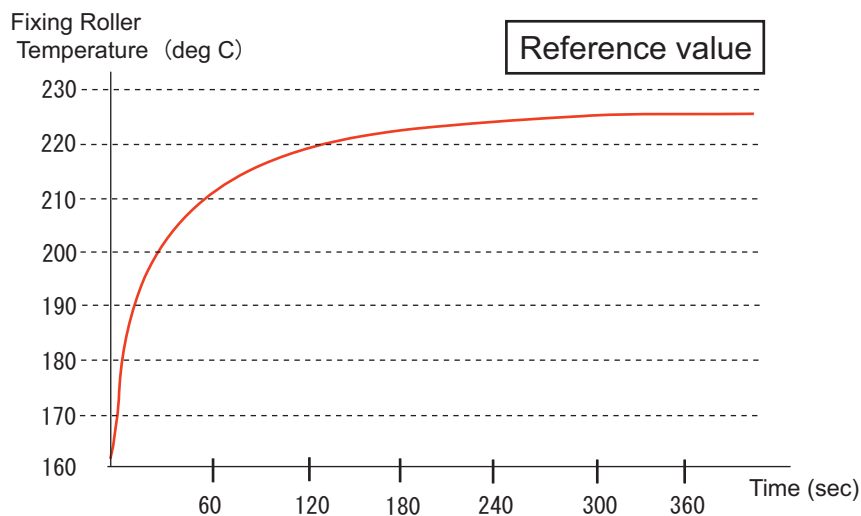
<IH (Induction Heating) method>

Supplying high frequency current to the coil inside the Heater Unit generates a high frequency magnetic field around the coil. By this magnetic field, an eddy current (induction current) runs through the Fixing Roller and the Fixing Roller generates electricity by itself.



2. Using magnetic shunt alloy to prevent temperature rise at the edge of the Fixing Roller This machine uses degaussing alloy as a material of the Fixing Roller to prevent temperature rise at the edge of the Fixing Roller (There is no control to cool the edge).

Magnetic shunt alloy becomes less likely to generate electric current by electromagnetic induction because of its characteristic of losing magnetic property once it reaches a certain temperature (Curie temperature). This principle restricts excessive temperature rise of the Fixing Roller.



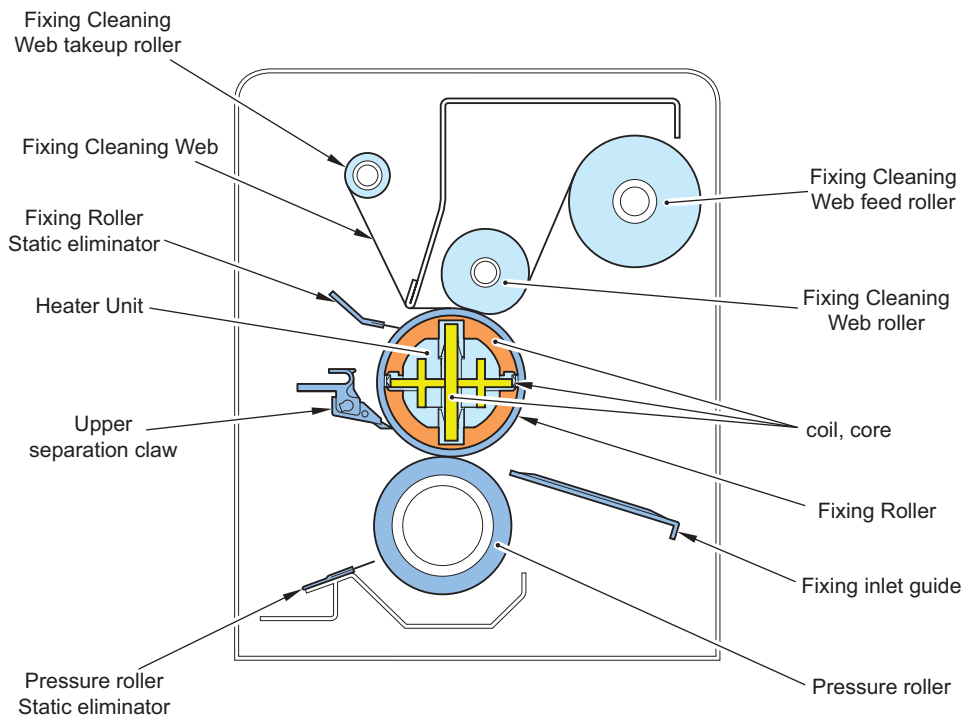
3. Making the Fixing Assembly as a unit
Maintenance performance has been improved by separating the Fixing Unit from the Host Machine to be assigned as a unit.
4. Saving energy
Improved toner allows reduction of fixing temperature that enables less energy consumption.

■ Specifications

Item		Function/method
Fixing method		Whole-circumference IH fixing method
Fixing Heater		IH heater
Fixing Roller		O/D: 40mm
Pressure Roller		O/D: 38mm
Control temperature		To be reduced accordingly from 195 deg C (at standby)
Fixing drive control		Switching the print speed and warm-up speed (low speed)
Thermistor	Fixing inlet side	Main Thermistor (contact type) The center of the Fixing Roller, Reciprocating width: 12mm Temperature control, Failure detection
		Sub Thermistor (contact type) The rear of the Fixing Roller, No reciprocation Failure detection
	Fixing outlet side	Sub Thermistor (contact type) The rear of the Fixing Roller, No reciprocation Failure detection
Thermal Switch		2 pc. (non-contact type)
Protective function		Yes (detection by the Thermistor and the Thermal Switch)
Separation mechanism		Upper Separation Claw: contact type, Reciprocating width: 3mm
Static Eliminator		Fixing Roller/ Pressure Roller
Cleaning mechanism		Fixing Cleaning Web
Inlet guide height control		No
Bias application		No
Control to prevent temperature rise at the edge		No
Disengagement mechanism		No
idle rotation during standby		YES
Other controls		See "Controls" described later.

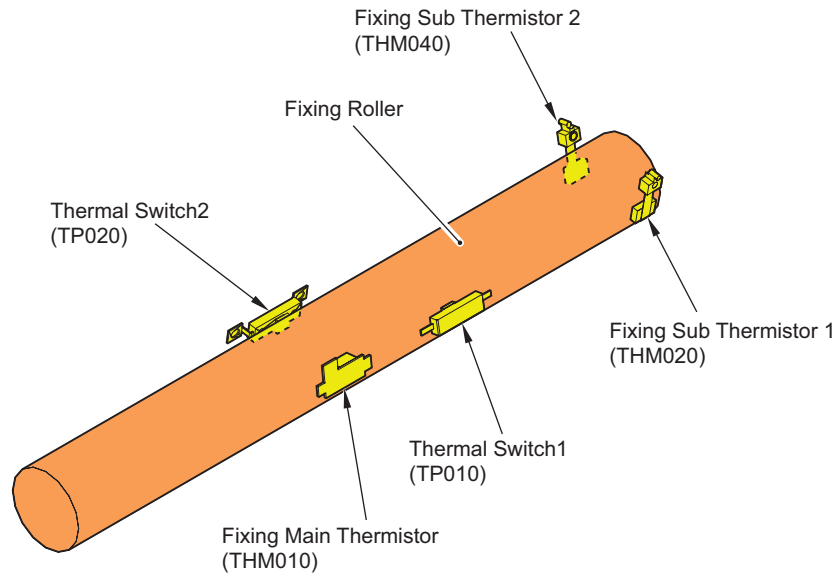
■ Parts configuration

● Cross-section view



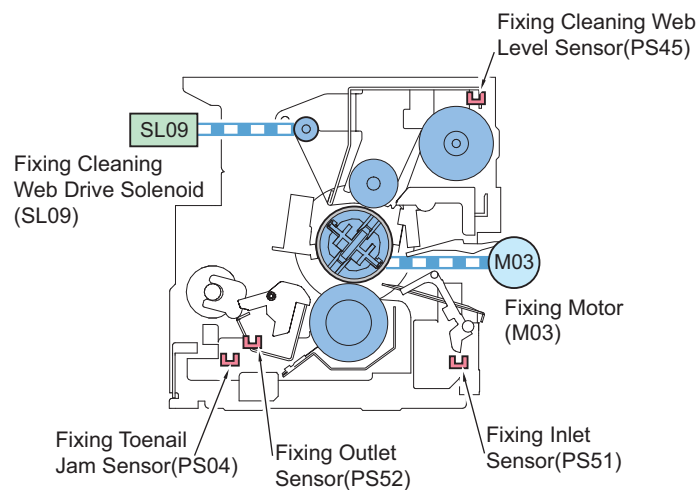
Parts name	Function/method
Fixing Roller	Heating toner and paper To prevent abnormal temperature rise at the edge by using the degaussing alloy material
Pressure Roller	Pressing and feeding paper
Heater Unit	Whole Circumference IH Heater
Coil Core	To heat the whole circumference of the Fixing Roller
Fixing Cleaning Web	To remove residual toner on the surface of the Fixing Roller
Fixing Cleaning Web Roller	
Fixing Cleaning Web Take-up Roller	
Fixing Cleaning Web Feed Roller	
Upper Separation Claw	To separate paper from the Fixing Roller (to prevent paper-wrapping) Reciprocating width: 3mm
Fixing Inlet Guide	Paper Feed Guide to the Fixing Assembly
Fixing Roller Static Eliminator	To prevent leak, static offset and noise
Pressure Roller Static Eliminator	

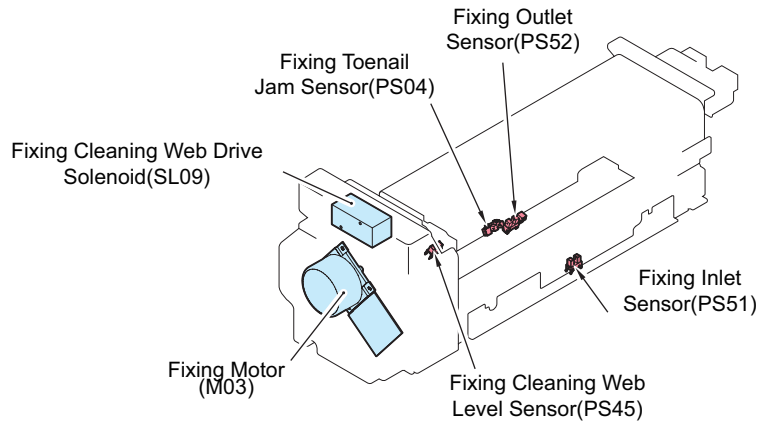
■ Thermistor, Thermal Switch



Code	Parts name	Function/method
THM010	Fixing Main Thermistor	Contact type temperature control, failure detection
THM020	Fixing Sub Thermistor 1	Contact type To detect failure with the coil at the fixing inlet side
THM040	Fixing Sub Thermistor 2	Contact type To detect failure with the coil at the fixing outlet side
TP010	Thermal Switch1	Non-Contact type (200 +/- 5 deg C) To prevent abnormal temperature rise(the fixing inlet side)
TP020	Thermal Switch2	Non-Contact type (200 +/- 5 deg C) To prevent abnormal temperature rise(the fixing outlet side)

■ Drive configuration

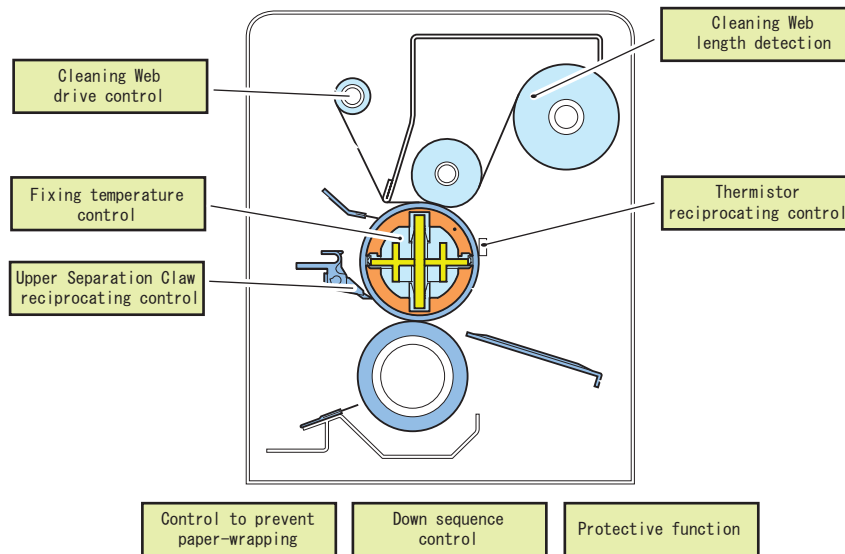




Code	Parts name	Function/method
M03	Fixing Motor	To control drive of the Fixing Motor
SL09	Fixing Cleaning Web Drive Solenoid	To control drive of the Cleaning Web
PS04	Fixing Toenail Jam Sensor	To prevent scratches on Fixing Roller due to jam
PS45	Fixing Cleaning Web Level Sensor	To detect length of the Cleaning Web
PS51	Fixing Inlet Sensor	To detect paper wrapping and stationary
PS52	Fixing Outlet Sensor	

Controls

Overview



NO	Control/Function	Overview
1	Fixing temperature control	To control temperature of the Fixing Roller to prevent fixing failure
2	Down sequence control	In the case of large difference between the target temperature and the detected temperature, this control drops productivity to prevent fixing failure and image failure.
3	Paper anti-wrapping control	To prevent failure of the Fixing Assembly caused by wrapping of paper around the Fixing Roller and the Pressure Roller.
4	Thermistor reciprocating control	To prevent scar on the Fixing Roller by the Main Thermistor, this control moves the Main Thermistor back and forth.
5	Upper Separation Claw reciprocating control	To prevent scar on the Fixing Roller by the Upper Separation Claw, this control moves the Upper Separation Claw back and forth.
6	Cleaning Web drive control	To prevent fixing offset, this control removes residual toner on the surface of the Fixing Roller.
7	Cleaning Web level detection	To detect level of the Cleaning Web.

NO	Control/Function	Overview
8	Protective function	To detect error by Thermistor. To detect error by Thermoswitch.

■ Fixing temperature control

● Overview

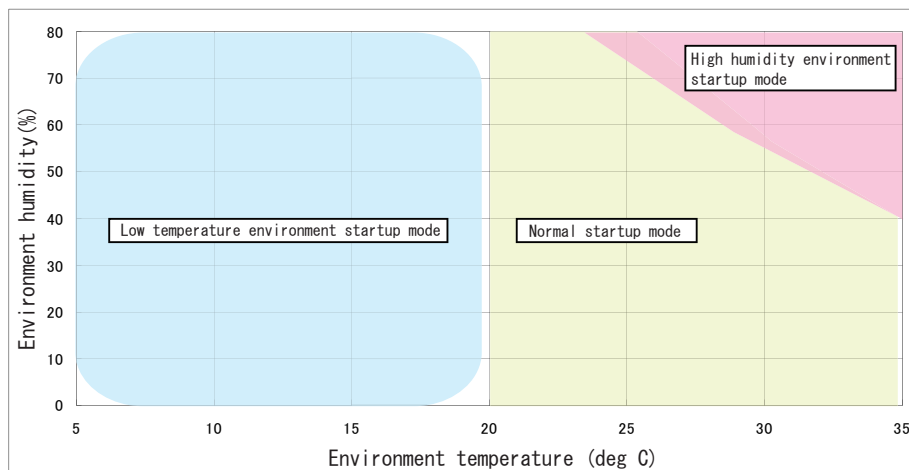
To prevent fixing failure, temperature control of the Fixing Roller is executed with the following timing.

NO	Temperature control	Overview
1	Temperature control during startup	To control temperature to reach the standby temperature. To be switched from the following 4 modes according to the environment temperature/ humidity and the temperature of the Fixing Roller: <ul style="list-style-type: none"> • Normal startup mode • Low temperature environment startup mode • High humidity environment startup mode • Recovery mode
2	Temperature control during standby	To control temperature so that printing can be performed immediately after receiving the print request signal
3	Temperature control during printing	To control temperature by the temperature table according to the paper type and the paper basis weight.
4	Other temperature adjustments	Following shows other temperature adjustments <ul style="list-style-type: none"> • To control temperature for reducing power consumption.

● Temperature Control during Startup

Temperature is controlled to reach the standby temperature.

The startup mode changes as needed by the environment temperature and humidity. When starting with the Fixing Roller temperature from 70 deg C or higher, the recovery mode is used.



<Normal startup mode>

In the case of reaching the target temperature within 60 seconds due to quick temperature rise of the Fixing Roller, the target temperature is maintained to be shifted to the Ready state after 60 seconds had passed.

Condition		
Environment temperature	Environment humidity	Fixing Roller temperature
20 deg C or higher	Low humidity environment (within 13g of absolute moisture content)	70 deg C or lower

NOTE:

In the case of selecting the fixing improvement mode in the following service mode, the machine does not enter the startup state for 60 seconds and waits until the specified time.

- Setting of fixing improvement mode (Lv.2)
COPIER > OPTION > IMG-FIX > FSPD-S1

<Low temperature environment startup mode>

After it reaches the target temperature, the target temperature is maintained until completion of the potential control, and then the machine enters Ready state.

Condition		
Environment temperature	Environment humidity	Fixing Roller temperature
Less than 20 deg C	-	70 deg C or lower

<High humidity environment startup mode>

After it reaches the target temperature, the target temperature is maintained until completion of developing idle rotation as well as completion of the potential control, and then the machine enters Ready state.

Condition		
Environment temperature	Environment humidity	Fixing Roller temperature
-	High humidity environment (13g or more absolute moisture content)	70 deg C or lower

<Recovery mode>

This mode is entered after Jam recovery, or when recovering from low power/power-saving mode.

The machine enters Ready state once it reaches the target temperature.

Condition		
Environment temperature	Environment humidity	Fixing Roller temperature
-	-	70 deg C or higher

• Temperature Control for Standby

To provide measures against temperature rise of the coil/Main Body and save energy consumption, the target temperature of Fixing Roller is reduced step by step on a specified time basis until it reaches a certain temperature. Additionally, during standby, the idle rotation operation is performed to evenly maintain the surface temperature of Fixing Roller.

The control temperature depends on the environment temperature and country/region.

• Temperature Control during Printing

To provide measures against temperature rise of the coil/Main Body and save energy consumption, the target temperature of Fixing Roller is reduced step by step on a specified time basis until it reaches a certain temperature.

The control temperature depends on the environment temperature/country/paper type.

Paper type	Paper weight (g/m2)
Plain paper, recycled paper, color paper, pre-punched paper	64 to 90
Heavy paper (plain paper, recycled paper, color paper, pre-punched paper)	91 to 256
Transparency, labels, tracing paper, tab paper, postcard	All paper weight
Bond paper	All paper weight
Thin paper (plain paper, recycled paper, color paper, pre-punched paper)	52 to 63

<Related error codes>

- E000: Fixing Assembly low temperature error
- E001: Fixing Assembly high temperature error
- E002: Fixing Assembly temperature rise error
- E003: Fixing Assembly temperature decrease error
- E004: IH power supply failure

CAUTION:

When any of the above Error Codes, E000 to E0004, is displayed, the error code display will not be cleared even though the Main Power Switch is turned OFF. In such a case, go through the following service mode to clear the error and turn OFF and then ON the power.

- Error code clear
COPIER > FUNCTION > CLEAR > ERR

<Related service modes>

- Setting of fixing improvement mode (Lv.2)
COPIER > OPTION > IMG-FIX > FSPD-S1
 - Setting of paper wrinkle prevention mode (Lv.2)
COPIER > OPTION > IMG-FIX > FX-WNKL
 - Set fixing control temperature table: Thin
COPIER > OPTION > IMG-FIX > TMP-TBL2
 - Set fixing control temperature table: Plain
COPIER > OPTION > CUSTOM > TEMP-TBL
 - Set fixing control temperature table*
COPIER > OPTION > IMG-FIX > TMP-TBL3
 - Set fixing control temperature table: Bond
COPIER > OPTION > IMG-FIX > TMP-TBL4
- * Temperature table for 91 g/m² to 256 g/m paper

● Other temperature adjustments

<Energy Saver mode>

By pressing the energy saver key on the Control Panel, energy consumption is reduced by reducing the control temperature when the Fixing Unit is at standby state according to the energy saving rate.

NOTE:

To be recovered to the normal mode according to the recovery mode.

<Related User Mode>

- The energy saving rate can be changed from "Settings/Registration > Preferences > Timer/Energy Settings > Change Energy Saver Mode".

<Low power mode>

To save energy, in the case that no operation has been executed for a certain period of time, this machine is automatically to be in Low Energy Mode. Power distribution to the Fixing Unit is turned OFF in Low Energy Mode.

NOTE:

To be recovered to the normal mode according to the temperature control at warm-up.

<Related User Mode>

- The time to change to the low power mode can be changed from "Settings/Registration > Preferences > Timer/Energy Settings > Auto Sleep Time".

■ Down sequence control

● Overview

In the case of great difference between the target temperature and the detected temperature at the start of printing or during printing, productivity is dropped to prevent fixing failure or image failure.

● Execution timing

- During printing
- At the start of printing and when the paper type is switched

• Control description

This control has the 3 types of down sequences according to the execution timing.

1. In the case of decrease in fixing temperature (during printing)

When the fixing temperature drops during the job, the productivity is dropped or the job is stopped to prevent fixing failure.

<Plain paper>

In case of plain paper, the fixing temperature of 100% productivity maintains, so the down sequence does not start.

NOTE:

In case of the default print temperature, 100% productivity is maintained.

When the print temperature is reduced by the service mode, the down sequence may be started according to the use environment.

<Heavy paper>

Right after the startup (including restoration from the sleep mode), a whole Fixing Assembly is not warm enough, so the down sequence may be started. However, as printing continues sequentially, the temperature of the Fixing Assembly is increased and reaches to the temperature of the 100% productivity

Plain paper 1,2			Plain paper 3,Heavy paper1to6	Thin paper1,2
Temperature	Level	Productivity		
20 deg C or higher	Start	100%	100%	100%
	Down1	85%	75%	75%
	Down2	70%	50%	-
	Stop	0%	0%	0%
15 deg C or higher - less than 20 deg C	Start	100%	100%	100%
	Down1	85%	75%	75%
	Down2	75%	50%	-
	Stop	0%	0%	0%
less than 15 deg C	Start	100%	100%	100%
	Down1	75%	75%	75%
	Down2	50%	50%	-
	Stop	0%	0%	0%

Bond paper			
Temperature	Level	Productivity(LTR)	Productivity (LTRR)
20 deg C or higher	Start	35ppm	5ppm
	Down1	-	-
	Down2	-	-
	Stop	0%	0%
15 deg C or higher - less than 20 deg C	Start	28%	28%
	Down1	-	-
	Down2	-	-
	Stop	0%	0%
less than 15 deg C	Start	28%	28%
	Down1	-	-
	Down2	-	-
	Stop	0%	0%

2. When printing is started and the paper type is switched

Because fixing temperature differs according to the paper type, switching the paper type causes downtime.

Up to 60 seconds downtime is expected with this machine (switching from heavy paper to thin paper). The following shows estimated downtime.

pattern of paper type switching	downtime (reference value)	Remarks
Plain paper -> Heavy paper	5 sec	-
Thin paper -> Heavy paper	10 sec	-
Heavy paper -> Plain paper	-	Switching the temperature control is conducted, but print operation continues, so downtime does not occur.
Heavy paper -> Thin paper	60 sec	-
Bond paper -> Heavy paper	-	Switching the temperature control is conducted, but print operation continues, so downtime does not occur.
Bond paper -> Plain paper	-	Switching the temperature control is conducted, but print operation continues, so downtime does not occur.
Bond paper -> Thin paper	60sec	-
Thin paper -> Bond paper	80sec	-
Plain paper -> Bond paper	30sec	-
Heavy paper -> Bond paper	10sec	-

3. When the quality priority mode is specified

Due to the temperature rising at the edge of the Fixing Roller, image failure may occur on halftone printing. To prevent image failure, user can enable the following mode from "Settings/Registration".

Settings/Registration > Function Settings > Common > Print Settings > Productivity/Image Quality Priority for Thin/Plain Paper

With this mode, idle rotation is executed to keep constant temperature on the Fixing Roller when above the certain level of temperature difference between the center and the edge of the Fixing Roller is detected. During idle rotation, paper feed is stopped, so the productivity is reduced.

NOTE:

When the quality priority mode is specified, productivity may be extremely reduced depending on use conditions (paper size, paper type, and print image). In such a case, the level of production reduction can be changed by the following service mode.

- Image quality/productivity level : Quality Priority (Lv.2)
COPIER > OPTION > IMG-FIX > FX-IMGLV

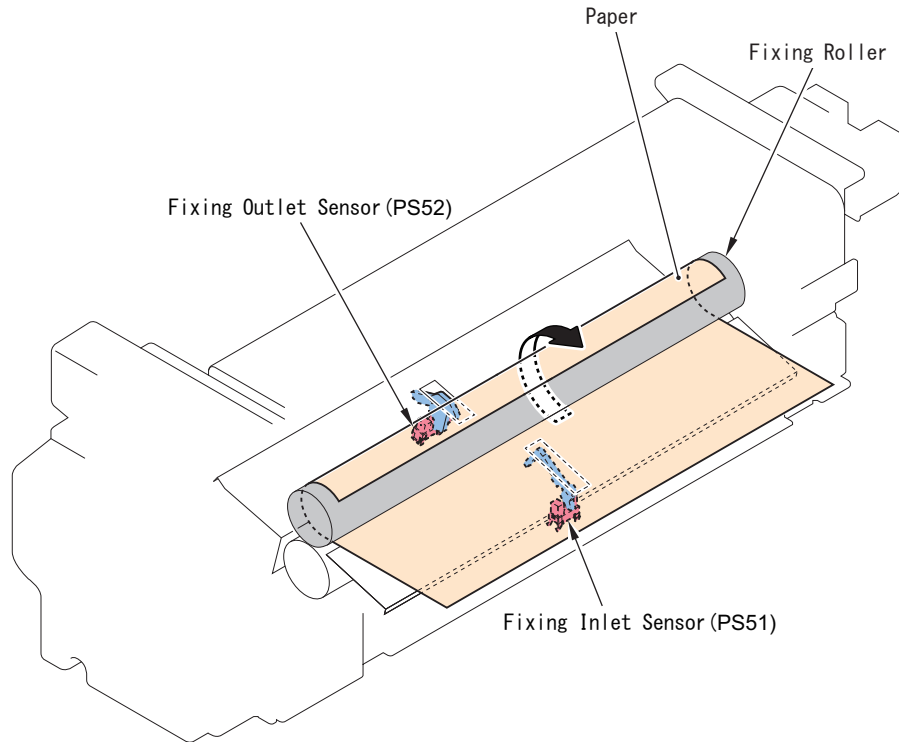
<Related Service Mode>

- Set fixing/productivity: Heavy paper
COPIER > OPTION > IMG-FIX > FIX-TEMP
- Set fixing/productivity: Plain paper A3+
COPIER > OPTION > IMG-FIX > FIX-TMP2
- Set fixing/productivity: Special paper A3+
COPIER > OPTION > IMG-FIX > FIX-TMP3
- Image quality/productivity level : Quality Priority (Lv.2)
COPIER > OPTION > IMG-FIX > FX-IMGLV

■ Paper Anti-wrapping Control

● Overview

With this control, failure of the Fixing Assembly caused by paper wrapping around the Fixing Roller and the Pressure Roller is prevented.



● Control description

In the case of delay jam at the fixing outlet, the DC Controller determines paper wrapping if the paper remains in the Fixing Assembly and executes the following.

- The brake is applied to the Fixing Motor to immediately stop operation of the Fixing Motor (to minimize the paper wrapping level)
- Power distribution to the coil is stopped (to ensure safety).
- A jam is displayed.(Jam Code:0111)
- Cleaning of the Fixing Roller is executed (5 times of web cleaning)

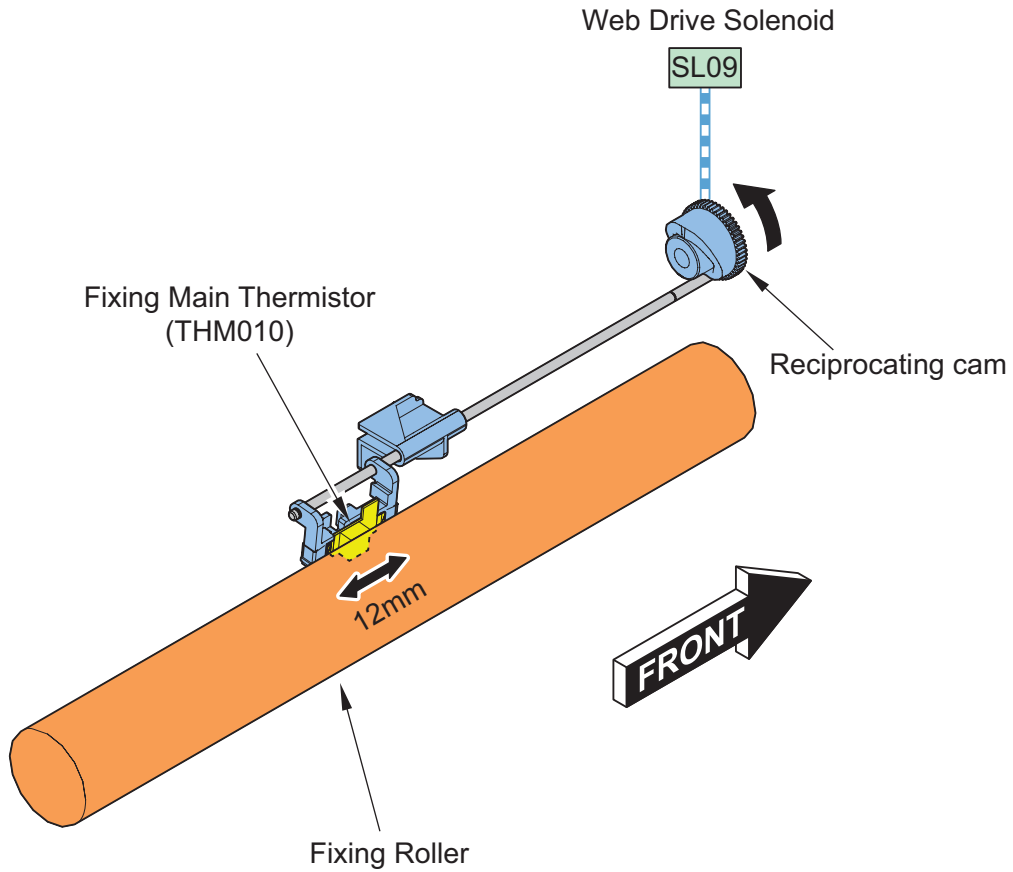
NOTE:

Paper presence in the Fixing Assembly is determined by the paper detection log with the Fixing Inlet Sensor (to see whether the paper passes through the Sensor).

■ Thermistor reciprocating control

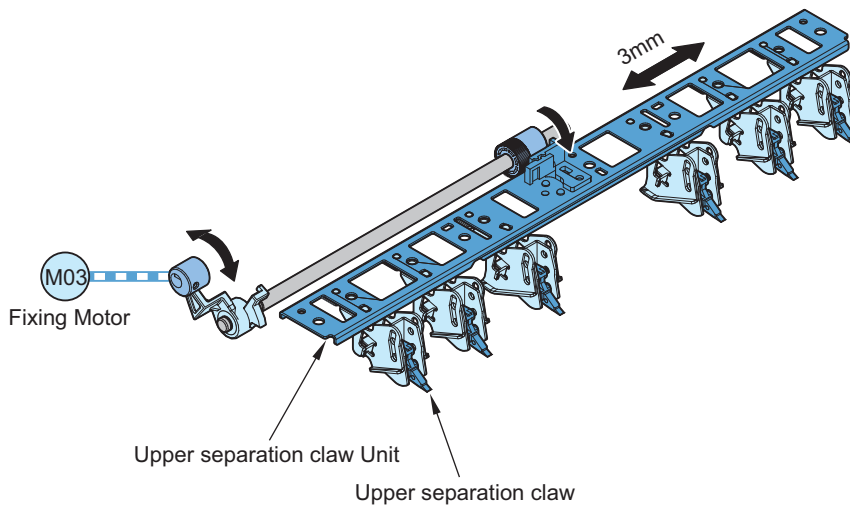
To prevent scar on the Fixing Roller by the Fixing Main Thermistor (THM010), the Fixing Main Thermistor is moved back and forth by 12mm in the shaft direction of the Fixing Roller.

The drive of the Fixing Cleaning Web Drive Solenoid (SL09) is transmitted to the Reciprocating Cam.



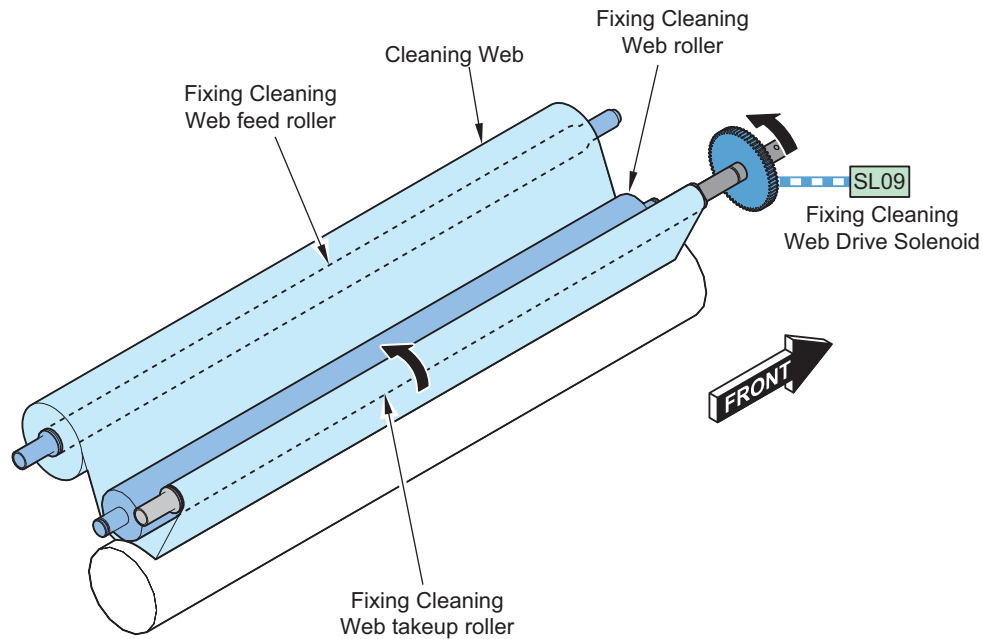
■ Upper separation claw reciprocating control

To prevent scar on the Fixing Roller by the Upper Separation Claw, the Upper Separation Claw is moved back and forth by 3mm in the direction of the Fixing Roller.



■ Cleaning web drive control

To prevent fixing offset, the residual toner on the surface of the Fixing Roller is removed with the Cleaning Web.



The take-up length of the Cleaning Web is determined by the paper size and the number of sheets (in 1 job).

Paper size	1st sheet	2nd sheet	3rd sheet	4th sheet or later
Small The size with less than 220mm length in feeding direction (LTR or less)	1-time	1-time	0-time	Repeat wrapping amount of the 1st to the 3rd sheet
Middle The size between 237mm and 364mm in feeding direction (B5R to LGL/B4)	1-time	1-time	1-time	
Large The size with 365mm or more length in feeding direction (B5R or more)	2-time	1-time	1-time	

When the paper is stationed in the Fixing Unit due to a jam or an error, the Fixing Web Drive Solenoid is turned ON for 5 times at the time of recovery.

<Related Error Code>

E005-0001:Error in Fixing Cleaning Web Drive Solenoid connection

<Related Service Mode>

- Setting of Fixing Web Solenoid ON times
COPIER > OPTION > IMG-FIX > CBLTINVL
Setting Value

0 :Normal

1 :1.5 times of normal*

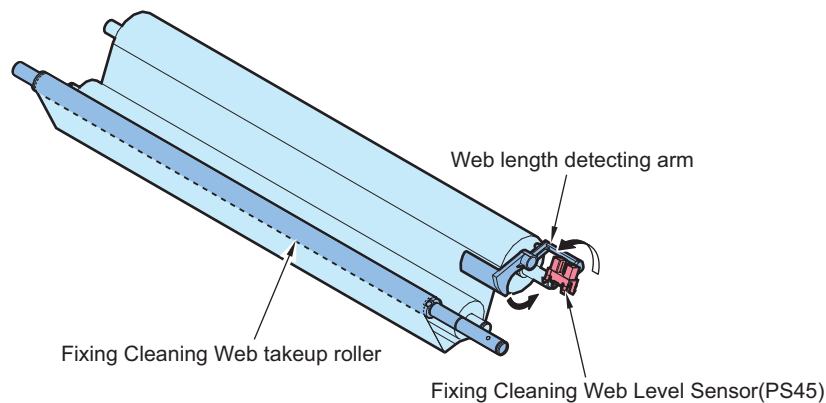
2 :0.5 times of normal

3 :0.75 times of normal

* Only for paper which length in feed direction is 236.0 mm or less or 364.0 mm or longer

■ Cleaning web length detection

When the length of the Cleaning Web is reduced, the Web Level Detection Arm is moved in the direction of the arrow to block the light path of the Fixing Cleaning Web Level Detection Sensor (PS45). When the Fixing Web Drive Solenoid has been turned ON for 4 times after the detection by this sensor, a fixing web length warning message is displayed on the Control Panel.



After the display of the fixing web length warning message, the number of turning ON the Fixing Cleaning Web Drive Solenoid is to be counted.

The Error Code “E005-0000” is displayed once the counter value reaches 65250 (97875 sheets of copy/print in A4 size)

CAUTION:

In the case of replacing the Fixing Cleaning Web, be sure to clear the Fixing Web Counter by the following Service Mode

- Fixing Cleaning Web take-up counter after the level warning
COPIER > COUNTER > MISC > FIX-WEB
- Fixing Cleaning Web take-up counter
COPIER > COUNTER > DRBL-1 > FX-WEB

<Related Error Code>

- E005-0000 : Error in absence of the Fixing Web
After the advance notice detection for the absence of the Fixing Web, the web has continued to be pulled for 65250 times.

<Related Service Mode>

- Set Fixing Web level alarm notice timing
COPIER > OPTION > IMG-FIX > WEB-LIFE
Setting Value
0 : Detection by the sensor
1 : Count of 500,000 sheets (on a A4 size conversion basis)
2 to 7: As the value is incremented by 1, the counted number of sheets is increased by 50,000 sheets. The maximum setting value is 7 (800,000 sheets).

■ Protective function

● Detecting an Error Using the Thermistor

In the event of the following, the machine will set the DC power (12 V) used to drive the AC relay (found on the fixing heater power supply PCB), thereby stopping the AC power to the fixing heater.

- the Fixing Main Thermistor (THM010)/Fixing sub thermistor1 (THM020)/Fixing sub thermistor2 (THM040) has detected overheating.
- the difference between temperature of each thermistors has deviated from a specific value.

● Detecting an Error Using the Thermal Switch

In response to a deviation in temperature (200 +/-5 deg C), bimetal contact of the thermal switch (TP010; non-contact type/TP020; non-contact type) will open to cut the power supply line (12 V) used to drive the AC relay on the fixing heater power supply PCB, thereby stopping the AC power to the fixing heater.

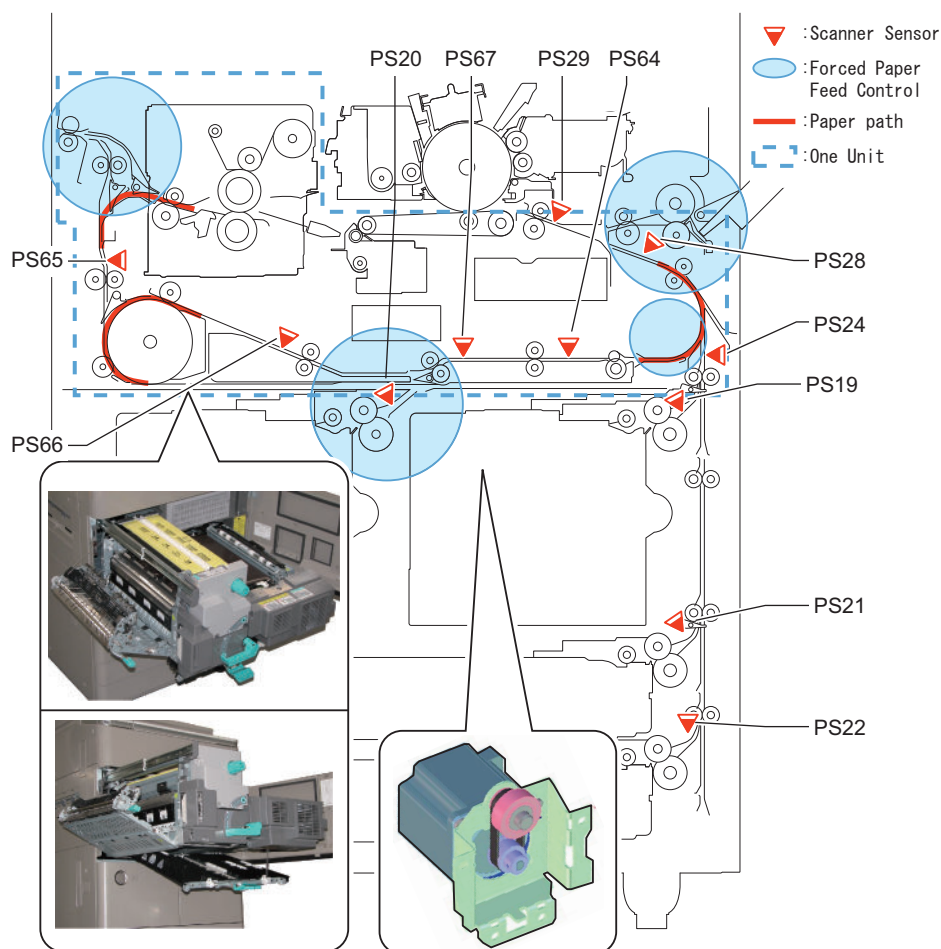
CAUTION:

Once the contact point of the Thermal Switch is open, it will not be recovered even though the high temperature becomes to be normal temperature. Be sure to eliminate the cause of the error, and then replace the Thermal Switch.

Pickup/Feed System

Overview

- Supported media (heavy paper) (52g/m² -> 256g/m²)
This feature is enabled by making gentler curve of the pre-registration path, reverse path and duplex merging path.
- Support of large size: 13" x 19" inch (330.2mm x 482.6mm)
This feature is enabled by broadening the feeding path width.
- Improved jam processing performance
This feature is enabled by making the Fixing/Feed Assembly and the Duplex Assembly as one unit as well as making the Delivery Unit and the Door of the Fixing Assembly as one unit.
This feature is enabled by using forcible paper feed control that feeds paper to the position where the jammed paper is easily removed in the case of paper jam.
- Improved Multi-purpose Tray usability
Automatic paper size recognition by the Multi-purpose Tray improves usability.
- Addition of the Double Feed Sensor (as an option)
Double feed detection during paper feed has been realized by the addition of the ultrasonic sensor on the feeding path.



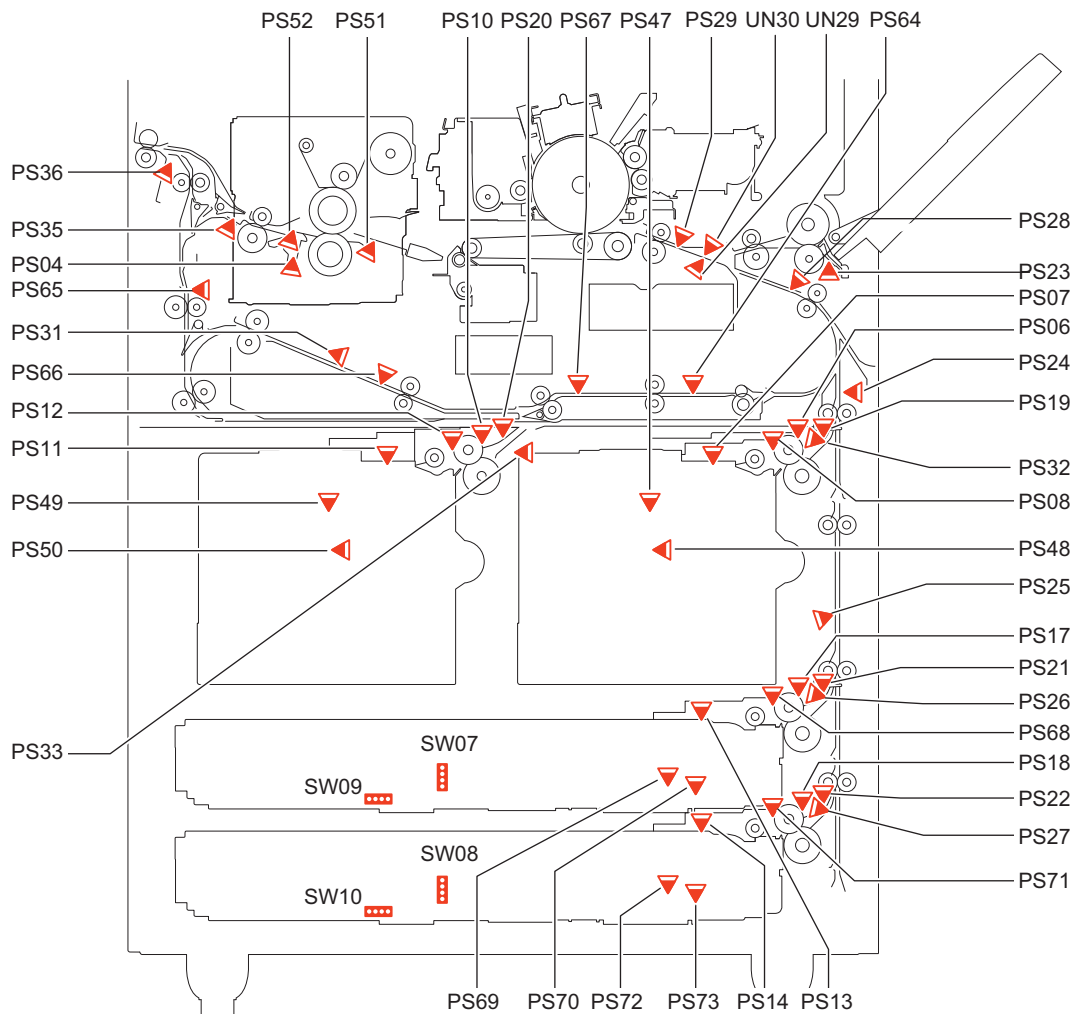
Specifications

These show major specifications of the Pickup/Feed System.

Item		Function/Method
Paper Storage Method		Front loading method
Pickup Method	Left/Right Deck	Separation retard method
	Cassette 3/4	Separation retard method
	Multi-purpose Tray	Simple retard method
Paper Feed Standard		Center
Paper stack capacity	Left/Right Deck	1500 sheets (80 g/m2)
	Cassette 3/4	550 sheets (80 g/m2)
	Multi-purpose Tray	100 sheets (80 g/m2)
Paper size	Left/Right Deck	A4, B5, LTR
	Cassette 3/4	A3, B4, A4R, A4, B5, B5R, A5, 11"x17" (279.4 x 431.8 mm), LGL, LTRR, LTR, EXECR, STMT, 8K, 16KR, 16K Custom paper size (139.7 x 182 to 297 x 431.8 mm)
	Multi-purpose Tray	A3, A4R, A4, B4, B5, B5R, A5, 11"x17" (279.4 x 431.8 mm), LGL, LTRR, LTR, STMT, EXECR, 8K, 16KR, Postcard, Reply Postcard, 4 on 1 Postcard Custom paper size (100 x 148 mm to 297 x 431.8 mm) Long Length Paper (297 to 630.0 mm)
Paper Grammage	Left/Right Deck	52 g/m2 to 220 g/m2
	Cassette 3/4	52 g/m2 to 220 g/m2
	Multi-purpose Tray	52 g/m2 to 256 g/m2 (Duplex printing 52 g/m2 to 220 g/m2)
Paper Size Switching	Left/Right Deck	Service Switching
	Cassette 3/4	Auto size detection
	Multi-purpose Tray	Auto size detection
Duplexing method		Through path
Transparency detection		N/A

■ Parts configuration

● Switch/Sensor

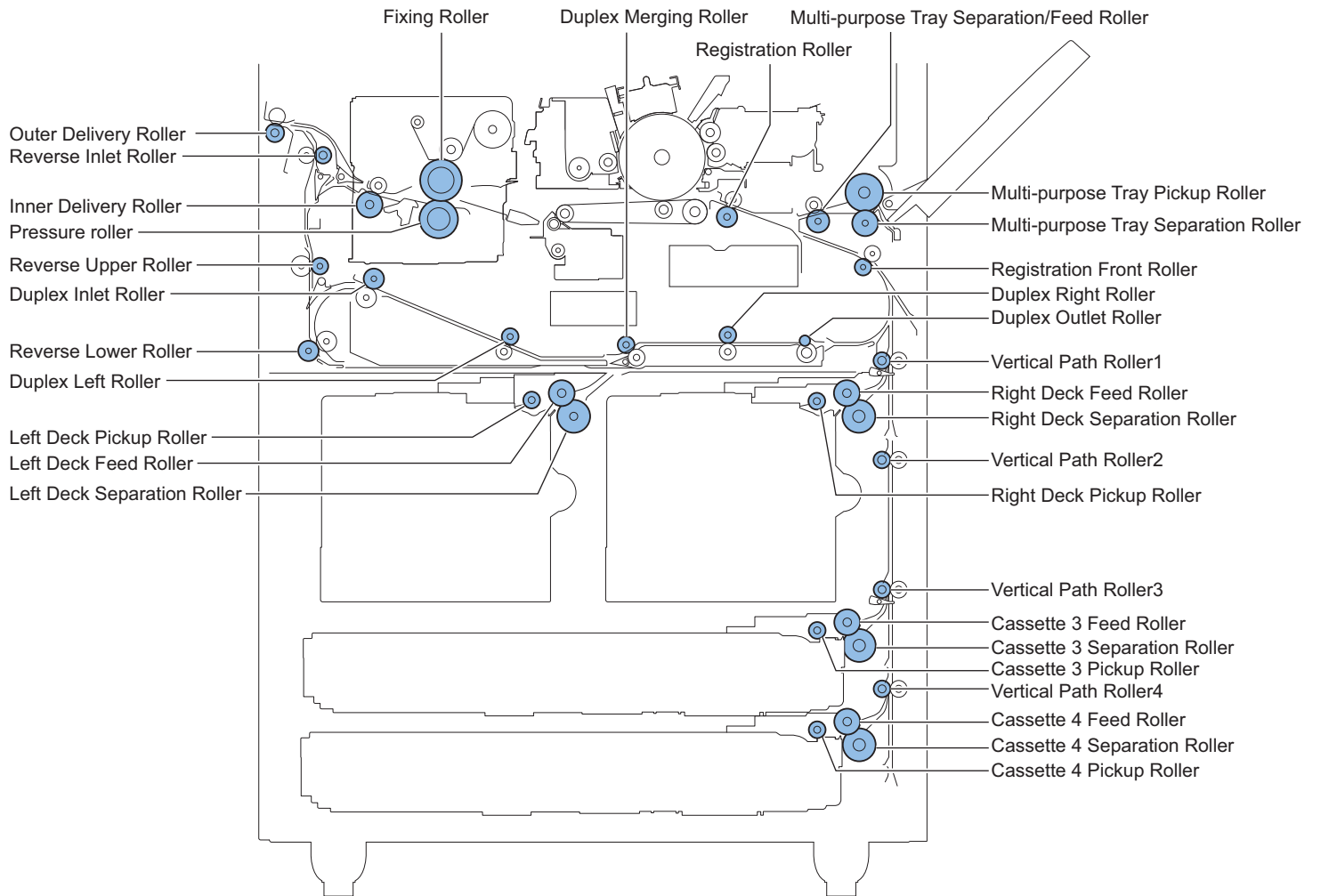


Sensor No.	Name
PS02	Vertical Path Cover Open/Close Sensor
PS03	Multi-purpose Cover Open/Close Sensor
PS04	Fixing Toenail Jam Sensor
PS06	Right Deck Paper Height Sensor
PS07	Right Deck Paper Sensor
PS08	Right Deck Upper Limit Sensor
PS10	Left Deck Paper Height Sensor
PS11	Left Deck Paper Sensor
PS12	Left Deck Paper Height Sensor
PS13	Cassette 3 Paper Sensor
PS14	Cassette 4 Paper Sensor
PS17	Cassette 3 Paper Height Sensor
PS18	Cassette 4 Paper Height Sensor
PS19*	Right Deck Pull Out Sensor
PS20*	Left Deck Pickup Sensor
PS21*	Vertical Path Sensor3
PS22*	Vertical Path Sensor4
PS23	Multi-purpose Tray Paper Sensor
PS24*/25	Vertical Path Sensor1/Vertical Path Sensor2
PS26/27	Cassette 3 Pickup Sensor/Cassette 4 Pickup Sensor
PS28*	Writing Judging Sensor

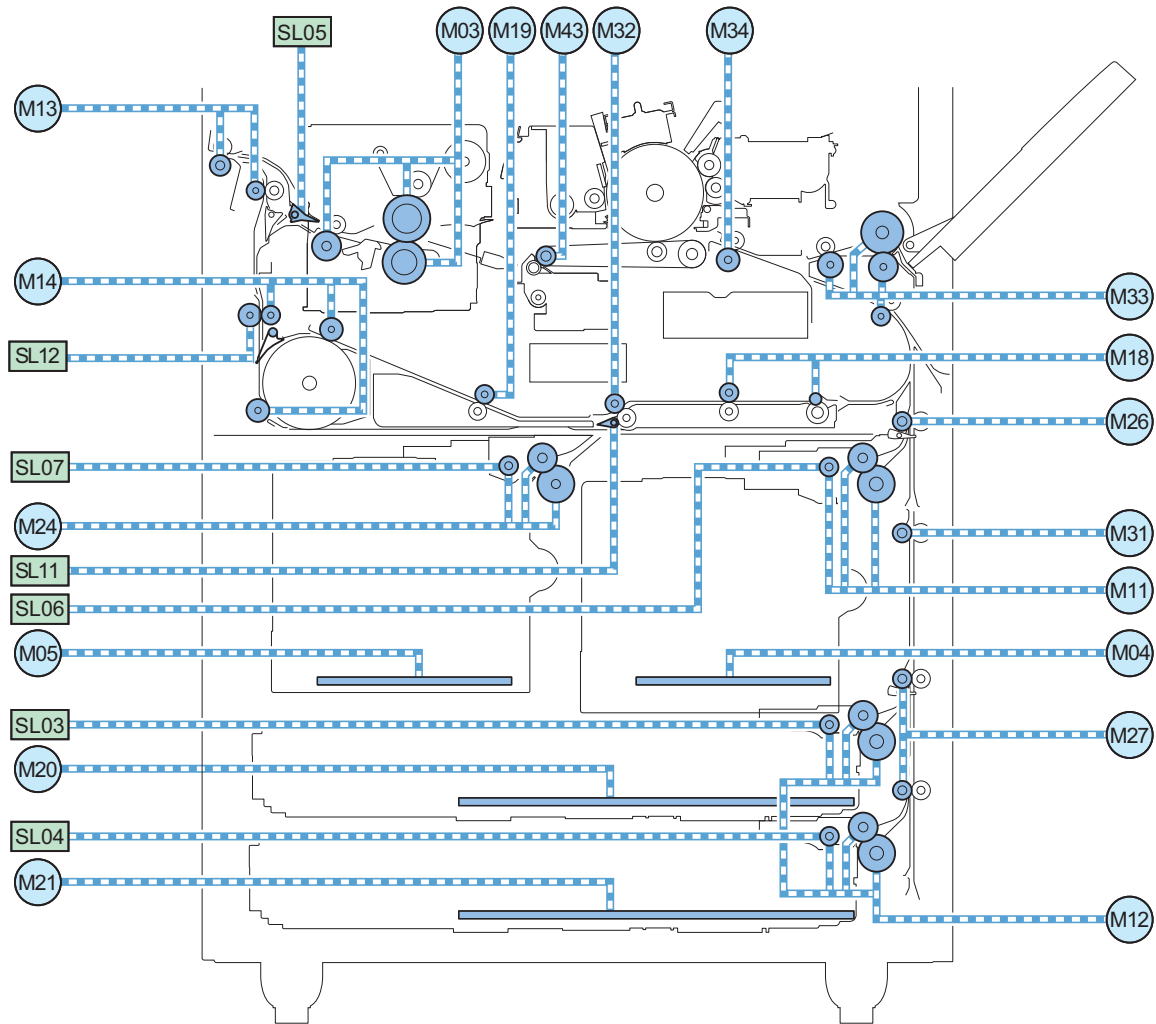
Sensor No.	Name
PS29*	Registration Sensor
PS31	Side Registration Sensor
PS32	Right Pickup Sensor
PS33	Left Deck Pull Out Sensor
PS35	Inner Delivery Sensor
PS36	Outer Delivery Sensor
PS47/48	Right Deck Paper Level Sensor 1/2
PS49/50	Left Deck Paper Level Sensor 1/2
PS51	Fixing Inlet Sensor
PS52	Fixing Outlet Sensor
PS64*	Duplex Outlet Sensor
PS65*	Reverse Vertical Path Sensor
PS66*	Duplex Left Sensor
PS67*	Duplex Merging Sensor
PS68	Cassette 3 Upper Limit Sensor
PS69/70	Cassette 3 Paper Level Sensor 1/Cassette 3 Paper Level Sensor 2
PS71	Cassette 4 Upper Limit Sensor
PS72/73	Cassette 4 Paper Level Sensor 1/Cassette 4 Paper Level Sensor 2
SW07	Cassette 3 Paper Width Detection Switch
SW08	Cassette 4 Paper Width Detection Switch
SW09	Cassette 3 Paper Length Detection Switch
SW10	Cassette 4 Paper Length Detection Switch
UN29	Double Feed Detection Sensor (Reception)(Option)
UN30	Double Feed Detection Sensor (Transmission)(Option)

*Scanner Sensor

• Roller



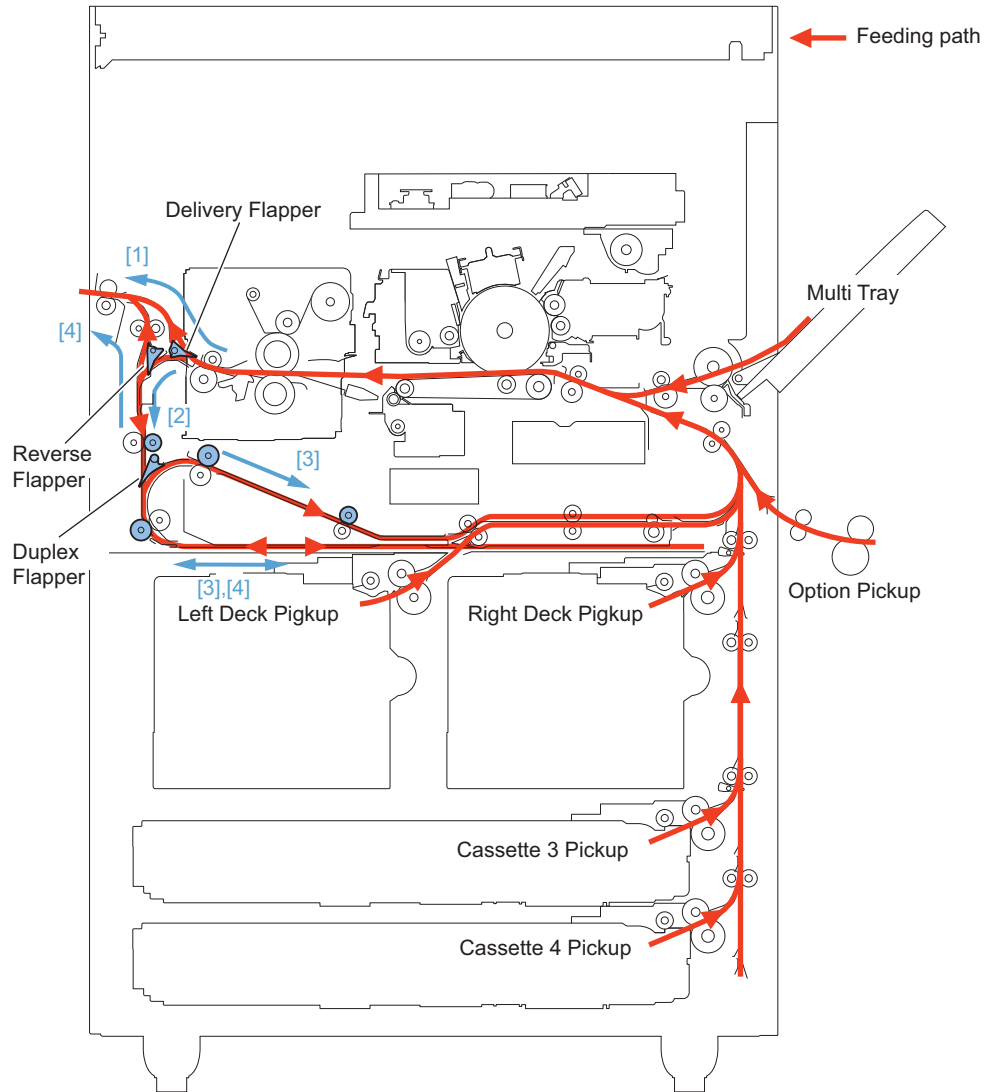
■ Drive Configuration



No.	Name
M03	Fixing Motor
M04	Right Deck Lifter Motor
M05	Left Deck Lifter Motor
M11	Right Deck Pickup Motor
M12	Cassette3/4 Pickup Motor
M13	Delivery Motor
M14	Reverse Motor
M18	Duplex Feed Right Motor
M19	Duplex Feed Left Motor
M20	Cassette3 Lifter Motor
M21	Cassette4 Lifter Motor
M24	Left Deck Pickup Motor
M26	Vertical Path Upper Motor
M27	Vertical Path Lower Motor
M31	Vertical Path Middle Motor
M32	Duplex Feed Merging Motor
M33	Multi-purpose Registration Front Motor
M34	Registration Motor
M43	ETB Motor
SL03	Cassette 3 Pickup Solenoid
SL04	Cassette 4 Pickup Solenoid
SL05	Reverse Upper Flapper Solenoid
SL06	Right Deck Pickup Solenoid

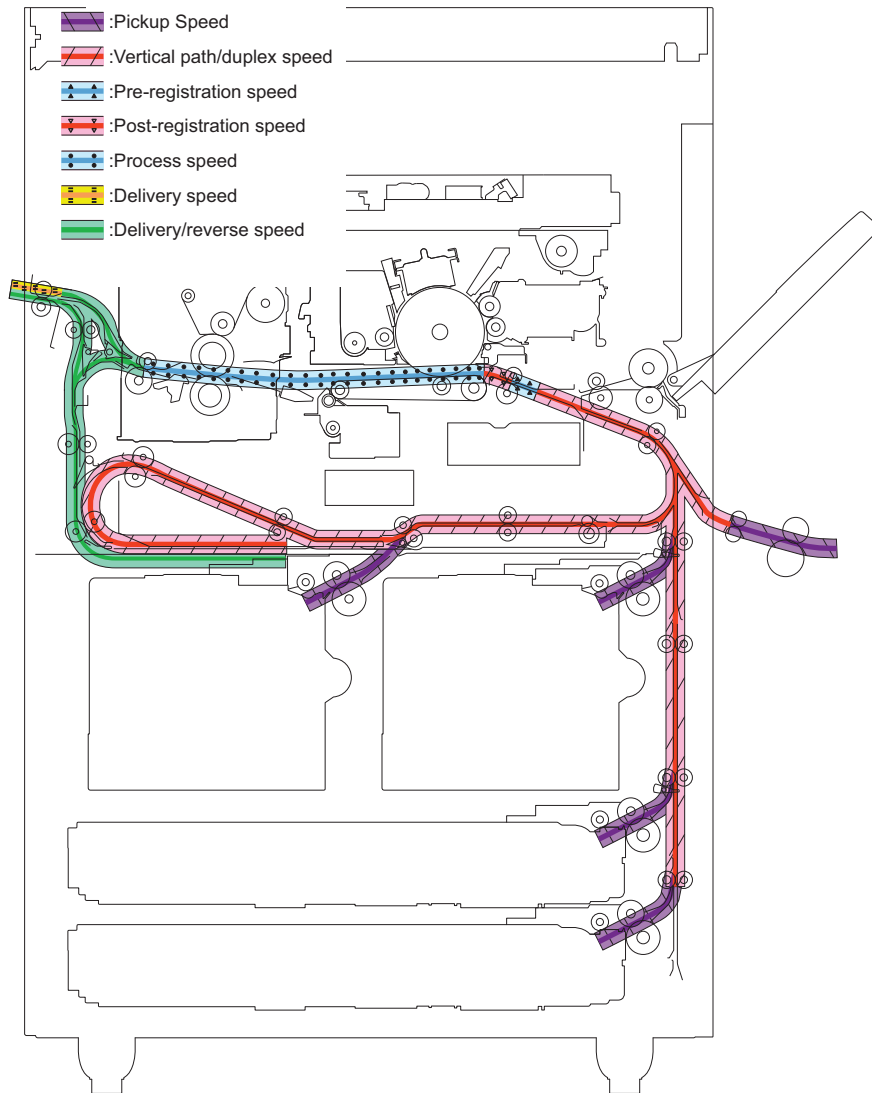
No.	Name
SL07	Left Deck Pickup Solenoid
SL11	Left Deck Merging Solenoid
SL12	Reverse Detachment Solenoid

■ Paper path

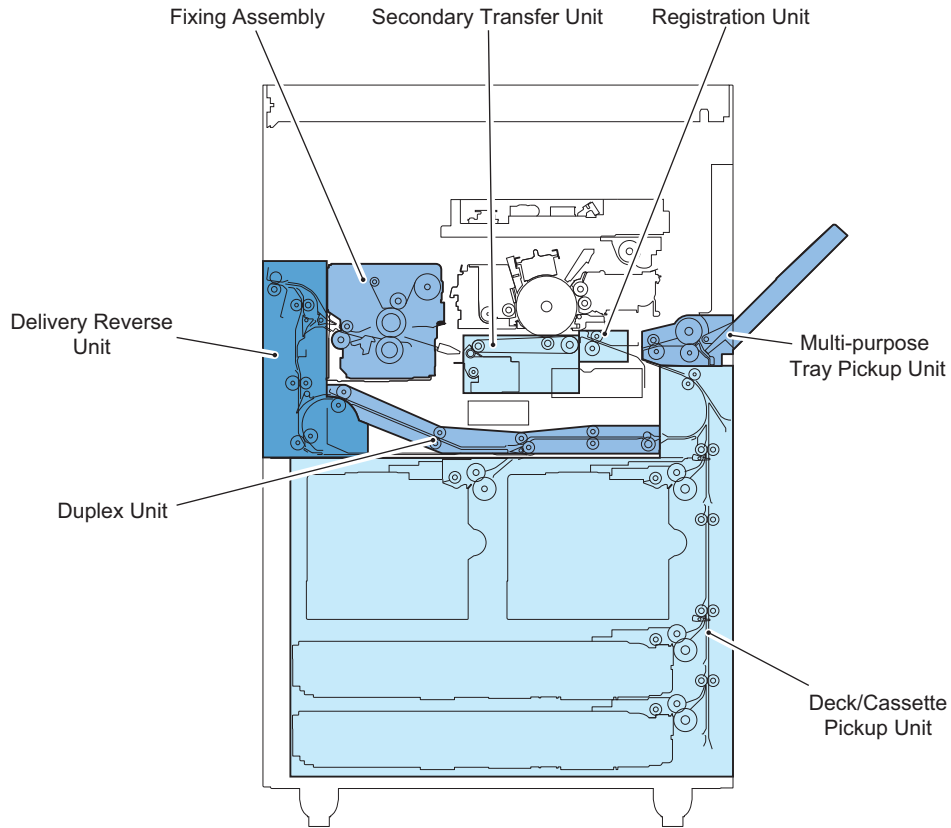


No.	Feeding path
[1]	1-side face-up delivery, duplex face-down delivery
[2]	1-side face-down delivery, duplex printing
[3]	Duplex printing
[4]	1-side face-down delivery

■ Interval speed



Print speed [ppm]	105	95	85
Pickup speed [mm/s]		500	
Vertical path/duplex speed [mm/s]		750	
Pre-registration speed [mm/s]		500	
Post-registration speed [mm/s]		750	
Process speed [mm/s]		500	
Delivery speed [mm/s]	face-up delivery, :500/face-down delivery, :1100		
Delivery/Reverse speed [mm/s]	1100		



Unit	Control
Deck/cassette pickup unit	Basic Movement
	Deck/Cassette Detection
	Paper Size Detection
	Paper Level Detection
	Paper Detection
	Lifter Control
	Pickup Retry Control
Multi-purpose pickup tray unit	Basic Movement
	Paper Size Detection
	Paper Detection
Pre-registration/Registration Unit	Pre-registration Control
	Registration Control
	Registration Deceleration Control
	Registration Acceleration Control
	Double Feed Detection(Optional)
Secondary transfer Unit	Post-transfer Guide Attraction Control
Delivery unit/Duplex unit	Face-up Delivery
	Face-down Delivery
	Duplex Reverse Delivery
	Side Registration Control
	Circulation quantity and limit
Jam detection	Jam Code List
	Forced Paper Feed Control

■ Deck/Cassette Pickup Unit

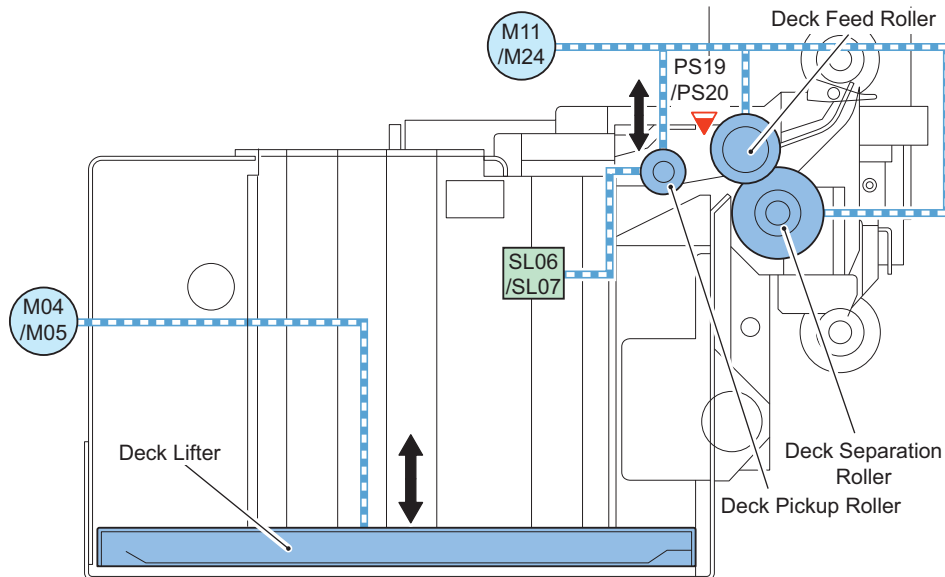
● Basic Movement

When Deck/Cassette is installed, Motor drives to maintain the height which paper surface attaches to Pickup Roller (This is the height of Pickup Roller when Pickup Solenoid is OFF).

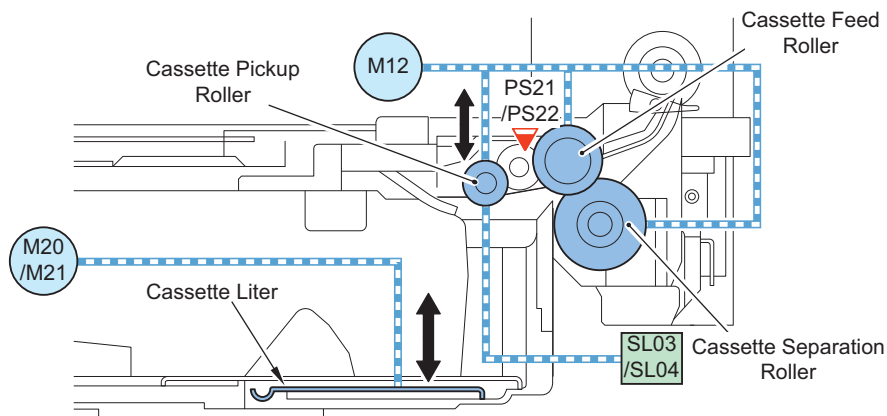
If the Pickup Motor (M11/M12/M24) is turned ON, the Pickup Roller will rotate and the paper will be fed.

When the Pickup Sensor (PS19/PS20/PS21/PS22) detects paper, the Pickup Solenoid (SL03/SL04/SL06/SL07) will turn ON, and Pickup Roller will draw away from paper surface. Only 1 sheet of paper is sent to feed path by the Feed Roller and the Separation Roller, and fed to Vertical Path Roller.

Deck



Cassette



NOTE:

The same single motor is used as a pickup motor for both Cassette 3 and Cassette 4.

The drive is transmitted to Cassette 3 when the motor is in normal rotation and the drive is transmitted to Cassette 4 when the motor is in reverse rotation. The drive is switched by the One-way Clutch.

<Related Service Mode>

- ON/OFF of Pickup Roller Post-Rotation on Right Deck
COPIER > OPTION > FEED-SW > DK1-TURN
- ON/OFF of Pickup Roller Post-Rotation on Left Deck
COPIER > OPTION > FEED-SW > DK2-TURN
- ON/OFF of Pickup Roller Post-Rotation on Cassette3
COPIER > OPTION > FEED-SW > DK3-TURN

- ON/OFF of Pickup Roller Post-Rotation on Cassette4
COPIER > OPTION > FEED-SW > DK4-TURN

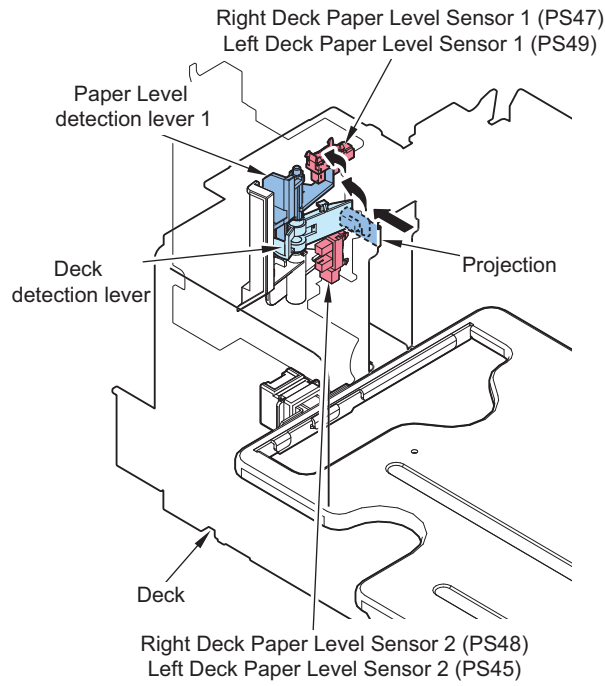
Setting Value 0: (Default), 1: ON after a job , 2 : ON at warm-up rotation , 3 : ON after a job and at warm-up rotation

• Deck/Cassette detection

Whether Deck/Cassette is installed is detected

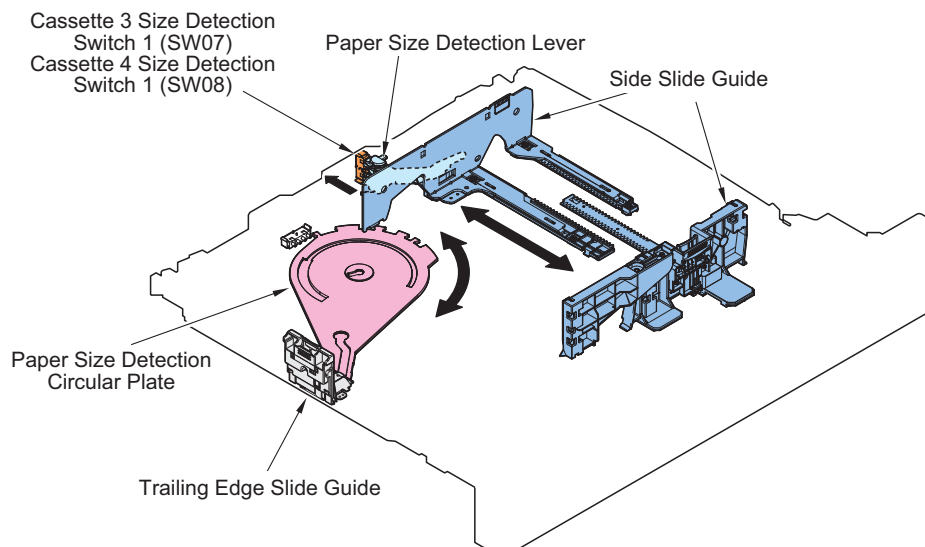
Deck

Deck is detected by Paper Level Sensor. When light from 2 Paper Level Sensors is not blocked, it is detected as no deck installed



Cassette

Cassette is detected by Paper Size Detection Switch. When all actuators of the Paper Size Detection Switch(SW07/SW08)are not pressed, it is detected as no cassette installed



• Paper Size Detection

Deck

Set in Service Mode.

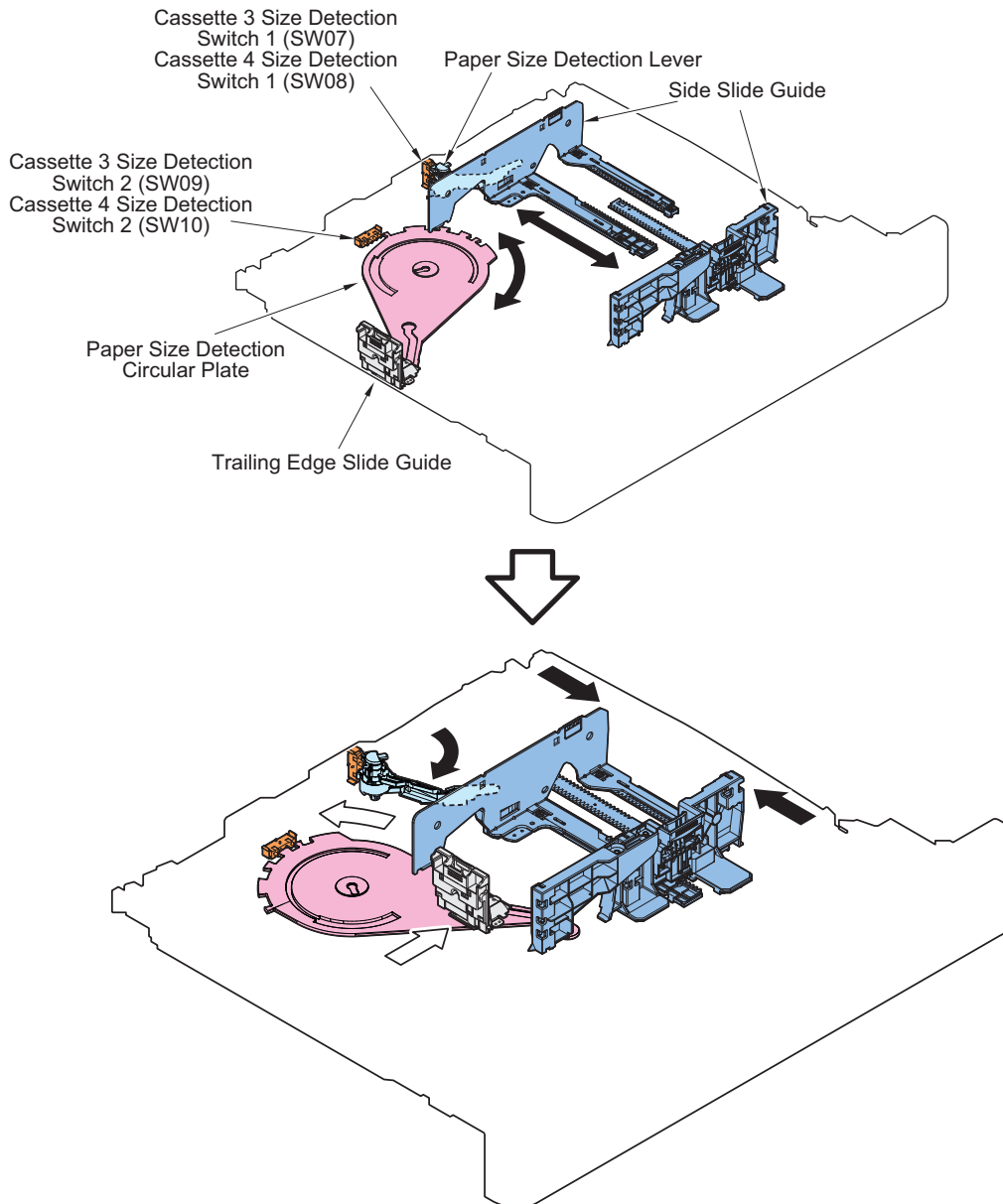
There is no mechanism to detect paper size.

<Related Service Mode>

- Right Deck Paper setting
COPIER > OPTION > CST > P-SZ-C1
- Left Deck Paper setting
COPIER > OPTION > CST > P-SZ-C2
Setting Value
0: A4 (default) ,1: B5 , 2: LTR

Cassette

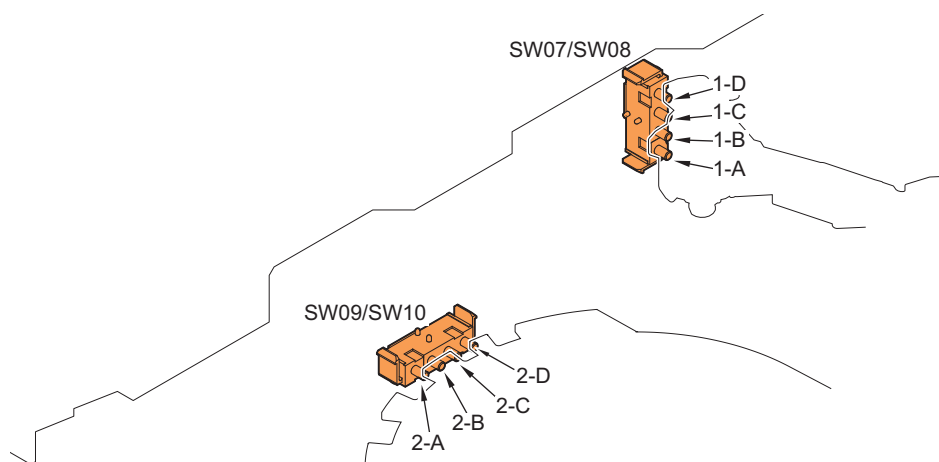
Paper size in cassette 3/4 is each detected by 2 paper size detection switches.
ON/OFF of 4-actuator in the Host Machine changes according to the Paper Size Detection Circular Plate/Lever Position linked to Trailing Edge/Side Slide Guide. Paper size is detected by two 4-actuator ON/OFF combinations. And, if all 4-actuator are OFF is detected, it means no-cassette.



Paper size detection Switch

Paper Size	Width (mm)	Length (mm)	Width SW07/SW08				Length SW09/SW10			
			1-A	1-B	1-C	1-D	2-A	2-B	2-C	2-D
B5	257.0	182.0	ON	-	-	ON	ON	ON	ON	ON
EXEC	267.0	184.0	ON	-	-	ON	ON	ON	ON	ON
16K	270.0	195.0	ON	-	-	ON	-	ON	ON	ON
A5-R	148.5	210.0	-	ON	-	ON	ON	-	ON	ON
A4	297.0	210.0	ON	-	ON	ON	ON	-	ON	ON

Paper Size	Width (mm)	Length (mm)	Width SW07/SW08				Length SW09/SW10			
			1-A	1-B	1-C	1-D	2-A	2-B	2-C	2-D
STMT-R	139.7	215.9	-	ON	-	ON	ON	-	ON	ON
LTR	279.4	215.9	ON	-	-	ON	ON	-	ON	ON
B5-R	182.0	257.0	-	ON	-	ON	ON	-	ON	-
			-	ON	-	ON	ON	ON	ON	-
16K-R	195.0	270.0	ON	ON	-	ON	ON	ON	-	ON
			-	ON	-	ON	ON	ON	-	ON
LTR-R	215.9	279.4	ON	ON	-	ON	-	ON	ON	ON
			ON	ON	-	ON	-	ON	ON	-
A4-R	210.0	297.0	ON	ON	-	ON	-	-	ON	ON
LGL	215.9	355.6	ON	ON	-	ON	ON	ON	-	-
B4	257.0	364.0	ON	-	-	ON	ON	ON	ON	-
8K	270.0	390.0	ON	-	-	ON	-	-	ON	ON
A3	297.0	420.0	ON	-	ON	ON	-	ON	-	-
LDR	279.4	431.8	ON	-	-	ON	-	-	ON	-
SRA3	320.0	450.0	ON	-	ON	-	-	-	-	ON
12 x 18	304.8	457.2	ON	-	ON	ON	-	-	-	ON
13 x 19	330.2	483.0	ON	-	ON	-	-	-	-	-
K_LGL	268.0	190.0	ON	-	-	ON	ON	ON	ON	ON
K_LGL-R	190.0	268.0	-	ON	-	ON	ON	ON	-	ON
G_LTR	267.0	203.0	ON	-	-	ON	-	ON	ON	ON
G_LTR-R	203.0	267.0	ON	ON	-	ON	ON	ON	-	ON
G_LGL	203.2	330.2	ON	ON	-	ON	-	ON	ON	-
OFI	216.0	317.0	ON	ON	-	ON	ON	ON	-	-
E_OFI	220.0	320.0	ON	ON	-	ON	ON	ON	-	-
M_OFI	216.0	341.0	ON	ON	-	ON	ON	-	ON	ON
B_OFI	216.0	355.0	ON	ON	-	ON	ON	ON	-	-
A_OFI	220.0	340.0	ON	ON	-	ON	-	-	ON	ON
FOLIO	216.0	330.0	ON	ON	-	ON	-	ON	ON	-
FLSP	216.0	330.0	ON	ON	-	ON	-	ON	ON	-
A_FLSP	206.0	337.0	ON	ON	-	ON	-	-	ON	ON
A_LTR	280.0	220.0	ON	-	-	ON	ON	-	ON	ON
A_LTR-R	220.0	280.0	ON	ON	-	ON	-	ON	ON	-
A_LGL	220.0	340.0	ON	ON	-	ON	-	-	ON	ON
FA4	216.0	343.0	ON	ON	-	ON	ON	-	-	ON
FB4	216.0	330.0	ON	ON	-	ON	-	ON	ON	-



<Related User Mode>




- Settings/registration > Preferences > Paper Settings > Paper Size Group for Auto Recognition in Drawer
Setting Value: All Sizes, A/B Size, Inch Size, A/K Size

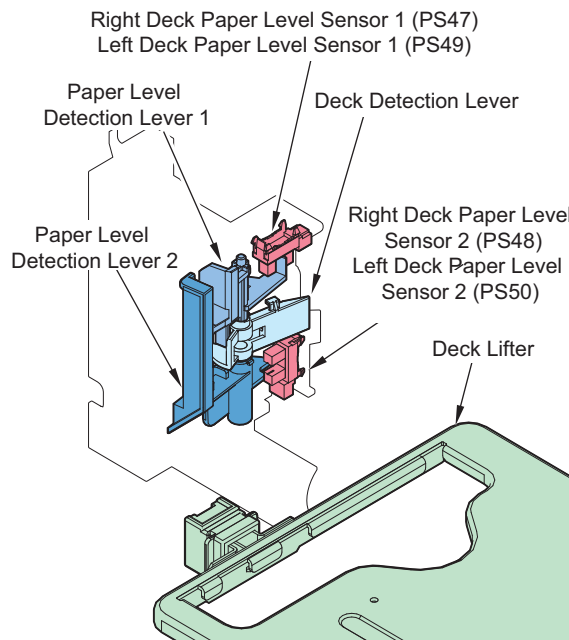
- Settings/registration > Preferences > Paper Settings > A5R/STMTR Original Selection
Setting value Cassette3: A5R, STMTR Cassette4: A5R, STMTR
- Settings/registration > Preferences > Paper Settings > B5/EXEC Original Selection
Setting value Cassette3: B5, EXEC Cassette4: B5, EXEC
- Settings/registration > Preferences > Paper Settings > Register Custom Size
Setting Value: Register, Delete, Rename

• Paper Level Detection

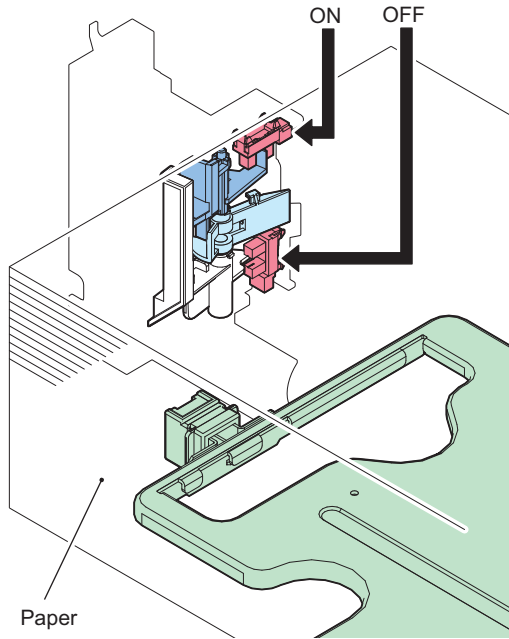
Paper level is detected by two Paper Level sensors in each cassette

Deck

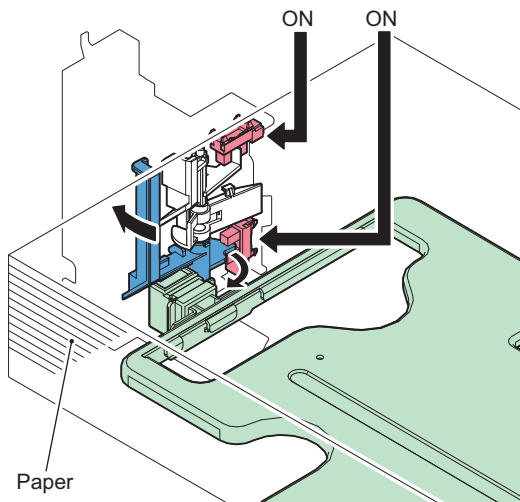
	Right Deck Paper Level Sensor 1 (PS47) Left Deck Paper Level Sensor 1 (PS49)	Right Deck Paper Level Sensor 2 (PS48) Left Deck Paper Level Sensor 2 (PS50)	Control Panel Screen Display
Full (100%~50%)	ON	OFF	
Half (50%~25%)	ON	ON	
Few (25% or less)	OFF	ON	



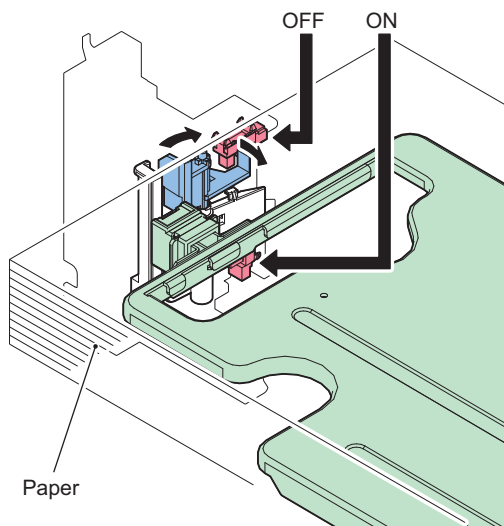
- Full (100%~50%)



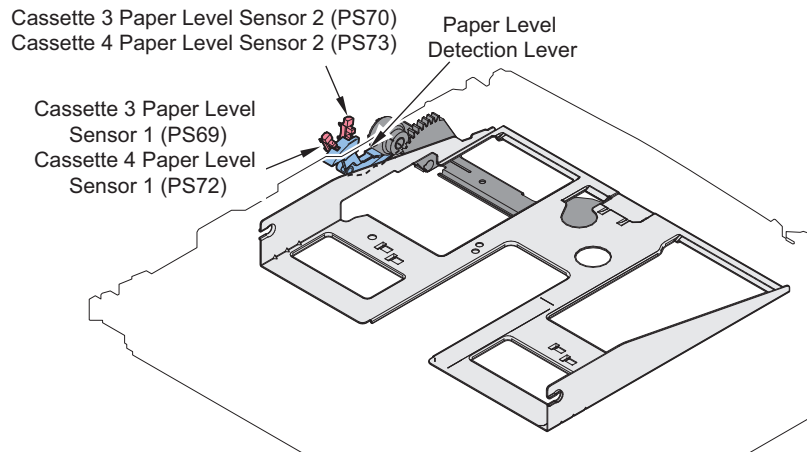
- Half (50%~25%)



- Few (25% or less)

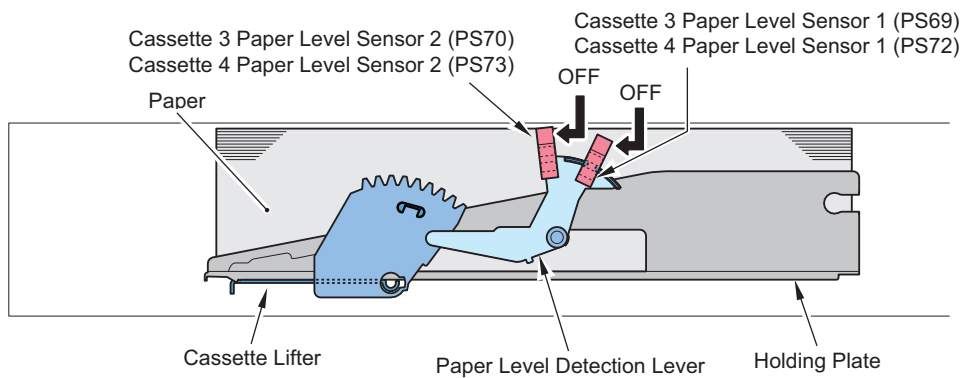


Cassette

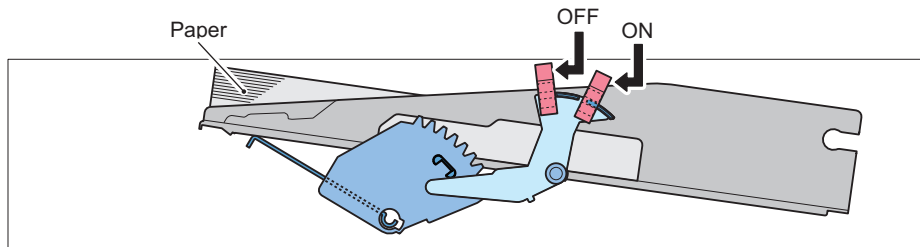


	Cassette 3 Paper Level Sensor 1 (PS69) Cassette 4 Paper Level Sensor 1 (PS72)	Cassette 3 Paper Level Sensor 2 (PS70) Cassette 4 Paper Level Sensor 2 (PS73)	Control Panel Screen Display
Full (100%~50%)	OFF	OFF	
Half (50%~25%)	ON	OFF	
Few (25% or less)	ON	ON	

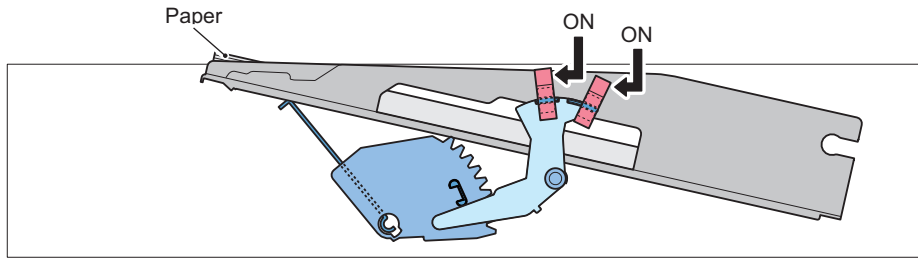
- Full (100%~50%)



- Half (50%~25%)



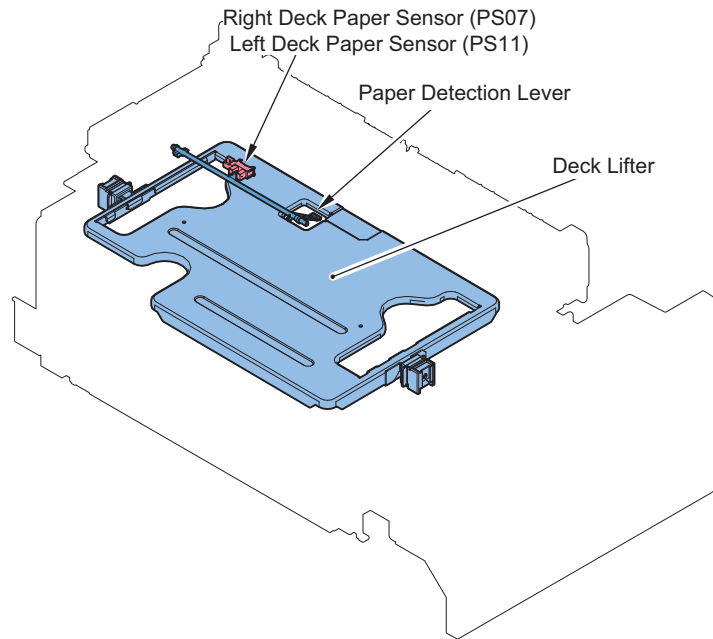
- Few (25% or less)



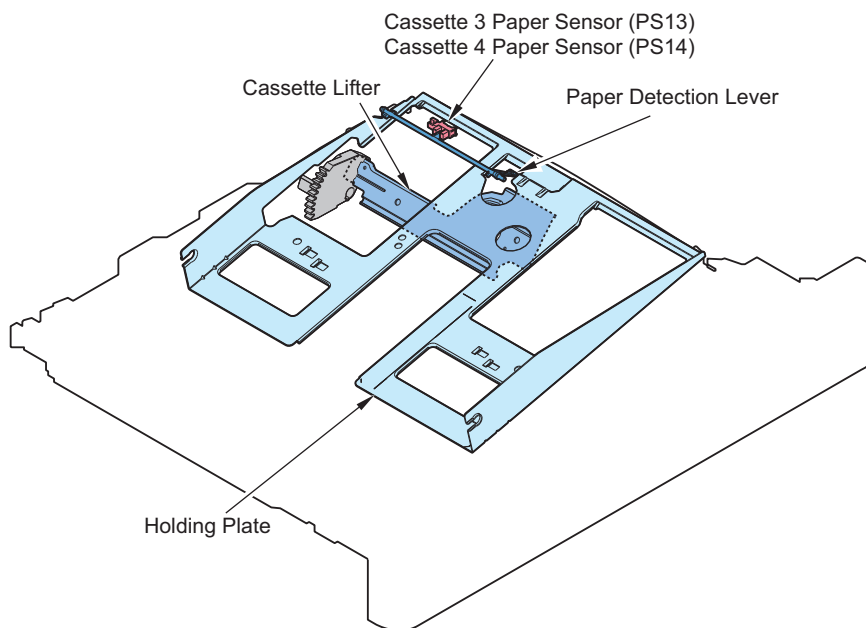
• Paper Detection

If paper is present, the Detection Lever is pushed upward when lifter ascends, and Paper Sensor is turned OFF.
 If paper finishes, the Detection Lever enters lifter hole, and Paper Sensor is turned ON

Deck



Cassette

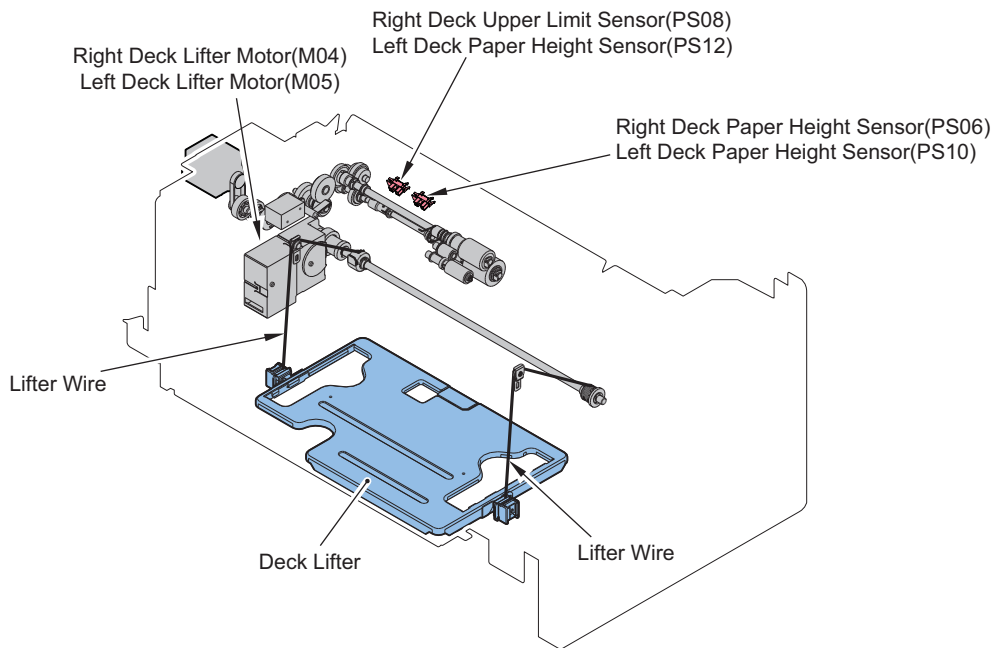


• Lifter Control

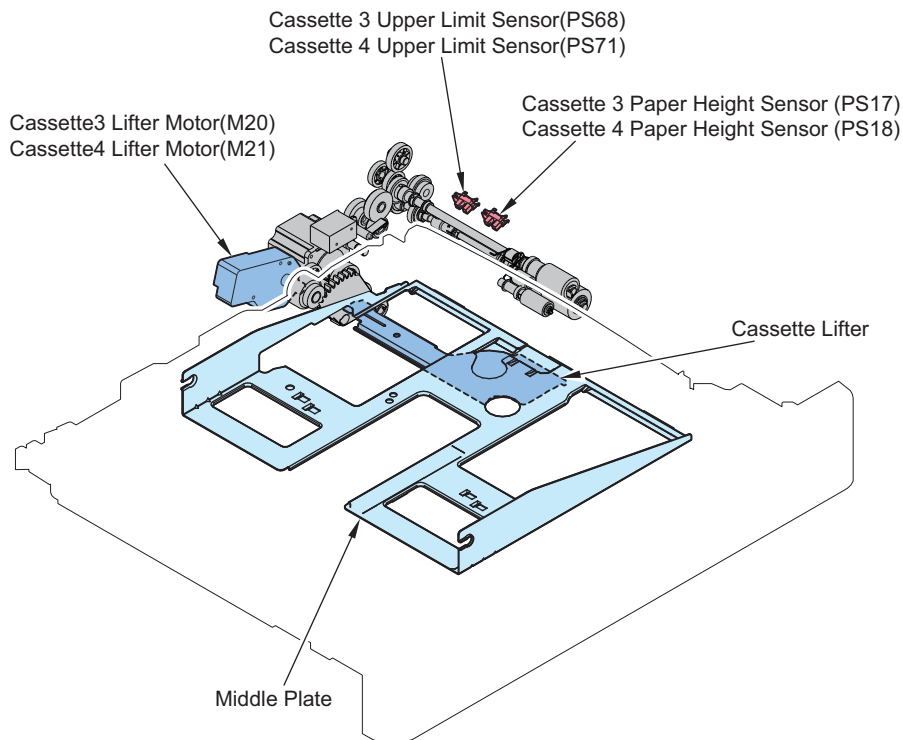
Paper is lifted to the pickup position by the Lifter.

In the machine configuration with the Deck / Cassette set, the Pickup Motor is driven to raise the Lifter to fit the paper level to the height of the pickup position. The Lifter is also raised when the Paper Level Sensor went OFF during the pickup operation.

Deck



Cassette



Lifter Error Detection

In case due to some reason the lifter keep ascending even the Paper Surface Height Sensor is turned ON, the Upper Limit Sensor is provided to prevent damage in this equipment due to the error in ascending.

And, if the lifter starts ascending, but not detected by the Paper Surface Sensor and the Upper Limit Sensor within 3 minutes, the alarm corresponds to the concerned Pickup Cassette will be triggered. The alarm will release if the corresponding deck/ cassette is open or closed, or the power is turned OFF/ON.

• Pickup Retry Control

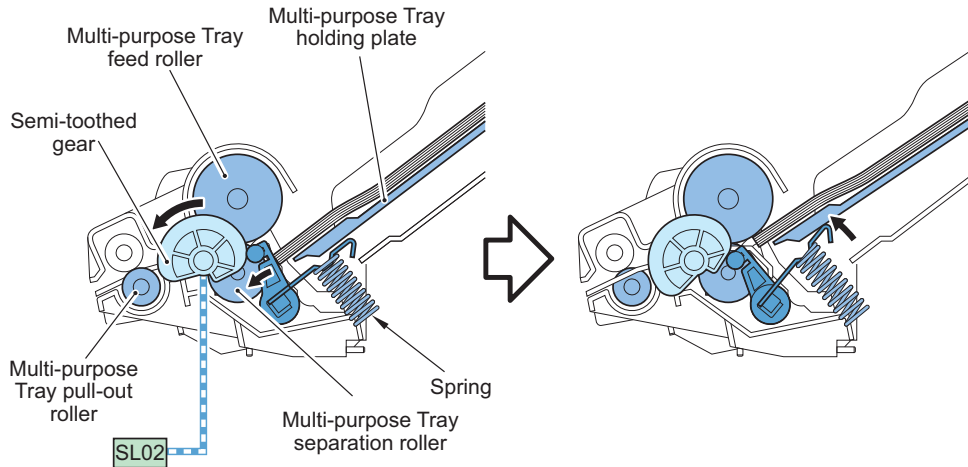
If paper leading edge is not detected by Pickup sensor within the specified time after pickup movement starts, it is not immediately determined as jam, and re-pickup movement will be executed.

During pickup retry, the Pickup Motor will be repeatedly turned ON/OFF with the Pickup Roller is in descended condition.

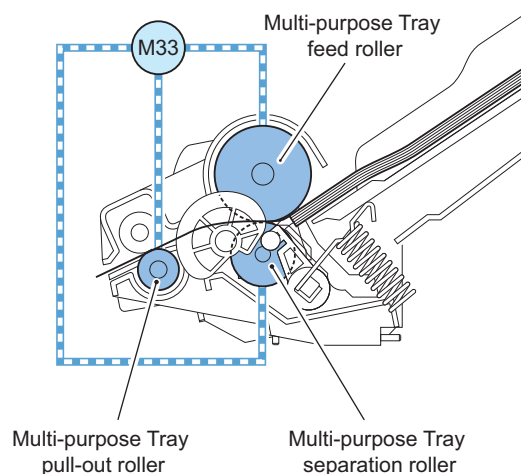
■ Multi-purpose Tray Pickup Unit

● Basic Movement

1. If the Multi-purpose Pickup Solenoid (SL02) is turned ON, the semi-toothed gear will rotate.
2. The holding plate Fixing Members will be released and the holding plate will ascend.

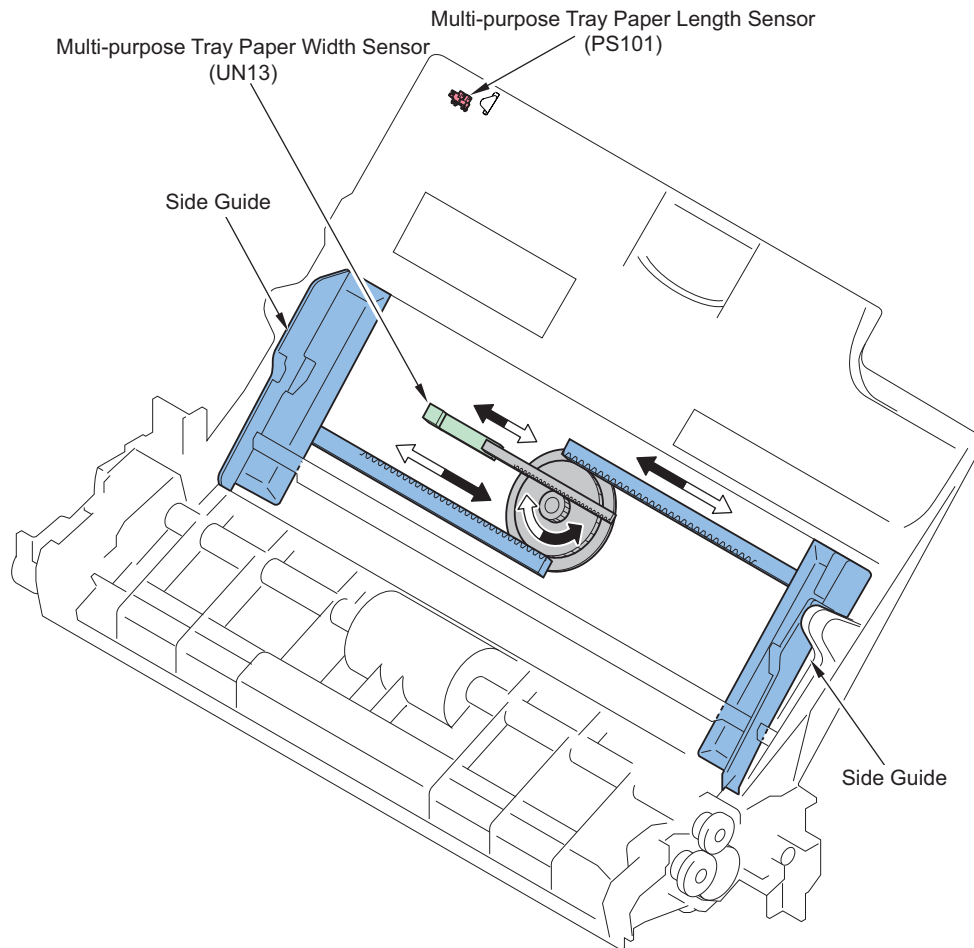


3. When the Pre-registration Multi-purpose Tray Drive Motor drives, the Multi-purpose Pull Out Roller and the Multi-purpose Feed Roller/Multi-purpose Separation Roller will rotate, and only 1 sheet of paper will be picked up/fed.



● Paper Size Detection

The paper width is detected according to the output value from the variable resistor (Multi-purpose Tray Paper Width Detection PCB (UN13)) driven by the Slide Guide movement. The Multi-purpose Tray Paper Length Sensor (PS101) detects paper length. Paper size is determined by paper width and the detection result of the Multi-purpose Tray Paper Length Sensor (PS101). Users should adjust the Slide Guides on the Multi-purpose Pickup Tray when loading the paper.



Size displayed is determined according to the auto-detected size (Multi-purpose Tray) setting for each country/region and the detection results of the 2 sensors.

Country/Region	Default setting
US	Inch size
CN	A/K Size
Other countries/regions	A/B size

Paper size	Paper width [mm]	Multi-purpose Tray Paper Width Sensor (UN13) detected width [mm]	Multi-purpose Tray Paper Length Sensor (PS101)	Displayed paper size		
				A/B size	Inch size	A/K Size
A3	297	293 to 303	ON	A3	12 x 18 / 11 x 17 / free	A3
A4	297	293 to 303	OFF	A4	LTR / free	A4
B4	257	253 to 263	ON	B4	11 x 17 / free	K8 / free
B5	257	253 to 263	OFF	B5	LTR / EXEC / free	K16 / free
A4R	210	206 to 216	ON/OFF	A4R	LGL / LTRR / free	A4R
B5R	182	178 to 188	OFF	B5R	Free	Free
A5R	148	144 to 154	OFF	A5R	STMTR / free	A5R
A6R	105	101 to 111	OFF	A6R	Free	A6R
11 x 17	279.4	275.4 to 285.4	ON	A3 / B4 / free	11 x 17	A3 / K8 / free
LTR	279.4	275.4 to 285.4	OFF	A4 / B5 / free	LTR	A4 / K16 / free
EXEC	266.7	262.7 to 272.7	OFF	B5 / free	EXEC	K16 / free
LGL	215.9	211.9 to 221.9	ON	A4R / free	LGL	A4R / free
LTRR	215.9	211.9 to 221.9	OFF	A4R / free	LTRR	A4R / free
STMTR	139.7	135.7 to 145.7	OFF	A5R / free	STMTR	A5R / free
K16	270	266 to 276	OFF	B5 / free	LTR / EXEC / free	K16
K8	270	266 to 276	ON	B4 / free	11 x 17 / free	K8
SRA3	-	-	-	Free	Free	Free

Paper size	Paper width [mm]	Multi-purpose Tray Paper Width Sensor (UN13) detected width [mm]	Multi-purpose Tray Paper Length Sensor (PS101)	Displayed paper size		
				A/B size	Inch size	A/K Size
12 x 18	-	-	-	A3 / free	Free	A3 / free
13 x 19	-	-	-	Free	Free	Free
Post-card	"Paper Settings" needs to be performed due to non-standard size.					
Custom size						

NOTE:

In the table above, the automatic size detection results shown with multiple sizes divided with "/" indicate any of the sizes may be detected depending on the position of the Slide Guides on the Multi-purpose Tray Pickup Tray.

e.g. If 11 x 17 paper is placed on the Multi-purpose Tray Pickup Tray under the A/B size setting, either A3, B4 or free size will be detected.

<Related service mode>

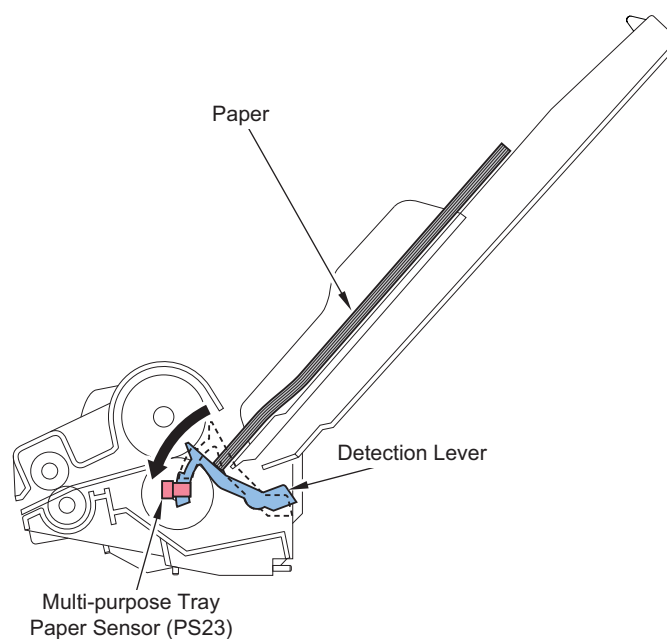
- Adjustment of Multi-purpose Tray A4R paper width
COPIER > ADJUST > CST-ADJ > MF-A4R
- Adjustment of Multi-purpose Tray A6R paper width
COPIER > ADJUST > CST-ADJ > MF-A6R
- Adjustment of Multi-purpose Tray A4 paper width
COPIER > ADJUST > CST-ADJ > MF-A4
- Registration of Multi-purpose Tray A4R standard width
COPIER > FUNCTION > CST > MF-A4R
- Registration of Multi-purpose Tray A6R standard width
COPIER > FUNCTION > CST > MF-A6R
- Registration of Multi-purpose Tray A4 standard width
COPIER > FUNCTION > CST > MF-A4

< Related user mode>

- Settings Menu > Preferences > Paper Settings > Paper Size Group for Auto Recognition in Drawer (Multi-purpose Tray)
Use this when changing the auto detection size for the Multi-purpose Tray.

• Paper Detection

When paper is set, Paper Presence Detection Lever will be pushed, and the Multi-purpose Tray Paper Sensor (PS23) will turn ON.

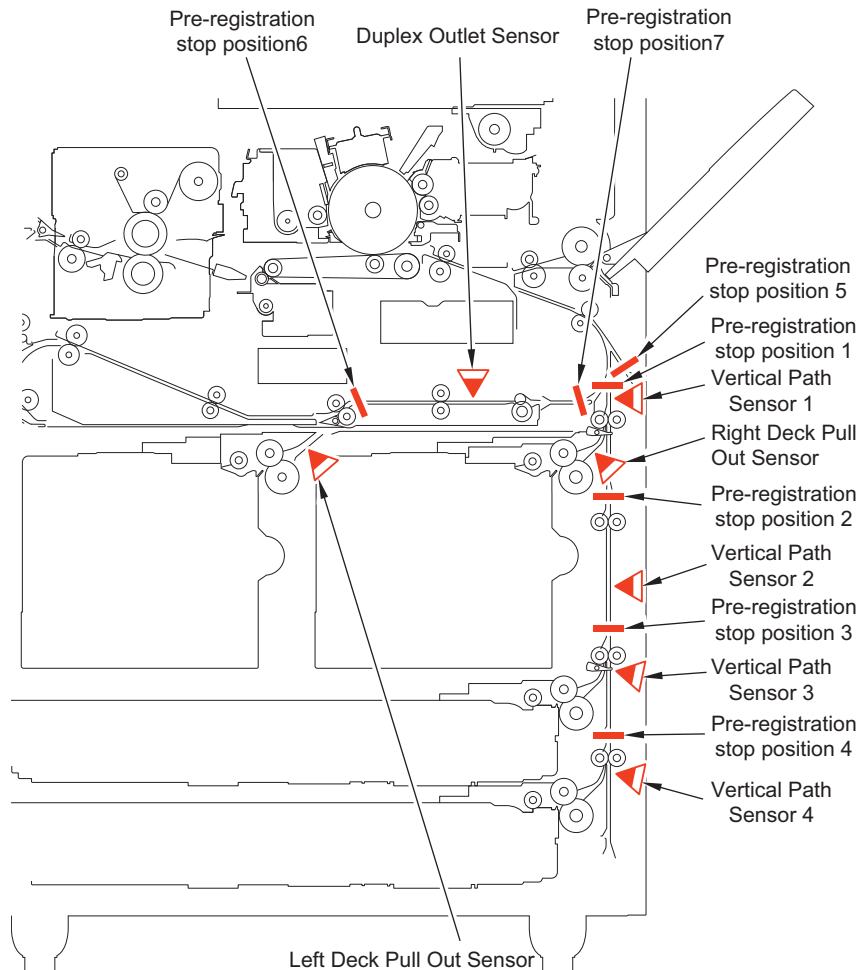


■ Registration Unit

● Pre-registration Control

Pickup processing time can vary depending on the paper type and paper size in use as well as the environment. Therefore, the machine executes pre-registration control to ease such variation.

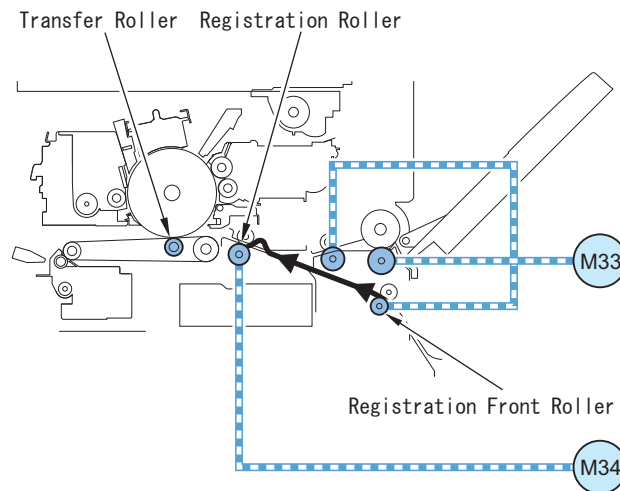
After the paper is picked up from the pickup cassette, the following reference sensor is used as a reference to feed the paper for a specified distance, and then the paper is stopped at the pre-registration position.



Stop position name	Pickup Assembly	Paper size	Reference sensor	Stop position
Pre-registration stop position 1	Right Deck	Size LTR (215.9mm)	Vertical Path Sensor1(PS24)	Vertical Path Roller 1 Downstream 10mm
	Cassette3			
	Cassette4			
Pre-registration stop position 2	Cassette3	LTRR=< Size =< A4R	Vertical Path Sensor2(PS25)	Vertical Path Roller 2 Downstream 10mm
	Cassette4			
Pre-registration stop position 3	Cassette3	11"x17"(431.8mm) < Size	Vertical Path Sensor3(PS26)	Vertical Path Roller 3 Downstream 10mm
	Cassette3 Cassette4	Size ≤ LTR LTRR < Size ≤ 11"x17"		
Pre-registration stop position 4	Cassette4	11"x17" < Size	Vertical Path Sensor4(PS27)	Vertical Path Roller 4 Downstream 10mm
Pre-registration stop position 5	OP Deck	All Size	Option Deck Pull Out Sensor	Vertical Path Upper Roller 1 Downstream 10mm
Pre-registration stop position 6	Left Deck	Size =< LTR	Left Deck Pull Out Sensor(PS33)	Duplex Merging Roller Downstream 10mm
Pre-registration stop position 7	Left Deck	Size =< LTR	Duplex Outlet Sensor(PS64)	Duplex Outlet Sensor(PS64) Downstream 10mm

• Registration Control

The Registration Motor (M34) is rotated to make the image on the drum and the paper to be aligned at the specified position and feeds the paper to the Transfer Assembly. The rotating speed of the Registration Motor (M34) is increased to be higher than the process speed and then reduced to meet the process speed.



<Related Service Mode>

Adjust register start timing

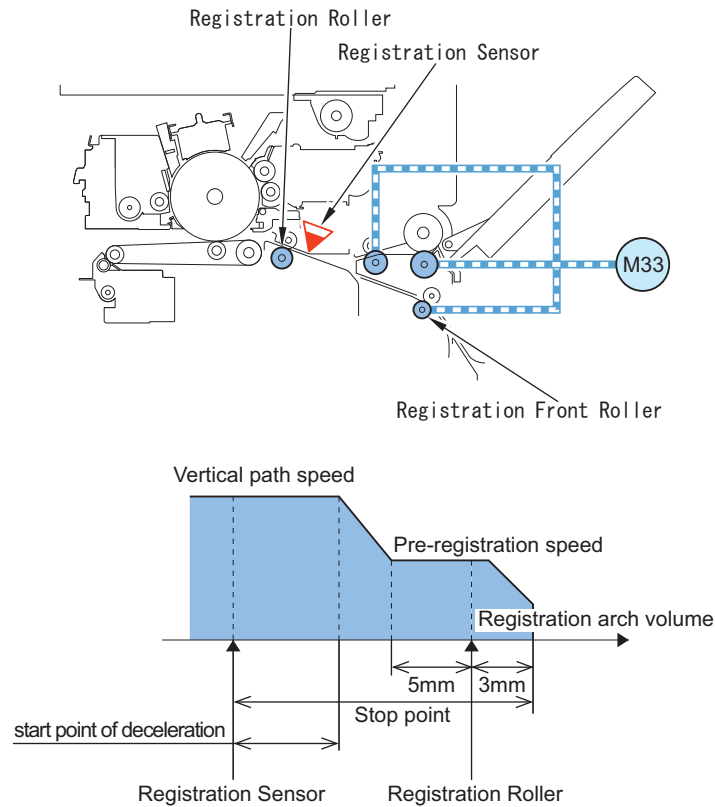
- Adjust register start timing: $\leq 90\text{g/m}^2$, 1st
COPIER > ADJUST > FEED-ADJ > REGIST
- Adjust register start timing: $\leq 90\text{g/m}^2$, MP Tray
COPIER > ADJUST > FEED-ADJ > RG-MF
- Adjust register start timing: $\geq 91\text{ g/m}^2$
COPIER > ADJUST > FEED-ADJ > REG-THCK
- Adjust register start timing: transparency, clear film
COPIER > ADJUST > FEED-ADJ > REG-OHT
- Adjust register start timing: $\leq 90\text{g/m}^2$, 2nd
COPIER > ADJUST > FEED-ADJ > REG-DUP1
- Adjust register start timing: $\geq 91\text{ g/m}^2$, 2nd
COPIER > ADJUST > FEED-ADJ > REG-DUP2

Adjust pre-registration arch amount

- Adjust pre-registration arch amount: cassette, $\leq 90\text{g/m}^2$
COPIER > ADJUST > FEED-ADJ > LP-FEED1
- Adjust pre-registration arch amount: cassette, $\geq 91\text{g/m}^2$
COPIER > ADJUST > FEED-ADJ > LP-FEED2
- Adjust pre-registration arch amount: MP Tray, $\leq 90\text{g/m}^2$
COPIER > ADJUST > FEED-ADJ > LP-MULT1
- Adjust pre-registration arch amount: MP Tray, $\geq 91\text{g/m}^2$
COPIER > ADJUST > FEED-ADJ > LP-MULT2
- Adjust pre-registration arch amount: 2-side, $\leq 90\text{g/m}^2$
COPIER > ADJUST > FEED-ADJ > LP-DUP1
- Adjust pre-registration arch amount: 2-side, $\geq 91\text{g/m}^2$
COPIER > ADJUST > FEED-ADJ > LP-DUP2

• Registration Deceleration Control

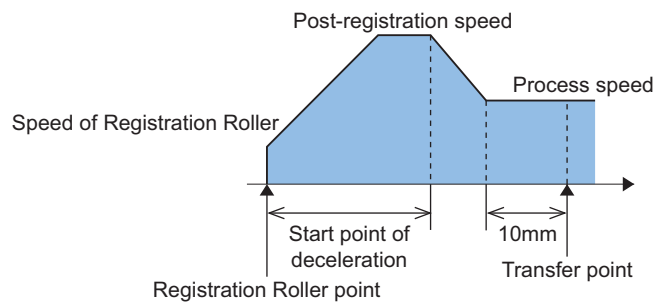
This control reduces speed of Multi-purpose Tray Registration Front Motor (M33) (Registration feed speed) by using Registration Sensor (PS29) as a reference and pushes the paper against the Registration Roller to reduce hitting noise.



Print speed [ppm]	105	95	85
Vertical path speed [mm/s]		750	
Registration feed speed [mm/s]		500	
start point of deceleration[mm]		4.5	
stop point [mm]	23 (20(distance between the Registration Sensor and the Registration Roller)+3(registration arch volume))		

• Registration Acceleration Control

The Registration Motor (M34) is rotated to make the image on the drum and the paper to be aligned at the specified position and feeds the paper to the Transfer Assembly. The rotating speed of the Registration Motor (M34) is increased to be higher than the process speed and then reduced to meet the process speed.



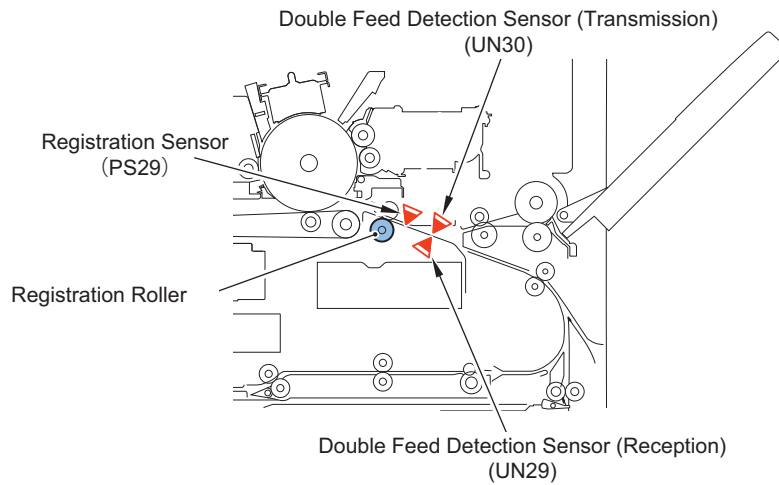
Print speed [ppm]	105	95	85
Post-registration speed[mm/s]		750	
Process speed[mm/s]		500	
start point of deceleration[mm]		45.5	

• Double Feed Detection (Option)

The Double Feed Sensors (Transmission/Reception) (UN29/UN30) are available as options for this machine to detect double feeding of paper.

The Double Feed Sensors (Transmission/Reception) (UN29/UN30) using ultrasonic method that are located in front of the Registration Roller perform double feed detection. Once it is judged that double feed has occurred, the machine stops operation due to a jam.

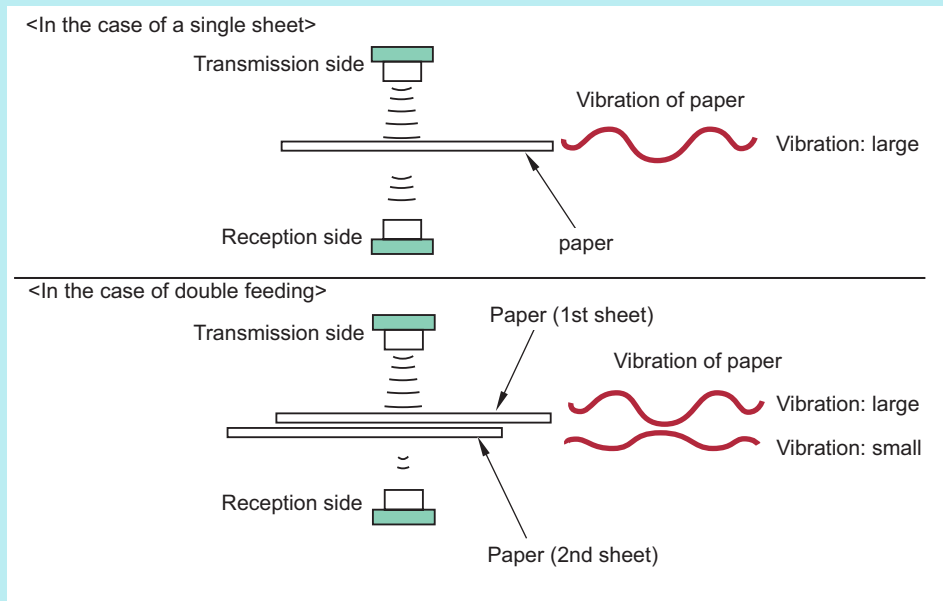
The sensors check the sensor level at the start of a job while there is no original and calculate the threshold value of double feed detection. Every time paper activates the Registration Sensor (PS29), detection is performed after the specified period of time has passed and the detection result is compared with the threshold value at the start of a job to judge whether double feed occurs.



NOTE:

With the ultrasonic method, the oscillation portion emits ultrasonic wave to the paper surface. In the result, new ultrasonic wave is generated as the paper vibrates, and the reception side reads the ultrasonic wave.

When double feed occurs, pitch of the vibration of the 2nd paper becomes low. The sensor uses the difference in pitch of the vibration to perform double feed detection.



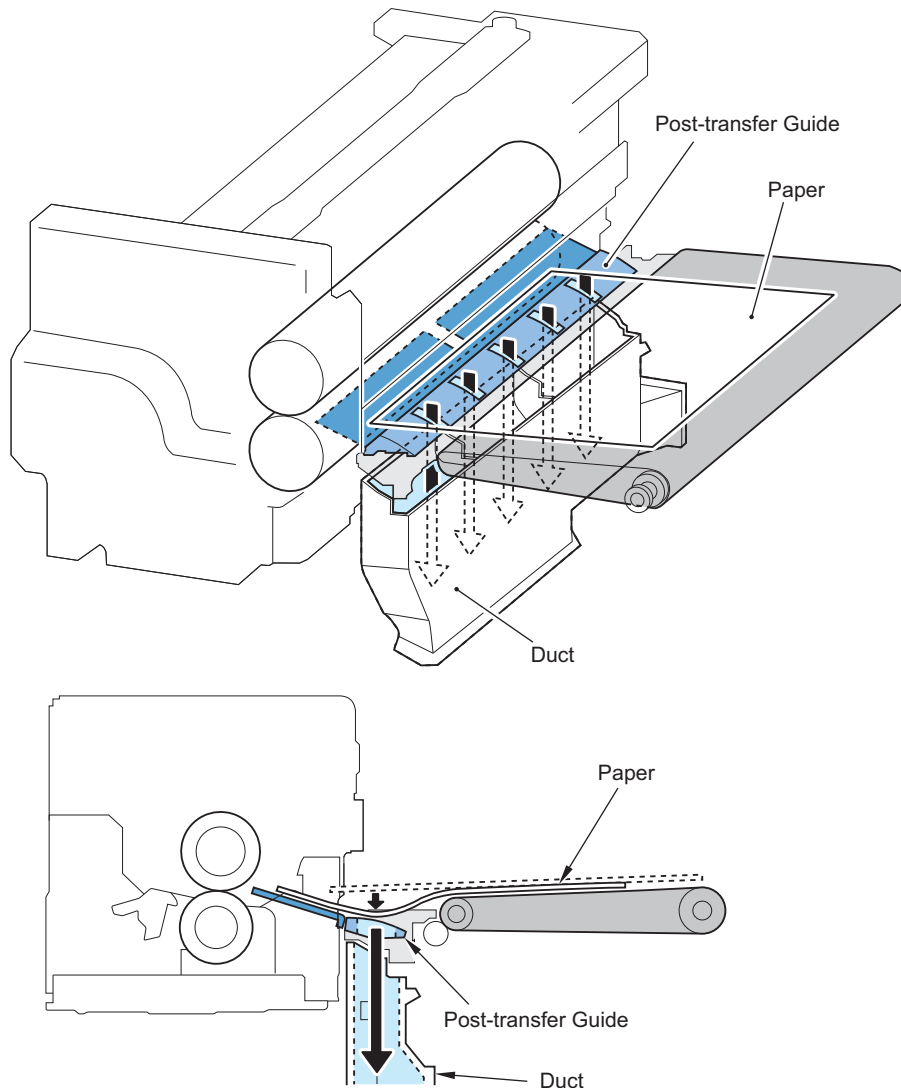
<Related Service Mode>

- ON/OFF of double feed detection (Lv.2)
COPIER > OPTION > FNC-SW > D-FDS-SW
- Operation check of Double Feed Sensor
COPIER > FUNCTION > PART-CHK > D-FDS
- Display Double Feed Detection Kit version
COPIER > DISPLAY > VERSION > D-OVLP

■ Transfer

● Post-transfer Guide Attraction Control

With this machine, paper is attracted to the Post-transfer Guide by exhaust from the Image Formation System Exhaust Fan (FM01). Therefore, behavior of papers between transfer and fixing becomes stable, which increase the paper feed capabilities.



■ Delivery/Reverse Unit

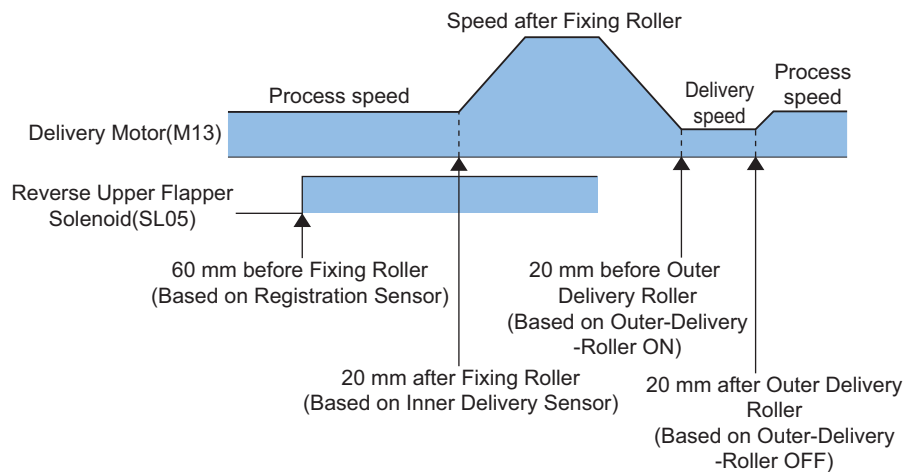
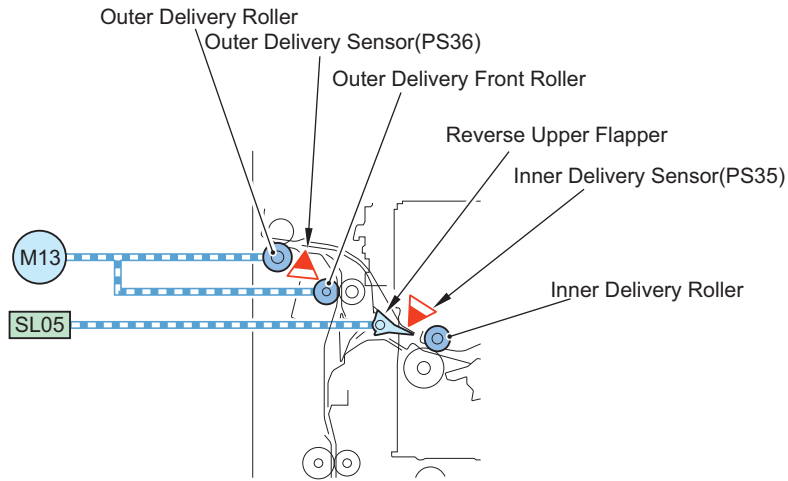
● Basic Operation

Face-up Delivery

1. The Reverse Upper Flapper Solenoid (SL05) is turned ON to switch the feeding path to the Delivery Assembly side.
2. Rotating speed of the Delivery Motor (M13) is increased once the paper's trailing edge passes through the Fixing Roller (fixing-through speed)
3. Feeding speed is reduced to meet the delivery speed once the paper's trailing edge reaches the specified position.

NOTE:

Delivery speed is changed according to the paper size. Delivery speed remains the same if delivery option is connected.



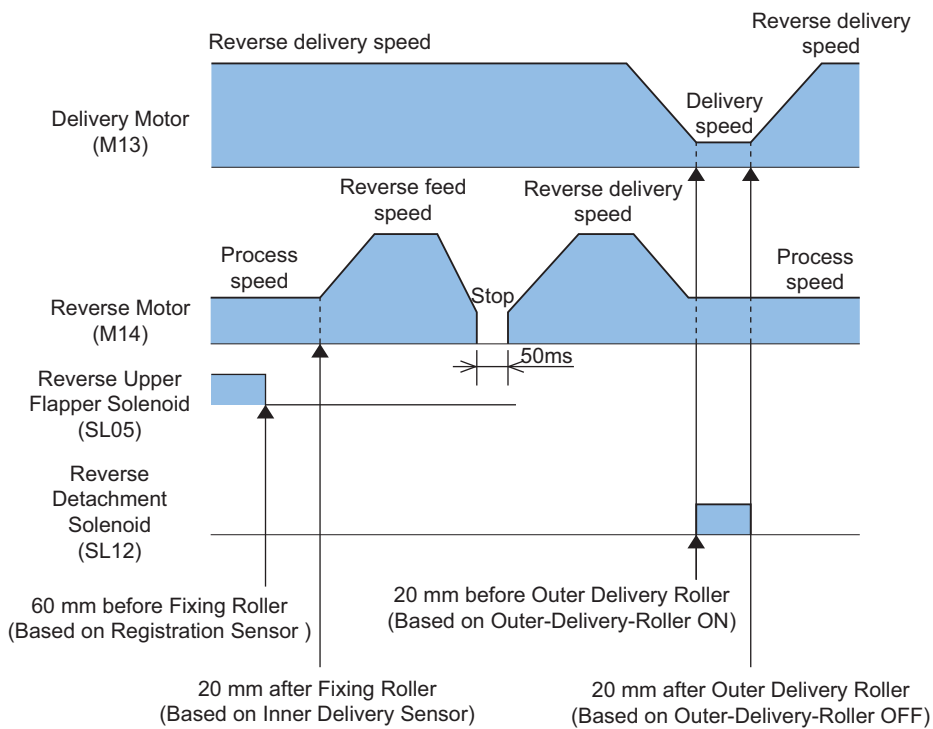
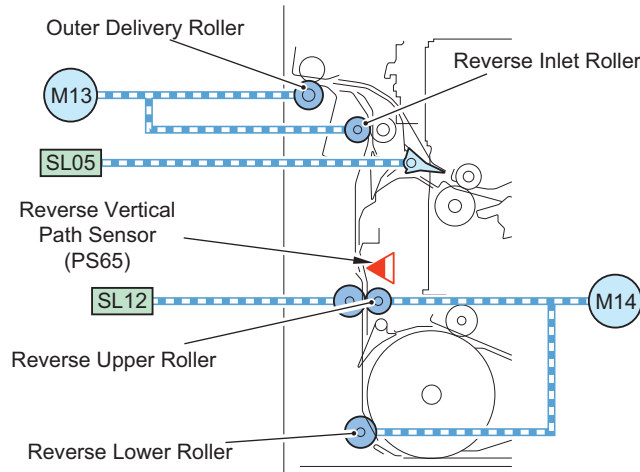
Print speed [ppm]	105	95	85
Process speed [mm/s]		500	
Speed after Fixing Roller[mm/s]		500	
Delivery speed [mm/s]		500	

Face-down Delivery

1. The Reverse Upper Flapper Solenoid (SL05) is turned OFF to switch the feeding path to the Delivery Assembly side.
2. Rotating speed of the Reverse Motor (M14) is increased (reverse feed speed) once the trailing edge of the preceding paper passes through the Fixing Roller to make the paper stopped/rotate reversely at the reverse position (reverse delivery speed)
3. In the case that the paper size is B5R or larger, once the leading edge of the preceding paper reaches the Outer Delivery Roller, the Reverse Detachment Solenoid (SL12) is turned ON to be prepared for entry of the succeeding paper and make the Reverse Roller disengaged.
4. Succeeding paper is fed to the reverse path to make the Reverse Motor (M14) stopped/rotate normally.
5. In the case that the paper size is B5R or larger, once the trailing edge of the preceding paper passes through the Reverse Upper Roller, the Reverse Detachment Solenoid is turned OFF to make the Reverse Upper Roller engaged.
6. Succeeding paper is fed to the reverse stop position.
7. Once the trailing edge of the preceding paper reaches the specified position, rotating speed of the Delivery Motor (M13) is reduced.

NOTE:

Delivery speed is changed according to the paper size. Delivery speed remains the same if delivery option is connected.

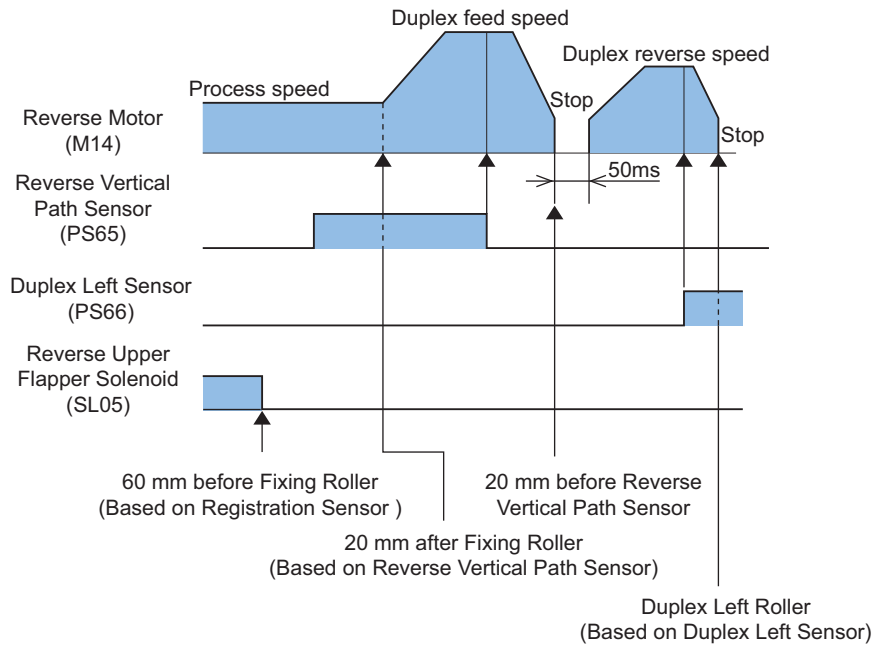
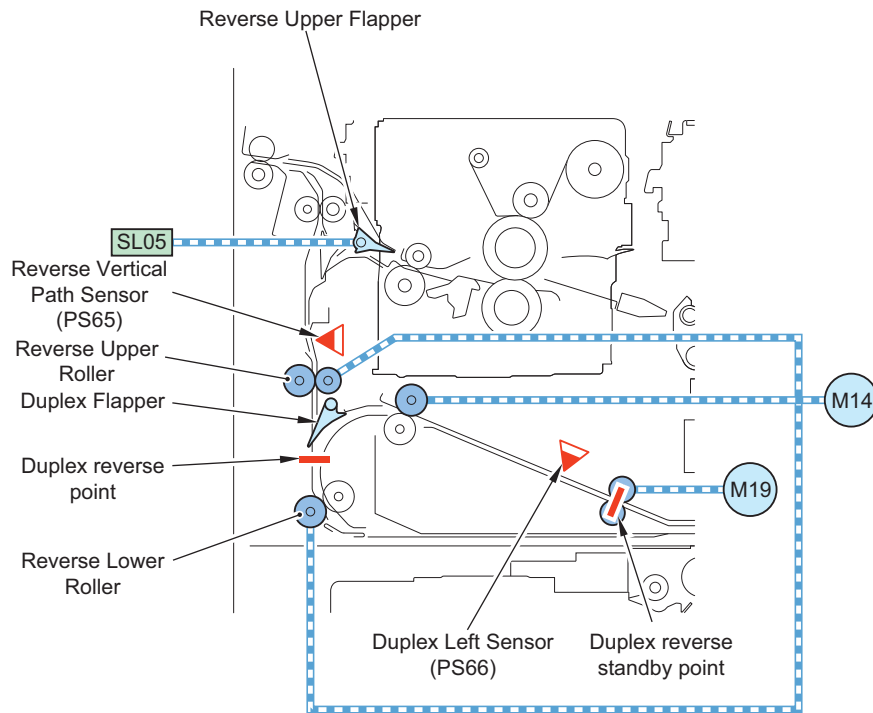


Print speed [ppm]	105	95	85
Process speed [mm/s]		500	
Reverse feed speed [mm/s]		1100	
Reverse delivery speed [mm/s]		1100	
Delivery speed [mm/s]		1100	

■ Duplex Unit

● Basic Operation

1. The Reverse Upper Flapper Solenoid (SL05) is turned OFF to switch the feeding path to the Reverse Assembly side.
2. When the paper's trailing edge passes through the Fixing Roller, rotating speed of the Reverse Motor (M14) is increased (duplex pull-in speed) to make the paper stopped at the duplex reverse position.
3. The Reverse Motor is driven by the duplex pull-in speed to feed the paper to the Duplex Assembly (the flapper feeds the paper to the Duplex Assembly). Then, the Duplex Left Sensor (PS66) detects the paper's leading edge, and the paper is fed for a specified distance to stop at the position of Duplex Left Roller.



Print speed [ppm]	105	95	85
Process speed [mm/s]		500	
Duplex feed speed [mm/s]		1100	
Duplex reverse speed [mm/s]		750	
Duplex delivery speed [mm/s]		750	

• Side Registration Control

In the case of printing the 2nd side of the 2-sided print, side registration displacement level is measured to adjust the write start timing and correct side registration.

<Execution timing>

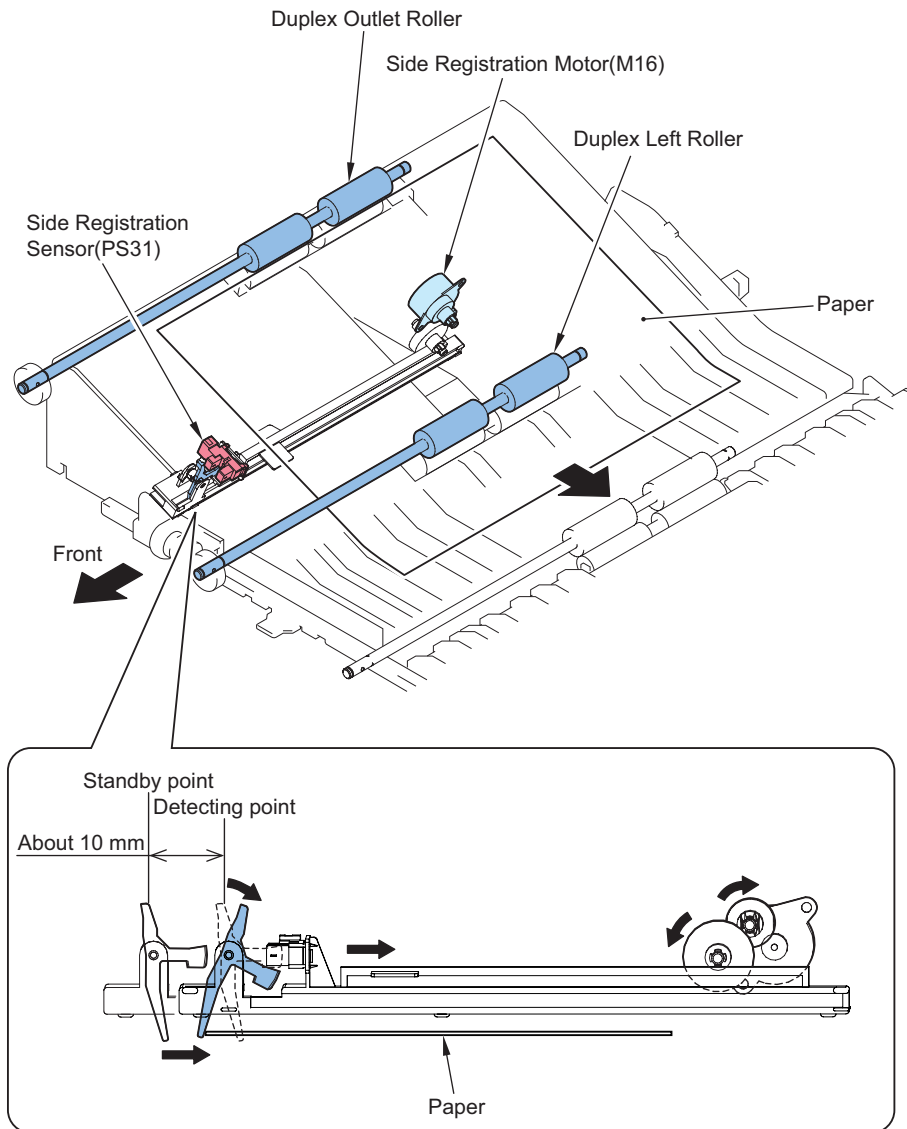
When the paper is stopped at the duplex standby position

<Control description>

Side Registration Sensor (PS31) detects side registration.

The side registration control executes detection of the home position as well as operation and detection of the standby position.

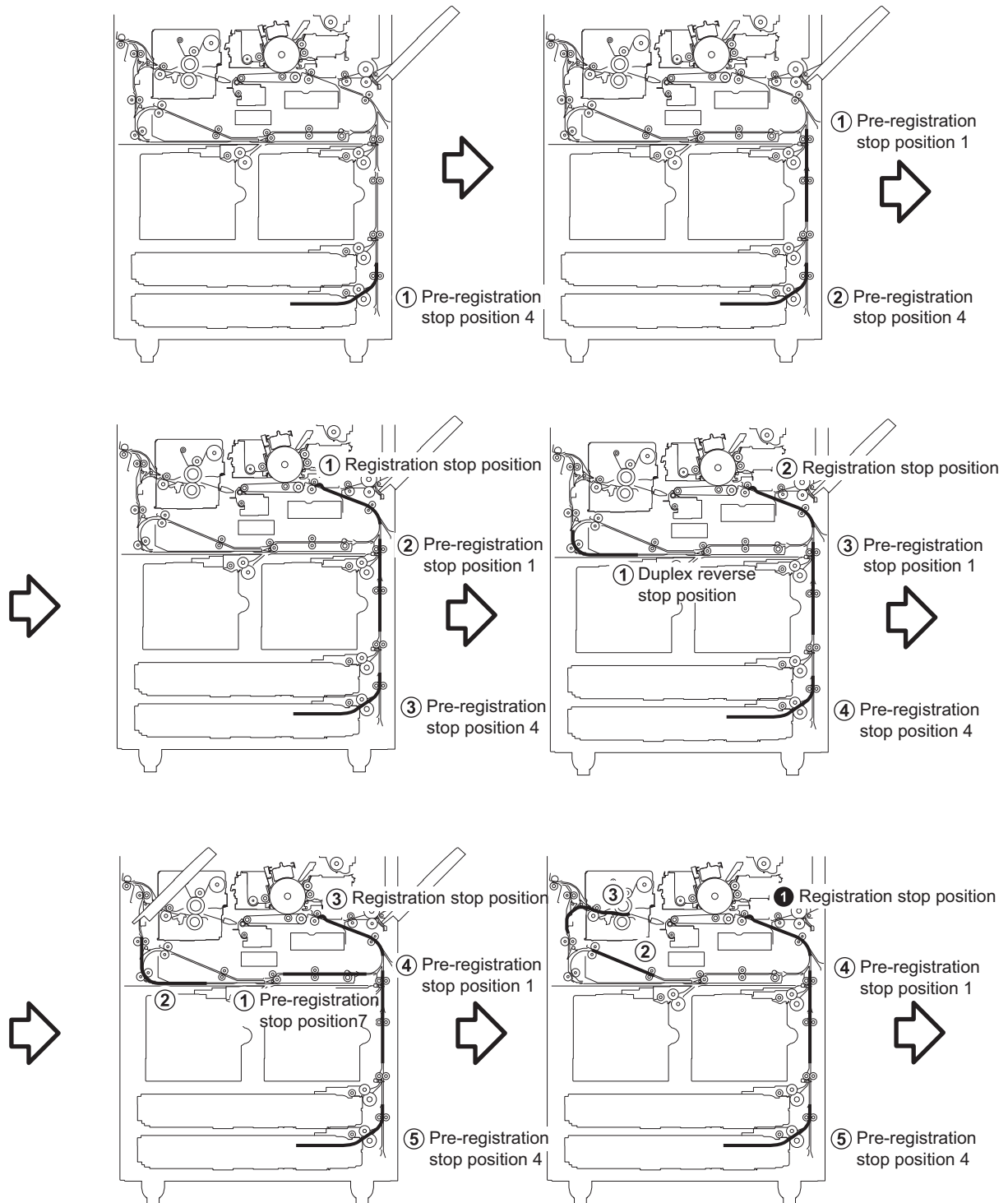
1. Home position operation
 Side Registration Unit is moved to the home position.
 Home position: at 13mm from the nominal dimension of A4 size
 Timing
 - When the main power is turned ON/when the Front Cover is closed/at the recovery from JAM process/at job completion
2. Standby position operation
 The unit is moved to the side registration standby position (10 mm front) corresponding the paper size.
3. Detection operation
 The Side Registration Motor (M16) is driven until Side Registration Sensor(PS31) is turned OFF to detect side registration displacement level from the travel distance.
4. The displacement level measured for side registration correction is converted into pixels to adjust the laser write start timing according to the displaced direction.
 The write start timing is pushed forward when the paper is displaced to the front.
 The write start timing is pushed back when the paper is displaced to the rear.

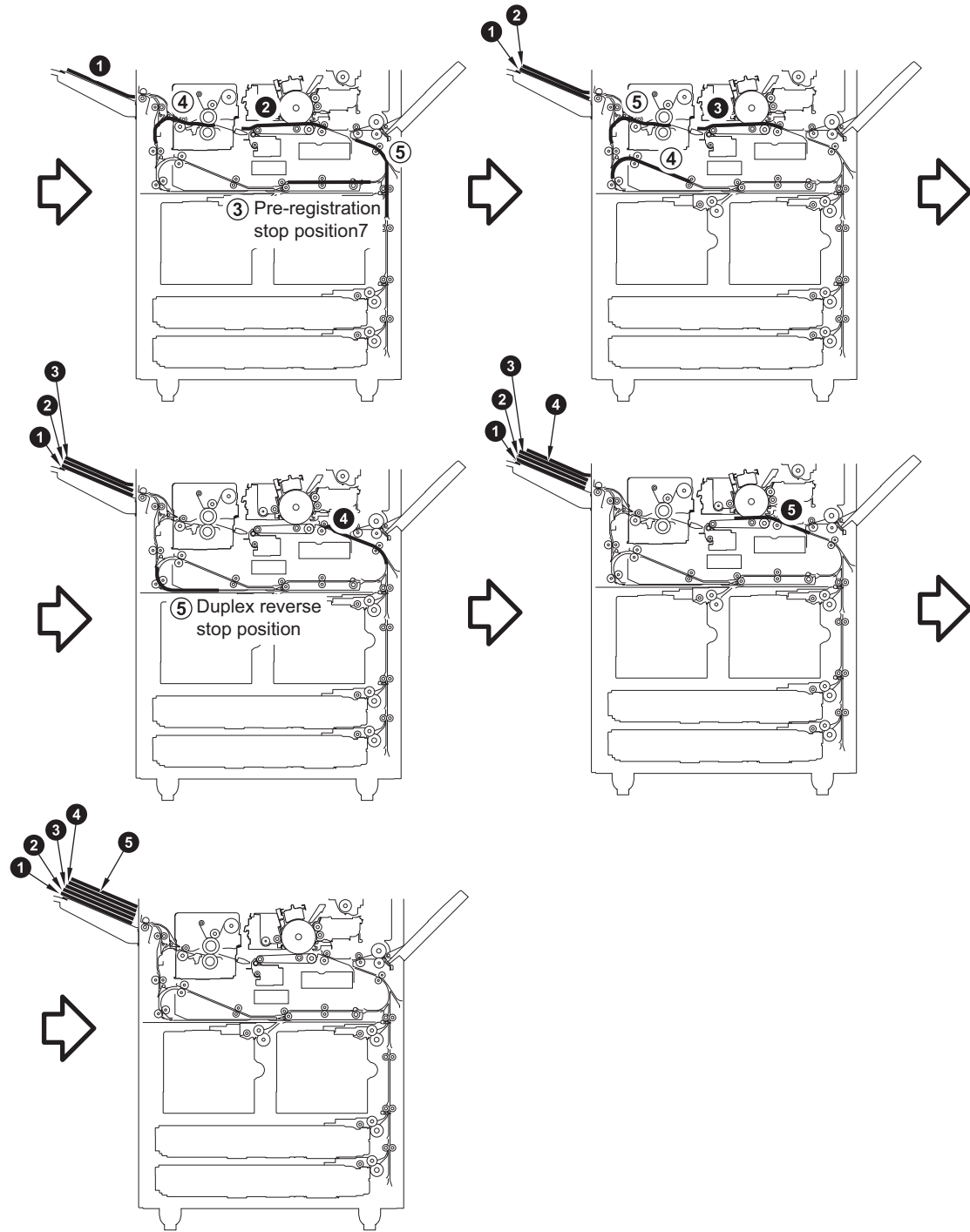


• **Circulation quantity and limit**

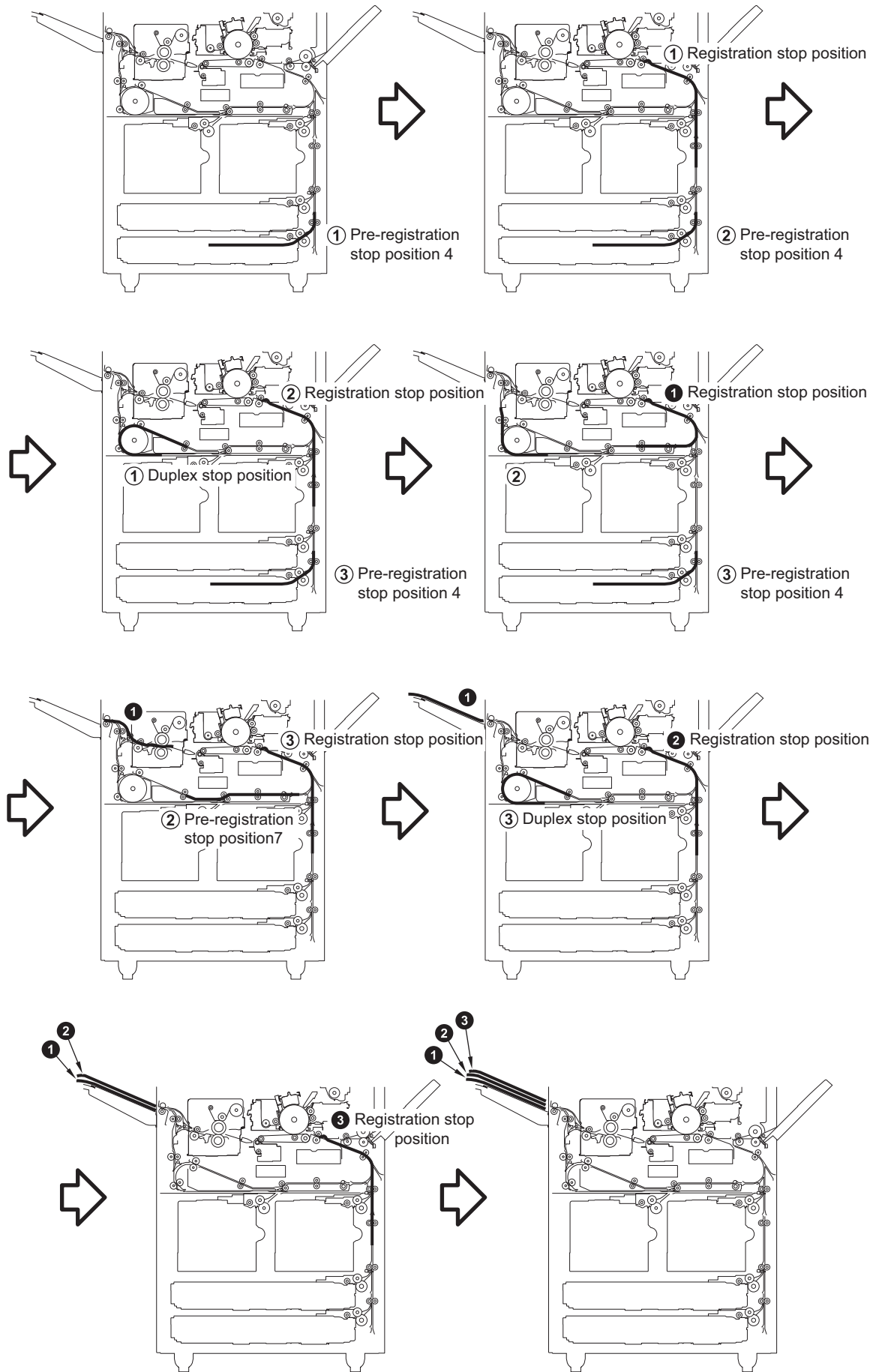
The numbers in white background and the numbers in black background show each the first page and second page.

Less than 314 mm in size/5 sheets in circulation (B5 to A4R)



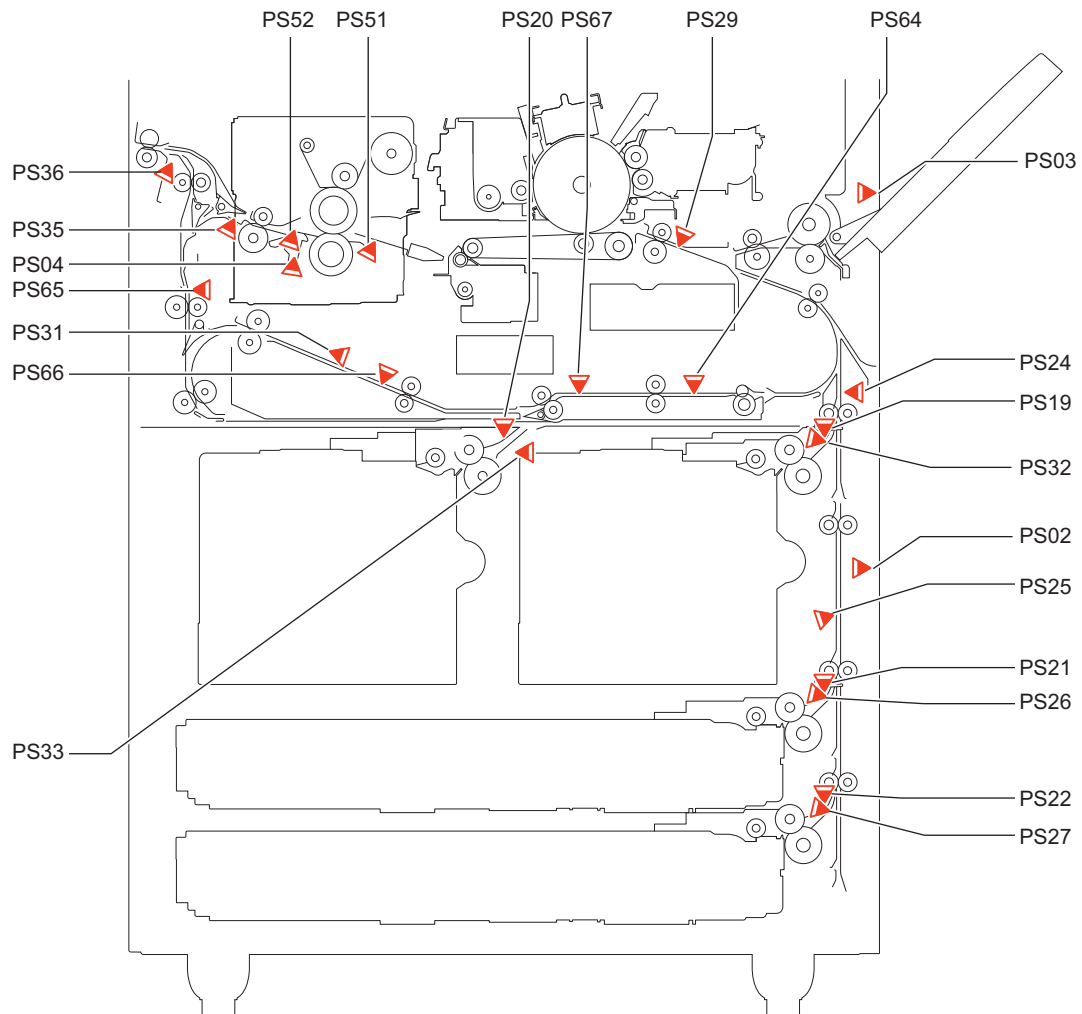


Exceeds 314 mm in size/3 sheets in circulation (B4 to 19.2 inch(483.0mm))



■ Jam Detection

● Jam Code List



Jam in Feed System

xx = 01: Delay, 02: Stationary, 0A: Residue

Yes: Detects, -: Does not detect

Sensor No.	Sensor name		Jam type		
			Delay	Stationary	Residue
xx01	PS19	Right Deck Pickup Sensor	Yes	-	
xx02	PS32	Right Deck Pull Out Sensor	Yes	Yes	Yes
xx03	PS24	Vertical Path Sensor1	Yes	Yes	Yes
xx04	PS28	Writing Judging Sensor	Yes	Yes	Yes
xx05	PS29	Registration Sensor	Yes	Yes	Yes
xx06	PS20	Left Deck Pickup Sensor	Yes	-	-
xx07	PS33	Left Deck Pull Out Sensor	Yes	Yes	Yes
xx08	PS67	Duplex Merging Sensor	Yes	Yes	Yes
xx09	PS64	Duplex Outlet Sensor	Yes	Yes	Yes
xx0A	PS21	Cassette 3 Pickup Sensor	Yes	-	-
xx0B	PS26	Vertical Path Sensor3	Yes	Yes	Yes
xx0C	PS25	Vertical Path Sensor2	Yes	Yes	Yes
xx0D	PS22	Cassette 4 Pickup Sensor	Yes	-	-
xx0E	PS27	Vertical Path Sensor4	Yes	Yes	Yes
xx0F	PS51	Fixing Inlet Sensor	-	-	Yes
xx10	PS04	Fixing Toenail Jam Sensor	-	-	Yes
xx11	PS52	Fixing Outlet Sensor	Yes	-	Yes

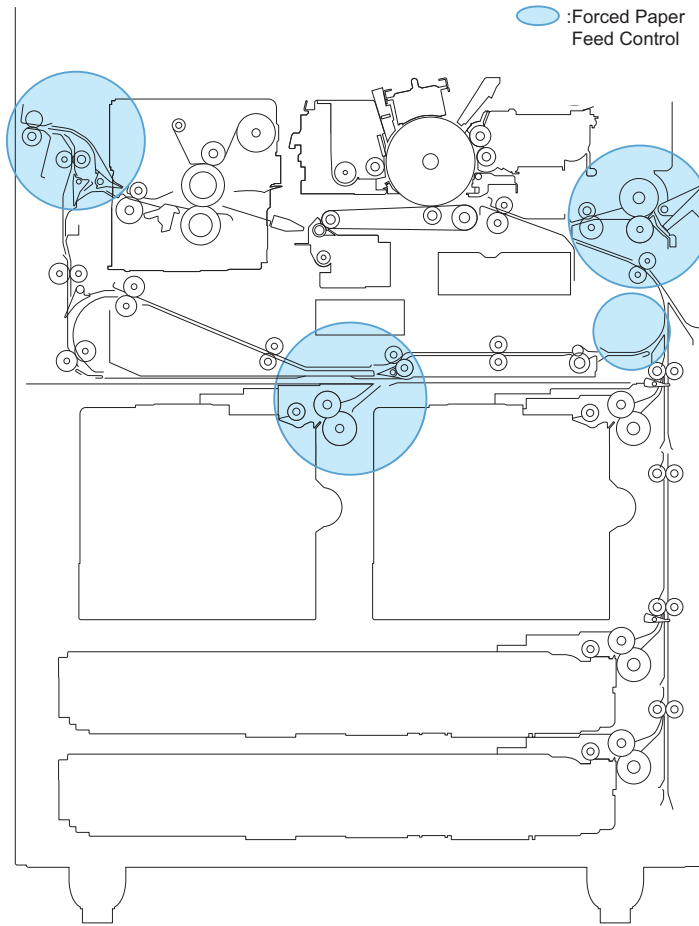
Sensor No.	Sensor name		Jam type			
			Delay	Stationary	Residue	
xx12	PS35	Inner Delivery Sensor	Yes	Yes	Yes	
xx13	PS36	Outer Delivery Sensor	Yes	Yes	Yes	
xx14	PS65	Reverse Vertical Path Sensor	Yes	Yes	Yes	
xx15	PS66	Duplex Left Sensor	Yes	Yes	Yes	
xx17	PS1	Deck Pickup Roller	Paer Deck / POD Deck	Yes	-	-
xx18	PS6	Deck Pull Out Sensor	Paer Deck / POD Deck	Yes	Yes	Yes
0305	PS29	Registration Sensor	early timing jam			

Other Jams

Sensor No.	Sensor name		Jam type
0B01	SW02	Front Door Open Detection Switch	Door Open jam
0B02	PS03	Vertical Path Cover Open/Close Sensor	Door Open jam
0B03	PS02	Multi-purpose Cover Open/Close Sensor	Door Open jam
0C10	PS04	Fixing Toenail Jam Sensor	Fixing Toenail jam
0CA1	-	FeedSts time out jam	REFEED command is not received. (Former: E240-0001)
0CA2	-	RefeedStart time out jam	RefeedStart command is not received. (Former: E240-0002)
0CA3	-	ImageSet time out jam	ImageSet command is not received. (Former: E240-0003)
0CA4	-	PageComplete time out jam	PageCompletemcommand is not received. (Former: E240-0004)
0CA5	-	Fixing temperature control time out jam	-
0CAF	-	Finisher time out jam	Erroneous communication with finisher.
0CF1	-	Retry jam	An error avoidance jam occurs when an error in the machine (excluding parts failure) was detected. it is detected as an error if the same symptom occurs again after the first retry.
0D91	-	Size error jam	A size error jam occurs when the difference between the paper length detected by the Cassette Guide Plate/specified on the Control Panel and the length measured by the Registration Sensor is out of the specified range.
0300	UN29	Double Feed Detection Sensor (Reception)	Double Feed jam
	UN30	Double Feed Detection Sensor (Transmission)	

• Forced Paper Feed Control

If there is paper in the following place after jam is detected, the paper will be forcedly fed to downstream direction. This control suppresses paper damage during jam handling.

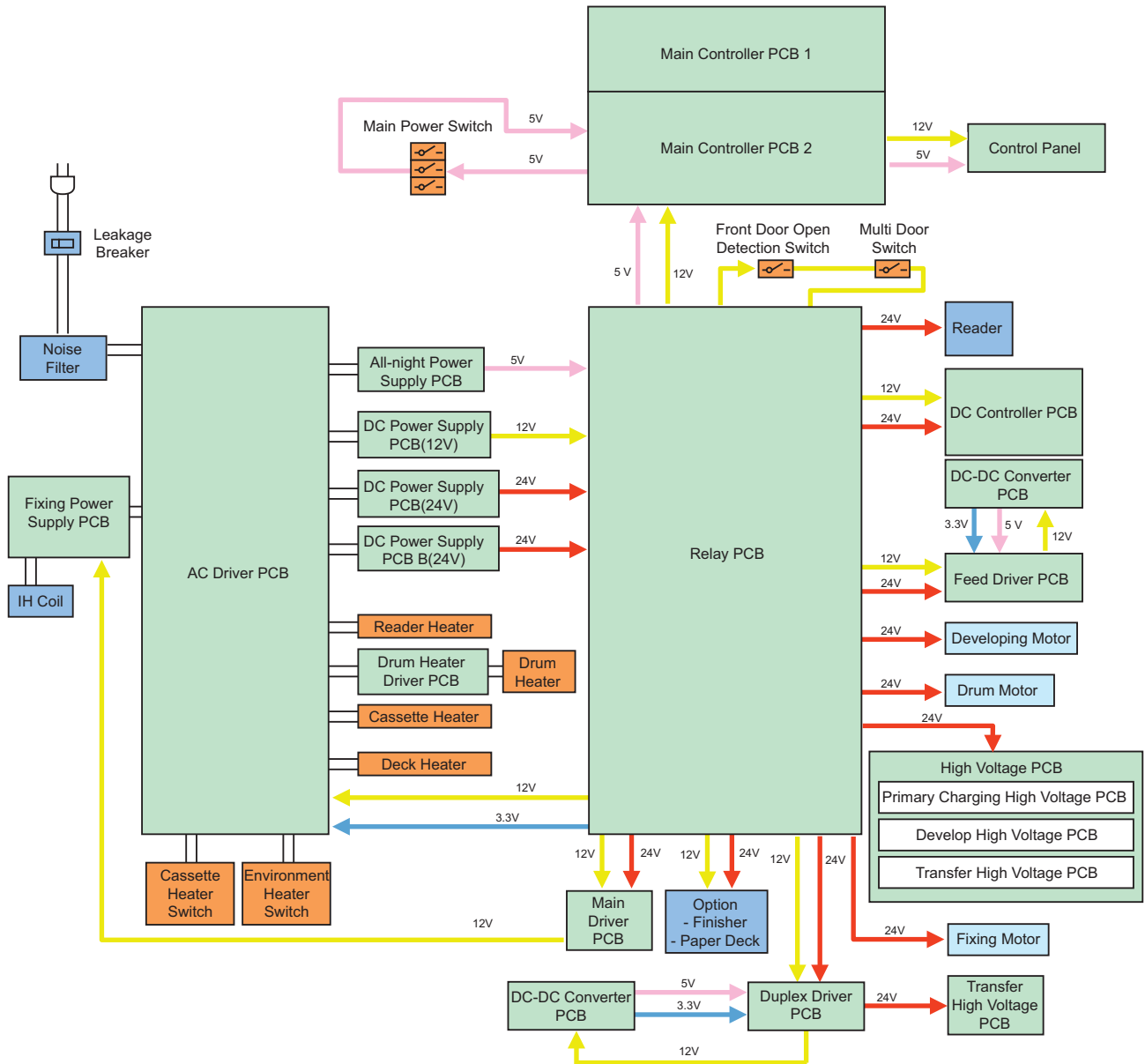


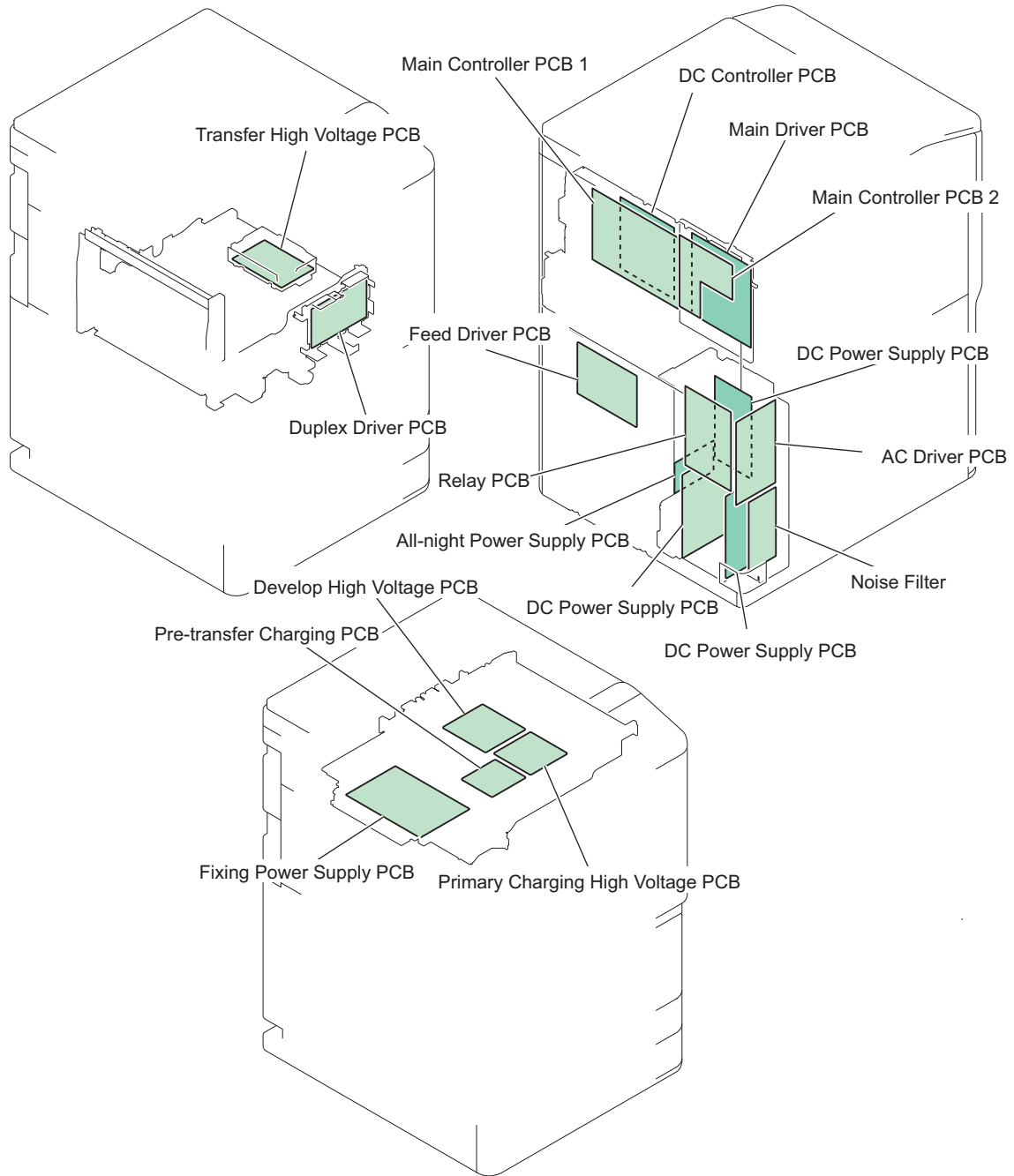
External Auxiliary System

Overview

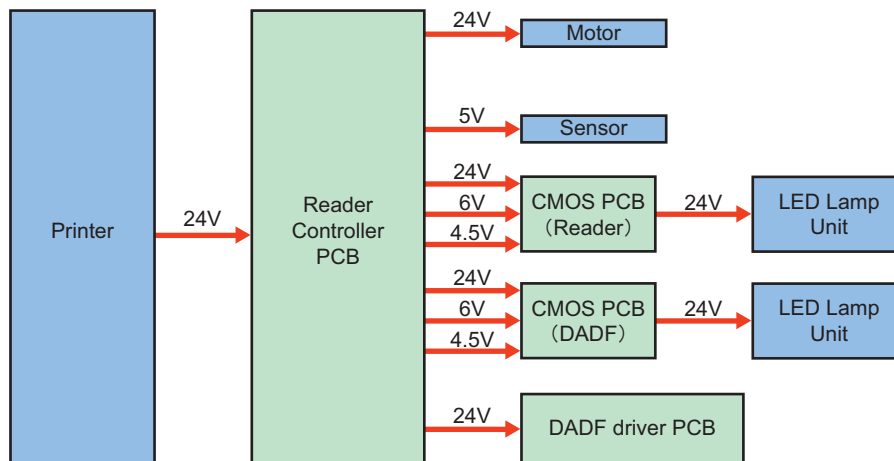
■ Power Supply Configuration

● Power Supply Configuration Inside the Host Machine





• Power Configuration of the Reader Unit



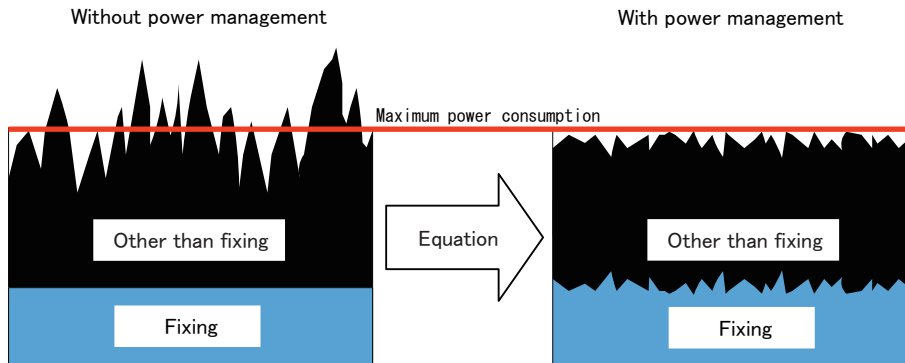
Controls

■ Power supply control

● Electric Power Management

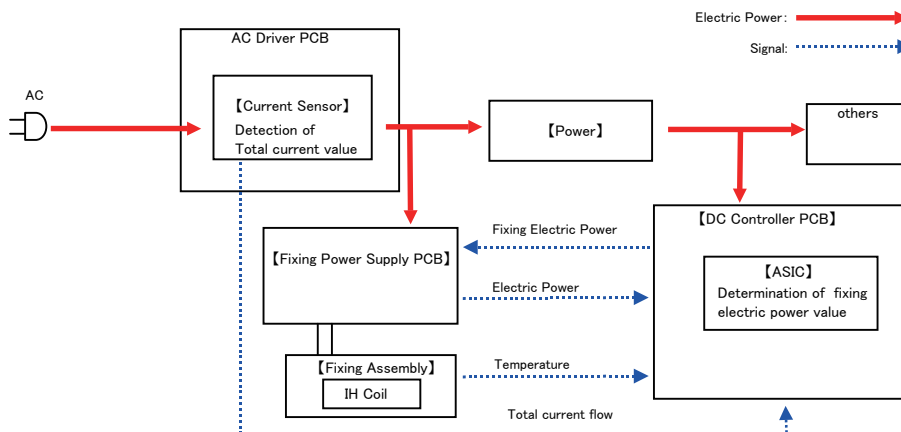
<Over View>

By equating the electric power in the machine, the maximum power consumption is reduced in comparison with the conventional models (iR7105/7095/7086 series).



<Control description>

This machine executes electric power management to prevent temporary power shortage. The electric power management detects current value of the entire product with the Current Sensor. In the case that the current value is likely to exceed the electric power reference value, the DC Controller temporarily reduces electric power supply to the fixing area to compensate for power shortage.



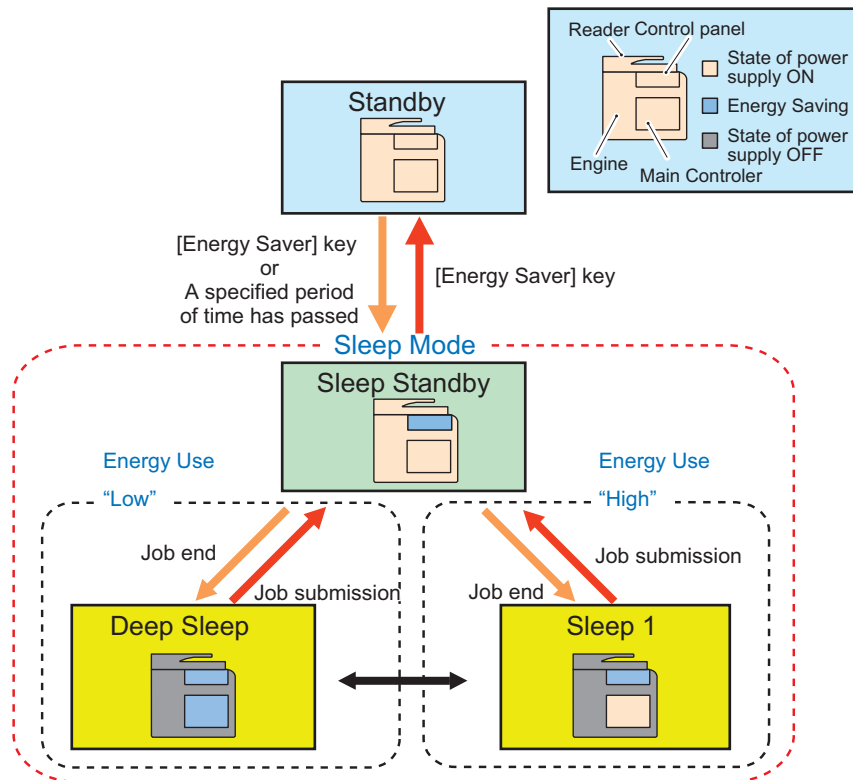
Current Sensor : Converts the flux occurred by current to the voltage.

● Power-saving Function

Overview

This machine has the following power supply mode: "Standby" and "Sleep".

"Sleep" is further divided into the following 5 modes: "Sleep Standby", "Sleep 1", "Sleep 1 (when [Consider Network Connection] is enabled)", "Sleep Exit", and "Deep Sleep".



*The time specified in Settings/Registration> Preferences> Timer/Energy Settings> Auto Sleep Time

Standby

The state where the machine is operating or can start operation immediately and all the power is supplied.

The machine enters Sleep mode when the [Energy Saver] key on the Control Panel is pressed or the specified period of time has passed.

The machine enters this mode when the Touch Panel Display on the Control Panel is tapped during Sleep Standby.

Sleep Standby

The state where only the Control Panel is turned OFF and power is supplied to all the other parts.

The machine enters Deep Sleep/Sleep 1 if there is no job after checking whether there is a job.

The machine enters this mode when a job is submitted during Sleep (Deep Sleep/Sleep 1).

Sleep 1

The state where the Control Panel is turned OFF and power is supplied only to the processing circuitry for the printer and scanner.

The All-night/Non-all-night Power Supply is supplied to the controller.

The machine enters this mode from Sleep Standby during Sleep if Sleep Mode Energy Use is set "High" in Settings/Registration > Preferences > Timer/Energy Settings > Sleep Mode Energy Use.

The machine enters Sleep Standby when a job is submitted during this mode.

The machine enters Standby when the Touch Panel Display on the Control Panel is tapped during this mode.

Sleep 1 (when [Consider Network Connection] is enabled)

The state where the Control Panel is turned OFF and only the All-night Power (5 V) is supplied to the printer/scanner/controller. This mode should be selected in advance in order to allow the machine to respond to requests for exiting Sleep from external sources such as faxes or the network.

The machine enters Sleep Standby when a job is submitted during this mode.

The machine enters Standby when the Touch Panel Display on the Control Panel is tapped during this mode.

CAUTION:

The machine can enter this mode if Settings/Registration > Preferences > Timer/Energy Settings > Sleep Mode Energy Use > Low > Consider Network Connection has been turned ON.

The machine does not enter this mode if a 2-, 3-, or 4-line Fax or a coin vendor is connected.

The machine does not enter Deep Sleep when this mode is activated.

Sleep Exit

The machine first enters this mode when returning to Standby from Sleep. The state where power supply is maintained to return from Sleep.

Deep Sleep

The state where the Control Panel is turned OFF and only the All-night Power (5 V) is supplied.

The machine enters this mode from Sleep Standby during Sleep.

The machine enters Sleep Standby when a job is submitted during this mode.

The machine enters Sleep Exit first, and then Standby when the Touch Panel Display on the Control Panel is tapped during this mode.

The machine does not enter this mode when any of the following "Conditions for Not Entering Deep Sleep" applies.

Conditions for Not Entering Deep Sleep Mode (Check Items)

Settings of Settings/Registration

When the following settings are enabled in the [Settings/Registration] menu, the machine does not enter Deep Sleep mode. The corresponding items are shown below.

Preferences > Timer/Energy Settings

- Sleep Mode Energy Use > High
- Sleep Mode Energy Use > Low > Compensate for Network Comm.
- Within the time specified in Auto Sleep Time

Preferences > Network

- NetWare Settings > Use NetWare > ON
- AppleTalk Settings > Use AppleTalk > ON
- TCP/IP Settings > BMLinkS Settings > Use BMLinkS > ON (*1)
- IEEE 802.1X Settings > Use IEEE 802.1X > ON
- TCP/IP Settings > IPv4 Settings > IP Address Settings > Auto IP > ON
- TCP/IP Settings > DNS Settings > mDNS Settings > Use mDNS > ON
- Google Cloud Print Settings > Use Google Cloud Print > ON (*2)
- TCP/IP Settings > SIP Settings > NGN Settings > Use NGN > ON (*1)
- Direct Connection Settings > Use Direct Connection > ON

Function Settings > Receive/Forward

- Fax Settings > Select RX Mode > Fax/Tel (Auto Switch) (*1)
- Fax Settings > Remote RX > ON (*1)
- Fax Settings > Set Number Display > ON (*1)

Function Settings > Send

- Fax Settings > Modem Dial-in Settings > ON (*1)

Other Settings

- Volume Settings key > Fax Volume Settings > Incoming Fax Ring > ON (*1)

*1: This may not be displayed depending on the country/region, model, and configuration of the options.

*2: This must be already registered on Google Cloud Print in advance.

Hardware status

- It is connected to the coin vendor.

System Performance Status

- The system is running/communicating.

CAUTION:

The system is in a running/communicating state for approx. 10 minutes after startup in many cases.

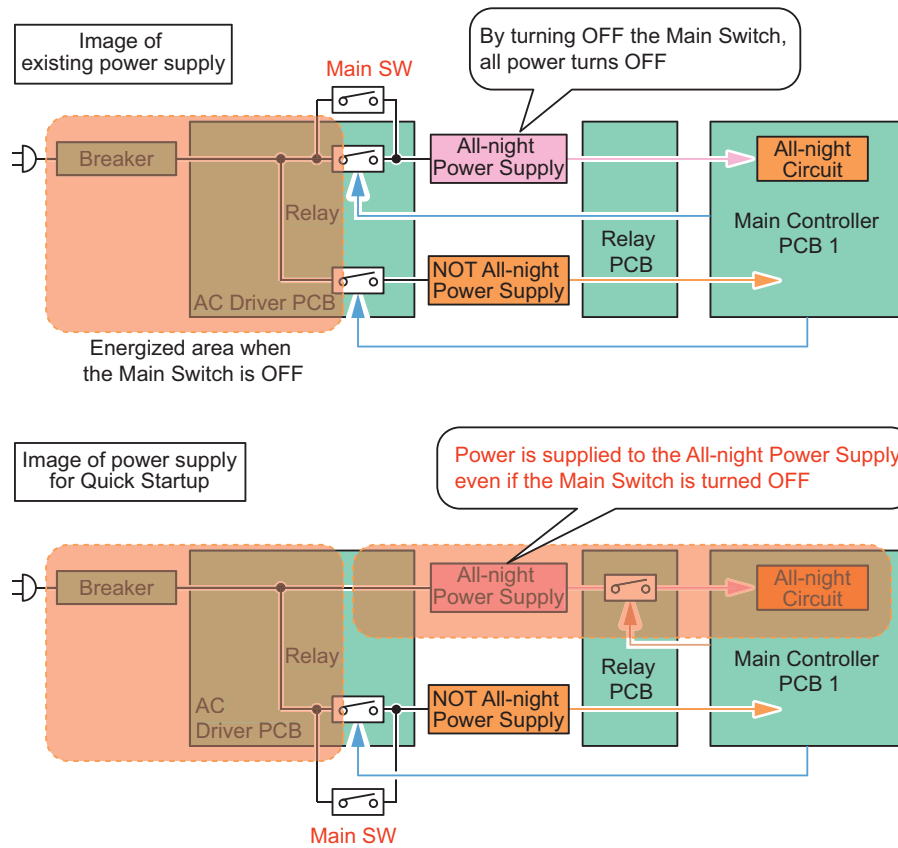
• Quick Startup

To realize faster startup, power configuration has been changed to always supply power to the All-night Power Supply PCB. Thereby, the main menu can be displayed after 7 seconds from turning ON the Main Power Supply Switch.

Although when the Main Power Supply Switch is OFF, power is supplied to the following PCBs.

- AC Driver PCB
- All-night Power Supply PCB

- Relay PCB
- Main Controller PCB 1



NOTE:

The quick startup function can be set from "Settings/Registration".

- Settings/Registration > Preferences > Timer/Energy Settings > Quick Startup Settings for Main Power
 [On]: Quick startup is executed (default)
 [Off]: Quick startup is not executed

Disconnect the plug from outlet or turn OFF the Breaker when performing work with the possibility to come in contact with the PCBs above. PCBs may get damage. If a conductive material comes in contact with the PCB, short circuit may occur in the PCB, and may cause damage on it.

The following illustration is used at the place where attention needs. When the following label is affixed, be sure to disconnect the plug from outlet or turn OFF the Breaker.



Conditions for not executing quick startup

This machine does not execute quick startup if the following conditions are met at first startup after the power plug is connected to the outlet.

Connection status of the hardware

- A coin vendor is connected.

Either of the following network settings is set to "ON":

Settings/Registration > Preferences > Network

- AppleTalk Settings > Use AppleTalk > ON
- Select Wired/Wireless LAN > Wireless LAN
- Bluetooth Settings > ON

When turning ON the main power of the machine after turning OFF the main power in any of the conditions below

- The system is running/communicating.

Others

- More than 110 hours have elapsed after quick startup
- When turning ON the main power of the machine in 20 seconds after turning OFF the main power
- Startup after 8 hours or more have passed since the power of this product was turned OFF
- When turning ON the main power of the machine after turning OFF the main power from the Remote UI
- The next time the power is turned ON after occurrence of the error code
- The next time the power is turned ON after shifting to the service mode screen

• Effects of Spanning Tree-supported Hub

If you set the network as a loop, data keeps staying in this loop and efficiency of data transfer might be decreased. In order to prevent this symptom, some hubs have the function called "spanning tree". If this function is enabled, the device newly connected to the hub can make data communication with network 10 to 50 seconds (time changes due to the conditions) after the connection. When the machine enters Deep sleep mode and restores from the sleep mode, the machine electrically disconnects with the network once. Therefore, if the machine connects with the spanning tree-installed hub, the machine cannot communicate with network for approximately 1 minute at a maximum after restoring from the Deep sleep mode.

For this reason, right after restoring from the Deep sleep mode, the following symptoms might occur: Device status cannot be collected, printing cannot be made, and login using a login application cannot be made. If such symptoms become any problems, perform the following operations.

- Using user mode, set not to enter the Deep sleep mode.
Preferences > Timer/Energy Settings > Sleep Mode Energy Use > High
- Disable the spanning tree function of hub.
- Request users to use the hub which supports Rapid Spanning-Tree
- Protocol (RSTP) that resolved such problems.

■ Heater Control

The power of this machine is supplied to each load side by linking with the following switches, etc.

<Operating condition>

Operating condition of the heater differs according to the status of the Environment Switch and the host machine.

A. In the case of normal image mode*1 (DRM-H-SW: "2")

<Environment Heater Switch: OFF>

Mode		Main Power OFF		sleep mode		WarmUp (Recovery)		Standby/Energy Saver		Copy/Print	
Switch	Main SW	OFF		ON							
	Cassette Heater SW	OFF	ON	OFF	ON	OFF	ON	OFF	ON	OFF	ON
Heater	Drum	OFF	OFF	OFF	OFF	ON*3	ON*3	ON	ON	ON	ON
	Cassette	OFF	OFF	OFF	OFF	OFF	ON	OFF	ON	OFF	ON
	Reader	OFF	OFF	OFF	OFF	OFF	OFF	OFF	OFF	OFF	OFF

<Environment Heater Switch: ON>

Mode		Main Power OFF		sleep mode		WarmUp (Recovery)		Standby/Energy Saver		Copy/Print	
Switch	Main SW	OFF		ON							
	Cassette Heater SW	OFF	ON	OFF	ON	OFF	ON	OFF	ON	OFF	ON
Heater	Drum	OFF	OFF	OFF	OFF	ON*3	ON*3	ON	ON	ON	ON
	Cassette	OFF	ON	OFF	ON	OFF	ON	OFF	ON	OFF	ON
	Reader	ON	ON	ON	ON	ON	OFF	OFF	OFF	OFF	OFF

B. In the case of image priority mode*1 (DRM-H-SW: "1")

<Environment Heater Switch: OFF>

Mode		Main Power OFF		sleep mode		WarmUp (Recovery)		Standby/Energy Saver		Copy/Print	
Switch	Main SW	OFF		ON							
	Cassette Heater SW	OFF	ON	OFF	ON	OFF	ON	OFF	ON	OFF	ON
Heater	Drum	OFF	OFF	OFF	OFF	ON*3	ON*3	ON	ON	ON	ON
	Cassette	OFF	OFF	OFF	OFF	OFF	ON	OFF	ON	OFF	ON
	Reader	OFF	OFF	OFF	OFF	OFF	OFF	OFF	OFF	OFF	OFF

<Environment Heater Switch: ON>

Mode		Main Power OFF		sleep mode		WarmUp (Recovery)		Standby/Energy Saver		Copy/Print	
Switch	Main SW	OFF		ON							
	Cassette Heater SW	OFF	ON	OFF	ON	OFF	ON	OFF	ON	OFF	ON
Heater	Drum	ON	ON	ON	ON	ON*3	ON*3	ON	ON	ON	ON
	Cassette	OFF	ON	OFF	ON	OFF	ON	OFF	ON	OFF	ON
	Reader	ON	ON	ON	ON	ON	OFF	OFF	OFF	OFF	OFF

*1: ON/OFF can be switched in the following service mode (Lv. 2).

COPIER > OPTION > IMG-MCON > DRM-H-SW

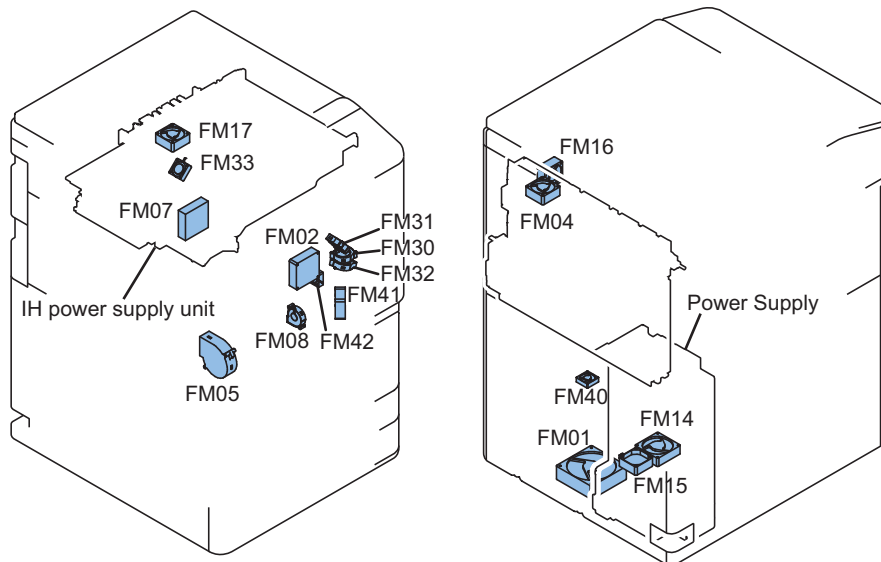
*2: When 1 or 2 is set in the following service mode, the Drum Heater is turned ON.

COPIER > OPTION > IMG-LSR > 2D-SHADE

*3: OFF when the detected temperature of the Environment Sensor is 15 deg C or higher.

■ Fan Control

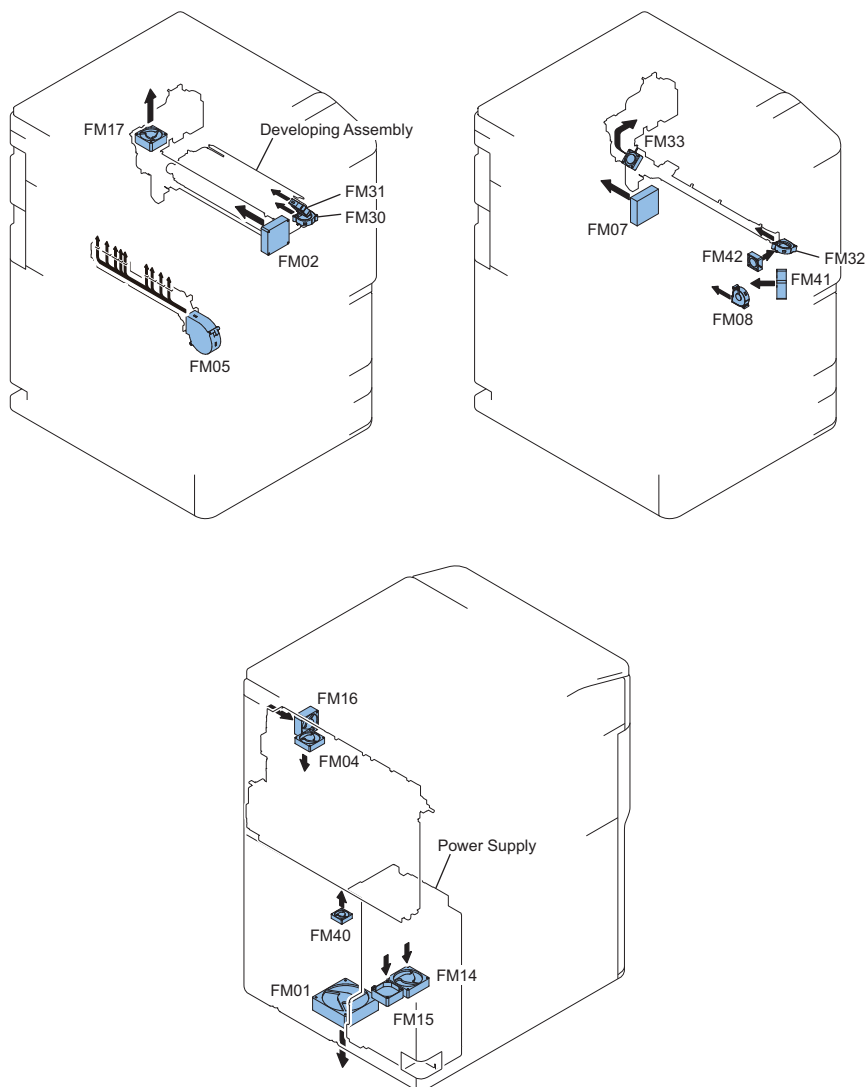
● Location of Fans



Circuit code	Name	Function	Error/Alarm code
FM01	Making Image Exhaust Fan	To exhaust air in the image formation area	E806-0000
FM02	Primary Charging Air-supply Fan	To intake air around the Primary Charging Assembly	E824-0000
FM04	Main Controller Cooling Fan	To cool the Main Controller PCB	E880-0001
FM05	Paper Cooling Fan	To cool the paper passing through the delivery area	33-0001
FM07	Fixing Power Supply Cooling Fan	To cool the fixing power supply	E804-0001

Circuit code	Name	Function	Error/Alarm code
FM08	Transfer Cleaner Cooling Fan	To cool the Transfer Cleaner / To cool the Duplex Feed Guide	E820-0002
FM14	Power Supply Cooling Fan 1	To cool the power supply	E804-0000
FM15	Power Supply Cooling Fan 2	To cool the power supply	E804-0000
FM16	Laser Scanner Cooling Fan	To cool the Laser Scanner	E121-0001
FM17	Primary Charging Exhaust Fan	To exhaust air around the Primary Charging Assembly	33-0027
FM30	Developer Lower Cooling Fan	To cool the Developing Unit	E820-0000
FM31	Developer Upper Cooling Fan	To cool the Developing Unit	E820-0001
FM32	Pre-transfer Charging Unit Air-supply Fan	To intake air around the Pre-transfer Charging Assembly	33-0026
FM33	Pre-transfer Charging Unit Exhaust Fan	To exhaust air around the Pretransfer Charging Assembly	
FM40	Feed Driver Cooling Fan	To cool the Feed Driver	33-0013
FM41	Duplex Driver Cooling Fan	To cool the Duplex Driver	33-0028
FM42	Registration Motor/Duplex Motor Cooling Fan	To cool the Duplex Motor and the Registration Motor	33-0002

• Airflow



Circuit code	Name	Function	Error/Alarm code
FM01	Making Image Exhaust Fan	To exhaust air in the image formation area	E806-0000
FM02	Primary Charging Air-supply Fan	To intake air around the Primary Charging Assembly	E824-0000
FM04	Main Controller Cooling Fan	To cool the Main Controller PCB	E880-0001

Circuit code	Name	Function	Error/Alarm code
FM05	Paper Cooling Fan	To cool the paper passing through the delivery area	33-0001
FM07	Fixing Power Supply Cooling Fan	To cool the fixing power supply	E804-0001
FM08	Transfer Cleaner Cooling Fan	To cool the Transfer Cleaner / To cool the Duplex Feed Guide	E820-0002
FM14	Power Supply Cooling Fan 1	To cool the power supply	E804-0000
FM15	Power Supply Cooling Fan 2	To cool the power supply	E804-0000
FM16	Laser Scanner Cooling Fan	To cool the Laser Scanner	E121-0001
FM17	Primary Charging Exhaust Fan	To exhaust air around the Primary Charging Assembly	33-0027
FM30	Developer Lower Cooling Fan	To cool the Developing Unit	E820-0000
FM31	Developer Upper Cooling Fan	To cool the Developing Unit	E820-0001
FM32	Pre-transfer Charging Unit Air-supply Fan	To intake air around the Pre-transfer Charging Assembly	33-0026
FM33	Pre-transfer Charging Unit Exhaust Fan	To exhaust air around the Pretransfer Charging Assembly	
FM40	Feed Driver Cooling Fan	To cool the Feed Driver	33-0013
FM41	Duplex Driver Cooling Fan	To cool the Duplex Driver	33-0028
FM42	Registration Motor/Duplex Motor Cooling Fan	To cool the Duplex Motor and the Registration Motor	33-0002

• Fan Sequence

NO.	NAME	WAIT UP	INTR	STBY	PRINT	LSTR	JAM	ERR	Power saving	DEEP Sleep
FM02	Primary Charging Air-supply Fan		■	■	■	■	■	■	■	■
FM03	Making Image Exhaust Fan		■	■	■	■	■	■	■	■
FM04	Main Controller Cooling Fan	Controller control								
FM05	Paper Cooling Fan		■	■	■	■	■	■	■	■
FM07	Fixing Power Supply Cooling Fan	■	■	■	■	■	■	■	■	■
FM08	Transfer Cleaner Cooling Fan		■	■	■	■	■	■	■	■
FM14	Power Supply Cooling Fan 1	■	■	■	■	■	■	■	■	■
FM15	Power Supply Cooling Fan 2	■	■	■	■	■	■	■	■	■
FM16	Laser Scanner Cooling Fan		■	■	■	■	■	■	■	■
FM17	Primary Charging Exhaust Fan		■	■	■	■	■	■	■	■
FM30	Developer Lower Cooling Fan		■	■	■	■	■	■	■	■
FM31	Developer Upper Cooling Fan		■	■	■	■	■	■	■	■
FM32	Pre-transfer Charging Unit Air-supply Fan		■	■	■	■	■	■	■	■
FM33	Pre-transfer Charging Unit Exhaust Fan		■	■	■	■	■	■	■	■
FM40	Feed Driver Cooling Fan		■	■	■	■	■	■	■	■
FM41	Duplex Driver Cooling Fan		■	■	■	■	■	■	■	■
FM42	Registration Motor/Duplex Motor Cooling Fan		■	■	■	■	■	■	■	■

■ :Full speed
 ■ :half speed

■ Counter control

Count-up timing differs according to the following.

- Print mode (1-sided page, 2nd side of 2-sided page, 1st side of 2-sided page)
- Delivery position (Finisher).

Delivery position		Print mode	
		1-sided print/2nd side of 2-sided print	1st side of the 2-sided print
		Count-up timing	
1	In the case of the Host Machine only	Reference Sensor: External Delivery Sensor (PS36)	
2	Staple Finisher-X1/Booklet Finisher-X1	Tray A (Upper Tray)	Reference Sensor: Feed Path Sensor (S102)
		Tray B (Lower Tray)	
		Saddle area	
3	Staple Finisher-AC1/Booklet Finisher-AC1	Tray A (Upper Tray)	Reference Sensor: Upper Escape Delivery Sensor(PS133)
		Tray B (Lower Tray)	Reference Sensor: Lower Escape Delivery Sensor(PS111)
		Tray C (Stack Tray)	Reference Sensor: Delivery Sensor(PS102)
		Saddle area	Reference Sensor: Saddle inlet sensor (S201)
4	Staple Finisher-W1/Booklet Finisher-W1	Tray A (Upper Tray)	Reference Sensor: Upper delivery sensor (PS5)
		Tray B (Lower Tray)	Reference Sensor: Lower delivery sensor (PS6)
		Saddle area	Reference Sensor: Saddle inlet sensor (PS101)
5	Booklet Trimmer-D1	Reference Sensor: Saddle inlet sensor (PS101)	

Default counters for each country/region (model) are listed below.

Target	Display number of each counter (in service mode) / item						Region Code
	Counter 1	Counter 2	Counter 3	Counter 4	Counter 5	Counter 6	
JP model Type1 (Conventional method)	Total1	*1	*1	*1	*1	*1	JP
	101	0	0	0	0	0	
JP model Type 2 (New method)	Total2	Copy(Total2)	TotalA2	*1	*1	*1	JP
	102	202	127	0	0	0	
Taiwan model	Total1	Total(Large)	Copy(Total1)	Copy(Large)	*1	*1	TW
	101	103	201	203	0	0	
UL model Type1 (Conventional method)	Total1	Total(Large)	Copy(Total1)	Copy(Large)	*1	*1	US
	101	103	201	203	0	0	
UL model Type 2 (New method)	Total2	Copy(Total2)	*1	*1	*1	*1	US
	102	202	0	0	0	0	
General model	Total1	Total(Large)	Copy(Total1)	Copy(Large)	*1	*1	SG/ KO/ CN
	101	103	201	203	0	0	
UK model Type1 (Conventional method)	Total(Black/Large)	Total(Black/Small)	Scan(Total1)	Print(Total1)	*1	*1	GB
	112	113	501	301	0	0	
240V UK model Type 2 (New method)	Total1	*1	*1	*1	*1	*1	GB
	101	0	0	0	0	0	
CA model	Total1	Total(Large)	Copy(Total1)	Copy(Large)	*1	*1	AU

Target	Display number of each counter (in service mode) / item						Region Code
	Counter 1	Counter 2	Counter 3	Counter 4	Counter 5	Counter 6	
CA model	101	103	201	203	0	0	AU
FRN model Type1 (Conventional method)	Total(Black/ Large)	Total(Black/ Small)	Scan(Total1)	Print(Total1)	*1	*1	FR
	112	113	501	301	0	0	
FRN model Type 2 (New method)	Total1	*1	*1	*1	*1	*1	FR
	101	0	0	0	0	0	
GER model Type1 (Conventional method)	Total(Black/ Large)	Total(Black/ Small)	Scan(Total1)	Print(Total1)	*1	*1	DE
	112	113	501	301	0	0	
GER model Type 2 (New method)	Total1	*1	*1	*1	*1	*1	DE
	101	0	0	0	0	0	
AMS model Type1 (Conventional method)	Total(Black/ Large)	Total(Black/ Small)	Scan(Total1)	Print(Total1)	*1	*1	ES/ SE/ PT/ NO/ DK/ FI/ PL/ HU/ CZ/ SI/ GR/ EE/ RU/ NL/ SK/ RO/ HR/ BG/ TR
	112	113	501	301	0	0	
AMS model Type 2 (New method)	Total1	*1	*1	*1	*1	*1	ES/ SE/ PT/ NO/ DK/ FI/ PL/ HU/ CZ/ SI/ GR/ EE/ RU/ NL/ SK/ RO/ HR/ BG/ TR
	101	0	0	0	0	0	
ITA model Type1 (Conventional method)	Total(Black/ Large)	Total(Black/ Small)	Scan(Total1)	Print(Total1)	*1	*1	IT
	112	113	501	301	0	0	
ITA model Type 2 (New method)	Total1	*1	*1	*1	*1	*1	IT
	101	0	0	0	0	0	
China	Total1	Total(Black/ Large)	Total(Black/ Small)	*1	*1	*1	CN
	101	112	113	0	0	0	

*1: Nothing is displayed as default. However, you can change this setting from the service mode.

Explanation of the list

- Large: Large size paper (when paper length exceeds 364 mm in paper feed direction)
- Small: Small size paper (when paper length is 364 mm or less in paper feed direction)
- Total: Copy + Print; 1 count up
- 2-Sided: 1 count up when auto 2-sided copy
- Change the Region code of CONFIG in the following service mode.
COPIER > OPTION > FNC-SW > CONFIG
- Three-digit number in the counter column shows the setting value of the following service mode items.
COPIER > OPTION > USER > COUNTER 1
COPIER > OPTION > USER > COUNTER 2
COPIER > OPTION > USER > COUNTER 3
COPIER > OPTION > USER > COUNTER 4
COPIER > OPTION > USER > COUNTER 5
COPIER > OPTION > USER > COUNTER 6
- COUNTER 2 to 6 can be changed in the following service mode.
COPIER > OPTION > USER
- The type of counter display can be switched between the former and new methods in the following service mode.
COPIER > OPTION > USER > CNT-SW

Region code	Region	Region code	Region	Region code	Region
JP	Japan	ES	Spain	RU	Russia
US	United States	SE	Sweden	SK	Slovakia
GB	United Kingdom	PT	Portugal	RO	Romania
FR	France	NO	Norway	HR	Croatia
DE	Germany	DK	Denmark	BG	Bulgaria
IT	Italy	FI	Finland	TR	Turkey
AU	Australia	PL	Poland	TH	Thailand
SG	Singapore	HU	Hungary	VN	Vietnam
NL	Netherlands	CZ	Czech Republic	AR	Argentine
KR	Korea	SI	Slovenia	IN	India
CN	China	GR	Greece		
TW	Taiwan	EE	Estonia		

Long Original Counter

- This machine has the Long Original Counter. When paper length in the paper feed direction exceeds 19.2" (487.8 mm), the 470s counters as well as normal counter are advanced.
471: Long original counter (Total)
473: Long original counter (Black and White)
- The counter values can be displayed by setting the following service mode(Lv.2).
COPIER > OPTION > USER > MF-LG-ST
Setting Value: 0: Hide, 1: Display (Default: Hide)



Technical Explanation (System)

Overview..... 226

Overview

For following items, refer to the "imageRUNNER ADVANCE V3.x System Service Manual".

- System Management
- Authentication
- Security Function
- Firmware Management
- Management of System Options
- MEAP Application Management
- Backup/Restoration
- Monitoring (e-Maintenance/imageWARE Remote) Function



Periodical Service

Periodically Replaced Parts.....	228
Consumable Parts.....	230
Periodical Maintenance.....	239

Periodically Replaced Parts

DADF

This DADF does not have parts that require periodical replacement.

Reader

This Reader does not have parts that require periodical replacement.

Printer

No.	Parts name	Parts number *1	Q'ty	Interval *2	Service mode		Alarm Code		Remark
					Parts counter (COUNTER > PRDC-1)	Consumption level (COUNTER > LIFE)	Prior notification	Replacement completion	
1	Primary Charging Wire	FB4-3687	2	500,000 sheets	PRM-WIRE		40-0133	43-0133	With spring: FL3-4558 In a high temperature/humidity environment (30 deg C/80%), it is 250,000 sheets.
2	Primary Charging Wire cleaner	FL2-7750	2	500,000 sheets	PRM-CLN		40-0350	43-0350	In a high temperature/humidity environment (30 deg C/80%), it is 250,000 sheets.
3	Primary Charging Wire Cleaner Holder	FL3-7560	2	500,000 sheets					
4	Grid Wire	FY1-0883	1	500,000 sheets	-		-	-	
5	Pre-transfer Charging Wire	FB4-3687	1	500,000 sheets	PO-WIRE		40-0376	43-0376	With spring: FL3-4559 In a high temperature/humidity environment (30 deg C/80%), it is 250,000 sheets.
6	Pre-transfer Charging Wire cleaner	FL2-7750	1	500,000 sheets	PO-CLN		40-0377	43-0377	In a high temperature/humidity environment (30 deg C/80%), it is 250,000 sheets.
7	Pre-transfer Charging Wire cleaner holder	FL3-7560	1	500,000 sheets					
8	Fixing Main Thermistor (THM010)	FK2-7692	1	500,000 sheets	FIX-TH1		40-0390	43-0390	
9	Fixing Sub Thermistor 1 (THM020)	FK2-7693	1	500,000 sheets	FIX-TH2		40-0391	43-0391	
10	Fixing Sub Thermistor 1 (THM020)	FK2-7693	1	500,000 sheets	FIX-TH2		40-0391	43-0391	

No.	Parts name	Parts number *1	Q'ty	Interval *2	Service mode		Alarm Code		Remark
					Parts counter (COUNTER > PRDC-1)	Consumption level (COUNTER > LIFE)	Prior notification	Replacement completion	
11	Ozone Filter	FL3-2134	1	6,000,00 0 sheets	OZ-FIL1		40-0483	43-0483	
12	Dustproof Filter	FC8-9564	1	2,000,00 0 sheets	AR-FIL1		40-0488	43-0488	

*1: The parts number may be changed due to engineering change.

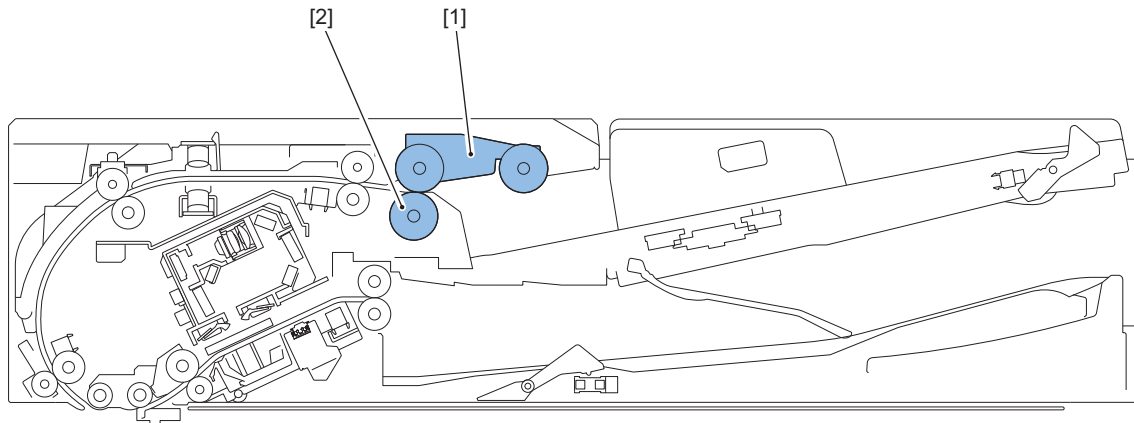
*2: All the values described in this column are estimated replacement timing in A4 size. The replacement timing is a reference value in the case of usage in general offices, and the actual value differs depending on the customer environment, operation conditions in the field, etc.



This Option does not have parts that require periodical replacement.

Consumable Parts

DADF



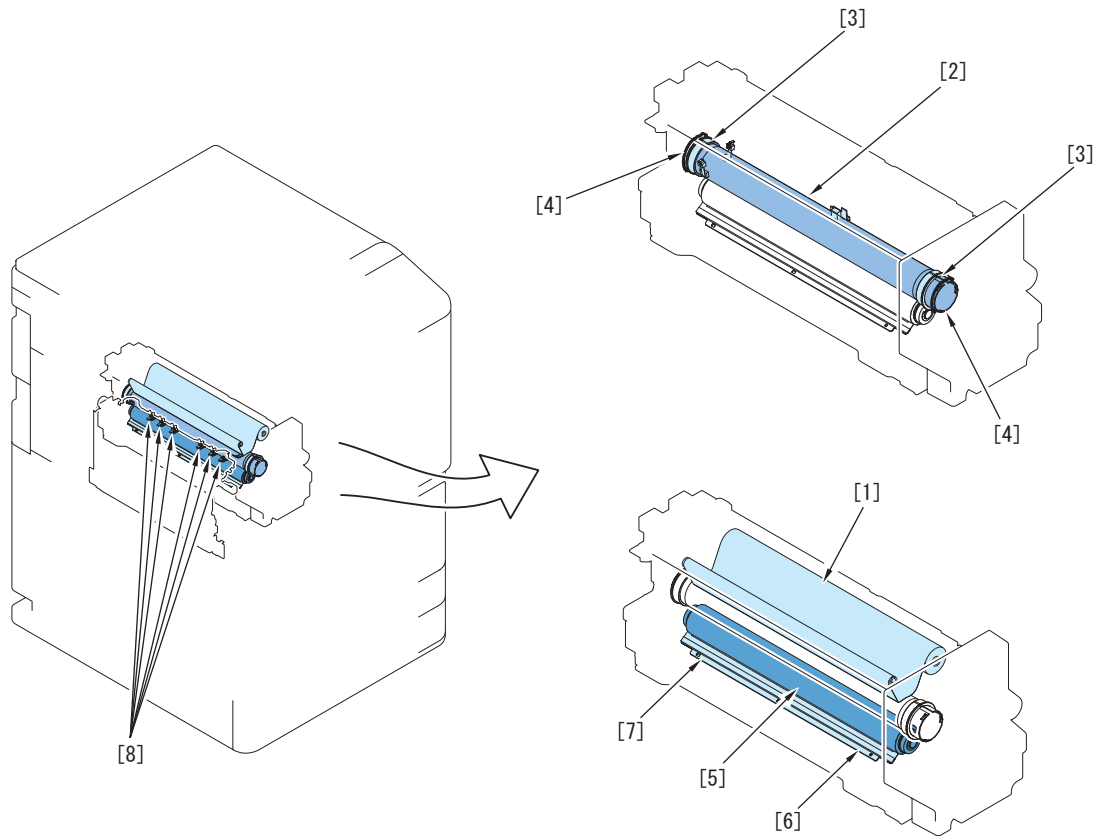
No.	Parts name	Parts number *1	Q'ty	Interval *2	Service Mode		Alarm Code	
					Parts counter (COUNTER > DRBL-2)	Consumption rate (COUNTER > LIFE)	Prior notification	Replacement completion notification
1	Pickup Roller Unit	FM1-T417	1	200,000 sheets	DF-PU-RL		40-0125	43-0125
2	Separation Roller	FM1-T423	1	200,000 sheets	DF-SP-RL		40-0092	43-0092

*1: The parts number may be changed due to engineering change.

*2: All the values described in this column are estimated replacement timing in A4 size. The replacement timing is a reference value in the case of usage in general offices, and the actual value differs depending on the customer environment, operation conditions in the field, etc.

Reader

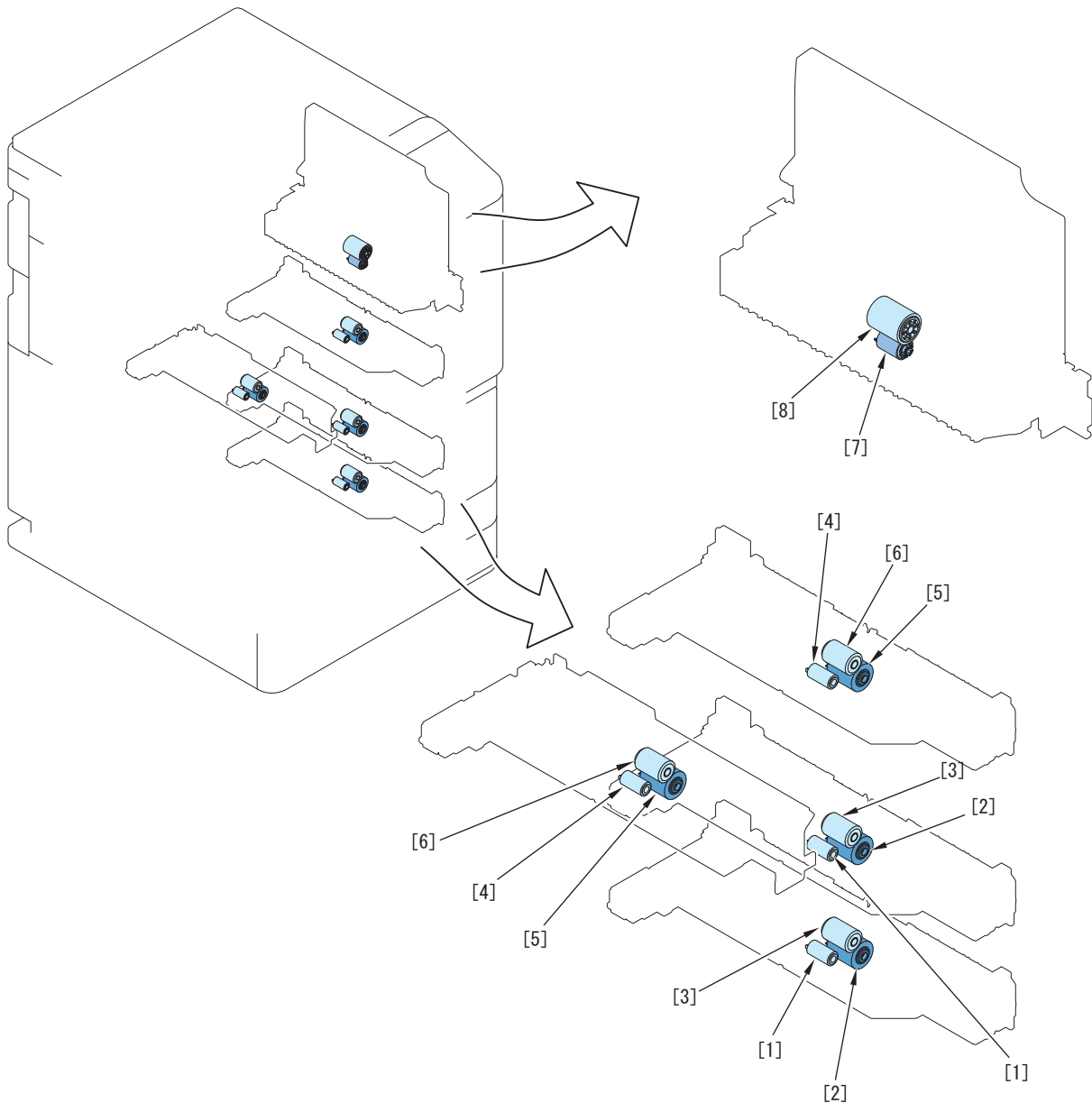
The reader does not have parts that are classified as durables.



No.	Parts name	Parts number *1	Q'ty	Interval *2	Service mode		Alarm Code		Remark
					Parts counter (COUNTER > DRBL-1)	Consumption rate (COUNTER > LIFE)	Prior notification	Replacement completion	
1	Fixing Cleaning Web	FE2-E539	1	500,000 sheets		FX-WEB1	-	43-0419	
2	Fixing Roller	FL3-3602	1	600,000 sheets		FX-UP-RL	40-0389	43-0389	
3	Fixing Roller Insulating Bush	FM1-C081	2	600,000 sheets		FX-IN-BS	40-0392	43-0392	
4	Fixing Roller Thrust retainer	FC6-3501	2	600,000 sheets		FX-RTNR	40-0394	43-0394	Be sure to replace it together with the Fixing Roller.
5	Pressure Roller Unit	FM4-3158	1	600,000 sheets		FX-LW-RL	40-0398	43-0398	
6	Pressure Roller Static Eliminator (Front)	FE2-3452	1	600,000 sheets		FX-L-STC	40-0402	43-0402	
7	Pressure Roller Static Eliminator (Rear)	FE2-3453	1	600,000 sheets					
8	Upper Separation Claw	FB5-3625	6	500,000 sheets		DLV-UCLW	40-0470	43-0470	Clean this part when it is not replaced. Clean with lint-free paper moistened with alcohol.

*1: The parts number may be changed due to engineering change.

*2: All the values described in this column are estimated replacement timing in A4 size. The replacement timing is a reference value in the case of usage in general offices, and the actual value differs depending on the customer environment, operation conditions in the field, etc.

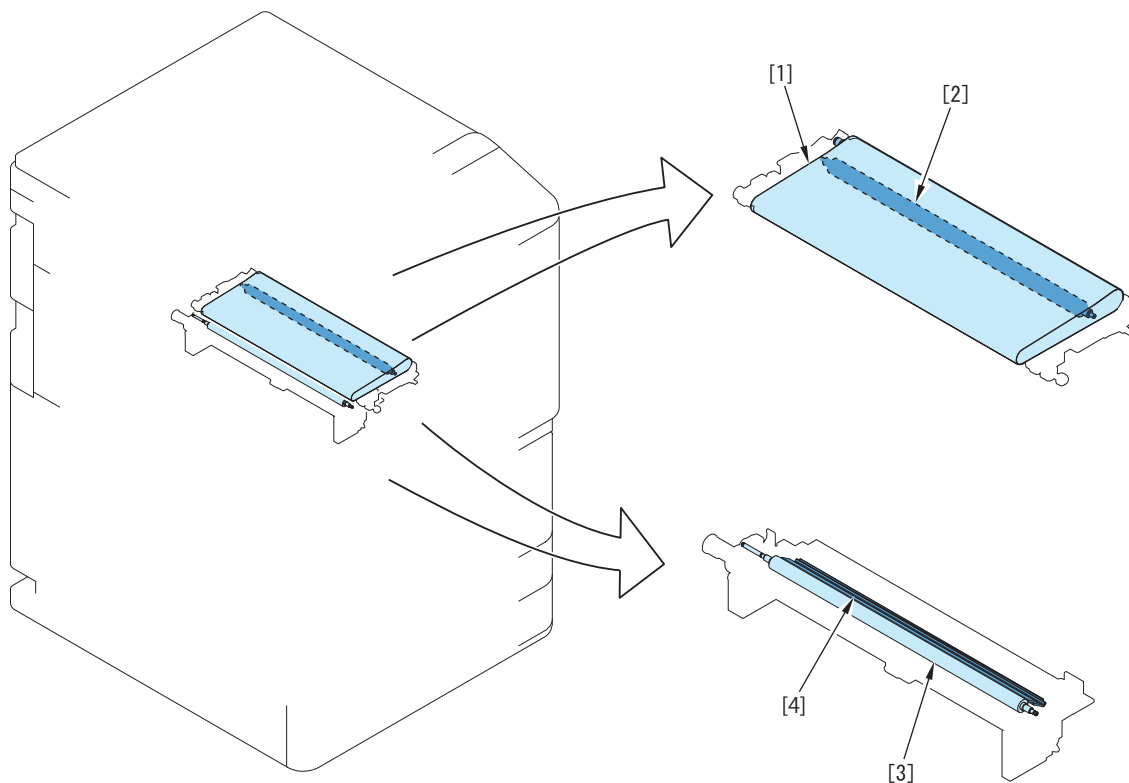


No.	Parts name	Parts number *1	Q'ty	Interval *2	Service mode		Alarm Code		Remark
					Parts counter (COUNTER > DRBL-1/2)	Consumption rate (COUNTER > LIFE)	Prior notification	Replacement completion	
1	Cassette 3 Pickup Roller / Cassette 4 Pickup Roller	FC5-2524	2	500,000 sheets	3: C3-PU-RL 4: C4-PU-RL	Right: 40-0085 Left: 40-0088	Right: 43-0085 Left: 43-0088	Actual use in terms of number of prints; 1 pc. each (3/4)	
2	Cassette 3 Feed Roller / Cassette 4 Feed Roller	FC5-2526	2	500,000 sheets	3: C3-FD-RL 4: C4-FD-RL	Right: 40-0086 Left: 40-0089	Right: 43-0086 Left: 43-0089	Actual use in terms of number of prints; 1 pc. each (3/4)	

No.	Parts name	Parts number *1	Q'ty	Interval *2	Service mode		Alarm Code		Remark
					Parts counter (COUNTER > DRBL-1/2)	Consumption rate (COUNTER > LIFE)	Prior notification	Replacement completion	
3	Cassette 3 Separation Roller / Cassette 4 Separation Roller	FC5-2528	2	500,000 sheets	3: C3-SP-RL 4: C4-SP-RL		Right: 40-0087 Left: 40-0090	Right: 43-0087 Left: 43-0090	Actual use in terms of number of prints; 1 pc. each (3/4)
4	Right Deck Pickup Roller / Left Deck Pickup Roller	FC5-2524	2	500,000 sheets	Right: C1-PU-RL Left: C2-PU-RL		Right: 40-0079 Left: 40-0082	Right: 43-0079 Left: 43-0082	Actual use in terms of number of prints. 1 pc. each (Left/Right)
5	Right Deck Feed Roller / Left Deck Feed Roller	FC5-2526	2	500,000 sheets	Right: C1-FD-RL Left: C2-FD-RL		Right: 40-0080 Left: 40-0083	Right: 43-0080 Left: 43-0083	Actual use in terms of number of prints. 1 pc. each (Left/Right)
6	Right Deck Separation Roller / Left Deck Separation Roller	FC5-2528	2	500,000 sheets	Right: C1-SP-RL Left: C2-SP-RL		Right: 40-0081 Left: 40-0084	Right: 43-0081 Left: 43-0084	Actual use in terms of number of prints. 1 pc. each (Left/Right)
7	Multi-purpose Tray Separation Roller	FC6-6661	1	120,000 sheets	M-SP-RL		40-0078	43-0078	Actual use in terms of number of prints
8	Multi-purpose Tray Feed Roller	FB1-8581	1	120,000 sheets	M-FD-RL		40-0077	43-0077	Actual use in terms of number of prints

*1: The parts number may be changed due to engineering change.

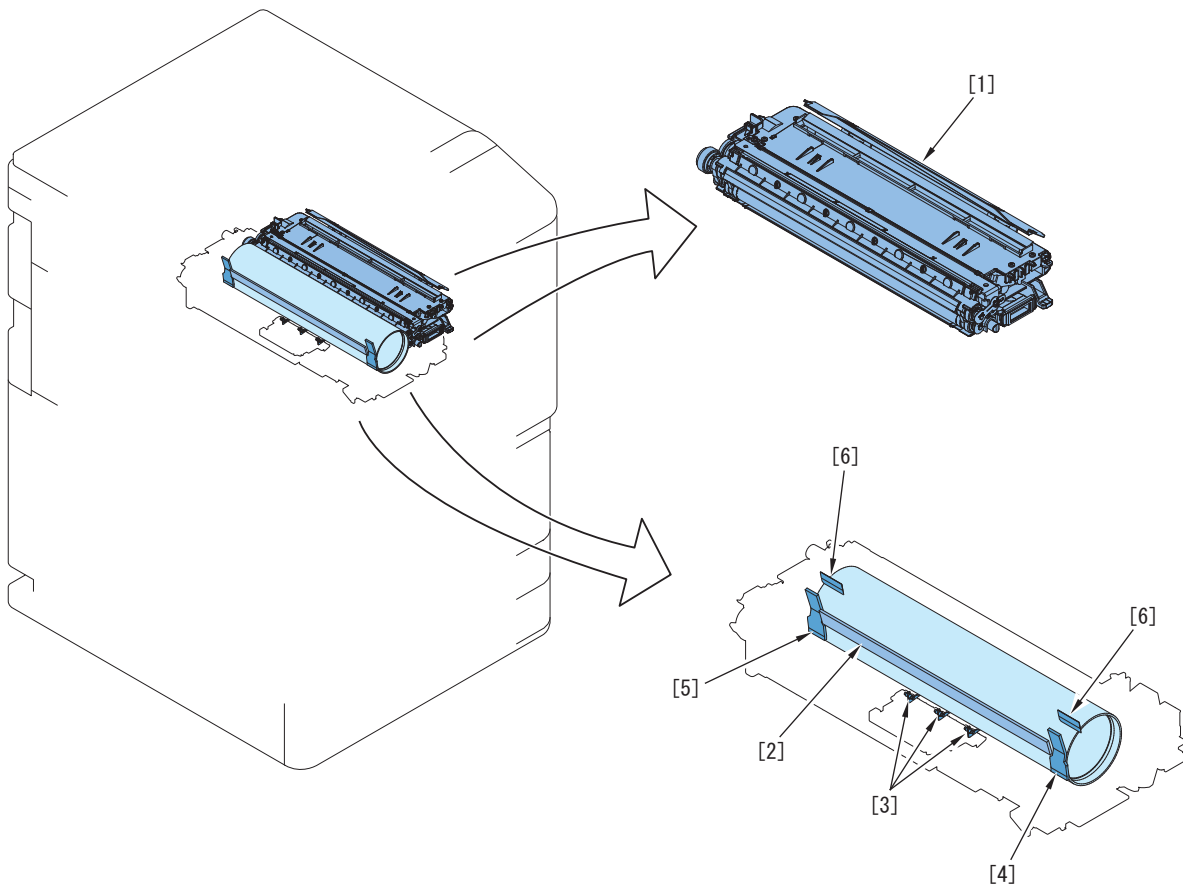
*2: All the values described in this column are estimated replacement timing in A4 size. The replacement timing is a reference value in the case of usage in general offices, and the actual value differs depending on the customer environment, operation conditions in the field, etc.



No.	Parts name	Parts number *1	Q'ty	Interval *2	Service mode		Alarm Code		Remark
					Parts counter (COUNTER > DRBL-1/2)	Consumption rate (COUNTER > LIFE)	Prior notification	Replacement completion	
1	ETB	FC8-7160	1	500,000 sheets	TR-BLT		40-0006	43-0006	
2	Transfer Roller	FC8-7159	1	500,000 sheets	TR-ROLL		40-0013	43-0013	
3	Brush Roller	FC8-7175	1	500,000 sheets	T-CN-BRU		40-0372	43-0372	
4	ETB Cleaning Blade	FC6-1647	1	500,000 sheets	T-CLN-BD		40-0370	43-0370	

*1: The parts number may be changed due to engineering change.

*2: All the values described in this column are estimated replacement timing in A4 size. The replacement timing is a reference value in the case of usage in general offices, and the actual value differs depending on the customer environment, operation conditions in the field, etc.

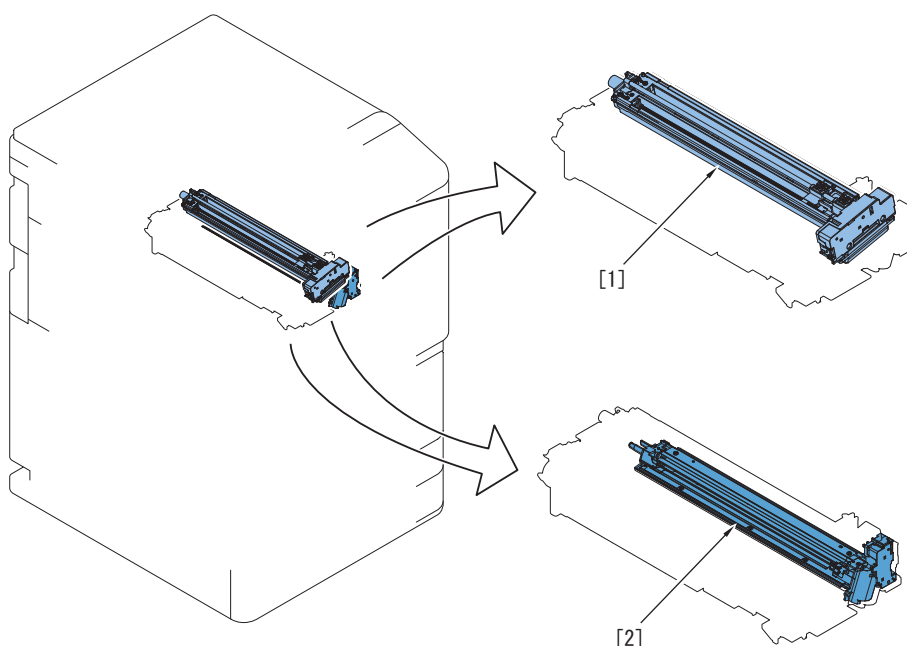


No.	Parts name	Parts number *1	Q'ty	Interval *2	Service mode		Alarm Code		Remark
					Parts counter (COUNTER > DRBL-1/2)	Consumption rate (COUNTER > LIFE)	Prior notification	Replacement completion	
1	Developing Assembly	FM4-5429	1	1,500,000 sheets	DV-UNT-K		40-0123	43-0123	500,000 in high temp/high hmdty environ (30 deg C/ 80%)

No.	Parts name	Parts number *1	Q'ty	Interval *2	Service mode		Alarm Code		Remark
					Parts counter (COUNTER > DRBL-1/2)	Consumption rate (COUNTER > LIFE)	Prior notification	Replacement completion	
2	Drum Cleaning Blade	FL3-6291	1	600,000 sheets	CLN-BLD		40-0193	43-0193	The blade movement is reversed at every 300,000 sheets (1-sided).
3	Drum Separation Claw	FB4-8018	3	500,000 sheets	SP-CLAW		40-0354	43-0354	In a high temperature/humidity environment (30 deg C/80%), it is 250,000 sheets.
4	Drum Front Side Seal	FC9-9024	1	500,000 sheets	BS-SL-F		40-0352	43-0352	
5	Drum Rear Side Seal	FC9-9024	1	500,000 sheets	BS-SL-R		40-0353	43-0353	
6	Pre-exposure Scraper	FC9-9153	2	500,000 sheets	EXP-SCRIP		40-0355	43-0355	Clean with lint-free paper moistened with alcohol.

*1: The parts number may be changed due to engineering change.

*2: All the values described in this column are estimated replacement timing in A4 size. The replacement timing is a reference value in the case of usage in general offices, and the actual value differs depending on the customer environment, operation conditions in the field, etc.



No.	Parts name	Parts number *1	Q'ty	Interval *2	Service mode		Alarm Code		Remark
					Parts counter (COUNTER > DRBL-1/2)	Consumption rate (COUNTER > LIFE)	Prior notification	Replacement completion	
1	Primary Charging Assembly	FM3-7288	1	1,500,000 sheets	PRM-UNIT		40-0173	43-0173	
2	Pre-transfer Charging Assembly	FM4-3149	1	1,500,000 sheets	PO-UNIT		40-0378	43-0378	

*1: The parts number may be changed due to engineering change.

*2: All the values described in this column are estimated replacement timing in A4 size. The replacement timing is a reference value in the case of usage in general offices, and the actual value differs depending on the customer environment, operation conditions in the field, etc.

Options

Paper Deck Unit-E1

No.	Parts name	Parts number	Q'ty	Interval	Service mode		Alarm Code	
					Parts counter (COUNTER > DRBL-2)	Consumption rate (COUNTER > LIFE)	Prior notification	Replacement completion notification
1	Deck Pickup Roller	FL0-4500	1	1,000,000 sheets		PD-PU-RL	40-0568	43-0568
2	Deck Feed Roller	FC0-9450	1	1,000,000 sheets		PD-FD-RL	40-0576	43-0576
3	Deck Separation Roller	FC0-9631	1	1,000,000 sheets		PD-SP-RL	40-0572	43-0572

POD Deck Lite-C1

No.	Parts name	Parts number	Q'ty	Interval	Service mode		Alarm Code	
					Parts counter (COUNTER > DRBL-2)	Consumption rate (COUNTER > LIFE)	Prior notification	Replacement completion notification
1	Deck Pickup Roller	FL0-4500	1	1,000,000 sheets		PD-PU-RL	40-0568	43-0568
2	Deck Feed Roller	FC0-9450	1	1,000,000 sheets		PD-FD-RL	40-0576	43-0576
3	Deck Separation Roller	FC0-9631	1	1,000,000 sheets		PD-SP-RL	40-0572	43-0572

Document Insertion Unit-N1

No.	Parts name	Parts number	Q'ty	Interval	Counter	
1	Upper Tray Pickup Roller	4A3-3870	2	100,000 sheets	DRBL-2	IS-P-RL1
2	Upper Tray Separation Roller	4A3-3868	1	100,000 sheets	DRBL-2	IS-S-RL1
3	Upper Tray Feed Roller	4A3-3869	1	100,000 sheets	DRBL-2	IS-F-RL1
4	Upper Tray Torque Limiter	4A3-3888	1	1,000,000 sheets	DRBL-2	IS-TQLM1
5	Lower Tray Pickup Roller	4A3-3870	2	100,000 sheets	DRBL-2	IS-P-RL2
6	Lower Tray Separation Roller	4A3-3868	1	100,000 sheets	DRBL-2	IS-S-RL2
7	Lower Tray Feed Roller	4A3-3869	1	100,000 sheets	DRBL-2	IS-F-RL2
8	Lower Tray Torque Limiter	4A3-3888	1	1,000,000 sheets	DRBL-2	IS-TQLM2

Paper Folding Unit-J1 does not have parts corresponding to consumable parts.

Staple Finisher-W1

No.	Parts name	Parts number	Q'ty	Interval	Counter	
1	Stapler	FM2-6541-030	1	500,000 times	DRBL-2	FIN-STPR
2	Feed Belt	FB5-9103	2	3,000,000 sheets	DRBL-2	SORT-2
3	Neat Paddle	FL3-7459	4	3,000,000 sheets	DRBL-2	FN-PDL-U

Booklet Finisher-W1

No.	Parts name	Parts number	Q'ty	Interval	Counter	
1	Stapler	FM2-6541-030	1	500,000 times	DRBL-2	FIN-STPR
2	Feed Belt	FB5-9103	2	3,000,000 sheets	DRBL-2	SORT-2
3	Neat Paddle	FL3-7459	4	3,000,000 sheets	DRBL-2	FN-PDL-U
4	Saddle Alignment Roller	FC8-7495	4	5,000,000 sheets	DRBL-2	SDL-JRL
5	Saddle Disengagement Roller	FL3-2010	2	1,000,000 sheets	DRBL-2	SDL-RL
6	Saddle Stapler	FM4-7572	1	300,000 times	DRBL-2	SDL-STPL

Staple Finisher-X1/Booklet Finisher-X1

No.	Parts name	Parts number	Q'ty	Interval	Counter	
1	Stack Delivery Upper Roller (Front/Rear)	FC9-3148	2	3,000,000 sheets	DRBL-2	SWG-DL-1
2	Stack Delivery Upper Roller (Center)	FC9-3149	1	3,000,000 sheets	DRBL-2	SWG-DL-2
3	Swing Guide Solenoid	FK2-8206	1	1,000,000 times	DRBL-2	SWG-SL
4	Paper Holding Torque Limiter	FC9-3323	1	1,000,000 times	DRBL-2	SWG-TQLM
5	Paper Return Guide Roller (Front)	FC9-3436	1	3,000,000 sheets	DRBL-2	SWG-RL
6	Paper Return Guide Roller (Rear)	FC9-3319	1	3,000,000 sheets	DRBL-2	SWG-RL
7	Torque Limiter (Tray 1/2 Paper Holder)	FC9-3111	3	1,000,000 times	DRBL-2	BEHLTQLM
8	Sub Guide Torque Limiter	FC9-3111	2	1,000,000 sheets	DRBL-2	SUB-TQLM
9	Staple Unit	FM0-2341	1	500,000 times	DRBL-2	FIN-STPR
10	Shutter Torque Limiter	FC9-3559	1	1,000,000 times	DRBL-2	SHT-TQLM
11	Tray 1 Torque Limiter	FC9-3559	2	200,000 times	DRBL-2	TRY-TQLM
12	Tray 2 Torque Limiter	FC9-3559	2	200,000 times	DRBL-2	TR2-TQLM

Staple Finisher-AC1

No.	Parts name	Parts number	Q'ty	Interval	Counter	
1	Staple Unit	FM1-H337	1	500,000 times	DRBL-2	FIN-STPR
2	Staple-free Staple Unit	FM1-K422	1	30,000 times	DRBL-2	FR-STPL
3	Stack Tray Torque Limiter	FE3-9778	2	200,000 times	DRBL-2	TRY-TQLM
4	Paddle Unit	FE3-6957	4	1,000,000 times	DRBL-2	FIN-MPDL
5	Paper Retainer Lever	FM1-U597	2	3,000,000 times	DRBL-2	

Booklet Finisher-AC1

No.	Parts name	Parts number	Q'ty	Interval	Counter	
1	Staple Unit	FM1-H337	1	500,000 times	DRBL-2	FIN-STPR
2	Stitcher Unit	FL0-6966	1	100,000 times	DRBL-2	SDL-STP
3	Staple-free Staple Unit	FM1-K422	1	30,000 times	DRBL-2	FR-STPL
4	Stack Tray Torque Limiter	FE3-9778	2	200,000 times	DRBL-2	TRY-TQLM
5	Paddle Unit	FE3-6957	4	1,000,000 times	DRBL-2	FIN-MPDL
6	Paper Retainer Lever	FM1-U597	2	3,000,000 times	DRBL-2	

Multi Function Professional Puncher-B1

No.	Area/Unit	Parts number	Q'ty	Period	Counter	
1	Punch module	115V: FC3-6919 230V: FC3-6918	1	15,000,000 sheets	DRBL-2	

Periodical Maintenance

Printer

△: Cleaning, ×: Lubrication, □: Adjustment, ◎: Inspection

	Location for maintenance	Interval	Details	Remark
1	Shield Plate for Charging Assemblies	500,000 pages	△	In a high temperature/humidity environment (30 deg C/80%), it is 250,000 sheets
2	Primary Duct Toner Blocking Sheet	500,000 pages	△	In a high temperature/humidity environment (30 deg C/80%), it is 250,000 sheets
3	Pre-transfer Charging Assembly Dust Collecting Roller Assembly	500,000 pages	△	In a high temperature/humidity environment (30 deg C/80%), it is 250,000 sheets
4	Pre-transfer Charging Assembly Dust Collecting Roller Electrode Assembly	500,000 pages	△	In a high temperature/humidity environment (30 deg C/80%), it is 250,000 sheets
5	ETB Drive Roller/Idler Roller	500,000 pages	△	
6	Dustproof Glass	500,000 pages	△	
7	Photosensitive Drum	300,000 pages	△	Use alcohol + cleaning powder (CK-0429) Perform when replacing the Cleaning Blade
8	Drum Heater Sliding Assembly	1,000,000 pages	△/×	
9	Drum Cleaning Unit Plate	500,000 pages	△	
10	Cleaner Separation Claw Mounting Plate	500,000 pages	△	
11	Developing Roller	500,000 pages	△	
12	Transfer Separation Guide/Static Eliminator	500,000 pages	△	
13	Delivery Separation Claw	500,000 pages	△	
14	Fixing Oil Receiver	500,000 pages	△	
15	Fixing Inlet Guide/ Sensor/ Dowel Assembly	500,000 pages	△	
16	Scanner Sensor (Pickup Assembly)	500,000 pages	△	Perform when replacing the Separation Roller
17	Scanner Sensor (Feed Assembly)	1,000,000 pages	△	
18	Developing Toner Blocking Sheet	500,000 pages	△	
19	Developing Assembly Lower Side	500,000 pages	△	
20	The host machine surface below the Developing Assembly	Whenever needed	△	Perform when removing the Developing Assembly
21	Feed Rollers (Brush)/Rollers/Guides	500,000 pages	△	
22	Registration Unit Magnet/Plastic Film	500,000 pages	△	
23	Patch Sensor	500,000 pages	△	
24	Waste Toner Container	500,000 pages	◎/△	Remove waste toner and clean the container when the message is displayed. Estimated by A4 size, image ratio 5%
25	Leakage Breaker	Once or twice/year	◎	

DADF

△: Cleaning, ×: Lubrication, □: Adjustment, ◎: Inspection

Single Pass DADF-C1

	Location for maintenance	Interval	Details	Remark
1	Post-Separation Sensor	When needed	△	Performed as needed during a visit for parts replacement, etc.
2	Registration Roller	When needed	△	
3	Lead Roller 1	When needed	△	
4	Lead Roller 2	When needed	△	
5	Delivery Roller	When needed	△	
6	Pullout Roller	When needed	△	

	Location for maintenance	Interval	Details	Remark
7	Rollers/Slave Rollers	When needed	△	Performed as needed during a visit for parts replacement, etc.
8	Original Tray Sensor	When needed	△	
9	Double Feed Sensor (lightemitting side)	When needed	△	
10	Double Feed Sensor (lightreceiving side)	When needed	△	
11	ADF height adjustment	When needed	□	

CAUTION:

See Service Manual of the ADF (Single Pass DADF-C1) for Cleaning/Check/Adjustment Locations, Parts Replacement and Cleaning Procedure of the ADF.

Options

△: Cleaning, ×: Lubrication, □: Adjustment, ◎: Inspection

POD Deck Lite-C1

	Location for maintenance	Interval	Details	Remark
1	Deck pull-put roller/collar	Whenever needed	△	
2	Deck Pickup Roller	Whenever needed	△	
3	Deck Feed Roller	Whenever needed	△	
4	Deck Separation Roller	Whenever needed	△	

Staple Finisher-X1/Booklet Finisher-X1

	Location for maintenance	Interval	Details	Remark
1	Transmission Sensor	Whenever needed	△	
2	Each Roller	Whenever needed	TBD Supported with conditions	

Staple Finisher-W1/Booklet Finisher-W2

	Location for maintenance	Interval	Details	Remark
1	Sensors	Follows the connected MFP host machine counters and the minimum maintenance interval of host machine	△	
2	Knurled Belt	Follows the connected MFP host machine counters and the minimum Surface maintenance interval of host machine	△	
3	Belt Roller		△	
4	Bottom Delivery Upper Roller		△	

Staple Finisher-AC1/Booklet Finisher-AC1

	Location for maintenance	Interval	Details	Remark
1	Transmission Sensor	Whenever needed	△	
2	Each Roller	Whenever needed	△	

Document Insertion Unit-N1

	Location for maintenance	Interval	Details	Remark
1	Insertion Separation Roller	40,000 pages	△	

	Location for maintenance	Interval	Details	Remark
2	Insertor Pickup Roller	40,000 pages	△	
3	Insertor Pick Roller	40,000 pages	△	

Paper Folding Unit-J1

	Location for maintenance	Interval	Details	Remark
1	Paper folding unit reflection sensor mirrors	Follow the minimum maintenance interval of host machine (4 locations)	△	Number of sheets fed to the paper folding unit
2	Fold Roller	200,000 pages	△	Number of sheets fed to the paper folding unit

Paper Deck Unit-E1

	Location for maintenance	Interval	Details	Remark
1	Deck pull-put roller/collar	Whenever needed	△	
2	Deck Pickup Roller	Whenever needed	△	
3	Deck Feed Roller	Whenever needed	△	
4	Deck Separation Roller	Whenever needed	△	

Booklet Trimmer-F1

	Location for maintenance	Interval	Details	Remark
1	Feed Belt	Every 200,000 booklets	△	Wipe soiling from surface using alcohol
2	Booklet Sensor	Every 200,000 booklets	△	Use the blower brush and remove dusts and oil



5

Parts Replacement and Cleaning

Preface.....	243
Parts List.....	244
Original Feed System.....	279
Original Exposure System.....	310
Controller System.....	330
Laser Exposure System.....	355
Image Formation System.....	362
Fixing System.....	479
Pickup Feed System.....	514
External Auxiliary System.....	574

Preface

Outline

This chapter describes disassembly and reassembly procedures of the printer.

The service technician is to identify the cause of printer failures according to the "Chapter 6 TROUBLESHOOTING" and to follow the disassembly procedures of each part to replace the defective parts or the consumable parts.

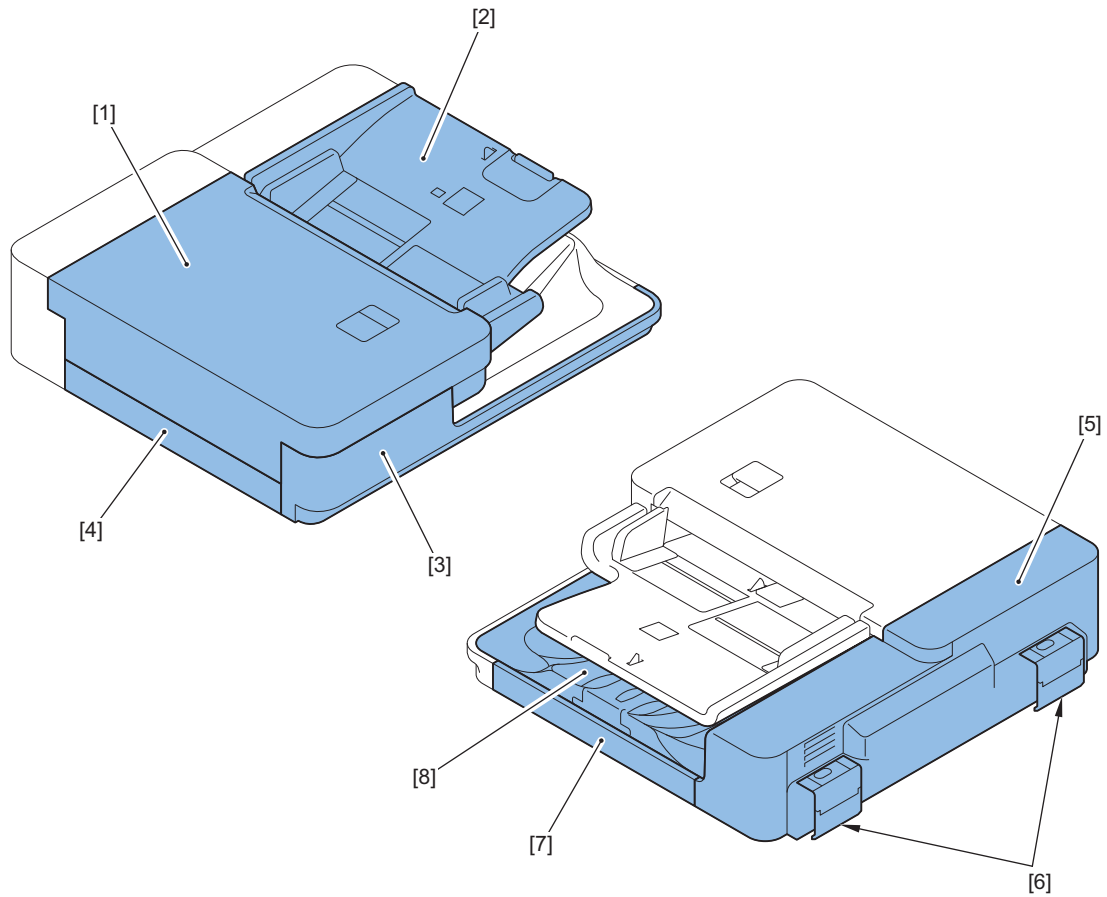
Note the following precautions when working on the printer.

1. CAUTION: Before disassembling or reassembling the printer, be sure to disconnect its power cord from the electrical outlet
2. During disassembly, reassembly or transportation of the printer, remove the cartridge if required.
When the cartridge is out of the printer, put it in a protective bag even in a short period of time to prevent the adverse effect of light.
3. Reassembling procedures are followed by the reverse of disassembly unless otherwise specified.
4. Note the length, diameters, and locations of screws as you remove them. When reassembling the printer, be sure to use them in their original locations.
5. Do not run the printer with any parts removed as a general rule.
6. Ground yourself by touching the metal part of the printer before handling the PCB to reduce the possibility of damage caused by static electricity.
7. When you replace the part that the rating plate or the product code label is attached, be sure to remove the rating plate or the product code label and put it to the new part.

Parts List

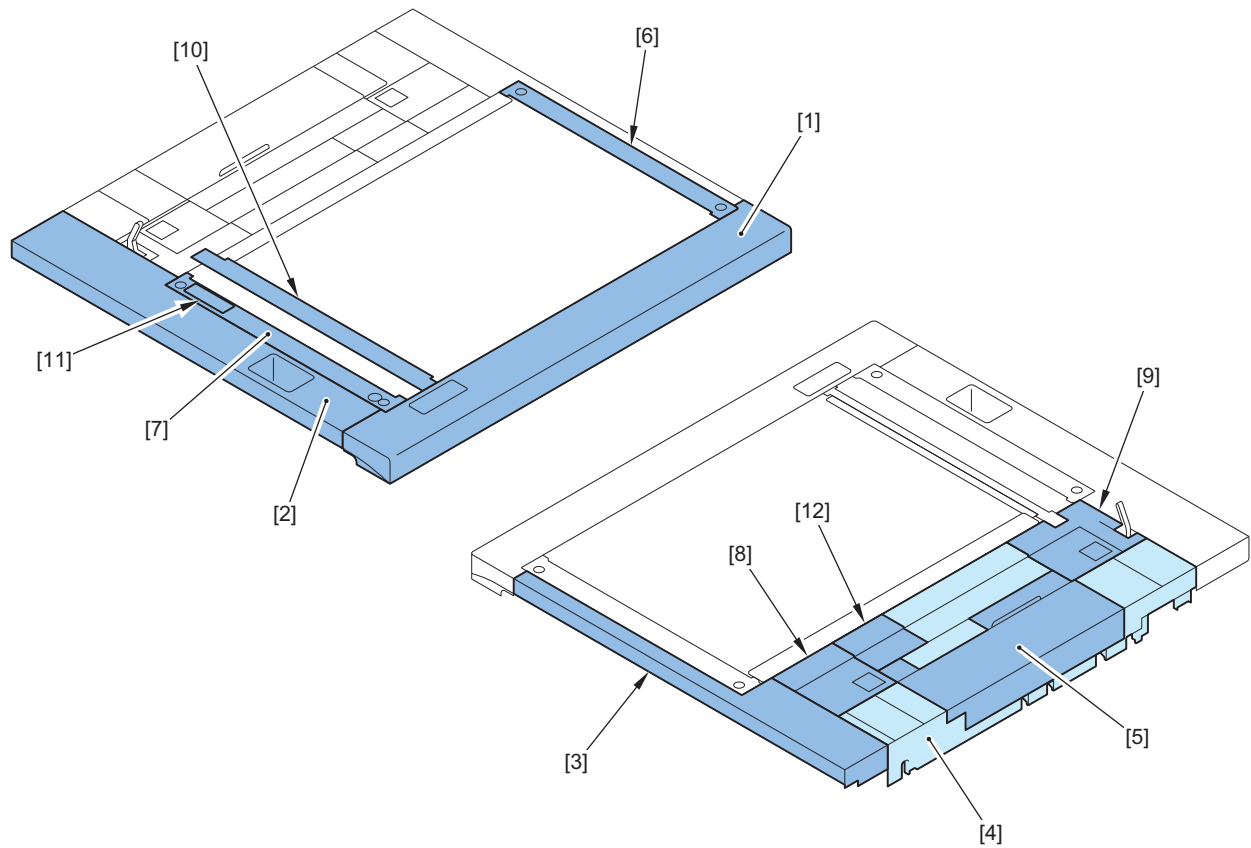
List of External / Internal Cover

■ ADF



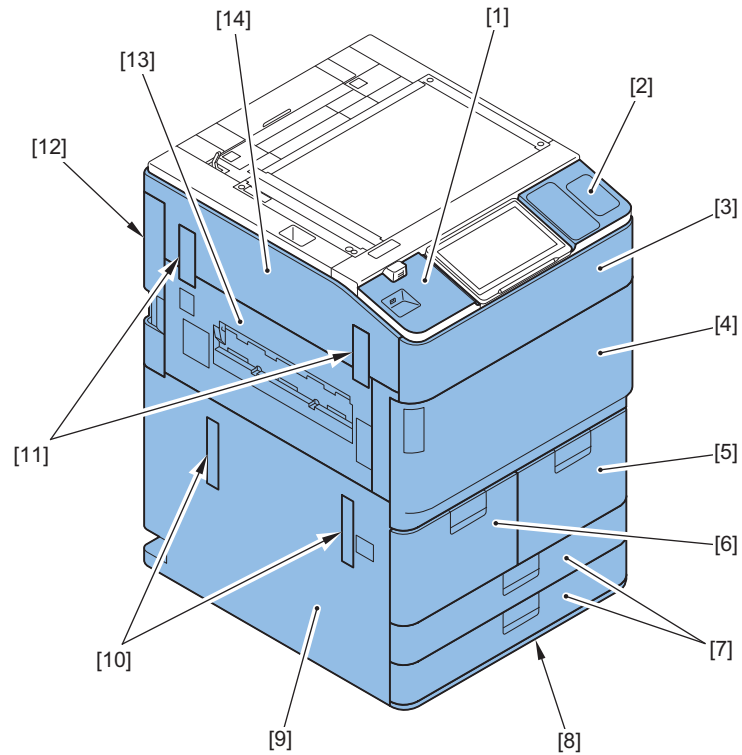
No.	Name	
[1]	Open/Close Cover	
[2]	Document Tray	
[3]	ADF Front Cover	
[4]	ADF Left Lower Cover	
[5]	ADF Rear Cover	
[6]	Hinge Cover	
[7]	ADF Right Cover	
[8]	Delivery Tray	

■ Reader

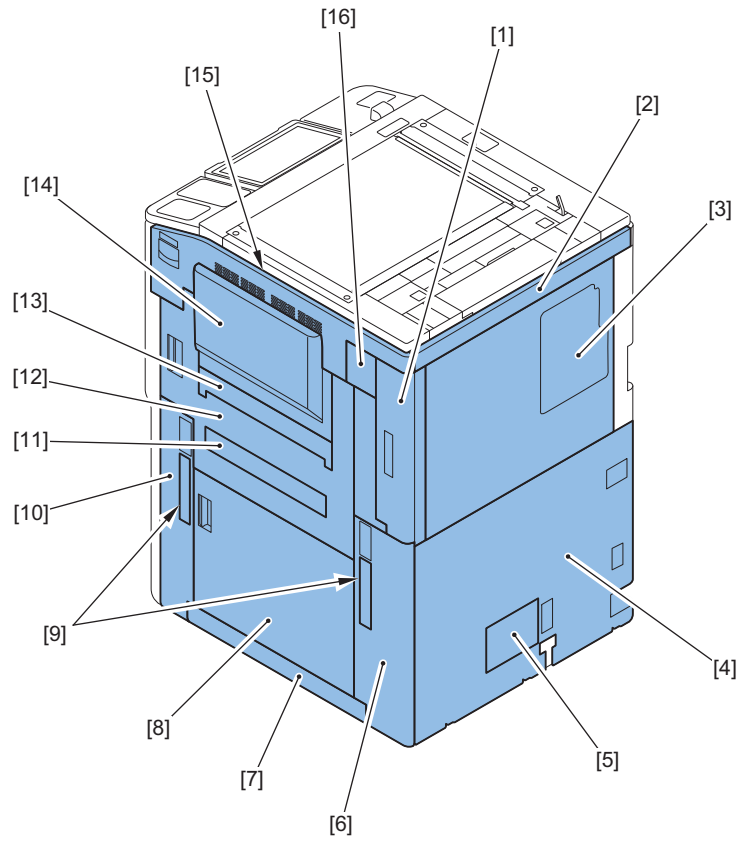


No.	Name	
[1]	Reader Front Cover	
[2]	Reader Left Cover	
[3]	Reader Right Cover	
[4]	Reader Rear Cover	
[5]	Maintenance Cover	
[6]	Glass Retainer Right Cover	
[7]	Glass Retainer Left Cover	
[8]	Right Hinge Lower Cover	
[9]	Left Hinge Lower Cover	
[10]	Jump Guide	
[11]	Left Upper Cover	
[12]	Maintenance Cover (Upper)	

■ Printer



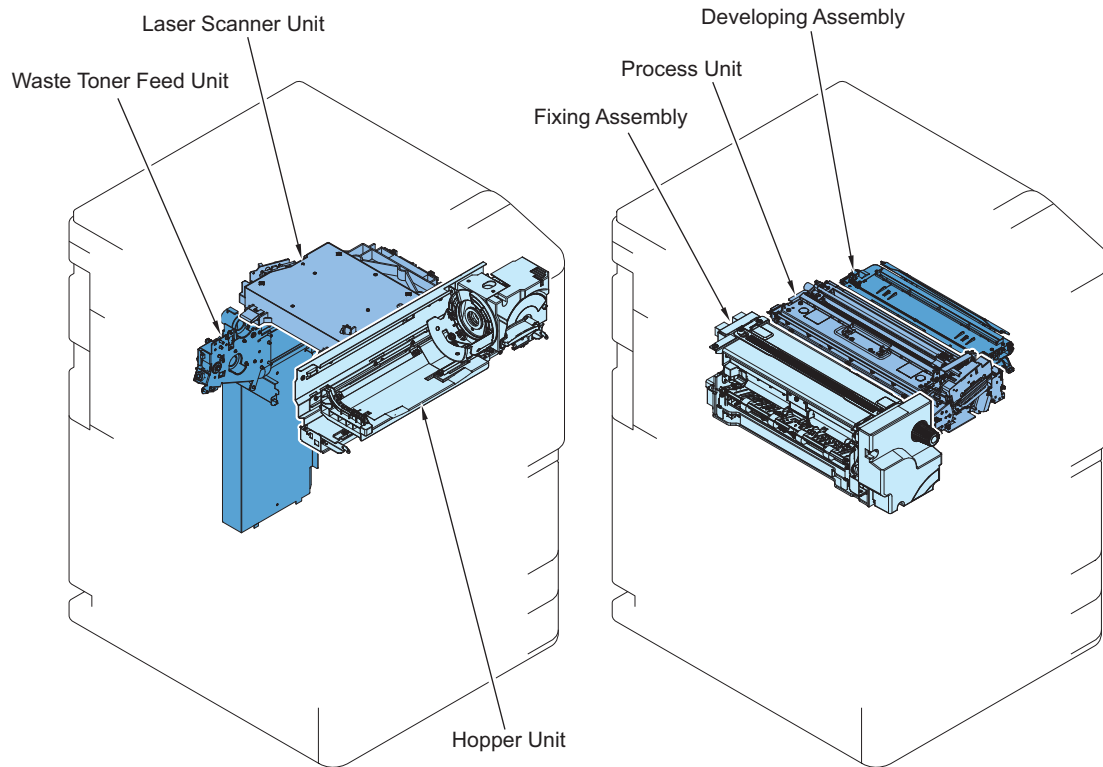
No.	Name	
[1]	Control Panel Left Upper Cover	
[2]	Control Panel Right Upper Cover	
[3]	Toner Replacement Cover	
[4]	Front Cover	
[5]	Deck Right Cover	
[6]	Deck Left Cover	
[7]	Cassette Front Cover	
[8]	Cassette Lower Cover	
[9]	Left Lower Cover	
[10]	Handle Cover	
[11]	Finisher Connector Cover	
[12]	Left Rear Cover	
[13]	Delivery Cover	
[14]	Left Upper Cover	



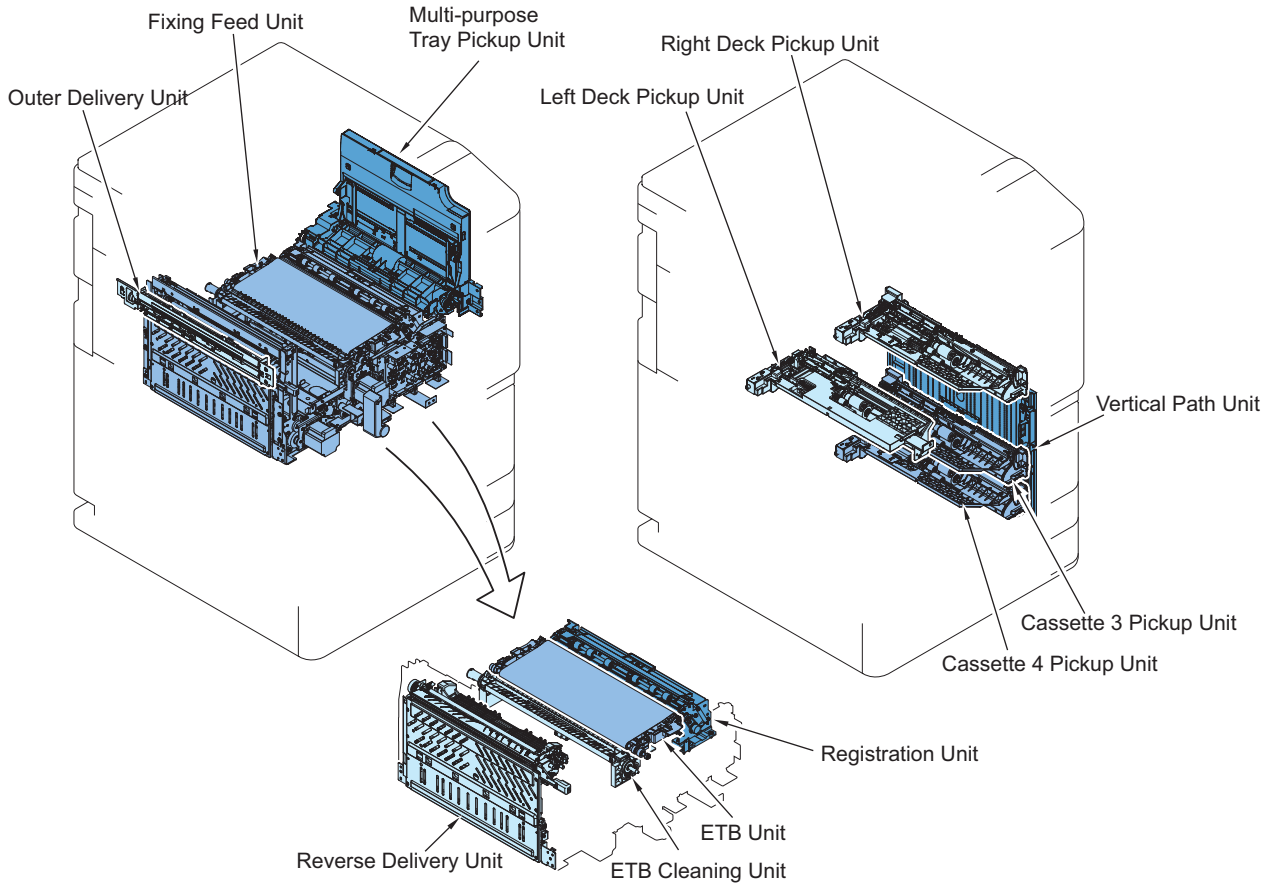
No.	Name	
[1]	Box Right Cover	
[2]	Box Upper Cover	
[3]	Rear Upper Cover	
[4]	Rear Lower Cover	
[5]	Filter Cover	
[6]	Waste Toner Container Cover	
[7]	Right Lower Middle Cover	
[8]	Vertical Path Cover	
[9]	Handle Cover	
[10]	Right Lower Front Cover	
[11]	Duplex Delivery Cover	
[12]	Right Door	
[13]	Multi-purpose Tray Sub Cover	
[14]	Multi-purpose Tray	
[15]	Right Upper Cover	
[16]	Right Rear Cover	

List of Main Unit

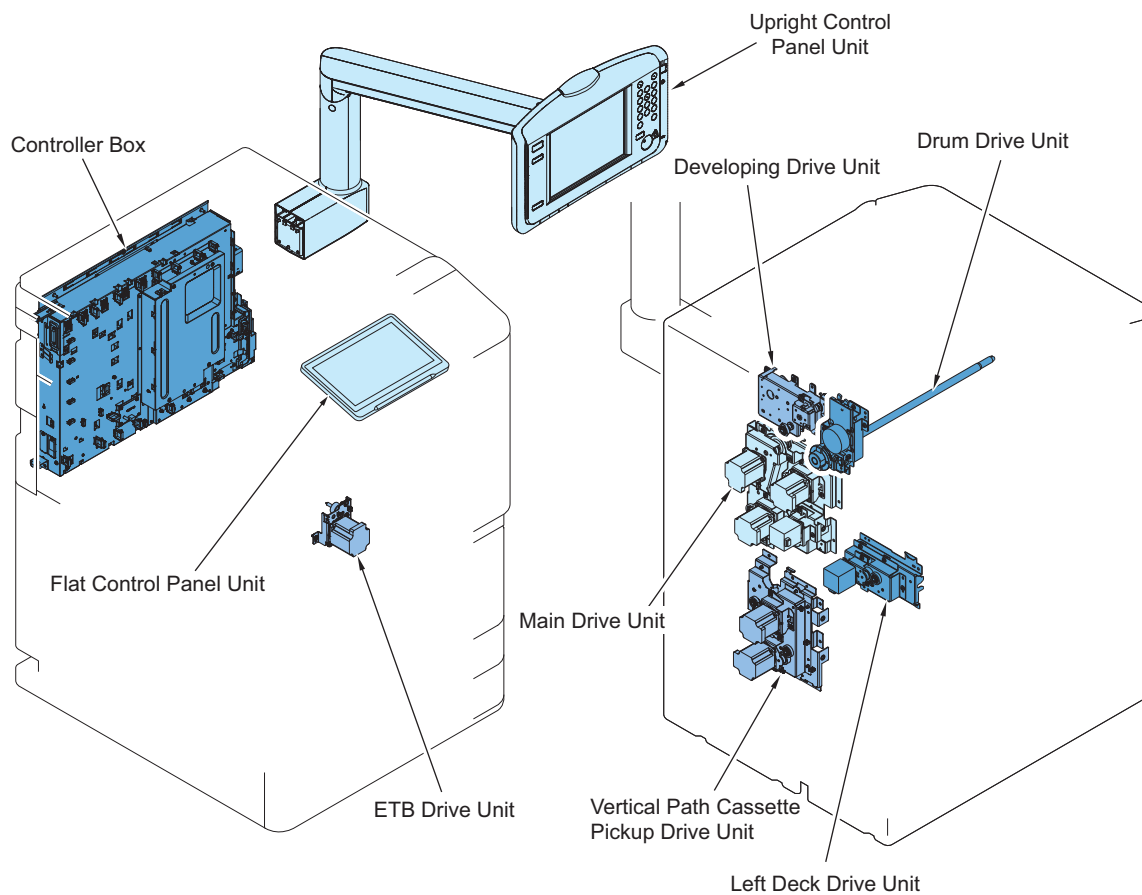
■ Printer



No	Name	Reference
[1]	Waste Toner Feed Unit	"Removing the Waste Toner Feed Unit" on page 467
[2]	Laser Scanner Unit	"Removing the Laser Scanner Unit" on page 355
[3]	Hopper Unit	"Removing the Hopper Unit" on page 451
[4]	Fixing Assembly	"Removing the Fixing Assembly" on page 479
[5]	Process Unit	"Removing the Process Unit" on page 391
[6]	Developing Assembly	"Removing the Developing Assembly" on page 411



No	名称	参照先
[7]	Outer Delivery Unit	-
[8]	Fixing Feed Unit	-
[9]	Multi-purpose Tray Pickup Unit	-
[10]	Left Deck Pickup Unit	"Removing the Left Deck Pickup Unit" on page 543
[11]	Right Deck Pickup Unit	"Removing the Right Deck Pickup Unit" on page 544
[12]	Vertical Path Unit	-
[13]	Cassette 3 Pickup Unit	"Removing the Cassettes 3 and 4 Pickup Unit" on page 546
[14]	Cassette 4 Pickup Unit	"Removing the Cassettes 3 and 4 Pickup Unit" on page 546
[15]	Registration Unit	"Removing the Registration Unit" on page 555
[16]	Reverse Delivery Unit	-
[17]	ETB Cleaning Unit	"Removing the ETB Unit" on page 418
[18]	ETB Unit	"Removing the ETB Unit" on page 418

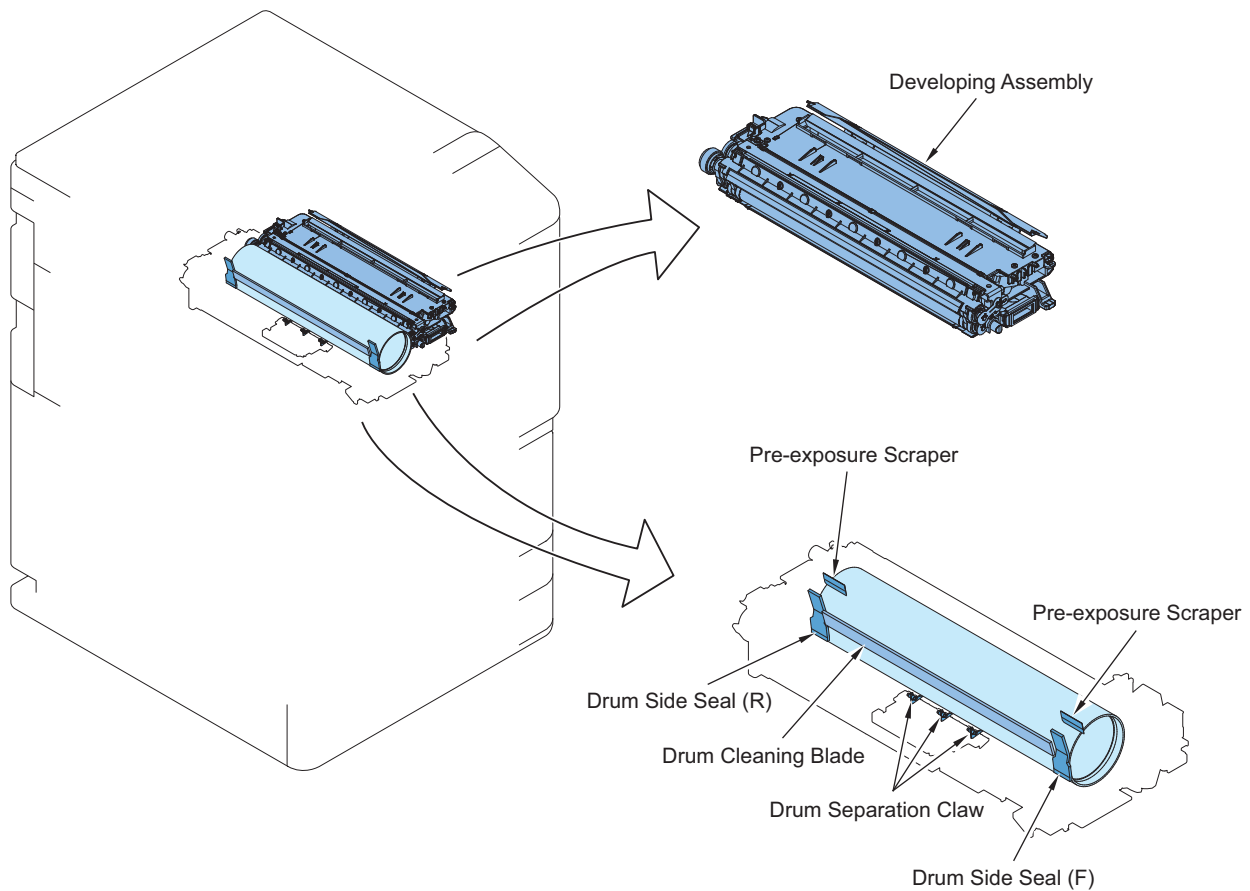


No	名称	参照先
[19]	Flat Control Panel Unit	"Removing the Flat Control Panel Unit" on page 339
[20]	Upright Control Panel Unit	"Removing the Upright Control Panel" on page 348
[21]	Controller Box	-
[22]	Drum Drive Unit	"Removing the Drum Drive Unit" on page 472
[23]	Developing Drive Unit	"Removing the Developing Drive Unit" on page 475
[24]	Main Drive Unit	"Removing the Main Drive Unit" on page 562
[25]	Vertical Path Cassette Pickup Drive Unit	"Removing the Vertical Path Cassette Pickup Drive Unit" on page 549
[26]	Left Deck Drive Unit	"Removing the Left Deck Pickup Drive Unit" on page 561
[27]	ETB Drive Unit	"Removing the ETB Drive Unit" on page 444

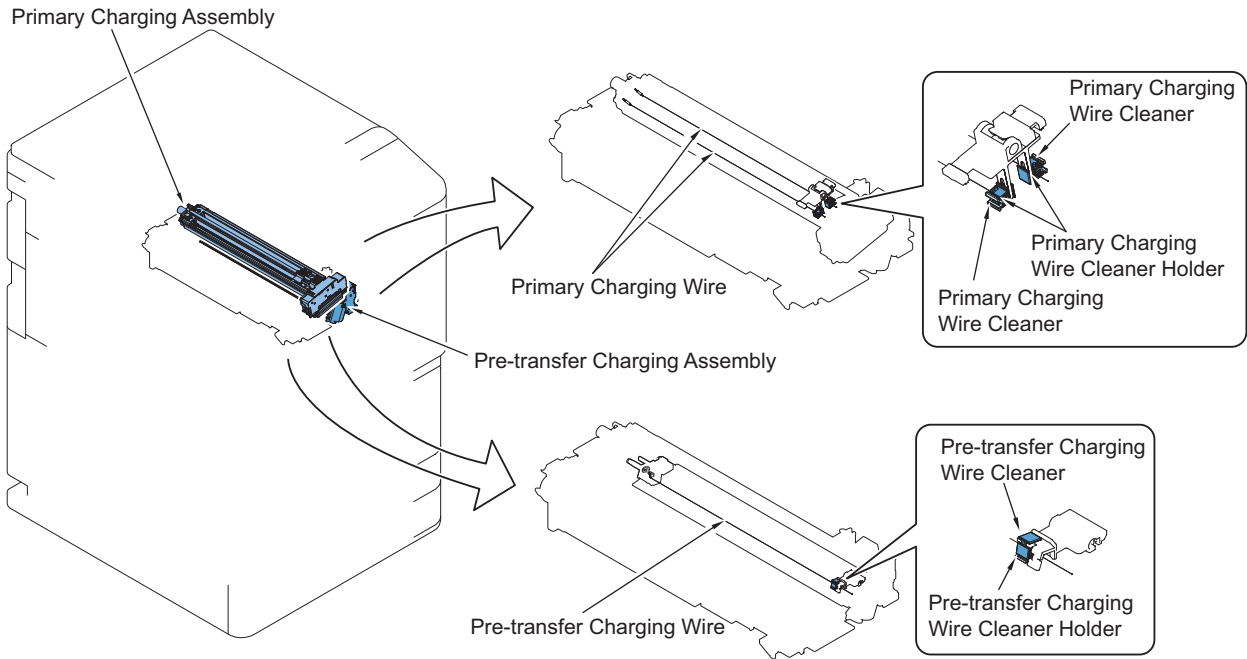
Periodic Replacing Parts, Durable Parts, Cleaning Parts

Printer

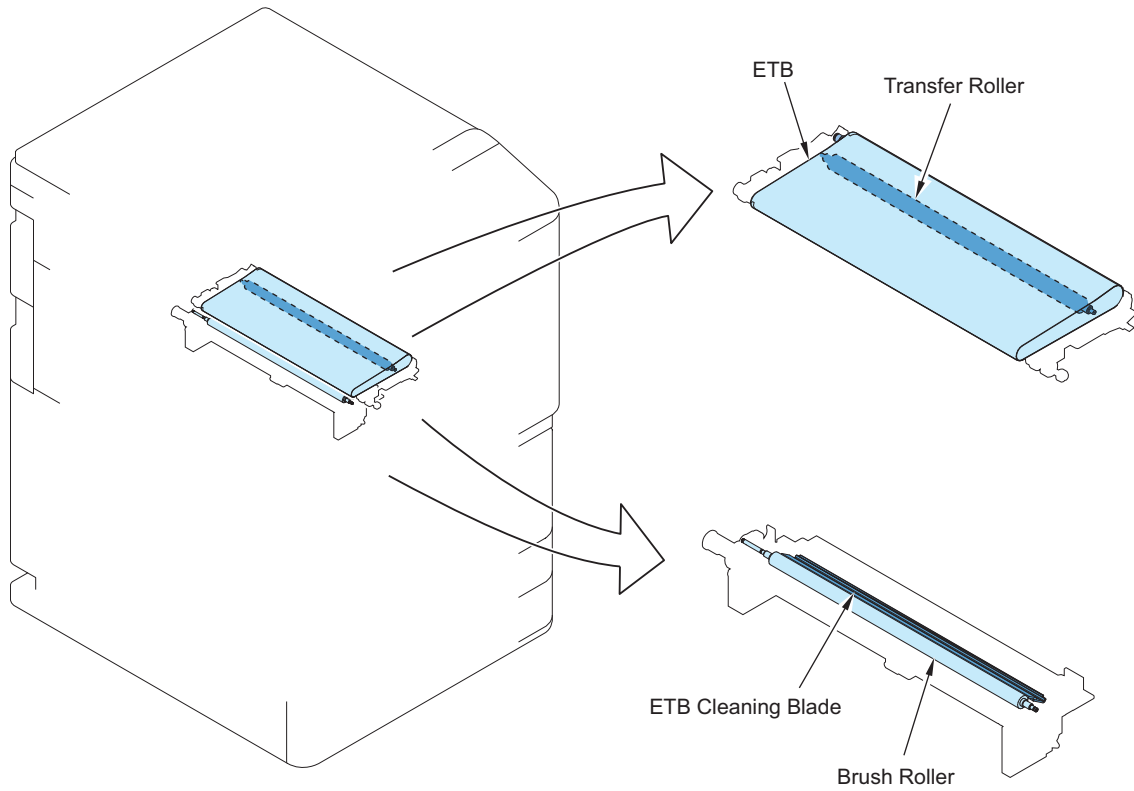
Periodic Replacing Parts, Durable Parts



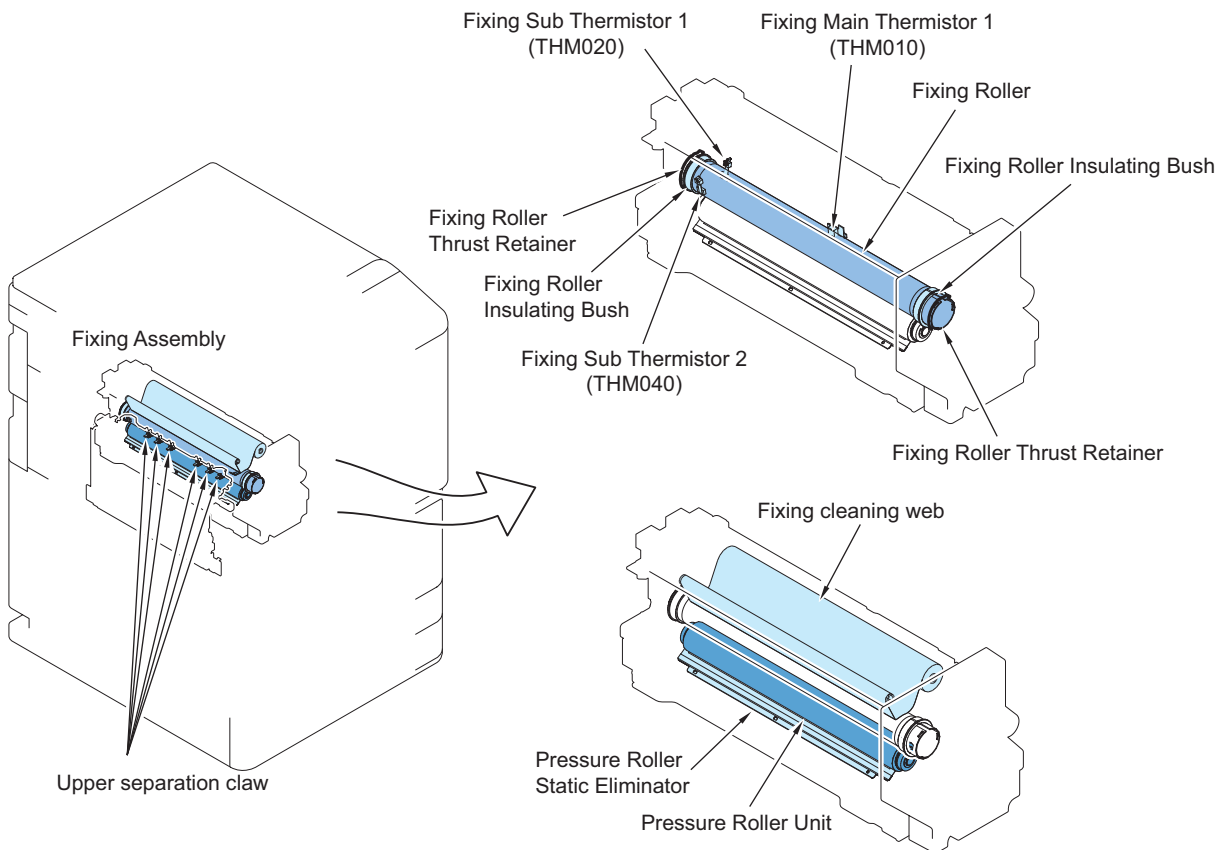
No	Name	Main Unit	Reference
[1]	Developing Assembly	Developing Assembly	"Removing the Developing Assembly" on page 411
[2]	Drum Side Seal(Rear)	Process Unit	"Removing the Side Seal" on page 410
[3]	Drum Cleaning Blade	Process Unit	"Removing the Drum Cleaning Blade" on page 396
[4]	Drum Separation Claw	Process Unit	"Removing the Cleaner Separation Claw" on page 409
[5]	Drum Side Seal(Front)	Process Unit	"Removing the Side Seal" on page 410
[6]	Pre-exposure Scraper	Drum Cleaning Unit	"Replacing the Pre-exposure Plastic Film" on page 399



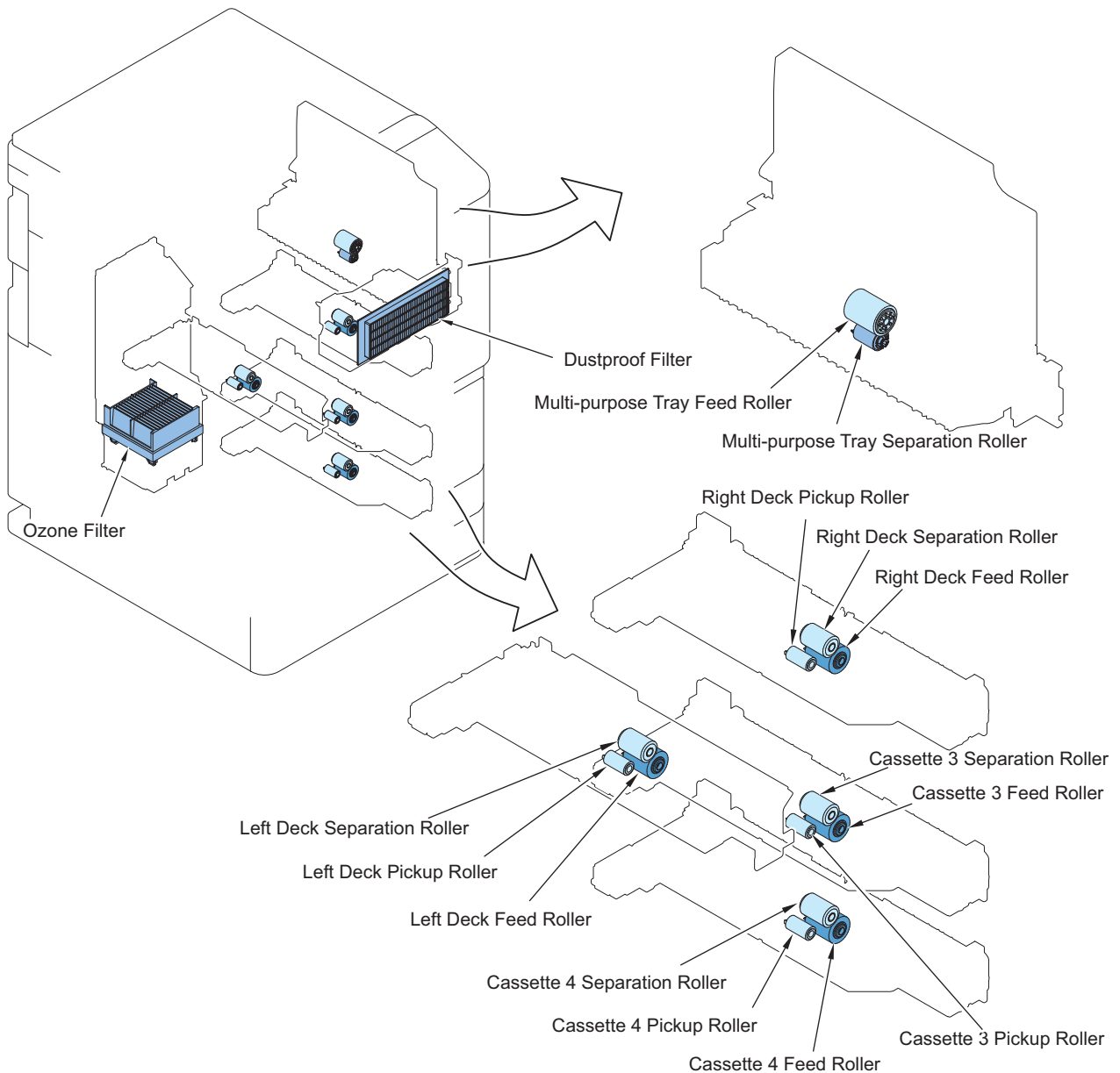
No	Name	Main Unit	Reference
[1]	Primary Charging Assembly	Process Unit	“Removing the Primary Charging Assembly” on page 362
[2]	Pre-transfer Charging Assembly	Process Unit	“Removing the Pre-transfer Charging Assembly” on page 380
[3]	Primary Charging Wire	Primary Charging Assembly	“Replacing the Primary Charging Wire” on page 375 Primary Charging Wire(with Spring)
[4]	Pre-transfer Charging Wire	Pre-transfer Charging Assembly	“Replacing the Pre-transfer Charging Wire” on page 386 Pre-transfer Charging Wire(with Spring)
[5]	Primary Charging Wire Cleaner	Primary Charging Assembly	“Removing the Primary Charging Wire Cleaner, Cleaner Holder (Right/Left)” on page 367
[6]	Primary Charging Wire Cleaner Holder	Primary Charging Assembly	“Removing the Primary Charging Wire Cleaner, Cleaner Holder (Right/Left)” on page 367
[7]	Pre-transfer Charging Wire Cleaner	Pre-transfer Charging Assembly	“Removing the Pre-transfer Charging Wire Cleaner, Cleaner Holder” on page 382
[8]	Pre-transfer Charging Wire Cleaner Holder	Pre-transfer Charging Assembly	“Removing the Pre-transfer Charging Wire Cleaner, Cleaner Holder” on page 382



No	Name	Main Unit	Reference
[1]	ETB	ETB Unit	“Removing the ETB Unit” on page 418
[2]	Transfer Roller	ETB Unit	“Removing the Transfer Roller” on page 425
[3]	ETB Cleaning Blade	ETB Cleaning Unit	“Removing the ETB Cleaning Blade” on page 427
[4]	Brush Roller	ETB Cleaning Unit	“Removing the ETB Brush Roller” on page 428

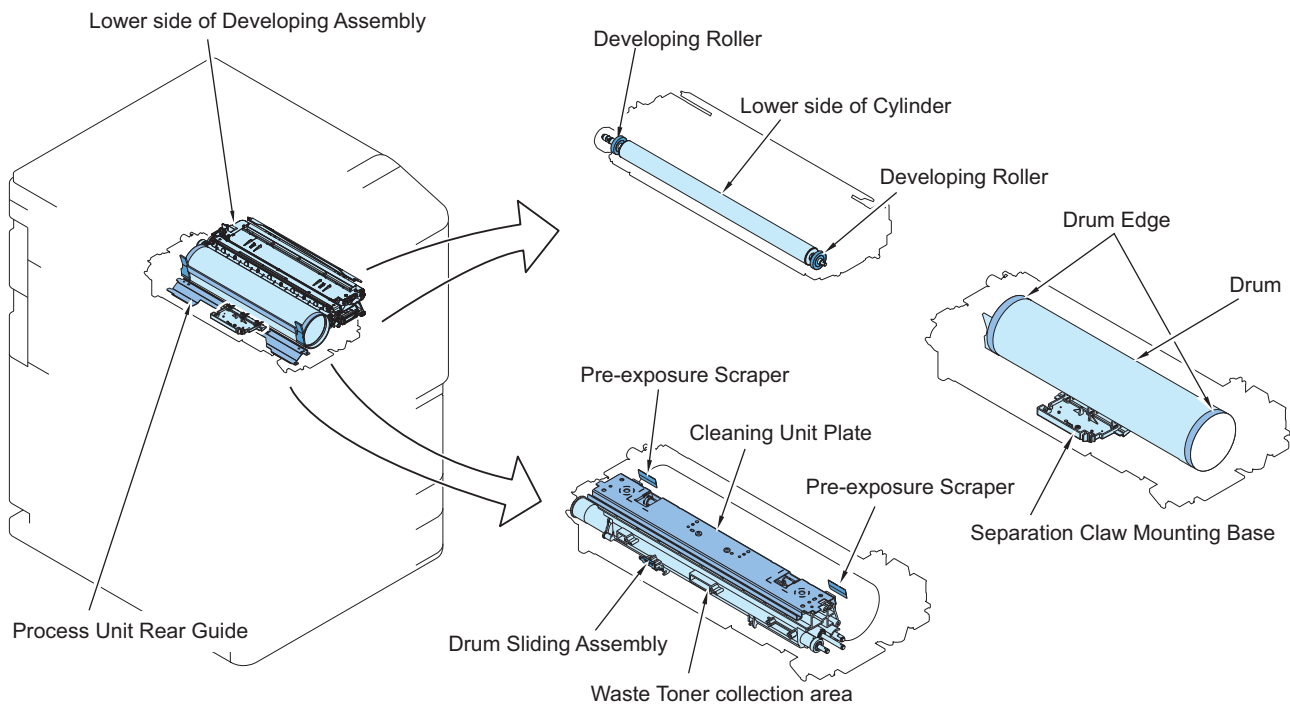


No	Name	Main Unit	Reference
[1]	Fixing Sub Thermister 1(THM020)	Fixing Assembly	"Removing the Sub Thermistor 1" on page 505
[2]	Fixing Main Thermister(THM010)	Fixing Assembly	"Removing the Main Thermistor" on page 503
[3]	Fixing Roller	Fixing Assembly	"Removing the Fixing Roller, Insulating Bush and Thrust Stopper" on page 497
[4]	Fixing Roller Insulating Bushing	Fixing Assembly	"Removing the Fixing Roller, Insulating Bush and Thrust Stopper" on page 497
[5]	Fixing Roller Thrust Retainer	Fixing Assembly	"Removing the Fixing Roller, Insulating Bush and Thrust Stopper" on page 497
[6]	Fixing Sub Thermister 2(THM040)	Fixing Assembly	"Removing the Sub Thermistor 2" on page 507
[7]	Fixing Cleaning Web	Fixing Assembly	"Removing the Fixing Cleaning Web" on page 488
[8]	Pressure Roller Static Eliminator (front)	Fixing Assembly	"Removing the Pressure Roller Static Eliminator" on page 501
[9]	Pressure Roller Static Eliminator (rear)	Fixing Assembly	"Removing the Pressure Roller Static Eliminator" on page 501
[10]	Pressure Roller Unit	Fixing Assembly	"Removing the Pressure Roller" on page 500
[11]	Upper Separation Claw	Fixing Assembly	"Removing the Upper Separation Claw" on page 508



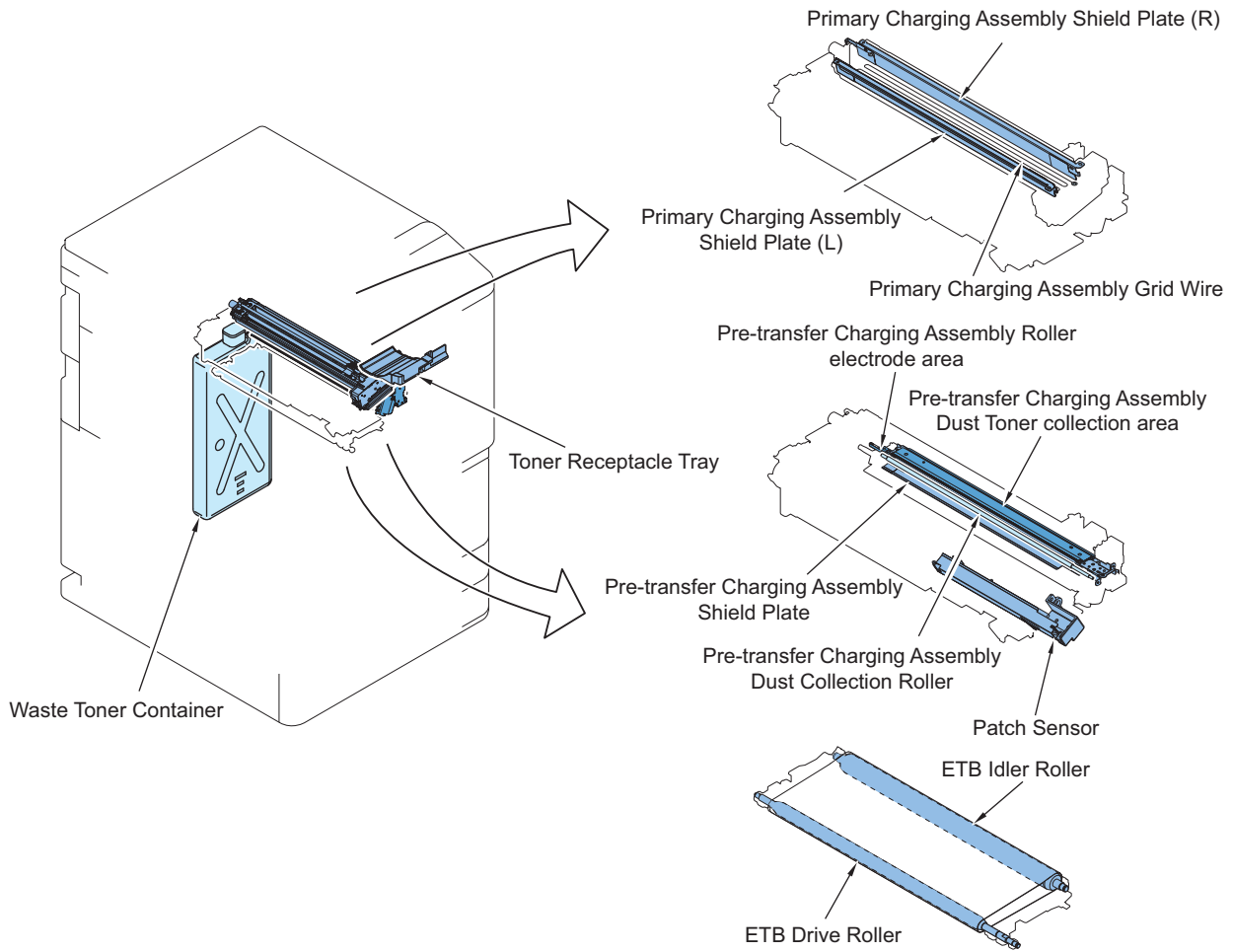
No	Name	Main Unit	Reference
[1]	Multi-purpose Tray Feed Roller	Multi-purpose Pickup Unit	"Removing the Multi-purpose Tray Feed Roller" on page 528
[2]	Multi-purpose Tray Separation Roller	Multi-purpose Pickup Unit	"Removing the Multi-purpose Tray Separation Roller" on page 529
[3]	Right Deck Pickup Roller	Right Deck Pickup Unit	"Removing the Right Deck Pickup Roller" on page 518
[4]	Right Deck Separation Roller	Right Deck Pickup Unit	"Removing the Right Deck Separation Roller/Cleaning the Right Deck Pickup Sensor (PS19)" on page 520
[5]	Right Deck Feed Roller	Right Deck Pickup Unit	"Removing the Right Deck Feed Roller" on page 519
[6]	Left Deck Separation Roller	Left Deck Pickup Unit	"Removing the Left Deck Separation Roller/Cleaning the Left Deck Pickup Sensor (PS20)" on page 517
[7]	Left Deck Pickup Roller	Left Deck Pickup Unit	"Removing the Left Deck Pickup Roller" on page 514
[8]	Left Deck Feed Roller	Left Deck Pickup Unit	"Removing the Left Deck Feed Roller" on page 515
[9]	Cassette 3 Separation Roller	Cassette 3 Pickup Unit	"Removing the Upper Cassette Separation Roller/Cleaning the Cassette 3 Pickup Sensor (PS21)" on page 523
[10]	Cassette 3 Feed Roller	Cassette 3 Pickup Unit	"Removing the Upper Cassette Feed Roller" on page 523
[11]	Cassette 3 Pickup Roller	Cassette 3 Pickup Unit	"Removing the Upper Cassette Pickup Roller" on page 522
[12]	Cassette 4 Separation Roller	Cassette 4 Pickup Unit	"Removing the Lower Cassette Separation Roller/Cleaning the Cassette 4 Pickup Sensor (PS22)" on page 526
[13]	Cassette 4 Pickup Roller	Cassette 4 Pickup Unit	"Removing the Lower Cassette Pickup Roller" on page 525
[14]	Cassette 4 Feed Roller	Cassette 4 Pickup Unit	"Removing the Lower Cassette Feed Roller" on page 526
[15]	Dustproof Filter	Product configuration	"Removing the Filter (for primary charging)" on page 574
[16]	Ozone Filter	Product configuration	"Removing the Ozone Filter" on page 574

• List of Cleaning Parts



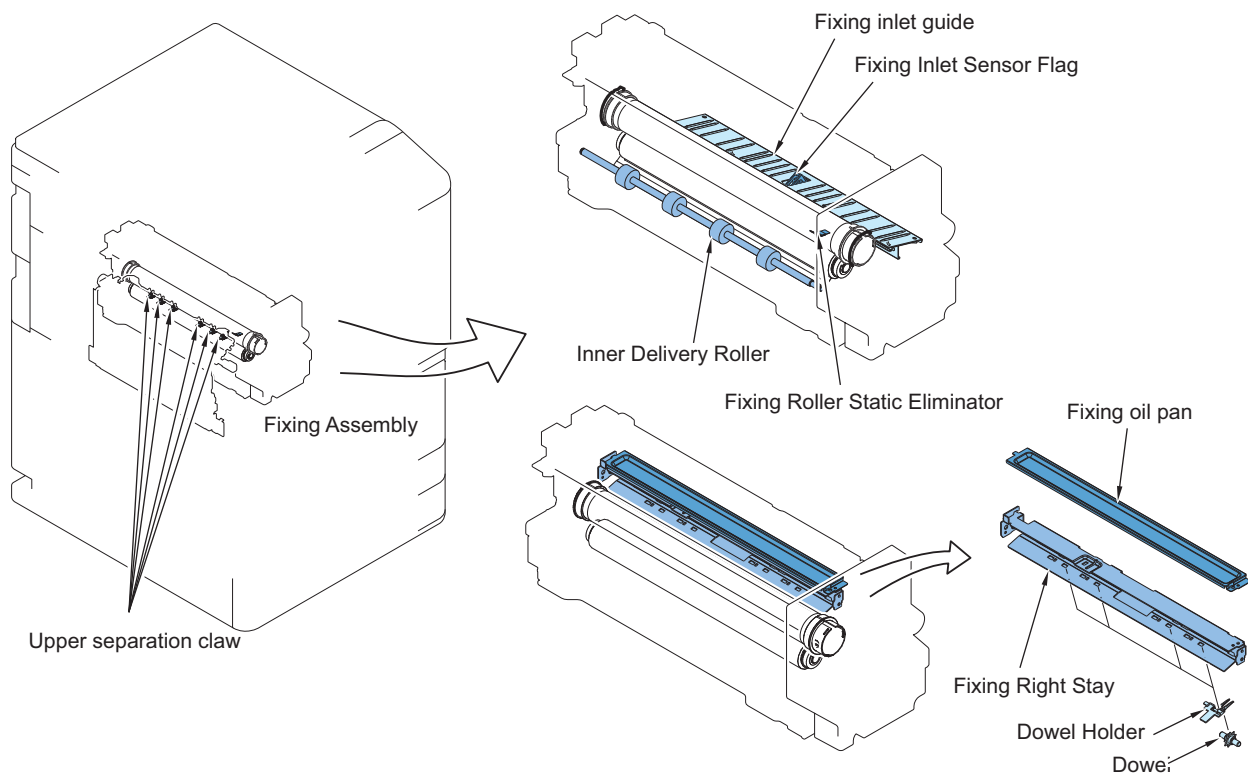
No	Name	Main Unit	Reference
[1]	Cleaning Unit Plate	Drum Cleaning Unit	"Cleaning the Drum Cleaning Unit" on page 397
[2]	Pre-exposure Scraper	Drum Cleaning Unit	"Cleaning the Drum Cleaning Unit" on page 397
[3]	Waste Toner Collection Area	Drum Cleaning Unit	"Cleaning the Drum Cleaning Unit" on page 397

No	Name	Main Unit	Reference
[4]	Separation Claw Mounting Base	Process Unit	"Cleaning the Process Unit" on page 393
[5]	Process Unit Rear Guide	Process Unit	"Cleaning the Process Unit" on page 393
[6]	Drum Sliding Assembly	Process Unit	"Cleaning the Process Unit" on page 393
[7]	Drum	Process Unit	"Cleaning Photosensitive Drum" on page 407
[8]	Drum Edge	Process Unit	"Cleaning the Drum edges" on page 408
[9]	Lower side of Developing Assembly	Developing Assembly	"Cleaning the Developing Assembly" on page 416
[10]	Developing Roller	Developing Assembly	"Cleaning the Developing Assembly" on page 416
[11]	Lower side of Cylinder	Developing Assembly	"Cleaning the Developing Assembly" on page 416

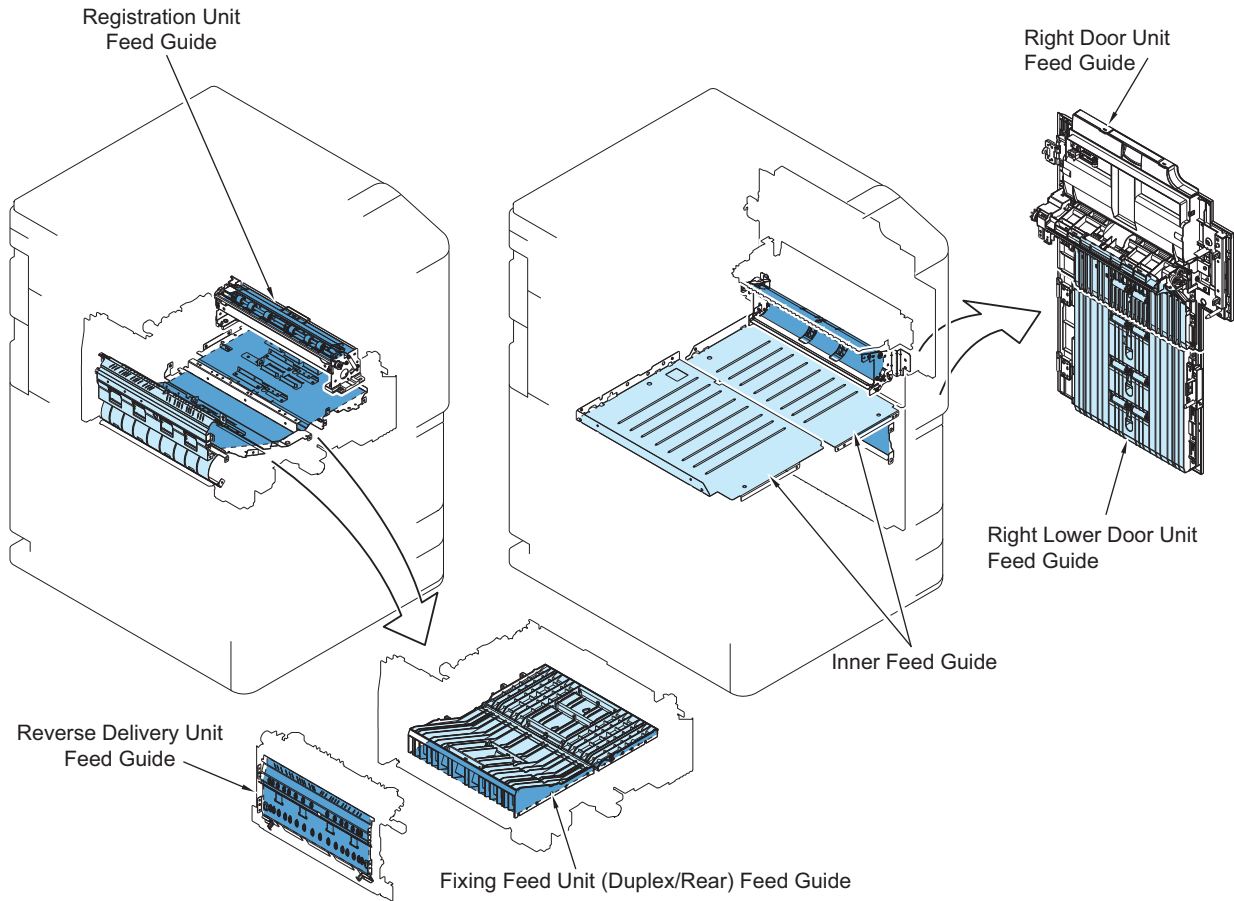


No	Name	Main Unit	Reference
[1]	Primary Charging Assembly Grid Wire	Primary Charging Assembly	"Cleaning the Primary Charging Assembly Grid Wire" on page 379
[2]	Primary Charging Assembly Shield Plate	Primary Charging Assembly	"Cleaning the Primary Charging Assembly Grid Wire" on page 379
[3]	Pre-transfer Charging Assembly Shield Plate	Pre-transfer Charging Assembly	"Cleaning the Pre-transfer Charging Wire" on page 389
[4]	Pre-transfer Charging Assembly Dust Collection Roller	Pre-transfer Charging Assembly	"Cleaning the Pre-transfer Charging Wire" on page 389
[5]	Pre-transfer Charging Assembly Roller Electrode Area	Pre-transfer Charging Assembly	"Cleaning the Pre-transfer Charging Wire" on page 389
[6]	Drum Cleaning Unit Toner Collection Area	Drum Cleaning Unit	"Cleaning the Pre-transfer Charging Wire" on page 389
[7]	Patch Sensor	Process Unit	"Cleaning the Process Unit" on page 393
[8]	ETB Drive Roller	ETB	"Cleaning the ETB" on page 424
[9]	ETB Idler Roller	ETB	"Cleaning the ETB" on page 424

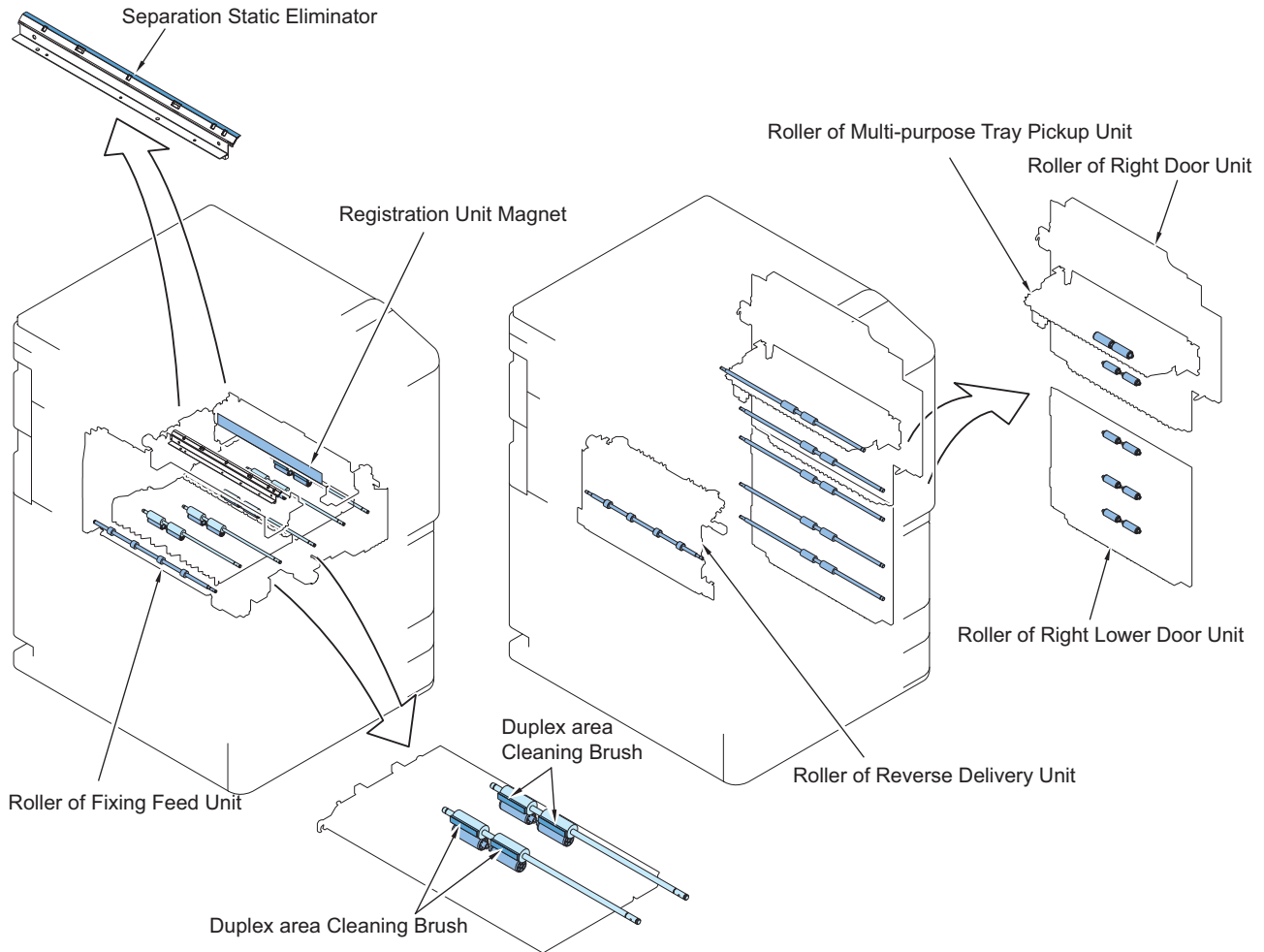
No	Name	Main Unit	Reference
[10]	Toner Receptacle Tray	Hopper Unit	"Removing the Toner Receptacle Tray" on page 450
[11]	Waste Toner Container	Hopper Unit	"Removing the Waste Toner Container" on page 431



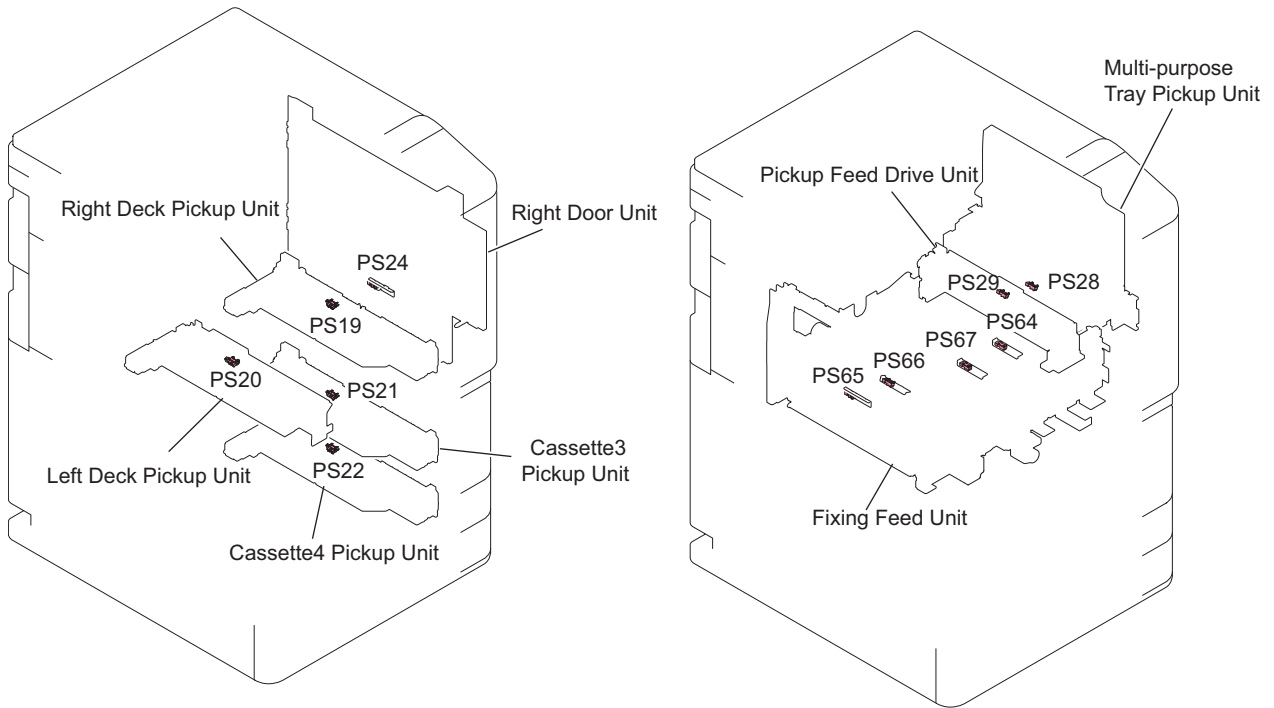
No	Name	Main Unit	Reference
[1]	Fixing Inlet Guide	Fixing Assembly	"Cleaning the Fixing Inlet Guide, Fixing Inlet Sensor Flag, Fixing Right Stay, Dowel, Dowel Holder" on page 484
[2]	Fixing Right Stay	Fixing Assembly	"Cleaning the Fixing Inlet Guide, Fixing Inlet Sensor Flag, Fixing Right Stay, Dowel, Dowel Holder" on page 484
[3]	Dowel	Fixing Assembly	"Cleaning the Fixing Inlet Guide, Fixing Inlet Sensor Flag, Fixing Right Stay, Dowel, Dowel Holder" on page 484
[4]	Dowel Holder	Fixing Assembly	"Cleaning the Fixing Inlet Guide, Fixing Inlet Sensor Flag, Fixing Right Stay, Dowel, Dowel Holder" on page 484
[5]	Fixing Oil Pan	Fixing Assembly	"Cleaning the Fixing Oil Pan" on page 488
[6]	Upper Separation Claw	Fixing Assembly	"Cleaning the Upper Separation Claw" on page 509
[7]	Fixing Roller Static Eliminator	Fixing Assembly	"Cleaning the Fixing Roller Static Eliminator" on page 493
[8]	Fixing Inlet Sensor Flag	Fixing Assembly	"Cleaning the Fixing Inlet Guide, Fixing Inlet Sensor Flag, Fixing Right Stay, Dowel, Dowel Holder" on page 484
[9]	Inner Delivery Roller	Fixing Assembly	"Cleaning the Inner Delivery Roller" on page 487



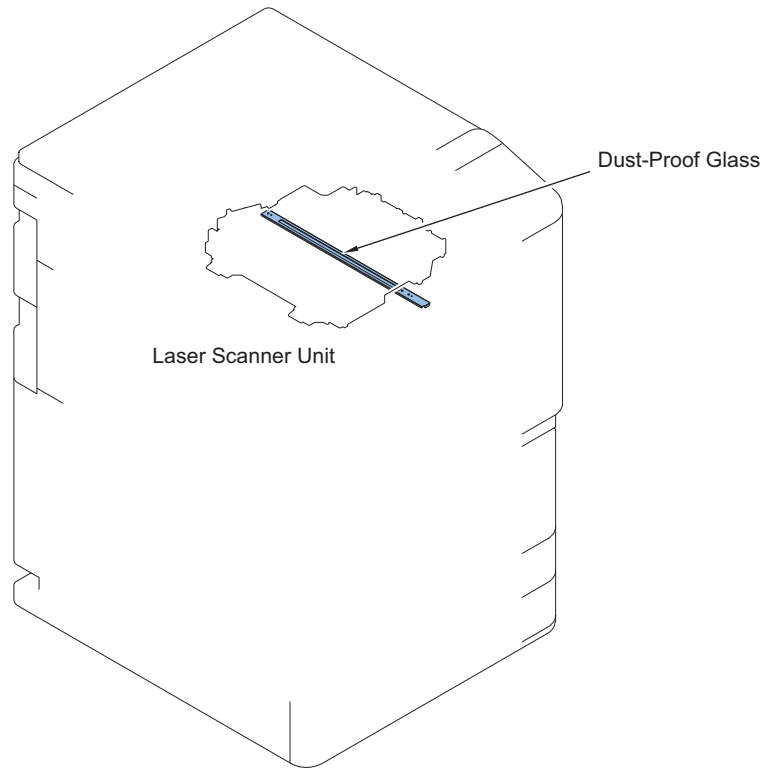
No	Name	Main Unit	Reference
[1]	Registration Unit Feed Guide	Fixing Feed Unit	"Cleaning the Pickup and Fixing Feed Assembly" on page 531
[2]	Reverse Delivery Unit Feed Guide	Reverse Delivery Unit	"Cleaning the Pickup and Fixing Feed Assembly" on page 531
[3]	Fixing Feed Unit (Duplex/Rear)Feed Guide	Fixing Feed Unit	"Cleaning the Pickup and Fixing Feed Assembly" on page 531
[4]	Inner Feed Guide	Product Specification	"Cleaning the Pickup and Fixing Feed Assembly" on page 531
[5]	Right Door Unit Feed Guide	Right Door Unit	"Cleaning the Pickup and Fixing Feed Assembly" on page 531
[6]	Right Lower Door Unit Feed Guide	Right Lower Door Unit	"Cleaning the Pickup and Fixing Feed Assembly" on page 531



No	Name	Main Unit	Reference
[1]	Roller of Fixing Feed Unit	Fixing Feed Unit	"Cleaning the Pickup and Fixing Feed Assembly" on page 531
[2]	Registration Unit Magnet	Registration Unit	"Cleaning the Pickup and Fixing Feed Assembly" on page 531
[3]	Roller of Multi-purpose Tray Pick-up Unit	Multi-purpose Tray Pick-up Unit	"Cleaning the Pickup and Fixing Feed Assembly" on page 531
[4]	Roller of Right Door Unit	Right Door Unit	"Cleaning the Pickup and Fixing Feed Assembly" on page 531
[5]	Roller of Right Lower Door Unit	Right Lower Door Unit	"Cleaning the Pickup and Fixing Feed Assembly" on page 531
[6]	Roller of Reverse Delivery Unit	Reverse Delivery Unit	"Cleaning the Pickup and Fixing Feed Assembly" on page 531
[7]	Duplex area Cleaning Brush	Fixing Feed Unit	"Cleaning the Pickup and Fixing Feed Assembly" on page 531
[8]	Separation Static Eliminator	Fixing Feed Unit	"Cleaning the Pickup and Fixing Feed Assembly" on page 531



No	Name	Main Unit	Reference
PS19	Right Deck Pickup Sensor	Right Deck Unit	"Removing the Right Deck Separation Roller/Cleaning the Right Deck Pickup Sensor (PS19)" on page 520
PS20	Left Deck Pickup Sensor	Left Deck Unit	"Removing the Left Deck Separation Roller/Cleaning the Left Deck Pickup Sensor (PS20)" on page 517
PS21	Cassette 3 Pickup Sensor	Cassette 3 Pickup Unit	"Removing the Upper Cassette Separation Roller/Cleaning the Cassette 3 Pickup Sensor (PS21)" on page 523
PS22	Cassette 4 Pickup Sensor	Cassette 4 Pickup Unit	"Removing the Lower Cassette Separation Roller/Cleaning the Cassette 4 Pickup Sensor (PS22)" on page 526
PS24	Vertical Path Sensor 1	Vertical Path Unit	"Cleaning the Pickup and Fixing Feed Assembly" on page 531
PS28	Writing Judging Sensor	Multi-purpose Tray Pickup Unit	"Cleaning the Pickup and Fixing Feed Assembly" on page 531
PS29	Registration Sensor	Pickup Feed Drive Unit	"Cleaning the Pickup and Fixing Feed Assembly" on page 531
PS64	Duplex Outlet Sensor	Fixing Feed Unit	"Cleaning the Pickup and Fixing Feed Assembly" on page 531
PS66	Duplex Left Sensor	Fixing Feed Unit	"Cleaning the Pickup and Fixing Feed Assembly" on page 531
PS67	Duplex Merging Sensor	Fixing Feed Unit	"Cleaning the Pickup and Fixing Feed Assembly" on page 531

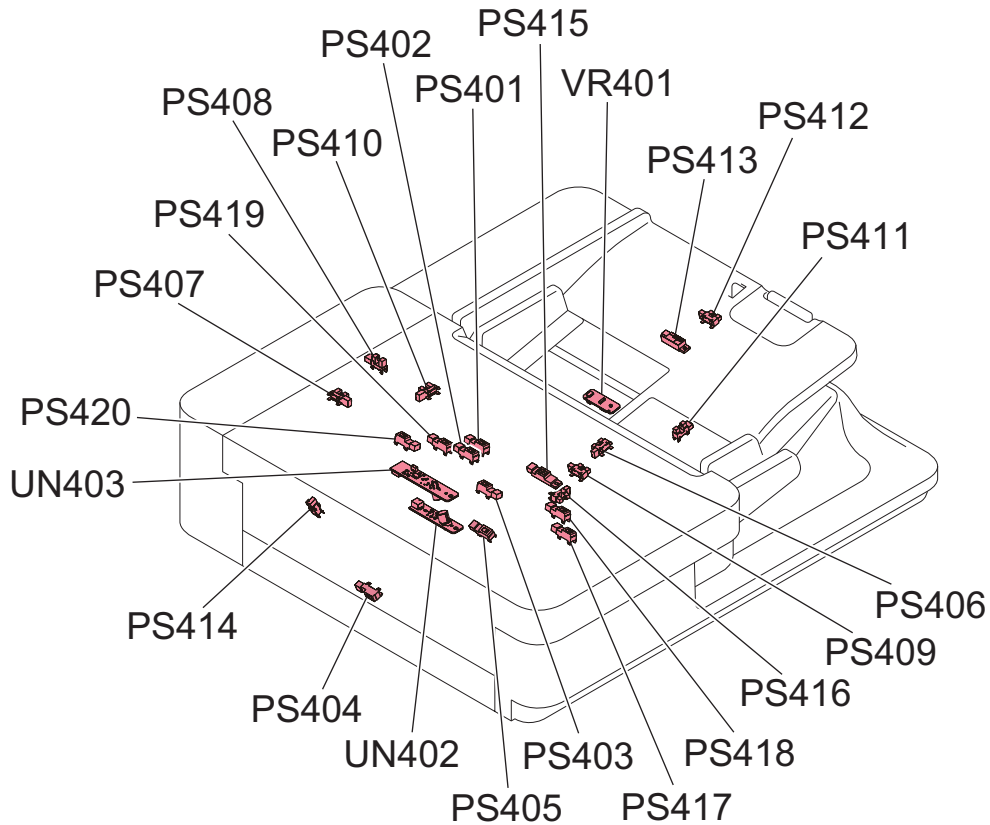


No	Name	Main Unit	Reference
[1]	Dustproof Glass	Product Configuration	"Cleaning the Dust Collecting Glass" on page 360

List of Electrical Parts

■ ADF

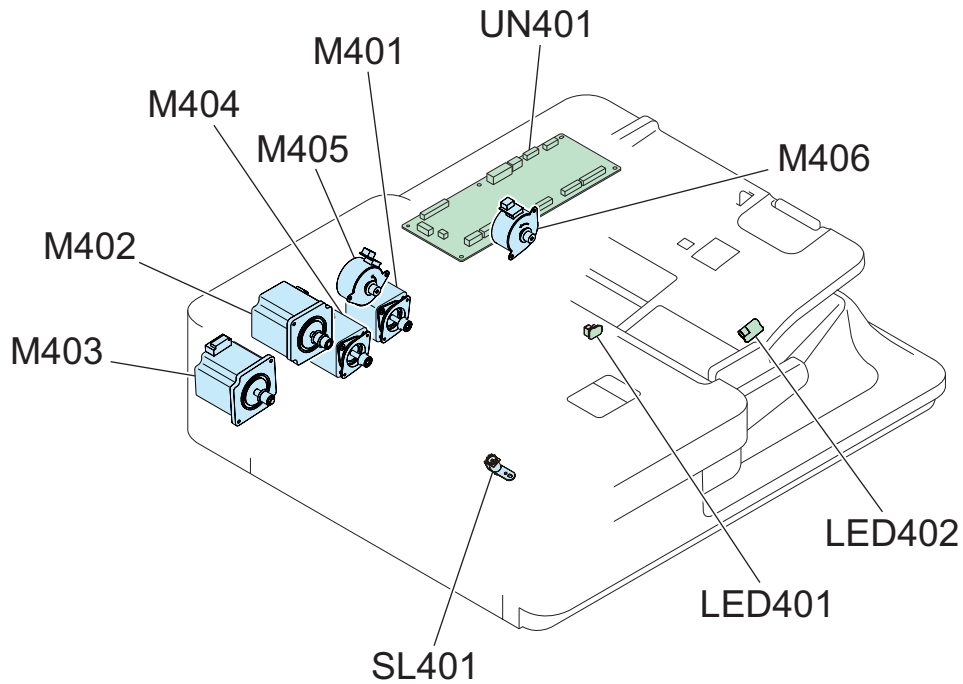
● Sensor



No.	Name
PS401	Pre-separation Sensor
PS402	Post-separation Sensor
PS403	Post-pullout Sensor
PS404	Lead Sensor
PS405	Pre-delivery Sensor
PS406	Tray Paper Surface Sensor
PS407	Cover Open/Closed Sensor
PS408	Pickup Roller Lifting HP Sensor
PS409	ADF Sleep Recover Sensor
PS410	Tray Lifting HP Sensor
PS411	AB/Inch Identification Sensor
PS412	LGL Sensor
PS413	Large Size/ Small Size Sensor
PS414	Paper Back Reading Glass HP Sensor
PS415	Original Sensor
PS416	Delivery Stack Detection Sensor
PS417	Skew Detection Sensor (Large, Front)
PS418	Skew Detection Sensor (Small, Front)
PS419	Skew Detection Sensor (Small, Rear)
PS420	Skew Detection Sensor (Large, Rear)

No.	Name
UN402	Double Feed Detection Sensor PCB (Transmission)
UN403	Double Feed Detection Sensor PCB (Reception)
VR401	Original Width Volume

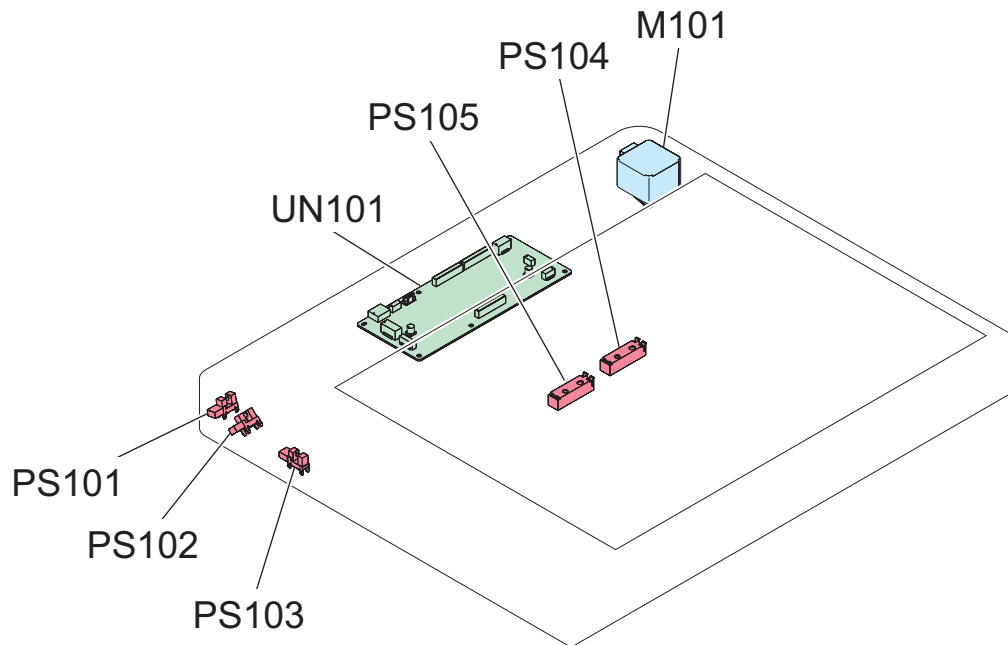
• Clutch / Solenoid / Motor / PCB



No.	Name
M401	ADF Pickup Motor
M402	ADF Pullout Motor
M403	Lead Motor
M404	ADF Delivery Motor
M405	Pickup Roller Lifting Motor
M406	Tray Lifting Motor
LED401	Original Set LED
LED402	Delivery LED
SL401	Stamp Solenoid
UN401	ADF Driver PCB

■ Reader

● Sensor / Motor / PCB

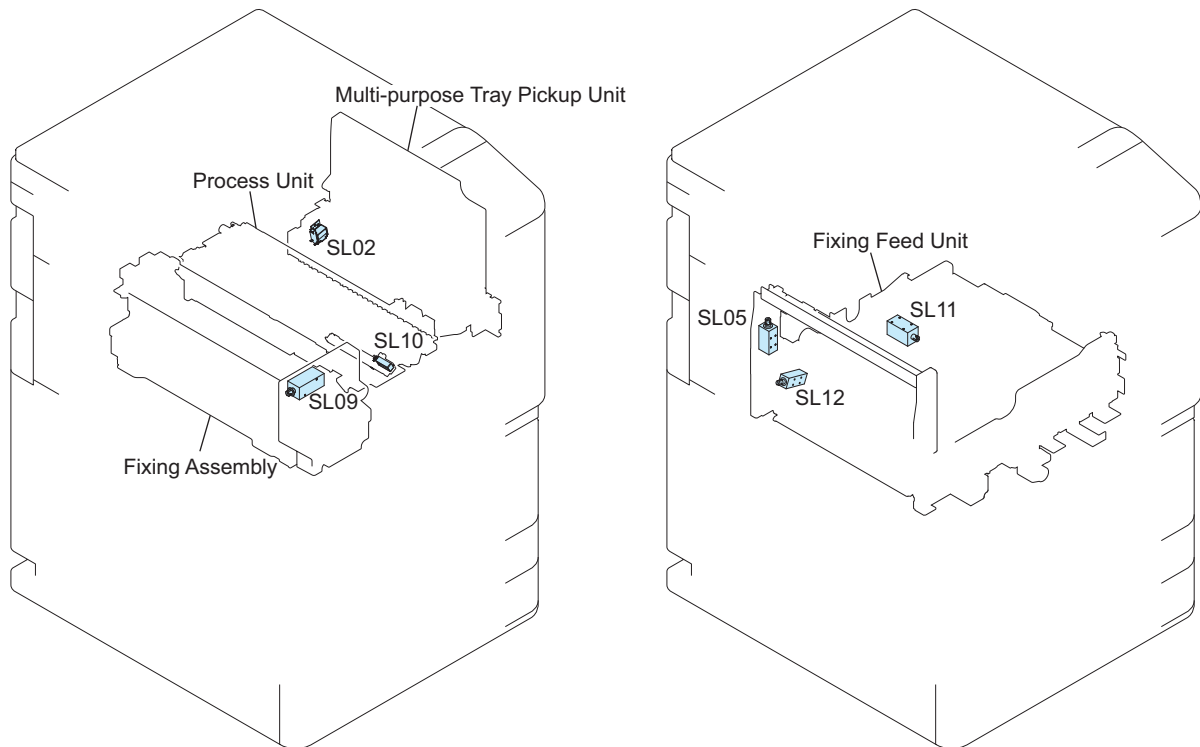


No	Name
M101	Reader Scanner Motor
PS101	ADF Open/Close Sensor 1
PS102	ADF Open/Close Sensor 2
PS103	Reader Scanner Unit HP Sensor
PS104	Original Size Sensor 1
PS105 *1	Original Size Sensor 2
UN101	Reader Controller PCB

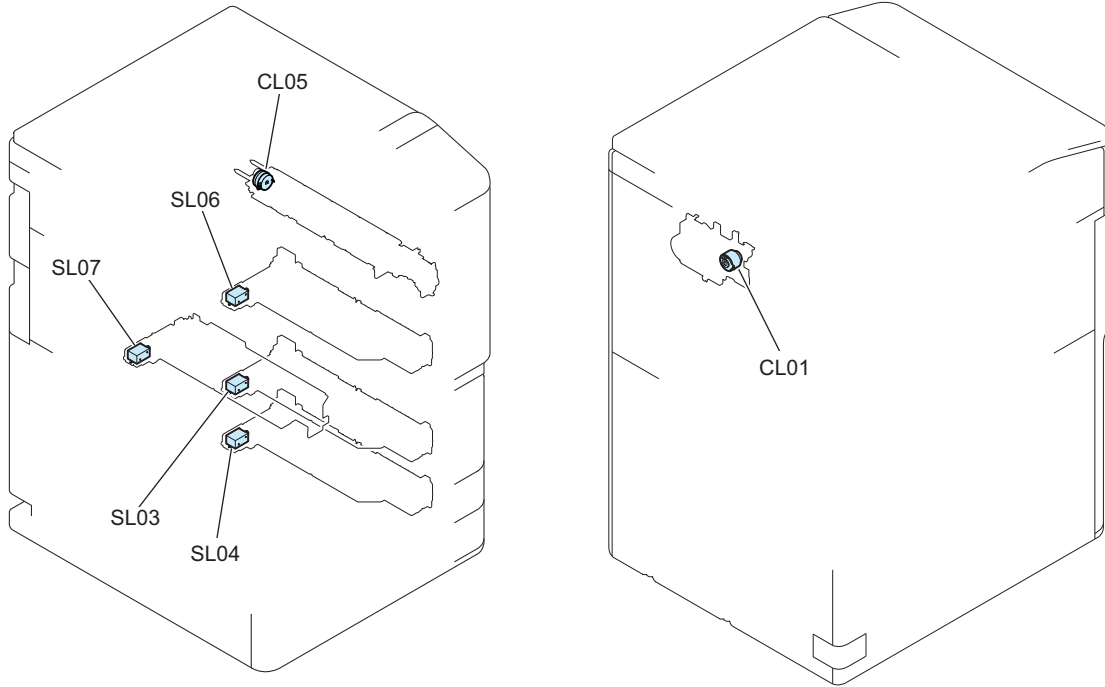
*1 : Use the AB/INCH type sensor option only when connected.

■ Printer

● Clutch / Solenoid

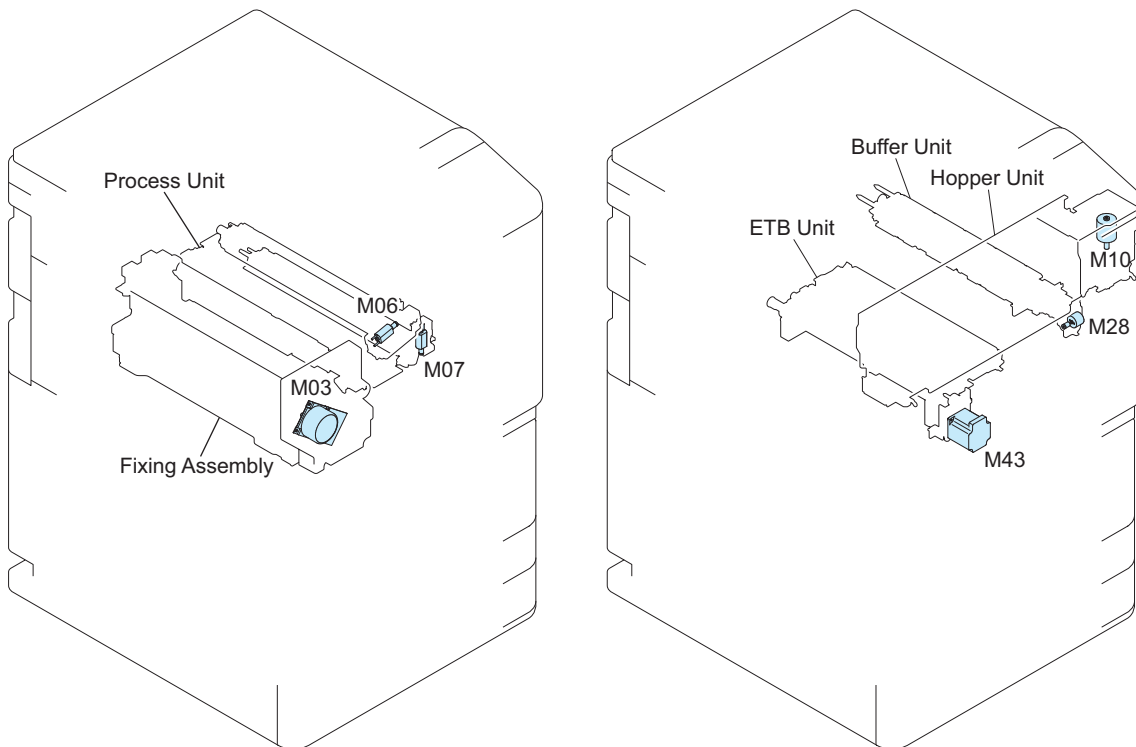


No	Name	Main Unit	COPIER > FUNCTION > PART-CHK		Reference
			Item No.	Remarks	
SL02	Multi-purpose Tray Pickup Solenoid	Multi-purpose Pickup Unit	SL > 1	SL-ON > OK	-
SL05	Reverse Upper Flapper Solenoid	Fixing Feed Unit	SL > 4	SL-ON > OK	-
SL09	Fixing Cleaning Web Drive Solenoid	Fixing Assembly	SL > 8	SL-ON > OK	-
SL10	Patch Sensor Shutter Solenoid	Process Unit	SL > 9	SL-ON > OK	-
SL11	Left Deck Merging Solenoid	Fixing Feed Unit	SL > 7	SL-ON > OK	-
SL12	Reverse Detachment Solenoid	Fixing Feed Unit	SL > 11	SL-ON > OK	-

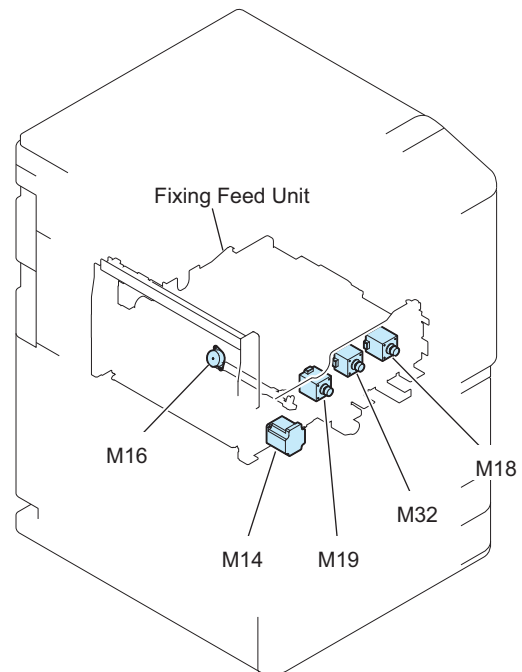
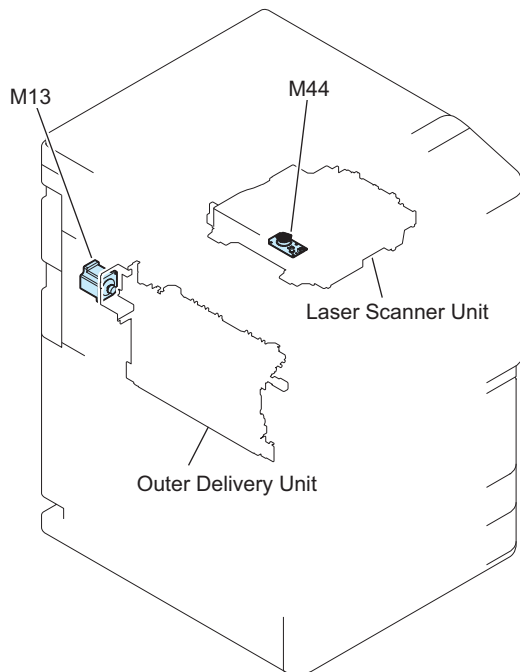


No	Name	Main Unit	COPIER > FUNCTION > PART-CHK		Reference
			Item No.	Remarks	
CL01	Developing Clutch	Developing Assembly	CL > 1	CL-ON > OK	-
CL05	Magnet Roller Clutch	Hopper Unit	CL > 2	CL-ON > OK	-
SL03	Cassette 3 Pickup Solenoid	Cassette 3 Pickup Unit	SL > 2	SL-ON > OK	-
SL04	Cassette 4 Pickup Solenoid	Cassette 4 Pickup Unit	SL > 3	SL-ON > OK	-
SL06	Right Deck Pickup Solenoid	Right Deck Pickup Unit	SL > 5	SL-ON > OK	-
SL07	Left Deck Pickup Solenoid	Left Deck Pickup Unit	SL > 6	SL-ON > OK	-

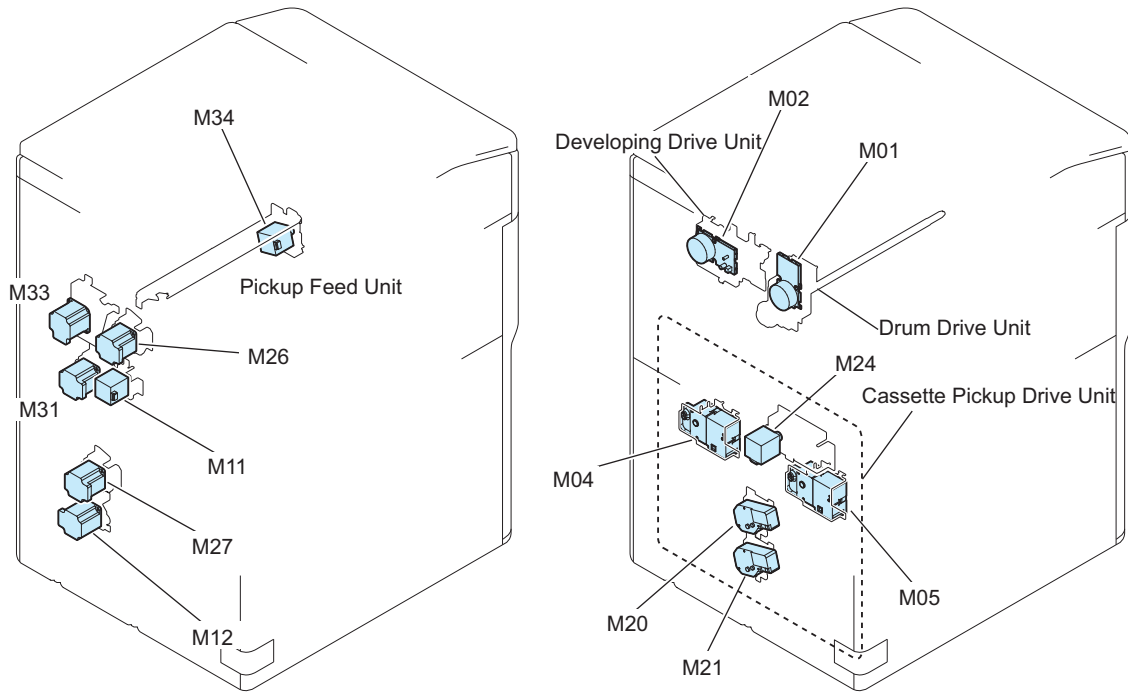
• List of Motor



No	Name	Main Unit	COPIER > FUNCTION > PART-CHK		Reference
			Item No.	Remarks	
M03	Fixing Motor	Fixing Assembly	MTR > 17	MTR-ON > OK	-
M06	Primary Charging Wire Cleaning Motor	Process Unit	-	-	-
M07	Pre-transfer Charging Wire Cleaning Motor	Process Unit	-	-	-
M10	Toner Supply Motor	Hopper Unit	-	-	-
M28	Toner Feed Motor	Buffer Unit	MTR > 2	MTR-ON > OK	-
M43	ETB Motor	ETB Unit	MTR > 14	MTR-ON > OK	-

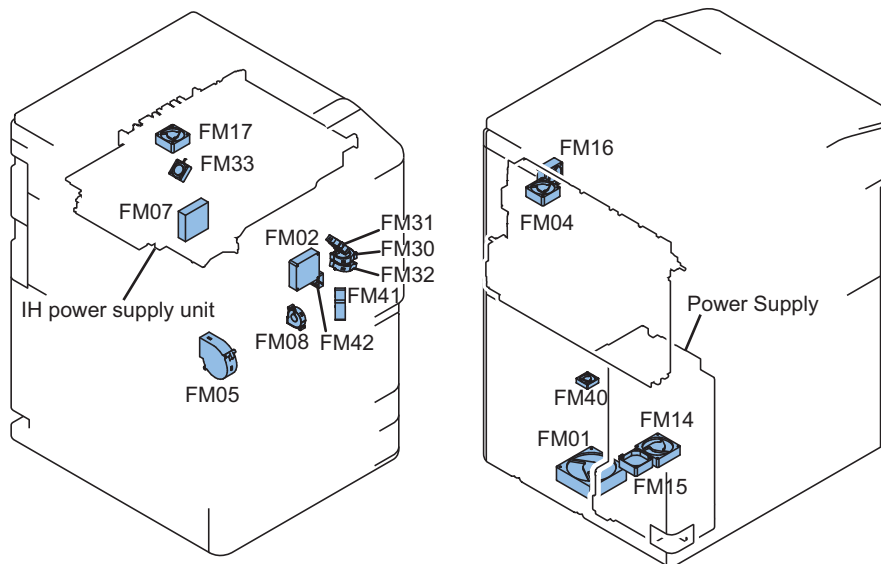


No	Name	Main Unit	COPIER > FUNCTION > PART-CHK		Reference
			Item No.	Remarks	
M13	Delivery Motor	Outer Delivery Unit	MTR > 3	MTR-ON > OK	-
M14	Reverse Motor	Fixing Feed Unit	MTR > 4	MTR-ON > OK	-
M16	Side Registration Motor	Fixing Feed Unit	MTR > 5	MTR-ON > OK	-
M18	Duplex Feed Right Motor	Fixing Feed Unit	MTR > 6	MTR-ON > OK	-
M19	Duplex Feed Left Motor	Fixing Feed Unit	MTR > 7	MTR-ON > OK	-
M32	Duplex Feed Merging Motor	Fixing Feed Unit	MTR > 11	MTR-ON > OK	-
M44	Laser Scanner Motor	Laser Scanner Unit	-	-	-



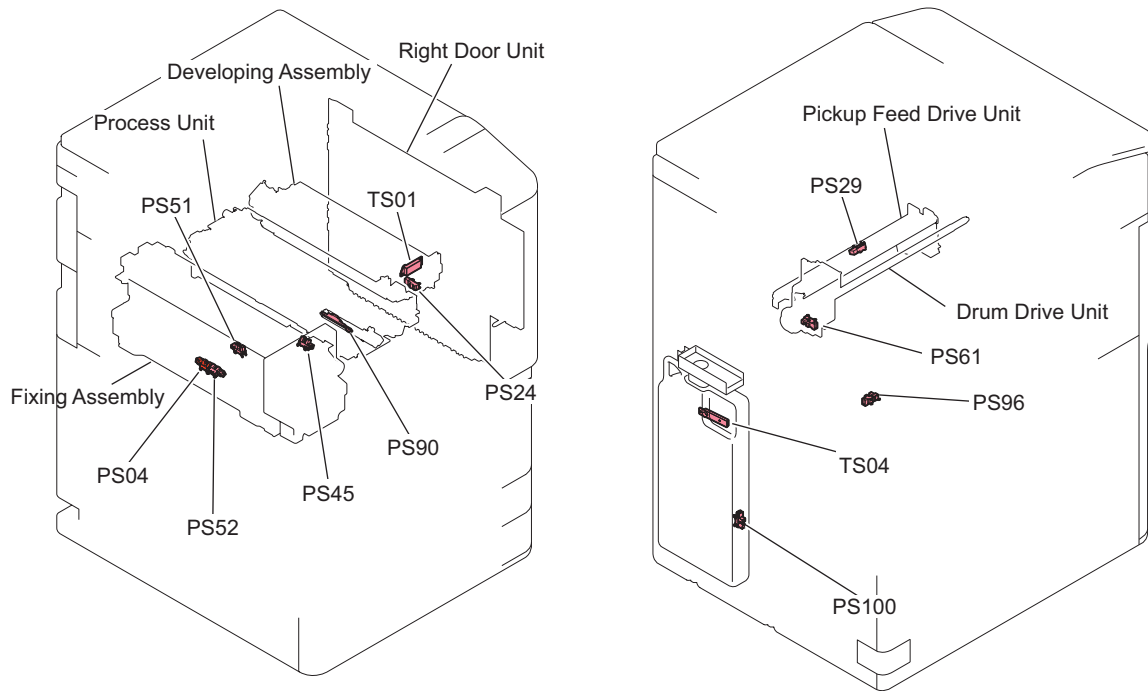
No	Name	Main Unit	COPIER > FUNCTION > PART-CHK		Reference
			Item No.	Remarks	
M01	Drum Motor	Drum Drive Unit	-	-	-
M02	Developing Motor	Developing Assembly Drive Unit	-	-	-
M04	Right Deck Lifter Motor	Cassette Pickup Drive Unit	-	-	-
M05	Left Deck Lifter Motor	Cassette Pickup Drive Unit	-	-	-
M11	Right Deck Pickup Motor	Pickup Feed Unit	-	-	-
M12	Cassette 3,4 Pickup Motor	Pickup Feed Unit	-	-	-
M20	Cassette 3 Lifter Motor	Cassette Pickup Drive Unit	-	-	-
M21	Cassette 4 Lifter Motor	Cassette Pickup Drive Unit	-	-	-
M24	Left Deck Pickup Motor	Cassette Pickup Drive Unit	-	-	-
M26	Vertical Path Upper Motor	Pickup Feed Unit	MTR > 8	MTR-ON > OK	-
M27	Vertical Path Lower Motor	Pickup Feed Unit	MTR > 9	MTR-ON > OK	-
M31	Vertical Path Middle Motor	Pickup Feed Unit	MTR > 10	MTR-ON > OK	-
M33	Multi-purpose Tray Registration Front Motor	Pickup Feed Unit	MTR > 12	MTR-ON > OK	-
M34	Registration Motor	Pickup Feed Unit	MTR > 13	MTR-ON > OK	-

• List of Fan

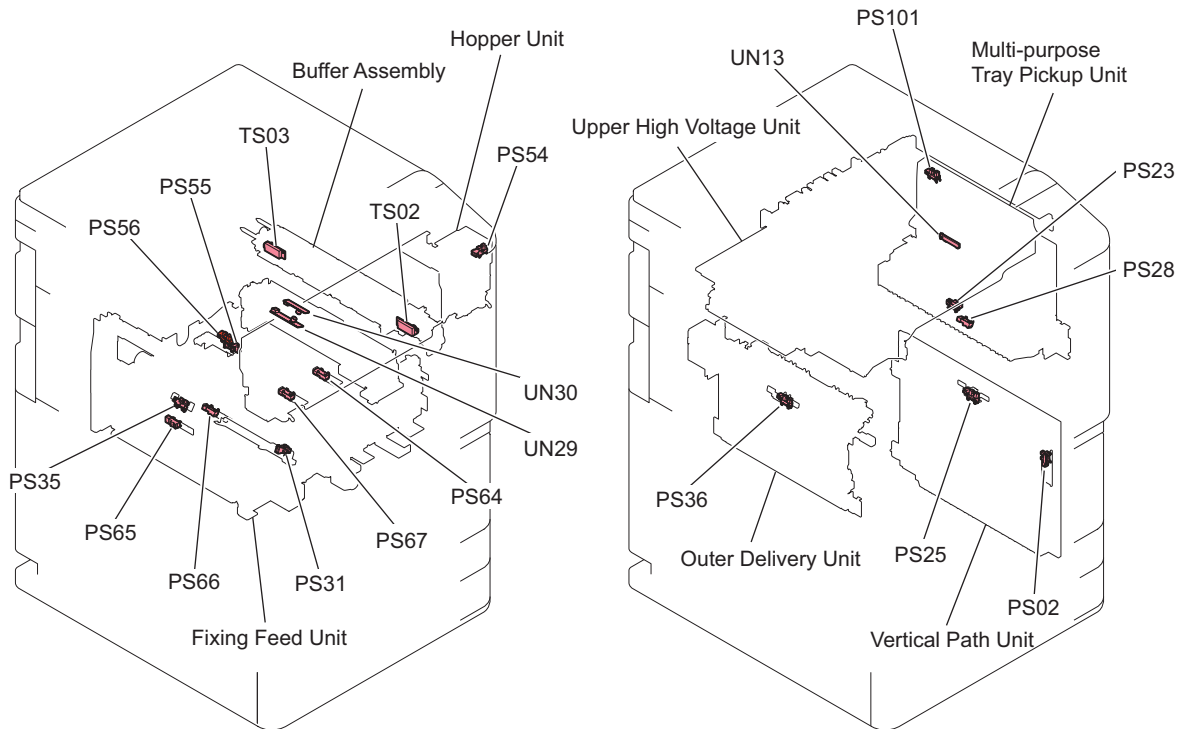


No.	Name	Main Unit	Reference
FM01	Making Image Exhaust Fan	Product configuration	-
FM02	Primary Charging Assembly Air Supply Fan	Product configuration	-
FM04	Main Controller Cooling Fan	Product configuration	-
FM05	Paper Cooling Fan	Product configuration	-
FM07	Fixing Power Supply Cooling Fan	Product configuration	-
FM08	Transfer Cleaner Cooling Fan	Product configuration	-
FM14	Power Supply Cooling Fan 1	Product configuration	-
FM15	Power Supply Cooling Fan 2	Product configuration	-
FM16	Laser Scanner Cooling Fan	Product configuration	-
FM17	Primary Charging Assembly Exhaust Fan	Product configuration	-
FM30	Developing Assembly Lower Cooling Fan	Product configuration	-
FM31	Developing Assembly Upper Cooling Fan	Product configuration	-
FM32	Pre-transfer Charging Assembly Air Supply Fan	Product configuration	-
FM33	Pre-transfer Charging Assembly Exhaust Fan	Product configuration	-
FM40	Feed Driver Cooling Fan	Product configuration	-
FM41	Duplex Driver Cooling Fan	Product configuration	-
FM42	Registration Motor/Duplex Motor Cooling Fan	Product configuration	-

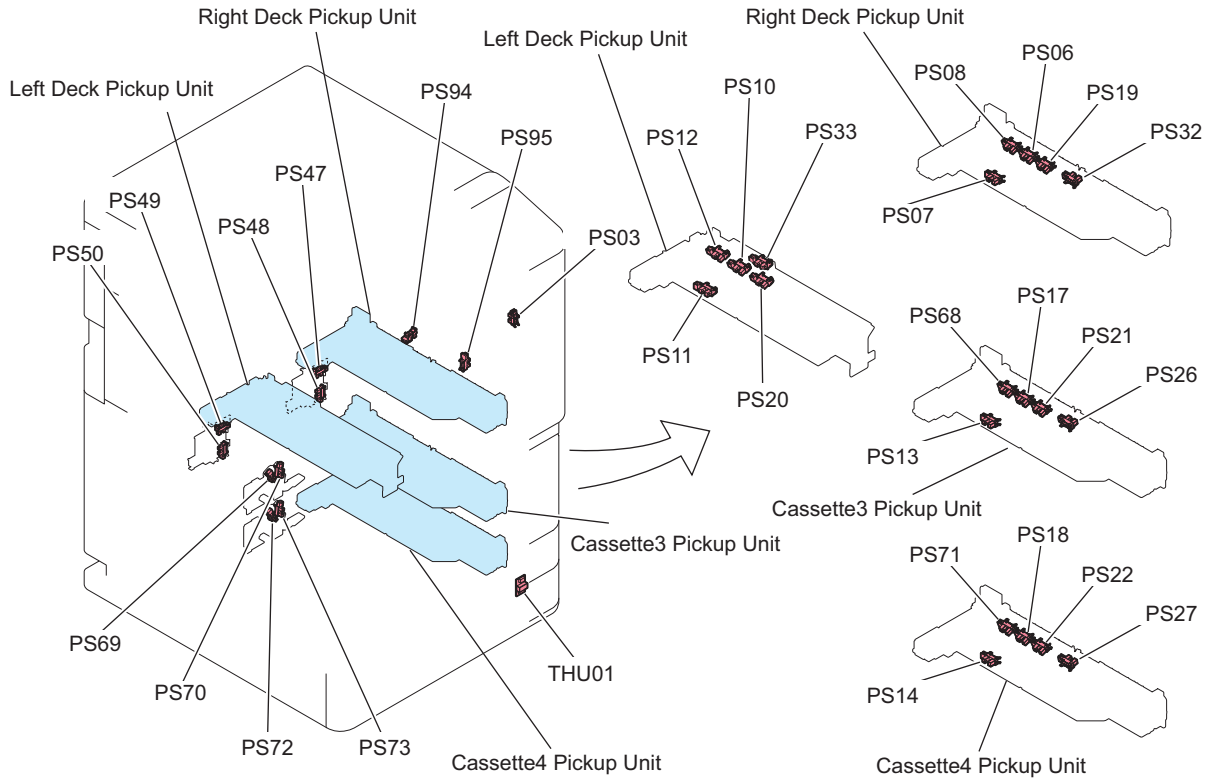
• Sensor



No.	Name	Main Unit	Reference
PS04	Fixing Toenail Jam Sensor	Fixing Assembly	-
PS24	Vertical Path Sensor 1	Vertical Path Unit	-
PS29	Registration Sensor	Pickup Feed Drive Unit	-
PS45	Fixing Cleaning Web Level Sensor	Fixing Assembly	-
PS51	Fixing Inlet Sensor	Fixing Assembly	-
PS52	Fixing Outlet Sensor	Fixing Assembly	-
PS61	Drum Home Position Sensor	Drum Drive Unit	-
PS90	Patch Sensor	Process Unit	"Removing the Patch Sensor" on page 441
PS96	Fixed Feed Lever Sensor	Fixing Feed Unit	-
PS100	Waste Toner Container Sensor	-	-
TS01	Developing Assembly Toner Sensor	Developing Assembly	-
TS04	Waste Toner Full Sensor	-	-



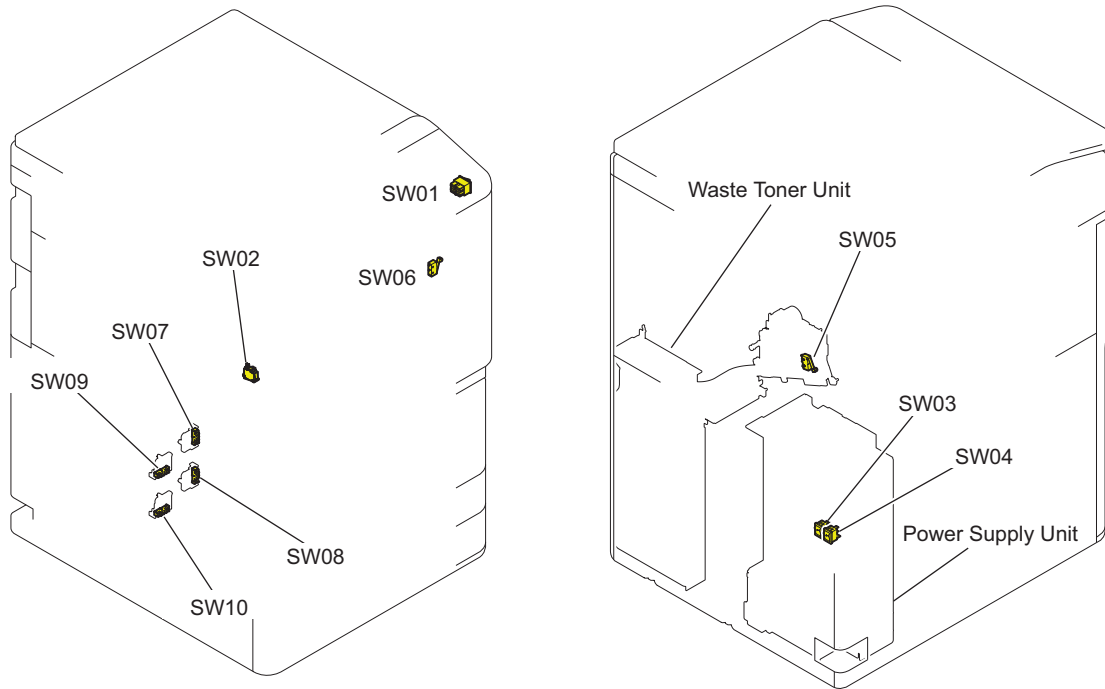
No.	Name	Main Unit	COPIER > FUNCTION > PART-CHK		Reference
			Item No.	Remarks	
PS02	Vertical Path Cover Open/Close Sensor	Vertical Path Unit	-	-	-
PS23	Multi-purpose Tray Paper Sensor	Multi-purpose Pickup Unit	-	-	-
PS25	Vertical Path Sensor 2	Vertical Path Unit	-	-	-
PS28	Writing Judging Sensor	Multi-purpose Pickup Unit	-	-	-
PS31	Side Registration Sensor	Fixing Feed Unit	-	-	-
PS35	Inner Delivery Sensor	Fixing Feed Unit	-	-	-
PS36	Outer Delivery Sensor	Outer Delivery Unit	-	-	-
PS54	Toner Exchange Cover Open/Close Sensor	Hopper Unit	-	-	-
PS55	Transfer Belt Engage Sensor	Fixing Feed Unit	-	-	-
PS56	Transfer Belt Disengage Sensor	Fixing Feed Unit	-	-	-
PS64	Duplex Outlet Sensor	Fixing Feed Unit	-	-	-
PS65	Reverse Vertical Path Sensor	Fixing Feed Unit	-	-	-
PS66	Duplex Left Sensor	Fixing Feed Unit	-	-	-
PS67	Duplex Merging Sensor	Fixing Feed Unit	-	-	-
PS101	Multi-purpose Tray Paper Length Sensor	Multi-purpose Pickup Unit	-	-	-
TS02	Buffer Toner Sensor 1	Hopper Unit	-	-	-
TS03	Buffer Toner Sensor 2	Hopper Unit	-	-	-
UN13	Multi-purpose Tray Paper Width Sensor	Multi-purpose Pickup Unit	-	-	-
UN29	Double Feed Detection Sensor (Reception)	Option	D-FDS	D-FDS > OK	-
UN30	Double Feed Detection Sensor (Transmission)	Option			-



No.	Name	Main Unit	Reference
PS03	Multi-purpose Tray Cover Open/Close Sensor	Multi-purpose Tray Pickup Unit	-
PS06	Right Deck Paper Height Sensor	Right Deck Unit	-
PS07	Right Deck Paper Sensor	Right Deck Unit	-
PS08	Right Deck Upper Limit Sensor	Right Deck Unit	-
PS10	Left Deck Paper Height Sensor	Left Deck Unit	-
PS11	Left Deck Paper Sensor	Left Deck Unit	-
PS12	Left Deck Upper Limit Sensor	Left Deck Unit	-
PS13	Cassette 3 Paper Sensor	Cassette 3 Pickup Unit	-
PS14	Cassette 4 Paper Sensor	Cassette 4 Pickup Unit	-
PS17	Cassette 3 Paper Height Sensor	Cassette 3 Pickup Unit	-
PS18	Cassette 4 Paper Height Sensor	Cassette 4 Pickup Unit	-
PS19	Right Deck Pickup Sensor	Right Deck Unit	-
PS20	Left Deck Pickup Sensor	Left Deck Unit	-
PS21	Cassette 3 Pickup Sensor	Cassette 3 Pickup Unit	-
PS22	Cassette 4 Pickup Sensor	Cassette 4 Pickup Unit	-
PS26	Vertical Path Sensor 3	Vertical Path Unit	-
PS27	Vertical Path Sensor 4	Vertical Path Unit	-
PS32	Right Deck Pull Out Sensor	Right Deck Unit	-
PS33	Left Deck Pull Out Sensor	Left Deck Unit	-
PS47	Right Deck Paper Level Sensor 1	Right Deck Unit	-
PS48	Right Deck Paper Level Sensor 2	Right Deck Unit	-
PS49	Left Deck Paper Level Sensor 1	Left Deck Unit	-
PS50	Left Deck Paper Level Sensor 2	Left Deck Unit	-
PS68	Cassette 3 Upper Limit Sensor	Cassette 3 Pickup Unit	-
PS69	Cassette 3 Paper Level Sensor 1	Cassette 3 Pickup Unit	-
PS70	Cassette 3 Paper Level Sensor 2	Cassette 3 Pickup Unit	-
PS71	Cassette 4 Upper Limit Sensor	Cassette 4 Pickup Unit	-
PS72	Cassette 4 Paper Level Sensor 1	Cassette 4 Pickup Unit	-
PS73	Cassette 4 Paper Level Sensor 2	Cassette 4 Pickup Unit	-
PS94	Primary Charging Assembly Shutter Open/Close Sensor	Primary Charging Assembly	-

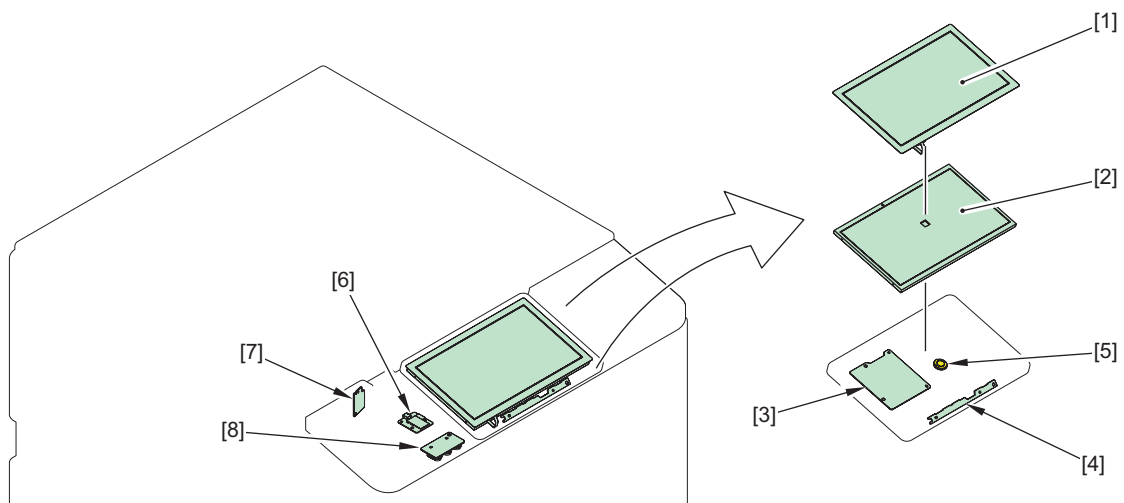
No.	Name	Main Unit	Reference
PS95	Pre-transfer Charging Assembly Shutter Open/Close Sensor	Pre-transfer Charging Assembly	-
THU01	Environment Sensor	Product configuration	-

• List of Switch

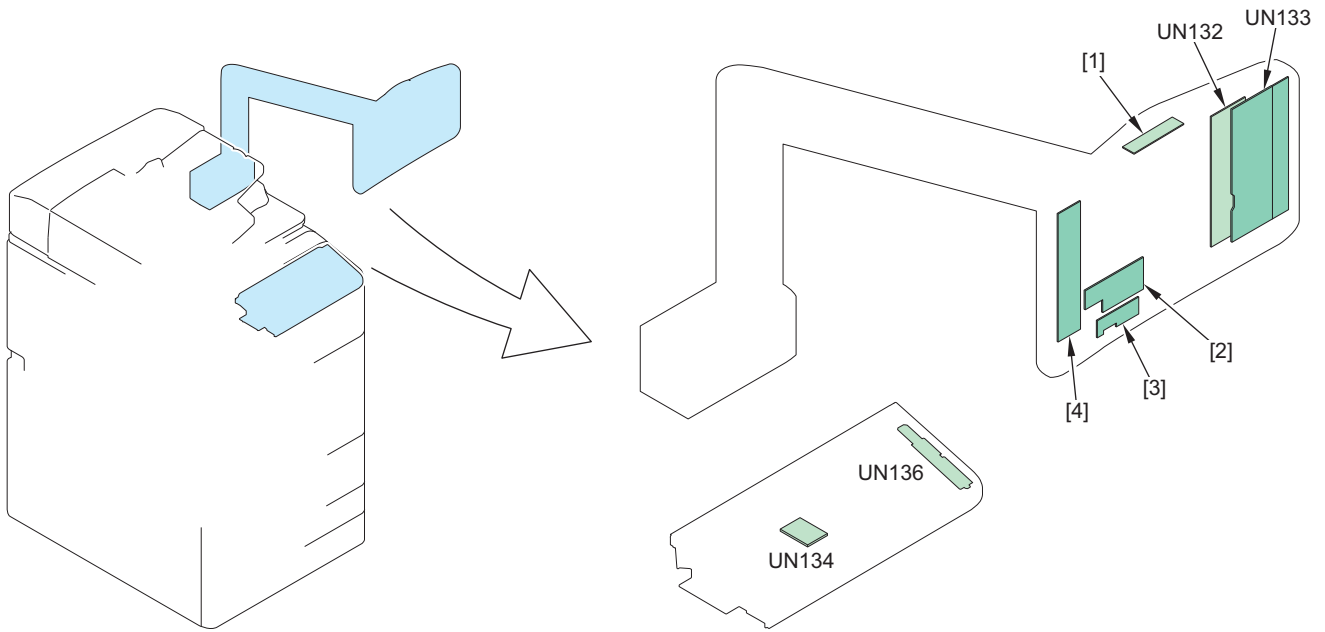


No	Name	Main Unit	Reference
SW01	Power Switch	Product configuration	-
SW02	Front Door Open Detection Switch	Product configuration	-
SW03	Environment Switch	Product configuration	-
SW04	Cassette Heater Switch	Product configuration	-
SW05	Waste Toner Lock Detection Switch	Waste Toner Unit	-
SW06	Multi Door Switch	Product configuration	-
SW07	Cassette 3 Paper Width Detection Switch	Cassette 3 Pickup Unit	-
SW08	Cassette 4 Paper Width Detection Switch	Cassette 4 Pickup Unit	-
SW09	Cassette 3 Paper Length Detection Switch	Cassette 3 Pickup Unit	-
SW10	Cassette 4 Paper Length Detection Switch	Cassette 4 Pickup Unit	-

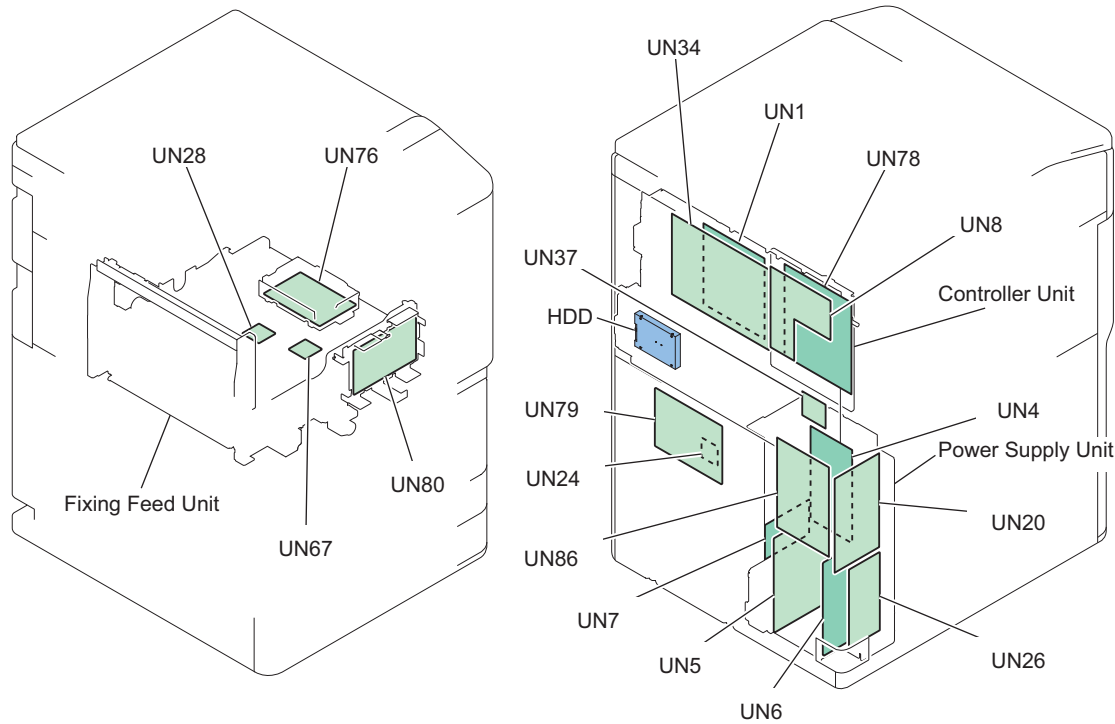
• List of PCB



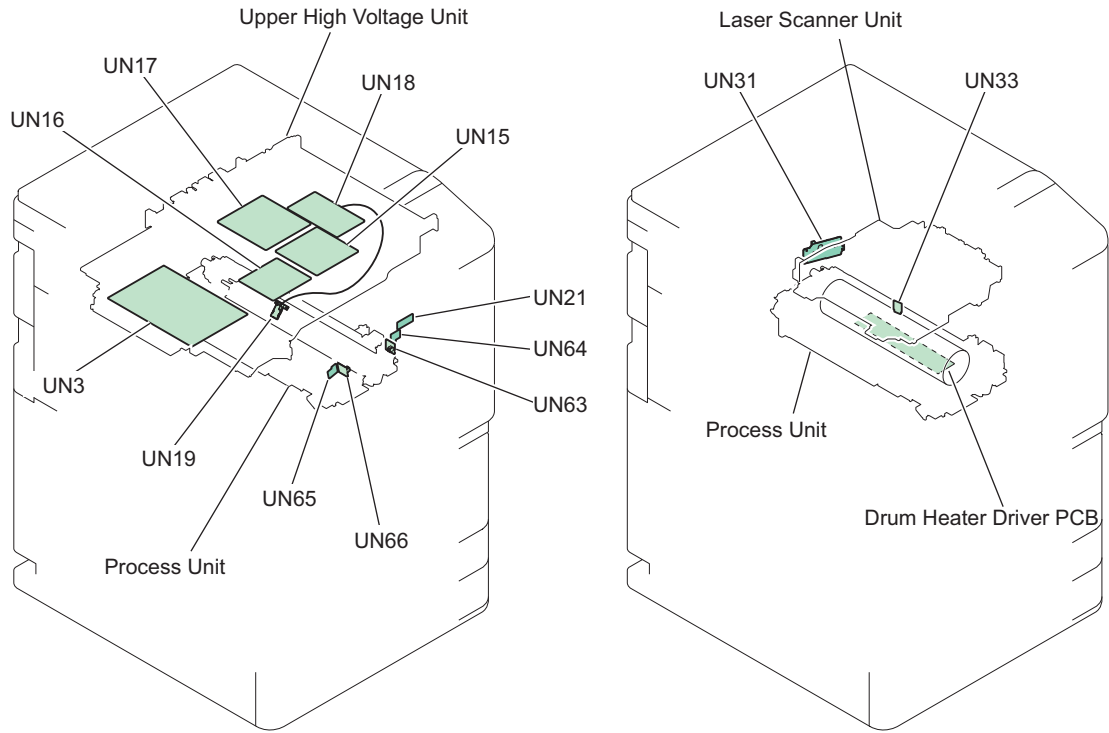
No.	Name	Main Unit	Reference
[1]	Touch Panel	Flat Control Panel Unit	"Removing the Control Panel CPU PCB/LCD Unit/LED PCB" on page 342
[2]	LCD Unit	Flat Control Panel Unit	
[3]	Control Panel CPU PCB	Flat Control Panel Unit	
[4]	Control Panel LED PCB	Flat Control Panel Unit	
[5]	Control Panel Speaker	Flat Control Panel Unit	
[6]	Wireless LAN PCB	Product configuration	-
[7]	Motion Sensor PCB	Product configuration	-
[8]	Switch PCB	Product configuration	-



No.	Name	Main Unit	Reference
UN132	Control Panel CPU PCB	Upright Control Panel Unit	"Removing the Control Panel CPU PCB (Upright Control Panel)" on page 349
UN133	Key Top PCB (Left)	Upright Control Panel Unit	"Removing the LCD Unit (Upright Control Panel)" on page 351
UN134	Relay PCB	Upright Control Panel Unit	-
UN136	NFC PCB	Upright Control Panel Unit	-
[1]	TALLY PCB	Upright Control Panel Unit	"Removing the LCD Unit (Upright Control Panel)" on page 351
[2]	LED Driver PCB	Upright Control Panel Unit	
[3]	Volume PCB	Upright Control Panel Unit	
[4]	Sub Key PCB	Upright Control Panel Unit	

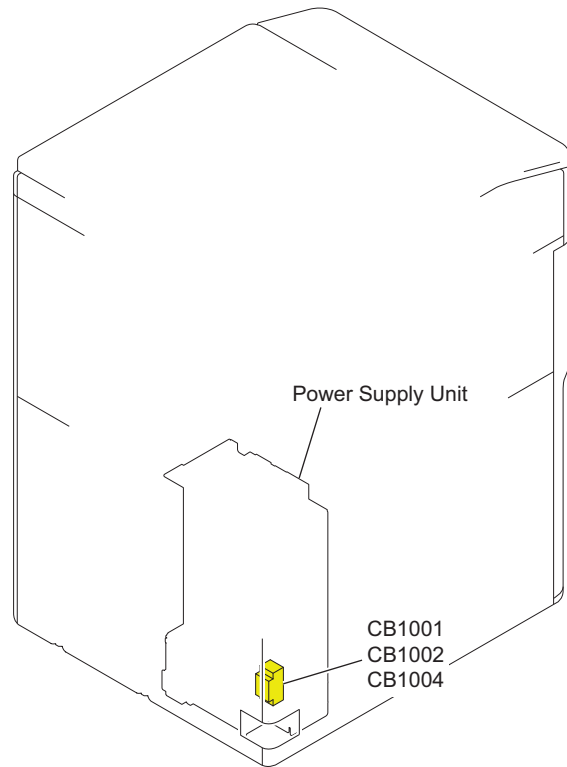
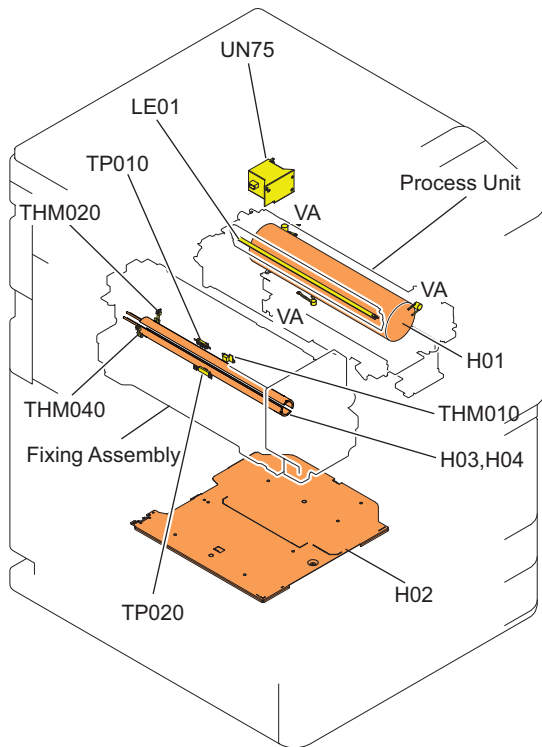


No.	Name	Main Unit	Reference
UN1	DC Controller PCB	Product configuration	"Removing the DC Controller PCB" on page 575
UN4	DC Power Supply PCB	Product configuration	-
UN5	DC Power Supply PCB	Product configuration	-
UN6	DC Power Supply PCB	Product configuration	-
UN7	All-night Power Supply PCB	Product configuration	-
UN8	Main Controller PCB 2	Product configuration	"Removing Main Controller PCB 2" on page 335
UN20	AC Driver PCB	Product configuration	-
UN24	DC-DC Converter PCB	Product configuration	-
UN26	Noise Filter	Product configuration	-
UN28	DC-DC Converter PCB	Product configuration	-
UN34	Main Controller PCB 1	Product configuration	"Removing Main Controller PCB 1" on page 333
UN37	CAN Transeiver PCB	Product configuration	"Removing the CAN Transeiver PCB" on page 585
UN67	Transfer High Voltage Resistance PCB	Product configuration	-
UN76	Transfer High Voltage PCB	Product configuration	-
UN78	Main Driver PCB	Product configuration	-
UN79	Feed Driver PCB	Product configuration	-
UN80	Duplex Driver PCB	Product configuration	-
UN86	Relay PCB	Product configuration	-



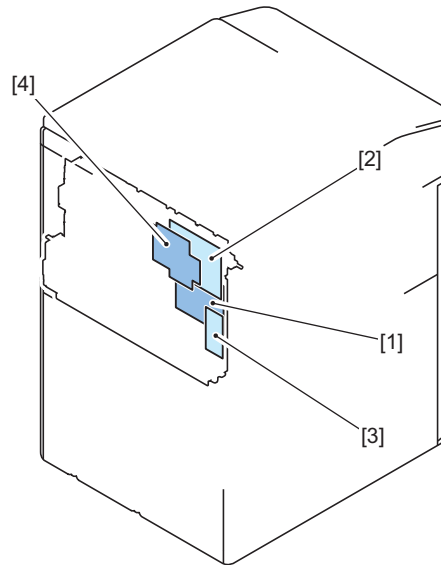
No.	Name	Main Unit	Reference
UN3	Fixing Power Supply PCB	Product configuration	-
UN15	Primary Charging High Voltage PCB	Product configuration	-
UN16	Pre-transfer Charging PCB	Product configuration	-
UN17	Develop High Voltage PCB	Product configuration	-
UN18	Voltage Control PCB	Product configuration	"Removing the Potential Control PCB Unit" on page 464
UN19	Voltage Sensor PCB	Product configuration	"Removing the Potential Control PCB Unit" on page 464
UN21	Drum ROM	Product configuration	-
UN31	Laser Driver PCB	Product configuration	-
UN33	BD PCB	Product configuration	-
UN63	Contact A PCB	Product configuration	-
UN64	Contact B PCB	Product configuration	-
UN65	Contact A PCB	Product configuration	-
UN66	Contact B PCB	Product configuration	-
-	Drum Heater Driver PCB	Product configuration	-

• Heater,others



No	Name	Main Unit	Reference
H01	Drum Heater	Process Unit	-
H02	Multi Cassette Heater	Product configuration	-
H03	Fixing Heater	Fixing Assembly	-
LE01	Pre-exposure LED	Process Unit	-
TP010	Fixing Thermal Switch 1	Fixing Assembly	-
TP020	Fixing Thermal Switch 2	Fixing Assembly	-
THM010	Fixing Main Thermistor	Fixing Assembly	-
THM020	Fixing Sub Thermistor 1	Fixing Assembly	-
THM040	Fixing Sub Thermistor 2	Fixing Assembly	-
CB1001	Leakage Breaker	Product configuration	-
CB1002	Leakage Breaker	Product configuration	-
CB1004	Leakage Breaker	Product configuration	-

■ Power Unit System



No.	Name
[1]	Fax PCB
[2]	2nd Line G3 FAX PCB
[3]	Modular PCB
[4]	G3 FAX Expansion PCB

Original Feed System

● Removing the ADF

■ Preparation

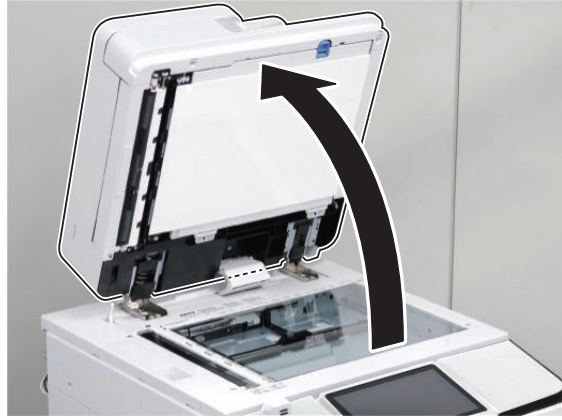
1. "Removing the Covers" on page 312

■ Procedure

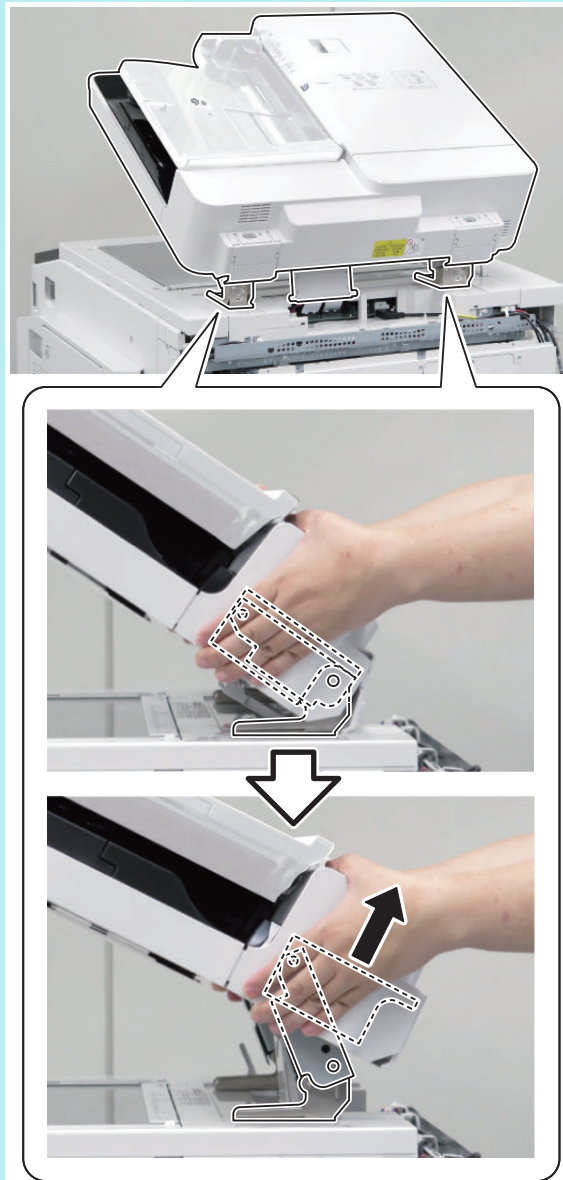
1.



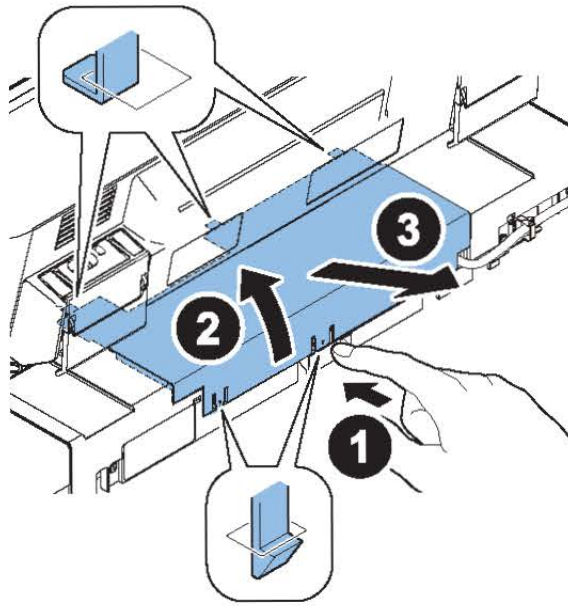
2.

**NOTE:**

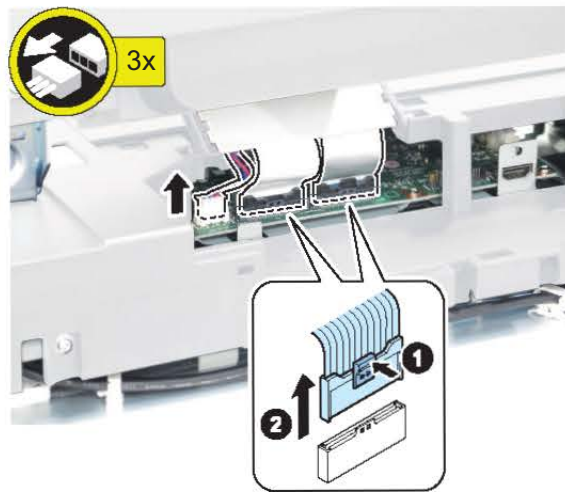
- When performing the following procedures, using ADF in the book mode makes the work easy.
- The book mode can be released by fully opening the ADF.



3.

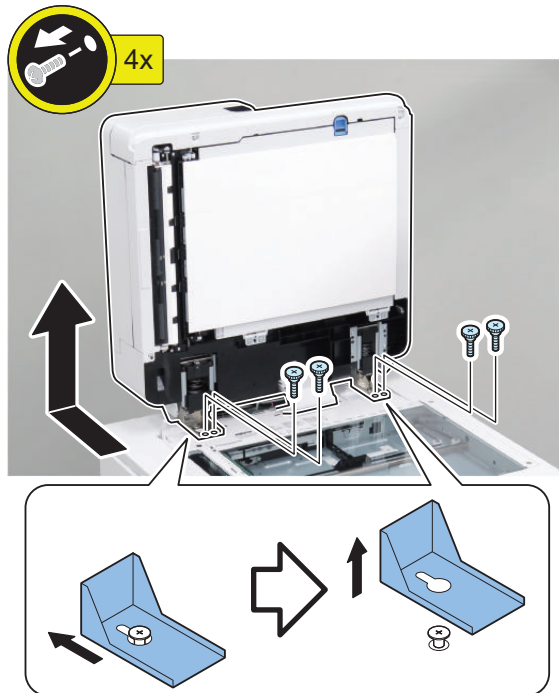


4.



5.

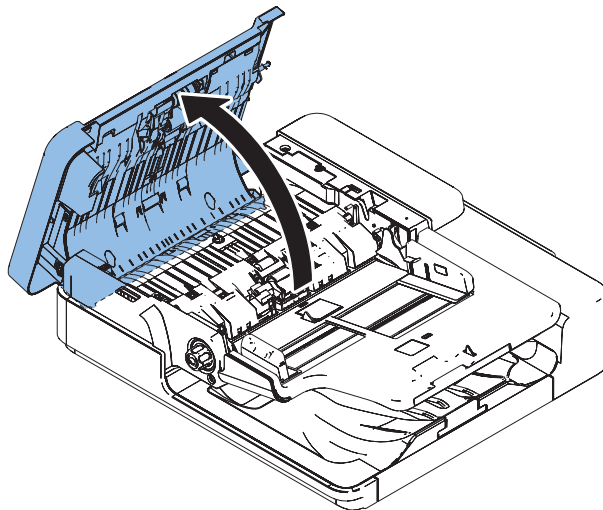
CAUTION:
Be careful not to drop the ADF.



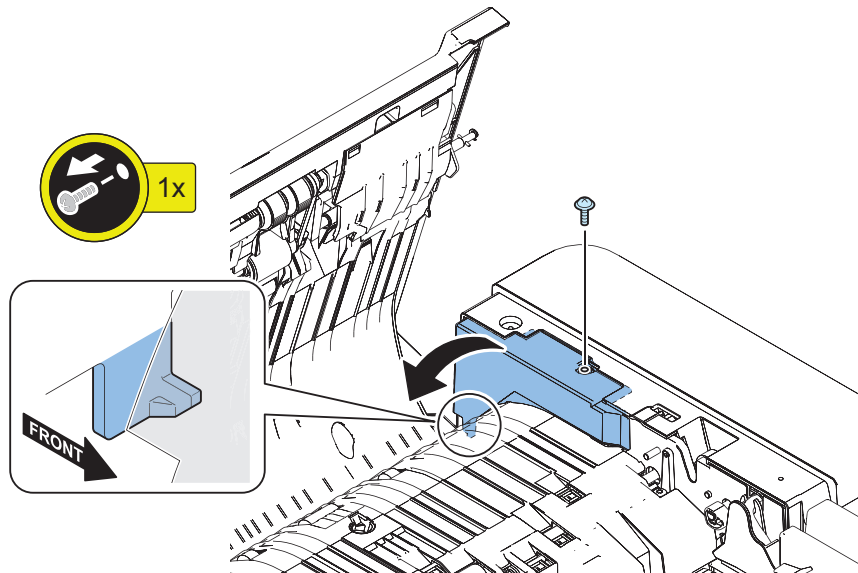
● Removing the Sensor Harness Cover

■ Procedure

1.



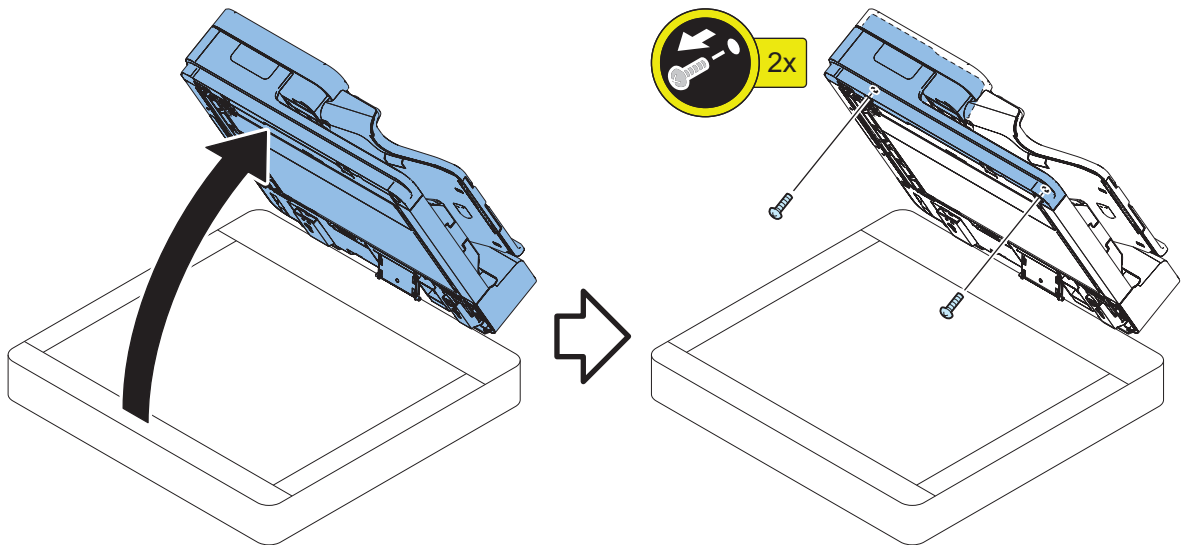
2.



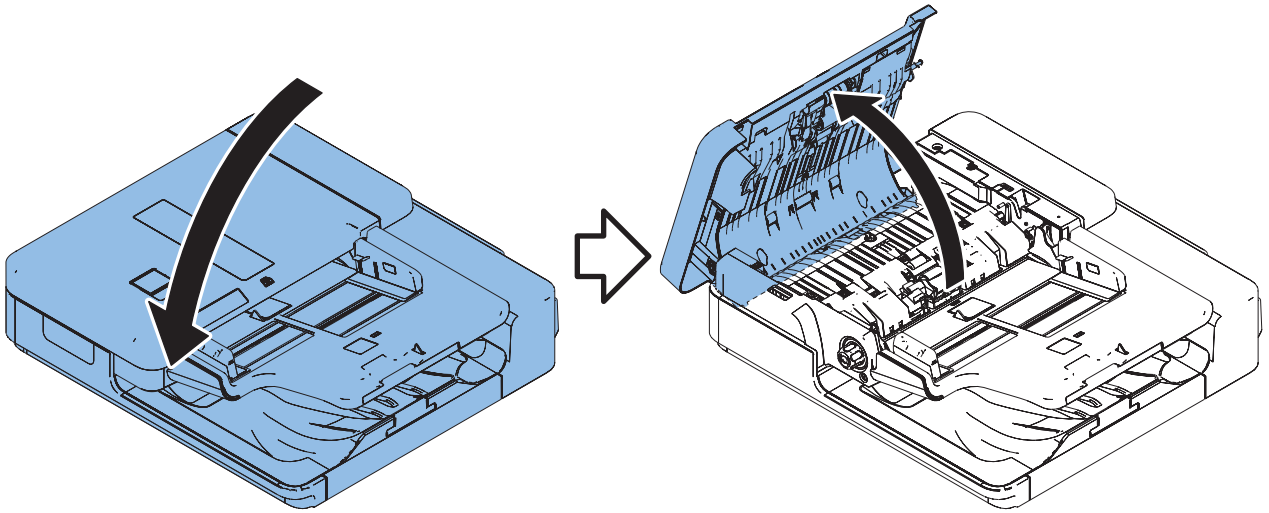
● Removing the ADF Front Cover

■ Procedure

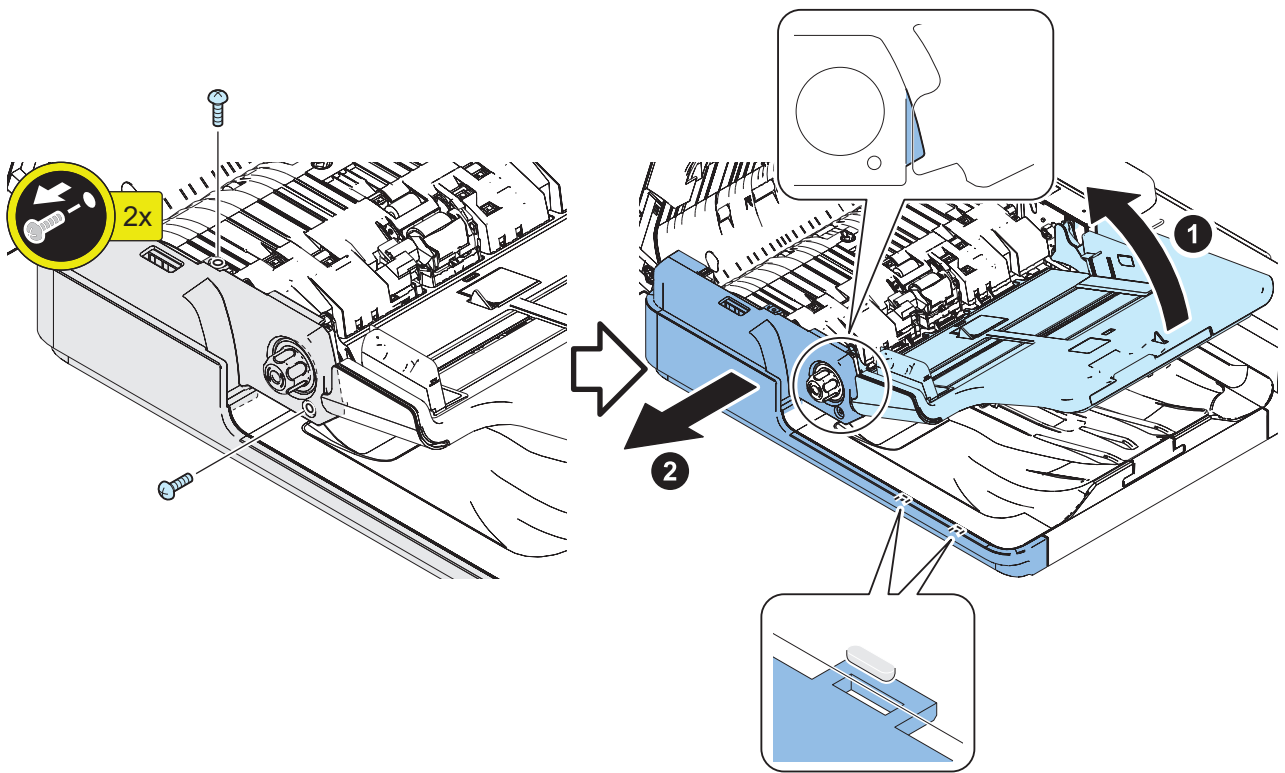
1.



2.



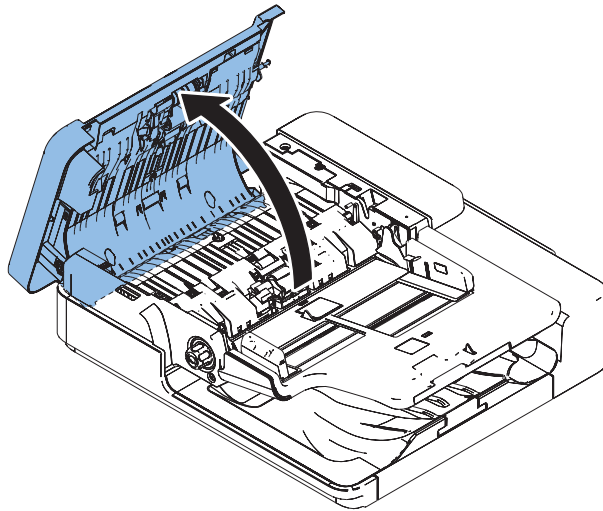
3.



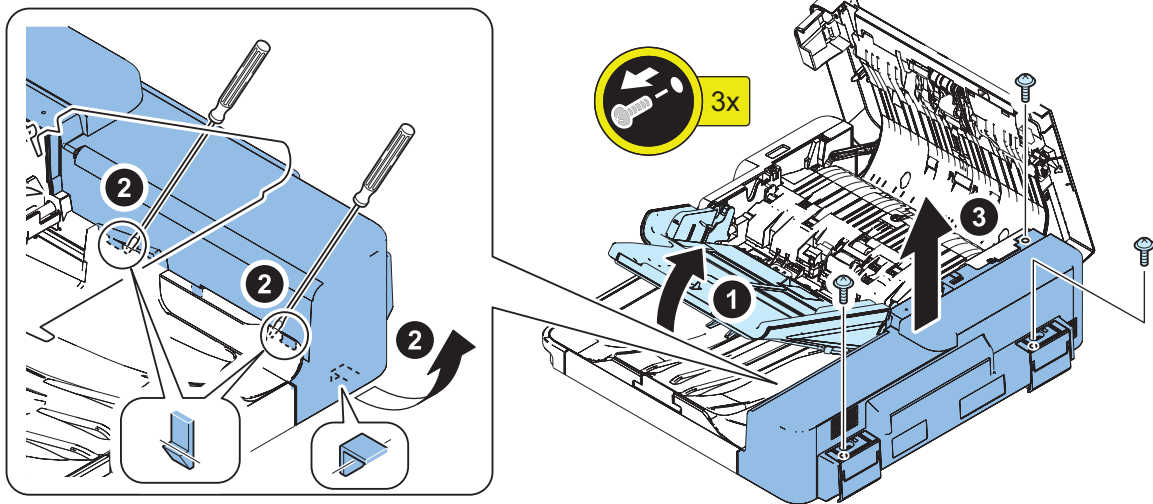
● Removing the ADF Rear Cover

■ Procedure

1.



2.



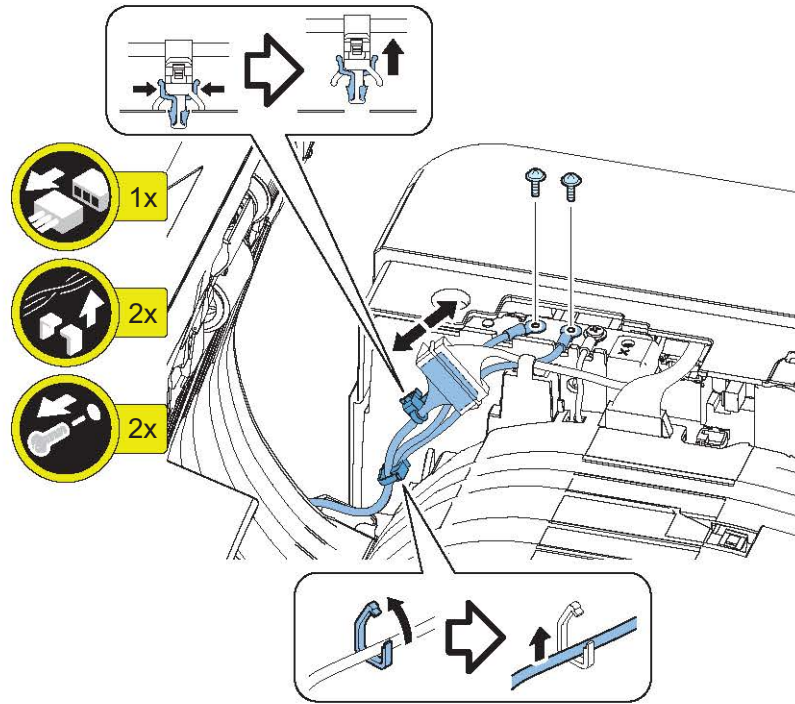
● Removing the Open/Close Cover

■ Preparation

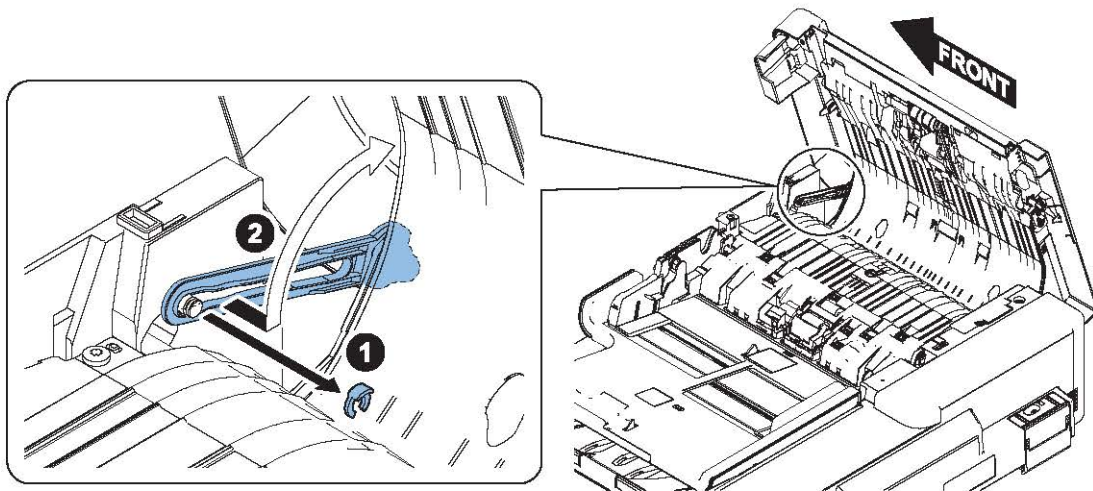
1. "Removing the ADF Front Cover" on page 283
2. "Removing the Sensor Harness Cover" on page 282

■ Procedure

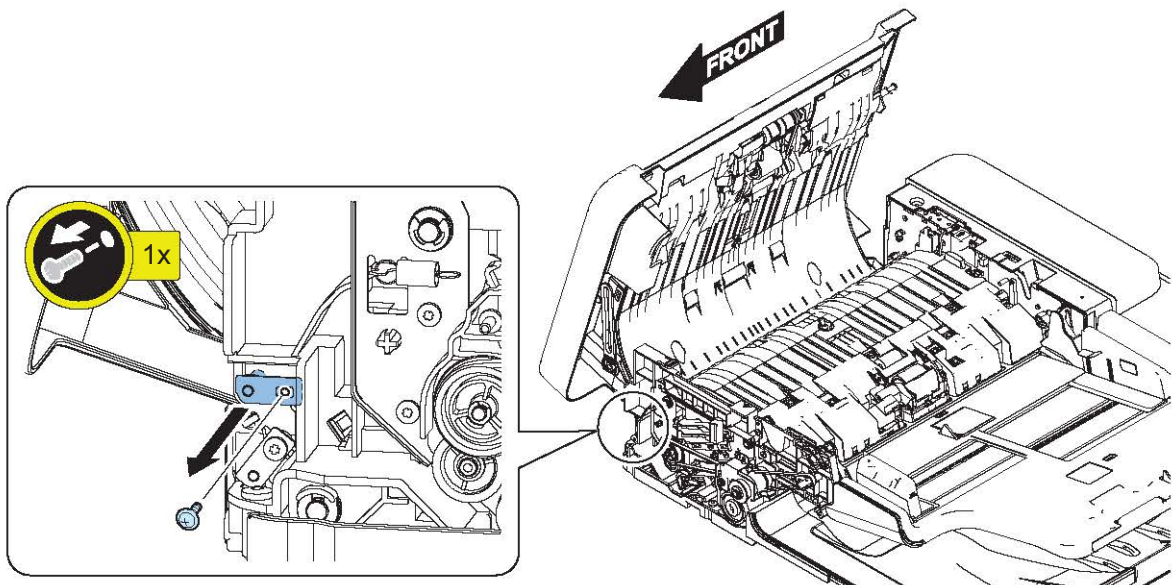
1.



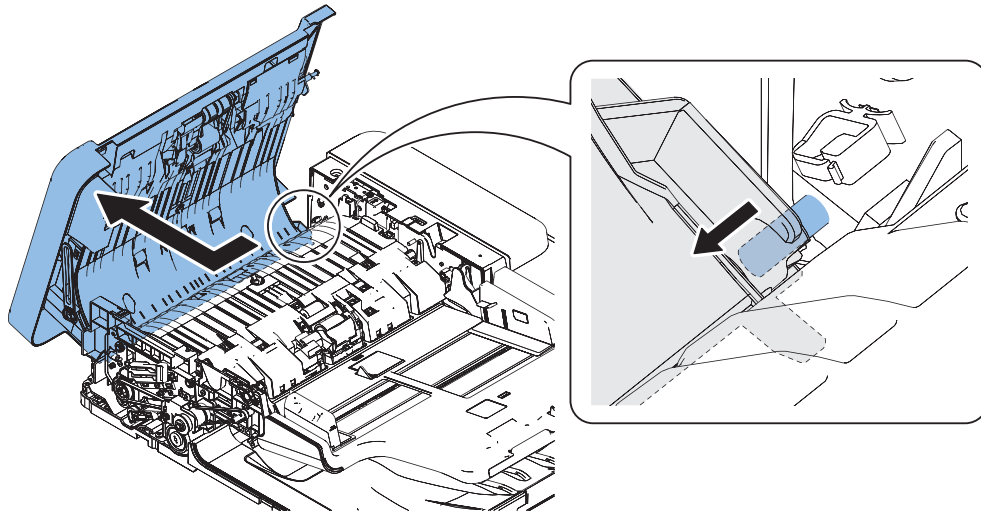
2.



3.



4.



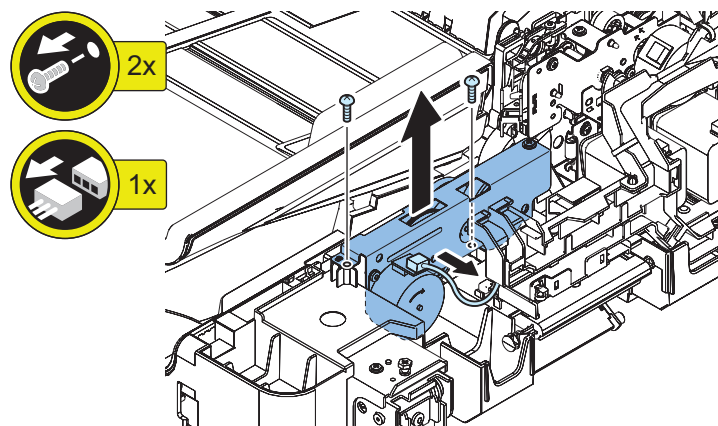
● Removing the Lifter Drive Unit

■ Preparation

1. "Removing the ADF Rear Cover" on page 284
2. "Removing the ADF Driver PCB" on page 297

■ Procedure

1.



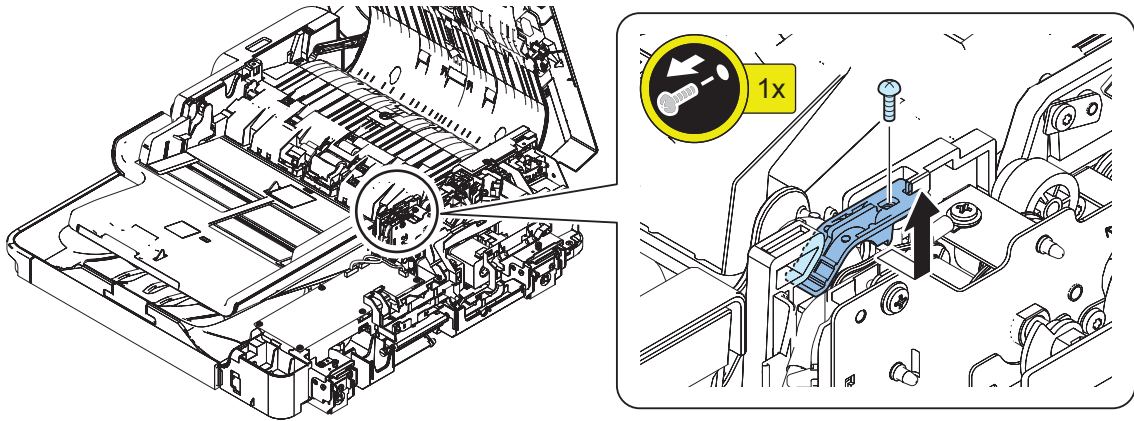
● Removing the Document Tray

■ Preparation

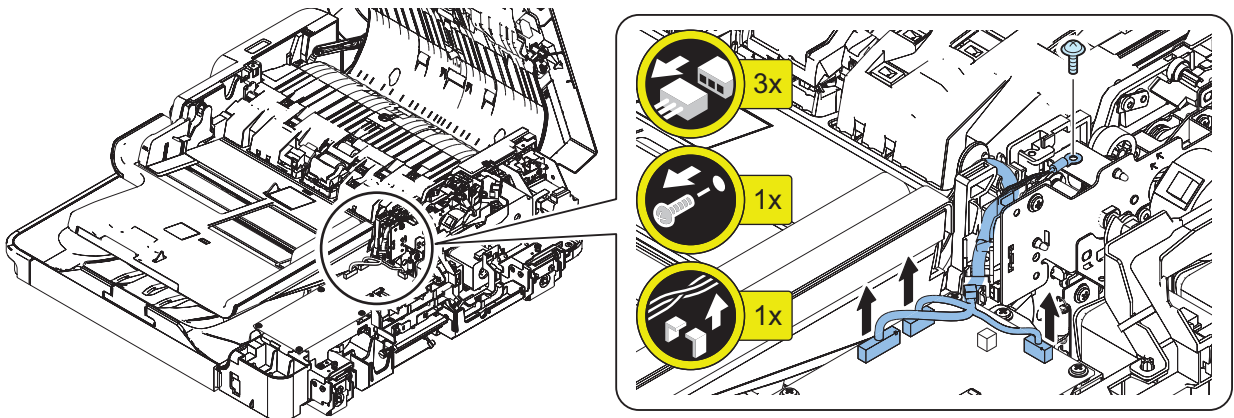
1. "Removing the ADF Rear Cover" on page 284

■ Procedure

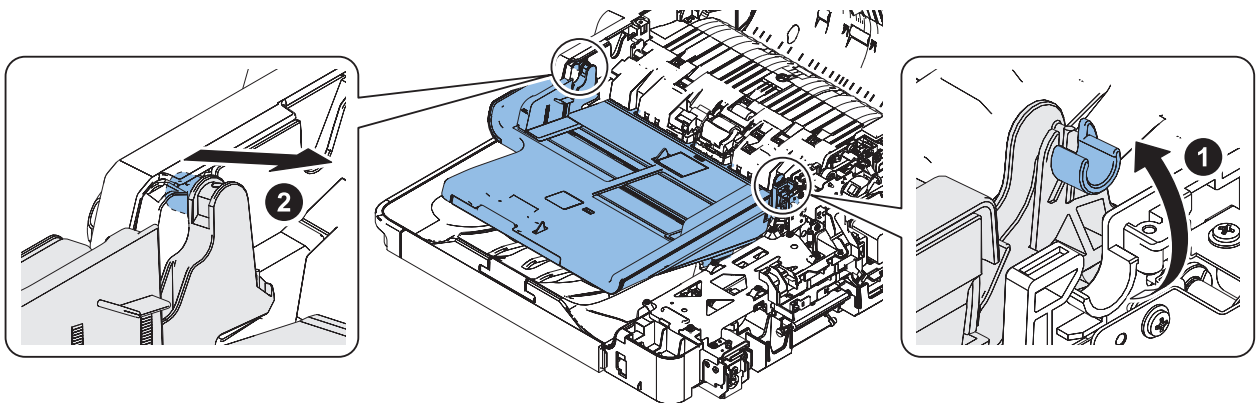
1.



2.



3.



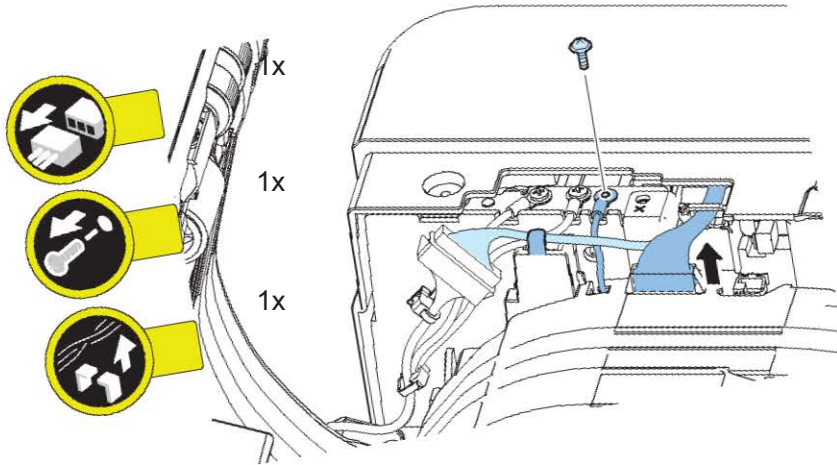
● Removing the ADF Scanner Unit

■ Preparation

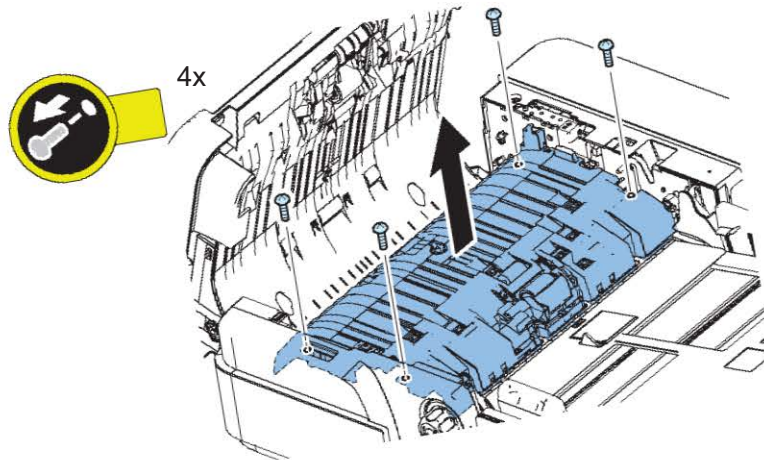
1. "Removing the Sensor Harness Cover" on page 282

■ Procedure

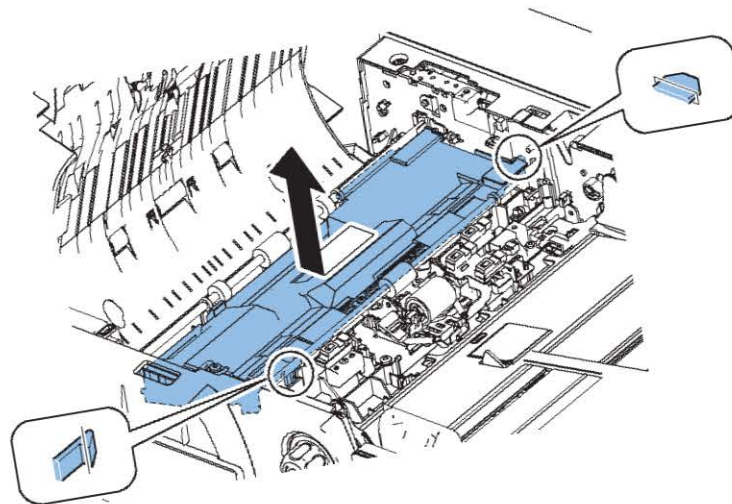
1.



2.



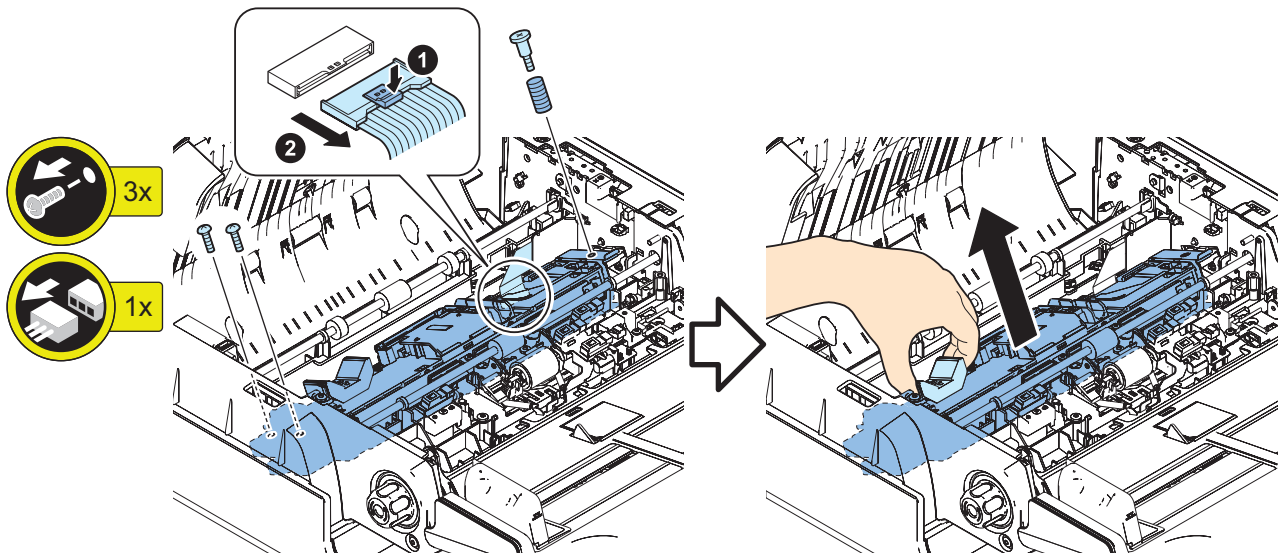
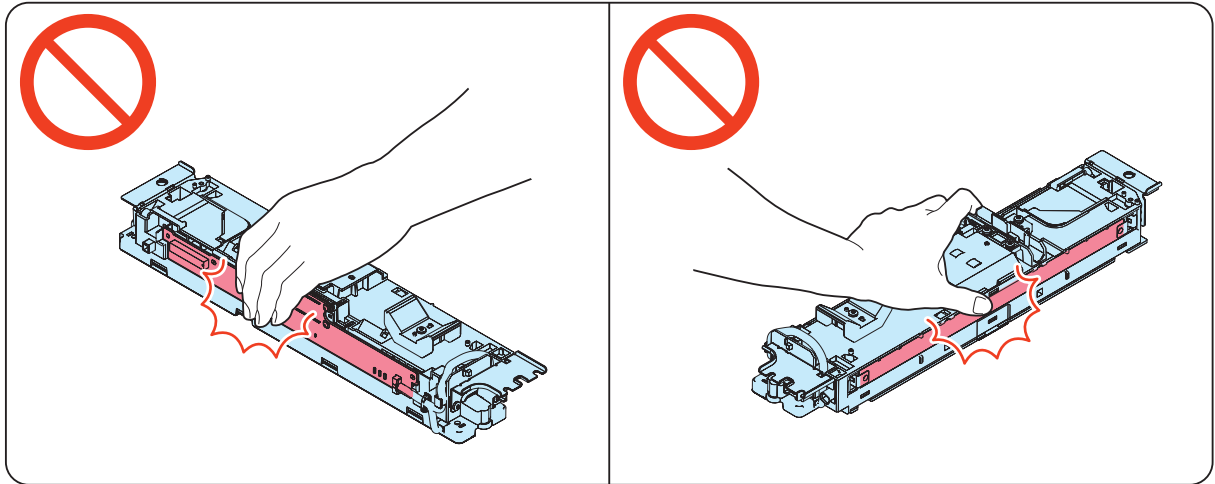
3.



4.

CAUTION:

Do not touch the Scanner Unit PCB and the mirror.



5. Actions after parts replacement: “ADF Scanner Unit” on page 641

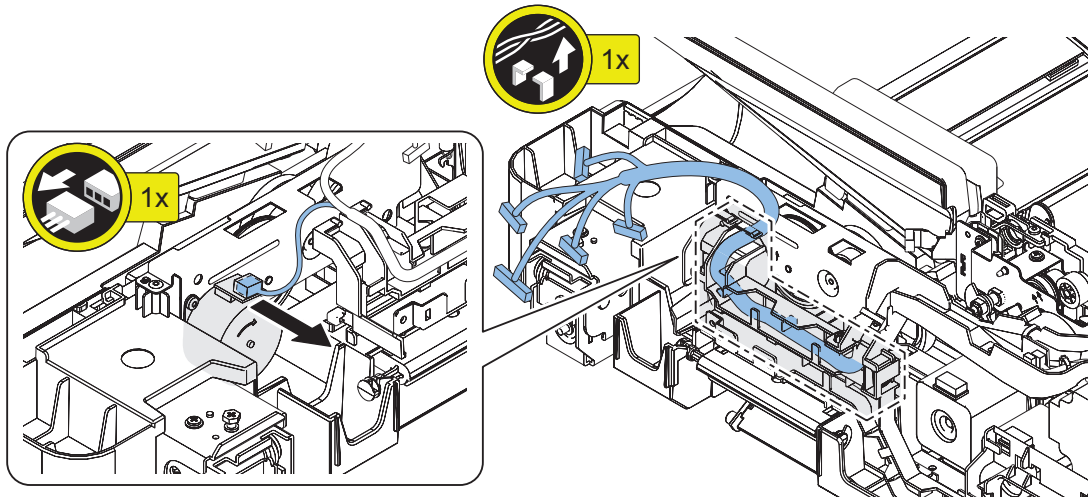
● Removing the Cable Guide Unit

■ Preparation

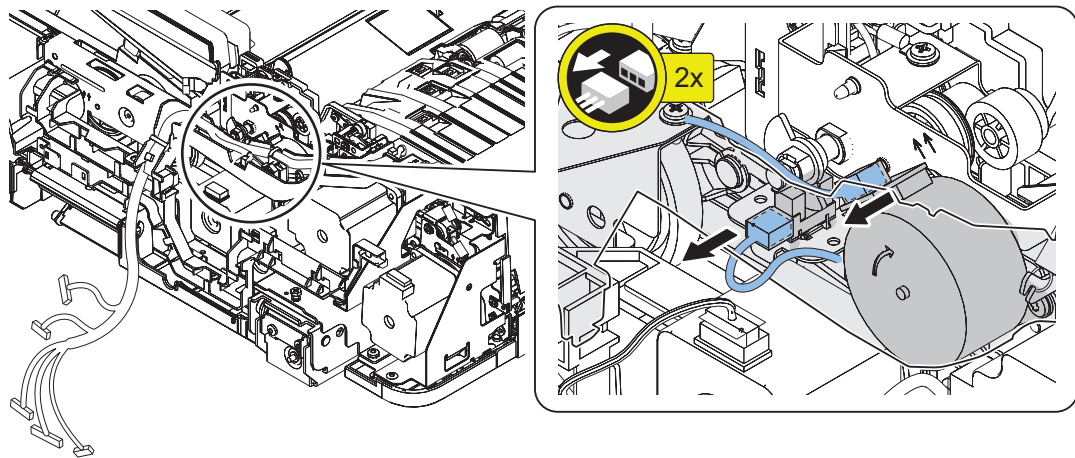
1. “Removing the ADF Rear Cover” on page 284
2. “Removing the Sensor Harness Cover” on page 282
3. “Removing the ADF Driver PCB” on page 297

■ Procedure

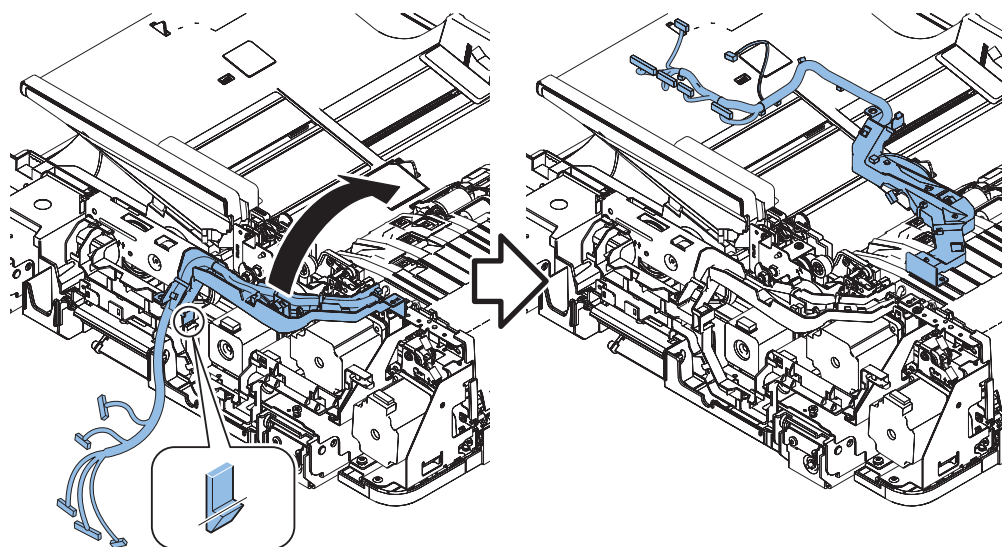
1.



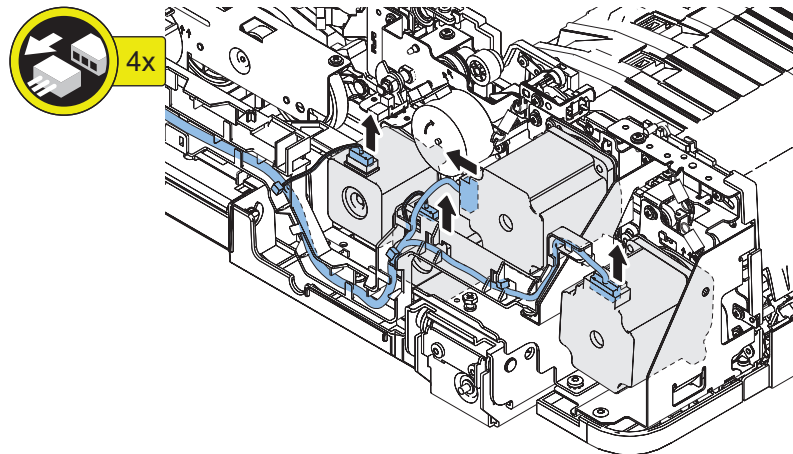
2.



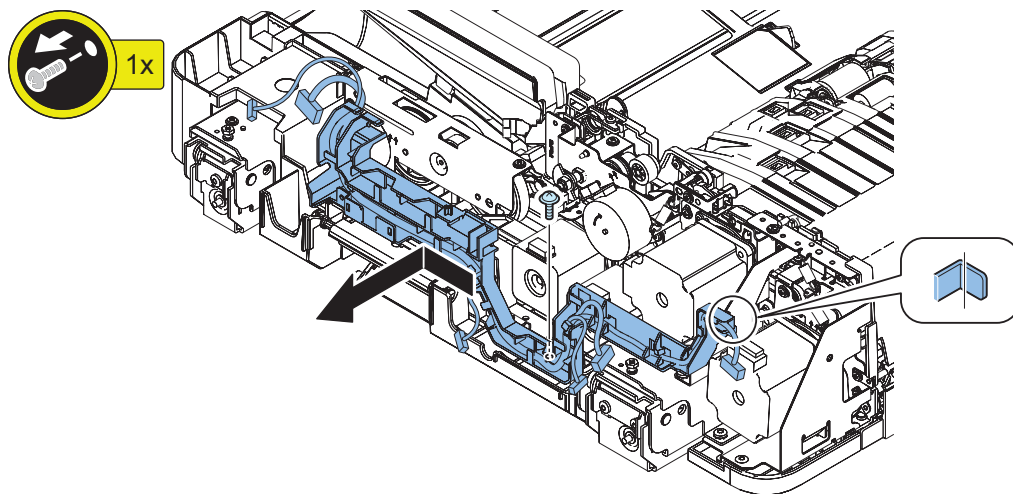
3.



4.



5.



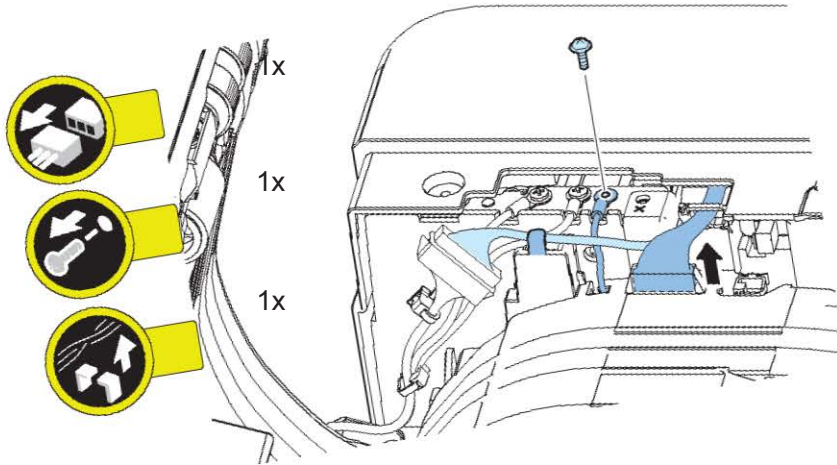
● Removing the Left Hinge

■ Preparation

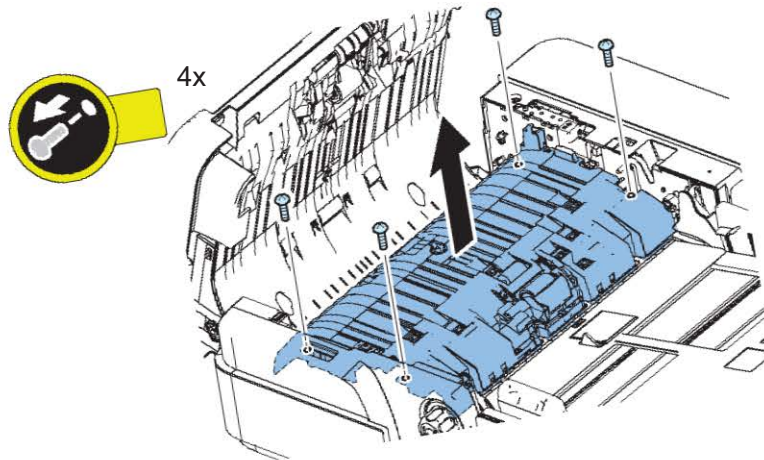
1. “Removing the ADF” on page 279
2. “Removing the ADF Rear Cover” on page 284
3. “Removing the Sensor Harness Cover” on page 282
4. “Removing the ADF Driver PCB” on page 297
5. “Removing the Cable Guide Unit” on page 290
6. “Removing the ADF Delivery Motor” on page 300
7. “Removing the ADF Pickup Motor Unit” on page 300
8. “Removing the ADF Pullout Motor Unit” on page 301
9. “Removing the Lead Motor Unit” on page 302

■ Procedure

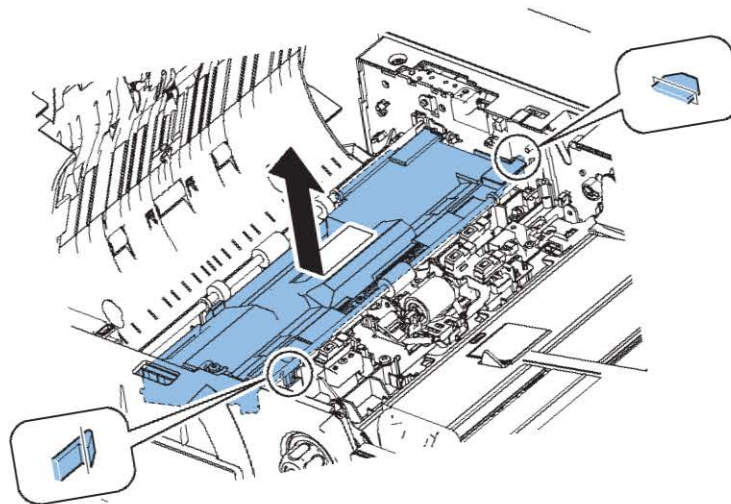
1.



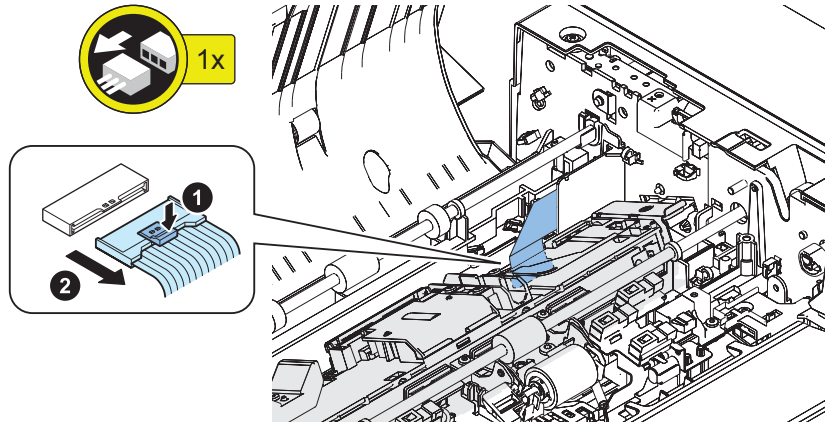
2.



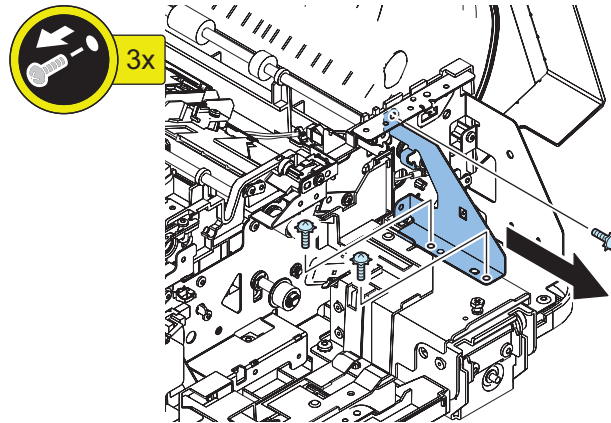
3.



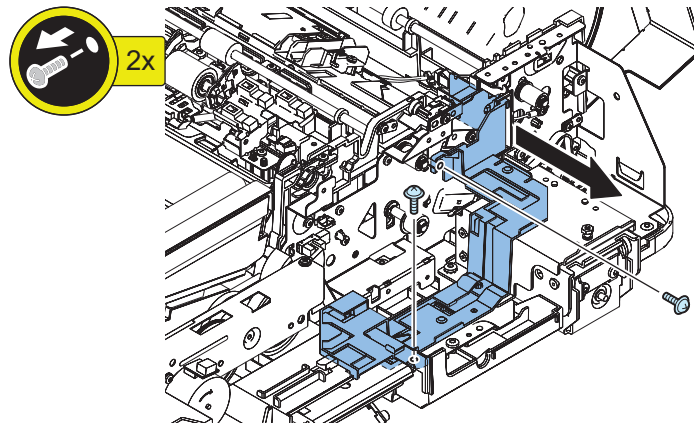
4.



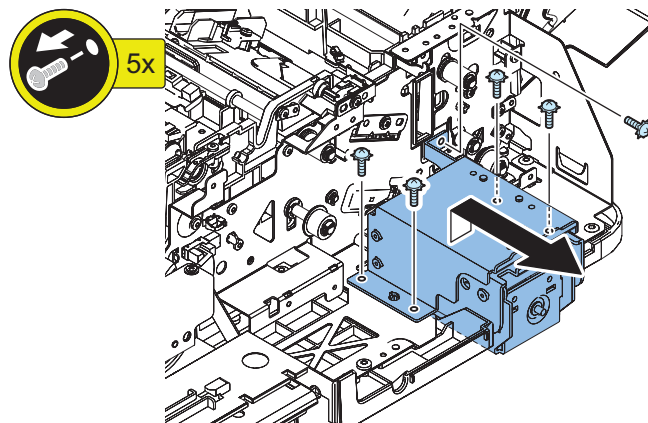
5.



6.



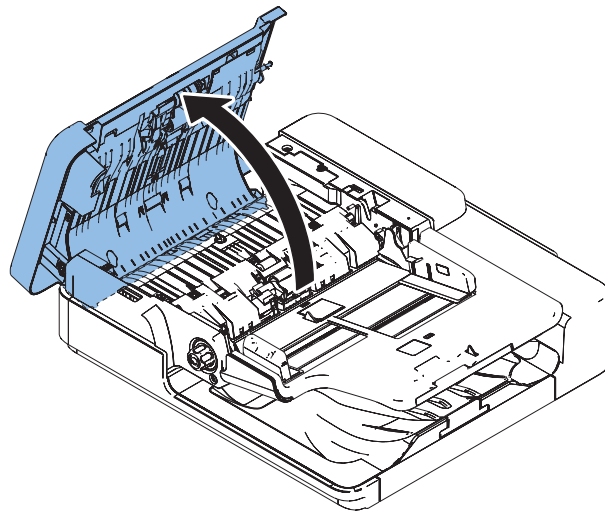
7.



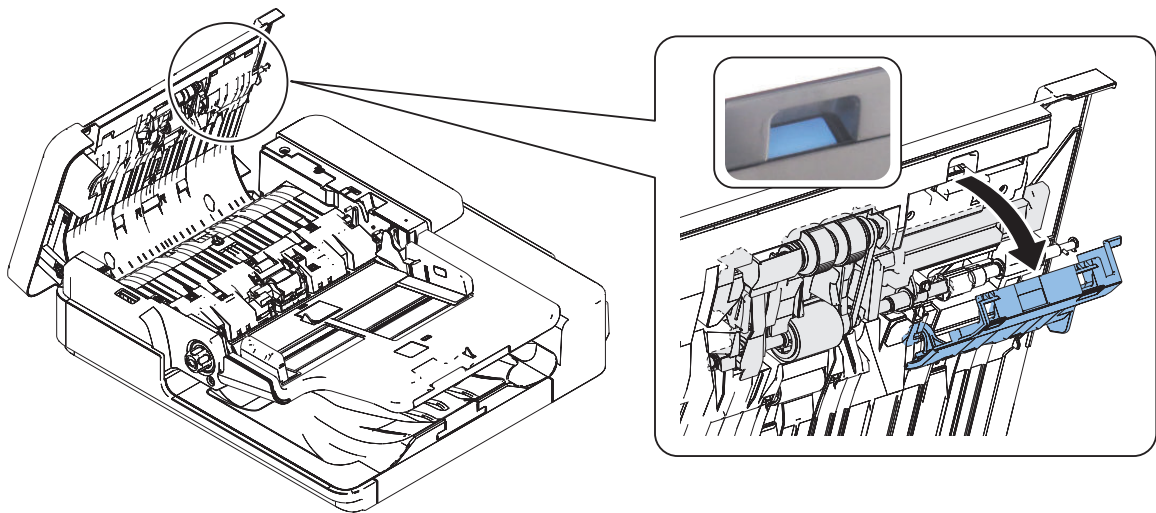
● Removing the Pickup Roller Unit

■ Procedure

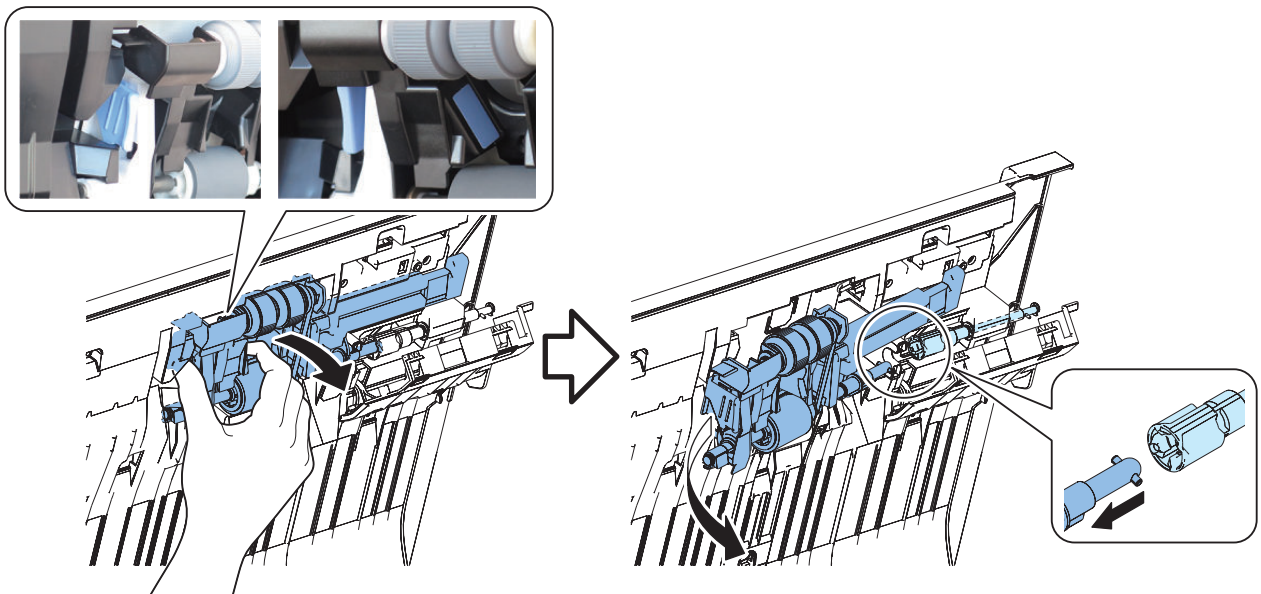
1.



2.



3.



■ Actions after Parts Replacement

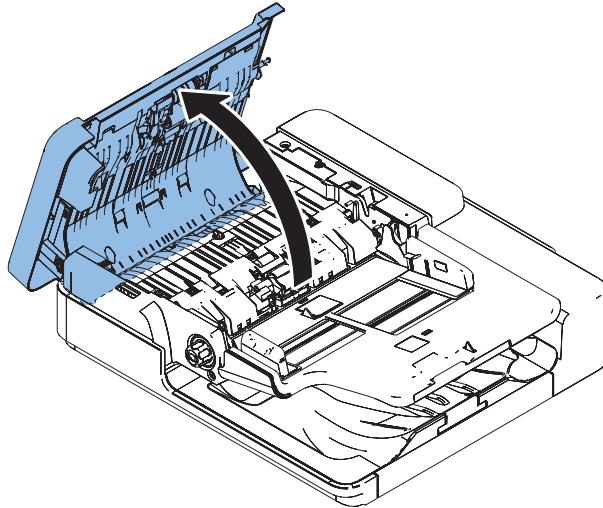
1. Clear the parts counter.

COPIER > COUNTER > DRBL-2 > DF-PU-RL

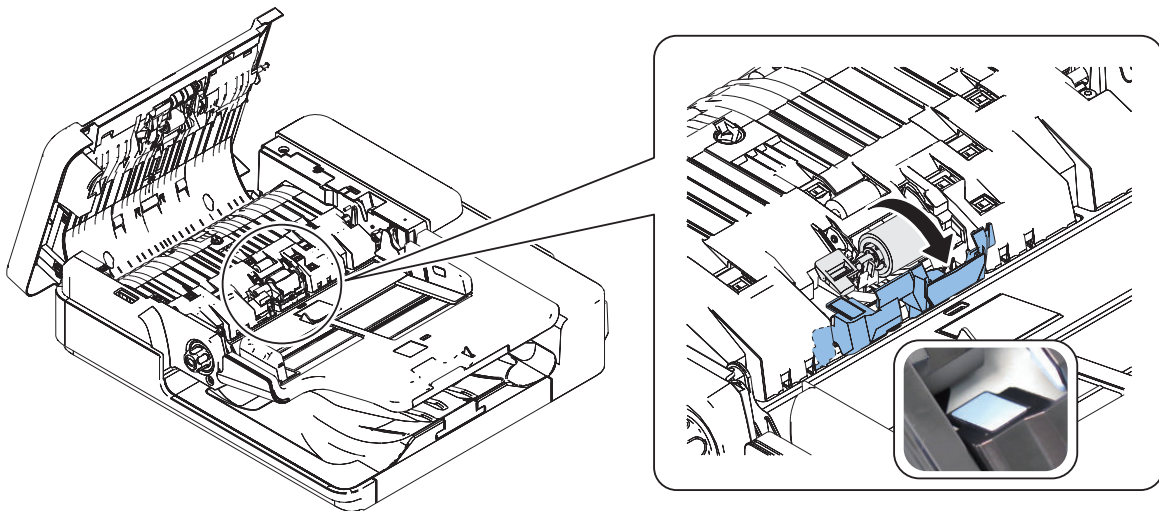
● Removing the Separation Roller Unit

■ Procedure

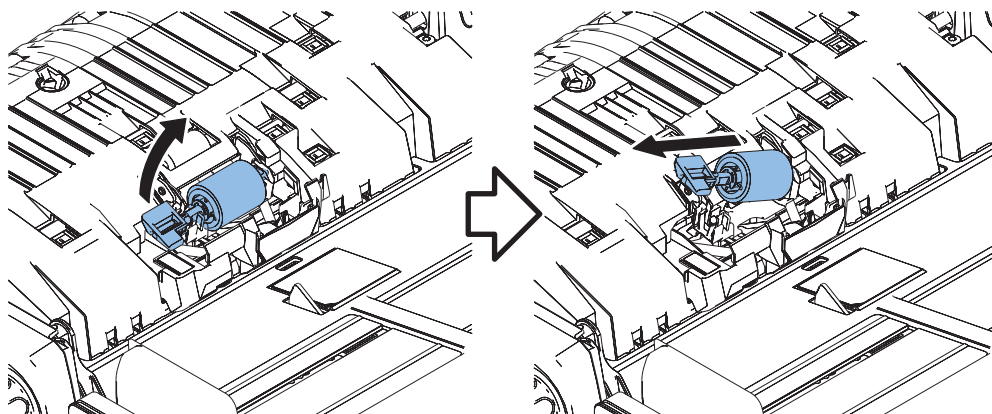
1.



2.



3.



■ Actions after Parts Replacement

1. Clear the parts counter.

COPIER > COUNTER > DRBL-2 > DF-SP-RL

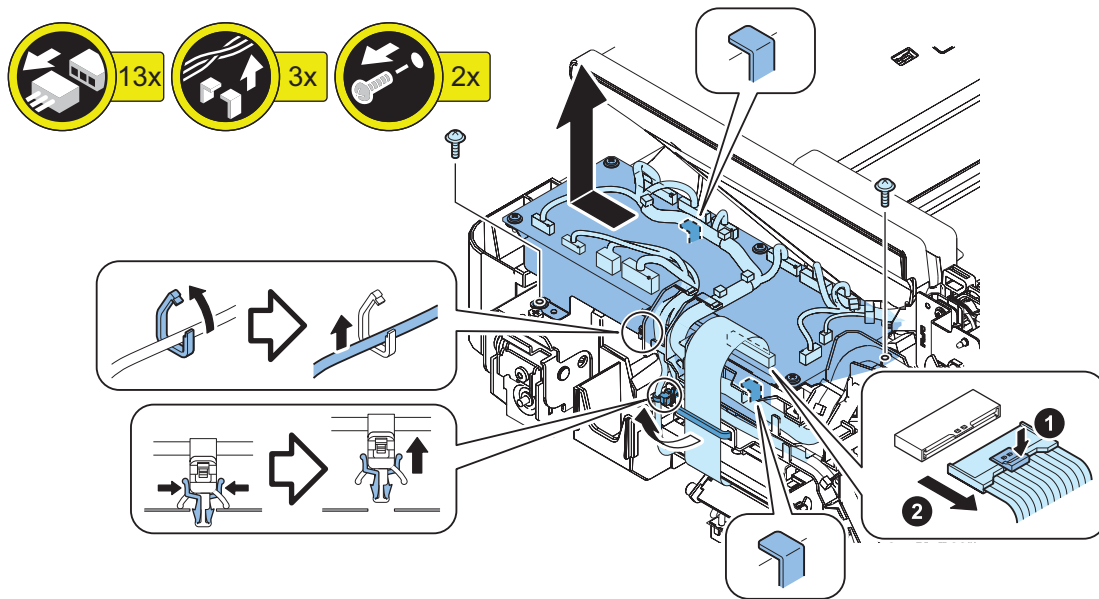
● Removing the ADF Driver PCB

■ Preparation

1. "Removing the ADF Rear Cover" on page 284

■ Procedure

1.



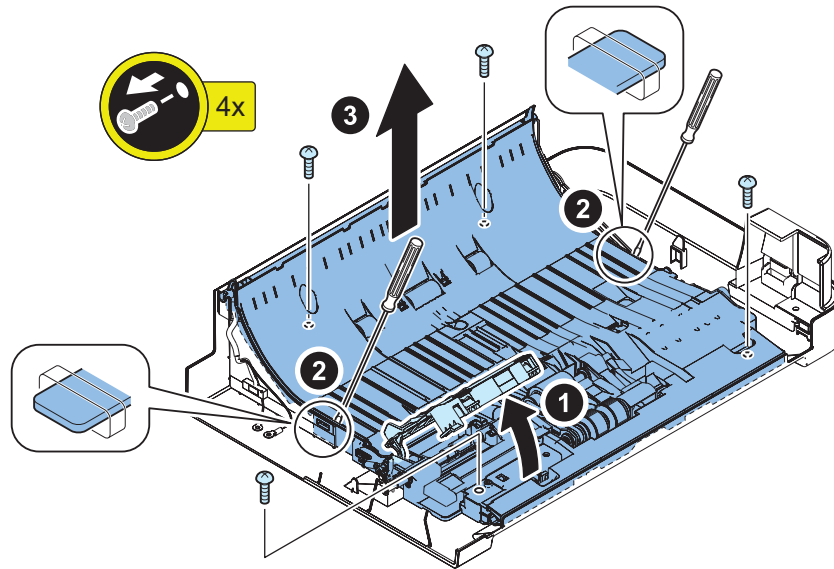
● Removing the Multi Feed Detect Sensor PCB

■ Preparation

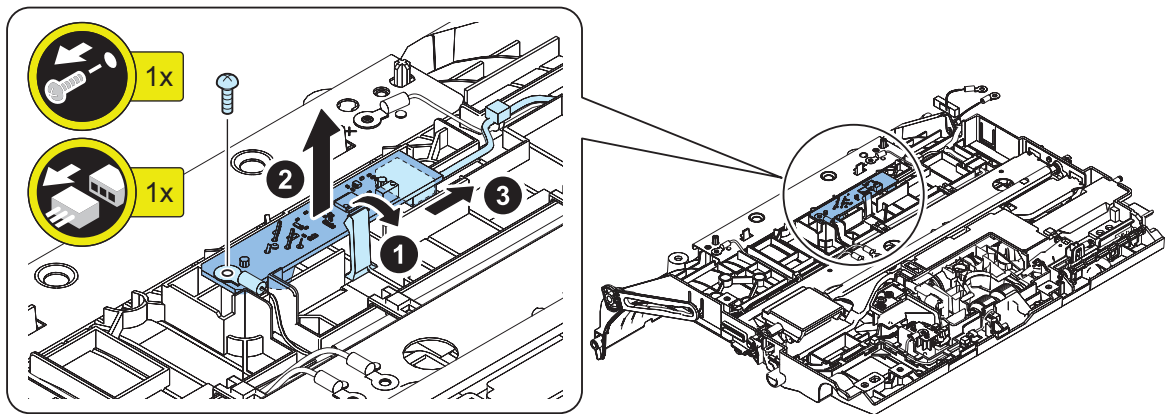
1. "Removing the ADF Front Cover" on page 283
2. "Removing the Sensor Harness Cover" on page 282
3. "Removing the Open/Close Cover" on page 285

■ Procedure

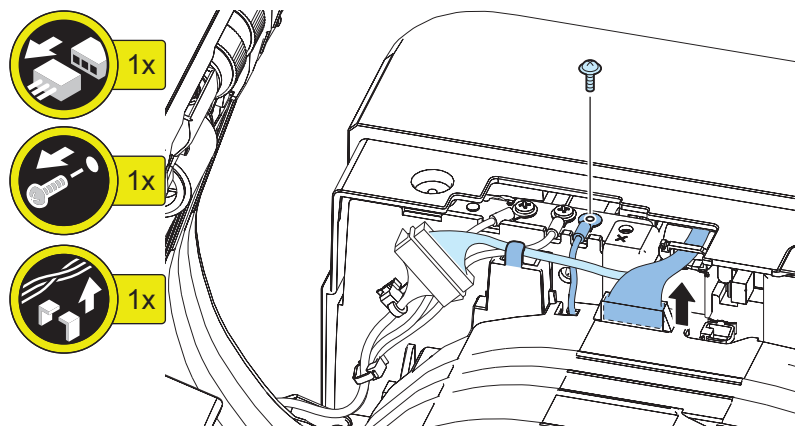
1.



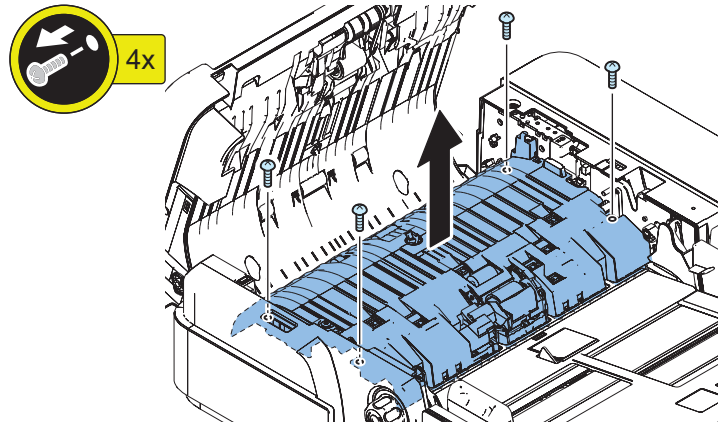
2.



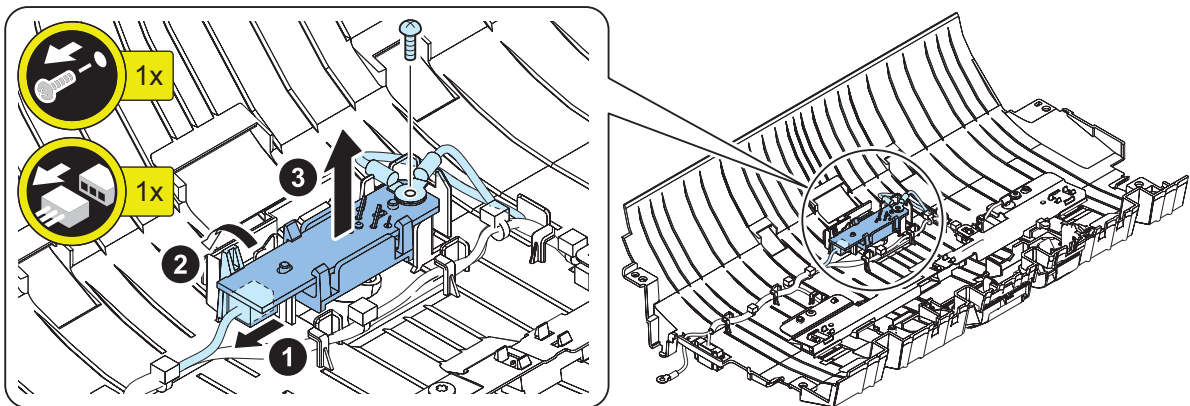
3.



4.



5.



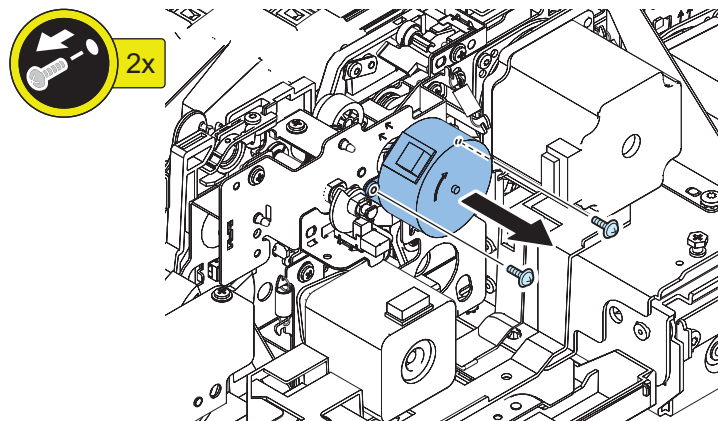
● Removing the Pickup Roller Lifting Motor

■ Preparation

1. "Removing the ADF Rear Cover" on page 284
2. "Removing the Sensor Harness Cover" on page 282
3. "Removing the ADF Driver PCB" on page 297
4. "Removing the Cable Guide Unit" on page 290
5. "Removing the ADF Delivery Motor" on page 300

■ Procedure

1.



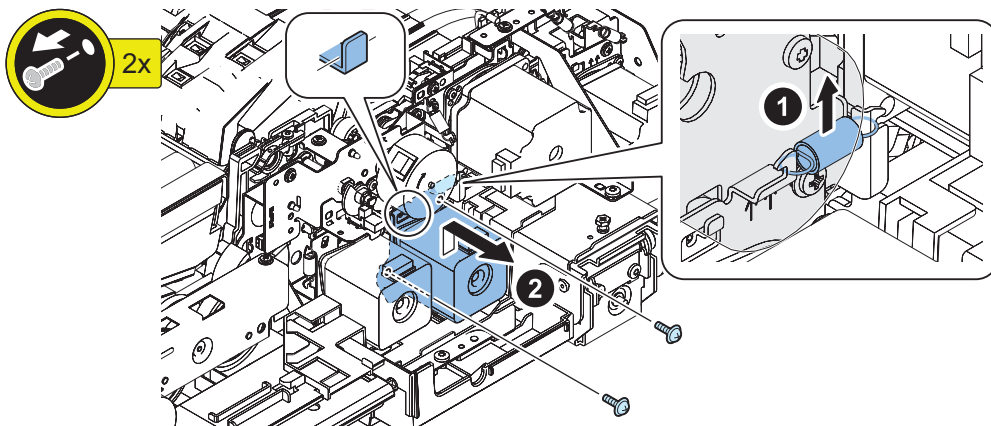
● Removing the ADF Delivery Motor

■ Preparation

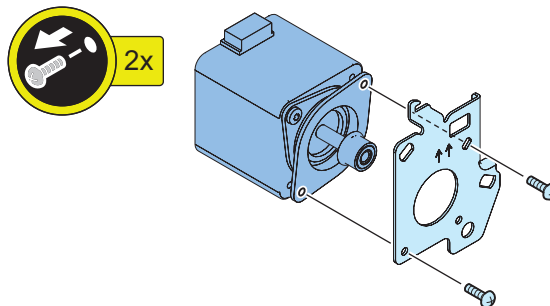
1. "Removing the ADF Rear Cover" on page 284
2. "Removing the Sensor Harness Cover" on page 282
3. "Removing the ADF Driver PCB" on page 297
4. "Removing the Cable Guide Unit" on page 290

■ Procedure

1.



2.



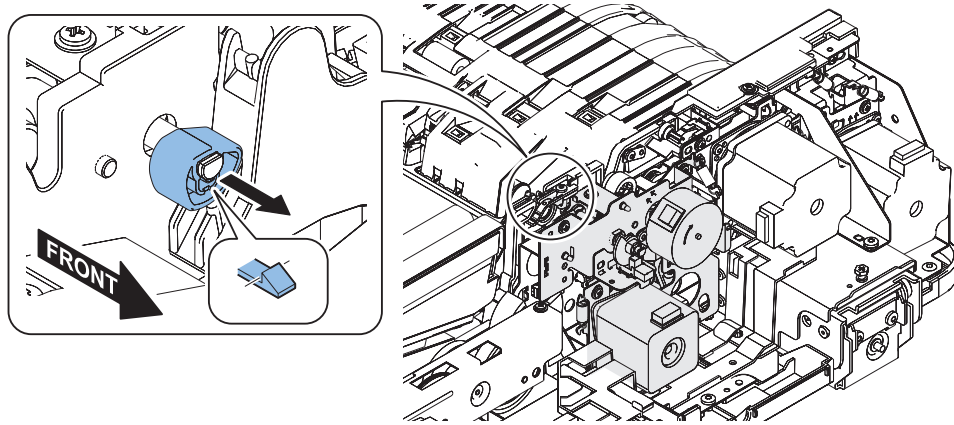
● Removing the ADF Pickup Motor Unit

■ Preparation

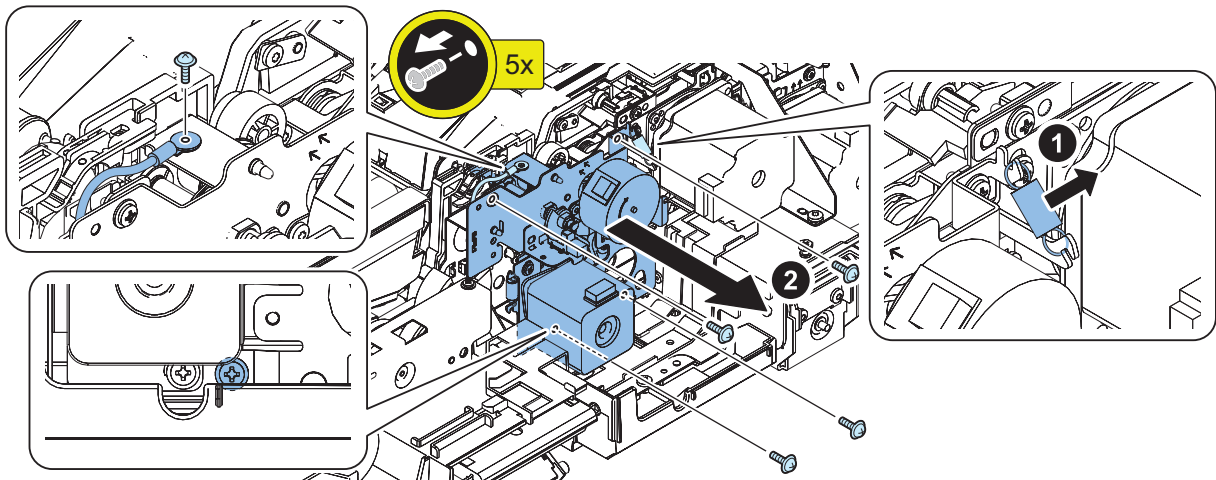
1. "Removing the ADF Rear Cover" on page 284
2. "Removing the Sensor Harness Cover" on page 282
3. "Removing the ADF Driver PCB" on page 297
4. "Removing the Cable Guide Unit" on page 290
5. "Removing the ADF Delivery Motor" on page 300

■ Procedure

1.



2.



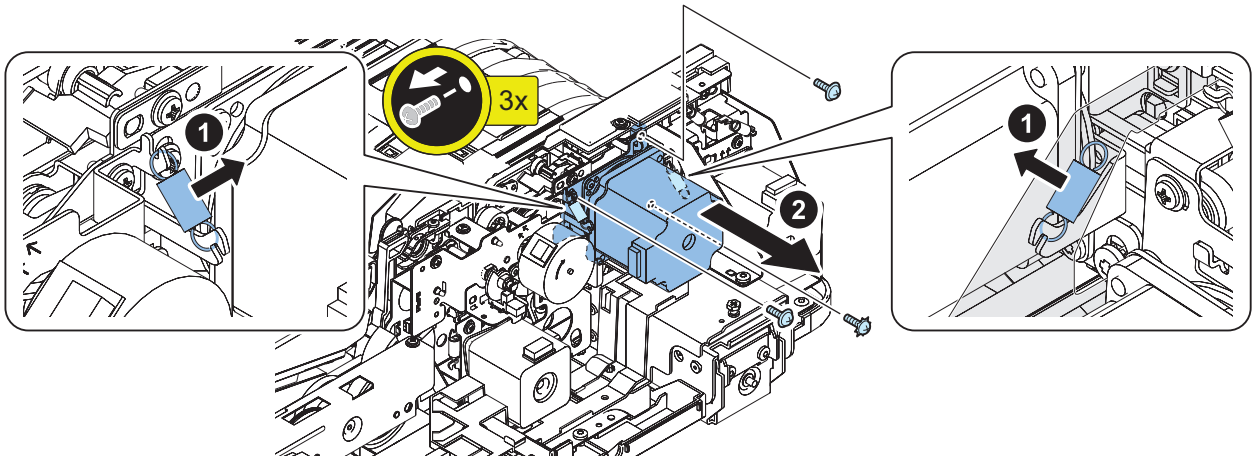
● Removing the ADF Pullout Motor Unit

■ Preparation

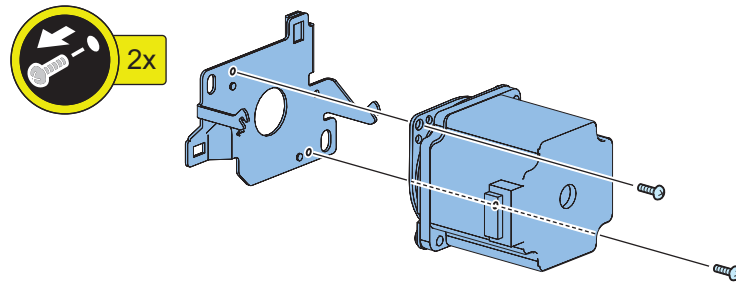
1. "Removing the ADF Rear Cover" on page 284
2. "Removing the Sensor Harness Cover" on page 282
3. "Removing the ADF Driver PCB" on page 297
4. "Removing the Cable Guide Unit" on page 290

■ Procedure

1.



2.



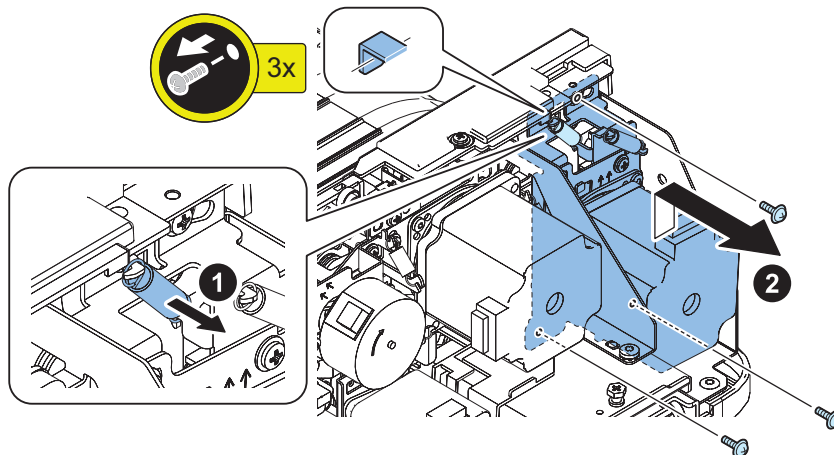
● Removing the Lead Motor Unit

■ Preparation

1. "Removing the ADF Rear Cover" on page 284
2. "Removing the Sensor Harness Cover" on page 282
3. "Removing the ADF Driver PCB" on page 297
4. "Removing the Cable Guide Unit" on page 290

■ Procedure

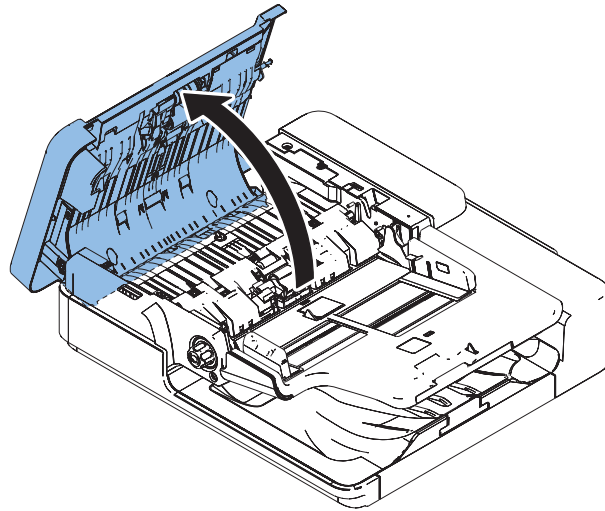
1.



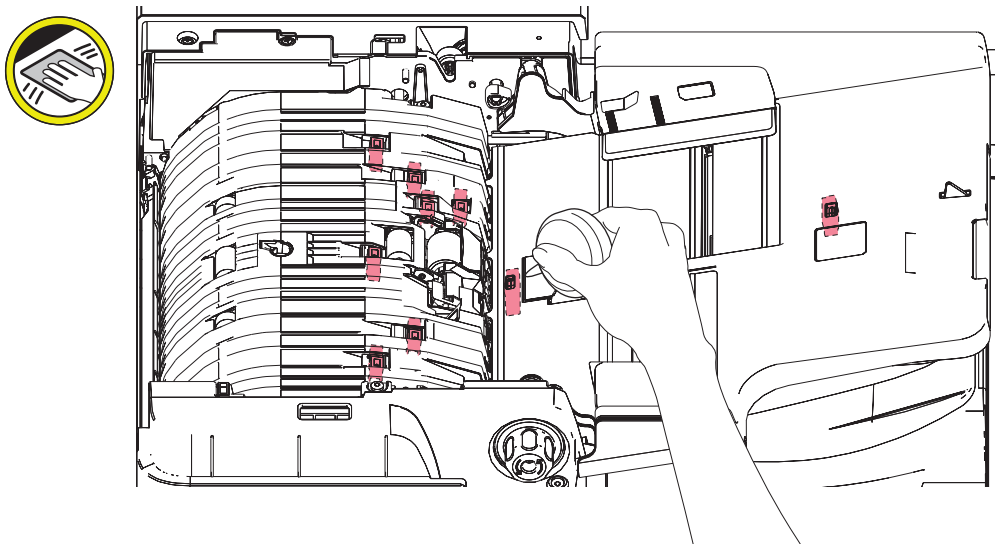
Cleaning the Sensor

■ Procedure

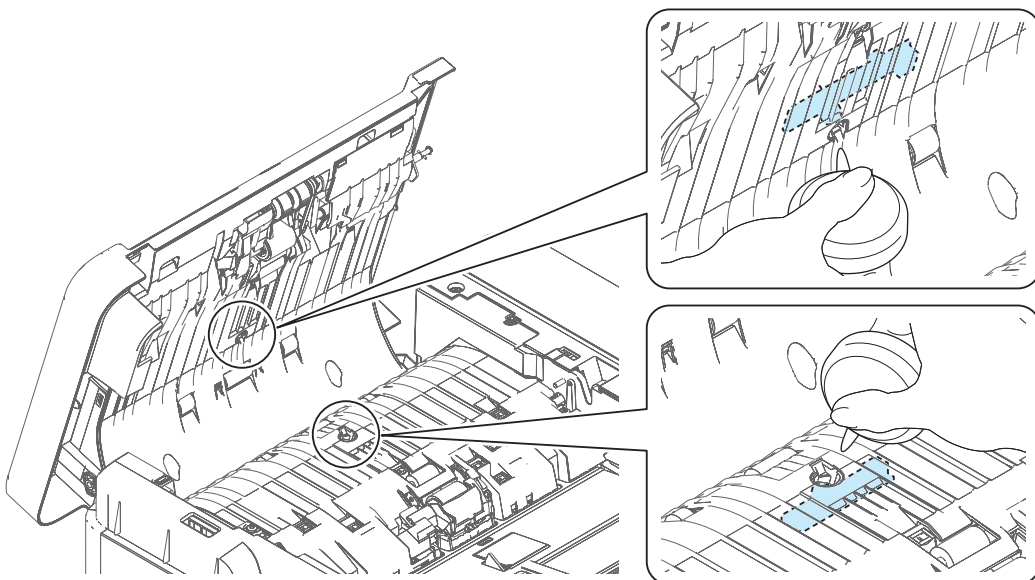
1.



2.



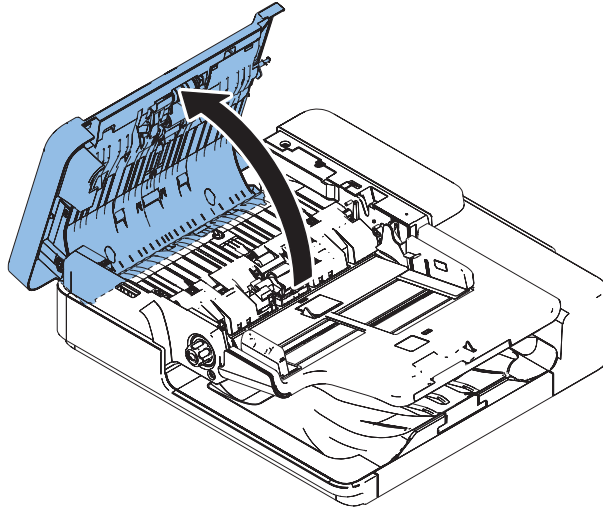
3.



Cleaning the Pullout Roller

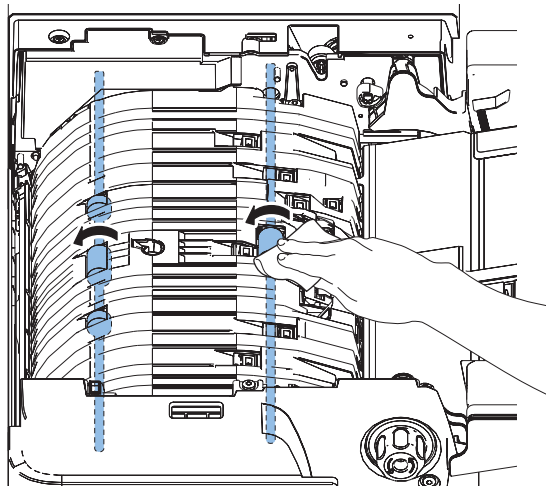
■ Procedure

1.



2. Clean the Roller with squeezed lint-free paper moistened with water while rolling the roller in the following service mode.

FEEDER > FUNCTION > ROLL-CLN



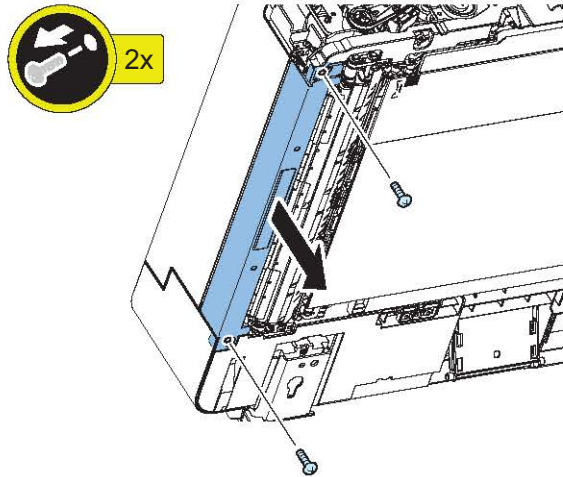
Cleaning the Lead Roller 1

■ Preparation

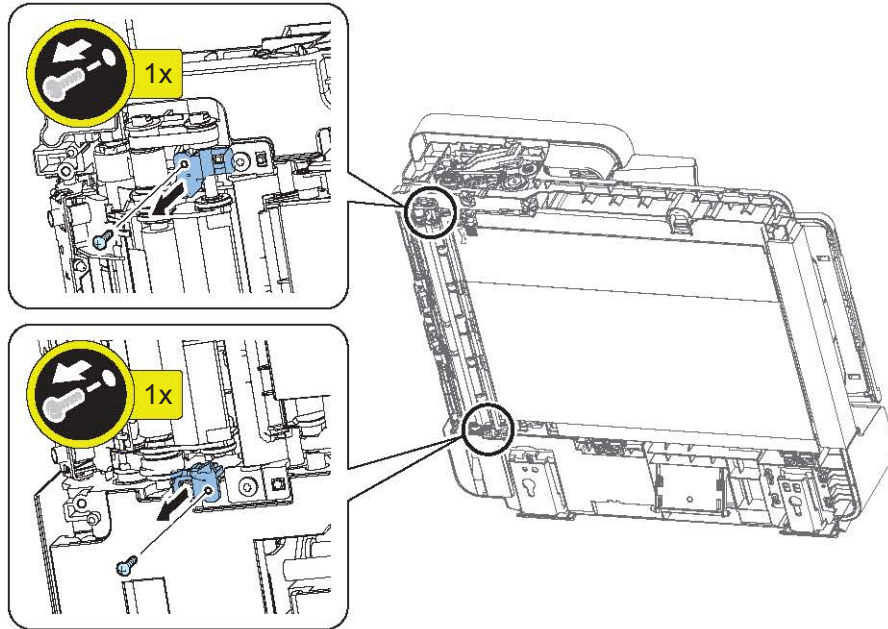
1. "Removing the ADF Front Cover " on page 283

■ Procedure

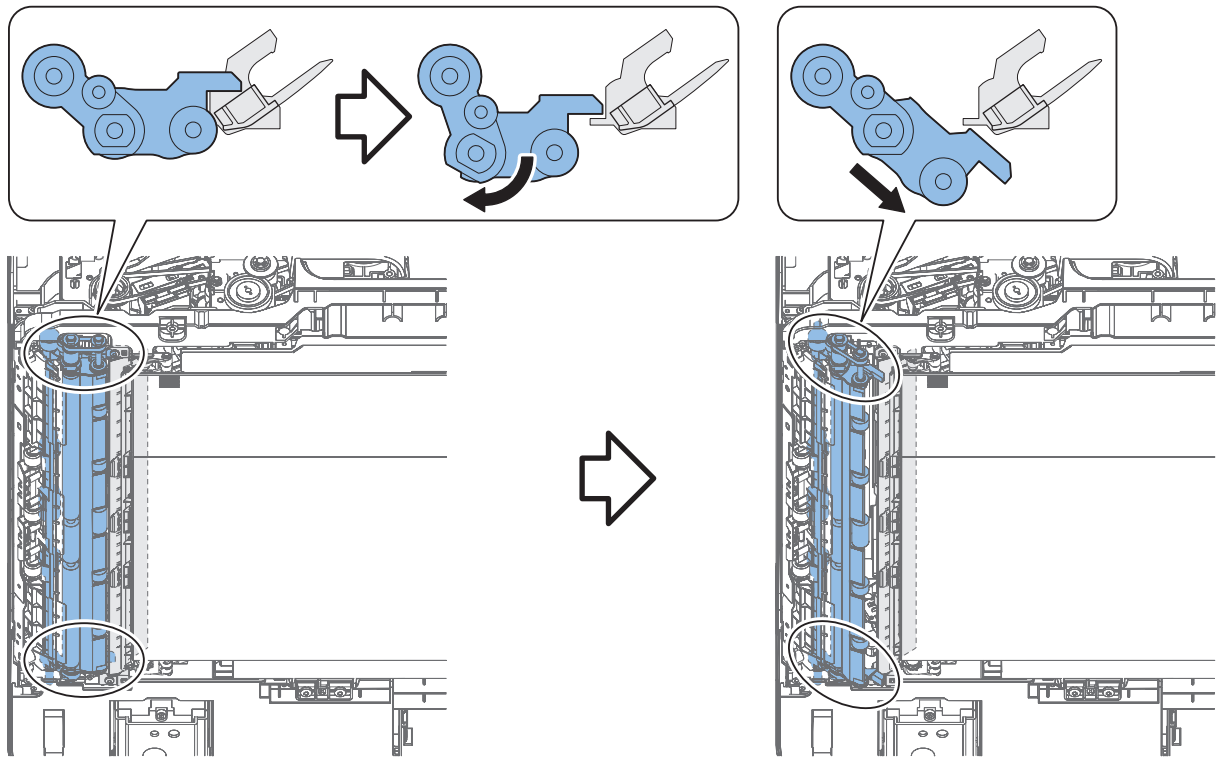
1.



2.

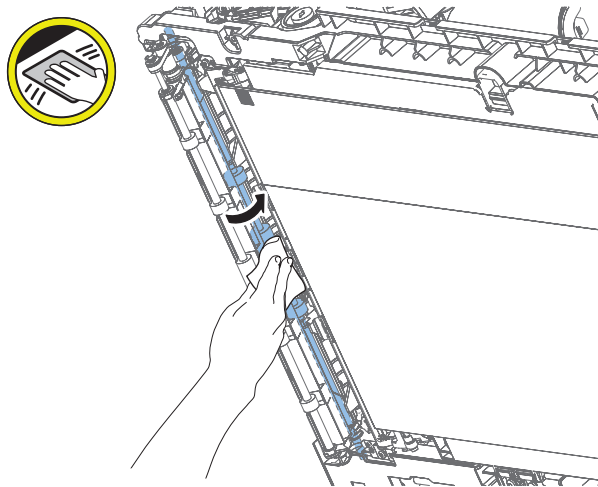


3.



4. Clean the Roller with squeezed lint-free paper moistened with water while rolling the roller in the following service mode.

FEEDER > FUNCTION > ROLL-CLN



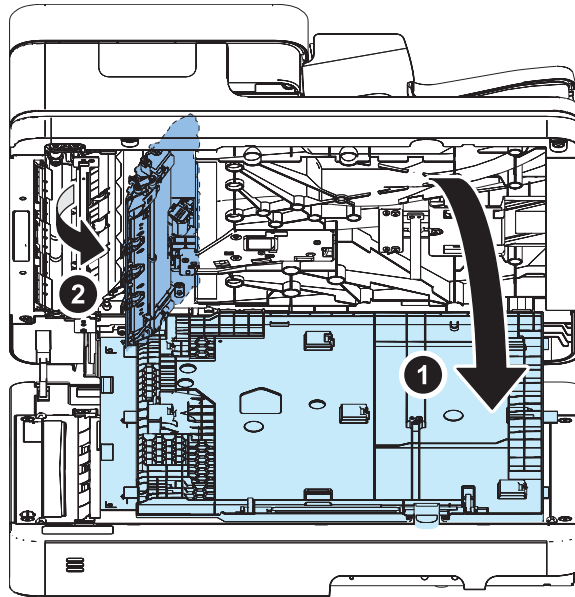
Cleaning the Lead Roller 2

■ Procedure

1.

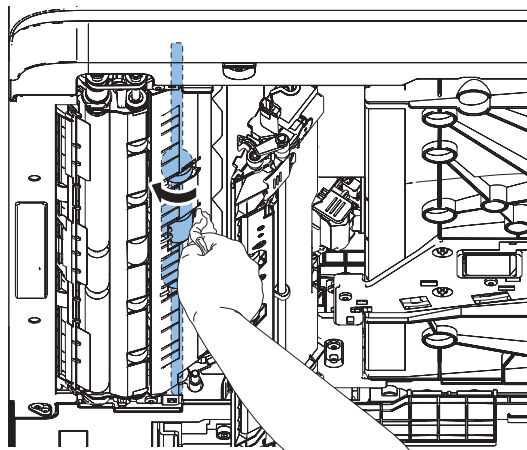


2.



3. Clean the Roller with squeezed lint-free paper moistened with water while rolling the roller in the following service mode.

FEEDER > FUNCTION > ROLL-CLN



Cleaning the Paper Back Reading Glass

■ Preparation

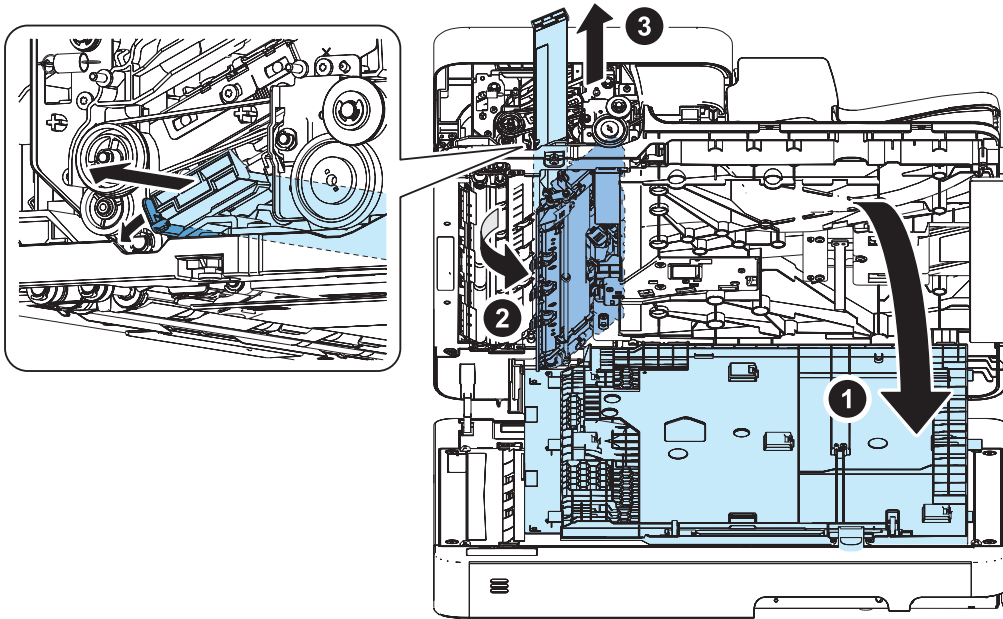
1. “Removing the ADF Front Cover ” on page 283

■ Procedure

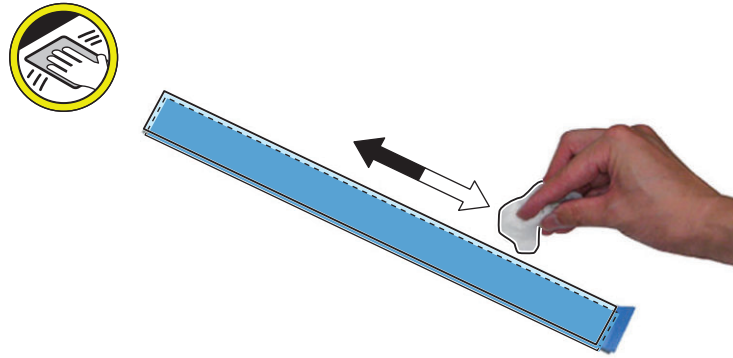
1.

CAUTION:

Open the White Plate before removing the Copyboard Glass as the Copyboard Glass is rubbed with the Plate.

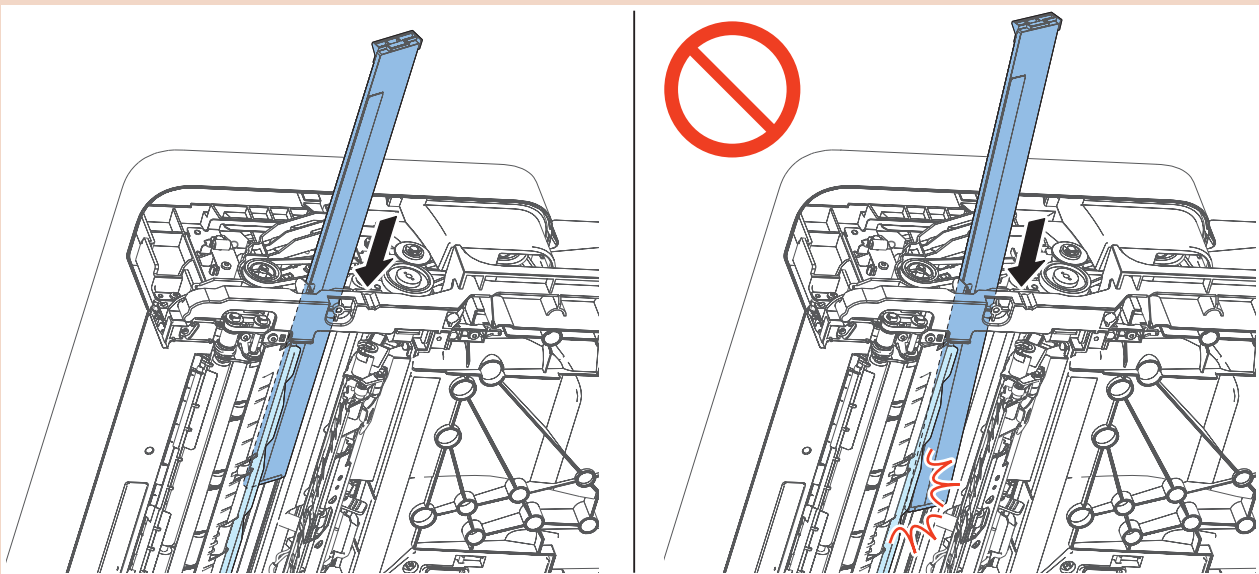


- 2.** Clean the front and back surface of the Copyboard Glass with squeezed lint-free paper moistened with water.



CAUTION:

When installing the Reading Glass, slowly and carefully slide it in. Do not install it over the film sheet.



Original Exposure System

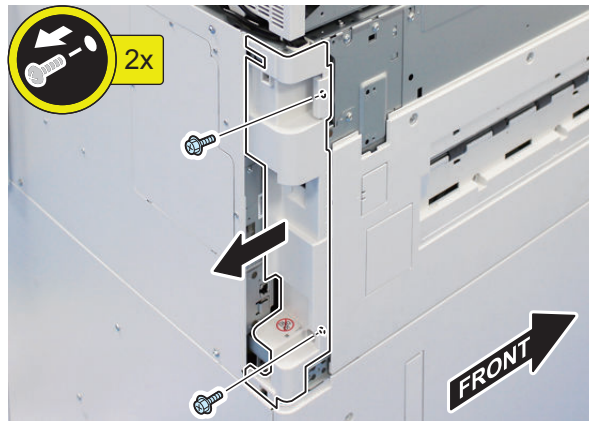
● Removing the Reader Unit

■ Preparation

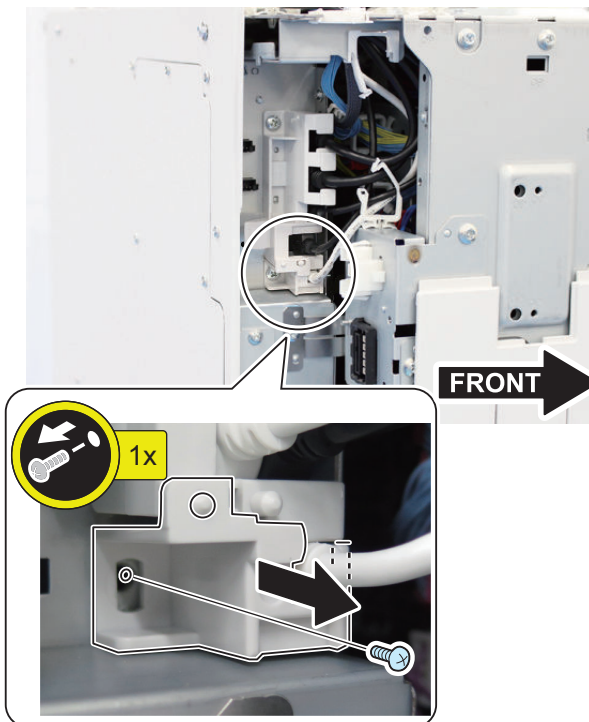
1. "Removing the Covers" on page 312
2. "Removing the ADF" on page 279

■ Procedure

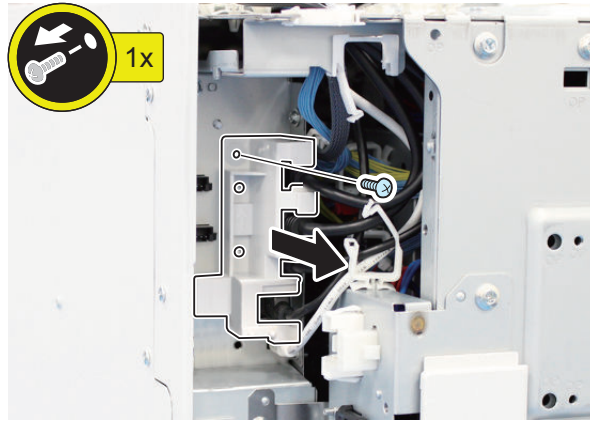
1.



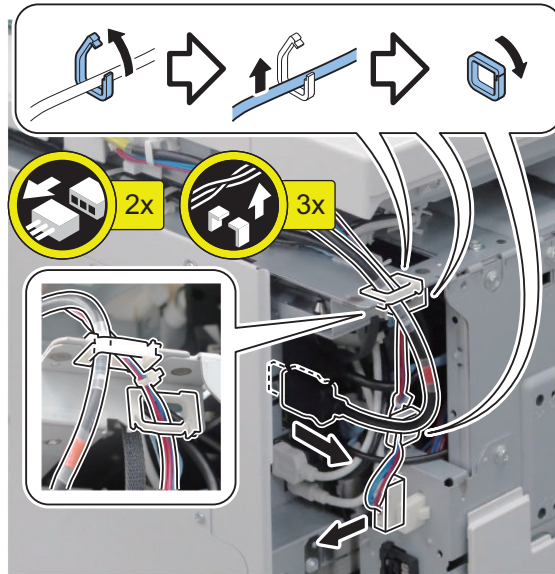
2.



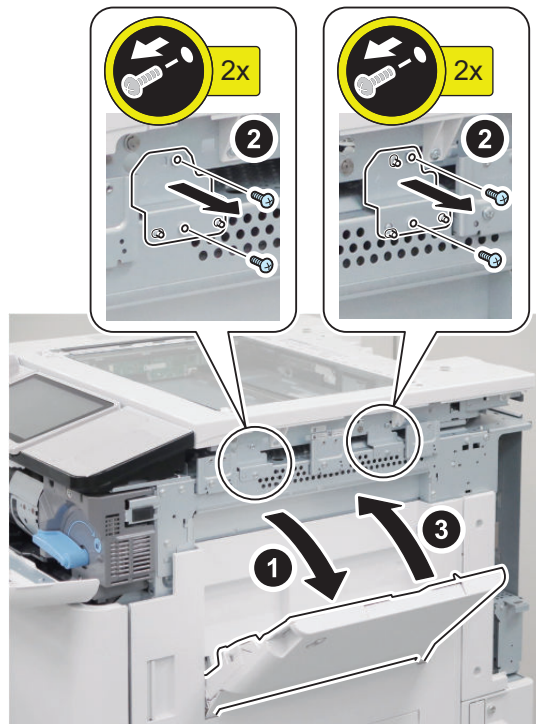
3.



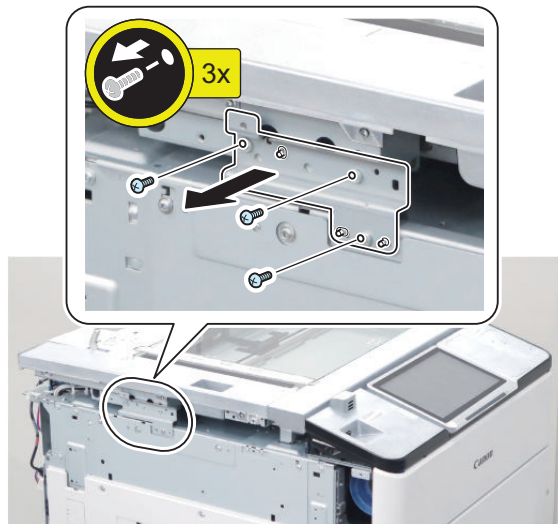
4.



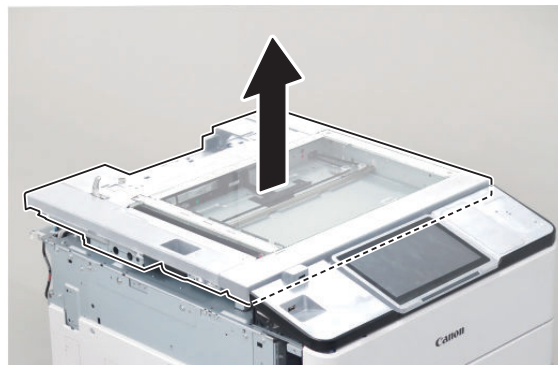
5.



6.

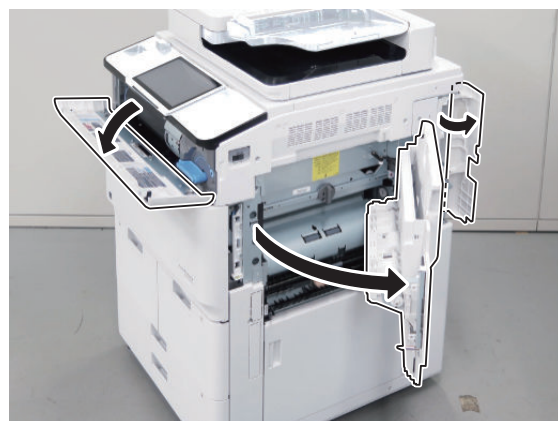


7.



Removing the Covers

1.



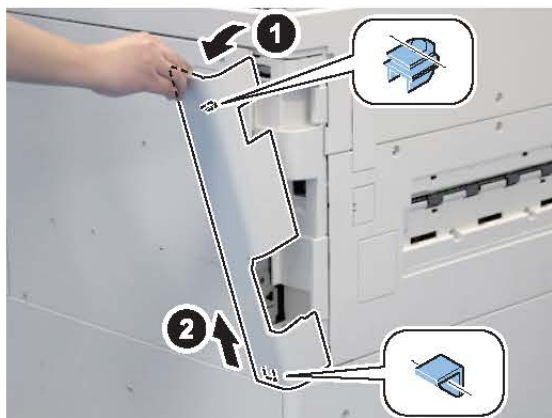
2.



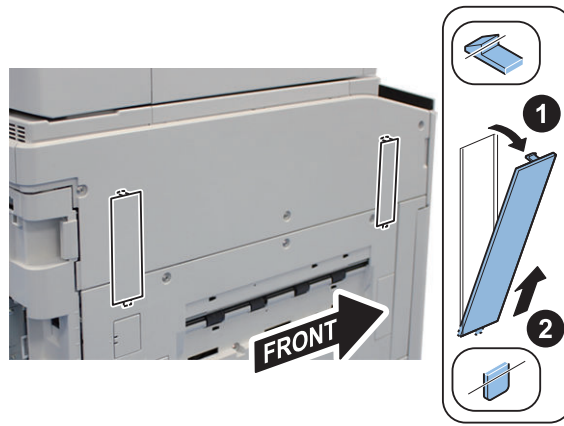
3.



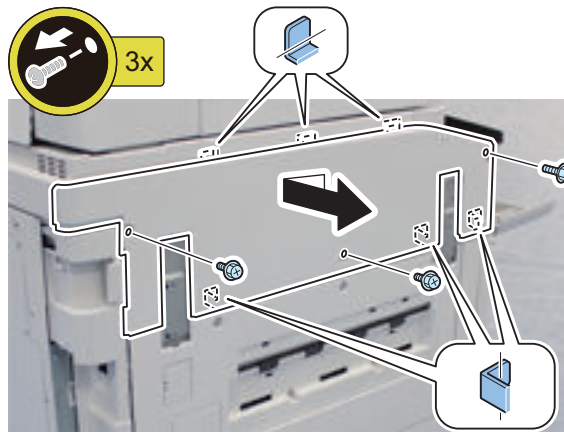
4.



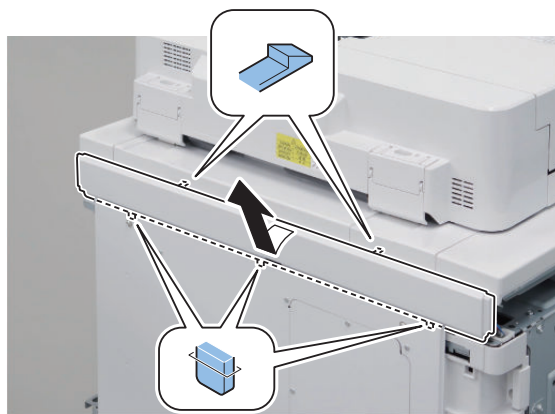
5.



6.



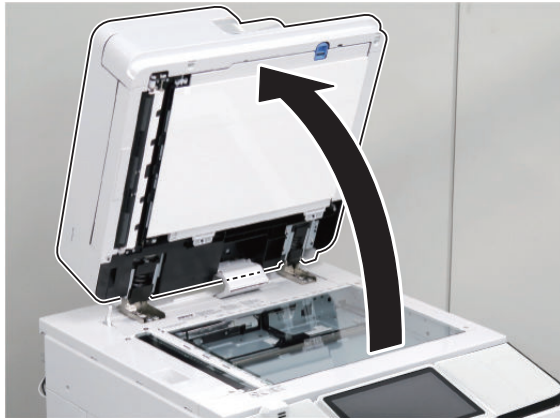
7.



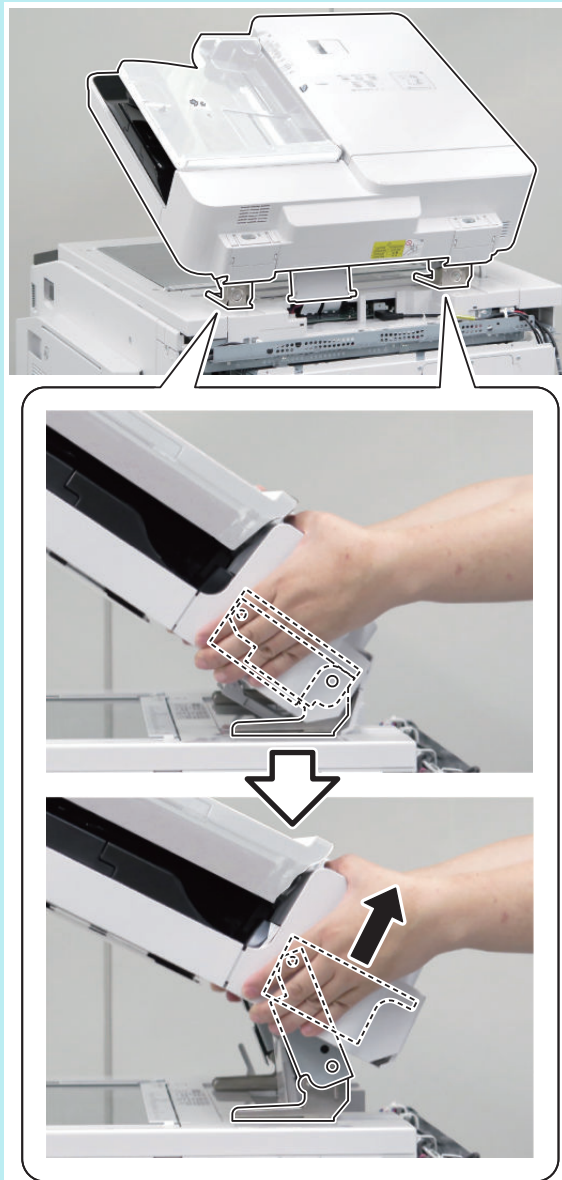
● Removing the Reader Controller PCB

■ Preparation

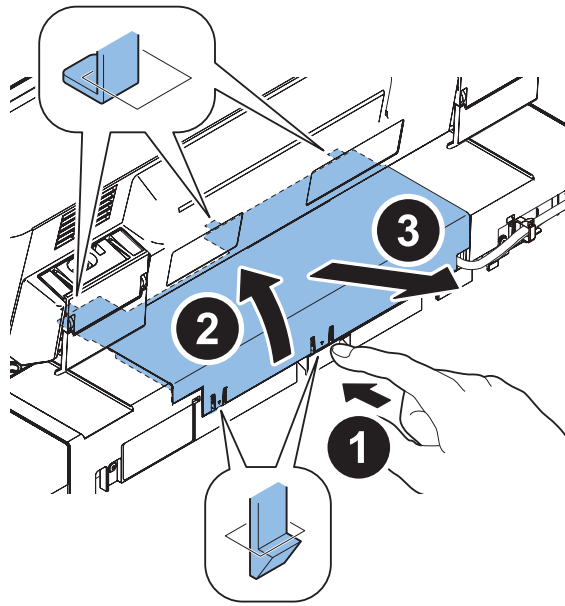
1. Actions before Parts Replacement: [“Reader Controller PCB” on page 642](#)
2. [“Removing the Covers” on page 312](#)

■ Procedure**1.****NOTE:**

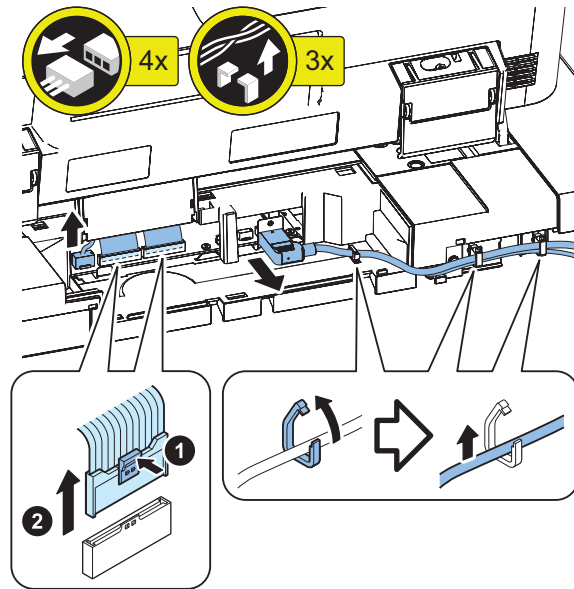
- When performing the following procedures, using ADF in the book mode makes the work easy.
- The book mode can be released by fully opening the ADF.



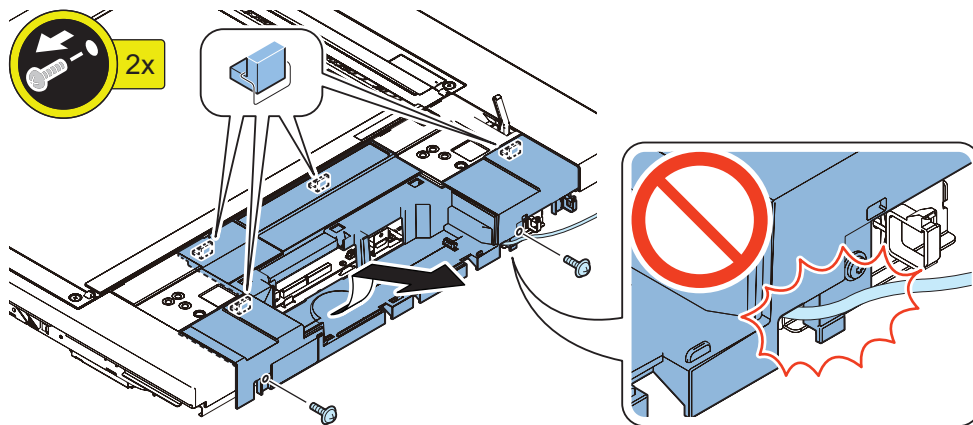
2.



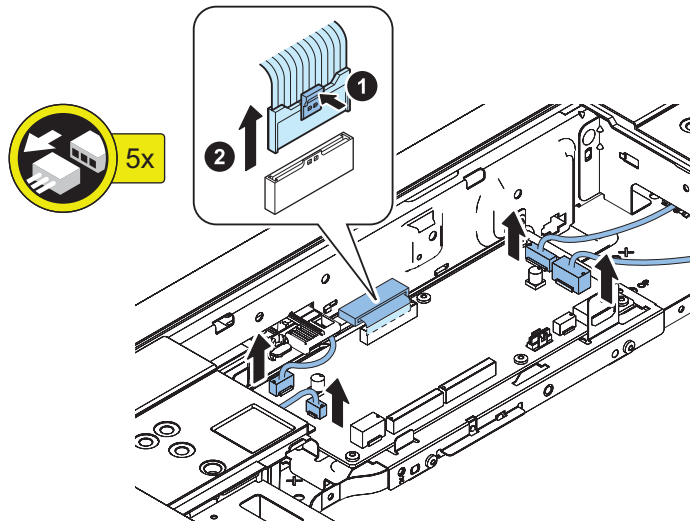
3.



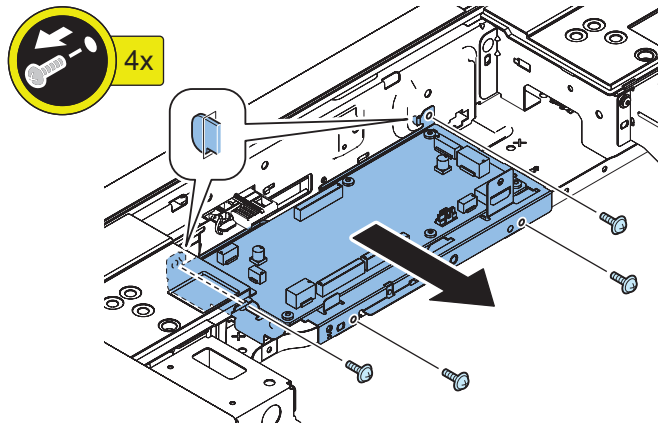
4.



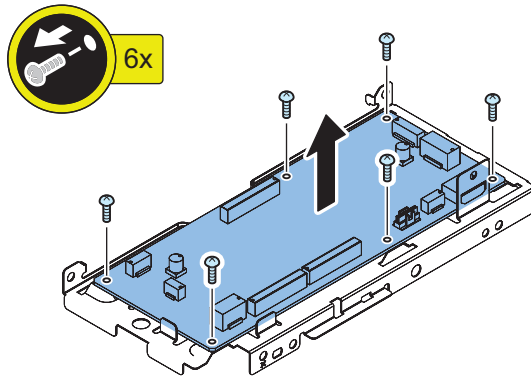
5.



6.



7.

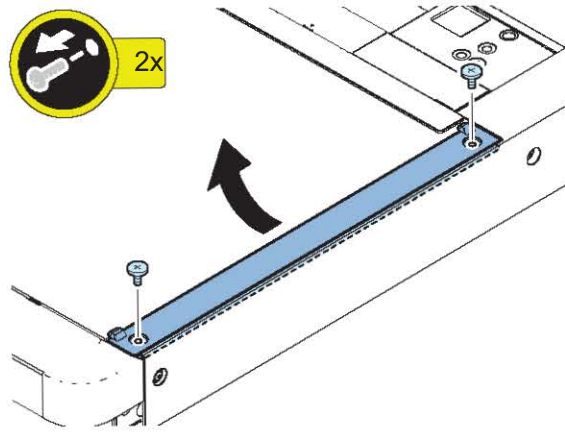


8. Actions after Replacement: [“Reader Controller PCB” on page 642](#)

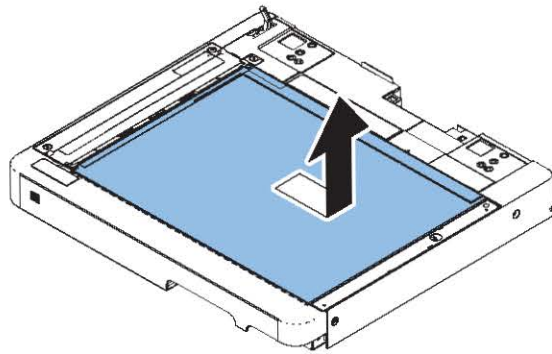
● Removing the Reader Scanner Unit

■ Procedure

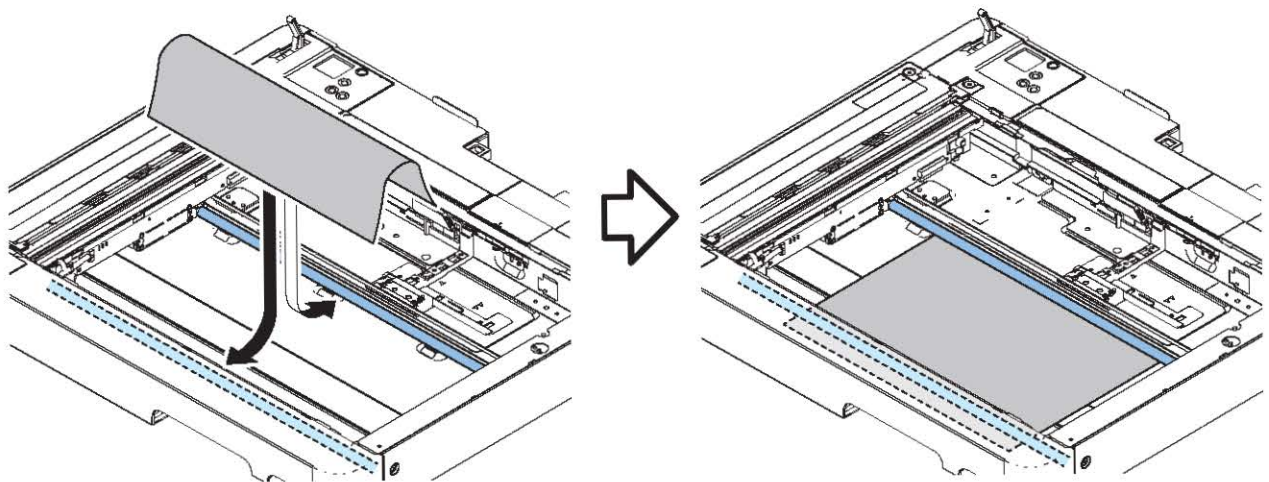
1.



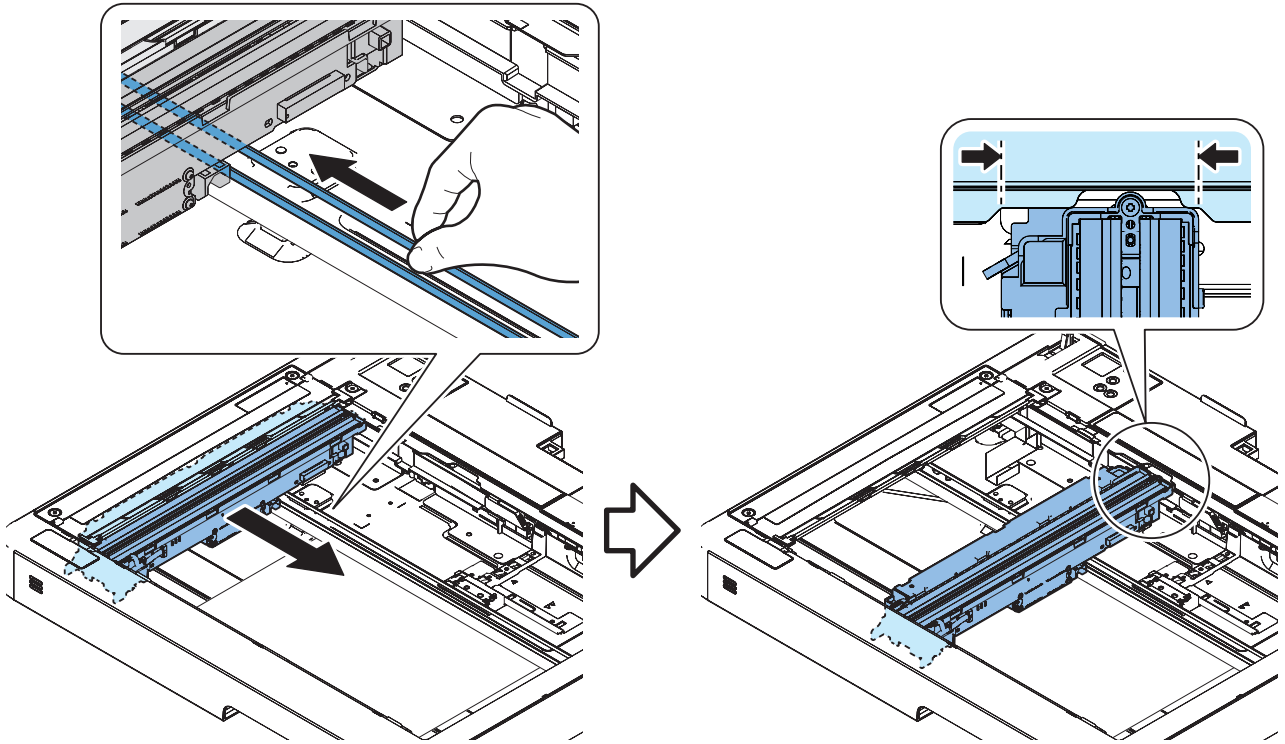
2.



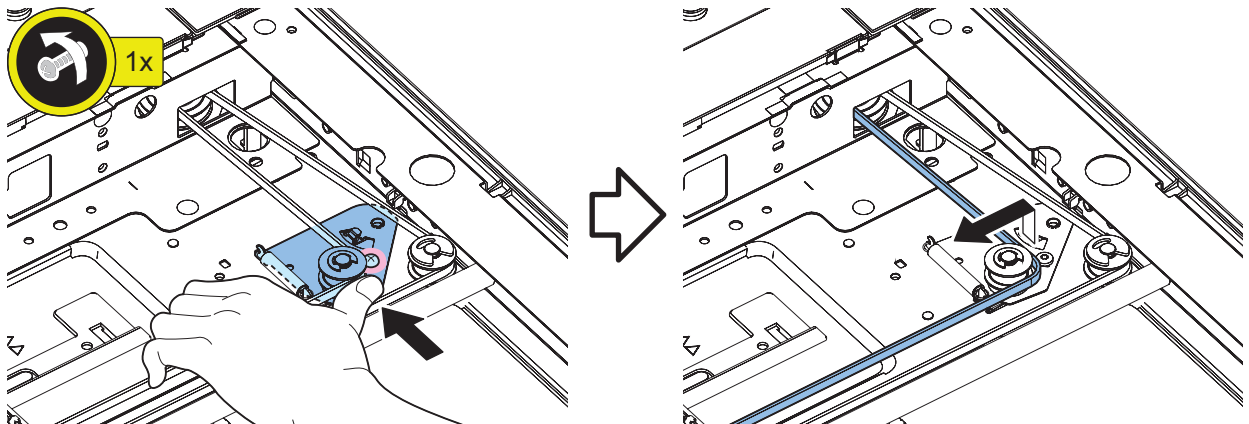
3.



4.

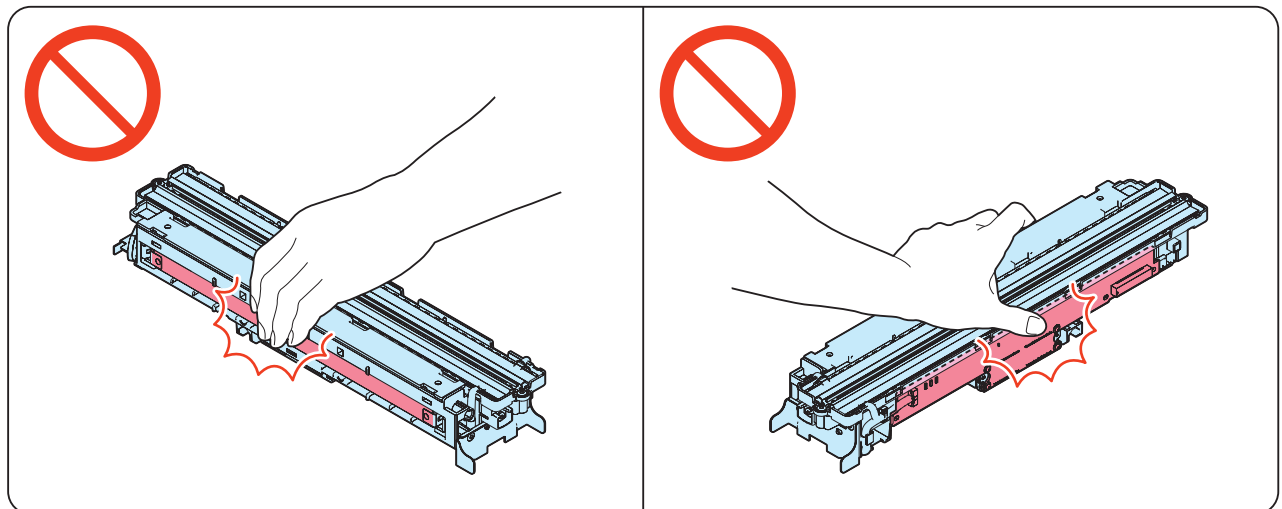


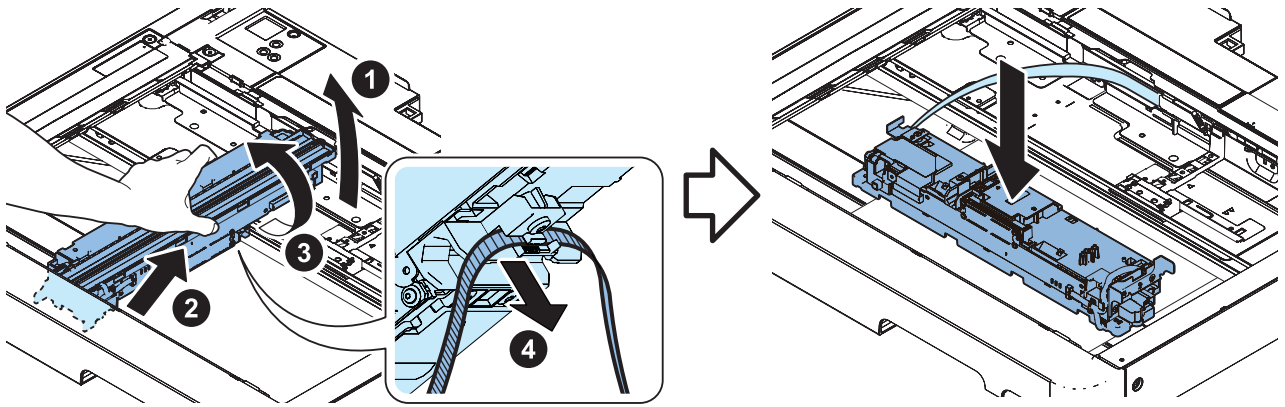
5.



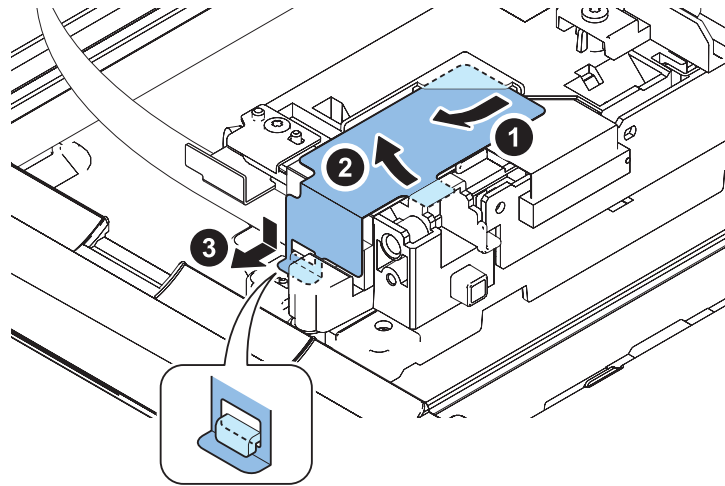
6.

CAUTION:
Do not touch the Scanner Unit PCB and the mirror.

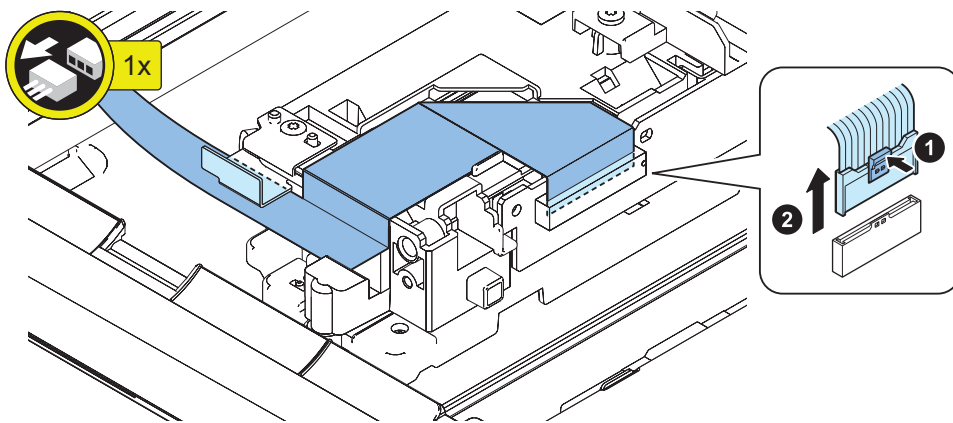




7.



8.

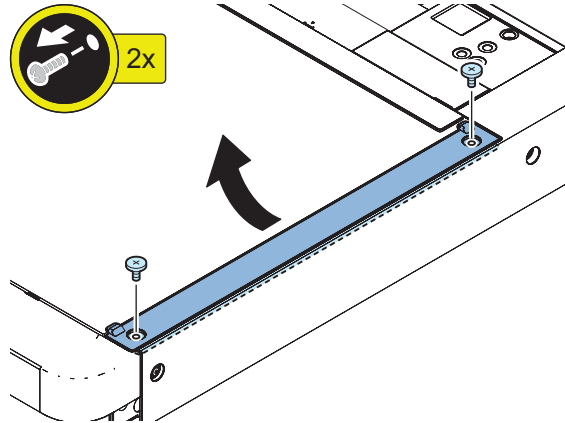


9. Actions after parts replacement: [“Reader Scanner Unit” on page 642](#)

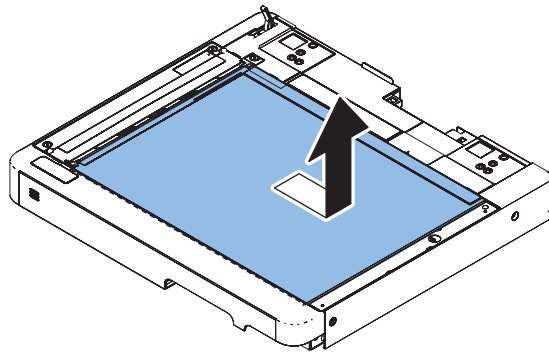
Cleaning the Reader Scanner Unit Scanner Mirror

■ Procedure

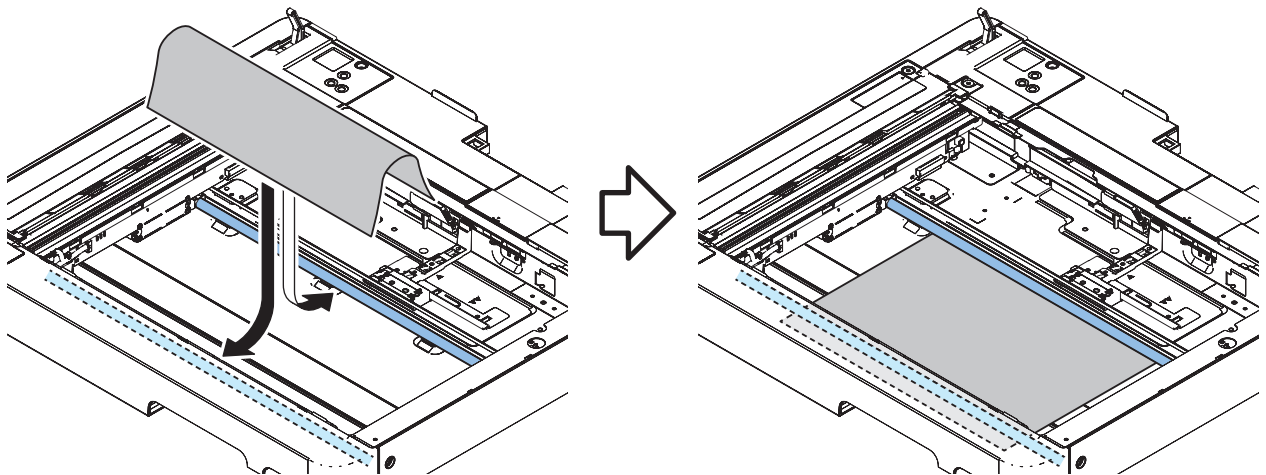
1.



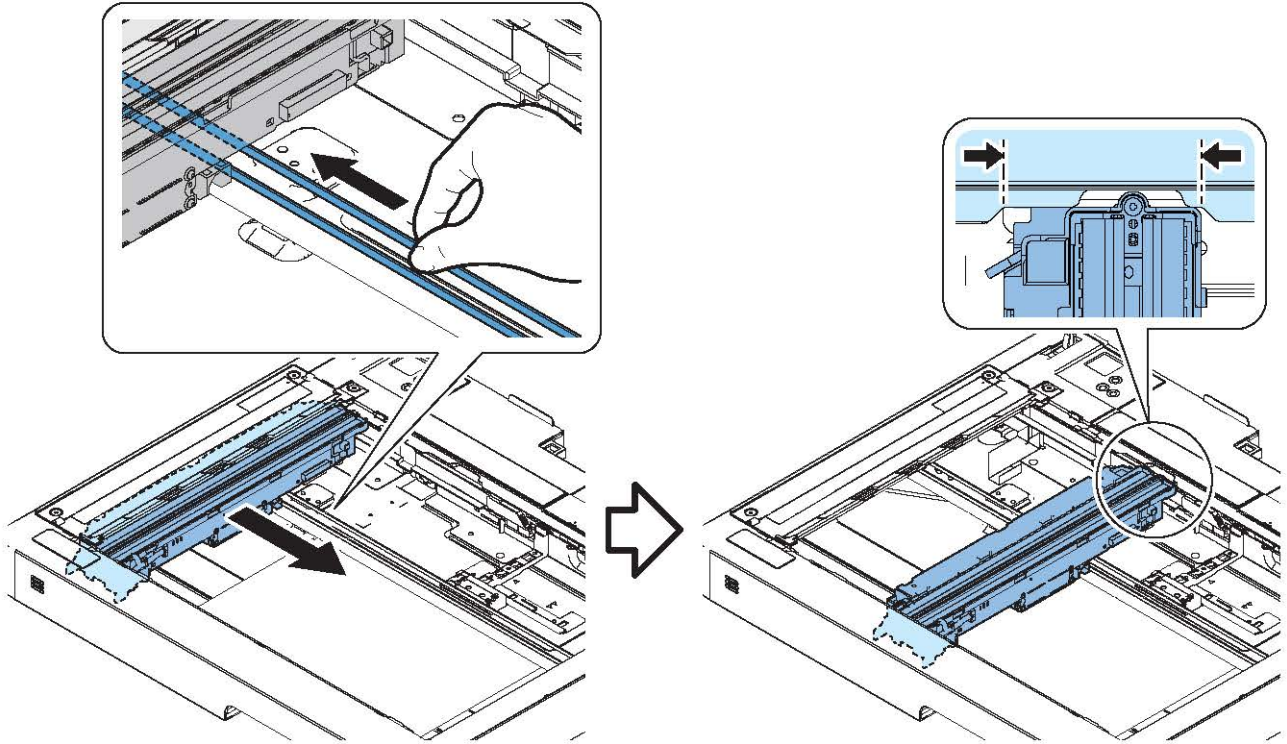
2.



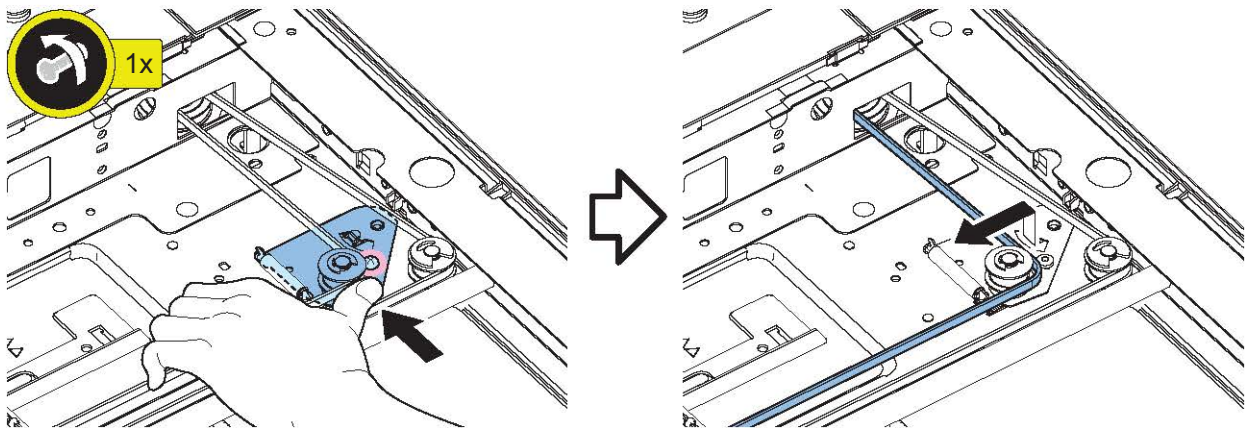
3.



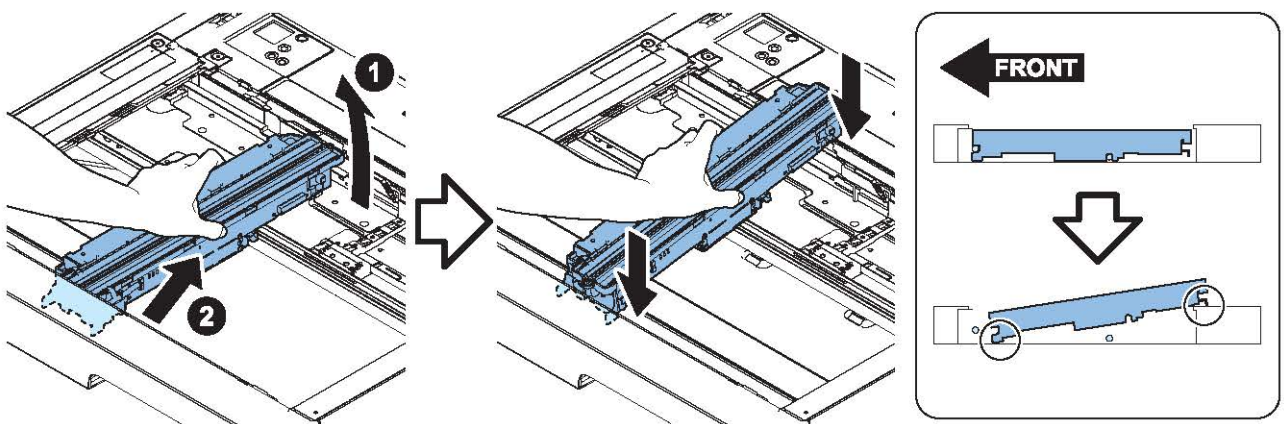
4.



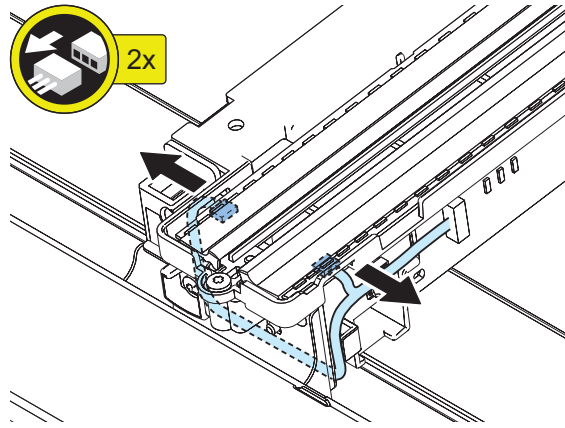
5.



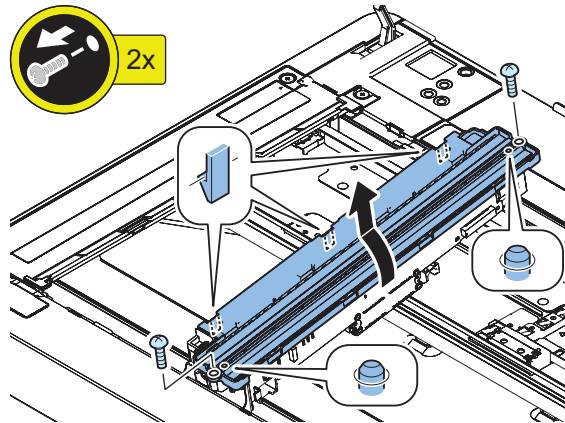
6.



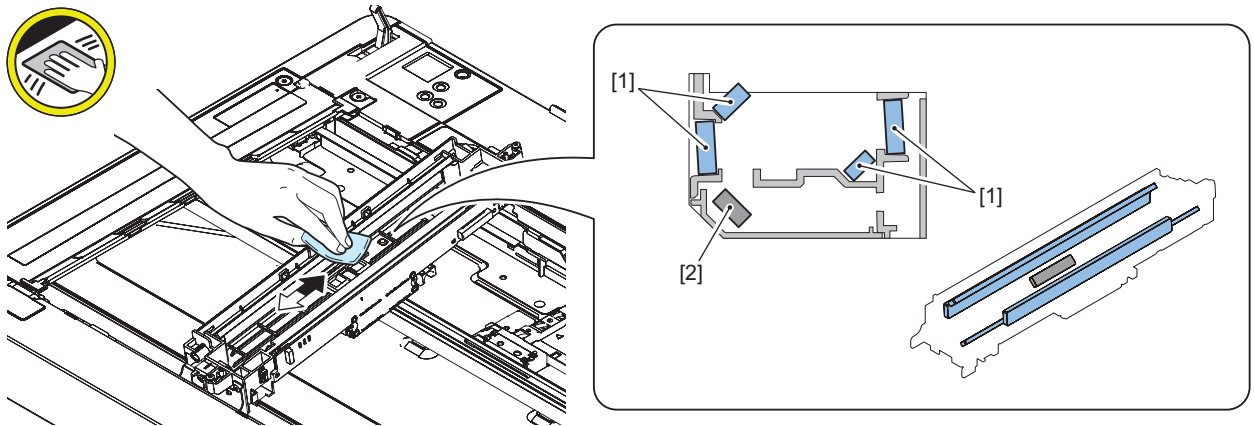
7.



8.



9. Clean the mirror [1] with lint-free paper. Use a cotton swab to clean the mirror [2].



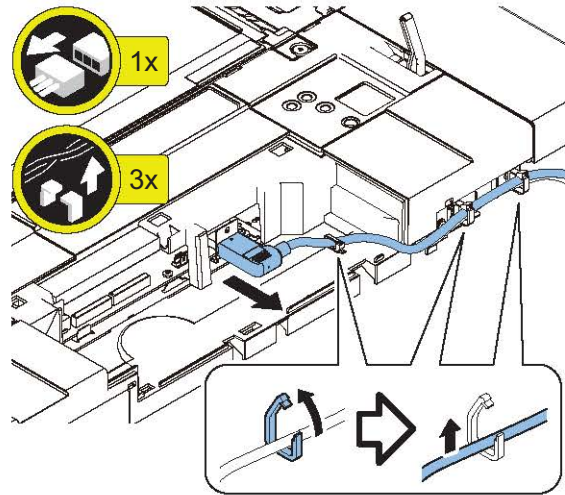
● Removing the Reader Scanner Motor

■ Preparation

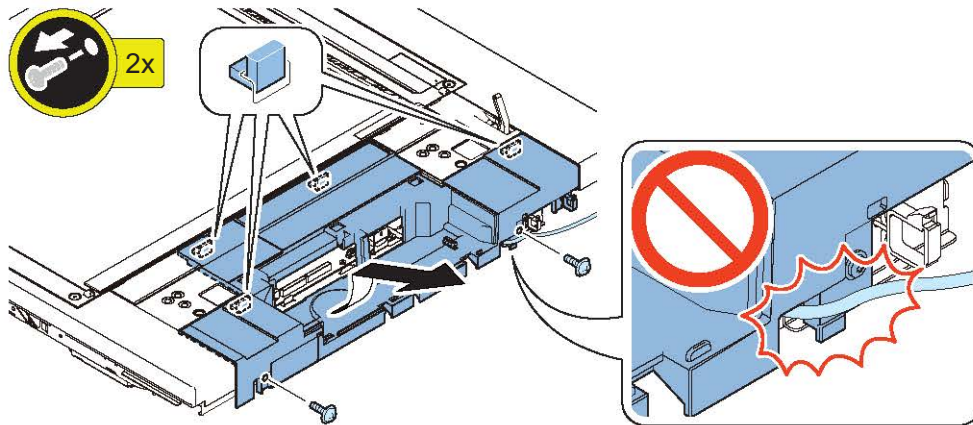
1. "Removing the Covers" on page 312
2. "Removing the ADF" on page 279

■ Procedure

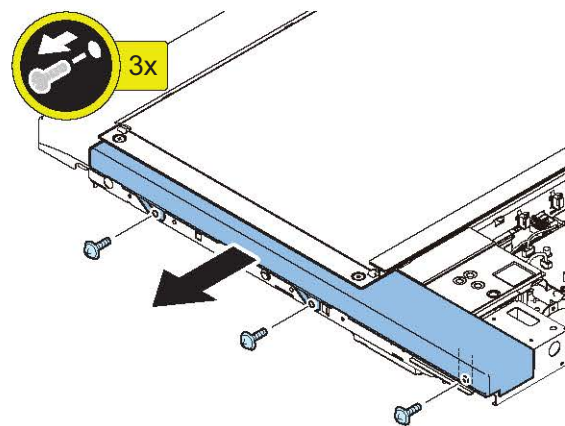
1.



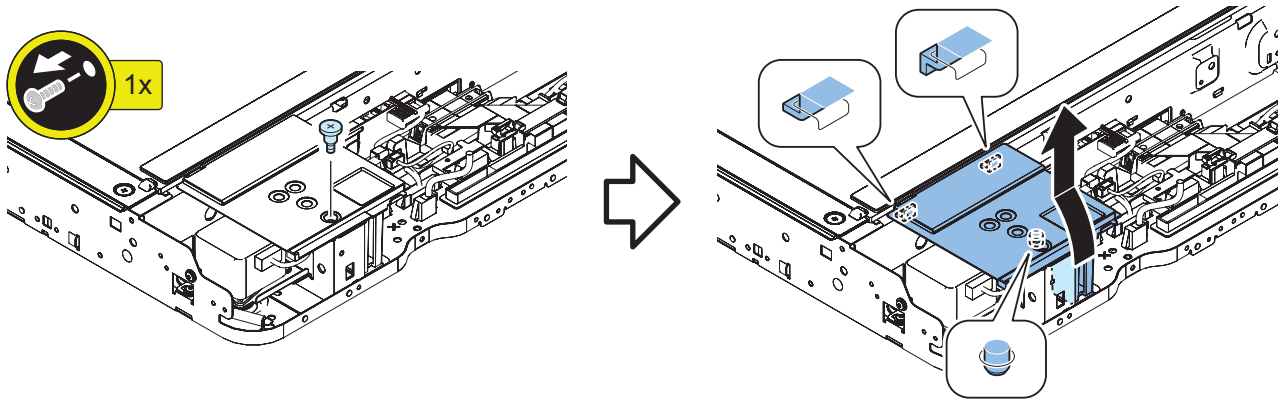
2.



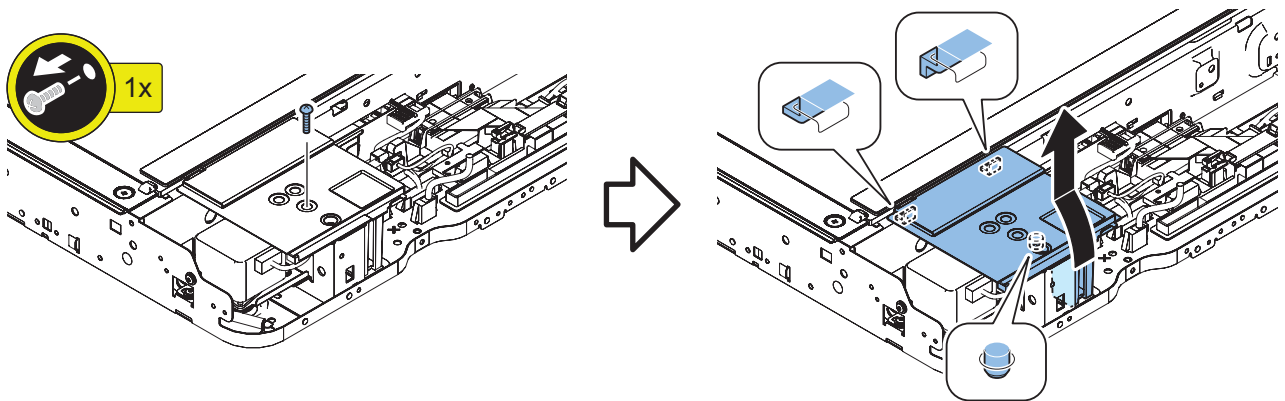
3.



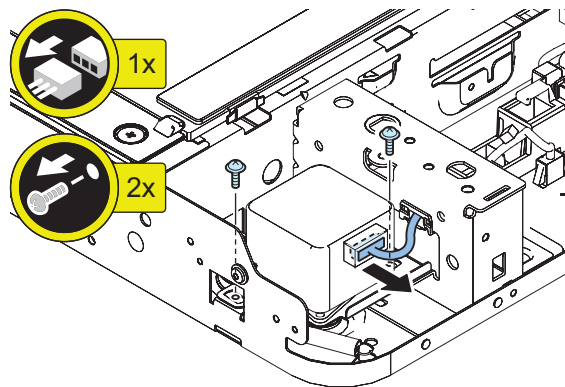
4. When ADF is installed.



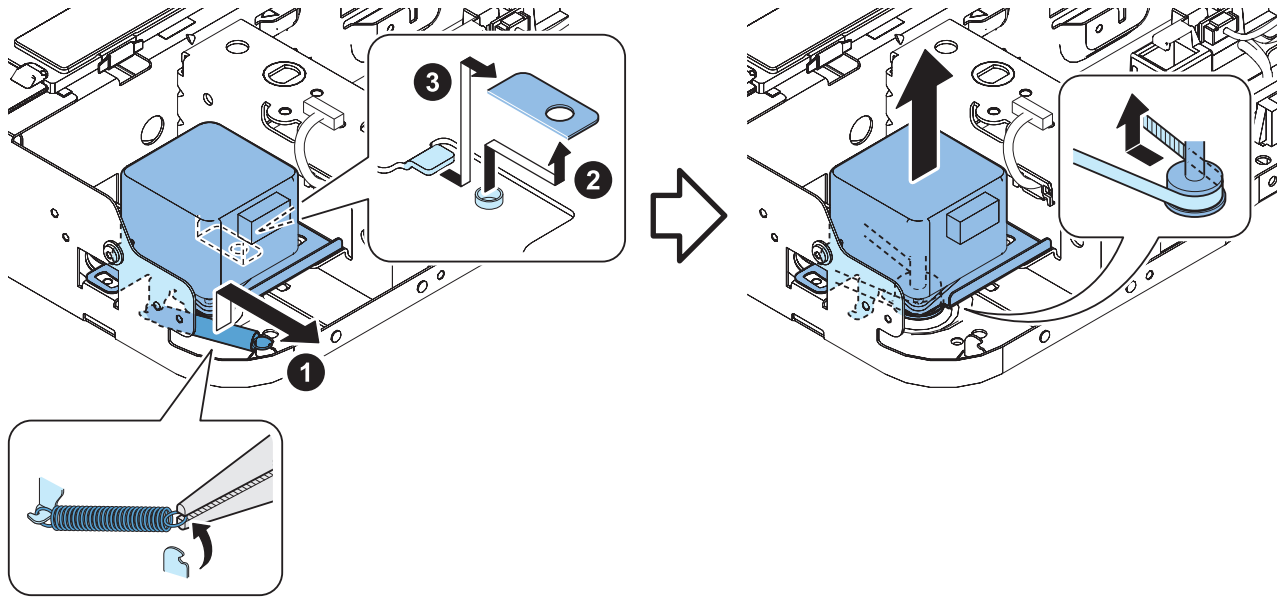
5. When Platen Cover is installed.



6.



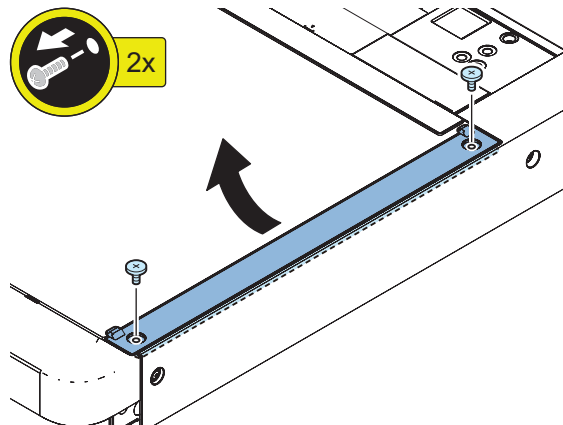
7.



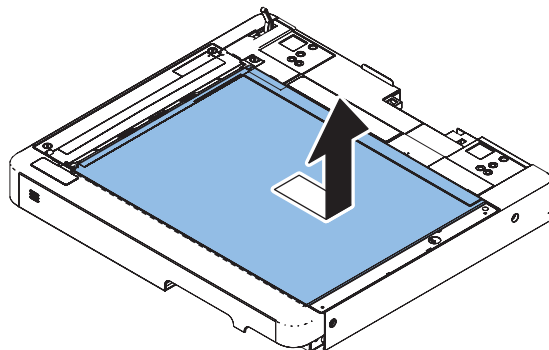
● Removing the Copyboard Glass

■ Procedure

1.



2.

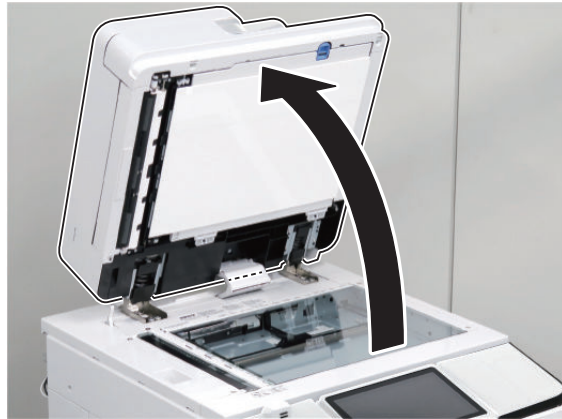


3. Actions after Replacement: [“Copyboard Glass” on page 643](#)

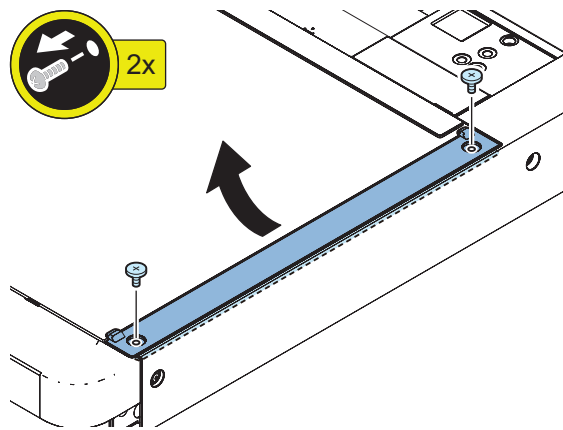
Cleaning the Copyboard Glass (Large)

■ Procedure

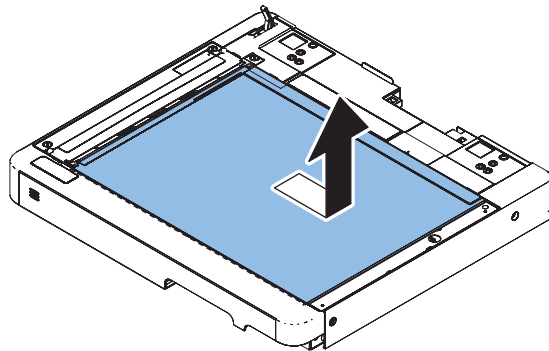
1.



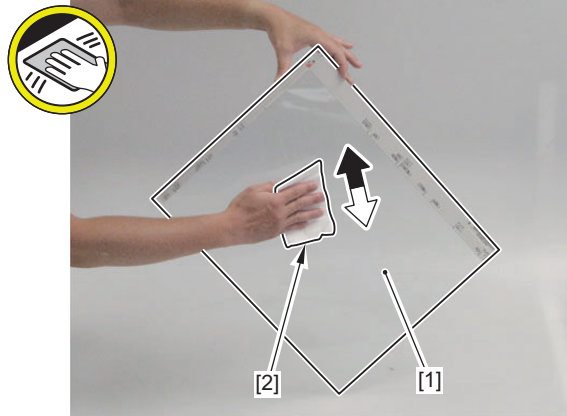
2.



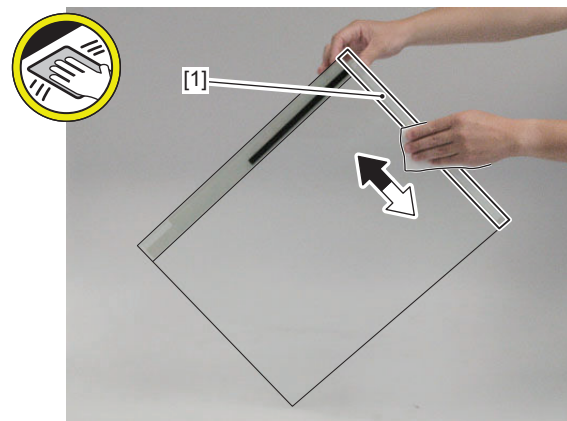
3.



4. Clean the front surface and back surface of the Copyboard Glass (Large) [1] with lint-free paper [2].



5. Clean the White Plate [1].

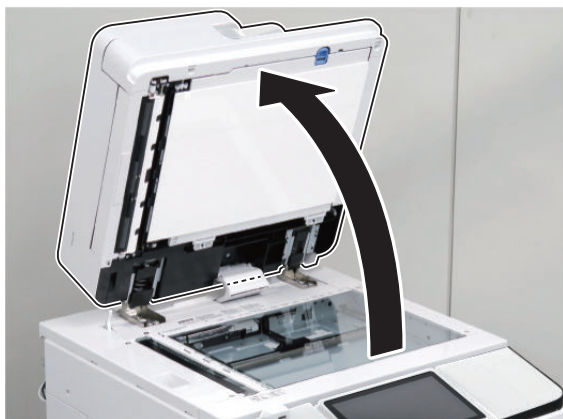


6. Install the Copyboard Glass (Large) and the Right Upper Panel to the original positions.

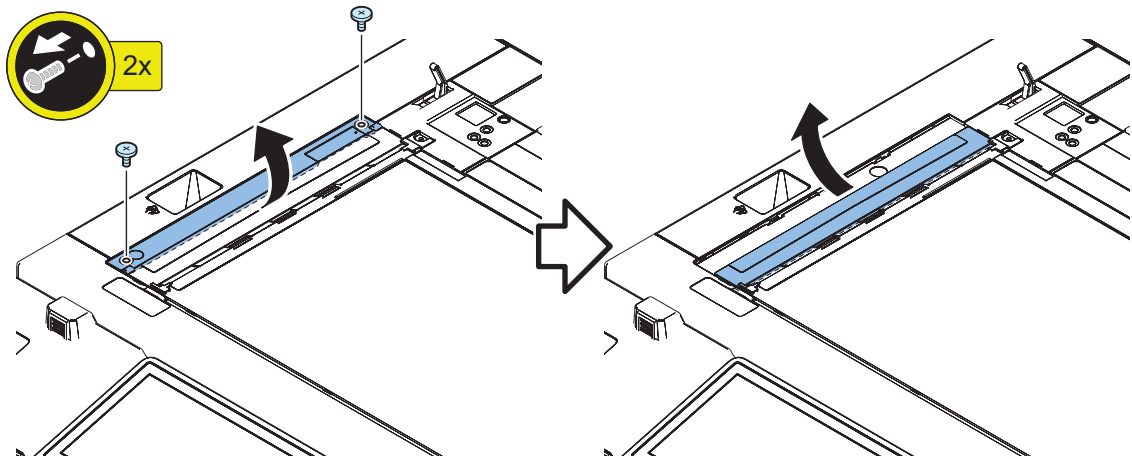
● Cleaning the Copyboard Glass (Small)

■ Procedure

- 1.



2.

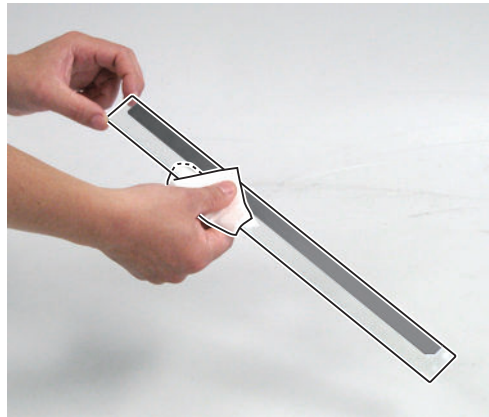


3.

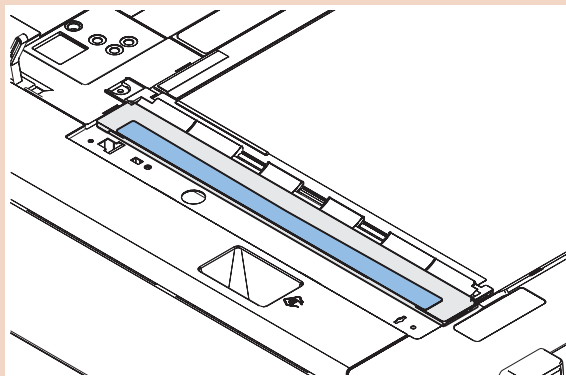
CAUTION:

To clean the Stream Reading Glass, wipe the glass for front and back using a lint-free paper wet with water and squeezed well, or a dry lint-free paper with Oil Glass Cleaner FY9-6035.

Clean the front surface and back surface of the Copyboard Glass (Small) with lint-free paper.

**CAUTION:**

When installing the Copyboard Glass (Small), install it in a way that the sticker affixed on the Copyboard Glass (Small) is located on the left side of its surface.



Controller System

Removing the HDD

Before Replacing

1. Back up the necessary data based on the table shown below.

2. Printing the set/registered data

- COPIER > FUNCTION > MISC-P > USER-PRT
- COPIER > FUNCTION > MISC-P > P-PRINT

Backup List

Backup target data	Backup Method			
	User	Service	DCM	Power OFF
	(excluding DCM)			
Address List	Yes*1	-	Yes*9	-
Forwarding Settings	Yes*1	-	Yes*9	-
Settings / Registration				
Preferences (Except for Paper Type Management Settings)	-	-	Yes*9	Yes*10
Adjustment/Maintenance(*)	-	-	Yes*9	Yes*10
Function Settings (Except for Printer Custom Settings, Forwarding Settings)	-	-	Yes*9	Yes*10
Set Destination (Except for Address List)	-	-	Yes*9	Yes*10
Management Settings (Except for Address List)	-	-	Yes*9	Yes*10
User authentication information used for local device authentication of UA (User Authentication)	Yes*2	-	Yes*9	-
Printer Settings	Yes*1	-	Yes*9	Yes*10
Set Paper Information	Yes*1	-	Yes*9	-
Setting items for each menu in Main Menu (Copy, Scan and Send, Fax, Scan and Store, Access Stored Files, Fax/I-Fax Inbox)				
Favorite Settings	Yes*1	Yes*8	Yes*9	-
Default Settings	-	Yes*8	Yes*9	-
Shortcut settings for "Options"	-	Yes*8	Yes*9	-
Previous Settings	-	Yes*8	-	-
Setting items for Quick Menu				
Button Size information	-	-	Yes*9	-
Wallpaper Setting	-	-	Yes*9	-
Button information in Quick Menu	-	-	Yes*9	-
Restrict Quick Menu	-	-	Yes*9	-
Setting items for Main Menu				
Button settings in Main Menu	-	-	Yes*9	-
Button settings on the top of the screen	-	-	Yes*9	-
Wallpaper Setting for Main Menu	-	-	Yes*9	-
Other settings for Main Menu	-	-	Yes*9	-
Function Settings > Store/Access Files				
Mail Box Settings (Register Box Name, PIN, Time Until File Auto Delete, Printer upon Storing from Printer Driver)	Yes*4	-	Yes*9	-
Image data in Mail Box, Fax Inbox, and Memory RX Inbox	Yes*4	-	-	-
Network Place Settings	-	-	Yes*9	Yes*10
Web browser settings				
Web Access setting information	-	Yes*8	Yes*9	-
MEAP settings				
MEAP application	-	Yes*8	-	-
License files for MEAP applications	Yes*5	-	-	-
Data saved using MEAP applications	Yes*5	Yes*8	Yes*9	-

Backup target data	Backup Method			
	User	Service	DCM	Power OFF
	(excluding DCM)			
SMS (Service Management Service) password	-	Yes*8	-	-
Universal data settings				
Unsent documents (documents waiting to be sent with the Delayed Send mode)	-	-	-	-
Job logs	-	-	-	-
Audit Log	Yes*6	-	-	-
Key Pair and Server Certificate in Certificate Settings in TCP/IP Settings in Network Set-tings in System Settings (from the Additional Functions screen)	-	-	Yes*9	-
Auto Adjust Gradation setting values	-	-	-	-
PS font	-	-	-	-
Key information to be used for encryption when TPM is OFF	-	-	-	-
Key and settings information to be used for encryption when TPM is ON	Yes*7	-	-	-
Personal Settings				
Display Language	-	-	Yes *9	-
Accessibility Settings	-	-	Yes *9	-
Default Screen	-	-	Yes *9	-
Default Job Settings	-	-	Yes *9	-
Quick Menu (Personal, layout of the Personal tab, and background of the Personal tab)	-	-	Yes *9	-
Address Book (Personal/Group)	Yes *1	-	Yes *9	-
Key ring (for host machine functions)	-	-	Yes *9	-
Personal settings of MEAP	Yes *11	Yes *8	Yes *9	-
Service Mode				
Service Mode setting values (MN-CON)	-	-	Yes*9	Yes*10

*1: Remote UI > Settings/Registration > Management Settings > Data Management > Import or Export

*2: Remote UI > Settings/Registration > Management Settings > User Management > Authentication Management > User Management

*3: Remote UI > Quick Menu > Export

*4: Remote UI > Settings/Registration > Management Settings > Data Management > Back Up or Restore

*5: Remote UI > Service Management Service

*6: Remote UI > Settings/Registration > Management Settings > Device Management > Save Audit Log

Audit log that was exported cannot be put back to the device from which the log was exported.

*7: Settings/Registration > Management Settings > Data Management > TPM Settings

*8: Download mode > [5]: Backup/Restore > [3] : MEAP Backup > Meapback.bin Backup is possible using SST or USB memory
The data saved using a MEAP application can be backed up only when the MEAP application has a backup function.

*9: Backup Method using DCM When You set it in COPIER> OPTION> USER> SMD-EXPT> ON, a backup/restore is possible in Service Mode Settings from the Remote UI. There is a backup button on the TOP page of the service mode.

1. Remote UI > Settings/Registration > Management Settings > Data Management > Import/Export All

2. Remote UI > Settings/Registration > Management Settings > Data Management > Import/Export

3. Service mode top screen > BACKUP

4. Web Service

*10: The setting value that was set when the main power was turned OFF the last time is automatically backed up to the Flash PCB. When a HDD is replaced with a new one, the setting value is automatically inherited from the Flash PCB at the time of HDD formatting.

*11: iWEMC DAM plug-in

■ Procedure

1. Open the Right Rear Cover 1.

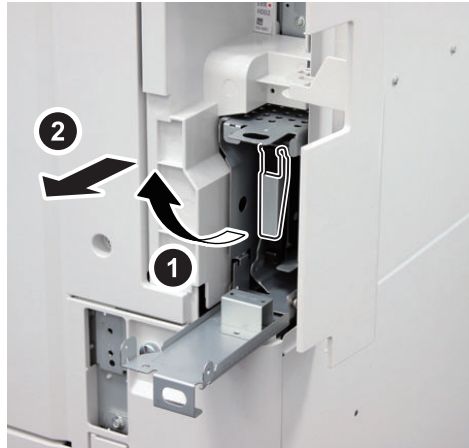


2. Open the HDD Front Cover.

- 1 Screw



3. Lift up the HDD Case Hinge and pull out the HDD.



CAUTION:

Points to Note when Installing the HDD

Be sure to push the HDD into the machine horizontally.

If it is not installed horizontally, it may cause poor contact/damage of connector or deformation of plate.

■ After Replacement

1. HDD format

Start the machine in safe mode, and format all partitions using SST or a USB memory.

2. Turning OFF and ON the main power switch

3. Restoring the backup data

4. Resetting/registering the data

While referring to the list which was printed before replacement, reset/register the data.

5. When the user generates and adds the encryption key, certificate and/or CA certificate, request the user to generate them again.

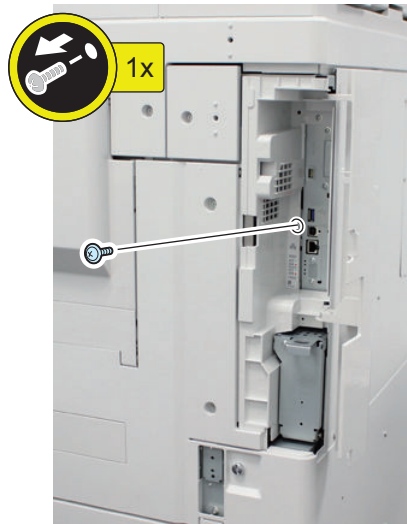
● Removing Main Controller PCB 1

■ Preparation

1. Open the Right Rear Cover 1.



2. Remove the 1 Screw.



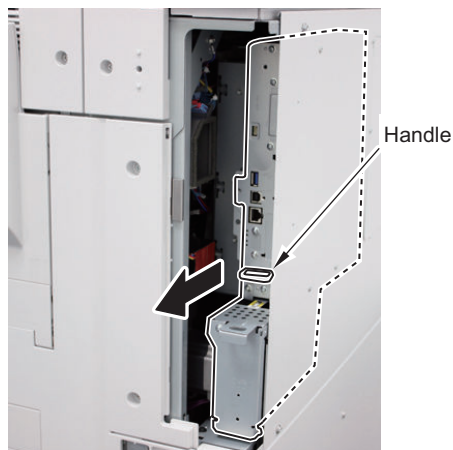
3. Remove the Side Cover.

- 1 Screw
- 1 Hook



■ Procedure

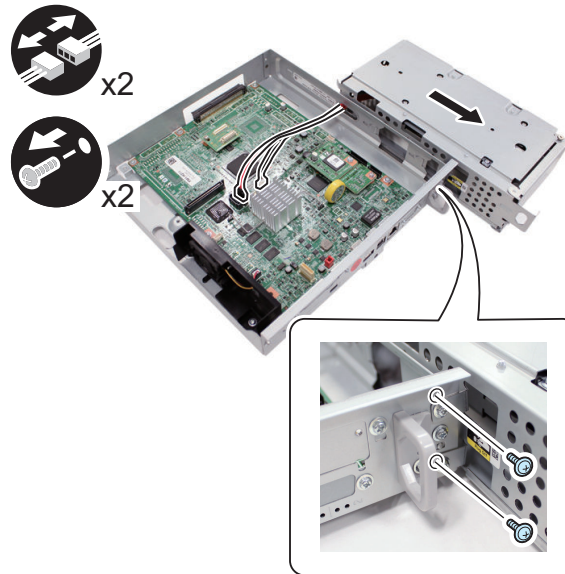
1. Remove the Main Controller PCB 1 and the HDD.



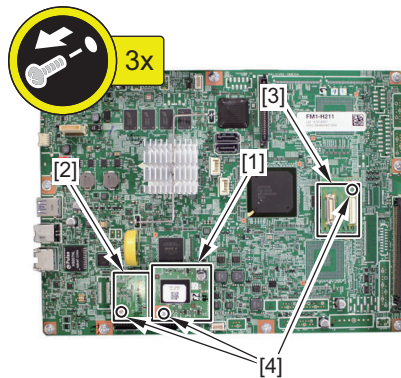
2. Disconnect the USB Cable and the Connector.

3. Remove the HDD.

- 2 Screws

**4. Remove the Flash PCB[1],TPM PCB[2],Memory PCB[3].**

- 3 Screws[4]

**■ After Replacement****1. Replace parts from an old PCB to a new PCB.**

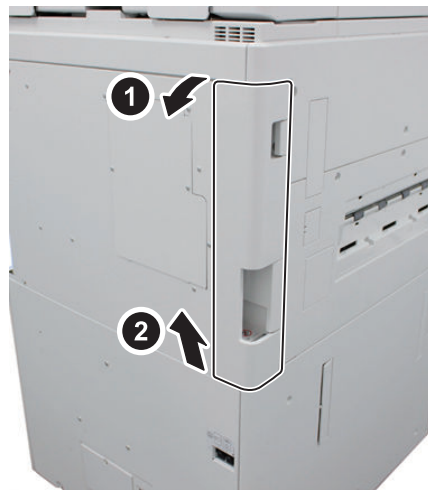
- Memory PCB
- FLASH PCB
- TPM PCB

● Removing Main Controller PCB 2**■ Preparation****NOTE:**

No action needs to be performed when replacing the parts of the Main Controller PCB 2.

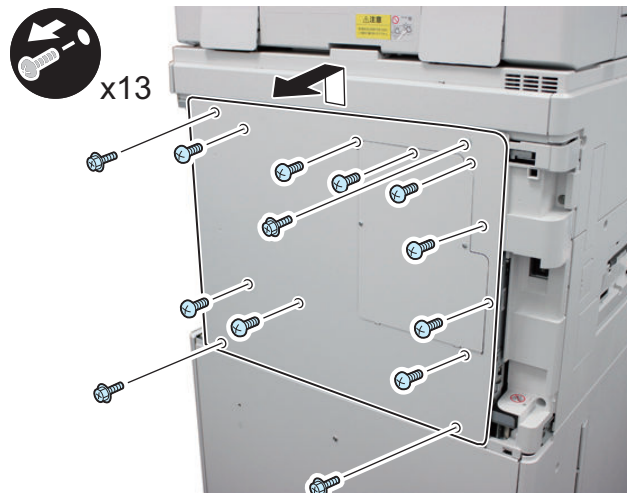
1. Remove the Main Controller PCB 1. ([“Removing Main Controller PCB 1” on page 333](#))

2. Remove the Left Rear Cover.



3. Remove the Rear Upper Cover.

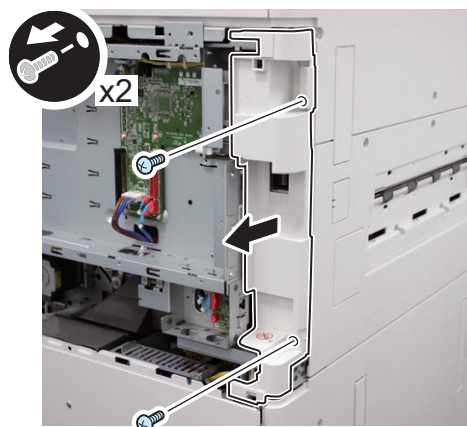
- 13 Screws



■ Procedure

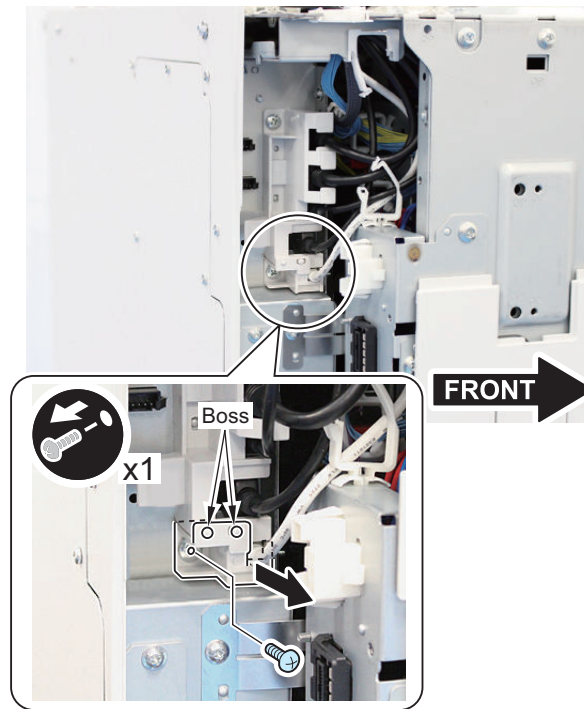
1. Remove the Left Rear Inner Cover.

- 2 Screws



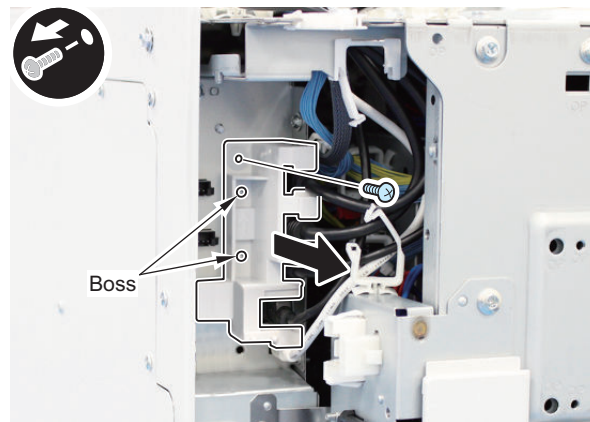
2. Remove the ECBOX Harness Guide (Lower).

- 1 Screw
- 2 Bosses



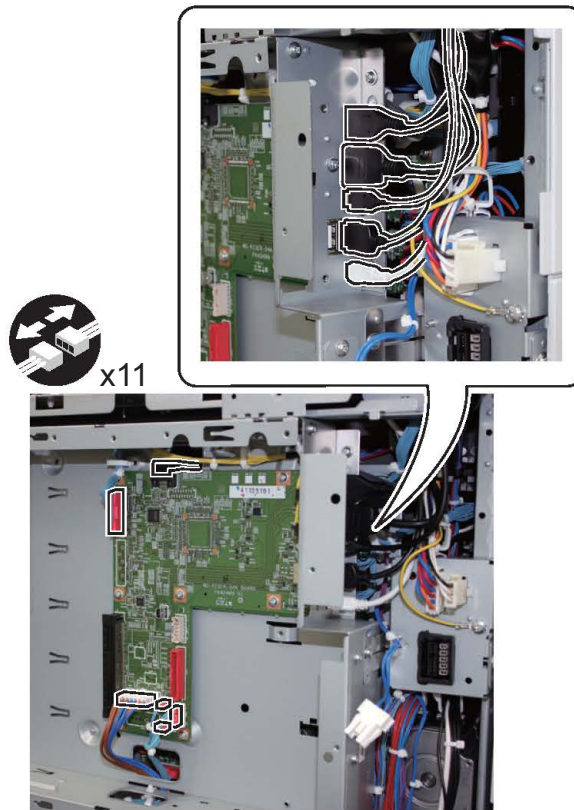
3. Remove the ECBOX Harness Guide (Upper).

- 1 Screw
- 1 Boss



4. Disconnect the All Cables and the All Connectors.

- 11 Connectors

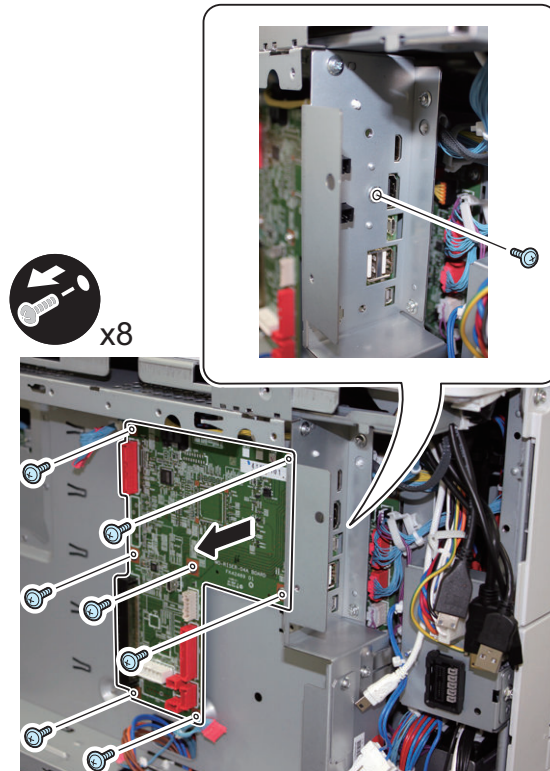


5. Remove the Main Controller PCB 2

- 8 Screws

CAUTION:

Be sure to hold the Main Controller PCB 2 so as not to drop it when removing it.



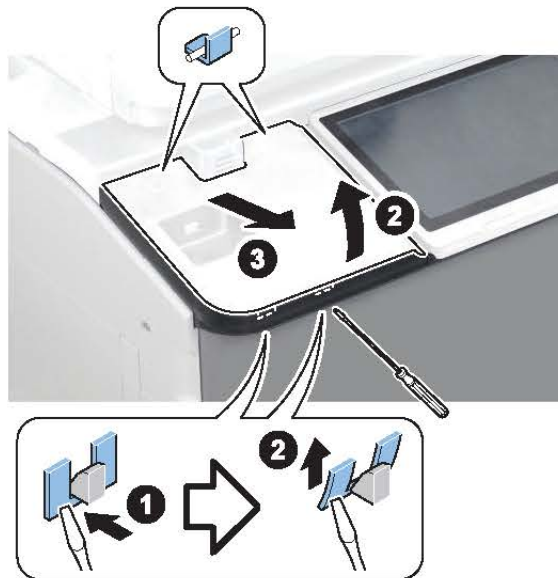
● Removing the Flat Control Panel Unit

■ Procedure

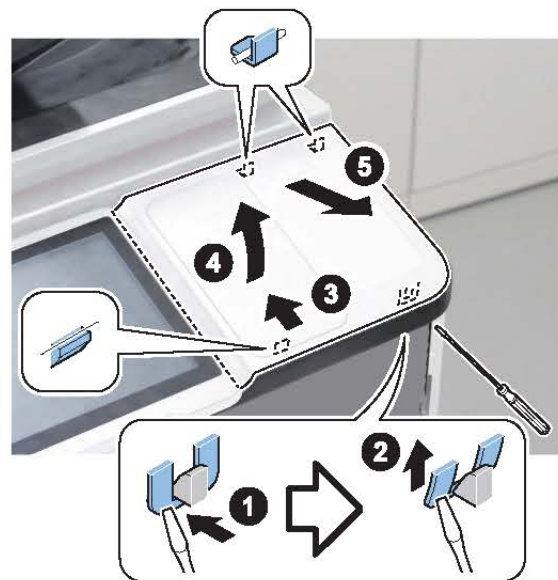
1.



2.



3.



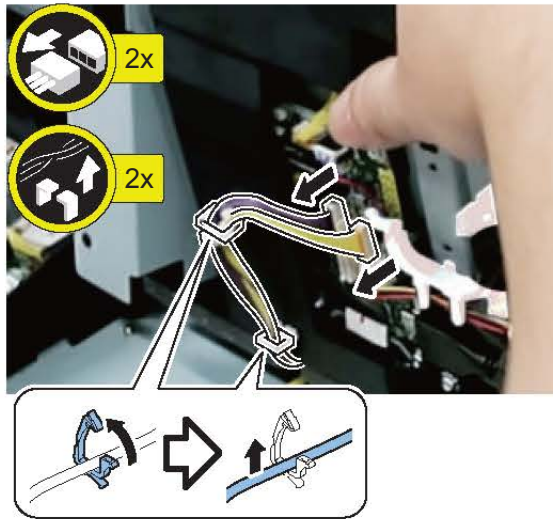
4.



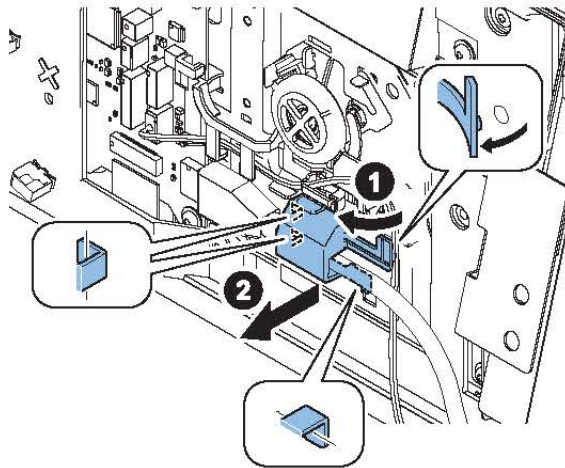
5.



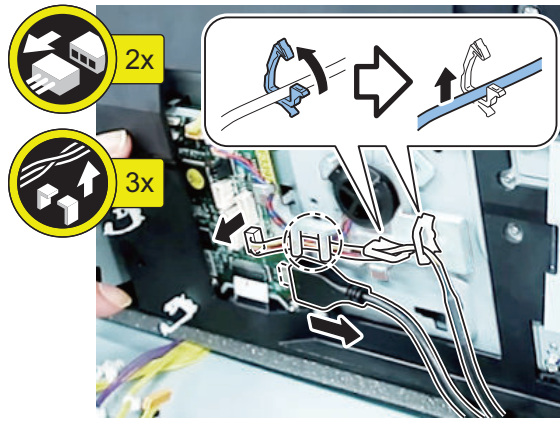
6.



7.



8.



9.



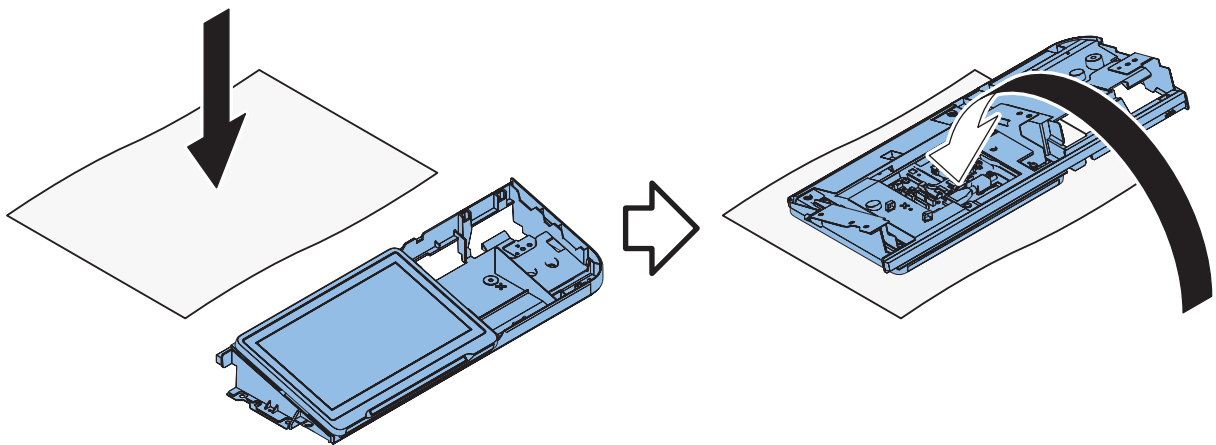
● Removing the Control Panel CPU PCB/LCD Unit/LED PCB

■ Preparation

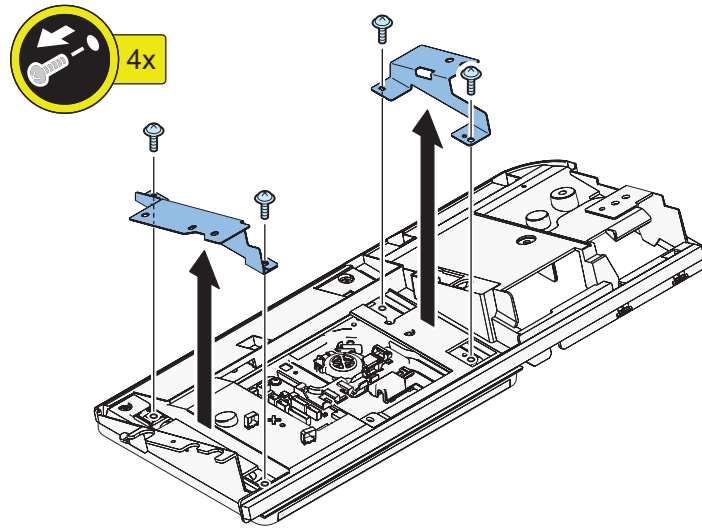
1. "Removing the Flat Control Panel Unit" on page 339

■ Procedure

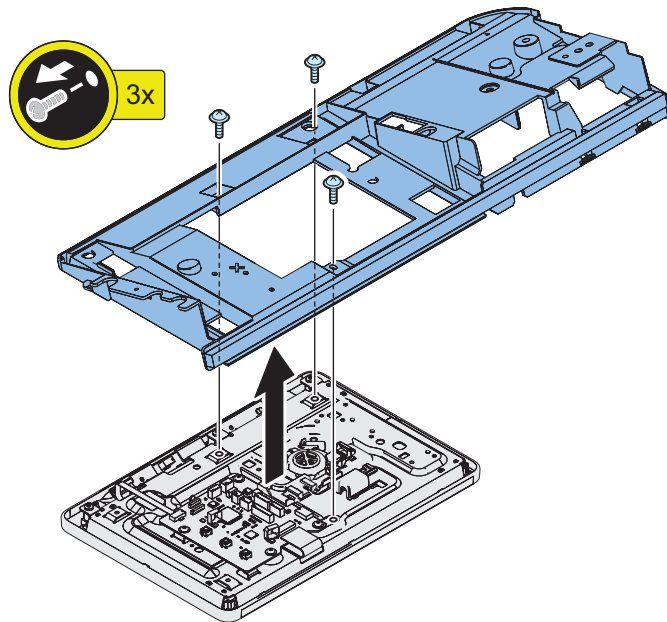
1.



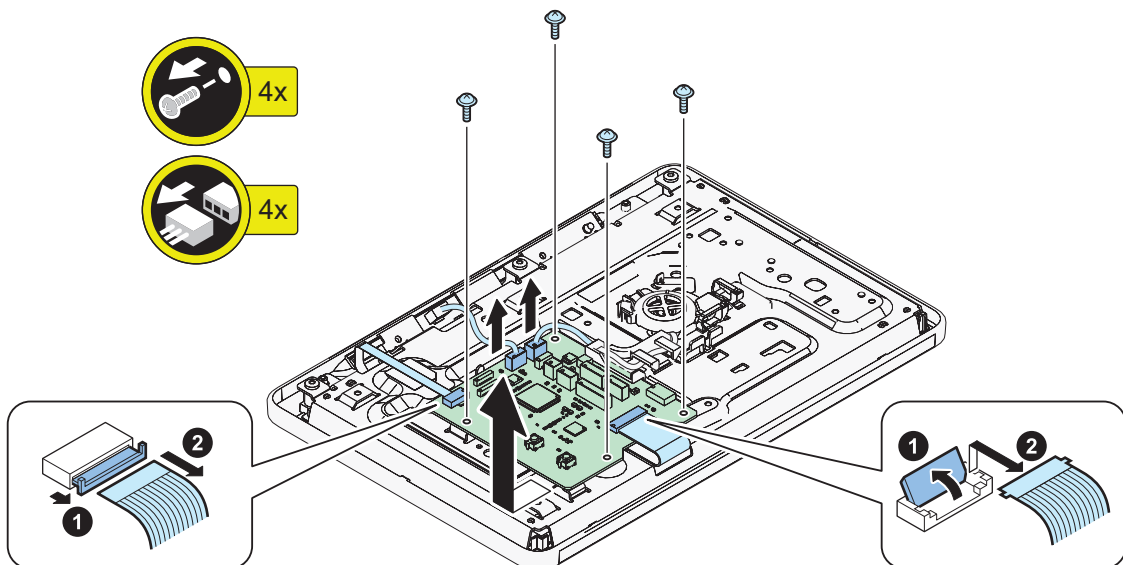
2.



3.

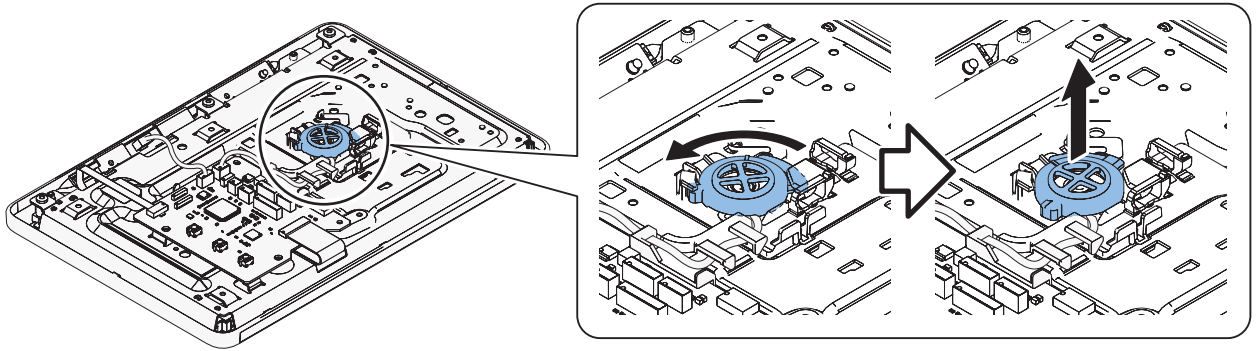


4. Removing the Control Panel CPU PCB



5. Removing the Speaker

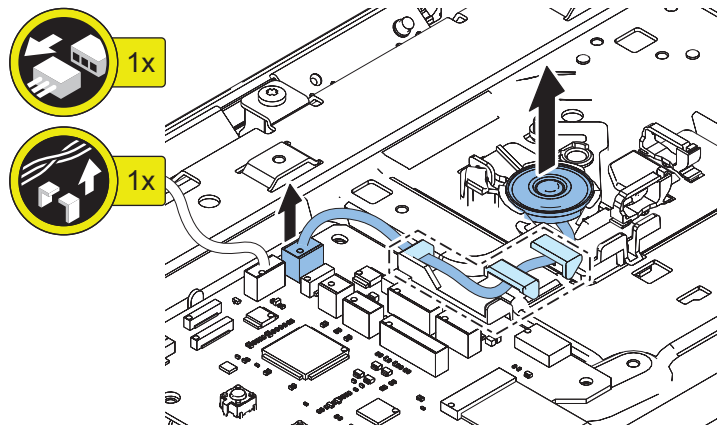
1.



2.

CAUTION:

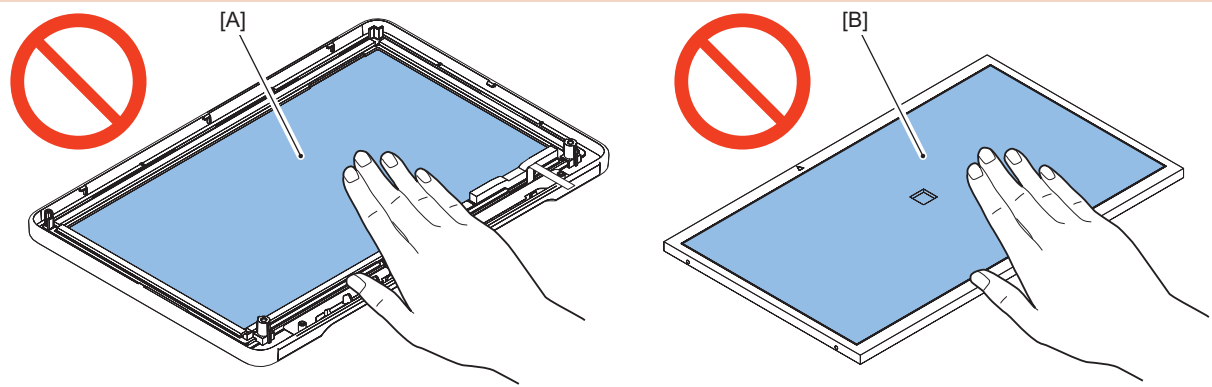
- Do not directly touch the speaker.
- Do not damage the speaker.



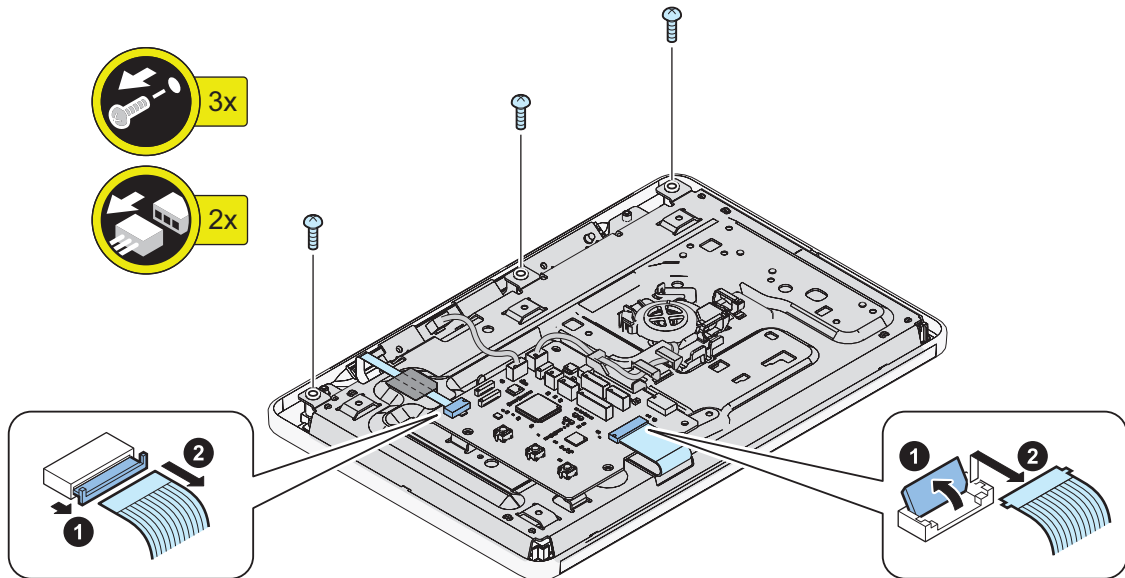
6. Removing the LCD Unit

CAUTION:

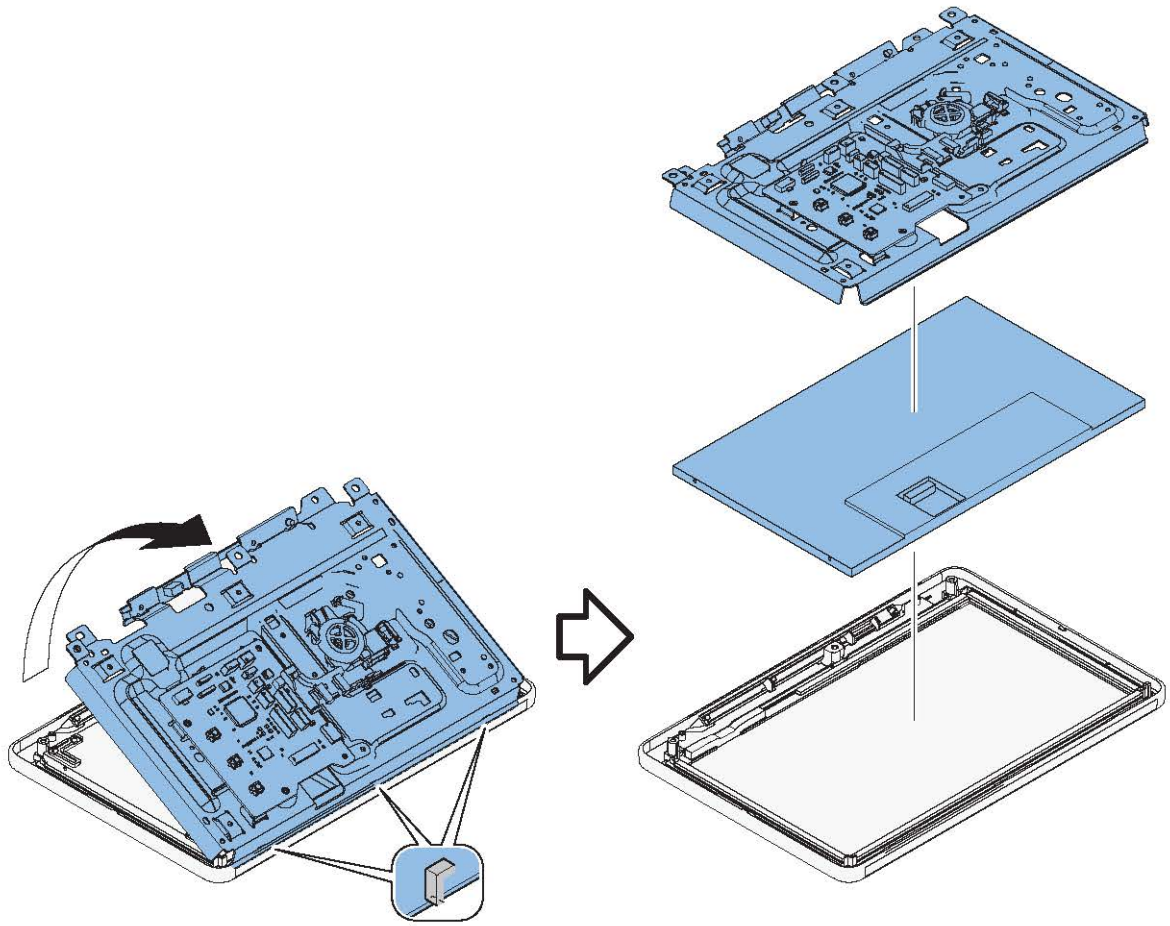
Do not touch the surface of the Touch Panel [A] and LCD Unit [B] when assembling/disassembling.



1.

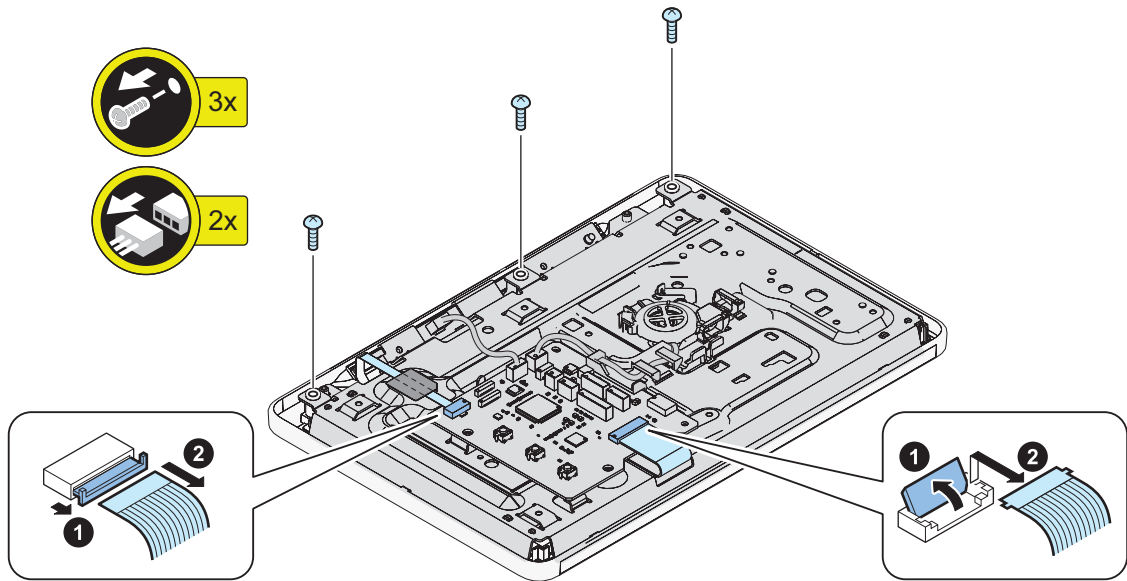


2.

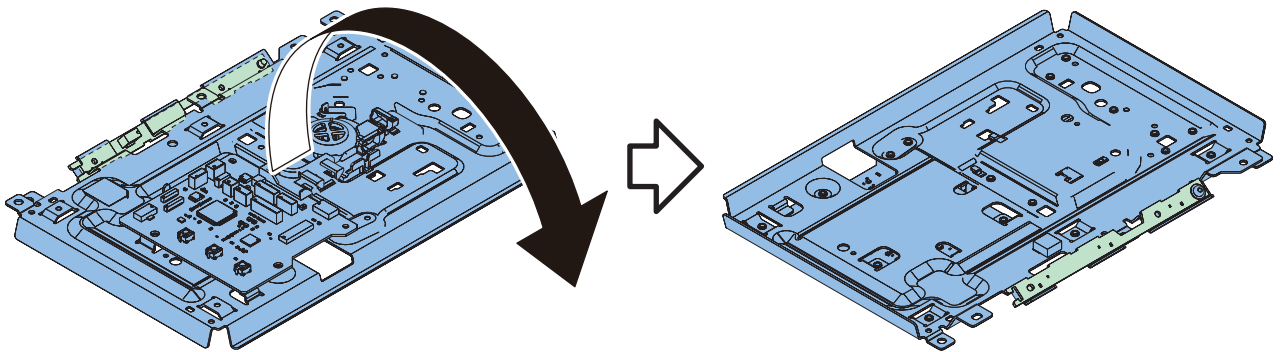


7. Removing the LED PCB

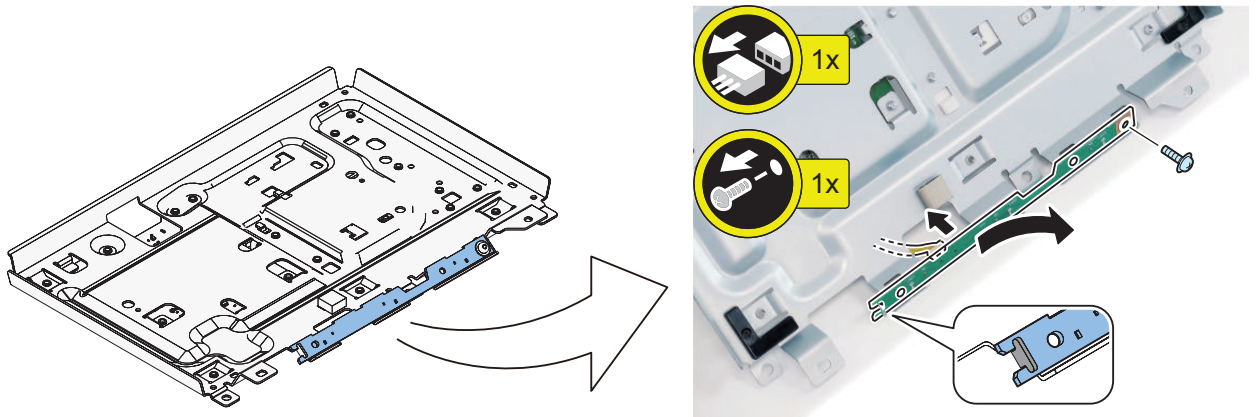
1.



2.



3.



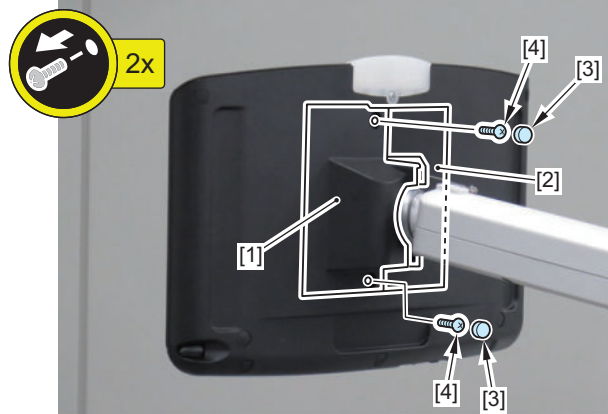
8. Actions after Replacement: "Control Panel Unit" on page 647

● Removing the Upright Control Panel

■ Procedure

1. Remove the Joint Cover R [1] and the Joint Cover L [2].

- 2 Rubber Caps [3]
- 2 Screws (P Tightening; M3x8) [4]



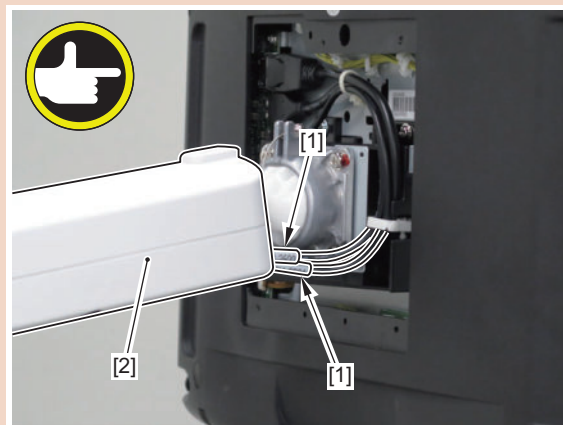
2. Disconnect the 3 cables [1].

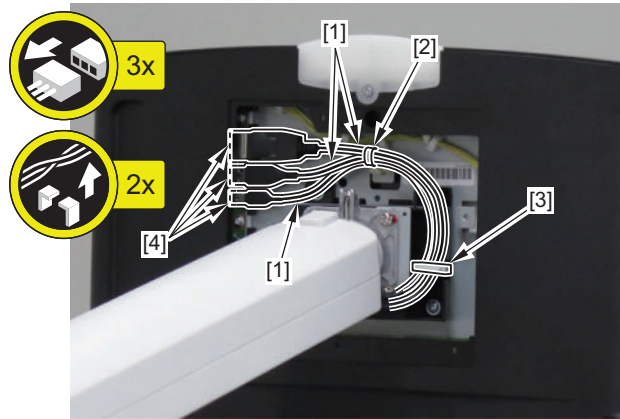
- 1 Reuse Band [2]
- 1 Wire Saddle [3]
- 3 Connectors [4]

CAUTION:

When assembling, pay attention to the following points.

- Check that the white tape [1] of the Control Panel Cable is completely outside the Pipe Cover [2].
- If not, make adjustments so that the white tape [1] can be seen from the Pipe Cover [2].
- Do not route the Control Panel Cable clockwise.



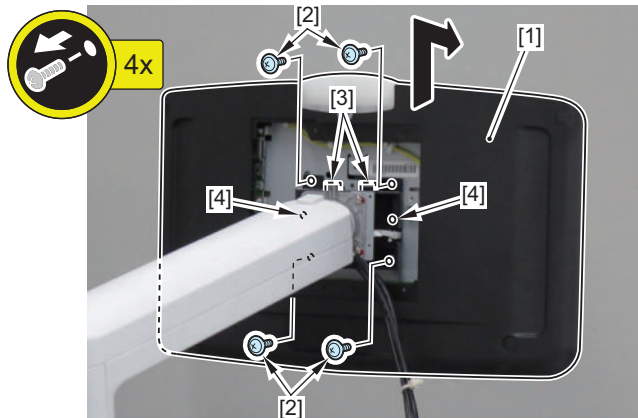


3. Remove the Upright Control Panel Unit [1].

- 4 Screws (TP; M4x8) [2]
- 2 Protrusions [3]
- 2 Bosses [4]

NOTE:

When assembling, be sure to tighten the screws from the upper part.



● Removing the Control Panel CPU PCB (Upright Control Panel)

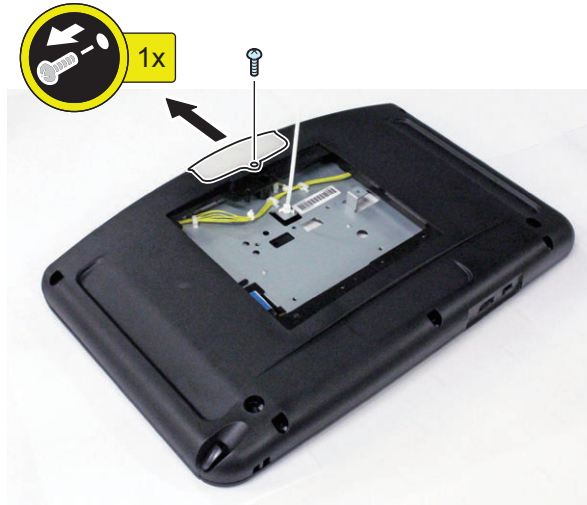
■ Preparation

1. Removing the Upright Control Panel. [“Removing the Upright Control Panel” on page 348](#)

■ Procedure

1. Remove the Tarry Lamp Cover.

- 1 Screw

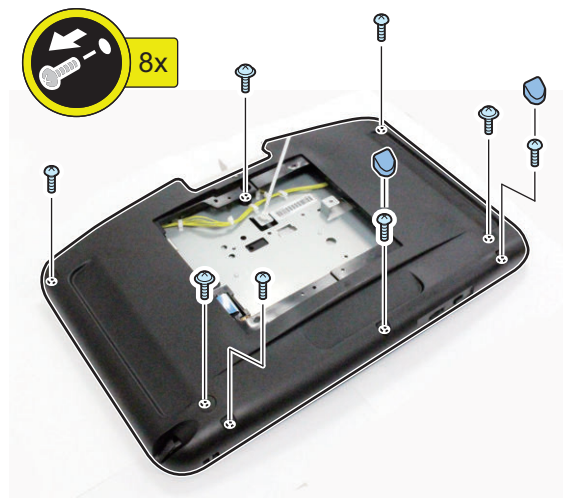


2. Remove the Panel Rear Cover.

- 2 Caps
- 8 Screws

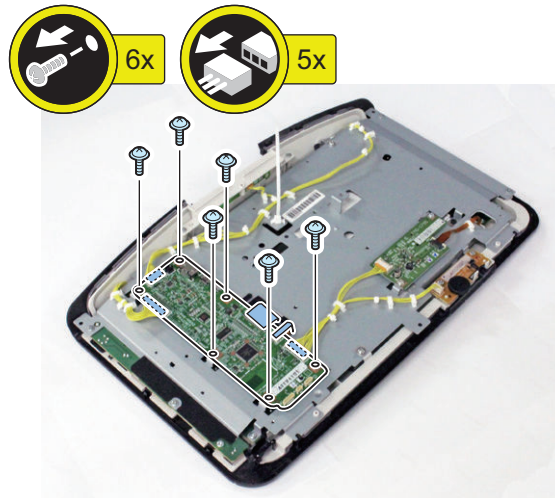
NOTE:

Be sure to remove the Touch Pen when removing the Rear Cover.



3. Remove the Control Panel CPU PCB.

- 6 Screws
- 3 Connectors
- 2 Flat Cables

**4. Actions after Replacement: “Upright Control Panel Adjustment” on page 648**

● Removing the LCD Unit (Upright Control Panel)

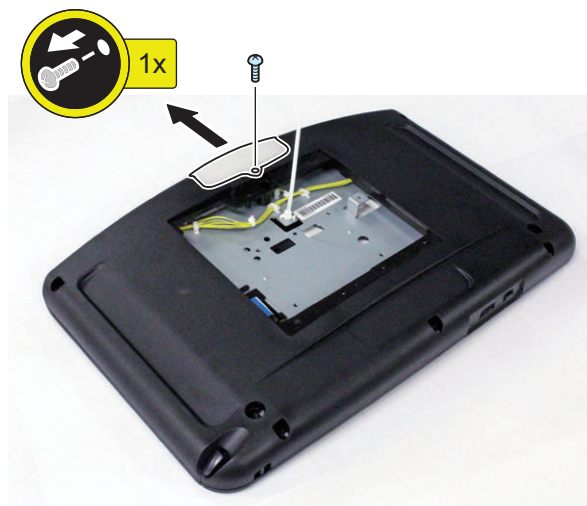
■ Preparation

1. Removing the Upright Control Panel. “Removing the Upright Control Panel” on page 348

■ Procedure

1. Remove the Tarry Lamp Cover.

- 1 Screw

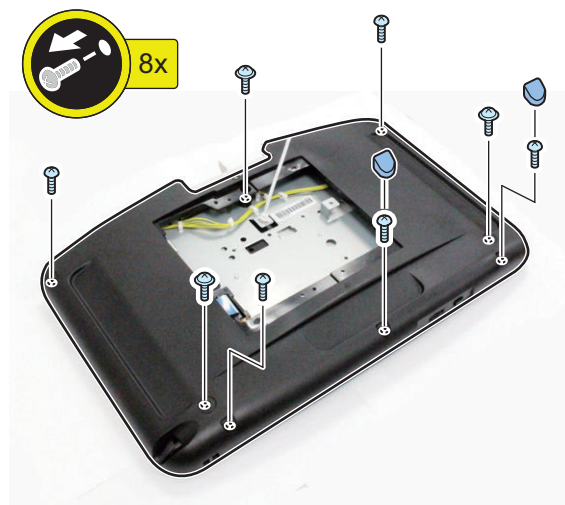


2. Remove the Panel Rear Cover.

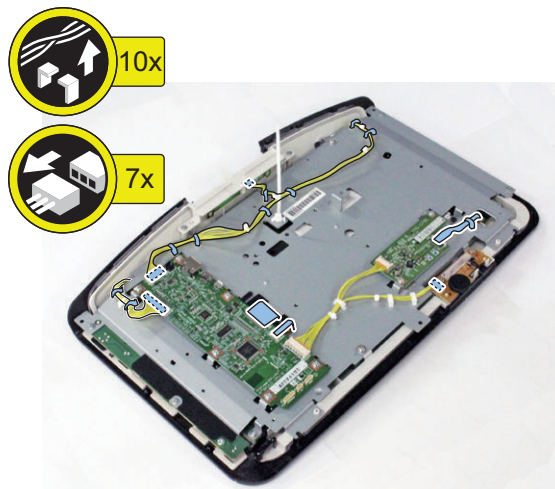
- 2 Caps
- 8 Screws

NOTE:

Be sure to remove the Touch Pen when removing the Rear Cover.

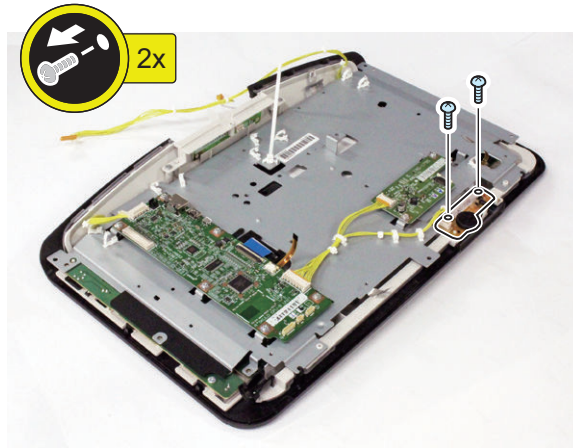
**3. Remove the Connectors and the Cables.**

- 4 Connectors
- 3 Flat Cables
- 10 Wire Saddles



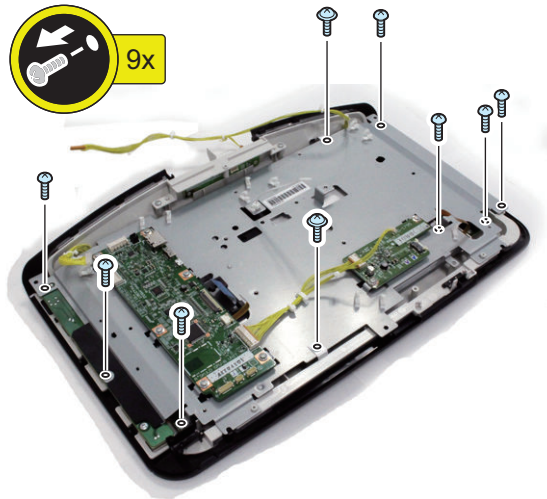
4. Remove the Volume PCB.

- 2 Screws

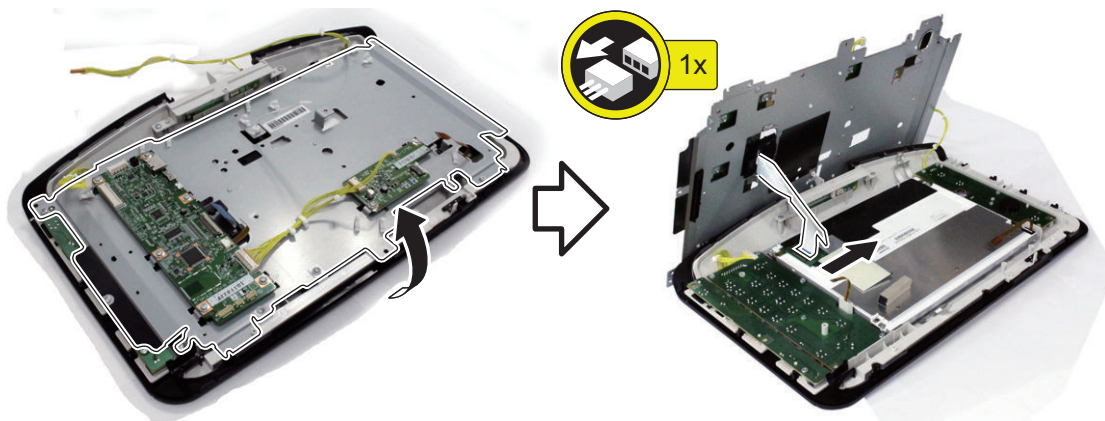


5. Remove the screws on the Control Panel Frame.

- 9 Screws

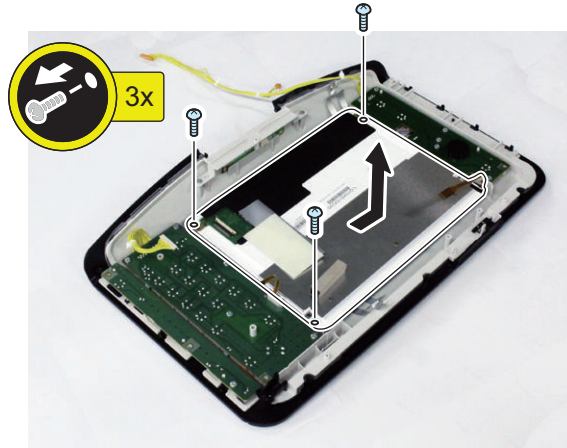


6. Lift up the Control Panel Frame, disconnect the Flat Cable, and remove the Control Panel Frame.



7. Remove the LCD Unit.

- 3 Screws



8. Actions after Replacement: [“Upright Control Panel Adjustment”](#) on page 648

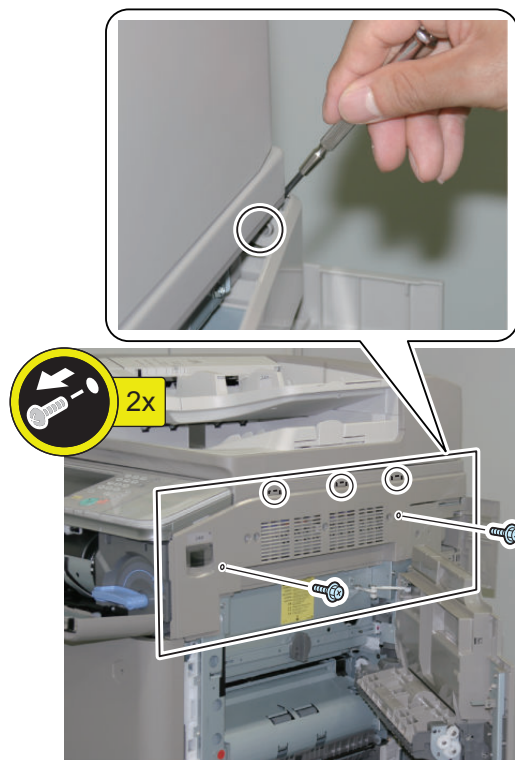
Laser Exposure System

● Removing the Laser Scanner Unit

■ Preparation

1. Removing the Right Upper Cover.

1. Open the Toner Exchange Cover.
2. Open the Right Cover.
3. Open the Right Rear Cover 1.
4. Remove the Right Upper Cover.
 - 2 Screws
 - 1 Boss
 - 3 Protrusions



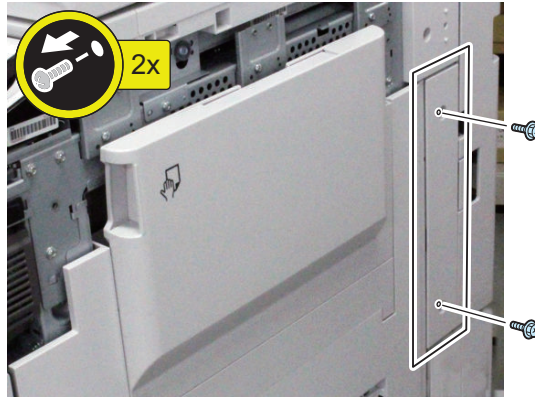
2. Removing the Right Cover.

NOTE:

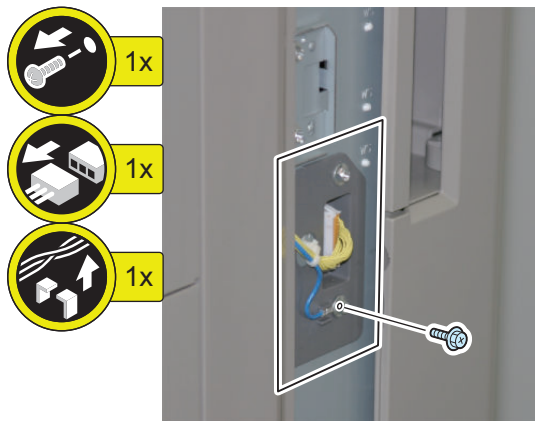
Laser Scanner Unit can be removed without removing the Right Cover.

However, removing the Right Cover is recommended here for better operability.

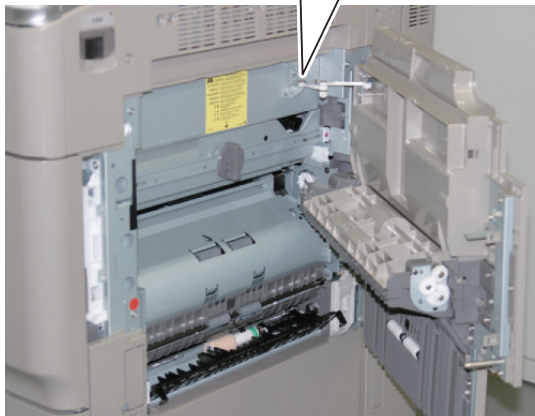
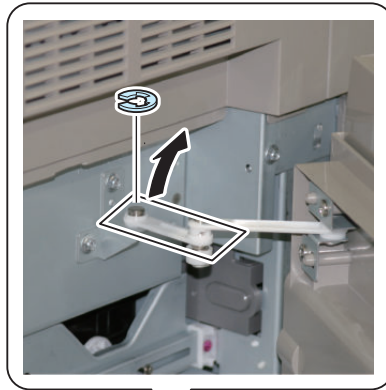
1. Remove the Right Rear Cover2.
 - 2 Screws



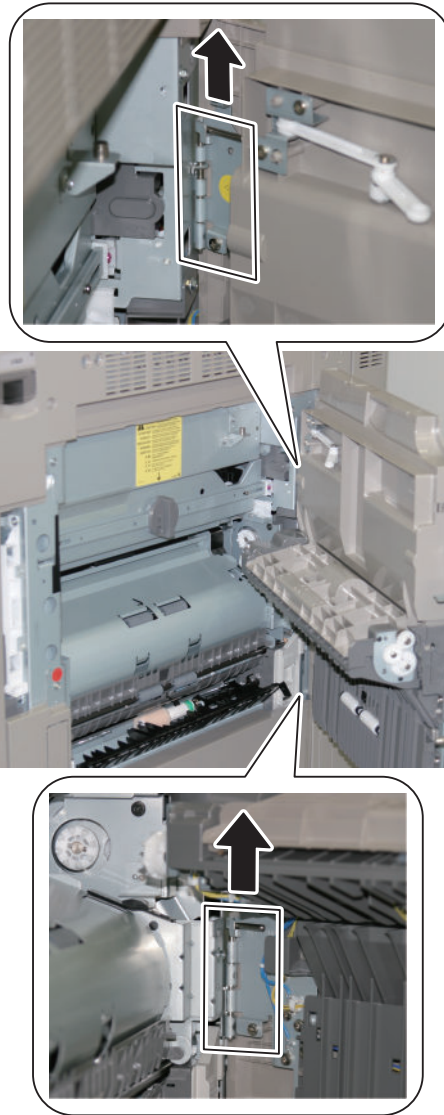
2. Disconnect the Connector and remove the Grounding Wire and the Reuse Band.
 - 1 Screw



3. Open the Right Cover.
4. Remove the E-ring to remove the Door Link.



5. Remove the 2 Hinge Pins to remove the Right Cover.

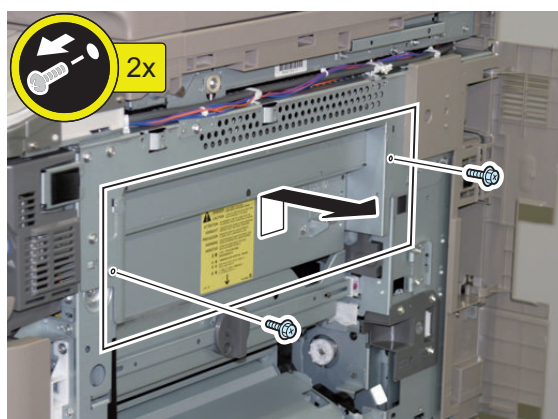


CAUTION:
To prevent falling of Right Cover, hold the Right Cover to remove the Hinge Pins.

■ <Procedure>

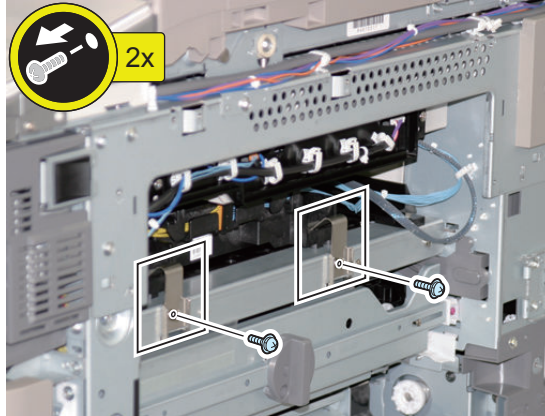
1. Lift the Plate to remove.

- 2 Screws

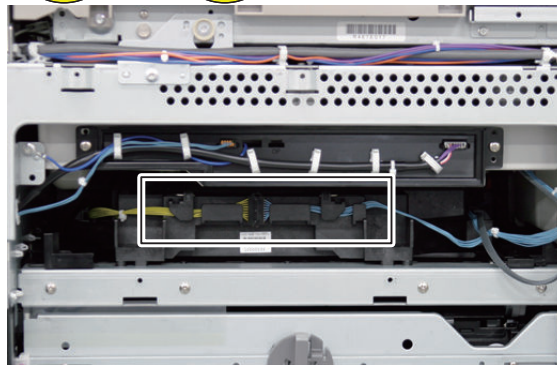


2. Remove the 2 Retainer Fixtures.

- 2 Screws

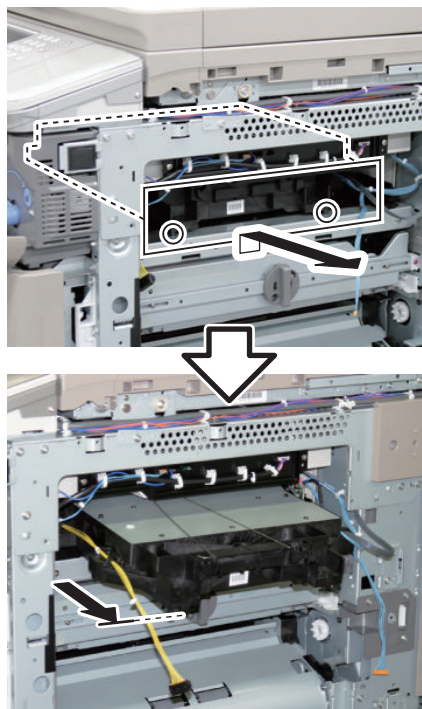


3. Free the Harness from the Harness Guide and Disconnect the Connector.

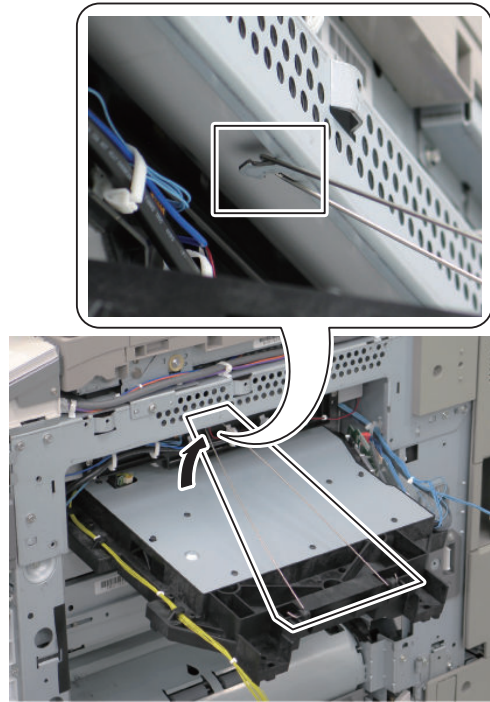


4. Pull out the Laser Scanner Unit halfway.

- 2 Bosses

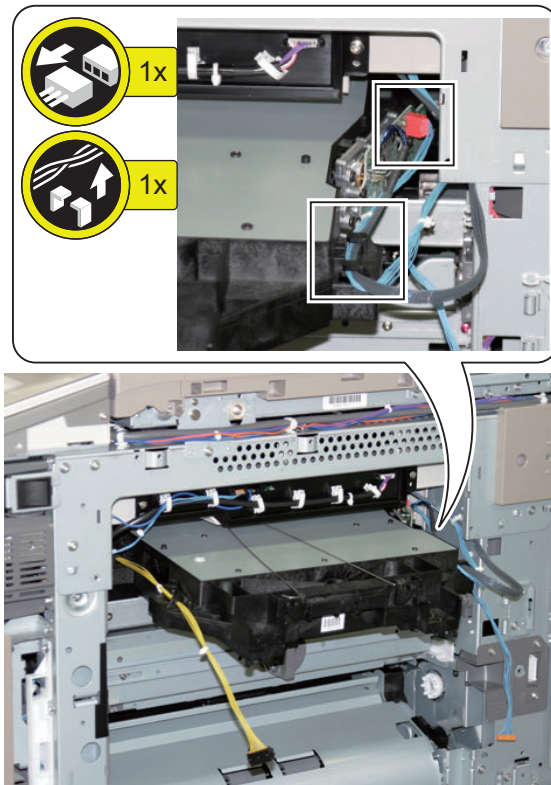


5. Hook the wire of the Laser Scanner Unit to the hook of the main body.



CAUTION:
Do not use the wire when the Right Cover is not removed.

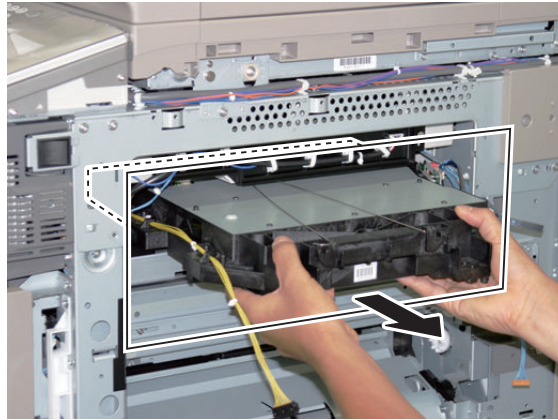
6. Free the Harness from the Harness Guide and Disconnect the Connector.



7. Remove the Laser Scanner Unit.

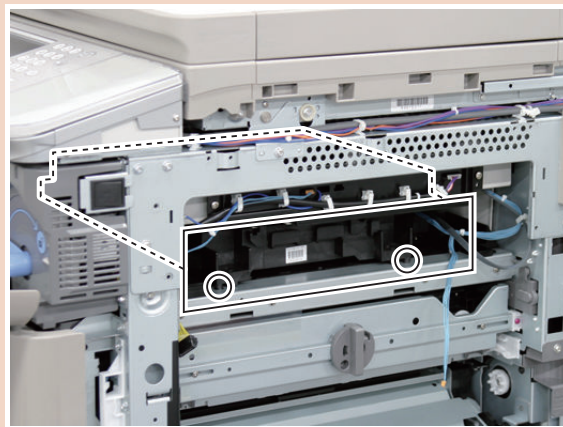
CAUTION:

Before removing the Laser Scanner Unit, check that the hooking wire of the unit is not hooked to the frame of the main body.



CAUTION:

When installing the Laser Scanner Unit, be sure to check that the bosses are fitted into the holes.



■ Adjustment when Replacing the Parts

1. **Execute the potential control.**
(Lv.1) COPIER > FUNCTION > DPC > DPC2
2. **Write the value in service label.**
(Lv.1) COPIER > ADJUST > LASER > PVE-OFST (Adjust of write start position of laser)

● Cleaning the Dust Collecting Glass

■ Preparation

1. **Open the Front Cover.**
2. **Remove the Primary Charging Assembly.** (“Removing the Primary Charging Assembly” on page 362)

■ <Procedure>

Removing the Dustproof Glass

1. Pull out the Dustproof Glass and clean it with lint-free paper.

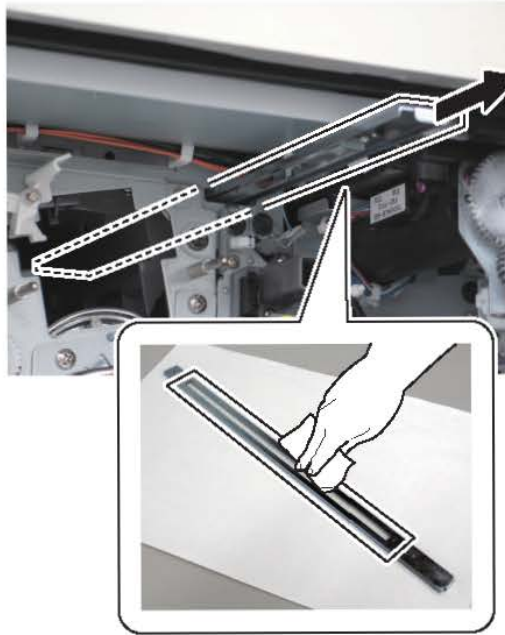


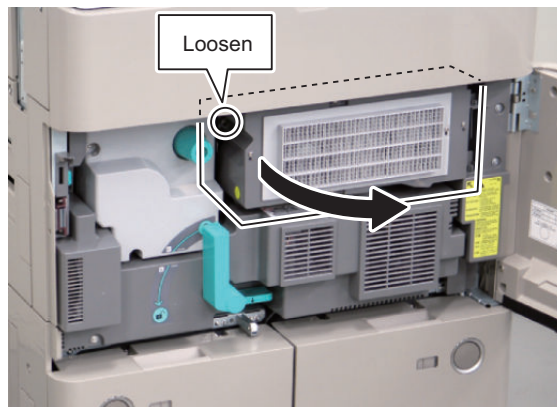
Image Formation System

● Removing the Primary Charging Assembly

■ <Preparation>

1. Open the Inner Cover.

1. Open the Front Cover.
2. Open the Inner Cover.
 - 1 Screw (to loosen)



■ <Procedure>

CAUTION:

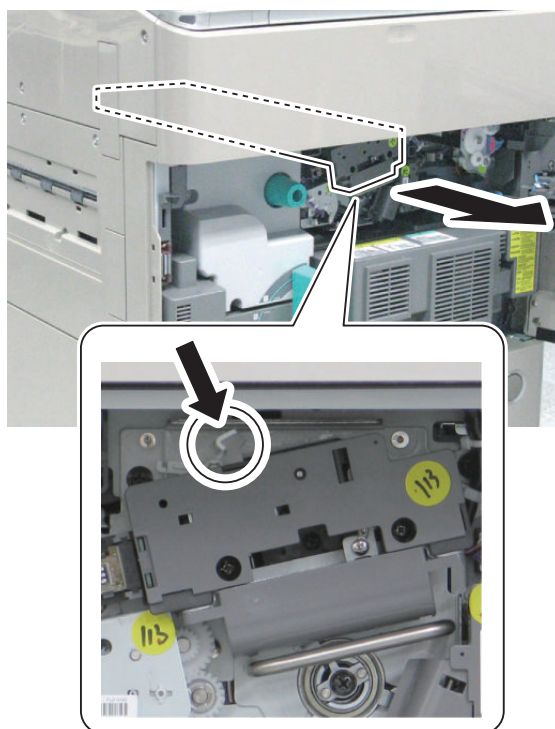
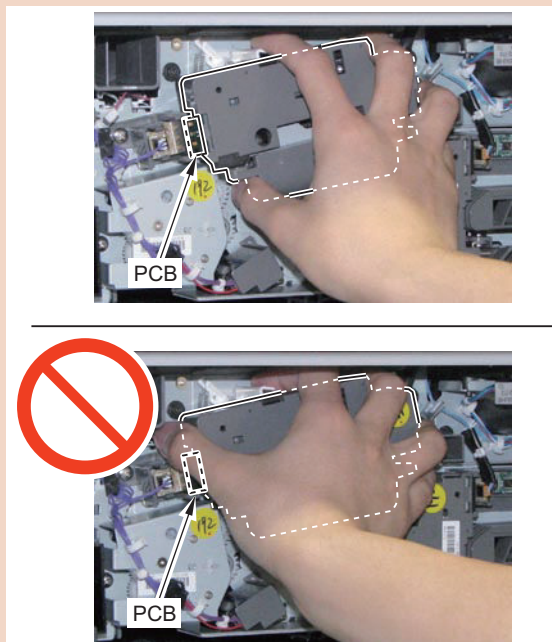
- When removing the Primary Charging Assembly and the Pre-transfer Charging Assembly, go through the following procedure while the Charging Shutter is open.
- At sleep mode, press the Power Switch on the Control Panel, check that the machine is in standby condition, turn OFF the Main Power, and then perform removing.
- In the case that the condition of the Charging Shutter (open/close) is unknown while the power of the host machine is OFF, turn ON the power, check that the machine is in standby condition, turn OFF the Main Power, and then perform removing.

If the above operations are not performed, it may be possible to remove the assembly while the Charging Shutter is closed, which may damage the drum or the shutter.

1. While pushing the Release Lever in the direction of the arrow, pull out the Primary Charging Assembly.

CAUTION:

When removing the Primary Charging Assembly, be careful not to hold the PCB of the Primary Charging Assembly.



■ Adjustment when Replacing the Parts

1. Clear the parts counter.
(Lv.1)COPIER > COUNTER > DRBL-1 > PRM-UNIT
2. Output a halftone image using the service mode.
(Lv.1)COPIER > TEST > PG > TYPE : 5

3. Execute the following procedure according to the density difference on the front and rear sides of the test print image.

- When the front side test print image is dark, execute step 3.
- When the rear side test print image is dark, execute step 4.
- When there is no uneven density, execute step 5 and the following.

When the front side test print image is dark

NOTE:

- When the front side test print image is dark [1], execute step 3 until the density becomes even. When the density becomes even, execute step 5 and the following.
- When the adjustment screw is turned clockwise, the Charging Wire goes down and up (gap between grid and Charging Wire becomes narrow and wide). As a result, the density of output image becomes light.

CAUTION:

- Be sure to adjust the dark side (density of the test print image) to be the light side.

4. Make the resin screws [A] and [C] a full turn clockwise. While referring to the replacement procedure of the Primary Charging Assembly, install it to the main body, output a test print and check the image.

CAUTION:

- Since uneven density might occur, be sure to adjust by turning the 2 adjustment screws with the same amount.



When the rear side test print image is dark

NOTE:

- When the rear side test print image is dark [2], execute step 4 until the density becomes even. When the density becomes even, execute step 5 and the following.
- When the adjustment screw is turned clockwise, the Charging Wire goes down and up (gap between grid and Charging Wire becomes narrow and wide). As a result, the density of output image becomes light.

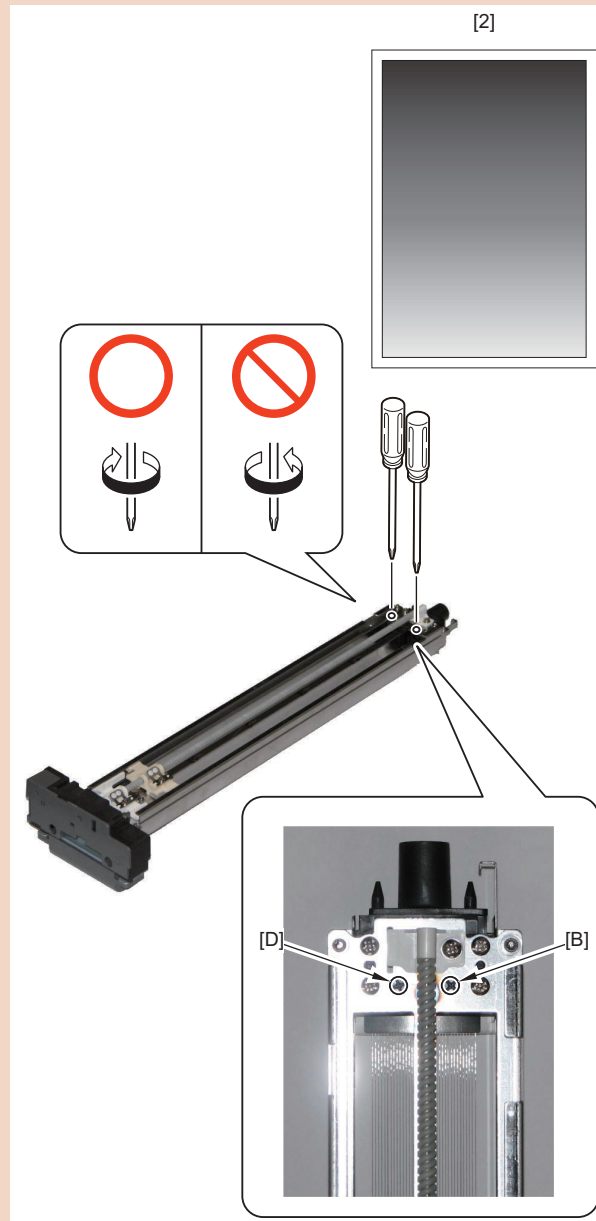
CAUTION:

- Be sure to adjust the dark side (density of the test print image) to be the light side.

5. Make the resin screws [B] and [D] a full turn clockwise. While referring to the replacement procedure of the Primary Charging Assembly, install it to the main body, output a test print and check the image.

CAUTION:

- Since uneven density might occur, be sure to adjust by turning the 2 adjustment screws with the same amount.



6. **Clean the Charging Wire. (necessary time : about 120 second)**

(Lv.1)COPIER > FUNCTION > CLAENING > WIRE-CLN

7. **Init of Primary Charging Wire current VL.**

(Lv.1)COPIER > FUNCTION > CLEAR > GRD-CRNT

8. **Execute the potential control.**

(Lv.1)COPIER > FUNCTION > DPC > DPC2

9. **Execute the density correction using the user mode.**

Settings/Registration > Adjustment/Maintenance > Adjust Image Quality > Correct Density

● Removing the Primary Charging Wire Cleaner, Cleaner Holder (Right/Left)

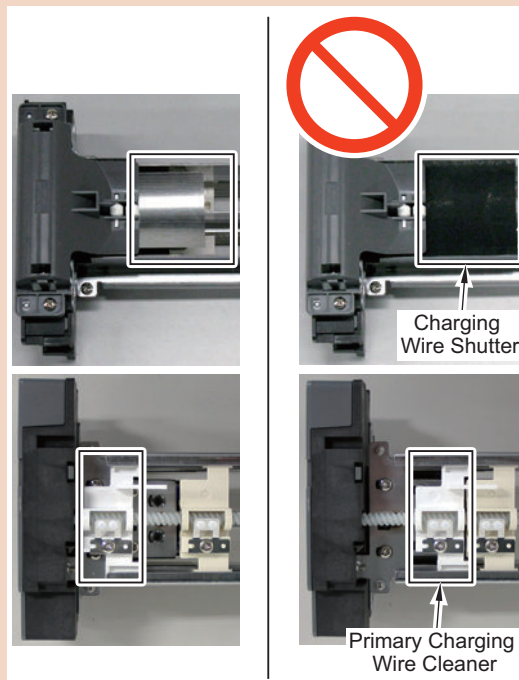
■ Preparation

1. Open the Inner Cover. (“Removing the Primary Charging Assembly” on page 362)
2. Remove the Primary Charging Assembly. (“Removing the Primary Charging Assembly” on page 362)

■ <Procedure>

CAUTION:

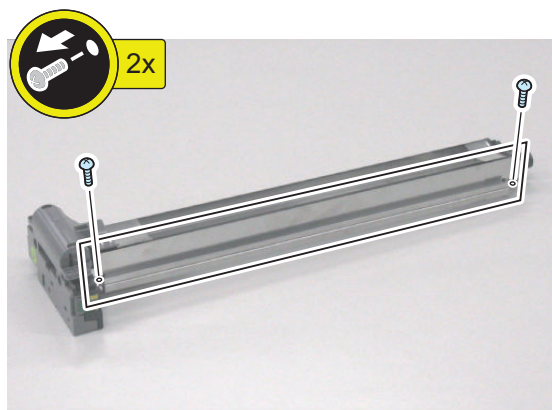
Do not move the Charging Wire Shutter; otherwise, the shutter can be damaged when installing the Charging Assembly. When the Charging Wire Shutter is moved by chance, be sure to move the Shutter until it is invisible.



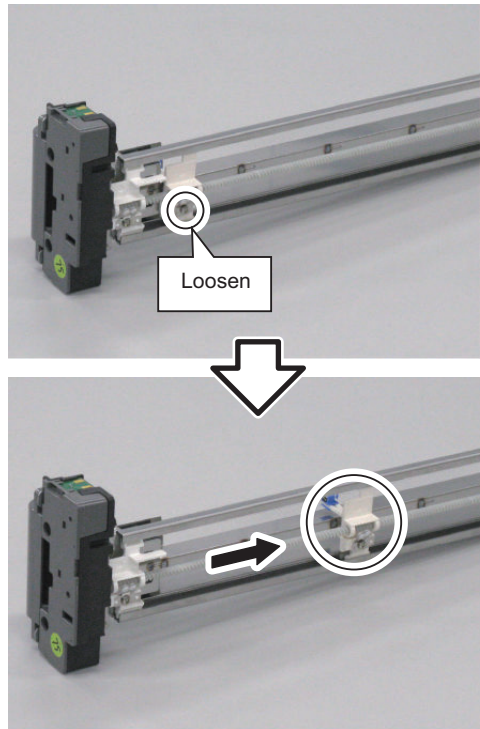
CAUTION:

Do not remove both Shield Plates (Right and Left) of the Primary Charging Assembly at the same time. Be sure to work on one Shield Plate at a time (otherwise, the Frame of the Primary Charging Assembly can be deformed).

1. Remove the Shield Plate (Right). When removing the Primary Charging Wire Cleaner Holder (Left), remove the Shield Plate (Left).
 - 2 Screws

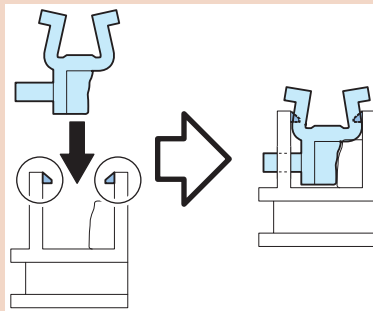


2. Loosen the screw to move the Primary Charging Assembly Cleaner to the center.

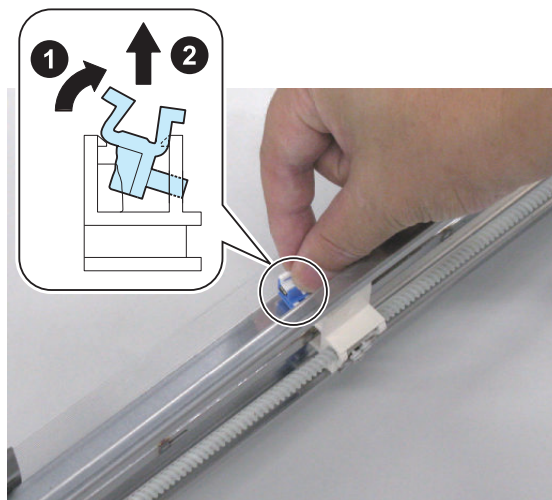


CAUTION:

Points to Caution when Installing the Primary Charging Wire Cleaner Holder
Be sure to push in the Primary Charging Wire Cleaner Holder until it is secured with the Claw.



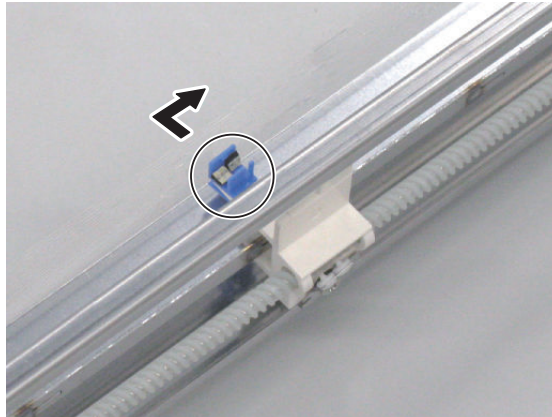
3. Bring up the Primary Charging Assembly and pinch the Hook to remove the Primary Charging Assembly Cleaner Holder (Right) in the direction of the arrow.



4. Remove the Primary Charging Wire Cleaner (Right) in the direction of the arrow.

CAUTION:

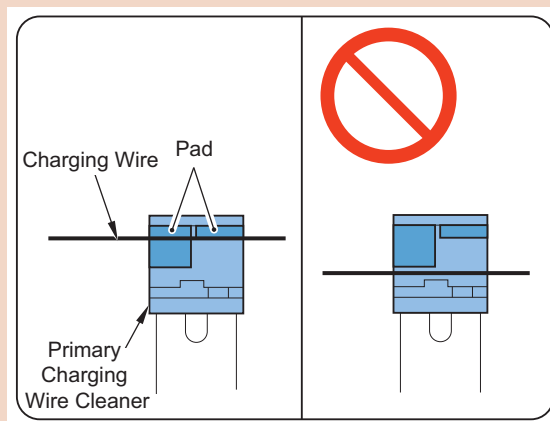
Be careful not to damage the Primary Charging Wire and the Grid Wire when removing the Primary Charging Wire Cleaner (Right).



CAUTION:

Points to Caution at Installation

Be sure to push the Charging Wire against the 2 pads of the Primary Charging Wire Cleaner to install.



■ Actions after Parts Replacement

1. Clear the Parts Counter.

(Lv.1) COPIER > COUNTER > PRDC-1 > PRM-CLN

● Replacing the Primary Charging Assembly Grid Wire

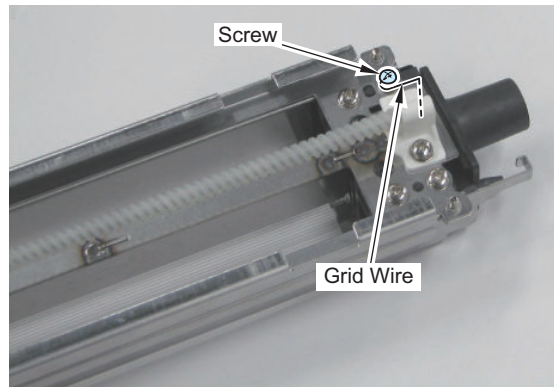
■ Preparation

1. Open the Front Cover.
2. Open the Inner Cover. (“Removing the Primary Charging Assembly” on page 362)
3. Remove the Primary Charging Assembly (“Removing the Primary Charging Assembly” on page 362)
4. Remove the Primary Charging Shutter Unit. (“Removing the Primary Charging Shutter Unit” on page 434)

■ Procedure

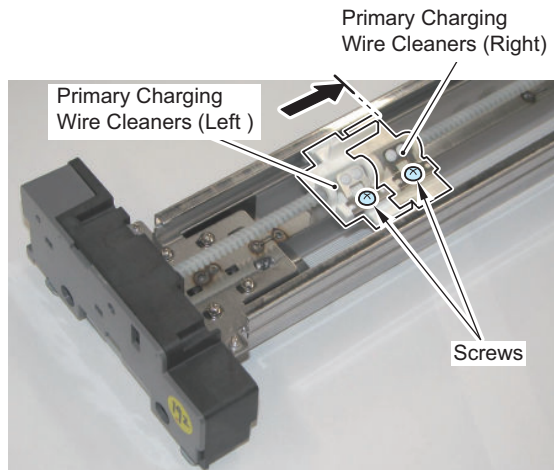
1. Remove the Primary Charging Assembly Grid Wire

- 1 Screw

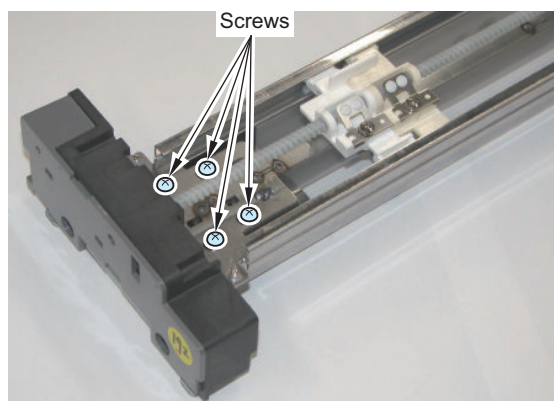


2. Shift the Primary Charging Wire Cleaners (Left and Right).

- 2 Screws (to loosen)

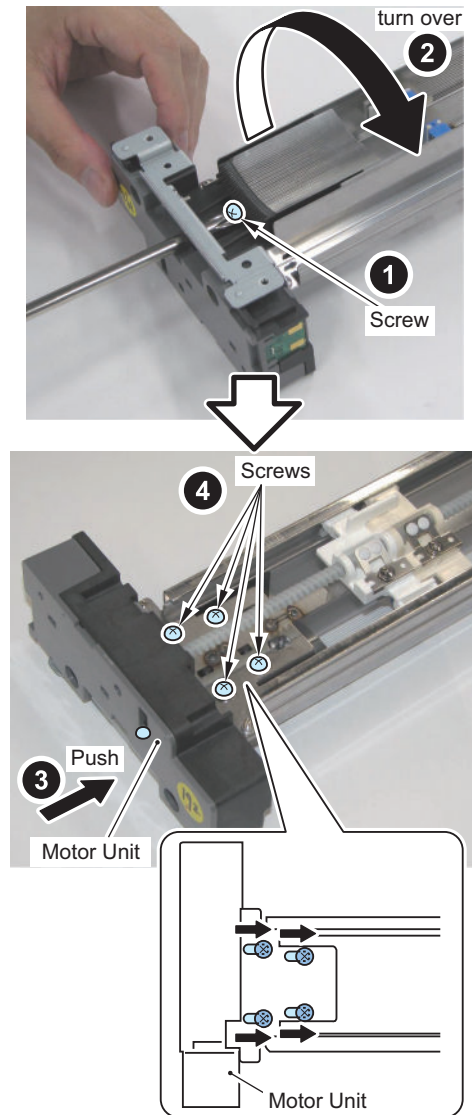


3. Loosen the 4 screws fixing the Motor Unit in the front.



4. Loosen the screw and turn over the Primary Charging Assembly.

5. Push the front Motor Unit in the direction of the arrow and tighten the 4 screws.



6. Untie approx. 5cm of the Charging Wire from the 0.1mm (wire-diameter) Charging Wire Reel to make a 2mm-diameter ring at the edge.

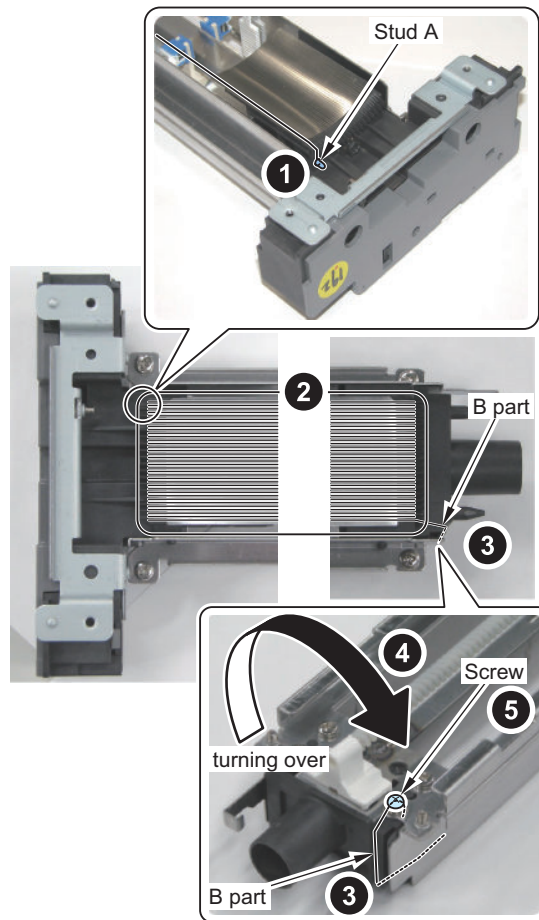
NOTE:

The ring can be easily made by the following procedure: Wrap the Charging Wire around the Hex Key to make a full round, and then turn the Hex Key for 3 to 4 times to twist the Charging Wire.

7. Cut the twisted Charging Wire (extra length) with nippers.

8. Hook the ring to the Stud A as shown in the figure.

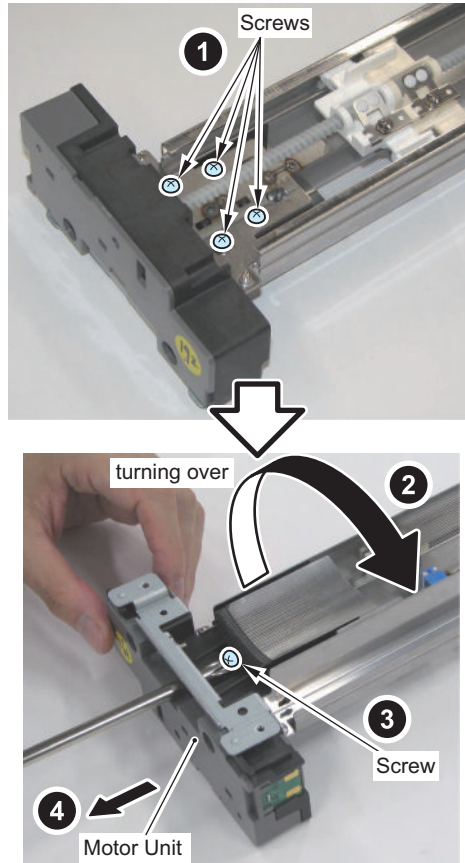
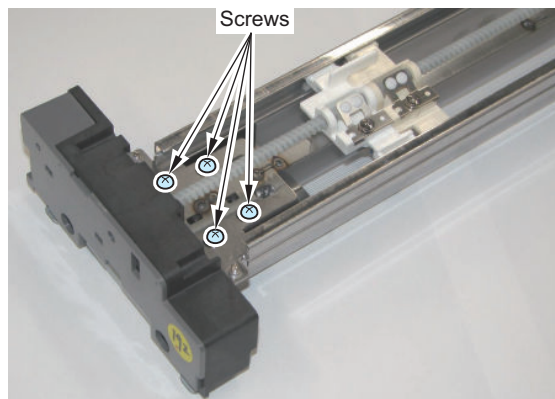
9. After setting the wire 35 times around, pass through B part. After turning over the Primary Charging Assembly, pass the wire between the washer and the Motor Unit, wrap around the screw clockwise to make a full round and secure with the screw.



10. Cut the extra length of the Charging Wire with nippers.

11. Loosen the 4 screws and tighten the screw until the tension of the Grid Wire is uniformed.

Be careful not to deform (bend) the Charging Assembly.

**12. Tighten the loosened 4 screws.****CAUTION:**

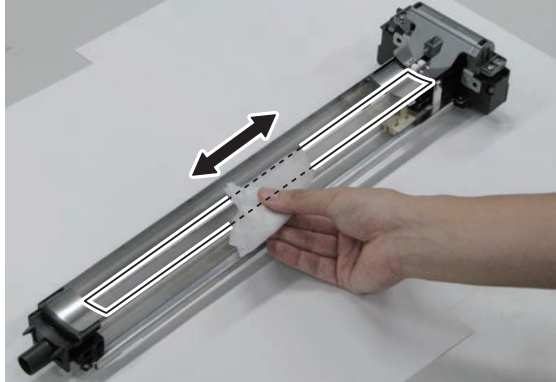
Be sure to check the following items.

- No bend or twist is found with the Grid Wire.
- The wire is set evenly spaced apart. (The Grid Wire is fitted into the groove of the Block.)

13. Remove the Shield Plate (Left) and pinch the Grid Wire from the left side to clean it on the left side with lint-free paper moistened with water.

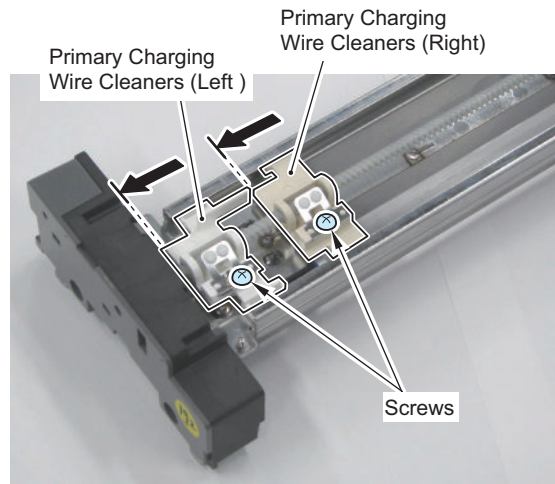
CAUTION:

- The frame of the Primary Charging Assembly may be distorted, so be careful not to remove both Left and Right Shield Plates simultaneously.

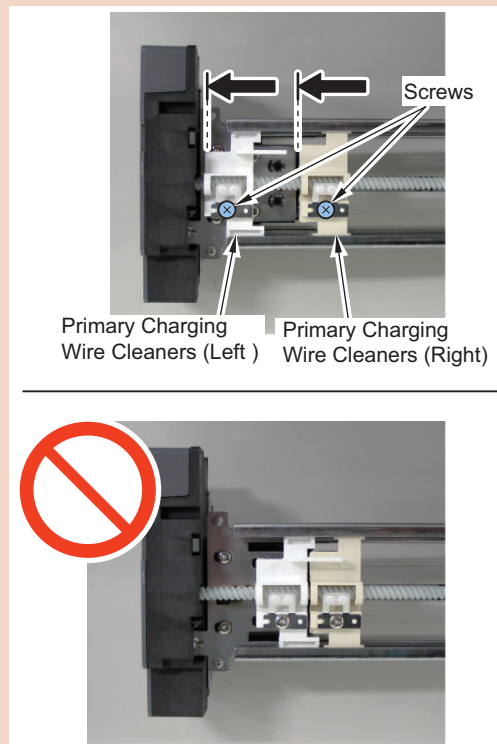


14. Shift the Primary Charging Wire Cleaners (Left and Right).

15. Tighten the 2 screws.

**CAUTION:**

Be sure to move the Primary Charging Wire Cleaners (Left and Right) until they stop and tighten the screws.

16. Install the Primary Charging Shutter Unit. ([“Removing the Primary Charging Shutter Unit”](#) on page 434)

Replacing the Primary Charging Wire

NOTE:

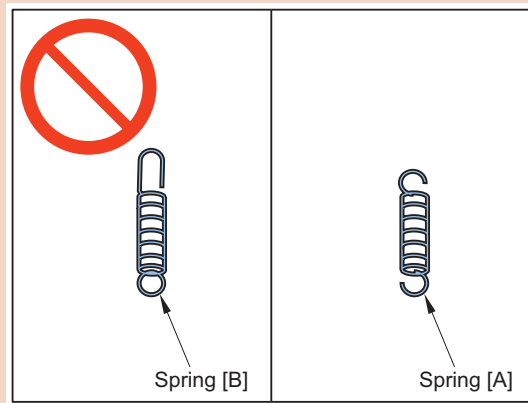
Replacement procedure is the same between the Primary Charging Wire (Left) and the Primary Charging Wire (Right). The following explains the procedure of the Primary Charging Wire (Right).

NOTE:

The Primary Charging Wire with spring is set as a service part.

CAUTION:

In the case of replacing the Charging Wire on a Charging Wire basis, be sure to use the dedicated Charging Wire Tension Spring (97-5527) [A]. Do not use the Spring [B] attached to the Charging Wire.



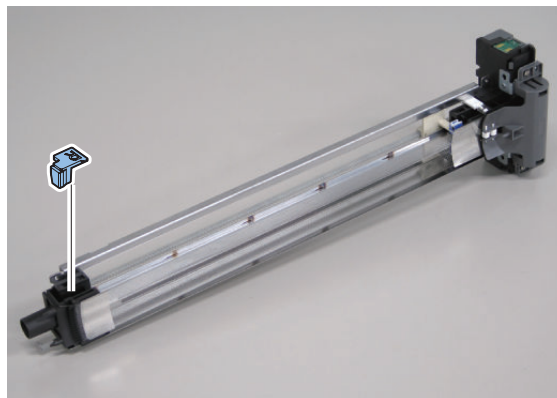
■ Preparation

1. Open the Front Cover.
2. Open the Inner Cover. (“[Removing the Primary Charging Assembly](#)” on page 362)
3. Remove the Primary Charging Assembly (“[Removing the Primary Charging Assembly](#)” on page 362)
4. Remove the Primary Charging Wire Cleaner Holder (Right). (“[Removing the Primary Charging Wire Cleaner, Cleaner Holder \(Right/Left\)](#)” on page 367)
5. Remove the Primary Charging Wire Cleaner (Right). (“[Removing the Primary Charging Wire Cleaner, Cleaner Holder \(Right/Left\)](#)” on page 367)

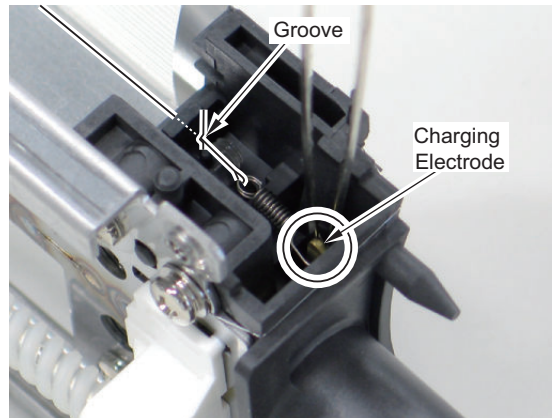
■ <Procedure>

● <Removing the Charging Wire>

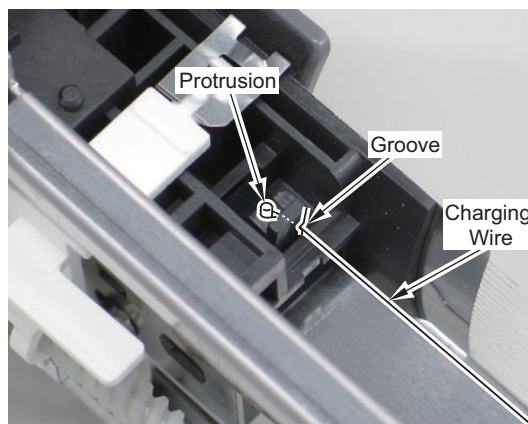
1. Remove the Sheet.



2. Use tweezers to hold the tip of the Spring at the rear side to remove the Spring from the charging electrode and remove the Charging Wire from the groove of the Positioning Block.



3. Remove the Charging Wire from the protrusion and the groove of the Positioning Block at the front side.



● <Installing the Charging Wire>

NOTE:

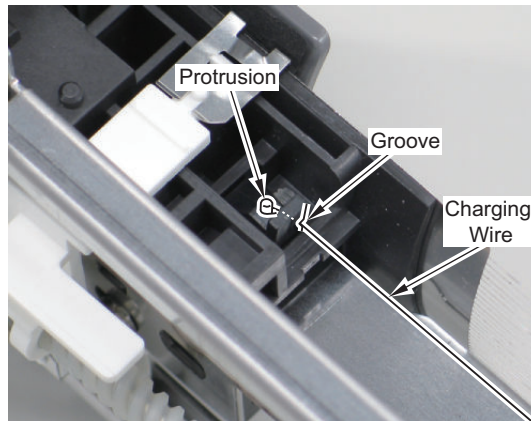
When installing the Charging Wire set as a service part, steps 4, 5, 7, and 8 are not required.

- 4) Untie approx. 5cm of the Charging Wire from the 0.06mm (wire-diameter) Charging Wire Reel to make a 2mm-diameter ring at the edge.

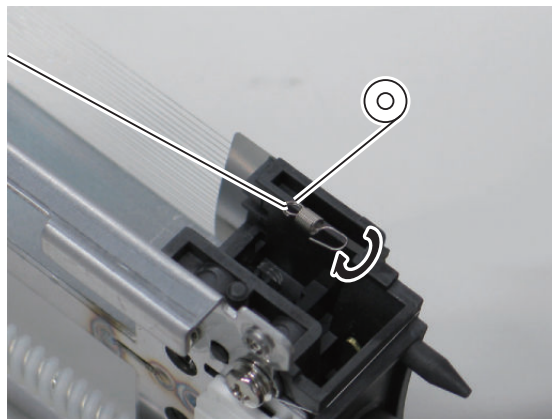
NOTE:

The ring can be easily made by the following procedure: Wrap the Charging Wire around the Hex Key to make a full round, and then turn it for 3 to 4 times to twist the Charging Wire.

- 5) Cut the edge of the twisted Charging Wire with nippers.
6) Hook the ring to the front protrusion of the Positioning Block to hook the Charging Wire to the groove.

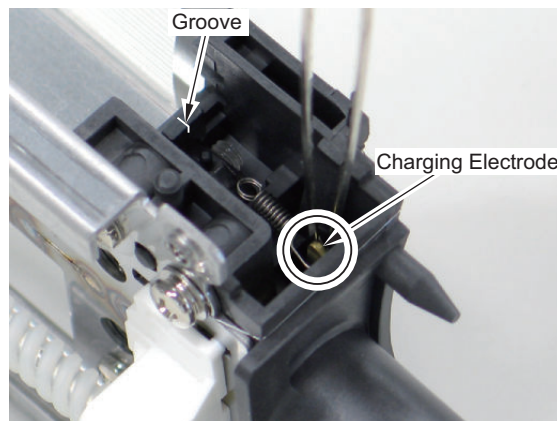


7) Hook the Charging Wire Tension Spring to the Charging Wire to twist with it.



8) Cut extra length of the Charging Wire with nippers.

9) Hook the Charging Wire to the rear groove of the Charging Wire Positioning Block and hold the edge of the Charging Wire Tension Spring with tweezers to hook it to the charging electrode.



CAUTION:

Be sure to keep the following in mind after installation.

- No bend or twist is found with the Charging Wire.
- The Charging Wire is fitted into the groove of the Charging Wire Positioning Block.

10) Clean the Charging Wire with lint-free paper moistened with alcohol.

11) Install the Primary Charging Wire Cleaner (Right).

12) Install the Primary Charging Wire Cleaner Holder (Right).

13) Install the Shield Plate (Right).

■ Adjustment when Replacing the Parts

1. **Clear the parts counter.**
(Lv.1)COPIER > COUNTER > PRDC-1 > PRM-WIRE
2. **Clean the Charging Wire. (necessary time : about 120 second)**
(Lv.1)COPIER > FUNCTION > CLEANING > WIRE-CLN
3. **Init of Primary Charging Wire current VL**
(Lv.1)COPIER > FUNCTION > CLEAR > GRD-CRNT
4. **Execute the potential control.**
(Lv.1)COPIER > FUNCTION > DPC > DPC2

● Cleaning the Primary Charging Assembly Grid Wire

■ Preparation

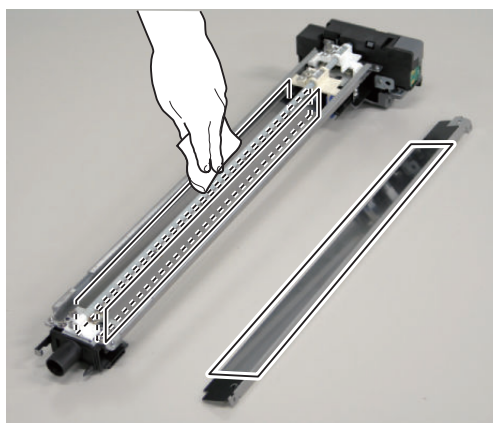
1. Open the Inner Cover. (“[Removing the Primary Charging Assembly](#)” on page 362)
2. Remove the Primary Charging Assembly (“[Removing the Primary Charging Assembly](#)” on page 362)
3. Remove the Primary Charging Wire Cleaner Holder. (“[Removing the Primary Charging Wire Cleaner, Cleaner Holder \(Right/Left\)](#)” on page 367)
4. Remove the Primary Charging Wire. (“[Replacing the Primary Charging Wire](#)” on page 375)

NOTE:

With this machine, discharge products tend to be accumulated inside the Charging Assembly. To remove the discharge products efficiently, clean with lint-free paper moistened with water. (If there is toner stain, clean with lint-free paper moistened with alcohol.)

■ <Procedure>

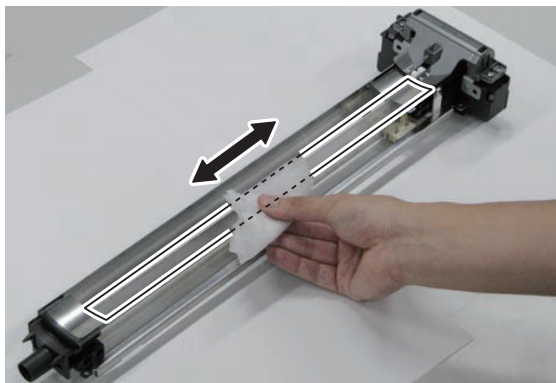
1. Clean the inside of Shield Plate (Right) and Inner Shield Plate (Left) removed from the Primary Charging Assembly with lint-free paper moistened with water.
2. Clean both sides of the Inner Shield Plate (Middle) of the Primary Charging Assembly with lint-free paper moistened with water.



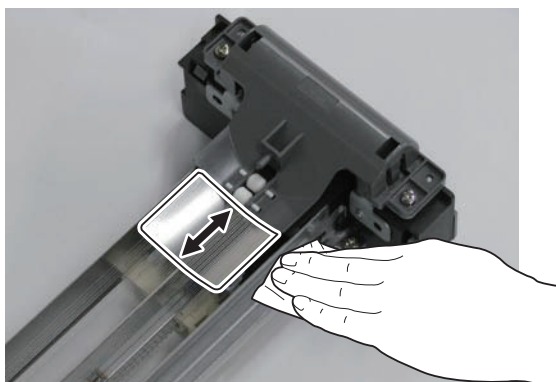
3. Remove the Shield Plate (Left) and pinch the Grid Wire from the left side to clean it on the left side with lint-free paper moistened with water.

CAUTION:

- The frame of the Primary Charging Assembly may be distorted, so be careful not to remove both Left and Right Shield Plates simultaneously.



4. Remove the Shield Plate (Right) and pinch the Grid Wire to clean it on the right side with lint-free paper moistened with water.



● Removing the Pre-transfer Charging Assembly

■ Preparation

1. Open the Inner Cover.(Refer to“[Removing the Primary Charging Assembly](#)” on page 362)

■ <Procedure>

CAUTION:

When removing the Primary Charging Assembly and the Pre-transfer Charging Assembly, go through the following procedure while the Charging Shutter is open.

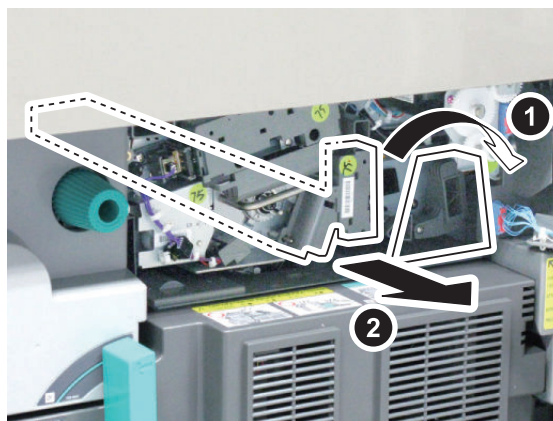
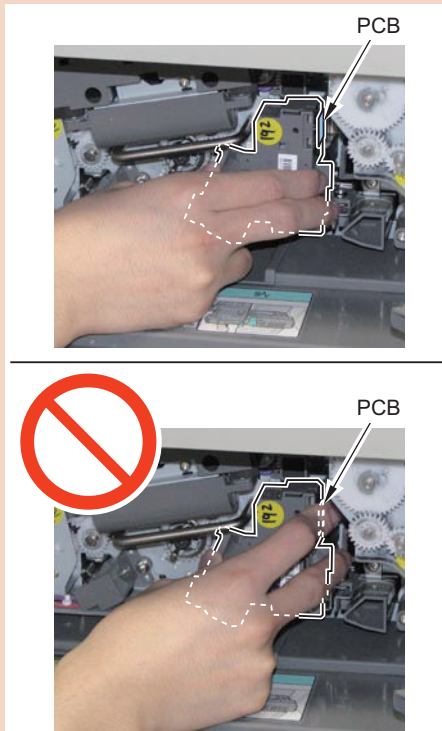
- At sleep mode, press the Power Switch on the Control Panel, check that the machine is in standby condition, turn OFF the Main Power, and then perform removing.
- In the case that the condition of the Charging Shutter (open/close) is unknown while the power of the host machine is OFF, turn ON the power, check that the machine is in standby condition, turn OFF the Main Power, and then perform removing.

If the above operations are not performed, it may be possible to remove the assembly while the Charging Shutter is closed, which may damage the drum or the shutter.

1. Turn the Lock Lever in the direction of the arrow to pull out the Pre-transfer Charging Assembly.

CAUTION:

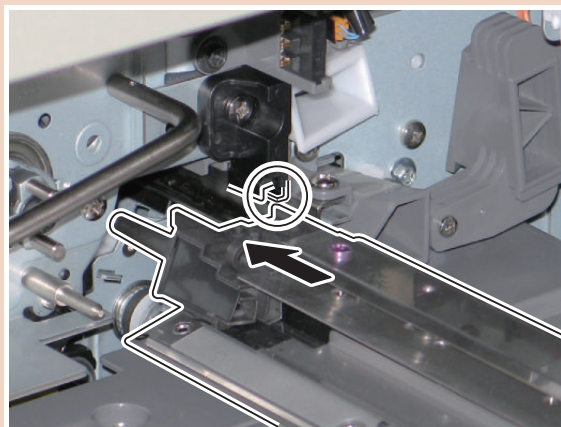
When removing the Pre-transfer Charging Assembly, be careful not to hold the PCB of the Pre-transfer Charging Assembly.



CAUTION:

Points to Caution at Installation

Be sure to fit the Transfer Charging Assembly to the groove on the host machine and install it horizontally.



■ Adjustment when Replacing the Parts

1. **Clear the parts counter.**
(Lv.1) COPIER > COUNTER > DRBL-1 > PO-UNIT
2. **Clean the Charging Wire. (necessary time : about 120 second)**
(Lv.1) COPIER > FUNCTION > CLEANING > WIRE-CLN

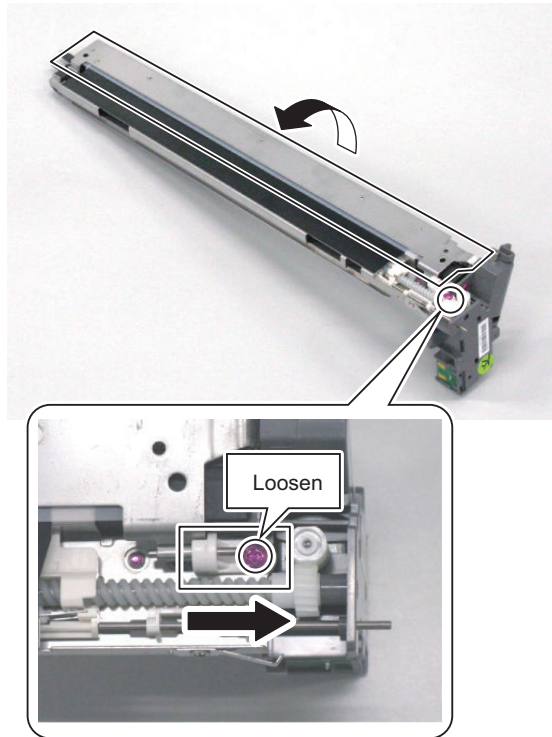
● Removing the Pre-transfer Charging Wire Cleaner, Cleaner Holder

■ Preparation

1. **Open the Inner Cover.**([“Removing the Primary Charging Assembly” on page 362](#))
2. **Remove the Pre-transfer Charging Assembly.** ([“Removing the Pre-transfer Charging Assembly” on page 380](#))

■ <Procedure>

1. Displace the Shield Plate Retainer Block to open the Shield Plate in the direction of the arrow.
 - 1 Screw (to loosen)

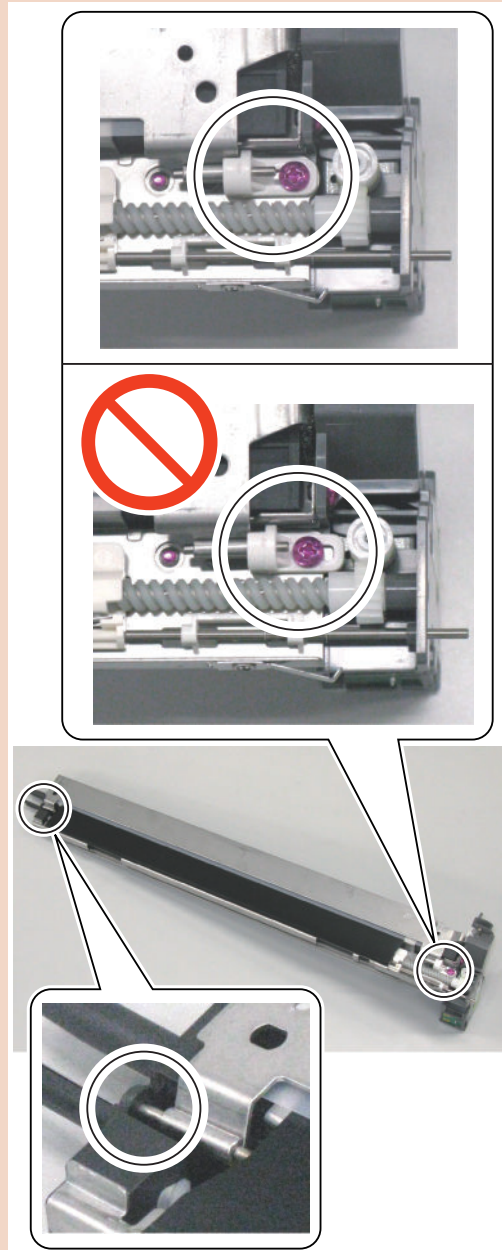


CAUTION:

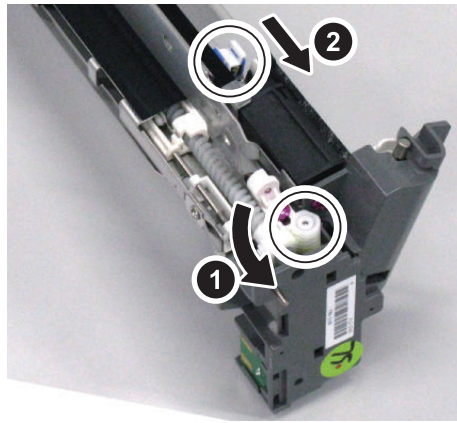
Points to Caution when Securing the Shield Plate

Move the Shield Plate Retainer Block fully to the inside to secure with the screw.

Check that the rear Pin is fitted into the Frame hole, and then move the Shield Plate back and forth to check that the Shield Plate is secured.

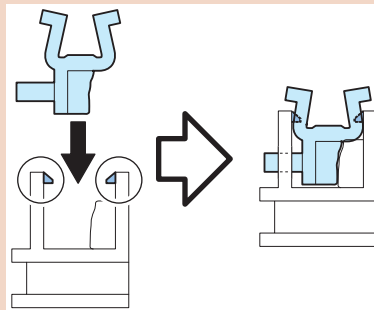


2. Turn the Gear by hand to move the Cleaning Pad Arm to the front.

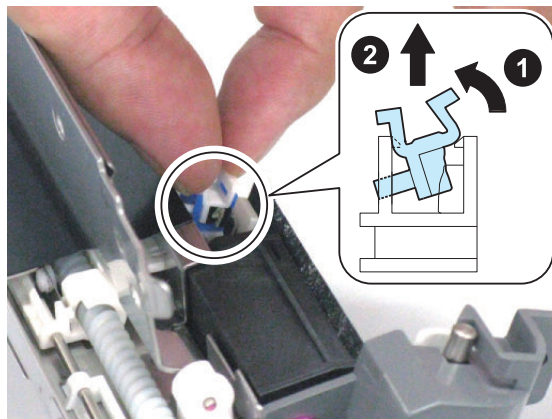


CAUTION:

Points to Caution when Installing the Pre-transfer Charging Wire Cleaner Holder
Push in the Pre-transfer Charging Wire Cleaner Holder until it is secured with the Claw.



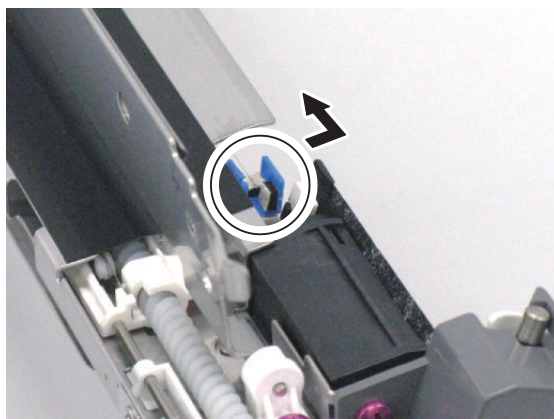
3. Pinch the Hook and turn it in the direction of the arrow to remove the Pre-transfer Charging Assembly Cleaner Holder.



4. Remove the Pre-transfer Charging Wire Cleaner in the direction of the arrow.

CAUTION:

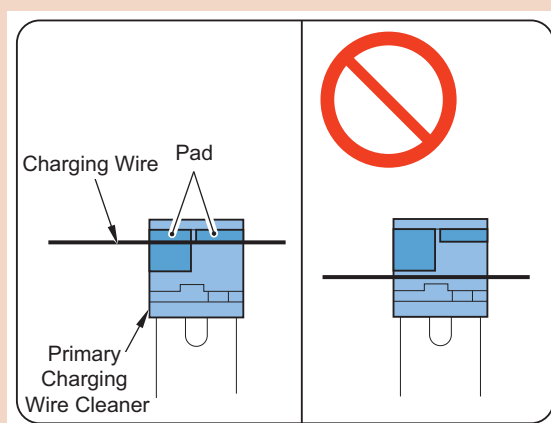
Be careful not to damage the Pre-transfer Charging Wire when removing the Pretransfer Charging Wire Cleaner.



CAUTION:

Points to Caution at Installation

Be sure to push the Charging Wire against the 2 pads of the Pre-transfer Charging Wire Cleaner to install.



■ Actions after Parts Replacement

1. Clear the Parts Counter.

(Lv.1) COPIER > COUNTER > PRDC-1 > PO-CLN

● Replacing the Pre-transfer Charging Wire

NOTE:

The Primary Charging Wire with spring is set as a service part.

■ Preparation

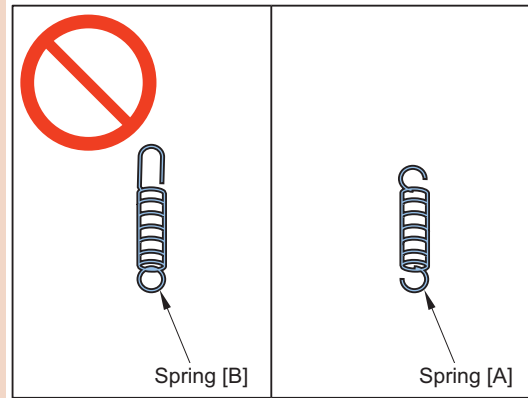
1. Open the Front Cover.
2. Open the Inner Cover. (“Removing the Primary Charging Assembly” on page 362)
3. Remove the Pre-transfer Charging Assembly. (“Removing the Pre-transfer Charging Assembly” on page 380)
4. Remove the Pre-transfer Charging Wire Cleaner Holder. (“Removing the Pre-transfer Charging Wire Cleaner, Cleaner Holder” on page 382)

5. Remove the Pre-transfer Charging Wire Cleaner. (“Removing the Pre-transfer Charging Wire Cleaner, Cleaner Holder” on page 382)

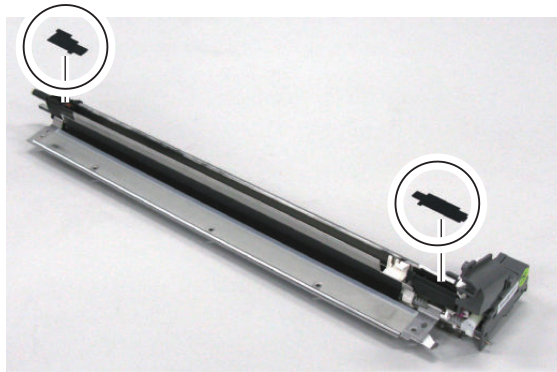
■ <Procedure>

CAUTION:

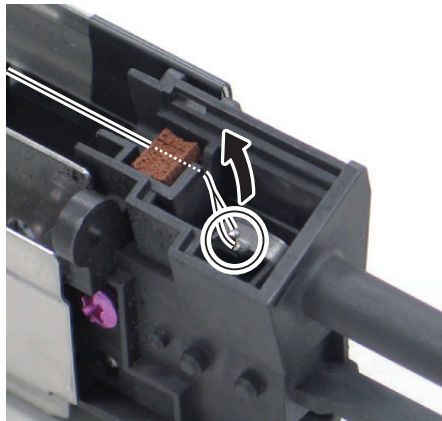
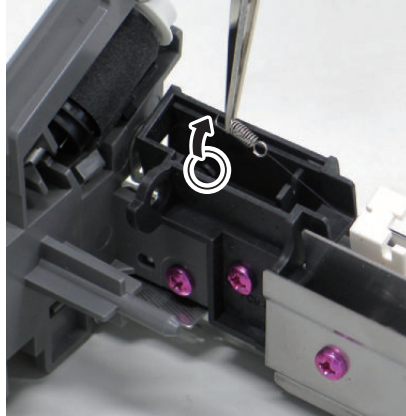
In the case of replacing the Charging Wire on a Charging Wire basis, be sure to use the dedicated Charging Wire Tension Spring (97-5527) [A]. Do not use the Spring [B] attached to the Charging Wire.



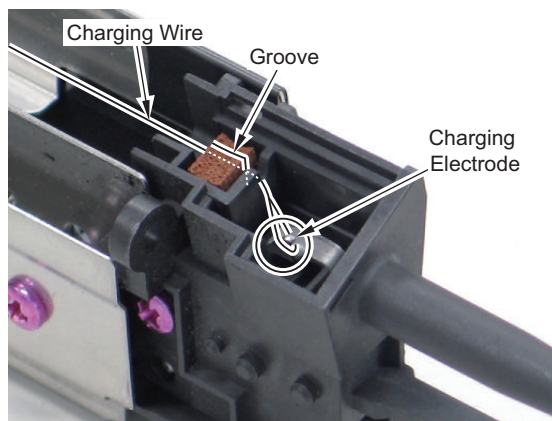
1. Remove the Pre-transfer Charging Assembly Covers (Front and Rear).



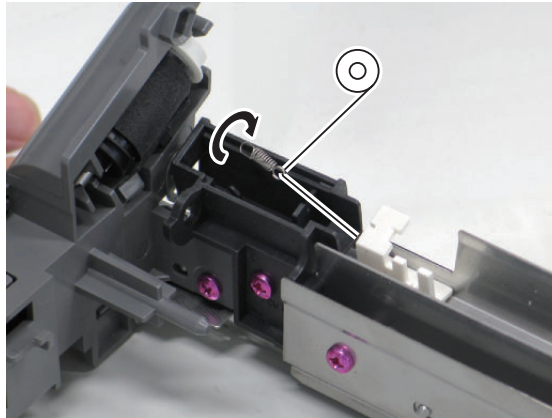
- Use tweezers to remove the front Spring from the Hook and then remove the Charging Wire from the rear charging electrode.



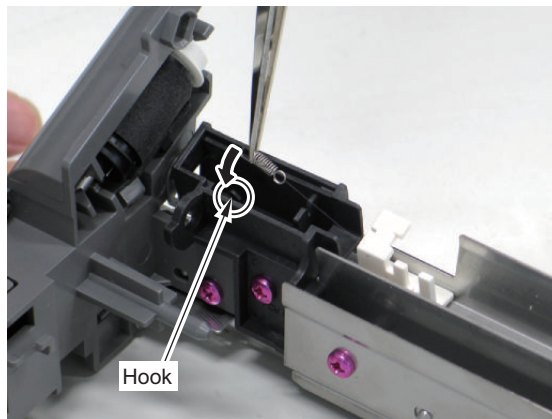
- Untie approx. 5cm of the Charging Wire from the 0.06mm (wire-diameter) Charging Wire Reel to make a 2mm-diameter ring at the edge.
- Cut the edge of the twisted Charging Wire with nippers.
- Hook the ring to the rear charging electrode of the Pre-charging Assembly and put the ring through the rear groove and the sponge groove.



6. On the front side of the Pre-charging Assembly, hook the Charging Wire Tension Spring to the Charging Wire to twist with it.



7. Cut extra length of the Charging Wire with nippers.
8. Hold the tip of the Spring with tweezers and hook the Charging Wire to the groove to hook the Spring to the Hook.



9. Clean the Charging Wire with lint-free paper moistened with alcohol.
10. Install the Pre-transfer Charging Assembly Covers (Front and Rear).
11. Install the Pre-transfer Charging Assembly Cleaner and the Pre-transfer Charging Assembly Cleaner Holder.

■ Adjustment when Replacing the Parts

1. Clear the parts counter.
(Lv.1) COPIER > COUNTER > PRDC-1 > PO-WIRE
2. Clean the Charging Wire. (necessary time : about 120 second)
(Lv.1) COPIER > FUNCTION > CLEANING > WIRE-CLN

● Cleaning the Pre-transfer Charging Wire

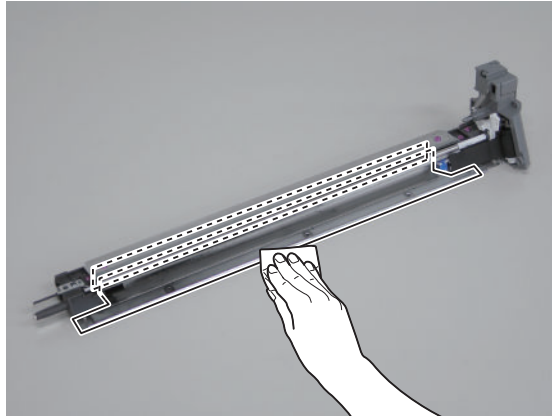
■ Preparation

1. Open the Front Cover.
2. Open the Inner Cover. (“Removing the Primary Charging Assembly” on page 362)
3. Remove the Pre-transfer Charging Assembly. (“Removing the Pre-transfer Charging Assembly” on page 380)
4. Remove the Pre-transfer Charging Wire Cleaner Holder. (“Removing the Pre-transfer Charging Wire Cleaner, Cleaner Holder” on page 382)
5. Remove the Pre-transfer Charging Wire Cleaner. (“Removing the Pre-transfer Charging Wire Cleaner, Cleaner Holder” on page 382)

6. Remove the Pre-transfer Charging Wire. (“Replacing the Pre-transfer Charging Wire” on page 386)

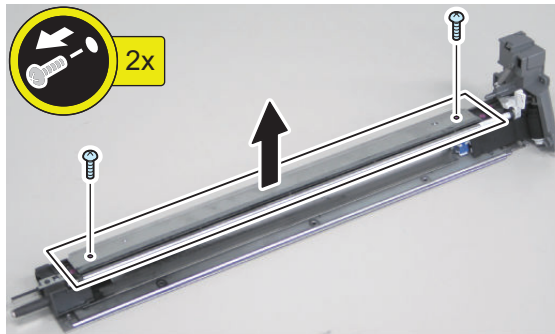
■ <Procedure>

1. Clean the Shield Plate with lint-free paper moistened with alcohol.

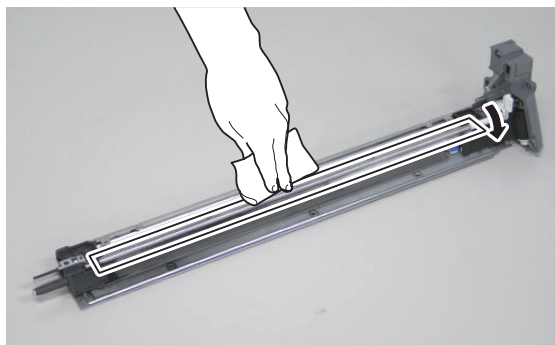


2. Remove the Plate.

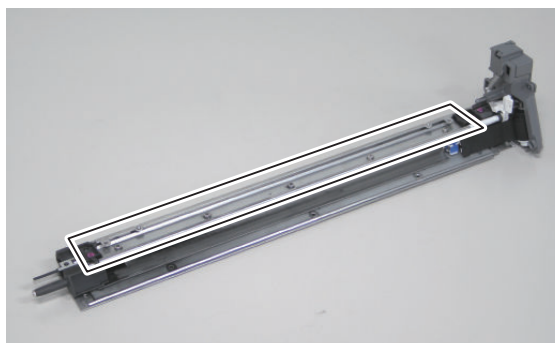
- 2 Screws



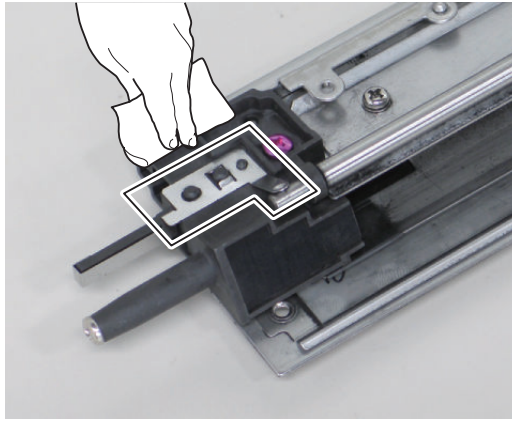
3. While rotating the Dust Collecting Roller, clean it with lint-free paper.



4. Remove toner in the toner collection area.



5. While rotating the Dust Collecting Roller, clean the electrode area with lint-free paper.



● Removing the Process Unit

■ Preparation

1. Open the Inner Cover. (“Removing the Primary Charging Assembly” on page 362)
2. Remove the Primary Charging Assembly. (“Removing the Primary Charging Assembly” on page 362)
3. Remove the Pre-transfer Charging Assembly. (“Removing the Pre-transfer Charging Assembly” on page 380)

■ <Procedure>

CAUTION:

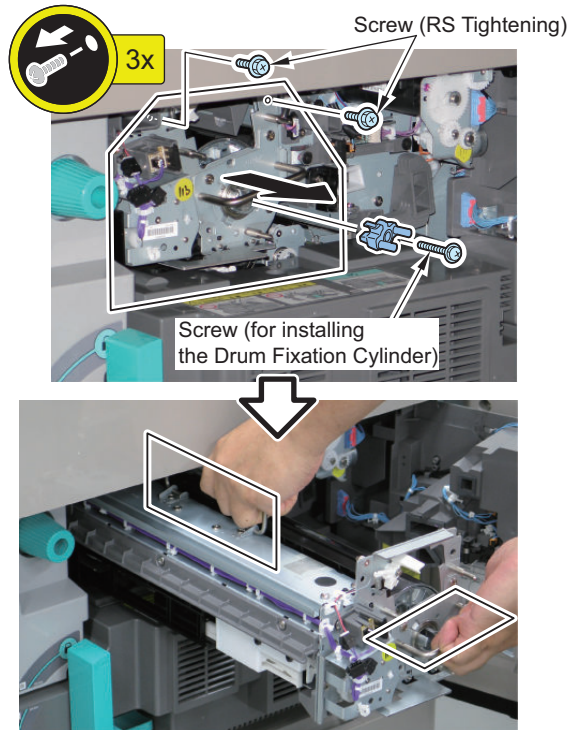
Do not touch the surface of the Photosensitive Drum.

1. Remove the Drum Fixation Cylinder to remove the Process Unit.

- 2 Screws
- 1 Screw (for installing the Drum Fixation Cylinder)

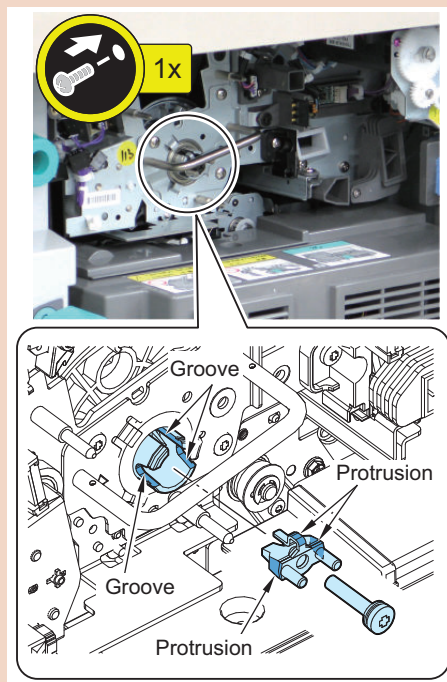
NOTE:

When removing the Process Unit, hold both the upper and front Handles to pull out the Process Unit.

**CAUTION:**

Points to Caution at Installation

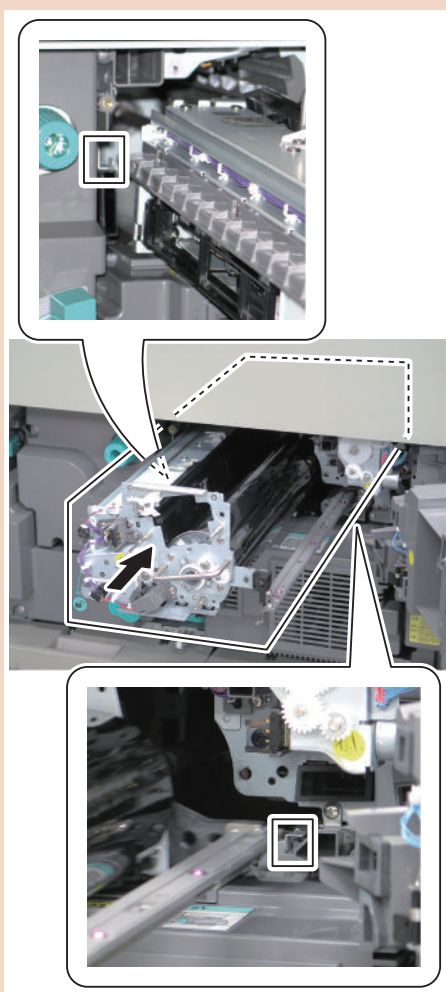
When installing the Process Unit, fit the 3 grooves at the edge of the Drum Shaft with the 3 protrusions of the Drum Fixation Cylinder to install the Drum Shaft Fixing Screw.



CAUTION:

Points to Caution at Installation

Be sure to fit the Drum Cleaning Unit to the rail on the host machine and install it horizontally.



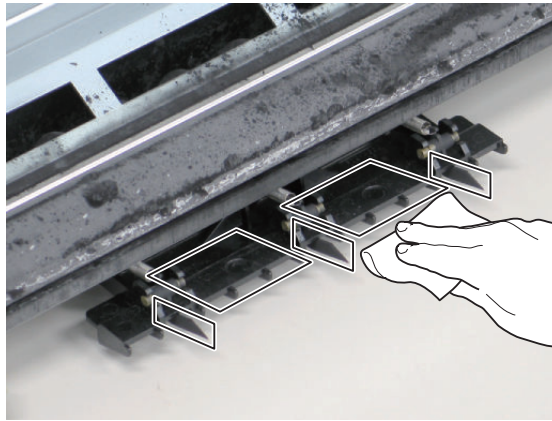
Cleaning the Process Unit

■ Preparation

1. Open the Inner Cover. (“Removing the Primary Charging Assembly” on page 362)
2. Remove the Primary Charging Assembly. (“Removing the Primary Charging Assembly” on page 362)
3. Remove the Pre-transfer Charging Assembly. (“Removing the Pre-transfer Charging Assembly” on page 380)
4. Remove the Process Unit. (“Removing the Process Unit” on page 391)
5. Remove the Drum Cleaning Unit. (“Removing the Drum Cleaning Unit” on page 394)
6. Remove the Drum Unit. (“Removing the Drum Unit” on page 400)

■ <Procedure>

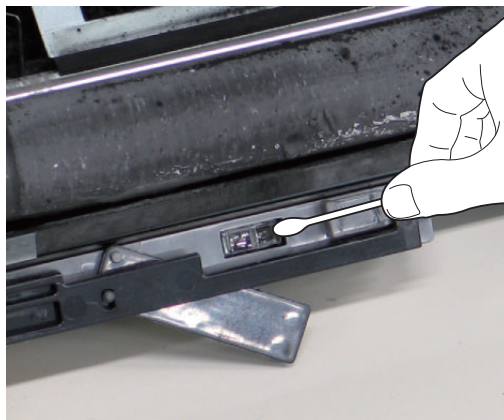
1. Clean the Separation Claw Mounting Base and Separation Claw with lint-free paper moistened with alcohol.



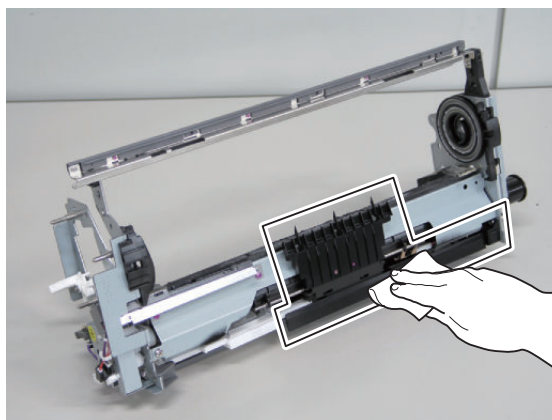
2. Clean the Patch Sensor with a wet and tightly-wrung cotton swab.

CAUTION:

Clean the Patch Sensor in the single direction, so that it is cleaned evenly.



3. Clean the rear side of the Process Unit with lint-free paper moistened with alcohol.



● Removing the Drum Cleaning Unit

■ Preparation

1. Open the Inner Cover. (“Removing the Primary Charging Assembly” on page 362)
2. Remove the Primary Charging Assembly. (“Removing the Primary Charging Assembly” on page 362)

3. Remove the Pre-transfer Charging Assembly. (“Removing the Pre-transfer Charging Assembly” on page 380)
4. Remove the Process Unit. (“Removing the Process Unit” on page 391)

■ <Procedure>

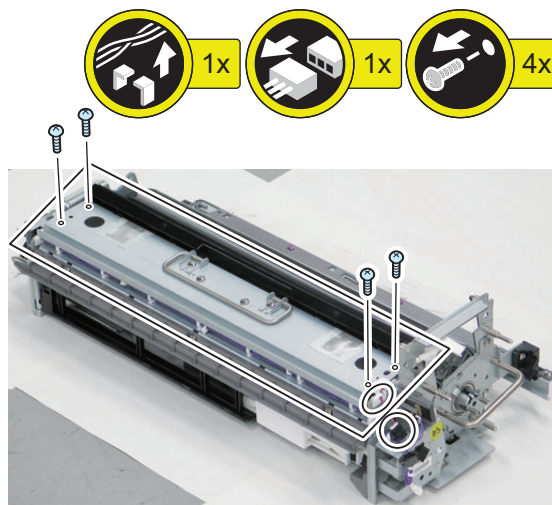
CAUTION:

Do not touch the surface of the Photosensitive Drum.

After removing the Drum Cleaning Unit, place paper over the Photosensitive Drum to block light.

1. Remove the Drum Cleaning Unit.

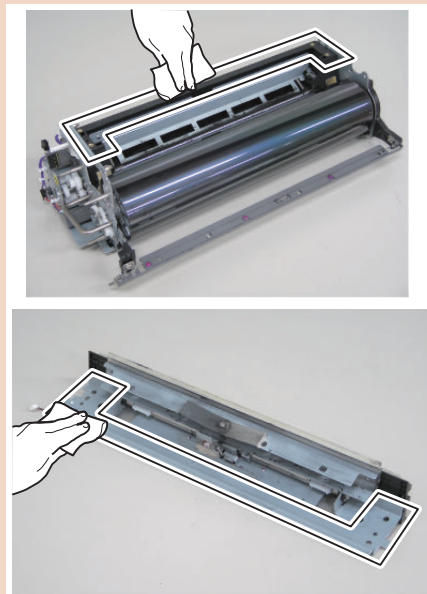
- Edge Saddle
- 1 Connector
- 4 Screws



CAUTION:

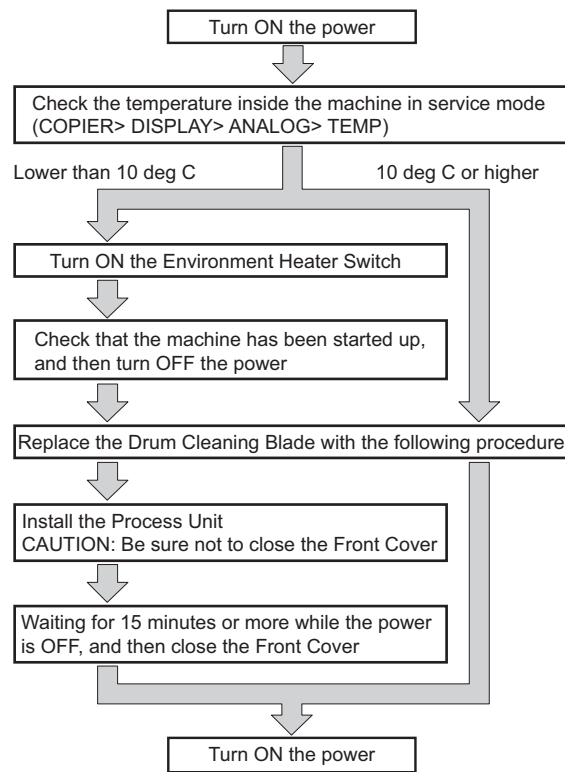
When installing the Drum Cleaning Unit, clean the area shown with lint-free paper moistened with alcohol.

If the Drum Cleaning Unit is installed without removing toner, it cannot be installed in the correct position, causing the cleaning error.



Removing the Drum Cleaning Blade

Procedure differs according to the temperature inside the machine. Be sure to perform the work by following the flow indicated below.

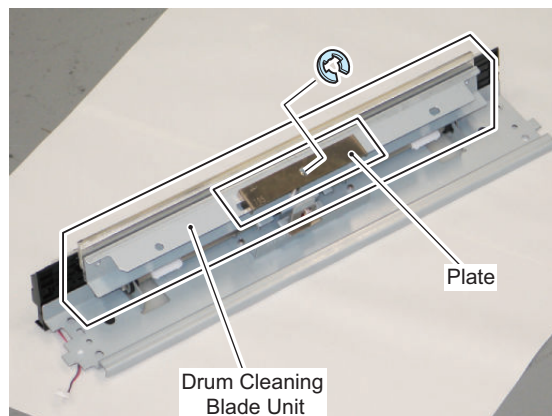


■ Preparation

1. Open the Inner Cover. (“Removing the Primary Charging Assembly” on page 362)
2. Remove the Primary Charging Assembly. (“Removing the Primary Charging Assembly” on page 362)
3. Remove the Pre-transfer Charging Assembly. (“Removing the Pre-transfer Charging Assembly” on page 380)
4. Remove the Process Unit (“Removing the Process Unit” on page 391)
5. Remove the Drum Cleaning Unit. (“Removing the Drum Cleaning Unit” on page 394)

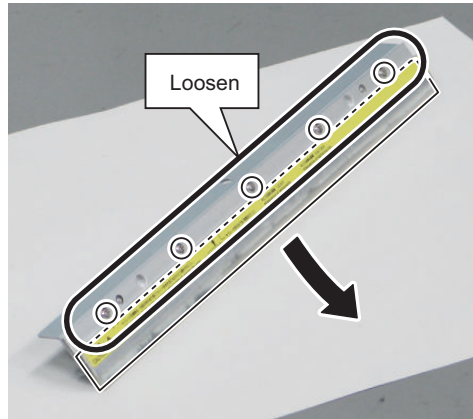
■ <Procedure>

1. Turn over the Drum Cleaning Unit to remove the Drum Cleaning Blade Unit.
 - 1 E-ring
 - 1 Plate



2. Remove the Drum Cleaning Blade.

- 5 Screws (to loosen)



CAUTION:

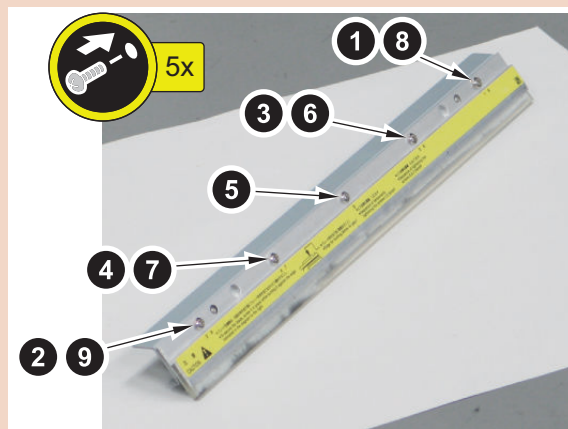
Points to Caution when Installing the Drum Cleaning Blade

Be sure to apply toner on the contact area (edge) on the Drum of the Drum Cleaning Blade. In particular, be sure to apply toner on both edges of the Blade.

CAUTION:

Points to Caution when Installing the Drum Cleaning Blade Unit

1. Wipe out the toner on both edges of the Drum Cleaning Unit before installation.
2. Be sure to fit in the center position, and then temporarily tighten the screws following the numeric order (from 1 to 4) and also securely tighten the screws (from 5 to 9).



■ Actions after Parts Replacement

1. Clear the parts counter.

(Lv.1) COPIER > COUNTER > DRBL-1 > CLN-BLD

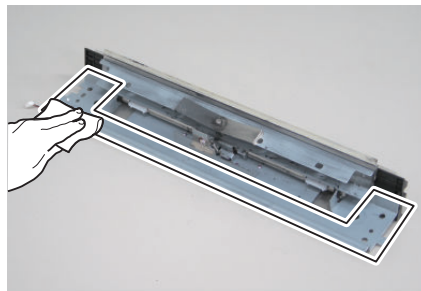
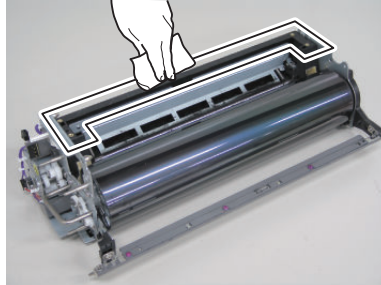
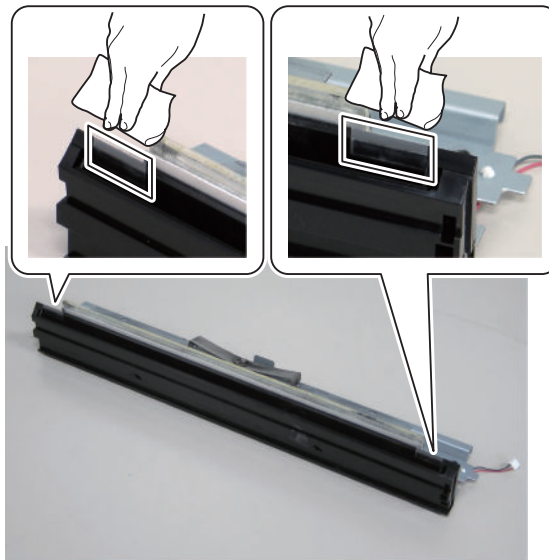
● Cleaning the Drum Cleaning Unit

■ Preparation

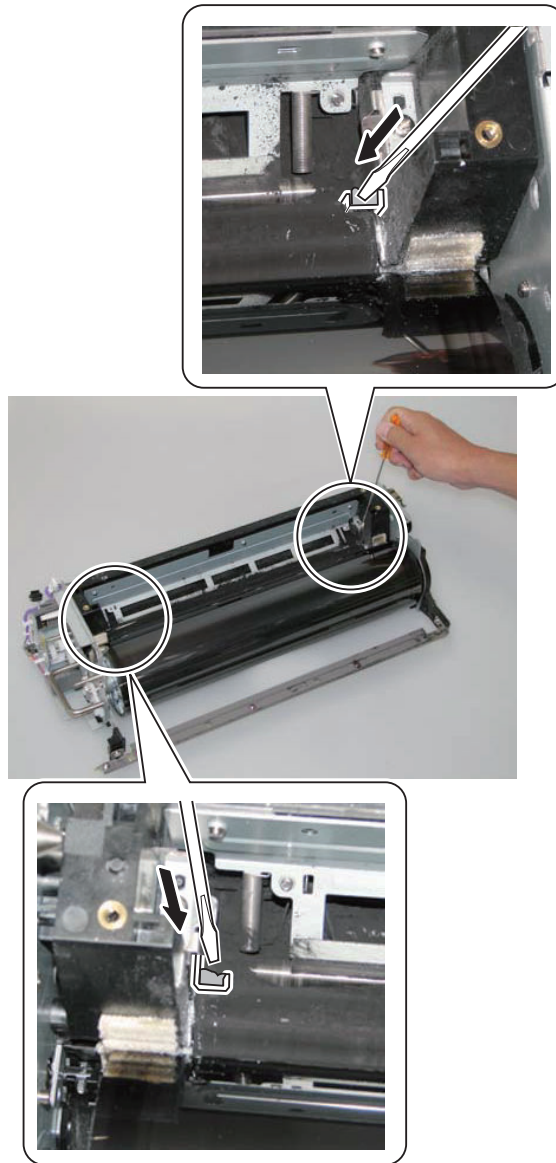
1. Open the Inner Cover. (“Removing the Primary Charging Assembly” on page 362)
2. Remove the Primary Charging Assembly. (“Removing the Primary Charging Assembly” on page 362)
3. Remove the Pre-transfer Charging Assembly. (“Removing the Pre-transfer Charging Assembly” on page 380)
4. Remove the Process Unit. (“Removing the Process Unit” on page 391)

5. Remove the Drum Cleaning Unit. (“Removing the Drum Cleaning Unit” on page 394)**■ <Procedure>****CAUTION:**

Do not touch the surface of the Photosensitive Drum.

1. Clean the Drum Cleaning Unit Plate with lint-free paper moistened with alcohol.**2. Clean the 2 Pre-exposure Plastic Films of the Drum Cleaning Blade Unit with lint-free paper.**

3. Crumb toner clusters in the toner collection area and then clean it.



● Replacing the Pre-exposure Plastic Film

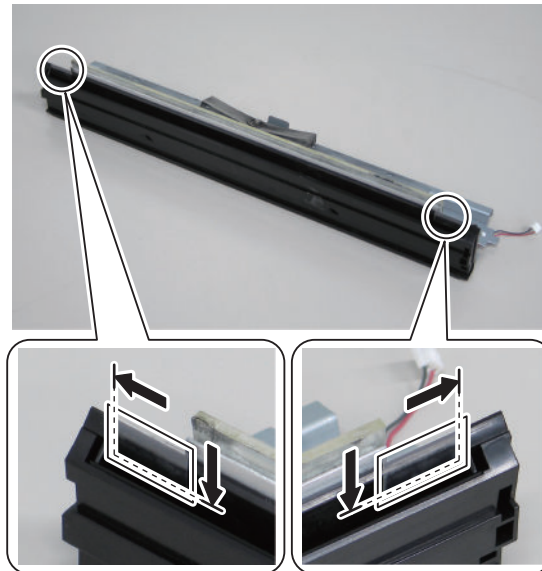
■ Preparation

1. Open the Inner Cover. (“Removing the Primary Charging Assembly” on page 362)
2. Remove the Primary Charging Assembly. (“Removing the Primary Charging Assembly” on page 362)
3. Remove the Pre-transfer Charging Assembly. (“Removing the Pre-transfer Charging Assembly” on page 380)
4. Remove the Process Unit. (“Removing the Process Unit” on page 391)
5. Remove the Drum Cleaning Unit. (“Removing the Drum Cleaning Unit” on page 394)

■ <Procedure>

1. Remove the Pre-exposure Plastic Film.

2. Fit the Pre-exposure Plastic Film to the edge and lower grooves of the Drum Cleaning Unit.



■ Actions after Parts Replacement

1. Clear the parts counter.
(Lv.1) COPIER > COUNTER > DRBL-1 > EXP-SCRIP

● Removing the Drum Unit

■ Preparation

1. Open the Inner Cover. (“Removing the Primary Charging Assembly” on page 362)
2. Remove the Primary Charging Assembly. (“Removing the Primary Charging Assembly” on page 362)
3. Remove the Pre-transfer Charging Assembly. (“Removing the Pre-transfer Charging Assembly” on page 380)
4. Remove the Process Unit (“Removing the Process Unit” on page 391)
5. Put paper on the Photosensitive Drum, so that it is not exposed to direct sunlight.
6. Remove the Drum Cleaning Blade. (“Removing the Drum Cleaning Blade” on page 396)

■ Procedure

CAUTION:

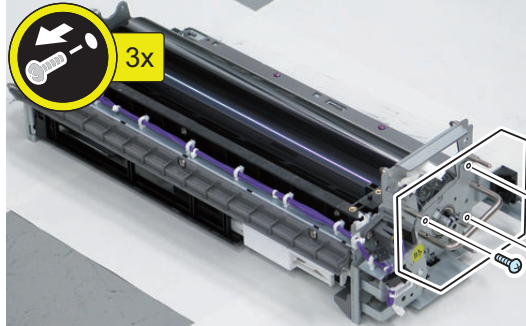
When handling the Process Unit and Photosensitive Drum, be sure to follow the following points to note.

1. When removing the Process Unit, be sure to block light to the Photosensitive Drum. Cover with the Photosensitive Drum Protection Sheet or wrap 5 or more papers around the drum to block light.
2. Do not place the Process Unit and Photosensitive Drum in a location where is exposed to direct rays of the sun (e.g. near the window).
3. Do not store in a location with high/low temperature/humidity, or in a location where temperature or humidity is dramatically changed.
4. Do not store in a dusty area or in a location full of ammonia gas or organic solvent gas.

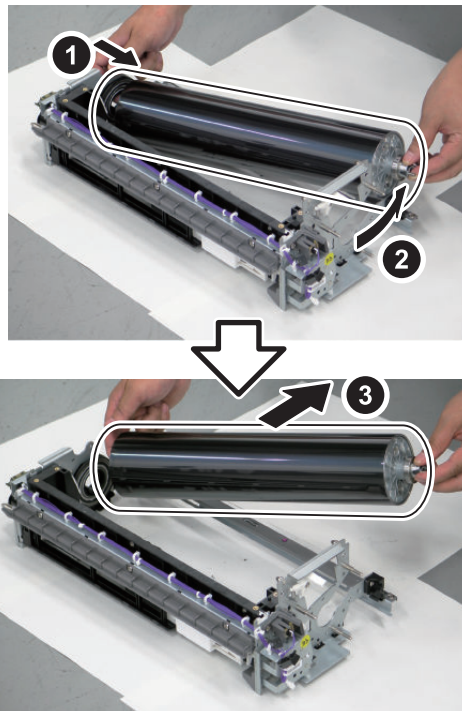
When installing a new Photosensitive Drum, be sure to remove the Lightproof Sheet after installing the drum to the main body. In addition, be sure to rotate the drum counterclockwise at removal of the Lightproof Sheet. If the drum is rotated clockwise, the Drum Cleaner Blade may be everted.

1. Remove the Drum Retainer Plate.

- 3 Screws



2. Push to move the rear side of the Photosensitive Drum with your fingers and pull out the Drum Unit to the front to remove.



● Removing the Photosensitive Drum

■ Preparation

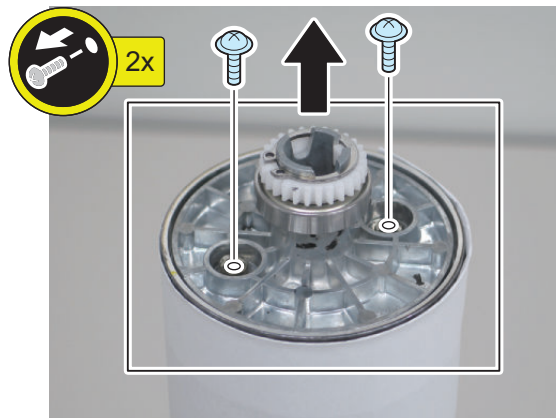
1. Open the Inner Cover. (“Removing the Primary Charging Assembly” on page 362)
2. Remove the Primary Charging Assembly. (“Removing the Primary Charging Assembly” on page 362)
3. Remove the Pre-transfer Charging Assembly. (“Removing the Pre-transfer Charging Assembly” on page 380)
4. Remove the Process Unit. (“Removing the Process Unit” on page 391)
5. Put paper on the Photosensitive Drum, so that it is not exposed to direct sunlight.
6. Remove the Drum Cleaning Blade. (“Removing the Drum Cleaning Blade” on page 396)
7. Remove the Drum Retainer Plate. (“Removing the Drum Unit” on page 400)
8. Remove the Drum Unit. (“Removing the Drum Unit” on page 400)

<Procedure>**CAUTION:**

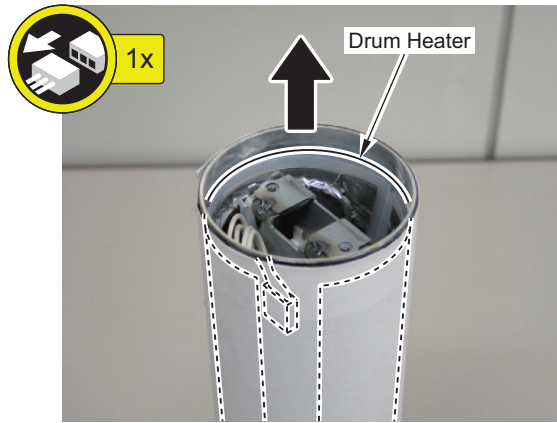
When handling the Process Unit and Photosensitive Drum, be sure to follow the following points to note.

1. When removing the Process Unit, be sure to block light to the Photosensitive Drum.
Cover with the Photosensitive Drum Protection Sheet or wrap 5 or more papers around the drum to block light.
2. Do not place the Process Unit and Photosensitive Drum in a location where is exposed to direct rays of the sun (e.g. near the window).
3. Do not store in a location with high/low temperature/humidity, or in a location where temperature or humidity is dramatically changed.
4. Do not store in a dusty area or in a location full of ammonia gas or organic solvent gas.

When installing a new Photosensitive Drum, be sure to remove the Lightproof Sheet after installing the drum to the main body. In addition, be sure to rotate the drum counterclockwise at removal of the Lightproof Sheet. If the drum is rotated clockwise, the Drum Cleaning Blade may be everted.

1. Wrap paper around the Drum Unit to block light.**2. Remove the 2 screws and the Flange.**

3. Disconnect the connector and remove the Drum Heater.



4. Remove the Heater Control PCB Unit.



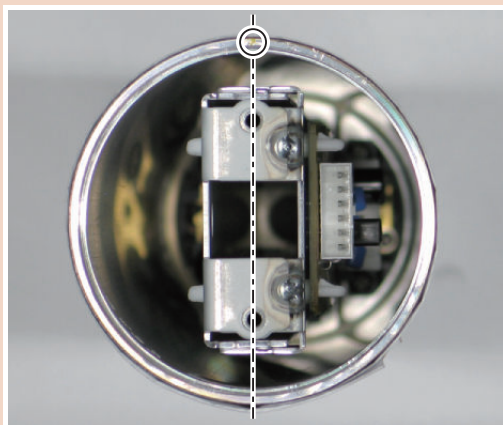
NOTE:

Serial ID of the drum is written on the seal inside the drum.



CAUTION:

- Align the yellow marker of the drum with the hole position of the unit when installing the Heater Control PCB Unit to the drum.



- When securing the Flange, align the protrusion of the Flange with the yellow marker to install.

**NOTE:**

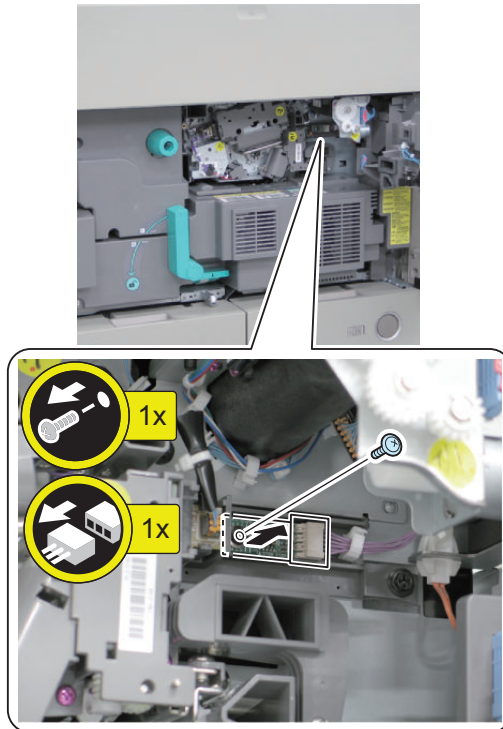
If the yellow marker is not aligned with the protrusion, the following control cannot be executed properly.

1. 2D shading
2. D-MAX control
3. D-half control

■ Adjustment when Replacing the Parts

1. Remove the EEROM.

- 1 Screw
- 1 Connector

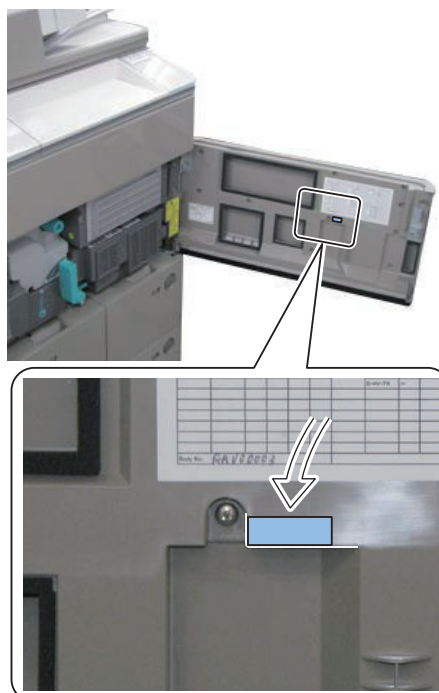


2. Replace the ROM connected to the host machine with the drum ROM included in the drum.

CAUTION:

If the ROM is not replaced, the replaced drum and the drum-unique data stored in the ROM are not matched. As a result, the 2D shading is not functioned normally.

3. Affix the ID Label included in the drum to the inside of the Front Cover.



4. Activate the drum replacement mode.

(Lv.1) COPIER > FUNCTION > INSTALL > DRM-INIT

5. Check the 2-dimensional shading ROM.

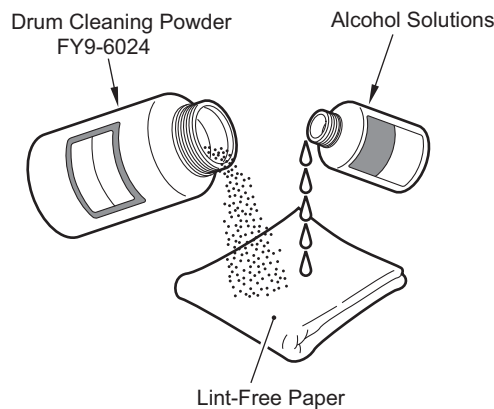
(Lv.1) COPIER > FUNCTION > 2D-SHADE > 2D-READ

6. Execute the auto adjust gradation using the user mode.

Settings/Registration > Adjustment/Maintenance > Image Quality Adjustment > Auto Adjust Gradation

Cleaning Photosensitive Drum

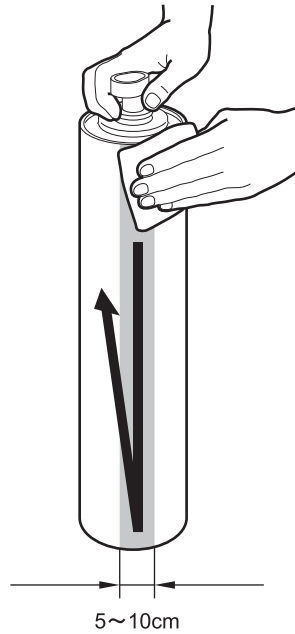
1. Moisten lint-free paper with 5 to 10 cc of alcohol solutions ; then, pour 0.2 to 0.3 g of the drum cleaning powder (FY9-6024) on the lint-free paper.
2. While butting the lint-free paper relatively strongly against the photosensitive drum, wipe the surface of the drum from the front to the rear and from the rear to the front.

**CAUTION:**

- Keep the widths of cleaning to 5 to 10 cm in the peripheral direction of the drum.
- Move the lint-free paper back and forth 15 to 20 times over a single area. Forcing the lint-free paper will not affect the life of the drum.

3. After the alcohol has evaporated, dry wipe the surface with the lint-free paper. If the area is uneven, go back to the step 1, and increase the back-and-forth movements.

4. Rotate the drum for the width (5 to 10 cm), and repeat the step 1 through 3 until the entire area of the surface has been cleaned.



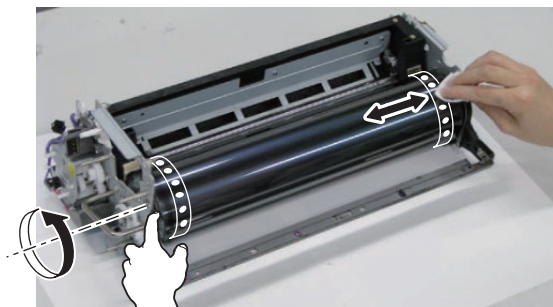
Cleaning the Drum edges

■ Preparation

1. Open the Inner Cover. (“Removing the Primary Charging Assembly” on page 362)
2. Remove the Primary Charging Assembly. (“Removing the Primary Charging Assembly” on page 362)
3. Remove the Pre-transfer Charging Assembly. (“Removing the Pre-transfer Charging Assembly” on page 380)
4. Remove the Process Unit. (“Removing the Process Unit” on page 391)
5. Put paper on the Photosensitive Drum, so that it is not exposed to direct sunlight.
6. Remove the Drum Cleaning Blade. (“Removing the Drum Cleaning Blade” on page 396)
7. Remove the Drum Retainer Plate. (“Removing the Drum Unit” on page 400)
8. Remove the Drum Unit. (“Removing the Drum Unit” on page 400)

■ <Procedure>

1. Rotate the Drum and dry wipe the soiling on the surface of the Drum edges with lint-free paper.



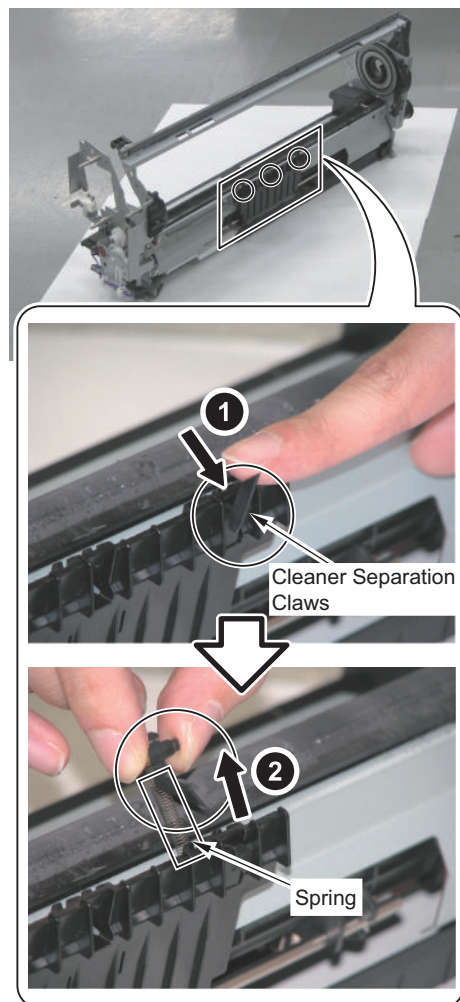
Removing the Cleaner Separation Claw

■ Preparation

1. Open the Inner Cover. (“Removing the Primary Charging Assembly” on page 362)
2. Remove the Primary Charging Assembly. (“Removing the Primary Charging Assembly” on page 362)
3. Remove the Pre-transfer Charging Assembly. (“Removing the Pre-transfer Charging Assembly” on page 380)
4. Remove the Process Unit. (“Removing the Process Unit” on page 391)
5. Remove the Drum Cleaning Blade. (“Removing the Drum Cleaning Blade” on page 396)
6. Remove the Drum Unit. (“Removing the Drum Unit” on page 400)

■ <Procedure>

1. Put the Process Unit Frame perpendicularly.
2. Remove the 3 Cleaner Separation Claws.
 - 1 Spring each



■ Actions after Parts Replacement

1. Clear the parts counter.
 - (Lv.1) COPIER > COUNTER > DRBL-1 > SP-CLAW

● Removing the Side Seal

■ Preparation

1. Open the Inner Cover. (“Removing the Primary Charging Assembly” on page 362)
2. Remove the Primary Charging Assembly. (“Removing the Primary Charging Assembly” on page 362)
3. Remove the Pre-transfer Charging Assembly. (“Removing the Pre-transfer Charging Assembly” on page 380)
4. Remove the Process Unit. (“Removing the Process Unit” on page 391)
5. Remove the Drum Cleaning Blade. (“Removing the Drum Cleaning Blade” on page 396)
6. Remove the Drum Unit. (“Removing the Drum Unit” on page 400)

■ Procedure

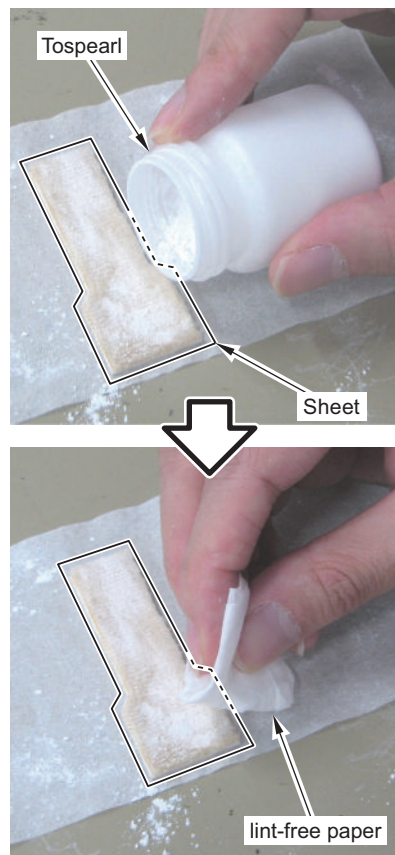
1. Remove the Side Seals (Front and Rear).



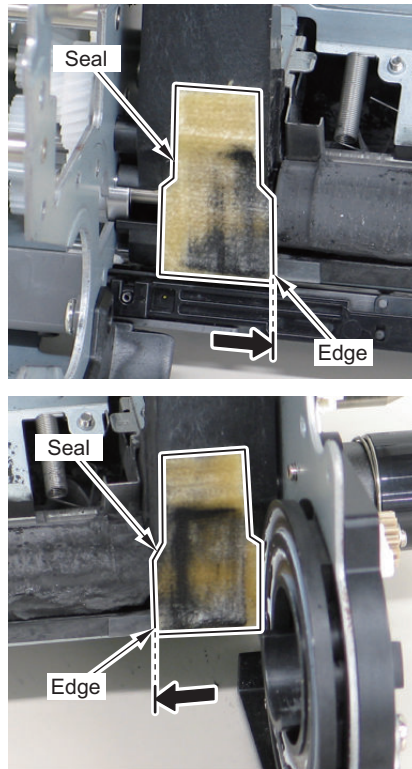
2. Apply Tospearl on the surfaces of the new Drum Side Seals (Front and Rear) and adhere it uniformly with lint-free paper.

NOTE:

In order to reduce adhesion of toner at both ends of the Photosensitive Drum



3. Align the Drum Side Seals (Front and Rear) with the edges of the sheets and affix them.

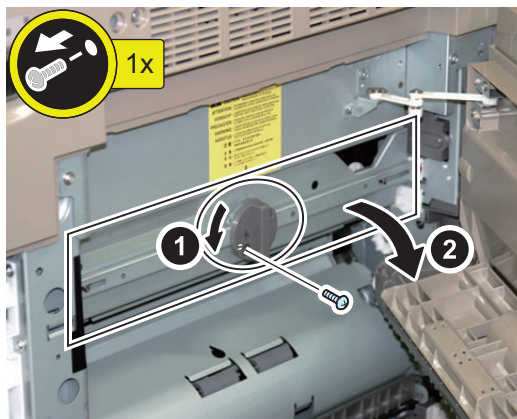


■ Actions after Parts Replacement

1. Clear the parts counter.
(Lv.1) COPIER > COUNTER > DRBL-1 > BS-SL-F
2. Clear the parts counter.
(Lv.1) COPIER > COUNTER > DRBL-1 > BS-SL-R

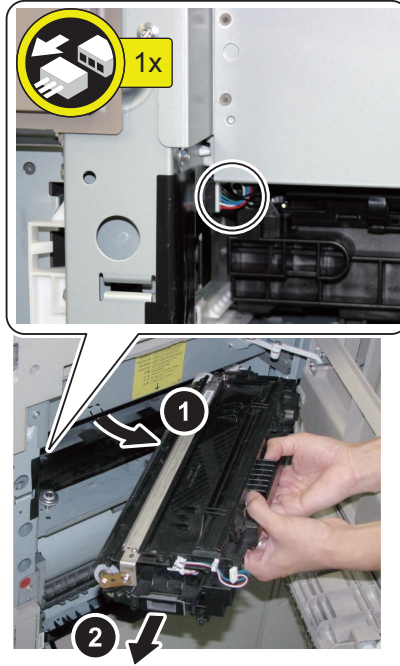
● Removing the Developing Assembly

1. Place paper underneath the Developing Assembly.
2. Open the Right Cover.
3. Turn the Tab to open the Plate Cover.
 - 1 Screw



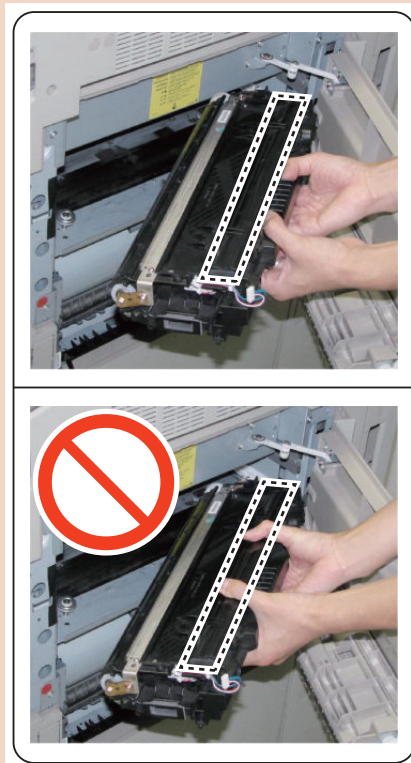
4. Remove the Developing Assembly by following the Rail.

- 1 Connector

**CAUTION:**

How to Hold the Developing Assembly

When holding the Developing Assembly, be sure to hold the handle of the Developing Assembly as shown in the figure. Do not touch the shutter area of the Developing Assembly. The shutter area is slippery, so it may cause a fall of the assembly.

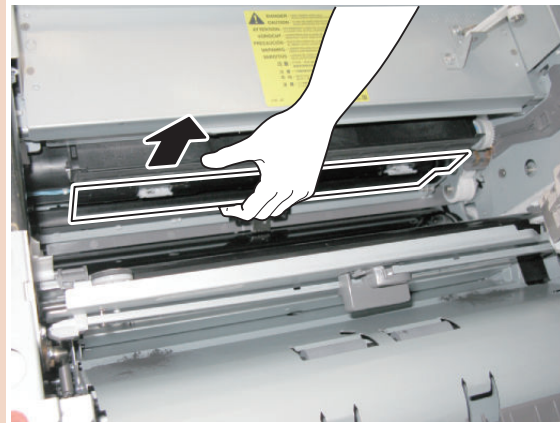


CAUTION:

Points to Caution when Installing the Developing Assembly

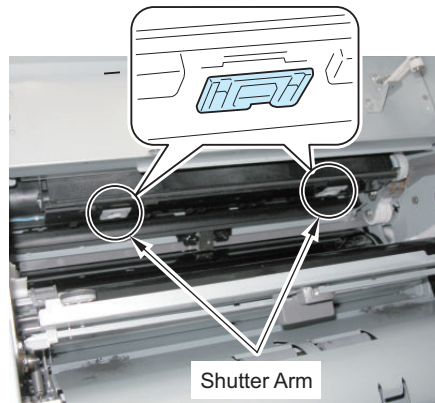
Before installing the Developing Assembly, check that the Buffer Shutter is not open.

If the Developing Assembly is forcibly installed while the Buffer Shutter is open, the shutter may get damage. When the Buffer Shutter is open, pull out the shutter to the front and then close it.

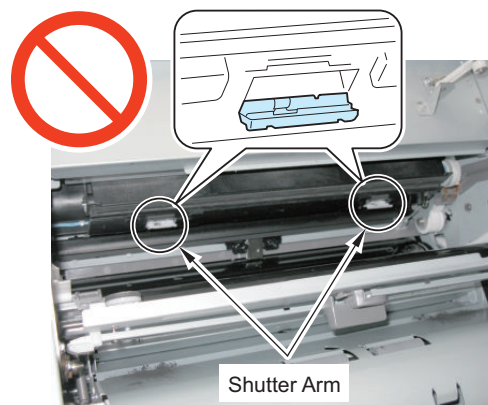


Whether the shutter is open or not can be checked with the Shutter Arm.

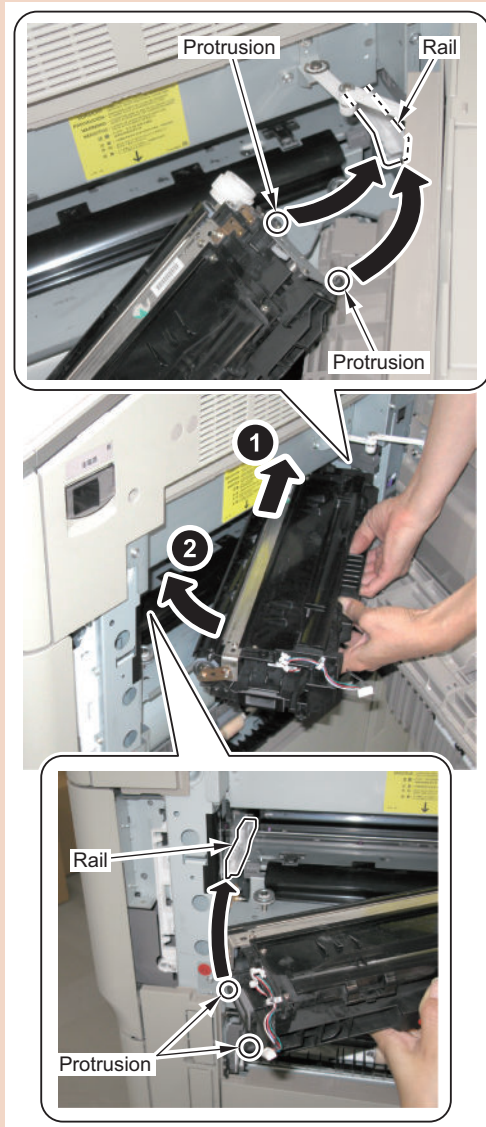
<Buffer Shutter is closed>



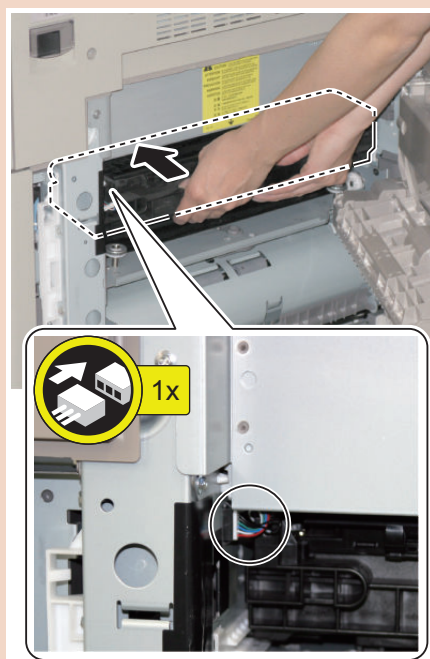
<Buffer Shutter is open>



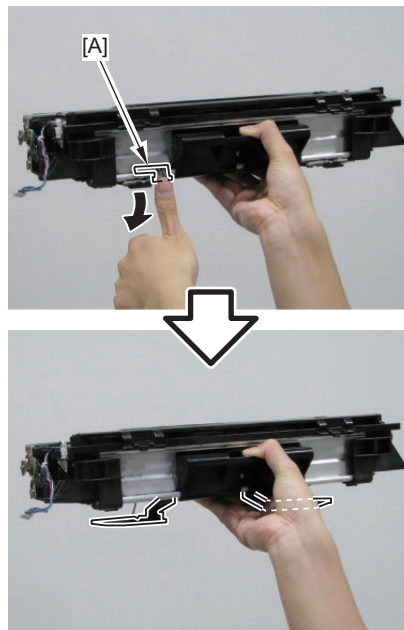
- As shown in the figure, hold the Developing Assembly and fit the protrusions at right and left sides of the Developing Assembly to the rail of the host machine.



- Install the Developing Assembly horizontally by following the rail.



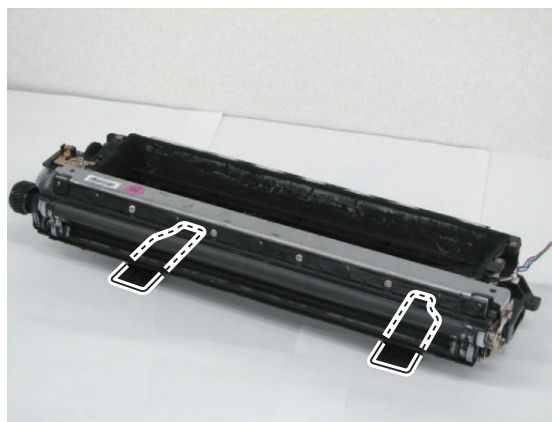
5. Push the [A] part of the Developing Assembly and extend the legs from the assembly.



CAUTION:

If the Developing Assembly is placed without extending the legs, it may cause the developing error due to scratches on the assembly.

6. Place the Developing Assembly.



NOTE:

When the Developing Assembly is put on the floor or the desk, be sure to place paper underneath to work on the Developing Assembly.

■ Adjustment when Replacing the Parts

1. Clear the parts counter.

(Lv.1) COPIER > COUNTER > DRBL-1 > DVG-CYL

2. Supplying Developing Assembly toner.

(Lv.1) COPIER > FUNCTION > INSTALL > TONER-S

Cleaning the Developing Assembly

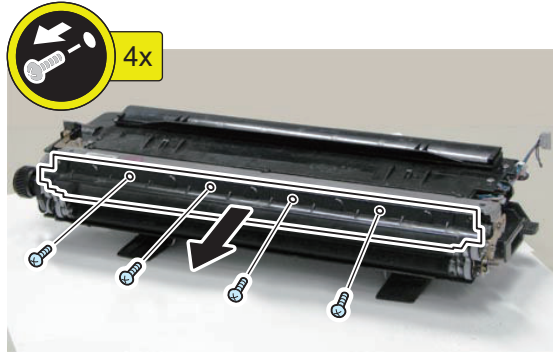
■ Preparation

1. Remove the Developing Assembly. (“Removing the Developing Assembly” on page 411)

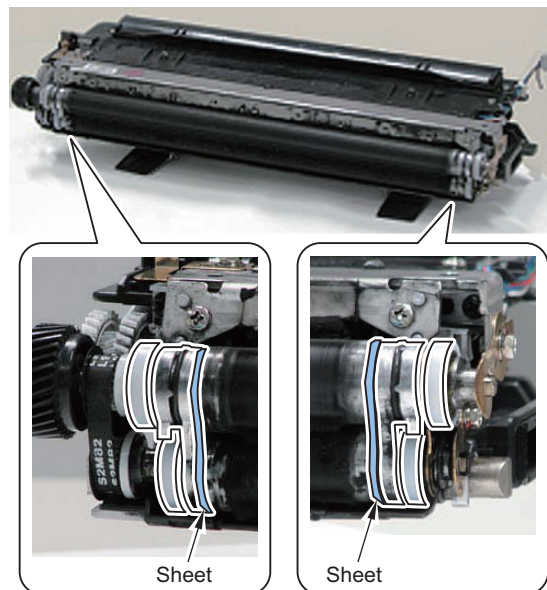
■ <Procedure>

1. Remove the Developing Sleeve Cover.

- 4 Screws



2. Clean the 4 Developing Rollers with lint-free paper moistened with alcohol while rotating them.
3. Clean the area outside of the sheet on the 2 Developing Sleeve Holders with lint-free paper moistened with alcohol.



4. Install the removed Developing Sleeve Cover.

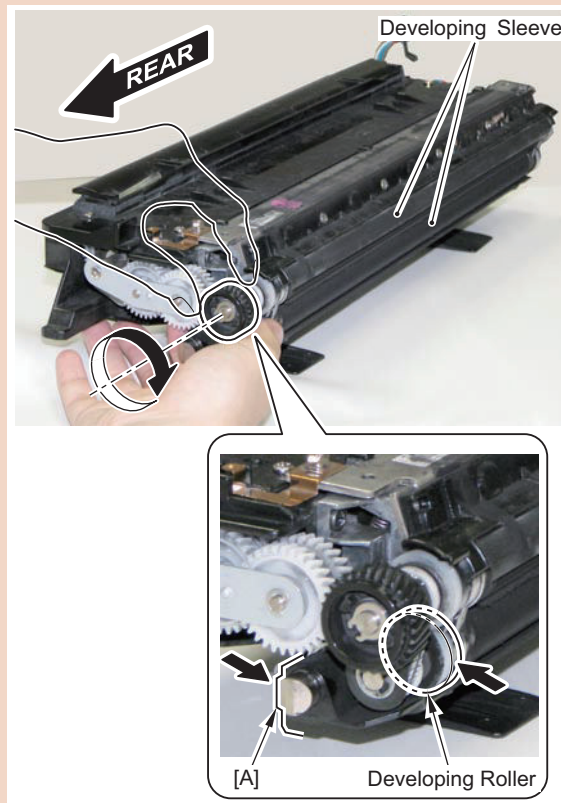
- 4 Screws

CAUTION:

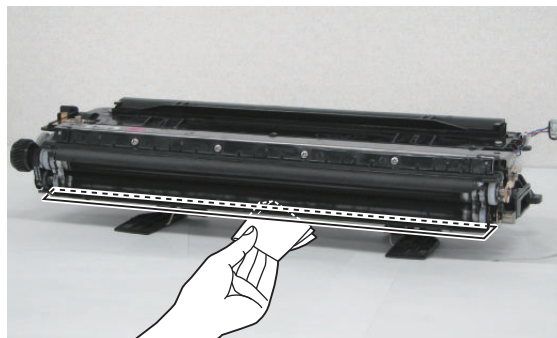
How to Check Scratches or Foreign Particles on the Developing Sleeve

While engaging the Developing Lower Sleeve with the inside of the Developing Assembly by pushing the Developing Roller at lower side, rotate the gear a full turn or more clockwise by viewing it from front side and check whether there are any scratches or foreign particles in the Developing Sleeve.

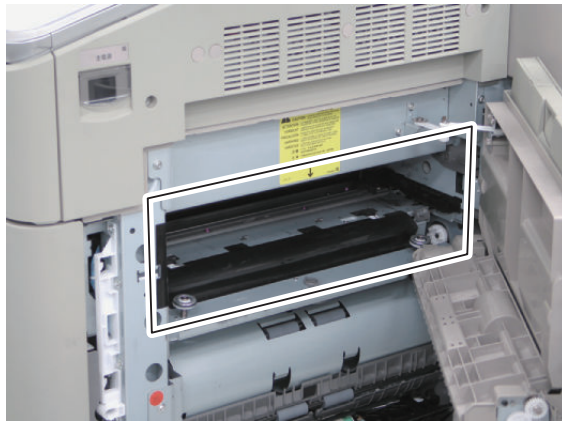
- When pushing the Developing Roller, be sure to hold the Developing Roller at lower side and [A] part of the Developing Assembly.
- Be sure to rotate the gear clockwise, and be careful not to rotate it counterclockwise.
- If rotating the gear without pushing the Developing Roller, toner will be accumulated between the Developing Lower Sleeve and the seal (Toner clusters). If pushing the Developing Assembly against the drum in this condition, the Developing Lower Sleeve does not move to the appropriate position because of the toner clusters. As a result, the gap between the Developing Upper Sleeve and the drum (SD gap) will be widened. It causes low density at rear or deterioration of developer because it becomes hard to deposit toner onto the drum.



5. Clean the lower side of Cylinder in the Developing Assembly with lint-free paper moistened with alcohol.



6. Remove toner in the main body.

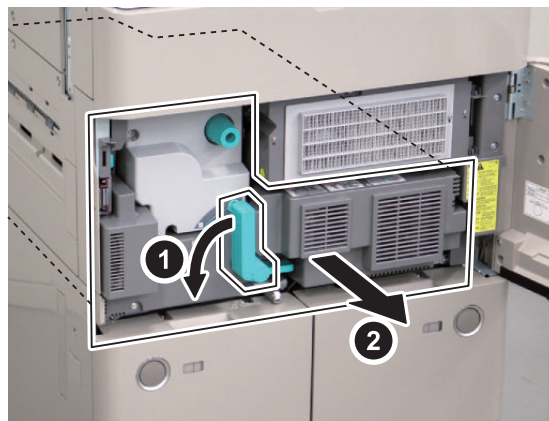


● Removing the ETB Unit

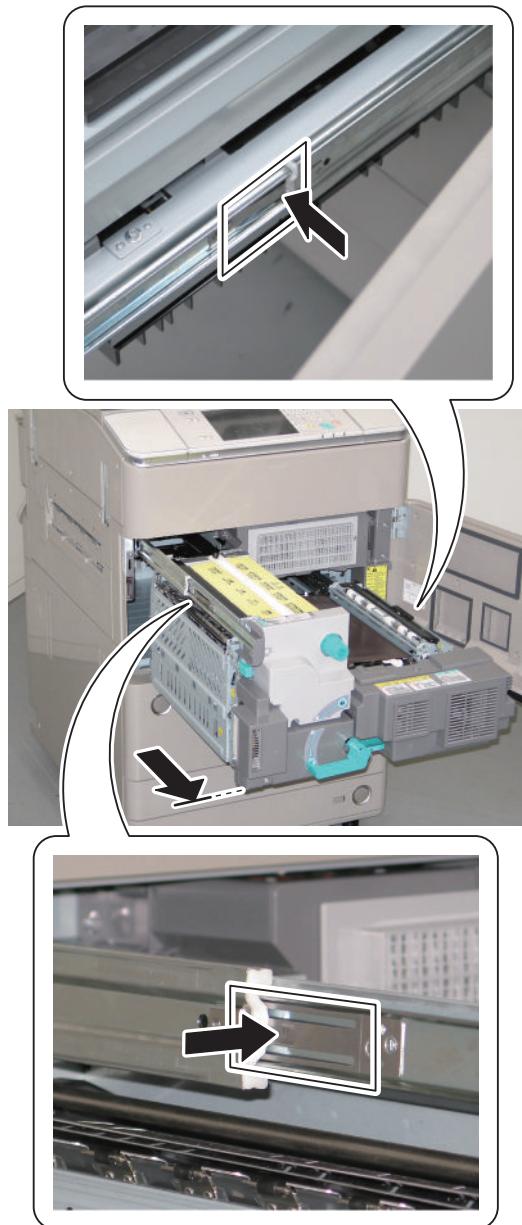
■ <Preparation>

1. Pull out the Fixing Feed Unit.

1. Open the Front Cover.
2. Turn the Fixing Feed Unit Pressure Release Lever in the direction of the arrow to pull out the Fixing Feed Unit.



3. Push to release the Release Springs at both sides of the Rail, and then further pull out the Fixing Feed Unit until it stops.

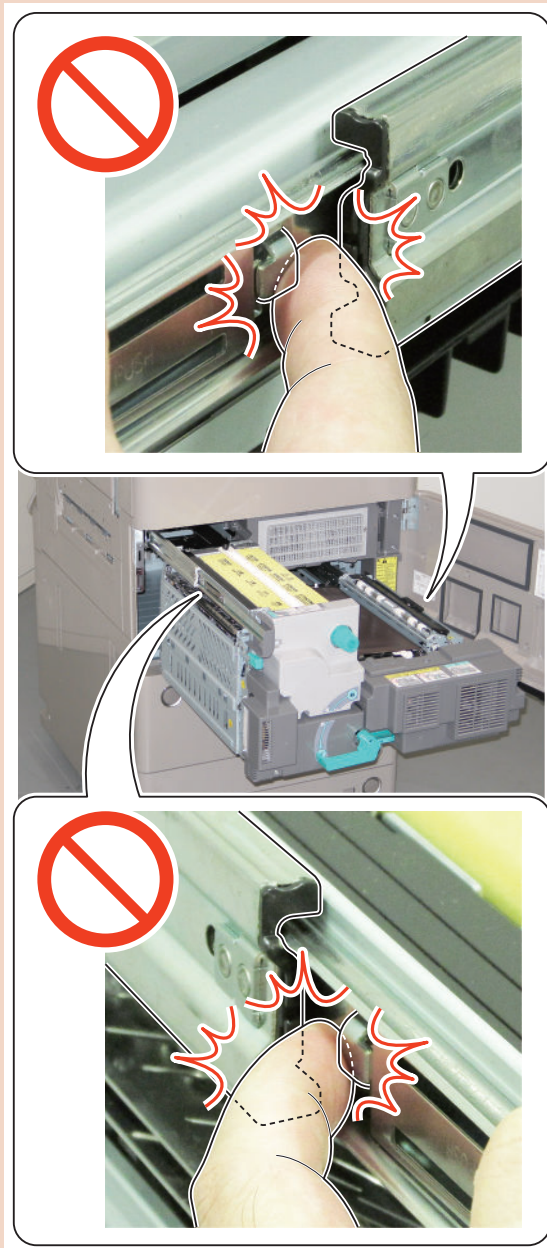


CAUTION:
Do not touch the surface of the ETB when handling the ETB Unit.

CAUTION:

Caution when pushing the Fixing Feed Unit in

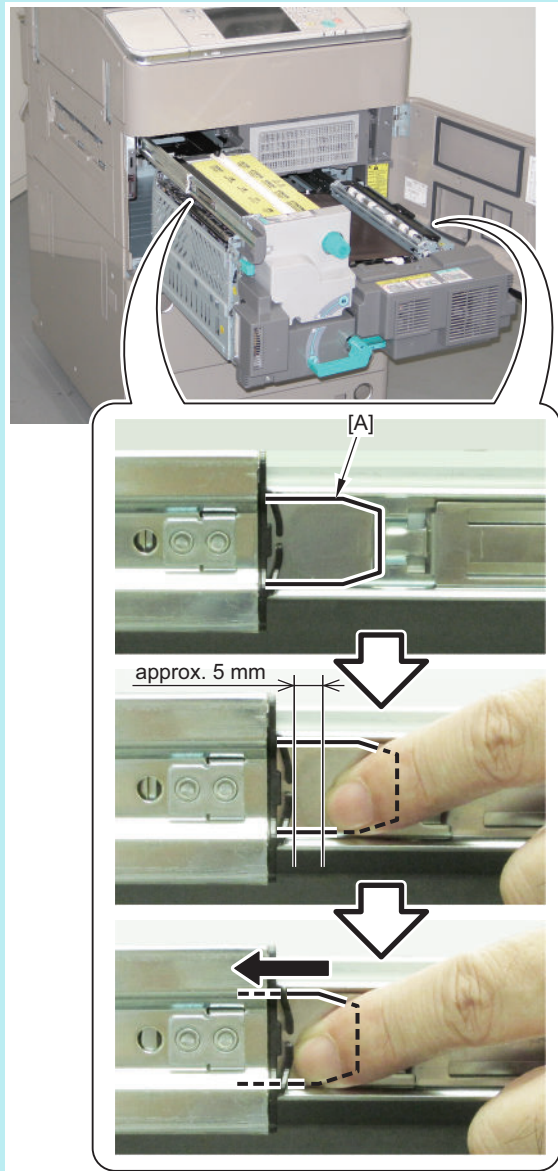
While pressing the Release Springs, slowly push the Fixing Feed Unit in so that the fingers do not get caught.



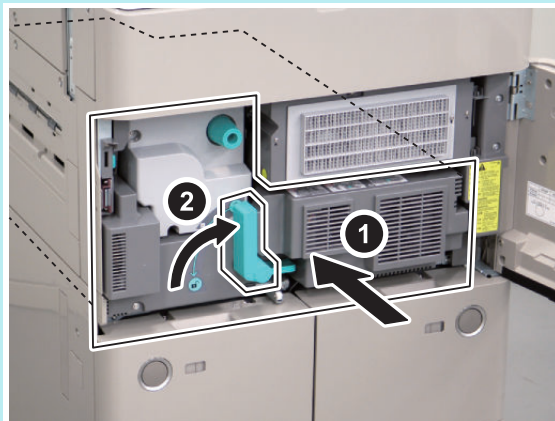
NOTE:

How to push the Fixing Feed Unit in

1. Release the Release Springs [A] on the side of either rail.
Slowly push the Fixing Feed Unit in by approximately 5 mm while keeping it level.



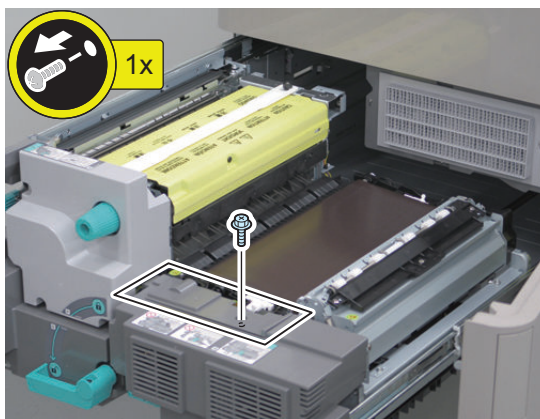
2. Take the fingers off the Release Springs and slowly push the Fixing Feed Unit in to the end.



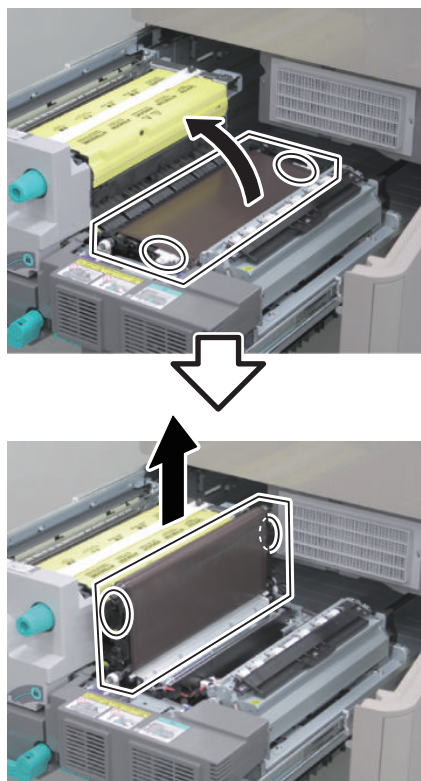
■ Procedure

1. Remove the Fixing Feed Right Front Upper Cover.

- 1 Screw



2. Hold the 2 Handles to remove the ETB Unit in the direction of the arrow.



■ Adjustment when Replacing the Parts

1. Clear the ETB control counter.

(Lv.1)COPIER > FUNCTION > CLEAR > TR-BLT

Parts counter(COPIER > COUNTER > DRBL-1 > TR-BLT)is also cleared coincidentally.

● Removing the ETB

■ Preparation

1. Pull out the Fixing Feed Unit.(“Removing the ETB Unit” on page 418)

2. Remove the ETB Unit. (“Removing the ETB Unit” on page 418)

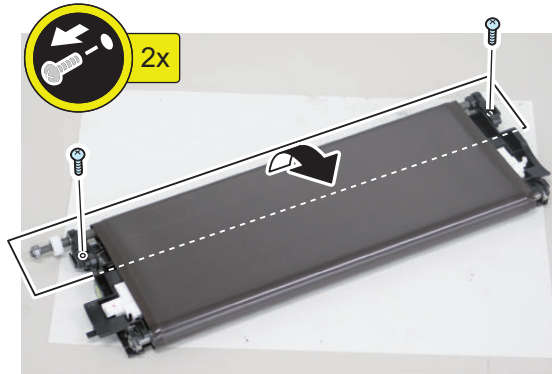
CAUTION:

Do not touch the surface of the ETB when handling the ETB Unit.

■ <Procedure>

1. Fold the ETB Drive Roller Unit.

- 2 Screws



2. Set up the ETB Unit to remove the Roller Unit from the ETB.



CAUTION:

- Be sure to hold within 10mm from both edges of the ETB when handling the ETB.
- Do not touch the surface of the ETB Drive Roller and the Transfer Roller; otherwise, it can cause image faults.

■ Actions after Parts Replacement

1. Clear the ETB control counter.

(Lv.1)COPIER > FUNCTION > CLEAR > TR-BLT

Parts counter(COPIER > COUNTER > DRBL-1 > TR-BLT)is also cleared coincidentally.

CAUTION:

Points to Caution when Installing the ETB

Set the ETB to make the ETB located inside the Guides at both edges.



● Cleaning the ETB

■ Preparation

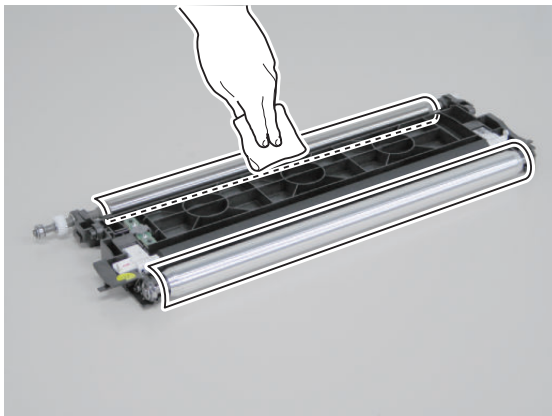
1. Pull out the Fixing Feed Unit. (“Removing the ETB Unit” on page 418)
2. Remove the ETB Unit. (“Removing the ETB Unit” on page 418)
3. Remove the Roller Unit from the ETB Unit.

■ <Procedure>

1. Clean the Transfer Roller and Drive Roller with lint-free paper moistened with alcohol.

CAUTION:

Do not touch the surface of the ETB Drive Roller and the Transfer Roller; otherwise, it can cause image faults.



● Removing the Transfer Roller

■ Preparation

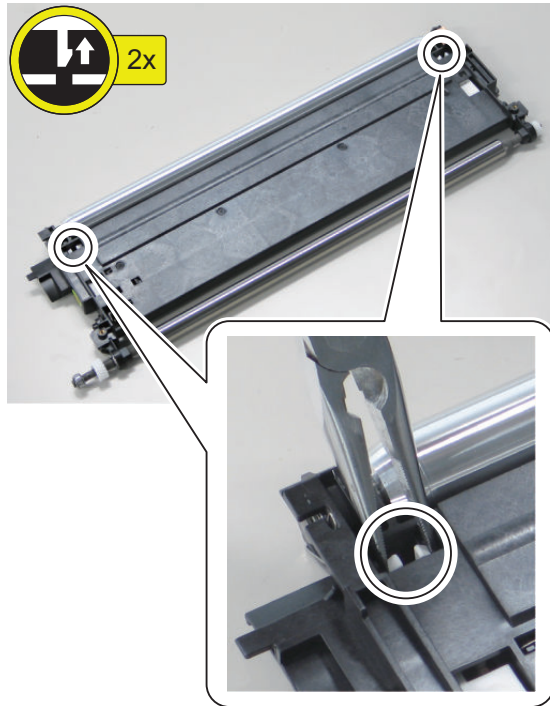
1. Pull out the Fixing Feed Unit. (“Removing the ETB Unit” on page 418)
2. Remove the ETB Unit. (“Removing the ETB Unit” on page 418)
3. Remove the ETB (“Removing the ETB” on page 422)

CAUTION:

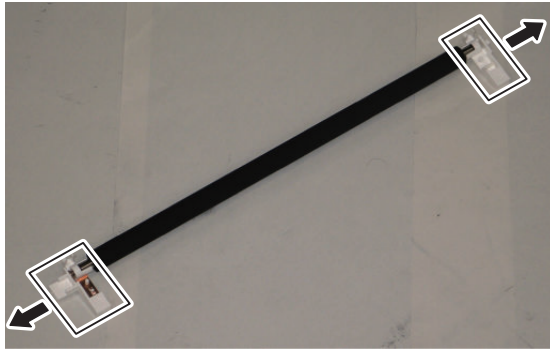
Do not touch the surface of the ETB Drive Roller and the Transfer Roller; otherwise, it can cause image faults.

■ <Procedure>

1. Turn over the Roller Unit to remove the Claw of the Transfer Roller Shaft Support with needlenose pliers.



2. Remove the Transfer Roller Shaft Support from the Transfer Roller.



NOTE:

When installing the Transfer Roller Shaft Support to the Roller Unit, be sure to check that the bosses of the Transfer Roller Shaft Support are fitted into the Springs.



■ Actions after Parts Replacement

1. Clear the parts counter.

(Lv.1) COPIER > COUNTER > DRBL-1 > TR-ROLL

● Removing the ETB Cleaning Blade

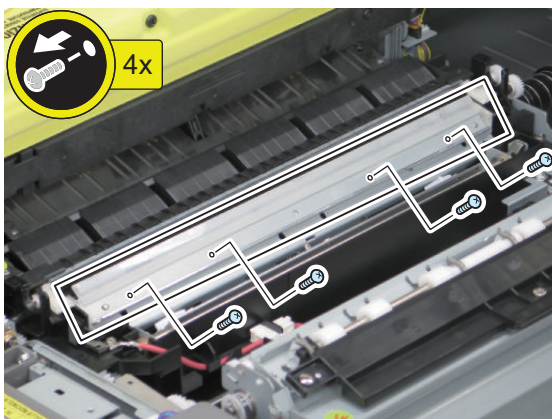
■ Preparation

1. Pull out the Fixing Feed Unit. (“Removing the ETB Unit” on page 418)
2. Remove the ETB Unit. (“Removing the ETB Unit” on page 418)

■ <Procedure>

1. Remove the ETB Cleaning Blade.

- 4 Screws



■ Actions after Parts Replacement

1. Clear the parts counter.

(Lv.1) COPIER > COUNTER > DRBL-1 > T-CLN-BD

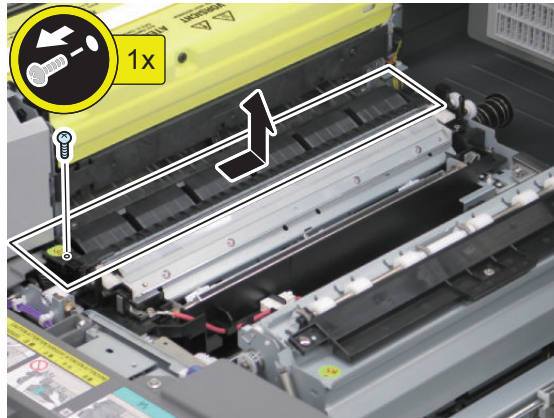
● Removing the ETB Brush Roller

■ Preparation

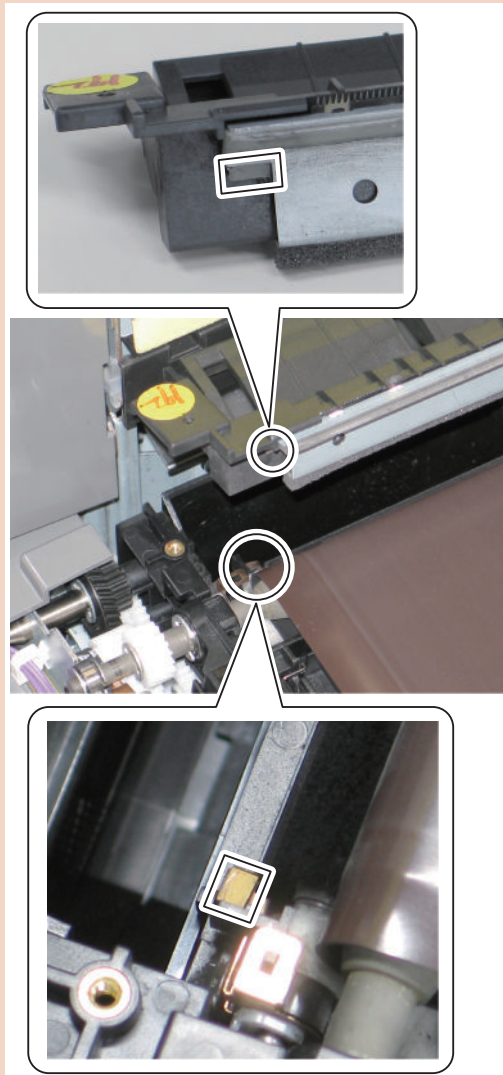
1. Pull out the Fixing Feed Unit. (“Removing the ETB Unit” on page 418)
2. Remove the ETB Unit. (“Removing the ETB Unit” on page 418)

<Procedure>**1. Remove the Post-transfer Guide.**

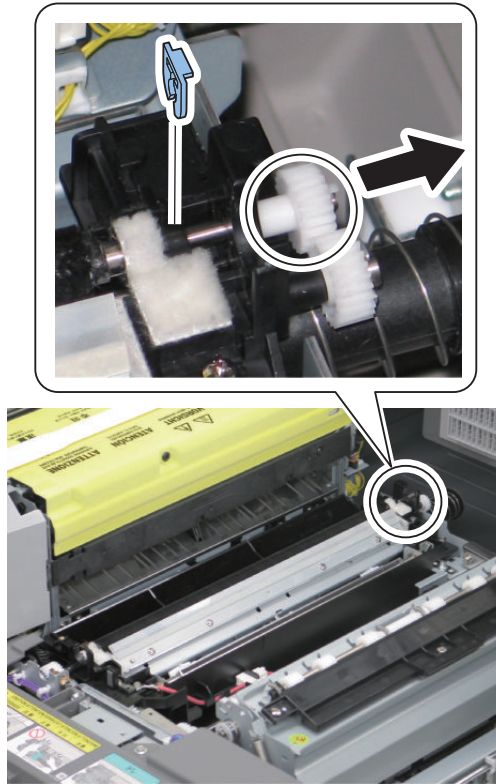
- 1 Screw

**CAUTION:**

- Be sure to keep in contact with the Grounding Plate when installing the Post-transfer Guide.
- Do not deform the Grounding Plate when installing the Post-transfer Guide.

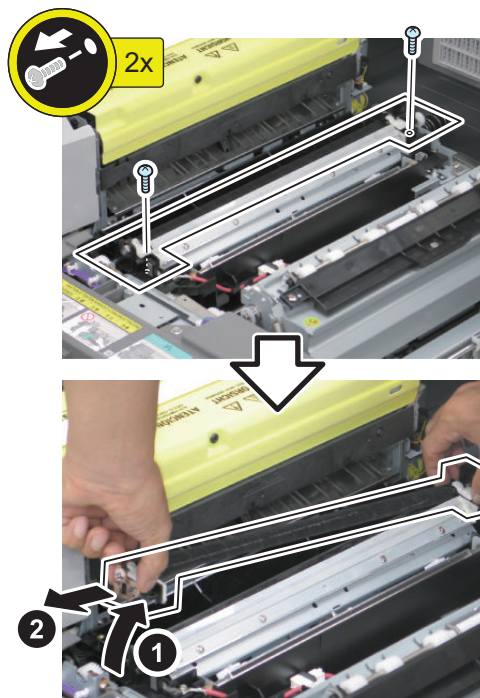


2. Remove the Connection Gear and the N-ring from the ETB Brush Roller.



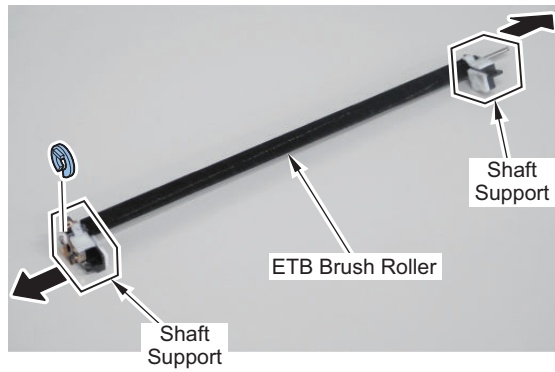
3. Remove the ETB Brush Roller Unit.

- 2 Screws



4. Remove the Shaft Support from the ETB Brush Roller.

- 1 N-ring



■ Actions after Parts Replacement

1. Clear the parts counter.

(Lv.1) COPIER > COUNTER > DRBL-1 > T-CN-BRU

● Removing the Waste Toner / Collecting the Waste Toner

■ Removing the Waste Toner Container

1. Loosen the 1 Coin Screw and then remove the Right Rear Lower Cover.



2. Remove the Waste Toner Container.



NOTE:

- In the case of toner spill when removing the Waste Toner Container, be sure to wipe out the spilled toner.
- After taking the Waste Toner Container out of the machine, be sure to promptly collect waste toner to prevent toner scattering.

■ Collecting the Waste Toner

1. Remove the cap from the side of the Waste Toner Container.



2. Close up the Waste Toner Container with the removed cap.



NOTE:

- In the case of toner spill when removing the cap, be sure to wipe off the spilled toner.
- Be sure to promptly put the cap back on the Waste Toner Container to prevent toner scattering.
- When disposing of the waste toner, be sure to follow all applicable regulations of the local government.
- Service part number of the Waste Toner Container: FM1-G392-000

■ Adjustment when Replacing the Parts

1. Set the new Waste Toner Container.

NOTE:

When replacing the Waste Toner Container with a new one after preparation warning or full warning is displayed, display on the LUI is cleared after a certain period of time has passed. The parts counter ((Lv.1) COPIER > COUNTER > DRBL-1 > WST-TNR) is automatically cleared at replacement.

NOTE:

Related service modes when a user replaces the Waste Toner Container

The Waste Toner Container preparation warning message can be set to be displayed or hidden by executing the following service mode.

(Lv.1) COPIER > OPTION > DSPLY-SW > WT-WARN

Setting value 0: Hide, 1: Display

Procedure for replacing the Waste Toner Container can be set to be displayed or hidden by executing the following service mode.

When a user replaces the Waste Toner Container, set 1.

(Lv.1) COPIER > OPTION > USER > W-TN-DSP

Setting value 0: OFF, 1: ON

Removing the Drum Heater

■ Preparation

1. Open the Inner Cover. (“Removing the Primary Charging Assembly” on page 362)
2. Remove the Primary Charging Assembly. (“Removing the Primary Charging Assembly” on page 362)
3. Remove the Pre-transfer Charging Assembly. (“Removing the Pre-transfer Charging Assembly” on page 380)
4. Remove the Process Unit. (“Removing the Process Unit” on page 391)
5. Put paper on the Photosensitive Drum, so that it is not exposed to direct sunlight.
6. Remove the Drum Cleaning Blade. (“Removing the Drum Cleaning Blade” on page 396)
7. Remove the Drum Retainer Plate. (“Removing the Drum Unit” on page 400)
8. Remove the Drum Unit. (“Removing the Drum Unit” on page 400)

■ <Procedure>

CAUTION:

When handling the Process Unit and Photosensitive Drum, be sure to follow the following points to note.

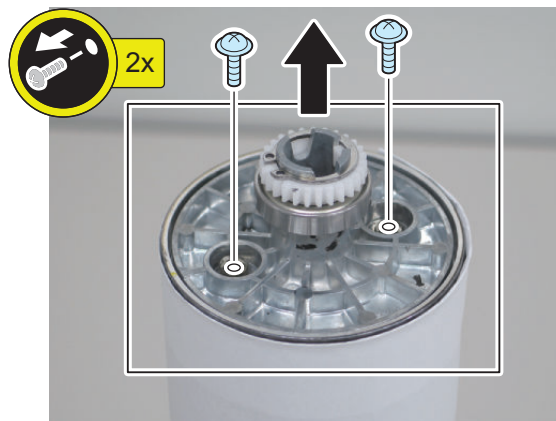
1. When removing the Process Unit, be sure to block light to the Photosensitive Drum.
Cover with the Photosensitive Drum Protection Sheet or wrap 5 or more papers around the drum to block light.
2. Do not place the Process Unit and Photosensitive Drum in a location where is exposed to direct rays of the sun (e.g. near the window).
3. Do not store in a location with high/low temperature/humidity, or in a location where temperature or humidity is dramatically changed.
4. Do not store in a dusty area or in a location full of ammonia gas or organic solvent gas.

When installing a new Photosensitive Drum, be sure to remove the Lightproof Sheet after installing the drum to the main body. In addition, be sure to rotate the drum counterclockwise at removal of the Lightproof Sheet. If the drum is rotated clockwise, the Drum Cleaner Blade may be everted.

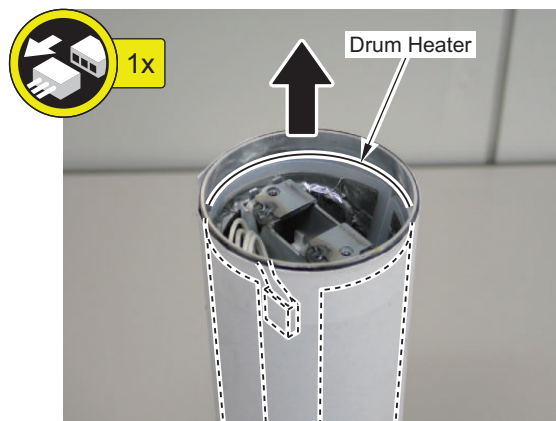
1. Wrap paper around the Drum Unit to block light.



2. Remove the 2 screws and the Flange.



3. Disconnect the connector and remove the Drum Heater.



● Removing the Primary Charging Shutter Unit

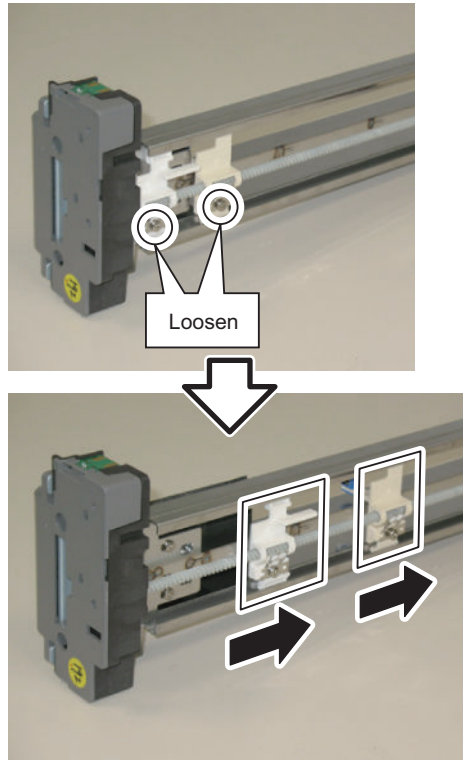
■ Preparation

1. Open the Front Cover.
2. Open the Inner Cover. ([“Removing the Primary Charging Assembly” on page 362](#))
3. Remove the Primary Charging Assembly. ([“Removing the Primary Charging Assembly” on page 362](#))

■ <Procedure>

1. Move the Primary Charging Wire Cleaners (Left and Right).

- 2 Screws (to loosen)

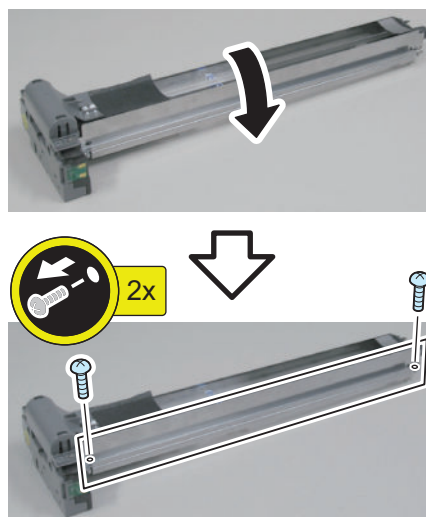


CAUTION:

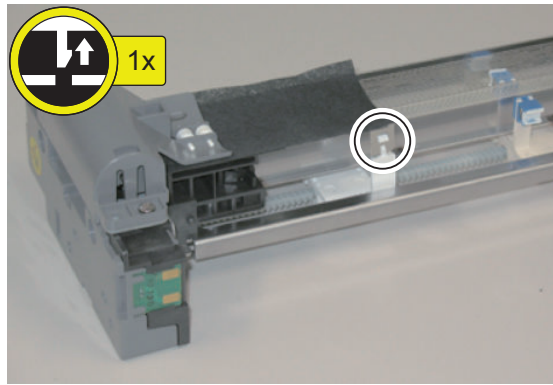
Do not remove both Shield Plates (Right and Left) of the Primary Charging Assembly at the same time. Be sure to work on one Shield Plate at a time. (Otherwise, the frame of the Primary Charging Assembly can be deformed.)

2. Move down the Primary Charging Assembly to remove the Shield Plate (Right).

- 2 Screws



3. Remove the Leaf Spring of the Primary Charging Shutter from the claw.

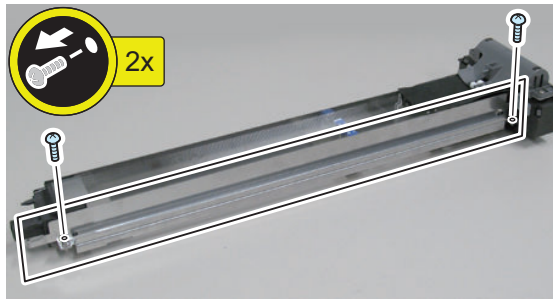


4. Install the Shield Plate (Right).

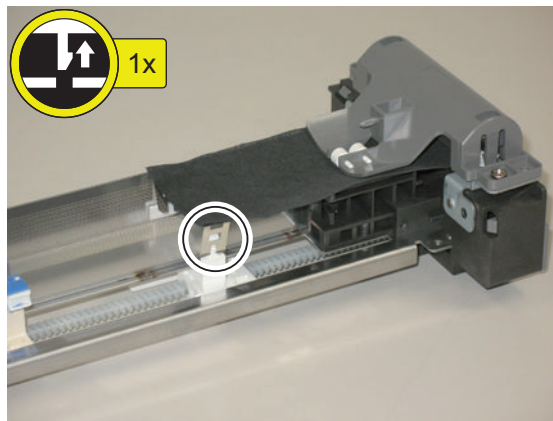
- 2 Screws

5. Remove the Shield Plate (Left).

- 2 Screws



6. Remove the Leaf Spring of the Primary Charging Shutter from the claw.



7. Install the Shield Plate (Left).

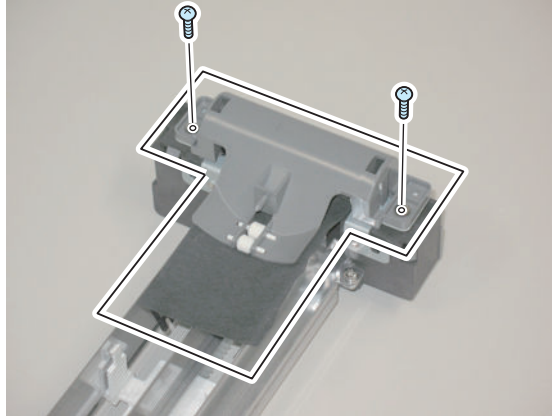
- 2 Screws

CAUTION:

Do not make the Leaf Spring caught by the Charging Wire when removing the Primary Charging Shutter Unit.

8. Remove the Primary Charging Shutter Unit.

- 2 Screws



■ <Installation Method>

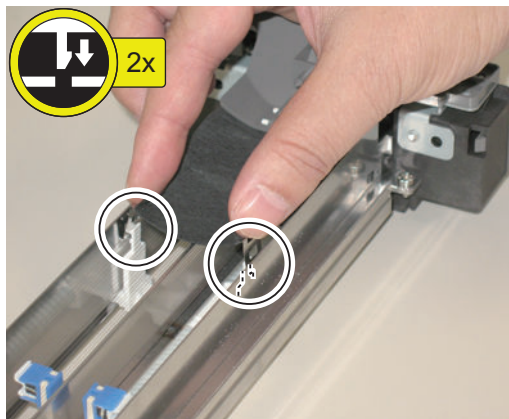
CAUTION:

Points to Caution at Installation

Be careful not to get the Leaf Spring caught by the Charging Wire to install it to the Cleaner Claw.

NOTE:

The Shield Plate does not need to be removed when installing the Shutter Unit.

1. Set the Leaf Spring of the Primary Charging Shutter to the Cleaner Claw.**2. Install the Primary Charging Shutter Unit.**

- 2 Screws

3. Return the Primary Charging Wire Cleaners (Left and Right) to the original position.

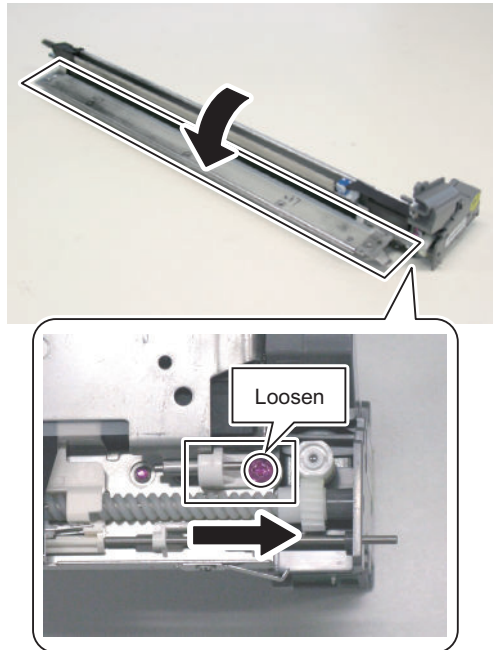
● Removing the Pre-transfer Charging Assembly Shutter Unit

■ Preparation

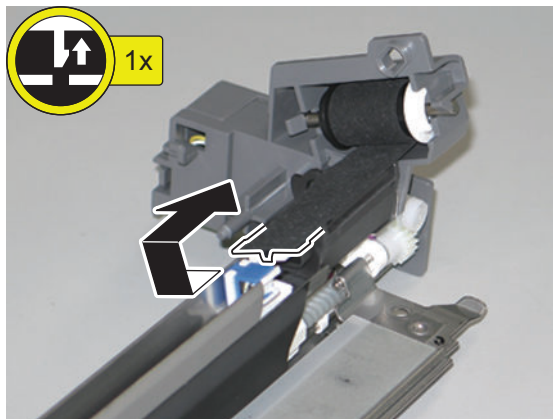
1. Open the Front Cover.
2. Open the Inner Cover. ([“Removing the Primary Charging Assembly” on page 362](#))
3. Remove the Pre-transfer Charging Assembly. ([“Removing the Pre-transfer Charging Assembly” on page 380](#))

■ Procedure

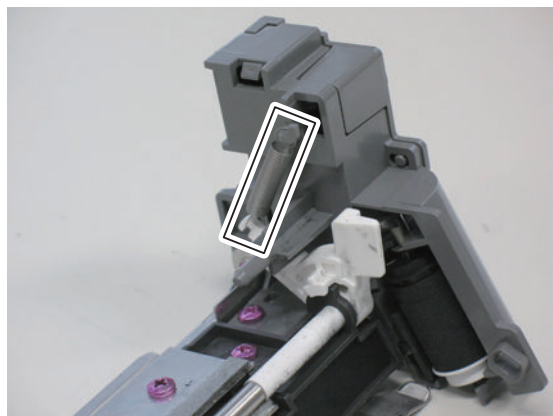
1. Move the Shield Plate Retainer Block to open the Shield Plate in the direction of the arrow.
 - 1 Screw (to loosen)



2. Remove the claw at the edge of the Shutter.



3. Remove the spring.

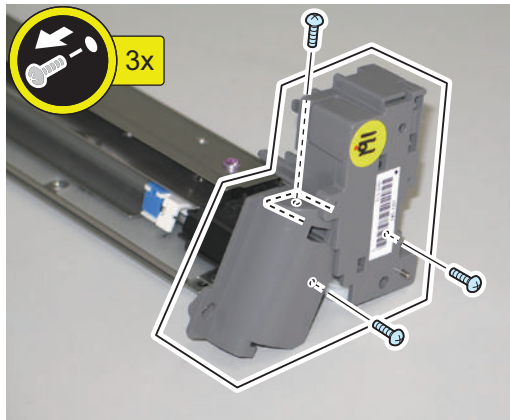


4. Hold the screw to remove the Pre-transfer Charging Assembly Shutter Unit while the Motor Unit is installed.

- 3 Screws

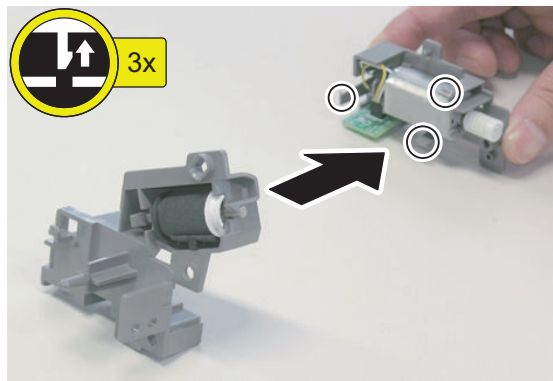
CAUTION:

Be careful not to remove the screw and the Screw Gear when removing the Pre-transfer Charging Assembly Shutter Unit.



5. Remove the Motor Unit from the Pre-transfer Charging Assembly Shutter Unit.

- 3 Claws



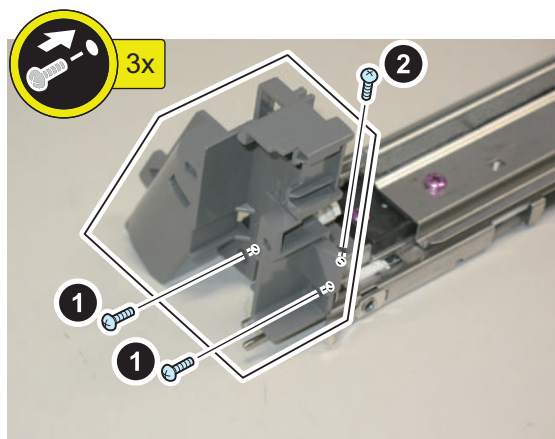
■ Installation Method

1. Install the Pre-transfer Charging Assembly Shutter Unit.

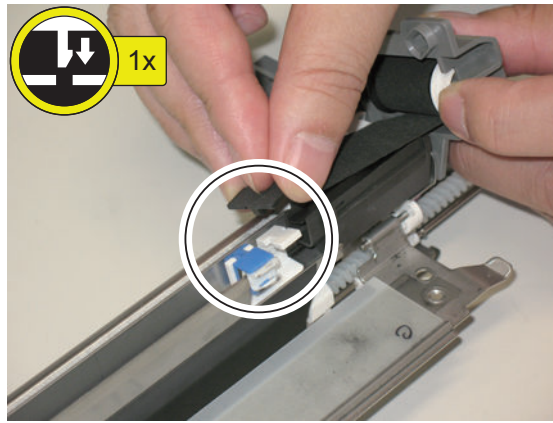
NOTE:

Be sure to put the protrusion of the Pre-transfer Charging Assembly Shutter Unit between the arms.

- 3 Screws



2. Pull the Shutter with your fingers to hook it to the Cleaner Unit.

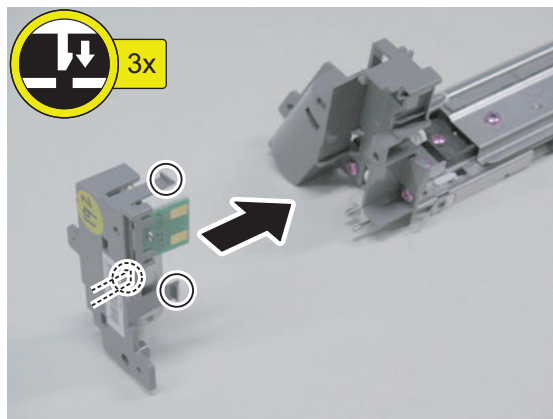
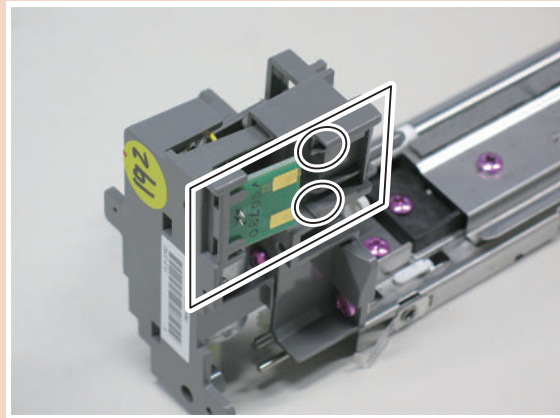


3. Install the Motor Unit.

- 3 Claws

CAUTION:

When installing the Motor Unit, fit the PCB into the slot.



NOTE:

Be sure to check that the rear shaft is secured.

4. Set the spring.

CAUTION:

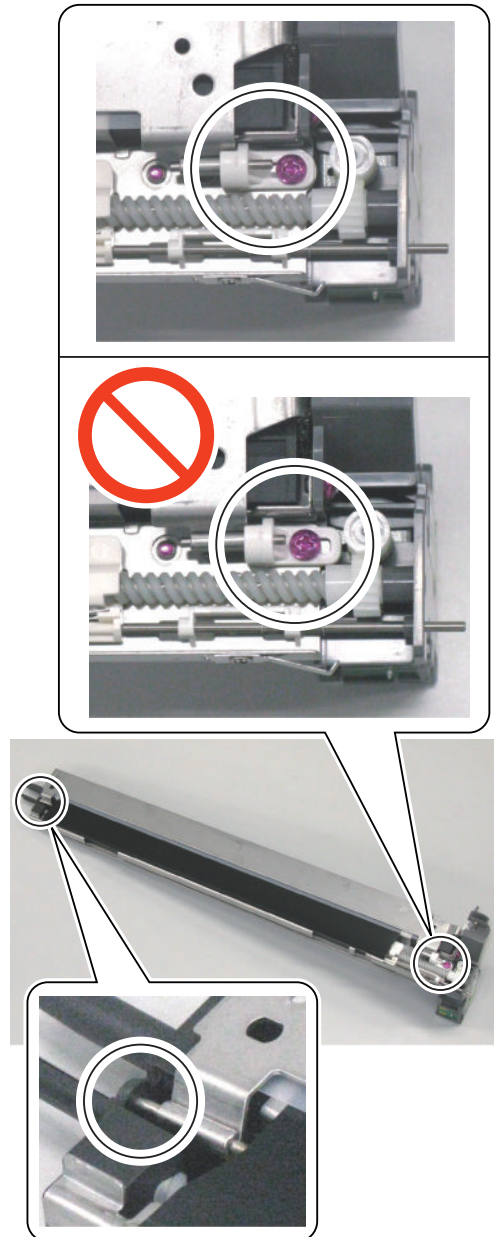
Be sure to feel tension when installing the spring; otherwise, it can cause image error.

5. Move the Shield Plate Retainer Block fully to the inside to secure with the screw.

CAUTION:

Points to Caution when Securing the Shield Plate

Be sure to check that the rear pin is fit into the frame hole.



NOTE:

Move the Shield Plate back and forth to check that the Shield Plate is secured.

● Removing the Patch Sensor

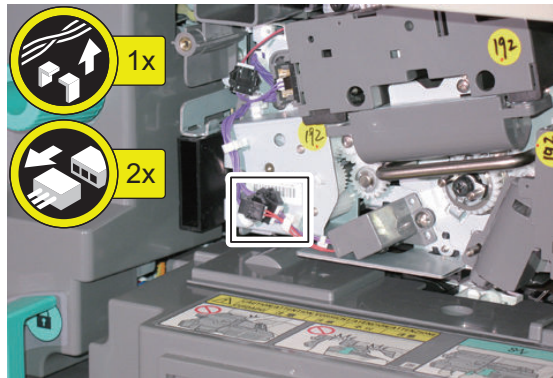
■ <Preparation>

1. Open the Front Cover.
2. Open the Inner Cover. (Refer to [“Removing the Primary Charging Assembly”](#) on page 362)

■ <Procedure>

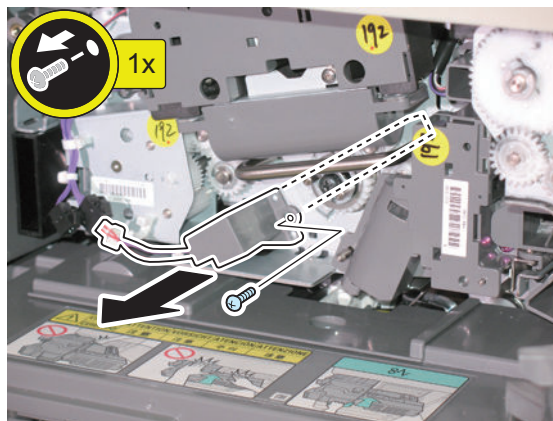
1. Remove the harness.

- 2 Connectors
- 1 Wire Saddle



2. Remove the Patch Sensor.

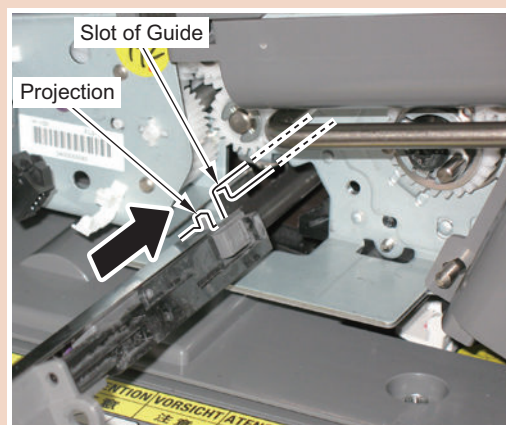
- 1 Screw



CAUTION:

Points to Caution when installing the Patch Sensor

Be sure to push in the Patch Sensor straight along with the groove of the guide; otherwise, the drum can be damaged.



■ Adjustment when Replacing the Parts

1. Adjust the intensity of the Patch Sensor.

(Lv.2) COPIER > FUNCTION > MISC-P > P-LED

Removing the Drum Brush Roller

CAUTION:

- Do not touch the Photosensitive Drum.
- Cover the Photosensitive Drum with paper to avoid direct exposure to light.

■ Preparation

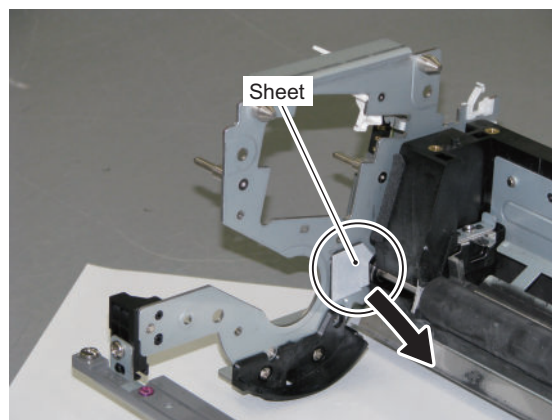
1. Open the Inner Cover. (“Removing the Primary Charging Assembly” on page 362)
2. Remove the Primary Charging Assembly. (“Removing the Primary Charging Assembly” on page 362)
3. Remove the Pre-transfer Charging Assembly. (“Removing the Pre-transfer Charging Assembly” on page 380)
4. Remove the Process Unit. (“Removing the Process Unit” on page 391)
5. Remove the Drum Cleaning Unit. (“Removing the Drum Cleaning Unit” on page 394)
6. Remove the Drum Unit. (“Removing the Drum Unit” on page 400)
7. Remove the Side Seal. (“Removing the Side Seal” on page 410)

■ Procedure

1. Remove the sheet.

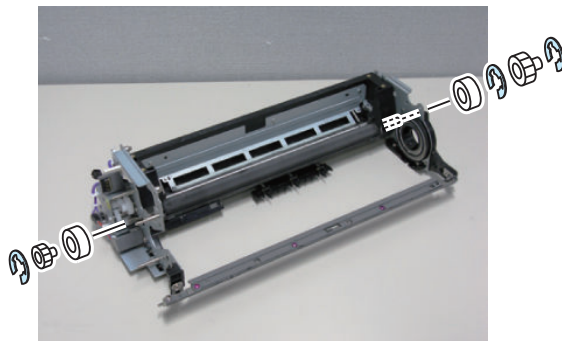
CAUTION:

The removed sheet will be used at the time of assembly, so be sure to remove the sheet neatly and keep it in a safe place.

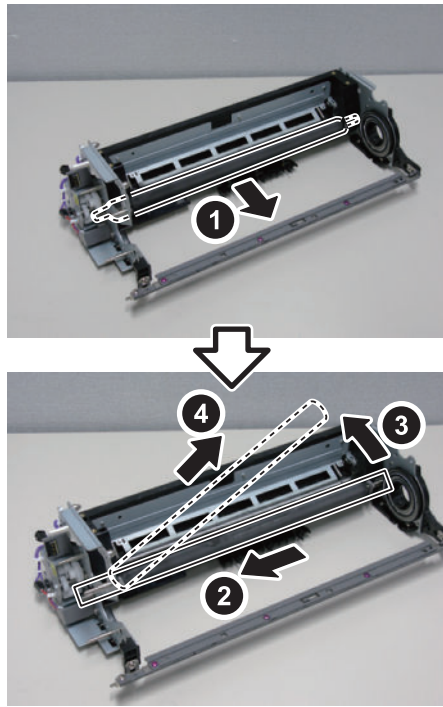


2. Remove the 2 Gears and the 2 Bearings.

- 3 E-rings



3. Remove the Drum Brush Roller by following the procedure as shown in the figure.



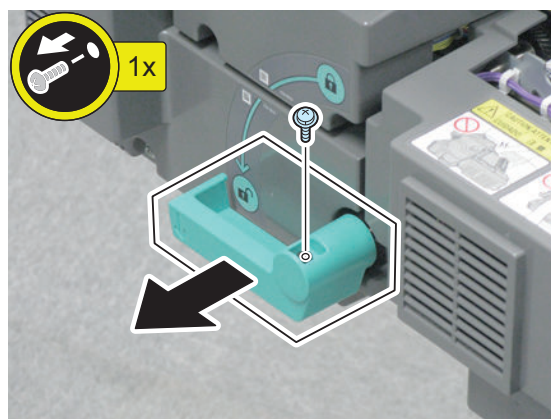
● Removing the ETB Drive Unit

■ Preparation

1. Pull out the Fixing Feed Unit. ("Removing the ETB Unit" on page 418)
2. Remove the ETB Unit ("Removing the ETB Unit" on page 418)

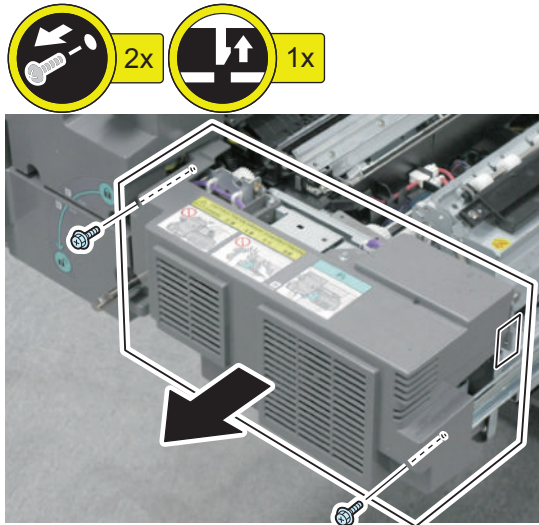
■ <Procedure>

1. Remove the Fixing Feed Lever.
 - 1 Screw

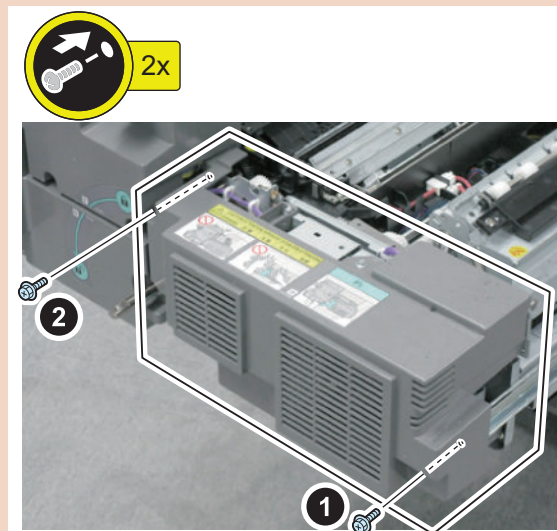


2. Remove the Fixing Feed Right Front Cover.

- 2 Screws
- 1 Claw

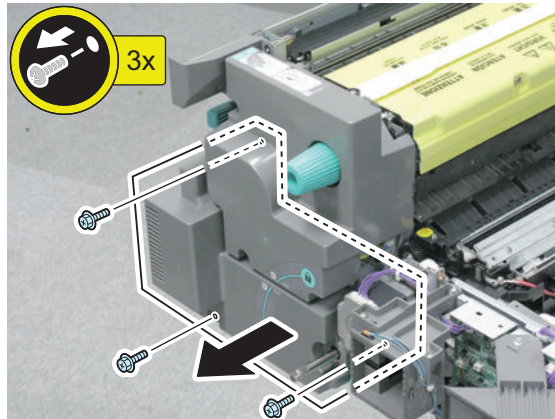
**CAUTION:**

When installing the Fixing Feed Right Front Cover, be sure to follow the order as shown in the figure to tighten screws.



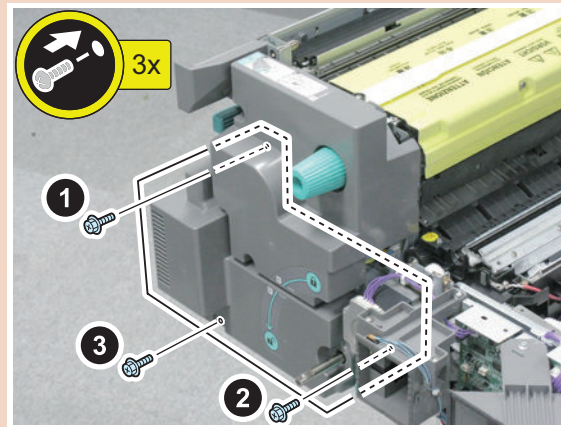
3. Remove the Fixing Feed Left Cover.

- 3 Screws



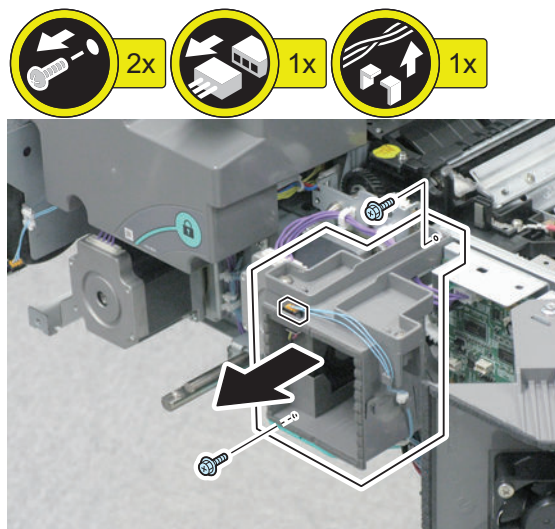
CAUTION:

When installing the Fixing Feed Left Cover, be sure to follow the order as shown in the figure to tighten screws.



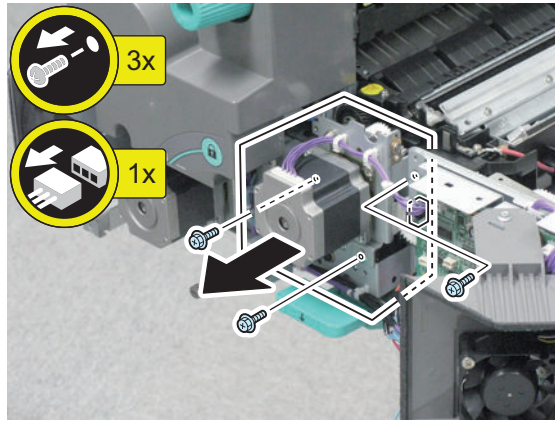
4. Remove the Duct.

- 2 Screws
- 1 Connector
- Harness

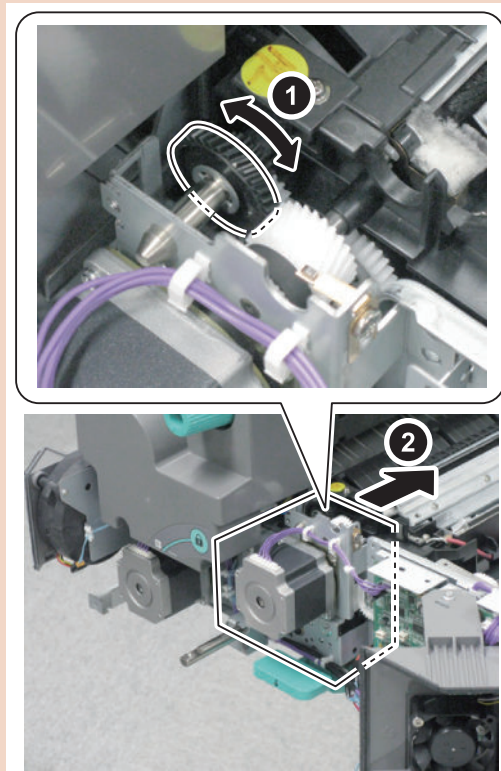


5. Remove the ETB Drive Unit.

- 3 Screws
- 1 Connector

**CAUTION:**

When installing, turn the gear so that the gear is engaged.



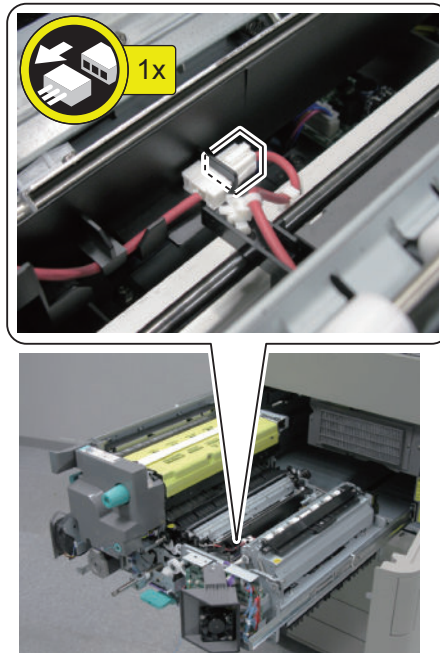
Removing the Transfer Cleaning Unit

■ Preparation

1. Pull out the Fixing Feed Unit. (“Removing the ETB Unit” on page 418)
2. Remove the ETB Unit. (“Removing the ETB Unit” on page 418)
3. Remove the ETB Drive Unit. (“Removing the ETB Drive Unit” on page 444)

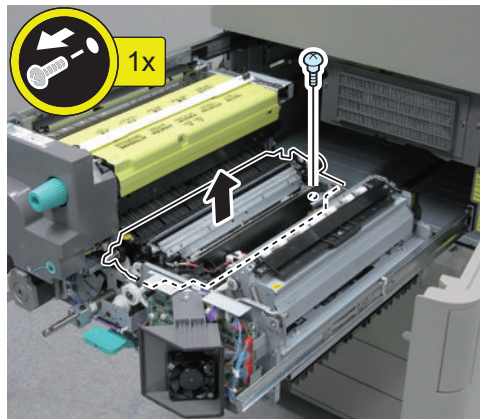
■ <Procedure>

1. Disconnect the connectors.



2. Remove the Transfer Cleaning Unit.

- 1 Stepped Screw



● Removing the Post-transfer Static Eliminator

■ <Preparation>

1. Pull out the Fixing Feed Unit. (Refer to “Removing the ETB Unit” on page 418)

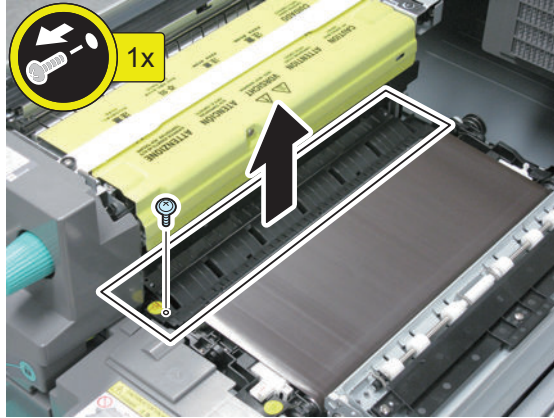
■ <Procedure>

CAUTION:

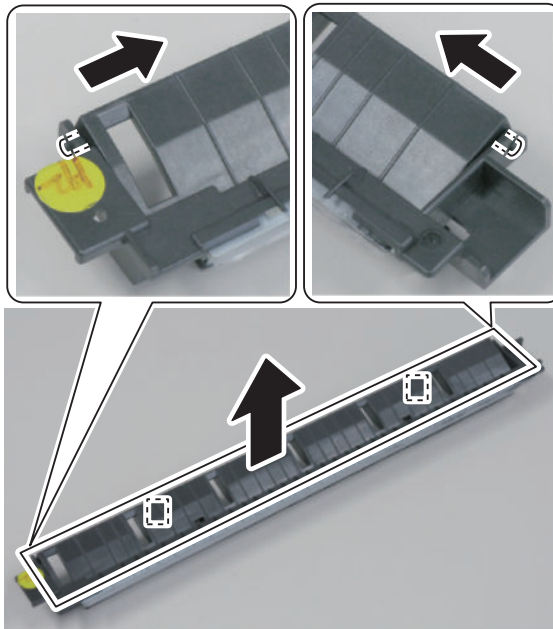
Do not touch the surface of the ETB when handling the ETB Unit.

1. Remove the Post-transfer Guide Unit.

- 1 Screw

**2. Remove the Post-transfer Guide.**

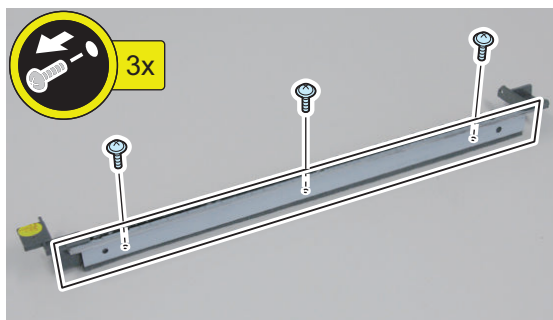
- 2 Protrusions
- 2 Springs

**CAUTION:**

Be careful not to lose the springs when removing the Post-transfer Guide.

3. Remove the Separation Guide Reinforcing Plate.

- 3 Screws



4. Remove the Post-transfer Static Eliminator.



Removing the Toner Receptacle Tray

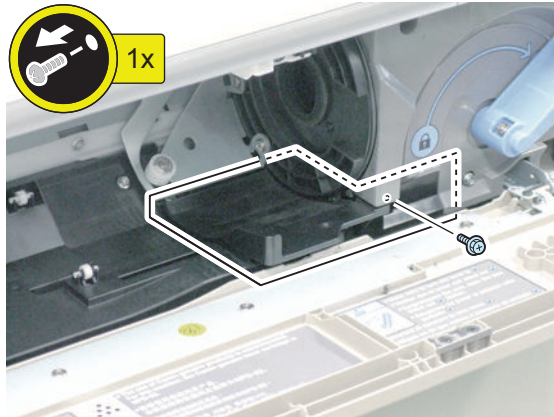
■ <Preparation>

1. Open the Front Upper Cover.
2. Remove the Toner Bottle.

■ <Procedure>

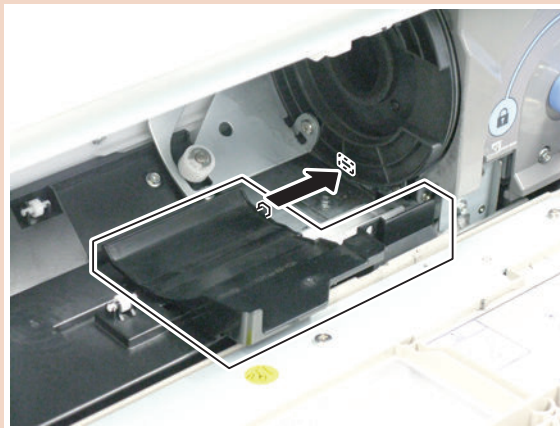
1. Remove the Toner Receptacle Tray.

- 1 Screw
- 1 Protrusion

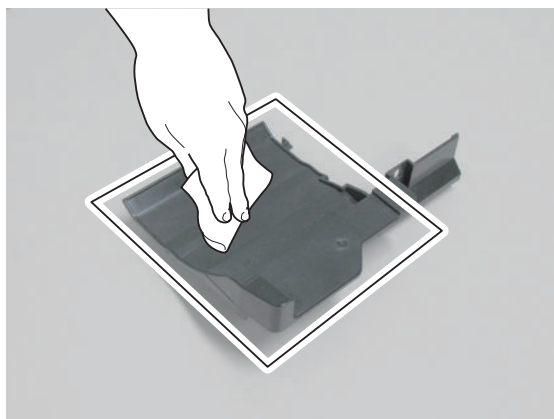


CAUTION:

1. Be sure to fit the protrusion into the groove of the plate to install.
2. Toner can be accumulated in the Toner Receptacle Tray; therefore, be careful not to spill toner when removing.



2. Clean the Toner Receptacle Tray with lint-free paper.



● Removing the Hopper Unit

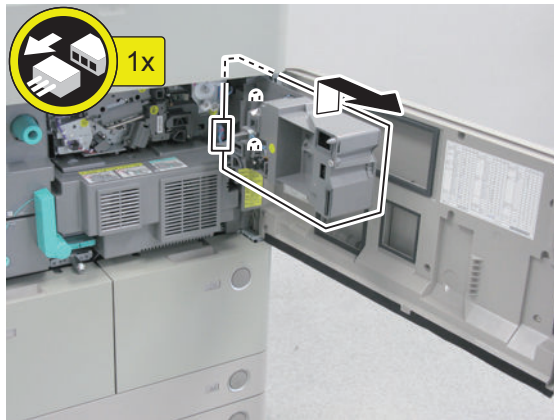
1. Open the Front Cover.

2. Open the Inner Cover (Primary Charging Air Supply Fan Unit).

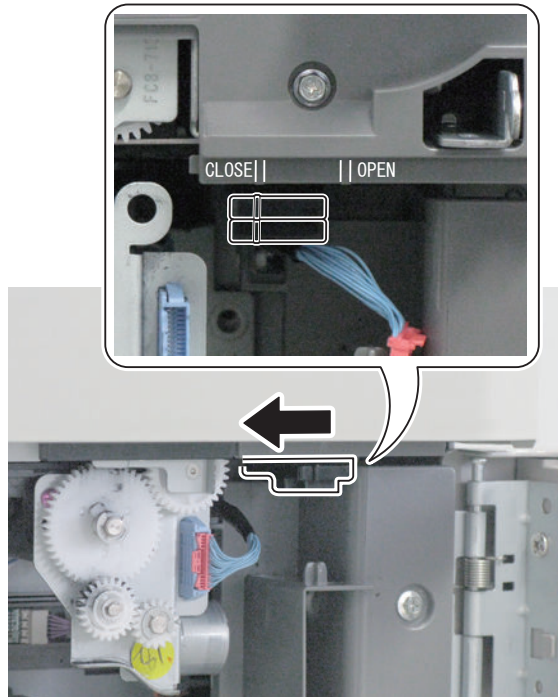
- 1 Screws (to loosen)

3. Remove the Inner Cover (Primary Charging Air Supply Fan Unit).

- 1 Connector
- 2 Protrusions



4. Move the lever in the direction of the arrow to close the Shutter.

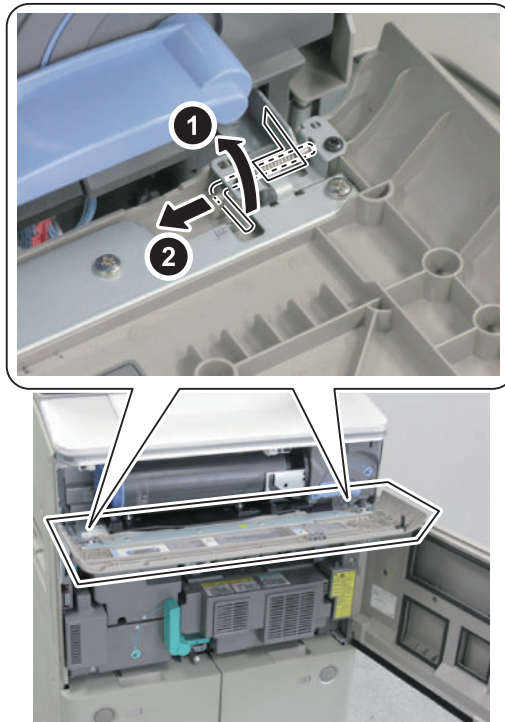


CAUTION:

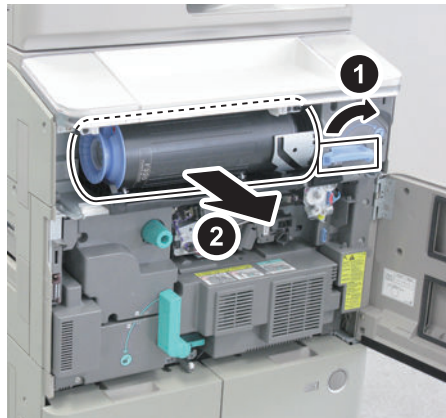
When starting the host machine, be sure to set the Shutter from CLOSE to OPEN.

5. Remove the Front Upper Cover.

- 2 Hinge Pins
- 2 Springs

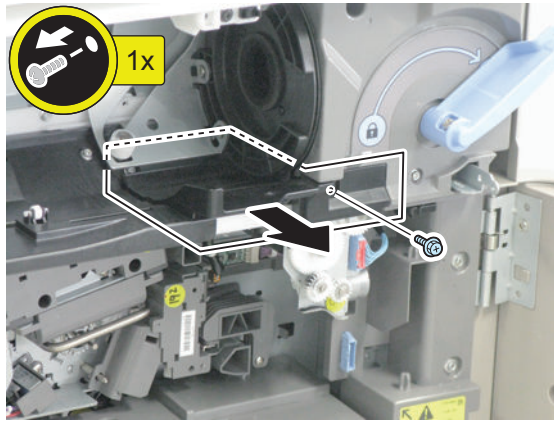


6. Release the Lock Lever to remove the Toner Bottle.



7. Remove the Toner Receptacle Tray.

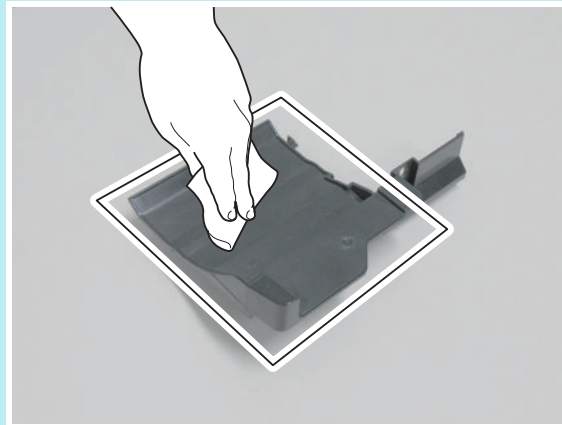
- 1 Screw
- 1 Protrusion

**CAUTION:**

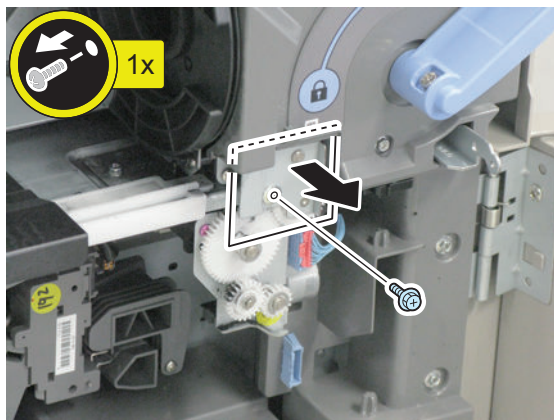
1. Toner can be accumulated in the Toner Receptacle Tray; therefore, be careful not to spill toner when removing.
2. Be sure to fit the protrusion into the groove of the plate to install.

NOTE:

Clean the Toner Receptacle Tray with lint-free paper.

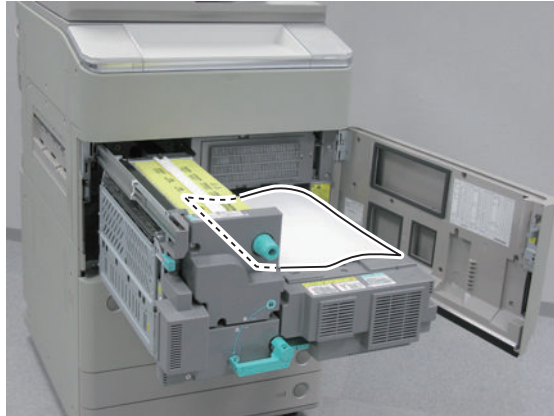
**8. Remove the Connecting Drive Unit.**

- 1 Screw

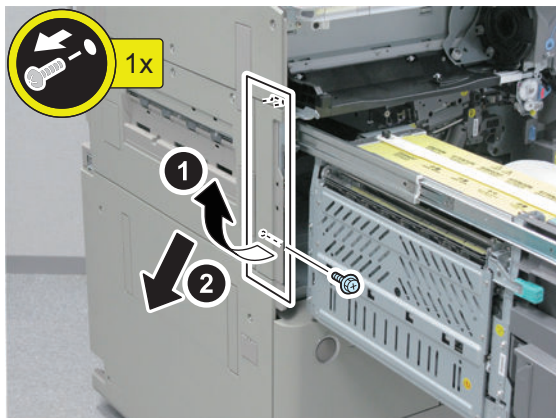


9. Pull out the Fixing Feed Unit.**CAUTION:**

When pulling out the Fixing Feed Unit, be sure to place paper over the ETB Unit for protection.

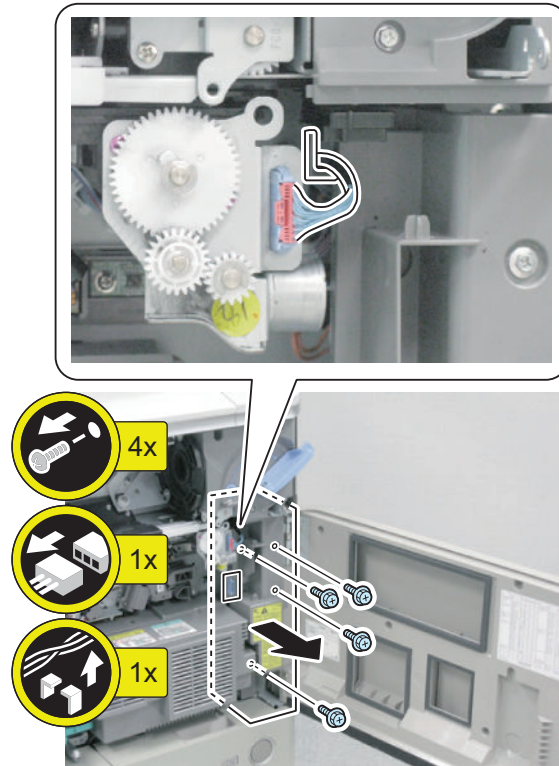
**10. Remove the Left Upper Cover 2.**

- 1 Screw
- 1 Protrusion

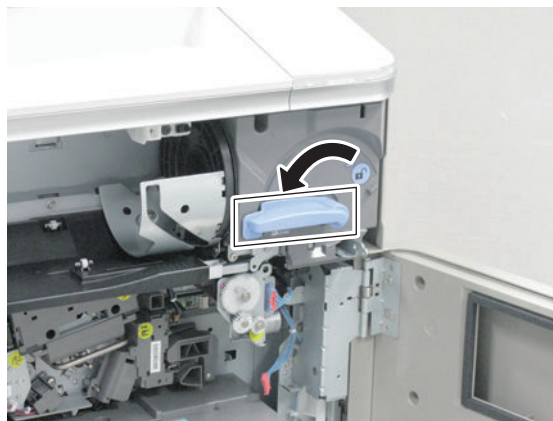
**11. Set the Fixing Feed Unit back.**

12. Remove the Right Upper Inner Cover.

- 4 Screws
- 1 Connector
- Harness



13. Set the Lock Lever back.

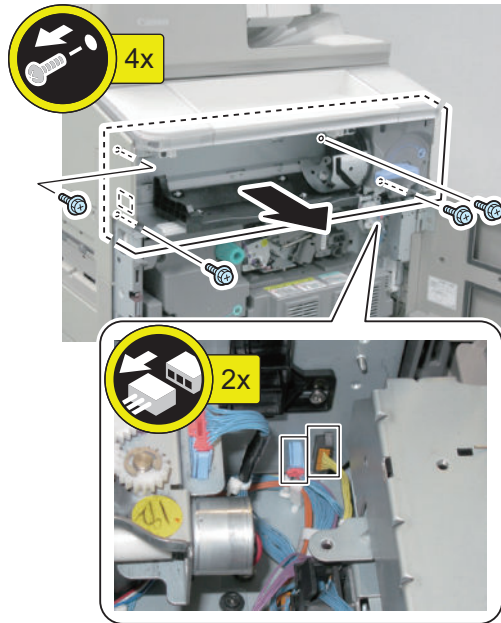


14. Remove the Hopper Unit.

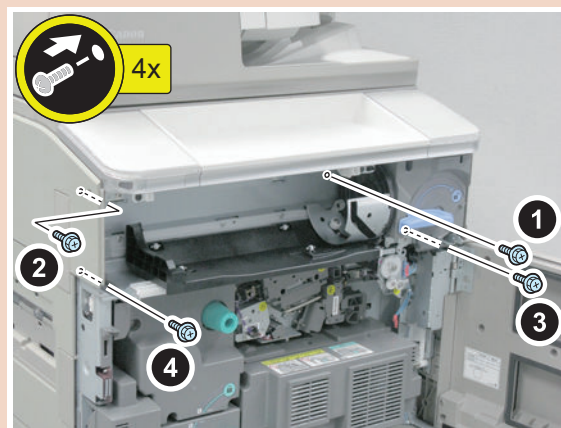
- 4 Screws
- 2 Connectors
- 1 Hook

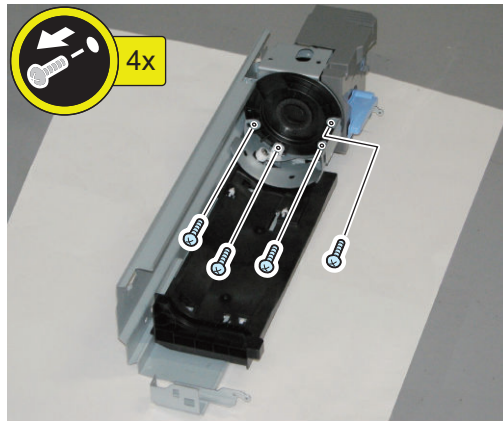
CAUTION:

Put the removed Hopper Unit on paper placed on the work space.

**CAUTION:**

When installing the Hopper Unit, be sure to follow the order as shown in the figure to tighten screws.



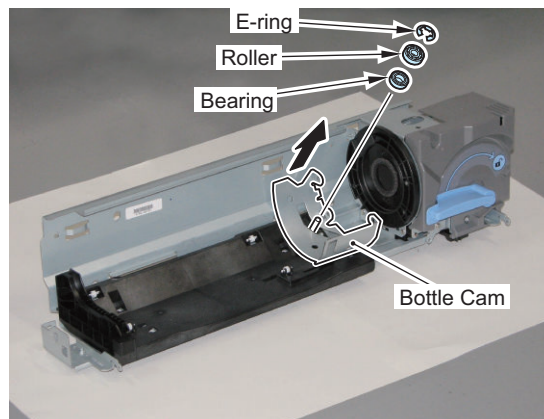
15. Remove the 4 Tapping Screws.**CAUTION:**

Points to Note when Installing the Tapping Screws

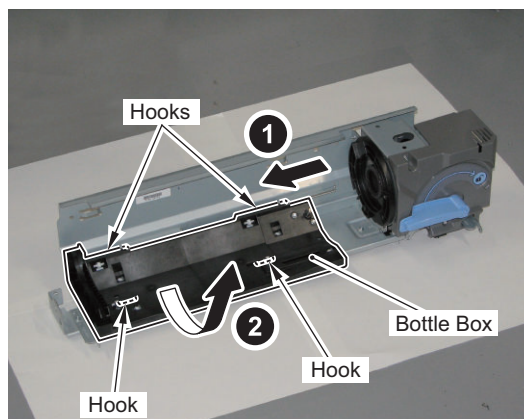
When tightening the Tapping Screws, turn them in the reverse direction to check the screw thread on the Hopper Unit side before tightening them. Otherwise, the screw thread on the Hopper Unit side may be broken, which makes it impossible to tighten the screw.

16. Remove the Bottle Cam.

- 1 E-ring
- 1 Roller
- 1 Bearing

**17. Remove the Bottle Box.**

- 4 Hooks



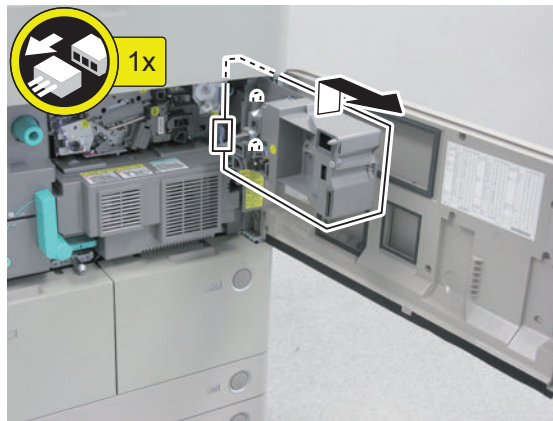
● Removing the Buffer Unit

■ Preparation

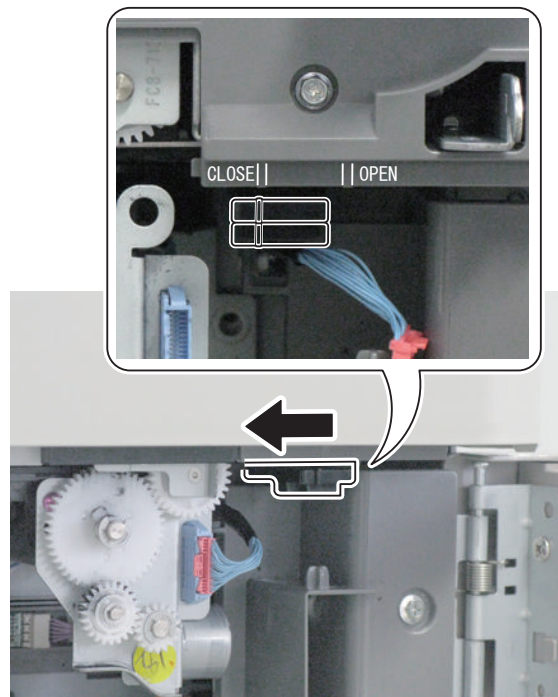
1. Open the Right Cover.
2. Remove the Developing Assembly. (“Removing the Developing Assembly” on page 411)

■ <Procedure>

1. Open the Front Cover.
2. Open the Inner Cover (Primary Charging Air Supply Fan Unit).
 - 1 Screws (to loosen)
3. Remove the Inner Cover (Primary Charging Air Supply Fan Unit).
 - 1 Connector
 - 2 Protrusions



4. Move the lever in the direction of the arrow to close the Shutter.

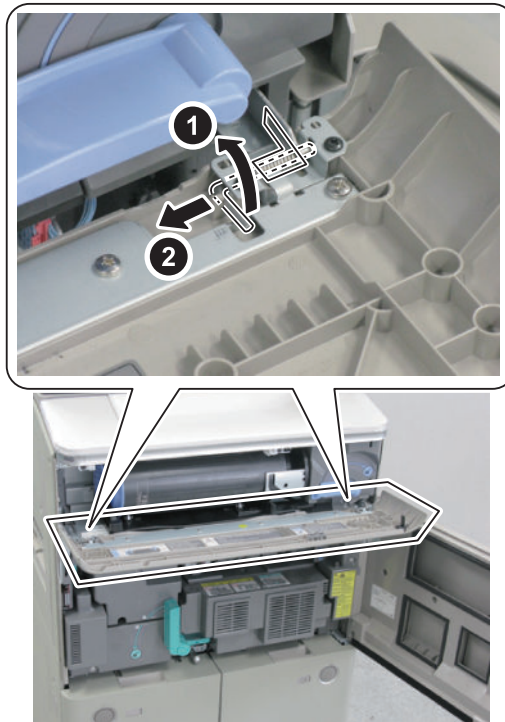


CAUTION:

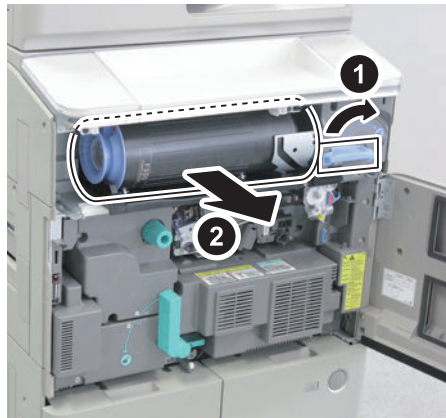
When starting the host machine, be sure to set the Shutter from CLOSE to OPEN.

5. Remove the Front Upper Cover.

- 2 Hinge Pins
- 2 Springs

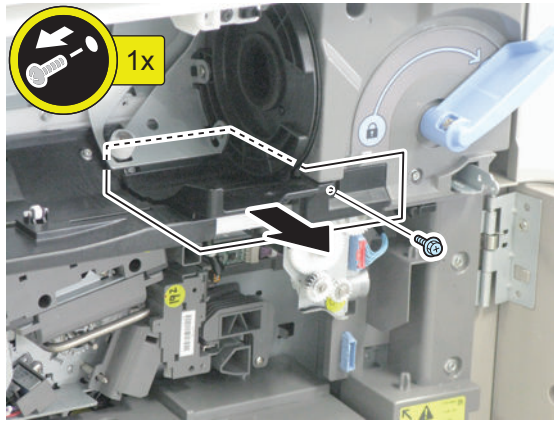


6. Release the Lock Lever to remove the Toner Bottle.



7. Remove the Toner Receptacle Tray.

- 1 Screw
- 1 Protrusion



CAUTION:

1. Be sure to fit the protrusion into the groove of the plate to install.
2. Toner can be accumulated in the Toner Receptacle Tray; therefore, be careful not to spill toner when removing.

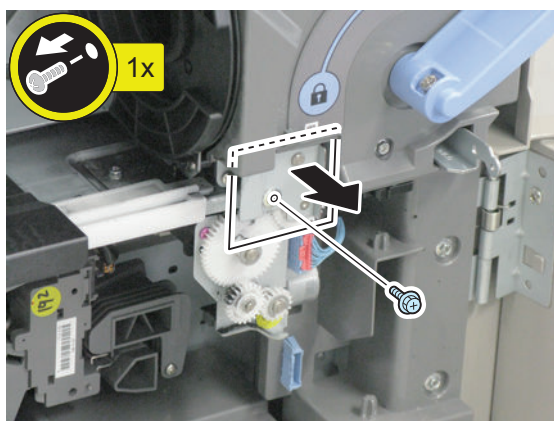
NOTE:

Clean the Toner Receptacle Tray with lint-free paper.

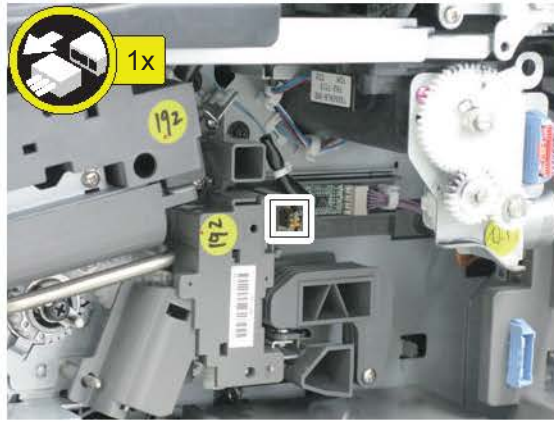


8. Remove the Connecting Drive Unit.

- 1 Screw

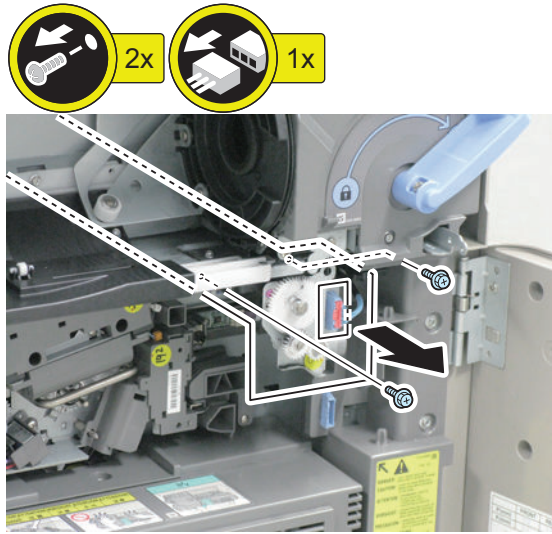


9. Disconnect the connector of the Pre-transfer Charging Assembly.



10. Remove the Buffer Unit.

- 2 Screws
- 1 Connector

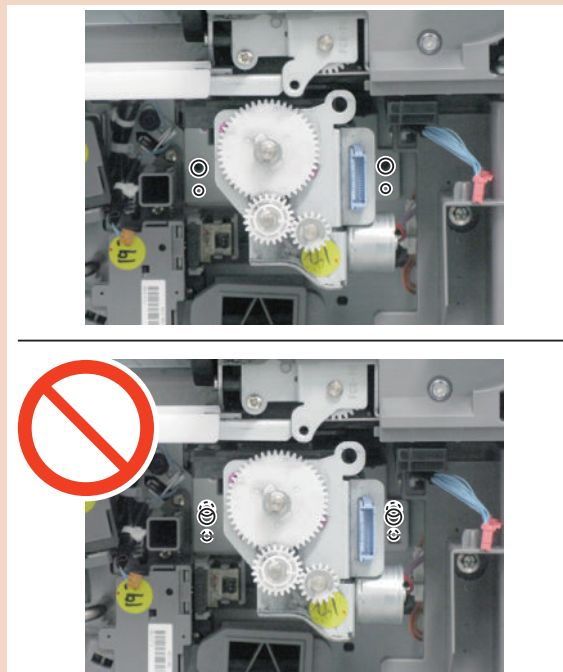
**CAUTION:**

When removing the Buffer Unit, be sure not to tilt the unit to prevent toner scattering.

CAUTION:

Points to Caution When Installing the Buffer Unit

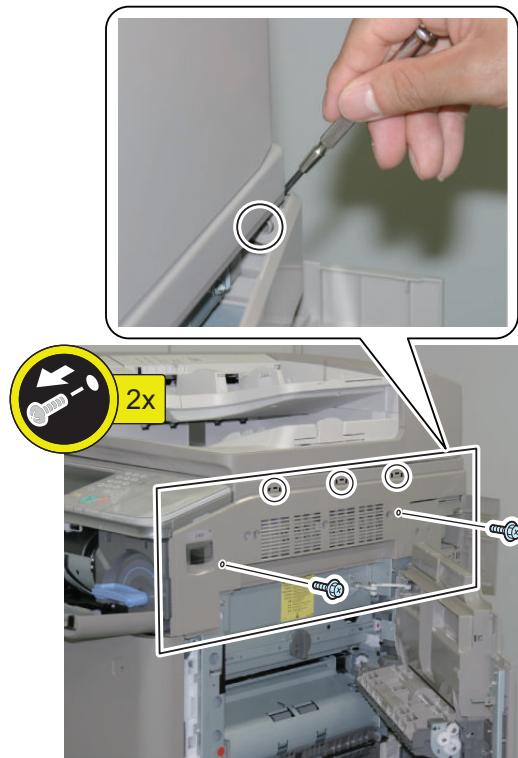
- Be sure to securely set the Buffer Unit on the Rail.
- Do not get the harness caught.
- Fit the emboss into the proper position; otherwise, toner can be scattered.
- Be sure to set the Shutter from CLOSE to OPEN.



● Removing the Potential Control PCB Unit

■ Preparation

1. Remove the Primary Charging Assembly Unit. (“Removing the Primary Charging Assembly” on page 362)
2. Remove the Pre-transfer Charging Assembly. (“Removing the Pre-transfer Charging Assembly” on page 380)
3. Remove the Process Unit. (“Removing the Process Unit” on page 391)
4. Remove the Hopper Unit. (“Removing the Hopper Unit” on page 451)
5. Open the Right Door.
6. Remove the Right Upper Cover.
 1. Open the Front Upper Cover.
 2. Open the Right Door.
 3. Open the Box Cover (Right).
 4. Remove the Right Upper Cover.
 - 2 Screws
 - 1 Boss
 - 3 Protrusions



■ Procedure

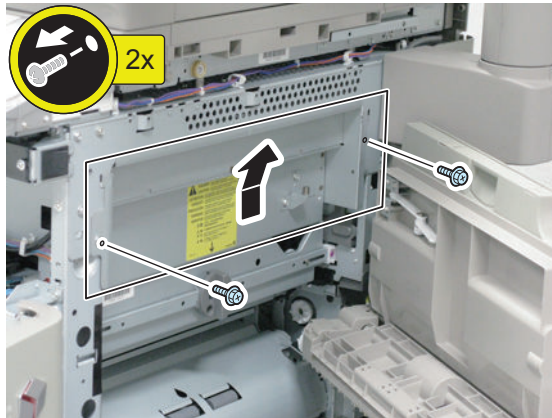
1. Remove the Right Door Link Unit from the pin.

- 1 E-ring



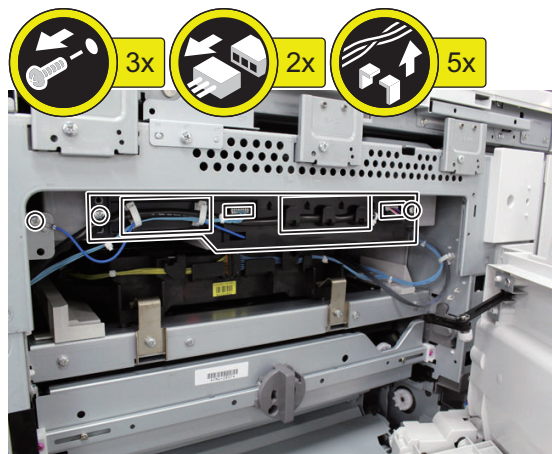
2. Remove the Right Shield Plate.

- 2 Screws



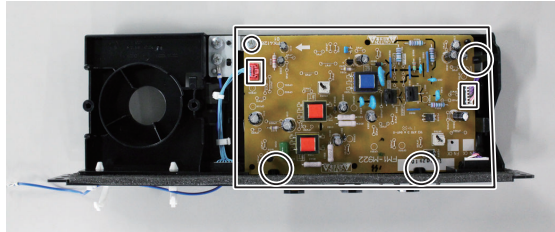
3. Remove the Potential Control Tray.

- 3 Screws
- 2 Connectors
- Wire Saddle



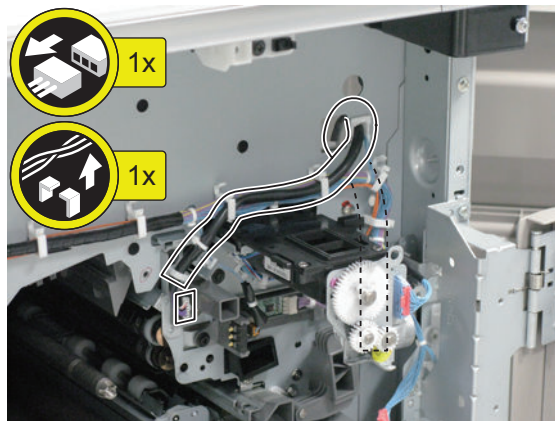
4. Remove the Potential Sensor Control PCB.

- 1 Screw
- 3 Claws
- 2 Connectors



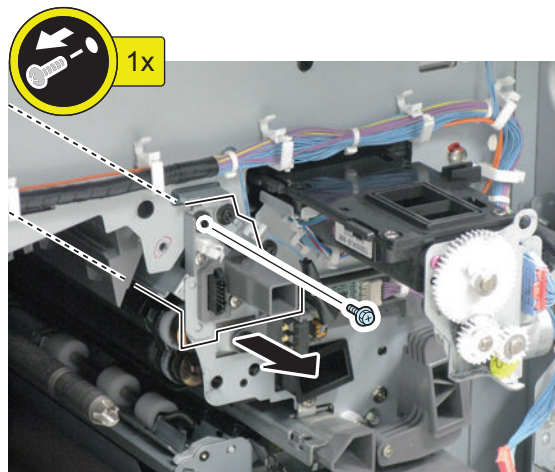
5. Remove the harness.

- 1 Connector
- Edge Saddle
- Wire Saddle



6. Remove the Potential Sensor.

- 1 Screw



■ Adjustment when Replacing the Parts

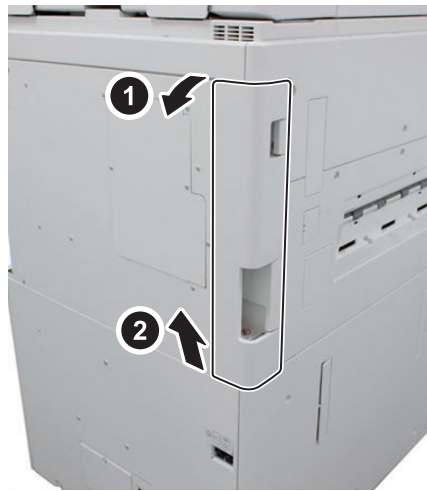
1. Adjust the Potential Sensor offset.

(Lv.1) COPIER > FUNCTION > DPC > OFST

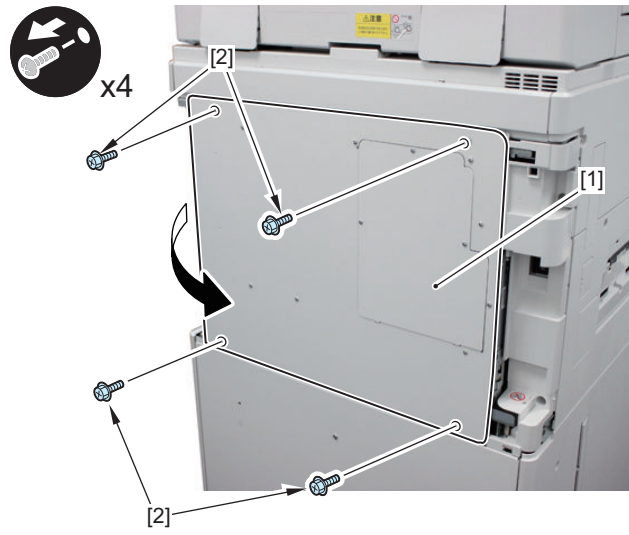
Removing the Waste Toner Feed Unit

■ Preparation

1. Remove the Left Rear Cover .



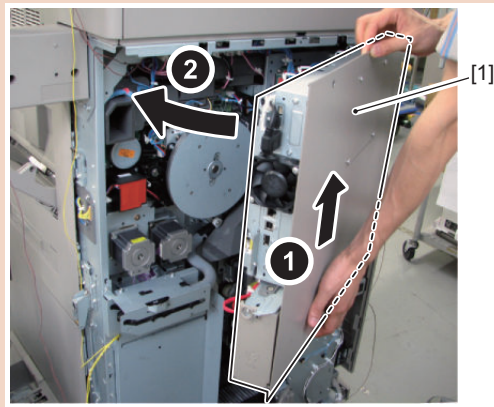
2. Open the Controller Box [1].
 - 4 Screws [2]



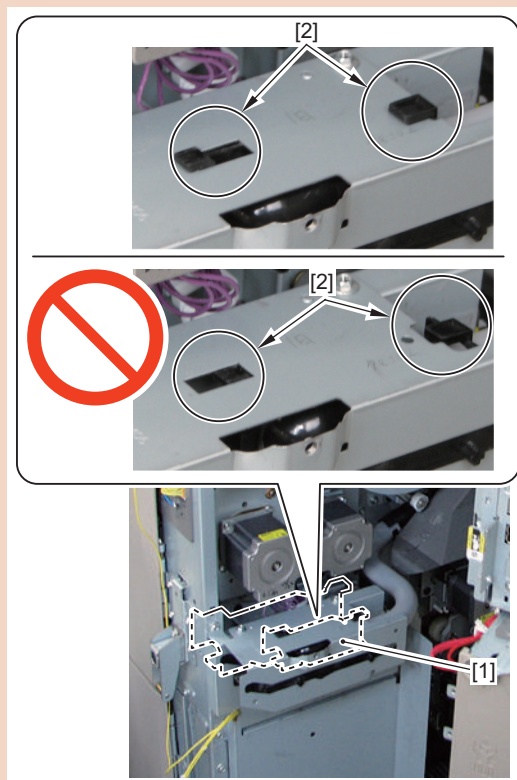
CAUTION:

Points to Note when Installing the Controller Box

While installing the Controller Box, be sure to lift it to avoid hitting the hook of the Waste Toner Container Shutter Unit.

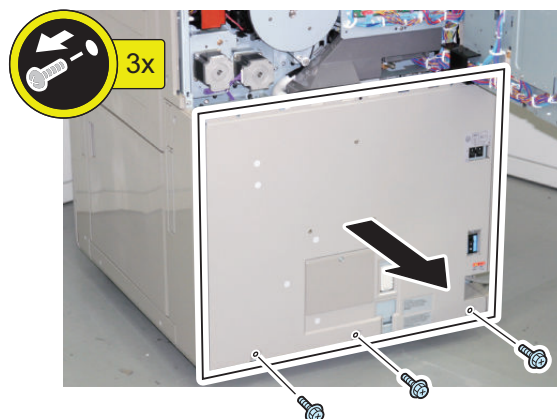


If the Inner Cover of the Controller Box hits the hook of the Waste Toner Container Shutter Unit, the hook may be removed.



3. Remove the Rear Lower Cover.

- 3 Screws



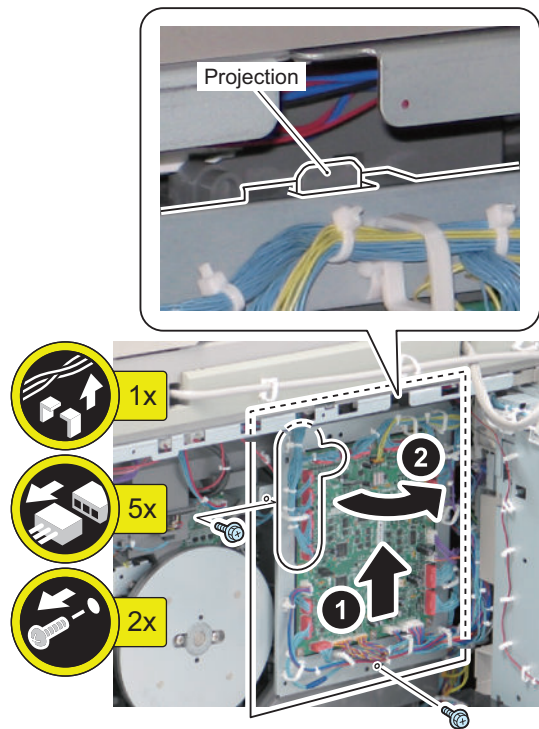
■ <Procedure>

1. Open the Motor Driver Support Plate.

- 2 Screws
- 5 Connectors
- Wire Saddle
- Reuse Band

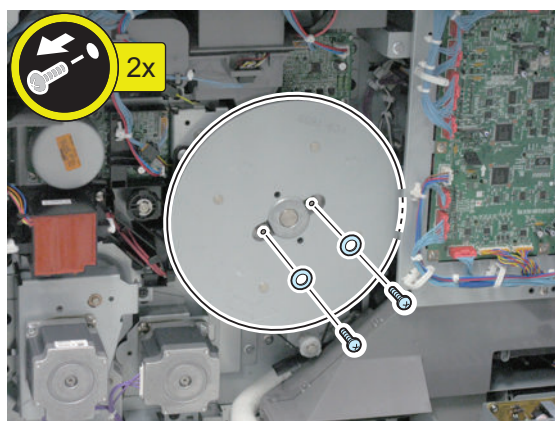
NOTE:

When opening the Motor Driver Support Plate, be sure to free from the protrusion.

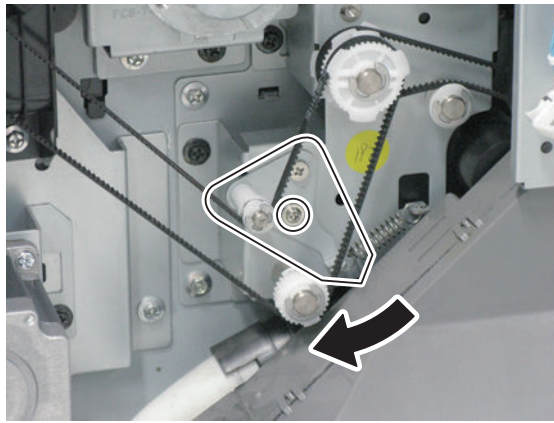


2. Remove the Flywheel.

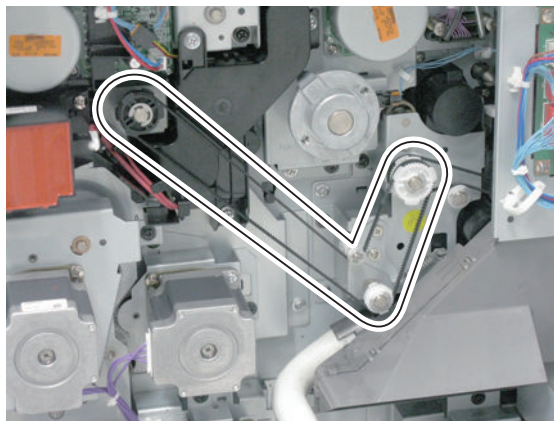
- 2 Screws



3. Loosen the screw and move the Belt Tensioner in the direction of the arrow, and then again tighten the screw.

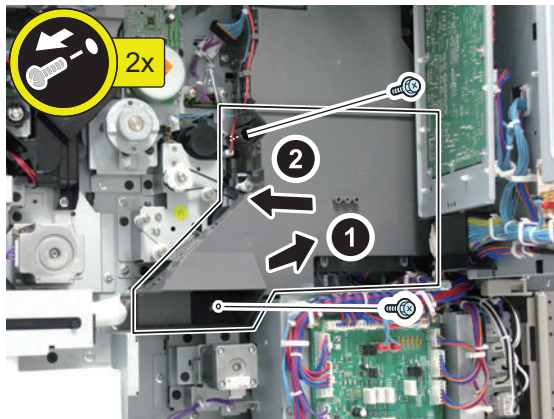


4. Remove the belt from the pulley.



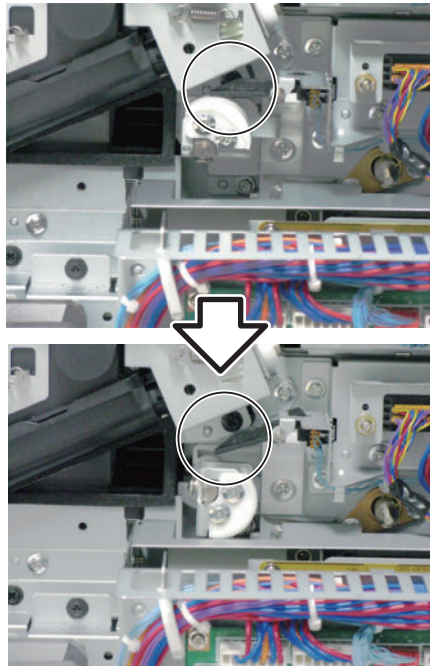
5. Remove the Duct.

- 2 Screws

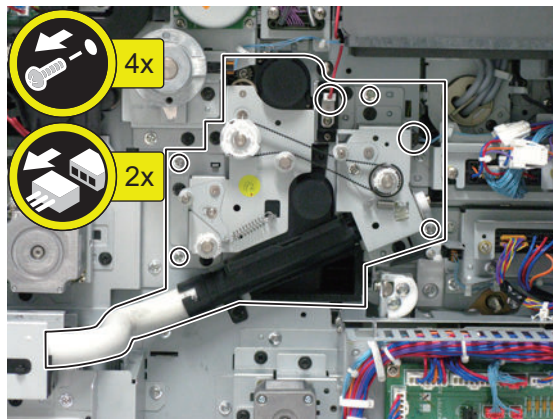


6. Open the Front Cover to move the Fixing Feed Lever down.

(To move the cam at the rear of the Fixing Feed Lever Shaft to the position where it does not interfere with the Waste Toner Feed Unit.)

**7. Remove the Waste Toner Feed Unit.**

- 2 Connectors
- 4 Screws



Removing the Drum Drive Unit

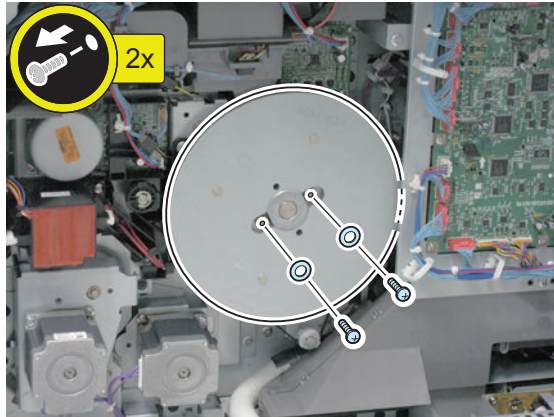
■ Preparation

1. Open the Inner Cover. (“[Removing the Primary Charging Assembly](#)” on page 362)
2. Remove the Primary Charging Assembly. (“[Removing the Primary Charging Assembly](#)” on page 362)
3. Remove the Pre-transfer Charging Assembly. (“[Removing the Pre-transfer Charging Assembly](#)” on page 380)
4. Remove the Process Unit. (“[Removing the Process Unit](#)” on page 391)
5. Remove the Left Rear Cover. (“[Removing the Waste Toner Feed Unit](#)” on page 467)
6. Open the Controller Box. (“[Removing the Waste Toner Feed Unit](#)” on page 467)

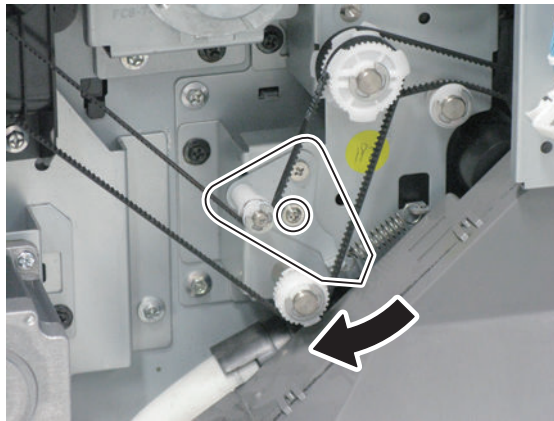
■ Procedure

1. Remove the Flywheel.

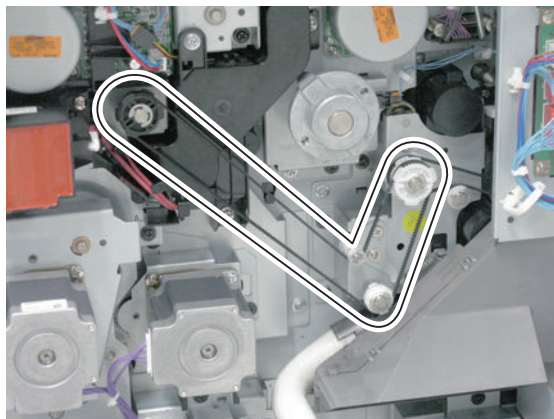
- 2 Screws
- 2 Washers



2. Loosen the screw and move the Belt Tensioner in the direction of the arrow, and then again tighten the screw.

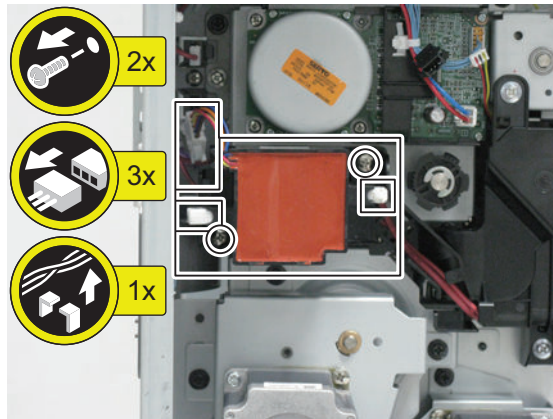


3. Remove the belt from the pully.



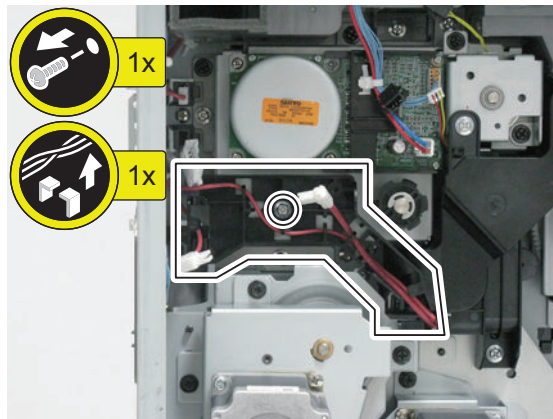
4. Remove the transformer.

- 2 Screws
- 3 Connectors
- 1 Wire Saddle



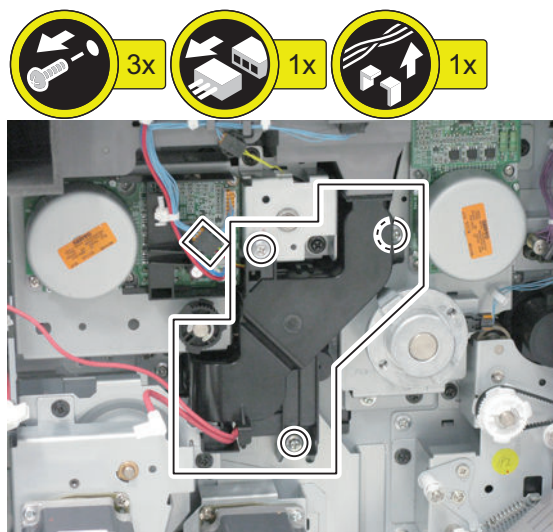
5. Free the harness and remove the Transformer Support Base.

- 1 Screw
- Harness



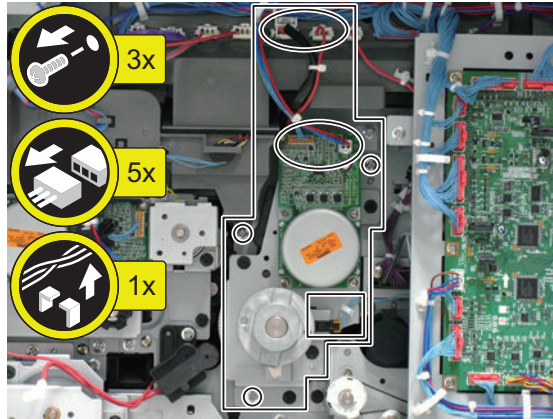
6. Remove the Duct Unit.

- 3 Screws
- 1 Connector
- Harness



7. Remove the Drum Drive Unit.

- 5 Connectors
- 1 Wire Saddle
- 3 Screws



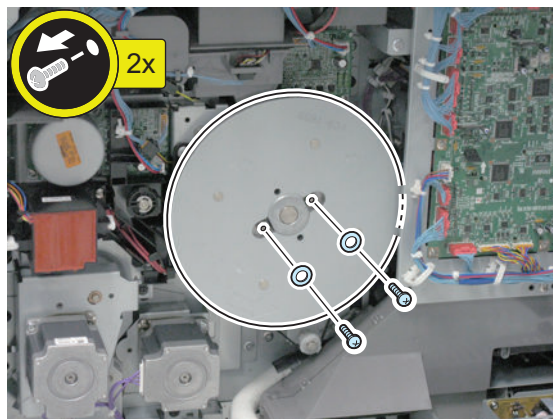
Removing the Developing Drive Unit

■ Preparation

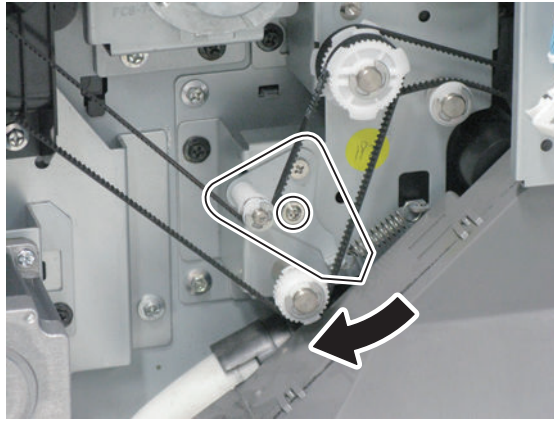
1. Remove the Developing Assembly (“Removing the Developing Assembly” on page 411)
2. Remove the Left Rear Cover. (“Removing the Waste Toner Feed Unit” on page 467)
3. Open the Controller Box. (“Removing the Waste Toner Feed Unit” on page 467)

■ <Procedure>

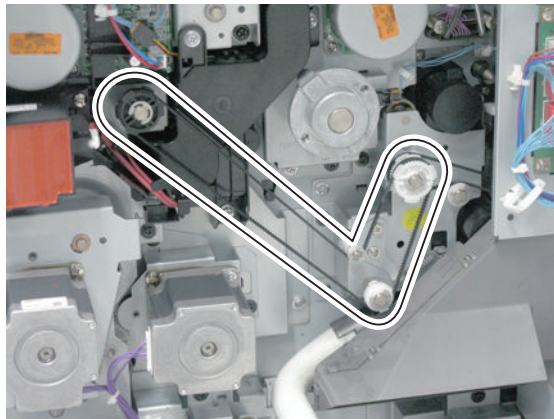
1. Remove the Flywheel.
 - 2 Screws
 - 2 Washers



2. Loosen the screw and move the Belt Tensioner in the direction of the arrow, and then again tighten the screw.

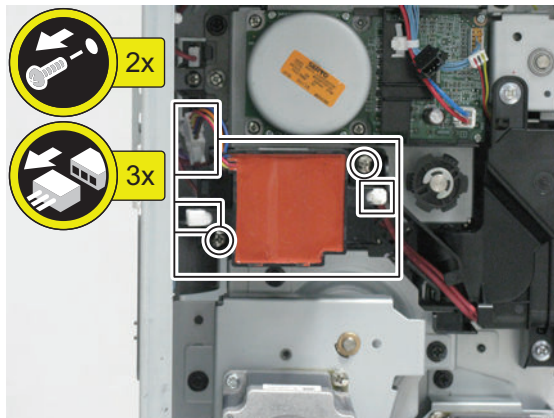


3. Remove the belt from the pulley.



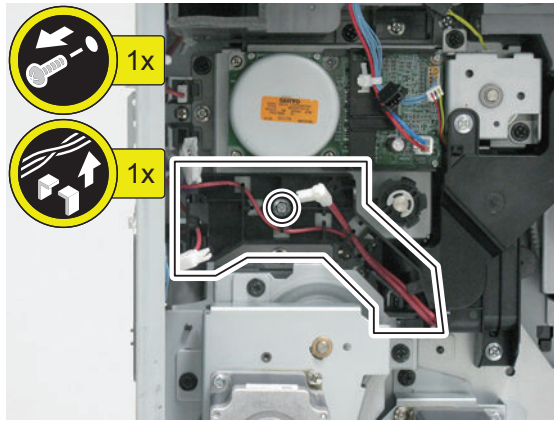
4. Remove the transformer.

- 2 Screws
- 3 Connectors



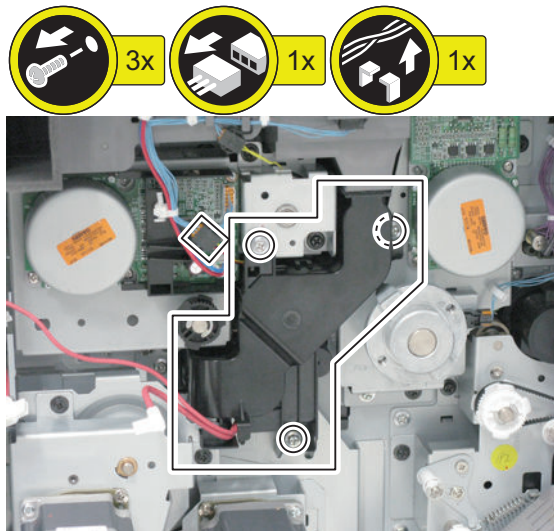
5. Free the harness and remove the Transformer Support Base.

- 1 Screw
- Harness



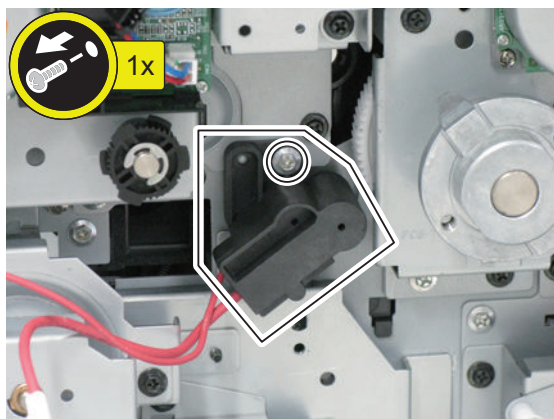
6. Remove the Duct Unit.

- 3 Screws
- 1 Connector
- Harness



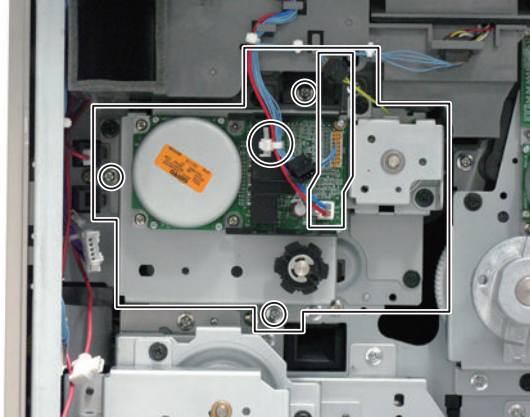
7. Disconnect the Pre-transfer Charging High Voltage Connector.

- 1 Screw



8. Remove the Developing Drive Unit.

- 3 Connectors
- 1 Reuse Band
- 3 Screws



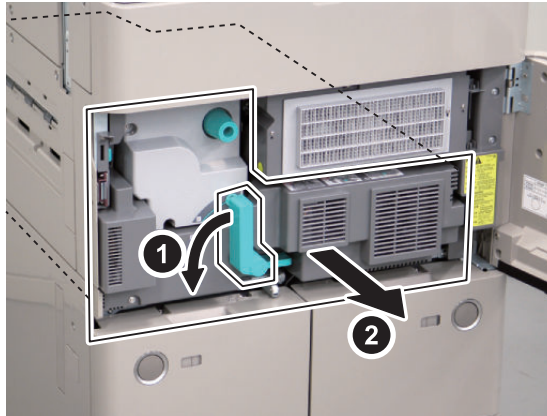
Fixing System

● Removing the Fixing Assembly

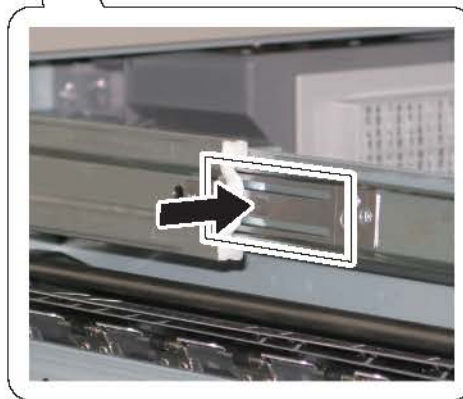
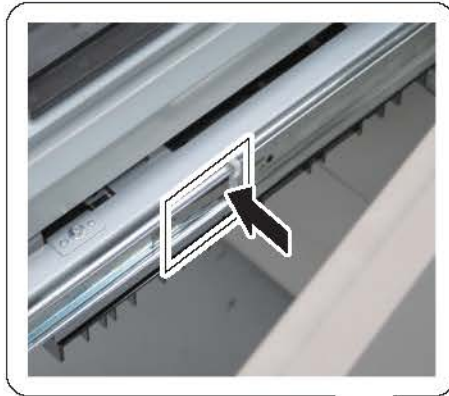
■ <Preparation>

1. Pull out the Fixing Feed Unit.

1. Open the Front Cover.
2. Turn the Fixing Feed Unit Pressure Release Lever in the direction of the arrow to pull out the Fixing Feed Unit.



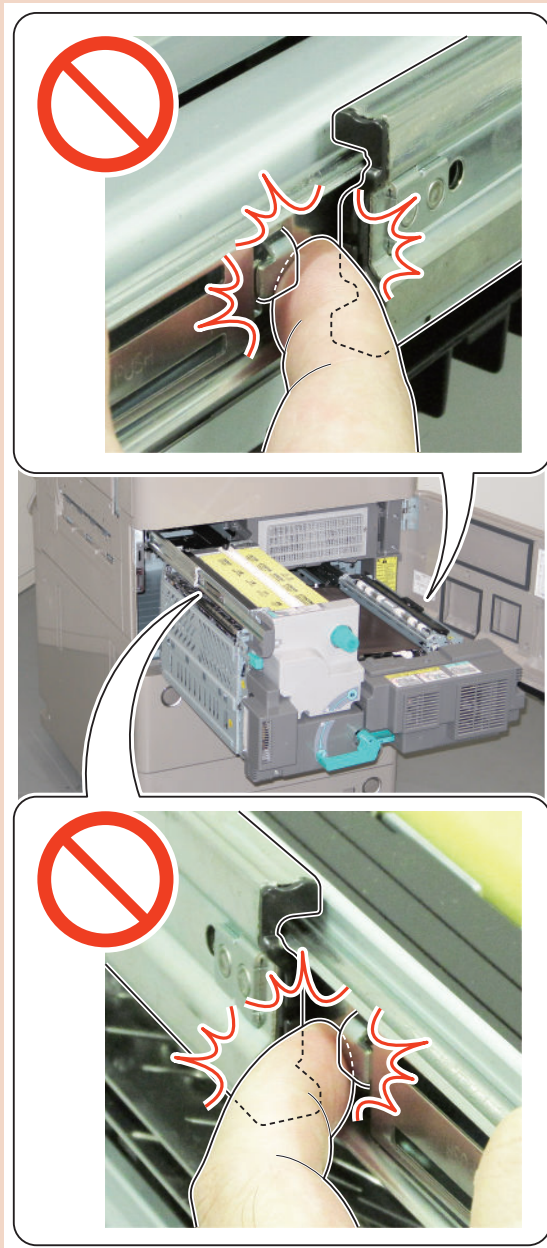
3. Push to release the Release Springs at both sides of the Rail, and then further pull out the Fixing Feed Unit until it stops.



CAUTION:

Caution when pushing the Fixing Feed Unit in

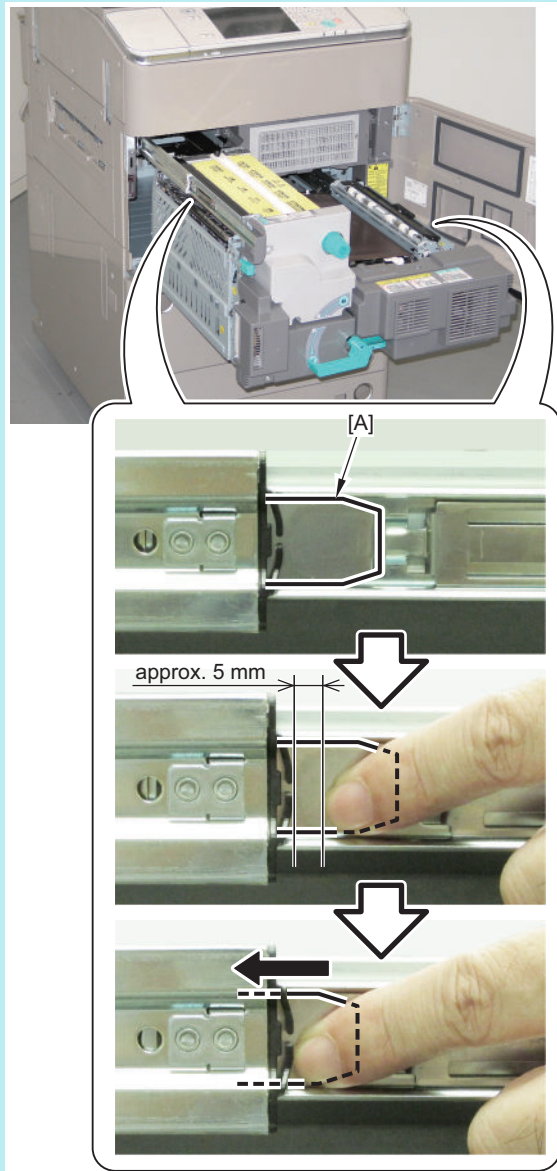
While pressing the Release Springs, slowly push the Fixing Feed Unit in so that the fingers do not get caught.



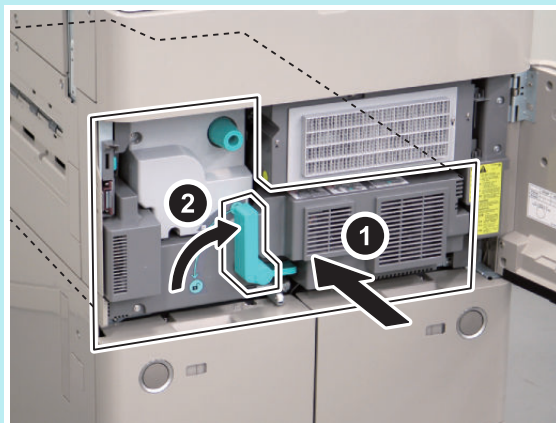
NOTE:

How to push the Fixing Feed Unit in

1. Release the Release Springs [A] on the side of either rail.
Slowly push the Fixing Feed Unit in by approximately 5 mm while keeping it level.



2. Take the fingers off the Release Springs and slowly push the Fixing Feed Unit in to the end.

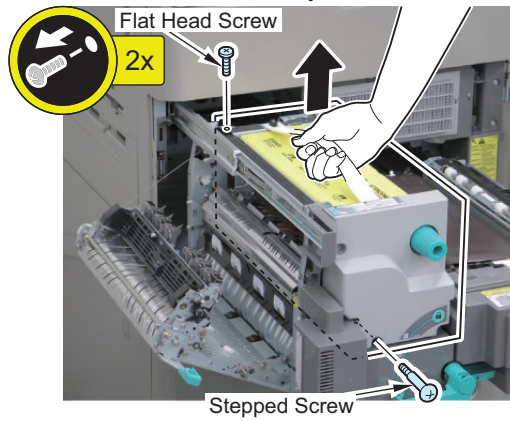
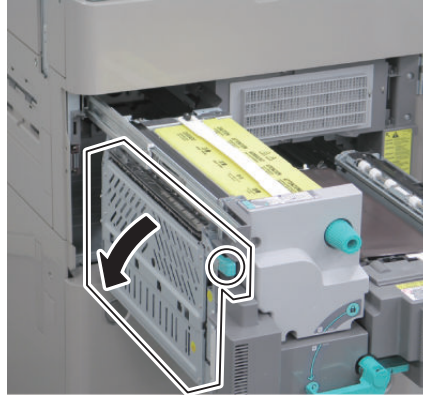


■ <Procedure>

1. Hold the Lever of the Feed Unit to open the Feed Unit.

2. Remove the Fixing Assembly.

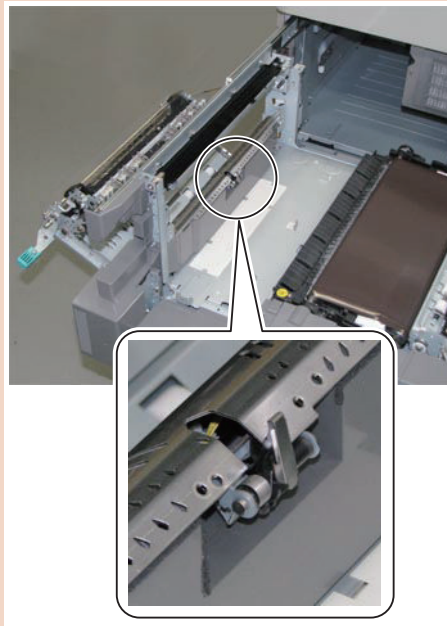
- 2 Screws



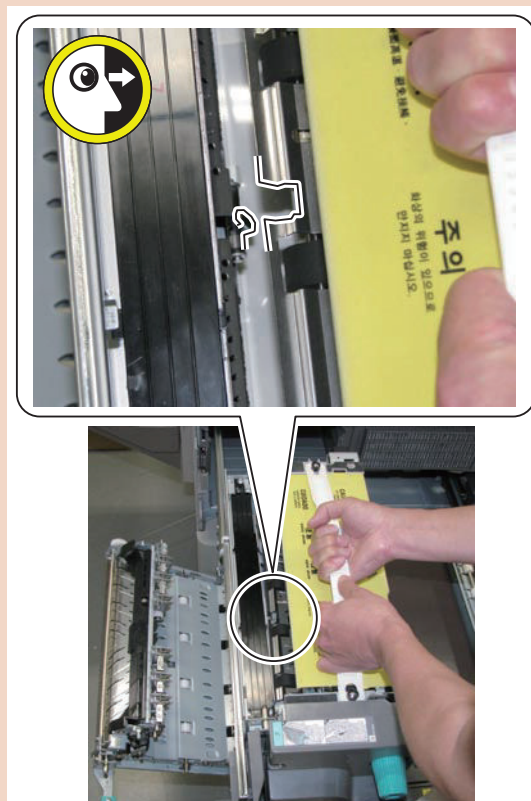
CAUTION:

Points to Caution at Installation

- Be careful not to damage the Inner Delivery Sensor Flag.



- When installing the Fixing Assembly, be sure that the Inner Delivery Sensor Flag passes through the cut-off of the Fixing Outlet Guide.



● Cleaning the Fixing Inlet Guide, Fixing Inlet Sensor Flag, Fixing Right Stay, Dowel, Dowel Holder

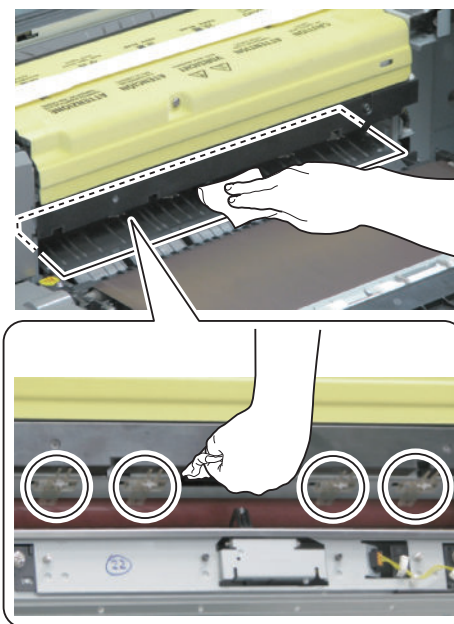
■ Preparation

1. Pull out the Fixing Feed Unit. (“Removing the Fixing Assembly” on page 479)

2. Remove the Fixing Assembly. (“Removing the Fixing Assembly” on page 479)

■ <Procedure>

1. Clean the Fixing Inlet Guide with lint-free paper moistened with alcohol.
2. Clean the Fixing Right Stay, Dowel, Dowel Holder with lint-free paper moistened with alcohol.

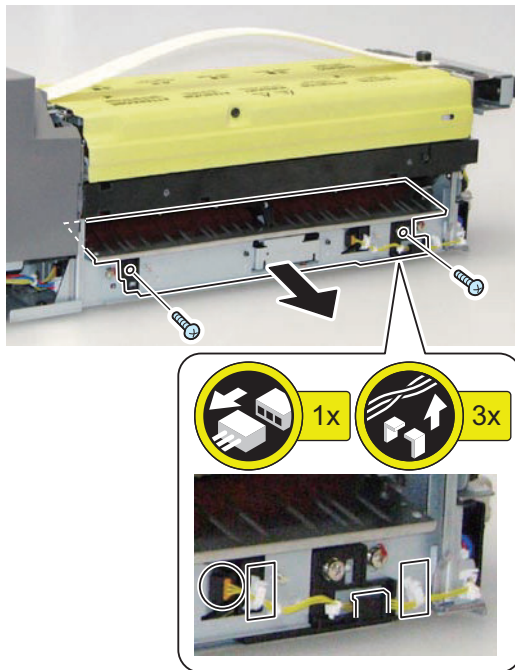
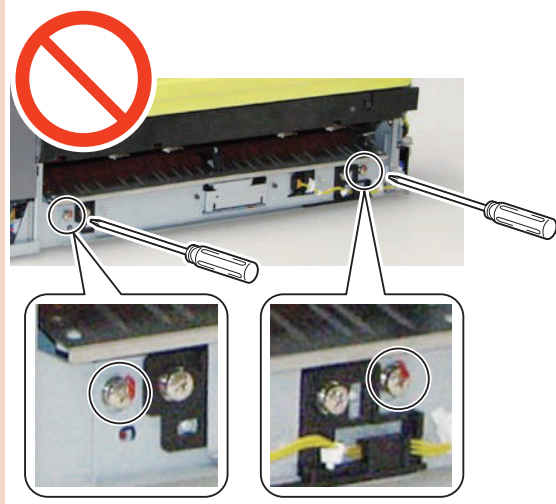


3. Remove the Fixing Inlet Guide Unit.

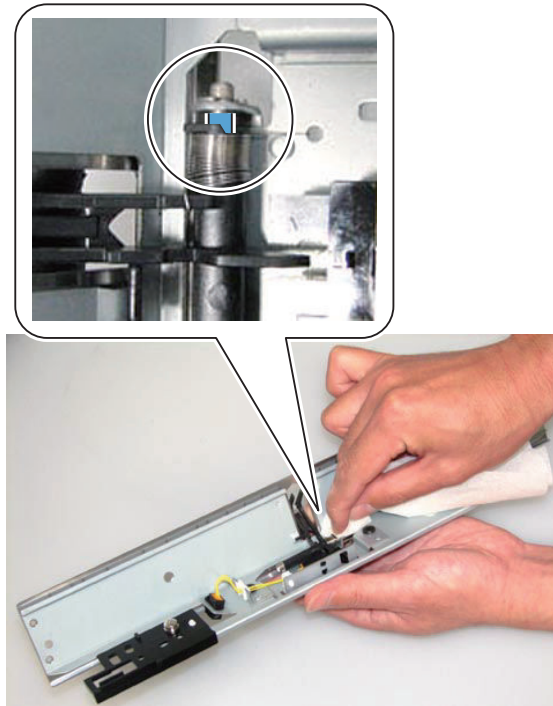
- 1 Connector
- 2 Wire Saddles
- 1 Harness Guide
- 2 Screws

CAUTION:

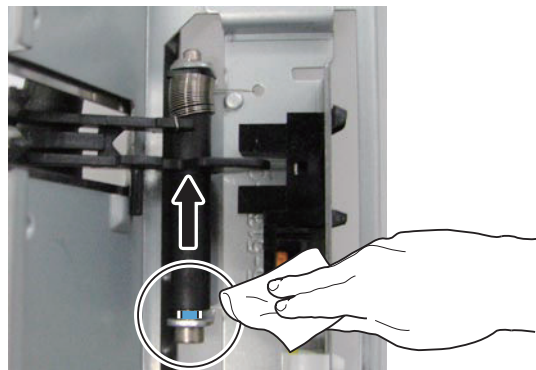
When removing the Fixing Inlet Guide Unit, be careful no to turn the 2 Adjustment Screws.



4. Turn over the Fixing Inlet Guide Unit, and insert lint-free paper into the clearance (front side) between the Fixing Inlet Sensor Flag Shaft and the Shaft Support Plate to remove the accumulated paper lint by dry wipe.



5. Slide the sensor flag to the rear side, and insert lint-free paper into the clearance (rear side) between the Fixing Inlet Sensor Flag Shaft and the Shaft Support Plate to remove the accumulated paper lint by dry wipe.



CAUTION:

Checking after Cleaning the Fixing Inlet Sensor Flag Shaft

Be sure to check that the sensor flag rotates and moves back and forth smoothly by moving it manually.

Cleaning the Inner Delivery Roller

■ Preparation

1. Pull out the Fixing Feed Unit. (“Removing the Fixing Assembly” on page 479)
2. Remove the Fixing Assembly. (“Removing the Fixing Assembly” on page 479)

■ <Procedure>

1. Clean the Inner Delivery Roller with lint-free paper moistened with alcohol.



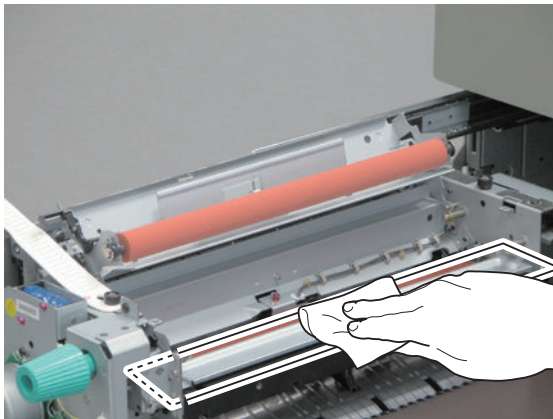
● Cleaning the Fixing Oil Pan

■ <Preparation>

1. Pull out the Fixing Feed Unit. (Refer to “Removing the Fixing Assembly” on page 479)
2. Remove the Fixing Front Cover. (Refer to “Removing the Fixing Cleaning Web” on page 488)
3. Remove the Fixing Upper Cover. (Refer to “Removing the Fixing Cleaning Web” on page 488)

■ <Procedure>

1. Clean the surface of the Fixing Oil Pan with lint-free paper.



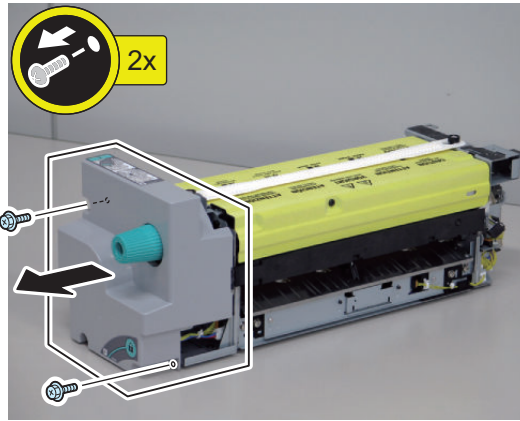
● Removing the Fixing Cleaning Web

■ Preparation

1. Pull out the Fixing Feed Unit. (“Removing the Fixing Assembly” on page 479)

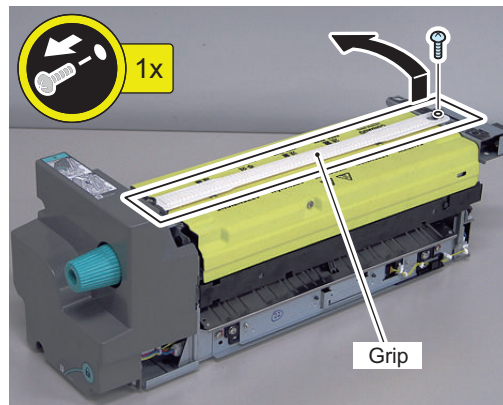
2. Remove the Fixing Front Cover.

1. Remove the Fixing Front Cover.
 - 2 Screws

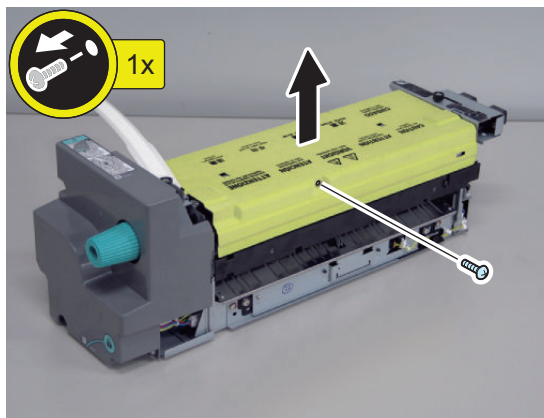


3. Remove the Fixing Upper Cover.

1. Remove the Handle
 - 1 Screw



2. Remove the Fixing Upper Cover.
 - 1 Screw



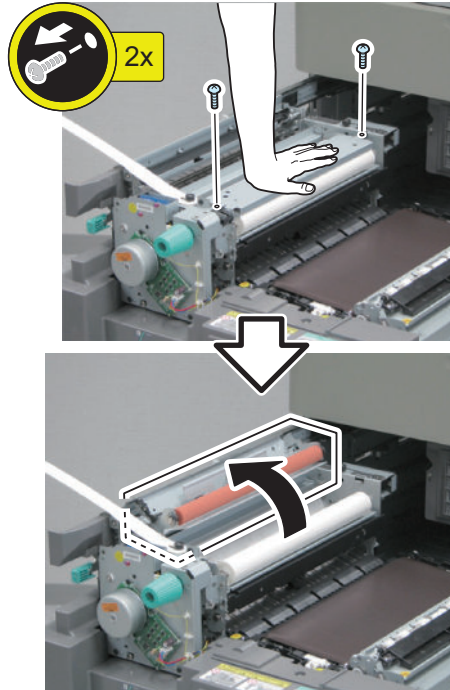
■ <Procedure>

1. Open the Fixing Cleaning Web Cover.

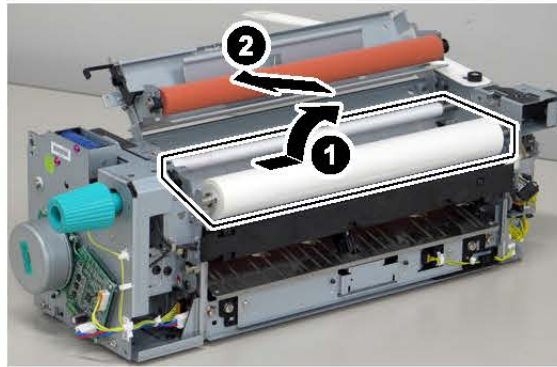
- 2 Screws

NOTE:

Because it is engaged, hold the Fixing Cleaning Web Cover to remove the screws.



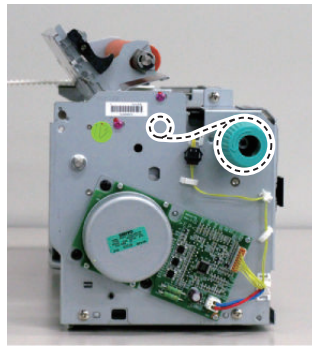
2. Remove the Fixing Cleaning Web.



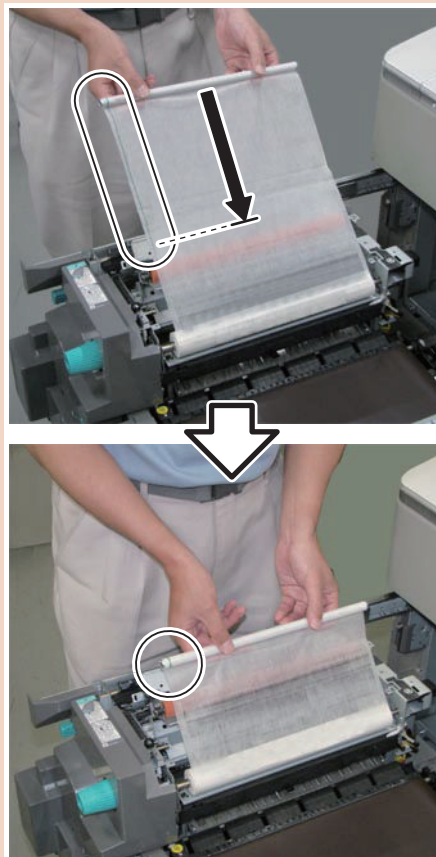
CAUTION:

Points to Caution at Installation

- Be sure to install the Fixing Cleaning Web in the correct direction.



- When installing the Fixing Cleaning Web, be sure to wind the web around the Web Take-up Roller until green and red line on the web disappears from view.



■ Actions after Parts Replacement

1. Clear the Fixing Cleaning Web take-up counter.(COPIER > COUNTER > MISC > FIX-WEB)
2. Clear the parts counter.(COPIER > COUNTER > DRBL-1 > FX-WEB)

● Cleaning the Fixing Roller Static Eliminator

■ <Preparation>

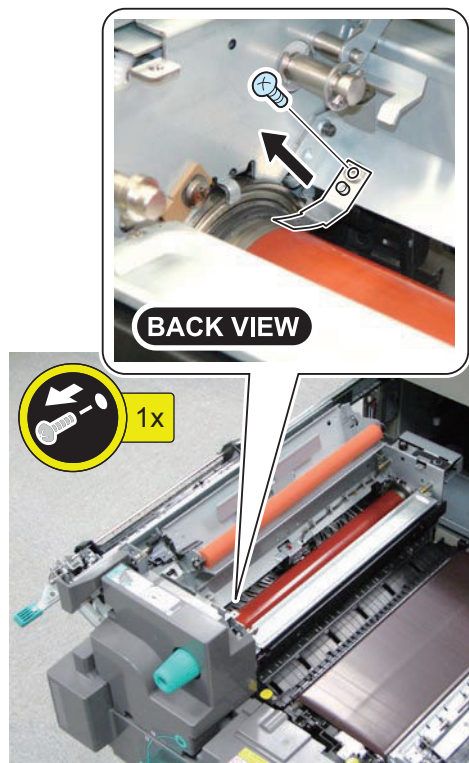
1. Pull out the Fixing Feed Unit. (Refer to “Removing the Fixing Assembly” on page 479)
2. Remove the Fixing Cleaning Web. (Refer to “Removing the Fixing Cleaning Web” on page 488)

■ <Procedure>

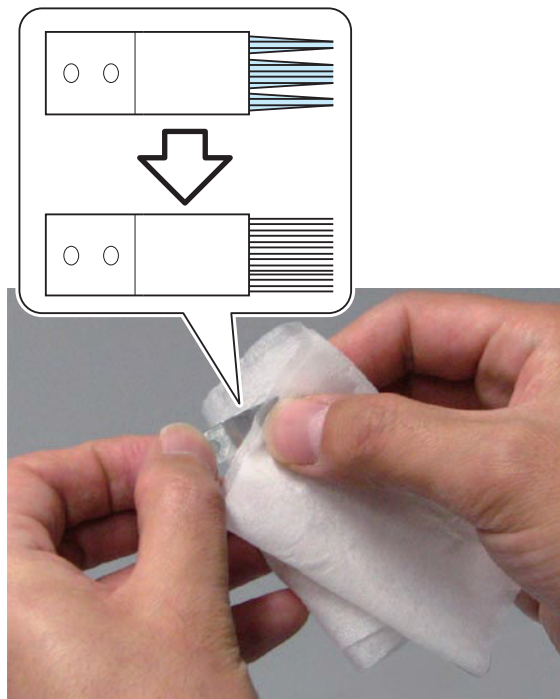
1. Remove the Fixing Roller Static Eliminator.
 - 1 Screw
 - 1 Boss

CAUTION:

When removing the Fixing Roller Static Eliminator, be careful not to drop it inside of the Fixing Assembly.



2. Dry wipe oil on the Fixing Roller and paper lint adhered on the Fixing Roller Static Eliminator with lint-free paper, and loosen up the strands of Static Eliminator clotted with oil.



● Separating the Fixing Upper Unit from the Fixing Lower Unit

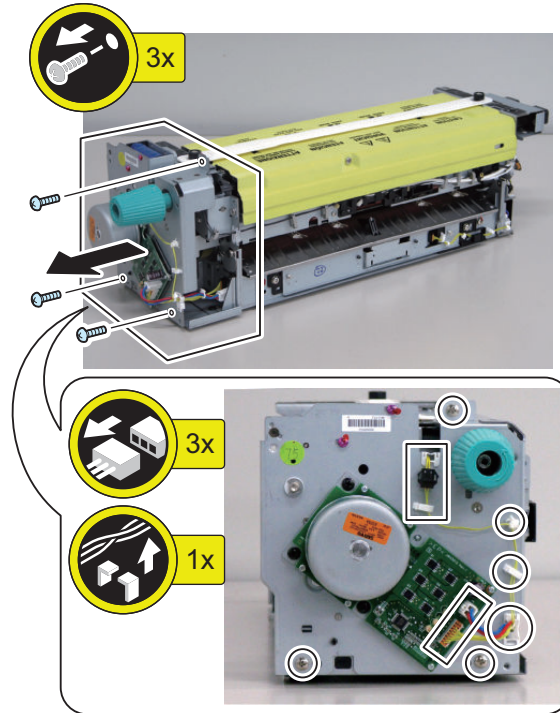
■ Preparation

1. Pull out the Fixing Feed Unit. (“Removing the Fixing Assembly” on page 479)
2. Remove the Fixing Assembly. (“Removing the Fixing Assembly” on page 479)
3. Remove the Fixing Front Cover. (“Removing the Fixing Cleaning Web” on page 488)

■ <Procedure>

1. Remove the Fixing Drive Unit.

- Wire Saddle
- Edge Saddle
- Reuse Band
- 3 Connectors
- 3 Screws

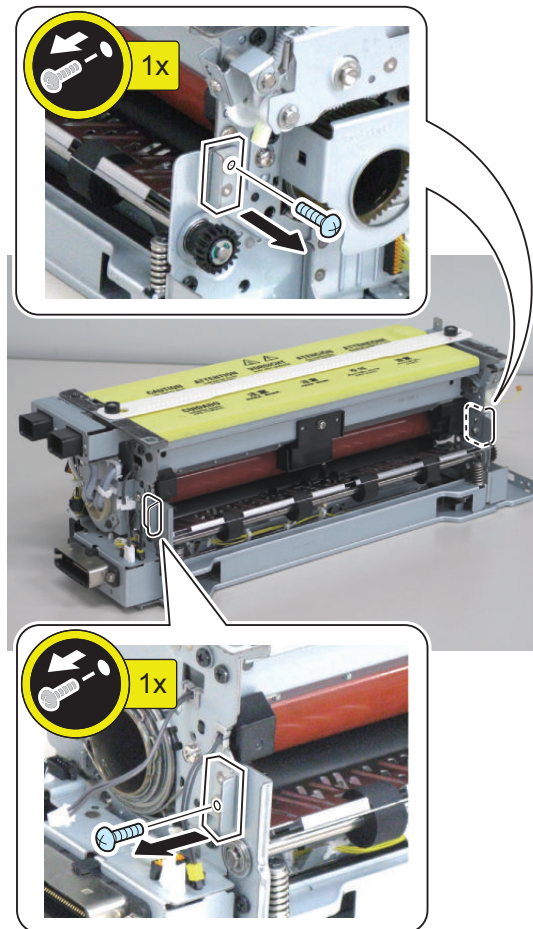


2. Remove the Fixing Pin.

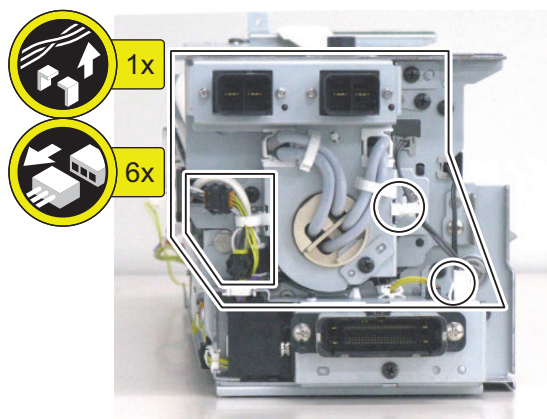
- 2 Screws

NOTE:

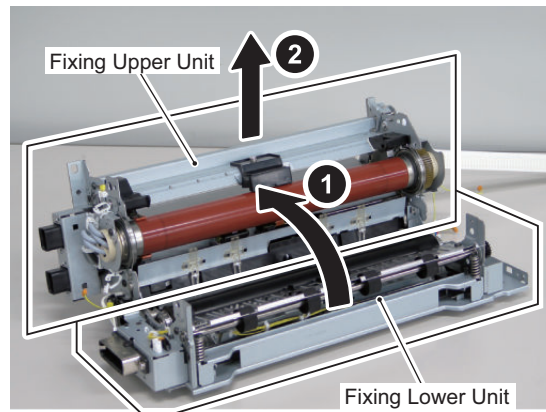
Because it is engaged, hold the Fixing Upper Unit to remove the Fixing Pin.

**3. Disconnect the Connectors of Heater Unit.**

- Wire Saddle
- 6 Connectors



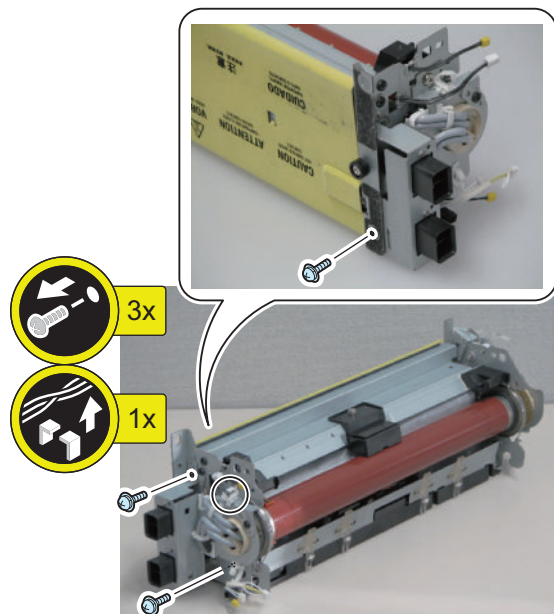
4. Separate the Fixing Upper Unit from the Fixing Lower Unit.



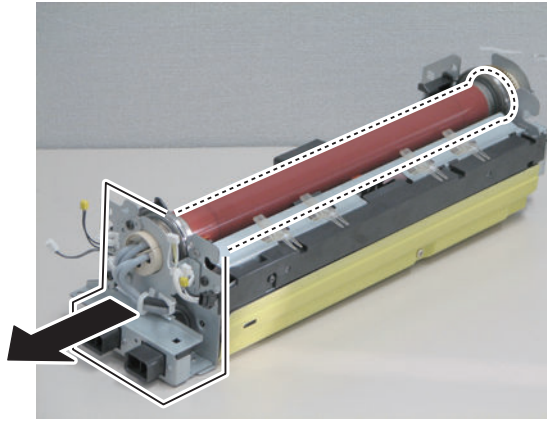
● Removing the Fixing Roller, Insulating Bush and Thrust Stopper

■ Preparation

1. Pull out the Fixing Feed Unit. (“Removing the Fixing Assembly” on page 479)
2. Remove the Fixing Assembly. (“Removing the Fixing Assembly” on page 479)
3. Remove the Fixing Front Cover. (“Removing the Fixing Cleaning Web” on page 488)
4. Separate the Fixing Upper Unit from the Fixing Lower Unit. (“Separating the Fixing Upper Unit from the Fixing Lower Unit” on page 494)
5. Remove the Heater Unit.
 1. Free the Harness from the Wire Saddle and remove the 3 screws.
 - 3 Screws

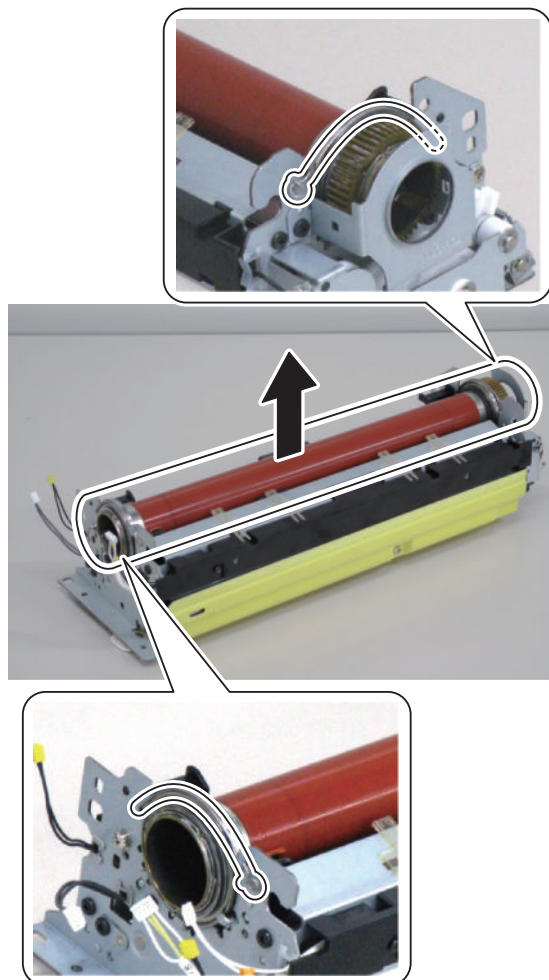


2. Remove the Heater Unit.

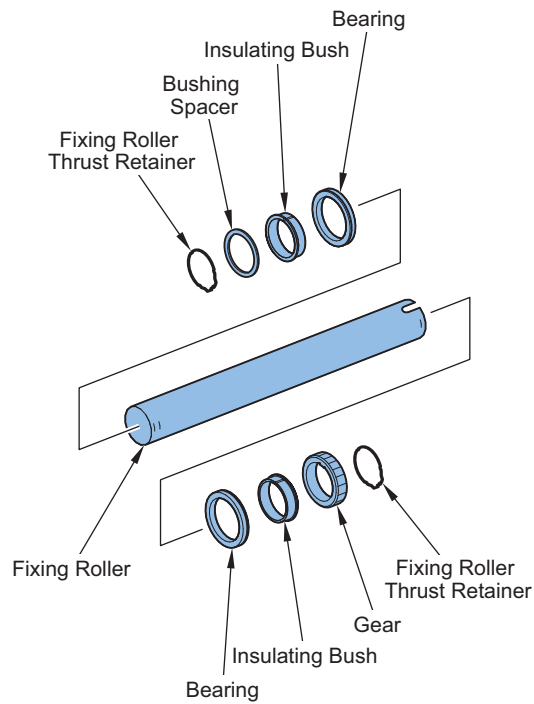


■ <Procedure>

1. Place the Fixing Upper Unit as shown in the figure and remove the Fixing Roller Bearing Retainer.
2. Remove the Fixing Roller Unit.



3. Remove the Thrust Stopper from the Fixing Roller Unit to remove the Fixing Roller.



CAUTION:

Points to Caution at Installation

Be sure to locate the groove of the Fixing Roller Bearing outside the Fixing Upper Unit to install.



CAUTION:

Points to Caution when Replacing the Fixing Roller

Do not reuse the once removed Thrust Stopper.

If the Thrust Stopper is reused, it may come off during printing.

■ Adjustment when Replacing the Parts

1. Grease Application

Apply approx. 20mg of grease (MOLYKOTE HP-300; CK-8012) to inner circumference and outer circumference of the Insulating Bush so that all circumferences are covered with white film.

2. Clear the parts counter.

(Lv.1) COPIER > COUNTER > DRBL-1 > FX-UP-RL

(Lv.1) COPIER > COUNTER > DRBL-1 > FX-IN-BS

(Lv.1) COPIER > COUNTER > DRBL-1 > FX-RTNR

● Removing the Pressure Roller

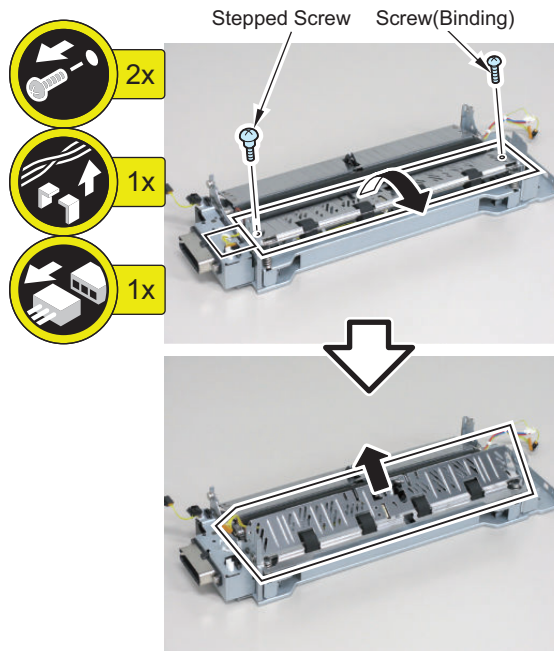
■ Preparation

1. Pull out the Fixing Feed Unit. (“Removing the Fixing Assembly” on page 479)
2. Remove the Fixing Assembly. (“Removing the Fixing Assembly” on page 479)
3. Remove the Fixing Front Cover. (“Removing the Fixing Cleaning Web” on page 488)
4. Separate the Fixing Upper Unit from the Fixing Lower Unit. (“Separating the Fixing Upper Unit from the Fixing Lower Unit” on page 494)

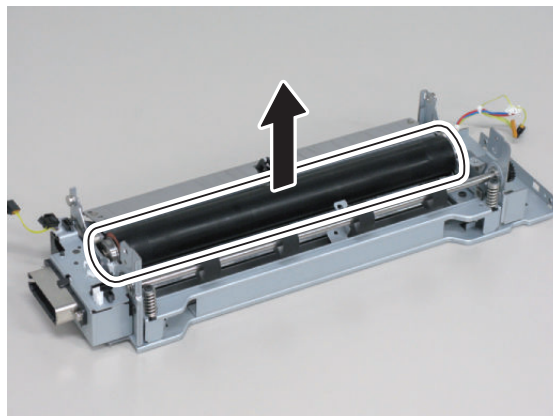
■ <Procedure>

1. Remove the Fixing Inlet Guide.

- 2 Screws
- Wire Saddle
- Edge Saddle
- 1 Connector



2. Remove the Pressure Roller Unit.



■ Actions after Parts Replacement

1. Clear the parts counter. (COPIER > COUNTER > DRBL-1 > FX-LW-RL)

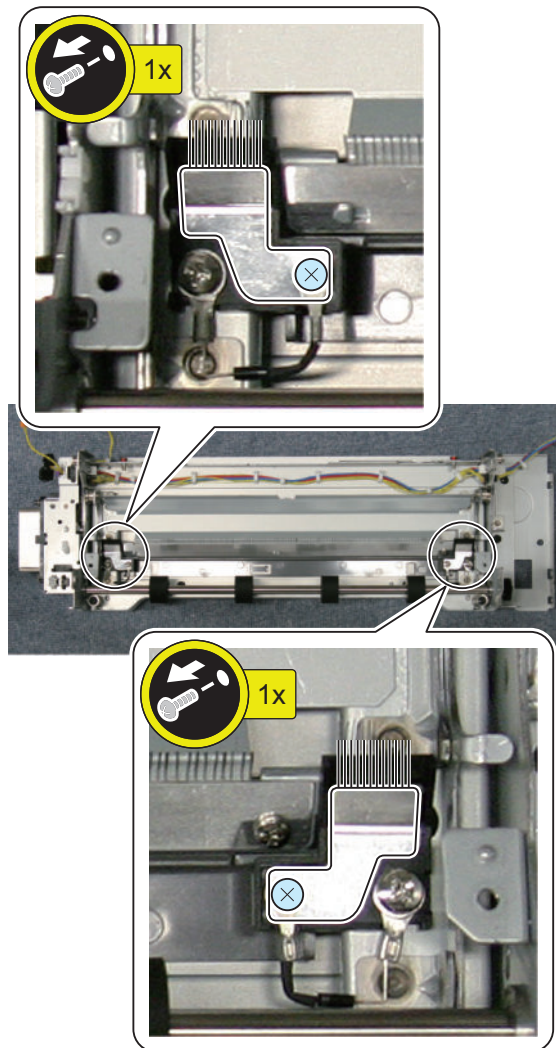
Removing the Pressure Roller Static Eliminator

■ Preparation

1. Pull out the Fixing Feed Unit. (“Removing the Fixing Assembly” on page 479)
2. Remove the Fixing Assembly. (“Removing the Fixing Assembly” on page 479)
3. Remove the Fixing Front Cover. (“Removing the Fixing Cleaning Web” on page 488)
4. Separate the Fixing Upper Unit from the Fixing Lower Unit. (“Separating the Fixing Upper Unit from the Fixing Lower Unit” on page 494)
5. Remove the Pressure Roller Unit. (“Removing the Pressure Roller” on page 500)

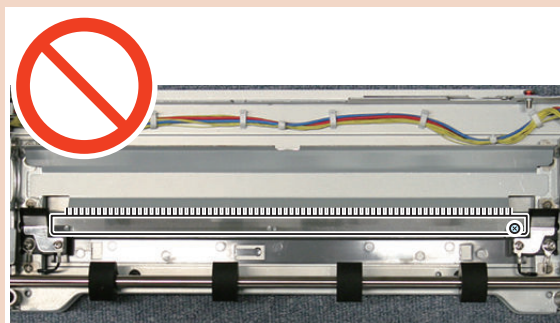
■ <Procedure>

1. Remove the Pressure Roller Static Eliminators (at the front and rear).
 - 2 Screws



CAUTION:

Do not remove the Static Eliminator with short bristles at the center because it is not a consumable part.



■ Actions after Parts Replacement

1. Clear the parts counter.(COPIER > COUNTER > DRBL-1 > FX-L-STC)

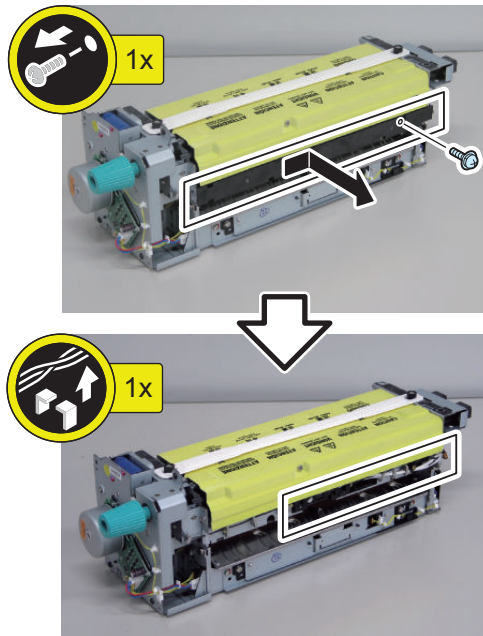
● Removing the Main Thermistor

■ Preparation

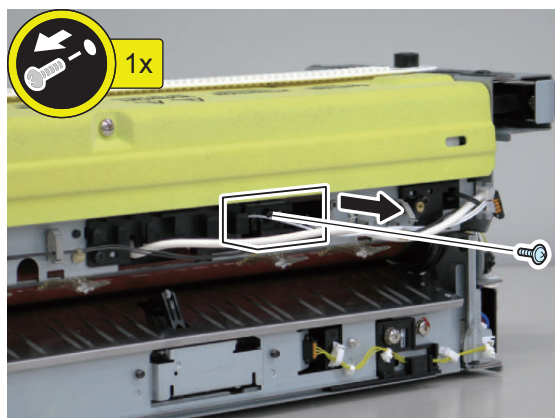
1. Pull out the Fixing Feed Unit. (“Removing the Fixing Assembly” on page 479)
2. Remove the Fixing Assembly. (“Removing the Fixing Assembly” on page 479)
3. Remove the Fixing Front Cover. (“Removing the Fixing Cleaning Web” on page 488)

■ <Procedure>

1. Remove the Harness Guide Cover and free the Harness from the Guide.
 - 1 Screw
 - Edge Saddle
 - Harness Guide

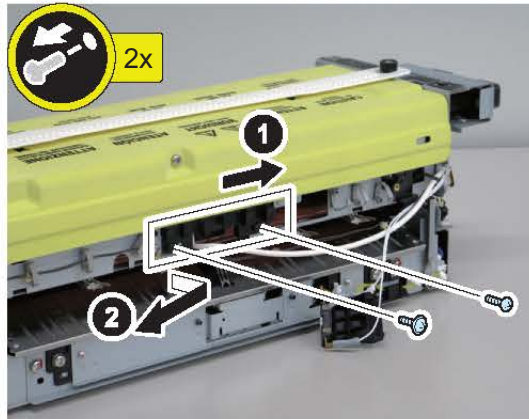


2. Remove the DC Thermoswitch Unit.
 - 1 Screw



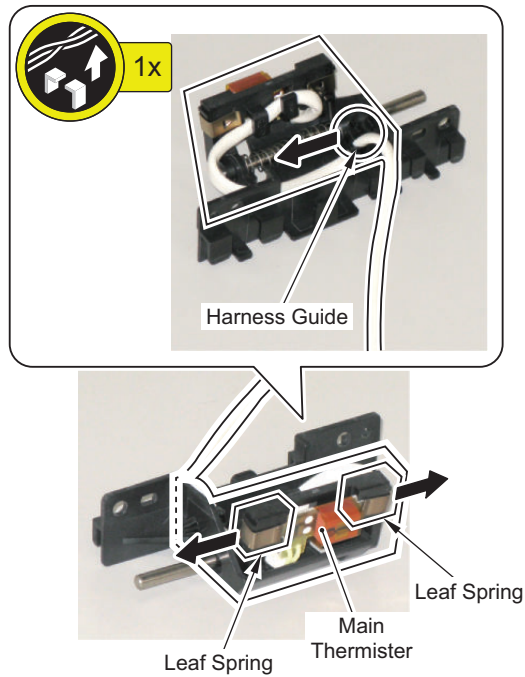
3. Remove the Main Thermistor Unit.

- 2 Screws



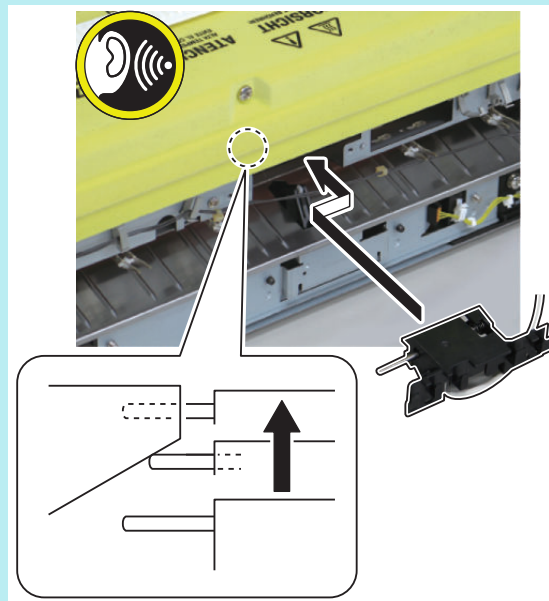
4. Remove the Copper Plate and the Harness Band to remove the Main Thermistor from the Main Thermistor Support Member.

- Harness Guide



NOTE:

When installing the Main Thermistor Unit, be sure to fit the shaft of Main Thermistor Unit in the shaft support until clicky sound is heard.



■ Actions after Parts Replacement

1. Clear the parts counter.(COPIER > COUNTER > PRDC-1 > FIX-TH1)

● Removing the Sub Thermistor 1

■ Preparation

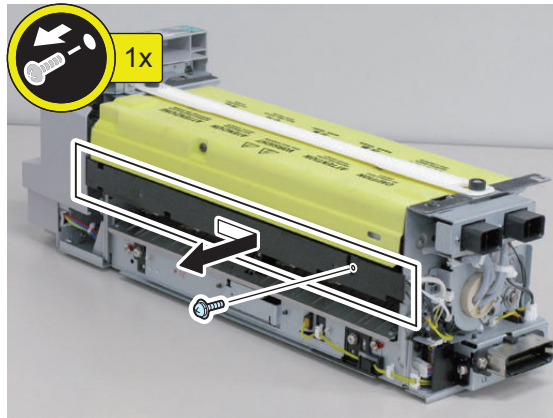
1. Pull out the Fixing Feed Unit.(“Removing the Fixing Assembly” on page 479)

2. Remove the Fixing Assembly. ("Removing the Fixing Assembly" on page 479)

■ <Procedure>

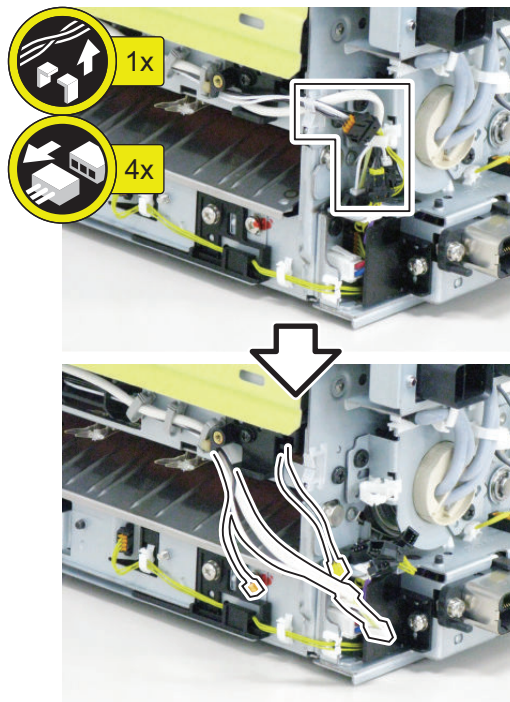
1. Remove the Harness Guide Cover.

- 1 Screw



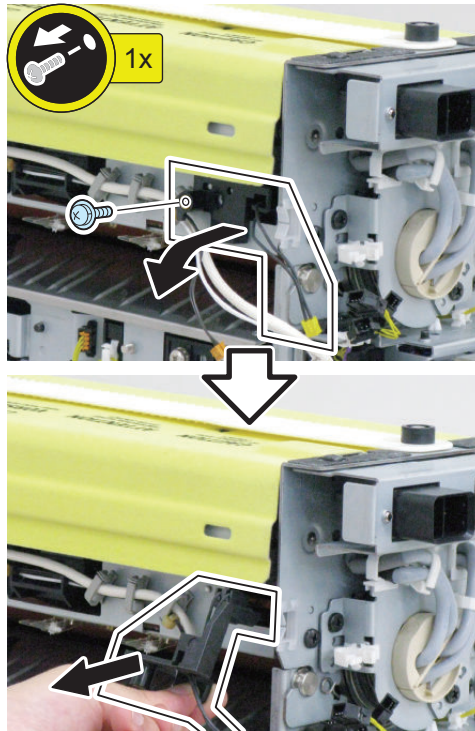
2. Remove the Harness to free as shown in the figure.

- 4 Connectors
- Edge Saddle
- Wire Saddle



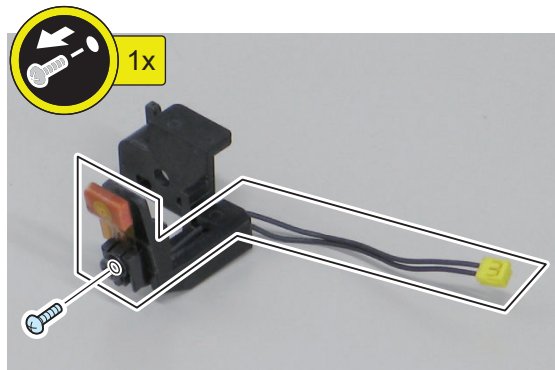
3. Remove the Fixing Sub Thermistor 1 Holder.

- 1 Screw



4. Remove the Fixing Sub Thermistor 1.

- 1 Screw



■ Actions after Parts Replacement

1. Clear the parts counter.
(Lv.1) COPIER > COUNTER > PRDC-1 > FIX-TH2

● Removing the Sub Thermistor 2

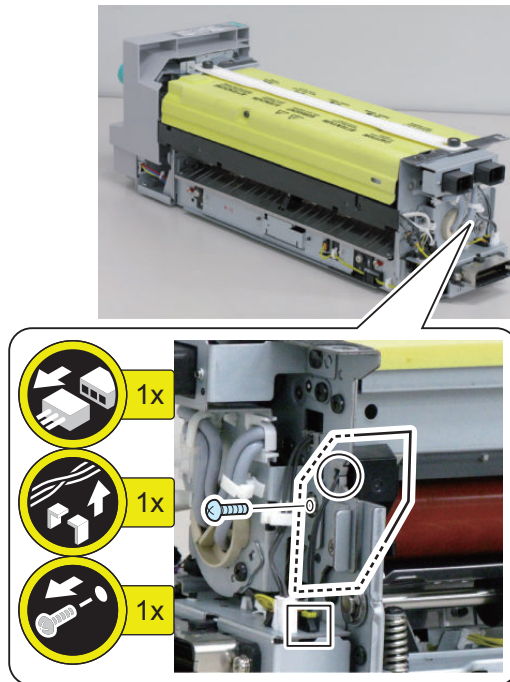
■ Preparation

1. Pull out the Fixing Feed Unit. (“Removing the Fixing Assembly” on page 479)
2. Remove the Fixing Assembly. (“Removing the Fixing Assembly” on page 479)
3. Remove the Sub Thermistor 1. (“Removing the Sub Thermistor 1” on page 505)

■ <Procedure>

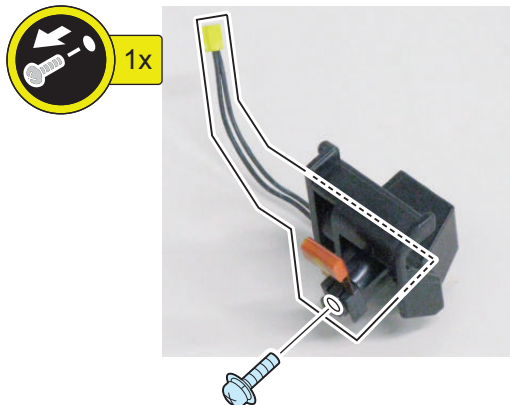
1. Remove the Fixing Sub Thermistor 2 Holder.

- 1 Connector
- Edge Saddle
- 1 Screw



2. Remove the Fixing Sub Thermistor 2.

- 1 Screw



■ Actions after Parts Replacement

1. Clear the parts counter.(COPIER > COUNTER > PRDC-1 > FIX-TH2)

● Removing the Upper Separation Claw

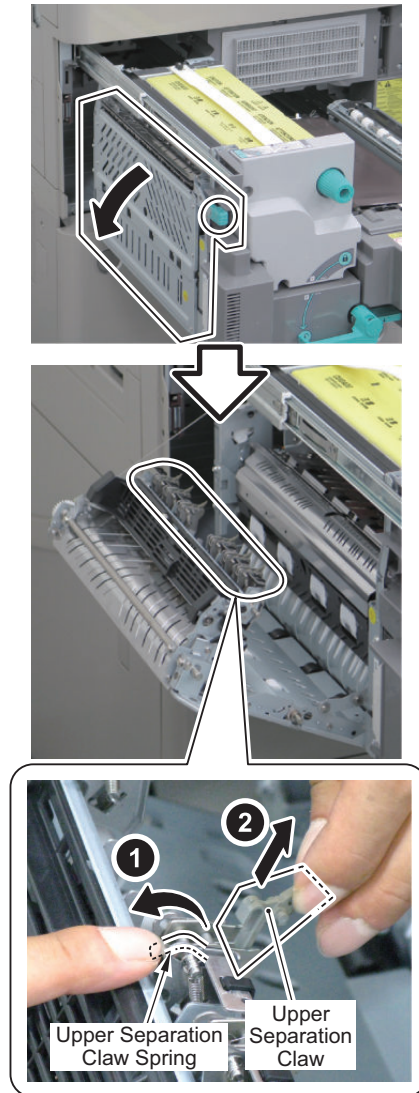
■ <Preparation>

1. Pull out the Fixing Feed Unit. (Refer to “Removing the Fixing Assembly” on page 479)

■ <Procedure>

1. Hold the Lever of the Left Guide to open the Left Guide.

2. While holding the Upper Separation Claw Retaining Spring, remove the Upper Separation Claw.



■ Actions after Parts Replacement

1. Clear the parts counter.(COPIER > COUNTER > DRBL-1 > DLV-UCLW)

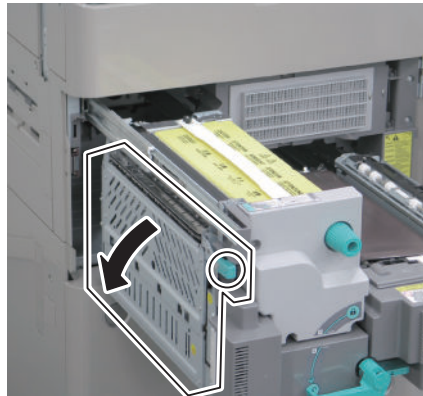
● Cleaning the Upper Separation Claw

■ <Preparation>

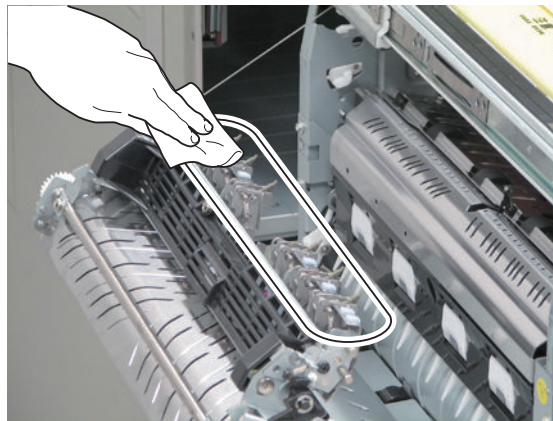
1. Pull out the Fixing Feed Unit. (Refer to“[Removing the Fixing Assembly](#)” on page 479)

■ Procedure

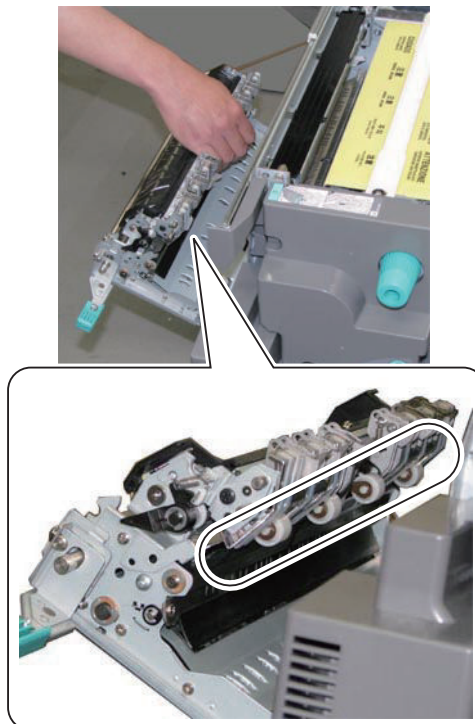
1. Hold the Lever of the Feed Unit to open the Feed Unit.



2. Clean the Upper Separation Claw with lint-free paper moistened.



3. Wipe toner off the 4 Inner Delivery Rollers with lint-free paper moistened with alcohol.



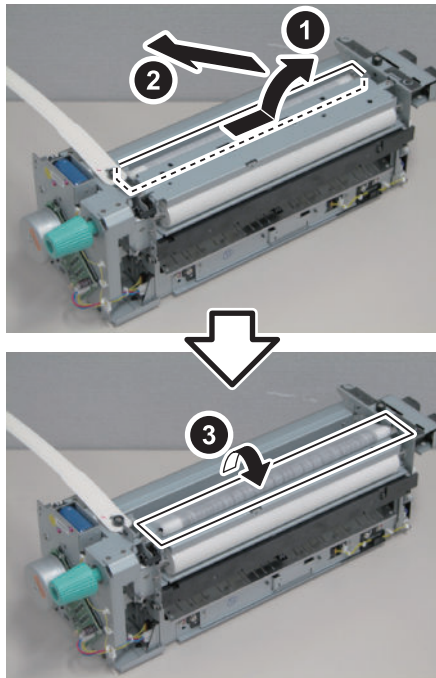
● Removing the Thermoswitch 2

■ Preparation

1. Pull out the Fixing Feed Unit. (“Removing the Fixing Assembly” on page 479)
2. Remove the Fixing Assembly. (“Removing the Fixing Assembly” on page 479)
3. Remove the Fixing Front Cover. (“Removing the Fixing Cleaning Web” on page 488)
4. Remove the Fixing Upper Cover. (“Removing the Fixing Cleaning Web” on page 488)

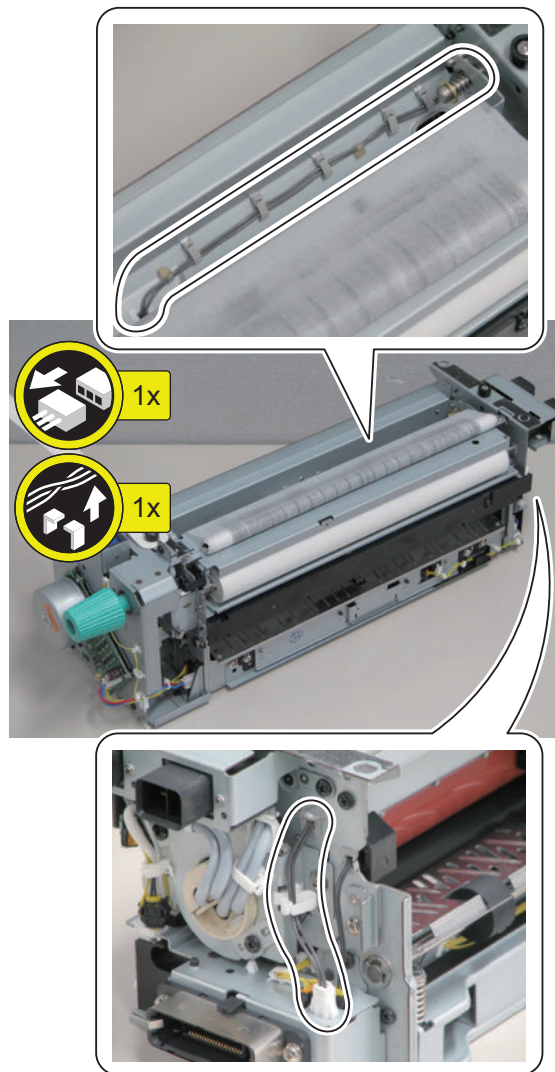
■ <Procedure>

1. Remove the Fixing Cleaning Web (take-up side).



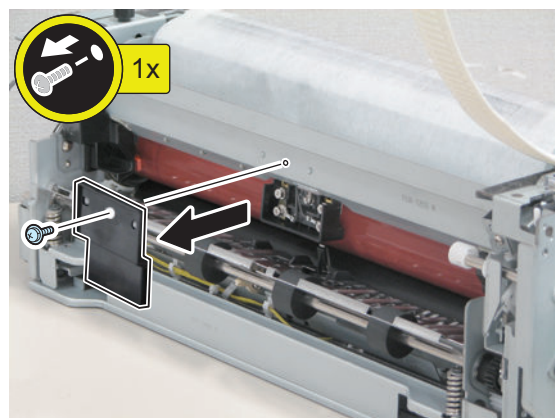
2. Free the harness of Thermoswitch 2.

- 1 Connector
- Wire Saddle



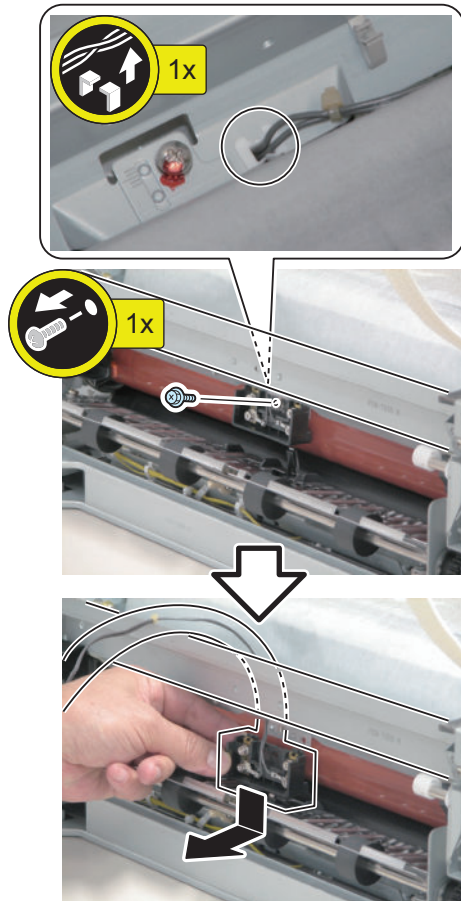
3. Remove the Thermoswitch Cover.

- 1 Screw



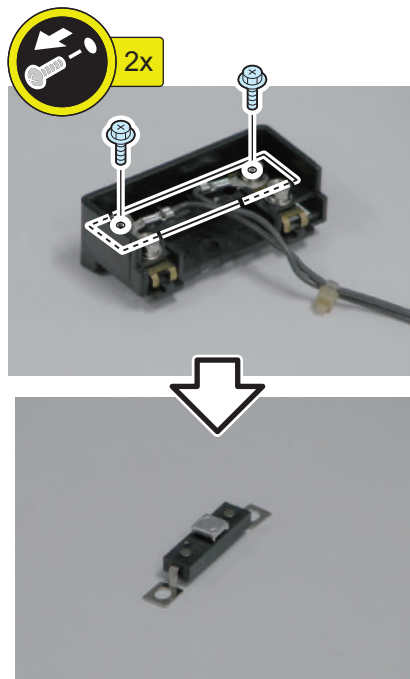
4. Free the harness from the Edge Saddle and remove the Thermoswitch 2 Unit.

- 1 Screw



5. Remove the Thermoswitch 2.

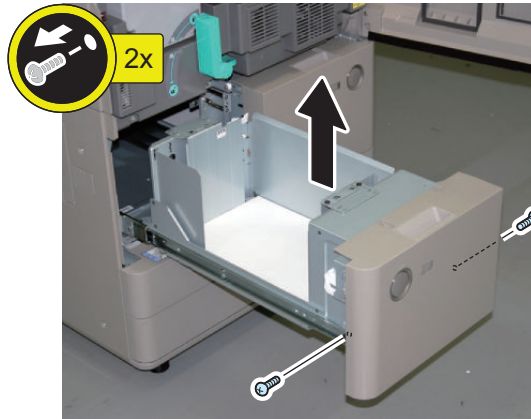
- 2 Screws



Pickup Feed System

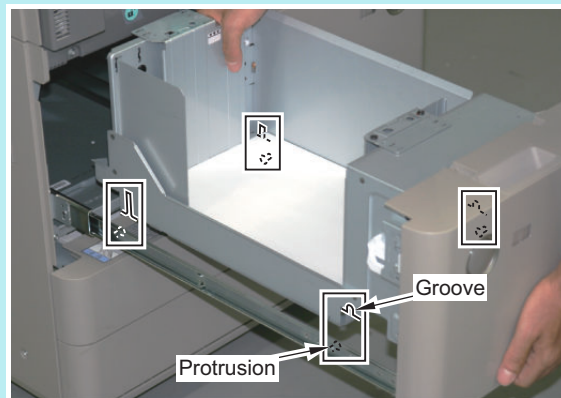
Removing the Left Pickup Deck

1. Open the Front Cover.
2. Pull out the Left Pickup Deck to remove.
 - 2 Screws



NOTE:

When installing the Left Pickup Deck, be sure to fit the 4 protrusions on the Rail into the 4 grooves of the Left Pickup Deck to install.



Removing the Left Deck Pickup Roller

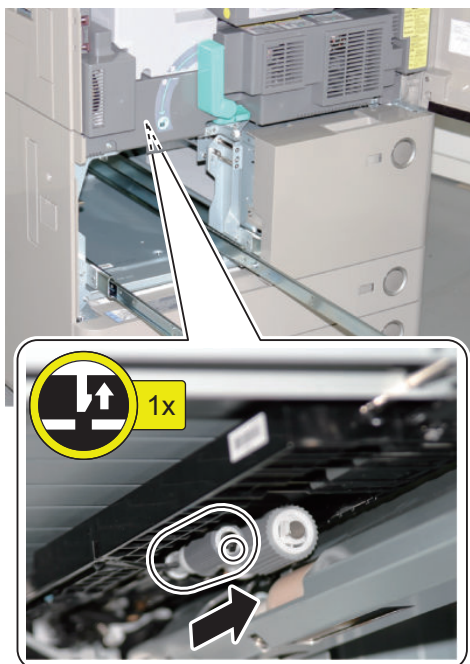
Preparation

1. Open the Front Cover.
2. Remove the Left Pickup Deck. (["Removing the Left Pickup Deck" on page 514](#))

■ <Procedure>

1. Remove the Left Deck Pickup Roller.

- 1 Claw



■ Actions after Parts Replacement

1. Clear the parts counter.(COPIER > COUNTER > DRBL-1 > C2-PU-RL)

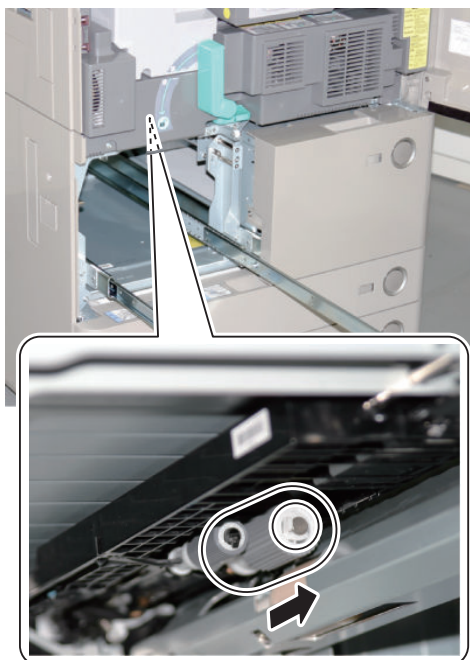
● Removing the Left Deck Feed Roller

■ Preparation

1. Open the Front Cover.
2. Remove the Left Pickup Deck.(“Removing the Left Pickup Deck” on page 514)

■ <Procedure>

1. Remove the Stopper to remove the Left Deck Feed Roller.



■ Actions after Parts Replacement

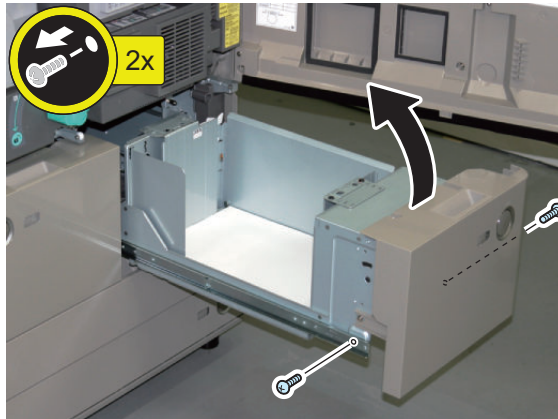
1. Clear the parts counter.(COPIER > COUNTER > DRBL-1 > C2-FD-RL)

● Removing the Right Pickup Deck

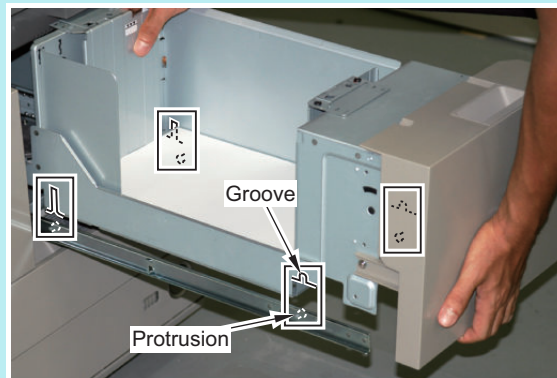
1. Open the Front Cover.

2. Pull out the Right Pickup Deck to remove.

- 2 Screws

**NOTE:**

When installing the Right Pickup Deck, be sure to fit the 4 protrusions on the Rail into the 4 grooves of the Right Pickup Deck to install.



● Removing the Left Deck Separation Roller/Cleaning the Left Deck Pickup Sensor (PS20)

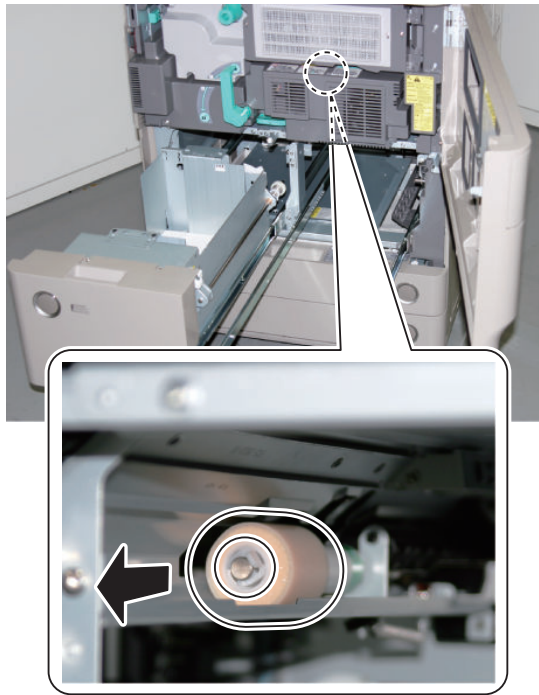
■ Preparation

1. Open the Front Cover.
2. Remove the Right Pickup Deck. (“Removing the Right Pickup Deck” on page 516)

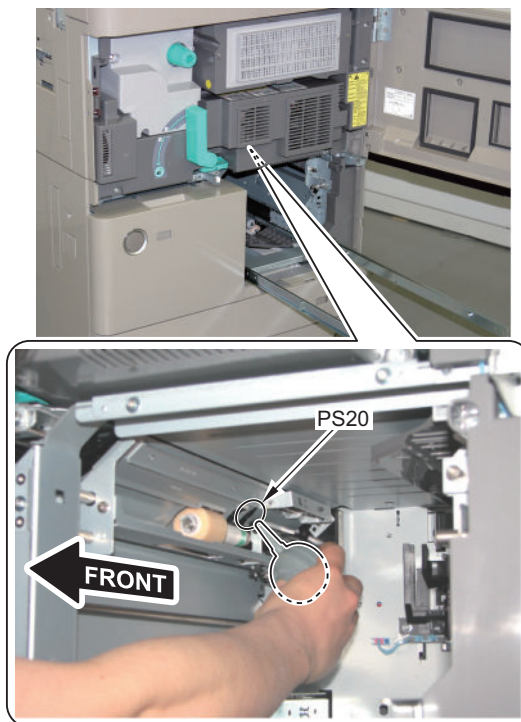
■ Procedure

1. Pull out the Left Pickup Deck.

2. Remove the Stopper to remove the Left Deck Separation Roller.



3. Clean paper dust on the Left Deck Pickup Sensor (PS20) with a blower when replacing the Separation Roller.



■ Actions after Parts Replacement

1. Clear the parts counter.

(Lv.1) COPIER > COUNTER > DRBL-1 > C2-SP-RL

● Removing the Right Deck Pickup Roller

■ Preparation

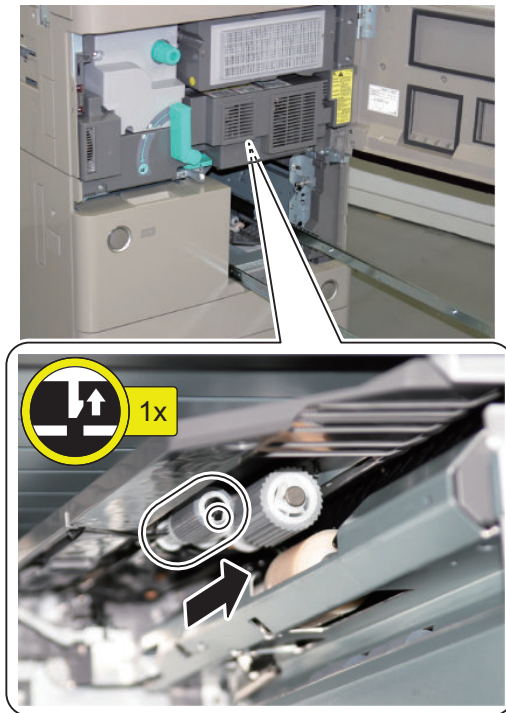
1. Open the Front Cover.

2. Remove the Right Pickup Deck.(Removing the Right Pickup Deck)

■ <Procedure>

1. Remove the Right Deck Pickup Roller.

- 1 Claw



■ Actions after Parts Replacement

1. Clear the parts counter.(COPIER > COUNTER > DRBL-1 > C1-PU-RL)

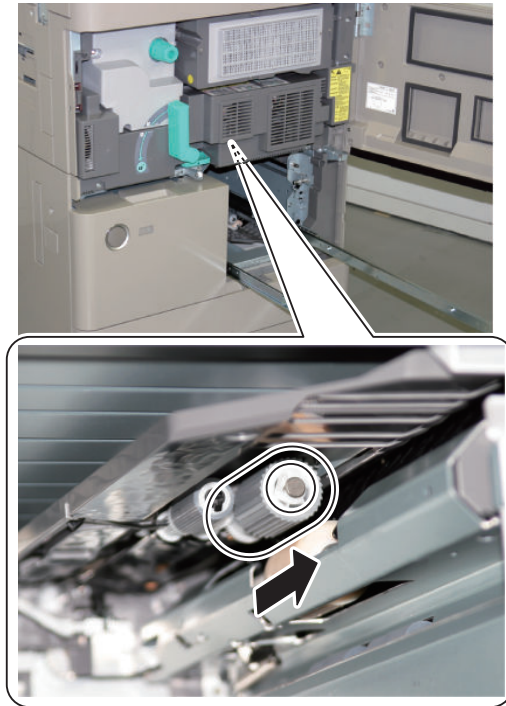
● Removing the Right Deck Feed Roller

■ Preparation

1. Open the Front Cover.
2. Remove the Right Pickup Deck.(Removing the Right Pickup Deck)

■ <Procedure>

1. Remove the Stopper to remove the Right Deck Feed Roller.



■ Actions after Parts Replacement

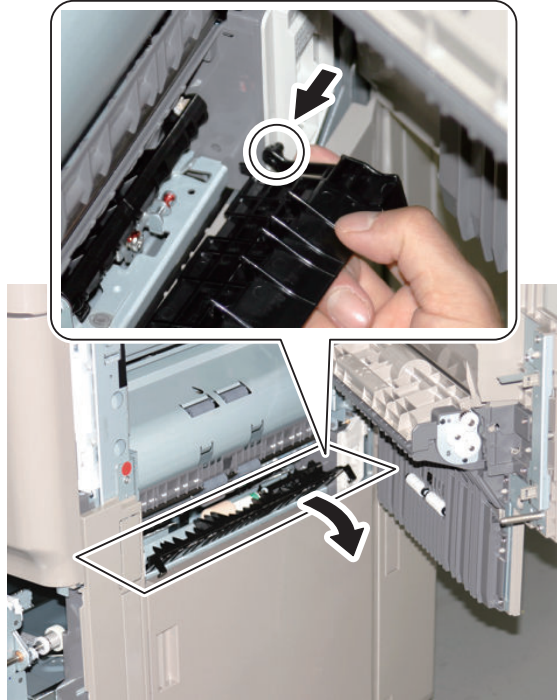
1. Clear the parts counter.(COPIER > COUNTER > DRBL-1 > C1-FD-RL)

● Removing the Right Deck Separation Roller/Cleaning the Right Deck Pickup Sensor (PS19)

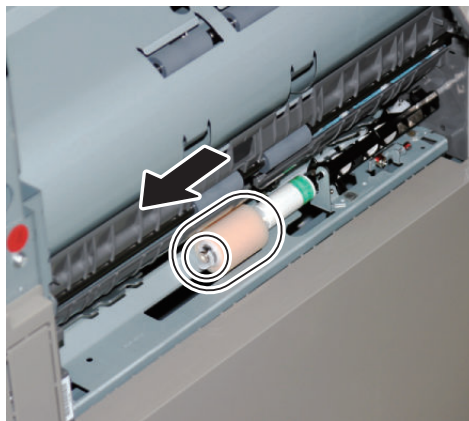
1. Open the Right Upper Cover.
2. Pull out the Right Pickup Deck.

3. Remove the Feed Guide.

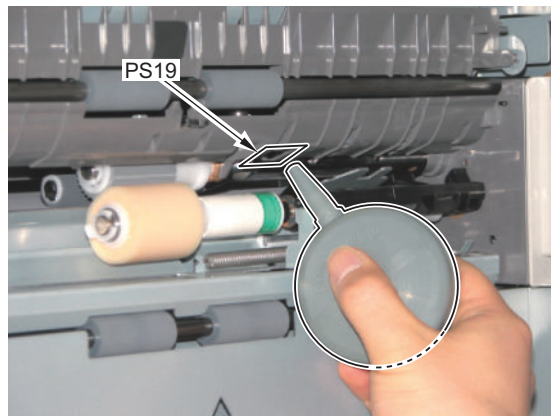
- 1 Boss



4. Remove the Stopper to remove the Right Deck Separation Roller.



5. Clean paper dust on the Right Deck Pickup Sensor (PS19) with a blower when replacing the Separation Roller.



■ Actions after Parts Replacement

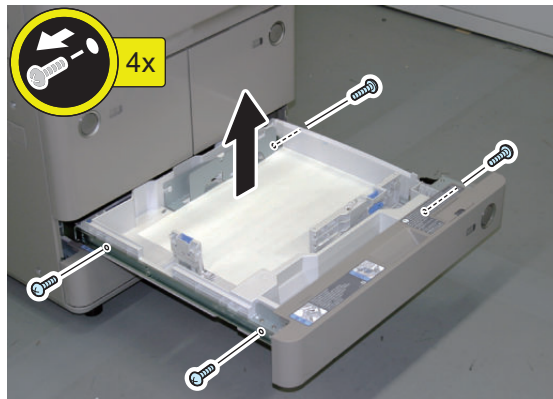
1. Clear the parts counter.

(Lv.1) COPIER > COUNTER > DRBL-1 > C1-SP-RL

● Removing the Upper Cassette

1. Pull out the Upper Cassette to remove.

- 4 Screws



● Removing the Upper Cassette Pickup Roller

■ Preparation

1. Remove the Upper Cassette. ("Removing the Upper Cassette" on page 522)

■ <Procedure>

1. Remove the Upper Cassette Pickup Roller.

- 1 Claw



■ Actions after Parts Replacement

1. Clear the parts counter. (COPIER > COUNTER > DRBL-1 > C3-PU-RL)

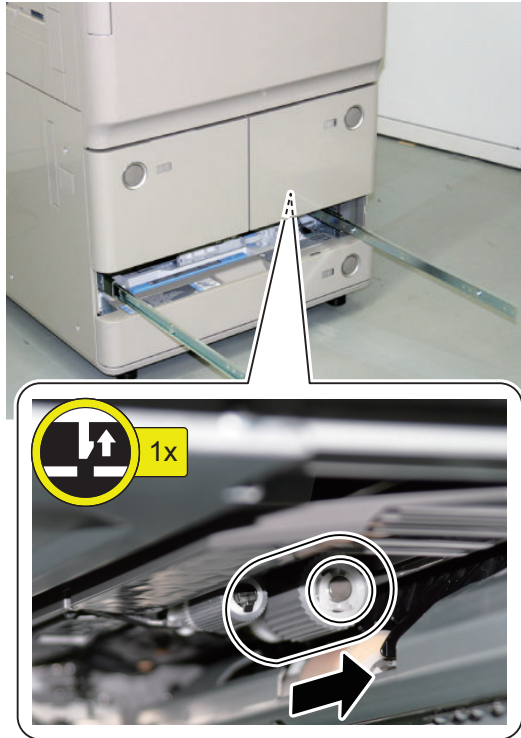
● Removing the Upper Cassette Feed Roller

■ Preparation

1. Remove the Upper Cassette. (“Removing the Upper Cassette” on page 522)

■ Procedure

1. Remove the Stopper to remove the Upper Cassette Feed Roller.



■ Actions after Parts Replacement

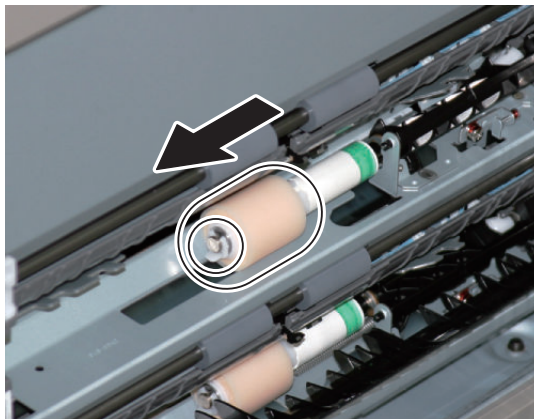
1. Clear the parts counter.(COPIER > COUNTER > DRBL-1 > C3-FD-RL)

● Removing the Upper Cassette Separation Roller/Cleaning the Cassette 3 Pickup Sensor (PS21)

1. Open the Right Lower Cover.
2. Remove the Upper Cassette. (“Removing the Upper Cassette” on page 522)

3. Remove the Feed Guide.

- 1 Boss

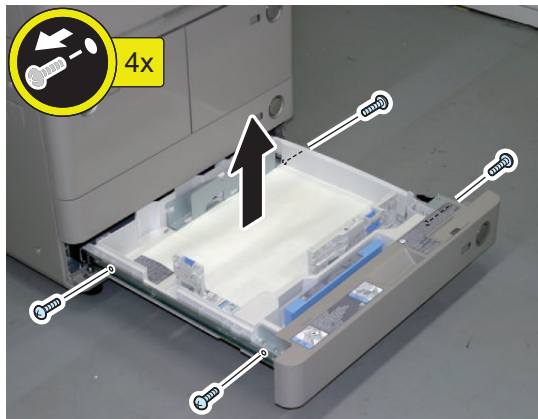
**4. Remove the Stopper to remove the Upper Cassette Separation Roller.****5. Clean paper dust on the Cassette 3 Pickup Sensor 2 (PS21) with a blower when replacing the Separation Roller.****■ Actions after Parts Replacement****1. Clear the parts counter.**

(Lv.1) COPIER > COUNTER > DRBL-1 > C3-SP-RL

● Removing the Lower Cassette

1. Pull out the Lower Cassette to remove.

- 4 Screws



● Removing the Lower Cassette Pickup Roller

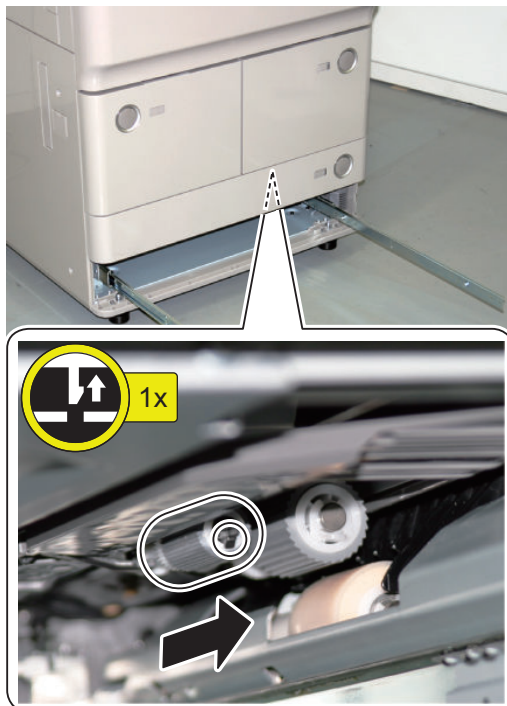
■ Preparation

1. Remove the Lower Cassette. ("Removing the Lower Cassette" on page 525)

■ <Procedure>

1. Remove the Lower Cassette Pickup Roller.

- 1 Claw



■ Actions after Parts Replacement

1. Clear the parts counter.(COPIER > COUNTER > DRBL-1 > C4-PU-RL)

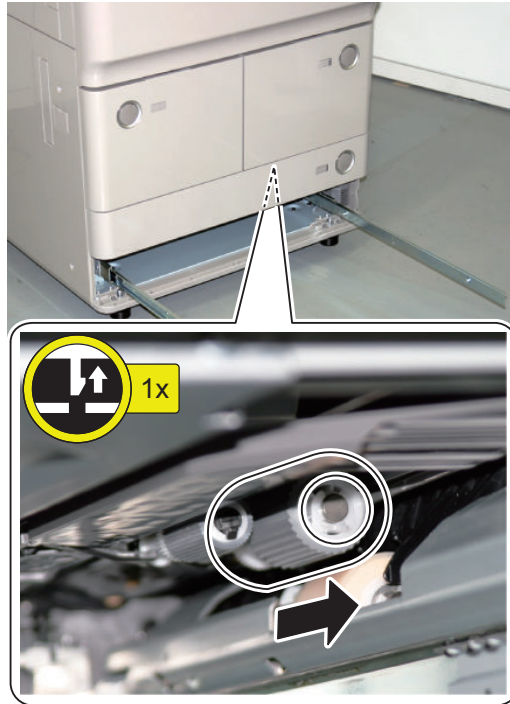
● Removing the Lower Cassette Feed Roller

■ Preparation

1. Remove the Lower Cassette.([Removing the Lower Cassette](#))

■ <Procedure>

1. Remove the Stopper to remove the Lower Cassette Feed Roller.



■ Actions after Parts Replacement

1. Clear the parts counter.(COPIER > COUNTER > DRBL-1 > C4-FD-RL)

● Removing the Lower Cassette Separation Roller/Cleaning the Cassette 4 Pickup Sensor (PS22)

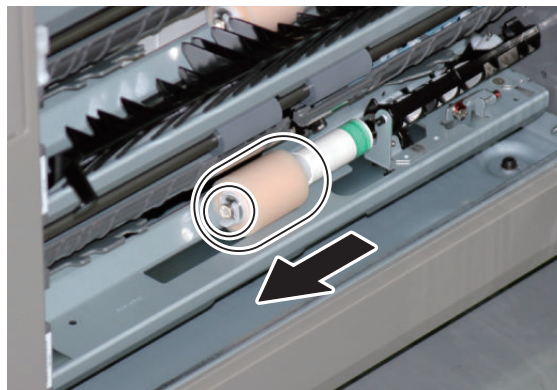
1. Open the Right Lower Cover.
2. Remove the Lower Cassette.([“Removing the Lower Cassette” on page 525](#))

3. Remove the Feed Guide.

- 1 Boss



4. Remove the Stopper to remove the Lower Cassette Separation Roller.



5. Clean paper dust on the Cassette 4 Pickup Sensor (PS22) with a blower when replacing the Separation Roller.



■ Actions after Parts Replacement

1. Clear the parts counter.

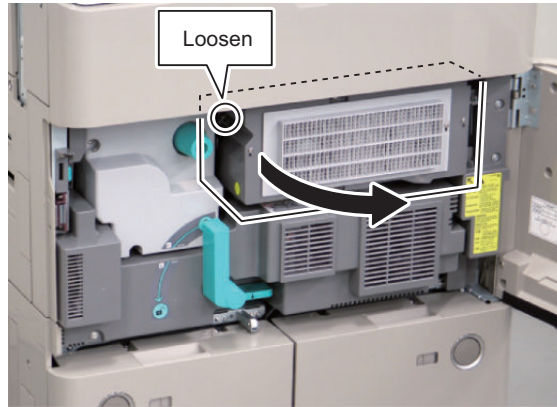
(Lv.1) COPIER > COUNTER > DRBL-1 > C4-SP-RL

● Removing the Multi-purpose Tray Feed Roller

■ <Preparation>

1. Open the Inner Cover.

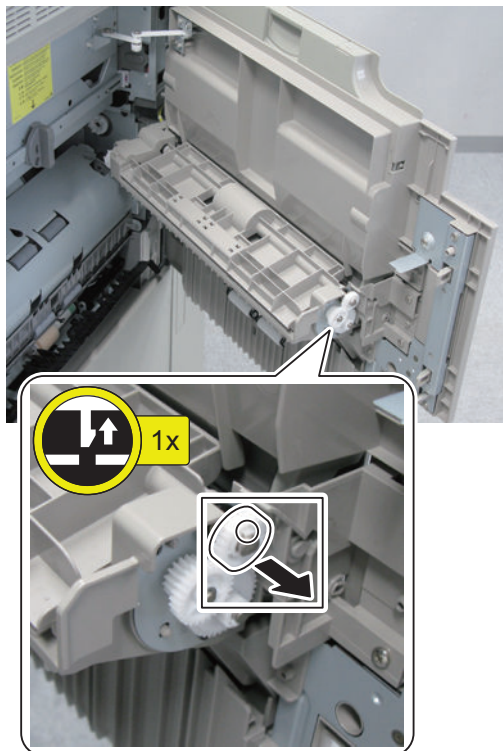
1. Open the Front Cover.
2. Open the Inner Cover.
 - 1 Screw (to loosen)



■ <Procedure>

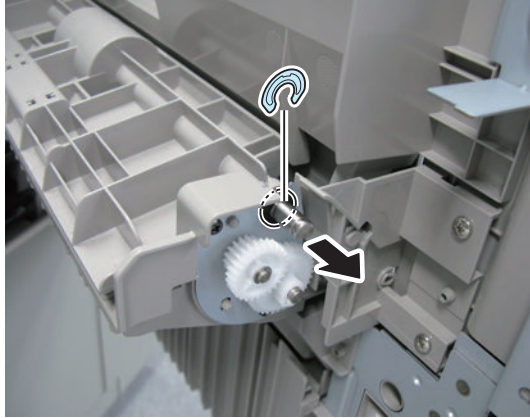
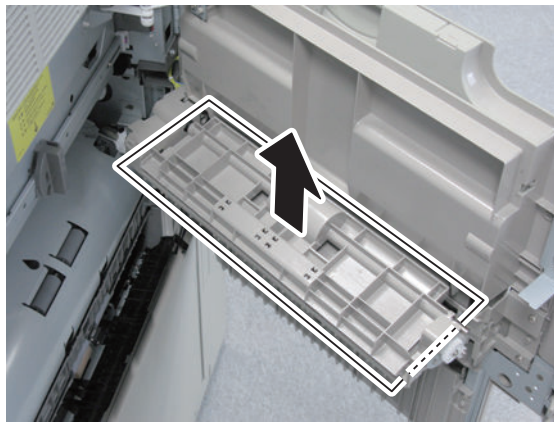
1. Remove the gear.

- 1 Claw

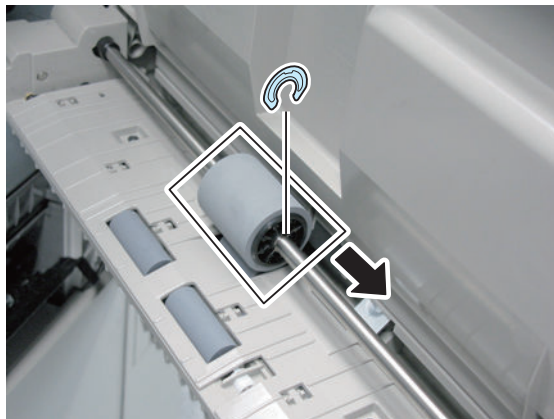


2. Remove the bushing.

- 1 E-ring

**3. Remove the Multi-purpose Tray Pickup Guide.****4. Remove the Multi-purpose Tray Feed Roller.**

- 1 E-ring

**■ Actions after Parts Replacement**

1. Clear the parts counter.(COPIER > COUNTER > DRBL-1 > M-FD-RL)

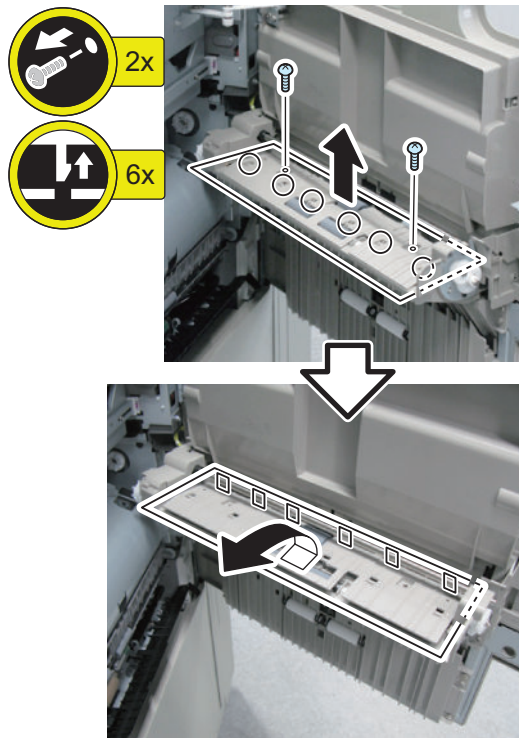
● Removing the Multi-purpose Tray Separation Roller**■ Preparation**

1. Open the Inner Cover.(“Removing the Multi-purpose Tray Feed Roller” on page 528)
2. Remove the Multi-purpose Tray Feed Roller.(“Removing the Multi-purpose Tray Feed Roller” on page 528)

■ <Procedure>

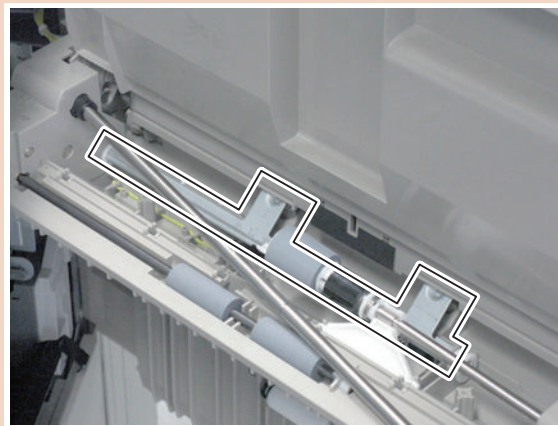
1. Remove the Multi-purpose Tray Lower Guide.

- 2 Screws
- 6 Claws
- 6 Protrusions



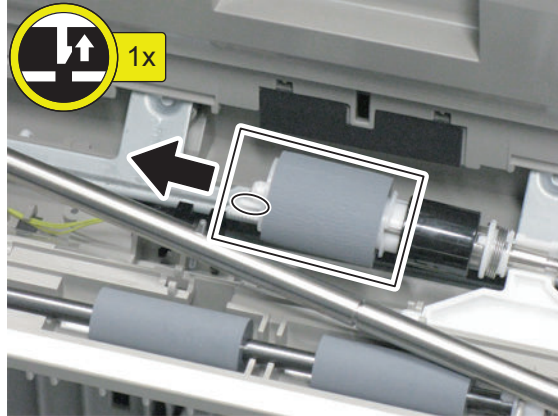
CAUTION:

Installation work gets difficult if the plate and the spring (as shown in the figure) are removed when removing the cover; therefore, be careful not to remove them.



2. Remove the Multi-purpose Tray Separation Roller.

- 1 Claw



■ Actions after Parts Replacement

1. Clear the parts counter.(COPIER > COUNTER > DRBL-1 > M-SP-RL)

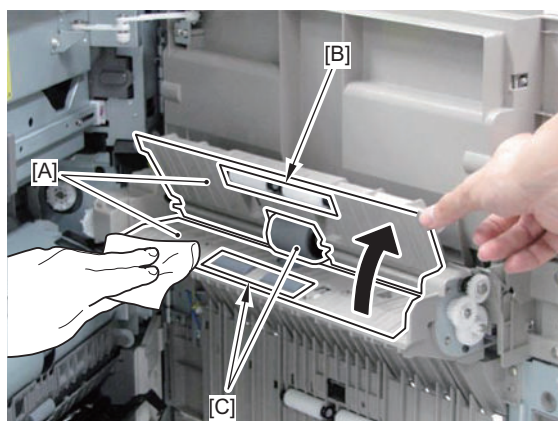
● Cleaning the Pickup and Fixing Feed Assembly

■ Cleaning the Vertical Path Assembly

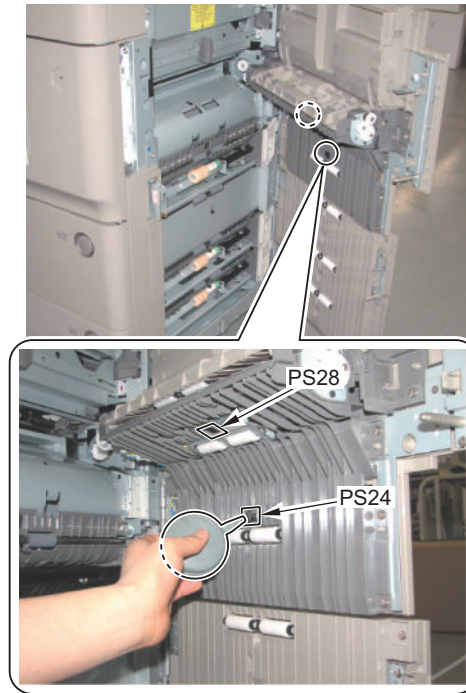
1. Open the Right Cover.
2. Open the Right Lower Cover.
3. Open the Multi-purpose Tray Pickup Guide Unit, and clean the 2 areas of the Feed Guide [A]. (Remove paper lint.)
4. Clean a whole circumference of 2 Rollers [B] and the 3 Rollers [C] by manually rotating them with lint-free paper moistened with alcohol.

CAUTION:

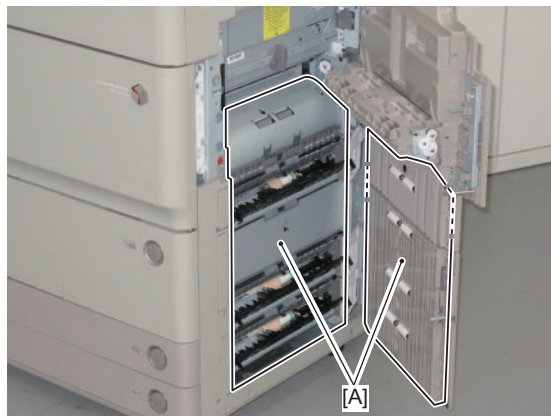
When rotating the Roller by hand, do not touch the surface of the Roller. Be sure to hold the side of the Roller to rotate manually.



5. Clean paper dust on the Vertical Path Sensor 1 (PS24) and the Writing Judging Sensor (PS28) with a blower.



6. Clean paper dust on the Feed Guide [A] with lint-free paper.



7. Clean a whole circumference of 10 Rollers by manually rotating them with lint-free paper moistened with alcohol.

CAUTION:

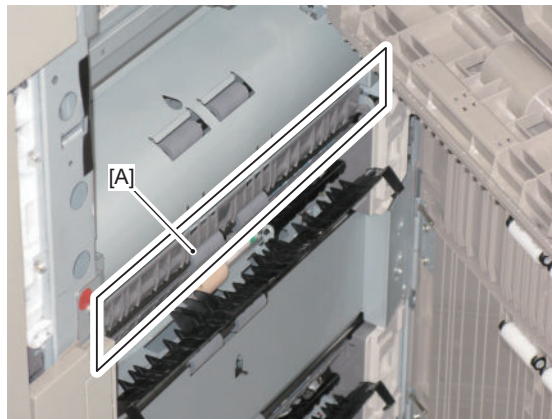
When rotating the Roller by hand, do not touch the surface of the Roller. Be sure to hold the side of the Roller to rotate manually.



8. Clean a whole circumference of 10 Rollers by manually rotating them with lint-free paper moistened with alcohol.

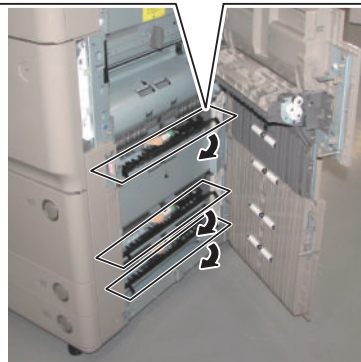
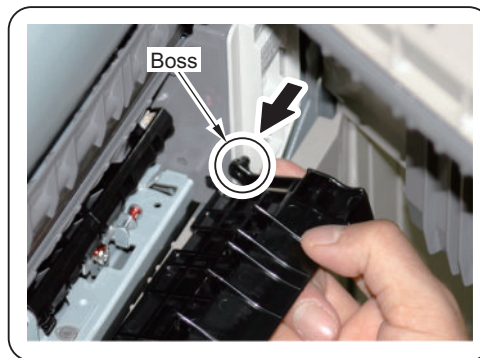


9. Open the Duplex Merging Guide and clean paper dust on the Feed Guide [A] with lint-free paper.

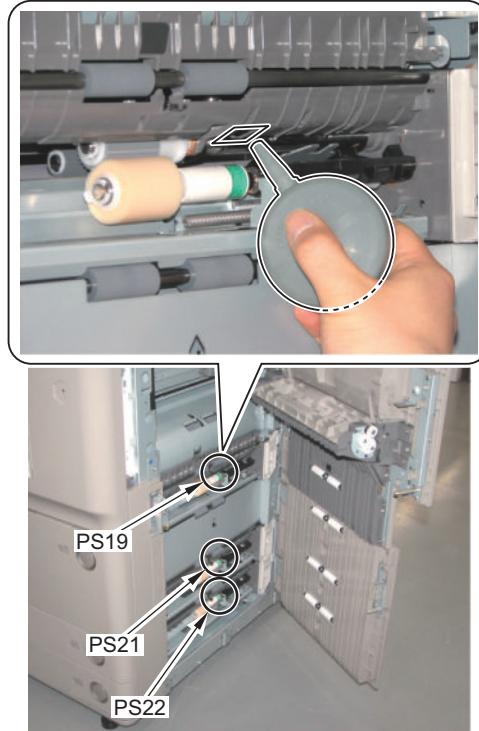


10. Remove the 3 Feed Guides.

- 1 Boss



11. Clean paper dust on the Right Deck Pickup Sensor (PS19), Cassette 3 Pickup Sensor (PS21), and Cassette 4 Pickup Sensor (PS22) with a blower.



12. Install the 3 Feed Guides whom I excluded.

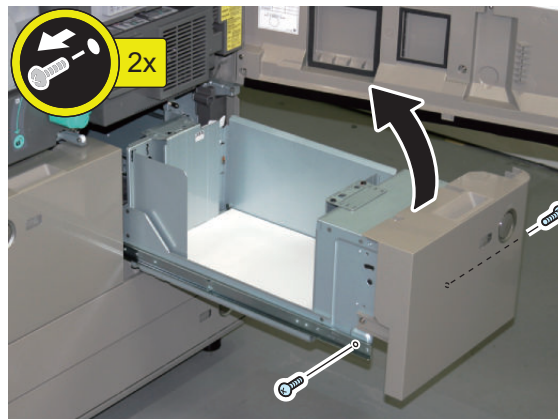
13. Close the Right Cover.

14. Close the Right Lower Cover.

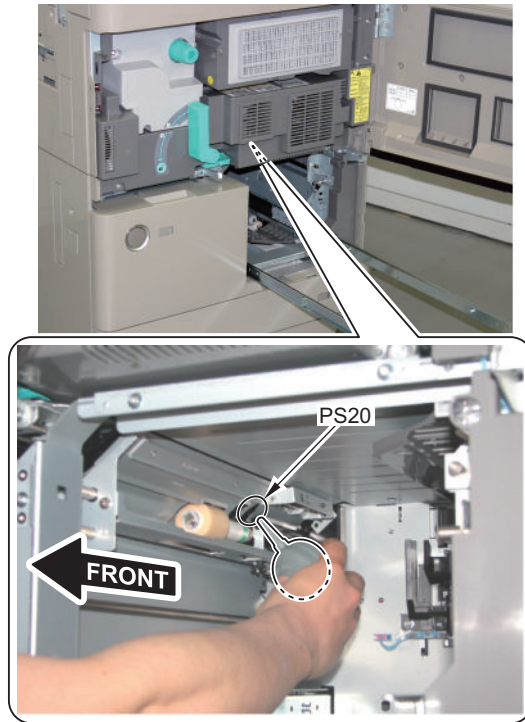
15. Open the Front Cover.

16. Pull out the Right Deck to remove.

- 2 Screws



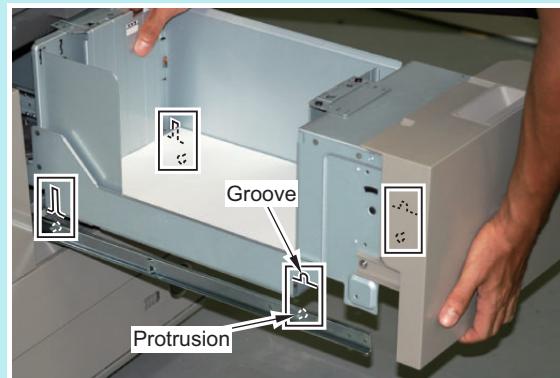
17. Clean paper dust on the Left Deck Pickup Sensor (PS20) with a blower.



18. Install the Right Deck and place it inside the host machine

NOTE:

When installing the Right Pickup Deck, be sure to fit the 4 protrusions on the Rail into the 4 grooves of the Right Pickup Deck to install.



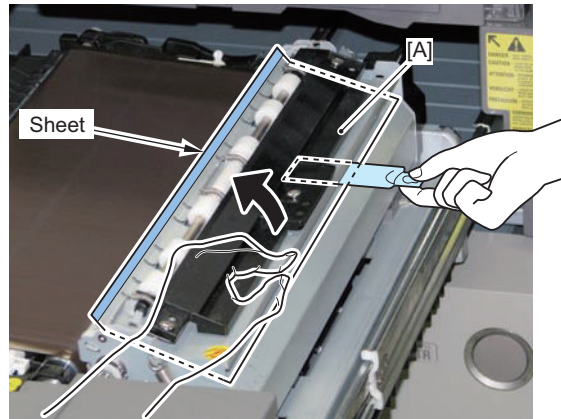
■ <Cleaning the Fixing Feed Assembly>

1. Open the Fixing Feed Unit fully.

2. Open the Registration Upper Guide, insert the paper lint cleaning tool into the clearance between the Registration Upper Guide and the Registration Lower Guide, and clean the feed area [A].

CAUTION:

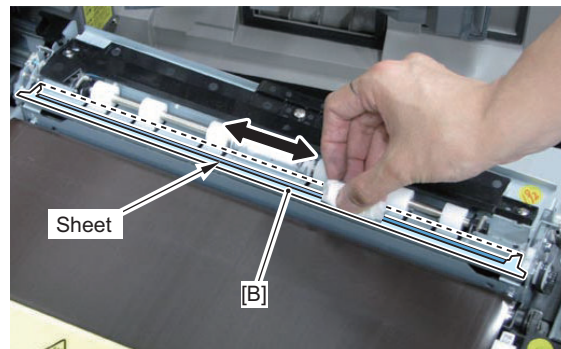
Be careful not to damage the sheet on the edge of the Registration Upper Guide.



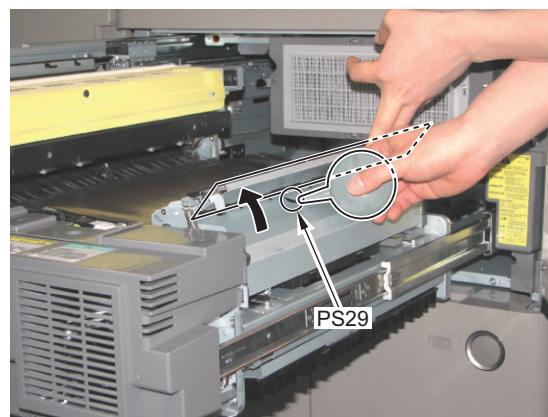
3. Insert lint-free paper into the clearance between the Registration Upper Guide and the Registration Lower Guide, and clean the feed area [B] and the sheet on the edge of the Registration Upper Guide.

CAUTION:

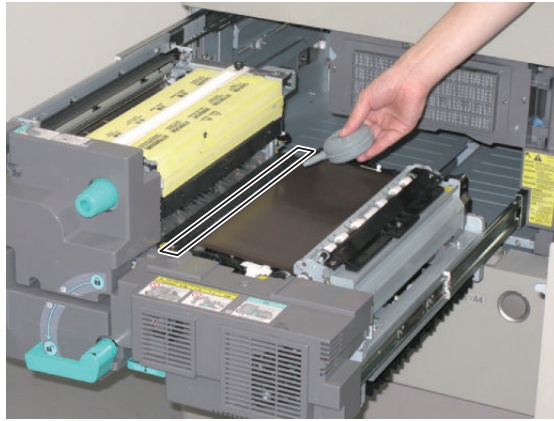
Be careful not to damage the sheet on the edge of the Registration Upper Guide.



4. Open the Registration Upper Guide and clean paper dust on the Registration Sensor (PS29) with a blower.

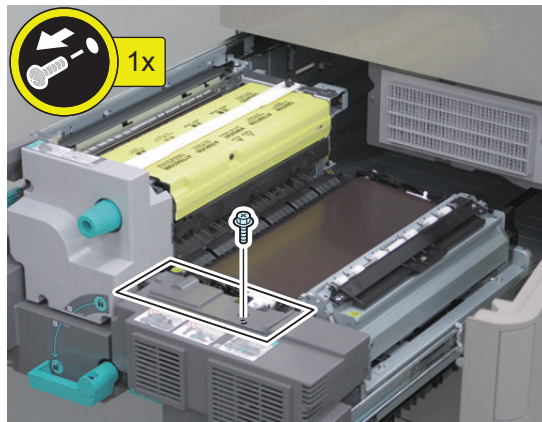


5. Point the leading edge of Blower to the Static Eliminator and clean adhered soiling.

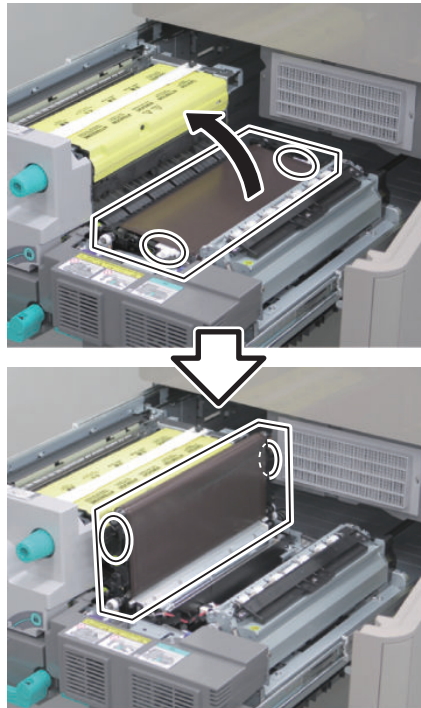


6. Remove the Fixing Feed Cover (Upper).

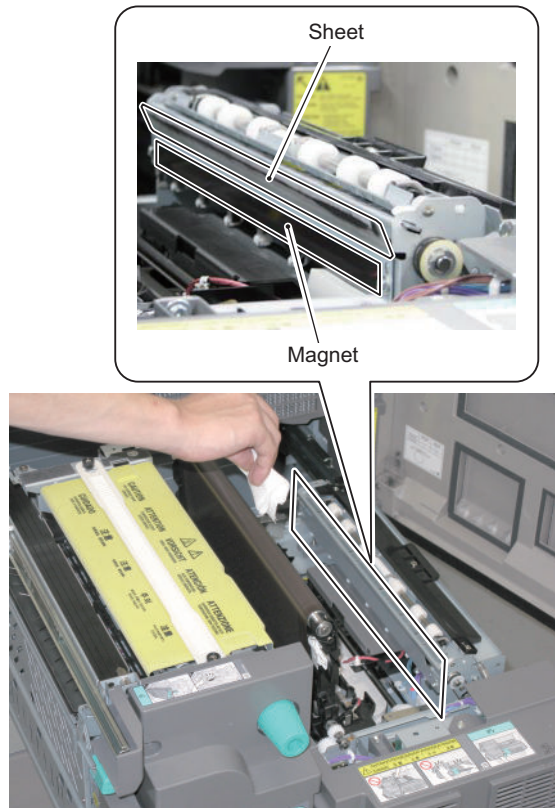
- 1 Screw



7. Hold the 2 handles to lift the ETB Unit in the direction of the arrow.

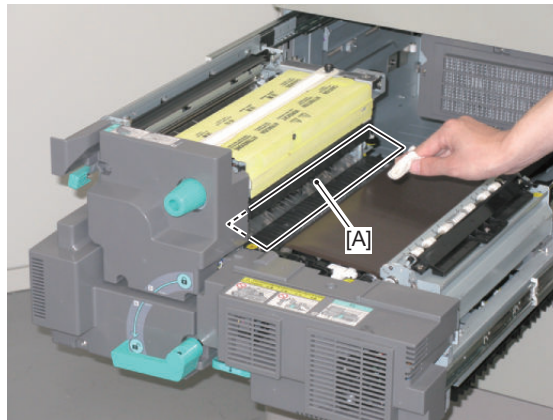


8. Clean the soiling adhered on the Magnet and the Sheet with lint-free paper moistened with alcohol.



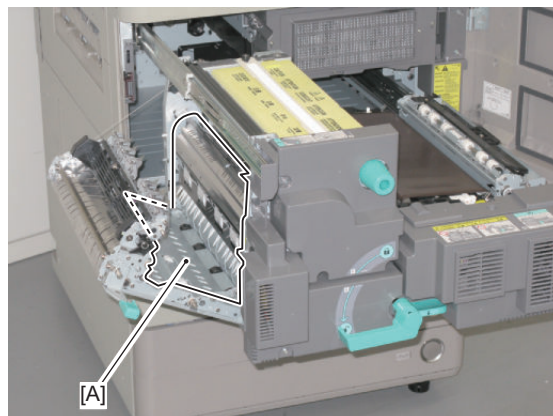
9. I return an ETB unit to the original position.

10. Clean the Fixing Inlet Guide [A] with lint-free paper moistened with alcohol.



11. Hold the lever of the Feed Unit to open the Feed Unit.

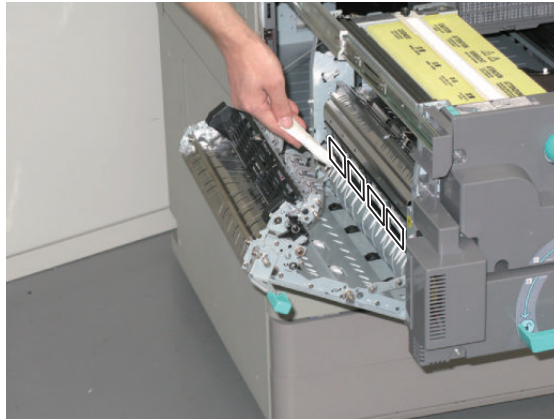
12. Clean paper dust on the Feed Guide [A] with lint-free paper.



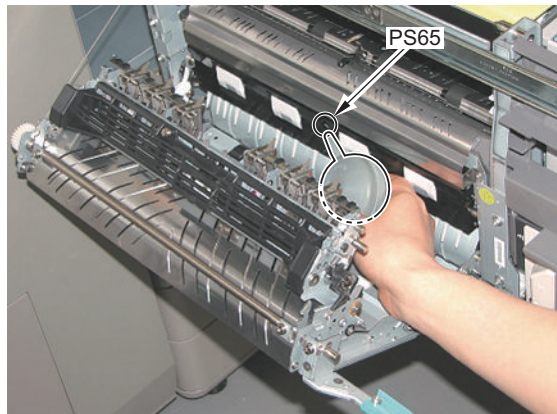
13. Clean a whole circumference of 4 Rollers by manually rotating them with lint-free paper moistened with alcohol.

CAUTION:

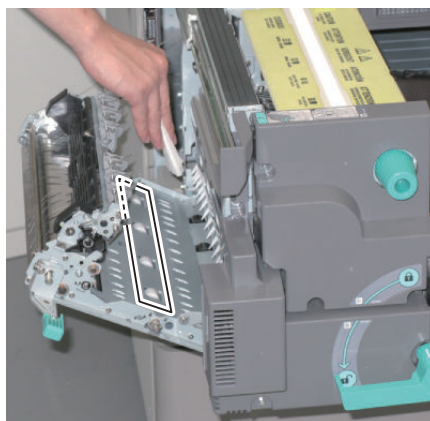
When rotating the Roller by hand, do not touch the surface of the Roller. Be sure to hold the side of the Roller to rotate manually.



14. Clean paper dust on the Reverse Vertical Path Sensor (PS65) with a blower.

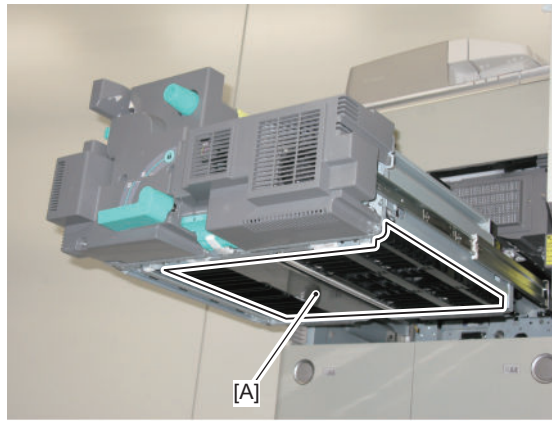


15. Clean a whole circumference of 4 Rollers by manually rotating them with lint-free paper moistened with alcohol.

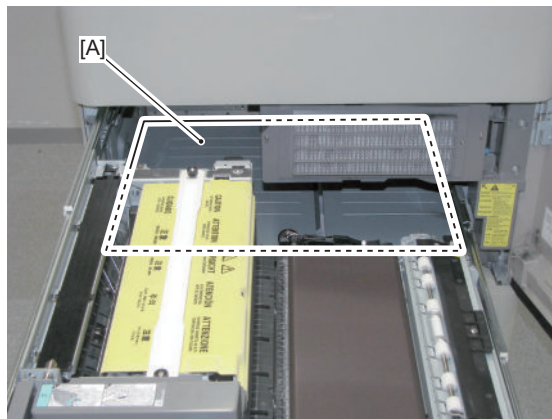


16. Hold the lever of the Feed Unit to close the Feed Unit.

17. Clean paper dust on the feed area [A] of the Reverse Path with lint-free paper.

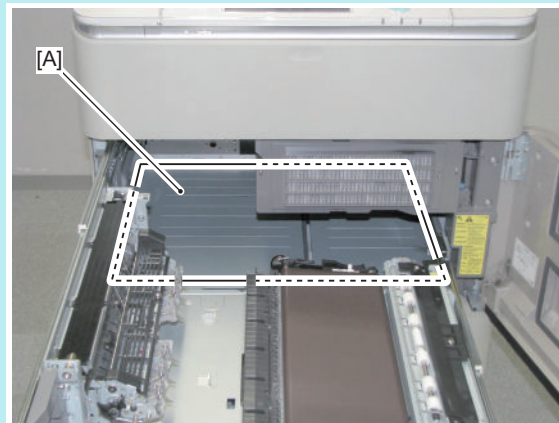


18. Clean paper dust on the feed area [A] inside the equipment with lint-free paper.



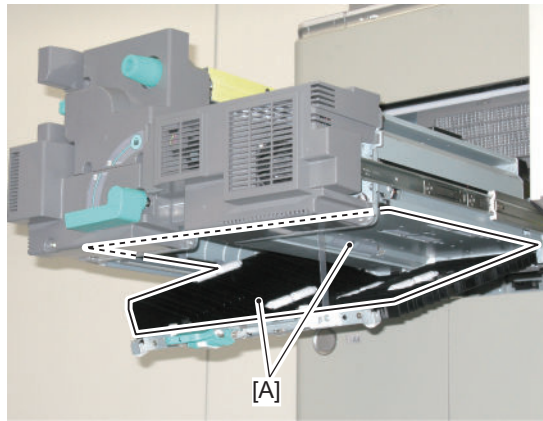
NOTE:

To clean the feed area [A] inside main body, removing the Fixing Assembly can improve the operability.



19. Open the Duplex Path.

20. Clean paper dust on the feed area [A] of the Duplex Path (Upper/Lower) with lint-free paper.



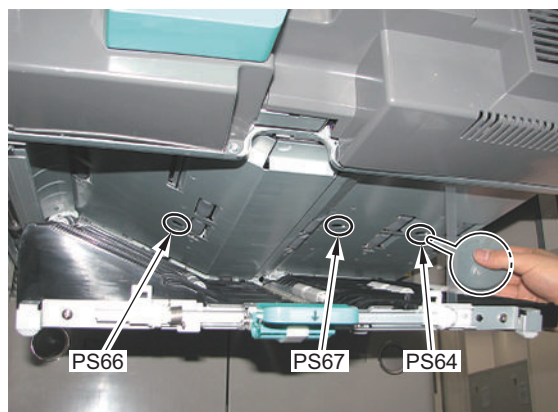
21. Clean a whole circumference of 10 Rollers by manually rotating them with lint-free paper moistened with alcohol.

CAUTION:

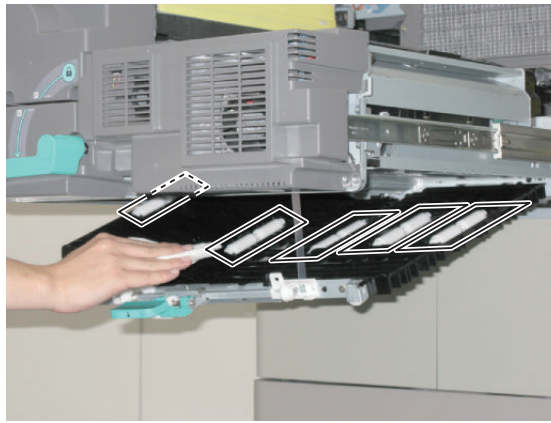
When rotating the Roller by hand, do not touch the surface of the Roller. Be sure to hold the side of the Roller to rotate manually.



22. Clean paper dust on the Duplex Outlet Sensor (PS64), Duplex Merge Sensor (PS67), and Duplex Left Sensor (PS66) with a blower.



23. Clean a whole circumference of 5 Rollers by manually rotating them with lint-free paper moistened with alcohol.



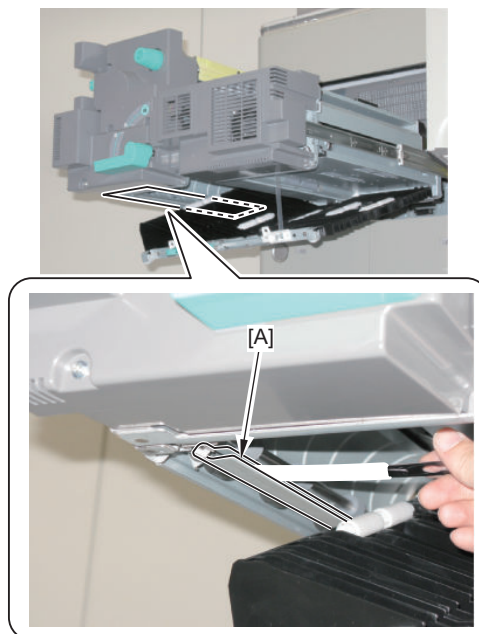
24. Place a paper on the Duplex Path. Then, point the leading edge of Blower to the Roller frame to remove paper lint.

NOTE:

The Cleaning Brush is engaged with 4 Rollers, causing accumulation of paper lint. By blowing air with the Blower, paper lint can be fallen down.



25. Insert the paper lint cleaning tool to the gap of Reverse Path [A] to remove paper lint.



26. Close the Duplex Path.

27. Install the Fixing Feed Cover (Upper).

28. Push in the Fixing Feed Unit.

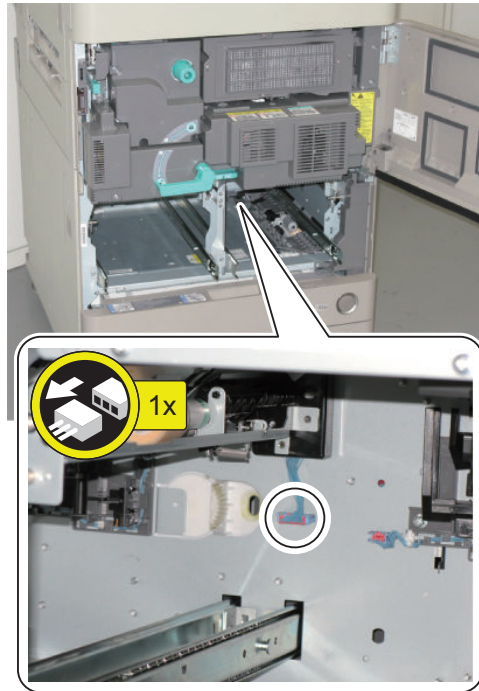
● Removing the Left Deck Pickup Unit

■ Preparation

1. Remove the Right Pickup Deck. ("Removing the Right Pickup Deck" on page 516)
2. Remove the Left Pickup Deck. ("Removing the Left Pickup Deck" on page 514)

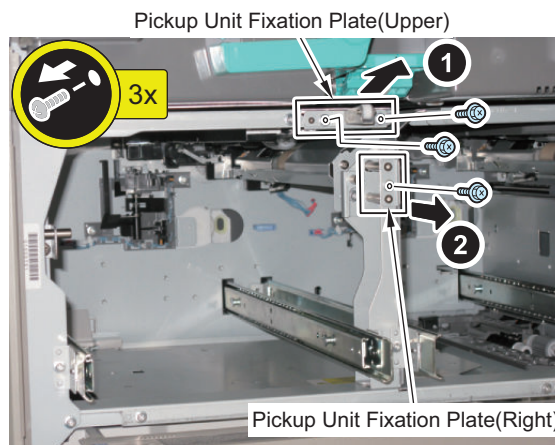
■ <Procedure>

1. Disconnect the Connectors.

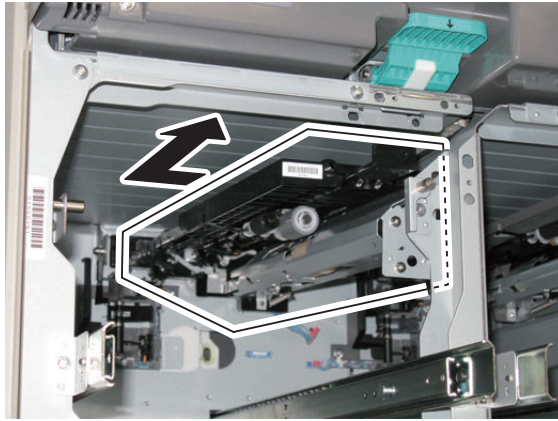


2. Remove the Pickup Unit Fixation Plate (Upper/Right).

- 3 Screws



3. Remove the Left Deck Pickup Unit.



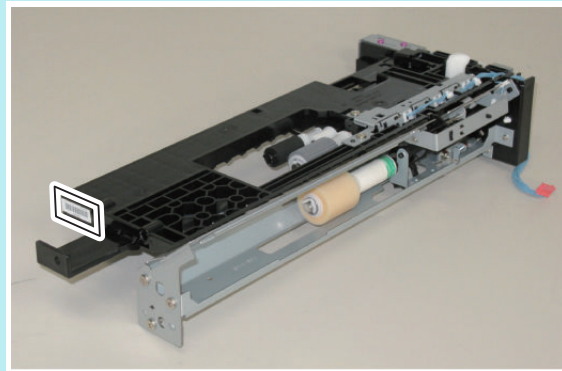
CAUTION:

Points to Caution at Installation

When installing the Left Deck Pickup Unit, pull out the Fixing Feed Unit for approx. 10cm to install, and then return the unit to its original position after installation.

NOTE:

Be sure to check that the parts number of Pickup Unit is correct.



● Removing the Right Deck Pickup Unit

■ Preparation

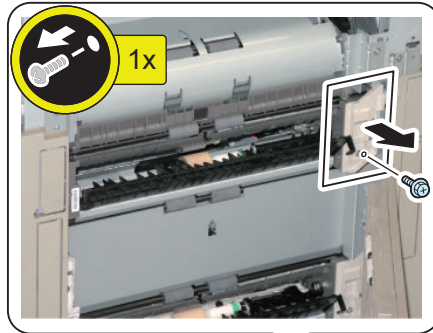
1. Remove the Right Cover. (“Removing the Laser Scanner Unit” on page 355)
2. Pull out the Right Deck. (“Removing the Right Pickup Deck” on page 516)

■ <Procedure>

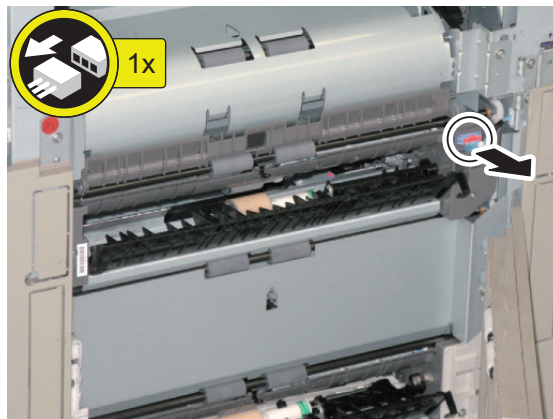
1. Open the Right Lower Cover.

2. Remove the Connector Cover.

- 1 Screw

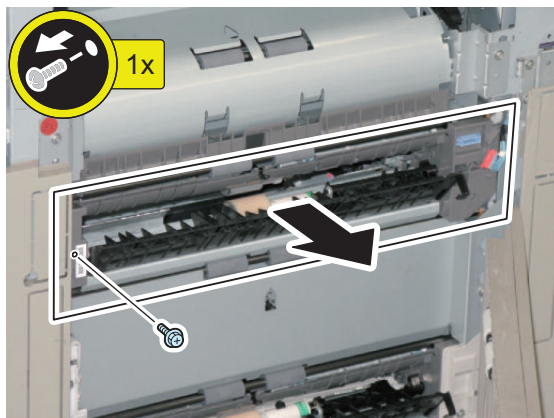


3. Disconnect the Connectors.



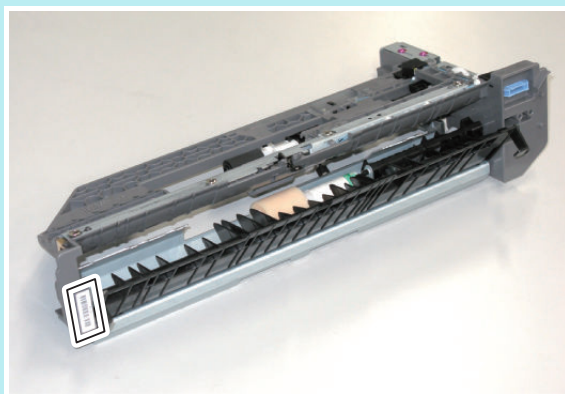
4. Remove the Right Deck Pickup Unit.

- 1 Screw



NOTE:

Be sure to check that the parts number of Pickup Unit is correct.

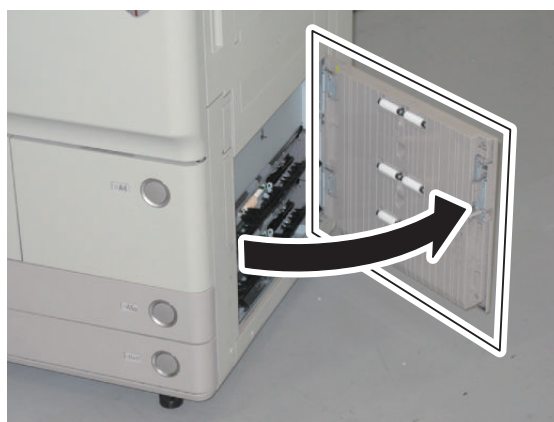


● Removing the Cassettes 3 and 4 Pickup Unit

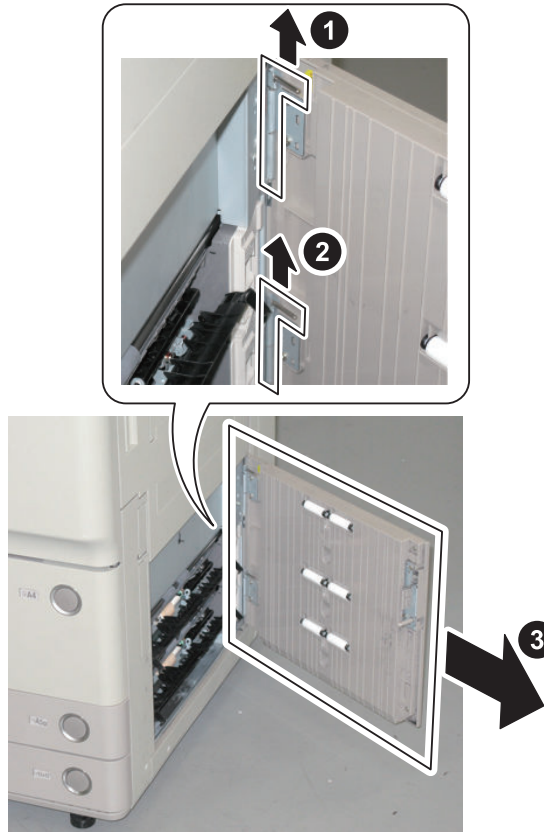
■ <Preparation>

1. Remove the Right Lower Cover.

1. Open the Right Lower Cover.



2. Remove the Right Lower Cover.
 - 2 Hinge Pins



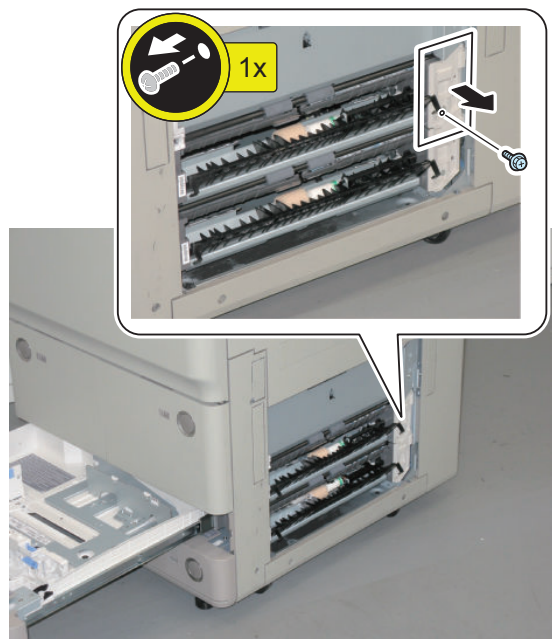
2. Pull out the Cassettes 3 and 4.

■ <Procedure>

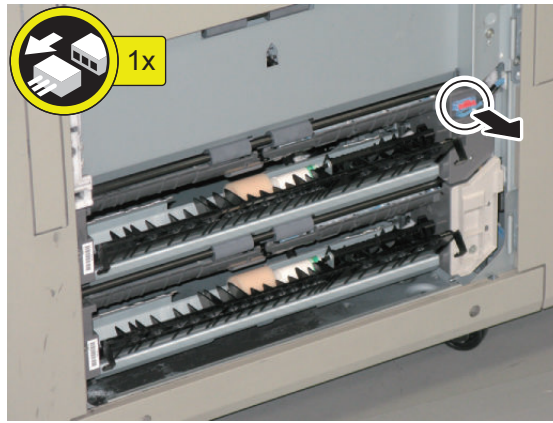
NOTE:

This procedure explains the case for Cassette 3 Pickup Unit.
Be sure to perform the same procedure when the Cassette 4 Pickup Unit is used.

1. Remove the Connector Cover.
 - 1 Screw

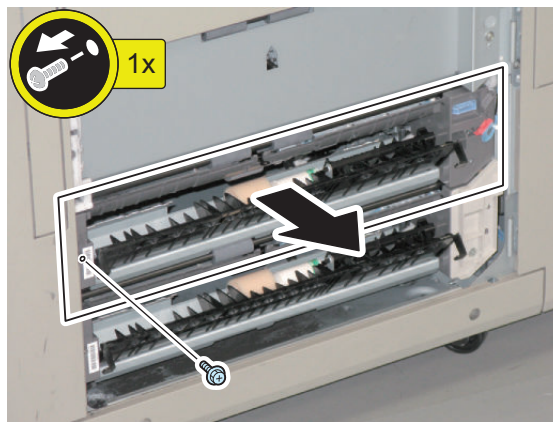


2. Disconnect the Connectors.



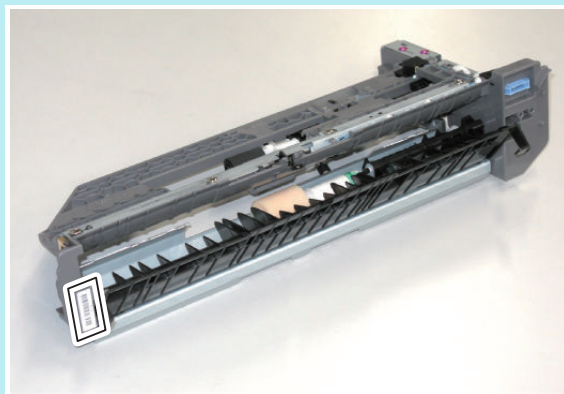
3. Remove the Pickup Unit.

- 1 Screw



NOTE:

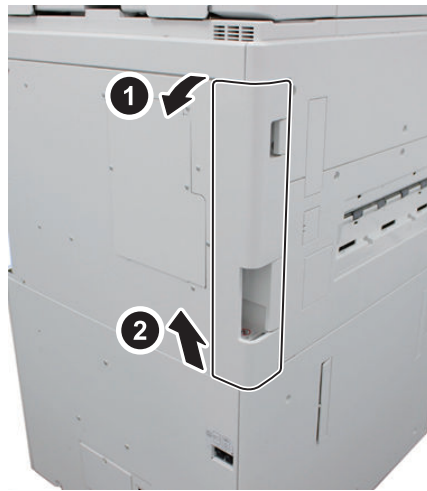
Be sure to check that the parts number of Pickup Unit is correct.



● Removing the Vertical Path Cassette Pickup Drive Unit

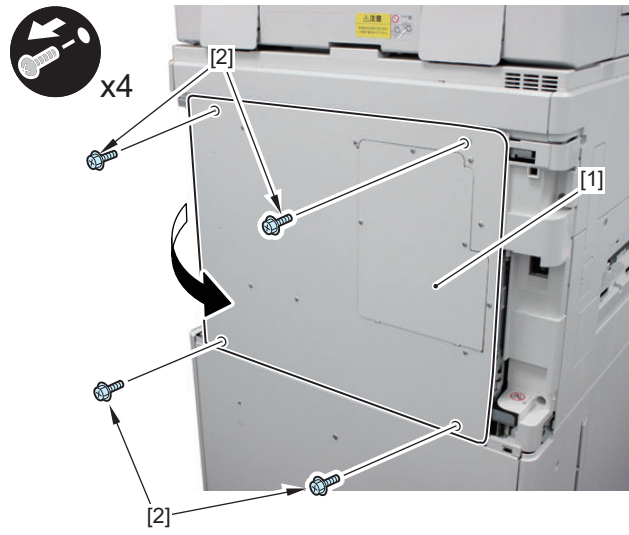
■ Preparation

1. Remove the Box Cover (Left).



2. Open the Controller Box in the direction of the arrow.

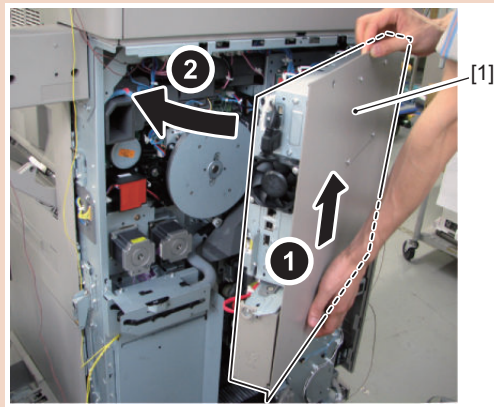
- 4 Screws



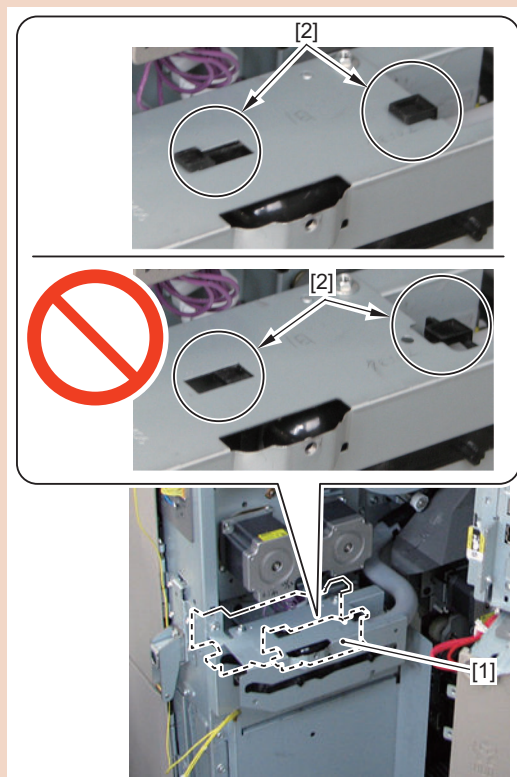
CAUTION:

Points to Note when Installing the Controller Box

While installing the Controller Box, be sure to lift it to avoid hitting the hook of the Waste Toner Container Shutter Unit.

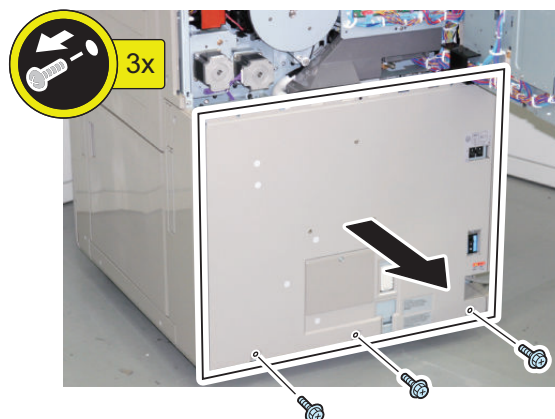


If the Inner Cover of the Controller Box hits the hook of the Waste Toner Container Shutter Unit, the hook may be removed.



3. Remove the Rear Lower Cover.

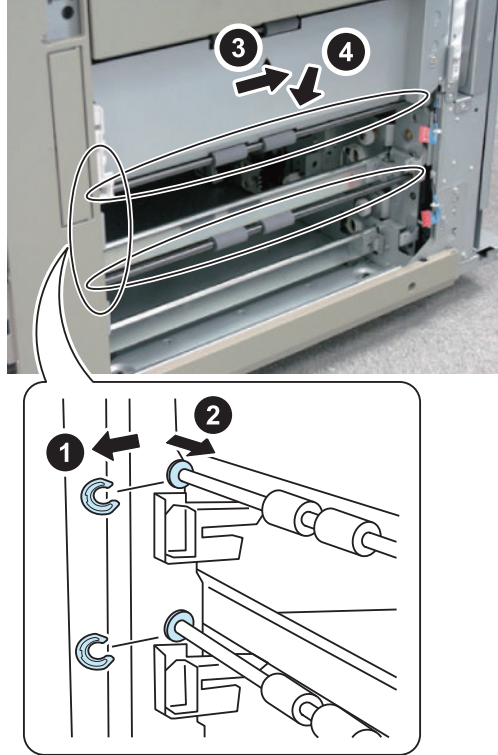
- 3 Screws



4. Remove the Waste Toner Container. (“Removing the Waste Toner Container” on page 431)
5. Remove the Cassette 3 and Cassette 4 Pickup Units. (“Removing the Cassettes 3 and 4 Pickup Unit” on page 546)

■ Procedure

1. Remove the 2 E-rings and move the bushings to remove the Vertical Path Rollers 3 and 4 in the direction of the arrow.

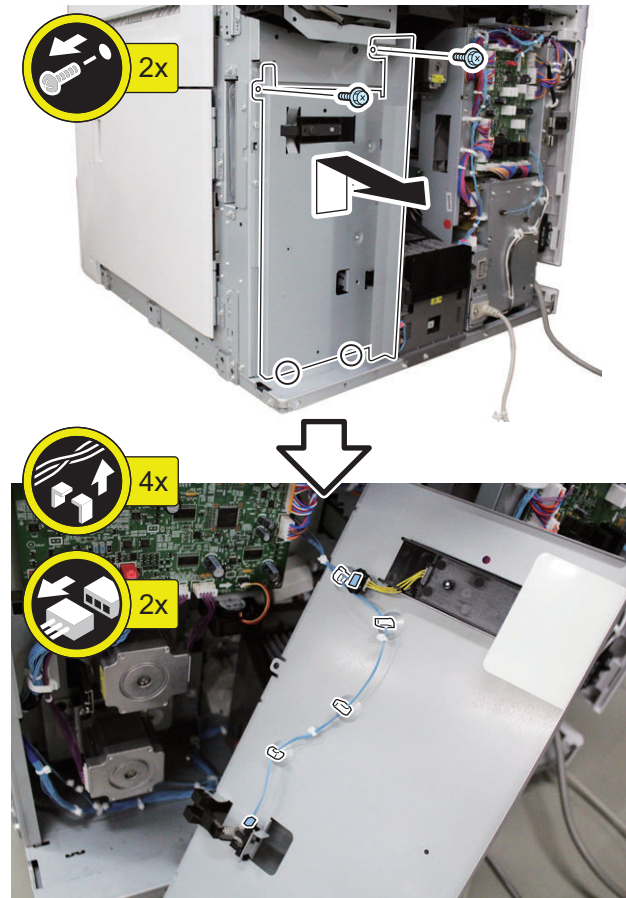


CAUTION:

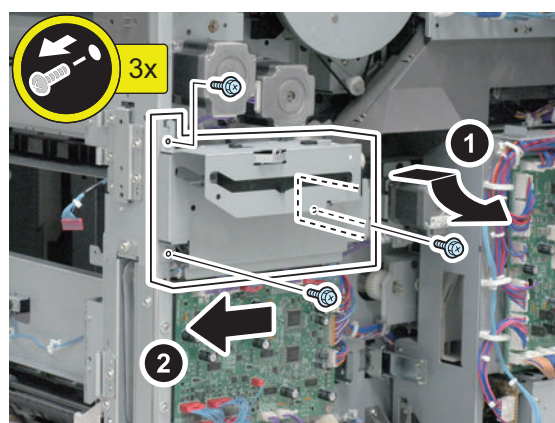
Do not lose the bushings when removing the Roller Shaft.

2. Remove the Shield Plate.

- 2 Screw
- 2 Protrusions
- 4 Wire Saddles
- 2 Connectors

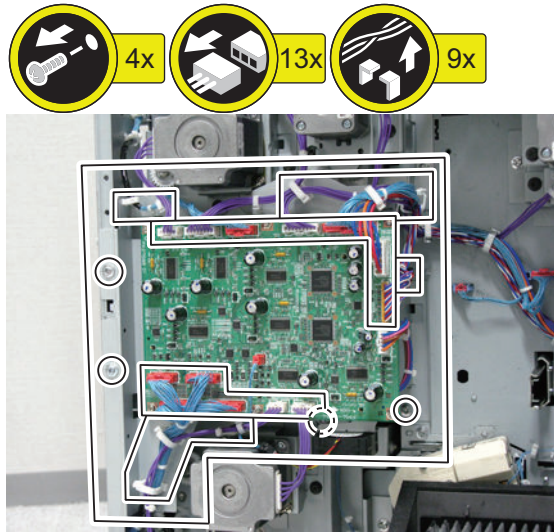
**3. Remove the Waste Toner Container Shutter Unit.**

- 3 Screws
- 1 Hook



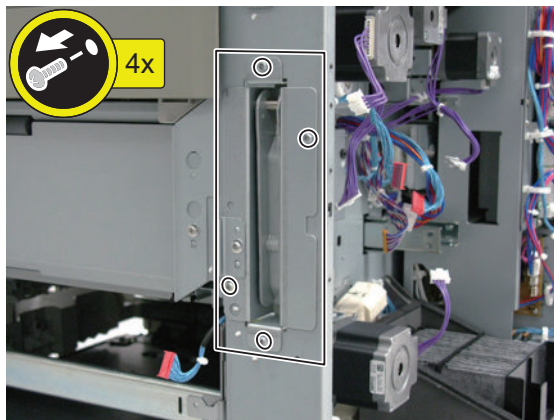
4. Remove the Feed Driver PCB Unit.

- 4 Screws
- 13 Connectors
- 9 Wire Saddles
- 1 Reuse Band
- Harness



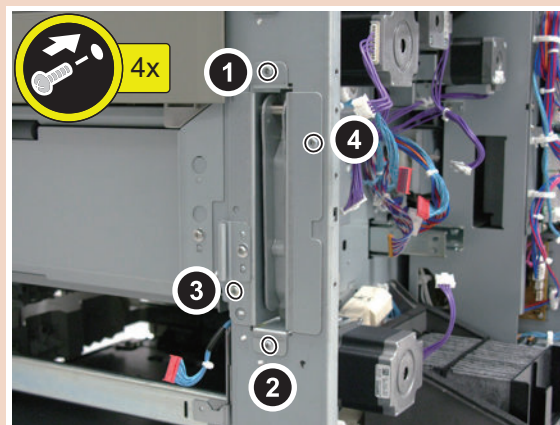
5. Remove the Right Rear Handle.

- 4 Screws



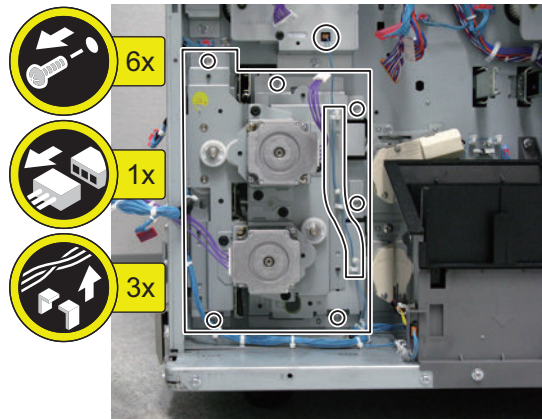
CAUTION:

When installing the handle, be sure to follow the order as shown in the figure to tighten screws.



6. Free the harness and remove the Vertical Path Cassette Drive Unit.

- 1 Connector
- 3 Wire Saddles
- 6 Screws

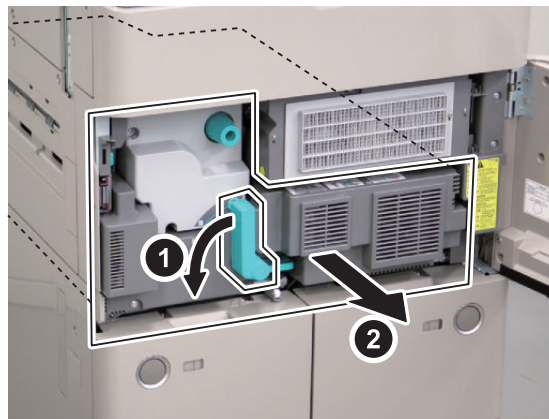


Removing the Registration Unit

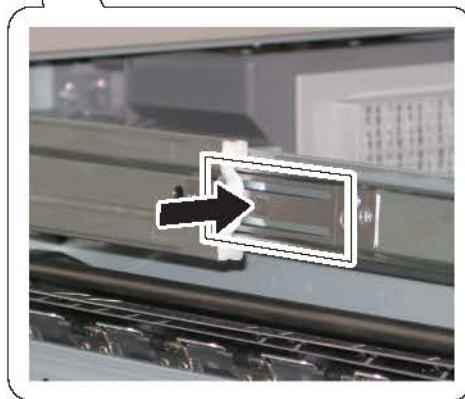
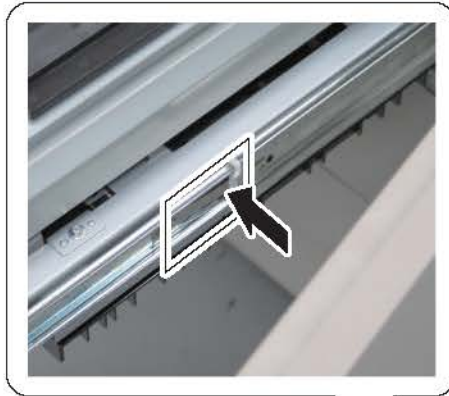
■ <Preparation>

1. Pull out the Fixing Feed Unit.

1. Open the Front Cover.
2. Turn the Fixing Feed Unit Pressure Release Lever in the direction of the arrow to pull out the Fixing Feed Unit.



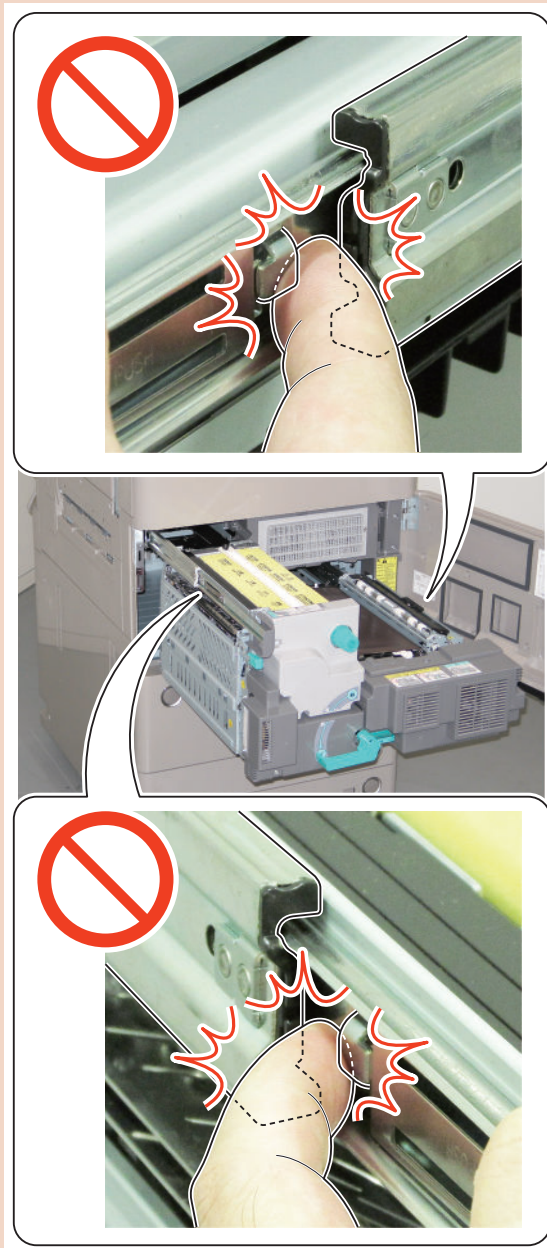
3. Push to release the Release Springs at both sides of the Rail, and then further pull out the Fixing Feed Unit until it stops.



CAUTION:

Caution when pushing the Fixing Feed Unit in

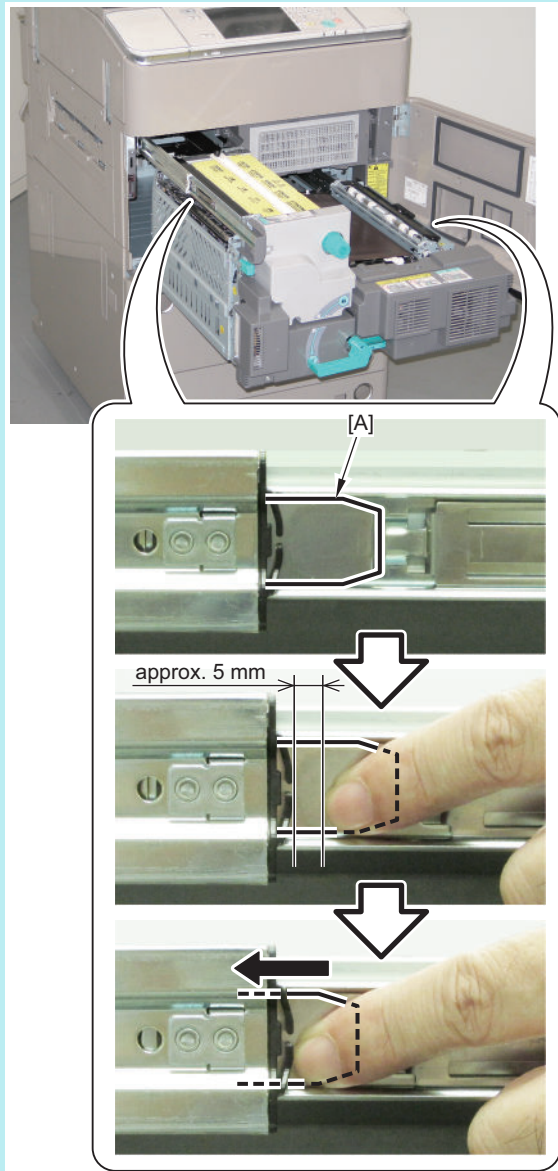
While pressing the Release Springs, slowly push the Fixing Feed Unit in so that the fingers do not get caught.



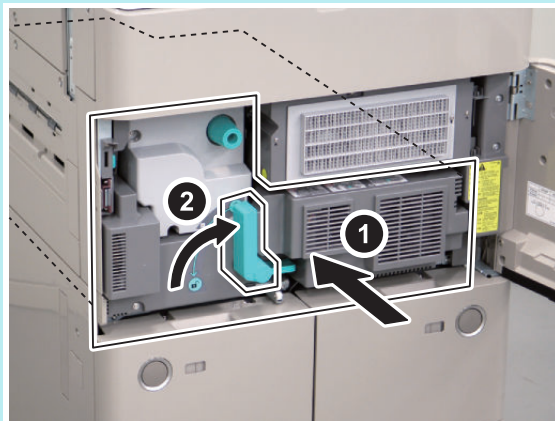
NOTE:

How to push the Fixing Feed Unit in

1. Release the Release Springs [A] on the side of either rail.
Slowly push the Fixing Feed Unit in by approximately 5 mm while keeping it level.



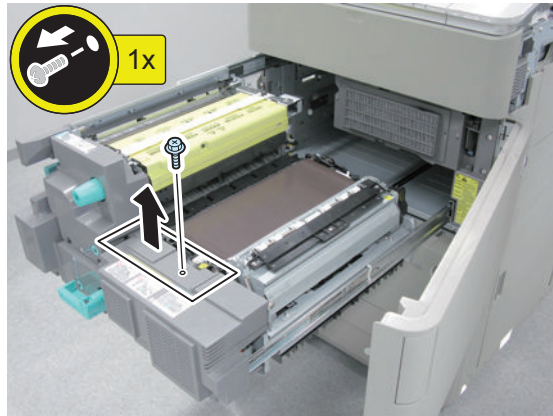
2. Take the fingers off the Release Springs and slowly push the Fixing Feed Unit in to the end.



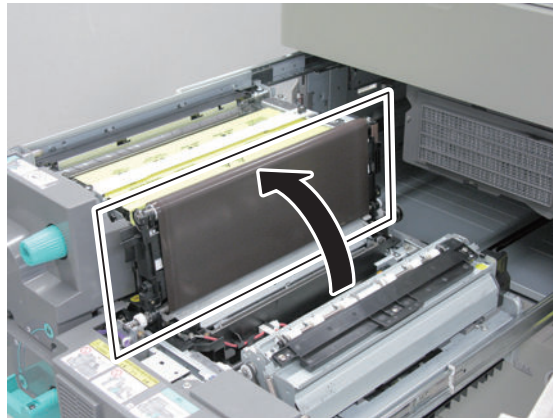
■ Procedure

1. Remove the Fixing Feed Right Front Upper Cover

- 1 Screw

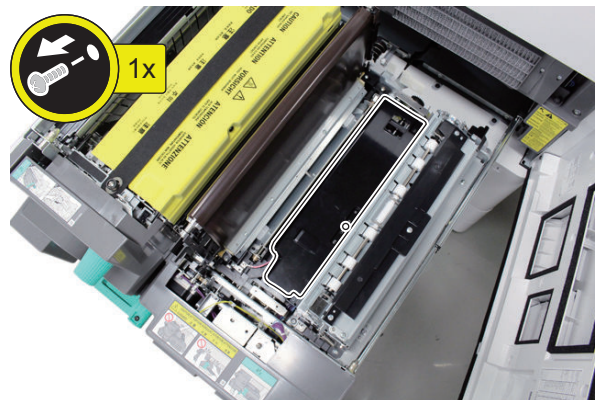


2. Lift the ETB Unit in the direction of the arrow.



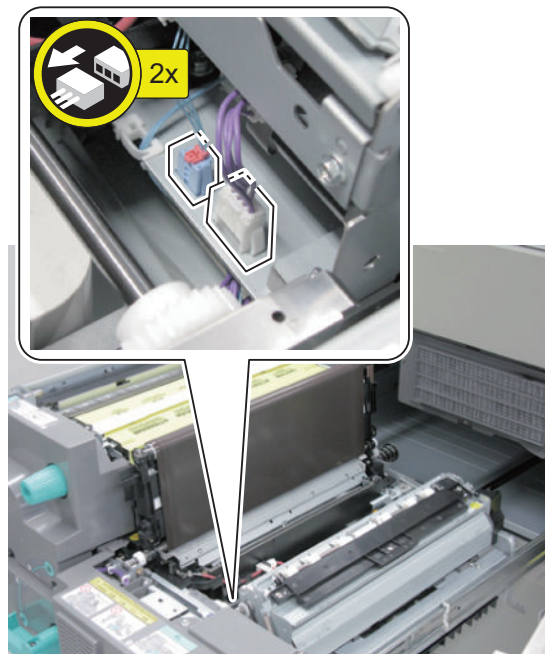
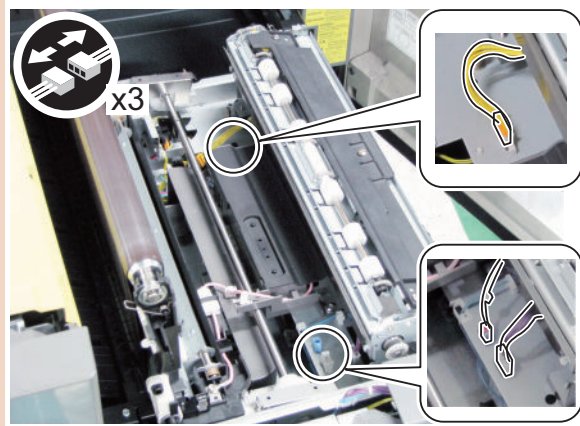
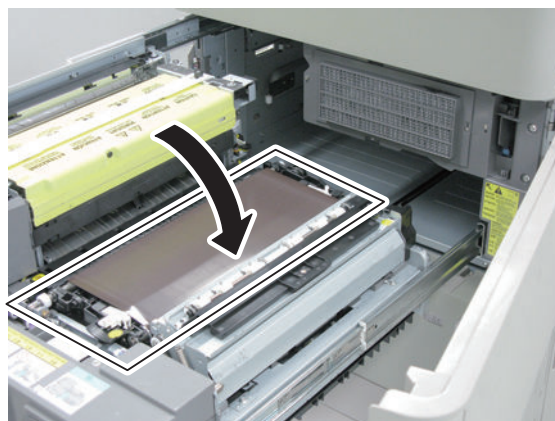
3. Remove the Cover.

- 1 Screw



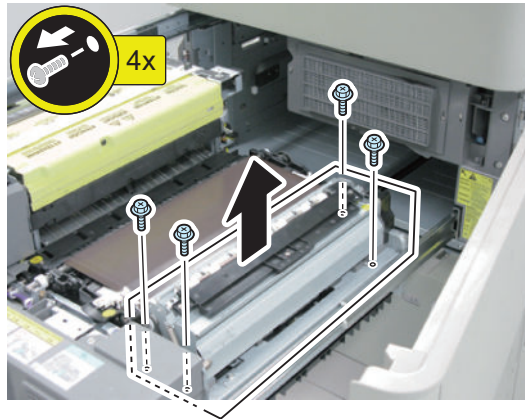
4. Disconnect the 2 Connectors.**CAUTION:**

When installing the optional Double Feed Detection Sensor
Disconnect the 3 Connectors.

**5. Set the ETB Unit back.**

6. Remove the Registration Unit.

- 4 Screws



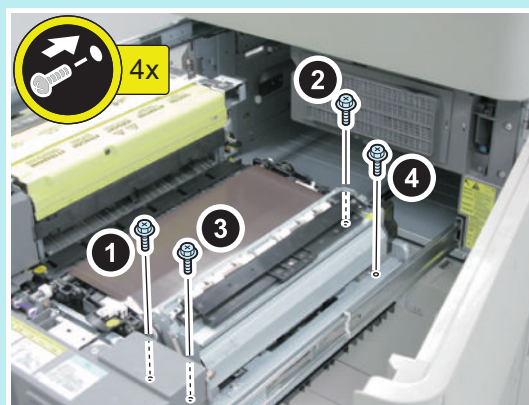
CAUTION:

When installing, be sure to check that the 2 Positioning Pins are secured.



NOTE:

When installing the Registration Unit, be sure to follow the order as shown in the figure to tighten screws.



● Removing the Left Deck Pickup Drive Unit

■ Preparation

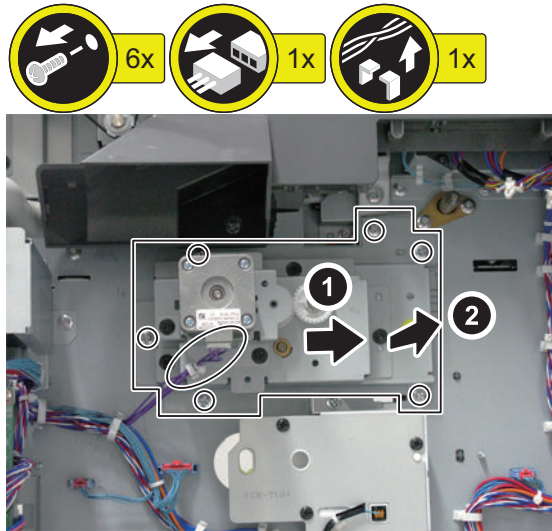
1. Remove the Box Cover (Left). (“Removing the Vertical Path Cassette Pickup Drive Unit” on page 549)
2. Open the Controller Box. (“Removing the Vertical Path Cassette Pickup Drive Unit” on page 549)

3. Remove the Rear Lower Cover. (“Removing the Vertical Path Cassette Pickup Drive Unit” on page 549)
4. Remove the Power Supply Assembly. (“Removing the Power Supply Assembly” on page 579)
5. Remove the Left Deck Pickup Unit. (“Removing the Left Deck Pickup Unit” on page 543)

■ <Procedure>

1. Remove the Left Deck Pickup Drive Unit in the direction of the arrow.

- 6 Screws
- 1 Connector
- 1 Wire Saddle



● Removing the Main Drive Unit

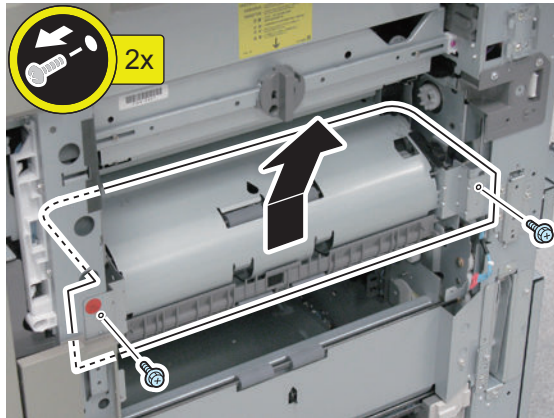
■ Preparation

1. Remove the Box Cover (Left). (“Removing the Vertical Path Cassette Pickup Drive Unit” on page 549)
2. Open the Controller Box. (“Removing the Vertical Path Cassette Pickup Drive Unit” on page 549)
3. Remove the Rear Lower Cover. (“Removing the Vertical Path Cassette Pickup Drive Unit” on page 549)
4. Remove the Waste Toner Container. (“Removing the Waste Toner Container” on page 431)
5. Remove the Right Lower Cover. (“Removing the Cassettes 3 and 4 Pickup Unit” on page 546)
6. Remove the Right Deck Pickup Unit. (“Removing the Right Deck Pickup Unit” on page 544)

■ Procedure

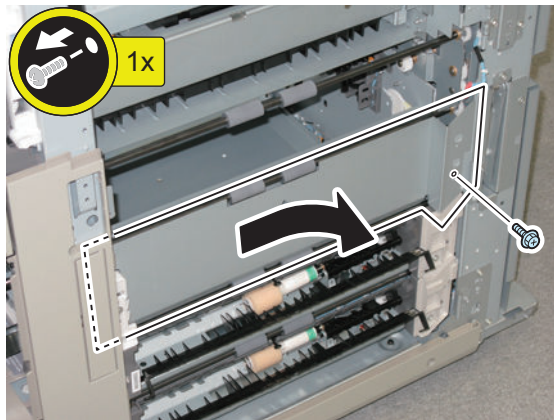
1. Remove the Pre-registration Guide Unit.

- 2 Screws

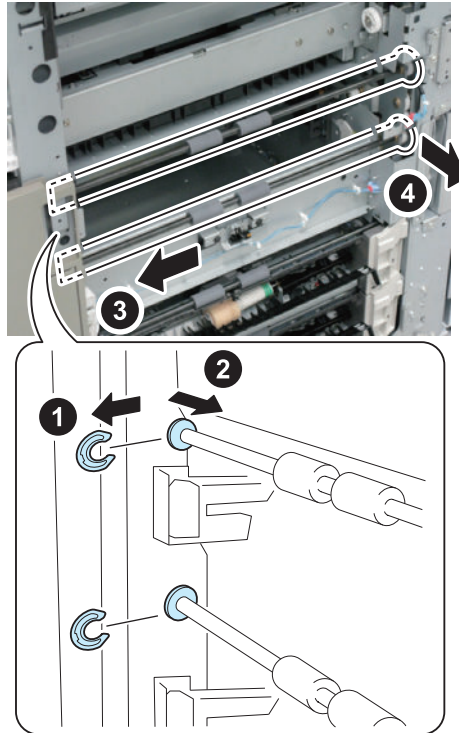


2. Remove the Middle Vertical Path Guide.

- 1 Screw



3. Remove the 2 E-rings and move the bushings to remove the Vertical Path Rollers 1 and 2 in the direction of the arrow.

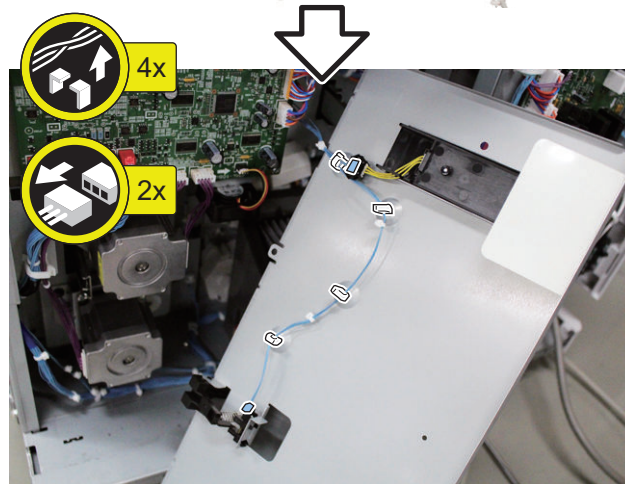
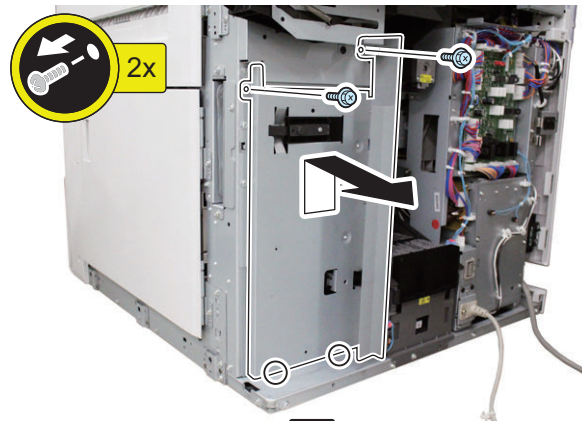


CAUTION:

Do not lose the bushings when removing the Vertical Path Rollers 1 and 2.

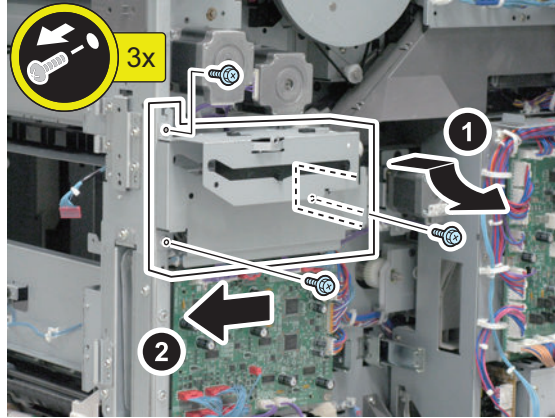
4. Remove the Shield Plate.

- 2 Screws
- 2 Protrusions
- 4 Wire Saddles
- 2 Connectors



5. Remove the Waste Toner Container Shutter Unit.

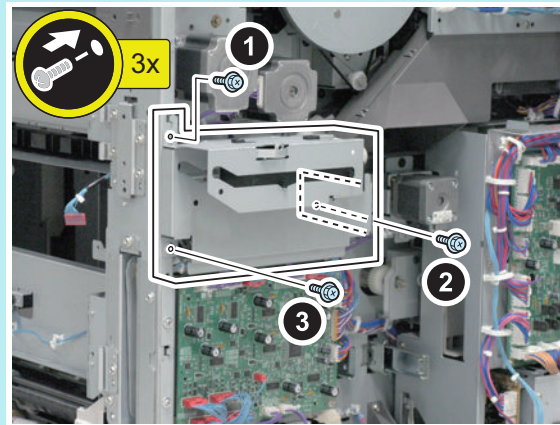
- 3 Screws

**CAUTION:**

When removing the Waste Toner Container Shutter Unit, be careful of toner scattering.

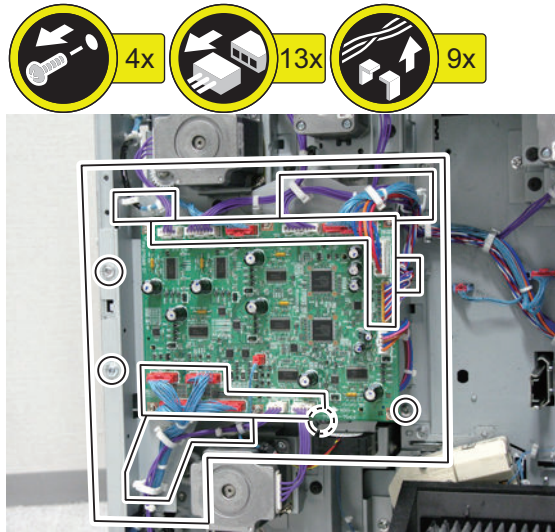
NOTE:

When installing the Waste Toner Container Shutter Unit, be sure to follow the order as shown in the figure to tighten screws.

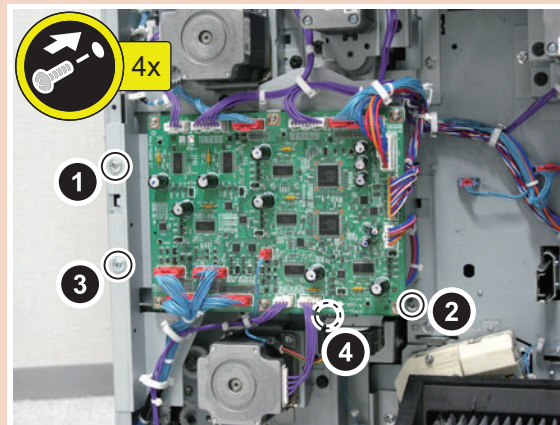


6. Remove the Feed Driver PCB Unit.

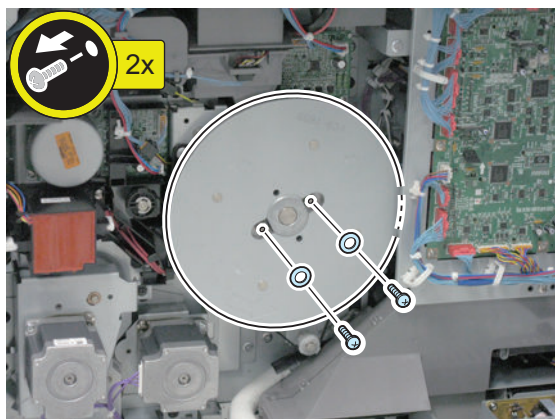
- 4 Screws
- 13 Connectors
- 9 Wire Saddles
- 1 Reuse Band
- Harness

**CAUTION:**

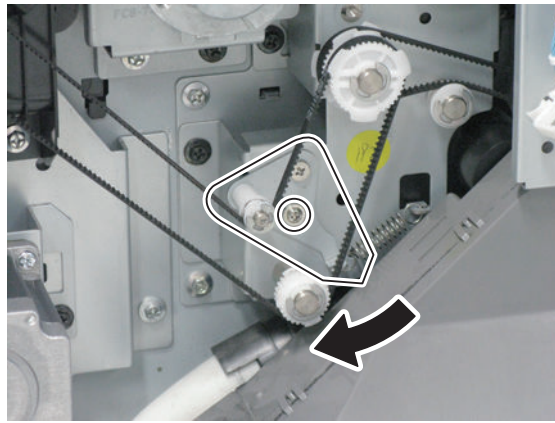
When installing the Feed Driver PCB Unit, be sure to follow the order as shown in the figure to tighten screws.

**7. Remove the Flywheel.**

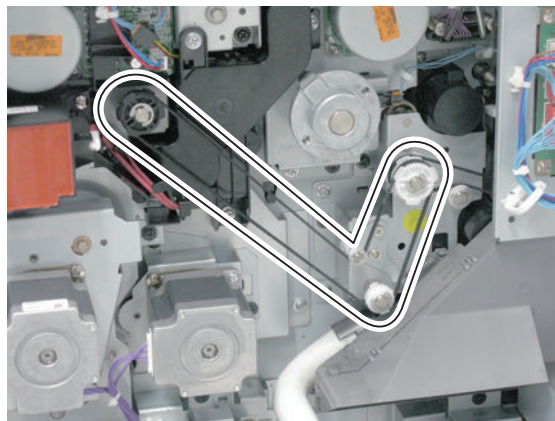
- 2 Screws
- 2 Washers



8. Loosen the screw and move the Belt Tensioner in the direction of the arrow, and then again tighten the screw.

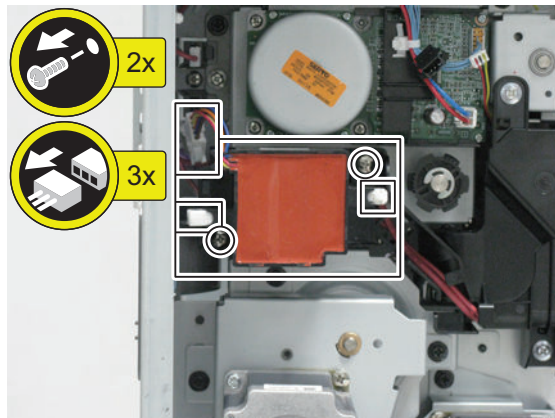


9. Remove the belt from the pulley.



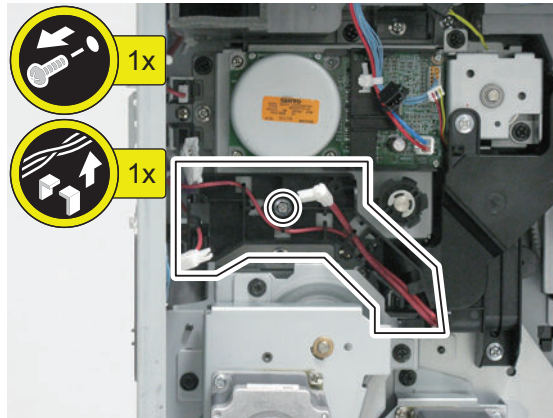
10. Remove the transformer.

- 2 Screws
- 3 Connectors



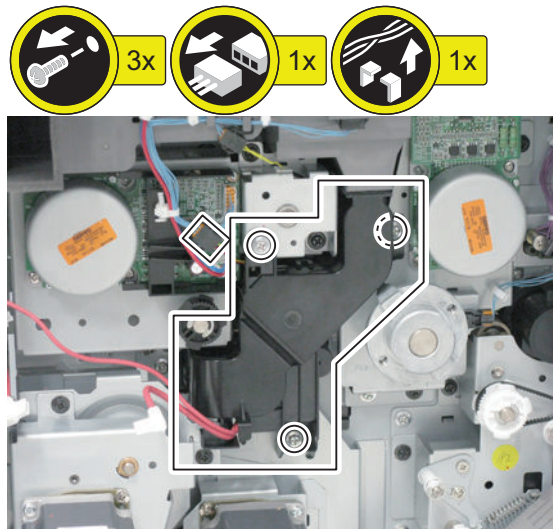
11. Free the harness and remove the Transformer Support Base.

- 1 Screw
- Harness



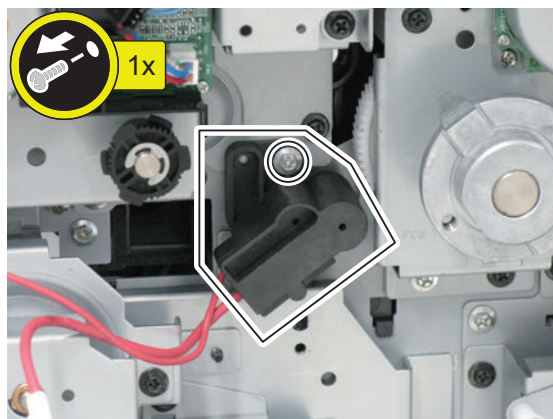
12. Remove the Duct Unit.

- 3 Screws
- 1 Connector
- Harness



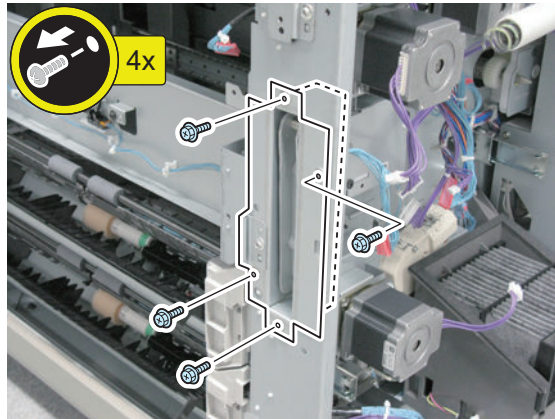
13. Disconnect the Pre-transfer Charging High Voltage Connector.

- 1 Screw



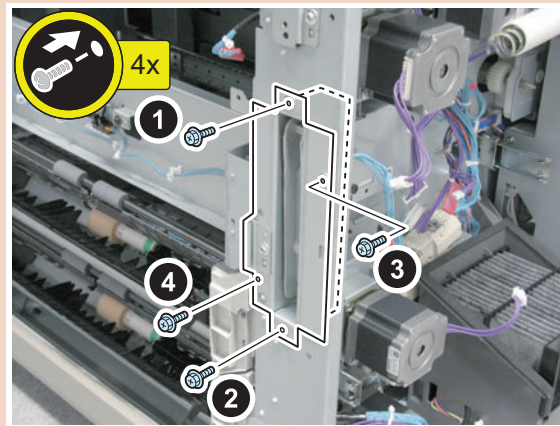
14. Remove the Right Rear Handle.

- 4 Screws



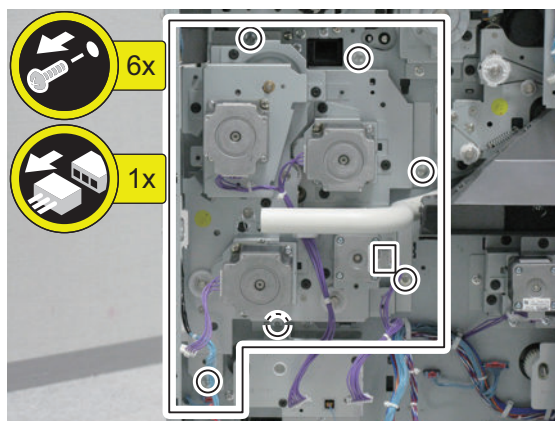
CAUTION:

When installing the Right Rear Handle, be sure to follow the order as shown in the figure to tighten screws.



15. Remove the Main Drive Unit.

- 6 Screws
- 1 Connector



● Removing the Double Feed Detection Sensor(Reception/Transmission)(Option)

CAUTION:

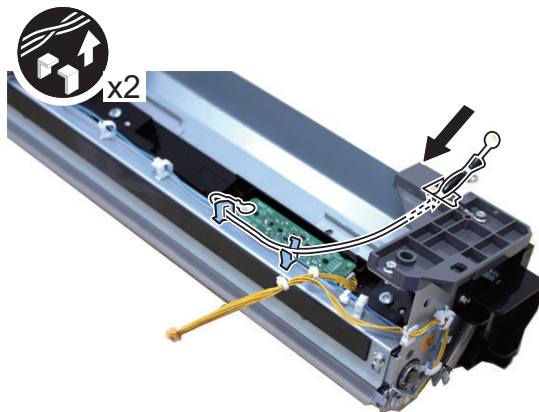
In the case of replacing the Double Feed Detection Sensor(Reception/Transmission), be sure to replace them together.

■ Preparation

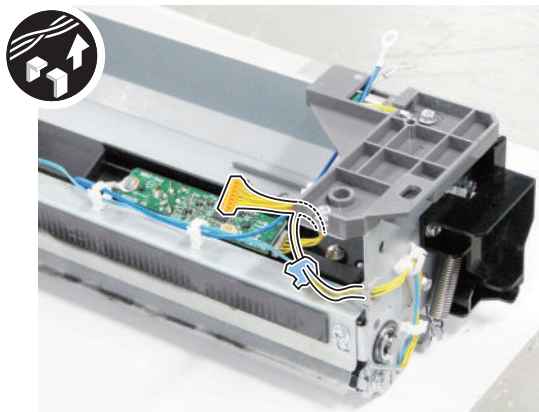
1. Remove the Registration Unit. (“Removing the Registration Unit” on page 555)

■ Procedure

1. Turn over the Registration Unit.
2. Free the Grounding Wire.
 - 2 Wire Saddles
 - 1 Harness Guide

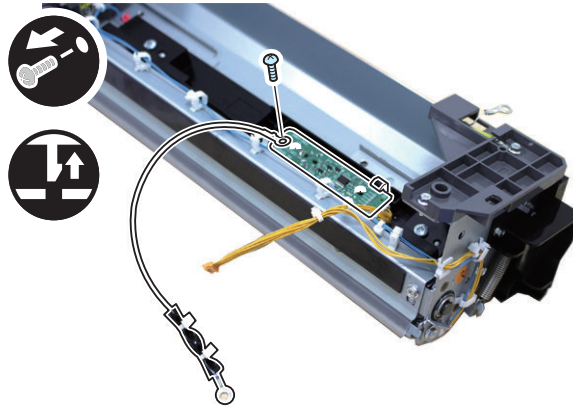


3. Free the Cable from the Wire Saddle.



4. Remove the Double Feed Detection Sensor(Reception) and the Grounding Wire.

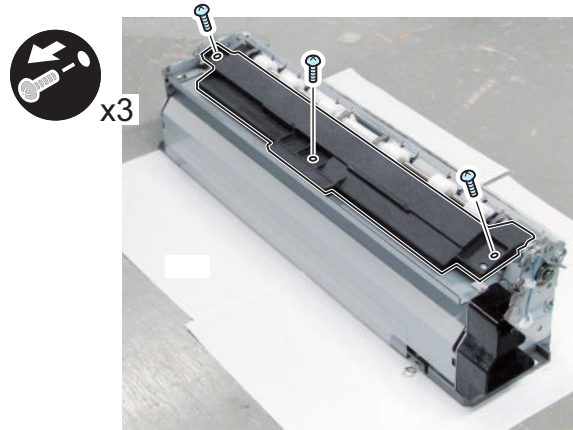
- 1 Screw
- 1 Claw



5. Return the Registration Unit.

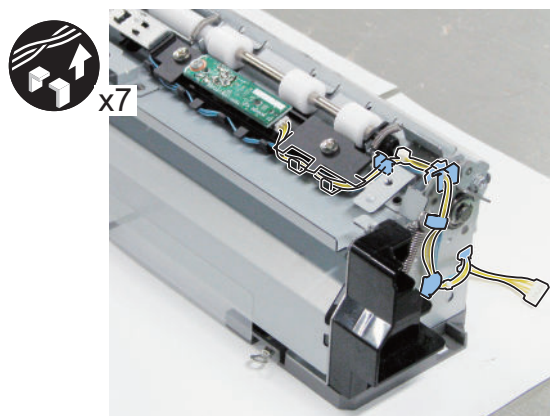
6. Remove the Registration Upper Guide.

- 3 Screws
- 2 Bosses



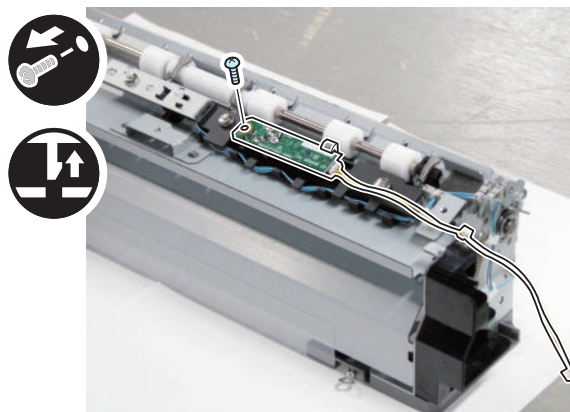
7. Free the Harness from the Harness Guide.

- 3 Edge Saddles
- 3 Wire Saddles
- 1 Harness Guide



8. Remove the Double Feed Detection Sensor(Transmission).

- 1 Screw
- 1 Claw



■ Actions after Parts Replacement

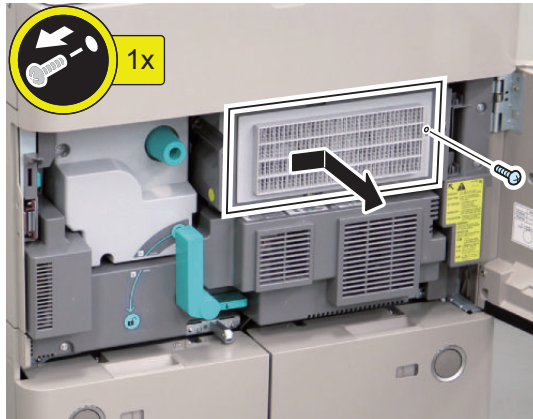
1. Check the Double Feed Detection Sensor.

(Lv.1)COPIER > FUNCTION > PART-CHK > D-FDS

External Auxiliary System

● Removing the Filter (for primary charging)

1. Open the Front Cover.
2. Remove the Filter (for primary charging).
 - 1 Screw

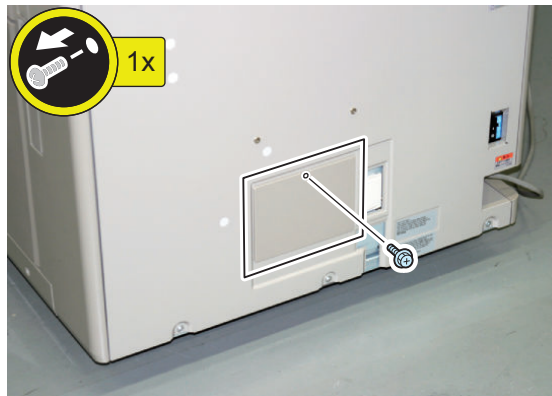


■ Actions after Parts Replacement

1. Clear the parts counter.(COPIER > COUNTER > PRDC-1 > AR-FIL1)

● Removing the Ozone Filter

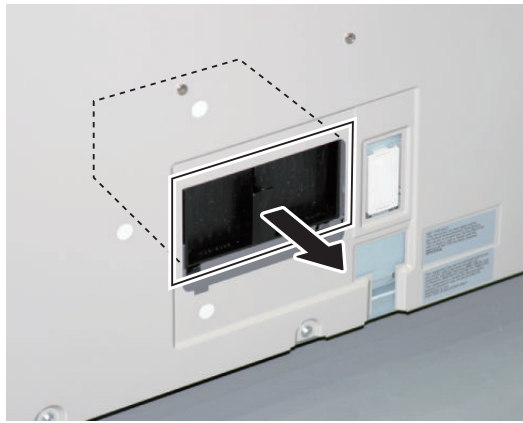
1. Remove the Filter Cover.
 - 1 Screw



NOTE:

To prevent falling of the Filter Cover, be sure to hold the Filter Cover to remove the screw.

2. Remove the Ozone Filter.



■ Actions after Parts Replacement

1. Clear the parts counter.(COPIER > COUNTER > PRDC-1 > OZ-FIL1)

● Removing the DC Controller PCB

■ Before Parts Replacement

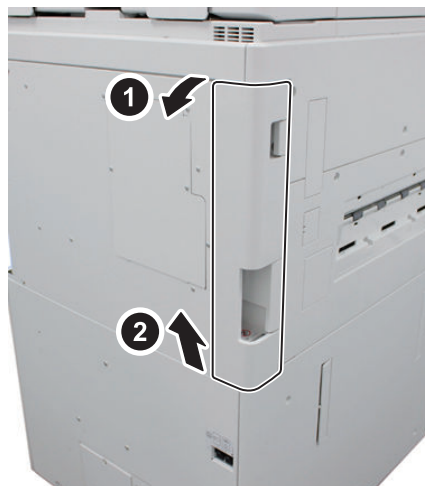
CAUTION:

When replacing the DC Controller PCB, be sure to use a new one. Do not use the DC Controller PCB which was used with another machine.

1. **Execute the following service mode to output setting values for just in case of restoration failure of backup data.**
COPIER > FUNCTION > MISC-P > P-PRINT
2. **Execute the following service mode to back up the service mode setting values.**
(Lv.2) COPIER > FUNCTION > SYSTEM > DSRAMBUP
During execution, "ACTIVE" flashes in the status column of the service mode.
It takes approx. 2 minutes. Upon success, [OK!] is displayed in the status column.
3. **After confirming that [OK!] is displayed in the status column of the service mode, turn OFF the power of the machine.**

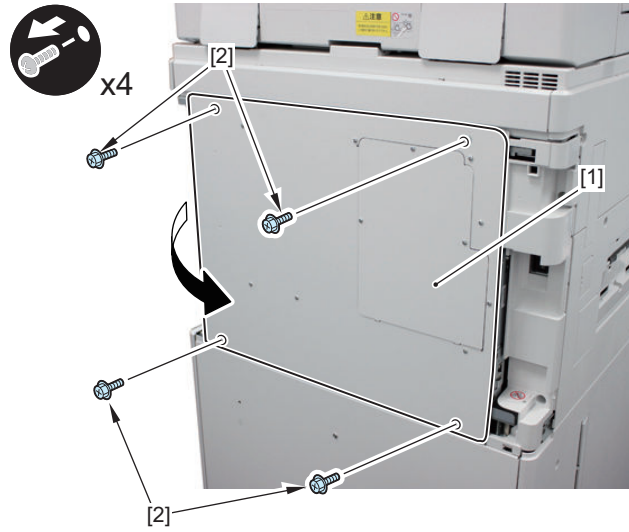
■ Preparation

1. Remove the Box Cover (Left).



2. Open the Controller Box [1] in the direction of the arrow.

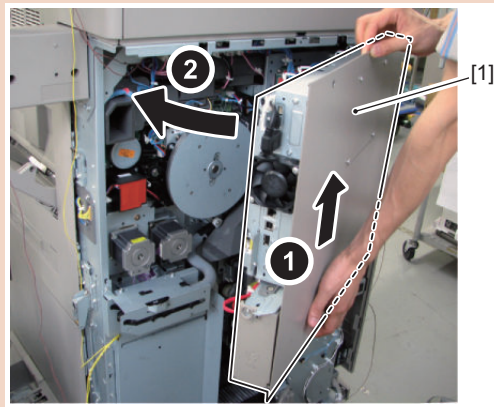
- 4 Screws [2]



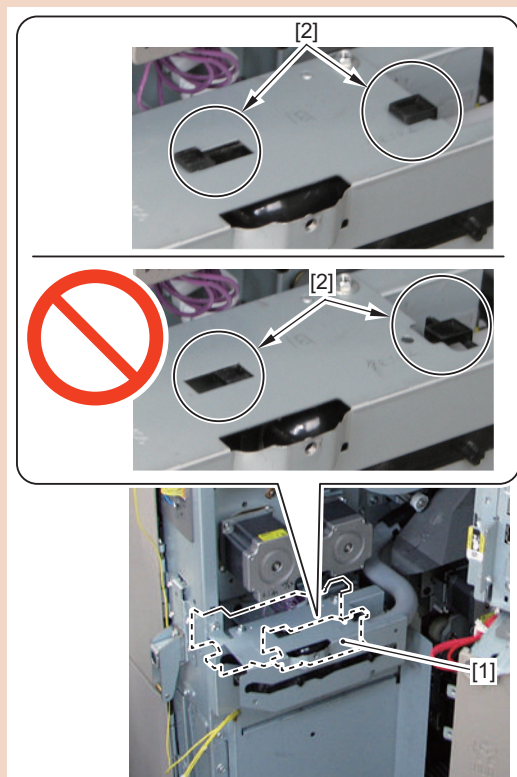
CAUTION:

Points to Note when Installing the Controller Box

While installing the Controller Box, be sure to lift it to avoid hitting the hook of the Waste Toner Container Shutter Unit.



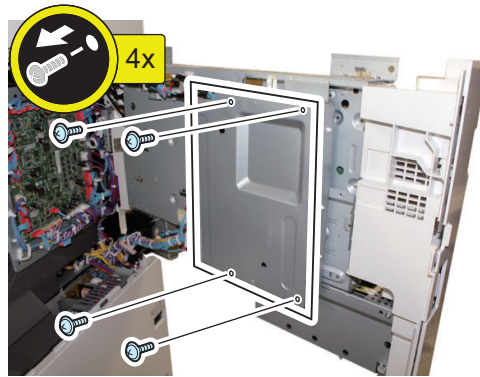
If the Inner Cover of the Controller Box hits the hook of the Waste Toner Container Shutter Unit, the hook may be removed.



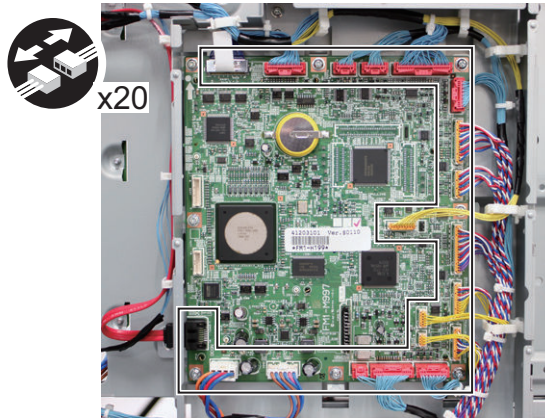
■ Procedure

1. Remove the Controller Box Inner Cover.

- 4 Screws (TP)

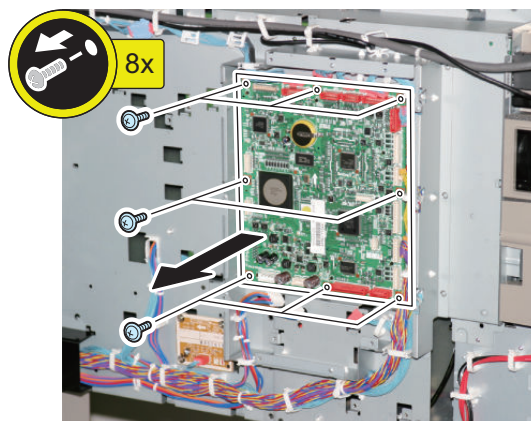


2. Disconnect the 20 Connectors.



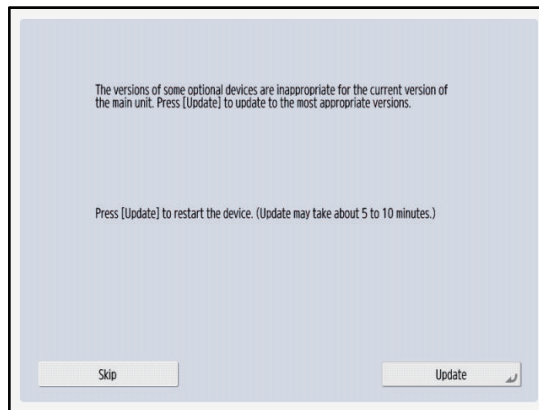
3. Remove the DC Controller PCB in the direction of the arrow.

- 8 Screws



■ Works During Parts Replacement

1. If the firmware combination is incorrect, execute an update with the Automatic Update function.



Screen example

CAUTION:

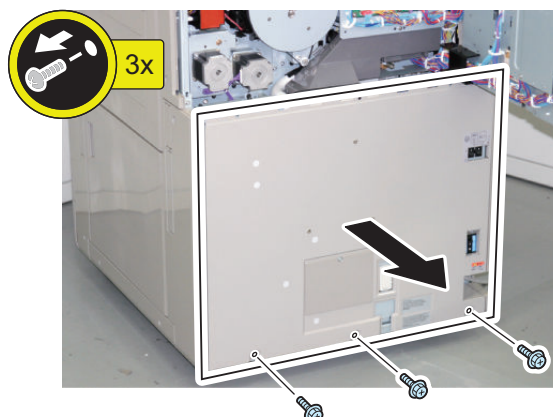
Automatic Update is available only when the following Service Mode settings are at 1 or 2.
(Lv.2) COPIER > OPTION > FNC-SW > VER-CHNG

2. When the setting value data is backed up before parts replacement, execute the following service mode to restore the backed-up setting value data.
(Lv.2) COPIER > FUNCTION > SYSTEM > DSRAMRES
During execution, "ACTIVE" flashes in the status column of the service mode.
It takes approx. 2 minutes. Upon success, [OK!] is displayed in the status column.
3. When setting values cannot be backed up before replacement or when the backed-up data cannot be restored in this step due to reasons such as damage of the DC Controller PCB, enter the values of each service mode item written on the service label or P-PRINT before parts replacement.

● Removing the Power Supply Assembly

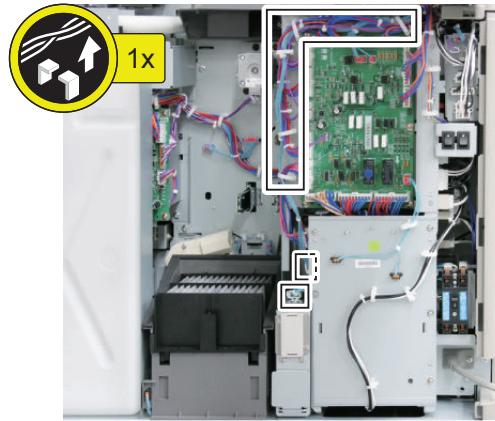
■ <Preparation>

1. Remove the Box Cover (Left). (Refer to "Removing the DC Controller PCB" on page 575)
2. Open the Controller Box. (Refer to "Removing the DC Controller PCB" on page 575)
3. Remove the Rear Lower Cover.
 1. Remove the Rear Lower Cover in the direction of the arrow.
 - 3 Screws

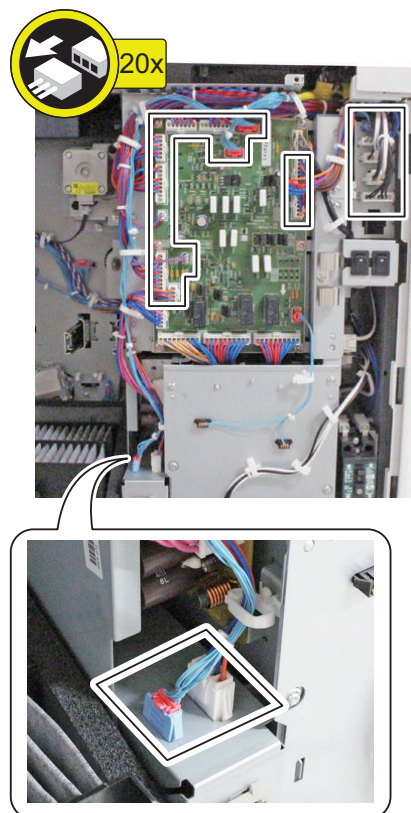


■ Procedure

1. Free the Harness from the Wire Saddle.

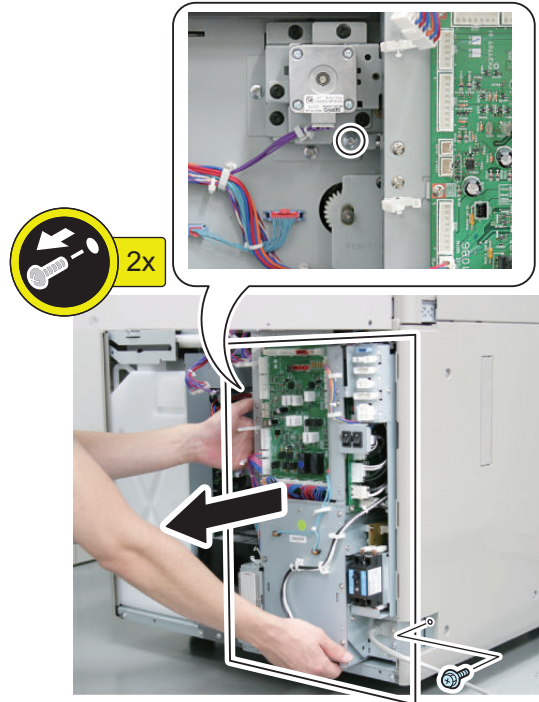


2. Disconnect the 20 Connectors and free the Harness to the top of the Power Supply Assembly.



3. Remove the Power Supply Assembly in the direction of the arrow.

- 2 Screws

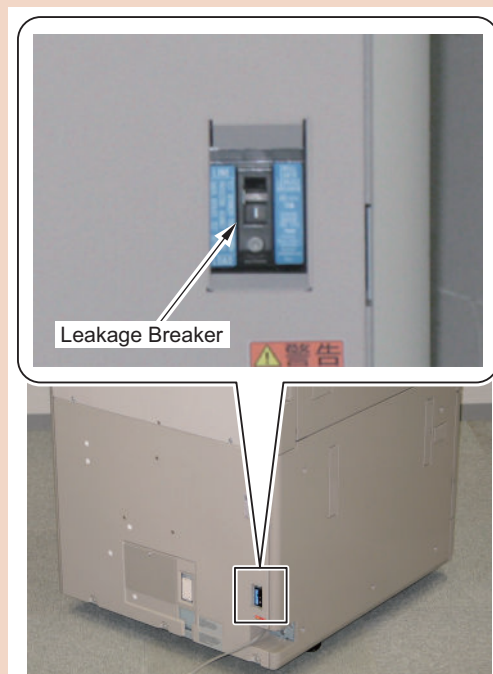


● Removing the Fixing Power Unit

CAUTION:

Points to Caution before Operation

When executing this procedure, be sure to turn OFF the breaker beforehand.



■ <Preparation>

1. Remove the Box Cover (Left). (Refer to “[Removing the DC Controller PCB](#)” on page 575)

■ <Procedure>

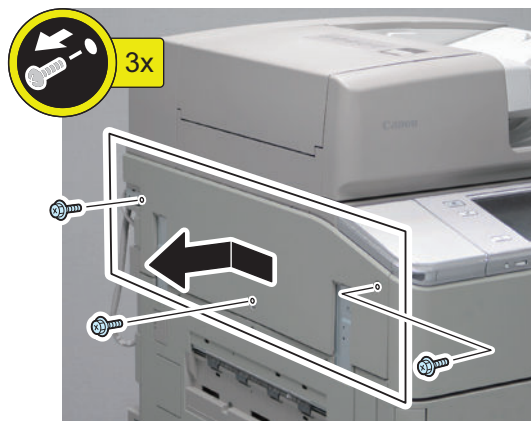
1. Open the 2 Finisher Connector Covers.

- 2 Claws



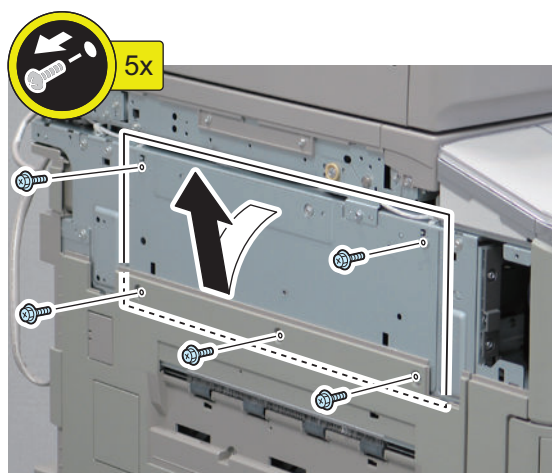
2. Remove the Left Upper Cover.

- 3 Screws



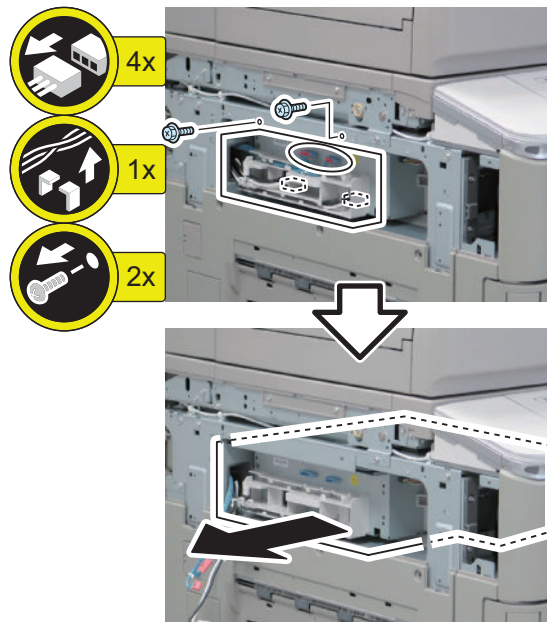
3. Remove the Left Upper Frame.

- 5 Screws

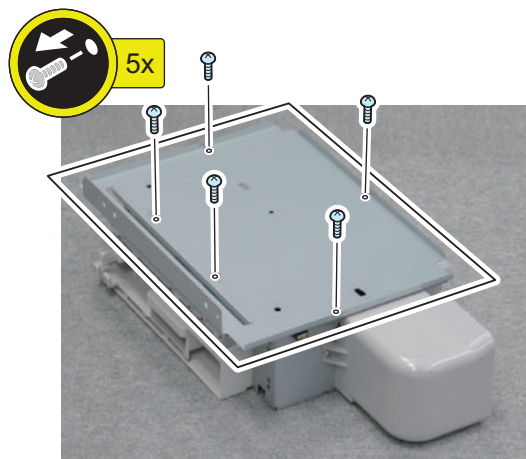


4. Free the harness and remove the Fixing Power Unit.

- 4 Connectors
- 2 Screws

**5. Remove the Fixing Power Unit Plate.**

- 5 Screws



Removing the Feed Driver PCB

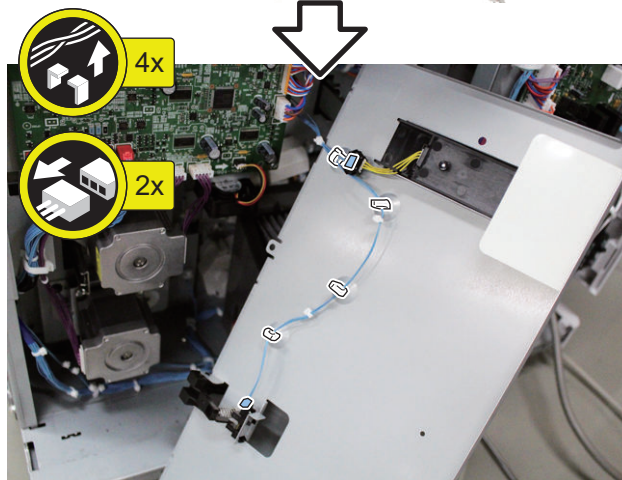
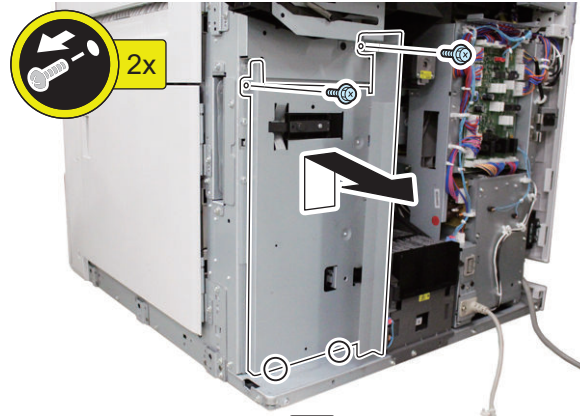
■ Preparation

1. Remove the Waste Toner Container. (“Removing the Waste Toner Container” on page 431)
2. Remove the Box Cover (Left). (“Removing the DC Controller PCB” on page 575)
3. Open the Controller Box. (“Removing the DC Controller PCB” on page 575)
4. Remove the Rear Lower Cover. (“Removing the Power Supply Assembly” on page 579)

■ Procedure

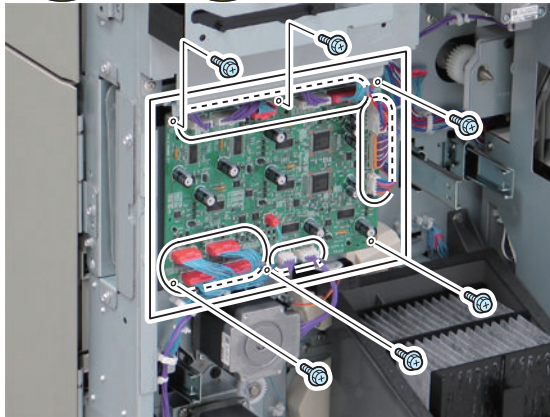
1. Remove the frame of Waste Toner Container.

- 2 Screws
- 2 Protrusions
- 4 Wire Saddles
- 2 Connectors



2. Remove the Feed Driver PCB.

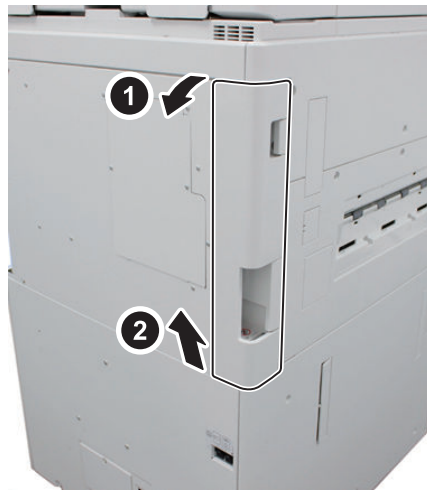
- 6 Screws
- 15 Connectors



● Removing the CAN Transeiver PCB

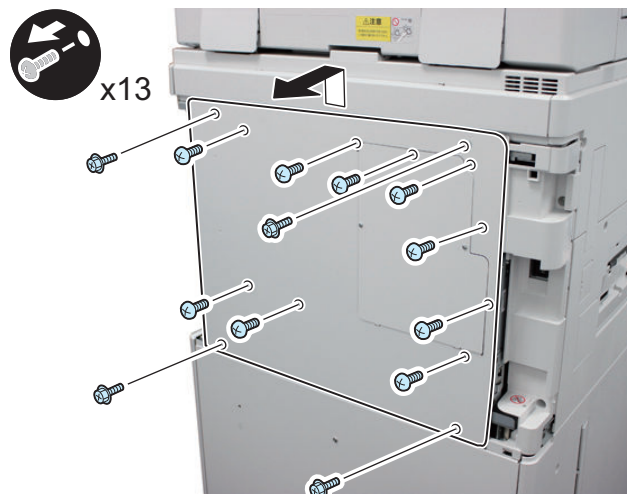
■ Preparation

1. Remove the Left Rear Cover.



2. Remove the Rear Cover.

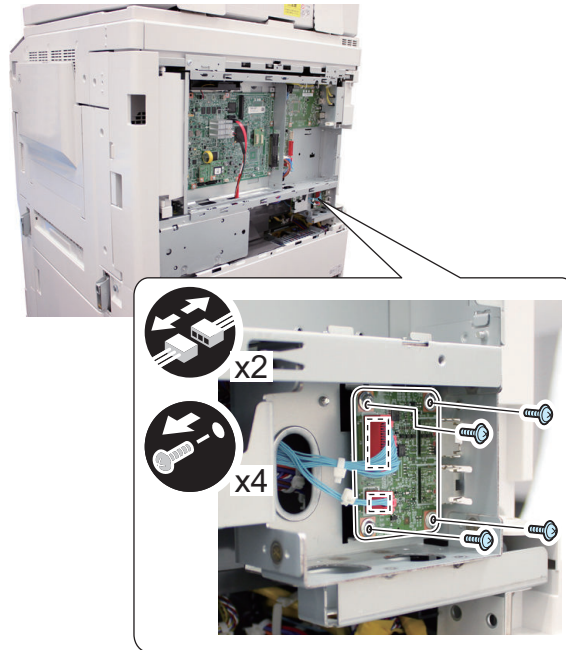
- 13 Screws



■ Procedure

1. Remove the CAN Transceiver PCB.

- 4 Screws
- 2 Connectors



● Removing the Upper High Voltage Unit

■ <Preparation>

1. Remove the Box Cover (Left). (Refer to [“Removing the DC Controller PCB”](#) on page 575)
2. Open the Controller Box. (Refer to [“Removing the DC Controller PCB”](#) on page 575)

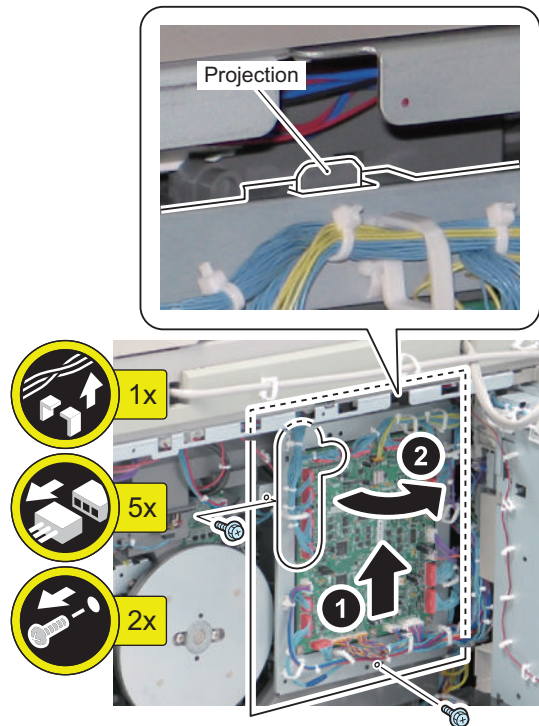
■ Procedure

1. Open the Motor Driver PCB Unit.

NOTE:

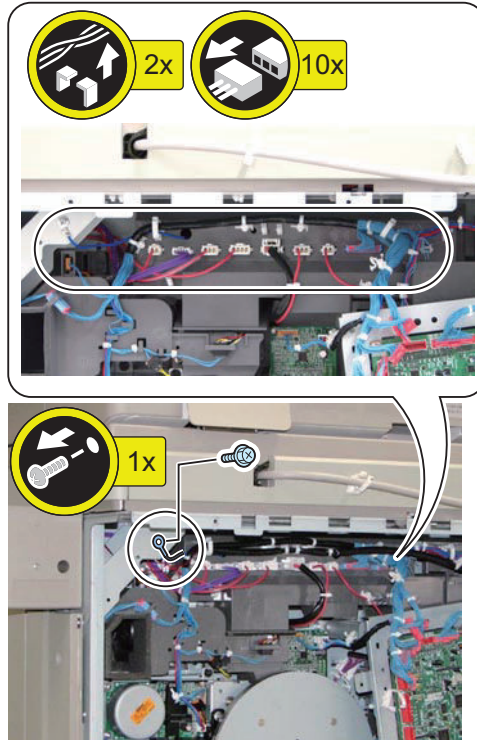
When opening the Motor Driver PCB Unit, free the top side from the protrusion.

- 5 Connectors
- 2 Screws
- Wire Saddle
- Reuse Band



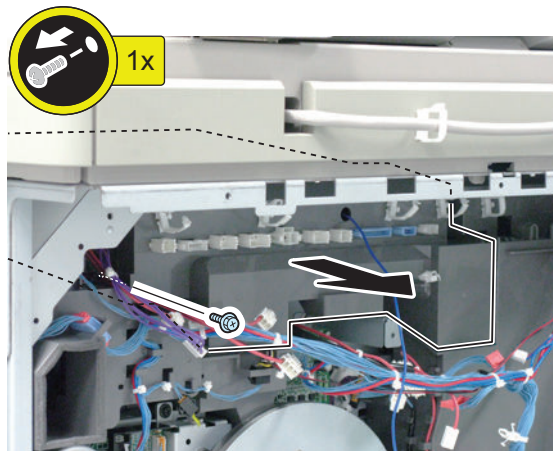
2. Disconnect the connector and Grounding Wire.

- 1 Screw



3. While avoiding the harness and Motor Driver PCB Unit, remove the Upper High Voltage Unit.

- 1 Screw



6

Adjustment

Pickup Feed System.....	590
Skew Adjustment (at Stream Scanning of Originals).....	600
Adjusting the Height.....	606
Right Angle Adjustment (Slant Adjustment).....	610
Light intensity adjustment	616
Automatic Adjustment of the Stream Reading Position (Automatic Adjustment of the Reading Position at ADF Reading).....	617
White Level Adjustment	618
Front/Back Side Difference Correction Adjustment.....	619
Parallelogram Correction.....	622
Angle Correction (Front / Back).....	623
Image Position Adjustment (at Stream Scanning of Originals).....	624
Other Adjustments.....	633
Original Feed System.....	641
Original Exposure System.....	642
Main Controller.....	644
Laser Exposure System.....	649
Image Formation System.....	650
Fixing System.....	658
External Auxiliary System.....	659

Pickup Feed System

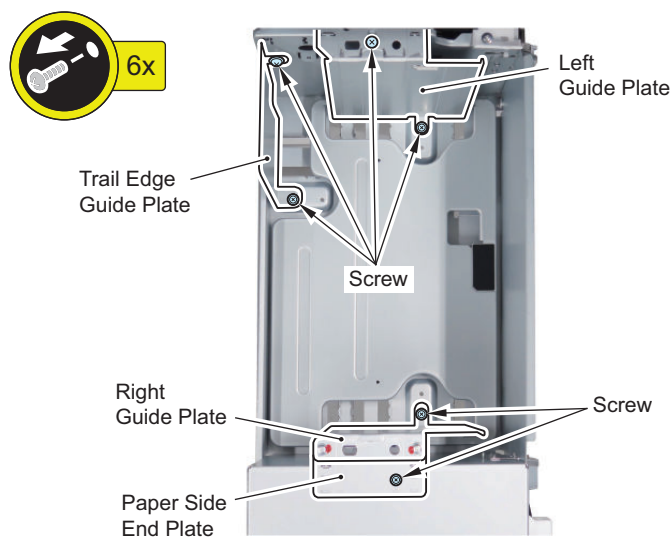
Setting the Deck

-
- 1. Pull out the Left and the Right Decks to the front.
-
- 2. Remove the 4 screws fixing the Trailing Edge Guide Plate, Left Guide Plate, Right Guide Plate, and Paper Side End Plate in place, and fix each of the Guide Plates at user's desired size.

NOTE:

Setting the Paper Side End Plate

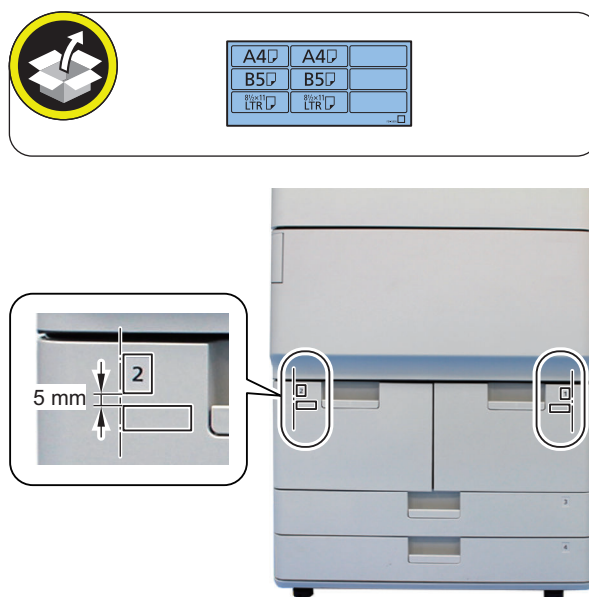
- Be sure to align the Paper Side End Plate with the position according to the size requested by the user, and secure the screw.
- When B5 size is set, the Paper Size End Plate cannot be fixed to the deck with the screw. In order to prevent the screw from being lost, be sure to secure the screw to the deck as shown below.



-
- 3. Put the specified size of papers in the Left/Right Deck, and push the Left/Right Deck in.



4. Affix Paper Size Labels (for Deck) according to the paper size, with the edge of each label aligned with the edge of the cassette number label. Approx. 5 mm away from the number label.

**NOTE:**

If Setup Guide is running, skip this procedure.

5. Register the type of paper loaded in the paper source.

1. Select the [Settings/Registration] > [Preferences] > [Paper Settings] > [Paper Settings].
2. Select the paper source where paper is loaded, and press [Set].
3. Select the paper type same as that of the loaded paper, and press [OK] > [OK].

NOTE:

If the corresponding paper type is not displayed on the simple settings screen, press [Detailed Settings] and make a selection on the detailed settings screen.

If the type of loaded paper is not displayed on the detailed settings screen, you can register it.

NOTE:

If Setup Guide is running, perform the following works after Setup Guide ends.



6. When the size has been changed, register the paper size for the Left and Right Deck in the service mode.

Right Deck :

COPIER > OPTION > CST > P-SZ-C1

Left Deck :

COPIER > OPTION > CST > P-SZ-C2



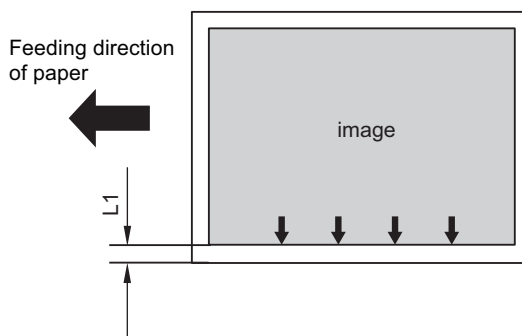
7. Exit from the service mode.

Image Position Adjustment

■ Left Edge Margin Adjustment (1st side)

-
1. After setting the service mode as follow, press the Start key and output a test print from each cassette and Deck.
COPIER > TEST > PG > TYPE = 5
COPIER > TEST > PG > PG-PICK = 1/2/3/4

-
2. Check that the left edge margin of the image (L1) is within 2.5 +/- 1.5mm. When the result is out of the specified range, perform adjustment by following the following procedure.



-
3. Adjust the image position in service mode.

NOTE:

<Setting Range>

-20 to 20 (0.1 mm per unit)

As the value is incremented by 1, the left edge margin is increased by 0.1mm.

Right Deck:

COPIER > ADJUST > FEED-ADJ > ADJ-C1

Left Deck:

COPIER > ADJUST > FEED-ADJ > ADJ-C2

Cassette3:

COPIER > ADJUST > FEED-ADJ > ADJ-C3

Cassette4:

COPIER > ADJUST > FEED-ADJ > ADJ-C4

-
4. When the setting value was changed in step 3, write down the new numerical value in the service label.

-
5. Exit from the service mode.

-
6. Perform printing again from the cassette/deck, and check that the left edge margin (L1) of the image is within 2.5 +/- 1.5 mm.

NOTE:

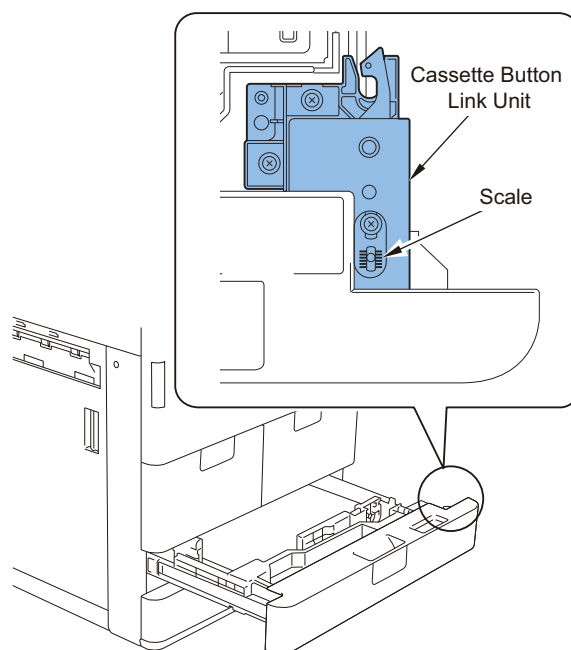
If the adjustment cannot be made with the setting value of -20 to 20 (adjustment amount: -2.0 to 2.0mm), execute step 7 and later steps.



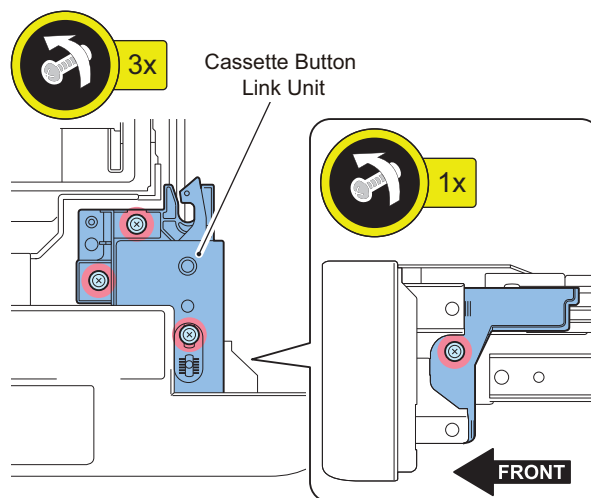
7. Pull out the Cassette.



8. Check the Cassette position by the scale of the Cassette Button Link Unit.



9. Loosen the 4 screws of the Cassette Button Link Unit.

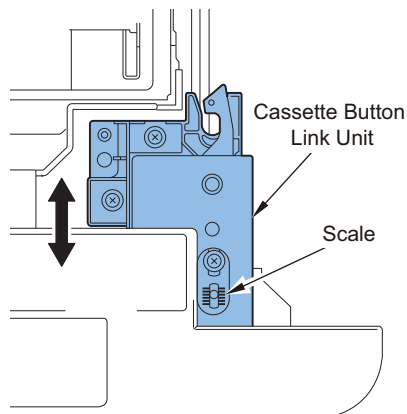




10. According to the scale in which the position was checked in step 8, adjust the position of the **Cassette Button Link Button**.

NOTE:

- In the case of larger margin at the rear side, move the Cassette Button Link Unit to the rear side.
- In the case of larger margin at the front side, move the Cassette Button Link Unit to the front side.



11. Tighten the 4 screws (which have been loosened in step 9).

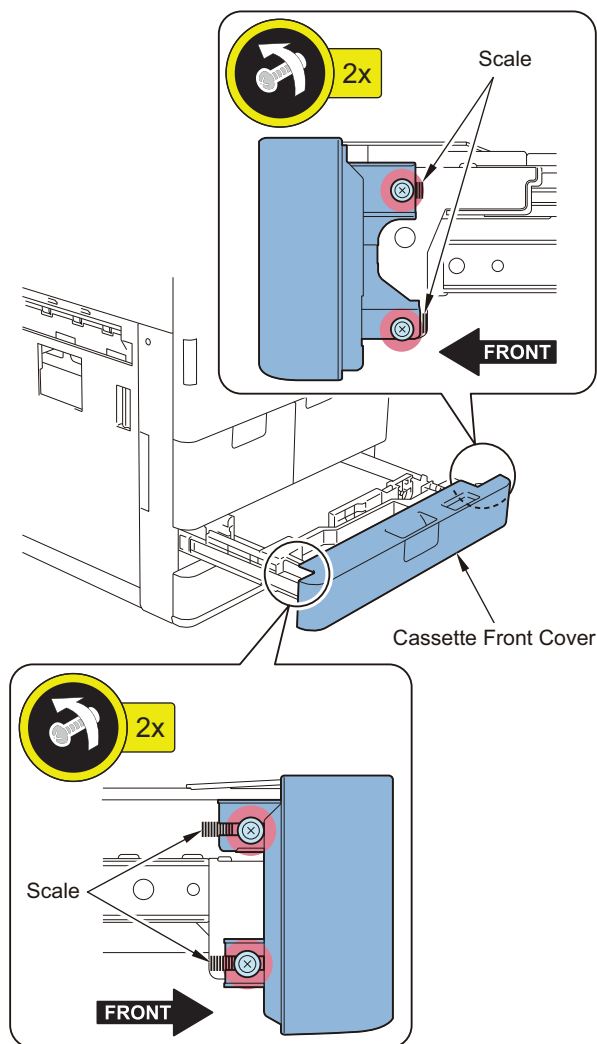
NOTE:

If you are concerned with alignment of the Cassette Front Cover, perform steps 12 to 14 to make an adjustment as necessary.



12. Loosen the 4 screws and adjust the position of the Cassette Front Cover by referring to the scale.

13. When moving the Cassette Button Link Unit, adjust the left side of the Cassette Front Cover by shifting it with the same shifting amount of the unit.



-
14. Once the position of the Cassette Front Cover is confirmed, tighten the 4 screws (which have been loosened in step 12).
-
15. Perform printing again from the cassette/deck, and check that the left edge margin (L1) of the image is within 2.5 +/- 1.5mm.

NOTE:

When a mechanical adjustment was made, be sure to execute the service mode again.

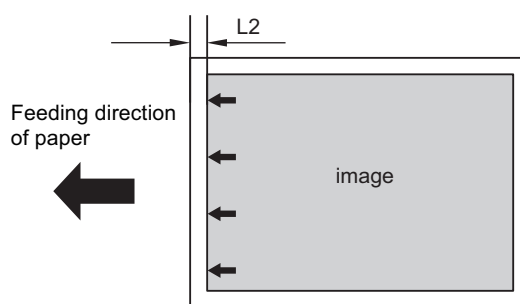
■ Leading Edge Margin Adjustment (1st side)

NOTE:

By executing the margin adjustment for the Cassette 3, the adjustment is applied to all source of paper.

-
1. After setting the service mode as follow, press the Start key and output a test print from Cassette 3.
 COPIER > TEST > PG > TYPE = 5
 COPIER > TEST > PG > PG-PICK = 3

-
2. Check that the leading edge margin of the image (L2) is within 2.5 +1.5/-0.5 mm. When the result is out of the specified range, perform adjustment by following the following procedure.



-
3. Adjust the image position in service mode.

NOTE:

<Setting Range>

-50 to 50 (0.1 mm per unit)

As the value is incremented by 1, the leading edge margin is decreased by 0.1mm.

COPIER > ADJUST > FEED-ADJ > REGIST

-
4. Perform printing again from the cassette 3, and check that the leading edge margin (L2) of the image is within 2.5 +1.5/-0.5 mm.
-
5. When the setting value was changed in step 3, write down the new numerical value in the service label.
-
6. Exit from the service mode.

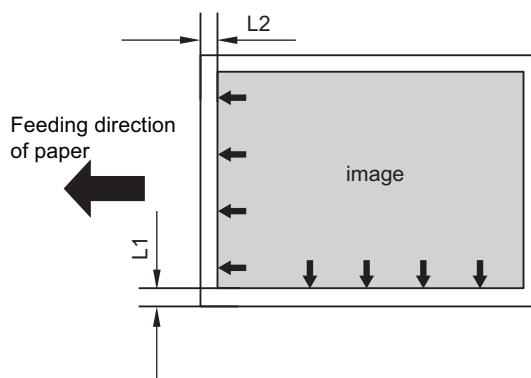
■ Left Edge/Leading Edge Margin Adjustment (2nd side)

NOTE:

By executing the margin adjustment for the Cassette 3, the adjustment is applied to all source of paper.

-
1. After setting the service mode as follow, press the Start key and output a test print from Cassette 3.
- COPIER > TEST > PG > TYPE = 5
 COPIER > TEST > PG > 2-SIDE = 1
 COPIER > TEST > PG > PG-PICK = 3

-
2. Check that the left edge margin (L1) and leading edge margin (L2) are within the range indicated below. When the result is out of the specified range, perform adjustment by following the following procedure.
- left edge margin L1: 2.5 +/-1.5 mm
 - leading edge margin L2 : 2.5 +1.5/-0.5 mm



-
3. Adjust the image position in service mode.
<left edge margin>

NOTE:

<Setting Range>

-50 to 50 (0.1 mm per unit)

As the value is incremented by 1, the left edge margin is increased by 0.1mm.

COPIER > ADJUST > FEED-ADJ > ADJ-REFE

<left edge margin>

NOTE:

<Setting Range>

-50 to 50 (0.1 mm per unit)

As the value is incremented by 1, the leading edge margin is decreased by 0.1mm.

COPIER > ADJUST > FEED-ADJ > REG-DUP1

-
4. Perform printing again from the cassette 3, and check that the left edge margin (L1) and leading edge margin (L2) of the image are within the range indicated below.
- left edge margin L1: 2.5 +/-1.5 mm
 - leading edge margin L2 : 2.5 +1.5/-0.5 mm

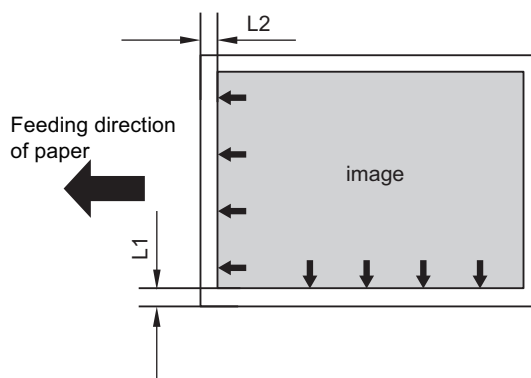
-
5. When the setting value was changed in step 3, write down the new numerical value in the service label.

-
6. Exit from the service mode.

■ Left Edge/Leading Edge Margin Adjustment of Multi-purpose Pickup Tray

-
1. After setting the service mode as follow, press the Start key and output a test print from Multi-purpose Pickup Tray.
- COPIER > TEST > PG > TYPE = 5
COPIER > TEST > PG > PG-PICK = 5

-
2. Check that the left edge margin (L1) and leading edge margin (L2) are within the range indicated below. When the result is out of the specified range, perform adjustment by following the following procedure.
- left edge margin L1: 2.5 +/-1.5 mm
 - leading edge margin L2: 2.5 +1.5/-0.5 mm



-
3. Adjust the image position in service mode.
<left edge margin>

NOTE:

<Setting Range>

-20 to 20 (0.1 mm per unit)

As the value is incremented by 1, the left edge margin is increased by 0.1mm.

COPIER > ADJUST > FEED-ADJ > ADJ-MF

<leading edge margin>

NOTE:

<Setting Range>

-50 to 50 (0.1 mm per unit)

As the value is incremented by 1, the leading edge margin is decreased by 0.1mm.

COPIER > ADJUST > FEED-ADJ > RG-MF

-
4. When the setting value was changed in step 3, write down the new numerical value in the service label.

-
5. Exit from the service mode.

-
6. Perform printing again from the Multi-purpose Pickup Tray, and check that the left edge margin (L1) and leading edge margin (L2) of the image are within the range indicated below.
- left edge margin L1: 2.5 +/-1.5 mm
 - leading edge margin L2: 2.5 +1.5/-0.5 mm

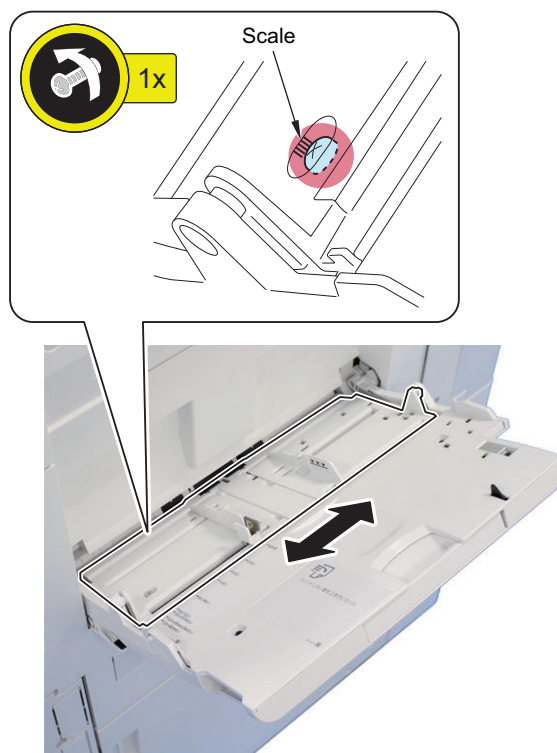
NOTE:

In the case of left edge margin: If the adjustment cannot be made with the setting value of -20 to 20 (adjustment amount: -2.0 to 2.0mm), execute step 7 and later steps.

-
7. Open the Multi-purpose Pickup Tray.

**8. Loosen the screw and adjust the position of the Slide Guide by referring to the scale.**

- In the case of larger margin at the rear side, move the Slide Guide to the front side.
- In the case of larger margin at the front side, move the Slide Guide to the rear side.

**9. Tighten the screw loosened in step 8.****10. Perform printing again from the Multi-purpose Pickup Tray, and check that the left edge margin (L1) and leading edge margin (L2) of the image are within the range indicated below.**

- left edge margin L1: 2.5 +/-1.5 mm
- leading edge margin L2: 2.5 +1.5/-0.5 mm

NOTE:

When a mechanical adjustment was made, be sure to execute the service mode again.

Skew Adjustment (at Stream Scanning of Originals)

If the images from stream scanned originals are skewed after the adjustments of the printer side is complete, perform skew adjustment according to the workflow.

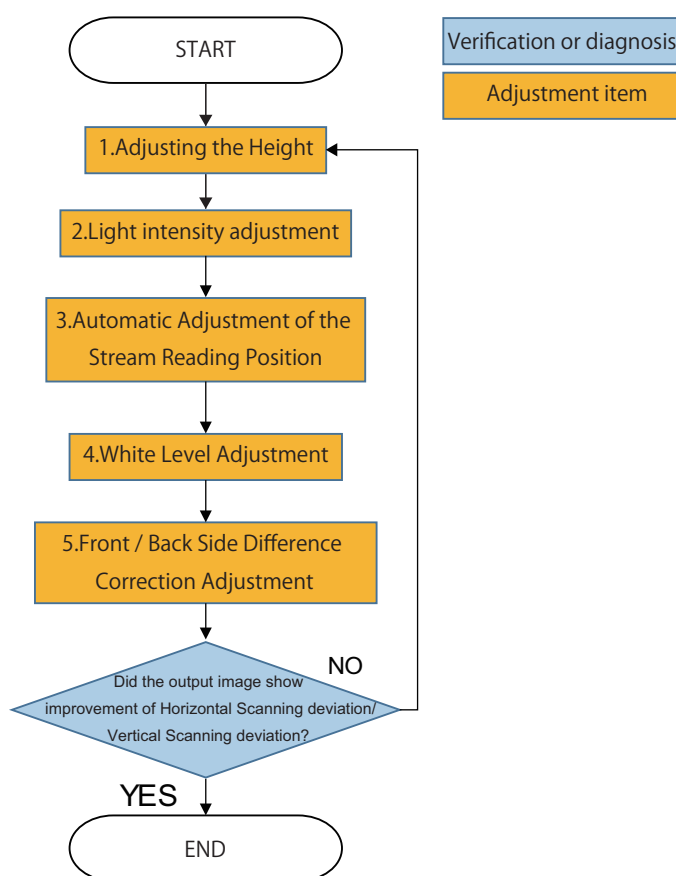
CAUTION:

The correction may not be performed under the following usage conditions because the skew cannot be detected.

- The Reading Glass or Feed Guide is soiled.
- The edge of original is bent / torn / missing.
- Translucent or thin originals are used.
- E202-0010 or E202-0002 is in the error log and not remedied, which occurs system degraded.

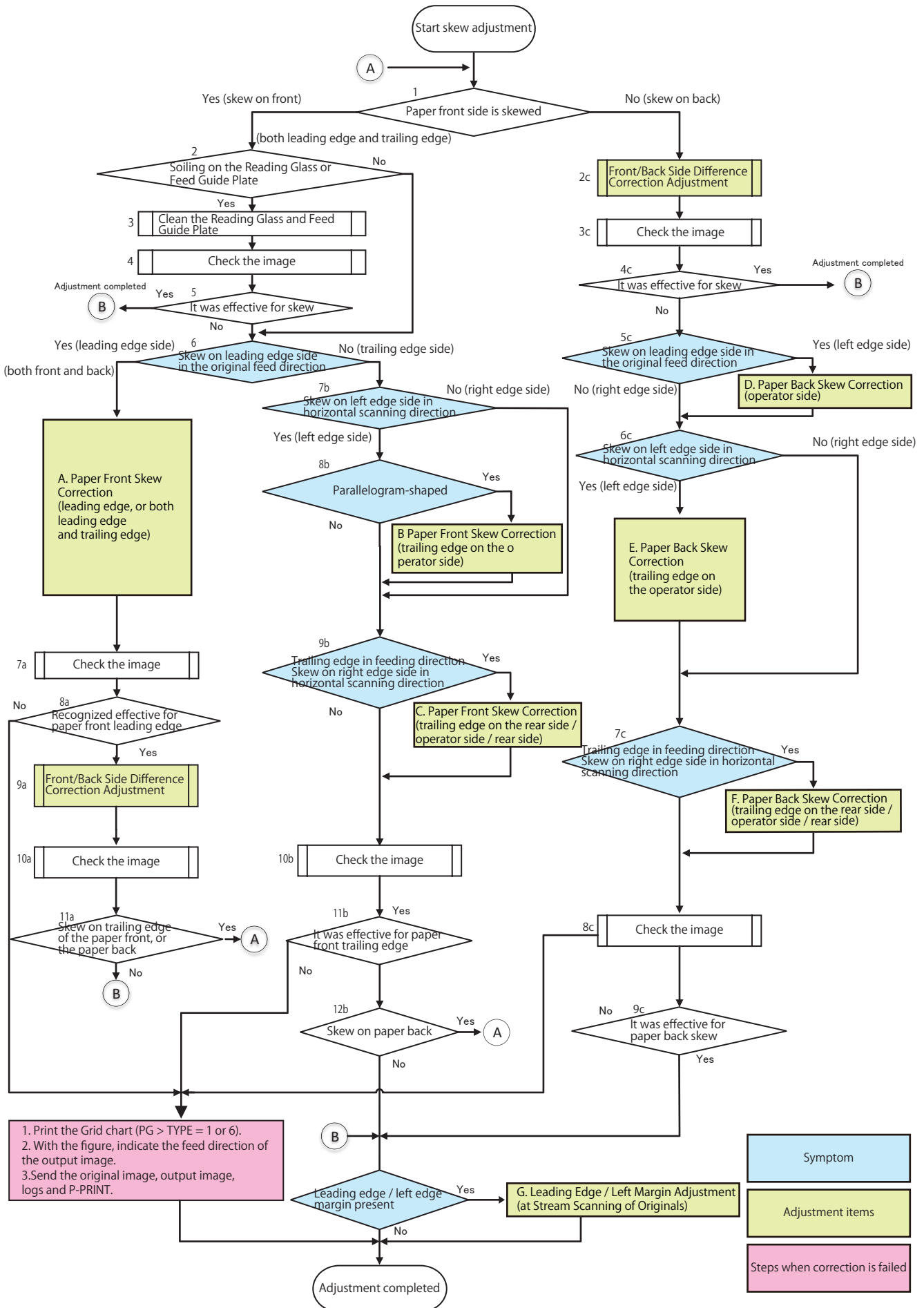
Workflow1

When skew or image deviation is not improved after execution of the work flow 1, the work flow 2 is executed.



Adjustment Items

1. "Adjusting the Height" on page 606
2. "Light intensity adjustment" on page 616
3. "Automatic Adjustment of the Stream Reading Position (Automatic Adjustment of the Reading Position at ADF Reading)" on page 617
4. "White Level Adjustment" on page 618
5. "Front/Back Side Difference Correction Adjustment" on page 619

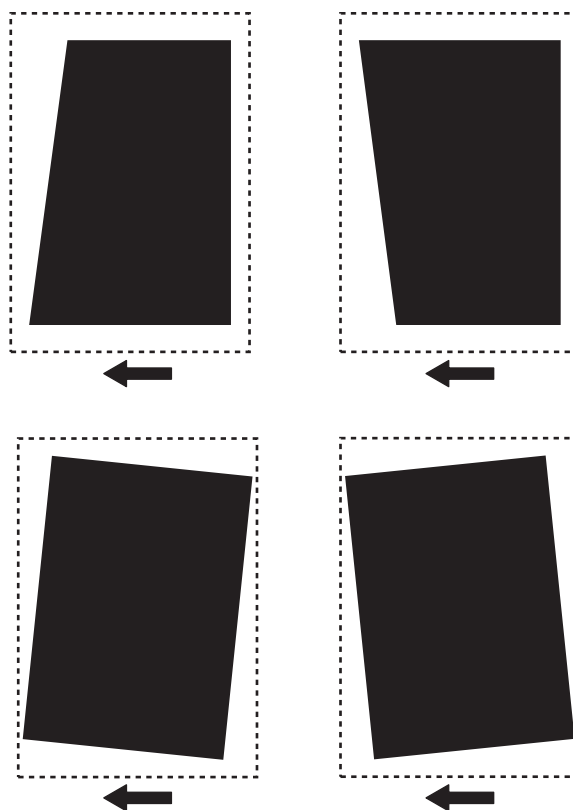


1. Print the Grid chart (PG > TYPE = 1 or 6).
 2. With the figure, indicate the feed direction of the output image.
 3. Send the original image, output image, logs and P-PRINT.

Symptom
Adjustment items
Steps when correction is failed

A. Paper Front Skew Correction (Leading Edge, or Both Leading Edge and Trailing Edge)

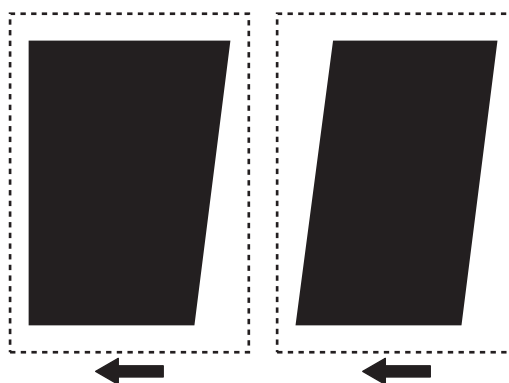
Correct skew with the following procedure if a skew occurs on leading edge, or both leading edge and trailing edge (on the front side of paper).



1. ["Adjusting the Height" on page 606](#)
2. ["Right Angle Adjustment \(Slant Adjustment\)" on page 610](#)
3. ["Light intensity adjustment" on page 616](#)
4. ["Automatic Adjustment of the Stream Reading Position \(Automatic Adjustment of the Reading Position at ADF Reading\)" on page 617](#)
5. ["White Level Adjustment" on page 618](#)
6. Check the image again. If the leading edge on the front side of the paper is corrected, perform "Difference correction adjustment of front and back sides". If a skew is occurring on the trailing edge of the front side of the paper, or back side of the paper, perform the appropriate skew correction item. If the skew on the front side is not corrected, contact the support department of the sales company.
["Front/Back Side Difference Correction Adjustment" on page 619](#)

B. Paper Front Skew Correction (Trailing Edge on the Operator Side)

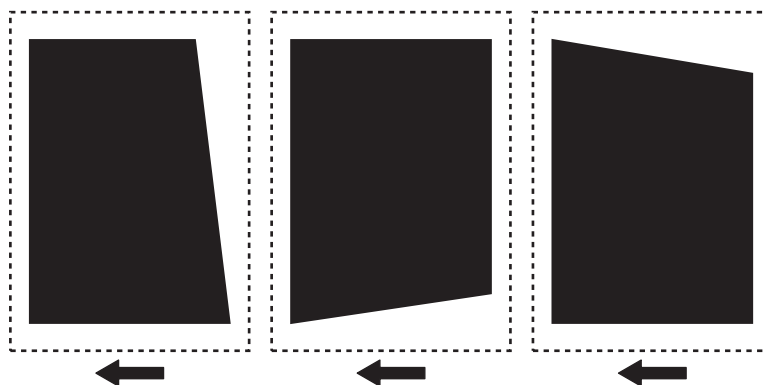
Correct skew with the following procedure if a skew occurs on trailing edge on the operator side (on the front side of paper).



1. "[Parallelogram Correction](#)" on page 622
2. Check the image again. If a skew is occurring on the back side of the paper, perform the appropriate skew correction item. If the skew on the front side is not corrected, contact the support department of the sales company.

C. Paper Front Skew Correction (Trailing Edge on the Rear Side / Operator Side / Rear Side)

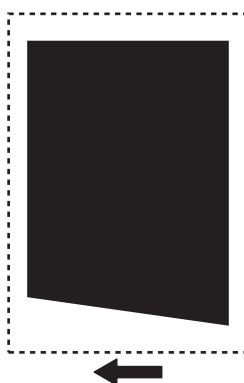
Correct skew with the following procedure if a skew occurs on trailing edge on the rear side / operator side / rear side (on the front side of paper).



1. "[Angle Correction \(Front / Back\)](#)" on page 623
2. Check the image again. If a skew is occurring on the back side of the paper, perform the appropriate skew correction item. Check the image again. If a skew has not been corrected on the front side of the paper, contact the support department of the sales company.

D. Paper Pack Skew Correction (Operator Side)

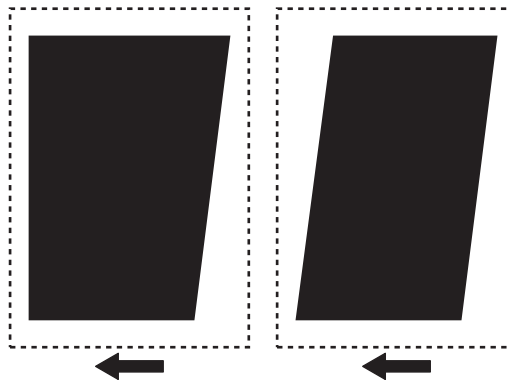
Correct skew with the following procedure if a skew occurs on the operator side (on the back side of paper).



1. "[Front/Back Side Difference Correction Adjustment](#)" on page 619
2. Check the image again. If a skew is occurring on the back side of the paper, contact the support department of the sales company.

E. Paper Back Skew Correction (Trailing Edge on the Operator Side)

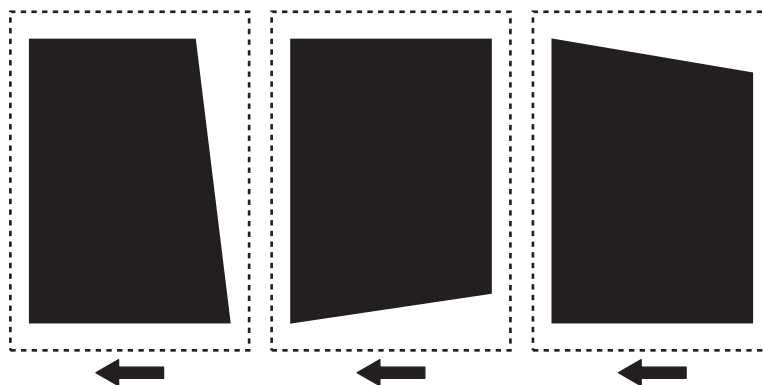
Correct skew with the following procedure if a skew occurs on trailing edge on the operator side (on the back side of paper).



1. [“Right Angle Adjustment \(Slant Adjustment\)” on page 610](#)
2. [“Light intensity adjustment ” on page 616](#)
3. [“White Level Adjustment ” on page 618](#)
4. Check the image again. If a skew is occurring on the back side of the paper, contact the support department of the sales company.

F. Paper Back Skew Correction (Trailing Edge on the Rear Side / Operator Side / Rear Side)

Correct skew with the following procedure if a skew occurs on trailing edge on the rear side / operator side / rear side (on the back side of paper).



1. [“Angle Correction \(Front / Back\)” on page 623](#)
2. Check the image again. If a skew is occurring on the back side of the paper, contact the support department of the sales company.

G. Edge Margin Adjustment after the Skew Adjustment (at Stream Scanning of the Originals)

When the leading edge / left edge margin of the image is out of the standard range after skew correction, adjust the leading edge / left edge margin using a test chart.

Reference: Standard value

- Leading edge: 4.0+1.5/-1.0 mm (front side, back side)
- Left edge: 2.5+/-1.5 mm (front side) / 2.5 + / -2.0 mm (back side)

1. [“Creating the Test Charts for Image Position Adjustment” on page 624](#)
2. **Adjust the leading edge margin of the image after skew correction in the following service modes.**
 - FEEDER > ADJUST > ADJ-T1 (Front)
 - FEEDER > ADJUST > ADJ-T2 (Back)

NOTE:

- Amount of change per 1 setting value 0.1 mm
- Adjustment range -15 to 15

3. Adjust the left edge margin of the image after skew correction in the following service modes.

- FEEDER > ADJUST > ADJ-L1 (Front)
- FEEDER > ADJUST > ADJ-L2 (Back)


NOTE:

- Amount of change per 1 setting value 0.1 mm
- Adjustment range -30 to 30

Adjusting the Height

Height Check Sheet Preparation or Creation

1. Prepare the check sheet used for height adjustment.

 Height check sheet

NOTE:

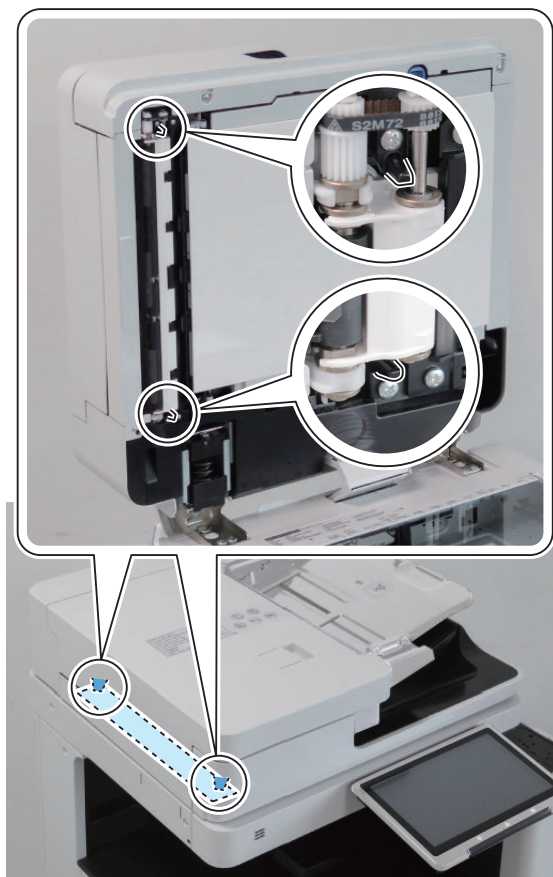
Points to Note when Creating the Check Sheet

- Output with A4 (paper size) or LTR (paper size)
- Use plain paper 1 to 3 (64 to 105 g/m²) (Paper Type).

Height Adjustment

Checking the Height

-
1. Check that the 2 Height Adjustment Bosses at the left front side and the left rear side are in contact with the Stream Reading Glass.

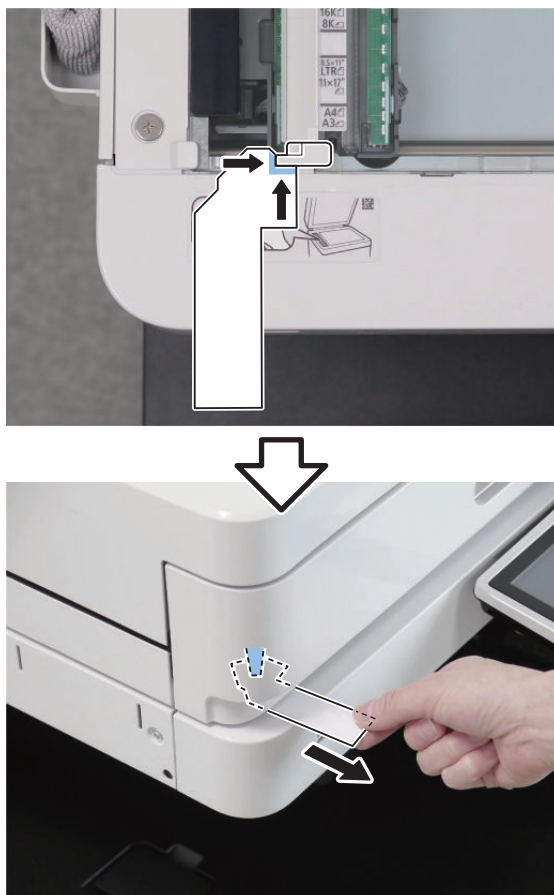


2. If they are not in contact, perform the height adjustment.
If it cannot be visually checked, perform "Checking the Height of the Height Adjustment Boss".

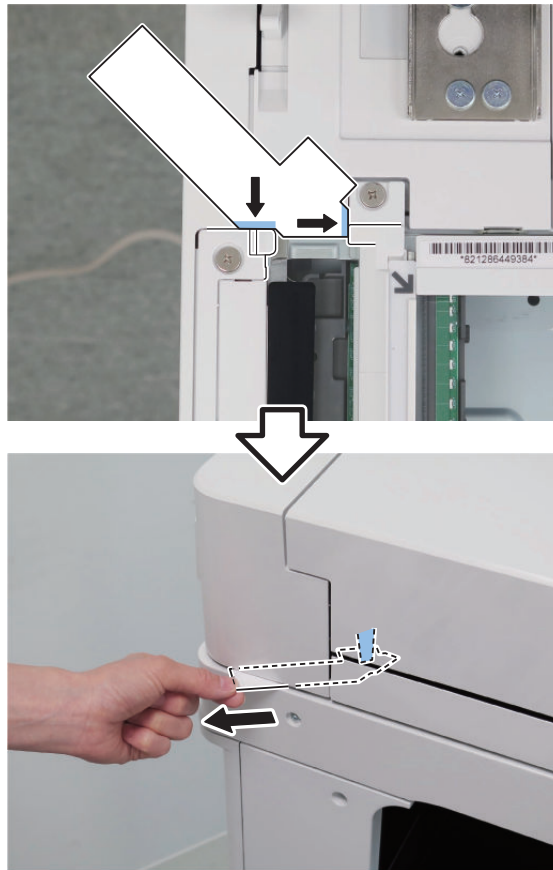
Checking the Height of the Height Adjustment Boss

-
1. Put a sheet of paper on the place where the protrusions touch the Stream Reading Glass, and check whether there is any resistance of the paper when closing the ADF.

<The Left Front Side>



<The Left Rear Side>



2. If there is no resistance, perform the height adjustment.

Height Adjustment Procedure

-
1. Adjust by turning the Fixation Screw on the upper side of Hinge.
 - If both front and rear side (or only front side) are not installed properly: Turn the Right Hinge Fixation Screw clockwise (black arrow) to correctly locate it at the front.



- If the rear side is not installed properly: Turn the Left Hinge Fixation Screw counterclockwise (white arrow).



2. Check the height again and see if it is at an appropriate height.

Right Angle Adjustment (Slant Adjustment)

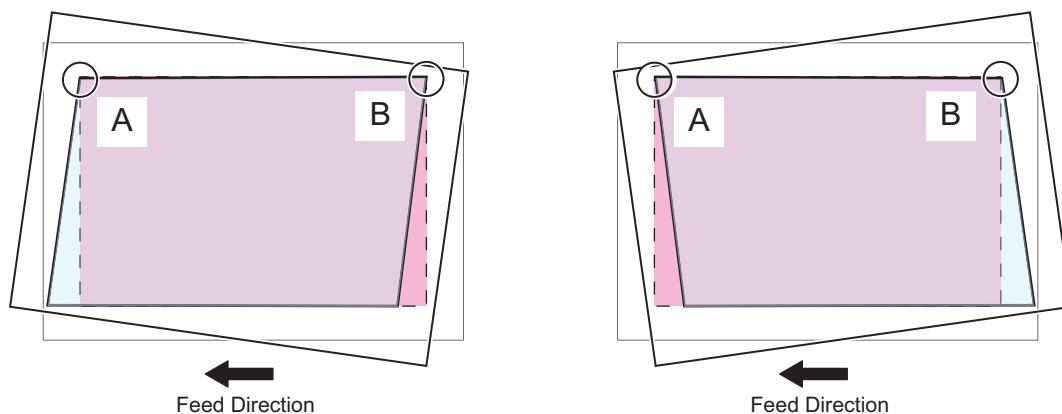
NOTE:

There are two adjustment methods: One for reading the front side (Scanner Unit on the Reader side) and another for reading the back side (Scanner Unit on the DADF side).

Adjustment of the Paper Front Reading



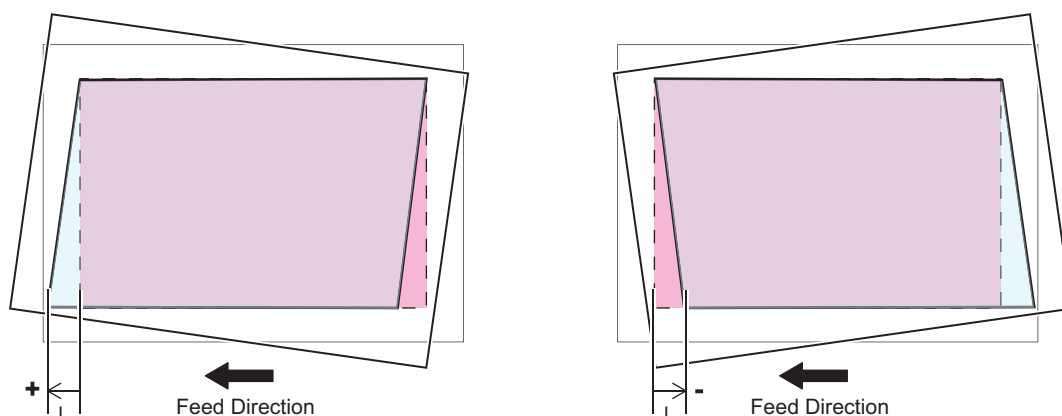
1. Prepare the test chart prepared below.
[“Creating the Test Charts for Image Position Adjustment” on page 624](#)
2. Set the value of following service mode to "1".
 FEEDER > OPTION > SKW-SW
3. Place a test chart on the ADF and perform 1-sided copy.
4. Overlap the test chart and the A and B sections of the copied paper.



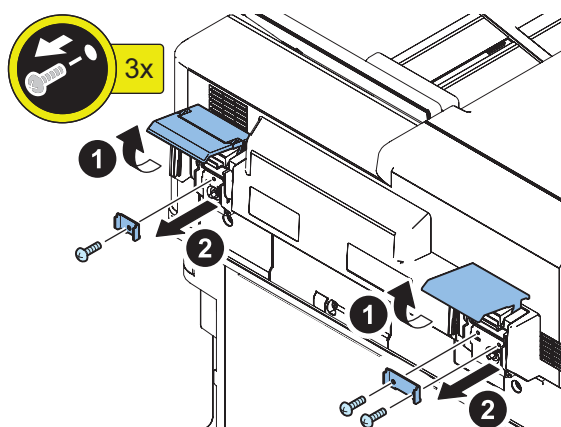
5. Measure the distance L between the test chart and the copied paper.

NOTE:

When the interval L is shifted to the left "+", and when the interval L is shifted to the right "-".



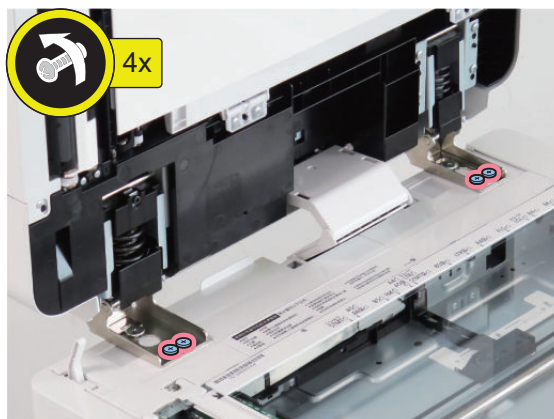
6. Open the Hinge cover, and remove the Hinge stopper.



CAUTION:

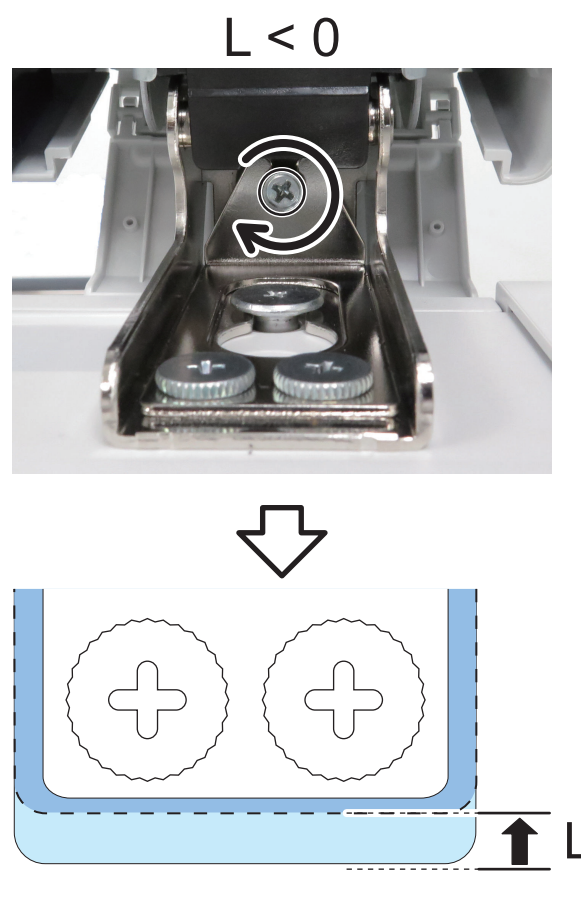
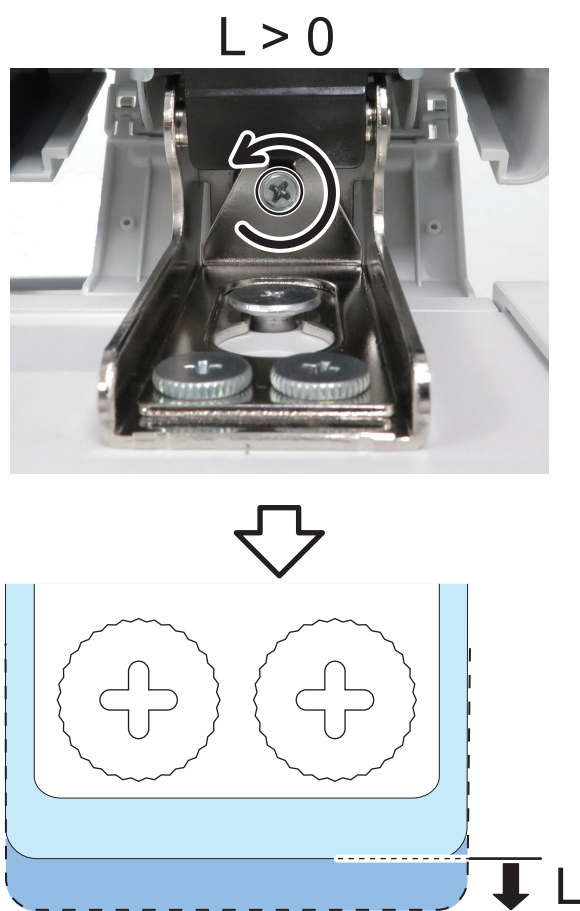
After adjustment, be sure to install the Hinge Stoppers.

7. Loosen the 4 Knurled Screws at the front part of the Right and Left Hinge Unit.



8. The fixing member is moved forward and backward by turning the screw by the value of the interval L between the test chart and the copied paper.

- $L > 0$: Turn the screw counterclockwise.
- $L < 0$: Turn the screw clockwise.

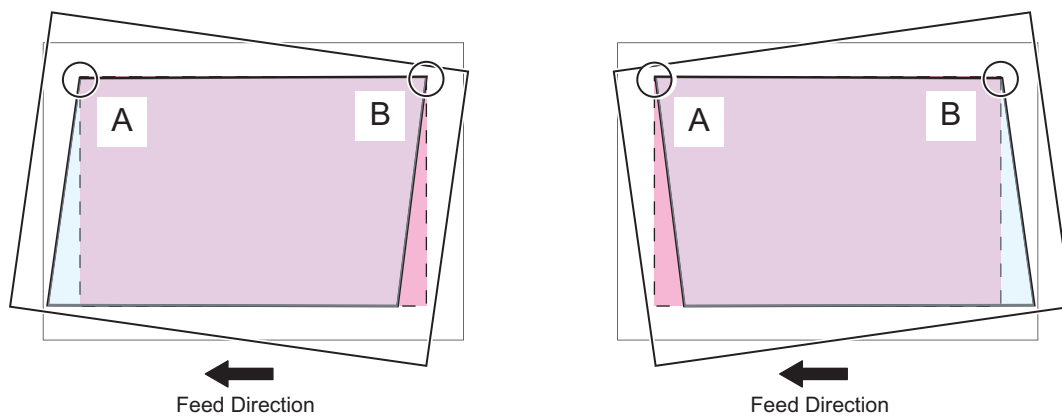


9. Tighten the 4 Knurled Screws.

Adjustment of the Paper Back Reading



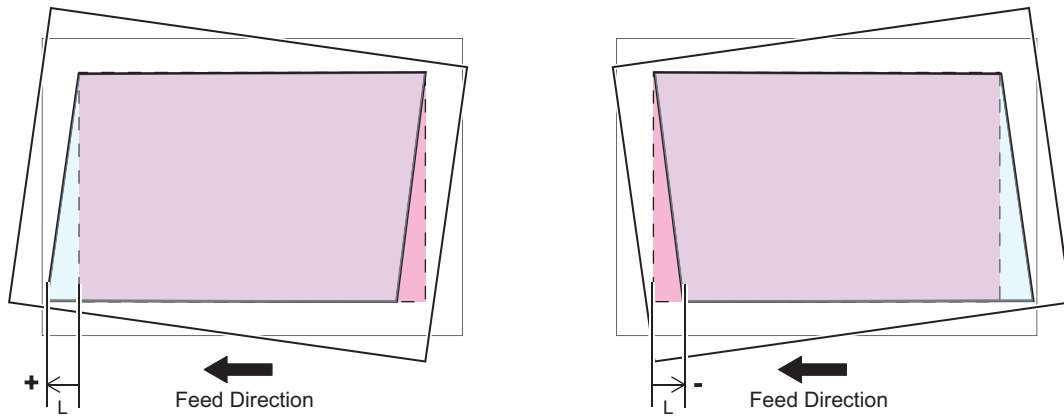
1. Place a test chart facing down on the ADF and perform 2-sided copy.
2. Overlap the test chart and the A and B sections of the copied paper.



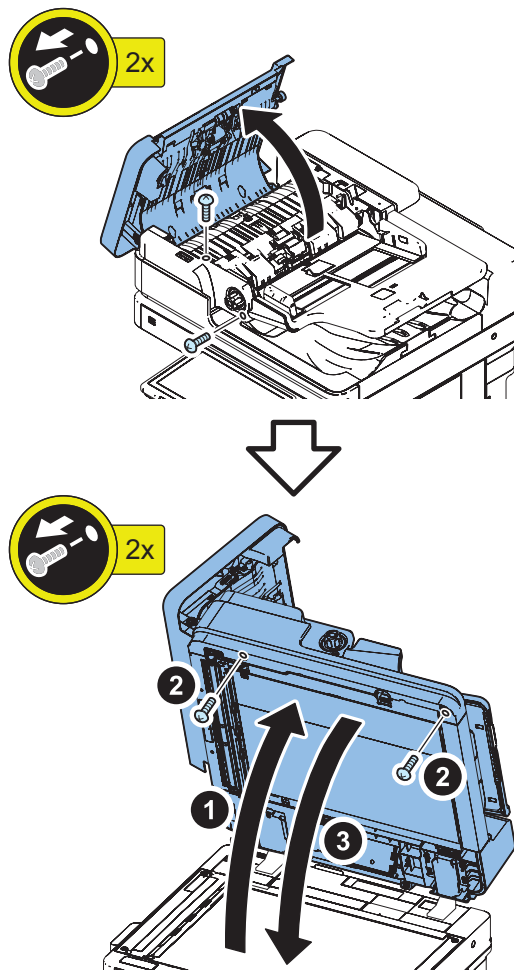
3. Measure the distance L between the test chart and the copied paper.

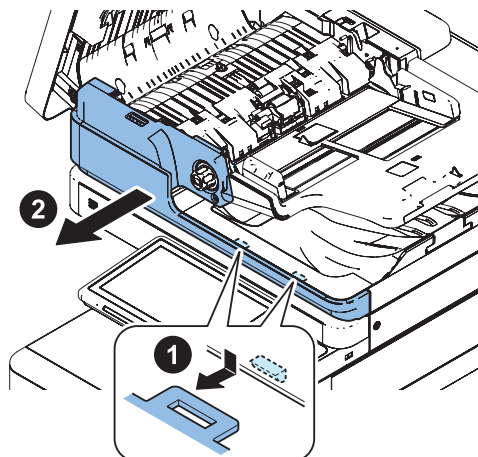
NOTE:

When the interval L is shifted to the left "+", and when the interval L is shifted to the right "-".



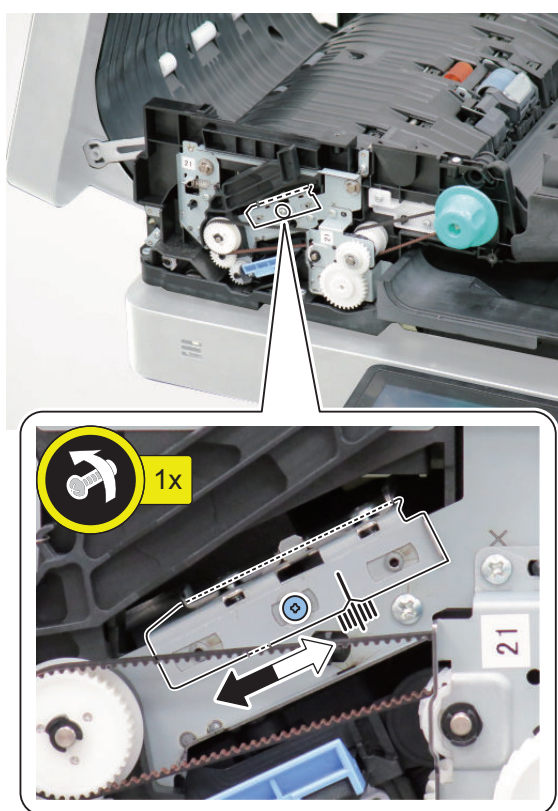
4. Open the Feeder Cover, and remove the Front Cover of the DADF.
 • 4 screws





5. Loosen the adjustment screw. Adjust the position of the guide supporting the Scanner Unit.

- L>0 : Move the Guide to the right side (white arrow).
- L<0 : Move the Guide to the left side (black arrow).



6. Tighten the adjustment screw.
7. Return the DADF Front Cover and the Feeder Cover to their original positions.
8. Set the value of following service mode to "0".
FEEDER > OPTION > SKW-SW

Light intensity adjustment

NOTE:

- This mode automatically performs adjustment.
- If "NG" is displayed after executing this mode, check that PCB and each connector are properly connected.

**1. Execute the following service mode with the ADF closed.**

COPIER >FUNCTION >CCD > LMPADJ

Automatic Adjustment of the Stream Reading Position (Automatic Adjustment of the Reading Position at ADF Reading)

NOTE:

- If the DADF is opened during adjustment, restart the adjustment.
- Enter the value after adjustment on the Service Label (on the back of the Reader Front Cover or Printer Front Cover). (The adjustment result is reflected to COPIER > ADJUST > ADJ-XY > STRD-POS.)
COPIER > ADJUST > ADJ-XY > STRD-POS

**1. Execute the following service mode item.**

COPIER > FUNCTION > INSTALL > STRD-POS

NOTE:

If "NG" is displayed after executing this mode, execute "Right Angle Adjustment (Slant Adjustment)" on the service manual.

2. Turn OFF/ON the main power of the Host Machine.

White Level Adjustment



1. Place a sheet of blank A4 or LTR size paper on the Copyboard Glass and close the ADF.

CAUTION:

When executing the white level adjustment using paper with smaller width, adjustment may not be executed properly.

2. Execute the service mode item.
COPIER > FUNCTION > CCD > DF-WLVL1
3. Remove the blank paper from the Copyboard Glass, and place it on the Document Pickup Tray of ADF.
4. Execute the service mode item.
COPIER > FUNCTION > CCD > DF-WLVL2
5. Place the blank paper on the Copyboard Glass again and close the ADF.
6. Execute the service mode item.
COPIER > FUNCTION > CCD > DF-WLVL3
7. Remove the blank paper from the Copy Board Glass, and place it on the Document Pickup Tray of ADF.
8. Execute the service mode item.
COPIER > FUNCTION > CCD > DF-WLVL4

Front/Back Side Difference Correction Adjustment

NOTE:

When the following items are adjusted or replaced, the difference correction adjustment of the Front/Back Side Difference Correction Adjustment is performed.

- Front/Back Side Difference Correction Adjustment
- Automatic Adjustment of the Stream Reading Position (Automatic Adjustment of the Reading Position at ADF Reading)
- Scanner Unit (Front/Back side)
- ADF

Front/Back Side Difference Correction Adjustment is performed by any of the following methods.

1. Automatic Front/Back Side Difference Correction Adjustment
To automatically correct a front/back side differences by making a chart by hand.
2. Manual Front/Back Side Difference Correction Adjustment (Manual Back Side Position Adjustment)
Print a single-sided grid chart and manually adjust the image position on the back side.

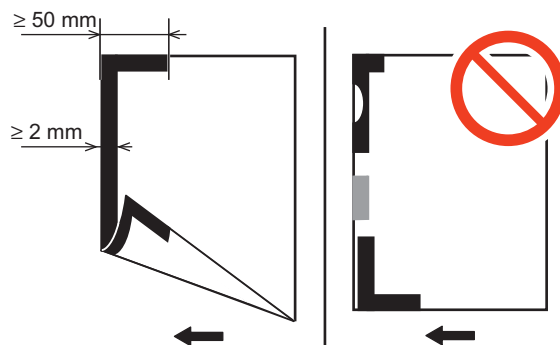
Automatic Front/Back Side Difference Correction Adjustment

NOTE:

If the chart in the following state is used, skew detection may not be possible and correction may not be possible.

- The painted part is not long enough.
- The painted part is chipped.
- The color is light.
- The edges are not painted.
- Broken/torn/chipped.
- Translucent, thin paper manuscript is used.
- The area painted black is not dry enough.

1. Use a chart of a service parts of a Automatic Front/Back Side Difference Correction Adjustment, or using A4 or LTR paper, the leading edge and the side edge of the front/back side in the feeding direction are painted black with magic, and a chart for Automatic Front/Back Side Difference Correction Adjustment is prepared.



2. Set the value of the service mode to "0" below.

- FEEDER > ADJUST > ADJ-T2/L2/ROT2 = 0

NOTE:

- The ADJ-T2/L2/ROT2 is an item for manually fine-adjusting the skew in the case that a deviation remains in the position of the back image to which the skew is automatically corrected after the Automatic Front/Back Side Difference Correction Adjustment.
- "0" is the value at the time of shipment from the factory. By resetting to the initial state, there is no unintended deviation due to manual correction with respect to the back surface image in which skew correction is automatically performed, so that a constant accuracy is guaranteed.

3. Set the document tray so that the black-painted portion becomes the leading edge in the feeding direction.

4. Automatic Front/Back Side Difference Correction Adjustment is performed in the following service mode.

- FEEDER > FUNCTION > ADJ-SKW

NOTE:

If "NG" is displayed after executing this mode, execute "Right Angle Adjustment (Slant Adjustment)" on the service manual.

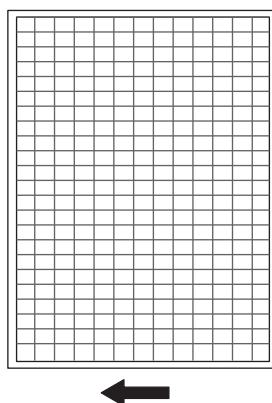
5. Write the adjusted values below on the service label.

- FEEDER > ADJUST > ADJ-DT
- FEEDER > ADJUST > ADJ-DL
- FEEDER > ADJUST > ADJ-DROT

Manual Front/Back Side Difference Correction Adjustment (Manual Back Side Position Adjustment)

1. Use A4 or LTR paper and set the service modes as follows. Print the test chart of the Manual Front/Back Side Difference Correction Adjustment (Manual Back Side Position Adjustment).

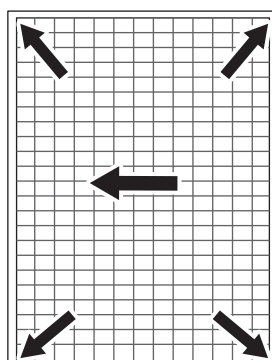
- COPIER > TEST > PG > TYPE = 1 or 6
- COPIER > TEST > PG > PG-PICK = To set the Pickup Cassette for test print output.



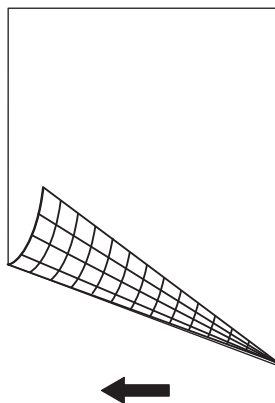
NOTE:

Pressing "i" (Information Button) displays the TYPE number.

2. Write the angle of the document and the arrow indicating the ADF feeding direction .



3. **Manual Front/Back Side Difference Correction Adjustment (Manual Back Side Position Adjustment) chart is set and printed on the document tray so that the print surface thereof becomes the back side.**



4. **Manually adjust an image according to the state of a printed image.**

Refer to the following Service Manual

- Adjustment > Original Feed System (Single Pass ADF) > Skew Adjustment (at Stream Scanning of Originals) > F. Paper Back Skew Correction (Trailing Edge on the Rear Side / Operator Side / Rear Side)
- Adjustment > Original Feed System (Single Pass ADF) > Skew Adjustment (at Stream Scanning of Originals) > G. Edge Margin Adjustment after the Skew Adjustment (at Stream Scanning of the Originals)

Parallelogram Correction

Perform parallelogram correction if a scanned image is parallelogram-shaped.

1. Correct the parallelogram in the following service modes.

- FEEDER > ADJUST > ADJ-PAR1 (Front)
- FEEDER > ADJUST > ADJ-PAR2 (Back)

NOTE:

- As the value is increased by 1, the image is corrected clockwise by 0.01 degree.
- As the value is decreased by 1, the image is corrected counterclockwise by 0.01 degree.

Angle Correction (Front / Back)

If the trailing edge of the scanned image is missing, perform angle correction.

1. Correct the amount of rotation in the following service modes.

- FEEDER > ADJUST > ADJ-ROT1 (Front)
- FEEDER > ADJUST > ADJ-ROT2 (Back)

NOTE:

- As the value is increased by 1, the image is corrected clockwise by 0.01 degree.
- As the value is decreased by 1, the image is corrected counterclockwise by 0.01 degree.

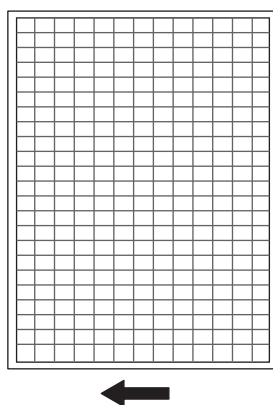
Image Position Adjustment (at Stream Scanning of Originals)

Adjust the image position of the side / leading edge using a test chart.

Creating the Test Charts for Image Position Adjustment

CAUTION:

Create the test charts for image position adjustment after completing adjustments on the printer side.



1. After setting the service modes as follows, press the Start key to output the test chart.

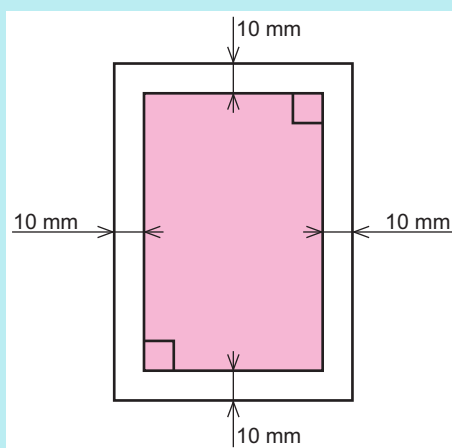
- COPIER > TEST > PG > TYPE = 1 or 6
- COPIER > TEST > PG > PG-PICK = To set the Pickup Cassette for test print output.

NOTE:

Pressing "i" (Information Button) displays the TYPE number.

NOTE:

- If the specified test chart cannot be output, draw a test chart on A3 or LDR paper with a rectangle whose four corners are 10 mm smaller than the paper.
- To draw characters and marks so that you can see the direction of the copied image.



Side Registration Adjustment

NOTE:

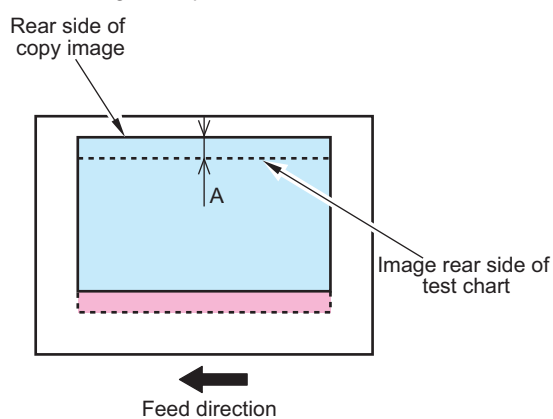
There are two adjustment methods: One for reading the front side (Scanner Unit on the Reader side) and another for reading the back side (Scanner Unit on the ADF side).

Adjustment of the Paper Front Reading

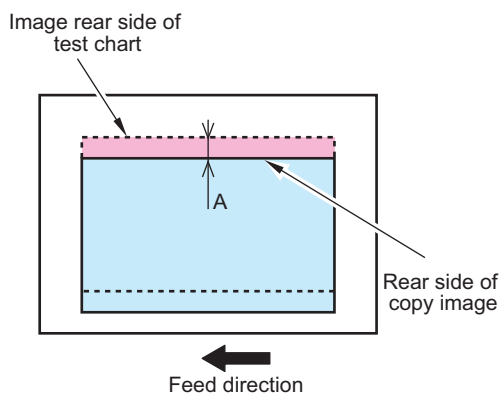


1. Prepare a test chart created below.
[“Creating the Test Charts for Image Position Adjustment” on page 624](#)
2. Set the following service mode to "1".
 FEEDER > OPTION > SKW-SW
3. Place a test chart on the ADF and perform 1-sided copy.
4. Overlay the copied paper onto the test chart.
5. Check whether the rear side of the copied image is within the standard.
 - Standard: $A \leq 1 \text{ mm}$

< If the image is displaced toward rear >



< If the image is displaced toward front >



6. If it is not within the standard range, adjust the image position in the following service mode.
 COPIER > ADJUST > ADJ-XY > ADJ-Y-DF

NOTE:

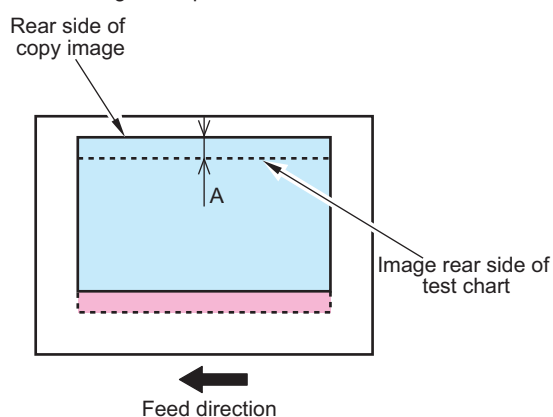
- If the copied image is displaced toward the rear side: Decrease the value (the image moves toward the front side)
- If the copied image is displaced toward the front side: Increase the value (the image moves toward the rear side)
- Amount of change per 1 setting value 0.1 mm
- Adjustment range -35 to 35

7. Copy the test chart again, and check that the image is within the ranges of the standard.
8. Write down the adjusted value in the service label (on the back of the Reader front cover back or Printer front cover).

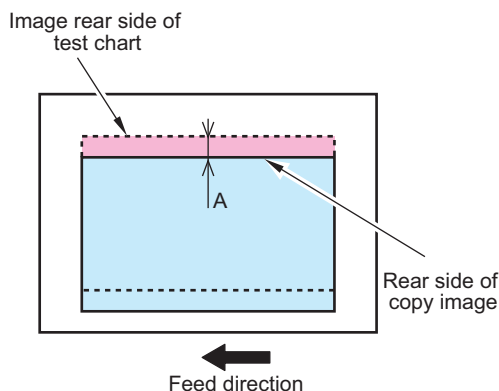
Adjustment of the Paper Back Reading

1. Place a test chart facing down on the ADF and perform 2-sided copy.
2. Overlay the copied paper onto the test chart.
3. Check whether the rear side of the copied image is within the standard.
 - Standard: $A \leq 2.0\text{mm}$

< If the image is displaced toward rear >



< If the image is displaced toward front >



4. If it is not within the standard range, adjust the image position in the following service mode.
COPIER > ADJUST > ADJ-XY > ADJY-DF2

NOTE:

- If the copied image is displaced toward the rear side: Decrease the value (the image moves toward the front side)
- If the copied image is displaced toward the front side: Increase the value (the image moves toward the rear side)
- Amount of change per 1 setting value 0.1 mm
- Adjustment range -35 to 35

5. Copy the test chart again, and check that the image is within the ranges of the standard.
6. Write down the adjusted value in the service label (on the back of the Reader front cover back or Printer front cover).
7. Set the following service mode to "0".
FEEDER > OPTION > SKW-SW

Leading Edge Margin Adjustment

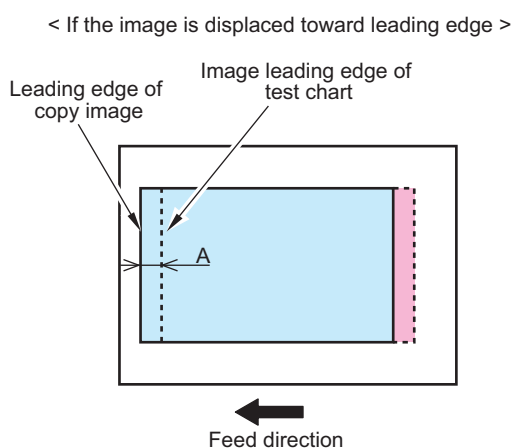
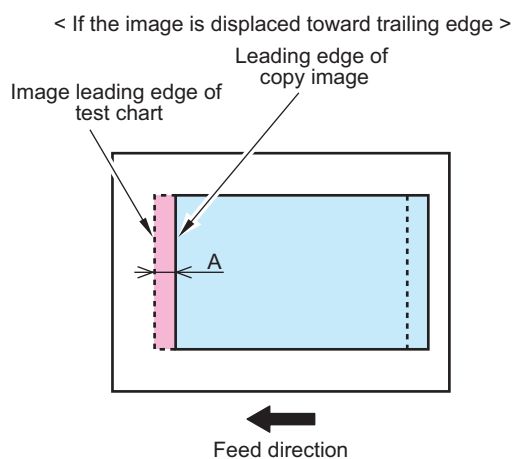
NOTE:

There are two adjustment methods: One for reading the front side (Scanner Unit on the Reader side) and another for reading the back side (Scanner Unit on the ADF side).

Adjustment of the Paper Front Reading



1. Prepare a test chart created below.
[“Creating the Test Charts for Image Position Adjustment” on page 624](#)
2. Set the following service mode to "1".
 FEEDER > OPTION > SKW-SW
3. Place a test chart on the ADF and perform 1-sided copy.
4. Overlay the copied paper onto the test chart.
5. Check that the leading edge of the copied image is within the standard range.
 - Standard: $A \leq 1 \text{ mm}$



6. If it is not within the standard range, adjust the image position in the following service mode.
 FEEDER > ADJUST > DOCST
 - If the copied image is displaced toward the trailing edge: Increase the value (move the image toward the leading edge)
 - If the copied image is displaced toward the leading edge: Decrease the value (move the image toward the trailing edge)
 Amount of change per 1 setting value 0.1 mm

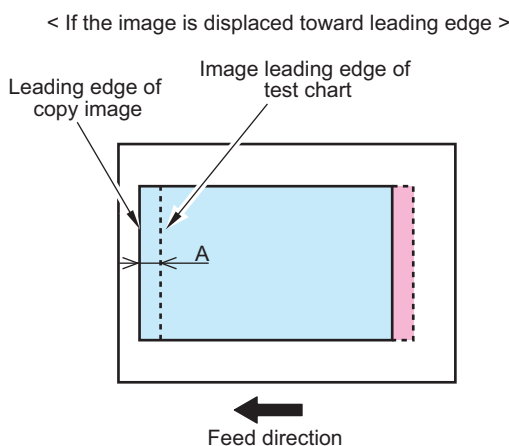
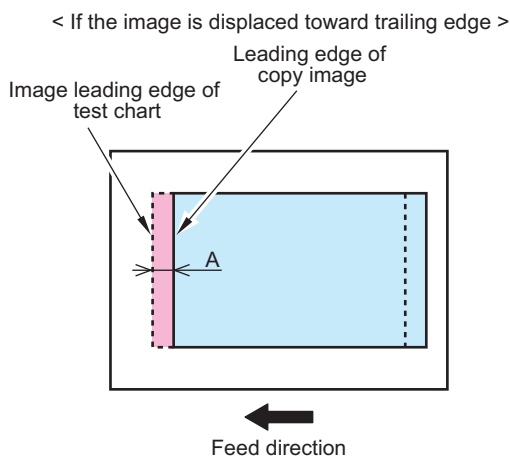
Adjustment range -50 to 50

7. Copy the test chart again, and check that the image is within the ranges of the standard.
8. Write down the adjusted value in the service label (on the back of the Reader front cover back or Printer front cover).

Adjustment of the Paper Back Reading



1. Place a test chart facing down on the ADF and perform 2-sided copy.
2. Overlay the copied paper onto the test chart.
3. Check that the leading edge of the copied image is within the standard range.
 - Standard: $A \leq 1.5\text{mm}$



4. If it is not within the standard range, adjust the image position in the following service mode.
 - FEEDER > ADJUST > DOCST2
 - If the copied image is displaced toward the trailing edge: Increase the value (move the image toward the leading edge)
 - If the copied image is displaced toward the leading edge: Decrease the value (move the image toward the trailing edge)
- Amount of change per 1 setting value 0.1 mm
- Adjustment range -50 to 50
5. Copy the test chart again, and check that the image is within the ranges of the standard.
6. Write down the adjusted value in the service label (on the back of the Reader front cover back or Printer front cover).
7. Set the following service mode to "0".
 - FEEDER > OPTION > SKW-SW

Magnification Ratio Adjustment

NOTE:

- There are two adjustment methods: One for Paper Front Reading (Scanner Unit on the Reader side), and the other for Paper Back Reading (Scanner Unit on the DADF side).
- This adjustment is performed by comparing the images printed with the stream reading and the copyboard reading.

Magnification ratio adjustment flow

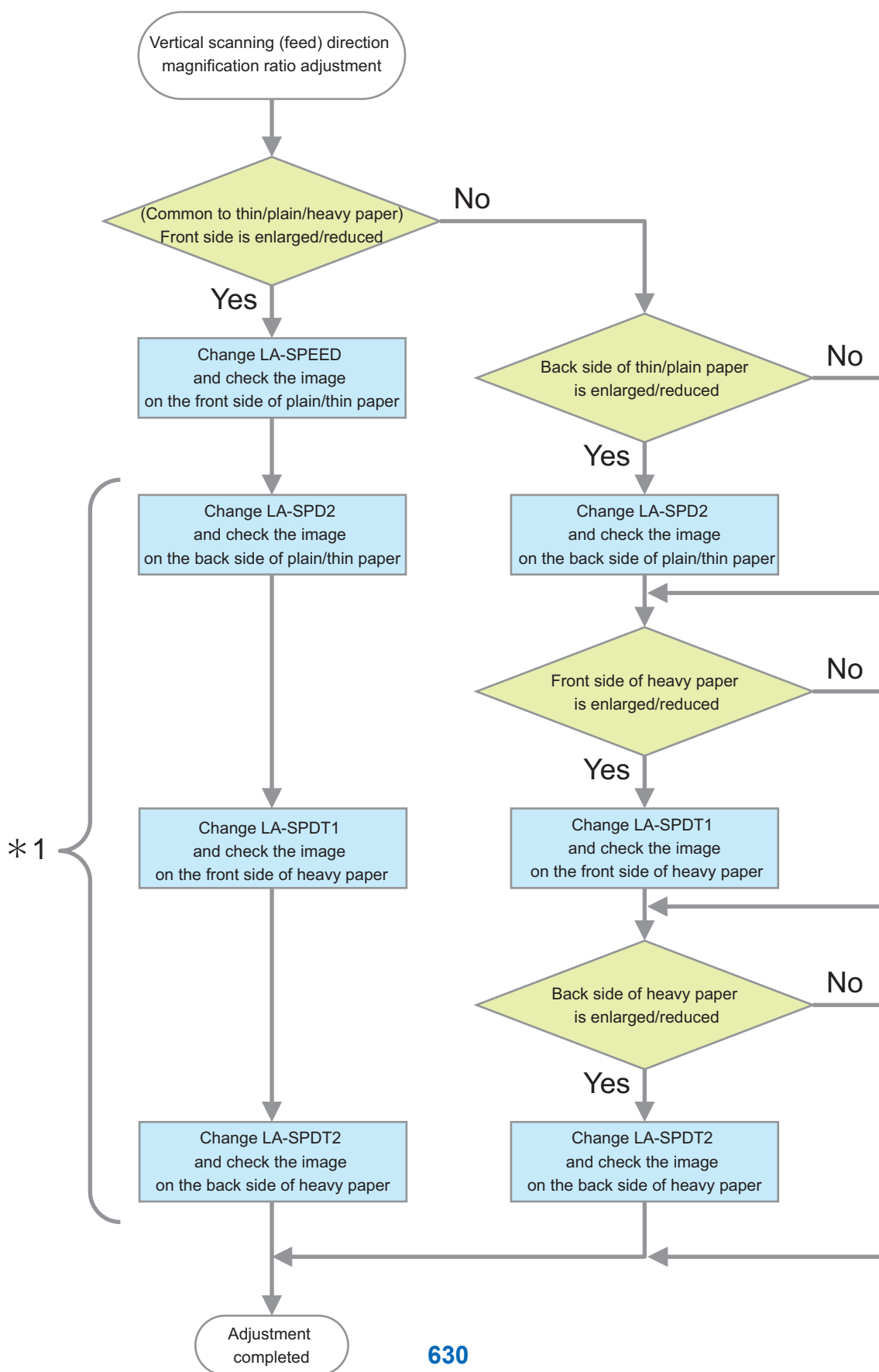
If it is not within the standard range, perform the adjustments "For plain/thin paper" and "For heavy paper".

NOTE:

- When checking with a copied image, adjust the magnification ratio of the printer in advance in PG.

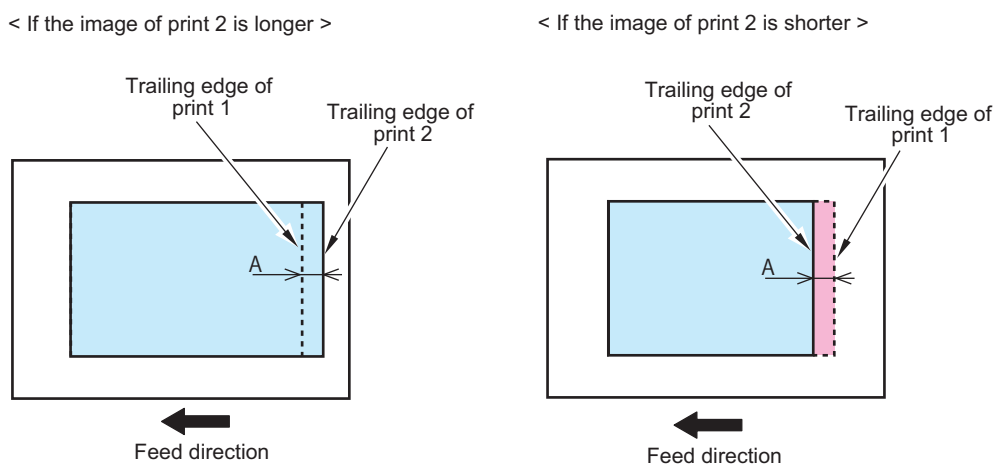
*1: Since LA-SPEED adjusts the speed of the Feed Motor, the magnification ratio of both front and back sides will be changed. After changing LA-SPEED, perform the following adjustments.

- FEEDER > ADJUST > LA-SPD2
- FEEDER > ADJUST > LA-SPDT1
- FEEDER > ADJUST > LA-SPDT2



■ Adjustment of the Paper Front Reading (For plain/thin or heavy paper)

1. Place a test chart on the Copyboard Glass of the connected device, and make a print. This is called Print 1.
2. Place a test chart on the Document Pickup Tray, and make a 1-sided print. This is called Print 2.
3. Overlay the Print 2 onto the Print 1.
4. Check if the trailing edge of the image on the Print 2 is within the standard range.
Standard: $A \leq 1 \text{ mm}$



5. If it is not within the standard range, make adjustments with the following service modes.

For plain/thin paper

FEEDER > ADJUST > LA-SPEED

- If the image on the Print 2 is longer: Increase the numeric value (i.e., make the stream reading speed "faster")
- If the image on the Print 2 is shorter: Decrease the numeric value (i.e., make the stream reading speed "slower")
- Amount of change per unit: 0.1%
- Adjustment range: -30 to +30

For heavy paper

CAUTION:

When feeding heavy paper, make sure to enter a correct adjustment value as it affects the image (expansion/contraction).

- Enter the LA-SPDT1 value recorded on the service label (on the back of the Reader Front Cover or the Printer Front Cover).
- In case an adjustment is made, check the LA-SPDT1 value with the following service mode and record it on the service label (on the back of the Reader Front Cover or the Printer Front Cover).
FEEDER > ADJUST > LA-SPDT1
- If the image on the Print 2 is longer: Increase the numeric value
- If the image on the Print 2 is shorter: Decrease the numeric value
- Amount of change per unit: 0.01%

NOTE:

Example: For A3 original [420 mm], the image is shortened by 0.042 mm as the numeric value is increased by 1.

- Adjustment range: -200 to +200

6. Make a print with the test chart again, and check that the image is within the standard range.

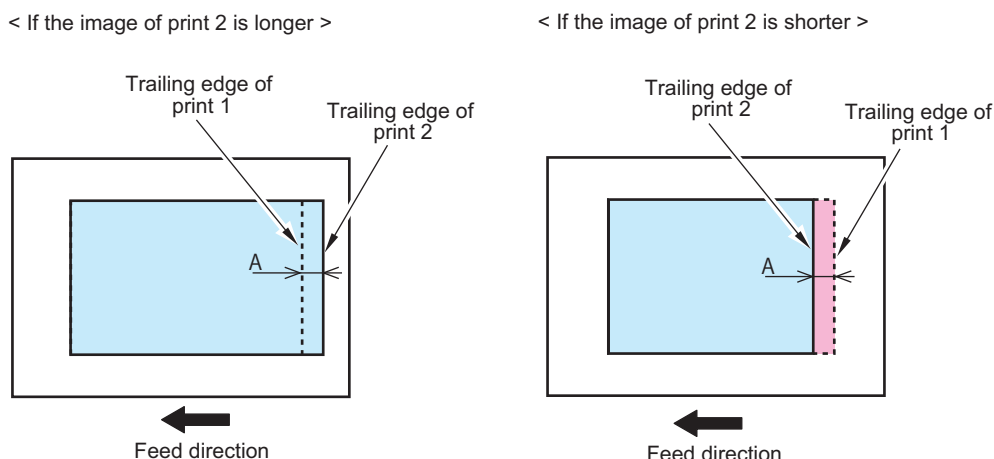
■ Adjustment of the Paper Back Reading (For plain/thin or heavy paper)

1. Place a test chart on the Copyboard Glass of the connected device, and make a print. This is called Print 1.
2. Place a test chart facing down on the Document Pickup Tray, and make a 2-sided print. This is called Print 2.

3. Overlay the Print 2 onto the Print 1.

4. Check if the trailing edge of the image on the Print 2 is within the standard range.

Standard: $A \leq 1 \text{ mm}$



5. If it is not within the standard range, make adjustments with the following service modes.

For plain/thin paper

- If the image on the Print 2 is longer: Increase the numeric value (i.e., make the length of the image in the vertical scanning direction shorter)
- If the image on the Print 2 is shorter: Decrease the numeric value (i.e., make the length of the image in the vertical scanning direction longer)
- Amount of change per unit: 0.01%
- Adjustment range: -200 to +200

FEEDER > ADJUST > LA-SPD2

For heavy paper

CAUTION:

When feeding heavy paper, make sure to enter a correct adjustment value as it affects the image (expansion/contraction).

- Enter the LA-SPDT2 value recorded on the service label (on the back of the Reader Front Cover or the Printer Front Cover).
- In case an adjustment is made, check the LA-SPDT2 value with the following service mode and record it on the service label (on the back of the Reader Front Cover or the Printer Front Cover).
FEEDER > ADJUST > LA-SPDT2
- If the image on the Print 2 is longer: Increase the numeric value
- If the image on the Print 2 is shorter: Decrease the numeric value
- Amount of change per unit: 0.01%

NOTE:

Example: For A3 original [420 mm], the image is shortened by 0.042 mm as the numeric value is increased by 1.

- Adjustment range: -200 to +200

6. Make a print with the test chart again, and check that the image is within the standard range.

Other Adjustments

Eased Angle Guide (Opening Angle of 90 Degrees)

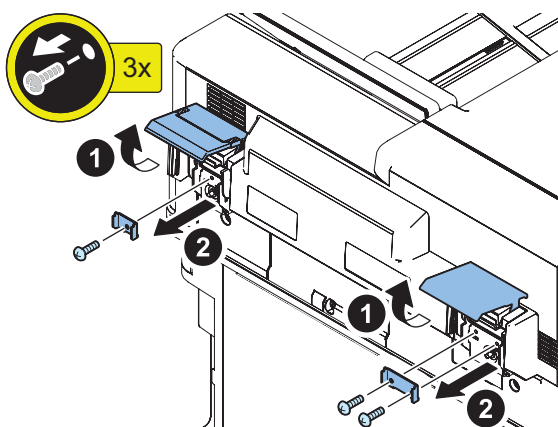
Change the opening angle of the ADF from 70 degrees to 90 degrees.

NOTE:

Some operation become easier by making the DADF opening angle wider.



1. Open the Hinge cover, and remove the Hinge stopper.
 - 3 Screws



CAUTION:

After adjustment, be sure to install the Hinge Stoppers.

Paper Tray Width Adjustment

When the following symptom occurs, adjust the paper tray width.

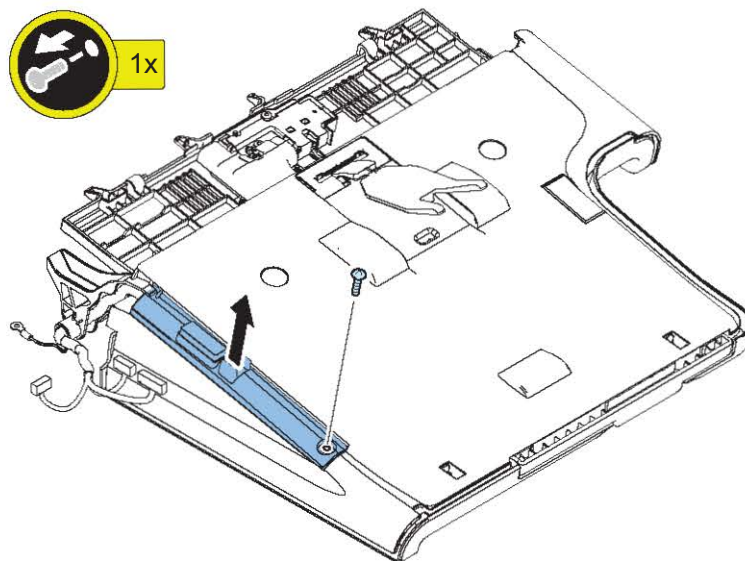
- The originals do not fit in the default paper tray width.
- The originals are placed at an angle.

■ Preparation

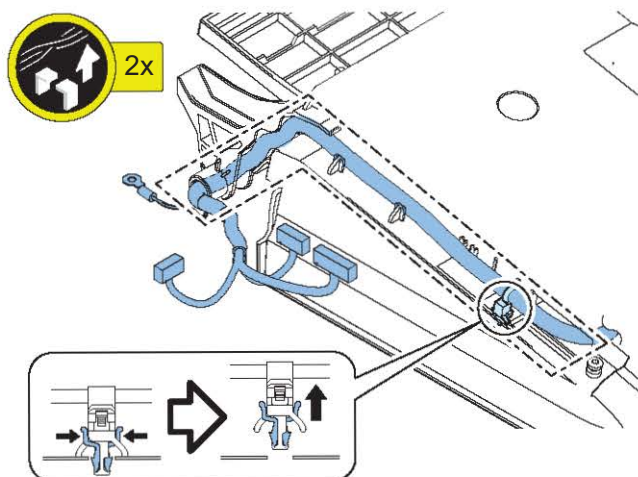
1. [“Removing the Document Tray” on page 287](#)

■ Procedure

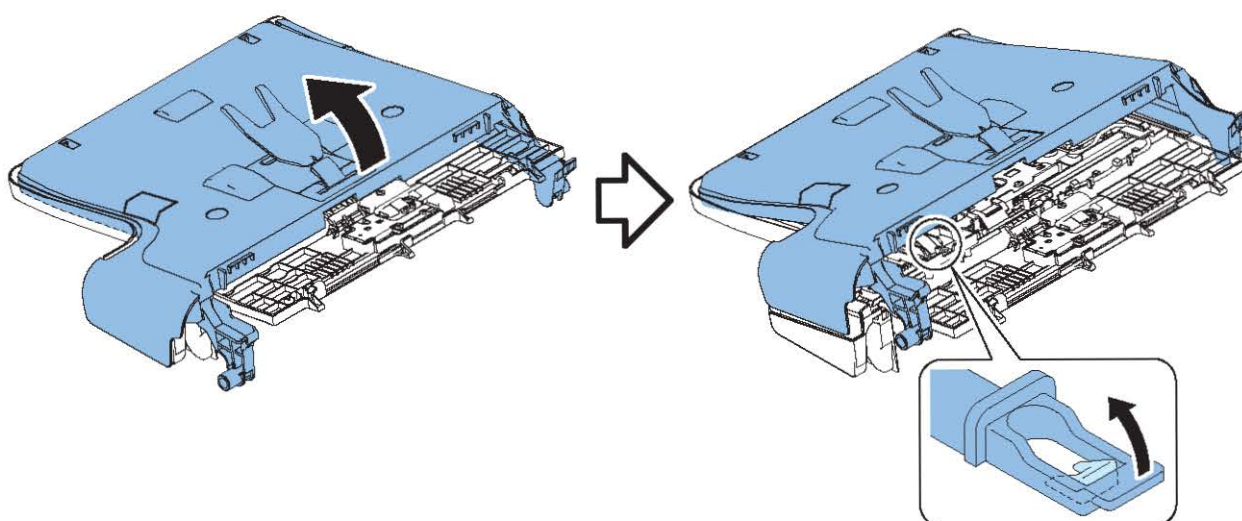
1.



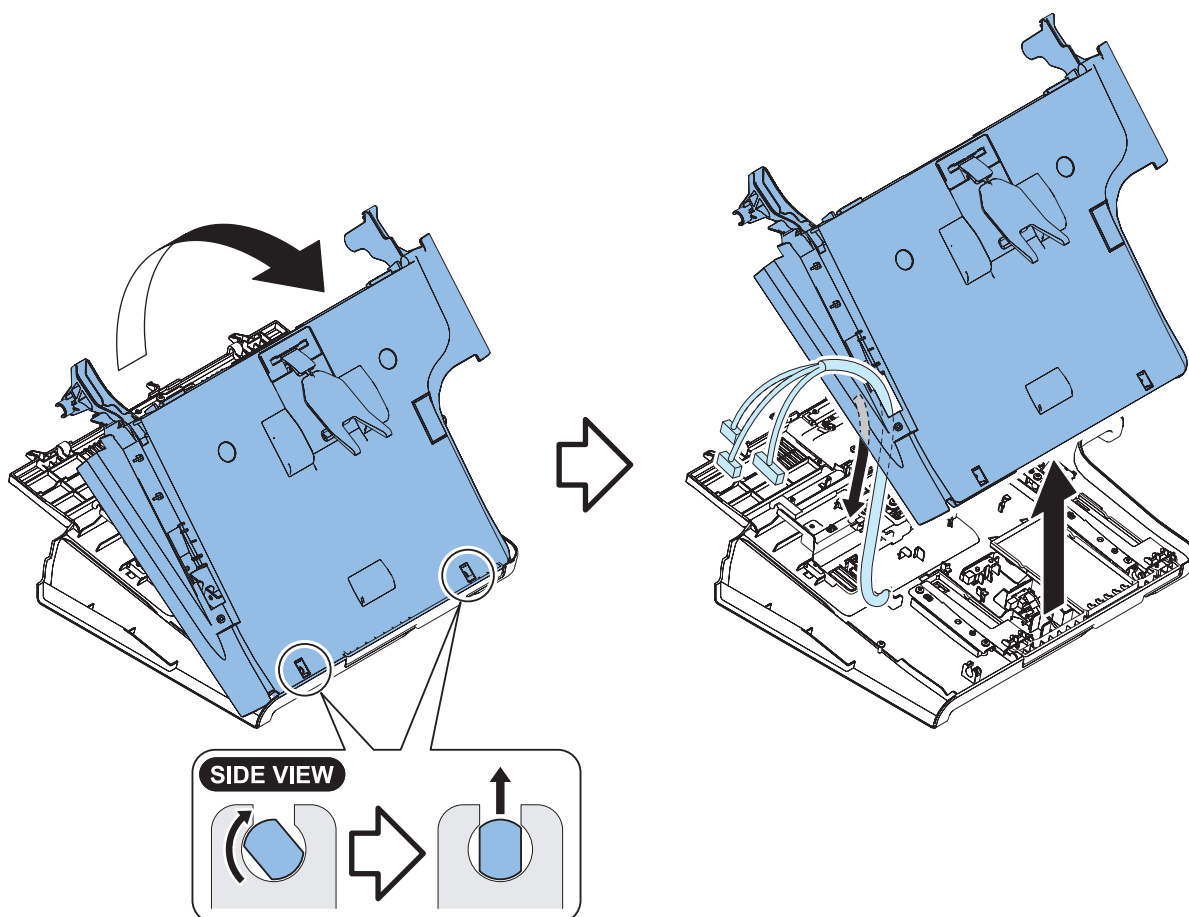
2.



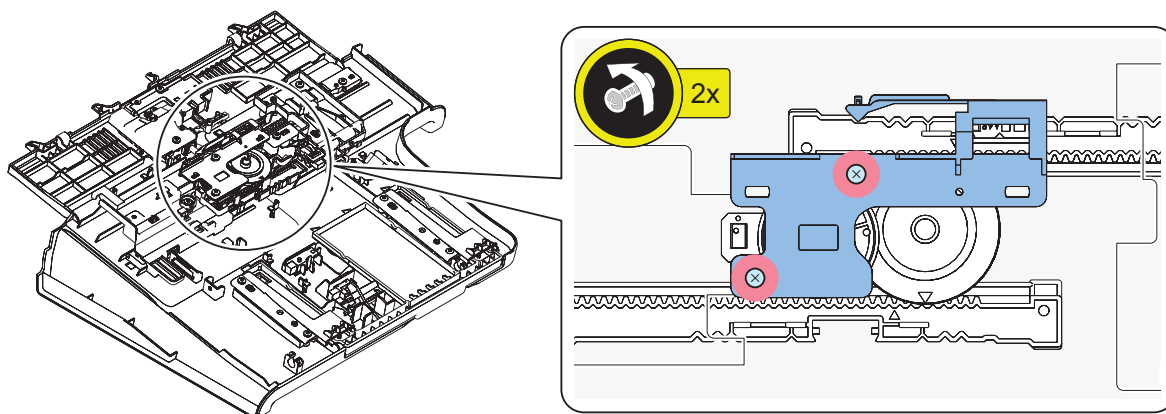
3.



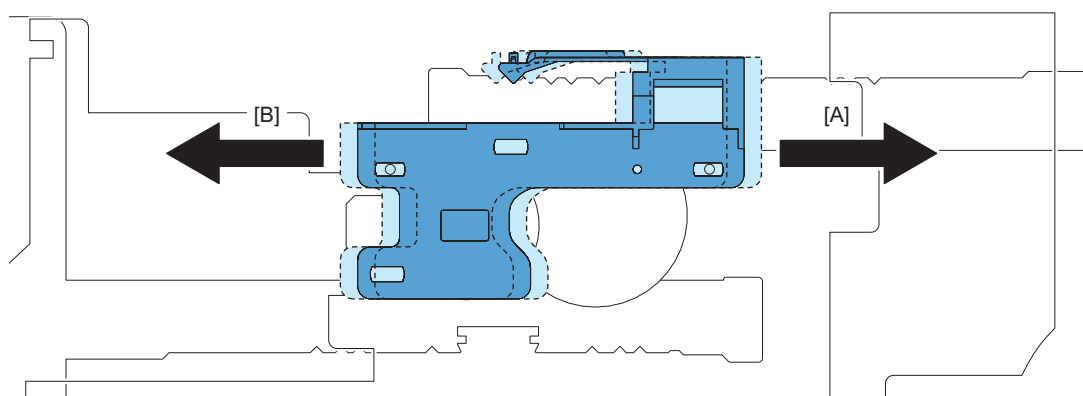
4.



5.



6.



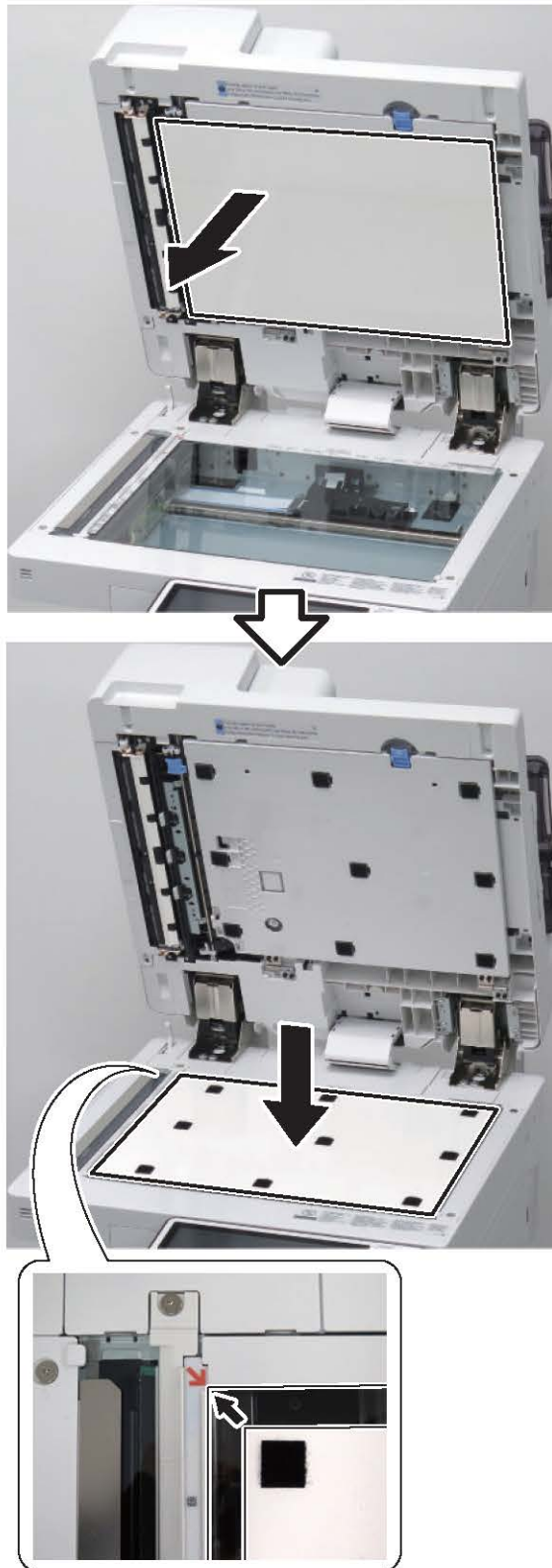
- [A] Broadens paper width.
- [B] Narrows paper width.

CAUTION:

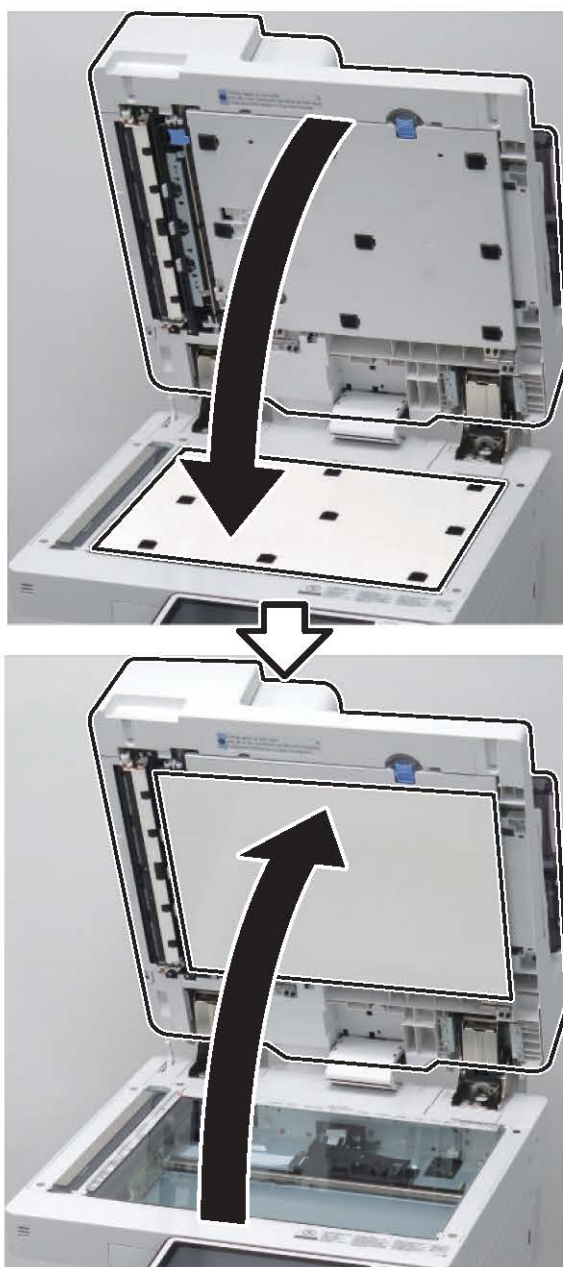
Paper width is changed for all paper sizes. Adjustable maximum paper width is 297mm (A3).

● Adjustment of the White Plate

□
1.

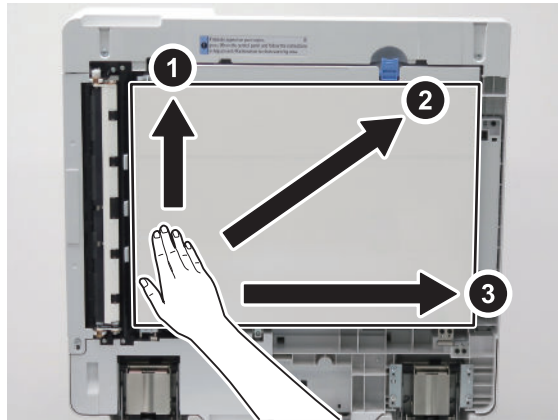


□
2.



□
3.**CAUTION:**

If the White Plate is pressed downward, it is placed on the Index Sheet, so be sure to press it upward.



□
4.**NOTE:**

- Be sure that there is no gap (for reference, 0.3 mm or less) between the White Plate and the Index Sheet.
- Check that the White Plate is not placed on the Index Sheet.



Original Feed System

ADF Scanner Unit

1. **To adjust the shading position automatically.**
COPIER > FUNCTION > INSTALL > RDSHDPOS
2. **To adjust the light intensity.**
COPIER > FUNCTION > CCD > LMPADJ
3. **To adjust the ADF scanning position automatically.**
COPIER > FUNCTION > INSTALL > STRD-POS
4. **Execute white level adjustment. Prepare a sheet of A4 or LTR size paper.**
 1. Place the paper on the Copy Board Glass.
COPIER > FUNCTION > CCD > DF-WLVL1
 2. Place the paper on the ADF Document Pickup Tray.
COPIER > FUNCTION > CCD > DF-WLVL2
 3. Place the paper on the Copy Board Glass.
COPIER > FUNCTION > CCD > DF-WLVL3
 4. Place the paper on the ADF Document Pickup Tray.
COPIER > FUNCTION > CCD > DF-WLVL4
5. **Place the adjustment chart, included in the package of the unit, on the ADF Document Pickup Tray.**
6. **Execute skew adjustment (front and back difference correction adjustment).**
FEEDER > FUNCTION > ADJ-SKW
7. **Write the values on the service label on the back of the Maintenance Cover.**
COPIER > ADJUST > CCD > DFTBK-G
COPIER > ADJUST > CCD > DFTBK-B
COPIER > ADJUST > CCD > DFTBK-R
COPIER > ADJUST > CCD > DFTBK-BW
FEEDER > ADJUST > ADJ-DT
FEEDER > ADJUST > ADJ-DL
FEEDER > ADJUST > ADJ-DROT

Pickup Roller Unit

■ Actions after Parts Replacement

1. **Clear the parts counter.**
COPIER > COUNTER > DRBL-2 > DF-PU-RL

Separation Roller

■ Actions after Parts Replacement

1. **Clear the parts counter.**
COPIER > COUNTER > DRBL-2 > DF-SP-RL

Stamp

■ Actions after Parts Replacement

1. **Clear the parts counter.**
COPIER > COUNTER > DRBL-2 > STAMP

Original Exposure System

Reader Controller PCB

■ Actions before Parts Replacement

1. **Back up the necessary data.**
 - COPIER > FUNCTION > SYSTEM > RSRAMBUP

NOTE:

If necessary, output the service mode setting values by P-PRINT before execution. COPIER > FUNCTION > MISC-P > P-PRINT

■ Actions after Parts Replacement

1. Turn **OFF** the power of the host machine and replace by the new Reader Controller PCB.
2. Turn **ON** the power of the host machine and use **SST** to download the latest system software (R-CON).
3. Perform the restoration of **SRAM** data of Reader Controller PCB.
 - COPIER > FUNCTION > SYSTEM > RSRAMRES
4. Turn **OFF** and then **ON** the power of the host machine.

Reader Scanner Unit

1. **To adjust the shading position automatically.**
COPIER > FUNCTION > INSTALL > RDSHDPOS
2. **To adjust the light intensity.**
COPIER > FUNCTION > CCD > LMPADJ
3. **To adjust the ADF scanning position automatically.**
COPIER > FUNCTION > INSTALL > STRD-POS
4. **Execute white level adjustment. Prepare a sheet of A4 or LTR size paper.**
 1. Place the paper on the Copy Board Glass.
COPIER > FUNCTION > CCD > DF-WLVL1
 2. Place the paper on the ADF Document Pickup Tray.
COPIER > FUNCTION > CCD > DF-WLVL2
 3. Place the paper on the Copy Board Glass.
COPIER > FUNCTION > CCD > DF-WLVL3
 4. Place the paper on the ADF Document Pickup Tray.
COPIER > FUNCTION > CCD > DF-WLVL4
5. **Place the adjustment chart, included in the package of the unit, on the ADF Document Pickup Tray.**
6. **Execute skew adjustment (front and back difference correction adjustment).**
FEEDER > FUNCTION > ADJ-SKW
7. **Write the values on the service label on the back of the Maintenance Cover.**
COPIER > ADJUST > CCD > SH-TRGT
COPIER > ADJUST > CCD > DFTAR-R
COPIER > ADJUST > CCD > DFTAR-G
COPIER > ADJUST > CCD > DFTAR-B
COPIER > ADJUST > CCD > DFTAR-BW
FEEDER > ADJUST > ADJ-DT
FEEDER > ADJUST > ADJ-DL
FEEDER > ADJUST > ADJ-DROT

Copyboard Glass

■ Actions after Parts Replacement

1. Enter the value (XXXXXXXXZZZZ) shown on the Barcode Label affixed at the upper Left of the Copy Board Glass.

COPIER > ADJUST > CCD > W-PLT-X

COPIER > ADJUST > CCD > W-PLT-Y

COPIER > ADJUST > CCD > W-PLT-Z



2. Adjust the shading position.

COPIER > FUNCTION > INSTALL > RDSHDPOS

3. Set the target value of B&W shading.

COPIER > FUNCTION > CCD > BW-TGT

4. Adjust the white level.

Prepare a sheet of A4 or LTR size paper.

1. Set a sheet of paper on the Copyboard Glass.
COPIER > FUNCTION > CCD > DF-WLVL1
2. Set a sheet of paper on the ADF Document Pickup Tray.
COPIER > FUNCTION > CCD > DF-WLVL2
3. Set a sheet of paper on the Copyboard Glass.
COPIER > FUNCTION > CCD > DF-WLVL3
4. Set a sheet of paper on the ADF Document Pickup Tray.
COPIER > FUNCTION > CCD > DF-WLVL4

5. Write the values on the service label on the back of the Maintenance Cover.

COPIER > ADJUST > CCD > SH-TRGT

COPIER > ADJUST > CCD > DFTAR-R

COPIER > ADJUST > CCD > DFTAR-G

COPIER > ADJUST > CCD > DFTAR-B

COPIER > ADJUST > CCD > DFTAR-BW

COPIER > ADJUST > CCD > DFTBK-G

COPIER > ADJUST > CCD > DFTBK-B

COPIER > ADJUST > CCD > DFTBK-R

COPIER > ADJUST > CCD > DFTBK-BW

Main Controller

Hard Disk

Overview

The following describes the tasks when replacing the HDD.

Note that procedures to backup/restore the data in the HDD is required when replacing the HDD.

Perform backup/restoration based on the following.

Backup List

Backup target data	Backup Method			
	User	Service	DCM	Power OFF
	(excluding DCM)			
Address List	Yes*1	-	Yes*9	-
Forwarding Settings	Yes*1	-	Yes*9	-
Settings / Registration				
Preferences (Except for Paper Type Management Settings)	-	-	Yes*9	Yes*10
Adjustment/Maintenance	-	-	Yes*9	Yes*10
Function Settings (Except for Printer Custom Settings, Forwarding Settings)	-	-	Yes*9	Yes*10
Set Destination (Except for Address List)	-	-	Yes*9	Yes*10
Management Settings (Except for Address List)	-	-	Yes*9	Yes*10
User authentication information used for local device authentication of UA (User Authentication)	Yes*2	-	Yes*9	-
Printer Settings	Yes*1	-	Yes*9	Yes*10
Set Paper Information	Yes*1	-	Yes*9	-
Setting items for each menu in Main Menu (Copy, Scan and Send, Fax, Scan and Store, Access Stored Files, Fax/I-Fax Inbox)				
Favorite Settings	Yes*1	Yes*8	Yes*9	-
Default Settings	-	Yes*8	Yes*9	-
Shortcut settings for "Options"	-	Yes*8	Yes*9	-
Previous Settings	-	Yes*8	-	-
Setting items for Quick Menu				
Button Size information	-	-	Yes*9	-
Wallpaper Setting	-	-	Yes*9	-
Button information in Quick Menu	-	-	Yes*9	-
Restrict Quick Menu	-	-	Yes*9	-
Setting items for Main Menu				
Button settings in Main Menu	-	-	Yes*9	-
Button settings on the top of the screen	-	-	Yes*9	-
Wallpaper Setting for Main Menu	-	-	Yes*9	-
Other settings for Main Menu	-	-	Yes*9	-
Function Settings > Store/Access Files				
Mail Box Settings (Register Box Name, PIN, Time Until File Auto Delete, Printer upon Storing from Printer Driver)	Yes*4	-	Yes*9	-
Image data in Mail Box, Fax Inbox, and Memory RX Inbox	Yes*4	-	-	-
Network Place Settings	-	-	Yes*9	Yes*10
Web browser settings				
Web Access setting information	-	Yes*8	Yes*9	-
MEAP settings				
MEAP application	-	Yes*8	-	-
License files for MEAP applications	Yes*5	-	-	-
Data saved using MEAP applications	Yes*5	△*8	Yes*9	-
SMS (Service Management Service) password	-	Yes*8	-	-
Universal data settings				

Backup target data	Backup Method			
	User	Service	DCM	Power OFF
	(excluding DCM)			
Unsent documents (documents waiting to be sent with the Delayed Send mode)	-	-	-	-
Job logs	-	-	-	-
Audit Log	Yes*6	-	-	-
Key Pair and Server Certificate in Certificate Settings in TCP/IP Settings in Network Settings in System Settings (from the Additional Functions screen)	-	-	Yes*9	-
Auto Adjust Gradation setting values	-	-	-	-
PS font	-	-	-	-
Key information to be used for encryption when TPM is OFF	-	-	-	-
Key and settings information to be used for encryption when TPM is ON	Yes*7	-	-	-
Personal Settings				
Display Language	-	-	Yes *9	-
Accessibility Settings	-	-	Yes *9	-
Default Screen	-	-	Yes *9	-
Default Job Settings	-	-	Yes *9	-
Quick Menu (Personal, layout of the Personal tab, and background of the Personal tab)	-	-	Yes *9	-
Address Book (Personal/Group)	Yes *1	-	Yes *9	-
Key ring (for host machine functions)	-	-	Yes *9	-
Personal settings of MEAP	Yes *11	Yes *8	Yes *9	-
Service Mode				
Service Mode setting values (MN-CON)	-	-	△*9	Yes*10

*1: Remote UI > Settings/Registration > Management Settings > Data Management > Import or Export

*2: Remote UI > Settings/Registration > Management Settings > User Management > Authentication Management > User Management

*3: Remote UI > Quick Menu > Export

*4: Remote UI > Settings/Registration > Management Settings > Data Management > Back Up or Restore

*5: Remote UI > Service Management Service

*6: Remote UI > Settings/Registration > Management Settings > Device Management > Save Audit Log

Audit log that was exported cannot be put back to the device from which the log was exported.

*7: Settings/Registration > Management Settings > Data Management > TPM Settings

*8: Download mode > [5]: Backup/Restore > [3] : MEAP Backup > Meapback.bin

Backup is possible using SST or USB memory

The data saved using a MEAP application can be backed up only when the MEAP application has a backup function.

*9: Backup Method using DCM When You set it in COPIER> OPTION> USER> SMD-EXPT> ON, a backup/restore is possible in Service Mode Settings from the Remote UI.

There is a backup button on the TOP page of the service mode.

- Remote UI > Settings/Registration > Management Settings > Data Management > Import/Export All
- Remote UI > Settings/Registration > Management Settings > Data Management > Import/Export
- Service mode top screen > BACKUP
- Web Service

*10: The setting value that was set when the main power was turned OFF the last time is automatically backed up to the Flash PCB. When a HDD is replaced with a new one, the setting value is automatically inherited from the Flash PCB at the time of HDD formatting.

*11: iWEMC DAM plug-in

■ Actions before Parts Replacement

1. Backup the required data based on the “Table: Backup List” on page 644.

2. Execute the following service mode and printout the setting data to be ready in case of failing to restore the data.

COPIER > FUNCTION > MISC-P > USER-PRT

COPIER > FUNCTION > MISC-P > P-PRINT

■ After Replacement

1. HDD format

Start the machine in safe mode, and format all partitions using SST or a USB memory.

2. Turning OFF and ON the main power switch

3. Restoring the backup data

4. Resetting/registering the data

While referring to the list which was printed before replacement, reset/register the data.

5. When the user generates and adds the encryption key, certificate and/or CA certificate, request the user to generate them again.

● Main controller PCB 1

When replacing the Main Controller PCB 1, perform the following works.

1. Replacing method (Refer to "Procedure" on page 334)
2. After Replacing (Refer to "After Replacement" on page 335)

CAUTION:

Prohibited Operation

Do not transfer the following parts to another model (which has a different serial number). If you fail to do so, the Main Body does not activate normally and this might cause to fail the restoration.

- Main controller PCB1
- FLASH PCB
- TPM PCB
- Memory PCB

■ After Replacement

1. Replace parts from an old PCB to a new PCB.

- Memory PCB
- FLASH PCB
- TPM PCB

● Main controller PCB 2

The actions at parts replacement are only for replacement of the Main Controller PCB 2.

● TPM PCB

When replacing the TPM PCB, refer to "Security Function (Encryption Key, Certificate and Protection of Password)" . (Refer to System Service Manual)

● FLASH PCB

Before replacing the FLASH PCB, contact the sales company.

CAUTION:

Points to Note Replace the Parts

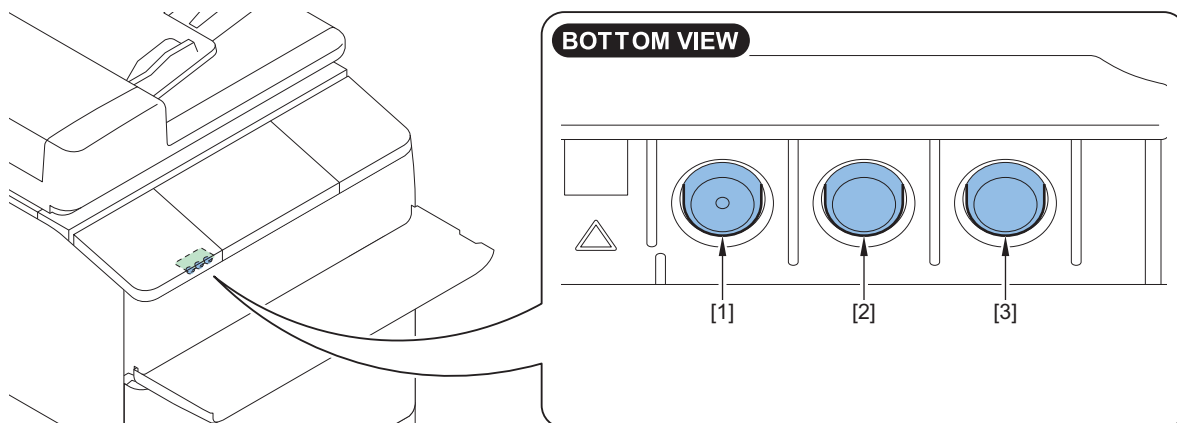
Do not remove it unless a failure is suspected. A FLASH PCB which had been used in another machine cannot be reused.

Control Panel Unit

When replacing the Touch Panel Unit, LCD Unit or the Control Panel CPU PCB, perform the following work.

Flat Control Panel Adjustment

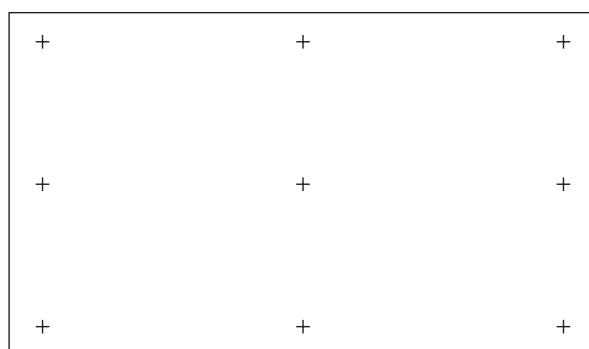
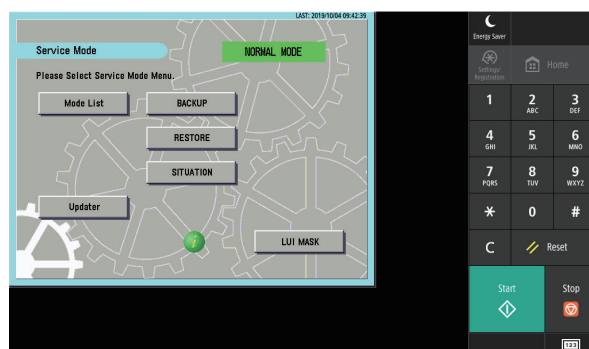
1. Open the Toner Exchange Cover.
2. Enter the Service Mode.
3. Press the Hard Key [1] 3 times to enter the coordinate adjustment mode.



4. Press "+" indicated on the Control Panel in order. The coordinate adjustment mode is automatically closed when all 9 "+" is pressed.

NOTE:

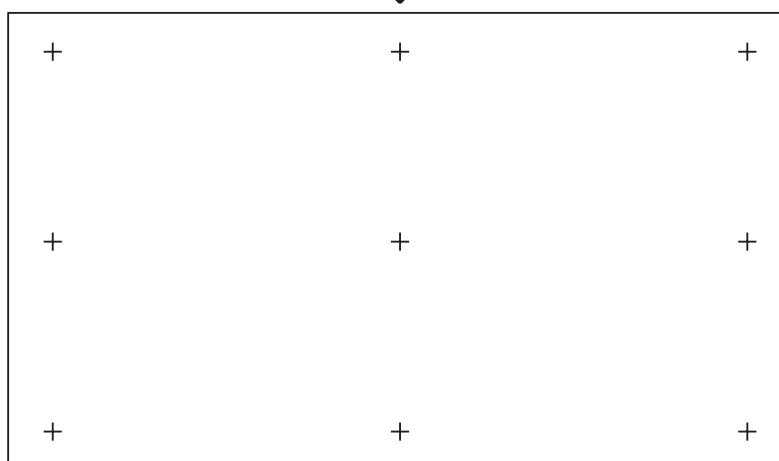
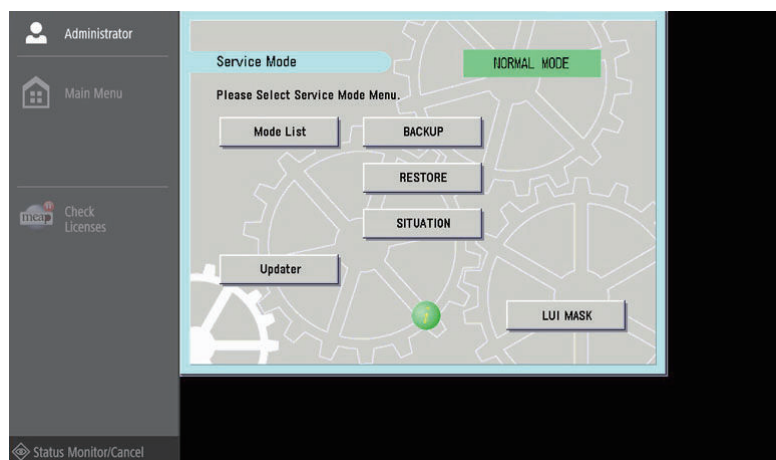
When the adjustment is not operated adequately, Re-adjust from procedure 3 after pressing all 9 "+" is pressed.



■ Upright Control Panel Adjustment

1. If the coordinate on the Touch Panel is not correct, adjustment of the Touch Panel may not be performed. In that case, the Touch Panel can be adjusted by performing the following menu operation using hardware keys.

- Press [5] key 3 times on the service mode top screen.



Laser Exposure System

Procedure of parts replacement

Refer to “Removing the Laser Scanner Unit” on page 355

Adjustment when Replacing the Parts

1. Execute the potential control.

(Lv.1) COPIER > FUNCTION > DPC > DPC2

2. Write the value in service label.

(Lv.1) COPIER > ADJUST > LASER > PVE-OFST (Adjust of write start position of laser)

Image Formation System

Primary Charging Wire

■ Procedure of parts replacement

Refer to “Replacing the Primary Charging Wire” on page 375.

■ Adjustment when Replacing the Parts

1. **Clear the parts counter.**
(Lv.1)COPIER > COUNTER > PRDC-1 > PRM-WIRE
2. **Clean the Charging Wire. (necessary time : about 120 second)**
(Lv.1)COPIER > FUNCTION > CLEANING > WIRE-CLN
3. **Init of Primary Charging Wire current VL**
(Lv.1)COPIER > FUNCTION > CLEAR > GRD-CRNT
4. **Execute the potential control.**
(Lv.1)COPIER > FUNCTION > DPC > DPC2

Primary Charging Assembly

■ Procedure of parts replacement

Refer to “Removing the Primary Charging Assembly” on page 362.

■ Adjustment when Replacing the Parts

1. **Clear the parts counter.**
(Lv.1)COPIER > COUNTER > DRBL-1 > PRM-UNIT
2. **Output a halftone image using the service mode.**
(Lv.1)COPIER > TEST > PG > TYPE : 5
3. **Execute the following procedure according to the density difference on the front and rear sides of the test print image.**
 - When the front side test print image is dark, execute step 3.
 - When the rear side test print image is dark, execute step 4.
 - When there is no uneven density, execute step 5 and the following.

When the front side test print image is dark

NOTE:

- When the front side test print image is dark [1], execute step 3 until the density becomes even. When the density becomes even, execute step 5 and the following.
- When the adjustment screw is turned clockwise, the Charging Wire goes down and up (gap between grid and Charging Wire becomes narrow and wide). As a result, the density of output image becomes light.

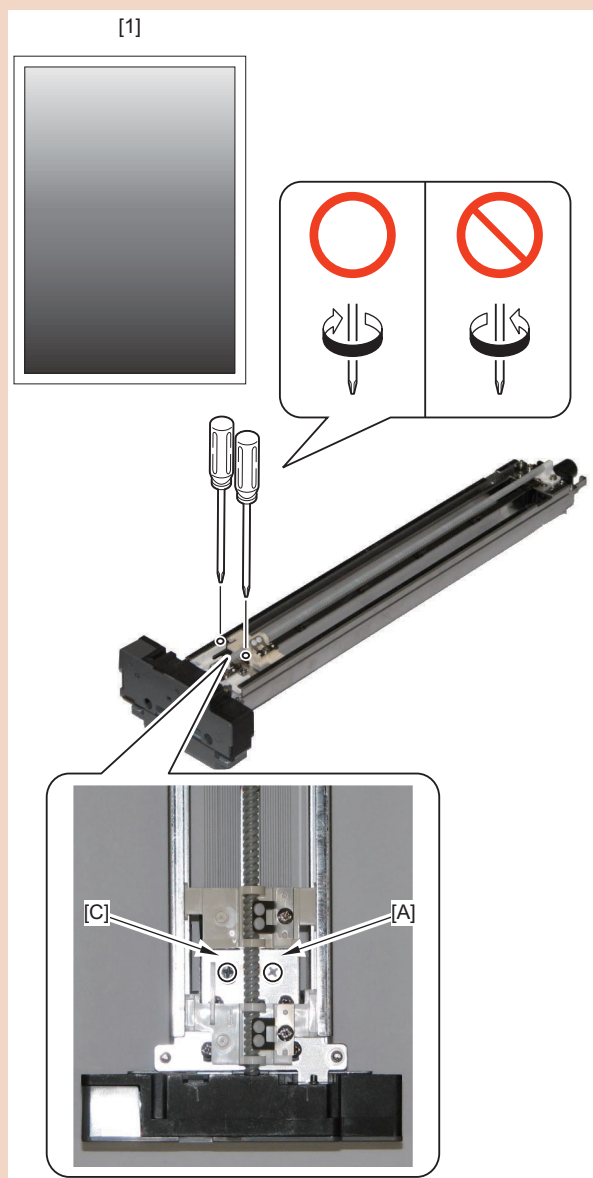
CAUTION:

- Be sure to adjust the dark side (density of the test print image) to be the light side.

4. Make the resin screws [A] and [C] a full turn clockwise. While referring to the replacement procedure of the Primary Charging Assembly, install it to the main body, output a test print and check the image.

CAUTION:

- Since uneven density might occur, be sure to adjust by turning the 2 adjustment screws with the same amount.



When the rear side test print image is dark

NOTE:

- When the rear side test print image is dark [2], execute step 4 until the density becomes even. When the density becomes even, execute step 5 and the following.
- When the adjustment screw is turned clockwise, the Charging Wire goes down and up (gap between grid and Charging Wire becomes narrow and wide). As a result, the density of output image becomes light.

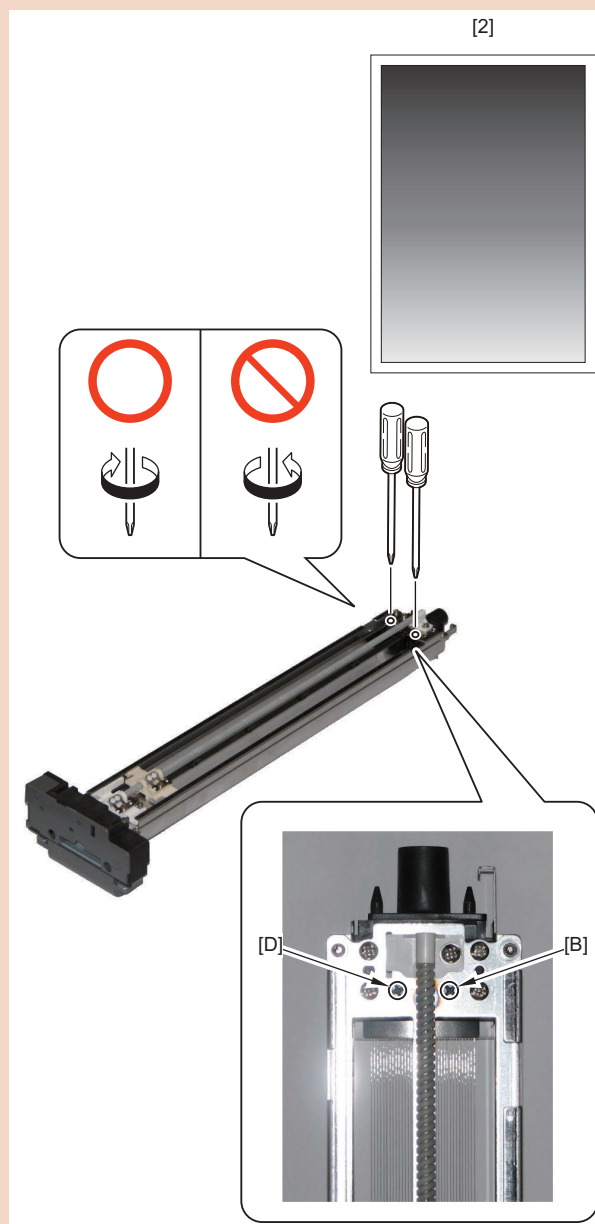
CAUTION:

- Be sure to adjust the dark side (density of the test print image) to be the light side.

5. Make the resin screws [B] and [D] a full turn clockwise. While referring to the replacement procedure of the Primary Charging Assembly, install it to the main body, output a test print and check the image.

CAUTION:

- Since uneven density might occur, be sure to adjust by turning the 2 adjustment screws with the same amount.



6. Clean the Charging Wire. (necessary time : about 120 second)

(Lv.1)COPIER > FUNCTION > CLAENING > WIRE-CLN

7. Init of Primary Charging Wire current VL.

(Lv.1)COPIER > FUNCTION > CLEAR > GRD-CRNT

8. Execute the potential control.

(Lv.1)COPIER > FUNCTION > DPC > DPC2

9. Execute the density correction using the user mode.

Settings/Registration > Adjustment/Maintenance > Adjust Image Quality > Correct Density

Pre-transfer Charging Assembly

■ Procedure of parts replacement

Refer to “[Removing the Pre-transfer Charging Assembly](#)” on page 380.

■ Adjustment when Replacing the Parts

1. **Clear the parts counter.**
(Lv.1) COPIER > COUNTER > DRBL-1 > PO-UNIT
2. **Clean the Charging Wire. (necessary time : about 120 second)**
(Lv.1) COPIER > FUNCTION > CLEANING > WIRE-CLN

Pre-transfer Charging Wire

■ Procedure of parts replacement

Refer to “[Replacing the Pre-transfer Charging Wire](#)” on page 386.

■ Adjustment when Replacing the Parts

1. **Clear the parts counter.**
(Lv.1) COPIER > COUNTER > PRDC-1 > PO-WIRE
2. **Clean the Charging Wire. (necessary time : about 120 second)**
(Lv.1) COPIER > FUNCTION > CLEANING > WIRE-CLN

Photosensitive Drum

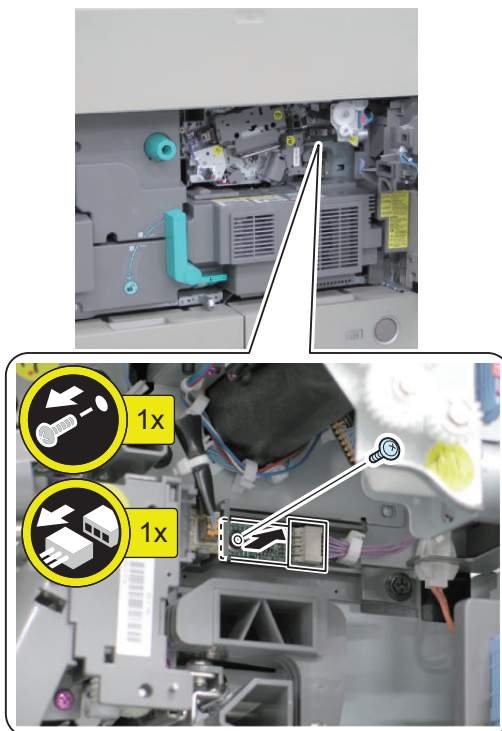
■ Procedure of parts replacement

Refer to “[Removing the Photosensitive Drum](#)” on page 401.

■ Adjustment when Replacing the Parts

1. Remove the EEROM.

- 1 Screw
- 1 Connector

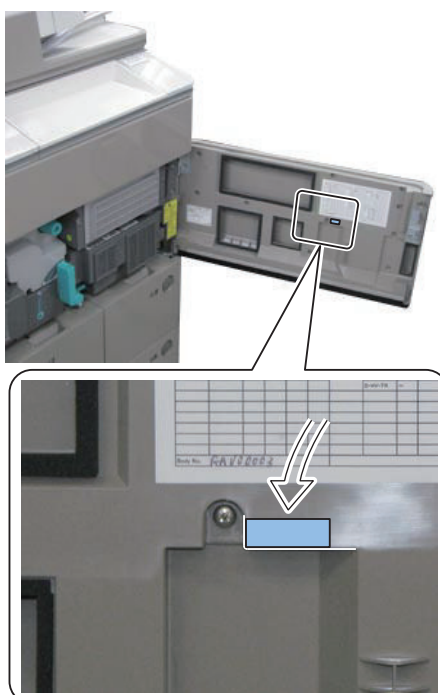


2. Replace the ROM connected to the host machine with the drum ROM included in the drum.

CAUTION:

If the ROM is not replaced, the replaced drum and the drum-unique data stored in the ROM are not matched. As a result, the 2D shading is not functioned normally.

3. Affix the ID Label included in the drum to the inside of the Front Cover.



4. **Activate the drum replacement mode.**
(Lv.1) COPIER > FUNCTION > INSTALL > DRM-INIT
5. **Check the 2-dimensional shading ROM.**
(Lv.1) COPIER > FUNCTION > 2D-SHADE > 2D-READ
6. **Execute the auto adjust gradation using the user mode.**
Settings/Registration > Adjustment/Maintenance > Image Quality Adjustment > Auto Adjust Gradation

● Drum Side Seals (Front and Rear)

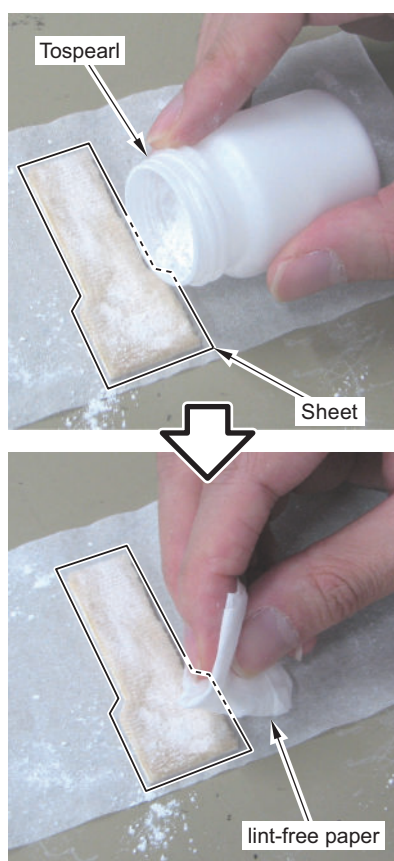
■ Procedure of parts replacement

Refer to “Removing the Side Seal” on page 410.

■ Adjustment when Replacing the Parts

1. Applying Tospearl

Apply Tospearl on the surfaces of the Drum Side Seals (Front and Rear) and adhere it uniformly with lint-free paper. In order to reduce adhesion of toner at both ends of the Photosensitive Drum.



2. Clear the parts counter.

(Lv.1) COPIER > COUNTER > DRBL-1 > BS-SL-F

(Lv.1) COPIER > COUNTER > DRBL-1 > BS-SL-R

● Developing Assembly

■ Procedure of parts replacement

Refer to “Removing the Developing Assembly” on page 411.

■ Adjustment when Replacing the Parts

1. **Clear the parts counter.**
(Lv.1) COPIER > COUNTER > DRBL-1 > DVG-CYL
2. **Supplying Developing Assembly toner.**
(Lv.1) COPIER > FUNCTION > INSTALL > TONER-S

● Potential Sensor / Potential Control PCB

■ Procedure of parts replacement

Refer to "Removing the Potential Control PCB Unit" on page 464.

■ Adjustment when Replacing the Parts

1. **Adjust the Potential Sensor offset.**
(Lv.1) COPIER > FUNCTION > DPC > OFST

● ETB Unit / ETB

■ Procedure of parts replacement

- Refer to "Removing the ETB Unit" on page 418.
- Refer to "Removing the ETB" on page 422.

■ Adjustment when Replacing the Parts

1. **Clear the ETB control counter.**
(Lv.1) COPIER > FUNCTION > CLEAR > TR-BLT
Parts counter (COPIER > COUNTER > DRBL-1 > TR-BLT) is also cleared coincidentally.

● Patch Sensor

■ Procedure of parts replacement

Refer to "Removing the Patch Sensor" on page 441.

■ Adjustment when Replacing the Parts

1. **Adjust the intensity of the Patch Sensor.**
(Lv.2) COPIER > FUNCTION > MISC-P > P-LED

● Waste Toner Container

■ Procedure of parts replacement

Refer to "Removing the Waste Toner Container" on page 431.

■ Adjustment when Replacing the Parts

1. **Set the new Waste Toner Container.**

NOTE:

When replacing the Waste Toner Container with a new one after preparation warning or full warning is displayed, display on the LUI is cleared after a certain period of time has passed. The parts counter ((Lv.1) COPIER > COUNTER > DRBL-1 > WST-TNR) is automatically cleared at replacement.

NOTE:

Related service modes when a user replaces the Waste Toner Container

The Waste Toner Container preparation warning message can be set to be displayed or hidden by executing the following service mode.

(Lv.1) COPIER > OPTION > DSPLY-SW > WT-WARN

Setting value 0: Hide, 1: Display

Procedure for replacing the Waste Toner Container can be set to be displayed or hidden by executing the following service mode.

When a user replaces the Waste Toner Container, set 1.

(Lv.1) COPIER > OPTION > USER > W-TN-DSP

Setting value 0: OFF, 1: ON

Fixing System

Fixing Roller

■ Procedure of parts replacement

Refer to “Removing the Fixing Roller, Insulating Bush and Thrust Stopper” on page 497.

■ Adjustment when Replacing the Parts

1. Grease Application

Apply approx. 20mg of grease (MOLYKOTE HP-300; CK-8012) to inner circumference and outer circumference of the Insulating Bush so that all circumferences are covered with white film.

2. Clear the parts counter.

(Lv.1) COPIER > COUNTER > DRBL-1 > FX-UP-RL

(Lv.1) COPIER > COUNTER > DRBL-1 > FX-IN-BS

(Lv.1) COPIER > COUNTER > DRBL-1 > FX-RTNR

External Auxiliary System

DC Controller PCB

Before Parts Replacement

CAUTION:

When replacing the DC Controller PCB, be sure to use a new one. Do not use the DC Controller PCB which was used with another machine.

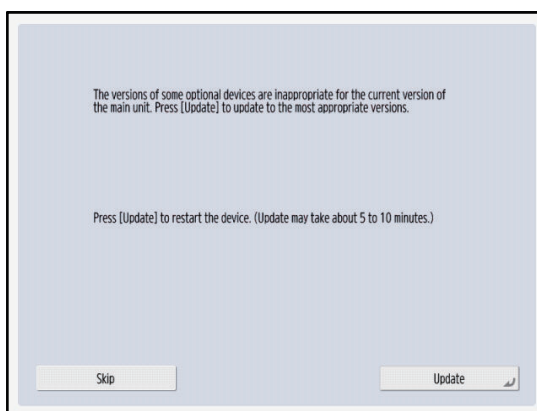
1. **Execute the following service mode to output setting values for just in case of restoration failure of backup data.**
COPIER > FUNCTION > MISC-P > P-PRINT
2. **Execute the following service mode to back up the service mode setting values.**
(Lv.2) COPIER > FUNCTION > SYSTEM > DSRAMBUP
During execution, "ACTIVE" flashes in the status column of the service mode.
It takes approx. 2 minutes. Upon success, [OK!] is displayed in the status column.
3. **After confirming that [OK!] is displayed in the status column of the service mode, turn OFF the power of the machine.**

Procedure of parts replacement

Refer to "Removing the DC Controller PCB" on page 575 .

Works During Parts Replacement

1. **If the firmware combination is incorrect, execute an update with the Automatic Update function.**



Screen example

CAUTION:

Automatic Update is available only when the following Service Mode settings are at 1 or 2.
(Lv.2) COPIER > OPTION > FNC-SW > VER-CHNG

2. **When the setting value data is backed up before parts replacement, execute the following service mode to restore the backed-up setting value data.**
(Lv.2) COPIER > FUNCTION > SYSTEM > DSRAMRES
During execution, "ACTIVE" flashes in the status column of the service mode.
It takes approx. 2 minutes. Upon success, [OK!] is displayed in the status column.
3. **When setting values cannot be backed up before replacement or when the backed-up data cannot be restored in this step due to reasons such as damage of the DC Controller PCB, enter the values of each service mode item written on the service label or P-PRINT before parts replacement.**



Troubleshooting

Making Initial Checks.....	661
Test Print.....	662
Image Faults.....	667
Feed Faults.....	696
Other.....	697
Debug Log.....	713
Startup System Failure Diagnosis.....	731
Controller Self Diagnosis.....	741

Making Initial Checks

List of Initial Check Items

Item	No.	Detail	Check
Site Environment	1	The voltage of the power supply is as rated ($\pm 10\%$).	
	2	The site is not a high temperature / humidity environment (near a water faucet, water boiler, humidifier), and it is not in a cold place. The machine is not near a source of fire or dust.	
	3	The site is not subject to ammonium gas.	
	4	The site is not exposed to direct rays of the sun. (Otherwise, provide curtains.)	
	5	The site is well ventilated, and the floor keeps the machine level.	
	6	The machine's power plug remains connected to the power outlet.	
Checking the Paper	7	The paper is of a recommended type.	
	8	The paper is not moist. Try paper fresh out of package.	
Checking the Placement of Paper	9	Check the cassette and the manual feed tray to see if the paper is not in excess of a specific level.	
	10	If a transparency is used, check to make sure that it is placed in the correct orientation in the manual feed tray.	
Checking the Durables	11	Check the table of durables to see if any has reached the end of its life.	
Checking the Periodically Replaced Parts	12	Check the scheduled servicing table and the periodically replaced parts table, and replace any part that has reached the time of replacement.	

Test Print

Overview

P G T Y P E	Pattern	Image check item											PCB to generate PG	
		Grada- tion	Fog ging	Tran- sfer fail- ure	Bla- ck line	Wh- ite line	Un- even pitch	Un- even den- sity (rear / front)	Right angle accu- racy Straigh- t line accu- racy	Side reg- istra- tion	Shoc- k	Mag- nifica- tion ratio		
0	Normal copy/print													-
1	Grid								Yes	Yes		Yes	Main Controller PCB 2	
2	17 gradations Tbic rank 2	Yes			Yes	Yes							Main Controller PCB 2	
3	17 gradations 600dpi (134- line screen or 141-line screen)	Yes			Yes	Yes							Main Controller PCB 2	
4	Solid white		Yes										Main Controller PCB 2	
5	Halftone (density: 80H, Tbic rank 2, without image correc- tion)			Yes	Yes	Yes	Yes	Yes			Yes		Main Controller PCB 2	
6	Halftone (density: 80H, 134- line screen or 141-line screen, without image correction)			Yes	Yes	Yes	Yes	Yes			Yes		Main Controller PCB 2	
7	Solid black			Yes		Yes	Yes	Yes					Main Controller PCB 2	
8	Horizontal line (4 dots, 27 spaces)				Yes	Yes	Yes	Yes					Main Controller PCB 2	
9	Horizontal line (6 dots, 50 spaces)				Yes	Yes	Yes	Yes					Main Controller PCB 2	
10	Horizontal line (2 dots, 3 spaces)				Yes	Yes	Yes	Yes					Main Controller PCB 2	
11	Halftone (density: 60H, Tbic rank 2, without image correc- tion)			Yes	Yes	Yes	Yes	Yes		Yes	Yes		Main Controller PCB 2	
12	Halftone (density: 60H, 134- line screen or 141-line screen, without image correction)			Yes	Yes	Yes	Yes	Yes			Yes		Main Controller PCB 2	
13	Halftone (density: 30H, Tbic rank 2, without image correc- tion)			Yes	Yes	Yes	Yes	Yes			Yes		Main Controller PCB 2	
14	Halftone (density: 30H, 134- line screen or 141-line screen, without image correction)			Yes	Yes	Yes	Yes	Yes			Yes		Main Controller PCB 2	
15	15 to 50: For development												-	

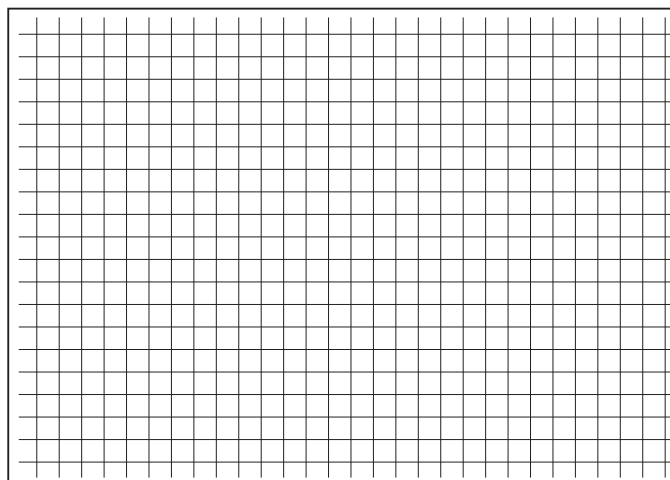
NOTE:

When outputting a halftone test print, be sure to use PG TYPE:6 except in the following cases.

- When checking the image of side registration adjustment, use PG TYPE:11.
- When the setting value of the following service mode(Lv.2) is "2" (TBIC is used for both the photo part and the text part), use PG TYPE:5.
COPIER > OPTION > USER > PH-D-SL2

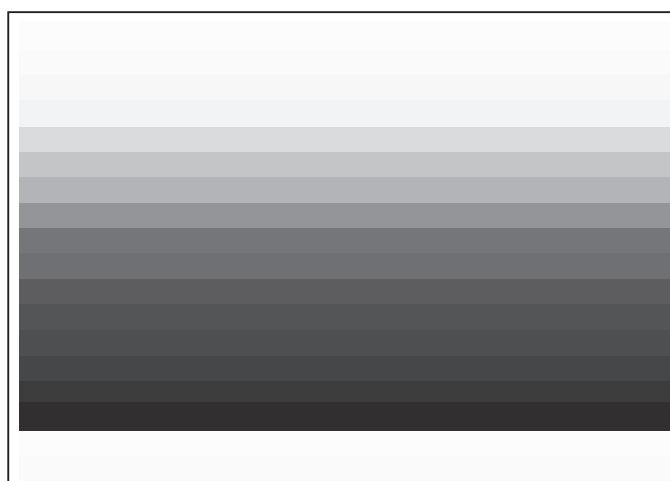
How to View the Test Print

■ Grid (TYPE=1)



Check item	Check method	Assumed cause
Right angle accuracy/ Straight line accuracy	Check whether lines in the horizontal/ vertical scanning directions are paralleled to the paper and these lines are at right angles to one another.	Feed system failure or Laser Scanner Unit failure is considered.
Side registration	Check the left margin.	Floor at the installation site is extremely distorted, or the feed system failure is considered.
Magnification ratio	Check whether the grid is printed at 9.99mm intervals. (Check the image on the second side at duplex printing.)	ETB and rollers' feed system failure or laser exposure system failure (drum, Laser Scanner) is considered.

■ 17 gradations (TYPE=2/3)



Check item	Check method	Assumed cause
Gradation	Check whether gradation in density is made appropriately.	Drum failure, laser exposure system failure or developing system failure is considered.
Black line	Check whether black lines appear on the image.	Laser light path failure, grid failure, developing system failure, cleaning (drum, ETB) failure or Pre-transfer Charging Assembly failure is considered.
White line	Check whether white lines appear on the image.	Primary Charging Wire failure or developing system failure is considered.

Solid white (TYPE=4)



Check item	Check method	Assumed cause
Fogging	Check whether foggy image appears in the blank area.	Drum failure, laser exposure system failure or developing system failure is considered.

Halftone (TYPE=5/6/11/12/13/14)



NOTE:

- When outputting a halftone test print, be sure to use PG TYPE:6 except in the following cases.
 - When checking the image of side registration adjustment, use PG TYPE:11.
 - When the setting value of the following service mode(Lv.2) is "2" (TBIC is used for both the photo part and the text part), use PG TYPE:5.
COPIER > OPTION > USER > PH-D-SL2
- When changing the density of the test print (TYPE=5), use the following service mode to change the density:
COPIER > TEST > PG > DENS-K

Check item	Check method	Assumed cause
Transfer failure	Check the evenness of halftone density. Check whether uneven image or foggy image appears.	Transfer system failure or Pre-transfer Charging Assembly failure is considered.
Black line	Check whether black lines appear on the image.	Laser light path failure, grid failure, developing system failure, cleaning (drum, ETB) failure or Pre-transfer Charging Assembly failure is considered.
White line	Check whether white lines appear on the image.	Primary Charging Wire failure or developing system failure is considered.

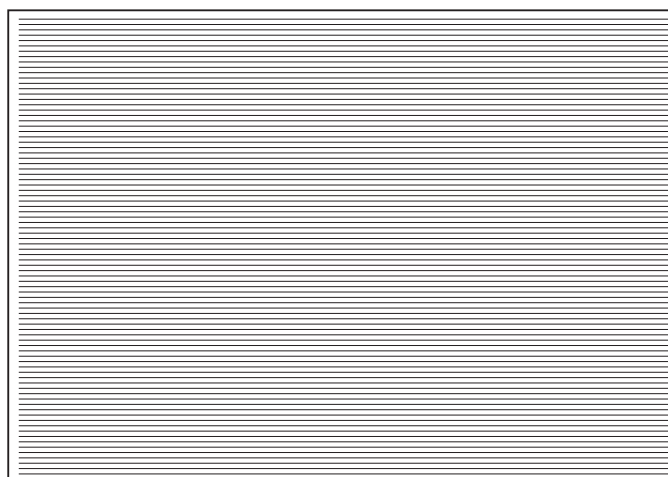
Check item	Check method	Assumed cause
Uneven pitch	Check whether lines appear on the image in the horizontal scanning direction.	Drum failure, developing system failure, laser exposure system failure or driverelated failure is considered.
Uneven density (rear/front)	Check the density difference between the front and rear sides.	Primary Charging Assembly failure, drum failure or developing system failure is considered.
Side registration	Check the left margin.	Floor at the installation site is extremely distorted, or the feed system failure is considered.
Shock	Check whether horizontal lines appear on the image.	ETB and rollers' feed system failure or laser exposure system failure (drum, Laser Scanner) is considered.

Solid black (TYPE=7)



Check item	Check method	Assumed cause
Transfer failure	Check the evenness of halftone density. Check whether uneven image or foggy image appears.	Transfer system failure or Pre-transfer Charging Assembly failure is considered.
Uneven pitch	Check whether lines appear on the image in the horizontal scanning direction.	Drum failure, developing system failure, laser exposure system failure or drive-related failure is considered.
Uneven density (rear/front)	Check the density difference between the front and rear sides.	Primary Charging Assembly failure, drum failure or developing system failure is considered.

Horizontal line (TYPE=8/9/10)



Check item	Check method	Assumed cause
Black line	Check whether black lines appear on the image.	Laser light path failure, grid failure, developing system failure, cleaning (drum, ETB) failure or Pre-transfer Charging Assembly failure is considered.
White line	Check whether white lines appear on the image.	Primary Charging Wire failure or developing system failure is considered.
Uneven pitch	Check whether lines appear on the image in the horizontal scanning direction.	Drum failure, developing system failure, laser exposure system failure or drive-related failure is considered.
Uneven density (rear/front)	Check the density difference between the front and rear sides.	Primary Charging Assembly failure, drum failure or developing system failure is considered.

Image Faults

Parts Pitch Related to Periodical Image Failure

Name	Outer Circumference (mm)
Photosensitive Drum	Approx. 264
Developing Cylinder	Approx. 63
Developing Roller	Approx. 64
Transfer Roller	Approx. 50
ETB	Approx. 298
Fixing Roller	Approx. 127
Pressure Roller	Approx. 120

CAUTION:

The outer circumference may be different from the width of the image failure depending on the factors including processing speed and/or amount of image shrink/expansion.

Image with a line on the trailing edge

[Location]

ETB

[Cause]

Lines occur on the image due to shock when distortion on the belt is released while rotation speed between the ETB and drum differs

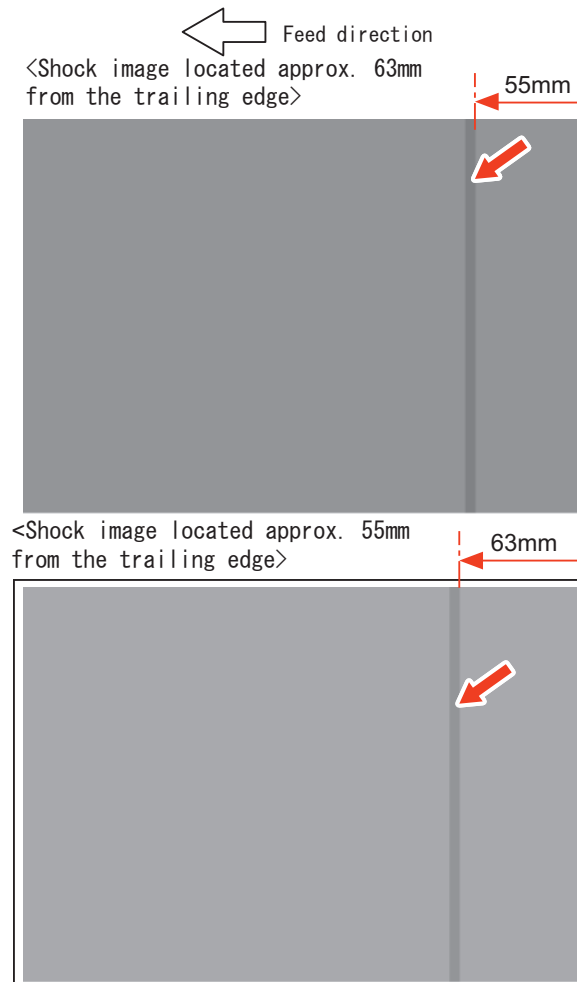
[Condition]

When replacing the ETB

[Field Remedy]

- Output a halftone image with the following conditions and check the output image
 COPIER > TEST > PG > TYPE 6
 COPIER > TEST > PG > PG-PICK A3 (LDR)
 Select the cassette which the following paper is set: or larger.
 Image with a line on the trailing edge: Go to step 2.
 Image without a line on the trailing edge: End
- Measure the distance from the trailing edge of the image with a line.
- Use the following service mode to make an adjustment.
 - Adjust the Transfer Belt speed
 COPIER > ADJUST > FEED-ADJ > TBLT-SPD
 A line on the image is located approx. 55mm from the trailing edge: Adjust the value by +10 gradually.
 A line on the image is located approx. 63mm from the trailing edge: Adjust the value by -10 gradually.
- Output a halftone image with the condition described in step 1 again and check the image.
 Image with a line on the trailing edge: Go to step 3.
 Image without a line on the trailing edge: End

[Image Sample]



Uneven density correction by 2D shading

To correct uneven image density caused by uneven potential on the surface of the Drum.

NOTE:

This machine performs two dimensional shading which replaces uneven potential of the Photosensitive Drum to the exposure amount to correct. (Default: two dimensional shading is disabled.) As the data of Drum's uneven potential, the data measured at the shipment of the Drum is used. Therefore, as the life of the Photosensitive Drum advances, it gets deteriorated, so the uneven potential becomes different from the one at the shipment of the Drum. Although the uneven potential of the Drum is changed due to the deterioration, the data can be corrected per horizontal/vertical scanning direction line by outputting a test pattern image with the following procedure.

CAUTION:

This adjustment is executed when the preferred image is not output even if the Primary Charging Wire height adjustment and secure watermark adjustment * are performed.

*Secure watermark adjustment: Function Settings>Common>Print Settings>Secure Watermark Settings>Adjust Background/Character Contrast

1. Check that the two dimensional shading is enabled.

- 1:When uneven image occurs
 - 2:When low edge density occurs
- COPIER>OPTION>IMG-LSR>2D-SHADE
- 1: Enabled(VD)
 - 2: Enabled(VL)

2. Read the two dimensional shading ROM data.

COPIER>FUNCTION>2D-SHADE>2D-READ

3. Read the two dimensional shading ROM data.

CAUTION:

Be sure to turn OFF and then ON the main power switch after step 2. Uneven density may be reduced by the two dimensional shading correction at the startup.

4. Output a halftone image with the following conditions and check if uneven density occurs.

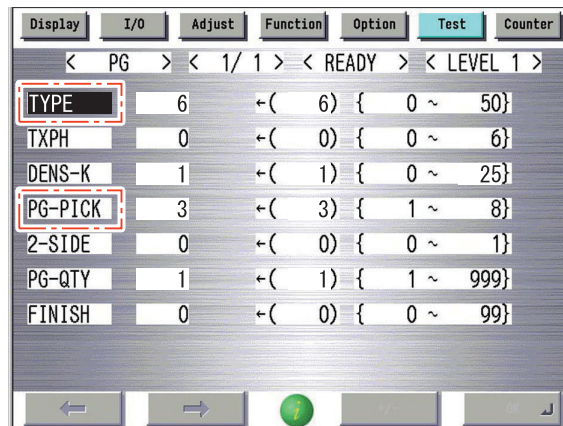
COPIER > TEST > PG > TYPE 6

COPIER > TEST > PG > PG-PICK A3 (LDR)

Select the cassette which the following paper is set or larger.

When uneven density is seen: Go to step 5.

When uneven density is not seen: Procedure is ended.



5. Output a test pattern for two dimensional shading.

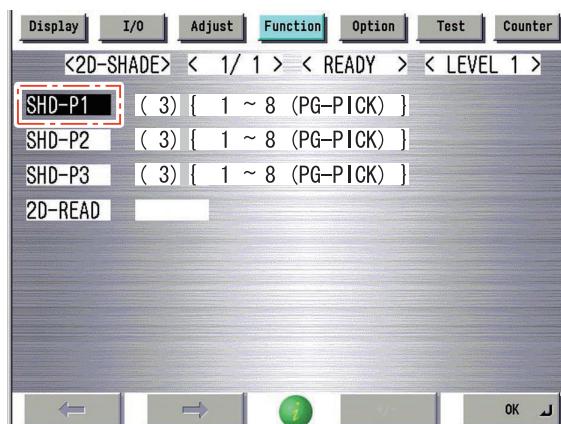
COPIER > FUNCTION > 2D-SHADE > SHD-P1

1. Set the cassette. Select the cassette which A3 (LDR) or larger paper is set.

Select "SHD-P1" and cassette using "numeric keypad".

2. Output 3 sheets of the test pattern.

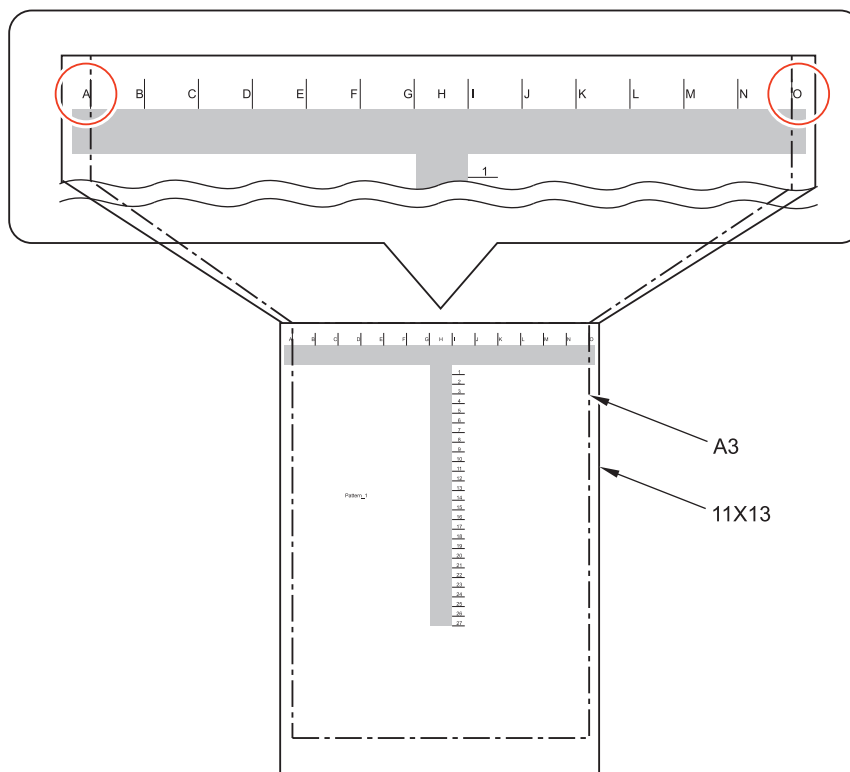
Press OK, output 1 sheet of the test pattern.



CAUTION:

It is difficult to judge whether uneven potential of the Photosensitive Drum causes uneven density of the output image, so output 3 sheets of the test print and adjust the area where all. (If the same symptom is seen on the same spot of all 3 sheets, it is possibly caused from the Drum.)

<Test pattern>

**NOTE:**

For the test print, the following 3 types can be output, but basically set SHD-P1 to output. The following shows the use case of each test print.

- When the image which uneven density occurs is the halftone image with light density
COPIER>FUNCTION>2D-SHADE>SHD-P1
- When the image which uneven density occurs is the halftone image with dark density
COPIER>FUNCTION>2D-SHADE>SHD-P2
- When the image which uneven density occurs is the halftone image with dark density
COPIER>FUNCTION>2D-SHADE>SHD-P3

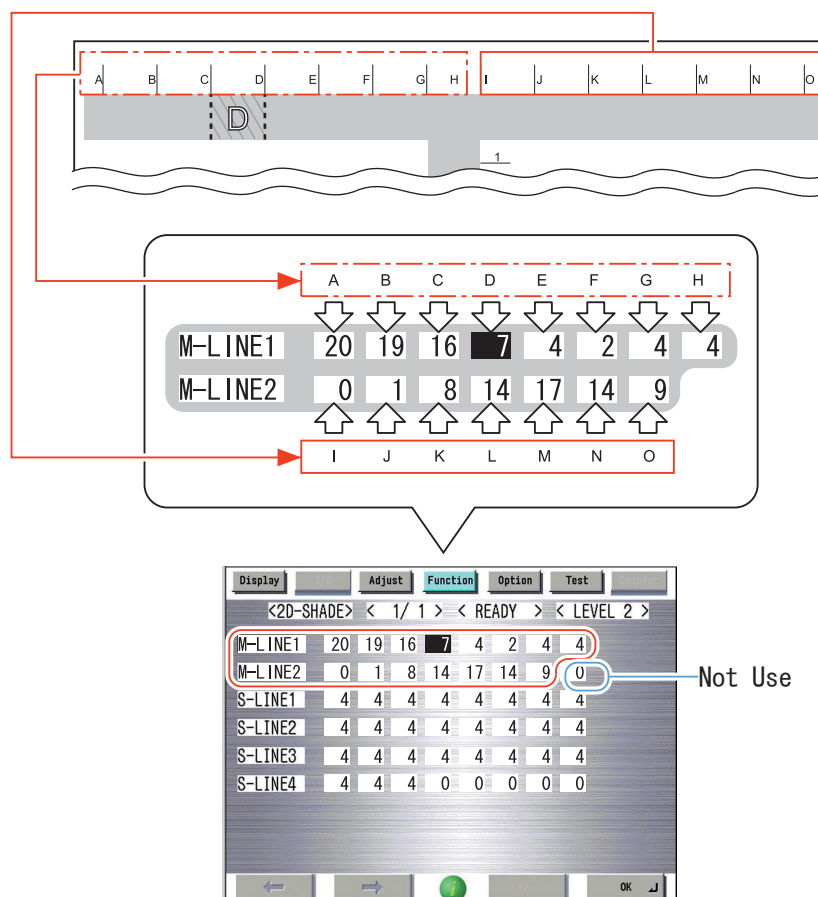
6. Check (T-shaped) halftone area of the output test print visually and adjust the area of uneven density.

1. Take a note to write down the values of the following service mode(Lv.2).
When the adjustment cannot be performed appropriately, these values are required to return to the initial values.
COPIER>FUNCTION>2D-SHADE>M-LINE1
COPIER>FUNCTION>2D-SHADE>M-LINE2
2. Adjust the target horizontal scanning direction (A to O) which uneven density is seen.
After selecting "M-LINE1/M-LINE2", select the target horizontal scanning window (A to O), and enter the numerical value using "numerical keypad".(Lv.2)
 - Horizontal scanning direction A to H
COPIER>FUNCTION>2D-SHADE>M-LINE1
 - Horizontal scanning direction I to O
COPIER>FUNCTION>2D-SHADE>M-LINE2

3. Turn OFF and then ON the main power switch to reflect the setting value.

CAUTION:

- Be sure to switch the screen after entering the value. Unless the screen is switched, the numerical value is not reflected. (Actually, the value is not reflected on the screen, but it is retained internally.)
- When the horizontal scanning direction (H line) is adjusted, the adjustment value of the vertical scanning direction (1 to 27) is also changed.
- As the value is larger, the density becomes lighter. As the value is smaller, the density becomes darker.
- Enter the adjustment value in a unit of +/- 30 gradually, output the test pattern and make adjustment while checking the test pattern. If the value is changed dramatically, the image error (white line) may occur.
- Entering 96 or larger value can generate an error in potential control (E061).
In the case of an error, adjust the setting value between 0 and 95.



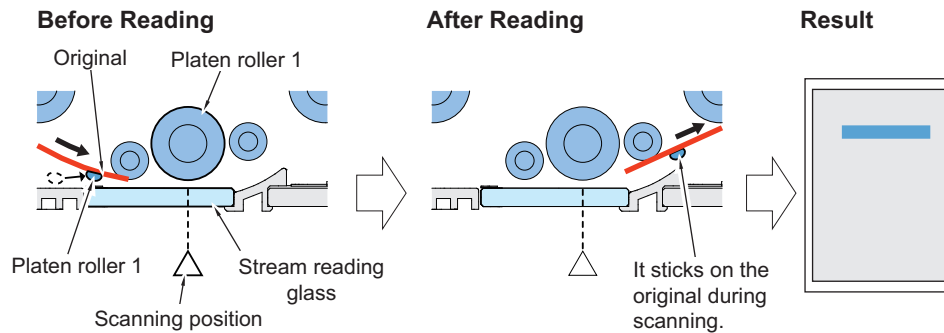
4. After the adjustment, output a test print and check the image to complete the procedure.

CAUTION:

If the image cannot be adjusted correctly even with this adjustment procedure, reenter the values written in step 6-1.

ADF black line

Image processing has been improved with this equipment, which applies optimal image processing to the text part and the photo part respectively. Improvement in image processing, however, highlights imperceptible dusts at the original scanning position, which may appear as a line on the image.



[Location]

ADF

[Cause]

At stream reading with the ADF, imperceptible dusts (paper dust, toner, dust, etc.) adhere and remain at the original scanning position, which causes a black line on the original image. (Occurrence frequency is roughly 3/10,000 of scanning documents)
The dusts causing a black line are delivered outside the ADF together with the scanning original; therefore, there will be no black line with the next original.

[Remedy]

Changing the setting value in the following service mode improves the problem of a black line.

- Text density adjustment when adjusting image density
COPIER > ADJUST > AE > AE-TBL
Setting value: Change the default (5) to 3
- Setting of the sharpness level on the image (Lv.2)
COPIER > OPTION > IMG-MCON > SHARP
Setting value: Change the default (3) to 1
- Setting of the halftone processing in text/photo mode (Lv.2)
COPIER > OPTION > USER > PH-D-SL2
Setting value: Change the default (0) to 2

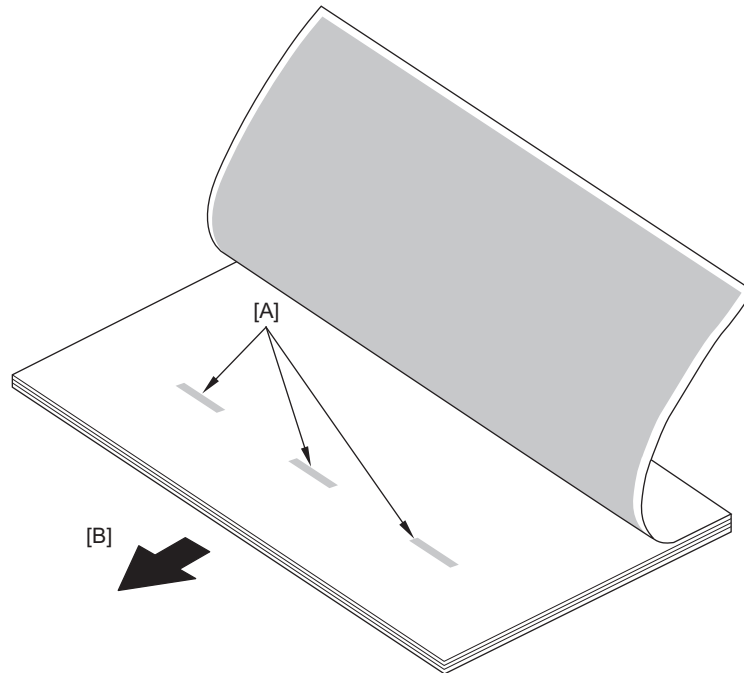
CAUTION:

When performing a field remedy, remind that the scan result changes as follows:

- Scanning of light halftone base is skipped (to be scanned as white color)
- Blur text outline due to reduced edge emphasis level with the text
- Photo part appears coarsely

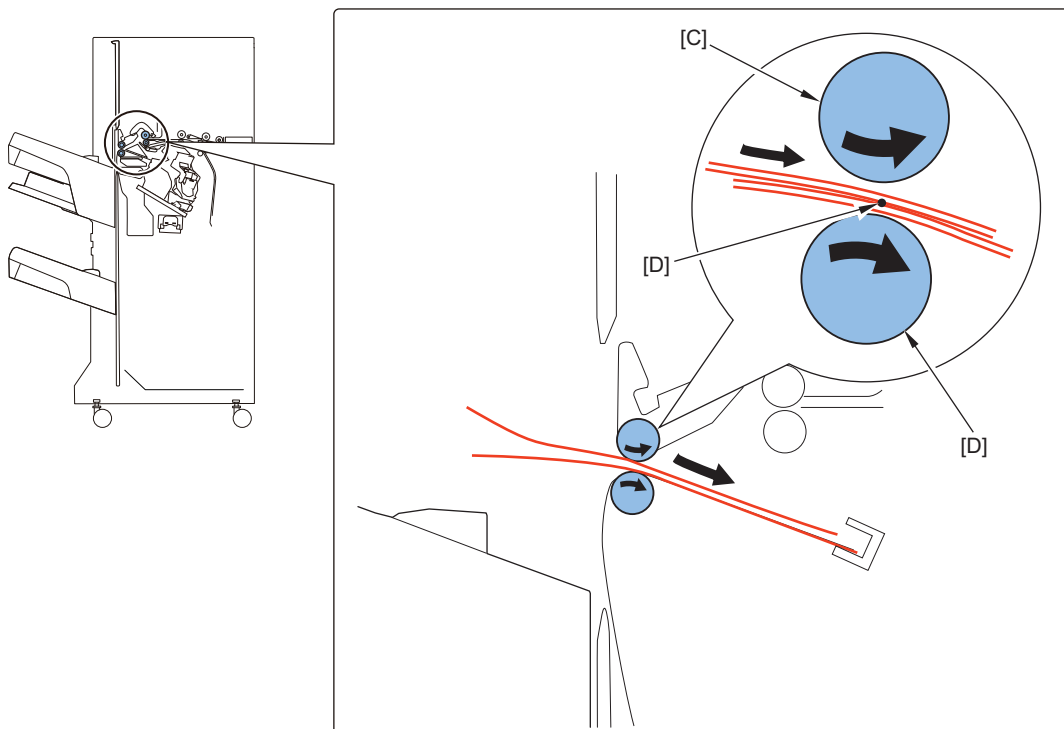
Bleed-thru/Soil appeared on the back of the paper (Staple Finisher-X1/Booklet Finisher-X1)

Soil [A] can appear on the back of the sheet in the shift mode/staple mode with Staple Finisher-X1/Booklet Finisher-X1.



[Cause]

While the paper is stacked to the Process Tray Assembly, two sheets are rubbed at where the sheets are nipped between the Stack Delivery Upper Roller [C] and the Stack Delivery Lower Roller [D], which results in soil on the paper. This symptom can occur with all paper types because soil on the back of the paper (bleed-thru) is caused by the rubbing of sheets, however, bleed-thru is likely to occur in the case of using "coated paper", which has high friction coefficient. This symptom is expected to occur when using coated paper together with plain paper; soil appears on the coated paper because the image on the plain paper is transferred to the coated paper.



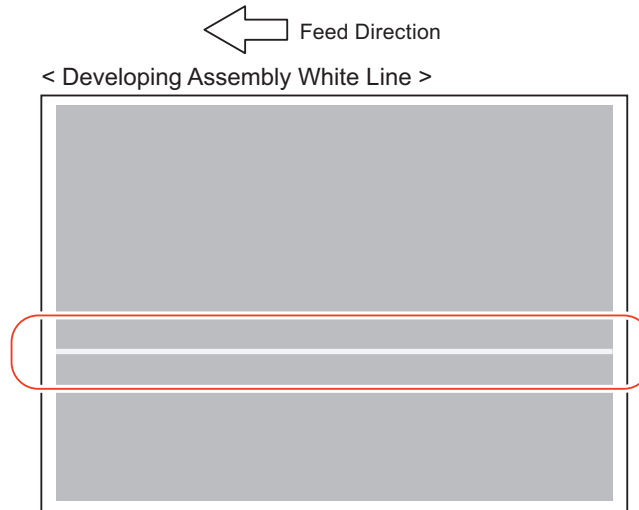
[Remedy]

Bleed-thru is improved by changing the setting value in the following service mode:

- ON/OFF the mode to prevent bleed-through
SORTER>OPTION>SLD-BCK
Value "1" is set as usual. Setting value will be changed to "2" when the alignment in Processing Tray is poor with the value "1".
Setting value:
0: OFF (default)
1: Raise a paper return roller and receive the buffered paper
2: Lower the paper return roller and receive the buffered paper

White line (foreign matter between Developing Sleeves)

Sample image



[Location]

Developing Assembly

[Cause]

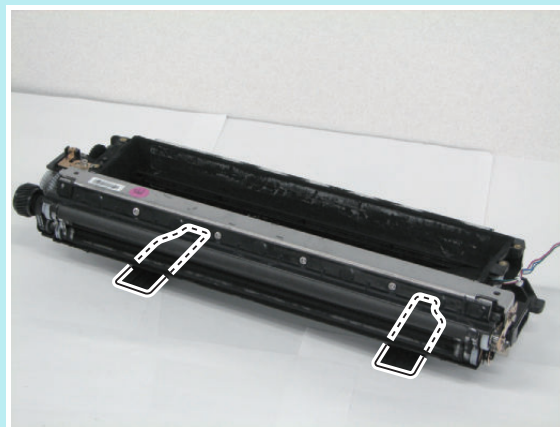
A line appears in toner coating when imperceptible foreign matter is caught between the 2 sleeves of the Developing Assembly. This can cause image failure of a white line in vertical scanning direction.

[Field Remedy]

1. Remove the Developing Assembly.

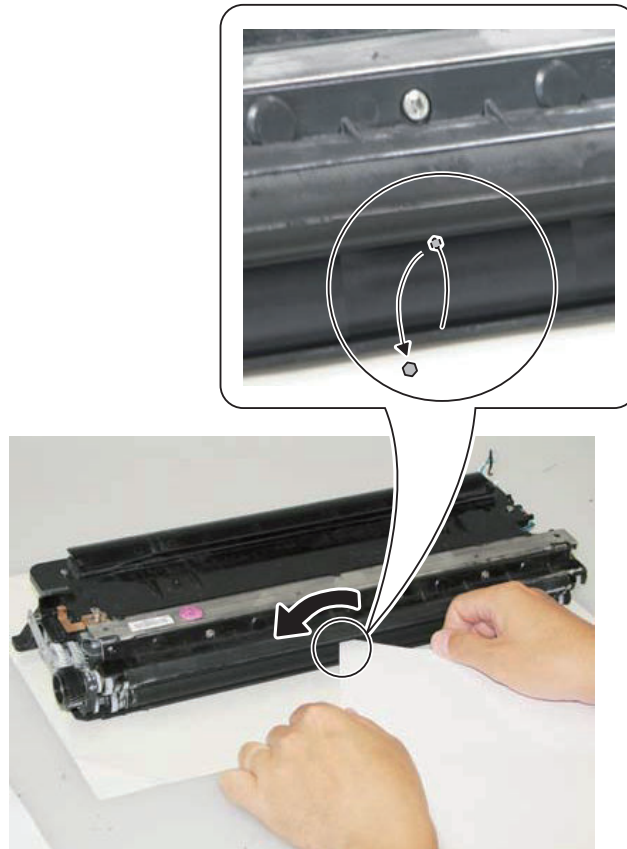
NOTE:

Be sure to place paper on a clean place and take out the foot of the Developing Assembly before placing the Developing Assembly.



2. remove foreign matter caught between the sleeves.

Insert a corner of the paper between the sleeves and scrape out and remove foreign matter from the side.

**NOTE:**

The location of foreign matter can be easily identified by using a blower to blow excess toner between the sleeves.

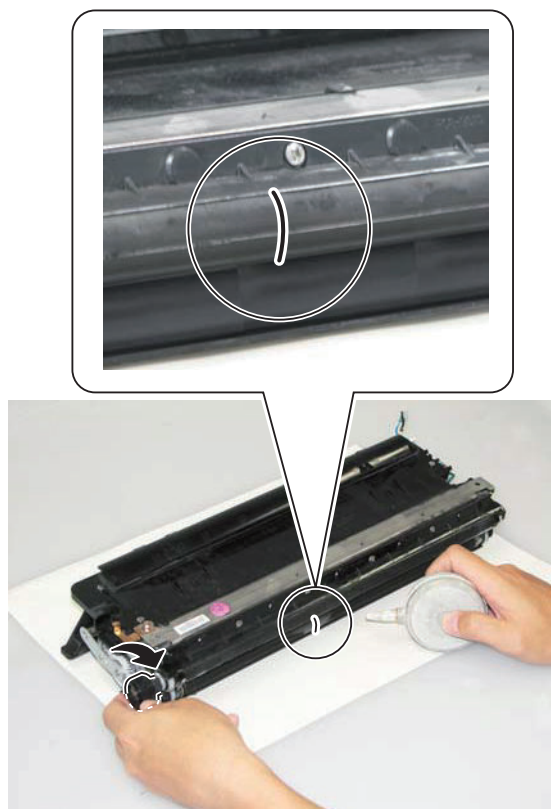
Be sure to use plain paper with around 75 g/m². (Too thick paper may not be fit into the gap. Too thin paper can be folded or ripped.)

If it is difficult to insert paper, turn the gear clockwise and counterclockwise for 2 teeth so that it gets easier to insert paper between the sleeves. Do not turn the gear counterclockwise for half round or more (otherwise, it can cause image failure due to collected toner between the sleeve and the blade or between the sleeves)

3. 3) Clean excess toner on the upper and lower sleeves.

Toner can be excessively attached because the toner is pushed to the sleeve when scraping out the foreign matter. Perform cleaning in the following steps because excess toner can cause uneven density.

1. While rotating the sleeve, blow the toner with the blower and then check for excess toner.



2. Pile up 3 sheets of lint-free paper and clean excess toner with the lint-free paper.

NOTE:

Do not apply force and lightly wipe out the excess toner. Rubbing the toner part can cause the rubbed part to be dark image.



3. Check if the toner blown by the blower is attached to the Developing Roller; if the toner is attached, wipe it with lint-free paper.
(Otherwise, the toner is fused to the Roller that causes banding)

4. Install the Developing Assembly.**5. Execute the following service mode.**

- Idle rotation of Developing Assembly
COPIER > FUNCTION > MISC-P > DV-RT
If the white spots persist, execute the service mode again.

CAUTION:

Heavy use can result in deterioration of developer or toner scattering.

White line (uneven density)

[Location]

Developing Assembly (Lower Sleeve)

[Cause]

Due to insufficient toner stirring in the Developing Assembly, uneven toner coating occurs in the Developing Lower Sleeve and an image failure of white lines may occur in the vertical scanning direction on the halftone image.

[Condition]

Right after toner is supplied to the Developing Assembly (COPIER > FUNCTION > INSTALL > TONER-S) at installation, replacement of the Sleeve Unit (Developing Assembly), or replacement of the Toner Container in the Developing Assembly (Target: A4; 5% duty image; within 10,000 sheets)

[Field Remedy]

1. Remove the Developing Assembly, and check whether uneven toner coating occurs in the Lower Sleeve.
2. When the uneven toner coating is seen in the Lower Sleeve, execute the following service mode.
COPIER > FUNCTION > DENS > DEV-AGG

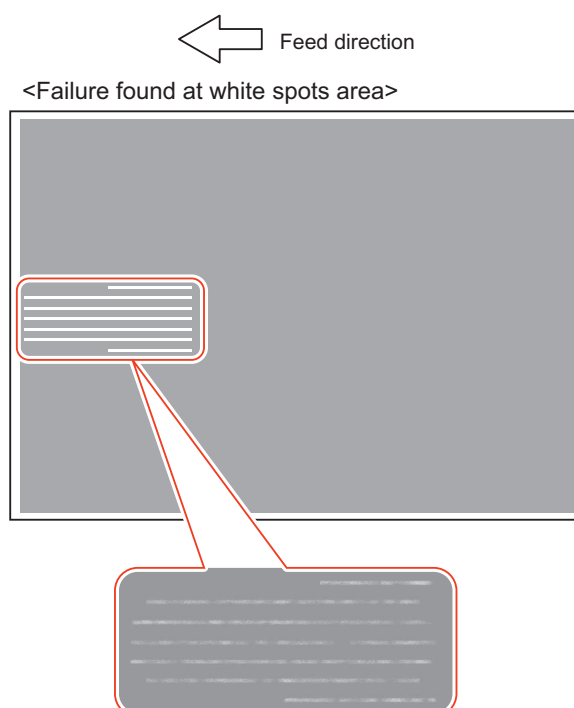
NOTE:

Make an idle rotation of the Developing Assembly forcibly and reduce the insufficient toner stirring. (To prevent the Drum Cleaning Blade from being everted, form a solid black image at regular intervals.) Rotation is executed for 10 minutes by default. (5-, 10-, 15-, 20- or 25-minute rotation can be selected.) When selecting the revolution, use service mode: COPIER > FUNCTION > DENS > AGG-SW.

CAUTION:

- Be sure not to use this mode longer than necessary. This may cause the Drum Cleaning Blade to be everted or toner to be scattered.

[Sample image]



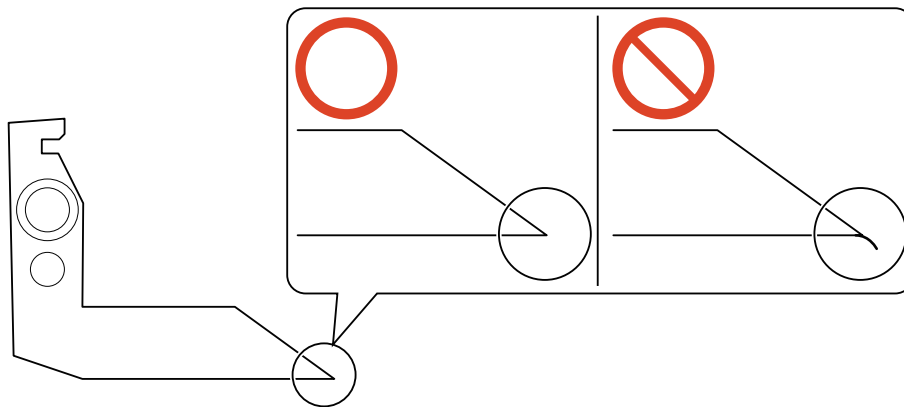
Separation Failure Jam due to Deformation of Separation Claw

[Location]

Drum Separation Claw

[Cause]

When the paper enters to the drum at separation failure, the Separation Claw may be deformed. When the Separation Claw is deformed, the paper is easily caught by the leading edge of the Separation Claw when the paper (especially curled paper) is fed, and a jam (Jam Code: 0205) is likely to occur.



[Condition]

Job after a jam which occurs when the paper enters to the drum When using curled paper (when using backside of printed paper, etc.)

[Field Remedy]

Replace the Separation Claw.

NOTE:

Replace the Separation Claw when a separation failure jam occurs even once.

● Image error due to soil attached to the Cleaning Brushes for the Duplex Right Roller and the Duplex Outlet Roller

[Location]

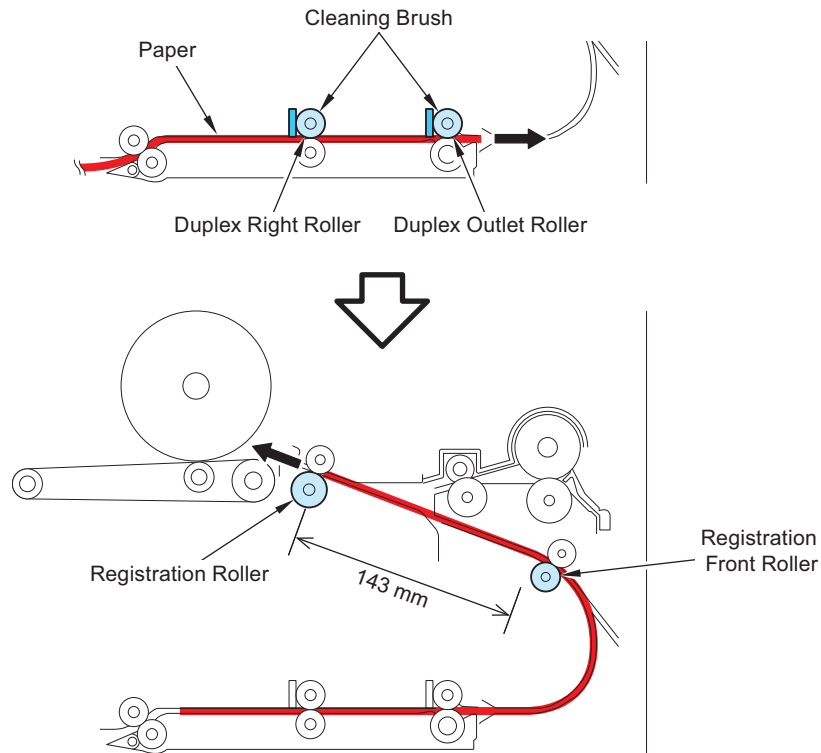
Fixing Feed Unit

[Cause]

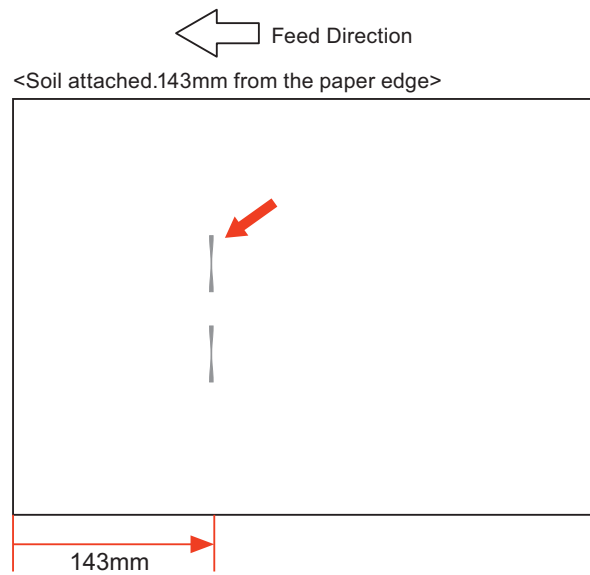
Soil attached to the 4 Cleaning Brushes contacting the Duplex Right Roller and the Duplex Outlet Roller

[Condition]

When soil is attached to the 4 Cleaning Brushes contacting the Duplex Right Roller and the Duplex Outlet Roller, paper is fed with minor soil (paper dust and toner) attached to it, and the soil is gradually attached to the Registration Front Roller. When the paper stops at the time of registration, the rotating Registration Front Roller contacts the paper, which causes two trails of soil of the roller width at 143mm from the paper edge.



[Image Sample]



[Field Remedy]

Follow the following procedure to replace the Cleaning Brushes contacting the Duplex Right Roller and the Duplex Outlet Roller and clean the relevant parts.

<Preparation>

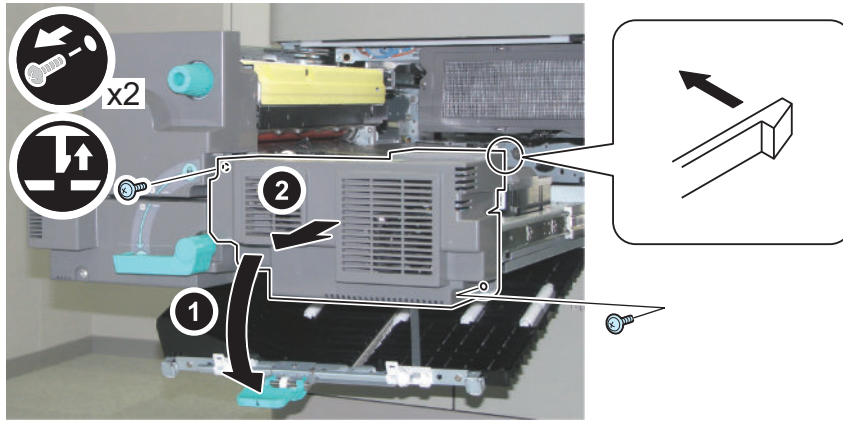
Remove the Registration Unit. (See [“Removing the Registration Unit”](#) on page 555)

<Procedure>

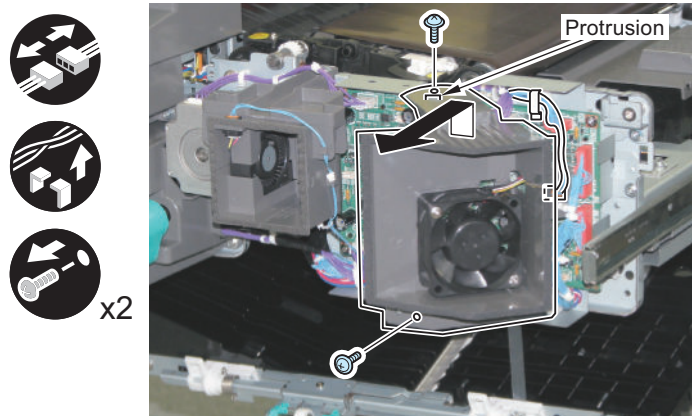
1. Open the Duplex Path.

2. Remove the Fixed Feed Cover 1.

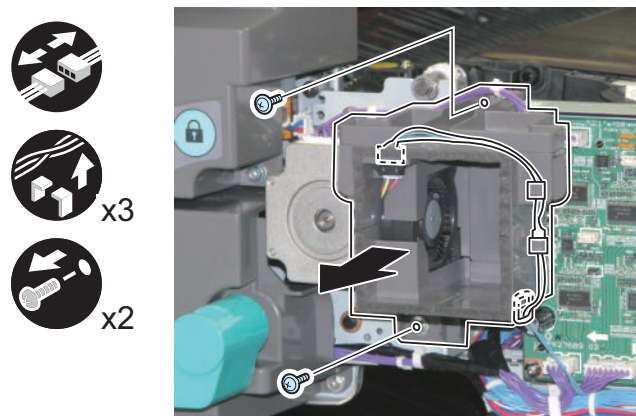
- 2 Screws
- 1 Claw

**3. Remove the right side Duct.**

- 1 Connector
- 1 Wire Saddle
- 2 Screws
- 1 Protrusion

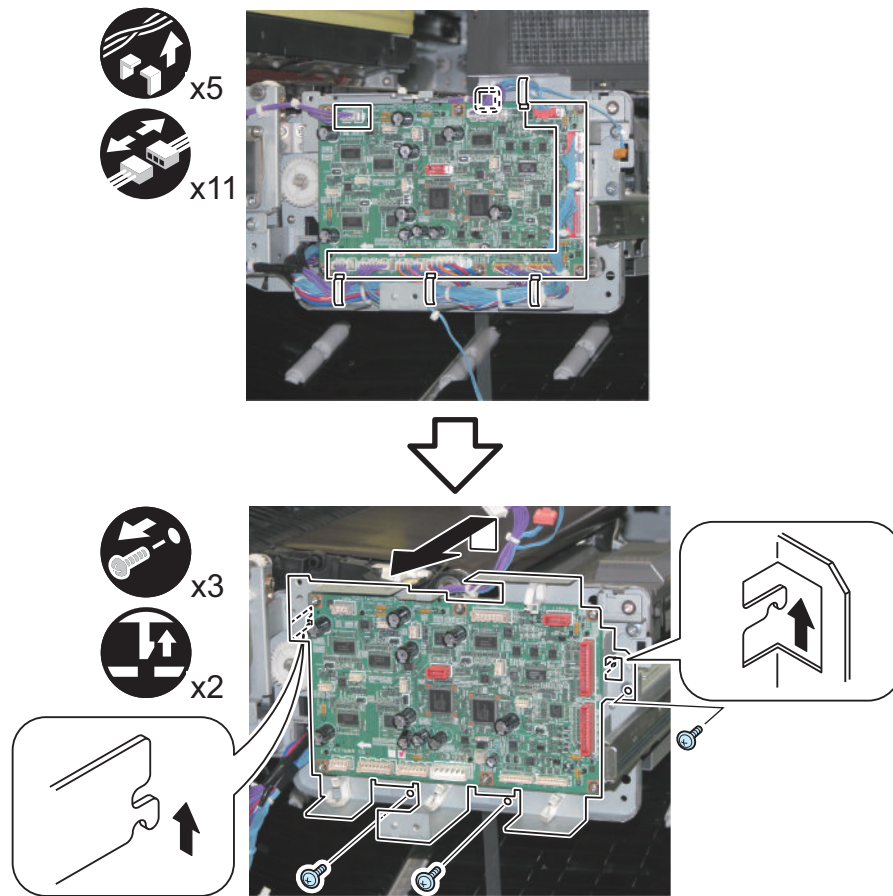
**4. Remove the left side Duct.**

- 1 Connector
- 2 Harness Guide
- 1 Wire Saddle
- 2 Screws



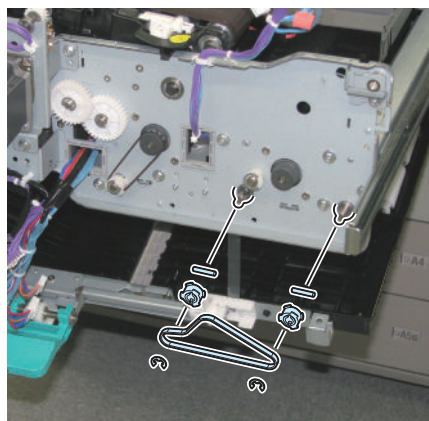
5. Remove the Duplex Driver PCB and the Mounting Base.

- 4 Wire Saddles
- 1 Edge Saddle
- 11 Connectors
- 3 Screws
- 2 Claws



6. Remove the following parts.

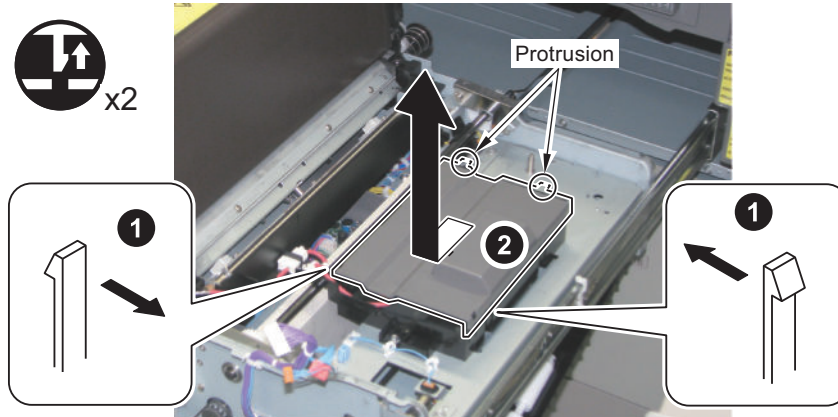
- 2 E-rings
- 1 Timing Belt
- 2 Pulleys
- 2 Parallel Pin



7. Lift the ETB Unit in the direction of the arrow.

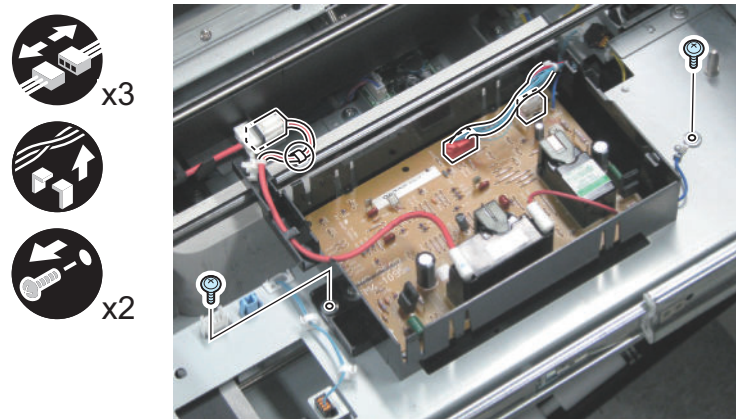
8. Free the 2 claws, and remove the Transfer High Voltage PCB Unit Upper Cover in the direction of the arrow.

- 2 Protrusions



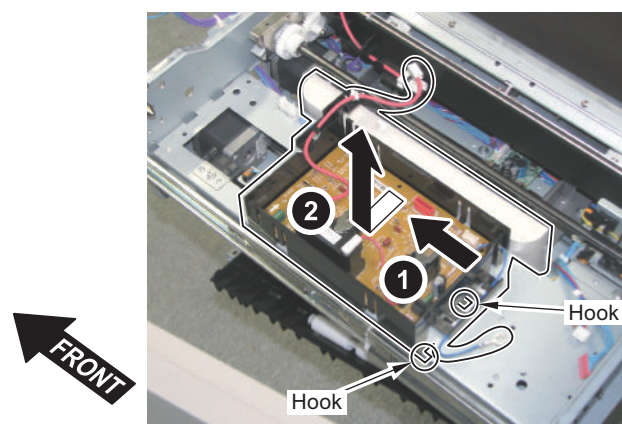
9. Remove the following parts.

- 3 Connectors
- 1 Wire Saddle
- 2 Screws



10. Remove the Transfer High Voltage PCB Unit in the direction of the arrow.

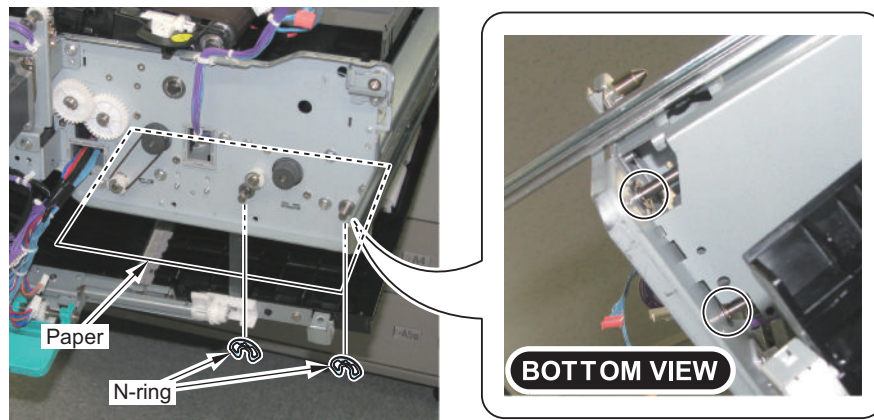
- 2 Hooks



11. Place a sheet of paper on the Duplex Path, and remove a N-ring each from the Duplex Right Roller and the Duplex Outlet Roller.

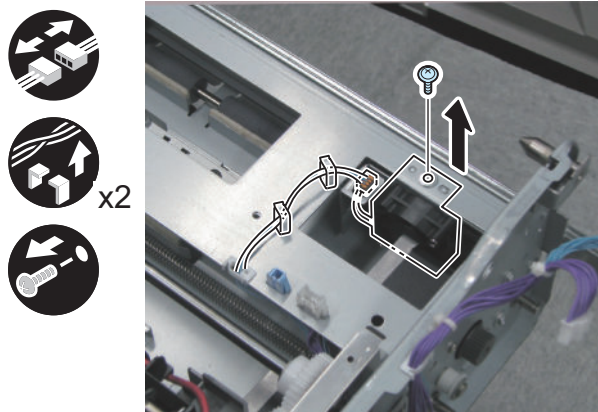
CAUTION:

Be sure to place a sheet of paper on the Duplex Path because paper dust drops during the following work.



12. Remove the Fan Unit.

- 2 Wire Saddles
- 1 Connector
- 1 Screws



13. Pull out the Duplex Right Roller and remove the shaft at the rear.

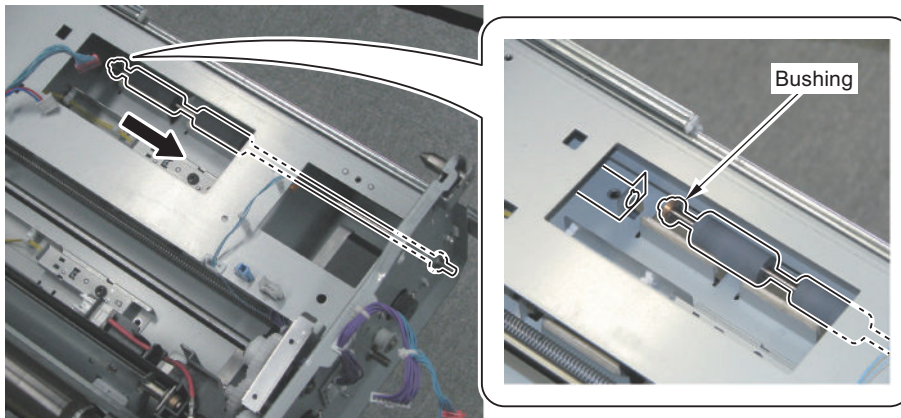
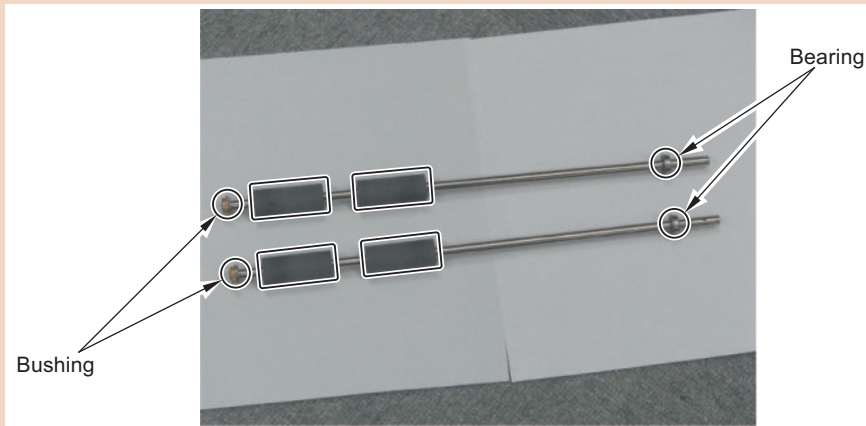
NOTE:

In this procedure, the procedure for removing the Duplex Right Roller is shown in steps 13 and 14. When removing the Duplex Outlet Roller, check the installation position in step 15 and remove the Duplex Outlet Roller by a similar procedure.

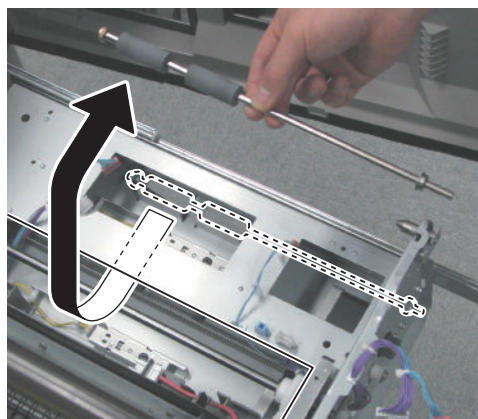
CAUTION:

oints to Caution at Work

- Be careful not to damage the surfaces of the Duplex Right Roller and the Duplex Outlet Roller.
- The bearing at the front and the bushing at the rear of the Duplex Right/Duplex Outlet Roller are not fixed, so be careful not to drop them.



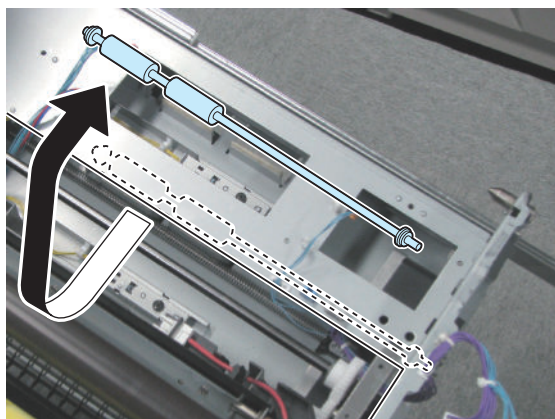
14. Move the Duplex Right Roller toward the rear and remove the shaft from the Fixing Feed Unit Side Plate. Then, move the Duplex Right Roller in the direction of the arrow and take it out from the opening on the top of the Fixing Feed Unit.



15. Remove the Duplex Outlet Roller in a similar procedure referring to the procedure for removing the Duplex Right Roller in steps 13 and 14.

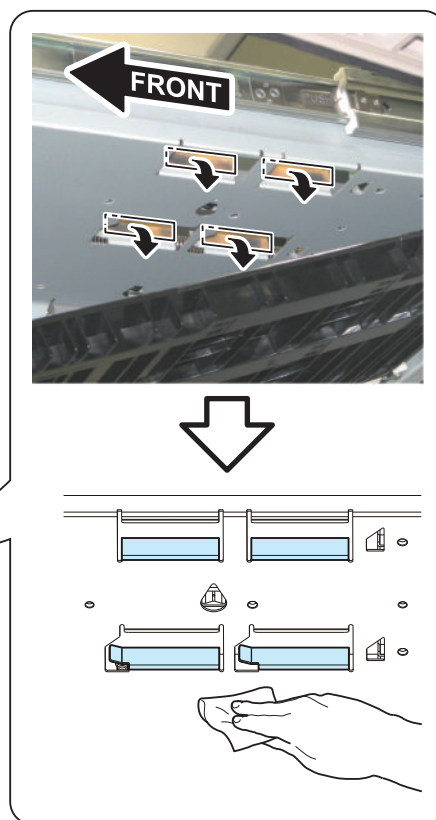
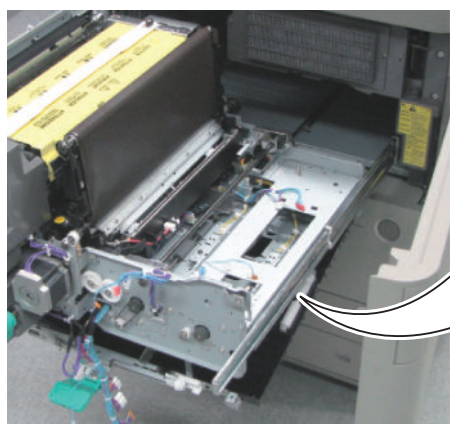
NOTE:

The installation position of the Duplex Outlet Roller is shown in the following figure.

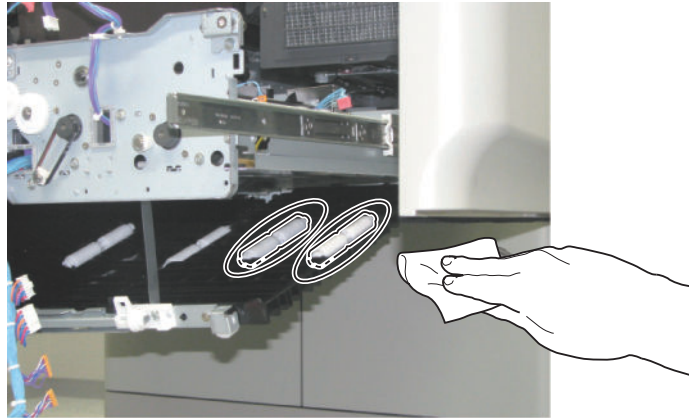


16. Remove the 4 Cleaning Brushes contacting the Duplex Right Roller and the Duplex Outlet Roller.

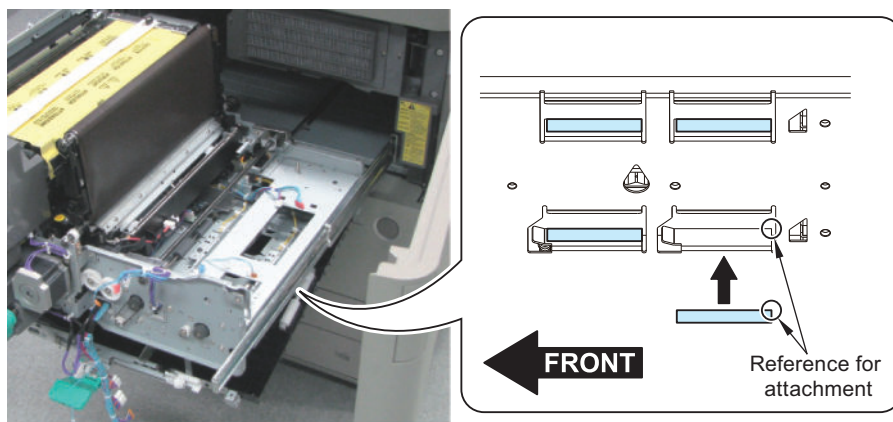
17. Clean the four areas where the Cleaning Brushes are attached with lint-free paper moistened with alcohol.



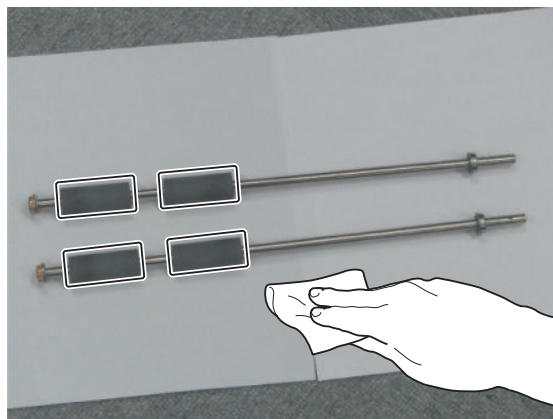
18. Remove the paper on the Duplex Path, and clean the entire perimeter of each of the 4 rollers with lint-free paper moistened with alcohol while rotating the roller by hand.



19. Attach new 4 Cleaning Brushes with reference to the upper right of the plate where they are going to be attached.



20. Clean the four areas on the removed Duplex Right Roller and the Duplex Outlet Roller with lint-free paper moistened with alcohol.

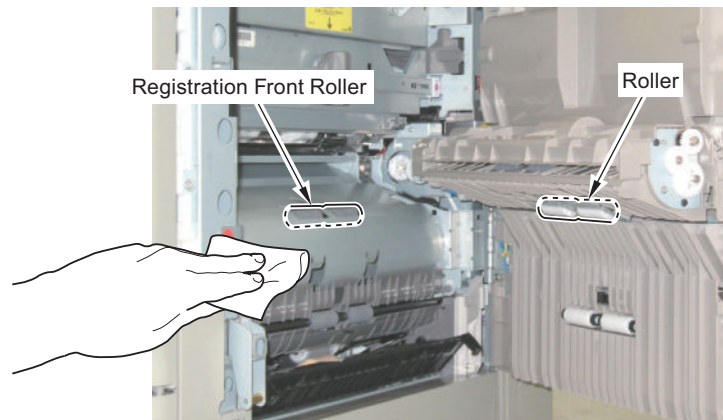


21. Install the removed parts in reverse order.
 22. Open the Right Door.
 23. Open the Right Lower Cover.

24. Clean the entire perimeter of each of the 2 rollers and Registration Front Roller with lint free moistened with alcohol while rotating the roller by hand.

CAUTION:

When rotating the roller by hand, be sure not to touch the surface of the roller but to hold a side face.

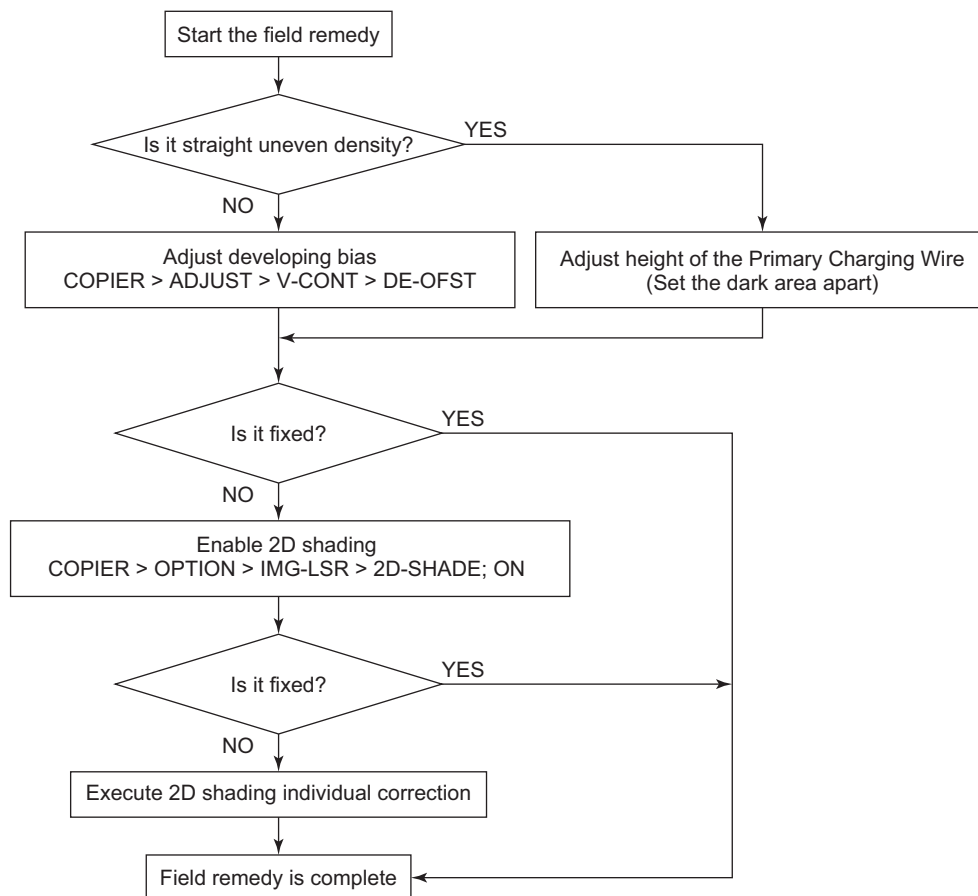


Uneven density

[Cause]

Uneven density occurs on the image because of uneven developing performance or change in drum characteristics due to wear.

[Field Remedy]





In the case of dark/light image at either the left or right side on the image in horizontal direction, adjust height of the Primary Charging Wire and check the output result. When making adjustment, execute the work while keeping the wire at dark area apart.



If it is not a straight uneven density, change the value of the following service mode in decrement of -10 and check the output result.

COPIER > ADJUST > V-CONT > DE-OFST

(Setting value: default 0, -10, -20, ...-50)

CAUTION:

Executing the above setting can generate smeared image or foggy image.

If the service mode has been changed, write the new adjustment value on the service label.

After switching the mode to enable 2D shading in the following service mode, turn OFF/ON the main power and check the output result.

After switching the mode to enable 2D shading in the following service mode, turn OFF/ON the main power and check the output result.

(For detailed procedure, see Troubleshooting > Uneven density correction by 2D shading > Step 1) to 3) (“[Uneven density correction by 2D shading](#)” on page 668))

COPIER > OPTION > IMG-LSR > 2D-SHADE

1: Enabled(VD), 2: Enabled(VL)

Output the test pattern for 2D shading and adjust the uneven density area individually.

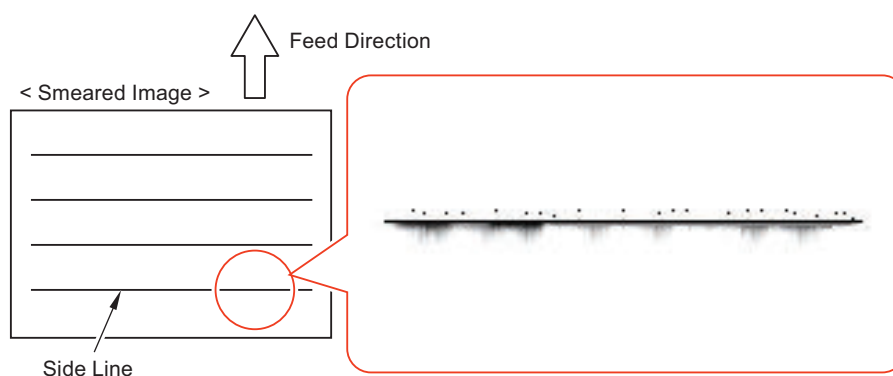
(For detailed procedure, see “Troubleshooting > Uneven density correction by 2D shading > Step 4) to 5)(“[Uneven density correction by 2D shading](#)” on page 668))

Smeared image

[Cause]

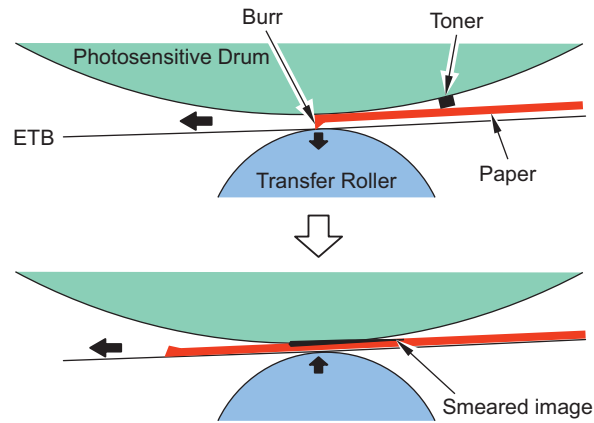
Excess toner is transferred on the paper that causes toner collapse at the time of fixing, which can generate smeared image on the image. The following are assumed causes of smeared image:

- When the paper type is changed
- Toner deterioration
- Rapid change in environment (High temperature <- -> Low temperature)

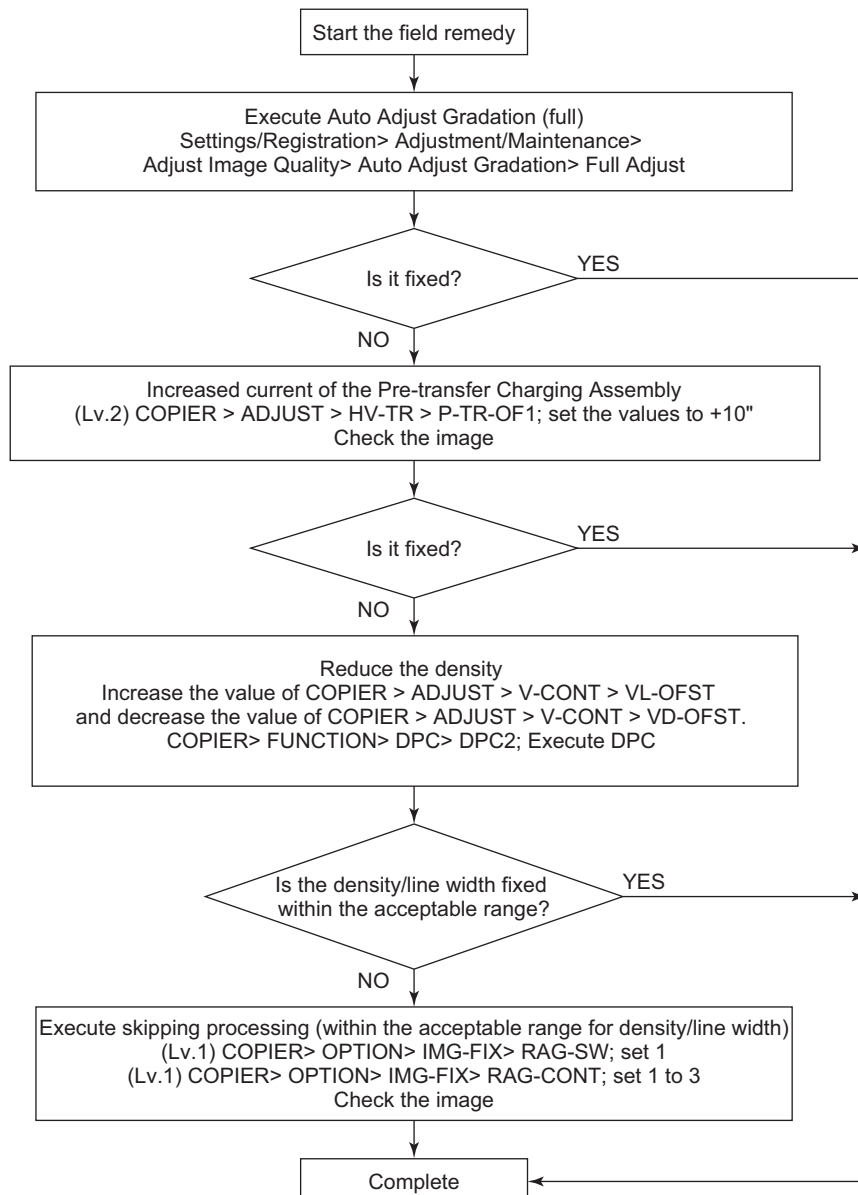


Smeared image may also occur exclusively in the area 5 to 10 mm from the leading edge of the paper when there is burr on the leading edge of the paper (jagged edge formed when the paper was cut by a cutter).

It is caused by toner being pushed backward by the power of the ETB, which is pushed down by the burr when it passes through the transfer nips, to go back to the original position.



[Field Remedy]



Select the following to execute Full Adjust: "Settings/Registration > Adjustment Maintenance > Adjust Image > Auto Adjust Gradation < Full Adjust"; and check the output result.

COPIER > ADJUST > HV-TR > P-TR-OF1

1. In the following service mode (Lv. 2), set "+10" in the rightmost field, and check the output result.

CAUTION:

Executing the above setting may cause the Pre-transfer Charging Wire to be easily soiled. Be sure to check for soiling of the Charging Wire at the time of inspection since heavy soiling may cause vertical lines to occur on the rear side of the image.

2. Decrease the value of the following service mode (LV. 1) from the default value 895 by +10.
COPIER > ADJUST > V-CONT > VL-OFST
3. Execute the following service mode, and then check the output result.
COPIER > FUNCTION > DPC > DPC2
If the symptom is not improved, increase the value in step 2) by +20,+30 and then execute step 3).
If the symptoms still persist, reduce the following service mode values to -10, -20, -30, and then perform step 3).
COPIER > ADJUST > V-CONT > VD-OFST

CAUTION:

Changing the above setting can cause reduced density or thinner line.

NOTE:

Simultaneous setting of smeared image suppression

Lv.2) COPIER> ADJUST> V-CONT> SMR-IPRV

When SMR-IPRV is set to 1, the offset values of the following service modes can be changed collectively.

- Lv.2) COPIER > ADJUST > HV-TR > P-TR-OF1 to 6 : +10
- Lv.1) COPIER > ADJUST > V-CONT > VL-OFST : +30
- Lv.1) COPIER > ADJUST > V-CONT > VD-OFST : -30

After changing the setting, turn the main power OFF/ON and execute auto adjust gradation.

If the smeared image is not improved within the acceptable range for density and line width, execute skipping process in the following procedure:

4. COPIER > OPTION > IMG-FIX > RAG-SW: change the value to 1
5. COPIER > OPTION > IMG-FIX > RAG-CONT: change to 1 and check the output result.
6. If the symptom is not improved, change the value in step 5) to 2, 3...and check the output result.

CAUTION:

Changing the above setting can cause minor skipping in the text part.

Adjusting the Edge Emphasis Level

The edge emphasis level of image can be adjusted in both user mode and service mode, but the use conditions differ.

	User mode	Service mode
Item code	Other Functions > Sharpness	Lv.2) COPIER> OPTION> IMG-MCON> SHARP
Operator	User	Service technician
Purpose	To make adjustment for each original to be copied	To set the central value of edge emphasis to control individual variability or environmental change during transportation/after installation.
Text/photo area	Individual	Batch
Setting range	-3 to +3 level	1 to 5
Default value	0 level	3
Setting value at power OFF/ON or at reset	Canceled (Default value can be retained.)	Retained

The following table shows the edge emphasis level by the combination of "SHARP" and "Sharpness" settings, using the relative value when the default is 100.

		User mode "Sharpness"						
		-3	-2	-1	0	+1	+2	+3
Service mode "SHARP"	1	25	40	50	60	100	140	175
	2		45	65	85	115	145	
	3		50	75	100	125	150	
	4		55	85	115	135	155	
	5		65	100	140	150	160	

Images become smoother as values in the table become smaller, while they become sharper as values become larger.

Note that, when "Sharpness" is the upper limit or lower limit, the relative value stays constant regardless of the "SHARP" setting, therefore the edge emphasis effect does not change even if the settings are changed.

Normally, adjustment is made for each copy on the Touch Panel based on the service mode setting, but depending on the environment or paper type (coarse surface, etc.), edge emphasis may not turn out the way the user expected.

In this case, edge emphasis level customized for the user can be set by setting the current value of "Sharpness" as the default value.

Example: In the case of the environment where the relative value "135" is suitable as the default value.

1. Set "SHARP" to "4".
2. Set "Sharpness", which is set to "+1" level, as the default in the user mode (Function Settings > Copy > Change Default Settings).

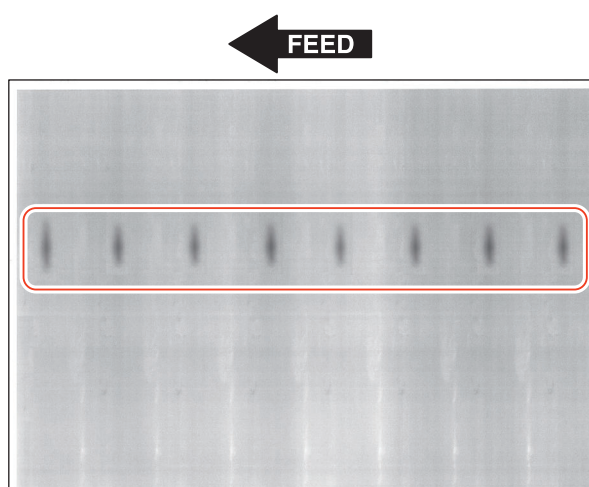
Soil at interval equal to Developing Sleeve circumference

[Location]

Developing Sleeve

[Cause]

If the surface of the sleeve is soiled, uneven toner coating occurs, causing the soiling of the same shape to appear at intervals equal to the circumference of the sleeve (approx. 63 mm) in the vertical scanning direction.



[Field Remedy]

1. Rotate the sleeve in the normal direction and identify the location where the soiling occurs.

CAUTION:

Do not turn the sleeve in the reverse direction.

2. Remove the toner found at that location using a blower, etc.

CAUTION:

If toner is dry wiped instead of removed, it may be fixed on the surface of the sleeve.

3. Wipe the surface of the sleeve with dry lint-free paper.

CAUTION:

Do not use water or alcohol.

4. Execute the following service mode to output a halftone image (TYPE 12), and check the image.

COPIER > TEST > PG > TYPE

If white spots occur, go to step 5.

5. Execute the following service mode.

COPIER > FUNCTION > MISC-P > DV-RT

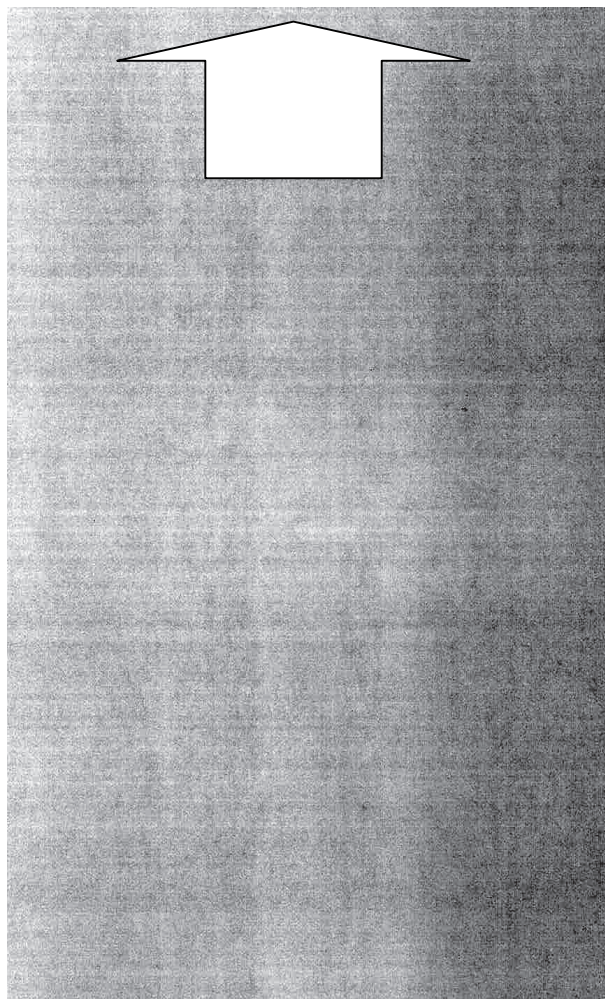
6. Check the image.

If the white spots persist, execute step 5 again.

CAUTION:

Heavy use of DEV-RT can result in deterioration of developer or toner scattering.

Image failure due to the temperature rising at the edge of the Fixing Roller (crepe mark)



<Location of Trouble>

Fixing Roller, Pressure Roller

<Cause>

This is the symptom which image error like crepe mark occurs when temperature at the edge of the Fixing Roller rises.

When the temperature rising at the edge occurs, the edge of the Pressure Roller made with rubber expands, giving the following influences on papers.

- Feed speed at the edge is increased, compared with the speed at the center.
- Tension is applied in the direction of both edges.

As it get close to the trailing edge, fixing is performed while a paper is distorted, causing an image error.

<Conditions>

Although all images have a possibility to have the error because the cause is temperature rising at the edge, the symptom is mainly significant with halftone images. The following shows estimated error occurrence with halftone image.

- When printing 200 sheets or more of small size paper continuously (approx. 1000 sheets in A4 size)
- When printing a large size sheet right after printing 100 sheets or more of small size paper continuously

<Field Remedy>

- 1. Go through the following: Settings/Registration > Function Settings > Common > Print Settings >Thin/Plain Paper Printing Priority Settings > Priority Settings ; and turn ON the item.**

By doing so, image error (crepe mark) will not occur.

With this setting, temperature difference between the center and the edge of the Fixing Roller is detected, and start idle rotation when temperature rising at the edge tends to occur.

During idle rotation, paper feed is stopped to keep constant temperature on the Fixing Roller, so the productivity is reduced.

- 2. Switching the image priority mode level.**

When the image priority mode is specified, productivity may be extremely reduced depending on use conditions (paper size, paper type, and print image).

In such a case, change the level of production reduction by the following service mode(Lv.2) .

COPIER > OPTION > IMG-FIX > FIX-IMGLV

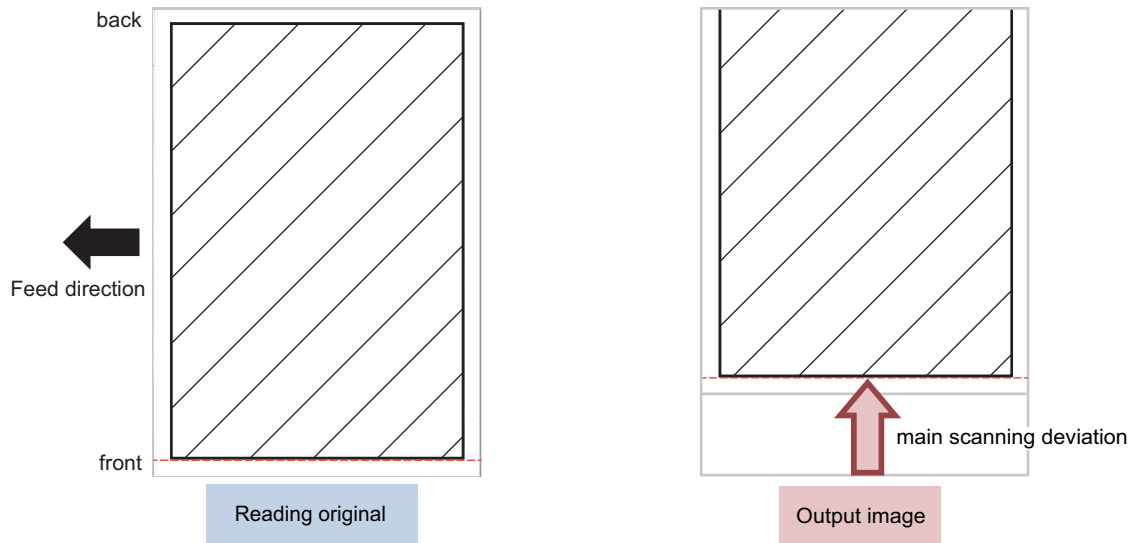
[Setting values]

0: Text document mode, 1: Photo document mode

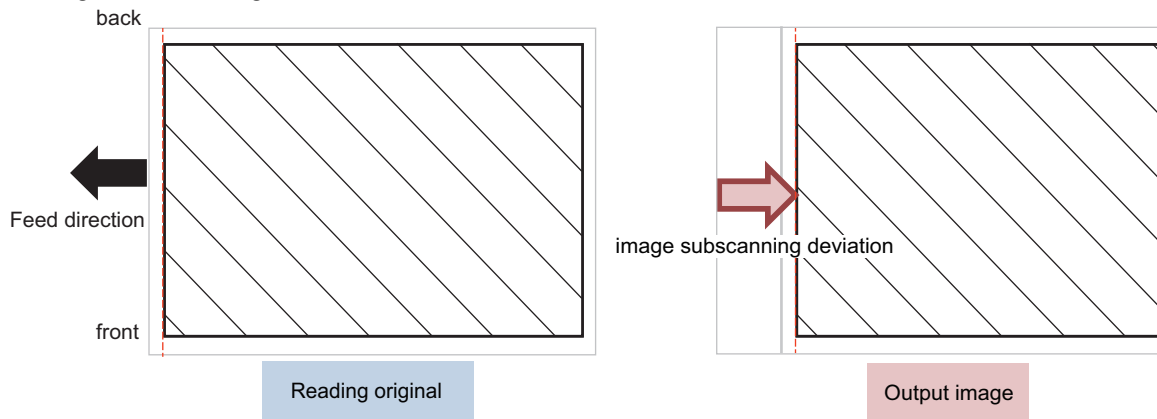
The output of the image is skewed or misaligned when scanned by ADF

This Machine does not Detection skew in Sensor, and corrects skew by Detection the shadow of Original from the scanned image. However, the height of ADF is uneven, the shadow of the Original and the Original appearing on the counter plate cannot be Detection as the edge of the Original, Reading images cannot be properly corrected.

■Image main scanning deviation



■Image subscanning deviation



[Location]

Single Pass ADF

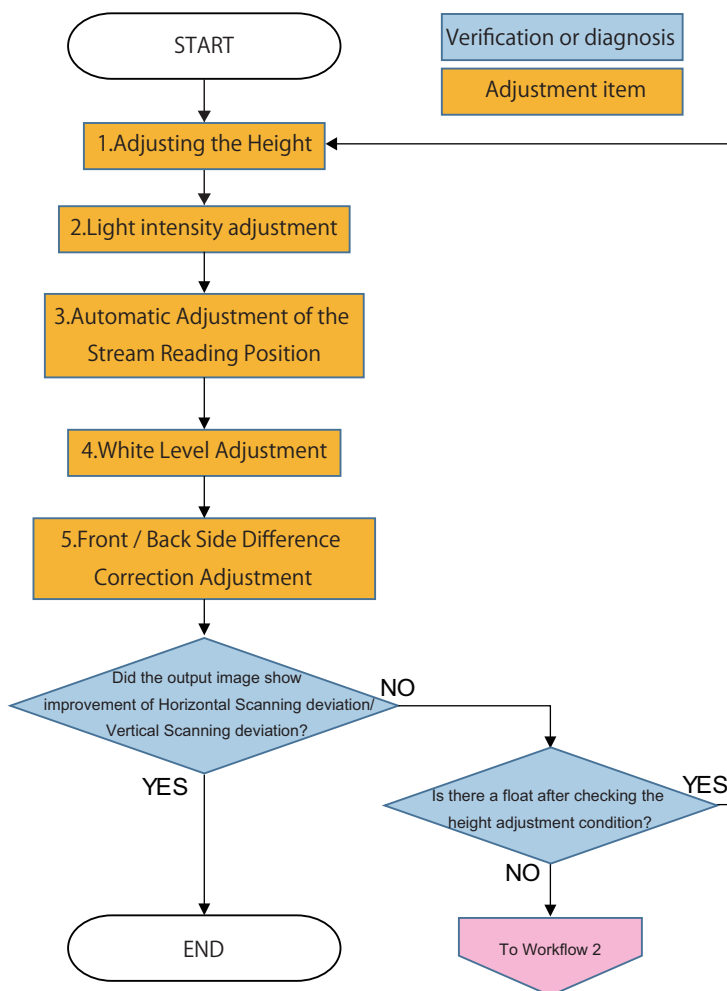
[Cause]

Due to the following reasons, the shadow of Original cannot be used as the Detection edge of Original, and the image of Reading suddenly becomes obliquely skewed or shifted toward Horizontal Scanning and Vertical Scanning.

- ADF Height Adjustment Not Appropriate
- Front side Scanner Unit feed Reading Location Not Appropriate

[Field Remedy]

Follow the flowchart below to make adjustments.



Adjustment items

1. "Adjusting the Height" on page 606
2. "Light intensity adjustment" on page 616
3. "Automatic Adjustment of the Stream Reading Position (Automatic Adjustment of the Reading Position at ADF Reading)" on page 617
4. "White Level Adjustment" on page 618
5. "Front/Back Side Difference Correction Adjustment" on page 619

See workflow 2 below

"Workflow2" on page 601

Feed Faults

Paper wrinkle

<Location>

Fixing Roller, Pressure Roller

<Cause>

Right after the startup, temperature is different between the center and the edge of the Fixing Roller (temperature: center > edge). Because a slippery solid black image does not match to the nip shape when it is fed, the center of paper is pulled toward the feeding direction, causing paper wrinkle.

<Condition>

Timing: Approx. 20 sheets immediately after the startup first time for the day

Paper size: Paper size larger than B4

<Field Remedy>

Normally, when printing to paper larger than A3 or LDR size paper at the start of printing in a high humidity environment, control temperature is increased by performing idle rotation.

Paper wrinkle which occurs at this time can be decreased, but first copy time becomes longer. In other cases, idle rotation is not performed.

If paper wrinkle occurs on paper larger than B4, increase the setting value from 2 in increments of 1 until paper wrinkle is alleviated.

If paper wrinkle occurs on B4 size paper, increase the setting value from 4 in increments of 1 until paper wrinkle is alleviated.

Change the value of the following service mode (LV. 2).

COPIER > OPTION > IMG-FIX > FX-WNKL

[Setting values]

0 to 6

0: OFF, 1: Normal, 2: Level 1, 3: Level 2, 4: Level 3, 5: Level 4, 6: Level 5

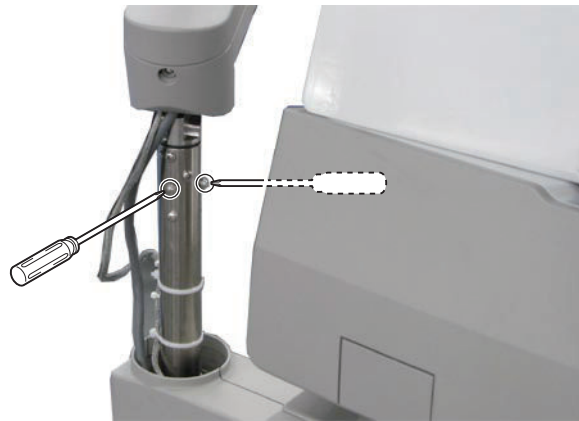
Other

Adjusting rotation of the Upright Control Panel Arm

If rotation of the Upright Control Panel Arm has become loose, retighten the Fixation Screws securing the Arm Rotation Adjustment Ring according to the following procedure.

<Procedure>

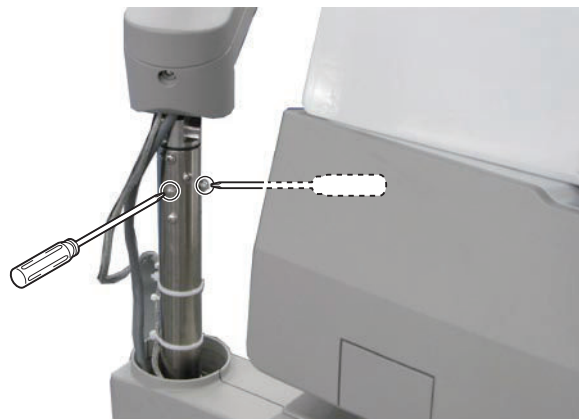
1. Remove the Shaft Support Cover (Left) and the Shaft Support Cover (Right).
2. Open the DADF and retighten the 2 Fixation Screws securing the Arm Rotation Adjustment Ring.



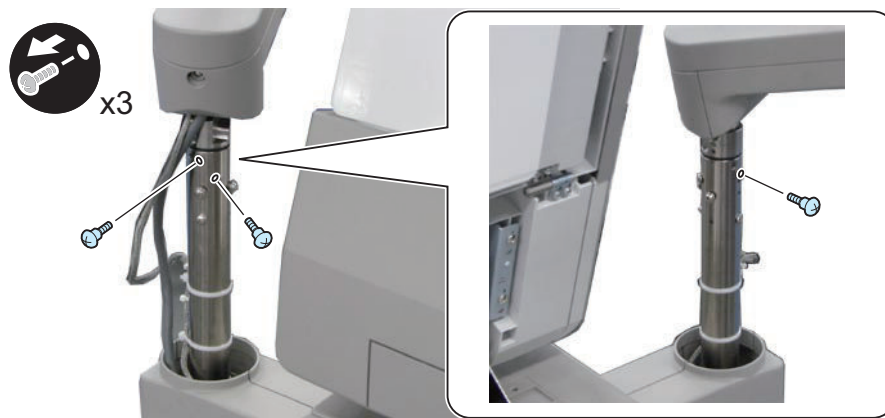
NOTE:

If rotation of the arm is still loose after retightening the Fixation Screws according to “Adjusting rotation of the Upright Control Panel Arm”, change the phase difference between the Arm Rotation Adjustment Ring and the Fixation Screws according to the following procedure.

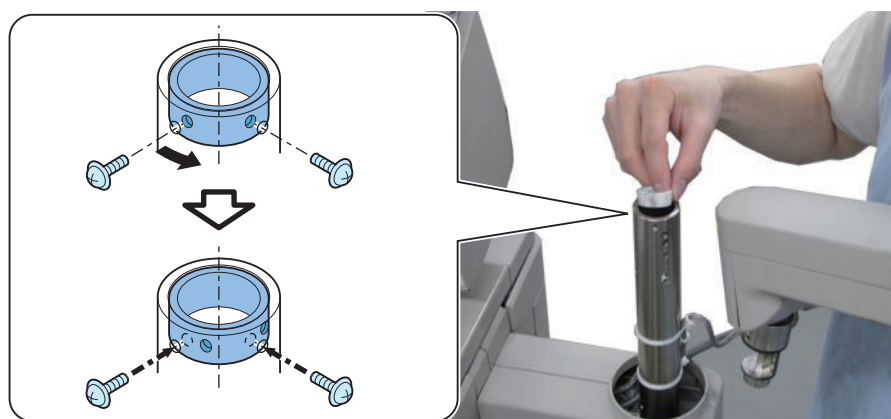
3. Open the DADF and loosen the 2 Fixation Screws securing the Arm Rotation Adjustment Ring.



4. Remove the 3 Stepped Screws securing the Arm Shaft.



5. Pull out the Upright Control Panel and the Arm Shaft, and rotate the Arm Rotation Adjustment Ring to change the phase so that the Fixation Screws do not contact with the dents formed by tightening the screws.



6. Insert the Upright Control Panel and the Arm Shaft, and retighten the 2 screws loosened in step 3.

7. Install the removed parts.

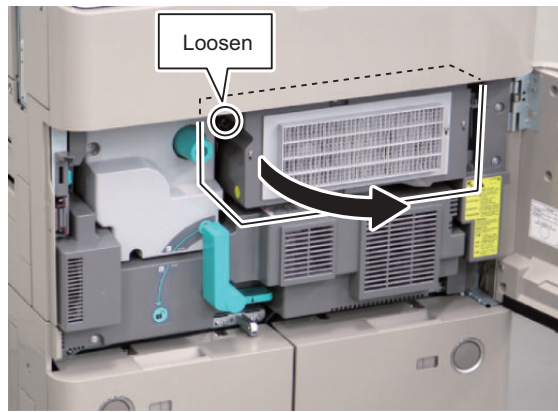
● Remedy to be implemented when the ETB Disengage Member (Transfer Frame Stopper) is left unremoved

When the power is turned ON after installation, E017-0003 may occur due to the ETB Disengage Member (Transfer Frame Stopper) left unremoved.

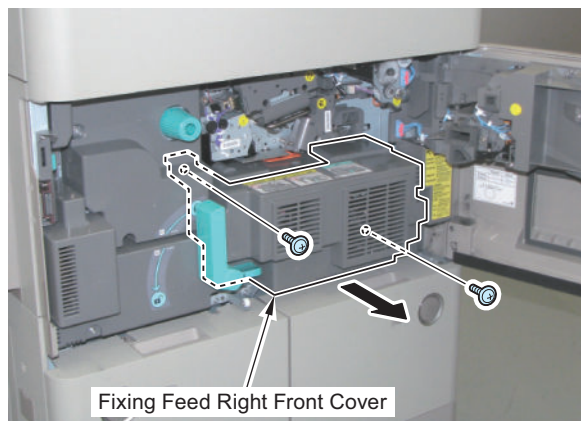
When this error occurs, the ETB Disengage Member (Transfer Frame Stopper) is caught between the ETB Unit and the plate of the machine and cannot be removed. Moreover, one side of the Photosensitive Drum is in contact with the ETB Unit, so pulling out the Fixing Feed Unit by sheer force may result in damage to the ETB Unit.

When the ETB Disengage Member (Transfer Frame Stopper) is left unremoved, follow the following steps to implement remedy.
<Field Remedy>

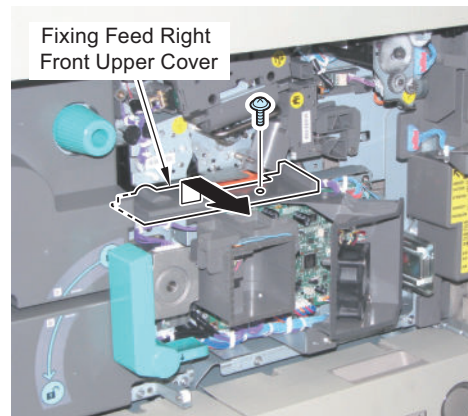
1. Turn OFF the power.

2. Open the Inner Cover.**3. Remove the Fixing Feed Right Front Cover.**

- 2 Screws

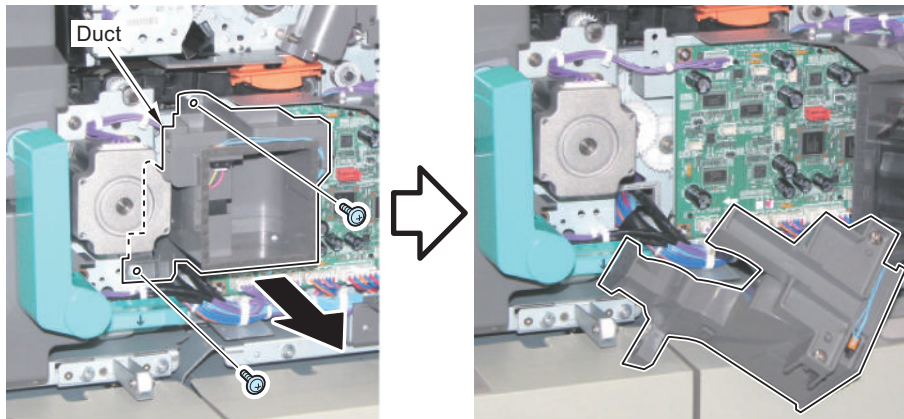
**4. Remove the Fixing Feed Right Front Upper Cover.**

- 1 Screw

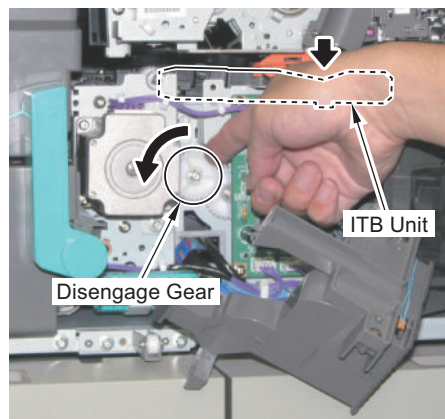
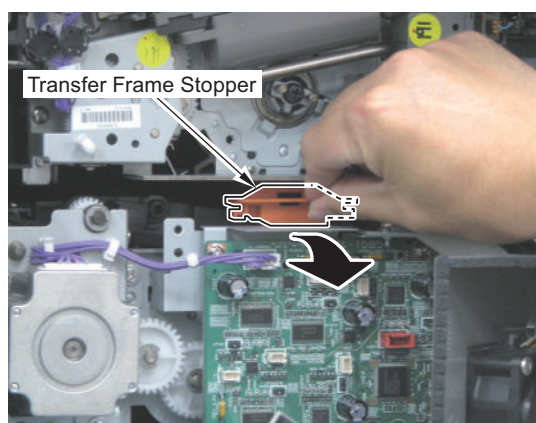


5. Remove the Fan Duct.

- 2 Screws

**6. Rotate the Disengage Gear about 90 degrees counterclockwise by hand and lower the ITB Unit.****CAUTION:**

The load of rotating the gear is heavy, so be careful not to get injured.

**7. Remove the Transfer Frame Stopper.**

Checking nip width

In the case of paper wrinkle or fixing failure, check that the fixing nip width is within the specified range. Note that the fixing nip width of this equipment cannot be adjusted in the field.

1. Print approx. 20 sheets of A4 size paper.
2. Set A4 size plain paper/recycled paper on the Multi-purpose Tray.

3. By executing the following service mode, paper is temporarily caught and stopped at the fixing nip, and then delivered after approx. 20 seconds.

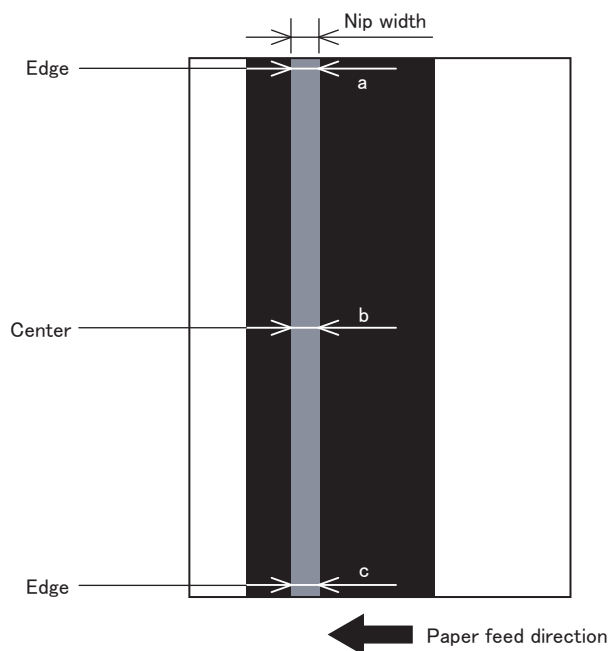
COPIER > FUNCTION > FIXING > NIP-CHK

4. Measure the nip width of delivered sheet.

If the nip widths are as follow it is judged as normal: 7.0 to 8.0 mm at the center (b), and difference between front (c) and rear (a) is within 0.5 mm.

In the case of failure, check if there are any damaged parts (*), and replace the damaged parts (if any).

* Gear, Bearing, Fixing Roller, Pressure Roller and Fixing Assembly



ETB Displacement

The ETB is configured to keep the center position in the unit. Therefore, position adjustment is not necessary at installation or after ETB replacement.

Even in the case of ETB displacement in the front or rear direction while the machine is running, there is no problem with the operation if it is within the appropriate range.

However, when the positional relationship between the Transfer Drum and the ETB Unit becomes displaced, the ETB may get damaged due to its full displacement.

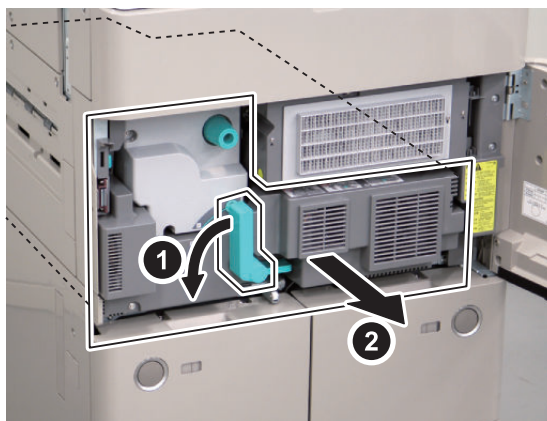
The following shows a method to check the appropriate range of the ETB position, and an adjustment method in case it is out of the range.

■ <Procedure for checking ETB full displacement>

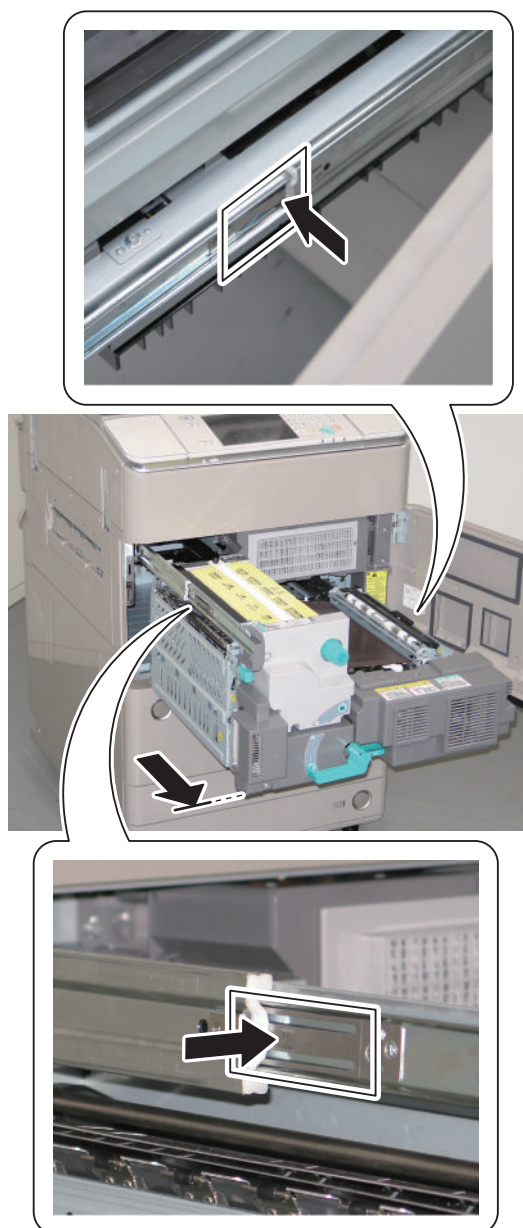
1. Pull out the Fixing Feed Unit.

1. Open the Front Cover.

- Turn the Fixing Feed Unit Pressure Release Lever in the direction of the arrow to pull out the Fixing Feed Unit.



- Push to release the Release Springs at both sides of the rail, and then further pull out the Fixing Feed Unit until it stops.

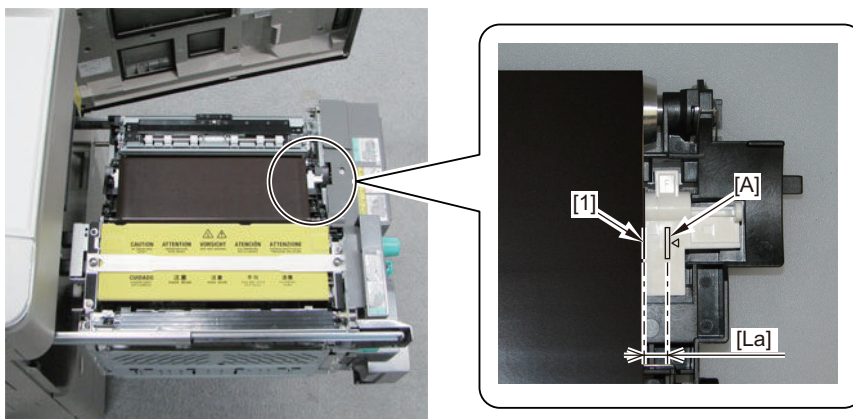
**CAUTION:**

Do not touch the surface of the ETB when handling the ETB Unit.

- Check whether the ETB is displaced toward the rear side or the front side of the host machine as follows.

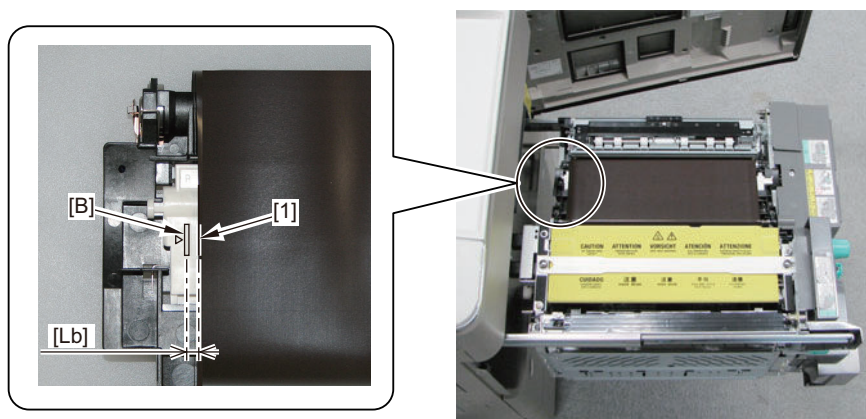
3. Checking the displacement toward the rear side of the machine

- Be sure to perform the following <Adjustment procedure> when there is a distance [La] of 8 mm or more between the mark [A] (the line) on the Transfer Roller Holder (Front) at the front side and the ETB edge [1]



4. Checking the displacement toward the front side of the machine

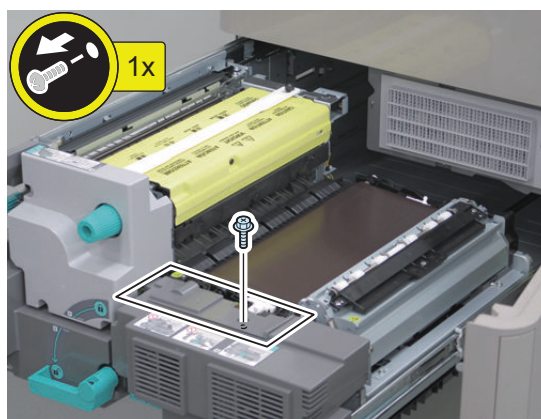
- Be sure to perform the following <Adjustment procedure> when there is a distance [Lb] of 8 mm or more between the mark [B] (the line) on the Transfer Roller Holder (Rear) at the rear side and the ETB edge [1]



■ <Adjustment procedure>

1. Remove the Fixing Feed Right Front Upper Cover.

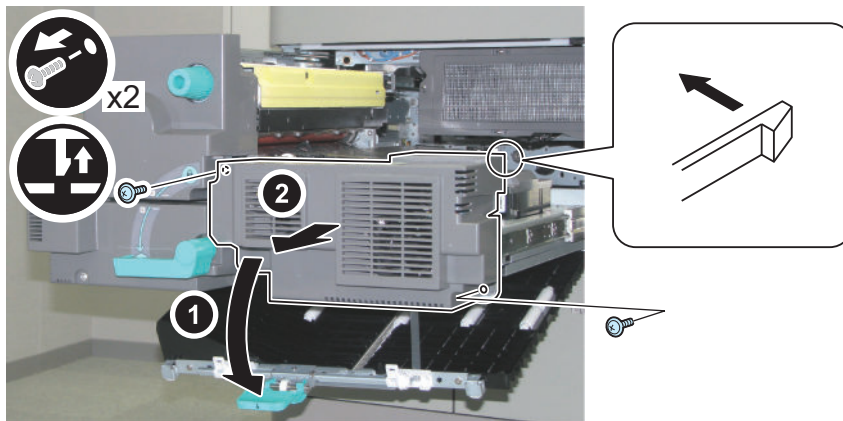
- 1 Screw



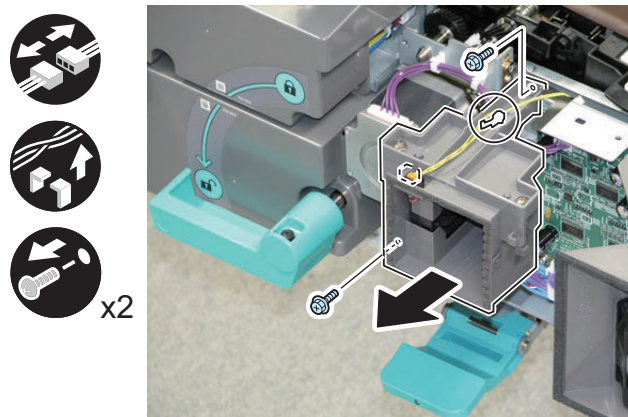
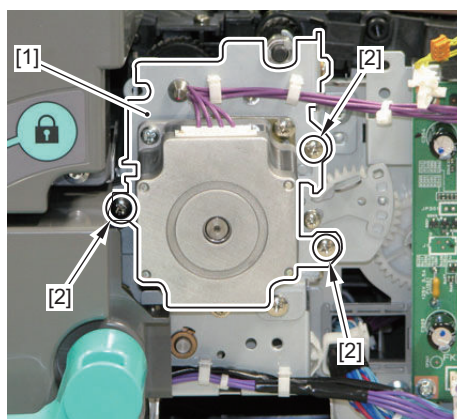
2. Open the Duplex Path.

3. Remove the Fixing Feed Cover 1.

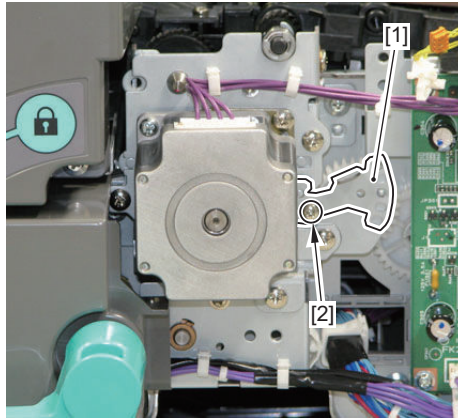
- 2 Screws
- 1 Claw

**4. Remove the duct.**

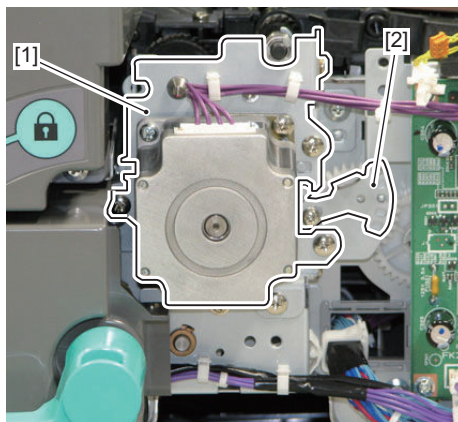
- 1 Connector
- 1 Reuse Band
- 2 Screws

**5. Loosen the 3 screws [2] of the ETB Drive Unit [1].**

6. Loosen the screw [2] of the Adjustment Cam [1].



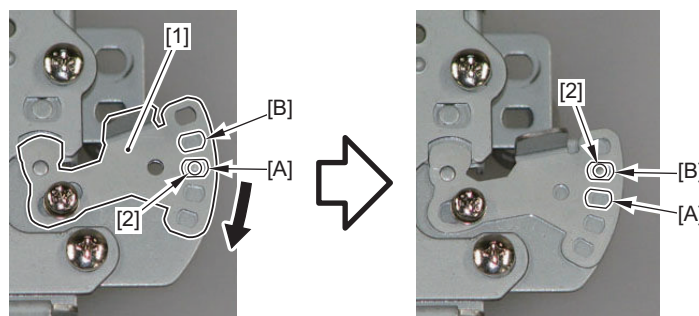
7. Adjust the ETB Drive Unit [1] and the Adjustment Cam [2] as follows according to the displacement direction of the ETB.



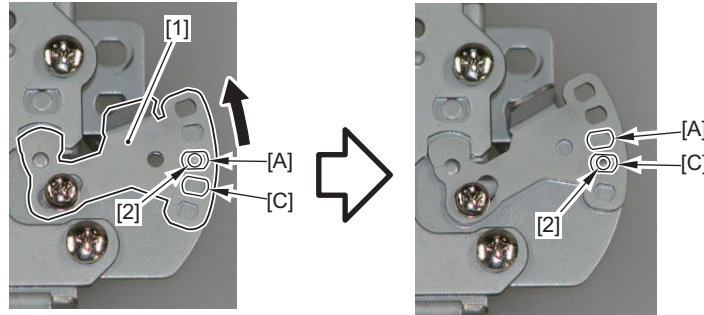
NOTE:

- Be sure to perform adjustment by referring to step 8 of <Procedure for checking ETB full displacement> when the ETB is displaced toward the front side, and to step 9 of the same procedure when the ETB is displaced toward the rear side.
- The holes at the top and the bottom of the Adjustment Cam are not used.

8. When the ETB is displaced toward the front side, release the hole [A] of the Adjustment Cam [1] from the boss [2] of the ETB Drive Support Plate B, and fit the hole [B] to the boss [2] of the ETB Drive Support Plate B.

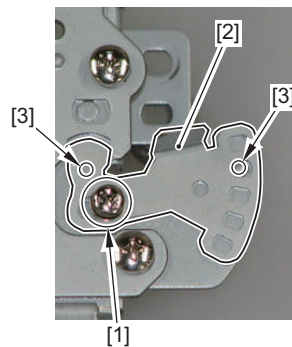


9. When the ETB is displaced toward the front side, release the hole [A] of the Adjustment Cam [1] from the boss [2] of the ETB Drive Support Plate B, and fit the hole [B] to the boss [2] of the ETB Drive Support Plate B.



10. Fully tighten the loosened screw [1] to secure the Adjustment Cam [2] (The figure shows the case when the ETB is displaced toward the front side).

- 2 Bosses [3]

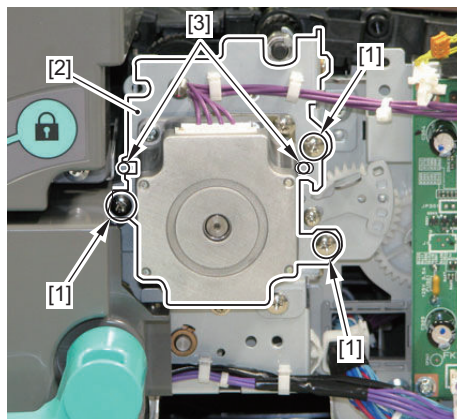


CAUTION:

Be sure to secure the Adjustment Cam [2] such that it will not be placed on top of the 2 bosses [3].

11. Fully tighten the 3 loosened screws [1] to secure the ETB Drive Support Plate A [2].

- 2 Bosses [3]



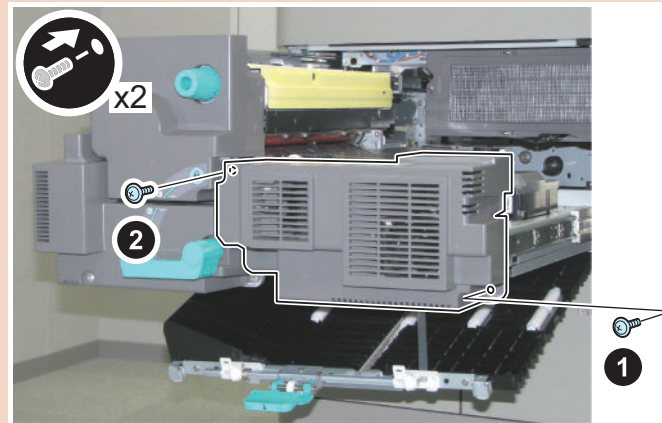
CAUTION:

Be sure to secure the ETB Drive Support Plate A [2] such that it will not be placed on top of the 2 bosses [3].

12. Reassemble the host machine back together in reverse order of the removal procedure.

CAUTION:

When installing the Fixing Feed Cover 1, be sure to follow the order as shown in the figure to tighten screws.



■ <Checking the improvement of ETB full displacement>

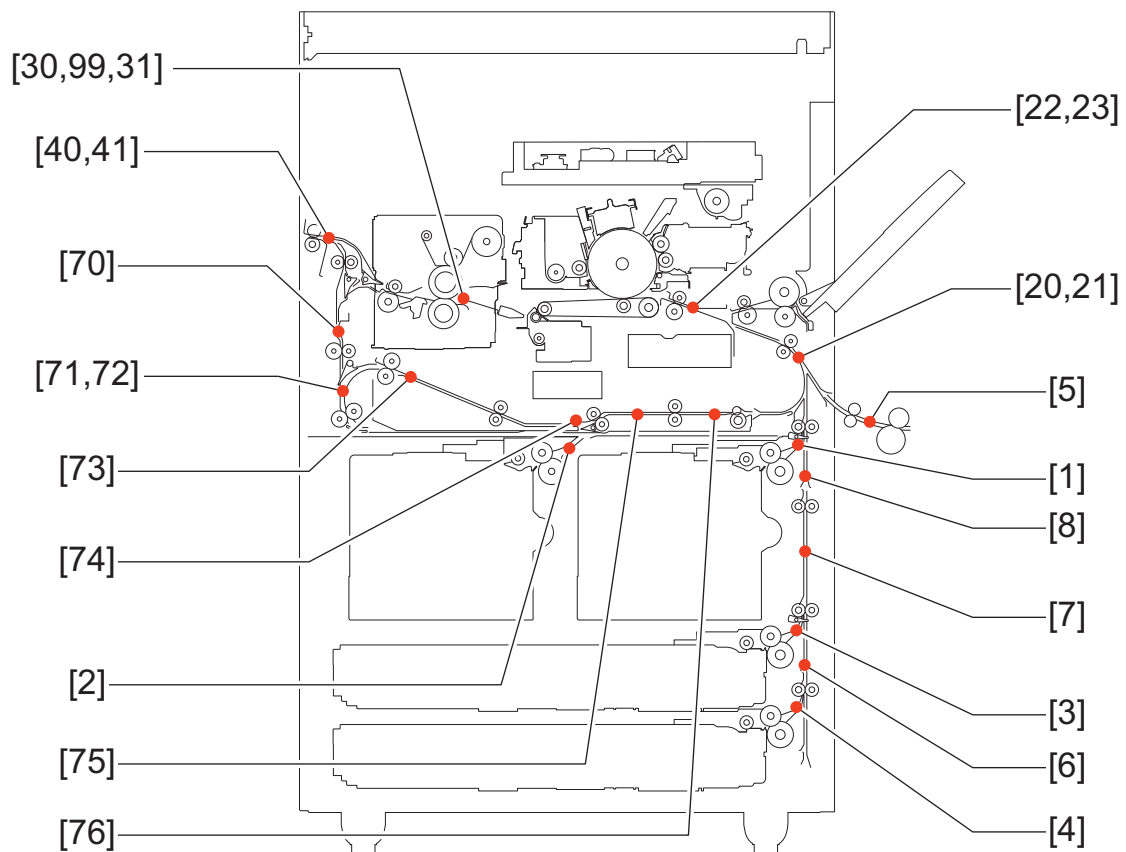
1. Perform double-sided feeding of the total of 200 sheets of A4 or letter size paper.
2. After feeding, perform <Procedure for checking ETB full displacement> to check that the ETB is no longer fully displaced

● Forcible stop of paper feed

Function Overview

Forcibly stop the paper at a specified position.

Next time a job occurs, the paper is forcibly stopped at the stop position (leading edge) shown in the figure.



Area	Stop position ID	Stop position	Area	Stop position ID	Stop position
Pickup to Vertical Path	1	Outlet of the Right Deck Pickup Assembly	Pre-/Post-fixing	30	Inlet of the Fixing Assembly
	2	Outlet of the Left Deck Pickup Assembly		31	Inlet of the Fixing Assembly (2nd side)
	3	Outlet of the Cassette 3 Pickup Assembly	Delivery	40	Delivery outlet
	4	Outlet of the Cassette 4 Pickup Assembly		41	Delivery outlet (2nd side)
	5	Outlet of the Pickup Option Deck	Reverse, Duplex standby	70	Inlet of the Reverse Assembly
	6	Vertical Path Assembly (Lower)		71	Duplex reverse point (before reverse)
	7	Vertical Path Assembly (Middle)		72	Duplex reverse point (at reverse)
	8	Vertical Path Assembly (Upper)		73	Inlet of the Duplex Feed Unit
	20	Outlet of the Vertical Path Assembly		74	Duplex Feed Unit (before merging)
	21	Outlet of the Vertical Path Assembly (2nd side)		75	Duplex Feed Unit (after merging)
Pre-registration	22	Inlet of the Registration Assembly	76	Outlet of the Duplex Feed Unit	
	23	Inlet of the Registration Assembly (2nd side)	Pre-/Post-fixing	99	Inlet of the Fixing Assembly (1st side, when checking image) *

*: If image and paper is A3/LDR size, not only paper but also image on the Photosensitive Drum can be checked.

Use case

- When bent paper/skew/wrinkles occur
- When jam occurs frequently

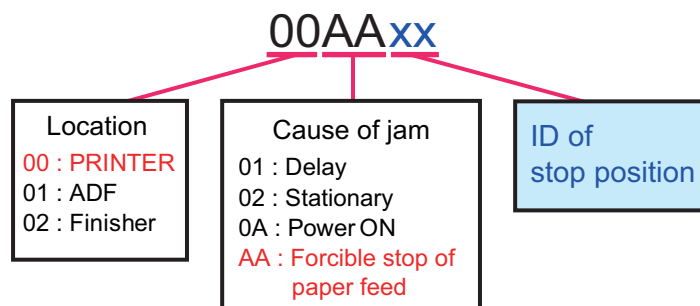
Points to note when using

- Remove the paper being stopped with the normal jam removal procedure. After jam removal, the job is automatically recovered.

- Display of standard jam code indicates that a jam occurs somewhere other than the specified position. Setting of forcible stop is enabled until paper stops at the specified position.
- the Setting is disabled for job where paper does not pass through the specified position.
- Unfixed toner may be adhered on paper depending on the stop position. Thus, handle it with care.

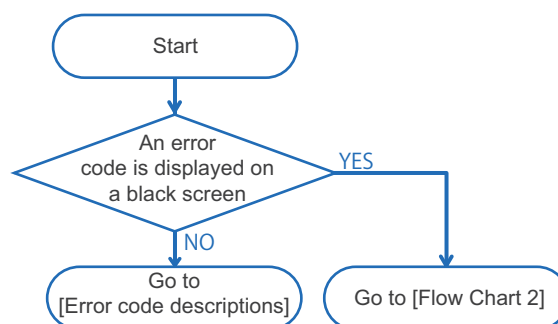
How to use

1. Set the stop position ID in the following service mode.
COPIER > TEST > P-STOP > PRINTER
2. Execute a job (copy or test print).
3. Paper stops at the designated position, and a jam code "00AAxx" is displayed.

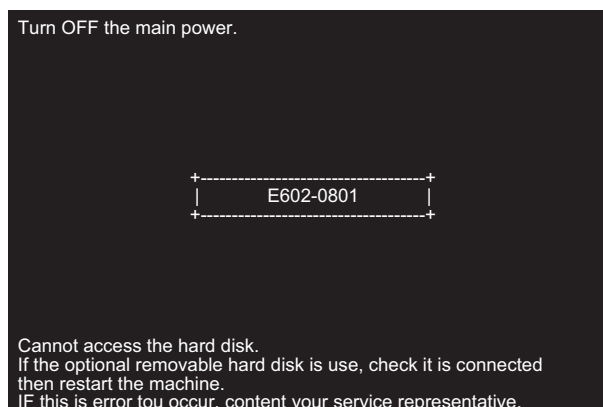


Remedies to be performed when E602-xxxx or E614-xxxx error is displayed

Remedy procedure for E602 or E614 differs according to the status of the screen where error is displayed. Check the remedy procedure by referring to the following flow chart.



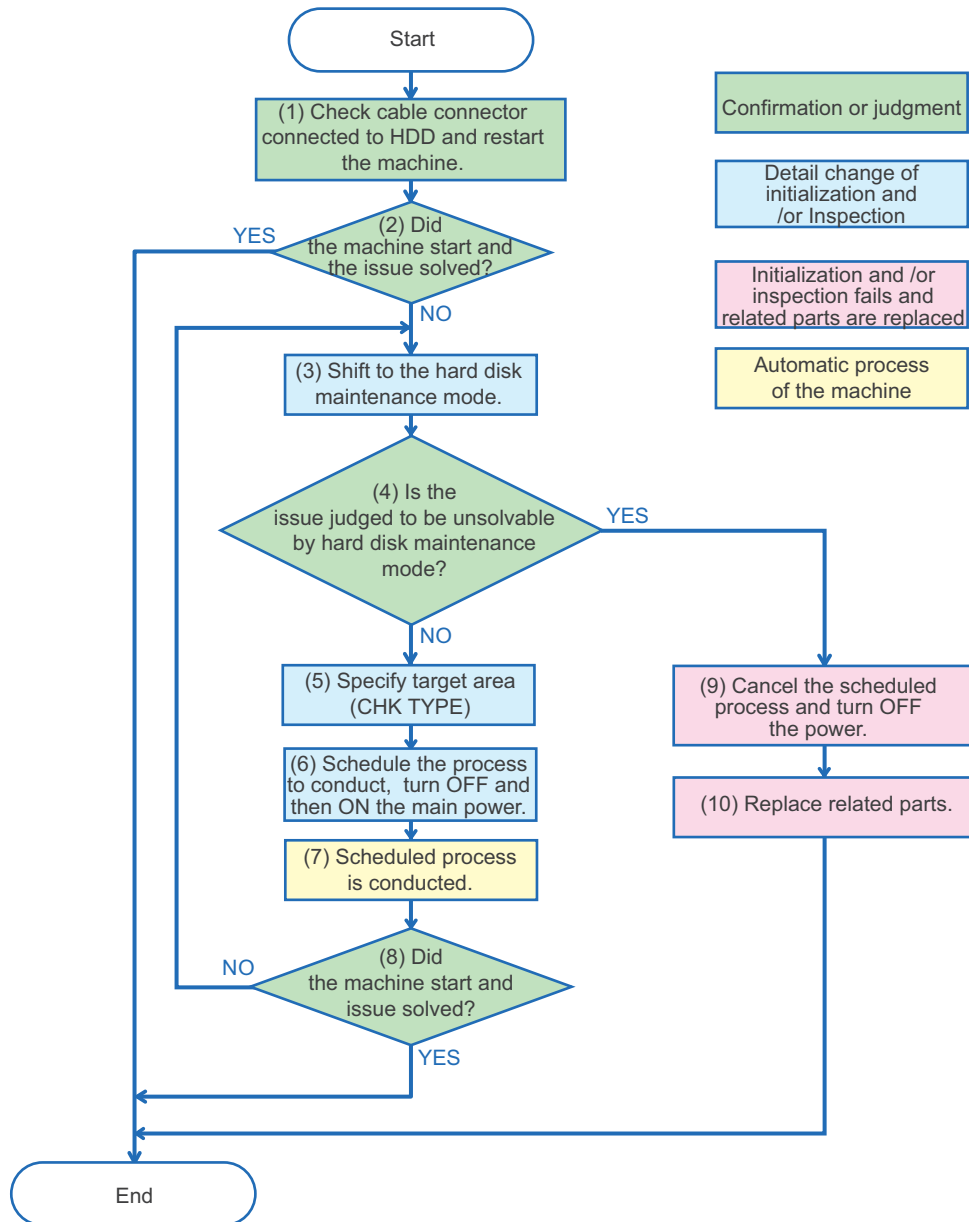
Flow Chart 1



Display Sample : If an error code is displayed on a black screen

Execute a remedy described in service mode by referring to [Error / Jam / Alarm](#) in the Service Manual.

If an error code and a message is displayed on a black screen (as above), shift to the hard disk maintenance mode referring to the Flow Chart 2 and execute the remedy described in [Error / Jam / Alarm](#) in the Service Manual.



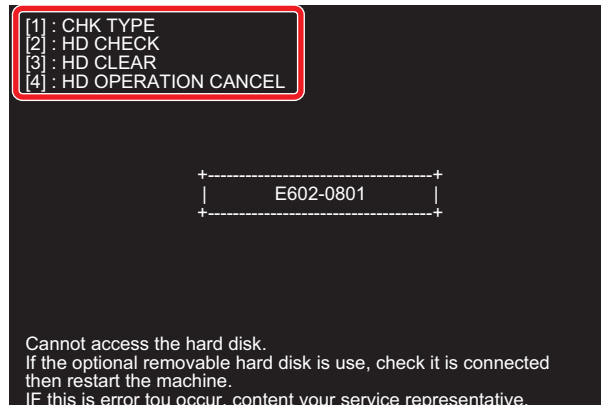
Flow Chart 2

CAUTION:

Numbers in the Flow Chart 2 are corresponding to the procedure numbers. Check the remedy procedure by referring to the flow chart.

1. Check cable connector connected to the hard disk and restart the machine.
2. Check if the machine is started normally. If the machine is started normally, the analysis is complete.

3. If the machine is not started normally, execute key operation to shift to the service mode for shifting to hard disk maintenance mode.

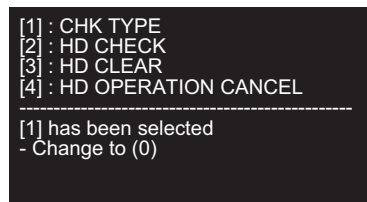


Example of hard disk maintenance mode screen

4. Determine if the issue is solved in the hard disk maintenance mode.

- Proceed to 5 for diagnosis for the first time or trying to restore with the hard disk maintenance mode.
- If the issue cannot be solved by hard disk maintenance (HD-CHECK/HD-CLEAR is not executed or issue unsolved even executed), proceed to 9.

5. Press "1" of Numeric Keypad, then two digits number to specify the target area (CHK TYPE).



CAUTION:

The CHK - TYPE to be specified needs to be entered in two digits even the number to be specified is one digit. Enter "01" to specify "1" and enter "04" to specify "4".

For example, in the case of the display (E602-0801), specify No. 8 because Partition No. 8 is in error. (Enter the number as "08")

If you made a mistake, press "1" again then enter two digits number.

6. Specify and schedule the process stated as a remedy for error code by referring to the Flow chart No.6, "Error / Jam / Alarm" in the Service Manual. Then turn OFF and then ON the main power of the machine.

- To schedule disk check (COPIER > FUNCTION > SYSTEM >HD-CHECK), select [2]:HD-CHECK.
- To schedule formatting (COPIER / FUNCTION / SYSTEM /HD-CLEAR), select [3]:HD CLEAR.

NOTE:

When the menu [2] to [4] is selected, key cannot be re-entered. If you made a wrong selection, Turn OFF and then ON the main power of the machine, shift to hard disk maintenance mode and specify again.

7. Scheduled process is automatically executed.

8. If the process is complete and the machine is restarted normally, analysis is complete.

The same black screen and the error code is displayed, shift back to the hard disk maintenance mode and conduct other maintenance.

9. Consider the HDD cannot be restored, select [4] and cancel the schedule. Switch OFF the main power of the machine.

```
[1] : CHK TYPE  
[2] : HD CHECK  
[3] : HD CLEAR  
[4] : HD OPERATION CANCEL
```

```
-----  
[4] has been selected  
Turn OFF the main power.
```

CAUTION:

Replacing HDD without canceling the schedule causes the scheduled process is executed to replaced HDD at the next normal startup.

When replacing parts, specify [4] to cancel the schedule.

10. Refer to the Service Manual to replace the related parts.

NOTE:

Related parts for E602

- Harness between main controller PCB and the HDD
- HDD
- Main Controller PCB

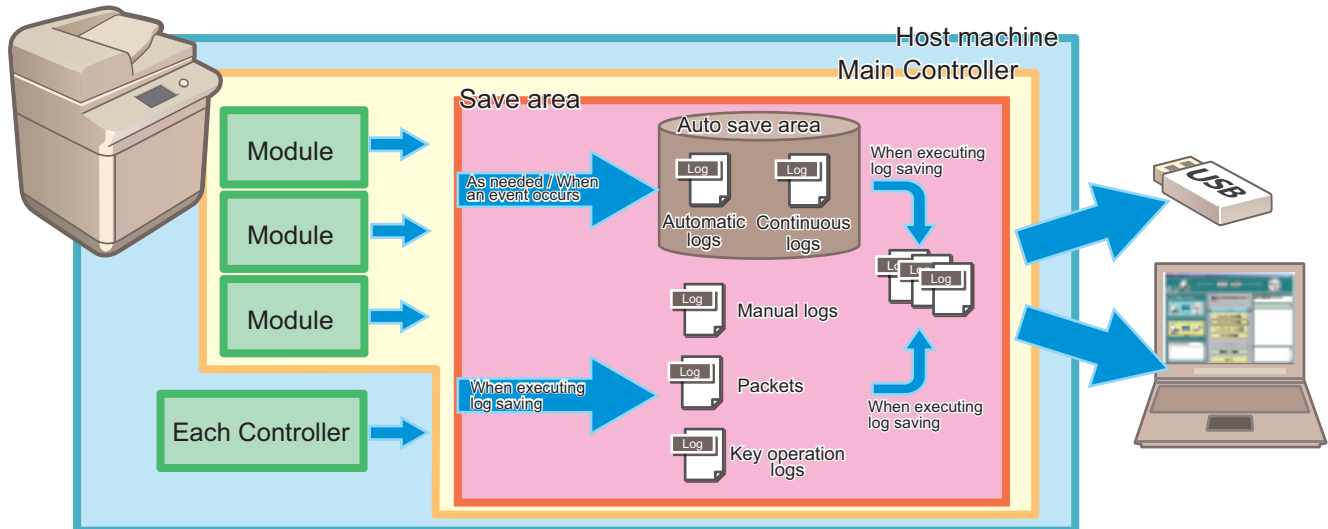
Related parts for E614

- Flash PCB
- Main Controller PCB

Debug Log

Function Overview

As for debug log, following logs are available: continuous log that saves the operation log, automatic log that is saved when an event occurs, manual log which is collected and saved each time at log saving, packet log, and key operation log.



NOTE:

Debug logs are used for analysis of program operations of the machine and identification of the problem by the developer.

This machine has a function for compiling operation history of each software module as debug logs and outputting them as unified logs for analyzing problems.

Since the frequency of outputting debug logs and the type of logs can be changed by the settings, the settings need to be changed according to the trouble that occurs and the situation.

Types of Debug Logs

Types of Debug Logs	Description
Sublogs	<p>Manual logs Logs collected in each module and controller are archived and can be collected when log saving is executed. Logs of the Main Controller, RCON, and DCON are saved together with automatic logs as up to 10 logs in total.</p> <p>Automatic logs Logs that are automatically saved to the machine when an event (exceptional behavior, error code, or reboot) occurs. Logs of the Main Controller, RCON, and DCON are saved together with manual logs as up to 10 logs in total.</p> <p>Continuous logs Logs that are continuously saved while the machine is running. Up to 100 logs of only the Main Controller can be stored.</p>
Key operation logs	History of key operations. Log collection starts by enabling the setting and starting the function. Logs that are archived and can be collected when log saving is executed.
Network packet logs	Logs of network packet data sent from or received by the host machine. Log collection starts by enabling the setting and starting the function. Logs that are archived and can be collected when log saving is executed.

Storage location and types of Sublogs

The locations where Sublogs are stored and the types of logs are shown below. Logs may be stored in controllers and parts other than those shown below.

Type	Automatic logs	Manual logs	Continuous logs
Main Controller	Yes (more detailed than continuous logs)	Yes (more detailed than continuous logs)	Yes
DCON	Yes	Yes	No
RCON	Yes	Yes	No

Cases Where Debug Logs Need to Be Collected

- When the result of identification of the cause shows that the trouble was caused by host machine (firmware, hardware-related controller)
- When the failure occurs only at the customer's site and cannot be reproduced by the department in charge of quality management or Canon Inc.

■ Sublogs

Sublog is the general term for the unified logs for analyzing problem in which operation histories of software modules are compiled as debug logs.

When a problem relating to the host machine occurs in the field and it is difficult to identify the cause of it at the user site, collecting Sublogs and sending them to Design Dept./R&D can improve the efficiency of analyzing the problem and reduce the time it takes to deal with the problem.

CAUTION:

- Sublogs are basically stored in volatile memory. Therefore, almost all information will be erased by turning OFF and ON the power before saving the log data. When obtaining the log data, make sure to implement the operation to save the log data (manually saving log) before turning OFF and ON the power.
- In order to prevent failure of collecting necessary information because the log is overwritten with the succeeding process, be sure to collect the Sublog while the symptom has occurred or immediately after the occurrence.
- Once the Sublog files are collected, they are deleted from the machine. In the case of collecting Sublogs consecutively, the number of continuous log files may be fewer than usual.

■ Key operation logs

This function collects the history of key operations in order to distinguish between a failure of the Main machine and an operation error of the user in the case of trouble of erroneous fax transmission.

If it cannot be denied the possibility that the user operation caused the error, collect the key operation logs.

The key operation log are stored/recovered in a form included in the Sublog files.

The following confidential information in the stored key operation log is masked.

- Personal identification number, PIN code, password, etc., to be entered
- Information that is hidden by turned letters on the UI screen

CAUTION:

To obtain permission from a user in advance for recording key operations for failure analysis.

■ Network packet logs

This function collects the transmitted and received network packet data as a debug log in the storage (capture).

When it is expected that the trouble was caused by network, collect network packet logs.

NOTE:

To use this function, you need to register a license, so you need to ask the Support Dept. of the sales company to issue a license.

CAUTION:

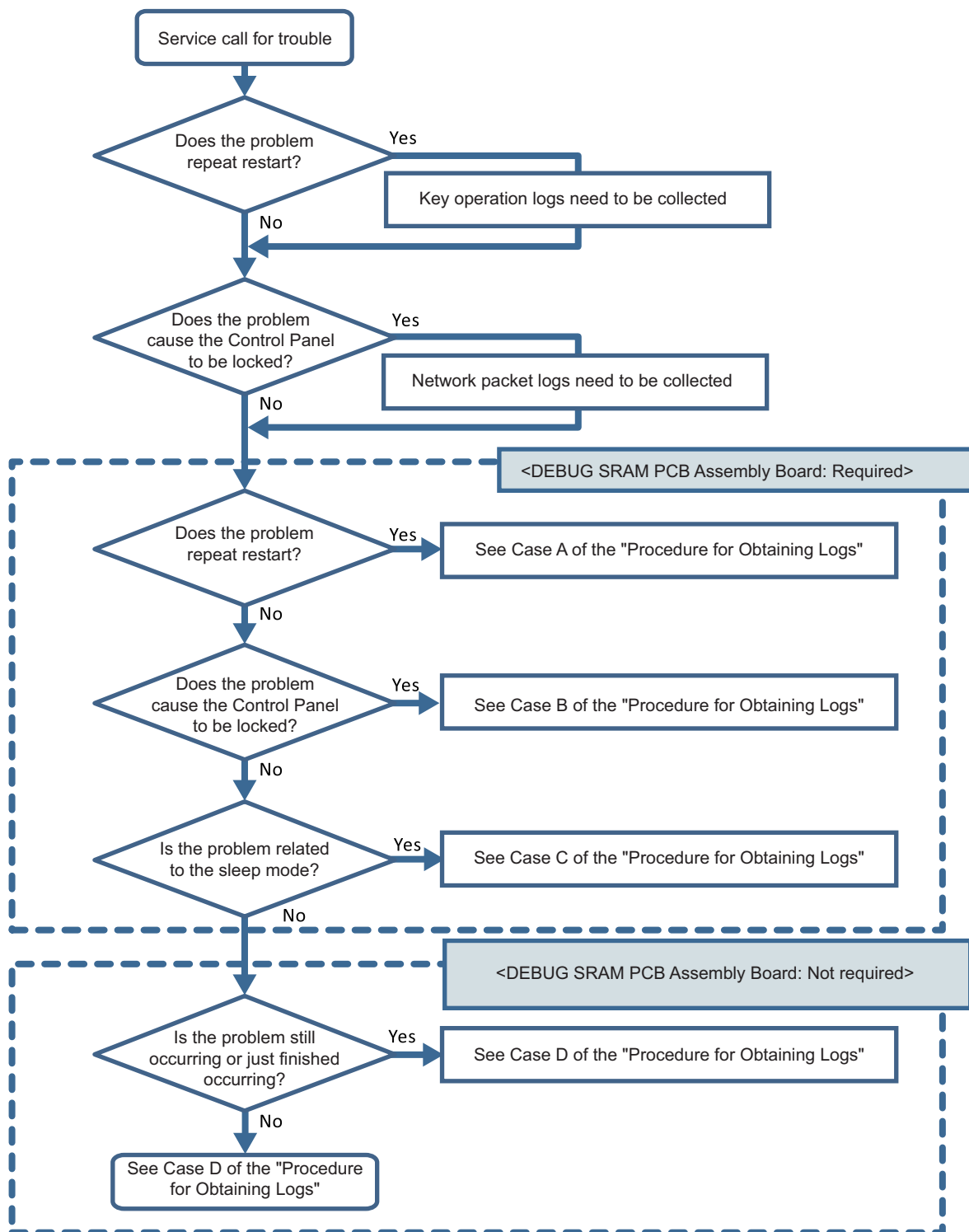
When obtaining the network packet log, explain to the user and obtain permission before proceeding.

CAUTION:

Under heavy network load environment, packets can be dropped.

■ Flow of Determining the Procedure for Collecting Logs

Check the following flow to determine the procedure for collecting logs according to the type of problem.



When the user's operation such as wrong fax transmission may be the cause of the problem, enable [Store Key Operation Log].

Procedure for Collecting Logs

Log Collection Procedure List

Problem Case	Details of Problem	DEBUG SRAM PCB Assembly Board	Procedure for Obtaining Logs
Case A	Problem that repeats re-start	Necessary	<ol style="list-style-type: none"> 1. Refer to “Preparation” on page 718 and make the preparations such as installing the DEBUG SRAM PCB Assembly Board or change the settings. 2. Execute log saving by referring to “Saving of Manual Logs, Network Packet Logs and Key Operation Logs” on page 721 immediately after restart. 3. Save and collect reports by referring to “Saving and Collecting Report Files” on page 723. 4. Collect debug logs by referring to “Collection of Log” on page 723.
Case B	Problem causing the Control Panel to be locked	Necessary	<ol style="list-style-type: none"> 1. Refer to “Preparation” on page 718 and make the preparations such as installing the DEBUG SRAM PCB Assembly Board or change the settings. 2. Turn OFF and then ON the power immediately after the Control Panel is locked. 3. Execute log saving by referring to “Saving of Manual Logs, Network Packet Logs and Key Operation Logs” on page 721 after startup. 4. Save and collect reports by referring to “Saving and Collecting Report Files” on page 723. 5. Collect debug logs by referring to “Collection of Log” on page 723.
Case C	Problem related to the sleep mode	Necessary	<ol style="list-style-type: none"> 1. Refer to “Preparation” on page 718 and make the preparations such as installing the DEBUG SRAM PCB Assembly Board or change the settings. 2. After the problem occurs, turn OFF and then ON the power if necessary, and execute log saving by referring to “Saving of Manual Logs, Network Packet Logs and Key Operation Logs” on page 721. 3. Save and collect reports by referring to “Saving and Collecting Report Files” on page 723. 4. Collect debug logs by referring to “Collection of Log” on page 723.
Case D	Problem when executing a job (Example: Printing is not performed, etc.)	Not necessary	<ol style="list-style-type: none"> 1. Execute log saving while the problem is occurring by referring to “Saving of Manual Logs, Network Packet Logs and Key Operation Logs” on page 721. 2. Execute log saving by referring to “Saving of Manual Logs, Network Packet Logs and Key Operation Logs” on page 721. 3. [xref to:GUID-4F090A35-9880-4821-8CFC-9561684129B1] Collect debug logs by referring to “Collection of Log” on page 723.
	When an E code error has occurred	Not necessary	Execute log saving by referring to “Saving of Manual Logs, Network Packet Logs and Key Operation Logs” on page 721 . However, if the background of the Control Panel is blank and an error code is displayed in text, logs cannot be obtained.
Case E	Problems other than above	Not necessary	Execute log saving by referring to “Saving of Manual Logs, Network Packet Logs and Key Operation Logs” on page 721 . Check with the user on the date and time when the problem occurred and the procedure.

Saving and Collecting Debug Logs

■ Tools Required

The following tools are necessary to save/collect debug logs of the machine.

Exporting to a USB Device

- USB device

When exporting debug logs to a USB device, use a USB device in which the system software for the machine is registered using SST.

Since the size and number of log files to collect varies according to the device status and the logs that have been saved, the size of the collected files may be several hundred MB. Therefore, it is recommended to use a USB device with 1 GB or more of free space.

The USB device must be formatted with the FAT file system.

CAUTION:

Be sure to check that the USB device has 1 GB or more of free space before collecting a log.

If capacity of the USB device is insufficient, logs that failed to be saved will be deleted so that analysis of the symptom cannot be performed.

Exporting to a PC

- PC with SST installed
- Network connection cable

When exporting debug logs to a PC, a PC with SST installed and a network connection cable are required.

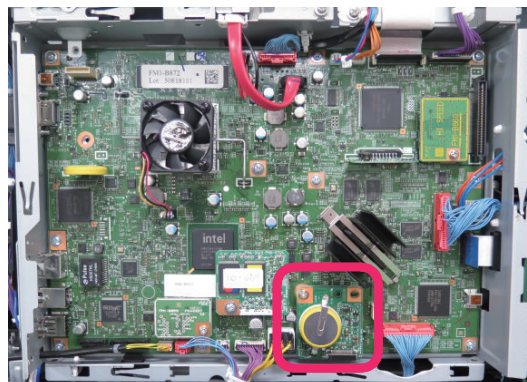
Common (When Exporting to a USB Device, or When Exporting to a PC)

- DEBUG SRAM PCB Assembly Board

In the following conditions, debug logs cannot be saved, therefore the DEBUG SRAM PCB Assembly Board is required.

- When restart is repeated
- When all the operations of the device are frozen and manual logs cannot be collected.
- When the machine would not recover from sleep mode

Refer to the following regarding installation on to the Controller PCB.



Reference example of installation

■ Work Flow

The flow of saving/collecting Sublogs is shown below.

1. Preparation

Refer to “[Flow of Determining the Procedure for Collecting Logs](#)” on page 715, and make the preparation as needed according to a situation where an event has occurred.

2. Reproduction of the symptom

Reproduce the symptom.

3. Saving Manual Logs

Save manual logs that require manual operation.

4. Output of reports

Output reports necessary for escalation.

5. Collecting log files

Start the machine in download mode, and save (collect) the log files to a USB device or a PC.

CAUTION:

In the case of analysis using Sublog, the following information needs to be obtained together with the Sublog.

- Symptom that has occurred (from service technician's viewpoint as far as possible)
- Date and time of the event (from an hour before the event to an hour after the event)
- Reports (P-Print, HIST-PRT, job logs, communication management report, etc.)
- Printed data and original at the time of reproduction (depends on the trouble that has occurred)

Besides Sublog, the above-mentioned information is required due to the following reasons:

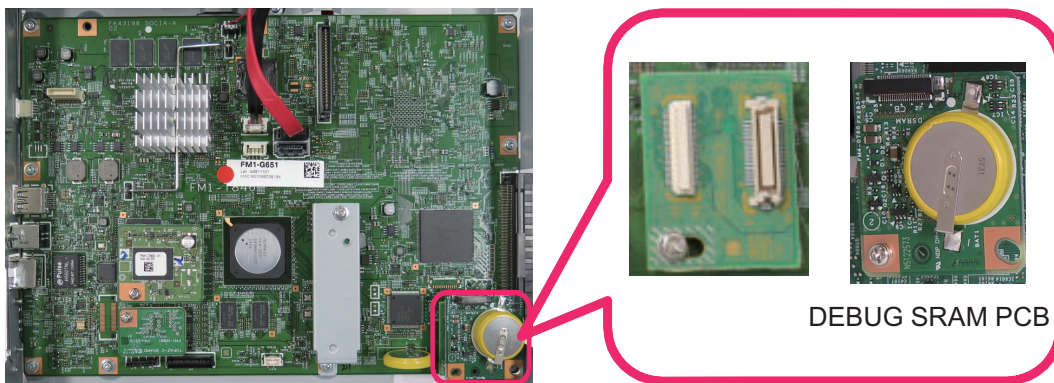
- Failures such as a process being stopped due to an error or an unintended behavior are easy to find, but failures such as "the behavior is slow" are difficult to analyze based on operation logs only.
- Since the number and size of the files are huge, the information helps to find the operation log where the problem occurred.
- When R&D reproduces the failure, it is necessary to use information such as the procedure used by the customer, frequency of use, and job data at the time of occurrence of the failure.

6. Remove the board installed in step 1 and return the settings back to the original values.

■ Preparation

Follow the procedure shown below to make preparations for collecting debug logs.

1. Refer to **“Flow of Determining the Procedure for Collecting Logs” on page 715** and when it is judged that **DEBUG SRAM PCB Assembly Board** is required, install the board.



2. Refer to **“Flow of Determining the Procedure for Collecting Logs” on page 715** and when it is judged that collection of the key operation logs is required, enable **[Store Key Operation Log]** by following the procedure shown below.
 1. Select [Settings/Registration] > [Management Settings] > [Device Management] > [Store Key Operation Log].
 2. Select [ON] and press [OK] to start saving key operation logs.

CAUTION:

When collecting the key operation logs, be sure to obtain user's permission in advance.

3. Refer to **“Flow of Determining the Procedure for Collecting Logs”** on page 715 and when it is judged that collection of the network packet logs is required, enable the network packet log collection function by following the procedure shown below and start the function.

1. Enter a license in the following menu to enable network packet capture.
[Settings/Registration] > [Management Settings] > [License/Other] > [Register License]

NOTE:

Use the license issued by the Support Dept. of the sales company to activate it.

2. Enable the setting (ON) in the following menu.
[Settings/Registration] > [Preferences] > [Network] > [Store Network Packet Log]
3. Set "1" in the following service mode (Lv.2).
Service mode > COPIER > TEST > NET-CAP > CAPOFFON
4. Refer to **“Initial setting of the network packet log collection function”** on page 720, and configure the required option settings.
5. Set "0" or "1" in the following service mode (Lv.2) to start capture of network packets.
Service mode > COPIER > TEST > NET-CAP > STT-STP
 - 0: Not automatically collect at startup (factory default setting)
 - 1: Automatically collects at startup
6. Execute the following service mode (Lv.2) to check the status of the capture.
Service mode > COPIER > TEST > NET-CAP > CAPSTATE
The following types of status are displayed.
 - RUNNING: Packets are being captured.
 - STOP: Packet capturing is stopped.
 - HDDFULL: The maximum amount of 1 GB of packets has been captured.

4. When an instruction to change the automatic log settings is given by the Support Dept. of the sales company, change the settings by referring to **“Automatic Log Settings”** on page 719.

• Automatic Log Settings

Automatic log is collected triggered by "occurrence of an unexpected error", "occurrence of an error code" or "restart of the machine".

If you want to change the triggers, change the setting in the following service mode.

COPIER > Function > DBG-LOG > LOG-TRIG

However, there is no need to change the setting unless otherwise instructed by the Support Dept. of the sales company. The events that trigger collection of automatic logs and their setting values are shown below.

List of conditions for automatic saving of logs and setting values

Setting value	Event condition for saving automatic log
101 (Default setting)	When an unexpected error occurs, an error code occurs, or the machine is restarted
111	Only when an unexpected error occurs
121	Only when an error code occurs
131	Only when the machine is restarted
201	When an unexpected error occurs, an error code occurs, the machine is restarted, or an alarm occurs
211	When an unexpected error occurs or an alarm occurs
221	When an error code occurs or an alarm occurs
231	When the machine is restarted or an alarm occurs
291	Only when an alarm occurs
301	When an unexpected error occurs, an error code occurs, the machine is restarted, or a jam occurs
311	When an unexpected error occurs or a jam occurs
321	When an error code occurs or a jam occurs
331	When the machine is restarted or a jam occurs
391	Only when a jam occurs

The procedure for changing the log auto save conditions with LOG-TRIG is indicated below.

1. Press [LOG-TRIG], enter the value for the conditions you want to set, and press [OK].
"ACTIVE!" flashes in the display column, and the log settings in the machine are changed.
2. When [OK!] is displayed in the display column, the work is complete.
If the processing fails, "NG" is displayed. It is not necessary to restart the device.

NOTE:

- A value between 0 and 99999 can be set, but make sure to set the value instructed by the Support Dept. of your sales company. Operations are not guaranteed when value other than the above is set.
- The displayed setting is not changed simply by changing the setting or pressing [DEFAULT]. It is necessary to exit the DBG-LOG screen once by pressing the [Reset] key, etc. and then display it again, after performing these operations.

Executing Auto Saving (Reference Example)

An example of executing auto saving using LOG-TRIG is shown below so that you can experience the log collection work. It is an example of log collection in the event of jam in the Delivery Assembly during copy operation.

1. Connect a USB device to the machine while the machine is ready for operation.
2. Set "301" in the following service mode (Lv.2).
 - COPIER > Function > DBG-LOG > LOG-TRIG
3. Make a copy. Open the Delivery Feed Assembly before paper is delivered from the Delivery Assembly to generate a jam.
4. When a jam occurs, confirm "Storing System Information..." is displayed at the bottom of the Control Panel.

• Initial setting of the network packet log collection function

When collecting the network packet logs, configure the initial settings as needed.

Setting the overwrite function

1. To enable this function, set "1" in the following service mode (Lv.2).

Service mode > COPIER > TEST > NET-CAP > OVERWRIT

NOTE:

When this setting is enabled, old logs will be overwritten. If the symptom cannot be reproduced, disable this setting (setting value: 0) and secure logs (save them using SST or USB). After securing the logs, enable the setting (setting value: 1) again.

Behavior when HDD reaches the limit

When this setting is enabled (setting value: 1), the following behaviors will occur when the HDD reaches the limit.

- When overwrite setting is ON
 - The oldest packet file is deleted. This "oldest file" is judged not by the date and time allocated to the file but by the last update time of the file.
 - If the HDD reaches the maximum size while retrieving packets, the oldest file will be deleted, and CAPSTATE of the capture, which continues the retrieval process for the file which is being saved, remains "RUNNING".
- When overwrite setting is OFF
 - The capture is stopped.
 - The CAPSTATE of the capture will be "HDDFULL". However, STT-STP will remain as Start (1) status. By changing STT-STP (0) to STTSTP (1), the capture resumes.
 - When the capture resumes, the capture starts if HDDFULL has been solved.
 - The CAPSTATE of the capture will be "RUNNING".
 - If HDDFULL has not been solved, an error is generated as the result of resuming the capture.
 - The CAPSTATE of the capture remains "HDDFULL".
 - If the capture is stopped while the CAPSTATE is "HDDFULL", the CAPSTATE of the capture remains "STOP".

Setting the encryption function

1. To enable this function, set "2" in the following service mode (Lv.2).

COPIER > TEST > NET-CAP > ENCDATA

- 0: Encrypted when data is extracted (factory default setting).
- 1: Not encrypted when data is extracted.
- 2: When data is extracted, a ciphertext file and a plaintext file are extracted.

The extension of extracted packet data will be "XXX.can" when encryption settings are enabled.

The extension of extracted packet data will be "XXX.cap" when encryption settings are disabled.

This setting only applies when extracting data by the USB flash drive.

NOTE:

When SST is used to collect data, both plaintext data and ciphertext data are extracted, and this setting is ignored.

Setting the payload drop function

- To enable this setting, set "1" in the following service mode (Lv.2).

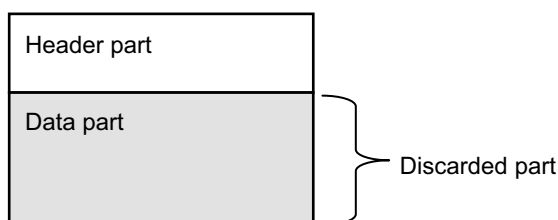
COPIER > TEST > NET-CAP > PAYLOAD

- 0: Not drop the payload (factory default settings)
- 1: Drop the payload

The obtained packet data includes a header part and data part. The header part includes data such as the TCP header and IP header. The data part includes the actual data.

Enabling this function discards the actual payload data and extracts only the data from the header part, which has the following effects.

- Can be used when customer data is not allowed to be extracted
- Can be used in an environment where traffic is highly overloaded



Packet data structure image

Setting the filter function

- To enable this function, set "1" in the following service mode (Lv.2).

COPIER > TEST > NET-CAP > SIMPFILT

- 0: All data is collected without being filtered (factory default setting).
- 1: Data is filtered.

If this function is enabled, only packet data that includes the machine's MAC address in the packet header is captured.

Setting the startup collection function

- To enable this function, set "1" in the following service mode (Lv.2).

COPIER > TEST > NET-CAP > PONSTART

- 0: Not automatically collect at startup (factory default setting)
- 1: Data is filtered.

If this function is enabled, only packet data that includes the machine's MAC address in the packet header is captured.

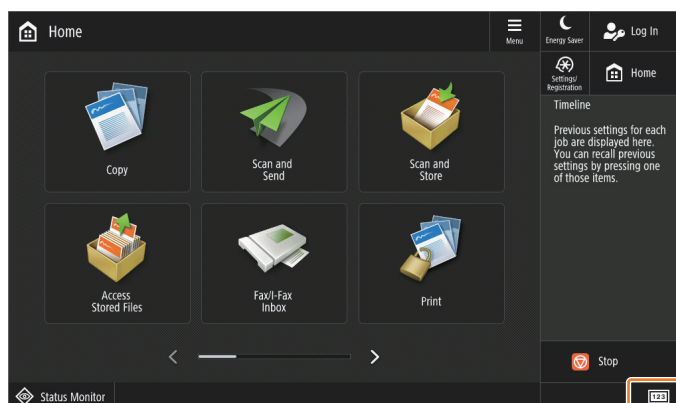
■ Saving of Manual Logs, Network Packet Logs and Key Operation Logs

Follow the procedure shown below to save debug logs (manual logs, network packet logs, and key operation logs) that require manual operation to the save area of the host machine.

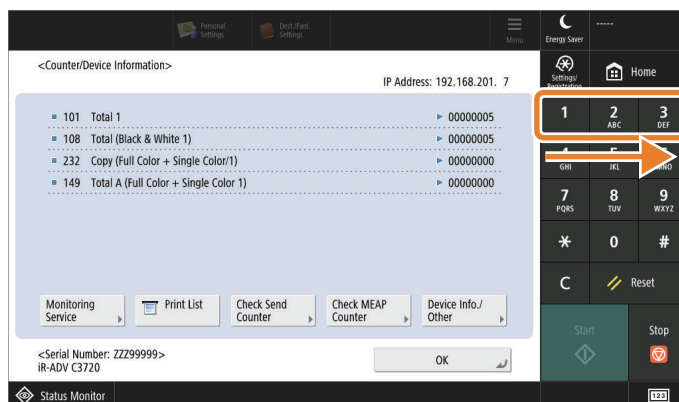
- After the symptom has reproduced, hold down the Counter key on the Control Panel for 10 seconds.

CAUTION:

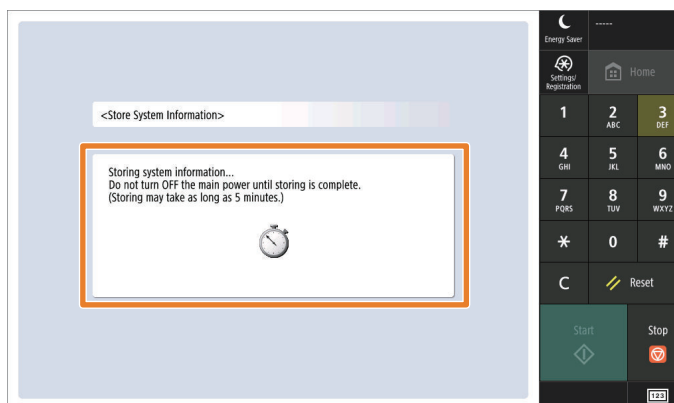
If power is turned OFF during the period from when the symptom occurs to when this procedure is completed, necessary log data will be deleted so that analysis cannot be performed.



2. When the software numeric keypad is displayed, press the numeric keys 1, 2, and 3, in that order.



3. Check that "Storing System Information..." is displayed on the Control Panel.



CAUTION:

- While logs are being saved, other operations cannot be performed.
- If the above screen or message is not displayed, press the Reset button and then try again from step 2.

NOTE:

When network packet logs have been collected and necessary network packets have been captured, stop the capture from the following menu.

[Settings/Registration] > [Preferences] > [Network] > [Store Network Packet Log]

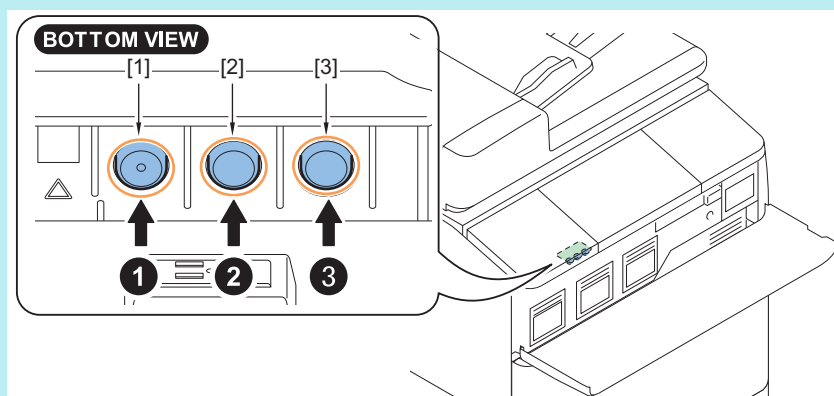
When this setting is disabled, all the service mode settings configured in step 3 are initialized.

Note that after completion of analysis of the network trouble, be sure to disable the network capture function. It is therefore necessary to disable and then transfer the license, but it is not necessary to transfer the LMS license after that.

NOTE:

When the Control Panel cannot be operated, store the log by the following button operation.

Service Button 1 > Service Button 2 > Service Button 3 (hold down only this button)

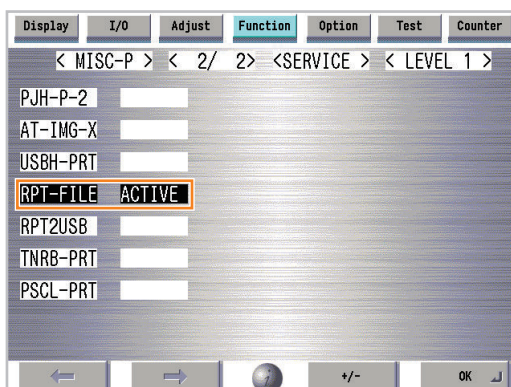


■ Saving and Collecting Report Files

Follow the procedure shown below to save report files to the Main Unit internal storage and collect them using a USB device.

1. Execute the following service mode to save report files.

COPIER > Function > MISC-P > RPT-FILE



2. Connect the USB and verify that Main machine recognizes the USB.

3. Execute the following service mode and retrieve the report file to USB.

COPIER > Function > MISC-P > RPT2USB



■ Collection of Log

Save the Sublogs stored in the host machine to a USB device or a PC with SST installed.

The procedure for storing Sublogs to a USB device differs from that for storing Sublogs to a PC

● Collecting into a USB Device

To save (collect) Sublogs to a USB device, perform the procedure shown below to collect the logs.

If SST is used to save (collect) Sublogs to a PC, this work is not necessary.

CAUTION:

If the log is stored multiple times to the USB flash drive on the host machine with the platform version 3.6 or earlier, make sure to move the stored log file to a different location each time.

Log files are stored in the root directory of USB flash drive. If multiple files are stored, the file, "LOGLIST.txt" is overwritten.

Note that on the host machine with the platform version 3.7 later, specifications are changed and this file is not overwritten.

1. Connect the USB flash drive to the machine.

2. Execute the following service mode.

COPIER > Function > SYSTEM > DOWNLOAD



3. The host machine will enter download mode. Press [8] on the Numeric Keypad.

```

[[[[[[[[ Root Menu (USB <v25.12> ]]]]]]]] (v25.12)
-----
[ 1 ] : Select Version
[ 4 ] : Clear/Format
[ 5 ] : Backup/Restore
[ 8 ] : Download File
[ 9 ] : Version Information
[ Reset ] : Start shutdown sequence
  
```

4. [Download File Menu] will appear. Press a numeric key for the file to download.

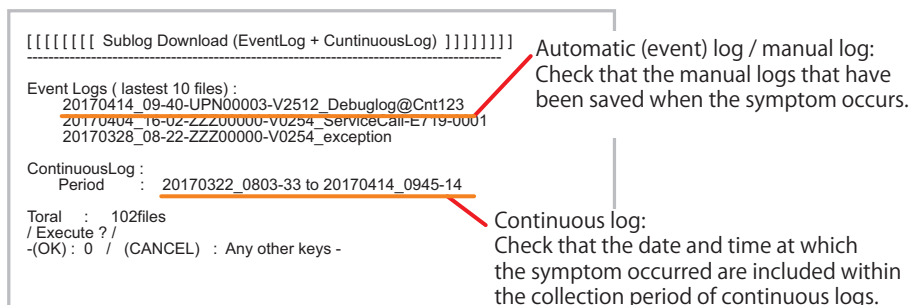
```

[[[[[[[[ Download File Menu (USB <v25.12> ]]]]]]]] (v25.12)
-----
[ 1 ] : SUBLOG Download
[ 4 ] : ServicePrint Download
[ 5 ] : NetCap Download
[ C ] : Return to Menu
  
```

- Press [1] key to download Sublog.
- Press [5] to download network packet log.

5. The files to be downloaded and the number of files are displayed. Check the following items and press [0] on the Numeric Keypad.

- Whether the manual log that was saved at the time of reproduction of the symptom is displayed under Event Logs
- Whether the date and time at which the symptom was reproduced is within the period of Continuous Log
Example: When the symptom was reproduced at 9:40 on April 14, 2017 and a manual log was saved
Check that the manual log that was generated at 9:40 on April 14, 2017 is displayed under Event Logs.
Check whether 9:40 on April 14, 2017 is included in the logged period(from 8:03:33 on March 22, 2017 to 9:45:14 April 14, 2017) of the ContinuousLog.



6. When downloading the log files is complete, the following message will appear. Press any key.

--- Please press any keys ---

```
[68/102]20170405_0949-57-ZZZ00000-2512-clog.bin
[69/102]20170405_0908-19-ZZZ00000-2512-clog.bin
[70/102]20170404_1822-52-ZZZ00000-2512-clog.bin
[71/102]20170404_1702-57-ZZZ00000-2512-clog.bin

[97/102]20170322_1324-37-ZZZ00000-2512-clog.bin
[98/102]20170322_1204-56-ZZZ00000-2512-clog.bin
[99/102]20170322_1102-52-ZZZ00000-2512-clog.bin
[100/102]20170322_0954-48-ZZZ00000-2512-clog.bin
[101/102]20170322_0848-16-ZZZ00000-2512-clog.bin
[102/102]20170322_0803-33-ZZZ00000-2512-clog.bin
Sub log full Download OK.
---Please press any keys---
```

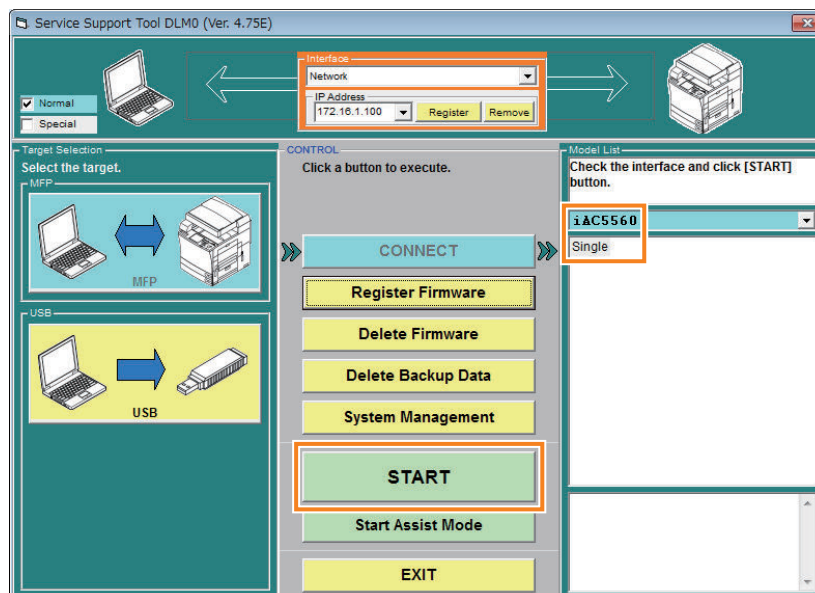
Do not turn OFF the power without.....

• Saving to a PC with SST installed

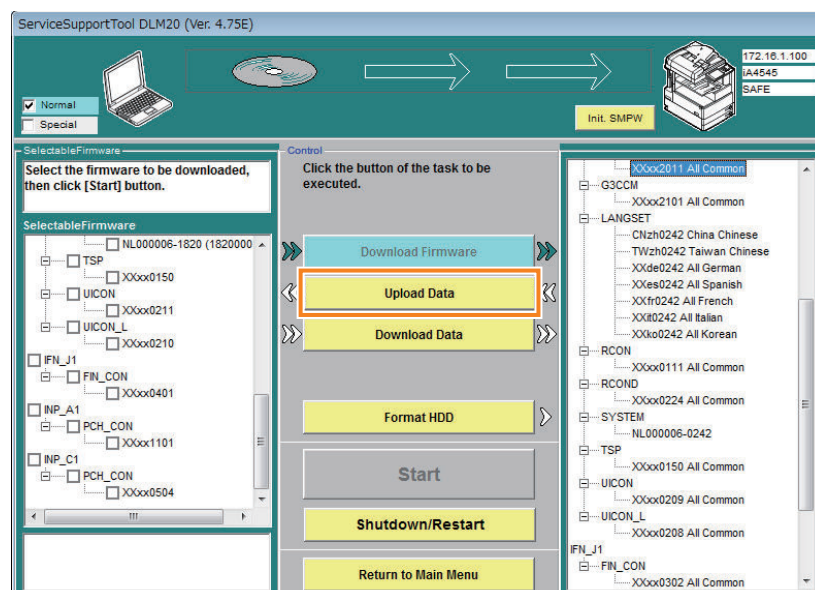
Follow the procedure shown below to save (collect) Sublogs to a PC using SST.

If a USB device is used to save (collect) Sublogs, this work is not necessary.

1. Connect a PC with SST installed to the network where the host machine is connected.
2. Start SST, and select the model name of the machine from Model List. Press the Start button.



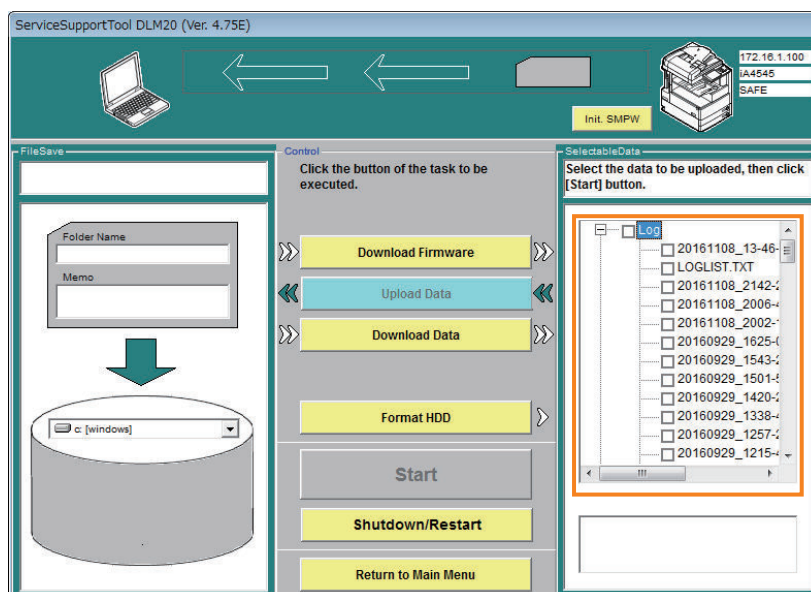
3. Click [Upload Data].



4. Check that continuous logs are stored in the device.

When connection with the device is completed, the screen shown below will appear. Select [Upload Data].

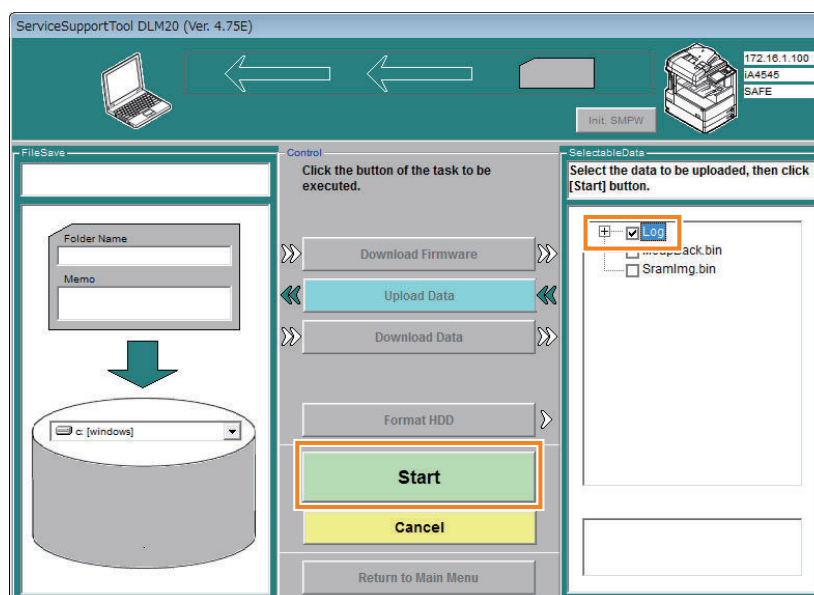
The set of data stored in the device is shown on the right. Click "+" at "Log" to expand the tree, and check that there are continuous logs (date_model number_clog.bin).



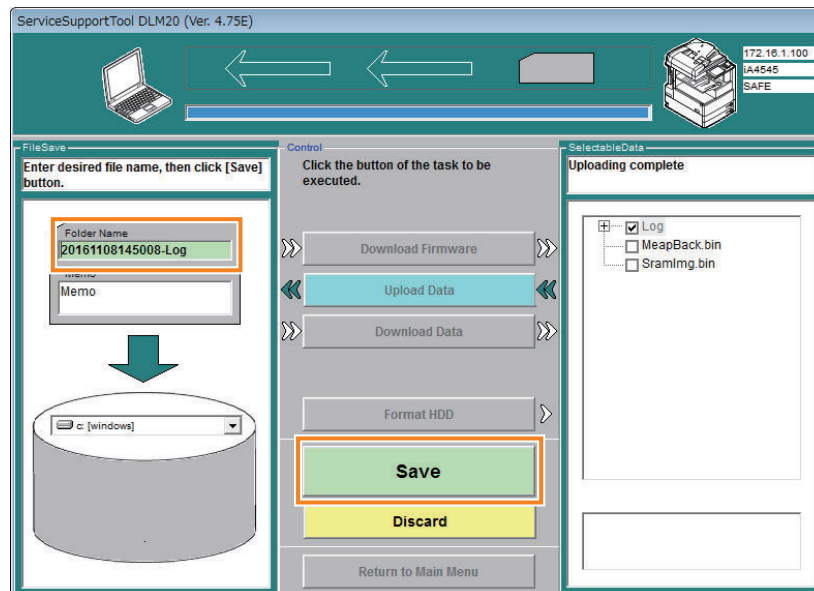
5. Select the data to upload, and click [Start].

Select the check box on the left of "Log", and click the "Start" button.

It is not necessary to select MeapBack.bin and SramImg.bin because they are not necessary for analysis.



6. Enter a file name (arbitrary), and click the SAVE button to save the file to the PC.



• Checking the Saved Files

NOTE:

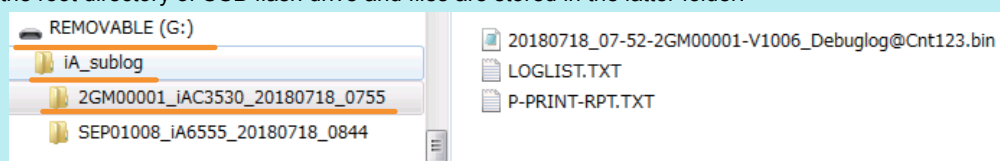
If log files are stored in the USB flash drive, the path to the storage destination is different by the platform version.

Platform version prior to 3.7

They are stored in the root directory of USB flash drive.

Platform version 3.7 or later

Folders of "iA_sublog" and "model name + serial number + date (year, month, day + hour, minute, second)" are automatically created in the root directory of USB flash drive and files are stored in the latter folder.



Sublog files

Check the saved log files whether the necessary log has been collected.

- Whether it is a log file of the target model (It contains the serial number of the target machine.)
- Whether the time and date the symptom occurred is included in the logged period. (Date and time in the log file name represent those of when the log collection is started. There are files with dates before the symptom occurs.)

Storage locations of log files

Storage locations of log files are shown below.

When using USB device: Root folder of the USB device

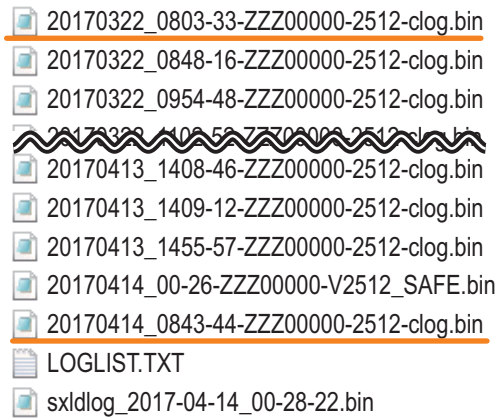
When using SST: PC's C:\ServData\\serial number folder

How to check the continuous log files

The continuous log files are stored in the log file storage location.

Check the names (date and time) of the files that end with "clog.bin" to see whether the date and time the symptom was reproduced is included.

In the case of the following figure, the oldest continuous log is 08:03:33 on March 22, 2017 and the latest file is 08:43:44 on April 14, 2017. The date and time the symptom was reproduced should be included within the period.



20161013_1733-36_ZZZ99999_1406_clog.bin

Data and time when a file was archived (year, month, day, hour, minute, second). Serial Number Firmware Version Identification indicating that it is a continuous log

File name of continuous log

How to check the manual log files and automatic (event) log files

The manual log files and automatic (event) log files are stored in the log file storage location.

At the time of collection, these logs will be archived as a one binary file (the name of the file ends with "_SAFE.bin").

20161013_19-34-ZZZ99999-V1406_SAFE.bin

YYYYMMDD_HH-MM Serial Number Firmware Version

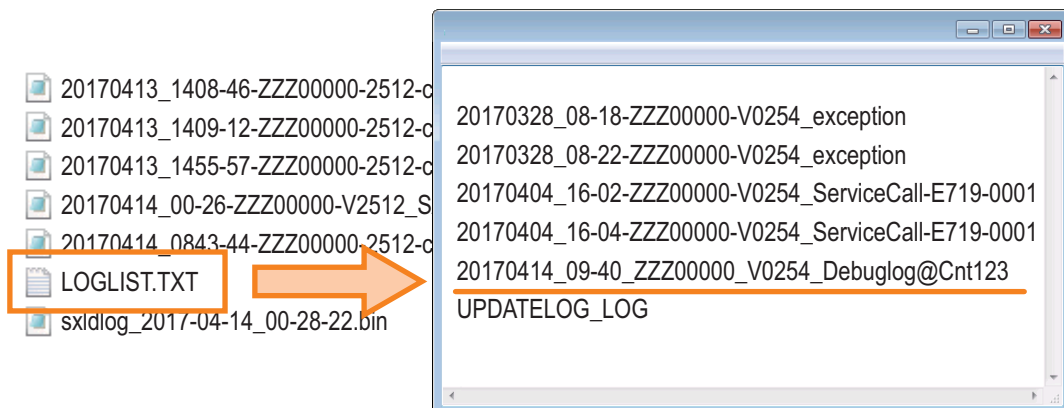
Which logs have been stored in this binary file is described in LOGLIST.TXT stored in the log file storage location.

Open this file to check the manual logs and automatic (event) logs.

CAUTION:

If a manual log was saved when the symptom was reproduced, check that a log with the date and time immediately after the reproduction is included.

If there is no log file collected immediately after the symptom was reproduced, the file may have been overwritten and lost.



20161013_10-10_ZZZ99999_V 1308_Debuglog@Cnt123

Data and time when key operation was performed (year, month, day, hour, minute, second). Serial Number Firmware Version Identification indicating that a key operation was performed

File name of manual log

20161012_14-48_ZZZ99999_V1406_Fatal00-exception

Data and time when an even occurred (year, month, day, hour, minute, second) Serial Number Firmware Version Cause of occurrence

20161012_14-48_ZZZ99999_V1406_ServiceCall-E719-0031

Data and time when an even occurred (year, month, day, hour, minute, second) Serial Number Firmware Version Cause of occurrence

File name of automatic log

How to check the network packet log files

The network packet log file is stored in the "NC + date" folder created in the log file storage location.

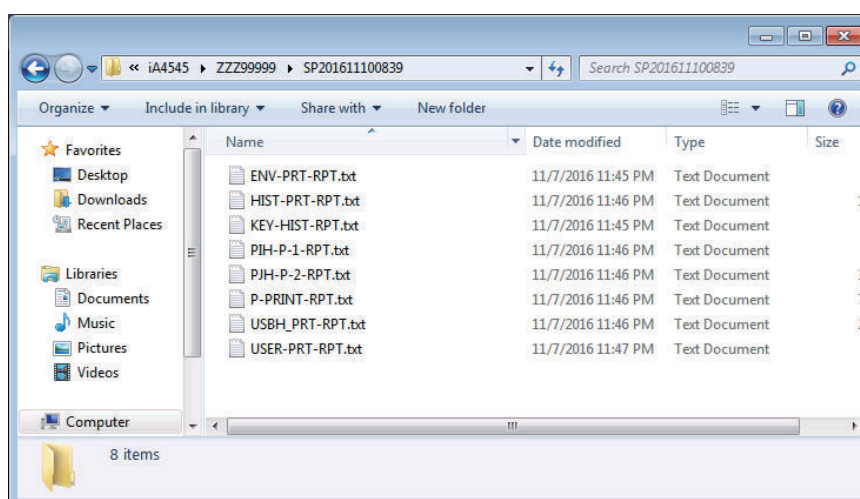
Open the folder and check that two types of files have been saved: a plaintext file which file name starts with "NC" and ends with ".cap", and a ciphertext file which file name starts with "NC" and ends with ".can".

Name	Date modified	Type
NC0110041155.can	1/22/2015 11:34 AM	CAN File
NC0110041155.cap	1/22/2015 11:34 AM	CAP File
NC0110044539.can	1/22/2015 11:34 AM	CAN File
NC0110044539.cap	1/22/2015 11:34 AM	CAP File
NC0110051028.can	1/22/2015 11:34 AM	CAN File
NC0110051028.cap	1/22/2015 11:34 AM	CAP File
NC0110051243.can	1/22/2015 11:34 AM	CAN File
NC0110051243.cap	1/22/2015 11:34 AM	CAP File
NC0110053134.can	1/22/2015 11:34 AM	CAN File
NC0110053134.cap	1/22/2015 11:34 AM	CAP File
NC1222190910.can	1/22/2015 11:34 AM	CAN File
NC1222190910.cap	1/22/2015 11:34 AM	CAP File
NC1226153347.can	1/22/2015 11:34 AM	CAN File
NC1226153347.cap	1/22/2015 11:34 AM	CAP File

Report files

Report files saved to the USB device are stored in the folder under the name shown below where the firmware is stored.

- [Serial No.] > SP [Date (year, month, day, hour, minute (12 digits))] L



Service Mode Relating to Debug Logs

Although the procedure for collecting debug logs of this equipment is as indicated above, there are other service modes related to debug logs.

Use the following service modes (Lv.2) as needed.

- COPIER > Function > DBG-LOG > HIT-ST5
- COPIER > Function > DBG-LOG > DEFAULT
- COPIER > Function > DBG-LOG > LOG-DEL

NOTE:

If log collection is continued or setting change is repeated when an abnormality is found in operation of the function related to debug logs, temporary files or log files may be remained in the machine. In that case, execute "DEFAULT" in service mode to clear the settings related to debug logs and repeat the operation again.

Confirming the Existence of Debug Logs (HIT-STS)

This service mode confirms whether debug logs exist in the auto save area.

"OK!" is displayed if logs exist in the auto save area.

NOTE:

"OK!" is displayed even after pressing the Counter key + numeric keys 1, 2, and 3.

Initializing the Debug Log Settings (DEFAULT)

This service mode changes all the settings related to debug logs back to the default (settings at the time of shipment).

- Be sure to perform when returning the device to the customer after completion of trouble investigation. (Operations required)
- Execute this service mode when resetting the settings related to debug logs during investigation of log collection and perform the operation again.

However, note that the log files automatically saved to the debug log save area in the controller are kept within the range not exceeding the upper limit.

If you want to delete the saved logs (want to use HIT-STS), use "LOG-DEL" indicated later.

Deleting the Automatically Saved Log Files (LOG-DEL)

This service mode deletes the automatically saved and stored log files. The settings of log operation such as trigger for saving log are not cleared.

Although it is not used normally (the upper limit of the number of saved logs is automatically controlled by firmware), it is necessary to delete logs with LOG-DEL once when judging whether logs are collected using HIT-STS after changing the trigger for saving log.

(It is because OK is displayed in HIT-STS as long as the saved logs exist.)

Startup System Failure Diagnosis

How to See the Startup System Failure Diagnosis

The goal of the startup system failure diagnosis is to be able to solve troubles associated with a Control Panel display failure by performing the following steps.

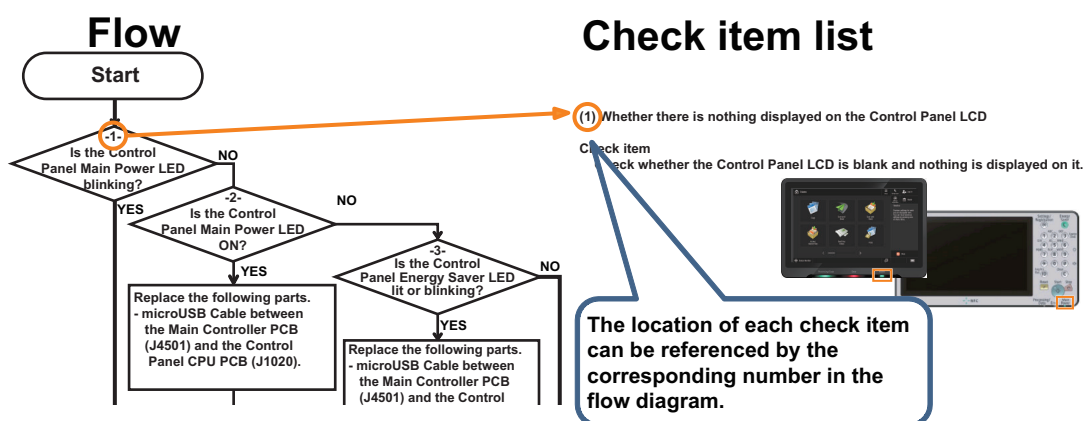
It is assumed that the users have already learned the following items:

- How to use a tester
- Roles of the All-night Power Supply (5 V) and Non-all-night Power Supply (12 V)
- How to back up data (HDD and Main Controller)

It is recommended to execute the diagnosis again after executing the diagnosis and troubleshooting to check that the machine starts normally.

Useful Operations

The items of detailed procedure explanation start with a description of the flow diagram. The items and procedures checked in the flow diagram are described separately in a check item table. The flow diagram contains numbers (e.g. (1)) corresponding to the check items so that the readers can grasp the relevant parts of the check item table.

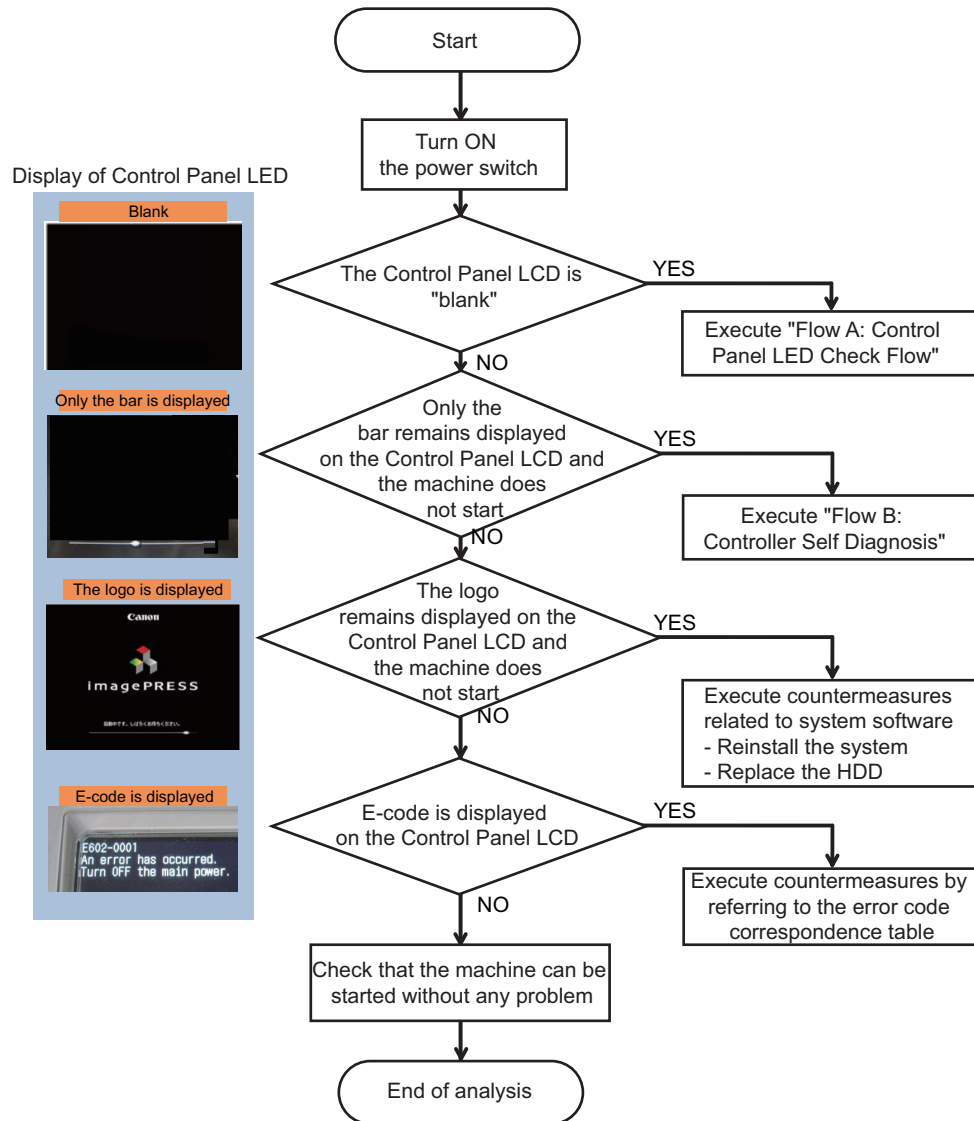


Startup Failure Analysis Policy

If the host machine does not start successfully even when its Power Switch is turned ON, one of the following displays will appear on the Control Panel LCD.

- Blank
- Only the bar is displayed
- The logo is displayed
- E-code is displayed

Execute troubleshooting by performing the procedure described in the reference according to the following flow.

**NOTE:**

It may take about 5 minutes or more to display E 602-0001.

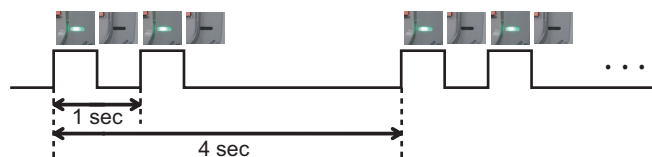
Flow A: Control Panel LED Check Flow

When the Control Panel LCD screen is "black", the location of the failure can be identified by checking whether initial rotation has been performed and the Control Panel LED status.

There are three types of LED status: On, Off, and blinking. As for blinking, there are the following two types of blinking.

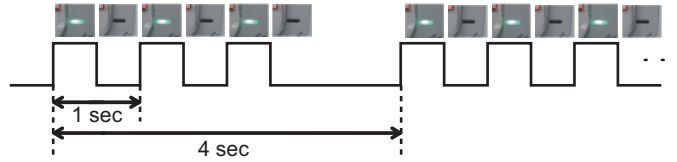
Pattern 1 (Controller error)

An LED blinks twice in 4 seconds.

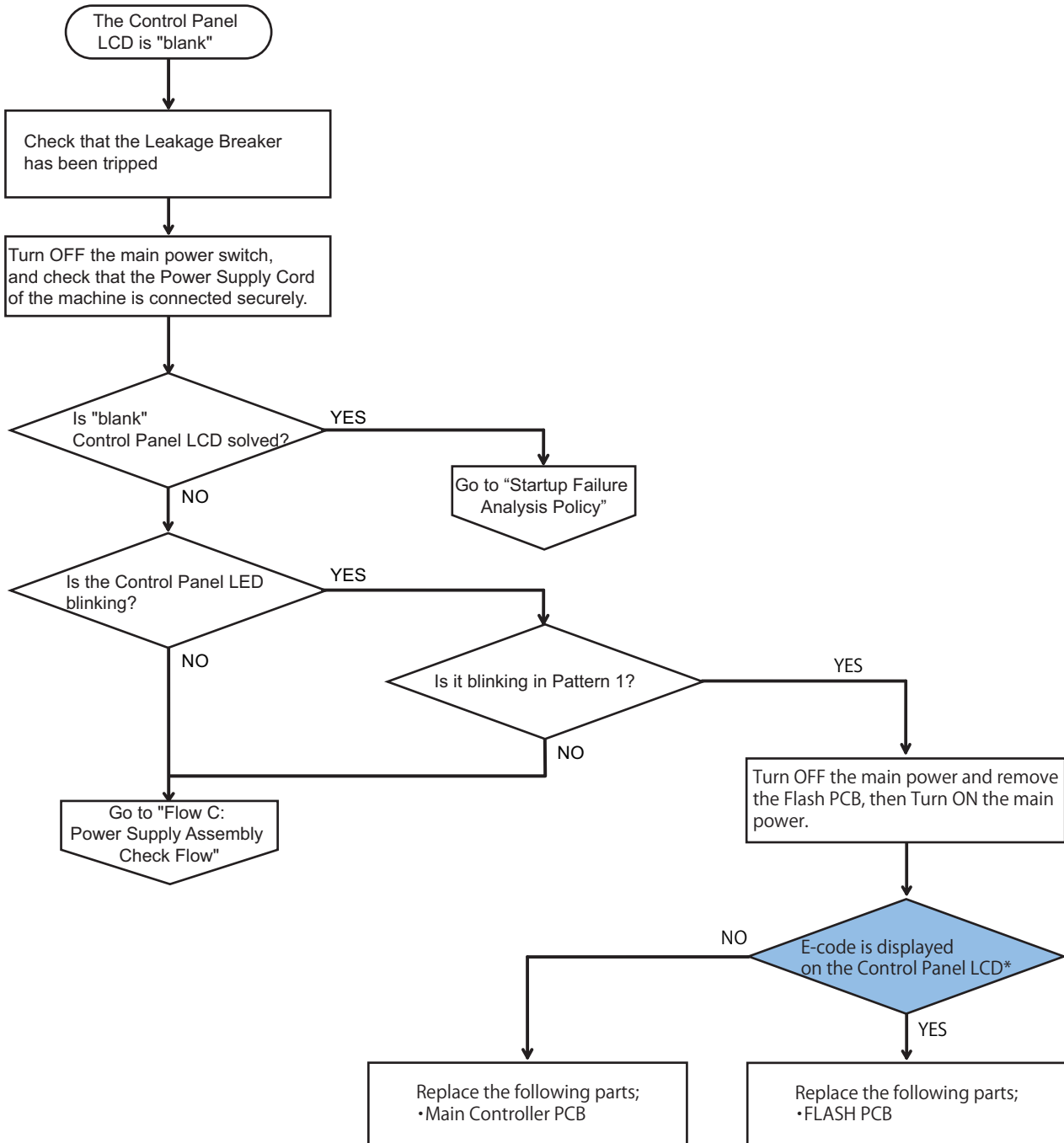


Pattern 2 (Power supply error)

- An LED blinks three times in 4 seconds.

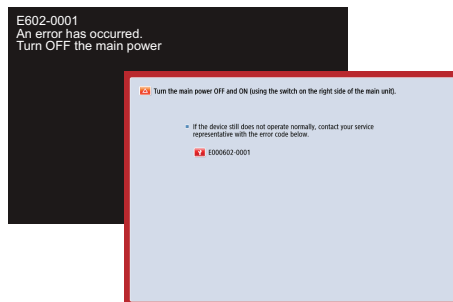


Identify the location of the failure according to the following flow.



***Check item**

E-code is displayed on the Control Panel LCD.



Display sample of an E-code

If an displayed error code starts with E602 or E614, see [“Remedies to be performed when E602-xxxx or E614-xxxx error is displayed” on page 709](#) to perform the remedy.

If the error codes other than above is displayed, see [“Error Code” on page 754](#) to perform the remedy.

Flow B: Controller Self Diagnosis

Reference : [“Controller Self Diagnosis” on page 741](#)

Flow C: Power Supply Assembly Check Flow

■ Status Check

If nothing is displayed on the Control Panel when the power of the host machine is turned ON, identify the location of the failure according to the flow.

■ Flow for narrowing down troubles

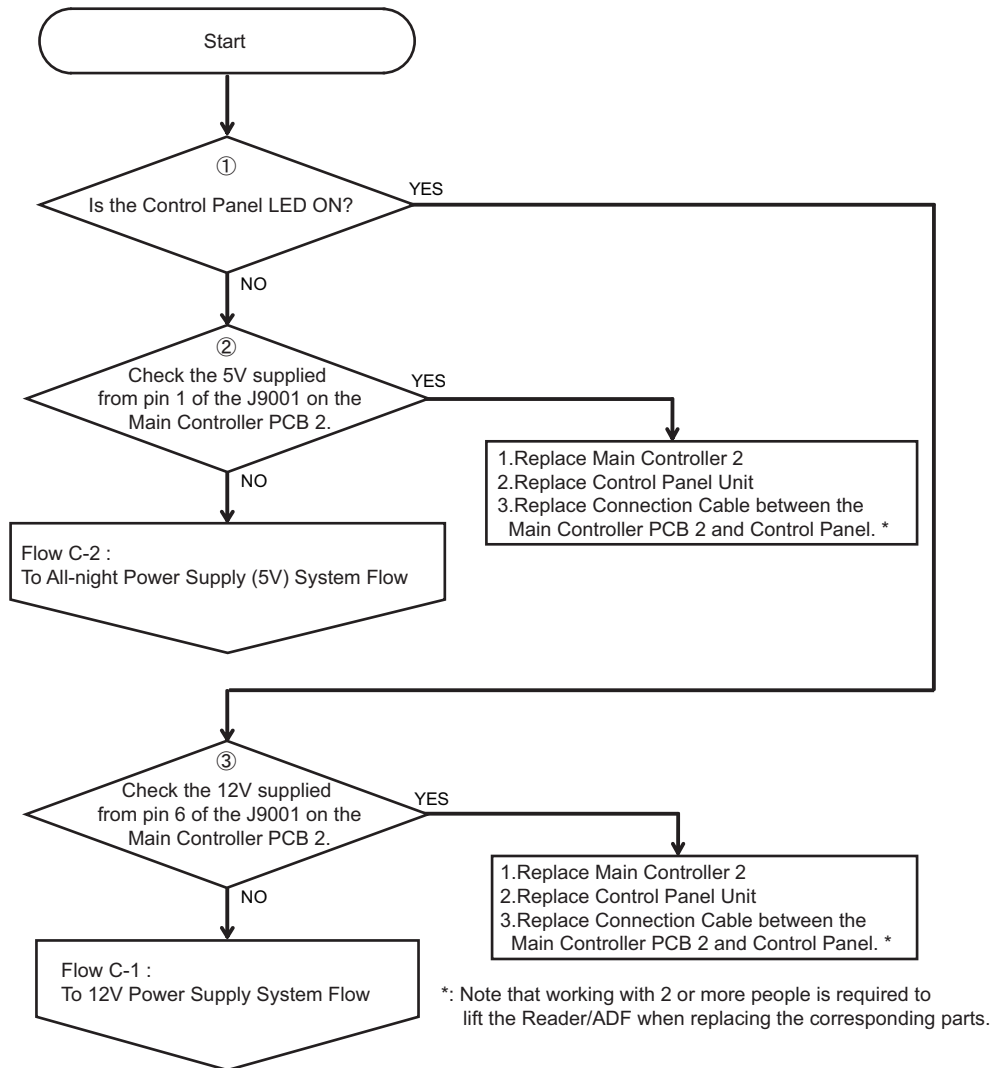
If the Main Power LED is ON, the All-night Power Supply (5 V) is being supplied.

If the 12 V Power Supply is activated, the Control Panel Backlight can be activated.

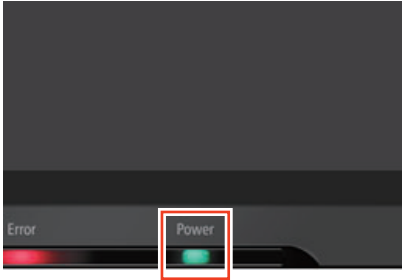
If the power-on signal is supplied to the 12 V power supply, the 12 V can still activate the Control Panel Backlight.

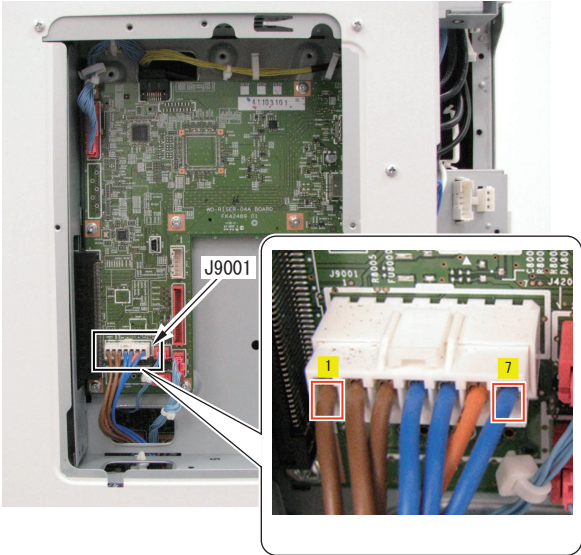
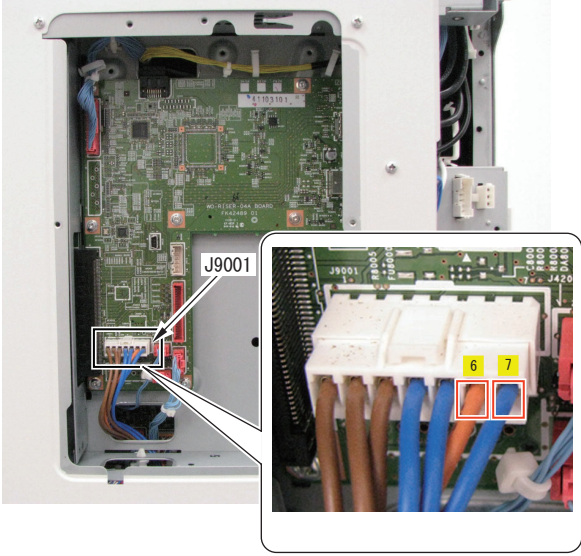
If the power-on signal is blocked, the 12 V power supply stops supplying power.

Consult this flow when checking the 5 V and 12 V power supplies and identifying the location of the failure in "Execution Flow for Control Panel Startup Failure" described below.



■ Check item

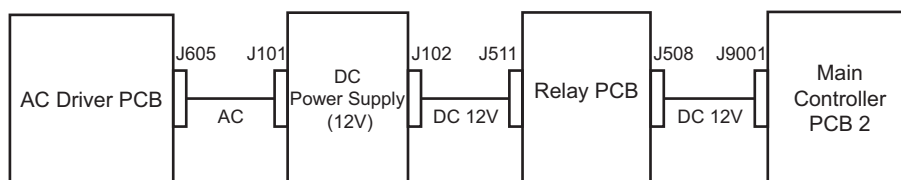
Item	Check item	Location
1	Control Panel LED	

Item	Check item	Location
2	Main Controller PCB 2 Check the pin 1 (5 V) of J9001. Example: Pin 1 (5 V) and pin 7 (GND) Normal value: 5 V	
3	Main Controller PCB 2 Check the pin 6 (12 V) of J9001. Example: Pin 6 (12V) and pin 7 (GND) Normal value: 12 V	

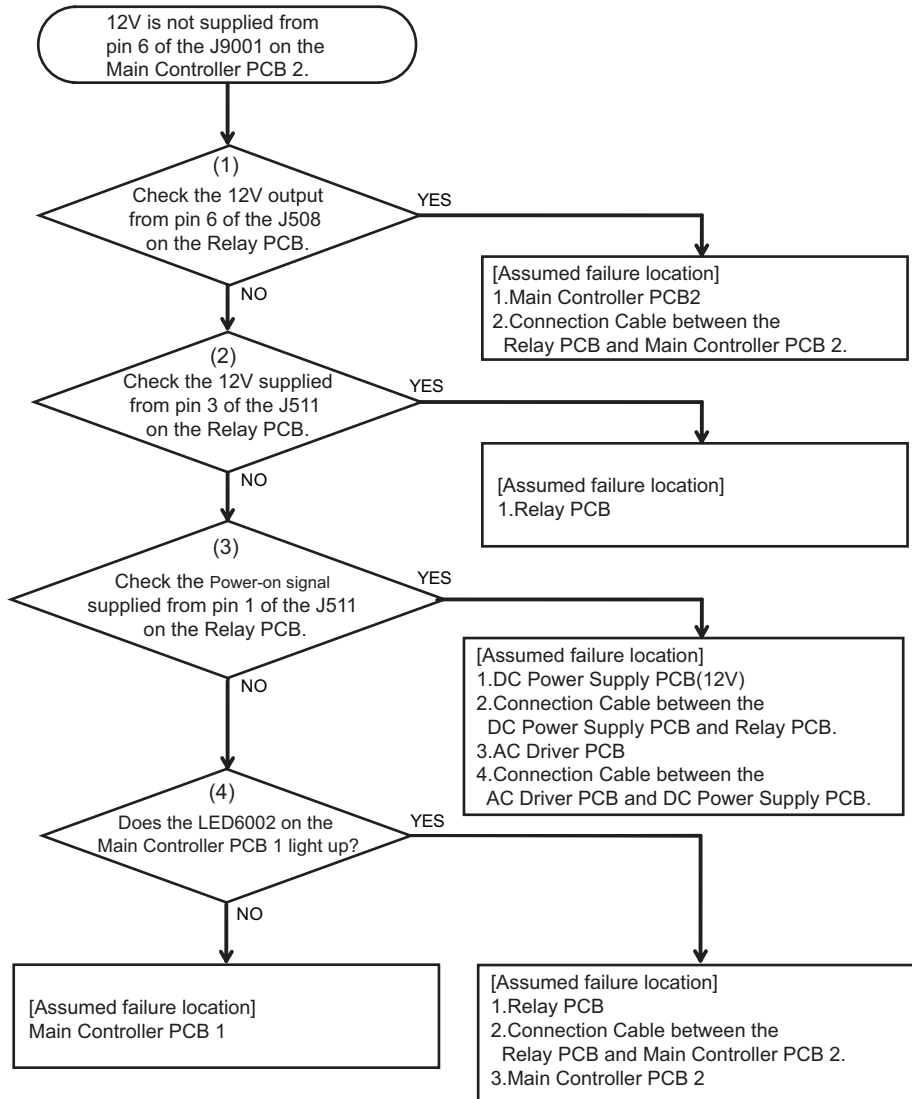
Flow C-1: DC Power (12 V) Check Flow

DC Power (12 V) Check Flow

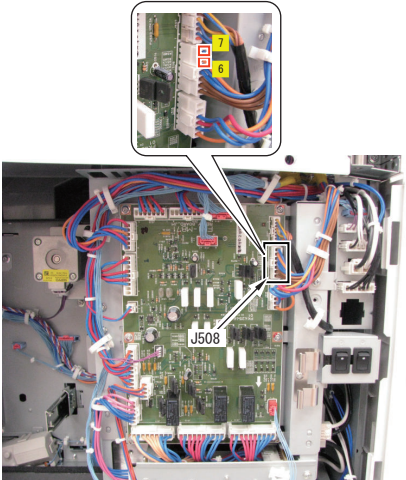
The following diagram shows the 12 V power supply route.

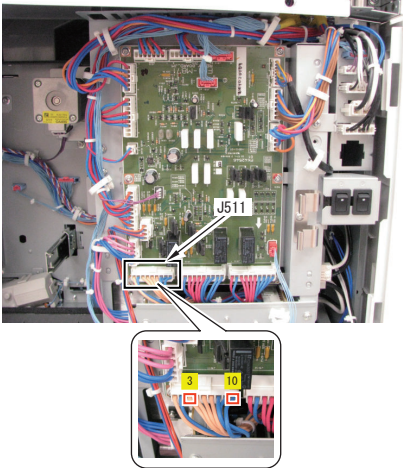
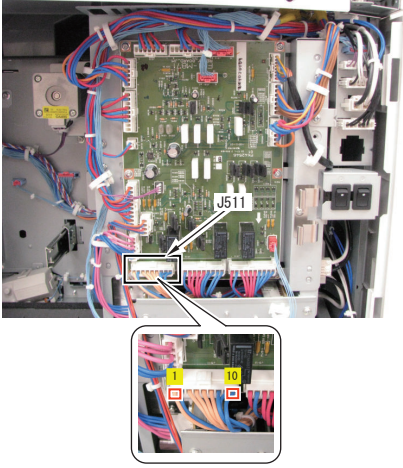
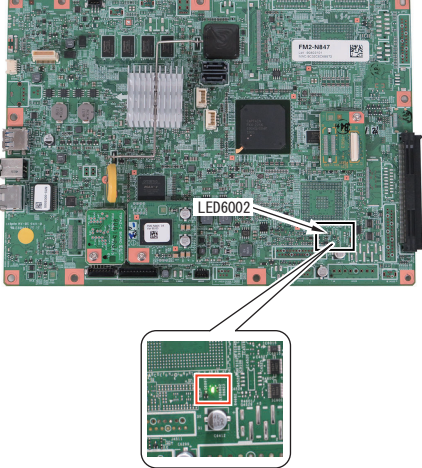


Identify the location of the assumed failure according to the following flow.



■ Check item

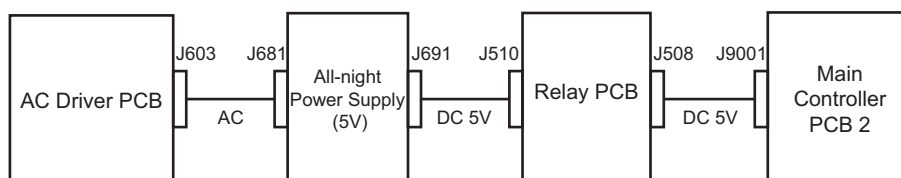
Item	Check item	Location
1	Relay PCB Connector side of J508 Example: Pin 6 (12 V) and pin 7 (GND) Normal value: 12 V	

Item	Check item	Location
2	Relay PCB Connector side of J511 Example: Pin 3 (12 V) and pin 10 (GND) Normal value: 12 V	
3	Relay PCB Connector side of J511 Example: Pin 1 (power-on signal) and pin 10 (GND) Normal value: Within 1.79 to 2.37 V	
4	Main Controller PCB 1 Check the LED6002 activation	

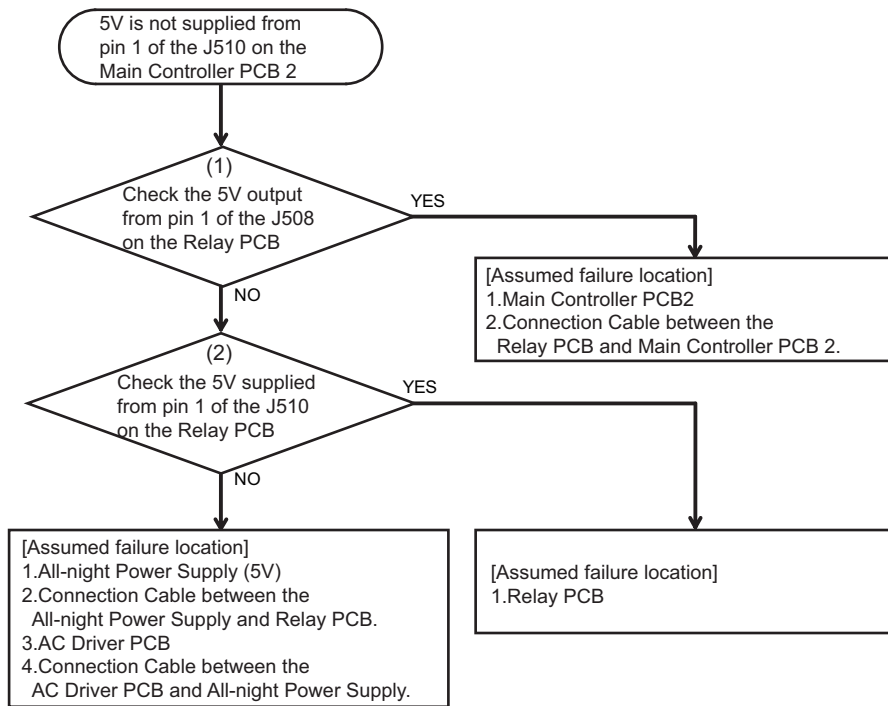
Flow C-2: All-night Power Supply (5 V) Check Flow

■ All-night Power Supply (5 V) Check Flow

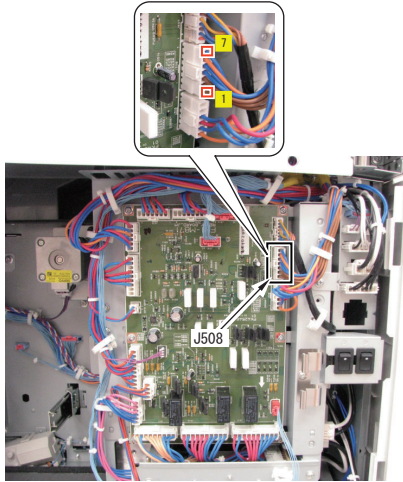
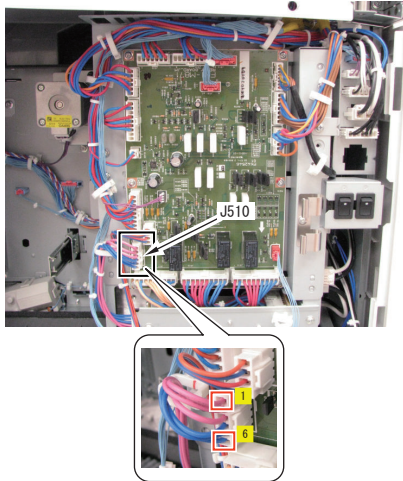
The following diagram shows the 5 V power supply route.



Identify the location of the assumed failure according to the following flow.



■ Check item

Item	Check item	Location
1	Relay PCB Connector side of J508 Example: Pin 1 (5 V) and pin 7 (GND) Normal value: 5 V	
2	Relay PCB Connector side of J510 Example: Pin 1 (5 V) and pin 6 (GND) Normal value: 5 V	

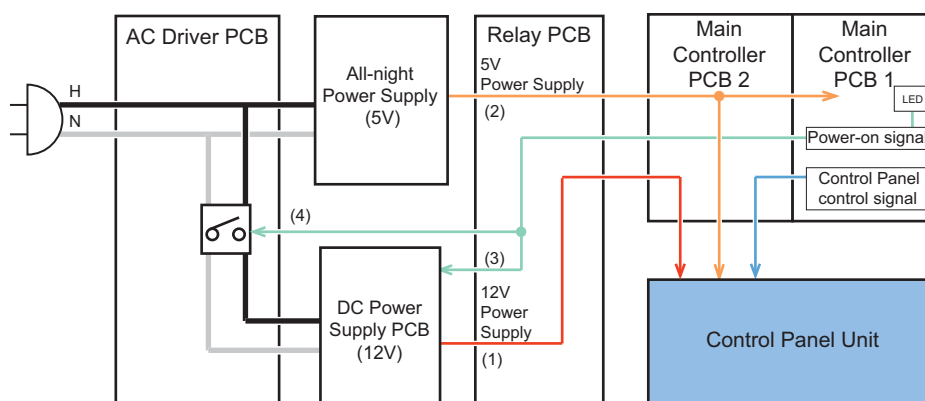
Reference: Activation Conditions of the Control Panel Backlight

■ Overview : 12 V Ppower Supply control

The Control Panel Backlight is turned ON when 12 V power is supplied from the Man Controller PCB 2.

The details of 12 V power supply route and route of power-on signal that controls power are shown below.

1. The Control Panel Backlight is turned ON when 12 V power is supplied. The 12 V power is supplied through the following route:
AC Driver PCB > DC Power Supply PCB (12 V) > Relay PCB > Main Controller PCB 2 > Control Panel
2. Supply of 12 V power is controlled by the power-on signal output from the Main Controller PCB 1. The 5 V power used for the Main Controller PCB 1 is supplied through the following route.
AC Driver PCB > All-night Power Supply PCB (5 V) > Relay PCB > Main Controller PCB 2 > Main Controller PCB 1
3. The Main Controller PCB 2 receives its power supply from the DC Power Supply PCB (12 V) and the power-on signal that controls the DC Power Supply PCB (12 V) is sent through the following route.
Main Controller PCB 1 > Main Controller PCB 2 > Relay PCB > DC Power Supply PCB (12 V)
4. The DC Power Supply PCB (12 V) receives its power supply from the AC Driver PCB and the power-on signal that controls the AC Driver PCB is sent through the following route.
Main Controller PCB 1 > Main Controller PCB 2 > Relay PCB > AC Driver PCB



NOTE:

- When the power-on signal output from the Main Controller PCB 1 is blocked, the power supply stops even if the Power Supply Unit is operating properly.
- The power-on signal is output at 3.3 V.

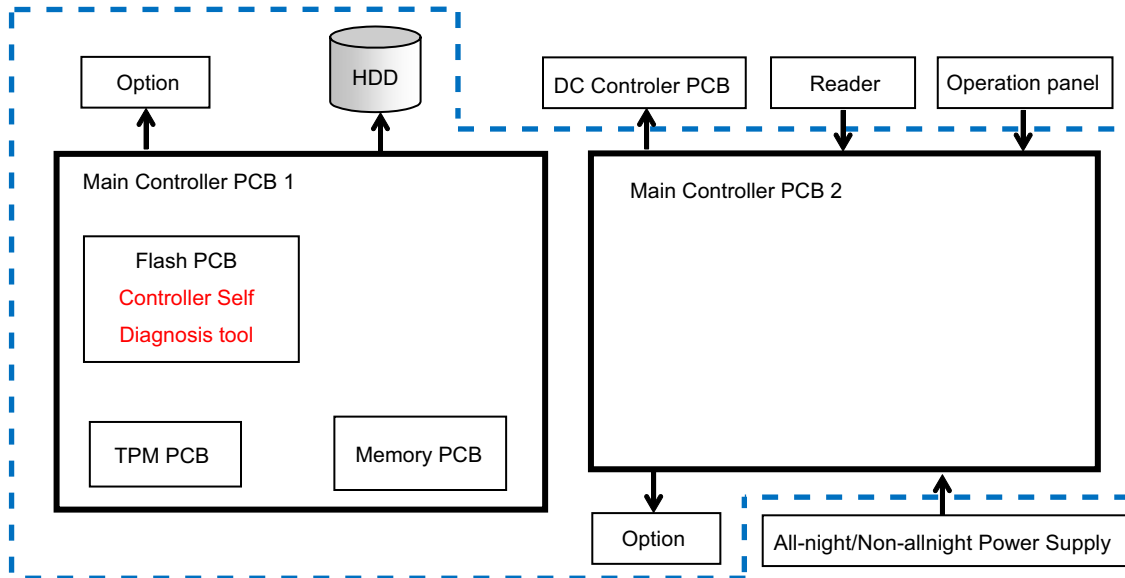
Controller Self Diagnosis

In order to reduce the time for identifying the cause of error occurred in the field and improve the accuracy of identifying the error locations, operation of the controller system error diagnosis tool added to the host machine and the remedies for errors are described.

This manual can be used when the host machine is in the following conditions.

- When a failure of the Main Controller PCB and the related PCBs (child PCBs such as TPM installed on the Main Controller PCB) is suspected

PCBs and units diagnosed by the tool are as follow:

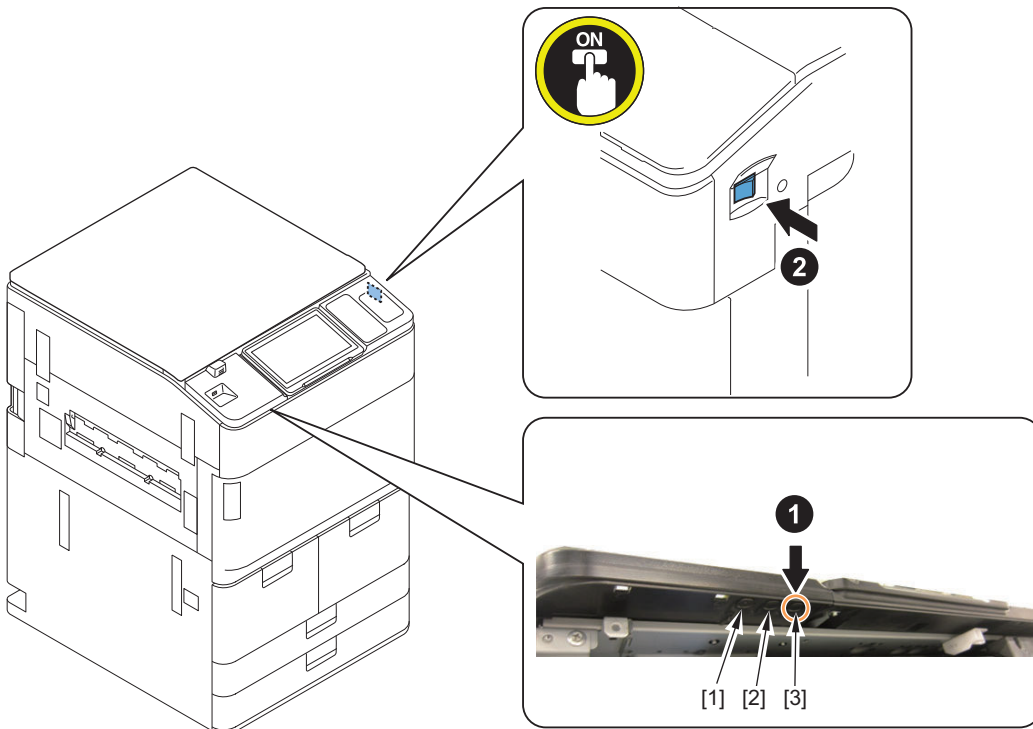


The area framed in blue (dotted line) in the figure shows the components to be checked by the controller system error diagnosis tool.

The Main Controller PCB, child PCBs installed on the Main Controller PCB and HDD are automatically checked, and the result is displayed on the Control Panel.

Startup Method

1. Turn ON the Main Power Switch while pressing the Service Button [3].



2. Keep pressing the numeric keys (for approx. 20 seconds) until the following screen appears on the Control Panel.

```

=====
BOX Checker Ver 0. 58
SCENARIO-1 Processing BoxMode check start. . .

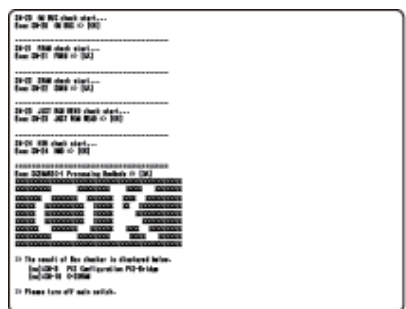
-----
SN-1 IA-DDR2 SDRAM check start. . .
    
```

Diagnosis Result

Diagnosis Time

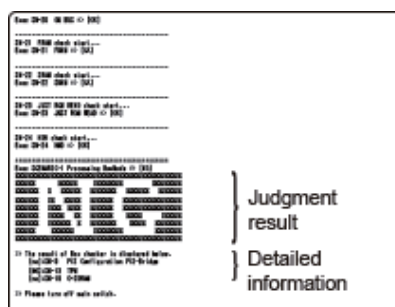
Diagnosis is completed in approx. 3 minutes.
The result is displayed on the Control Panel.

When the diagnosis result is normal



When an error is detected by diagnosis

Detailed information is displayed under the judgment result. In detailed information, the name of the test where the error was detected is displayed.



How to view the error result

The following screen is an enlarged view of the detailed information indicated above.

Explanation of the detailed error information is described.

```
>> The result of Box checker is displayed below.
[no] : SN-9 PCI Configuration PCI-Bridge
[NG] : SN-13 TPM
[no] : SN-19 O-SDRAM

>> Please Turn off main switch.
```

[NO] means that optional PCBs are not mounted.

A fault has occurred when [NO] is displayed irrespective of whether the Option PCB is attached.

[NG] means that an error occurred to PCBs mounted as standard.

■ Controller System Error Diagnosis Table

The error locations are identified according to the following table.

Test name	Detailed test name	Presumed failure location	Remedy	Relevant Error Code
SN-1 MN-DDR3 SDRAM	Check the SDRAM of the Main Controller PCB1	• Main Controller PCB1	Replacement of the Main Controller PCB1	-
SN-2 SM BUS MN DDR3 On Board	Check the circuit in the Main Controller PCB1	• Main Controller PCB1	Replacement of the Main Controller PCB1	-
SN-5 PCI Configuration Caiman	Check the circuit in the Main Controller PCB1	• Main Controller PCB1	Replacement of the Main Controller PCB1	-
SN-8 CPLD	Check the circuit in the Main Controller PCB1	• Main Controller PCB1	Replacement of the Main Controller PCB1	-
SN-9 LANC FLASH	Check the circuit in the Main Controller PCB1	• Main Controller PCB1	Replacement of the Main Controller PCB1	-
SN-10 RTC CHECK	Check RTC setting time	• Main Controller PCB1	Replacement of the Main Controller PCB1	-
SN-11 TPM	Check TPM PCB device Remarks: It is always [NG] in machines for China because the TPM PCB is not installed.	• Main Controller PCB1 • TPM PCB	1. Replacement of the TPM PCB 2. Replacement of the Main Controller PCB1	E746
SN-12 SOC DDR3 SDRAM	Check the circuit in the Main Controller PCB1	• Main Controller PCB1 • Main Controller PCB2	Replacement of the Main Controller PCB1	-
SN-13 FRAM	Check the Memory PCB lead	• Memory PCB	1. Check the Memory PCB installation 2. Replace the Memory PCB	E355

• HDD S.M.A.R.T Information

S.M.A.R.T Check

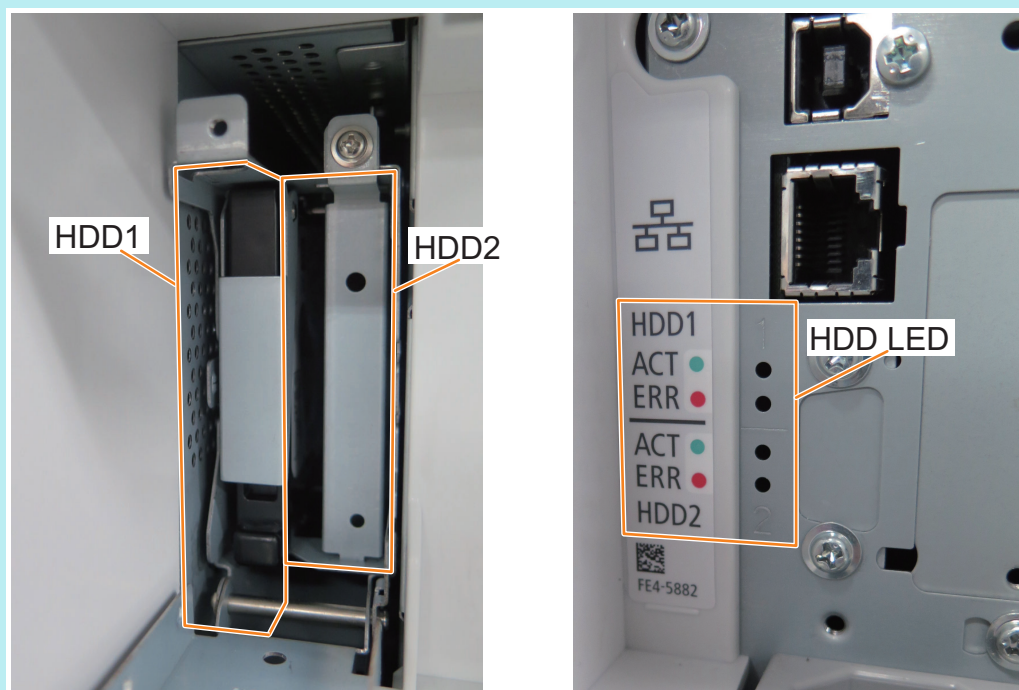
S.M.A.R.T Check	Description	Remedy
05: Reallocated Sectors Count: [000000000000]	Number of alternative processed defective sectors	If a numeric value besides [000000000000] is displayed, backup is recommended to avoid losing customer data.
c5: Current Pending Sector Count: [000000000000]	Number of pending sectors (sectors that may have defective sectors)	If a numeric value apart from [000000000000] is displayed, backup is recommended to avoid losing customer data.
c6: Uncorrectable Sector Count: [000000000000]	Number of defective sectors (uncorrectable sectors) which do not allow alternative processing	If a numeric value apart from [000000000000] is displayed, <ul style="list-style-type: none"> • backup is recommended to avoid losing customer data. • Replace the HDD * Alarm 31-0008 may have occurred in the Host Machine.

NOTE:

When replacing one of the mirrored HDDs, replace the HDD indicated in the controller self-diagnosis result or indicated by the error display of the HDD LED.

Of the two HDDs installed, the HDD installed on the front side is the HDD 1 (on the left in the picture), and the HDD installed on the rear side is the HDD 2 (on the right in the picture).

The location of the LED and the location of the HDD differ depending on the model. A reference example is shown below.



Reference example

● Limitations

- If there is a problem with the test name (SN-1, 2, 8, 12), this diagnosis tool itself will not startup.
- When no PCBs are installed on the Main Controller PCB, the following judgment results are displayed.

Standard PCB: [NG]

Optional PCB: [OK]

However, [NO] is displayed in detailed error information for optional PCBs.



Error/Jam/Alarm

Outline.....	747
Error Code.....	754
Error Code (FAX).....	977
Limited Functions Mode.....	980
Alarm Code.....	981
Jam Code.....	1039

Outline

This chapter describes various codes which are displayed when a failure occurs on the product. These are classified into 3 codes as follows.

Code type	Explanation
Error code	This code is displayed when an error occurs on the machine.
Jam code	This code is displayed when a jam occurs inside the machine.
Alarm code	This code is displayed when a function of the machine is malfunctioned.

Error code notation

An error code is shown in 7-digit [E000XXX] on the display on the operation panel. However, [000] in 2 to 4 digit is not used. Thus, an error code is described as [EXXX] using 5 to 7 digit in the service manual. (e.g.: E012 = E000012)

Location Code

Error code, jam code, and alarm code include the location information.

Location information is displayed as 2-digit numbers as follows. In the jam display screen, the "L" row corresponds to the location code.

No.	DATE	TIME1	TIME2	L	CODE	P	CNTR	SIZE
01	0401	1618	1620	02	1400	00	473634	-----
02	0401	1422	1423	00	0205	F0	503838	A4
03	0325	1056	1057	00	0205	F0	251303	A4
04	0324	1057	1059	00	0093	F0	502120	-----
05	0316	1721	1721	00	0205	F0	500558	A4
06	0313	1557	1558	00	0113	01	469400	A4
07	0311	0939	0941	00	0205	01	499686	A4
08	0311	0930	0930	00	0113	02	499603	A4

Location code display example

Device	Location code		
	JAM	ERR	ALARM
imageRUNNER ADVANCE DX 8705/ 8795/ 8786 series	00	Main Controller = 00 Printer engine = 05	Others of listed below
Duplex Color Image Reader Unit	01	04	02,33,50
Paper Deck Unit-E1	00	05	04
POD Deck Lite-C1	00	05	04
Multi Function Professional Puncher-B1	IPC:02 CAN:31	IPC:02 CAN:31	-
Document Insertion Unit-N1	IPC:02 CAN:71	IPC:02 CAN:71	67
Paper Folding Unit-J1	02	02	-
Staple Finisher-W1/Booklet Finisher-W2	02	02	64
Staple Finisher-X1/Booklet Finisher-X1	02	02	61,62,64,65
Staple Finisher-AC1, Booklet Finisher-AC1	02	02	61,62,64,65
Booklet Trimmer-F1	-	02	-
FAX Board	-	07	-

Pickup Position Code

When a jam occurs, the pickup location is indicated with the following pickup position code. (On the jam display screen, the pickup position code is shown in the "P" column.)

Display									
I/O									
Adjust									
Function									
Option									
Test									
Counter									
< JAM > < 1/ 7 > < READY > < LEVEL 1 >									
No.	DATE	TIME1	TIME2	L	CODE	P	CNTR	SIZE	
01	0401	1618	1620	02	1400	00	473634	-----	
02	0401	1422	1423	00	0205	F0	503838	A4	
03	0325	1056	1057	00	0205	F0	251303	A4	
04	0324	1057	1059	00	0D93	F0	502120	-----	
05	0316	1721	1721	00	0205	F0	500558	A4	
06	0313	1557	1558	00	0113	01	469400	A4	
07	0311	0939	0941	00	0205	01	499686	A4	
08	0311	0930	0930	00	0113	02	499603	A4	

Display example of pickup position code

Pickup position code	Pickup position
00	At Finisher jam/At error avoidance jam/At ADF jam without pickup operation (at SEND, Inbox, etc.)
01	Cassette 1
02	Cassette 2
03	Cassette 3
04	Cassette 4
05	Multi-purpose Tray Pickup Assembly
F0	2-sided

Pickup size

When a jam occurs, a paper size is displayed. (The row displaying "SIZE" on the jam screen refers to the paper size.)

Display									
I/O									
Adjust									
Function									
Option									
Test									
Counter									
< JAM > < 1/ 7 > < READY > < LFWFI 1 >									
No.	DATE	TIME1	TIME2	L	CODE	P	CNTR	SIZE	
01	0401	1618	1620	02	1400	00	473634	-----	
02	0401	1422	1423	00	0205	F0	503838	A4	
03	0325	1056	1057	00	0205	F0	251303	A4	
04	0324	1057	1059	00	0D93	F0	502120	-----	
05	0316	1721	1721	00	0205	F0	500558	A4	
06	0313	1557	1558	00	0113	01	469400	A4	
07	0311	0939	0941	00	0205	01	499686	A4	
08	0311	0930	0930	00	0113	02	499603	A4	

Due to the limitation of displayable number of characters, some paper size names are omitted. The following is the list of displayed row of texts and corresponding paper sizes.

* The following is based on the display specification and not all paper sizes can actually be used.

Display	Paper Size	Display	Paper Size
A0	A0	LDR	LEDGER
A1	A1	LDRFB	LEDGERFULLBLEED
A2	A2	LGL	LEGAL
A3	A3	LTR	LETTER
A3FB	A3FULLBLEED	EXE	EXECUTIVE
A4	A4	STMT	STATEMENT
A5	A5	10x8	10x8
A6	A6	12x18	12x18
A7	A7	13x19	13x19
I-B0	ISOB0	15x11	15x11
I-B1	ISOB1	17x22	17x22
I-B2	ISOB2	18x24	18x24
I-B3	ISOB3	A-FLS	Australian-FOOLSCAP
I-B4	ISOB4	ALGL	Argentina-LEGAL
I-B5	ISOB5	ALTR	Argentina-LETTER
I-B6	ISOB6	OFI	OFICIO
I-B7	ISOB7	A-OFI	Argentina-OFICIO
I-C0	ISOC0	B-OFI	Bolivia-OFICIO
I-C1	ISOC1	E-OFI	Ecuador-OFICIO
I-C2	ISOC2	M-OFI	Mexico-OFICIO
I-C3	ISOC3	KLGL	Korea-LEGAL
I-C4	ISOC4	GLGL	Government-LEGAL
I-C5	ISOC5	GLTR	Government-LETTER
I-C6	ISOC6	IND-LGL	India-LEGAL
I-C7	ISOC7	COM10	COM10
I-SRA3	SRA3	DL	DL
J-B0	JISB0	E_C2	Nagagata 2
J-B1	JISB1	E_C3	Nagagata 3
J-B2	JISB2	E_C4	Nagagata 4
J-B3	JISB3	E_C5	Nagagata 5
J-B4	JISB4	E-K2	Kakugata 2
J-B5	JISB5	E_K3	Kakugata 3
J-B6	JISB6	E_K4	Kakugata 4
J-B7	JISB7	E_K5	Kakugata 5
K16	K16	E_K6	Kakugata 6
K8	K8	E_K7	Kakugata 7
ND-PCD	Newdry Postcard	E_K8	Kakugata 8
OTHER	OTHER	E_Y1	Yougata 1
PCARD	Postcard	E-Y2	Yougata 2
PCARD4	4 on 1 Postcard	E_Y3	Yougata 3
F4A	F4A	E-Y4	Yougata 4
F4B	F4B	E_Y5	Yougata 5
FLSC	FOOLCAP	E_Y6	Yougata 6
FOLIO	FLIO	E_Y7	Yougata 7
FREE	FREE SIZE	EVLP_YN3	Yougatanaga 3
ICARD	INDEXCARD	E-B5	B5 Envelope
USER	Custom	E-C5	C5 Envelope
		MONA	MONARCH
		EVLP	Unknown size envelope

Points to Note When Clearing MN-CON

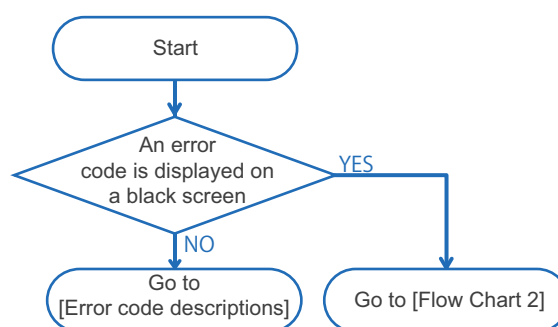
- Execution of clearing MN-COM deletes all data in Address Book, Forwarding Settings, Settings/Registration (Adjustment/Maintenance, Function Settings, Set Destination, Management Settings, TPM Settings), etc. Before execution of this operation, ask user to back up the data and get approval for this operation.
- Clearing MN-CON will clear the service mode setting values. Be sure to enter the service mode setting values again in accordance with the configuration of the options of the host machine and requests from the user.
- When clearing MN-CON while any login application other than User Authentication is, error such as not displayed login screen occurred. In this case, access SMS once and switch login application to User Authentication to recover to the normal status.

Points to Note When Clearing HDD

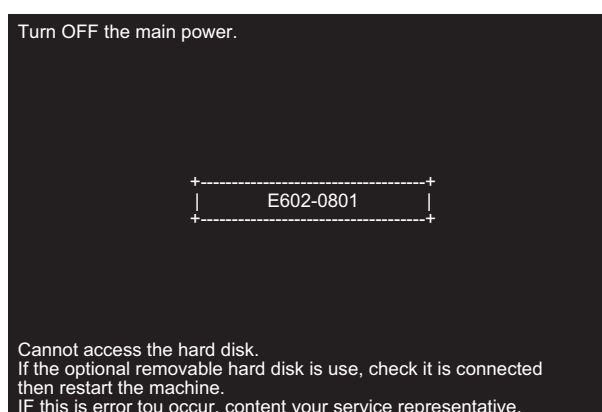
As a remedy for error codes (E602-XXXX), HDD partition is selected and the target partition may be cleared. When clearing partition, be sure to check which data will be deleted by referring Detail of HDD partition and explain to the user before starting work.

Remedies to be performed when E602-xxxx or E614-xxxx error is displayed

Remedy procedure for E602 or E614 differs according to the status of the screen where error is displayed. Check the remedy procedure by referring to the following flow chart.

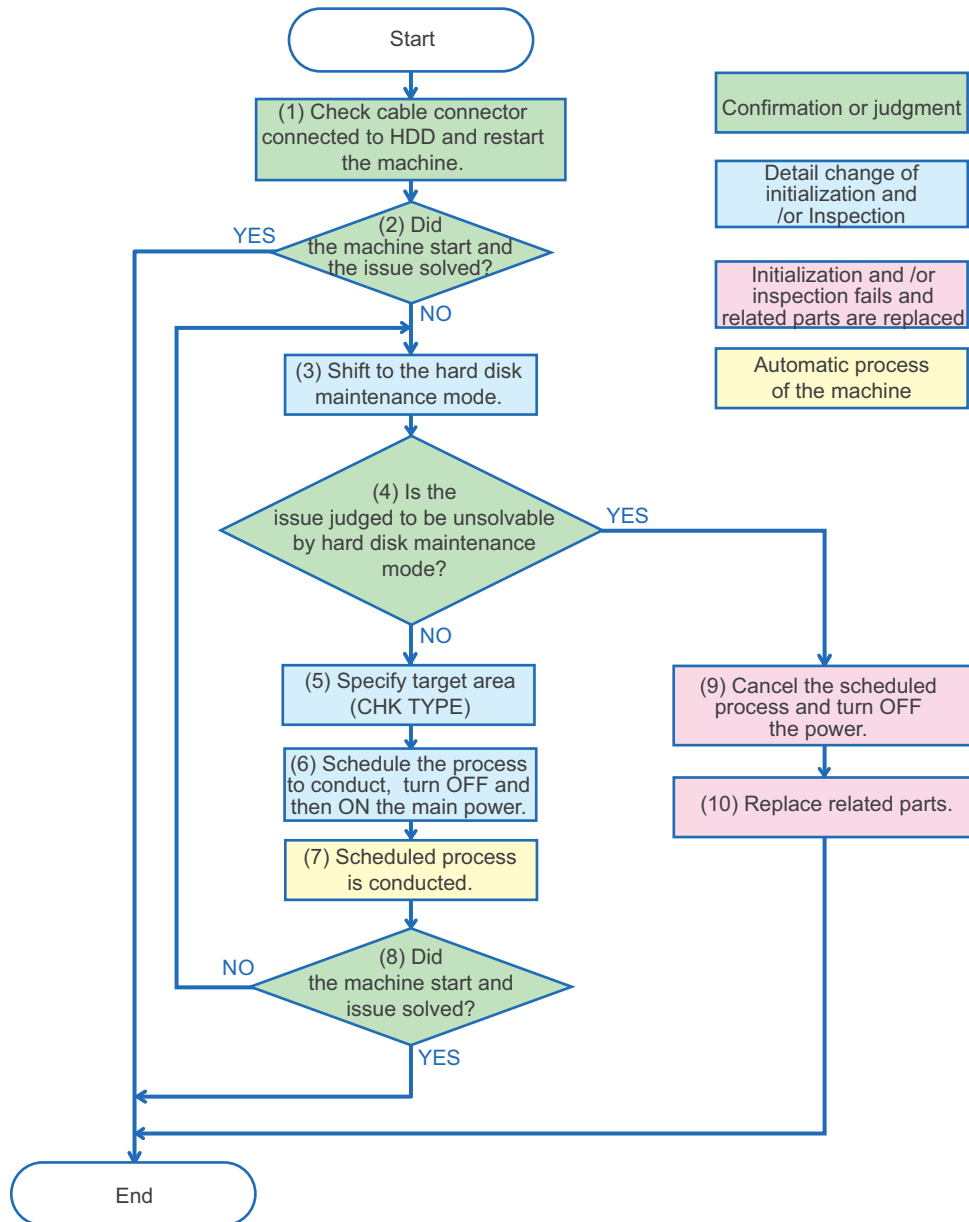


Flow Chart 1



Display Sample : If an error code is displayed on a black screen

Execute a remedy described in service mode by referring to [Error / Jam / Alarm](#) in the Service Manual. If an error code and a message is displayed on a black screen (as above), shift to the hard disk maintenance mode referring to the Flow Chart 2 and execute the remedy described in [Error / Jam / Alarm](#) in the Service Manual.



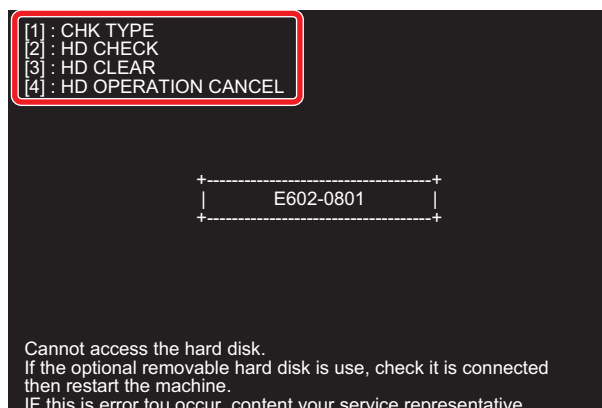
Flow Chart 2

CAUTION:

Numbers in the Flow Chart 2 are corresponding to the procedure numbers. Check the remedy procedure by referring to the flow chart.

1. Check cable connector connected to the hard disk and restart the machine.
2. Check if the machine is started normally. If the machine is started normally, the analysis is complete.

3. If the machine is not started normally, execute key operation to shift to the service mode for shifting to hard disk maintenance mode.

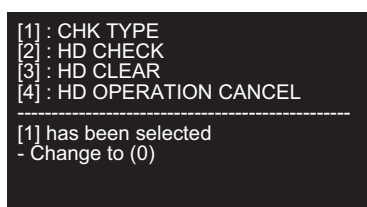


Example of hard disk maintenance mode screen

4. Determine if the issue is solved in the hard disk maintenance mode.

- Proceed to 5 for diagnosis for the first time or trying to restore with the hard disk maintenance mode.
- If the issue cannot be solved by hard disk maintenance (HD-CHECK/HD-CLEAR is not executed or issue unsolved even executed), proceed to 9.

5. Press "1" of Numeric Keypad, then two digits number to specify the target area (CHK TYPE).



CAUTION:

The CHK - TYPE to be specified needs to be entered in two digits even the number to be specified is one digit. Enter "01" to specify "1" and enter "04" to specify "4".

For example, in the case of the display (E602-0801), specify No. 8 because Partition No. 8 is in error. (Enter the number as "08")

If you made a mistake, press "1" again then enter two digits number.

6. Specify and schedule the process stated as a remedy for error code by referring to the Flow chart No.6, "Error / Jam / Alarm" in the Service Manual. Then turn OFF and then ON the main power of the machine.

- To schedule disk check (COPIER > FUNCTION > SYSTEM >HD-CHECK), select [2]:HD-CHECK.
- To schedule formatting (COPIER / FUNCTION / SYSTEM /HD-CLEAR), select [3]:HD CLEAR.

NOTE:

When the menu [2] to [4] is selected, key cannot be re-entered. If you made a wrong selection, Turn OFF and then ON the main power of the machine, shift to hard disk maintenance mode and specify again.

7. Scheduled process is automatically executed.

8. If the process is complete and the machine is restarted normally, analysis is complete.

The same black screen and the error code is displayed, shift back to the hard disk maintenance mode and conduct other maintenance.

9. Consider the HDD cannot be restored, select [4] and cancel the schedule. Switch OFF the main power of the machine.

```
[1] : CHK TYPE
[2] : HD CHECK
[3] : HD CLEAR
[4] : HD OPERATION CANCEL
```

```
-----
[4] has been selected
Turn OFF the main power.
```

CAUTION:

Replacing HDD without canceling the schedule causes the scheduled process is executed to replaced HDD at the next normal startup.

When replacing parts, specify [4] to cancel the schedule.

10. Refer to the Service Manual to replace the related parts.

NOTE:

Related parts for E602

- Harness between main controller PCB and the HDD
- HDD
- Main Controller PCB

Related parts for E614

- Flash PCB
- Main Controller PCB

Error Code

Error Code Details

E000-0001-05	Fixing Thermistor low temperature detection error
Detection Description	After temperature control of the Fixing Roller, the Fixing Main Thermistor detected 70 deg C or lower.
Remedy	<p>[Related parts]</p> <ul style="list-style-type: none"> - Harness between the Main Driver PCB (UN78/J129, J104 and J105) and the Fixing Drawer Unit (J3001) (Unit of replacement: CABLE, FIXING DRAWER) - Harness between the Fixing Main Thermistor (THM01/J3271) and the Fixing Drawer Unit (J3200) (Unit of replacement: CABLE, FIXING DC DRAWER) - Harnesses from the Main Driver PCB to the Fixing Power Supply PCB 1. Main Driver PCB (UN78/J118 and J119) to Relay Connector (19P and 13P) (Unit of replacement: CABLE, MAIN DRIVER IH) 2. Relay Connector (19P and 13P) to Fixing Power Supply PCB (UN3/J316 and J313) (Unit of replacement: CABLE, IH SIGNAL) - Harness between the Fixing Power Supply PCB (UN3/J9004) and the Fixing Heater (CB1005) (Unit of replacement: CABLE, IH DRAWER) - Harness between the Main Driver PCB (UN78/J108 and J101) and the Relay PCB (UN86/J522 and J515) (Unit of replacement: CABLE, SIGNAL) - Harness between the DC Controller PCB (UN1/J414, J411, J412 and J413) and the Main Driver PCB (UN78/J128, J126, J125 and J124) (Unit of replacement: CABLE, SIGNAL) - Fixing Heater Unit (CB1005) - Fixing Main Thermistor (THM01) (Unit of replacement: THERMISTOR UNIT, MAIN) - Fixing Power Supply PCB (UN3) (Unit of replacement: IH POWER SUPPLY PCB ASS'Y) - Main Driver PCB (UN78) (Unit of replacement: MAIN DRIVE DRIVER PCB ASS'Y) - Relay PCB (UN86) (Unit of replacement: RELAY PCB ASSEMBLY) - DC Controller PCB (UN1) (Unit of replacement: DC CONTROLLER PCB ASS'Y) <p>[Remedy] Check/replace the related harness/cable, connector and parts. After performing the remedy work, go through the following to clear the error: COPIER> FUNCTION> CLEAR> ERR.</p> <p>[Reference] Before replacing the DC Controller PCB, back up the service mode data (approx. 2 min) and restore the backup data after the replacement so the data may be able to be protected.</p> <ul style="list-style-type: none"> - Backup: COPIER (LEVEL2)> FUNCTION> SYSTEM> DSRAMBUP - Restoration: COPIER (LEVEL2)> FUNCTION> SYSTEM> DSRAMRES

E000-0002-05	Fixing Thermistor low temperature detection error
Detection Description	After temperature control of the Fixing Roller, the Fixing Main Thermistor detected 10 deg C or lower.
Remedy	<p>[Related parts]</p> <ul style="list-style-type: none"> - Harness between the Main Driver PCB (UN78/J129, J104 and J105) and the Fixing Drawer Unit (J3001) (Unit of replacement: CABLE, FIXING DRAWER) - Harness between the Fixing Main Thermistor (THM01/J3271) and the Fixing Drawer Unit (J3200) (Unit of replacement: CABLE, FIXING DC DRAWER) - Harnesses from the Main Driver PCB to the Fixing Power Supply PCB <ol style="list-style-type: none"> 1. Main Driver PCB (UN78/J118 and J119) to Relay Connector (19P and 13P) (Unit of replacement: CABLE, MAIN DRIVER IH) 2. Relay Connector (19P and 13P) to Fixing Power Supply PCB (UN3/J316 and J313) (Unit of replacement: CABLE, IH SIGNAL) - Harness between the Fixing Power Supply PCB (UN3/J9004) and the Fixing Heater (CB1005) (Unit of replacement: CABLE, IH DRAWER) - Harness between the Main Driver PCB (UN78/J108 and J101) and the Relay PCB (UN86/J522 and J515) (Unit of replacement: CABLE, SIGNAL) - Harness between the DC Controller PCB (UN1/J414, J411, J412 and J413) and the Main Driver PCB (UN78/J128, J126, J125 and J124) (Unit of replacement: CABLE, SIGNAL) - Fixing Heater Unit (CB1005) - Fixing Main Thermistor (THM01) (Unit of replacement: THERMISTOR UNIT, MAIN) - Fixing Power Supply PCB (UN3) (Unit of replacement: IH POWER SUPPLY PCB ASS'Y) - Main Driver PCB (UN78) (Unit of replacement: MAIN DRIVE DRIVER PCB ASS'Y) - Relay PCB (UN86) (Unit of replacement: RELAY PCB ASSEMBLY) - DC Controller PCB (UN1) (Unit of replacement: DC CONTROLLER PCB ASS'Y) <p>[Remedy] Check/replace the related harness/cable, connector and parts. After performing the remedy work, go through the following to clear the error: COPIER> FUNCTION> CLEAR> ERR.</p> <p>[Reference] Before replacing the DC Controller PCB, back up the service mode data (approx. 2 min) and restore the backup data after the replacement so the data may be able to be protected.</p> <ul style="list-style-type: none"> - Backup: COPIER (LEVEL2)> FUNCTION> SYSTEM> DSRAMBUP - Restoration: COPIER (LEVEL2)> FUNCTION> SYSTEM> DSRAMRES
E000-0010-05	Fixing Thermistor low temperature detection error
Detection Description	Turning OFF and then ON the power without clearing the error.
Remedy	<p>[Remedy]</p> <p>Go through the following to clear the error: COPIER> FUNCTION> CLEAR> ERR.</p>

E001-0002-05	Fixing Thermistor high temperature detection error
Detection Description	The Fixing Main Thermistor in the Fixing Assembly detected 230 deg C or higher.
Remedy	<p>[Related parts]</p> <ul style="list-style-type: none"> - Harness between the Main Driver PCB (UN78/J129, J104 and J105) and the Fixing Drawer Unit (J3001) (Unit of replacement: CABLE, FIXING DRAWER) - Harness between the Fixing Thermistor (THM01/J3271, THM02/J3206 and THM04/J3204) and the Fixing Drawer Unit (J3200) (Unit of replacement: CABLE, FIXING DC DRAWER) - Harnesses from the Main Driver PCB to the Fixing Power Supply PCB <ol style="list-style-type: none"> 1. Main Driver PCB (UN78/J118 and J119) to Relay Connector (19P and 13P) (Unit of replacement: CABLE, MAIN DRIVER IH) 2. Relay Connector (19P and 13P) to Fixing Power Supply PCB (UN3/J316 and J313) (Unit of replacement: CABLE, IH SIGNAL) - Harness between the Main Driver PCB (UN78/J108 and J101) and the Relay PCB (UN86/J522 and J515) (Unit of replacement: CABLE, SIGNAL) - Harness between the DC Controller PCB (UN1/J414, J411, J412 and J413) and the Main Driver PCB (UN78/J128, J126, J125 and J124) (Unit of replacement: CABLE, SIGNAL) - Fixing Main Thermistor (THM01) (Unit of replacement: THERMISTOR UNIT, MAIN) - Fixing Sub Thermistor 1 and 2 (THM02 and THM04) (Unit of replacement: THERMISTOR UNIT, SUB) - Fixing Upper Unit (Unit of replacement: FIXING ASS'Y, UPPER) - Fixing Power Supply PCB (UN3) (Unit of replacement: IH POWER SUPPLY PCB ASS'Y) - Main Driver PCB (UN78) (Unit of replacement: MAIN DRIVE DRIVER PCB ASS'Y) - Relay PCB (UN86) (Unit of replacement: RELAY PCB ASSEMBLY) - DC Controller PCB (UN1) (Unit of replacement: DC CONTROLLER PCB ASS'Y) <p>[Remedy] Check/replace the related harness/cable, connector and parts. After performing the remedy work, go through the following to clear the error: COPIER> FUNCTION> CLEAR> ERR.</p> <p>[Reference] Before replacing the DC Controller PCB, back up the service mode data (approx. 2 min) and restore the backup data after the replacement so the data may be able to be protected.</p> <ul style="list-style-type: none"> - Backup: COPIER (LEVEL2)> FUNCTION> SYSTEM> DSRAMBUP - Restoration: COPIER (LEVEL2)> FUNCTION> SYSTEM> DSRAMRES

E001-0003-05	Fixing Thermistor high temperature detection error
Detection Description	The FixingThermistor detects hardware overheating.
Remedy	<p>[Related parts]</p> <ul style="list-style-type: none"> - Harness between the Main Driver PCB (UN78/J129, J104 and J105) and the Fixing Drawer Unit (J3001) (Unit of replacement: CABLE, FIXING DRAWER) - Harness between the Fixing Thermistor (THM01/J3271, THM02/J3206 and THM04/J3204) and the Fixing Drawer Unit (J3200) (Unit of replacement: CABLE, FIXING DC DRAWER) - Harnesses from the Main Driver PCB to the Fixing Power Supply PCB <ol style="list-style-type: none"> 1. Main Driver PCB (UN78/J118 and J119) to Relay Connector (19P and 13P) (Unit of replacement: CABLE, MAIN DRIVER IH) 2. Relay Connector (19P and 13P) to Fixing Power Supply PCB (UN3/J316 and J133) (Unit of replacement: CABLE, IH SIGNAL) - Harness between the Main Driver PCB (UN78/J108 and J101) and the Relay PCB (UN86/J522 and J515) (Unit of replacement: CABLE, SIGNAL) - Harness between the DC Controller PCB (UN1/J414, J411, J412 and J413) and the Main Driver PCB (UN78/J128, J126, J125 and J124) (Unit of replacement: CABLE, SIGNAL) - Fixing Main Thermistor (THM01) (Unit of replacement: THERMISTOR UNIT, MAIN) - Fixing Sub Thermistor 1 and 2 (THM02 and THM04) (Unit of replacement: THERMISTOR UNIT, SUB) - Fixing Upper Unit (Unit of replacement: FIXING ASS'Y, UPPER) - Fixing Power Supply PCB (UN3) (Unit of replacement: IH POWER SUPPLY PCB ASS'Y) - Main Driver PCB (UN78) (Unit of replacement: MAIN DRIVE DRIVER PCB ASS'Y) - Relay PCB (UN86) (Unit of replacement: RELAY PCB ASSEMBLY) - DC Controller PCB (UN1) (Unit of replacement: DC CONTROLLER PCB ASS'Y) <p>[Remedy] Check/replace the related harness/cable, connector and parts. After performing the remedy work, go through the following to clear the error: COPIER> FUNCTION> CLEAR> ERR.</p> <p>[Reference] Before replacing the DC Controller PCB, back up the service mode data (approx. 2 min) and restore the backup data after the replacement so the data may be able to be protected.</p> <ul style="list-style-type: none"> - Backup: COPIER (LEVEL2)> FUNCTION> SYSTEM> DSRAMBUP - Restoration: COPIER (LEVEL2)> FUNCTION> SYSTEM> DSRAMRES

E001-0004-05	Fixing Thermistor high temperature detection error
Detection Description	Abnormal temperature difference among the Thermistors was detected.
Remedy	<p>[Related parts]</p> <ul style="list-style-type: none"> - Harness between the Main Driver PCB (UN78/J129, J104 and J105) and the Fixing Drawer Unit (J3001) (Unit of replacement: CABLE, FIXING DRAWER) - Harness between the Fixing Thermistor (THM01/J3271, THM02/J3206 and THM04/J3204) and the Fixing Drawer Unit (J3200) (Unit of replacement: CABLE, FIXING DC DRAWER) - Harnesses from the Main Driver PCB to the Fixing Power Supply PCB <ol style="list-style-type: none"> 1. Main Driver PCB (UN78/J118 and J119) to Relay Connector (19P and 13P) (Unit of replacement: CABLE, MAIN DRIVER IH) 2. Relay Connector (19P and 13P) to Fixing Power Supply PCB (UN3/J316 and J313) (Unit of replacement: CABLE, IH SIGNAL) - Harness between the Main Driver PCB (UN78/J108 and J101) and the Relay PCB (UN86/J522 and J515) (Unit of replacement: CABLE, SIGNAL) - Harness between the DC Controller PCB (UN1/J414, J411, J412 and J413) and the Main Driver PCB (UN78/J128, J126, J125 and J124) (Unit of replacement: CABLE, SIGNAL) - Fixing Main Thermistor (THM01) (Unit of replacement: THERMISTOR UNIT, MAIN) - Fixing Sub Thermistor 1 and 2 (THM02 and THM04) (Unit of replacement: THERMISTOR UNIT, SUB) - Fixing Upper Unit (Unit of replacement: FIXING ASS'Y, UPPER) - Fixing Power Supply PCB (UN3) (Unit of replacement: IH POWER SUPPLY PCB ASS'Y) - Main Driver PCB (UN78) (Unit of replacement: MAIN DRIVE DRIVER PCB ASS'Y) - Relay PCB (UN86) (Unit of replacement: RELAY PCB ASSEMBLY) - DC Controller PCB (UN1) (Unit of replacement: DC CONTROLLER PCB ASS'Y) <p>[Remedy] Check/replace the related harness/cable, connector and parts. After performing the remedy work, go through the following to clear the error: COPIER> FUNCTION> CLEAR> ERR.</p> <p>[Reference] Before replacing the DC Controller PCB, back up the service mode data (approx. 2 min) and restore the backup data after the replacement so the data may be able to be protected.</p> <ul style="list-style-type: none"> - Backup: COPIER (LEVEL2)> FUNCTION> SYSTEM> DSRAMBUP - Restoration: COPIER (LEVEL2)> FUNCTION> SYSTEM> DSRAMRES
E001-0010-05	Fixing Thermistor high temperature detection error
Detection Description	Turning OFF and then ON the power without clearing the error.
Remedy	<p>[Remedy]</p> <p>Go through the following to clear the error: COPIER> FUNCTION> CLEAR> ERR.</p>

E002-0001-05	Fixing Thermistor temperature increase detection error
Detection Description	After the start of temperature control of the Fixing Roller, the Fixing Main Thermistor detected abnormal temperature rise.
Remedy	<p>[Related parts]</p> <ul style="list-style-type: none"> - Harness between the Main Driver PCB (UN78/J129, J104 and J105) and the Fixing Drawer Unit (J3001) (Unit of replacement: CABLE, FIXING DRAWER) - Harness between the Fixing Main Thermistor (THM01/J3271) and the Fixing Drawer Unit (J3200) (Unit of replacement: CABLE, FIXING DC DRAWER) - Harnesses from the Main Driver PCB to the Fixing Power Supply PCB <ol style="list-style-type: none"> 1. Main Driver PCB (UN78/J118 and J119) to Relay Connector (19P and 13P) (Unit of replacement: CABLE, MAIN DRIVER IH) 2. Relay Connector (19P and 13P) to Fixing Power Supply PCB (UN3/J316 and J313) (Unit of replacement: CABLE, IH SIGNAL) - Harness between the Main Driver PCB (UN78/J108 and J101) and the Relay PCB (UN86/J522 and J515) (Unit of replacement: CABLE, SIGNAL) - Harness between the DC Controller PCB (UN1/J414, J411, J412 and J413) and the Main Driver PCB (UN78/J128, J126, J125 and J124) (Unit of replacement: CABLE, SIGNAL) - Fixing Main Thermistor (THM01) (Unit of replacement: THERMISTOR UNIT, MAIN) - Fixing Upper Unit (Unit of replacement: FIXING ASS'Y, UPPER) - Fixing Power Supply PCB (UN3) (Unit of replacement: IH POWER SUPPLY PCB ASS'Y) - Main Driver PCB (UN78) (Unit of replacement: MAIN DRIVE DRIVER PCB ASS'Y) - Relay PCB (UN86) (Unit of replacement: RELAY PCB ASSEMBLY) - DC Controller PCB (UN1) (Unit of replacement: DC CONTROLLER PCB ASS'Y) <p>[Remedy] Check/replace the related harness/cable, connector and parts. After performing the remedy work, go through the following to clear the error: COPIER> FUNCTION> CLEAR> ERR.</p> <p>[Reference] Before replacing the DC Controller PCB, back up the service mode data (approx. 2 min) and restore the backup data after the replacement so the data may be able to be protected.</p> <ul style="list-style-type: none"> - Backup: COPIER (LEVEL2)> FUNCTION> SYSTEM> DSRAMBUP - Restoration: COPIER (LEVEL2)> FUNCTION> SYSTEM> DSRAMRES
E002-0010-05	Fixing Thermistor low temperature detection error
Detection Description	Turning OFF and then ON the power without clearing the error.
Remedy	<p>[Remedy]</p> <p>Go through the following to clear the error: COPIER> FUNCTION> CLEAR> ERR.</p>

E003-0000-05	Fixing Thermistor temperature decrease error
Detection Description	The Fixing Main Thermistor detects 70 degC or lower for 2 seconds or longer although the temperature reached above 100 degC after starting the Fixing Roller temperature control.
Remedy	<p>[Related parts]</p> <ul style="list-style-type: none"> - Harness between the Main Driver PCB (UN78/J129, J104 and J105) and the Fixing Drawer Unit (J3001) (Unit of replacement: CABLE, FIXING DRAWER) - Harness between the Fixing Main Thermistor (THM01/J3271) and the Fixing Drawer Unit (J3200) (Unit of replacement: CABLE, FIXING DC DRAWER) - Harnesses from the Main Driver PCB to the Fixing Power Supply PCB <ol style="list-style-type: none"> 1. Main Driver PCB (UN78/J118 and J119) to Relay Connector (19P and 13P) (Unit of replacement: CABLE, MAIN DRIVER IH) 2. Relay Connector (19P and 13P) to Fixing Power Supply PCB (UN3/J316 and J313) (Unit of replacement: CABLE, IH SIGNAL) - Harness between the Main Driver PCB (UN78/J108 and J101) and the Relay PCB (UN86/J522 and J515) (Unit of replacement: CABLE, SIGNAL) - Harness between the DC Controller PCB (UN1/J414, J411, J412 and J413) and the Main Driver PCB (UN78/J128, J126, J125 and J124) (Unit of replacement: CABLE, SIGNAL) - Fixing Main Thermistor (THM01) (Unit of replacement: THERMISTOR UNIT, MAIN) - Fixing Upper Unit (Unit of replacement: FIXING ASS'Y, UPPER) - Fixing Power Supply PCB (UN3) (Unit of replacement: IH POWER SUPPLY PCB ASS'Y) - Main Driver PCB (UN78) (Unit of replacement: MAIN DRIVE DRIVER PCB ASS'Y) - Relay PCB (UN86) (Unit of replacement: RELAY PCB ASSEMBLY) - DC Controller PCB (UN1) (Unit of replacement: DC CONTROLLER PCB ASS'Y) <p>[Remedy] Check/replace the related harness/cable, connector and parts. After performing the remedy work, go through the following to clear the error: COPIER> FUNCTION> CLEAR> ERR.</p> <p>[Reference] Before replacing the DC Controller PCB, back up the service mode data (approx. 2 min) and restore the backup data after the replacement so the data may be able to be protected.</p> <ul style="list-style-type: none"> - Backup: COPIER (LEVEL2)> FUNCTION> SYSTEM> DSRAMBUP - Restoration: COPIER (LEVEL2)> FUNCTION> SYSTEM> DSRAMRES
E003-0010-05	Fixing Thermistor low temperature detection error
Detection Description	Turning OFF and then ON the power without clearing the error.
Remedy	<p>[Remedy]</p> <p>Go through the following to clear the error: COPIER> FUNCTION> CLEAR> ERR.</p>
E004-0001-05	Fixing Power Supply error
Detection Description	An error in the fixing current was detected.
Remedy	<p>[Related parts]</p> <ul style="list-style-type: none"> - Harnesses from the Main Driver PCB to the Fixing Power Supply PCB <ol style="list-style-type: none"> 1. Main Driver PCB (UN78/J118 and J119) to Relay Connector (19P and 13P) (Unit of replacement: CABLE, MAIN DRIVER IH) 2. Relay Connector (19P and 13P) to Fixing Power Supply PCB (UN3/J316 and J313) (Unit of replacement: CABLE, IH SIGNAL) - Fixing Power Supply PCB (UN3) (Unit of replacement: IH POWER SUPPLY PCB ASS'Y) - Main Driver PCB (UN78) (Unit of replacement: MAIN DRIVE DRIVER PCB ASS'Y) <p>[Remedy] Check/replace the related harness/cable, connector and parts. After performing the remedy work, go through the following to clear the error: COPIER> FUNCTION> CLEAR> ERR.</p>
E004-0010-05	Fixing Thermistor low temperature detection error
Detection Description	Turning OFF and then ON the power without clearing the error.
Remedy	<p>[Remedy]</p> <p>Go through the following to clear the error: COPIER> FUNCTION> CLEAR> ERR.</p>

E004-0205-05	Fixing Power Supply error
Detection Description	Detect that the Fixing Main Thermistor is not connected.
Remedy	<p>[Related parts]</p> <ul style="list-style-type: none"> - Harness between the Main Driver PCB (UN78/J104 and J105) and the Fixing Drawer Unit (J3001) (Unit of replacement: CABLE, FIXING DRAWER) - Harness between the Fixing Drawer Unit (J3200) and the Fixing Main Thermistor (THM01/J3271) (Unit of replacement: CABLE, FIXING DC DRAWER) - Fixing Main Thermistor (Unit of replacement: THERMISTOR UNIT, MAIN) - Main Driver PCB (UN78) (Unit of replacement: MAIN DRIVE DRIVER PCB ASS'Y) <p>[Remedy] Check/replace the related harness/cable, connector and parts. After performing the remedy work, go through the following to clear the error: COPIER> FUNCTION> CLEAR> ERR.</p>
E005-0000-05	Fixing Cleaning Web absent error
Detection Description	After noticing the Fixing Cleaning Web absent, the web was pulled out 65250 times.
Remedy	<p>[Related parts]</p> <ul style="list-style-type: none"> - DC Controller PCB (UN1) (Unit of replacement: DC CONTROLLER PCB ASS'Y) <p>[Remedy] Perform the following in the order while checking whether the error is cleared.</p> <ol style="list-style-type: none"> 1. Replace the Fixing Cleaning Web. (Unit of replacement: CLEANER SUPPLY ROLL) 2. Replace the Fixing Cleaning Web Level Sensor (PS45). 3. Replace the DC Controller PCB (UN1). (Unit of replacement: DC CONTROLLER PCB ASS'Y) <p>After performing the remedy work, perform the following.</p> <ul style="list-style-type: none"> - Clear the counter value of the Fixing Cleaning Web (COPIER> COUNTER> MISC> FIXWEB). Then, turn OFF and then ON the main power. - Go through the following to clear the error: COPIER> FUNCTION> CLEAR> ERR. <p>[Reference] Before replacing the DC Controller PCB, back up the service mode data (approx. 2 min) and restore the backup data after the replacement so the data may be able to be protected.</p> <ul style="list-style-type: none"> - Backup: COPIER (LEVEL2)> FUNCTION> SYSTEM> DSRAMBUP - Restoration: COPIER (LEVEL2)> FUNCTION> SYSTEM> DSRAMBUP
E005-0001-05	Error in Fixing Cleaning Web Drive Solenoid connection
Detection Description	Disconnection of the Fixing Cleaning Web Drive Solenoid was detected at power-on.
Remedy	<p>[Related parts]</p> <ul style="list-style-type: none"> - Harnesses from the Fixing Cleaning Web Drive Solenoid to the Fixing Drawer Unit <ol style="list-style-type: none"> 1. Fixing Cleaning Web Drive Solenoid (SL09/J2162) to Relay Connector (9P) to Relay Connector (9P) (Unit of replacement: CABLE, FIXING MOTOR, 1, CABLE, FIXING MOTOR) 2. Relay Connector (9P) to Fixing Drawer Unit (J3200) (Unit of replacement: CABLE, FIXING DC DRAWER) <ul style="list-style-type: none"> - Harness between the Main Driver PCB (UN78/J129, J104 and J105) and the Fixing Drawer Unit (J3001) (Unit of replacement: CABLE, FIXING DRAWER) - Harness between the Main Driver PCB (UN78/J108 and J101) and the Relay PCB (UN86/J522 and J515) (Unit of replacement: CABLE, SIGNAL) - Harness between the Relay PCB (UN86/J512) and the DC Power Supply PCB (24V) (J202A) (Unit of replacement: CABLE, DC 24V, A) - Harness between the Relay PCB (UN86/J513) and the DC Power Supply PCB (24V) (J202B) (Unit of replacement: CABLE, DC 24V, B) - Harness between the AC Driver PCB (UN20/J606) and the DC Power Supply PCB (24V) (J102A/J102B) (Unit of replacement: CABLE, AC MAIN) - Harness between the AC Driver PCB (UN20/J611) and the Relay PCB (UN86/J507F) (Unit of replacement: CABLE, AC DRIVER RELAY) - Fixing Cleaning Web Drive Solenoid (SL09) - DC Power Supply PCB (24V) (Unit of replacement: 24V POWER SUPPLY ASS'Y, LEFT) - DC Power Supply PCB (24V) (Unit of replacement: 24V POWER SUPPLY ASS'Y, RIGHT) - Relay PCB (UN86) (Unit of replacement: RELAY PCB ASSEMBLY) - Main Driver PCB (UN78) (Unit of replacement: MAIN DRIVE DRIVER PCB ASS'Y) - AC Driver PCB (Unit of replacement: AC DRIVER PCB ASS'Y) <p>[Remedy] Check/replace the related harness/cable, connector and parts. After performing the remedy work, go through the following to clear the error: COPIER> FUNCTION> CLEAR> ERR.</p>

E012-0001-05	Drum Motor error
Detection Description	Lock error of the Drum Motor was detected.
Remedy	<p>[Related parts]</p> <ul style="list-style-type: none"> - Harness between the Main Driver PCB (UN78/J109) and the Drum Motor (M01/J2138) (Unit of replacement: CABLE, MAIN, REAR UPPER) - Harnesses from the Relay PCB to the Drum Motor <ol style="list-style-type: none"> 1. Relay PCB (UN86/J520) to Relay Connector (5P) (Unit of replacement: CABLE, SIGNAL) 2. Relay Connector (5P) to Drum Motor (M01/J2151) (Unit of replacement: CABLE, MAIN, REAR UPPER) - Drum Motor (M01) - Drum Drive Unit (Unit of replacement: DRUM DRIVE ASS'Y) - Main Driver PCB (UN78) (Unit of replacement: MAIN DRIVE DRIVER PCB ASS'Y) - Relay PCB (UN86) (Unit of replacement: RELAY PCB ASSEMBLY) - DC Controller PCB (UN1) (Unit of replacement: DC CONTROLLER PCB ASS'Y) <p>[Remedy] Perform the following in the order while checking whether the error is cleared.</p> <ul style="list-style-type: none"> - If the gear group of the Drum Drive Unit is not rotated, replace the unit. - Check/replace the related harness/cable, connector and parts. <p>[Reference] Before replacing the DC Controller PCB, back up the service mode data (approx. 2 min) and restore the backup data after the replacement so the data may be able to be protected.</p> <ul style="list-style-type: none"> - Backup: COPIER (LEVEL2)> FUNCTION> SYSTEM> DSRAMBUP - Restoration: COPIER (LEVEL2)> FUNCTION> SYSTEM> DSRAMRES
E013-0001-05	Waste Toner Lock detection error
Detection Description	The Waste Toner Lock Detection Switch detects locked at power-on.
Remedy	<p>[Related parts]</p> <ul style="list-style-type: none"> - Harness between the Main Driver PCB (UN78/J103) and the Waste Toner Lock Detection Switch (SW05/J3050) (Unit of replacement: CABLE, MAIN DRIVER RELAY) - Waste Toner Lock Detection Switch (SW05) (Unit of replacement: CABLE, LOCK DETECT SWITCH) - Main Driver PCB (UN78) (Unit of replacement: MAIN DRIVE DRIVER PCB ASS'Y) <p>[Remedy] Check/replace the related harness/cable, connector and parts.</p>
E013-0002-05	Waste Toner Lock detection error
Detection Description	The Waste Toner Lock Detection Switch detects locked while the Developing Assembly is driven.
Remedy	<p>[Related parts]</p> <ul style="list-style-type: none"> - Harness between the Main Driver PCB (UN78/J103) and the Waste Toner Lock Detection Switch (SW05/J3050) (Unit of replacement: CABLE, MAIN DRIVER RELAY) - Waste Toner Lock Detection Switch (SW05) (Unit of replacement: CABLE, LOCK DETECT SWITCH) - Main Driver PCB (UN78) (Unit of replacement: MAIN DRIVE DRIVER PCB ASS'Y) - DC Controller PCB (UN1) (Unit of replacement: DC CONTROLLER PCB ASS'Y) <p>[Remedy] Perform the following in the order while checking whether the error is cleared.</p> <ol style="list-style-type: none"> 1. Check the Waste Toner Container and the Waste Toner Pipe, and remove clogged toner if there is any. 2. Check/replace the related harness/cable, connector and parts. <p>[Reference] Before replacing the DC Controller PCB, back up the service mode data (approx. 2 min) and restore the backup data after the replacement so the data may be able to be protected.</p> <ul style="list-style-type: none"> - Backup: COPIER (LEVEL2)> FUNCTION> SYSTEM> DSRAMBUP - Restoration: COPIER (LEVEL2)> FUNCTION> SYSTEM> DSRAMRES

E013-0003-05	Waste toner full detection error
Detection Description	Output was detected while the Waste Toner Full Sensor was OFF.
Remedy	<p>[Related parts]</p> <ul style="list-style-type: none"> - Harnesses from the Main Driver PCB to the Toner Sensor 1. Main Driver PCB (UN78/J151) to Relay Connector (7P) (Unit of replacement: CABLE, DECK, LEFT) 2. Relay Connector (7P) to Relay Connector (4P) (Unit of replacement: CABLE, WASTE TONER RELAY, 2) 3. Relay Connector (4P) to Toner Sensor (TS04/J5003) (Unit of replacement: CABLE, WASTE TONER RELAY, 3) - Toner Sensor (TS04) (Unit of replacement: SENSOR, TONER) - Main Driver PCB (UN78) (Unit of replacement: MAIN DRIVE DRIVER PCB ASS'Y) - DC Controller PCB (UN1) (Unit of replacement: DC CONTROLLER PCB ASS'Y) <p>[Remedy] Check/replace the related harness/cable, connector and parts.</p> <p>[Reference] Before replacing the DC Controller PCB, back up the service mode data (approx. 2 min) and restore the backup data after the replacement so the data may be able to be protected.</p> <ul style="list-style-type: none"> - Backup: COPIER (LEVEL2)> FUNCTION> SYSTEM> DSRAMBUP - Restoration: COPIER (LEVEL2)> FUNCTION> SYSTEM> DSRAMRES
E014-0001-05	Fixing Motor error
Detection Description	Lock error of the Fixing Motor was detected.
Remedy	<p>[Related parts]</p> <ul style="list-style-type: none"> - Harness between the Main Driver PCB (UN78/J104 and J105) and the Fixing Drawer Unit (J3001) (Unit of replacement: CABLE, FIXING DRAWER) - Harness between the Relay PCB (UN86/J520) and the Fixing Drawer Unit (J3218M) (Unit of replacement: CABLE, SIGNAL) - Harness between the Fixing Drawer Unit (J3200) and the Fixing Motor (M03/J2163P) (Unit of replacement: CABLE, FIXING MOTOR, 1) - Fixing Drive Unit (Unit of replacement: FIXING DRIVE ASS'Y) - Fixing Drive Gear (Unit of replacement: GEAR,71T/26T, GEAR, 20T, GEAR, 33T/20T, GEAR, 16T/38T) - Fixing Motor (M03) - Relay PCB (UN86) (Unit of replacement: RELAY PCB ASSEMBLY) - Main Driver PCB (UN78) (Unit of replacement: MAIN DRIVE DRIVER PCB ASS'Y) <p>[Remedy] Check/replace the related harness/cable, connector and parts.</p>

E017-0001-05	ETB disengagement error
Detection Description	Disengagement of the ETB is not completed within the specified period of time.
Remedy	<p>[Related parts]</p> <ul style="list-style-type: none"> - Harnesses from the Duplex Driver PCB to the ETB Disengage Sensor 1. Duplex Driver PCB (UN80/J343) to Relay Connector (8P) (Unit of replacement: CABLE, FIXING/FEEDER DRAWER) 2. Relay Connector (8P) to ETB Engage Sensor (PS55/J2100) (Unit of replacement: SOLENOID ASSEMBLY) 3. Relay Connector (8P) to ETB Disengage Sensor (PS56/J2101) (Unit of replacement: SOLENOID ASSEMBLY) - Harness between the Duplex Driver PCB (UN80/J331) and the Duplex Feed Left Motor (M19/J2111) (Unit of replacement: CABLE, MOTOR) - Harness between the DC Controller PCB (UN1/J431, J9, J432 and J8) and the Fixing Feed Drawer Unit (J5005) (Unit of replacement: CABLE, SIGNAL) - Harness between the Duplex Driver PCB (UN80/J300 and J301) and the Fixing Feed Drawer Unit (J5005) (Unit of replacement: CABLE, FIXING/FEEDER DRAWER) - ETB Engage Sensor (PS55) - ETB Disengage Sensor (PS56) - Duplex Feed Left Motor (M19) - Duplex Driver PCB (UN80) (Unit of replacement: DUPLEXING DRIVER PCB ASSEMBLY) - DC Controller PCB (UN1) (Unit of replacement: DC CONTROLLER PCB ASS'Y) <p>[Remedy] Check/replace the related harness/cable, connector and parts. [Reference] Before replacing the DC Controller PCB, back up the service mode data (approx. 2 min) and restore the backup data after the replacement so the data may be able to be protected.</p> <ul style="list-style-type: none"> - Backup: COPIER (LEVEL2)> FUNCTION> SYSTEM> DSRAMBUP - Restoration: COPIER (LEVEL2)> FUNCTION> SYSTEM> DSRAMRES
E017-0002-05	ETB engagement error
Detection Description	Engagement of the ETB is not completed within the specified period of time.
Remedy	<p>[Related parts]</p> <ul style="list-style-type: none"> - Harnesses from the Duplex Driver PCB to the ETB Engage Sensor 1. Duplex Driver PCB (UN80/J343) to Relay Connector (8P) (Unit of replacement: CABLE, FIXING/FEEDER DRAWER) 2. Relay Connector (8P) to ETB Engage Sensor (PS55/J2100) (Unit of replacement: SOLENOID ASSEMBLY) 3. Relay Connector (8P) to ETB Disengage Sensor (PS56/J2101) (Unit of replacement: SOLENOID ASSEMBLY) - Harness between the Duplex Driver PCB (UN80/J331) and the Duplex Feed Left Motor (M19/J2111) (Unit of replacement: CABLE, MOTOR) - Harness between the DC Controller PCB (UN1/J431, J9, J432 and J8) and the Fixing Feed Drawer Unit (J5005) (Unit of replacement: CABLE, SIGNAL) - ETB Engage Sensor (PS55) - ETB Disengage Sensor (PS56) - Duplex Feed Left Motor (M19) - Duplex Driver PCB (UN80) (Unit of replacement: DUPLEXING DRIVER PCB ASSEMBLY) - DC Controller PCB (UN1) (Unit of replacement: DC CONTROLLER PCB ASS'Y) <p>[Remedy] Check/replace the related harness/cable, connector and parts. [Reference] Before replacing the DC Controller PCB, back up the service mode data (approx. 2 min) and restore the backup data after the replacement so the data may be able to be protected.</p> <ul style="list-style-type: none"> - Backup: COPIER (LEVEL2)> FUNCTION> SYSTEM> DSRAMBUP - Restoration: COPIER (LEVEL2)> FUNCTION> SYSTEM> DSRAMRES

E017-0003-05	ETB HP error
Detection Description	Engagement of the ETB was not completed at initialization.
Remedy	<p>[Related parts]</p> <ul style="list-style-type: none"> - Harnesses from the Duplex Driver PCB to the ETB Disengage Sensor 1. Duplex Driver PCB (UN80/J343) to Relay Connector (8P) (Unit of replacement: CABLE, FIXING/FEEDER DRAWER) 2. Relay Connector (8P) to ETB Engage Sensor (PS55/J2100) (Unit of replacement: SOLENOID ASSEMBLY) 3. Relay Connector (8P) to ETB Disengage Sensor (PS56/J2101) (Unit of replacement: SOLENOID ASSEMBLY) - Harness between the Duplex Driver PCB (UN80/J331) and the Duplex Feed Left Motor (M19/J2111) (Unit of replacement: CABLE, MOTOR) - Harness between the DC Controller PCB (UN1/J431, J9, J432 and J8) and the Fixing Feed Drawer Unit (J5005) (Unit of replacement: CABLE, SIGNAL) - Harness between the Duplex Driver PCB (UN80/J300 and J301) and the Fixing Feed Drawer Unit (J5005) (Unit of replacement: CABLE, FIXING/FEEDER DRAWER) - ETB Engage Sensor (PS55) - ETB Disengage Sensor (PS56) - Duplex Feed Left Motor (M19) - Duplex Driver PCB (UN80) (Unit of replacement: DUPLEXING DRIVER PCB ASSEMBLY) - DC Controller PCB (UN1) (Unit of replacement: DC CONTROLLER PCB ASS'Y) <p>[Remedy]</p> <ul style="list-style-type: none"> - Check the ETB Disengagement Member (Transfer Frame Stopper). If it is left unremoved, remove it. - Check/replace the related harness/cable, connector and parts. <p>[Reference]</p> <ul style="list-style-type: none"> - To remove the ETB Disengagement Member, refer to the troubleshooting "Remedy to be implemented when the ETB Disengagement Member (Transfer Frame Stopper) is left unremoved" in the Service Manual. - Before replacing the DC Controller PCB, back up the service mode data (approx. 2 min) and restore the backup data after the replacement so the data may be able to be protected. - Backup: COPIER (LEVEL2)> FUNCTION> SYSTEM> DSRAMBUP - Restoration: COPIER (LEVEL2)> FUNCTION> SYSTEM> DSRAMRES

E020-0000-05	Developing Assembly toner absent error
Detection Description	The state without toner in the Developing Assembly was detected consecutively.
Remedy	<p>[Related parts]</p> <ul style="list-style-type: none"> - Harnesses from the Main Driver PCB to the Developing Toner Sensor <ol style="list-style-type: none"> 1. Main Driver PCB (UN78/J114) to Relay Connector (31P) (Unit of replacement: CABLE, MAIN DRIVER, REAR UPPER) 2. Relay Connector (31P) to Relay Connector (25P) (Unit of replacement: CABLE, RELAY, FRONT) 3. Relay Connector (25P) to Developing Toner Sensor (TS01/J2133) (Unit of replacement: CABLE, MAIN DRIVER, FRONT) - Harnesses from the Main Driver PCB to the Buffer Unit <ol style="list-style-type: none"> 1. Main Driver PCB (UN78/J115) to Relay Connector (21P) (Unit of replacement: CABLE, MAIN DRIVER, REAR UPPER) 2. Relay Harness (21P) (Unit of replacement: CABLE, RELAY, FRONT) 3. Relay Connector (21P) to Buffer Unit (J3124) (Unit of replacement: CABLE, MAIN DRIVER, FRONT) - Harness connecting from the Buffer Unit (J3124) to the Magnet Roller Clutch (CL05/J2036), Toner Feed Motor (M28/J2035) and Buffer Toner Sensor 2 (TS03/J2039) (Unit of replacement: CABLE, BUFFER) - Developing Toner Sensor (TS01) - Magnet Roller Clutch (CL05) - Toner Feed Motor (M28) - Buffer Toner Sensor 2 (TS03) - Main Driver PCB (UN78) (Unit of replacement: MAIN DRIVE DRIVER PCB ASS'Y) - DC Controller PCB (UN1) (Unit of replacement: DC CONTROLLER PCB ASS'Y) <p>[Remedy] Check/replace the related harness/cable, connector and parts. [Reference] Before replacing the DC Controller PCB, back up the service mode data (approx. 2 min) and restore the backup data after the replacement so the data may be able to be protected. - Backup: COPIER (LEVEL2)> FUNCTION> SYSTEM> DSRAMBUP - Restoration: COPIER (LEVEL2)> FUNCTION> SYSTEM> DSRAMRES</p>
E020-0001-05	Error in Developing Toner Sensor connection detection
Detection Description	The connection detection port was OFF at power-on.
Remedy	<p>[Related parts]</p> <ul style="list-style-type: none"> - Harnesses from the main Driver PCB to the Developing Toner Sensor <ol style="list-style-type: none"> 1. Main Driver PCB (UN78/J114) to Relay Connector (31P) (Unit of replacement: CABLE, MAIN DRIVER, REAR UPPER) 2. Relay Connector (31P) to Relay Connector (25P) (Unit of replacement: CABLE, RELAY, FRONT) 3. Relay Connector (25P) to Developing Toner Sensor (TS01/J2133) (Unit of replacement: CABLE, MAIN DRIVER, FRONT) - Developing Toner Sensor (TS01) - Main Driver PCB (UN78) (Unit of replacement: MAIN DRIVE DRIVER PCB ASS'Y) - DC Controller PCB (UN1) (Unit of replacement: DC CONTROLLER PCB ASS'Y) <p>[Remedy] Check/replace the related harness/cable, connector and parts. [Reference] Before replacing the DC Controller PCB, back up the service mode data (approx. 2 min) and restore the backup data after the replacement so the data may be able to be protected. - Backup: COPIER (LEVEL2)> FUNCTION> SYSTEM> DSRAMBUP - Restoration: COPIER (LEVEL2)> FUNCTION> SYSTEM> DSRAMRES</p>

E020-0002-05	Error in Buffer Toner Sensor connection detection
Detection Description	The connection detection port was OFF at power-on.
Remedy	<p>[Related parts]</p> <ul style="list-style-type: none"> - Harnesses from the Main Driver PCB to the Buffer Unit 1. Main Driver PCB (UN78/J115) to Relay Connector (21P) (Unit of replacement: CABLE, MAIN DRIVER, REAR UPPER) 2. Relay Harness (21P) (Unit of replacement: CABLE, RELAY, FRONT) 3. Relay Connector (21P) to Buffer Unit (J3124) (Unit of replacement: CABLE, MAIN DRIVER, FRONT) - Harness between the Buffer Unit (J3124) to the Buffer Toner Sensor 2 (TS03/J2039) (Unit of replacement: CABLE, BUFFER) - Buffer Toner Sensor 2 (TS03) - Main Driver PCB (UN78) (Unit of replacement: MAIN DRIVE DRIVER PCB ASS'Y) - DC Controller PCB (UN1) (Unit of replacement: DC CONTROLLER PCB ASS'Y) <p>[Remedy] Check/replace the related harness/cable, connector and parts. [Reference] Before replacing the DC Controller PCB, back up the service mode data (approx. 2 min) and restore the backup data after the replacement so the data may be able to be protected.</p> <ul style="list-style-type: none"> - Backup: COPIER (LEVEL2)> FUNCTION> SYSTEM> DSRAMBUP - Restoration: COPIER (LEVEL2)> FUNCTION> SYSTEM> DSRAMRES
E020-0003-05	Error in the Toner Excess Supply Sensor connection detection
Detection Description	The connection detection port was OFF at power-on.
Remedy	<p>[Related parts]</p> <ul style="list-style-type: none"> - Harnesses from the Main Driver PCB to the Buffer Unit 1. Main Driver PCB (UN78/J115) to Relay Connector (21P) (Unit of replacement: CABLE, MAIN DRIVER, REAR UPPER) 2. Relay Harness (21P) (Unit of replacement: CABLE, RELAY, FRONT) 3. Relay Connector (21P) to Buffer Unit (J3124) (Unit of replacement: CABLE, MAIN DRIVER, FRONT) - Harness between the Buffer Unit (J3124) and the Toner Excess Supply Sensor (TS02/J2038) (Unit of replacement: CABLE, BUFFER) - Toner Excess Supply Sensor (TS02) - Main Driver PCB (UN78) (Unit of replacement: MAIN DRIVE DRIVER PCB ASS'Y) - DC Controller PCB (UN1) (Unit of replacement: DC CONTROLLER PCB ASS'Y) <p>[Remedy] Check/replace the related harness/cable, connector and parts. [Reference] Before replacing the DC Controller PCB, back up the service mode data (approx. 2 min) and restore the backup data after the replacement so the data may be able to be protected.</p> <ul style="list-style-type: none"> - Backup: COPIER (LEVEL2)> FUNCTION> SYSTEM> DSRAMBUP - Restoration: COPIER (LEVEL2)> FUNCTION> SYSTEM> DSRAMRES
E020-0004-05	Error in Developing Buffer Clutch connection detection
Detection Description	The connection detection port was OFF 2 consecutive times at power-on and 100 ms polling of normal status.
Remedy	<p>[Related parts]</p> <ul style="list-style-type: none"> - Harnesses from the Main Driver PCB to the Buffer Unit 1. Main Driver PCB (UN78/J115) to Relay Connector (21P) (Unit of replacement: CABLE, MAIN DRIVER, REAR UPPER) 2. Relay Harness (21P) (Unit of replacement: CABLE, RELAY, FRONT) 3. Relay Connector (21P) to Buffer Unit (J3124) (Unit of replacement: CABLE, MAIN DRIVER, FRONT) - Harness between the Buffer Unit (J3124) and the Developing Buffer Clutch (CL05/J2036) (Unit of replacement: CABLE, BUFFER) - Developing Buffer Clutch (CL05) - Main Driver PCB (UN78) (Unit of replacement: MAIN DRIVE DRIVER PCB ASS'Y) - DC Controller PCB (UN1) (Unit of replacement: DC CONTROLLER PCB ASS'Y)[7100-0001] <p>[Remedy] Check/replace the related harness/cable, connector and parts. [Reference] Before replacing the DC Controller PCB, back up the service mode data (approx. 2 min) and restore the backup data after the replacement so the data may be able to be protected.</p> <ul style="list-style-type: none"> - Backup: COPIER (LEVEL2)> FUNCTION> SYSTEM> DSRAMBUP - Restoration: COPIER (LEVEL2)> FUNCTION> SYSTEM> DSRAMRES

E020-0020-05	Developing Toner Sensor Cleaning Scraper error
Detection Description	Disengagement of the Developing Toner Sensor Cleaning Scraper was detected.
Remedy	[Remedy] Replace the Developing Assembly.
E020-0021-05	Developing Toner Sensor Cleaning Scraper error
Detection Description	It was detected that the Developing Toner Sensor Cleaning Scraper was being bent.
Remedy	[Remedy] Replace the Developing Assembly.
E023-0001-05	Developing Motor error
Detection Description	Lock error of the Developing Motor was detected.
Remedy	[Related parts] - Harness connecting from the Main Driver PCB (UN78/J109) to the Developing Motor (M02/J2139) and Developing Clutch (CL01/J2006) (Unit of replacement: CABLE, MAIN, REAR UPPER) - Harnesses from the Relay PCB to the Developing Motor 1. Relay PCB (UN86/J520) to Relay Connector (5P) (Unit of replacement: CABLE, SIGNAL) 2. Relay Connector (5P) to Developing Motor (M02/J2152) (Unit of replacement: CABLE, MAIN, REAR UPPER) - Developing Motor (M02) - Developing Clutch (CL01) - Main Driver PCB (UN78) (Unit of replacement: MAIN DRIVE DRIVER PCB ASS'Y) - Relay PCB (UN86) (Unit of replacement: RELAY PCB ASSEMBLY) - DC Controller PCB (UN1) (Unit of replacement: DC CONTROLLER PCB ASS'Y) [Remedy] Check/replace the related harness/cable, connector and parts. [Reference] Before replacing the DC Controller PCB, back up the service mode data (approx. 2 min) and restore the backup data after the replacement so the data may be able to be protected. - Backup: COPIER (LEVEL2)> FUNCTION> SYSTEM> DSRAMBUP - Restoration: COPIER (LEVEL2)> FUNCTION> SYSTEM> DSRAMRES
E023-0002-05	Error in Developing Clutch connection detection
Detection Description	Connection of the Developing Clutch cannot be detected.
Remedy	[Related parts] - Harness between the Main Driver PCB (UN78/J109) and the Developing Clutch (CL01/J2006) (Unit of replacement: CABLE, MAIN, REAR UPPER) - Harness between the Main Driver PCB (UN78/J101) and the Relay PCB (UN86/J515) (Unit of replacement: CABLE, SIGNAL) - Harness between the Relay PCB (UN86/J513) and the DC Power Supply PCB (24V) (J202B) (Unit of replacement: CABLE, DC 24V, B) - Developing Clutch (CL01) - Main Driver PCB (UN78) (Unit of replacement: MAIN DRIVE DRIVER PCB ASS'Y) - Relay PCB (UN86) (Unit of replacement: RELAY PCB ASSEMBLY) - DC Power Supply PCB (24V) (Unit of replacement: 24V POWER SUPPLY ASS'Y, RIGHT) - DC Controller PCB (UN1) (Unit of replacement: DC CONTROLLER PCB ASS'Y) [Remedy] Check/replace the related harness/cable, connector and parts. [Reference] Before replacing the DC Controller PCB, back up the service mode data (approx. 2 min) and restore the backup data after the replacement so the data may be able to be protected. - Backup: COPIER (LEVEL2)> FUNCTION> SYSTEM> DSRAMBUP - Restoration: COPIER (LEVEL2)> FUNCTION> SYSTEM> DSRAMRES

E025-0001-05	Toner Feed Motor error
Detection Description	Overcurrent of the Toner Feed Motor was detected.
Remedy	<p>[Related parts]</p> <ul style="list-style-type: none"> - Harnesses from the Main Driver PCB to the Buffer Unit 1. Main Driver PCB (UN78/J115) to Relay Connector (21P) (Unit of replacement: CABLE, MAIN DRIVER, REAR UPPER) 2. Relay Harness (21P) (Unit of replacement: CABLE, RELAY, FRONT) 3. Relay Connector (21P) to Buffer Unit (J3124) (Unit of replacement: CABLE, MAIN DRIVER, FRONT) - Harness between the Buffer Unit (J3124) and the Toner Feed Motor (M28/J2035) (Unit of replacement: CABLE, BUFFER) - Toner Feed Motor (M28) - Main Driver PCB (UN78) (Unit of replacement: MAIN DRIVE DRIVER PCB ASS'Y) - DC Controller PCB (UN1) (Unit of replacement: DC CONTROLLER PCB ASS'Y) <p>[Remedy] Check/replace the related harness/cable, connector and parts. [Reference] Before replacing the DC Controller PCB, back up the service mode data (approx. 2 min) and restore the backup data after the replacement so the data may be able to be protected.</p> <ul style="list-style-type: none"> - Backup: COPIER (LEVEL2)> FUNCTION> SYSTEM> DSRAMBUP - Restoration: COPIER (LEVEL2)> FUNCTION> SYSTEM> DSRAMRES
E027-0001-05	Toner Supply Motor error
Detection Description	Lock error of the Toner Supply Motor was detected.
Remedy	<p>[Related parts]</p> <ul style="list-style-type: none"> - Harnesses from the Main Driver PCB to the Toner Supply Motor 1. Main Driver PCB (UN78/J117) to Relay Connector (6P) (Unit of replacement: CABLE, MAIN DRIVER, REAR UPPER) 2. Relay Harness (6P) (Unit of replacement: CABLE, RELAY, FRONT) 3. Relay Connector (6P) to Toner Supply Motor (M10/J2037) (Unit of replacement: CABLE, MAIN DRIVER, FRONT) - Toner Supply Motor (M10) - Main Driver PCB (UN78) (Unit of replacement: MAIN DRIVE DRIVER PCB ASS'Y) - DC Controller PCB (UN1) (Unit of replacement: DC CONTROLLER PCB ASS'Y) <p>[Remedy] - Remove and then reinstall the Toner Container, and check if the error is cleared. - If the error is not cleared, check/replace the related harness/cable, connector and parts. [Reference] Before replacing the DC Controller PCB, back up the service mode data (approx. 2 min) and restore the backup data after the replacement so the data may be able to be protected.</p> <ul style="list-style-type: none"> - Backup: COPIER (LEVEL2)> FUNCTION> SYSTEM> DSRAMBUP - Restoration: COPIER (LEVEL2)> FUNCTION> SYSTEM> DSRAMRES
E041-0001-05	Right Deck Lifter Motor error
Detection Description	Overcurrent of the Right Deck Lifter Motor was detected.
Remedy	<p>[Remedy] Perform the following in the order while checking whether the error is cleared.</p> <ol style="list-style-type: none"> 1. Check for displacement of the wire of the Right Deck Lifter, and correct it if necessary. 2. Check for smoothness of the movement of the Base Plate of the Right Deck, and correct it if necessary. 3. Replace the Right Deck Lifter Motor (M04).
E041-0002-05	Left Deck Lifter Motor error
Detection Description	Overcurrent of the Left Deck Lifter Motor was detected.
Remedy	<p>[Remedy] Perform the following in the order while checking whether the error is cleared.</p> <ol style="list-style-type: none"> 1. Check for displacement of the wire of the Left Deck Lifter, and correct it if necessary. 2. Check for smoothness of the movement of the Base Plate of the Left Deck, and correct it if necessary. 3. Replace the Left Deck Lifter Motor (M05).

E041-0003-05	Cassette 3 Lifter Motor error
Detection Description	Overcurrent of the Cassette 3 Lifter Motor was detected.
Remedy	[Remedy] Perform the following in the order while checking whether the error is cleared. 1. Check for error around the Cassette 3 Lifter, and correct it if necessary. 2. Check for smoothness of the movement of the Base Plate of the Cassette 3, and correct it if necessary. 3. Replace the Cassette 3 Lifter Motor (M20).
E041-0004-05	Cassette 4 Lifter Motor error
Detection Description	Overcurrent of the Cassette 4 Lifter Motor was detected.
Remedy	[Remedy] Perform the following in the order while checking whether the error is cleared. 1. Check for error around the Cassette 4 Lifter, and correct it if necessary. 2. Check for smoothness of the movement of the Base Plate of the Cassette 4, and correct it if necessary. 3. Replace the Cassette 4 Lifter Motor (M21).
E053-0001-05	Error in Reverse Upper Flapper Solenoid connection detection
Detection Description	Connection of the Reverse Upper Flapper Solenoid cannot be detected 5 times with 20 msec time interval.
Remedy	[Related parts] - Harness between the Duplex (UN80/J340) and the Reverse Upper Flapper Solenoid (SL05/J2115) (Unit of replacement: CABLE, FIXING/FEEDER DRAWER) - Harness between the Duplex Driver PCB (UN80/J300, J301 and J310) and the Fixing Feed Drawer Unit (J5005) (Unit of replacement: CABLE, FIXING/FEEDER DRAWER) - Harness between the DC Controller PCB (UN1/J431, J9, J432 and J8) and the Fixing Feed Drawer Unit (J5005) (Unit of replacement: CABLE, SIGNAL) - Harness between the Main Driver PCB (UN78/J108) and the Relay PCB (UN86/J522) (Unit of replacement: CABLE, SIGNAL) - Harness between the Relay PCB (UN86/J517) and the Fixing Feed Drawer Unit (J5005) (Unit of replacement: CABLE, FIXING/FEEDER DRAWER) - Reverse Upper Flapper Solenoid (Unit of replacement: REVERSE SOLENOID ASS'Y) - Duplex Driver PCB (UN80) (Unit of replacement: DUPLEXING DRIVER PCB ASSEMBLY) - Relay PCB (UN86) (Unit of replacement: RELAY PCB ASSEMBLY) - Main Driver PCB (UN78) (Unit of replacement: MAIN DRIVE DRIVER PCB ASS'Y) - DC Controller PCB (UN1) (Unit of replacement: DC CONTROLLER PCB ASS'Y) [Remedy] Check/replace the related harness/cable, connector and parts. [Reference] Before replacing the DC Controller PCB, back up the service mode data (approx. 2 min) and restore the backup data after the replacement so the data may be able to be protected. - Backup: COPIER (LEVEL2)> FUNCTION> SYSTEM> DSRAMBUP - Restoration: COPIER (LEVEL2)> FUNCTION> SYSTEM> DSRAMRES

E060-0001-05	Primary Charging Shutter HP open error
Detection Description	The Primary Charging Shutter Sensor detected the open status although the shutter of the Primary Charging Assembly was moved to the close position.
Remedy	<p>[Related parts]</p> <ul style="list-style-type: none"> - Harnesses from the Main Driver PCB to the Primary Charging Wire Cleaning Motor <ol style="list-style-type: none"> 1. Main Driver PCB (UN78/J107) to Relay Connector (12P) (Unit of replacement: CABLE, MAIN, REAR UPPER) 2. Relay Connector (12P) to Relay Connector (20P) (Unit of replacement: CABLE, AP. KIT DRAWER) 3. Relay Connector (20P) to Primary Charging Wire Cleaning Motor (M06/J3107) (Unit of replacement: DRAWER ASSEMBLY) - Harnesses from the Main Driver PCB to the Primary Charging Shutter Sensor <ol style="list-style-type: none"> 1. Main Driver PCB (UN78/J114) to Relay Connector (31P) (Unit of replacement: CABLE, MAIN DRIVER, REAR UPPER) 2. Relay Connector (31P) to Relay Connector (25P) (Unit of replacement: CABLE, MAIN, REAR UPPER) 3. Relay Connector (25P) to Primary Charging Shutter Sensor (PS94/J2029) (Unit of replacement: CABLE, MAIN DRIVER, FRONT) - Primary Charging Wire Cleaning Motor (M06) - Primary Charging Shutter Sensor (PS94) - Slide Pin - Primary Charging Assembly - Primary Charging Shutter (Unit of replacement: SHUTTER UNIT) - Main Driver PCB (UN78) (Unit of replacement: MAIN DRIVE DRIVER PCB ASS'Y) - DC Controller PCB (UN1) (Unit of replacement: DC CONTROLLER PCB ASS'Y) <p>[Remedy] Perform the following in the order while checking whether the error is cleared.</p> <ol style="list-style-type: none"> 1. Check the Primary Charging Shutter. <ol style="list-style-type: none"> a. If the Primary Charging Shutter and the Cleaning Pad do not work (stop at HP at front side), <ul style="list-style-type: none"> - Check/replace the Primary Charging Wire Cleaning Motor. b. If the Primary Charging Shutter and the Cleaning Pad stop at rear side (close position), <ul style="list-style-type: none"> - Check/replace the Primary Charging Shutter Sensor. c. If the Primary Charging Shutter and the Cleaning Pad stop halfway, <ul style="list-style-type: none"> - Check/replace the Slide Pin. d. If the Primary Charging Shutter stops at front side but the Cleaning Pad moves to rear until it stops, <ul style="list-style-type: none"> - Check/replace the shutter and the Slide Pin. e. Replace the Primary Charging Assembly. 2. Check/replace the related harness/cable, connector and parts. <p>[Reference] Before replacing the DC Controller PCB, back up the service mode data (approx. 2 min) and restore the backup data after the replacement so the data may be able to be protected.</p> <ul style="list-style-type: none"> - Backup: COPIER (LEVEL2)> FUNCTION> SYSTEM> DSRAMBUP - Restoration: COPIER (LEVEL2)> FUNCTION> SYSTEM> DSRAMRES

E060-0002-05	Primary Charging Shutter HP close error
Detection Description	The Primary Charging Shutter Sensor detected the close status although the shutter of the Primary Charging Assembly was moved to the open position.
Remedy	<p>[Related parts]</p> <ul style="list-style-type: none"> - Harnesses from the Main Driver PCB to the Primary Charging Wire Cleaning Motor <ol style="list-style-type: none"> 1. Main Driver PCB (UN78/J107) to Relay Connector (12P) (Unit of replacement: CABLE, MAIN, REAR UPPER) 2. Relay Connector (12P) to Relay Connector (20P) (Unit of replacement: CABLE, AP. KIT DRAWER) 3. Relay Connector (20P) to Primary Charging Wire Cleaning Motor (M06/J3107) (Unit of replacement: DRAWER ASSEMBLY) - Harnesses from the Main Driver PCB to the Primary Charging Shutter Sensor <ol style="list-style-type: none"> 1. Main Driver PCB (UN78/J114) to Relay Connector (31P) (Unit of replacement: CABLE, MAIN DRIVER, REAR UPPER) 2. Relay Connector (31P) to Relay Connector (25P) (Unit of replacement: CABLE, MAIN, REAR UPPER) 3. Relay Connector (25P) to Primary Charging Shutter Sensor (PS94/J2029) (Unit of replacement: CABLE, MAIN DRIVER, FRONT) - Primary Charging Wire Cleaning Motor (M06) - Primary Charging Shutter Sensor (PS94) - Slide Pin - Primary Charging Assembly - Primary Charging Shutter (Unit of replacement: SHUTTER UNIT) - Main Driver PCB (UN78) (Unit of replacement: MAIN DRIVE DRIVER PCB ASS'Y) - DC Controller PCB (UN1) (Unit of replacement: DC CONTROLLER PCB ASS'Y) <p>[Remedy] Perform the following in the order while checking whether the error is cleared.</p> <ol style="list-style-type: none"> 1. Check the Primary Charging Shutter. <ol style="list-style-type: none"> a. If the Primary Charging Shutter and the Cleaning Pad do not work (stop at HP at front side), <ul style="list-style-type: none"> - Check/replace the Primary Charging Wire Cleaning Motor. b. If the Primary Charging Shutter and the Cleaning Pad stop at rear side (close position), <ul style="list-style-type: none"> - Check/replace the Primary Charging Shutter Sensor. c. If the Primary Charging Shutter and the Cleaning Pad stop halfway, <ul style="list-style-type: none"> - Check/replace the Slide Pin. d. Replace the Primary Charging Assembly. 2. Check/replace the related harness/cable, connector and parts. <p>[Reference] Before replacing the DC Controller PCB, back up the service mode data (approx. 2 min) and restore the backup data after the replacement so the data may be able to be protected.</p> <ul style="list-style-type: none"> - Backup: COPIER (LEVEL2)> FUNCTION> SYSTEM> DSRAMBUP - Restoration: COPIER (LEVEL2)> FUNCTION> SYSTEM> DSRAMRES

E061-0001-05	Potential control error (VL)
Detection Description	The dark area potential (VL) failed to be 200 V or less at potential control.
Remedy	<p>[Related parts]</p> <ul style="list-style-type: none"> - Harnesses from the Main Driver PCB to the Pre-exposure LED 1. Main Driver PCB (UN78/J107) to Relay Connector (12P) (Unit of replacement: CABLE, MAIN, REAR UPPER) 2. Relay Connector (12P) to Relay Connector (20P) (Unit of replacement: CABLE, AP. KIT DRAWER) 3. Relay Connector (20P) to Pre-exposure LED (LE01/J2141) (Unit of replacement: DRAWER ASSEMBLY) - Harnesses from the Main Driver PCB to the Primary Charging High Voltage PCB 1. Main Driver PCB (UN78/J111) to Relay Connector (9P) (Unit of replacement: CABLE, MAIN, REAR UPPER) 2. Relay Connector (9P) to Primary Charging High Voltage PCB (J3501) (Unit of replacement: HIGH VOLTAGE PCB ASS'Y) - Harnesses from the Main Driver PCB to the Potential Sensor 1. Main Driver PCB (UN78/J114) to Relay Connector (31P) (Unit of replacement: CABLE, MAIN DRIVER, REAR UPPER) 2. Relay Connector (31P) to Relay Connector (25P) (Unit of replacement: CABLE, RELAY, FRONT) 3. Relay Connector (25P) to Relay Connector (7P) (Unit of replacement: CABLE, MAIN DRIVER, FRONT) 4. Relay Connector (7P) to Potential Sensor (EPC01/J5014) (Unit of replacement: CABLE, POTENTIAL SENSOR) - Harness between the Main Driver PCB (UN78/J109) and the Drum Motor (M01/J2138) (Unit of replacement: CABLE, MAIN, REAR UPPER) - Primary Charging Assembly - Laser Scanner Unit - Potential Sensor (EPC01) (Unit of replacement: POTENTIAL MEASURING PCB ASS'Y) - Primary Charging High Voltage PCB (Unit of replacement: HIGH VOLTAGE PCB ASS'Y) - Drum Motor (M01) - Pre-exposure LED (LE01) - Main Driver PCB (UN78) (Unit of replacement: MAIN DRIVE DRIVER PCB ASS'Y) - DC Controller PCB (UN1) (Unit of replacement: DC CONTROLLER PCB ASS'Y) <p>[Remedy] Check/replace the related harness/cable, connector and parts.</p> <p>[Reference] Before replacing the DC Controller PCB, back up the service mode data (approx. 2 min) and restore the backup data after the replacement so the data may be able to be protected.</p> <ul style="list-style-type: none"> - Backup: COPIER (LEVEL2)> FUNCTION> SYSTEM> DSRAMBUP - Restoration: COPIER (LEVEL2)> FUNCTION> SYSTEM> DSRAMRES

E061-0101-05	Potential control error (VD)
Detection Description	Potential in the dark area did not fall within the range (target value +/-5 V) although retry was executed 8 times at VD potential control.
Remedy	<p>[Related parts]</p> <ul style="list-style-type: none"> - Harnesses from the Main Driver PCB to the Pre-exposure LED <ol style="list-style-type: none"> 1. Main Driver PCB (UN78/J107) to Relay Connector (12P) (Unit of replacement: CABLE, MAIN, REAR UPPER) 2. Relay Connector (12P) to Relay Connector (20P) (Unit of replacement: CABLE, AP. KIT DRAWER) 3. Relay Connector (20P) to Pre-exposure LED (LE01/J2141) (Unit of replacement: DRAWER ASSEMBLY) - Harnesses from the Main Driver PCB to the Primary Charging High Voltage PCB <ol style="list-style-type: none"> 1. Main Driver PCB (UN78/J111) to Relay Connector (9P) (Unit of replacement: CABLE, MAIN, REAR UPPER) 2. Relay Connector (9P) to Primary Charging High Voltage PCB (J3501) (Unit of replacement: HIGH VOLTAGE PCB ASS'Y) - Harness between the Main Driver PCB (UN78/J109) and the Drum Motor (M01/J2138) (Unit of replacement: CABLE, MAIN, REAR UPPER) - Primary Charging Assembly - Primary Charging High Voltage PCB (Unit of replacement: HIGH VOLTAGE PCB ASS'Y) - Drum Motor (M01) - Pre-exposure LED (LE01) - Main Driver PCB (UN78) (Unit of replacement: MAIN DRIVE DRIVER PCB ASS'Y) - DC Controller PCB (UN1) (Unit of replacement: DC CONTROLLER PCB ASS'Y) <p>[Remedy] Perform the following in the order while checking whether the error is cleared.</p> <ol style="list-style-type: none"> 1. If the current value of the Primary Charging Roller (COPIER (LEVEL2)> DISPLAY> DPOT> PRIM-C) is 1550 micro A or higher, perform the following. <ol style="list-style-type: none"> a. Set 100 V for the grid voltage of the Primary Charging Assembly (COPIER> ADJUST> HV-PRI> PRI-GRID). b. Execute potential control (COPIER> FUNCTION> DPC> DPC). 2. Check/replace the related harness/cable, connector and parts. <p>[Reference] Before replacing the DC Controller PCB, back up the service mode data (approx. 2 min) and restore the backup data after the replacement so the data may be able to be protected.</p> <ul style="list-style-type: none"> - Backup: COPIER (LEVEL2)> FUNCTION> SYSTEM> DSRAMBUP - Restoration: COPIER (LEVEL2)> FUNCTION> SYSTEM> DSRAMRES
E064-00FF-05	High voltage setting error
Detection Description	With the state in which the developing AC is output, 600 V or higher developing DC output was detected.
Remedy	<p>[Related parts]</p> <ul style="list-style-type: none"> - DC Controller PCB (UN1) (Unit of replacement: DC CONTROLLER PCB ASS'Y) <p>[Remedy] Perform the following in the order while checking whether the error is cleared.</p> <ol style="list-style-type: none"> 1. Turn OFF and then ON the power of the host machine. 2. Replace the DC Controller PCB. (Unit of replacement: DC CONTROLLER PCB ASS'Y) <p>[Reference] Before replacing the DC Controller PCB, back up the service mode data (approx. 2 min) and restore the backup data after the replacement so the data may be able to be protected.</p> <ul style="list-style-type: none"> - Backup: COPIER (LEVEL2)> FUNCTION> SYSTEM> DSRAMBUP - Restoration: COPIER (LEVEL2)> FUNCTION> SYSTEM> DSRAMRES

E065-0001-05	Primary charging/grid high voltage output leak error
Detection Description	The leak detection signal was detected 5 times in a row for every 20 msec.
Remedy	<p>[Related parts]</p> <ul style="list-style-type: none"> - Harness between the Main Driver PCB (UN78/J111) and the High Voltage Unit (J3097) (Unit of replacement: CABLE, MAIN, REAR UPPER) - Harness between the Relay PCB (UN86/J519) and the High Voltage Unit (J3099) (Unit of replacement: CABLE, SIGNAL) - Harnesses in the High Voltage Unit (J3098L, J3511, J3544, J3097L, J3501, J3500, J3545, J3510 and J3099M) (Unit of replacement: CABLE, HIGH VOLTAGE SIGNAL) - Primary Grid High Voltage Connector (Unit of replacement: DRUM DRIVE ASS'Y) - Primary Charging High Voltage PCB (Unit of replacement: HIGH VOLTAGE PCB ASS'Y) - Main Driver PCB (UN78) (Unit of replacement: MAIN DRIVE DRIVER PCB ASS'Y) <p>[Remedy] Check/replace the related harness/cable, connector and parts.</p>
E066-0001-05	Pre-transfer Charging Shutter HP open error
Detection Description	The Pre-transfer Charging Shutter Sensor detects that the shutter is opened although it is moved to the close position.
Remedy	<p>[Related parts]</p> <ul style="list-style-type: none"> - Harnesses from the Main Driver PCB to the Pre-transfer Charging Wire Cleaning Motor <ol style="list-style-type: none"> 1. Main Driver PCB (UN78/J114) to Relay Connector (31P) (Unit of replacement: CABLE, MAIN DRIVER, REAR UPPER) 2. Relay Connector (31P) to Relay Connector (25P) (Unit of replacement: CABLE, MAIN, REAR UPPER) 3. Relay Connector (25P) to Pre-transfer Charging Wire Cleaning Motor (M7/J3108) (Unit of replacement: CABLE, MAIN DRIVER, FRONT) - Harnesses from the Main Driver PCB to the Pre-transfer Charging Shutter Sensor <ol style="list-style-type: none"> 1. Main Driver PCB (UN78/J130) to Relay Connector (17P) (Unit of replacement: CABLE, MAIN DRIVER, REAR UPPER) 2. Relay Harness (17P) (Unit of replacement: CABLE, RELAY, FRONT, CABLE, MAIN DRIVER, FRONT) 3. Relay Connector (17P) to Pre-transfer Charging Shutter Sensor (PS95/J2114) (Unit of replacement: CABLE, FAN) - Pre-transfer Charging Wire Cleaning Motor (M7) - Pre-transfer Charging Shutter Sensor (PS95) - Pre-transfer Charging Shutter (Unit of replacement: SHUTTER UNIT) - Slide Pin - Pre-transfer Charging Assembly - Main Driver PCB (UN78) (Unit of replacement: MAIN DRIVE DRIVER PCB ASS'Y) - DC Controller PCB (UN1) (Unit of replacement: DC CONTROLLER PCB ASS'Y) <p>[Remedy] Perform the following in the order while checking whether the error is cleared.</p> <ol style="list-style-type: none"> 1. Check the Pre-transfer Charging Shutter. <ol style="list-style-type: none"> a. If the Pre-transfer Charging Shutter does not work (stops at HP at front side), <ul style="list-style-type: none"> - Check/replace the Pre-transfer Charging Wire Cleaning Motor. b. If the Pre-transfer Charging Shutter stops at rear side (close position), <ol style="list-style-type: none"> a. Check and close the Primary Fan Duct if it is open. b. Check/replace the Pre-transfer Charging Shutter Sensor. c. If the Pre-transfer Charging Shutter stops halfway, <ol style="list-style-type: none"> a. Check/replace the Slide Pin. b. Replace the Pre-transfer Charging Assembly. 2. Check/replace the related harness/cable, connector and parts. <p>[Reference] Before replacing the DC Controller PCB, back up the service mode data (approx. 2 min) and restore the backup data after the replacement so the data may be able to be protected.</p> <ul style="list-style-type: none"> - Backup: COPIER (LEVEL2)> FUNCTION> SYSTEM> DSRAMBUP - Restoration: COPIER (LEVEL2)> FUNCTION> SYSTEM> DSRAMRES

E066-0002-05	Pre-transfer Charging Shutter HP close error
Detection Description	The Pre-transfer Charging Shutter Sensor detects that the shutter is closed although it is moved to the open position.
Remedy	<p>[Related parts]</p> <ul style="list-style-type: none"> - Harnesses from the Main Driver PCB to the Pre-transfer Charging Wire Cleaning Motor <ol style="list-style-type: none"> 1. Main Driver PCB (UN78/J114) to Relay Connector (31P) (Unit of replacement: CABLE, MAIN DRIVER, REAR UPPER) 2. Relay Connector (31P) to Relay Connector (25P) (Unit of replacement: CABLE, MAIN, REAR UPPER) 3. Relay Connector (25P) to Pre-transfer Charging Wire Cleaning Motor (M7/J3108) (Unit of replacement: CABLE, MAIN DRIVER, FRONT) - Harnesses from the Main Driver PCB to the Pre-transfer Charging Shutter Sensor <ol style="list-style-type: none"> 1. Main Driver PCB (UN78/J130) to Relay Connector (17P) (Unit of replacement: CABLE, MAIN DRIVER, REAR UPPER) 2. Relay Harness (17P) (Unit of replacement: CABLE, RELAY, FRONT, CABLE, MAIN DRIVER, FRONT) 3. Relay Connector (17P) to Pre-transfer Charging Shutter Sensor (PS95/J2114) (Unit of replacement: CABLE, FAN) - Pre-transfer Charging Wire Cleaning Motor (M7) - Pre-transfer Charging Shutter Sensor (PS95) - Pre-transfer Charging Shutter (Unit of replacement: SHUTTER UNIT) - Slide Pin - Pre-transfer Charging Assembly - Main Driver PCB (UN78) (Unit of replacement: MAIN DRIVE DRIVER PCB ASS'Y) - DC Controller PCB (UN1) (Unit of replacement: DC CONTROLLER PCB ASS'Y) <p>[Remedy] Perform the following in the order while checking whether the error is cleared.</p> <ol style="list-style-type: none"> 1. Check the Pre-transfer Charging Shutter. <ol style="list-style-type: none"> a. If the Pre-transfer Charging Shutter does not work (stops at HP at front side), <ul style="list-style-type: none"> - Check/replace the Pre-transfer Charging Wire Cleaning Motor. b. If the Pre-transfer Charging Shutter stops at rear side (close position), <ol style="list-style-type: none"> a. Check and close the Primary Fan Duct if it is open. b. Check/replace the Pre-transfer Charging Shutter Sensor. c. If the Pre-transfer Charging Shutter stops halfway, <ol style="list-style-type: none"> a. Check/replace the Slide Pin. b. Replace the Pre-transfer Charging Assembly. 2. Check/replace the related harness/cable, connector and parts. <p>[Reference] Before replacing the DC Controller PCB, back up the service mode data (approx. 2 min) and restore the backup data after the replacement so the data may be able to be protected.</p> <ul style="list-style-type: none"> - Backup: COPIER (LEVEL2)> FUNCTION> SYSTEM> DSRAMBUP - Restoration: COPIER (LEVEL2)> FUNCTION> SYSTEM> DSRAMRES

E067-0001-05	Developing high voltage output leak error
Detection Description	The leak detection signal was detected 5 times in a row for every 20 msec.
Remedy	<p>[Related parts]</p> <ul style="list-style-type: none"> - Harness between the Main Driver PCB (UN78/J112) and the High Voltage Unit (J3098) (Unit of replacement: CABLE, MAIN, REAR UPPER) - Harness between the Relay PCB (UN86/J519) and the High Voltage Unit (J3099) (Unit of replacement: CABLE, SIGNAL) - Harnesses in the High Voltage Unit (J3098L, J3511, J3544, J3097L, J3501, J3500, J3545, J3510 and J3099M) (Unit of replacement: CABLE, HIGH VOLTAGE SIGNAL) - Developing Assembly - Develop High Voltage PCB (Unit of replacement: HIGH VOLTAGE PCB ASS'Y) - Main Driver PCB (UN78) (Unit of replacement: MAIN DRIVE DRIVER PCB ASS'Y) <p>[Remedy] Perform the following in the order while checking whether the error is cleared.</p> <ol style="list-style-type: none"> 1. Check the contact point of the Developing Assembly, and remove soiling. 2. Check/replace the related harness/cable, connector and parts.

E068-0001-05	Pre-transfer charging high voltage output leak error
Detection Description	The leak detection signal was detected 5 times in a row for every 20 msec.
Remedy	<p>[Related parts]</p> <ul style="list-style-type: none"> - Harness between the Main Driver PCB (UN78/J112) and the High Voltage Unit (J3098) (Unit of replacement: CABLE, MAIN, REAR UPPER) - Harness between the Relay PCB (UN86/J519) and the High Voltage Unit (J3099) (Unit of replacement: CABLE, SIGNAL) - Harnesses in the High Voltage Unit (J3098L, J3511, J3544, J3097L, J3501, J3500, J3545, J3510 and J3099M) (Unit of replacement: CABLE, HIGH VOLTAGE SIGNAL) - Pre-transfer Charging Assembly - Pre-transfer High Voltage Connector (Unit of replacement: CABLE, PRE-TRANS. CORONA H.V.) - Pre-transfer Charging PCB (Unit of replacement: PRE-TRANSFER CHARGE PCB ASS'Y) - Main Driver PCB (UN78) (Unit of replacement: MAIN DRIVE DRIVER PCB ASS'Y) <p>[Remedy] Check/replace the related harness/cable, connector and parts.</p>
E069-0001-05	Transfer high voltage output leak error
Detection Description	The leak detection signal was detected 5 times in a row for every 20 msec.
Remedy	<p>[Related parts]</p> <ul style="list-style-type: none"> - Harness between the Duplex Driver PCB (UN80/J311 and J343) and the Transfer High Voltage PCB (UN76/J3061 and J3062) (Unit of replacement: CABLE, FIXING/FEEDER DRAWER) - Harness connecting the Transfer High Voltage PCB (UN76/FT20), the Relay Connector (J3306) and the Transfer High Voltage Resistance PCB (Unit of replacement: CABLE, TRANSFER HIGH VOLTAGE) - Transfer High Voltage PCB (UN76) (Unit of replacement: HIGH VOLTAGE PCB ASS'Y) - ETB Unit (Unit of replacement: E.T.BELT ASSEMBLY) - Duplex Driver PCB (UN80) (Unit of replacement: DUPLEXING DRIVER PCB ASSEMBLY) <p>[Remedy] Check/replace the related harness/cable, connector and parts.</p>
E100-1130-05	Scanner Motor BD unlock error
Detection Description	Locked state was not detected within the specified period of time at start-up.
Remedy	<p>[Related parts]</p> <ul style="list-style-type: none"> - Harness between the DC Controller PCB (UN1/J472) and the Laser Driver PCB (UN31/J9912) (Unit of replacement: CABLE, LASER) - Harness between the DC Controller PCB (UN1/J471) and the Laser Driver PCB (UN31/J2169) - Harnesses from the DC Controller PCB to the BD PCB and the Polygon Motor <ol style="list-style-type: none"> 1. DC Controller PCB (J472) to Relay Connector (9P) (Unit of replacement: CABLE, LASER) 2. Relay Connector (9P) to Relay Connector (9P) 3. Relay Connector (9P) to BD PCB (J2160) and Laser Scanner Motor (J2159) <ul style="list-style-type: none"> - Scanner Unit (Unit of replacement: LASER SCANNER UNIT) - Laser Driver PCB (Unit of replacement: READER CONTROLLER PCB ASSEMBLY) - DC Controller PCB (Unit of replacement: DC CONTROLLER PCB ASS'Y) <p>[Remedy] Perform the following in the order while checking whether the error is cleared.</p> <ol style="list-style-type: none"> 1. Check that all covers (Front Cover, etc.) that can be opened and closed are closed. 2. Check/replace the related harness/cable, connector and parts. 3. If replaced with a new laser scanner unit, confirm that the DC controller board and software are also new. <p>[Reference]</p> <ul style="list-style-type: none"> - A new version of the software is installed on a new type of DC controller board (Service Parts). - Condensation inside the host machine or the Scanner Unit may trigger this error. In that case, leave the machine or the unit as it is until condensation disappears. - Before replacing the DC Controller PCB, back up the service mode data (approx. 2 min) and restore the backup data after the replacement so the data may be able to be protected. - Backup: COPIER (LEVEL2)> FUNCTION> SYSTEM> DSRAMBUP - Restoration: COPIER (LEVEL2)> FUNCTION> SYSTEM> DSRAMRES

E100-1140-05	Scanner Motor BD unlock error
Detection Description	Locked state was not detected within the specified period of time at start-up.
Remedy	<p>[Related parts]</p> <ul style="list-style-type: none"> - Harness between the DC Controller PCB (UN1/J472) and the Laser Driver PCB (UN31/J9912) (Unit of replacement: CABLE, LASER) - Harness between the DC Controller PCB (UN1/J471) and the Laser Driver PCB (UN31/J2169) - Harnesses from the DC Controller PCB to the BD PCB and the Laser Scanner Motor <ol style="list-style-type: none"> 1. DC Controller PCB (J472) to Relay Connector (9P) (Unit of replacement: CABLE, LASER) 2. Relay Connector (9P) to Relay Connector (9P) 3. Relay Connector (9P) to BD PCB (J2160) and Laser Scanner Motor (J2159) - Scanner Unit (Unit of replacement: LASER SCANNER UNIT) - Laser Driver PCB (Unit of replacement: READER CONTROLLER PCB ASSEMBLY) - DC Controller PCB (Unit of replacement: DC CONTROLLER PCB ASS'Y) <p>[Remedy] Perform the following in the order while checking whether the error is cleared.</p> <ol style="list-style-type: none"> 1. Check that all covers (Front Cover, etc.) that can be opened and closed are closed. 2. Check/replace the related harness/cable, connector and parts. 3. If replaced with a new laser scanner unit, confirm that the DC controller board and software are also new. <p>[Reference]</p> <ul style="list-style-type: none"> - A new version of the software is installed on a new type of DC controller board (Service Parts). - Condensation inside the host machine or the Scanner Unit may trigger this error. In that case, leave the machine or the unit as it is until condensation disappears. - Before replacing the DC Controller PCB, back up the service mode data (approx. 2 min) and restore the backup data after the replacement so the data may be able to be protected. - Backup: COPIER (LEVEL2)> FUNCTION> SYSTEM> DSRAMBUP - Restoration: COPIER (LEVEL2)> FUNCTION> SYSTEM> DSRAMRES
E100-1150-05	Scanner Motor BD unlock error
Detection Description	Locked state was not detected within the specified period of time at start-up.
Remedy	<p>[Related parts]</p> <ul style="list-style-type: none"> - Harness between the DC Controller PCB (UN1/J472) and the Laser Driver PCB (UN31/J9912) (Unit of replacement: CABLE, LASER) - Harness between the DC Controller PCB (UN1/J471) and the Laser Driver PCB (UN31/J2169) - Harnesses from the DC Controller PCB to the BD PCB and the Polygon Motor <ol style="list-style-type: none"> 1. DC Controller PCB (J472) to Relay Connector (9P) (Unit of replacement: CABLE, LASER) 2. Relay Connector (9P) to Relay Connector (9P) 3. Relay Connector (9P) to BD PCB (J2160) and Polygon Motor (J2159) - Scanner Unit (Unit of replacement: LASER SCANNER UNIT) - Laser Driver PCB (Unit of replacement: READER CONTROLLER PCB ASSEMBLY) - DC Controller PCB (Unit of replacement: DC CONTROLLER PCB ASS'Y) <p>[Remedy] Perform the following in the order while checking whether the error is cleared.</p> <ol style="list-style-type: none"> 1. Check that all covers (Front Cover, etc.) that can be opened and closed are closed. 2. Check/replace the related harness/cable, connector and parts. <p>[Reference]</p> <ul style="list-style-type: none"> - Condensation inside the host machine or the Scanner Unit may trigger this error. In that case, leave the machine or the unit as it is until condensation disappears. - Before replacing the DC Controller PCB, back up the service mode data (approx. 2 min) and restore the backup data after the replacement so the data may be able to be protected. - Backup: COPIER (LEVEL2)> FUNCTION> SYSTEM> DSRAMBUP - Restoration: COPIER (LEVEL2)> FUNCTION> SYSTEM> DSRAMRES

E100-1230-05	Scanner Motor BD unlock error
Detection Description	The BD lock was unlocked although it had been locked once.
Remedy	<p>[Related parts]</p> <ul style="list-style-type: none"> - Harness between the DC Controller PCB (UN1/J472) and the Laser Driver PCB (UN31/J9912) (Unit of replacement: CABLE, LASER) - Harness between the DC Controller PCB (UN1/J471) and the Laser Driver PCB (UN31/J2169) - Harnesses from the DC Controller PCB to the BD PCB and the Polygon Motor <ol style="list-style-type: none"> 1. DC Controller PCB (J472) to Relay Connector (9P) (Unit of replacement: CABLE, LASER) 2. Relay Connector (9P) to Relay Connector (9P) 3. Relay Connector (9P) to BD PCB (J2160) and Polygon Motor (J2159) <ul style="list-style-type: none"> - Scanner Unit (Unit of replacement: LASER SCANNER UNIT) - Laser Driver PCB (Unit of replacement: READER CONTROLLER PCB ASSEMBLY) - DC Controller PCB (Unit of replacement: DC CONTROLLER PCB ASS'Y) <p>[Remedy] Perform the following in the order while checking whether the error is cleared.</p> <ol style="list-style-type: none"> 1. Check that all covers (Front Cover, etc.) that can be opened and closed are closed. 2. Check/replace the related harness/cable, connector and parts. <p>[Reference]</p> <ul style="list-style-type: none"> - Condensation inside the host machine or the Scanner Unit may trigger this error. In that case, leave the machine or the unit as it is until condensation disappears. - Before replacing the DC Controller PCB, back up the service mode data (approx. 2 min) and restore the backup data after the replacement so the data may be able to be protected. - Backup: COPIER (LEVEL2)> FUNCTION> SYSTEM> DSRAMBUP - Restoration: COPIER (LEVEL2)> FUNCTION> SYSTEM> DSRAMRES
E100-1250-05	Scanner Motor BD unlock error
Detection Description	The BD lock was unlocked although it had been locked once.
Remedy	<p>[Related parts]</p> <ul style="list-style-type: none"> - Harness between the DC Controller PCB (UN1/J472) and the Laser Driver PCB (UN31/J9912) (Unit of replacement: CABLE, LASER) - Harness between the DC Controller PCB (UN1/J471) and the Laser Driver PCB (UN31/J2169) - Harnesses from the DC Controller PCB to the BD PCB and the Polygon Motor <ol style="list-style-type: none"> 1. DC Controller PCB (J472) to Relay Connector (9P) (Unit of replacement: CABLE, LASER) 2. Relay Connector (9P) to Relay Connector (9P) 3. Relay Connector (9P) to BD PCB (J2160) and Polygon Motor (J2159) <ul style="list-style-type: none"> - Scanner Unit (Unit of replacement: LASER SCANNER UNIT) - Laser Driver PCB (Unit of replacement: READER CONTROLLER PCB ASSEMBLY) - DC Controller PCB (Unit of replacement: DC CONTROLLER PCB ASS'Y) <p>[Remedy] Perform the following in the order while checking whether the error is cleared.</p> <ol style="list-style-type: none"> 1. Check that all covers (Front Cover, etc.) that can be opened and closed are closed. 2. Check/replace the related harness/cable, connector and parts. <p>[Reference]</p> <ul style="list-style-type: none"> - Condensation inside the host machine or the Scanner Unit may trigger this error. In that case, leave the machine or the unit as it is until condensation disappears. - Before replacing the DC Controller PCB, back up the service mode data (approx. 2 min) and restore the backup data after the replacement so the data may be able to be protected. - Backup: COPIER (LEVEL2)> FUNCTION> SYSTEM> DSRAMBUP - Restoration: COPIER (LEVEL2)> FUNCTION> SYSTEM> DSRAMRES

E100-1330-05	Scanner Motor BD unlock error
Detection Description	During the Polygon speed change, lock was unlocked for 1 second or longer.
Remedy	<p>[Related parts]</p> <ul style="list-style-type: none"> - Harness between the DC Controller PCB (UN1/J472) and the Laser Driver PCB (UN31/J9912) (Unit of replacement: CABLE, LASER) - Harness between the DC Controller PCB (UN1/J471) and the Laser Driver PCB (UN31/J2169) - Harnesses from the DC Controller PCB to the BD PCB and the Polygon Motor <ol style="list-style-type: none"> 1. DC Controller PCB (J472) to Relay Connector (9P) (Unit of replacement: CABLE, LASER) 2. Relay Connector (9P) to Relay Connector (9P) 3. Relay Connector (9P) to BD PCB (J2160) and Polygon Motor (J2159) <ul style="list-style-type: none"> - Scanner Unit (Unit of replacement: LASER SCANNER UNIT) - Laser Driver PCB (Unit of replacement: READER CONTROLLER PCB ASSEMBLY) - DC Controller PCB (Unit of replacement: DC CONTROLLER PCB ASS'Y) <p>[Remedy] Perform the following in the order while checking whether the error is cleared.</p> <ol style="list-style-type: none"> 1. Check that all covers (Front Cover, etc.) that can be opened and closed are closed. 2. Check/replace the related harness/cable, connector and parts. <p>[Reference]</p> <ul style="list-style-type: none"> - Condensation inside the host machine or the Scanner Unit may trigger this error. In that case, leave the machine or the unit as it is until condensation disappears. - Before replacing the DC Controller PCB, back up the service mode data (approx. 2 min) and restore the backup data after the replacement so the data may be able to be protected. - Backup: COPIER (LEVEL2)> FUNCTION> SYSTEM> DSRAMBUP - Restoration: COPIER (LEVEL2)> FUNCTION> SYSTEM> DSRAMRES
E100-1350-05	Scanner Motor BD unlock error
Detection Description	During the Polygon speed change, lock was unlocked for 1 second or longer.
Remedy	<p>[Related parts]</p> <ul style="list-style-type: none"> - Harness between the DC Controller PCB (UN1/J472) and the Laser Driver PCB (UN31/J9912) (Unit of replacement: CABLE, LASER) - Harness between the DC Controller PCB (UN1/J471) and the Laser Driver PCB (UN31/J2169) - Harnesses from the DC Controller PCB to the BD PCB and the Polygon Motor <ol style="list-style-type: none"> 1. DC Controller PCB (J472) to Relay Connector (9P) (Unit of replacement: CABLE, LASER) 2. Relay Connector (9P) to Relay Connector (9P) 3. Relay Connector (9P) to BD PCB (J2160) and Polygon Motor (J2159) <ul style="list-style-type: none"> - Scanner Unit (Unit of replacement: LASER SCANNER UNIT) - Laser Driver PCB (Unit of replacement: READER CONTROLLER PCB ASSEMBLY) - DC Controller PCB (Unit of replacement: DC CONTROLLER PCB ASS'Y) <p>[Remedy] Perform the following in the order while checking whether the error is cleared.</p> <ol style="list-style-type: none"> 1. Check that all covers (Front Cover, etc.) that can be opened and closed are closed. 2. Check/replace the related harness/cable, connector and parts. <p>[Reference]</p> <ul style="list-style-type: none"> - Condensation inside the host machine or the Scanner Unit may trigger this error. In that case, leave the machine or the unit as it is until condensation disappears. - Before replacing the DC Controller PCB, back up the service mode data (approx. 2 min) and restore the backup data after the replacement so the data may be able to be protected. - Backup: COPIER (LEVEL2)> FUNCTION> SYSTEM> DSRAMBUP - Restoration: COPIER (LEVEL2)> FUNCTION> SYSTEM> DSRAMRES

E100-FFFF-05		Scanner Motor BD unlock error
Detection Description	Failed to get the Detailed Code.	
Remedy	<p>[Related parts]</p> <ul style="list-style-type: none"> - Harness between the DC Controller PCB (UN1/J472) and the Laser Driver PCB (UN31/J9912) (Unit of replacement: CABLE, LASER) - Harness between the DC Controller PCB (UN1/J471) and the Laser Driver PCB (UN31/J2169) - Harnesses from the DC Controller PCB to the BD PCB and the Polygon Motor <ol style="list-style-type: none"> 1. DC Controller PCB (J472) to Relay Connector (9P) (Unit of replacement: CABLE, LASER) 2. Relay Connector (9P) to Relay Connector (9P) 3. Relay Connector (9P) to BD PCB (J2160) and Polygon Motor (J2159) <ul style="list-style-type: none"> - Scanner Unit (Unit of replacement: LASER SCANNER UNIT) - Laser Driver PCB (Unit of replacement: READER CONTROLLER PCB ASSEMBLY) - DC Controller PCB (Unit of replacement: DC CONTROLLER PCB ASS'Y) <p>[Remedy] Perform the following in the order while checking whether the error is cleared.</p> <ol style="list-style-type: none"> 1. Check that all covers (Front Cover, etc.) that can be opened and closed are closed. 2. Check/replace the related harness/cable, connector and parts. <p>[Reference]</p> <ul style="list-style-type: none"> - Condensation inside the host machine or the Scanner Unit may trigger this error. In that case, leave the machine or the unit as it is until condensation disappears. - Before replacing the DC Controller PCB, back up the service mode data (approx. 2 min) and restore the backup data after the replacement so the data may be able to be protected. - Backup: COPIER (LEVEL2)> FUNCTION> SYSTEM> DSRAMBUP - Restoration: COPIER (LEVEL2)> FUNCTION> SYSTEM> DSRAMRES 	
E102-0001-05		EEPROM error
Detection Description	Failed to write to EEPROM.	
Remedy	<p>[Related parts]</p> <ul style="list-style-type: none"> - Harness between the DC Controller PCB (UN1/J472) and the Laser Driver PCB (UN31/J9912) (Unit of replacement: CABLE, LASER) - Harness between the DC Controller PCB (UN1/J471) and the Laser Driver PCB (UN31/J2169) - Harnesses from the DC Controller PCB to the BD PCB and the Polygon Motor <ol style="list-style-type: none"> 1. DC Controller PCB (J472) to Relay Connector (9P) (Unit of replacement: CABLE, LASER) 2. Relay Connector (9P) to Relay Connector (9P) 3. Relay Connector (9P) to BD PCB (J2160) and Polygon Motor (J2159) <ul style="list-style-type: none"> - Scanner Unit (Unit of replacement: LASER SCANNER UNIT) - Laser Driver PCB (Unit of replacement: READER CONTROLLER PCB ASSEMBLY) - DC Controller PCB (Unit of replacement: DC CONTROLLER PCB ASS'Y) <p>[Remedy] Perform the following in the order while checking whether the error is cleared.</p> <ol style="list-style-type: none"> 1. Check that all covers (Front Cover, etc.) that can be opened and closed are closed. 2. Check/replace the related harness/cable, connector and parts. <p>[Reference]</p> <ul style="list-style-type: none"> - Condensation inside the host machine or the Scanner Unit may trigger this error. In that case, leave the machine or the unit as it is until condensation disappears. - Before replacing the DC Controller PCB, back up the service mode data (approx. 2 min) and restore the backup data after the replacement so the data may be able to be protected. - Backup: COPIER (LEVEL2)> FUNCTION> SYSTEM> DSRAMBUP - Restoration: COPIER (LEVEL2)> FUNCTION> SYSTEM> DSRAMRES 	
E103-0001-05		Different Laser Scanner Unit model error
Detection Description	The scanner for iR-ADV 6555 series has been installed to iR-ADV 8505 series machine, and vice versa.	
Remedy	<p>[Remedy]</p> <p>Replace the Laser Scanner Unit with the one for the correct model.</p>	

E110-1110-05	Scanner Motor FG unlock error
Detection Description	Locked state was not detected within the specified period of time at start-up.
Remedy	<p>[Related parts]</p> <ul style="list-style-type: none"> - Harness between the DC Controller PCB (UN1/J472) and the Laser Driver PCB (UN31/J9912) (Unit of replacement: CABLE, LASER) - Harness between the DC Controller PCB (UN1/J471) and the Laser Driver PCB (UN31/J2169) - Harnesses from the DC Controller PCB to the BD PCB and the Polygon Motor <ol style="list-style-type: none"> 1. DC Controller PCB (J472) to Relay Connector (9P) (Unit of replacement: CABLE, LASER) 2. Relay Connector (9P) to Relay Connector (9P) 3. Relay Connector (9P) to BD PCB (J2160) and Polygon Motor (J2159) <ul style="list-style-type: none"> - Scanner Unit (Unit of replacement: LASER SCANNER UNIT) - Laser Driver PCB (Unit of replacement: READER CONTROLLER PCB ASSEMBLY) - DC Controller PCB (Unit of replacement: DC CONTROLLER PCB ASS'Y) <p>[Remedy] Perform the following in the order while checking whether the error is cleared.</p> <ol style="list-style-type: none"> 1. Check that all covers (Front Cover, etc.) that can be opened and closed are closed. 2. Check/replace the related harness/cable, connector and parts. <p>[Reference] Before replacing the DC Controller PCB, back up the service mode data (approx. 2 min) and restore the backup data after the replacement so the data may be able to be protected.</p> <ul style="list-style-type: none"> - Backup: COPIER (LEVEL2)> FUNCTION> SYSTEM> DSRAMBUP - Restoration: COPIER (LEVEL2)> FUNCTION> SYSTEM> DSRAMRES
E110-1114-05	Scanner Motor FG unlock error
Detection Description	Locked state was not detected within the specified period of time at start-up.
Remedy	<p>[Related parts]</p> <ul style="list-style-type: none"> - Harness between the DC Controller PCB (UN1/J472) and the Laser Driver PCB (UN31/J9912) (Unit of replacement: CABLE, LASER) - Harness between the DC Controller PCB (UN1/J471) and the Laser Driver PCB (UN31/J2169) - Harnesses from the DC Controller PCB to the BD PCB and the Polygon Motor <ol style="list-style-type: none"> 1. DC Controller PCB (J472) to Relay Connector (9P) (Unit of replacement: CABLE, LASER) 2. Relay Connector (9P) to Relay Connector (9P) 3. Relay Connector (9P) to BD PCB (J2160) and Polygon Motor (J2159) <ul style="list-style-type: none"> - Scanner Unit (Unit of replacement: LASER SCANNER UNIT) - Laser Driver PCB (Unit of replacement: READER CONTROLLER PCB ASSEMBLY) - DC Controller PCB (Unit of replacement: DC CONTROLLER PCB ASS'Y) <p>[Remedy] Perform the following in the order while checking whether the error is cleared.</p> <ol style="list-style-type: none"> 1. Check that all covers (Front Cover, etc.) that can be opened and closed are closed. 2. Check/replace the related harness/cable, connector and parts. <p>[Reference] Before replacing the DC Controller PCB, back up the service mode data (approx. 2 min) and restore the backup data after the replacement so the data may be able to be protected.</p> <ul style="list-style-type: none"> - Backup: COPIER (LEVEL2)> FUNCTION> SYSTEM> DSRAMBUP - Restoration: COPIER (LEVEL2)> FUNCTION> SYSTEM> DSRAMRES

E110-11F0-05	Scanner Motor FG unlock error
Detection Description	Locked state was not detected within the specified period of time at start-up.
Remedy	<p>[Related parts]</p> <ul style="list-style-type: none"> - Harness between the DC Controller PCB (UN1/J472) and the Laser Driver PCB (UN31/J9912) (Unit of replacement: CABLE, LASER) - Harness between the DC Controller PCB (UN1/J471) and the Laser Driver PCB (UN31/J2169) - Harnesses from the DC Controller PCB to the BD PCB and the Polygon Motor <ol style="list-style-type: none"> 1. DC Controller PCB (J472) to Relay Connector (9P) (Unit of replacement: CABLE, LASER) 2. Relay Connector (9P) to Relay Connector (9P) 3. Relay Connector (9P) to BD PCB (J2160) and Polygon Motor (J2159) <ul style="list-style-type: none"> - Scanner Unit (Unit of replacement: LASER SCANNER UNIT) - Laser Driver PCB (Unit of replacement: READER CONTROLLER PCB ASSEMBLY) - DC Controller PCB (Unit of replacement: DC CONTROLLER PCB ASS'Y) <p>[Remedy] Perform the following in the order while checking whether the error is cleared.</p> <ol style="list-style-type: none"> 1. Check that all covers (Front Cover, etc.) that can be opened and closed are closed. 2. Check/replace the related harness/cable, connector and parts. <p>[Reference] Before replacing the DC Controller PCB, back up the service mode data (approx. 2 min) and restore the backup data after the replacement so the data may be able to be protected.</p> <ul style="list-style-type: none"> - Backup: COPIER (LEVEL2)> FUNCTION> SYSTEM> DSRAMBUP - Restoration: COPIER (LEVEL2)> FUNCTION> SYSTEM> DSRAMRES
E110-11F4-05	Scanner Motor FG unlock error
Detection Description	Locked state was not detected within the specified period of time at start-up.
Remedy	<p>[Related parts]</p> <ul style="list-style-type: none"> - Harness between the DC Controller PCB (UN1/J472) and the Laser Driver PCB (UN31/J9912) (Unit of replacement: CABLE, LASER) - Harness between the DC Controller PCB (UN1/J471) and the Laser Driver PCB (UN31/J2169) - Harnesses from the DC Controller PCB to the BD PCB and the Polygon Motor <ol style="list-style-type: none"> 1. DC Controller PCB (J472) to Relay Connector (9P) (Unit of replacement: CABLE, LASER) 2. Relay Connector (9P) to Relay Connector (9P) 3. Relay Connector (9P) to BD PCB (J2160) and Polygon Motor (J2159) <ul style="list-style-type: none"> - Scanner Unit (Unit of replacement: LASER SCANNER UNIT) - Laser Driver PCB (Unit of replacement: READER CONTROLLER PCB ASSEMBLY) - DC Controller PCB (Unit of replacement: DC CONTROLLER PCB ASS'Y) <p>[Remedy] Perform the following in the order while checking whether the error is cleared.</p> <ol style="list-style-type: none"> 1. Check that all covers (Front Cover, etc.) that can be opened and closed are closed. 2. Check/replace the related harness/cable, connector and parts. <p>[Reference] Before replacing the DC Controller PCB, back up the service mode data (approx. 2 min) and restore the backup data after the replacement so the data may be able to be protected.</p> <ul style="list-style-type: none"> - Backup: COPIER (LEVEL2)> FUNCTION> SYSTEM> DSRAMBUP - Restoration: COPIER (LEVEL2)> FUNCTION> SYSTEM> DSRAMRES

E110-1210-05	Scanner Motor FG unlock error
Detection Description	Locked state was not detected within the specified period of time at start-up.
Remedy	<p>[Related parts]</p> <ul style="list-style-type: none"> - Harness between the DC Controller PCB (UN1/J472) and the Laser Driver PCB (UN31/J9912) (Unit of replacement: CABLE, LASER) - Harness between the DC Controller PCB (UN1/J471) and the Laser Driver PCB (UN31/J2169) - Harnesses from the DC Controller PCB to the BD PCB and the Polygon Motor <ol style="list-style-type: none"> 1. DC Controller PCB (J472) to Relay Connector (9P) (Unit of replacement: CABLE, LASER) 2. Relay Connector (9P) to Relay Connector (9P) 3. Relay Connector (9P) to BD PCB (J2160) and Polygon Motor (J2159) <ul style="list-style-type: none"> - Scanner Unit (Unit of replacement: LASER SCANNER UNIT) - Laser Driver PCB (Unit of replacement: READER CONTROLLER PCB ASSEMBLY) - DC Controller PCB (Unit of replacement: DC CONTROLLER PCB ASS'Y) <p>[Remedy] Perform the following in the order while checking whether the error is cleared.</p> <ol style="list-style-type: none"> 1. Check that all covers (Front Cover, etc.) that can be opened and closed are closed. 2. Check/replace the related harness/cable, connector and parts. <p>[Reference] Before replacing the DC Controller PCB, back up the service mode data (approx. 2 min) and restore the backup data after the replacement so the data may be able to be protected.</p> <ul style="list-style-type: none"> - Backup: COPIER (LEVEL2)> FUNCTION> SYSTEM> DSRAMBUP - Restoration: COPIER (LEVEL2)> FUNCTION> SYSTEM> DSRAMRES
E110-1214-05	Scanner Motor FG unlock error
Detection Description	Locked state was not detected within the specified period of time at start-up.
Remedy	<p>[Related parts]</p> <ul style="list-style-type: none"> - Harness between the DC Controller PCB (UN1/J472) and the Laser Driver PCB (UN31/J9912) (Unit of replacement: CABLE, LASER) - Harness between the DC Controller PCB (UN1/J471) and the Laser Driver PCB (UN31/J2169) - Harnesses from the DC Controller PCB to the BD PCB and the Polygon Motor <ol style="list-style-type: none"> 1. DC Controller PCB (J472) to Relay Connector (9P) (Unit of replacement: CABLE, LASER) 2. Relay Connector (9P) to Relay Connector (9P) 3. Relay Connector (9P) to BD PCB (J2160) and Polygon Motor (J2159) <ul style="list-style-type: none"> - Scanner Unit (Unit of replacement: LASER SCANNER UNIT) - Laser Driver PCB (Unit of replacement: READER CONTROLLER PCB ASSEMBLY) - DC Controller PCB (Unit of replacement: DC CONTROLLER PCB ASS'Y) <p>[Remedy] Perform the following in the order while checking whether the error is cleared.</p> <ol style="list-style-type: none"> 1. Check that all covers (Front Cover, etc.) that can be opened and closed are closed. 2. Check/replace the related harness/cable, connector and parts. <p>[Reference] Before replacing the DC Controller PCB, back up the service mode data (approx. 2 min) and restore the backup data after the replacement so the data may be able to be protected.</p> <ul style="list-style-type: none"> - Backup: COPIER (LEVEL2)> FUNCTION> SYSTEM> DSRAMBUP - Restoration: COPIER (LEVEL2)> FUNCTION> SYSTEM> DSRAMRES

E110-12F0-05	Scanner Motor FG unlock error
Detection Description	Locked state was not detected within the specified period of time at start-up.
Remedy	<p>[Related parts]</p> <ul style="list-style-type: none"> - Harness between the DC Controller PCB (UN1/J472) and the Laser Driver PCB (UN31/J9912) (Unit of replacement: CABLE, LASER) - Harness between the DC Controller PCB (UN1/J471) and the Laser Driver PCB (UN31/J2169) - Harnesses from the DC Controller PCB to the BD PCB and the Polygon Motor <ol style="list-style-type: none"> 1. DC Controller PCB (J472) to Relay Connector (9P) (Unit of replacement: CABLE, LASER) 2. Relay Connector (9P) to Relay Connector (9P) 3. Relay Connector (9P) to BD PCB (J2160) and Polygon Motor (J2159) <ul style="list-style-type: none"> - Scanner Unit (Unit of replacement: LASER SCANNER UNIT) - Laser Driver PCB (Unit of replacement: READER CONTROLLER PCB ASSEMBLY) - DC Controller PCB (Unit of replacement: DC CONTROLLER PCB ASS'Y) <p>[Remedy] Perform the following in the order while checking whether the error is cleared.</p> <ol style="list-style-type: none"> 1. Check that all covers (Front Cover, etc.) that can be opened and closed are closed. 2. Check/replace the related harness/cable, connector and parts. <p>[Reference] Before replacing the DC Controller PCB, back up the service mode data (approx. 2 min) and restore the backup data after the replacement so the data may be able to be protected.</p> <ul style="list-style-type: none"> - Backup: COPIER (LEVEL2)> FUNCTION> SYSTEM> DSRAMBUP - Restoration: COPIER (LEVEL2)> FUNCTION> SYSTEM> DSRAMRES
E110-12F4-05	Scanner Motor FG unlock error
Detection Description	Locked state was not detected within the specified period of time at start-up.
Remedy	<p>[Related parts]</p> <ul style="list-style-type: none"> - Harness between the DC Controller PCB (UN1/J472) and the Laser Driver PCB (UN31/J9912) (Unit of replacement: CABLE, LASER) - Harness between the DC Controller PCB (UN1/J471) and the Laser Driver PCB (UN31/J2169) - Harnesses from the DC Controller PCB to the BD PCB and the Polygon Motor <ol style="list-style-type: none"> 1. DC Controller PCB (J472) to Relay Connector (9P) (Unit of replacement: CABLE, LASER) 2. Relay Connector (9P) to Relay Connector (9P) 3. Relay Connector (9P) to BD PCB (J2160) and Polygon Motor (J2159) <ul style="list-style-type: none"> - Scanner Unit (Unit of replacement: LASER SCANNER UNIT) - Laser Driver PCB (Unit of replacement: READER CONTROLLER PCB ASSEMBLY) - DC Controller PCB (Unit of replacement: DC CONTROLLER PCB ASS'Y) <p>[Remedy] Perform the following in the order while checking whether the error is cleared.</p> <ol style="list-style-type: none"> 1. Check that all covers (Front Cover, etc.) that can be opened and closed are closed. 2. Check/replace the related harness/cable, connector and parts. <p>[Reference] Before replacing the DC Controller PCB, back up the service mode data (approx. 2 min) and restore the backup data after the replacement so the data may be able to be protected.</p> <ul style="list-style-type: none"> - Backup: COPIER (LEVEL2)> FUNCTION> SYSTEM> DSRAMBUP - Restoration: COPIER (LEVEL2)> FUNCTION> SYSTEM> DSRAMRES

E110-1310-05	Scanner Motor FG unlock error
Detection Description	Locked state was not detected within the specified period of time at start-up.
Remedy	<p>[Related parts]</p> <ul style="list-style-type: none"> - Harness between the DC Controller PCB (UN1/J472) and the Laser Driver PCB (UN31/J9912) (Unit of replacement: CABLE, LASER) - Harness between the DC Controller PCB (UN1/J471) and the Laser Driver PCB (UN31/J2169) - Harnesses from the DC Controller PCB to the BD PCB and the Polygon Motor <ol style="list-style-type: none"> 1. DC Controller PCB (J472) to Relay Connector (9P) (Unit of replacement: CABLE, LASER) 2. Relay Connector (9P) to Relay Connector (9P) 3. Relay Connector (9P) to BD PCB (J2160) and Polygon Motor (J2159) <ul style="list-style-type: none"> - Scanner Unit (Unit of replacement: LASER SCANNER UNIT) - Laser Driver PCB (Unit of replacement: READER CONTROLLER PCB ASSEMBLY) - DC Controller PCB (Unit of replacement: DC CONTROLLER PCB ASS'Y) <p>[Remedy] Perform the following in the order while checking whether the error is cleared.</p> <ol style="list-style-type: none"> 1. Check that all covers (Front Cover, etc.) that can be opened and closed are closed. 2. Check/replace the related harness/cable, connector and parts. <p>[Reference] Before replacing the DC Controller PCB, back up the service mode data (approx. 2 min) and restore the backup data after the replacement so the data may be able to be protected.</p> <ul style="list-style-type: none"> - Backup: COPIER (LEVEL2)> FUNCTION> SYSTEM> DSRAMBUP - Restoration: COPIER (LEVEL2)> FUNCTION> SYSTEM> DSRAMRES
E110-1314-05	Scanner Motor FG unlock error
Detection Description	Locked state was not detected within the specified period of time at start-up.
Remedy	<p>[Related parts]</p> <ul style="list-style-type: none"> - Harness between the DC Controller PCB (UN1/J472) and the Laser Driver PCB (UN31/J9912) (Unit of replacement: CABLE, LASER) - Harness between the DC Controller PCB (UN1/J471) and the Laser Driver PCB (UN31/J2169) - Harnesses from the DC Controller PCB to the BD PCB and the Polygon Motor <ol style="list-style-type: none"> 1. DC Controller PCB (J472) to Relay Connector (9P) (Unit of replacement: CABLE, LASER) 2. Relay Connector (9P) to Relay Connector (9P) 3. Relay Connector (9P) to BD PCB (J2160) and Polygon Motor (J2159) <ul style="list-style-type: none"> - Scanner Unit (Unit of replacement: LASER SCANNER UNIT) - Laser Driver PCB (Unit of replacement: READER CONTROLLER PCB ASSEMBLY) - DC Controller PCB (Unit of replacement: DC CONTROLLER PCB ASS'Y) <p>[Remedy] Perform the following in the order while checking whether the error is cleared.</p> <ol style="list-style-type: none"> 1. Check that all covers (Front Cover, etc.) that can be opened and closed are closed. 2. Check/replace the related harness/cable, connector and parts. <p>[Reference] Before replacing the DC Controller PCB, back up the service mode data (approx. 2 min) and restore the backup data after the replacement so the data may be able to be protected.</p> <ul style="list-style-type: none"> - Backup: COPIER (LEVEL2)> FUNCTION> SYSTEM> DSRAMBUP - Restoration: COPIER (LEVEL2)> FUNCTION> SYSTEM> DSRAMRES

E110-13F0-05	Scanner Motor FG unlock error
Detection Description	Locked state was not detected within the specified period of time at start-up.
Remedy	<p>[Related parts]</p> <ul style="list-style-type: none"> - Harness between the DC Controller PCB (UN1/J472) and the Laser Driver PCB (UN31/J9912) (Unit of replacement: CABLE, LASER) - Harness between the DC Controller PCB (UN1/J471) and the Laser Driver PCB (UN31/J2169) - Harnesses from the DC Controller PCB to the BD PCB and the Polygon Motor <ol style="list-style-type: none"> 1. DC Controller PCB (J472) to Relay Connector (9P) (Unit of replacement: CABLE, LASER) 2. Relay Connector (9P) to Relay Connector (9P) 3. Relay Connector (9P) to BD PCB (J2160) and Polygon Motor (J2159) <ul style="list-style-type: none"> - Scanner Unit (Unit of replacement: LASER SCANNER UNIT) - Laser Driver PCB (Unit of replacement: READER CONTROLLER PCB ASSEMBLY) - DC Controller PCB (Unit of replacement: DC CONTROLLER PCB ASS'Y) <p>[Remedy] Perform the following in the order while checking whether the error is cleared.</p> <ol style="list-style-type: none"> 1. Check that all covers (Front Cover, etc.) that can be opened and closed are closed. 2. Check/replace the related harness/cable, connector and parts. <p>[Reference] Before replacing the DC Controller PCB, back up the service mode data (approx. 2 min) and restore the backup data after the replacement so the data may be able to be protected.</p> <ul style="list-style-type: none"> - Backup: COPIER (LEVEL2)> FUNCTION> SYSTEM> DSRAMBUP - Restoration: COPIER (LEVEL2)> FUNCTION> SYSTEM> DSRAMRES
E110-13F4-05	Scanner Motor FG unlock error
Detection Description	Locked state was not detected within the specified period of time at start-up.
Remedy	<p>[Related parts]</p> <ul style="list-style-type: none"> - Harness between the DC Controller PCB (UN1/J472) and the Laser Driver PCB (UN31/J9912) (Unit of replacement: CABLE, LASER) - Harness between the DC Controller PCB (UN1/J471) and the Laser Driver PCB (UN31/J2169) - Harnesses from the DC Controller PCB to the BD PCB and the Polygon Motor <ol style="list-style-type: none"> 1. DC Controller PCB (J472) to Relay Connector (9P) (Unit of replacement: CABLE, LASER) 2. Relay Connector (9P) to Relay Connector (9P) 3. Relay Connector (9P) to BD PCB (J2160) and Polygon Motor (J2159) <ul style="list-style-type: none"> - Scanner Unit (Unit of replacement: LASER SCANNER UNIT) - Laser Driver PCB (Unit of replacement: READER CONTROLLER PCB ASSEMBLY) - DC Controller PCB (Unit of replacement: DC CONTROLLER PCB ASS'Y) <p>[Remedy] Perform the following in the order while checking whether the error is cleared.</p> <ol style="list-style-type: none"> 1. Check that all covers (Front Cover, etc.) that can be opened and closed are closed. 2. Check/replace the related harness/cable, connector and parts. <p>[Reference] Before replacing the DC Controller PCB, back up the service mode data (approx. 2 min) and restore the backup data after the replacement so the data may be able to be protected.</p> <ul style="list-style-type: none"> - Backup: COPIER (LEVEL2)> FUNCTION> SYSTEM> DSRAMBUP - Restoration: COPIER (LEVEL2)> FUNCTION> SYSTEM> DSRAMRES

E110-FFFF-05	Scanner Motor FG unlock error
Detection Description	Failed to get the Detailed Code.
Remedy	<p>[Related parts]</p> <ul style="list-style-type: none"> - Harness between the DC Controller PCB (UN1/J472) and the Laser Driver PCB (UN31/J9912) (Unit of replacement: CABLE, LASER) - Harness between the DC Controller PCB (UN1/J471) and the Laser Driver PCB (UN31/J2169) - Harnesses from the DC Controller PCB to the BD PCB and the Polygon Motor <ol style="list-style-type: none"> 1. DC Controller PCB (J472) to Relay Connector (9P) (Unit of replacement: CABLE, LASER) 2. Relay Connector (9P) to Relay Connector (9P) 3. Relay Connector (9P) to BD PCB (J2160) and Polygon Motor (J2159) <ul style="list-style-type: none"> - Scanner Unit (Unit of replacement: LASER SCANNER UNIT) - Laser Driver PCB (Unit of replacement: READER CONTROLLER PCB ASSEMBLY) - DC Controller PCB (Unit of replacement: DC CONTROLLER PCB ASS'Y) <p>[Remedy] Perform the following in the order while checking whether the error is cleared.</p> <ol style="list-style-type: none"> 1. Check that all covers (Front Cover, etc.) that can be opened and closed are closed. 2. Check/replace the related harness/cable, connector and parts. <p>[Reference] Before replacing the DC Controller PCB, back up the service mode data (approx. 2 min) and restore the backup data after the replacement so the data may be able to be protected.</p> <ul style="list-style-type: none"> - Backup: COPIER (LEVEL2)> FUNCTION> SYSTEM> DSRAMBUP - Restoration: COPIER (LEVEL2)> FUNCTION> SYSTEM> DSRAMRES
E121-0001-05	Laser Scanner Cooling Fan error
Detection Description	The fan stop signal was detected consecutively although the Laser Scanner Cooling Fan was turned ON.
Remedy	<p>[Related parts]</p> <ul style="list-style-type: none"> - Harness between the Main Driver PCB (UN78/J109) and the Laser Scanner Cooling Fan (FM16/J2007) - Laser Scanner Cooling Fan (FM16) - Main Driver PCB (UN78) (Unit of replacement: MAIN DRIVE DRIVER PCB ASS'Y) <p>[Remedy] Check/replace the related harness/cable, connector and parts.</p>
E197-0001-05	Serial communication error
Detection Description	A communication error between the DC Controller PCB and the Main Driver PCB was detected.
Remedy	<p>[Related parts]</p> <ul style="list-style-type: none"> - Harness between the DC Controller PCB (UN1/J411, J412, J413 and J414) and the Main Driver PCB (UN78/J126, J125, J124 and J128) (Unit of replacement: CABLE, SIGNAL) - Harness between the Main Driver PCB (UN78/J101) and the Relay PCB (UN86/J515) (Unit of replacement: CABLE, SIGNAL) - Harness between the DC Controller PCB (UN1/J451) and the Relay PCB (UN86/J514) (Unit of replacement: CABLE, SIGNAL) - Main Driver PCB (UN78) (Unit of replacement: MAIN DRIVE DRIVER PCB ASS'Y) - Relay PCB (UN86) (Unit of replacement: RELAY PCB ASSEMBLY) - DC Controller PCB (UN1) (Unit of replacement: DC CONTROLLER PCB ASS'Y) <p>[Remedy] Check/replace the related harness/cable, connector and parts.</p> <p>[Reference] Before replacing the DC Controller PCB, back up the service mode data (approx. 2 min) and restore the backup data after the replacement so the data may be able to be protected.</p> <ul style="list-style-type: none"> - Backup: COPIER (LEVEL2)> FUNCTION> SYSTEM> DSRAMBUP - Restoration: COPIER (LEVEL2)> FUNCTION> SYSTEM> DSRAMRES

E197-0002-05	Serial communication error
Detection Description	A communication error between the DC Controller PCB and the Feed Driver PCB was detected.
Remedy	<p>[Related parts]</p> <ul style="list-style-type: none"> - Harnesses from the DC Controller PCB to the Feed Driver PCB 1. DC Controller PCB (UN1/J421) to Relay Connector (17P) (Unit of replacement: CABLE, SIGNAL) 2. Relay Connector (17P) to Feed Driver PCB (UN79/J204) (Unit of replacement: CABLE, SERIAL) - Harness between the Feed Driver PCB (UN79/J218) and the DC-DC Converter PCB (PCB08/J9033) (Unit of replacement: CABLE, DC) - Harness between the Feed Driver PCB (UN79/J201) and the Relay PCB (UN86/J516) (Unit of replacement: CABLE, DECK, LEFT) - Harness between the DC Controller PCB (UN1/J451) and the Relay PCB (UN86/J514) (Unit of replacement: CABLE, SIGNAL) - Feed Driver PCB (UN79) (Unit of replacement: FEED DRIVER PCB ASSEMBLY) - DC-DC Converter PCB (PCB08) (Unit of replacement: DC-DC CONVERT PCB ASS'Y) - Relay PCB (UN86) (Unit of replacement: RELAY PCB ASSEMBLY) - DC Controller PCB (UN1) (Unit of replacement: DC CONTROLLER PCB ASS'Y) <p>[Remedy] Check/replace the related harness/cable, connector and parts. [Reference] Before replacing the DC Controller PCB, back up the service mode data (approx. 2 min) and restore the backup data after the replacement so the data may be able to be protected.</p> <ul style="list-style-type: none"> - Backup: COPIER (LEVEL2)> FUNCTION> SYSTEM> DSRAMBUP - Restoration: COPIER (LEVEL2)> FUNCTION> SYSTEM> DSRAMRES
E197-0003-05	Serial communication error
Detection Description	A communication error between the DC Controller PCB and the Duplex Driver PCB was detected.
Remedy	<p>[Related parts]</p> <ul style="list-style-type: none"> - Harness between the DC Controller PCB (UN1/J431, J9, J432 and J8) and the Fixing Feed Drawer Unit (J5005) (Unit of replacement: CABLE, SIGNAL) - Harness between the Duplex Driver (UN80/J300, J301 and J310) and the Fixing Feed Drawer Unit (J5005) (Unit of replacement: CABLE, FIXING/FEEDER DRAWER) - Harness between the Duplex Driver PCB (UN80/J311) and the DC-DC Converter PCB (PCB08/J9034) (Unit of replacement: CABLE, FIXING/FEEDER DRAWER) - Harness between the Relay PCB (UN86/J517) and the Fixing Feed Drawer Unit (J5005) (Unit of replacement: CABLE, FIXING/FEEDER DRAWER) - Harness between the DC Controller PCB (UN1/J451) and the Relay PCB (UN86/J514) (Unit of replacement: CABLE, SIGNAL) - DC-DC Converter PCB (PCB08) (Unit of replacement: DC-DC CONVERT PCB ASS'Y) - Duplex Driver PCB (UN80) (Unit of replacement: DUPLEXING DRIVER PCB ASSEMBLY) - Relay PCB (UN86) (Unit of replacement: RELAY PCB ASSEMBLY) - DC Controller PCB (UN1) (Unit of replacement: DC CONTROLLER PCB ASS'Y) <p>[Remedy] Check/replace the related harness/cable, connector and parts. [Reference] Before replacing the DC Controller PCB, back up the service mode data (approx. 2 min) and restore the backup data after the replacement so the data may be able to be protected.</p> <ul style="list-style-type: none"> - Backup: COPIER (LEVEL2)> FUNCTION> SYSTEM> DSRAMBUP - Restoration: COPIER (LEVEL2)> FUNCTION> SYSTEM> DSRAMRES
E197-0004-05	Serial communication error
Detection Description	Disconnection of the harness between the DC Controller PCB and the Relay PCB was detected.
Remedy	<p>[Related parts]</p> <ul style="list-style-type: none"> - Harness between the DC Controller PCB (UN1/J451) and the Relay PCB (UN86/J514) (Unit of replacement: CABLE, SIGNAL) - Relay PCB (UN86) (Unit of replacement: RELAY PCB ASSEMBLY) - DC Controller PCB (UN1) (Unit of replacement: DC CONTROLLER PCB ASS'Y) <p>[Remedy] Check/replace the related harness/cable, connector and parts. [Reference] Before replacing the DC Controller PCB, back up the service mode data (approx. 2 min) and restore the backup data after the replacement so the data may be able to be protected.</p> <ul style="list-style-type: none"> - Backup: COPIER (LEVEL2)> FUNCTION> SYSTEM> DSRAMBUP - Restoration: COPIER (LEVEL2)> FUNCTION> SYSTEM> DSRAMRES

E197-0005-05	Serial communication error
Detection Description	Disconnection of the harness between the DC Controller PCB and the Main Driver PCB was detected.
Remedy	<p>[Related parts]</p> <ul style="list-style-type: none"> - Harness between the DC Controller PCB (UN1/J413) and the Main Driver PCB (UN78/J124) (Unit of replacement: CABLE, SIGNAL) - Main Driver PCB (UN78) (Unit of replacement: MAIN DRIVE DRIVER PCB ASS'Y) - DC Controller PCB (UN1) (Unit of replacement: DC CONTROLLER PCB ASS'Y) <p>[Remedy] Check/replace the related harness/cable, connector and parts. [Reference] Before replacing the DC Controller PCB, back up the service mode data (approx. 2 min) and restore the backup data after the replacement so the data may be able to be protected.</p> <ul style="list-style-type: none"> - Backup: COPIER (LEVEL2)> FUNCTION> SYSTEM> DSRAMBUP - Restoration: COPIER (LEVEL2)> FUNCTION> SYSTEM> DSRAMRES
E197-0006-05	Serial communication error
Detection Description	Disconnection of the harness between the DC Controller PCB and the Duplex Driver PCB was detected.
Remedy	<p>[Related parts]</p> <ul style="list-style-type: none"> - Harness between the DC Controller PCB (UN1/J431, J9, J432 and J8) and the Fixing Feed Drawer Unit (J5005) (Unit of replacement: CABLE, SIGNAL) - Harness between the Duplex Driver PCB (UN80/J300 and J301) and the Fixing Feed Drawer Unit (J5005) (Unit of replacement: CABLE, FIXING/FEEDER DRAWER) - Duplex Driver PCB (UN80) (Unit of replacement: DUPLEXING DRIVER PCB ASSEMBLY) - DC Controller PCB (UN1) (Unit of replacement: DC CONTROLLER PCB ASS'Y) <p>[Remedy] Check/replace the related harness/cable, connector and parts. [Reference] Before replacing the DC Controller PCB, back up the service mode data (approx. 2 min) and restore the backup data after the replacement so the data may be able to be protected.</p> <ul style="list-style-type: none"> - Backup: COPIER (LEVEL2)> FUNCTION> SYSTEM> DSRAMBUP - Restoration: COPIER (LEVEL2)> FUNCTION> SYSTEM> DSRAMRES
E197-0008-05	Serial communication error
Detection Description	Disconnection of the harness between the Main Driver PCB and the Fixing Drawer Unit was detected.
Remedy	<p>[Related parts]</p> <ul style="list-style-type: none"> - Harness between the Main Driver PCB (UN78/J104 and J105) and the Fixing Drawer Unit (J3001) (Unit of replacement: CABLE, FIXING DRAWER) - Fixing Drawer Unit (J3200) (Unit of replacement: CABLE, FIXING DC DRAWER) - Main Driver PCB (UN78) (Unit of replacement: MAIN DRIVE DRIVER PCB ASS'Y) <p>[Remedy] Check/replace the related harness/cable, connector and parts.</p>
E197-0009-05	Serial communication error
Detection Description	Disconnection of the harness between the Main Driver PCB and the Process Assembly was detected.
Remedy	<p>[Related parts]</p> <ul style="list-style-type: none"> - Harnesses from the Main Driver PCB to the AP Drawer Unit <ol style="list-style-type: none"> 1. Main Driver PCB (UN78/J107) to Relay Connector (12P) (Unit of replacement: CABLE, MAIN, REAR UPPER) 2. Relay Connector (12P) to AP Drawer Unit (J3060) (Unit of replacement: CABLE, AP. KIT DRAWER) <ul style="list-style-type: none"> - AP Drawer Unit (Unit of replacement: DRAWER ASSEMBLY) - Main Driver PCB (UN78) (Unit of replacement: MAIN DRIVE DRIVER PCB ASS'Y) <p>[Remedy] Check/replace the related harness/cable, connector and parts.</p>

E197-0010-05	Serial communication error
Detection Description	Disconnection of the harness between the Main Driver PCB and the Primary Charging High Voltage PCB was detected.
Remedy	<p>[Related parts]</p> <ul style="list-style-type: none"> - Harnesses from the Main Driver PCB to the Primary Charging High Voltage PCB 1. Main Driver PCB (UN78/J111) to Relay Connector (9P) (Unit of replacement: CABLE, MAIN, REAR UPPER) 2. Relay Connector (9P) to Primary Charging High Voltage PCB (UN15/J3501) (Unit of replacement: CABLE, HIGH VOLTAGE SIGNAL) - Primary Charging High Voltage PCB (UN15) (Unit of replacement: HIGH VOLTAGE PCB ASS'Y) - Main Driver PCB (UN78) (Unit of replacement: MAIN DRIVE DRIVER PCB ASS'Y) <p>[Remedy] Check/replace the related harness/cable, connector and parts.</p>
E197-0011-05	Serial communication error
Detection Description	Disconnection of the harness between the Main Driver PCB and the Develop High Voltage PCB was detected.
Remedy	<p>[Related parts]</p> <ul style="list-style-type: none"> - Harnesses from the Main Driver PCB to the Develop High Voltage PCB 1. Main Driver PCB (UN78/J112) to Relay Connector (25P) (Unit of replacement: CABLE, MAIN, REAR UPPER) 2. Relay Connector (25P) to Develop High Voltage PCB (UN17/J3511) (Unit of replacement: CABLE, HIGH VOLTAGE SIGNAL) - Develop High Voltage PCB (UN17) (Unit of replacement: HIGH VOLTAGE PCB ASS'Y) - Main Driver PCB (UN78) (Unit of replacement: MAIN DRIVE DRIVER PCB ASS'Y) <p>[Remedy] Check/replace the related harness/cable, connector and parts.</p>
E197-0012-05	Serial communication error
Detection Description	Disconnection of the harness between the Duplex Driver PCB and the Transfer High Voltage PCB was detected.
Remedy	<p>[Related parts]</p> <ul style="list-style-type: none"> - Harness between the Duplex Driver PCB (UN80/J311 and J343) and the Transfer High Voltage PCB (UN76/J3061 and J3062) (Unit of replacement: CABLE, FIXING/FEEDER DRAWER) - Transfer High Voltage PCB (UN76) (Unit of replacement: HIGH VOLTAGE PCB ASS'Y) - Duplex Driver PCB (UN80) (Unit of replacement: DUPLEXING DRIVER PCB ASSEMBLY) <p>[Remedy] Check/replace the related harness/cable, connector and parts.</p>
E199-0000-05	Error in high voltage sequence
Detection Description	Error for collecting log.
Remedy	<p>[Remedy] Collect debug log and contact to the sales company.</p> <p>[Reference] By setting "COPIER (LEVEL2)> OPTION> FNC-SW> SELF-CHK" to "1", it is handled as an error.</p>
E202-0001-04	Reader Scanner Unit HP error
Detection Description	The Reader Scanner Unit could not detect the home position when starting scanning operation.
Remedy	<p>[Related parts]</p> <ul style="list-style-type: none"> - Harness between the Scanner Unit HP Sensor(PS103/J1082) and the Reader Controller PCB (UN101/J108) (Unit of replacement: DF MOUNT ASSEMBLY, L) - Harness between the Scanner Motor (M101/J1091) and the Reader Controller PCB (UN101/J109) (Unit of replacement: CABLE, MOTOR) - Scanner Unit HP Sensor (PS103) - Scanner Motor (M101) - Reader Controller PCB (UN101) (Unit of replacement: READER CONTROLLER PCB ASSEMBLY) <p>[Remedy] Check/replace the related harness/cable, connector and parts.</p> <p>[Reference] Before replacing the Reader Controller PCB, back up the service mode data (approx. 2 min) and restore the backup data after the replacement so the data may be able to be protected.</p> <ul style="list-style-type: none"> - Backup: COPIER (LEVEL2)> FUNCTION> SYSTEM> RSRAMBUP - Restoration: COPIER (LEVEL2)> FUNCTION> SYSTEM> RSRAMRES

E202-0002-04	Reader Scanner Unit HP error
Detection Description	The Reader Scanner Unit could not detect the home position when completing scanning operation.
Remedy	<p>[Related parts]</p> <ul style="list-style-type: none"> - Harness between the Scanner Unit HP Sensor(PS103/J1082) and the Reader Controller PCB (UN101/J108) (Unit of replacement: DF MOUNT ASSEMBLY, L) - Harness between the Scanner Motor (M101/J1091) and the Reader Controller PCB (UN101/J109) (Unit of replacement: CABLE, MOTOR) - Scanner Unit HP Sensor (PS103) - Scanner Motor (M101) - Reader Controller PCB (UN101) (Unit of replacement: READER CONTROLLER PCB ASSEMBLY) <p>[Remedy] Check/replace the related harness/cable, connector and parts. [Reference] Before replacing the Reader Controller PCB, back up the service mode data (approx. 2 min) and restore the backup data after the replacement so the data may be able to be protected.</p> <ul style="list-style-type: none"> - Backup: COPIER (LEVEL2)> FUNCTION> SYSTEM> RSRAMBUP - Restoration: COPIER (LEVEL2)> FUNCTION> SYSTEM> RSRAMRES
E202-0003-04	Reader Scanner Unit HP error
Detection Description	An error in the Reader Scanner Unit position was detected when reading of a job was started.
Remedy	<p>[Related parts]</p> <ul style="list-style-type: none"> - Harness between the Scanner Unit HP Sensor(PS103/J1082) and the Reader Controller PCB (UN101/J108) (Unit of replacement: DF MOUNT ASSEMBLY, L) - Harness between the Scanner Motor (M101/J1091) and the Reader Controller PCB (UN101/J109) (Unit of replacement: CABLE, MOTOR) - Scanner Unit HP Sensor (PS103) - Scanner Motor (M101) - Reader Controller PCB (UN101) (Unit of replacement: READER CONTROLLER PCB ASSEMBLY) <p>[Remedy] Check/replace the related harness/cable, connector and parts. [Reference] Before replacing the Reader Controller PCB, back up the service mode data (approx. 2 min) and restore the backup data after the replacement so the data may be able to be protected.</p> <ul style="list-style-type: none"> - Backup: COPIER (LEVEL2)> FUNCTION> SYSTEM> RSRAMBUP - Restoration: COPIER (LEVEL2)> FUNCTION> SYSTEM> RSRAMRES
E202-0010-04	Reader Scanner Unit HP error
Detection Description	The Reader Scanner Unit could not detect the home position when starting scanning operation.
Remedy	<p>[Related parts]</p> <ul style="list-style-type: none"> - Harness between the Reader Controller PCB (UN101/J108) and the Scanner Unit HP Sensor (PS103/J1082) - Harness between the Reader Controller PCB (UN101/J109) and the Scanner Motor (M101/J1091) - Scanner Unit HP Sensor (PS103) - Scanner Motor (M101) - Reader Controller PCB (UN101) <p>[Remedy] Check/replace the related harness/cable, connector and parts. [Reference] Before replacing the Reader Controller PCB, back up the service mode data (approx. 2 min) and restore the backup data after the replacement so the data may be able to be protected.</p> <ul style="list-style-type: none"> - Backup: COPIER (LEVEL2)> FUNCTION> SYSTEM> RSRAMBUP - Restoration: COPIER (LEVEL2)> FUNCTION> SYSTEM> RSRAMRES

E202-0101-04	DADF Scanner Unit HP error
Detection Description	The DADF Scanner Unit could not detect the home position when starting scanning operation.
Remedy	<p>[Related parts]</p> <ul style="list-style-type: none"> - Harnesses from the Glass HP Sensor(PS414/J4071) to the DADF Driver PCB(UN401/J407) 1. Glass HP Sensor (PS414/J4071) to Relay Connector (9P) (Unit of replacement: CABLE, READ 2 SENSOR) 2. Relay Connector (9P) to DADF Driver PCB (UN401/J407) (Unit of replacement: CABLE, MAIN SENSOR) - Harnesses from the Glass Shift Motor to the DADF Driver PCB 1. Glass Shift Motor (M403/J4041) to DADF Driver PCB (UN401/J404) (Unit of replacement: CABLE, MOTOR) - Glass HP Sensor (PS414) - Glass Shift Motor (M403) - DADF Driver PCB (UN401) (Unit of replacement: DF DRIVER PCB ASSEMBLY) <p>[Remedy] Check/replace the related harness/cable, connector and parts.</p>
E202-0102-04	DADF Scanner Unit HP error
Detection Description	The DADF Scanner Unit could not detect the home position when completing scanning operation.
Remedy	<p>[Related parts]</p> <ul style="list-style-type: none"> - Harnesses from the Glass HP Sensor(PS414/J4071) to the DADF Driver PCB(UN401/J407) 1. Glass HP Sensor (PS414/J4071) to Relay Connector (9P) 2. Relay Connector (9P) to DADF Driver PCB (UN401/J407) (Unit of replacement: CABLE, MAIN SENSOR) - Harnesses from the Glass Shift Motor to the DADF Driver PCB 1. Glass Shift Motor (M403/J4041) to DADF Driver PCB (UN401/J404) (Unit of replacement: CABLE, MOTOR) - Glass HP Sensor (PS414) - Glass Shift Motor (M403) - DADF Driver PCB (UN401) (Unit of replacement: DF DRIVER PCB ASSEMBLY) <p>[Remedy] Check/replace the related harness/cable, connector and parts.</p>

E227-0101-04	Power supply error
Detection Description	The DADF Driver PCB did not detect 24 V when the main power was turned ON.
Remedy	<p>[Related parts]</p> <ul style="list-style-type: none"> - Harness between the Reader Controller PCB (UN101/J104) and the DADF Driver PCB (UN401/J402) (Unit of replacement: ADF POWER CABLE) - Harnesses from the Reader Controller PCB to the Relay PCB <ol style="list-style-type: none"> 1. Reader Controller PCB (UN101/J101) to Relay Connector (6P) (Unit of replacement: CABLE, READER POWER SUPPLY) 2. Relay Connector (6P) to Relay PCB (UN86/J505) (Unit of replacement: CABLE, SIGNAL) <ul style="list-style-type: none"> - Harness between the Relay PCB (UN86/J512) and the DC Power Supply PCB (24V) (J202A) (Unit of replacement: CABLE, DC 24V, A) - Harness between the Relay PCB (UN86/J513) and the DC Power Supply PCB (24V) (J202B) (Unit of replacement: CABLE, DC 24V, B) - Harness between the DC Power Supply PCB (24V) (J102A/J102B) and the AC Driver PCB (UN20/J606) (Unit of replacement: CABLE, AC MAIN) - Harness between the Relay PCB (UN86/J518 and J514) and the DC Controller PCB (UN1/J401 and J451) (Unit of replacement: CABLE, SIGNAL) - Reader Controller PCB (UN101) (Unit of replacement: READER CONTROLLER PCB ASSEMBLY) - DADF Driver PCB (UN401) (Unit of replacement: DF DRIVER PCB ASSEMBLY) - Relay PCB (UN86) (Unit of replacement: RELAY PCB ASSEMBLY) - DC Power Supply PCB (24V) (Unit of replacement: 24V POWER SUPPLY ASS'Y, LEFT) - DC Power Supply PCB (24V) (Unit of replacement: 24V POWER SUPPLY ASS'Y, RIGHT) - AC Driver PCB (UN20) (Unit of replacement: AC DRIVER PCB ASS'Y) - DC Controller PCB (UN1) (Unit of replacement: DC CONTROLLER PCB ASS'Y) <p>[Remedy] Check/replace the related harness/cable, connector and parts.</p> <p>[Reference]</p> <ul style="list-style-type: none"> - When an error is detected, conduction of 24 V is stopped. At power check, check if 24 V is conducted or rated voltage is output by repeating power cycling of the machine. - Before replacing the Reader Controller PCB, back up the service mode data (approx. 2 min) and restore the backup data after the replacement so the data may be able to be protected. Backup: COPIER (LEVEL2)> FUNCTION> SYSTEM> RSRAMBUP Restoration: COPIER (LEVEL2)> FUNCTION> SYSTEM> RSRAMRES - Before replacing the DC Controller PCB, back up the service mode data (approx. 2 min) and restore the backup data after the replacement so the data may be able to be protected. Backup: COPIER (LEVEL2)> FUNCTION> SYSTEM> DSRAMBUP Restoration: COPIER (LEVEL2)> FUNCTION> SYSTEM> DSRAMRES
E240-0001-05	Controller communication error
Detection Description	Pickup request waiting status was detected.
Remedy	<p>[Related parts]</p> <ul style="list-style-type: none"> - Harness between the Main Controller PCB 2 (UN8/J5201) and the DC Controller PCB (UN1/J443) (Unit of replacement: CABLE, COMMUNICATION) - Harness between the Main Controller PCB 2 (UN8/J5202) and the DC Controller PCB (UN1/J442) (Unit of replacement: CABLE, SIGNAL) - DC Controller PCB (UN1) (Unit of replacement: DC CONTROLLER PCB ASS'Y) - Main Controller PCB 2 (UN8) (Unit of replacement: MAIN CONTROLLER PCB ASS'Y, 2) - Main Controller PCB 1 (UN34) (Unit of replacement: MAIN CONTROLLER PCB ASS'Y, 1) <p>[Remedy] Check/replace the related harness/cable, connector and parts.</p> <p>[Reference] Before replacing the DC Controller PCB, back up the service mode data (approx. 2 min) and restore the backup data after the replacement so the data may be able to be protected.</p> <ul style="list-style-type: none"> - Backup: COPIER (LEVEL2)> FUNCTION> SYSTEM> DSRAMBUP - Restoration: COPIER (LEVEL2)> FUNCTION> SYSTEM> DSRAMRES

E240-0002-05	Controller communication error
Detection Description	Image output request waiting status was detected.
Remedy	<p>[Related parts]</p> <ul style="list-style-type: none"> - Harness between the Main Controller PCB 2 (UN8/J5201) and the DC Controller PCB (UN1/J443) (Unit of replacement: CABLE, COMMUNICATION) - Harness between the Main Controller PCB 2 (UN8/J5202) and the DC Controller PCB (UN1/J442) (Unit of replacement: CABLE, SIGNAL) - DC Controller PCB (UN1) (Unit of replacement: DC CONTROLLER PCB ASS'Y) - Main Controller PCB 2 (UN8) (Unit of replacement: MAIN CONTROLLER PCB ASS'Y, 2) - Main Controller PCB 1 (UN34) (Unit of replacement: MAIN CONTROLLER PCB ASS'Y, 1) <p>[Remedy] Check/replace the related harness/cable, connector and parts. [Reference] Before replacing the DC Controller PCB, back up the service mode data (approx. 2 min) and restore the backup data after the replacement so the data may be able to be protected.</p> <ul style="list-style-type: none"> - Backup: COPIER (LEVEL2)> FUNCTION> SYSTEM> DSRAMBUP - Restoration: COPIER (LEVEL2)> FUNCTION> SYSTEM> DSRAMRES
E246-0001-00	System error
Detection Description	System error
Remedy	Contact to the sales company.
E246-0002-00	System error
Detection Description	System error
Remedy	Contact to the sales company.
E246-0003-00	System error
Detection Description	System error
Remedy	Contact to the sales company.
E246-0004-00	System error
Detection Description	System error
Remedy	Contact the service company office
E246-0005-00	System error
Detection Description	System error
Remedy	Contact to the sales company.
E247-0001-00	System error
Detection Description	System error
Remedy	Contact to the sales company.
E247-0002-00	System error
Detection Description	System error
Remedy	Contact to the sales company.
E247-0003-00	System error
Detection Description	System error
Remedy	Contact to the sales company.
E247-0004-00	System error
Detection Description	System error
Remedy	Contact to the sales company.

E248-0001-04	EEPROM error
Detection Description	Reading error was detected when the Main Controller PCB 1 read the Reader backup value in the Reader Controller PCB.
Remedy	<p>[Related parts]</p> <ul style="list-style-type: none"> - Reader Controller PCB (UN101) (Unit of replacement: READER CONTROLLER PCB ASSEMBLY) <p>[Remedy] Check/replace the Reader Controller PCB (UN101). (Unit of replacement: READER CONTROLLER PCB ASSEMBLY)</p> <p>[Reference] Before replacing the Reader Controller PCB, back up the service mode data (approx. 2 min) and restore the backup data after the replacement so the data may be able to be protected.</p> <ul style="list-style-type: none"> - Backup: COPIER (LEVEL2)> FUNCTION> SYSTEM> RSRAMBUP - Restoration: COPIER (LEVEL2)> FUNCTION> SYSTEM> RSRAMRES
E248-0002-04	EEPROM error
Detection Description	The Main Controller PCB 1 failed writing of the Reader backup value in the Reader Controller PCB.
Remedy	<p>[Related parts]</p> <ul style="list-style-type: none"> - Reader Controller PCB (UN101) (Unit of replacement: READER CONTROLLER PCB ASSEMBLY) <p>[Remedy] Check/replace the Reader Controller PCB (UN101). (Unit of replacement: READER CONTROLLER PCB ASSEMBLY)</p> <p>[Reference] Before replacing the Reader Controller PCB, back up the service mode data (approx. 2 min) and restore the backup data after the replacement so the data may be able to be protected.</p> <ul style="list-style-type: none"> - Backup: COPIER (LEVEL2)> FUNCTION> SYSTEM> RSRAMBUP - Restoration: COPIER (LEVEL2)> FUNCTION> SYSTEM> RSRAMRES
E248-0005-04	Scanner Unit EEPROM error
Detection Description	EEPROM reading error(At power-on)
Remedy	<p>[Related parts] Scanner Unit (Front side)</p> <p>[Remedy] Perform the following in the order while checking whether the error is cleared.</p> <ol style="list-style-type: none"> 1. Replace the Scanner Unit (Front side).
E248-0006-04	Scanner Unit EEPROM error
Detection Description	EEPROM writing error
Remedy	<p>[Related parts] Scanner Unit (Front side)</p> <p>[Remedy] Perform the following in the order while checking whether the error is cleared.</p> <ol style="list-style-type: none"> 1. Replace the Scanner Unit (Front side).
E248-0105-04	Scanner Unit EEPROM error
Detection Description	Scanner unit reading error(At power-on)
Remedy	<p>[Related parts] Scanner Unit (Back side)</p> <p>[Remedy] Perform the following in the order while checking whether the error is cleared.</p> <ol style="list-style-type: none"> 1. Replace the Scanner Unit (Back side).
E248-0106-04	Scanner Unit EEPROM error
Detection Description	EEPROM writing error
Remedy	<p>[Related parts] Scanner Unit (Back side)</p> <p>[Remedy] Perform the following in the order while checking whether the error is cleared.</p> <ol style="list-style-type: none"> 1. Replace the Scanner Unit (Back side).
E263-0000-05	Current Sensor error
Detection Description	An error in voltage of the Current Sensor was detected.
Remedy	<p>[Related parts]</p> <ul style="list-style-type: none"> - Harnesses from the AC Driver PCB to the Main Driver PCB <ol style="list-style-type: none"> 1. AC Driver PCB (UN20/J615) to Relay Connector (13P) (Unit of replacement: CABLE, SIGNAL) 2. Relay Connector (13P) to Main Driver PCB (UN78/J103) (Unit of replacement: CABLE, MAIN DRIVER RELAY) <ul style="list-style-type: none"> - AC Driver PCB (Unit of replacement: AC DRIVER PCB ASS'Y) - Main Driver PCB (UN78) (Unit of replacement: MAIN DRIVE DRIVER PCB ASS'Y) <p>[Remedy] Check/replace the related harness/cable, connector and parts.</p>

E263-0001-05	Current Sensor error
Detection Description	It was detected that the value of the Current Sensor was higher than the upper limit.
Remedy	<p>[Related parts]</p> <ul style="list-style-type: none"> - Harnesses from the AC Driver PCB to the Main Driver PCB 1. AC Driver PCB (UN20/J615) to Relay Connector (13P) (Unit of replacement: CABLE, SIGNAL) 2. Relay Connector (13P) to Main Driver PCB (UN78/J103) (Unit of replacement: CABLE, MAIN DRIVER RELAY) - AC Driver PCB (Unit of replacement: AC DRIVER PCB ASS'Y) - Main Driver PCB (UN78) (Unit of replacement: MAIN DRIVE DRIVER PCB ASS'Y) <p>[Remedy] Check/replace the related harness/cable, connector and parts.</p>
E263-0002-05	Current Sensor error
Detection Description	It was detected that the value of the Current Sensor was lower than the lower limit.
Remedy	<p>[Related parts]</p> <ul style="list-style-type: none"> - Harnesses from the AC Driver PCB to the Main Driver PCB 1. AC Driver PCB (UN20/J615) to Relay Connector (13P) (Unit of replacement: CABLE, SIGNAL) 2. Relay Connector (13P) to Main Driver PCB (UN78/J103) (Unit of replacement: CABLE, MAIN DRIVER RELAY) - AC Driver PCB (Unit of replacement: AC DRIVER PCB ASS'Y) - Main Driver PCB (UN78) (Unit of replacement: MAIN DRIVE DRIVER PCB ASS'Y) <p>[Remedy] Check/replace the related harness/cable, connector and parts.</p>
E270-0001-04	Scanner Unit (Reader) communication error
Detection Description	The vertical scanning synchronous signal (VSYNC) was not transmitted appropriately at the Scanner Unit (Reader) side communicating with the Reader Controller PCB.
Remedy	<p>[Related parts]</p> <ul style="list-style-type: none"> - Flat Cable between the Reader Controller PCB and Scanner Unit (Reader) (Unit of replacement: Flat Cable) - Scanner Unit (Unit of replacement: Scanner Unit) - Reader Controller PCB (Unit of replacement: Reader Controller PCB) <p>[Remedy] Check/replace the related harness/cable, connector and parts.</p>
E270-0101-04	Scanner Unit (DADF) communication error
Detection Description	The vertical scanning synchronous signal (VSYNC) was not transmitted appropriately at the Scanner Unit (DADF) side communicating with the Reader Controller PCB.
Remedy	<p>[Related parts]</p> <ul style="list-style-type: none"> - Flat Cable between the Reader Controller PCB and Scanner Unit (DADF) (Unit of replacement: Flat Cable) - Scanner Unit (Unit of replacement: Scanner Unit) - Reader Controller PCB (Unit of replacement: Reader Controller PCB) <p>[Remedy] Check/replace the related harness/cable, connector and parts.</p>
E280-0001-04	Communication error
Detection Description	Communication between the Reader Controller PCB and the Reader Scanner Unit was not completed within the specified period of time.
Remedy	<p>[Related parts]</p> <ul style="list-style-type: none"> - Harness between the Reader Scanner Unit (UN102/J1021) and the Reader Controller PCB (UN101/J102) (Unit of replacement: FLEXIBLE FLAT CABLE UNIT) - Harness between the Reader Controller PCB (UN101/J112) and the Main Controller PCB 2 (UN8/J4031) (Unit of replacement: CABLE, INTERFACE) - Reader Scanner Unit (UN102) (Unit of replacement: SCANNER UNIT, READER) - Reader Controller PCB (UN101) (Unit of replacement: READER CONTROLLER PCB ASSEMBLY) <p>[Remedy] Check/replace the related harness/cable, connector and parts.</p> <p>[Reference] Before replacing the Reader Controller PCB, back up the service mode data (approx. 2 min) and restore the backup data after the replacement so the data may be able to be protected.</p> <ul style="list-style-type: none"> - Backup: COPIER (LEVEL2)> FUNCTION> SYSTEM> RSRAMBUP - Restoration: COPIER (LEVEL2)> FUNCTION> SYSTEM> RSRAMRES

E280-0002-04	Communication error
Detection Description	Disconnection of FFC between the Reader Controller PCB and the Reader Scanner Unit was detected.
Remedy	[Related parts] - Harness between the Reader Scanner Unit (UN102/J1021) and the Reader Controller PCB (UN101/J102) (Unit of replacement: FLEXIBLE FLAT CABLE UNIT) - Harness between the Reader Controller PCB (UN101/J112) and the Main Controller PCB 2 (UN8/J4031) (Unit of replacement: CABLE, INTERFACE) [Remedy] Check/replace the related harness/cable, connector and parts.
E280-0003-04	Scanner Unit (Reader) communication error
Detection Description	Reading or writing error was detected between the Reader Controller PCB and the Scanner Unit (Reader).
Remedy	[Related parts] - Flat Cable between the Reader Controller PCB and Scanner Unit (Reader) (Unit of replacement: Flat Cable) - Scanner Unit (Unit of replacement: Scanner Unit) - Reader Controller PCB (Unit of replacement: Reader Controller PCB) [Remedy] Check/replace the related harness/cable, connector and parts.
E280-0004-04	Scanner Unit (Reader) communication error
Detection Description	Image data check error was detected between the Reader Controller PCB and the Scanner Unit (Reader).
Remedy	[Related parts] - Flat Cable between the Reader Controller PCB and Scanner Unit (Reader) (Unit of replacement: Flat Cable) - Scanner Unit (Unit of replacement: Scanner Unit) - Reader Controller PCB (Unit of replacement: Reader Controller PCB) [Remedy] Check/replace the related harness/cable, connector and parts.
E280-0101-04	Communication error
Detection Description	Communication between the Reader Controller PCB and the DADF Scanner Unit was not completed within the specified period of time.
Remedy	[Related parts] - Harness between the DADF Scanner Unit (UN102/J1021) and the Reader Controller PCB (UN101/J102) (Unit of replacement: FLEXIBLE FLAT CABLE UNIT) - Harness between the Reader Controller PCB (UN101/J112) and the Main Controller PCB 2 (UN8/J4031) (Unit of replacement: CABLE, INTERFACE) - DADF Scanner Unit (Unit of replacement: SCANNER UNIT, ADF) - Reader Controller PCB (UN101) (Unit of replacement: READER CONTROLLER PCB ASSEMBLY) [Remedy] Check/replace the related harness/cable, connector and parts. [Reference] Before replacing the Reader Controller PCB, back up the service mode data (approx. 2 min) and restore the backup data after the replacement so the data may be able to be protected. - Backup: COPIER (LEVEL2)> FUNCTION> SYSTEM> RSRAMBUP - Restoration: COPIER (LEVEL2)> FUNCTION> SYSTEM> RSRAMRES
E280-0102-04	Communication error
Detection Description	Disconnection of FFC between the Reader Controller PCB and the DADF Scanner Unit was detected.
Remedy	[Related parts] - Harness between the DADF Scanner Unit (UN102/J1021) and the Reader Controller PCB (UN101/J102) (Unit of replacement: FLEXIBLE FLAT CABLE UNIT) - Harness between the Reader Controller PCB (UN101/J112) and the Main Controller PCB 2 (UN8/J4031) (Unit of replacement: CABLE, INTERFACE) [Remedy] Check/replace the related harness/cable, connector and parts.

E280-0103-04	Scanner Unit (DADF) communication error
Detection Description	Reading or writing error was detected between the Reader Controller PCB and the Scanner Unit (DADF).
Remedy	[Related parts] - Flat Cable between the Reader Controller PCB and Scanner Unit (DADF) (Unit of replacement: Flat Cable) - Scanner Unit (Unit of replacement: Scanner Unit) - Reader Controller PCB (Unit of replacement: Reader Controller PCB) [Remedy] Check/replace the related harness/cable, connector and parts.
E280-0104-04	Scanner Unit (DADF) communication error
Detection Description	Image data check error was detected between the Reader Controller PCB and the Scanner Unit (DADF).
Remedy	[Related parts] - Flat Cable between the Reader Controller PCB and Scanner Unit (DADF) (Unit of replacement: Flat Cable) - Scanner Unit (Unit of replacement: Scanner Unit) - Reader Controller PCB (Unit of replacement: Reader Controller PCB) [Remedy] Check/replace the related harness/cable, connector and parts.
E302-0001-04	Error in paper front white shading
Detection Description	An access error to the paper front white shading RAM or a paper front white shading value that was higher than the specified value was detected.
Remedy	[Related parts] - Harness between the Reader Scanner Unit (UN102/J1021) and the Reader Controller PCB (UN101/J102) (Unit of replacement: FLEXIBLE FLAT CABLE UNIT) - Harness between the Reader Controller PCB (UN101/J112) and the Main Controller PCB 2 (UN8/J4031) (Unit of replacement: CABLE, INTERFACE) - Reader Scanner Unit (UN102) (Unit of replacement: SCANNER UNIT, READER) - Reader Controller PCB (UN101) (Unit of replacement: READER CONTROLLER PCB ASSEMBLY) [Remedy] 1. Clean the LED, mirror, and Stream Reading Glass of Scanner Unit. 2. Check/replace the related harness/cable, connector and parts. [Reference] Before replacing the Reader Controller PCB, back up the service mode data (approx. 2 min) and restore the backup data after the replacement so the data may be able to be protected. - Backup: COPIER (LEVEL2)> FUNCTION> SYSTEM> RSRAMBUP - Restoration: COPIER (LEVEL2)> FUNCTION> SYSTEM> RSRAMRES
E302-0002-04	Error in paper front black shading
Detection Description	An access error to the paper front black shading RAM or a paper front black shading value that was higher than the specified value was detected.
Remedy	[Related parts] - Harness between the Reader Scanner Unit (UN102/J1021) and the Reader Controller PCB (UN101/J102) (Unit of replacement: FLEXIBLE FLAT CABLE UNIT) - Harness between the Reader Controller PCB (UN101/J112) and the Main Controller PCB 2 (UN8/J4031) (Unit of replacement: CABLE, INTERFACE) - Reader Scanner Unit (UN102) (Unit of replacement: SCANNER UNIT, READER) - Reader Controller PCB (UN101) (Unit of replacement: READER CONTROLLER PCB ASSEMBLY) [Remedy] Check/replace the related harness/cable, connector and parts. [Reference] Before replacing the Reader Controller PCB, back up the service mode data (approx. 2 min) and restore the backup data after the replacement so the data may be able to be protected. - Backup: COPIER (LEVEL2)> FUNCTION> SYSTEM> RSRAMBUP - Restoration: COPIER (LEVEL2)> FUNCTION> SYSTEM> RSRAMRES

E302-0101-04	Error in paper back white shading
Detection Description	An access error to the paper back white shading RAM or a paper back white shading value that was higher than the specified value was detected.
Remedy	<p>[Related parts]</p> <ul style="list-style-type: none"> - Harness between the DADF Scanner Unit (UN102/J1021) and the Reader Controller PCB (UN101/J102) (Unit of replacement: FLEXIBLE FLAT CABLE UNIT) - Harness between the Reader Controller PCB (UN101/J112) and the Main Controller PCB 2 (UN8/J4031) (Unit of replacement: CABLE, INTERFACE) - DADF Scanner Unit (Unit of replacement: SCANNER UNIT, ADF) - Reader Controller PCB (UN101) (Unit of replacement: READER CONTROLLER PCB ASSEMBLY) <p>[Remedy]</p> <ol style="list-style-type: none"> 1. Clean the LED, mirror, and Stream Reading Glass of Scanner Unit. 2. Check/replace the related harness/cable, connector and parts. <p>[Reference] Before replacing the Reader Controller PCB, back up the service mode data (approx. 2 min) and restore the backup data after the replacement so the data may be able to be protected.</p> <ul style="list-style-type: none"> - Backup: COPIER (LEVEL2)> FUNCTION> SYSTEM> RSRAMBUP - Restoration: COPIER (LEVEL2)> FUNCTION> SYSTEM> RSRAMRES
E302-0102-04	Error in paper back black shading
Detection Description	An access error to the paper back black shading RAM or a paper back black shading value that was higher than the specified value was detected.
Remedy	<p>[Related parts]</p> <ul style="list-style-type: none"> - Harness between the DADF Scanner Unit (UN102/J1021) and the Reader Controller PCB (UN101/J102) (Unit of replacement: FLEXIBLE FLAT CABLE UNIT) - Harness between the Reader Controller PCB (UN101/J112) and the Main Controller PCB 2 (UN8/J4031) (Unit of replacement: CABLE, INTERFACE) - DADF Scanner Unit (Unit of replacement: SCANNER UNIT, ADF) - Reader Controller PCB (UN101) (Unit of replacement: READER CONTROLLER PCB ASSEMBLY) <p>[Remedy] Check/replace the related harness/cable, connector and parts.</p> <p>[Reference] Before replacing the Reader Controller PCB, back up the service mode data (approx. 2 min) and restore the backup data after the replacement so the data may be able to be protected.</p> <ul style="list-style-type: none"> - Backup: COPIER (LEVEL2)> FUNCTION> SYSTEM> RSRAMBUP - Restoration: COPIER (LEVEL2)> FUNCTION> SYSTEM> RSRAMRES
E315-0007-00	Image process device timeout error
Detection Description	Image compression process was not completed within the specified period of time (120 sec) at scanning.
Remedy	<p>[Related parts]</p> <ul style="list-style-type: none"> - Harness between the Reader Controller PCB (UN101/J112) and Main Controller PCB 2 (UN8/J4031) (Unit of replacement: CABLE, INTERFACE) - Main Controller PCB 2 (UN8) (Unit of replacement: MAIN CONTROLLER PCB ASS'Y, 2) - Main Controller PCB 1 (UN34) (Unit of replacement: MAIN CONTROLLER PCB ASS'Y, 1) - Reader Controller PCB (UN101) (Unit of replacement: READER CONTROLLER PCB ASSEMBLY) <p>[Points to note at work] After performing the remedy, check that the copy image is output normally.</p> <p>[Remedy] Perform the following in the order while checking whether the error is cleared.</p> <ol style="list-style-type: none"> 1. Reinstall the latest system software using SST or a USB memory. 2. Check/replace the related harness/cable, connector and parts. <p>[Reference] Before replacing the Reader Controller PCB, back up the service mode data (approx. 2 min) and restore the backup data after the replacement so the data may be able to be protected.</p> <ul style="list-style-type: none"> - Backup: COPIER (LEVEL2)> FUNCTION> SYSTEM> RSRAMBUP - Restoration: COPIER (LEVEL2)> FUNCTION> SYSTEM> RSRAMRES

E315-000D-00	Image process device timeout error
Detection Description	Processing of a JBIG-compressed data was not completed within the specified period of time (120 sec) at printing or SEND.
Remedy	[Related parts] - Main Controller PCB. (UN34) (Unit of replacement: MAIN CONTROLLER PCB ASS'Y, 1) [Remedy]Perform the following in the order while checking whether the error is cleared. 1. Reinstall the latest system software using SST or a USB memory. 2. Replace the Main Controller PCB. (UN34) (Unit of replacement: MAIN CONTROLLER PCB ASS'Y, 1)
E315-000F-00	Image process device timeout error
Detection Description	Duplication of image data in the memory was not completed within the specified period of time (120 sec).
Remedy	[Related parts] - Main Controller PCB. (UN34) (Unit of replacement: MAIN CONTROLLER PCB ASS'Y, 1) [Remedy]Perform the following in the order while checking whether the error is cleared. 1. Reinstall the latest system software using SST or a USB memory. 2. Replace the Main Controller PCB. (UN34) (Unit of replacement: MAIN CONTROLLER PCB ASS'Y, 1)
E315-0027-00	Image process device timeout error
Detection Description	Image processing (change in magnification ratio, rotating, and shifting) was not completed normally within the specified period of time (120 sec).
Remedy	[Related parts] - Main Controller PCB. (UN34) (Unit of replacement: MAIN CONTROLLER PCB ASS'Y, 1) [Remedy]Perform the following in the order while checking whether the error is cleared. 1. Reinstall the latest system software using SST or a USB memory. 2. Replace the Main Controller PCB. (UN34) (Unit of replacement: MAIN CONTROLLER PCB ASS'Y, 1)
E315-0033-00	Image process device timeout error
Detection Description	Processing to clear image data in the memory was not completed normally within the specified period of time (120 sec).
Remedy	[Related parts] - Main Controller PCB. (UN34) (Unit of replacement: MAIN CONTROLLER PCB ASS'Y, 1) [Remedy]Perform the following in the order while checking whether the error is cleared. 1. Reinstall the latest system software using SST or a USB memory. 2. Replace the Main Controller PCB. (UN34) (Unit of replacement: MAIN CONTROLLER PCB ASS'Y, 1)
E315-0035-00	Image process device timeout error
Detection Description	Processing to clear image data in the memory was not completed normally within the specified period of time (120 sec).
Remedy	[Related parts] - Main Controller PCB. (UN34) (Unit of replacement: MAIN CONTROLLER PCB ASS'Y, 1) [Remedy]Perform the following in the order while checking whether the error is cleared. 1. Reinstall the latest system software using SST or a USB memory. 2. Replace the Main Controller PCB. (UN34) (Unit of replacement: MAIN CONTROLLER PCB ASS'Y, 1)

E315-0100-00	Image process device timeout error
Detection Description	Image transfer could not be started because the signal that is a trigger to start printing was not detected within the specified period of time (60 sec) at printing.
Remedy	<p>[Related parts]</p> <ul style="list-style-type: none"> - Harness between the Reader Controller PCB (UN101/J112) and Main Controller PCB 2 (UN8/J4031) (Unit of replacement: CABLE, INTERFACE) - Main Controller PCB 2 (UN8) (Unit of replacement: MAIN CONTROLLER PCB ASS'Y, 2) - Main Controller PCB 1 (UN34) (Unit of replacement: MAIN CONTROLLER PCB ASS'Y, 1) - Reader Controller PCB (UN101) (Unit of replacement: READER CONTROLLER PCB ASSEMBLY) <p>[Points to note at work] After performing the remedy, check that the copy image is output normally. [Remedy] Perform the following in the order while checking whether the error is cleared.</p> <ol style="list-style-type: none"> 1. Reinstall the latest system software using SST or a USB memory. 2. Check/replace the related harness/cable, connector and parts. <p>[Reference] Before replacing the Reader Controller PCB, back up the service mode data (approx. 2 min) and restore the backup data after the replacement so the data may be able to be protected.</p> <ul style="list-style-type: none"> - Backup: COPIER (LEVEL2)> FUNCTION> SYSTEM> RSRAMBUP - Restoration: COPIER (LEVEL2)> FUNCTION> SYSTEM> RSRAMRES
E315-0500-00	Image process device timeout error
Detection Description	Transfer of image signal was not completed within the specified period of time (120 sec) at scanning.
Remedy	<p>[Related parts]</p> <ul style="list-style-type: none"> - Harness between the Reader Controller PCB (UN101/J112) and Main Controller PCB 2 (UN8/J4031) (Unit of replacement: CABLE, INTERFACE) - Main Controller PCB 2 (UN8) (Unit of replacement: MAIN CONTROLLER PCB ASS'Y, 2) - Main Controller PCB 1 (UN34) (Unit of replacement: MAIN CONTROLLER PCB ASS'Y, 1) - Reader Controller PCB (UN101) (Unit of replacement: READER CONTROLLER PCB ASSEMBLY) <p>[Points to note at work] After performing the remedy, check that the copy image is output normally. [Remedy] Perform the following in the order while checking whether the error is cleared.</p> <ol style="list-style-type: none"> 1. Reinstall the latest system software using SST or a USB memory. 2. Check/replace the related harness/cable, connector and parts. <p>[Reference] Before replacing the Reader Controller PCB, back up the service mode data (approx. 2 min) and restore the backup data after the replacement so the data may be able to be protected.</p> <ul style="list-style-type: none"> - Backup: COPIER (LEVEL2)> FUNCTION> SYSTEM> RSRAMBUP - Restoration: COPIER (LEVEL2)> FUNCTION> SYSTEM> RSRAMRES
E315-0510-00	Image process device timeout error
Detection Description	Image processing was not completed within the specified period of time (30 sec) at scanning.
Remedy	<p>[Related parts]</p> <ul style="list-style-type: none"> - Harness between the Reader Controller PCB (UN101/J112) and Main Controller PCB 2 (UN8/J4031) (Unit of replacement: CABLE, INTERFACE) - Main Controller PCB 2 (UN8) (Unit of replacement: MAIN CONTROLLER PCB ASS'Y, 2) - Main Controller PCB 1 (UN34) (Unit of replacement: MAIN CONTROLLER PCB ASS'Y, 1) - Reader Controller PCB (UN101) (Unit of replacement: READER CONTROLLER PCB ASSEMBLY) <p>[Points to note at work] After performing the remedy, check that the copy image is output normally. [Remedy] Perform the following in the order while checking whether the error is cleared.</p> <ol style="list-style-type: none"> 1. Reinstall the latest system software using SST or a USB memory. 2. Check/replace the related harness/cable, connector and parts. <p>[Reference] Before replacing the Reader Controller PCB, back up the service mode data (approx. 2 min) and restore the backup data after the replacement so the data may be able to be protected.</p> <ul style="list-style-type: none"> - Backup: COPIER (LEVEL2)> FUNCTION> SYSTEM> RSRAMBUP - Restoration: COPIER (LEVEL2)> FUNCTION> SYSTEM> RSRAMRES

E315-0520-00	Image process device timeout error
Detection Description	Image processing was not completed within the specified period of time (120 sec) at scanning.
Remedy	[Related parts] - Main Controller PCB. (UN34) (Unit of replacement: MAIN CONTROLLER PCB ASS'Y, 1) [Points to note at work] After performing the remedy, check that the copy image is output normally. [Remedy] Perform the following in the order while checking whether the error is cleared. 1. Reinstall the latest system software using SST or a USB memory. 2. Replace the Main Controller PCB. (UN34) (Unit of replacement: MAIN CONTROLLER PCB ASS'Y, 1)
E315-0530-00	Image process device error
Detection Description	Compression processing of the scanned image into JPEG was terminated abnormally.
Remedy	[Related parts] - Main Controller PCB. (UN34) (Unit of replacement: MAIN CONTROLLER PCB ASS'Y, 1) [Points to note at work] After performing the remedy, check that the copy image is output normally. [Remedy] Perform the following in the order while checking whether the error is cleared. 1. Reinstall the latest system software using SST or a USB memory. 2. Replace the Main Controller PCB. (UN34) (Unit of replacement: MAIN CONTROLLER PCB ASS'Y, 1)
E315-0531-00	Image process device timeout error
Detection Description	Compression processing of the scanned image into JPEG was not completed within the specified period of time (120 sec).
Remedy	[Related parts] - Harness between the Reader Controller PCB (UN101/J112) and Main Controller PCB 2 (UN8/J4031) (Unit of replacement: CABLE, INTERFACE) - Main Controller PCB 2 (UN8) (Unit of replacement: MAIN CONTROLLER PCB ASS'Y, 2) - Main Controller PCB 1 (UN34) (Unit of replacement: MAIN CONTROLLER PCB ASS'Y, 1) - Reader Controller PCB (UN101) (Unit of replacement: READER CONTROLLER PCB ASSEMBLY) [Points to note at work] After performing the remedy, check that the copy image is output normally. [Remedy] Perform the following in the order while checking whether the error is cleared. 1. Reinstall the latest system software using SST or a USB memory. 2. Check/replace the related harness/cable, connector and parts. [Reference] Before replacing the Reader Controller PCB, back up the service mode data (approx. 2 min) and restore the backup data after the replacement so the data may be able to be protected. - Backup: COPIER (LEVEL2)> FUNCTION> SYSTEM> RSRAMBUP - Restoration: COPIER (LEVEL2)> FUNCTION> SYSTEM> RSRAMRES
E315-0540-00	Image process device error
Detection Description	An error occurred during decompression of JPEG.
Remedy	[Related parts] - Main Controller PCB. (UN34) (Unit of replacement: MAIN CONTROLLER PCB ASS'Y, 1) [Remedy] Perform the following in the order while checking whether the error is cleared. 1. Reinstall the latest system software using SST or a USB memory. 2. Replace the Main Controller PCB. (UN34) (Unit of replacement: MAIN CONTROLLER PCB ASS'Y, 1)
E315-0541-00	Image process device timeout error
Detection Description	Decompression of JPEG was not completed within the specified period of time (120 sec).
Remedy	[Related parts] - Main Controller PCB. (UN34) (Unit of replacement: MAIN CONTROLLER PCB ASS'Y, 1) [Remedy] Perform the following in the order while checking whether the error is cleared. 1. Reinstall the latest system software using SST or a USB memory. 2. Replace the Main Controller PCB. (UN34) (Unit of replacement: MAIN CONTROLLER PCB ASS'Y, 1)

E315-0561-00	Image process device timeout error
Detection Description	Image transfer was not completed within the specified period of time (120 sec) after the start of printing.
Remedy	<p>[Related parts]</p> <ul style="list-style-type: none"> - Harness between the Reader Controller PCB (UN101/J112) and Main Controller PCB 2 (UN8/J4031) (Unit of replacement: CABLE, INTERFACE) - Main Controller PCB 2 (UN8) (Unit of replacement: MAIN CONTROLLER PCB ASS'Y, 2) - Main Controller PCB 1 (UN34) (Unit of replacement: MAIN CONTROLLER PCB ASS'Y, 1) - Reader Controller PCB (UN101) (Unit of replacement: READER CONTROLLER PCB ASSEMBLY) <p>[Points to note at work] After performing the remedy, check that the copy image is output normally. [Remedy] Perform the following in the order while checking whether the error is cleared.</p> <ol style="list-style-type: none"> 1. Reinstall the latest system software using SST or a USB memory. 2. Check/replace the related harness/cable, connector and parts. <p>[Reference] Before replacing the Reader Controller PCB, back up the service mode data (approx. 2 min) and restore the backup data after the replacement so the data may be able to be protected.</p> <ul style="list-style-type: none"> - Backup: COPIER (LEVEL2)> FUNCTION> SYSTEM> RSRAMBUP - Restoration: COPIER (LEVEL2)> FUNCTION> SYSTEM> RSRAMRES
E330-0001-05	Image signal communication error
Detection Description	An image signal communication error between the DC Controller PCB and the Main Controller PCB was detected.
Remedy	<p>[Related parts]</p> <ul style="list-style-type: none"> - Harness between the DC Controller PCB (UN1/J443) and the Main Controller PCB 2 (UN8/J711) (Unit of replacement: CABLE, SIGNAL) - Main Controller PCB 2 (UN8) (Unit of replacement: MAIN CONTROLLER PCB ASS'Y, 2) - Main Controller PCB 1 (UN34) (Unit of replacement: MAIN CONTROLLER PCB ASS'Y, 1) - DC Controller PCB (UN1) (Unit of replacement: DC CONTROLLER PCB ASS'Y) <p>[Remedy] Check/replace the related harness/cable, connector and parts. [Reference] Before replacing the DC Controller PCB, back up the service mode data (approx. 2 min) and restore the backup data after the replacement so the data may be able to be protected.</p> <ul style="list-style-type: none"> - Backup: COPIER (LEVEL2)> FUNCTION> SYSTEM> DSRAMBUP - Restoration: COPIER (LEVEL2)> FUNCTION> SYSTEM> DSRAMRES
E350-0001-00	System error
Detection Description	System error
Remedy	Contact to the sales company.
E350-0002-00	System error
Detection Description	System error
Remedy	Contact to the sales company.
E350-0003-00	System error
Detection Description	System error
Remedy	Contact to the sales company.
E350-3000-00	System error
Detection Description	System error
Remedy	Contact to the sales company.
E351-0000-00	System error
Detection Description	System error
Remedy	Contact to the sales company.
E354-0001-00	System error
Detection Description	System error
Remedy	Contact to the sales company.

E354-0002-00	System error
Detection Description	System error
Remedy	Contact to the sales company.
E355-0001-00	System error
Detection Description	System error
Remedy	Contact to the sales company.
E355-0002-00	System error
Detection Description	System error
Remedy	Contact to the sales company.
E355-0003-00	System error
Detection Description	System error
Remedy	Contact to the sales company.
E400-0002-04	Communication error
Detection Description	A communication error between the Reader Controller PCB and the DADF Driver PCB was detected.
Remedy	<p>[Related parts]</p> <ul style="list-style-type: none"> - Harness between the DADF Driver PCB (UN401/J401) and the Reader Controller PCB (UN101/J104) (Unit of replacement: CABLE, FLAT) - Harness between the DADF Driver PCB (UN401/J402) and the Reader Controller PCB (UN101/J104) (Unit of replacement: CABLE, ADF POWER SUPPLY) - DADF Driver PCB (UN401) (Unit of replacement: DF DRIVER PCB ASSEMBLY) - Reader Controller PCB (UN101) (Unit of replacement: READER CONTROLLER PCB ASSEMBLY) <p>[Remedy] Check/replace the related harness/cable, connector and parts. [Reference] Before replacing the Reader Controller PCB, back up the service mode data (approx. 2 min) and restore the backup data after the replacement so the data may be able to be protected.</p> <ul style="list-style-type: none"> - Backup: COPIER (LEVEL2)> FUNCTION> SYSTEM> RSRAMBUP - Restoration: COPIER (LEVEL2)> FUNCTION> SYSTEM> RSRAMRES
E400-0003-04	Communication error
Detection Description	Disconnection of the harness between the Reader Controller PCB and the DADF Driver PCB was detected.
Remedy	<p>[Related parts]</p> <ul style="list-style-type: none"> - Harness between the DADF Driver PCB (UN401/J401) and the Reader Controller PCB (UN101/J104) (Unit of replacement: CABLE, FLAT) - Harness between the DADF Driver PCB (UN401/J402) and the Reader Controller PCB (UN101/J104) (Unit of replacement: CABLE, ADF POWER SUPPLY) - DADF Driver PCB (UN401) (Unit of replacement: DF DRIVER PCB ASSEMBLY) - Reader Controller PCB (UN101) (Unit of replacement: READER CONTROLLER PCB ASSEMBLY) <p>[Remedy] Check/replace the related harness/cable, connector and parts. [Reference] Before replacing the Reader Controller PCB, back up the service mode data (approx. 2 min) and restore the backup data after the replacement so the data may be able to be protected.</p> <ul style="list-style-type: none"> - Backup: COPIER (LEVEL2)> FUNCTION> SYSTEM> RSRAMBUP - Restoration: COPIER (LEVEL2)> FUNCTION> SYSTEM> RSRAMRES

E401-0001-04	Pickup Roller Unit Lifting HP Sensor error
Detection Description	The Pickup Roller Unit Lifting HP Sensor in the DADF did not detect the ON status.
Remedy	<p>[Related parts]</p> <ul style="list-style-type: none"> - Harnesses from the Pickup Roller Unit Lifting HP Sensor(PS408/J4064) to the DADF Driver PCB(UN401/J406) - Harness between the Pickup Roller Unit Lifting Motor (M405/J4052) and the DADF Driver PCB (UN401/J405) (Unit of replacement: CABLE, REAR MOTOR, 2) - Pickup Roller Unit Lifting HP Sensor (PS408) - Pickup Roller Unit Lifting Motor (M405) - DADF Driver PCB (UN401) (Unit of replacement: DF DRIVER PCB ASSEMBLY) <p>[Remedy] Check/replace the related harness/cable, connector and parts.</p>
E401-0002-04	Pickup Roller Unit Lifting HP Sensor error
Detection Description	The Pickup Roller Unit Lifting HP Sensor in the DADF did not detect the OFF status.
Remedy	<p>[Related parts]</p> <ul style="list-style-type: none"> - Harnesses from the Pickup Roller Unit Lifting HP Sensor(PS408/J4064) to the DADF Driver PCB(UN401/J406) - Harness between the Pickup Roller Unit Lifting Motor (M405/J4052) and the DADF Driver PCB (UN401/J405) (Unit of replacement: CABLE, REAR MOTOR, 2) - Pickup Roller Unit Lifting HP Sensor (PS408) - Pickup Roller Unit Lifting Motor (M405) - DADF Driver PCB (UN401) (Unit of replacement: DF DRIVER PCB ASSEMBLY) <p>[Remedy] Check/replace the related harness/cable, connector and parts.</p>
E407-0001-04	Tray Lifter Motor error
Detection Description	The Tray Home Position Sensor in the DADF did not detect the ON status within the specified period of time.
Remedy	<p>[Related parts]</p> <ul style="list-style-type: none"> - Harnesses from the Tray Home Position Sensor(PS410/J4131) to the DADF Driver PCB(UN401/J413) - Tray Home Position Sensor (PS410) - Tray Lifter Motor (M406) - DADF Driver PCB (UN401) (Unit of replacement: DF DRIVER PCB ASSEMBLY) <p>[Remedy] Check/replace the related harness/cable, connector and parts.</p>
E407-0002-04	Tray Lifter Motor error
Detection Description	<ul style="list-style-type: none"> - The Paper Surface Sensor in the DADF did not turned ON within the specified period of time when lifting up the lifter. - The Tray Home Position Sensor in the DADF did not detect the OFF status within the specified period of time.
Remedy	<p>[Related parts]</p> <ul style="list-style-type: none"> - Harnesses from the Paper Surface Sensor to the DADF Driver PCB 1. Paper Surface Sensor (SR406/J4104) to Relay Connector (5P) (Unit of replacement: CABLE, PAPER PICK-UP REAR, UP.) 2. Relay Connector (5P) to Relay Connector (10P) 3. Relay Connector (10P) to DADF Driver PCB (UN401/J409) (Unit of replacement: CABLE, MAIN SENSOR) - Harnesses from the Tray Home Position Sensor(PS410/J4131) to the DADF Driver PCB(UN401/J413) - Paper Surface Sensor (SR406) - Tray Home Position Sensor (PS410) - Tray Lifter Motor (M406) - DADF Driver PCB (UN401) (Unit of replacement: DF DRIVER PCB ASSEMBLY) <p>[Remedy] Check/replace the related harness/cable, connector and parts.</p>

E423-0001-04	SDRAM error in the Reader Controller PCB
Detection Description	Either an access error to SDRAM in the Reader Controller PCB or an error at data inspection was detected.
Remedy	<p>[Related parts]</p> <ul style="list-style-type: none"> - Reader Controller PCB (UN101) (Unit of replacement: READER CONTROLLER PCB ASSEMBLY) <p>[Remedy] Replace the Reader Controller PCB (UN101). (Unit of replacement: READER CONTROLLER PCB ASSEMBLY)</p> <p>[Reference] Before replacing the Reader Controller PCB, back up the service mode data (approx. 2 min) and restore the backup data after the replacement so the data may be able to be protected.</p> <ul style="list-style-type: none"> - Backup: COPIER (LEVEL2)> FUNCTION> SYSTEM> RSRAMBUP - Restoration: COPIER (LEVEL2)> FUNCTION> SYSTEM> RSRAMRES
E500-0001-05	Communication error
Detection Description	A communication error between the DC Controller PCB and the POD Deck was detected.
Remedy	<p>[Related parts]</p> <ul style="list-style-type: none"> - Harnesses from the DC Controller PCB to the Deck Driver PCB 1. DC Controller PCB (UN1/J461) to Relay Connector (9P) (Unit of replacement: CABLE, SIGNAL) 2. Relay PCB (UN86/J502) to Relay Connector (4P) (Unit of replacement: CABLE, DECK, DC) 3. Relay Connector (9P and 4P) to Deck Lattice Connector (Unit of replacement: CABLE, DECK CONNECTOR) 4. Deck Lattice Connector to Deck Driver PCB - Deck Driver PCB - DC Controller PCB (UN1) (Unit of replacement: DC CONTROLLER PCB ASS'Y) <p>[Remedy] Perform the following in the order while checking whether the error is cleared.</p> <ol style="list-style-type: none"> 1. Check that the Power Supply Cable is connected to the deck/there is electrical current in the outlet/breaker of the deck is ON. 2. Check/replace the related harness/cable, connector and parts. <p>[Reference]</p> <ul style="list-style-type: none"> - After replacement of the Deck Driver PCB, refer to "Adjustments> Adjustment when Replacing the Parts" in the Service Manual. - Before replacing the DC Controller PCB, back up the service mode data (approx. 2 min) and restore the backup data after the replacement so the data may be able to be protected. - Backup: COPIER (LEVEL2)> FUNCTION> SYSTEM> DSRAMBUP - Restoration: COPIER (LEVEL2)> FUNCTION> SYSTEM> DSRAMRES
E500-0002-05	Communication error
Detection Description	A communication error between the DC Controller PCB and the Side Paper Deck was detected.
Remedy	<p>[Related parts]</p> <ul style="list-style-type: none"> - Harnesses from the DC Controller PCB to the Deck Driver PCB 1. DC Controller PCB (UN1/J461) to Relay Connector (9P) (Unit of replacement: CABLE, SIGNAL) 2. Relay PCB (UN86/J502) to Relay Connector (4P) (Unit of replacement: CABLE, DECK, DC) 3. Relay Connector (9P and 4P) to Deck Lattice Connector (Unit of replacement: CABLE, DECK CONNECTOR) 4. Deck Lattice Connector to Deck Driver PCB - Deck Driver PCB - DC Controller PCB (UN1) (Unit of replacement: DC CONTROLLER PCB ASS'Y) <p>[Remedy] Check/replace the related harness/cable, connector and parts.</p> <p>[Reference]</p> <ul style="list-style-type: none"> - After replacement of the Deck Driver PCB, refer to "Adjustments> Adjustment when Replacing the Parts" in the Service Manual. - Before replacing the DC Controller PCB, back up the service mode data (approx. 2 min) and restore the backup data after the replacement so the data may be able to be protected. - Backup: COPIER (LEVEL2)> FUNCTION> SYSTEM> DSRAMBUP - Restoration: COPIER (LEVEL2)> FUNCTION> SYSTEM> DSRAMRES

E500-0022-02	Communication error
Detection Description	FIN-W1/SADDLE FIN-W1 A communication error between the host machine and the Finisher was detected. Or the drive did not stop due to a software failure.
Remedy	FIN-W1/SADDLE FIN-W1 [Remedy] If the problem is not solved by turning OFF and then ON the main power, contact to the sales company.
E500-0098-02	Error due to unexpected operation
Detection Description	-
Remedy	If an error cannot be released by turning OFF/ON the power, contact a sales company.
E500-0099-02	Communication error
Detection Description	FIN-W1/SADDLE FIN-W1 A communication error between the host machine and the Finisher was detected. Or the drive did not stop due to a software failure.
Remedy	FIN-W1/SADDLE FIN-W1 [Remedy] If the problem is not solved by turning OFF and then ON the main power, contact to the sales company.
E500-00A1-02	Error due to unexpected operation
Detection Description	-
Remedy	If an error cannot be released by turning OFF/ON the power, contact a sales company.
E500-00A2-02	Error due to unexpected operation
Detection Description	-
Remedy	If an error cannot be released by turning OFF/ON the power, contact a sales company.
E500-00A3-02	Error due to unexpected operation
Detection Description	-
Remedy	If an error cannot be released by turning OFF/ON the power, contact a sales company.
E500-00A4-02	Error due to unexpected operation
Detection Description	-
Remedy	If an error cannot be released by turning OFF/ON the power, contact a sales company.
E500-00D4-02	Error due to unexpected operation
Detection Description	-
Remedy	If an error cannot be released by turning OFF/ON the power, contact a sales company.
E501-0001-71	Communication error (Document Insertion Unit-M1)
Detection Description	Communication failed 5 consecutive times.
Remedy	[Related parts] - Harnesses from the Insertion Unit Controller PCB (PCB3) to the Option Controller PCB (PCB4) - Insertion Unit Controller PCB (PCB3) - Option Controller PCB (PCB4) [Remedy] Check/replace the related harness/cable, connector and parts. [Reference] When replacing the Insertion Unit Controller PCB, refer to "Adjustments> Adjustment when Replacing the Parts" in the Service Manual.
E501-FF01-71	Communication error (Insertion Unit-N1)
Detection Description	Timeout error of communication start between the inserter control PCB and the option controller PCB
Remedy	[Related parts] - Harnesses from the Insertion Unit Controller PCB (PCB3) to the Option Controller PCB - Insertion Unit Controller PCB - Option Controller PCB [Remedy] Check/replace the related harness/cable, connector and parts. [Reference] When replacing the Insertion Unit Controller PCB, refer to "Adjustments> Adjustment when Replacing the Parts" in the Service Manual.

E501-FF02-71	Communication error (Insertion Unit-N1)
Detection Description	Timeout error of communication end between the inserter control PCB and the option controller PCB
Remedy	<p>[Related parts]</p> <ul style="list-style-type: none"> - Harnesses from the Insertion Unit Controller PCB (PCB3) to the Option Controller PCB - Insertion Unit Controller PCB - Option Controller PCB <p>[Remedy] Check/replace the related harness/cable, connector and parts. [Reference] When replacing the Insertion Unit Controller PCB, refer to "Adjustments> Adjustment when Replacing the Parts" in the Service Manual.</p>
E503-0001-02	Error in communication between the Finisher - Saddle Stitcher (Finisher-X1)
Detection Description	Communication failed between the Finisher and the Saddle Stitcher
Remedy	<p>[Related parts]</p> <ul style="list-style-type: none"> - Harnesses from the Finisher Controller PCB to the Saddle Stitcher Controller PCB - Finisher Controller PCB (PBA101) - Saddle Stitcher Controller PCB (PBA201) <p>[Remedy] Check/replace the related harness/cable, connector and parts. [Reference] When replacing the Finisher Controller PCB, refer to "Adjustments> Adjustment when Replacing the Parts" in the Service Manual.</p>
E503-0002-02	Error in communication between the Finisher - Saddle Stitcher (Finisher-X1)
Detection Description	Communication failed between the Finisher and the Saddle Stitcher
Remedy	<p>[Related parts]</p> <ul style="list-style-type: none"> - Harnesses from the Finisher Controller PCB to the Saddle Stitcher Controller PCB - Finisher Controller PCB (PBA101) - Saddle Stitcher Controller PCB (PBA201) <p>[Remedy] Check/replace the related harness/cable, connector and parts. [Reference] When replacing the Finisher Controller PCB, refer to "Adjustments> Adjustment when Replacing the Parts" in the Service Manual.</p>

E503-0006-02	communication error between the finisher and the paper folding unit (FIN-W1/SADDLE FIN-W1/Finisher-X1/Paper Folding Unit-J1)
Detection Description	Communication failed from the finisher to the paper folding unit
Remedy	<p>a. FIN-W1/SADDLE FIN-W1</p> <p>[Related parts]</p> <ul style="list-style-type: none"> - AC Cable of the Paper Folding Unit - Cable between the Finisher and the Paper Folding Unit - Paper Folding Unit Controller PCB - Finisher Controller PCB (UN3) (Unit of replacement: FINISHER CONTROLLER PCB ASS'Y) <p>[Remedy] Perform the following in the order while checking whether the error is cleared.</p> <ol style="list-style-type: none"> 1. Check that the breaker of the Paper Folding Unit is ON. 2. Check that the Power Supply Cable is connected to the Paper Folding Unit/there is electrical current in the outlet. 3. Check/replace the related harness/cable, connector and parts. <p>[Reference]</p> <ul style="list-style-type: none"> - After replacement of the Finisher Controller PCB, refer to "Adjustments> Adjustment when Replacing the Parts> Points to Note when Replacing the Finisher Controller PCB" in the Service Manual for the Finisher. - After replacement of the Paper Folding Unit Controller PCB, refer to "Adjustments> Adjustment when Replacing the Parts> Points to Note when Replacing the DC Controller PCB" in the Service Manual for the Paper Folding Unit. <p>b. STAPLE FIN-X1/BOOKLET FIN-X1</p> <p>[Related parts]</p> <ul style="list-style-type: none"> - Harnesses from the Finisher Controller PCB to the Paper Folding Unit Controller PCB - Finisher Controller PCB (PBA101) - Paper Folding Unit Controller PCB (PCB1) <p>[Remedy] Check/replace the related harness/cable, connector and parts.</p> <p>[Reference]</p> <ul style="list-style-type: none"> -When replacing the Finisher Controller PCB, refer to "Adjustments> Adjustment when Replacing the Parts" in the Service Manual. -When replacing the Paper Folding Unit Controller PCB, refer to "Adjustments> Adjustment when Replacing the Parts" in the Service Manual.

E503-0021-02

a. Error in communication between the Finisher - Insertion Unit (Finisher-X1) b. Error in communication between the Finisher and Saddle Unit (Finisher-AC1)**Detection Description**

- a. Communication failed between Finisher - Insertion Unit
 b. Communication error between the Finisher Controller PCB and the Saddle Stitcher Controller PCB was detected. (Command transmission error)

Remedy**a. STAPLE FIN-X1/BOOKLET FIN-X1**

[Related parts]

- Harnesses from the Finisher Controller PCB to the Insertion Unit Controller PCB
- Finisher Controller PCB (PBA101)
- Insertion Unit Controller PCB(PCB3)

[Remedy] Perform the following in the order while checking whether the error is cleared.

1. Check that the breaker of the Insertion Unit is ON.
2. Check that the Power Supply Cable is connected to the Insertion Unit/there is electrical current in the outlet.
3. Check/replace the related harness/cable, connector and parts.

[Reference]

- When replacing the Finisher Controller PCB, refer to "Adjustment> Action on parts replacement" in the Service Manual.
- When replacing the Insertion Unit Controller PCB, refer to "Adjustment> Adjustment at Time of Parts Replacement" in the Service Manual.

b. STAPLE FIN-AC1/BOOKLET FIN-AC1

[Related parts]

- Harnesses and connectors from the Finisher Controller PCB to the Saddle Stitcher Controller PCB
- Finisher Controller PCB (PCB101)
- Saddle Stitcher Controller PCB (PCB201)

[Remedy] Perform the following in the order while checking whether the error is cleared.

1. Check/replace the harness and connector between the Finisher Controller PCB and the Saddle Stitcher Controller PCB.
2. Replace the Finisher Controller PCB.

[Reference] When replacing the Finisher Controller PCB, refer to "Adjustment> When Replacing the Parts" in the Service Manual.

3. Replace the Saddle Stitcher Controller PCB.

E503-0022-02	a. Error in communication between the Finisher - Insertion Unit (Finisher-X1/Document Insertion Unit-N1) b. Error in communication between the Finisher and Saddle Unit (Finisher-AC1)
Detection Description	a. Communication failed between Finisher - Insertion Unit b. Communication error between the Finisher Controller PCB and the Saddle Stitcher Controller PCB was detected. (Command reception error)
Remedy	<p>a. STAPLE FIN-X1/BOOKLET FIN-X1 [Related parts] - Harnesses from the Finisher Controller PCB to the Insertion Unit Controller PCB - Insertion Unit Controller PCB(PCB3) - Finisher Controller PCB (PBA101) [Remedy] Perform the following in the order while checking whether the error is cleared.</p> <ol style="list-style-type: none"> 1. Check that the breaker of the Insertion Unit is ON. 2. Check that the Power Supply Cable is connected to the Insertion Unit/there is electrical current in the outlet. 3. Check/replace the related harness/cable, connector and parts. <p>[Reference] - When replacing the Finisher Controller PCB, refer to "Adjustment> Action on parts replacement" in the Service Manual. - When replacing the Insertion Unit Controller PCB, refer to "Adjustment> Adjustment at Time of Parts Replacement" in the Service Manual.</p> <p>b. STAPLE FIN-AC1/BOOKLET FIN-AC1 [Related parts] - Harnesses and connectors from the Finisher Controller PCB to the Saddle Stitcher Controller PCB - Finisher Controller PCB (PCB101) - Saddle Stitcher Controller PCB (PCB201) [Remedy] Perform the following in the order while checking whether the error is cleared.</p> <ol style="list-style-type: none"> 1. Check/replace the harness and connector between the Finisher Controller PCB and the Saddle Stitcher Controller PCB. 2. Replace the Finisher Controller PCB. <p>[Reference] When replacing the Finisher Controller PCB, refer to "Adjustment> When Replacing the Parts" in the Service Manual. 3. Replace the Saddle Stitcher Controller PCB.</p>
E503-0031-02	Error in communication between the Finisher and Puncher Unit (Finisher-AC1)
Detection Description	Communication error between the Finisher Controller PCB and the Puncher Controller PCB was detected. (Command transmission error)
Remedy	<p>STAPLE FIN-AC1/BOOKLET FIN-AC1 [Related parts] - Harnesses and connectors from the Finisher Controller PCB to the Puncher Controller PCB - Finisher Controller PCB (PCB101) - Puncher Controller PCB (PCB301) [Remedy] Perform the following in the order while checking whether the error is cleared.</p> <ol style="list-style-type: none"> 1. Check/replace the harness and connector between the Finisher Controller PCB and the Puncher Controller PCB. 2. Replace the Finisher Controller PCB. <p>[Reference] When replacing the Finisher Controller PCB, refer to "Adjustment> When Replacing the Parts" in the Service Manual. 3. Replace the Puncher Controller PCB. [Reference] When replacing the Puncher Controller PCB, refer to "Adjustment> When Replacing the Parts" in the Service Manual.</p>

E503-0032-02	Error in communication between the Finisher and Puncher Unit (Finisher-AC1)
Detection Description	Communication error between the Finisher Controller PCB and the Puncher Controller PCB was detected. (Command reception error)
Remedy	<p>STAPLE FIN-AC1/BOOKLET FIN-AC1</p> <p>[Related parts]</p> <ul style="list-style-type: none"> - Harnesses and connectors from the Finisher Controller PCB to the Puncher Controller PCB - Finisher Controller PCB (PCB101) - Puncher Controller PCB (PCB301) <p>[Remedy] Perform the following in the order while checking whether the error is cleared.</p> <ol style="list-style-type: none"> 1. Check/replace the harness and connector between the Finisher Controller PCB and the Puncher Controller PCB. 2. Replace the Finisher Controller PCB. <p>[Reference] When replacing the Finisher Controller PCB, refer to "Adjustment> When Replacing the Parts" in the Service Manual.</p> <ol style="list-style-type: none"> 3. Replace the Puncher Controller PCB. <p>[Reference] When replacing the Puncher Controller PCB, refer to "Adjustment> When Replacing the Parts" in the Service Manual.</p>
E503-0041-02	Communication error between Finisher and Multi Function Professional Puncher (M.F PRO PUNCHER-B1/FIN-W1/SADDLE FIN-W1/FINISHER-X1)
Detection Description	An error was detected in communication from the finisher to the Multi Function Professional Puncher.
Remedy	<p>[Related parts]</p> <ul style="list-style-type: none"> - Harness between the BOARD, OPCON PCB and the Finisher Controller PCB - BOARD, OPCON PCB - Finisher Controller PCB <p>[Remedy] Check/replace the related harness/cable, connector and parts.</p>
E503-0042-02	Communication error between Finisher and Multi Function Professional Puncher (M.F PRO Puncher-B1/FIN-W1/SADDLE FIN-W1/FINISHER-X1)
Detection Description	An error was detected in communication from the Multi Function Professional Puncher to the finisher.
Remedy	<p>[Related parts]</p> <ul style="list-style-type: none"> - Harness between the BOARD, OPCON PCB and the Finisher Controller PCB - BOARD, OPCON PCB - Finisher Controller PCB <p>[Remedy] Check/replace the related harness/cable, connector and parts.</p>
E503-0051-02	Communication Error in the Multi Function Professional Puncher(M.F PRO Puncher-B1)
Detection Description	A communication error was detected in the Multi Function Professional Puncher.
Remedy	<p>[Related parts]</p> <ul style="list-style-type: none"> - Harness between the BOARD, COMMUNICATION and the BOARD, OPCON PCB - BOARD, COMMUNICATION - BOARD, OPCON PCB <p>[Remedy] Check/replace the related harness/cable, connector and parts.</p>
E503-0051-31	Communication Error in the Multi Function Professional Puncher(M.F PRO Puncher-B1)
Detection Description	A communication error was detected in the Multi Function Professional Puncher.
Remedy	<p>[Related parts]</p> <ul style="list-style-type: none"> - Harness between the BOARD, COMMUNICATION and the BOARD, OPCON PCB - BOARD, COMMUNICATION - BOARD, OPCON PCB <p>[Remedy] Check/replace the related harness/cable, connector and parts.</p>

E503-0054-02	Communication Error in the Multi Function Professional Puncher(M.F PRO Puncher-B1)
Detection Description	<ul style="list-style-type: none"> - The puncher did not become start status within 3 sec although the operation start signal was sent when starting a job. - The puncher did not become stop status within 3 sec although the end signal was sent at completion of a job.
Remedy	<p>[Related parts]</p> <ul style="list-style-type: none"> - Harness between the BRACKET, INTERLOCK, FRONT DOOR and the BOARD, COMMUNICATION - BRACKET, INTERLOCK, FRONT DOOR - BOARD, COMMUNICATION <p>[Remedy]</p> <ol style="list-style-type: none"> 1. If there is any residual paper in the Multi Function Professional Puncher, remove it. 2. If the Door Open message does not disappear, check/replace the related harness/cable, connector and parts between the BOARD, COMMUNICATION and the BRACKET, INTERLOCK, FRONT DOOR. 3. Check/replace the related harness/cable, connector and parts.
E503-0054-31	Communication Error in the Multi Function Professional Puncher(M.F PRO Puncher-B1)
Detection Description	<ul style="list-style-type: none"> - The puncher did not become start status within 3 sec although a signal to start operation was sent when starting a job. - The puncher did not become stop status within 3 sec although the end signal was sent at completion of a job.
Remedy	<p>[Related parts]</p> <ul style="list-style-type: none"> - Harness between the BRACKET, INTERLOCK, FRONT DOOR and the BOARD, COMMUNICATION - BRACKET, INTERLOCK, FRONT DOOR - BOARD, COMMUNICATION <p>[Remedy]</p> <ol style="list-style-type: none"> 1. If there is any residual paper in the Multi Function Professional Puncher, remove it. 2. If the Door Open message does not disappear, check/replace the related harness/cable, connector and parts between the BOARD, COMMUNICATION and the BRACKET, INTERLOCK, FRONT DOOR. 3. Check/replace the related harness/cable, connector and parts.
E503-0055-02	Communication Error in the Multi Function Professional Puncher(M.F PRO Puncher-B1)
Detection Description	<ul style="list-style-type: none"> - Status of the ready-to-operate signal did not become ON at power-on or recovery from energy saver mode. - Version information could not be communicated within the Multi Function Professional Puncher.
Remedy	<p>[Related parts]</p> <ul style="list-style-type: none"> - Harness between the BRACKET, INTERLOCK, FRONT DOOR and the BOARD, COMMUNICATION - Harness between the BOARD, COMMUNICATION and the BOARD, OPCON PCB - BRACKET, INTERLOCK, FRONT DOOR - BOARD, COMMUNICATION - BOARD, OPCON PCB <p>[Remedy]</p> <ol style="list-style-type: none"> 1. If there is any residual paper in the Multi Function Professional Puncher, remove it. 2. If the Door Open message does not disappear, check/replace the related harness/cable, connector and parts between the BOARD, COMMUNICATION and the BRACKET, INTERLOCK, FRONT DOOR. 3. Check/replace the related harness/cable, connector and parts between the BOARD, COMMUNICATION and the BOARD, OPCON PCB.

E503-0055-31	Communication Error in the Multi Function Professional Puncher(M.F PRO Puncher-B1)
Detection Description	- Status of the ready-to-operate signal did not become ON at power-on or recovery from energy saver mode. - Version information could not be communicated within the Multi Function Professional Puncher.
Remedy	[Related parts] - Harness between the BRACKET, INTERLOCK, FRONT DOOR and the BOARD, COMMUNICATION - Harness between the BOARD, COMMUNICATION and the BOARD, OPCON PCB - BRACKET, INTERLOCK, FRONT DOOR - BOARD, COMMUNICATION - BOARD, OPCON PCB [Remedy] 1. If there is any residual paper in the Multi Function Professional Puncher, remove it. 2. If the Door Open message does not disappear, check/replace the related harness/cable, connector and parts between the BOARD, COMMUNICATION and the BRACKET, INTERLOCK, FRONT DOOR. 3. Check/replace the related harness/cable, connector and parts between the BOARD, COMMUNICATION and the BOARD, OPCON PCB.
E503-0056-02	Communication Error in the Multi Function Professional Puncher(M.F PRO Puncher-B1)
Detection Description	The status of connection signal from the puncher did not become ON at power-on.
Remedy	[Related parts] - Harness between the BOARD, COMMUNICATION and the BOARD, OPCON PCB - BOARD, COMMUNICATION - BOARD, OPCON PCB [Remedy] 1. Check the connector connection between the BOARD, COMMUNICATION and the BOARD, OPCON PCB. 2. Check/replace the related harness/cable, connector and parts.
E503-0056-31	Communication Error in the Multi Function Professional Puncher(M.F PRO Puncher-B1)
Detection Description	The status of connection signal from the puncher did not become ON at power-on.
Remedy	[Related parts] - Harness between the BOARD, COMMUNICATION and the BOARD, OPCON PCB - BOARD, COMMUNICATION - BOARD, OPCON PCB [Remedy] 1. Check the connector connection between the BOARD, COMMUNICATION and the BOARD, OPCON PCB. 2. Check/replace the related harness/cable, connector and parts.

E503-0061-02	a. Error in communication between the Finisher - Paper Folding Unit (Finisher-X1) b. Error in communication between the IC of Finisher Controller PCB (Finisher-AC1)
Detection Description	<p>a. Communication failed between the Finisher - Paper Folding Unit b. Communication error between the IC of Finisher Controller PCB was detected. (Command transmission error)</p>
Remedy	<p>a. STAPLE FIN-X1/BOOKLET FIN-X1 [Related parts] - Harnesses from the Finisher Controller PCB to the Paper Folding Unit Controller PCB - Finisher Controller PCB (PBA101) - Paper Folding Unit Controller PCB (PCB1) [Remedy] Perform the following in the order while checking whether the error is cleared. 1. Check that the breaker of the Paper Folding Unit is ON. 2. Check that the Power Supply Cable is connected to the Paper Folding Unit/there is electrical current in the outlet. 3. Check/replace the related harness/cable, connector and parts. [Reference] - When replacing the Finisher Controller PCB, refer to "Adjustment> Action on parts replacement" in the Service Manual. - When replacing the Paper Folding Unit Controller PCB, refer to "Adjustment> Adjustment at Time of Parts Replacement" in the Service Manual. b. STAPLE FIN-AC1/BOOKLET FIN-AC1 [Related parts] - Finisher Controller PCB (PCB101) [Remedy] Replace the Finisher Controller PCB. [Reference] When replacing the Finisher Controller PCB, refer to "Adjustment> When Replacing the Parts" in the Service Manual.</p>
E503-0062-02	a. Error in communication between the Finisher - Paper Folding Unit (Paper Folding Unit-J1/Finisher-X1) b. Error in communication between the IC of Finisher Controller PCB (Finisher-AC1)
Detection Description	<p>a. Communication failed between the Finisher - Paper Folding Unit b. Communication error between the IC of Finisher Controller PCB was detected. (Command reception error)</p>
Remedy	<p>a. STAPLE FIN-X1/BOOKLET FIN-X1 [Related parts] - Harnesses from the Finisher Controller PCB to the Paper Folding Unit Controller PCB - Finisher Controller PCB (PBA101) - Paper Folding Unit Controller PCB (PCB1) [Remedy] Perform the following in the order while checking whether the error is cleared. 1. Check that the breaker of the Paper Folding Unit is ON. 2. Check that the Power Supply Cable is connected to the Paper Folding Unit/there is electrical current in the outlet. 3. Check/replace the related harness/cable, connector and parts. [Reference] - When replacing the Finisher Controller PCB, refer to "Adjustment> Action on parts replacement" in the Service Manual. - When replacing the Paper Folding Unit Controller PCB, refer to "Adjustment> Adjustment at Time of Parts Replacement" in the Service Manual. b. STAPLE FIN-AC1/BOOKLET FIN-AC1 [Related parts] - Finisher Controller PCB (PCB101) [Remedy] Replace the Finisher Controller PCB. [Reference] When replacing the Finisher Controller PCB, refer to "Adjustment> When Replacing the Parts" in the Service Manual.</p>

E503-0071-02	Communication error
Detection Description	STAPLE FIN-AC1/BOOKLET FIN-AC1, Finisher Jogger Kit A communication error between the Finisher and the Finisher Jogger Kit was detected. (Command transmission error)
Remedy	STAPLE FIN-AC1/BOOKLET FIN-AC1, Finisher Jogger Kit [Related parts] - Harnesses from the Finisher Controller PCB to the Neat Controller PCB - Neat Controller PCB - Finisher Controller PCB [Remedy] Check/replace the related harness/cable, connector and parts. [Reference] When replacing the Finisher Controller PCB, refer to "Adjustments> Adjustment when Replacing the Parts" in the Service Manual for the Finisher. [Reference] When replacing the Neat Controller PCB, refer to "Adjustments> Adjustment when Replacing the Parts" in the Service Manual for the Finisher Jogger Kit.
E503-0072-02	Communication error
Detection Description	STAPLE FIN-AC1/BOOKLET FIN-AC1, Finisher Jogger Kit A communication error between the Finisher and the Finisher Jogger Kit was detected. (Command reception error)
Remedy	STAPLE FIN-AC1/BOOKLET FIN-AC1, Finisher Jogger Kit [Related parts] - Harnesses from the Finisher Controller PCB to the Neat Controller PCB - Neat Controller PCB - Finisher Controller PCB [Remedy] Check/replace the related harness/cable, connector and parts. [Reference] When replacing the Finisher Controller PCB, refer to "Adjustments> Adjustment when Replacing the Parts" in the Service Manual for the Finisher. [Reference] When replacing the Neat Controller PCB, refer to "Adjustments> Adjustment when Replacing the Parts" in the Service Manual for the Finisher Jogger Kit.
E503-0081-02	Error in communication between the Saddle Stitcher - Trimmer (Finisher-X1)
Detection Description	Communication failed between the Finisher - Trimmer
Remedy	[Related parts] - Harnesses from the Saddle Stitcher Controller PCB to the Trimmer Controller PCB - Trimmer Controller PCB (PCB1) - Saddle Stitcher Controller PCB (PBA201) - Finisher Controller PCB (PBA101) [Remedy] Check/replace the related harness/cable, connector and parts. [Reference] When replacing the Finisher Controller PCB, refer to "Adjustments> Adjustment when Replacing the Parts" in the Service Manual.
E503-0082-02	Error in communication between the Saddle Stitcher - Trimmer (Finisher-X1)
Detection Description	Communication failed between the Finisher - Trimmer
Remedy	[Related parts] - Harnesses from the Saddle Stitcher Controller PCB to the Trimmer Controller PCB - Trimmer Controller PCB(PCB1) - Saddle Stitcher Controller PCB (PBA201) - Finisher Controller PCB (PBA101) [Remedy] Check/replace the related harness/cable, connector and parts. [Reference] When replacing the Finisher Controller PCB, refer to "Adjustments> Adjustment when Replacing the Parts" in the Service Manual.

E503-8004-02	Communication error
Detection Description	FIN-W1/SADDLE FIN-W1 A communication error between the Finisher and the Trimmer was detected.
Remedy	FIN-W1/SADDLE FIN-W1 [Related parts] - AC Cable of the Trimmer - Cable between the Finisher and the Trimmer - Finisher Controller PCB (UN3) (Unit of replacement: FINISHER CONTROLLER PCB ASS'Y) [Remedy] Check/replace the related harness/cable, connector and parts. [Reference] After replacement of the Finisher Controller PCB, refer to "Adjustments> Adjustment when Replacing the Parts> Points to Note when Replacing the Finisher Controller PCB" in the Service Manual for the Finisher.
E505-0001-02	a. Finisher back-up RAM (EEPROM) error (Finisher-X1) b. Finisher data error (Finisher-AC1) c. Backup data error (failed data reading) (Document Insertion Unit-N1; Location Inf. 71)
Detection Description	a. The checksum for the EEPROM data has an error. (The value written in EEPROM and the value extracted from EEPROM doesn't conform.) b. The data read from Finisher Controller PCB has an error. (The read data doesn't match with the written data.) c. Data failed to be read properly
Remedy	a. STAPLE FIN-X1/BOOKLET FIN-X1 [Related parts] - Finisher Controller PCB (PBA101) [Remedy] Check/replace the Finisher Controller PCB (PBA101). [Reference] When replacing the Finisher Controller PCB, refer to "Adjustments> Adjustment when Replacing the Parts" in the Service Manual. b. STAPLE FIN-AC1/BOOKLET FIN-AC1 [Related parts] - Finisher Controller PCB (PCB101) [Remedy] Replace the Finisher Controller PCB (PCB101). [Reference] When replacing the Finisher Controller PCB, refer to "Adjustments> Adjustment when Replacing the Parts" in the Service Manual. c. INSERTION UNIT-N1 [Related parts] - Insertion Unit Controller PCB (PCB3) [Remedy] Check/replace the related harness/cable, connector and parts. [Reference] When replacing the Insertion Unit Controller PCB, refer to "Adjustments> Adjustment when Replacing the Parts" in the Service Manual.
E505-0001-71	Backup data error (failed data reading) (Document Insertion Unit-M1)
Detection Description	Data failed to be read properly
Remedy	[Related parts] - Insertion Unit Controller PCB (PCB3) [Remedy] Check/replace the related harness/cable, connector and parts. [Reference] When replacing the Insertion Unit Controller PCB, refer to "Adjustments> Adjustment when Replacing the Parts" in the Service Manual.
E505-0002-71	Backup data error (failure in writing data) (Document Insertion Unit-M1)
Detection Description	Data could not be written correctly.
Remedy	[Related parts] - Insertion Unit Controller PCB (PCB3) [Remedy] Check/replace the related harness/cable, connector and parts. [Reference] When replacing the Insertion Unit Controller PCB, refer to "Adjustments> Adjustment when Replacing the Parts" in the Service Manual.

E505-0003-02	Back-up RAM error (Document Insertion Unit-N1)
Detection Description	The value written in EEPROM and the value extracted from EEPROM doesn't conform.
Remedy	[Related parts] - Insertion Unit Controller PCB (PCB3) [Remedy] Check/replace the related harness/cable, connector and parts. [Reference] - When replacing the Insertion Unit Controller PCB, refer to "Adjustments> Adjustment when Replacing the Parts" in the Service Manual.
E505-0004-02	a. Back-up RAM error (Multi Function Professional Puncher-B1) b. Puncher unit data error (Finisher-AC1)
Detection Description	a. The checksum for the EEPROM data has an error. (The value written in EEPROM and the value extracted from EEPROM doesn't conform.) b. The data read from Puncher Controller PCB has an error. (The read data doesn't match with the written data.)
Remedy	a. MULTI FUNCTION PROFESSIONAL Puncher-B1 [Related parts] - Multi Function Professional Puncher Controller PCB [Remedy] Check/replace Multi Function Professional Puncher Controller PCB. b. STAPLE FIN-AC1/BOOKLET FIN-AC1 [Related parts] - Puncher Controller PCB (PCB301) [Remedy] Replace the Puncher Controller PCB. [Reference] When replacing the Puncher Controller PCB, refer to "Adjustment> When Replacing the Parts" in the Service Manual.
E505-0005-02	Error in the Paper Folding Unit backup RAM (Paper Folding Unit-J1)
Detection Description	Read-write on EPROM is failed to detect.
Remedy	[Remedy] Check/replace the related harness/cable, connector and parts. [Reference] When replacing the Paper Folding Unit Controller PCB, refer to "Adjustments> Adjustment when Replacing the Parts" in the Service Manual.
E505-0006-02	Jogger Kit data error
Detection Description	Finisher Jogger Kit The data read from Neat Controller PCB has an error. (The read data doesn't match with the written data.)
Remedy	Finisher Jogger Kit [Related parts] - Neat Controller PCB [Remedy] Replace the Neat Controller PCB. [Reference] When replacing the Neat Controller PCB, refer to "Adjustments> Adjustment when Replacing the Parts" in the Service Manual for the Finisher Jogger Kit.
E505-0008-02	Error in the EEROM reading (Paper Folding Unit-J1)
Detection Description	Reading error on EEPROM
Remedy	[Remedy] Check/replace the related harness/cable, connector and parts. [Reference] When replacing the Paper Folding Unit Controller PCB, refer to "Adjustments> Adjustment when Replacing the Parts" in the Service Manual.
E505-0009-02	Error in the EEROM writing (Paper Folding Unit-J1)
Detection Description	Writing error on EEPROM
Remedy	[Remedy] Check/replace the related harness/cable, connector and parts. [Reference] When replacing the Paper Folding Unit Controller PCB, refer to "Adjustments> Adjustment when Replacing the Parts" in the Service Manual.

E509-0001-02	Finisher unsupported error (Finisher-X1)
Detection Description	A wrong Finisher was connected.
Remedy	[Related parts] - Finisher Controller PCB (PBA101) [Remedy] - Check/replace whether it is a supported Finisher. - Check/replace the related harness/cable, connector and parts. [Reference] When replacing the Finisher Controller PCB, refer to "Adjustments> Adjustment when Replacing the Parts" in the Service Manual.
E509-0002-02	Software authentication error
Detection Description	FIN-W1/SADDLE FIN-W1 An error in the combination of the BOOTROM and the firmware was detected.
Remedy	FIN-W1/SADDLE FIN-W1 [Remedy] Enter safe mode using (2+8) startup, and reinstall the system software using SST or a USB memory device.
E509-0004-02	Error due to non-compatible trimmer
Detection Description	BOOKLET TRIMMER-D1 A trimmer which cannot be connected to the host machine was detected.
Remedy	BOOKLET TRIMMER-D1 Connect the trimmer (BOOKLET TRIMMER-D1) for this model.
E509-0051-02	Mismatch of software in the Multi Function Professional Puncher (M.F PRO Puncher-B1)
Detection Description	Mismatch of software in the Multi Function Professional Puncher was detected.
Remedy	Reinstall the system software using SST or a USB memory.
E509-0051-31	Mismatch of software in the Multi Function Professional Puncher (M.F PRO Puncher-B1)
Detection Description	Mismatch of software in the Multi Function Professional Puncher was detected.
Remedy	Reinstall the system software using SST or a USB memory.
E509-0052-02	Mismatch of version in the Multi Function Professional Puncher (M.F PRO Puncher-B1)
Detection Description	Mismatch of version of software in the Multi Function Professional Puncher was detected.
Remedy	Reinstall the system software using SST or a USB memory.
E509-0052-31	Mismatch of version in the Multi Function Professional Puncher (M.F PRO Puncher-B1)
Detection Description	Mismatch of version of software in the Multi Function Professional Puncher was detected.
Remedy	Reinstall the system software using SST or a USB memory.

E514-8001-02	a. Processing Tray HP error (Finisher-W1) b. Error in the Gripper Base Motor (Finisher-X1) c. Error in the Paper End Assist Motor (Finisher-AC1)
Detection Description	<p>a. The Processing Tray HP Sensor was not turned ON although 5 sec had passed after the Assist Motor operation started.</p> <p>b. The gripper does not come off the Gripper Base Rear Sensor when the Gripper Base Motor has been driven for 3 seconds.</p> <p>c. The assist belt does not come off the Paper End Assist HP Sensor when the Paper End Assist Motor has been driven for 1 second.</p>
Remedy	<p>a. FIN-W1/SADDLE FIN-W1 [Related parts]</p> <ul style="list-style-type: none"> - Harnesses from the Finisher Controller PCB to the Processing Tray HP Sensor 1. Finisher Controller PCB (UN3/J139) to Relay Connector (31P) (Unit of replacement: CABLE, JOG-T) 2. Relay Connector (31P) to Relay Connector (16P) (Unit of replacement: CABLE, JOG-U) 3. Relay Connector (16P) to Processing Tray HP Sensor (PS13) (Unit of replacement: CABLE, BJOG) - Harnesses from the Finisher Controller PCB to the Assist Motor 1. Finisher Controller PCB (UN3/J111) to Relay Connector (12P) (Unit of replacement: CABLE, JOG-T) 2. Relay Connector (J12P) to Assist Motor (M12/J632) (Unit of replacement: CABLE, JOG-U) <p>- Processing Tray HP Sensor (PS13)</p> <p>- Assist Motor (M12)</p> <p>- Finisher Controller PCB (UN3) (Unit of replacement: FINISHER CONTROLLER PCB ASS'Y)</p> <p>[Remedy] Check/replace the related harness/cable, connector and parts. [Reference] After replacement of the Finisher Controller PCB, refer to "Adjustments> Adjustment when Replacing the Parts> Points to Note when Replacing the Finisher Controller PCB" in the Service Manual for the Finisher.</p> <p>b. STAPLE FIN-X1/BOOKLET FIN-X1 [Related parts]</p> <ul style="list-style-type: none"> - Harnesses from the Gripper Base Rear Sensor (S117) to the Finisher Controller PCB - Harnesses from the Gripper Base Motor (M116) to the Finisher Controller PCB - Gripper Base Rear Sensor (S117) - Gripper Base Motor (M116) - Finisher Controller PCB (PBA101) <p>[Remedy] Check/replace the related harness/cable, connector and parts. [Reference] When replacing the Finisher Controller PCB, refer to "Adjustments> Adjustment when Replacing the Parts" in the Service Manual.</p> <p>b. STAPLE FIN-X1/BOOKLET FIN-X1 [Related parts]</p> <ul style="list-style-type: none"> - Harnesses from the Gripper Base Rear Sensor (S117) to the Finisher Controller PCB - Harnesses from the Gripper Base Motor (M116) to the Finisher Controller PCB - Gripper Base Rear Sensor (S117) - Gripper Base Motor (M116) - Finisher Controller PCB (PBA101) <p>[Remedy] Check/replace the related harness/cable, connector and parts. [Reference] When replacing the Finisher Controller PCB, refer to "Adjustment> Action on parts replacement" in the Service Manual.</p> <p>c. STAPLE FIN-AC1/BOOKLET FIN-AC1 [Related parts]</p> <ul style="list-style-type: none"> - Harnesses from the Paper End Assist HP Sensor (PS123) to the Finisher Controller PCB - Harnesses from the Paper End Assist Motor (M113) to the Finisher Controller PCB - Paper End Assist HP Sensor (PS123) - Paper End Assist Motor (M113) - Finisher Controller PCB (PCB101) <p>[Remedy] Check/replace the related harness/cable, connector and parts. [Reference] When replacing the Finisher Controller PCB, refer to "Adjustment> When Replacing the Parts" in the Service Manual.</p>

E514-8002-02	a. Processing Tray HP error (Finisher-W1) b. Error in the Gripper Base Motor (Finisher-X1) c. Error in the Paper End Assist Motor (Finisher-AC1)
Detection Description	<p>a. The Processing Tray HP Sensor was not turned OFF although 5 sec had passed after the Assist Motor operation started.</p> <p>b. The Gripper Base Rear Sensor dose not detect the gripper when the Gripper Base Motor has been driven for 3 seconds.</p> <p>c. The Paper End Assist HP Sensor does not detect the assist belt when the Paper End Assist Motor has been driven for 2 seconds.</p>
Remedy	<p>a. FIN-W1/SADDLE FIN-W1 [Related parts]</p> <ul style="list-style-type: none"> - Harnesses from the Finisher Controller PCB to the Processing Tray HP Sensor 1. Finisher Controller PCB (UN3/J139) to Relay Connector (31P) (Unit of replacement: CABLE, JOG-T) 2. Relay Connector (31P) to Relay Connector (16P) (Unit of replacement: CABLE, JOG-U) 3. Relay Connector (16P) to Processing Tray HP Sensor (PS13) (Unit of replacement: CABLE, BJOG) - Harnesses from the Finisher Controller PCB to the Assist Motor 1. Finisher Controller PCB (UN3/J111) to Relay Connector (12P) (Unit of replacement: CABLE, JOG-T) 2. Relay Connector (J12P) to Assist Motor (M12/J632) (Unit of replacement: CABLE, JOG-U) <p>- Processing Tray HP Sensor (PS13)</p> <p>- Assist Motor (M12)</p> <p>- Finisher Controller PCB (UN3) (Unit of replacement: FINISHER CONTROLLER PCB ASS'Y)</p> <p>[Remedy] Check/replace the related harness/cable, connector and parts. [Reference] After replacement of the Finisher Controller PCB, refer to "Adjustments> Adjustment when Replacing the Parts> Points to Note when Replacing the Finisher Controller PCB" in the Service Manual for the Finisher.</p> <p>b. STAPLE FIN-X1/BOOKLET FIN-X1 [Related parts]</p> <ul style="list-style-type: none"> - Harnesses from the Gripper Base Rear Sensor (S117) to the Finisher Controller PCB - Harnesses from the Gripper Base Motor (M116) to the Finisher Controller PCB - Gripper Base Rear Sensor (S117) - Gripper Base Motor (M116) - Finisher Controller PCB (PBA101) <p>[Remedy] Check/replace the related harness/cable, connector and parts. [Reference] When replacing the Finisher Controller PCB, refer to "Adjustments> Adjustment when Replacing the Parts" in the Service Manual.</p> <p>c. STAPLE FIN-AC1/BOOKLET FIN-AC1 [Related parts]</p> <ul style="list-style-type: none"> - Harnesses from the Front Alignment HP Sensor (PS115) to the Finisher Controller PCB - Harnesses from the Front Alignment Motor (M107) to the Finisher Controller PCB - Front Alignment HP Sensor (PS115) - Front Alignment Motor (M107) - Finisher Controller PCB (PCB101) <p>[Reference] When replacing the Finisher Controller PCB, refer to "Adjustment> When Replacing the Parts" in the Service Manual.</p>

E514-8003-02	Error in the Gripper Motor (Finisher-X1)
Detection Description	The gripper does not come off the Gripper HP Sensor when the Gripper Motor has been driven for 3 seconds.
Remedy	<p>[Related parts]</p> <ul style="list-style-type: none"> - Harnesses from the Gripper HP Sensor (S140) to the Finisher Controller PCB - Harnesses from the Gripper Motor (M117) to the Finisher Controller PCB - Gripper HP Sensor (S140) - Gripper Motor (M117) - Finisher Controller PCB (PBA101) <p>[Remedy] Check/replace the related harness/cable, connector and parts. [Reference] When replacing the Finisher Controller PCB, refer to "Adjustments> Adjustment when Replacing the Parts" in the Service Manual.</p>

E514-8004-02	Error in the Gripper Motor (Finisher-X1)
Detection Description	The Gripper HP Sensor does not detect the gripper when the Gripper Motor has been driven for 3 seconds.
Remedy	<p>[Related parts]</p> <ul style="list-style-type: none"> - Harnesses from the Gripper HP Sensor (S140) to the Finisher Controller PCB - Harnesses from the Gripper Motor (M117) to the Finisher Controller PCB - Gripper HP Sensor (S140) - Gripper Motor (M117) - Finisher Controller PCB (PBA101) <p>[Remedy] Check/replace the related harness/cable, connector and parts. [Reference] When replacing the Finisher Controller PCB, refer to "Adjustments> Adjustment when Replacing the Parts" in the Service Manual.</p>
E514-8005-02	Error in the Gripper Motor (Finisher-X1)
Detection Description	The gripper does not come off the Position Sensor when the Gripper Motor has been driven for 3 seconds.
Remedy	<p>[Related parts]</p> <ul style="list-style-type: none"> - Harnesses from the Gripper HP Sensor (S140) to the Finisher Controller PCB - Harnesses from the Gripper Motor (M117) to the Finisher Controller PCB - Gripper HP Sensor (S140) - Gripper Motor (M117) - Finisher Controller PCB (PBA101) <p>[Remedy] Check/replace the related harness/cable, connector and parts. [Reference] When replacing the Finisher Controller PCB, refer to "Adjustments> Adjustment when Replacing the Parts" in the Service Manual.</p>
E514-8006-02	Error in the Gripper Motor (Finisher-X1)
Detection Description	The Gripper Position Sensor does not detect the gripper when the Gripper Motor has been driven for 3 seconds.
Remedy	<p>[Related parts]</p> <ul style="list-style-type: none"> - Harnesses from the Gripper Position Sensor (S115) to the Finisher Controller PCB - Harnesses from the Gripper Motor (M117) to the Finisher Controller PCB - Gripper Position Sensor (S115) - Gripper Motor (M117) - Finisher Controller PCB (PBA101) <p>[Remedy] Check/replace the related harness/cable, connector and parts. [Reference] When replacing the Finisher Controller PCB, refer to "Adjustments> Adjustment when Replacing the Parts" in the Service Manual.</p>
E518-8001-02	Error in the Fold Feed Motor (Paper Folding Unit-J1)
Detection Description	A lock signal is continuous to detected for specific time after Folding Feed Motor drives.
Remedy	<p>[Related parts]</p> <ul style="list-style-type: none"> -Harnesses from the Paper Folding Unit Controller PCB to the Fold Feed Motor (M11) -Fold Feed Motor (M11) -Paper Folding Unit Controller PCB (PCB1) <p>[Remedy] Check/replace the related harness/cable, connector and parts. [Reference] When replacing the Paper Folding Unit Controller PCB, refer to "Adjustments> Adjustment when Replacing the Parts" in the Service Manual.</p>
E530-8000-02	Error in the Front or Rear Alignment Motor (Finisher-X1)
Detection Description	The Front or Rear Alignment Motor operate abnormally during initialization.
Remedy	<p>[Related parts]</p> <ul style="list-style-type: none"> - Harnesses from the Front/Rear Alignment HP Sensor (S108/S109) to the Finisher Controller PCB - Harnesses from the Front/Rear Alignment Motor (M108/M109) to the Finisher Controller PCB - Front/Rear Alignment HP Sensor (S108/S109) - Front/Rear Alignment Motor (M108/M109) - Finisher Controller PCB (PBA101) <p>[Remedy] Check/replace the related harness/cable, connector and parts. [Reference] When replacing the Finisher Controller PCB, refer to "Adjustments> Adjustment when Replacing the Parts" in the Service Manual.</p>

E530-8001-02

a. Rear Alignment Guide HP error (Finisher-W1) b. Error in the Front Alignment Motor (Finisher-X1) c. Error in the Front Alignment Motor (Finisher-AC1)**Detection Description**

- a. The Rear Alignment Guide HP Sensor was not turned ON although 5 sec had passed after the Rear Alignment Motor operation started.
- b. The front alignment plate does not come off the Front Alignment HP Sensor when the Front Alignment Motor has been driven for 4 seconds.
- c. The front alignment plate does not come off the Front Alignment HP Sensor when the Front Alignment Motor has been driven for 1 second.

Remedy**a. FIN-W1/SADDLE FIN-W1**

[Related parts]

- Harnesses from the Finisher Controller PCB to the Rear Alignment Guide HP Sensor
 1. Finisher Controller PCB (UN3/J139) to Relay Connector (31P) (Unit of replacement: CABLE, JOG-T)
 2. Relay Connector (31P) to Relay Connector (16P) (Unit of replacement: CABLE, JOG-U)
 3. Relay Connector (16P) to Rear Alignment Guide HP Sensor (PS12/J608) (Unit of replacement: CABLE, BJOG)
- Harnesses from the Finisher Controller PCB to the Rear Alignment Motor
 1. Finisher Controller PCB (UN3/J139) to Relay Connector (31P) (Unit of replacement: CABLE, JOG-T)
 2. Relay Connector (31P) to Relay Connector (16P) (Unit of replacement: CABLE, JOG-U)
 3. Relay Connector (16P) to Rear Alignment Motor (M10/J612) (Unit of replacement: CABLE, BJOG)
- Rear Alignment Guide HP Sensor (PS12)
- Rear Alignment Motor (M10)
- Finisher Controller PCB (UN3) (Unit of replacement: FINISHER CONTROLLER PCB ASS'Y)

[Remedy] Check/replace the related harness/cable, connector and parts.

[Reference] After replacement of the Finisher Controller PCB, refer to "Adjustments> Adjustment when Replacing the Parts> Points to Note when Replacing the Finisher Controller PCB" in the Service Manual for the Finisher.

b. STAPLE FIN-X1/BOOKLET FIN-X1

[Related parts]

- Harnesses from the Front Alignment HP Sensor (S108) to the Finisher Controller PCB
- Harnesses from the Front Alignment Motor (M108) to the Finisher Controller PCB
- Front Alignment HP Sensor (S108)
- Front Alignment Motor (M108)
- Finisher Controller PCB (PBA101)

[Remedy] Check/replace the related harness/cable, connector and parts.

[Reference] When replacing the Finisher Controller PCB, refer to "Adjustments> Adjustment when Replacing the Parts" in the Service Manual.

c. STAPLE FIN-AC1/BOOKLET FIN-AC1

[Related parts]

- Harnesses from the Front Alignment HP Sensor (PS115) to the Finisher Controller PCB
- Harnesses from the Front Alignment Motor (M107) to the Finisher Controller PCB
- Front Alignment HP Sensor (PS115)
- Front Alignment Motor (M107)
- Finisher Controller PCB (PCB101)

[Reference] When replacing the Finisher Controller PCB, refer to "Adjustment> When Replacing the Parts" in the Service Manual.

E530-8002-02

a. Rear Alignment Guide HP error (Finisher-W1) b. Error in the Front Alignment Motor (Finisher-X1) c. Error in the Front Alignment Motor (Finisher-AC1)
Detection Description

- a. The Rear Alignment Guide HP Sensor was not turned OFF although 5 sec had passed after the Rear Alignment Motor operation started.
- b. The Front Alignment HP Sensor does not detect the Front Alignment plate when the Front Alignment Motor has been driven for 4 seconds.
- c. The Front Alignment HP Sensor does not detect the Front Alignment plate when the Front Alignment Motor has been driven for 1 second.

Remedy

a. FIN-W1/SADDLE FIN-W1

[Related parts]

- Harnesses from the Finisher Controller PCB to the Rear Alignment Guide HP Sensor
 1. Finisher Controller PCB (UN3/J139) to Relay Connector (31P) (Unit of replacement: CABLE, JOG-T)
 2. Relay Connector (31P) to Relay Connector (16P) (Unit of replacement: CABLE, JOG-U)
 3. Relay Connector (16P) to Rear Alignment Guide HP Sensor (PS12/J608) (Unit of replacement: CABLE, BJOG)
- Harnesses from the Finisher Controller PCB to the Rear Alignment Motor
 1. Finisher Controller PCB (UN3/J139) to Relay Connector (31P) (Unit of replacement: CABLE, JOG-T)
 2. Relay Connector (31P) to Relay Connector (16P) (Unit of replacement: CABLE, JOG-U)
 3. Relay Connector (16P) to Rear Alignment Motor (M10/J612) (Unit of replacement: CABLE, BJOG)
- Rear Alignment Guide HP Sensor (PS12)
- Rear Alignment Motor (M10)
- Finisher Controller PCB (UN3) (Unit of replacement: FINISHER CONTROLLER PCB ASS'Y)

[Remedy] Check/replace the related harness/cable, connector and parts.

[Reference] After replacement of the Finisher Controller PCB, refer to "Adjustments> Adjustment when Replacing the Parts> Points to Note when Replacing the Finisher Controller PCB" in the Service Manual for the Finisher.

b. STAPLE FIN-X1/BOOKLET FIN-X1

[Related parts]

- Harnesses from the Front Alignment HP Sensor (S108) to the Finisher Controller PCB
- Harnesses from the Front Alignment Motor (M108) to the Finisher Controller PCB
- Front Alignment HP Sensor (S108)
- Front Alignment Motor (M108)
- Finisher Controller PCB (PBA101)

[Remedy] Check/replace the related harness/cable, connector and parts.

[Reference] When replacing the Finisher Controller PCB, refer to "Adjustments> Adjustment when Replacing the Parts" in the Service Manual.

c. STAPLE FIN-AC1/BOOKLET FIN-AC1

[Related parts]

- Harnesses from the Front Alignment HP Sensor (PS115) to the Finisher Controller PCB
- Harnesses from the Front Alignment Motor (M107) to the Finisher Controller PCB
- Front Alignment HP Sensor (PS115)
- Front Alignment Motor (M107)
- Finisher Controller PCB (PCB1)

[Reference] When replacing the Finisher Controller PCB, refer to "Adjustment> When Replacing the Parts" in the Service Manual.

E531-8001-02

a. Staple HP error (Finisher-W1) b. Error in the Staple Motor (Finisher-X1) c. Error in the Staple Motor (Finisher-AC1)**Detection Description**

- a. The Staple HP Sensor was not turned ON although 0.5 sec had passed after the Staple Motor operation started.
- b. The staple unit does not come off the Staple HP Sensor when the Staple Motor has been driven for 400 msec.
- c. The staple unit does not come off the Staple HP Sensor when the Staple Motor has been driven for 0.4 seconds.

Remedy**a. FIN-W1/SADDLE FIN-W1**

[Related parts]

- Harnesses from the Finisher Controller PCB to the Staple HP Sensor

1. Finisher Controller PCB (UN3/J122) to Relay Connector (15P) (Unit of replacement: HOLDER, STAPLER CABLE, UPPER)

2. Relay Connector (15P) to Staple HP Sensor (PS27/J678) (Unit of replacement: CABLE, STAPLE SENSOR)

- Harnesses from the Finisher Controller PCB to the Staple Unit

1. Finisher Controller PCB (UN3/J123) to Staple Driver PCB (UN6/J311) (Unit of replacement: HOLDER, STAPLER CABLE, UPPER)

2. Staple Driver PCB (UN6/J315 and J316) to Staple Unit (J672 and J673) (Unit of replacement: CABLE, STAPLE ASSEMBLY)

- Staple Driver PCB (UN6) (Unit of replacement: STAPLE DRIVER PCB ASSEMBLY)

- Staple HP Sensor (PS27)

- Stapler (Unit of replacement: STAPLER ASSEMBLY)

- Finisher Controller PCB (UN3) (Unit of replacement: FINISHER CONTROLLER PCB ASS'Y)

[Remedy] Check/replace the related harness/cable, connector and parts.

[Reference] After replacement of the Finisher Controller PCB, refer to "Adjustments> Adjustment when Replacing the Parts> Points to Note when Replacing the Finisher Controller PCB" in the Service Manual for the Finisher.

b. STAPLE FIN-X1/BOOKLET FIN-X1

[Related parts]

- Harnesses from the Staple Position Switch (SW103) to the Finisher Controller PCB

- Harnesses from the Staple Unit to the Finisher Controller PCB

- Staple Position Switch (SW103)

- Staple Unit

- Finisher Controller PCB (PBA101)

[Remedy] Check/replace the related harness/cable, connector and parts.

[Reference] When replacing the Finisher Controller PCB, refer to "Adjustments> Adjustment when Replacing the Parts" in the Service Manual.

c. STAPLE FIN-AC1/BOOKLET FIN-AC1

[Related parts]

- Harnesses from the Stapler Unit to the Stapler Relay PCB

- Harnesses from the Stapler Unit Relay PCB to the Finisher Controller PCB

- Stapler Unit

- Stapler Unit Relay PCB (PCB102)

- Finisher Controller PCB (PCB101)

[Reference] When replacing the Finisher Controller PCB, refer to "Adjustment> When Replacing the Parts" in the Service Manual.

E531-8002-02	a. Staple HP error (Finisher-W1) b. Error in the Staple Motor (Finisher-X1) c. Error in the Staple Motor (Finisher-AC1)
Detection Description	<p>a. The Staple HP Sensor was not turned OFF although 0.5 sec had passed after the Staple Motor operation started.</p> <p>b. The Staple HP Sensor does not detect the staple unit when the Staple Motor has been driven for 400 msec.</p> <p>c. The Staple HP Sensor does not detect the staple unit when the Staple Motor has been driven for 0.4 seconds.</p>
Remedy	<p>a. FIN-W1/SADDLE FIN-W1 [Related parts]</p> <ul style="list-style-type: none"> - Harnesses from the Finisher Controller PCB to the Staple HP Sensor 1. Finisher Controller PCB (UN3/J122) to Relay Connector (15P) (Unit of replacement: HOLDER, STAPLER CABLE, UPPER) 2. Relay Connector (15P) to Staple HP Sensor (PS27/J678) (Unit of replacement: CABLE, STAPLE SENSOR) - Harnesses from the Finisher Controller PCB to the Staple Unit 1. Finisher Controller PCB (UN3/J123) to Staple Driver PCB (UN6/J311) (Unit of replacement: HOLDER, STAPLER CABLE, UPPER) 2. Staple Driver PCB (UN6/J315 and J316) to Staple Unit (J672 and J673) (Unit of replacement: CABLE, STAPLE ASSEMBLY) - Staple Driver PCB (UN6) (Unit of replacement: STAPLE DRIVER PCB ASSEMBLY) - Staple HP Sensor (PS27) - Stapler (Unit of replacement: STAPLER ASSEMBLY) - Finisher Controller PCB (UN3) (Unit of replacement: FINISHER CONTROLLER PCB ASS'Y) <p>[Remedy] Check/replace the related harness/cable, connector and parts. [Reference] After replacement of the Finisher Controller PCB, refer to "Adjustments> Adjustment when Replacing the Parts> Points to Note when Replacing the Finisher Controller PCB" in the Service Manual for the Finisher.</p> <p>b. STAPLE FIN-X1/BOOKLET FIN-X1 [Related parts]</p> <ul style="list-style-type: none"> - Harnesses from the Staple Unit to the Finisher Controller PCB - Staple Unit - Finisher Controller PCB (PBA101) <p>[Remedy] Check/replace the related harness/cable, connector and parts. [Reference] When replacing the Finisher Controller PCB, refer to "Adjustments> Adjustment when Replacing the Parts" in the Service Manual.</p> <p>c. STAPLE FIN-AC1/BOOKLET FIN-AC1 [Related parts]</p> <ul style="list-style-type: none"> - Harnesses from the Stapler Unit to the Stapler Relay PCB - Harnesses from the Stapler Unit Relay PCB to the Finisher Controller PCB - Stapler Unit - Stapler Unit Relay PCB (PCB102) - Finisher Controller PCB (PCB101) <p>[Remedy] Check/replace the related harness/cable, connector and parts. [Reference] When replacing the Finisher Controller PCB, refer to "Adjustment> When Replacing the Parts" in the Service Manual.</p>
E532-8000-02	Error in the Staple Shift Motor (Finisher-X1)
Detection Description	The Staple Shift Motor operate abnormally during initialization.
Remedy	<p>STAPLE FIN-X1/BOOKLET FIN-X1 [Related parts]</p> <ul style="list-style-type: none"> - Harnesses from the Stapler Shift HP Sensor (S107) to the Finisher Controller PCB - Harnesses from the Staple Shift Motor (M107) to the Finisher Controller PCB - Stapler Shift HP Sensor (S107) - Staple Shift Motor (M107) - Finisher Controller PCB (PBA101) <p>[Remedy] Check/replace the related harness/cable, connector and parts. [Reference] When replacing the Finisher Controller PCB, refer to "Adjustments> Adjustment when Replacing the Parts" in the Service Manual.</p>

E532-8001-02	a. Staple HP error (Finisher-W1) b. Error in the Stapler Shift Motor (Finisher-X1) c. Error in the Stapler Shift Motor (Finisher-AC1)
Detection Description	<p>a. The Staple HP Sensor was not turned ON although 10 sec had passed after the Staple Shift Motor operation started.</p> <p>b. The staple unit does not come off the Stapler Shift HP Sensor when the Staple Shift Motor has been driven for 5 seconds.</p> <p>c. The stapler unit does not come off the Stapler Shift HP Sensor when the Stapler Shift Motor has been driven for 1 second.</p>
Remedy	<p>a. FIN-W1/SADDLE FIN-W1 [Related parts]</p> <ul style="list-style-type: none"> - Harnesses from the Finisher Controller PCB to the Staple HP Sensor 1. Finisher Controller PCB (UN3/J122) to Relay Connector (15P) (Unit of replacement: HOLDER, STAPLER CABLE, UPPER) 2. Relay Connector (15P) to Staple HP Sensor (PS27/J678) (Unit of replacement: CABLE, STAPLE SENSOR) - Harnesses from the Finisher Controller PCB to the Staple Unit 1. Finisher Controller PCB (UN3/J123) to Staple Driver PCB (UN6/J311) (Unit of replacement: HOLDER, STAPLER CABLE, UPPER) 2. Staple Driver PCB (UN6/J317) to Staple Move Motor (M21/J671) (Unit of replacement: HOLDER, STAPLER CABLE, UPPER) - Staple Driver PCB (UN6) (Unit of replacement: STAPLE DRIVER PCB ASSEMBLY) - Staple HP Sensor (PS27) - Staple Move Motor (M21) - Finisher Controller PCB (UN3) (Unit of replacement: FINISHER CONTROLLER PCB ASS'Y) <p>[Remedy] Check/replace the related harness/cable, connector and parts. [Reference] After replacement of the Finisher Controller PCB, refer to "Adjustments> Adjustment when Replacing the Parts> Points to Note when Replacing the Finisher Controller PCB" in the Service Manual for the Finisher.</p> <p>b. STAPLE FIN-X1/BOOKLET FIN-X1 [Related parts]</p> <ul style="list-style-type: none"> - Harnesses from the Stapler Shift HP Sensor (S107) to the Finisher Controller PCB - Harnesses from the Staple Shift Motor (M107) to the Finisher Controller PCB - Stapler Shift HP Sensor (S107) - Staple Shift Motor (M107) - Finisher Controller PCB (PBA101) <p>[Remedy] Check/replace the related harness/cable, connector and parts. [Reference] When replacing the Finisher Controller PCB, refer to "Adjustments> Adjustment when Replacing the Parts" in the Service Manual.</p> <p>c. STAPLE FIN-AC1/BOOKLET FIN-AC1 [Related parts]</p> <ul style="list-style-type: none"> - Harnesses from the Stapler Shift HP Sensor (PS124) to the Finisher Controller PCB - Harnesses from the Stapler Shift Motor (M114) to the Finisher Controller PCB - Stapler Shift HP Sensor (PS124) - Stapler Shift Motor (M114) - Finisher Controller PCB (PCB101) <p>[Remedy] Check/replace the related harness/cable, connector and parts. [Reference] When replacing the Finisher Controller PCB, refer to "Adjustment> When Replacing the Parts" in the Service Manual.</p>

E532-8002-02	a. Staple HP error (Finisher-W1) b. Error in the Stapler Shift Motor (Finisher-X1) c. Error in the Stapler Shift Motor (Finisher-AC1)
Detection Description	<p>a. The Staple HP Sensor was not turned OFF although 2 sec had passed after the Staple Shift Motor operation started.</p> <p>b. The Stapler Shift HP Sensor does not detect the staple unit when the Staple Shift Motor has been driven for 5 seconds.</p> <p>c. The Stapler Shift HP Sensor does not detect the stapler unit when the Stapler Shift Motor has been driven for 15 seconds.</p>
Remedy	<p>a. FIN-W1/SADDLE FIN-W1 [Related parts]</p> <ul style="list-style-type: none"> - Harnesses from the Finisher Controller PCB to the Staple HP Sensor 1. Finisher Controller PCB (UN3/J122) to Relay Connector (15P) (Unit of replacement: HOLDER, STAPLER CABLE, UPPER) 2. Relay Connector (15P) to Staple HP Sensor (PS27/J678) (Unit of replacement: CABLE, STAPLE SENSOR) - Harnesses from the Finisher Controller PCB to the Staple Unit 1. Finisher Controller PCB (UN3/J123) to Staple Driver PCB (UN6/J311) (Unit of replacement: HOLDER, STAPLER CABLE, UPPER) 2. Staple Driver PCB (UN6/J317) to Staple Move Motor (M21/J671) (Unit of replacement: HOLDER, STAPLER CABLE, UPPER) - Staple Driver PCB (UN6) (Unit of replacement: STAPLE DRIVER PCB ASSEMBLY) - Staple HP Sensor (PS27) - Staple Move Motor (M21) - Finisher Controller PCB (UN3) (Unit of replacement: FINISHER CONTROLLER PCB ASS'Y) <p>[Remedy] Check/replace the related harness/cable, connector and parts. [Reference] After replacement of the Finisher Controller PCB, refer to "Adjustments> Adjustment when Replacing the Parts> Points to Note when Replacing the Finisher Controller PCB" in the Service Manual for the Finisher.</p> <p>b. STAPLE FIN-X1/BOOKLET FIN-X1 [Related parts]</p> <ul style="list-style-type: none"> - Harnesses from the Stapler Shift HP Sensor (S107) to the Finisher Controller PCB - Harnesses from the Staple Shift Motor (M107) to the Finisher Controller PCB - Stapler Shift HP Sensor (S107) - Staple Shift Motor (M107) - Finisher Controller PCB (PBA101) <p>[Remedy] Check/replace the related harness/cable, connector and parts. [Reference] When replacing the Finisher Controller PCB, refer to "Adjustments> Adjustment when Replacing the Parts" in the Service Manual.</p> <p>c. STAPLE FIN-AC1/BOOKLET FIN-AC1 [Related parts]</p> <ul style="list-style-type: none"> - Harnesses from the Stapler Shift HP Sensor (PS124) to the Finisher Controller PCB - Harnesses from the Stapler Shift Motor (M114) to the Finisher Controller PCB - Stapler Shift HP Sensor (PS124) - Stapler Shift Motor (M114) - Finisher Controller PCB (PCB101) <p>[Remedy] Check/replace the related harness/cable, connector and parts. [Reference] When replacing the Finisher Controller PCB, refer to "Adjustment> When Replacing the Parts" in the Service Manual.</p>
E533-8001-02	Staple-free Binding Motor Clock error (Finisher-AC1)
Detection Description	The clock signal from the Staple-free Binding Motor Clock Sensor does not detect during from 0.24 seconds to 0.25 seconds after operating the Staple-free Binding Motor.
Remedy	<p>STAPLE FIN-AC1/BOOKLET FIN-AC1 [Related parts]</p> <ul style="list-style-type: none"> - Harnesses from the Staple-free Binding Unit to the Finisher Controller PCB - Staple-free Binding Unit - Finisher Controller PCB (PCB101) <p>[Remedy] Check/replace the related harness/cable, connector and parts. [Reference] When replacing the Finisher Controller PCB, refer to "Adjustment> When Replacing the Parts" in the Service Manual.</p>

E533-8002-02	Error in the Staple-free Binding Motor (Finisher-AC1)
Detection Description	The staple-free binding unit does not come off the Staple-free Binding HP Sensor when the Staple-free Binding Motor has been driven for 0.25 seconds.
Remedy	<p>STAPLE FIN-AC1/BOOKLET FIN-AC1</p> <p>[Related parts]</p> <ul style="list-style-type: none"> - Harnesses from the Staple-free Binding Unit to the Finisher Controller PCB - Staple-free Binding Unit - Finisher Controller PCB (PCB101) <p>[Remedy] Check/replace the related harness/cable, connector and parts. [Reference] When replacing the Finisher Controller PCB, refer to "Adjustment> When Replacing the Parts" in the Service Manual.</p>
E533-8003-02	Error in the Staple-free Binding Motor (Finisher-AC1)
Detection Description	The clock signal from the Staple-free Binding Motor Clock Sensor does not detect during from 0.24 seconds to 0.25 seconds after operating the Staple-free Binding Motor, and the staple-free binding unit does not come off the Staple-free Binding HP Sensor when the Staple-free Binding Motor has been driven for 0.25 seconds.
Remedy	<p>STAPLE FIN-AC1/BOOKLET FIN-AC1</p> <p>[Related parts]</p> <ul style="list-style-type: none"> - Harnesses from the Staple-free Binding Unit to the Finisher Controller PCB - Staple-free Binding Unit - Finisher Controller PCB (PCB101) <p>[Remedy] Check/replace the related harness/cable, connector and parts. [Reference] When replacing the Finisher Controller PCB, refer to "Adjustment> When Replacing the Parts" in the Service Manual.</p>
E533-8004-02	Staple-free binding time out error (Finisher-AC1)
Detection Description	The staple-free binding does not be executed within 2 seconds after starting the operation. (The rotation speed of the motor that detected by the Staple-free Binding Motor Clock Sensor don't decrease.)
Remedy	<p>STAPLE FIN-AC1/BOOKLET FIN-AC1</p> <p>[Related parts]</p> <ul style="list-style-type: none"> - Harnesses from the Staple-free Binding Unit to the Finisher Controller PCB - Staple-free Binding Unit - Finisher Controller PCB (PCB101) <p>[Remedy] Check/replace the related harness/cable, connector and parts. [Reference] When replacing the Finisher Controller PCB, refer to "Adjustment> When Replacing the Parts" in the Service Manual.</p>
E533-8005-02	Error in the Staple-free Binding Motor (Finisher-AC1)
Detection Description	The Staple-free Binding HP Sensor does not detect the staple-free binding part when the Staple-free Binding Motor has been driven. (The return operation of the binding parts isn't completed.)
Remedy	<p>STAPLE FIN-AC1/BOOKLET FIN-AC1</p> <p>[Related parts]</p> <ul style="list-style-type: none"> - Harnesses from the Staple-free Binding Unit to the Finisher Controller PCB - Staple-free Binding Unit - Finisher Controller PCB (PCB101) <p>[Remedy] Check/replace the related harness/cable, connector and parts. [Reference] When replacing the Finisher Controller PCB, refer to "Adjustment> When Replacing the Parts" in the Service Manual.</p>

E535-0001-02	Error in the Swing Guide Motor (Finisher-X1)
Detection Description	The swing guide does not come off the Swing Guide HP Sensor when the Swing Guide Motor has been driven for 3 seconds.
Remedy	<p>[Related parts]</p> <ul style="list-style-type: none"> - Harnesses from the Swing Guide HP Sensor (S110) to the Finisher Controller PCB - Harnesses from the Swing Guide Motor (M110) to the Finisher Controller PCB - Swing Guide HP Sensor (S110) - Swing Guide Motor (M110) - Finisher Controller PCB (PBA101) <p>[Remedy] Check/replace the related harness/cable, connector and parts. [Reference] When replacing the Finisher Controller PCB, refer to "Adjustments> Adjustment when Replacing the Parts" in the Service Manual.</p>
E535-0002-02	Error in the Swing Guide Motor (Finisher-X1)
Detection Description	The Swing Guide HP Sensor does not detect the swing guide when the Swing Guide Motor has been driven for 3 seconds.
Remedy	<p>[Related parts]</p> <ul style="list-style-type: none"> - Harnesses from the Swing Guide HP Sensor (S110) to the Finisher Controller PCB - Harnesses from the Swing Guide Motor (M110) to the Finisher Controller PCB - Swing Guide HP Sensor (S110) - Swing Guide Motor (M110) - Finisher Controller PCB (PBA101) <p>[Remedy] Check/replace the related harness/cable, connector and parts. [Reference] When replacing the Finisher Controller PCB, refer to "Adjustments> Adjustment when Replacing the Parts" in the Service Manual.</p>
E535-0003-02	Error in the Swing Guide Motor (Finisher-X1)
Detection Description	The Swing Guide Height Detection Sensor failed to be ON even though specified period of time has passed when lowering the swing guide.
Remedy	<p>[Related parts]</p> <ul style="list-style-type: none"> - Harnesses from the Swing Guide Height Detection Sensor (S118) to the Finisher Controller PCB - Harnesses from the Swing Guide Motor (M110) to the Finisher Controller PCB - Swing Guide Height Detection Sensor (S118) - Swing Guide Motor (M110) - Finisher Controller PCB (PBA101) <p>[Remedy] Check/replace the related harness/cable, connector and parts. [Reference] When replacing the Finisher Controller PCB, refer to "Adjustments> Adjustment when Replacing the Parts" in the Service Manual.</p>
E535-0004-02	Error in the Swing Guide Motor (Finisher-X1)
Detection Description	The Swing Guide Height Detection Sensor failed to be OFF even though specified period of time has passed when raising the swing unit.
Remedy	<p>[Related parts]</p> <ul style="list-style-type: none"> - Harnesses from the Swing Guide Height Detection Sensor (S118) to the Finisher Controller PCB - Harnesses from the Swing Guide Motor (M110) to the Finisher Controller PCB - Swing Guide Height Detection Sensor (S118) - Swing Guide Motor (M110) - Finisher Controller PCB (PBA101) <p>[Remedy] Check/replace the related harness/cable, connector and parts. [Reference] When replacing the Finisher Controller PCB, refer to "Adjustments> Adjustment when Replacing the Parts" in the Service Manual.</p>

E535-8001-02**a. Swing Guide HP error (Finisher-W1) b. Error in the Swing Guide Motor (Finisher-AC1)****Detection Description**

- a. The Swing Guide HP Sensor was not turned ON although 5 sec had passed after the Swing Guide Motor operation started.
- b. The swing guide does not come off the Swing Guide HP Sensor when the Swing Guide Motor has been driven for 1 second.

Remedy**a. FIN-W1/SADDLE FIN-W1**

[Related parts]

- Harnesses from the Finisher Controller PCB to the Swing Guide Motor

1. Finisher Controller PCB (UN3/J141) to Relay Connector (6P) (Unit of replacement: CABLE, JOG-T)

2. Relay Connector (6P) to Relay Connector (6P) (Unit of replacement: CABLE, JOG-U)

3. Relay Connector (6P) to Swing Guide Motor (M18/J630) (Unit of replacement: CABLE, YDG-M)

- Harnesses from the Finisher Controller PCB to the Swing Guide HP Sensor

1. Finisher Controller PCB (UN3/J106) to Relay Connector (25P) (Unit of replacement: CABLE, JOG-T)

2. Relay Connector (25P) to Relay Connector (3P) (Unit of replacement: CABLE, JOG-U)

3. Relay Connector (3P) to Swing Guide HP Sensor (PS44/J616) (Unit of replacement: OPERATION ASSEMBLY)

- Swing Guide Motor (M18)

- Swing Guide HP Sensor (PS44)

- Finisher Controller PCB (UN3) (Unit of replacement: FINISHER CONTROLLER PCB ASS'Y)

[Remedy] Check/replace the related harness/cable, connector and parts.

[Reference] After replacement of the Finisher Controller PCB, refer to "Adjustments> Adjustment when Replacing the Parts> Points to Note when Replacing the Finisher Controller PCB" in the Service Manual for the Finisher.

b. STAPLE FIN-AC1/BOOKLET FIN-AC1

[Related parts]

- Harnesses from the Swing Guide HP Sensor (PS119) to the Finisher Controller PCB

- Harnesses from the Swing Guide Motor (M110) to the Finisher Controller PCB

- Swing Guide HP Sensor (PS119)

- Swing Guide Motor (M110)

- Finisher Controller PCB (PCB101)

[Remedy] Check/replace the related harness/cable, connector and parts.

[Reference] When replacing the Finisher Controller PCB, refer to "Adjustment> When Replacing the Parts" in the Service Manual.

E535-8002-02

a. Swing Guide HP error (Finisher-W1) b. Error in the Swing Guide Motor (Finisher-AC1)

Detection Description

- a. The Swing Guide HP Sensor was not turned OFF although 5 sec had passed after the Swing Guide Motor operation started.
- b. The Swing Guide HP Sensor does not detect the swing guide when the Swing Guide Motor has been driven for 1 second.

Remedy

a. FIN-W1/SADDLE FIN-W1

[Related parts]

- Harnesses from the Finisher Controller PCB to the Swing Guide Motor

1. Finisher Controller PCB (UN3/J141) to Relay Connector (6P) (Unit of replacement: CABLE, JOG-T)

2. Relay Connector (6P) to Relay Connector (6P) (Unit of replacement: CABLE, JOG-U)

3. Relay Connector (6P) to Swing Guide Motor (M18/J630) (Unit of replacement: CABLE, YDG-M)

- Harnesses from the Finisher Controller PCB to the Swing Guide HP Sensor

1. Finisher Controller PCB (UN3/J106) to Relay Connector (25P) (Unit of replacement: CABLE, JOG-T)

2. Relay Connector (25P) to Relay Connector (3P) (Unit of replacement: CABLE, JOG-U)

3. Relay Connector (3P) to Swing Guide HP Sensor (PS44/J616) (Unit of replacement: OPERATION ASSEMBLY)

- Swing Guide Motor (M18)

- Swing Guide HP Sensor (PS44)

- Finisher Controller PCB (UN3) (Unit of replacement: FINISHER CONTROLLER PCB ASS'Y)

[Remedy] Check/replace the related harness/cable, connector and parts.

[Reference] After replacement of the Finisher Controller PCB, refer to "Adjustments> Adjustment when Replacing the Parts> Points to Note when Replacing the Finisher Controller PCB" in the Service Manual for the Finisher.

b. STAPLE FIN-AC1/BOOKLET FIN-AC1

[Related parts]

- Harnesses from the Swing Guide HP Sensor (PS119) to the Finisher Controller PCB

- Harnesses from the Swing Guide Motor (M110) to the Finisher Controller PCB

- Swing Guide HP Sensor (PS119)

- Swing Guide Motor (M110)

- Finisher Controller PCB (PCB101)

[Remedy] Check/replace the related harness/cable, connector and parts.

[Reference] When replacing the Finisher Controller PCB, refer to "Adjustment> When Replacing the Parts" in the Service Manual.

E537-8001-02

a. Front Alignment Guide HP error (Finisher-W1) b. Error in the Rear Alignment Motor (Finisher-X1) c. Error in the Rear Alignment Motor (Finisher-AC1)**Detection Description**

- a. The Front Alignment Guide HP Sensor was not turned ON although 5 sec had passed after the Front Alignment Motor started the operation.
- b. The rear alignment plate does not come off the Rear Alignment HP Sensor when the Rear Alignment Motor has been driven for 4 seconds.
- c. The rear alignment plate does not come off the Rear Alignment HP Sensor when the Rear Alignment Motor has been driven for 1 second.

Remedy**a. FIN-W1/SADDLE FIN-W1**

[Related parts]

- Harnesses from the Finisher Controller PCB to the Front Alignment Guide HP Sensor
 1. Finisher Controller PCB (UN3/J139) to Relay Connector (31P) (Unit of replacement: CABLE, JOG-T)
 2. Relay Connector (31P) to Relay Connector (14P) (Unit of replacement: CABLE, JOG-U)
 3. Relay Connector (14P) to Front Alignment Guide HP Sensor (PS11/J605) (Unit of replacement: CABLE, FJOG)
- Harnesses from the Finisher Controller PCB to the Front Alignment Motor
 1. Finisher Controller PCB (UN3/J139) to Relay Connector (31P) (Unit of replacement: CABLE, JOG-T)
 2. Relay Connector (31P) to Relay Connector (14P) (Unit of replacement: CABLE, JOG-U)
 3. Relay Connector (14P) to Front Alignment Motor (M9/J606) (Unit of replacement: CABLE, FJOG)
- Front Alignment Guide HP Sensor (PS11)
- Front Alignment Motor (M9)
- Finisher Controller PCB (UN3) (Unit of replacement: FINISHER CONTROLLER PCB ASS'Y)

[Remedy] Check/replace the related harness/cable, connector and parts.

[Reference] After replacement of the Finisher Controller PCB, refer to "Adjustments> Adjustment when Replacing the Parts> Points to Note when Replacing the Finisher Controller PCB" in the Service Manual for the Finisher.

b. STAPLE FIN-X1/BOOKLET FIN-X1

[Related parts]

- Harnesses from the Rear Alignment HP Sensor (S109) to the Finisher Controller PCB
- Harnesses from the Rear Alignment Motor (M109) to the Finisher Controller PCB
- Rear Alignment HP Sensor (S109)
- Rear Alignment Motor (M109)
- Finisher Controller PCB (PBA101)

[Remedy] Check/replace the related harness/cable, connector and parts.

[Reference] When replacing the Finisher Controller PCB, refer to "Adjustments> Adjustment when Replacing the Parts" in the Service Manual.

c. STAPLE FIN-AC1/BOOKLET FIN-AC1

[Related parts]

- Harnesses from the Rear Alignment HP Sensor (PS116) to the Finisher Controller PCB
- Harnesses from the Rear Alignment Motor (M108) to the Finisher Controller PCB
- Rear Alignment HP Sensor (PS116)
- Rear Alignment Motor (M108)
- Finisher Controller PCB (PCB101)

[Remedy] Check/replace the related harness/cable, connector and parts.

[Reference] When replacing the Finisher Controller PCB, refer to "Adjustment> When Replacing the Parts" in the Service Manual.

E537-8002-02

a. Front Alignment Guide HP error (Finisher-W1) b. Error in the Rear Alignment Motor (Finisher-X1) c. Error in the Rear Alignment Motor (Finisher-AC1)
Detection Description

- a. The Front Alignment Guide HP Sensor was not turned OFF although 5 sec had passed after the Front Alignment Motor operation started.
- b. The Rear Alignment HP Sensor does not detect the rear alignment plate when the Rear Alignment Motor has been driven for 4 seconds.
- c. The Rear Alignment HP Sensor does not detect the rear alignment plate when the Rear Alignment Motor has been driven for 1 second.

Remedy

a. FIN-W1/SADDLE FIN-W1

[Related parts]

- Harnesses from the Finisher Controller PCB to the Front Alignment Guide HP Sensor

1. Finisher Controller PCB (UN3/J139) to Relay Connector (31P) (Unit of replacement: CABLE, JOG-T)

2. Relay Connector (31P) to Relay Connector (14P) (Unit of replacement: CABLE, JOG-U)

3. Relay Connector (14P) to Front Alignment Guide HP Sensor (PS11/J605) (Unit of replacement: CABLE, FJOG)

- Harnesses from the Finisher Controller PCB to the Front Alignment Motor

1. Finisher Controller PCB (UN3/J139) to Relay Connector (31P) (Unit of replacement: CABLE, JOG-T)

2. Relay Connector (31P) to Relay Connector (14P) (Unit of replacement: CABLE, JOG-U)

3. Relay Connector (14P) to Front Alignment Motor (M9/J606) (Unit of replacement: CABLE, FJOG)

- Front Alignment Guide HP Sensor (PS11)

- Front Alignment Motor (M9)

- Finisher Controller PCB (UN3) (Unit of replacement: FINISHER CONTROLLER PCB ASS'Y)

[Remedy] Check/replace the related harness/cable, connector and parts.

[Reference] After replacement of the Finisher Controller PCB, refer to "Adjustments> Adjustment when Replacing the Parts> Points to Note when Replacing the Finisher Controller PCB" in the Service Manual for the Finisher.

b. STAPLE FIN-X1/BOOKLET FIN-X1

[Related parts]

- Harnesses from the Rear Alignment HP Sensor (S109) to the Finisher Controller PCB

- Harnesses from the Rear Alignment Motor (M109) to the Finisher Controller PCB

- Rear Alignment HP Sensor (S109)

- Rear Alignment Motor (M109)

- Finisher Controller PCB (PBA101)

[Remedy] Check/replace the related harness/cable, connector and parts.

[Reference] When replacing the Finisher Controller PCB, refer to "Adjustments> Adjustment when Replacing the Parts" in the Service Manual.

c. STAPLE FIN-AC1/BOOKLET FIN-AC1

[Related parts]

- Harnesses from the Rear Alignment HP Sensor (PS116) to the Finisher Controller PCB

- Harnesses from the Rear Alignment Motor (M108) to the Finisher Controller PCB

- Rear Alignment HP Sensor (PS116)

- Rear Alignment Motor (M108)

- Finisher Controller PCB (PCB101)

[Remedy] Check/replace the related harness/cable, connector and parts.

[Reference] When replacing the Finisher Controller PCB, refer to "Adjustment> When Replacing the Parts" in the Service Manual.

E539-8001-02	Delivery angle change HP error
Detection Description	FIN-W1/SADDLE FIN-W1 The Delivery Angle HP Sensor was not turned ON although 5 sec had passed after the Delivery Angle Adjustment Motor started the operation.
Remedy	FIN-W1/SADDLE FIN-W1 [Related parts] - Harnesses from the Finisher Controller PCB to the Delivery Angle HP Sensor 1. Finisher Controller PCB (UN3/J106) to Relay Connector (25P) (Unit of replacement: CABLE, JOG-T) 2. Relay Connector (25P) to Delivery Angle HP Sensor (PS45/J650) (Unit of replacement: CABLE, JOG-U) - Harnesses from the Finisher Controller PCB to the Delivery Angle Adjustment Motor 1. Finisher Controller PCB (UN3/J140) to Relay Connector (19P) (Unit of replacement: CABLE, JOG-T) 2. Relay Connector (19P) to Delivery Angle Adjustment Motor (M28/J651) (Unit of replacement: CABLE, JOG-U) - Delivery Angle HP Sensor (PS45) - Delivery Angle Adjustment Motor (M28) - Finisher Controller PCB (UN3) (Unit of replacement: FINISHER CONTROLLER PCB ASS'Y) [Remedy] Check/replace the related harness/cable, connector and parts. [Reference] After replacement of the Finisher Controller PCB, refer to "Adjustments> Adjustment when Replacing the Parts> Points to Note when Replacing the Finisher Controller PCB" in the Service Manual for the Finisher.
E539-8002-02	Delivery angle change HP error
Detection Description	FIN-W1/SADDLE FIN-W1 The Delivery Angle HP Sensor was not turned OFF although 5 sec had passed after the Delivery Angle Adjustment Motor started the operation.
Remedy	FIN-W1/SADDLE FIN-W1 [Related parts] - Harnesses from the Finisher Controller PCB to the Delivery Angle HP Sensor 1. Finisher Controller PCB (UN3/J106) to Relay Connector (25P) (Unit of replacement: CABLE, JOG-T) 2. Relay Connector (25P) to Delivery Angle HP Sensor (PS45/J650) (Unit of replacement: CABLE, JOG-U) - Harnesses from the Finisher Controller PCB to the Delivery Angle Adjustment Motor 1. Finisher Controller PCB (UN3/J140) to Relay Connector (19P) (Unit of replacement: CABLE, JOG-T) 2. Relay Connector (19P) to Delivery Angle Adjustment Motor (M28/J651) (Unit of replacement: CABLE, JOG-U) - Delivery Angle HP Sensor (PS45) - Delivery Angle Adjustment Motor (M28) - Finisher Controller PCB (UN3) (Unit of replacement: FINISHER CONTROLLER PCB ASS'Y) [Remedy] Check/replace the related harness/cable, connector and parts. [Reference] After replacement of the Finisher Controller PCB, refer to "Adjustments> Adjustment when Replacing the Parts> Points to Note when Replacing the Finisher Controller PCB" in the Service Manual for the Finisher.

E540-8001-02

a. Tray A (Upper Tray) lifting error (Finisher-W1) b. Tray 1 time out error (Finisher-X1) c. Stack tray time out error (Finisher-AC1)

Detection Description

- a. The Tray A Lifting Motor Rotation Sensor was not turned OFF although 800 sec had passed after the Tray A Lifting Motor started the operation.
- b. The tray 1 does not return to home position when the Tray 1 Shift Motor has been driven for 20 seconds.
The tray 1 does not come off the Tray 1 Area Sensor at the same area when the Tray 1 Shift Motor has been driven for 4 seconds.
- c. The operation of the stack tray don't finish when the Stack Tray Shift Motor has been driven for 28 seconds.
The stack tray does not come off the same area when the Stack Tray Shift Motor has been driven for 15 seconds.

Remedy

a. FIN-W1/SADDLE FIN-W1

[Related parts]

- Harnesses from the Finisher Controller PCB to the Tray A Lifting Motor

1. Finisher Controller PCB (UN3/J109A) to Tray A Motor Driver PCB (UN10/J292A) (Unit of replacement: CABLE ASSEMBLY, A)

2. Tray A Motor Driver PCB (UN10/J291A) to Tray A Lifting Motor (M22) (Unit of replacement: STEPPING MOTOR UNIT)

- Tray A Lifting Motor Rotation Sensor (PS34)

- Tray A Lifting Motor (M22)

- Tray A Motor Driver PCB (UN10) (Unit of replacement: MOTOR DRIVER PCB ASSEMBLY)

- Finisher Controller PCB (UN3) (Unit of replacement: FINISHER CONTROLLER PCB ASS'Y)

[Remedy] Check/replace the related harness/cable, connector and parts.

[Reference] After replacement of the Finisher Controller PCB, refer to "Adjustments> Adjustment when Replacing the Parts> Points to Note when Replacing the Finisher Controller PCB" in the Service Manual for the Finisher.

b. STAPLE FIN-X1/BOOKLET FIN-X1

[Related parts]

- Harnesses from the Tray 1 Area Sensors (S122/S123/S124) to the Finisher Controller PCB

- Harnesses from the Tray 1 Shift Motor (M105) to the Finisher Controller PCB

- Tray 1 Area Sensors (S122/S123/S124)

- Tray 1 Shift Motor (M105)

- Finisher Controller PCB (PBA101)

[Remedy] Check/replace the related harness/cable, connector and parts.

[Reference] When replacing the Finisher Controller PCB, refer to "Adjustments> Adjustment when Replacing the Parts" in the Service Manual.

c. STAPLE FIN-AC1/BOOKLET FIN-AC1

[Related parts]

- Harnesses from the Stack Tray HP Sensor (PS106) to the Finisher Controller PCB

- Harnesses from the Stack Tray Full Sensor 1/2/3 (PS107/PS108/PS109) to the Finisher Controller PCB

- Harnesses from the Stack Tray Upper Limit Sensor (PS110) to the Finisher Controller PCB

- Harnesses from the Stack Tray Shift Motor (M105) to the Finisher Controller PCB

- Stack Tray HP Sensor (PS106)

- Stack Tray Full Sensor 1/2/3 (PS107/PS108/PS109)

- Stack Tray Upper Limit Sensor (PS110)

- Stack Tray Shift Motor (M105)

- Finisher Controller PCB (PCB101)

[Remedy] Check/replace the related harness/cable, connector and parts.

[Reference] When replacing the Finisher Controller PCB, refer to "Adjustment> When Replacing the Parts" in the Service Manual.

<p>E540-8002-02</p> <p>Detection Description</p> <p>Remedy</p>	<p>a. Tray A (Upper Tray) area error (Finisher-W1) b. Tray 1 area error (Finisher-X1) c. Stack tray area error (Finisher-AC1)</p> <p>a. Tray A (Upper Tray) was detected as being at a lower position than Tray B (Lower Tray). The Tray A Position Sensor detected a non-contiguous area.</p> <p>b. The tray 1 detects the discontinuous area with the Tray 1 Area Sensors.</p> <p>c. The stack tray detects the discontinuous area during the operation.</p> <hr/> <p>a. FIN-W1/SADDLE FIN-W1 [Related parts]</p> <ul style="list-style-type: none"> - Harness between the Finisher Controller PCB (UN3/J109B) and the Tray A Third Position Sensor (PS49/J2534) (Unit of replacement: CABLE ASSEMBLY, A) - Harness between the Finisher Controller PCB (UN3/J109B) and the Tray A Fourth Position Sensor (PS50/J2533) (Unit of replacement: CABLE ASSEMBLY, A) - Tray A Third Position Sensor (PS49) - Tray A Fourth Position Sensor (PS50) - Finisher Controller PCB (UN3) (Unit of replacement: FINISHER CONTROLLER PCB ASS'Y) <p>[Remedy] Check/replace the related harness/cable, connector and parts. [Reference] After replacement of the Finisher Controller PCB, refer to "Adjustments> Adjustment when Replacing the Parts> Points to Note when Replacing the Finisher Controller PCB" in the Service Manual for the Finisher.</p> <p>b. STAPLE FIN-X1/BOOKLET FIN-X1 [Related parts]</p> <ul style="list-style-type: none"> - Harnesses from the Tray 1 Area Sensors (S122/S123/S124) to the Finisher Controller PCB - Harnesses from the Tray 1 Shift Motor (M105) to the Finisher Controller PCB - Tray 1 Area Sensors (S122/S123/S124) - Tray 1 Shift Motor (M105) - Finisher Controller PCB (PBA101) <p>[Remedy] Check/replace the related harness/cable, connector and parts. [Reference] When replacing the Finisher Controller PCB, refer to "Adjustments> Adjustment when Replacing the Parts" in the Service Manual.</p> <p>c. STAPLE FIN-AC1/BOOKLET FIN-AC1 [Related parts]</p> <ul style="list-style-type: none"> - Harnesses from the Stack Tray HP Sensor (PS106) to the Finisher Controller PCB - Harnesses from the Stack Tray Full Sensor 1/2/3 (PS107/PS108/PS109) to the Finisher Controller PCB - Harnesses from the Stack Tray Upper Limit Sensor (PS110) to the Finisher Controller PCB - Harnesses from the Stack Tray Shift Motor (M105) to the Finisher Controller PCB - Stack Tray HP Sensor (PS106) - Stack Tray Full Sensor 1/2/3 (PS107/PS108/PS109) - Stack Tray Upper Limit Sensor (PS110) - Stack Tray Shift Motor (M105) - Finisher Controller PCB (PCB101) <p>[Remedy] Check/replace the related harness/cable, connector and parts. [Reference] When replacing the Finisher Controller PCB, refer to "Adjustment> When Replacing the Parts" in the Service Manual.</p>
<p>E540-8003-02</p> <p>Detection Description</p> <p>Remedy</p>	<p>Error in the Tray 1 Lower Safety Switch (Finisher-X1)</p> <p>The Tray 1 Lower Safety Switch is turned ON while the tray 1 operates.</p> <hr/> <p>STAPLE FIN-X1/BOOKLET FIN-X1 [Related parts]</p> <ul style="list-style-type: none"> - Harnesses from the Tray 1 Lower Safety Switch (SW110) to the Finisher Controller PCB - Harnesses from the Tray 1 Shift Motor (M105) to the Finisher Controller PCB - Tray 1 Lower Safety Switch (SW110) - Tray 1 Shift Motor (M105) - Finisher Controller PCB (PBA101) <p>[Remedy] Check/replace the related harness/cable, connector and parts. [Reference] When replacing the Finisher Controller PCB, refer to "Adjustments> Adjustment when Replacing the Parts" in the Service Manual.</p>

E540-8004-02	Stack tray paper surface detection error (Finisher-AC1)
Detection Description	The Stack Tray Paper Surface Sensor does not turn off when the stack tray has been lowered for 10 seconds.
Remedy	<p>STAPLE FIN-AC1/BOOKLET FIN-AC1</p> <p>[Related parts]</p> <ul style="list-style-type: none"> - Harnesses from the Stack Tray Paper Surface Sensor (light-emitting) (PBA101) to the Finisher Controller PCB - Harnesses from the Stack Tray Paper Surface Sensor (light-receiving) (PBA102/PBA103) to the Finisher Controller PCB - Harnesses from the Stack Tray Shift Motor (M105) to the Finisher Controller PCB - Stack Tray Paper Surface Sensor (light-emitting) (PBA101) - Stack Tray Paper Surface Sensor (light-receiving) (PBA102/PBA103) - Stack Tray Shift Motor (M105) - Finisher Controller PCB (PCB101) <p>[Remedy] Check/replace the related harness/cable, connector and parts.</p> <p>[Reference] When replacing the Finisher Controller PCB, refer to "Adjustment> When Replacing the Parts" in the Service Manual.</p>
E540-8013-02	Error in the Swing Guide Safety Switch (Finisher-X1)
Detection Description	The Swing Guide Safety Switch (front/rear) is turned ON while the tray 1 operates.
Remedy	<p>[Related parts]</p> <ul style="list-style-type: none"> - Harnesses from the Swing Guide Safety Switch (front/rear) (SW102/SW104) to the Finisher Controller PCB - Harnesses from the Staple Position Switch (SW103) to the Finisher Controller PCB - Harnesses from the Swing Guide Solenoid (SL101) to the Finisher Controller PCB - Harnesses from the Tray 1 Shift Motor (M105) to the Finisher Controller PCB - Swing Guide Safety Switch (front/rear) (SW102/SW104) - Staple Position Switch (SW103) - Swing Guide Solenoid (SL101) - Tray 1 Shift Motor (M105) - Finisher Controller PCB (PBA101) <p>[Remedy] Check/replace the related harness/cable, connector and parts.</p> <p>[Reference] When replacing the Finisher Controller PCB, refer to "Adjustments> Adjustment when Replacing the Parts" in the Service Manual.</p>
E540-8081-02	Time out error by the tray 1 foreign matter detection (Finisher-X1)
Detection Description	<p>The tray 1 does not return to home position when the Tray 1 Shift Motor has been driven for 20 seconds at the down start of the tray 1.</p> <p>The tray 1 does not come off the Tray 1 Area Sensor at the same area when the Tray 1 Shift Motor has been driven for 4 seconds at the down start of tray 1.</p>
Remedy	<p>[Related parts]</p> <ul style="list-style-type: none"> - Harnesses from the Tray 1 Area Sensors (S122/S123/S124) to the Finisher Controller PCB - Harnesses from the Tray 1 Shift Motor (M105) to the Finisher Controller PCB - Tray 1 Area Sensors (S122/S123/S124) - Tray 1 Shift Motor (M105) - Finisher Controller PCB (PBA101) <p>[Remedy]</p> <ul style="list-style-type: none"> - If there is the foreign matter under the tray 1, remove it. - Check/replace the related harness/cable, connector and parts. <p>[Reference] When replacing the Finisher Controller PCB, refer to "Adjustments> Adjustment when Replacing the Parts" in the Service Manual.</p>

E540-8082-02	Area error by tray 1 foreign matter detection (Finisher-X1)
Detection Description	The tray 1 detects the discontinuous area with the Tray 1 Area Sensors in the down movement of the tray 1.
Remedy	<p>[Related parts]</p> <ul style="list-style-type: none"> - Harnesses from the Tray 1 Area Sensors (S122/S123/S124) to the Finisher Controller PCB - Harnesses from the Tray 1 Shift Motor (M105) to the Finisher Controller PCB - Tray 1 Area Sensors (S122/S123/S124) - Tray 1 Shift Motor (M105) - Finisher Controller PCB (PBA101) <p>[Remedy]</p> <ul style="list-style-type: none"> - If there is the foreign matter under the tray 1, remove it. - Check/replace the related harness/cable, connector and parts. <p>[Reference] When replacing the Finisher Controller PCB, refer to "Adjustments> Adjustment when Replacing the Parts" in the Service Manual.</p>
E540-80FF-02	Tray A (Upper Tray) shift timeout error
Detection Description	FIN-W1/SADDLE FIN-W1 The lifting operation did not complete although 25 sec had passed after the Tray A Lifting Motor started the operation.
Remedy	<p>FIN-W1/SADDLE FIN-W1</p> <p>[Related parts]</p> <ul style="list-style-type: none"> - Harnesses from the Finisher Controller PCB to the Tray A Lifting Motor <ol style="list-style-type: none"> 1. Finisher Controller PCB (UN3/J109A) to Tray A Motor Driver PCB (UN10/J292A) (Unit of replacement: CABLE ASSEMBLY, A) 2. Tray A Motor Driver PCB (UN10/J291A) to Tray A Lifting Motor (M22) (Unit of replacement: STEPPING MOTOR UNIT) <ul style="list-style-type: none"> - Tray A Lifting Motor Rotation Sensor (PS34) (Unit of replacement: IC,PHOTO-INTERRUPTER,LG248NL1A) - Tray A Lifting Motor (M22) (Unit of replacement: STEPPING MOTOR UNIT) - Tray A Motor Driver PCB (UN10) (Unit of replacement: MOTOR DRIVER PCB ASSEMBLY) - Finisher Controller PCB (UN3) (Unit of replacement: FINISHER CONTROLLER PCB ASS'Y) <p>[Remedy] Check/replace the related harness/cable, connector and parts.</p> <p>[Reference] After replacement of the Finisher Controller PCB, refer to "Adjustments> Adjustment when Replacing the Parts> Points to Note when Replacing the Finisher Controller PCB" in the Service Manual for the Finisher.</p>

E542-8001-02	a. Tray B (Lower Tray) lifting error b. Tray 2 time out error (Finisher-X1)
Detection Description	<p>a. FIN-W1/SADDLE FIN-W1 The Tray B Lifting Motor Rotation Sensor was not turned OFF although 800 sec had passed after the Tray B Lifting Motor started the operation.</p> <p>b. The tray 2 does not return to home position when the Tray 2 Shift Motor has been driven for 20 seconds. The tray 2 does not come off the Tray 2 Area Sensor at the same area when the Tray 2 Shift Motor has been driven for 4 seconds.</p>
Remedy	<p>a. FIN-W1/SADDLE FIN-W1 [Related parts] - Harnesses from the Finisher Controller PCB to the Tray B Lifting Motor 1. Finisher Controller PCB (UN3/J108A) to Tray B Motor Driver PCB (UN11/J292B) (Unit of replacement: CABLE ASSEMBLY, B) 2. Tray B Motor Driver PCB (UN11/J291B) to Tray B Lifting Motor (M23) (Unit of replacement: STEPPING MOTOR UNIT) - Tray B Lifting Motor Rotation Sensor (PS35) - Tray B Lifting Motor (M23) - Finisher Controller PCB (UN3) (Unit of replacement: FINISHER CONTROLLER PCB ASS'Y) [Remedy] Check/replace the related harness/cable, connector and parts. [Reference] After replacement of the Finisher Controller PCB, refer to "Adjustments> Adjustment when Replacing the Parts> Points to Note when Replacing the Finisher Controller PCB" in the Service Manual for the Finisher.</p> <p>b. STAPLE FIN-X1/BOOKLET FIN-X1 [Related parts] - Harnesses from the Tray 2 Area Sensors (S125/S126/S127) to the Finisher Controller PCB - Harnesses from the Tray 2 Shift Motor (M217) to the Finisher Controller PCB - Tray 2 Area Sensors (S125/S126/S127) - Tray 2 Shift Motor (M217) - Finisher Controller PCB (PBA101) [Remedy] Check/replace the related harness/cable, connector and parts. [Reference] When replacing the Finisher Controller PCB, refer to "Adjustments> Adjustment when Replacing the Parts" in the Service Manual.</p>

E542-8002-02	a. Tray B (Lower Tray) area error b. Tray 2 area error (Finisher-X1)
Detection Description	a. FIN-W1/SADDLE FIN-W1 - Tray A (Upper Tray) was detected as being at a lower position than Tray B (Lower Tray). - The Tray B Position Sensor detected a non-contiguous area. b. The tray 2 detects the discontinuous area with the Tray 2 Area Sensors.
Remedy	a. FIN-W1/SADDLE FIN-W1 [Related parts] - Harness between the Finisher Controller PCB (UN3/J108B) and the Tray B First Position Sensor (PS51/J2543) (Unit of replacement: CABLE ASSEMBLY, B) - Harness between the Finisher Controller PCB (UN3/J108B) and the Tray B Third Position Sensor (PS52/J2542) (Unit of replacement: CABLE ASSEMBLY, B) - Harness between the Finisher Controller PCB (UN3/J108B) and the Tray B Fourth Position Sensor (PS53/J2541) (Unit of replacement: CABLE ASSEMBLY, B) - Tray B First Position Sensor (PS51) - Tray B Third Position Sensor (PS52) - Tray B Fourth Position Sensor (PS53) - Finisher Controller PCB (UN3) (Unit of replacement: FINISHER CONTROLLER PCB ASS'Y) [Remedy] Check/replace the related harness/cable, connector and parts. [Reference] After replacement of the Finisher Controller PCB, refer to "Adjustments> Adjustment when Replacing the Parts> Points to Note when Replacing the Finisher Controller PCB" in the Service Manual for the Finisher. b. STAPLE FIN-X1/BOOKLET FIN-X1 [Related parts] - Harnesses from the Tray 2 Area Sensors (S125/S126/S127) to the Finisher Controller PCB - Harnesses from the Tray 2 Paper Sensor (S105) to the Finisher Controller PCB - Harnesses from the Tray 2 Shift Motor (M217) to the Finisher Controller PCB - Tray 2 Area Sensors (S125/S126/S127) - Tray 2 Paper Sensor (S105) - Tray 2 Shift Motor (M217) - Finisher Controller PCB (PBA101) [Remedy] Check/replace the related harness/cable, connector and parts. [Reference] When replacing the Finisher Controller PCB, refer to "Adjustments> Adjustment when Replacing the Parts" in the Service Manual.
E542-8003-02	Error in the Tray 1 Lower Safety Switch (Finisher-X1)
Detection Description	The Tray 1 Lower Safety Switch is turned ON while the tray 2 operates.
Remedy	[Related parts] - Harnesses from the Tray 1 Lower Safety Switch (SW110) or the Tray 2 Shift Motor (M217) to the Finisher Controller PCB - Harnesses from the Tray 2 Shift Motor (M217) to the Finisher Controller PCB - Tray 1 Lower Safety Switch (SW110) - Tray 2 Shift Motor (M217) - Finisher Controller PCB (PBA101) [Remedy] Check/replace the related harness/cable, connector and parts. [Reference] When replacing the Finisher Controller PCB, refer to "Adjustments> Adjustment when Replacing the Parts" in the Service Manual.

E542-8013-02	Error in the Swing Guide Safety Switch (Finisher-X1)
Detection Description	The Swing Guide Safety Switch (front/rear) is turned ON while the tray 2 operates.
Remedy	<p>[Related parts]</p> <ul style="list-style-type: none"> - Harnesses from the Swing Guide Safety Switch (front/rear) (SW102/SW104) to the Finisher Controller PCB - Harnesses from the Staple Position Switch (SW103) to the Finisher Controller PCB - Harnesses from the Swing Guide Solenoid (SL101) to the Finisher Controller PCB - Harnesses from the Tray 2 Shift Motor (M217) to the Finisher Controller PCB - Swing Guide Safety Switch (front/rear) (SW102/SW104) - Staple Position Switch (SW103) - Swing Guide Solenoid (SL101) - Tray 2 Shift Motor (M217) - Finisher Controller PCB (PBA101) <p>[Remedy] Check/replace the related harness/cable, connector and parts. [Reference] When replacing the Finisher Controller PCB, refer to "Adjustments> Adjustment when Replacing the Parts" in the Service Manual.</p>
E542-8081-02	Time out error by the tray 2 foreign matter detection (Finisher-X1)
Detection Description	<p>The tray2 does not return to home position when the tray2 Shift Motor has been driven for 20 seconds at the down start of the tray2.</p> <p>The tray2 does not come off the tray2 Area Sensor at the same area when the tray2 Shift Motor has been driven for 4 seconds at the down start of tray2.</p>
Remedy	<p>[Related parts]</p> <ul style="list-style-type: none"> - Harnesses from the Tray 2 Area Sensors (S125/S126/S127) to the Finisher Controller PCB - Harnesses from the Tray 2 Shift Motor (M217) to the Finisher Controller PCB - Tray 2 Area Sensors (S125/S126/S127) - Tray 2 Shift Motor (M217) - Finisher Controller PCB (PBA101) <p>[Remedy] - If there is the foreign matter under the tray 2, remove it. - Check/replace the related harness/cable, connector and parts. [Reference] When replacing the Finisher Controller PCB, refer to "Adjustments> Adjustment when Replacing the Parts" in the Service Manual.</p>
E542-8082-02	Area error by tray 2 foreign matter detection (Finisher-X1)
Detection Description	The tray2 detects the discontinuous area with the tray2 Area Sensors in the down movement of the tray2.
Remedy	<p>[Related parts]</p> <ul style="list-style-type: none"> - Harnesses from the Tray 2 Area Sensors (S125/S126/S127) to the Finisher Controller PCB - Harnesses from the Tray 2 Shift Motor (M217) to the Finisher Controller PCB - Tray 2 Area Sensors (S125/S126/S127) - Tray 2 Shift Motor (M217) - Finisher Controller PCB (PBA101) <p>[Remedy] - If there is the foreign matter under the tray 2, remove it. - Check/replace the related harness/cable, connector and parts. [Reference] When replacing the Finisher Controller PCB, refer to "Adjustments> Adjustment when Replacing the Parts" in the Service Manual.</p>

E542-80FF-02	Tray B (Lower Tray) shift timeout error
Detection Description	FIN-W1/SADDLE FIN-W1 The lifting operation did not complete although 25 sec had passed after the Lower Tray Lifting Motor started the operation.
Remedy	FIN-W1/SADDLE FIN-W1 [Related parts] - Harnesses from the Finisher Controller PCB to the Tray B Lifting Motor 1. Finisher Controller PCB (UN3/J108A) to Tray B Motor Driver PCB (UN11/J292B) (Unit of replacement: CABLE ASSEMBLY, B) 2. Tray B Motor Driver PCB (UN11/J291B) to Tray B Lifting Motor (M23) (Unit of replacement: STEPPING MOTOR UNIT) - Tray B Lifting Motor Rotation Sensor (PS35) (Unit of replacement: IC,PHOTO-INTERRUPTER,LG248NL1A) - Tray B Lifting Motor (M23) (Unit of replacement: STEPPING MOTOR UNIT) - Finisher Controller PCB (UN3) (Unit of replacement: FINISHER CONTROLLER PCB ASS'Y) [Remedy] Check/replace the related harness/cable, connector and parts. [Reference] After replacement of the Finisher Controller PCB, refer to "Adjustments> Adjustment when Replacing the Parts> Points to Note when Replacing the Finisher Controller PCB" in the Service Manual for the Finisher.
E544-0001-02	a. Upper Neat Stack Unit Return Roller HP error b. Neat Paddle Lift HP error
Detection Description	a. FIN-W1/SADDLE FIN-W1 The Upper Neat Stack Unit Return Roller HP Sensor was not turned ON although 1 sec had passed after the Upper Neat Stack Unit Return Roller Lifting Motor started the operation. b. Finisher Jogger Kit The Paddle did not move from the home position although the Neat Paddle Lift Motor was driven for 72 msec.
Remedy	a. FIN-W1/SADDLE FIN-W1 [Related parts] - Harnesses from the Neat Driver PCB to the Upper Neat Stack Unit Return Roller Lifting Motor 1. Neat Driver PCB (UN201/J505) to Relay Connector (17P) (Unit of replacement: CABLE, UPPER NEAT) 2. Relay Connector (17P) to Upper Neat Stack Unit Return Roller Lifting Motor (M209) (Unit of replacement: CABLE, UPPER NEAT UNIT) - Harnesses from the Neat Driver PCB to the Upper Neat Stack Unit Return Roller HP Sensor 1. Neat Driver PCB (UN201/J503) to Relay Connector (13P) (Unit of replacement: CABLE, UPPER NEAT) 2. Relay Connector (13P) to Upper Neat Stack Unit Return Roller HP Sensor (PS209) (Unit of replacement: CABLE, UPPER NEAT UNIT) - Upper Neat Stack Unit Return Roller Lifting Motor (M209) - Upper Neat Stack Unit Return Roller HP Sensor (PS209) [Remedy] Check/replace the related harness/cable, connector and parts. b. Finisher Jogger Kit [Related parts] - Harnesses from the Neat Controller PCB to the Neat Paddle Lift HP Sensor - Harnesses from the Neat Controller PCB to the Neat Paddle Lift Motor - Neat Paddle Lift HP Sensor - Neat Paddle Lift Motor - Neat Controller PCB [Remedy] Check/replace the related harness/cable, connector and parts. [Reference] When replacing the Neat Controller PCB, refer to "Adjustments> Adjustment when Replacing the Parts" in the Service Manual for the Finisher Jogger Kit.

E544-0002-02		a. Upper Neat Stack Unit Return Roller HP error b. Neat Paddle Lift HP error
Detection Description	a. FIN-W1/SADDLE FIN-W1 The Upper Neat Stack Unit Return Roller HP Sensor was not turned OFF although 1 sec had passed after the Upper Neat Stack Unit Return Roller Lifting Motor started the operation.	
	b. Finisher Jogger Kit The Paddle did not return to the home position although the Neat Paddle Lift Motor was driven for 337 msec.	
Remedy	a. FIN-W1/SADDLE FIN-W1 [Related parts] - Harnesses from the Neat Driver PCB to the Upper Neat Stack Unit Return Roller Lifting Motor 1. Neat Driver PCB (UN201/J505) to Relay Connector (17P) (Unit of replacement: CABLE, UPPER NEAT) 2. Relay Connector (17P) to Upper Neat Stack Unit Return Roller Lifting Motor (M209) (Unit of replacement: CABLE, UPPER NEAT UNIT) - Harnesses from the Neat Driver PCB to the Upper Neat Stack Unit Return Roller HP Sensor 1. Neat Driver PCB (UN201/J503) to Relay Connector (13P) (Unit of replacement: CABLE, UPPER NEAT) 2. Relay Connector (13P) to Upper Neat Stack Unit Return Roller HP Sensor (PS209) (Unit of replacement: CABLE, UPPER NEAT UNIT) - Upper Neat Stack Unit Return Roller Lifting Motor (M209) - Upper Neat Stack Unit Return Roller HP Sensor (PS209) [Remedy] Check/replace the related harness/cable, connector and parts.	
	b. Finisher Jogger Kit [Related parts] - Harnesses from the Neat Controller PCB to the Neat Paddle Lift HP Sensor - Harnesses from the Neat Controller PCB to the Neat Paddle Lift Motor - Neat Paddle Lift HP Sensor - Neat Paddle Lift Motor - Neat Controller PCB [Remedy] Check/replace the related harness/cable, connector and parts. [Reference] When replacing the Neat Controller PCB, refer to "Adjustments> Adjustment when Replacing the Parts" in the Service Manual for the Finisher Jogger Kit.	
E545-0001-02		Neat Front Alignment Plate HP error
Detection Description	The Front Alignment Plate did not move from the home position although the Neat Front Alignment Motor was driven for 102 msec.	
Remedy	Finisher Jogger Kit [Related parts] - Harnesses from the Neat Controller PCB to the Neat Front Alignment HP Sensor - Harnesses from the Neat Controller PCB to the Neat Front Alignment Motor - Neat Front Alignment HP Sensor - Neat Front Alignment Motor - Neat Controller PCB [Remedy] Check/replace the related harness/cable, connector and parts. [Reference] When replacing the Neat Controller PCB, refer to "Adjustments> Adjustment when Replacing the Parts" in the Service Manual for the Finisher Jogger Kit.	
E545-0002-02		Neat Front Alignment Plate HP error
Detection Description	The Front Alignment Plate did not return to the home position although the Neat Front Alignment Motor was driven for 1433 msec.	
Remedy	Finisher Jogger Kit [Related parts] - Harnesses from the Neat Controller PCB to the Neat Front Alignment HP Sensor - Harnesses from the Neat Controller PCB to the Neat Front Alignment Motor - Neat Front Alignment HP Sensor - Neat Front Alignment Motor - Neat Controller PCB [Remedy] Check/replace the related harness/cable, connector and parts. [Reference] When replacing the Neat Controller PCB, refer to "Adjustments> Adjustment when Replacing the Parts" in the Service Manual for the Finisher Jogger Kit.	

E546-0001-02	Neat Rear Alignment Plate HP error
Detection Description	The Rear Alignment Plate did not move from the home position although the Neat Rear Alignment Motor was driven for 95 msec.
Remedy	<p>Finisher Jogger Kit [Related parts]</p> <ul style="list-style-type: none"> - Harnesses from the Neat Controller PCB to the Neat Rear Alignment HP Sensor - Harnesses from the Neat Controller PCB to the Neat Rear Alignment Motor - Neat Rear Alignment HP Sensor - Neat Rear Alignment Motor - Neat Controller PCB <p>[Remedy] Check/replace the related harness/cable, connector and parts. [Reference] When replacing the Neat Controller PCB, refer to "Adjustments> Adjustment when Replacing the Parts" in the Service Manual for the Finisher Jogger Kit.</p>
E546-0002-02	Neat Rear Alignment Plate HP error
Detection Description	The Rear Alignment Plate did not return to the home position although the Neat Rear Alignment Motor was driven for 1680 msec.
Remedy	<p>Finisher Jogger Kit [Related parts]</p> <ul style="list-style-type: none"> - Harnesses from the Neat Controller PCB to the Neat Rear Alignment HP Sensor - Harnesses from the Neat Controller PCB to the Neat Rear Alignment Motor - Neat Rear Alignment HP Sensor - Neat Rear Alignment Motor - Neat Controller PCB <p>[Remedy] Check/replace the related harness/cable, connector and parts. [Reference] When replacing the Neat Controller PCB, refer to "Adjustments> Adjustment when Replacing the Parts" in the Service Manual for the Finisher Jogger Kit.</p>
E547-0001-02	Neat Alignment Plate Lift HP error
Detection Description	The Alignment Plate did not move from the home position although the Neat Alignment Plate Lift Motor was driven for 72 msec.
Remedy	<p>Finisher Jogger Kit [Related parts]</p> <ul style="list-style-type: none"> - Harnesses from the Neat Controller PCB to the Neat Alignment Plate Lift HP Sensor - Harnesses from the Neat Controller PCB to the Neat Alignment Plate Lift Motor - Neat Alignment Plate Lift HP Sensor - Neat Alignment Plate Lift Motor - Neat Controller PCB <p>[Remedy] Check/replace the related harness/cable, connector and parts. [Reference] When replacing the Neat Controller PCB, refer to "Adjustments> Adjustment when Replacing the Parts" in the Service Manual for the Finisher Jogger Kit.</p>
E547-0002-02	Neat Alignment Plate Lift HP error
Detection Description	The Alignment Plate did not return to the home position although the Neat Alignment Plate Lift Motor was driven for 346 msec.
Remedy	<p>Finisher Jogger Kit [Related parts]</p> <ul style="list-style-type: none"> - Harnesses from the Neat Controller PCB to the Neat Rear Alignment HP Sensor - Harnesses from the Neat Controller PCB to the Neat Rear Alignment Motor - Neat Rear Alignment HP Sensor - Neat Rear Alignment Motor - Neat Controller PCB <p>[Remedy] Check/replace the related harness/cable, connector and parts. [Reference] When replacing the Neat Controller PCB, refer to "Adjustments> Adjustment when Replacing the Parts" in the Service Manual for the Finisher Jogger Kit.</p>

E548-0001-02	Lower Neat Stack Unit Return Roller HP error
Detection Description	FIN-W1/SADDLE FIN-W1 The Lower Neat Stack Unit Return Roller HP Sensor was not turned ON although 1 sec had passed after the Lower Neat Stack Unit Return Roller Lifting Motor started the operation.
Remedy	FIN-W1/SADDLE FIN-W1 [Related parts] - Harnesses from the Neat Driver PCB to the Lower Neat Stack Unit Return Roller Lifting Motor 1. Neat Driver PCB (UN201/J506) to Relay Connector (29P) (Unit of replacement: CABLE, JOG-T) 2. Relay Connector (29P) to Relay Connector (5P) (Unit of replacement: CABLE, JOG-U) 3. Relay Connector (5P) to Lower Neat Stack Unit Return Roller Lifting Motor (M208/J2511) (Unit of replacement: CABLE, LWR-NEAT-RTN-RLR-UP-M) - Harnesses from the Neat Driver PCB to the Lower Neat Stack Unit Return Roller HP Sensor 1. Neat Driver PCB (UN201/J504) to Relay Connector (29P) (Unit of replacement: CABLE, JOG-T) 2. Relay Connector (29P) to Relay Connector (3P) (Unit of replacement: CABLE, JOG-U) 3. Relay Connector (3P) to Relay Connector (3P) (Unit of replacement: CABLE, JOG-U) 4. Relay Connector (3P) to Lower Neat Stack Unit Return Roller HP Sensor (PS208/J2517) (Unit of replacement: CABLE, YDG) - Lower Neat Stack Unit Return Roller Lifting Motor (M208) - Lower Neat Stack Unit Return Roller HP Sensor (PS208) [Remedy] Check/replace the related harness/cable, connector and parts.
E548-0002-02	Lower Neat Stack Unit Return Roller HP error
Detection Description	FIN-W1/SADDLE FIN-W1 The Lower Neat Stack Unit Return Roller HP Sensor was not turned OFF although 1 sec had passed after the Lower Neat Stack Unit Return Roller Lifting Motor started the operation.
Remedy	FIN-W1/SADDLE FIN-W1 [Related parts] - Harnesses from the Neat Driver PCB to the Lower Neat Stack Unit Return Roller Lifting Motor 1. Neat Driver PCB (UN201/J506) to Relay Connector (29P) (Unit of replacement: CABLE, JOG-T) 2. Relay Connector (29P) to Relay Connector (5P) (Unit of replacement: CABLE, JOG-U) 3. Relay Connector (5P) to Lower Neat Stack Unit Return Roller Lifting Motor (M208/J2511) (Unit of replacement: CABLE, LWR-NEAT-RTN-RLR-UP-M) - Harnesses from the Neat Driver PCB to the Lower Neat Stack Unit Return Roller HP Sensor 1. Neat Driver PCB (UN201/J504) to Relay Connector (29P) (Unit of replacement: CABLE, JOG-T) 2. Relay Connector (29P) to Relay Connector (3P) (Unit of replacement: CABLE, JOG-U) 3. Relay Connector (3P) to Relay Connector (3P) (Unit of replacement: CABLE, JOG-U) 4. Relay Connector (3P) to Lower Neat Stack Unit Return Roller HP Sensor (PS208/J2517) (Unit of replacement: CABLE, YDG) - Lower Neat Stack Unit Return Roller Lifting Motor (M208) - Lower Neat Stack Unit Return Roller HP Sensor (PS208) [Remedy] Check/replace the related harness/cable, connector and parts.

E551-0001-02	a. Power Supply Cooling Fan error b. Error in the Power Supply Fan of the Finisher (Finisher-X1) c. Error in the Power Supply Fan of the Inserter (Document Insertion Unit-N1; Location Inf. 71)
Detection Description	<p>a. FIN-W1/SADDLE FIN-W1 Operation was not performed although 5 sec had passed after the operation of the Power Supply Cooling Fan 1 and 2 started.</p> <p>b. The lock signal is detected 1.2 seconds or more while the fan operates.</p> <p>c. The lock signal is detected ON while the power supply fan operates or the lock signal is detected OFF while the power supply fan stops.</p>
Remedy	<p>a. FIN-W1/SADDLE FIN-W1 [Related parts] - Harness between the Finisher Controller PCB (UN3/J103) and the Power Supply Cooling Fan 1 (FM1/J1003) (Unit of replacement: CABLE, DC) - Harness between the Finisher Controller PCB (UN3/J103) and the Power Supply Cooling Fan 2 (FM4/J1020) (Unit of replacement: CABLE, DC) - Power Supply Cooling Fan 1 and 2 (FM1 and FM4) - Finisher Controller PCB (UN3) (Unit of replacement: FINISHER CONTROLLER PCB ASS'Y) [Remedy] Check/replace the related harness/cable, connector and parts. [Reference] After replacement of the Finisher Controller PCB, refer to "Adjustments> Adjustment when Replacing the Parts> Points to Note when Replacing the Finisher Controller PCB" in the Service Manual for the Finisher.</p> <p>b. STAPLE FIN-X1/BOOKLET FIN-X1 [Related parts] - Harnesses from the Power Supply Fan (FAN101) to the Finisher Controller PCB - Power Supply Fan (FAN101) - Finisher Controller PCB (PBA101) [Remedy] Check/replace the related harness/cable, connector and parts. [Reference] When replacing the Finisher Controller PCB, refer to "Adjustments> Adjustment when Replacing the Parts" in the Service Manual.</p> <p>c. Document Insertion Unit-N1 [Related parts] - Harnesses from the Insertion Unit Controller PCB (PCB3) to the Power Supply Fan (F1) - Insertion Unit Controller PCB (PCB3) - Power Supply Fan (F1) [Remedy] Check/replace the related harness/cable, connector and parts. [Reference] When replacing the Insertion Unit Controller PCB, refer to "Adjustments> Adjustment when Replacing the Parts" in the Service Manual.</p>
E551-0001-71	Error in the Power Supply Fan (Document Insertion Unit-M1)
Detection Description	<p>- Fan lock detection signal is detected ON while the Power Supply Fan is driven</p> <p>- Fan lock detection signal is detected OFF while the Power Supply Fan is stopped</p>
Remedy	<p>[Related parts] - Harnesses from the Insertion Unit Controller PCB (PCB3) to the Power Supply Fan (F1) - Insertion Unit Controller PCB (PCB3) - Power Supply Fan (F1) [Remedy] Check/replace the related harness/cable, connector and parts. [Reference] When replacing the Insertion Unit Controller PCB, refer to "Adjustments> Adjustment when Replacing the Parts" in the Service Manual.</p>

E551-0002-02		a. Feed Cooling Fan error b. Error in the Power Supply Fan of the Finisher (Finisher-X1)
Detection Description	a. FIN-W1/SADDLE FIN-W1 Operation was not performed although 5 sec had passed after the Feed Cooling Fan operation started.	b. The lock status is released when the fan stops.
Remedy	<p>a. FIN-W1/SADDLE FIN-W1</p> <p>[Related parts]</p> <ul style="list-style-type: none"> -Harnesses from the Finisher Controller PCB to the Feed Cooling Fan 1 1. Finisher Controller PCB (UN3/J127) to Relay Connector (3P) (Unit of replacement: CABLE, FEED UNIT) 2. Relay Connector (3P) to Feed Cooling Fan 1 (FM2/J518L) - Harnesses from the Finisher Controller PCB to the Feed Cooling Fan 2 1. Finisher Controller PCB (UN3/J127) to Relay Connector (3P) (Unit of replacement: CABLE, FEED UNIT) 2. Relay Connector (3P) to Feed Cooling Fan 2 (FM3/J519L) - Feed Cooling Fan 1 (FM2) - Feed Cooling Fan 2 (FM3) - Finisher Controller PCB (UN3) (Unit of replacement: FINISHER CONTROLLER PCB ASS'Y) <p>[Remedy] Check/replace the related harness/cable, connector and parts. [Reference] After replacement of the Finisher Controller PCB, refer to "Adjustments> Adjustment when Replacing the Parts> Points to Note when Replacing the Finisher Controller PCB" in the Service Manual for the Finisher.</p> <p>b. STAPLE FIN-X1/BOOKLET FIN-X1</p> <p>[Related parts]</p> <ul style="list-style-type: none"> - Harnesses from the Power Supply Fan (FAN101) to the Finisher Controller PCB - Power Supply Fan (FAN101) - Finisher Controller PCB (PBA101) <p>[Remedy] Check/replace the related harness/cable, connector and parts. [Reference] When replacing the Finisher Controller PCB, refer to "Adjustments> Adjustment when Replacing the Parts" in the Service Manual.</p>	
E551-0003-02		Error in the Heat Exhaust Fan of the Finisher (Finisher-X1)
Detection Description	The lock signal is detected 1.2 seconds or more while the fan operates.	
Remedy	<p>[Related parts]</p> <ul style="list-style-type: none"> - Harnesses from the Heat Exhaust Fan (FAN102) to the Finisher Controller PCB - Heat Exhaust Fan (FAN102) - Finisher Controller PCB (PBA101) <p>[Remedy] Check/replace the related harness/cable, connector and parts. [Reference] When replacing the Finisher Controller PCB, refer to "Adjustment> Action on parts replacement" in the Service Manual.</p>	

E551-0004-02	a. Error in the Heat Exhaust Fan of the Finisher (Finisher-X1) b. Error in the Cooling Fan of the Paper Folding Unit (Paper Folding Unit-J1)
Detection Description	a. The lock status is released when the fan stops. b. The lock status is released when the fan rotates or the lock status is performed when the fan stops.
Remedy	a. STAPLE FIN-X1/BOOKLET FIN-X1 [Related parts] - Harnesses from the Heat Exhaust Fan (FAN102) to the Finisher Controller PCB - Heat Exhaust Fan (FAN102) - Finisher Controller PCB (PBA101) [Remedy] Check/replace the related harness/cable, connector and parts. [Reference] When replacing the Finisher Controller PCB, refer to "Adjustment> Action on parts replacement" in the Service Manual. b. PFU-J1 [Related parts] - Harnesses from the Cooling Fan (F1) to the Finisher Controller PCB - Cooling Fan (F1) - Paper Folding Unit Controller PCB (PCB1) [Remedy] Check/replace the related harness/cable, connector and parts. [Reference] When replacing the Finisher Controller PCB, refer to "Adjustment> When Replacing the Parts" in the Service Manual.
E551-0011-02	Error in the Power Supply Fan (Document Insertion Unit-N1)
Detection Description	The lock signal is detected for the specified times while the fan operates.
Remedy	[Related parts] - Harnesses from the Insertion Unit Controller PCB (PCB3) to the Power Supply Fan (F1) - Insertion Unit Controller PCB (PCB3) - Power Supply Fan (F1) [Remedy] Check/replace the related harness/cable, connector and parts. [Reference] When replacing the Insertion Unit Controller PCB, refer to "Adjustments> Adjustment when Replacing the Parts" in the Service Manual.
E551-0021-02	Error in the Power Supply Fan
Detection Description	The lock signal is detected for the specific time after the fan operates.
Remedy	[Related parts] -Harnesses from the Paper Folding Unit Controller PCB to the Fan(F1). -Fan(F1) -Paper Folding Unit Controller PCB (PCB1) [Remedy] Check/replace the related harness/cable, connector and parts. [Reference] When replacing the Paper Folding Unit Controller PCB, refer to "Adjustments> Adjustment when Replacing the Parts" in the Service Manual.
E551-0031-02	Error in the Power Supply Fan of the Professional Puncher
Detection Description	The lock signal is detected 1.2 sec. or more while the fan operates.
Remedy	[Related parts] - Harnesses from the Power Supply Fan (FAN101) to the Finisher Controller PCB - Power Supply Fan (FAN101) - Finisher Controller PCB (PBA101) [Remedy] Check/replace the related harness/cable, connector and parts. [Reference] When replacing the Finisher Controller PCB, refer to "Adjustments> Adjustment when Replacing the Parts" in the Service Manual.
E551-0032-02	Error in the Power Supply Fan of the Finisher (Finisher-X1)
Detection Description	The lock status is released when the fan stops.
Remedy	[Related parts] - Harnesses from the Power Supply Fan (FAN101) to the Finisher Controller PCB - Power Supply Fan (FAN101) - Finisher Controller PCB (PBA101) [Remedy] Check/replace the related harness/cable, connector and parts. [Reference] When replacing the Finisher Controller PCB, refer to "Adjustments> Adjustment when Replacing the Parts" in the Service Manual.

E553-8001-02	Error in the Lower Escape Delivery Shift Motor (Finisher-AC1)
Detection Description	The lower escape delivery roller does not come off the Lower Escape Delivery Roller HP Sensor when the Lower Escape Delivery Shift Motor has been driven for 1 second.
Remedy	<p>STAPLE FIN-AC1/BOOKLET FIN-AC1</p> <p>[Related parts]</p> <ul style="list-style-type: none"> - Harnesses from the Lower Escape Delivery Roller HP Sensor (PS112) to the Finisher Controller PCB - Harnesses from the Lower Escape Delivery Shift Motor (M106) to the Finisher Controller PCB - Lower Escape Delivery Roller HP Sensor (PS112) - Lower Escape Delivery Shift Motor (M106) - Finisher Controller PCB (PCB101) <p>[Remedy] Check/replace the related harness/cable, connector and parts. [Reference] When replacing the Finisher Controller PCB, refer to "Adjustment> When Replacing the Parts" in the Service Manual.</p>
E553-8002-02	Error in the Lower Escape Delivery Shift Motor (Finisher-AC1)
Detection Description	The Lower Escape Delivery Roller HP Sensor does not detect the lower escape delivery roller when the Lower Escape Delivery Shift Motor has been driven for 1 second.
Remedy	<p>STAPLE FIN-AC1/BOOKLET FIN-AC1</p> <p>[Related parts]</p> <ul style="list-style-type: none"> - Harnesses from the Lower Escape Delivery Roller HP Sensor (PS112) to the Finisher Controller PCB - Harnesses from the Lower Escape Delivery Shift Motor (M106) to the Finisher Controller PCB - Lower Escape Delivery Roller HP Sensor (PS112) - Lower Escape Delivery Shift Motor (M106) - Finisher Controller PCB (PCB101) <p>[Remedy] Check/replace the related harness/cable, connector and parts. [Reference] When replacing the Finisher Controller PCB, refer to "Adjustment> When Replacing the Parts" in the Service Manual.</p>
E553-8003-02	Error in the Upper Escape Delivery Shift Motor (Finisher-AC1)
Detection Description	The upper escape delivery roller does not come off the Upper Escape Delivery Roller HP Sensor when the Upper Escape Delivery Shift Motor has been driven for 1 second.
Remedy	<p>STAPLE FIN-AC1/BOOKLET FIN-AC1</p> <p>[Related parts]</p> <ul style="list-style-type: none"> - Harnesses from the Upper Escape Delivery Roller HP Sensor (PS134) to the Finisher Controller PCB - Harnesses from the Upper Escape Delivery Shift Motor (M119) to the Finisher Controller PCB - Upper Escape Delivery Roller HP Sensor (PS134) - Upper Escape Delivery Shift Motor (M119) - Finisher Controller PCB (PCB101) <p>[Remedy] Check/replace the related harness/cable, connector and parts. [Reference] When replacing the Finisher Controller PCB, refer to "Adjustment> When Replacing the Parts" in the Service Manual.</p>
E553-8004-02	Error in the Upper Escape Delivery Shift Motor (Finisher-AC1)
Detection Description	The Upper Escape Delivery Roller HP Sensor does not detect the upper escape delivery roller when the Upper Escape Delivery Shift Motor has been driven for 1 second.
Remedy	<p>STAPLE FIN-AC1/BOOKLET FIN-AC1</p> <p>[Related parts]</p> <ul style="list-style-type: none"> - Harnesses from the Upper Escape Delivery Roller HP Sensor (PS134) to the Finisher Controller PCB - Harnesses from the Upper Escape Delivery Shift Motor (M119) to the Finisher Controller PCB - Upper Escape Delivery Roller HP Sensor (PS134) - Upper Escape Delivery Shift Motor (M119) - Finisher Controller PCB (PCB101) <p>[Reference] When replacing the Finisher Controller PCB, refer to "Adjustment> When Replacing the Parts" in the Service Manual.</p>

E553-8011-02	Error in the Flapper Motor (Finisher-AC1)
Detection Description	The flapper does not come off the Flapper HP Sensor when the Flapper Motor has been driven for 1 second.
Remedy	<p>STAPLE FIN-AC1/BOOKLET FIN-AC1</p> <p>[Related parts]</p> <ul style="list-style-type: none"> - Harnesses from the Flapper HP Sensor (PS105) to the Finisher Controller PCB - Harnesses from the Flapper Motor (M104) to the Finisher Controller PCB - Flapper HP Sensor (PS105) - Flapper Motor (M104) - Finisher Controller PCB (PCB101) <p>[Remedy] Check/replace the related harness/cable, connector and parts. [Reference] When replacing the Finisher Controller PCB, refer to "Adjustment> When Replacing the Parts" in the Service Manual.</p>
E553-8012-02	Error in the Flapper Motor (Finisher-AC1)
Detection Description	The Flapper HP Sensor does not detect the flapper when the Flapper Motor has been driven for 1 second.
Remedy	<p>STAPLE FIN-AC1/BOOKLET FIN-AC1</p> <p>[Related parts]</p> <ul style="list-style-type: none"> - Harnesses from the Flapper HP Sensor (PS105) to the Finisher Controller PCB - Harnesses from the Flapper Motor (M104) to the Finisher Controller PCB - Flapper HP Sensor (PS105) - Flapper Motor (M104) - Finisher Controller PCB (PCB101) <p>[Remedy] Check/replace the related harness/cable, connector and parts. [Reference] When replacing the Finisher Controller PCB, refer to "Adjustment> When Replacing the Parts" in the Service Manual.</p>
E553-8013-02	Error in the Escape Flapper Motor (Finisher-AC1)
Detection Description	The escape flapper does not come off the Escape Flapper HP Sensor when the Escape Flapper Motor has been driven for 1 second.
Remedy	<p>STAPLE FIN-AC1/BOOKLET FIN-AC1</p> <p>[Related parts]</p> <ul style="list-style-type: none"> - Harnesses from the Escape Flapper HP Sensor (PS132) to the Finisher Controller PCB - Harnesses from the Escape Flapper Motor (M118) to the Finisher Controller PCB - Escape Flapper HP Sensor (PS132) - Escape Flapper Motor (M118) - Finisher Controller PCB (PCB101) <p>[Remedy] Check/replace the related harness/cable, connector and parts. [Reference] When replacing the Finisher Controller PCB, refer to "Adjustment> When Replacing the Parts" in the Service Manual.</p>
E553-8014-02	Error in the Escape Flapper Motor (Finisher-AC1)
Detection Description	The Escape Flapper HP Sensor does not detect the escape flapper when the Escape Flapper Motor has been driven for 1 second.
Remedy	<p>STAPLE FIN-AC1/BOOKLET FIN-AC1</p> <p>[Related parts]</p> <ul style="list-style-type: none"> - Harnesses from the Escape Flapper HP Sensor (PS132) to the Finisher Controller PCB - Harnesses from the Escape Flapper Motor (M118) to the Finisher Controller PCB - Escape Flapper HP Sensor (PS132) - Escape Flapper Motor (M118) - Finisher Controller PCB (PCB101) <p>[Remedy] Check/replace the related harness/cable, connector and parts. [Reference] When replacing the Finisher Controller PCB, refer to "Adjustment> When Replacing the Parts" in the Service Manual.</p>

E553-80F1-02	Error in the Saddle Feed/Paddle Motor (Finisher-AC1)
Detection Description	The paddle does not come off the Saddle Paddle HP Sensor when the Saddle Feed/Paddle Motor has been driven for 1 second.
Remedy	<p>STAPLE FIN-AC1/BOOKLET FIN-AC1</p> <p>[Related parts]</p> <ul style="list-style-type: none"> - Harnesses from the Saddle Paddle HP Sensor (PS206) to the Saddle Stitcher Controller PCB - Harnesses from the Saddle Feed/Paddle Motor (M201) to the Saddle Stitcher Controller PCB - Saddle Paddle HP Sensor (PS206) - Saddle Feed/Paddle Motor (M201) - Saddle Stitcher Controller PCB (PCB201) - Finisher Controller PCB (PCB101) <p>[Remedy] Check/replace the related harness/cable, connector and parts. [Reference] When replacing the Finisher Controller PCB, refer to "Adjustment> When Replacing the Parts" in the Service Manual.</p>
E553-80F2-02	Error in the Saddle Feed/Paddle Motor (Finisher-AC1)
Detection Description	The Saddle Paddle HP Sensor does not detect the paddle when the Saddle Feed/Paddle Motor has been driven for 1 second.
Remedy	<p>STAPLE FIN-AC1/BOOKLET FIN-AC1</p> <p>[Related parts]</p> <ul style="list-style-type: none"> - Harnesses from the Saddle Paddle HP Sensor (PS206) to the Saddle Stitcher Controller PCB - Harnesses from the Saddle Feed/Paddle Motor (M201) to the Saddle Stitcher Controller PCB - Saddle Paddle HP Sensor (PS206) - Saddle Feed/Paddle Motor (M201) - Saddle Stitcher Controller PCB (PCB201) - Finisher Controller PCB (PCB101) <p>[Remedy] Check/replace the related harness/cable, connector and parts. [Reference] When replacing the Finisher Controller PCB, refer to "Adjustment> When Replacing the Parts" in the Service Manual. [Reference] When replacing the Finisher Controller PCB, refer to "Adjustment> When Replacing the Parts" in the Service Manual.</p>
E554-8002-02	Safety switch ON error (Finisher-AC1)
Detection Description	The Front Cover Switch is turned OFF for 0.3 seconds when the Front Cover Sensor is ON.
Remedy	<p>STAPLE FIN-AC1/BOOKLET FIN-AC1</p> <p>[Related parts]</p> <ul style="list-style-type: none"> - Harnesses from the Front Cover Switch (SW101) to the Finisher Controller PCB - Front Cover Switch (SW101) - Finisher Controller PCB (PCB101) <p>[Remedy] Check/replace the related harness/cable, connector and parts. [Reference] When replacing the Finisher Controller PCB, refer to "Adjustment> When Replacing the Parts" in the Service Manual.</p>
E562-8001-02	Error in the Slowdown Timing Sensor (Paper Folding Unit-J1)
Detection Description	The receiving-light intensity is not within the threshold while the emitting-light intensity is adjusted within the threshold at the sensor adjustment.
Remedy	<p>[Related parts]</p> <ul style="list-style-type: none"> -Harnesses from the Paper Folding Unit Controller PCB to the Slowdown Timing Sensor (S30). -Slowdown Timing Sensor (S30) -Paper Folding Unit Controller PCB (PCB1) <p>[Remedy] Check/replace the related harness/cable, connector and parts. [Reference] When replacing the Paper Folding Unit Controller PCB, refer to "Adjustments> Adjustment when Replacing the Parts" in the Service Manual.</p>

E562-8002-02	Error in the Release Timing Sensor (Paper Folding Unit-J1)
Detection Description	The receiving-light intensity is not within the threshold while the emitting-light intensity is adjusted within the threshold at the sensor adjustment.
Remedy	<p>[Related parts]</p> <ul style="list-style-type: none"> -Harnesses from the Paper Folding Unit Controller PCB to the Release Timing Sensor (S31). -Release Timing Sensor (S31) -Paper Folding Unit Controller PCB (PCB1) <p>[Remedy] Check/replace the related harness/cable, connector and parts. [Reference] When replacing the Paper Folding Unit Controller PCB, refer to "Adjustments> Adjustment when Replacing the Parts" in the Service Manual.</p>
E562-8003-02	Error in the Fold Position Sensor (Paper Folding Unit-J1)
Detection Description	The receiving-light intensity is not within the threshold while the emitting-light intensity is adjusted within the threshold at the sensor adjustment.
Remedy	<p>[Related parts]</p> <ul style="list-style-type: none"> -Harnesses from the Paper Folding Unit Controller PCB to the Fold Position Sensor (S32). -Fold Position Sensor (S32) -Paper Folding Unit Controller PCB (PCB1) <p>[Remedy] Check/replace the related harness/cable, connector and parts. [Reference] When replacing the Paper Folding Unit Controller PCB, refer to "Adjustments> Adjustment when Replacing the Parts" in the Service Manual.</p>
E562-8004-02	Error in the Upper Stopper HP Sensor (Paper Folding Unit-J1)
Detection Description	The receiving-light intensity is not within the threshold while the emitting-light intensity is adjusted within the threshold at the sensor adjustment.
Remedy	<p>[Related parts]</p> <ul style="list-style-type: none"> -Harnesses from the Paper Folding Unit Controller PCB to the Upper Stopper HP Sensor (S23). -Upper Stopper HP Sensor (S23) -Paper Folding Unit Controller PCB (PCB1) <p>[Remedy] Check/replace the related harness/cable, connector and parts. [Reference] When replacing the Paper Folding Unit Controller PCB, refer to "Adjustments> Adjustment when Replacing the Parts" in the Service Manual.</p>
E566-8001-02	Side Registration Detection Unit HP error
Detection Description	<p>FIN-W1/SADDLE FIN-W1</p> <p>The Side Registration Detection Unit HP Sensor was not turned ON although 3 sec had passed after the Side Registration Detection Unit Shift Motor started the operation.</p>
Remedy	<p>FIN-W1/SADDLE FIN-W1</p> <p>[Related parts]</p> <ul style="list-style-type: none"> - Harness between the Feed Motor Driver PCB (UN5/J281) and the Side Registration Detection Unit Shift Motor (M6/J530) - Harnesses from the Finisher Controller PCB to the Side Registration Detection Unit HP Sensor <ol style="list-style-type: none"> 1. Finisher Controller PCB (UN3/J128) to Relay Connector (3P) (Unit of replacement: CABLE, FEED UNIT) 2. Relay Connector (3P) to Side Registration Detection Unit HP Sensor (PS7/J512) (Unit of replacement: DETECT DRIVE ASSEMBLY) <ul style="list-style-type: none"> - Side Registration Detection Unit Shift Motor (M6) - Side Registration Detection Unit HP Sensor (PS7) - Finisher Controller PCB (UN3) (Unit of replacement: FINISHER CONTROLLER PCB ASS'Y) <p>[Remedy] Check/replace the related harness/cable, connector and parts. [Reference] After replacement of the Finisher Controller PCB, refer to "Adjustments> Adjustment when Replacing the Parts> Points to Note when Replacing the Finisher Controller PCB" in the Service Manual for the Finisher.</p>

E566-8002-02	Side Registration Detection Unit HP error
Detection Description	FIN-W1/SADDLE FIN-W1 The Side Registration Detection Unit HP Sensor was not turned OFF although 3 sec had passed after the Side Registration Detection Unit Shift Motor started the operation.
Remedy	FIN-W1/SADDLE FIN-W1 [Related parts] - Harness between the Feed Motor Driver PCB (UN5/J281) and the Side Registration Detection Unit Shift Motor (M6/J530) - Harnesses from the Finisher Controller PCB to the Side Registration Detection Unit HP Sensor 1. Finisher Controller PCB (UN3/J128) to Relay Connector (3P) (Unit of replacement: CABLE, FEED UNIT) 2. Relay Connector (3P) to Side Registration Detection Unit HP Sensor (PS7/J512) (Unit of replacement: DETECT DRIVE ASSEMBLY) - Side Registration Detection Unit Shift Motor (M6) - Side Registration Detection Unit HP Sensor (PS7) - Finisher Controller PCB (UN3) (Unit of replacement: FINISHER CONTROLLER PCB ASS'Y) [Remedy] Check/replace the related harness/cable, connector and parts. [Reference] After replacement of the Finisher Controller PCB, refer to "Adjustments> Adjustment when Replacing the Parts> Points to Note when Replacing the Finisher Controller PCB" in the Service Manual for the Finisher.
E567-8001-02	Shift Roller Unit HP error
Detection Description	FIN-W1/SADDLE FIN-W1 The Shift Roller Unit HP Sensor was not turned ON although 5 sec had passed after the operation started.
Remedy	FIN-W1/SADDLE FIN-W1 [Related parts] - Harness between the Feed Motor Driver PCB (UN5/J282) and the Side Registration Shift Motor (M7/J532) - Harnesses from the Finisher Controller PCB to the Shift Roller Unit HP Sensor 1. Finisher Controller PCB (UN3/J128) to Relay Connector (3P) (Unit of replacement: CABLE, FEED UNIT) 2. Relay Connector (3P) to Shift Roller Unit HP Sensor (PS8/J513) (Unit of replacement: CABLE, SHIFT) - Side Registration Shift Motor (M7) - Shift Roller Unit HP Sensor (PS8) - Finisher Controller PCB (UN3) (Unit of replacement: FINISHER CONTROLLER PCB ASS'Y) [Remedy] Check/replace the related harness/cable, connector and parts. [Reference] After replacement of the Finisher Controller PCB, refer to "Adjustments> Adjustment when Replacing the Parts> Points to Note when Replacing the Finisher Controller PCB" in the Service Manual for the Finisher.

E567-8002-02	Shift Roller Unit HP error
Detection Description	FIN-W1/SADDLE FIN-W1 The Shift Roller Unit HP Sensor was not turned OFF although 5 sec had passed after the operation started.
Remedy	FIN-W1/SADDLE FIN-W1 [Related parts] - Harness between the Feed Motor Driver PCB (UN5/J282) and the Side Registration Shift Motor (M7/J532) - Harnesses from the Finisher Controller PCB to the Shift Roller Unit HP Sensor 1. Finisher Controller PCB (UN3/J128) to Relay Connector (3P) (Unit of replacement: CABLE, FEED UNIT) 2. Relay Connector (3P) to Shift Roller Unit HP Sensor (PS8/J513) (Unit of replacement: CABLE, SHIFT) - Side Registration Shift Motor (M7) - Shift Roller Unit HP Sensor (PS8) - Finisher Controller PCB (UN3) (Unit of replacement: FINISHER CONTROLLER PCB ASS'Y) [Remedy] Check/replace the related harness/cable, connector and parts. [Reference] After replacement of the Finisher Controller PCB, refer to "Adjustments> Adjustment when Replacing the Parts> Points to Note when Replacing the Finisher Controller PCB" in the Service Manual for the Finisher.
E568-8001-02	a. Feed Roller HP error b. Error in the Feed Roller Disengage/Buffer Flapper Motor (Finisher-X1)
Detection Description	a. FIN-W1/SADDLE FIN-W1 The Feed Roller HP Sensor was not turned ON although 5 sec had passed after the Feed Roller Disengagement Motor started the operation. b. The disengage roller does not come off the Feed Roller Separation HP Sensor when the Feed Roller Disengage/Buffer Flapper Motor has been driven for 3 seconds.
Remedy	a. FIN-W1/SADDLE FIN-W1 [Related parts] - Harness between the Feed Motor Driver PCB (UN5/J286) and the Feed Roller Disengagement Motor (M8/J535) (Unit of replacement: CABLE, GUIDE UPPER) - Harness between the Feed Motor Driver PCB (UN5/J286) to the Feed Roller HP Sensor (PS9/J538) (Unit of replacement: CABLE, GUIDE UPPER) - Feed Roller Disengagement Motor (M8) - Feed Roller HP Sensor (PS9) - Finisher Controller PCB (UN3) (Unit of replacement: FINISHER CONTROLLER PCB ASS'Y) [Remedy] Check/replace the related harness/cable, connector and parts. [Reference] After replacement of the Finisher Controller PCB, refer to "Adjustments> Adjustment when Replacing the Parts> Points to Note when Replacing the Finisher Controller PCB" in the Service Manual for the Finisher. b. STAPLE FIN-X1/BOOKLET FIN-X1 [Related parts] - Harnesses from the Feed Roller Separation HP Sensor (S111) to the Finisher Controller PCB - Harnesses from the Feed Roller Disengage/Buffer Flapper Motor (M119) to the Finisher Controller PCB - Feed Roller Separation HP Sensor (S111) - Feed Roller Disengage/Buffer Flapper Motor (M119) - Finisher Controller PCB (PBA101) [Remedy] Check/replace the related harness/cable, connector and parts. [Reference] When replacing the Finisher Controller PCB, refer to "Adjustments> Adjustment when Replacing the Parts" in the Service Manual.

E568-8002-02	a. Feed Roller HP error b. Error in the Feed Roller Disengage/Buffer Flapper Motor (Finisher-X1)
Detection Description	<p>a. FIN-W1/SADDLE FIN-W1 The Feed Roller HP Sensor was not turned OFF although 5 sec had passed after the Feed Roller Disengagement Motor started the operation.</p> <p>b. The Feed Roller Separation HP Sensor does not detect the disengage roller when the Feed Roller Disengage/Buffer Flapper Motor has been driven for 3 seconds.</p>
Remedy	<p>a. FIN-W1/SADDLE FIN-W1 [Related parts] - Harness between the Feed Motor Driver PCB (UN5/J286) and the Feed Roller Disengagement Motor (M8/J535) (Unit of replacement: CABLE, GUIDE UPPER) - Harness between the Feed Motor Driver PCB (UN5/J286) to the Feed Roller HP Sensor (PS9/J538) (Unit of replacement: CABLE, GUIDE UPPER) - Feed Roller Disengagement Motor (M8) - Feed Roller HP Sensor (PS9) - Finisher Controller PCB (UN3) (Unit of replacement: FINISHER CONTROLLER PCB ASS'Y) [Remedy] Check/replace the related harness/cable, connector and parts. [Reference] After replacement of the Finisher Controller PCB, refer to "Adjustments> Adjustment when Replacing the Parts> Points to Note when Replacing the Finisher Controller PCB" in the Service Manual for the Finisher.</p> <p>b. STAPLE FIN-X1/BOOKLET FIN-X1 [Related parts] - Harnesses from the Feed Roller Separation HP Sensor (S111) to the Finisher Controller PCB - Harnesses from the Feed Roller Disengage/Buffer Flapper Motor (M119) to the Finisher Controller PCB - Feed Roller Separation HP Sensor (S111) - Feed Roller Disengage/Buffer Flapper Motor (M119) - Finisher Controller PCB (PBA101) [Remedy] Check/replace the related harness/cable, connector and parts. [Reference] When replacing the Finisher Controller PCB, refer to "Adjustments> Adjustment when Replacing the Parts" in the Service Manual.</p>
E568-8003-02	Error in the Feed Roller Disengage/Buffer Flapper Motor (Finisher-X1)
Detection Description	The buffer flapper does not come off the Buffer Flapper HP Sensor when the Feed Roller Disengage/Buffer Flapper Motor has been driven for 3 seconds.
Remedy	<p>[Related parts] - Harnesses from the Buffer Flapper HP Sensor (S142) to the Finisher Controller PCB - Harnesses from the Feed Roller Disengage/Buffer Flapper Motor (M119) to the Finisher Controller PCB - Buffer Flapper HP Sensor (S142) - Feed Roller Disengage/Buffer Flapper Motor (M119) - Finisher Controller PCB (PBA101) [Remedy] Check/replace the related harness/cable, connector and parts. [Reference] When replacing the Finisher Controller PCB, refer to "Adjustments> Adjustment when Replacing the Parts" in the Service Manual.</p>
E568-8004-02	Error in the Feed Roller Disengage/Buffer Flapper Motor (Finisher-X1)
Detection Description	The Buffer Flapper HP Sensor does not detect the buffer flapper when the Feed Roller Disengage/Buffer Flapper Motor has been driven for 3 seconds.
Remedy	<p>[Related parts] - Harnesses from the Buffer Flapper HP Sensor (S142) to the Finisher Controller PCB - Harnesses from the Feed Roller Disengage/Buffer Flapper Motor (M119) to the Finisher Controller PCB - Buffer Flapper HP Sensor (S142) - Feed Roller Disengage/Buffer Flapper Motor (M119) - Finisher Controller PCB (PBA101) [Remedy] Check/replace the related harness/cable, connector and parts. [Reference] When replacing the Finisher Controller PCB, refer to "Adjustments> Adjustment when Replacing the Parts" in the Service Manual.</p>

E569-8001-02	Error in the Upper Stopper Motor (Paper Folding Unit-J1)
Detection Description	The Upper Stopper Motor failed to move from the Upper Stopper HP Sensor position after the Upper Stopper Motor drives for the specified pulse.
Remedy	<p>[Related parts]</p> <ul style="list-style-type: none"> -Harnesses from the Paper Folding Unit Controller PCB to the Upper Stopper HP Sensor (S23). -Harnesses from the Paper Folding Unit Controller PCB to the Upper Stopper Motor (M8). -Upper Stopper HP Sensor (S23) -Upper Stopper Motor (M8) -Paper Folding Unit Controller PCB (PCB1) <p>[Remedy] Check/replace the related harness/cable, connector and parts. [Reference] When replacing the Paper Folding Unit Controller PCB, refer to "Adjustments> Adjustment when Replacing the Parts" in the Service Manual.</p>
E569-8002-02	Error in the Upper Stopper Motor (Paper Folding Unit-J1)
Detection Description	The Upper Stopper Motor failed to return to the Upper Stopper HP Sensor position after the Upper Stopper Motor drives for the specified pulse.
Remedy	<p>[Related parts]</p> <ul style="list-style-type: none"> -Harnesses from the Paper Folding Unit Controller PCB to the Upper Stopper HP Sensor (S23). -Harnesses from the Paper Folding Unit Controller PCB to the Upper Stopper Motor (M8). -Upper Stopper HP Sensor (S23) -Upper Stopper Motor (M8) -Paper Folding Unit Controller PCB (PCB1) <p>[Remedy] Check/replace the related harness/cable, connector and parts. [Reference] When replacing the Paper Folding Unit Controller PCB, refer to "Adjustments> Adjustment when Replacing the Parts" in the Service Manual.</p>
E569-8003-02	Error in the Upper Stopper Motor (Paper Folding Unit-J1)
Detection Description	The Upper Stopper Motor failed to move from the Upper Stopper HP Sensor position after the Upper Stopper Motor drives for the specified pulse.
Remedy	<p>[Related parts]</p> <ul style="list-style-type: none"> -Harnesses from the Paper Folding Unit Controller PCB to the Upper Stopper HP Sensor (S23). -Harnesses from the Paper Folding Unit Controller PCB to the Upper Stopper Motor (M8). -Upper Stopper HP Sensor (S23) -Upper Stopper Motor (M8) -Paper Folding Unit Controller PCB (PCB1) <p>[Remedy] Check/replace the related harness/cable, connector and parts. [Reference] When replacing the Paper Folding Unit Controller PCB, refer to "Adjustments> Adjustment when Replacing the Parts" in the Service Manual.</p>
E569-8004-02	Error in the Upper Stopper Motor (Paper Folding Unit-J1)
Detection Description	The Upper Stopper Motor failed to return to the Upper Stopper HP Sensor position after the Upper Stopper Motor drives for the specified pulse.
Remedy	<p>[Related parts]</p> <ul style="list-style-type: none"> -Harnesses from the Paper Folding Unit Controller PCB to the Upper Stopper HP Sensor (S23). -Harnesses from the Paper Folding Unit Controller PCB to the Upper Stopper Motor (M8). -Upper Stopper HP Sensor (S23) -Upper Stopper Motor (M8) -Paper Folding Unit Controller PCB (PCB1) <p>[Remedy] Check/replace the related harness/cable, connector and parts. [Reference] When replacing the Paper Folding Unit Controller PCB, refer to "Adjustments> Adjustment when Replacing the Parts" in the Service Manual.</p>

E56A-8001-02	Error in the C-fold Stopper Motor (Paper Folding Unit-J1)
Detection Description	The C-fold Stopper Motor failed to move from the C-fold Stopper HP Sensor position after the C-fold Stopper Motor drives for the specified pulse.
Remedy	<p>[Related parts]</p> <ul style="list-style-type: none"> -Harnesses from the Paper Folding Unit Controller PCB to the C-fold Stopper HP Sensor(S24). -Harnesses from the Paper Folding Unit Controller PCB to the C-fold Stopper Motor(M9). -C-fold Stopper HP Sensor(S24) -C-fold Stopper Motor(M9) -Paper Folding Unit Controller PCB (PCB1) <p>[Remedy] Check/replace the related harness/cable, connector and parts. [Reference] When replacing the Paper Folding Unit Controller PCB, refer to "Adjustments> Adjustment when Replacing the Parts" in the Service Manual.</p>
E56A-8002-02	Error in the C-fold Stopper Motor (Paper Folding Unit-J1)
Detection Description	The C-fold Stopper Motor failed to return to the C-fold Stopper HP Sensor position after the C-fold Stopper Motor drives for the specified pulse.
Remedy	<p>[Related parts]</p> <ul style="list-style-type: none"> -Harnesses from the Paper Folding Unit Controller PCB to the C-fold Stopper HP Sensor(S24). -Harnesses from the Paper Folding Unit Controller PCB to the C-fold Stopper Motor(M9). -C-fold Stopper HP Sensor(S24) -C-fold Stopper Motor(M9) -Paper Folding Unit Controller PCB (PCB1) <p>[Remedy] Check/replace the related harness/cable, connector and parts. [Reference] When replacing the Paper Folding Unit Controller PCB, refer to "Adjustments> Adjustment when Replacing the Parts" in the Service Manual.</p>
E56B-8001-02	Error in the Folding Tray Motor (Paper Folding Unit-J1)
Detection Description	The Folding Tray Motor failed to move from the Folding Tray HP Sensor position after the Folding Tray Motor drives for the specified pulse.
Remedy	<p>[Related parts]</p> <ul style="list-style-type: none"> -Harnesses from the Paper Folding Unit Controller PCB to the Fold Tray HP Sensor(S28). -Harnesses from the Paper Folding Unit Controller PCB to the Folding Tray Motor(M7). -Fold Tray HP Sensor(S28) -Folding Tray Motor(M7) -Paper Folding Unit Controller PCB (PCB1) <p>[Remedy] Check/replace the related harness/cable, connector and parts. [Reference] When replacing the Paper Folding Unit Controller PCB, refer to "Adjustments> Adjustment when Replacing the Parts" in the Service Manual.</p>
E56B-8002-02	Error in the Folding Tray Motor (Paper Folding Unit-J1)
Detection Description	The Folding Tray Motor failed to return to the Folding Tray HP Sensor position after the Folding Tray Motor drives for the specified pulse.
Remedy	<p>[Related parts]</p> <ul style="list-style-type: none"> -Harnesses from the Paper Folding Unit Controller PCB to the Fold Tray HP Sensor(S28). -Harnesses from the Paper Folding Unit Controller PCB to the Folding Tray Motor(M7). -Fold Tray HP Sensor(S28) -Folding Tray Motor(M7) -Paper Folding Unit Controller PCB (PCB1) <p>[Remedy] Check/replace the related harness/cable, connector and parts. [Reference] When replacing the Paper Folding Unit Controller PCB, refer to "Adjustments> Adjustment when Replacing the Parts" in the Service Manual.</p>

E56D-8001-02	a. Error in the Stacking Tray Paper Retainer Motor (Finisher-X1) b. Error in the Paper Retainer Lever Motor (Finisher-AC1)
Detection Description	<p>a. The stacking tray paper retainer does not come off the Stacking Tray Paper Retainer HP Sensor when the Stacking Tray Paper Retainer Motor has been driven for 3 seconds.</p> <p>b. The Paper Retainer Lever does not come off the Paper Retainer Lever Motor Lever HP Sensor when the Paper Retainer Lever Motor has been driven for 1 second.</p>
Remedy	<p>a. STAPLE FIN-X1/BOOKLET FIN-X1 [Related parts]</p> <ul style="list-style-type: none"> - Harnesses from the Stacking Tray Paper Retainer HP Sensor (S114) to the Finisher Controller PCB - Harnesses from the Stacking Tray Paper Retainer Motor (M114) to the Finisher Controller PCB - Stacking Tray Paper Retainer HP Sensor (S114) - Stacking Tray Paper Retainer Motor (M114) - Finisher Controller PCB (PBA101) <p>[Remedy] Check/replace the related harness/cable, connector and parts. [Reference] When replacing the Finisher Controller PCB, refer to "Adjustments> Adjustment when Replacing the Parts" in the Service Manual.</p> <p>b. STAPLE FIN-AC1/BOOKLET FIN-AC1 [Related parts]</p> <ul style="list-style-type: none"> - Harnesses from the Paper Retainer Lever HP Sensor (PS217) to the Finisher Controller PCB - Harnesses from the Paper Retainer Lever Motor (M209) to the Finisher Controller PCB - Paper Retainer Lever HP Sensor (PS217) - Paper Retainer Lever Motor (M209) - Finisher Controller PCB (PCB101) <p>[Remedy] Check/replace the related harness/cable, connector and parts. [Reference] When replacing the Finisher Controller PCB, refer to "Adjustment> When Replacing the Parts" in the Service Manual.</p>
E56D-8002-02	a. Error in the Stacking Tray Paper Retainer Motor (Finisher-X1) b. Error in the Paper Retainer Lever Motor (Finisher-AC1)
Detection Description	<p>a. The Stacking Tray Paper Retainer HP Sensor does not detect the stacking tray paper retainer when the Stacking Tray Paper Retainer Motor has been driven for 3 seconds.</p> <p>b. The Paper Retainer Lever HP Sensor does not detect the Paper Retainer Lever when the Paper Retainer Lever Motor has been driven for 1 second.</p>
Remedy	<p>a. STAPLE FIN-X1/BOOKLET FIN-X1 [Related parts]</p> <ul style="list-style-type: none"> - Harnesses from the Stacking Tray Paper Retainer HP Sensor (S114) to the Finisher Controller PCB - Harnesses from the Stacking Tray Paper Retainer Motor (M114) to the Finisher Controller PCB - Stacking Tray Paper Retainer HP Sensor (S114) - Stacking Tray Paper Retainer Motor (M114) - Finisher Controller PCB (PBA101) <p>[Remedy] Check/replace the related harness/cable, connector and parts. [Reference] When replacing the Finisher Controller PCB, refer to "Adjustments> Adjustment when Replacing the Parts" in the Service Manual.</p> <p>b. STAPLE FIN-AC1/BOOKLET FIN-AC1 [Related parts]</p> <ul style="list-style-type: none"> - Harnesses from the Paper Retainer Lever HP Sensor (PS217) to the Finisher Controller PCB - Harnesses from the Paper Retainer Lever Motor (M209) to the Finisher Controller PCB - Paper Retainer Lever HP Sensor (PS217) - Paper Retainer Lever Motor (M209) - Finisher Controller PCB (PCB101) <p>[Remedy] Check/replace the related harness/cable, connector and parts. [Reference] When replacing the Finisher Controller PCB, refer to "Adjustment> When Replacing the Parts" in the Service Manual.</p>

E56E-8001-02	Error in the Leading Edge Press Guide Motor (Paper Folding Unit-J1)
Detection Description	The Leading Edge Press Guide Motor failed to move from the Folding Tray HP Sensor position after the Leading Edge Press Guide Motor drives for the specified pulse.
Remedy	<p>[Related parts]</p> <ul style="list-style-type: none"> -Harnesses from the Paper Folding Unit Controller PCB to the Leading Edge Press Guide HP Sensor(S25). -Harnesses from the Paper Folding Unit Controller PCB to the Leading Edge Press Guide Motor(M10). -Leading Edge Press Guide HP Sensor(S25) -Leading Edge Press Guide Motor(M10) -Paper Folding Unit Controller PCB (PCB1) <p>[Remedy] Check/replace the related harness/cable, connector and parts. [Reference] When replacing the Paper Folding Unit Controller PCB, refer to "Adjustments> Adjustment when Replacing the Parts" in the Service Manual.</p>
E56E-8002-02	Error in the Leading Edge Press Guide Motor (Paper Folding Unit-J1)
Detection Description	The Leading Edge Press Guide Motor failed to return to the Folding Tray HP Sensor position after the Leading Edge Press Guide Motor drives for the specified pulse.
Remedy	<p>[Related parts]</p> <ul style="list-style-type: none"> -Harnesses from the Paper Folding Unit Controller PCB to the Leading Edge Press Guide HP Sensor(S25). -Harnesses from the Paper Folding Unit Controller PCB to the Leading Edge Press Guide Motor(M10). -Leading Edge Press Guide HP Sensor(S25) -Leading Edge Press Guide Motor(M10) -Paper Folding Unit Controller PCB (PCB1) <p>[Remedy] Check/replace the related harness/cable, connector and parts. [Reference] When replacing the Paper Folding Unit Controller PCB, refer to "Adjustments> Adjustment when Replacing the Parts" in the Service Manual.</p>
E56F-8001-02	Inlet Roller HP error
Detection Description	<p>FIN-W1/SADDLE FIN-W1</p> <p>The Inlet Roller HP Sensor was not turned ON although 5 sec had passed after the Inlet Roller Disengagement Motor started the operation.</p>
Remedy	<p>FIN-W1/SADDLE FIN-W1</p> <p>[Related parts]</p> <ul style="list-style-type: none"> - Harnesses from the Feed Motor Driver PCB to the Inlet Roller Disengagement Motor 1. Feed Motor Driver PCB (UN5/J278) to Relay Connector (11P) (Unit of replacement: CABLE, FEED UNIT) 2. Relay Connector (11P) to Inlet Roller Disengagement Motor (M27/J542) (Unit of replacement: ESTRANGEMENT MOTOR ASS'Y) - Harnesses from the Feed Motor Driver PCB to the Inlet Roller HP Sensor 1. Feed Motor Driver PCB (UN5/J278) to Relay Connector (11P) (Unit of replacement: CABLE, FEED UNIT) 2. Relay Connector (11P) to Inlet Roller HP Sensor (PS43/J544) (Unit of replacement: ESTRANGEMENT MOTOR ASS'Y) - Inlet Roller Disengagement Motor (M27) (Unit of replacement: MOTOR, STEPPING, DC) - Inlet Roller HP Sensor (PS43) (Unit of replacement: IC,PHOTO-INTERRUPTER,LG248NL1A) - Finisher Controller PCB (UN3) (Unit of replacement: FINISHER CONTROLLER PCB ASS'Y) <p>[Remedy] Check/replace the related harness/cable, connector and parts. [Reference] After replacement of the Finisher Controller PCB, refer to "Adjustments> Adjustment when Replacing the Parts> Points to Note when Replacing the Finisher Controller PCB" in the Service Manual for the Finisher.</p>

E56F-8002-02	Inlet Roller HP error
Detection Description	FIN-W1/SADDLE FIN-W1 The Inlet Roller HP Sensor was not turned OFF although 5 sec had passed after the Inlet Roller Disengagement Motor started the operation.
Remedy	FIN-W1/SADDLE FIN-W1 [Related parts] - Harnesses from the Feed Motor Driver PCB to the Inlet Roller Disengagement Motor 1. Feed Motor Driver PCB (UN5/J278) to Relay Connector (11P) (Unit of replacement: CABLE, FEED UNIT) 2. Relay Connector (11P) to Inlet Roller Disengagement Motor (M27/J542) (Unit of replacement: ESTRANGEMENT MOTOR ASS'Y) - Harnesses from the Feed Motor Driver PCB to the Inlet Roller HP Sensor 1. Feed Motor Driver PCB (UN5/J278) to Relay Connector (11P) (Unit of replacement: CABLE, FEED UNIT) 2. Relay Connector (11P) to Inlet Roller HP Sensor (PS43/J544) (Unit of replacement: ESTRANGEMENT MOTOR ASS'Y) - Inlet Roller Disengagement Motor (M27) (Unit of replacement: MOTOR, STEPPING, DC) - Inlet Roller HP Sensor (PS43) (Unit of replacement: IC,PHOTO-INTERRUPTER,LG248NL1A) - Finisher Controller PCB (UN3) (Unit of replacement: FINISHER CONTROLLER PCB ASS'Y) [Remedy] Check/replace the related harness/cable, connector and parts. [Reference] After replacement of the Finisher Controller PCB, refer to "Adjustments> Adjustment when Replacing the Parts> Points to Note when Replacing the Finisher Controller PCB" in the Service Manual for the Finisher.
E577-8001-02	a. Paddle rotation HP error (Finisher-W1) b. Error in the Stack Delivery/Paddle Motor (Finisher-AC1)
Detection Description	a. The Paddle Rotation HP Sensor was not turned ON although 5 sec had passed after the Paddle Rotation Motor started the operation. b. The paddle does not come off the Paddle HP Sensor when the Stack Delivery/Paddle Motor has been driven for 1 second.
Remedy	a. FIN-W1/SADDLE FIN-W1 [Related parts] - Harnesses from the Finisher Controller PCB to the Paddle Rotation Motor 1. Finisher Controller PCB (UN3/J140) to Relay Connector (19P) (Unit of replacement: CABLE, JOG-T) 2. Relay Connector (19P) to Relay Connector (5P) (Unit of replacement: CABLE, JOG-U) 3. Relay Connector (5P) to Paddle Rotation Motor (M14/J628) (Unit of replacement: CABLE, PDL-ROT-M-T) - Harnesses from the Finisher Controller PCB to the Paddle Rotation HP Sensor 1. Finisher Controller PCB (UN3/J106) to Relay Connector (25P) (Unit of replacement: CABLE, JOG-T) 2. Relay Connector (25P) to Relay Connector (3P) (Unit of replacement: CABLE, JOG-U) 3. Relay Connector (3P) to Paddle Rotation HP Sensor (PS20/J619) (Unit of replacement: OPERATION ASSEMBLY) - Paddle Rotation Motor (M14) - Paddle Rotation HP Sensor (PS20) - Finisher Controller PCB (UN3) (Unit of replacement: FINISHER CONTROLLER PCB ASS'Y) [Remedy] Check/replace the related harness/cable, connector and parts. [Reference] After replacement of the Finisher Controller PCB, refer to "Adjustments> Adjustment when Replacing the Parts> Points to Note when Replacing the Finisher Controller PCB" in the Service Manual for the Finisher. b. STAPLE FIN-AC1/BOOKLET FIN-AC1 [Related parts] - Harnesses from the Paddle HP Sensor (PS120) to the Finisher Controller PCB - Harnesses from the Stack Delivery/Paddle Motor (M103) to the Finisher Controller PCB - Paddle HP Sensor (PS120) - Stack Delivery/Paddle Motor (M103) - Finisher Controller PCB (PCB101) [Remedy] Check/replace the related harness/cable, connector and parts. [Reference] When replacing the Finisher Controller PCB, refer to "Adjustment> When Replacing the Parts" in the Service Manual.

E577-8002-02	a. Paddle rotation HP error (Finisher-W1) b. Error in the Stack Delivery/Paddle Motor (Finisher-AC1)
Detection Description	<p>a. The Paddle Rotation HP Sensor was not turned OFF although 5 sec had passed after the Paddle Rotation Motor started the operation.</p> <p>b. The Paddle HP Sensor does not detect the paddle when the Stack Delivery/Paddle Motor has been driven for 1 second.</p>
Remedy	<p>a. FIN-W1/SADDLE FIN-W1 [Related parts]</p> <ul style="list-style-type: none"> - Harnesses from the Finisher Controller PCB to the Paddle Rotation Motor 1. Finisher Controller PCB (UN3/J140) to Relay Connector (19P) (Unit of replacement: CABLE, JOG-T) 2. Relay Connector (19P) to Relay Connector (5P) (Unit of replacement: CABLE, JOG-U) 3. Relay Connector (5P) to Paddle Rotation Motor (M14/J628) (Unit of replacement: CABLE, PDL-ROT-M-T) - Harnesses from the Finisher Controller PCB to the Paddle Rotation HP Sensor 1. Finisher Controller PCB (UN3/J106) to Relay Connector (25P) (Unit of replacement: CABLE, JOG-T) 2. Relay Connector (25P) to Relay Connector (3P) (Unit of replacement: CABLE, JOG-U) 3. Relay Connector (3P) to Paddle Rotation HP Sensor (PS20/J619) (Unit of replacement: OPERATION ASSEMBLY) - Paddle Rotation Motor (M14) - Paddle Rotation HP Sensor (PS20) - Finisher Controller PCB (UN3) (Unit of replacement: FINISHER CONTROLLER PCB ASS'Y) <p>[Remedy] Check/replace the related harness/cable, connector and parts. [Reference] After replacement of the Finisher Controller PCB, refer to "Adjustments> Adjustment when Replacing the Parts> Points to Note when Replacing the Finisher Controller PCB" in the Service Manual for the Finisher.</p> <p>b. STAPLE FIN-AC1/BOOKLET FIN-AC1 [Related parts]</p> <ul style="list-style-type: none"> - Harnesses from the Paddle HP Sensor (PS120) to the Finisher Controller PCB - Harnesses from the Stack Delivery/Paddle Motor (M103) to the Finisher Controller PCB - Paddle HP Sensor (PS120) - Stack Delivery/Paddle Motor (M103) - Finisher Controller PCB (PCB101) <p>[Remedy] Check/replace the related harness/cable, connector and parts. [Reference] When replacing the Finisher Controller PCB, refer to "Adjustment> When Replacing the Parts" in the Service Manual.</p>
E577-8003-02	Paddle lifting HP error
Detection Description	<p>FIN-W1/SADDLE FIN-W1</p> <p>The Paddle Lifting HP Sensor was not turned ON although 5 sec had passed after the Paddle Lifting Motor started the operation.</p>
Remedy	<p>FIN-W1/SADDLE FIN-W1 [Related parts]</p> <ul style="list-style-type: none"> - Harnesses from the Finisher Controller PCB to the Paddle Lifting Motor 1. Finisher Controller PCB (UN3/J140) to Relay Connector (19P) (Unit of replacement: CABLE, JOG-T) 2. Relay Connector (19P) to Paddle Lifting Motor (M15/J627) (Unit of replacement: CABLE, JOG-U) - Harnesses from the Finisher Controller PCB to the Paddle Lifting HP Sensor 1. Finisher Controller PCB (UN3/J106) to Relay Connector (25P) (Unit of replacement: CABLE, JOG-T) 2. Relay Connector (25P) to Paddle Lifting HP Sensor (PS21/J613) (Unit of replacement: CABLE, JOG-U) - Paddle Lifting Motor (M15) - Paddle Lifting HP Sensor (PS21) - Finisher Controller PCB (UN3) (Unit of replacement: FINISHER CONTROLLER PCB ASS'Y) <p>[Remedy] Check/replace the related harness/cable, connector and parts. [Reference] After replacement of the Finisher Controller PCB, refer to "Adjustments> Adjustment when Replacing the Parts> Points to Note when Replacing the Finisher Controller PCB" in the Service Manual for the Finisher.</p>

E577-8004-02	Paddle lifting HP error
Detection Description	FIN-W1/SADDLE FIN-W1 The Paddle Lifting HP Sensor was not turned OFF although 5 sec had passed after the Paddle Lifting Motor started the operation.
Remedy	FIN-W1/SADDLE FIN-W1 [Related parts] - Harnesses from the Finisher Controller PCB to the Paddle Lifting Motor 1. Finisher Controller PCB (UN3/J140) to Relay Connector (19P) (Unit of replacement: CABLE, JOG-T) 2. Relay Connector (19P) to Paddle Lifting Motor (M15/J627) (Unit of replacement: CABLE, JOG-U) - Harnesses from the Finisher Controller PCB to the Paddle Lifting HP Sensor 1. Finisher Controller PCB (UN3/J106) to Relay Connector (25P) (Unit of replacement: CABLE, JOG-T) 2. Relay Connector (25P) to Paddle Lifting HP Sensor (PS21/J613) (Unit of replacement: CABLE, JOG-U) - Paddle Lifting Motor (M15) - Paddle Lifting HP Sensor (PS21) - Finisher Controller PCB (UN3) (Unit of replacement: FINISHER CONTROLLER PCB ASS'Y) [Remedy] Check/replace the related harness/cable, connector and parts. [Reference] After replacement of the Finisher Controller PCB, refer to "Adjustments> Adjustment when Replacing the Parts> Points to Note when Replacing the Finisher Controller PCB" in the Service Manual for the Finisher.

E578-8001-02	a. Feed knurling HP error (Finisher-W1) b. Error in the Paper Return Guide Motor (Finisher-X1) c. Error in the Return Roller Lift Motor (Finisher-AC1)
Detection Description	<p>a. The Feed Belt HP Sensor was not turned ON although 5 sec had passed after the Feed Shift Motor started the operation.</p> <p>b. The paper return guide does not come off the Paper Return Guide HP Sensor when the Paper Return Guide Motor has been driven for 3 seconds.</p> <p>c. The return roller does not come off the Return Roller HP Sensor when the Return Roller Lift Motor has been driven for 1 second.</p>
Remedy	<p>a. FIN-W1/SADDLE FIN-W1 [Related parts]</p> <ul style="list-style-type: none"> - Harnesses from the Finisher Controller PCB to the Feed Belt Shift Motor 1. Finisher Controller PCB (UN3/J129) to Relay Connector (11P) (Unit of replacement: CABLE, FEED UNIT) 2. Relay Connector (11P) to Feed Belt Shift Motor (M17/J640) (Unit of replacement: CABLE, KNURLED UNIT) - Harnesses from the Finisher Controller PCB to the Feed Belt HP Sensor 1. Finisher Controller PCB (UN3/J129) to Relay Connector (11P) (Unit of replacement: CABLE, FEED UNIT) 2. Relay Connector (11P) to Feed Belt HP Sensor (PS25/J639) (Unit of replacement: CABLE, KNURLED UNIT) - Feed Belt Shift Motor (M17) - Feed Belt HP Sensor (PS25) - Finisher Controller PCB (UN3) (Unit of replacement: FINISHER CONTROLLER PCB ASS'Y) <p>[Remedy] Check/replace the related harness/cable, connector and parts. [Reference] After replacement of the Finisher Controller PCB, refer to "Adjustments> Adjustment when Replacing the Parts> Points to Note when Replacing the Finisher Controller PCB" in the Service Manual for the Finisher.</p> <p>b. STAPLE FIN-X1/BOOKLET FIN-X1 [Related parts]</p> <ul style="list-style-type: none"> - Harnesses from the Paper Return Guide HP Sensor (S112) to the Finisher Controller PCB - Harnesses from the Paper Return Guide Motor (M112) to the Finisher Controller PCB - Paper Return Guide HP Sensor (S112) - Paper Return Guide Motor (M112) - Finisher Controller PCB (PBA101) <p>[Remedy] Check/replace the related harness/cable, connector and parts. [Reference] When replacing the Finisher Controller PCB, refer to "Adjustments> Adjustment when Replacing the Parts" in the Service Manual.</p> <p>c. STAPLE FIN-AC1/BOOKLET FIN-AC1 [Related parts]</p> <ul style="list-style-type: none"> - Harnesses from the Return Roller HP Sensor (PS121) to the Finisher Controller PCB - Harnesses from the Return Roller Lift Motor (M111) to the Finisher Controller PCB - Return Roller HP Sensor (PS121) - Return Roller Lift Motor (M111) - Finisher Controller PCB (PCB101) <p>[Remedy] Check/replace the related harness/cable, connector and parts. [Reference] When replacing the Finisher Controller PCB, refer to "Adjustment> When Replacing the Parts" in the Service Manual.</p>

E578-8002-02	a. Feed knurling HP error (Finisher-W1) b. Error in the Paper Return Guide Motor (Finisher-X1) c. Error in the Return Roller Lift Motor (Finisher-AC1)
Detection Description	<p>a. The Feed Belt HP Sensor was not turned OFF although 5 sec had passed after the Feed Shift Motor started the operation.</p> <p>b. The Paper Return Guide HP Sensor does not detect the paper return guide when the Paper Return Guide Motor has been driven for 3 seconds.</p> <p>c. The Return Roller HP Sensor does not detect the return roller when the Return Roller Lift Motor has been driven for 1 second.</p>
Remedy	<p>a. FIN-W1/SADDLE FIN-W1 [Related parts]</p> <ul style="list-style-type: none"> - Harnesses from the Finisher Controller PCB to the Feed Belt Shift Motor 1. Finisher Controller PCB (UN3/J129) to Relay Connector (11P) (Unit of replacement: CABLE, FEED UNIT) 2. Relay Connector (11P) to Feed Belt Shift Motor (M17/J640) (Unit of replacement: CABLE, KNURLED UNIT) - Harnesses from the Finisher Controller PCB to the Feed Belt HP Sensor 1. Finisher Controller PCB (UN3/J129) to Relay Connector (11P) (Unit of replacement: CABLE, FEED UNIT) 2. Relay Connector (11P) to Feed Belt HP Sensor (PS25/J639) (Unit of replacement: CABLE, KNURLED UNIT) - Feed Belt Shift Motor (M17) - Feed Belt HP Sensor (PS25) - Finisher Controller PCB (UN3) (Unit of replacement: FINISHER CONTROLLER PCB ASS'Y) <p>[Remedy] Check/replace the related harness/cable, connector and parts. [Reference] After replacement of the Finisher Controller PCB, refer to "Adjustments> Adjustment when Replacing the Parts> Points to Note when Replacing the Finisher Controller PCB" in the Service Manual for the Finisher.</p> <p>b. STAPLE FIN-X1/BOOKLET FIN-X1 [Related parts]</p> <ul style="list-style-type: none"> - Harnesses from the Paper Return Guide HP Sensor (S112) to the Finisher Controller PCB - Harnesses from the Paper Return Guide Motor (M112) to the Finisher Controller PCB - Paper Return Guide HP Sensor (S112) - Paper Return Guide Motor (M112) - Finisher Controller PCB (PBA101) <p>[Remedy] Check/replace the related harness/cable, connector and parts. [Reference] When replacing the Finisher Controller PCB, refer to "Adjustments> Adjustment when Replacing the Parts" in the Service Manual.</p> <p>c. STAPLE FIN-AC1/BOOKLET FIN-AC1 [Related parts]</p> <ul style="list-style-type: none"> - Harnesses from the Return Roller HP Sensor (PS121) to the Finisher Controller PCB - Harnesses from the Return Roller Lift Motor (M111) to the Finisher Controller PCB - Return Roller HP Sensor (PS121) - Return Roller Lift Motor (M111) - Finisher Controller PCB (PCB101) <p>[Remedy] Check/replace the related harness/cable, connector and parts. [Reference] When replacing the Finisher Controller PCB, refer to "Adjustment> When Replacing the Parts" in the Service Manual.</p>

E57A-8001-02	Process Tray HP error
Detection Description	FIN-W1/SADDLE FIN-W1 The Process Tray HP Sensor was not turned ON although 5 sec had passed after the Process Stopper Shift Motor started the operation.
Remedy	FIN-W1/SADDLE FIN-W1 [Related parts] - Harnesses from the Finisher Controller PCB to the Process Stopper Shift Motor 1. Finisher Controller PCB (UN3/J139) to Relay Connector (31P) (Unit of replacement: CABLE, JOG-T) 2. Relay Connector (31P) to Relay Connector (14P) (Unit of replacement: CABLE, JOG-U) 3. Relay Connector (14P) to Process Stopper Shift Motor (M11/J607) (Unit of replacement: CABLE, FJOG) - Harnesses from the Finisher Controller PCB to the Process Tray HP Sensor 1. Finisher Controller PCB (UN3/J139) to Relay Connector (31P) (Unit of replacement: CABLE, JOG-T) 2. Relay Connector (31P) to Relay Connector (16P) (Unit of replacement: CABLE, JOG-U) 3. Relay Connector (16P) to Process Tray HP Sensor (PS13/J611) (Unit of replacement: CABLE, BJOG) - Process Stopper Shift Motor (M11) - Process Tray HP Sensor (PS13) - Finisher Controller PCB (UN3) (Unit of replacement: FINISHER CONTROLLER PCB ASS'Y) [Remedy] Check/replace the related harness/cable, connector and parts. [Reference] After replacement of the Finisher Controller PCB, refer to "Adjustments> Adjustment when Replacing the Parts> Points to Note when Replacing the Finisher Controller PCB" in the Service Manual for the Finisher.
E57A-8002-02	Process Tray HP error
Detection Description	FIN-W1/SADDLE FIN-W1 The Process Tray HP Sensor was not turned OFF although 5 sec had passed after the Process Stopper Shift Motor started the operation.
Remedy	FIN-W1/SADDLE FIN-W1 [Related parts] - Harnesses from the Finisher Controller PCB to the Process Stopper Shift Motor 1. Finisher Controller PCB (UN3/J139) to Relay Connector (31P) (Unit of replacement: CABLE, JOG-T) 2. Relay Connector (31P) to Relay Connector (14P) (Unit of replacement: CABLE, JOG-U) 3. Relay Connector (14P) to Process Stopper Shift Motor (M11/J607) (Unit of replacement: CABLE, FJOG) - Harnesses from the Finisher Controller PCB to the Process Tray HP Sensor 1. Finisher Controller PCB (UN3/J139) to Relay Connector (31P) (Unit of replacement: CABLE, JOG-T) 2. Relay Connector (31P) to Relay Connector (16P) (Unit of replacement: CABLE, JOG-U) 3. Relay Connector (16P) to Process Tray HP Sensor (PS13/J611) (Unit of replacement: CABLE, BJOG) - Process Stopper Shift Motor (M11) - Process Tray HP Sensor (PS13) - Finisher Controller PCB (UN3) (Unit of replacement: FINISHER CONTROLLER PCB ASS'Y) [Remedy] Check/replace the related harness/cable, connector and parts. [Reference] After replacement of the Finisher Controller PCB, refer to "Adjustments> Adjustment when Replacing the Parts> Points to Note when Replacing the Finisher Controller PCB" in the Service Manual for the Finisher.

E57A-8003-02	Process Stopper operation error
Detection Description	FIN-W1/SADDLE FIN-W1 Operation could not be started because the Process Stopper interfered with the Stapler.
Remedy	FIN-W1/SADDLE FIN-W1 [Related parts] - Harnesses from the Finisher Controller PCB to the Process Stopper Shift Motor 1. Finisher Controller PCB (UN3/J139) to Relay Connector (31P) (Unit of replacement: CABLE, JOG-T) 2. Relay Connector (31P) to Relay Connector (14P) (Unit of replacement: CABLE, JOG-U) 3. Relay Connector (14P) to Process Stopper Shift Motor (M11/J607) (Unit of replacement: CABLE, FJOG) - Process Stopper Shift Motor (M11) - Finisher Controller PCB (UN3) (Unit of replacement: FINISHER CONTROLLER PCB ASS'Y) [Remedy] Check/replace the related harness/cable, connector and parts. [Reference] After replacement of the Finisher Controller PCB, refer to "Adjustments> Adjustment when Replacing the Parts> Points to Note when Replacing the Finisher Controller PCB" in the Service Manual for the Finisher.

E57B-8001-02

a. Paper Trailing Edge Drop Guide HP error (Finisher-W1) b. Error in the Paper Trailing Edge Pushing Guide Motor (Finisher-X1) c. Error in the Paper End Pushing Guide Motor (Finisher-AC1)

Detection Description

- a. The Paper Trailing Edge Drop Guide HP Sensor was not turned ON although 5 sec had passed after the Paper Trailing Edge Drop Motor started the operation.
- b. The paper trailing edge pushing guide does not come off the Paper Trailing Edge Pushing Guide HP Sensor when the Paper Trailing Edge Pushing Guide Motor has been driven for 3 seconds.
- c. The paper end pushing guide does not come off the Paper End Pushing Guide HP Sensor when the Paper End Pushing Guide Motor has been driven for 1 second.

Remedy

a. FIN-W1/SADDLE FIN-W1

[Related parts]

- Harnesses from the Feed Motor Driver PCB to the Paper Trailing Edge Drop Guide HP Sensor
- 1. Feed Motor Driver PCB (UN5/J277) to Relay Connector (7P)
- 2. Relay Connector (7P) to Paper Trailing Edge Drop Guide HP Sensor (PS24/J510) (Unit of replacement: CABLE, DNSORT SENSOR)
- Paper Trailing Edge Drop Motor (M16)
- Paper Trailing Edge Drop Guide HP Sensor (PS24)
- Finisher Controller PCB (UN3) (Unit of replacement: FINISHER CONTROLLER PCB ASS'Y)

[Remedy] Check/replace the related harness/cable, connector and parts.

[Reference] After replacement of the Finisher Controller PCB, refer to "Adjustments> Adjustment when Replacing the Parts> Points to Note when Replacing the Finisher Controller PCB" in the Service Manual for the Finisher.

b. STAPLE FIN-X1/BOOKLET FIN-X1

[Related parts]

- Harnesses from the Paper Trailing Edge Pushing Guide HP Sensor (S113) to the Finisher Controller PCB
- Harnesses from the Paper Trailing Edge Pushing Guide Motor (M113) to the Finisher Controller PCB
- Paper Trailing Edge Pushing Guide HP Sensor (S113)
- Paper Trailing Edge Pushing Guide Motor (M113)
- Finisher Controller PCB (PBA101)

[Remedy] Check/replace the related harness/cable, connector and parts.

[Reference] When replacing the Finisher Controller PCB, refer to "Adjustments> Adjustment when Replacing the Parts" in the Service Manual.

c. STAPLE FIN-AC1/BOOKLET FIN-AC1

[Related parts]

- Harnesses from the Paper End Pushing Guide HP Sensor (PS122) to the Finisher Controller PCB
- Harnesses from the Paper End Pushing Guide Motor (M112) to the Finisher Controller PCB
- Paper End Pushing Guide HP Sensor (PS122)
- Paper End Pushing Guide Motor (M112)
- Finisher Controller PCB (PCB101)

[Remedy] Check/replace the related harness/cable, connector and parts.

[Reference] When replacing the Finisher Controller PCB, refer to "Adjustment> When Replacing the Parts" in the Service Manual.

E57B-8002-02

a. Paper Trailing Edge Drop Guide HP error (Finisher-W1) b. Error in the Paper Trailing Edge Pushing Guide Motor (Finisher-X1) c. Error in the Paper End Pushing Guide Motor (Finisher-AC1)

Detection Description

- a. The Paper Trailing Edge Drop Guide HP Sensor was not turned OFF although 5 sec had passed after the Paper Trailing Edge Drop Motor started the operation.
- b. The Paper Trailing Edge Pushing Guide HP Sensor does not detect the paper trailing edge pushing guide when the Paper Trailing Edge Pushing Guide Motor has been driven for 3 seconds.
- c. The Paper End Pushing Guide HP Sensor does not detect the paper end pushing guide when the Paper End Pushing Guide Motor has been driven for 1 second.

Remedy

a. FIN-W1/SADDLE FIN-W1

[Related parts]

- Harnesses from the Feed Motor Driver PCB to the Paper Trailing Edge Drop Guide HP Sensor
- 1. Feed Motor Driver PCB (UN5/J277) to Relay Connector (7P)
- 2. Relay Connector (7P) to Paper Trailing Edge Drop Guide HP Sensor (PS24/J510) (Unit of replacement: CABLE, DNSORT SENSOR)
- Paper Trailing Edge Drop Motor (M16)
- Paper Trailing Edge Drop Guide HP Sensor (PS24)
- Finisher Controller PCB (UN3) (Unit of replacement: FINISHER CONTROLLER PCB ASS'Y)

[Remedy] Check/replace the related harness/cable, connector and parts.

[Reference] After replacement of the Finisher Controller PCB, refer to "Adjustments> Adjustment when Replacing the Parts> Points to Note when Replacing the Finisher Controller PCB" in the Service Manual for the Finisher.

b. STAPLE FIN-X1/BOOKLET FIN-X1

[Related parts]

- Harnesses from the Paper Trailing Edge Pushing Guide HP Sensor (S113) to the Finisher Controller PCB
- Harnesses from the Paper Trailing Edge Pushing Guide Motor (M113) to the Finisher Controller PCB
- Paper Trailing Edge Pushing Guide HP Sensor (S113)
- Paper Trailing Edge Pushing Guide Motor (M113)
- Finisher Controller PCB (PBA101)

[Remedy] Check/replace the related harness/cable, connector and parts.

[Reference] When replacing the Finisher Controller PCB, refer to "Adjustments> Adjustment when Replacing the Parts" in the Service Manual.

c. STAPLE FIN-AC1/BOOKLET FIN-AC1

[Related parts]

- Harnesses from the Paper End Pushing Guide HP Sensor (PS122) to the Finisher Controller PCB
- Harnesses from the Paper End Pushing Guide Motor (M112) to the Finisher Controller PCB
- Paper End Pushing Guide HP Sensor (PS122)
- Paper End Pushing Guide Motor (M112)
- Finisher Controller PCB (PCB101)

[Remedy] Check/replace the related harness/cable, connector and parts.

[Reference] When replacing the Finisher Controller PCB, refer to "Adjustment> When Replacing the Parts" in the Service Manual.

E57C-8001-02 a. Upper Guide HP Error b. Error in the Processing Tray Paper Retainer Motor (Finisher-X1)**Detection Description**

a. FIN-W1/SADDLE FIN-W1

The Upper Guide HP Sensor was not turned ON although 5 sec had passed after the Upper Guide Motor started the operation.

b. The paper retainer does not come off the Paper Retainer HP Sensor when the Processing Tray Paper Retainer Motor has been driven for 3 seconds.

Remedy

a. FIN-W1/SADDLE FIN-W1

[Related parts]

- Harnesses from the Finisher Controller PCB to the Upper Guide Motor

1. Finisher Controller PCB (UN3/J129) to Relay Connector (11P) (Unit of replacement: CABLE, FEED UNIT)

2. Relay Connector (11P) to Upper Guide Motor (M20/J641) (Unit of replacement: CABLE, KNURLED UNIT)

- Harness between the Finisher Controller PCB (UN3/J127) and the Upper Guide HP Sensor (PS26/J638) (Unit of replacement: CABLE, FEED UNIT)

- Upper Guide Motor (M20)

- Upper Guide HP Sensor (PS26)

- Finisher Controller PCB (UN3) (Unit of replacement: FINISHER CONTROLLER PCB ASS'Y)

[Remedy] Check/replace the related harness/cable, connector and parts.

[Reference] After replacement of the Finisher Controller PCB, refer to "Adjustments> Adjustment when Replacing the Parts> Points to Note when Replacing the Finisher Controller PCB" in the Service Manual for the Finisher.

b. STAPLE FIN-X1/BOOKLET FIN-X1

[Related parts]

- Harnesses from the Paper Retainer HP Sensor (S135) to the Finisher Controller PCB

- Harnesses from the Processing Tray Paper Retainer Motor (M118) to the Finisher Controller PCB

- Paper Retainer HP Sensor (S135)

- Processing Tray Paper Retainer Motor (M118)

- Finisher Controller PCB (PBA101)

[Remedy] Check/replace the related harness/cable, connector and parts.

[Reference] When replacing the Finisher Controller PCB, refer to "Adjustments> Adjustment when Replacing the Parts" in the Service Manual.

E57C-8002-02 a. Upper Guide HP Error b. Error in the Processing Tray Paper Retainer Motor (Finisher-X1)**Detection Description**

a. FIN-W1/SADDLE FIN-W1

The Upper Guide HP Sensor was not turned OFF although 5 sec had passed after the Upper Guide Motor started the operation.

b. The Paper Retainer HP Sensor does not detect the paper retainer when the Processing Tray Paper Retainer Motor has been driven for 3 seconds.

Remedy

a. FIN-W1/SADDLE FIN-W1

[Related parts]

- Harnesses from the Finisher Controller PCB to the Upper Guide Motor

1. Finisher Controller PCB (UN3/J129) to Relay Connector (11P) (Unit of replacement: CABLE, FEED UNIT)

2. Relay Connector (11P) to Upper Guide Motor (M20/J641) (Unit of replacement: CABLE, KNURLED UNIT)

- Harness between the Finisher Controller PCB (UN3/J127) and the Upper Guide HP Sensor (PS26/J638) (Unit of replacement: CABLE, FEED UNIT)

- Upper Guide Motor (M20)

- Upper Guide HP Sensor (PS26)

- Finisher Controller PCB (UN3) (Unit of replacement: FINISHER CONTROLLER PCB ASS'Y)

[Remedy] Check/replace the related harness/cable, connector and parts.

[Reference] After replacement of the Finisher Controller PCB, refer to "Adjustments> Adjustment when Replacing the Parts> Points to Note when Replacing the Finisher Controller PCB" in the Service Manual for the Finisher.

b. STAPLE FIN-X1/BOOKLET FIN-X1

[Related parts]

- Harnesses from the Paper Retainer HP Sensor (S135) to the Finisher Controller PCB

- Harnesses from the Processing Tray Paper Retainer Motor (M118) to the Finisher Controller PCB

- Paper Retainer HP Sensor (S135)

- Processing Tray Paper Retainer Motor (M118)

- Finisher Controller PCB (PBA101)

[Remedy] Check/replace the related harness/cable, connector and parts.

[Reference] When replacing the Finisher Controller PCB, refer to "Adjustments> Adjustment when Replacing the Parts" in the Service Manual.

E583-8001-02

a. Stack Delivery Auxiliary Tray HP error (Finisher-W1) b. Error in the Tray Auxiliary Guide Motor (Finisher-X1) c. Error in the Tray Auxiliary Guide Motor (Finisher-AC1)**Detection Description**

- a. The Stack Delivery Auxiliary Tray HP Sensor was not turned ON although 5 sec had passed after the Stack Delivery Auxiliary Tray Motor started the operation.
- b. The tray auxiliary guide does not come off the Tray Auxiliary Guide Front/Rear HP Sensors when the Tray Auxiliary Guide Motor has been driven for 3 seconds.
- c. The tray auxiliary guides don't come off the Front/Rear Tray Auxiliary Guide HP Sensors when the Tray Auxiliary Guide Motor has been driven for 1 second.

Remedy**a. FIN-W1/SADDLE FIN-W1**

[Related parts]

- Harnesses connecting the Stack Delivery Auxiliary Tray Motor (M13/J629), the Relay Connector (J629/J633) and the Finisher Controller PCB (UN3/J140)

- Harnesses from the Finisher Controller PCB to the Stack Delivery Auxiliary Tray Motor

1. Finisher Controller PCB (UN3/J140) to Relay Connector (19P) (Unit of replacement: CABLE, JOG-T)

2. Relay Connector (19P) to Stack Delivery Auxiliary Tray Motor (M13/J629) (Unit of replacement: MOTOR, STEPPING, DC)

- Harnesses from the Finisher Controller PCB to the Stack Delivery Auxiliary Tray HP Sensor

1. Finisher Controller PCB (UN3/J106) to Relay Connector (25P) (Unit of replacement: CABLE, JOG-T)

2. Relay Connector (25P) to Relay Connector (4P) (Unit of replacement: CABLE, JOG-U)

3. Relay Connector (4P) to Stack Delivery Auxiliary Tray HP Sensor (PS14/J617) (Unit of replacement: TRAY AUXILIARY PLATE ASSEMBLY)

- Stack Delivery Auxiliary Tray Motor (M13)

- Stack Delivery Auxiliary Tray HP Sensor (PS14)

- Finisher Controller PCB (UN3) (Unit of replacement: FINISHER CONTROLLER PCB ASS'Y)

[Remedy] Check/replace the related harness/cable, connector and parts.

[Reference] After replacement of the Finisher Controller PCB, refer to "Adjustments> Adjustment when Replacing the Parts> Points to Note when Replacing the Finisher Controller PCB" in the Service Manual for the Finisher.

b. STAPLE FIN-X1/BOOKLET FIN-X1

[Related parts]

- Harnesses from the Tray Auxiliary Guide Front HP Sensor (S137) to the Finisher Controller PCB

- Harnesses from the Tray Auxiliary Guide Rear HP Sensor (S136) to the Finisher Controller PCB

- Tray Auxiliary Guide Motor (M120)

- Tray Auxiliary Guide Front HP Sensor (S137)

- Tray Auxiliary Guide Rear HP Sensor (S136)

- Tray Auxiliary Guide Motor (M120)

- Finisher Controller PCB (PBA101)

[Remedy] Check/replace the related harness/cable, connector and parts.

[Reference] When replacing the Finisher Controller PCB, refer to "Adjustments> Adjustment when Replacing the Parts" in the Service Manual.

c. STAPLE FIN-AC1/BOOKLET FIN-AC1

[Related parts]

- Harnesses from the Front Tray Auxiliary Guide HP Sensor (PS117) to the Finisher Controller PCB

- Harnesses from the Rear Tray Auxiliary Guide HP Sensor (PS118) to the Finisher Controller PCB

- Harnesses from the Tray Auxiliary Guide Motor (M109) to the Finisher Controller PCB

- Front Tray Auxiliary Guide HP Sensor (PS117)

- Rear Tray Auxiliary Guide HP Sensor (PS118)

- Tray Auxiliary Guide Motor (M109)

- Finisher Controller PCB (PCB101)

[Remedy] Check/replace the related harness/cable, connector and parts.

[Reference] When replacing the Finisher Controller PCB, refer to "Adjustment> When Replacing the Parts" in the Service Manual.

E583-8002-02

a. Stack Delivery Auxiliary Tray HP error (Finisher-W1) b. Error in the Tray Auxiliary Guide Motor (Finisher-X1) c. Error in the Tray Auxiliary Guide Motor (Finisher-AC1)**Detection Description**

- a. The Stack Delivery Auxiliary Tray HP Sensor was not turned OFF although 5 sec had passed after the Stack Delivery Auxiliary Tray Motor started the operation.
- b. The Tray Auxiliary Guide Front/Rear HP Sensors does not detect the tray auxiliary guide when the Tray Auxiliary Guide Motor has been driven for 3 seconds.
- c. The Front/Rear Tray Auxiliary Guide HP Sensors don't detect the tray auxiliary guides when the Tray Auxiliary Guide Motor has been driven for 1 second.

Remedy**a. FIN-W1/SADDLE FIN-W1**

[Related parts]

- Harnesses connecting the Stack Delivery Auxiliary Tray Motor (M13/J629), the Relay Connector (J629/J633) and the Finisher Controller PCB (UN3/J140)

- Harnesses from the Finisher Controller PCB to the Stack Delivery Auxiliary Tray Motor

1. Finisher Controller PCB (UN3/J140) to Relay Connector (19P) (Unit of replacement: CABLE, JOG-T)

2. Relay Connector (19P) to Stack Delivery Auxiliary Tray Motor (M13/J629) (Unit of replacement: MOTOR, STEPPING, DC)

- Harnesses from the Finisher Controller PCB to the Stack Delivery Auxiliary Tray HP Sensor

1. Finisher Controller PCB (UN3/J106) to Relay Connector (25P) (Unit of replacement: CABLE, JOG-T)

2. Relay Connector (25P) to Relay Connector (4P) (Unit of replacement: CABLE, JOG-U)

3. Relay Connector (4P) to Stack Delivery Auxiliary Tray HP Sensor (PS14/J617) (Unit of replacement: TRAY AUXILIARY PLATE ASSEMBLY)

- Stack Delivery Auxiliary Tray Motor (M13)

- Stack Delivery Auxiliary Tray HP Sensor (PS14)

- Finisher Controller PCB (UN3) (Unit of replacement: FINISHER CONTROLLER PCB ASS'Y)

[Remedy] Check/replace the related harness/cable, connector and parts.

[Reference] After replacement of the Finisher Controller PCB, refer to "Adjustments> Adjustment when Replacing the Parts> Points to Note when Replacing the Finisher Controller PCB" in the Service Manual for the Finisher.

b. STAPLE FIN-X1/BOOKLET FIN-X1

[Related parts]

- Harnesses from the Tray Auxiliary Guide Front HP Sensor (S137) to the Finisher Controller PCB

- Harnesses from the Tray Auxiliary Guide Rear HP Sensor (S136) to the Finisher Controller PCB

- Tray Auxiliary Guide Motor (M120)

- Tray Auxiliary Guide Front HP Sensor (S137)

- Tray Auxiliary Guide Rear HP Sensor (S136)

- Tray Auxiliary Guide Motor (M120)

- Finisher Controller PCB (PBA101)

[Remedy] Check/replace the related harness/cable, connector and parts.

[Reference] When replacing the Finisher Controller PCB, refer to "Adjustments> Adjustment when Replacing the Parts" in the Service Manual.

c. STAPLE FIN-AC1/BOOKLET FIN-AC1

[Related parts]

- Harnesses from the Front Tray Auxiliary Guide HP Sensor (PS117) to the Finisher Controller PCB

- Harnesses from the Rear Tray Auxiliary Guide HP Sensor (PS118) to the Finisher Controller PCB

- Harnesses from the Tray Auxiliary Guide Motor (M109) to the Finisher Controller PCB

- Front Tray Auxiliary Guide HP Sensor (PS117)

- Rear Tray Auxiliary Guide HP Sensor (PS118)

- Tray Auxiliary Guide Motor (M109)

- Finisher Controller PCB (PCB101)

[Remedy] Check/replace the related harness/cable, connector and parts.

[Reference] When replacing the Finisher Controller PCB, refer to "Adjustment> When Replacing the Parts" in the Service Manual.

E584-8001-02	Error in the Stack Delivery Lower/Shutter Motor (Finisher-X1)
Detection Description	The shutter does not come off the Shutter HP Sensor when the Stack Delivery Lower/Shutter Motor has been driven for 3 seconds.
Remedy	<p>[Related parts]</p> <ul style="list-style-type: none"> - Harnesses from the Shutter HP Sensor (S106) to the Finisher Controller PCB - Harnesses from the Stack Delivery Lower/Shutter Motor (M122) to the Finisher Controller PCB - Shutter HP Sensor (S106) - Stack Delivery Lower/Shutter Motor (M122) - Finisher Controller PCB (PBA101) <p>[Remedy] Check/replace the related harness/cable, connector and parts. [Reference] When replacing the Finisher Controller PCB, refer to "Adjustments> Adjustment when Replacing the Parts" in the Service Manual.</p>
E584-8002-02	Error in the stack delivery lower/shutter motor (Finisher-X1)
Detection Description	The shutter HP sensor does not detect the shutter.
Remedy	<p>[Related parts]</p> <ul style="list-style-type: none"> - Harnesses from the Shutter HP Sensor (S106) to the Finisher Controller PCB - Harnesses from the Stack Delivery Lower/Shutter Motor (M122) to the Finisher Controller PCB - Shutter HP Sensor (S106) - Stack Delivery Lower/Shutter Motor (M122) - Finisher Controller PCB (PBA101) <p>[Remedy] Check/replace the related harness/cable, connector and parts. [Reference] When replacing the Finisher Controller PCB, refer to "Adjustments> Adjustment when Replacing the Parts" in the Service Manual.</p>
E584-8003-02	Error in the Stack Delivery Lower/Shutter Motor (Finisher-X1)
Detection Description	The shutter does not come off the Shutter Close Detection Sensor when the Stack Delivery Lower/Shutter Motor has been driven for 3 seconds.
Remedy	<p>[Related parts]</p> <ul style="list-style-type: none"> - Harnesses from the Shutter Close Detection Sensor (S148) to the Finisher Controller PCB - Harnesses from the Stack Delivery Lower/Shutter Motor (M122) to the Finisher Controller PCB - Shutter Close Detection Sensor (S148) - Stack Delivery Lower/Shutter Motor (M122) - Finisher Controller PCB <p>[Remedy] Check/replace the related harness/cable, connector and parts. [Reference] When replacing the Finisher Controller PCB, refer to "Adjustments> Adjustment when Replacing the Parts" in the Service Manual.</p>
E584-8004-02	Error in the Stack Delivery Lower/Shutter Motor (Finisher-X1)
Detection Description	The Shutter Close Detection Sensor does not detect the shutter when the Stack Delivery Lower/Shutter Motor has been driven for 3 seconds.
Remedy	<p>[Related parts]</p> <ul style="list-style-type: none"> - Harnesses from the Shutter Close Detection Sensor (S148) to the Finisher Controller PCB - Harnesses from the Stack Delivery Lower/Shutter Motor (M122) to the Finisher Controller PCB - Shutter Close Detection Sensor (S148) - Stack Delivery Lower/Shutter Motor (M122) - Finisher Controller PCB (PBA101) <p>[Remedy] Check/replace the related harness/cable, connector and parts. [Reference] When replacing the Finisher Controller PCB, refer to "Adjustments> Adjustment when Replacing the Parts" in the Service Manual.</p>

E585-8001-02	Stack Retainer HP error
Detection Description	FIN-W1/SADDLE FIN-W1 The Stack Retainer HP Sensor was not turned ON although 0.25 sec had passed after the Stack Retainer Motor started the operation.
Remedy	FIN-W1/SADDLE FIN-W1 [Related parts] - Harnesses from the Finisher Controller PCB to the Stack Retainer Motor 1. Finisher Controller PCB (UN3/J152) to Relay Connector (7P) (Unit of replacement: CABLE, JOG-T) 2. Relay Connector (7P) to Stack Retainer Motor (M201/J2598) (Unit of replacement: CABLE, JOG-U) - Harnesses from the Finisher Controller PCB to the Stack Retainer HP Sensor 1. Finisher Controller PCB (UN3/J152) to Relay Connector (7P) (Unit of replacement: CABLE, JOG-T) 2. Relay Connector (7P) to Stack Retainer HP Sensor (PS201/J2599) (Unit of replacement: CABLE, JOG-U) - Stack Retainer HP Sensor (PS201) (Unit of replacement: IC,PHOTO-INTERRUPTER,LG248NL1A) - Stack Retainer Motor (M20) (Unit of replacement: MOTOR, STEPPING, DC) - Finisher Controller PCB (UN3) (Unit of replacement: FINISHER CONTROLLER PCB ASS'Y) [Remedy] Check/replace the related harness/cable, connector and parts. [Reference] After replacement of the Finisher Controller PCB, refer to "Adjustments> Adjustment when Replacing the Parts> Points to Note when Replacing the Finisher Controller PCB" in the Service Manual for the Finisher.
E585-8002-02	Stack Retainer HP error
Detection Description	FIN-W1/SADDLE FIN-W1 The Stack Retainer HP Sensor was not turned OFF although 0.25 sec had passed after the Stack Retainer Motor started the operation.
Remedy	FIN-W1/SADDLE FIN-W1 [Related parts] - Harnesses from the Finisher Controller PCB to the Stack Retainer Motor 1. Finisher Controller PCB (UN3/J152) to Relay Connector (7P) (Unit of replacement: CABLE, JOG-T) 2. Relay Connector (7P) to Stack Retainer Motor (M201/J2598) (Unit of replacement: CABLE, JOG-U) - Harnesses from the Finisher Controller PCB to the Stack Retainer HP Sensor 1. Finisher Controller PCB (UN3/J152) to Relay Connector (7P) (Unit of replacement: CABLE, JOG-T) 2. Relay Connector (7P) to Stack Retainer HP Sensor (PS201/J2599) (Unit of replacement: CABLE, JOG-U) - Stack Retainer HP Sensor (PS201) (Unit of replacement: IC,PHOTO-INTERRUPTER,LG248NL1A) - Stack Retainer Motor (M20) (Unit of replacement: MOTOR, STEPPING, DC) - Finisher Controller PCB (UN3) (Unit of replacement: FINISHER CONTROLLER PCB ASS'Y) [Remedy] Check/replace the related harness/cable, connector and parts. [Reference] After replacement of the Finisher Controller PCB, refer to "Adjustments> Adjustment when Replacing the Parts> Points to Note when Replacing the Finisher Controller PCB" in the Service Manual for the Finisher.

E590-8000-02	Punch Motor detection error
Detection Description	PUNCHER UNIT-BS1/BT1/BU1 The punch did not move although 0.2 sec had passed after the Punch Motor started the operation.
Remedy	PUNCHER UNIT-BS1/BT1/BU1 [Related parts] <ul style="list-style-type: none"> - Harness between the Finisher Controller PCB (UN3/J131) and the Punch Motor (M24/J571) (Unit of replacement: CABLE, PUNCH) - Harness between the Finisher Controller PCB (UN3/J130) and the Punch Motor Clock Sensor (PS38/J575) (Unit of replacement: CABLE, PUNCH) - Harness between the Finisher Controller PCB (UN3/J130) and the Punch Front Sensor (PS37/J573) (Unit of replacement: CABLE, PUNCH) - Harness between the Finisher Controller PCB (UN3/J130) and the Punch 2/3 Hole Sensor (PS39/J572) (Unit of replacement: CABLE, PUNCH) - Harness between the Finisher Controller PCB (UN3/J130) and the Punch Motor HP Sensor (PS36/J574) (Unit of replacement: CABLE, PUNCH) - Punch Motor Clock Sensor (PS38) (Unit of replacement: IC, PHOTO-INTERRUPTER) - Punch Front Sensor (PS37) (Unit of replacement: IC, PHOTO-INTERRUPTER) - Punch 2/3 Hole Sensor (PS39) (Unit of replacement: IC, PHOTO-INTERRUPTER) - Punch Motor HP Sensor (PS36) (Unit of replacement: IC, PHOTO-INTERRUPTER) - Punch Motor (M24) (Unit of replacement: MOTOR, STEPPING, DC) - Punch Unit (Unit of replacement: PUNCHER UNIT-BS1/BT1/BU1) - Finisher Controller PCB (UN3) (Unit of replacement: FINISHER CONTROLLER PCB ASS'Y) [Remedy] Check/replace the related harness/cable, connector and parts. [Reference] After replacement of the Finisher Controller PCB, refer to "Adjustments> Adjustment when Replacing the Parts> Points to Note when Replacing the Finisher Controller PCB" in the Service Manual for the Finisher.

E590-8001-02

a. Punch Motor HP error (Puncher Unit-BS1/BT1/BU1) b. Error in the Punch Motor (Puncher Unit-BE1/BF1/BG1/BH1) c. Error in the Punch Motor (Puncher Unit-A1)**Detection Description**

- a. The Punch Motor HP Sensor was not turned ON although 500 sec had passed after the Punch Motor started the operation.
- b. During initialization, the Punch HP Sensor does not detect the Puncher when the Punch Motor has been driven for 500 msec. after the Puncher has come off the Punch HP Sensor. After initialization, the Punch Motor does not return to home position.
- c. The punch does not come off the Punch HP Sensor when the Punch Motor has been driven for 0.2 seconds.

Remedy**a. PUNCHER UNIT-BS1/BT1/BU1**

[Related parts]

- Harness between the Finisher Controller PCB (UN3/J131) and the Punch Motor (M24/J571) (Unit of replacement: CABLE, PUNCH)
- Harness between the Finisher Controller PCB (UN3/J130) and the Punch Motor Clock Sensor (PS38/J575) (Unit of replacement: CABLE, PUNCH)
- Harness between the Finisher Controller PCB (UN3/J130) and the Punch Front Sensor (PS37/J573) (Unit of replacement: CABLE, PUNCH)
- Harness between the Finisher Controller PCB (UN3/J130) and the Punch 2/3 Hole Sensor (PS39/J572) (Unit of replacement: CABLE, PUNCH)
- Harness between the Finisher Controller PCB (UN3/J130) and the Punch Motor HP Sensor (PS36/J574) (Unit of replacement: CABLE, PUNCH)
- Punch Motor Clock Sensor (PS38) (Unit of replacement: IC, PHOTO-INTERRUPTER)
- Punch Front Sensor (PS37) (Unit of replacement: IC, PHOTO-INTERRUPTER)
- Punch 2/3 Hole Sensor (PS39) (Unit of replacement: IC, PHOTO-INTERRUPTER)
- Punch Motor HP Sensor (PS36) (Unit of replacement: IC, PHOTO-INTERRUPTER)
- Punch Motor (M24) (Unit of replacement: MOTOR, STEPPING, DC)
- Punch Unit (Unit of replacement: PUNCHER UNIT-BS1/BT1/BU1)
- Finisher Controller PCB (UN3) (Unit of replacement: FINISHER CONTROLLER PCB ASS'Y)

[Remedy] Check/replace the related harness/cable, connector and parts.

[Reference] After replacement of the Finisher Controller PCB, refer to "Adjustments> Adjustment when Replacing the Parts> Points to Note when Replacing the Finisher Controller PCB" in the Service Manual for the Finisher.

b. Puncher Unit-BE1/BF1/BG1/BH1

[Related parts]

- Harnesses from the Punch HP Sensor (S104) to the Puncher Driver PCB
- Harnesses from the Punch Motor Clock Sensor (S105) to the Puncher Driver PCB
- Harnesses from the Punch Motor (M102) to the Puncher Driver PCB
- Punch HP Sensor (S104)
- Punch Motor Clock Sensor (S105)
- Punch Motor (M102)
- Puncher Driver PCB (PCB1)
- Finisher Controller PCB (PBA101)

[Remedy] Check/replace the related harness/cable, connector and parts.

[Reference] When replacing the Finisher Controller PCB, refer to "Adjustments> Adjustment when Replacing the Parts" in the Service Manual.

c. Puncher Unit-A1

[Related parts]

- Harnesses from the Punch HP Sensor 1 (PS303) to the Puncher Relay PCB
- Harnesses from the Punch HP Sensor 2 (PS304) to the Puncher Relay PCB
- Harnesses from the Punch Motor Clock Sensor (PS305) to the Puncher Relay PCB
- Harnesses from the Punch Motor (M301) to the Puncher Relay PCB
- Punch HP Sensor 1 (PS303)
- Punch HP Sensor 2 (PS304)
- Punch Motor Clock Sensor (PS305)
- Punch Motor (M301)
- Puncher Relay PCB (PCB302)
- Puncher Controller PCB (PCB301)
- Finisher Controller PCB (PCB101)

[Remedy] Check/replace the related harness/cable, connector and parts.

[Reference] When replacing the Puncher Controller PCB, refer to "Adjustment> When Replacing the Parts" in the Service Manual.

[Reference] When replacing the Finisher Controller PCB, refer to "Adjustment> When Replacing the Parts" in the Service Manual.

E590-8002-02

a. Punch Motor HP error (Puncher Unit-BS1/BT1/BU1) b. Error in the Punch Motor (Puncher Unit-BE1/BF1/BG1/BH1) c. Error in the Punch Motor (Puncher Unit-A1)

Detection Description

- a. The Punch Motor HP Sensor was not turned OFF although 500 sec had passed after the Punch Motor started the operation.
- b. The Puncher does not come off the Punch HP Sensor when the Punch Motor has been driven for 200 msec.
The Puncher does not come off the Punch HP Sensor during initialization.
- c. The Punch HP Sensor does not detect the punch during initialization.
The Punch HP Sensor does not detect the punch when the Punch Motor has been driven for 0.4 seconds for returning the punch after the punch jam.

Remedy

a. PUNCHER UNIT-BS1/BT1/BU1

[Related parts]

- Harness between the Finisher Controller PCB (UN3/J131) and the Punch Motor (M24/J571) (Unit of replacement: CABLE, PUNCH)
- Harness between the Finisher Controller PCB (UN3/J130) and the Punch Motor Clock Sensor (PS38/J575) (Unit of replacement: CABLE, PUNCH)
- Harness between the Finisher Controller PCB (UN3/J130) and the Punch Front Sensor (PS37/J573) (Unit of replacement: CABLE, PUNCH)
- Harness between the Finisher Controller PCB (UN3/J130) and the Punch 2/3 Hole Sensor (PS39/J572) (Unit of replacement: CABLE, PUNCH)
- Harness between the Finisher Controller PCB (UN3/J130) and the Punch Motor HP Sensor (PS36/J574) (Unit of replacement: CABLE, PUNCH)
- Punch Motor Clock Sensor (PS38) (Unit of replacement: IC, PHOTO-INTERRUPTER)
- Punch Front Sensor (PS37) (Unit of replacement: IC, PHOTO-INTERRUPTER)
- Punch 2/3 Hole Sensor (PS39) (Unit of replacement: IC, PHOTO-INTERRUPTER)
- Punch Motor HP Sensor (PS36) (Unit of replacement: IC, PHOTO-INTERRUPTER)
- Punch Motor (M24) (Unit of replacement: MOTOR, STEPPING, DC)
- Punch Unit (Unit of replacement: PUNCHER UNIT-BS1/BT1/BU1)
- Finisher Controller PCB (UN3) (Unit of replacement: FINISHER CONTROLLER PCB ASS'Y)

[Remedy] Check/replace the related harness/cable, connector and parts.

[Reference] After replacement of the Finisher Controller PCB, refer to "Adjustments> Adjustment when Replacing the Parts> Points to Note when Replacing the Finisher Controller PCB" in the Service Manual for the Finisher.

b. Puncher Unit-BE1/BF1/BG1/BH1

[Related parts]

- Harnesses from the Punch HP Sensor (S104) to the Puncher Driver PCB
- Harnesses from the Punch Motor Clock Sensor (S105) to the Puncher Driver PCB
- Harnesses from the Punch Motor (M102) to the Puncher Driver PCB
- Punch HP Sensor (S104)
- Punch Motor Clock Sensor (S105)
- Punch Motor (M102)
- Puncher Driver PCB (PCB1)
- Finisher Controller PCB (PBA101)

[Remedy] Check/replace the related harness/cable, connector and parts.

[Reference] When replacing the Finisher Controller PCB, refer to "Adjustments> Adjustment when Replacing the Parts" in the Service Manual.

c. Puncher Unit-A1

[Related parts]

- Harnesses from the Punch HP Sensor 1 (PS303) to the Puncher Relay PCB
- Harnesses from the Punch HP Sensor 2 (PS304) to the Puncher Relay PCB
- Harnesses from the Punch Motor Clock Sensor (PS305) to the Puncher Relay PCB
- Harnesses from the Punch Motor (M301) to the Puncher Relay PCB
- Punch HP Sensor 1 (PS303)
- Punch HP Sensor 2 (PS304)
- Punch Motor Clock Sensor (PS305)
- Punch Motor (M301)
- Puncher Relay PCB (PCB302)
- Puncher Controller PCB (PCB301)
- Finisher Controller PCB (PCB101)

[Remedy] Check/replace the related harness/cable, connector and parts.

[Reference] When replacing the Puncher Controller PCB, refer to "Adjustment> When Replacing the Parts" in the Service Manual.

[Reference] When replacing the Finisher Controller PCB, refer to "Adjustment> When Replacing the Parts" in the Service Manual.

E590-8003-02	Punch Motor clock error (Puncher Unit-BE1/BF1/BG1/BH1)
Detection Description	The drive pulse of the Punch Motor does not reach 100 pulses when the Punch Motor has been driven for 100 msec. after the Puncher has come off the Punch HP Sensor.
Remedy	<p>[Related parts]</p> <ul style="list-style-type: none"> - Harnesses from the Punch HP Sensor (S104) to the Puncher Driver PCB - Harnesses from the Punch Motor Clock Sensor (S105) to the Puncher Driver PCB - Harnesses from the Punch Motor (M102) to the Puncher Driver PCB - Punch HP Sensor (S104) - Punch Motor Clock Sensor (S105) - Punch Motor (M102) - Puncher Driver PCB (PCB1) - Finisher Controller PCB (PBA101) <p>[Remedy] Check/replace the related harness/cable, connector and parts. [Reference] When replacing the Finisher Controller PCB, refer to "Adjustments> Adjustment when Replacing the Parts" in the Service Manual.</p>
E590-8004-02	Punch switching error
Detection Description	<p>PUNCHER UNIT-BS1/BT1/BU1</p> <p>The Punch Motor home position could not be detected when switching the 2-hole/3-hole and 2-hole/4-hole (France) operations.</p>
Remedy	<p>PUNCHER UNIT-BS1/BT1/BU1</p> <p>[Related parts]</p> <ul style="list-style-type: none"> - Harness between the Finisher Controller PCB (UN3/J131) and the Punch Motor (M24/J571) (Unit of replacement: CABLE, PUNCH) - Harness between the Finisher Controller PCB (UN3/J130) and the Punch Motor Clock Sensor (PS38/J575) (Unit of replacement: CABLE, PUNCH) - Harness between the Finisher Controller PCB (UN3/J130) and the Punch Front Sensor (PS37/J573) (Unit of replacement: CABLE, PUNCH) - Harness between the Finisher Controller PCB (UN3/J130) and the Punch 2/3 Hole Sensor (PS39/J572) (Unit of replacement: CABLE, PUNCH) - Harness between the Finisher Controller PCB (UN3/J130) and the Punch Motor HP Sensor (PS36/J574) (Unit of replacement: CABLE, PUNCH) - Punch Motor Clock Sensor (PS38) (Unit of replacement: IC, PHOTO-INTERRUPTER) - Punch Front Sensor (PS37) (Unit of replacement: IC, PHOTO-INTERRUPTER) - Punch 2/3 Hole Sensor (PS39) (Unit of replacement: IC, PHOTO-INTERRUPTER) - Punch Motor HP Sensor (PS36) (Unit of replacement: IC, PHOTO-INTERRUPTER) - Punch Motor (M24) (Unit of replacement: MOTOR, STEPPING, DC) - Punch Unit (Unit of replacement: PUNCHER UNIT-BS1/BT1/BU1) - Finisher Controller PCB (UN3) (Unit of replacement: FINISHER CONTROLLER PCB ASS'Y) <p>[Remedy] Check/replace the related harness/cable, connector and parts. [Reference] After replacement of the Finisher Controller PCB, refer to "Adjustments> Adjustment when Replacing the Parts> Points to Note when Replacing the Finisher Controller PCB" in the Service Manual for the Finisher.</p>
E591-0001-02	Upper limit error with Punch Waste Sensor (Puncher Unit-BE1/BF1/BG1/BH1)
Detection Description	The light-receiving voltage was 3.0V or less despite increase in sensor light-emission.
Remedy	<p>[Related parts]</p> <ul style="list-style-type: none"> - Punch Waste Sensor (PCB2) - Puncher Driver PCB (PCB1) - Finisher Controller PCB (PBA101) <p>[Remedy] Check/replace the related harness/cable, connector and parts. [Reference] When replacing the Finisher Controller PCB, refer to "Adjustments> Adjustment when Replacing the Parts" in the Service Manual.</p>

E591-0002-02	Lower limit error with Punch Waste Sensor (Puncher Unit-BE1/BF1/BG1/BH1)
Detection Description	The light-receiving voltage was 2.0V or more despite decrease in sensor light-emission.
Remedy	<p>[Related parts]</p> <ul style="list-style-type: none"> - Punch Waste Sensor (PCB2) - Puncher Driver PCB (PCB1) - Finisher Controller PCB (PBA101) <p>[Remedy] Check/replace the related harness/cable, connector and parts. [Reference] When replacing the Finisher Controller PCB, refer to "Adjustments> Adjustment when Replacing the Parts" in the Service Manual.</p>
E592-0003-02	Upper limit error with Puncher Side Registration Sensor (B5R) (Puncher Unit-BE1/BF1/BG1/BH1)
Detection Description	The light-receiving voltage (PTR5) was 2.5V or less despite increase in sensor light-emission (LED5).
Remedy	<p>[Related parts]</p> <ul style="list-style-type: none"> - Puncher Side Registration Sensor (PCB3/PCB4) - Puncher Driver PCB (PCB1) - Finisher Controller PCB (PBA101) <p>[Remedy] Check/replace the related harness/cable, connector and parts. [Reference] When replacing the Finisher Controller PCB, refer to "Adjustments> Adjustment when Replacing the Parts" in the Service Manual.</p>
E592-0004-02	Lower limit error with Puncher Side Registration Sensor (B5R) (Puncher Unit-BE1/BF1/BG1/BH1)
Detection Description	The light-receiving voltage was 2.0V or more despite decrease in sensor light-emission.
Remedy	<p>[Related parts]</p> <ul style="list-style-type: none"> - Puncher Side Registration Sensor (PCB3/PCB4) - Puncher Driver PCB (PCB1) - Finisher Controller PCB (PBA101) <p>[Remedy] Check/replace the related harness/cable, connector and parts. [Reference] When replacing the Finisher Controller PCB, refer to "Adjustments> Adjustment when Replacing the Parts" in the Service Manual.</p>
E592-0005-02	Upper limit error with Puncher Side Registration Sensor (A4R) (Puncher Unit-BE1/BF1/BG1/BH1)
Detection Description	The light-receiving voltage (PTR5) was 2.5V or less despite increase in sensor light-emission (LED5).
Remedy	<p>[Related parts]</p> <ul style="list-style-type: none"> - Puncher Side Registration Sensor (PCB3/PCB4) - Puncher Driver PCB (PCB1) - Finisher Controller PCB (PBA101) <p>[Remedy] Check/replace the related harness/cable, connector and parts. [Reference] When replacing the Finisher Controller PCB, refer to "Adjustments> Adjustment when Replacing the Parts" in the Service Manual.</p>
E592-0006-02	Lower limit error with Puncher Side Registration Sensor (A4R) (Puncher Unit-BE1/BF1/BG1/BH1)
Detection Description	The light-receiving voltage was 2.0V or more despite decrease in sensor light-emission.
Remedy	<p>[Related parts]</p> <ul style="list-style-type: none"> - Puncher Side Registration Sensor (PCB3/PCB4) - Puncher Driver PCB (PCB1) - Finisher Controller PCB (PBA101) <p>[Remedy] Check/replace the related harness/cable, connector and parts. [Reference] When replacing the Finisher Controller PCB, refer to "Adjustments> Adjustment when Replacing the Parts" in the Service Manual.</p>

E592-0007-02	Upper limit error with Puncher Side Registration Sensor (B4) (Puncher Unit-BE1/BF1/BG1/BH1)
Detection Description	The light-receiving voltage (PTR5) was 2.5V or less despite increase in sensor light-emission (LED5).
Remedy	<p>[Related parts]</p> <ul style="list-style-type: none"> - Puncher Side Registration Sensor (PCB3/PCB4) - Puncher Driver PCB (PCB1) - Finisher Controller PCB (PBA101) <p>[Remedy] Check/replace the related harness/cable, connector and parts. [Reference] When replacing the Finisher Controller PCB, refer to "Adjustments> Adjustment when Replacing the Parts" in the Service Manual.</p>
E592-0008-02	Lower limit error with Puncher Side Registration Sensor (B4) (Puncher Unit-BE1/BF1/BG1/BH1)
Detection Description	The light-receiving voltage was 2.0V or more despite decrease in sensor light-emission.
Remedy	<p>[Related parts]</p> <ul style="list-style-type: none"> - Puncher Side Registration Sensor (PCB3/PCB4) - Puncher Driver PCB (PCB1) - Finisher Controller PCB (PBA101) <p>[Remedy] Check/replace the related harness/cable, connector and parts. [Reference] When replacing the Finisher Controller PCB, refer to "Adjustments> Adjustment when Replacing the Parts" in the Service Manual.</p>
E592-0009-02	Upper limit error with Puncher Side Registration Sensor (LDR) (Puncher Unit-BE1/BF1/BG1/BH1)
Detection Description	The light-receiving voltage (PTR5) was 2.5V or less despite increase in sensor light-emission (LED5).
Remedy	<p>[Related parts]</p> <ul style="list-style-type: none"> - Puncher Side Registration Sensor (PCB3/PCB4) - Puncher Driver PCB (PCB1) - Finisher Controller PCB (PBA101) <p>[Remedy] Check/replace the related harness/cable, connector and parts. [Reference] When replacing the Finisher Controller PCB, refer to "Adjustments> Adjustment when Replacing the Parts" in the Service Manual.</p>
E592-000A-02	Lower limit error with Puncher Side Registration Sensor (11"X17") (Puncher Unit-BE1/BF1/BG1/BH1)
Detection Description	The light-receiving voltage was 2.0V or more despite decrease in sensor light-emission.
Remedy	<p>[Related parts]</p> <ul style="list-style-type: none"> - Puncher Side Registration Sensor (PCB3/PCB4) - Puncher Driver PCB (PCB1) - Finisher Controller PCB (PBA101) <p>[Remedy] Check/replace the related harness/cable, connector and parts. [Reference] When replacing the Finisher Controller PCB, refer to "Adjustments> Adjustment when Replacing the Parts" in the Service Manual.</p>
E592-000B-02	Upper limit error with Puncher Side Registration Sensor (A3) (Puncher Unit-BE1/BF1/BG1/BH1)
Detection Description	The light-receiving voltage (PTR5) was 2.5V or less despite increase in sensor light-emission (LED5).
Remedy	<p>[Related parts]</p> <ul style="list-style-type: none"> - Puncher Side Registration Sensor (PCB3/PCB4) - Puncher Driver PCB (PCB1) - Finisher Controller PCB (PBA101) <p>[Remedy] Check/replace the related harness/cable, connector and parts. [Reference] When replacing the Finisher Controller PCB, refer to "Adjustments> Adjustment when Replacing the Parts" in the Service Manual.</p>

E592-000C-02	Lower limit error with Puncher Side Registration Sensor (A3) (Puncher Unit-BE1/BF1/BG1/BH1)
Detection Description	The light-receiving voltage was 2.0V or more despite decrease in sensor light-emission.
Remedy	<p>[Related parts]</p> <ul style="list-style-type: none"> - Puncher Side Registration Sensor (PCB3/PCB4) - Puncher Driver PCB (PCB1) - Finisher Controller PCB (PBA101) <p>[Remedy] Check/replace the related harness/cable, connector and parts. [Reference] When replacing the Finisher Controller PCB, refer to "Adjustments> Adjustment when Replacing the Parts" in the Service Manual.</p>
E593-8001-02	a. Error in the Punch Slide Motor (Puncher Unit-BE1/BF1/BG1/BH1) b. Error in the Punch Shift Motor (Puncher Unit-A1)
Detection Description	<p>a. The punch unit does not come off the Horizontal Registration HP Sensor when the Punch Slide Motor has been driven for 680 msec.</p> <p>b. The punch unit does not come off the Punch Slide HP Sensor when shifting the punch unit by 9mm toward rear.</p>
Remedy	<p>a. Puncher Unit-BE1/BF1/BG1/BH1</p> <p>[Related parts]</p> <ul style="list-style-type: none"> - Harnesses from the Horizontal Registration HP Sensor (S101) to the Puncher Driver PCB - Harnesses from the Punch Slide Motor (M101) to the Puncher Driver PCB - Horizontal Registration HP Sensor (S101) - Punch Slide Motor (M101) - Puncher Driver PCB (PCB1) - Finisher Controller PCB (PBA101) <p>[Remedy] Check/replace the related harness/cable, connector and parts. [Reference] When replacing the Finisher Controller PCB, refer to "Adjustment> Action on parts replacement" in the Service Manual.</p> <p>b. Puncher Unit-A1</p> <p>[Related parts]</p> <ul style="list-style-type: none"> - Harnesses from the Punch Slide HP Sensor (PS302) to the Puncher Controller PCB - Harnesses from the Punch Shift Motor (M302) to the Puncher Controller PCB - Punch Slide HP Sensor (PS302) - Punch Shift Motor (M302) - Puncher Controller PCB (PCB301) - Finisher Controller PCB (PCB101) <p>[Remedy] Check/replace the related harness/cable, connector and parts. [Reference] When replacing the Puncher Controller PCB, refer to "Adjustment> When Replacing the Parts" in the Service Manual. [Reference] When replacing the Finisher Controller PCB, refer to "Adjustment> When Replacing the Parts" in the Service Manual.</p>

E593-8002-02	a. Error in the Punch Slide Motor (Puncher Unit-BE1/BF1/BG1/BH1) b. Error in the Punch Shift Motor (Puncher Unit-A1)
Detection Description	<p>a. The Horizontal Registration HP Sensor does not detect the punch unit when the Punch Slide Motor has been driven for 3.3 seconds.</p> <p>b. The Punch Slide HP Sensor does not detect the punch unit when shifting the punch unit by 37mm toward front.</p>
Remedy	<p>a. Puncher Unit-BE1/BF1/BG1/BH1 [Related parts]</p> <ul style="list-style-type: none"> - Harnesses from the Horizontal Registration HP Sensor (S101) to the Puncher Driver PCB - Harnesses from the Punch Slide Motor (M101) to the Puncher Driver PCB - Horizontal Registration HP Sensor (S101) - Punch Slide Motor (M101) - Puncher Driver PCB (PCB1) - Finisher Controller PCB (PBA101) <p>[Remedy] Check/replace the related harness/cable, connector and parts. [Reference] When replacing the Finisher Controller PCB, refer to "Adjustment> Action on parts replacement" in the Service Manual.</p> <p>b. Puncher Unit-A1 [Related parts]</p> <ul style="list-style-type: none"> - Harnesses from the Punch Slide HP Sensor (PS302) to the Puncher Controller PCB - Harnesses from the Punch Shift Motor (M302) to the Puncher Controller PCB - Punch Slide HP Sensor (PS302) - Punch Shift Motor (M302) - Puncher Controller PCB (PCB301) - Finisher Controller PCB (PCB101) <p>[Remedy] Check/replace the related harness/cable, connector and parts. [Reference] When replacing the Puncher Controller PCB, refer to "Adjustment> When Replacing the Parts" in the Service Manual. [Reference] When replacing the Finisher Controller PCB, refer to "Adjustment> When Replacing the Parts" in the Service Manual.</p>
E5A3-0001-02	Error in the Registration Motor (Inner Booklet Trimmer-A1)
Detection Description	<p>The Registration HP Sensor does not turn ON when the Registration Motor has been driven for 2.933 seconds.</p>
Remedy	<p>[Related parts]</p> <ul style="list-style-type: none"> - Harnesses from the Registration HP Sensor (S105) or the Registration Motor (M102) to the Trimmer Controller PCB - Harnesses from the Registration Motor (M102) to the Trimmer Controller PCB - Registration HP Sensor (S105) - Registration Motor (M102) - Trimmer Controller PCB (PCB1) <p>[Remedy] Check/replace the related harness/cable, connector and parts.</p>
E5A3-0002-02	Error in the Registration Motor (Inner Booklet Trimmer-A1)
Detection Description	<p>The Registration HP Sensor does not turn OFF when the Registration Motor has been driven for 670 msec.</p>
Remedy	<p>[Related parts]</p> <ul style="list-style-type: none"> - Harnesses from the Registration HP Sensor (S105) or the Registration Motor (M102) to the Trimmer Controller PCB - Harnesses from the Registration Motor (M102) to the Trimmer Controller PCB - Registration HP Sensor (S105) - Registration Motor (M102) - Trimmer Controller PCB (PCB1) <p>[Remedy] Check/replace the related harness/cable, connector and parts.</p>

E5A4-8001-02	Error in the Press Motor (Inner Booklet Trimmer-A1)
Detection Description	The Press Motor HP Sensor does not turn ON when the Press Motor has been driven for 926 msec.
Remedy	<p>[Related parts]</p> <ul style="list-style-type: none"> - Harnesses from the Press Motor HP Sensor (S106) to the Trimmer Controller PCB - Harnesses from the Press Motor (M105) to the Trimmer Controller PCB - Press Motor HP Sensor (S106) - Press Motor (M105) - Trimmer Controller PCB (PCB1) <p>[Remedy] Check/replace the related harness/cable, connector and parts.</p>
E5A4-8002-02	Error in the Press Motor (Inner Booklet Trimmer-A1)
Detection Description	The Press Motor HP Sensor does not turn OFF when the Press Motor has been driven for 601 msec.
Remedy	<p>[Related parts]</p> <ul style="list-style-type: none"> - Harnesses from the Press Motor HP Sensor (S106) to the Trimmer Controller PCB - Harnesses from the Press Motor (M105) to the Trimmer Controller PCB - Press Motor HP Sensor (S106) - Press Motor (M105) - Trimmer Controller PCB (PCB1) <p>[Remedy] Check/replace the related harness/cable, connector and parts.</p>
E5A7-8011-02	Transport Hook Home Position Sensor detection error
Detection Description	BOOKLET TRIMMER-F1 The Transport Hook Home Position Sensor was not turned ON.
Remedy	<p>BOOKLET TRIMMER-F1</p> <p>[Related parts]</p> <ul style="list-style-type: none"> - Harnesses connecting the Transport Hook Home Position Sensor (PI04/J28), the Relay Connector (J21) and the Trimmer Controller PCB (QPM-324/CON8) - Harnesses connecting the Transport Hook Motor (M02/J25), the Relay Connector (J22) and the Stepper Motor Driver PCB (QPM-973/CON104) - Transport Hook Home Position Sensor (PI04) - Transport Hook Motor (M02) <p>[Points to note at work] When checking the harness/cable or connector, perform the following work.</p> <ol style="list-style-type: none"> 1. Disconnect and then connect the connector to check that there is no bent pin and cable disconnection. 2. Visually check that the harness is not caught or open circuit. 3. If there is any error, replace the corresponding harness/cable. <p>[Remedy] Check/replace the related parts.</p> <p>[Reference] After replacement of the Transport Hook Home Position Sensor, refer to "Adjustments> Home Position Calibration" in the Service Manual.</p>
E5A7-8012-02	Transport Hook Home Position Sensor detection error
Detection Description	BOOKLET TRIMMER-F1 The Transport Hook Home Position Sensor was not turned OFF.
Remedy	<p>BOOKLET TRIMMER-F1</p> <p>[Related parts]</p> <ul style="list-style-type: none"> - Harnesses connecting the Transport Hook Home Position Sensor (PI04/J28), the Relay Connector (J21) and the Trimmer Controller PCB (QPM-324/CON8) - Harnesses connecting the Transport Hook Motor (M02/J25), the Relay Connector (J22) and the Stepper Motor Driver PCB (QPM-973/CON104) - Transport Hook Home Position Sensor (PI04) - Transport Hook Motor (M02) <p>[Points to note at work] When checking the harness/cable or connector, perform the following work.</p> <ol style="list-style-type: none"> 1. Disconnect and then connect the connector to check that there is no bent pin and cable disconnection. 2. Visually check that the harness is not caught or open circuit. 3. If there is any error, replace the corresponding harness/cable. <p>[Remedy] Check/replace the related parts.</p> <p>[Reference] After replacement of the Transport Hook Home Position Sensor, refer to "Adjustments> Home Position Calibration" in the Service Manual.</p>

E5A7-8021-02	Top-bottom Guide Home Position Sensor detection error
Detection Description	BOOKLET TRIMMER-F1 The Top-bottom Guide Home Position Sensor was not turned ON.
Remedy	BOOKLET TRIMMER-F1 [Related parts] - Harnesses connecting the Top-bottom Guide Home Position Sensor (PI03/J27), the Relay Connector (J21) and the Trimmer Controller PCB (QPM-324/CON8) - Harnesses between the Top-bottom Guide Motor (M03/J23) and the Stepper Motor Driver PCB (QPW-973/CON104) - Top-bottom Guide Home Position Sensor (PI03) - Top-bottom Guide Motor (M03) [Points to note at work] When checking the harness/cable or connector, perform the following work. 1. Disconnect and then connect the connector to check that there is no bent pin and cable disconnection. 2. Visually check that the harness is not caught or open circuit. 3. If there is any error, replace the corresponding harness/cable. [Remedy] Check/replace the related parts. [Reference] After replacement of the Transport Hook Home Position Sensor, refer to "Adjustments> Home Position Calibration" in the Service Manual.
E5A7-8022-02	Top-bottom Guide Home Position Sensor detection error
Detection Description	BOOKLET TRIMMER-F1 The Top-bottom Guide Home Position Sensor was not turned OFF.
Remedy	BOOKLET TRIMMER-F1 [Related parts] - Harnesses connecting the Top-bottom Guide Home Position Sensor (PI03/J27), the Relay Connector (J21) and the Trimmer Controller PCB (QPM-324/CON8) - Harnesses between the Top-bottom Guide Motor (M03/J23) and the Stepper Motor Driver PCB (QPW-973/CON104) - Top-bottom Guide Home Position Sensor (PI03) - Top-bottom Guide Motor (M03) [Points to note at work] When checking the harness/cable or connector, perform the following work. 1. Disconnect and then connect the connector to check that there is no bent pin and cable disconnection. 2. Visually check that the harness is not caught or open circuit. 3. If there is any error, replace the corresponding harness/cable. [Remedy] Check/replace the related parts. [Reference] After replacement of the Transport Hook Home Position Sensor, refer to "Adjustments> Home Position Calibration" in the Service Manual.
E5A7-8025-02	EEPROM error (Booklet Trimmer)
Detection Description	BOOKLET TRIMMER-F1 A numerical value error was detected for the retained home position.
Remedy	BOOKLET TRIMMER-F1 Replace the Trimmer Controller PCB (QPM-324). [Reference] After the replacement, refer to "Adjustments> Home Position Calibration" in the Service Manual.

E5A7-8033-02	Trim Section Transport Motor Driver error
Detection Description	BOOKLET TRIMMER-D1 An error was detected in the Trim Section Transport Motor Driver PCB.
Remedy	BOOKLET TRIMMER-D1 [Related parts] - Harness between the Trim Section Transport Motor (M04) and the Trim Section Transport Motor Driver PCB (A04/CN3) - Trim Section Transport Motor (M04) - Trim Section Transport Motor Driver PCB (A04) [Points to note at work] When checking the harness/cable or connector, perform the following work. 1. Disconnect and then connect the connector to check that there is no bent pin and cable disconnection. 2. Visually check that the harness is not caught or open circuit. 3. If there is any error, replace the corresponding harness/cable. [Remedy] Check/replace the related parts.
E5A7-8043-02	Knife Motor Driver error
Detection Description	BOOKLET TRIMMER-D1 An error was detected in the Knife Motor Driver PCB.
Remedy	BOOKLET TRIMMER-D1 [Related parts] - Harness between the Knife Motor (M05) and the Trim Section Transport Motor Driver PCB (A04/CN3) - Knife Motor (M05) - Knife Motor Driver PCB (A05) [Points to note at work] When checking the harness/cable or connector, perform the following work. 1. Disconnect and then connect the connector to check that there is no bent pin and cable disconnection. 2. Visually check that the harness is not caught or open circuit. 3. If there is any error, replace the corresponding harness/cable. [Remedy] Check/replace the related parts.
E5A7-8044-02	Upper Knife Upper Limit Sensor detection error
Detection Description	BOOKLET TRIMMER-F1 The Upper Knife Upper Limit Sensor was not turned ON although the Upper Knife moved a certain amount.
Remedy	BOOKLET TRIMMER-F1 [Related parts] - Harnesses connecting the Upper Knife Upper Limit Sensor (PI06/J54), the Trimmer Controller PCB (QPM-324/CON5) - Harness between the Knife Motor (M05) and the Knife Motor Driver PCB (A05/CN3, 4) - Upper Knife Upper Limit Sensor (PI06) - Knife Motor (M05) - Knife Motor Driver PCB (A05) - Trimmer Controller PCB (QPM-324) [Points to note at work] When checking the harness/cable or connector, perform the following work. 1. Disconnect and then connect the connector to check that there is no bent pin and cable disconnection. 2. Visually check that the harness is not caught or open circuit. 3. If there is any error, replace the corresponding harness/cable. [Remedy] Check/replace the related parts. [Reference] After replacement of the Trimmer Controller PCB, refer to "Adjustments> Home Position Calibration" in the Service Manual.

E5A7-8051-02	Stopper Home Position Sensor detection error
Detection Description	BOOKLET TRIMMER-F1 The Stopper Home Position Sensor was not turned ON.
Remedy	BOOKLET TRIMMER-F1 [Related parts] - Harnesses connecting the Stopper Home Position Sensor (PI05/J68), the Relay Connector (J63) and the Trimmer Controller PCB (QPM-324/CON5) - Harnesses connecting the Stopper Move Motor (M06/J69), the Relay Connector (J63) and the Stepper Motor Driver PCB (QPW-973/CON103) - Stopper Home Position Sensor (PI05) - Trimmer Controller PCB (QPM-324) - Stopper Move Motor (M06) - Stepper Motor Driver PCB (QPW-973) [Points to note at work] When checking the harness/cable or connector, perform the following work. 1. Disconnect and then connect the connector to check that there is no bent pin and cable disconnection. 2. Visually check that the harness is not caught or open circuit. 3. If there is any error, replace the corresponding harness/cable. [Remedy] Check/replace the related parts. [Reference] After replacement of the Trimmer Controller PCB, refer to "Adjustments> Home Position Calibration" in the Service Manual.
E5A7-8052-02	Stopper Home Position Sensor detection error
Detection Description	BOOKLET TRIMMER-F1 The Stopper Home Position Sensor was not turned OFF.
Remedy	BOOKLET TRIMMER-F1 [Related parts] - Harnesses connecting the Stopper Home Position Sensor (PI05/J68), the Relay Connector (J63) and the Trimmer Controller PCB (QPM-324/CON5) - Harnesses connecting the Stopper Move Motor (M06/J69), the Relay Connector (J63) and the Stepper Motor Driver PCB (QPW-973/CON103) - Stopper Home Position Sensor (PI05) - Trimmer Controller PCB (QPM-324) - Stopper Move Motor (M06) - Stepper Motor Driver PCB (QPW-973) [Points to note at work] When checking the harness/cable or connector, perform the following work. 1. Disconnect and then connect the connector to check that there is no bent pin and cable disconnection. 2. Visually check that the harness is not caught or open circuit. 3. If there is any error, replace the corresponding harness/cable. [Remedy] Check/replace the related parts. [Reference] After replacement of the Trimmer Controller PCB, refer to "Adjustments> Home Position Calibration" in the Service Manual.
E5A7-8055-02	EEPROM error
Detection Description	BOOKLET TRIMMER-F1 An error with the numerical value for the retained home position of the Knife Stopper Positioning Motor was detected.
Remedy	BOOKLET TRIMMER-F1 Replace the Trimmer Controller PCB (QPM-324). [Reference] After the replacement, refer to "Adjustments> Home Position Calibration" in the Service Manual.

E5A7-8061-02	Delivery Roller Home Position Sensor detection error
Detection Description	BOOKLET TRIMMER-D1 The Delivery Roller Home Position Sensor was not turned ON.
Remedy	BOOKLET TRIMMER-D1 [Related parts] - Harnesses connecting the Delivery Roller Home Position Sensor (PI14/J114), the Relay Connector (J37/J1) and the Trimmer Controller PCB (QPM-220/CON12) - Delivery Roller Motor (M08) - Delivery Roller Home Position Sensor (PI14) - Trimmer Controller PCB (QPM-220) [Points to note at work] When checking the harness/cable or connector, perform the following work. 1. Disconnect and then connect the connector to check that there is no bent pin and cable disconnection. 2. Visually check that the harness is not caught or open circuit. 3. If there is any error, replace the corresponding harness/cable. [Remedy] Check/replace the related parts. [Reference] After replacement of the Delivery Roller Home Position Sensor, refer to "Adjustments> Home Position Calibration" in the Service Manual.
E5A7-8062-02	Delivery Roller Home Position Sensor detection error
Detection Description	BOOKLET TRIMMER-D1 The Delivery Roller Home Position Sensor was not turned OFF.
Remedy	BOOKLET TRIMMER-D1 [Related parts] - Harnesses connecting the Delivery Roller Home Position Sensor (PI14/J114), the Relay Connector (J37/J1) and the Trimmer Controller PCB (QPM-220/CON12) - Delivery Roller Motor (M08) - Delivery Roller Home Position Sensor (PI14) - Trimmer Controller PCB (QPM-220) [Points to note at work] When checking the harness/cable or connector, perform the following work. 1. Disconnect and then connect the connector to check that there is no bent pin and cable disconnection. 2. Visually check that the harness is not caught or open circuit. 3. If there is any error, replace the corresponding harness/cable. [Remedy] Check/replace the related parts. [Reference] After replacement of the Delivery Roller Home Position Sensor, refer to "Adjustments> Home Position Calibration" in the Service Manual.
E5A7-8065-02	EEPROM error
Detection Description	BOOKLET TRIMMER-D1 An error with the numerical value for the retained home position of the Delivery Roller Motor was detected.
Remedy	BOOKLET TRIMMER-D1 Replace the Trimmer Controller PCB (QPM-220). [Reference] After the replacement, refer to "Adjustments> Home Position Calibration" in the Service Manual.
E5A7-8073-02	Main Drive Motor Driver error
Detection Description	BOOKLET TRIMMER-D1 An error was detected in the Main Drive Motor Driver PCB.
Remedy	BOOKLET TRIMMER-D1 [Related parts] - Harness between the Main Drive Motor (M10) and the Main Drive Motor Driver PCB (A10/CN3) - Main Drive Motor (M10) - Main Drive Motor Driver PCB (A10) [Points to note at work] When checking the harness/cable or connector, perform the following work. 1. Disconnect and then connect the connector to check that there is no bent pin and cable disconnection. 2. Visually check that the harness is not caught or open circuit. 3. If there is any error, replace the corresponding harness/cable. [Remedy] Check/replace the related parts.

E5A7-8088-02	Command transmission retry error
Detection Description	BOOKLET TRIMMER-F1 Sending of a command to the Two-Knife Trimmer was retried 4 times.
Remedy	BOOKLET TRIMMER-F1 [Points to note at work] When checking the harness/cable or connector, perform the following work. 1. Disconnect and then connect the connector to check that there is no bent pin and cable disconnection. 2. Visually check that the harness is not caught or open circuit. 3. If there is any error, replace the corresponding harness/cable. [Remedy] Check the harness between the Booklet Trimmer and the Two-Knife Booklet Trimmer.
E5A7-8089-02	Command transmission retry error
Detection Description	BOOKLET TRIMMER-F1 Reception failure command from the Two-Knife Booklet Trimmer was received 5 consecutive times.
Remedy	Check/replace the harness between the Booklet Trimmer and the Two-Knife Booklet Trimmer.
E5A7-8095-02	BOOKLET TRIMMER-F1 EEPROM error
Detection Description	BOOKLET TRIMMER-F1 A numerical value error was detected for the retained home position.
Remedy	BOOKLET TRIMMER-F1 Replace the Trimmer Controller PCB (QPM-324). [Reference] After the replacement, refer to "Adjustments> Home Position Calibration" in the Service Manual.
E5A7-8099-02	BOOKLET TRIMMER-F1 Abnormality of the software program was detected.
Detection Description	BOOKLET TRIMMER-F1 Abnormality of the software program was detected.
Remedy	To install the latest software program of a BOOKLET TRIMMER-F1.
E5A7-80A7-02	Switching Power Supply Cooling Fan error
Detection Description	Booklet Trimmer Output pulse from the Switching Power Supply Cooling Fan was not detected.
Remedy	Booklet Trimmer [Related parts] - Harness between the Booklet Trimmer Controller PCB (QPM-254/CON10) and the Power Supply (G00/CON2) - Power Supply (G00) - Remote Power Relay (K00) - Booklet Trimmer Controller PCB (QPM-254) [Remedy] Check/replace the related harness/cable, connector and parts. [Reference] After replacement of the Booklet Trimmer Controller PCB, refer to "Adjustments> Home Position Calibration" in the Service Manual.
E5A7-80A8-02	Power Supply error
Detection Description	Booklet Trimmer Power supply of 24 VDC was not detected. Meltdown of 24V fuse
Remedy	Booklet Trimmer [Related parts] - Harness between the Booklet Trimmer Controller PCB (QPM-324/COM12) and the Power Supply (G01/J201) - Power Supply (G00) - Remote Power Relay (K00) - Booklet Trimmer Controller PCB (QPM-254) [Remedy] Check/replace the related harness/cable, connector and parts. [Reference] After replacement of the Booklet Trimmer Controller PCB, refer to "Adjustments> Home Position Calibration" in the Service Manual.

E5A7-80A9-02	Power Supply error
Detection Description	Booklet Trimmer Power supply of 5 VDC was not detected. Meltdown of 5V fuse
Remedy	Booklet Trimmer [Related parts] - Harness between the Booklet Trimmer Controller PCB (QPM-324/COM12) and the Power Supply (G01/J201) - Power Supply (G00) - Remote Power Relay (K00) - Booklet Trimmer Controller PCB (QPM-254) [Remedy] Check/replace the related harness/cable, connector and parts. [Reference] After replacement of the Booklet Trimmer Controller PCB, refer to "Adjustments> Home Position Calibration" in the Service Manual.
E5AA-8001-02	Error in the Cutter Motor (Inner Booklet Trimmer-A1)
Detection Description	The home position of the trimming blade is not detected when the Cutter Motor has been driven for 5 seconds.
Remedy	[Related parts] - Harnesses from the Cutter Motor Clock Sensor (S108) to the Trimmer Controller PCB - Harnesses from the Cutter Motor (M106) to the Trimmer Controller PCB - Cutter Motor Clock Sensor (S108) - Cutter Motor (M106) - Trimmer Controller PCB (PCB1) [Remedy] Check/replace the related harness/cable, connector and parts.
E5AA-8002-02	Error in the Cutter Motor (Inner Booklet Trimmer-A1)
Detection Description	The Cutter Motor Clock Sensor does not come off the home position of the trimming blade when the Cutter Motor has been driven for 500 msec.
Remedy	[Related parts] - Harnesses from the Cutter Motor Clock Sensor (S108) to the Trimmer Controller PCB - Harnesses from the Cutter Motor (M106) to the Trimmer Controller PCB - Cutter Motor Clock Sensor (S108) - Cutter Motor (M106) - Trimmer Controller PCB (PCB1) [Remedy] Check/replace the related harness/cable, connector and parts.
E5AA-8003-02	Cutter Motor Clock Error (Inner Booklet Trimmer-A1)
Detection Description	The Cutter Motor Clock Sensor does not detect the Motor clock when the Cutter Motor has been driven for 625 msec.
Remedy	[Related parts] - Harnesses from the Cutter Motor Clock Sensor (S108) to the Trimmer Controller PCB - Harnesses from the Cutter Motor (M106) to the Trimmer Controller PCB - Cutter Motor Clock Sensor (S108) - Cutter Motor (M106) - Trimmer Controller PCB (PCB1) [Remedy] Check/replace the related harness/cable, connector and parts.
E5AE-8000-02	Trimmer Stationary Paper Error (Inner Booklet Trimmer-A1)
Detection Description	The Inlet Sensor detects the stationary paper after performing the paper delivery operation.
Remedy	[Related parts] - Harnesses from the Inlet Sensor (S101) to the Trimmer Controller PCB - Inlet Sensor (S101) is faulty. - Trimmer Controller PCB (PCB1) [Remedy] - If the paper has jammed in the Trimmer, remove it. - Check/replace the related harness/cable, connector and parts.

E5BA-8001-02	Error in the Front Estrangement Motor (Inner Booklet Trimmer-A1)
Detection Description	The Front Estrangement Motor HP Sensor does not turn ON when the Front Estrangement Motor has been driven for 191msec.
Remedy	[Related parts] <ul style="list-style-type: none"> - Harnesses from the Front Estrangement Motor HP Sensor (S102) to the Trimmer Controller PCB - Harnesses from the Front Estrangement Motor (M103) to the Trimmer Controller PCB - Front Estrangement Motor HP Sensor (S102) - Front Estrangement Motor (M103) - Trimmer Controller PCB (PCB1) [Remedy] Check/replace the related harness/cable, connector and parts.
E5BA-8002-02	Error in the Front Estrangement Motor (Inner Booklet Trimmer-A1)
Detection Description	The Front Estrangement Motor HP Sensor does not turn OFF when the Front Estrangement Motor has been driven for 724 msec. after the Front Estrangement Motor HP Sensor has turned ON.
Remedy	[Related parts] <ul style="list-style-type: none"> - Harnesses from the Front Estrangement Motor HP Sensor (S102) to the Trimmer Controller PCB - Harnesses from the Front Estrangement Motor (M103) to the Trimmer Controller PCB - Front Estrangement Motor HP Sensor (S102) - Front Estrangement Motor (M103) - Trimmer Controller PCB (PCB1) [Remedy] Check/replace the related harness/cable, connector and parts.
E5BA-8011-02	Error in the Rear Estrangement Motor (Inner Booklet Trimmer-A1)
Detection Description	The Rear Estrangement Motor HP Sensor does not turn ON when the Rear Estrangement Motor has been driven for 180 msec.
Remedy	[Related parts] <ul style="list-style-type: none"> - Harnesses from the Rear Estrangement Motor HP Sensor (S104) to the Trimmer Controller PCB - Harnesses from the Rear Estrangement Motor (M104) to the Trimmer Controller PCB - Rear Estrangement Motor HP Sensor (S104) - Rear Estrangement Motor (M104) - Trimmer Controller PCB (PCB1) [Remedy] Check/replace the related harness/cable, connector and parts.
E5BA-8012-02	Error in the Rear Estrangement Motor (Inner Booklet Trimmer-A1)
Detection Description	The Rear Estrangement Motor HP Sensor does not turn OFF when the Rear Estrangement Motor has been driven for 537 msec.
Remedy	[Related parts] <ul style="list-style-type: none"> - Harnesses from the Rear Estrangement Motor HP Sensor (S104) to the Trimmer Controller PCB - Harnesses from the Rear Estrangement Motor (M104) to the Trimmer Controller PCB - Rear Estrangement Motor HP Sensor (S104) - Rear Estrangement Motor (M104) - Trimmer Controller PCB (PCB1) [Remedy] Check/replace the related harness/cable, connector and parts.
E5BB-8001-02	Error in the Waste Paper Full Sensor (Inner Booklet Trimmer-A1)
Detection Description	The A/D input value does not enter into the D/A output upper limit of the Waste Paper Full Sensor.
Remedy	[Related parts] <ul style="list-style-type: none"> - Harnesses from the Waste Paper Full Sensor (emitting/receiving) (S011) to the Trimmer Controller PCB - Waste Paper Full Sensor (emitting/receiving) (S011) - Trimmer Controller PCB (PCB1) [Remedy] Check/replace the related harness/cable, connector and parts.

E5BB-8002-02	Error in the Waste Paper Full Sensor (Inner Booklet Trimmer-A1)
Detection Description	The A/D input value does not enter into the D/A output lower limit of the Waste Paper Full Sensor.
Remedy	[Related parts] - Harnesses from the Waste Paper Full Sensor (emitting/receiving) (S011) to the Trimmer Controller PCB - Waste Paper Full Sensor (emitting/receiving) (S011) - Trimmer Controller PCB (PCB1) [Remedy] Check/replace the related harness/cable, connector and parts.

E5F0-8001-02	a. Saddle Leading Edge Stopper HP error (Finisher-W1) b. Error in the Saddle Lead Edge Stopper Motor (Finisher-X1) c. Error in the Saddle Paper End Stopper Motor (Finisher-AC1)
Detection Description	<p>a. The Saddle Leading Edge Stopper Home Position Sensor was not turned ON although 5.5 sec had passed after the Saddle Leading Edge Stopper started the operation.</p> <p>b. The Saddle Lead Edge Stopper HP Sensor does not detect the Saddle lead edge stopper when the Saddle lead edge stopper has been moved for 182 mm by Saddle Lead Edge Stopper Motor.</p> <p>c. The saddle paper end stopper does not come off the Saddle Paper End Stopper HP Sensor when the Saddle Paper End Stopper Motor has been driven for 1 second.</p>
Remedy	<p>a. FIN-W1/SADDLE FIN-W1 [Related parts]</p> <ul style="list-style-type: none"> - Harnesses from the Saddle Stitcher Controller PCB to the Saddle Leading Edge Stopper Home Position Sensor 1. Saddle Stitcher Controller PCB (UN101/J213) to Relay Connector (17P) (Unit of replacement: CABLE, SADDLE SENSOR, FRONT) 2. Relay Connector (17P) to Relay Connector (17P) (Unit of replacement: SADDLE ASSEMBLY) 3. Relay Connector (17P) to Saddle Leading Edge Stopper Home Position Sensor (PS105/J929) (Unit of replacement: EDGE STOPPER ASSEMBLY) - Harnesses from the Saddle Stitcher Controller PCB to the Saddle Lead Edge Stopper Motor 1. Saddle Stitcher Controller PCB (UN101/J213) to Relay Connector (17P) (Unit of replacement: CABLE, SADDLE SENSOR, FRONT) 2. Relay Connector (17P) to Relay Connector (17P) (Unit of replacement: SADDLE ASSEMBLY) 3. Relay Connector (17P) to Saddle Lead Edge Stopper Motor (M103/J925) (Unit of replacement: EDGE STOPPER ASSEMBLY) - Saddle Leading Edge Stopper Home Position Sensor (PS105) - Saddle Leading Edge Stopper Motor (M103) - Saddle Stitcher Controller PCB (UN101) (Unit of replacement: SADDLE DRIVER PCB ASS'Y) - Finisher Controller PCB (UN3) (Unit of replacement: FINISHER CONTROLLER PCB ASS'Y) <p>[Remedy] Check/replace the related harness/cable, connector and parts. [Reference] After replacement of the Finisher Controller PCB, refer to "Adjustments> Adjustment when Replacing the Parts> Points to Note when Replacing the Finisher Controller PCB" in the Service Manual for the Finisher.</p> <p>b. STAPLE FIN-X1/BOOKLET FIN-X1 [Related parts]</p> <ul style="list-style-type: none"> - Harnesses from the Saddle Lead Edge Stopper HP Sensor (S205) to the Saddle Stitcher Controller PCB - Harnesses from the Saddle Lead Edge Stopper Motor (M203) to the Saddle Stitcher Controller PCB - Saddle Lead Edge Stopper HP Sensor (S205) - Saddle Lead Edge Stopper Motor (M203) - Saddle Stitcher Controller PCB (PBA201) - Finisher Controller PCB (PBA101) <p>[Remedy] Check/replace the related harness/cable, connector and parts. [Reference] When replacing the Finisher Controller PCB, refer to "Adjustments> Adjustment when Replacing the Parts" in the Service Manual.</p> <p>c. STAPLE FIN-AC1/BOOKLET FIN-AC1 [Related parts]</p> <ul style="list-style-type: none"> - Harnesses from the Saddle Paper End Stopper HP Sensor (PS210) to the Saddle Stitcher Controller PCB - Harnesses from the Saddle Paper End Stopper Motor (M206) to the Saddle Stitcher Controller PCB - Saddle Paper End Stopper HP Sensor (PS210) - Saddle Paper End Stopper Motor (M206) - Saddle Stitcher Controller PCB (PCB201) - Finisher Controller PCB (PCB101) <p>[Remedy] Check/replace the related harness/cable, connector and parts. [Reference] When replacing the Finisher Controller PCB, refer to "Adjustment> When Replacing the Parts" in the Service Manual.</p>

E5F0-8002-02

a. Saddle Leading Edge Stopper HP error (Finisher-W1) b. Error in the Saddle Lead Edge Stopper Motor (Finisher-X1) c. Error in the Saddle Paper End Stopper Motor (Finisher-AC1)**Detection Description**

- a. The Saddle Leading Edge Stopper Home Position Sensor was not turned OFF although 5.5 sec had passed after the Saddle Leading Edge Stopper started the operation.
- b. The Saddle lead edge stopper does not come off the Saddle Lead Edge Stopper HP Sensor when the Saddle Lead Edge Stopper Motor has been driven for 50 pulses.
- c. The Saddle Paper End Stopper HP Sensor does not detect the saddle paper end stopper when the Saddle Paper End Stopper Motor has been driven for 4 seconds.

Remedy**a. FIN-W1/SADDLE FIN-W1**

[Related parts]

- Harnesses from the Saddle Stitcher Controller PCB to the Saddle Leading Edge Stopper Home Position Sensor

1. Saddle Stitcher Controller PCB (UN101/J213) to Relay Connector (17P) (Unit of replacement: CABLE, SADDLE SENSOR, FRONT)

2. Relay Connector (17P) to Relay Connector (17P) (Unit of replacement: SADDLE ASSEMBLY)

3. Relay Connector (17P) to Saddle Leading Edge Stopper Home Position Sensor (PS105/J929) (Unit of replacement: EDGE STOPPER ASSEMBLY)

- Harnesses from the Saddle Stitcher Controller PCB to the Saddle Lead Edge Stopper Motor

1. Saddle Stitcher Controller PCB (UN101/J213) to Relay Connector (17P) (Unit of replacement: CABLE, SADDLE SENSOR, FRONT)

2. Relay Connector (17P) to Relay Connector (17P) (Unit of replacement: SADDLE ASSEMBLY)

3. Relay Connector (17P) to Saddle Lead Edge Stopper Motor (M103/J925) (Unit of replacement: EDGE STOPPER ASSEMBLY)

- Saddle Leading Edge Stopper Home Position Sensor (PS105)

- Saddle Leading Edge Stopper Motor (M103)

- Saddle Stitcher Controller PCB (UN101) (Unit of replacement: SADDLE DRIVER PCB ASS'Y)

- Finisher Controller PCB (UN3) (Unit of replacement: FINISHER CONTROLLER PCB ASS'Y)

[Remedy] Check/replace the related harness/cable, connector and parts.

[Reference] After replacement of the Finisher Controller PCB, refer to "Adjustments> Adjustment when Replacing the Parts> Points to Note when Replacing the Finisher Controller PCB" in the Service Manual for the Finisher.

b. STAPLE FIN-X1/BOOKLET FIN-X1

[Related parts]

- Harnesses from the Saddle Lead Edge Stopper HP Sensor (S205) to the Saddle Stitcher Controller PCB

- Harnesses from the Saddle Lead Edge Stopper Motor (M203) to the Saddle Stitcher Controller PCB

- Saddle Lead Edge Stopper HP Sensor (S205)

- Saddle Lead Edge Stopper Motor (M203)

- Saddle Stitcher Controller PCB (PBA201)

- Finisher Controller PCB (PBA101)

[Remedy] Check/replace the related harness/cable, connector and parts.

[Reference] When replacing the Finisher Controller PCB, refer to "Adjustments> Adjustment when Replacing the Parts" in the Service Manual.

c. STAPLE FIN-AC1/BOOKLET FIN-AC1

[Related parts]

- Harnesses from the Saddle Paper End Stopper HP Sensor (PS210) to the Saddle Stitcher Controller PCB

- Harnesses from the Saddle Paper End Stopper Motor (M206) to the Saddle Stitcher Controller PCB

- Saddle Paper End Stopper HP Sensor (PS210)

- Saddle Paper End Stopper Motor (M206)

- Saddle Stitcher Controller PCB (PCB201)

- Finisher Controller PCB (PCB101)

[Remedy] Check/replace the related harness/cable, connector and parts.

[Reference] When replacing the Finisher Controller PCB, refer to "Adjustment> When Replacing the Parts" in the Service Manual.

E5F1-8000-02	Saddle Fold/Feed Motor error
Detection Description	FIN-W1/SADDLE FIN-W1 The Saddle Fold/Feed Motor did not rotate although 1 sec had passed after the motor started the operation.
Remedy	FIN-W1/SADDLE FIN-W1 [Related parts] - Harnesses from the Saddle Stitcher Controller PCB to the Saddle Fold/Feed Motor 1. Saddle Stitcher Controller PCB (UN101/J210) to Relay Connector (2P) (Unit of replacement: SADDLE ASSEMBLY) 2. Relay Connector (2P) to Saddle Fold/Feed Motor (M106/J902) (Unit of replacement: MOTOR, DC) - Harnesses from the Saddle Stitcher Controller PCB to the Saddle Fold/Feed Motor Rotation Sensor 1. Saddle Stitcher Controller PCB (UN101/J213) to Relay Connector (5P) (Unit of replacement: CABLE, SADDLE SENSOR, FRONT) 2. Relay Connector (5P) to Saddle Fold/Feed Motor Rotation Sensor (PS114/J946) (Unit of replacement: CABLE, LED PCB) - Harness between the Finisher Controller PCB (UN3/J103) and the Relay PCB (UN7/J413) (Unit of replacement: CABLE, DC) - Saddle Fold/Feed Motor (M106) - Saddle Fold/Feed Motor Rotation Sensor (PS114) - Saddle Stitcher Controller PCB (UN101) (Unit of replacement: SADDLE DRIVER PCB ASS'Y) - Finisher Controller PCB (UN3) (Unit of replacement: FINISHER CONTROLLER PCB ASS'Y) [Remedy] Check/replace the related harness/cable, connector and parts. [Reference] After replacement of the Finisher Controller PCB, refer to "Adjustments> Adjustment when Replacing the Parts> Points to Note when Replacing the Finisher Controller PCB" in the Service Manual for the Finisher.

E5F1-8001-02	a. Saddle Fold/Feed Motor error b. Saddle Folder/Feeder Clock Error (Finisher-X1)
Detection Description	<p>a. FIN-W1/SADDLE FIN-W1 The Saddle Fold/Feed Motor Rotation Sensor was not turned ON although paper was fed for the specified distance after the sensor was turned OFF.</p> <p>b. The drive speed of the Saddle Folder/Feeder Motor is less than 5 mm/sec.</p>
Remedy	<p>a. FIN-W1/SADDLE FIN-W1 [Related parts] - Harnesses from the Saddle Stitcher Controller PCB to the Saddle Fold/Feed Motor Rotation Sensor</p> <ol style="list-style-type: none"> 1. Saddle Stitcher Controller PCB (UN101/J213) to Relay Connector (5P) (Unit of replacement: CABLE, SADDLE SENSOR, FRONT) 2. Relay Connector (5P) to Saddle Fold/Feed Motor Rotation Sensor (PS114/J946) (Unit of replacement: CABLE, LED PCB) <p>- Harnesses from the Saddle Stitcher Controller PCB to the Saddle Fold/Feed Motor</p> <ol style="list-style-type: none"> 1. Saddle Stitcher Controller PCB (UN101/J210) to Relay Connector (2P) (Unit of replacement: SADDLE ASSEMBLY) 2. Relay Connector (2P) to Saddle Fold/Feed Motor (M106/J902) (Unit of replacement: MOTOR, DC) <p>- Saddle Fold/Feed Motor Rotation Sensor (PS114) - Saddle Fold/Feed Motor (M106) - Saddle Stitcher Controller PCB (UN101) (Unit of replacement: SADDLE DRIVER PCB ASS'Y) - Finisher Controller PCB (UN3) (Unit of replacement: FINISHER CONTROLLER PCB ASS'Y)</p> <p>[Remedy] Check/replace the related harness/cable, connector and parts. [Reference] After replacement of the Finisher Controller PCB, refer to "Adjustments> Adjustment when Replacing the Parts> Points to Note when Replacing the Finisher Controller PCB" in the Service Manual for the Finisher.</p> <p>b. STAPLE FIN-X1/BOOKLET FIN-X1 [Related parts] - Harnesses from the Saddle Folder/Feeder Motor Sensor (S214) to the Saddle Stitcher Controller PCB - Harnesses from the Saddle Folder/Feeder Motor (M206) to the Saddle Stitcher Controller PCB - Saddle Folder/Feeder Motor Sensor (S214) - Saddle Folder/Feeder Motor (M206) - Saddle Stitcher Controller PCB (PBA201) - Finisher Controller PCB (PBA101)</p> <p>[Remedy] Check/replace the related harness/cable, connector and parts. [Reference] When replacing the Finisher Controller PCB, refer to "Adjustments> Adjustment when Replacing the Parts" in the Service Manual.</p>

E5F1-8002-02	a. Saddle Fold/Feed Motor error b. Error in the Saddle Folder/Feeder Motor (Finisher-X1)
Detection Description	<p>a. FIN-W1/SADDLE FIN-W1 The Saddle Fold/Feed Motor Rotation Sensor was not turned OFF although paper was fed for the specified distance after the Saddle Fold/Feed Motor started the operation.</p> <p>b. The Saddle Folder HP Sensor does not detect the home position of the paper fold roller during initialization.</p>
Remedy	<p>a. FIN-W1/SADDLE FIN-W1 [Related parts] - Harnesses from the Saddle Stitcher Controller PCB to the Saddle Fold/Feed Motor Rotation Sensor 1. Saddle Stitcher Controller PCB (UN101/J213) to Relay Connector (5P) (Unit of replacement: CABLE, SADDLE SENSOR, FRONT) 2. Relay Connector (5P) to Saddle Fold/Feed Motor Rotation Sensor (PS114/J946) (Unit of replacement: CABLE, LED PCB) - Harnesses from the Saddle Stitcher Controller PCB to the Saddle Fold/Feed Motor 1. Saddle Stitcher Controller PCB (UN101/J210) to Relay Connector (2P) (Unit of replacement: SADDLE ASSEMBLY) 2. Relay Connector (2P) to Saddle Fold/Feed Motor (M106/J902) (Unit of replacement: MOTOR, DC) - Saddle Fold/Feed Motor Rotation Sensor (PS114) - Saddle Fold/Feed Motor (M106) - Saddle Stitcher Controller PCB (UN101) (Unit of replacement: SADDLE DRIVER PCB ASS'Y) - Finisher Controller PCB (UN3) (Unit of replacement: FINISHER CONTROLLER PCB ASS'Y) [Remedy] Check/replace the related harness/cable, connector and parts. [Reference] After replacement of the Finisher Controller PCB, refer to "Adjustments> Adjustment when Replacing the Parts> Points to Note when Replacing the Finisher Controller PCB" in the Service Manual for the Finisher.</p> <p>b. STAPLE FIN-X1/BOOKLET FIN-X1 [Related parts] - Harnesses from the Saddle Folder HP Sensor (S229) to the Saddle Stitcher Controller PCB - Harnesses from the Saddle Folder/Feeder Motor (M206) to the Saddle Stitcher Controller PCB - Saddle Folder HP Sensor (S229) - Saddle Folder/Feeder Motor (M206) - Saddle Stitcher Controller PCB (PBA201) - Finisher Controller PCB (PBA101) [Remedy] Check/replace the related harness/cable, connector and parts. [Reference] When replacing the Finisher Controller PCB, refer to "Adjustments> Adjustment when Replacing the Parts" in the Service Manual.</p>
E5F1-8003-02	Saddle Delivery Motor clock error (Finisher-AC1)
Detection Description	The lock state of Saddle Delivery Motor is detected 0.2 seconds or more while the motor operates.
Remedy	<p>STAPLE FIN-AC1/BOOKLET FIN-AC1 [Related parts] - Harnesses from the Saddle Delivery Motor Clock Sensor (PS211) to the Saddle Stitcher Controller PCB - Harnesses from the Saddle Delivery Motor (M207) to the Saddle Stitcher Controller PCB - Saddle Delivery Motor Clock Sensor (PS211) - Saddle Delivery Motor (M207) - Saddle Stitcher Controller PCB (PCB201) - Finisher Controller PCB (PCB101) [Remedy] Check/replace the related harness/cable, connector and parts. [Reference] When replacing the Finisher Controller PCB, refer to "Adjustment> When Replacing the Parts" in the Service Manual.</p>

E5F2-8001-02	a. Saddle Roller Guide HP error b. Error in the Saddle Roller Guide Motor (Finisher-X1)
Detection Description	<p>a. FIN-W1/SADDLE FIN-W1 The Saddle Roller Guide HP Sensor was not turned ON although 1 sec had passed after the Saddle Roller Guide Motor started the operation.</p> <p>b. The Saddle Roller Guide HP Sensor does not detect the Saddle roller guide when the saddle roller guide has been moved for 20 mm by Saddle Roller Guide Motor.</p>
Remedy	<p>a. FIN-W1/SADDLE FIN-W1 [Related parts]</p> <ul style="list-style-type: none"> - Harness between the Saddle Stitcher Controller PCB (UN101/J209) and the Saddle Roller Guide HP Sensor (PS107/J944) (Unit of replacement: CABLE, SADDLE SENSOR, RIGHT) - Harnesses from the Saddle Stitcher Controller PCB to the Saddle Roller Guide Motor <ol style="list-style-type: none"> 1. Saddle Stitcher Controller PCB (UN101/J204) to Relay Connector (4P) (Unit of replacement: SADDLE ASSEMBLY) 2. Relay Connector (4P) to Saddle Roller Guide Motor (M104/J905) (Unit of replacement: MOTOR, STEPPING, DC) <ul style="list-style-type: none"> - Saddle Roller Guide HP Sensor (PS107) - Saddle Roller Guide Motor (M104) - Saddle Stitcher Controller PCB (UN101) (Unit of replacement: SADDLE DRIVER PCB ASS'Y) - Finisher Controller PCB (UN3) (Unit of replacement: FINISHER CONTROLLER PCB ASS'Y) <p>[Remedy] Check/replace the related harness/cable, connector and parts. [Reference] After replacement of the Finisher Controller PCB, refer to "Adjustments> Adjustment when Replacing the Parts> Points to Note when Replacing the Finisher Controller PCB" in the Service Manual for the Finisher.</p> <p>b. STAPLE FIN-X1/BOOKLET FIN-X1 [Related parts]</p> <ul style="list-style-type: none"> - Harnesses from the Saddle Roller Guide HP Sensor (S207) to the Saddle Stitcher Controller PCB - Harnesses from the Saddle Roller Guide Motor (M204) to the Saddle Stitcher Controller PCB - Saddle Roller Guide HP Sensor (S207) - Saddle Roller Guide Motor (M204) - Saddle Stitcher Controller PCB (PBA201) - Finisher Controller PCB (PBA101) <p>[Remedy] Check/replace the related harness/cable, connector and parts. [Reference] When replacing the Finisher Controller PCB, refer to "Adjustments> Adjustment when Replacing the Parts" in the Service Manual.</p>

E5F2-8002-02

a. Saddle Roller Guide HP error b. Error in the Saddle Roller Guide Motor (Finisher-X1)

Detection Description

a. FIN-W1/SADDLE FIN-W1

The Saddle Roller Guide HP Sensor was not turned OFF although 1 sec had passed after the Saddle Roller Guide Motor started the operation.

b. The saddle roller guide does not come off the Saddle Roller Guide HP Sensor when the Saddle Roller Guide Motor has been driven for 50 pulses.

Remedy

a. FIN-W1/SADDLE FIN-W1

[Related parts]

- Harness between the Saddle Stitcher Controller PCB (UN101/J209) and the Saddle Roller Guide HP Sensor (PS107/J944) (Unit of replacement: CABLE, SADDLE SENSOR, RIGHT)

- Harnesses from the Saddle Stitcher Controller PCB to the Saddle Roller Guide Motor

1. Saddle Stitcher Controller PCB (UN101/J204) to Relay Connector (4P) (Unit of replacement: SADDLE ASSEMBLY)

2. Relay Connector (4P) to Saddle Roller Guide Motor (M104/J905) (Unit of replacement: MOTOR, STEPPING, DC)

- Saddle Roller Guide HP Sensor (PS107)

- Saddle Roller Guide Motor (M104)

- Saddle Stitcher Controller PCB (UN101) (Unit of replacement: SADDLE DRIVER PCB ASS'Y)

- Finisher Controller PCB (UN3) (Unit of replacement: FINISHER CONTROLLER PCB ASS'Y)

[Remedy] Check/replace the related harness/cable, connector and parts.

[Reference] After replacement of the Finisher Controller PCB, refer to "Adjustments> Adjustment when Replacing the Parts> Points to Note when Replacing the Finisher Controller PCB" in the Service Manual for the Finisher.

b. STAPLE FIN-X1/BOOKLET FIN-X1

[Related parts]

- Harnesses from the Saddle Roller Guide HP Sensor (S207) to the Saddle Stitcher Controller PCB

- Harnesses from the Saddle Roller Guide Motor (M204) to the Saddle Stitcher Controller PCB

- Saddle Roller Guide HP Sensor (S207)

- Saddle Roller Guide Motor (M204)

- Saddle Stitcher Controller PCB (PBA201)

- Finisher Controller PCB (PBA101)

[Remedy] Check/replace the related harness/cable, connector and parts.

[Reference] When replacing the Finisher Controller PCB, refer to "Adjustments> Adjustment when Replacing the Parts" in the Service Manual.

E5F3-8001-02

a. Saddle Alignment Plate HP error (Finisher-W1) b. Error in the Saddle Alignment Guide Motor (Finisher-X1) c. Error in the Saddle Alignment Motor (Finisher-AC1)**Detection Description**

- a. The Saddle Alignment Plate HP Sensor was not turned ON although 1.5 sec had passed after the Saddle Alignment Guide Motor started the operation.
- b. The Saddle Alignment Plate HP Sensor does not detect the saddle alignment guide when the saddle alignment guide has been moved for 177 mm by Saddle Alignment Guide Motor.
- c. The saddle alignment plate does not come off the Saddle Alignment HP Sensor when the Saddle Alignment Motor has been driven for 1 second.

Remedy**a. FIN-W1/SADDLE FIN-W1**

[Related parts]

- Harnesses from the Saddle Stitcher Controller PCB to the Saddle Alignment Plate HP Sensor
 1. Saddle Stitcher Controller PCB (UN101/J213) to Relay Connector (17P) (Unit of replacement: CABLE, SADDLE SENSOR, FRONT)
 2. Relay Connector (17P) to Relay Connector (17P) (Unit of replacement: SADDLE ASSEMBLY)
 3. Relay Connector (17P) to Saddle Alignment Plate HP Sensor (PS106/J928) (Unit of replacement: EDGE STOPPER ASSEMBLY)
- Harnesses from the Saddle Stitcher Controller PCB to the Saddle Alignment Guide Motor
 1. Saddle Stitcher Controller PCB (UN101/J213) to Relay Connector (17P) (Unit of replacement: CABLE, SADDLE SENSOR, FRONT)
 2. Relay Connector (17P) to Relay Connector (17P) (Unit of replacement: SADDLE ASSEMBLY)
 3. Relay Connector (17P) to Saddle Alignment Guide Motor (M102/J923) (Unit of replacement: EDGE STOPPER ASSEMBLY)
- Saddle Alignment Plate HP Sensor (PS106)
- Saddle Alignment Guide Motor (M102)
- Saddle Stitcher Controller PCB (UN101) (Unit of replacement: SADDLE DRIVER PCB ASS'Y)
- Finisher Controller PCB (UN3) (Unit of replacement: FINISHER CONTROLLER PCB ASS'Y)

[Remedy] Check/replace the related harness/cable, connector and parts.

[Reference] After replacement of the Finisher Controller PCB, refer to "Adjustments> Adjustment when Replacing the Parts> Points to Note when Replacing the Finisher Controller PCB" in the Service Manual for the Finisher.

b. STAPLE FIN-X1/BOOKLET FIN-X1

[Related parts]

- Harnesses from the Saddle Alignment Plate HP Sensor (S206) to the Saddle Stitcher Controller PCB
- Harnesses from the Saddle Alignment Guide Motor (M202) to the Saddle Stitcher Controller PCB
- Saddle Alignment Plate HP Sensor (S206)
- Saddle Alignment Guide Motor (M202)
- Saddle Stitcher Controller PCB (PBA201)
- Finisher Controller PCB (PBA101)

[Remedy] Check/replace the related harness/cable, connector and parts.

[Reference] When replacing the Finisher Controller PCB, refer to "Adjustments> Adjustment when Replacing the Parts" in the Service Manual.

c. STAPLE FIN-AC1/BOOKLET FIN-AC1

[Related parts]

- Harnesses from the Saddle Alignment HP Sensor (PS207) to the Saddle Stitcher Controller PCB
- Harnesses from the Saddle Alignment Motor (M203) to the Saddle Stitcher Controller PCB
- Saddle Alignment HP Sensor (PS207)
- Saddle Alignment Motor (M203)
- Saddle Stitcher Controller PCB (PCB201)
- Finisher Controller PCB (PCB101)

[Remedy] Check/replace the related harness/cable, connector and parts.

[Reference] When replacing the Finisher Controller PCB, refer to "Adjustment> When Replacing the Parts" in the Service Manual.

E5F3-8002-02

a. Saddle Alignment Plate HP error (Finisher-W1) b. Error in the Saddle Alignment Guide Motor (Finisher-X1) c. Error in the Saddle Alignment Motor (Finisher-AC1)**Detection Description**

- a. The Saddle Alignment Plate HP Sensor was not turned OFF although 1.5 sec had passed after the Saddle Alignment Guide Motor started the operation.
- b. The saddle alignment guide does not come off the Saddle Alignment Plate HP Sensor when the Saddle Alignment Guide Motor has been driven for 50 pulses.
- c. The Saddle Alignment HP Sensor does not detect the saddle alignment plate when the Saddle Alignment Motor has been driven for 1 second.

Remedy**a. FIN-W1/SADDLE FIN-W1**

[Related parts]

- Harnesses from the Saddle Stitcher Controller PCB to the Saddle Alignment Plate HP Sensor
 1. Saddle Stitcher Controller PCB (UN101/J213) to Relay Connector (17P) (Unit of replacement: CABLE, SADDLE SENSOR, FRONT)
 2. Relay Connector (17P) to Relay Connector (17P) (Unit of replacement: SADDLE ASSEMBLY)
 3. Relay Connector (17P) to Saddle Alignment Plate HP Sensor (PS106/J928) (Unit of replacement: EDGE STOPPER ASSEMBLY)
- Harnesses from the Saddle Stitcher Controller PCB to the Saddle Alignment Guide Motor
 1. Saddle Stitcher Controller PCB (UN101/J213) to Relay Connector (17P) (Unit of replacement: CABLE, SADDLE SENSOR, FRONT)
 2. Relay Connector (17P) to Relay Connector (17P) (Unit of replacement: SADDLE ASSEMBLY)
 3. Relay Connector (17P) to Saddle Alignment Guide Motor (M102/J923) (Unit of replacement: EDGE STOPPER ASSEMBLY)
- Saddle Alignment Plate HP Sensor (PS106)
- Saddle Alignment Guide Motor (M102)
- Saddle Stitcher Controller PCB (UN101) (Unit of replacement: SADDLE DRIVER PCB ASS'Y)
- Finisher Controller PCB (UN3) (Unit of replacement: FINISHER CONTROLLER PCB ASS'Y)

[Remedy] Check/replace the related harness/cable, connector and parts.

[Reference] After replacement of the Finisher Controller PCB, refer to "Adjustments> Adjustment when Replacing the Parts> Points to Note when Replacing the Finisher Controller PCB" in the Service Manual for the Finisher.

b. STAPLE FIN-X1/BOOKLET FIN-X1

[Related parts]

- Harnesses from the Saddle Alignment Plate HP Sensor (S206) to the Saddle Stitcher Controller PCB
- Harnesses from the Saddle Alignment Guide Motor (M202) to the Saddle Stitcher Controller PCB
- Saddle Alignment Plate HP Sensor (S206)
- Saddle Alignment Guide Motor (M202)
- Saddle Stitcher Controller PCB (PBA201)
- Finisher Controller PCB (PBA101)

[Remedy] Check/replace the related harness/cable, connector and parts.

[Reference] When replacing the Finisher Controller PCB, refer to "Adjustments> Adjustment when Replacing the Parts" in the Service Manual.

c. STAPLE FIN-AC1/BOOKLET FIN-AC1

[Related parts]

- Harnesses from the Saddle Alignment HP Sensor (PS207) to the Saddle Stitcher Controller PCB
- Harnesses from the Saddle Alignment Motor (M203) to the Saddle Stitcher Controller PCB
- Saddle Alignment HP Sensor (PS207)
- Saddle Alignment Motor (M203)
- Saddle Stitcher Controller PCB (PCB201)
- Finisher Controller PCB (PCB101)

[Remedy] Check/replace the related harness/cable, connector and parts.

[Reference] When replacing the Finisher Controller PCB, refer to "Adjustment> When Replacing the Parts" in the Service Manual.

E5F4-8001-02**a. Saddle Staple (Rear) error (Finisher-W1) b. Error in the Saddle Stitcher Motor (Finisher-X1) c. Error in the Saddle Stitcher Motor (Finisher-AC1)****Detection Description**

- a. The Saddle Staple HP Sensor was not turned ON although 0.8 sec had passed after the Saddle Staple Unit started the operation.
- b. The Saddle Stitcher HP Sensor does not detect the saddle stitcher unit when the Saddle Stitcher Motor has been driven for 480 msec.
- c. The saddle stitcher does not come off the Saddle Stitcher HP Sensor when the Saddle Stitcher Motor has been driven for 1.2 seconds.

Remedy**a. FIN-W1/SADDLE FIN-W1**

[Related parts]

- Harnesses from the Saddle Staple Unit to the Saddle Stitcher Controller PCB

1. Saddle Staple Unit (J904) to Relay Connector (10P) (Unit of replacement: CABLE, SADDLE STOPPER)

2. Relay Connector (10P) to Saddle Stitcher Controller PCB (UN101/J207) (Unit of replacement: CABLE, SADDLE SENSOR, RIGHT)

- Saddle Staple Unit (Unit of replacement: SADDLE STAPLER ASSEMBLY)

- Saddle Stitcher Controller PCB (UN101) (Unit of replacement: SADDLE DRIVER PCB ASS'Y)

[Remedy] Check/replace the related harness/cable, connector and parts.

b. STAPLE FIN-X1/BOOKLET FIN-X1

[Related parts]

- Harnesses from the Saddle Stitcher HP Sensor (S223) to the Saddle Stitcher Controller PCB

- Harnesses from the Saddle Stitcher Motor (M209) to the Saddle Stitcher Controller PCB

- Saddle Stitcher HP Sensor (S223)

- Saddle Stitcher Motor (M209)

- Saddle Stitcher Controller PCB (PBA201)

- Finisher Controller PCB (PBA101)

[Remedy] Check/replace the related harness/cable, connector and parts.

[Reference] When replacing the Finisher Controller PCB, refer to "Adjustments> Adjustment when Replacing the Parts" in the Service Manual.

c. STAPLE FIN-AC1/BOOKLET FIN-AC1

[Related parts]

- Harnesses from the Saddle Stitcher HP Sensor (PS215) to the Saddle Stitcher Controller PCB

- Harnesses from the Saddle Stitcher Motor (M208) to the Saddle Stitcher Controller PCB

- Saddle Stitcher HP Sensor (PS215)

- Saddle Stitcher Motor (M208)

- Saddle Stitcher Controller PCB (PCB201)

- Finisher Controller PCB (PCB101)

[Remedy] Check/replace the related harness/cable, connector and parts.

[Reference] When replacing the Finisher Controller PCB, refer to "Adjustment> When Replacing the Parts" in the Service Manual.

E5F4-8002-02	a. Saddle Staple (Rear) error (Finisher-W1) b. Error in the Saddle Stitcher Motor (Finisher-X1) c. Error in the Saddle Stitcher Motor (Finisher-AC1)
Detection Description	<p>a. The Saddle Staple HP Sensor was not turned OFF although 0.5 sec had passed after the Saddle Staple Unit started the operation.</p> <p>b. The Saddle Stitcher unit does not come off the Saddle Stitcher HP Sensor when the Saddle Stitcher Motor has been driven for 480msec.</p> <p>c. The Saddle Stitcher HP Sensor does not detect the saddle stitcher when the Saddle Stitcher Motor has been driven for 1.2 seconds.</p>
Remedy	<p>a. FIN-W1/SADDLE FIN-W1 [Related parts]</p> <ul style="list-style-type: none"> - Harnesses from the Saddle Staple Unit to the Saddle Stitcher Controller PCB <ol style="list-style-type: none"> 1. Saddle Staple Unit (J904) to Relay Connector (10P) (Unit of replacement: CABLE, SADDLE STOPPER) 2. Relay Connector (10P) to Saddle Stitcher Controller PCB (UN101/J207) (Unit of replacement: CABLE, SADDLE SENSOR, RIGHT) <ul style="list-style-type: none"> - Saddle Staple Unit (Unit of replacement: SADDLE STAPLER ASSEMBLY) - Saddle Stitcher Controller PCB (UN101) (Unit of replacement: SADDLE DRIVER PCB ASS'Y) <p>[Remedy] Check/replace the related harness/cable, connector and parts.</p> <p>b. STAPLE FIN-X1/BOOKLET FIN-X1 [Related parts]</p> <ul style="list-style-type: none"> - Harnesses from the Saddle Stitcher HP Sensor (S223) to the Saddle Stitcher Controller PCB - Harnesses from the Saddle Stitcher Motor (M209) to the Saddle Stitcher Controller PCB - Saddle Stitcher HP Sensor (S223) - Saddle Stitcher Motor (M209) - Saddle Stitcher Controller PCB (PBA201) - Finisher Controller PCB (PBA101) <p>[Remedy] Check/replace the related harness/cable, connector and parts. [Reference] When replacing the Finisher Controller PCB, refer to "Adjustments> Adjustment when Replacing the Parts" in the Service Manual.</p> <p>c. STAPLE FIN-AC1/BOOKLET FIN-AC1 [Related parts]</p> <ul style="list-style-type: none"> - Harnesses from the Saddle Stitcher HP Sensor (PS215) to the Saddle Stitcher Controller PCB - Harnesses from the Saddle Stitcher Motor (M208) to the Saddle Stitcher Controller PCB - Saddle Stitcher HP Sensor (PS215) - Saddle Stitcher Motor (M208) - Saddle Stitcher Controller PCB (PCB201) - Finisher Controller PCB (PCB101) <p>[Remedy] Check/replace the related harness/cable, connector and parts. [Reference] When replacing the Finisher Controller PCB, refer to "Adjustment> When Replacing the Parts" in the Service Manual.</p>
E5F5-8001-02	Error in the Saddle Trailing Edge Retainer Motor (Finisher-X1)
Detection Description	<p>The Saddle Trailing Edge Retainer Move HP Sensor does not detect the saddle trailing edge retainer when the saddle trailing edge retainer has been moved for 96 mm by Saddle Trailing Edge Retainer Motor.</p>
Remedy	<p>[Related parts]</p> <ul style="list-style-type: none"> - Harnesses from the Saddle Trailing Edge Retainer Move HP Sensor (S219) to the Saddle Stitcher Controller PCB - Harnesses from the Saddle Trailing Edge Retainer Motor (M210) to the Saddle Stitcher Controller PCB - Saddle Trailing Edge Retainer Move HP Sensor (S219) - Saddle Trailing Edge Retainer Motor (M210) - Saddle Stitcher Controller PCB (PBA201) - Finisher Controller PCB (PBA101) <p>[Remedy] Check/replace the related harness/cable, connector and parts. [Reference] When replacing the Finisher Controller PCB, refer to "Adjustments> Adjustment when Replacing the Parts" in the Service Manual.</p>

E5F5-8002-02	Error in the Saddle Trailing Edge Retainer Motor (Finisher-X1)
Detection Description	The Saddle trailing edge retainer does not come off the Saddle Trailing Edge Retainer Move HP Sensor when the Saddle Trailing Edge Retainer Motor has been driven for 50 pulses.
Remedy	<p>[Related parts]</p> <ul style="list-style-type: none"> - Harnesses from the Saddle Trailing Edge Retainer Move HP Sensor (S219) to the Saddle Stitcher Controller PCB - Harnesses from the Saddle Trailing Edge Retainer Motor (M210) to the Saddle Stitcher Controller PCB - Saddle Trailing Edge Retainer Move HP Sensor (S219) - Saddle Trailing Edge Retainer Motor (M210) - Saddle Stitcher Controller PCB (PBA201) - Finisher Controller PCB (PBA101) <p>[Remedy] Check/replace the related harness/cable, connector and parts.</p> <p>[Reference] When replacing the Finisher Controller PCB, refer to "Adjustments> Adjustment when Replacing the Parts" in the Service Manual.</p>

E5F6-8001-02

a. Saddle Paper Thrust Plate HP error (Finisher-W1) b. Error in the Saddle Paper Push-on Plate Motor (Finisher-X1) c. Error in the Saddle Paper Pushing Plate/Folding Motor (Finisher-AC1)
Detection Description

- a. The Saddle Paper Thrust Plate HP Sensor was not turned ON although 0.8 sec had passed after the Saddle Paper Thrust Plate Motor started the operation.
- b. The Saddle Paper Push-on Plate HP Sensor does not detect the saddle paper push-on plate when the Saddle Paper Push-on Plate Motor has been driven for 500 msec.
- c. The saddle paper pushing plate does not come off the Saddle Paper Pushing Plate HP Sensor when the Saddle Paper Pushing Plate/Folding Motor has been driven for 1 second.

Remedy

a. FIN-W1/SADDLE FIN-W1

[Related parts]

- Harness between the Saddle Stitcher Controller PCB (UN101/J209) and the Saddle Paper Thrust Plate HP Sensor (PS108/J937) (Unit of replacement: CABLE, SADDLE SENSOR, RIGHT)
- Harnesses from the Saddle Paper Thrust Plate Motor to the Saddle Stitcher Controller PCB
- 1. Saddle Stitcher Controller PCB (UN101/J206) to Relay Connector (4P) (Unit of replacement: SADDLE ASSEMBLY)
- 2. Relay Connector (4P) to Relay Connector (4P) (Unit of replacement: SADDLE ASSEMBLY)
- 3. Relay Connector (4P) to Saddle Paper Thrust Plate Motor (M105/J901) (Unit of replacement: MOTOR, DC)

- Saddle Paper Thrust Plate HP Sensor (PS108)

- Saddle Paper Thrust Plate Motor (M105)

- Saddle Stitcher Controller PCB (UN101) (Unit of replacement: SADDLE DRIVER PCB ASS'Y)

- Finisher Controller PCB (UN3) (Unit of replacement: FINISHER CONTROLLER PCB ASS'Y)

[Remedy] Check/replace the related harness/cable, connector and parts.

[Reference] After replacement of the Finisher Controller PCB, refer to "Adjustments> Adjustment when Replacing the Parts> Points to Note when Replacing the Finisher Controller PCB" in the Service Manual for the Finisher.

b. STAPLE FIN-X1/BOOKLET FIN-X1

[Related parts]

- Harnesses from the Saddle Paper Push-on Plate HP Sensor (S218) to the Saddle Stitcher Controller PCB

- Harnesses from the Saddle Paper Push-on Plate Motor (M205) to the Saddle Stitcher Controller PCB

- Saddle Paper Push-on Plate HP Sensor (S218)

- Saddle Paper Push-on Plate Motor (M205)

- Saddle Stitcher Controller PCB (PBA201)

- Finisher Controller PCB (PBA101)

[Remedy] Check/replace the related harness/cable, connector and parts.

[Reference] When replacing the Finisher Controller PCB, refer to "Adjustments> Adjustment when Replacing the Parts" in the Service Manual.

c. STAPLE FIN-AC1/BOOKLET FIN-AC1

[Related parts]

- Harnesses from the Saddle Paper Pushing Plate HP Sensor (PS208) to the Saddle Stitcher Controller PCB

- Harnesses from the Saddle Paper Pushing Plate/Folding Motor (M204) to the Saddle Stitcher Controller PCB

- Saddle Paper Pushing Plate HP Sensor (PS208)

- Saddle Paper Pushing Plate/Folding Motor (M204)

- Saddle Stitcher Controller PCB (PCB201)

- Finisher Controller PCB (PCB101)

[Remedy] Check/replace the related harness/cable, connector and parts.

[Reference] When replacing the Finisher Controller PCB, refer to "Adjustment> When Replacing the Parts" in the Service Manual.

E5F6-8002-02

a. Saddle Paper Thrust Plate HP error (Finisher-W1) b. Error in the Saddle Paper Push-on Plate Motor (Finisher-X1) c. Error in the Saddle Paper Pushing Plate/Folding Motor (Finisher-AC1)
Detection Description

- a. The Saddle Paper Thrust Plate HP Sensor was not turned OFF although 0.8 sec had passed after the Saddle Paper Thrust Plate Motor started the operation.
- b. The saddle paper push-on plate does not come off the Saddle Paper Push-on Plate HP Sensor when the Saddle Paper Push-on Plate Motor has been driven for 150 msec.
- c. The Saddle Paper Pushing Plate HP Sensor does not detect the saddle paper pushing plate when the Saddle Paper Pushing Plate/Folding Motor has been driven for 3 seconds.

Remedy

a. FIN-W1/SADDLE FIN-W1

[Related parts]

- Harness between the Saddle Stitcher Controller PCB (UN101/J209) and the Saddle Paper Thrust Plate HP Sensor (PS108/J937) (Unit of replacement: CABLE, SADDLE SENSOR, RIGHT)
- Harnesses from the Saddle Paper Thrust Plate Motor to the Saddle Stitcher Controller PCB
 1. Saddle Stitcher Controller PCB (UN101/J206) to Relay Connector (4P) (Unit of replacement: SADDLE ASSEMBLY)
 2. Relay Connector (4P) to Relay Connector (4P) (Unit of replacement: SADDLE ASSEMBLY)
 3. Relay Connector (4P) to Saddle Paper Thrust Plate Motor (M105/J901) (Unit of replacement: MOTOR, DC)

- Saddle Paper Thrust Plate HP Sensor (PS108)

- Saddle Paper Thrust Plate Motor (M105)

- Saddle Stitcher Controller PCB (UN101) (Unit of replacement: SADDLE DRIVER PCB ASS'Y)

- Finisher Controller PCB (UN3) (Unit of replacement: FINISHER CONTROLLER PCB ASS'Y)

[Remedy] Check/replace the related harness/cable, connector and parts.

[Reference] After replacement of the Finisher Controller PCB, refer to "Adjustments> Adjustment when Replacing the Parts> Points to Note when Replacing the Finisher Controller PCB" in the Service Manual for the Finisher.

b. STAPLE FIN-X1/BOOKLET FIN-X1

[Related parts]

- Harnesses from the Saddle Paper Push-on Plate HP Sensor (S218) to the Saddle Stitcher Controller PCB

- Harnesses from the Saddle Paper Push-on Plate Motor (M205) to the Saddle Stitcher Controller PCB

- Saddle Paper Push-on Plate HP Sensor (S218)

- Saddle Paper Push-on Plate Motor (M205)

- Saddle Stitcher Controller PCB (PBA201)

- Finisher Controller PCB (PBA101)

[Remedy] Check/replace the related harness/cable, connector and parts.

[Reference] When replacing the Finisher Controller PCB, refer to "Adjustments> Adjustment when Replacing the Parts" in the Service Manual.

c. STAPLE FIN-AC1/BOOKLET FIN-AC1

[Related parts]

- Harnesses from the Saddle Paper Pushing Plate HP Sensor (PS208) to the Saddle Stitcher Controller PCB

- Harnesses from the Saddle Paper Pushing Plate/Folding Motor (M204) to the Saddle Stitcher Controller PCB

- Saddle Paper Pushing Plate HP Sensor (PS208)

- Saddle Paper Pushing Plate/Folding Motor (M204)

- Saddle Stitcher Controller PCB (PCB201)

- Finisher Controller PCB (PCB101)

[Remedy] Check/replace the related harness/cable, connector and parts.

[Reference] When replacing the Finisher Controller PCB, refer to "Adjustment> When Replacing the Parts" in the Service Manual.

E5F6-8003-02	a. Saddle Paper Push-on Plate Motor clock error (Finisher-X1) b. Saddle Paper Pushing Plate/Folding Motor clock error (Finisher-AC1)
Detection Description	<p>a. The drive speed of the Saddle Paper Push-on Plate Motor is less than 6 clocks. b. The lock state of Saddle Paper Pushing Plate/Folding Motor is detected 0.2 seconds or more while the motor operates.</p>
Remedy	<p>a. STAPLE FIN-X1/BOOKLET FIN-X1 [Related parts] - Harnesses from the Saddle Paper Push-on Plate Motor Sensor (S213) to the Saddle Stitcher Controller PCB - Harnesses from the Saddle Paper Push-on Plate Motor (M205) to the Saddle Stitcher Controller PCB - Saddle Paper Push-on Plate Motor Sensor (S213) - Saddle Paper Push-on Plate Motor (M205) - Saddle Stitcher Controller PCB (PBA201) - Finisher Controller PCB (PBA101) [Remedy] Check/replace the related harness/cable, connector and parts. [Reference] When replacing the Finisher Controller PCB, refer to "Adjustment> Action on parts replacement" in the Service Manual.</p> <p>b. STAPLE FIN-AC1/BOOKLET FIN-AC1 [Related parts] - Harnesses from the Saddle Paper Pushing Plate/Folding Motor Clock Sensor (PS212) to the Saddle Stitcher Controller PCB - Harnesses from the Saddle Paper Pushing Plate/Folding Motor (M204) to the Saddle Stitcher Controller PCB - Saddle Paper Pushing Plate/Folding Motor Clock Sensor (PS212) - Saddle Paper Pushing Plate/Folding Motor (M204) - Saddle Stitcher Controller PCB (PCB201) - Finisher Controller PCB (PCB101) [Remedy] Check/replace the related harness/cable, connector and parts. [Reference] When replacing the Finisher Controller PCB, refer to "Adjustment> When Replacing the Parts" in the Service Manual.</p>
E5F7-8001-02	Error in the Saddle Trailing Edge Retainer Motor (Finisher-X1)
Detection Description	<p>The Saddle Trailing Edge Retainer HP Sensor does not detect the Saddle trailing edge retainer when the Saddle Trailing Edge Retainer Motor has been driven for 80 pulses.</p>
Remedy	<p>[Related parts] - Harnesses from the Saddle Trailing Edge Retainer HP Sensor (S221) to the Saddle Stitcher Controller PCB - Harnesses from the Saddle Trailing Edge Retainer Motor (M210) to the Saddle Stitcher Controller PCB - Saddle Trailing Edge Retainer HP Sensor (S221) - Saddle Trailing Edge Retainer Motor (M210) - Saddle Stitcher Controller PCB (PBA201) - Finisher Controller PCB (PBA101) [Remedy] Check/replace the related harness/cable, connector and parts. [Reference] When replacing the Finisher Controller PCB, refer to "Adjustments> Adjustment when Replacing the Parts" in the Service Manual.</p>

E5F7-8002-02	Error in the Saddle Trailing Edge Retainer Motor (Finisher-X1)
<p>Detection Description</p>	<p>The saddle trailing edge retainer does not come off the Saddle Trailing Edge Retainer HP Sensor when the Saddle Trailing Edge Retainer Motor has been driven for 50 pulses.</p> <hr/> <p>Remedy</p> <p>[Related parts]</p> <ul style="list-style-type: none"> - Harnesses from the Saddle Trailing Edge Retainer HP Sensor (S221) to the Saddle Stitcher Controller PCB - Harnesses from the Saddle Trailing Edge Retainer Motor (M210) to the Saddle Stitcher Controller PCB - Saddle Trailing Edge Retainer HP Sensor (S221) - Saddle Trailing Edge Retainer Motor (M210) - Saddle Stitcher Controller PCB (PBA201) - Finisher Controller PCB (PBA101) <p>[Remedy] Check/replace the related harness/cable, connector and parts. [Reference] When replacing the Finisher Controller PCB, refer to "Adjustments> Adjustment when Replacing the Parts" in the Service Manual.</p>
E5F8-8001-02	a. Error in the Saddle Tapping Motor (Finisher-X1) b. Error in the Saddle Switching Lever Motor (Finisher-AC1)
<p>Detection Description</p>	<p>a. The Saddle Paper Tapping HP Sensor does not detect the Saddle tapping plate when the Saddle Tapping Motor has been driven for 50 pulses. b. The saddle switching lever does not come off the Saddle Switching Lever HP Sensor when the Saddle Switching Lever Motor has been driven for 1 second.</p> <hr/> <p>Remedy</p> <p>a. STAPLE FIN-X1/BOOKLET FIN-X1</p> <p>[Related parts]</p> <ul style="list-style-type: none"> - Harnesses from the Saddle Paper Tapping HP Sensor (S215) to the Saddle Stitcher Controller PCB - Harnesses from the Saddle Tapping Motor (M213) to the Saddle Stitcher Controller PCB - Saddle Paper Tapping HP Sensor (S215) - Saddle Tapping Motor (M213) - Saddle Stitcher Controller PCB (PBA201) - Finisher Controller PCB (PBA101) <p>[Remedy] Check/replace the related harness/cable, connector and parts. [Reference] When replacing the Finisher Controller PCB, refer to "Adjustment> Action on parts replacement" in the Service Manual.</p> <p>b. STAPLE FIN-AC1/BOOKLET FIN-AC1</p> <p>[Related parts]</p> <ul style="list-style-type: none"> - Harnesses from the Saddle Switching Lever HP Sensor (PS205) to the Saddle Stitcher Controller PCB - Harnesses from the Saddle Switching Lever Motor (M202) to the Saddle Stitcher Controller PCB - Saddle Switching Lever HP Sensor (PS205) - Saddle Switching Lever Motor (M202) - Saddle Stitcher Controller PCB (PCB201) - Finisher Controller PCB (PCB101) <p>[Remedy] Check/replace the related harness/cable, connector and parts. [Reference] When replacing the Finisher Controller PCB, refer to "Adjustment> When Replacing the Parts" in the Service Manual.</p>

E5F8-8002-02	a. Error in the Saddle Tapping Motor (Finisher-X1) b. Error in the Saddle Switching Lever Motor (Finisher-AC1)
Detection Description	<p>a. The saddle tapping plate does not come off the Saddle Paper Tapping HP Sensor when the Saddle Tapping Motor has been driven for 50 pulses.</p> <p>b. The Saddle Switching Lever HP Sensor does not detect the saddle switching lever when the Saddle Switching Lever Motor has been driven for 1 second.</p>
Remedy	<p>a. STAPLE FIN-X1/BOOKLET FIN-X1 [Related parts]</p> <ul style="list-style-type: none"> - Harnesses from the Saddle Paper Tapping HP Sensor (S215) to the Saddle Stitcher Controller PCB - Harnesses from the Saddle Tapping Motor (M213) to the Saddle Stitcher Controller PCB - Saddle Paper Tapping HP Sensor (S215) - Saddle Tapping Motor (M213) - Saddle Stitcher Controller PCB (PBA201) - Finisher Controller PCB (PBA101) <p>[Remedy] Check/replace the related harness/cable, connector and parts. [Reference] When replacing the Finisher Controller PCB, refer to "Adjustment> Action on parts replacement" in the Service Manual.</p> <p>b. STAPLE FIN-AC1/BOOKLET FIN-AC1 [Related parts]</p> <ul style="list-style-type: none"> - Harnesses from the Saddle Switching Lever HP Sensor (PS205) to the Saddle Stitcher Controller PCB - Harnesses from the Saddle Switching Lever Motor (M202) to the Saddle Stitcher Controller PCB - Saddle Switching Lever HP Sensor (PS205) - Saddle Switching Lever Motor (M202) - Saddle Stitcher Controller PCB (PCB201) - Finisher Controller PCB (PCB101) <p>[Remedy] Check/replace the related harness/cable, connector and parts. [Reference] When replacing the Finisher Controller PCB, refer to "Adjustment> When Replacing the Parts" in the Service Manual.</p>
E5F9-8001-02	Error in the Saddle Lead-in Roller Disengage Motor (Finisher-X1)
Detection Description	<p>The Saddle Lead-in Roller HP Sensor does not detect the Saddle lead-in roller when the Saddle Lead-in Roller Disengage Motor has been driven for 50 pulses.</p>
Remedy	<p>[Related parts]</p> <ul style="list-style-type: none"> - Harnesses from the Saddle Lead-in Roller HP Sensor (S222) to the Saddle Stitcher Controller PCB - Harnesses from the Saddle Lead-in Roller Disengage Motor (M214) to the Saddle Stitcher Controller PCB - Saddle Lead-in Roller HP Sensor (S222) - Saddle Lead-in Roller Disengage Motor (M214) - Saddle Stitcher Controller PCB (PBA201) - Finisher Controller PCB (PBA101) <p>[Remedy] Check/replace the related harness/cable, connector and parts. [Reference] When replacing the Finisher Controller PCB, refer to "Adjustments> Adjustment when Replacing the Parts" in the Service Manual.</p>

E5F9-8002-02	Error in the Saddle Lead-in Roller Disengage Motor (Finisher-X1)
Detection Description	The saddle lead-in roller does not come off the Saddle Lead-in Roller HP Sensor when the Saddle Lead-in Roller Disengage Motor has been driven for 50 pulses.
Remedy	<p>[Related parts]</p> <ul style="list-style-type: none"> - Harnesses from the Saddle Lead-in Roller HP Sensor (S222) to the Saddle Stitcher Controller PCB - Harnesses from the Saddle Lead-in Roller Disengage Motor (M214) to the Saddle Stitcher Controller PCB - Saddle Lead-in Roller HP Sensor (S222) - Saddle Lead-in Roller Disengage Motor (M214) - Saddle Stitcher Controller PCB (PBA201) - Finisher Controller PCB (PBA101) <p>[Remedy] Check/replace the related harness/cable, connector and parts. [Reference] When replacing the Finisher Controller PCB, refer to "Adjustments> Adjustment when Replacing the Parts" in the Service Manual.</p>
E5FA-8000-02	Saddle Press Motor error
Detection Description	FIN-W1/SADDLE FIN-W1 The Saddle Press Motor did not move although 0.2 sec had passed after the motor started the operation.
Remedy	<p>FIN-W1/SADDLE FIN-W1</p> <p>[Related parts]</p> <ul style="list-style-type: none"> - Harnesses from the Saddle Stitcher Controller PCB to the Saddle Press Position Sensor 1. Saddle Stitcher Controller PCB (UN101/J207) to Relay Connector (9P) (Unit of replacement: CABLE, SADDLE SENSOR, RIGHT) 2. Relay Connector (9P) to Relay Connector (9P) (Unit of replacement: SADDLE ASSEMBLY) 3. Relay Connector (9P) to Saddle Press Position Sensor (PS116/J913) (Unit of replacement: CABLE, PRESS SENSOR) - Saddle Press Motor (M108) - Saddle Press Position Sensor (PS116) - Saddle Stitcher Controller PCB (UN101) (Unit of replacement: SADDLE DRIVER PCB ASS'Y) <p>[Remedy] Check/replace the related harness/cable, connector and parts.</p>

E5FA-8001-02	a. Saddle Press Motor error (Finisher-W1) b. Error in the Saddle Gripper Motor (Finisher-AC1)
Detection Description	<p>a. The Saddle Press Motor did not move although 0.2 sec had passed after the motor started the operation.</p> <p>b. The saddle gripper does not come off the Saddle Gripper HP Sensor when the Saddle Gripper Motor has been driven for 1 second.</p>
Remedy	<p>a. FIN-W1/SADDLE FIN-W1 [Related parts]</p> <ul style="list-style-type: none"> - Harnesses from the Saddle Stitcher Controller PCB to the Saddle Press Position Sensor 1. Saddle Stitcher Controller PCB (UN101/J207) to Relay Connector (9P) (Unit of replacement: CABLE, SADDLE SENSOR, RIGHT) 2. Relay Connector (9P) to Relay Connector (9P) (Unit of replacement: SADDLE ASSEMBLY) 3. Relay Connector (9P) to Saddle Press Position Sensor (PS116/J913) (Unit of replacement: CABLE, PRESS SENSOR) - Saddle Press Motor (M108) - Saddle Press Position Sensor (PS116) - Saddle Stitcher Controller PCB (UN101) (Unit of replacement: SADDLE DRIVER PCB ASS'Y) <p>[Remedy] Check/replace the related harness/cable, connector and parts.</p> <p>b. STAPLE FIN-AC1/BOOKLET FIN-AC1 [Related parts]</p> <ul style="list-style-type: none"> - Harnesses from the Saddle Gripper HP Sensor (PS209) to the Saddle Stitcher Controller PCB - Harnesses from the Saddle Gripper Motor (M205) to the Saddle Stitcher Controller PCB - Saddle Gripper HP Sensor (PS209) - Saddle Gripper Motor (M205) - Saddle Stitcher Controller PCB (PCB201) - Finisher Controller PCB (PCB101) <p>[Remedy] Check/replace the related harness/cable, connector and parts. [Reference] When replacing the Finisher Controller PCB, refer to "Adjustment> When Replacing the Parts" in the Service Manual.</p>
E5FA-8002-02	a. Saddle press position detection error (Finisher-W1) b. Error in the Saddle Gripper Motor (Finisher-AC1)
Detection Description	<p>a. The Saddle Press Position Sensor was not turned ON although 10 sec had passed after the Saddle Press Motor started the operation.</p> <p>b. The Saddle Gripper HP Sensor does not detect the saddle gripper when the Saddle Gripper Motor has been driven for 1 second.</p>
Remedy	<p>a. FIN-W1/SADDLE FIN-W1 [Related parts]</p> <ul style="list-style-type: none"> - Harnesses from the Saddle Stitcher Controller PCB to the Saddle Press Position Sensor 1. Saddle Stitcher Controller PCB (UN101/J207) to Relay Connector (9P) (Unit of replacement: CABLE, SADDLE SENSOR, RIGHT) 2. Relay Connector (9P) to Relay Connector (9P) (Unit of replacement: SADDLE ASSEMBLY) 3. Relay Connector (9P) to Saddle Press Position Sensor (PS116/J913) (Unit of replacement: CABLE, PRESS SENSOR) - Saddle Press Motor (M108) - Saddle Press Position Sensor (PS116) - Saddle Stitcher Controller PCB (UN101) (Unit of replacement: SADDLE DRIVER PCB ASS'Y) <p>[Remedy] Check/replace the related harness/cable, connector and parts.</p> <p>b. STAPLE FIN-AC1/BOOKLET FIN-AC1 [Related parts]</p> <ul style="list-style-type: none"> - Harnesses from the Saddle Gripper HP Sensor (PS209) to the Saddle Stitcher Controller PCB - Harnesses from the Saddle Gripper Motor (M205) to the Saddle Stitcher Controller PCB - Saddle Gripper HP Sensor (PS209) - Saddle Gripper Motor (M205) - Saddle Stitcher Controller PCB (PCB201) - Finisher Controller PCB (PCB101) <p>[Remedy] Check/replace the related harness/cable, connector and parts. [Reference] When replacing the Finisher Controller PCB, refer to "Adjustment> When Replacing the Parts" in the Service Manual.</p>

E5FB-8001-02	Saddle Pull-in Roller HP error
Detection Description	FIN-W1/SADDLE FIN-W1 The Saddle Pull-in Roller HP Sensor was not turned ON although 0.5 sec had passed after the Saddle Pull-in Roller Disengagement Motor started the operation.
Remedy	FIN-W1/SADDLE FIN-W1 [Related parts] - Harness between the Saddle Stitcher Controller PCB (UN101/J204) and the Saddle Pull-in Roller Disengagement Motor (M114/J1012) (Unit of replacement: CABLE, SADDLE SENSOR, RIGHT) - Harness between the Saddle Stitcher Controller PCB (UN101/J209) and the Saddle Pull-in Roller HP Sensor (PS122/J122) (Unit of replacement: CABLE, SADDLE SENSOR, RIGHT) - Saddle Pull-in Roller Disengagement Motor (M114) - Saddle Pull-in Roller HP Sensor (PS122) - Saddle Stitcher Controller PCB (UN101) (Unit of replacement: SADDLE DRIVER PCB ASS'Y) [Remedy] Check/replace the related harness/cable, connector and parts.
E5FB-8002-02	Saddle Pull-in Roller HP error
Detection Description	FIN-W1/SADDLE FIN-W1 The Saddle Pull-in Roller HP Sensor was not turned OFF although 0.5 sec had passed after the Saddle Pull-in Roller Disengagement Motor started the operation.
Remedy	FIN-W1/SADDLE FIN-W1 [Related parts] - Harness between the Saddle Stitcher Controller PCB (UN101/J204) and the Saddle Pull-in Roller Disengagement Motor (M114/J1012) (Unit of replacement: CABLE, SADDLE SENSOR, RIGHT) - Harness between the Saddle Stitcher Controller PCB (UN101/J209) and the Saddle Pull-in Roller HP Sensor (PS122/J122) (Unit of replacement: CABLE, SADDLE SENSOR, RIGHT) - Saddle Pull-in Roller Disengagement Motor (M114) - Saddle Pull-in Roller HP Sensor (PS122) - Saddle Stitcher Controller PCB (UN101) (Unit of replacement: SADDLE DRIVER PCB ASS'Y) [Remedy] Check/replace the related harness/cable, connector and parts.
E5FC-8001-02	Saddle Paper Tapping HP error
Detection Description	FIN-W1/SADDLE FIN-W1 The Saddle Paper Tapping HP Sensor was not turned ON although 0.5 sec had passed after the Saddle Tapping Motor started the operation.
Remedy	FIN-W1/SADDLE FIN-W1 [Related parts] - Harness between the Saddle Stitcher Controller PCB (UN101/J204) and the Saddle Tapping Motor (M113/J910) (Unit of replacement: SADDLE ASSEMBLY) - Harness between the Saddle Stitcher Controller PCB (UN101/J209) and the Saddle Paper Tapping HP Sensor (PS118/J945) (Unit of replacement: CABLE, SADDLE SENSOR, RIGHT) - Saddle Tapping Motor (M113) - Saddle Paper Tapping HP Sensor (PS118) - Saddle Stitcher Controller PCB (UN101) (Unit of replacement: SADDLE DRIVER PCB ASS'Y) [Remedy] Check/replace the related harness/cable, connector and parts.
E5FC-8002-02	Saddle Paper Tapping HP error
Detection Description	FIN-W1/SADDLE FIN-W1 The Saddle Paper Tapping HP Sensor was not turned OFF although 0.5 sec had passed after the Saddle Tapping Motor started the operation.
Remedy	FIN-W1/SADDLE FIN-W1 [Related parts] - Harness between the Saddle Stitcher Controller PCB (UN101/J204) and the Saddle Tapping Motor (M113/J910) (Unit of replacement: SADDLE ASSEMBLY) - Harness between the Saddle Stitcher Controller PCB (UN101/J209) and the Saddle Paper Tapping HP Sensor (PS118/J945) (Unit of replacement: CABLE, SADDLE SENSOR, RIGHT) - Saddle Tapping Motor (M113) - Saddle Paper Tapping HP Sensor (PS118) - Saddle Stitcher Controller PCB (UN101) (Unit of replacement: SADDLE DRIVER PCB ASS'Y) [Remedy] Check/replace the related harness/cable, connector and parts.

E5FD-8001-02	Saddle Trailing Edge Retainer Shift HP error
Detection Description	FIN-W1/SADDLE FIN-W1 The Saddle Trailing Edge Retainer Shift HP Sensor was not turned ON although 3 sec had passed after the Saddle Trailing Edge Shift Motor started the operation.
Remedy	FIN-W1/SADDLE FIN-W1 [Related parts] - Harnesses from the Saddle Stitcher Controller PCB to the Saddle Trailing Edge Shift Motor 1. Saddle Stitcher Controller PCB (UN101/J214) to Relay Connector (14P) (Unit of replacement: CABLE, SADDLE SENSOR, FRONT) 2. Relay Connector (14P) to Saddle Trailing Edge Shift Motor (M111/J911) (Unit of replacement: CABLE, GUIDE, RIGHT) - Harnesses from the Saddle Stitcher Controller PCB to the Saddle Trailing Edge Retainer Shift HP Sensor 1. Saddle Stitcher Controller PCB (UN101/J214) to Relay Connector (14P) (Unit of replacement: CABLE, SADDLE SENSOR, FRONT) 2. Relay Connector (14P) to Saddle Trailing Edge Retainer Shift HP Sensor (PS119/J916) (Unit of replacement: CABLE, GUIDE, RIGHT) - Saddle Trailing Edge Shift Motor (M111) - Saddle Trailing Edge Retainer Shift HP Sensor (PS119) - Saddle Stitcher Controller PCB (UN101) (Unit of replacement: SADDLE DRIVER PCB ASS'Y) [Remedy] Check/replace the related harness/cable, connector and parts.
E5FD-8002-02	Saddle Trailing Edge Retainer Shift HP error
Detection Description	FIN-W1/SADDLE FIN-W1 The Saddle Trailing Edge Retainer Shift HP Sensor was not turned OFF although 3 sec had passed after the Saddle Trailing Edge Shift Motor started the operation.
Remedy	FIN-W1/SADDLE FIN-W1 [Related parts] - Harnesses from the Saddle Stitcher Controller PCB to the Saddle Trailing Edge Shift Motor 1. Saddle Stitcher Controller PCB (UN101/J214) to Relay Connector (14P) (Unit of replacement: CABLE, SADDLE SENSOR, FRONT) 2. Relay Connector (14P) to Saddle Trailing Edge Shift Motor (M111/J911) (Unit of replacement: CABLE, GUIDE, RIGHT) - Harnesses from the Saddle Stitcher Controller PCB to the Saddle Trailing Edge Retainer Shift HP Sensor 1. Saddle Stitcher Controller PCB (UN101/J214) to Relay Connector (14P) (Unit of replacement: CABLE, SADDLE SENSOR, FRONT) 2. Relay Connector (14P) to Saddle Trailing Edge Retainer Shift HP Sensor (PS119/J916) (Unit of replacement: CABLE, GUIDE, RIGHT) - Saddle Trailing Edge Shift Motor (M111) - Saddle Trailing Edge Retainer Shift HP Sensor (PS119) - Saddle Stitcher Controller PCB (UN101) (Unit of replacement: SADDLE DRIVER PCB ASS'Y) [Remedy] Check/replace the related harness/cable, connector and parts.

E5FE-8001-02	Saddle Trailing Edge Retainer HP error
Detection Description	FIN-W1/SADDLE FIN-W1 The Saddle Trailing Edge Retainer HP Sensor was not turned ON although 0.5 sec had passed after the Saddle Trailing Edge Retainer Motor started the operation.
Remedy	FIN-W1/SADDLE FIN-W1 [Related parts] - Harnesses from the Saddle Stitcher Controller PCB to the Saddle Trailing Edge Retainer Motor 1. Saddle Stitcher Controller PCB (UN101/J214) to Relay Connector (14P) (Unit of replacement: CABLE, SADDLE SENSOR, FRONT) 2. Relay Connector (14P) to Saddle Trailing Edge Retainer Motor (M110/J915) (Unit of replacement: CABLE, GUIDE, RIGHT) - Harnesses from the Saddle Stitcher Controller PCB to the Saddle Trailing Edge Retainer HP Sensor 1. Saddle Stitcher Controller PCB (UN101/J214) to Relay Connector (14P) (Unit of replacement: CABLE, SADDLE SENSOR, FRONT) 2. Relay Connector (14P) to Saddle Trailing Edge Retainer HP Sensor (PS121/J917) (Unit of replacement: CABLE, GUIDE, RIGHT) - Saddle Trailing Edge Retainer Motor (M110) - Saddle Trailing Edge Retainer HP Sensor (PS121) - Saddle Stitcher Controller PCB (UN101) (Unit of replacement: SADDLE DRIVER PCB ASS'Y) [Remedy] Check/replace the related harness/cable, connector and parts.
E5FE-8002-02	Saddle Trailing Edge Retainer HP error
Detection Description	FIN-W1/SADDLE FIN-W1 The Saddle Trailing Edge Retainer HP Sensor was not turned OFF although 0.5 sec had passed after the Saddle Trailing Edge Retainer Motor started the operation.
Remedy	FIN-W1/SADDLE FIN-W1 [Related parts] - Harnesses from the Saddle Stitcher Controller PCB to the Saddle Trailing Edge Retainer Motor 1. Saddle Stitcher Controller PCB (UN101/J214) to Relay Connector (14P) (Unit of replacement: CABLE, SADDLE SENSOR, FRONT) 2. Relay Connector (14P) to Saddle Trailing Edge Retainer Motor (M110/J915) (Unit of replacement: CABLE, GUIDE, RIGHT) - Harnesses from the Saddle Stitcher Controller PCB to the Saddle Trailing Edge Retainer HP Sensor 1. Saddle Stitcher Controller PCB (UN101/J214) to Relay Connector (14P) (Unit of replacement: CABLE, SADDLE SENSOR, FRONT) 2. Relay Connector (14P) to Saddle Trailing Edge Retainer HP Sensor (PS121/J917) (Unit of replacement: CABLE, GUIDE, RIGHT) - Saddle Trailing Edge Retainer Motor (M110) - Saddle Trailing Edge Retainer HP Sensor (PS121) - Saddle Stitcher Controller PCB (UN101) (Unit of replacement: SADDLE DRIVER PCB ASS'Y) [Remedy] Check/replace the related harness/cable, connector and parts.

E5FF-8001-02	Saddle Clamp HP error
Detection Description	<p>FIN-W1/SADDLE FIN-W1</p> <p>The Saddle Clamp HP Sensor was not turned ON although 1 sec had passed after the Saddle Clamp Motor started the operation.</p>
Remedy	<p>FIN-W1/SADDLE FIN-W1</p> <p>[Related parts]</p> <ul style="list-style-type: none"> - Harnesses from the Saddle Stitcher Controller PCB to the Saddle Clamp Motor 1. Saddle Stitcher Controller PCB (UN101/J215) to Relay Connector (3P) (Unit of replacement: SADDLE ASSEMBLY) 2. Relay Connector (3P) to Saddle Clamp Motor (M115/J2002) (Unit of replacement: SADDLE ASSEMBLY) - Harnesses from the Saddle Stitcher Controller PCB to the Saddle Clamp HP Sensor 1. Saddle Stitcher Controller PCB (UN101/J216) to Relay Connector (7P) (Unit of replacement: SADDLE ASSEMBLY) 2. Relay Connector (7P) to Saddle Clamp HP Sensor (PS123/J2004) (Unit of replacement: CLAMP ASSEMBLY) - Saddle Clamp Motor (M115) (Unit of replacement: MOTOR, DC) - Saddle Clamp HP Sensor (PS123) (Unit of replacement: IC,PHOTO-INTERRUPTER,LG248NL1A) - Saddle Stitcher Controller PCB (UN101) (Unit of replacement: SADDLE DRIVER PCB ASS'Y) <p>[Remedy] Check/replace the related harness/cable, connector and parts.</p>
E5FF-8002-02	Saddle Clamp HP error
Detection Description	<p>FIN-W1/SADDLE FIN-W1</p> <p>The Saddle Clamp HP Sensor was not turned OFF although 1 sec had passed after the Saddle Clamp Motor started the operation.</p>
Remedy	<p>FIN-W1/SADDLE FIN-W1</p> <p>[Related parts]</p> <ul style="list-style-type: none"> - Harnesses from the Saddle Stitcher Controller PCB to the Saddle Clamp Motor 1. Saddle Stitcher Controller PCB (UN101/J215) to Relay Connector (3P) (Unit of replacement: SADDLE ASSEMBLY) 2. Relay Connector (3P) to Saddle Clamp Motor (M115/J2002) (Unit of replacement: SADDLE ASSEMBLY) - Harnesses from the Saddle Stitcher Controller PCB to the Saddle Clamp HP Sensor 1. Saddle Stitcher Controller PCB (UN101/J216) to Relay Connector (7P) (Unit of replacement: SADDLE ASSEMBLY) 2. Relay Connector (7P) to Saddle Clamp HP Sensor (PS123/J2004) (Unit of replacement: CLAMP ASSEMBLY) - Saddle Clamp Motor (M115) (Unit of replacement: MOTOR, DC) - Saddle Clamp HP Sensor (PS123) (Unit of replacement: IC,PHOTO-INTERRUPTER,LG248NL1A) - Saddle Stitcher Controller PCB (UN101) (Unit of replacement: SADDLE DRIVER PCB ASS'Y) <p>[Remedy] Check/replace the related harness/cable, connector and parts.</p>
E602-0001-00	HDD error
Detection Description	<p>HDD failed to be Ready, or HDD was not formatted.</p> <p>When this error occurs, the system has not been started normally. Therefore, it may not be recorded in the error log.</p>
Remedy	<p>[Related parts]</p> <ul style="list-style-type: none"> - Cable between the Main Controller PCB (UN34/J6003, J6004) and the HDD (Unit of replacement: CABLE, HARD DISK DRIVE, 1) - HDD (Unit of replacement: HARD DISK DRIVE) - Main Controller PCB (UN34) (Unit of replacement: MAIN CONTROLLER PCB ASS'Y, 1) <p>[Remedy] Perform the following in the order while checking whether the error is cleared.</p> <ol style="list-style-type: none"> 1. Check the related harness/cable and connector. 2. If the above-mentioned service mode cannot be executed due to an error, etc., enter safe mode. Then format the HDD using SST or a USB flash drive. 3. Reinstall the system software using SST or a USB flash drive. 4. Check/replace the related parts.

E602-0020-00	HDD error
Detection Description	Corruption of database managing user mode/service mode data was detected.
Remedy	<p>[Related parts] - HDD</p> <p>[Remedy]While this error occurs, backup of the setting values is disabled. In addition, it may not be recorded in the error log. Perform the following in the order while checking whether the error is cleared.</p> <ol style="list-style-type: none"> 1. Turn OFF and then ON the main power. 2. enter safe mode, and format the HDD using a USB flash drive. 3. Replace the HDD.
E602-0101-00	HDD error
Detection Description	<p>An error was detected in the PDL-related file storage area. (Initialization failed at startup or I/O error at startup)</p> <p>When this error occurs, the system has not been started normally. Therefore, it may not be recorded in the error log.</p>
Remedy	<p>[Related parts] - Cable between the Main Controller PCB (UN34/J6003, J6004) and the HDD (Unit of replacement: CABLE, HARD DISK DRIVE, 1) - HDD (Unit of replacement: HARD DISK DRIVE) - Main Controller PCB (UN34) (Unit of replacement: MAIN CONTROLLER PCB ASS'Y, 1)</p> <p>[Remedy] Perform the following in the order while checking whether the error is cleared. When prioritizing clearing of the error, skip Remedies 2 and 3. Although the error is cleared by "HD-CHECK", it may occur again. Thus, perform Remedies 1 to 4.</p> <ol style="list-style-type: none"> 1. Check the related harness/cable and connector. 2. Select COPIER> FUNCTION> SYSTEM> CHK-TYPE> "1", and execute "HD-CHECK". Then, turn OFF and then ON the main power. 3. Obtain the necessary backup data by referring to "Appendix> Backup Data List" in the System Service Manual. 4. Select COPIER> FUNCTION> SYSTEM> CHK-TYPE> "1", and execute "HD-CLEAR". Then, turn OFF and then ON the main power to delete the data in the corresponding partition. 5. If the above-mentioned service mode cannot be executed due to an error, etc., enter safe mode. Then format the HDD using SST or a USB flash drive. 6. Check/replace the related parts. <p>[Reference] When replacing the HDD, back up the setting values by referring to "Chapter 5. Adjustment> Actions when Replacing the Parts> HDD" in the Service Manual.</p>

E602-0111-00	HDD error
Detection Description	An error was detected in the PDL-related file storage area. (File could not be written in the HDD after startup or I/O error after startup)
Remedy	<p>[Related parts]</p> <ul style="list-style-type: none"> - Cable between the Main Controller PCB (UN34/J6003, J6004) and the HDD (Unit of replacement: CABLE, HARD DISK DRIVE, 1) - HDD (Unit of replacement: HARD DISK DRIVE) - Main Controller PCB (UN34) (Unit of replacement: MAIN CONTROLLER PCB ASS'Y, 1) <p>[Remedy] Perform the following in the order while checking whether the error is cleared. When prioritizing clearing of the error, skip Remedies 2 and 3.</p> <p>Although the error is cleared by "HD-CHECK", it may occur again. Thus, perform Remedies 1 to 4.</p> <ol style="list-style-type: none"> 1. Check the related harness/cable and connector. 2. Select COPIER> FUNCTION> SYSTEM> CHK-TYPE> "1", and execute "HD-CHECK". Then, turn OFF and then ON the main power. 3. Obtain the necessary backup data by referring to "Appendix> Backup Data List" in the System Service Manual. 4. Select COPIER> FUNCTION> SYSTEM> CHK-TYPE> "1", and execute "HD-CLEAR". Then, turn OFF and then ON the main power to delete the data in the corresponding partition. 5. If the above-mentioned service mode cannot be executed due to an error, etc., enter safe mode. Then format the HDD using SST or a USB flash drive. 6. Check/replace the related parts. <p>[Reference] When replacing the HDD, back up the setting values by referring to "Chapter 5. Adjustment> Actions when Replacing the Parts> HDD" in the Service Manual.</p>
E602-0201-00	HDD error
Detection Description	<p>An error was detected in the storage area of image data after startup. (Initialization failed at startup or I/O error at startup)</p> <p>When this error occurs, the system has not been started normally. Therefore, it may not be recorded in the error log.</p>
Remedy	<p>[Related parts]</p> <ul style="list-style-type: none"> - Cable between the Main Controller PCB (UN34/J6003, J6004) and the HDD (Unit of replacement: CABLE, HARD DISK DRIVE, 1) - HDD (Unit of replacement: HARD DISK DRIVE) - Main Controller PCB (UN34) (Unit of replacement: MAIN CONTROLLER PCB ASS'Y, 1) <p>[Remedy] Perform the following in the order while checking whether the error is cleared. When prioritizing clearing of the error, skip Remedies 2 and 3.</p> <p>Although the error is cleared by "HD-CHECK", it may occur again. Thus, perform Remedies 1 to 4.</p> <ol style="list-style-type: none"> 1. Check the related harness/cable and connector. 2. Select COPIER> FUNCTION> SYSTEM> CHK-TYPE> "2", and execute "HD-CHECK". Then, turn OFF and then ON the main power. 3. Obtain the necessary backup data by referring to "Appendix> Backup Data List" in the System Service Manual. 4. Select COPIER> FUNCTION> SYSTEM> CHK-TYPE> "2", and execute "HD-CLEAR". Then, turn OFF and then ON the main power to delete the data in the corresponding partition. 5. If the above-mentioned service mode cannot be executed due to an error, etc., enter safe mode. Then format the HDD using SST or a USB flash drive. 6. Check/replace the related parts. <p>[Reference] When replacing the HDD, back up the setting values by referring to "Chapter 5. Adjustment> Actions when Replacing the Parts> HDD" in the Service Manual.</p>

E602-0211-00	HDD error
Detection Description	An error was detected in the storage area of image data after startup. (File could not be written in the HDD after startup or I/O error after startup)
Remedy	<p>[Related parts]</p> <ul style="list-style-type: none"> - Cable between the Main Controller PCB (UN34/J6003, J6004) and the HDD (Unit of replacement: CABLE, HARD DISK DRIVE, 1) - HDD (Unit of replacement: HARD DISK DRIVE) - Main Controller PCB (UN34) (Unit of replacement: MAIN CONTROLLER PCB ASS'Y, 1) <p>[Remedy] Perform the following in the order while checking whether the error is cleared. When prioritizing clearing of the error, skip Remedies 2 and 3.</p> <p>Although the error is cleared by "HD-CHECK", it may occur again. Thus, perform Remedies 1 to 4.</p> <ol style="list-style-type: none"> 1. Check the related harness/cable and connector. 2. Select COPIER> FUNCTION> SYSTEM> CHK-TYPE> "2", and execute "HD-CHECK". Then, turn OFF and then ON the main power. 3. Obtain the necessary backup data by referring to "Appendix> Backup Data List" in the System Service Manual. 4. Select COPIER> FUNCTION> SYSTEM> CHK-TYPE> "2", and execute "HD-CLEAR". Then, turn OFF and then ON the main power to delete the data in the corresponding partition. 5. If the above-mentioned service mode cannot be executed due to an error, etc., enter safe mode. Then format the HDD using SST or a USB flash drive. 6. Check/replace the related parts. <p>[Reference] When replacing the HDD, back up the setting values by referring to "Chapter 5. Adjustment> Actions when Replacing the Parts> HDD" in the Service Manual.</p>
E602-0301-00	HDD error
Detection Description	<p>An error was detected in the MEAP-related area. (Initialization failed at startup or I/O error at startup)</p> <p>When this error occurs, the system has not been started normally. Therefore, it may not be recorded in the error log.</p>
Remedy	<p>[Related parts]</p> <ul style="list-style-type: none"> - Cable between the Main Controller PCB (UN34/J6003, J6004) and the HDD (Unit of replacement: CABLE, HARD DISK DRIVE, 1) - HDD (Unit of replacement: HARD DISK DRIVE) - Main Controller PCB (UN34) (Unit of replacement: MAIN CONTROLLER PCB ASS'Y, 1) <p>[Remedy] Perform the following in the order while checking whether the error is cleared. When prioritizing clearing of the error, skip Remedies 2 and 3.</p> <p>Although the error is cleared by "HD-CHECK", it may occur again. Thus, perform Remedies 1 to 4.</p> <ol style="list-style-type: none"> 1. Check the related harness/cable and connector. 2. Select COPIER> FUNCTION> SYSTEM> CHK-TYPE> "3", and execute "HD-CHECK". Then, turn OFF and then ON the main power. 3. Obtain the necessary backup data by referring to "Appendix> Backup Data List" in the System Service Manual. 4. Select COPIER> FUNCTION> SYSTEM> CHK-TYPE> "3", and execute "HD-CLEAR". Then, turn OFF and then ON the main power to delete the data in the corresponding partition. 5. If the above-mentioned service mode cannot be executed due to an error, etc., enter safe mode. Then format the HDD using SST or a USB flash drive. 6. Check/replace the related parts. <p>[Reference] When replacing the HDD, back up the setting values by referring to "Chapter 5. Adjustment> Actions when Replacing the Parts> HDD" in the Service Manual.</p>

E602-0311-00	HDD error
Detection Description	An error was detected in the MEAP-related area. (File could not be written in the HDD after startup or I/O error after startup)
Remedy	<p>[Related parts]</p> <ul style="list-style-type: none"> - Cable between the Main Controller PCB (UN34/J6003, J6004) and the HDD (Unit of replacement: CABLE, HARD DISK DRIVE, 1) - HDD (Unit of replacement: HARD DISK DRIVE) - Main Controller PCB (UN34) (Unit of replacement: MAIN CONTROLLER PCB ASS'Y, 1) <p>[Remedy] Perform the following in the order while checking whether the error is cleared. When prioritizing clearing of the error, skip Remedies 2 and 3.</p> <p>Although the error is cleared by "HD-CHECK", it may occur again. Thus, perform Remedies 1 to 4.</p> <ol style="list-style-type: none"> 1. Check the related harness/cable and connector. 2. Select COPIER> FUNCTION> SYSTEM> CHK-TYPE> "3", and execute "HD-CHECK". Then, turn OFF and then ON the main power. 3. Obtain the necessary backup data by referring to "Appendix> Backup Data List" in the System Service Manual. 4. Select COPIER> FUNCTION> SYSTEM> CHK-TYPE> "3", and execute "HD-CLEAR". Then, turn OFF and then ON the main power to delete the data in the corresponding partition. 5. If the above-mentioned service mode cannot be executed due to an error, etc., enter safe mode. Then format the HDD using SST or a USB flash drive. 6. Check/replace the related parts. <p>[Reference] When replacing the HDD, back up the setting values by referring to "Chapter 5. Adjustment> Actions when Replacing the Parts> HDD" in the Service Manual.</p>
E602-0401-00	HDD error
Detection Description	Logical partition error was detected. (Initialization failed at startup or I/O error at startup) When this error occurs, the system has not been started normally. Therefore, it may not be recorded in the error log.
Remedy	<p>[Related parts]</p> <ul style="list-style-type: none"> - Cable between the Main Controller PCB (UN34/J6003, J6004) and the HDD (Unit of replacement: CABLE, HARD DISK DRIVE, 1) - HDD (Unit of replacement: HARD DISK DRIVE) - Main Controller PCB (UN34) (Unit of replacement: MAIN CONTROLLER PCB ASS'Y, 1) <p>[Remedy] Perform the following in the order while checking whether the error is cleared. When prioritizing clearing of the error, skip Remedies 2 and 3.</p> <p>Although the error is cleared by "HD-CHECK", it may occur again. Thus, perform Remedies 1 to 4.</p> <ol style="list-style-type: none"> 1. Check the related harness/cable and connector. 2. Select COPIER> FUNCTION> SYSTEM> CHK-TYPE> "4", and execute "HD-CHECK". Then, turn OFF and then ON the main power. 3. Obtain the necessary backup data by referring to "Appendix> Backup Data List" in the System Service Manual. 4. Select COPIER> FUNCTION> SYSTEM> CHK-TYPE> "4", and execute "HD-CLEAR". Then, turn OFF and then ON the main power to delete the data in the corresponding partition. 5. If the above-mentioned service mode cannot be executed due to the error, enter safe mode. Then format the HDD using SST or a USB flash drive. 6. Check/replace the related parts. <p>[Reference] When replacing the HDD, back up the setting values by referring to "Chapter 5. Adjustment> Actions when Replacing the Parts> HDD" in the Service Manual.</p>

E602-0411-00	HDD error
Detection Description	Logical partition error was detected. (File could not be written in the HDD after startup or I/O error after startup)
Remedy	<p>[Related parts]</p> <ul style="list-style-type: none"> - Cable between the Main Controller PCB (UN34/J6003, J6004) and the HDD (Unit of replacement: CABLE, HARD DISK DRIVE, 1) - HDD (Unit of replacement: HARD DISK DRIVE) - Main Controller PCB (UN34) (Unit of replacement: MAIN CONTROLLER PCB ASS'Y, 1) <p>[Remedy] Perform the following in the order while checking whether the error is cleared. When prioritizing clearing of the error, skip Remedies 2 and 3.</p> <p>Although the error is cleared by "HD-CHECK", it may occur again. Thus, perform Remedies 1 to 4.</p> <ol style="list-style-type: none"> 1. Check the related harness/cable and connector. 2. Select COPIER> FUNCTION> SYSTEM> CHK-TYPE> "4", and execute "HD-CHECK". Then, turn OFF and then ON the main power. 3. Obtain the necessary backup data by referring to "Appendix> Backup Data List" in the System Service Manual. 4. Select COPIER> FUNCTION> SYSTEM> CHK-TYPE> "4", and execute "HD-CLEAR". Then, turn OFF and then ON the main power to delete the data in the corresponding partition. 5. If the above-mentioned service mode cannot be executed due to the error, enter safe mode. Then format the HDD using SST or a USB flash drive. 6. Check/replace the related parts. <p>[Reference] When replacing the HDD, back up the setting values by referring to "Chapter 5. Adjustment> Actions when Replacing the Parts> HDD" in the Service Manual.</p>
E602-0501-00	HDD error
Detection Description	<p>An error was detected in the storage area of image data after startup. (Initialization failed at startup or I/O error at startup)</p> <p>When this error occurs, the system has not been started normally. Therefore, it may not be recorded in the error log.</p>
Remedy	<p>[Related parts]</p> <ul style="list-style-type: none"> - Cable between the Main Controller PCB (UN34/J6003, J6004) and the HDD (Unit of replacement: CABLE, HARD DISK DRIVE, 1) - HDD (Unit of replacement: HARD DISK DRIVE) - Main Controller PCB (UN34) (Unit of replacement: MAIN CONTROLLER PCB ASS'Y, 1) <p>[Remedy] Perform the following in the order while checking whether the error is cleared. When prioritizing clearing of the error, skip Remedies 2 and 3.</p> <p>Although the error is cleared by "HD-CHECK", it may occur again. Thus, perform Remedies 1 to 4.</p> <ol style="list-style-type: none"> 1. Check the related harness/cable and connector. 2. Select COPIER> FUNCTION> SYSTEM> CHK-TYPE> "5", and execute "HD-CHECK". Then, turn OFF and then ON the main power. 3. Obtain the necessary backup data by referring to "Appendix> Backup Data List" in the System Service Manual. 4. Select COPIER> FUNCTION> SYSTEM> CHK-TYPE> "5", and execute "HD-CLEAR". Then, turn OFF and then ON the main power to delete the data in the corresponding partition. 5. If the above-mentioned service mode cannot be executed due to an error, etc., enter safe mode. Then format the HDD using SST or a USB flash drive. 6. Check/replace the related parts. <p>[Reference] When replacing the HDD, back up the setting values by referring to "Chapter 5. Adjustment> Actions when Replacing the Parts> HDD" in the Service Manual.</p>

E602-0511-00	HDD error
Detection Description	An error was detected in the storage area of image data after startup. (File could not be written in the HDD after startup or I/O error after startup)
Remedy	<p>[Related parts]</p> <ul style="list-style-type: none"> - Cable between the Main Controller PCB (UN34/J6003, J6004) and the HDD (Unit of replacement: CABLE, HARD DISK DRIVE, 1) - HDD (Unit of replacement: HARD DISK DRIVE) - Main Controller PCB (UN34) (Unit of replacement: MAIN CONTROLLER PCB ASS'Y, 1) <p>[Remedy] Perform the following in the order while checking whether the error is cleared. When prioritizing clearing of the error, skip Remedies 2 and 3.</p> <p>Although the error is cleared by "HD-CHECK", it may occur again. Thus, perform Remedies 1 to 4.</p> <ol style="list-style-type: none"> 1. Check the related harness/cable and connector. 2. Select COPIER> FUNCTION> SYSTEM> CHK-TYPE> "5", and execute "HD-CHECK". Then, turn OFF and then ON the main power. 3. Obtain the necessary backup data by referring to "Appendix> Backup Data List" in the System Service Manual. 4. Select COPIER> FUNCTION> SYSTEM> CHK-TYPE> "5", and execute "HD-CLEAR". Then, turn OFF and then ON the main power to delete the data in the corresponding partition. 5. If the above-mentioned service mode cannot be executed due to an error, etc., enter safe mode. Then format the HDD using SST or a USB flash drive. 6. Check/replace the related parts. <p>[Reference] When replacing the HDD, back up the setting values by referring to "Chapter 5. Adjustment> Actions when Replacing the Parts> HDD" in the Service Manual.</p>
E602-0601-00	HDD error
Detection Description	<p>An error was detected in the storage area of image data after startup. (Initialization failed at startup or I/O error at startup)</p> <p>When this error occurs, the system has not been started normally. Therefore, it may not be recorded in the error log.</p>
Remedy	<p>[Related parts]</p> <ul style="list-style-type: none"> - Cable between the Main Controller PCB (UN34/J6003, J6004) and the HDD (Unit of replacement: CABLE, HARD DISK DRIVE, 1) - HDD (Unit of replacement: HARD DISK DRIVE) - Main Controller PCB (UN34) (Unit of replacement: MAIN CONTROLLER PCB ASS'Y, 1) <p>[Remedy] Perform the following in the order while checking whether the error is cleared. When prioritizing clearing of the error, skip Remedies 2 and 3.</p> <p>Although the error is cleared by "HD-CHECK", it may occur again. Thus, perform Remedies 1 to 4.</p> <ol style="list-style-type: none"> 1. Check the related harness/cable and connector. 2. Select COPIER> FUNCTION> SYSTEM> CHK-TYPE> "6", and execute "HD-CHECK". Then, turn OFF and then ON the main power. 3. Obtain the necessary backup data by referring to "Appendix> Backup Data List" in the System Service Manual. 4. Select COPIER> FUNCTION> SYSTEM> CHK-TYPE> "6", and execute "HD-CLEAR". Then, turn OFF and then ON the main power to delete the data in the corresponding partition. 5. If the above-mentioned service mode cannot be executed due to an error, etc., enter safe mode. Then format the HDD using SST or a USB flash drive. 6. Check/replace the related parts. <p>[Reference] When replacing the HDD, back up the setting values by referring to "Chapter 5. Adjustment> Actions when Replacing the Parts> HDD" in the Service Manual.</p>

E602-0611-00	HDD error
Detection Description	An error was detected in the storage area of image data after startup. (File could not be written in the HDD after startup or I/O error after startup)
Remedy	<p>[Related parts]</p> <ul style="list-style-type: none"> - Cable between the Main Controller PCB (UN34/J6003, J6004) and the HDD (Unit of replacement: CABLE, HARD DISK DRIVE, 1) - HDD (Unit of replacement: HARD DISK DRIVE) - Main Controller PCB (UN34) (Unit of replacement: MAIN CONTROLLER PCB ASS'Y, 1) <p>[Remedy] Perform the following in the order while checking whether the error is cleared. When prioritizing clearing of the error, skip Remedies 2 and 3.</p> <p>Although the error is cleared by "HD-CHECK", it may occur again. Thus, perform Remedies 1 to 4.</p> <ol style="list-style-type: none"> 1. Check the related harness/cable and connector. 2. Select COPIER> FUNCTION> SYSTEM> CHK-TYPE> "6", and execute "HD-CHECK". Then, turn OFF and then ON the main power. 3. Obtain the necessary backup data by referring to "Appendix> Backup Data List" in the System Service Manual. 4. Select COPIER> FUNCTION> SYSTEM> CHK-TYPE> "6", and execute "HD-CLEAR". Then, turn OFF and then ON the main power to delete the data in the corresponding partition. 5. If the above-mentioned service mode cannot be executed due to an error, etc., enter safe mode. Then format the HDD using SST or a USB flash drive. 6. Check/replace the related parts. <p>[Reference] When replacing the HDD, back up the setting values by referring to "Chapter 5. Adjustment> Actions when Replacing the Parts> HDD" in the Service Manual.</p>
E602-0701-00	HDD error
Detection Description	<p>An error was detected in general application temporary area (temporary file). (Initialization failed at startup or I/O error at startup)</p> <p>When this error occurs, the system has not been started normally. Therefore, it may not be recorded in the error log.</p>
Remedy	<p>[Related parts]</p> <ul style="list-style-type: none"> - Cable between the Main Controller PCB (UN34/J6003, J6004) and the HDD (Unit of replacement: CABLE, HARD DISK DRIVE, 1) - HDD (Unit of replacement: HARD DISK DRIVE) - Main Controller PCB (UN34) (Unit of replacement: MAIN CONTROLLER PCB ASS'Y, 1) <p>[Remedy] Perform the following in the order while checking whether the error is cleared. When prioritizing clearing of the error, skip Remedies 2 and 3.</p> <p>Although the error is cleared by "HD-CHECK", it may occur again. Thus, perform Remedies 1 to 4.</p> <ol style="list-style-type: none"> 1. Check the related harness/cable and connector. 2. Select COPIER> FUNCTION> SYSTEM> CHK-TYPE> "7", and execute "HD-CHECK". Then, turn OFF and then ON the main power. 3. Obtain the necessary backup data by referring to "Appendix> Backup Data List" in the System Service Manual. 4. Select COPIER> FUNCTION> SYSTEM> CHK-TYPE> "7", and execute "HD-CLEAR". Then, turn OFF and then ON the main power to delete the data in the corresponding partition. 5. If the above-mentioned service mode cannot be executed due to an error, etc., enter safe mode. Then format the HDD using SST or a USB flash drive. 6. Check/replace the related parts. <p>[Reference] When replacing the HDD, back up the setting values by referring to "Chapter 5. Adjustment> Actions when Replacing the Parts> HDD" in the Service Manual.</p>

E602-0711-00	HDD error
Detection Description	An error was detected in general application temporary area (temporary file). (File could not be written in the HDD after startup or I/O error after startup)
Remedy	<p>[Related parts]</p> <ul style="list-style-type: none"> - Cable between the Main Controller PCB (UN34/J6003, J6004) and the HDD (Unit of replacement: CABLE, HARD DISK DRIVE, 1) - HDD (Unit of replacement: HARD DISK DRIVE) - Main Controller PCB (UN34) (Unit of replacement: MAIN CONTROLLER PCB ASS'Y, 1) <p>[Remedy] Perform the following in the order while checking whether the error is cleared. When prioritizing clearing of the error, skip Remedies 2 and 3.</p> <p>Although the error is cleared by "HD-CHECK", it may occur again. Thus, perform Remedies 1 to 4.</p> <ol style="list-style-type: none"> 1. Check the related harness/cable and connector. 2. Select COPIER> FUNCTION> SYSTEM> CHK-TYPE> "7", and execute "HD-CHECK". Then, turn OFF and then ON the main power. 3. Obtain the necessary backup data by referring to "Appendix> Backup Data List" in the System Service Manual. 4. Select COPIER> FUNCTION> SYSTEM> CHK-TYPE> "7", and execute "HD-CLEAR". Then, turn OFF and then ON the main power to delete the data in the corresponding partition. 5. If the above-mentioned service mode cannot be executed due to an error, etc., enter safe mode. Then format the HDD using SST or a USB flash drive. 6. Check/replace the related parts. <p>[Reference] When replacing the HDD, back up the setting values by referring to "Chapter 5. Adjustment> Actions when Replacing the Parts> HDD" in the Service Manual.</p>
E602-0801-00	HDD error
Detection Description	<p>An error was detected in the general application-related area. (Initialization failed at startup or I/O error at startup)</p> <p>When this error occurs, the system has not been started normally. Therefore, it may not be recorded in the error log.</p>
Remedy	<p>[Related parts]</p> <ul style="list-style-type: none"> - Cable between the Main Controller PCB (UN34/J6003, J6004) and the HDD (Unit of replacement: CABLE, HARD DISK DRIVE, 1) - HDD (Unit of replacement: HARD DISK DRIVE) - Main Controller PCB (UN34) (Unit of replacement: MAIN CONTROLLER PCB ASS'Y, 1) <p>[Remedy] Perform the following in the order while checking whether the error is cleared. When prioritizing clearing of the error, skip Remedies 2 and 3.</p> <p>Although the error is cleared by "HD-CHECK", it may occur again. Thus, perform Remedies 1 to 4.</p> <ol style="list-style-type: none"> 1. Check the related harness/cable and connector. 2. Select COPIER> FUNCTION> SYSTEM> CHK-TYPE> "8", and execute "HD-CHECK". Then, turn OFF and then ON the main power. 3. Obtain the necessary backup data by referring to "Appendix> Backup Data List" in the System Service Manual. 4. Select COPIER> FUNCTION> SYSTEM> CHK-TYPE> "8", and execute "HD-CLEAR". Then, turn OFF and then ON the main power to delete the data in the corresponding partition. 5. If the above-mentioned service mode cannot be executed due to an error, etc., enter safe mode. Then format the HDD using SST or a USB flash drive. 6. Check/replace the related parts. <p>[Reference] When replacing the HDD, back up the setting values by referring to "Chapter 5. Adjustment> Actions when Replacing the Parts> HDD" in the Service Manual.</p>

E602-0811-00	HDD error
Detection Description	An error was detected in the general application-related area. (File could not be written in the HDD after startup or I/O error after startup)
Remedy	<p>[Related parts]</p> <ul style="list-style-type: none"> - Cable between the Main Controller PCB (UN34/J6003, J6004) and the HDD (Unit of replacement: CABLE, HARD DISK DRIVE, 1) - HDD (Unit of replacement: HARD DISK DRIVE) - Main Controller PCB (UN34) (Unit of replacement: MAIN CONTROLLER PCB ASS'Y, 1) <p>[Remedy] Perform the following in the order while checking whether the error is cleared. When prioritizing clearing of the error, skip Remedies 2 and 3.</p> <p>Although the error is cleared by "HD-CHECK", it may occur again. Thus, perform Remedies 1 to 4.</p> <ol style="list-style-type: none"> 1. Check the related harness/cable and connector. 2. Select COPIER> FUNCTION> SYSTEM> CHK-TYPE> "8", and execute "HD-CHECK". Then, turn OFF and then ON the main power. 3. Obtain the necessary backup data by referring to "Appendix> Backup Data List" in the System Service Manual. 4. Select COPIER> FUNCTION> SYSTEM> CHK-TYPE> "8", and execute "HD-CLEAR". Then, turn OFF and then ON the main power to delete the data in the corresponding partition. 5. If the above-mentioned service mode cannot be executed due to an error, etc., enter safe mode. Then format the HDD using SST or a USB flash drive. 6. Check/replace the related parts. <p>[Reference] When replacing the HDD, back up the setting values by referring to "Chapter 5. Adjustment> Actions when Replacing the Parts> HDD" in the Service Manual.</p>
E602-0901-00	HDD error
Detection Description	<p>An error was detected in PDL spool data (temporary file). (Initialization failed at startup or I/O error at startup)</p> <p>When this error occurs, the system has not been started normally. Therefore, it may not be recorded in the error log.</p>
Remedy	<p>[Related parts]</p> <ul style="list-style-type: none"> - Cable between the Main Controller PCB (UN34/J6003, J6004) and the HDD (Unit of replacement: CABLE, HARD DISK DRIVE, 1) - HDD (Unit of replacement: HARD DISK DRIVE) - Main Controller PCB (UN34) (Unit of replacement: MAIN CONTROLLER PCB ASS'Y, 1) <p>[Remedy] Perform the following in the order while checking whether the error is cleared. When prioritizing clearing of the error, skip Remedies 2 and 3.</p> <p>Although the error is cleared by "HD-CHECK", it may occur again. Thus, perform Remedies 1 to 4.</p> <ol style="list-style-type: none"> 1. Check the related harness/cable and connector. 2. Select COPIER> FUNCTION> SYSTEM> CHK-TYPE> "9", and execute "HD-CHECK". Then, turn OFF and then ON the main power. 3. Obtain the necessary backup data by referring to "Appendix> Backup Data List" in the System Service Manual. 4. Select COPIER> FUNCTION> SYSTEM> CHK-TYPE> "9", and execute "HD-CLEAR". Then, turn OFF and then ON the main power to delete the data in the corresponding partition. 5. If the above-mentioned service mode cannot be executed due to an error, etc., enter safe mode. Then format the HDD using SST or a USB flash drive. 6. Check/replace the related parts. <p>[Reference] When replacing the HDD, back up the setting values by referring to "Chapter 5. Adjustment> Actions when Replacing the Parts> HDD" in the Service Manual.</p>

E602-0911-00	HDD error
Detection Description	An error was detected in PDL spool data (temporary file). (File could not be written in the HDD after startup or I/O error after startup)
Remedy	<p>[Related parts]</p> <ul style="list-style-type: none"> - Cable between the Main Controller PCB (UN34/J6003, J6004) and the HDD (Unit of replacement: CABLE, HARD DISK DRIVE, 1) - HDD (Unit of replacement: HARD DISK DRIVE) - Main Controller PCB (UN34) (Unit of replacement: MAIN CONTROLLER PCB ASS'Y, 1) <p>[Remedy] Perform the following in the order while checking whether the error is cleared. When prioritizing clearing of the error, skip Remedies 2 and 3.</p> <p>Although the error is cleared by "HD-CHECK", it may occur again. Thus, perform Remedies 1 to 4.</p> <ol style="list-style-type: none"> 1. Check the related harness/cable and connector. 2. Select COPIER> FUNCTION> SYSTEM> CHK-TYPE> "9", and execute "HD-CHECK". Then, turn OFF and then ON the main power. 3. Obtain the necessary backup data by referring to "Appendix> Backup Data List" in the System Service Manual. 4. Select COPIER> FUNCTION> SYSTEM> CHK-TYPE> "9", and execute "HD-CLEAR". Then, turn OFF and then ON the main power to delete the data in the corresponding partition. 5. If the above-mentioned service mode cannot be executed due to an error, etc., enter safe mode. Then format the HDD using SST or a USB flash drive. 6. Check/replace the related parts. <p>[Reference] When replacing the HDD, back up the setting values by referring to "Chapter 5. Adjustment> Actions when Replacing the Parts> HDD" in the Service Manual.</p>
E602-1001-00	HDD error
Detection Description	<p>An error was detected in the SEND-related area. (Initialization failed at startup or I/O error at startup)</p> <p>When this error occurs, the system has not been started normally. Therefore, it may not be recorded in the error log.</p>
Remedy	<p>[Related parts]</p> <ul style="list-style-type: none"> - Cable between the Main Controller PCB (UN34/J6003, J6004) and the HDD (Unit of replacement: CABLE, HARD DISK DRIVE, 1) - HDD (Unit of replacement: HARD DISK DRIVE) - Main Controller PCB (UN34) (Unit of replacement: MAIN CONTROLLER PCB ASS'Y, 1) <p>[Remedy] Perform the following in the order while checking whether the error is cleared. When prioritizing clearing of the error, skip Remedies 2 and 3.</p> <p>Although the error is cleared by "HD-CHECK", it may occur again. Thus, perform Remedies 1 to 4.</p> <ol style="list-style-type: none"> 1. Check the related harness/cable and connector. 2. Select COPIER> FUNCTION> SYSTEM> CHK-TYPE> "10", and execute "HD-CHECK". Then, turn OFF and then ON the main power. 3. Obtain the necessary backup data by referring to "Appendix> Backup Data List" in the System Service Manual. 4. Select COPIER> FUNCTION> SYSTEM> CHK-TYPE> "10", and execute "HD-CLEAR". Then, turn OFF and then ON the main power to delete the data in the corresponding partition. 5. If the above-mentioned service mode cannot be executed due to an error, etc., enter safe mode. Then format the HDD using SST or a USB flash drive. 6. Check/replace the related parts. <p>[Reference] When replacing the HDD, back up the setting values by referring to "Chapter 5. Adjustment> Actions when Replacing the Parts> HDD" in the Service Manual.</p>

E602-1011-00	HDD error
Detection Description	An error was detected in the SEND-related area. (File could not be written in the HDD after startup or I/O error after startup)
Remedy	<p>[Related parts]</p> <ul style="list-style-type: none"> - Cable between the Main Controller PCB (UN34/J6003, J6004) and the HDD (Unit of replacement: CABLE, HARD DISK DRIVE, 1) - HDD (Unit of replacement: HARD DISK DRIVE) - Main Controller PCB (UN34) (Unit of replacement: MAIN CONTROLLER PCB ASS'Y, 1) <p>[Remedy] Perform the following in the order while checking whether the error is cleared. When prioritizing clearing of the error, skip Remedies 2 and 3.</p> <p>Although the error is cleared by "HD-CHECK", it may occur again. Thus, perform Remedies 1 to 4.</p> <ol style="list-style-type: none"> 1. Check the related harness/cable and connector. 2. Select COPIER> FUNCTION> SYSTEM> CHK-TYPE> "10", and execute "HD-CHECK". Then, turn OFF and then ON the main power. 3. Obtain the necessary backup data by referring to "Appendix> Backup Data List" in the System Service Manual. 4. Select COPIER> FUNCTION> SYSTEM> CHK-TYPE> "10", and execute "HD-CLEAR". Then, turn OFF and then ON the main power to delete the data in the corresponding partition. 5. If the above-mentioned service mode cannot be executed due to an error, etc., enter safe mode. Then format the HDD using SST or a USB flash drive. 6. Check/replace the related parts. <p>[Reference] When replacing the HDD, back up the setting values by referring to "Chapter 5. Adjustment> Actions when Replacing the Parts> HDD" in the Service Manual.</p>
E602-1101-00	HDD error
Detection Description	<p>An error was detected in the update-related area. (Initialization failed at startup or I/O error at startup)</p> <p>When this error occurs, the system has not been started normally. Therefore, it may not be recorded in the error log.</p>
Remedy	<p>[Related parts]</p> <ul style="list-style-type: none"> - Cable between the Main Controller PCB (UN34/J6003, J6004) and the HDD (Unit of replacement: CABLE, HARD DISK DRIVE, 1) - HDD (Unit of replacement: HARD DISK DRIVE) - Main Controller PCB (UN34) (Unit of replacement: MAIN CONTROLLER PCB ASS'Y, 1) <p>[Remedy] Perform the following in the order while checking whether the error is cleared. When prioritizing clearing of the error, skip Remedies 2 and 3.</p> <p>Although the error is cleared by "HD-CHECK", it may occur again. Thus, perform Remedies 1 to 4.</p> <ol style="list-style-type: none"> 1. Check the related harness/cable and connector. 2. Select COPIER> FUNCTION> SYSTEM> CHK-TYPE> "11", and execute "HD-CHECK". Then, turn OFF and then ON the main power. 3. Obtain the necessary backup data by referring to "Appendix> Backup Data List" in the System Service Manual. 4. Select COPIER> FUNCTION> SYSTEM> CHK-TYPE> "11", and execute "HD-CLEAR". Then, turn OFF and then ON the main power to delete the data in the corresponding partition. 5. If the above-mentioned service mode cannot be executed due to an error, etc., enter safe mode. Then format the HDD using SST or a USB flash drive. 6. Check/replace the related parts. <p>[Reference] When replacing the HDD, back up the setting values by referring to "Chapter 5. Adjustment> Actions when Replacing the Parts> HDD" in the Service Manual.</p>

E602-1111-00	HDD error
Detection Description	An error was detected in the update-related area. (File could not be written in the HDD after startup or I/O error after startup)
Remedy	<p>[Related parts]</p> <ul style="list-style-type: none"> - Cable between the Main Controller PCB (UN34/J6003, J6004) and the HDD (Unit of replacement: CABLE, HARD DISK DRIVE, 1) - HDD (Unit of replacement: HARD DISK DRIVE) - Main Controller PCB (UN34) (Unit of replacement: MAIN CONTROLLER PCB ASS'Y, 1) <p>[Remedy] Perform the following in the order while checking whether the error is cleared. When prioritizing clearing of the error, skip Remedies 2 and 3.</p> <p>Although the error is cleared by "HD-CHECK", it may occur again. Thus, perform Remedies 1 to 4.</p> <ol style="list-style-type: none"> 1. Check the related harness/cable and connector. 2. Select COPIER> FUNCTION> SYSTEM> CHK-TYPE> "11", and execute "HD-CHECK". Then, turn OFF and then ON the main power. 3. Obtain the necessary backup data by referring to "Appendix> Backup Data List" in the System Service Manual. 4. Select COPIER> FUNCTION> SYSTEM> CHK-TYPE> "11", and execute "HD-CLEAR". Then, turn OFF and then ON the main power to delete the data in the corresponding partition. 5. If the above-mentioned service mode cannot be executed due to an error, etc., enter safe mode. Then format the HDD using SST or a USB flash drive. 6. Check/replace the related parts. <p>[Reference] When replacing the HDD, back up the setting values by referring to "Chapter 5. Adjustment> Actions when Replacing the Parts> HDD" in the Service Manual.</p>
E602-1201-00	HDD error
Detection Description	<p>An error was detected in the license-related area. (Initialization failed at startup or I/O error at startup)</p> <p>When this error occurs, the system has not been started normally. Therefore, it may not be recorded in the error log.</p>
Remedy	<p>[Related parts]</p> <ul style="list-style-type: none"> - Cable between the Main Controller PCB (UN34/J6003, J6004) and the HDD (Unit of replacement: CABLE, HARD DISK DRIVE, 1) - HDD (Unit of replacement: HARD DISK DRIVE) - Main Controller PCB (UN34) (Unit of replacement: MAIN CONTROLLER PCB ASS'Y, 1) <p>[Remedy] Perform the following in the order while checking whether the error is cleared. Although the error is cleared by "HD-CHECK", it may occur again. Thus, perform Remedies 1 to 5.</p> <ol style="list-style-type: none"> 1. Check the related harness/cable and connector. 2. Turn OFF and then ON the main power, and check whether the error is cleared. 3. Select COPIER> FUNCTION> SYSTEM> CHK-TYPE> "12", and execute "HD-CHECK". Then, turn OFF and then ON the main power. 4. Obtain the necessary backup data by referring to "Appendix> Backup Data List" in the System Service Manual. 5. enter safe mode, and format the HDD using SST or a USB flash drive. 6. Check/replace the related parts. <p>[Reference] When replacing the HDD, back up the setting values by referring to "Chapter 5. Adjustment> Actions when Replacing the Parts> HDD" in the Service Manual.</p>

E602-1211-00	HDD error
Detection Description	An error was detected in the license-related area. (File could not be written in the HDD after startup or I/O error after startup)
Remedy	<p>[Related parts]</p> <ul style="list-style-type: none"> - Cable between the Main Controller PCB (UN34/J6003, J6004) and the HDD (Unit of replacement: CABLE, HARD DISK DRIVE, 1) - HDD (Unit of replacement: HARD DISK DRIVE) - Main Controller PCB (UN34) (Unit of replacement: MAIN CONTROLLER PCB ASS'Y, 1) <p>[Remedy] Perform the following in the order while checking whether the error is cleared. Although the error is cleared by "HD-CHECK", it may occur again. Thus, perform Remedies 1 to 5.</p> <ol style="list-style-type: none"> 1. Check the related harness/cable and connector. 2. Turn OFF and then ON the main power, and check whether the error is cleared. 3. Select COPIER> FUNCTION> SYSTEM> CHK-TYPE> "12", and execute "HD-CHECK". Then, turn OFF and then ON the main power. 4. Obtain the necessary backup data by referring to "Appendix> Backup Data List" in the System Service Manual. 5. enter safe mode, and format the HDD using SST or a USB flash drive. 6. Check/replace the related parts. <p>[Reference] When replacing the HDD, back up the setting values by referring to "Chapter 5. Adjustment> Actions when Replacing the Parts> HDD" in the Service Manual.</p>
E602-1301-00	HDD error
Detection Description	An error was detected in the system area. (Initialization failed at startup or I/O error at startup) When this error occurs, the system has not been started normally. Therefore, it may not be recorded in the error log.
Remedy	<p>[Related parts]</p> <ul style="list-style-type: none"> - Cable between the Main Controller PCB (UN34/J6003, J6004) and the HDD (Unit of replacement: CABLE, HARD DISK DRIVE, 1) - HDD (Unit of replacement: HARD DISK DRIVE) - Main Controller PCB (UN34) (Unit of replacement: MAIN CONTROLLER PCB ASS'Y, 1) <p>[Remedy] Perform the following in the order while checking whether the error is cleared. Although the error is cleared by "HD-CHECK", it may occur again. Thus, perform Remedies 1 to 5.</p> <ol style="list-style-type: none"> 1. Check the related harness/cable and connector. 2. Turn OFF and then ON the main power, and check whether the error is cleared. 3. Select COPIER> FUNCTION> SYSTEM> CHK-TYPE> "13", and execute "HD-CHECK". Then, turn OFF and then ON the main power. 4. Obtain the necessary backup data by referring to "Appendix> Backup Data List" in the System Service Manual. 5. enter safe mode, and format the HDD using SST or a USB flash drive. 6. Check/replace the related parts. <p>[Reference] When replacing the HDD, back up the setting values by referring to "Chapter 5. Adjustment> Actions when Replacing the Parts> HDD" in the Service Manual.</p>

E602-1311-00	HDD error
Detection Description	An error was detected in the system area. (File could not be written in the HDD after startup or I/O error after startup)
Remedy	<p>[Related parts]</p> <ul style="list-style-type: none"> - Cable between the Main Controller PCB (UN34/J6003, J6004) and the HDD (Unit of replacement: CABLE, HARD DISK DRIVE, 1) - HDD (Unit of replacement: HARD DISK DRIVE) - Main Controller PCB (UN34) (Unit of replacement: MAIN CONTROLLER PCB ASS'Y, 1) <p>[Remedy] Perform the following in the order while checking whether the error is cleared. Although the error is cleared by "HD-CHECK", it may occur again. Thus, perform Remedies 1 to 5.</p> <ol style="list-style-type: none"> 1. Check the related harness/cable and connector. 2. Turn OFF and then ON the main power, and check whether the error is cleared. 3. Select COPIER> FUNCTION> SYSTEM> CHK-TYPE> "13", and execute "HD-CHECK". Then, turn OFF and then ON the main power. 4. Obtain the necessary backup data by referring to "Appendix> Backup Data List" in the System Service Manual. 5. enter safe mode, and format the HDD using SST or a USB flash drive. 6. Check/replace the related parts. <p>[Reference] When replacing the HDD, back up the setting values by referring to "Chapter 5. Adjustment> Actions when Replacing the Parts> HDD" in the Service Manual.</p>
E602-1371-00	System verification error
Detection Description	At startup, a verification error occurred due to invalid data of a MEAP login application.
Remedy	<p>[Remedy]</p> <ol style="list-style-type: none"> 1. Set the following service mode setting value to 1: COPIER > OPTION > USER > MEAPSAFE 2. Turn OFF and then ON the main power. 3. Reinstall the corresponding MEAP application from RUI. <p>[Caution]</p> <p>After performing the remedy work, return the MEAPSAFE value to 0 and turn OFF and then ON the main power.</p>
E602-1372-00	Verification error by "Falsification detection at startup" function
Detection Description	At startup, a verification error occurred due to invalid data in the MEAP area.
Remedy	<p>[Remedy] Perform the following in the order while checking whether the error is cleared.</p> <ol style="list-style-type: none"> 1. Turn OFF and then ON the main power, and check whether the error is cleared. 2. Select COPIER> FUNCTION> SYSTEM> CHK-TYPE> "13", and execute "HD-CHECK". Then, turn OFF and then ON the main power. 3. Obtain necessary backup data referring to "Appendix > Backup Data List" in System Service Manual. 4. Select COPIER> FUNCTION> SYSTEM> CHK-TYPE> "13", and execute "HD-CLEAR". Then, turn OFF and then ON the main power to delete the data in the corresponding partition. 5. Re-install MEAP application(s) via RUI and restore the backup data. <p>[Reference]</p> <p>Restore the backup data if the data has been deleted.</p>

E602-1401-00	HDD error
Detection Description	<p>An error was detected in SWAP (temporary file/alternative memory area). (Initialization failed at startup or I/O error at startup)</p> <p>When this error occurs, the system has not been started normally. Therefore, it may not be recorded in the error log.</p>
Remedy	<p>[Related parts]</p> <ul style="list-style-type: none"> - Cable between the Main Controller PCB (UN34/J6003, J6004) and the HDD (Unit of replacement: CABLE, HARD DISK DRIVE, 1) - HDD (Unit of replacement: HARD DISK DRIVE) - Main Controller PCB (UN34) (Unit of replacement: MAIN CONTROLLER PCB ASS'Y, 1) <p>[Remedy] Perform the following in the order while checking whether the error is cleared. When prioritizing clearing of the error, skip Remedies 2 and 3.</p> <p>Although the error is cleared by "HD-CHECK", it may occur again. Thus, perform Remedies 1 to 4.</p> <ol style="list-style-type: none"> 1. Check the related harness/cable and connector. 2. Select COPIER> FUNCTION> SYSTEM> CHK-TYPE> "14", and execute "HD-CHECK". Then, turn OFF and then ON the main power. 3. Obtain the necessary backup data by referring to "Appendix> Backup Data List" in the System Service Manual. 4. Select COPIER> FUNCTION> SYSTEM> CHK-TYPE> "14", and execute "HD-CLEAR". Then, turn OFF and then ON the main power to delete the data in the corresponding partition. 5. If the above-mentioned service mode cannot be executed due to an error, etc., enter safe mode. Then format the HDD using SST or a USB flash drive. 6. Check/replace the related parts. <p>[Reference] When replacing the HDD, back up the setting values by referring to "Chapter 5. Adjustment> Actions when Replacing the Parts> HDD" in the Service Manual.</p>
E602-1411-00	HDD error
Detection Description	<p>An error was detected in SWAP (temporary file/alternative memory area). (File could not be written in the HDD after startup or I/O error after startup)</p>
Remedy	<p>[Related parts]</p> <ul style="list-style-type: none"> - Cable between the Main Controller PCB (UN34/J6003, J6004) and the HDD (Unit of replacement: CABLE, HARD DISK DRIVE, 1) - HDD (Unit of replacement: HARD DISK DRIVE) - Main Controller PCB (UN34) (Unit of replacement: MAIN CONTROLLER PCB ASS'Y, 1) <p>[Remedy] Perform the following in the order while checking whether the error is cleared. When prioritizing clearing of the error, skip Remedies 2 and 3.</p> <p>Although the error is cleared by "HD-CHECK", it may occur again. Thus, perform Remedies 1 to 4.</p> <ol style="list-style-type: none"> 1. Check the related harness/cable and connector. 2. Select COPIER> FUNCTION> SYSTEM> CHK-TYPE> "14", and execute "HD-CHECK". Then, turn OFF and then ON the main power. 3. Obtain the necessary backup data by referring to "Appendix> Backup Data List" in the System Service Manual. 4. Select COPIER> FUNCTION> SYSTEM> CHK-TYPE> "14", and execute "HD-CLEAR". Then, turn OFF and then ON the main power to delete the data in the corresponding partition. 5. If the above-mentioned service mode cannot be executed due to an error, etc., enter safe mode. Then format the HDD using SST or a USB flash drive. 6. Check/replace the related parts. <p>[Reference] When replacing the HDD, back up the setting values by referring to "Chapter 5. Adjustment> Actions when Replacing the Parts> HDD" in the Service Manual.</p>

E602-1701-00	HDD error
Detection Description	An error was detected in the debug log area. (Initialization failed at startup or I/O error at startup) When this error occurs, the system has not been started normally. Therefore, it may not be recorded in the error log.
Remedy	<p>[Related parts]</p> <ul style="list-style-type: none"> - Cable between the Main Controller PCB (UN34/J6003, J6004) and the HDD (Unit of replacement: CABLE, HARD DISK DRIVE, 1) - HDD (Unit of replacement: HARD DISK DRIVE) - Main Controller PCB (UN34) (Unit of replacement: MAIN CONTROLLER PCB ASS'Y, 1) <p>[Remedy] Perform the following in the order while checking whether the error is cleared. When prioritizing clearing of the error, skip Remedies 2 and 3. Although the error is cleared by "HD-CHECK", it may occur again. Thus, perform Remedies 1 to 4.</p> <ol style="list-style-type: none"> 1. Check the related harness/cable and connector. 2. Select COPIER> FUNCTION> SYSTEM> CHK-TYPE> "17", and execute "HD-CHECK". Then, turn OFF and then ON the main power. 3. Obtain the necessary backup data by referring to "Appendix> Backup Data List" in the System Service Manual. 4. Select COPIER> FUNCTION> SYSTEM> CHK-TYPE> "17", and execute "HD-CLEAR". Then, turn OFF and then ON the main power to delete the data in the corresponding partition. 5. enter safe mode, and format the HDD using SST or a USB flash drive. 6. Check/replace the related parts. <p>[Reference] When replacing the HDD, back up the setting values by referring to "Chapter 5. Adjustment> Actions when Replacing the Parts> HDD" in the Service Manual.</p>
E602-1711-00	HDD error
Detection Description	An error was detected in the debug log area. (File could not be written in the HDD after startup or I/O error after startup)
Remedy	<p>[Related parts]</p> <ul style="list-style-type: none"> - Cable between the Main Controller PCB (UN34/J6003, J6004) and the HDD (Unit of replacement: CABLE, HARD DISK DRIVE, 1) - HDD (Unit of replacement: HARD DISK DRIVE) - Main Controller PCB (UN34) (Unit of replacement: MAIN CONTROLLER PCB ASS'Y, 1) <p>[Remedy] Perform the following in the order while checking whether the error is cleared. When prioritizing clearing of the error, skip Remedies 2 and 3. Although the error is cleared by "HD-CHECK", it may occur again. Thus, perform Remedies 1 to 4.</p> <ol style="list-style-type: none"> 1. Check the related harness/cable and connector. 2. Select COPIER> FUNCTION> SYSTEM> CHK-TYPE> "17", and execute "HD-CHECK". Then, turn OFF and then ON the main power. 3. Obtain the necessary backup data by referring to "Appendix> Backup Data List" in the System Service Manual. 4. Select COPIER> FUNCTION> SYSTEM> CHK-TYPE> "17", and execute "HD-CLEAR". Then, turn OFF and then ON the main power to delete the data in the corresponding partition. 5. If the above-mentioned service mode cannot be executed due to an error, etc., enter safe mode. Then format the HDD using SST or a USB flash drive. 6. Check/replace the related parts. <p>[Reference] When replacing the HDD, back up the setting values by referring to "Chapter 5. Adjustment> Actions when Replacing the Parts> HDD" in the Service Manual.</p>

E602-1801-00	HDD error
Detection Description	<p>An error was detected in the image data storage area in Advanced Box. (Initialization failed at startup or I/O error at startup)</p> <p>When this error occurs, the system has not been started normally. Therefore, it may not be recorded in the error log.</p>
Remedy	<p>[Related parts]</p> <ul style="list-style-type: none"> - Cable between the Main Controller PCB (UN34/J6003, J6004) and the HDD (Unit of replacement: CABLE, HARD DISK DRIVE, 1) - HDD (Unit of replacement: HARD DISK DRIVE) - Main Controller PCB (UN34) (Unit of replacement: MAIN CONTROLLER PCB ASS'Y, 1) <p>[Remedy] Perform the following in the order while checking whether the error is cleared. When prioritizing clearing of the error, skip Remedies 2 and 3.</p> <p>Although the error is cleared by "HD-CHECK", it may occur again. Thus, perform Remedies 1 to 4.</p> <ol style="list-style-type: none"> 1. Check the related harness/cable and connector. 2. Select COPIER> FUNCTION> SYSTEM> CHK-TYPE> "18", and execute "HD-CHECK". Then, turn OFF and then ON the main power. 3. Obtain the necessary backup data by referring to "Appendix> Backup Data List" in the System Service Manual. 4. Select COPIER> FUNCTION> SYSTEM> CHK-TYPE> "18", and execute "HD-CLEAR". Then, turn OFF and then ON the main power to delete the data in the corresponding partition. 5. enter safe mode, and format the HDD using SST or a USB flash drive. 6. Check/replace the related parts. <p>[Reference] When replacing the HDD, back up the setting values by referring to "Chapter 5. Adjustment> Actions when Replacing the Parts> HDD" in the Service Manual.</p>
E602-1811-00	HDD error
Detection Description	<p>An error was detected in the image data storage area in Advanced Box. (File could not be written in the HDD after startup or I/O error after startup)</p>
Remedy	<p>[Related parts]</p> <ul style="list-style-type: none"> - Cable between the Main Controller PCB (UN34/J6003, J6004) and the HDD (Unit of replacement: CABLE, HARD DISK DRIVE, 1) - HDD (Unit of replacement: HARD DISK DRIVE) - Main Controller PCB (UN34) (Unit of replacement: MAIN CONTROLLER PCB ASS'Y, 1) <p>[Remedy] Perform the following in the order while checking whether the error is cleared. When prioritizing clearing of the error, skip Remedies 2 and 3.</p> <p>Although the error is cleared by "HD-CHECK", it may occur again. Thus, perform Remedies 1 to 4.</p> <ol style="list-style-type: none"> 1. Check the related harness/cable and connector. 2. Select COPIER> FUNCTION> SYSTEM> CHK-TYPE> "18", and execute "HD-CHECK". Then, turn OFF and then ON the main power. 3. Obtain the necessary backup data by referring to "Appendix> Backup Data List" in the System Service Manual. 4. Select COPIER> FUNCTION> SYSTEM> CHK-TYPE> "18", and execute "HD-CLEAR". Then, turn OFF and then ON the main power to delete the data in the corresponding partition. 5. enter safe mode, and format the HDD using SST or a USB flash drive. 6. Check/replace the related parts. <p>[Reference] When replacing the HDD, back up the setting values by referring to "Chapter 5. Adjustment> Actions when Replacing the Parts> HDD" in the Service Manual.</p>

E602-1901-00	HDD error
Detection Description	<p>An error was detected in the storage area of data for printing. (Initialization failed at startup or I/O error at startup)</p> <p>When this error occurs, the system has not been started normally. Therefore, it may not be recorded in the error log.</p>
Remedy	<p>[Related parts]</p> <ul style="list-style-type: none"> - Cable between the Main Controller PCB (UN34/J6003, J6004) and the HDD (Unit of replacement: CABLE, HARD DISK DRIVE, 1) - HDD (Unit of replacement: HARD DISK DRIVE) - Main Controller PCB (UN34) (Unit of replacement: MAIN CONTROLLER PCB ASS'Y, 1) <p>[Remedy] Perform the following in the order while checking whether the error is cleared. When prioritizing clearing of the error, skip Remedies 2 and 3.</p> <p>Although the error is cleared by "HD-CHECK", it may occur again. Thus, perform Remedies 1 to 4.</p> <ol style="list-style-type: none"> 1. Check the related harness/cable and connector. 2. Select COPIER> FUNCTION> SYSTEM> CHK-TYPE> "19", and execute "HD-CHECK". Then, turn OFF and then ON the main power. 3. Obtain the necessary backup data by referring to "Appendix> Backup Data List" in the System Service Manual. 4. Select COPIER> FUNCTION> SYSTEM> CHK-TYPE> "19", and execute "HD-CLEAR". Then, turn OFF and then ON the main power to delete the data in the corresponding partition. 5. enter safe mode, and format the HDD using SST or a USB flash drive. 6. Check/replace the related parts. <p>[Reference] When replacing the HDD, back up the setting values by referring to "Chapter 5. Adjustment> Actions when Replacing the Parts> HDD" in the Service Manual.</p>
E602-1911-00	HDD error
Detection Description	<p>An error was detected in the storage area of data for printing. (File could not be written in the HDD after startup or I/O error after startup)</p>
Remedy	<p>[Related parts]</p> <ul style="list-style-type: none"> - Cable between the Main Controller PCB (UN34/J6003, J6004) and the HDD (Unit of replacement: CABLE, HARD DISK DRIVE, 1) - HDD (Unit of replacement: HARD DISK DRIVE) - Main Controller PCB (UN34) (Unit of replacement: MAIN CONTROLLER PCB ASS'Y, 1) <p>[Remedy] Perform the following in the order while checking whether the error is cleared. When prioritizing clearing of the error, skip Remedies 2 and 3.</p> <p>Although the error is cleared by "HD-CHECK", it may occur again. Thus, perform Remedies 1 to 4.</p> <ol style="list-style-type: none"> 1. Check the related harness/cable and connector. 2. Select COPIER> FUNCTION> SYSTEM> CHK-TYPE> "19", and execute "HD-CHECK". Then, turn OFF and then ON the main power. 3. Obtain the necessary backup data by referring to "Appendix> Backup Data List" in the System Service Manual. 4. Select COPIER> FUNCTION> SYSTEM> CHK-TYPE> "19", and execute "HD-CLEAR". Then, turn OFF and then ON the main power to delete the data in the corresponding partition. 5. If the above-mentioned service mode cannot be executed due to an error, etc., enter safe mode. Then format the HDD using SST or a USB flash drive. 6. Check/replace the related parts. <p>[Reference] When replacing the HDD, back up the setting values by referring to "Chapter 5. Adjustment> Actions when Replacing the Parts> HDD" in the Service Manual.</p>
E602-2000-00	HDD error
Detection Description	<p>I/O error was detected in the file system after startup.</p>
Remedy	<p>[Remedy] Perform the following in the order while checking whether the error is cleared.</p> <ol style="list-style-type: none"> 1. Check that the HDD optional board is properly installed. 2. Turn ON the main power, and check whether the error is cleared. 3. Execute the key clear using SST (to make an unformatted disk). <p>[CAUTION] E602-0001 will be indicated if activating the machine with the unformatted disk. Therefore, be sure to format the HDD.</p> <ol style="list-style-type: none"> 4. enter safe mode, and format the HDD using SST or a USB flash drive.

E602-5001-00	Encryption Chip error
Detection Description	Error of the encryption chip on the Main Controller
Remedy	[Related parts] Main Controller PCB [Remedy] Replace the Main Controller PCB
E602-5002-00	HDD error
Detection Description	A non-genuine HDD was detected.
Remedy	[Related parts] HDD [Remedy] 1. Replace the HDD with a genuine one. [Reference] When replacing the HDD, back up the setting values by referring to "Chapter 5. Adjustment> Actions when Replacing the Parts> HDD" in the Service Manual. 2. Format the HDD using SST or a USB flash drive.
E602-FF01-00	HDD error
Detection Description	An unidentified HDD error was detected at startup. When this error occurs, the system has not been started normally. Therefore, it may not be recorded in the error log.
Remedy	[Related parts] - Main Controller PCB (UN34) (Unit of replacement: MAIN CONTROLLER PCB ASS'Y, 1) - HDD (Unit of replacement: HARD DISK DRIVE) [Reference] For backup and restoration, refer to "Appendix> Backup Data List" in the System Service Manual. [Remedy] Perform the following in the order while checking whether the error is cleared. 1. Check the related harness/cable and connector. 2. Format the HDD using SST or a USB flash drive. 3. Check/replace the related parts. [Reference] When replacing the HDD, back up the setting values by referring to "Chapter 5. Adjustment> Actions when Replacing the Parts> HDD" in the Service Manual.
E602-FF11-00	HDD error
Detection Description	An unidentified HDD error was detected after startup.
Remedy	[Related parts] - Main Controller PCB (UN34) (Unit of replacement: MAIN CONTROLLER PCB ASS'Y, 1) - HDD (Unit of replacement: HARD DISK DRIVE) [Reference] For backup and restoration, refer to "Appendix> Backup Data List" in the System Service Manual. [Remedy] Perform the following in the order while checking whether the error is cleared. 1. Check the related harness/cable and connector. 2. Format the HDD using SST or a USB flash drive. 3. Check/replace the related parts. [Reference] When replacing the HDD, back up the setting values by referring to "Chapter 5. Adjustment> Actions when Replacing the Parts> HDD" in the Service Manual.
E612-0007-00	System error
Detection Description	Initial license has not yet been registered.
Remedy	Register the initial license (speed license).
E614-0001-00	Flash PCB error
Detection Description	The Flash PCB could not be recognized, or the Flash PCB was not formatted.
Remedy	[Related parts] - Sata Flash PCB (Unit of replacement: SATA-FLASH PCB ASS'Y) - Main Controller PCB (UN34) (Unit of replacement: MAIN CONTROLLER PCB ASS'Y, 1) [Remedy] Perform the following in the order while checking whether the error is cleared. - Reinstall the necessary application software once the error is cleared. 1. After turning OFF the main power, remove and then install the Flash PCB again to check that it is installed properly. 2. After replacing the Flash PCB, reinstall the system software using SST or a USB flash drive. 3. Replace the Main Controller PCB.

E614-0002-00	Error in system on the Flash PCB
Detection Description	The file system could not be initialized normally at startup. When this error occurs, the system has not been started normally. Therefore, it may not be recorded in the error log.
Remedy	[Related parts] - Sata Flash PCB (Unit of replacement: SATA-FLASH PCB ASS'Y) - Main Controller PCB (UN34) (Unit of replacement: MAIN CONTROLLER PCB ASS'Y, 1) [Reference] For backup and restoration, refer to "Appendix> Backup Data List" in the System Service Manual. [Remedy] Perform the following in the order while checking whether the error is cleared. - Reinstall the necessary application software once the error is cleared. 1. After turning OFF the main power, remove and then install the Flash PCB to check that it is installed properly. 2. After replacing the Flash PCB, reinstall the system software using SST or a USB flash drive. 3. Replace the Main Controller PCB.
E614-0006-00	Error in system on the Flash PCB
Detection Description	Bootable was not found on the Flash PCB.
Remedy	[Related parts] - Sata Flash PCB (Unit of replacement: SATA-FLASH PCB ASS'Y) - Main Controller PCB (UN34) (Unit of replacement: MAIN CONTROLLER PCB ASS'Y, 1) [Remedy] Perform the following in the order while checking whether the error is cleared. - Reinstall the necessary application software once the error is cleared. 1. After turning OFF the main power, remove and then install the Flash PCB again to check that it is installed properly. 2. After replacing the Flash PCB, reinstall the system software using SST or a USB flash drive. 3. Replace the Main Controller PCB.
E614-0071-00	System verification error
Detection Description	At normal startup, an error may occur due to invalid data of the firmware for startup. When this error occurs, the system has not been started normally. Therefore, it is not recorded in the error log.
Remedy	[Related parts] - Flash PCB [Remedy] Perform the following in the order while checking whether the error is cleared. 1. Start the machine in safe mode, and reinstall the system using SST or a USB flash drive. * [2]: Select Update (Overwrite all) to update the system. 2. Replace the FLASH PCB, and reinstall the system software using SST or a USB flash drive.
E614-0072-00	System verification error
Detection Description	At normal startup, an error may occur due to invalid data of the firmware for safe mode startup. When this error occurs, the system has not been started normally. Therefore, it is not recorded in the error log.
Remedy	[Related parts] - Flash PCB [Remedy] 1. Replace the Flash PCB and reinstall the system using SST or a USB flash drive.
E614-0073-00	System verification error
Detection Description	At startup in safe mode, an error may occur due to invalid data of the startup firmware. When this error occurs, the system has not been started normally. Therefore, it is not recorded in the error log.
Remedy	[Related parts] - Flash PCB [Remedy] 1. Replace the Flash PCB and reinstall the system using SST or a USB flash drive.

E614-0074-00	Start system verification function error
Detection Description	At startup in safe mode, an error may occur due to invalid data of the firmware for safe mode startup. When this error occurs, the system has not been started normally. Therefore, it is not recorded in the error log.
Remedy	[Related parts] - Flash PCB [Remedy] 1. Replace the Flash PCB and reinstall the system using SST or a USB flash drive.
E614-0101-00	Error in system on the Flash PCB
Detection Description	An error was detected in the system area. (Initialization failed at startup or I/O error at startup) When this error occurs, the system has not been started normally. Therefore, it may not be recorded in the error log.
Remedy	[Related parts] - Sata Flash PCB (Unit of replacement: SATA-FLASH PCB ASS'Y) - Main Controller PCB (UN34) (Unit of replacement: MAIN CONTROLLER PCB ASS'Y, 1) [Remedy] Perform the following in the order while checking whether the error is cleared. Although the error is cleared by "HD-CHECK", it may occur again. Thus, perform Remedies 1 to 4. 1. Check the related harness/cable and connector. 2. Select COPIER> FUNCTION> SYSTEM> CHK-TYPE> "0", and execute "HD-CHECK". Then, turn OFF and then ON the main power. 3. Obtain the necessary backup data by referring to "Appendix> Backup Data List" in the System Service Manual. 4. After replacing the Flash PCB, reinstall the system software using SST or a USB flash drive. 5. Replace the Main Controller PCB.
E614-0111-00	Error in system on the Flash PCB
Detection Description	An error was detected in the system area. (File could not be written in the Flash PCB after startup or I/O error after startup)
Remedy	[Related parts] - Sata Flash PCB (Unit of replacement: SATA-FLASH PCB ASS'Y) - Main Controller PCB (UN34) (Unit of replacement: MAIN CONTROLLER PCB ASS'Y, 1) [Remedy] Perform the following in the order while checking whether the error is cleared. Although the error is cleared by "HD-CHECK", it may occur again. Thus, perform Remedies 1 to 4. 1. Check the related harness/cable and connector. 2. Select COPIER> FUNCTION> SYSTEM> CHK-TYPE> "0", and execute "HD-CHECK". Then, turn OFF and then ON the main power. 3. Obtain the necessary backup data by referring to "Appendix> Backup Data List" in the System Service Manual. 4. After replacing the Flash PCB, reinstall the system software using SST or a USB flash drive. 5. Replace the Main Controller PCB.
E614-0201-00	Error in system on the Flash PCB
Detection Description	An error was detected in the system area. (Initialization failed at startup or I/O error at startup) When this error occurs, the system has not been started normally. Therefore, it may not be recorded in the error log.
Remedy	[Related parts] - Sata Flash PCB (Unit of replacement: SATA-FLASH PCB ASS'Y) - Main Controller PCB (UN34) (Unit of replacement: MAIN CONTROLLER PCB ASS'Y, 1) [Remedy] Perform the following in the order while checking whether the error is cleared. Although the error is cleared by "HD-CHECK", it may occur again. Thus, perform Remedies 1 to 4. 1. Check the related harness/cable and connector. 2. Select COPIER> FUNCTION> SYSTEM> CHK-TYPE> "0", and execute "HD-CHECK". Then, turn OFF and then ON the main power. 3. Obtain the necessary backup data by referring to "Appendix> Backup Data List" in the System Service Manual. 4. After replacing the Flash PCB, reinstall the system software using SST or a USB flash drive. 5. Replace the Main Controller PCB.

E614-0211-00	Error in system on the Flash PCB
Detection Description	An error was detected in the system area. (File could not be written in the Flash PCB after startup or I/O error after startup)
Remedy	<p>[Related parts]</p> <ul style="list-style-type: none"> - Sata Flash PCB (Unit of replacement: SATA-FLASH PCB ASS'Y) - Main Controller PCB (UN34) (Unit of replacement: MAIN CONTROLLER PCB ASS'Y, 1) <p>[Remedy] Perform the following in the order while checking whether the error is cleared. Although the error is cleared by "HD-CHECK", it may occur again. Thus, perform Remedies 1 to 4.</p> <ol style="list-style-type: none"> 1. Check the related harness/cable and connector. 2. Select COPIER> FUNCTION> SYSTEM> CHK-TYPE> "0", and execute "HD-CHECK". Then, turn OFF and then ON the main power. 3. Obtain the necessary backup data by referring to "Appendix> Backup Data List" in the System Service Manual. 4. After replacing the Flash PCB, reinstall the system software using SST or a USB flash drive. 5. Replace the Main Controller PCB.
E614-0301-00	Error in system on the Flash PCB
Detection Description	An error was detected in the system area. (Initialization failed at startup or I/O error at startup) When this error occurs, the system has not been started normally. Therefore, it may not be recorded in the error log.
Remedy	<p>[Related parts]</p> <ul style="list-style-type: none"> - Sata Flash PCB (Unit of replacement: SATA-FLASH PCB ASS'Y) - Main Controller PCB (UN34) (Unit of replacement: MAIN CONTROLLER PCB ASS'Y, 1) <p>[Remedy] Perform the following in the order while checking whether the error is cleared. Although the error is cleared by "HD-CHECK", it may occur again. Thus, perform Remedies 1 to 4.</p> <ol style="list-style-type: none"> 1. Check the related harness/cable and connector. 2. Select COPIER> FUNCTION> SYSTEM> CHK-TYPE> "0", and execute "HD-CHECK". Then, turn OFF and then ON the main power. 3. Obtain the necessary backup data by referring to "Appendix> Backup Data List" in the System Service Manual. 4. After replacing the Flash PCB, reinstall the system software using SST or a USB flash drive. 5. Replace the Main Controller PCB.
E614-0311-00	Error in system on the Flash PCB
Detection Description	An error was detected in the system area. (File could not be written in the Flash PCB after startup or I/O error after startup)
Remedy	<p>[Related parts]</p> <ul style="list-style-type: none"> - Sata Flash PCB (Unit of replacement: SATA-FLASH PCB ASS'Y) - Main Controller PCB (UN34) (Unit of replacement: MAIN CONTROLLER PCB ASS'Y, 1) <p>[Remedy] Perform the following in the order while checking whether the error is cleared. Although the error is cleared by "HD-CHECK", it may occur again. Thus, perform Remedies 1 to 4.</p> <ol style="list-style-type: none"> 1. Check the related harness/cable and connector. 2. Select COPIER> FUNCTION> SYSTEM> CHK-TYPE> "0", and execute "HD-CHECK". Then, turn OFF and then ON the main power. 3. Obtain the necessary backup data by referring to "Appendix> Backup Data List" in the System Service Manual. 4. After replacing the Flash PCB, reinstall the system software using SST or a USB flash drive. 5. Replace the Main Controller PCB.
E614-0401-00	Error in system on the Flash PCB
Detection Description	Logical partition error was detected. (Initialization failed at startup or I/O error at startup) When this error occurs, the system has not been started normally. Therefore, it may not be recorded in the error log.
Remedy	<p>[Related parts]</p> <ul style="list-style-type: none"> - Sata Flash PCB (Unit of replacement: SATA-FLASH PCB ASS'Y) - Main Controller PCB (UN34) (Unit of replacement: MAIN CONTROLLER PCB ASS'Y, 1) <p>[Remedy] Perform the following in the order while checking whether the error is cleared.</p> <ol style="list-style-type: none"> 1. Obtain the necessary backup data by referring to "Appendix> Backup Data List" in the System Service Manual. 2. After replacing the Flash PCB, reinstall the system software using SST or a USB flash drive. 3. Replace the Main Controller PCB.

E614-0411-00	Error in system on the Flash PCB
Detection Description	Logical partition error was detected. (File could not be written in the Flash PCB after startup or I/O error after startup)
Remedy	<p>[Related parts]</p> <ul style="list-style-type: none"> - Sata Flash PCB (Unit of replacement: SATA-FLASH PCB ASS'Y) - Main Controller PCB (UN34) (Unit of replacement: MAIN CONTROLLER PCB ASS'Y, 1) <p>[Remedy] Perform the following in the order while checking whether the error is cleared.</p> <ol style="list-style-type: none"> 1. Obtain the necessary backup data by referring to "Appendix> Backup Data List" in the System Service Manual. 2. After replacing the Flash PCB, reinstall the system software using SST or a USB flash drive. 3. Replace the Main Controller PCB.
E614-0501-00	Error in file system on the Flash PCB
Detection Description	<p>An error was detected in the general application-related area. (Initialization failed at startup or I/O error at startup)</p> <p>When this error occurs, the system has not been started normally. Therefore, it may not be recorded in the error log.</p>
Remedy	<p>[Related parts]</p> <ul style="list-style-type: none"> - Sata Flash PCB (Unit of replacement: SATA-FLASH PCB ASS'Y) - Main Controller PCB (UN34) (Unit of replacement: MAIN CONTROLLER PCB ASS'Y, 1) <p>[Remedy] Perform the following in the order while checking whether the error is cleared. When prioritizing clearing of the error, skip Remedies 2 and 3.</p> <p>Although the error is cleared by "HD-CHECK", it may occur again. Thus, perform Remedies 1 to 4.</p> <ol style="list-style-type: none"> 1. Check the related harness/cable and connector. 2. Select COPIER> FUNCTION> SYSTEM> CHK-TYPE> "8", and execute "HD-CHECK". Then, turn OFF and then ON the main power. 3. Obtain the necessary backup data by referring to "Appendix> Backup Data List" in the System Service Manual. 4. Select COPIER> FUNCTION> SYSTEM> CHK-TYPE> "8", and execute "HD-CLEAR". Then, turn OFF and then ON the main power to delete the data in the corresponding partition. 5. Enter safe mode, and reinstall the system software using SST or a USB flash drive. 6. Check/replace the related parts.
E614-0511-00	Error in file system on the Flash PCB
Detection Description	An error was detected in the general application-related area. (File could not be written in the Flash PCB after startup or I/O error after startup)
Remedy	<p>[Related parts]</p> <ul style="list-style-type: none"> - Sata Flash PCB (Unit of replacement: SATA-FLASH PCB ASS'Y) - Main Controller PCB (UN34) (Unit of replacement: MAIN CONTROLLER PCB ASS'Y, 1) <p>[Remedy] Perform the following in the order while checking whether the error is cleared. When prioritizing clearing of the error, skip Remedies 2 and 3.</p> <p>Although the error is cleared by "HD-CHECK", it may occur again. Thus, perform Remedies 1 to 4.</p> <ol style="list-style-type: none"> 1. Check the related harness/cable and connector. 2. Select COPIER> FUNCTION> SYSTEM> CHK-TYPE> "8", and execute "HD-CHECK". Then, turn OFF and then ON the main power. 3. Obtain the necessary backup data by referring to "Appendix> Backup Data List" in the System Service Manual. 4. Select COPIER> FUNCTION> SYSTEM> CHK-TYPE> "8", and execute "HD-CLEAR". Then, turn OFF and then ON the main power to delete the data in the corresponding partition. 5. Enter safe mode, and reinstall the system software using SST or a USB flash drive. 6. Check/replace the related parts.

E614-0601-00	Error in system on the Flash PCB
Detection Description	An error was detected in the license-related area. (Initialization failed at startup or I/O error at startup) When this error occurs, the system has not been started normally. Therefore, it may not be recorded in the error log.
Remedy	[Related parts] - Sata Flash PCB (Unit of replacement: SATA-FLASH PCB ASS'Y) - Main Controller PCB (UN34) (Unit of replacement: MAIN CONTROLLER PCB ASS'Y, 1) [Remedy] Perform the following in the order while checking whether the error is cleared. 1. Obtain the necessary backup data by referring to "Appendix> Backup Data List" in the System Service Manual. 2. After replacing the Flash PCB, reinstall the system software using SST or a USB flash drive. 3. Replace the Main Controller PCB.
E614-0611-00	Error in system on the Flash PCB
Detection Description	An error was detected in the license-related area. (File could not be written in the Flash PCB after startup or I/O error after startup)
Remedy	[Related parts] - Sata Flash PCB (Unit of replacement: SATA-FLASH PCB ASS'Y) - Main Controller PCB (UN34) (Unit of replacement: MAIN CONTROLLER PCB ASS'Y, 1) [Remedy] Perform the following in the order while checking whether the error is cleared. 1. Obtain the necessary backup data by referring to "Appendix> Backup Data List" in the System Service Manual. 2. After replacing the Flash PCB, reinstall the system software using SST or a USB flash drive. 3. Replace the Main Controller PCB.
E614-0701-00	Error in file system on the Flash PCB
Detection Description	An error was detected in system setting value (service mode, etc.) storage area. (Initialization failed at startup or I/O error at startup) When this error occurs, the system has not been started normally. Therefore, it may not be recorded in the error log.
Remedy	[Related parts] - Sata Flash PCB (Unit of replacement: SATA-FLASH PCB ASS'Y) - Main Controller PCB (UN34) (Unit of replacement: MAIN CONTROLLER PCB ASS'Y, 1) [Remedy] Perform the following in the order while checking whether the error is cleared. When prioritizing clearing of the error, skip Remedies 2 and 3. Although the error is cleared by "HD-CHECK", it may occur again. Thus, perform Remedies 1 to 4. 1. Check the related harness/cable and connector. 2. Select COPIER> FUNCTION> SYSTEM> CHK-TYPE> "8", and execute "HD-CHECK". Then, turn OFF and then ON the main power. 3. Obtain the necessary backup data by referring to "Appendix> Backup Data List" in the System Service Manual. 4. Select COPIER> FUNCTION> SYSTEM> CHK-TYPE> "8", and execute "HD-CLEAR". Then, turn OFF and then ON the main power to delete the data in the corresponding partition. 5. Check/replace the related parts.

E614-0711-00	Error in file system on the Flash PCB
Detection Description	An error was detected in system setting value (service mode, etc.) storage area. (File could not be written in the Flash PCB after startup or I/O error after startup)
Remedy	<p>[Related parts]</p> <ul style="list-style-type: none"> - Sata Flash PCB (Unit of replacement: SATA-FLASH PCB ASS'Y) - Main Controller PCB (UN34) (Unit of replacement: MAIN CONTROLLER PCB ASS'Y, 1) <p>[Remedy] Perform the following in the order while checking whether the error is cleared. When prioritizing clearing of the error, skip Remedies 2 and 3.</p> <p>Although the error is cleared by "HD-CHECK", it may occur again. Thus, perform Remedies 1 to 4.</p> <ol style="list-style-type: none"> 1. Check the related harness/cable and connector. 2. Select COPIER> FUNCTION> SYSTEM> CHK-TYPE> "8", and execute "HD-CHECK". Then, turn OFF and then ON the main power. 3. Obtain the necessary backup data by referring to "Appendix> Backup Data List" in the System Service Manual. 4. Select COPIER> FUNCTION> SYSTEM> CHK-TYPE> "8", and execute "HD-CLEAR". Then, turn OFF and then ON the main power to delete the data in the corresponding partition. 5. Check/replace the related parts.
E614-4000-00	Error in system on the Flash PCB
Detection Description	<p>The OS could not be recognized.</p> <p>When this error occurs, the system has not been started normally. Therefore, it may not be recorded in the error log.</p>
Remedy	<p>[Related parts]</p> <ul style="list-style-type: none"> - Sata Flash PCB (Unit of replacement: SATA-FLASH PCB ASS'Y) - Main Controller PCB (UN34) (Unit of replacement: MAIN CONTROLLER PCB ASS'Y, 1) <p>[Remedy] Perform the following in the order while checking whether the error is cleared.</p> <ol style="list-style-type: none"> 1. After turning OFF the main power, remove and then install the Flash PCB again to check that it is installed properly. 2. After replacing the Flash PCB, reinstall the system software using SST or a USB flash drive. 3. Check that the HDD and the cables are properly installed. 4. Enter safe mode, and format the HDD using SST or a USB flash drive. 5. If another error occurs, clear the error by performing the remedy for it. 6. Replace the Main Controller PCB.
E614-4001-00	Error in system on the Flash PCB
Detection Description	<p>The OS boot file was not found.</p> <p>When this error occurs, the system has not been started normally. Therefore, it may not be recorded in the error log.</p>
Remedy	<p>[Related parts]</p> <ul style="list-style-type: none"> - Sata Flash PCB (Unit of replacement: SATA-FLASH PCB ASS'Y) - Main Controller PCB (UN34) (Unit of replacement: MAIN CONTROLLER PCB ASS'Y, 1) <p>[Remedy] Perform the following in the order while checking whether the error is cleared.</p> <ol style="list-style-type: none"> 1. After turning OFF the main power, remove and then install the Flash PCB again to check that it is installed properly. 2. After replacing the Flash PCB, reinstall the system software using SST or a USB flash drive. 3. Check that the HDD and the cables are properly installed. 4. Enter safe mode, and format the HDD using SST or a USB flash drive. 5. If another error occurs, clear the error by performing the remedy for it. 6. Replace the Main Controller PCB.

E614-4002-00	Error in system on the Flash PCB
Detection Description	The OS kernel was not found. When this error occurs, the system has not been started normally. Therefore, it may not be recorded in the error log.
Remedy	[Related parts] - Sata Flash PCB (Unit of replacement: SATA-FLASH PCB ASS'Y) - Main Controller PCB (UN34) (Unit of replacement: MAIN CONTROLLER PCB ASS'Y, 1) [Remedy]Perform the following in the order while checking whether the error is cleared. 1. After turning OFF the main power, remove and then install the Flash PCB again to check that it is installed properly. 2. After replacing the Flash PCB, reinstall the system software using SST or a USB flash drive. 3. Check that the HDD and the cables are properly installed. 4. Enter safe mode, and format the HDD using SST or a USB flash drive. 5. If another error occurs, clear the error by performing the remedy for it. 6. Replace the Main Controller PCB.
E614-4003-00	Error in system on the Flash PCB
Detection Description	The OS boot loader was not found. When this error occurs, the system has not been started normally. Therefore, it may not be recorded in the error log.
Remedy	[Related parts] - Sata Flash PCB (Unit of replacement: SATA-FLASH PCB ASS'Y) - Main Controller PCB (UN34) (Unit of replacement: MAIN CONTROLLER PCB ASS'Y, 1) [Remedy]Perform the following in the order while checking whether the error is cleared. 1. After turning OFF the main power, remove and then install the Flash PCB again to check that it is installed properly. 2. After replacing the Flash PCB, reinstall the system software using SST or a USB flash drive. 3. Check that the HDD and the cables are properly installed. 4. Enter safe mode, and format the HDD using SST or a USB flash drive. 5. If another error occurs, clear the error by performing the remedy for it. 6. Replace the Main Controller PCB.
E614-4010-00	Error in system on the Flash PCB
Detection Description	The OS in safe mode could not be recognized. When this error occurs, the system has not been started normally. Therefore, it may not be recorded in the error log.
Remedy	[Related parts] - Sata Flash PCB (Unit of replacement: SATA-FLASH PCB ASS'Y) [Remedy]Perform the following in the order while checking whether the error is cleared. 1. After turning OFF the main power, remove and then install the Flash PCB again to check that it is installed properly. 2. After replacing the Flash PCB, reinstall the system software using SST or a USB flash drive.
E614-4011-00	Error in system on the Flash PCB
Detection Description	The file for booting the OS in safe mode was not found. When this error occurs, the system has not been started normally. Therefore, it may not be recorded in the error log.
Remedy	[Related parts] - Sata Flash PCB (Unit of replacement: SATA-FLASH PCB ASS'Y) [Remedy]Perform the following in the order while checking whether the error is cleared. 1. After turning OFF the main power, remove and then install the Flash PCB again to check that it is installed properly. 2. After replacing the Flash PCB, reinstall the system software using SST or a USB flash drive.

E614-4012-00	Error in system on the Flash PCB
Detection Description	The kernel in safe mode was not found. When this error occurs, the system has not been started normally. Therefore, it may not be recorded in the error log.
Remedy	[Related parts] - Sata Flash PCB (Unit of replacement: SATA-FLASH PCB ASS'Y) [Remedy]Perform the following in the order while checking whether the error is cleared. 1. After turning OFF the main power, remove and then install the Flash PCB again to check that it is installed properly. 2. After replacing the Flash PCB, reinstall the system software using SST or a USB flash drive.
E614-9000-00	Error in system on the Flash PCB
Detection Description	SRAM device access-related error (at startup) When this error occurs, the system has not been started normally. Therefore, it may not be recorded in the error log.
Remedy	[Related parts] - Sata Flash PCB (Unit of replacement: SATA-FLASH PCB ASS'Y) [Remedy]Perform the following in the order while checking whether the error is cleared. 1. After turning OFF the main power, remove and then install the Flash PCB again to check that it is installed properly. 2. After replacing the Flash PCB, reinstall the system software using SST or a USB flash drive.
E614-9001-00	Error in system on the Flash PCB
Detection Description	Error in memory allocation/invalid memory (at startup) When this error occurs, the system has not been started normally. Therefore, it may not be recorded in the error log.
Remedy	[Related parts] - Sata Flash PCB (Unit of replacement: SATA-FLASH PCB ASS'Y) [Remedy]Perform the following in the order while checking whether the error is cleared. 1. After turning OFF the main power, remove and then install the Flash PCB again to check that it is installed properly. 2. After replacing the Flash PCB, reinstall the system software using SST or a USB flash drive.
E614-9002-00	Error in system on the Flash PCB
Detection Description	Setting file error was detected at startup. When this error occurs, the system has not been started normally. Therefore, it may not be recorded in the error log.
Remedy	[Related parts] - Sata Flash PCB (Unit of replacement: SATA-FLASH PCB ASS'Y) [Remedy]Perform the following in the order while checking whether the error is cleared. 1. After turning OFF the main power, remove and then install the Flash PCB again to check that it is installed properly. 2. After replacing the Flash PCB, reinstall the system software using SST or a USB flash drive.
E614-9003-00	Error in system on the Flash PCB
Detection Description	Parameter error was detected at startup. When this error occurs, the system has not been started normally. Therefore, it may not be recorded in the error log.
Remedy	[Related parts] - Sata Flash PCB (Unit of replacement: SATA-FLASH PCB ASS'Y) [Remedy]Perform the following in the order while checking whether the error is cleared. 1. After turning OFF the main power, remove and then install the Flash PCB again to check that it is installed properly. 2. After replacing the Flash PCB, reinstall the system software using SST or a USB flash drive.

E614-9004-00	Error in system on the Flash PCB
Detection Description	Startup error was detected. When this error occurs, the system has not been started normally. Therefore, it may not be recorded in the error log.
Remedy	[Related parts] - Sata Flash PCB (Unit of replacement: SATA-FLASH PCB ASS'Y) [Remedy] Perform the following in the order while checking whether the error is cleared. 1. After turning OFF the main power, remove and then install the Flash PCB again to check that it is installed properly. 2. After replacing the Flash PCB, reinstall the system software using SST or a USB flash drive.
E614-FF01-00	Error in system on the Flash PCB
Detection Description	An unidentified Flash error was detected at startup. (Initialization failed at startup or I/O error at startup) When this error occurs, the system has not been started normally. Therefore, it may not be recorded in the error log.
Remedy	[Related parts] - Sata Flash PCB (Unit of replacement: SATA-FLASH PCB ASS'Y) - Main Controller PCB (UN34) (Unit of replacement: MAIN CONTROLLER PCB ASS'Y, 1) [Remedy] Perform the following in the order while checking whether the error is cleared. Although the error is cleared by "HD-CHECK", it may occur again. Thus, perform Remedies 1 to 5. 1. Check the related harness/cable and connector. 2. Select COPIER> FUNCTION> SYSTEM> CHK-TYPE> "0", and execute "HD-CHECK". Then, turn OFF and then ON the main power. 3. Obtain the necessary backup data by referring to "Appendix> Backup Data List" in the System Service Manual. 4. After replacing the Flash PCB, reinstall the system software using SST or a USB flash drive. 5. Replace the Main Controller PCB.
E614-FF11-00	Error in system on the Flash PCB
Detection Description	An unidentified Flash error was detected at startup. (File could not be written in the Flash PCB after startup or I/O error after startup)
Remedy	[Related parts] - Sata Flash PCB (Unit of replacement: SATA-FLASH PCB ASS'Y) - Main Controller PCB (UN34) (Unit of replacement: MAIN CONTROLLER PCB ASS'Y, 1) [Remedy] Perform the following in the order while checking whether the error is cleared. Although the error is cleared by "HD-CHECK", it may occur again. Thus, perform Remedies 1 to 5. 1. Check the related harness/cable and connector. 2. Select COPIER> FUNCTION> SYSTEM> CHK-TYPE> "0", and execute "HD-CHECK". Then, turn OFF and then ON the main power. 3. Obtain the necessary backup data by referring to "Appendix> Backup Data List" in the System Service Manual. 4. After replacing the Flash PCB, reinstall the system software using SST or a USB flash drive. 5. Replace the Main Controller PCB.
E615-0001-00	Error in self-diagnosis of the encryption module
Detection Description	An error was detected in self-diagnosis of the encryption library.
Remedy	[Remedy] Perform the following in the order while checking whether the error is cleared. - Reinstall the necessary application software and restore the backup data once the error is cleared. 1. After reinstalling the system software using SST or a USB memory, turn OFF and then ON the main power. 2. Obtain the necessary backup data by referring to the backup data list. 3. Enter safe mode, and execute [4] Clear/Format> [2] Flash Format (Flash format) using a USB memory. 4. After replacing the Flash PCB, reinstall the system software using SST or a USB memory. [Reference] For backup and restoration, refer to "Adjustment> Main Controller System" and "Appendix> Backup Data List" in the Service Manual.

E674-0001-07	Fax Board communication error
Detection Description	An error was detected for the specified number of times in communication with the Fax Board.
Remedy	[Related parts] - Harness between the Fax Board and the Main Controller PCB 2 (UN8/J701) (Unit of replacement: CABLE, SIGNAL) - Fax Board - Main Controller PCB 2 (UN8) (Unit of replacement: MAIN CONTROLLER PCB ASSEMBLY, 2) [Remedy] Check/replace the related harness/cable, connector and parts.
E674-0002-07	Fax Board communication error
Detection Description	An error was detected for the specified number of times in communication with the Fax Board.
Remedy	[Related parts] - Harness between the Fax Board and the Main Controller PCB 2 (UN8/J701) (Unit of replacement: CABLE, SIGNAL) - Fax Board - Main Controller PCB 2 (UN8) (Unit of replacement: MAIN CONTROLLER PCB ASSEMBLY, 2) [Remedy] Check/replace the related harness/cable, connector and parts.
E674-0004-07	Fax Board communication error
Detection Description	A communication error occurred when accessing the modem IC used for fax.
Remedy	[Related parts] - Harness between the Fax Board and the Main Controller PCB 2 (UN8/J701) (Unit of replacement: CABLE, SIGNAL) - Fax Board - Main Controller PCB 2 (UN8) (Unit of replacement: MAIN CONTROLLER PCB ASSEMBLY, 2) [Remedy] Check/replace the related harness/cable, connector and parts.
E674-0008-07	Fax Board communication error
Detection Description	A communication error occurred when accessing the port IC used for fax.
Remedy	[Related parts] - Harness between the Fax Board and the Main Controller PCB 2 (UN8/J701) (Unit of replacement: CABLE, SIGNAL) - Fax Board - Main Controller PCB 2 (UN8) (Unit of replacement: MAIN CONTROLLER PCB ASSEMBLY, 2) [Remedy] Check/replace the related harness/cable, connector and parts.
E674-000C-07	Fax Board communication error
Detection Description	An error was detected when accessing the modem IC and the port IC used for fax.
Remedy	[Related parts] - Harness between the Fax Board and the Main Controller PCB 2 (UN8/J701) (Unit of replacement: CABLE, SIGNAL) - Fax Board - Main Controller PCB 2 (UN8) (Unit of replacement: MAIN CONTROLLER PCB ASSEMBLY, 2) [Remedy] Check/replace the related harness/cable, connector and parts.
E674-0010-07	Fax Board communication error
Detection Description	A communication error occurred when opening the Timer Device used for fax.
Remedy	[Related parts] - Main Controller PCB 2 (UN8) (Unit of replacement: MAIN CONTROLLER PCB ASSEMBLY, 2) [Remedy] Replace the Main Controller PCB 2 (UN8) (Unit of replacement: MAIN CONTROLLER PCB ASSEMBLY, 2)
E674-0011-07	Fax Board communication error
Detection Description	A communication error occurred when starting the Timer Device used for fax.
Remedy	[Related parts] - Main Controller PCB 2 (UN8) (Unit of replacement: MAIN CONTROLLER PCB ASSEMBLY, 2) [Remedy] Replace the Main Controller PCB 2 (UN8) (Unit of replacement: MAIN CONTROLLER PCB ASSEMBLY, 2)

E674-0020-07	Fax Board communication error
Detection Description	An error occurred in the modem IC used for fax.
Remedy	[Related parts] - Harness between the Fax Board and the Main Controller PCB 2 (UN8/J701) (Unit of replacement: CABLE, SIGNAL) - Fax Board - Main Controller PCB 2 (UN8) (Unit of replacement: MAIN CONTROLLER PCB ASSEMBLY, 2) [Remedy] Check/replace the related harness/cable, connector and parts.
E674-0021-07	Fax Board communication error
Detection Description	A Fax Board for non-supported modem has been connected.
Remedy	Replace it with a genuine Fax Board (for 1-line, 2-line, or 3/4-line).
E674-0030-07	Fax Board communication error
Detection Description	Check sum error
Remedy	System software download for 2 line FAX
E674-0100-07	Fax Board communication error
Detection Description	After completion of fax communication, writing of the communication information (log) failed, and the log could not be read.
Remedy	Turn OFF and then ON the main power. If it occurs when the power is turned OFF and then ON after executing FAX > Clear > ALL, execute FAX > Clear > ALL and turn OFF and then ON the power again. [CAUTION] The previous communication information (log) will be cleared by turning OFF and then ON the main power.
E674-0200-07	HDD access error
Detection Description	An error occurred when accessing the HDD.
Remedy	[Related parts] - HDD (Unit of replacement: HARD DISK DRIVE) - Main Controller PCB 2 (UN8) (Unit of replacement: MAIN CONTROLLER PCB ASSEMBLY, 2) [Remedy] Perform the following in the order while checking whether the error is cleared. 1. After deleting the system software using a USB memory, reinstall it using SST or a USB memory. 2. After replacing the HDD, execute [4] Clear/Format> [1] Disk Format (HDD format) using SST or a USB memory. 3. Replace the Main Controller PCB 1.
E674-0300-07	Fax configuration error
Detection Description	It was detected that there was a Fax Board for multiple lines installed while the IP Fax license was enabled.
Remedy	- Remove the Fax Board for multiple lines to use the machine as an IP Fax model. - Uninstall the IP Fax license to use the machine as a G3 Fax model.
E674-0301-07	Fax configuration error
Detection Description	It was detected that there was no 1-line Fax Board installed while the IP Fax license was enabled.
Remedy	- Install the Fax Board (1-line) to use the machine as an IP Fax model. - Uninstall the IP Fax license and install the G3 Fax Board to use the machine as a G3 Fax model.
E677-0001-00	Print server error
Detection Description	Exhaust Fan operation error on the print server is detected.
Remedy	Perform the following in the order while checking whether the error is cleared. 1. Check power supply to the Exhaust Fan. 2. Replace the Exhaust Fan.
E677-0003-00	Print server error
Detection Description	Error was detected at the configuration check performed at startup.
Remedy	Perform the following in the order while checking whether the error is cleared. 1. Check the connection cable between the host machine and the print server. 2. Reinstall the system of the print server.

E677-0004-00	Print server error
Detection Description	CPU Fan operation error on the print server is detected.
Remedy	Perform the following in the order while checking whether the error is cleared. 1. Check power supply to the CPU Fan. 2. Replace the CPU Fan.
E677-0010-00	Print server error
Detection Description	Not proper print server is connected.
Remedy	Perform the following in the order while checking whether the error is cleared. 1. Replace the print server with the proper one. 2. Reinstall the system of the print server.
E677-0080-00	Print server error
Detection Description	A communication error between the print server and the host machine was detected.
Remedy	Perform the following in the order while checking whether the error is cleared. 1. Check the connection cable between the host machine and the print server. 2. Reinstall the system of the print server.
E710-0001-00	IPC initialization error
Detection Description	The machine did not become ready status within 3 sec after startup of the IPC Chip.
Remedy	Check the connection cable between the host machine and the Finisher.
E711-0001-05	IPC communication error (time out error)
Detection Description	Timeout was detected in communication between the host machine and the finisher.
Remedy	<p>a. FIN-W1/SADDLE FIN-W1 [Related parts]</p> <ul style="list-style-type: none"> - Harness between the DC Controller PCB (UN1/J1 and J7) and the CAN Transceiver (J3 and J4) (Unit of replacement: CABLE, INTERFACE, CAN) - Harness between the Finisher Controller PCB and the CAN Transceiver - CAN Transceiver Cable - CAN Transceiver PCB (Unit of replacement: TRANSCEIVER PCB ASSEMBLY, CAN) - Finisher Controller PCB - DC Controller PCB (UN1) (Unit of replacement: DC CONTROLLER PCB ASS'Y) <p>b. STAPLE FIN-X1/BOOKLET FIN-X1 [Related parts]</p> <ul style="list-style-type: none"> - Harnesses from the DC Controller PCB/Relay PCB to the Finisher Lattice Connector 1. DC Controller PCB (UN1/J462) to Relay Connector (9P) (Unit of replacement: CABLE, SIGNAL) 2. Relay PCB (UN86/J505) to Relay Connector (4P) (Unit of replacement: CABLE, SIGNAL) 3. Relay Connector (9P and 4P) to Finisher Lattice Connector (J9043) (Unit of replacement: CABLE, FINISHER CONNECTOR) - Finisher Controller PCB - Relay PCB (UN86) (Unit of replacement: RELAY PCB ASSEMBLY) - DC Controller PCB (UN1) (Unit of replacement: DC CONTROLLER PCB ASS'Y) <p>[Remedy] Check/replace the related harness/cable, connector and parts. [Reference]</p> <ul style="list-style-type: none"> - Before replacing the DC Controller PCB, back up the service mode data (approx. 2 min) and restore the backup data after the replacement so the data may be able to be protected. Backup: COPIER (LEVEL2)> FUNCTION> SYSTEM> DSRAMBUP Restoration: COPIER (LEVEL2)> FUNCTION> SYSTEM> DSRAMRES - After replacement of the Finisher Controller PCB, refer to "Adjustments> Adjustment when Replacing the Parts" in the Service Manual for the Finisher.

E711-0008-05	IPC communication error (initialization error)
Detection Description	An initialization error was detected in communication between the host machine and the finisher.
Remedy	<p>a. FIN-W1/SADDLE FIN-W1 [Related parts]</p> <ul style="list-style-type: none"> - Harness between the DC Controller PCB (UN1/J1 and J7) and the CAN Transceiver (J3 and J4) (Unit of replacement: CABLE, INTERFACE, CAN) - Harness between the Finisher Controller PCB and the CAN Transceiver - CAN Transceiver Cable - CAN Transceiver PCB (Unit of replacement: TRANSCEIVER PCB ASSEMBLY, CAN) - Finisher Controller PCB - DC Controller PCB (UN1) (Unit of replacement: DC CONTROLLER PCB ASS'Y) <p>b. STAPLE FIN-X1/BOOKLET FIN-X1 [Related parts]</p> <ul style="list-style-type: none"> - Harnesses from the DC Controller PCB/Relay PCB to the Finisher Lattice Connector 1. DC Controller PCB (UN1/J462) to Relay Connector (9P) (Unit of replacement: CABLE, SIGNAL) 2. Relay PCB (UN86/J505) to Relay Connector (4P) (Unit of replacement: CABLE, SIGNAL) 3. Relay Connector (9P and 4P) to Finisher Lattice Connector (J9043) (Unit of replacement: CABLE, FINISHER CONNECTOR) - Finisher Controller PCB - Relay PCB (UN86) (Unit of replacement: RELAY PCB ASSEMBLY) - DC Controller PCB (UN1) (Unit of replacement: DC CONTROLLER PCB ASS'Y) <p>[Remedy] Check/replace the related harness/cable, connector and parts. [Reference]</p> <ul style="list-style-type: none"> - Before replacing the DC Controller PCB, back up the service mode data (approx. 2 min) and restore the backup data after the replacement so the data may be able to be protected. Backup: COPIER (LEVEL2)> FUNCTION> SYSTEM> DSRAMBUP Restoration: COPIER (LEVEL2)> FUNCTION> SYSTEM> DSRAMRES - After replacement of the Finisher Controller PCB, refer to "Adjustments> Adjustment when Replacing the Parts" in the Service Manual for the Finisher.
E711-0020-05	IPC communication error (recovery error)
Detection Description	A recovery error was detected in communication between the host machine and the finisher.
Remedy	<p>a. FIN-W1/SADDLE FIN-W1 [Related parts]</p> <ul style="list-style-type: none"> - Harness between the DC Controller PCB (UN1/J1 and J7) and the CAN Transceiver (J3 and J4) (Unit of replacement: CABLE, INTERFACE, CAN) - Harness between the Finisher Controller PCB and the CAN Transceiver - CAN Transceiver Cable - CAN Transceiver PCB (Unit of replacement: TRANSCEIVER PCB ASSEMBLY, CAN) - Finisher Controller PCB - DC Controller PCB (UN1) (Unit of replacement: DC CONTROLLER PCB ASS'Y) <p>b. STAPLE FIN-X1/BOOKLET FIN-X1 [Related parts]</p> <ul style="list-style-type: none"> - Harnesses from the DC Controller PCB/Relay PCB to the Finisher Lattice Connector 1. DC Controller PCB (UN1/J462) to Relay Connector (9P) (Unit of replacement: CABLE, SIGNAL) 2. Relay PCB (UN86/J505) to Relay Connector (4P) (Unit of replacement: CABLE, SIGNAL) 3. Relay Connector (9P and 4P) to Finisher Lattice Connector (J9043) (Unit of replacement: CABLE, FINISHER CONNECTOR) - Finisher Controller PCB - Relay PCB (UN86) (Unit of replacement: RELAY PCB ASSEMBLY) - DC Controller PCB (UN1) (Unit of replacement: DC CONTROLLER PCB ASS'Y) <p>[Remedy] Check/replace the related harness/cable, connector and parts. [Reference]</p> <ul style="list-style-type: none"> - Before replacing the DC Controller PCB, back up the service mode data (approx. 2 min) and restore the backup data after the replacement so the data may be able to be protected. Backup: COPIER (LEVEL2)> FUNCTION> SYSTEM> DSRAMBUP Restoration: COPIER (LEVEL2)> FUNCTION> SYSTEM> DSRAMRES - After replacement of the Finisher Controller PCB, refer to "Adjustments> Adjustment when Replacing the Parts" in the Service Manual for the Finisher.

E711-0101-05	IPC communication error (over run error)
Detection Description	Overrun was detected in CAN communication between the host machine and the finisher.
Remedy	<p>[Related parts]</p> <ul style="list-style-type: none"> - Harness between the DC Controller PCB (UN1/J1 and J7) and the CAN Transceiver PCB (J3 and J4) (Unit of replacement: CABLE, INTERFACE, CAN) - Harness between the Finisher Controller PCB and the CAN Transceiver PCB - CAN Transceiver Cable - CAN Transceiver PCB (Unit of replacement: TRANSCEIVER PCB ASSEMBLY, CAN) - Finisher Controller PCB - DC Controller PCB (UN1) (Unit of replacement: DC CONTROLLER PCB ASS'Y) <p>[Remedy] Check/replace the related harness/cable, connector and parts.</p> <p>[Reference]</p> <ul style="list-style-type: none"> - Before replacing the DC Controller PCB, back up the service mode data (approx. 2 min) and restore the backup data after the replacement so the data may be able to be protected. Backup: COPIER (LEVEL2)> FUNCTION> SYSTEM> DSRAMBUP Restoration: COPIER (LEVEL2)> FUNCTION> SYSTEM> DSRAMRES - After replacement of the Finisher Controller PCB, refer to "Adjustments> Adjustment when Replacing the Parts" in the Service Manual for the Finisher.
E711-0102-05	IPC communication error (error in the number of devices)
Detection Description	An error in the number of devices at reconfiguration was detected in CAN communication between the host machine and the finisher.
Remedy	<p>[Related parts]</p> <ul style="list-style-type: none"> - Harness between the DC Controller PCB (UN1/J1 and J7) and the CAN Transceiver PCB (J3 and J4) (Unit of replacement: CABLE, INTERFACE, CAN) - Harness between the Finisher Controller PCB and the CAN Transceiver PCB - CAN Transceiver Cable - CAN Transceiver PCB (Unit of replacement: TRANSCEIVER PCB ASSEMBLY, CAN) - Finisher Controller PCB - DC Controller PCB (UN1) (Unit of replacement: DC CONTROLLER PCB ASS'Y) <p>[Remedy] Check/replace the related harness/cable, connector and parts.</p> <p>[Reference]</p> <ul style="list-style-type: none"> - Before replacing the DC Controller PCB, back up the service mode data (approx. 2 min) and restore the backup data after the replacement so the data may be able to be protected. Backup: COPIER (LEVEL2)> FUNCTION> SYSTEM> DSRAMBUP Restoration: COPIER (LEVEL2)> FUNCTION> SYSTEM> DSRAMRES - After replacement of the Finisher Controller PCB, refer to "Adjustments> Adjustment when Replacing the Parts" in the Service Manual for the Finisher.

E713-0001-05	Finisher communication error (retransmission request reception error)
<p>Detection Description</p> <p>Remedy</p>	<p>A retransmission request reception error was detected consecutively in communication between the host machine and the finisher.</p> <hr/> <p>a. FIN-W1/SADDLE FIN-W1 [Related parts]</p> <ul style="list-style-type: none"> - Harness between the DC Controller PCB (UN1/J1 and J7) and the CAN Transceiver (J3 and J4) (Unit of replacement: CABLE, INTERFACE, CAN) - Harness between the Finisher Controller PCB and the CAN Transceiver - CAN Transceiver Cable - CAN Transceiver PCB (Unit of replacement: TRANSCEIVER PCB ASSEMBLY, CAN) - Finisher Controller PCB - DC Controller PCB (UN1) (Unit of replacement: DC CONTROLLER PCB ASS'Y) <p>b. STAPLE FIN-X1/BOOKLET FIN-X1 [Related parts]</p> <ul style="list-style-type: none"> - Harnesses from the DC Controller PCB/Relay PCB to the Finisher Lattice Connector 1. DC Controller PCB (UN1/J462) to Relay Connector (9P) (Unit of replacement: CABLE, SIGNAL) 2. Relay PCB (UN86/J505) to Relay Connector (4P) (Unit of replacement: CABLE, SIGNAL) 3. Relay Connector (9P and 4P) to Finisher Lattice Connector (J9043) (Unit of replacement: CABLE, FINISHER CONNECTOR) - Finisher Controller PCB - Relay PCB (UN86) (Unit of replacement: RELAY PCB ASSEMBLY) - DC Controller PCB (UN1) (Unit of replacement: DC CONTROLLER PCB ASS'Y) <p>[Remedy] Check/replace the related harness/cable, connector and parts. [Reference]</p> <ul style="list-style-type: none"> - Before replacing the DC Controller PCB, back up the service mode data (approx. 2 min) and restore the backup data after the replacement so the data may be able to be protected. Backup: COPIER (LEVEL2)> FUNCTION> SYSTEM> DSRAMBUP Restoration: COPIER (LEVEL2)> FUNCTION> SYSTEM> DSRAMRES - After replacement of the Finisher Controller PCB, refer to "Adjustments> Adjustment when Replacing the Parts" in the Service Manual for the Finisher.
E713-0002-05	Finisher communication error (transmission error of retransmission request)
<p>Detection Description</p> <p>Remedy</p>	<p>A transmission error of retransmission request was detected consecutively in communication between the host machine and the finisher.</p> <hr/> <p>a. FIN-W1/SADDLE FIN-W1 [Related parts]</p> <ul style="list-style-type: none"> - Harness between the DC Controller PCB (UN1/J1 and J7) and the CAN Transceiver (J3 and J4) (Unit of replacement: CABLE, INTERFACE, CAN) - Harness between the Finisher Controller PCB and the CAN Transceiver - CAN Transceiver Cable - CAN Transceiver PCB (Unit of replacement: TRANSCEIVER PCB ASSEMBLY, CAN) - Finisher Controller PCB - DC Controller PCB (UN1) (Unit of replacement: DC CONTROLLER PCB ASS'Y) <p>b. STAPLE FIN-X1/BOOKLET FIN-X1 [Related parts]</p> <ul style="list-style-type: none"> - Harnesses from the DC Controller PCB/Relay PCB to the Finisher Lattice Connector 1. DC Controller PCB (UN1/J462) to Relay Connector (9P) (Unit of replacement: CABLE, SIGNAL) 2. Relay PCB (UN86/J505) to Relay Connector (4P) (Unit of replacement: CABLE, SIGNAL) 3. Relay Connector (9P and 4P) to Finisher Lattice Connector (J9043) (Unit of replacement: CABLE, FINISHER CONNECTOR) - Finisher Controller PCB - Relay PCB (UN86) (Unit of replacement: RELAY PCB ASSEMBLY) - DC Controller PCB (UN1) (Unit of replacement: DC CONTROLLER PCB ASS'Y) <p>[Remedy] Check/replace the related harness/cable, connector and parts. [Reference]</p> <ul style="list-style-type: none"> - Before replacing the DC Controller PCB, back up the service mode data (approx. 2 min) and restore the backup data after the replacement so the data may be able to be protected. Backup: COPIER (LEVEL2)> FUNCTION> SYSTEM> DSRAMBUP Restoration: COPIER (LEVEL2)> FUNCTION> SYSTEM> DSRAMRES - After replacement of the Finisher Controller PCB, refer to "Adjustments> Adjustment when Replacing the Parts" in the Service Manual for the Finisher.

E713-0004-05	Finisher communication error (reception timeout error)
<p>Detection Description</p> <p>Remedy</p>	<p>Reception incomplete was detected for more than the specified period of time in communication between the host machine and the finisher.</p> <hr/> <p>a. FIN-W1/SADDLE FIN-W1 [Related parts]</p> <ul style="list-style-type: none"> - Harness between the DC Controller PCB (UN1/J1 and J7) and the CAN Transceiver (J3 and J4) (Unit of replacement: CABLE, INTERFACE, CAN) - Harness between the Finisher Controller PCB and the CAN Transceiver - CAN Transceiver Cable - CAN Transceiver PCB (Unit of replacement: TRANSCEIVER PCB ASSEMBLY, CAN) - Finisher Controller PCB - DC Controller PCB (UN1) (Unit of replacement: DC CONTROLLER PCB ASS'Y) <p>b. STAPLE FIN-X1/BOOKLET FIN-X1 [Related parts]</p> <ul style="list-style-type: none"> - Harnesses from the DC Controller PCB/Relay PCB to the Finisher Lattice Connector 1. DC Controller PCB (UN1/J462) to Relay Connector (9P) (Unit of replacement: CABLE, SIGNAL) 2. Relay PCB (UN86/J505) to Relay Connector (4P) (Unit of replacement: CABLE, SIGNAL) 3. Relay Connector (9P and 4P) to Finisher Lattice Connector (J9043) (Unit of replacement: CABLE, FINISHER CONNECTOR) - Finisher Controller PCB - Relay PCB (UN86) (Unit of replacement: RELAY PCB ASSEMBLY) - DC Controller PCB (UN1) (Unit of replacement: DC CONTROLLER PCB ASS'Y) <p>[Remedy] Check/replace the related harness/cable, connector and parts. [Reference]</p> <ul style="list-style-type: none"> - Before replacing the DC Controller PCB, back up the service mode data (approx. 2 min) and restore the backup data after the replacement so the data may be able to be protected. Backup: COPIER (LEVEL2)> FUNCTION> SYSTEM> DSRAMBUP Restoration: COPIER (LEVEL2)> FUNCTION> SYSTEM> DSRAMRES - After replacement of the Finisher Controller PCB, refer to "Adjustments> Adjustment when Replacing the Parts" in the Service Manual for the Finisher.
E713-0008-05	Finisher communication error (checksum error)
<p>Detection Description</p> <p>Remedy</p>	<p>A checksum error was detected in communication between the host machine and the finisher.</p> <hr/> <p>a. FIN-W1/SADDLE FIN-W1 [Related parts]</p> <ul style="list-style-type: none"> - Harness between the DC Controller PCB (UN1/J1 and J7) and the CAN Transceiver (J3 and J4) (Unit of replacement: CABLE, INTERFACE, CAN) - Harness between the Finisher Controller PCB and the CAN Transceiver - CAN Transceiver Cable - CAN Transceiver PCB (Unit of replacement: TRANSCEIVER PCB ASSEMBLY, CAN) - Finisher Controller PCB - DC Controller PCB (UN1) (Unit of replacement: DC CONTROLLER PCB ASS'Y) <p>b. STAPLE FIN-X1/BOOKLET FIN-X1 [Related parts]</p> <ul style="list-style-type: none"> - Harnesses from the DC Controller PCB/Relay PCB to the Finisher Lattice Connector 1. DC Controller PCB (UN1/J462) to Relay Connector (9P) (Unit of replacement: CABLE, SIGNAL) 2. Relay PCB (UN86/J505) to Relay Connector (4P) (Unit of replacement: CABLE, SIGNAL) 3. Relay Connector (9P and 4P) to Finisher Lattice Connector (J9043) (Unit of replacement: CABLE, FINISHER CONNECTOR) - Finisher Controller PCB - Relay PCB (UN86) (Unit of replacement: RELAY PCB ASSEMBLY) - DC Controller PCB (UN1) (Unit of replacement: DC CONTROLLER PCB ASS'Y) <p>[Remedy] Check/replace the related harness/cable, connector and parts. [Reference]</p> <ul style="list-style-type: none"> - Before replacing the DC Controller PCB, back up the service mode data (approx. 2 min) and restore the backup data after the replacement so the data may be able to be protected. Backup: COPIER (LEVEL2)> FUNCTION> SYSTEM> DSRAMBUP Restoration: COPIER (LEVEL2)> FUNCTION> SYSTEM> DSRAMRES - After replacement of the Finisher Controller PCB, refer to "Adjustments> Adjustment when Replacing the Parts" in the Service Manual for the Finisher.

E713-0010-05	Finisher communication error (time out error)
Detection Description	Timeout was detected in communication between the host machine and the finisher.
Remedy	<p>a. FIN-W1/SADDLE FIN-W1 [Related parts]</p> <ul style="list-style-type: none"> - Harness between the DC Controller PCB (UN1/J1 and J7) and the CAN Transceiver (J3 and J4) (Unit of replacement: CABLE, INTERFACE, CAN) - Harness between the Finisher Controller PCB and the CAN Transceiver - CAN Transceiver Cable - CAN Transceiver PCB (Unit of replacement: TRANSCEIVER PCB ASSEMBLY, CAN) - Finisher Controller PCB - DC Controller PCB (UN1) (Unit of replacement: DC CONTROLLER PCB ASS'Y) <p>b. STAPLE FIN-X1/BOOKLET FIN-X1 [Related parts]</p> <ul style="list-style-type: none"> - Harnesses from the DC Controller PCB/Relay PCB to the Finisher Lattice Connector 1. DC Controller PCB (UN1/J462) to Relay Connector (9P) (Unit of replacement: CABLE, SIGNAL) 2. Relay PCB (UN86/J505) to Relay Connector (4P) (Unit of replacement: CABLE, SIGNAL) 3. Relay Connector (9P and 4P) to Finisher Lattice Connector (J9043) (Unit of replacement: CABLE, FINISHER CONNECTOR) - Finisher Controller PCB - Relay PCB (UN86) (Unit of replacement: RELAY PCB ASSEMBLY) - DC Controller PCB (UN1) (Unit of replacement: DC CONTROLLER PCB ASS'Y) <p>[Remedy] Check/replace the related harness/cable, connector and parts. [Reference]</p> <ul style="list-style-type: none"> - Before replacing the DC Controller PCB, back up the service mode data (approx. 2 min) and restore the backup data after the replacement so the data may be able to be protected. Backup: COPIER (LEVEL2)> FUNCTION> SYSTEM> DSRAMBUP Restoration: COPIER (LEVEL2)> FUNCTION> SYSTEM> DSRAMRES - After replacement of the Finisher Controller PCB, refer to "Adjustments> Adjustment when Replacing the Parts" in the Service Manual for the Finisher.
E713-0011-05	Finisher communication error (NACK reception error)
Detection Description	Retransmission of NACK was detected consecutively in communication between the host machine and the finisher.
Remedy	<p>a. FIN-W1/SADDLE FIN-W1 [Related parts]</p> <ul style="list-style-type: none"> - Harness between the DC Controller PCB (UN1/J1 and J7) and the CAN Transceiver (J3 and J4) (Unit of replacement: CABLE, INTERFACE, CAN) - Harness between the Finisher Controller PCB and the CAN Transceiver - CAN Transceiver Cable - CAN Transceiver PCB (Unit of replacement: TRANSCEIVER PCB ASSEMBLY, CAN) - Finisher Controller PCB - DC Controller PCB (UN1) (Unit of replacement: DC CONTROLLER PCB ASS'Y) <p>b. STAPLE FIN-X1/BOOKLET FIN-X1 [Related parts]</p> <ul style="list-style-type: none"> - Harnesses from the DC Controller PCB/Relay PCB to the Finisher Lattice Connector 1. DC Controller PCB (UN1/J462) to Relay Connector (9P) (Unit of replacement: CABLE, SIGNAL) 2. Relay PCB (UN86/J505) to Relay Connector (4P) (Unit of replacement: CABLE, SIGNAL) 3. Relay Connector (9P and 4P) to Finisher Lattice Connector (J9043) (Unit of replacement: CABLE, FINISHER CONNECTOR) - Finisher Controller PCB - Relay PCB (UN86) (Unit of replacement: RELAY PCB ASSEMBLY) - DC Controller PCB (UN1) (Unit of replacement: DC CONTROLLER PCB ASS'Y) <p>[Remedy] Check/replace the related harness/cable, connector and parts. [Reference]</p> <ul style="list-style-type: none"> - Before replacing the DC Controller PCB, back up the service mode data (approx. 2 min) and restore the backup data after the replacement so the data may be able to be protected. Backup: COPIER (LEVEL2)> FUNCTION> SYSTEM> DSRAMBUP Restoration: COPIER (LEVEL2)> FUNCTION> SYSTEM> DSRAMRES - After replacement of the Finisher Controller PCB, refer to "Adjustments> Adjustment when Replacing the Parts" in the Service Manual for the Finisher.

E713-0020-05	Finisher communication error (invalid BCC in received data)
<p>Detection Description</p>	<p>Invalid BCC in received data was detected in communication between the host machine and the finisher.</p> <hr/> <p>Remedy</p> <p>a. FIN-W1/SADDLE FIN-W1 [Related parts]</p> <ul style="list-style-type: none"> - Harness between the DC Controller PCB (UN1/J1 and J7) and the CAN Transceiver (J3 and J4) (Unit of replacement: CABLE, INTERFACE, CAN) - Harness between the Finisher Controller PCB and the CAN Transceiver - CAN Transceiver Cable - CAN Transceiver PCB (Unit of replacement: TRANSCEIVER PCB ASSEMBLY, CAN) - Finisher Controller PCB - DC Controller PCB (UN1) (Unit of replacement: DC CONTROLLER PCB ASS'Y) <p>b. STAPLE FIN-X1/BOOKLET FIN-X1 [Related parts]</p> <ul style="list-style-type: none"> - Harnesses from the DC Controller PCB/Relay PCB to the Finisher Lattice Connector 1. DC Controller PCB (UN1/J462) to Relay Connector (9P) (Unit of replacement: CABLE, SIGNAL) 2. Relay PCB (UN86/J505) to Relay Connector (4P) (Unit of replacement: CABLE, SIGNAL) 3. Relay Connector (9P and 4P) to Finisher Lattice Connector (J9043) (Unit of replacement: CABLE, FINISHER CONNECTOR) - Finisher Controller PCB - Relay PCB (UN86) (Unit of replacement: RELAY PCB ASSEMBLY) - DC Controller PCB (UN1) (Unit of replacement: DC CONTROLLER PCB ASS'Y) <p>[Remedy] Check/replace the related harness/cable, connector and parts. [Reference]</p> <ul style="list-style-type: none"> - Before replacing the DC Controller PCB, back up the service mode data (approx. 2 min) and restore the backup data after the replacement so the data may be able to be protected. Backup: COPIER (LEVEL2)> FUNCTION> SYSTEM> DSRAMBUP Restoration: COPIER (LEVEL2)> FUNCTION> SYSTEM> DSRAMRES - After replacement of the Finisher Controller PCB, refer to "Adjustments> Adjustment when Replacing the Parts" in the Service Manual for the Finisher.
<p>E713-0021-05</p> <p>Detection Description</p>	<p>Finisher communication error (reception timeout error)</p> <p>Reception incomplete was detected consecutively in communication between the host machine and the finisher.</p> <hr/> <p>Remedy</p> <p>a. FIN-W1/SADDLE FIN-W1 [Related parts]</p> <ul style="list-style-type: none"> - Harness between the DC Controller PCB (UN1/J1 and J7) and the CAN Transceiver (J3 and J4) (Unit of replacement: CABLE, INTERFACE, CAN) - Harness between the Finisher Controller PCB and the CAN Transceiver - CAN Transceiver Cable - CAN Transceiver PCB (Unit of replacement: TRANSCEIVER PCB ASSEMBLY, CAN) - Finisher Controller PCB - DC Controller PCB (UN1) (Unit of replacement: DC CONTROLLER PCB ASS'Y) <p>b. STAPLE FIN-X1/BOOKLET FIN-X1 [Related parts]</p> <ul style="list-style-type: none"> - Harnesses from the DC Controller PCB/Relay PCB to the Finisher Lattice Connector 1. DC Controller PCB (UN1/J462) to Relay Connector (9P) (Unit of replacement: CABLE, SIGNAL) 2. Relay PCB (UN86/J505) to Relay Connector (4P) (Unit of replacement: CABLE, SIGNAL) 3. Relay Connector (9P and 4P) to Finisher Lattice Connector (J9043) (Unit of replacement: CABLE, FINISHER CONNECTOR) - Finisher Controller PCB - Relay PCB (UN86) (Unit of replacement: RELAY PCB ASSEMBLY) - DC Controller PCB (UN1) (Unit of replacement: DC CONTROLLER PCB ASS'Y) <p>[Remedy] Check/replace the related harness/cable, connector and parts. [Reference]</p> <ul style="list-style-type: none"> - Before replacing the DC Controller PCB, back up the service mode data (approx. 2 min) and restore the backup data after the replacement so the data may be able to be protected. Backup: COPIER (LEVEL2)> FUNCTION> SYSTEM> DSRAMBUP Restoration: COPIER (LEVEL2)> FUNCTION> SYSTEM> DSRAMRES - After replacement of the Finisher Controller PCB, refer to "Adjustments> Adjustment when Replacing the Parts" in the Service Manual for the Finisher.

E713-0022-05	Finisher communication error (undefined error)
Detection Description	An undefined error was detected consecutively in communication between the host machine and the finisher.
Remedy	<p>a. FIN-W1/SADDLE FIN-W1 [Related parts]</p> <ul style="list-style-type: none"> - Harness between the DC Controller PCB (UN1/J1 and J7) and the CAN Transceiver (J3 and J4) (Unit of replacement: CABLE, INTERFACE, CAN) - Harness between the Finisher Controller PCB and the CAN Transceiver - CAN Transceiver Cable - CAN Transceiver PCB (Unit of replacement: TRANSCEIVER PCB ASSEMBLY, CAN) - Finisher Controller PCB - DC Controller PCB (UN1) (Unit of replacement: DC CONTROLLER PCB ASS'Y) <p>b. STAPLE FIN-X1/BOOKLET FIN-X1 [Related parts]</p> <ul style="list-style-type: none"> - Harnesses from the DC Controller PCB/Relay PCB to the Finisher Lattice Connector 1. DC Controller PCB (UN1/J462) to Relay Connector (9P) (Unit of replacement: CABLE, SIGNAL) 2. Relay PCB (UN86/J505) to Relay Connector (4P) (Unit of replacement: CABLE, SIGNAL) 3. Relay Connector (9P and 4P) to Finisher Lattice Connector (J9043) (Unit of replacement: CABLE, FINISHER CONNECTOR) - Finisher Controller PCB - Relay PCB (UN86) (Unit of replacement: RELAY PCB ASSEMBLY) - DC Controller PCB (UN1) (Unit of replacement: DC CONTROLLER PCB ASS'Y) <p>[Remedy] Check/replace the related harness/cable, connector and parts. [Reference]</p> <ul style="list-style-type: none"> - Before replacing the DC Controller PCB, back up the service mode data (approx. 2 min) and restore the backup data after the replacement so the data may be able to be protected. Backup: COPIER (LEVEL2)> FUNCTION> SYSTEM> DSRAMBUP Restoration: COPIER (LEVEL2)> FUNCTION> SYSTEM> DSRAMRES - After replacement of the Finisher Controller PCB, refer to "Adjustments> Adjustment when Replacing the Parts" in the Service Manual for the Finisher.
E713-0030-05	Finisher communication error (initialization error)
Detection Description	An initialization error was detected in communication between the host machine and the finisher.
Remedy	<p>a. FIN-W1/SADDLE FIN-W1 [Related parts]</p> <ul style="list-style-type: none"> - Harness between the DC Controller PCB (UN1/J1 and J7) and the CAN Transceiver (J3 and J4) (Unit of replacement: CABLE, INTERFACE, CAN) - Harness between the Finisher Controller PCB and the CAN Transceiver - CAN Transceiver Cable - CAN Transceiver PCB (Unit of replacement: TRANSCEIVER PCB ASSEMBLY, CAN) - Finisher Controller PCB - DC Controller PCB (UN1) (Unit of replacement: DC CONTROLLER PCB ASS'Y) <p>b. STAPLE FIN-X1/BOOKLET FIN-X1 [Related parts]</p> <ul style="list-style-type: none"> - Harnesses from the DC Controller PCB/Relay PCB to the Finisher Lattice Connector 1. DC Controller PCB (UN1/J462) to Relay Connector (9P) (Unit of replacement: CABLE, SIGNAL) 2. Relay PCB (UN86/J505) to Relay Connector (4P) (Unit of replacement: CABLE, SIGNAL) 3. Relay Connector (9P and 4P) to Finisher Lattice Connector (J9043) (Unit of replacement: CABLE, FINISHER CONNECTOR) - Finisher Controller PCB - Relay PCB (UN86) (Unit of replacement: RELAY PCB ASSEMBLY) - DC Controller PCB (UN1) (Unit of replacement: DC CONTROLLER PCB ASS'Y) <p>[Remedy] Check/replace the related harness/cable, connector and parts. [Reference]</p> <ul style="list-style-type: none"> - Before replacing the DC Controller PCB, back up the service mode data (approx. 2 min) and restore the backup data after the replacement so the data may be able to be protected. Backup: COPIER (LEVEL2)> FUNCTION> SYSTEM> DSRAMBUP Restoration: COPIER (LEVEL2)> FUNCTION> SYSTEM> DSRAMRES - After replacement of the Finisher Controller PCB, refer to "Adjustments> Adjustment when Replacing the Parts" in the Service Manual for the Finisher.

E717-0001-00	Communication error with the NE Controller
Detection Description	Error when the NE Controller is started. The NE Controller which was connected before turning OFF the power is not connected at power-on.
Remedy	[Remedy] Check the cable, and then go through the following to clear the error: Service Mode> COPIER> FUNCTION> CLEAR> ERR.
E717-0002-00	Communication error with the NE Controller
Detection Description	IPC error at NE Controller operation. Open circuit of IPC, unable to recover the IPC communication.
Remedy	[Remedy] Check the cable, and then go through the following to clear the error: Service Mode> COPIER> FUNCTION> CLEAR> ERR.
E719-0001-00	Coin vendor error
Detection Description	The coin vendor which was connected before turning OFF the main power was not connected at power-on.
Remedy	[Remedy] Check/replace the cable between the charging management equipment and the host machine. [Reference] When operating the machine without the charging management equipment, execute "COPIER> FUNCTION> CLEAR> ERR". (It is designed to generate an error to prevent the misuse by removing the charging management equipment.)
E719-0002-00	Coin vendor error
Detection Description	IPC error when the coin vendor is running - Open circuit of the IPC, or IPC communication could not be recovered. - Open circuit of the pickup/delivery signal cable was detected. - Invalid connection was detected.
Remedy	[Remedy] Check/replace the cable between the charging management equipment and the host machine. [Reference] When operating the machine without the charging management equipment, execute "COPIER> FUNCTION> CLEAR> ERR". (It is designed to generate an error to prevent the misuse by removing the charging management equipment.)
E719-0003-00	Coin vendor error
Detection Description	A communication error with the coin vendor was detected during unit price acquisition at startup.
Remedy	[Remedy] Check/replace the cable between the charging management equipment and the host machine. [Reference] When operating the machine without the charging management equipment, execute "COPIER> FUNCTION> CLEAR> ERR". (It is designed to generate an error to prevent the misuse by removing the charging management equipment.)
E719-0021-00	Coin vendor error
Detection Description	Communication with the coin vendor could not be established at startup of the host machine.
Remedy	[Remedy] 1. Check/replace the cable between the charging management equipment and the host machine. 2. Check the power of the charging.
E719-0022-00	Coin vendor error
Detection Description	Communication with the coin vendor could not be established at startup of the host machine.
Remedy	[Remedy] 1. Check/replace the cable between the charging management equipment and the host machine. 2. Check the power of the charging.

E719-0031-00	Card Reader communication error
Detection Description	Communication with the Card Reader could not be established at startup.
Remedy	<p>[Remedy] Perform the following in the order while checking whether the error is cleared.</p> <ol style="list-style-type: none"> 1. Check/replace the harness between the Card Reader and the Main Controller PCB (PWB1/J4023 (white connector at the upper side). 2. Replace the Card Reader. <p>[Reference] In the case of operating the device without the Card Reader which had been used, execute "COPIER> FUNCTION> CLEAR> CARD" after removing the Card Reader.</p>
E719-0032-00	Card Reader communication error
Detection Description	Although communication with the Card Reader was available at startup, it became unavailable in the middle of it.
Remedy	<p>[Remedy] Perform the following in the order while checking whether the error is cleared.</p> <ol style="list-style-type: none"> 1. Check/replace the harness between the Card Reader and the Main Controller PCB (PWB1/J4023 (white connector at the upper side). 2. Replace the Card Reader. <p>[Reference] In the case of operating the device without the Card Reader which had been used, execute "COPIER> FUNCTION> CLEAR> CARD" after removing the Card Reader.</p>
E719-0041-00	Coin vendor error
Detection Description	Communication with the coin vendor could not be established at startup of the host machine. (Charge mode (COIN = 6) has been set.)
Remedy	<p>[Remedy]</p> <ol style="list-style-type: none"> 1. If it operates in charge mode (COIN = 6) <ul style="list-style-type: none"> - Check that it is the supported charging management equipment. - Check the cable to be connected. - Check the power of the charging management equipment. 2. If charge mode is canceled <ul style="list-style-type: none"> - Select COPIER> OPTION> ACC> COIN> "0", and turn OFF and then ON the main power.
E719-0042-00	Coin vendor error
Detection Description	Communication with the coin vendor could not be established at startup of the host machine. (Charge mode (COIN = 6) has been set.)
Remedy	<p>[Remedy]</p> <ol style="list-style-type: none"> 1. If it operates in charge mode (COIN = 6) <ul style="list-style-type: none"> - Check that it is the supported charging management equipment. - Check the cable to be connected. - Check the power of the charging management equipment. 2. If charge mode is canceled <ul style="list-style-type: none"> - Select COPIER> OPTION> ACC> COIN> "0", and turn OFF and then ON the main power.
E720-0001-05	Error due to non-compatible Finisher
Detection Description	A finisher not supported by the host machine has been connected.
Remedy	Connect the finisher (STAPLE FIN-W1/SADDLE FIN-W1, STAPLE FIN-X1/BOOKLET FIN-X1) for this model.
E720-0002-05	Error due to non-compatible option deck
Detection Description	An option deck not supported by the host machine has been connected.
Remedy	Connect the option deck (POD DECK LITE-C1) for this model.
E720-0100-05	Error due to non-compatible Finisher
Detection Description	STAPLE FIN-X1/SADDLE FIN-X1 has been connected to iR-ADV 8505/8595 PRO for Japan.
Remedy	Connect the finisher (STAPLE FIN-W1/SADDLE FIN-W1) for this model.
E720-0202-05	Error due to non-compatible Finisher
Detection Description	A finisher not supported by the host machine has been connected.
Remedy	Check the configuration of options and connect the optional equipment for this model.

E720-0231-05	Error due to non-compatible delivery option
Detection Description	A puncher unit not supported by the host machine has been connected.
Remedy	Check the configuration of options and connect the optional equipment for this model.
E720-0251-05	Error due to non-compatible delivery option
Detection Description	A stacker not supported by the host machine has been connected.
Remedy	Check the configuration of options and connect the optional equipment for this model.
E720-0252-05	Error due to non-compatible delivery option
Detection Description	A stacker not supported by the host machine has been connected.
Remedy	Check the configuration of options and connect the optional equipment for this model.
E720-0261-05	Error due to non-compatible delivery option
Detection Description	A perfect binder not supported by the host machine has been connected.
Remedy	Check the configuration of options and connect the optional equipment for this model.
E720-0271-05	Error due to non-compatible delivery option
Detection Description	An inserter not supported by the host machine has been connected.
Remedy	Check the configuration of options and connect the optional equipment for this model.
E720-0400-05	Error due to non-compatible delivery option
Detection Description	A finisher not supported by the host machine has been connected.
Remedy	Check the configuration of options and connect the optional equipment for this model.
E720-0401-05	Error due to non-compatible delivery option
Detection Description	A finisher not supported by the host machine has been connected.
Remedy	Check the configuration of options and connect the optional equipment for this model.
E720-0402-05	Error due to non-compatible delivery option
Detection Description	A finisher/inserter not supported by the host machine has been connected.
Remedy	Check the configuration of options and connect the optional equipment for this model.
E720-0500-05	Error due to non-compatible delivery option
Detection Description	A shift tray not supported by the host machine has been connected.
Remedy	Check the configuration of options and connect the optional equipment for this model.
E720-0501-05	Delivery option detection error
Detection Description	A shift tray not supported by the host machine has been connected.
Remedy	Check the configuration of options.
E730-9004-00	Third party PDL communication error
Detection Description	Communication error with the print server.
Remedy	[Related parts] - Main Controller PCB (UN34) (Unit of replacement: MAIN CONTROLLER PCB ASS'Y, 1) [Remedy]Perform the following in the order while checking whether the error is cleared. 1. Turn OFF and then ON the power. 2. Check the cable connection. 3. Replace the Open I/F PCB, F Link PCB (Main/Sub). 4. Replace the Main Controller PCB.
E730-9005-00	Third party PDL communication error
Detection Description	Error in video cable connection with the print server.
Remedy	[Related parts] - Main Controller PCB (UN34) (Unit of replacement: MAIN CONTROLLER PCB ASS'Y, 1) [Remedy]Perform the following in the order while checking whether the error is cleared. 1. Turn OFF and then ON the power. 2. Check the cable connection. 3. Replace the Open I/F PCB, F Link PCB (Main/Sub). 4. Replace the Main Controller PCB.

E730-A006-00	PDL communication error
Detection Description	Response from PDL could not be detected.
Remedy	<p>[Related parts]</p> <ul style="list-style-type: none"> - Main Controller PCB (UN34) (Unit of replacement: MAIN CONTROLLER PCB ASS'Y, 1) <p>[Remedy]Perform the following in the order while checking whether the error is cleared.</p> <ol style="list-style-type: none"> 1. Select "Settings/Registration> Function Settings> Printer> Printer Settings> Utility> Initialize Printer", and execute PDL reset processing. 2. Reinstall the system software. 3. Replace the Main Controller PCB 1 (UN34) (Unit of replacement: MAIN CONTROLLER PCB ASS'Y, 1)
E730-A007-00	Mismatch of PDL version
Detection Description	Version of the host machine control software and version of PDL control software were different.
Remedy	<p>[Related parts]</p> <ul style="list-style-type: none"> - Main Controller PCB (UN34) (Unit of replacement: MAIN CONTROLLER PCB ASS'Y, 1) <p>[Remedy]Perform the following in the order while checking whether the error is cleared.</p> <ol style="list-style-type: none"> 1. Reinstall the system software. 2. Replace the Main Controller PCB 1 (UN34) (Unit of replacement: MAIN CONTROLLER PCB ASS'Y, 1)
E730-B013-00	PDL embedded font error
Detection Description	Font data was corrupted.
Remedy	<p>[Related parts]</p> <ul style="list-style-type: none"> - Main Controller PCB (UN34) (Unit of replacement: MAIN CONTROLLER PCB ASS'Y, 1) <p>[Remedy]Perform the following in the order while checking whether the error is cleared.</p> <ol style="list-style-type: none"> 1. Reinstall the system software. 2. Replace the Main Controller PCB 1 (UN34) (Unit of replacement: MAIN CONTROLLER PCB ASS'Y, 1)
E732-0000-04	Communication error
Detection Description	Negotiation between the Reader Controller and the Main Controller failed.
Remedy	<p>[Related parts]</p> <ul style="list-style-type: none"> - Harness between the Reader Controller PCB (UN101/J112) and the Main Controller PCB 2 (UN8/J4031) (Unit of replacement: CABLE, INTERFACE) - Harnesses from the Relay PCB to the Reader Controller PCB <ol style="list-style-type: none"> 1. Relay PCB (UN86/J505) to Relay Connector (6P) (Unit of replacement: CABLE, SIGNAL) 2. Relay Connector (6P) to Reader Controller PCB (UN101/J101) (Unit of replacement: CABLE, READER POWER SUPPLY) <ul style="list-style-type: none"> - Main Controller PCB 2 (UN8) (Unit of replacement: MAIN CONTROLLER PCB ASS'Y, 2) - Main Controller PCB 1 (UN34) (Unit of replacement: MAIN CONTROLLER PCB ASSEMBLY, 1) - Reader Controller PCB (UN101) (Unit of replacement: READER CONTROLLER PCB ASSEMBLY) - Relay PCB (UN86) (Unit of replacement: RELAY PCB ASSEMBLY) <p>[Points to note at work] After performing the remedy, check that the copy image is output normally.</p> <p>[Remedy] Check/replace the related harness/cable, connector and parts.</p> <p>[Reference] Before replacing the Reader Controller PCB, back up the service mode data (approx. 2 min) and restore the backup data after the replacement so the data may be able to be protected.</p> <ul style="list-style-type: none"> - Backup: COPIER (LEVEL2)> FUNCTION> SYSTEM> RSRAMBUP - Restoration: COPIER (LEVEL2)> FUNCTION> SYSTEM> RSRAMRES

E732-0001-04	Communication error
Detection Description	A communication error between the Reader Controller PCB and the Main Controller PCB 1 was detected at startup/recovery from sleep.
Remedy	<p>[Related parts]</p> <ul style="list-style-type: none"> - Harness between the Reader Controller PCB (UN101/J112) and the Main Controller PCB 2 (UN8/J4031) (Unit of replacement: CABLE, INTERFACE) - Harnesses from the Relay PCB to the Reader Controller PCB <ol style="list-style-type: none"> 1. Relay PCB (UN86/J505) to Relay Connector (6P) (Unit of replacement: CABLE, SIGNAL) 2. Relay Connector (6P) to Reader Controller PCB (UN101/J101) (Unit of replacement: CABLE, READER POWER SUPPLY) - Main Controller PCB 2 (UN8) (Unit of replacement: MAIN CONTROLLER PCB ASS'Y, 2) - Main Controller PCB 1 (UN34) (Unit of replacement: MAIN CONTROLLER PCB ASSEMBLY, 1) - Reader Controller PCB (UN101) (Unit of replacement: READER CONTROLLER PCB ASSEMBLY) - Relay PCB (UN86) (Unit of replacement: RELAY PCB ASSEMBLY) <p>[Points to note at work] After performing the remedy, check that the copy image is output normally.</p> <p>[Remedy] Check/replace the related harness/cable, connector and parts.</p> <p>[Reference] Before replacing the Reader Controller PCB, back up the service mode data (approx. 2 min) and restore the backup data after the replacement so the data may be able to be protected.</p> <ul style="list-style-type: none"> - Backup: COPIER (LEVEL2)> FUNCTION> SYSTEM> RSRAMBUP - Restoration: COPIER (LEVEL2)> FUNCTION> SYSTEM> RSRAMRES
E732-0010-00	Scanner communication error
Detection Description	A signal to start image transfer could not be detected at scanning although the specified period of time (120 sec) has passed.
Remedy	<p>[Related parts]</p> <ul style="list-style-type: none"> - Harness between the Reader Controller PCB (UN101/J112) and the Main Controller PCB 2 (UN8/J4031) (Unit of replacement: CABLE, INTERFACE) - Main Controller PCB 2 (UN8) (Unit of replacement: MAIN CONTROLLER PCB ASS'Y, 2) - Main Controller PCB 1 (UN34) (Unit of replacement: MAIN CONTROLLER PCB ASS'Y, 1) - Reader Controller PCB (UN101) (Unit of replacement: READER CONTROLLER PCB ASSEMBLY) <p>[Points to note at work] After performing the remedy, check that the copy image is output normally.</p> <p>[Remedy] Perform the following in the order while checking whether the error is cleared.</p> <ol style="list-style-type: none"> 1. Reinstall the latest system software using SST or a USB memory. 2. Check/replace the related harness/cable, connector and parts. <p>[Reference] Before replacing the Reader Controller PCB, back up the service mode data (approx. 2 min) and restore the backup data after the replacement so the data may be able to be protected.</p> <ul style="list-style-type: none"> - Backup: COPIER (LEVEL2)> FUNCTION> SYSTEM> RSRAMBUP - Restoration: COPIER (LEVEL2)> FUNCTION> SYSTEM> RSRAMRES
E732-0020-00	Scanner communication error
Detection Description	A communication error between the Reader Controller PCB and the Main Controller PCB was detected.
Remedy	<p>[Related parts]</p> <ul style="list-style-type: none"> - Harness between the Reader Controller PCB and the Riser PCB - Reader Controller PCB - Riser PCB - Main Controller PCB <p>[Remedy] Check/replace the related harness/cable, connector and parts.</p> <p>[Reference] Before replacing the Reader Controller PCB, back up the service mode data (approx. 2 min) and restore the backup data after the replacement so the data may be able to be protected.</p> <ul style="list-style-type: none"> - Backup: COPIER (LEVEL2)> FUNCTION> SYSTEM> RSRAMBUP - Restoration: COPIER (LEVEL2)> FUNCTION> SYSTEM> RSRAMRES

E732-0021-00	Scanner communication error
Detection Description	A communication error between the Reader Controller PCB and the Main Controller PCB was detected.
Remedy	<p>[Related parts]</p> <ul style="list-style-type: none"> - Harness between the Reader Controller PCB and the Riser PCB - Reader Controller PCB - Riser PCB - Main Controller PCB <p>[Remedy] Check/replace the related harness/cable, connector and parts. [Reference] Before replacing the Reader Controller PCB, back up the service mode data (approx. 2 min) and restore the backup data after the replacement so the data may be able to be protected.</p> <ul style="list-style-type: none"> - Backup: COPIER (LEVEL2)> FUNCTION> SYSTEM> RSRAMBUP - Restoration: COPIER (LEVEL2)> FUNCTION> SYSTEM> RSRAMRES
E732-0022-00	Scanner communication error
Detection Description	A communication error between the Reader Controller PCB and the Main Controller PCB was detected.
Remedy	<p>[Related parts]</p> <ul style="list-style-type: none"> - Harness between the Reader Controller PCB and the Riser PCB - Reader Controller PCB - Riser PCB - Main Controller PCB <p>[Remedy] Check/replace the related harness/cable, connector and parts. [Reference] Before replacing the Reader Controller PCB, back up the service mode data (approx. 2 min) and restore the backup data after the replacement so the data may be able to be protected.</p> <ul style="list-style-type: none"> - Backup: COPIER (LEVEL2)> FUNCTION> SYSTEM> RSRAMBUP - Restoration: COPIER (LEVEL2)> FUNCTION> SYSTEM> RSRAMRES
E732-0023-04	Communication error
Detection Description	A communication error between the Reader Controller PCB and the Main Controller PCB 1 was detected at startup/recovery from sleep.
Remedy	<p>[Related parts]</p> <ul style="list-style-type: none"> - Harness between the Reader Controller PCB (UN101/J112) and the Main Controller PCB 2 (UN8/J4031) (Unit of replacement: CABLE, INTERFACE) - Harnesses from the Relay PCB to the Reader Controller PCB <ol style="list-style-type: none"> 1. Relay PCB (UN86/J505) to Relay Connector (6P) (Unit of replacement: CABLE, SIGNAL) 2. Relay Connector (6P) to Reader Controller PCB (UN101/J101) (Unit of replacement: CABLE, READER POWER SUPPLY) - Main Controller PCB 2 (UN8) (Unit of replacement: MAIN CONTROLLER PCB ASS'Y, 2) - Main Controller PCB 1 (UN34) (Unit of replacement: MAIN CONTROLLER PCB ASSEMBLY, 1) - Reader Controller PCB (UN101) (Unit of replacement: READER CONTROLLER PCB ASSEMBLY) - Relay PCB (UN86) (Unit of replacement: RELAY PCB ASSEMBLY) <p>[Points to note at work] After performing the remedy, check that the copy image is output normally. [Remedy] Check/replace the related harness/cable, connector and parts. [Reference] Before replacing the Reader Controller PCB, back up the service mode data (approx. 2 min) and restore the backup data after the replacement so the data may be able to be protected.</p> <ul style="list-style-type: none"> - Backup: COPIER (LEVEL2)> FUNCTION> SYSTEM> RSRAMBUP - Restoration: COPIER (LEVEL2)> FUNCTION> SYSTEM> RSRAMRES
E732-0F01-04	Communication error
Detection Description	Communication error that can be recovered by reboot If it is detected again immediately after reboot, E732-0001 is generated.
Remedy	It is not necessary to perform a remedy because the machine is automatically rebooted after log collection.
E732-0F23-04	Communication error
Detection Description	Communication error that can be recovered by reboot If it is detected again immediately after reboot, E732-0023 is generated.
Remedy	It is not necessary to perform a remedy because the machine is automatically rebooted after log collection.

E732-8888-00	Error in the reader type
Detection Description	When a scanner for the different model is detected during the communication with the reader.
Remedy	Replace to the proper reader.
E732-9999-00	Reader detection error
Detection Description	The Reader was detected with a printer model for the first time. Only the message "Turn OFF and then ON the power" is displayed on the screen instead of displaying an error code. The error log is recorded in "COPIER> DISPLAY> ERR".
Remedy	[Remedy] Turn OFF and then ON the main power.
E733-0000-05	Printer communication error
Detection Description	A communication error between the DC Controller PCB and the Main Controller PCB was detected at startup.
Remedy	[Related parts] - Harness between the Main Controller PCB 2 (UN8/J5201) and the DC Controller PCB (UN1/J443) (Unit of replacement: CABLE, COMMUNICATION) - Harness between the Main Controller PCB 2 (UN8/J5202) and the DC Controller PCB (UN1/J442) (Unit of replacement: CABLE, SIGNAL) - Connector between the Main Controller PCB 1 (UN34) and the Main Controller PCB 2 (UN8) - DC Controller PCB (UN1) (Unit of replacement: DC CONTROLLER PCB ASS'Y) - Main Controller PCB 2 (UN8) (Unit of replacement: MAIN CONTROLLER PCB ASS'Y, 2) - Main Controller PCB 1 (UN34) (Unit of replacement: MAIN CONTROLLER PCB ASS'Y, 1) [Remedy] Check/replace the related harness/cable, connector and parts. [Reference] Before replacing the DC Controller PCB, back up the service mode data (approx. 2 min) and restore the backup data after the replacement so the data may be able to be protected. - Backup: COPIER (LEVEL2)> FUNCTION> SYSTEM> DSRAMBUP - Restoration: COPIER (LEVEL2)> FUNCTION> SYSTEM> DSRAMRES
E733-0001-05	Printer communication error
Detection Description	A communication error between the DC Controller PCB and the Main Controller PCB was detected.
Remedy	[Related parts] - Harness between the Main Controller PCB 2 (UN8/J5201) and the DC Controller PCB (UN1/J443) (Unit of replacement: CABLE, COMMUNICATION) - Harness between the Main Controller PCB 2 (UN8/J5202) and the DC Controller PCB (UN1/J442) (Unit of replacement: CABLE, SIGNAL) - Connector between the Main Controller PCB 1 (UN34) and the Main Controller PCB 2 (UN8) - DC Controller PCB (UN1) (Unit of replacement: DC CONTROLLER PCB ASS'Y) - Main Controller PCB 2 (UN8) (Unit of replacement: MAIN CONTROLLER PCB ASS'Y, 2) - Main Controller PCB 1 (UN34) (Unit of replacement: MAIN CONTROLLER PCB ASS'Y, 1) [Remedy] Check/replace the related harness/cable, connector and parts. [Reference] Before replacing the DC Controller PCB, back up the service mode data (approx. 2 min) and restore the backup data after the replacement so the data may be able to be protected. - Backup: COPIER (LEVEL2)> FUNCTION> SYSTEM> DSRAMBUP - Restoration: COPIER (LEVEL2)> FUNCTION> SYSTEM> DSRAMRES
E733-0002-05	Printer communication error
Detection Description	A communication error between the DC Controller PCB and the Main Controller PCB was detected.
Remedy	[Related parts] - Harness between the Main Controller PCB 2 (UN8/J5201) and the DC Controller PCB (UN1/J443) (Unit of replacement: CABLE, COMMUNICATION) - Harness between the Main Controller PCB 2 (UN8/J5202) and the DC Controller PCB (UN1/J442) (Unit of replacement: CABLE, SIGNAL) - Connector between the Main Controller PCB 1 (UN34) and the Main Controller PCB 2 (UN8) - DC Controller PCB (UN1) (Unit of replacement: DC CONTROLLER PCB ASS'Y) - Main Controller PCB 2 (UN8) (Unit of replacement: MAIN CONTROLLER PCB ASS'Y, 2) - Main Controller PCB 1 (UN34) (Unit of replacement: MAIN CONTROLLER PCB ASS'Y, 1) [Remedy] Check/replace the related harness/cable, connector and parts. [Reference] Before replacing the DC Controller PCB, back up the service mode data (approx. 2 min) and restore the backup data after the replacement so the data may be able to be protected. - Backup: COPIER (LEVEL2)> FUNCTION> SYSTEM> DSRAMBUP - Restoration: COPIER (LEVEL2)> FUNCTION> SYSTEM> DSRAMRES

E733-0004-05	Printer communication error
Detection Description	Communication error between the Main Controller PCB and the DC Controller PCB
Remedy	[Remedy] 1. Reinstall the system software using SST or a USB flash drive. 2. Replace the Main Controller PCB. 3. Replace the DC Controller PCB.
E733-0005-05	Communication error between the Main Controller PCB and the DC Controller PCB
Detection Description	Communication error between the Main Controller PCB and the DC Controller PCB
Remedy	[Remedy] 1. Reinstall the system software using SST or a USB flash drive. 2. Replace the Main Controller PCB. 3. Replace the DC Controller PCB.
E733-0006-05	Communication error between the Main Controller PCB and the DC Controller PCB
Detection Description	Communication error between the Main Controller PCB and the DC Controller PCB
Remedy	[Remedy] 1. Reinstall the system software using SST or a USB flash drive. 2. Replace the Main Controller PCB. 3. Replace the DC Controller PCB.
E733-0010-00	Printer communication error
Detection Description	A communication error between the DC Controller PCB and the Main Controller PCB was detected.
Remedy	[Related parts] - Harness between the Main Controller PCB 2 (PPWB2/J5201) and the DC Controller PCB (UN1/J443) (Unit of replacement: CABLE, COMMUNICATION) - Harness between the Main Controller PCB 2 (PPWB2/J5202) and the DC Controller PCB (UN1/J442) (Unit of replacement: CABLE, SIGNAL) - DC Controller PCB (UN1) (Unit of replacement: DC CONTROLLER PCB ASS'Y) - Main Controller PCB 2 (UN8) (Unit of replacement: MAIN CONTROLLER PCB ASS'Y, 2) - Main Controller PCB 1 (UN34) (Unit of replacement: MAIN CONTROLLER PCB ASS'Y, 1) [Remedy] Perform the following in the order while checking whether the error is cleared. 1. Reinstall the latest system software using SST or a USB memory. 2. Check/replace the related harness/cable, connector and parts. [Reference] Before replacing the DC Controller PCB, back up the service mode data (approx. 2 min) and restore the backup data after the replacement so the data may be able to be protected. - Backup: COPIER (LEVEL2)> FUNCTION> SYSTEM> DSRAMBUP - Restoration: COPIER (LEVEL2)> FUNCTION> SYSTEM> DSRAMRES
E733-0F00-05	Printer communication error
Detection Description	Communication error that can be recovered by reboot If it is detected again immediately after reboot, E733-0000 is generated.
Remedy	It is not necessary to perform a remedy because the machine is automatically rebooted after log collection.
E733-0F01-05	Printer communication error
Detection Description	Communication error that can be recovered by reboot If it is detected again immediately after reboot, E733-0001 is generated.
Remedy	It is not necessary to perform a remedy because the machine is automatically rebooted after log collection.
E733-0F02-05	Printer communication error
Detection Description	Communication error that can be recovered by reboot If it is detected again immediately after reboot, E733-0002 is generated.
Remedy	It is not necessary to perform a remedy because the machine is automatically rebooted after log collection.

E733-0F04-05	Printer communication error
Detection Description	Communication error that can be recovered by reboot If it is detected again immediately after reboot, E733-0004 is generated.
Remedy	It is not necessary to perform a remedy because the machine is automatically rebooted.
E733-0F05-05	Printer communication error
Detection Description	Communication error that can be recovered by reboot If it is detected again immediately after reboot, E733-0005 is generated.
Remedy	It is not necessary to perform a remedy because the machine is automatically rebooted.
E733-0F06-05	Printer communication error
Detection Description	Communication error that can be recovered by reboot If it is detected again immediately after reboot, E733-0006 is generated.
Remedy	It is not necessary to perform a remedy because the machine is automatically rebooted.
E733-9999-05	Printer communication error
Detection Description	The Finisher connection information differs between the Riser PCB and the DC Controller PCB.
Remedy	Turn OFF and then ON the power
E733-F000-05	Printer communication error
Detection Description	Communication error that can be recovered by reboot If it is detected again immediately after reboot, E733-0000 is generated.
Remedy	It is not necessary to perform a remedy because the machine is automatically rebooted after log collection.
E733-F001-05	Printer communication error
Detection Description	Communication error that can be recovered by reboot If it is detected again immediately after reboot, E733-0001 is generated.
Remedy	It is not necessary to perform a remedy because the machine is automatically rebooted after log collection.
E733-F002-05	Printer communication error
Detection Description	Communication error that can be recovered by reboot If it is detected again immediately after reboot, E733-0002 is generated.
Remedy	It is not necessary to perform a remedy because the machine is automatically rebooted after log collection.
E743-0000-04	Communication error
Detection Description	The Reader Controller PCB detected a communication error between the Main Controller PCB 1 and the Reader Controller PCB.
Remedy	[Related parts] - Harness between the Reader Controller PCB (UN101/J112) and the Main Controller PCB 2 (UN8/J4031) (Unit of replacement: CABLE, INTERFACE) - Reader Controller PCB (UN101) (Unit of replacement: READER CONTROLLER PCB ASSEMBLY) - Main Controller PCB 2 (UN8) (Unit of replacement: MAIN CONTROLLER PCB ASS'Y, 2) - Main Controller PCB 1 (UN34) (Unit of replacement: MAIN CONTROLLER PCB ASSEMBLY, 1) [Remedy] Check/replace the related harness/cable, connector and parts. [Reference] Before replacing the Reader Controller PCB, back up the service mode data (approx. 2 min) and restore the backup data after the replacement so the data may be able to be protected. - Backup: COPIER (LEVEL2)> FUNCTION> SYSTEM> RSRAMBUP - Restoration: COPIER (LEVEL2)> FUNCTION> SYSTEM> RSRAMRES
E744-0001-00	Language file error
Detection Description	The language file in the HDD was not supported by the version of Bootable.
Remedy	[Remedy] Reinstall the correct language file or system software using SST or a USB memory.

E744-2000-00	Controller firmware mismatch
Detection Description	Invalid controller firmware was detected.
Remedy	[Related parts] - HDD [Remedy] This error normally does not occur. This error occurs when using the HDD which was used with another model. Replace the HDD with the one which was originally installed or a new one for the model.
E744-4000-05	Error due to the DC Controller PCB not compatible with the model
Detection Description	The DC Controller PCB which was used with another model was detected.
Remedy	[Related parts] - DC Controller PCB (UN1) (Unit of replacement: DC CONTROLLER PCB ASS'Y) [Remedy] Replace the DC Controller PCB (UN1). (Unit of replacement: DC CONTROLLER PCB ASSEMBLY) [Reference] Before replacing the DC Controller PCB, back up the service mode data (approx. 2 min) and restore the backup data after the replacement so the data may be able to be protected. - Backup: COPIER (LEVEL2)> FUNCTION> SYSTEM> DSRAMBUP - Restoration: COPIER (LEVEL2)> FUNCTION> SYSTEM> DSRAMRES
E744-5000-07	Mismatch of software version for fax
Detection Description	After the Fax Board (option) has been installed, mismatch of version of software in the Fax Board was detected at transmission and reception.
Remedy	[Remedy] Upgrade the system software version to the latest one.
E746-0003-00	Image Analysis Board error
Detection Description	Different Image Analysis PCB model.
Remedy	[Remedy] Perform the following in the order while checking whether the error is cleared. 1. Check that the Image Analysis Board is installed properly by removing and then installing it again. 2. Turn OFF and then ON the main power, and check whether the error is cleared. 3. After replacing the Image Analysis Board, reinstall the firmware of the Image Analysis Board or the system software which version is supported by this model using SST or a USB memory.
E746-0021-00	Image Analysis Board error
Detection Description	Self-check NG of Image Analysis Board
Remedy	[Remedy] Perform the following in the order while checking whether the error is cleared. 1. Check that the Image Analysis Board is installed properly by removing and then installing it again. 2. Turn OFF and then ON the main power, and check whether the error is cleared. 3. After replacing the Image Analysis Board, reinstall the firmware of the Image Analysis Board or the system software which version is supported by this model using SST or a USB memory.
E746-0022-00	Image Analysis Board error
Detection Description	Wrong version of the Image Analysis Board was detected.
Remedy	[Remedy] Perform the following in the order while checking whether the error is cleared. 1. Reinstall the firmware of the Image Analysis Board or the system software which version is supported by this model using SST or a USB memory. 2. After replacing the Image Analysis Board, perform step 1.
E746-0023-00	Image Analysis Board error
Detection Description	Communication from the Image Analysis Board could not be detected.
Remedy	[Remedy] Perform the following in the order while checking whether the error is cleared. 1. Check that the Image Analysis Board is installed properly by removing and then installing it again. 2. Turn OFF and then ON the main power, and check whether the error is cleared. 3. After replacing the Image Analysis Board, reinstall the firmware of the Image Analysis Board or the system software which version is supported by this model using SST or a USB memory.

E746-0024-00	Image Analysis Board error
Detection Description	An error in the operation of the Image Analysis Board was detected.
Remedy	<p>[Remedy] Perform the following in the order while checking whether the error is cleared.</p> <ol style="list-style-type: none"> 1. Check that the Image Analysis Board is installed properly by removing and then installing it again. 2. Turn OFF and then ON the main power, and check whether the error is cleared. 3. After replacing the Image Analysis Board, reinstall the firmware of the Image Analysis Board or the system software which version is supported by this model using SST or a USB memory.
E746-0031-00	TPM error
Detection Description	A communication error has occurred between the Main Controller PCB and the TPM PCB at startup.
Remedy	<p>[Related parts] - TPM PCB</p> <p>[Remedy] Check/replace the TPM PCB.</p> <p>[Reference] After replacing the TPM PCB, if the TPM key was backed up, restore the key.</p> <ol style="list-style-type: none"> 1. Connect the USB memory which stores the TPM key. 2. Execute "Settings/Registration> Log In> Management Settings> Data Management> TPM Settings> Restore TPM Key". <p>[CAUTION] Ask the customer to enter "System Manager ID" and "System Manager PIN" when logging in.</p> <ol style="list-style-type: none"> 3. Enter the password set at backup operation. 4. When the restoration completion screen is displayed, click "OK". Remove the USB memory, and turn OFF and then ON the main power.
E746-0032-00	TPM error
Detection Description	Mismatch of the TPM key was detected.
Remedy	<p>[Related parts] - TPM PCB - HDD</p> <p>[Remedy] Perform the following in the order while checking whether the error is cleared.</p> <ol style="list-style-type: none"> 1. Format the HDD and reinstall the system software using SST or a USB flash drive. 2. Replace the TPM PCB. <p>[Reference] After replacing the TPM PCB, if the TPM key was backed up, restore the key.</p> <ol style="list-style-type: none"> 1. Connect the USB memory which stores the TPM key. 2. Execute "Settings/Registration> Log In> Management Settings> Data Management> TPM Settings> Restore TPM Key". <p>[CAUTION] Ask the customer to enter "System Manager ID" and "System Manager PIN" when logging in.</p> <ol style="list-style-type: none"> 3. Enter the password set at backup operation. 4. When the restoration completion screen is displayed, click "OK". Remove the USB memory, and turn OFF and then ON the main power.

E746-0033-00	TPM error
Detection Description	It was detected that data in TPM was inconsistent.
Remedy	<p>[Related parts]</p> <ul style="list-style-type: none"> - TPM PCB - HDD <p>[Remedy]</p> <p>If the TPM key was backed up,</p> <ul style="list-style-type: none"> - Restore the TPM key. <ol style="list-style-type: none"> 1. Connect the USB memory which stores the TPM key. 2. Execute "Settings/Registration> Log In> Management Settings> Data Management> TPM Settings> Restore TPM Key". <p>[CAUTION] Ask the customer to enter "System Manager ID" and "System Manager PIN" when logging in.</p> <ol style="list-style-type: none"> 3. Enter the password set at backup operation. 4. When the restoration completion screen is displayed, click "OK". Remove the USB memory, and turn OFF and then ON the main power. <p>If the TPM key was not backed up,</p> <ul style="list-style-type: none"> - Format the HDD and reinstall the system software using SST or a USB flash drive.
E746-0034-00	TPM auto recovery error
Detection Description	The error occurred when clearing HDD while TPM setting was ON.
Remedy	<p>[Related parts]</p> <ul style="list-style-type: none"> - HDD <p>[Remedy]</p> <p>It is recovered by turning OFF and then ON the power.</p> <p>If the error is not cleared, format the HDD and reinstall the system software using SST or a USB flash drive.</p>
E746-0035-00	TPM version error
Detection Description	TPM PCB which cannot be used in this machine was installed.
Remedy	<p>[Related parts]</p> <ul style="list-style-type: none"> - TPM PCB <p>[Remedy]</p> <p>Install the TPM PCB for this model.</p>
E748-2000-00	Main Controller PCB access error
Detection Description	Main Controller PCB Chip access error.
Remedy	<p>[Related parts]</p> <ul style="list-style-type: none"> - Main Controller PCB 1 (UN34) (Unit of replacement: MAIN CONTROLLER PCB ASS'Y, 1) <p>[Remedy]Replace the Main Controller PCB 1 (UN34) (Unit of replacement: MAIN CONTROLLER PCB ASS'Y, 1)</p>
E748-2001-00	Main Controller PCB access error
Detection Description	Main Controller PCB memory access error.
Remedy	<p>[Related parts]</p> <ul style="list-style-type: none"> - Main Controller PCB 1 (UN34) (Unit of replacement: MAIN CONTROLLER PCB ASS'Y, 1) <p>[Remedy]Replace the Main Controller PCB 1 (UN34) (Unit of replacement: MAIN CONTROLLER PCB ASS'Y, 1)</p>

E748-2010-00	Flash PCB error / HDD error
Detection Description	IPL (startup program) was not found, or the HDD could not be recognized.
Remedy	<p>[Related parts]</p> <ul style="list-style-type: none"> - Cable between the Main Controller PCB 1 (UN34/J6003,J6004) and the HDD (Unit of replacement: CABLE, HARD DISK DRIVE, 1) - SATA-FLASH PCB (UN46) <p>[Remedy] Perform the following in the order while checking whether the error is cleared.</p> <ol style="list-style-type: none"> 1. Disconnect the cable between the Main Controller PCB and the HDD, and turn ON the main power. <ol style="list-style-type: none"> a. When the error code has not been changed: <ol style="list-style-type: none"> 1. Obtain the necessary backup data by referring to the backup data list. 2. After replacing the Flash PCB, reinstall the system software using SST or a USB memory. 3. Restore the backup data. b. When the error code has been changed to another one, see the remedy for the corresponding code. <p>[Reference] For backup and restoration, refer to "Adjustment> Main Controller System" and "Appendix> Backup Data List" in the Service Manual.</p>
E748-2011-00	Flash PCB error
Detection Description	OS is not found
Remedy	<p>[Related parts]</p> <ul style="list-style-type: none"> - SATA-FLASH PCB (UN46) <p>[Remedy]After replacing the SATA-FLASH PCB (UN46) (unit of replacement: SATA-FLASH PCB ASS'Y), reinstall the system software using SST or a USB memory.</p>
E748-2012-00	Flash PCB error
Detection Description	Cannot mount the OS in safe mode startup or No OS startup script
Remedy	<p>[Related parts]</p> <ul style="list-style-type: none"> - SATA-FLASH PCB (UN46) <p>[Remedy]After replacing the SATA-FLASH PCB (UN46) (unit of replacement: SATA-FLASH PCB ASS'Y), reinstall the system software using SST or a USB memory.</p>
E748-2021-00	Main Controller PCB access error
Detection Description	Main controller board 2 access errors
Remedy	<p>[Related parts]</p> <ul style="list-style-type: none"> - Main Controller PCB 1 (UN34) (Unit of replacement: MAIN CONTROLLER PCB ASS'Y, 1) <p>[Remedy]Replace the Main Controller PCB 1 (UN34) (Unit of replacement: MAIN CONTROLLER PCB ASS'Y, 1)</p>
E748-2022-00	Main controller startup error
Detection Description	An fatal error was detected in the Main Controller at startup
Remedy	Replace the Main Controller PCB
E748-2023-00	Main Controller PCB access error
Detection Description	Main controller board 2 access errors
Remedy	<p>[Related parts]</p> <ul style="list-style-type: none"> - Main Controller PCB 1 (UN34) (Unit of replacement: MAIN CONTROLLER PCB ASS'Y, 1) <p>[Remedy]Replace the Main Controller PCB 1 (UN34) (Unit of replacement: MAIN CONTROLLER PCB ASS'Y, 1)</p>
E748-2024-00	Main Controller PCB access error
Detection Description	Main controller board 2 access errors
Remedy	<p>[Related parts]</p> <ul style="list-style-type: none"> - Main Controller PCB 1 (UN34) (Unit of replacement: MAIN CONTROLLER PCB ASS'Y, 1) <p>[Remedy]Replace the Main Controller PCB 1 (UN34) (Unit of replacement: MAIN CONTROLLER PCB ASS'Y, 1)</p>

E748-4910-00	Main Controller PCB access error
Detection Description	Main controller board 2 access errors
Remedy	[Related parts] - Main Controller PCB 1 (UN34) (Unit of replacement: MAIN CONTROLLER PCB ASS'Y, 1) [Remedy]Replace the Main Controller PCB 1 (UN34) (Unit of replacement: MAIN CONTROLLER PCB ASS'Y, 1)
E748-7011-00	Start system verification function error
Detection Description	At startup, an error may occur due to invalid data of the OS boot loader on the flash PCB. When this error occurs, the system has not been started normally. Therefore, it is not recorded in the error log.
Remedy	[Related parts] - Flash PCB [Remedy] 1. Replace the Flash PCB and reinstall the system using SST or a USB flash drive.
E748-7021-00	Start system verification function error
Detection Description	At startup, an error may occur due to invalid data of the OS kernel on the flash PCB. When this error occurs, the system has not been started normally. Therefore, it is not recorded in the error log.
Remedy	[Related parts] - Flash PCB [Remedy] 1. Replace the Flash PCB and reinstall the system using SST or a USB flash drive.
E748-7022-00	Start system verification function error
Detection Description	At startup, an error may occur due to invalid data of the OS kernel on the flash PCB. When this error occurs, the system has not been started normally. Therefore, it is not recorded in the error log.
Remedy	[Related parts] - Flash PCB [Remedy] 1. Replace the Flash PCB and reinstall the system using SST or a USB flash drive.
E748-9000-00	System error
Detection Description	System error
Remedy	Contact to the sales company.
E753-0001-00	Download error
Detection Description	Update of the Main Controller PCB ended in failure.
Remedy	[Related parts] - SATA-FLASH PCB (UN46) [Remedy]Perform the following in the order while checking whether the error is cleared. 1. Reinstall the system software using SST or a USB memory. 2. After replacing the Sata Flash PCB (UN46) (Unit of replacement: SATA-FLASH PCB ASS'Y), reinstall the system software using SST or a USB memory. 3. Collect debug log and contact to the sales company.

E804-0000-00	Power Supply Cooling Fan error
Detection Description	It was detected that the Power Supply Cooling Fan was locked.
Remedy	<p>[Related parts]</p> <ul style="list-style-type: none"> - Harnesses from the Relay PCB to the Power Supply Cooling Fan 1 1. Relay PCB (UN86/J509) to Relay Connector (3P) (Unit of replacement: CABLE, POWER FAN) 2. Relay Connector (3P) to Power Supply Cooling Fan 1 (FM14/J2134) (Unit of replacement: CABLE, POWER FAN) - Harness between the Relay PCB (UN86/J509) and the Power Supply Cooling Fan 2 (FM15/J2154) (Unit of replacement: CABLE, POWER FAN) - Power Supply Cooling Fan 1 (FM14) - Power Supply Cooling Fan 2 (FM15) - Relay PCB (UN86) (Unit of replacement: RELAY PCB ASSEMBLY) <p>[Remedy] Check/replace the related harness/cable, connector and parts.</p>
E804-0000-05	Power Supply Cooling Fan error
Detection Description	It was detected that the Power Supply Cooling Fan was locked.
Remedy	<p>[Related parts]</p> <ul style="list-style-type: none"> - Harnesses from the Relay PCB to the Power Supply Cooling Fan 1 1. Relay PCB (UN86/J509) to Relay Connector (3P) (Unit of replacement: CABLE, POWER FAN) 2. Relay Connector (3P) to Power Supply Cooling Fan 1 (FM14/J2134) (Unit of replacement: CABLE, POWER FAN) - Harness between the Relay PCB (UN86/J509) to Power Supply Cooling Fan 2 (FM15/J2154) (Unit of replacement: CABLE, POWER FAN) - Power Supply Cooling Fan 1 (FM14) - Power Supply Cooling Fan 2 (FM15) - Relay PCB (UN86) (Unit of replacement: RELAY PCB ASSEMBLY) <p>[Remedy] Check/replace the related harness/cable, connector and parts.</p>
E804-0001-05	Fixing Power Supply Cooling Fan error
Detection Description	It was detected that the Fixing Power Supply Cooling Fan was locked.
Remedy	<p>[Related parts]</p> <ul style="list-style-type: none"> - Harnesses from the Relay PCB to the Fixing Power Supply Cooling Fan 1. Main Driver PCB (UN78/J119) to Relay Connector (13P) (Unit of replacement: CABLE, MAIN DRIVER IH) 2. Relay Connector (13P) to Fixing Power Supply Cooling Fan (FM7/J2130) (Unit of replacement: CABLE, IH SIGNAL) - Power Supply Cooling Fan (FM7) - Main Driver PCB (UN78) (Unit of replacement: MAIN DRIVE DRIVER PCB ASS'Y) <p>[Remedy] Check/replace the related harness/cable, connector and parts.</p>
E806-0000-05	Making Image Exhaust Fan error
Detection Description	It was detected that the Making Image Exhaust Fan was locked.
Remedy	<p>[Related parts]</p> <ul style="list-style-type: none"> - Harnesses from the Feed Driver PCB to the Making Image Exhaust Fan 1. Feed Driver PCB (UN79/J225) to Relay Connector (3P) (Unit of replacement: CABLE, CASSETTE, 3 , 4) 2. Relay Connector (3P) to Making Image Exhaust Fan (FM03/J2088) (Unit of replacement: CABLE, FAN) - Making Image Exhaust Fan (FM03) (Unit of replacement: FAN UNIT) - Feed Driver PCB (UN79) (Unit of replacement: FEED DRIVER PCB ASSEMBLY) <p>[Remedy] Check/replace the related harness/cable, connector and parts.</p>

E808-0001-05	Fixing Power Supply error
Detection Description	Overvoltage was detected at power-on. - 145 V or higher for 100V/120V machine - 290 V or higher for 230V machine
Remedy	[Related parts] - Harnesses from the Main Driver PCB to the Fixing Power Supply PCB 1. Main Driver PCB (UN78/J118 and J119) to Relay Connector (19P and 13P) (Unit of replacement: CABLE, MAIN DRIVER IH) 2. Relay Connector (19P and 13P) to Fixing Power Supply PCB (UN3/J316 and J313) (Unit of replacement: CABLE, IH SIGNAL) - Harnesses from the AC Driver PCB to the Fixing Power Supply PCB 1. AC Driver PCB (UN20/J601) to Relay Connector (2P) (Unit of replacement: CABLE, AC-IH) 2. Relay Connector (2P) to Fixing Power Supply PCB (UN3/J2401) (Unit of replacement: CABLE, AC MAIN BODY) - Fixing Power Supply PCB (UN3) (Unit of replacement: IH POWER SUPPLY PCB ASS'Y) - Main Driver PCB (UN78) (Unit of replacement: MAIN DRIVE DRIVER PCB ASS'Y) [Remedy] - Check the voltage of the outlet, and connect the machine to the correct outlet if it is wrong. - Check/replace the related harness/cable, connector and parts.
E808-0002-05	Fixing Power Supply error
Detection Description	Under voltage was detected at power-on. - 75 V or lower for 100V/120V machine - 150 V or lower for 230V machine
Remedy	[Related parts] - Harnesses from the Main Driver PCB to the Fixing Power Supply PCB 1. Main Driver PCB (UN78/J118 and J119) to Relay Connector (19P and 13P) (Unit of replacement: CABLE, MAIN DRIVER IH) 2. Relay Connector (19P and 13P) to Fixing Power Supply PCB (UN3/J316 and J313) (Unit of replacement: CABLE, IH SIGNAL) - Harnesses from the AC Driver PCB to the Fixing Power Supply PCB 1. AC Driver PCB (UN20/J601) to Relay Connector (2P) (Unit of replacement: CABLE, AC-IH) 2. Relay Connector (2P) to Fixing Power Supply PCB (UN3/J2401) (Unit of replacement: CABLE, AC MAIN BODY) - Fixing Power Supply PCB (UN3) (Unit of replacement: IH POWER SUPPLY PCB ASS'Y) - Main Driver PCB (UN78) (Unit of replacement: MAIN DRIVE DRIVER PCB ASS'Y) [Remedy] - Check the voltage of the outlet, and connect the machine to the correct outlet if it is wrong. - Check/replace the related harness/cable, connector and parts.
E808-0003-05	Fixing Power Supply error
Detection Description	Inlet current is 1 A or lower for 1 second or longer although the maximum voltage is output.
Remedy	[Related parts] - Harnesses from the Main Driver PCB to the Fixing Power Supply PCB 1. Main Driver PCB (UN78/J118 and J119) to Relay Connector (19P and 13P) (Unit of replacement: CABLE, MAIN DRIVER IH) 2. Relay Connector (19P and 13P) to Fixing Power Supply PCB (UN3/J316 and J313) (Unit of replacement: CABLE, IH SIGNAL) - Harness between the Fixing Power Supply PCB (UN3/J9904) and the Fixing Heater (CB1006 and CB1007/J9072 and J9071) (Unit of replacement: CABLE, IH DRAWER) - Fixing Power Supply PCB (UN3) (Unit of replacement: IH POWER SUPPLY PCB ASS'Y) - Fixing Heater (CB1006 and CB1007) (Unit of replacement: FIXING HEATER UNIT) - Main Driver PCB (UN78) (Unit of replacement: MAIN DRIVE DRIVER PCB ASS'Y) [Remedy] - Clean the Fixing Power Supply Cooling Fan and the Louver on right side of the host machine to remove dust. - Check/replace the related harness/cable, connector and parts.

E808-0004-05	Fixing Power Supply error
Detection Description	Detected OFF with output 12 V of the Main Driver PCB.
Remedy	<p>[Related parts]</p> <ul style="list-style-type: none"> - Harnesses from the Main Driver PCB to the Fixing Power Supply PCB 1. Main Driver PCB (UN78/J118 and J119) to Relay Connector (19P and 13P) (Unit of replacement: CABLE, MAIN DRIVER IH) 2. Relay Connector (19P and 13P) to Fixing Power Supply PCB (UN3/J316 and J313) (Unit of replacement: CABLE, IH SIGNAL) - Fixing Power Supply PCB (UN3) (Unit of replacement: IH POWER SUPPLY PCB ASS'Y) - Main Driver PCB (UN78) (Unit of replacement: MAIN DRIVE DRIVER PCB ASS'Y) <p>[Remedy] Check/replace the related harness/cable, connector and parts.</p>
E808-0005-05	Fixing Power Supply error
Detection Description	Detected OFF with output 12 V of the Fixing Power Supply after IH relay is turned ON.
Remedy	<p>[Related parts]</p> <ul style="list-style-type: none"> - Harnesses from the Main Driver PCB to the Fixing Thermoswitch 1. Main Driver PCB (UN78/J129) to Relay Connector (3P) to Fixing Drawer Unit (J3001) (Unit of replacement: CABLE, FIXING DRAWER) 2. Fixing Drawer Unit (J3200) to Fixing Thermoswitch (TP01 and TP02) (Unit of replacement: CABLE, FIXING DC DRAWER) - Harnesses from the Main Driver PCB to the Fixing Power Supply PCB 1. Main Driver PCB (UN78/J118 and J119) to Relay Connector (19P and 13P) (Unit of replacement: CABLE, MAIN DRIVER IH) 2. Relay Connector (19P and 13P) to Fixing Power Supply PCB (UN3/J316 and J313) (Unit of replacement: CABLE, IH SIGNAL) - Fixing Power Supply PCB (UN3) (Unit of replacement: IH POWER SUPPLY PCB ASS'Y) - Main Driver PCB (UN78) (Unit of replacement: MAIN DRIVE DRIVER PCB ASS'Y) - Fixing Thermoswitch (TP01 and TP02) (Unit of replacement: THERMOSWITCH) <p>[Remedy] Check/replace the related harness/cable, connector and parts.</p>
E808-0006-05	Fixing Power Supply error
Detection Description	An error in ASIC on the DC Controller was detected.
Remedy	<p>[Related parts]</p> <ul style="list-style-type: none"> - DC Controller PCB (UN1) (Unit of replacement: DC CONTROLLER PCB ASS'Y) <p>[Remedy] Perform the following in the order while checking whether the error is cleared.</p> <ol style="list-style-type: none"> 1. Turn OFF and then ON the power of the host machine. 2. Replace the DC Controller PCB. (Unit of replacement: DC CONTROLLER PCB ASS'Y) <p>[Reference] Before replacing the DC Controller PCB, back up the service mode data (approx. 2 min) and restore the backup data after the replacement so the data may be able to be protected.</p> <ul style="list-style-type: none"> - Backup: COPIER (LEVEL2)> FUNCTION> SYSTEM> DSRAMBUP - Restoration: COPIER (LEVEL2)> FUNCTION> SYSTEM> DSRAMRES
E808-0007-05	Fixing Power Supply error
Detection Description	An error in voltage inside the Fixing Power Supply PCB was detected.
Remedy	<p>[Related parts]</p> <ul style="list-style-type: none"> - Harnesses from the Main Driver PCB to the Fixing Power Supply PCB 1. Main Driver PCB (UN78/J118 and J119) to Relay Connector (19P and 13P) (Unit of replacement: CABLE, MAIN DRIVER IH) 2. Relay Connector (19P and 13P) to Fixing Power Supply PCB (UN3/J316 and J313) (Unit of replacement: CABLE, IH SIGNAL) - Fixing Power Supply PCB (UN3) (Unit of replacement: IH POWER SUPPLY PCB ASS'Y) - DC Controller PCB (UN1) (Unit of replacement: DC CONTROLLER PCB ASS'Y) <p>[Remedy] Check/replace the related harness/cable, connector and parts.</p> <p>[Reference] Before replacing the DC Controller PCB, back up the service mode data (approx. 2 min) and restore the backup data after the replacement so the data may be able to be protected.</p> <ul style="list-style-type: none"> - Backup: COPIER (LEVEL2)> FUNCTION> SYSTEM> DSRAMBUP - Restoration: COPIER (LEVEL2)> FUNCTION> SYSTEM> DSRAMRES

E808-0008-05	Fixing Power Supply error
Detection Description	Current fluctuation error of the Fixing Assembly was detected.
Remedy	<p>[Related parts]</p> <ul style="list-style-type: none"> - Harnesses from the Main Driver PCB to the Fixing Power Supply PCB 1. Main Driver PCB (UN78/J118 and J119) to Relay Connector (19P and 13P) (Unit of replacement: CABLE, MAIN DRIVER IH) 2. Relay Connector (19P and 13P) to Fixing Power Supply PCB (UN3/J316 and J313) (Unit of replacement: CABLE, IH SIGNAL) - Harness between the Fixing Power Supply PCB (UN3/J9904) and the Fixing Heater (Unit of replacement: CABLE, IH DRAWER) - Fixing Heater Unit - Fixing Roller - Fixing Power Supply PCB (UN3) - Main Driver PCB (UN78) <p>[Remedy] Check/replace the related harness/cable, connector and parts.</p>
E808-0009-05	Fixing Power Supply error
Detection Description	Unable to clear the error flag at power-on.
Remedy	<p>[Related parts]</p> <ul style="list-style-type: none"> - DC Controller PCB (UN1) (Unit of replacement: DC CONTROLLER PCB ASS'Y) <p>[Remedy] Perform the following in the order while checking whether the error is cleared.</p> <ol style="list-style-type: none"> 1. Turn OFF and then ON the power of the host machine. 2. Replace the DC Controller PCB. (Unit of replacement: DC CONTROLLER PCB ASS'Y) <p>[Reference] Before replacing the DC Controller PCB, back up the service mode data (approx. 2 min) and restore the backup data after the replacement so the data may be able to be protected.</p> <ul style="list-style-type: none"> - Backup: COPIER (LEVEL2)> FUNCTION> SYSTEM> DSRAMBUP - Restoration: COPIER (LEVEL2)> FUNCTION> SYSTEM> DSRAMRES
E820-0000-05	Developer Lower Cooling Fan error
Detection Description	The Fan stop signal is detected for 5 seconds or longer and retry is failed 4 times in a row although the Developer Lower Cooling Fan is turned ON.
Remedy	<p>[Related parts]</p> <ul style="list-style-type: none"> - Harnesses from the Main Driver PCB to the Developer Lower Cooling Fan 1. Main Driver PCB (UN78/J130) to Relay Connector (17P) (Unit of replacement: CABLE, MAIN DRIVER, REAR UPPER) 2. Relay Harness (17P) (Unit of replacement: CABLE, RELAY, FRONT, CABLE, MAIN DRIVER, FRONT) 3. Relay Connector (17P) to Developer Lower Cooling Fan (FM30/J2170) (Unit of replacement: CABLE, FAN) - Developer Lower Cooling Fan (FM30) - Main Driver PCB (UN78) (Unit of replacement: MAIN DRIVE DRIVER PCB ASS'Y) <p>[Remedy] Check/replace the related harness/cable, connector and parts.</p>
E820-0001-05	Developer Upper Cooling Fan error
Detection Description	The Fan stop signal is detected for 5 seconds or longer and retry is failed 4 times in a row although the Developer Upper Cooling Fan is turned ON.
Remedy	<p>[Related parts]</p> <ul style="list-style-type: none"> - Harnesses from the Main Driver PCB to the Developer Upper Cooling Fan 1. Main Driver PCB (UN78/J130) to Relay Connector (17P) (Unit of replacement: CABLE, MAIN DRIVER, REAR UPPER) 2. Relay Harness (17P) (Unit of replacement: CABLE, RELAY, FRONT, CABLE, MAIN DRIVER, FRONT) 3. Relay Connector (17P) to Developer Upper Cooling Fan (FM31/J2171) (Unit of replacement: CABLE, FAN) - Developer Upper Cooling Fan (FM31) - Main Driver PCB (UN78) (Unit of replacement: MAIN DRIVE DRIVER PCB ASS'Y) <p>[Remedy] Check/replace the related harness/cable, connector and parts.</p>

E820-0002-05	Duplex Driver Cooling Fan error
Detection Description	The Fan stop signal is detected for 5 seconds or longer and retry is failed 4 times in a row although the Duplex Driver Cooling Fan is turned ON.
Remedy	<p>[Related parts]</p> <ul style="list-style-type: none"> - Harnesses from the Duplex Driver PCB to the Transfer Cleaner Cooling Fan 1. Duplex Driver PCB (UN80/J340) to Relay Connector (3P) (Unit of replacement: CABLE, FIXING/FEEDER DRAWER) 2. Relay Connector (3P) to Transfer Cleaner Cooling Fan (FM08/J2121) (Unit of replacement: CABLE, DUPLEXING FEED FAN) - Transfer Cleaner Cooling Fan (FM08) - Duplex Driver PCB (UN80) (Unit of replacement: DUPLEXING DRIVER PCB ASSEMBLY) <p>[Remedy] Check/replace the related harness/cable, connector and parts.</p>
E824-0000-05	Primary Charging Air Supply Fan error
Detection Description	The Fan stop signal is detected for 5 seconds or longer and retry is failed 4 times in a row although the Primary Charging Air Supply Fan is turned ON.
Remedy	<p>[Related parts]</p> <ul style="list-style-type: none"> - Harnesses from the Main Driver PCB to the Primary Charging Air Supply Fan 1. Main Driver PCB (UN78/J130) to Relay Connector (17P) (Unit of replacement: CABLE, MAIN DRIVER, REAR UPPER) 2. Relay Harness (17P) (Unit of replacement: CABLE, RELAY, FRONT, CABLE, MAIN DRIVER, FRONT) 3. Relay Connector (17P) to Primary Charging Air Supply Fan (FM02/J2131) (Unit of replacement: CABLE, FAN) - Primary Charging Air Supply Fan (FM02) - Main Driver PCB (UN78) (Unit of replacement: MAIN DRIVE DRIVER PCB ASS'Y) <p>[Remedy] Check/replace the related harness/cable, connector and parts.</p>
E850-0000-05	Double feed detection error
Detection Description	Initialization of the Double Feeding Detection Kit failed.
Remedy	<p>[Related parts]</p> <ul style="list-style-type: none"> - Harnesses from the Fixing Feed Drawer Unit to the Double Feeding Detection Kit 1. Fixing Feed Drawer Unit (J5005L) to Relay Connector (8P) (Unit of replacement: CABLE, FIXING/FEEDER DRAWER) 2. Relay Connector (8P) to Double Feeding Detection Kit (J5006) (Unit of replacement: CABLE, SIGNAL CONNECTING) - Harness between the DC Controller PCB (UN1/J9, J431, J8 and J432) and the Fixing Feed Drawer Unit (J5005D) (Unit of replacement: CABLE, SIGNAL) - Double Feeding Detection Kit (Unit of replacement: DOUBLE FEED DETECTION KIT) - DC Controller PCB (UN1) (Unit of replacement: DC CONTROLLER PCB ASS'Y) <p>[Remedy] Perform the following in the order while checking whether the error is cleared.</p> <ol style="list-style-type: none"> 1. Check/replace the harness and sensor in the Double Feeding Detection Kit. 2. Check/replace the related harness/cable, connector and parts. <p>[Reference] Before replacing the DC Controller PCB, back up the service mode data (approx. 2 min) and restore the backup data after the replacement so the data may be able to be protected.</p> <ul style="list-style-type: none"> - Backup: COPIER (LEVEL2)> FUNCTION> SYSTEM> DSRAMBUP - Restoration: COPIER (LEVEL2)> FUNCTION> SYSTEM> DSRAMRES
E880-0001-00	Controller Fan error
Detection Description	It was detected that the Controller Fan was locked.
Remedy	<p>[Related parts]</p> <ul style="list-style-type: none"> - Controller Cooling Fan (FM04) - Main Controller PCB 1 (UN34) (Unit of replacement: MAIN CONTROLLER PCB ASS'Y, 1) <p>[Remedy] Perform the following in the order while checking whether the error is cleared.</p> <ol style="list-style-type: none"> 1. Check the connector of the Controller Cooling Fan. 2. Visually check that the Controller Cooling Fan is rotated. <ol style="list-style-type: none"> a. If it is not rotated, replace the Controller Cooling Fan. b. If it is rotated, replace the Main Controller PCB.

E881-0001-00	Board over heat error
Detection Description	Abnormal temperature of the Main Controller CPU was detected.
Remedy	<p>[Related parts]</p> <ul style="list-style-type: none"> - Main Controller PCB 1 (UN34) (Unit of replacement: MAIN CONTROLLER PCB ASS'Y, 1) - Main Controller PCB 2 (UN8) (Unit of replacement: MAIN CONTROLLER PCB ASS'Y, 2) <p>[Remedy] Perform the following in the order while checking whether the error is cleared.</p> <p>a. If the error occurred during a service visit and then occurred again:</p> <ol style="list-style-type: none"> 1. Replace the Main Controller PCB 1. 2. Replace the Main Controller PCB 2. <p>[CAUTION] When replacing the Main Controller PCB 2, execute "Adjustment after the Main Controller PCB 2 replacement" in situation mode.</p> <p>b. If the error does not occur during a service visit but is found in the log:</p> <ol style="list-style-type: none"> 1. Clean the inlet on the side where the fan is installed and remove dust. 2. Remove dust from the fan in the Controller Box. 3. If the space on the side where the fan is installed is less than 10 cm, ask the customer to secure enough space.
E890-0000-05	Double feed detection error
Detection Description	A communication error of the Double Feed Detection Sensor was detected.
Remedy	<p>[Related parts]</p> <ul style="list-style-type: none"> - Harnesses from the Fixing Feed Drawer Unit to the Double Feeding Detection Kit 1. Fixing Feed Drawer Unit (J5005L) to Relay Connector (8P) (Unit of replacement: CABLE, FIXING/FEEDER DRAWER) 2. Relay Connector (8P) to Double Feeding Detection Kit (J5006) (Unit of replacement: CABLE, SIGNAL CONNECTING) - Harness between the DC Controller PCB (UN1/J9, J431, J8 and J432) and the Fixing Feed Drawer Unit (J5005D) (Unit of replacement: CABLE, SIGNAL) - Double Feeding Detection Kit (Unit of replacement: DOUBLE FEED DETECTION KIT) - DC Controller PCB (UN1) (Unit of replacement: DC CONTROLLER PCB ASS'Y) <p>[Remedy] Perform the following in the order while checking whether the error is cleared.</p> <ol style="list-style-type: none"> 1. Check/replace the harness and sensor in the Double Feeding Detection Kit. 2. Check/replace the related harness/cable, connector and parts. <p>[Reference] Before replacing the DC Controller PCB, back up the service mode data (approx. 2 min) and restore the backup data after the replacement so the data may be able to be protected.</p> <ul style="list-style-type: none"> - Backup: COPIER (LEVEL2)> FUNCTION> SYSTEM> DSRAMBUP - Restoration: COPIER (LEVEL2)> FUNCTION> SYSTEM> DSRAMRES
E996-007F-04	Code unspecified error (PRINTER)
Detection Description	This is displayed when the error code is unspecified or software sequence error (when the jam code is unspecified) occurs.
Remedy	<p>[Remedy] Collect debug log and contact the sales company.</p> <p>[Reference] By setting "COPIER (LEVEL2) > OPTION > FNC-SW > JM-ERR-R" to "1", it is handled as an error instead of a jam from the first occurrence.</p>
E996-0CA1-05	Error for collecting sequence jam log (Printer)
Detection Description	Error for collecting jam log (Printer)
Remedy	<p>[Remedy] Collect debug log and contact to the sales company.</p> <p>[Reference] By setting "COPIER (LEVEL2)> OPTION> FNC-SW> JM-ERR-D" to "1", it is handled as an error instead of a jam from the first occurrence.</p>
E996-0CA2-05	Error for collecting sequence jam log (Printer)
Detection Description	Error for collecting jam log (Printer)
Remedy	<p>[Remedy] Collect debug log and contact to the sales company.</p> <p>[Reference] By setting "COPIER (LEVEL2)> OPTION> FNC-SW> JM-ERR-D" to "1", it is handled as an error instead of a jam from the first occurrence.</p>

E996-0CA3-05	Error for collecting sequence jam log (Printer)
Detection Description	Error for collecting jam log (Printer)
Remedy	[Remedy] Collect debug log and contact to the sales company. [Reference] By setting "COPIER (LEVEL2)> OPTION> FNC-SW> JM-ERR-D" to "1", it is handled as an error instead of a jam from the first occurrence.
E996-0CA4-05	Error for collecting sequence jam log (Printer)
Detection Description	Error for collecting jam log (Printer)
Remedy	[Remedy] Collect debug log and contact to the sales company. [Reference] By setting "COPIER (LEVEL2)> OPTION> FNC-SW> JM-ERR-D" to "1", it is handled as an error instead of a jam from the first occurrence.
E996-0CA5-05	Error for collecting sequence jam log (Printer)
Detection Description	Error for collecting jam log (Printer)
Remedy	[Remedy] Collect debug log and contact to the sales company. [Reference] By setting "COPIER (LEVEL2)> OPTION> FNC-SW> JM-ERR-D" to "1", it is handled as an error instead of a jam from the first occurrence.
E996-0CAF-05	Error for collecting sequence jam log (Printer)
Detection Description	Error for collecting jam log (Printer)
Remedy	[Remedy] Collect debug log and contact to the sales company. [Reference] By setting "COPIER (LEVEL2)> OPTION> FNC-SW> JM-ERR-D" to "1", it is handled as an error instead of a jam from the first occurrence.
E996-0CE0-05	Code unspecified error (DADF)
Detection Description	This is displayed when the error code is unspecified or software sequence error (when the jam code is unspecified) occurs.
Remedy	[Remedy] Collect debug log and contact the sales company. [Reference] By setting "COPIER (LEVEL2) > OPTION > FNC-SW > JM-ERR-R" to "1", it is handled as an error instead of a jam from the first occurrence.

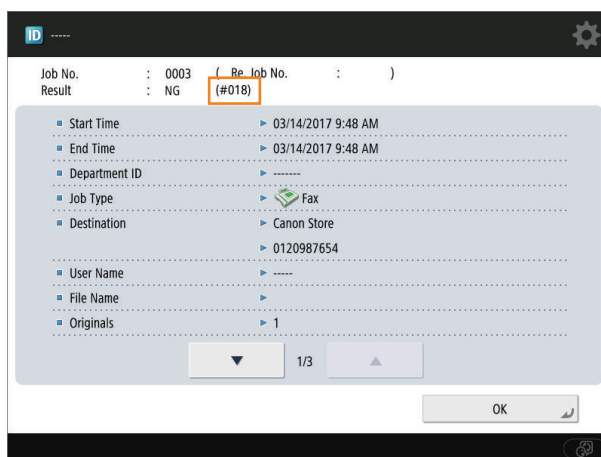
Error Code (FAX)

How to View Fax Error Codes

When the service mode #1 SSSW SW01 Bit0 is set to "1" after installing the Fax Board, service error code is output on the communication management report, reception result report, and error transmission report in the event that the communication is resulted in an error.

Moreover, when an error occurs, the error code can be checked by performing the following procedure.

Status Monitor/Cancel > Send > Job Log > Details



The error codes displayed on the screen are shown in a list in "User Error Codes" and "Service Error Codes".

For remedies for user error codes, refer to the User's Guide. For remedies for service error codes, refer to "G3/G4 Facsimile Error Code List (REVISION 2)" (document number: HY8-23A0-020) provided as a separate volume.

User error codes

Regarding the user error codes, refer to Top > Troubleshooting > A Message or a Number Starting with "#" (an Error Code) Is Displayed > Countermeasures for Each Error Code.

Service Error Code

Code	Cause	Remedy
##3016	[T/R] An instruction of disconnection (BYE) was received from the network at an unexpected time.	Perform a communication again.

*1: G3FAX

*2: IPFAX

No.*1	No.*2	T/R	Description
##100	##3100	[T]	at time of transmission, the procedural signal has been transmitted more than specified.
##101	##3101	[T/R]	the modem speed does not match that of the other party.
##102	##3102	[T]	at time of transmission, fall-back cannot be used.
##103	##3103	[R]	at time of reception, EOL cannot be detected for 5 sec (15 sec if CBT).
##104	##3104	[T]	at time of transmission, RTN or PIN is received.
##106	##3106	[R]	at time of reception, the procedural signal is received for 6 sec while in wait for the signal.
##107	##3107	[R]	at time of reception, the transmitting party cannot use fall-back.
##109	##3109	[T]	at time of transmission, a signal other than DIS, DTC, FTT, CFR, or CRP is received, and the procedural signal has been sent more than specified.
##111	##3111	[T/R]	memory error has occurred.

No.*1	No.*2	T/R	Description
##114	##3114	[R]	at time of reception, RTN is transmitted.
##116	##3116	[T/R]	Disconnection of loop current was detected during communication.
##200	##3200	[R]	at time of reception, no image carrier is detected for 5 sec.
##201	##3201	[T/R]	DCN is received outside the normal parity procedure.
##204	##3204	[T]	DTC without transmission data is received.
##220	##3220	[T/R]	system error (main program out of control) has occurred.
##223	##3223	[T/R]	while a communication is under way, the line is cut.
##224	##3224	[T/R]	in communication, an error has occurred in the procedural signal.
##226	##3226	[T/R]	the stack printer has fallen outside the RAM area.
##227	##3227	[R]	An attempt was made to record a file without image.
##229	##3229	[R]	the recording unit has remained locked for 1 min.
##230	##3230	[T/R]	A unit for controlling the display has malfunctioned.
##231	##3231	[T/R]	A unit for controlling the Control Panel buttons has malfunctioned.
##232	##3232	[T]	encoding error has occurred.
##237	##3237	[R]	decoding error has occurred.
##238	##3238	[R]	the print control unit is out of order.
##261	##3261	[T/R]	system error has occurred.
##280	##3280	[T]	at time of transmission, the procedural signal has been transmitted more than specified.
##281	##3281	[T]	at time of transmission, the procedural signal has been transmitted more than specified.
##282	##3282	[T]	at time of transmission, the procedural signal has been transmitted more than specified.
##283	##3283	[T]	at time of transmission, the procedural signal has been transmitted more than specified.
##284	##3284	[T]	at time of transmission, DCN is received after transmission of TCF.
##285	##3285	[T]	at time of transmission, DCN is received after transmission of EOP.
##286	##3286	[T]	at time of transmission, DCN is received after transmission of EOM.
##287	##3287	[T]	at time of transmission DCN is received after transmission of MPS.
##288	##3288	[T]	after transmission of EOP, a signal other than PIN, PIP, MCF, RTP, or RTN has been received.
##289	##3289	[T]	after transmission of EOM, a signal other than PIN, PIP, MCF, RTP, or RTN has been received.
##290	##3290	[T]	after transmission of MPS, a signal other than PIN, PIP, MCF, RTP, or RTN has been received.
##670	##3670	[T]	at time of V.8 late start, the V.8 ability of DIS front the receiving party is expected to be detected, and the CI signal is expected to be transmitted in response; however, the procedure fails to advance, and the line is released because of T1 time-out.
##671	##3671	[R]	at time of V.8 arrival, procedure fails to move to phase 2 after detection of CM signal from caller, causing T1 time-out and releasing line.
##672	##3672	[T]	at time of V.34 transmission, a shift in procedure from phase 2 to phase 3 and thereafter stops, causing the machine to release the line and suffer T1 timeout.
##673	##3673	[R]	at time of V.34 reception, a shift in procedure from phase 2 to phase 3 and thereafter stops, causing the machine to release the line and suffer T1 timeout.
##674	##3674	[T]	at time of V.34 transmission, a shift in procedure from phase 3 and phase 4 to the control channel and thereafter stops, causing the machine to release the line and suffer T1 timeout.
##675	##3675	[R]	at time of V.34 reception, a shift in procedure from phase 3 and phase 4 to the control channel and thereafter stops, causing the machine to release the line and suffer T1 timeout.
##750	##3750	[T]	at time of ECM transmission, no meaningful signal is received after transmission of PPS-NULL, causing the procedural signal to be transmitted more than specified.
##752	##3752	[T]	at time of ECM transmission, DCN is received after transmission of PPS-NULL.
##753	##3753	[T]	at time of ECM transmission, the procedural signal has been transmitted more than specified after transmission of PPS-NULL, or T5 time-out (60 sec) has occurred.
##754	##3754	[T]	at time of ECM transmission, the procedural signal has been transmitted more than specified after transmission of PPS-NULL.

No.*1	No.*2	T/R	Description
##755	##3755	[T]	at time of ECM transmission, no meaningful signal is received after transmission of PPS-MPS, causing the procedural signal to be transmitted more than specified.
##757	##3757	[T]	at time of ECM transmission, DCN is received after retransmission of PPS-MPS.
##758	##3758	[T]	at time of ECM transmission, the procedural signal has been transmitted more than specified after transmission of PPS-MPS, or T5 time-out (60 sec) has occurred.
##759	##3759	[T]	at time of ECM transmission, the procedural signal has been transmitted more than specified after transmission of PPS-MPS.
##760	##3760	[T]	at time of ECM transmission, no meaningful signal is received after transmission of PPS-EOM, causing the procedural signal to be transmitted more than specified.
##762	##3762	[T]	at time of ECM transmission, DCN is received after transmission of PPS-EOM.
##763	##3763	[T]	at time of ECM transmission, the procedural signal has been transmitted more than specified after transmission of PPS-MPS, or T5 time-out (60 sec) has occurred.
##764	##3764	[T]	at time of ECM transmission, the procedural signal has been transmitted more than specified after transmission of PPS-EOM.
##765	##3765	[T]	at time of ECM transmission, no meaningful signal is received after transmission of PPS-EOP, causing the procedural signal to be transmitted more than specified.
##767	##3767	[T]	at time of ECM transmission, DCN is received after transmission of PPS-EOP.
##768	##3768	[T]	at time of ECM transmission, the procedural signal has been transmitted more than specified after transmission of PPS-EOP, or T5 time-out (60 sec) has occurred.
##769	##3769	[T]	at time of ECM transmission, the procedural signal has been transmitted more than specified after transmission of PPS-EOP.
##770	##3770	[T]	at time of ECM transmission, no meaningful signal is received after transmission of EOR-NULL, causing the procedural signal to be transmitted more than specified.
##772	##3772	[T]	at time of ECM transmission, DCN is received after transmission of EOR-NULL.
##773	##3773	[T]	at time of ECM transmission, the procedural signal has been transmitted more than specified after transmission of EOR-NULL, or T5 time-out (60 sec) has occurred.
##774	##3774	[T]	at time of ECM transmission, ERR is received after transmission of EOR-NULL.
##775	##3775	[T]	at time of ECM transmission, no meaningful signal is received after transmission of EOR-MPS, causing the procedural signal to be transmitted more than specified.
##777	##3777	[T]	at time of ECM transmission, DCN is received after transmission of EOR-MPS.
##778	##3778	[T]	at time of ECM transmission, the procedural signal has been transmitted more than specified after transmission EOR-MPS, or T5 time-out (60 sec) has occurred.
##779	##3779	[T]	at time of ECM transmission, ERR is received after transmission of EOR-MPS.
##780	##3780	[T]	at time of ECM transmission, no meaningful signal is received after transmission of EOR-EOM, causing the procedural signal to be transmitted more than specified.
##782	##3782	[T]	at time of ECM transmission, DCN is received after transmission of EOR-EOM.
##783	##3783	[T]	at time of ECM transmission, the procedural signal has been transmitted more than specified after transmission of EOR-EOM, or T5 time-out (60 sec) has occurred.
##784	##3784	[T]	at time of ECM transmission, ERR is received after transmission of EOR-EOM.
##785	##3785	[T]	at time of ECM transmission, no meaningful signal is received after transmission of EOR-EOP, causing the procedural signal to be transmitted more than specified.
##787	##3787	[T]	at time of ECM transmission, DCN is received after transmission of EOR-EOP.
##788	##3788	[T]	at time of ECM transmission, the procedural signal has been transmitted more than specified after transmission of EOR-EOP, or T5 time-out (60 sec) has occurred.
##789	##3789	[T]	at time of ECM transmission, ERR is received after transmission of EOR-EOP.
##790	##3790	[R]	at time of ECM reception, ERR is transmitted after transmission of EOR-Q.
##791	##3791	[T/R]	while ECM mode procedure is under way, a signal other than a meaningful signal is received.
##792	##3792	[R]	at time of ECM reception, PPS-NULL cannot be detected over partial page processing.
##793	##3793	[R]	at time of ECM reception, no effective frame is received while high-speed signal reception is under way, thus causing time-out.
##794	##3794	[T]	at time of ECM reception, PPR with all 0s is received.
##795	##3795	[T/R]	a fault has occurred in code processing for communication.
##796	##3796	[T/R]	a fault has occurred in code processing for communication.

Limited Functions Mode

Original Exposure System

When the error code is detected with the DADF, the Reader Limited Functions Mode is temporarily entered. After this, by turning OFF and then ON the main power switch, the DADF Limited Functions Mode is entered.

Yes: Available, No: Not available

	Copyboard reading	Stream scanning
Reader	No	No
DADF	Yes	No

NOTE:

The Printing function of host machine is available even in the Limited Functions Mode.

■ Relevant error code

Reader Limited Functions

Code	Detail Code	Details
E202	0001	Reader Scanner Unit HP error
	0002	
	0003	
	0010	
E227	0101	Power supply (24V) error
E248	0001	EEPROM error
	0002	
E270	0001	Scanner Unit (Paper Front) VSYNC signal error
	0002	HSYNC error
E280	0001	Communication error between Reader Controller PCB and Scanner Unit (Reader)
	0002	
	0003	
E302	0001	Error in paper front shading
	0002	
E423	0001	SDRAM error in the Reader Controller PCB

DADF Limited Functions

Code	Detail Code	Details
E202	0101	Scanner Unit (DADF) HP error
	0102	
E270	0101	Scanner Unit (Paper Back) VSYNC signal error
E280	0101	Communication error between Reader Controller PCB and Scanner Unit (DADF)
	0102	
	0103	
E302	0101	Error in paper back shading
	0102	
E400	0002	Communication error between Reader Controller PCB and DADF
	0003	
E401	0001	Pickup Roller Unit lifting error
	0002	
E407	0001	Tray Lifting Motor error
	0002	

Alarm Code

Alarm Code Details

00-0085	A notice of state
A. Operation / B. Cause / C. Remedy	-
00-0246	Error code display (4-digit)
A. Operation / B. Cause / C. Remedy	Soft counter PCB cannot write normally
00-0247	Error code display (4-digit)
A. Operation / B. Cause / C. Remedy	Soft counter PCB cannot restore data
01-0001	Notification of disabled to obtain counter values for a certain period of time
A. Operation / B. Cause / C. Remedy	Counter information is not set to UGW * Not displayed on service mode history due to the alarm being generated by UGW
01-0002	No change in device status after specified period of time has passed (RDS server creates)
A. Operation / B. Cause / C. Remedy	-
01-0004	Notification of IP address change
A. Operation / B. Cause / C. Remedy	IP address has been changed * Not displayed on service mode history due to the alarm being generated by UGW
01-0005	Restricted operation notification
A. Operation / B. Cause / C. Remedy	The device entered limited function mode for some reason. * Not displayed on service mode history due to the alarm being generated by UGW
02-0020	Dust correction (paper front) occurrence
A. Operation / B. Cause / C. Remedy	Movement: Execute correction process to the pixel where dust is detected (image on paper front) Cause: Dust is detected on the Stream Read Glass (paper front). Measures: Clean the Stream Read Glass (paper front), and check if the Platen Roller 1 is soiled. If necessary, clean it.
02-0021	Dust correction (paper back) occurrence
A. Operation / B. Cause / C. Remedy	Movement: Execute correction process to the pixel where dust is detected (image on paper back with 1-Path DADF). Cause: Dust is detected on the Scanner Glass (paper back). Measures: Clean and check the Scanner Glass (paper back), and check if the Platen Roller 2 is soiled.
02-0025	Insufficient Scanner Unit LED light intensity alarm
A. Operation / B. Cause / C. Remedy	In the case that the light intensity is insufficient at LED lighting. (Some of the LEDs are OFF. Scanning can be continued.)

04-0001	Right Deck Lifter error
A. Operation / B. Cause / C. Remedy	<p>Movement: The Right Deck Lifter Motor (M4) is stopped. Not using the Right Deck.</p> <p>Cause: The Right Deck Lifter does not rise, failure of the Right Deck Paper Height Sensor (PS6).</p> <p>Measures:</p> <ol style="list-style-type: none"> 1. Turn OFF/ON the power. <p>When it is recovered, the measure is completed. If it is not recovered, execute the following measures.</p> <ol style="list-style-type: none"> 2. Check if the Deck Lifter rises. <p>If not, execute the following measures. If an alarm occurs although it rises, execute step 5 and later steps.</p> <ol style="list-style-type: none"> 3. Check the connection between the Right Deck Lifter Motor (M4) and the Feed Driver PCB (PCB3). Motor side: J2069, PCB side: J225 4. Replace the Right Deck. 5. Check the connection between the Right Deck Paper Height Sensor (PS6) and the Feed Driver PCB (PCB3). Sensor side: J2063, J3633 (relay), PCB side: J222 6. Check the operation of the Right Deck Paper Height Sensor (PS6), and replace it. 7. Replace the Feed Driver PCB (PCB3).
04-0002	Left Deck Lifter error
A. Operation / B. Cause / C. Remedy	<p>Movement: The Left Deck Lifter Motor (M5) is stopped. Not using the Left Deck.</p> <p>Cause: The Left Deck Lifter does not rise, failure of the Left Deck Paper Height Sensor (PS10).</p> <p>Measures:</p> <ol style="list-style-type: none"> 1. Turn OFF and then ON the power. <p>When it is recovered, the measure is completed. If it is not recovered, execute the following measures.</p> <ol style="list-style-type: none"> 2. Check if the Deck Lifter rises. <p>If not, execute the following measures. If an alarm occurs although it rises, execute step 5 and later steps.</p> <ol style="list-style-type: none"> 3. Check the connection between the Left Deck Lifter Motor (M5) and the Feed Driver PCB (PCB3). Motor side: J2051, PCB side: J225 4. Replace the Left Deck. 5. Check the connection between the Left Deck Paper Height Sensor (PS10) and the Feed Driver PCB (PCB3). Sensor side: J2045, J3634 (relay), PCB side: J221 6. Check the operation of the Left Deck Paper Height Sensor (PS10), and replace it if necessary. 7. Replace the Feed Driver PCB (PCB3).
04-0003	Cassette 3 Lifter error
A. Operation / B. Cause / C. Remedy	<p>Movement: The Cassette 3 Lifter Motor (M20) is stopped. Not using the Cassette 3.</p> <p>Cause: The Cassette Lifter does not rise, failure of the Cassette 3 Paper Height Sensor (PS17).</p> <p>Measures:</p> <ol style="list-style-type: none"> 1. Turn OFF and then ON the power. <p>When it is recovered, the measure is completed. If it is not recovered, execute the following measures.</p> <ol style="list-style-type: none"> 2. Check if the Deck Lifter rises. <p>If not, execute the following measures. If an alarm occurs although it rises, execute step 5 and later steps.</p> <ol style="list-style-type: none"> 3. Check the connection between the Cassette 3 Lifter Motor (M20) and the Feed Driver PCB (PCB3). Motor side: J2072, PCB side: J225 4. Replace the Cassette 3. 5. Check the connection between the Cassette 3 Paper Height Sensor (PS17) and the Feed Driver PCB (PCB3). Sensor side: J2080, J3635 (relay), PCB side: J223 6. Check the operation of the Cassette 3 Paper Height Sensor (PS17), and replace it if necessary. 7. Replace the Feed Driver PCB (PCB3).

04-0004	Cassette 4 Lifter error
A. Operation / B. Cause / C. Remedy	<p>Movement: The Cassette 4 Lifter Motor (M21) is stopped. Not using the Cassette 4.</p> <p>Cause: The Cassette 4 Lifter does not rise, failure of the Cassette 4 Paper Height Sensor (PS18).</p> <p>Measures:</p> <ol style="list-style-type: none"> 1. Turn OFF and then ON the power. <p>When it is recovered, the measure is completed. If it is not recovered, execute the following measures.</p> <ol style="list-style-type: none"> 2. Check if the Deck Lifter rises. <p>If not, execute the following measures. If an alarm occurs although it rises, execute step 5 and later steps.</p> <ol style="list-style-type: none"> 3. Check the connection between the Cassette 4 Lifter Motor (M21) and the Feed Driver PCB (PCB3). Motor side: J2074, PCB side: J225 4. Replace the Cassette 4. 5. Check the connection between the Cassette 4 Paper Height Sensor (PS18) and the Feed Driver PCB (PCB3). Sensor side: J2091, J3636 (relay), PCB side: J224 6. Check the operation of the Cassette 4 Paper Height Sensor (PS18), and replace it if necessary. 7. Replace the Feed Driver PCB (PCB3).
04-0010	Notification of jam left untouched
A. Operation / B. Cause / C. Remedy	<p>Jam is left untouched</p> <p>* Not displayed on service mode history due to the alarm being generated by UGW</p>
04-0069	Error in Right Deck Pickup Solenoid connection
A. Operation / B. Cause / C. Remedy	<p>Movement: Jam occurred when picking up from the Right Deck.</p> <p>Cause: Connection of the Right Deck Pickup Solenoid (SL6) cannot be detected.</p> <p>Measures:</p> <ol style="list-style-type: none"> 1. Check the connection of the Right Deck Pickup Solenoid (SL6). Solenoid side: J2070, Pickup Unit side: J3633, Feed Driver PCB side: J222 2. Replace the Right Deck Pickup Solenoid (SL6). 3. Replace the Feed Driver PCB (PCB3).
04-0070	Error in Left Deck Pickup Solenoid connection
A. Operation / B. Cause / C. Remedy	<p>Movement: Jam occurred when picking up from the Left Deck.</p> <p>Cause: Connection of the Left Deck Pickup Solenoid (SL7) cannot be detected.</p> <p>Measures:</p> <ol style="list-style-type: none"> 1. Check the connection of the Left Deck Pickup Solenoid (SL7). Solenoid side: J2052, Pickup Unit side: J3634, Feed Driver PCB side: J221 2. Replace the Left Deck Pickup Solenoid (SL7). 3. Replace the Feed Driver PCB (PCB3).
04-0071	Error in Cassette 3 Pickup Solenoid connection
A. Operation / B. Cause / C. Remedy	<p>Movement: Jam occurred when picking up from the Cassette 3.</p> <p>Cause: Connection of the Cassette 3 Pickup Solenoid (SL3) cannot be detected.</p> <p>Measures:</p> <ol style="list-style-type: none"> 1. Check the connection of the Cassette 3 Pickup Solenoid (SL3). Solenoid side: J2073, Pickup Unit side: J3635, Feed Driver PCB side: J223 2. Replace the Cassette 3 Pickup Solenoid (SL3). 3. Replace the Feed Driver PCB (PCB3).
04-0072	Error in Cassette 4 Pickup Solenoid connection
A. Operation / B. Cause / C. Remedy	<p>Movement: Jam occurred when picking up from the Cassette 4.</p> <p>Cause: Connection of the Cassette 4 Pickup Solenoid (SL4) cannot be detected.</p> <p>Measures:</p> <ol style="list-style-type: none"> 1. Check the connection of the Cassette 4 Pickup Solenoid (SL4). Solenoid side: J2075, Pickup Unit side: J3636, Feed Driver PCB side: J224 2. Replace the Cassette 4 Pickup Solenoid (SL4). 3. Replace the Feed Driver PCB (PCB3).

04-0073	Error in Multi-purpose Pickup Solenoid connection
A. Operation / B. Cause / C. Remedy	<p>Movement: Jam occurred when picking up from the Multi-purpose Tray.</p> <p>Cause: Connection of the Multi-purpose Pickup Solenoid (SL2) cannot be detected.</p> <p>Measures:</p> <ol style="list-style-type: none"> 1. Check the connection of the Multi-purpose Pickup Solenoid (SL2). Solenoid side: J2001, Relay: J3060, J3121, J3235, Main Driver PCB side: J106 2. Replace the Multi-purpose Pickup Solenoid (SL2). 3. Replace the Main Driver PCB (PCB2).
04-0074	Error in Left Deck Merging Solenoid connection
A. Operation / B. Cause / C. Remedy	<p>Movement: Jam occurred when picking up from the Left Deck.</p> <p>Cause: Connection of the Left Deck Merging Solenoid (SL11) cannot be detected.</p> <p>Measures:</p> <ol style="list-style-type: none"> 1. Check the connection of the Left Deck Merging Solenoid (SL11). Solenoid side: J2106, Relay side: J3270, Duplex Driver PCB side: J343 2. Replace the Left Deck Merging Solenoid (SL11). 3. Replace the Duplex Driver PCB (PCB4).
04-0075	Error in Reverse Detachment Solenoid connection
A. Operation / B. Cause / C. Remedy	<p>Movement: Jam occurred at the time of large size paper reverse delivery.</p> <p>Cause: Connection of the Reverse Detachment Solenoid (SL12) cannot be detected.</p> <p>Measures:</p> <ol style="list-style-type: none"> 1. Check the connection of the Reverse Detachment Solenoid (SL12). Solenoid side: J2176, Duplex Driver PCB side: J340 2. Replace the Reverse Detachment Solenoid (SL12). 3. Replace the Duplex Driver PCB (PCB4).
04-1537	Deck Lifter descent alarm (POD Deck Lite/Paper Deck Unit)
A. Operation / B. Cause / C. Remedy	<p>Cause:</p> <ul style="list-style-type: none"> - Error in the Lifter Plate or error in the Lifter Wire - Error in the Deck Lifter Motor or error in the harness - Error in the Deck Lifter Lower Position Sensor or error in the harness - Error in the Relay Paper Sensor or error in the harness <p>Detection condition/timing: The Deck Lifter Lower Position Sensor was not turned ON within the specified period of time when lowering the lifter.</p> <p>Movement/symptom: The machine automatically enters limited functions mode. (The Deck cannot be used.)</p> <p>Measures:</p> <ol style="list-style-type: none"> 1. Open the compartment and check for any foreign matter in it. If there is any foreign matter, remove it. 2. Check that the Lifter Plate is not caught by the Side Guide. If there is a catch, repair it. 3. Remove the deck front cover, and check that the lifter wire is properly installed (no coming off, disconnection, slack, or winding in the reverse direction). If there is an error, repair it. <p>When the lifter wire is wound in the reverse direction at the deck lifter alarm (04-1537) occurrence, execute the following service mode.</p> <ul style="list-style-type: none"> - Drive of Deck Lifter Motor: COPIER> FUNCTION> CST> DK1-LIFT <ol style="list-style-type: none"> 4. Execute service mode: COPIER> FUNCTION> CLEAR> DK-RCV and clear the Deck Lifter descent alarm. 5. Turn OFF/ON the main power switch. 6. Push the Relay Paper Sensor Flag and check that the Lifter Plate being lowered stops at the lowest position. <ol style="list-style-type: none"> a. If it is not lowered: <ul style="list-style-type: none"> - Check/replace the harness and connector between the Deck Driver PCB and the Relay Paper Sensor. - Check/replace the harness and connector between the Box Driver PCB and the Deck Lifter Motor. - Replace the Relay Paper Sensor. - Replace the Box Driver PCB. b. Although it is lowered, it does not stop at the lowest position. <ul style="list-style-type: none"> - Check/replace the harness and connector between the Box Driver PCB and the Deck Lifter Lower Position Sensor. - Replace the Box Driver PCB. - Replace the Deck Lifter Lower Position Sensor.

04-1539	Deck Paper Level Sensor alarm (POD Deck Lite/Paper Deck Unit)
A. Operation / B. Cause / C. Remedy	<p>Cause:</p> <ul style="list-style-type: none"> - Error in the Lifter Plate or error in the Lifter Wire - Error in the Paper Level Sensor or error in the harness - Error in the Relay Paper Sensor or error in the harness - Error in the Deck Lifter Motor or error in the harness <p>Detection condition/timing: The Deck Paper Level Sensor was not turned ON within the specified period of time when raising the lifter.</p> <p>Movement/symptom: The machine automatically enters limited functions mode. (The Deck cannot be used.)</p> <p>Measures:</p> <ol style="list-style-type: none"> 1. Open the compartment and check that the Lifter Plate is not caught by the Side Guide. If there is a catch, repair it. 2. Remove the deck front cover, and check that the lifter wire is properly installed (no coming off, disconnection, or slack). If there is an error, repair it. 3. Remove the deck right cover, close the compartment. 4. Turn OFF/ON the main power switch, and check if the Lifter Plate is raised from the right side. 5. If it is not raised, execute the following operations. <ul style="list-style-type: none"> - Check/replace the harness and connector between the Deck Driver PCB and the Paper Level Sensor. - Check/replace the harness and connector between the Deck Driver PCB and the Relay Paper Sensor. - Check/replace the harness and connector between the Box Driver PCB and the Deck Lifter Motor. - Check/replace the harness and connector between the Box Driver PCB and the Deck Driver PCB. - Replace the Paper Level Sensor. - Replace the Relay Paper Sensor. - Replace the Deck Lifter Motor. - Replace the Box Driver PCB. - Replace the Deck Driver PCB.
04-1542	Deck Lifter upper limit alarm (POD Deck Lite/Paper Deck Unit)
A. Operation / B. Cause / C. Remedy	<p>Cause:</p> <ul style="list-style-type: none"> - Error in the Deck Lifter Upper Limit Sensor 1/2 or error in the harness - Error in the Paper Level Sensor or error in the harness <p>Detection condition/timing: The Deck Lifter Upper Limit Sensor 1/2 were turned ON while raising the lifter.</p> <p>Movement/symptom: The machine automatically enters limited functions mode. (The Deck cannot be used.)</p> <p>Measures:</p> <ol style="list-style-type: none"> 1. Check for any damaged parts around the flag of the Deck Lifter Upper Limit Sensor 1/2. 2. Check/replace the harness and connector between the Box Driver PCB and the Deck Lifter Upper Limit Sensor 1/2. 3. Check/replace the harness and connector between the Box Driver PCB and the Paper Level Sensor. 4. Replace the Deck Lifter Upper Limit Sensor 1/2. 5. Replace the Paper Level Sensor. 6. Replace the Box Driver PCB.

04-1543	Deck lifter lower limit alarm (POD Deck Lite/Paper Deck Unit)
A. Operation / B. Cause / C. Remedy	<p>Cause:</p> <ul style="list-style-type: none"> - Error in the Deck Lifter Lower Position Sensor or error in the harness - Error in the Deck Lifter Lower Limit Switch or error in the harness <p>Detection condition/timing: The Deck Lifter Lower Limit Switch was turned ON while lowering the lifter.</p> <p>Movement/symptom: The machine automatically enters limited functions mode. (The Deck cannot be used.)</p> <p>Measures:</p> <ol style="list-style-type: none"> 1. Check for any damaged parts around the flag of the Deck Lifter Lower Position Sensor. If there are damaged parts, replace it. 2. Check/replace the harness and connector between the Box Driver PCB and the Deck Lifter Lower Position Sensor. 3. Check/replace the harness and connector between the Box Driver PCB and the Deck Lifter Lower Limit Switch. 4. Check/replace the harness and connector between the Box Driver PCB and the Deck Lifter Lower Limit Switch. 5. Replace the Deck Lifter Lower Position Sensor. 6. Replace the Deck Lifter Lower Limit Switch. 7. Replace the Box Driver PCB.
04-1553	Deck Warming Fan alarm (POD Deck Lite)
A. Operation / B. Cause / C. Remedy	<p>Cause: Error in the Warming Fan (FM2) or error in the harness</p> <p>Detection condition/timing: Rotation speed error of the Warming Fan was detected.</p> <p>Movement/symptom: The machine automatically enters limited functions mode. (The Deck cannot be used.)</p> <p>Measures:</p> <ol style="list-style-type: none"> 1. Check/replace the harness and connector between the Swing Driver PCB and the Warming Fan. 2. Check/replace the harness and connector between the Swing Driver PCB and the Box Driver PCB. 3. Check/replace the harness and connector between the Box Driver PCB and the Deck Driver PCB. 4. Replace the Warming Fan. 5. Replace the Swing Driver PCB. 6. Replace the Box Driver PCB. 7. Replace the Deck Driver PCB.
04-1555	Deck Cooling Fan alarm (POD Deck Lite)
A. Operation / B. Cause / C. Remedy	<p>Cause: Error in the Cooling Fan (FM3) or error in the harness</p> <p>Detection condition/timing: Rotation speed error of the Cooling Fan was detected.</p> <p>Movement/symptom: The machine automatically enters limited functions mode. (The Deck cannot be used.)</p> <p>Measures:</p> <ol style="list-style-type: none"> 1. Check/replace the harness and connector between the Swing Driver PCB and the Cooling Fan. 2. Check/replace the harness and connector between the Swing Driver PCB and the Box Driver PCB. 3. Check/replace the harness and connector between the Box Driver PCB and the Deck Driver PCB. 4. Replace the Cooling Fan. 5. Replace the Swing Driver PCB. 6. Replace the Box Driver PCB. 7. Replace the Deck Driver PCB.

04-1581	Deck Swing HP Sensor alarm (POD Deck Lite)
A. Operation / B. Cause / C. Remedy	<p>Cause:</p> <ul style="list-style-type: none"> - Error in the Swing HP Sensor (SR16) or error in the harness - Error in the Swing Motor (M4) or error in the harness <p>Detection condition/timing: There was no change in the Swing HP Sensor although a specified period of time has passed.</p> <p>Movement/symptom: The machine automatically enters limited functions mode. (The Deck cannot be used.)</p> <p>Measures:</p> <ol style="list-style-type: none"> 1. Check/replace the harness and connector between the Swing Driver PCB and the Swing HP Sensor. 2. Check/replace the harness and connector between the Swing Driver PCB and the Swing Motor. 3. Check/replace the harness and connector between the Swing Driver PCB and the Box Driver PCB. 4. Check/replace the harness and connector between the Box Driver PCB and the Deck Driver PCB. 5. Replace the Swing HP Sensor. 6. Replace the Swing Motor. 7. Replace the Swing Driver PCB. 8. Replace the Box Driver PCB. 9. Replace the Deck Driver PCB.
04-1582	Deck Power Supply Cooling Fan alarm (POD Deck Lite)
A. Operation / B. Cause / C. Remedy	<p>Cause: Error in the Power Supply Cooling Fan (FM1) or error in the harness</p> <p>Detection condition/timing: The lock signal of the Power Supply Cooling Fan could not be detected for 1 sec.</p> <p>Movement/symptom: The machine automatically enters limited functions mode. (The Deck cannot be used.)</p> <p>Measures:</p> <ol style="list-style-type: none"> 1. Check/replace the harness and connector between the Deck Driver PCB and the Power Supply Cooling Fan. 2. Replace the Power Supply Cooling Fan. 3. Replace the Deck Driver PCB.
04-1583	Deck Air Heater low temperature alarm (POD Deck Lite)
A. Operation / B. Cause / C. Remedy	<p>Cause: Error in the Air Heater (H2) or error in the harness</p> <p>Detection condition/timing: After the Air Heater was turned on, the heater Ready signal is not turned on within 6 minutes.</p> <p>Movement/symptom: The machine automatically enters limited functions mode. (The Deck cannot be used.)</p> <p>Measures:</p> <ol style="list-style-type: none"> 1. Check/replace the harness and connector between the Air Heater Driver PCB and the Air Heater. 2. Replace the Air Heater. 3. Replace the Air Heater Driver PCB. 4. Replace the Deck Driver PCB.
04-1584	Deck Air Heater overheating alarm (POD Deck Lite)
A. Operation / B. Cause / C. Remedy	<p>Cause: Error in the Air Heater (H2) or error in the harness</p> <p>Detection condition/timing: After the Air Heater was turned on, the heater error signal was turned on 2 minutes or later.</p> <p>Movement/symptom: The machine automatically enters limited functions mode. (The Deck cannot be used.)</p> <p>Measures:</p> <ol style="list-style-type: none"> 1. Check/replace the harness and connector between the Air Heater Driver PCB and the Air Heater. 2. Replace the Air Heater. 3. Replace the Air Heater Driver PCB. 4. Replace the Deck Driver PCB.

04-1585	Deck Pickup Release Solenoid Cooling Fan alarm (POD Deck Lite/Paper Deck Unit)
A. Operation / B. Cause / C. Remedy	<p>Cause: Error in the Pickup Release Solenoid Cooling Fan (FM4) or error in the harness</p> <p>Detection condition/timing: The fan lock detection signal is not detected ON while the Pickup Release Solenoid Cooling Fan is driven.</p> <p>Movement/symptom: The machine automatically enters limited functions mode. (The Deck cannot be used.)</p> <p>Measures:</p> <ol style="list-style-type: none"> 1.Check/replace the harness and connector between the Deck Driver PCB and the Pickup Release Solenoid Cooling Fan. 2.Replace the Pickup Release Solenoid Cooling Fan. 3.Replace the Deck Driver PCB.
04-1586	Deck interlock alarm (POD Deck Lite/Paper Deck Unit)
A. Operation / B. Cause / C. Remedy	<p>Cause:</p> <ul style="list-style-type: none"> - Error in the Compartment Open/Close Sensor or error in the harness - Error in the Compartment Open/Close Switch or error in the harness <p>Detection condition/timing: The interlock was not detected with the Compartment Open/Close Sensor ON.</p> <p>Movement/symptom: The machine automatically enters limited functions mode. (The Deck cannot be used.)</p> <p>Measures:</p> <ol style="list-style-type: none"> 1.Check if the compartment is halfway closed. If it is halfway closed, close it properly. 2.Close the compartment and check whether the Compartment Open/Close Sensor and the Compartment Open/Close Switch respond normally by I/O of the service mode. 3.Check/replace the harness (integrated with a switch) and connector between the Deck Driver PCB and the Compartment Open/Close Switch. 4.Check/replace the harness and connector between the Deck Driver PCB and the Compartment Open/Close Sensor. 5.Replace the Compartment Open/Close Sensor. 6.Replace the Deck Driver PCB.
04-1587	Deck Pickup Motor disengagement alarm (POD Deck Lite/Paper Deck Unit)
A. Operation / B. Cause / C. Remedy	<p>Cause:</p> <ul style="list-style-type: none"> - Error in the Deck Pickup Motor or error in the harness - Error in the Separation Roller Sensor or error in the harness - Error in the Pickup Assembly <p>Detection condition/timing: The Separation Roller Sensor did not respond when disengaging the Feed/Separation Roller.</p> <p>Movement/symptom: The machine automatically enters limited functions mode. (The Deck cannot be used.)</p> <p>Measures:</p> <ol style="list-style-type: none"> 1.Check/replace the harness and connector between the Deck Driver PCB and the Deck Pickup Motor. 2.Check/replace the harness and connector between the Deck Driver PCB and the Separation Roller Sensor. 3.Replace the Deck Pickup Motor and Separation Roller Sensor. 4.Replace the Deck Driver PCB. 5.Check the rear coupling of the Deck Pickup Assembly. If there is an error, replace it.
06-0003	Fixing Web prior notification alarm
A. Operation / B. Cause / C. Remedy	The life value of a target part reached the number of days left as set in COPIER > OPTION > PM-DLV-D > FX-WEB1.
09-0006	2D Shading ROM error 1
A. Operation / B. Cause / C. Remedy	<p>Movement: Turn OFF the 2D Shading.</p> <p>Cause: After clearing the drum, not reading the EEPROM.</p> <p>Measures: Execute COPIER>FUNCTION>2D-SHADE>2D-READ.</p>

09-0007	2D Shading ROM error 2
A. Operation / B. Cause / C. Remedy	<p>Movement: Turn OFF the 2D Shading.</p> <p>Cause: After reading ROM data, calculated checksum value and checksum of ROM does not match.</p> <p>Measures: Install the correct ROM.</p>
09-0008	Drum HP signal noise alarm
A. Operation / B. Cause / C. Remedy	<p>Movement: Only when the 2D shading is ON, the accuracy of shading is degraded and an image error occurs.</p> <p>Uneven density may occur.</p> <p>Cause: The Drum HP cycle is shorter than the specified cycle.</p> <p>Measures:</p> <ol style="list-style-type: none"> 1. Install the Drum HP Sensor (PS61) and check the connector. 2. Check the Drum HP Flag. 3. Check the harness between the Drum HP Sensor (PS61) and the Main Driver PCB (PCB2). (Between J2137 and J107) 4. Replace the Drum HP Sensor (PS61). 5. Replace the Main Driver PCB (PCB2). 6. Check the harness between the Main Driver PCB (PCB2) and the DCON PCB (PCB1). (Between J125 and J411 and between J126 and J412) 7. Replace the DCON PCB (PCB1).
09-0009	Drum HP signal absence alarm
A. Operation / B. Cause / C. Remedy	<p>Movement: Only when the 2D shading is ON, the accuracy of shading is degraded and an image error occurs.</p> <p>Uneven density may occur.</p> <p>Cause: The Drum HP cycle is longer than the specified cycle.</p> <p>Measures:</p> <ol style="list-style-type: none"> 1. Install the Drum HP Sensor (PS61) and check the connector. 2. Check the Drum HP Flag. 3. Check the harness between the Drum HP Sensor (PS61) and the Main Driver PCB (PCB2). (Between J2137 and J107) 4. Replace the Drum HP Sensor (PS61). 5. Replace the Main Driver PCB (PCB2). 6. Check the harness between the Main Driver PCB (PCB2) and the DCON PCB (PCB1). (Between J125 and J411 and between J126 and J412) 7. Replace the DCON PCB (PCB1).
10-0001	Toner Low (Black) alarm
A. Operation / B. Cause / C. Remedy	<p>Low toner was detected and UGW generated an alarm.</p> <p>* Not displayed on service mode history due to the alarm being generated by UGW</p>
10-0002	Toner Low (Cyan) alarm
A. Operation / B. Cause / C. Remedy	<p>Low toner was detected and UGW generated an alarm.</p> <p>* Not displayed on service mode history due to the alarm being generated by UGW</p>
10-0003	Toner Low (Magenta) alarm
A. Operation / B. Cause / C. Remedy	<p>Low toner was detected and UGW generated an alarm.</p> <p>* Not displayed on service mode history due to the alarm being generated by UGW</p>
10-0004	Toner Low (Yellow) alarm
A. Operation / B. Cause / C. Remedy	<p>Low toner was detected and UGW generated an alarm.</p> <p>* Not displayed on service mode history due to the alarm being generated by UGW</p>

10-0006	Patch Sensor error 1
A. Operation / B. Cause / C. Remedy	<p>Movement: Not update the D-max control value.</p> <p>Cause: At LED light intensity correction, P(0) is at target value or higher, or P(6) is at target value or lower.</p> <p>Measures:</p> <ol style="list-style-type: none"> 1. Clean the Patch Sensor (PS90). 2. Check the connector connection of the Patch Sensor (PS90). Sensor: J2143, Relay: J3255, J3060, J3177, Main Driver PCB (PCB2): J107 3. Check the connector connection of the Patch Sensor Shutter Solenoid (SL10). Sensor: J2143, Relay: J3249, J3060, J3177, Main Driver PCB (PCB2): J107 4. Replace the Patch Sensor (PS90). 5. Replace the Patch Sensor Shutter Solenoid (SL10). 6. Replace the Patch Shutter.
10-0007	Patch Sensor error 2
A. Operation / B. Cause / C. Remedy	<p>Movement: Not update the D-max control value.</p> <p>Cause: Max-Min of the background is 100 level or higher.</p> <p>Measures:</p> <ol style="list-style-type: none"> 1. Clean the Patch Sensor (PS90). 2. Check the connector connection of the Patch Sensor (PS90). Sensor: J2143, Relay: J3255, J3060, J3177, Main Driver PCB (PCB2): J107 3. Check the connector connection of the Patch Sensor Shutter Solenoid (SL10). Sensor: J2143, Relay: J3249, J3060, J3177, Main Driver PCB (PCB2): J107 4. Replace the Patch Sensor (PS90). 5. Replace the Patch Sensor Shutter Solenoid (SL10). 6. Replace the Patch Shutter.
10-0008	Patch Sensor error 3
A. Operation / B. Cause / C. Remedy	<p>Movement: Not update the D-max control value.</p> <p>Cause: Patch density is too dark.</p> <p>Measures:</p> <ol style="list-style-type: none"> 1. Clean the Patch Sensor (PS90). 2. Check the connector connection of the Patch Sensor (PS90). Sensor: J2143, Relay: J3255, J3060, J3177, Main Driver PCB (PCB2): J107 3. Check the connector connection of the Patch Sensor Shutter Solenoid (SL10). Sensor: J2143, Relay: J3249, J3060, J3177, Main Driver PCB (PCB2): J107 4. Replace the Patch Sensor (PS90). 5. Replace the Patch Sensor Shutter Solenoid (SL10). 6. Replace the Patch Shutter.
10-0009	Patch Sensor error 4
A. Operation / B. Cause / C. Remedy	<p>Movement: Not update the D-max control value.</p> <p>Cause: Patch density is too light.</p> <p>Supplement for cause (alarm detection at installation and at replacement of the Developing Assembly):</p> <p>Although this alarm is detected right after installation and replacement of the Developing Assembly, it is not an error. The alarm is detected because toner in the Developing Assembly is empty. When the patch density becomes normal by executing toner stirring (COPIER>FUNCTION>INSTALL>TONER-S) and auto gradation adjustment, the alarm is cleared. If the date and time of occurrence of the alarm differs from the timing of installation and replacement of the Developing Assembly, perform the following measures.</p> <p>Measures:</p> <ol style="list-style-type: none"> 1. Clean the Patch Sensor (PS90). 2. Check the connector connection of the Patch Sensor (PS90). Sensor: J2143, Relay: J3255, J3060, J3177, Main Driver PCB (PCB2): J107 3. Check the connector connection of the Patch Sensor Shutter Solenoid (SL10). Sensor: J2143, Relay: J3249, J3060, J3177, Main Driver PCB (PCB2): J107 4. Replace the Patch Sensor (PS90). 5. Replace the Patch Sensor Shutter Solenoid (SL10). 6. Replace the Patch Shutter.

10-0010	D-max control contrast potential (Vcont) error 1
A. Operation / B. Cause / C. Remedy	<p>Movement: Vcont of D-max control is between 150V and 270V, and correction amount at a time is 50V or less.</p> <p>Cause: Vcont calculated with D-max control is less than 150V.</p> <p>Measures:</p> <p>If density of output image is sufficient, measures are not needed.</p> <p>When the density is light (dark), execute PASCAL.</p> <p>If the problem is not corrected, check/replace the Developing Assembly.</p>
10-0011	D-max control contrast potential (Vcont) error 2
A. Operation / B. Cause / C. Remedy	<p>Movement: Vcont of D-max control is between 150V and 270V, and correction amount at a time is 50V.</p> <p>Cause: Vcont calculated with D-max control is greater than 270V.</p> <p>Measures:</p> <p>If density of output image is sufficient, measures are not needed.</p> <p>When the density is light (dark), execute PASCAL.</p> <p>If the problem is not corrected, check/replace the Developing Assembly.</p>
10-0012	D-max control contrast potential (Vcont) error 3
A. Operation / B. Cause / C. Remedy	<p>Movement: Vcont of D-max control is between 150V and 270V, and correction amount at a time is 50V or less.</p> <p>Cause: Difference of Vcont from its of the last D-max control is 50V or higher.</p> <p>Supplement for cause (alarm detection at installation and replacement of the Developing Assembly):</p> <p>Although the alarm is detected after execution of auto gradation adjustment (full adjust) at installation and replacement of the Developing Assembly, it is not an error.</p> <p>The alarm is detected because "previous Vcont" that is a target for comparison is 0V at installation. At replacement of the Developing Assembly, "previous Vcont" that is a target for comparison is the value determined by the original Developing Assembly. Therefore, depending on the individual difference in the Developing Assembly, 50V or more difference occurs and the alarm is detected. The alarm is cleared by either re-executing auto gradation adjustment (full adjust) or printing 6,000 or more sheets (auto execution of D-max control).</p> <p>If the date and time of occurrence of the alarm differs from the timing of installation and replacement of the Developing Assembly, perform the following measures.</p> <p>Measures:</p> <p>If density of output image is sufficient, measures are not needed.</p> <p>When the density is light (dark), execute PASCAL.</p> <p>If the problem is not corrected, check/replace the Developing Assembly.</p>
10-0020	Toner (Bk) prior notification alarm
A. Operation / B. Cause / C. Remedy	The life value of a target part reached the number of days left as set in COPIER > OPTION > PM-DLV-D > TONER-K.
10-0100	Toner bottle change notification alarm
A. Operation / B. Cause / C. Remedy	The replacement of the Toner Cartridge was detected.
10-0404	Toner Bottle empty alarm (Bk)
A. Operation / B. Cause / C. Remedy	It was detected that Toner (Bk) was emptied.
10-F020	Toner (Bk) high consumption alarm
A. Operation / B. Cause / C. Remedy	It was detected that the target part was at a high level of daily consumption.
11-0001	Waste Toner Container full
A. Operation / B. Cause / C. Remedy	<p>Movement: A message "The waste toner container is full." is displayed on the Control Panel, and the machine is stopped.</p> <p>Cause: Detected waste toner bottle full.</p> <p>Measures: Clean the Waste Toner Container. Reset the Waste Toner Counter.</p>

11-0010	Near Full Waste Toner Container
A. Operation / B. Cause / C. Remedy	Operation; A message is displayed on the Control Panel (printing is still possible) Cause: The following two conditions were met. - Waste Toner Full Level Sensor Detection - The threshold number of days left as set in COPIER > OPTION > PM-DLV-D > WST-TNR was reached.
11-0100	Waste Toner Container replacement completion alarm
A. Operation / B. Cause / C. Remedy	Completion of Waste Toner Container replacement was detected.
11-F010	Waste Toner Container high consumption alarm
A. Operation / B. Cause / C. Remedy	It was detected that the target part was at a high level of daily consumption.
13-002F	For R&D
A. Operation / B. Cause / C. Remedy	
13-0FFC	For R&D
A. Operation / B. Cause / C. Remedy	
13-0FFD	For R&D
A. Operation / B. Cause / C. Remedy	
13-0FFF	For R&D
A. Operation / B. Cause / C. Remedy	
14-0000	For R&D
A. Operation / B. Cause / C. Remedy	
14-0001	For R&D
A. Operation / B. Cause / C. Remedy	
14-1000	For R&D
A. Operation / B. Cause / C. Remedy	
30-0004	Pre-transfer Charging PCB Harness disconnection (connection error)
A. Operation / B. Cause / C. Remedy	Movement: Pre-transfer charging high voltage is not output. An image error like discharge trace occurs. Cause: Connection error of the Pre-transfer Charging PCB (PCB26). Measures: 1. Check the connection between the Main Driver PCB (PCB2) and the High Voltage Unit. Main Driver PCB side: J112, High Voltage Unit side: J3098 2. Check the connection inside of the High Voltage Unit. High Voltage Unit inlet side: J3098, Pre-transfer Charging PCB side: J3544 3. Replace the Pre-transfer Charging PCB (PCB26). 4. Replace the Main Driver PCB (PCB2).
31-0005	Environment Sensor reading alarm
A. Operation / B. Cause / C. Remedy	Movement: It becomes as follow: environment temperature= 0 degC, environment humidity= 0%. Cause: Connection of the Environment Sensor cannot be detected. Measures: 1) Check the connection of the Environment Sensor (THU1). 2) Replace the Environment Sensor (THU1).

31-0006	HDD failure when equipped with the mirroring function
A. Operation / B. Cause / C. Remedy	HDD failure when equipped with the mirroring function
31-0007	Error in Patch Sensor Shutter Solenoid connection
A. Operation / B. Cause / C. Remedy	<p>Movement: Patch control (D-max/D-half control) is not executed. Use the previous correction value.</p> <p>Cause: Connection of the Patch Sensor Shutter Solenoid (SL10) cannot be detected.</p> <p>Measures:</p> <ol style="list-style-type: none"> 1. Check the connection of the Patch Sensor Shutter Solenoid (SL10). Solenoid side: J3049, Relay: J3060, J3177, Main Driver PCB side: J107 2. Replace the Patch Sensor Shutter Solenoid (SL10). 3. Replace the Main Driver PCB (PCB2).
31-0008	HDD failure prediction alarm
A. Operation / B. Cause / C. Remedy	<p>Movement: HDD failure is expected to occur in a short time due to occurrence of physical error in HDD. It does not occur in the HDD of mirroring configuration.</p> <p>Cause: Error in the S.M.A.R.T. value of HDD</p> <p>Measures:</p> <ol style="list-style-type: none"> 1. Back up the data stored in HDD. 2. Replace the HDD. 3. Restore the data. <p>S.M.A.R.T. (Self-Monitoring Analysis and Reporting Technology): Self-diagnosis function built in the HDD. The occurrence rate of reading error, reading and writing speed, the total number of Motor start-up and stop times, the total length of power-on time, etc. are monitored.</p>
31-0009	FLASH failure prediction alarm
A. Operation / B. Cause / C. Remedy	<p>Cause: Error in the S.M.A.R.T. value of FLASH memory It indicates a physical error of the FLASH memory, which is expected to soon lead to a failure.</p> <p>*: S.M.A.R.T. (Self-Monitoring Analysis and Reporting Technology) = It is a self-diagnosis function built in the FLASH memory, and monitors the occurrence rate of reading errors, reading/writing speed, total number of times of motor start-up/stop, total length of power-on time, etc. Continuously using the machine without taking any measures may lead to E614.</p> <p>Measures: Back up the data stored in the FLASH memory, and restore the data after replacing the FLASH memory.</p>
31-0010	The configuration of an option controlled by the Main Controller has been changed
A. Operation / B. Cause / C. Remedy	<p>A change in configuration of an option such as a change in the configuration of the Fax Board, a change in the configuration of the Voice Board, or a change in the configuration of the option HDD, which requires turning OFF and then ON the power, was detected.</p> <p>Detection condition/timing:At the time of startup only</p> <p>Remedy:Turn OFF and then ON the main power.</p>
31-0020	The configuration of an option controlled by the RCON has been changed
A. Operation / B. Cause / C. Remedy	<p>Due to a change in the configuration related to the scanner, a change in the hardware configuration which requires turning OFF and then ON the power was detected.</p> <p>Detection condition/timing:At the time of startup only</p> <p>Remedy:Turn OFF and then ON the main power.</p>
31-0030	The configuration of an option controlled by the DCON has been changed
A. Operation / B. Cause / C. Remedy	<p>Due to a change in the configuration related to the printer, a change in the hardware configuration which requires turning OFF and then ON the power was detected.</p> <p>Detection condition/timing:At the time of startup only</p> <p>Remedy:Turn OFF and then ON the main power.</p>
31-0106	For R&D
A. Operation / B. Cause / C. Remedy	-
31-0116	For R&D
A. Operation / B. Cause / C. Remedy	-

31-0126	For R&D
A. Operation / B. Cause / C. Remedy	-
31-0136	For R&D
A. Operation / B. Cause / C. Remedy	-
31-01F1	For R&D
A. Operation / B. Cause / C. Remedy	-
31-01F2	For R&D
A. Operation / B. Cause / C. Remedy	-
31-01F3	For R&D
A. Operation / B. Cause / C. Remedy	-
31-01F4	For R&D
A. Operation / B. Cause / C. Remedy	-
31-01F5	For R&D
A. Operation / B. Cause / C. Remedy	-
31-01F6	For R&D
A. Operation / B. Cause / C. Remedy	-

32-0002	Potential control (VL control) error
A. Operation / B. Cause / C. Remedy	<p>Cause: The measured value in the dark area (VL) differs over +/-10V but less than +/-30V than the target potential at potential control.</p> <p>Movement: Not reflecting the result of VL control. To the laser power determined with VL control, the power with which the previous potential control was succeeded (within target potential +/-10V) is applied.</p> <p>Measures: If there is no influence on image, measures are not needed. If not, execute the following measures.</p> <ol style="list-style-type: none"> 1. Check the installation of the Pre-exposure LED (connector connection, open circuit, the caught cable). 2. Check the installation of the Primary Charging Assembly (connector connection, open circuit, the caught cable). 3. Check the fixation state of the Drum and the Drum Shaft (check if the drum fixation cylinder is properly installed). 4. Check if the Dustproof Glass is soiled. If necessary, clean it. 5. Check the installation of the Laser Scanner Unit (connector connection, open circuit, the caught cable). 6. Check the installation and connection of the Primary Charging High Voltage PCB (PCB11) (connector connection, open circuit, the caught cable). 7. Check the installation of the Potential Sensor (connector connection, open circuit, the caught cable). 8. Check the installation and connection of the Drum Motor (M1) (connector connection, open circuit, the caught cable). 9. Replace the parts. <ul style="list-style-type: none"> - Primary Charging Assembly - Laser Scanner Unit - Potential Sensor - Primary Charging High Voltage PCB (PCB11) - Drum Motor (M1) - Main Driver PCB (PCB2) - DC Controller PCB (PCB1)
33-0001	Delivery Assembly Decurler Fan alarm
A. Operation / B. Cause / C. Remedy	<p>Movement: No change.</p> <p>Cause: Connector disconnection of the Paper Cooling Fan (FM5). Failure of the Paper Cooling Fan (FM5).</p> <p>Measures: Check the connector -> Replace the Paper Cooling Fan (FM5).</p>
33-0002	Feed Fan alarm
A. Operation / B. Cause / C. Remedy	<p>Movement: No change.</p> <p>Cause: Connector disconnection of the Registration Motor/Duplex Motor Cooling Fan (FM42). Failure of the Registration Motor/Duplex Motor Cooling Fan (FM42).</p> <p>Measures: Check the connector -> Replace the Registration Motor/Duplex Motor Cooling Fan (FM42).</p>
33-0010	Stream Reading Fan alarm
A. Operation / B. Cause / C. Remedy	<p>Movement: Nothing in particular (Fan stops).</p> <p>Cause: The Fan rotation signal cannot be detected after 3 seconds have passed since the Scanner Unit Heat Exhaust Fan (FM1) is turned ON.</p> <p>Measures: Check the connector connection -> Replace the Scanner Unit Heat Exhaust Fan (FM1).</p>
33-0013	Power Unit Fan 1 alarm
A. Operation / B. Cause / C. Remedy	<p>Movement: No change.</p> <p>Cause: Connector disconnection of the Feed Driver Cooling Fan (FM40). Failure of the Feed Driver Cooling Fan (FM40).</p> <p>Measures: Check the connector -> Replace the Feed Driver Cooling Fan (FM40).</p>

33-0022	Read Motor Cooling Fan alarm
A. Operation / B. Cause / C. Remedy	Movement: Nothing in particular (Fan stops). Cause: The Fan rotation signal cannot be detected after 3 seconds have passed since the Motor Driver Cooling Fan (FM1) or the Read Motor Cooling Fan (FM2) is turned ON. Measures: Check the connector connection -> Replace the Motor Driver Cooling Fan (FM1) or the Read Motor Cooling Fan (FM2).
33-0023	Scanner Unit (DADF) Cooling Fan alarm
A. Operation / B. Cause / C. Remedy	Movement: Nothing in particular (Fan stops). Cause: The Fan rotation signal cannot be detected after 3 seconds have passed since the (DADF) Scanner Unit Cooling Fan (FM3) is turned ON. Measures: Check the connector connection -> Replace the DADF Scanner Unit Cooling Fan (FM3).
33-0025	Scanner Unit (Reader) Cooling Fan alarm
A. Operation / B. Cause / C. Remedy	Movement: Nothing in particular (Fan stops). Cause: The Fan rotation signal cannot be detected after 3 seconds have passed since the (Reader) Scanner Unit Cooling Fan (FM2) is turned ON. Measures: Check the connector connection -> Replace the (Reader) Scanner Unit Cooling Fan (FM2).
33-0026	Charging Assembly Fan 1 alarm
A. Operation / B. Cause / C. Remedy	Movement: No change. Cause: Connector disconnection of the Pre-transfer Charging Assembly Air Supply Fan (FM32) or the Pre-transfer Charging Assembly Exhaust Fan (FM33). Failure of the Pre-transfer Charging Assembly Air Supply Fan (FM32) or the Pre-transfer Charging Assembly Exhaust Fan (FM33). Measures: Check the connector connection -> Replace the Pre-transfer Charging Assembly Air Supply Fan (FM32) or the Pre-transfer Charging Assembly Exhaust Fan (FM33).
33-0027	Charging Assembly Fan 2 alarm
A. Operation / B. Cause / C. Remedy	Movement: No change. Cause: Connector disconnection of the Primary Charging Assembly Exhaust Fan (FM17). Failure of the Primary Charging Assembly Exhaust Fan (FM17). Measures: Check the connector -> Replace the Primary Charging Assembly Exhaust Fan (FM17).
33-0028	Power Unit Fan 2 alarm
A. Operation / B. Cause / C. Remedy	Movement: No change. Cause: Connector disconnection of the Duplex Driver Cooling Fan (FM41). Failure of the Duplex Driver Cooling Fan (FM41). Measures: Check the connector -> Replace the Duplex Driver Cooling Fan (FM41).
37-0001	For R&D
A. Operation / B. Cause / C. Remedy	-
37-0002	For R&D
A. Operation / B. Cause / C. Remedy	-
37-0003	For R&D
A. Operation / B. Cause / C. Remedy	-
37-0004	For R&D
A. Operation / B. Cause / C. Remedy	-
37-0005	For R&D
A. Operation / B. Cause / C. Remedy	-

37-0006	For R&D
A. Operation / B. Cause / C. Remedy	-
37-0007	For R&D
A. Operation / B. Cause / C. Remedy	-
37-1000	For R&D
A. Operation / B. Cause / C. Remedy	-
37-2000	For R&D
A. Operation / B. Cause / C. Remedy	-
38-0001	For R&D
A. Operation / B. Cause / C. Remedy	-
38-0002	For R&D
A. Operation / B. Cause / C. Remedy	-
38-0101	Application-generated alarm
A. Operation / B. Cause / C. Remedy	Data Backup Service Application Error (Error by the rock-out of the Device Configuration Management function), Error message (E-code: EBD0001) * This alarm is not displayed on LUI due to the alarm being generated by the application.
38-0102	Application-generated alarm
A. Operation / B. Cause / C. Remedy	Data Backup Service Application Error (Error when Device Configuration Management data export), Error message (E-code: EBD0002) * This alarm is not displayed on LUI due to the alarm being generated by the application.
38-0103	Application-generated alarm
A. Operation / B. Cause / C. Remedy	Data Backup Service Application Error (Error for MDAS4BR not to be available), Error message (E-code: EBD0003) * This alarm is not displayed on LUI due to the alarm being generated by the application.
38-0104	Application-generated alarm
A. Operation / B. Cause / C. Remedy	Data Backup Service Application Error (Error when Address book (ADB) folder setting export), Error message (E-code: EBA0001) * This alarm is not displayed on LUI due to the alarm being generated by the application.
38-0105	Application-generated alarm
A. Operation / B. Cause / C. Remedy	Data Backup Service Application Error (Error with the expiration of the start time for scheduled backup), Error message (E-code: EBS9997) * This alarm is not displayed on LUI due to the alarm being generated by the application.
38-0106	Application-generated alarm
A. Operation / B. Cause / C. Remedy	Data Backup Service Application Error (Error with the power supply of the device having been shut down forcibly), Error message (E-code: EBS9998) * This alarm is not displayed on LUI due to the alarm being generated by the application.
38-0107	Application-generated alarm
A. Operation / B. Cause / C. Remedy	Data Backup Service Application Error (System error of the export), Error message (E-code: EBS9999) * This alarm is not displayed on LUI due to the alarm being generated by the application.

38-0108	Application-generated alarm
A. Operation / B. Cause / C. Remedy	Data Backup Service Application Error (Communication error with CBIO backup service (DCFS)), Error message (E-code: EBC0001) * This alarm is not displayed on LUI due to the alarm being generated by the application.
38-0109	Application-generated alarm
A. Operation / B. Cause / C. Remedy	Data Backup Service Application Error (Error on the CBIO backup service (DCFS) side), Error message (E-code: EBC0002) * This alarm is not displayed on LUI due to the alarm being generated by the application.
38-0110	Application-generated alarm
A. Operation / B. Cause / C. Remedy	Data Backup Service Application Error (Error with the backup refusal on the CBIO backup service (DCFS) side), Error message (E-code: EBC0003) * This alarm is not displayed on LUI due to the alarm being generated by the application.
38-0111	Application-generated alarm
A. Operation / B. Cause / C. Remedy	Data Backup Service Application Error (System error by the communication with CBIO backup service (DCFS)), Error message (E-code: EBC9999) * This alarm is not displayed on LUI due to the alarm being generated by the application.
38-0112	Application-generated alarm
A. Operation / B. Cause / C. Remedy	Data Backup Service Application Error (Error for Access Token Provider to be unconnected, or not to be installed), Error message (E-code: EAC0001) * This alarm is not displayed on LUI due to the alarm being generated by the application.
38-0113	Application-generated alarm
A. Operation / B. Cause / C. Remedy	Data Backup Service Application Error (Error by the certification failure of the Access Token Provider), Error message (E-code: EAC0002) * This alarm is not displayed on LUI due to the alarm being generated by the application.
38-0114	Application-generated alarm
A. Operation / B. Cause / C. Remedy	Data Backup Service Application Error (Error of the communication time-out of the Access Token Provider), Error message (E-code: EAC0003) * This alarm is not displayed on LUI due to the alarm being generated by the application.
38-0115	Application-generated alarm
A. Operation / B. Cause / C. Remedy	Data Backup Service Application Error (Communication error of the Access Token Provider by the network origin at proxy effective time), Error message (E-code: EAC0004) * This alarm is not displayed on LUI due to the alarm being generated by the application.
38-0116	Application-generated alarm
A. Operation / B. Cause / C. Remedy	Data Backup Service Application Error (The error that proxy connection of the Access Token Provider failed in at proxy effective time), Error message (E-code: EAC0005) * This alarm is not displayed on LUI due to the alarm being generated by the application.
38-0117	Application-generated alarm
A. Operation / B. Cause / C. Remedy	Data Backup Service Application Error (Communication error of the Access Token Provider by the network origin at the time of proxy invalidity), Error message (E-code: EAC0006) * This alarm is not displayed on LUI due to the alarm being generated by the application.

38-0118	Application-generated alarm
A. Operation / B. Cause / C. Remedy	Data Backup Service Application Error (Communication error of the Access Token Provider that name solution was not possible), Error message (E-code: EAC0007) * This alarm is not displayed on LUI due to the alarm being generated by the application.
38-0119	Application-generated alarm
A. Operation / B. Cause / C. Remedy	Data Backup Service Application Error (System error of the Access Token Provider in other factors), Error message (E-code: EAC9999) * This alarm is not displayed on LUI due to the alarm being generated by the application.
39-0111	Application-generated alarm
A. Operation / B. Cause / C. Remedy	Service call application Error message (E-code) * This alarm is not displayed on LUI due to the alarm being generated by the application.
39-0210	Application-generated alarm
A. Operation / B. Cause / C. Remedy	Service call application Paper jam_Inside the machine_Not specified * This alarm is not displayed on LUI due to the alarm being generated by the application.
39-0211	Application-generated alarm
A. Operation / B. Cause / C. Remedy	Service call application Paper jam_Inside the machine_Frequently * This alarm is not displayed on LUI due to the alarm being generated by the application.
39-0212	Application-generated alarm
A. Operation / B. Cause / C. Remedy	Service call application Paper jam_Inside the machine_Occasionally * This alarm is not displayed on LUI due to the alarm being generated by the application.
39-0213	Application-generated alarm
A. Operation / B. Cause / C. Remedy	Service call application Paper jam_Inside the machine_First time in the day * This alarm is not displayed on LUI due to the alarm being generated by the application.
39-0220	Application-generated alarm
A. Operation / B. Cause / C. Remedy	Service call application Paper jam_Document Feeder_Not specified * This alarm is not displayed on LUI due to the alarm being generated by the application.
39-0221	Application-generated alarm
A. Operation / B. Cause / C. Remedy	Service call application Paper jam_Document Feeder_Frequently * This alarm is not displayed on LUI due to the alarm being generated by the application.
39-0222	Application-generated alarm
A. Operation / B. Cause / C. Remedy	Service call application Paper jam_Document Feeder_Occasionally * This alarm is not displayed on LUI due to the alarm being generated by the application.
39-0223	Application-generated alarm
A. Operation / B. Cause / C. Remedy	Service call application Paper jam_Document Feeder_First time in the day * This alarm is not displayed on LUI due to the alarm being generated by the application.
39-0230	Application-generated alarm
A. Operation / B. Cause / C. Remedy	Service call application Paper jam_Cassette_Not specified * This alarm is not displayed on LUI due to the alarm being generated by the application.

39-0231	Application-generated alarm
A. Operation / B. Cause / C. Remedy	Service call application Paper jam_Cassette_Cassette 1 * This alarm is not displayed on LUI due to the alarm being generated by the application.
39-0232	Application-generated alarm
A. Operation / B. Cause / C. Remedy	Service call application Paper jam_Cassette_Cassette 2 * This alarm is not displayed on LUI due to the alarm being generated by the application.
39-0233	Application-generated alarm
A. Operation / B. Cause / C. Remedy	Service call application Paper jam_Cassette_Cassette 3 * This alarm is not displayed on LUI due to the alarm being generated by the application.
39-0234	Application-generated alarm
A. Operation / B. Cause / C. Remedy	Service call application Paper jam_Cassette_Cassette 4 * This alarm is not displayed on LUI due to the alarm being generated by the application.
39-0235	Application-generated alarm
A. Operation / B. Cause / C. Remedy	Service call application Spare (Not selectable) * This alarm is not displayed on LUI due to the alarm being generated by the application.
39-0240	Application-generated alarm
A. Operation / B. Cause / C. Remedy	Service call application Paper jam_Multi-purpose Tray_Not specified * This alarm is not displayed on LUI due to the alarm being generated by the application.
39-0241	Application-generated alarm
A. Operation / B. Cause / C. Remedy	Service call application Paper jam_Multi-purpose Tray_Envelope * This alarm is not displayed on LUI due to the alarm being generated by the application.
39-0242	Application-generated alarm
A. Operation / B. Cause / C. Remedy	Service call application Paper jam_Multi-purpose Tray_Postcard * This alarm is not displayed on LUI due to the alarm being generated by the application.
39-0243	Application-generated alarm
A. Operation / B. Cause / C. Remedy	Service call application Paper jam_Multi-purpose Tray_Plain paper * This alarm is not displayed on LUI due to the alarm being generated by the application.
39-0244	Application-generated alarm
A. Operation / B. Cause / C. Remedy	Service call application Paper jam_Multi-purpose Tray_Label paper * This alarm is not displayed on LUI due to the alarm being generated by the application.
39-0245	Application-generated alarm
A. Operation / B. Cause / C. Remedy	Service call application Paper jam_Multi-purpose Tray_Heavy paper * This alarm is not displayed on LUI due to the alarm being generated by the application.
39-0250	Application-generated alarm
A. Operation / B. Cause / C. Remedy	Service call application Paper jam_Outlet_Not specified * This alarm is not displayed on LUI due to the alarm being generated by the application.

39-0251	Application-generated alarm
A. Operation / B. Cause / C. Remedy	Service call application Paper jam_Outlet_Frequently * This alarm is not displayed on LUI due to the alarm being generated by the application.
39-0252	Application-generated alarm
A. Operation / B. Cause / C. Remedy	Service call application Paper jam_Outlet_Occasionally * This alarm is not displayed on LUI due to the alarm being generated by the application.
39-0253	Application-generated alarm
A. Operation / B. Cause / C. Remedy	Service call application Paper jam_Outlet_First time in the day * This alarm is not displayed on LUI due to the alarm being generated by the application.
39-0260	Application-generated alarm
A. Operation / B. Cause / C. Remedy	Service call application Paper jam_At 2-sided printing_Not specified * This alarm is not displayed on LUI due to the alarm being generated by the application.
39-0261	Application-generated alarm
A. Operation / B. Cause / C. Remedy	Service call application Paper jam_At 2-sided printing_Frequently * This alarm is not displayed on LUI due to the alarm being generated by the application.
39-0262	Application-generated alarm
A. Operation / B. Cause / C. Remedy	Service call application Paper jam_At 2-sided printing_Occasionally * This alarm is not displayed on LUI due to the alarm being generated by the application.
39-0263	Application-generated alarm
A. Operation / B. Cause / C. Remedy	Service call application Paper jam_At 2-sided printing_First time in the day * This alarm is not displayed on LUI due to the alarm being generated by the application.
39-0290	Application-generated alarm
A. Operation / B. Cause / C. Remedy	Service call application Paper jam_Others * This alarm is not displayed on LUI due to the alarm being generated by the application.
39-0310	Application-generated alarm
A. Operation / B. Cause / C. Remedy	Service call application Image failure_Displacement_Color not specified * This alarm is not displayed on LUI due to the alarm being generated by the application.
39-0311	Application-generated alarm
A. Operation / B. Cause / C. Remedy	Service call application Image failure_Displacement_Black * This alarm is not displayed on LUI due to the alarm being generated by the application.
39-0312	Application-generated alarm
A. Operation / B. Cause / C. Remedy	Service call application Image failure_Displacement_Yellow * This alarm is not displayed on LUI due to the alarm being generated by the application.
39-0313	Application-generated alarm
A. Operation / B. Cause / C. Remedy	Service call application Image failure_Displacement_Magenta * This alarm is not displayed on LUI due to the alarm being generated by the application.

39-0314	Application-generated alarm
A. Operation / B. Cause / C. Remedy	Service call application Image failure_Displacement_Cyan * This alarm is not displayed on LUI due to the alarm being generated by the application.
39-0320	Application-generated alarm
A. Operation / B. Cause / C. Remedy	Service call application Image failure_Blank image_Color not specified * This alarm is not displayed on LUI due to the alarm being generated by the application.
39-0321	Application-generated alarm
A. Operation / B. Cause / C. Remedy	Service call application Image failure_Blank image_Black * This alarm is not displayed on LUI due to the alarm being generated by the application.
39-0322	Application-generated alarm
A. Operation / B. Cause / C. Remedy	Service call application Image failure_Blank image_Yellow * This alarm is not displayed on LUI due to the alarm being generated by the application.
39-0323	Application-generated alarm
A. Operation / B. Cause / C. Remedy	Service call application Image failure_Blank image_Magenta * This alarm is not displayed on LUI due to the alarm being generated by the application.
39-0324	Application-generated alarm
A. Operation / B. Cause / C. Remedy	Service call application Image failure_Blank image_Cyan * This alarm is not displayed on LUI due to the alarm being generated by the application.
39-0330	Application-generated alarm
A. Operation / B. Cause / C. Remedy	Service call application Image failure_Soiling_Color not specified * This alarm is not displayed on LUI due to the alarm being generated by the application.
39-0331	Application-generated alarm
A. Operation / B. Cause / C. Remedy	Service call application Image failure_Soiling_Black * This alarm is not displayed on LUI due to the alarm being generated by the application.
39-0332	Application-generated alarm
A. Operation / B. Cause / C. Remedy	Service call application Image failure_Soiling_Yellow * This alarm is not displayed on LUI due to the alarm being generated by the application.
39-0333	Application-generated alarm
A. Operation / B. Cause / C. Remedy	Service call application Image failure_Soiling_Magenta * This alarm is not displayed on LUI due to the alarm being generated by the application.
39-0334	Application-generated alarm
A. Operation / B. Cause / C. Remedy	Service call application Image failure_Soiling_Cyan * This alarm is not displayed on LUI due to the alarm being generated by the application.
39-0340	Application-generated alarm
A. Operation / B. Cause / C. Remedy	Service call application Image failure_Lines_Color not specified * This alarm is not displayed on LUI due to the alarm being generated by the application.

39-0341	Application-generated alarm
A. Operation / B. Cause / C. Remedy	Service call application Image failure_Lines_Black * This alarm is not displayed on LUI due to the alarm being generated by the application.
39-0342	Application-generated alarm
A. Operation / B. Cause / C. Remedy	Service call application Image failure_Lines_Yellow * This alarm is not displayed on LUI due to the alarm being generated by the application.
39-0343	Application-generated alarm
A. Operation / B. Cause / C. Remedy	Service call application Image failure_Lines_Magenta * This alarm is not displayed on LUI due to the alarm being generated by the application.
39-0344	Application-generated alarm
A. Operation / B. Cause / C. Remedy	Service call application Image failure_Lines_Cyan * This alarm is not displayed on LUI due to the alarm being generated by the application.
39-0350	Application-generated alarm
A. Operation / B. Cause / C. Remedy	Service call application Image failure_Light_Color not specified * This alarm is not displayed on LUI due to the alarm being generated by the application.
39-0351	Application-generated alarm
A. Operation / B. Cause / C. Remedy	Service call application Image failure_Light_Black * This alarm is not displayed on LUI due to the alarm being generated by the application.
39-0352	Application-generated alarm
A. Operation / B. Cause / C. Remedy	Service call application Image failure_Light_Yellow * This alarm is not displayed on LUI due to the alarm being generated by the application.
39-0353	Application-generated alarm
A. Operation / B. Cause / C. Remedy	Service call application Image failure_Light_Magenta * This alarm is not displayed on LUI due to the alarm being generated by the application.
39-0354	Application-generated alarm
A. Operation / B. Cause / C. Remedy	Service call application Image failure_Light_Cyan * This alarm is not displayed on LUI due to the alarm being generated by the application.
39-0360	Application-generated alarm
A. Operation / B. Cause / C. Remedy	Service call application Image failure_Hue_Color not specified * This alarm is not displayed on LUI due to the alarm being generated by the application.
39-0361	Application-generated alarm
A. Operation / B. Cause / C. Remedy	Service call application Image failure_Hue_Black * This alarm is not displayed on LUI due to the alarm being generated by the application.
39-0362	Application-generated alarm
A. Operation / B. Cause / C. Remedy	Service call application Image failure_Hue_Yellow * This alarm is not displayed on LUI due to the alarm being generated by the application.

39-0363	Application-generated alarm
A. Operation / B. Cause / C. Remedy	Service call application Image failure_Hue_Magenta * This alarm is not displayed on LUI due to the alarm being generated by the application.
39-0364	Application-generated alarm
A. Operation / B. Cause / C. Remedy	Service call application Image failure_Hue_Cyan * This alarm is not displayed on LUI due to the alarm being generated by the application.
39-0370	Application-generated alarm
A. Operation / B. Cause / C. Remedy	Service call application Image failure_Dark_Color not specified * This alarm is not displayed on LUI due to the alarm being generated by the application.
39-0371	Application-generated alarm
A. Operation / B. Cause / C. Remedy	Service call application Image failure_Dark_Black * This alarm is not displayed on LUI due to the alarm being generated by the application.
39-0372	Application-generated alarm
A. Operation / B. Cause / C. Remedy	Service call application Image failure_Dark_Yellow * This alarm is not displayed on LUI due to the alarm being generated by the application.
39-0373	Application-generated alarm
A. Operation / B. Cause / C. Remedy	Service call application Image failure_Dark_Magenta * This alarm is not displayed on LUI due to the alarm being generated by the application.
39-0374	Application-generated alarm
A. Operation / B. Cause / C. Remedy	Service call application Image failure_Dark_Cyan * This alarm is not displayed on LUI due to the alarm being generated by the application.
39-0380	Application-generated alarm
A. Operation / B. Cause / C. Remedy	Service call application Image failure_Color displacement_Color not specified * This alarm is not displayed on LUI due to the alarm being generated by the application.
39-0381	Application-generated alarm
A. Operation / B. Cause / C. Remedy	Service call application Image failure_Color displacement_Black * This alarm is not displayed on LUI due to the alarm being generated by the application.
39-0382	Application-generated alarm
A. Operation / B. Cause / C. Remedy	Service call application Image failure_Color displacement_Yellow * This alarm is not displayed on LUI due to the alarm being generated by the application.
39-0383	Application-generated alarm
A. Operation / B. Cause / C. Remedy	Service call application Image failure_Color displacement_Magenta * This alarm is not displayed on LUI due to the alarm being generated by the application.
39-0384	Application-generated alarm
A. Operation / B. Cause / C. Remedy	Service call application Image failure_Color displacement_Cyan * This alarm is not displayed on LUI due to the alarm being generated by the application.

39-0390	Application-generated alarm
A. Operation / B. Cause / C. Remedy	Service call application Image failure_Others * This alarm is not displayed on LUI due to the alarm being generated by the application.
39-0511	Application-generated alarm
A. Operation / B. Cause / C. Remedy	Service call application Operation failure_Print * This alarm is not displayed on LUI due to the alarm being generated by the application.
39-0520	Application-generated alarm
A. Operation / B. Cause / C. Remedy	Service call application Operation failure_Fax_Not specified * This alarm is not displayed on LUI due to the alarm being generated by the application.
39-0521	Application-generated alarm
A. Operation / B. Cause / C. Remedy	Service call application Operation failure_Fax_Transmission and reception * This alarm is not displayed on LUI due to the alarm being generated by the application.
39-0522	Application-generated alarm
A. Operation / B. Cause / C. Remedy	Service call application Operation failure_Fax_Reception * This alarm is not displayed on LUI due to the alarm being generated by the application.
39-0523	Application-generated alarm
A. Operation / B. Cause / C. Remedy	Service call application Operation failure_Fax_Transmission * This alarm is not displayed on LUI due to the alarm being generated by the application.
39-0524	Application-generated alarm
A. Operation / B. Cause / C. Remedy	Service call application Operation failure_Fax_Forwarding * This alarm is not displayed on LUI due to the alarm being generated by the application.
39-0530	Application-generated alarm
A. Operation / B. Cause / C. Remedy	Service call application Operation failure_Control Panel_Not specified * This alarm is not displayed on LUI due to the alarm being generated by the application.
39-0531	Application-generated alarm
A. Operation / B. Cause / C. Remedy	Service call application Operation failure_Control Panel_Slow response * This alarm is not displayed on LUI due to the alarm being generated by the application.
39-0532	Application-generated alarm
A. Operation / B. Cause / C. Remedy	Service call application Operation failure_Control Panel_Occasional freeze-up (Not work) * This alarm is not displayed on LUI due to the alarm being generated by the application.
39-0541	Application-generated alarm
A. Operation / B. Cause / C. Remedy	Service call application Operation failure_Scan (SEND) * This alarm is not displayed on LUI due to the alarm being generated by the application.
39-0551	Application-generated alarm
A. Operation / B. Cause / C. Remedy	Service call application Operation failure_Abnormal noise_Main * This alarm is not displayed on LUI due to the alarm being generated by the application.

39-0552	Application-generated alarm
A. Operation / B. Cause / C. Remedy	Service call application Operation failure_Abnormal noise_Options * This alarm is not displayed on LUI due to the alarm being generated by the application.
39-0590	Application-generated alarm
A. Operation / B. Cause / C. Remedy	Service call application Operation failure_Others * This alarm is not displayed on LUI due to the alarm being generated by the application.
39-0611	Application-generated alarm
A. Operation / B. Cause / C. Remedy	Service call application Settings_Training * This alarm is not displayed on LUI due to the alarm being generated by the application.
39-0612	Application-generated alarm
A. Operation / B. Cause / C. Remedy	Service call application Settings_Addition * This alarm is not displayed on LUI due to the alarm being generated by the application.
39-0621	Application-generated alarm
A. Operation / B. Cause / C. Remedy	Service call application Settings_Forwarding_Fax * This alarm is not displayed on LUI due to the alarm being generated by the application.
39-0622	Application-generated alarm
A. Operation / B. Cause / C. Remedy	Service call application Settings_Forwarding_SEND * This alarm is not displayed on LUI due to the alarm being generated by the application.
39-0631	Application-generated alarm
A. Operation / B. Cause / C. Remedy	Service call application Settings_Printer driver installation * This alarm is not displayed on LUI due to the alarm being generated by the application.
39-0641	Application-generated alarm
A. Operation / B. Cause / C. Remedy	Service call application Settings_Address book * This alarm is not displayed on LUI due to the alarm being generated by the application.
39-0651	Application-generated alarm
A. Operation / B. Cause / C. Remedy	Service call application Settings_Network * This alarm is not displayed on LUI due to the alarm being generated by the application.
39-0690	Application-generated alarm
A. Operation / B. Cause / C. Remedy	Service call application Settings_Others * This alarm is not displayed on LUI due to the alarm being generated by the application.
39-0811	Application-generated alarm
A. Operation / B. Cause / C. Remedy	Service call application Order_Toner_Black * This alarm is not displayed on LUI due to the alarm being generated by the application.
39-0812	Application-generated alarm
A. Operation / B. Cause / C. Remedy	Service call application Order_Toner_Yellow * This alarm is not displayed on LUI due to the alarm being generated by the application.

39-0813	Application-generated alarm
A. Operation / B. Cause / C. Remedy	Service call application Order_Toner_Magenta * This alarm is not displayed on LUI due to the alarm being generated by the application.
39-0814	Application-generated alarm
A. Operation / B. Cause / C. Remedy	Service call application Order_Toner_Cyan * This alarm is not displayed on LUI due to the alarm being generated by the application.
39-0821	Application-generated alarm
A. Operation / B. Cause / C. Remedy	Service call application Order_Waste Toner Container * This alarm is not displayed on LUI due to the alarm being generated by the application.
39-1111	Application-generated alarm
A. Operation / B. Cause / C. Remedy	Service call application Error message (E-code)_(Cancel) * This alarm is not displayed on LUI due to the alarm being generated by the application.
39-1210	Application-generated alarm
A. Operation / B. Cause / C. Remedy	Service call application Paper jam_Inside the machine_Not specified_(Cancel) * This alarm is not displayed on LUI due to the alarm being generated by the application.
39-1211	Application-generated alarm
A. Operation / B. Cause / C. Remedy	Service call application Paper jam_Inside the machine_Frequently_(Cancel) * This alarm is not displayed on LUI due to the alarm being generated by the application.
39-1212	Application-generated alarm
A. Operation / B. Cause / C. Remedy	Service call application Paper jam_Inside the machine_Occasionally_(Cancel) * This alarm is not displayed on LUI due to the alarm being generated by the application.
39-1213	Application-generated alarm
A. Operation / B. Cause / C. Remedy	Service call application Paper jam_Inside the machine_First time in the day_(Cancel) * This alarm is not displayed on LUI due to the alarm being generated by the application.
39-1220	Application-generated alarm
A. Operation / B. Cause / C. Remedy	Service call application Paper jam_Document Feeder_Not specified_(Cancel) * This alarm is not displayed on LUI due to the alarm being generated by the application.
39-1221	Application-generated alarm
A. Operation / B. Cause / C. Remedy	Service call application Paper jam_Document Feeder_Frequently_(Cancel) * This alarm is not displayed on LUI due to the alarm being generated by the application.
39-1222	Application-generated alarm
A. Operation / B. Cause / C. Remedy	Service call application Paper jam_Document Feeder_Occasionally_(Cancel) * This alarm is not displayed on LUI due to the alarm being generated by the application.
39-1223	Application-generated alarm
A. Operation / B. Cause / C. Remedy	Service call application Paper jam_Document Feeder_First time in the day_(Cancel) * This alarm is not displayed on LUI due to the alarm being generated by the application.

39-1230	Application-generated alarm
A. Operation / B. Cause / C. Remedy	Service call application Paper jam_Cassette_Not specified_(Cancel) * This alarm is not displayed on LUI due to the alarm being generated by the application.
39-1231	Application-generated alarm
A. Operation / B. Cause / C. Remedy	Service call application Paper jam_Cassette_Cassette 1_(Cancel) * This alarm is not displayed on LUI due to the alarm being generated by the application.
39-1232	Application-generated alarm
A. Operation / B. Cause / C. Remedy	Service call application Paper jam_Cassette_Cassette 2_(Cancel) * This alarm is not displayed on LUI due to the alarm being generated by the application.
39-1233	Application-generated alarm
A. Operation / B. Cause / C. Remedy	Service call application Paper jam_Cassette_Cassette 3_(Cancel) * This alarm is not displayed on LUI due to the alarm being generated by the application.
39-1234	Application-generated alarm
A. Operation / B. Cause / C. Remedy	Service call application Paper jam_Cassette_Cassette 4_(Cancel) * This alarm is not displayed on LUI due to the alarm being generated by the application.
39-1235	Application-generated alarm
A. Operation / B. Cause / C. Remedy	Service call application Spare (Cancel) * This alarm is not displayed on LUI due to the alarm being generated by the application.
39-1240	Application-generated alarm
A. Operation / B. Cause / C. Remedy	Service call application Paper jam_Multi-purpose Tray_Not specified_(Cancel) * This alarm is not displayed on LUI due to the alarm being generated by the application.
39-1241	Application-generated alarm
A. Operation / B. Cause / C. Remedy	Service call application Paper jam_Multi-purpose Tray_Envelope_(Cancel) * This alarm is not displayed on LUI due to the alarm being generated by the application.
39-1242	Application-generated alarm
A. Operation / B. Cause / C. Remedy	Service call application Paper jam_Multi-purpose Tray_Postcard_(Cancel) * This alarm is not displayed on LUI due to the alarm being generated by the application.
39-1243	Application-generated alarm
A. Operation / B. Cause / C. Remedy	Service call application Paper jam_Multi-purpose Tray_Plain paper_(Cancel) * This alarm is not displayed on LUI due to the alarm being generated by the application.
39-1244	Application-generated alarm
A. Operation / B. Cause / C. Remedy	Service call application Paper jam_Multi-purpose Tray_Label paper_(Cancel) * This alarm is not displayed on LUI due to the alarm being generated by the application.
39-1245	Application-generated alarm
A. Operation / B. Cause / C. Remedy	Service call application Paper jam_Multi-purpose Tray_Heavy paper_(Cancel) * This alarm is not displayed on LUI due to the alarm being generated by the application.

39-1250	Application-generated alarm
A. Operation / B. Cause / C. Remedy	Service call application Paper jam_Outlet_Not specified_(Cancel) * This alarm is not displayed on LUI due to the alarm being generated by the application.
39-1251	Application-generated alarm
A. Operation / B. Cause / C. Remedy	Service call application Paper jam_Outlet_Frequently_(Cancel) * This alarm is not displayed on LUI due to the alarm being generated by the application.
39-1252	Application-generated alarm
A. Operation / B. Cause / C. Remedy	Service call application Paper jam_Outlet_Occasionally_(Cancel) * This alarm is not displayed on LUI due to the alarm being generated by the application.
39-1253	Application-generated alarm
A. Operation / B. Cause / C. Remedy	Service call application Paper jam_Outlet_First time in the day_(Cancel) * This alarm is not displayed on LUI due to the alarm being generated by the application.
39-1260	Application-generated alarm
A. Operation / B. Cause / C. Remedy	Service call application Paper jam_At 2-sided printing_Not specified_(Cancel) * This alarm is not displayed on LUI due to the alarm being generated by the application.
39-1261	Application-generated alarm
A. Operation / B. Cause / C. Remedy	Service call application Paper jam_At 2-sided printing_Frequently_(Cancel) * This alarm is not displayed on LUI due to the alarm being generated by the application.
39-1262	Application-generated alarm
A. Operation / B. Cause / C. Remedy	Service call application Paper jam_At 2-sided printing_Occasionally_(Cancel) * This alarm is not displayed on LUI due to the alarm being generated by the application.
39-1263	Application-generated alarm
A. Operation / B. Cause / C. Remedy	Service call application Paper jam_At 2-sided printing_First time in the day_(Cancel) * This alarm is not displayed on LUI due to the alarm being generated by the application.
39-1290	Application-generated alarm
A. Operation / B. Cause / C. Remedy	Service call application Paper jam_Others_(Cancel) * This alarm is not displayed on LUI due to the alarm being generated by the application.
39-1310	Application-generated alarm
A. Operation / B. Cause / C. Remedy	Service call application Image failure_Displacement_Color not specified_(Cancel) * This alarm is not displayed on LUI due to the alarm being generated by the application.
39-1311	Application-generated alarm
A. Operation / B. Cause / C. Remedy	Service call application Image failure_Displacement_Black_(Cancel) * This alarm is not displayed on LUI due to the alarm being generated by the application.
39-1312	Application-generated alarm
A. Operation / B. Cause / C. Remedy	Service call application Image failure_Displacement_Yellow_(Cancel) * This alarm is not displayed on LUI due to the alarm being generated by the application.

39-1313	Application-generated alarm
A. Operation / B. Cause / C. Remedy	Service call application Image failure_Displacement_Magenta_(Cancel) * This alarm is not displayed on LUI due to the alarm being generated by the application.
39-1314	Application-generated alarm
A. Operation / B. Cause / C. Remedy	Service call application Image failure_Displacement_Cyan_(Cancel) * This alarm is not displayed on LUI due to the alarm being generated by the application.
39-1320	Application-generated alarm
A. Operation / B. Cause / C. Remedy	Service call application Image failure_Blank image_Color not specified_(Cancel) * This alarm is not displayed on LUI due to the alarm being generated by the application.
39-1321	Application-generated alarm
A. Operation / B. Cause / C. Remedy	Service call application Image failure_Blank image_Black_(Cancel) * This alarm is not displayed on LUI due to the alarm being generated by the application.
39-1322	Application-generated alarm
A. Operation / B. Cause / C. Remedy	Service call application Image failure_Blank image_Yellow_(Cancel) * This alarm is not displayed on LUI due to the alarm being generated by the application.
39-1323	Application-generated alarm
A. Operation / B. Cause / C. Remedy	Service call application Image failure_Blank image_Magenta_(Cancel) * This alarm is not displayed on LUI due to the alarm being generated by the application.
39-1324	Application-generated alarm
A. Operation / B. Cause / C. Remedy	Service call application Image failure_Blank image_Cyan_(Cancel) * This alarm is not displayed on LUI due to the alarm being generated by the application.
39-1330	Application-generated alarm
A. Operation / B. Cause / C. Remedy	Service call application Image failure_Soiling_Color not specified_(Cancel) * This alarm is not displayed on LUI due to the alarm being generated by the application.
39-1331	Application-generated alarm
A. Operation / B. Cause / C. Remedy	Service call application Image failure_Soiling_Black_(Cancel) * This alarm is not displayed on LUI due to the alarm being generated by the application.
39-1332	Application-generated alarm
A. Operation / B. Cause / C. Remedy	Service call application Image failure_Soiling_Yellow_(Cancel) * This alarm is not displayed on LUI due to the alarm being generated by the application.
39-1333	Application-generated alarm
A. Operation / B. Cause / C. Remedy	Service call application Image failure_Soiling_Magenta_(Cancel) * This alarm is not displayed on LUI due to the alarm being generated by the application.
39-1334	Application-generated alarm
A. Operation / B. Cause / C. Remedy	Service call application Image failure_Soiling_Cyan_(Cancel) * This alarm is not displayed on LUI due to the alarm being generated by the application.

39-1340	Application-generated alarm
A. Operation / B. Cause / C. Remedy	Service call application Image failure_Lines_Color not specified_(Cancel) * This alarm is not displayed on LUI due to the alarm being generated by the application.
39-1341	Application-generated alarm
A. Operation / B. Cause / C. Remedy	Service call application Image failure_Lines_Black_(Cancel) * This alarm is not displayed on LUI due to the alarm being generated by the application.
39-1342	Application-generated alarm
A. Operation / B. Cause / C. Remedy	Service call application Image failure_Lines_Yellow_(Cancel) * This alarm is not displayed on LUI due to the alarm being generated by the application.
39-1343	Application-generated alarm
A. Operation / B. Cause / C. Remedy	Service call application Image failure_Lines_Magenta_(Cancel) * This alarm is not displayed on LUI due to the alarm being generated by the application.
39-1344	Application-generated alarm
A. Operation / B. Cause / C. Remedy	Service call application Image failure_Lines_Cyan_(Cancel) * This alarm is not displayed on LUI due to the alarm being generated by the application.
39-1350	Application-generated alarm
A. Operation / B. Cause / C. Remedy	Service call application Image failure_Light_Color not specified_(Cancel) * This alarm is not displayed on LUI due to the alarm being generated by the application.
39-1351	Application-generated alarm
A. Operation / B. Cause / C. Remedy	Service call application Image failure_Light_Black_(Cancel) * This alarm is not displayed on LUI due to the alarm being generated by the application.
39-1352	Application-generated alarm
A. Operation / B. Cause / C. Remedy	Service call application Image failure_Light_Yellow_(Cancel) * This alarm is not displayed on LUI due to the alarm being generated by the application.
39-1353	Application-generated alarm
A. Operation / B. Cause / C. Remedy	Service call application Image failure_Light_Magenta_(Cancel) * This alarm is not displayed on LUI due to the alarm being generated by the application.
39-1354	Application-generated alarm
A. Operation / B. Cause / C. Remedy	Service call application Image failure_Light_Cyan_(Cancel) * This alarm is not displayed on LUI due to the alarm being generated by the application.
39-1360	Application-generated alarm
A. Operation / B. Cause / C. Remedy	Service call application Image failure_Hue_Color not specified_(Cancel) * This alarm is not displayed on LUI due to the alarm being generated by the application.
39-1361	Application-generated alarm
A. Operation / B. Cause / C. Remedy	Service call application Image failure_Hue_Black_(Cancel) * This alarm is not displayed on LUI due to the alarm being generated by the application.

39-1362	Application-generated alarm
A. Operation / B. Cause / C. Remedy	Service call application Image failure_Hue_Yellow_(Cancel) * This alarm is not displayed on LUI due to the alarm being generated by the application.
39-1363	Application-generated alarm
A. Operation / B. Cause / C. Remedy	Service call application Image failure_Hue_Magenta_(Cancel) * This alarm is not displayed on LUI due to the alarm being generated by the application.
39-1364	Application-generated alarm
A. Operation / B. Cause / C. Remedy	Service call application Image failure_Hue_Cyan_(Cancel) * This alarm is not displayed on LUI due to the alarm being generated by the application.
39-1370	Application-generated alarm
A. Operation / B. Cause / C. Remedy	Service call application Image failure_Dark_Color not specified_(Cancel) * This alarm is not displayed on LUI due to the alarm being generated by the application.
39-1371	Application-generated alarm
A. Operation / B. Cause / C. Remedy	Service call application Image failure_Dark_Black_(Cancel) * This alarm is not displayed on LUI due to the alarm being generated by the application.
39-1372	Application-generated alarm
A. Operation / B. Cause / C. Remedy	Service call application Image failure_Dark_Yellow_(Cancel) * This alarm is not displayed on LUI due to the alarm being generated by the application.
39-1373	Application-generated alarm
A. Operation / B. Cause / C. Remedy	Service call application Image failure_Dark_Magenta_(Cancel) * This alarm is not displayed on LUI due to the alarm being generated by the application.
39-1374	Application-generated alarm
A. Operation / B. Cause / C. Remedy	Service call application Image failure_Dark_Cyan_(Cancel) * This alarm is not displayed on LUI due to the alarm being generated by the application.
39-1380	Application-generated alarm
A. Operation / B. Cause / C. Remedy	Service call application Image failure_Color displacement_Color not specified_(Cancel) * This alarm is not displayed on LUI due to the alarm being generated by the application.
39-1381	Application-generated alarm
A. Operation / B. Cause / C. Remedy	Service call application Image failure_Color displacement_Black_(Cancel) * This alarm is not displayed on LUI due to the alarm being generated by the application.
39-1382	Application-generated alarm
A. Operation / B. Cause / C. Remedy	Service call application Image failure_Color displacement_Yellow_(Cancel) * This alarm is not displayed on LUI due to the alarm being generated by the application.
39-1383	Application-generated alarm
A. Operation / B. Cause / C. Remedy	Service call application Image failure_Color displacement_Magenta_(Cancel) * This alarm is not displayed on LUI due to the alarm being generated by the application.

39-1384	Application-generated alarm
A. Operation / B. Cause / C. Remedy	Service call application Image failure_Color displacement_Cyan_(Cancel) * This alarm is not displayed on LUI due to the alarm being generated by the application.
39-1390	Application-generated alarm
A. Operation / B. Cause / C. Remedy	Service call application Image failure_Others_(Cancel) * This alarm is not displayed on LUI due to the alarm being generated by the application.
39-1511	Application-generated alarm
A. Operation / B. Cause / C. Remedy	Service call application Image failure_Print_(Cancel) * This alarm is not displayed on LUI due to the alarm being generated by the application.
39-1520	Application-generated alarm
A. Operation / B. Cause / C. Remedy	Service call application Operation failure_Fax_Not specified_(Cancel) * This alarm is not displayed on LUI due to the alarm being generated by the application.
39-1521	Application-generated alarm
A. Operation / B. Cause / C. Remedy	Service call application Operation failure_Fax_Transmission and reception_(Cancel) * This alarm is not displayed on LUI due to the alarm being generated by the application.
39-1522	Application-generated alarm
A. Operation / B. Cause / C. Remedy	Service call application Operation failure_Fax_Reception_(Cancel) * This alarm is not displayed on LUI due to the alarm being generated by the application.
39-1523	Application-generated alarm
A. Operation / B. Cause / C. Remedy	Service call application Operation failure_Fax_Transmission_(Cancel) * This alarm is not displayed on LUI due to the alarm being generated by the application.
39-1524	Application-generated alarm
A. Operation / B. Cause / C. Remedy	Service call application Operation failure_Fax_Forwarding_(Cancel) * This alarm is not displayed on LUI due to the alarm being generated by the application.
39-1530	Application-generated alarm
A. Operation / B. Cause / C. Remedy	Service call application Operation failure_Control Panel_Not specified_(Cancel) * This alarm is not displayed on LUI due to the alarm being generated by the application.
39-1531	Application-generated alarm
A. Operation / B. Cause / C. Remedy	Service call application Operation failure_Control Panel_Slow response_(Cancel) * This alarm is not displayed on LUI due to the alarm being generated by the application.
39-1532	Application-generated alarm
A. Operation / B. Cause / C. Remedy	Service call application Operation failure_Control Panel_Occasional freeze-up (Not work)_(Cancel) * This alarm is not displayed on LUI due to the alarm being generated by the application.
39-1541	Application-generated alarm
A. Operation / B. Cause / C. Remedy	Service call application Operation failure_Scan (SEND)_(Cancel) * This alarm is not displayed on LUI due to the alarm being generated by the application.

39-1551	Application-generated alarm
A. Operation / B. Cause / C. Remedy	Service call application Operation failure_Abnormal noise_Main_(Cancel) * This alarm is not displayed on LUI due to the alarm being generated by the application.
39-1552	Application-generated alarm
A. Operation / B. Cause / C. Remedy	Service call application Operation failure_Abnormal noise_Options_(Cancel) * This alarm is not displayed on LUI due to the alarm being generated by the application.
39-1590	Application-generated alarm
A. Operation / B. Cause / C. Remedy	Service call application Operation failure_Others_(Cancel) * This alarm is not displayed on LUI due to the alarm being generated by the application.
39-1611	Application-generated alarm
A. Operation / B. Cause / C. Remedy	Service call application Settings_Training_(Cancel) * This alarm is not displayed on LUI due to the alarm being generated by the application.
39-1612	Application-generated alarm
A. Operation / B. Cause / C. Remedy	Service call application Settings_Addition_(Cancel) * This alarm is not displayed on LUI due to the alarm being generated by the application.
39-1621	Application-generated alarm
A. Operation / B. Cause / C. Remedy	Service call application Settings_Forwarding_Fax_(Cancel) * This alarm is not displayed on LUI due to the alarm being generated by the application.
39-1622	Application-generated alarm
A. Operation / B. Cause / C. Remedy	Service call application Settings_Forwarding_SEND_(Cancel) * This alarm is not displayed on LUI due to the alarm being generated by the application.
39-1631	Application-generated alarm
A. Operation / B. Cause / C. Remedy	Service call application Settings_Printer driver installation_(Cancel) * This alarm is not displayed on LUI due to the alarm being generated by the application.
39-1641	Application-generated alarm
A. Operation / B. Cause / C. Remedy	Service call application Settings_Address book_(Cancel) * This alarm is not displayed on LUI due to the alarm being generated by the application.
39-1651	Application-generated alarm
A. Operation / B. Cause / C. Remedy	Service call application Settings_Network_(Cancel) * This alarm is not displayed on LUI due to the alarm being generated by the application.
39-1690	Application-generated alarm
A. Operation / B. Cause / C. Remedy	Service call application Settings_Others_(Cancel) * This alarm is not displayed on LUI due to the alarm being generated by the application.
39-1811	Application-generated alarm
A. Operation / B. Cause / C. Remedy	Service call application Order_Toner_Black_(Cancel) * This alarm is not displayed on LUI due to the alarm being generated by the application.

39-1812	Application-generated alarm
A. Operation / B. Cause / C. Remedy	Service call application Order_Toner_Yellow_(Cancel) * This alarm is not displayed on LUI due to the alarm being generated by the application.
39-1813	Application-generated alarm
A. Operation / B. Cause / C. Remedy	Service call application Order_Toner_Magenta_(Cancel) * This alarm is not displayed on LUI due to the alarm being generated by the application.
39-1814	Application-generated alarm
A. Operation / B. Cause / C. Remedy	Service call application Order_Toner_Cyan_(Cancel) * This alarm is not displayed on LUI due to the alarm being generated by the application.
39-1821	Application-generated alarm
A. Operation / B. Cause / C. Remedy	Service call application Order_Waste Toner Container_(Cancel) * This alarm is not displayed on LUI due to the alarm being generated by the application.
39-19EE	Application-generated alarm
A. Operation / B. Cause / C. Remedy	Service call application Test signal * This alarm is not displayed on LUI due to the alarm being generated by the application.
39-19FF	Application-generated alarm
A. Operation / B. Cause / C. Remedy	Service call application Remedy completed * This alarm is not displayed on LUI due to the alarm being generated by the application.
39-2111	Application-generated alarm
A. Operation / B. Cause / C. Remedy	Service call application Error message (E-code)_(Customer information change) * This alarm is not displayed on LUI due to the alarm being generated by the application.
39-2210	Application-generated alarm
A. Operation / B. Cause / C. Remedy	Service call application Paper jam_Inside the machine_Not specified_(Customer information change) * This alarm is not displayed on LUI due to the alarm being generated by the application.
39-2211	Application-generated alarm
A. Operation / B. Cause / C. Remedy	Service call application Paper jam_Inside the machine_Frequently_(Customer information change) * This alarm is not displayed on LUI due to the alarm being generated by the application.
39-2212	Application-generated alarm
A. Operation / B. Cause / C. Remedy	Service call application Paper jam_Inside the machine_Occasionally_(Customer information change) * This alarm is not displayed on LUI due to the alarm being generated by the application.
39-2213	Application-generated alarm
A. Operation / B. Cause / C. Remedy	Service call application Paper jam_Inside the machine_First time in the day_(Customer information change) * This alarm is not displayed on LUI due to the alarm being generated by the application.
39-2220	Application-generated alarm
A. Operation / B. Cause / C. Remedy	Service call application Paper jam_Document Feeder_Not specified_(Customer information change) * This alarm is not displayed on LUI due to the alarm being generated by the application.

39-2221	Application-generated alarm
A. Operation / B. Cause / C. Remedy	Service call application Paper jam_Document Feeder_Frequently_(Customer information change) * This alarm is not displayed on LUI due to the alarm being generated by the application.
39-2222	Application-generated alarm
A. Operation / B. Cause / C. Remedy	Service call application Paper jam_Document Feeder_Occasionally_(Customer information change) * This alarm is not displayed on LUI due to the alarm being generated by the application.
39-2223	Application-generated alarm
A. Operation / B. Cause / C. Remedy	Service call application Paper jam_Document Feeder_First time in the day_(Customer information change) * This alarm is not displayed on LUI due to the alarm being generated by the application.
39-2230	Application-generated alarm
A. Operation / B. Cause / C. Remedy	Service call application Paper jam_Cassette_Not specified_(Customer information change) * This alarm is not displayed on LUI due to the alarm being generated by the application.
39-2231	Application-generated alarm
A. Operation / B. Cause / C. Remedy	Service call application Paper jam_Cassette_Cassette 1_(Customer information change) * This alarm is not displayed on LUI due to the alarm being generated by the application.
39-2232	Application-generated alarm
A. Operation / B. Cause / C. Remedy	Service call application Paper jam_Cassette_Cassette 2_(Customer information change) * This alarm is not displayed on LUI due to the alarm being generated by the application.
39-2233	Application-generated alarm
A. Operation / B. Cause / C. Remedy	Service call application Paper jam_Cassette_Cassette 3_(Customer information change) * This alarm is not displayed on LUI due to the alarm being generated by the application.
39-2234	Application-generated alarm
A. Operation / B. Cause / C. Remedy	Service call application Paper jam_Cassette_Cassette 4_(Customer information change) * This alarm is not displayed on LUI due to the alarm being generated by the application.
39-2240	Application-generated alarm
A. Operation / B. Cause / C. Remedy	Service call application Paper jam_Multi-purpose Tray_Not specified_(Customer information change) * This alarm is not displayed on LUI due to the alarm being generated by the application.
39-2241	Application-generated alarm
A. Operation / B. Cause / C. Remedy	Service call application Paper jam_Multi-purpose Tray_Envelope_(Customer information change) * This alarm is not displayed on LUI due to the alarm being generated by the application.
39-2242	Application-generated alarm
A. Operation / B. Cause / C. Remedy	Service call application Paper jam_Multi-purpose Tray_Postcard_(Customer information change) * This alarm is not displayed on LUI due to the alarm being generated by the application.
39-2243	Application-generated alarm
A. Operation / B. Cause / C. Remedy	Service call application Paper jam_Multi-purpose Tray_Plain paper_(Customer information change) * This alarm is not displayed on LUI due to the alarm being generated by the application.

39-2244	Application-generated alarm
A. Operation / B. Cause / C. Remedy	Service call application Paper jam_Multi-purpose Tray_Label paper_(Customer information change) * This alarm is not displayed on LUI due to the alarm being generated by the application.
39-2245	Application-generated alarm
A. Operation / B. Cause / C. Remedy	Service call application Paper jam_Multi-purpose Tray_Heavy paper_(Customer information change) * This alarm is not displayed on LUI due to the alarm being generated by the application.
39-2250	Application-generated alarm
A. Operation / B. Cause / C. Remedy	Service call application Paper jam_Outlet_Not specified_(Customer information change) * This alarm is not displayed on LUI due to the alarm being generated by the application.
39-2251	Application-generated alarm
A. Operation / B. Cause / C. Remedy	Service call application Paper jam_Outlet_Frequently_(Customer information change) * This alarm is not displayed on LUI due to the alarm being generated by the application.
39-2252	Application-generated alarm
A. Operation / B. Cause / C. Remedy	Service call application Paper jam_Outlet_Occasionally_(Customer information change) * This alarm is not displayed on LUI due to the alarm being generated by the application.
39-2253	Application-generated alarm
A. Operation / B. Cause / C. Remedy	Service call application Paper jam_Outlet_First time in the day_(Customer information change) * This alarm is not displayed on LUI due to the alarm being generated by the application.
39-2260	Application-generated alarm
A. Operation / B. Cause / C. Remedy	Service call application Paper jam_At 2-sided printing_Not specified_(Customer information change) * This alarm is not displayed on LUI due to the alarm being generated by the application.
39-2261	Application-generated alarm
A. Operation / B. Cause / C. Remedy	Service call application Paper jam_At 2-sided printing_Frequently_(Customer information change) * This alarm is not displayed on LUI due to the alarm being generated by the application.
39-2262	Application-generated alarm
A. Operation / B. Cause / C. Remedy	Service call application Paper jam_At 2-sided printing_Occasionally_(Customer information change) * This alarm is not displayed on LUI due to the alarm being generated by the application.
39-2263	Application-generated alarm
A. Operation / B. Cause / C. Remedy	Service call application Paper jam_At 2-sided printing_First time in the day_(Customer information change) * This alarm is not displayed on LUI due to the alarm being generated by the application.
39-2290	Application-generated alarm
A. Operation / B. Cause / C. Remedy	Service call application Paper jam_Others_(Customer information change) * This alarm is not displayed on LUI due to the alarm being generated by the application.
39-2310	Application-generated alarm
A. Operation / B. Cause / C. Remedy	Service call application Image failure_Displacement_Color not specified_(Customer information change) * This alarm is not displayed on LUI due to the alarm being generated by the application.

39-2311	Application-generated alarm
A. Operation / B. Cause / C. Remedy	Service call application Image failure_Displacement_Black_(Customer information change) * This alarm is not displayed on LUI due to the alarm being generated by the application.
39-2312	Application-generated alarm
A. Operation / B. Cause / C. Remedy	Service call application Image failure_Displacement_Yellow_(Customer information change) * This alarm is not displayed on LUI due to the alarm being generated by the application.
39-2313	Application-generated alarm
A. Operation / B. Cause / C. Remedy	Service call application Image failure_Displacement_Magenta_(Customer information change) * This alarm is not displayed on LUI due to the alarm being generated by the application.
39-2314	Application-generated alarm
A. Operation / B. Cause / C. Remedy	Service call application Image failure_Displacement_Cyan_(Customer information change) * This alarm is not displayed on LUI due to the alarm being generated by the application.
39-2320	Application-generated alarm
A. Operation / B. Cause / C. Remedy	Service call application Image failure_Blank image_Color not specified_(Customer information change) * This alarm is not displayed on LUI due to the alarm being generated by the application.
39-2321	Application-generated alarm
A. Operation / B. Cause / C. Remedy	Service call application Image failure_Blank image_Black_(Customer information change) * This alarm is not displayed on LUI due to the alarm being generated by the application.
39-2322	Application-generated alarm
A. Operation / B. Cause / C. Remedy	Service call application Image failure_Blank image_Yellow_(Customer information change) * This alarm is not displayed on LUI due to the alarm being generated by the application.
39-2323	Application-generated alarm
A. Operation / B. Cause / C. Remedy	Service call application Image failure_Blank image_Magenta_(Customer information change) * This alarm is not displayed on LUI due to the alarm being generated by the application.
39-2324	Application-generated alarm
A. Operation / B. Cause / C. Remedy	Service call application Image failure_Blank image_Cyan_(Customer information change) * This alarm is not displayed on LUI due to the alarm being generated by the application.
39-2330	Application-generated alarm
A. Operation / B. Cause / C. Remedy	Service call application Image failure_Soiling_Color not specified_(Customer information change) * This alarm is not displayed on LUI due to the alarm being generated by the application.
39-2331	Application-generated alarm
A. Operation / B. Cause / C. Remedy	Service call application Image failure_Soiling_Black_(Customer information change) * This alarm is not displayed on LUI due to the alarm being generated by the application.
39-2332	Application-generated alarm
A. Operation / B. Cause / C. Remedy	Service call application Image failure_Soiling_Yellow_(Customer information change) * This alarm is not displayed on LUI due to the alarm being generated by the application.

39-2333	Application-generated alarm
A. Operation / B. Cause / C. Remedy	Service call application Image failure_Soiling_Magenta_(Customer information change) * This alarm is not displayed on LUI due to the alarm being generated by the application.
39-2334	Application-generated alarm
A. Operation / B. Cause / C. Remedy	Service call application Image failure_Soiling_Cyan_(Customer information change) * This alarm is not displayed on LUI due to the alarm being generated by the application.
39-2340	Application-generated alarm
A. Operation / B. Cause / C. Remedy	Service call application Image failure_Lines_Color not specified_(Customer information change) * This alarm is not displayed on LUI due to the alarm being generated by the application.
39-2341	Application-generated alarm
A. Operation / B. Cause / C. Remedy	Service call application Image failure_Lines_Black_(Customer information change) * This alarm is not displayed on LUI due to the alarm being generated by the application.
39-2342	Application-generated alarm
A. Operation / B. Cause / C. Remedy	Service call application Image failure_Lines_Yellow_(Customer information change) * This alarm is not displayed on LUI due to the alarm being generated by the application.
39-2343	Application-generated alarm
A. Operation / B. Cause / C. Remedy	Service call application Image failure_Lines_Magenta_(Customer information change) * This alarm is not displayed on LUI due to the alarm being generated by the application.
39-2344	Application-generated alarm
A. Operation / B. Cause / C. Remedy	Service call application Image failure_Lines_Cyan_(Customer information change) * This alarm is not displayed on LUI due to the alarm being generated by the application.
39-2350	Application-generated alarm
A. Operation / B. Cause / C. Remedy	Service call application Image failure_Light_Color not specified_(Customer information change) * This alarm is not displayed on LUI due to the alarm being generated by the application.
39-2351	Application-generated alarm
A. Operation / B. Cause / C. Remedy	Service call application Image failure_Light_Black_(Customer information change) * This alarm is not displayed on LUI due to the alarm being generated by the application.
39-2352	Application-generated alarm
A. Operation / B. Cause / C. Remedy	Service call application Image failure_Light_Yellow_(Customer information change) * This alarm is not displayed on LUI due to the alarm being generated by the application.
39-2353	Application-generated alarm
A. Operation / B. Cause / C. Remedy	Service call application Image failure_Light_Magenta_(Customer information change) * This alarm is not displayed on LUI due to the alarm being generated by the application.
39-2354	Application-generated alarm
A. Operation / B. Cause / C. Remedy	Service call application Image failure_Light_Cyan_(Customer information change) * This alarm is not displayed on LUI due to the alarm being generated by the application.

39-2360	Application-generated alarm
A. Operation / B. Cause / C. Remedy	Service call application Image failure_Hue_Color not specified_(Customer information change) * This alarm is not displayed on LUI due to the alarm being generated by the application.
39-2361	Application-generated alarm
A. Operation / B. Cause / C. Remedy	Service call application Image failure_Hue_Black_(Customer information change) * This alarm is not displayed on LUI due to the alarm being generated by the application.
39-2362	Application-generated alarm
A. Operation / B. Cause / C. Remedy	Service call application Image failure_Hue_Yellow_(Customer information change) * This alarm is not displayed on LUI due to the alarm being generated by the application.
39-2363	Application-generated alarm
A. Operation / B. Cause / C. Remedy	Service call application Image failure_Hue_Magenta_(Customer information change) * This alarm is not displayed on LUI due to the alarm being generated by the application.
39-2364	Application-generated alarm
A. Operation / B. Cause / C. Remedy	Service call application Image failure_Hue_Cyan_(Customer information change) * This alarm is not displayed on LUI due to the alarm being generated by the application.
39-2370	Application-generated alarm
A. Operation / B. Cause / C. Remedy	Service call application Image failure_Dark_Color not specified_(Customer information change) * This alarm is not displayed on LUI due to the alarm being generated by the application.
39-2371	Application-generated alarm
A. Operation / B. Cause / C. Remedy	Service call application Image failure_Dark_Black_(Customer information change) * This alarm is not displayed on LUI due to the alarm being generated by the application.
39-2372	Application-generated alarm
A. Operation / B. Cause / C. Remedy	Service call application Image failure_Dark_Yellow_(Customer information change) * This alarm is not displayed on LUI due to the alarm being generated by the application.
39-2373	Application-generated alarm
A. Operation / B. Cause / C. Remedy	Service call application Image failure_Dark_Magenta_(Customer information change) * This alarm is not displayed on LUI due to the alarm being generated by the application.
39-2374	Application-generated alarm
A. Operation / B. Cause / C. Remedy	Service call application Image failure_Dark_Cyan_(Customer information change) * This alarm is not displayed on LUI due to the alarm being generated by the application.
39-2380	Application-generated alarm
A. Operation / B. Cause / C. Remedy	Service call application Image failure_Color displacement_Color not specified_(Customer information change) * This alarm is not displayed on LUI due to the alarm being generated by the application.
39-2381	Application-generated alarm
A. Operation / B. Cause / C. Remedy	Service call application Image failure_Color displacement_Black_(Customer information change) * This alarm is not displayed on LUI due to the alarm being generated by the application.

39-2382	Application-generated alarm
A. Operation / B. Cause / C. Remedy	Service call application Image failure_Color displacement_Yellow_(Customer information change) * This alarm is not displayed on LUI due to the alarm being generated by the application.
39-2383	Application-generated alarm
A. Operation / B. Cause / C. Remedy	Service call application Image failure_Color displacement_Magenta_(Customer information change) * This alarm is not displayed on LUI due to the alarm being generated by the application.
39-2384	Application-generated alarm
A. Operation / B. Cause / C. Remedy	Service call application Image failure_Color displacement_Cyan_(Customer information change) * This alarm is not displayed on LUI due to the alarm being generated by the application.
39-2390	Application-generated alarm
A. Operation / B. Cause / C. Remedy	Service call application Image failure_Others_(Customer information change) * This alarm is not displayed on LUI due to the alarm being generated by the application.
39-2511	Application-generated alarm
A. Operation / B. Cause / C. Remedy	Service call application Operation failure_Print_(Customer information change) * This alarm is not displayed on LUI due to the alarm being generated by the application.
39-2520	Application-generated alarm
A. Operation / B. Cause / C. Remedy	Service call application Operation failure_Fax_Not specified_(Customer information change) * This alarm is not displayed on LUI due to the alarm being generated by the application.
39-2521	Application-generated alarm
A. Operation / B. Cause / C. Remedy	Service call application Operation failure_Fax_Transmission and reception_(Customer information change) * This alarm is not displayed on LUI due to the alarm being generated by the application.
39-2522	Application-generated alarm
A. Operation / B. Cause / C. Remedy	Service call application Operation failure_Fax_Reception_(Customer information change) * This alarm is not displayed on LUI due to the alarm being generated by the application.
39-2523	Application-generated alarm
A. Operation / B. Cause / C. Remedy	Service call application Operation failure_Fax_Transmission_(Customer information change) * This alarm is not displayed on LUI due to the alarm being generated by the application.
39-2524	Application-generated alarm
A. Operation / B. Cause / C. Remedy	Service call application Operation failure_Fax_Forwarding_(Customer information change) * This alarm is not displayed on LUI due to the alarm being generated by the application.
39-2530	Application-generated alarm
A. Operation / B. Cause / C. Remedy	Service call application Operation failure_Control Panel_Not specified_(Customer information change) * This alarm is not displayed on LUI due to the alarm being generated by the application.
39-2531	Application-generated alarm
A. Operation / B. Cause / C. Remedy	Service call application Operation failure_Control Panel_Slow response_(Customer information change) * This alarm is not displayed on LUI due to the alarm being generated by the application.

39-2532	Application-generated alarm
A. Operation / B. Cause / C. Remedy	Service call application Operation failure_Control Panel_Occasional freeze-up (Not work)_(Customer information change) * This alarm is not displayed on LUI due to the alarm being generated by the application.
39-2541	Application-generated alarm
A. Operation / B. Cause / C. Remedy	Service call application Operation failure_Scan (SEND)_(Customer information change) * This alarm is not displayed on LUI due to the alarm being generated by the application.
39-2551	Application-generated alarm
A. Operation / B. Cause / C. Remedy	Service call application Operation failure_Abnormal noise_Main_(Customer information change) * This alarm is not displayed on LUI due to the alarm being generated by the application.
39-2552	Application-generated alarm
A. Operation / B. Cause / C. Remedy	Service call application Operation failure_Abnormal noise_Options_(Customer information change) * This alarm is not displayed on LUI due to the alarm being generated by the application.
39-2590	Application-generated alarm
A. Operation / B. Cause / C. Remedy	Service call application Operation failure_Others_(Customer information change) * This alarm is not displayed on LUI due to the alarm being generated by the application.
39-2611	Application-generated alarm
A. Operation / B. Cause / C. Remedy	Service call application Settings_Training_(Customer information change) * This alarm is not displayed on LUI due to the alarm being generated by the application.
39-2612	Application-generated alarm
A. Operation / B. Cause / C. Remedy	Service call application Settings_Addition_(Customer information change) * This alarm is not displayed on LUI due to the alarm being generated by the application.
39-2621	Application-generated alarm
A. Operation / B. Cause / C. Remedy	Service call application Settings_Forwarding_Fax_(Customer information change) * This alarm is not displayed on LUI due to the alarm being generated by the application.
39-2622	Application-generated alarm
A. Operation / B. Cause / C. Remedy	Service call application Settings_Forwarding_SEND_(Customer information change) * This alarm is not displayed on LUI due to the alarm being generated by the application.
39-2631	Application-generated alarm
A. Operation / B. Cause / C. Remedy	Service call application Settings_Printer driver installation_(Customer information change) * This alarm is not displayed on LUI due to the alarm being generated by the application.
39-2641	Application-generated alarm
A. Operation / B. Cause / C. Remedy	Service call application Settings_Address book_(Customer information change) * This alarm is not displayed on LUI due to the alarm being generated by the application.
39-2651	Application-generated alarm
A. Operation / B. Cause / C. Remedy	Service call application Settings_Network_(Customer information change) * This alarm is not displayed on LUI due to the alarm being generated by the application.

39-2690	Application-generated alarm
A. Operation / B. Cause / C. Remedy	Service call application Settings_Others_(Customer information change) * This alarm is not displayed on LUI due to the alarm being generated by the application.
39-2811	Application-generated alarm
A. Operation / B. Cause / C. Remedy	Service call application Order_Toner_Black_(Customer information change) * This alarm is not displayed on LUI due to the alarm being generated by the application.
39-2812	Application-generated alarm
A. Operation / B. Cause / C. Remedy	Service call application Order_Toner_Yellow_(Customer information change) * This alarm is not displayed on LUI due to the alarm being generated by the application.
39-2813	Application-generated alarm
A. Operation / B. Cause / C. Remedy	Service call application Order_Toner_Magenta_(Customer information change) * This alarm is not displayed on LUI due to the alarm being generated by the application.
39-2814	Application-generated alarm
A. Operation / B. Cause / C. Remedy	Service call application Order_Toner_Cyan_(Customer information change) * This alarm is not displayed on LUI due to the alarm being generated by the application.
39-2821	Application-generated alarm
A. Operation / B. Cause / C. Remedy	Service call application Order_Waste Toner Container_(Customer information change) * This alarm is not displayed on LUI due to the alarm being generated by the application.
40-0006	ITB prior notification alarm
A. Operation / B. Cause / C. Remedy	The life value of a target part reached the number of days left as set in COPIER > OPTION > PM-DLV-D > TR-BLT.
40-0013	Transfer Roller prior notification alarm
A. Operation / B. Cause / C. Remedy	The life value of a target part reached the number of days left as set in COPIER > OPTION > PM-DLV-D > TR-ROLL.
40-0073	Drum Unit (K) prior notification alarm
A. Operation / B. Cause / C. Remedy	The life value of a target part reached the number of days left as set in COPIER > OPTION > PM-DLV-D > PT-DRM.
40-0123	Developing Assembly prior notification alarm
A. Operation / B. Cause / C. Remedy	The life value of a target part reached the number of days left as set in COPIER > OPTION > PM-DLV-D > DV-UNT-K.
40-0193	Drum Cleaning Blade prior notification alarm
A. Operation / B. Cause / C. Remedy	The life value of a target part reached the number of days left as set in COPIER > OPTION > PM-DLV-D > CLN-BLD.
40-0370	ITB Cleaning Blade prior notification alarm
A. Operation / B. Cause / C. Remedy	The life value of a target part reached the number of days left as set in COPIER > OPTION > PM-DLV-D > T-CLN-BD.
40-0372	Brush Roller prior notification alarm
A. Operation / B. Cause / C. Remedy	The life value of a target part reached the number of days left as set in COPIER > OPTION > PM-DLV-D > T-CN-BRU.
40-0389	Fixing Roller prior notification alarm
A. Operation / B. Cause / C. Remedy	The life value of a target part reached the number of days left as set in COPIER > OPTION > PM-DLV-D > FX-UP-RL.

40-0398	Pressure Roller prior notification alarm
A. Operation / B. Cause / C. Remedy	The life value of a target part reached the number of days left as set in COPIER > OPTION > PM-DLV-D > FX-LW-RL.
43-0006	ITB replacement completion alarm
A. Operation / B. Cause / C. Remedy	ITB counter was cleared.
43-0013	Transfer Roller replacement completion alarm
A. Operation / B. Cause / C. Remedy	Transfer Roller counter was cleared.
43-0073	Drum Unit (K) replacement completion alarm
A. Operation / B. Cause / C. Remedy	Drum Unit (K) counter was cleared.
43-0077	Multi-purpose Tray Feed Roller replacement completion alarm
A. Operation / B. Cause / C. Remedy	Multi-purpose Tray Feed Roller counter was cleared.
43-0078	Multi-purpose Tray Separation Roller replacement completion alarm
A. Operation / B. Cause / C. Remedy	Multi-purpose Tray Separation Roller counter was cleared.
43-0079	Right Deck Pickup Roller replacement completion alarm
A. Operation / B. Cause / C. Remedy	Right Deck Pickup Roller counter was cleared.
43-0080	Right Deck Feed Roller replacement completion alarm
A. Operation / B. Cause / C. Remedy	Right Deck Feed Roller counter was cleared.
43-0081	Right Deck Separation Roller replacement completion alarm
A. Operation / B. Cause / C. Remedy	Right Deck Separation Roller counter was cleared.
43-0082	Left Deck Pickup Roller replacement completion alarm
A. Operation / B. Cause / C. Remedy	Left Deck Pickup Roller counter was cleared.
43-0083	Left Deck Feed Roller replacement completion alarm
A. Operation / B. Cause / C. Remedy	Left Deck Feed Roller counter was cleared.
43-0084	Left Deck Separation Roller replacement completion alarm
A. Operation / B. Cause / C. Remedy	Left Deck Separation Roller counter was cleared.
43-0085	Cassette 3 Pickup Roller replacement completion alarm
A. Operation / B. Cause / C. Remedy	Cassette 3 Pickup Roller counter was cleared.
43-0086	Cassette 3 Feed Roller replacement completion alarm
A. Operation / B. Cause / C. Remedy	Cassette 3 Feed Roller counter was cleared.
43-0087	Cassette 3 Separation Roller replacement completion alarm
A. Operation / B. Cause / C. Remedy	Cassette 3 Separation Roller counter was cleared.
43-0088	Cassette 4 Pickup Roller replacement completion alarm
A. Operation / B. Cause / C. Remedy	Cassette 4 Pickup Roller counter was cleared.

43-0089	Cassette 4 Feed Roller replacement completion alarm
A. Operation / B. Cause / C. Remedy	Cassette 4 Feed Roller counter was cleared.
43-0090	Cassette 4 Separation Roller replacement completion alarm
A. Operation / B. Cause / C. Remedy	Cassette 4 Separation Roller counter was cleared.
43-0092	Separation Roller (DADF) replacement completion alarm
A. Operation / B. Cause / C. Remedy	Separation Roller (DADF) counter was cleared.
43-0123	Developing Assembly replacement completion alarm
A. Operation / B. Cause / C. Remedy	Developing Assembly counter was cleared.
43-0125	Pickup Roller (DADF) replacement completion alarm
A. Operation / B. Cause / C. Remedy	Pickup Roller (DADF) counter was cleared.
43-0133	Primary Charging Wire replacement completion alarm
A. Operation / B. Cause / C. Remedy	Primary Charging Wire counter was cleared.
43-0173	Primary Charging Assembly replacement completion alarm
A. Operation / B. Cause / C. Remedy	Primary Charging Assembly counter was cleared.
43-0193	Drum Cleaning Blade replacement completion alarm
A. Operation / B. Cause / C. Remedy	Drum Cleaning Blade counter was cleared.
43-0350	Primary Charging Wire Cleaning Pad replacement completion alarm
A. Operation / B. Cause / C. Remedy	Primary Charging Wire Cleaning Pad counter was cleared.
43-0352	Drum Cleaner Side Seal (Front) replacement completion alarm
A. Operation / B. Cause / C. Remedy	Drum Cleaner Side Seal (Front) counter was cleared.
43-0353	Drum Cleaner Side Seal (Rear) replacement completion alarm
A. Operation / B. Cause / C. Remedy	Drum Cleaner Side Seal (Rear) counter was cleared.
43-0354	Drum Separation Claw replacement completion alarm
A. Operation / B. Cause / C. Remedy	Drum Separation Claw counter was cleared.
43-0355	Pre-exposure Scraper replacement completion alarm
A. Operation / B. Cause / C. Remedy	Pre-exposure Scraper counter was cleared.
43-0370	ITB Cleaning Blade replacement completion alarm
A. Operation / B. Cause / C. Remedy	ITB Cleaning Blade counter was cleared.
43-0372	Brush Roller replacement completion alarm
A. Operation / B. Cause / C. Remedy	Brush Roller counter was cleared.
43-0376	Primary Pre-transfer Charging Wire replacement completion alarm
A. Operation / B. Cause / C. Remedy	Primary Pre-transfer Charging Wire counter was cleared.

43-0377	Primary Pre-transfer Charging Wire Cleaning Pad replacement completion alarm
A. Operation / B. Cause / C. Remedy	Primary Pre-transfer Charging Wire Cleaning Pad counter was cleared.
43-0378	Primary Pre-transfer Charging Assembly replacement completion alarm
A. Operation / B. Cause / C. Remedy	Primary Pre-transfer Charging Assembly counter was cleared.
43-0389	Fixing Roller replacement completion alarm
A. Operation / B. Cause / C. Remedy	Fixing Roller counter was cleared.
43-0390	Fixing Main Thermistor replacement completion alarm
A. Operation / B. Cause / C. Remedy	Fixing Main Thermistor counter was cleared.
43-0391	Fixing Sub Thermistor replacement completion alarm
A. Operation / B. Cause / C. Remedy	Fixing Sub Thermistor counter was cleared.
43-0392	Fixing Roller Insulating Bushing replacement completion alarm
A. Operation / B. Cause / C. Remedy	Fixing Roller Insulating Bushing counter was cleared.
43-0394	Fixing Roller Thrust Retainer replacement completion alarm
A. Operation / B. Cause / C. Remedy	Fixing Roller Thrust Retainer counter was cleared.
43-0398	Pressure Roller replacement completion alarm
A. Operation / B. Cause / C. Remedy	Pressure Roller counter was cleared.
43-0402	Pressure Roller Static Eliminator replacement completion alarm
A. Operation / B. Cause / C. Remedy	Pressure Roller Static Eliminator counter was cleared.
43-0419	Fixing Web replacement completion alarm
A. Operation / B. Cause / C. Remedy	Fixing Web counter was cleared.
43-0470	Upper Separation Claw replacement completion alarm
A. Operation / B. Cause / C. Remedy	Upper Separation Claw counter was cleared.
43-0483	Ozone Filter replacement completion alarm
A. Operation / B. Cause / C. Remedy	Ozone Filter counter was cleared.
43-0488	Dustproof Filter replacement completion alarm
A. Operation / B. Cause / C. Remedy	Dustproof Filter counter was cleared.
43-0568	Pickup Roller (Deck) replacement completion alarm
A. Operation / B. Cause / C. Remedy	Pickup Roller (Deck) counter was cleared.
43-0572	Separation Roller Parts (Deck) replacement completion alarm
A. Operation / B. Cause / C. Remedy	Separation Roller Parts (Deck) counter was cleared.
43-0576	Feed Roller (Deck) replacement completion alarm
A. Operation / B. Cause / C. Remedy	Feed Roller (Deck) counter was cleared.

43-0611	Stapler (Fin-W1/X1/AC1) replacement completion alarm
A. Operation / B. Cause / C. Remedy	The Stapler (Fin-W1/X1/AC1) counter was cleared.
43-0612	Saddle Stitcher (Fin-AC1) replacement completion alarm
A. Operation / B. Cause / C. Remedy	Saddle Stitcher (Fin-AC1) counter was cleared.
43-0613	Saddle Stitcher (Fin-W1/X1) replacement completion alarm
A. Operation / B. Cause / C. Remedy	Saddle Stitcher (Fin-W1/X1) counter was cleared.
43-0631	Staple-free Binding Unit (Fin-AC1) replacement completion alarm
A. Operation / B. Cause / C. Remedy	Staple-free Binding Unit (Fin-AC1) counter was cleared.
43-0651	Process Tray Torque Limiter (Fin-X1) replacement completion alarm
A. Operation / B. Cause / C. Remedy	Process Tray Torque Limiter (Fin-X1) counter was cleared.
43-0652	Grate-shaped Upper Guide Shutter Torque Limiter (Fin-X1) replacement completion alarm
A. Operation / B. Cause / C. Remedy	Grate-shaped Upper Guide Shutter Torque Limiter (Fin-X1) counter was cleared.
43-0653	Sub Guide Torque Limiter (Fin-X1) replacement completion alarm
A. Operation / B. Cause / C. Remedy	Sub Guide Torque Limiter (Fin-X1) counter was cleared.
43-0654	Processing Tray Paper Holding Torque Limiter (Fin-X1) replacement completion alarm
A. Operation / B. Cause / C. Remedy	Processing Tray Paper Holding Torque Limiter (Fin-X1) counter was cleared.
43-0655	Tray Torque Limiter (Fin-X1/AC1) replacement completion alarm
A. Operation / B. Cause / C. Remedy	Tray Torque Limiter (Fin-X1/AC1) counter was cleared.
43-0656	Tray 2 Torque Limiter (Fin-X1) replacement completion alarm
A. Operation / B. Cause / C. Remedy	Tray 2 Torque Limiter (Fin-X1) counter was cleared.
43-0681	Paddle Unit (Fin-AC1) replacement completion alarm
A. Operation / B. Cause / C. Remedy	Paddle Unit (Fin-AC1) counter was cleared.
43-0703	Neat Paddle (Upper) (Fin-W1) replacement completion alarm
A. Operation / B. Cause / C. Remedy	Neat Paddle (Upper) (Fin-W1) counter was cleared.
43-0704	Neat Paddle (Lower) (Fin-W1) replacement completion alarm
A. Operation / B. Cause / C. Remedy	Neat Paddle (Lower) (Fin-W1) counter was cleared.
43-0706	Saddle Alignment Roller (Fin-W1) replacement completion alarm
A. Operation / B. Cause / C. Remedy	Saddle Alignment Roller (Fin-W1) counter was cleared.
43-0707	Saddle Disengagement Roller (Fin-W1) replacement completion alarm
A. Operation / B. Cause / C. Remedy	Saddle Disengagement Roller (Fin-W1) counter was cleared.
43-0709	Stack Delivery Upper Roller (Front/Rear) (Fin-X1) replacement completion alarm
A. Operation / B. Cause / C. Remedy	Stack Delivery Upper Roller (Front/Rear) (Fin-X1) counter was cleared.

43-0710	Stack Delivery Upper Roller (Center) (Fin-X1) replacement completion alarm
A. Operation / B. Cause / C. Remedy	Stack Delivery Upper Roller (Center) (Fin-X1) counter was cleared.
43-0711	Process Tray Paper Return Roller (Front/Rear) (Fin-X1) replacement completion alarm
A. Operation / B. Cause / C. Remedy	Process Tray Paper Return Roller (Front/Rear) (Fin-X1) counter was cleared.
43-0751	Cutter Unit (Fin-X1) replacement completion alarm
A. Operation / B. Cause / C. Remedy	Cutter Unit (Fin-X1) counter was cleared.
43-0767	Swing Guide Solenoid (Fin-X1) replacement completion alarm
A. Operation / B. Cause / C. Remedy	Swing Guide Solenoid (Fin-X1) counter was cleared.
43-0876	Punch Unit (Fin-W1/X1/AC1) replacement completion alarm
A. Operation / B. Cause / C. Remedy	Punch Unit (Fin-W1/X1/AC1) counter was cleared.
43-0877	Feed Belt (Fin-W1) replacement completion alarm
A. Operation / B. Cause / C. Remedy	Feed Belt (Fin-W1) counter was cleared.
43-0878	Paper Retainer Lever (Fin-AC1) replacement completion alarm
A. Operation / B. Cause / C. Remedy	Paper Retainer Lever (Fin-AC1) counter was cleared.
43-1611	Torque Limiter (INS) replacement completion alarm
A. Operation / B. Cause / C. Remedy	Torque Limiter (INS) counter was cleared.
43-1612	Lower Tray Torque Limiter (INS) replacement completion alarm
A. Operation / B. Cause / C. Remedy	Lower Tray Torque Limiter (INS) counter was cleared.
43-1633	Upper Tray Pickup Roller (INS) replacement completion alarm
A. Operation / B. Cause / C. Remedy	Upper Tray Pickup Roller (INS) counter was cleared.
43-1634	Lower Tray Pickup Roller (INS) replacement completion alarm
A. Operation / B. Cause / C. Remedy	Lower Tray Pickup Roller (INS) counter was cleared.
50-0007	Insufficient light intensity in Post-separation Sensor 3
A. Operation / B. Cause / C. Remedy	Movement: Nothing in particular. Cause: Light intensity is insufficient when adjusting output of the Post-separation Sensor 3 (SR20). Measures: Clean the Post-separation Sensor 3 (SR20) (periodical maintenance).
50-0008	Insufficient light intensity in Lead Sensor 1
A. Operation / B. Cause / C. Remedy	Movement: Nothing in particular. Cause: Light intensity is insufficient when adjusting output of the Lead Sensor 1 (SR22). Measures: Clean the Lead Sensor 1 (SR22) (periodical maintenance).
50-0009	Insufficient light intensity in Delivery Sensor
A. Operation / B. Cause / C. Remedy	Movement: Nothing in particular. Cause: Light intensity is insufficient when adjusting output of the Delivery Sensor (SR21). Measures: Clean the Delivery Sensor (SR21) (periodical maintenance).

50-0010	Alarm due to original separation failure
A. Operation / B. Cause / C. Remedy	Movement: Nothing in particular. Cause: Condition unable to separate 1st sheet of original from the ADF occurs 3 times. Measures: Check the rotation of the Pickup Motor (M1) -> Check the life of the Pickup Roller -> Check if the paper lint is at the pickup slot.
50-0013	Insufficient light intensity in Registration Sensor
A. Operation / B. Cause / C. Remedy	Movement: Nothing in particular. Cause: Light intensity is insufficient when adjusting output of the Registration Sensor (SR23). Measures: Clean the Registration Sensor (SR23) (periodical maintenance).
50-0014	Insufficient Scanner Unit (Paper Back) LED light intensity alarm (Some of the LEDs are OFF. Scanning can be continued.)
A. Operation / B. Cause / C. Remedy	In the case that the light intensity is insufficient at LED lighting.
50-0015	ADF Double Feed Detection Sensor trouble
A. Operation / B. Cause / C. Remedy	Cause: Failure of the Double Feed Sensor installed in the ADF Detection condition/timing: - When a paper feed error of the Double Feed Sensor was detected at power-on - When an error of the output value of the Double Feed Sensor was detected during ADF job (While an ADF job is being executed, it is handled as a jam once and retry is performed.) Clearing condition: When communication and the sensor output value are normal at power-on Movement/symptom: "Check area where multi. sheet feed was detected. (Call serv. rep.)" is displayed in the status line. Although reading from the ADF is possible, double feed cannot be detected when it occurs. Message displayed on the Control Panel: Check area where multi. sheet feed was detected. (Call serv. rep.) Measures: Check for any foreign matter, clean paper lint, disconnect and then connect the connectors, replace the Double Feed Detection PCB, replace the RCON/DF Driver PCB, replace the harnesses
60-0001	Shift Tray alarm
A. Operation / B. Cause / C. Remedy	Movement: Shift Tray operation is stopped. Cause: Home position at startup of the host machine cannot be detected. Measure: Check connector disconnection of the HP Sensor (Front) (PS101) and the HP Sensor (Rear) (PS102) -> Replace the HP Sensor (Front) (PS101) and the HP Sensor (Rear) (PS102).
61-0002	Finisher Staple Free Stapling alarm
A. Operation / B. Cause / C. Remedy	Cause: The staple free staple unit is broken. Operation : Operation stops as jam. After jam processing, the paper is delivered without stapling until a job is finished. Recovery method : Replace the Staple free staple unit. After performing the remedy work, go through the following to clear the alarm: SORTER> FUNCTION> EMSG-CLR.
64-0001	Delivery Fan (Upper) alarm
A. Operation / B. Cause / C. Remedy	-
64-0002	Delivery Fan (Lower) alarm
A. Operation / B. Cause / C. Remedy	-

64-0003	a.Finisher Upper Neat Stack Unit Alignment Plate Lifting Alarm b.Neat Alignment Lift Alarm
A. Operation / B. Cause / C. Remedy	<p>a.FIN-W1</p> <p>(1) The HP Sensor is not turned ON although 1 sec has passed since the start of operation.</p> <p>(2) The HP Sensor is not turned OFF although 1 sec has passed since the start of operation.</p> <p>b.Finisher Jogger Kit</p> <p>Contents:</p> <p>1.The Alignment Plate Lift HP Sensor (PS1) is not turned ON although 346 msec has passed since the start of operation.</p> <p>2.The Alignment Plate Lift HP Sensor (PS1) is not turned OFF although 72msec has passed since the start of operation.</p> <p>Operation: The alignment plate and the paddle unit of the neat alignment unit move away. While failure has occurred (an alarm has occurred), the neat alignment operation is not performed.</p> <p>Measures:</p> <p>1.Check/replace the harness and connector between the Neat Controller PCB and the Neat Alignment Plate Lift HP Sensor.</p> <p>2.Check/replace the harness and connector between the Neat Controller PCB and the Neat Alignment Plate Lift Motor.</p> <p>3.Replace the Neat Alignment Plate Lift HP Sensor.</p> <p>4.Replace the Neat Alignment Plate Lift Motor.</p> <p>5.Replace the Neat Controller PCB.</p>
64-0004	Finisher Upper Neat Stack Unit Front Alignment Plate Alarm
A. Operation / B. Cause / C. Remedy	<p>(1) The operation is not completed although 3 sec have passed since the start of operation.</p> <p>(2) The HP Sensor is not turned OFF although 1 sec has passed since the start of operation.</p> <p>(3) The alignment operation is not completed although 400 msec have passed during the alignment operation.</p>
64-0005	Finisher Upper Neat Stack Unit Rear Alignment Plate Alarm
A. Operation / B. Cause / C. Remedy	<p>(1) The operation is not completed although 3 sec have passed since the start of operation.</p> <p>(2) The HP Sensor is not turned OFF although 1 sec has passed since the start of operation.</p> <p>(3) The alignment operation is not completed although 400 msec have passed during the alignment operation.</p>
64-0006	Finisher Lower Neat Stack Unit Alignment Plate Lifting Alarm
A. Operation / B. Cause / C. Remedy	<p>(1) The HP Sensor is not turned ON although 1 sec has passed since the start of operation.</p> <p>(2) The HP Sensor is not turned OFF although 1 sec has passed since the start of operation.</p>
64-0007	Finisher Lower Neat Stack Unit Front Alignment Plate Alarm
A. Operation / B. Cause / C. Remedy	<p>(1) The operation is not completed although 3 sec have passed since the start of operation.</p> <p>(2) The HP Sensor is not turned OFF although 1 sec has passed since the start of operation.</p> <p>(3) The alignment operation is not completed although 400 msec have passed during the alignment operation.</p>
64-0008	Finisher Lower Neat Stack Unit Rear Alignment Plate Alarm
A. Operation / B. Cause / C. Remedy	<p>(1) The operation is not completed although 3 sec have passed since the start of operation.</p> <p>(2) The HP Sensor is not turned OFF although 1 sec has passed since the start of operation.</p> <p>(3) The alignment operation is not completed although 400 msec have passed during the alignment operation.</p>

64-0009	a.Finisher Upper Neat Stack Unit Return Roller Lifting Alarm b.Neat Paddle Lift Alarm
A. Operation / B. Cause / C. Remedy	<p>a.FIN-W1 Contents: 1.The HP Sensor is not turned ON even though 1 sec has passed since the start of operation. 2.The HP Sensor is not turned OFF even though 1 sec has passed since the start of operation. Measures: 1. Check for any disconnection/improper connection of the connectors. => Disconnect and then connect them if necessary. - Upper Neat Stack Unit Return Roller HP Sensor (PS209) - Upper Neat Stack Unit Return Roller Lifting Motor (M209) 2. Replace the Upper Neat Stack Unit Return Roller HP Sensor (PS209). 3. Replace the Upper Neat Stack Unit Return Roller Lifting Motor (M209). 4. Replace the Finisher Controller PCB.</p> <p>b.Finisher Jogger Kit Contents: 1.The Paddle Lift HP Sensor (PS4) is not turned ON although 337 msec has passed since the start of operation. 2.The Paddle Lift HP Sensor (PS4) is not turned OFF although 72msec has passed since the start of operation. Operation: The alignment plate and the paddle unit of the neat alignment unit move away. While failure has occurred (an alarm has occurred), the neat alignment operation is not performed. Measures: 1.Check/replace the harness and connector between the Neat Controller PCB and the Neat Paddle Lift HP Sensor. 2.Check/replace the harness and connector between the Neat Controller PCB and the Neat Paddle Lift Motor. 3.Replace the Neat Paddle Lift HP Sensor. 4.Replace the Neat Paddle Lift Motor. 5.Replace the Neat Controller PCB.</p>
64-000A	Lower Neat Stack Unit Return Roller Lifting Alarm
A. Operation / B. Cause / C. Remedy	<p>(1) The HP Sensor is not turned ON although 1 sec has passed since the start of operation. (2) The HP Sensor is not turned OFF although 1 sec has passed since the start of operation.</p>
67-0001	Inserter: Drive Switch Motor does not go through the home position.
A. Operation / B. Cause / C. Remedy	<p>Movement:Drive Switch Motor (M4) is stopped urgently. Cause: It does not go through the home position even though the Drive Switch Motor (M4) is operated by the specified pulse. Measures: 1. Turn OFF and then ON the power. 2. Check for any disconnection/improper connection of the connectors. 3. Replace the Drive Switchover Sensor (S1) 4. Replace harnesses from the Insertion Unit Controller PCB (PCB3) to the Drive Switchover Sensor (S1) 5. Replace the Drive Switchover Motor (M4) 6. Replace harnesses from the Insertion Unit Controller PCB (PCB3) to the Drive Switchover Motor (M4) 7. Replace theInsertion Unit Controller PCB (PCB3)</p>

67-0002	Insertor: Drive Switch Motor does not return to the home position.
A. Operation / B. Cause / C. Remedy	<p>Movement: Drive Switch Motor (M4) is stopped urgently.</p> <p>Cause: It does not go through the home position even though the Drive Switch Motor (M4) is operated by the specified pulse.</p> <p>Measures:</p> <ol style="list-style-type: none"> 1. Turn OFF and then ON the power. 2. Check for any disconnection/improper connection of the connectors. 3. Replace the Drive Switchover Sensor (S1) 4. Replace harnesses from the Insertion Unit Controller PCB (PCB3) to the Drive Switchover Sensor (S1) 5. Replace the Drive Switchover Motor (M4) 6. Replace harnesses from the Insertion Unit Controller PCB (PCB3) to the Drive Switchover Motor (M4) 7. Replace the Insertion Unit Controller PCB (PCB3)
67-0003	Insertor: Upper Tray Lift Motor does not go through the home position.
A. Operation / B. Cause / C. Remedy	<p>Movement: Upper Tray Lift Motor (M2) is stopped urgently.</p> <p>Cause: It does not go through the home position even though the Upper Tray Lift Motor (M2) is operated by the specified pulse.</p> <p>Measures:</p> <ol style="list-style-type: none"> 1. Turn OFF and then ON the power. 2. Check for any disconnection/improper connection of the connectors. 3. Replace the Upper Tray Lower Limit Sensor (S4) 4. Replace harnesses from the Insertion Unit Controller PCB (PCB3) to the Upper Tray Lower Limit Sensor (S4) 5. Replace the Upper Tray Lift Motor (M2) 6. Replace harnesses from the Insertion Unit Controller PCB (PCB3) to the Upper Tray Lift Motor (M2) 7. Replace the Insertion Unit Controller PCB (PCB3)
67-0004	Insertor: Upper Tray Lift Motor does not return to the home position.
A. Operation / B. Cause / C. Remedy	<p>Movement: Upper Tray Lift Motor (M2) is stopped urgently.</p> <p>Cause: It does not go through the home position even though the Upper Tray Lift Motor (M2) is operated by the specified pulse.</p> <p>Measures:</p> <ol style="list-style-type: none"> 1. Turn OFF and then ON the power. 2. Check for any disconnection/improper connection of the connectors. 3. Replace the Upper Tray Lower Limit Sensor (S4) 4. Replace harnesses from the Insertion Unit Controller PCB (PCB3) to the Upper Tray Lower Limit Sensor (S4) 5. Replace the Upper Tray Lift Motor (M2) 6. Replace harnesses from the Insertion Unit Controller PCB (PCB3) to the Upper Tray Lift Motor (M2) 7. Replace the Insertion Unit Controller PCB (PCB3)
67-0005	Insertor: Lower Tray Lift Motor does not go through the home position.
A. Operation / B. Cause / C. Remedy	<p>Movement: Lower Tray Lift Motor (M3) is stopped urgently.</p> <p>Cause: It does not go through the home position even though the Lower Tray Lift Motor (M3) is operated by the specified pulse.</p> <p>Measures:</p> <ol style="list-style-type: none"> 1. Turn OFF and then ON the power. 2. Check for any disconnection/improper connection of the connectors. 3. Replace the Lower Tray Lower Limit Sensor (S5) 4. Replace harnesses from the Insertion Unit Controller PCB (PCB3) to the Lower Tray Lower Limit Sensor (S5) 5. Replace the Lower Tray Lift Motor (M3) 6. Replace harnesses from the Insertion Unit Controller PCB (PCB3) to the Lower Tray Lift Motor (M3) 7. Replace the Insertion Unit Controller PCB (PCB3)

67-0006	Inserter: Lower Tray Lift Motor does not return to the home position.
A. Operation / B. Cause / C. Remedy	<p>Movement: Lower Tray Lift Motor (M3) is stopped urgently.</p> <p>Cause: It does not go through the home position even though the Lower Tray Lift Motor (M3) is operated by the specified pulse.</p> <p>Measures:</p> <ol style="list-style-type: none"> 1. Turn OFF and then ON the power. 2. Check for any disconnection/improper connection of the connectors. 3. Replace the Lower Tray Lower Limit Sensor (S5) 4. Replace harnesses from the Insertion Unit Controller PCB (PCB3) to the Lower Tray Lower Limit Sensor (S5) 5. Replace the Lower Tray Lift Motor (M3) 6. Replace harnesses from the Insertion Unit Controller PCB (PCB3) to the Lower Tray Lift Motor (M3) 7. Replace the Insertion Unit Controller PCB (PCB3)
67-0007	Inserter: Upper Tray Width Sensor is broken.
A. Operation / B. Cause / C. Remedy	<p>Movement: None</p> <p>Cause: At the first initialization of Inserter, there is an error in A/D value of A4 vertical width or A4 horizontal width of Upper Tray that is saved in EEPROM.</p> <p>Measures:</p> <ol style="list-style-type: none"> 1. Turn OFF and then ON the power. 2. Check for any disconnection/improper connection of the connectors. 3. Replace the Upper Tray Width Sensor (S10) 4. Replace harnesses from the Insertion Unit Controller PCB (PCB3) to the Upper Tray Width Sensor (S10) 5. Replace the Insertion Unit Controller PCB (PCB3)
67-0008	Inserter: Lower Tray Width Sensor is broken.
A. Operation / B. Cause / C. Remedy	<p>Movement: None</p> <p>Cause: At the first initialization of Inserter, there is an error in A/D value of A4 vertical width or A4 horizontal width of Lower Tray that is saved in EEPROM.</p> <p>Measures:</p> <ol style="list-style-type: none"> 1. Turn OFF and then ON the power. 2. Check for any disconnection/improper connection of the connectors. 3. Replace the Lower Tray Width Sensor (S13) 4. Replace harnesses from the Insertion Unit Controller PCB (PCB3) to the Lower Tray Width Sensor (S13) 5. Replace the Insertion Unit Controller PCB (PCB3)
70-0071	Verification error by Falsification detection at startup function
A. Operation / B. Cause / C. Remedy	<p>Cause:</p> <p>At normal startup, verification error occurred due to invalid data of the firmware (for startup in safe mode).</p> <p>Measures:</p> <ol style="list-style-type: none"> 1. Replace the Flash PCB, and reinstall the system software using SST or a USB flash drive. 2. Settings/Registration > Management Settings > Security Settings > System verification at startup > OFF
70-0086	For R&D
A. Operation / B. Cause / C. Remedy	

70-0087	Firmware combination mismatch
A. Operation / B. Cause / C. Remedy	<p>Cause: An option with the firmware which version is newer than that of the firmware installed in the host machine was detected. It is an alarm when the automatic update cancellation message is displayed on the Control Panel.</p> <p>Detection condition: When the following two conditions are satisfied: 1. "1" is set in COPIER>Option>FNC-SW>VER-CHNG. 2. The version of the firmware installed in the option that has been installed to the host machine is newer than that of the firmware in the host machine.</p> <p>Timing: At startup Movement/symptom: Cancel the automatic update. Measures: Update the firmware of the host machine.</p>
73-0004	For R&D
A. Operation / B. Cause / C. Remedy	-
73-0006	LIPS
A. Operation / B. Cause / C. Remedy	Error in configuration acquisition/management
73-0007	For R&D
A. Operation / B. Cause / C. Remedy	-
73-0008	For R&D
A. Operation / B. Cause / C. Remedy	-
73-0009	For R&D
A. Operation / B. Cause / C. Remedy	-
73-0011	For R&D
A. Operation / B. Cause / C. Remedy	-
73-0014	For R&D
A. Operation / B. Cause / C. Remedy	-
73-0015	For R&D
A. Operation / B. Cause / C. Remedy	-
73-0017	For R&D
A. Operation / B. Cause / C. Remedy	-
73-0021	For R&D
A. Operation / B. Cause / C. Remedy	-
73-0024	For R&D
A. Operation / B. Cause / C. Remedy	-
73-0026	For R&D
A. Operation / B. Cause / C. Remedy	-

75-0001	For R&D
A. Operation / B. Cause / C. Remedy	-
75-0002	For R&D
A. Operation / B. Cause / C. Remedy	-
76-0001	For R&D
A. Operation / B. Cause / C. Remedy	-
76-0002	Font
A. Operation / B. Cause / C. Remedy	Fails to secure the work area to analyze the font that is downloaded at "Resource Download".
76-0003	For R&D
A. Operation / B. Cause / C. Remedy	-
76-0004	For R&D
A. Operation / B. Cause / C. Remedy	-
76-0005	For R&D
A. Operation / B. Cause / C. Remedy	-
76-0006	For R&D
A. Operation / B. Cause / C. Remedy	-
76-0007	For R&D
A. Operation / B. Cause / C. Remedy	-
76-0008	For R&D
A. Operation / B. Cause / C. Remedy	-
77-0001	For R&D
A. Operation / B. Cause / C. Remedy	-
77-0002	For R&D
A. Operation / B. Cause / C. Remedy	-
77-0003	For R&D
A. Operation / B. Cause / C. Remedy	-
77-0005	For R&D
A. Operation / B. Cause / C. Remedy	-
77-0006	For R&D
A. Operation / B. Cause / C. Remedy	-
78-0001	For R&D
A. Operation / B. Cause / C. Remedy	-

78-0002	For R&D
A. Operation / B. Cause / C. Remedy	-
78-0003	For R&D
A. Operation / B. Cause / C. Remedy	-
78-0004	For R&D
A. Operation / B. Cause / C. Remedy	-
78-0005	For R&D
A. Operation / B. Cause / C. Remedy	-
79-0001	For R&D
A. Operation / B. Cause / C. Remedy	-
79-0002	For R&D
A. Operation / B. Cause / C. Remedy	-
79-0003	Canon-made PCL
A. Operation / B. Cause / C. Remedy	Overflow of work memory for translator
79-0004	Canon-made PCL
A. Operation / B. Cause / C. Remedy	Download overflow
80-0001	For R&D
A. Operation / B. Cause / C. Remedy	-
80-0003	For R&D
A. Operation / B. Cause / C. Remedy	-
80-0004	For R&D
A. Operation / B. Cause / C. Remedy	-
80-0007	For R&D
A. Operation / B. Cause / C. Remedy	-
80-0008	For R&D
A. Operation / B. Cause / C. Remedy	-
80-0009	For R&D
A. Operation / B. Cause / C. Remedy	-
80-0010	For R&D
A. Operation / B. Cause / C. Remedy	-
80-0011	For R&D
A. Operation / B. Cause / C. Remedy	-

80-0012	For R&D
A. Operation / B. Cause / C. Remedy	-
80-0013	For R&D
A. Operation / B. Cause / C. Remedy	-
80-0015	BDL
A. Operation / B. Cause / C. Remedy	Print data cannot process this version.
80-0016	For R&D
A. Operation / B. Cause / C. Remedy	-
80-0019	For R&D
A. Operation / B. Cause / C. Remedy	-
81-0001	Imaging
A. Operation / B. Cause / C. Remedy	Fails to allocate the memory.
81-0002	Imaging
A. Operation / B. Cause / C. Remedy	Rendering error
81-0003	For R&D
A. Operation / B. Cause / C. Remedy	-
81-0004	For R&D
A. Operation / B. Cause / C. Remedy	-
81-0005	For R&D
A. Operation / B. Cause / C. Remedy	-
81-0006	For R&D
A. Operation / B. Cause / C. Remedy	-
81-0007	For R&D
A. Operation / B. Cause / C. Remedy	-
83-0005	PDF
A. Operation / B. Cause / C. Remedy	PDF memory full
83-0015	PDF
A. Operation / B. Cause / C. Remedy	PDF data decoding error
83-0016	PDF
A. Operation / B. Cause / C. Remedy	Page range error
83-0017	For R&D
A. Operation / B. Cause / C. Remedy	-

83-0020	Reception of ESCP unanalyzable data
A. Operation / B. Cause / C. Remedy	Since PDL automatic judgment may be wrong, select the appropriate PDL in Settings/Registration > Function Settings > Printer > Printer Settings > Settings > Printer Operation Mode, and send the data.
83-0021	Reception of I5577 unanalyzable data
A. Operation / B. Cause / C. Remedy	Since PDL automatic judgment may be wrong, select the appropriate PDL in Settings/Registration > Function Settings > Printer > Printer Settings > Settings > Printer Operation Mode, and send the data.
83-0022	Reception of HPGL unanalyzable data
A. Operation / B. Cause / C. Remedy	Since PDL automatic judgment may be wrong, select the appropriate PDL in Settings/Registration > Function Settings > Printer > Printer Settings > Settings > Printer Operation Mode, and send the data.
83-0023	Reception of N201 unanalyzable data
A. Operation / B. Cause / C. Remedy	Since PDL automatic judgment may be wrong, select the appropriate PDL in Settings/Registration > Function Settings > Printer > Printer Settings > Settings > Printer Operation Mode, and send the data.
84-0001	For R&D
A. Operation / B. Cause / C. Remedy	-
84-0002	For R&D
A. Operation / B. Cause / C. Remedy	-
84-0003	XPS print range error
A. Operation / B. Cause / C. Remedy	-
84-0004	For R&D
A. Operation / B. Cause / C. Remedy	-
84-0005	For R&D
A. Operation / B. Cause / C. Remedy	-
84-0006	For R&D
A. Operation / B. Cause / C. Remedy	-
84-0007	For R&D
A. Operation / B. Cause / C. Remedy	-
84-0008	XPS non-support image error
A. Operation / B. Cause / C. Remedy	-
84-0009	For R&D
A. Operation / B. Cause / C. Remedy	-

Jam Code

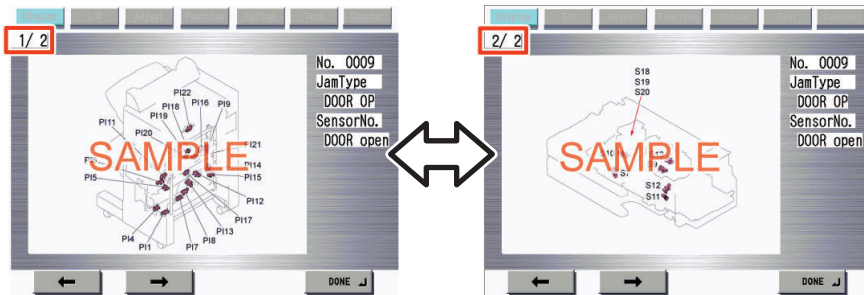
Jam Type

Type	Overview of detection	Check items (in arbitrary order)
DELAY	A delay jam occurs when a sensor was not turned ON although a specified period of time had passed after the start of detection by the sensor.	<ul style="list-style-type: none"> • Remaining paper at the upstream of the target sensor • Soiling on the target sensor • Displacement of the target sensor position • Failure of the target sensor • Soiling (grease)/deterioration/failure of a drive motor located upstream of the target sensor • Soiling (paper dust)/deterioration/failure of a drive roller located upstream of the target sensor
STNRY	A stationary jam occurs when a sensor was not turned OFF although a specified period of time had passed after the sensor was turned ON.	<ul style="list-style-type: none"> • Remaining paper near the target sensor • Soiling on the target sensor • Displacement of the target sensor position • Failure of the target sensor • Soiling (grease)/deterioration/failure of a drive motor located upstream of the target sensor • Soiling (paper dust)/deterioration/failure of a drive roller located upstream of the target sensor
DOOR OP	A door open jam occurs when a sensor detected door open during printing operation.	<ul style="list-style-type: none"> • Door open during printing
COVER OP	A door open jam occurs when a sensor detected cover open during printing operation.	<ul style="list-style-type: none"> • Cover open during printing
ADF OPEN	A door open jam occurs when a sensor detected ADF open during printing operation.	<ul style="list-style-type: none"> • ADF open during printing
SEQUENCE	<p>A sequence jam occurs when there was an error in sensor detection signal at printing operation sequence.</p> <p>Since the jam may occur due to sporadic noise with software of each equipment or communication line (interruption of communication), failure of the part is not the cause of the jam. After the jam is removed, the machine works.</p>	<ul style="list-style-type: none"> • Opening/closing of the door • Turning OFF and then ON the power • Error near the target sensor (soiling/displacement/failure of the sensor, error in harness/open circuit of harness, soiling (grease)/deterioration/failure of a drive motor, or soiling (paper dust)/deterioration/failure of a drive roller)
POWER ON	A power-on jam occurs when a sensor detected ON state at power-on.	<ul style="list-style-type: none"> • Remaining paper in the machine • Soiling on the target sensor • Failure of the target sensor • Foreign matter on the target sensor (paper dust, paper lint)
ERROR	<p>An error avoidance jam occurs when an error in the machine (excluding parts failure) was detected. Printing operation is suspended to avoid error occurrence by error code; therefore, parts failure is not the cause of the jam.</p> <p>After the jam is removed, the machine works.</p> <p>If it is due to parts failure, an error code instead of the error avoidance jam is displayed on UI and printing operation is suspended. In such case, service technician should perform remedial work for the error code.</p>	<ul style="list-style-type: none"> • Opening/closing of the door after jam removal • Turning OFF and then ON the power after jam removal
SIZE ERR	A size error jam occurs when the difference between the paper length detected by the Cassette Guide Plate/specified on the Control Panel and the length measured by the Registration Sensor is out of the specified range.	<ul style="list-style-type: none"> • Difference in paper size • Wrong paper size setting • Error in the Document Size Sensor (soiling/displacement/failure of the sensor) • Error in the Paper Size Detection Unit (failure of mechanical structure for size detection, failure of the Guide Plate, or failure of the Cassette Size Switch)
P-STOP	<p>Forcible stop of paper feed</p> <p>It occurs when a sheet of paper stops at the position specified in service mode.</p>	<ul style="list-style-type: none"> • Using at problem analysis.

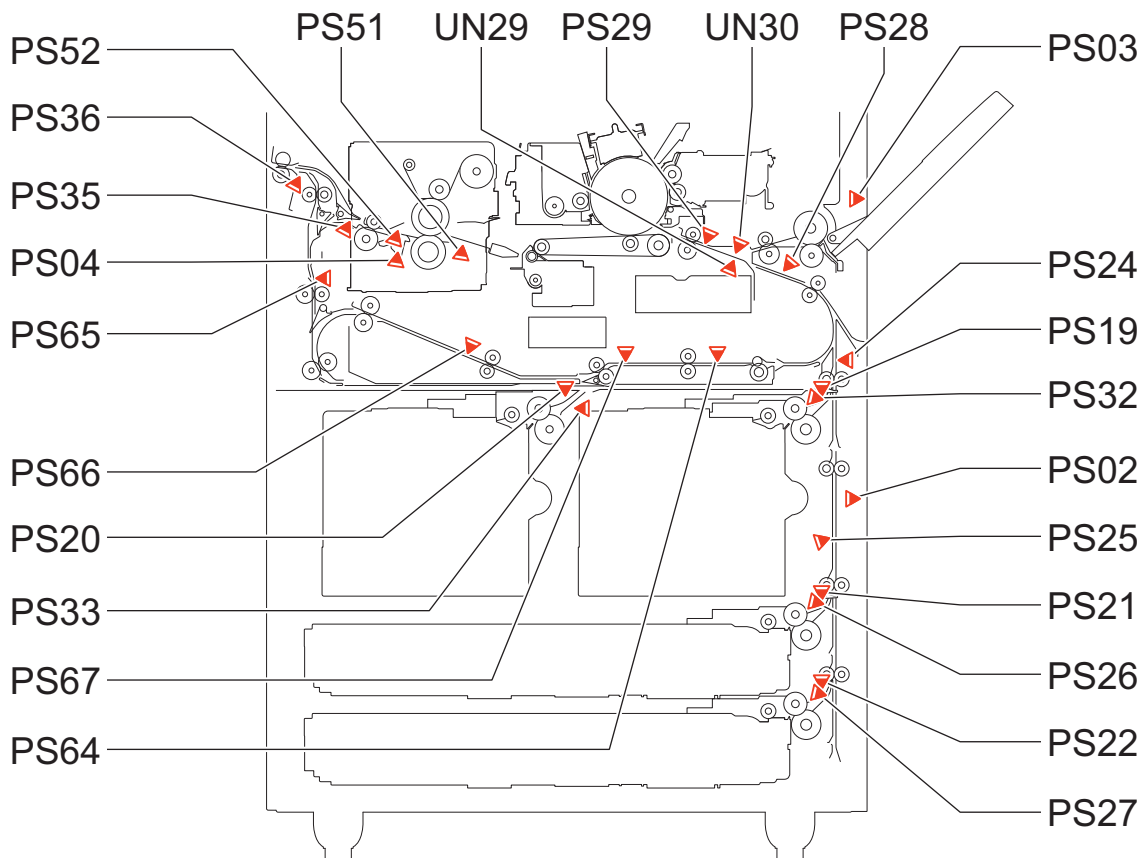
Type	Overview of detection	Check items (in arbitrary order)
Wrapping jam	When the first sensor after the fixing roller is turned ON is turned OFF immediately detection after the detection. Alternatively, when the second sensor after fixing roller is turned ON and immediately after detection, the first sensor is detection turned OFF.	<ul style="list-style-type: none"> Fixing Assembly remaining in Paper Failure of the target sensor Fixing Assembly failure Paper Type Confirmation (Check if paper type cannot be used.)

Jam screen display specification

Due to one jam code being used for multiple options, the illustration for the different option may be displayed on the jam screen. In this case, "1/2" or similar information is displayed on top left side of the screen and this area can be pushed. This operation can be used to switch information on the screen.



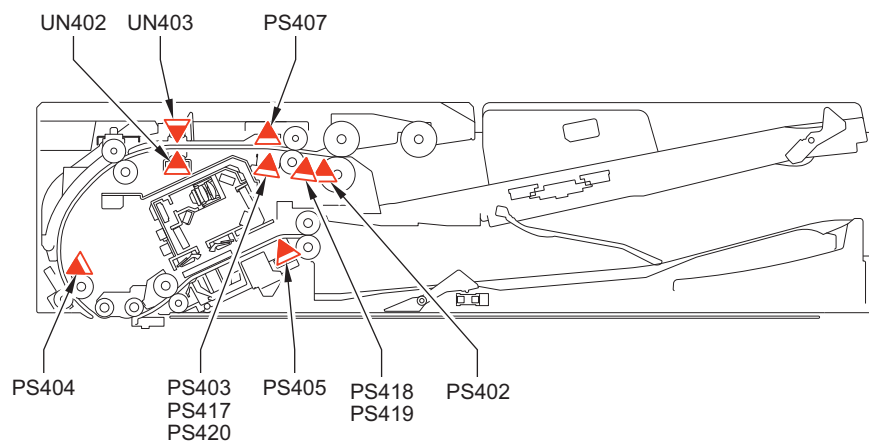
Main Unit

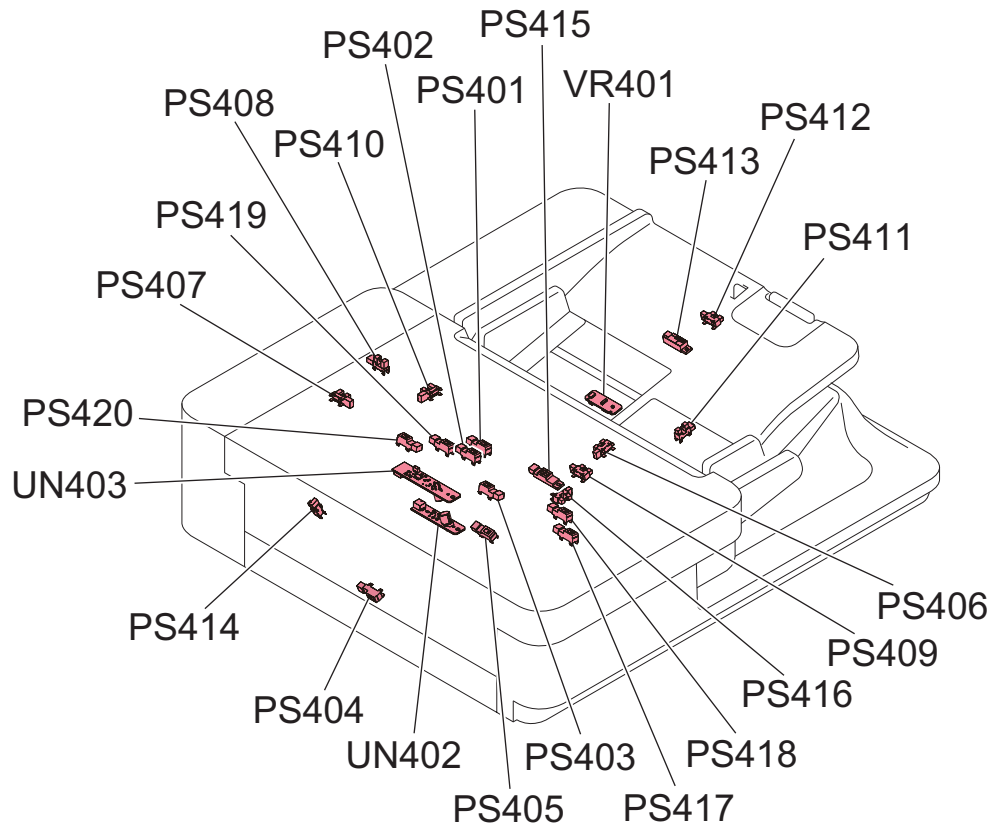


ACC ID	Jam Code	Type	Sensor Name/Description	Sensor ID
00	0101	DELAY	Right Deck Pickup Sensor 1	PS19
00	0102	DELAY	Right Deck Pull Out Sensor	PS32
00	0103	DELAY	Vertical Path Sensor 1	PS24

ACC ID	Jam Code	Type	Sensor Name/Description	Sensor ID
00	0104	DELAY	Writing Judging Sensor	PS28
00	0105	DELAY	Registration Sensor	PS29
00	0106	DELAY	Left Deck Pickup Sensor 1	PS20
00	0107	DELAY	Left Deck Pull Out Sensor	PS33
00	0108	DELAY	Duplex Merging Sensor	PS67
00	0109	DELAY	Duplex Outlet Sensor	PS64
00	010A	DELAY	Cassette 3 Pickup Sensor 1	PS21
00	010B	DELAY	Vertical Path Sensor 3	PS26
00	010C	DELAY	Vertical Path Sensor 2	PS25
00	010D	DELAY	Cassette 4 Pickup Sensor 1	PS22
00	010E	DELAY	Vertical Path Sensor 4	PS27
00	0111	DELAY	Fixing Outlet Sensor	PS52
00	0112	DELAY	Inner Delivery Sensor	PS35
00	0113	DELAY	Outer Delivery Sensor	PS36
00	0114	DELAY	Reverse Vertical Path Sensor	PS65
00	0115	DELAY	Duplex Left Sensor	PS66
00	0202	STNRY	Right Deck Pull Out Sensor	PS32
00	0203	STNRY	Vertical Path Sensor 1	PS24
00	0204	STNRY	Writing Judging Sensor	PS28
00	0205	STNRY	Registration Sensor	PS29
00	0207	STNRY	Left Deck Pull Out Sensor	PS33
00	0208	STNRY	Duplex Merging Sensor	PS67
00	0209	STNRY	Duplex Outlet Sensor	PS64
00	020B	STNRY	Vertical Path Sensor 3	PS26
00	020C	STNRY	Vertical Path Sensor 2	PS25
00	020E	STNRY	Vertical Path Sensor 4	PS27
00	0212	STNRY	Inner Delivery Sensor	PS35
00	0213	STNRY	Outer Delivery Sensor	PS36
00	0214	STNRY	Reverse Vertical Path Sensor	PS65
00	0215	STNRY	Duplex Left Sensor	PS66
00	0300	OVERLAP	Double Feed Detection Sensor	UN29,UN30
00	0305	TIMING NG	Registration Sensor	PS29
00	0A02	POWER ON	Right Deck Pull Out Sensor	PS32
00	0A03	POWER ON	Vertical Path Sensor 1	PS24
00	0A04	POWER ON	Writing Judging Sensor	PS28
00	0A05	POWER ON	Registration Sensor	PS29
00	0A07	POWER ON	Left Deck Pull Out Sensor	PS33
00	0A08	POWER ON	Duplex Merging Sensor	PS67
00	0A09	POWER ON	Duplex Outlet Sensor	PS64
00	0A0B	POWER ON	Vertical Path Sensor 3	PS26
00	0A0C	POWER ON	Vertical Path Sensor 2	PS25
00	0A0E	POWER ON	Vertical Path Sensor 4	PS27
00	0A0F	POWER ON	Fixing Entrance Sensor	PS51
00	0A10	POWER ON	Fixing Toenail	PS4
00	0A11	POWER ON	Fixing Outlet Sensor	PS52
00	0A12	POWER ON	Inner Delivery Sensor	PS35
00	0A13	POWER ON	Outer Delivery Sensor	PS36
00	0A14	POWER ON	Reverse Vertical Path Sensor	PS65
00	0A15	POWER ON	Duplex Left Sensor	PS66
00	0B00	DOOR OP	Door Open	-
00	0B01	DOOR OP	Front cover open/close sensor	-
00	0B02	DOOR OP	Manua cover open/close sensor	-
00	0B03	DOOR OP	Vertical Path Cover Open/Close Sensor	-
00	0C10	OTHER	Fixing Toenail jam	PS4

ACC ID	Jam Code	Type	Sensor Name/Description	Sensor ID
00	0CA1	OTHER	FeedSts time out jam	-
00	0CA2	OTHER	RefeedStart time out jam	-
00	0CA3	OTHER	ImageSet time out jam	-
00	0CA4	OTHER	PageComplete time out jam	-
00	0CA5	OTHER	Fixing temperature control time out jam	-
00	0CAF	OTHER	FeedSts time out jam	-
00	0CF1	OTHER	Retry jam	-
00	0D91	OTHER	Different Size jam(short paper length)	-
00	AA01	P-STOP	Jam upon executing paper feed stop mode	-
00	AA02	P-STOP	Jam upon executing paper feed stop mode	-
00	AA03	P-STOP	Jam upon executing paper feed stop mode	-
00	AA04	P-STOP	Jam upon executing paper feed stop mode	-
00	AA05	P-STOP	Jam upon executing paper feed stop mode	-
00	AA06	P-STOP	Jam upon executing paper feed stop mode	-
00	AA07	P-STOP	Jam upon executing paper feed stop mode	-
00	AA08	P-STOP	Jam upon executing paper feed stop mode	-
00	AA20	P-STOP	Jam upon executing paper feed stop mode	-
00	AA21	P-STOP	Jam upon executing paper feed stop mode	-
00	AA22	P-STOP	Jam upon executing paper feed stop mode	-
00	AA23	P-STOP	Jam upon executing paper feed stop mode	-
00	AA30	P-STOP	Jam upon executing paper feed stop mode	-
00	AA31	P-STOP	Jam upon executing paper feed stop mode	-
00	AA40	P-STOP	Jam upon executing paper feed stop mode	-
00	AA41	P-STOP	Jam upon executing paper feed stop mode	-
00	AA70	P-STOP	Jam upon executing paper feed stop mode	-
00	AA71	P-STOP	Jam upon executing paper feed stop mode	-
00	AA72	P-STOP	Jam upon executing paper feed stop mode	-
00	AA73	P-STOP	Jam upon executing paper feed stop mode	-
00	AA74	P-STOP	Jam upon executing paper feed stop mode	-
00	AA75	P-STOP	Jam upon executing paper feed stop mode	-
00	AA76	P-STOP	Jam upon executing paper feed stop mode	-
00	AA99	P-STOP	Jam upon executing paper feed stop mode	-

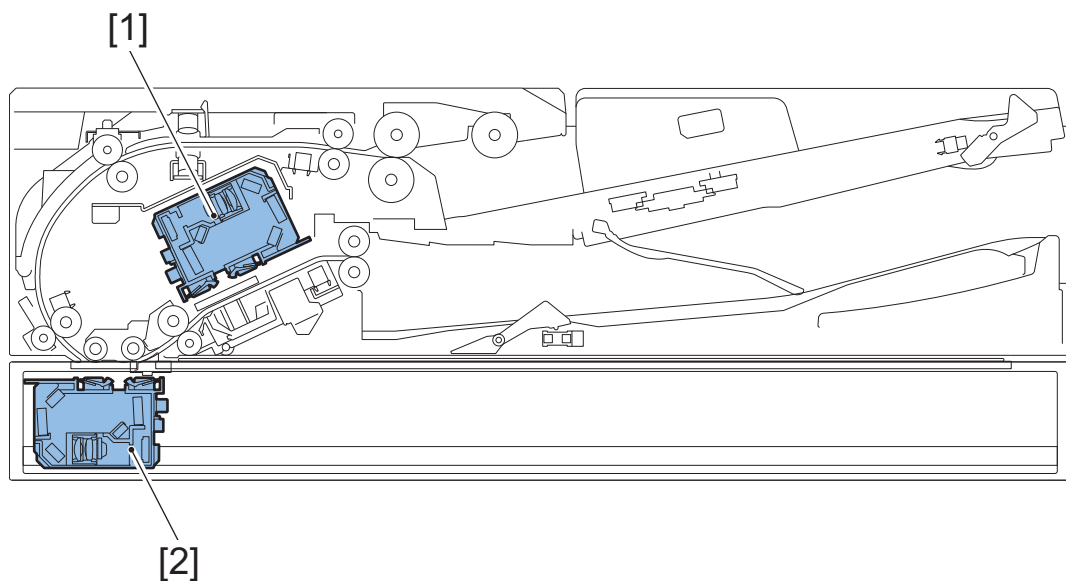




ACC ID	Jam Code	TYPE	Sensor Name/Description	Sensor ID
01	0003	DELAY	Post-separation Sensor	PS402
01	0004	STNRY	Post-separation Sensor	PS402
01	0005	DELAY	Post-pullout Sensor	PS403
01	0006	STNRY	Post-pullout Sensor	PS403
01	0007	DELAY	Lead Sensor	PS404
01	0008	STNRY	Lead Sensor	PS404
01	0009	DELAY	Delivery Sensor	PS405
01	0010	STNRY	Delivery Sensor	PS405
01	0015	OTHER	Skew Detection Sensor (Large, Front) Skew Detection Sensor (Small, Front) Skew Detection Sensor (Small, Rear) Skew Detection Sensor (Large, Rear)	PS417,PS418,PS419,PS420
01	0020	DOUBLE	Double Feed Sensor PCB (transmission/reception)	UN402,UN403
01	0021	OTHER	Double Feed Sensor PCB (transmission/reception)	UN402,UN403
01	0043	DELAY	Post-separation Sensor	PS402
01	0044	STNRY	Post-separation Sensor	PS402
01	0045	DELAY	Post-pullout Sensor	PS403
01	0046	STNRY	Post-pullout Sensor	PS403
01	0047	DELAY	Lead Sensor	PS404
01	0048	STNRY	Lead Sensor	PS404
01	0049	DELAY	Delivery Sensor	PS405
01	0050	STNRY	Delivery Sensor	PS405
01	0055	OTHER	Skew Detection Sensor (Large, Front) Skew Detection Sensor (Small, Front) Skew Detection Sensor (Small, Rear) Skew Detection Sensor (Large, Rear)	PS417,PS418,PS419,PS420
01	0060	DOUBLE	Double Feed Sensor PCB (transmission/reception)	UN402,UN403
01	0061	OTHER	Double Feed Sensor PCB (transmission/reception)	UN402,UN403

ACC ID	Jam Code	TYPE	Sensor Name/Description	Sensor ID
01	0062	ERROR	Double Feed Sensor PCB (transmission/reception)	UN402,UN403
01	0063	OTHER	Double Feed Sensor PCB (transmission/reception)	UN402,UN403
01	007F	SEQUENCE	-	-
01	0090	ADF OPEN	Copyboard Cover Open/Closed Sensor (Front/Rear)	PS101,PS102
01	0091	ADF OPEN	Copyboard Cover Open/Closed Sensor (Front/Rear)	PS101,PS102
01	0092	COVER OP	Cover Open/Closed Sensor	PS407
01	0093	COVER OP	Cover Open/Closed Sensor	PS407
01	0094	POWER ON	Post-separation Sensor Post-pullout Sensor Lead Sensor Pre-delivery Sensor	PS402,PS403,PS404,PS405
01	0095	OTHER	Original Sensor	PS415
01	0096	OTHER	-	-
01	00A2	POWER ON	Post-separation Sensor	PS402
01	00A3	POWER ON	Post-pullout Sensor	PS403
01	00A4	POWER ON	Lead Sensor	PS404
01	00A6	POWER ON	Delivery Sensor	PS405
01	0071	SEQUENCE	-	-

UniFlow (Advanced Scanning)



ACC ID	Jam Code	TYPE	Sensor Name/Description	Sensor ID
01	0025	OTHER	Detected skew greater than the maximum correctable amount	[1],[2]
01	0026	OTHER	Unable to detect skew due to unexpected originals	[1],[2]

■ 010025: Jam Code (UniFlow) 0025

Detection Description

Jam Type: Other Jams

Detected skew greater than the maximum correctable skew amount when performing Advanced Scan.

Remedy

1. Set the original again by following the displayed instruction.
 - When setting originals with mixed Free sizes, set each sheet of original to align with the center.

CAUTION:

Be aware that an image loss or a paper jam may be caused if the center of the original is off by 10 mm or more from the center of the Tray.

- When setting originals with mixed standard size paper, set by aligning the edge of originals to the rear of feeder.

NOTE:

Adjust by aligning the Side Guide Plate (Paper Guide) to the large paper.

2. Perform skew adjustment referring to chapter 6 "Adjustment".

■ 010026: Jam Code (UniFlow) 0026

Detection Description

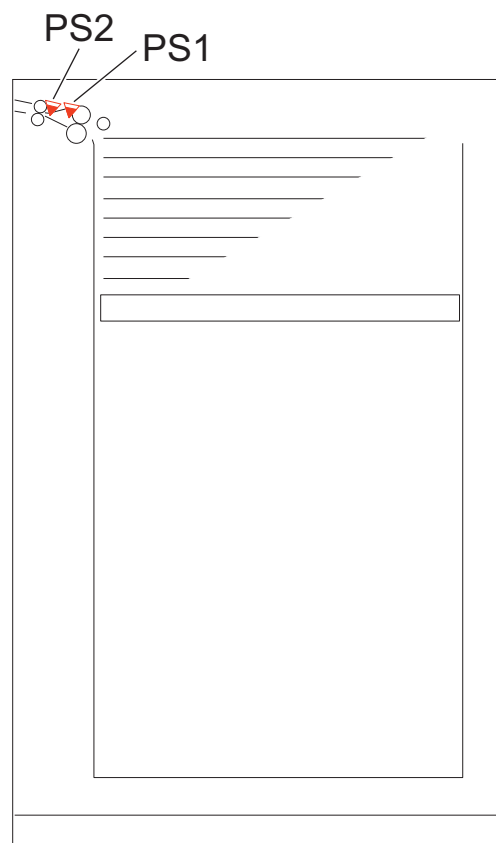
Jam Type: Other Jams

Detected skew greater than the maximum correctable skew amount when performing Advanced Scan.

Remedy

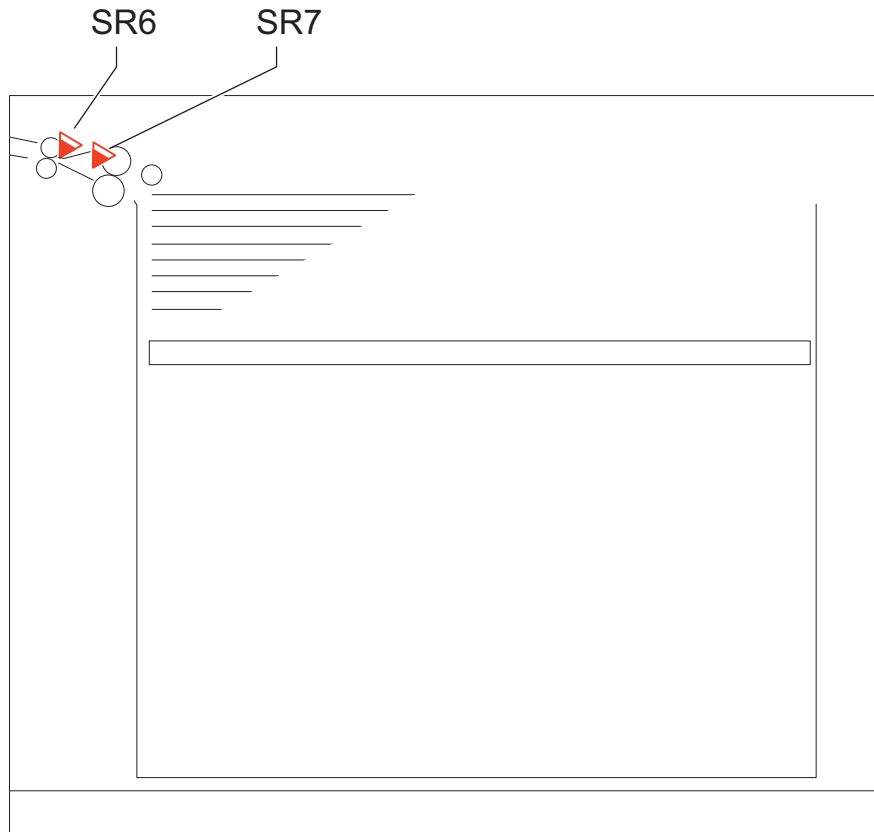
1. Check if the original size is out of specification.
2. If the original is bent, modify it.
3. Change the original stacking direction (with the less damaged end of the original as its leading edge).
4. Change the document reading method.
 - Settings/Registration > Function Settings > Common > Scan Settings > Original Thickness Defaults for Scan from Feeder

● Paper Deck Unit-E1



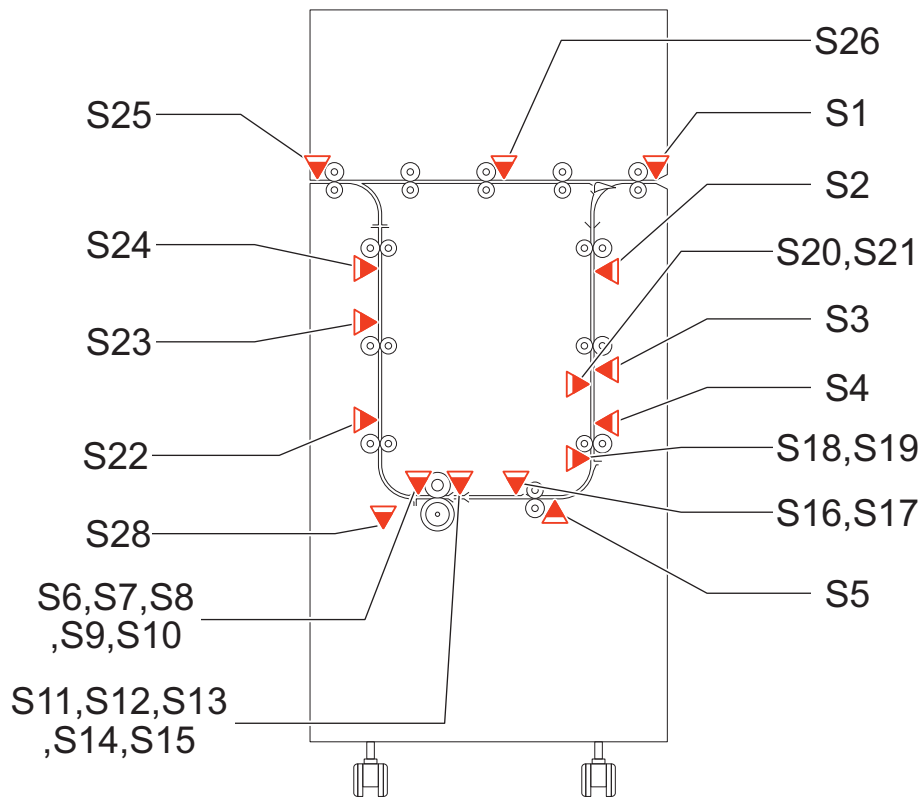
ACC ID	Jam Code	Type	Sensor Name/Description	Sensor ID
00	0117	DELAY	Deck pickup sensor	PS1
00	0118	DELAY	Deck pull-out sensor	PS2
00	0218	STNRY	Deck pull-out sensor	PS2
00	0A18	POWER ON	Deck pull-out sensor	PS2

POD Deck Lite-C1



ACC ID	Jam Code	Type	Sensor Name/Description	Sensor ID
00	0117	DELAY	Deck pickup sensor	SR7
00	0118	DELAY	Deck pull-out sensor	SR6
00	0218	STNRY	Deck pull-out sensor	SR6
00	0A18	POWER ON	Deck pull-out sensor	SR6

Multi Function Professional Puncher-B1



■ IPC Connection

ACC ID	Jam Code	Type	Sensor Name/Description	Sensor ID
02	1150	STNRY	Entry Sensor	S1
02	1151	STNRY	Entrance Panel Sensor	S2
02	1152	STNRY	Entrance Panel Sensor	S3
02	1153	STNRY	Entrance Panel Sensor	S4
02	1154	STNRY	Acceleration Sensor	S5
02	1155	STNRY	Angle Measurement Sensor	S6
02	1156	STNRY	Angle Measurement Sensor	S7
02	1157	STNRY	Angle Measurement Sensor	S8
02	1158	STNRY	Angle Measurement Sensor	S9
02	1159	STNRY	Angle Measurement Sensor	S10
02	115A	STNRY	Alignment Sensor	S11
02	115B	STNRY	Alignment Sensor	S12
02	115C	STNRY	Alignment Sensor	S13
02	115D	STNRY	Alignment Sensor	S14
02	115E	STNRY	Alignment Sensor	S15
02	115F	STNRY	Backgage for Trail Edge Sensor	S16
02	1160	STNRY	Backgage for Trail Edge Sensor	S17
02	1161	STNRY	Double Punch Backgage for Large Sheets Sensor	S18
02	1162	STNRY	Double Punch Backgage for Large Sheets Sensor	S19
02	1163	STNRY	Double Punch Backgage for XL Sheets Sensor	S20
02	1164	STNRY	Double Punch Backgage for XL Sheets Sensor	S21
02	1165	STNRY	Exit Panel Sensor	S22
02	1166	STNRY	Exit Panel Sensor	S23
02	1167	STNRY	Deceleration Sensor	S24

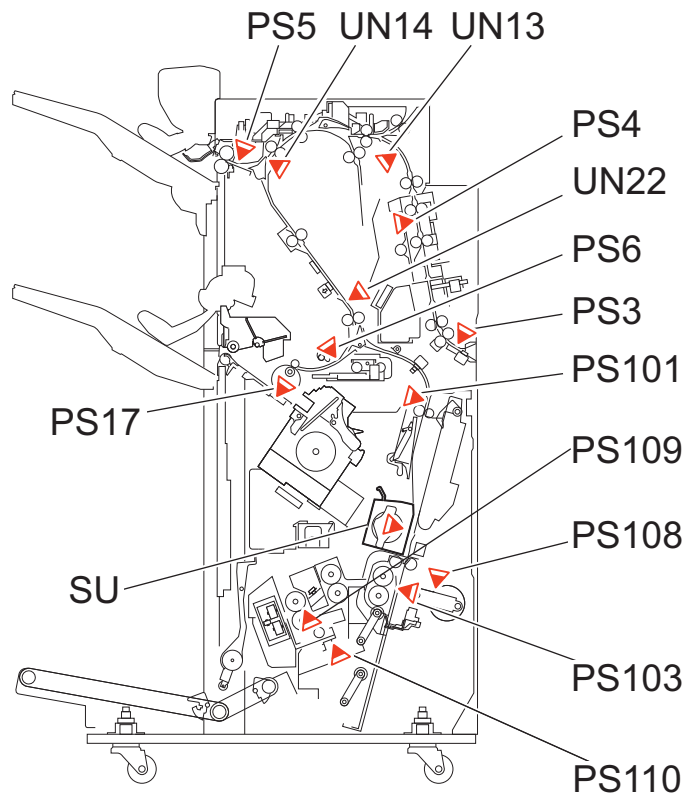
ACC ID	Jam Code	Type	Sensor Name/Description	Sensor ID
02	1168	STNRY	Exit Sensor	S25
02	1169	STNRY	Bypass Sensor	S26
02	116A	STNRY	Align Home Sensor	S28
02	1371	POWER ON	-	-
02	1472	COVER OP	-	-
02	1773	INIT ROT	-	-
02	1C74	TIME OUT	-	-
02	1F75	OTHER	-	-
02	1F76	TIME OUT	-	-
02	1F77	TIMING NG	-	-
02	1F78	TIMING NG	-	-
02	1F79	UP DEVICE	-	-
02	1F7A	UP DEVICE	-	-
02	1F7D	STOP	-	-

■ CAN Connection

ACC ID	Jam Code	Type	Sensor Name/Description	Sensor ID
31	1150	STNRY	Entry Sensor	S1
31	1151	STNRY	Entrance Panel Sensor	S2
31	1152	STNRY	Entrance Panel Sensor	S3
31	1153	STNRY	Entrance Panel Sensor	S4
31	1154	STNRY	Acceleration Sensor	S5
31	1155	STNRY	Angle Measurement Sensor	S6
31	1156	STNRY	Angle Measurement Sensor	S7
31	1157	STNRY	Angle Measurement Sensor	S8
31	1158	STNRY	Angle Measurement Sensor	S9
31	1159	STNRY	Angle Measurement Sensor	S10
31	115A	STNRY	Alignment Sensor	S11
31	115B	STNRY	Alignment Sensor	S12
31	115C	STNRY	Alignment Sensor	S13
31	115D	STNRY	Alignment Sensor	S14
31	115E	STNRY	Alignment Sensor	S15
31	115F	STNRY	Backgage for Trail Edge Sensor	S16
31	1160	STNRY	Backgage for Trail Edge Sensor	S17
31	1161	STNRY	Double Punch Backgage for Large Sheets Sensor	S18
31	1162	STNRY	Double Punch Backgage for Large Sheets Sensor	S19
31	1163	STNRY	Double Punch Backgage for XL Sheets Sensor	S20
31	1164	STNRY	Double Punch Backgage for XL Sheets Sensor	S21
31	1165	STNRY	Exit Panel Sensor	S22
31	1166	STNRY	Exit Panel Sensor	S23
31	1167	STNRY	Deceleration Sensor	S24
31	1168	STNRY	Exit Sensor	S25
31	1169	STNRY	Bypass Sensor	S26
31	116A	STNRY	Align Home Sensor	S28
31	1270	OTHER	-	-
31	1350	POWER ON	Entry Sensor	S1
31	1351	POWER ON	Entrance Panel Sensor	S2
31	1352	POWER ON	Entrance Panel Sensor	S3
31	1353	POWER ON	Entrance Panel Sensor	S4
31	1354	POWER ON	Acceleration Sensor	S5
31	1355	POWER ON	Angle Measurement Sensor	S6
31	1356	POWER ON	Angle Measurement Sensor	S7
31	1357	POWER ON	Angle Measurement Sensor	S8

ACC ID	Jam Code	Type	Sensor Name/Description	Sensor ID
31	1358	POWER ON	Angle Measurement Sensor	S9
31	1359	POWER ON	Angle Measurement Sensor	S10
31	135A	POWER ON	Alignment Sensor	S11
31	135B	POWER ON	Alignment Sensor	S12
31	135C	POWER ON	Alignment Sensor	S13
31	135D	POWER ON	Alignment Sensor	S14
31	135E	POWER ON	Alignment Sensor	S15
31	135F	POWER ON	Backgage for Trail Edge Sensor	S16
31	1360	POWER ON	Backgage for Trail Edge Sensor	S17
31	1361	POWER ON	Double Punch Backgage for Large Sheets Sensor	S18
31	1362	POWER ON	Double Punch Backgage for Large Sheets Sensor	S19
31	1363	POWER ON	Double Punch Backgage for XL Sheets Sensor	S20
31	1364	POWER ON	Double Punch Backgage for XL Sheets Sensor	S21
31	1365	POWER ON	Exit Panel Sensor	S22
31	1366	POWER ON	Exit Panel Sensor	S23
31	1367	POWER ON	Deceleration Sensor	S24
31	1368	POWER ON	Exit Sensor	S25
31	1369	POWER ON	Bypass Sensor	S26
31	136A	POWER ON	Align Home Sensor	S28
31	1472	COVER OP	-	-
31	1773	INIT ROT	-	-
31	1C74	TIME OUT	-	-
31	1F75	OTHER	-	-
31	1F76	TIME OUT	-	-
31	1F77	TIMING NG	-	-
31	1F78	TIMING NG	-	-
31	1F7B	TIME OUT	-	-
31	1F7C	TIME OUT	-	-
31	1F7E	UP DEVICE	-	-
31	FF7F	UP DEVICE	-	-

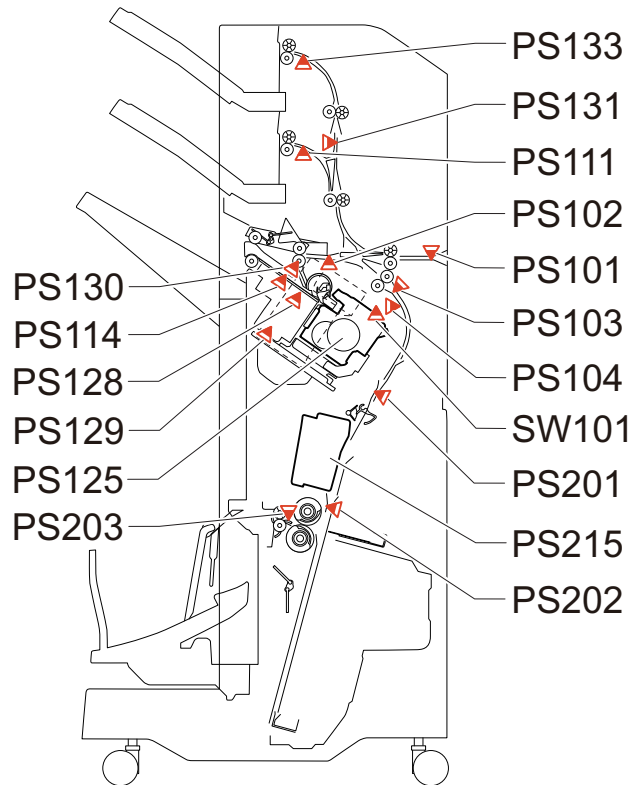
Staple Finisher-W1 PRO / Booklet Finisher-W1 PRO



ACC ID	Jam Code	Type	Sensor Name/Description	Sensor ID
02	1002	DELAY	Inlet Sensor	PS3
02	1004	DELAY	Shift Unit Trailing Edge Sensor	PS4
02	1006	DELAY	Buffer Path 1 Sensor PCB	UN13
02	1008	DELAY	Buffer Path 2 Sensor PCB	UN14
02	100A	DELAY	Upper Delivery Sensor	PS5
02	100C	DELAY	Lower Path Sensor PCB	UN22
02	100E	DELAY	Lower Delivery Sensor	PS6
02	1042	DELAY	Saddle Inlet Sensor	PS101
02	1046	DELAY	Saddle Vertical Path Sensor	PS103
02	104A	DELAY	Saddle Press Front Sensor	PS116
02	1054	DELAY	Saddle Press HP Sensor	PS113
02	1103	STNRY	Inlet Sensor	PS3
02	1105	STNRY	Shift Unit Trailing Edge Sensor	PS4
02	1107	STNRY	Buffer Path 1 Sensor PCB	UN13
02	1109	STNRY	Buffer Path 2 Sensor PCB	UN14
02	110B	STNRY	Upper Delivery Sensor	PS5
02	110D	STNRY	Lower Path Sensor PCB	UN22
02	110F	STNRY	Lower Delivery Sensor	PS6
02	1143	STNRY	Saddle Inlet Sensor	PS101
02	1147	STNRY	Saddle Vertical Path Sensor	PS103
02	114B	STNRY	Saddle Press Front Sensor	PS116
02	1155	STNRY	Saddle Press HP Sensor	PS113
02	1231	RESIDUAL	-	-
02	1303	POWER ON	Inlet Sensor	PS3
02	1305	POWER ON	Shift Unit Trailing Edge Sensor	PS4
02	1307	POWER ON	Buffer Path 1 Sensor PCB	UN13

ACC ID	Jam Code	Type	Sensor Name/Description	Sensor ID
02	1309	POWER ON	Buffer Path 2 Sensor PCB	UN14
02	130B	POWER ON	Upper Delivery Sensor	PS5
02	130D	POWER ON	Lower Path Sensor PCB	UN22
02	130F	POWER ON	Lower Delivery Sensor	PS6
02	1320	POWER ON	-	-
02	1343	POWER ON	Saddle Inlet Sensor	PS101
02	1347	POWER ON	Saddle Vertical Path Sensor	PS103
02	134B	POWER ON	Saddle Press Front Sensor	PS116
02	1422	DOOR OP	-	-
02	1524	STP	Staple HP Sensor	-
02	1550	SDL STP	Saddle Staple HP Sensor	-
02	1703	INIT ROT	Inlet Sensor	PS3
02	1705	INIT ROT	Shift Unit Trailing Edge Sensor	PS4
02	1707	INIT ROT	Buffer Path 1 Sensor PCB	UN13
02	1709	INIT ROT	Buffer Path 2 Sensor PCB	UN14
02	170B	INIT ROT	Upper Delivery Sensor	PS5
02	170D	INIT ROT	Lower Path Sensor PCB	UN22
02	170F	INIT ROT	Lower Delivery Sensor	PS6
02	1721	INIT ROT	-	-
02	1725	INIT ROT	Processing Tray Paper Sensor	PS17
02	1743	INIT ROT	Saddle Inlet Sensor	PS101
02	1747	INIT ROT	Saddle Vertical Path Sensor	PS103
02	174B	INIT ROT	Saddle Press Front Sensor	PS116
02	1C01	RETRY ERR	-	-
02	1F03	UP DEVICE	-	-
02	1F25	OTHER	-	-
02	1F30	UP DEVICE	-	-
02	1F31	UP DEVICE	-	-
02	1F52	OTHER	Saddle Press HP Sensor	PS110
02	1FFF	ERROR	-	-

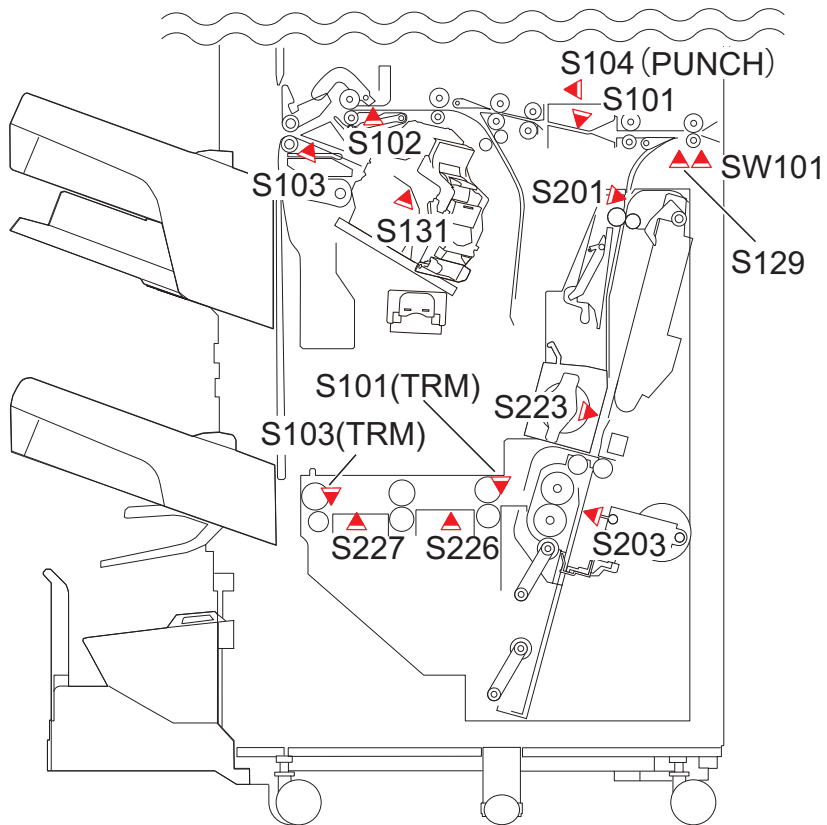
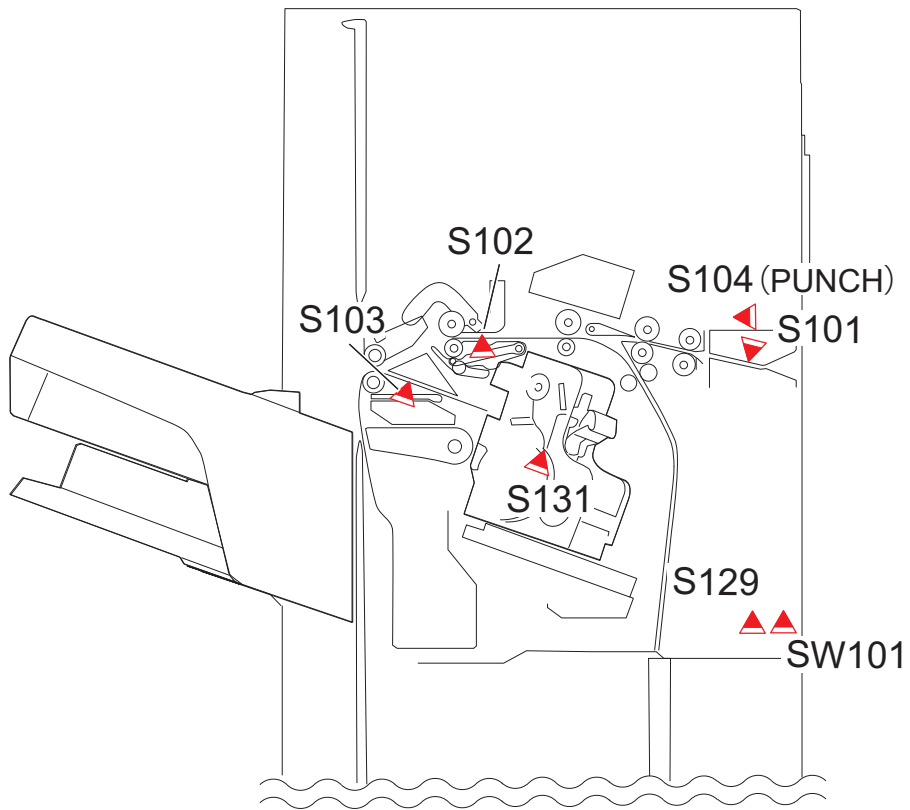
Staple Finisher-AC1/Booklet Finisher-AC1



ACC ID	Jam Code	Type	Sensor Name/Description	Sensor ID
02	1001	DELAY	Inlet Sensor	PS101
02	1002	DELAY	Delivery Sensor	PS102
02	1003	DELAY	Buffer Sensor	PS103
02	1004	DELAY	Lower Escape Delivery Sensor	PS111
02	1005	DELAY	Upper Escape Delivery Sensor	PS133
02	1006	DELAY	Escape Feed Sensor	PS131
02	1008	DELAY	Saddle Delivery Sensor	PS203
02	1009	DELAY	Saddle Inlet Sensor	PS201
02	1101	STNRY	Inlet Sensor	PS101
02	1102	STNRY	Delivery Sensor	PS102
02	1103	STNRY	Buffer Sensor	PS103
02	1104	STNRY	Lower Escape Delivery Sensor	PS111
02	1105	STNRY	Upper Escape Delivery Sensor	PS133
02	1106	STNRY	Escape Feed Sensor	PS131
02	1108	STNRY	Saddle Delivery Sensor	PS203
02	1109	STNRY	Saddle Inlet Sensor	PS201
02	1200	TIMING	-	-
02	1301	POWER ON	Inlet Sensor	PS101
02	1302	POWER ON	Delivery Sensor	PS102
02	1303	POWER ON	Buffer Sensor	PS103
02	1304	POWER ON	Lower Escape Delivery Sensor	PS111
02	1305	POWER ON	Upper Escape Delivery Sensor	PS133
02	1306	POWER ON	Escape Feed Sensor	PS131
02	1307	POWER ON	Saddle Processing Tray Paper Sensor	PS202
02	1308	POWER ON	Saddle Delivery Sensor	PS203
02	1309	POWER ON	Saddle Inlet Sensor	PS201
02	1400	COVER OP	Front Cover Sensor/Front Cover Switch	PS104,SW101
02	1500	STAPLE	Staple HP Sensor	PS125
02	1501	SDL STP	Saddle Stitcher HP Sensor	PS215

ACC ID	Jam Code	Type	Sensor Name/Description	Sensor ID
02	1801	ERROR	Staple-free Binding Motor Clock Sensor	PS130
02	1802	ERROR	Staple-free Binding HP Sensor	PS129
02	1803	ERROR	-	-
02	1804	ERROR	-	-
02	1805	ERROR	-	-
02	1C14	ERROR	-	-
02	1C30	ERROR	-	-
02	1C32	ERROR	-	-
02	1C33	ERROR	-	-
02	1C35	ERROR	-	-
02	1C37	ERROR	-	-
02	1C40	ERROR	-	-
02	1C53	ERROR	-	-
02	1C77	ERROR	-	-
02	1C78	ERROR	-	-
02	1C7B	ERROR	-	-
02	1C83	ERROR	-	-
02	1CF0	ERROR	-	-
02	1CF1	ERROR	-	-
02	1CF3	ERROR	-	-
02	1CF6	ERROR	-	-
02	1CF8	ERROR	-	-
02	1CFA	ERROR	-	-
02	1F01	OTHER	-	-
02	1F32	OTHER	-	-
02	1F90	SEQUENCE	-	-

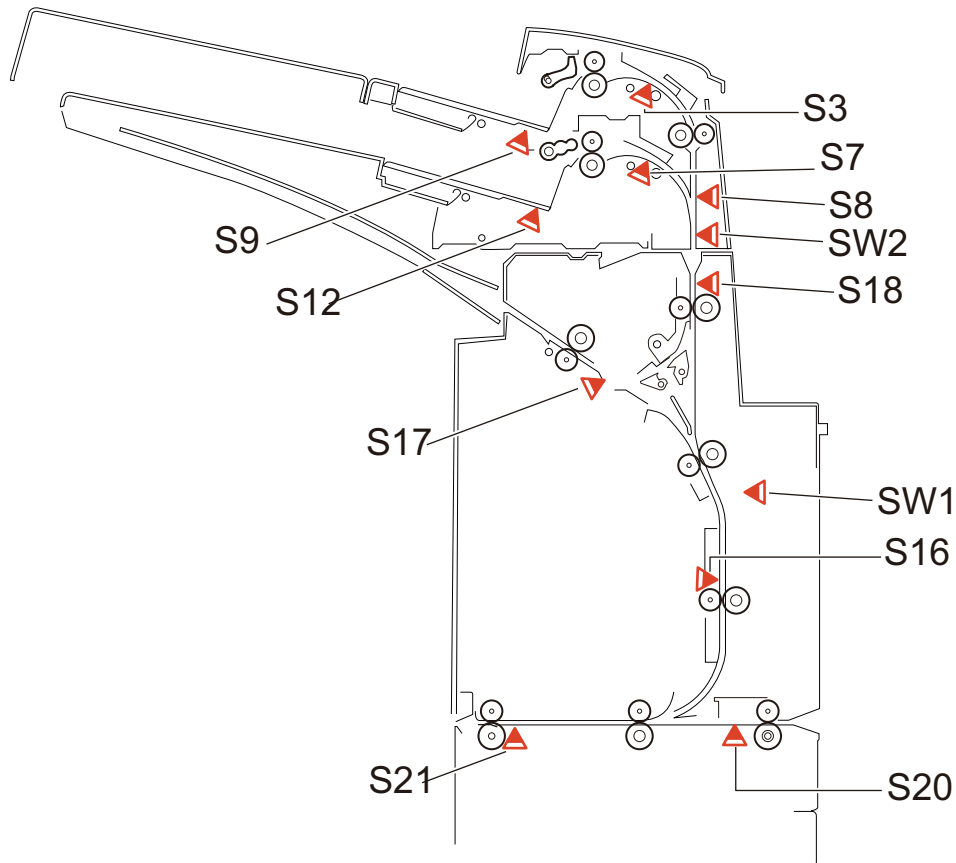
Staple Finisher-X1/Booklet Finisher-X1



ACC ID	Jam Code	Type	Sensor Name/Description	Sensor ID
02	1011	DELAY	Inlet sensor	S101

ACC ID	Jam Code	Type	Sensor Name/Description	Sensor ID
02	1012	DELAY	Delivery sensor	S102
02	1121	STNRY	Inlet Sensor	S101
02	1122	STNRY	Delivery sensor	S102
02	112E	SEQ NG	-	-
02	112F	ERROR	-	-
02	1205	TIMING	Inlet sensor	S101
02	1307	POWER ON	S101: Inlet sensor S102: Delivery sensor S103: Processing Tray Paper Sensor	S101,S102,S103
02	1408	COVER OP	S129: Front cover sensor SW101: Front cover swith	S129,SW101
02	1488	COVER OP	S129: Front cover sensor SW101: Front cover swith	S129,SW101
02	148B	COVER OP	S129: Front cover sensor SW101: Front cover swith	S129,SW101
02	1506	STP	Staple HP Sensor	S131
02	1F45	PUNCH	Punch HP Sensor	S104(PUNCH)
02	1F4F	ERROR	-	-
02	1091	DELAY	Saddle delivery sensor 2	S227
02	1092	DELAY	Saddle delivery sensor 1	S226
02	1093	DELAY	Saddle inlet sensor	S201
02	1094	DELAY	Trimmer inlet sensor	S101(TRM)
02	1096	DELAY	Saddle Vertical Path Sensor	S203
02	11A1	STNRY	Saddle delivery sensor 2	S227
02	11A2	STNRY	Saddle delivery sensor 1	S226
02	11A3	STNRY	Saddle inlet sensor	S201
02	11A4	STNRY	Trimmer Inlet Sensor	S101(TRM)
02	11AF	ERROR	-	-
02	1387	POWER ON	S201: Saddle inlet sensor S203: Saddle vertical path sensor S226: Saddle delivery sensor 1 S227: Saddle delivery sensor 2	S201,S203,S226,S227
02	138A	POWER ON	S101(TRM): Inlet sensor S103(TRM): Delivery sensor	S101(TRM),S103(TRM)
02	1408	COVER OP	S129: Front cover sensor SW101: Front cover swith	S129,SW101
02	1488	COVER OP	S129: Front cover sensor SW101: Front cover swith	S129,SW101
02	148B	COVER OP	S129: Front cover sensor SW101: Front cover swith	S129,SW101
02	1586	SDL STP	Saddle stitcher HP sensor	S223
02	1F8F	ERROR	-	-

Document Insertion Unit-N1



■ IPC Connection

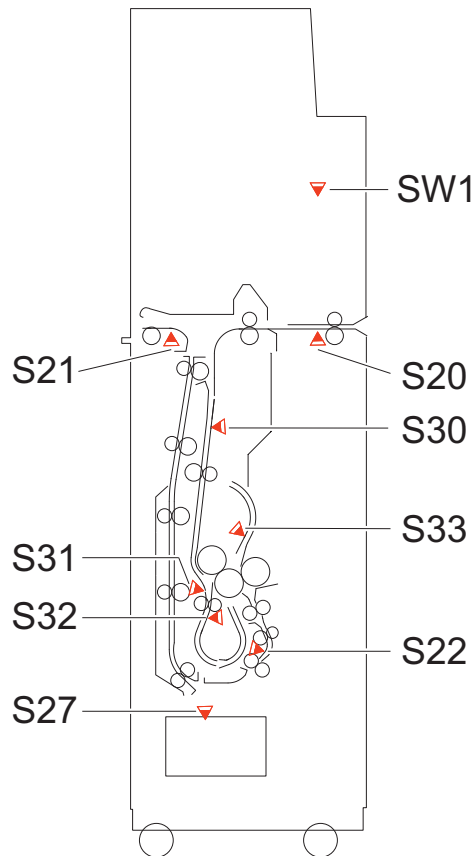
ACC ID	Jam Code	Type	Sensor Name/Description	Sensor ID
02	10E0	DELAY	Entrance Sensor	S20
02	10E2	DELAY	Delivery Sensor 2	S21
02	10E4	DELAY	Upper Tray Registration Sensor/Lower Tray Registration Sensor	S3, S7
02	10E5	DELAY	Middle Feed Sensor	S8
02	10E6	DELAY	Reverse Entrance Sensor	S18
02	10E7	DELAY	Reverse Sensor	S17
02	10E8	DELAY	Reverse Timing Sensor	S16
02	10EF	DELAY	Lower Tray Registration Sensor	S7
02	11F0	STNRY	Entrance Sensor	S20
02	11F2	STNRY	Delivery Sensor 2	S21
02	11F4	STNRY	Upper Tray Registration Sensor/Lower Tray Registration Sensor	S3,S7
02	11F5	STNRY	Middle Feed Sensor	S8
02	11F6	STNRY	Reverse Entrance Sensor	S18
02	11F7	STNRY	Reverse Sensor	S17
02	11F8	STNRY	Reverse Timing Sensor	S16
02	11FF	STNRY	Lower Tray Registration Sensor	S7
02	13CD	POWER ON	Power on jam	-
02	14CC	DOOR OP	Caver Open jam	SW1,SW2
02	1FC0	TIME OUT	Failed to detect OFF of EntryStart although a specified period of time has passed after replying ON of EntryStartAck	-

ACC ID	Jam Code	Type	Sensor Name/Description	Sensor ID
02	1FC1	TIME OUT	1. Failed to detect ON of EjectStartAck although a specified period of time has passed 2. Failed to detect OFF of EjectStartAck although a specified period of time has passed after notifying OFF of EjectStart.	-
02	1FC2	DOOR OP	Upper Tray Empty Sensor	S9
02	1FC3	DOOR OP	Lower Tray Empty Sensor	S12
02	1FC4	OTHER	Different Inserter Width jam	S10
02	1FCE	ERROR	Error avoidance jam	-
02	1FCF	STOP	Press Stop key	-

■ CAN Connection

ACC ID	Jam Code	Type	Sensor Name/Description	Sensor ID
71	20E0	DELAY	Entrance Sensor	S20
71	20E2	DELAY	Delivery Sensor 2	S21
71	20E4	DELAY	Upper Tray Registration Sensor / Lower Tray Registration Sensor	S3, S7
71	20E5	DELAY	Middle Feed Sensor	S8
71	20E6	DELAY	Reverse Entrance Sensor	S18
71	20E7	DELAY	Reverse Sensor	S17
71	20E8	DELAY	Reverse Timing Sensor	S16
71	20EF	DELAY	Lower Tray Registration Sensor	S7
71	21F0	STNRY	Entrance Sensor	S20
71	21F2	STNRY	Delivery Sensor 2	S21
71	21F4	STNRY	Upper Tray Registration Sensor / Lower Tray Registration Sensor	S3,S7
71	21F5	STNRY	Middle Feed Sensor	S8
71	21F6	STNRY	Reverse Entrance Sensor	S18
71	21F7	STNRY	Reverse Sensor	S17
71	21F8	STNRY	Reverse Timing Sensor	S16
71	21FF	STNRY	Lower Tray Registration Sensor	S7
71	2200	OTHER	Timing error	-
71	2300	POWER ON	Power on jam	-
71	23F0	POWER ON	Entrance Sensor	S20
71	23F2	POWER ON	Delivery Sensor 2	S21
71	23F4	POWER ON	Upper tray registration sensor	S3
71	23F5	POWER ON	Lower Tray Registration Sensor	S7
71	23F6	POWER ON	Middle Feed Sensor	S8
71	23F7	POWER ON	Reverse Entrance Sensor	S18
71	23F8	POWER ON	Reverse Sensor	S17
71	23F9	POWER ON	Reverse Timing Sensor	S16
71	2400	DOOR OP	Caver Open jam	SW1,SW2
71	2C00	OTHER	Sequence error jam	-
71	2C01	ERROR	Error avoidance jam	-
71	2FC0	TIME OUT	EntryStart time out jam	-
71	2FC1	TIME OUT	EjectStartAck time out jam	-
71	2FC2	DOOR OP	Upper Tray Empty Sensor	S9
71	2FC3	DOOR OP	Lower Tray Empty Sensor	S12
71	2FC4	OTHER	Different Inserter Width jam	S10
71	2FCF	STOP	Press Stop key	-

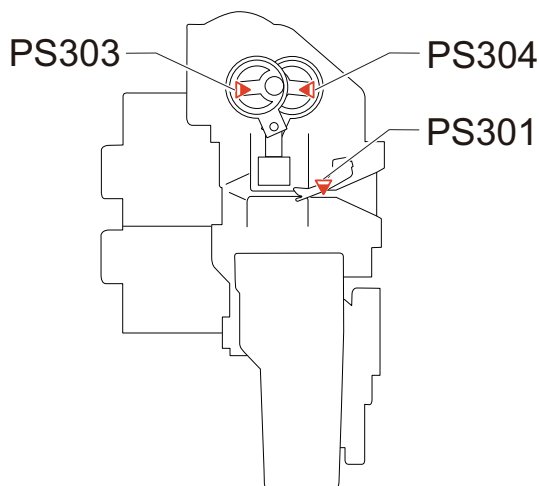
Paper Folding Unit-J1



ACC ID	Jam Code	Type	Sensor Name/Description	Sensor ID
02	1082	DELAY	Entrance Sensor	S20
02	1084	DELAY	Delivery Sensor 2	S21
02	1086	DELAY	Slowdown Timing Sensor	S30
02	1088	DELAY	Release Timing Sensor	S31
02	108A	DELAY	Fold Position Sensor	S32
02	108C	DELAY	Upper Stopper Paper Sensor	S33
02	108E	DELAY	Delivery Sensor 1	S22
02	1092	DELAY	Fold Tray Paper Sensor	S27
02	10E1	DELAY	Entrance Sensor	S20
02	10E3	DELAY	Delivery Sensor 2	S21
02	10E9	DELAY	Slowdown Timing Sensor	S30
02	10EA	DELAY	Release Timing Sensor	S31
02	10EB	DELAY	Fold Position Sensor	S32
02	10EC	DELAY	Upper Stopper Paper Sensor	S33
02	10ED	DELAY	Delivery Sensor 1	S22
02	10EE	DELAY	Paper Folding Unit-J1:Fold Tray Paper Sensor	S27
02	1183	STNRY	Entrance Sensor	S20
02	1185	STNRY	Delivery Sensor 2	S21
02	1187	STNRY	Slowdown Timing Sensor	S30
02	1189	STNRY	Release Timing Sensor	S31
02	118B	STNRY	Fold Position Sensor	S32
02	118D	STNRY	Upper Stopper Paper Sensor	S33
02	118F	STNRY	Delivery Sensor 1	S22
02	1193	STNRY	Fold Tray Paper Sensor	S27
02	11F1	STNRY	Entrance Sensor	S20
02	11F3	STNRY	Delivery Sensor 2	S21

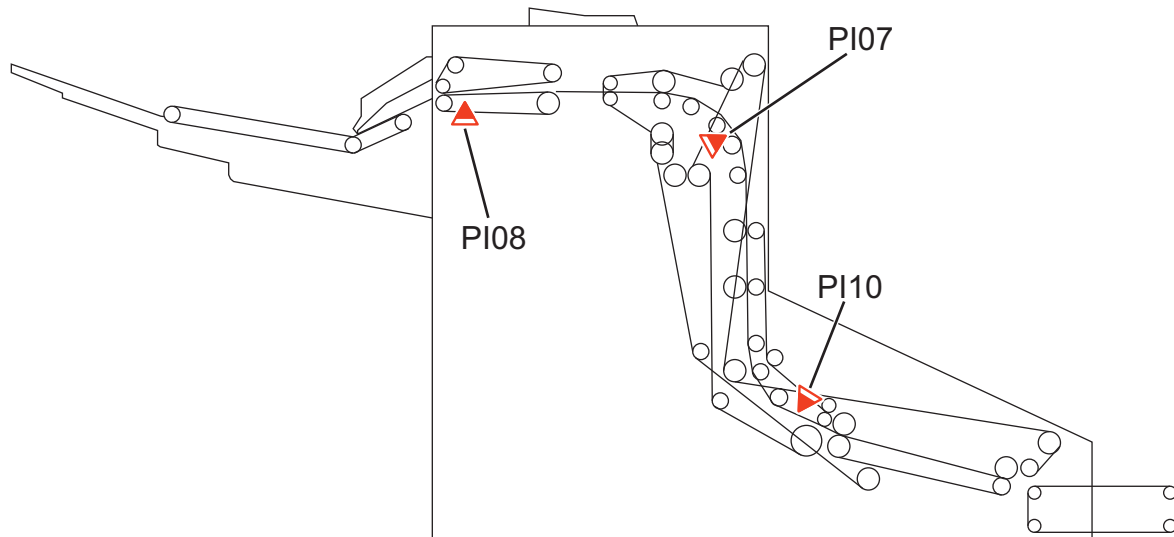
ACC ID	Jam Code	Type	Sensor Name/Description	Sensor ID
02	11F9	STNRY	Slowdown Timing Sensor	S30
02	11FA	STNRY	Release Timing Sensor	S31
02	11FB	STNRY	Fold Position Sensor	S32
02	11FC	STNRY	Upper Stopper Paper Sensor	S33
02	11FD	STNRY	Delivery Sensor 1	S22
02	11FE	STNRY	Fold Tray Paper Sensor	S27
02	1383	POWER ON	Entrance Sensor	S20
02	1385	POWER ON	Delivery Sensor 2	S21
02	1387	POWER ON	Slowdown Timing Sensor	S30
02	1389	POWER ON	Release Timing Sensor	S31
02	138B	POWER ON	Fold Position Sensor	S32
02	138D	POWER ON	Upper Stopper Paper Sensor	S33
02	138F	POWER ON	Delivery Sensor 1	S22
02	1393	POWER ON	Fold Tray Paper Sensor	S27
02	13DD	POWER ON	-	-
02	149B	COVER OP	Front Upper Cover Switch	SW1
02	14DC	COVER OP	Front Upper Cover Switch	SW1
02	179C	POWER ON	-	-
02	1C9D	ERROR	-	-
02	1F9A	OTHER	-	-
02	1F9E	STOP	-	-
02	1FD0	TIME OUT	-	-
02	1FD1	TIME OUT	-	-
02	1FDE	ERROR	-	-
02	1FDF	STOP	-	-

PUNCHER UNIT-A1



ACC ID	Jam Code	Type	Sensor Name/Description	Sensor ID
02	1600	PUNCH	Punch HP Sensor 1/Punch HP Sensor 2	PS303,PS304
02	1C90	ERROR	-	-
02	1C93	ERROR	-	-

Booklet Trimmer-F1



ACC ID	Jam Code	Type	Sensor Name/Description	Sensor ID
02	10C4	DELAY	Vertical Transport Section Entrance Booklet Sensor	PI10
02	10CC	DELAY	Vertical Transport Section Exit Booklet Sensor	PI07
02	10CE	DELAY	Stopper Booklet Sensor	PI08
02	11C5	STNRY	Vertical Transport Section Entrance Booklet Sensor	PI10
02	11CD	STNRY	Vertical Transport Section Exit Booklet Sensor	PI07
02	11CF	STNRY	Stopper Booklet Sensor	PI08
02	1FDF	OTHER	-	-

Jam Code Details

■ 000101: JamCode (Main Unit) 0101

[Symptom/Question]

000101: JamCode (Main Unit) 0101

[Remedy/Answer]

Jam Type : Delay jam

Sensor Name : Right Deck Pickup Sensor 1

Sensor No. : PS19

Overview of detection

A delay jam occurs when a sensor was not turned ON although a specified period of time had passed after the start of detection by the sensor.

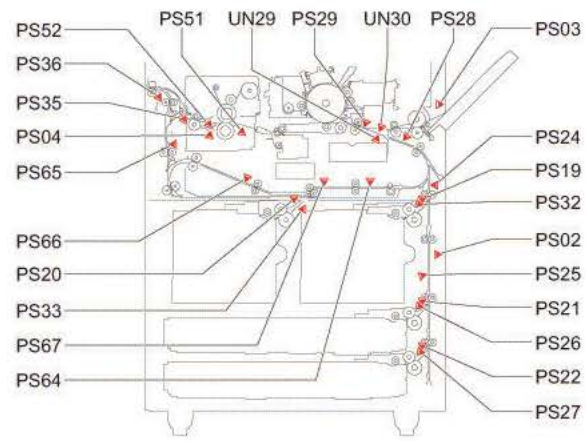
I/O: Service Mode > SITUATION > Sensor Check

Check items (in arbitrary order)

- Remaining paper at the upstream of the target sensor
- Soiling on the target sensor

Displacement of the target sensor position

- Failure of the target sensor
- Soiling (grease)/deterioration/Failure of a drive motor located upstream of the target sensor
- Soiling (paper dust)/deterioration/Failure of a drive roller located upstream of the target sensor



■ 000102: JamCode (Main Unit) 0102

[Symptom/Question]

000102: JamCode (Main Unit) 0102

[Remedy/Answer]

Jam Type : Delay jam

Sensor Name : Right Deck Pull Out Sensor

Sensor No. : PS32

Overview of detection

A delay jam occurs when a sensor was not turned ON although a specified period of time had passed after the start of detection by the sensor.

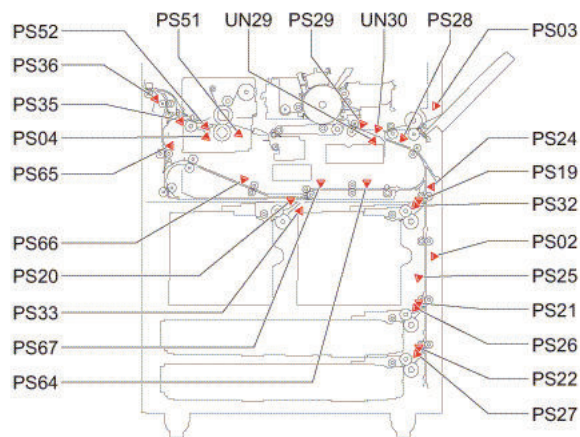
I/O: Service Mode > SITUATION > Sensor Check

Check items (in arbitrary order)

- Remaining paper at the upstream of the target sensor
- Soiling on the target sensor

Displacement of the target sensor position

- Failure of the target sensor
- Soiling (grease)/deterioration/Failure of a drive motor located upstream of the target sensor
- Soiling (paper dust)/deterioration/Failure of a drive roller located upstream of the target sensor



■ 000103: JamCode (Main Unit) 0103

[Symptom/Question]

000103: JamCode (Main Unit) 0103

[Remedy/Answer]

Jam Type : Delay jam

Sensor Name : Vertical Path Sensor 1

Sensor No. : PS24

Overview of detection

A delay jam occurs when a sensor was not turned ON although a specified period of time had passed after the start of detection by the sensor.

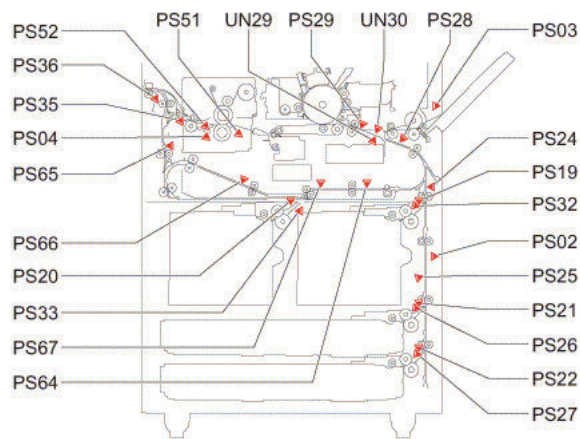
I/O: Service Mode > SITUATION > Sensor Check

Check items (in arbitrary order)

- Remaining paper at the upstream of the target sensor
- Soiling on the target sensor

Displacement of the target sensor position

- Failure of the target sensor
- Soiling (grease)/deterioration/Failure of a drive motor located upstream of the target sensor
- Soiling (paper dust)/deterioration/Failure of a drive roller located upstream of the target sensor



■ 000104: JamCode (Main Unit) 0104

[Symptom/Question]

000104: JamCode (Main Unit) 0104

[Remedy/Answer]

Jam Type : Delay jam

Sensor Name : Writing Judging Sensor

Sensor No. : PS28

Overview of detection

A delay jam occurs when a sensor was not turned ON although a specified period of time had passed after the start of detection by the sensor.

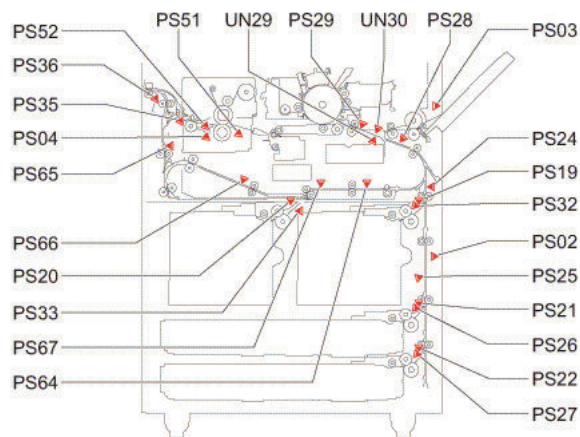
I/O: Service Mode > SITUATION > Sensor Check

Check items (in arbitrary order)

- Remaining paper at the upstream of the target sensor
- Soiling on the target sensor

Displacement of the target sensor position

- Failure of the target sensor
- Soiling (grease)/deterioration/Failure of a drive motor located upstream of the target sensor
- Soiling (paper dust)/deterioration/Failure of a drive roller located upstream of the target sensor



■ 000105: JamCode (Main Unit) 0105

[Symptom/Question]

000105: JamCode (Main Unit) 0105

[Remedy/Answer]

Jam Type : Delay jam

Sensor Name : Registration Sensor

Sensor No. : PS29

Overview of detection

A delay jam occurs when a sensor was not turned ON although a specified period of time had passed after the start of detection by the sensor.

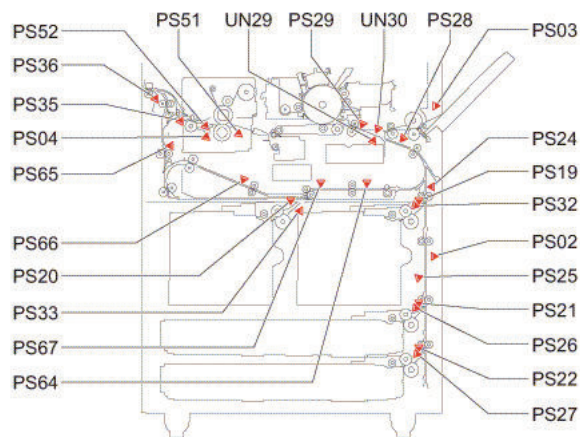
I/O: Service Mode > SITUATION > Sensor Check

Check items (in arbitrary order)

- Remaining paper at the upstream of the target sensor
- Soiling on the target sensor

Displacement of the target sensor position

- Failure of the target sensor
- Soiling (grease)/deterioration/Failure of a drive motor located upstream of the target sensor
- Soiling (paper dust)/deterioration/Failure of a drive roller located upstream of the target sensor



■ 000106: JamCode (Main Unit) 0106

[Symptom/Question]

000106: JamCode (Main Unit) 0106

[Remedy/Answer]

Jam Type : Delay jam

Sensor Name : Left Deck Pickup Sensor 1

Sensor No. : PS20

Overview of detection

A delay jam occurs when a sensor was not turned ON although a specified period of time had passed after the start of detection by the sensor.

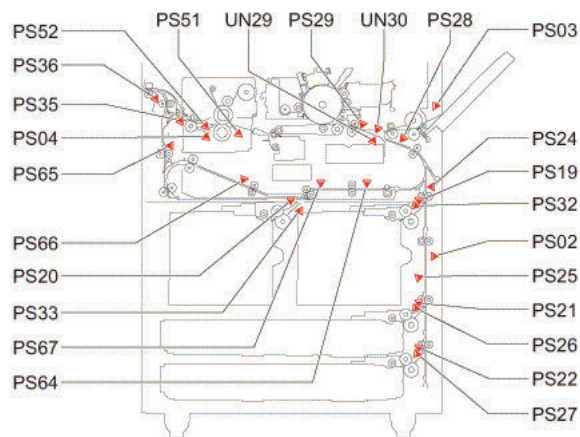
I/O: Service Mode > SITUATION > Sensor Check

Check items (in arbitrary order)

- Remaining paper at the upstream of the target sensor
- Soiling on the target sensor

Displacement of the target sensor position

- Failure of the target sensor
- Soiling (grease)/deterioration/Failure of a drive motor located upstream of the target sensor
- Soiling (paper dust)/deterioration/Failure of a drive roller located upstream of the target sensor



■ 000107: JamCode (Main Unit) 0107

[Symptom/Question]

000107: JamCode (Main Unit) 0107

[Remedy/Answer]

Jam Type : Delay jam

Sensor Name : Left Deck Pull Out Sensor

Sensor No. : PS33

Overview of detection

A delay jam occurs when a sensor was not turned ON although a specified period of time had passed after the start of detection by the sensor.

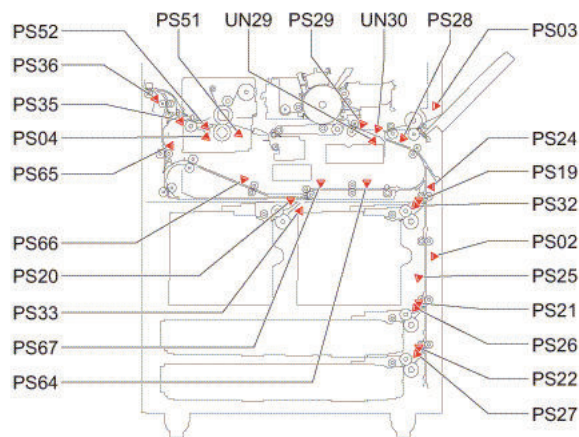
I/O: Service Mode > SITUATION > Sensor Check

Check items (in arbitrary order)

- Remaining paper at the upstream of the target sensor
- Soiling on the target sensor

Displacement of the target sensor position

- Failure of the target sensor
- Soiling (grease)/deterioration/Failure of a drive motor located upstream of the target sensor
- Soiling (paper dust)/deterioration/Failure of a drive roller located upstream of the target sensor



■ 000108: JamCode (Main Unit) 0108

[Symptom/Question]

000108: JamCode (Main Unit) 0108

[Remedy/Answer]

Jam Type : Delay jam

Sensor Name : Duplex Merging Sensor

Sensor No. : PS67

Overview of detection

A delay jam occurs when a sensor was not turned ON although a specified period of time had passed after the start of detection by the sensor.

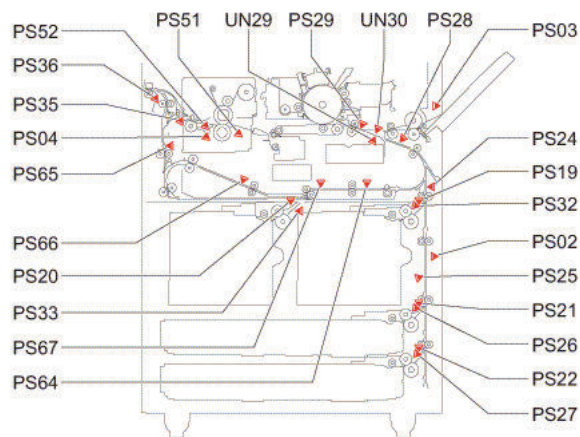
I/O: Service Mode > SITUATION > Sensor Check

Check items (in arbitrary order)

- Remaining paper at the upstream of the target sensor
- Soiling on the target sensor

Displacement of the target sensor position

- Failure of the target sensor
- Soiling (grease)/deterioration/Failure of a drive motor located upstream of the target sensor
- Soiling (paper dust)/deterioration/Failure of a drive roller located upstream of the target sensor



■ 000109: JamCode (Main Unit) 0109

[Symptom/Question]

000109: JamCode (Main Unit) 0109

[Remedy/Answer]

Jam Type : Delay jam

Sensor Name : Duplex Outlet Sensor

Sensor No. : PS64

Overview of detection

A delay jam occurs when a sensor was not turned ON although a specified period of time had passed after the start of detection by the sensor.

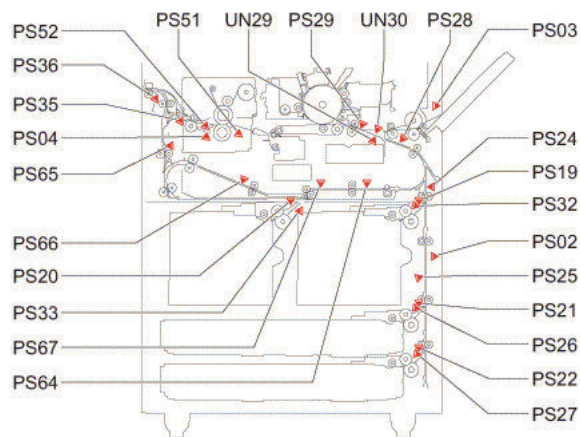
I/O: Service Mode > SITUATION > Sensor Check

Check items (in arbitrary order)

- Remaining paper at the upstream of the target sensor
- Soiling on the target sensor

Displacement of the target sensor position

- Failure of the target sensor
- Soiling (grease)/deterioration/Failure of a drive motor located upstream of the target sensor
- Soiling (paper dust)/deterioration/Failure of a drive roller located upstream of the target sensor



■ 00010A: JamCode (Main Unit) 010A

[Symptom/Question]

00010A: JamCode (Main Unit) 010A

[Remedy/Answer]

Jam Type : Delay jam

Sensor Name : Cassette 3 Pickup Sensor 1

Sensor No. : PS21

Overview of detection

A delay jam occurs when a sensor was not turned ON although a specified period of time had passed after the start of detection by the sensor.

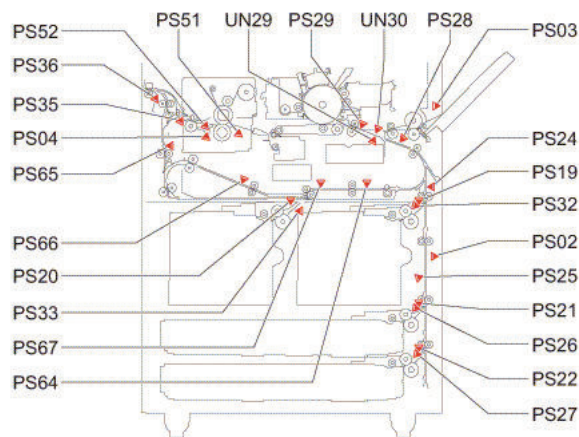
I/O: Service Mode > SITUATION > Sensor Check

Check items (in arbitrary order)

- Remaining paper at the upstream of the target sensor
- Soiling on the target sensor

Displacement of the target sensor position

- Failure of the target sensor
- Soiling (grease)/deterioration/Failure of a drive motor located upstream of the target sensor
- Soiling (paper dust)/deterioration/Failure of a drive roller located upstream of the target sensor



■ 00010B: JamCode (Main Unit) 010B

[Symptom/Question]

00010B: JamCode (Main Unit) 010B

[Remedy/Answer]

Jam Type : Delay jam

Sensor Name : Vertical Path Sensor 3

Sensor No. : PS26

Overview of detection

A delay jam occurs when a sensor was not turned ON although a specified period of time had passed after the start of detection by the sensor.

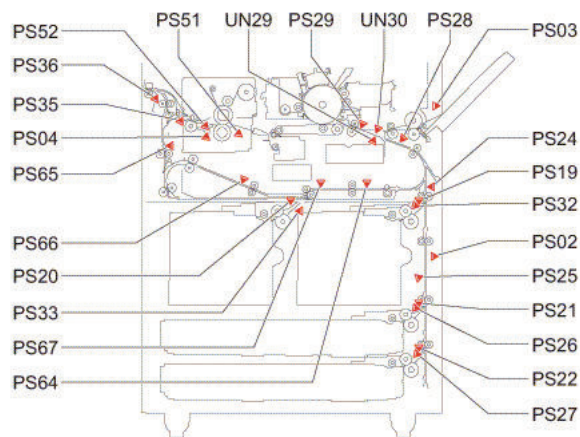
I/O: Service Mode > SITUATION > Sensor Check

Check items (in arbitrary order)

- Remaining paper at the upstream of the target sensor
- Soiling on the target sensor

Displacement of the target sensor position

- Failure of the target sensor
- Soiling (grease)/deterioration/Failure of a drive motor located upstream of the target sensor
- Soiling (paper dust)/deterioration/Failure of a drive roller located upstream of the target sensor



■ 00010C: JamCode (Main Unit) 010C

[Symptom/Question]

00010C: JamCode (Main Unit) 010C

[Remedy/Answer]

Jam Type : Delay jam

Sensor Name : Vertical Path Sensor 2

Sensor No. : PS25

Overview of detection

A delay jam occurs when a sensor was not turned ON although a specified period of time had passed after the start of detection by the sensor.

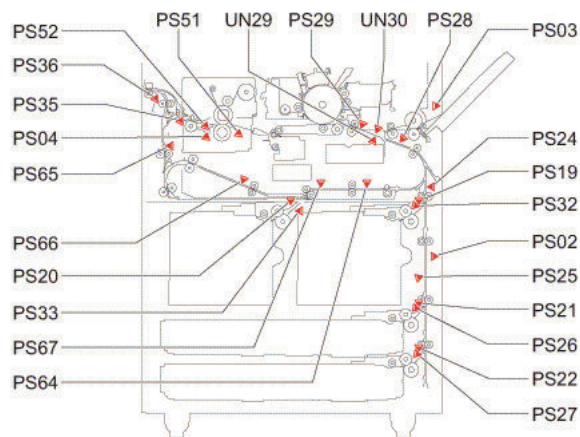
I/O: Service Mode > SITUATION > Sensor Check

Check items (in arbitrary order)

- Remaining paper at the upstream of the target sensor
- Soiling on the target sensor

Displacement of the target sensor position

- Failure of the target sensor
- Soiling (grease)/deterioration/Failure of a drive motor located upstream of the target sensor
- Soiling (paper dust)/deterioration/Failure of a drive roller located upstream of the target sensor



■ 00010D: JamCode (Main Unit) 010D

[Symptom/Question]

00010D: JamCode (Main Unit) 010D

[Remedy/Answer]

Jam Type : Delay jam

Sensor Name : Cassette 4 Pickup Sensor 1

Sensor No. : PS22

Overview of detection

A delay jam occurs when a sensor was not turned ON although a specified period of time had passed after the start of detection by the sensor.

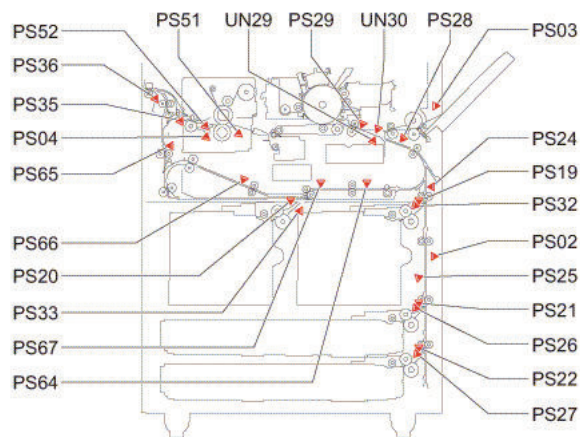
I/O: Service Mode > SITUATION > Sensor Check

Check items (in arbitrary order)

- Remaining paper at the upstream of the target sensor
- Soiling on the target sensor

Displacement of the target sensor position

- Failure of the target sensor
- Soiling (grease)/deterioration/Failure of a drive motor located upstream of the target sensor
- Soiling (paper dust)/deterioration/Failure of a drive roller located upstream of the target sensor



■ 00010E: JamCode (Main Unit) 010E

[Symptom/Question]

00010E: JamCode (Main Unit) 010E

[Remedy/Answer]

Jam Type : Delay jam

Sensor Name : Vertical Path Sensor 4

Sensor No. : PS27

Overview of detection

A delay jam occurs when a sensor was not turned ON although a specified period of time had passed after the start of detection by the sensor.

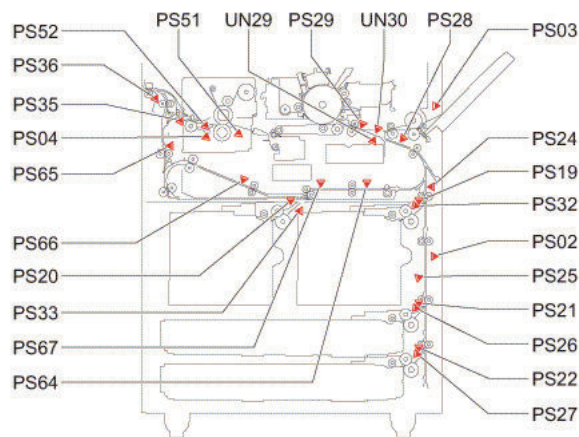
I/O: Service Mode > SITUATION > Sensor Check

Check items (in arbitrary order)

- Remaining paper at the upstream of the target sensor
- Soiling on the target sensor

Displacement of the target sensor position

- Failure of the target sensor
- Soiling (grease)/deterioration/Failure of a drive motor located upstream of the target sensor
- Soiling (paper dust)/deterioration/Failure of a drive roller located upstream of the target sensor



■ 000111: JamCode (Main Unit) 0111

[Symptom/Question]

000111: JamCode (Main Unit) 0111

[Remedy/Answer]

Jam Type : Delay jam

Sensor Name : Fixing Outlet Sensor

Sensor No. : PS52

Overview of detection

A delay jam occurs when a sensor was not turned ON although a specified period of time had passed after the start of detection by the sensor.

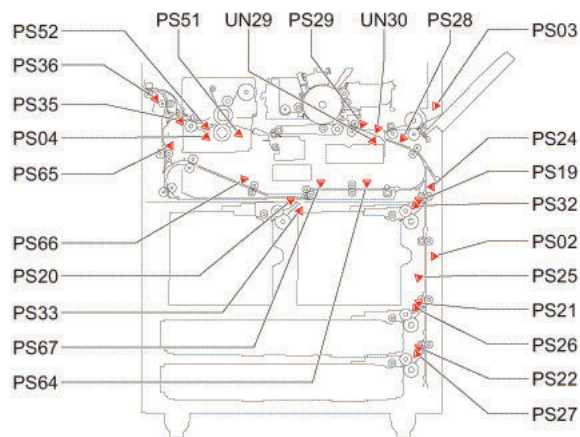
I/O: Service Mode > SITUATION > Sensor Check

Check items (in arbitrary order)

- Remaining paper at the upstream of the target sensor
- Soiling on the target sensor

Displacement of the target sensor position

- Failure of the target sensor
- Soiling (grease)/deterioration/Failure of a drive motor located upstream of the target sensor
- Soiling (paper dust)/deterioration/Failure of a drive roller located upstream of the target sensor



■ 000112: JamCode (Main Unit) 0112

[Symptom/Question]

000112: JamCode (Main Unit) 0112

[Remedy/Answer]

Jam Type : Delay jam

Sensor Name : Inner Delivery Sensor

Sensor No. : PS35

Overview of detection

A delay jam occurs when a sensor was not turned ON although a specified period of time had passed after the start of detection by the sensor.

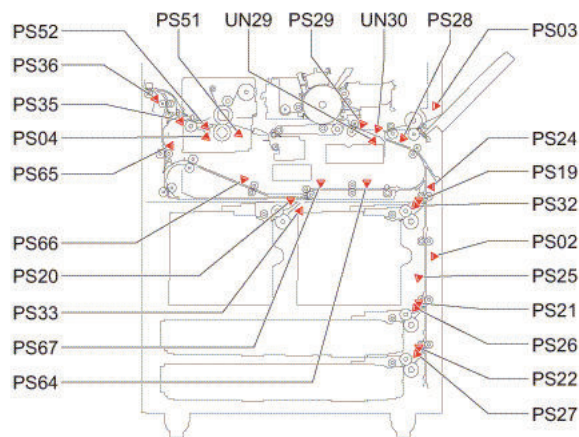
I/O: Service Mode > SITUATION > Sensor Check

Check items (in arbitrary order)

- Remaining paper at the upstream of the target sensor
- Soiling on the target sensor

Displacement of the target sensor position

- Failure of the target sensor
- Soiling (grease)/deterioration/Failure of a drive motor located upstream of the target sensor
- Soiling (paper dust)/deterioration/Failure of a drive roller located upstream of the target sensor



■ 000113: JamCode (Main Unit) 0113

[Symptom/Question]

000113: JamCode (Main Unit) 0113

[Remedy/Answer]

Jam Type : Delay jam

Sensor Name : Outer Delivery Sensor

Sensor No. : PS36

Overview of detection

A delay jam occurs when a sensor was not turned ON although a specified period of time had passed after the start of detection by the sensor.

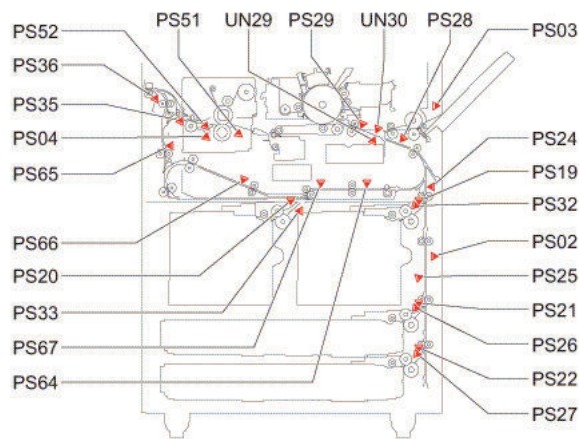
I/O: Service Mode > SITUATION > Sensor Check

Check items (in arbitrary order)

- Remaining paper at the upstream of the target sensor
- Soiling on the target sensor

Displacement of the target sensor position

- Failure of the target sensor
- Soiling (grease)/deterioration/Failure of a drive motor located upstream of the target sensor
- Soiling (paper dust)/deterioration/Failure of a drive roller located upstream of the target sensor



■ 000114: JamCode (Main Unit) 0114

[Symptom/Question]

000114: JamCode (Main Unit) 0114

[Remedy/Answer]

Jam Type : Delay jam

Sensor Name : Reverse Vertical Path Sensor

Sensor No. : PS65

Overview of detection

A delay jam occurs when a sensor was not turned ON although a specified period of time had passed after the start of detection by the sensor.

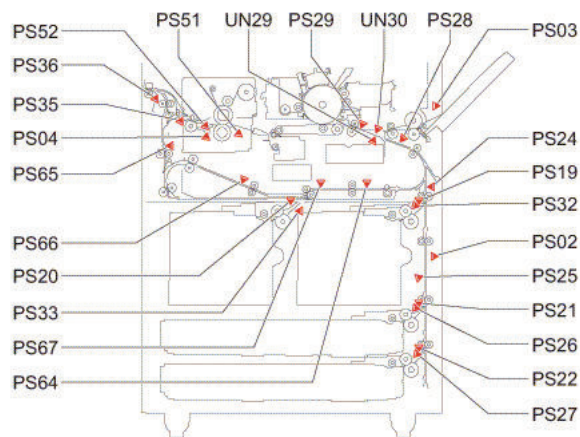
I/O: Service Mode > SITUATION > Sensor Check

Check items (in arbitrary order)

- Remaining paper at the upstream of the target sensor
- Soiling on the target sensor

Displacement of the target sensor position

- Failure of the target sensor
- Soiling (grease)/deterioration/Failure of a drive motor located upstream of the target sensor
- Soiling (paper dust)/deterioration/Failure of a drive roller located upstream of the target sensor



■ 000115: JamCode (Main Unit) 0115

[Symptom/Question]

000115: JamCode (Main Unit) 0115

[Remedy/Answer]

Jam Type : Delay jam

Sensor Name : Duplex Left Sensor

Sensor No. : PS66

Overview of detection

A delay jam occurs when a sensor was not turned ON although a specified period of time had passed after the start of detection by the sensor.

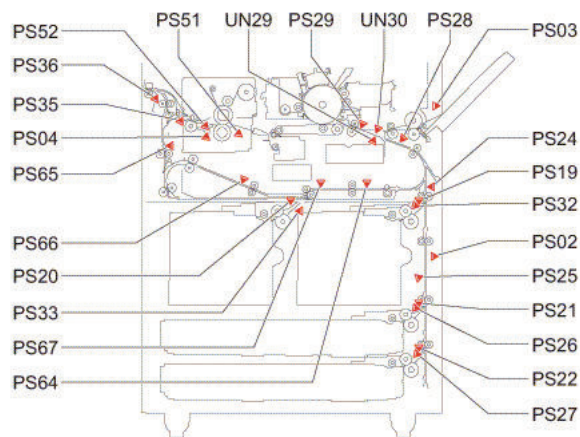
I/O: Service Mode > SITUATION > Sensor Check

Check items (in arbitrary order)

- Remaining paper at the upstream of the target sensor
- Soiling on the target sensor

Displacement of the target sensor position

- Failure of the target sensor
- Soiling (grease)/deterioration/Failure of a drive motor located upstream of the target sensor
- Soiling (paper dust)/deterioration/Failure of a drive roller located upstream of the target sensor



■ 000117: JamCode (POD Deck Lite-C1) 0117

[Symptom/Question]

000117: JamCode (POD Deck Lite-C1) 0117

[Remedy/Answer]

Jam Type : Delay jam

Sensor Name : Deck pickup sensor

Sensor No. : SR7

Overview of detection

A delay jam occurs when a sensor was not turned ON although a specified period of time had passed after the start of detection by the sensor.

I/O: Service Mode > SITUATION > Sensor Check

Check items (in arbitrary order)

- Remaining paper at the upstream of the target sensor
- Soiling on the target sensor

Displacement of the target sensor position

- Failure of the target sensor
- Soiling (grease)/deterioration/Failure of a drive motor located upstream of the target sensor
- Soiling (paper dust)/deterioration/Failure of a drive roller located upstream of the target sensor



■ 000117: JamCode (Paper Deck Unit-E1) 0117

[Symptom/Question]

000117: JamCode (Paper Deck Unit-E1) 0117

[Remedy/Answer]

Jam Type : Delay jam

Sensor Name : Deck pickup sensor

Sensor No. : PS1

Overview of detection

A delay jam occurs when a sensor was not turned ON although a specified period of time had passed after the start of detection by the sensor.

I/O: Service Mode > SITUATION > Sensor Check

Check items (in arbitrary order)

- Remaining paper at the upstream of the target sensor
- Soiling on the target sensor

Displacement of the target sensor position

- Failure of the target sensor
- Soiling (grease)/deterioration/Failure of a drive motor located upstream of the target sensor
- Soiling (paper dust)/deterioration/Failure of a drive roller located upstream of the target sensor



■ 000118: JamCode (POD Deck Lite-C1) 0118

[Symptom/Question]

000118: JamCode (POD Deck Lite-C1) 0118

[Remedy/Answer]

Jam Type : Delay jam

Sensor Name : Deck pull-out sensor

Sensor No. : SR6

Overview of detection

A delay jam occurs when a sensor was not turned ON although a specified period of time had passed after the start of detection by the sensor.

I/O: Service Mode > SITUATION > Sensor Check

Check items (in arbitrary order)

- Remaining paper at the upstream of the target sensor
- Soiling on the target sensor

Displacement of the target sensor position

- Failure of the target sensor
- Soiling (grease)/deterioration/Failure of a drive motor located upstream of the target sensor
- Soiling (paper dust)/deterioration/Failure of a drive roller located upstream of the target sensor



■ 000118: JamCode (Paper Deck Unit-E1) 0118

[Symptom/Question]

000118: JamCode (Paper Deck Unit-E1) 0118

[Remedy/Answer]

Jam Type : Delay jam

Sensor Name : Deck pull-out sensor

Sensor No. : PS2

Overview of detection

A delay jam occurs when a sensor was not turned ON although a specified period of time had passed after the start of detection by the sensor.

I/O: Service Mode > SITUATION > Sensor Check

Check items (in arbitrary order)

- Remaining paper at the upstream of the target sensor
- Soiling on the target sensor

Displacement of the target sensor position

- Failure of the target sensor
- Soiling (grease)/deterioration/Failure of a drive motor located upstream of the target sensor
- Soiling (paper dust)/deterioration/Failure of a drive roller located upstream of the target sensor



■ 000202: JamCode (Main Unit) 0202

[Symptom/Question]

000202: JamCode (Main Unit) 0202

[Remedy/Answer]

Jam Type : Stationary jam

Sensor Name : Right Deck Pull Out Sensor

Sensor No. : PS32

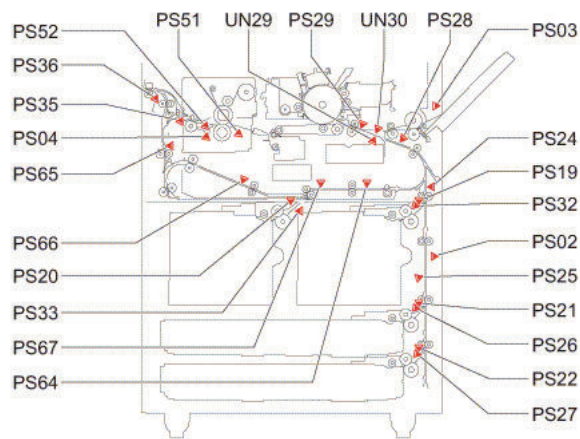
Overview of detection

A stationary jam occurs when a sensor was not turned OFF although a specified period of time had passed after the sensor was turned ON.

I/O: Service Mode > SITUATION > Sensor Check

Check items (in arbitrary order)

- Remaining paper near the target sensor
- Soiling on the target sensor
- Displacement of the target sensor position
- Failure of the target sensor
- Soiling (grease)/deterioration/failure of a drive motor located upstream of the target sensor
- Soiling (paper dust)/deterioration/failure of a drive roller located upstream of the target sensor



■ 000203: JamCode (Main Unit) 0203

[Symptom/Question]

000203: JamCode (Main Unit) 0203

[Remedy/Answer]

Jam Type : Stationary jam

Sensor Name : Vertical Path Sensor 1

Sensor No. : PS24

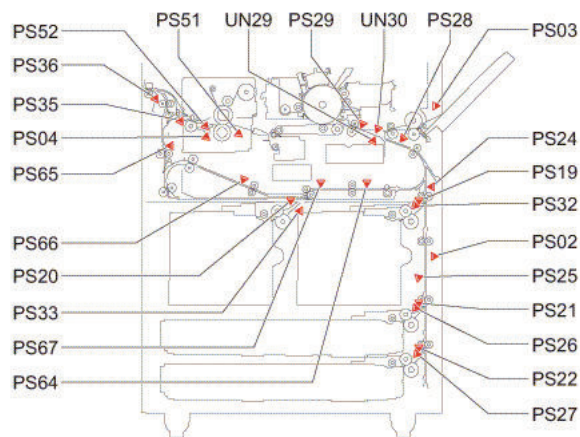
Overview of detection

A stationary jam occurs when a sensor was not turned OFF although a specified period of time had passed after the sensor was turned ON.

I/O: Service Mode > SITUATION > Sensor Check

Check items (in arbitrary order)

- Remaining paper near the target sensor
- Soiling on the target sensor
- Displacement of the target sensor position
- Failure of the target sensor
- Soiling (grease)/deterioration/failure of a drive motor located upstream of the target sensor
- Soiling (paper dust)/deterioration/failure of a drive roller located upstream of the target sensor



■ 000204: JamCode (Main Unit) 0204

[Symptom/Question]

000204: JamCode (Main Unit) 0204

[Remedy/Answer]

Jam Type : Stationary jam

Sensor Name : Writing Judging Sensor

Sensor No. : PS28

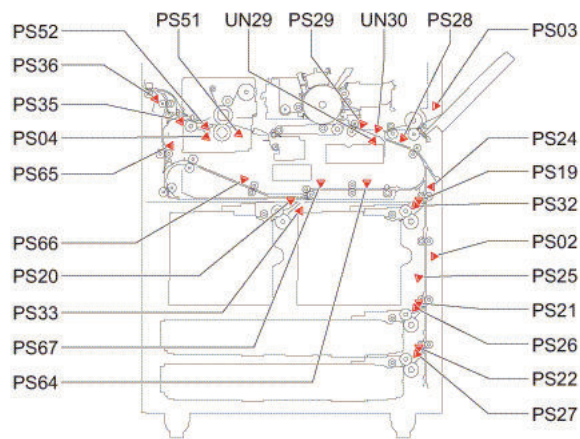
Overview of detection

A stationary jam occurs when a sensor was not turned OFF although a specified period of time had passed after the sensor was turned ON.

I/O: Service Mode > SITUATION > Sensor Check

Check items (in arbitrary order)

- Remaining paper near the target sensor
- Soiling on the target sensor
- Displacement of the target sensor position
- Failure of the target sensor
- Soiling (grease)/deterioration/failure of a drive motor located upstream of the target sensor
- Soiling (paper dust)/deterioration/failure of a drive roller located upstream of the target sensor



■ 000205: JamCode (Main Unit) 0205

[Symptom/Question]

000205: JamCode (Main Unit) 0205

[Remedy/Answer]

Jam Type : Stationary jam

Sensor Name : Registration Sensor

Sensor No. : PS29

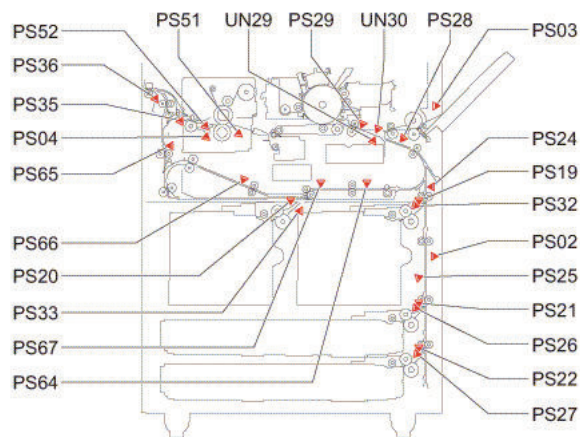
Overview of detection

A stationary jam occurs when a sensor was not turned OFF although a specified period of time had passed after the sensor was turned ON.

I/O: Service Mode > SITUATION > Sensor Check

Check items (in arbitrary order)

- Remaining paper near the target sensor
- Soiling on the target sensor
- Displacement of the target sensor position
- Failure of the target sensor
- Soiling (grease)/deterioration/failure of a drive motor located upstream of the target sensor
- Soiling (paper dust)/deterioration/failure of a drive roller located upstream of the target sensor



■ 000207: JamCode (Main Unit) 0207

[Symptom/Question]

000207: JamCode (Main Unit) 0207

[Remedy/Answer]

Jam Type : Stationary jam

Sensor Name : Left Deck Pull Out Sensor

Sensor No. : PS33

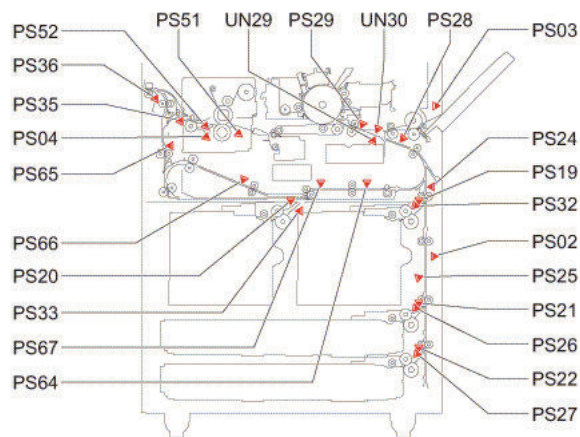
Overview of detection

A stationary jam occurs when a sensor was not turned OFF although a specified period of time had passed after the sensor was turned ON.

I/O: Service Mode > SITUATION > Sensor Check

Check items (in arbitrary order)

- Remaining paper near the target sensor
- Soiling on the target sensor
- Displacement of the target sensor position
- Failure of the target sensor
- Soiling (grease)/deterioration/failure of a drive motor located upstream of the target sensor
- Soiling (paper dust)/deterioration/failure of a drive roller located upstream of the target sensor



■ 000208: JamCode (Main Unit) 0208

[Symptom/Question]

000208: JamCode (Main Unit) 0208

[Remedy/Answer]

Jam Type : Stationary jam

Sensor Name : Duplex Merging Sensor

Sensor No. : PS67

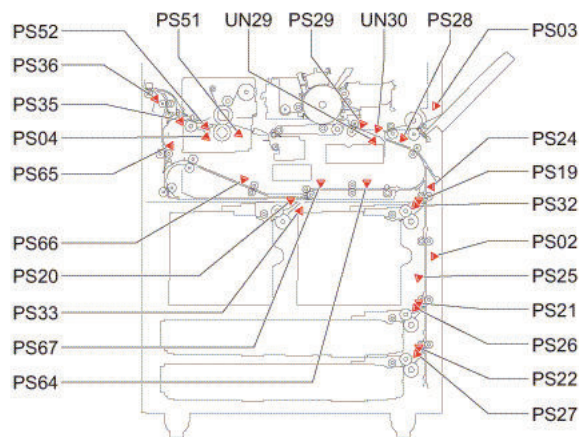
Overview of detection

A stationary jam occurs when a sensor was not turned OFF although a specified period of time had passed after the sensor was turned ON.

I/O: Service Mode > SITUATION > Sensor Check

Check items (in arbitrary order)

- Remaining paper near the target sensor
- Soiling on the target sensor
- Displacement of the target sensor position
- Failure of the target sensor
- Soiling (grease)/deterioration/failure of a drive motor located upstream of the target sensor
- Soiling (paper dust)/deterioration/failure of a drive roller located upstream of the target sensor



■ 000209: JamCode (Main Unit) 0209

[Symptom/Question]

000209: JamCode (Main Unit) 0209

[Remedy/Answer]

Jam Type : Stationary jam

Sensor Name : Duplex Outlet Sensor

Sensor No. : PS64

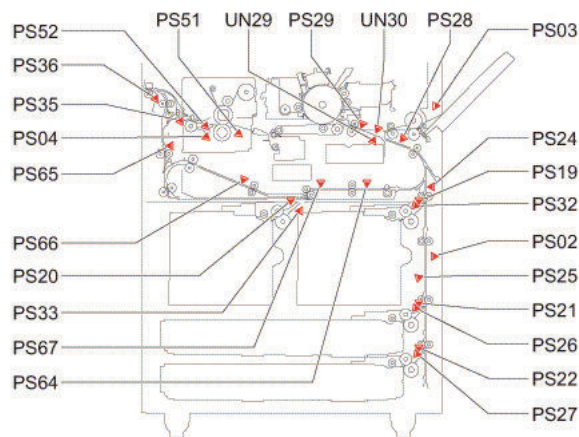
Overview of detection

A stationary jam occurs when a sensor was not turned OFF although a specified period of time had passed after the sensor was turned ON.

I/O: Service Mode > SITUATION > Sensor Check

Check items (in arbitrary order)

- Remaining paper near the target sensor
- Soiling on the target sensor
- Displacement of the target sensor position
- Failure of the target sensor
- Soiling (grease)/deterioration/failure of a drive motor located upstream of the target sensor
- Soiling (paper dust)/deterioration/failure of a drive roller located upstream of the target sensor



■ 00020B: JamCode (Main Unit) 020B

[Symptom/Question]

00020B: JamCode (Main Unit) 020B

[Remedy/Answer]

Jam Type : Stationary jam

Sensor Name : Vertical Path Sensor 3

Sensor No. : PS26

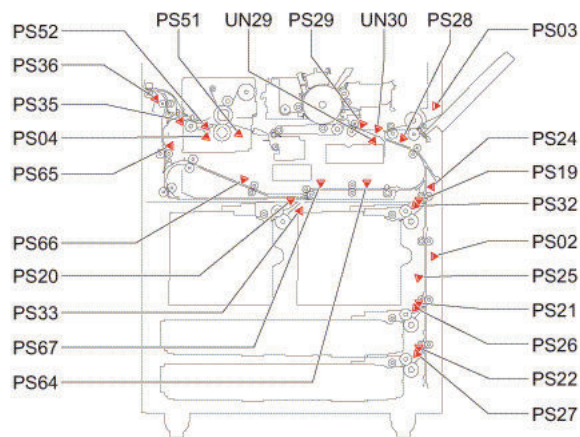
Overview of detection

A stationary jam occurs when a sensor was not turned OFF although a specified period of time had passed after the sensor was turned ON.

I/O: Service Mode > SITUATION > Sensor Check

Check items (in arbitrary order)

- Remaining paper near the target sensor
- Soiling on the target sensor
- Displacement of the target sensor position
- Failure of the target sensor
- Soiling (grease)/deterioration/failure of a drive motor located upstream of the target sensor
- Soiling (paper dust)/deterioration/failure of a drive roller located upstream of the target sensor



■ 00020C: JamCode (Main Unit) 020C

[Symptom/Question]

00020C: JamCode (Main Unit) 020C

[Remedy/Answer]

Jam Type : Stationary jam

Sensor Name : Vertical Path Sensor 2

Sensor No. : PS25

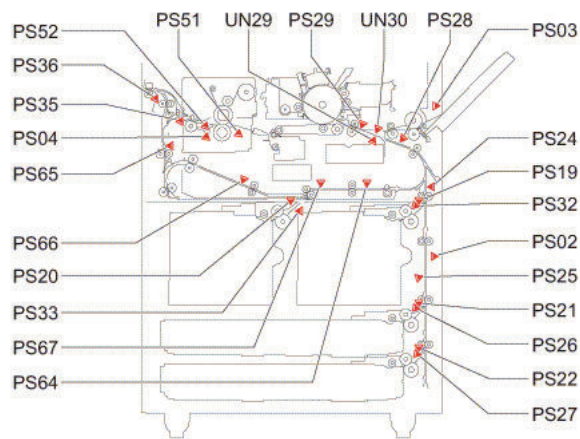
Overview of detection

A stationary jam occurs when a sensor was not turned OFF although a specified period of time had passed after the sensor was turned ON.

I/O: Service Mode > SITUATION > Sensor Check

Check items (in arbitrary order)

- Remaining paper near the target sensor
- Soiling on the target sensor
- Displacement of the target sensor position
- Failure of the target sensor
- Soiling (grease)/deterioration/failure of a drive motor located upstream of the target sensor
- Soiling (paper dust)/deterioration/failure of a drive roller located upstream of the target sensor



■ 00020E: JamCode (Main Unit) 020E

[Symptom/Question]

00020E: JamCode (Main Unit) 020E

[Remedy/Answer]

Jam Type : Stationary jam

Sensor Name : Vertical Path Sensor 4

Sensor No. : PS27

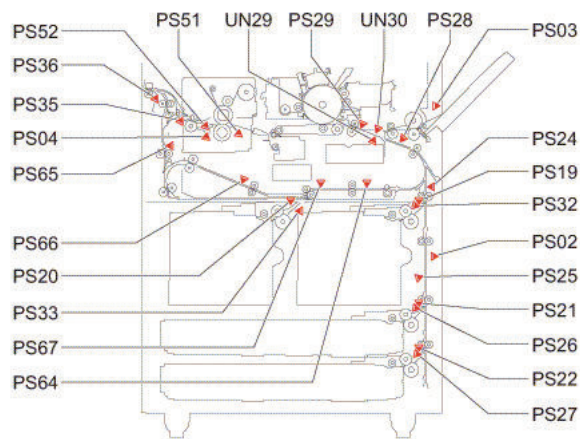
Overview of detection

A stationary jam occurs when a sensor was not turned OFF although a specified period of time had passed after the sensor was turned ON.

I/O: Service Mode > SITUATION > Sensor Check

Check items (in arbitrary order)

- Remaining paper near the target sensor
- Soiling on the target sensor
- Displacement of the target sensor position
- Failure of the target sensor
- Soiling (grease)/deterioration/failure of a drive motor located upstream of the target sensor
- Soiling (paper dust)/deterioration/failure of a drive roller located upstream of the target sensor



■ 000212: JamCode (Main Unit) 0212

[Symptom/Question]

000212: JamCode (Main Unit) 0212

[Remedy/Answer]

Jam Type : Stationary jam

Sensor Name : Inner Delivery Sensor

Sensor No. : PS35

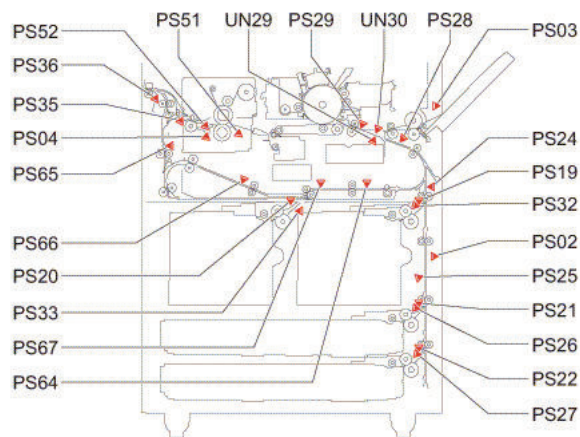
Overview of detection

A stationary jam occurs when a sensor was not turned OFF although a specified period of time had passed after the sensor was turned ON.

I/O: Service Mode > SITUATION > Sensor Check

Check items (in arbitrary order)

- Remaining paper near the target sensor
- Soiling on the target sensor
- Displacement of the target sensor position
- Failure of the target sensor
- Soiling (grease)/deterioration/failure of a drive motor located upstream of the target sensor
- Soiling (paper dust)/deterioration/failure of a drive roller located upstream of the target sensor



■ 000213: JamCode (Main Unit) 0213

[Symptom/Question]

000213: JamCode (Main Unit) 0213

[Remedy/Answer]

Jam Type : Stationary jam

Sensor Name : Outer Delivery Sensor

Sensor No. : PS36

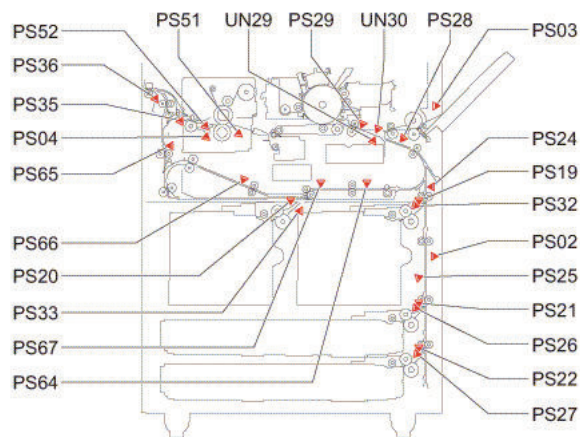
Overview of detection

A stationary jam occurs when a sensor was not turned OFF although a specified period of time had passed after the sensor was turned ON.

I/O: Service Mode > SITUATION > Sensor Check

Check items (in arbitrary order)

- Remaining paper near the target sensor
- Soiling on the target sensor
- Displacement of the target sensor position
- Failure of the target sensor
- Soiling (grease)/deterioration/failure of a drive motor located upstream of the target sensor
- Soiling (paper dust)/deterioration/failure of a drive roller located upstream of the target sensor



■ 000214: JamCode (Main Unit) 0214

[Symptom/Question]

000214: JamCode (Main Unit) 0214

[Remedy/Answer]

Jam Type : Stationary jam

Sensor Name : Reverse Vertical Path Sensor

Sensor No. : PS65

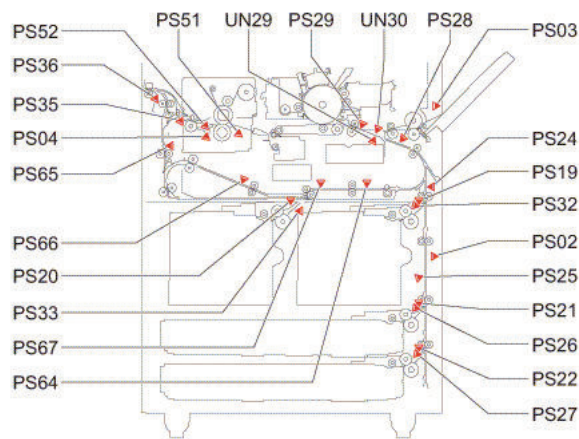
Overview of detection

A stationary jam occurs when a sensor was not turned OFF although a specified period of time had passed after the sensor was turned ON.

I/O: Service Mode > SITUATION > Sensor Check

Check items (in arbitrary order)

- Remaining paper near the target sensor
- Soiling on the target sensor
- Displacement of the target sensor position
- Failure of the target sensor
- Soiling (grease)/deterioration/failure of a drive motor located upstream of the target sensor
- Soiling (paper dust)/deterioration/failure of a drive roller located upstream of the target sensor



■ 000215: JamCode (Main Unit) 0215

[Symptom/Question]

000215: JamCode (Main Unit) 0215

[Remedy/Answer]

Jam Type : Stationary jam

Sensor Name : Duplex Left Sensor

Sensor No. : PS66

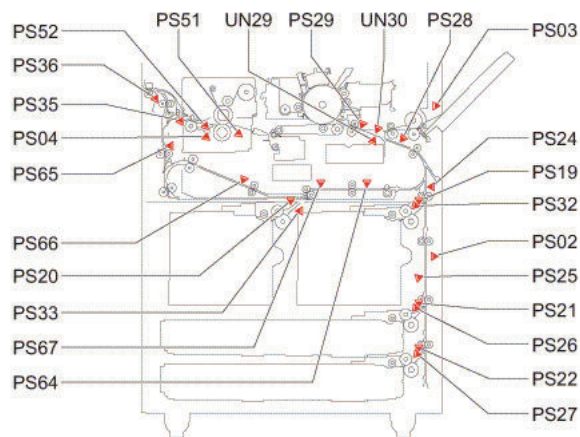
Overview of detection

A stationary jam occurs when a sensor was not turned OFF although a specified period of time had passed after the sensor was turned ON.

I/O: Service Mode > SITUATION > Sensor Check

Check items (in arbitrary order)

- Remaining paper near the target sensor
- Soiling on the target sensor
- Displacement of the target sensor position
- Failure of the target sensor
- Soiling (grease)/deterioration/failure of a drive motor located upstream of the target sensor
- Soiling (paper dust)/deterioration/failure of a drive roller located upstream of the target sensor



■ 000218: JamCode (POD Deck Lite-C1) 0218

[Symptom/Question]

000218: JamCode (POD Deck Lite-C1) 0218

[Remedy/Answer]

Jam Type : Stationary jam

Sensor Name : Deck pull-out sensor

Sensor No. : SR6

Overview of detection

A stationary jam occurs when a sensor was not turned OFF although a specified period of time had passed after the sensor was turned ON.

I/O: Service Mode > SITUATION > Sensor Check

Check items (in arbitrary order)

- Remaining paper near the target sensor
- Soiling on the target sensor
- Displacement of the target sensor position
- Failure of the target sensor
- Soiling (grease)/deterioration/failure of a drive motor located upstream of the target sensor
- Soiling (paper dust)/deterioration/failure of a drive roller located upstream of the target sensor



■ 000218: JamCode (Paper Deck Unit-E1) 0218

[Symptom/Question]

000218: JamCode (Paper Deck Unit-E1) 0218

[Remedy/Answer]

Jam Type : Stationary jam

Sensor Name : Deck pull-out sensor

Sensor No. : PS2

Overview of detection

A stationary jam occurs when a sensor was not turned OFF although a specified period of time had passed after the sensor was turned ON.

I/O: Service Mode > SITUATION > Sensor Check

Check items (in arbitrary order)

- Remaining paper near the target sensor
- Soiling on the target sensor
- Displacement of the target sensor position
- Failure of the target sensor
- Soiling (grease)/deterioration/failure of a drive motor located upstream of the target sensor
- Soiling (paper dust)/deterioration/failure of a drive roller located upstream of the target sensor



■ 000300: JamCode (Main Unit) 0300

[Symptom/Question]

000300: JamCode (Main Unit) 0300

[Remedy/Answer]

Jam Type : Double Feed

Sensor Name : Double Feed Detection Sensor

Sensor No. : UN29,UN30

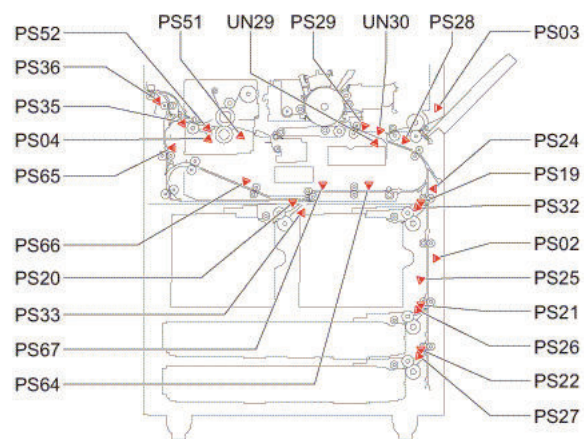
Overview of detection

-

I/O: Service Mode > SITUATION > Sensor Check

Check items (in arbitrary order)

-



■ 000305: JamCode (Main Unit) 0305

[Symptom/Question]

000305: JamCode (Main Unit) 0305

[Remedy/Answer]

Jam Type : OTHER

Sensor Name : Registration Sensor

Sensor No. : PS29

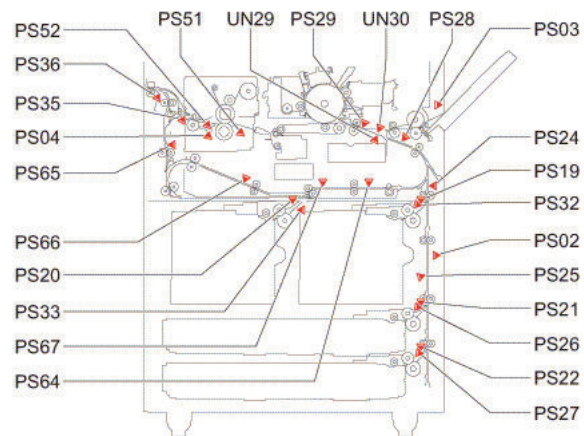
Overview of detection

-

I/O: Service Mode > SITUATION > Sensor Check

Check items (in arbitrary order)

-



■ 000A02: JamCode (Main Unit) 0A02

[Symptom/Question]

000A02: JamCode (Main Unit) 0A02

[Remedy/Answer]

Jam Type : Power-on jam

Sensor Name : Right Deck Pull Out Sensor

Sensor No. : PS32

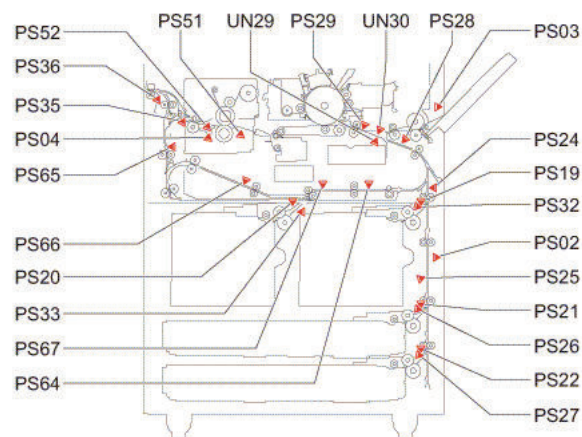
Overview of detection

A power-on jam occurs when a sensor detected ON state at power-on.

I/O: Service Mode > SITUATION > Sensor Check

Check items (in arbitrary order)

- Remaining paper in the machine
- Soiling on the target sensor
- Failure of the target sensor
- Foreign matter on the target sensor (paper dust, paper lint)



■ 000A03: JamCode (Main Unit) 0A03

[Symptom/Question]

000A03: JamCode (Main Unit) 0A03

[Remedy/Answer]

Jam Type : Power-on jam

Sensor Name : Vertical Path Sensor 1

Sensor No. : PS24

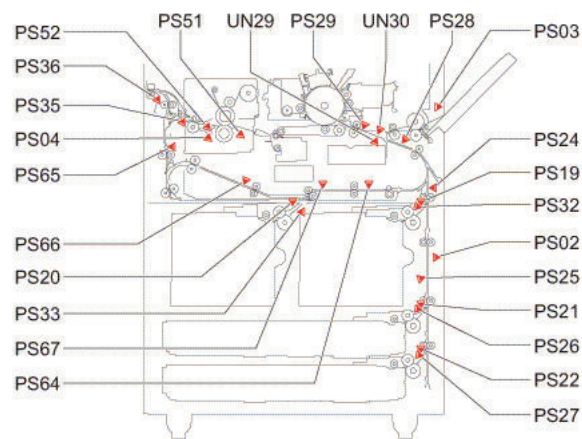
Overview of detection

A power-on jam occurs when a sensor detected ON state at power-on.

I/O: Service Mode > SITUATION > Sensor Check

Check items (in arbitrary order)

- Remaining paper in the machine
- Soiling on the target sensor
- Failure of the target sensor
- Foreign matter on the target sensor (paper dust, paper lint)



■ 000A04: JamCode (Main Unit) 0A04

[Symptom/Question]

000A04: JamCode (Main Unit) 0A04

[Remedy/Answer]

Jam Type : Power-on jam

Sensor Name : Writing Judging Sensor

Sensor No. : PS28

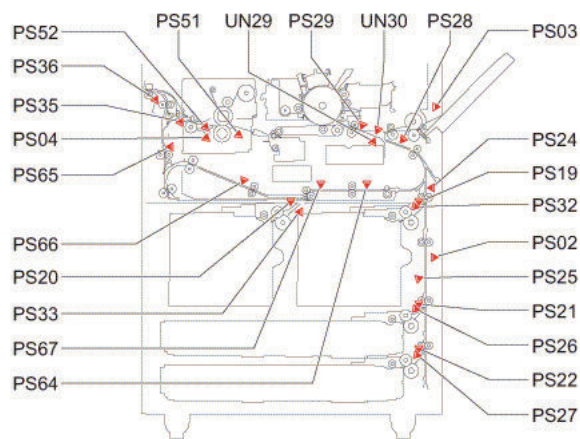
Overview of detection

A power-on jam occurs when a sensor detected ON state at power-on.

I/O: Service Mode > SITUATION > Sensor Check

Check items (in arbitrary order)

- Remaining paper in the machine
- Soiling on the target sensor
- Failure of the target sensor
- Foreign matter on the target sensor (paper dust, paper lint)



■ 000A05: JamCode (Main Unit) 0A05

[Symptom/Question]

000A05: JamCode (Main Unit) 0A05

[Remedy/Answer]

Jam Type : Power-on jam

Sensor Name : Registration Sensor

Sensor No. : PS29

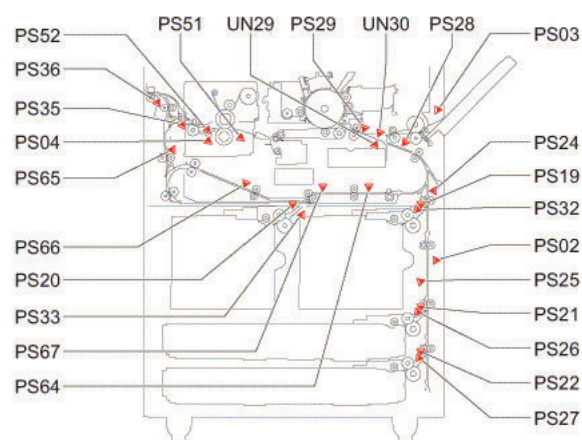
Overview of detection

A power-on jam occurs when a sensor detected ON state at power-on.

I/O: Service Mode > SITUATION > Sensor Check

Check items (in arbitrary order)

- Remaining paper in the machine
- Soiling on the target sensor
- Failure of the target sensor
- Foreign matter on the target sensor (paper dust, paper lint)



■ 000A07: JamCode (Main Unit) 0A07

[Symptom/Question]

000A07: JamCode (Main Unit) 0A07

[Remedy/Answer]

Jam Type : Power-on jam

Sensor Name : Left Deck Pull Out Sensor

Sensor No. : PS33

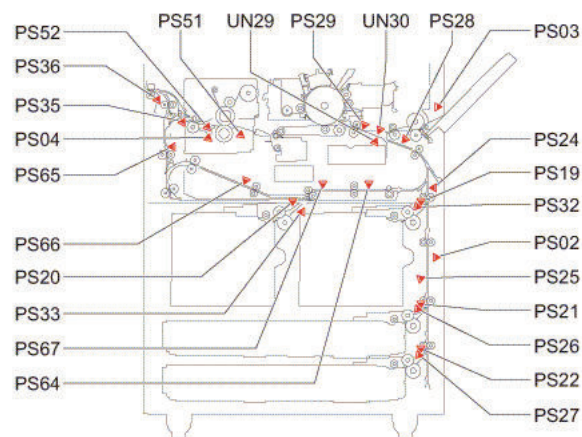
Overview of detection

A power-on jam occurs when a sensor detected ON state at power-on.

I/O: Service Mode > SITUATION > Sensor Check

Check items (in arbitrary order)

- Remaining paper in the machine
- Soiling on the target sensor
- Failure of the target sensor
- Foreign matter on the target sensor (paper dust, paper lint)



■ 000A08: JamCode (Main Unit) 0A08

[Symptom/Question]

000A08: JamCode (Main Unit) 0A08

[Remedy/Answer]

Jam Type : Power-on jam

Sensor Name : Duplex Merging Sensor

Sensor No. : PS67

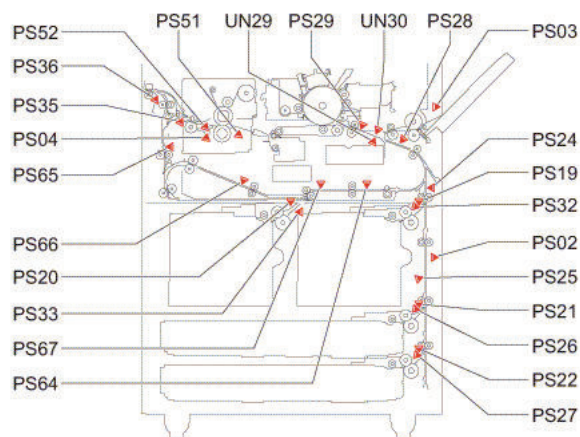
Overview of detection

A power-on jam occurs when a sensor detected ON state at power-on.

I/O: Service Mode > SITUATION > Sensor Check

Check items (in arbitrary order)

- Remaining paper in the machine
- Soiling on the target sensor
- Failure of the target sensor
- Foreign matter on the target sensor (paper dust, paper lint)



■ 000A09: JamCode (Main Unit) 0A09

[Symptom/Question]

000A09: JamCode (Main Unit) 0A09

[Remedy/Answer]

Jam Type : Power-on jam

Sensor Name : Duplex Outlet Sensor

Sensor No. : PS64

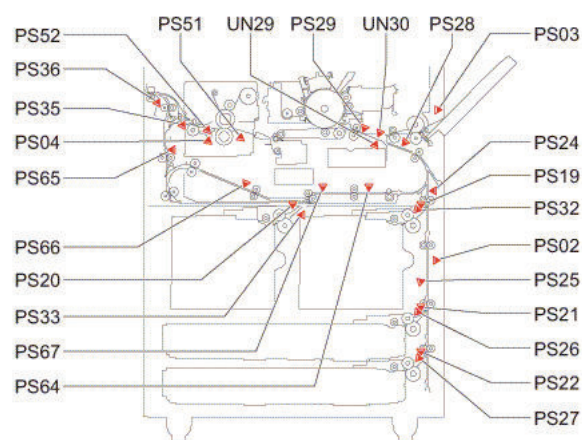
Overview of detection

A power-on jam occurs when a sensor detected ON state at power-on.

I/O: Service Mode > SITUATION > Sensor Check

Check items (in arbitrary order)

- Remaining paper in the machine
- Soiling on the target sensor
- Failure of the target sensor
- Foreign matter on the target sensor (paper dust, paper lint)



■ 000A0B: JamCode (Main Unit) 0A0B

[Symptom/Question]

000A0B: JamCode (Main Unit) 0A0B

[Remedy/Answer]

Jam Type : Power-on jam

Sensor Name : Vertical Path Sensor 3

Sensor No. : PS26

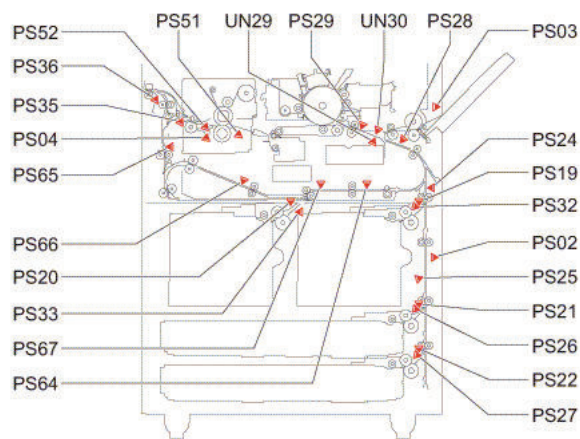
Overview of detection

A power-on jam occurs when a sensor detected ON state at power-on.

I/O: Service Mode > SITUATION > Sensor Check

Check items (in arbitrary order)

- Remaining paper in the machine
- Soiling on the target sensor
- Failure of the target sensor
- Foreign matter on the target sensor (paper dust, paper lint)



■ 000A0C: JamCode (Main Unit) 0A0C

[Symptom/Question]

000A0C: JamCode (Main Unit) 0A0C

[Remedy/Answer]

Jam Type : Power-on jam

Sensor Name : Vertical Path Sensor 2

Sensor No. : PS25

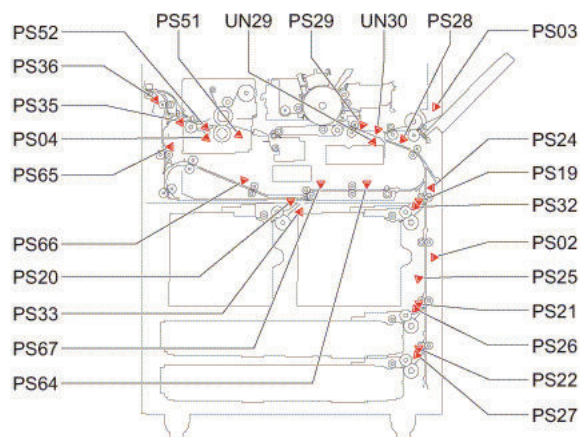
Overview of detection

A power-on jam occurs when a sensor detected ON state at power-on.

I/O: Service Mode > SITUATION > Sensor Check

Check items (in arbitrary order)

- Remaining paper in the machine
- Soiling on the target sensor
- Failure of the target sensor
- Foreign matter on the target sensor (paper dust, paper lint)



■ 000A0E: JamCode (Main Unit) 0A0E

[Symptom/Question]

000A0E: JamCode (Main Unit) 0A0E

[Remedy/Answer]

Jam Type : Power-on jam

Sensor Name : Vertical Path Sensor 4

Sensor No. : PS27

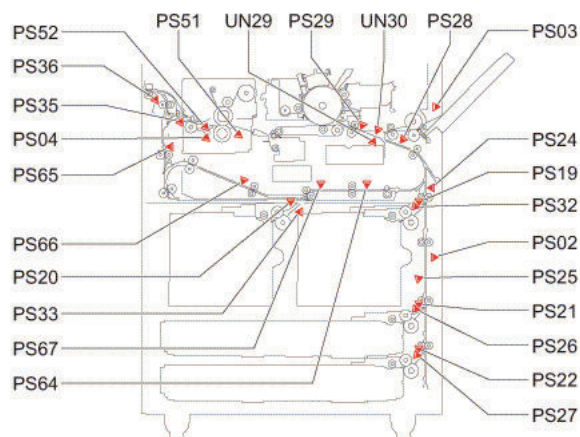
Overview of detection

A power-on jam occurs when a sensor detected ON state at power-on.

I/O: Service Mode > SITUATION > Sensor Check

Check items (in arbitrary order)

- Remaining paper in the machine
- Soiling on the target sensor
- Failure of the target sensor
- Foreign matter on the target sensor (paper dust, paper lint)



■ 000A0F: JamCode (Main Unit) 0A0F

[Symptom/Question]

000A0F: JamCode (Main Unit) 0A0F

[Remedy/Answer]

Jam Type : Power-on jam

Sensor Name : Fixing Entrance Sensor

Sensor No. : PS51

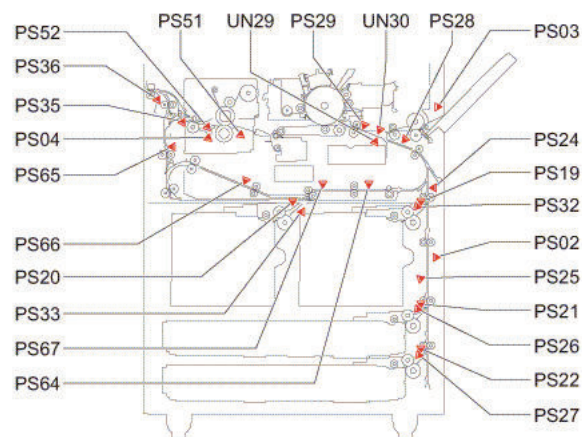
Overview of detection

A power-on jam occurs when a sensor detected ON state at power-on.

I/O: Service Mode > SITUATION > Sensor Check

Check items (in arbitrary order)

- Remaining paper in the machine
- Soiling on the target sensor
- Failure of the target sensor
- Foreign matter on the target sensor (paper dust, paper lint)



■ 000A10: JamCode (Main Unit) 0A10

[Symptom/Question]

000A10: JamCode (Main Unit) 0A10

[Remedy/Answer]

Jam Type : Power-on jam

Sensor Name : Fixing Toenail

Sensor No. : PS4

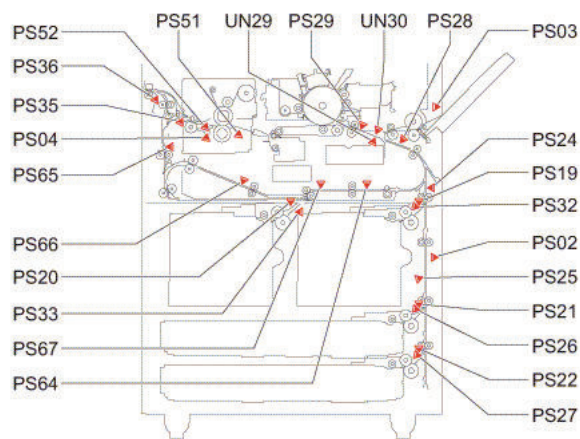
Overview of detection

A power-on jam occurs when a sensor detected ON state at power-on.

I/O: Service Mode > SITUATION > Sensor Check

Check items (in arbitrary order)

- Remaining paper in the machine
- Soiling on the target sensor
- Failure of the target sensor
- Foreign matter on the target sensor (paper dust, paper lint)



■ 000A11: JamCode (Main Unit) 0A11

[Symptom/Question]

000A11: JamCode (Main Unit) 0A11

[Remedy/Answer]

Jam Type : Power-on jam

Sensor Name : Fixing Outlet Sensor

Sensor No. : PS52

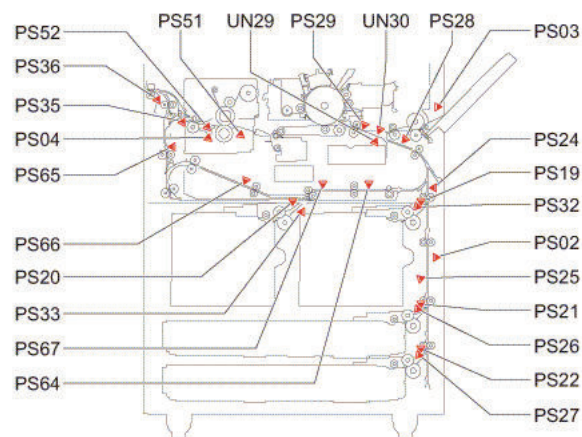
Overview of detection

A power-on jam occurs when a sensor detected ON state at power-on.

I/O: Service Mode > SITUATION > Sensor Check

Check items (in arbitrary order)

- Remaining paper in the machine
- Soiling on the target sensor
- Failure of the target sensor
- Foreign matter on the target sensor (paper dust, paper lint)



■ 000A12: JamCode (Main Unit) 0A12

[Symptom/Question]

000A12: JamCode (Main Unit) 0A12

[Remedy/Answer]

Jam Type : Power-on jam

Sensor Name : Inner Delivery Sensor

Sensor No. : PS35

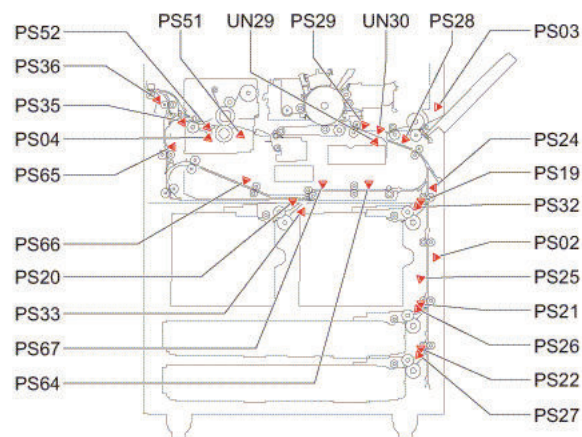
Overview of detection

A power-on jam occurs when a sensor detected ON state at power-on.

I/O: Service Mode > SITUATION > Sensor Check

Check items (in arbitrary order)

- Remaining paper in the machine
- Soiling on the target sensor
- Failure of the target sensor
- Foreign matter on the target sensor (paper dust, paper lint)



■ 000A13: JamCode (Main Unit) 0A13

[Symptom/Question]

000A13: JamCode (Main Unit) 0A13

[Remedy/Answer]

Jam Type : Power-on jam

Sensor Name : Outer Delivery Sensor

Sensor No. : PS36

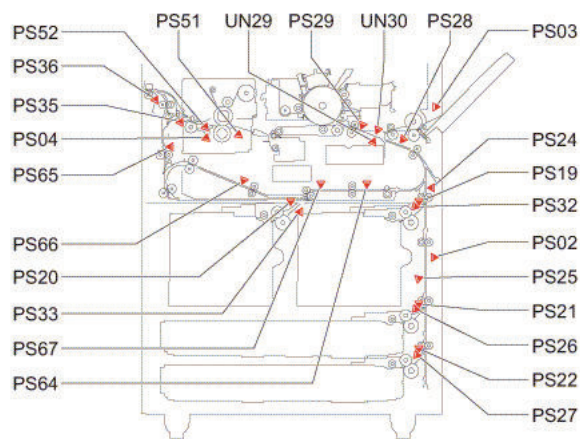
Overview of detection

A power-on jam occurs when a sensor detected ON state at power-on.

I/O: Service Mode > SITUATION > Sensor Check

Check items (in arbitrary order)

- Remaining paper in the machine
- Soiling on the target sensor
- Failure of the target sensor
- Foreign matter on the target sensor (paper dust, paper lint)



■ 000A14: JamCode (Main Unit) 0A14

[Symptom/Question]

000A14: JamCode (Main Unit) 0A14

[Remedy/Answer]

Jam Type : Power-on jam

Sensor Name : Reverse Vertical Path Sensor

Sensor No. : PS65

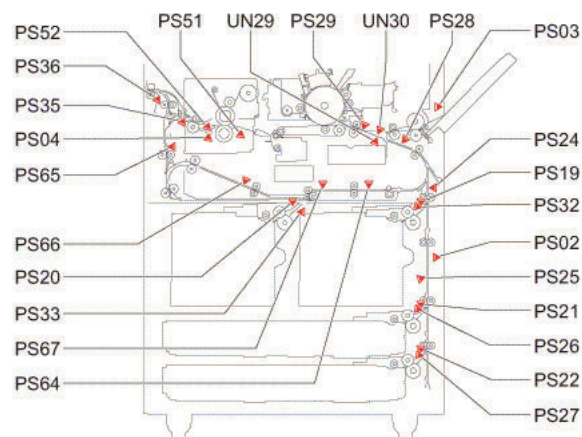
Overview of detection

A power-on jam occurs when a sensor detected ON state at power-on.

I/O: Service Mode > SITUATION > Sensor Check

Check items (in arbitrary order)

- Remaining paper in the machine
- Soiling on the target sensor
- Failure of the target sensor
- Foreign matter on the target sensor (paper dust, paper lint)



■ 000A15: JamCode (Main Unit) 0A15

[Symptom/Question]

000A15: JamCode (Main Unit) 0A15

[Remedy/Answer]

Jam Type : Power-on jam

Sensor Name : Duplex Left Sensor

Sensor No. : PS66

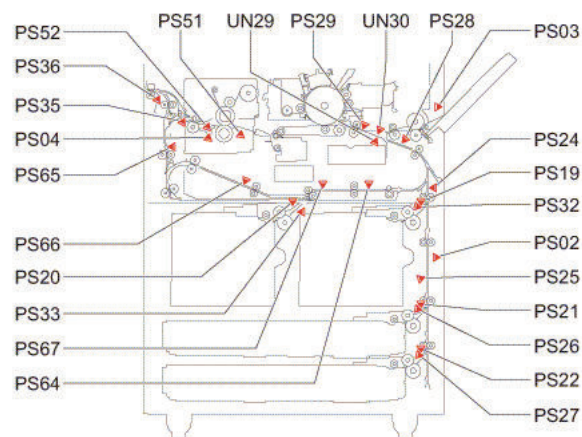
Overview of detection

A power-on jam occurs when a sensor detected ON state at power-on.

I/O: Service Mode > SITUATION > Sensor Check

Check items (in arbitrary order)

- Remaining paper in the machine
- Soiling on the target sensor
- Failure of the target sensor
- Foreign matter on the target sensor (paper dust, paper lint)



■ 000A18: JamCode (POD Deck Lite-C1) 0A18

[Symptom/Question]

000A18: JamCode (POD Deck Lite-C1) 0A18

[Remedy/Answer]

Jam Type : Power-on jam

Sensor Name : Deck pull-out sensor

Sensor No. : SR6

Overview of detection

A power-on jam occurs when a sensor detected ON state at power-on.

I/O: Service Mode > SITUATION > Sensor Check

Check items (in arbitrary order)

- Remaining paper in the machine
- Soiling on the target sensor
- Failure of the target sensor
- Foreign matter on the target sensor (paper dust, paper lint)



■ 000A18: JamCode (Paper Deck Unit-E1) 0A18

[Symptom/Question]

000A18: JamCode (Paper Deck Unit-E1) 0A18

[Remedy/Answer]

Jam Type : Power-on jam

Sensor Name : Deck pull-out sensor

Sensor No. : PS2

Overview of detection

A power-on jam occurs when a sensor detected ON state at power-on.

I/O: Service Mode > SITUATION > Sensor Check

Check items (in arbitrary order)

- Remaining paper in the machine
- Soiling on the target sensor
- Failure of the target sensor
- Foreign matter on the target sensor (paper dust, paper lint)



■ 000B01: JamCode (Main Unit) 0B01

[Symptom/Question]

000B01: JamCode (Main Unit) 0B01

[Remedy/Answer]

Jam Type : Door open jam

Sensor Name : Front cover open/close sensor

Sensor No. : DOOR OP

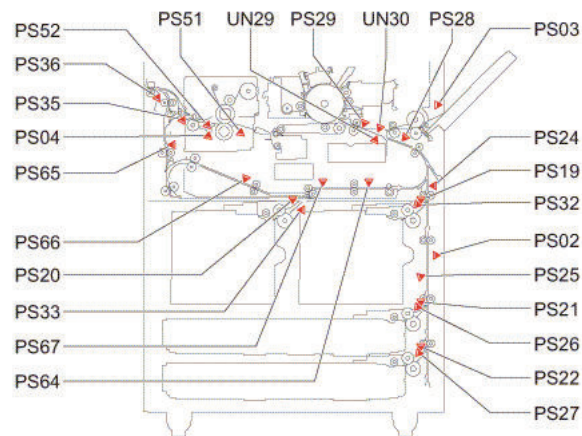
Overview of detection

A door open jam occurs when a sensor detected door open during printing operation.

I/O: Service Mode > SITUATION > Sensor Check

Check items (in arbitrary order)

- Door open during printing



■ 000B02: JamCode (Main Unit) 0B02

[Symptom/Question]

000B02: JamCode (Main Unit) 0B02

[Remedy/Answer]

Jam Type : Door open jam

Sensor Name : Manua cover open/close sensor

Sensor No. : DOOR OP

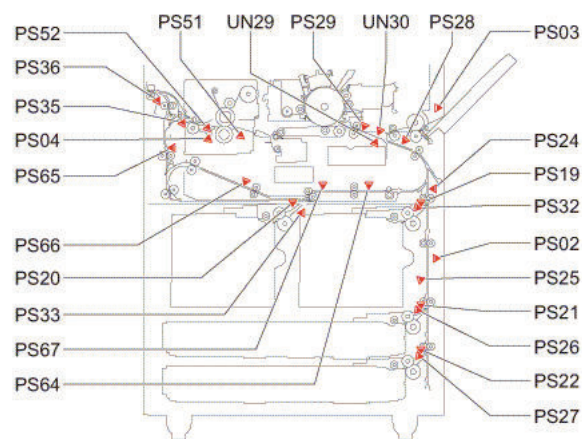
Overview of detection

A door open jam occurs when a sensor detected door open during printing operation.

I/O: Service Mode > SITUATION > Sensor Check

Check items (in arbitrary order)

- Door open during printing



■ 000B03: JamCode (Main Unit) 0B03

[Symptom/Question]

000B03: JamCode (Main Unit) 0B03

[Remedy/Answer]

Jam Type : Door open jam

Sensor Name : Vertical Path Cover Open/Close Sensor

Sensor No. : DOOR OP

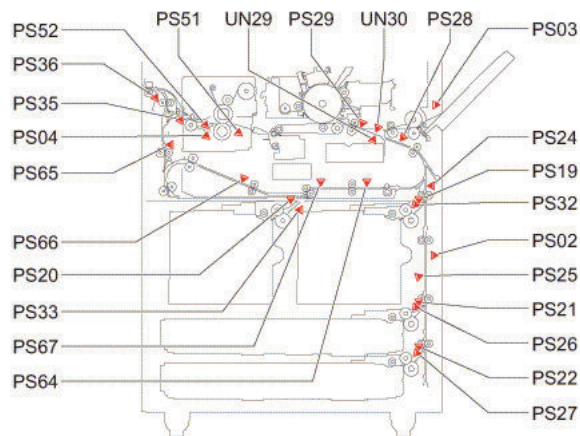
Overview of detection

A door open jam occurs when a sensor detected door open during printing operation.

I/O: Service Mode > SITUATION > Sensor Check

Check items (in arbitrary order)

- Door open during printing



■ 000C10: JamCode (Main Unit) 0C10

[Symptom/Question]

000C10: JamCode (Main Unit) 0C10

[Remedy/Answer]

Jam Type : OTHER

Sensor Name : Fixing Toenail jam

Sensor No. : PS4

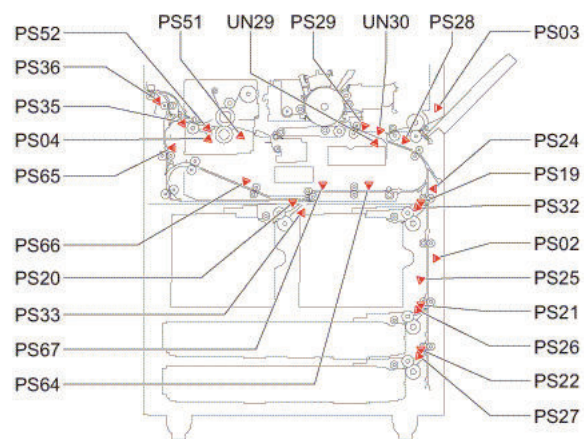
Overview of detection

-

I/O: Service Mode > SITUATION > Sensor Check

Check items (in arbitrary order)

-



■ 000CA1: JamCode (Main Unit) 0CA1

[Symptom/Question]

000CA1: JamCode (Main Unit) 0CA1

[Remedy/Answer]

Jam Type : OTHER

Sensor Name : FeedSts time out jam

Sensor No. : OTHER

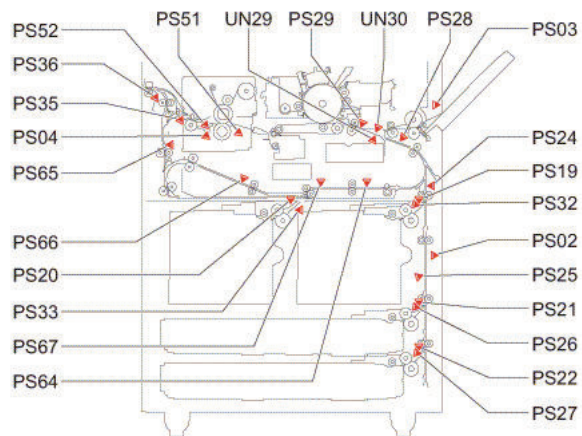
Overview of detection

-

I/O: Service Mode > SITUATION > Sensor Check

Check items (in arbitrary order)

-



■ 000CA2: JamCode (Main Unit) 0CA2

[Symptom/Question]

000CA2: JamCode (Main Unit) 0CA2

[Remedy/Answer]

Jam Type : OTHER

Sensor Name : RefeedStart time out jam

Sensor No. : OTHER

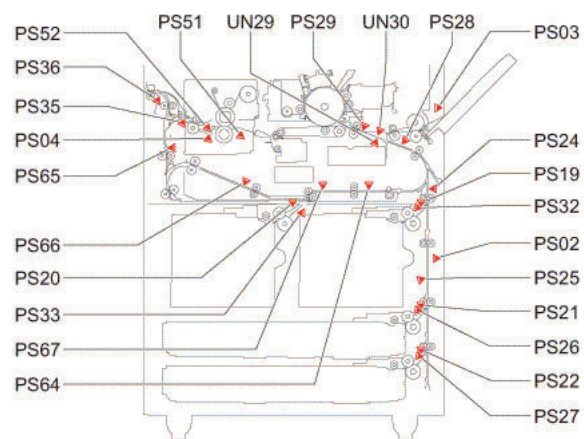
Overview of detection

-

I/O: Service Mode > SITUATION > Sensor Check

Check items (in arbitrary order)

-



■ 000CA3: JamCode (Main Unit) 0CA3

[Symptom/Question]

000CA3: JamCode (Main Unit) 0CA3

[Remedy/Answer]

Jam Type : OTHER

Sensor Name : ImageSet time out jam

Sensor No. : OTHER

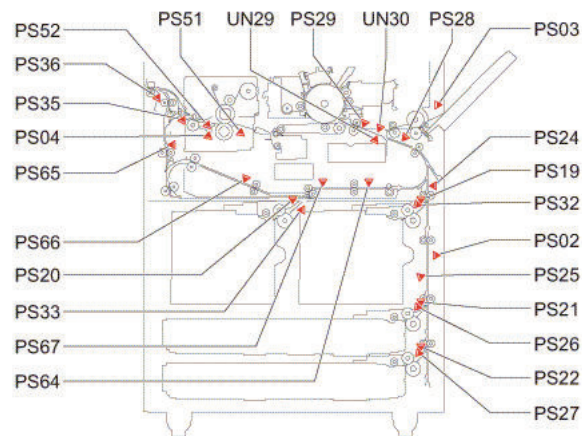
Overview of detection

-

I/O: Service Mode > SITUATION > Sensor Check

Check items (in arbitrary order)

-



■ 000CA4: JamCode (Main Unit) 0CA4

[Symptom/Question]

000CA4: JamCode (Main Unit) 0CA4

[Remedy/Answer]

Jam Type : OTHER

Sensor Name : PageComplete time out jam

Sensor No. : OTHER

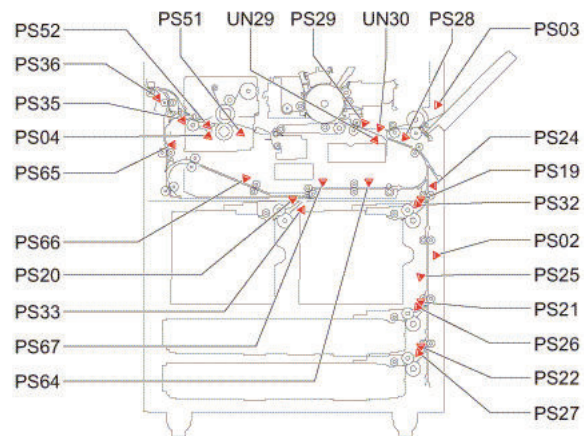
Overview of detection

-

I/O: Service Mode > SITUATION > Sensor Check

Check items (in arbitrary order)

-



■ 000CA5: JamCode (Main Unit) 0CA5

[Symptom/Question]

000CA5: JamCode (Main Unit) 0CA5

[Remedy/Answer]

Jam Type : OTHER

Sensor Name : Fixing temperature control time out jam

Sensor No. : OTHER

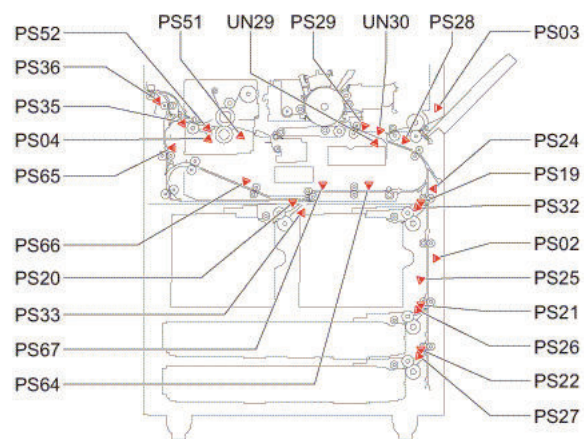
Overview of detection

-

I/O: Service Mode > SITUATION > Sensor Check

Check items (in arbitrary order)

-



■ 000CAF: JamCode (Main Unit) 0CAF

[Symptom/Question]

000CAF: JamCode (Main Unit) 0CAF

[Remedy/Answer]

Jam Type : OTHER

Sensor Name : -

Sensor No. : -

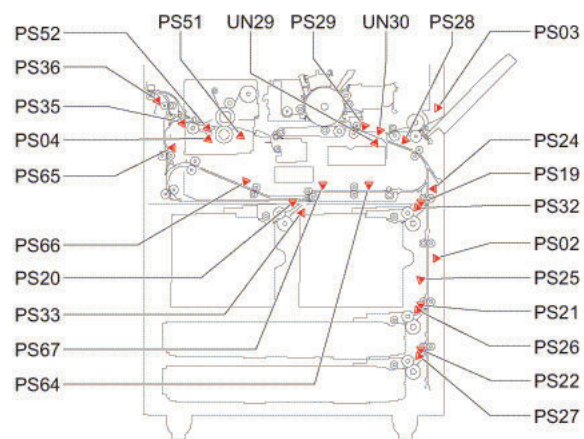
Overview of detection

-

I/O: Service Mode > SITUATION > Sensor Check

Check items (in arbitrary order)

-



■ 000CE0: JamCode (Main Unit) 0CE0

[Symptom/Question]

000CE0: JamCode (Main Unit) 0CE0

[Remedy/Answer]

Jam Type : Sequence jam

Sensor Name : -

Sensor No. : -

Overview of detection

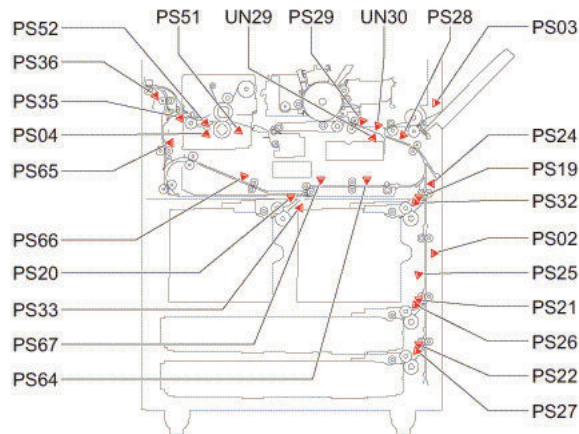
A sequence jam occurs when there was an error in sensor detection signal at printing operation sequence.

Since the jam may occur due to sporadic noise with software of each equipment or communication line (interruption of communication), failure of the part is not the cause of the jam. After the jam is removed, the machine works.

I/O: Service Mode > SITUATION > Sensor Check

Check items (in arbitrary order)

- Opening/closing of the door
- Turning OFF and then ON the power
- Error near the target sensor (soiling/displacement/failure of the sensor, error in harness/open circuit of harness, soiling (grease)/deterioration/failure of a drive motor, or soiling (paper dust)/deterioration/failure of a drive roller)



■ 000CF1: JamCode (Main Unit) 0CF1

[Symptom/Question]

000CF1: JamCode (Main Unit) 0CF1

[Remedy/Answer]

Jam Type : OTHER

Sensor Name : Retry jam

Sensor No. : OTHER

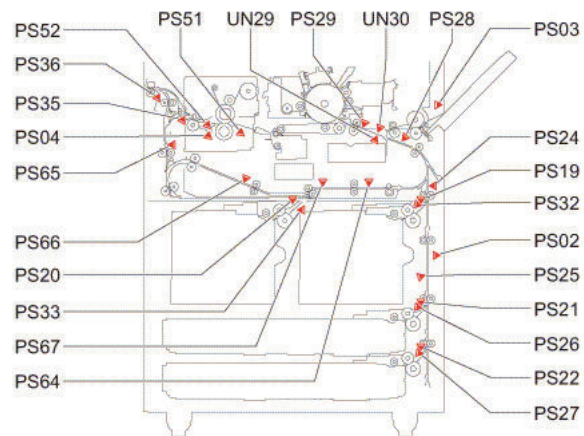
Overview of detection

-

I/O: Service Mode > SITUATION > Sensor Check

Check items (in arbitrary order)

-



■ 000D91: JamCode (Main Unit) 0D91

[Symptom/Question]

000D91: JamCode (Main Unit) 0D91

[Remedy/Answer]

Jam Type : OTHER

Sensor Name : Different Size jam(short paper length)

Sensor No. : OTHER

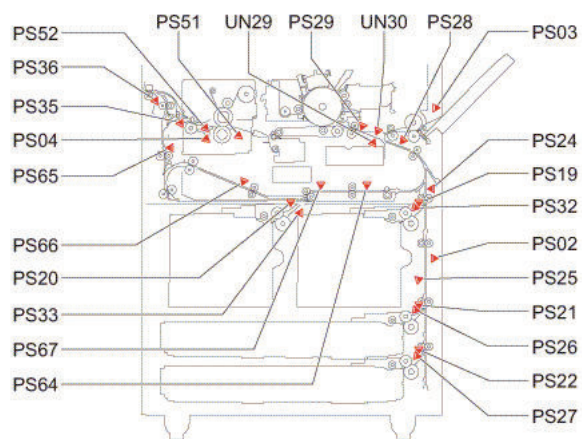
Overview of detection

-

I/O: Service Mode > SITUATION > Sensor Check

Check items (in arbitrary order)

-



■ 00AA01: JamCode (Main Unit) AA01

[Symptom/Question]

00AA01: JamCode (Main Unit) AA01

[Remedy/Answer]

Jam Type : Forcible stop of paper feed

Sensor Name : -

Sensor No. : -

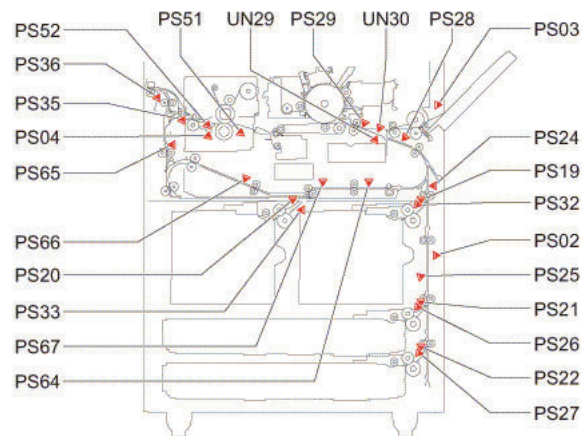
Overview of detection

It occurs when a sheet of paper stops at the position specified in service mode.

I/O: Service Mode > SITUATION > Sensor Check

Check items (in arbitrary order)

- Using at problem analysis.



■ 00AA02: JamCode (Main Unit) AA02

[Symptom/Question]

00AA02: JamCode (Main Unit) AA02

[Remedy/Answer]

Jam Type : Forcible stop of paper feed

Sensor Name : -

Sensor No. : -

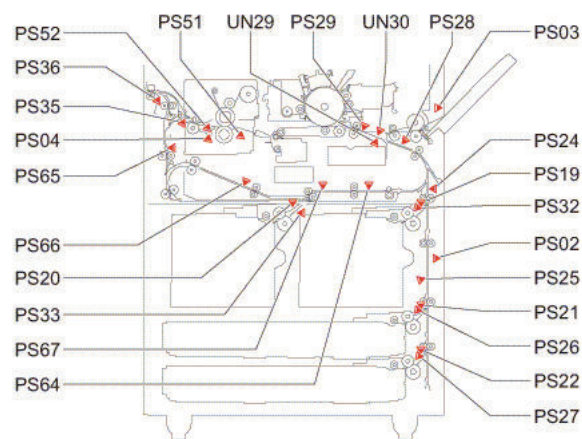
Overview of detection

It occurs when a sheet of paper stops at the position specified in service mode.

I/O: Service Mode > SITUATION > Sensor Check

Check items (in arbitrary order)

- Using at problem analysis.



■ 00AA03: JamCode (Main Unit) AA03

[Symptom/Question]

00AA03: JamCode (Main Unit) AA03

[Remedy/Answer]

Jam Type : Forcible stop of paper feed

Sensor Name : -

Sensor No. : -

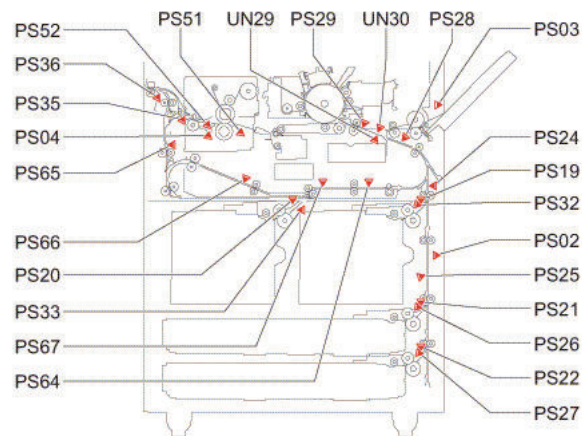
Overview of detection

It occurs when a sheet of paper stops at the position specified in service mode.

I/O: Service Mode > SITUATION > Sensor Check

Check items (in arbitrary order)

- Using at problem analysis.



■ 00AA04: JamCode (Main Unit) AA04

[Symptom/Question]

00AA04: JamCode (Main Unit) AA04

[Remedy/Answer]

Jam Type : Forcible stop of paper feed

Sensor Name : -

Sensor No. : -

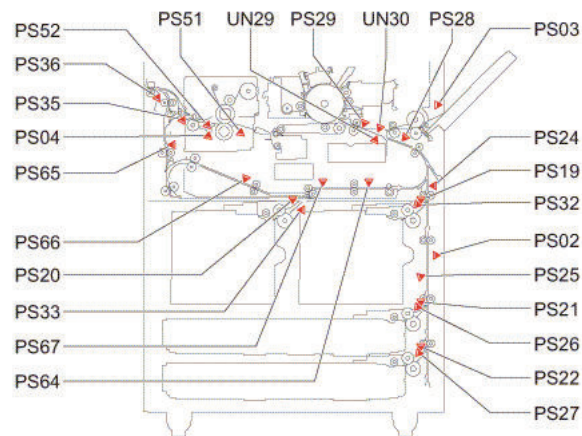
Overview of detection

It occurs when a sheet of paper stops at the position specified in service mode.

I/O: Service Mode > SITUATION > Sensor Check

Check items (in arbitrary order)

- Using at problem analysis.



■ 00AA05: JamCode (Main Unit) AA05

[Symptom/Question]

00AA05: JamCode (Main Unit) AA05

[Remedy/Answer]

Jam Type : Forcible stop of paper feed

Sensor Name : -

Sensor No. : -

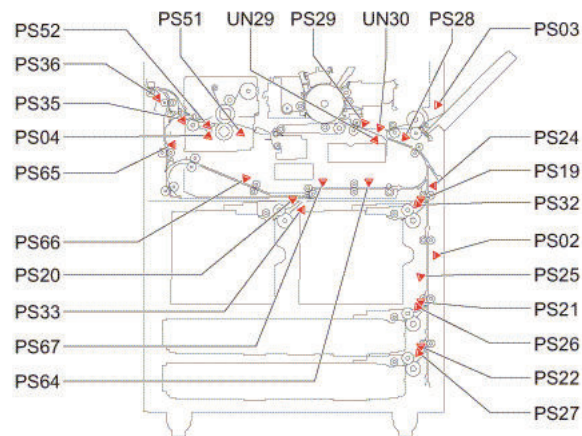
Overview of detection

It occurs when a sheet of paper stops at the position specified in service mode.

I/O: Service Mode > SITUATION > Sensor Check

Check items (in arbitrary order)

- Using at problem analysis.



■ 00AA06: JamCode (Main Unit) AA06

[Symptom/Question]

00AA06: JamCode (Main Unit) AA06

[Remedy/Answer]

Jam Type : Forcible stop of paper feed

Sensor Name : -

Sensor No. : -

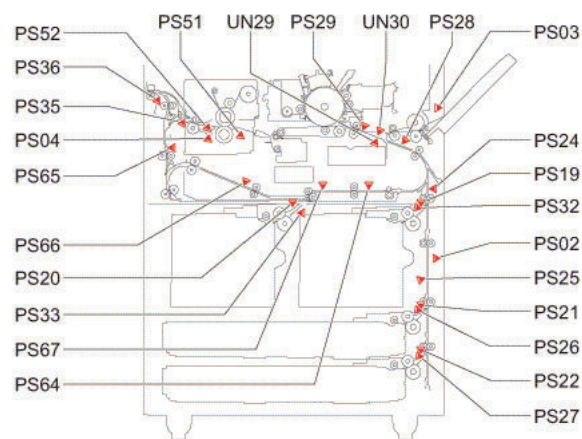
Overview of detection

It occurs when a sheet of paper stops at the position specified in service mode.

I/O: Service Mode > SITUATION > Sensor Check

Check items (in arbitrary order)

- Using at problem analysis.



■ 00AA07: JamCode (Main Unit) AA07

[Symptom/Question]

00AA07: JamCode (Main Unit) AA07

[Remedy/Answer]

Jam Type : Forcible stop of paper feed

Sensor Name : -

Sensor No. : -

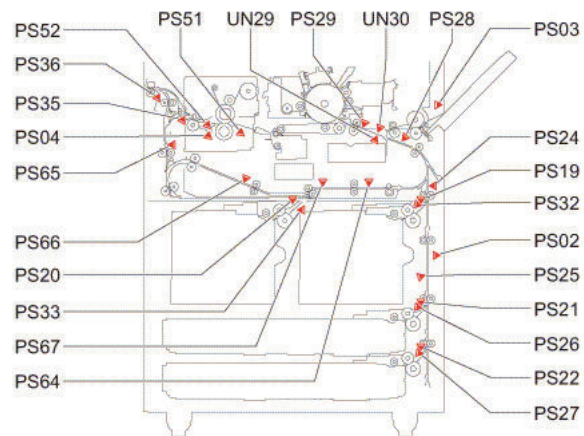
Overview of detection

It occurs when a sheet of paper stops at the position specified in service mode.

I/O: Service Mode > SITUATION > Sensor Check

Check items (in arbitrary order)

- Using at problem analysis.



■ 00AA08: JamCode (Main Unit) AA08

[Symptom/Question]

00AA08: JamCode (Main Unit) AA08

[Remedy/Answer]

Jam Type : Forcible stop of paper feed

Sensor Name : -

Sensor No. : -

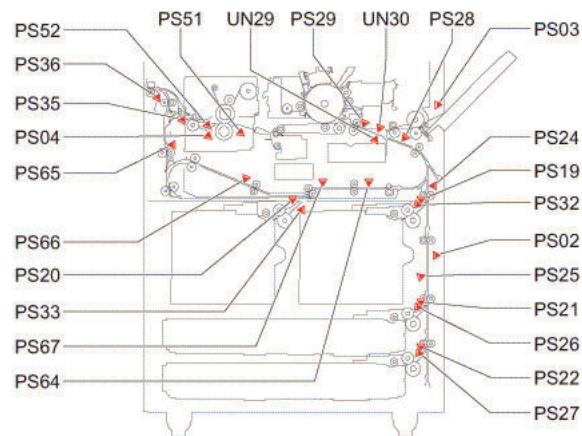
Overview of detection

It occurs when a sheet of paper stops at the position specified in service mode.

I/O: Service Mode > SITUATION > Sensor Check

Check items (in arbitrary order)

- Using at problem analysis.



■ 00AA20: JamCode (Main Unit) AA20

[Symptom/Question]

00AA20: JamCode (Main Unit) AA20

[Remedy/Answer]

Jam Type : Forcible stop of paper feed

Sensor Name : -

Sensor No. : -

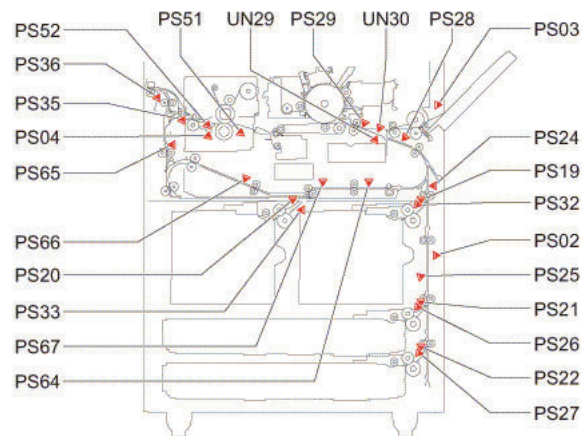
Overview of detection

It occurs when a sheet of paper stops at the position specified in service mode.

I/O: Service Mode > SITUATION > Sensor Check

Check items (in arbitrary order)

- Using at problem analysis.



■ 00AA21: JamCode (Main Unit) AA21

[Symptom/Question]

00AA21: JamCode (Main Unit) AA21

[Remedy/Answer]

Jam Type : Forcible stop of paper feed

Sensor Name : -

Sensor No. : -

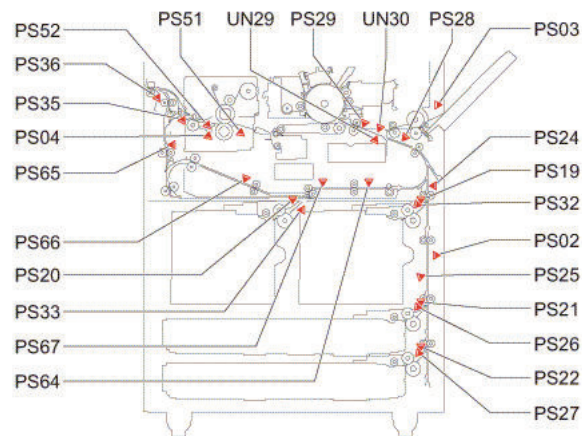
Overview of detection

It occurs when a sheet of paper stops at the position specified in service mode.

I/O: Service Mode > SITUATION > Sensor Check

Check items (in arbitrary order)

- Using at problem analysis.



■ 00AA22: JamCode (Main Unit) AA22

[Symptom/Question]

00AA22: JamCode (Main Unit) AA22

[Remedy/Answer]

Jam Type : Forcible stop of paper feed

Sensor Name : -

Sensor No. : -

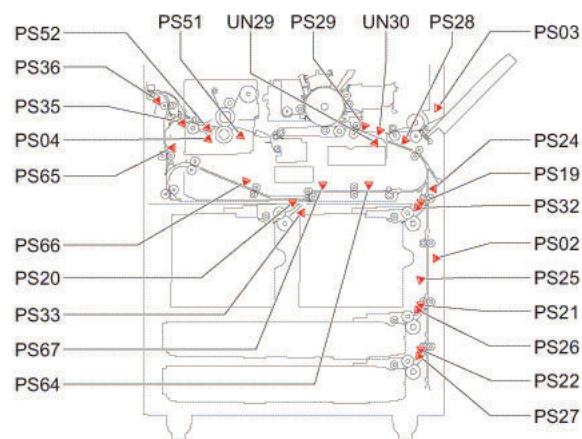
Overview of detection

It occurs when a sheet of paper stops at the position specified in service mode.

I/O: Service Mode > SITUATION > Sensor Check

Check items (in arbitrary order)

- Using at problem analysis.



■ 00AA23: JamCode (Main Unit) AA23

[Symptom/Question]

00AA23: JamCode (Main Unit) AA23

[Remedy/Answer]

Jam Type : Forcible stop of paper feed

Sensor Name : -

Sensor No. : -

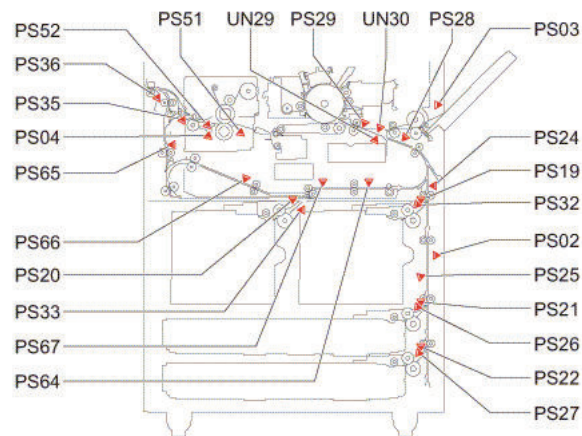
Overview of detection

It occurs when a sheet of paper stops at the position specified in service mode.

I/O: Service Mode > SITUATION > Sensor Check

Check items (in arbitrary order)

- Using at problem analysis.



■ 00AA30: JamCode (Main Unit) AA30

[Symptom/Question]

00AA30: JamCode (Main Unit) AA30

[Remedy/Answer]

Jam Type : Forcible stop of paper feed

Sensor Name : -

Sensor No. : -

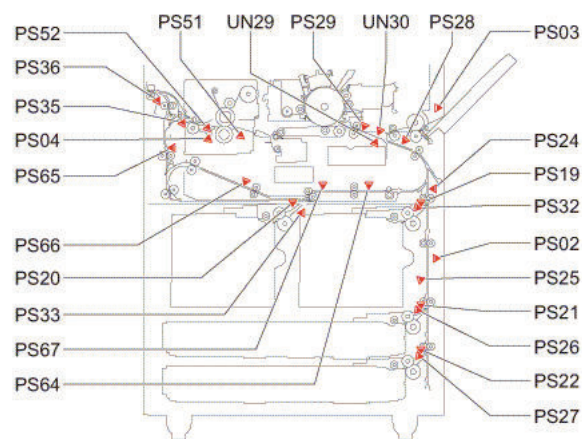
Overview of detection

It occurs when a sheet of paper stops at the position specified in service mode.

I/O: Service Mode > SITUATION > Sensor Check

Check items (in arbitrary order)

- Using at problem analysis.



■ 00AA31: JamCode (Main Unit) AA31

[Symptom/Question]

00AA31: JamCode (Main Unit) AA31

[Remedy/Answer]

Jam Type : Forcible stop of paper feed

Sensor Name : -

Sensor No. : -

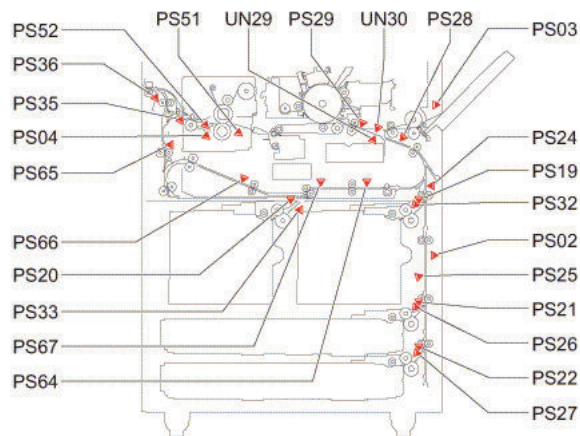
Overview of detection

It occurs when a sheet of paper stops at the position specified in service mode.

I/O: Service Mode > SITUATION > Sensor Check

Check items (in arbitrary order)

- Using at problem analysis.



■ 00AA40: JamCode (Main Unit) AA40

[Symptom/Question]

00AA40: JamCode (Main Unit) AA40

[Remedy/Answer]

Jam Type : Forcible stop of paper feed

Sensor Name : -

Sensor No. : -

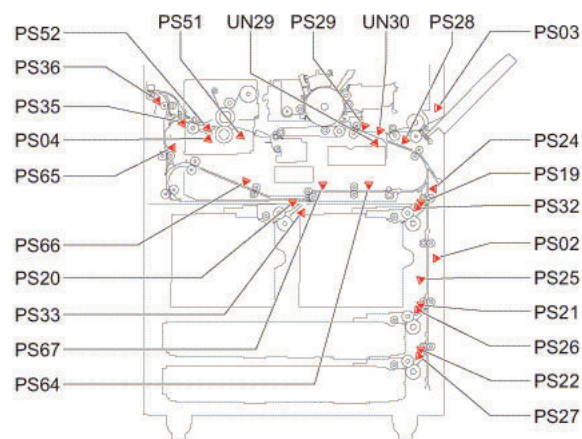
Overview of detection

It occurs when a sheet of paper stops at the position specified in service mode.

I/O: Service Mode > SITUATION > Sensor Check

Check items (in arbitrary order)

- Using at problem analysis.



■ 00AA41: JamCode (Main Unit) AA41

[Symptom/Question]

00AA41: JamCode (Main Unit) AA41

[Remedy/Answer]

Jam Type : Forcible stop of paper feed

Sensor Name : -

Sensor No. : -

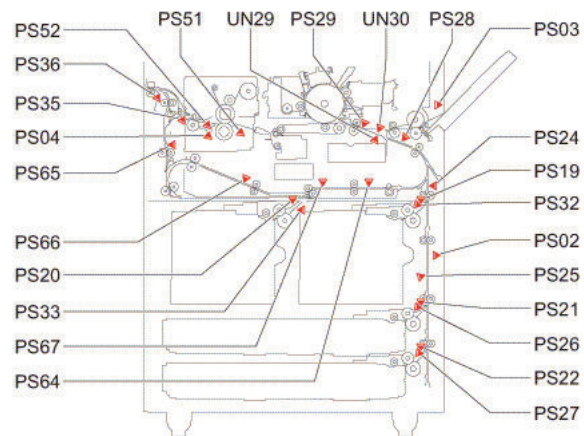
Overview of detection

It occurs when a sheet of paper stops at the position specified in service mode.

I/O: Service Mode > SITUATION > Sensor Check

Check items (in arbitrary order)

- Using at problem analysis.



■ 00AA70: JamCode (Main Unit) AA70

[Symptom/Question]

00AA70: JamCode (Main Unit) AA70

[Remedy/Answer]

Jam Type : Forcible stop of paper feed

Sensor Name : -

Sensor No. : -

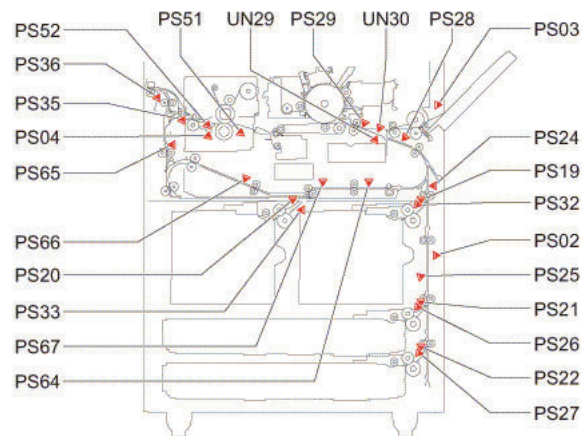
Overview of detection

It occurs when a sheet of paper stops at the position specified in service mode.

I/O: Service Mode > SITUATION > Sensor Check

Check items (in arbitrary order)

- Using at problem analysis.



■ 00AA71: JamCode (Main Unit) AA71

[Symptom/Question]

00AA71: JamCode (Main Unit) AA71

[Remedy/Answer]

Jam Type : Forcible stop of paper feed

Sensor Name : -

Sensor No. : -

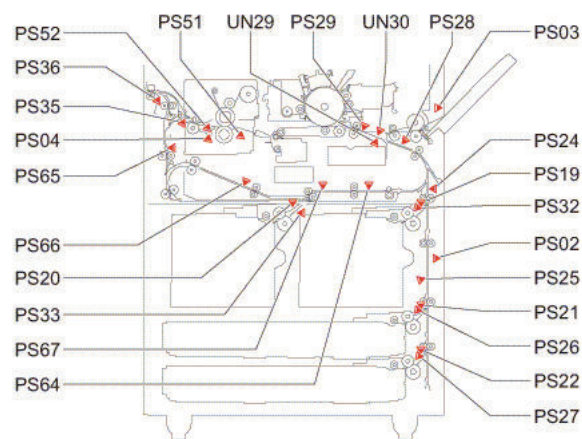
Overview of detection

It occurs when a sheet of paper stops at the position specified in service mode.

I/O: Service Mode > SITUATION > Sensor Check

Check items (in arbitrary order)

- Using at problem analysis.



■ 00AA72: JamCode (Main Unit) AA72

[Symptom/Question]

00AA72: JamCode (Main Unit) AA72

[Remedy/Answer]

Jam Type : Forcible stop of paper feed

Sensor Name : -

Sensor No. : -

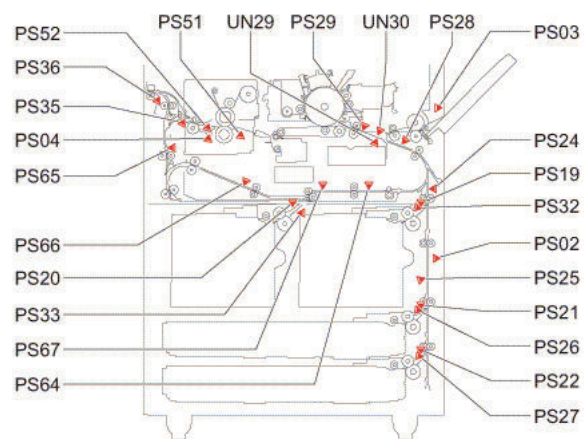
Overview of detection

It occurs when a sheet of paper stops at the position specified in service mode.

I/O: Service Mode > SITUATION > Sensor Check

Check items (in arbitrary order)

- Using at problem analysis.



■ 00AA73: JamCode (Main Unit) AA73

[Symptom/Question]

00AA73: JamCode (Main Unit) AA73

[Remedy/Answer]

Jam Type : Forcible stop of paper feed

Sensor Name : -

Sensor No. : -

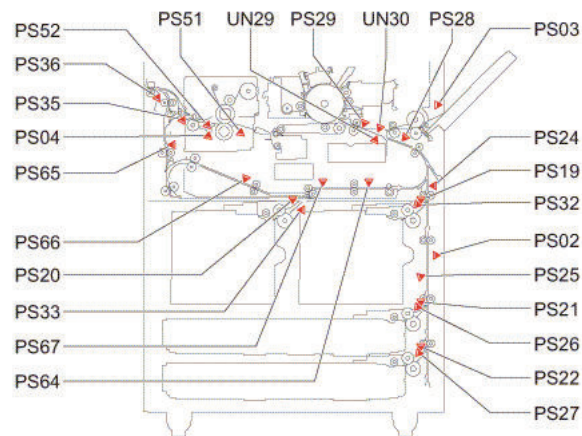
Overview of detection

It occurs when a sheet of paper stops at the position specified in service mode.

I/O: Service Mode > SITUATION > Sensor Check

Check items (in arbitrary order)

- Using at problem analysis.



■ 00AA74: JamCode (Main Unit) AA74

[Symptom/Question]

00AA74: JamCode (Main Unit) AA74

[Remedy/Answer]

Jam Type : Forcible stop of paper feed

Sensor Name : -

Sensor No. : -

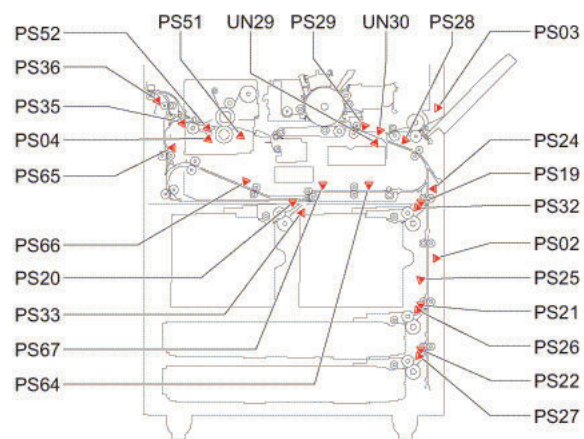
Overview of detection

It occurs when a sheet of paper stops at the position specified in service mode.

I/O: Service Mode > SITUATION > Sensor Check

Check items (in arbitrary order)

- Using at problem analysis.



■ 00AA75: JamCode (Main Unit) AA75

[Symptom/Question]

00AA75: JamCode (Main Unit) AA75

[Remedy/Answer]

Jam Type : Forcible stop of paper feed

Sensor Name : -

Sensor No. : -

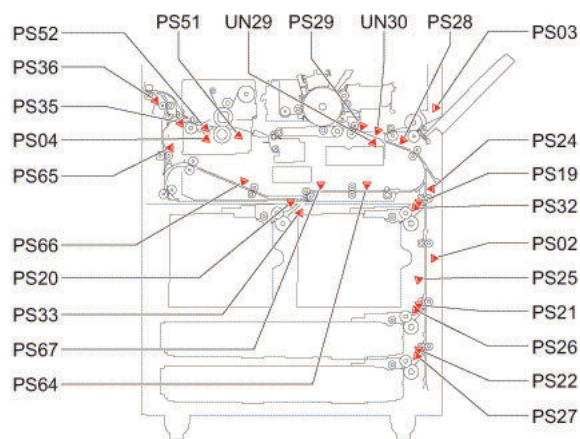
Overview of detection

It occurs when a sheet of paper stops at the position specified in service mode.

I/O: Service Mode > SITUATION > Sensor Check

Check items (in arbitrary order)

- Using at problem analysis.



■ 00AA76: JamCode (Main Unit) AA76

[Symptom/Question]

00AA76: JamCode (Main Unit) AA76

[Remedy/Answer]

Jam Type : Forcible stop of paper feed

Sensor Name : -

Sensor No. : -

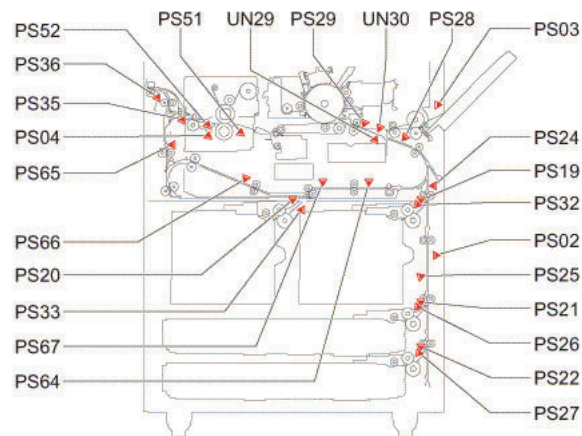
Overview of detection

It occurs when a sheet of paper stops at the position specified in service mode.

I/O: Service Mode > SITUATION > Sensor Check

Check items (in arbitrary order)

- Using at problem analysis.



■ 00AA99: JamCode (Main Unit) AA99

[Symptom/Question]

00AA99: JamCode (Main Unit) AA99

[Remedy/Answer]

Jam Type : Forcible stop of paper feed

Sensor Name : -

Sensor No. : -

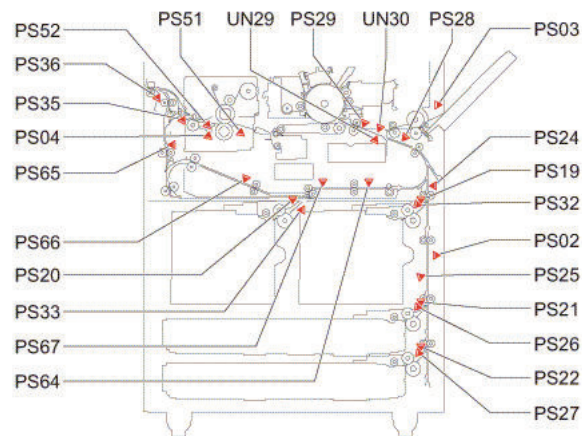
Overview of detection

It occurs when a sheet of paper stops at the position specified in service mode.

I/O: Service Mode > SITUATION > Sensor Check

Check items (in arbitrary order)

- Using at problem analysis.



■ 010003: JamCode (ADF) 0003

[Symptom/Question]

010003: JamCode (ADF) 0003

[Remedy/Answer]

Jam Type : Delay jam

Sensor Name : Post-separation Sensor

Sensor No. : PS402

Overview of detection

A delay jam occurs when a sensor was not turned ON although a specified period of time had passed after the start of detection by the sensor.

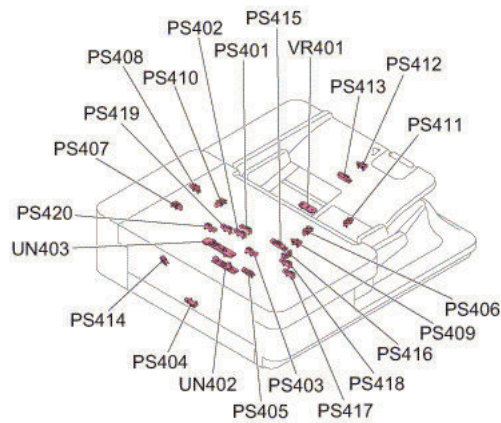
I/O: Service Mode > SITUATION > Sensor Check

Check items (in arbitrary order)

- Remaining paper at the upstream of the target sensor
- Soiling on the target sensor

Displacement of the target sensor position

- Failure of the target sensor
- Soiling (grease)/deterioration/Failure of a drive motor located upstream of the target sensor
- Soiling (paper dust)/deterioration/Failure of a drive roller located upstream of the target sensor



■ 010004: JamCode (ADF) 0004

[Symptom/Question]

010004: JamCode (ADF) 0004

[Remedy/Answer]

Jam Type : Stationary jam

Sensor Name : Post-separation Sensor

Sensor No. : PS402

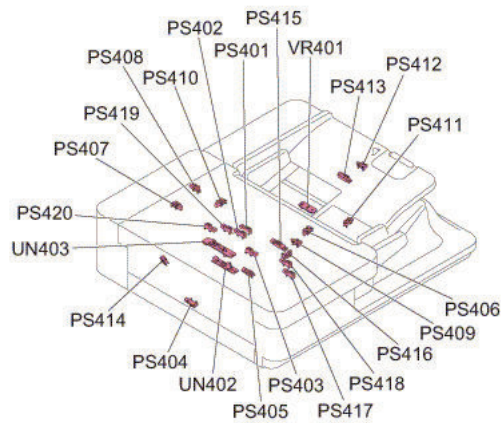
Overview of detection

A stationary jam occurs when a sensor was not turned OFF although a specified period of time had passed after the sensor was turned ON.

I/O: Service Mode > SITUATION > Sensor Check

Check items (in arbitrary order)

- Remaining paper near the target sensor
- Soiling on the target sensor
- Displacement of the target sensor position
- Failure of the target sensor
- Soiling (grease)/deterioration/failure of a drive motor located upstream of the target sensor
- Soiling (paper dust)/deterioration/failure of a drive roller located upstream of the target sensor



■ 010005: JamCode (ADF) 0005

[Symptom/Question]

010005: JamCode (ADF) 0005

[Remedy/Answer]

Jam Type : Delay jam

Sensor Name : Post-pullout Sensor

Sensor No. : PS403

Overview of detection

A delay jam occurs when a sensor was not turned ON although a specified period of time had passed after the start of detection by the sensor.

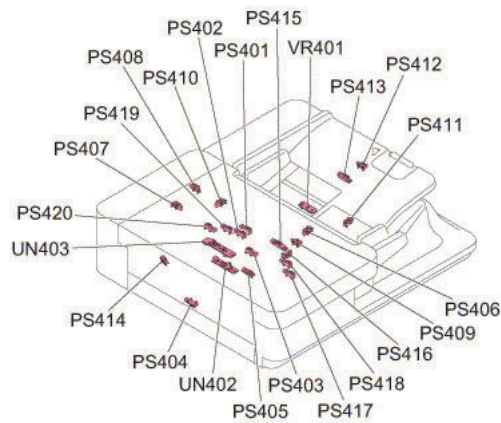
I/O: Service Mode > SITUATION > Sensor Check

Check items (in arbitrary order)

- Remaining paper at the upstream of the target sensor
- Soiling on the target sensor

Displacement of the target sensor position

- Failure of the target sensor
- Soiling (grease)/deterioration/Failure of a drive motor located upstream of the target sensor
- Soiling (paper dust)/deterioration/Failure of a drive roller located upstream of the target sensor



■ 010006: JamCode (ADF) 0006

[Symptom/Question]

010006: JamCode (ADF) 0006

[Remedy/Answer]

Jam Type : Stationary jam

Sensor Name : Post-pullout Sensor

Sensor No. : PS403

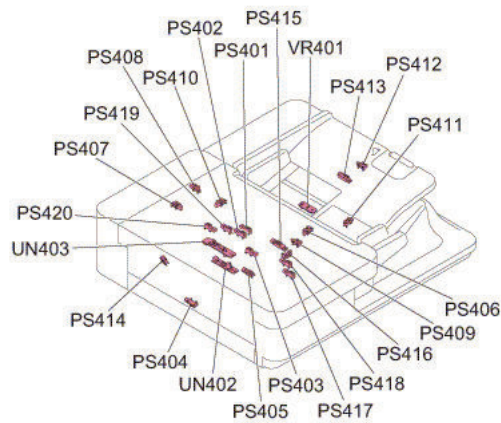
Overview of detection

A stationary jam occurs when a sensor was not turned OFF although a specified period of time had passed after the sensor was turned ON.

I/O: Service Mode > SITUATION > Sensor Check

Check items (in arbitrary order)

- Remaining paper near the target sensor
- Soiling on the target sensor
- Displacement of the target sensor position
- Failure of the target sensor
- Soiling (grease)/deterioration/failure of a drive motor located upstream of the target sensor
- Soiling (paper dust)/deterioration/failure of a drive roller located upstream of the target sensor



■ 010007: JamCode (ADF) 0007

[Symptom/Question]

010007: JamCode (ADF) 0007

[Remedy/Answer]

Jam Type : Delay jam

Sensor Name : Lead Sensor

Sensor No. : PS404

Overview of detection

A delay jam occurs when a sensor was not turned ON although a specified period of time had passed after the start of detection by the sensor.

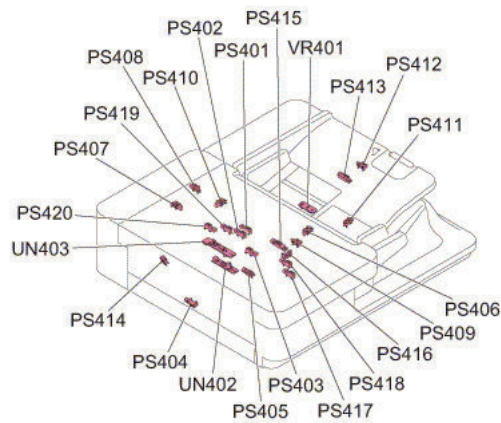
I/O: Service Mode > SITUATION > Sensor Check

Check items (in arbitrary order)

- Remaining paper at the upstream of the target sensor
- Soiling on the target sensor

Displacement of the target sensor position

- Failure of the target sensor
- Soiling (grease)/deterioration/Failure of a drive motor located upstream of the target sensor
- Soiling (paper dust)/deterioration/Failure of a drive roller located upstream of the target sensor



■ 010008: JamCode (ADF) 0008

[Symptom/Question]

010008: JamCode (ADF) 0008

[Remedy/Answer]

Jam Type : Stationary jam

Sensor Name : Lead Sensor

Sensor No. : PS404

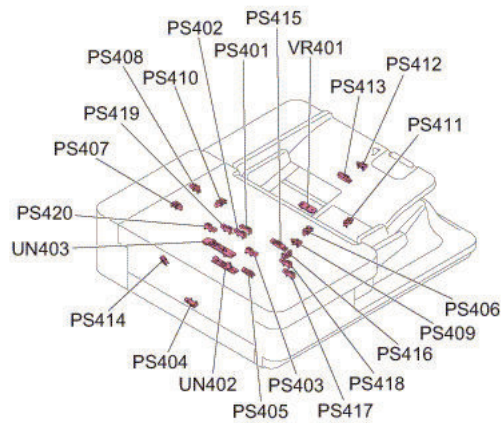
Overview of detection

A stationary jam occurs when a sensor was not turned OFF although a specified period of time had passed after the sensor was turned ON.

I/O: Service Mode > SITUATION > Sensor Check

Check items (in arbitrary order)

- Remaining paper near the target sensor
- Soiling on the target sensor
- Displacement of the target sensor position
- Failure of the target sensor
- Soiling (grease)/deterioration/failure of a drive motor located upstream of the target sensor
- Soiling (paper dust)/deterioration/failure of a drive roller located upstream of the target sensor



■ 010009: JamCode (ADF) 0009

[Symptom/Question]

010009: JamCode (ADF) 0009

[Remedy/Answer]

Jam Type : Delay jam

Sensor Name : Delivery Sensor

Sensor No. : PS405

Overview of detection

A delay jam occurs when a sensor was not turned ON although a specified period of time had passed after the start of detection by the sensor.

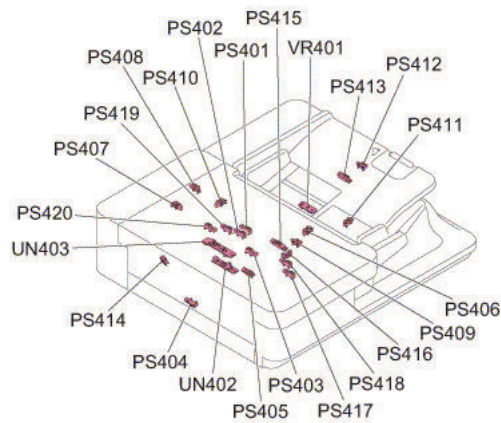
I/O: Service Mode > SITUATION > Sensor Check

Check items (in arbitrary order)

- Remaining paper at the upstream of the target sensor
- Soiling on the target sensor

Displacement of the target sensor position

- Failure of the target sensor
- Soiling (grease)/deterioration/Failure of a drive motor located upstream of the target sensor
- Soiling (paper dust)/deterioration/Failure of a drive roller located upstream of the target sensor



■ 010010: JamCode (ADF) 0010

[Symptom/Question]

010010: JamCode (ADF) 0010

[Remedy/Answer]

Jam Type : Stationary jam

Sensor Name : Delivery Sensor

Sensor No. : PS405

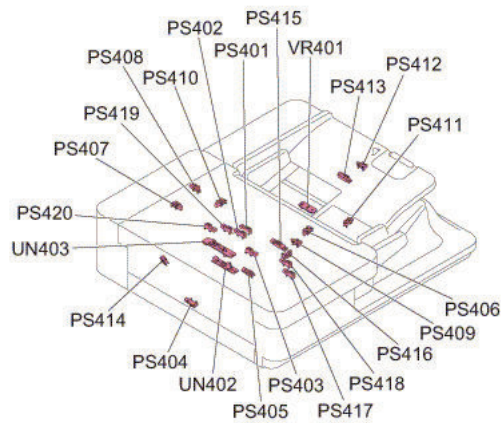
Overview of detection

A stationary jam occurs when a sensor was not turned OFF although a specified period of time had passed after the sensor was turned ON.

I/O: Service Mode > SITUATION > Sensor Check

Check items (in arbitrary order)

- Remaining paper near the target sensor
- Soiling on the target sensor
- Displacement of the target sensor position
- Failure of the target sensor
- Soiling (grease)/deterioration/failure of a drive motor located upstream of the target sensor
- Soiling (paper dust)/deterioration/failure of a drive roller located upstream of the target sensor



■ 010015: JamCode (ADF) 0015

[Symptom/Question]

010015: JamCode (ADF) 0015

[Remedy/Answer]

Jam Type : OTHER

Sensor Name : Skew Detection Sensor (Large, Front)

Skew Detection Sensor (Small, Front)

Skew Detection Sensor (Small, Rear)

Skew Detection Sensor (Large, Rear)

Sensor No. : PS417,PS418,PS419,PS420

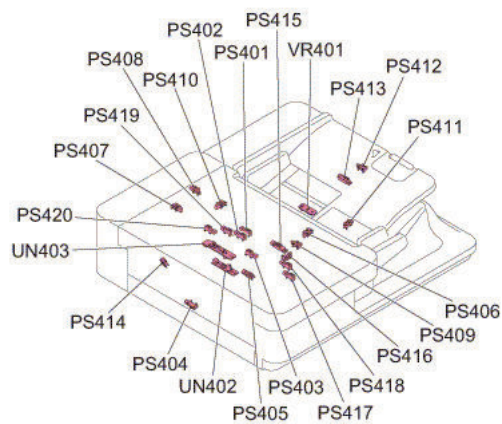
Overview of detection

-

I/O: Service Mode > SITUATION > Sensor Check

Check items (in arbitrary order)

-



■ 010020: JamCode (ADF) 0020

[Symptom/Question]

010020: JamCode (ADF) 0020

[Remedy/Answer]

Jam Type : Double Feed

Sensor Name : Double Feed Sensor PCB (transmission/reception)

Sensor No. : UN402,UN403

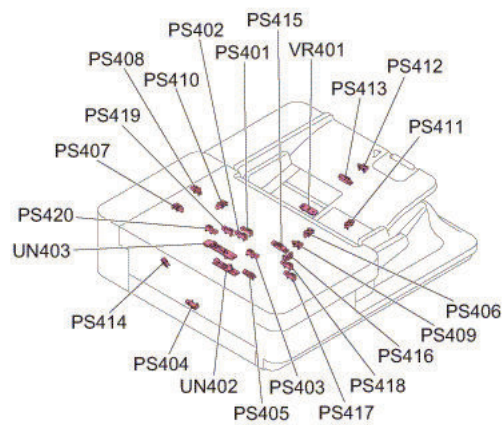
Overview of detection

-

I/O: Service Mode > SITUATION > Sensor Check

Check items (in arbitrary order)

-



■ 010021: JamCode (ADF) 0021

[Symptom/Question]

010021: JamCode (ADF) 0021

[Remedy/Answer]

Jam Type : OTHER

Sensor Name : Double Feed Sensor PCB (transmission/reception)

Sensor No. : UN402,UN403

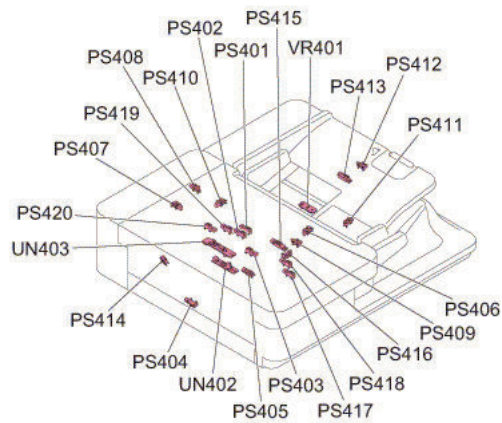
Overview of detection

-

I/O: Service Mode > SITUATION > Sensor Check

Check items (in arbitrary order)

-



■ 010025: JamCode (ADF) 0025

[Symptom/Question]

010025: JamCode (ADF) 0025

[Remedy/Answer]

Jam Type : OTHER

Sensor Name : Scanner Unit

Sensor No. : [1],[2]

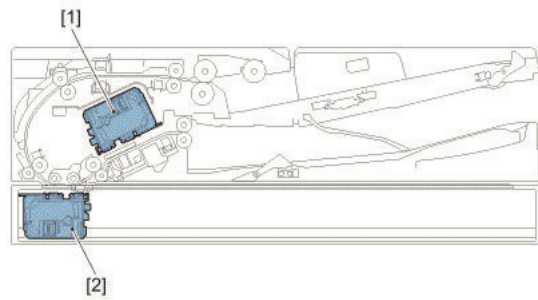
Overview of detection

-

I/O: Service Mode > SITUATION > Sensor Check

Check items (in arbitrary order)

-



■ 010026: JamCode (ADF) 0026

[Symptom/Question]

010026: JamCode (ADF) 0026

[Remedy/Answer]

Jam Type : OTHER

Sensor Name : Scanner Unit

Sensor No. : [1],[2]

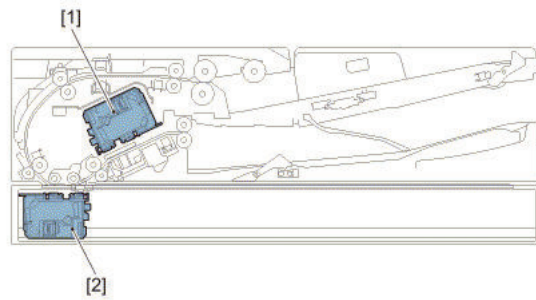
Overview of detection

-

I/O: Service Mode > SITUATION > Sensor Check

Check items (in arbitrary order)

-



■ 010043: JamCode (ADF) 0043

[Symptom/Question]

010043: JamCode (ADF) 0043

[Remedy/Answer]

Jam Type : Delay jam

Sensor Name : Post-separation Sensor

Sensor No. : PS402

Overview of detection

A delay jam occurs when a sensor was not turned ON although a specified period of time had passed after the start of detection by the sensor.

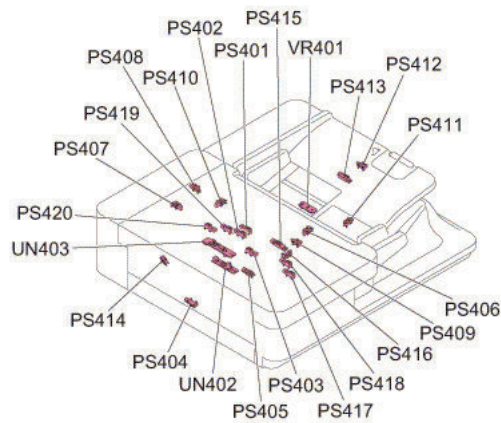
I/O: Service Mode > SITUATION > Sensor Check

Check items (in arbitrary order)

- Remaining paper at the upstream of the target sensor
- Soiling on the target sensor

Displacement of the target sensor position

- Failure of the target sensor
- Soiling (grease)/deterioration/Failure of a drive motor located upstream of the target sensor
- Soiling (paper dust)/deterioration/Failure of a drive roller located upstream of the target sensor



■ 010044: JamCode (ADF) 0044

[Symptom/Question]

010044: JamCode (ADF) 0044

[Remedy/Answer]

Jam Type : Stationary jam

Sensor Name : Post-separation Sensor

Sensor No. : PS402

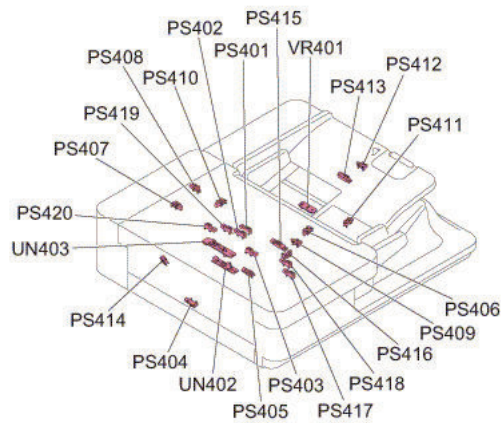
Overview of detection

A stationary jam occurs when a sensor was not turned OFF although a specified period of time had passed after the sensor was turned ON.

I/O: Service Mode > SITUATION > Sensor Check

Check items (in arbitrary order)

- Remaining paper near the target sensor
- Soiling on the target sensor
- Displacement of the target sensor position
- Failure of the target sensor
- Soiling (grease)/deterioration/failure of a drive motor located upstream of the target sensor
- Soiling (paper dust)/deterioration/failure of a drive roller located upstream of the target sensor



■ 010045: JamCode (ADF) 0045

[Symptom/Question]

010045: JamCode (ADF) 0045

[Remedy/Answer]

Jam Type : Delay jam

Sensor Name : Post-pullout Sensor

Sensor No. : PS403

Overview of detection

A delay jam occurs when a sensor was not turned ON although a specified period of time had passed after the start of detection by the sensor.

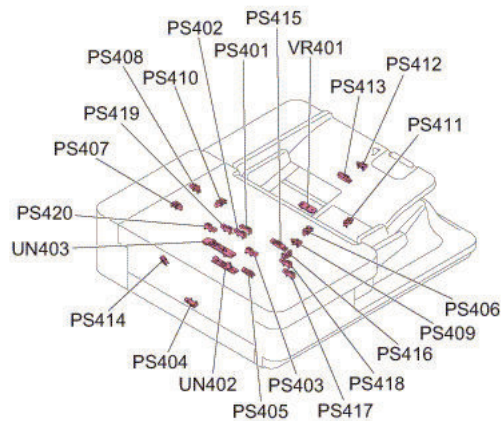
I/O: Service Mode > SITUATION > Sensor Check

Check items (in arbitrary order)

- Remaining paper at the upstream of the target sensor
- Soiling on the target sensor

Displacement of the target sensor position

- Failure of the target sensor
- Soiling (grease)/deterioration/Failure of a drive motor located upstream of the target sensor
- Soiling (paper dust)/deterioration/Failure of a drive roller located upstream of the target sensor



■ 010046: JamCode (ADF) 0046

[Symptom/Question]

010046: JamCode (ADF) 0046

[Remedy/Answer]

Jam Type : Stationary jam

Sensor Name : Post-pullout Sensor

Sensor No. : PS403

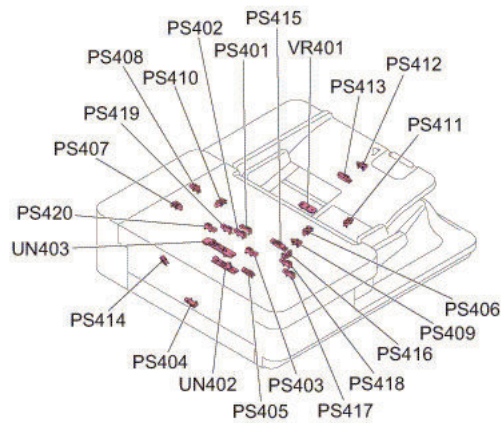
Overview of detection

A stationary jam occurs when a sensor was not turned OFF although a specified period of time had passed after the sensor was turned ON.

I/O: Service Mode > SITUATION > Sensor Check

Check items (in arbitrary order)

- Remaining paper near the target sensor
- Soiling on the target sensor
- Displacement of the target sensor position
- Failure of the target sensor
- Soiling (grease)/deterioration/failure of a drive motor located upstream of the target sensor
- Soiling (paper dust)/deterioration/failure of a drive roller located upstream of the target sensor



■ 010047: JamCode (ADF) 0047

[Symptom/Question]

010047: JamCode (ADF) 0047

[Remedy/Answer]

Jam Type : Delay jam

Sensor Name : Lead Sensor

Sensor No. : PS404

Overview of detection

A delay jam occurs when a sensor was not turned ON although a specified period of time had passed after the start of detection by the sensor.

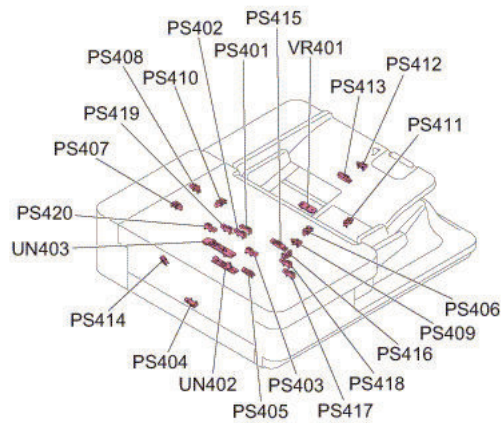
I/O: Service Mode > SITUATION > Sensor Check

Check items (in arbitrary order)

- Remaining paper at the upstream of the target sensor
- Soiling on the target sensor

Displacement of the target sensor position

- Failure of the target sensor
- Soiling (grease)/deterioration/Failure of a drive motor located upstream of the target sensor
- Soiling (paper dust)/deterioration/Failure of a drive roller located upstream of the target sensor



■ 010048: JamCode (ADF) 0048

[Symptom/Question]

010048: JamCode (ADF) 0048

[Remedy/Answer]

Jam Type : Stationary jam

Sensor Name : Lead Sensor

Sensor No. : PS404

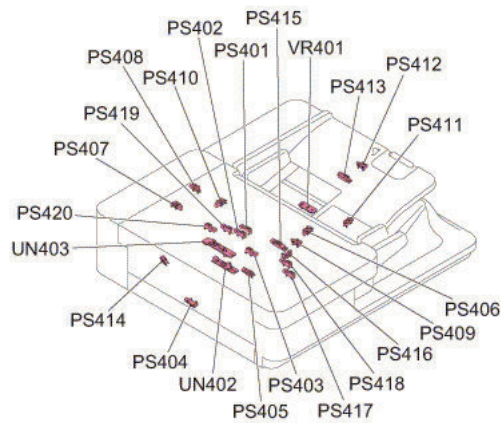
Overview of detection

A stationary jam occurs when a sensor was not turned OFF although a specified period of time had passed after the sensor was turned ON.

I/O: Service Mode > SITUATION > Sensor Check

Check items (in arbitrary order)

- Remaining paper near the target sensor
- Soiling on the target sensor
- Displacement of the target sensor position
- Failure of the target sensor
- Soiling (grease)/deterioration/failure of a drive motor located upstream of the target sensor
- Soiling (paper dust)/deterioration/failure of a drive roller located upstream of the target sensor



■ 010049: JamCode (ADF) 0049

[Symptom/Question]

010049: JamCode (ADF) 0049

[Remedy/Answer]

Jam Type : Delay jam

Sensor Name : Delivery Sensor

Sensor No. : PS405

Overview of detection

A delay jam occurs when a sensor was not turned ON although a specified period of time had passed after the start of detection by the sensor.

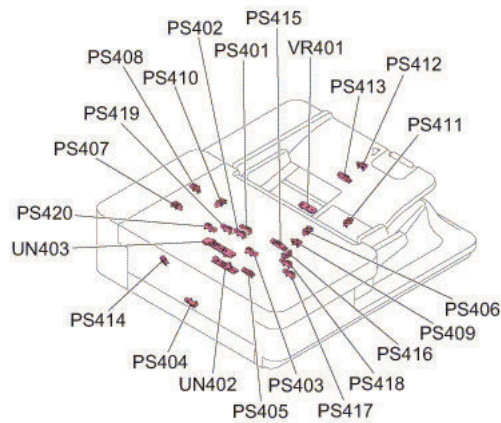
I/O: Service Mode > SITUATION > Sensor Check

Check items (in arbitrary order)

- Remaining paper at the upstream of the target sensor
- Soiling on the target sensor

Displacement of the target sensor position

- Failure of the target sensor
- Soiling (grease)/deterioration/Failure of a drive motor located upstream of the target sensor
- Soiling (paper dust)/deterioration/Failure of a drive roller located upstream of the target sensor



■ 010050: JamCode (ADF) 0050

[Symptom/Question]

010050: JamCode (ADF) 0050

[Remedy/Answer]

Jam Type : Stationary jam

Sensor Name : Delivery Sensor

Sensor No. : PS405

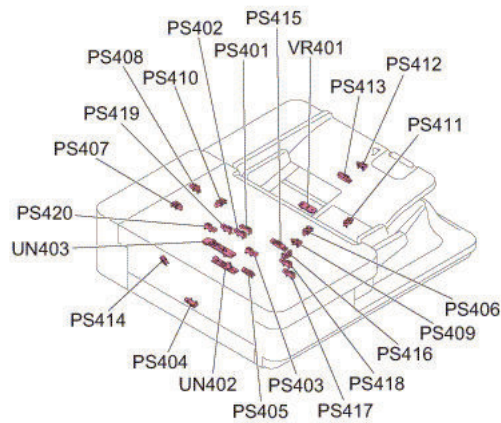
Overview of detection

A stationary jam occurs when a sensor was not turned OFF although a specified period of time had passed after the sensor was turned ON.

I/O: Service Mode > SITUATION > Sensor Check

Check items (in arbitrary order)

- Remaining paper near the target sensor
- Soiling on the target sensor
- Displacement of the target sensor position
- Failure of the target sensor
- Soiling (grease)/deterioration/failure of a drive motor located upstream of the target sensor
- Soiling (paper dust)/deterioration/failure of a drive roller located upstream of the target sensor



■ 010055: JamCode (ADF) 0055

[Symptom/Question]

010055: JamCode (ADF) 0055

[Remedy/Answer]

Jam Type : OTHER

Sensor Name : Skew Detection Sensor (Large, Front)

Skew Detection Sensor (Small, Front)

Skew Detection Sensor (Small, Rear)

Skew Detection Sensor (Large, Rear)

Sensor No. : PS417,PS418,PS419,PS420

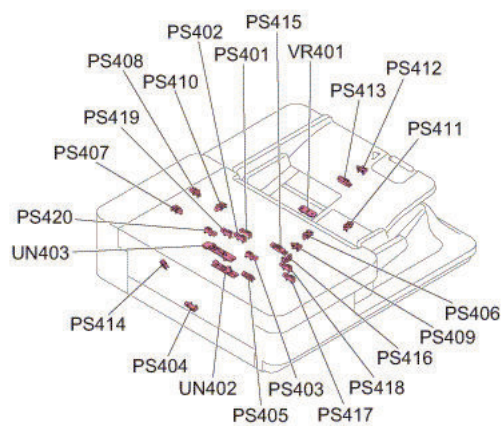
Overview of detection

-

I/O: Service Mode > SITUATION > Sensor Check

Check items (in arbitrary order)

-



■ 010060: JamCode (ADF) 0060

[Symptom/Question]

010060: JamCode (ADF) 0060

[Remedy/Answer]

Jam Type : Double Feed

Sensor Name : Double Feed Sensor PCB (transmission/reception)

Sensor No. : UN402,UN403

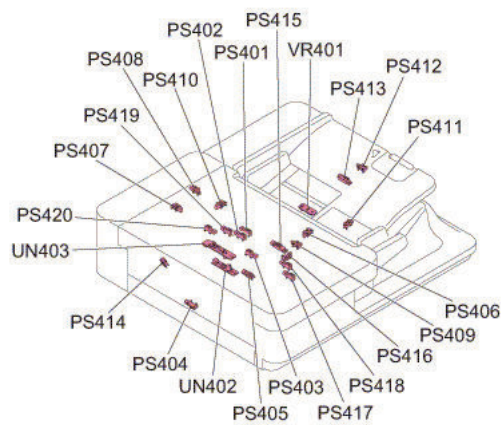
Overview of detection

-

I/O: Service Mode > SITUATION > Sensor Check

Check items (in arbitrary order)

-



■ 010061: JamCode (ADF) 0061

[Symptom/Question]

010061: JamCode (ADF) 0061

[Remedy/Answer]

Jam Type : OTHER

Sensor Name : Double Feed Sensor PCB (transmission/reception)

Sensor No. : UN402,UN403

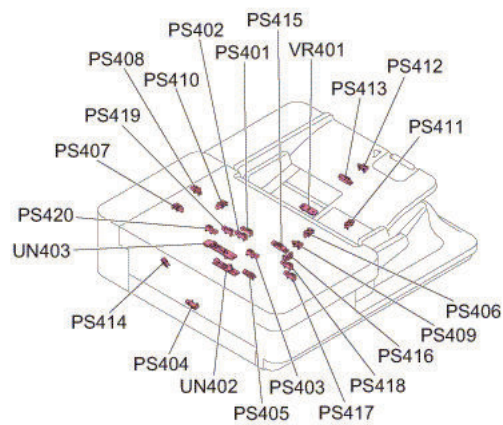
Overview of detection

-

I/O: Service Mode > SITUATION > Sensor Check

Check items (in arbitrary order)

-



■ 010062: JamCode (ADF) 0062

[Symptom/Question]

010062: JamCode (ADF) 0062

[Remedy/Answer]

Jam Type : Error avoidance

Sensor Name : Double Feed Sensor PCB (transmission/reception)

Sensor No. : UN402,UN403

Overview of detection

An error avoidance jam occurs when an error in the machine (excluding parts failure) was detected.

Printing operation is suspended to avoid error occurrence by error code; therefore, parts failure is not the cause of the jam.

After the jam is removed, the machine works.

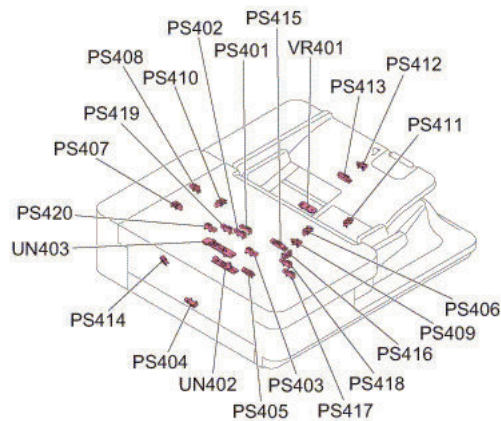
If it is due to parts failure, an error code instead of the error avoidance jam is displayed on UI and printing operation is suspended.

In such case, service technician should perform remedial work for the error code.

I/O: Service Mode > SITUATION > Sensor Check

Check items (in arbitrary order)

- Opening/closing of the door after jam removal
- Turning OFF and then ON the power after jam removal



■ 010063: JamCode (ADF) 0063

[Symptom/Question]

010063: JamCode (ADF) 0063

[Remedy/Answer]

Jam Type : OTHER

Sensor Name : Double Feed Sensor PCB (transmission/reception)

Sensor No. : UN402,UN403

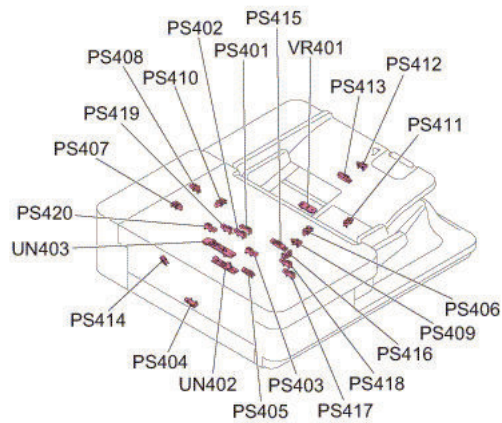
Overview of detection

-

I/O: Service Mode > SITUATION > Sensor Check

Check items (in arbitrary order)

-



■ 010071: JamCode (ADF) 0071

[Symptom/Question]

010071: JamCode (ADF) 0071

[Remedy/Answer]

Jam Type : Sequence jam

Sensor Name : -

Sensor No. : -

Overview of detection

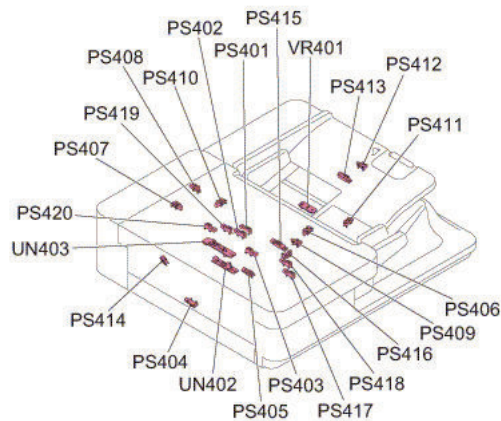
A sequence jam occurs when there was an error in sensor detection signal at printing operation sequence.

Since the jam may occur due to sporadic noise with software of each equipment or communication line (interruption of communication), failure of the part is not the cause of the jam. After the jam is removed, the machine works.

I/O: Service Mode > SITUATION > Sensor Check

Check items (in arbitrary order)

- Opening/closing of the door
- Turning OFF and then ON the power
- Error near the target sensor (soiling/displacement/failure of the sensor, error in harness/open circuit of harness, soiling (grease)/deterioration/failure of a drive motor, or soiling (paper dust)/deterioration/failure of a drive roller)



■ 01007F: JamCode (ADF) 007F

[Symptom/Question]

01007F: JamCode (ADF) 007F

[Remedy/Answer]

Jam Type : Sequence jam

Sensor Name : -

Sensor No. : -

Overview of detection

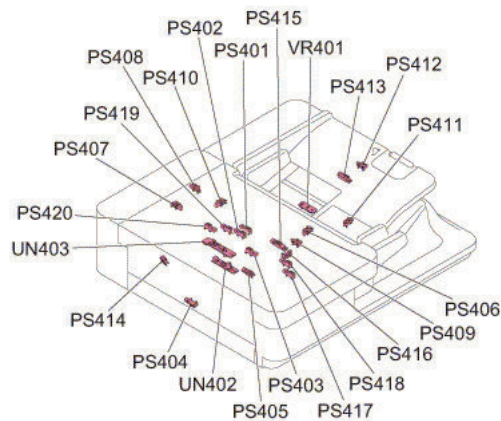
A sequence jam occurs when there was an error in sensor detection signal at printing operation sequence.

Since the jam may occur due to sporadic noise with software of each equipment or communication line (interruption of communication), failure of the part is not the cause of the jam. After the jam is removed, the machine works.

I/O: Service Mode > SITUATION > Sensor Check

Check items (in arbitrary order)

- Opening/closing of the door
- Turning OFF and then ON the power
- Error near the target sensor (soiling/displacement/failure of the sensor, error in harness/open circuit of harness, soiling (grease)/deterioration/failure of a drive motor, or soiling (paper dust)/deterioration/failure of a drive roller)



■ 010090: JamCode (Reader) 0090

[Symptom/Question]

010090: JamCode (Reader) 0090

[Remedy/Answer]

Jam Type : ADF OPEN

Sensor Name : Copyboard Cover Open/Closed Sensor (Front/Rear)

Sensor No. : PS101,PS102

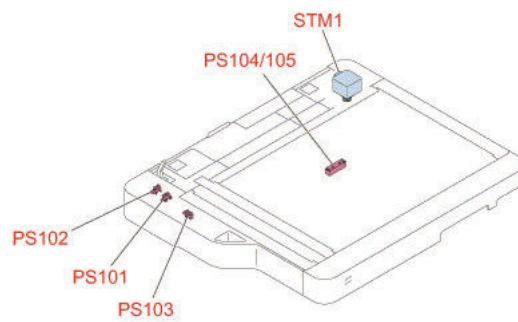
Overview of detection

A door open jam occurs when a sensor detected ADF open during printing operation.

I/O: Service Mode > SITUATION > Sensor Check

Check items (in arbitrary order)

- ADF open during printing



■ 010091: JamCode (Reader) 0091

[Symptom/Question]

010091: JamCode (Reader) 0091

[Remedy/Answer]

Jam Type : ADF OPEN

Sensor Name : Copyboard Cover Open/Closed Sensor (Front/Rear)

Sensor No. : PS101,PS102

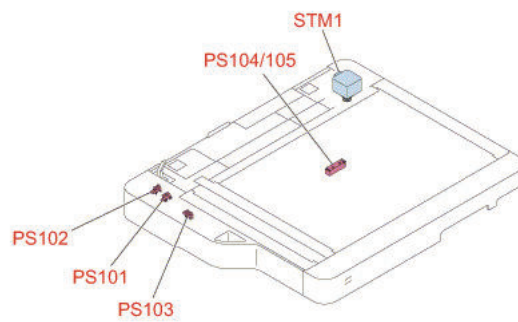
Overview of detection

A door open jam occurs when a sensor detected ADF open during printing operation.

I/O: Service Mode > SITUATION > Sensor Check

Check items (in arbitrary order)

- ADF open during printing



■ 010092: JamCode (ADF) 0092

[Symptom/Question]

010092: JamCode (ADF) 0092

[Remedy/Answer]

Jam Type : COVER Open jam

Sensor Name : Cover Open/Closed Sensor

Sensor No. : PS407

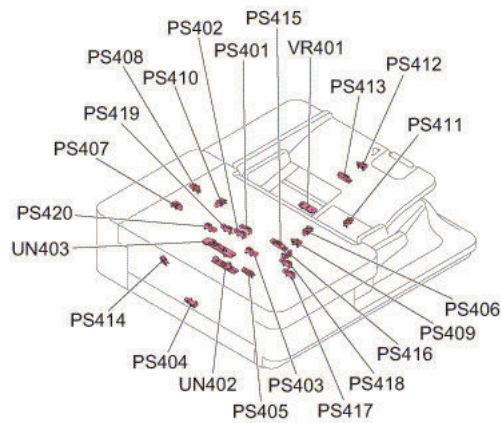
Overview of detection

A door open jam occurs when a sensor detected cover open during printing operation.

I/O: Service Mode > SITUATION > Sensor Check

Check items (in arbitrary order)

- Cover open during printing



■ 010093: JamCode (ADF) 0093

[Symptom/Question]

010093: JamCode (ADF) 0093

[Remedy/Answer]

Jam Type : COVER Open jam

Sensor Name : Cover Open/Closed Sensor

Sensor No. : PS407

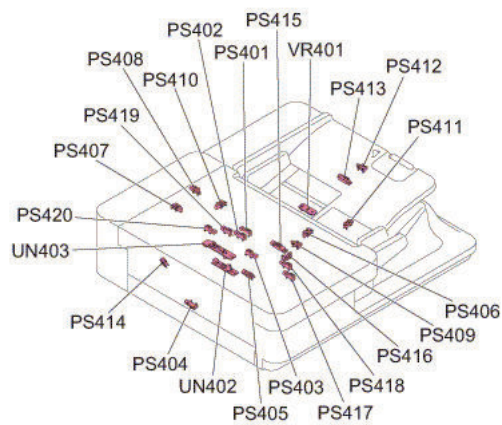
Overview of detection

A door open jam occurs when a sensor detected cover open during printing operation.

I/O: Service Mode > SITUATION > Sensor Check

Check items (in arbitrary order)

- Cover open during printing



■ 010094: JamCode (ADF) 0094

[Symptom/Question]

010094: JamCode (ADF) 0094

[Remedy/Answer]

Jam Type : Power-on jam

Sensor Name : Post-separation Sensor

Post-pullout Sensor

Lead Sensor

Pre-delivery Sensor

Sensor No. : PS402,PS403,PS404,PS405

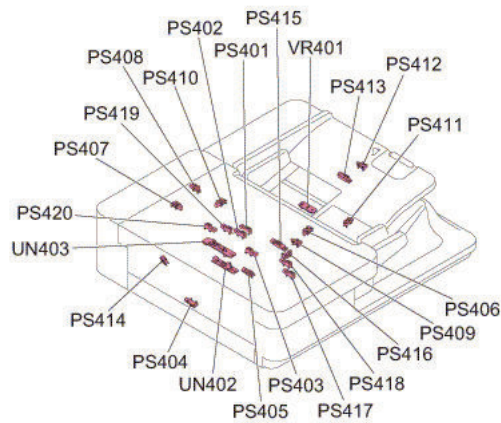
Overview of detection

A power-on jam occurs when a sensor detected ON state at power-on.

I/O: Service Mode > SITUATION > Sensor Check

Check items (in arbitrary order)

- Remaining paper in the machine
- Soiling on the target sensor
- Failure of the target sensor
- Foreign matter on the target sensor (paper dust, paper lint)



■ 010095: JamCode (ADF) 0095

[Symptom/Question]

010095: JamCode (ADF) 0095

[Remedy/Answer]

Jam Type : OTHER

Sensor Name : Original Sensor

Sensor No. : PS415

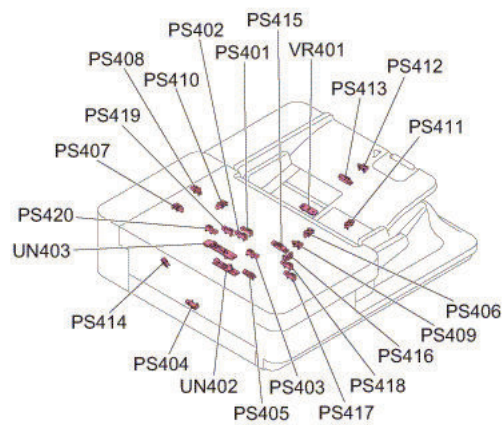
Overview of detection

-

I/O: Service Mode > SITUATION > Sensor Check

Check items (in arbitrary order)

-



■ 010096: JamCode (ADF) 0096

[Symptom/Question]

010096: JamCode (ADF) 0096

[Remedy/Answer]

Jam Type : OTHER

Sensor Name : -

Sensor No. : -

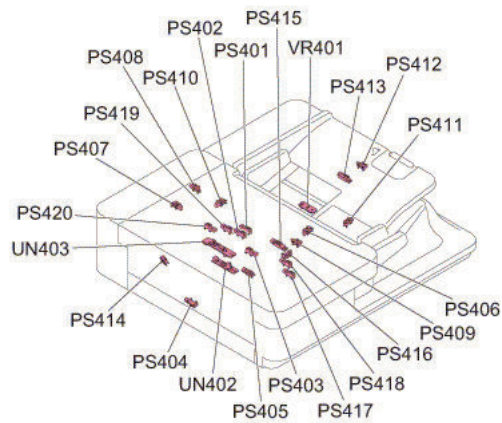
Overview of detection

-

I/O: Service Mode > SITUATION > Sensor Check

Check items (in arbitrary order)

-



■ 0100A2: JamCode (ADF) 00A2

[Symptom/Question]

0100A2: JamCode (ADF) 00A2

[Remedy/Answer]

Jam Type : Power-on jam

Sensor Name : Post-separation Sensor

Sensor No. : PS402

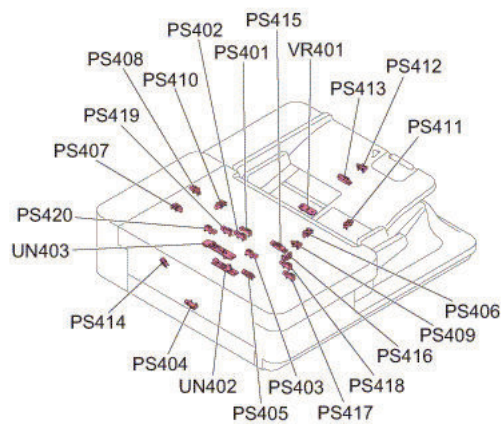
Overview of detection

A power-on jam occurs when a sensor detected ON state at power-on.

I/O: Service Mode > SITUATION > Sensor Check

Check items (in arbitrary order)

- Remaining paper in the machine
- Soiling on the target sensor
- Failure of the target sensor
- Foreign matter on the target sensor (paper dust, paper lint)



■ 0100A3: JamCode (ADF) 00A3

[Symptom/Question]

0100A3: JamCode (ADF) 00A3

[Remedy/Answer]

Jam Type : Power-on jam

Sensor Name : Post-pullout Sensor

Sensor No. : PS403

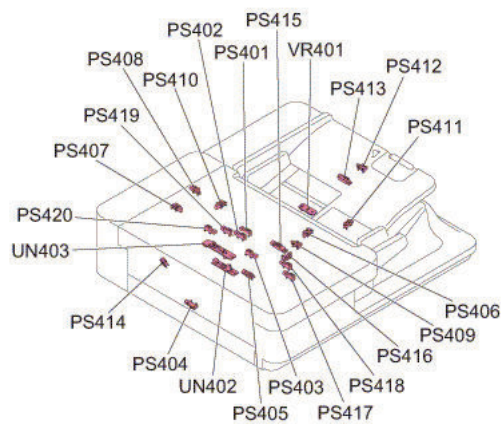
Overview of detection

A power-on jam occurs when a sensor detected ON state at power-on.

I/O: Service Mode > SITUATION > Sensor Check

Check items (in arbitrary order)

- Remaining paper in the machine
- Soiling on the target sensor
- Failure of the target sensor
- Foreign matter on the target sensor (paper dust, paper lint)



■ 0100A4: JamCode (ADF) 00A4

[Symptom/Question]

0100A4: JamCode (ADF) 00A4

[Remedy/Answer]

Jam Type : Power-on jam

Sensor Name : Lead Sensor

Sensor No. : PS404

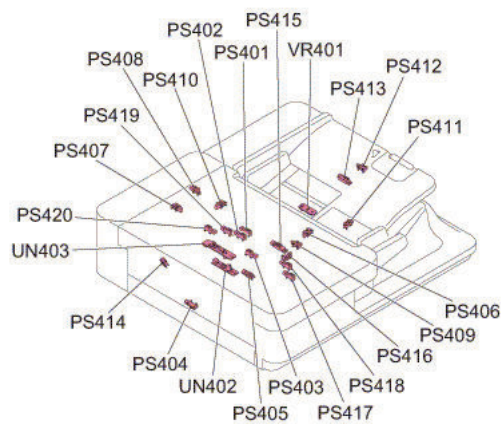
Overview of detection

A power-on jam occurs when a sensor detected ON state at power-on.

I/O: Service Mode > SITUATION > Sensor Check

Check items (in arbitrary order)

- Remaining paper in the machine
- Soiling on the target sensor
- Failure of the target sensor
- Foreign matter on the target sensor (paper dust, paper lint)



■ 0100A6: JamCode (ADF) 00A6

[Symptom/Question]

0100A6: JamCode (ADF) 00A6

[Remedy/Answer]

Jam Type : Power-on jam

Sensor Name : Delivery Sensor

Sensor No. : PS405

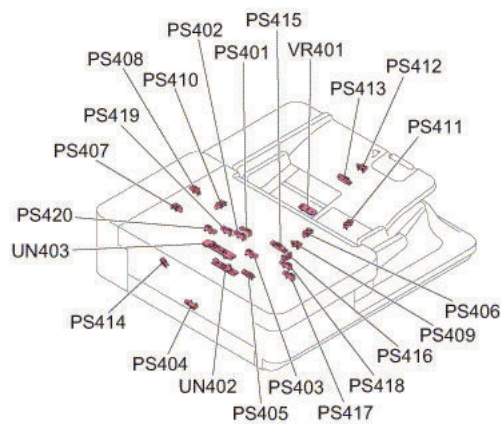
Overview of detection

A power-on jam occurs when a sensor detected ON state at power-on.

I/O: Service Mode > SITUATION > Sensor Check

Check items (in arbitrary order)

- Remaining paper in the machine
- Soiling on the target sensor
- Failure of the target sensor
- Foreign matter on the target sensor (paper dust, paper lint)



■ 021001: JamCode (Staple/Booklet Finisher-AC1) 1001

[Symptom/Question]

021001: JamCode (Staple/Booklet Finisher-AC1) 1001

[Remedy/Answer]

Jam Type : Delay jam

Sensor Name : Inlet Sensor

Sensor No. : PS101

Overview of detection

A delay jam occurs when a sensor was not turned ON although a specified period of time had passed after the start of detection by the sensor.

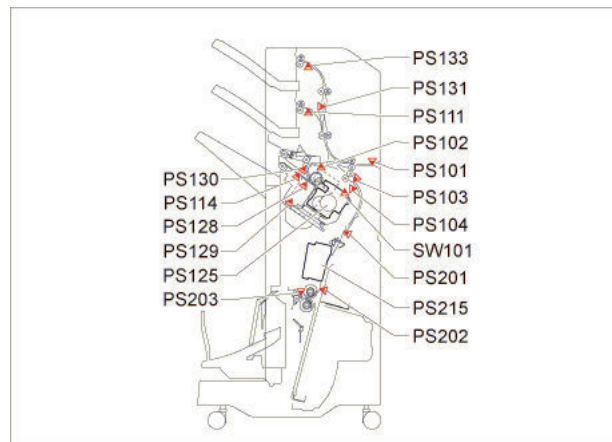
I/O: Service Mode > SITUATION > Sensor Check

Check items (in arbitrary order)

- Remaining paper at the upstream of the target sensor
- Soiling on the target sensor

Displacement of the target sensor position

- Failure of the target sensor
- Soiling (grease)/deterioration/Failure of a drive motor located upstream of the target sensor
- Soiling (paper dust)/deterioration/Failure of a drive roller located upstream of the target sensor



■ 021002: JamCode (Staple/Booklet Finisher-AC1) 1002

[Symptom/Question]

021002: JamCode (Staple/Booklet Finisher-AC1) 1002

[Remedy/Answer]

Jam Type : Delay jam

Sensor Name : Delivery Sensor

Sensor No. : PS102

Overview of detection

A delay jam occurs when a sensor was not turned ON although a specified period of time had passed after the start of detection by the sensor.

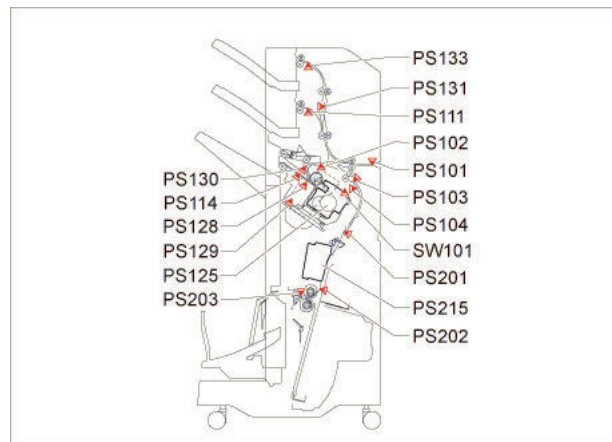
I/O: Service Mode > SITUATION > Sensor Check

Check items (in arbitrary order)

- Remaining paper at the upstream of the target sensor
- Soiling on the target sensor

Displacement of the target sensor position

- Failure of the target sensor
- Soiling (grease)/deterioration/Failure of a drive motor located upstream of the target sensor
- Soiling (paper dust)/deterioration/Failure of a drive roller located upstream of the target sensor



■ 021002: JamCode (Staple/ Booklet Finisher-W1 PRO) 1002

[Symptom/Question]

021002: JamCode (Staple/ Booklet Finisher-W1 PRO) 1002

[Remedy/Answer]

Jam Type : Delay jam

Sensor Name : Inlet Sensor

Sensor No. : PS3

Overview of detection

A delay jam occurs when a sensor was not turned ON although a specified period of time had passed after the start of detection by the sensor.

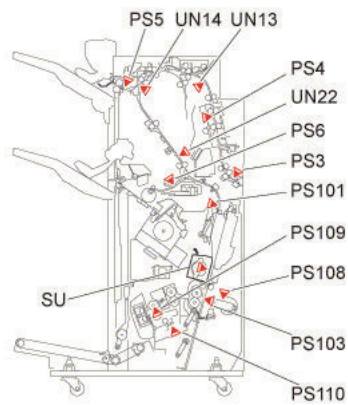
I/O: Service Mode > SITUATION > Sensor Check

Check items (in arbitrary order)

- Remaining paper at the upstream of the target sensor
- Soiling on the target sensor

Displacement of the target sensor position

- Failure of the target sensor
- Soiling (grease)/deterioration/Failure of a drive motor located upstream of the target sensor
- Soiling (paper dust)/deterioration/Failure of a drive roller located upstream of the target sensor



■ 021003: JamCode (Staple/Booklet Finisher-AC1) 1003

[Symptom/Question]

021003: JamCode (Staple/Booklet Finisher-AC1) 1003

[Remedy/Answer]

Jam Type : Delay jam

Sensor Name : Buffer Sensor

Sensor No. : PS103

Overview of detection

A delay jam occurs when a sensor was not turned ON although a specified period of time had passed after the start of detection by the sensor.

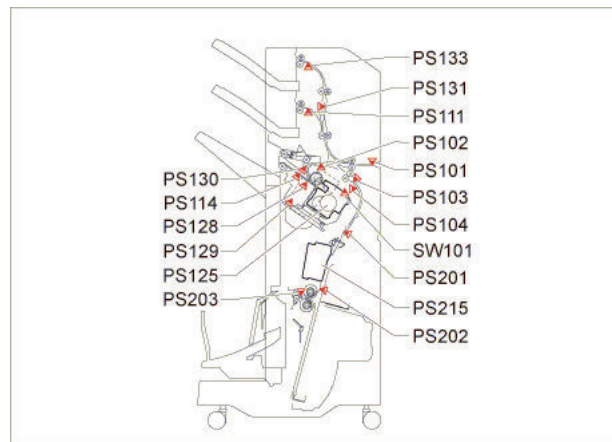
I/O: Service Mode > SITUATION > Sensor Check

Check items (in arbitrary order)

- Remaining paper at the upstream of the target sensor
- Soiling on the target sensor

Displacement of the target sensor position

- Failure of the target sensor
- Soiling (grease)/deterioration/Failure of a drive motor located upstream of the target sensor
- Soiling (paper dust)/deterioration/Failure of a drive roller located upstream of the target sensor



■ 021004: JamCode (Staple/Booklet Finisher-AC1) 1004

[Symptom/Question]

021004: JamCode (Staple/Booklet Finisher-AC1) 1004

[Remedy/Answer]

Jam Type : Delay jam

Sensor Name : Lower Escape Delivery Sensor

Sensor No. : PS111

Overview of detection

A delay jam occurs when a sensor was not turned ON although a specified period of time had passed after the start of detection by the sensor.

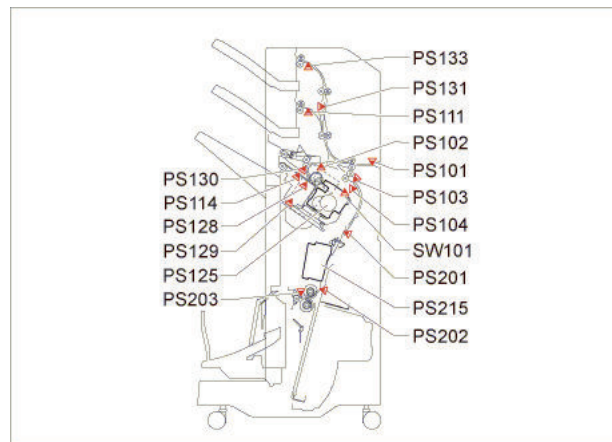
I/O: Service Mode > SITUATION > Sensor Check

Check items (in arbitrary order)

- Remaining paper at the upstream of the target sensor
- Soiling on the target sensor

Displacement of the target sensor position

- Failure of the target sensor
- Soiling (grease)/deterioration/Failure of a drive motor located upstream of the target sensor
- Soiling (paper dust)/deterioration/Failure of a drive roller located upstream of the target sensor



■ 021004: JamCode (Staple/ Booklet Finisher-W1 PRO) 1004

[Symptom/Question]

021004: JamCode (Staple/ Booklet Finisher-W1 PRO) 1004

[Remedy/Answer]

Jam Type : Delay jam

Sensor Name : Shift Unit Trailing Edge Sensor

Sensor No. : PS4

Overview of detection

A delay jam occurs when a sensor was not turned ON although a specified period of time had passed after the start of detection by the sensor.

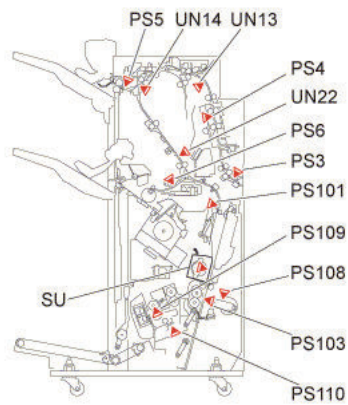
I/O: Service Mode > SITUATION > Sensor Check

Check items (in arbitrary order)

- Remaining paper at the upstream of the target sensor
- Soiling on the target sensor

Displacement of the target sensor position

- Failure of the target sensor
- Soiling (grease)/deterioration/Failure of a drive motor located upstream of the target sensor
- Soiling (paper dust)/deterioration/Failure of a drive roller located upstream of the target sensor



■ 021005: JamCode (Staple/Booklet Finisher-AC1) 1005

[Symptom/Question]

021005: JamCode (Staple/Booklet Finisher-AC1) 1005

[Remedy/Answer]

Jam Type : Delay jam

Sensor Name : Upper Escape Delivery Sensor

Sensor No. : PS133

Overview of detection

A delay jam occurs when a sensor was not turned ON although a specified period of time had passed after the start of detection by the sensor.

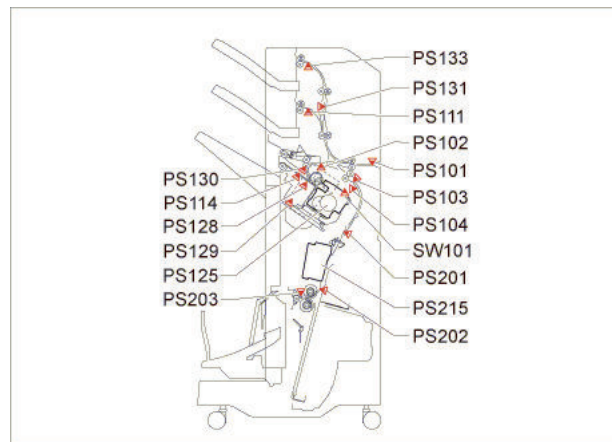
I/O: Service Mode > SITUATION > Sensor Check

Check items (in arbitrary order)

- Remaining paper at the upstream of the target sensor
- Soiling on the target sensor

Displacement of the target sensor position

- Failure of the target sensor
- Soiling (grease)/deterioration/Failure of a drive motor located upstream of the target sensor
- Soiling (paper dust)/deterioration/Failure of a drive roller located upstream of the target sensor



■ 021006: JamCode (Staple/Booklet Finisher-AC1) 1006

[Symptom/Question]

021006: JamCode (Staple/Booklet Finisher-AC1) 1006

[Remedy/Answer]

Jam Type : Delay jam

Sensor Name : Escape Feed Sensor

Sensor No. : PS131

Overview of detection

A delay jam occurs when a sensor was not turned ON although a specified period of time had passed after the start of detection by the sensor.

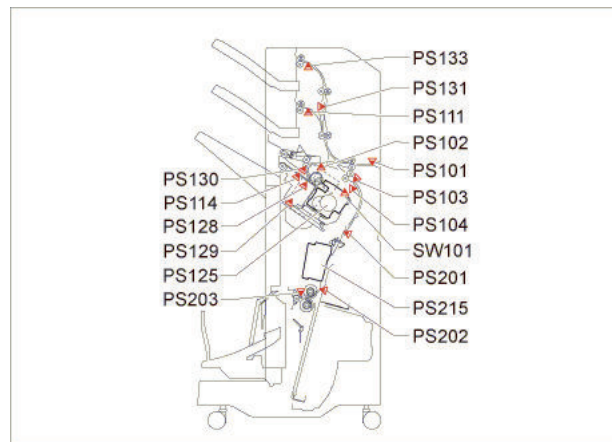
I/O: Service Mode > SITUATION > Sensor Check

Check items (in arbitrary order)

- Remaining paper at the upstream of the target sensor
- Soiling on the target sensor

Displacement of the target sensor position

- Failure of the target sensor
- Soiling (grease)/deterioration/Failure of a drive motor located upstream of the target sensor
- Soiling (paper dust)/deterioration/Failure of a drive roller located upstream of the target sensor



■ 021006: JamCode (Staple/ Booklet Finisher-W1 PRO) 1006

[Symptom/Question]

021006: JamCode (Staple/ Booklet Finisher-W1 PRO) 1006

[Remedy/Answer]

Jam Type : Delay jam

Sensor Name : Buffer Path 1 Sensor PCB

Sensor No. : UN13

Overview of detection

A delay jam occurs when a sensor was not turned ON although a specified period of time had passed after the start of detection by the sensor.

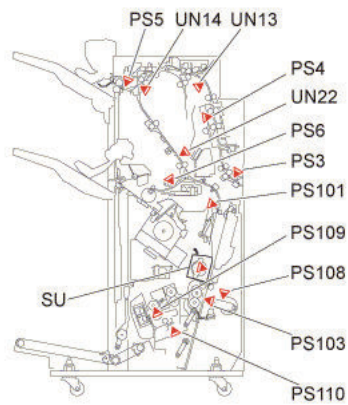
I/O: Service Mode > SITUATION > Sensor Check

Check items (in arbitrary order)

- Remaining paper at the upstream of the target sensor
- Soiling on the target sensor

Displacement of the target sensor position

- Failure of the target sensor
- Soiling (grease)/deterioration/Failure of a drive motor located upstream of the target sensor
- Soiling (paper dust)/deterioration/Failure of a drive roller located upstream of the target sensor



■ 021008: JamCode (Staple/Booklet Finisher-AC1) 1008

[Symptom/Question]

021008: JamCode (Staple/Booklet Finisher-AC1) 1008

[Remedy/Answer]

Jam Type : Delay jam

Sensor Name : Saddle Delivery Sensor

Sensor No. : PS203

Overview of detection

A delay jam occurs when a sensor was not turned ON although a specified period of time had passed after the start of detection by the sensor.

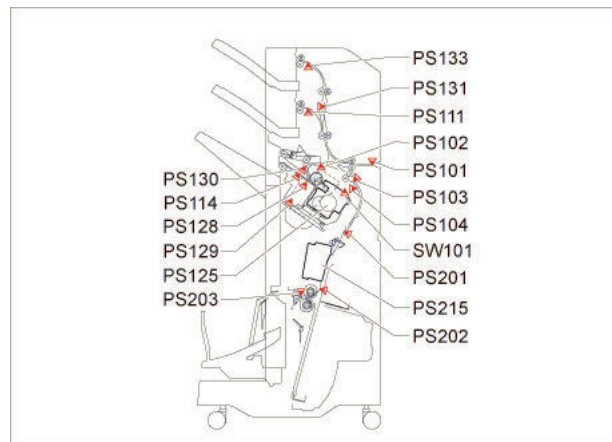
I/O: Service Mode > SITUATION > Sensor Check

Check items (in arbitrary order)

- Remaining paper at the upstream of the target sensor
- Soiling on the target sensor

Displacement of the target sensor position

- Failure of the target sensor
- Soiling (grease)/deterioration/Failure of a drive motor located upstream of the target sensor
- Soiling (paper dust)/deterioration/Failure of a drive roller located upstream of the target sensor



■ 021008: JamCode (Staple/ Booklet Finisher-W1 PRO) 1008

[Symptom/Question]

021008: JamCode (Staple/ Booklet Finisher-W1 PRO) 1008

[Remedy/Answer]

Jam Type : Delay jam

Sensor Name : Buffer Path 2 Sensor PCB

Sensor No. : UN14

Overview of detection

A delay jam occurs when a sensor was not turned ON although a specified period of time had passed after the start of detection by the sensor.

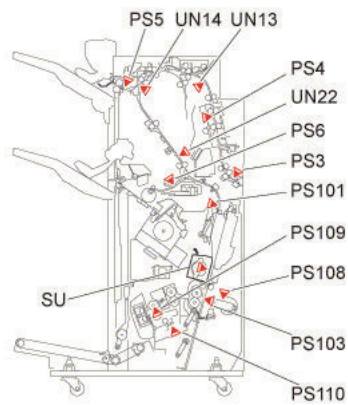
I/O: Service Mode > SITUATION > Sensor Check

Check items (in arbitrary order)

- Remaining paper at the upstream of the target sensor
- Soiling on the target sensor

Displacement of the target sensor position

- Failure of the target sensor
- Soiling (grease)/deterioration/Failure of a drive motor located upstream of the target sensor
- Soiling (paper dust)/deterioration/Failure of a drive roller located upstream of the target sensor



■ 021009: JamCode (Staple/Booklet Finisher-AC1) 1009

[Symptom/Question]

021009: JamCode (Staple/Booklet Finisher-AC1) 1009

[Remedy/Answer]

Jam Type : Delay jam

Sensor Name : Saddle Inlet Sensor

Sensor No. : PS201

Overview of detection

A delay jam occurs when a sensor was not turned ON although a specified period of time had passed after the start of detection by the sensor.

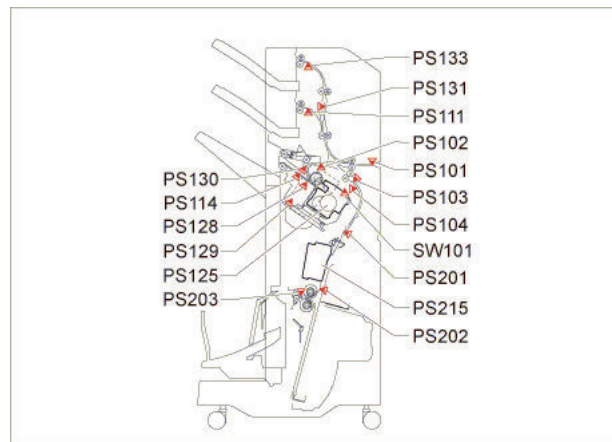
I/O: Service Mode > SITUATION > Sensor Check

Check items (in arbitrary order)

- Remaining paper at the upstream of the target sensor
- Soiling on the target sensor

Displacement of the target sensor position

- Failure of the target sensor
- Soiling (grease)/deterioration/Failure of a drive motor located upstream of the target sensor
- Soiling (paper dust)/deterioration/Failure of a drive roller located upstream of the target sensor



■ 02100A: JamCode (Staple/ Booklet Finisher-W1 PRO) 100A

[Symptom/Question]

02100A: JamCode (Staple/ Booklet Finisher-W1 PRO) 100A

[Remedy/Answer]

Jam Type : Delay jam

Sensor Name : Upper Delivery Sensor

Sensor No. : PS5

Overview of detection

A delay jam occurs when a sensor was not turned ON although a specified period of time had passed after the start of detection by the sensor.

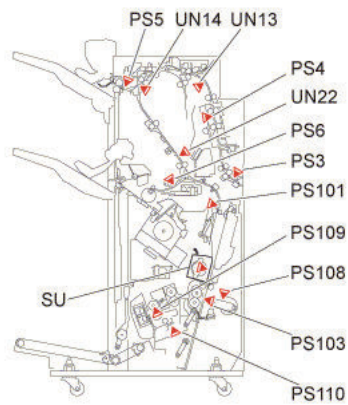
I/O: Service Mode > SITUATION > Sensor Check

Check items (in arbitrary order)

- Remaining paper at the upstream of the target sensor
- Soiling on the target sensor

Displacement of the target sensor position

- Failure of the target sensor
- Soiling (grease)/deterioration/Failure of a drive motor located upstream of the target sensor
- Soiling (paper dust)/deterioration/Failure of a drive roller located upstream of the target sensor



■ 02100C: JamCode (Staple/ Booklet Finisher-W1 PRO) 100C

[Symptom/Question]

02100C: JamCode (Staple/ Booklet Finisher-W1 PRO) 100C

[Remedy/Answer]

Jam Type : Delay jam

Sensor Name : Lower Path Sensor PCB

Sensor No. : UN22

Overview of detection

A delay jam occurs when a sensor was not turned ON although a specified period of time had passed after the start of detection by the sensor.

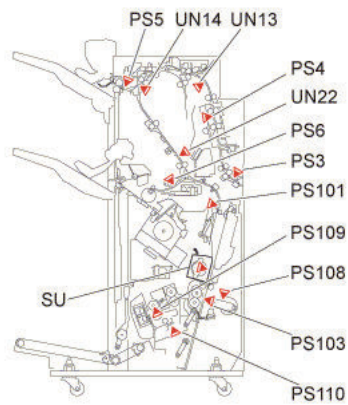
I/O: Service Mode > SITUATION > Sensor Check

Check items (in arbitrary order)

- Remaining paper at the upstream of the target sensor
- Soiling on the target sensor

Displacement of the target sensor position

- Failure of the target sensor
- Soiling (grease)/deterioration/Failure of a drive motor located upstream of the target sensor
- Soiling (paper dust)/deterioration/Failure of a drive roller located upstream of the target sensor



■ 02100E: JamCode (Staple/ Booklet Finisher-W1 PRO) 100E

[Symptom/Question]

02100E: JamCode (Staple/ Booklet Finisher-W1 PRO) 100E

[Remedy/Answer]

Jam Type : Delay jam

Sensor Name : Lower Delivery Sensor

Sensor No. : PS6

Overview of detection

A delay jam occurs when a sensor was not turned ON although a specified period of time had passed after the start of detection by the sensor.

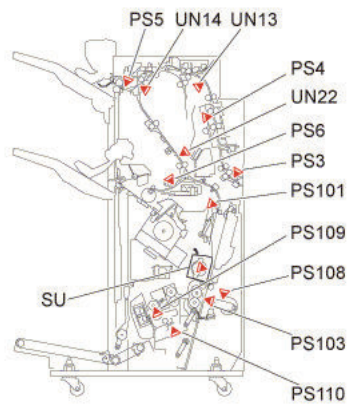
I/O: Service Mode > SITUATION > Sensor Check

Check items (in arbitrary order)

- Remaining paper at the upstream of the target sensor
- Soiling on the target sensor

Displacement of the target sensor position

- Failure of the target sensor
- Soiling (grease)/deterioration/Failure of a drive motor located upstream of the target sensor
- Soiling (paper dust)/deterioration/Failure of a drive roller located upstream of the target sensor



■ 021011: JamCode (Staple/Booklet Finisher-X1) 1011

[Symptom/Question]

021011: JamCode (Staple/Booklet Finisher-X1) 1011

[Remedy/Answer]

Jam Type : Delay jam

Sensor Name : Inlet sensor

Sensor No. : S101

Overview of detection

A delay jam occurs when a sensor was not turned ON although a specified period of time had passed after the start of detection by the sensor.

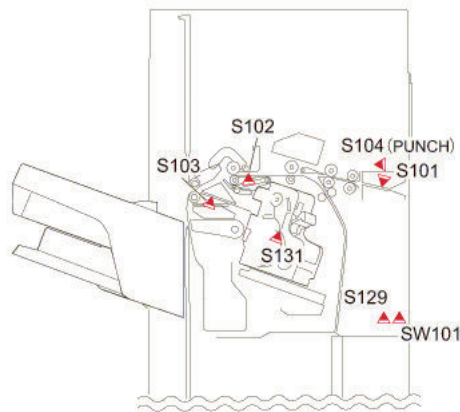
I/O: Service Mode > SITUATION > Sensor Check

Check items (in arbitrary order)

- Remaining paper at the upstream of the target sensor
- Soiling on the target sensor

Displacement of the target sensor position

- Failure of the target sensor
- Soiling (grease)/deterioration/Failure of a drive motor located upstream of the target sensor
- Soiling (paper dust)/deterioration/Failure of a drive roller located upstream of the target sensor



■ 021012: JamCode (Staple/Booklet Finisher-X1) 1012

[Symptom/Question]

021012: JamCode (Staple/Booklet Finisher-X1) 1012

[Remedy/Answer]

Jam Type : Delay jam

Sensor Name : Delivery sensor

Sensor No. : S102

Overview of detection

A delay jam occurs when a sensor was not turned ON although a specified period of time had passed after the start of detection by the sensor.

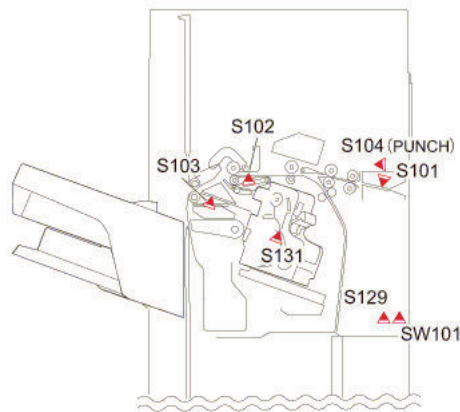
I/O: Service Mode > SITUATION > Sensor Check

Check items (in arbitrary order)

- Remaining paper at the upstream of the target sensor
- Soiling on the target sensor

Displacement of the target sensor position

- Failure of the target sensor
- Soiling (grease)/deterioration/Failure of a drive motor located upstream of the target sensor
- Soiling (paper dust)/deterioration/Failure of a drive roller located upstream of the target sensor



■ 021042: JamCode (Staple/ Booklet Finisher-W1 PRO) 1042

[Symptom/Question]

021042: JamCode (Staple/ Booklet Finisher-W1 PRO) 1042

[Remedy/Answer]

Jam Type : Delay jam

Sensor Name : Saddle Inlet Sensor

Sensor No. : PS101

Overview of detection

A delay jam occurs when a sensor was not turned ON although a specified period of time had passed after the start of detection by the sensor.

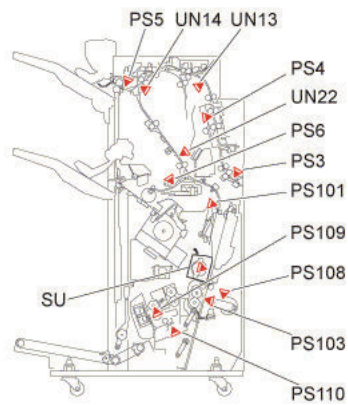
I/O: Service Mode > SITUATION > Sensor Check

Check items (in arbitrary order)

- Remaining paper at the upstream of the target sensor
- Soiling on the target sensor

Displacement of the target sensor position

- Failure of the target sensor
- Soiling (grease)/deterioration/Failure of a drive motor located upstream of the target sensor
- Soiling (paper dust)/deterioration/Failure of a drive roller located upstream of the target sensor



■ 021046: JamCode (Staple/ Booklet Finisher-W1 PRO) 1046

[Symptom/Question]

021046: JamCode (Staple/ Booklet Finisher-W1 PRO) 1046

[Remedy/Answer]

Jam Type : Delay jam

Sensor Name : Saddle Vertical Path Sensor

Sensor No. : PS103

Overview of detection

A delay jam occurs when a sensor was not turned ON although a specified period of time had passed after the start of detection by the sensor.

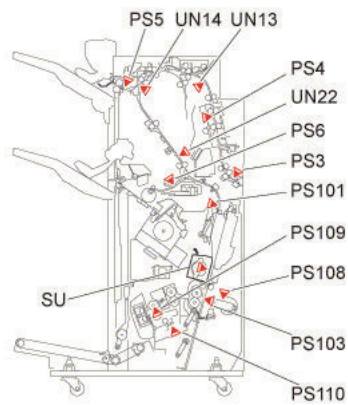
I/O: Service Mode > SITUATION > Sensor Check

Check items (in arbitrary order)

- Remaining paper at the upstream of the target sensor
- Soiling on the target sensor

Displacement of the target sensor position

- Failure of the target sensor
- Soiling (grease)/deterioration/Failure of a drive motor located upstream of the target sensor
- Soiling (paper dust)/deterioration/Failure of a drive roller located upstream of the target sensor



■ 02104A: JamCode (Staple/ Booklet Finisher-W1 PRO) 104A

[Symptom/Question]

02104A: JamCode (Staple/ Booklet Finisher-W1 PRO) 104A

[Remedy/Answer]

Jam Type : Delay jam

Sensor Name : Saddle Press Front Sensor

Sensor No. : PS116

Overview of detection

A delay jam occurs when a sensor was not turned ON although a specified period of time had passed after the start of detection by the sensor.

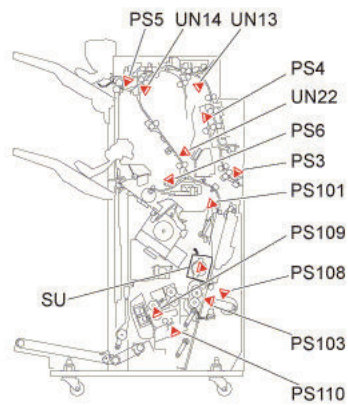
I/O: Service Mode > SITUATION > Sensor Check

Check items (in arbitrary order)

- Remaining paper at the upstream of the target sensor
- Soiling on the target sensor

Displacement of the target sensor position

- Failure of the target sensor
- Soiling (grease)/deterioration/Failure of a drive motor located upstream of the target sensor
- Soiling (paper dust)/deterioration/Failure of a drive roller located upstream of the target sensor



■ 021054: JamCode (Staple/ Booklet Finisher-W1 PRO) 1054

[Symptom/Question]

021054: JamCode (Staple/ Booklet Finisher-W1 PRO) 1054

[Remedy/Answer]

Jam Type : Delay jam

Sensor Name : Saddle Press HP Sensor

Sensor No. : PS113

Overview of detection

A delay jam occurs when a sensor was not turned ON although a specified period of time had passed after the start of detection by the sensor.

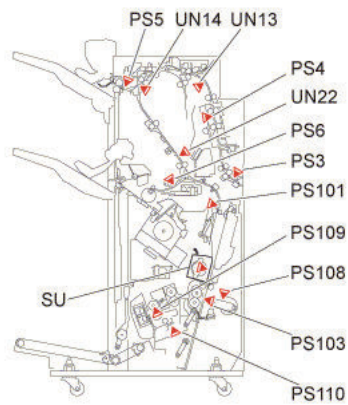
I/O: Service Mode > SITUATION > Sensor Check

Check items (in arbitrary order)

- Remaining paper at the upstream of the target sensor
- Soiling on the target sensor

Displacement of the target sensor position

- Failure of the target sensor
- Soiling (grease)/deterioration/Failure of a drive motor located upstream of the target sensor
- Soiling (paper dust)/deterioration/Failure of a drive roller located upstream of the target sensor



■ 021082: JamCode (Paper Folding Unit-J1) 1082

[Symptom/Question]

021082: JamCode (Paper Folding Unit-J1) 1082

[Remedy/Answer]

Jam Type : Delay jam

Sensor Name : Entrance Sensor

Sensor No. : S20

Overview of detection

A delay jam occurs when a sensor was not turned ON although a specified period of time had passed after the start of detection by the sensor.

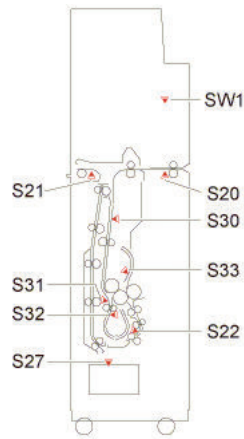
I/O: Service Mode > SITUATION > Sensor Check

Check items (in arbitrary order)

- Remaining paper at the upstream of the target sensor
- Soiling on the target sensor

Displacement of the target sensor position

- Failure of the target sensor
- Soiling (grease)/deterioration/Failure of a drive motor located upstream of the target sensor
- Soiling (paper dust)/deterioration/Failure of a drive roller located upstream of the target sensor



■ 021084: JamCode (Paper Folding Unit-J1) 1084

[Symptom/Question]

021084: JamCode (Paper Folding Unit-J1) 1084

[Remedy/Answer]

Jam Type : Delay jam

Sensor Name : Delivery Sensor 2

Sensor No. : S21

Overview of detection

A delay jam occurs when a sensor was not turned ON although a specified period of time had passed after the start of detection by the sensor.

I/O: Service Mode > SITUATION > Sensor Check

Check items (in arbitrary order)

- Remaining paper at the upstream of the target sensor
- Soiling on the target sensor

Displacement of the target sensor position

- Failure of the target sensor
- Soiling (grease)/deterioration/Failure of a drive motor located upstream of the target sensor
- Soiling (paper dust)/deterioration/Failure of a drive roller located upstream of the target sensor



■ 021086: JamCode (Paper Folding Unit-J1) 1086

[Symptom/Question]

021086: JamCode (Paper Folding Unit-J1) 1086

[Remedy/Answer]

Jam Type : Delay jam

Sensor Name : Slowdown Timing Sensor

Sensor No. : S30

Overview of detection

A delay jam occurs when a sensor was not turned ON although a specified period of time had passed after the start of detection by the sensor.

I/O: Service Mode > SITUATION > Sensor Check

Check items (in arbitrary order)

- Remaining paper at the upstream of the target sensor
- Soiling on the target sensor

Displacement of the target sensor position

- Failure of the target sensor
- Soiling (grease)/deterioration/Failure of a drive motor located upstream of the target sensor
- Soiling (paper dust)/deterioration/Failure of a drive roller located upstream of the target sensor



■ 021088: JamCode (Paper Folding Unit-J1) 1088

[Symptom/Question]

021088: JamCode (Paper Folding Unit-J1) 1088

[Remedy/Answer]

Jam Type : Delay jam

Sensor Name : Release Timing Sensor

Sensor No. : S31

Overview of detection

A delay jam occurs when a sensor was not turned ON although a specified period of time had passed after the start of detection by the sensor.

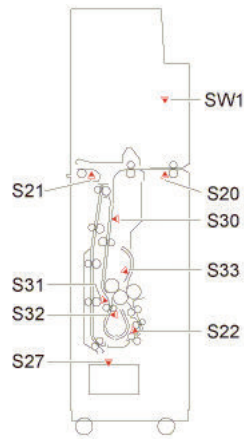
I/O: Service Mode > SITUATION > Sensor Check

Check items (in arbitrary order)

- Remaining paper at the upstream of the target sensor
- Soiling on the target sensor

Displacement of the target sensor position

- Failure of the target sensor
- Soiling (grease)/deterioration/Failure of a drive motor located upstream of the target sensor
- Soiling (paper dust)/deterioration/Failure of a drive roller located upstream of the target sensor



■ 02108A: JamCode (Paper Folding Unit-J1) 108A

[Symptom/Question]

02108A: JamCode (Paper Folding Unit-J1) 108A

[Remedy/Answer]

Jam Type : Delay jam

Sensor Name : Fold Position Sensor

Sensor No. : S32

Overview of detection

A delay jam occurs when a sensor was not turned ON although a specified period of time had passed after the start of detection by the sensor.

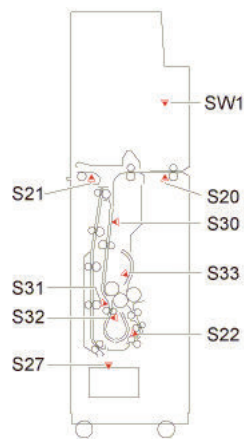
I/O: Service Mode > SITUATION > Sensor Check

Check items (in arbitrary order)

- Remaining paper at the upstream of the target sensor
- Soiling on the target sensor

Displacement of the target sensor position

- Failure of the target sensor
- Soiling (grease)/deterioration/Failure of a drive motor located upstream of the target sensor
- Soiling (paper dust)/deterioration/Failure of a drive roller located upstream of the target sensor



■ 02108C: JamCode (Paper Folding Unit-J1) 108C

[Symptom/Question]

02108C: JamCode (Paper Folding Unit-J1) 108C

[Remedy/Answer]

Jam Type : Delay jam

Sensor Name : Upper Stopper Paper Sensor

Sensor No. : S33

Overview of detection

A delay jam occurs when a sensor was not turned ON although a specified period of time had passed after the start of detection by the sensor.

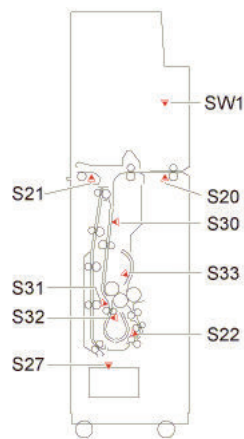
I/O: Service Mode > SITUATION > Sensor Check

Check items (in arbitrary order)

- Remaining paper at the upstream of the target sensor
- Soiling on the target sensor

Displacement of the target sensor position

- Failure of the target sensor
- Soiling (grease)/deterioration/Failure of a drive motor located upstream of the target sensor
- Soiling (paper dust)/deterioration/Failure of a drive roller located upstream of the target sensor



■ 02108E: JamCode (Paper Folding Unit-J1) 108E

[Symptom/Question]

02108E: JamCode (Paper Folding Unit-J1) 108E

[Remedy/Answer]

Jam Type : Delay jam

Sensor Name : Delivery Sensor 1

Sensor No. : S22

Overview of detection

A delay jam occurs when a sensor was not turned ON although a specified period of time had passed after the start of detection by the sensor.

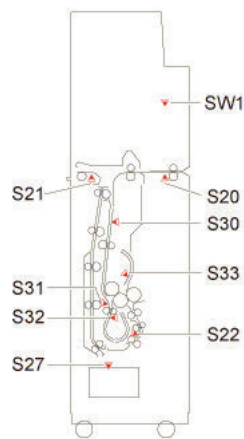
I/O: Service Mode > SITUATION > Sensor Check

Check items (in arbitrary order)

- Remaining paper at the upstream of the target sensor
- Soiling on the target sensor

Displacement of the target sensor position

- Failure of the target sensor
- Soiling (grease)/deterioration/Failure of a drive motor located upstream of the target sensor
- Soiling (paper dust)/deterioration/Failure of a drive roller located upstream of the target sensor



■ 021091: JamCode (Staple/Booklet Finisher-X1) 1091

[Symptom/Question]

021091: JamCode (Staple/Booklet Finisher-X1) 1091

[Remedy/Answer]

Jam Type : Delay jam

Sensor Name : Saddle delivery sensor 2

Sensor No. : S227

Overview of detection

A delay jam occurs when a sensor was not turned ON although a specified period of time had passed after the start of detection by the sensor.

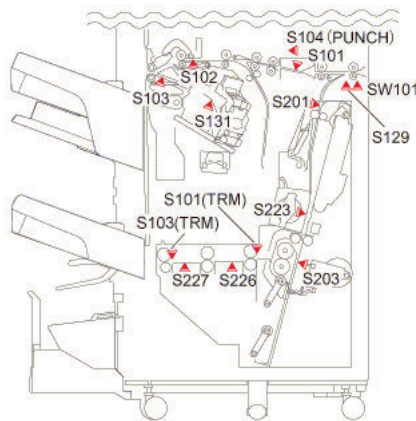
I/O: Service Mode > SITUATION > Sensor Check

Check items (in arbitrary order)

- Remaining paper at the upstream of the target sensor
- Soiling on the target sensor

Displacement of the target sensor position

- Failure of the target sensor
- Soiling (grease)/deterioration/Failure of a drive motor located upstream of the target sensor
- Soiling (paper dust)/deterioration/Failure of a drive roller located upstream of the target sensor



■ 021092: JamCode (Staple/Booklet Finisher-X1) 1092

[Symptom/Question]

021092: JamCode (Staple/Booklet Finisher-X1) 1092

[Remedy/Answer]

Jam Type : Delay jam

Sensor Name : Booklet Finisher-X1:Saddle Delivery Sensor 1

Sensor No. : S226

Overview of detection

A delay jam occurs when a sensor was not turned ON although a specified period of time had passed after the start of detection by the sensor.

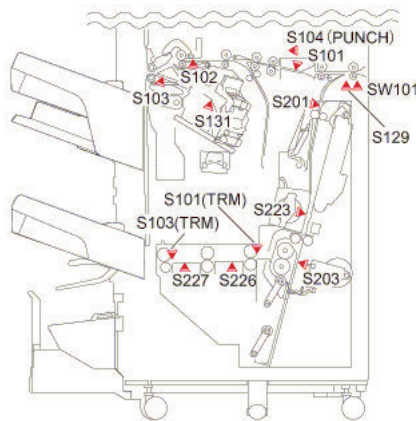
I/O: Service Mode > SITUATION > Sensor Check

Check items (in arbitrary order)

- Remaining paper at the upstream of the target sensor
- Soiling on the target sensor

Displacement of the target sensor position

- Failure of the target sensor
- Soiling (grease)/deterioration/Failure of a drive motor located upstream of the target sensor
- Soiling (paper dust)/deterioration/Failure of a drive roller located upstream of the target sensor



■ 021092: JamCode (Paper Folding Unit-J1) 1092

[Symptom/Question]

021092: JamCode (Paper Folding Unit-J1) 1092

[Remedy/Answer]

Jam Type : Delay jam

Sensor Name : Paper Folding Unit-J1: Fold Tray Paper Sensor

Sensor No. : S27

Overview of detection

A delay jam occurs when a sensor was not turned ON although a specified period of time had passed after the start of detection by the sensor.

I/O: Service Mode > SITUATION > Sensor Check

Check items (in arbitrary order)

- Remaining paper at the upstream of the target sensor
- Soiling on the target sensor

Displacement of the target sensor position

- Failure of the target sensor
- Soiling (grease)/deterioration/Failure of a drive motor located upstream of the target sensor
- Soiling (paper dust)/deterioration/Failure of a drive roller located upstream of the target sensor



■ 021093: JamCode (Staple/Booklet Finisher-X1) 1093

[Symptom/Question]

021093: JamCode (Staple/Booklet Finisher-X1) 1093

[Remedy/Answer]

Jam Type : Delay jam

Sensor Name : Saddle inlet sensor

Sensor No. : S201

Overview of detection

A delay jam occurs when a sensor was not turned ON although a specified period of time had passed after the start of detection by the sensor.

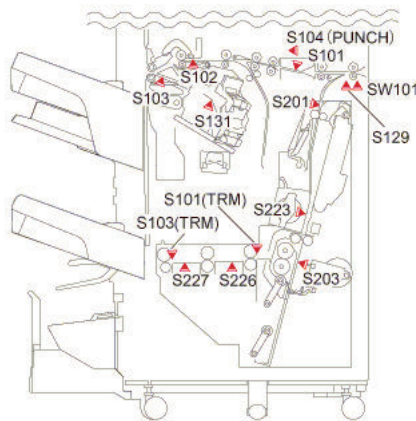
I/O: Service Mode > SITUATION > Sensor Check

Check items (in arbitrary order)

- Remaining paper at the upstream of the target sensor
- Soiling on the target sensor

Displacement of the target sensor position

- Failure of the target sensor
- Soiling (grease)/deterioration/Failure of a drive motor located upstream of the target sensor
- Soiling (paper dust)/deterioration/Failure of a drive roller located upstream of the target sensor



■ 021094: JamCode (Staple/Booklet Finisher-X1) 1094

[Symptom/Question]

021094: JamCode (Staple/Booklet Finisher-X1) 1094

[Remedy/Answer]

Jam Type : Delay jam

Sensor Name : Trimmer inlet sensor

Sensor No. : S101(TRM)

Overview of detection

A delay jam occurs when a sensor was not turned ON although a specified period of time had passed after the start of detection by the sensor.

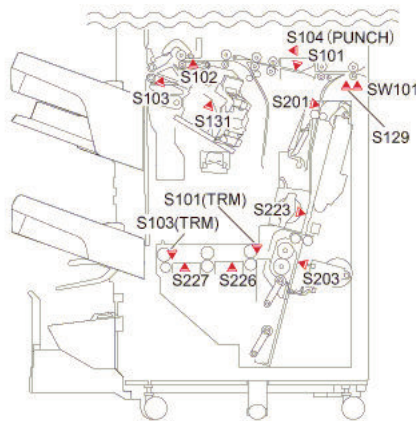
I/O: Service Mode > SITUATION > Sensor Check

Check items (in arbitrary order)

- Remaining paper at the upstream of the target sensor
- Soiling on the target sensor

Displacement of the target sensor position

- Failure of the target sensor
- Soiling (grease)/deterioration/Failure of a drive motor located upstream of the target sensor
- Soiling (paper dust)/deterioration/Failure of a drive roller located upstream of the target sensor



■ 021096: JamCode (Staple/Booklet Finisher-X1) 1096

[Symptom/Question]

021096: JamCode (Staple/Booklet Finisher-X1) 1096

[Remedy/Answer]

Jam Type : Delay jam

Sensor Name : Saddle Vertical Path Sensor

Sensor No. : S203

Overview of detection

A delay jam occurs when a sensor was not turned ON although a specified period of time had passed after the start of detection by the sensor.

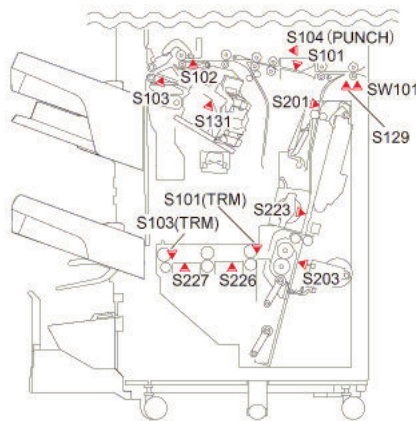
I/O: Service Mode > SITUATION > Sensor Check

Check items (in arbitrary order)

- Remaining paper at the upstream of the target sensor
- Soiling on the target sensor

Displacement of the target sensor position

- Failure of the target sensor
- Soiling (grease)/deterioration/Failure of a drive motor located upstream of the target sensor
- Soiling (paper dust)/deterioration/Failure of a drive roller located upstream of the target sensor



■ 0210E0: JamCode (Document Insertion Unit-N1) 10E0

[Symptom/Question]

0210E0: JamCode (Document Insertion Unit-N1) 10E0

[Remedy/Answer]

Jam Type : Delay jam

Sensor Name : Entrance Sensor

Sensor No. : S20

Overview of detection

A delay jam occurs when a sensor was not turned ON although a specified period of time had passed after the start of detection by the sensor.

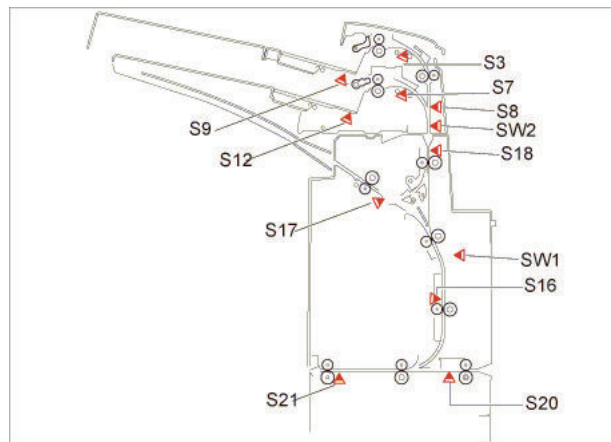
I/O: Service Mode > SITUATION > Sensor Check

Check items (in arbitrary order)

- Remaining paper at the upstream of the target sensor
- Soiling on the target sensor

Displacement of the target sensor position

- Failure of the target sensor
- Soiling (grease)/deterioration/Failure of a drive motor located upstream of the target sensor
- Soiling (paper dust)/deterioration/Failure of a drive roller located upstream of the target sensor



■ 0210E1: JamCode (Paper Folding Unit-J1) 10E1

[Symptom/Question]

0210E1: JamCode (Paper Folding Unit-J1) 10E1

[Remedy/Answer]

Jam Type : Delay jam

Sensor Name : Entrance Sensor

Sensor No. : S20

Overview of detection

A delay jam occurs when a sensor was not turned ON although a specified period of time had passed after the start of detection by the sensor.

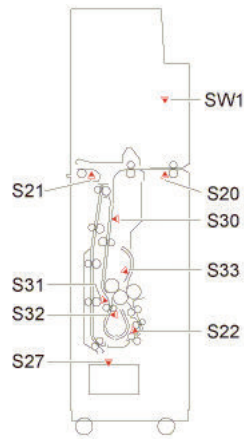
I/O: Service Mode > SITUATION > Sensor Check

Check items (in arbitrary order)

- Remaining paper at the upstream of the target sensor
- Soiling on the target sensor

Displacement of the target sensor position

- Failure of the target sensor
- Soiling (grease)/deterioration/Failure of a drive motor located upstream of the target sensor
- Soiling (paper dust)/deterioration/Failure of a drive roller located upstream of the target sensor



■ 0210E2: JamCode (Document Insertion Unit-N1) 10E2

[Symptom/Question]

0210E2: JamCode (Document Insertion Unit-N1) 10E2

[Remedy/Answer]

Jam Type : Delay jam

Sensor Name : Delivery Sensor 2

Sensor No. : S21

Overview of detection

A delay jam occurs when a sensor was not turned ON although a specified period of time had passed after the start of detection by the sensor.

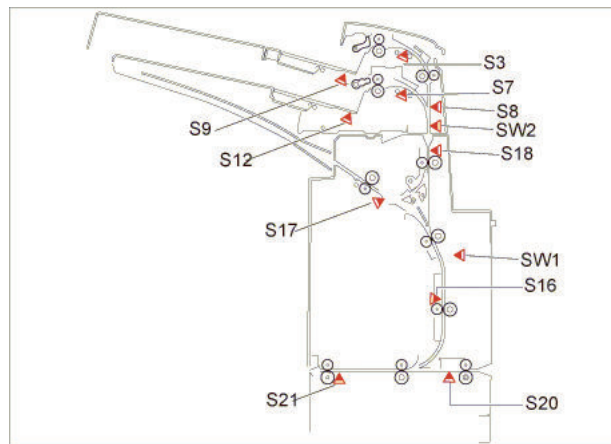
I/O: Service Mode > SITUATION > Sensor Check

Check items (in arbitrary order)

- Remaining paper at the upstream of the target sensor
- Soiling on the target sensor

Displacement of the target sensor position

- Failure of the target sensor
- Soiling (grease)/deterioration/Failure of a drive motor located upstream of the target sensor
- Soiling (paper dust)/deterioration/Failure of a drive roller located upstream of the target sensor



■ 0210E3: JamCode (Paper Folding Unit-J1) 10E3

[Symptom/Question]

0210E3: JamCode (Paper Folding Unit-J1) 10E3

[Remedy/Answer]

Jam Type : Delay jam

Sensor Name : Delivery Sensor 2

Sensor No. : S21

Overview of detection

A delay jam occurs when a sensor was not turned ON although a specified period of time had passed after the start of detection by the sensor.

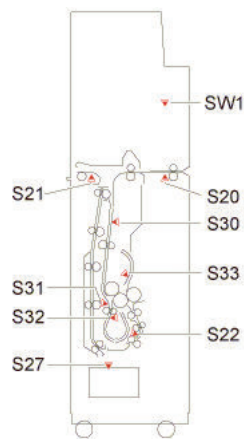
I/O: Service Mode > SITUATION > Sensor Check

Check items (in arbitrary order)

- Remaining paper at the upstream of the target sensor
- Soiling on the target sensor

Displacement of the target sensor position

- Failure of the target sensor
- Soiling (grease)/deterioration/Failure of a drive motor located upstream of the target sensor
- Soiling (paper dust)/deterioration/Failure of a drive roller located upstream of the target sensor



■ 0210E4: JamCode (Document Insertion Unit-N1) 10E4

[Symptom/Question]

0210E4: JamCode (Document Insertion Unit-N1) 10E4

[Remedy/Answer]

Jam Type : Delay jam

Sensor Name : Upper Tray Registration Sensor

Sensor No. : S3

Overview of detection

A delay jam occurs when a sensor was not turned ON although a specified period of time had passed after the start of detection by the sensor.

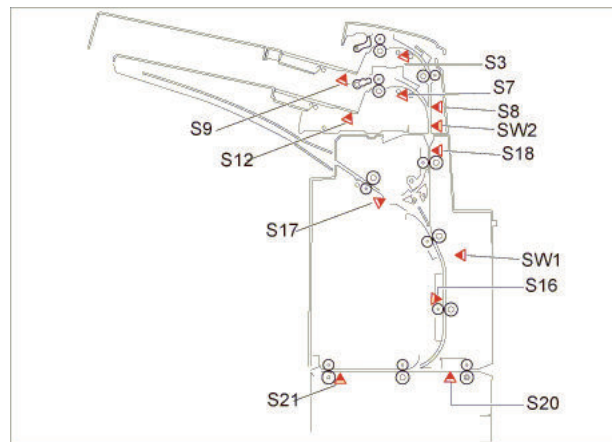
I/O: Service Mode > SITUATION > Sensor Check

Check items (in arbitrary order)

- Remaining paper at the upstream of the target sensor
- Soiling on the target sensor

Displacement of the target sensor position

- Failure of the target sensor
- Soiling (grease)/deterioration/Failure of a drive motor located upstream of the target sensor
- Soiling (paper dust)/deterioration/Failure of a drive roller located upstream of the target sensor



■ 0210E5: JamCode (Document Insertion Unit-N1) 10E5

[Symptom/Question]

0210E5: JamCode (Document Insertion Unit-N1) 10E5

[Remedy/Answer]

Jam Type : Delay jam

Sensor Name : Middle Feed Sensor

Sensor No. : S8

Overview of detection

A delay jam occurs when a sensor was not turned ON although a specified period of time had passed after the start of detection by the sensor.

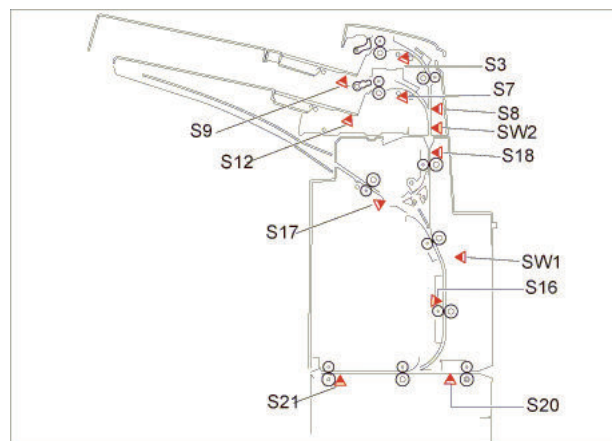
I/O: Service Mode > SITUATION > Sensor Check

Check items (in arbitrary order)

- Remaining paper at the upstream of the target sensor
- Soiling on the target sensor

Displacement of the target sensor position

- Failure of the target sensor
- Soiling (grease)/deterioration/Failure of a drive motor located upstream of the target sensor
- Soiling (paper dust)/deterioration/Failure of a drive roller located upstream of the target sensor



■ 0210E6: JamCode (Document Insertion Unit-N1) 10E6

[Symptom/Question]

0210E6: JamCode (Document Insertion Unit-N1) 10E6

[Remedy/Answer]

Jam Type : Delay jam

Sensor Name : Reverse Entrance Sensor

Sensor No. : S18

Overview of detection

A delay jam occurs when a sensor was not turned ON although a specified period of time had passed after the start of detection by the sensor.

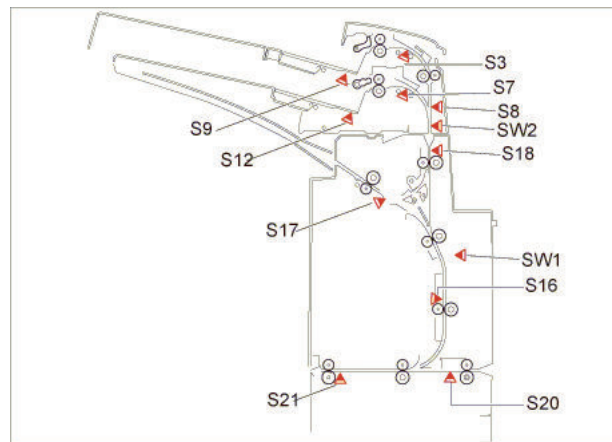
I/O: Service Mode > SITUATION > Sensor Check

Check items (in arbitrary order)

- Remaining paper at the upstream of the target sensor
- Soiling on the target sensor

Displacement of the target sensor position

- Failure of the target sensor
- Soiling (grease)/deterioration/Failure of a drive motor located upstream of the target sensor
- Soiling (paper dust)/deterioration/Failure of a drive roller located upstream of the target sensor



■ 0210E7: JamCode (Document Insertion Unit-N1) 10E7

[Symptom/Question]

0210E7: JamCode (Document Insertion Unit-N1) 10E7

[Remedy/Answer]

Jam Type : Delay jam

Sensor Name : Reverse Sensor

Sensor No. : S17

Overview of detection

A delay jam occurs when a sensor was not turned ON although a specified period of time had passed after the start of detection by the sensor.

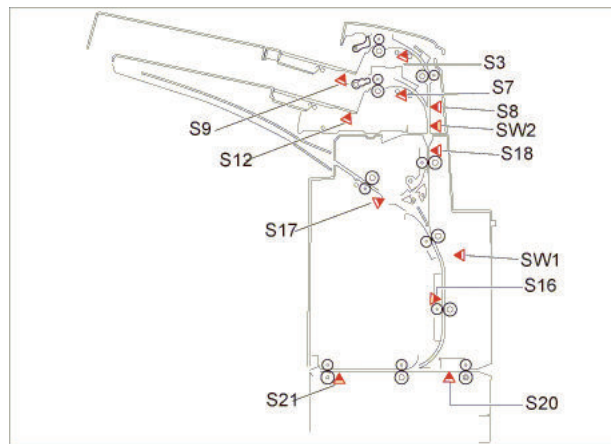
I/O: Service Mode > SITUATION > Sensor Check

Check items (in arbitrary order)

- Remaining paper at the upstream of the target sensor
- Soiling on the target sensor

Displacement of the target sensor position

- Failure of the target sensor
- Soiling (grease)/deterioration/Failure of a drive motor located upstream of the target sensor
- Soiling (paper dust)/deterioration/Failure of a drive roller located upstream of the target sensor



■ 0210E8: JamCode (Document Insertion Unit-N1) 10E8

[Symptom/Question]

0210E8: JamCode (Document Insertion Unit-N1) 10E8

[Remedy/Answer]

Jam Type : Delay jam

Sensor Name : Reverse Timing Sensor

Sensor No. : S16

Overview of detection

A delay jam occurs when a sensor was not turned ON although a specified period of time had passed after the start of detection by the sensor.

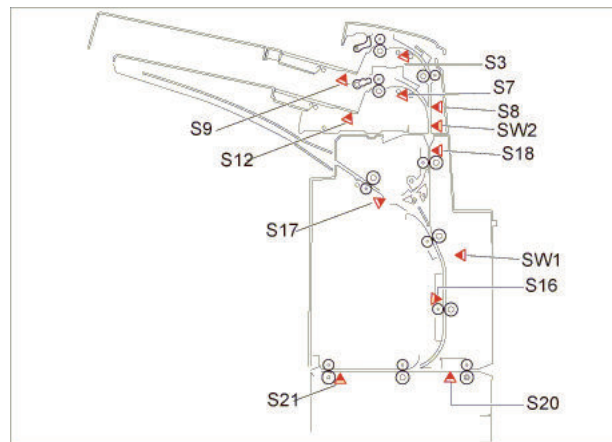
I/O: Service Mode > SITUATION > Sensor Check

Check items (in arbitrary order)

- Remaining paper at the upstream of the target sensor
- Soiling on the target sensor

Displacement of the target sensor position

- Failure of the target sensor
- Soiling (grease)/deterioration/Failure of a drive motor located upstream of the target sensor
- Soiling (paper dust)/deterioration/Failure of a drive roller located upstream of the target sensor



■ 0210E9: JamCode (Paper Folding Unit-J1) 10E9

[Symptom/Question]

0210E9: JamCode (Paper Folding Unit-J1) 10E9

[Remedy/Answer]

Jam Type : Delay jam

Sensor Name : Slowdown Timing Sensor

Sensor No. : S30

Overview of detection

A delay jam occurs when a sensor was not turned ON although a specified period of time had passed after the start of detection by the sensor.

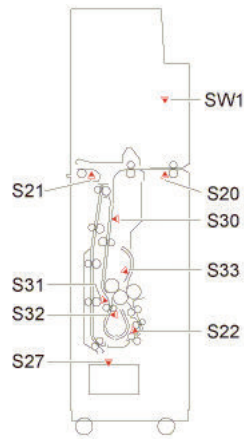
I/O: Service Mode > SITUATION > Sensor Check

Check items (in arbitrary order)

- Remaining paper at the upstream of the target sensor
- Soiling on the target sensor

Displacement of the target sensor position

- Failure of the target sensor
- Soiling (grease)/deterioration/Failure of a drive motor located upstream of the target sensor
- Soiling (paper dust)/deterioration/Failure of a drive roller located upstream of the target sensor



■ 0210EA: JamCode (Paper Folding Unit-J1) 10EA

[Symptom/Question]

0210EA: JamCode (Paper Folding Unit-J1) 10EA

[Remedy/Answer]

Jam Type : Delay jam

Sensor Name : Release Timing Sensor

Sensor No. : S31

Overview of detection

A delay jam occurs when a sensor was not turned ON although a specified period of time had passed after the start of detection by the sensor.

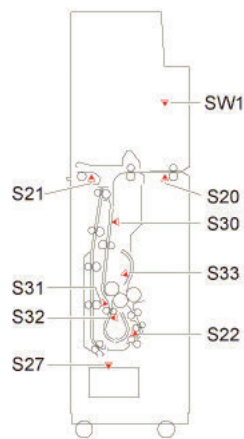
I/O: Service Mode > SITUATION > Sensor Check

Check items (in arbitrary order)

- Remaining paper at the upstream of the target sensor
- Soiling on the target sensor

Displacement of the target sensor position

- Failure of the target sensor
- Soiling (grease)/deterioration/Failure of a drive motor located upstream of the target sensor
- Soiling (paper dust)/deterioration/Failure of a drive roller located upstream of the target sensor



■ 0210EB: JamCode (Paper Folding Unit-J1) 10EB

[Symptom/Question]

0210EB: JamCode (Paper Folding Unit-J1) 10EB

[Remedy/Answer]

Jam Type : Delay jam

Sensor Name : Fold Position Sensor

Sensor No. : S32

Overview of detection

A delay jam occurs when a sensor was not turned ON although a specified period of time had passed after the start of detection by the sensor.

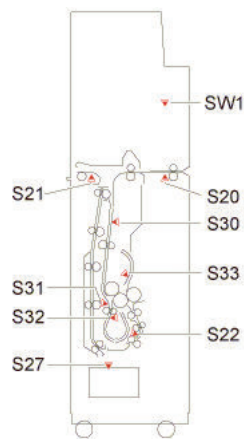
I/O: Service Mode > SITUATION > Sensor Check

Check items (in arbitrary order)

- Remaining paper at the upstream of the target sensor
- Soiling on the target sensor

Displacement of the target sensor position

- Failure of the target sensor
- Soiling (grease)/deterioration/Failure of a drive motor located upstream of the target sensor
- Soiling (paper dust)/deterioration/Failure of a drive roller located upstream of the target sensor



■ 0210EC: JamCode (Paper Folding Unit-J1) 10EC

[Symptom/Question]

0210EC: JamCode (Paper Folding Unit-J1) 10EC

[Remedy/Answer]

Jam Type : Delay jam

Sensor Name : Upper Stopper Paper Sensor

Sensor No. : S33

Overview of detection

A delay jam occurs when a sensor was not turned ON although a specified period of time had passed after the start of detection by the sensor.

I/O: Service Mode > SITUATION > Sensor Check

Check items (in arbitrary order)

- Remaining paper at the upstream of the target sensor
- Soiling on the target sensor

Displacement of the target sensor position

- Failure of the target sensor
- Soiling (grease)/deterioration/Failure of a drive motor located upstream of the target sensor
- Soiling (paper dust)/deterioration/Failure of a drive roller located upstream of the target sensor



■ 0210ED: JamCode (Paper Folding Unit-J1) 10ED

[Symptom/Question]

0210ED: JamCode (Paper Folding Unit-J1) 10ED

[Remedy/Answer]

Jam Type : Delay jam

Sensor Name : Delivery Sensor 1

Sensor No. : S22

Overview of detection

A delay jam occurs when a sensor was not turned ON although a specified period of time had passed after the start of detection by the sensor.

I/O: Service Mode > SITUATION > Sensor Check

Check items (in arbitrary order)

- Remaining paper at the upstream of the target sensor
- Soiling on the target sensor

Displacement of the target sensor position

- Failure of the target sensor
- Soiling (grease)/deterioration/Failure of a drive motor located upstream of the target sensor
- Soiling (paper dust)/deterioration/Failure of a drive roller located upstream of the target sensor



■ 0210EE: JamCode (Paper Folding Unit-J1) 10EE

[Symptom/Question]

0210EE: JamCode (Paper Folding Unit-J1) 10EE

[Remedy/Answer]

Jam Type : Delay jam

Sensor Name : Fold Tray Paper Sensor

Sensor No. : S27

Overview of detection

A delay jam occurs when a sensor was not turned ON although a specified period of time had passed after the start of detection by the sensor.

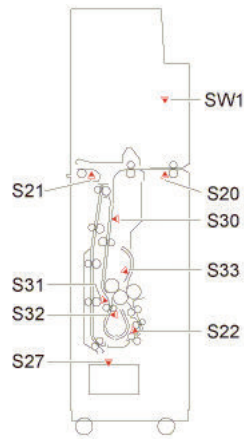
I/O: Service Mode > SITUATION > Sensor Check

Check items (in arbitrary order)

- Remaining paper at the upstream of the target sensor
- Soiling on the target sensor

Displacement of the target sensor position

- Failure of the target sensor
- Soiling (grease)/deterioration/Failure of a drive motor located upstream of the target sensor
- Soiling (paper dust)/deterioration/Failure of a drive roller located upstream of the target sensor



■ 0210EF: JamCode (Document Insertion Unit-N1) 10EF

[Symptom/Question]

0210EF: JamCode (Document Insertion Unit-N1) 10EF

[Remedy/Answer]

Jam Type : Delay jam

Sensor Name : Lower tray registration sensor

Sensor No. : S7

Overview of detection

A delay jam occurs when a sensor was not turned ON although a specified period of time had passed after the start of detection by the sensor.

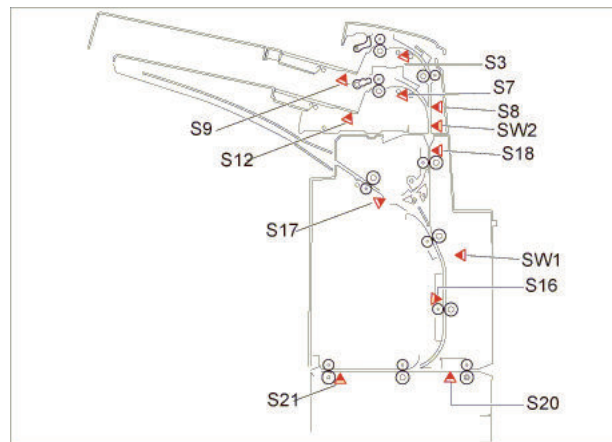
I/O: Service Mode > SITUATION > Sensor Check

Check items (in arbitrary order)

- Remaining paper at the upstream of the target sensor
- Soiling on the target sensor

Displacement of the target sensor position

- Failure of the target sensor
- Soiling (grease)/deterioration/Failure of a drive motor located upstream of the target sensor
- Soiling (paper dust)/deterioration/Failure of a drive roller located upstream of the target sensor



■ 021101: JamCode (Staple/Booklet Finisher-AC1) 1101

[Symptom/Question]

021101: JamCode (Staple/Booklet Finisher-AC1) 1101

[Remedy/Answer]

Jam Type : Stationary jam

Sensor Name : Inlet Sensor

Sensor No. : PS101

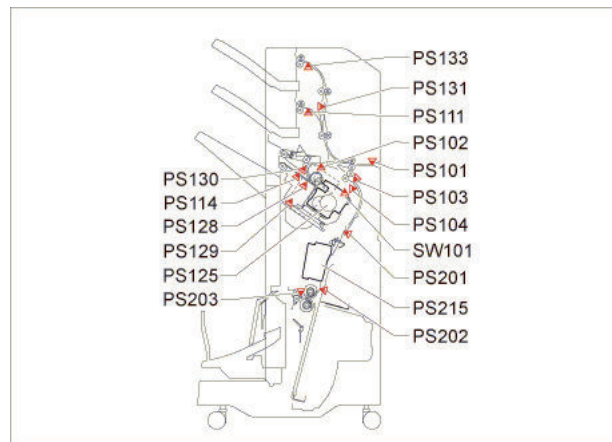
Overview of detection

A stationary jam occurs when a sensor was not turned OFF although a specified period of time had passed after the sensor was turned ON.

I/O: Service Mode > SITUATION > Sensor Check

Check items (in arbitrary order)

- Remaining paper near the target sensor
- Soiling on the target sensor
- Displacement of the target sensor position
- Failure of the target sensor
- Soiling (grease)/deterioration/failure of a drive motor located upstream of the target sensor
- Soiling (paper dust)/deterioration/failure of a drive roller located upstream of the target sensor



■ 021102: JamCode (Staple/Booklet Finisher-AC1) 1102

[Symptom/Question]

021102: JamCode (Staple/Booklet Finisher-AC1) 1102

[Remedy/Answer]

Jam Type : Stationary jam

Sensor Name : Delivery Sensor

Sensor No. : PS102

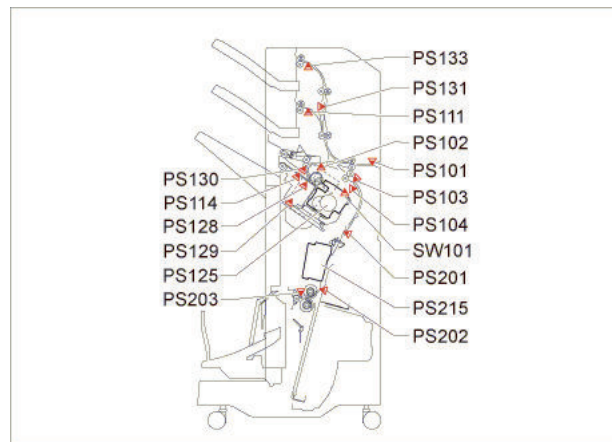
Overview of detection

A stationary jam occurs when a sensor was not turned OFF although a specified period of time had passed after the sensor was turned ON.

I/O: Service Mode > SITUATION > Sensor Check

Check items (in arbitrary order)

- Remaining paper near the target sensor
- Soiling on the target sensor
- Displacement of the target sensor position
- Failure of the target sensor
- Soiling (grease)/deterioration/failure of a drive motor located upstream of the target sensor
- Soiling (paper dust)/deterioration/failure of a drive roller located upstream of the target sensor



■ 021103: JamCode (Staple/Booklet Finisher-AC1) 1103

[Symptom/Question]

021103: JamCode (Staple/Booklet Finisher-AC1) 1103

[Remedy/Answer]

Jam Type : Stationary jam

Sensor Name : Buffer Sensor

Sensor No. : PS103

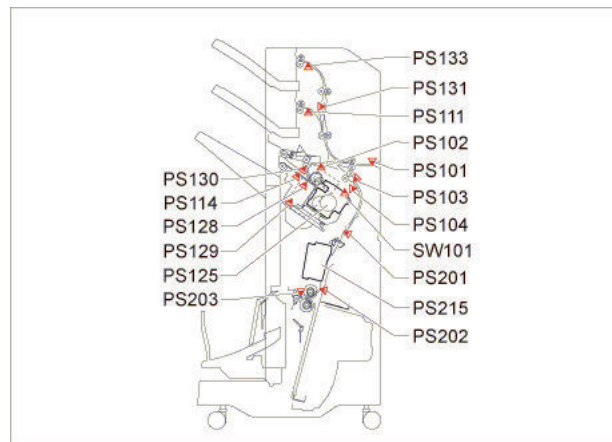
Overview of detection

A stationary jam occurs when a sensor was not turned OFF although a specified period of time had passed after the sensor was turned ON.

I/O: Service Mode > SITUATION > Sensor Check

Check items (in arbitrary order)

- Remaining paper near the target sensor
- Soiling on the target sensor
- Displacement of the target sensor position
- Failure of the target sensor
- Soiling (grease)/deterioration/failure of a drive motor located upstream of the target sensor
- Soiling (paper dust)/deterioration/failure of a drive roller located upstream of the target sensor



■ 021103: JamCode (Staple/ Booklet Finisher-W1 PRO) 1103

[Symptom/Question]

021103: JamCode (Staple/ Booklet Finisher-W1 PRO) 1103

[Remedy/Answer]

Jam Type : Stationary jam

Sensor Name : Inlet Sensor

Sensor No. : PS3

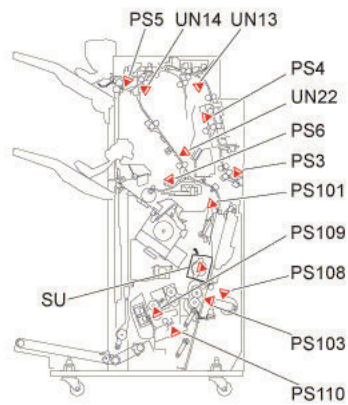
Overview of detection

A stationary jam occurs when a sensor was not turned OFF although a specified period of time had passed after the sensor was turned ON.

I/O: Service Mode > SITUATION > Sensor Check

Check items (in arbitrary order)

- Remaining paper near the target sensor
- Soiling on the target sensor
- Displacement of the target sensor position
- Failure of the target sensor
- Soiling (grease)/deterioration/failure of a drive motor located upstream of the target sensor
- Soiling (paper dust)/deterioration/failure of a drive roller located upstream of the target sensor



■ 021104: JamCode (Staple/Booklet Finisher-AC1) 1104

[Symptom/Question]

021104: JamCode (Staple/Booklet Finisher-AC1) 1104

[Remedy/Answer]

Jam Type : Stationary jam

Sensor Name : Lower Escape Delivery Sensor

Sensor No. : PS111

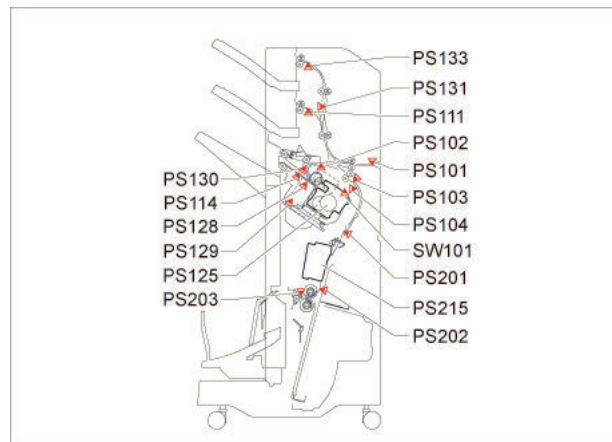
Overview of detection

A stationary jam occurs when a sensor was not turned OFF although a specified period of time had passed after the sensor was turned ON.

I/O: Service Mode > SITUATION > Sensor Check

Check items (in arbitrary order)

- Remaining paper near the target sensor
- Soiling on the target sensor
- Displacement of the target sensor position
- Failure of the target sensor
- Soiling (grease)/deterioration/failure of a drive motor located upstream of the target sensor
- Soiling (paper dust)/deterioration/failure of a drive roller located upstream of the target sensor



■ 021105: JamCode (Staple/Booklet Finisher-AC1) 1105

[Symptom/Question]

021105: JamCode (Staple/Booklet Finisher-AC1) 1105

[Remedy/Answer]

Jam Type : Stationary jam

Sensor Name : Upper Escape Delivery Sensor

Sensor No. : PS133

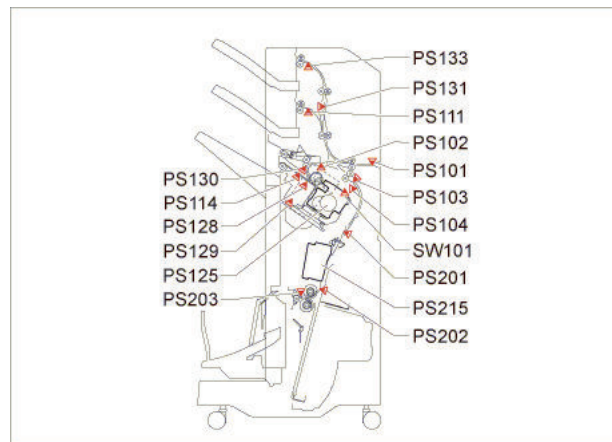
Overview of detection

A stationary jam occurs when a sensor was not turned OFF although a specified period of time had passed after the sensor was turned ON.

I/O: Service Mode > SITUATION > Sensor Check

Check items (in arbitrary order)

- Remaining paper near the target sensor
- Soiling on the target sensor
- Displacement of the target sensor position
- Failure of the target sensor
- Soiling (grease)/deterioration/failure of a drive motor located upstream of the target sensor
- Soiling (paper dust)/deterioration/failure of a drive roller located upstream of the target sensor



■ 021105: JamCode (Staple/ Booklet Finisher-W1 PRO) 1105

[Symptom/Question]

021105: JamCode (Staple/ Booklet Finisher-W1 PRO) 1105

[Remedy/Answer]

Jam Type : Stationary jam

Sensor Name : Shift Unit Trailing Edge Sensor

Sensor No. : PS4

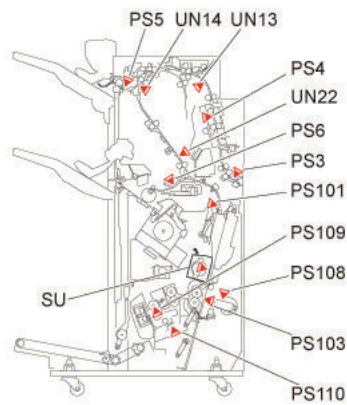
Overview of detection

A stationary jam occurs when a sensor was not turned OFF although a specified period of time had passed after the sensor was turned ON.

I/O: Service Mode > SITUATION > Sensor Check

Check items (in arbitrary order)

- Remaining paper near the target sensor
- Soiling on the target sensor
- Displacement of the target sensor position
- Failure of the target sensor
- Soiling (grease)/deterioration/failure of a drive motor located upstream of the target sensor
- Soiling (paper dust)/deterioration/failure of a drive roller located upstream of the target sensor



■ 021106: JamCode (Staple/Booklet Finisher-AC1) 1106

[Symptom/Question]

021106: JamCode (Staple/Booklet Finisher-AC1) 1106

[Remedy/Answer]

Jam Type : Stationary jam

Sensor Name : Escape Feed Sensor

Sensor No. : PS131

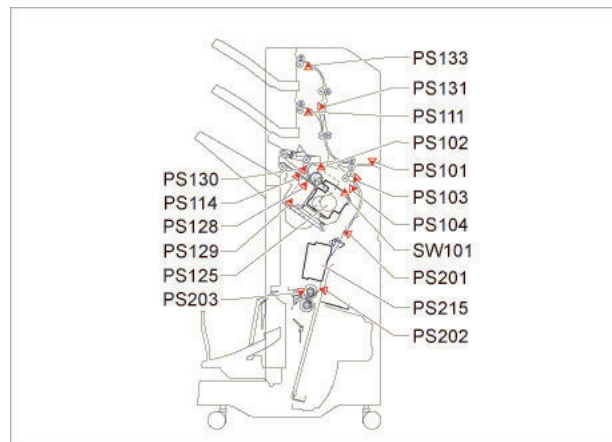
Overview of detection

A stationary jam occurs when a sensor was not turned OFF although a specified period of time had passed after the sensor was turned ON.

I/O: Service Mode > SITUATION > Sensor Check

Check items (in arbitrary order)

- Remaining paper near the target sensor
- Soiling on the target sensor
- Displacement of the target sensor position
- Failure of the target sensor
- Soiling (grease)/deterioration/failure of a drive motor located upstream of the target sensor
- Soiling (paper dust)/deterioration/failure of a drive roller located upstream of the target sensor



■ 021107: JamCode (Staple/ Booklet Finisher-W1 PRO) 1107

[Symptom/Question]

021107: JamCode (Staple/ Booklet Finisher-W1 PRO) 1107

[Remedy/Answer]

Jam Type : Stationary jam

Sensor Name : Buffer Path 1 Sensor PCB

Sensor No. : UN13

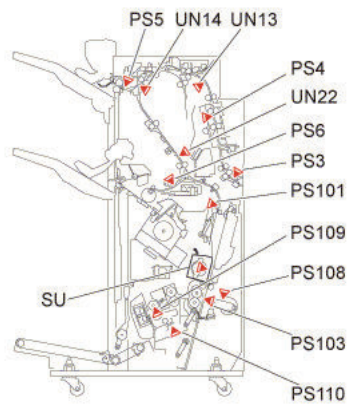
Overview of detection

A stationary jam occurs when a sensor was not turned OFF although a specified period of time had passed after the sensor was turned ON.

I/O: Service Mode > SITUATION > Sensor Check

Check items (in arbitrary order)

- Remaining paper near the target sensor
- Soiling on the target sensor
- Displacement of the target sensor position
- Failure of the target sensor
- Soiling (grease)/deterioration/failure of a drive motor located upstream of the target sensor
- Soiling (paper dust)/deterioration/failure of a drive roller located upstream of the target sensor



■ 021108: JamCode (Staple/Booklet Finisher-AC1) 1108

[Symptom/Question]

021108: JamCode (Staple/Booklet Finisher-AC1) 1108

[Remedy/Answer]

Jam Type : Stationary jam

Sensor Name : Saddle Delivery Sensor

Sensor No. : PS203

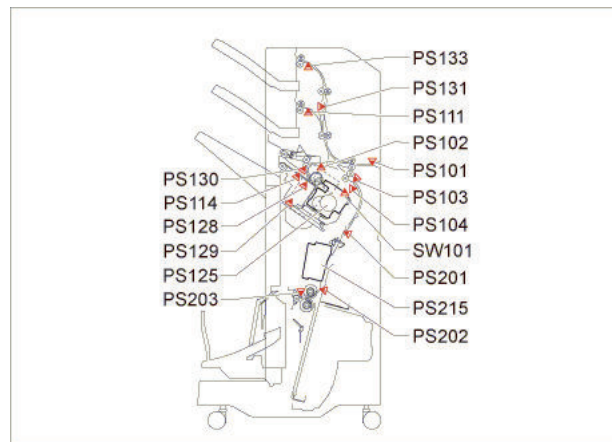
Overview of detection

A stationary jam occurs when a sensor was not turned OFF although a specified period of time had passed after the sensor was turned ON.

I/O: Service Mode > SITUATION > Sensor Check

Check items (in arbitrary order)

- Remaining paper near the target sensor
- Soiling on the target sensor
- Displacement of the target sensor position
- Failure of the target sensor
- Soiling (grease)/deterioration/failure of a drive motor located upstream of the target sensor
- Soiling (paper dust)/deterioration/failure of a drive roller located upstream of the target sensor



■ 021109: JamCode (Staple/Booklet Finisher-AC1) 1109

[Symptom/Question]

021109: JamCode (Staple/Booklet Finisher-AC1) 1109

[Remedy/Answer]

Jam Type : Stationary jam

Sensor Name : Saddle Inlet Sensor

Sensor No. : PS201

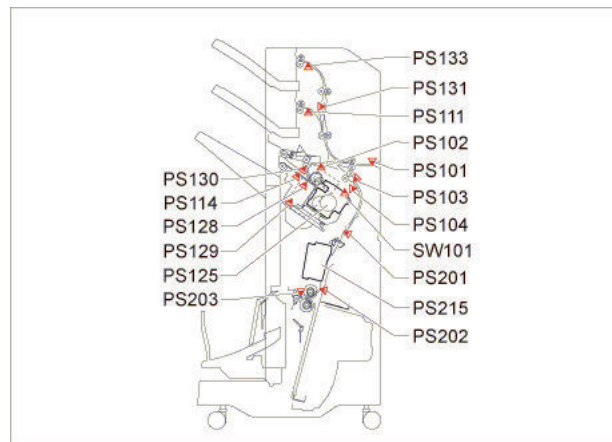
Overview of detection

A stationary jam occurs when a sensor was not turned OFF although a specified period of time had passed after the sensor was turned ON.

I/O: Service Mode > SITUATION > Sensor Check

Check items (in arbitrary order)

- Remaining paper near the target sensor
- Soiling on the target sensor
- Displacement of the target sensor position
- Failure of the target sensor
- Soiling (grease)/deterioration/failure of a drive motor located upstream of the target sensor
- Soiling (paper dust)/deterioration/failure of a drive roller located upstream of the target sensor



■ 021109: JamCode (Staple/ Booklet Finisher-W1 PRO) 1109

[Symptom/Question]

021109: JamCode (Staple/ Booklet Finisher-W1 PRO) 1109

[Remedy/Answer]

Jam Type : Stationary jam

Sensor Name : Buffer Path 2 Sensor PCB

Sensor No. : UN14

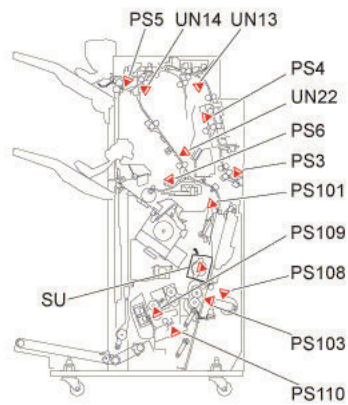
Overview of detection

A stationary jam occurs when a sensor was not turned OFF although a specified period of time had passed after the sensor was turned ON.

I/O: Service Mode > SITUATION > Sensor Check

Check items (in arbitrary order)

- Remaining paper near the target sensor
- Soiling on the target sensor
- Displacement of the target sensor position
- Failure of the target sensor
- Soiling (grease)/deterioration/failure of a drive motor located upstream of the target sensor
- Soiling (paper dust)/deterioration/failure of a drive roller located upstream of the target sensor



■ 02110B: JamCode (Staple/ Booklet Finisher-W1 PRO) 110B

[Symptom/Question]

02110B: JamCode (Staple/ Booklet Finisher-W1 PRO) 110B

[Remedy/Answer]

Jam Type : Stationary jam

Sensor Name : Upper Delivery Sensor

Sensor No. : PS5

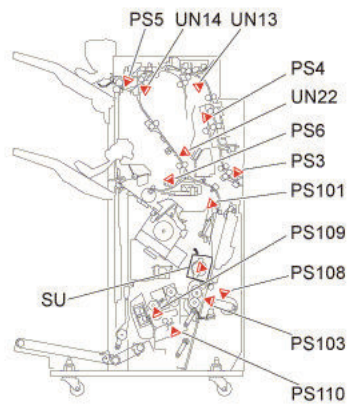
Overview of detection

A stationary jam occurs when a sensor was not turned OFF although a specified period of time had passed after the sensor was turned ON.

I/O: Service Mode > SITUATION > Sensor Check

Check items (in arbitrary order)

- Remaining paper near the target sensor
- Soiling on the target sensor
- Displacement of the target sensor position
- Failure of the target sensor
- Soiling (grease)/deterioration/failure of a drive motor located upstream of the target sensor
- Soiling (paper dust)/deterioration/failure of a drive roller located upstream of the target sensor



■ 02110D: JamCode (Staple/ Booklet Finisher-W1 PRO) 110D

[Symptom/Question]

02110D: JamCode (Staple/ Booklet Finisher-W1 PRO) 110D

[Remedy/Answer]

Jam Type : Stationary jam

Sensor Name : Lower Path Sensor PCB

Sensor No. : UN22

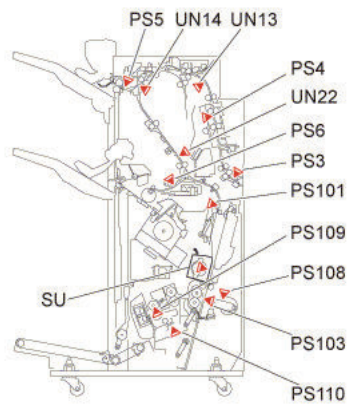
Overview of detection

A stationary jam occurs when a sensor was not turned OFF although a specified period of time had passed after the sensor was turned ON.

I/O: Service Mode > SITUATION > Sensor Check

Check items (in arbitrary order)

- Remaining paper near the target sensor
- Soiling on the target sensor
- Displacement of the target sensor position
- Failure of the target sensor
- Soiling (grease)/deterioration/failure of a drive motor located upstream of the target sensor
- Soiling (paper dust)/deterioration/failure of a drive roller located upstream of the target sensor



■ 02110F: JamCode (Staple/ Booklet Finisher-W1 PRO) 110F

[Symptom/Question]

02110F: JamCode (Staple/ Booklet Finisher-W1 PRO) 110F

[Remedy/Answer]

Jam Type : Stationary jam

Sensor Name : Lower Delivery Sensor

Sensor No. : PS6

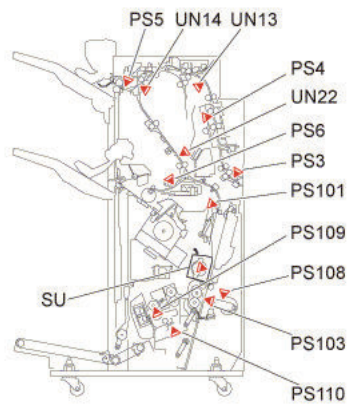
Overview of detection

A stationary jam occurs when a sensor was not turned OFF although a specified period of time had passed after the sensor was turned ON.

I/O: Service Mode > SITUATION > Sensor Check

Check items (in arbitrary order)

- Remaining paper near the target sensor
- Soiling on the target sensor
- Displacement of the target sensor position
- Failure of the target sensor
- Soiling (grease)/deterioration/failure of a drive motor located upstream of the target sensor
- Soiling (paper dust)/deterioration/failure of a drive roller located upstream of the target sensor



■ 021121: JamCode (Staple/Booklet Finisher-X1) 1121

[Symptom/Question]

021121: JamCode (Staple/Booklet Finisher-X1) 1121

[Remedy/Answer]

Jam Type : Stationary jam

Sensor Name : Inlet Sensor

Sensor No. : S101

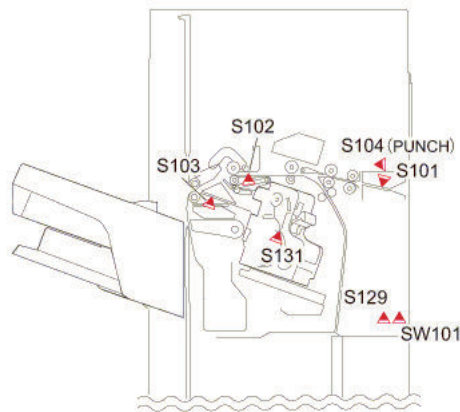
Overview of detection

A stationary jam occurs when a sensor was not turned OFF although a specified period of time had passed after the sensor was turned ON.

I/O: Service Mode > SITUATION > Sensor Check

Check items (in arbitrary order)

- Remaining paper near the target sensor
- Soiling on the target sensor
- Displacement of the target sensor position
- Failure of the target sensor
- Soiling (grease)/deterioration/failure of a drive motor located upstream of the target sensor
- Soiling (paper dust)/deterioration/failure of a drive roller located upstream of the target sensor



■ 021122: JamCode (Staple/Booklet Finisher-X1) 1122

[Symptom/Question]

021122: JamCode (Staple/Booklet Finisher-X1) 1122

[Remedy/Answer]

Jam Type : Stationary jam

Sensor Name : Delivery sensor

Sensor No. : S102

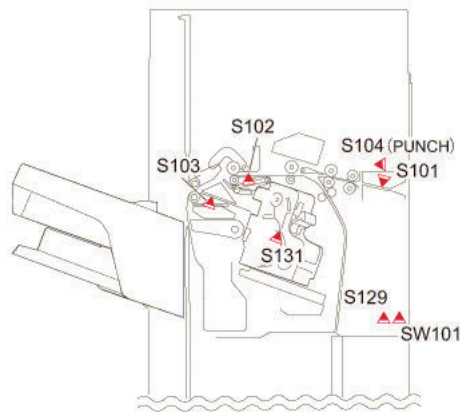
Overview of detection

A stationary jam occurs when a sensor was not turned OFF although a specified period of time had passed after the sensor was turned ON.

I/O: Service Mode > SITUATION > Sensor Check

Check items (in arbitrary order)

- Remaining paper near the target sensor
- Soiling on the target sensor
- Displacement of the target sensor position
- Failure of the target sensor
- Soiling (grease)/deterioration/failure of a drive motor located upstream of the target sensor
- Soiling (paper dust)/deterioration/failure of a drive roller located upstream of the target sensor



■ 02112E: JamCode (Staple/Booklet Finisher-X1) 112E

[Symptom/Question]

02112E: JamCode (Staple/Booklet Finisher-X1) 112E

[Remedy/Answer]

Jam Type : Sequence jam

Sensor Name : -

Sensor No. : -

Overview of detection

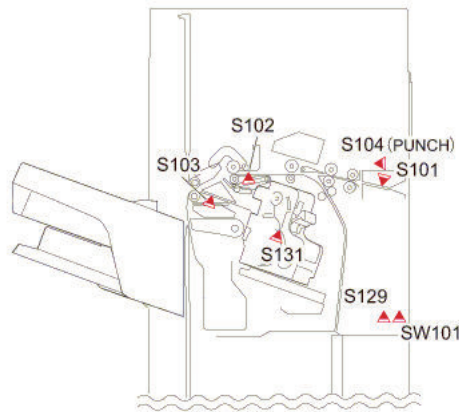
A sequence jam occurs when there was an error in sensor detection signal at printing operation sequence.

Since the jam may occur due to sporadic noise with software of each equipment or communication line (interruption of communication), failure of the part is not the cause of the jam. After the jam is removed, the machine works.

I/O: Service Mode > SITUATION > Sensor Check

Check items (in arbitrary order)

- Opening/closing of the door
- Turning OFF and then ON the power
- Error near the target sensor (soiling/displacement/failure of the sensor, error in harness/open circuit of harness, soiling (grease)/deterioration/failure of a drive motor, or soiling (paper dust)/deterioration/failure of a drive roller)



■ 02112F: JamCode (Staple/Booklet Finisher-X1) 112F

[Symptom/Question]

02112F: JamCode (Staple/Booklet Finisher-X1) 112F

[Remedy/Answer]

Jam Type : Error avoidance

Sensor Name : -

Sensor No. : -

Overview of detection

An error avoidance jam occurs when an error in the machine (excluding parts failure) was detected.

Printing operation is suspended to avoid error occurrence by error code; therefore, parts failure is not the cause of the jam.

After the jam is removed, the machine works.

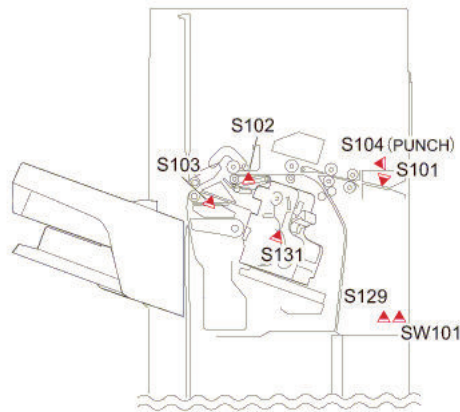
If it is due to parts failure, an error code instead of the error avoidance jam is displayed on UI and printing operation is suspended.

In such case, service technician should perform remedial work for the error code.

I/O: Service Mode > SITUATION > Sensor Check

Check items (in arbitrary order)

- Opening/closing of the door after jam removal
- Turning OFF and then ON the power after jam removal



■ 021143: JamCode (Staple/ Booklet Finisher-W1 PRO) 1143

[Symptom/Question]

021143: JamCode (Staple/ Booklet Finisher-W1 PRO) 1143

[Remedy/Answer]

Jam Type : Stationary jam

Sensor Name : Saddle Inlet Sensor

Sensor No. : PS101

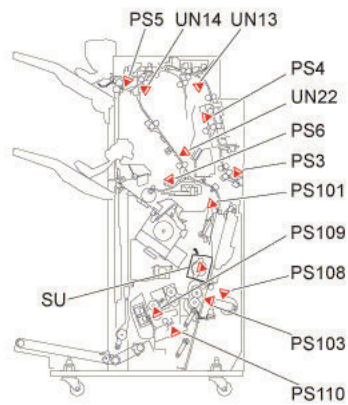
Overview of detection

A stationary jam occurs when a sensor was not turned OFF although a specified period of time had passed after the sensor was turned ON.

I/O: Service Mode > SITUATION > Sensor Check

Check items (in arbitrary order)

- Remaining paper near the target sensor
- Soiling on the target sensor
- Displacement of the target sensor position
- Failure of the target sensor
- Soiling (grease)/deterioration/failure of a drive motor located upstream of the target sensor
- Soiling (paper dust)/deterioration/failure of a drive roller located upstream of the target sensor



■ 021147: JamCode (Staple/ Booklet Finisher-W1 PRO) 1147

[Symptom/Question]

021147: JamCode (Staple/ Booklet Finisher-W1 PRO) 1147

[Remedy/Answer]

Jam Type : Stationary jam

Sensor Name : Saddle Vertical Path Sensor

Sensor No. : PS103

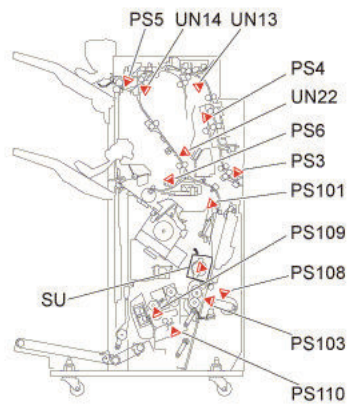
Overview of detection

A stationary jam occurs when a sensor was not turned OFF although a specified period of time had passed after the sensor was turned ON.

I/O: Service Mode > SITUATION > Sensor Check

Check items (in arbitrary order)

- Remaining paper near the target sensor
- Soiling on the target sensor
- Displacement of the target sensor position
- Failure of the target sensor
- Soiling (grease)/deterioration/failure of a drive motor located upstream of the target sensor
- Soiling (paper dust)/deterioration/failure of a drive roller located upstream of the target sensor



■ 02114B: JamCode (Staple/ Booklet Finisher-W1 PRO) 114B

[Symptom/Question]

02114B: JamCode (Staple/ Booklet Finisher-W1 PRO) 114B

[Remedy/Answer]

Jam Type : Stationary jam

Sensor Name : Saddle Press Front Sensor

Sensor No. : PS116

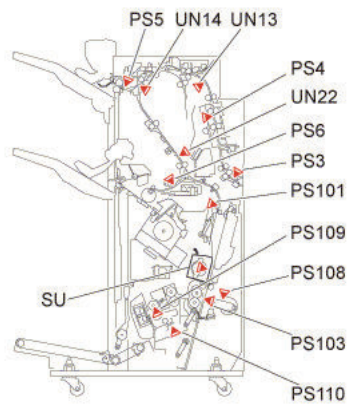
Overview of detection

A stationary jam occurs when a sensor was not turned OFF although a specified period of time had passed after the sensor was turned ON.

I/O: Service Mode > SITUATION > Sensor Check

Check items (in arbitrary order)

- Remaining paper near the target sensor
- Soiling on the target sensor
- Displacement of the target sensor position
- Failure of the target sensor
- Soiling (grease)/deterioration/failure of a drive motor located upstream of the target sensor
- Soiling (paper dust)/deterioration/failure of a drive roller located upstream of the target sensor



■ 021150: JamCode (Multi Function Professional Puncher-B1) 1150

[Symptom/Question]

021150: JamCode (Multi Function Professional Puncher-B1) 1150

[Remedy/Answer]

Jam Type : Stationary jam

Sensor Name : Entry Sensor

Sensor No. : S1

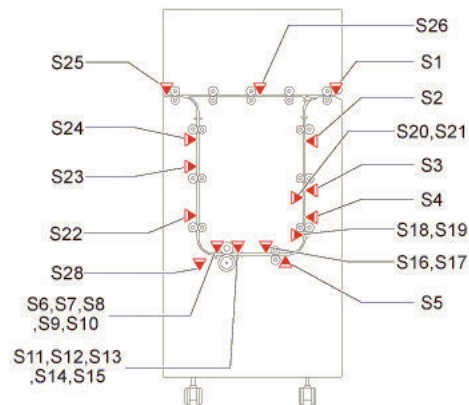
Overview of detection

A stationary jam occurs when a sensor was not turned OFF although a specified period of time had passed after the sensor was turned ON.

I/O: Service Mode > SITUATION > Sensor Check

Check items (in arbitrary order)

- Remaining paper near the target sensor
- Soiling on the target sensor
- Displacement of the target sensor position
- Failure of the target sensor
- Soiling (grease)/deterioration/failure of a drive motor located upstream of the target sensor
- Soiling (paper dust)/deterioration/failure of a drive roller located upstream of the target sensor



■ 021151: JamCode (Multi Function Professional Puncher-B1) 1151

[Symptom/Question]

021151: JamCode (Multi Function Professional Puncher-B1) 1151

[Remedy/Answer]

Jam Type : Stationary jam

Sensor Name : Entrance Panel Sensor

Sensor No. : S2

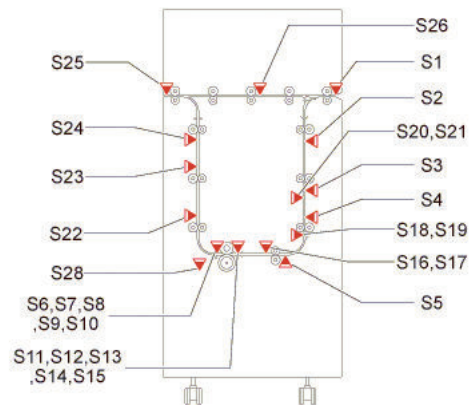
Overview of detection

A stationary jam occurs when a sensor was not turned OFF although a specified period of time had passed after the sensor was turned ON.

I/O: Service Mode > SITUATION > Sensor Check

Check items (in arbitrary order)

- Remaining paper near the target sensor
- Soiling on the target sensor
- Displacement of the target sensor position
- Failure of the target sensor
- Soiling (grease)/deterioration/failure of a drive motor located upstream of the target sensor
- Soiling (paper dust)/deterioration/failure of a drive roller located upstream of the target sensor



■ 021152: JamCode (Multi Function Professional Puncher-B1) 1152

[Symptom/Question]

021152: JamCode (Multi Function Professional Puncher-B1) 1152

[Remedy/Answer]

Jam Type : Stationary jam

Sensor Name : Entrance Panel Sensor

Sensor No. : S3

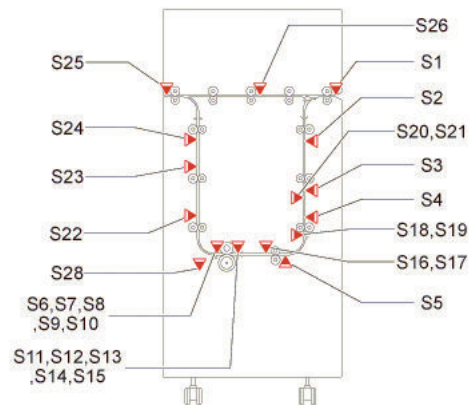
Overview of detection

A stationary jam occurs when a sensor was not turned OFF although a specified period of time had passed after the sensor was turned ON.

I/O: Service Mode > SITUATION > Sensor Check

Check items (in arbitrary order)

- Remaining paper near the target sensor
- Soiling on the target sensor
- Displacement of the target sensor position
- Failure of the target sensor
- Soiling (grease)/deterioration/failure of a drive motor located upstream of the target sensor
- Soiling (paper dust)/deterioration/failure of a drive roller located upstream of the target sensor



■ 021153: JamCode (Multi Function Professional Puncher-B1) 1153

[Symptom/Question]

021153: JamCode (Multi Function Professional Puncher-B1) 1153

[Remedy/Answer]

Jam Type : Stationary jam

Sensor Name : Entrance Panel Sensor

Sensor No. : S4

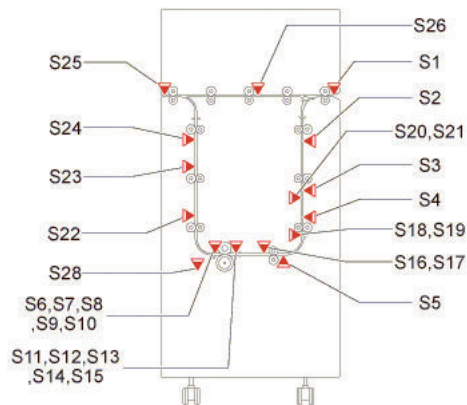
Overview of detection

A stationary jam occurs when a sensor was not turned OFF although a specified period of time had passed after the sensor was turned ON.

I/O: Service Mode > SITUATION > Sensor Check

Check items (in arbitrary order)

- Remaining paper near the target sensor
- Soiling on the target sensor
- Displacement of the target sensor position
- Failure of the target sensor
- Soiling (grease)/deterioration/failure of a drive motor located upstream of the target sensor
- Soiling (paper dust)/deterioration/failure of a drive roller located upstream of the target sensor



■ 021154: JamCode (Multi Function Professional Puncher-B1) 1154

[Symptom/Question]

021154: JamCode (Multi Function Professional Puncher-B1) 1154

[Remedy/Answer]

Jam Type : Stationary jam

Sensor Name : Acceleration Sensor

Sensor No. : S5

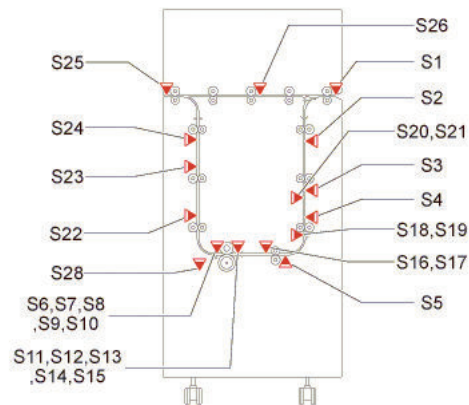
Overview of detection

A stationary jam occurs when a sensor was not turned OFF although a specified period of time had passed after the sensor was turned ON.

I/O: Service Mode > SITUATION > Sensor Check

Check items (in arbitrary order)

- Remaining paper near the target sensor
- Soiling on the target sensor
- Displacement of the target sensor position
- Failure of the target sensor
- Soiling (grease)/deterioration/failure of a drive motor located upstream of the target sensor
- Soiling (paper dust)/deterioration/failure of a drive roller located upstream of the target sensor



■ 021155: JamCode (Multi Function Professional Puncher-B1) 1155

[Symptom/Question]

021155: JamCode (Multi Function Professional Puncher-B1) 1155

[Remedy/Answer]

Jam Type : Stationary jam

Sensor Name : Angle Measurement Sensor

Sensor No. : S6

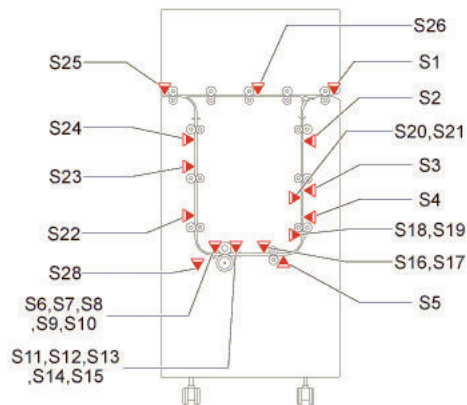
Overview of detection

A stationary jam occurs when a sensor was not turned OFF although a specified period of time had passed after the sensor was turned ON.

I/O: Service Mode > SITUATION > Sensor Check

Check items (in arbitrary order)

- Remaining paper near the target sensor
- Soiling on the target sensor
- Displacement of the target sensor position
- Failure of the target sensor
- Soiling (grease)/deterioration/failure of a drive motor located upstream of the target sensor
- Soiling (paper dust)/deterioration/failure of a drive roller located upstream of the target sensor



■ 021155: JamCode (Staple/ Booklet Finisher-W1 PRO) 1155

[Symptom/Question]

021155: JamCode (Staple/ Booklet Finisher-W1 PRO) 1155

[Remedy/Answer]

Jam Type : Stationary jam

Sensor Name : Saddle Press HP Sensor

Sensor No. : PS113

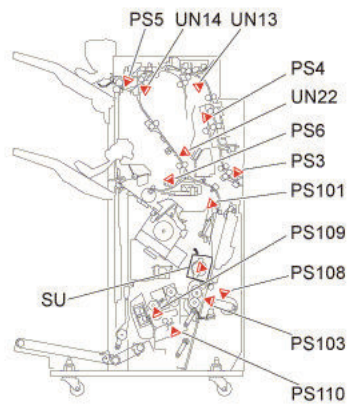
Overview of detection

A stationary jam occurs when a sensor was not turned OFF although a specified period of time had passed after the sensor was turned ON.

I/O: Service Mode > SITUATION > Sensor Check

Check items (in arbitrary order)

- Remaining paper near the target sensor
- Soiling on the target sensor
- Displacement of the target sensor position
- Failure of the target sensor
- Soiling (grease)/deterioration/failure of a drive motor located upstream of the target sensor
- Soiling (paper dust)/deterioration/failure of a drive roller located upstream of the target sensor



■ 021156: JamCode (Multi Function Professional Puncher-B1) 1156

[Symptom/Question]

021156: JamCode (Multi Function Professional Puncher-B1) 1156

[Remedy/Answer]

Jam Type : Stationary jam

Sensor Name : Angle Measurement Sensor

Sensor No. : S7

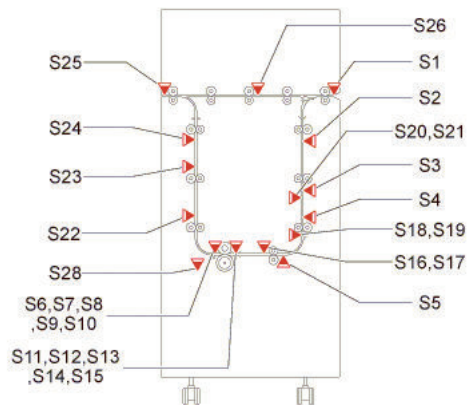
Overview of detection

A stationary jam occurs when a sensor was not turned OFF although a specified period of time had passed after the sensor was turned ON.

I/O: Service Mode > SITUATION > Sensor Check

Check items (in arbitrary order)

- Remaining paper near the target sensor
- Soiling on the target sensor
- Displacement of the target sensor position
- Failure of the target sensor
- Soiling (grease)/deterioration/failure of a drive motor located upstream of the target sensor
- Soiling (paper dust)/deterioration/failure of a drive roller located upstream of the target sensor



■ 021157: JamCode (Multi Function Professional Puncher-B1) 1157

[Symptom/Question]

021157: JamCode (Multi Function Professional Puncher-B1) 1157

[Remedy/Answer]

Jam Type : Stationary jam

Sensor Name : Angle Measurement Sensor

Sensor No. : S8

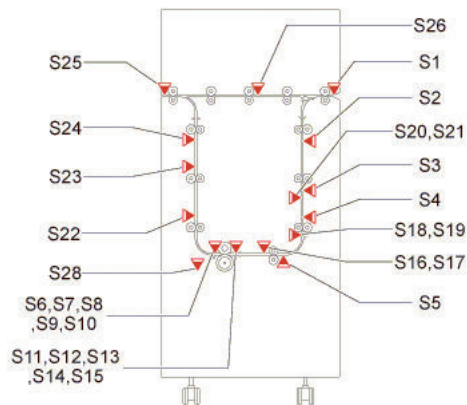
Overview of detection

A stationary jam occurs when a sensor was not turned OFF although a specified period of time had passed after the sensor was turned ON.

I/O: Service Mode > SITUATION > Sensor Check

Check items (in arbitrary order)

- Remaining paper near the target sensor
- Soiling on the target sensor
- Displacement of the target sensor position
- Failure of the target sensor
- Soiling (grease)/deterioration/failure of a drive motor located upstream of the target sensor
- Soiling (paper dust)/deterioration/failure of a drive roller located upstream of the target sensor



■ 021158: JamCode (Multi Function Professional Puncher-B1) 1158

[Symptom/Question]

021158: JamCode (Multi Function Professional Puncher-B1) 1158

[Remedy/Answer]

Jam Type : Stationary jam

Sensor Name : Angle Measurement Sensor

Sensor No. : S9

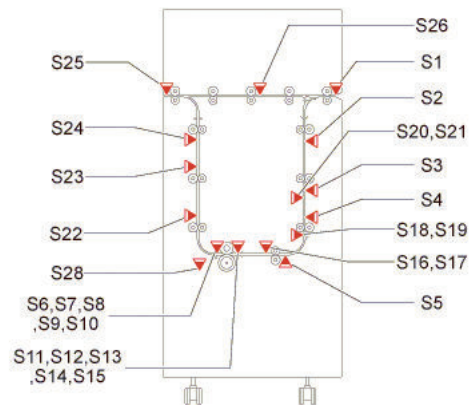
Overview of detection

A stationary jam occurs when a sensor was not turned OFF although a specified period of time had passed after the sensor was turned ON.

I/O: Service Mode > SITUATION > Sensor Check

Check items (in arbitrary order)

- Remaining paper near the target sensor
- Soiling on the target sensor
- Displacement of the target sensor position
- Failure of the target sensor
- Soiling (grease)/deterioration/failure of a drive motor located upstream of the target sensor
- Soiling (paper dust)/deterioration/failure of a drive roller located upstream of the target sensor



■ 021159: JamCode (Multi Function Professional Puncher-B1) 1159

[Symptom/Question]

021159: JamCode (Multi Function Professional Puncher-B1) 1159

[Remedy/Answer]

Jam Type : Stationary jam

Sensor Name : Angle Measurement Sensor

Sensor No. : S10

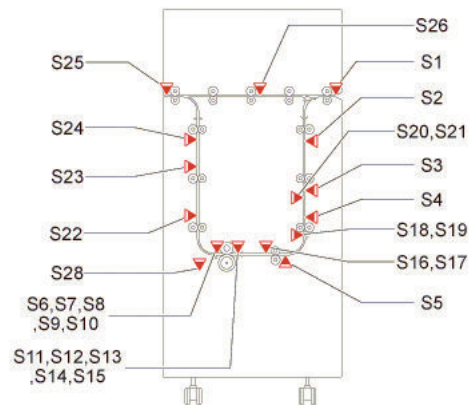
Overview of detection

A stationary jam occurs when a sensor was not turned OFF although a specified period of time had passed after the sensor was turned ON.

I/O: Service Mode > SITUATION > Sensor Check

Check items (in arbitrary order)

- Remaining paper near the target sensor
- Soiling on the target sensor
- Displacement of the target sensor position
- Failure of the target sensor
- Soiling (grease)/deterioration/failure of a drive motor located upstream of the target sensor
- Soiling (paper dust)/deterioration/failure of a drive roller located upstream of the target sensor



■ 02115A: JamCode (Multi Function Professional Puncher-B1) 115A

[Symptom/Question]

02115A: JamCode (Multi Function Professional Puncher-B1) 115A

[Remedy/Answer]

Jam Type : Stationary jam

Sensor Name : Alignment Sensor

Sensor No. : S11

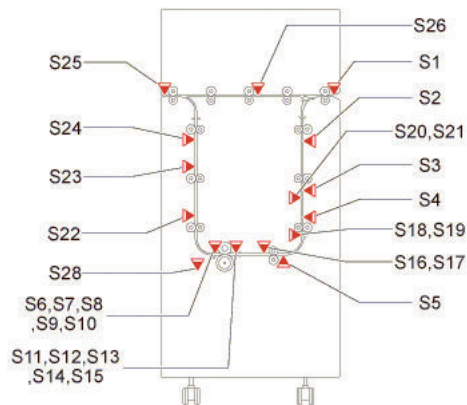
Overview of detection

A stationary jam occurs when a sensor was not turned OFF although a specified period of time had passed after the sensor was turned ON.

I/O: Service Mode > SITUATION > Sensor Check

Check items (in arbitrary order)

- Remaining paper near the target sensor
- Soiling on the target sensor
- Displacement of the target sensor position
- Failure of the target sensor
- Soiling (grease)/deterioration/failure of a drive motor located upstream of the target sensor
- Soiling (paper dust)/deterioration/failure of a drive roller located upstream of the target sensor



■ 02115B: JamCode (Multi Function Professional Puncher-B1) 115B

[Symptom/Question]

02115B: JamCode (Multi Function Professional Puncher-B1) 115B

[Remedy/Answer]

Jam Type : Stationary jam

Sensor Name : Alignment Sensor

Sensor No. : S12

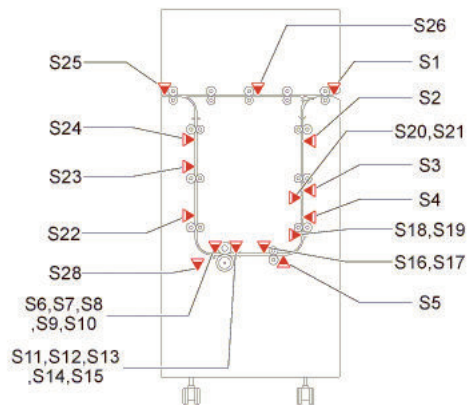
Overview of detection

A stationary jam occurs when a sensor was not turned OFF although a specified period of time had passed after the sensor was turned ON.

I/O: Service Mode > SITUATION > Sensor Check

Check items (in arbitrary order)

- Remaining paper near the target sensor
- Soiling on the target sensor
- Displacement of the target sensor position
- Failure of the target sensor
- Soiling (grease)/deterioration/failure of a drive motor located upstream of the target sensor
- Soiling (paper dust)/deterioration/failure of a drive roller located upstream of the target sensor



■ 02115C: JamCode (Multi Function Professional Puncher-B1) 115C

[Symptom/Question]

02115C: JamCode (Multi Function Professional Puncher-B1) 115C

[Remedy/Answer]

Jam Type : Stationary jam

Sensor Name : Alignment Sensor

Sensor No. : S13

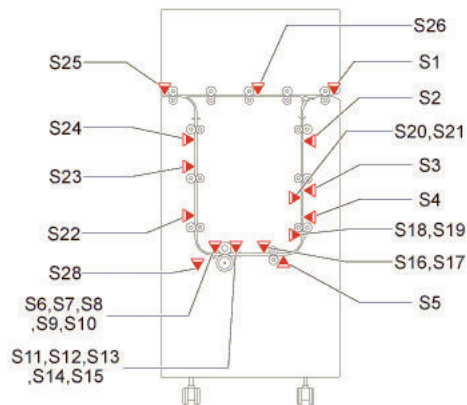
Overview of detection

A stationary jam occurs when a sensor was not turned OFF although a specified period of time had passed after the sensor was turned ON.

I/O: Service Mode > SITUATION > Sensor Check

Check items (in arbitrary order)

- Remaining paper near the target sensor
- Soiling on the target sensor
- Displacement of the target sensor position
- Failure of the target sensor
- Soiling (grease)/deterioration/failure of a drive motor located upstream of the target sensor
- Soiling (paper dust)/deterioration/failure of a drive roller located upstream of the target sensor



■ 02115D: JamCode (Multi Function Professional Puncher-B1) 115D

[Symptom/Question]

02115D: JamCode (Multi Function Professional Puncher-B1) 115D

[Remedy/Answer]

Jam Type : Stationary jam

Sensor Name : Alignment Sensor

Sensor No. : S14

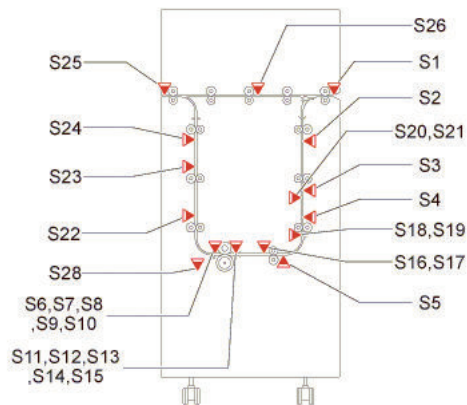
Overview of detection

A stationary jam occurs when a sensor was not turned OFF although a specified period of time had passed after the sensor was turned ON.

I/O: Service Mode > SITUATION > Sensor Check

Check items (in arbitrary order)

- Remaining paper near the target sensor
- Soiling on the target sensor
- Displacement of the target sensor position
- Failure of the target sensor
- Soiling (grease)/deterioration/failure of a drive motor located upstream of the target sensor
- Soiling (paper dust)/deterioration/failure of a drive roller located upstream of the target sensor



■ 02115E: JamCode (Multi Function Professional Puncher-B1) 115E

[Symptom/Question]

02115E: JamCode (Multi Function Professional Puncher-B1) 115E

[Remedy/Answer]

Jam Type : Stationary jam

Sensor Name : Alignment Sensor

Sensor No. : S15

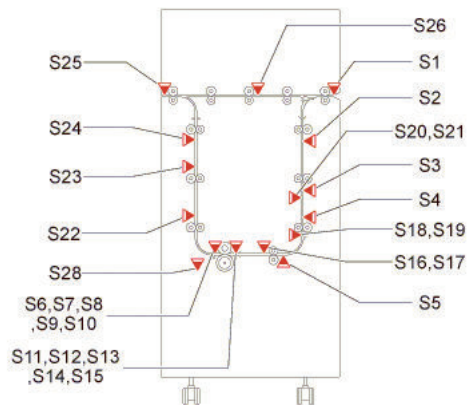
Overview of detection

A stationary jam occurs when a sensor was not turned OFF although a specified period of time had passed after the sensor was turned ON.

I/O: Service Mode > SITUATION > Sensor Check

Check items (in arbitrary order)

- Remaining paper near the target sensor
- Soiling on the target sensor
- Displacement of the target sensor position
- Failure of the target sensor
- Soiling (grease)/deterioration/failure of a drive motor located upstream of the target sensor
- Soiling (paper dust)/deterioration/failure of a drive roller located upstream of the target sensor



■ 02115F: JamCode (Multi Function Professional Puncher-B1) 115F

[Symptom/Question]

02115F: JamCode (Multi Function Professional Puncher-B1) 115F

[Remedy/Answer]

Jam Type : Stationary jam

Sensor Name : Backgage for Trail Edge Sensor

Sensor No. : S16

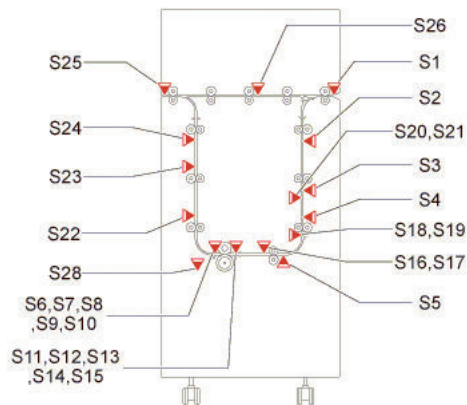
Overview of detection

A stationary jam occurs when a sensor was not turned OFF although a specified period of time had passed after the sensor was turned ON.

I/O: Service Mode > SITUATION > Sensor Check

Check items (in arbitrary order)

- Remaining paper near the target sensor
- Soiling on the target sensor
- Displacement of the target sensor position
- Failure of the target sensor
- Soiling (grease)/deterioration/failure of a drive motor located upstream of the target sensor
- Soiling (paper dust)/deterioration/failure of a drive roller located upstream of the target sensor



■ 021160: JamCode (Multi Function Professional Puncher-B1) 1160

[Symptom/Question]

021160: JamCode (Multi Function Professional Puncher-B1) 1160

[Remedy/Answer]

Jam Type : Stationary jam

Sensor Name : Backgage for Trail Edge Sensor

Sensor No. : S17

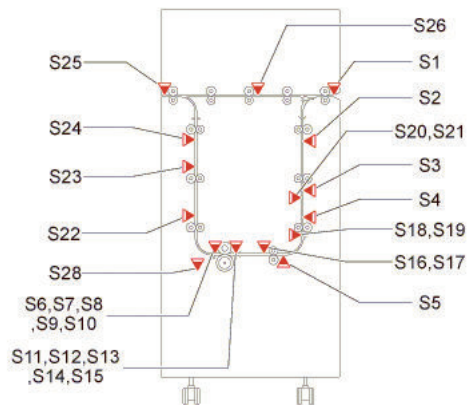
Overview of detection

A stationary jam occurs when a sensor was not turned OFF although a specified period of time had passed after the sensor was turned ON.

I/O: Service Mode > SITUATION > Sensor Check

Check items (in arbitrary order)

- Remaining paper near the target sensor
- Soiling on the target sensor
- Displacement of the target sensor position
- Failure of the target sensor
- Soiling (grease)/deterioration/failure of a drive motor located upstream of the target sensor
- Soiling (paper dust)/deterioration/failure of a drive roller located upstream of the target sensor



■ 021161: JamCode (Multi Function Professional Puncher-B1) 1161

[Symptom/Question]

021161: JamCode (Multi Function Professional Puncher-B1) 1161

[Remedy/Answer]

Jam Type : Stationary jam

Sensor Name : Double Punch Backgage for Large Sheets Sensor

Sensor No. : S18

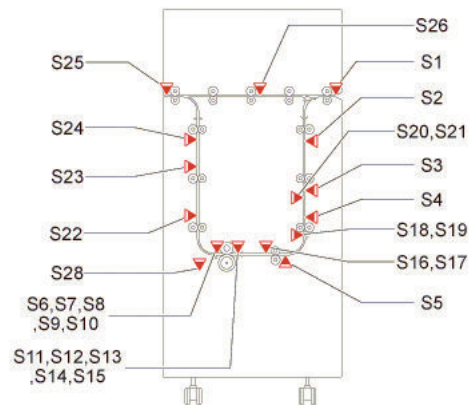
Overview of detection

A stationary jam occurs when a sensor was not turned OFF although a specified period of time had passed after the sensor was turned ON.

I/O: Service Mode > SITUATION > Sensor Check

Check items (in arbitrary order)

- Remaining paper near the target sensor
- Soiling on the target sensor
- Displacement of the target sensor position
- Failure of the target sensor
- Soiling (grease)/deterioration/failure of a drive motor located upstream of the target sensor
- Soiling (paper dust)/deterioration/failure of a drive roller located upstream of the target sensor



■ 021162: JamCode (Multi Function Professional Puncher-B1) 1162

[Symptom/Question]

021162: JamCode (Multi Function Professional Puncher-B1) 1162

[Remedy/Answer]

Jam Type : Stationary jam

Sensor Name : Double Punch Backgage for Large Sheets Sensor

Sensor No. : S19

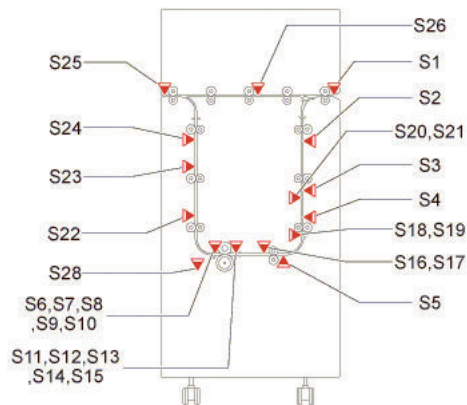
Overview of detection

A stationary jam occurs when a sensor was not turned OFF although a specified period of time had passed after the sensor was turned ON.

I/O: Service Mode > SITUATION > Sensor Check

Check items (in arbitrary order)

- Remaining paper near the target sensor
- Soiling on the target sensor
- Displacement of the target sensor position
- Failure of the target sensor
- Soiling (grease)/deterioration/failure of a drive motor located upstream of the target sensor
- Soiling (paper dust)/deterioration/failure of a drive roller located upstream of the target sensor



■ 021163: JamCode (Multi Function Professional Puncher-B1) 1163

[Symptom/Question]

021163: JamCode (Multi Function Professional Puncher-B1) 1163

[Remedy/Answer]

Jam Type : Stationary jam

Sensor Name : Double Punch Backgage for XL Sheets Sensor

Sensor No. : S20

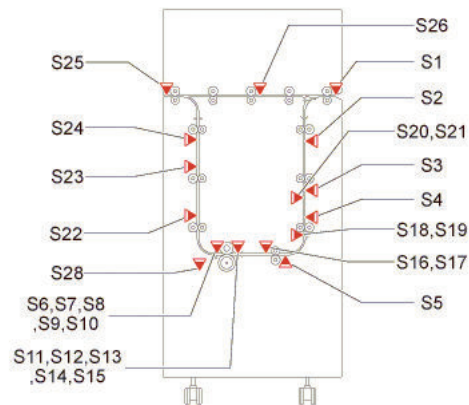
Overview of detection

A stationary jam occurs when a sensor was not turned OFF although a specified period of time had passed after the sensor was turned ON.

I/O: Service Mode > SITUATION > Sensor Check

Check items (in arbitrary order)

- Remaining paper near the target sensor
- Soiling on the target sensor
- Displacement of the target sensor position
- Failure of the target sensor
- Soiling (grease)/deterioration/failure of a drive motor located upstream of the target sensor
- Soiling (paper dust)/deterioration/failure of a drive roller located upstream of the target sensor



■ 021164: JamCode (Multi Function Professional Puncher-B1) 1164

[Symptom/Question]

021164: JamCode (Multi Function Professional Puncher-B1) 1164

[Remedy/Answer]

Jam Type : Stationary jam

Sensor Name : Double Punch Backgage for XL Sheets Sensor

Sensor No. : S21

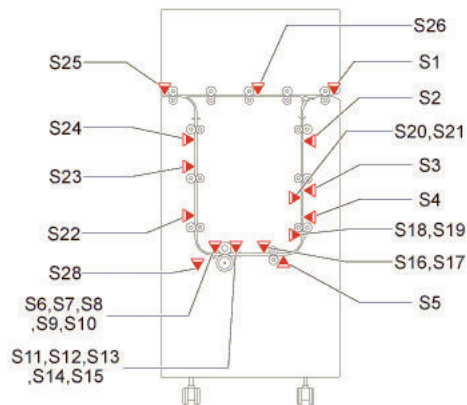
Overview of detection

A stationary jam occurs when a sensor was not turned OFF although a specified period of time had passed after the sensor was turned ON.

I/O: Service Mode > SITUATION > Sensor Check

Check items (in arbitrary order)

- Remaining paper near the target sensor
- Soiling on the target sensor
- Displacement of the target sensor position
- Failure of the target sensor
- Soiling (grease)/deterioration/failure of a drive motor located upstream of the target sensor
- Soiling (paper dust)/deterioration/failure of a drive roller located upstream of the target sensor



■ 021165: JamCode (Multi Function Professional Puncher-B1) 1165

[Symptom/Question]

021165: JamCode (Multi Function Professional Puncher-B1) 1165

[Remedy/Answer]

Jam Type : Stationary jam

Sensor Name : Exit Panel Sensor

Sensor No. : S22

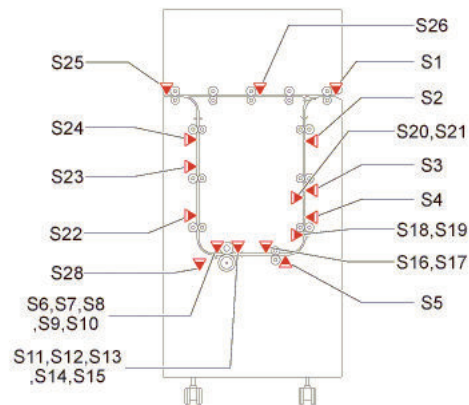
Overview of detection

A stationary jam occurs when a sensor was not turned OFF although a specified period of time had passed after the sensor was turned ON.

I/O: Service Mode > SITUATION > Sensor Check

Check items (in arbitrary order)

- Remaining paper near the target sensor
- Soiling on the target sensor
- Displacement of the target sensor position
- Failure of the target sensor
- Soiling (grease)/deterioration/failure of a drive motor located upstream of the target sensor
- Soiling (paper dust)/deterioration/failure of a drive roller located upstream of the target sensor



■ 021166: JamCode (Multi Function Professional Puncher-B1) 1166

[Symptom/Question]

021166: JamCode (Multi Function Professional Puncher-B1) 1166

[Remedy/Answer]

Jam Type : Stationary jam

Sensor Name : Exit Panel Sensor

Sensor No. : S23

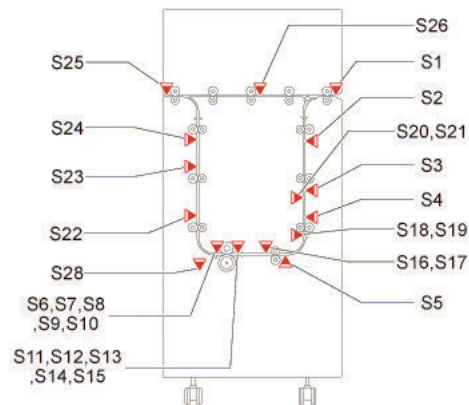
Overview of detection

A stationary jam occurs when a sensor was not turned OFF although a specified period of time had passed after the sensor was turned ON.

I/O: Service Mode > SITUATION > Sensor Check

Check items (in arbitrary order)

- Remaining paper near the target sensor
- Soiling on the target sensor
- Displacement of the target sensor position
- Failure of the target sensor
- Soiling (grease)/deterioration/failure of a drive motor located upstream of the target sensor
- Soiling (paper dust)/deterioration/failure of a drive roller located upstream of the target sensor



■ 021167: JamCode (Multi Function Professional Puncher-B1) 1167

[Symptom/Question]

021167: JamCode (Multi Function Professional Puncher-B1) 1167

[Remedy/Answer]

Jam Type : Stationary jam

Sensor Name : Deceleration Sensor

Sensor No. : S24

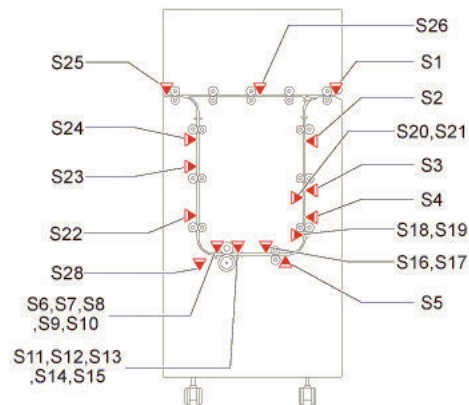
Overview of detection

A stationary jam occurs when a sensor was not turned OFF although a specified period of time had passed after the sensor was turned ON.

I/O: Service Mode > SITUATION > Sensor Check

Check items (in arbitrary order)

- Remaining paper near the target sensor
- Soiling on the target sensor
- Displacement of the target sensor position
- Failure of the target sensor
- Soiling (grease)/deterioration/failure of a drive motor located upstream of the target sensor
- Soiling (paper dust)/deterioration/failure of a drive roller located upstream of the target sensor



■ 021168: JamCode (Multi Function Professional Puncher-B1) 1168

[Symptom/Question]

021168: JamCode (Multi Function Professional Puncher-B1) 1168

[Remedy/Answer]

Jam Type : Stationary jam

Sensor Name : Exit Sensor

Sensor No. : S25

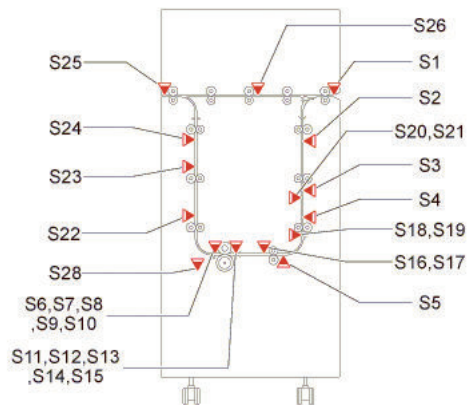
Overview of detection

A stationary jam occurs when a sensor was not turned OFF although a specified period of time had passed after the sensor was turned ON.

I/O: Service Mode > SITUATION > Sensor Check

Check items (in arbitrary order)

- Remaining paper near the target sensor
- Soiling on the target sensor
- Displacement of the target sensor position
- Failure of the target sensor
- Soiling (grease)/deterioration/failure of a drive motor located upstream of the target sensor
- Soiling (paper dust)/deterioration/failure of a drive roller located upstream of the target sensor



■ 021169: JamCode (Multi Function Professional Puncher-B1) 1169

[Symptom/Question]

021169: JamCode (Multi Function Professional Puncher-B1) 1169

[Remedy/Answer]

Jam Type : Stationary jam

Sensor Name : -

Sensor No. : S26

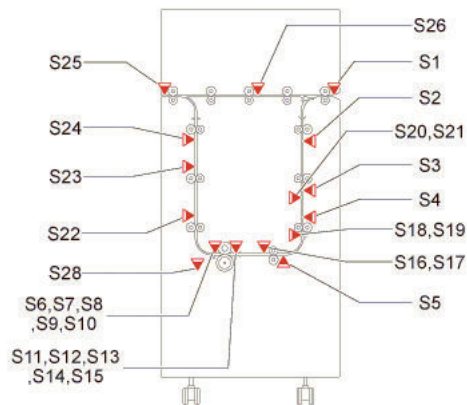
Overview of detection

A stationary jam occurs when a sensor was not turned OFF although a specified period of time had passed after the sensor was turned ON.

I/O: Service Mode > SITUATION > Sensor Check

Check items (in arbitrary order)

- Remaining paper near the target sensor
- Soiling on the target sensor
- Displacement of the target sensor position
- Failure of the target sensor
- Soiling (grease)/deterioration/failure of a drive motor located upstream of the target sensor
- Soiling (paper dust)/deterioration/failure of a drive roller located upstream of the target sensor



■ 02116A: JamCode (Multi Function Professional Puncher-B1) 116A

[Symptom/Question]

02116A: JamCode (Multi Function Professional Puncher-B1) 116A

[Remedy/Answer]

Jam Type : Stationary jam

Sensor Name : Align Home Sensor

Sensor No. : S28

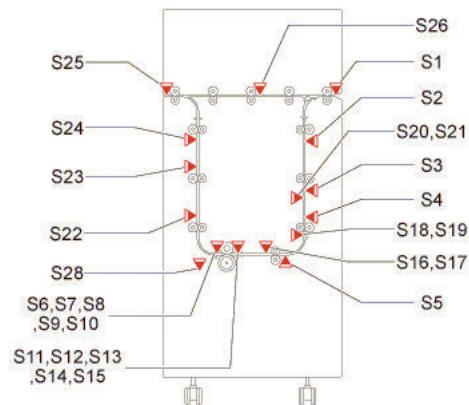
Overview of detection

A stationary jam occurs when a sensor was not turned OFF although a specified period of time had passed after the sensor was turned ON.

I/O: Service Mode > SITUATION > Sensor Check

Check items (in arbitrary order)

- Remaining paper near the target sensor
- Soiling on the target sensor
- Displacement of the target sensor position
- Failure of the target sensor
- Soiling (grease)/deterioration/failure of a drive motor located upstream of the target sensor
- Soiling (paper dust)/deterioration/failure of a drive roller located upstream of the target sensor



■ 021183: JamCode (Paper Folding Unit-J1) 1183

[Symptom/Question]

021183: JamCode (Paper Folding Unit-J1) 1183

[Remedy/Answer]

Jam Type : Stationary jam

Sensor Name : Entrance Sensor

Sensor No. : S20

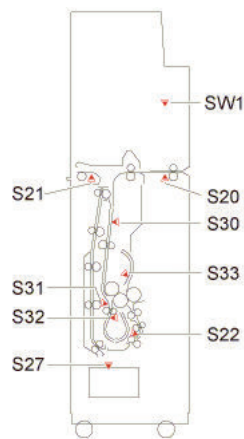
Overview of detection

A stationary jam occurs when a sensor was not turned OFF although a specified period of time had passed after the sensor was turned ON.

I/O: Service Mode > SITUATION > Sensor Check

Check items (in arbitrary order)

- Remaining paper near the target sensor
- Soiling on the target sensor
- Displacement of the target sensor position
- Failure of the target sensor
- Soiling (grease)/deterioration/failure of a drive motor located upstream of the target sensor
- Soiling (paper dust)/deterioration/failure of a drive roller located upstream of the target sensor



■ 021185: JamCode (Paper Folding Unit-J1) 1185

[Symptom/Question]

021185: JamCode (Paper Folding Unit-J1) 1185

[Remedy/Answer]

Jam Type : Stationary jam

Sensor Name : Delivery Sensor 2

Sensor No. : S21

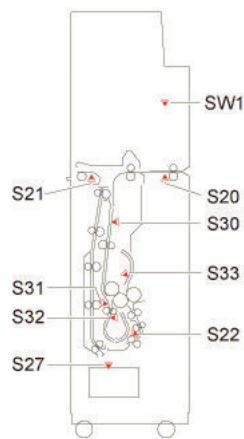
Overview of detection

A stationary jam occurs when a sensor was not turned OFF although a specified period of time had passed after the sensor was turned ON.

I/O: Service Mode > SITUATION > Sensor Check

Check items (in arbitrary order)

- Remaining paper near the target sensor
- Soiling on the target sensor
- Displacement of the target sensor position
- Failure of the target sensor
- Soiling (grease)/deterioration/failure of a drive motor located upstream of the target sensor
- Soiling (paper dust)/deterioration/failure of a drive roller located upstream of the target sensor



■ 021187: JamCode (Paper Folding Unit-J1) 1187

[Symptom/Question]

021187: JamCode (Paper Folding Unit-J1) 1187

[Remedy/Answer]

Jam Type : Stationary jam

Sensor Name : Slowdown Timing Sensor

Sensor No. : S30

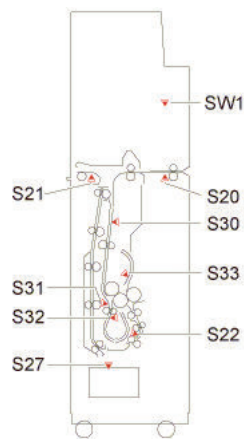
Overview of detection

A stationary jam occurs when a sensor was not turned OFF although a specified period of time had passed after the sensor was turned ON.

I/O: Service Mode > SITUATION > Sensor Check

Check items (in arbitrary order)

- Remaining paper near the target sensor
- Soiling on the target sensor
- Displacement of the target sensor position
- Failure of the target sensor
- Soiling (grease)/deterioration/failure of a drive motor located upstream of the target sensor
- Soiling (paper dust)/deterioration/failure of a drive roller located upstream of the target sensor



■ 021189: JamCode (Paper Folding Unit-J1) 1189

[Symptom/Question]

021189: JamCode (Paper Folding Unit-J1) 1189

[Remedy/Answer]

Jam Type : Stationary jam

Sensor Name : Release Timing Sensor

Sensor No. : S31

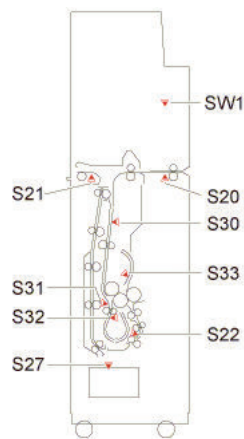
Overview of detection

A stationary jam occurs when a sensor was not turned OFF although a specified period of time had passed after the sensor was turned ON.

I/O: Service Mode > SITUATION > Sensor Check

Check items (in arbitrary order)

- Remaining paper near the target sensor
- Soiling on the target sensor
- Displacement of the target sensor position
- Failure of the target sensor
- Soiling (grease)/deterioration/failure of a drive motor located upstream of the target sensor
- Soiling (paper dust)/deterioration/failure of a drive roller located upstream of the target sensor



■ 02118B: JamCode (Paper Folding Unit-J1) 118B

[Symptom/Question]

02118B: JamCode (Paper Folding Unit-J1) 118B

[Remedy/Answer]

Jam Type : Stationary jam

Sensor Name : Fold Position Sensor

Sensor No. : S32

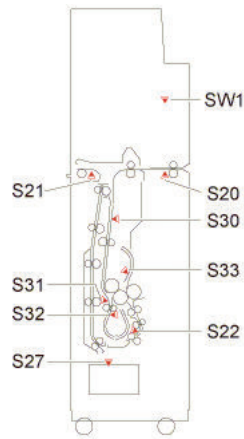
Overview of detection

A stationary jam occurs when a sensor was not turned OFF although a specified period of time had passed after the sensor was turned ON.

I/O: Service Mode > SITUATION > Sensor Check

Check items (in arbitrary order)

- Remaining paper near the target sensor
- Soiling on the target sensor
- Displacement of the target sensor position
- Failure of the target sensor
- Soiling (grease)/deterioration/failure of a drive motor located upstream of the target sensor
- Soiling (paper dust)/deterioration/failure of a drive roller located upstream of the target sensor



■ 02118D: JamCode (Paper Folding Unit-J1) 118D

[Symptom/Question]

02118D: JamCode (Paper Folding Unit-J1) 118D

[Remedy/Answer]

Jam Type : Stationary jam

Sensor Name : Upper Stopper Paper Sensor

Sensor No. : S33

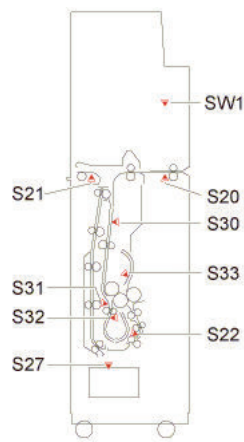
Overview of detection

A stationary jam occurs when a sensor was not turned OFF although a specified period of time had passed after the sensor was turned ON.

I/O: Service Mode > SITUATION > Sensor Check

Check items (in arbitrary order)

- Remaining paper near the target sensor
- Soiling on the target sensor
- Displacement of the target sensor position
- Failure of the target sensor
- Soiling (grease)/deterioration/failure of a drive motor located upstream of the target sensor
- Soiling (paper dust)/deterioration/failure of a drive roller located upstream of the target sensor



■ 02118F: JamCode (Paper Folding Unit-J1) 118F

[Symptom/Question]

02118F: JamCode (Paper Folding Unit-J1) 118F

[Remedy/Answer]

Jam Type : Stationary jam

Sensor Name : Delivery Sensor 1

Sensor No. : S22

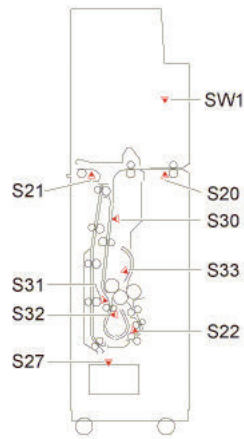
Overview of detection

A stationary jam occurs when a sensor was not turned OFF although a specified period of time had passed after the sensor was turned ON.

I/O: Service Mode > SITUATION > Sensor Check

Check items (in arbitrary order)

- Remaining paper near the target sensor
- Soiling on the target sensor
- Displacement of the target sensor position
- Failure of the target sensor
- Soiling (grease)/deterioration/failure of a drive motor located upstream of the target sensor
- Soiling (paper dust)/deterioration/failure of a drive roller located upstream of the target sensor



■ 021193: JamCode (Paper Folding Unit-J1) 1193

[Symptom/Question]

021193: JamCode (Paper Folding Unit-J1) 1193

[Remedy/Answer]

Jam Type : Stationary jam

Sensor Name : Fold Tray Paper Sensor

Sensor No. : S27

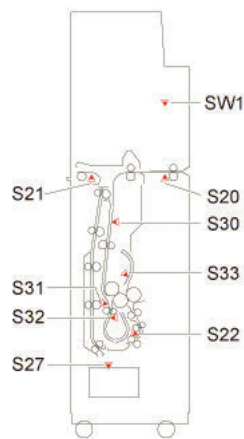
Overview of detection

A stationary jam occurs when a sensor was not turned OFF although a specified period of time had passed after the sensor was turned ON.

I/O: Service Mode > SITUATION > Sensor Check

Check items (in arbitrary order)

- Remaining paper near the target sensor
- Soiling on the target sensor
- Displacement of the target sensor position
- Failure of the target sensor
- Soiling (grease)/deterioration/failure of a drive motor located upstream of the target sensor
- Soiling (paper dust)/deterioration/failure of a drive roller located upstream of the target sensor



■ 0211A1: JamCode (Staple/Booklet Finisher-X1) 11A1

[Symptom/Question]

0211A1: JamCode (Staple/Booklet Finisher-X1) 11A1

[Remedy/Answer]

Jam Type : Stationary jam

Sensor Name : Saddle delivery sensor 2

Sensor No. : S227

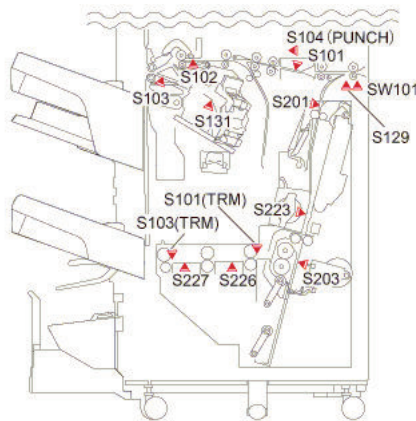
Overview of detection

A stationary jam occurs when a sensor was not turned OFF although a specified period of time had passed after the sensor was turned ON.

I/O: Service Mode > SITUATION > Sensor Check

Check items (in arbitrary order)

- Remaining paper near the target sensor
- Soiling on the target sensor
- Displacement of the target sensor position
- Failure of the target sensor
- Soiling (grease)/deterioration/failure of a drive motor located upstream of the target sensor
- Soiling (paper dust)/deterioration/failure of a drive roller located upstream of the target sensor



■ 0211A2: JamCode (Staple/Booklet Finisher-X1) 11A2

[Symptom/Question]

0211A2: JamCode (Staple/Booklet Finisher-X1) 11A2

[Remedy/Answer]

Jam Type : Stationary jam

Sensor Name : Saddle delivery sensor 1

Sensor No. : S226

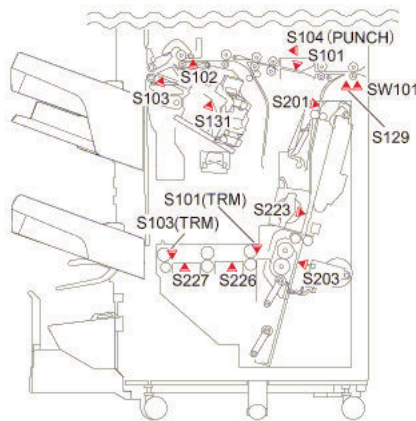
Overview of detection

A stationary jam occurs when a sensor was not turned OFF although a specified period of time had passed after the sensor was turned ON.

I/O: Service Mode > SITUATION > Sensor Check

Check items (in arbitrary order)

- Remaining paper near the target sensor
- Soiling on the target sensor
- Displacement of the target sensor position
- Failure of the target sensor
- Soiling (grease)/deterioration/failure of a drive motor located upstream of the target sensor
- Soiling (paper dust)/deterioration/failure of a drive roller located upstream of the target sensor



■ 0211A3: JamCode (Staple/Booklet Finisher-X1) 11A3

[Symptom/Question]

0211A3: JamCode (Staple/Booklet Finisher-X1) 11A3

[Remedy/Answer]

Jam Type : Stationary jam

Sensor Name : Saddle inlet sensor

Sensor No. : S201

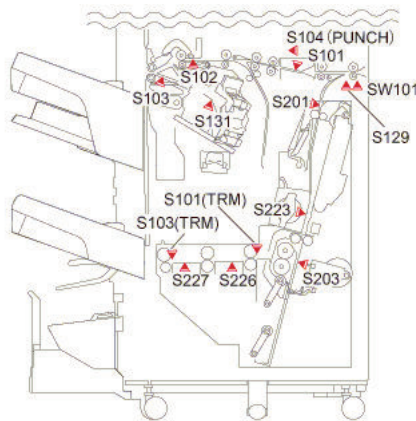
Overview of detection

A stationary jam occurs when a sensor was not turned OFF although a specified period of time had passed after the sensor was turned ON.

I/O: Service Mode > SITUATION > Sensor Check

Check items (in arbitrary order)

- Remaining paper near the target sensor
- Soiling on the target sensor
- Displacement of the target sensor position
- Failure of the target sensor
- Soiling (grease)/deterioration/failure of a drive motor located upstream of the target sensor
- Soiling (paper dust)/deterioration/failure of a drive roller located upstream of the target sensor



■ 0211A4: JamCode (Staple/Booklet Finisher-X1) 11A4

[Symptom/Question]

0211A4: JamCode (Staple/Booklet Finisher-X1) 11A4

[Remedy/Answer]

Jam Type : Stationary jam

Sensor Name : Trimmer Inlet Sensor

Sensor No. : S101(TRM)

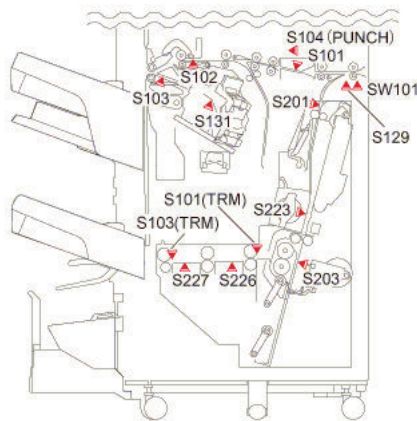
Overview of detection

A stationary jam occurs when a sensor was not turned OFF although a specified period of time had passed after the sensor was turned ON.

I/O: Service Mode > SITUATION > Sensor Check

Check items (in arbitrary order)

- Remaining paper near the target sensor
- Soiling on the target sensor
- Displacement of the target sensor position
- Failure of the target sensor
- Soiling (grease)/deterioration/failure of a drive motor located upstream of the target sensor
- Soiling (paper dust)/deterioration/failure of a drive roller located upstream of the target sensor



■ 0211AF: JamCode (Staple/Booklet Finisher-X1) 11AF

[Symptom/Question]

0211AF: JamCode (Staple/Booklet Finisher-X1) 11AF

[Remedy/Answer]

Jam Type : Error avoidance

Sensor Name : -

Sensor No. : -

Overview of detection

An error avoidance jam occurs when an error in the machine (excluding parts failure) was detected.

Printing operation is suspended to avoid error occurrence by error code; therefore, parts failure is not the cause of the jam.

After the jam is removed, the machine works.

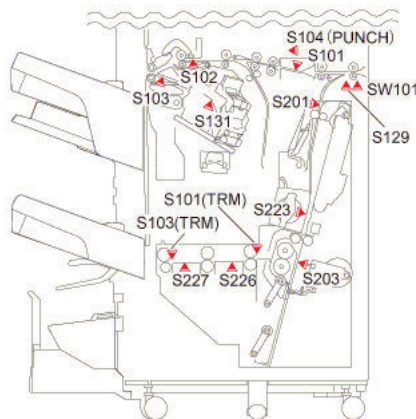
If it is due to parts failure, an error code instead of the error avoidance jam is displayed on UI and printing operation is suspended.

In such case, service technician should perform remedial work for the error code.

I/O: Service Mode > SITUATION > Sensor Check

Check items (in arbitrary order)

- Opening/closing of the door after jam removal
- Turning OFF and then ON the power after jam removal



■ 0211F0: JamCode (Document Insertion Unit-N1) 11F0

[Symptom/Question]

0211F0: JamCode (Document Insertion Unit-N1) 11F0

[Remedy/Answer]

Jam Type : Stationary jam

Sensor Name : Entrance Sensor

Sensor No. : S20

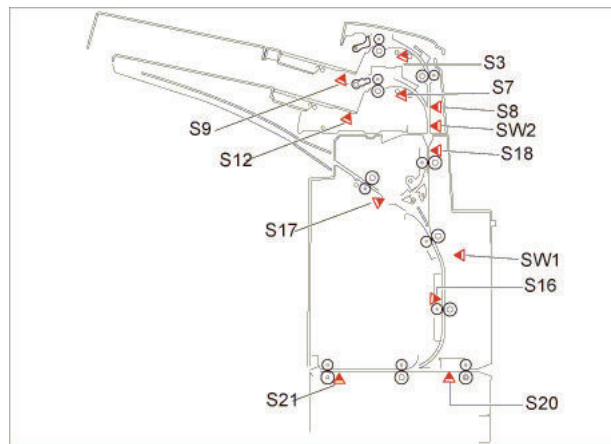
Overview of detection

A stationary jam occurs when a sensor was not turned OFF although a specified period of time had passed after the sensor was turned ON.

I/O: Service Mode > SITUATION > Sensor Check

Check items (in arbitrary order)

- Remaining paper near the target sensor
- Soiling on the target sensor
- Displacement of the target sensor position
- Failure of the target sensor
- Soiling (grease)/deterioration/failure of a drive motor located upstream of the target sensor
- Soiling (paper dust)/deterioration/failure of a drive roller located upstream of the target sensor



■ 0211F1: JamCode (Paper Folding Unit-J1) 11F1

[Symptom/Question]

0211F1: JamCode (Paper Folding Unit-J1) 11F1

[Remedy/Answer]

Jam Type : Stationary jam

Sensor Name : Entrance Sensor

Sensor No. : S20

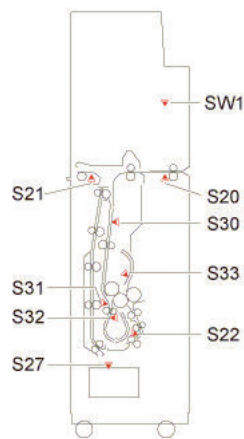
Overview of detection

A stationary jam occurs when a sensor was not turned OFF although a specified period of time had passed after the sensor was turned ON.

I/O: Service Mode > SITUATION > Sensor Check

Check items (in arbitrary order)

- Remaining paper near the target sensor
- Soiling on the target sensor
- Displacement of the target sensor position
- Failure of the target sensor
- Soiling (grease)/deterioration/failure of a drive motor located upstream of the target sensor
- Soiling (paper dust)/deterioration/failure of a drive roller located upstream of the target sensor



■ 0211F2: JamCode (Document Insertion Unit-N1) 11F2

[Symptom/Question]

0211F2: JamCode (Document Insertion Unit-N1) 11F2

[Remedy/Answer]

Jam Type : Stationary jam

Sensor Name : Delivery Sensor 2

Sensor No. : S21

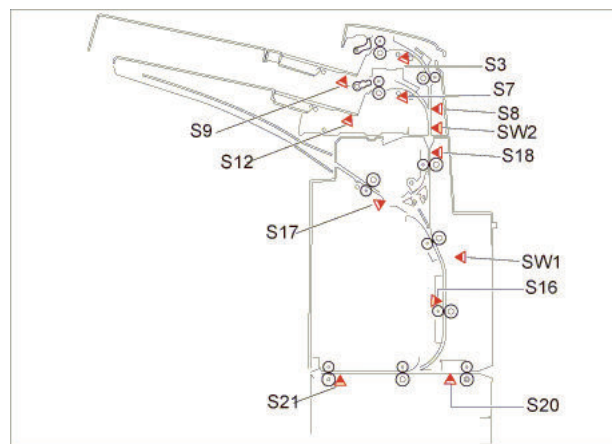
Overview of detection

A stationary jam occurs when a sensor was not turned OFF although a specified period of time had passed after the sensor was turned ON.

I/O: Service Mode > SITUATION > Sensor Check

Check items (in arbitrary order)

- Remaining paper near the target sensor
- Soiling on the target sensor
- Displacement of the target sensor position
- Failure of the target sensor
- Soiling (grease)/deterioration/failure of a drive motor located upstream of the target sensor
- Soiling (paper dust)/deterioration/failure of a drive roller located upstream of the target sensor



■ 0211F3: JamCode (Paper Folding Unit-J1) 11F3

[Symptom/Question]

0211F3: JamCode (Paper Folding Unit-J1) 11F3

[Remedy/Answer]

Jam Type : Stationary jam

Sensor Name : Delivery Sensor 2

Sensor No. : S21

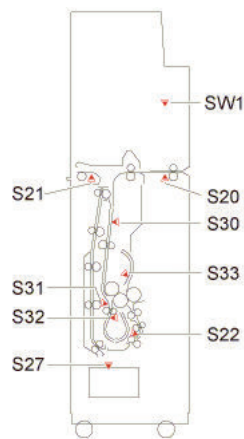
Overview of detection

A stationary jam occurs when a sensor was not turned OFF although a specified period of time had passed after the sensor was turned ON.

I/O: Service Mode > SITUATION > Sensor Check

Check items (in arbitrary order)

- Remaining paper near the target sensor
- Soiling on the target sensor
- Displacement of the target sensor position
- Failure of the target sensor
- Soiling (grease)/deterioration/failure of a drive motor located upstream of the target sensor
- Soiling (paper dust)/deterioration/failure of a drive roller located upstream of the target sensor



■ 0211F4: JamCode (Document Insertion Unit-N1) 11F4

[Symptom/Question]

0211F4: JamCode (Document Insertion Unit-N1) 11F4

[Remedy/Answer]

Jam Type : Stationary jam

Sensor Name : Upper Tray Registration Sensor

Sensor No. : S3

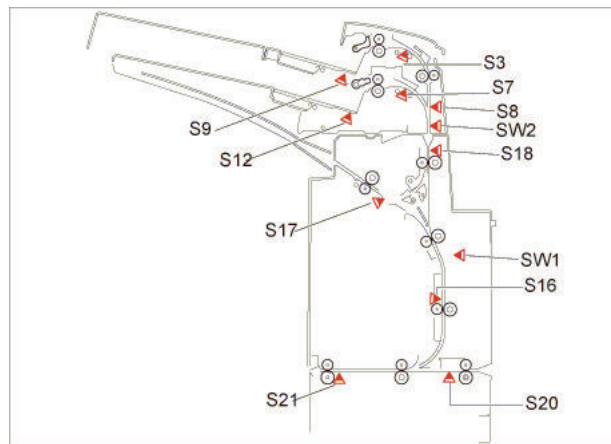
Overview of detection

A stationary jam occurs when a sensor was not turned OFF although a specified period of time had passed after the sensor was turned ON.

I/O: Service Mode > SITUATION > Sensor Check

Check items (in arbitrary order)

- Remaining paper near the target sensor
- Soiling on the target sensor
- Displacement of the target sensor position
- Failure of the target sensor
- Soiling (grease)/deterioration/failure of a drive motor located upstream of the target sensor
- Soiling (paper dust)/deterioration/failure of a drive roller located upstream of the target sensor



■ 0211F5: JamCode (Document Insertion Unit-N1) 11F5

[Symptom/Question]

0211F5: JamCode (Document Insertion Unit-N1) 11F5

[Remedy/Answer]

Jam Type : Stationary jam

Sensor Name : Middle Feed Sensor

Sensor No. : S8

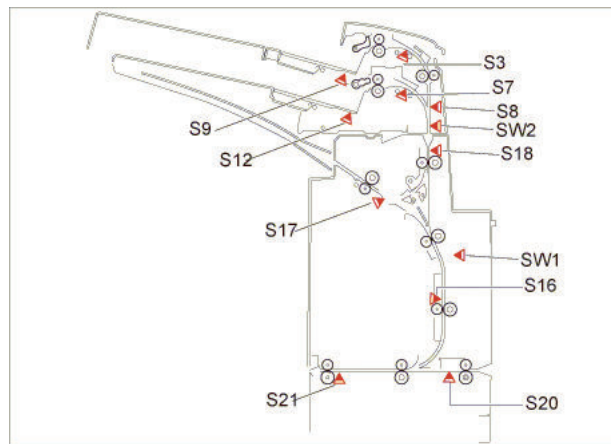
Overview of detection

A stationary jam occurs when a sensor was not turned OFF although a specified period of time had passed after the sensor was turned ON.

I/O: Service Mode > SITUATION > Sensor Check

Check items (in arbitrary order)

- Remaining paper near the target sensor
- Soiling on the target sensor
- Displacement of the target sensor position
- Failure of the target sensor
- Soiling (grease)/deterioration/failure of a drive motor located upstream of the target sensor
- Soiling (paper dust)/deterioration/failure of a drive roller located upstream of the target sensor



■ 0211F6: JamCode (Document Insertion Unit-N1) 11F6

[Symptom/Question]

0211F6: JamCode (Document Insertion Unit-N1) 11F6

[Remedy/Answer]

Jam Type : Stationary jam

Sensor Name : Reverse Entrance Sensor

Sensor No. : S18

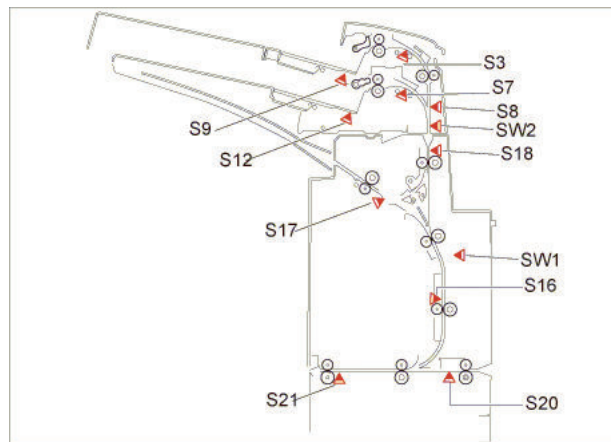
Overview of detection

A stationary jam occurs when a sensor was not turned OFF although a specified period of time had passed after the sensor was turned ON.

I/O: Service Mode > SITUATION > Sensor Check

Check items (in arbitrary order)

- Remaining paper near the target sensor
- Soiling on the target sensor
- Displacement of the target sensor position
- Failure of the target sensor
- Soiling (grease)/deterioration/failure of a drive motor located upstream of the target sensor
- Soiling (paper dust)/deterioration/failure of a drive roller located upstream of the target sensor



■ 0211F7: JamCode (Document Insertion Unit-N1) 11F7

[Symptom/Question]

0211F7: JamCode (Document Insertion Unit-N1) 11F7

[Remedy/Answer]

Jam Type : Stationary jam

Sensor Name : Reverse Sensor

Sensor No. : S17

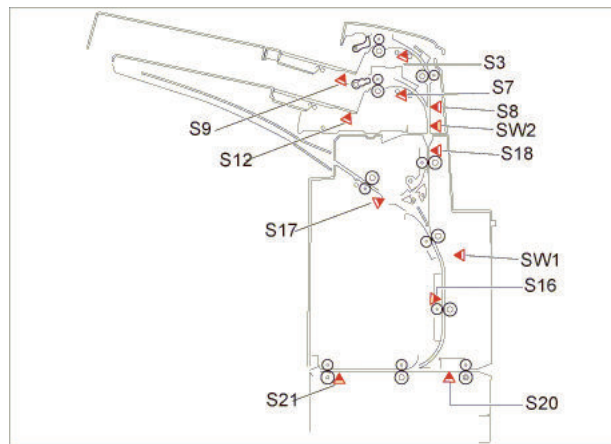
Overview of detection

A stationary jam occurs when a sensor was not turned OFF although a specified period of time had passed after the sensor was turned ON.

I/O: Service Mode > SITUATION > Sensor Check

Check items (in arbitrary order)

- Remaining paper near the target sensor
- Soiling on the target sensor
- Displacement of the target sensor position
- Failure of the target sensor
- Soiling (grease)/deterioration/failure of a drive motor located upstream of the target sensor
- Soiling (paper dust)/deterioration/failure of a drive roller located upstream of the target sensor



■ 0211F8: JamCode (Document Insertion Unit-N1) 11F8

[Symptom/Question]

0211F8: JamCode (Document Insertion Unit-N1) 11F8

[Remedy/Answer]

Jam Type : Stationary jam

Sensor Name : Reverse Timing Sensor

Sensor No. : S16

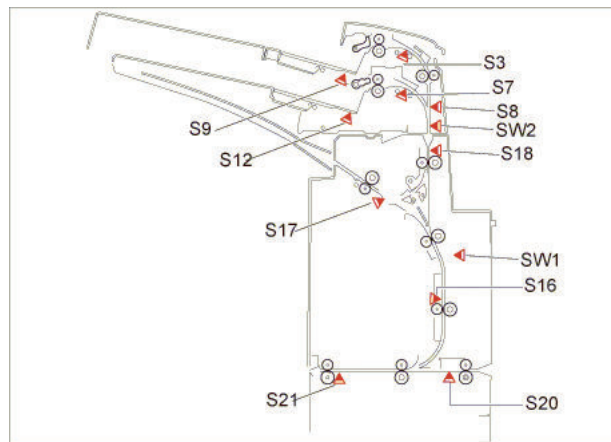
Overview of detection

A stationary jam occurs when a sensor was not turned OFF although a specified period of time had passed after the sensor was turned ON.

I/O: Service Mode > SITUATION > Sensor Check

Check items (in arbitrary order)

- Remaining paper near the target sensor
- Soiling on the target sensor
- Displacement of the target sensor position
- Failure of the target sensor
- Soiling (grease)/deterioration/failure of a drive motor located upstream of the target sensor
- Soiling (paper dust)/deterioration/failure of a drive roller located upstream of the target sensor



■ 0211F9: JamCode (Paper Folding Unit-J1) 11F9

[Symptom/Question]

0211F9: JamCode (Paper Folding Unit-J1) 11F9

[Remedy/Answer]

Jam Type : Stationary jam

Sensor Name : Slowdown Timing Sensor

Sensor No. : S30

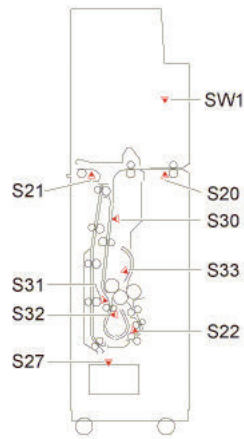
Overview of detection

A stationary jam occurs when a sensor was not turned OFF although a specified period of time had passed after the sensor was turned ON.

I/O: Service Mode > SITUATION > Sensor Check

Check items (in arbitrary order)

- Remaining paper near the target sensor
- Soiling on the target sensor
- Displacement of the target sensor position
- Failure of the target sensor
- Soiling (grease)/deterioration/failure of a drive motor located upstream of the target sensor
- Soiling (paper dust)/deterioration/failure of a drive roller located upstream of the target sensor



■ 0211FA: JamCode (Paper Folding Unit-J1) 11FA

[Symptom/Question]

0211FA: JamCode (Paper Folding Unit-J1) 11FA

[Remedy/Answer]

Jam Type : Stationary jam

Sensor Name : Release Timing Sensor

Sensor No. : S31

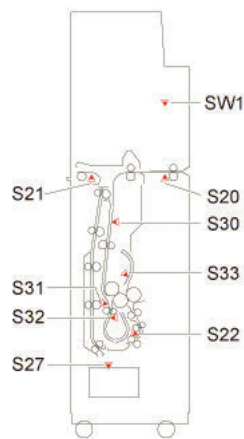
Overview of detection

A stationary jam occurs when a sensor was not turned OFF although a specified period of time had passed after the sensor was turned ON.

I/O: Service Mode > SITUATION > Sensor Check

Check items (in arbitrary order)

- Remaining paper near the target sensor
- Soiling on the target sensor
- Displacement of the target sensor position
- Failure of the target sensor
- Soiling (grease)/deterioration/failure of a drive motor located upstream of the target sensor
- Soiling (paper dust)/deterioration/failure of a drive roller located upstream of the target sensor



■ 0211FB: JamCode (Paper Folding Unit-J1) 11FB

[Symptom/Question]

0211FB: JamCode (Paper Folding Unit-J1) 11FB

[Remedy/Answer]

Jam Type : Stationary jam

Sensor Name : Fold Position Sensor

Sensor No. : S32

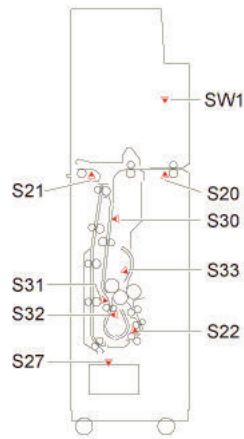
Overview of detection

A stationary jam occurs when a sensor was not turned OFF although a specified period of time had passed after the sensor was turned ON.

I/O: Service Mode > SITUATION > Sensor Check

Check items (in arbitrary order)

- Remaining paper near the target sensor
- Soiling on the target sensor
- Displacement of the target sensor position
- Failure of the target sensor
- Soiling (grease)/deterioration/failure of a drive motor located upstream of the target sensor
- Soiling (paper dust)/deterioration/failure of a drive roller located upstream of the target sensor



■ 0211FC: JamCode (Paper Folding Unit-J1) 11FC

[Symptom/Question]

0211FC: JamCode (Paper Folding Unit-J1) 11FC

[Remedy/Answer]

Jam Type : Stationary jam

Sensor Name : Upper Stopper Paper Sensor

Sensor No. : S33

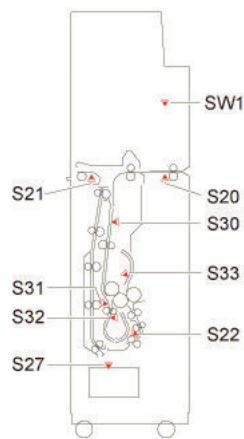
Overview of detection

A stationary jam occurs when a sensor was not turned OFF although a specified period of time had passed after the sensor was turned ON.

I/O: Service Mode > SITUATION > Sensor Check

Check items (in arbitrary order)

- Remaining paper near the target sensor
- Soiling on the target sensor
- Displacement of the target sensor position
- Failure of the target sensor
- Soiling (grease)/deterioration/failure of a drive motor located upstream of the target sensor
- Soiling (paper dust)/deterioration/failure of a drive roller located upstream of the target sensor



■ 0211FD: JamCode (Paper Folding Unit-J1) 11FD

[Symptom/Question]

0211FD: JamCode (Paper Folding Unit-J1) 11FD

[Remedy/Answer]

Jam Type : Stationary jam

Sensor Name : Delivery Sensor 1

Sensor No. : S22

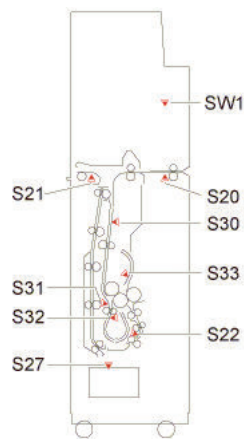
Overview of detection

A stationary jam occurs when a sensor was not turned OFF although a specified period of time had passed after the sensor was turned ON.

I/O: Service Mode > SITUATION > Sensor Check

Check items (in arbitrary order)

- Remaining paper near the target sensor
- Soiling on the target sensor
- Displacement of the target sensor position
- Failure of the target sensor
- Soiling (grease)/deterioration/failure of a drive motor located upstream of the target sensor
- Soiling (paper dust)/deterioration/failure of a drive roller located upstream of the target sensor



■ 0211FE: JamCode (Paper Folding Unit-J1) 11FE

[Symptom/Question]

0211FE: JamCode (Paper Folding Unit-J1) 11FE

[Remedy/Answer]

Jam Type : Stationary jam

Sensor Name : Fold Tray Paper Sensor

Sensor No. : S27

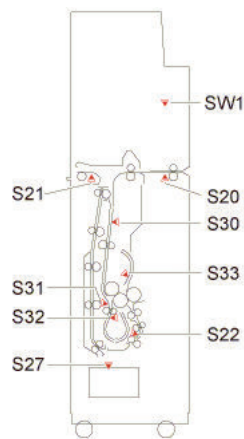
Overview of detection

A stationary jam occurs when a sensor was not turned OFF although a specified period of time had passed after the sensor was turned ON.

I/O: Service Mode > SITUATION > Sensor Check

Check items (in arbitrary order)

- Remaining paper near the target sensor
- Soiling on the target sensor
- Displacement of the target sensor position
- Failure of the target sensor
- Soiling (grease)/deterioration/failure of a drive motor located upstream of the target sensor
- Soiling (paper dust)/deterioration/failure of a drive roller located upstream of the target sensor



■ 0211FF: JamCode (Document Insertion Unit-N1) 11FF

[Symptom/Question]

0211FF: JamCode (Document Insertion Unit-N1) 11FF

[Remedy/Answer]

Jam Type : Stationary jam

Sensor Name : Lower Tray Registration Sensor

Sensor No. : S7

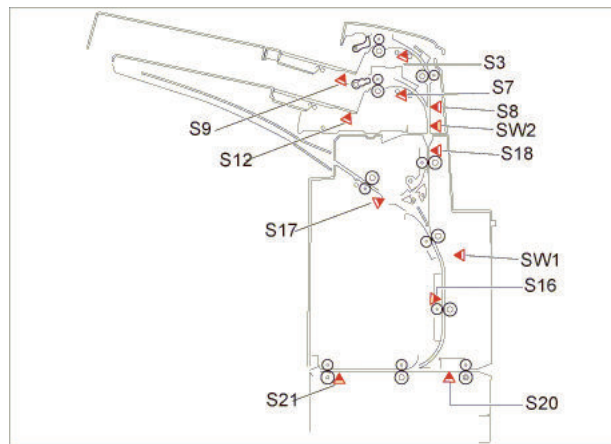
Overview of detection

A stationary jam occurs when a sensor was not turned OFF although a specified period of time had passed after the sensor was turned ON.

I/O: Service Mode > SITUATION > Sensor Check

Check items (in arbitrary order)

- Remaining paper near the target sensor
- Soiling on the target sensor
- Displacement of the target sensor position
- Failure of the target sensor
- Soiling (grease)/deterioration/failure of a drive motor located upstream of the target sensor
- Soiling (paper dust)/deterioration/failure of a drive roller located upstream of the target sensor



■ 021200: JamCode (Staple/Booklet Finisher-AC1) 1200

[Symptom/Question]

021200: JamCode (Staple/Booklet Finisher-AC1) 1200

[Remedy/Answer]

Jam Type : OTHER

Sensor Name : -

Sensor No. : -

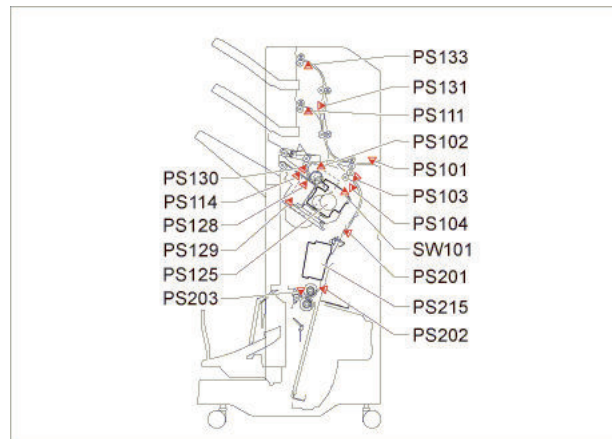
Overview of detection

-

I/O: Service Mode > SITUATION > Sensor Check

Check items (in arbitrary order)

-



■ 021205: JamCode (Staple/Booklet Finisher-X1) 1205

[Symptom/Question]

021205: JamCode (Staple/Booklet Finisher-X1) 1205

[Remedy/Answer]

Jam Type : OTHER

Sensor Name : Inlet sensor

Sensor No. : S101

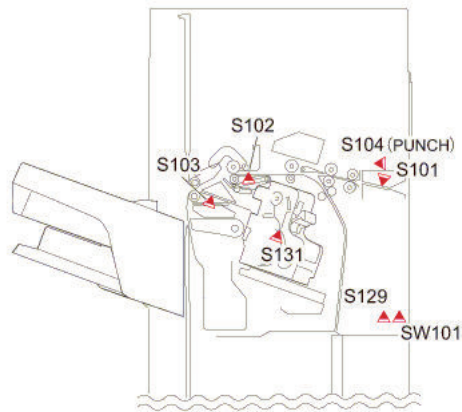
Overview of detection

-

I/O: Service Mode > SITUATION > Sensor Check

Check items (in arbitrary order)

-



■ 021231: JamCode (Staple/ Booklet Finisher-W1 PRO) 1231

[Symptom/Question]

021231: JamCode (Staple/ Booklet Finisher-W1 PRO) 1231

[Remedy/Answer]

Jam Type : OTHER

Sensor Name : -

Sensor No. : -

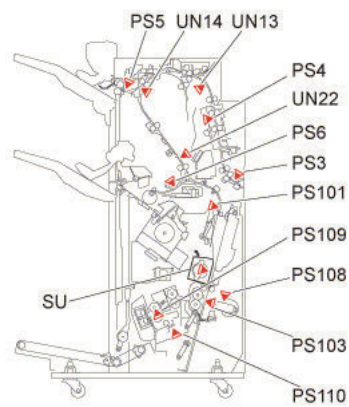
Overview of detection

-

I/O: Service Mode > SITUATION > Sensor Check

Check items (in arbitrary order)

-



■ 021301: JamCode (Staple/Booklet Finisher-AC1) 1301

[Symptom/Question]

021301: JamCode (Staple/Booklet Finisher-AC1) 1301

[Remedy/Answer]

Jam Type : Power-on jam

Sensor Name : Inlet Sensor

Sensor No. : PS101

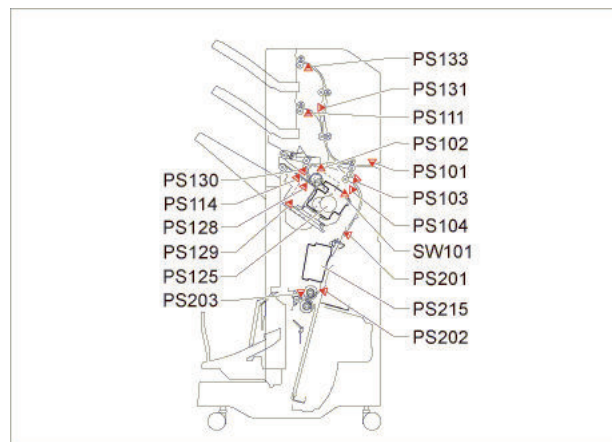
Overview of detection

A power-on jam occurs when a sensor detected ON state at power-on.

I/O: Service Mode > SITUATION > Sensor Check

Check items (in arbitrary order)

- Remaining paper in the machine
- Soiling on the target sensor
- Failure of the target sensor
- Foreign matter on the target sensor (paper dust, paper lint)



■ 021302: JamCode (Staple/Booklet Finisher-AC1) 1302

[Symptom/Question]

021302: JamCode (Staple/Booklet Finisher-AC1) 1302

[Remedy/Answer]

Jam Type : Power-on jam

Sensor Name : Delivery Sensor

Sensor No. : PS102

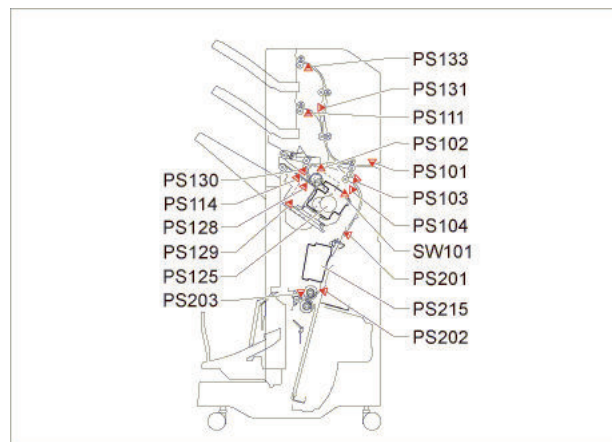
Overview of detection

A power-on jam occurs when a sensor detected ON state at power-on.

I/O: Service Mode > SITUATION > Sensor Check

Check items (in arbitrary order)

- Remaining paper in the machine
- Soiling on the target sensor
- Failure of the target sensor
- Foreign matter on the target sensor (paper dust, paper lint)



■ 021303: JamCode (Staple/Booklet Finisher-AC1) 1303

[Symptom/Question]

021303: JamCode (Staple/Booklet Finisher-AC1) 1303

[Remedy/Answer]

Jam Type : Power-on jam

Sensor Name : Buffer Sensor

Sensor No. : PS103

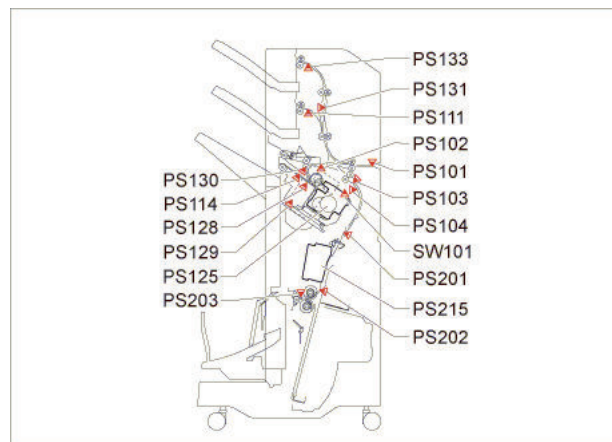
Overview of detection

A power-on jam occurs when a sensor detected ON state at power-on.

I/O: Service Mode > SITUATION > Sensor Check

Check items (in arbitrary order)

- Remaining paper in the machine
- Soiling on the target sensor
- Failure of the target sensor
- Foreign matter on the target sensor (paper dust, paper lint)



■ 021303: JamCode (Staple/ Booklet Finisher-W1 PRO) 1303

[Symptom/Question]

021303: JamCode (Staple/ Booklet Finisher-W1 PRO) 1303

[Remedy/Answer]

Jam Type : Power-on jam

Sensor Name : Inlet Sensor

Sensor No. : PS3

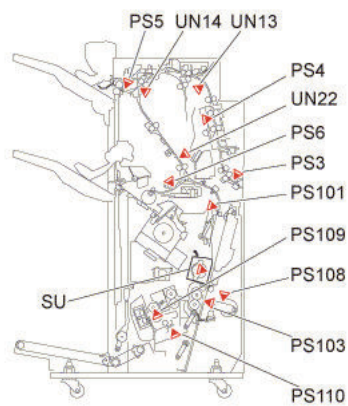
Overview of detection

A power-on jam occurs when a sensor detected ON state at power-on.

I/O: Service Mode > SITUATION > Sensor Check

Check items (in arbitrary order)

- Remaining paper in the machine
- Soiling on the target sensor
- Failure of the target sensor
- Foreign matter on the target sensor (paper dust, paper lint)



■ 021304: JamCode (Staple/Booklet Finisher-AC1) 1304

[Symptom/Question]

021304: JamCode (Staple/Booklet Finisher-AC1) 1304

[Remedy/Answer]

Jam Type : Power-on jam

Sensor Name : Lower Escape Delivery Sensor

Sensor No. : PS111

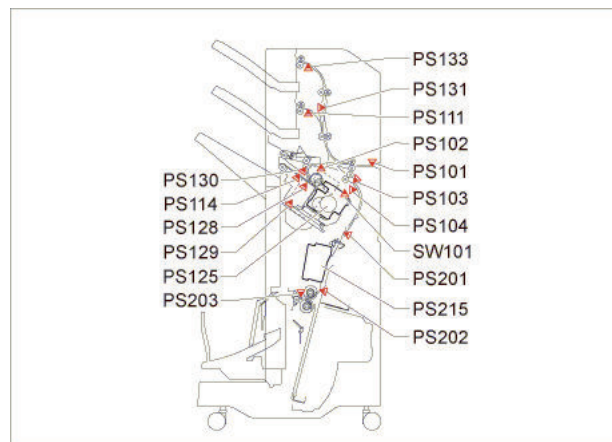
Overview of detection

A power-on jam occurs when a sensor detected ON state at power-on.

I/O: Service Mode > SITUATION > Sensor Check

Check items (in arbitrary order)

- Remaining paper in the machine
- Soiling on the target sensor
- Failure of the target sensor
- Foreign matter on the target sensor (paper dust, paper lint)



■ 021305: JamCode (Staple/Booklet Finisher-AC1) 1305

[Symptom/Question]

021305: JamCode (Staple/Booklet Finisher-AC1) 1305

[Remedy/Answer]

Jam Type : Power-on jam

Sensor Name : Upper Escape Delivery Sensor

Sensor No. : PS133

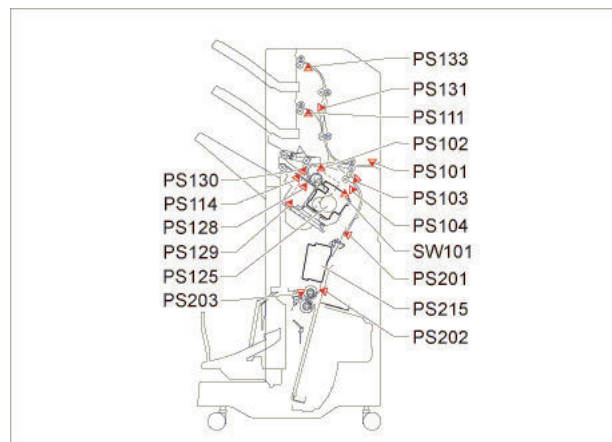
Overview of detection

A power-on jam occurs when a sensor detected ON state at power-on.

I/O: Service Mode > SITUATION > Sensor Check

Check items (in arbitrary order)

- Remaining paper in the machine
- Soiling on the target sensor
- Failure of the target sensor
- Foreign matter on the target sensor (paper dust, paper lint)



■ 021305: JamCode (Staple/ Booklet Finisher-W1 PRO) 1305

[Symptom/Question]

021305: JamCode (Staple/ Booklet Finisher-W1 PRO) 1305

[Remedy/Answer]

Jam Type : Power-on jam

Sensor Name : Shift Unit Trailing Edge Sensor

Sensor No. : PS4

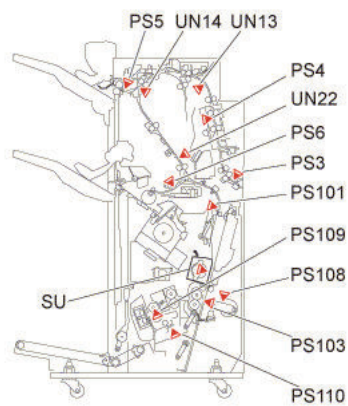
Overview of detection

A power-on jam occurs when a sensor detected ON state at power-on.

I/O: Service Mode > SITUATION > Sensor Check

Check items (in arbitrary order)

- Remaining paper in the machine
- Soiling on the target sensor
- Failure of the target sensor
- Foreign matter on the target sensor (paper dust, paper lint)



■ 021306: JamCode (Staple/Booklet Finisher-AC1) 1306

[Symptom/Question]

021306: JamCode (Staple/Booklet Finisher-AC1) 1306

[Remedy/Answer]

Jam Type : Power-on jam

Sensor Name : Escape Feed Sensor

Sensor No. : PS131

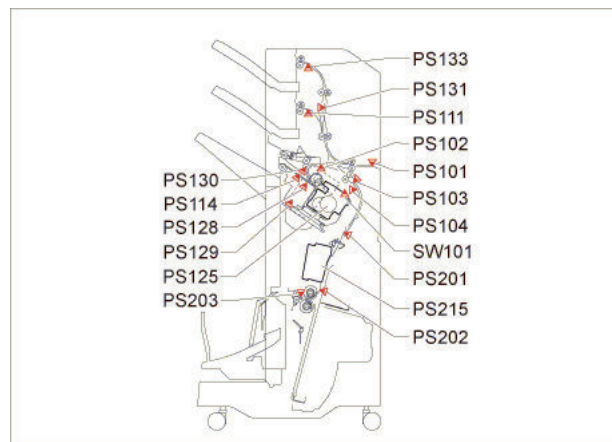
Overview of detection

A power-on jam occurs when a sensor detected ON state at power-on.

I/O: Service Mode > SITUATION > Sensor Check

Check items (in arbitrary order)

- Remaining paper in the machine
- Soiling on the target sensor
- Failure of the target sensor
- Foreign matter on the target sensor (paper dust, paper lint)



■ 021307: JamCode (Staple/Booklet Finisher-AC1) 1307

[Symptom/Question]

021307: JamCode (Staple/Booklet Finisher-AC1) 1307

[Remedy/Answer]

Jam Type : Power-on jam

Sensor Name : Saddle Processing Tray Paper Sensor

Sensor No. : PS202

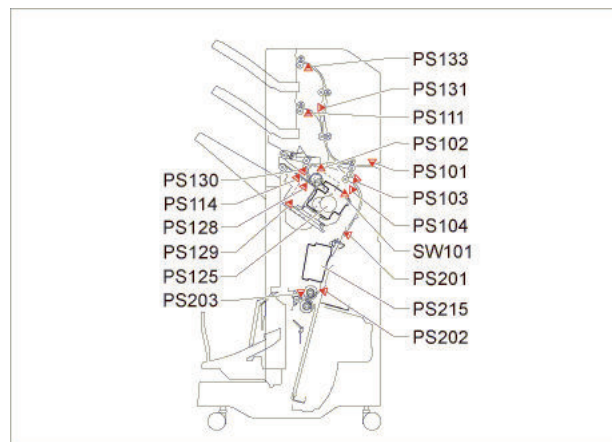
Overview of detection

A power-on jam occurs when a sensor detected ON state at power-on.

I/O: Service Mode > SITUATION > Sensor Check

Check items (in arbitrary order)

- Remaining paper in the machine
- Soiling on the target sensor
- Failure of the target sensor
- Foreign matter on the target sensor (paper dust, paper lint)



■ 021307: JamCode (Staple/ Booklet Finisher-W1 PRO) 1307

[Symptom/Question]

021307: JamCode (Staple/ Booklet Finisher-W1 PRO) 1307

[Remedy/Answer]

Jam Type : Power-on jam

Sensor Name : Buffer Path 1 Sensor PCB

Sensor No. : UN13

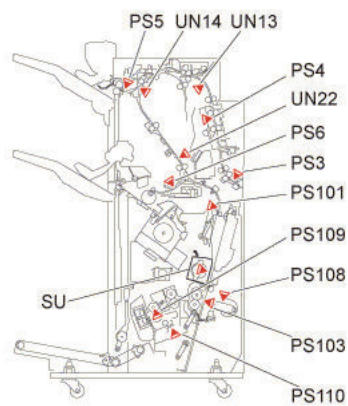
Overview of detection

A power-on jam occurs when a sensor detected ON state at power-on.

I/O: Service Mode > SITUATION > Sensor Check

Check items (in arbitrary order)

- Remaining paper in the machine
- Soiling on the target sensor
- Failure of the target sensor
- Foreign matter on the target sensor (paper dust, paper lint)



■ 021307: JamCode (Staple/Booklet Finisher-X1) 1307

[Symptom/Question]

021307: JamCode (Staple/Booklet Finisher-X1) 1307

[Remedy/Answer]

Jam Type : Power-on jam

Sensor Name : S101:Inlet sensor

S102:Delivery sensor

S103:Processing Tray Paper Sensor

Sensor No. : S101,S102,S103

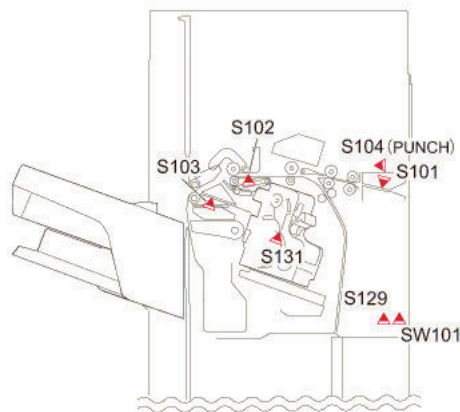
Overview of detection

A power-on jam occurs when a sensor detected ON state at power-on.

I/O: Service Mode > SITUATION > Sensor Check

Check items (in arbitrary order)

- Remaining paper in the machine
- Soiling on the target sensor
- Failure of the target sensor
- Foreign matter on the target sensor (paper dust, paper lint)



■ 021308: JamCode (Staple/Booklet Finisher-AC1) 1308

[Symptom/Question]

021308: JamCode (Staple/Booklet Finisher-AC1) 1308

[Remedy/Answer]

Jam Type : Power-on jam

Sensor Name : Saddle Delivery Sensor

Sensor No. : PS203

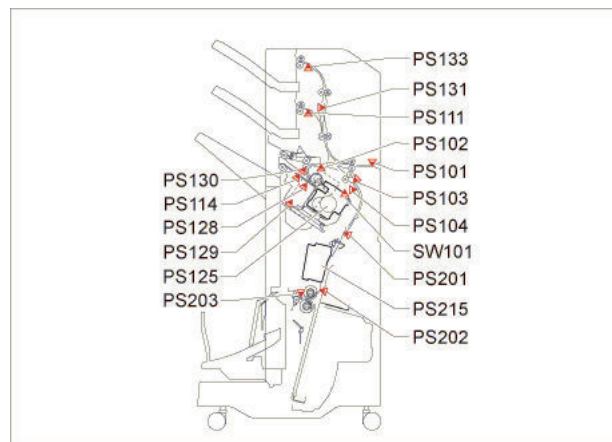
Overview of detection

A power-on jam occurs when a sensor detected ON state at power-on.

I/O: Service Mode > SITUATION > Sensor Check

Check items (in arbitrary order)

- Remaining paper in the machine
- Soiling on the target sensor
- Failure of the target sensor
- Foreign matter on the target sensor (paper dust, paper lint)



■ 021309: JamCode (Staple/Booklet Finisher-AC1) 1309

[Symptom/Question]

021309: JamCode (Staple/Booklet Finisher-AC1) 1309

[Remedy/Answer]

Jam Type : Power-on jam

Sensor Name : Saddle Inlet Sensor

Sensor No. : PS201

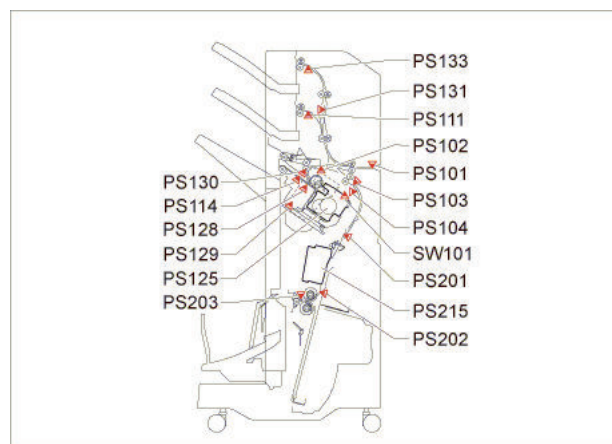
Overview of detection

A power-on jam occurs when a sensor detected ON state at power-on.

I/O: Service Mode > SITUATION > Sensor Check

Check items (in arbitrary order)

- Remaining paper in the machine
- Soiling on the target sensor
- Failure of the target sensor
- Foreign matter on the target sensor (paper dust, paper lint)



■ 021309: JamCode (Staple/ Booklet Finisher-W1 PRO) 1309

[Symptom/Question]

021309: JamCode (Staple/ Booklet Finisher-W1 PRO) 1309

[Remedy/Answer]

Jam Type : Power-on jam

Sensor Name : Buffer Path 2 Sensor PCB

Sensor No. : UN14

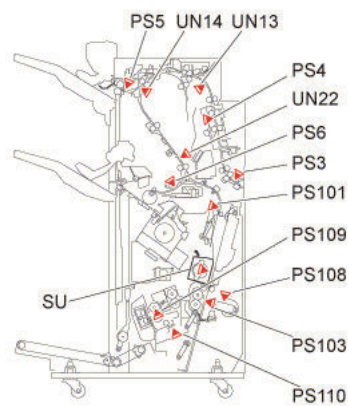
Overview of detection

A power-on jam occurs when a sensor detected ON state at power-on.

I/O: Service Mode > SITUATION > Sensor Check

Check items (in arbitrary order)

- Remaining paper in the machine
- Soiling on the target sensor
- Failure of the target sensor
- Foreign matter on the target sensor (paper dust, paper lint)



■ 02130B: JamCode (Staple/ Booklet Finisher-W1 PRO) 130B

[Symptom/Question]

02130B: JamCode (Staple/ Booklet Finisher-W1 PRO) 130B

[Remedy/Answer]

Jam Type : Power-on jam

Sensor Name : Upper Delivery Sensor

Sensor No. : PS5

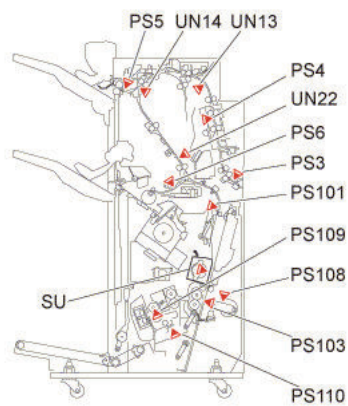
Overview of detection

A power-on jam occurs when a sensor detected ON state at power-on.

I/O: Service Mode > SITUATION > Sensor Check

Check items (in arbitrary order)

- Remaining paper in the machine
- Soiling on the target sensor
- Failure of the target sensor
- Foreign matter on the target sensor (paper dust, paper lint)



■ 02130D: JamCode (Staple/ Booklet Finisher-W1 PRO) 130D

[Symptom/Question]

02130D: JamCode (Staple/ Booklet Finisher-W1 PRO) 130D

[Remedy/Answer]

Jam Type : Power-on jam

Sensor Name : Lower Path Sensor PCB

Sensor No. : UN22

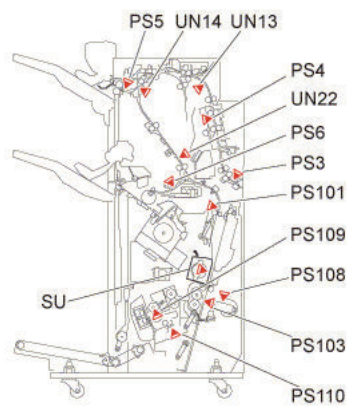
Overview of detection

A power-on jam occurs when a sensor detected ON state at power-on.

I/O: Service Mode > SITUATION > Sensor Check

Check items (in arbitrary order)

- Remaining paper in the machine
- Soiling on the target sensor
- Failure of the target sensor
- Foreign matter on the target sensor (paper dust, paper lint)



■ 02130F: JamCode (Staple/ Booklet Finisher-W1 PRO) 130F

[Symptom/Question]

02130F: JamCode (Staple/ Booklet Finisher-W1 PRO) 130F

[Remedy/Answer]

Jam Type : Power-on jam

Sensor Name : Lower Delivery Sensor

Sensor No. : PS6

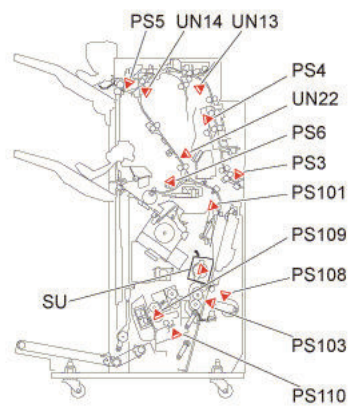
Overview of detection

A power-on jam occurs when a sensor detected ON state at power-on.

I/O: Service Mode > SITUATION > Sensor Check

Check items (in arbitrary order)

- Remaining paper in the machine
- Soiling on the target sensor
- Failure of the target sensor
- Foreign matter on the target sensor (paper dust, paper lint)



■ 021320: JamCode (Staple/ Booklet Finisher-W1 PRO) 1320

[Symptom/Question]

021320: JamCode (Staple/ Booklet Finisher-W1 PRO) 1320

[Remedy/Answer]

Jam Type : Power-on jam

Sensor Name : -

Sensor No. : -

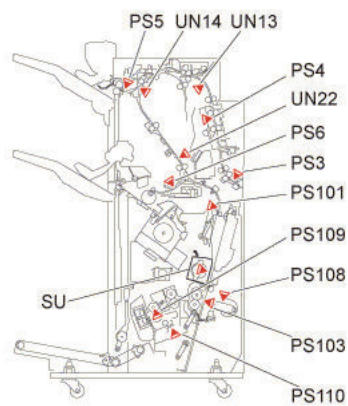
Overview of detection

A power-on jam occurs when a sensor detected ON state at power-on.

I/O: Service Mode > SITUATION > Sensor Check

Check items (in arbitrary order)

- Remaining paper in the machine
- Soiling on the target sensor
- Failure of the target sensor
- Foreign matter on the target sensor (paper dust, paper lint)



■ 021343: JamCode (Staple/ Booklet Finisher-W1 PRO) 1343

[Symptom/Question]

021343: JamCode (Staple/ Booklet Finisher-W1 PRO) 1343

[Remedy/Answer]

Jam Type : Power-on jam

Sensor Name : Saddle Inlet Sensor

Sensor No. : PS101

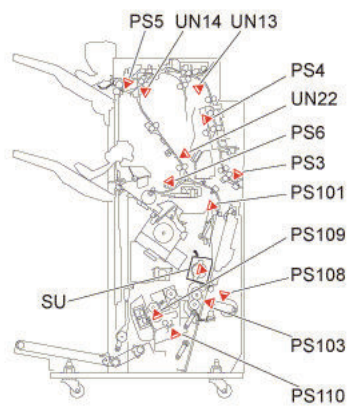
Overview of detection

A power-on jam occurs when a sensor detected ON state at power-on.

I/O: Service Mode > SITUATION > Sensor Check

Check items (in arbitrary order)

- Remaining paper in the machine
- Soiling on the target sensor
- Failure of the target sensor
- Foreign matter on the target sensor (paper dust, paper lint)



■ 021347: JamCode (Staple/ Booklet Finisher-W1 PRO) 1347

[Symptom/Question]

021347: JamCode (Staple/ Booklet Finisher-W1 PRO) 1347

[Remedy/Answer]

Jam Type : Power-on jam

Sensor Name : Saddle Vertical Path Sensor

Sensor No. : PS103

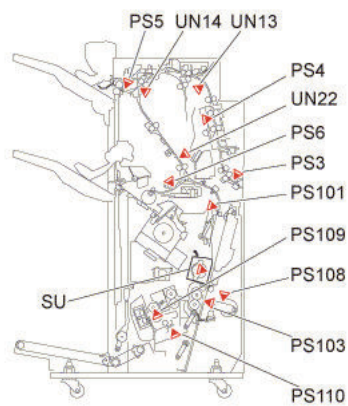
Overview of detection

A power-on jam occurs when a sensor detected ON state at power-on.

I/O: Service Mode > SITUATION > Sensor Check

Check items (in arbitrary order)

- Remaining paper in the machine
- Soiling on the target sensor
- Failure of the target sensor
- Foreign matter on the target sensor (paper dust, paper lint)



■ 02134B: JamCode (Staple/ Booklet Finisher-W1 PRO) 134B

[Symptom/Question]

02134B: JamCode (Staple/ Booklet Finisher-W1 PRO) 134B

[Remedy/Answer]

Jam Type : Power-on jam

Sensor Name : Saddle Press Front Sensor

Sensor No. : PS116

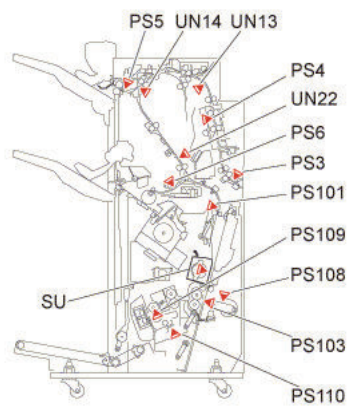
Overview of detection

A power-on jam occurs when a sensor detected ON state at power-on.

I/O: Service Mode > SITUATION > Sensor Check

Check items (in arbitrary order)

- Remaining paper in the machine
- Soiling on the target sensor
- Failure of the target sensor
- Foreign matter on the target sensor (paper dust, paper lint)



■ 021371: JamCode (Multi Function Professional Puncher-B1) 1371

[Symptom/Question]

021371: JamCode (Multi Function Professional Puncher-B1) 1371

[Remedy/Answer]

Jam Type : Power-on jam

Sensor Name : -

Sensor No. : -

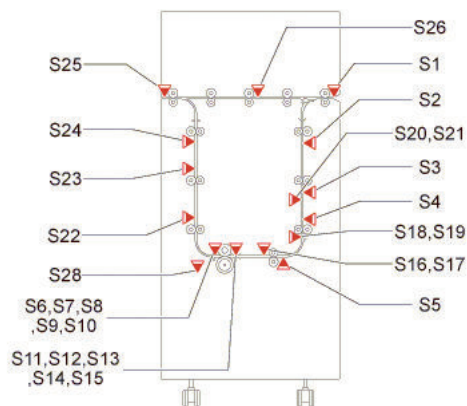
Overview of detection

A power-on jam occurs when a sensor detected ON state at power-on.

I/O: Service Mode > SITUATION > Sensor Check

Check items (in arbitrary order)

- Remaining paper in the machine
- Soiling on the target sensor
- Failure of the target sensor
- Foreign matter on the target sensor (paper dust, paper lint)



■ 021383: JamCode (Paper Folding Unit-J1) 1383

[Symptom/Question]

021383: JamCode (Paper Folding Unit-J1) 1383

[Remedy/Answer]

Jam Type : Power-on jam

Sensor Name : Entrance Sensor

Sensor No. : S20

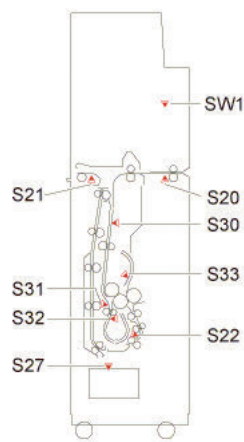
Overview of detection

A power-on jam occurs when a sensor detected ON state at power-on.

I/O: Service Mode > SITUATION > Sensor Check

Check items (in arbitrary order)

- Remaining paper in the machine
- Soiling on the target sensor
- Failure of the target sensor
- Foreign matter on the target sensor (paper dust, paper lint)



■ 021385: JamCode (Paper Folding Unit-J1) 1385

[Symptom/Question]

021385: JamCode (Paper Folding Unit-J1) 1385

[Remedy/Answer]

Jam Type : Power-on jam

Sensor Name : Delivery Sensor 2

Sensor No. : S21

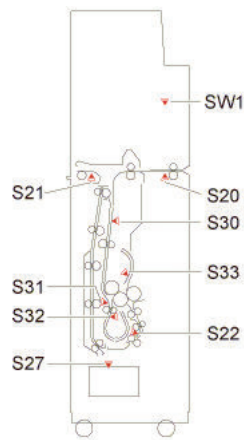
Overview of detection

A power-on jam occurs when a sensor detected ON state at power-on.

I/O: Service Mode > SITUATION > Sensor Check

Check items (in arbitrary order)

- Remaining paper in the machine
- Soiling on the target sensor
- Failure of the target sensor
- Foreign matter on the target sensor (paper dust, paper lint)



■ 021387: JamCode (Staple/Booklet Finisher-X1) 1387

[Symptom/Question]

021387: JamCode (Staple/Booklet Finisher-X1) 1387

[Remedy/Answer]

Jam Type : Power-on jam

Sensor Name : S201:Saddle inlet sensor

S203:Saddle vertical path sensor

S226:Saddle delivery sensor 1

S227:Saddle delivery sensor 2

Sensor No. : S201,S203,S226,S227

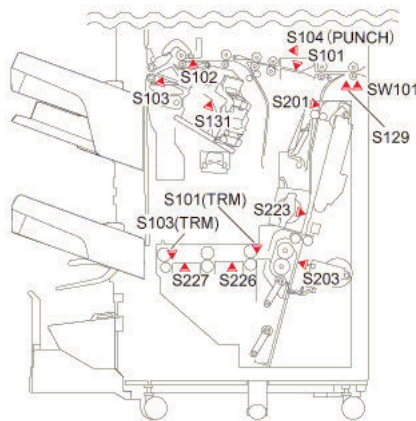
Overview of detection

A power-on jam occurs when a sensor detected ON state at power-on.

I/O: Service Mode > SITUATION > Sensor Check

Check items (in arbitrary order)

- Remaining paper in the machine
- Soiling on the target sensor
- Failure of the target sensor
- Foreign matter on the target sensor (paper dust, paper lint)



■ 021387: JamCode (Paper Folding Unit-J1) 1387

[Symptom/Question]

021387: JamCode (Paper Folding Unit-J1) 1387

[Remedy/Answer]

Jam Type : Power-on jam

Sensor Name : Slowdown Timing Sensor

Sensor No. : S30

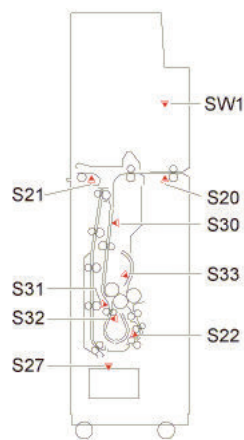
Overview of detection

A power-on jam occurs when a sensor detected ON state at power-on.

I/O: Service Mode > SITUATION > Sensor Check

Check items (in arbitrary order)

- Remaining paper in the machine
- Soiling on the target sensor
- Failure of the target sensor
- Foreign matter on the target sensor (paper dust, paper lint)



■ 021389: JamCode (Paper Folding Unit-J1) 1389

[Symptom/Question]

021389: JamCode (Paper Folding Unit-J1) 1389

[Remedy/Answer]

Jam Type : Power-on jam

Sensor Name : Release Timing Sensor

Sensor No. : S31

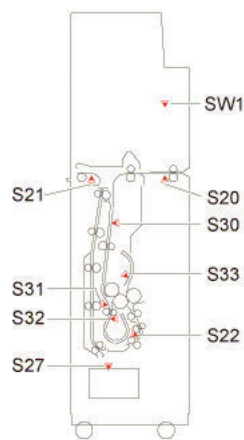
Overview of detection

A power-on jam occurs when a sensor detected ON state at power-on.

I/O: Service Mode > SITUATION > Sensor Check

Check items (in arbitrary order)

- Remaining paper in the machine
- Soiling on the target sensor
- Failure of the target sensor
- Foreign matter on the target sensor (paper dust, paper lint)



■ 02138A: JamCode (Staple/Booklet Finisher-X1) 138A

[Symptom/Question]

02138A: JamCode (Staple/Booklet Finisher-X1) 138A

[Remedy/Answer]

Jam Type : Power-on jam

Sensor Name : S101(TRM):Inlet sensor

S103(TRM):Delivery sensor

Sensor No. : S101(TRM),S103(TRM)

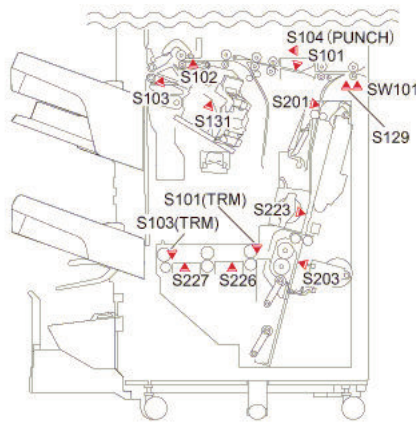
Overview of detection

A power-on jam occurs when a sensor detected ON state at power-on.

I/O: Service Mode > SITUATION > Sensor Check

Check items (in arbitrary order)

- Remaining paper in the machine
- Soiling on the target sensor
- Failure of the target sensor
- Foreign matter on the target sensor (paper dust, paper lint)



■ 02138B: JamCode (Paper Folding Unit-J1) 138B

[Symptom/Question]

02138B: JamCode (Paper Folding Unit-J1) 138B

[Remedy/Answer]

Jam Type : Power-on jam

Sensor Name : Fold Position Sensor

Sensor No. : S32

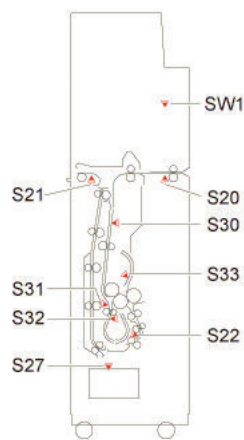
Overview of detection

A power-on jam occurs when a sensor detected ON state at power-on.

I/O: Service Mode > SITUATION > Sensor Check

Check items (in arbitrary order)

- Remaining paper in the machine
- Soiling on the target sensor
- Failure of the target sensor
- Foreign matter on the target sensor (paper dust, paper lint)



■ 02138D: JamCode (Paper Folding Unit-J1) 138D

[Symptom/Question]

02138D: JamCode (Paper Folding Unit-J1) 138D

[Remedy/Answer]

Jam Type : Power-on jam

Sensor Name : Upper Stopper Paper Sensor

Sensor No. : S33

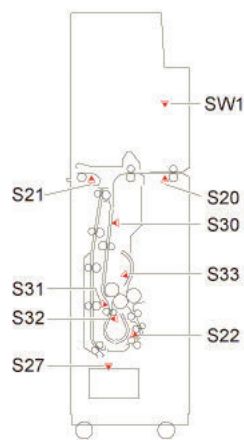
Overview of detection

A power-on jam occurs when a sensor detected ON state at power-on.

I/O: Service Mode > SITUATION > Sensor Check

Check items (in arbitrary order)

- Remaining paper in the machine
- Soiling on the target sensor
- Failure of the target sensor
- Foreign matter on the target sensor (paper dust, paper lint)



■ 02138F: JamCode (Paper Folding Unit-J1) 138F

[Symptom/Question]

02138F: JamCode (Paper Folding Unit-J1) 138F

[Remedy/Answer]

Jam Type : Power-on jam

Sensor Name : Delivery Sensor 1

Sensor No. : S22

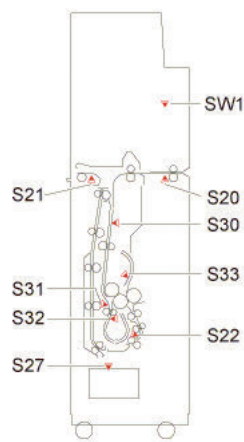
Overview of detection

A power-on jam occurs when a sensor detected ON state at power-on.

I/O: Service Mode > SITUATION > Sensor Check

Check items (in arbitrary order)

- Remaining paper in the machine
- Soiling on the target sensor
- Failure of the target sensor
- Foreign matter on the target sensor (paper dust, paper lint)



■ 021393: JamCode (Paper Folding Unit-J1) 1393

[Symptom/Question]

021393: JamCode (Paper Folding Unit-J1) 1393

[Remedy/Answer]

Jam Type : Power-on jam

Sensor Name : Fold Tray Paper Sensor

Sensor No. : S27

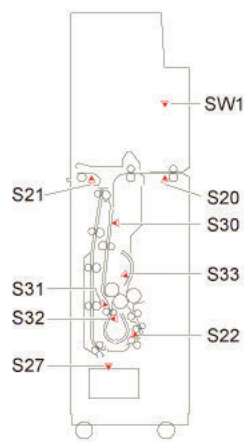
Overview of detection

A power-on jam occurs when a sensor detected ON state at power-on.

I/O: Service Mode > SITUATION > Sensor Check

Check items (in arbitrary order)

- Remaining paper in the machine
- Soiling on the target sensor
- Failure of the target sensor
- Foreign matter on the target sensor (paper dust, paper lint)



■ 0213CD: JamCode (Document Insertion Unit-N1) 13CD

[Symptom/Question]

0213CD: JamCode (Document Insertion Unit-N1) 13CD

[Remedy/Answer]

Jam Type : Power-on jam

Sensor Name : -

Sensor No. : -

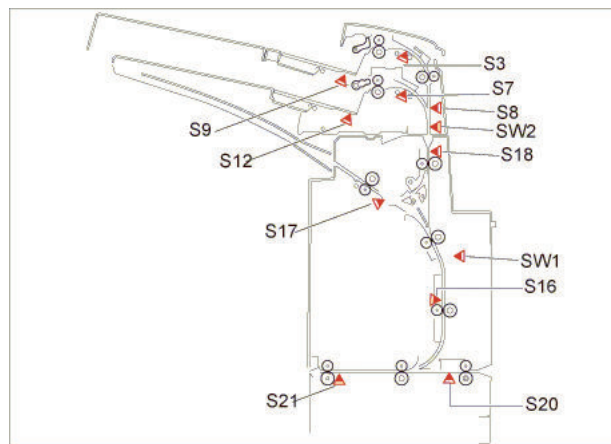
Overview of detection

A power-on jam occurs when a sensor detected ON state at power-on.

I/O: Service Mode > SITUATION > Sensor Check

Check items (in arbitrary order)

- Remaining paper in the machine
- Soiling on the target sensor
- Failure of the target sensor
- Foreign matter on the target sensor (paper dust, paper lint)



■ 0213DD: JamCode (Paper Folding Unit-J1) 13DD

[Symptom/Question]

0213DD: JamCode (Paper Folding Unit-J1) 13DD

[Remedy/Answer]

Jam Type : Power-on jam

Sensor Name : -

Sensor No. : -

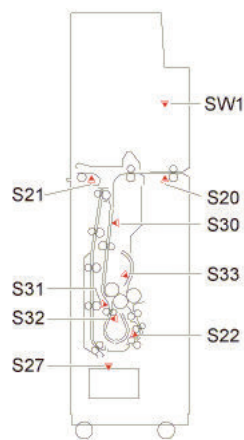
Overview of detection

A power-on jam occurs when a sensor detected ON state at power-on.

I/O: Service Mode > SITUATION > Sensor Check

Check items (in arbitrary order)

- Remaining paper in the machine
- Soiling on the target sensor
- Failure of the target sensor
- Foreign matter on the target sensor (paper dust, paper lint)



■ 021400: JamCode (Staple/Booklet Finisher-AC1) 1400

[Symptom/Question]

021400: JamCode (Staple/Booklet Finisher-AC1) 1400

[Remedy/Answer]

Jam Type : COVER Open jam

Sensor Name : Front Cover Sensor/Front Cover Switch

Sensor No. : PS104,SW101

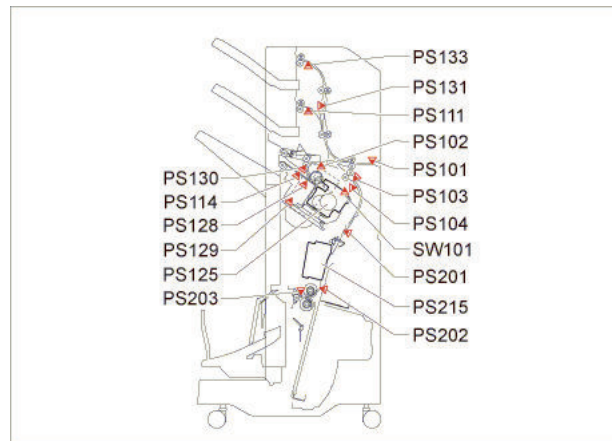
Overview of detection

A door open jam occurs when a sensor detected cover open during printing operation.

I/O: Service Mode > SITUATION > Sensor Check

Check items (in arbitrary order)

- Cover open during printing



■ 021408: JamCode (Staple/Booklet Finisher-X1) 1408

[Symptom/Question]

021408: JamCode (Staple/Booklet Finisher-X1) 1408

[Remedy/Answer]

Jam Type : COVER Open jam

Sensor Name : S129:Front cover sensor

Sensor No. : S129,SW101

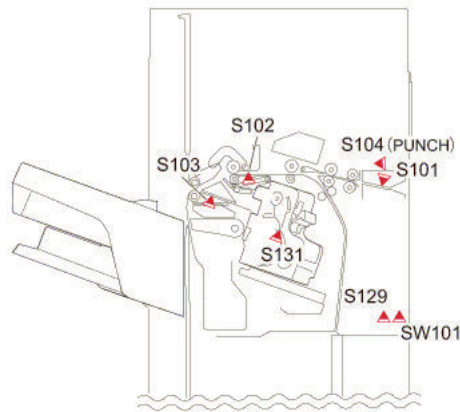
Overview of detection

A door open jam occurs when a sensor detected cover open during printing operation.

I/O: Service Mode > SITUATION > Sensor Check

Check items (in arbitrary order)

- Cover open during printing



■ 021422: JamCode (Staple/ Booklet Finisher-W1 PRO) 1422

[Symptom/Question]

021422: JamCode (Staple/ Booklet Finisher-W1 PRO) 1422

[Remedy/Answer]

Jam Type : Door open jam

Sensor Name : -

Sensor No. : -

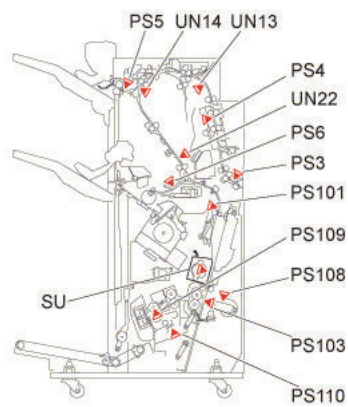
Overview of detection

A door open jam occurs when a sensor detected door open during printing operation.

I/O: Service Mode > SITUATION > Sensor Check

Check items (in arbitrary order)

- Door open during printing



■ 021472: JamCode (Multi Function Professional Puncher-B1) 1472

[Symptom/Question]

021472: JamCode (Multi Function Professional Puncher-B1) 1472

[Remedy/Answer]

Jam Type : COVER Open jam

Sensor Name : -

Sensor No. : -

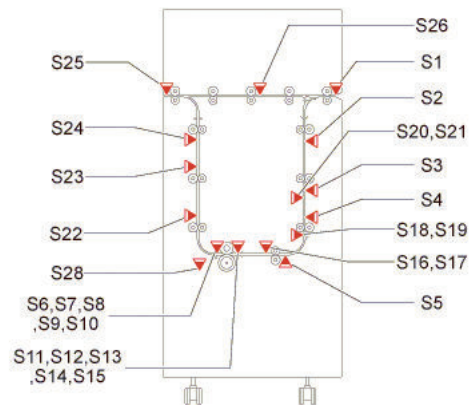
Overview of detection

A door open jam occurs when a sensor detected cover open during printing operation.

I/O: Service Mode > SITUATION > Sensor Check

Check items (in arbitrary order)

- Cover open during printing



■ 021488: JamCode (Staple/Booklet Finisher-X1) 1488

[Symptom/Question]

021488: JamCode (Staple/Booklet Finisher-X1) 1488

[Remedy/Answer]

Jam Type : COVER Open jam

Sensor Name : S129:Front cover sensor

Sensor No. : S129,SW101

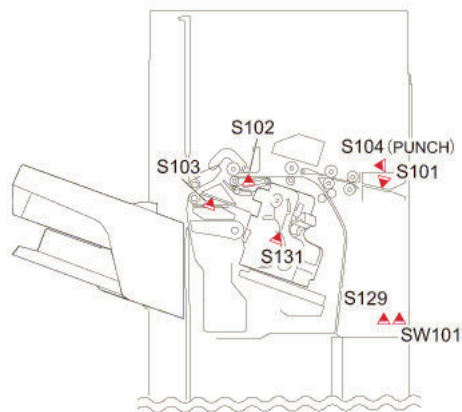
Overview of detection

A door open jam occurs when a sensor detected cover open during printing operation.

I/O: Service Mode > SITUATION > Sensor Check

Check items (in arbitrary order)

- Cover open during printing



■ 02148B: JamCode (Staple/Booklet Finisher-X1) 148B

[Symptom/Question]

02148B: JamCode (Staple/Booklet Finisher-X1) 148B

[Remedy/Answer]

Jam Type : COVER Open jam

Sensor Name : S129:Front cover sensor

Sensor No. : S129,SW101

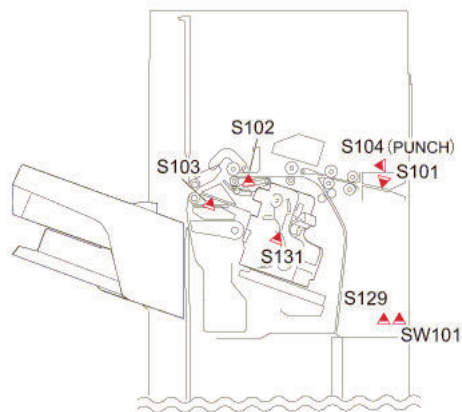
Overview of detection

A door open jam occurs when a sensor detected cover open during printing operation.

I/O: Service Mode > SITUATION > Sensor Check

Check items (in arbitrary order)

- Cover open during printing



■ 02149B: JamCode (Paper Folding Unit-J1) 149B

[Symptom/Question]

02149B: JamCode (Paper Folding Unit-J1) 149B

[Remedy/Answer]

Jam Type : COVER Open jam

Sensor Name : Front Upper Cover Switch

Sensor No. : SW1

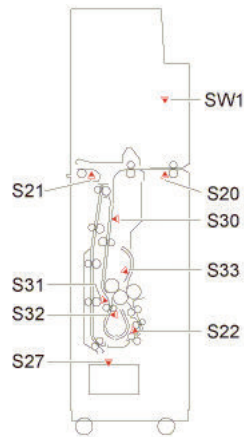
Overview of detection

A door open jam occurs when a sensor detected cover open during printing operation.

I/O: Service Mode > SITUATION > Sensor Check

Check items (in arbitrary order)

- Cover open during printing



■ 0214CC: JamCode (Document Insertion Unit-N1) 14CC

[Symptom/Question]

0214CC: JamCode (Document Insertion Unit-N1) 14CC

[Remedy/Answer]

Jam Type : Door open jam

Sensor Name : Cover Open jam

Sensor No. : SW1,SW2

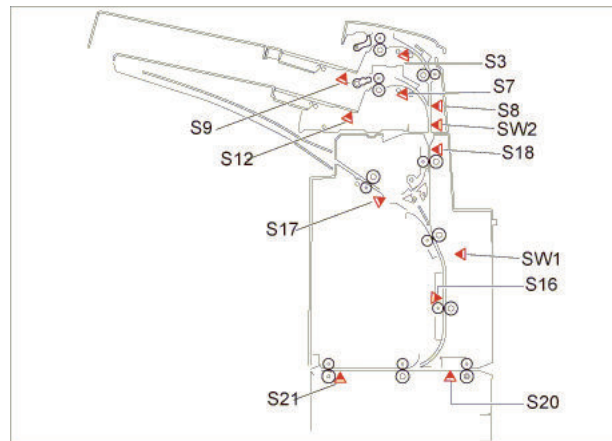
Overview of detection

A door open jam occurs when a sensor detected door open during printing operation.

I/O: Service Mode > SITUATION > Sensor Check

Check items (in arbitrary order)

- Door open during printing



■ 0214DC: JamCode (Paper Folding Unit-J1) 14DC

[Symptom/Question]

0214DC: JamCode (Paper Folding Unit-J1) 14DC

[Remedy/Answer]

Jam Type : COVER Open jam

Sensor Name : Front Upper Cover Switch

Sensor No. : SW1

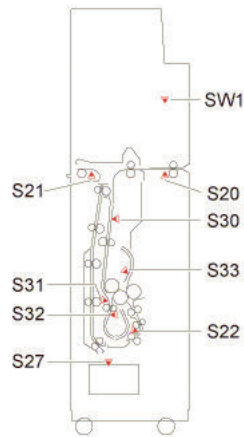
Overview of detection

A door open jam occurs when a sensor detected cover open during printing operation.

I/O: Service Mode > SITUATION > Sensor Check

Check items (in arbitrary order)

- Cover open during printing



■ 021500: JamCode (Staple/Booklet Finisher-AC1) 1500

[Symptom/Question]

021500: JamCode (Staple/Booklet Finisher-AC1) 1500

[Remedy/Answer]

Jam Type : STAPLE

Sensor Name : Staple HP Sensor

Sensor No. : PS125

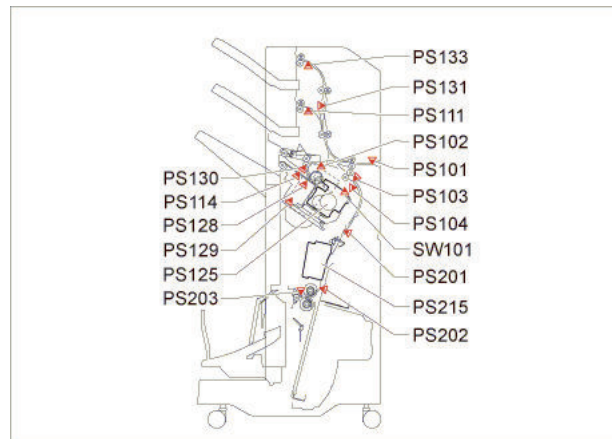
Overview of detection

-

I/O: Service Mode > SITUATION > Sensor Check

Check items (in arbitrary order)

-



■ 021501: JamCode (Staple/Booklet Finisher-AC1) 1501

[Symptom/Question]

021501: JamCode (Staple/Booklet Finisher-AC1) 1501

[Remedy/Answer]

Jam Type : SDL STP

Sensor Name : Saddle Stitcher HP Sensor

Sensor No. : PS215

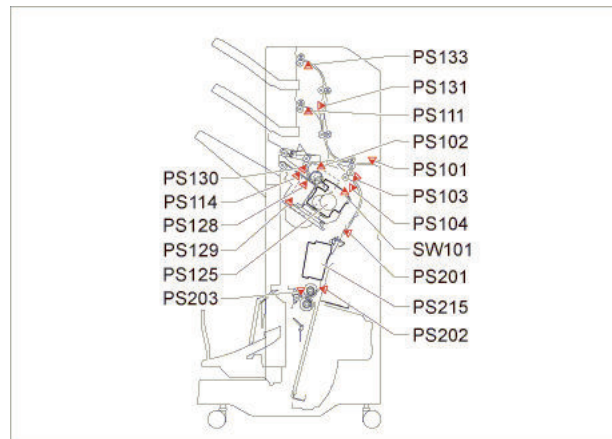
Overview of detection

-

I/O: Service Mode > SITUATION > Sensor Check

Check items (in arbitrary order)

-



■ 021506: JamCode (Staple/Booklet Finisher-X1) 1506

[Symptom/Question]

021506: JamCode (Staple/Booklet Finisher-X1) 1506

[Remedy/Answer]

Jam Type : STAPLE

Sensor Name : Staple HP sensor

Sensor No. : S131

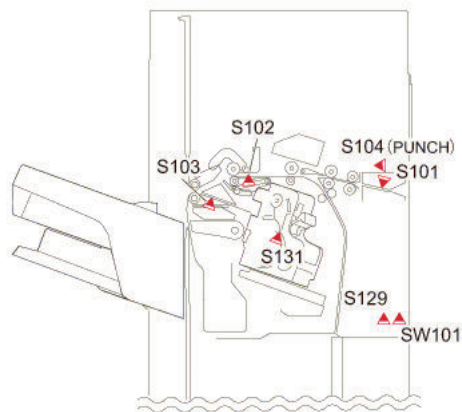
Overview of detection

-

I/O: Service Mode > SITUATION > Sensor Check

Check items (in arbitrary order)

-



■ 021524: JamCode (Staple/ Booklet Finisher-W1 PRO) 1524

[Symptom/Question]

021524: JamCode (Staple/ Booklet Finisher-W1 PRO) 1524

[Remedy/Answer]

Jam Type : STAPLE

Sensor Name : Staple HP Sensor

Sensor No. : -

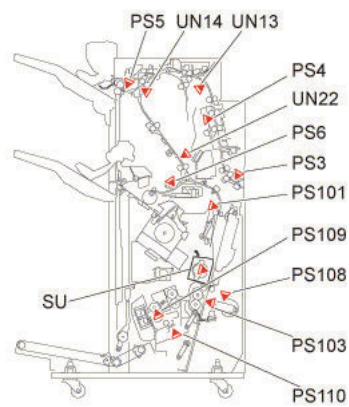
Overview of detection

-

I/O: Service Mode > SITUATION > Sensor Check

Check items (in arbitrary order)

-



■ 021550: JamCode (Staple/ Booklet Finisher-W1 PRO) 1550

[Symptom/Question]

021550: JamCode (Staple/ Booklet Finisher-W1 PRO) 1550

[Remedy/Answer]

Jam Type : SDL STP

Sensor Name : Saddle Staple HP Sensor

Sensor No. : -

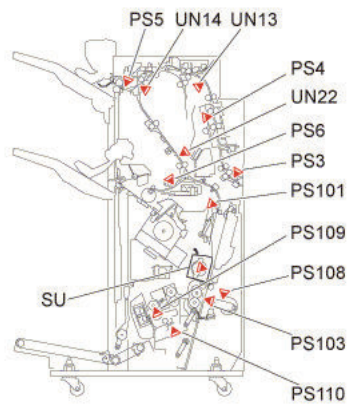
Overview of detection

-

I/O: Service Mode > SITUATION > Sensor Check

Check items (in arbitrary order)

-



■ 021586: JamCode (Staple/Booklet Finisher-X1) 1586

[Symptom/Question]

021586: JamCode (Staple/Booklet Finisher-X1) 1586

[Remedy/Answer]

Jam Type : SDL STP

Sensor Name : Saddle sticher HP sensor

Sensor No. : S223

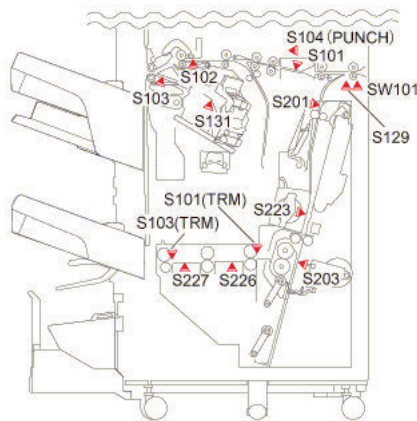
Overview of detection

-

I/O: Service Mode > SITUATION > Sensor Check

Check items (in arbitrary order)

-



■ 021600: JamCode (PUNCHER UNIT-A1) 1600

[Symptom/Question]

021600: JamCode (PUNCHER UNIT-A1) 1600

[Remedy/Answer]

Jam Type : PUNCH

Sensor Name : Punch HP Sensor 1/Punch HP Sensor 2

Sensor No. : PS303,PS304

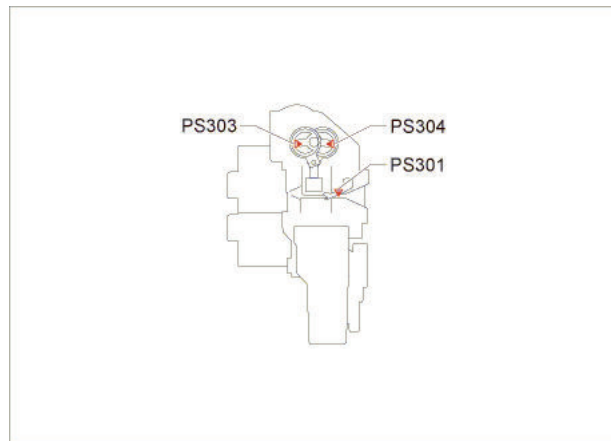
Overview of detection

-

I/O: Service Mode > SITUATION > Sensor Check

Check items (in arbitrary order)

-



■ 021703: JamCode (Staple/ Booklet Finisher-W1 PRO) 1703

[Symptom/Question]

021703: JamCode (Staple/ Booklet Finisher-W1 PRO) 1703

[Remedy/Answer]

Jam Type : OTHER

Sensor Name : Inlet Sensor

Sensor No. : PS3

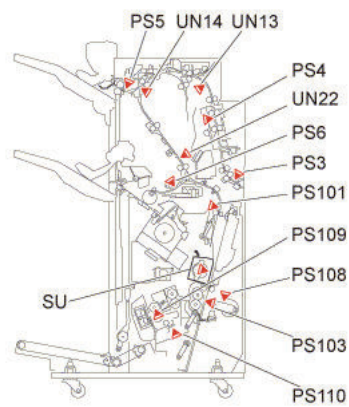
Overview of detection

-

I/O: Service Mode > SITUATION > Sensor Check

Check items (in arbitrary order)

-



■ 021705: JamCode (Staple/ Booklet Finisher-W1 PRO) 1705

[Symptom/Question]

021705: JamCode (Staple/ Booklet Finisher-W1 PRO) 1705

[Remedy/Answer]

Jam Type : OTHER

Sensor Name : Shift Unit Trailing Edge Sensor

Sensor No. : PS4

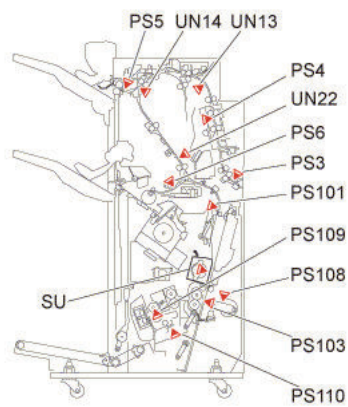
Overview of detection

-

I/O: Service Mode > SITUATION > Sensor Check

Check items (in arbitrary order)

-



■ 021707: JamCode (Staple/ Booklet Finisher-W1 PRO) 1707

[Symptom/Question]

021707: JamCode (Staple/ Booklet Finisher-W1 PRO) 1707

[Remedy/Answer]

Jam Type : OTHER

Sensor Name : Buffer Path 1 Sensor PCB

Sensor No. : UN13

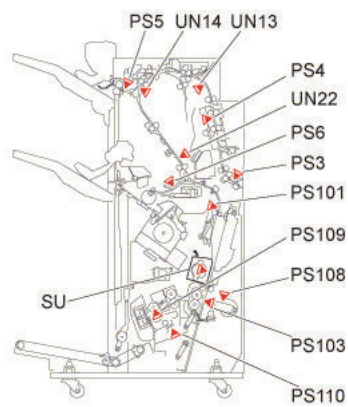
Overview of detection

-

I/O: Service Mode > SITUATION > Sensor Check

Check items (in arbitrary order)

-



■ 021709: JamCode (Staple/ Booklet Finisher-W1 PRO) 1709

[Symptom/Question]

021709: JamCode (Staple/ Booklet Finisher-W1 PRO) 1709

[Remedy/Answer]

Jam Type : OTHER

Sensor Name : Buffer Path 2 Sensor PCB

Sensor No. : UN14

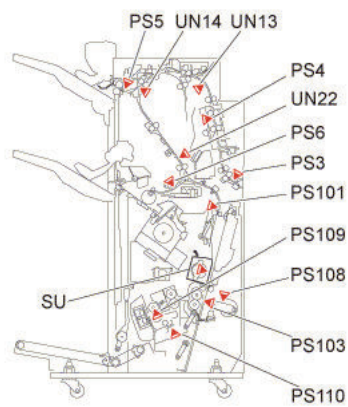
Overview of detection

-

I/O: Service Mode > SITUATION > Sensor Check

Check items (in arbitrary order)

-



■ 02170B: JamCode (Staple/ Booklet Finisher-W1 PRO) 170B

[Symptom/Question]

02170B: JamCode (Staple/ Booklet Finisher-W1 PRO) 170B

[Remedy/Answer]

Jam Type : OTHER

Sensor Name : Upper Delivery Sensor

Sensor No. : PS5

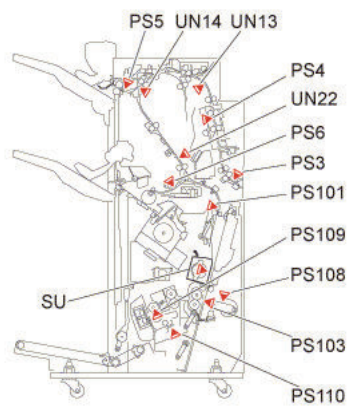
Overview of detection

-

I/O: Service Mode > SITUATION > Sensor Check

Check items (in arbitrary order)

-



■ 02170D: JamCode (Staple/ Booklet Finisher-W1 PRO) 170D

[Symptom/Question]

02170D: JamCode (Staple/ Booklet Finisher-W1 PRO) 170D

[Remedy/Answer]

Jam Type : OTHER

Sensor Name : Lower Path Sensor PCB

Sensor No. : UN22

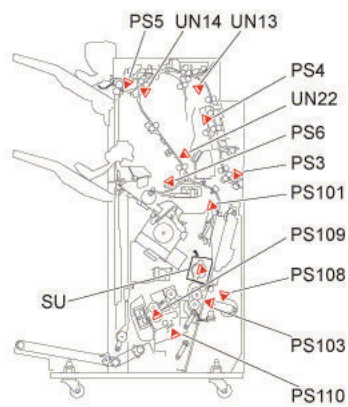
Overview of detection

-

I/O: Service Mode > SITUATION > Sensor Check

Check items (in arbitrary order)

-



■ 02170F: JamCode (Staple/ Booklet Finisher-W1 PRO) 170F

[Symptom/Question]

02170F: JamCode (Staple/ Booklet Finisher-W1 PRO) 170F

[Remedy/Answer]

Jam Type : OTHER

Sensor Name : Lower Delivery Sensor

Sensor No. : PS6

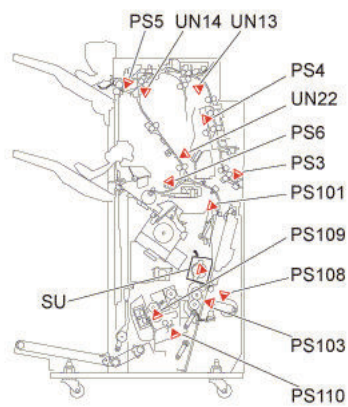
Overview of detection

-

I/O: Service Mode > SITUATION > Sensor Check

Check items (in arbitrary order)

-



■ 021721: JamCode (Staple/ Booklet Finisher-W1 PRO) 1721

[Symptom/Question]

021721: JamCode (Staple/ Booklet Finisher-W1 PRO) 1721

[Remedy/Answer]

Jam Type : OTHER

Sensor Name : -

Sensor No. : -

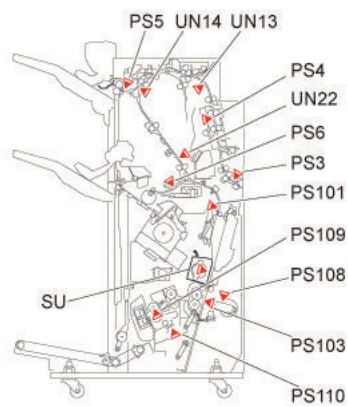
Overview of detection

-

I/O: Service Mode > SITUATION > Sensor Check

Check items (in arbitrary order)

-



■ 021725: JamCode (Staple/ Booklet Finisher-W1 PRO) 1725

[Symptom/Question]

021725: JamCode (Staple/ Booklet Finisher-W1 PRO) 1725

[Remedy/Answer]

Jam Type : OTHER

Sensor Name : Processing Tray Paper Sensor

Sensor No. : PS17

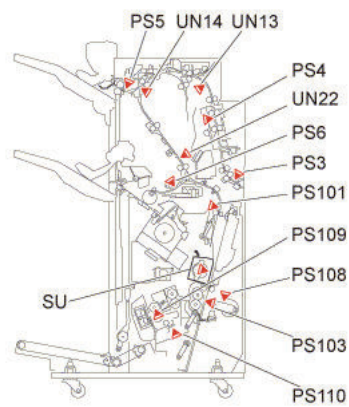
Overview of detection

-

I/O: Service Mode > SITUATION > Sensor Check

Check items (in arbitrary order)

-



■ 021743: JamCode (Staple/ Booklet Finisher-W1 PRO) 1743

[Symptom/Question]

021743: JamCode (Staple/ Booklet Finisher-W1 PRO) 1743

[Remedy/Answer]

Jam Type : OTHER

Sensor Name : Saddle Inlet Sensor

Sensor No. : PS101

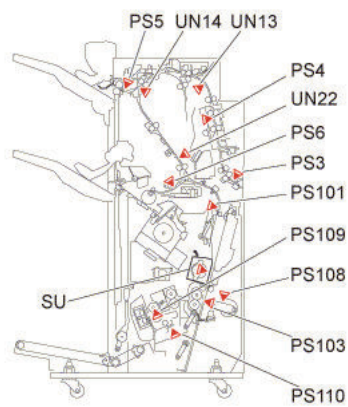
Overview of detection

-

I/O: Service Mode > SITUATION > Sensor Check

Check items (in arbitrary order)

-



■ 021747: JamCode (Staple/ Booklet Finisher-W1 PRO) 1747

[Symptom/Question]

021747: JamCode (Staple/ Booklet Finisher-W1 PRO) 1747

[Remedy/Answer]

Jam Type : OTHER

Sensor Name : Saddle Vertical Path Sensor

Sensor No. : PS103

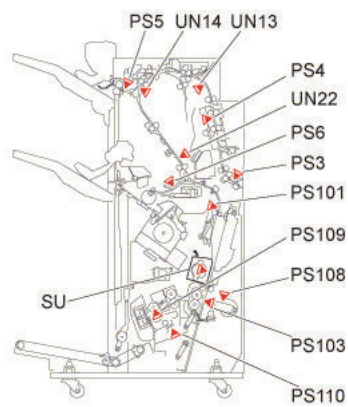
Overview of detection

-

I/O: Service Mode > SITUATION > Sensor Check

Check items (in arbitrary order)

-



■ 02174B: JamCode (Staple/ Booklet Finisher-W1 PRO) 174B

[Symptom/Question]

02174B: JamCode (Staple/ Booklet Finisher-W1 PRO) 174B

[Remedy/Answer]

Jam Type : OTHER

Sensor Name : Saddle Press Front Sensor

Sensor No. : PS116

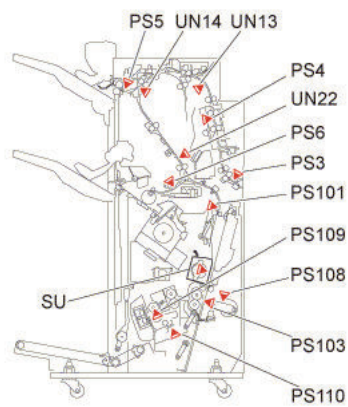
Overview of detection

-

I/O: Service Mode > SITUATION > Sensor Check

Check items (in arbitrary order)

-



■ 021773: JamCode (Multi Function Professional Puncher-B1) 1773

[Symptom/Question]

021773: JamCode (Multi Function Professional Puncher-B1) 1773

[Remedy/Answer]

Jam Type : OTHER

Sensor Name : -

Sensor No. : -

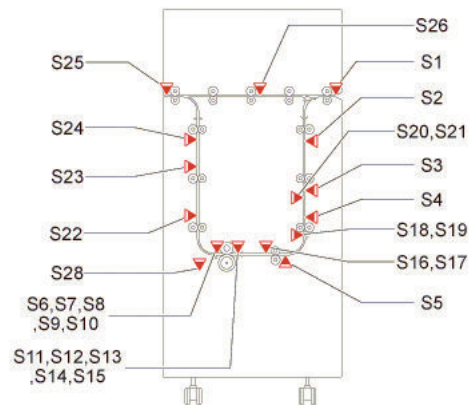
Overview of detection

-

I/O: Service Mode > SITUATION > Sensor Check

Check items (in arbitrary order)

-



■ 02179C: JamCode (Paper Folding Unit-J1) 179C

[Symptom/Question]

02179C: JamCode (Paper Folding Unit-J1) 179C

[Remedy/Answer]

Jam Type : Power-on jam

Sensor Name : -

Sensor No. : -

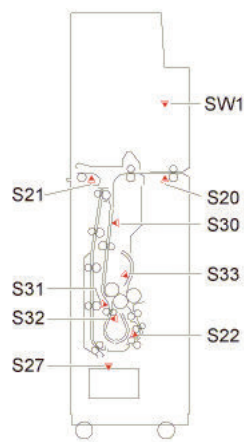
Overview of detection

A power-on jam occurs when a sensor detected ON state at power-on.

I/O: Service Mode > SITUATION > Sensor Check

Check items (in arbitrary order)

- Remaining paper in the machine
- Soiling on the target sensor
- Failure of the target sensor
- Foreign matter on the target sensor (paper dust, paper lint)



■ 021801: JamCode (Staple/Booklet Finisher-AC1) 1801

[Symptom/Question]

021801: JamCode (Staple/Booklet Finisher-AC1) 1801

[Remedy/Answer]

Jam Type : Error avoidance

Sensor Name : Staple-free Binding Motor Clock Sensor

Sensor No. : PS130

Overview of detection

An error avoidance jam occurs when an error in the machine (excluding parts failure) was detected.

Printing operation is suspended to avoid error occurrence by error code; therefore, parts failure is not the cause of the jam.

After the jam is removed, the machine works.

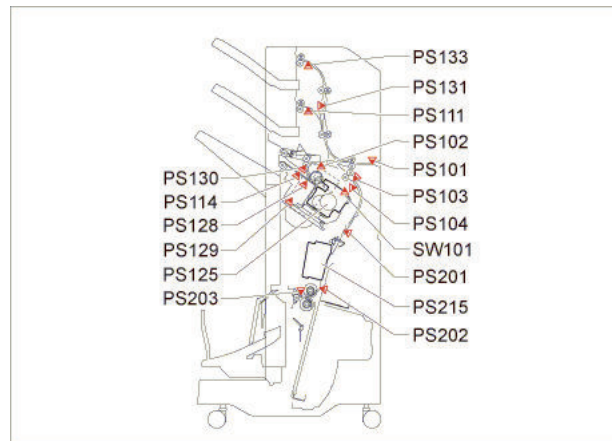
If it is due to parts failure, an error code instead of the error avoidance jam is displayed on UI and printing operation is suspended.

In such case, service technician should perform remedial work for the error code.

I/O: Service Mode > SITUATION > Sensor Check

Check items (in arbitrary order)

- Opening/closing of the door after jam removal
- Turning OFF and then ON the power after jam removal



■ 021802: JamCode (Staple/Booklet Finisher-AC1) 1802

[Symptom/Question]

021802: JamCode (Staple/Booklet Finisher-AC1) 1802

[Remedy/Answer]

Jam Type : Error avoidance

Sensor Name : Staple-free Binding HP Sensor

Sensor No. : PS129

Overview of detection

An error avoidance jam occurs when an error in the machine (excluding parts failure) was detected.

Printing operation is suspended to avoid error occurrence by error code; therefore, parts failure is not the cause of the jam.

After the jam is removed, the machine works.

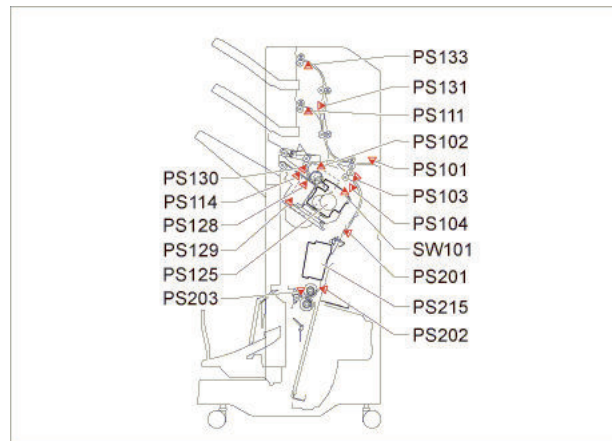
If it is due to parts failure, an error code instead of the error avoidance jam is displayed on UI and printing operation is suspended.

In such case, service technician should perform remedial work for the error code.

I/O: Service Mode > SITUATION > Sensor Check

Check items (in arbitrary order)

- Opening/closing of the door after jam removal
- Turning OFF and then ON the power after jam removal



■ 021803: JamCode (Staple/Booklet Finisher-AC1) 1803

[Symptom/Question]

021803: JamCode (Staple/Booklet Finisher-AC1) 1803

[Remedy/Answer]

Jam Type : Error avoidance

Sensor Name : -

Sensor No. : -

Overview of detection

An error avoidance jam occurs when an error in the machine (excluding parts failure) was detected.

Printing operation is suspended to avoid error occurrence by error code; therefore, parts failure is not the cause of the jam.

After the jam is removed, the machine works.

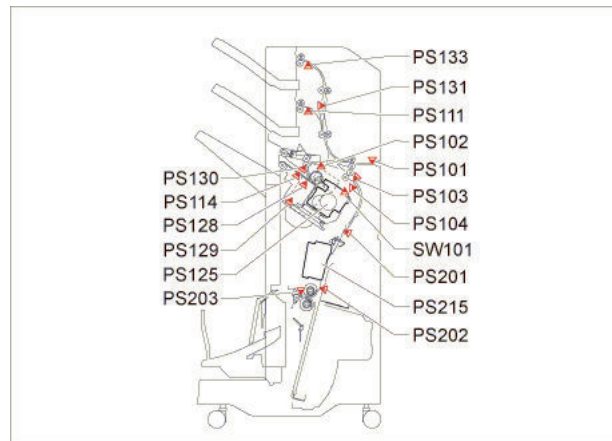
If it is due to parts failure, an error code instead of the error avoidance jam is displayed on UI and printing operation is suspended.

In such case, service technician should perform remedial work for the error code.

I/O: Service Mode > SITUATION > Sensor Check

Check items (in arbitrary order)

- Opening/closing of the door after jam removal
- Turning OFF and then ON the power after jam removal



■ 021804: JamCode (Staple/Booklet Finisher-AC1) 1804

[Symptom/Question]

021804: JamCode (Staple/Booklet Finisher-AC1) 1804

[Remedy/Answer]

Jam Type : Error avoidance

Sensor Name : -

Sensor No. : -

Overview of detection

An error avoidance jam occurs when an error in the machine (excluding parts failure) was detected.

Printing operation is suspended to avoid error occurrence by error code; therefore, parts failure is not the cause of the jam.

After the jam is removed, the machine works.

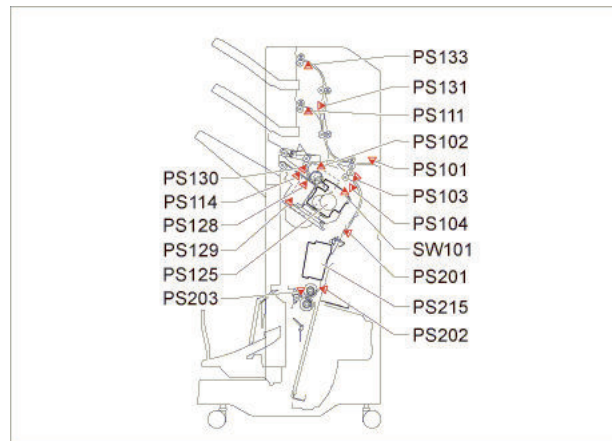
If it is due to parts failure, an error code instead of the error avoidance jam is displayed on UI and printing operation is suspended.

In such case, service technician should perform remedial work for the error code.

I/O: Service Mode > SITUATION > Sensor Check

Check items (in arbitrary order)

- Opening/closing of the door after jam removal
- Turning OFF and then ON the power after jam removal



■ 021805: JamCode (Staple/Booklet Finisher-AC1) 1805

[Symptom/Question]

021805: JamCode (Staple/Booklet Finisher-AC1) 1805

[Remedy/Answer]

Jam Type : Error avoidance

Sensor Name : -

Sensor No. : -

Overview of detection

An error avoidance jam occurs when an error in the machine (excluding parts failure) was detected.

Printing operation is suspended to avoid error occurrence by error code; therefore, parts failure is not the cause of the jam.

After the jam is removed, the machine works.

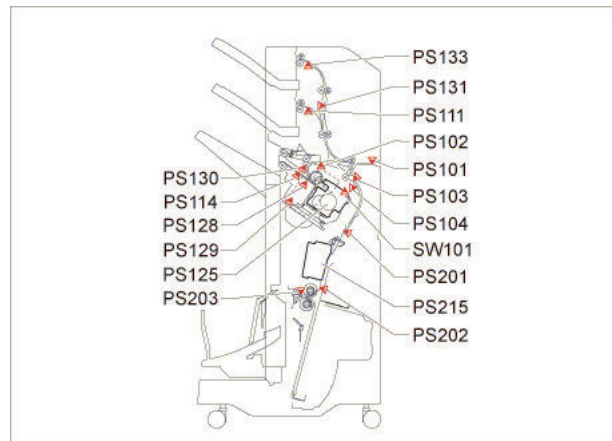
If it is due to parts failure, an error code instead of the error avoidance jam is displayed on UI and printing operation is suspended.

In such case, service technician should perform remedial work for the error code.

I/O: Service Mode > SITUATION > Sensor Check

Check items (in arbitrary order)

- Opening/closing of the door after jam removal
- Turning OFF and then ON the power after jam removal



■ 021C01: JamCode (Staple/ Booklet Finisher-W1 PRO) 1C01

[Symptom/Question]

021C01: JamCode (Staple/ Booklet Finisher-W1 PRO) 1C01

[Remedy/Answer]

Jam Type : OTHER

Sensor Name : -

Sensor No. : -

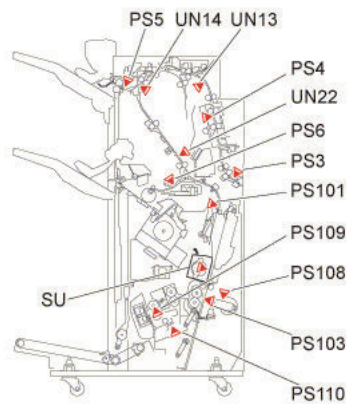
Overview of detection

-

I/O: Service Mode > SITUATION > Sensor Check

Check items (in arbitrary order)

-



■ 021C14: JamCode (Staple/Booklet Finisher-AC1) 1C14

[Symptom/Question]

021C14: JamCode (Staple/Booklet Finisher-AC1) 1C14

[Remedy/Answer]

Jam Type : Error avoidance

Sensor Name : -

Sensor No. : -

Overview of detection

An error avoidance jam occurs when an error in the machine (excluding parts failure) was detected.

Printing operation is suspended to avoid error occurrence by error code; therefore, parts failure is not the cause of the jam.

After the jam is removed, the machine works.

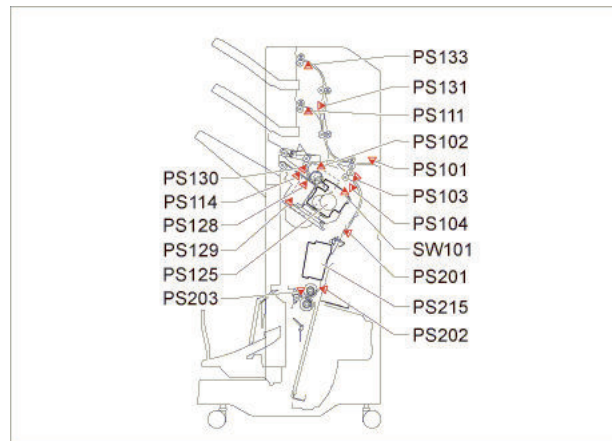
If it is due to parts failure, an error code instead of the error avoidance jam is displayed on UI and printing operation is suspended.

In such case, service technician should perform remedial work for the error code.

I/O: Service Mode > SITUATION > Sensor Check

Check items (in arbitrary order)

- Opening/closing of the door after jam removal
- Turning OFF and then ON the power after jam removal



■ 021C30: JamCode (Staple/Booklet Finisher-AC1) 1C30

[Symptom/Question]

021C30: JamCode (Staple/Booklet Finisher-AC1) 1C30

[Remedy/Answer]

Jam Type : Error avoidance

Sensor Name : -

Sensor No. : -

Overview of detection

An error avoidance jam occurs when an error in the machine (excluding parts failure) was detected.

Printing operation is suspended to avoid error occurrence by error code; therefore, parts failure is not the cause of the jam.

After the jam is removed, the machine works.

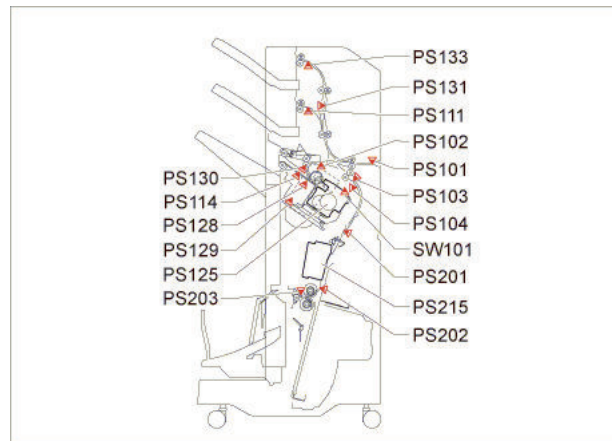
If it is due to parts failure, an error code instead of the error avoidance jam is displayed on UI and printing operation is suspended.

In such case, service technician should perform remedial work for the error code.

I/O: Service Mode > SITUATION > Sensor Check

Check items (in arbitrary order)

- Opening/closing of the door after jam removal
- Turning OFF and then ON the power after jam removal



■ 021C32: JamCode (Staple/Booklet Finisher-AC1) 1C32

[Symptom/Question]

021C32: JamCode (Staple/Booklet Finisher-AC1) 1C32

[Remedy/Answer]

Jam Type : Error avoidance

Sensor Name : -

Sensor No. : -

Overview of detection

An error avoidance jam occurs when an error in the machine (excluding parts failure) was detected.

Printing operation is suspended to avoid error occurrence by error code; therefore, parts failure is not the cause of the jam.

After the jam is removed, the machine works.

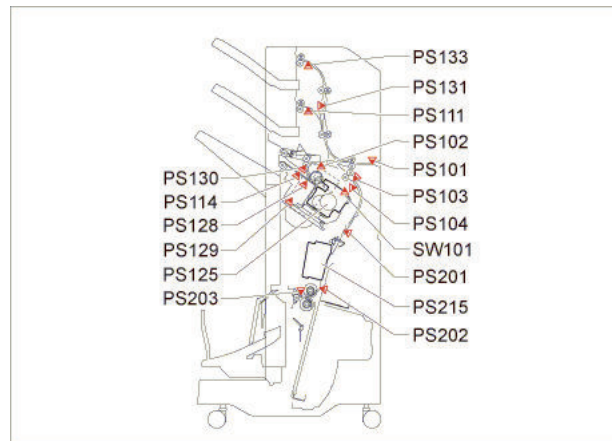
If it is due to parts failure, an error code instead of the error avoidance jam is displayed on UI and printing operation is suspended.

In such case, service technician should perform remedial work for the error code.

I/O: Service Mode > SITUATION > Sensor Check

Check items (in arbitrary order)

- Opening/closing of the door after jam removal
- Turning OFF and then ON the power after jam removal



■ 021C35: JamCode (Staple/Booklet Finisher-AC1) 1C35

[Symptom/Question]

021C35: JamCode (Staple/Booklet Finisher-AC1) 1C35

[Remedy/Answer]

Jam Type : Error avoidance

Sensor Name : -

Sensor No. : -

Overview of detection

An error avoidance jam occurs when an error in the machine (excluding parts failure) was detected.

Printing operation is suspended to avoid error occurrence by error code; therefore, parts failure is not the cause of the jam.

After the jam is removed, the machine works.

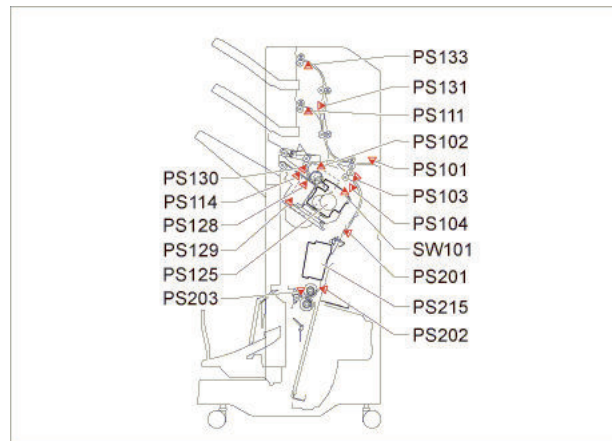
If it is due to parts failure, an error code instead of the error avoidance jam is displayed on UI and printing operation is suspended.

In such case, service technician should perform remedial work for the error code.

I/O: Service Mode > SITUATION > Sensor Check

Check items (in arbitrary order)

- Opening/closing of the door after jam removal
- Turning OFF and then ON the power after jam removal



■ 021C37: JamCode (Staple/Booklet Finisher-AC1) 1C37

[Symptom/Question]

021C37: JamCode (Staple/Booklet Finisher-AC1) 1C37

[Remedy/Answer]

Jam Type : Error avoidance

Sensor Name : -

Sensor No. : -

Overview of detection

An error avoidance jam occurs when an error in the machine (excluding parts failure) was detected.

Printing operation is suspended to avoid error occurrence by error code; therefore, parts failure is not the cause of the jam.

After the jam is removed, the machine works.

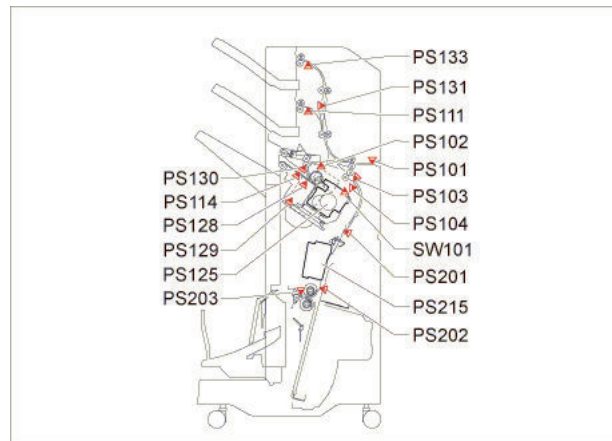
If it is due to parts failure, an error code instead of the error avoidance jam is displayed on UI and printing operation is suspended.

In such case, service technician should perform remedial work for the error code.

I/O: Service Mode > SITUATION > Sensor Check

Check items (in arbitrary order)

- Opening/closing of the door after jam removal
- Turning OFF and then ON the power after jam removal



■ 021C40: JamCode (Staple/Booklet Finisher-AC1) 1C40

[Symptom/Question]

021C40: JamCode (Staple/Booklet Finisher-AC1) 1C40

[Remedy/Answer]

Jam Type : Error avoidance

Sensor Name : -

Sensor No. : -

Overview of detection

An error avoidance jam occurs when an error in the machine (excluding parts failure) was detected.

Printing operation is suspended to avoid error occurrence by error code; therefore, parts failure is not the cause of the jam.

After the jam is removed, the machine works.

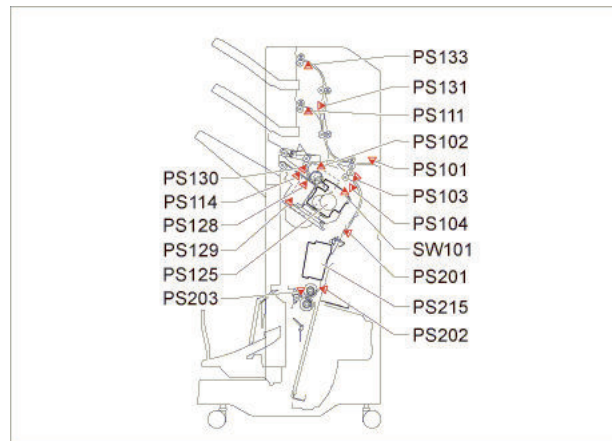
If it is due to parts failure, an error code instead of the error avoidance jam is displayed on UI and printing operation is suspended.

In such case, service technician should perform remedial work for the error code.

I/O: Service Mode > SITUATION > Sensor Check

Check items (in arbitrary order)

- Opening/closing of the door after jam removal
- Turning OFF and then ON the power after jam removal



■ 021C53: JamCode (Staple/Booklet Finisher-AC1) 1C53

[Symptom/Question]

021C53: JamCode (Staple/Booklet Finisher-AC1) 1C53

[Remedy/Answer]

Jam Type : Error avoidance

Sensor Name : -

Sensor No. : -

Overview of detection

An error avoidance jam occurs when an error in the machine (excluding parts failure) was detected.

Printing operation is suspended to avoid error occurrence by error code; therefore, parts failure is not the cause of the jam.

After the jam is removed, the machine works.

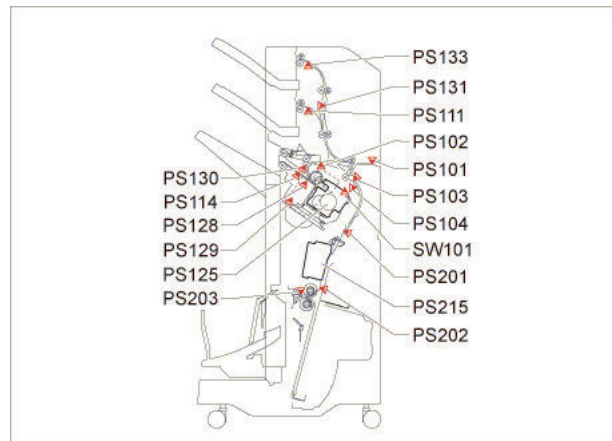
If it is due to parts failure, an error code instead of the error avoidance jam is displayed on UI and printing operation is suspended.

In such case, service technician should perform remedial work for the error code.

I/O: Service Mode > SITUATION > Sensor Check

Check items (in arbitrary order)

- Opening/closing of the door after jam removal
- Turning OFF and then ON the power after jam removal



■ 021C54: JamCode (Staple/Booklet Finisher-AC1) 1C54

[Symptom/Question]

021C54: JamCode (Staple/Booklet Finisher-AC1) 1C54

[Remedy/Answer]

Jam Type : Error avoidance

Sensor Name : -

Sensor No. : -

Overview of detection

An error avoidance jam occurs when an error in the machine (excluding parts failure) was detected.

Printing operation is suspended to avoid error occurrence by error code; therefore, parts failure is not the cause of the jam.

After the jam is removed, the machine works.

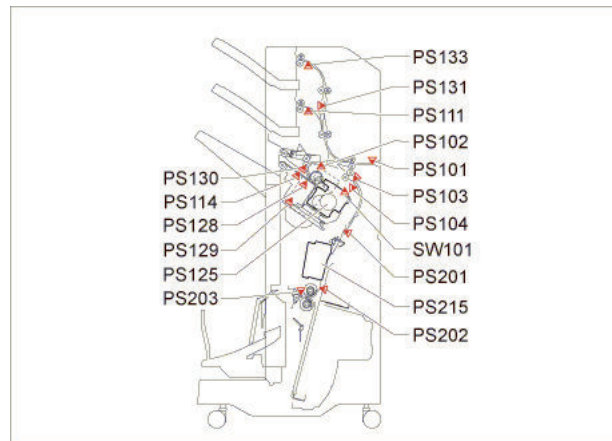
If it is due to parts failure, an error code instead of the error avoidance jam is displayed on UI and printing operation is suspended.

In such case, service technician should perform remedial work for the error code.

I/O: Service Mode > SITUATION > Sensor Check

Check items (in arbitrary order)

- Opening/closing of the door after jam removal
- Turning OFF and then ON the power after jam removal



■ 021C6D: JamCode (Staple/Booklet Finisher-AC1) 1C6D

[Symptom/Question]

021C6D: JamCode (Staple/Booklet Finisher-AC1) 1C6D

[Remedy/Answer]

Jam Type : Error avoidance

Sensor Name : -

Sensor No. : -

Overview of detection

An error avoidance jam occurs when an error in the machine (excluding parts failure) was detected.

Printing operation is suspended to avoid error occurrence by error code; therefore, parts failure is not the cause of the jam.

After the jam is removed, the machine works.

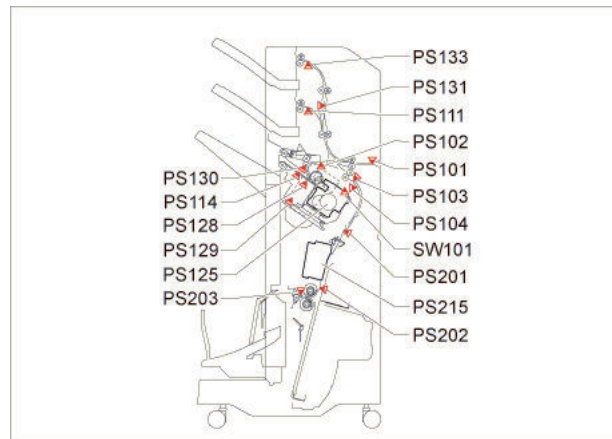
If it is due to parts failure, an error code instead of the error avoidance jam is displayed on UI and printing operation is suspended.

In such case, service technician should perform remedial work for the error code.

I/O: Service Mode > SITUATION > Sensor Check

Check items (in arbitrary order)

- Opening/closing of the door after jam removal
- Turning OFF and then ON the power after jam removal



■ 021C74: JamCode (Multi Function Professional Puncher-B1) 1C74

[Symptom/Question]

021C74: JamCode (Multi Function Professional Puncher-B1) 1C74

[Remedy/Answer]

Jam Type : OTHER

Sensor Name : -

Sensor No. : -

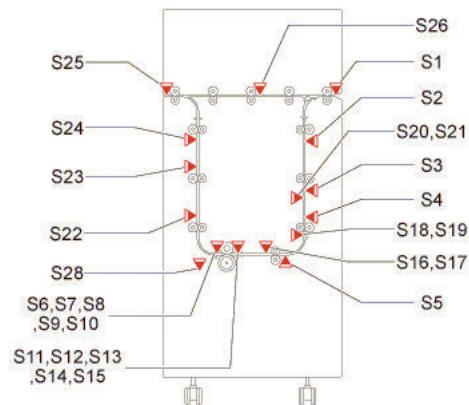
Overview of detection

-

I/O: Service Mode > SITUATION > Sensor Check

Check items (in arbitrary order)

-



■ 021C77: JamCode (Staple/Booklet Finisher-AC1) 1C77

[Symptom/Question]

021C77: JamCode (Staple/Booklet Finisher-AC1) 1C77

[Remedy/Answer]

Jam Type : Error avoidance

Sensor Name : -

Sensor No. : -

Overview of detection

An error avoidance jam occurs when an error in the machine (excluding parts failure) was detected.

Printing operation is suspended to avoid error occurrence by error code; therefore, parts failure is not the cause of the jam.

After the jam is removed, the machine works.

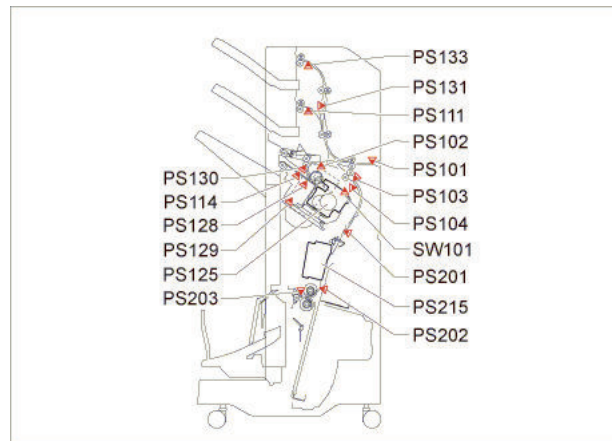
If it is due to parts failure, an error code instead of the error avoidance jam is displayed on UI and printing operation is suspended.

In such case, service technician should perform remedial work for the error code.

I/O: Service Mode > SITUATION > Sensor Check

Check items (in arbitrary order)

- Opening/closing of the door after jam removal
- Turning OFF and then ON the power after jam removal



■ 021C78: JamCode (Staple/Booklet Finisher-AC1) 1C78

[Symptom/Question]

021C78: JamCode (Staple/Booklet Finisher-AC1) 1C78

[Remedy/Answer]

Jam Type : Error avoidance

Sensor Name : -

Sensor No. : -

Overview of detection

An error avoidance jam occurs when an error in the machine (excluding parts failure) was detected.

Printing operation is suspended to avoid error occurrence by error code; therefore, parts failure is not the cause of the jam.

After the jam is removed, the machine works.

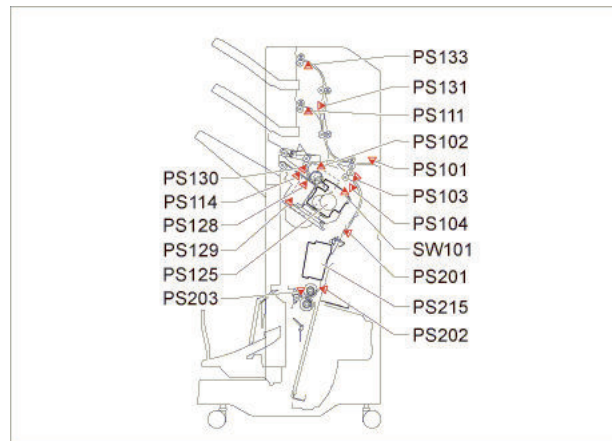
If it is due to parts failure, an error code instead of the error avoidance jam is displayed on UI and printing operation is suspended.

In such case, service technician should perform remedial work for the error code.

I/O: Service Mode > SITUATION > Sensor Check

Check items (in arbitrary order)

- Opening/closing of the door after jam removal
- Turning OFF and then ON the power after jam removal



■ 021C7B: JamCode (Staple/Booklet Finisher-AC1) 1C7B

[Symptom/Question]

021C7B: JamCode (Staple/Booklet Finisher-AC1) 1C7B

[Remedy/Answer]

Jam Type : Error avoidance

Sensor Name : -

Sensor No. : -

Overview of detection

An error avoidance jam occurs when an error in the machine (excluding parts failure) was detected.

Printing operation is suspended to avoid error occurrence by error code; therefore, parts failure is not the cause of the jam.

After the jam is removed, the machine works.

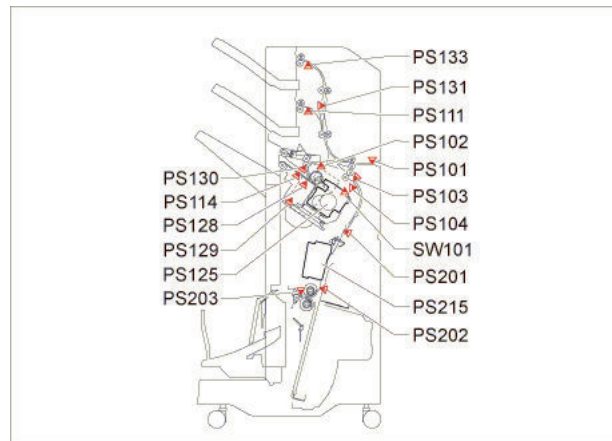
If it is due to parts failure, an error code instead of the error avoidance jam is displayed on UI and printing operation is suspended.

In such case, service technician should perform remedial work for the error code.

I/O: Service Mode > SITUATION > Sensor Check

Check items (in arbitrary order)

- Opening/closing of the door after jam removal
- Turning OFF and then ON the power after jam removal



■ 021C83: JamCode (Staple/Booklet Finisher-AC1) 1C83

[Symptom/Question]

021C83: JamCode (Staple/Booklet Finisher-AC1) 1C83

[Remedy/Answer]

Jam Type : Error avoidance

Sensor Name : -

Sensor No. : -

Overview of detection

An error avoidance jam occurs when an error in the machine (excluding parts failure) was detected.

Printing operation is suspended to avoid error occurrence by error code; therefore, parts failure is not the cause of the jam.

After the jam is removed, the machine works.

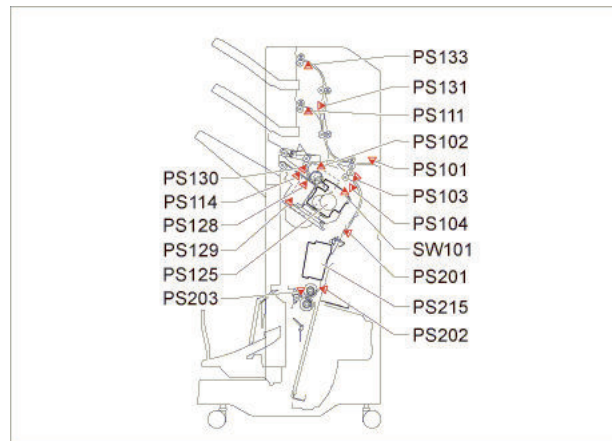
If it is due to parts failure, an error code instead of the error avoidance jam is displayed on UI and printing operation is suspended.

In such case, service technician should perform remedial work for the error code.

I/O: Service Mode > SITUATION > Sensor Check

Check items (in arbitrary order)

- Opening/closing of the door after jam removal
- Turning OFF and then ON the power after jam removal



■ 021C90: JamCode (PUNCHER UNIT-A1) 1C90

[Symptom/Question]

021C90: JamCode (PUNCHER UNIT-A1) 1C90

[Remedy/Answer]

Jam Type : Error avoidance

Sensor Name : -

Sensor No. : -

Overview of detection

An error avoidance jam occurs when an error in the machine (excluding parts failure) was detected.

Printing operation is suspended to avoid error occurrence by error code; therefore, parts failure is not the cause of the jam.

After the jam is removed, the machine works.

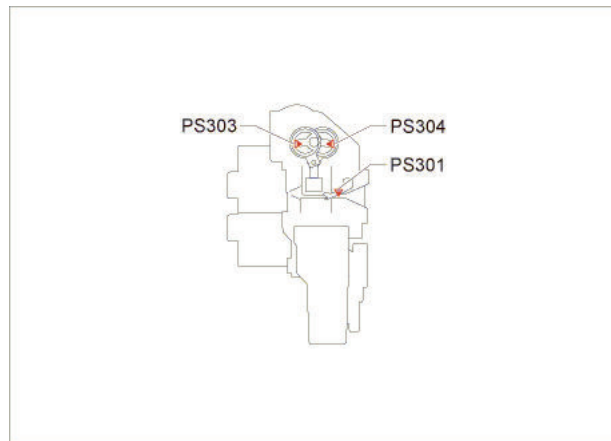
If it is due to parts failure, an error code instead of the error avoidance jam is displayed on UI and printing operation is suspended.

In such case, service technician should perform remedial work for the error code.

I/O: Service Mode > SITUATION > Sensor Check

Check items (in arbitrary order)

- Opening/closing of the door after jam removal
- Turning OFF and then ON the power after jam removal



■ 021C93: JamCode (PUNCHER UNIT-A1) 1C93

[Symptom/Question]

021C93: JamCode (PUNCHER UNIT-A1) 1C93

[Remedy/Answer]

Jam Type : Error avoidance

Sensor Name : -

Sensor No. : -

Overview of detection

An error avoidance jam occurs when an error in the machine (excluding parts failure) was detected.

Printing operation is suspended to avoid error occurrence by error code; therefore, parts failure is not the cause of the jam.

After the jam is removed, the machine works.

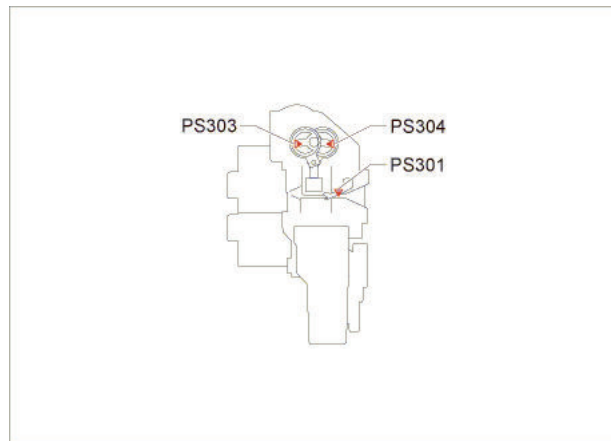
If it is due to parts failure, an error code instead of the error avoidance jam is displayed on UI and printing operation is suspended.

In such case, service technician should perform remedial work for the error code.

I/O: Service Mode > SITUATION > Sensor Check

Check items (in arbitrary order)

- Opening/closing of the door after jam removal
- Turning OFF and then ON the power after jam removal



■ 021C9D: JamCode (Paper Folding Unit-J1) 1C9D

[Symptom/Question]

021C9D: JamCode (Paper Folding Unit-J1) 1C9D

[Remedy/Answer]

Jam Type : Error avoidance

Sensor Name : -

Sensor No. : -

Overview of detection

An error avoidance jam occurs when an error in the machine (excluding parts failure) was detected.

Printing operation is suspended to avoid error occurrence by error code; therefore, parts failure is not the cause of the jam.

After the jam is removed, the machine works.

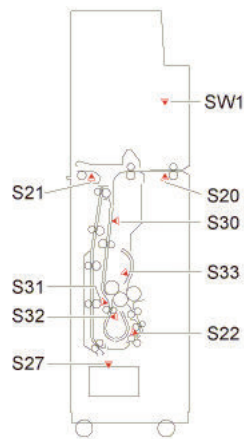
If it is due to parts failure, an error code instead of the error avoidance jam is displayed on UI and printing operation is suspended.

In such case, service technician should perform remedial work for the error code.

I/O: Service Mode > SITUATION > Sensor Check

Check items (in arbitrary order)

- Opening/closing of the door after jam removal
- Turning OFF and then ON the power after jam removal



■ 021CF0: JamCode (Staple/Booklet Finisher-AC1) 1CF0

[Symptom/Question]

021CF0: JamCode (Staple/Booklet Finisher-AC1) 1CF0

[Remedy/Answer]

Jam Type : Error avoidance

Sensor Name : -

Sensor No. : -

Overview of detection

An error avoidance jam occurs when an error in the machine (excluding parts failure) was detected.

Printing operation is suspended to avoid error occurrence by error code; therefore, parts failure is not the cause of the jam.

After the jam is removed, the machine works.

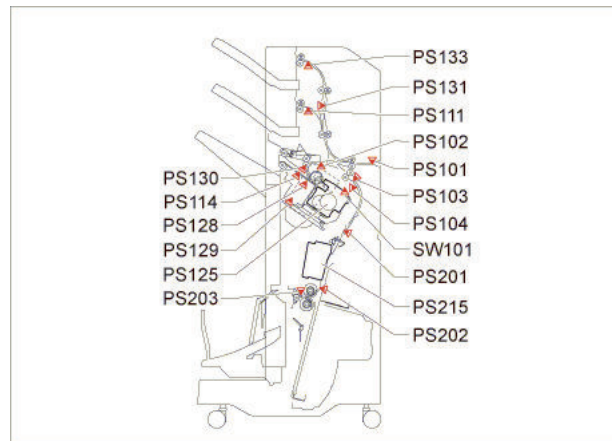
If it is due to parts failure, an error code instead of the error avoidance jam is displayed on UI and printing operation is suspended.

In such case, service technician should perform remedial work for the error code.

I/O: Service Mode > SITUATION > Sensor Check

Check items (in arbitrary order)

- Opening/closing of the door after jam removal
- Turning OFF and then ON the power after jam removal



■ 021CF1: JamCode (Staple/Booklet Finisher-AC1) 1CF1

[Symptom/Question]

021CF1: JamCode (Staple/Booklet Finisher-AC1) 1CF1

[Remedy/Answer]

Jam Type : Error avoidance

Sensor Name : -

Sensor No. : -

Overview of detection

An error avoidance jam occurs when an error in the machine (excluding parts failure) was detected.

Printing operation is suspended to avoid error occurrence by error code; therefore, parts failure is not the cause of the jam.

After the jam is removed, the machine works.

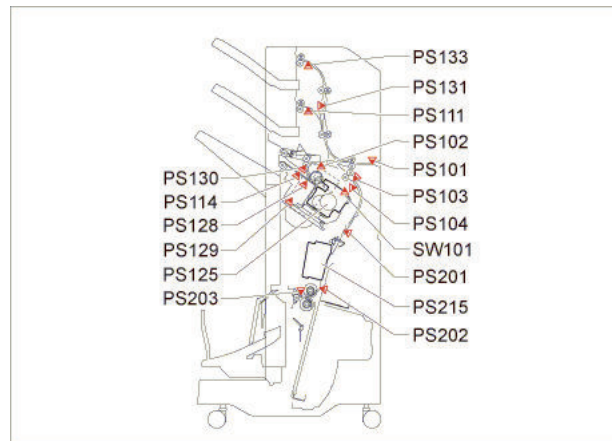
If it is due to parts failure, an error code instead of the error avoidance jam is displayed on UI and printing operation is suspended.

In such case, service technician should perform remedial work for the error code.

I/O: Service Mode > SITUATION > Sensor Check

Check items (in arbitrary order)

- Opening/closing of the door after jam removal
- Turning OFF and then ON the power after jam removal



■ 021CF3: JamCode (Staple/Booklet Finisher-AC1) 1CF3

[Symptom/Question]

021CF3: JamCode (Staple/Booklet Finisher-AC1) 1CF3

[Remedy/Answer]

Jam Type : Error avoidance

Sensor Name : -

Sensor No. : -

Overview of detection

An error avoidance jam occurs when an error in the machine (excluding parts failure) was detected.

Printing operation is suspended to avoid error occurrence by error code; therefore, parts failure is not the cause of the jam.

After the jam is removed, the machine works.

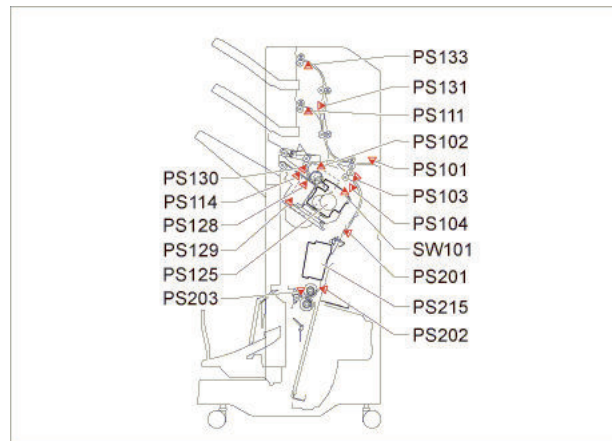
If it is due to parts failure, an error code instead of the error avoidance jam is displayed on UI and printing operation is suspended.

In such case, service technician should perform remedial work for the error code.

I/O: Service Mode > SITUATION > Sensor Check

Check items (in arbitrary order)

- Opening/closing of the door after jam removal
- Turning OFF and then ON the power after jam removal



■ 021CF6: JamCode (Staple/Booklet Finisher-AC1) 1CF6

[Symptom/Question]

021CF6: JamCode (Staple/Booklet Finisher-AC1) 1CF6

[Remedy/Answer]

Jam Type : Error avoidance

Sensor Name : -

Sensor No. : -

Overview of detection

An error avoidance jam occurs when an error in the machine (excluding parts failure) was detected.

Printing operation is suspended to avoid error occurrence by error code; therefore, parts failure is not the cause of the jam.

After the jam is removed, the machine works.

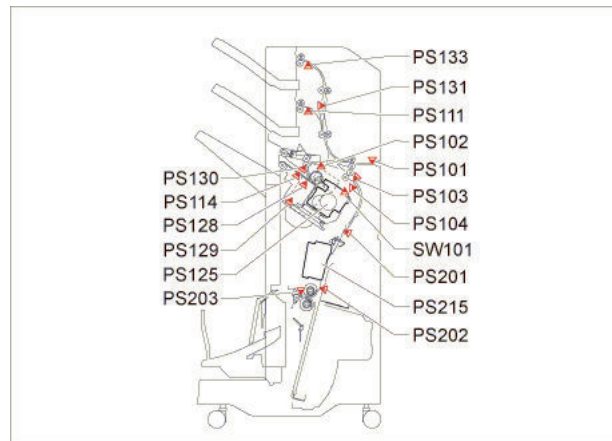
If it is due to parts failure, an error code instead of the error avoidance jam is displayed on UI and printing operation is suspended.

In such case, service technician should perform remedial work for the error code.

I/O: Service Mode > SITUATION > Sensor Check

Check items (in arbitrary order)

- Opening/closing of the door after jam removal
- Turning OFF and then ON the power after jam removal



■ 021CF8: JamCode (Staple/Booklet Finisher-AC1) 1CF8

[Symptom/Question]

021CF8: JamCode (Staple/Booklet Finisher-AC1) 1CF8

[Remedy/Answer]

Jam Type : Error avoidance

Sensor Name : -

Sensor No. : -

Overview of detection

An error avoidance jam occurs when an error in the machine (excluding parts failure) was detected.

Printing operation is suspended to avoid error occurrence by error code; therefore, parts failure is not the cause of the jam.

After the jam is removed, the machine works.

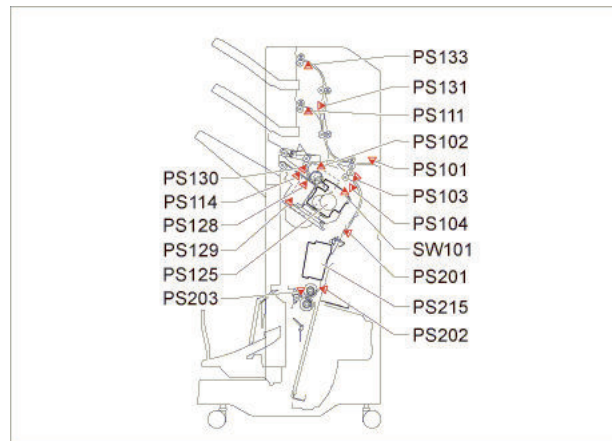
If it is due to parts failure, an error code instead of the error avoidance jam is displayed on UI and printing operation is suspended.

In such case, service technician should perform remedial work for the error code.

I/O: Service Mode > SITUATION > Sensor Check

Check items (in arbitrary order)

- Opening/closing of the door after jam removal
- Turning OFF and then ON the power after jam removal



■ 021CFA: JamCode (Staple/Booklet Finisher-AC1) 1CFA

[Symptom/Question]

021CFA: JamCode (Staple/Booklet Finisher-AC1) 1CFA

[Remedy/Answer]

Jam Type : Error avoidance

Sensor Name : -

Sensor No. : -

Overview of detection

An error avoidance jam occurs when an error in the machine (excluding parts failure) was detected.

Printing operation is suspended to avoid error occurrence by error code; therefore, parts failure is not the cause of the jam.

After the jam is removed, the machine works.

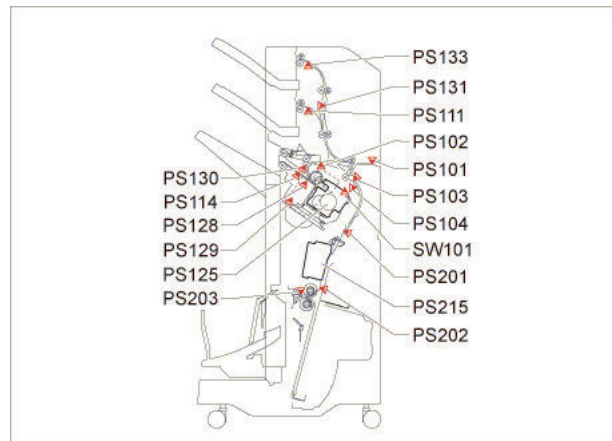
If it is due to parts failure, an error code instead of the error avoidance jam is displayed on UI and printing operation is suspended.

In such case, service technician should perform remedial work for the error code.

I/O: Service Mode > SITUATION > Sensor Check

Check items (in arbitrary order)

- Opening/closing of the door after jam removal
- Turning OFF and then ON the power after jam removal



■ 021F01: JamCode (Staple/Booklet Finisher-AC1) 1F01

[Symptom/Question]

021F01: JamCode (Staple/Booklet Finisher-AC1) 1F01

[Remedy/Answer]

Jam Type : OTHER

Sensor Name : -

Sensor No. : -

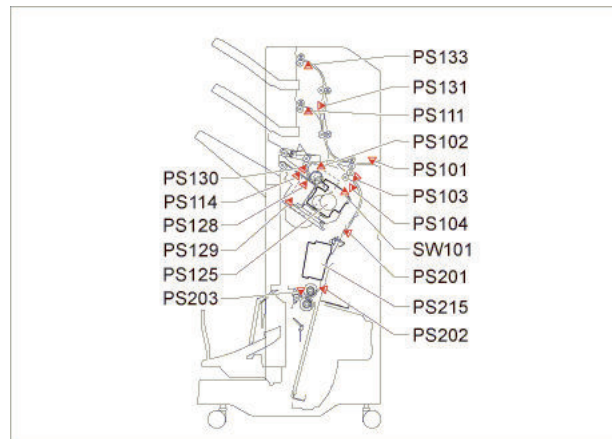
Overview of detection

-

I/O: Service Mode > SITUATION > Sensor Check

Check items (in arbitrary order)

-



■ 021F03: JamCode (Staple/ Booklet Finisher-W1 PRO) 1F03

[Symptom/Question]

021F03: JamCode (Staple/ Booklet Finisher-W1 PRO) 1F03

[Remedy/Answer]

Jam Type : OTHER

Sensor Name : -

Sensor No. : -

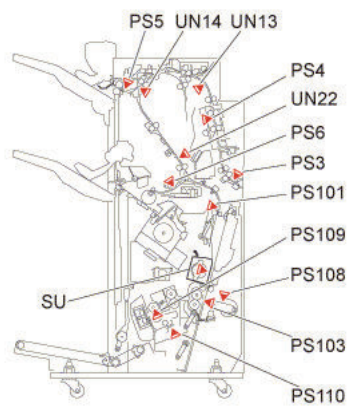
Overview of detection

-

I/O: Service Mode > SITUATION > Sensor Check

Check items (in arbitrary order)

-



■ 021F25: JamCode (Staple/ Booklet Finisher-W1 PRO) 1F25

[Symptom/Question]

021F25: JamCode (Staple/ Booklet Finisher-W1 PRO) 1F25

[Remedy/Answer]

Jam Type : OTHER

Sensor Name : -

Sensor No. : -

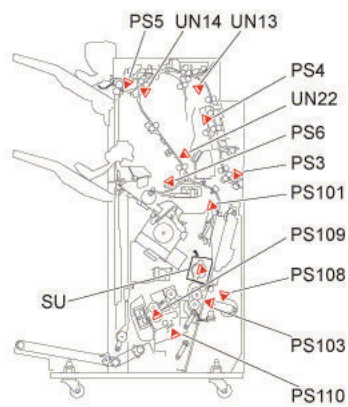
Overview of detection

-

I/O: Service Mode > SITUATION > Sensor Check

Check items (in arbitrary order)

-



■ 021F30: JamCode (Staple/ Booklet Finisher-W1 PRO) 1F30

[Symptom/Question]

021F30: JamCode (Staple/ Booklet Finisher-W1 PRO) 1F30

[Remedy/Answer]

Jam Type : OTHER

Sensor Name : -

Sensor No. : -

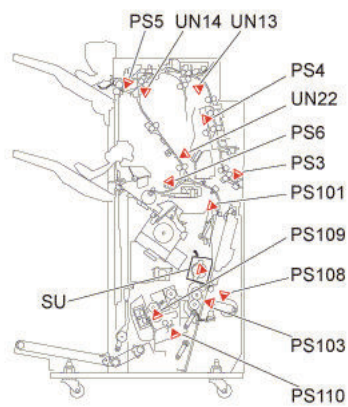
Overview of detection

-

I/O: Service Mode > SITUATION > Sensor Check

Check items (in arbitrary order)

-



■ 021F31: JamCode (Staple/ Booklet Finisher-W1 PRO) 1F31

[Symptom/Question]

021F31: JamCode (Staple/ Booklet Finisher-W1 PRO) 1F31

[Remedy/Answer]

Jam Type : OTHER

Sensor Name : -

Sensor No. : -

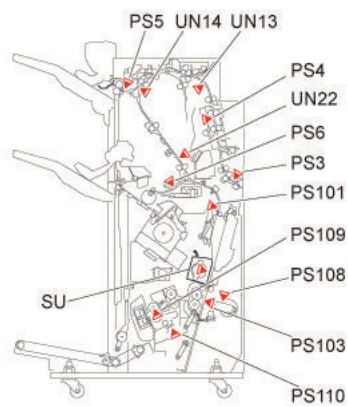
Overview of detection

-

I/O: Service Mode > SITUATION > Sensor Check

Check items (in arbitrary order)

-



■ 021F32: JamCode (Staple/Booklet Finisher-AC1) 1F32

[Symptom/Question]

021F32: JamCode (Staple/Booklet Finisher-AC1) 1F32

[Remedy/Answer]

Jam Type : OTHER

Sensor Name : -

Sensor No. : -

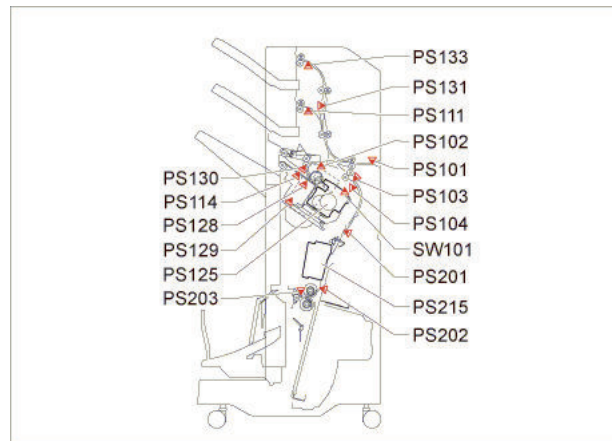
Overview of detection

-

I/O: Service Mode > SITUATION > Sensor Check

Check items (in arbitrary order)

-



■ 021F45: JamCode (Staple/Booklet Finisher-X1) 1F45

[Symptom/Question]

021F45: JamCode (Staple/Booklet Finisher-X1) 1F45

[Remedy/Answer]

Jam Type : PUNCH

Sensor Name : Punch HP Sensor

Sensor No. : S104(PUNCH)

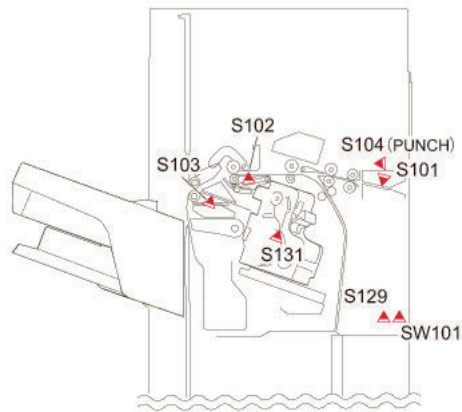
Overview of detection

-

I/O: Service Mode > SITUATION > Sensor Check

Check items (in arbitrary order)

-



■ 021F4F: JamCode (Staple/Booklet Finisher-X1) 1F4F

[Symptom/Question]

021F4F: JamCode (Staple/Booklet Finisher-X1) 1F4F

[Remedy/Answer]

Jam Type : Error avoidance

Sensor Name : -

Sensor No. : -

Overview of detection

An error avoidance jam occurs when an error in the machine (excluding parts failure) was detected.

Printing operation is suspended to avoid error occurrence by error code; therefore, parts failure is not the cause of the jam.

After the jam is removed, the machine works.

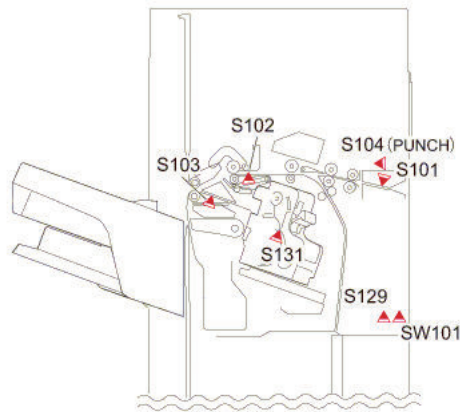
If it is due to parts failure, an error code instead of the error avoidance jam is displayed on UI and printing operation is suspended.

In such case, service technician should perform remedial work for the error code.

I/O: Service Mode > SITUATION > Sensor Check

Check items (in arbitrary order)

- Opening/closing of the door after jam removal
- Turning OFF and then ON the power after jam removal



■ 021F52: JamCode (Staple/ Booklet Finisher-W1 PRO) 1F52

[Symptom/Question]

021F52: JamCode (Staple/ Booklet Finisher-W1 PRO) 1F52

[Remedy/Answer]

Jam Type : OTHER

Sensor Name : Saddle Press HP Sensor

Sensor No. : PS110

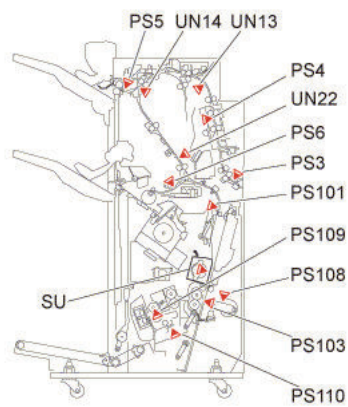
Overview of detection

-

I/O: Service Mode > SITUATION > Sensor Check

Check items (in arbitrary order)

-



■ 021F58: JamCode (Staple/ Booklet Finisher-W1 PRO) 1F58

[Symptom/Question]

021F58: JamCode (Staple/ Booklet Finisher-W1 PRO) 1F58

[Remedy/Answer]

Jam Type : OTHER

Sensor Name : Saddle Folding Roller HP Sensor

Sensor No. : PS124

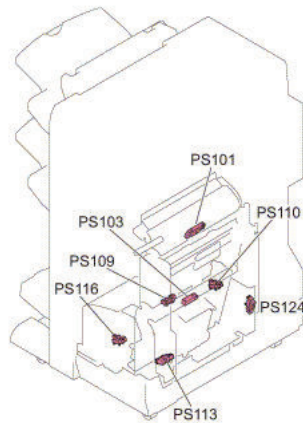
Overview of detection

-

I/O: Service Mode > SITUATION > Sensor Check

Check items (in arbitrary order)

-



■ 021F75: JamCode (Multi Function Professional Puncher-B1) 1F75

[Symptom/Question]

021F75: JamCode (Multi Function Professional Puncher-B1) 1F75

[Remedy/Answer]

Jam Type : OTHER

Sensor Name : -

Sensor No. : -

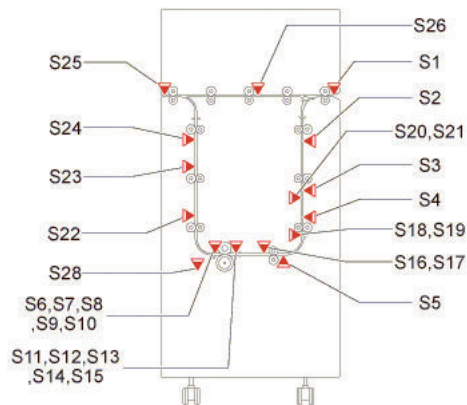
Overview of detection

-

I/O: Service Mode > SITUATION > Sensor Check

Check items (in arbitrary order)

-



■ 021F76: JamCode (Multi Function Professional Puncher-B1) 1F76

[Symptom/Question]

021F76: JamCode (Multi Function Professional Puncher-B1) 1F76

[Remedy/Answer]

Jam Type : OTHER

Sensor Name : -

Sensor No. : -

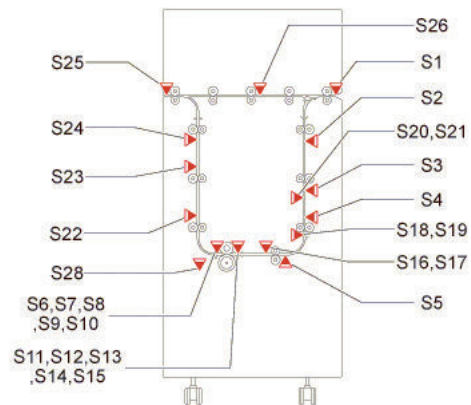
Overview of detection

-

I/O: Service Mode > SITUATION > Sensor Check

Check items (in arbitrary order)

-



■ 021F77: JamCode (Multi Function Professional Puncher-B1) 1F77

[Symptom/Question]

021F77: JamCode (Multi Function Professional Puncher-B1) 1F77

[Remedy/Answer]

Jam Type : OTHER

Sensor Name : -

Sensor No. : -

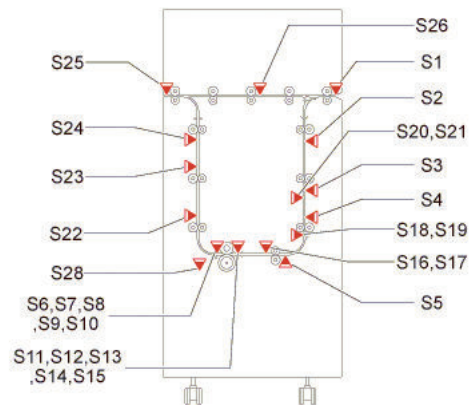
Overview of detection

-

I/O: Service Mode > SITUATION > Sensor Check

Check items (in arbitrary order)

-



■ 021F78: JamCode (Multi Function Professional Puncher-B1) 1F78

[Symptom/Question]

021F78: JamCode (Multi Function Professional Puncher-B1) 1F78

[Remedy/Answer]

Jam Type : OTHER

Sensor Name : -

Sensor No. : -

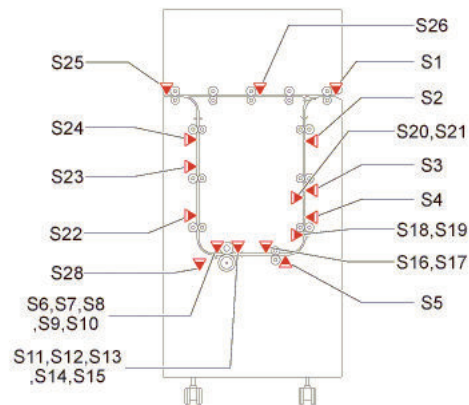
Overview of detection

-

I/O: Service Mode > SITUATION > Sensor Check

Check items (in arbitrary order)

-



■ 021F79: JamCode (Multi Function Professional Puncher-B1) 1F79

[Symptom/Question]

021F79: JamCode (Multi Function Professional Puncher-B1) 1F79

[Remedy/Answer]

Jam Type : OTHER

Sensor Name : -

Sensor No. : -

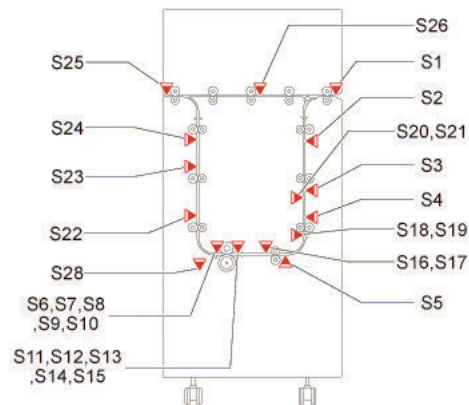
Overview of detection

-

I/O: Service Mode > SITUATION > Sensor Check

Check items (in arbitrary order)

-



■ 021F7A: JamCode (Multi Function Professional Puncher-B1) 1F7A

[Symptom/Question]

021F7A: JamCode (Multi Function Professional Puncher-B1) 1F7A

[Remedy/Answer]

Jam Type : OTHER

Sensor Name : -

Sensor No. : -

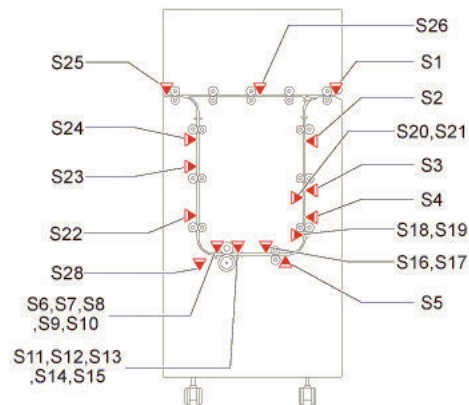
Overview of detection

-

I/O: Service Mode > SITUATION > Sensor Check

Check items (in arbitrary order)

-



■ 021F7D: JamCode (Multi Function Professional Puncher-B1) 1F7D

[Symptom/Question]

021F7D: JamCode (Multi Function Professional Puncher-B1) 1F7D

[Remedy/Answer]

Jam Type : OTHER

Sensor Name : -

Sensor No. : -

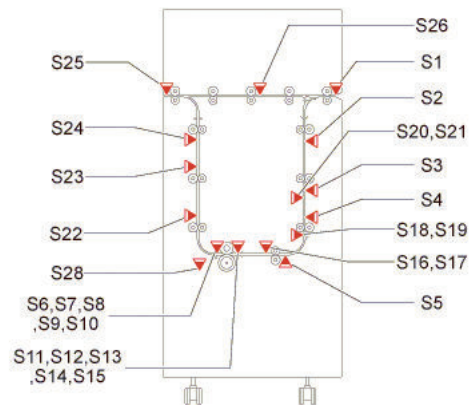
Overview of detection

-

I/O: Service Mode > SITUATION > Sensor Check

Check items (in arbitrary order)

-



■ 021F8F: JamCode (Staple/Booklet Finisher-X1) 1F8F

[Symptom/Question]

021F8F: JamCode (Staple/Booklet Finisher-X1) 1F8F

[Remedy/Answer]

Jam Type : Error avoidance

Sensor Name : -

Sensor No. : -

Overview of detection

An error avoidance jam occurs when an error in the machine (excluding parts failure) was detected.

Printing operation is suspended to avoid error occurrence by error code; therefore, parts failure is not the cause of the jam.

After the jam is removed, the machine works.

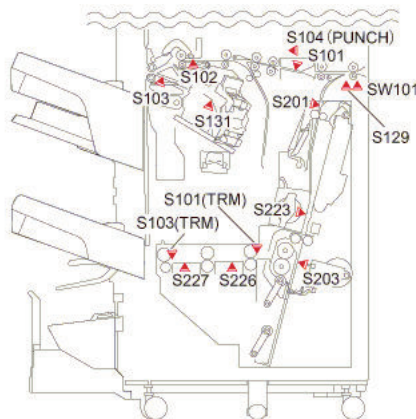
If it is due to parts failure, an error code instead of the error avoidance jam is displayed on UI and printing operation is suspended.

In such case, service technician should perform remedial work for the error code.

I/O: Service Mode > SITUATION > Sensor Check

Check items (in arbitrary order)

- Opening/closing of the door after jam removal
- Turning OFF and then ON the power after jam removal



■ 021F90: JamCode (Staple/Booklet Finisher-AC1) 1F90

[Symptom/Question]

021F90: JamCode (Staple/Booklet Finisher-AC1) 1F90

[Remedy/Answer]

Jam Type : Sequence jam

Sensor Name : -

Sensor No. : -

Overview of detection

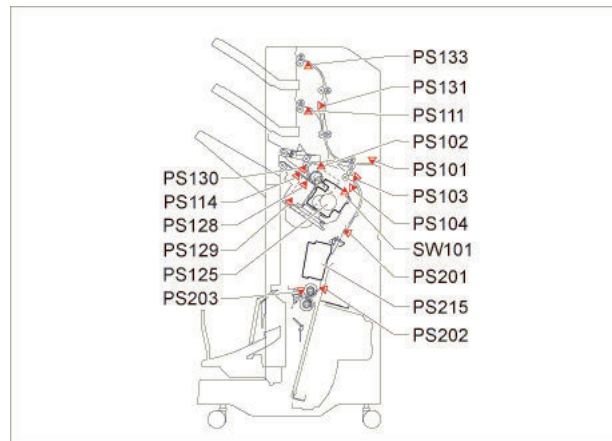
A sequence jam occurs when there was an error in sensor detection signal at printing operation sequence.

Since the jam may occur due to sporadic noise with software of each equipment or communication line (interruption of communication), failure of the part is not the cause of the jam. After the jam is removed, the machine works.

I/O: Service Mode > SITUATION > Sensor Check

Check items (in arbitrary order)

- Opening/closing of the door
- Turning OFF and then ON the power
- Error near the target sensor (soiling/displacement/failure of the sensor, error in harness/open circuit of harness, soiling (grease)/deterioration/failure of a drive motor, or soiling (paper dust)/deterioration/failure of a drive roller)



■ 021F9A: JamCode (Paper Folding Unit-J1) 1F9A

[Symptom/Question]

021F9A: JamCode (Paper Folding Unit-J1) 1F9A

[Remedy/Answer]

Jam Type : OTHER

Sensor Name : -

Sensor No. : -

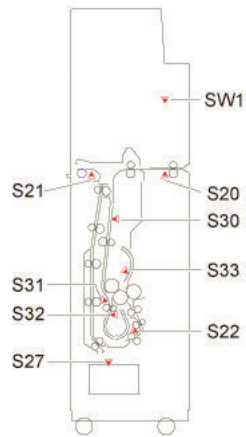
Overview of detection

-

I/O: Service Mode > SITUATION > Sensor Check

Check items (in arbitrary order)

-



■ 021F9E: JamCode (Paper Folding Unit-J1) 1F9E

[Symptom/Question]

021F9E: JamCode (Paper Folding Unit-J1) 1F9E

[Remedy/Answer]

Jam Type : OTHER

Sensor Name : -

Sensor No. : -

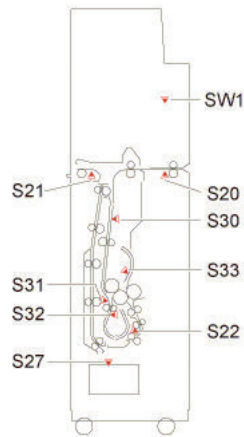
Overview of detection

-

I/O: Service Mode > SITUATION > Sensor Check

Check items (in arbitrary order)

-



■ 021FC0: JamCode (Document Insertion Unit-N1) 1FC0

[Symptom/Question]

021FC0: JamCode (Document Insertion Unit-N1) 1FC0

[Remedy/Answer]

Jam Type : OTHER

Sensor Name : -

Sensor No. : -

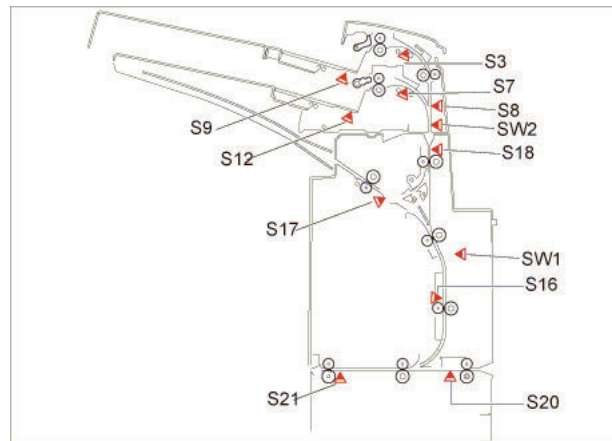
Overview of detection

-

I/O: Service Mode > SITUATION > Sensor Check

Check items (in arbitrary order)

-



■ 021FC1: JamCode (Document Insertion Unit-N1) 1FC1

[Symptom/Question]

021FC1: JamCode (Document Insertion Unit-N1) 1FC1

[Remedy/Answer]

Jam Type : OTHER

Sensor Name : -

Sensor No. : -

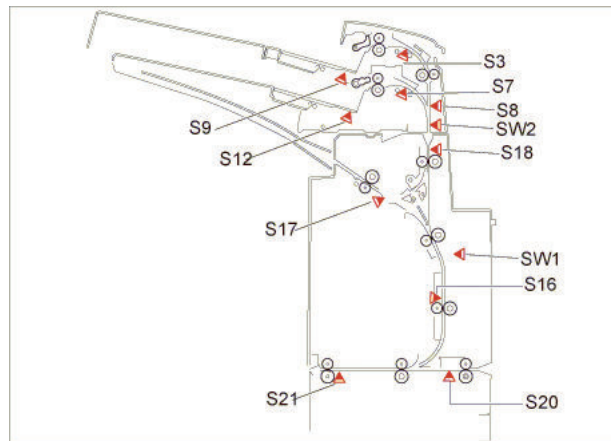
Overview of detection

-

I/O: Service Mode > SITUATION > Sensor Check

Check items (in arbitrary order)

-



■ 021FC2: JamCode (Document Insertion Unit-N1) 1FC2

[Symptom/Question]

021FC2: JamCode (Document Insertion Unit-N1) 1FC2

[Remedy/Answer]

Jam Type : Door open jam

Sensor Name : Upper Tray Empty Sensor

Sensor No. : S9

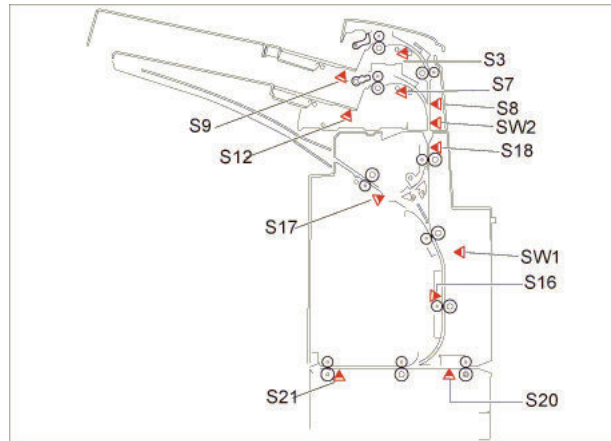
Overview of detection

A door open jam occurs when a sensor detected door open during printing operation.

I/O: Service Mode > SITUATION > Sensor Check

Check items (in arbitrary order)

- Door open during printing



■ 021FC3: JamCode (Document Insertion Unit-N1) 1FC3

[Symptom/Question]

021FC3: JamCode (Document Insertion Unit-N1) 1FC3

[Remedy/Answer]

Jam Type : Door open jam

Sensor Name : Lower Tray Empty Sensor

Sensor No. : S12

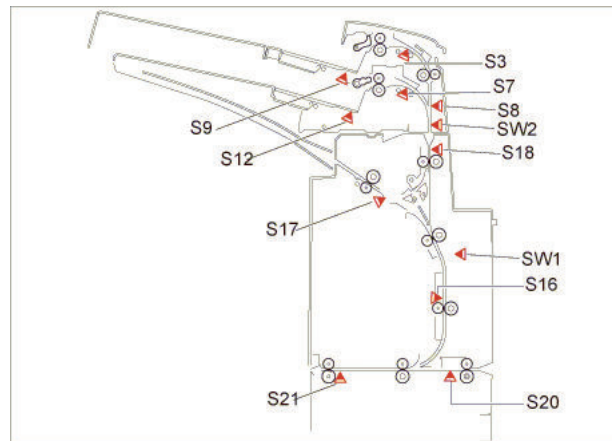
Overview of detection

A door open jam occurs when a sensor detected door open during printing operation.

I/O: Service Mode > SITUATION > Sensor Check

Check items (in arbitrary order)

- Door open during printing



■ 021FC4: JamCode (Document Insertion Unit-N1) 1FC4

[Symptom/Question]

021FC4: JamCode (Document Insertion Unit-N1) 1FC4

[Remedy/Answer]

Jam Type : OTHER

Sensor Name : -

Sensor No. : -

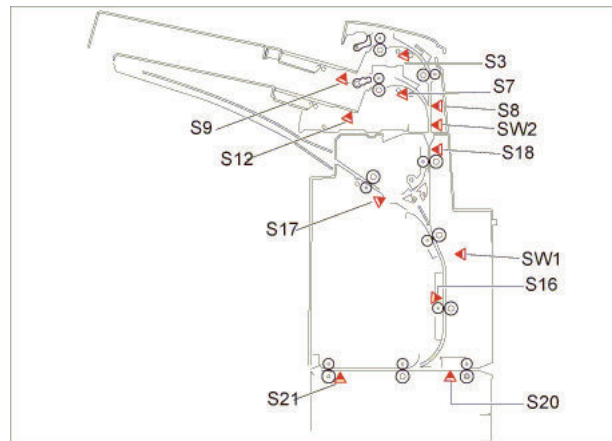
Overview of detection

-

I/O: Service Mode > SITUATION > Sensor Check

Check items (in arbitrary order)

-



■ 021FCE: JamCode (Document Insertion Unit-N1) 1FCE

[Symptom/Question]

021FCE: JamCode (Document Insertion Unit-N1) 1FCE

[Remedy/Answer]

Jam Type : Error avoidance

Sensor Name : -

Sensor No. : -

Overview of detection

An error avoidance jam occurs when an error in the machine (excluding parts failure) was detected.

Printing operation is suspended to avoid error occurrence by error code; therefore, parts failure is not the cause of the jam.

After the jam is removed, the machine works.

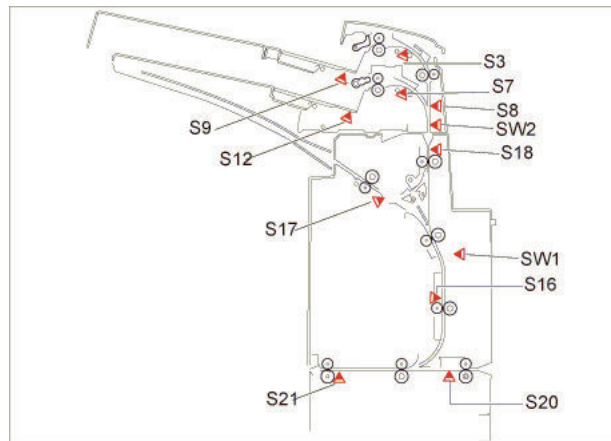
If it is due to parts failure, an error code instead of the error avoidance jam is displayed on UI and printing operation is suspended.

In such case, service technician should perform remedial work for the error code.

I/O: Service Mode > SITUATION > Sensor Check

Check items (in arbitrary order)

- Opening/closing of the door after jam removal
- Turning OFF and then ON the power after jam removal



■ 021FCF: JamCode (Document Insertion Unit-N1) 1FCF

[Symptom/Question]

021FCF: JamCode (Document Insertion Unit-N1) 1FCF

[Remedy/Answer]

Jam Type : OTHER

Sensor Name : -

Sensor No. : -

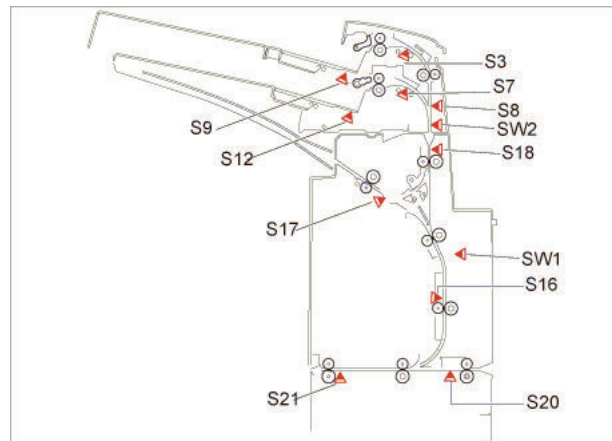
Overview of detection

-

I/O: Service Mode > SITUATION > Sensor Check

Check items (in arbitrary order)

-



■ 021FD0: JamCode (Paper Folding Unit-J1) 1FD0

[Symptom/Question]

021FD0: JamCode (Paper Folding Unit-J1) 1FD0

[Remedy/Answer]

Jam Type : OTHER

Sensor Name : -

Sensor No. : -

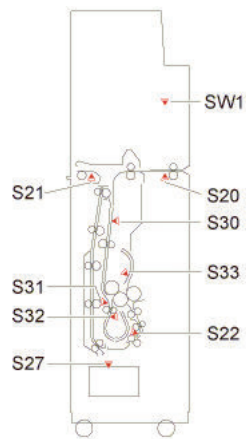
Overview of detection

-

I/O: Service Mode > SITUATION > Sensor Check

Check items (in arbitrary order)

-



■ 021FD1: JamCode (Paper Folding Unit-J1) 1FD1

[Symptom/Question]

021FD1: JamCode (Paper Folding Unit-J1) 1FD1

[Remedy/Answer]

Jam Type : OTHER

Sensor Name : -

Sensor No. : -

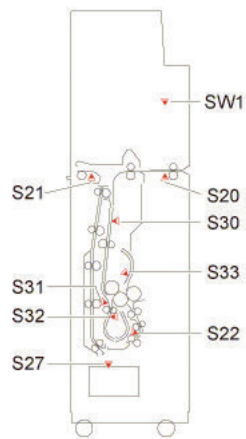
Overview of detection

-

I/O: Service Mode > SITUATION > Sensor Check

Check items (in arbitrary order)

-



■ 021FDE: JamCode (Paper Folding Unit-J1) 1FDE

[Symptom/Question]

021FDE: JamCode (Paper Folding Unit-J1) 1FDE

[Remedy/Answer]

Jam Type : Error avoidance

Sensor Name : -

Sensor No. : -

Overview of detection

An error avoidance jam occurs when an error in the machine (excluding parts failure) was detected.

Printing operation is suspended to avoid error occurrence by error code; therefore, parts failure is not the cause of the jam.

After the jam is removed, the machine works.

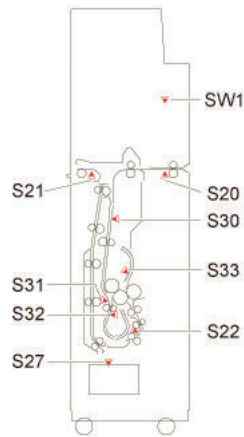
If it is due to parts failure, an error code instead of the error avoidance jam is displayed on UI and printing operation is suspended.

In such case, service technician should perform remedial work for the error code.

I/O: Service Mode > SITUATION > Sensor Check

Check items (in arbitrary order)

- Opening/closing of the door after jam removal
- Turning OFF and then ON the power after jam removal



■ 021FDF: JamCode (Paper Folding Unit-J1) 1FDF

[Symptom/Question]

021FDF: JamCode (Paper Folding Unit-J1) 1FDF

[Remedy/Answer]

Jam Type : OTHER

Sensor Name : -

Sensor No. : -

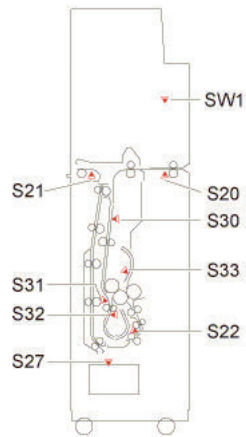
Overview of detection

-

I/O: Service Mode > SITUATION > Sensor Check

Check items (in arbitrary order)

-



■ 021FFF: JamCode (Staple/ Booklet Finisher-W1 PRO) 1FFF

[Symptom/Question]

021FFF: JamCode (Staple/ Booklet Finisher-W1 PRO) 1FFF

[Remedy/Answer]

Jam Type : Error avoidance

Sensor Name : -

Sensor No. : -

Overview of detection

An error avoidance jam occurs when an error in the machine (excluding parts failure) was detected.

Printing operation is suspended to avoid error occurrence by error code; therefore, parts failure is not the cause of the jam.

After the jam is removed, the machine works.

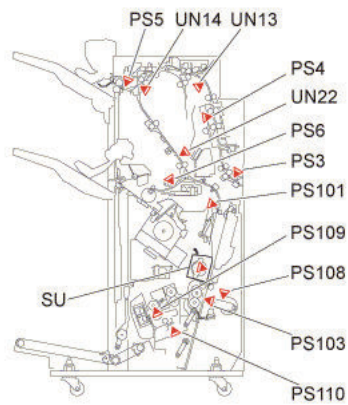
If it is due to parts failure, an error code instead of the error avoidance jam is displayed on UI and printing operation is suspended.

In such case, service technician should perform remedial work for the error code.

I/O: Service Mode > SITUATION > Sensor Check

Check items (in arbitrary order)

- Opening/closing of the door after jam removal
- Turning OFF and then ON the power after jam removal



■ 311150: JamCode (Multi Function Professional Puncher-B1) 1150

[Symptom/Question]

311150: JamCode (Multi Function Professional Puncher-B1) 1150

[Remedy/Answer]

Jam Type : Stationary jam

Sensor Name : Entry Sensor

Sensor No. : S1

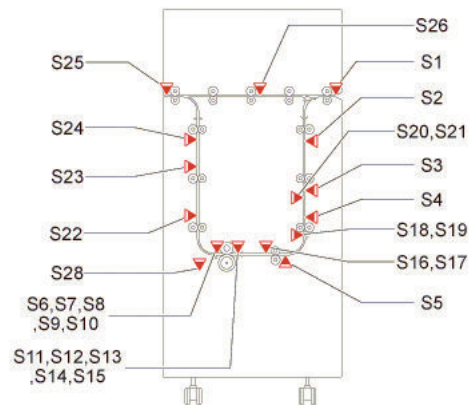
Overview of detection

A stationary jam occurs when a sensor was not turned OFF although a specified period of time had passed after the sensor was turned ON.

I/O: Service Mode > SITUATION > Sensor Check

Check items (in arbitrary order)

- Remaining paper near the target sensor
- Soiling on the target sensor
- Displacement of the target sensor position
- Failure of the target sensor
- Soiling (grease)/deterioration/failure of a drive motor located upstream of the target sensor
- Soiling (paper dust)/deterioration/failure of a drive roller located upstream of the target sensor



■ 311151: JamCode (Multi Function Professional Puncher-B1) 1151

[Symptom/Question]

311151: JamCode (Multi Function Professional Puncher-B1) 1151

[Remedy/Answer]

Jam Type : Stationary jam

Sensor Name : Entrance Panel Sensor

Sensor No. : S2

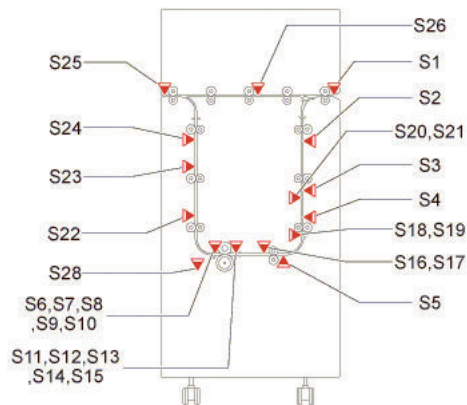
Overview of detection

A stationary jam occurs when a sensor was not turned OFF although a specified period of time had passed after the sensor was turned ON.

I/O: Service Mode > SITUATION > Sensor Check

Check items (in arbitrary order)

- Remaining paper near the target sensor
- Soiling on the target sensor
- Displacement of the target sensor position
- Failure of the target sensor
- Soiling (grease)/deterioration/failure of a drive motor located upstream of the target sensor
- Soiling (paper dust)/deterioration/failure of a drive roller located upstream of the target sensor



■ 311152: JamCode (Multi Function Professional Puncher-B1) 1152

[Symptom/Question]

311152: JamCode (Multi Function Professional Puncher-B1) 1152

[Remedy/Answer]

Jam Type : Stationary jam

Sensor Name : Entrance Panel Sensor

Sensor No. : S3

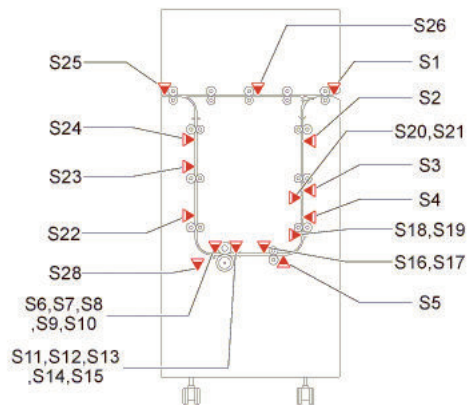
Overview of detection

A stationary jam occurs when a sensor was not turned OFF although a specified period of time had passed after the sensor was turned ON.

I/O: Service Mode > SITUATION > Sensor Check

Check items (in arbitrary order)

- Remaining paper near the target sensor
- Soiling on the target sensor
- Displacement of the target sensor position
- Failure of the target sensor
- Soiling (grease)/deterioration/failure of a drive motor located upstream of the target sensor
- Soiling (paper dust)/deterioration/failure of a drive roller located upstream of the target sensor



■ 311153: JamCode (Multi Function Professional Puncher-B1) 1153

[Symptom/Question]

311153: JamCode (Multi Function Professional Puncher-B1) 1153

[Remedy/Answer]

Jam Type : Stationary jam

Sensor Name : Entrance Panel Sensor

Sensor No. : S4

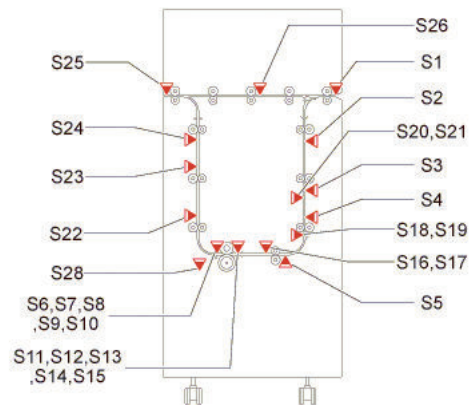
Overview of detection

A stationary jam occurs when a sensor was not turned OFF although a specified period of time had passed after the sensor was turned ON.

I/O: Service Mode > SITUATION > Sensor Check

Check items (in arbitrary order)

- Remaining paper near the target sensor
- Soiling on the target sensor
- Displacement of the target sensor position
- Failure of the target sensor
- Soiling (grease)/deterioration/failure of a drive motor located upstream of the target sensor
- Soiling (paper dust)/deterioration/failure of a drive roller located upstream of the target sensor



■ 311154: JamCode (Multi Function Professional Puncher-B1) 1154

[Symptom/Question]

311154: JamCode (Multi Function Professional Puncher-B1) 1154

[Remedy/Answer]

Jam Type : Stationary jam

Sensor Name : Acceleration Sensor

Sensor No. : S5

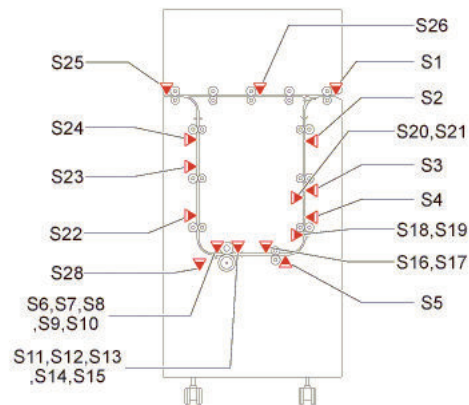
Overview of detection

A stationary jam occurs when a sensor was not turned OFF although a specified period of time had passed after the sensor was turned ON.

I/O: Service Mode > SITUATION > Sensor Check

Check items (in arbitrary order)

- Remaining paper near the target sensor
- Soiling on the target sensor
- Displacement of the target sensor position
- Failure of the target sensor
- Soiling (grease)/deterioration/failure of a drive motor located upstream of the target sensor
- Soiling (paper dust)/deterioration/failure of a drive roller located upstream of the target sensor



■ 311155: JamCode (Multi Function Professional Puncher-B1) 1155

[Symptom/Question]

311155: JamCode (Multi Function Professional Puncher-B1) 1155

[Remedy/Answer]

Jam Type : Stationary jam

Sensor Name : Angle Measurement Sensor

Sensor No. : S6

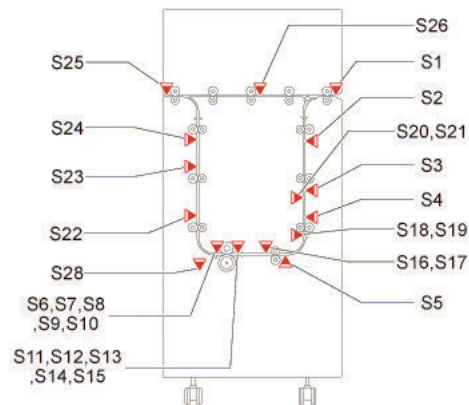
Overview of detection

A stationary jam occurs when a sensor was not turned OFF although a specified period of time had passed after the sensor was turned ON.

I/O: Service Mode > SITUATION > Sensor Check

Check items (in arbitrary order)

- Remaining paper near the target sensor
- Soiling on the target sensor
- Displacement of the target sensor position
- Failure of the target sensor
- Soiling (grease)/deterioration/failure of a drive motor located upstream of the target sensor
- Soiling (paper dust)/deterioration/failure of a drive roller located upstream of the target sensor



■ 311156: JamCode (Multi Function Professional Puncher-B1) 1156

[Symptom/Question]

311156: JamCode (Multi Function Professional Puncher-B1) 1156

[Remedy/Answer]

Jam Type : Stationary jam

Sensor Name : Angle Measurement Sensor

Sensor No. : S7

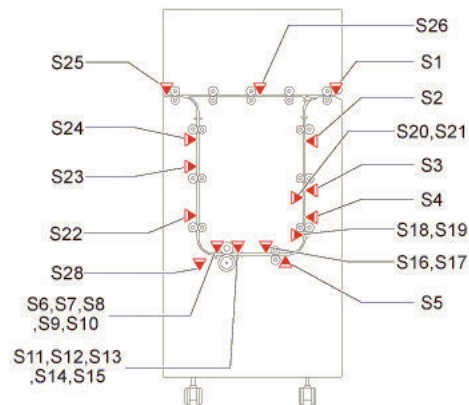
Overview of detection

A stationary jam occurs when a sensor was not turned OFF although a specified period of time had passed after the sensor was turned ON.

I/O: Service Mode > SITUATION > Sensor Check

Check items (in arbitrary order)

- Remaining paper near the target sensor
- Soiling on the target sensor
- Displacement of the target sensor position
- Failure of the target sensor
- Soiling (grease)/deterioration/failure of a drive motor located upstream of the target sensor
- Soiling (paper dust)/deterioration/failure of a drive roller located upstream of the target sensor



■ 311157: JamCode (Multi Function Professional Puncher-B1) 1157

[Symptom/Question]

311157: JamCode (Multi Function Professional Puncher-B1) 1157

[Remedy/Answer]

Jam Type : Stationary jam

Sensor Name : Angle Measurement Sensor

Sensor No. : S8

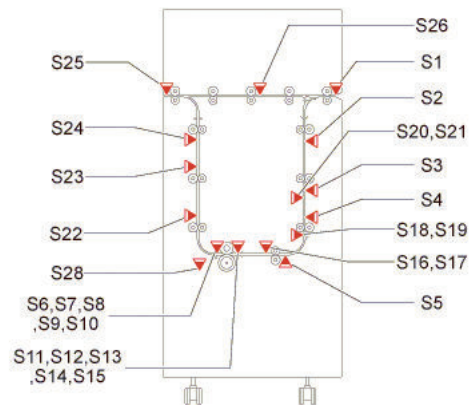
Overview of detection

A stationary jam occurs when a sensor was not turned OFF although a specified period of time had passed after the sensor was turned ON.

I/O: Service Mode > SITUATION > Sensor Check

Check items (in arbitrary order)

- Remaining paper near the target sensor
- Soiling on the target sensor
- Displacement of the target sensor position
- Failure of the target sensor
- Soiling (grease)/deterioration/failure of a drive motor located upstream of the target sensor
- Soiling (paper dust)/deterioration/failure of a drive roller located upstream of the target sensor



■ 311158: JamCode (Multi Function Professional Puncher-B1) 1158

[Symptom/Question]

311158: JamCode (Multi Function Professional Puncher-B1) 1158

[Remedy/Answer]

Jam Type : Stationary jam

Sensor Name : Angle Measurement Sensor

Sensor No. : S9

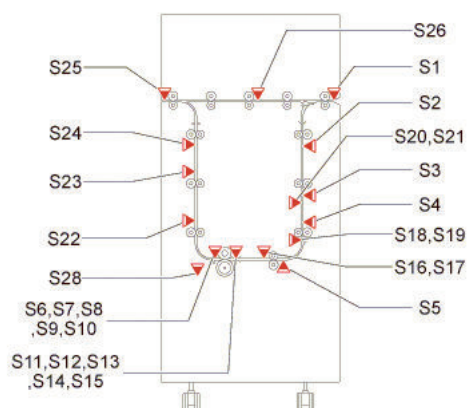
Overview of detection

A stationary jam occurs when a sensor was not turned OFF although a specified period of time had passed after the sensor was turned ON.

I/O: Service Mode > SITUATION > Sensor Check

Check items (in arbitrary order)

- Remaining paper near the target sensor
- Soiling on the target sensor
- Displacement of the target sensor position
- Failure of the target sensor
- Soiling (grease)/deterioration/failure of a drive motor located upstream of the target sensor
- Soiling (paper dust)/deterioration/failure of a drive roller located upstream of the target sensor



■ 311159: JamCode (Multi Function Professional Puncher-B1) 1159

[Symptom/Question]

311159: JamCode (Multi Function Professional Puncher-B1) 1159

[Remedy/Answer]

Jam Type : Stationary jam

Sensor Name : Angle Measurement Sensor

Sensor No. : S10

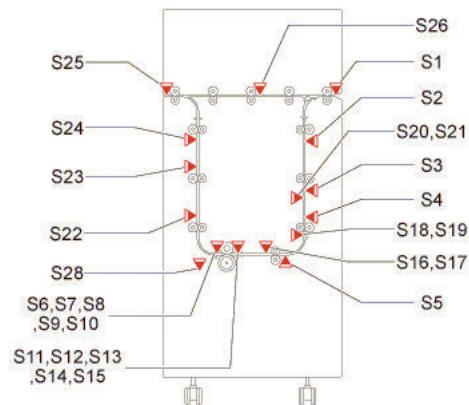
Overview of detection

A stationary jam occurs when a sensor was not turned OFF although a specified period of time had passed after the sensor was turned ON.

I/O: Service Mode > SITUATION > Sensor Check

Check items (in arbitrary order)

- Remaining paper near the target sensor
- Soiling on the target sensor
- Displacement of the target sensor position
- Failure of the target sensor
- Soiling (grease)/deterioration/failure of a drive motor located upstream of the target sensor
- Soiling (paper dust)/deterioration/failure of a drive roller located upstream of the target sensor



■ 31115A: JamCode (Multi Function Professional Puncher-B1) 115A

[Symptom/Question]

31115A: JamCode (Multi Function Professional Puncher-B1) 115A

[Remedy/Answer]

Jam Type : Stationary jam

Sensor Name : Alignment Sensor

Sensor No. : S11

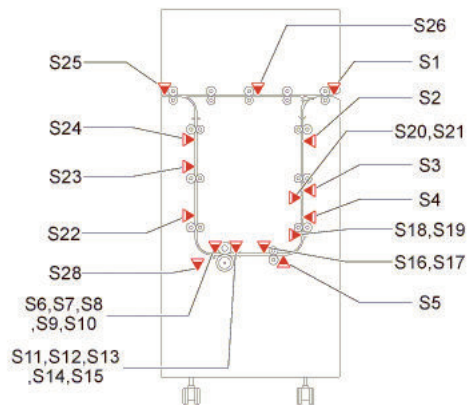
Overview of detection

A stationary jam occurs when a sensor was not turned OFF although a specified period of time had passed after the sensor was turned ON.

I/O: Service Mode > SITUATION > Sensor Check

Check items (in arbitrary order)

- Remaining paper near the target sensor
- Soiling on the target sensor
- Displacement of the target sensor position
- Failure of the target sensor
- Soiling (grease)/deterioration/failure of a drive motor located upstream of the target sensor
- Soiling (paper dust)/deterioration/failure of a drive roller located upstream of the target sensor



■ 31115B: JamCode (Multi Function Professional Puncher-B1) 115B

[Symptom/Question]

31115B: JamCode (Multi Function Professional Puncher-B1) 115B

[Remedy/Answer]

Jam Type : Stationary jam

Sensor Name : Alignment Sensor

Sensor No. : S12

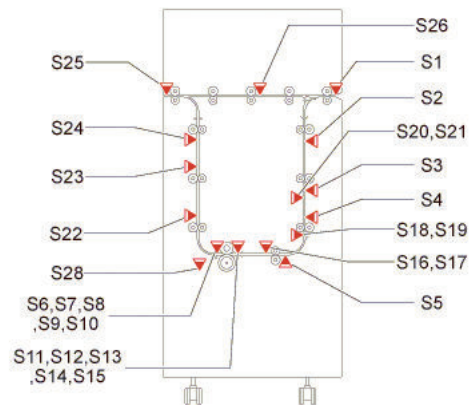
Overview of detection

A stationary jam occurs when a sensor was not turned OFF although a specified period of time had passed after the sensor was turned ON.

I/O: Service Mode > SITUATION > Sensor Check

Check items (in arbitrary order)

- Remaining paper near the target sensor
- Soiling on the target sensor
- Displacement of the target sensor position
- Failure of the target sensor
- Soiling (grease)/deterioration/failure of a drive motor located upstream of the target sensor
- Soiling (paper dust)/deterioration/failure of a drive roller located upstream of the target sensor



■ 31115C: JamCode (Multi Function Professional Puncher-B1) 115C

[Symptom/Question]

31115C: JamCode (Multi Function Professional Puncher-B1) 115C

[Remedy/Answer]

Jam Type : Stationary jam

Sensor Name : Alignment Sensor

Sensor No. : S13

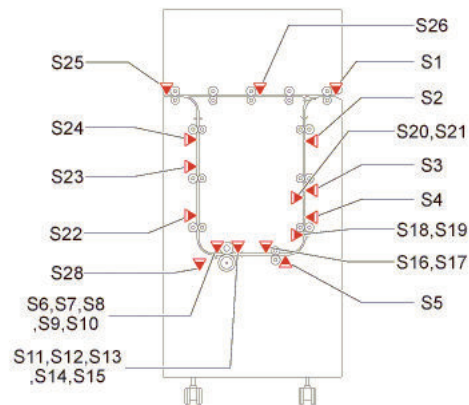
Overview of detection

A stationary jam occurs when a sensor was not turned OFF although a specified period of time had passed after the sensor was turned ON.

I/O: Service Mode > SITUATION > Sensor Check

Check items (in arbitrary order)

- Remaining paper near the target sensor
- Soiling on the target sensor
- Displacement of the target sensor position
- Failure of the target sensor
- Soiling (grease)/deterioration/failure of a drive motor located upstream of the target sensor
- Soiling (paper dust)/deterioration/failure of a drive roller located upstream of the target sensor



■ 31115D: JamCode (Multi Function Professional Puncher-B1) 115D

[Symptom/Question]

31115D: JamCode (Multi Function Professional Puncher-B1) 115D

[Remedy/Answer]

Jam Type : Stationary jam

Sensor Name : Alignment Sensor

Sensor No. : S14

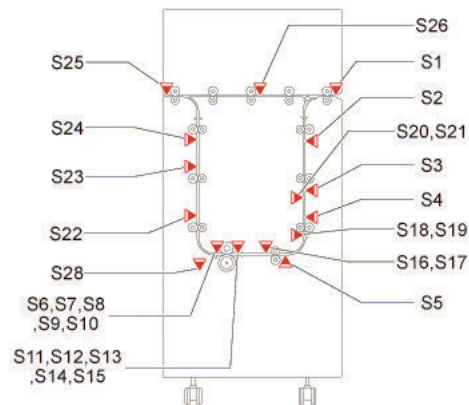
Overview of detection

A stationary jam occurs when a sensor was not turned OFF although a specified period of time had passed after the sensor was turned ON.

I/O: Service Mode > SITUATION > Sensor Check

Check items (in arbitrary order)

- Remaining paper near the target sensor
- Soiling on the target sensor
- Displacement of the target sensor position
- Failure of the target sensor
- Soiling (grease)/deterioration/failure of a drive motor located upstream of the target sensor
- Soiling (paper dust)/deterioration/failure of a drive roller located upstream of the target sensor



■ 31115E: JamCode (Multi Function Professional Puncher-B1) 115E

[Symptom/Question]

31115E: JamCode (Multi Function Professional Puncher-B1) 115E

[Remedy/Answer]

Jam Type : Stationary jam

Sensor Name : Alignment Sensor

Sensor No. : S15

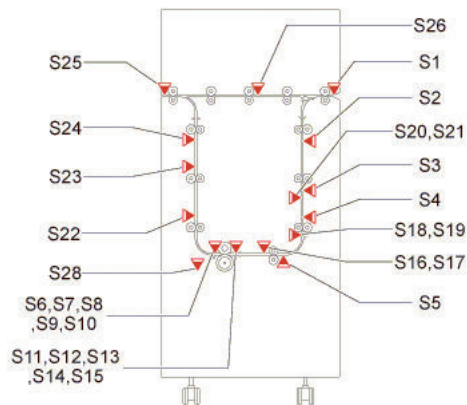
Overview of detection

A stationary jam occurs when a sensor was not turned OFF although a specified period of time had passed after the sensor was turned ON.

I/O: Service Mode > SITUATION > Sensor Check

Check items (in arbitrary order)

- Remaining paper near the target sensor
- Soiling on the target sensor
- Displacement of the target sensor position
- Failure of the target sensor
- Soiling (grease)/deterioration/failure of a drive motor located upstream of the target sensor
- Soiling (paper dust)/deterioration/failure of a drive roller located upstream of the target sensor



■ 31115F: JamCode (Multi Function Professional Puncher-B1) 115F

[Symptom/Question]

31115F: JamCode (Multi Function Professional Puncher-B1) 115F

[Remedy/Answer]

Jam Type : Stationary jam

Sensor Name : Backgage for Trail Edge Sensor

Sensor No. : S16

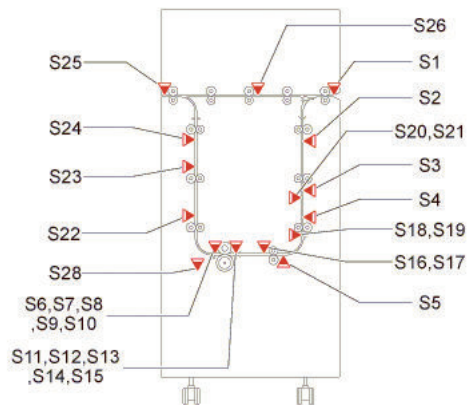
Overview of detection

A stationary jam occurs when a sensor was not turned OFF although a specified period of time had passed after the sensor was turned ON.

I/O: Service Mode > SITUATION > Sensor Check

Check items (in arbitrary order)

- Remaining paper near the target sensor
- Soiling on the target sensor
- Displacement of the target sensor position
- Failure of the target sensor
- Soiling (grease)/deterioration/failure of a drive motor located upstream of the target sensor
- Soiling (paper dust)/deterioration/failure of a drive roller located upstream of the target sensor



■ 311160: JamCode (Multi Function Professional Puncher-B1) 1160

[Symptom/Question]

311160: JamCode (Multi Function Professional Puncher-B1) 1160

[Remedy/Answer]

Jam Type : Stationary jam

Sensor Name : Backgage for Trail Edge Sensor

Sensor No. : S17

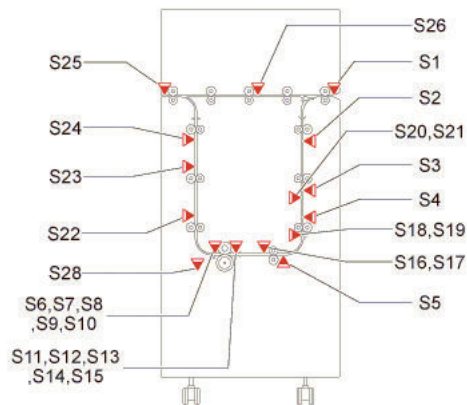
Overview of detection

A stationary jam occurs when a sensor was not turned OFF although a specified period of time had passed after the sensor was turned ON.

I/O: Service Mode > SITUATION > Sensor Check

Check items (in arbitrary order)

- Remaining paper near the target sensor
- Soiling on the target sensor
- Displacement of the target sensor position
- Failure of the target sensor
- Soiling (grease)/deterioration/failure of a drive motor located upstream of the target sensor
- Soiling (paper dust)/deterioration/failure of a drive roller located upstream of the target sensor



■ 311161: JamCode (Multi Function Professional Puncher-B1) 1161

[Symptom/Question]

311161: JamCode (Multi Function Professional Puncher-B1) 1161

[Remedy/Answer]

Jam Type : Stationary jam

Sensor Name : Double Punch Backgage for Large Sheets Sensor

Sensor No. : S18

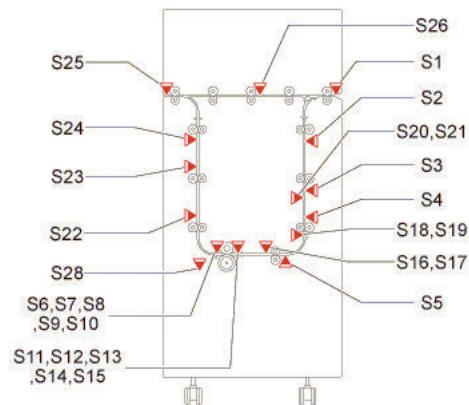
Overview of detection

A stationary jam occurs when a sensor was not turned OFF although a specified period of time had passed after the sensor was turned ON.

I/O: Service Mode > SITUATION > Sensor Check

Check items (in arbitrary order)

- Remaining paper near the target sensor
- Soiling on the target sensor
- Displacement of the target sensor position
- Failure of the target sensor
- Soiling (grease)/deterioration/failure of a drive motor located upstream of the target sensor
- Soiling (paper dust)/deterioration/failure of a drive roller located upstream of the target sensor



■ 311162: JamCode (Multi Function Professional Puncher-B1) 1162

[Symptom/Question]

311162: JamCode (Multi Function Professional Puncher-B1) 1162

[Remedy/Answer]

Jam Type : Stationary jam

Sensor Name : Double Punch Backgage for Large Sheets Sensor

Sensor No. : S19

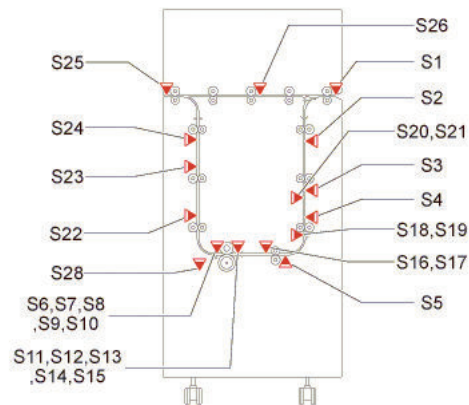
Overview of detection

A stationary jam occurs when a sensor was not turned OFF although a specified period of time had passed after the sensor was turned ON.

I/O: Service Mode > SITUATION > Sensor Check

Check items (in arbitrary order)

- Remaining paper near the target sensor
- Soiling on the target sensor
- Displacement of the target sensor position
- Failure of the target sensor
- Soiling (grease)/deterioration/failure of a drive motor located upstream of the target sensor
- Soiling (paper dust)/deterioration/failure of a drive roller located upstream of the target sensor



■ 311163: JamCode (Multi Function Professional Puncher-B1) 1163

[Symptom/Question]

311163: JamCode (Multi Function Professional Puncher-B1) 1163

[Remedy/Answer]

Jam Type : Stationary jam

Sensor Name : Double Punch Backgage for XL Sheets Sensor

Sensor No. : S20

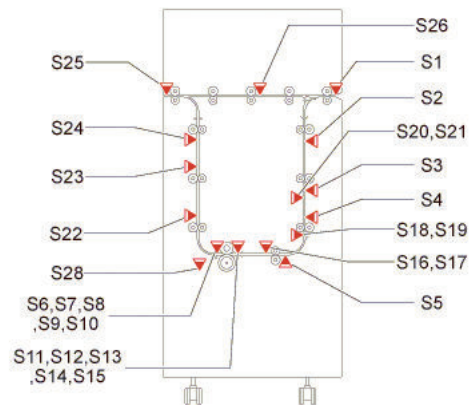
Overview of detection

A stationary jam occurs when a sensor was not turned OFF although a specified period of time had passed after the sensor was turned ON.

I/O: Service Mode > SITUATION > Sensor Check

Check items (in arbitrary order)

- Remaining paper near the target sensor
- Soiling on the target sensor
- Displacement of the target sensor position
- Failure of the target sensor
- Soiling (grease)/deterioration/failure of a drive motor located upstream of the target sensor
- Soiling (paper dust)/deterioration/failure of a drive roller located upstream of the target sensor



■ 311164: JamCode (Multi Function Professional Puncher-B1) 1164

[Symptom/Question]

311164: JamCode (Multi Function Professional Puncher-B1) 1164

[Remedy/Answer]

Jam Type : Stationary jam

Sensor Name : Double Punch Backgage for XL Sheets Sensor

Sensor No. : S21

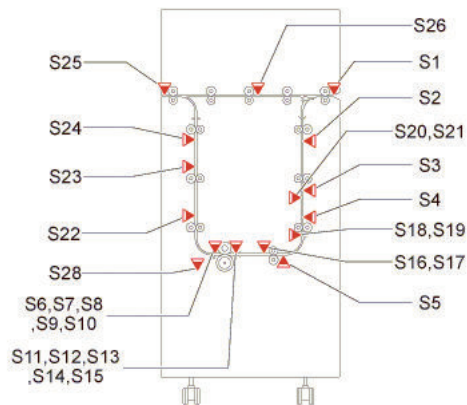
Overview of detection

A stationary jam occurs when a sensor was not turned OFF although a specified period of time had passed after the sensor was turned ON.

I/O: Service Mode > SITUATION > Sensor Check

Check items (in arbitrary order)

- Remaining paper near the target sensor
- Soiling on the target sensor
- Displacement of the target sensor position
- Failure of the target sensor
- Soiling (grease)/deterioration/failure of a drive motor located upstream of the target sensor
- Soiling (paper dust)/deterioration/failure of a drive roller located upstream of the target sensor



■ 311165: JamCode (Multi Function Professional Puncher-B1) 1165

[Symptom/Question]

311165: JamCode (Multi Function Professional Puncher-B1) 1165

[Remedy/Answer]

Jam Type : Stationary jam

Sensor Name : Exit Panel Sensor

Sensor No. : S22

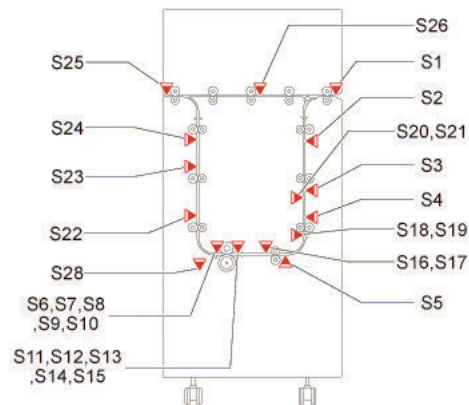
Overview of detection

A stationary jam occurs when a sensor was not turned OFF although a specified period of time had passed after the sensor was turned ON.

I/O: Service Mode > SITUATION > Sensor Check

Check items (in arbitrary order)

- Remaining paper near the target sensor
- Soiling on the target sensor
- Displacement of the target sensor position
- Failure of the target sensor
- Soiling (grease)/deterioration/failure of a drive motor located upstream of the target sensor
- Soiling (paper dust)/deterioration/failure of a drive roller located upstream of the target sensor



■ 311166: JamCode (Multi Function Professional Puncher-B1) 1166

[Symptom/Question]

311166: JamCode (Multi Function Professional Puncher-B1) 1166

[Remedy/Answer]

Jam Type : Stationary jam

Sensor Name : Exit Panel Sensor

Sensor No. : S23

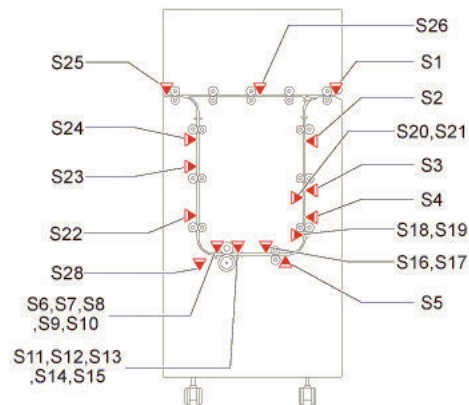
Overview of detection

A stationary jam occurs when a sensor was not turned OFF although a specified period of time had passed after the sensor was turned ON.

I/O: Service Mode > SITUATION > Sensor Check

Check items (in arbitrary order)

- Remaining paper near the target sensor
- Soiling on the target sensor
- Displacement of the target sensor position
- Failure of the target sensor
- Soiling (grease)/deterioration/failure of a drive motor located upstream of the target sensor
- Soiling (paper dust)/deterioration/failure of a drive roller located upstream of the target sensor



■ 311167: JamCode (Multi Function Professional Puncher-B1) 1167

[Symptom/Question]

311167: JamCode (Multi Function Professional Puncher-B1) 1167

[Remedy/Answer]

Jam Type : Stationary jam

Sensor Name : Deceleration Sensor

Sensor No. : S24

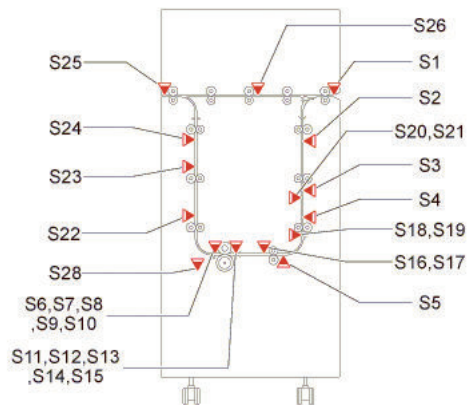
Overview of detection

A stationary jam occurs when a sensor was not turned OFF although a specified period of time had passed after the sensor was turned ON.

I/O: Service Mode > SITUATION > Sensor Check

Check items (in arbitrary order)

- Remaining paper near the target sensor
- Soiling on the target sensor
- Displacement of the target sensor position
- Failure of the target sensor
- Soiling (grease)/deterioration/failure of a drive motor located upstream of the target sensor
- Soiling (paper dust)/deterioration/failure of a drive roller located upstream of the target sensor



■ 311168: JamCode (Multi Function Professional Puncher-B1) 1168

[Symptom/Question]

311168: JamCode (Multi Function Professional Puncher-B1) 1168

[Remedy/Answer]

Jam Type : Stationary jam

Sensor Name : Exit Sensor

Sensor No. : S25

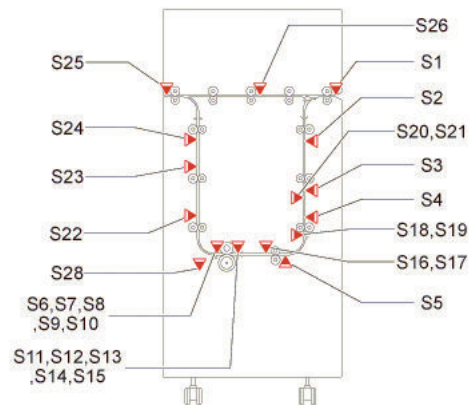
Overview of detection

A stationary jam occurs when a sensor was not turned OFF although a specified period of time had passed after the sensor was turned ON.

I/O: Service Mode > SITUATION > Sensor Check

Check items (in arbitrary order)

- Remaining paper near the target sensor
- Soiling on the target sensor
- Displacement of the target sensor position
- Failure of the target sensor
- Soiling (grease)/deterioration/failure of a drive motor located upstream of the target sensor
- Soiling (paper dust)/deterioration/failure of a drive roller located upstream of the target sensor



■ 311169: JamCode (Multi Function Professional Puncher-B1) 1169

[Symptom/Question]

311169: JamCode (Multi Function Professional Puncher-B1) 1169

[Remedy/Answer]

Jam Type : Stationary jam

Sensor Name : Bypass Sensor

Sensor No. : S26

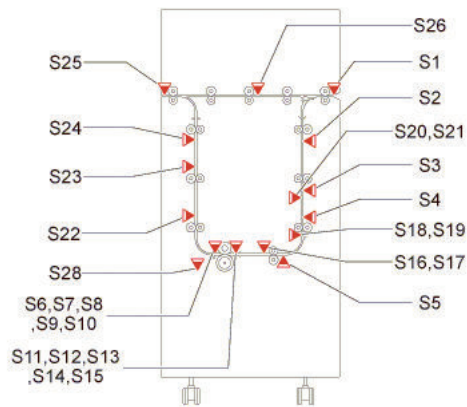
Overview of detection

A stationary jam occurs when a sensor was not turned OFF although a specified period of time had passed after the sensor was turned ON.

I/O: Service Mode > SITUATION > Sensor Check

Check items (in arbitrary order)

- Remaining paper near the target sensor
- Soiling on the target sensor
- Displacement of the target sensor position
- Failure of the target sensor
- Soiling (grease)/deterioration/failure of a drive motor located upstream of the target sensor
- Soiling (paper dust)/deterioration/failure of a drive roller located upstream of the target sensor



■ 31116A: JamCode (Multi Function Professional Puncher-B1) 116A

[Symptom/Question]

31116A: JamCode (Multi Function Professional Puncher-B1) 116A

[Remedy/Answer]

Jam Type : Stationary jam

Sensor Name : Align Home Sensor

Sensor No. : S28

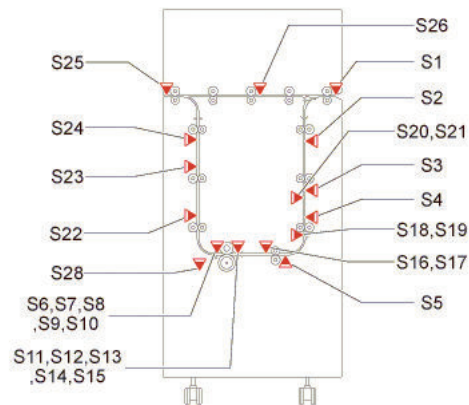
Overview of detection

A stationary jam occurs when a sensor was not turned OFF although a specified period of time had passed after the sensor was turned ON.

I/O: Service Mode > SITUATION > Sensor Check

Check items (in arbitrary order)

- Remaining paper near the target sensor
- Soiling on the target sensor
- Displacement of the target sensor position
- Failure of the target sensor
- Soiling (grease)/deterioration/failure of a drive motor located upstream of the target sensor
- Soiling (paper dust)/deterioration/failure of a drive roller located upstream of the target sensor



■ 311270: JamCode (Multi Function Professional Puncher-B1) 1270

[Symptom/Question]

311270: JamCode (Multi Function Professional Puncher-B1) 1270

[Remedy/Answer]

Jam Type : OTHER

Sensor Name : -

Sensor No. : -

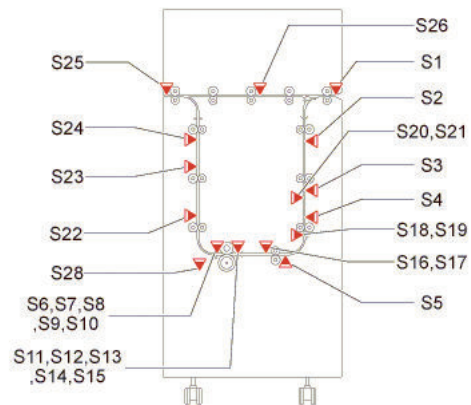
Overview of detection

-

I/O: Service Mode > SITUATION > Sensor Check

Check items (in arbitrary order)

-



■ 311350: JamCode (Multi Function Professional Puncher-B1) 1350

[Symptom/Question]

311350: JamCode (Multi Function Professional Puncher-B1) 1350

[Remedy/Answer]

Jam Type : Power-on jam

Sensor Name : Entry Sensor

Sensor No. : S1

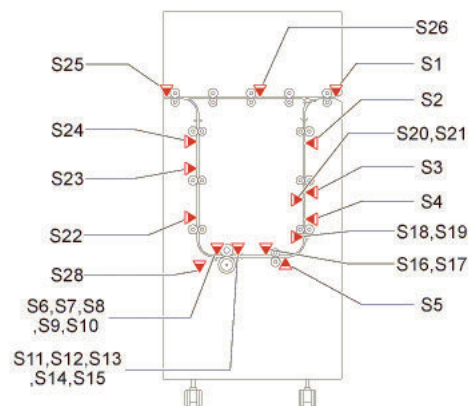
Overview of detection

A power-on jam occurs when a sensor detected ON state at power-on.

I/O: Service Mode > SITUATION > Sensor Check

Check items (in arbitrary order)

- Remaining paper in the machine
- Soiling on the target sensor
- Failure of the target sensor
- Foreign matter on the target sensor (paper dust, paper lint)



■ 311351: JamCode (Multi Function Professional Puncher-B1) 1351

[Symptom/Question]

311351: JamCode (Multi Function Professional Puncher-B1) 1351

[Remedy/Answer]

Jam Type : Power-on jam

Sensor Name : Entrance Panel Sensor

Sensor No. : S2

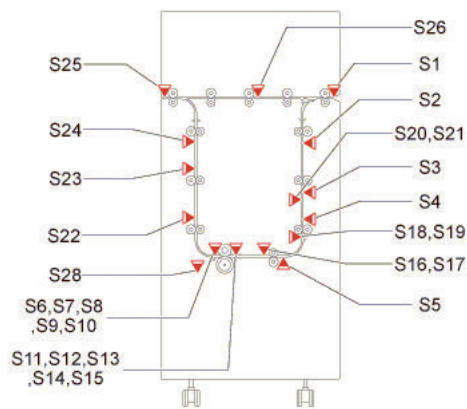
Overview of detection

A power-on jam occurs when a sensor detected ON state at power-on.

I/O: Service Mode > SITUATION > Sensor Check

Check items (in arbitrary order)

- Remaining paper in the machine
- Soiling on the target sensor
- Failure of the target sensor
- Foreign matter on the target sensor (paper dust, paper lint)



■ 311352: JamCode (Multi Function Professional Puncher-B1) 1352

[Symptom/Question]

311352: JamCode (Multi Function Professional Puncher-B1) 1352

[Remedy/Answer]

Jam Type : Power-on jam

Sensor Name : Entrance Panel Sensor

Sensor No. : S3

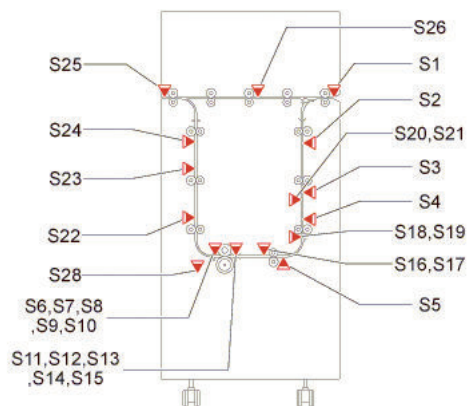
Overview of detection

A power-on jam occurs when a sensor detected ON state at power-on.

I/O: Service Mode > SITUATION > Sensor Check

Check items (in arbitrary order)

- Remaining paper in the machine
- Soiling on the target sensor
- Failure of the target sensor
- Foreign matter on the target sensor (paper dust, paper lint)



■ 311353: JamCode (Multi Function Professional Puncher-B1) 1353

[Symptom/Question]

311353: JamCode (Multi Function Professional Puncher-B1) 1353

[Remedy/Answer]

Jam Type : Power-on jam

Sensor Name : Entrance Panel Sensor

Sensor No. : S4

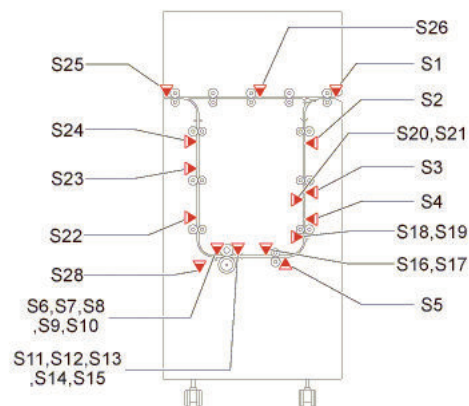
Overview of detection

A power-on jam occurs when a sensor detected ON state at power-on.

I/O: Service Mode > SITUATION > Sensor Check

Check items (in arbitrary order)

- Remaining paper in the machine
- Soiling on the target sensor
- Failure of the target sensor
- Foreign matter on the target sensor (paper dust, paper lint)



■ 311354: JamCode (Multi Function Professional Puncher-B1) 1354

[Symptom/Question]

311354: JamCode (Multi Function Professional Puncher-B1) 1354

[Remedy/Answer]

Jam Type : Power-on jam

Sensor Name : Acceleration Sensor

Sensor No. : S5

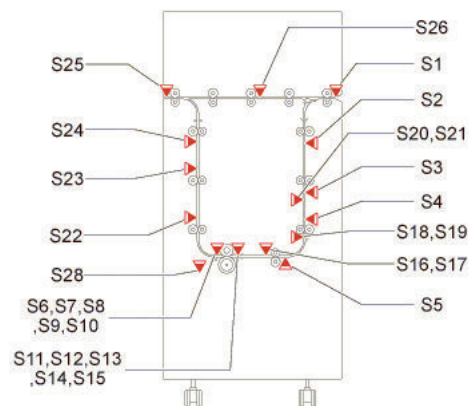
Overview of detection

A power-on jam occurs when a sensor detected ON state at power-on.

I/O: Service Mode > SITUATION > Sensor Check

Check items (in arbitrary order)

- Remaining paper in the machine
- Soiling on the target sensor
- Failure of the target sensor
- Foreign matter on the target sensor (paper dust, paper lint)



■ 311355: JamCode (Multi Function Professional Puncher-B1) 1355

[Symptom/Question]

311355: JamCode (Multi Function Professional Puncher-B1) 1355

[Remedy/Answer]

Jam Type : Power-on jam

Sensor Name : Angle Measurement Sensor

Sensor No. : S6

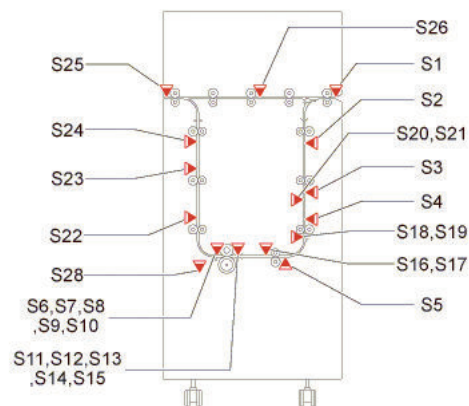
Overview of detection

A power-on jam occurs when a sensor detected ON state at power-on.

I/O: Service Mode > SITUATION > Sensor Check

Check items (in arbitrary order)

- Remaining paper in the machine
- Soiling on the target sensor
- Failure of the target sensor
- Foreign matter on the target sensor (paper dust, paper lint)



■ 311356: JamCode (Multi Function Professional Puncher-B1) 1356

[Symptom/Question]

311356: JamCode (Multi Function Professional Puncher-B1) 1356

[Remedy/Answer]

Jam Type : Power-on jam

Sensor Name : Angle Measurement Sensor

Sensor No. : S7

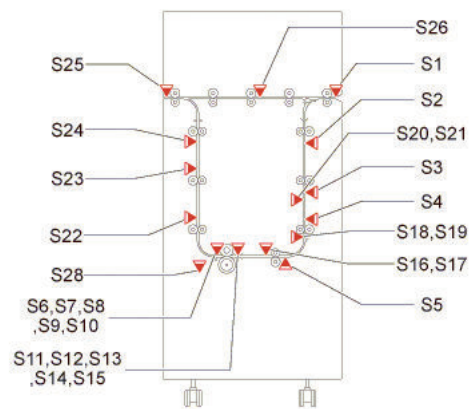
Overview of detection

A power-on jam occurs when a sensor detected ON state at power-on.

I/O: Service Mode > SITUATION > Sensor Check

Check items (in arbitrary order)

- Remaining paper in the machine
- Soiling on the target sensor
- Failure of the target sensor
- Foreign matter on the target sensor (paper dust, paper lint)



■ 311357: JamCode (Multi Function Professional Puncher-B1) 1357

[Symptom/Question]

311357: JamCode (Multi Function Professional Puncher-B1) 1357

[Remedy/Answer]

Jam Type : Power-on jam

Sensor Name : Angle Measurement Sensor

Sensor No. : S8

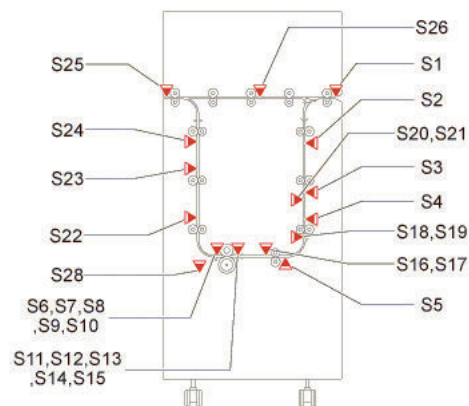
Overview of detection

A power-on jam occurs when a sensor detected ON state at power-on.

I/O: Service Mode > SITUATION > Sensor Check

Check items (in arbitrary order)

- Remaining paper in the machine
- Soiling on the target sensor
- Failure of the target sensor
- Foreign matter on the target sensor (paper dust, paper lint)



■ 311358: JamCode (Multi Function Professional Puncher-B1) 1358

[Symptom/Question]

311358: JamCode (Multi Function Professional Puncher-B1) 1358

[Remedy/Answer]

Jam Type : Power-on jam

Sensor Name : Angle Measurement Sensor

Sensor No. : S9

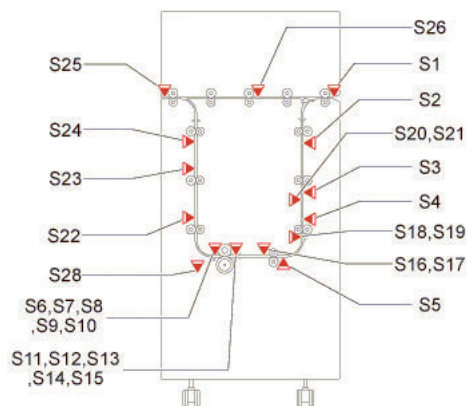
Overview of detection

A power-on jam occurs when a sensor detected ON state at power-on.

I/O: Service Mode > SITUATION > Sensor Check

Check items (in arbitrary order)

- Remaining paper in the machine
- Soiling on the target sensor
- Failure of the target sensor
- Foreign matter on the target sensor (paper dust, paper lint)



■ 311359: JamCode (Multi Function Professional Puncher-B1) 1359

[Symptom/Question]

311359: JamCode (Multi Function Professional Puncher-B1) 1359

[Remedy/Answer]

Jam Type : Power-on jam

Sensor Name : Angle Measurement Sensor

Sensor No. : S10

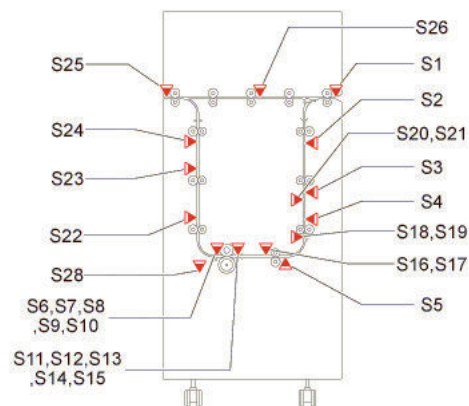
Overview of detection

A power-on jam occurs when a sensor detected ON state at power-on.

I/O: Service Mode > SITUATION > Sensor Check

Check items (in arbitrary order)

- Remaining paper in the machine
- Soiling on the target sensor
- Failure of the target sensor
- Foreign matter on the target sensor (paper dust, paper lint)



■ 31135A: JamCode (Multi Function Professional Puncher-B1) 135A

[Symptom/Question]

31135A: JamCode (Multi Function Professional Puncher-B1) 135A

[Remedy/Answer]

Jam Type : Power-on jam

Sensor Name : Alignment Sensor

Sensor No. : S11

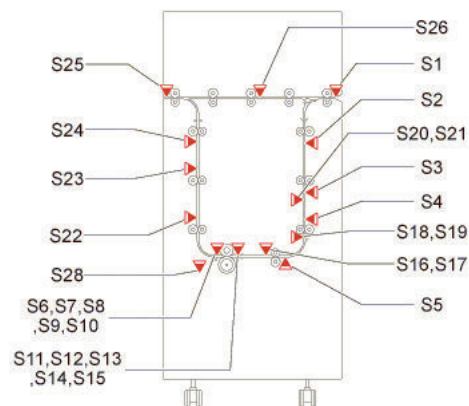
Overview of detection

A power-on jam occurs when a sensor detected ON state at power-on.

I/O: Service Mode > SITUATION > Sensor Check

Check items (in arbitrary order)

- Remaining paper in the machine
- Soiling on the target sensor
- Failure of the target sensor
- Foreign matter on the target sensor (paper dust, paper lint)



■ 31135B: JamCode (Multi Function Professional Puncher-B1) 135B

[Symptom/Question]

31135B: JamCode (Multi Function Professional Puncher-B1) 135B

[Remedy/Answer]

Jam Type : Power-on jam

Sensor Name : Alignment Sensor

Sensor No. : S12

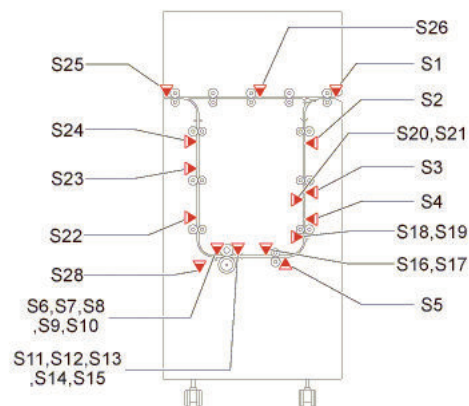
Overview of detection

A power-on jam occurs when a sensor detected ON state at power-on.

I/O: Service Mode > SITUATION > Sensor Check

Check items (in arbitrary order)

- Remaining paper in the machine
- Soiling on the target sensor
- Failure of the target sensor
- Foreign matter on the target sensor (paper dust, paper lint)



■ 31135C: JamCode (Multi Function Professional Puncher-B1) 135C

[Symptom/Question]

31135C: JamCode (Multi Function Professional Puncher-B1) 135C

[Remedy/Answer]

Jam Type : Power-on jam

Sensor Name : Alignment Sensor

Sensor No. : S13

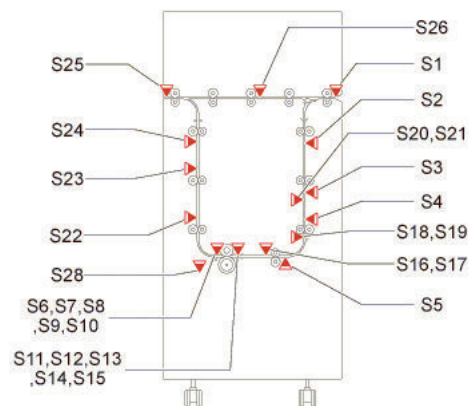
Overview of detection

A power-on jam occurs when a sensor detected ON state at power-on.

I/O: Service Mode > SITUATION > Sensor Check

Check items (in arbitrary order)

- Remaining paper in the machine
- Soiling on the target sensor
- Failure of the target sensor
- Foreign matter on the target sensor (paper dust, paper lint)



■ 31135D: JamCode (Multi Function Professional Puncher-B1) 135D

[Symptom/Question]

31135D: JamCode (Multi Function Professional Puncher-B1) 135D

[Remedy/Answer]

Jam Type : Power-on jam

Sensor Name : Alignment Sensor

Sensor No. : S14

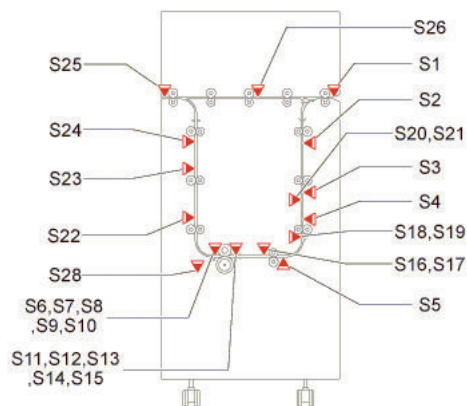
Overview of detection

A power-on jam occurs when a sensor detected ON state at power-on.

I/O: Service Mode > SITUATION > Sensor Check

Check items (in arbitrary order)

- Remaining paper in the machine
- Soiling on the target sensor
- Failure of the target sensor
- Foreign matter on the target sensor (paper dust, paper lint)



■ 31135E: JamCode (Multi Function Professional Puncher-B1) 135E

[Symptom/Question]

31135E: JamCode (Multi Function Professional Puncher-B1) 135E

[Remedy/Answer]

Jam Type : Power-on jam

Sensor Name : Alignment Sensor

Sensor No. : S15

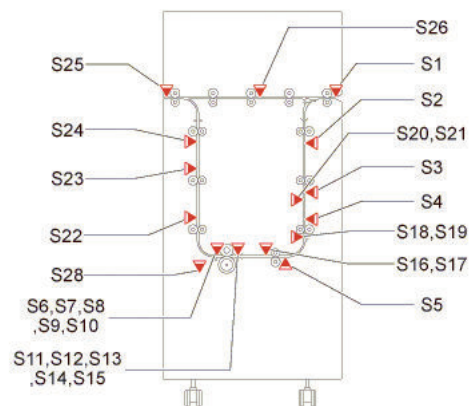
Overview of detection

A power-on jam occurs when a sensor detected ON state at power-on.

I/O: Service Mode > SITUATION > Sensor Check

Check items (in arbitrary order)

- Remaining paper in the machine
- Soiling on the target sensor
- Failure of the target sensor
- Foreign matter on the target sensor (paper dust, paper lint)



■ 31135F: JamCode (Multi Function Professional Puncher-B1) 135F

[Symptom/Question]

31135F: JamCode (Multi Function Professional Puncher-B1) 135F

[Remedy/Answer]

Jam Type : Power-on jam

Sensor Name : Backgage for Trail Edge Sensor

Sensor No. : S16

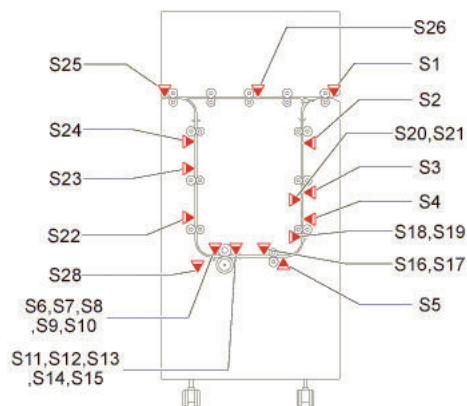
Overview of detection

A power-on jam occurs when a sensor detected ON state at power-on.

I/O: Service Mode > SITUATION > Sensor Check

Check items (in arbitrary order)

- Remaining paper in the machine
- Soiling on the target sensor
- Failure of the target sensor
- Foreign matter on the target sensor (paper dust, paper lint)



■ 311360: JamCode (Multi Function Professional Puncher-B1) 1360

[Symptom/Question]

311360: JamCode (Multi Function Professional Puncher-B1) 1360

[Remedy/Answer]

Jam Type : Power-on jam

Sensor Name : Backgage for Trail Edge Sensor

Sensor No. : S17

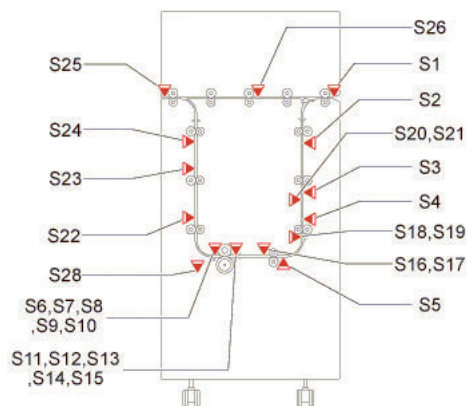
Overview of detection

A power-on jam occurs when a sensor detected ON state at power-on.

I/O: Service Mode > SITUATION > Sensor Check

Check items (in arbitrary order)

- Remaining paper in the machine
- Soiling on the target sensor
- Failure of the target sensor
- Foreign matter on the target sensor (paper dust, paper lint)



■ 311361: JamCode (Multi Function Professional Puncher-B1) 1361

[Symptom/Question]

311361: JamCode (Multi Function Professional Puncher-B1) 1361

[Remedy/Answer]

Jam Type : Power-on jam

Sensor Name : Double Punch Backgague for Large Sheets Sensor

Sensor No. : S18

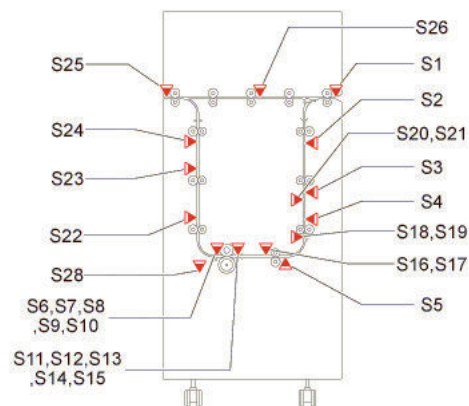
Overview of detection

A power-on jam occurs when a sensor detected ON state at power-on.

I/O: Service Mode > SITUATION > Sensor Check

Check items (in arbitrary order)

- Remaining paper in the machine
- Soiling on the target sensor
- Failure of the target sensor
- Foreign matter on the target sensor (paper dust, paper lint)



■ 311362: JamCode (Multi Function Professional Puncher-B1) 1362

[Symptom/Question]

311362: JamCode (Multi Function Professional Puncher-B1) 1362

[Remedy/Answer]

Jam Type : Power-on jam

Sensor Name : Double Punch Backgague for Large Sheets Sensor

Sensor No. : S19

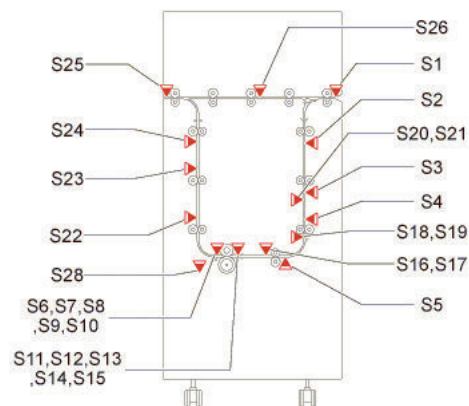
Overview of detection

A power-on jam occurs when a sensor detected ON state at power-on.

I/O: Service Mode > SITUATION > Sensor Check

Check items (in arbitrary order)

- Remaining paper in the machine
- Soiling on the target sensor
- Failure of the target sensor
- Foreign matter on the target sensor (paper dust, paper lint)



■ 311363: JamCode (Multi Function Professional Puncher-B1) 1363

[Symptom/Question]

311363: JamCode (Multi Function Professional Puncher-B1) 1363

[Remedy/Answer]

Jam Type : Power-on jam

Sensor Name : Double Punch Backgage for XL Sheets Sensor

Sensor No. : S20

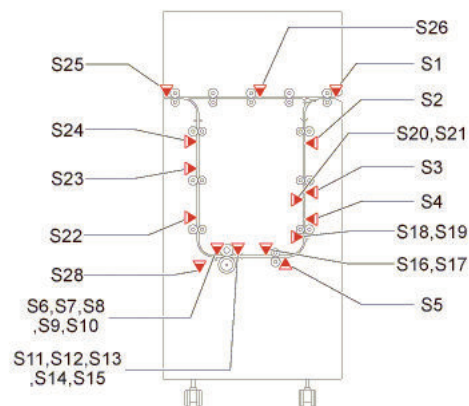
Overview of detection

A power-on jam occurs when a sensor detected ON state at power-on.

I/O: Service Mode > SITUATION > Sensor Check

Check items (in arbitrary order)

- Remaining paper in the machine
- Soiling on the target sensor
- Failure of the target sensor
- Foreign matter on the target sensor (paper dust, paper lint)



■ 311364: JamCode (Multi Function Professional Puncher-B1) 1364

[Symptom/Question]

311364: JamCode (Multi Function Professional Puncher-B1) 1364

[Remedy/Answer]

Jam Type : Power-on jam

Sensor Name : Double Punch Backgague for XL Sheets Sensor

Sensor No. : S21

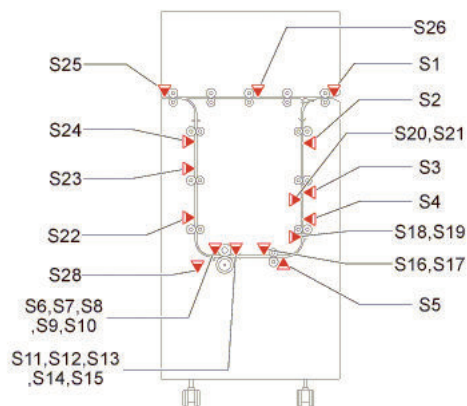
Overview of detection

A power-on jam occurs when a sensor detected ON state at power-on.

I/O: Service Mode > SITUATION > Sensor Check

Check items (in arbitrary order)

- Remaining paper in the machine
- Soiling on the target sensor
- Failure of the target sensor
- Foreign matter on the target sensor (paper dust, paper lint)



■ 311365: JamCode (Multi Function Professional Puncher-B1) 1365

[Symptom/Question]

311365: JamCode (Multi Function Professional Puncher-B1) 1365

[Remedy/Answer]

Jam Type : Power-on jam

Sensor Name : Exit Panel Sensor

Sensor No. : S22

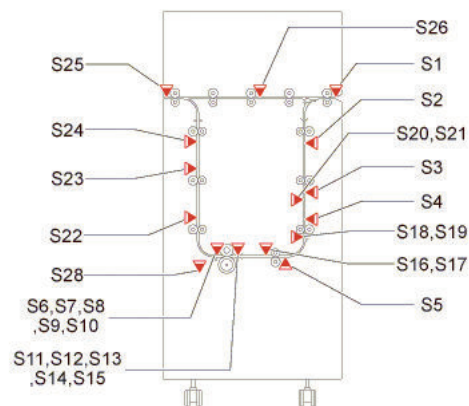
Overview of detection

A power-on jam occurs when a sensor detected ON state at power-on.

I/O: Service Mode > SITUATION > Sensor Check

Check items (in arbitrary order)

- Remaining paper in the machine
- Soiling on the target sensor
- Failure of the target sensor
- Foreign matter on the target sensor (paper dust, paper lint)



■ 311366: JamCode (Multi Function Professional Puncher-B1) 1366

[Symptom/Question]

311366: JamCode (Multi Function Professional Puncher-B1) 1366

[Remedy/Answer]

Jam Type : Power-on jam

Sensor Name : Exit Panel Sensor

Sensor No. : S23

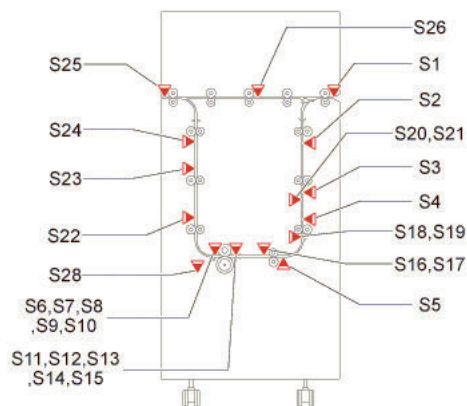
Overview of detection

A power-on jam occurs when a sensor detected ON state at power-on.

I/O: Service Mode > SITUATION > Sensor Check

Check items (in arbitrary order)

- Remaining paper in the machine
- Soiling on the target sensor
- Failure of the target sensor
- Foreign matter on the target sensor (paper dust, paper lint)



■ 311367: JamCode (Multi Function Professional Puncher-B1) 1367

[Symptom/Question]

311367: JamCode (Multi Function Professional Puncher-B1) 1367

[Remedy/Answer]

Jam Type : Power-on jam

Sensor Name : Deceleration Sensor

Sensor No. : S24

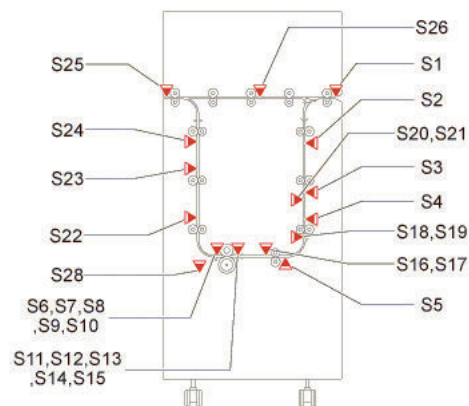
Overview of detection

A power-on jam occurs when a sensor detected ON state at power-on.

I/O: Service Mode > SITUATION > Sensor Check

Check items (in arbitrary order)

- Remaining paper in the machine
- Soiling on the target sensor
- Failure of the target sensor
- Foreign matter on the target sensor (paper dust, paper lint)



■ 311368: JamCode (Multi Function Professional Puncher-B1) 1368

[Symptom/Question]

311368: JamCode (Multi Function Professional Puncher-B1) 1368

[Remedy/Answer]

Jam Type : Power-on jam

Sensor Name : Exit Sensor

Sensor No. : S25

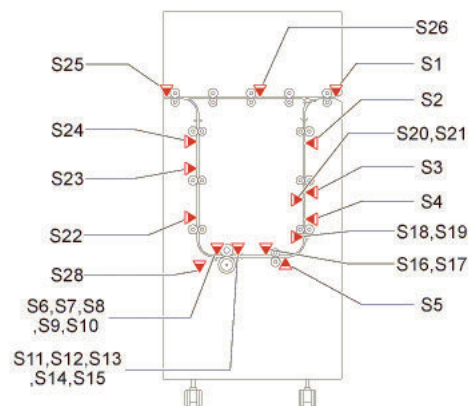
Overview of detection

A power-on jam occurs when a sensor detected ON state at power-on.

I/O: Service Mode > SITUATION > Sensor Check

Check items (in arbitrary order)

- Remaining paper in the machine
- Soiling on the target sensor
- Failure of the target sensor
- Foreign matter on the target sensor (paper dust, paper lint)



■ 311369: JamCode (Multi Function Professional Puncher-B1) 1369

[Symptom/Question]

311369: JamCode (Multi Function Professional Puncher-B1) 1369

[Remedy/Answer]

Jam Type : Power-on jam

Sensor Name : Bypass Sensor

Sensor No. : S26

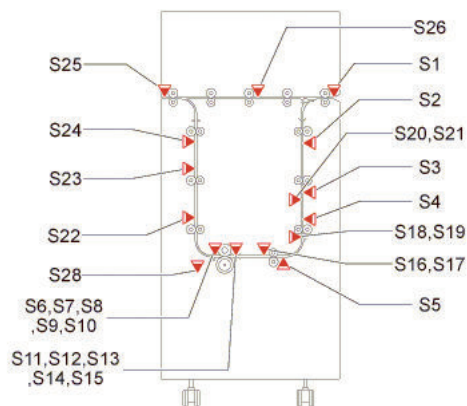
Overview of detection

A power-on jam occurs when a sensor detected ON state at power-on.

I/O: Service Mode > SITUATION > Sensor Check

Check items (in arbitrary order)

- Remaining paper in the machine
- Soiling on the target sensor
- Failure of the target sensor
- Foreign matter on the target sensor (paper dust, paper lint)



■ 31136A: JamCode (Multi Function Professional Puncher-B1) 136A

[Symptom/Question]

31136A: JamCode (Multi Function Professional Puncher-B1) 136A

[Remedy/Answer]

Jam Type : Power-on jam

Sensor Name : Align Home Sensor

Sensor No. : S28

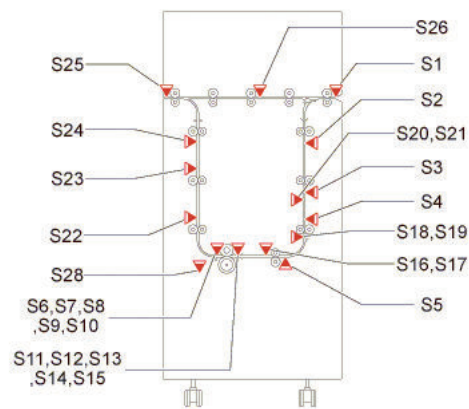
Overview of detection

A power-on jam occurs when a sensor detected ON state at power-on.

I/O: Service Mode > SITUATION > Sensor Check

Check items (in arbitrary order)

- Remaining paper in the machine
- Soiling on the target sensor
- Failure of the target sensor
- Foreign matter on the target sensor (paper dust, paper lint)



■ 311472: JamCode (Multi Function Professional Puncher-B1) 1472

[Symptom/Question]

311472: JamCode (Multi Function Professional Puncher-B1) 1472

[Remedy/Answer]

Jam Type : COVER Open jam

Sensor Name : -

Sensor No. : -

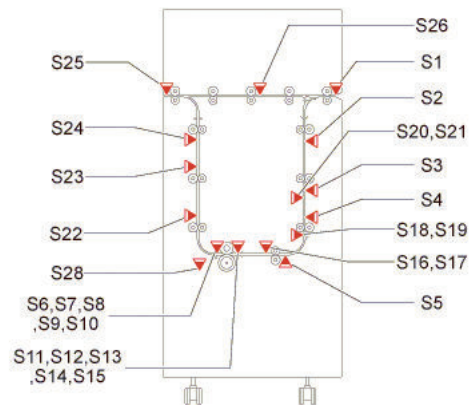
Overview of detection

A door open jam occurs when a sensor detected cover open during printing operation.

I/O: Service Mode > SITUATION > Sensor Check

Check items (in arbitrary order)

- Cover open during printing



■ 311773: JamCode (Multi Function Professional Puncher-B1) 1773

[Symptom/Question]

311773: JamCode (Multi Function Professional Puncher-B1) 1773

[Remedy/Answer]

Jam Type : OTHER

Sensor Name : -

Sensor No. : -

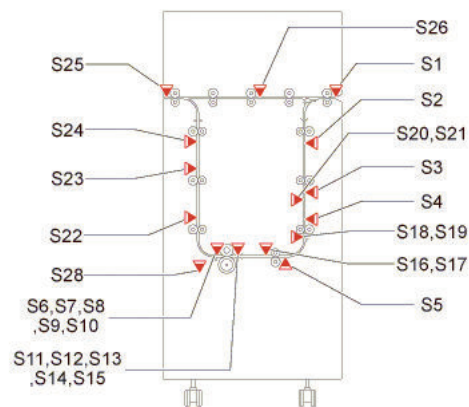
Overview of detection

-

I/O: Service Mode > SITUATION > Sensor Check

Check items (in arbitrary order)

-



■ 311C74: JamCode (Multi Function Professional Puncher-B1) 1C74

[Symptom/Question]

311C74: JamCode (Multi Function Professional Puncher-B1) 1C74

[Remedy/Answer]

Jam Type : OTHER

Sensor Name : -

Sensor No. : -

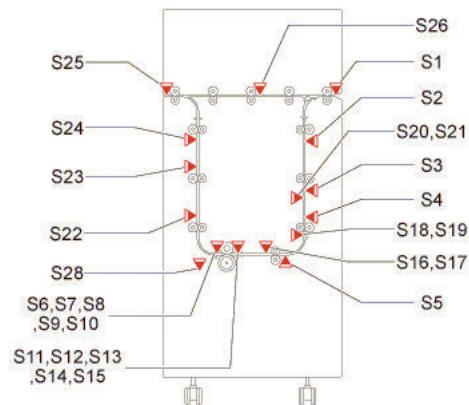
Overview of detection

-

I/O: Service Mode > SITUATION > Sensor Check

Check items (in arbitrary order)

-



■ 311F75: JamCode (Multi Function Professional Puncher-B1) 1F75

[Symptom/Question]

311F75: JamCode (Multi Function Professional Puncher-B1) 1F75

[Remedy/Answer]

Jam Type : OTHER

Sensor Name : -

Sensor No. : -

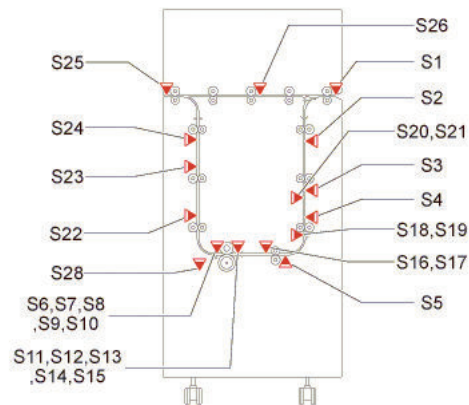
Overview of detection

-

I/O: Service Mode > SITUATION > Sensor Check

Check items (in arbitrary order)

-



■ 311F76: JamCode (Multi Function Professional Puncher-B1) 1F76

[Symptom/Question]

311F76: JamCode (Multi Function Professional Puncher-B1) 1F76

[Remedy/Answer]

Jam Type : OTHER

Sensor Name : -

Sensor No. : -

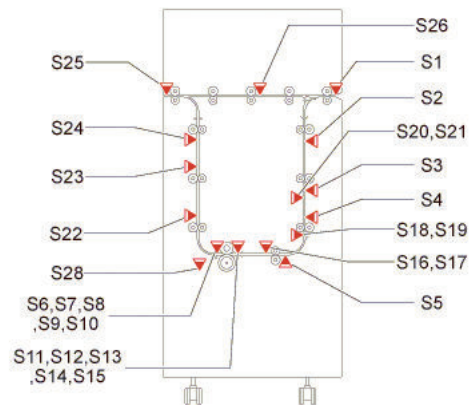
Overview of detection

-

I/O: Service Mode > SITUATION > Sensor Check

Check items (in arbitrary order)

-



■ 311F77: JamCode (Multi Function Professional Puncher-B1) 1F77

[Symptom/Question]

311F77: JamCode (Multi Function Professional Puncher-B1) 1F77

[Remedy/Answer]

Jam Type : OTHER

Sensor Name : -

Sensor No. : -

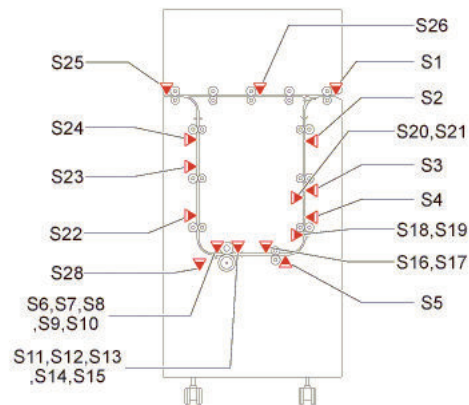
Overview of detection

-

I/O: Service Mode > SITUATION > Sensor Check

Check items (in arbitrary order)

-



■ 311F78: JamCode (Multi Function Professional Puncher-B1) 1F78

[Symptom/Question]

311F78: JamCode (Multi Function Professional Puncher-B1) 1F78

[Remedy/Answer]

Jam Type : OTHER

Sensor Name : -

Sensor No. : -

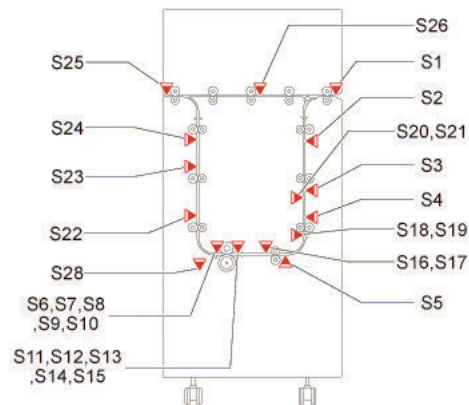
Overview of detection

-

I/O: Service Mode > SITUATION > Sensor Check

Check items (in arbitrary order)

-



■ 311F7B: JamCode (Multi Function Professional Puncher-B1) 1F7B

[Symptom/Question]

311F7B: JamCode (Multi Function Professional Puncher-B1) 1F7B

[Remedy/Answer]

Jam Type : OTHER

Sensor Name : -

Sensor No. : -

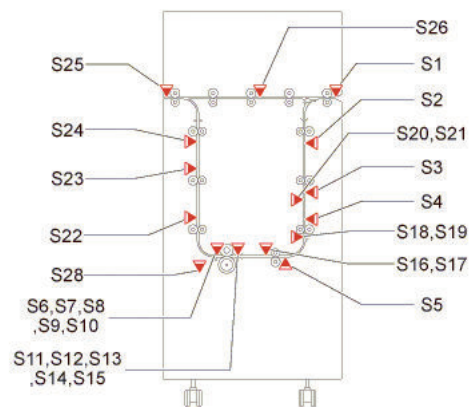
Overview of detection

-

I/O: Service Mode > SITUATION > Sensor Check

Check items (in arbitrary order)

-



■ 311F7C: JamCode (Multi Function Professional Puncher-B1) 1F7C

[Symptom/Question]

311F7C: JamCode (Multi Function Professional Puncher-B1) 1F7C

[Remedy/Answer]

Jam Type : OTHER

Sensor Name : -

Sensor No. : -

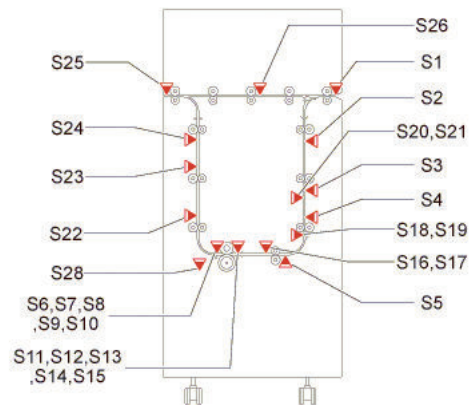
Overview of detection

-

I/O: Service Mode > SITUATION > Sensor Check

Check items (in arbitrary order)

-



■ 311F7E: JamCode (Multi Function Professional Puncher-B1) 1F7E

[Symptom/Question]

311F7E: JamCode (Multi Function Professional Puncher-B1) 1F7E

[Remedy/Answer]

Jam Type : OTHER

Sensor Name : -

Sensor No. : -

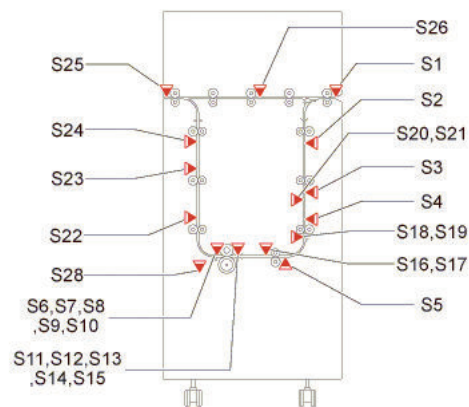
Overview of detection

-

I/O: Service Mode > SITUATION > Sensor Check

Check items (in arbitrary order)

-



■ 31FF7F: JamCode (Multi Function Professional Puncher-B1) FF7F

[Symptom/Question]

31FF7F: JamCode (Multi Function Professional Puncher-B1) FF7F

[Remedy/Answer]

Jam Type : OTHER

Sensor Name : -

Sensor No. : -

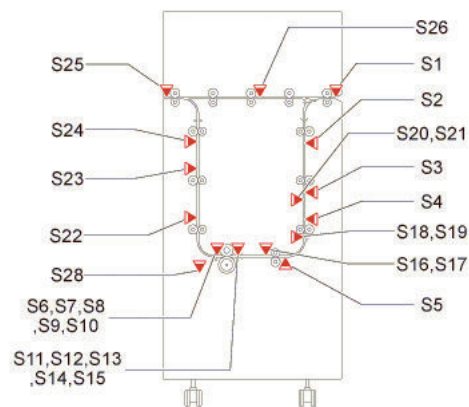
Overview of detection

-

I/O: Service Mode > SITUATION > Sensor Check

Check items (in arbitrary order)

-



■ 7120E0: JamCode (Document Insertion Unit-N1) 20E0

[Symptom/Question]

7120E0: JamCode (Document Insertion Unit-N1) 20E0

[Remedy/Answer]

Jam Type : Delay jam

Sensor Name : Entrance Sensor

Sensor No. : S20

Overview of detection

A delay jam occurs when a sensor was not turned ON although a specified period of time had passed after the start of detection by the sensor.

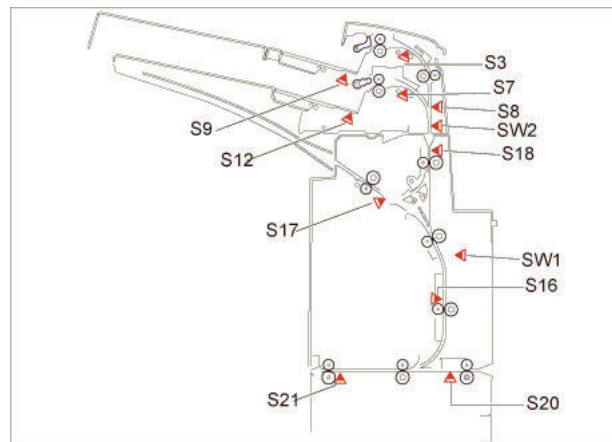
I/O: Service Mode > SITUATION > Sensor Check

Check items (in arbitrary order)

- Remaining paper at the upstream of the target sensor
- Soiling on the target sensor

Displacement of the target sensor position

- Failure of the target sensor
- Soiling (grease)/deterioration/Failure of a drive motor located upstream of the target sensor
- Soiling (paper dust)/deterioration/Failure of a drive roller located upstream of the target sensor



■ 7120E2: JamCode (Document Insertion Unit-N1) 20E2

[Symptom/Question]

7120E2: JamCode (Document Insertion Unit-N1) 20E2

[Remedy/Answer]

Jam Type : Delay jam

Sensor Name : Delivery Sensor 2

Sensor No. : S21

Overview of detection

A delay jam occurs when a sensor was not turned ON although a specified period of time had passed after the start of detection by the sensor.

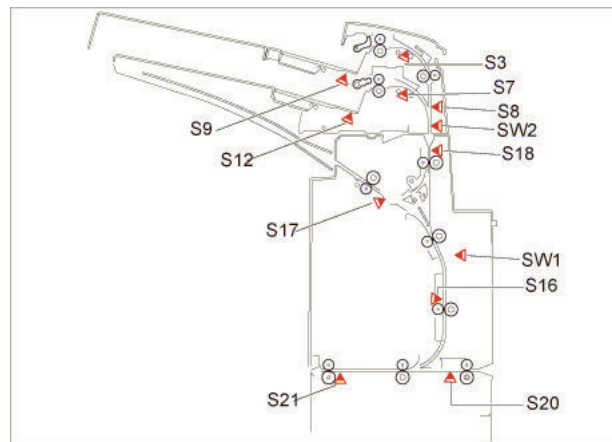
I/O: Service Mode > SITUATION > Sensor Check

Check items (in arbitrary order)

- Remaining paper at the upstream of the target sensor
- Soiling on the target sensor

Displacement of the target sensor position

- Failure of the target sensor
- Soiling (grease)/deterioration/Failure of a drive motor located upstream of the target sensor
- Soiling (paper dust)/deterioration/Failure of a drive roller located upstream of the target sensor



■ 7120E4: JamCode (Document Insertion Unit-N1) 20E4

[Symptom/Question]

7120E4: JamCode (Document Insertion Unit-N1) 20E4

[Remedy/Answer]

Jam Type : Delay jam

Sensor Name : Upper tray registration sensor

Sensor No. : S3

Overview of detection

A delay jam occurs when a sensor was not turned ON although a specified period of time had passed after the start of detection by the sensor.

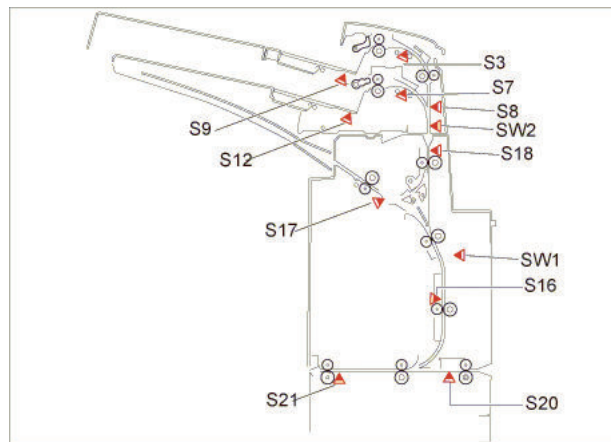
I/O: Service Mode > SITUATION > Sensor Check

Check items (in arbitrary order)

- Remaining paper at the upstream of the target sensor
- Soiling on the target sensor

Displacement of the target sensor position

- Failure of the target sensor
- Soiling (grease)/deterioration/Failure of a drive motor located upstream of the target sensor
- Soiling (paper dust)/deterioration/Failure of a drive roller located upstream of the target sensor



■ 7120E5: JamCode (Document Insertion Unit-N1) 20E5

[Symptom/Question]

7120E5: JamCode (Document Insertion Unit-N1) 20E5

[Remedy/Answer]

Jam Type : Delay jam

Sensor Name : Middle Feed Sensor

Sensor No. : S8

Overview of detection

A delay jam occurs when a sensor was not turned ON although a specified period of time had passed after the start of detection by the sensor.

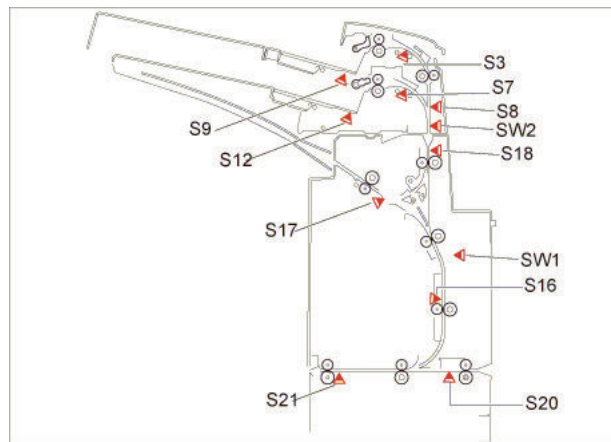
I/O: Service Mode > SITUATION > Sensor Check

Check items (in arbitrary order)

- Remaining paper at the upstream of the target sensor
- Soiling on the target sensor

Displacement of the target sensor position

- Failure of the target sensor
- Soiling (grease)/deterioration/Failure of a drive motor located upstream of the target sensor
- Soiling (paper dust)/deterioration/Failure of a drive roller located upstream of the target sensor



■ 7120E6: JamCode (Document Insertion Unit-N1) 20E6

[Symptom/Question]

7120E6: JamCode (Document Insertion Unit-N1) 20E6

[Remedy/Answer]

Jam Type : Delay jam

Sensor Name : Reverse Entrance Sensor

Sensor No. : S18

Overview of detection

A delay jam occurs when a sensor was not turned ON although a specified period of time had passed after the start of detection by the sensor.

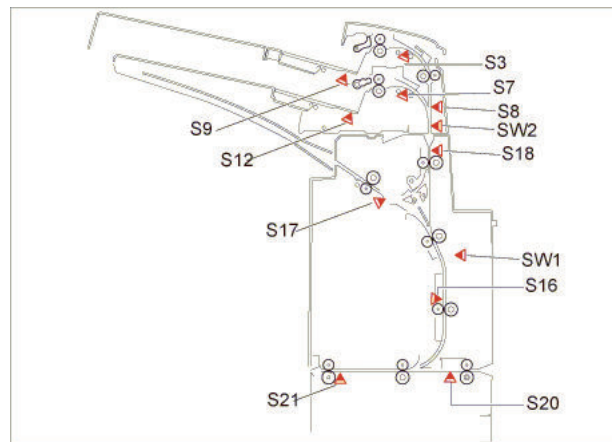
I/O: Service Mode > SITUATION > Sensor Check

Check items (in arbitrary order)

- Remaining paper at the upstream of the target sensor
- Soiling on the target sensor

Displacement of the target sensor position

- Failure of the target sensor
- Soiling (grease)/deterioration/Failure of a drive motor located upstream of the target sensor
- Soiling (paper dust)/deterioration/Failure of a drive roller located upstream of the target sensor



■ 7120E7: JamCode (Document Insertion Unit-N1) 20E7

[Symptom/Question]

7120E7: JamCode (Document Insertion Unit-N1) 20E7

[Remedy/Answer]

Jam Type : Delay jam

Sensor Name : Reverse Sensor

Sensor No. : S17

Overview of detection

A delay jam occurs when a sensor was not turned ON although a specified period of time had passed after the start of detection by the sensor.

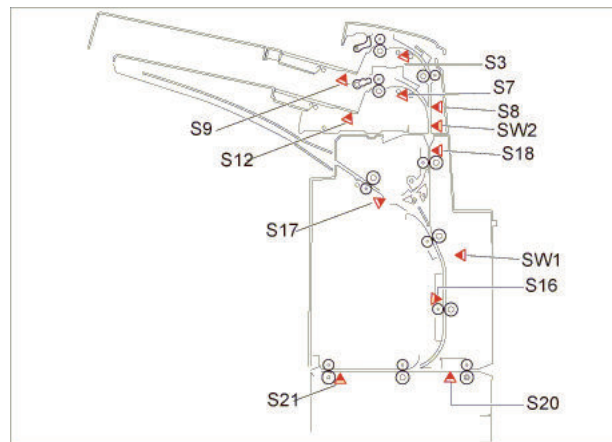
I/O: Service Mode > SITUATION > Sensor Check

Check items (in arbitrary order)

- Remaining paper at the upstream of the target sensor
- Soiling on the target sensor

Displacement of the target sensor position

- Failure of the target sensor
- Soiling (grease)/deterioration/Failure of a drive motor located upstream of the target sensor
- Soiling (paper dust)/deterioration/Failure of a drive roller located upstream of the target sensor



■ 7120E8: JamCode (Document Insertion Unit-N1) 20E8

[Symptom/Question]

7120E8: JamCode (Document Insertion Unit-N1) 20E8

[Remedy/Answer]

Jam Type : Delay jam

Sensor Name : Reverse Timing Sensor

Sensor No. : S16

Overview of detection

A delay jam occurs when a sensor was not turned ON although a specified period of time had passed after the start of detection by the sensor.

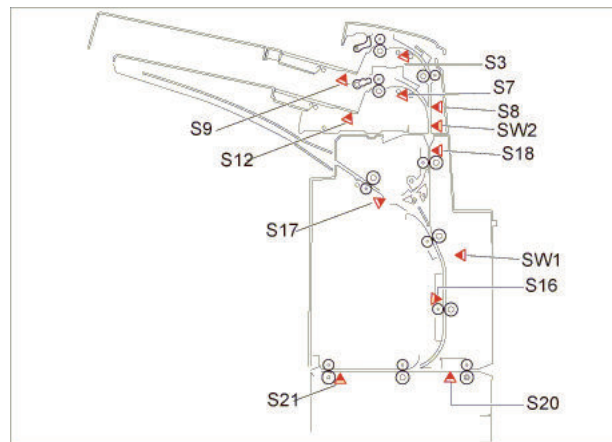
I/O: Service Mode > SITUATION > Sensor Check

Check items (in arbitrary order)

- Remaining paper at the upstream of the target sensor
- Soiling on the target sensor

Displacement of the target sensor position

- Failure of the target sensor
- Soiling (grease)/deterioration/Failure of a drive motor located upstream of the target sensor
- Soiling (paper dust)/deterioration/Failure of a drive roller located upstream of the target sensor



■ 7120EF: JamCode (Document Insertion Unit-N1) 20EF

[Symptom/Question]

7120EF: JamCode (Document Insertion Unit-N1) 20EF

[Remedy/Answer]

Jam Type : Delay jam

Sensor Name : Lower tray registration sensor

Sensor No. : S7

Overview of detection

A delay jam occurs when a sensor was not turned ON although a specified period of time had passed after the start of detection by the sensor.

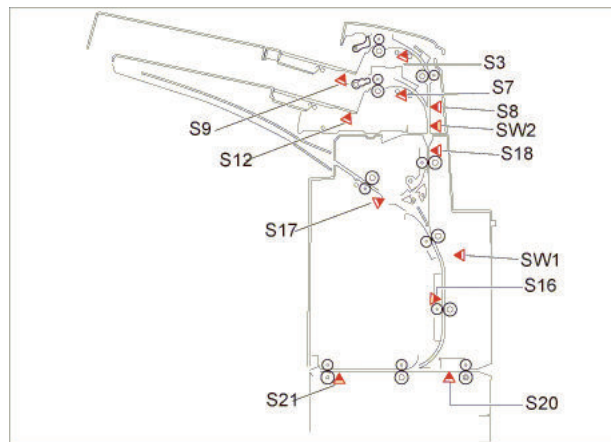
I/O: Service Mode > SITUATION > Sensor Check

Check items (in arbitrary order)

- Remaining paper at the upstream of the target sensor
- Soiling on the target sensor

Displacement of the target sensor position

- Failure of the target sensor
- Soiling (grease)/deterioration/Failure of a drive motor located upstream of the target sensor
- Soiling (paper dust)/deterioration/Failure of a drive roller located upstream of the target sensor



■ 7121F0: JamCode (Document Insertion Unit-N1) 21F0

[Symptom/Question]

7121F0: JamCode (Document Insertion Unit-N1) 21F0

[Remedy/Answer]

Jam Type : Stationary jam

Sensor Name : Entrance Sensor

Sensor No. : S20

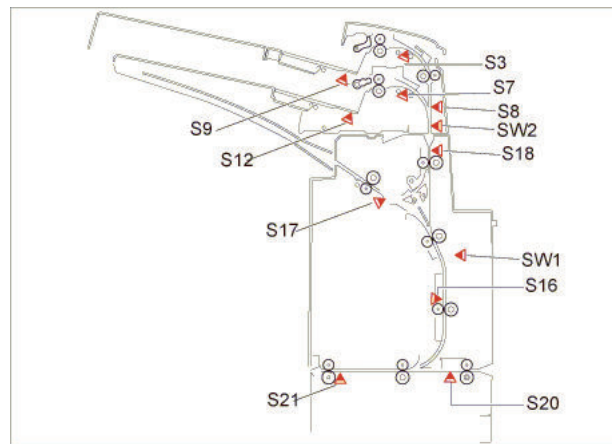
Overview of detection

A stationary jam occurs when a sensor was not turned OFF although a specified period of time had passed after the sensor was turned ON.

I/O: Service Mode > SITUATION > Sensor Check

Check items (in arbitrary order)

- Remaining paper near the target sensor
- Soiling on the target sensor
- Displacement of the target sensor position
- Failure of the target sensor
- Soiling (grease)/deterioration/failure of a drive motor located upstream of the target sensor
- Soiling (paper dust)/deterioration/failure of a drive roller located upstream of the target sensor



■ 7121F2: JamCode (Document Insertion Unit-N1) 21F2

[Symptom/Question]

7121F2: JamCode (Document Insertion Unit-N1) 21F2

[Remedy/Answer]

Jam Type : Stationary jam

Sensor Name : Delivery Sensor 2

Sensor No. : S21

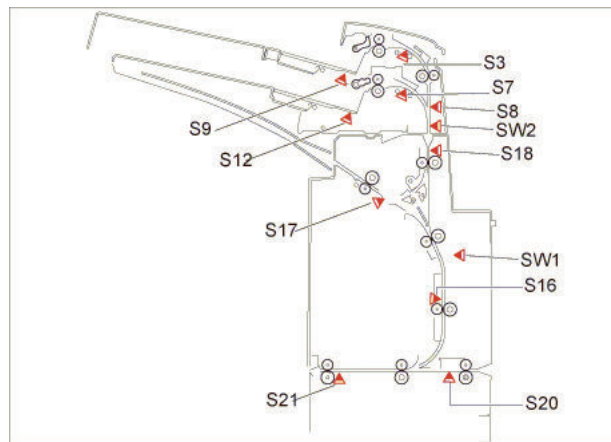
Overview of detection

A stationary jam occurs when a sensor was not turned OFF although a specified period of time had passed after the sensor was turned ON.

I/O: Service Mode > SITUATION > Sensor Check

Check items (in arbitrary order)

- Remaining paper near the target sensor
- Soiling on the target sensor
- Displacement of the target sensor position
- Failure of the target sensor
- Soiling (grease)/deterioration/failure of a drive motor located upstream of the target sensor
- Soiling (paper dust)/deterioration/failure of a drive roller located upstream of the target sensor



■ 7121F4: JamCode (Document Insertion Unit-N1) 21F4

[Symptom/Question]

7121F4: JamCode (Document Insertion Unit-N1) 21F4

[Remedy/Answer]

Jam Type : Stationary jam

Sensor Name : Upper tray registration sensor

Sensor No. : S3

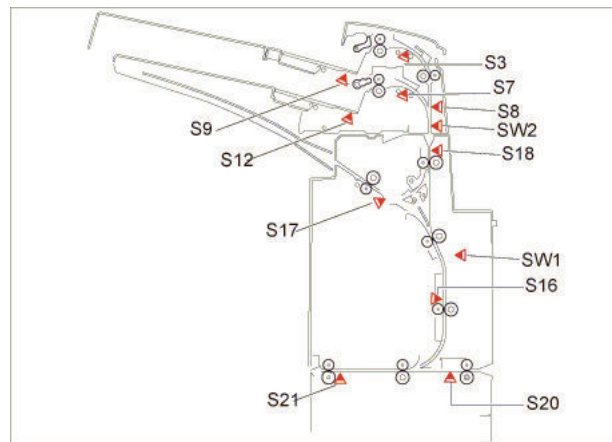
Overview of detection

A stationary jam occurs when a sensor was not turned OFF although a specified period of time had passed after the sensor was turned ON.

I/O: Service Mode > SITUATION > Sensor Check

Check items (in arbitrary order)

- Remaining paper near the target sensor
- Soiling on the target sensor
- Displacement of the target sensor position
- Failure of the target sensor
- Soiling (grease)/deterioration/failure of a drive motor located upstream of the target sensor
- Soiling (paper dust)/deterioration/failure of a drive roller located upstream of the target sensor



■ 7121F5: JamCode (Document Insertion Unit-N1) 21F5

[Symptom/Question]

7121F5: JamCode (Document Insertion Unit-N1) 21F5

[Remedy/Answer]

Jam Type : Stationary jam

Sensor Name : Middle Feed Sensor

Sensor No. : S8

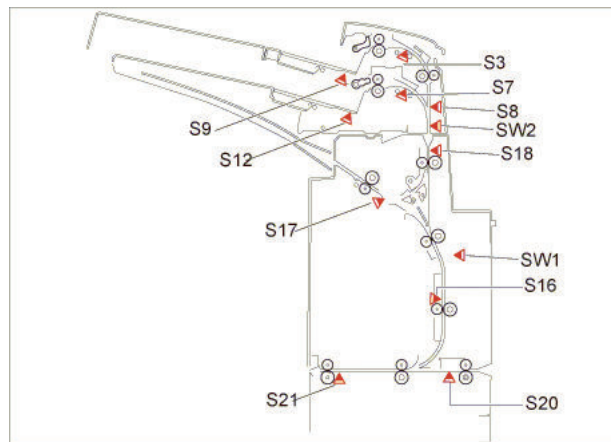
Overview of detection

A stationary jam occurs when a sensor was not turned OFF although a specified period of time had passed after the sensor was turned ON.

I/O: Service Mode > SITUATION > Sensor Check

Check items (in arbitrary order)

- Remaining paper near the target sensor
- Soiling on the target sensor
- Displacement of the target sensor position
- Failure of the target sensor
- Soiling (grease)/deterioration/failure of a drive motor located upstream of the target sensor
- Soiling (paper dust)/deterioration/failure of a drive roller located upstream of the target sensor



■ 7121F6: JamCode (Document Insertion Unit-N1) 21F6

[Symptom/Question]

7121F6: JamCode (Document Insertion Unit-N1) 21F6

[Remedy/Answer]

Jam Type : Stationary jam

Sensor Name : Reverse Entrance Sensor

Sensor No. : S18

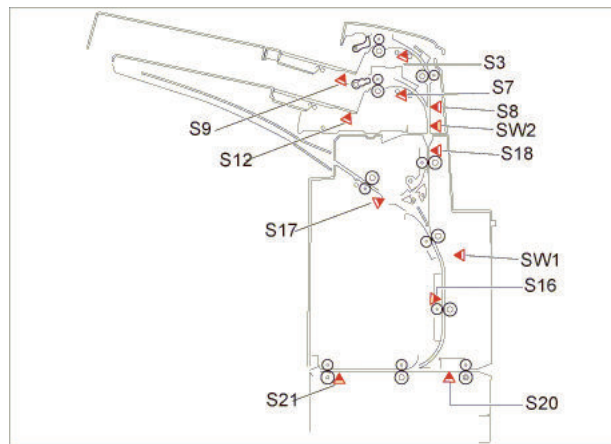
Overview of detection

A stationary jam occurs when a sensor was not turned OFF although a specified period of time had passed after the sensor was turned ON.

I/O: Service Mode > SITUATION > Sensor Check

Check items (in arbitrary order)

- Remaining paper near the target sensor
- Soiling on the target sensor
- Displacement of the target sensor position
- Failure of the target sensor
- Soiling (grease)/deterioration/failure of a drive motor located upstream of the target sensor
- Soiling (paper dust)/deterioration/failure of a drive roller located upstream of the target sensor



■ 7121F7: JamCode (Document Insertion Unit-N1) 21F7

[Symptom/Question]

7121F7: JamCode (Document Insertion Unit-N1) 21F7

[Remedy/Answer]

Jam Type : Stationary jam

Sensor Name : Reverse Sensor

Sensor No. : S17

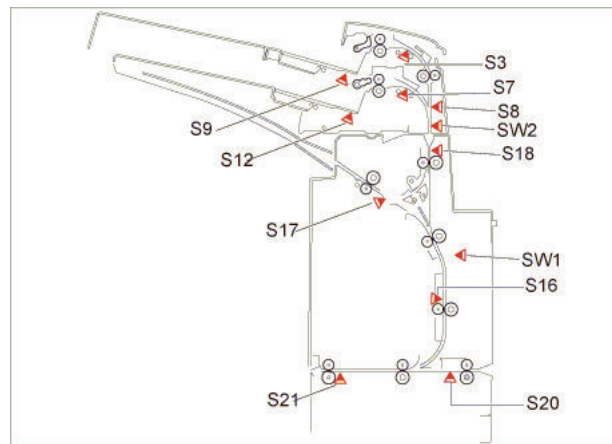
Overview of detection

A stationary jam occurs when a sensor was not turned OFF although a specified period of time had passed after the sensor was turned ON.

I/O: Service Mode > SITUATION > Sensor Check

Check items (in arbitrary order)

- Remaining paper near the target sensor
- Soiling on the target sensor
- Displacement of the target sensor position
- Failure of the target sensor
- Soiling (grease)/deterioration/failure of a drive motor located upstream of the target sensor
- Soiling (paper dust)/deterioration/failure of a drive roller located upstream of the target sensor



■ 7121F8: JamCode (Document Insertion Unit-N1) 21F8

[Symptom/Question]

7121F8: JamCode (Document Insertion Unit-N1) 21F8

[Remedy/Answer]

Jam Type : Stationary jam

Sensor Name : Reverse Timing Sensor

Sensor No. : S16

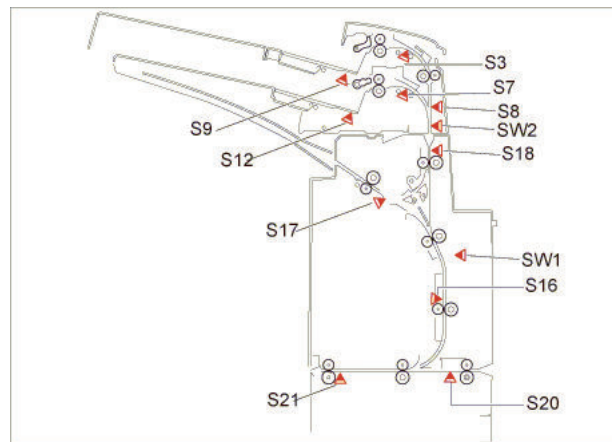
Overview of detection

A stationary jam occurs when a sensor was not turned OFF although a specified period of time had passed after the sensor was turned ON.

I/O: Service Mode > SITUATION > Sensor Check

Check items (in arbitrary order)

- Remaining paper near the target sensor
- Soiling on the target sensor
- Displacement of the target sensor position
- Failure of the target sensor
- Soiling (grease)/deterioration/failure of a drive motor located upstream of the target sensor
- Soiling (paper dust)/deterioration/failure of a drive roller located upstream of the target sensor



■ 7121FF: JamCode (Document Insertion Unit-N1) 21FF

[Symptom/Question]

7121FF: JamCode (Document Insertion Unit-N1) 21FF

[Remedy/Answer]

Jam Type : Stationary jam

Sensor Name : Lower tray registration sensor

Sensor No. : S7

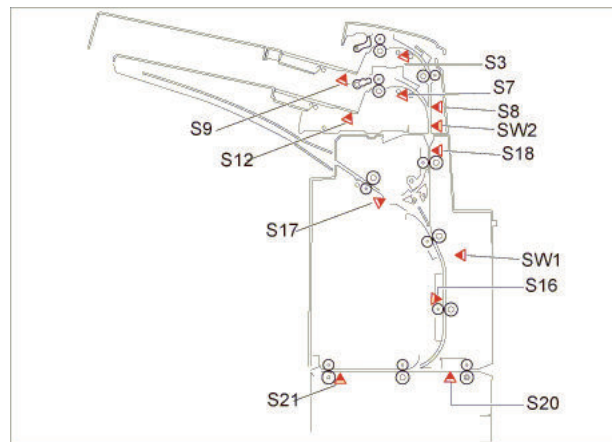
Overview of detection

A stationary jam occurs when a sensor was not turned OFF although a specified period of time had passed after the sensor was turned ON.

I/O: Service Mode > SITUATION > Sensor Check

Check items (in arbitrary order)

- Remaining paper near the target sensor
- Soiling on the target sensor
- Displacement of the target sensor position
- Failure of the target sensor
- Soiling (grease)/deterioration/failure of a drive motor located upstream of the target sensor
- Soiling (paper dust)/deterioration/failure of a drive roller located upstream of the target sensor



■ 712200: JamCode (Document Insertion Unit-N1) 2200

[Symptom/Question]

712200: JamCode (Document Insertion Unit-N1) 2200

[Remedy/Answer]

Jam Type : OTHER

Sensor Name : -

Sensor No. : -

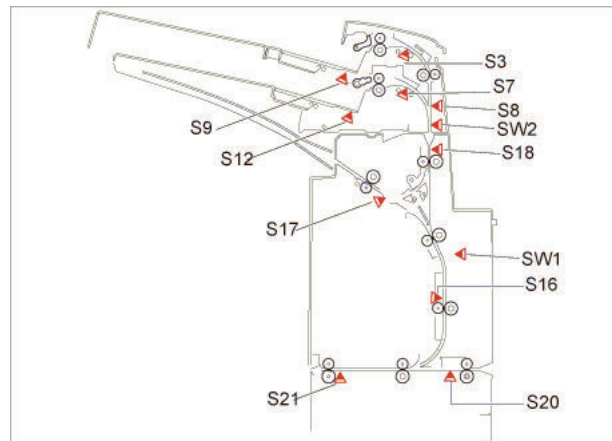
Overview of detection

-

I/O: Service Mode > SITUATION > Sensor Check

Check items (in arbitrary order)

-



■ 712300: JamCode (Document Insertion Unit-N1) 2300

[Symptom/Question]

712300: JamCode (Document Insertion Unit-N1) 2300

[Remedy/Answer]

Jam Type : Power-on jam

Sensor Name : -

Sensor No. : -

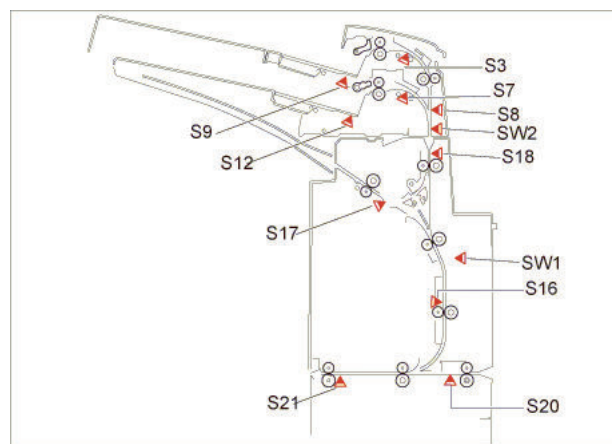
Overview of detection

A power-on jam occurs when a sensor detected ON state at power-on.

I/O: Service Mode > SITUATION > Sensor Check

Check items (in arbitrary order)

- Remaining paper in the machine
- Soiling on the target sensor
- Failure of the target sensor
- Foreign matter on the target sensor (paper dust, paper lint)



■ 7123F0: JamCode (Document Insertion Unit-N1) 23F0

[Symptom/Question]

7123F0: JamCode (Document Insertion Unit-N1) 23F0

[Remedy/Answer]

Jam Type : Power-on jam

Sensor Name : Entrance Sensor

Sensor No. : S20

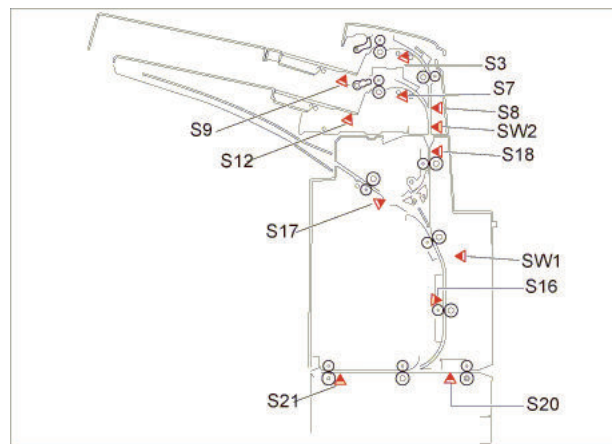
Overview of detection

A power-on jam occurs when a sensor detected ON state at power-on.

I/O: Service Mode > SITUATION > Sensor Check

Check items (in arbitrary order)

- Remaining paper in the machine
- Soiling on the target sensor
- Failure of the target sensor
- Foreign matter on the target sensor (paper dust, paper lint)



■ 7123F2: JamCode (Document Insertion Unit-N1) 23F2

[Symptom/Question]

7123F2: JamCode (Document Insertion Unit-N1) 23F2

[Remedy/Answer]

Jam Type : Power-on jam

Sensor Name : Delivery Sensor 2

Sensor No. : S21

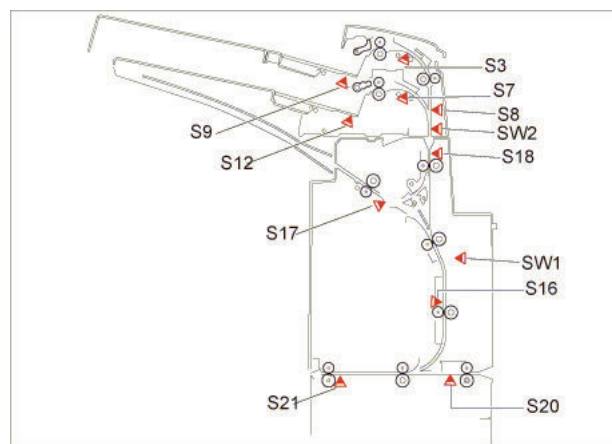
Overview of detection

A power-on jam occurs when a sensor detected ON state at power-on.

I/O: Service Mode > SITUATION > Sensor Check

Check items (in arbitrary order)

- Remaining paper in the machine
- Soiling on the target sensor
- Failure of the target sensor
- Foreign matter on the target sensor (paper dust, paper lint)



■ 7123F4: JamCode (Document Insertion Unit-N1) 23F4

[Symptom/Question]

7123F4: JamCode (Document Insertion Unit-N1) 23F4

[Remedy/Answer]

Jam Type : Power-on jam

Sensor Name : Upper tray registration sensor

Sensor No. : S3

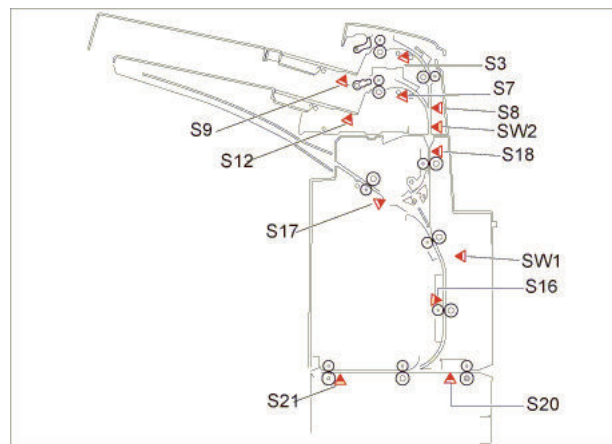
Overview of detection

A power-on jam occurs when a sensor detected ON state at power-on.

I/O: Service Mode > SITUATION > Sensor Check

Check items (in arbitrary order)

- Remaining paper in the machine
- Soiling on the target sensor
- Failure of the target sensor
- Foreign matter on the target sensor (paper dust, paper lint)



■ 7123F5: JamCode (Document Insertion Unit-N1) 23F5

[Symptom/Question]

7123F5: JamCode (Document Insertion Unit-N1) 23F5

[Remedy/Answer]

Jam Type : Power-on jam

Sensor Name : Middle Feed Sensor

Sensor No. : S8

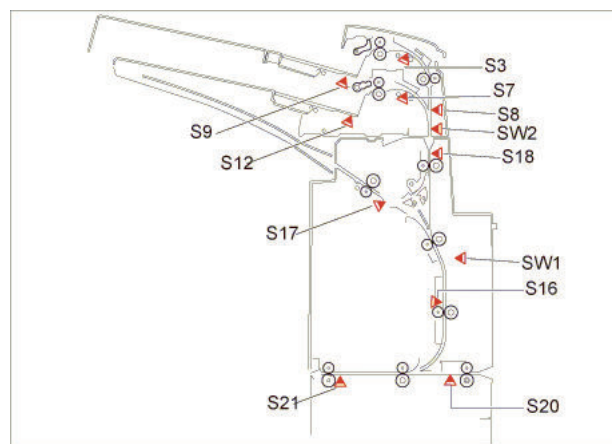
Overview of detection

A power-on jam occurs when a sensor detected ON state at power-on.

I/O: Service Mode > SITUATION > Sensor Check

Check items (in arbitrary order)

- Remaining paper in the machine
- Soiling on the target sensor
- Failure of the target sensor
- Foreign matter on the target sensor (paper dust, paper lint)



■ 7123F6: JamCode (Document Insertion Unit-N1) 23F6

[Symptom/Question]

7123F6: JamCode (Document Insertion Unit-N1) 23F6

[Remedy/Answer]

Jam Type : Power-on jam

Sensor Name : Reverse Entrance Sensor

Sensor No. : S18

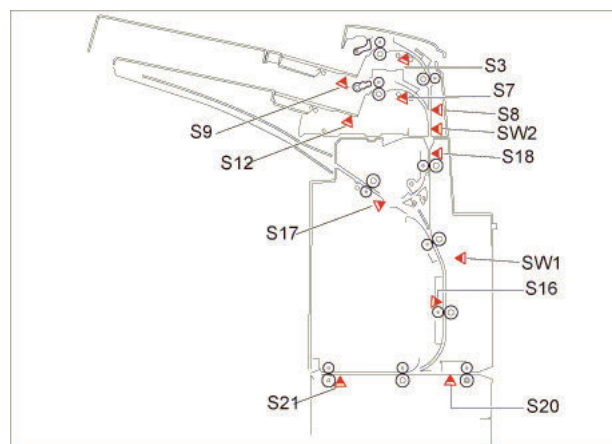
Overview of detection

A power-on jam occurs when a sensor detected ON state at power-on.

I/O: Service Mode > SITUATION > Sensor Check

Check items (in arbitrary order)

- Remaining paper in the machine
- Soiling on the target sensor
- Failure of the target sensor
- Foreign matter on the target sensor (paper dust, paper lint)



■ 7123F7: JamCode (Document Insertion Unit-N1) 23F7

[Symptom/Question]

7123F7: JamCode (Document Insertion Unit-N1) 23F7

[Remedy/Answer]

Jam Type : Power-on jam

Sensor Name : Reverse Sensor

Sensor No. : S17

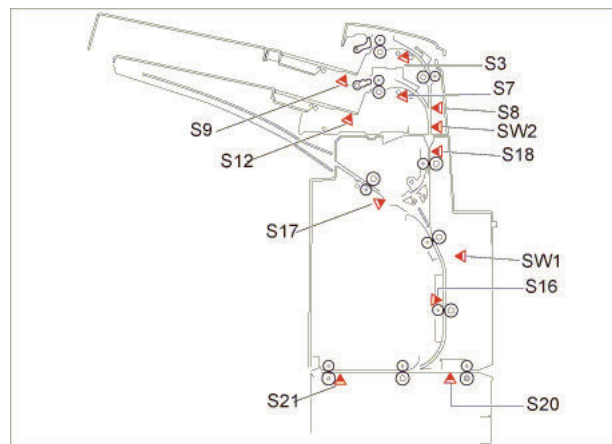
Overview of detection

A power-on jam occurs when a sensor detected ON state at power-on.

I/O: Service Mode > SITUATION > Sensor Check

Check items (in arbitrary order)

- Remaining paper in the machine
- Soiling on the target sensor
- Failure of the target sensor
- Foreign matter on the target sensor (paper dust, paper lint)



■ 7123F8: JamCode (Document Insertion Unit-N1) 23F8

[Symptom/Question]

7123F8: JamCode (Document Insertion Unit-N1) 23F8

[Remedy/Answer]

Jam Type : Power-on jam

Sensor Name : Reverse Timing Sensor

Sensor No. : S16

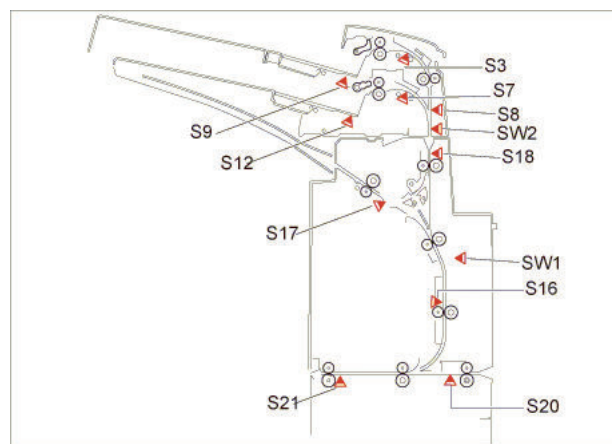
Overview of detection

A power-on jam occurs when a sensor detected ON state at power-on.

I/O: Service Mode > SITUATION > Sensor Check

Check items (in arbitrary order)

- Remaining paper in the machine
- Soiling on the target sensor
- Failure of the target sensor
- Foreign matter on the target sensor (paper dust, paper lint)



■ 7123FF: JamCode (Document Insertion Unit-N1) 23FF

[Symptom/Question]

7123FF: JamCode (Document Insertion Unit-N1) 23FF

[Remedy/Answer]

Jam Type : Power-on jam

Sensor Name : Lower tray registration sensor

Sensor No. : S7

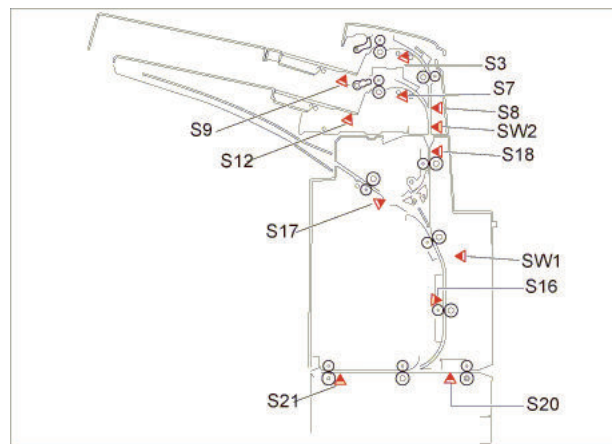
Overview of detection

A power-on jam occurs when a sensor detected ON state at power-on.

I/O: Service Mode > SITUATION > Sensor Check

Check items (in arbitrary order)

- Remaining paper in the machine
- Soiling on the target sensor
- Failure of the target sensor
- Foreign matter on the target sensor (paper dust, paper lint)



■ 712400: JamCode (Document Insertion Unit-N1) 2400

[Symptom/Question]

712400: JamCode (Document Insertion Unit-N1) 2400

[Remedy/Answer]

Jam Type : Door open jam

Sensor Name : Caver Open jam

Sensor No. : SW1,SW2

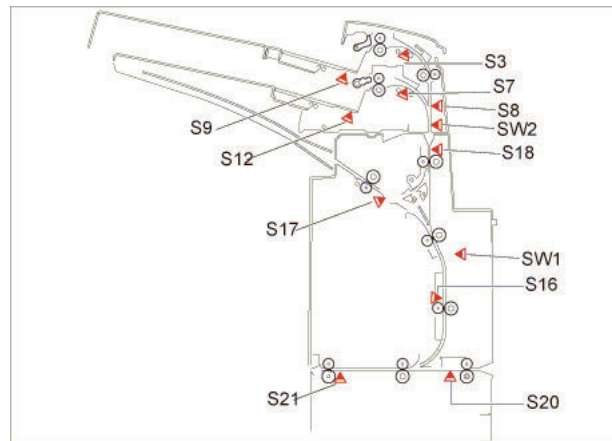
Overview of detection

A door open jam occurs when a sensor detected door open during printing operation.

I/O: Service Mode > SITUATION > Sensor Check

Check items (in arbitrary order)

- Door open during printing



■ 712C00: JamCode (Document Insertion Unit-N1) 2C00

[Symptom/Question]

712C00: JamCode (Document Insertion Unit-N1) 2C00

[Remedy/Answer]

Jam Type : OTHER

Sensor Name : -

Sensor No. : -

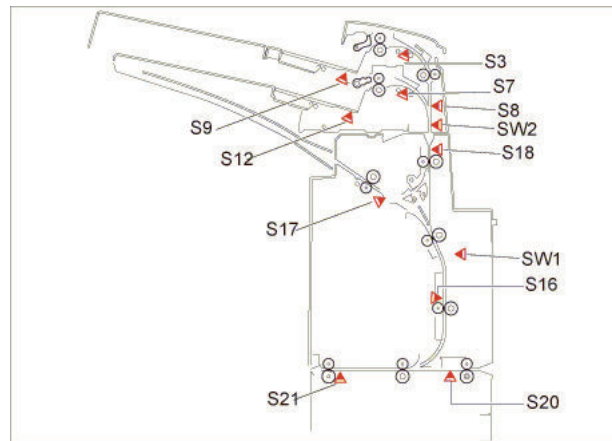
Overview of detection

-

I/O: Service Mode > SITUATION > Sensor Check

Check items (in arbitrary order)

-



■ 712C01: JamCode (Document Insertion Unit-N1) 2C01

[Symptom/Question]

712C01: JamCode (Document Insertion Unit-N1) 2C01

[Remedy/Answer]

Jam Type : Error avoidance

Sensor Name : -

Sensor No. : -

Overview of detection

An error avoidance jam occurs when an error in the machine (excluding parts failure) was detected.

Printing operation is suspended to avoid error occurrence by error code; therefore, parts failure is not the cause of the jam.

After the jam is removed, the machine works.

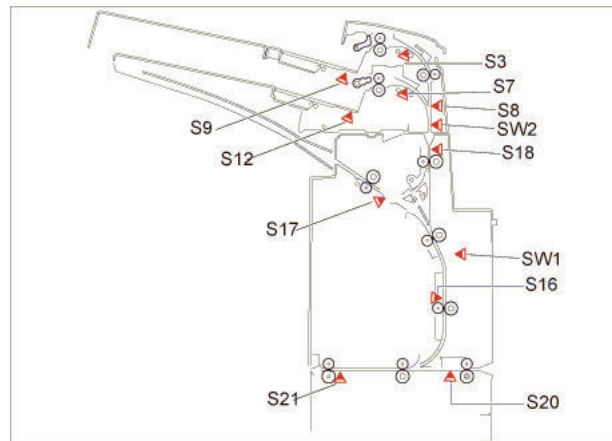
If it is due to parts failure, an error code instead of the error avoidance jam is displayed on UI and printing operation is suspended.

In such case, service technician should perform remedial work for the error code.

I/O: Service Mode > SITUATION > Sensor Check

Check items (in arbitrary order)

- Opening/closing of the door after jam removal
- Turning OFF and then ON the power after jam removal



■ 712FC0: JamCode (Document Insertion Unit-N1) 2FC0

[Symptom/Question]

712FC0: JamCode (Document Insertion Unit-N1) 2FC0

[Remedy/Answer]

Jam Type : OTHER

Sensor Name : -

Sensor No. : -

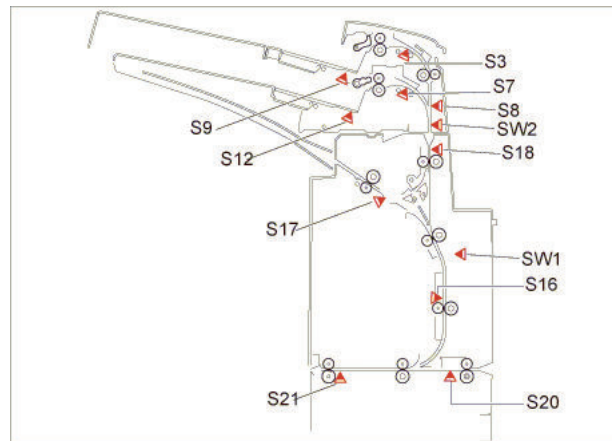
Overview of detection

-

I/O: Service Mode > SITUATION > Sensor Check

Check items (in arbitrary order)

-



■ 712FC1: JamCode (Document Insertion Unit-N1) 2FC1

[Symptom/Question]

712FC1: JamCode (Document Insertion Unit-N1) 2FC1

[Remedy/Answer]

Jam Type : OTHER

Sensor Name : -

Sensor No. : -

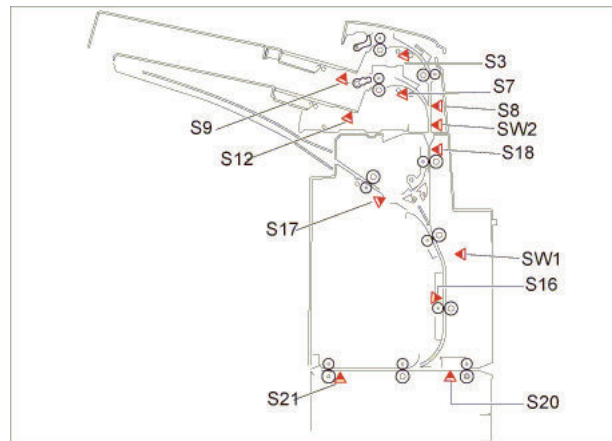
Overview of detection

-

I/O: Service Mode > SITUATION > Sensor Check

Check items (in arbitrary order)

-



■ 712FC2: JamCode (Document Insertion Unit-N1) 2FC2

[Symptom/Question]

712FC2: JamCode (Document Insertion Unit-N1) 2FC2

[Remedy/Answer]

Jam Type : Door open jam

Sensor Name : Upper Tray Empty Sensor

Sensor No. : S9

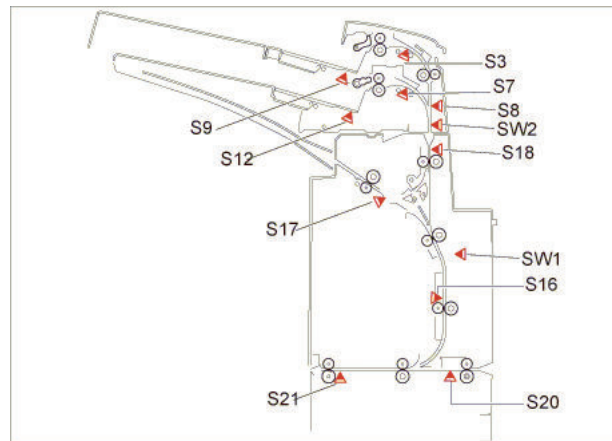
Overview of detection

A door open jam occurs when a sensor detected door open during printing operation.

I/O: Service Mode > SITUATION > Sensor Check

Check items (in arbitrary order)

- Door open during printing



■ 712FC3: JamCode (Document Insertion Unit-N1) 2FC3

[Symptom/Question]

712FC3: JamCode (Document Insertion Unit-N1) 2FC3

[Remedy/Answer]

Jam Type : Door open jam

Sensor Name : Lower Tray Empty Sensor

Sensor No. : S12

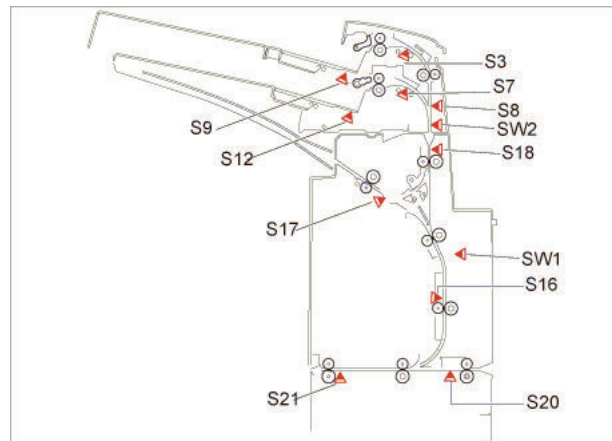
Overview of detection

A door open jam occurs when a sensor detected door open during printing operation.

I/O: Service Mode > SITUATION > Sensor Check

Check items (in arbitrary order)

- Door open during printing



■ 712FC4: JamCode (Document Insertion Unit-N1) 2FC4

[Symptom/Question]

712FC4: JamCode (Document Insertion Unit-N1) 2FC4

[Remedy/Answer]

Jam Type : OTHER

Sensor Name : -

Sensor No. : -

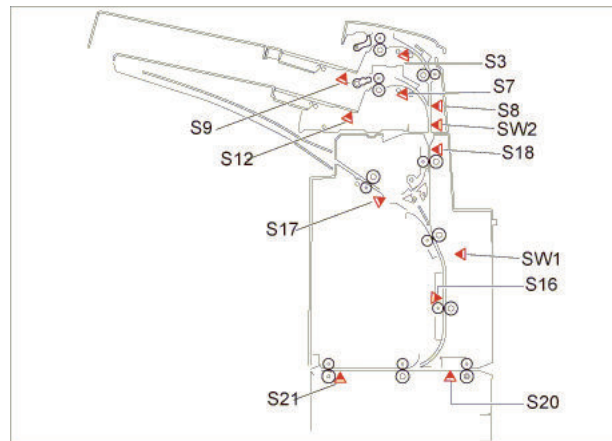
Overview of detection

-

I/O: Service Mode > SITUATION > Sensor Check

Check items (in arbitrary order)

-



■ 712FCF: JamCode (Document Insertion Unit-N1) 2FCF

[Symptom/Question]

712FCF: JamCode (Document Insertion Unit-N1) 2FCF

[Remedy/Answer]

Jam Type : OTHER

Sensor Name : -

Sensor No. : -

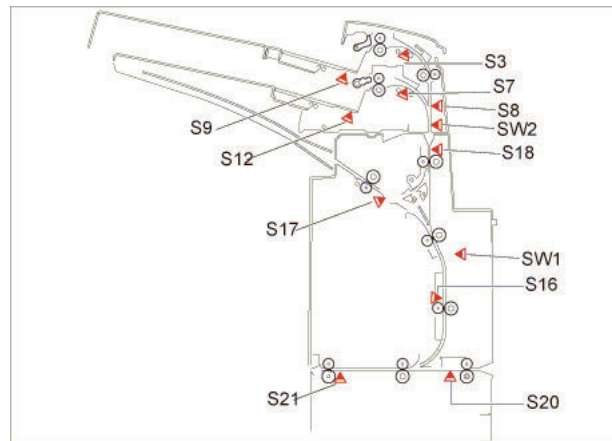
Overview of detection

-

I/O: Service Mode > SITUATION > Sensor Check

Check items (in arbitrary order)

-





Service Mode

Overview.....	1557
COPIER (Service mode for printer)	1574
FEEDER (ADF service mode).....	1884
SORTER (Service mode for delivery options).....	1893
BOARD (Option board setting mode)	1944
FAX (Service Mode for FAX).....	1945

Overview

It is possible to see each item of service mode so that those who access to service mode can understand how to use them. The main types of this machine's service mode are shown below.

Basic Operations

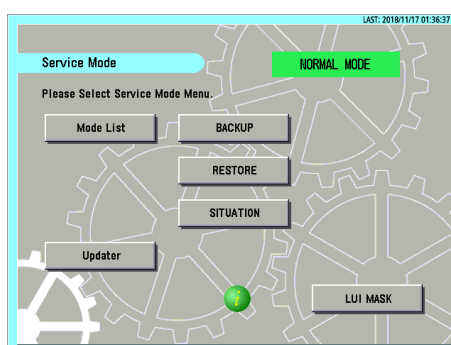
This section describes the basic operation of service mode.

■ Entering Service Mode

For information on how to enter service mode, contact the Support Dept. of the sales company.

■ Service Mode Menu

Press the button in the service mode menu to display the initial screen of each mode. The differences between these modes are described below.



Top Screen

MODELIST

In this mode, functions for referring to each item in service mode, etc. are available.

Updater

This button is used to access the CDS and UGW servers and update system software.

BACKUP

This button is used to back up the service mode setting values.

RESTORE

This button is used to restore the service mode setting values backed up by [BACKUP].

SITUATION

This function displays service mode items according to the situation.

LUI MASK

This button is used to display a mask screen to prevent operations from being performed from the Control Panel while the service mode is being accessed from a remote PC.

NOTE:

For the detailed information on how to use Updater, BACKUP, and RESTORE, refer to the imageRUNNER ADVANCE System Service Manual.

■ Description of Service Mode Items

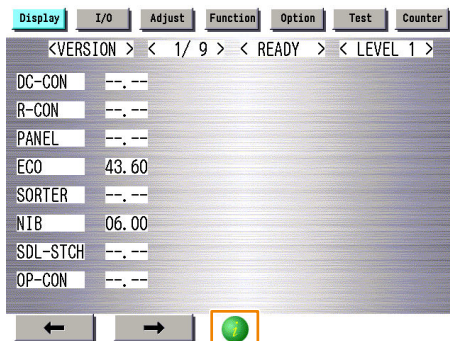
The description of the initial screen, the main items, the intermediate items and the sub items can be displayed. After selecting any item of the initial screen, main item, the intermediate item or the sub item, pressing "i" (Information Button) displays the description of the selected item (hereinafter referred to as the service mode contents).

CAUTION:

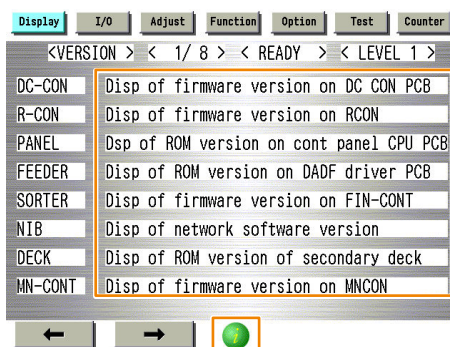
- Displayed language of the service mode contents can be selected from J/E/F/I/G/S/C/K/T.
- The service mode contents can be upgraded using SST or a USB flash drive just like other system software.

Example: COPIER > DISPLAY > VERSION screen

1. Press the [i] button.

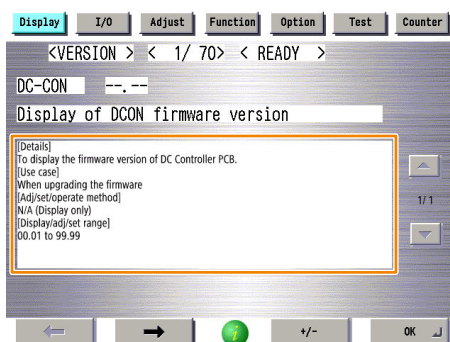


2. The title of each sub item is displayed.



To check the details of each item, select the relevant item and press the [i] button.

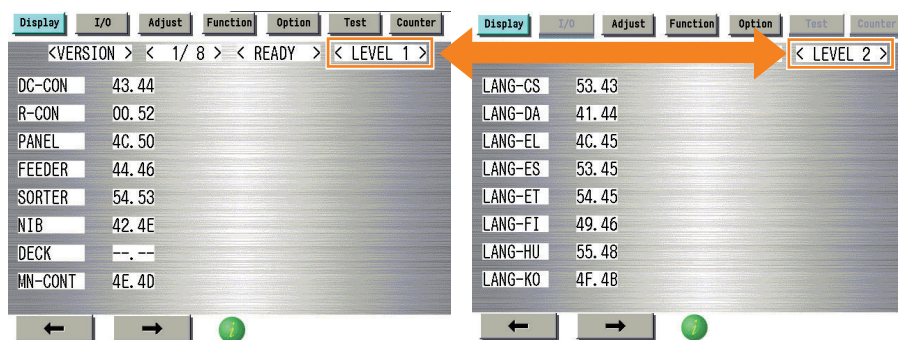
3. A detailed description of the sub item (specifications and use methods, setting screen, etc.) is displayed.



■ Switching the Screen Display (Level 1 <->2)

Switching of screens between Level 1 and Level 2 becomes easier.

By pressing <LEVEL 1> at the upper right of the screen while Level 1 screen is displayed, the screen is switched to Level 2 screen.



Examples of Screen Display

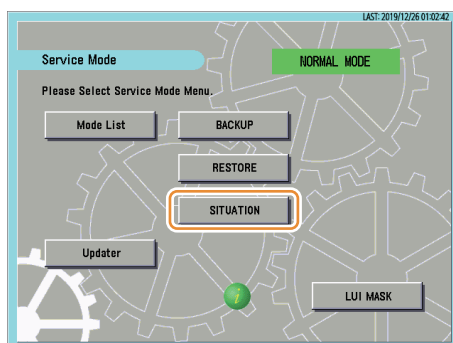
NOTE:

This key combination can be used to enter the Level 2 screen.

- Mode List screen > [Settings/Registration] > [2]

SITUATION Mode

Situation mode has been implemented in this machine to improve workability and searchability at the site. This mode makes it possible to easily use the service mode appropriate for the scene at the site.

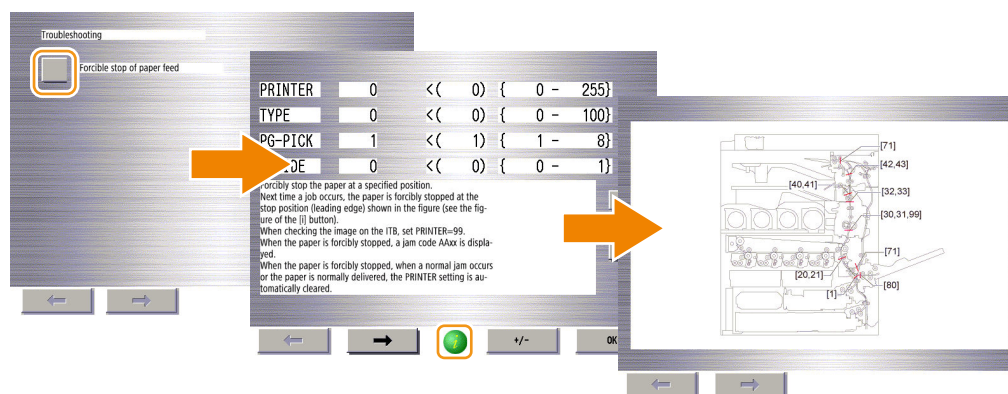


The following items are available in situation mode.

- Install:
To be referred at installation of the machine.
- Troubleshooting:
To be referred at problem solving.
- Parts Replacement:
To be referred at parts replacement.
- Major Adjustment:
To be referred at installation of the machine.
- Sensor Check:
To be referred at checking of the sensor.
- Part Check:
To be referred at operation check of the part.

The following three points are made available depending on each situation:

- Display of related service mode that requires adjustment
- Display of causes and remedies
- Display of related images

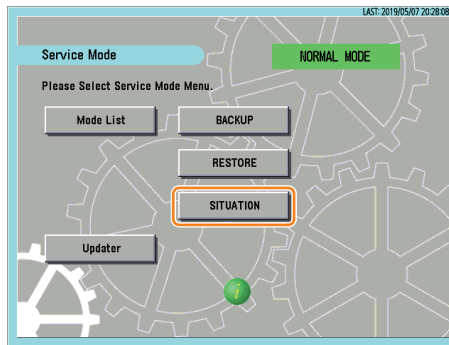


■ How to Use Sensor Check

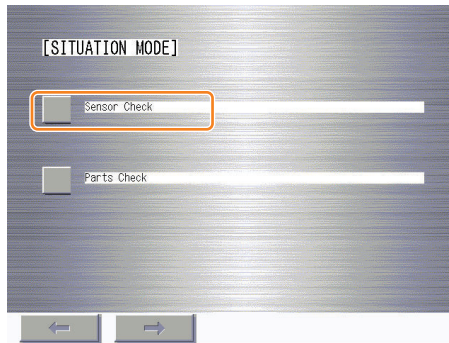
You can find a desired electrical component in Sensor Check of situation mode to review its I/O info. To do this, follow the procedure below.

1. Start service mode.

2. Select "SITUATION".

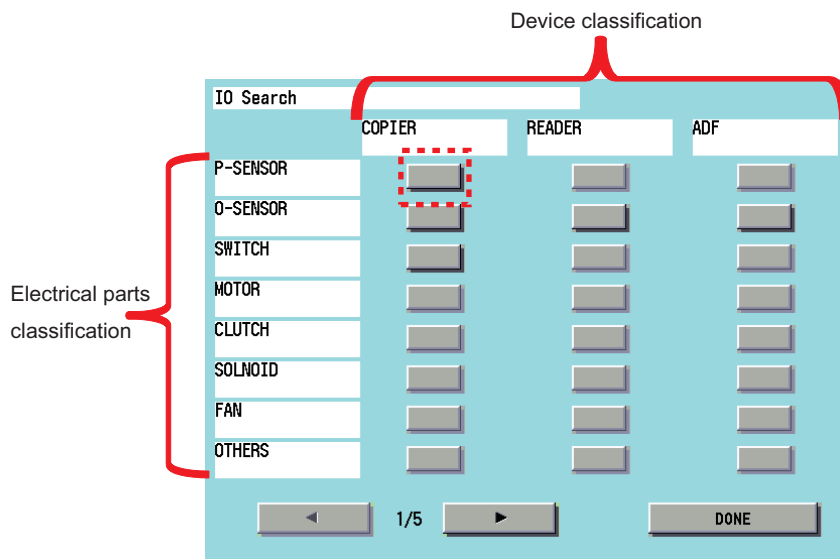


3. On the "SITUATION MODE" screen, select "Sensor Check".

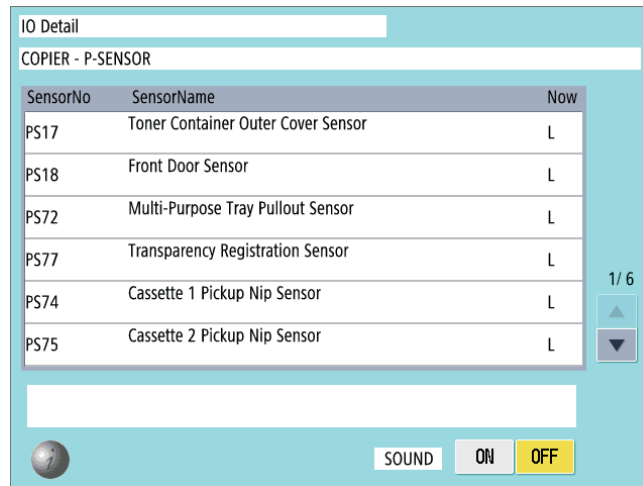


4. Press a button according to the type of electrical component and the corresponding device type.

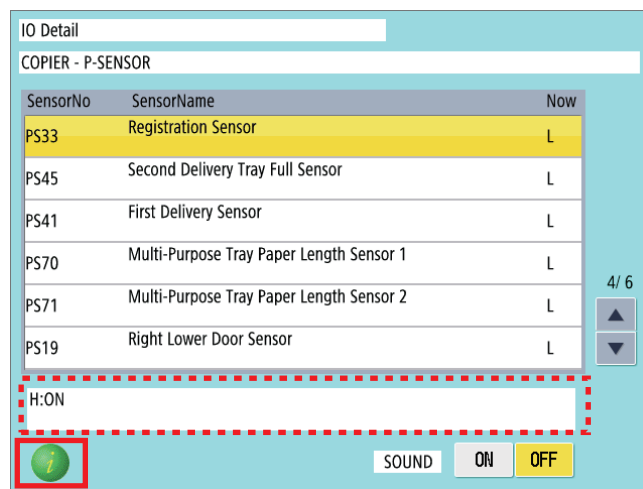
Example: In the case of the Registration Sensor of the host machine, press the button (red dotted frame) at "COPIER"/"P-SENSOR".



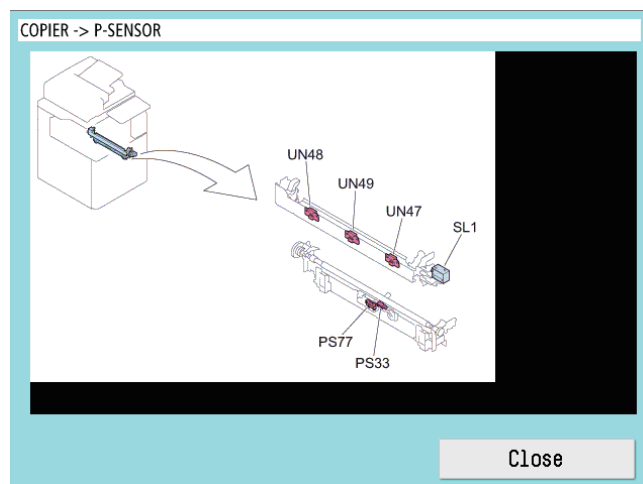
5. A list of electrical component types for the selected device is displayed.



6. Select an electrical component to display the details in the frame (red dotted frame) at the bottom of the screen.



7. Press the [i] button to display the screen showing the locations of electrical components.



■ How to Use Parts Check

In the Parts Check of situation mode, among electrical components used (motors, fans, solenoids, and clutches), those that can operate alone can be operated from the screen and the operations can be checked. The operation procedure is shown below.

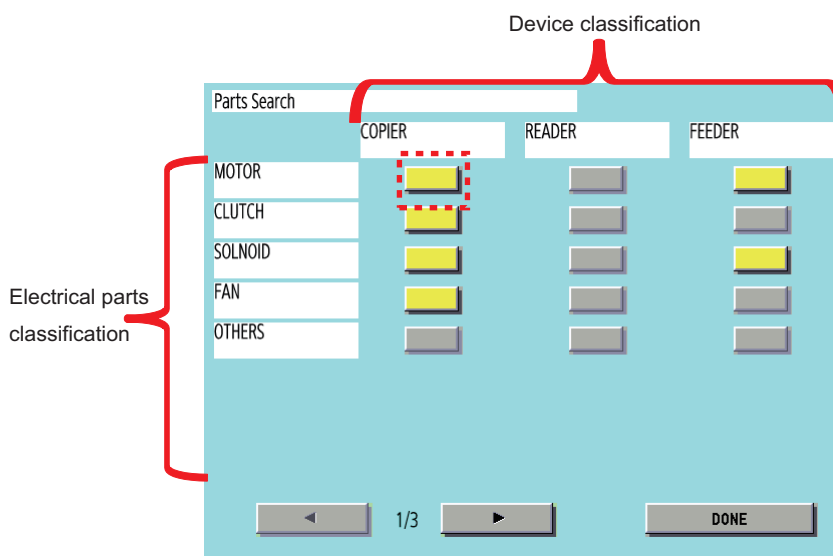
NOTE:

The service mode used below utilizes the system where electrical components used are operated by control signals sent from the DC Controller. If a control signal is sent but the electrical component does not operate, a failure of the electrical component, open circuit of the cable for transmitting control signals, or poor contact of the connector is suspected.

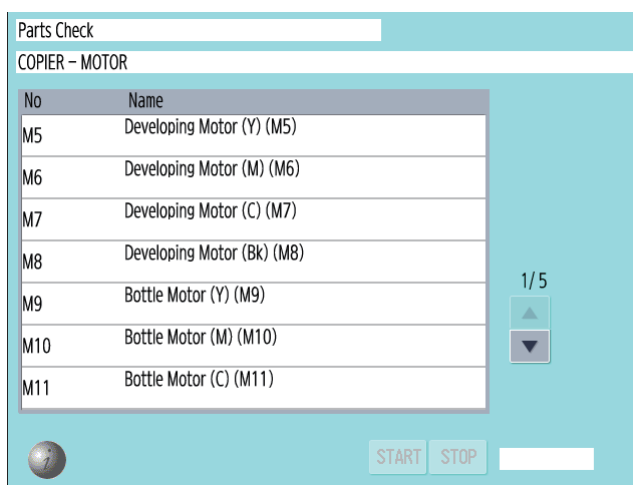
1. Select **SERVICE MODE > SITUATION > Parts Check**.

2. Press a button according to the type of electrical component and the corresponding device type.

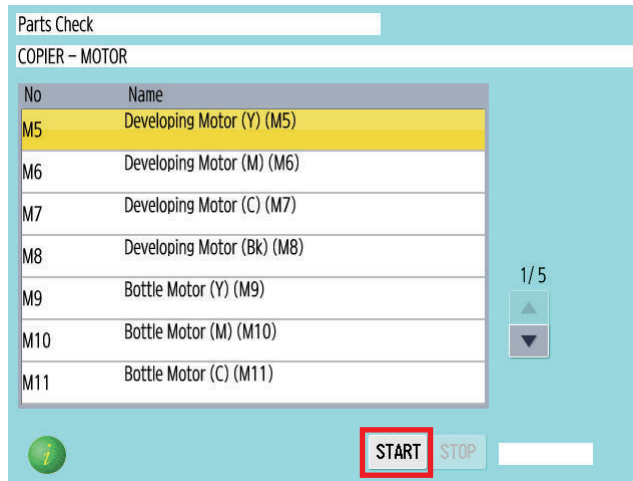
Example: In the case of a motor of the host machine, press the button (red dotted frame) at "COPIER"/"MOTOR".



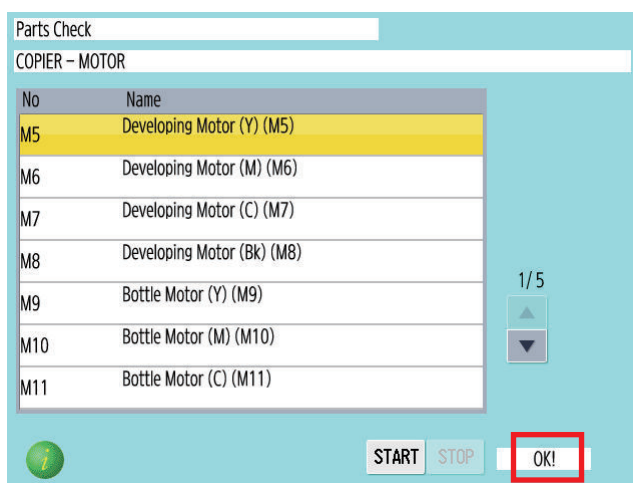
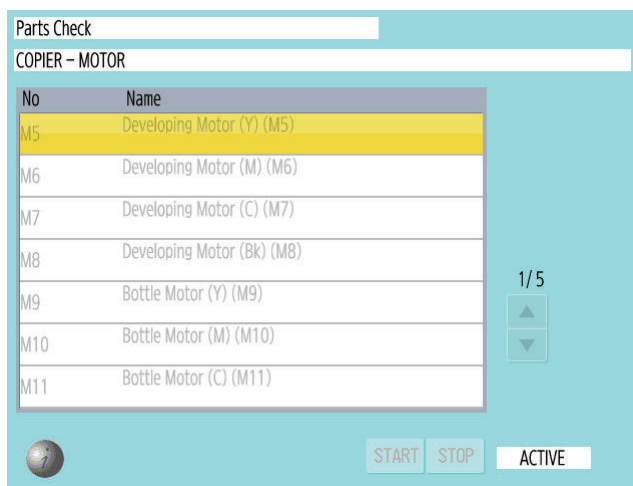
3. A list of electrical component types for the selected device whose operation can be checked is displayed.



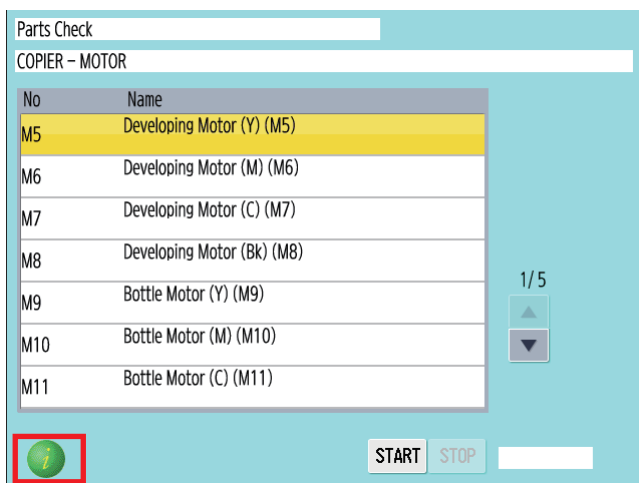
4. Select the electrical component you want to operate and then press the Start button to send a signal for driving the selected electrical component for a specified period of time from the DC Controller.



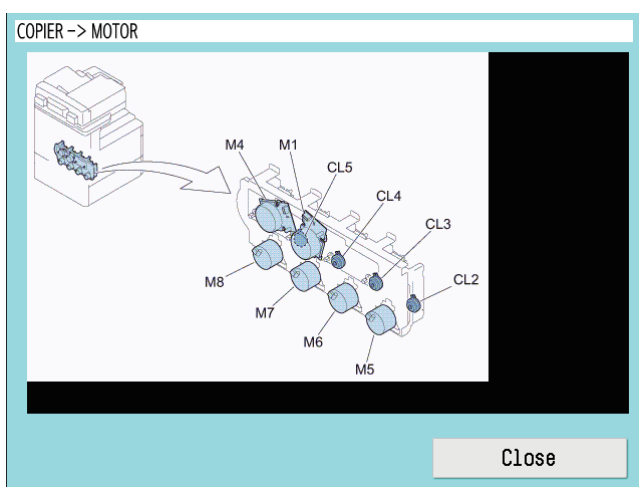
5. "ACTIVE" is displayed while the electrical component is driven. After the electrical component has been driven for a specified period of time, "OK!" is displayed if transmission of the drive signal succeeded, or "NG !" is displayed if failed.



Press the [i] button to display the screen showing the locations of electrical components.



6. The screen showing the locations of electrical components is displayed.



Security Support

A password can be specified to prevent unauthorized access to the service mode.

Related Service Mode:

Setting password type when the screen is switched to the service mode

- COPIER > OPTION > FNC-SW > PSWD-SW (Level 1)

The password for service engineer when the screen is switched to the service mode

- (Level 2) COPIER > OPTION > FNC-SW > SM-PSWD

■ Procedure for Setting Password

1. Set "1" or "2" in the following service mode.

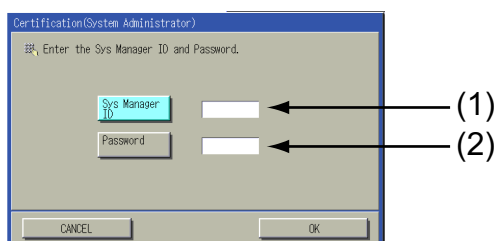
- COPIER > OPTION > FNC-SW > PSWD-SW
<Setting range>
- 0: No password [Default]
- 1: Service technician
- 2: System administrator + Service technician

CAUTION:

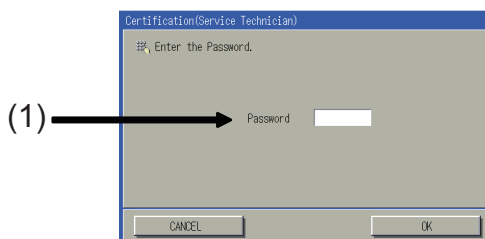
- This setting is enabled without restarting the host machine.
- After setting the password, the following screen will be displayed by accessing service mode.
- Therefore, when the PSWD-SW is set to "2" (system administrator + service technician), enter the system administrator password ([System Manager ID] and [System Manager PIN] in [Settings/Registrations] > [Management Settings] > [User Management] > [System Manager Information Settings]), and then press the [OK] button.

2. Follow the following procedure to check that you can login to service mode.

1. When setting PSWD-SW to "1" (system administrator) or "2" (ServiceMode_070Backup) in step 1, the system administrator password entry screen will be displayed, so enter the system administrator ID in [Sys Manager ID] (1) and system administrator password in [Password] (2), and then press the [OK] button.



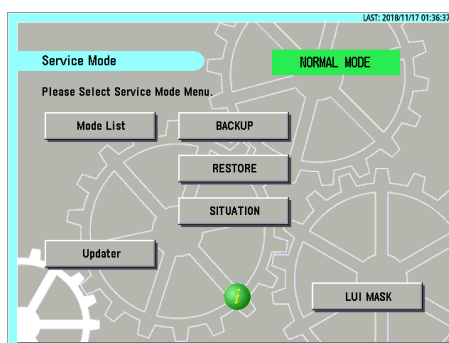
2. When setting PSWD-SW to "2" (system administrator + service technician) in step 1, the service technician password entry screen will be displayed after step 2. Enter the service technician password in [Password] (1), and then press the [OK] button.



CAUTION:

- The service technician password is the password set in COPIER > OPTION > FNC-SW > SM-PSWD.
- If you forget the password for service technician, disable the password function using the Service Support Tool (SST).

Check that you can access service mode and finish the work.



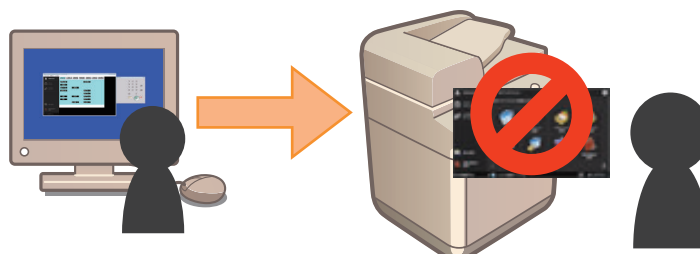
■ Function to Mask the Screen during Remote Access

This function ensures security during servicing work using remote connection.

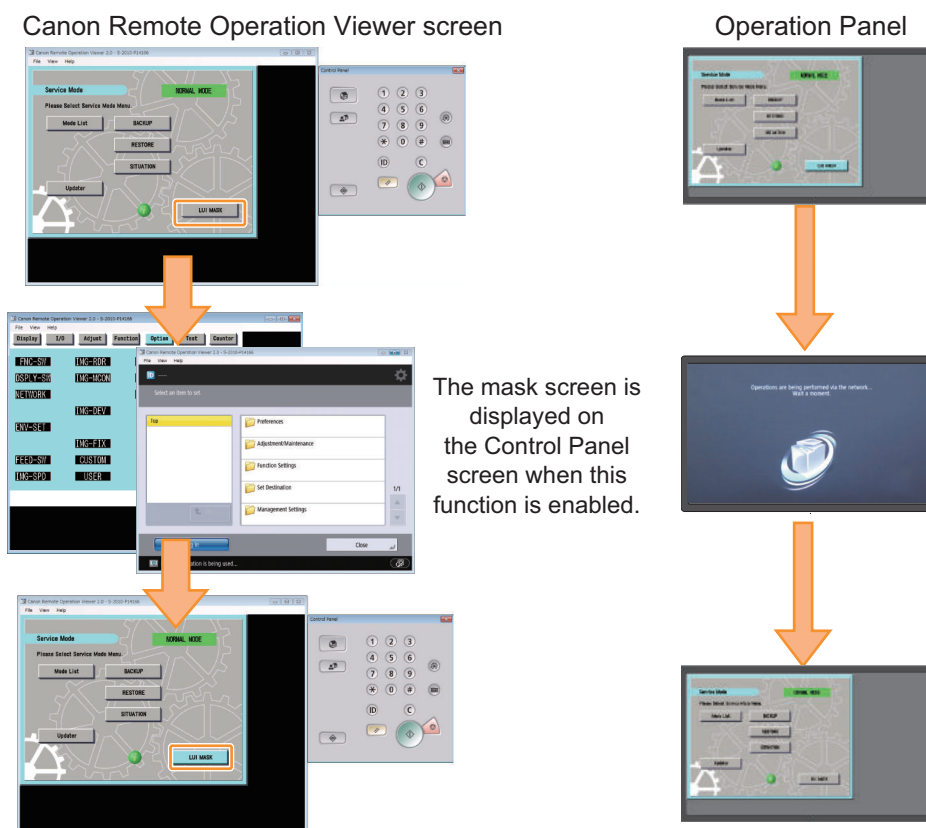
The machine has an option called Remote Operation Viewer for remote control via a network. This option enables a service technician to perform maintenance on the machine from a remote location.

However, the same screen is displayed on the Remote Operation Viewer screen and the Control Panel during the work, which carries the following risks.

- The screen being operated can be seen by the user.
- During remote operation, the user may perform an operation on the Control Panel and an unexpected processing may be executed.



To solve these security problems, a function has been added to display a message on the Control Panel screen when the machine is being operated remotely using Remote Operation Viewer in order to prevent the user from performing unexpected operations. As shown in the figure below, the mask screen is displayed when this function is enabled.

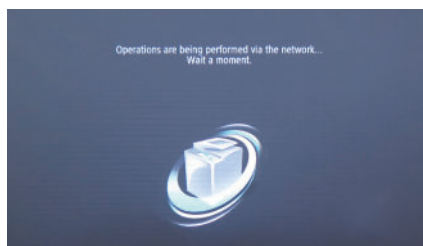


Examples of Screen Display

Functional Specification

The specifications of this function are shown below.

- When this function is enabled, a mask screen is displayed on the Control Panel. When the function is disabled, the original screen is displayed again.



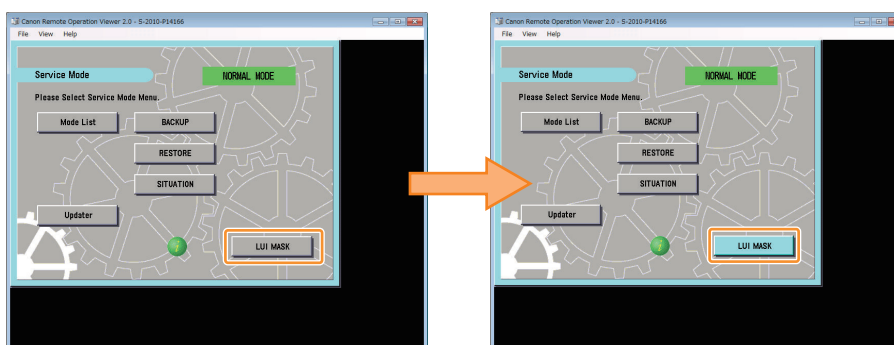
Example of the displayed mask screen

- This function is disabled when the following operations are performed.
 - Press [LUI MASK] on the service mode top screen.
 - Exit Remote Operation Viewer.
 - The remote access is disconnected due to a network failure, etc.
 - The machine is shut down (power down) or restarted.
- If this function is disabled while the service mode is being operated, the service mode is forcibly exited, and the previous screen is displayed. (However, the service mode is not forcibly terminated if the Updater screen has been accessed from service mode.)
- When this function is enabled, all operations (operations from the Touch Panel or hardware keys) other than screen brightness adjustment and operation on the Energy Saver key are disabled.

• Procedure for Enabling This Function

The procedure for enabling this function is shown below.

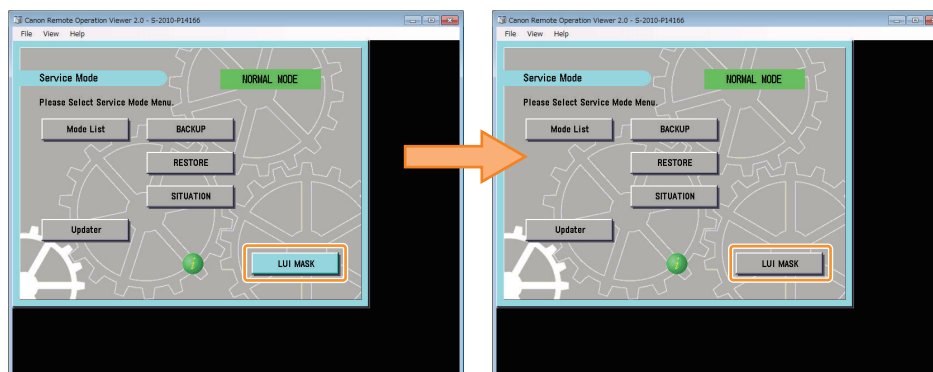
1. Use the Remote Operation Viewer to access the machine, and start service mode.
2. Press [LUI MASK], and check that the button is enabled (has turned light blue).



• Procedure for Disabling This Function

The procedure for disabling this function is shown below.

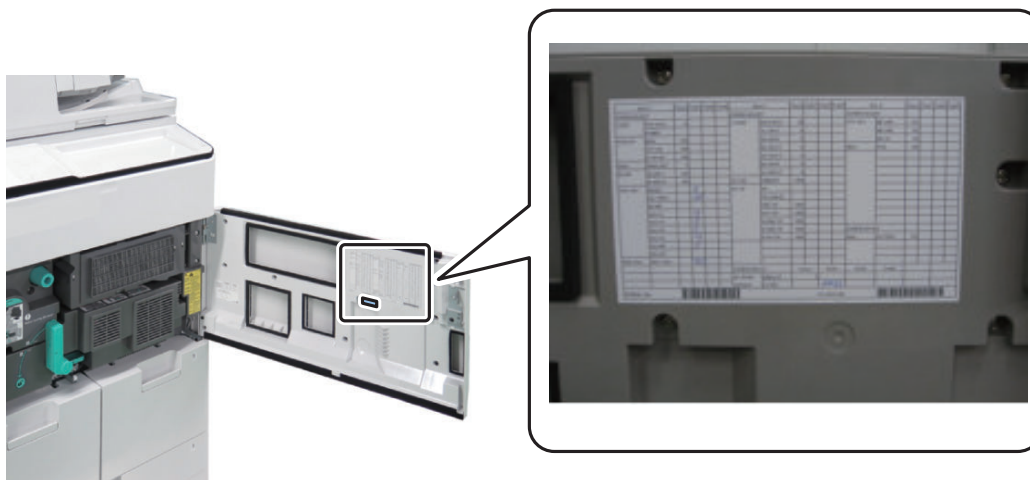
1. Perform one of the following operations.
 - Access the service mode, press [LUI MASK], and check that the button is disabled (has turned gray).



- Exit the Remote Operation Viewer.
- Disconnect the network (disconnect the network cable, disable the network function, etc.).
- Shut down or restart the machine.

Service Mode Backup

Adjustment is made to every machine at the time of shipment to write the adjustment value in the service label. When replacing the DC Controller PCB or clearing RAM, the adjusted values of ADJUST and OPTION return to the default; therefore, be sure to adjust the value in the field, and in the case of changing the service mode value, be sure to write down the changed value in the service label. When the corresponding item is not found on the service label, write the value in blank field.



Place of service label

Output of Service Print Data

- The service print data such as P-PRINT can be output as a file.
- By executing the following service mode, data at the time can be saved in the Storage
Service Mode Level 1 > Copier > Function > MISC-P > RPT-FILE
- The saved data will be deleted from the Storage when it is exported to SST or a USB flash drive.
- When multiple service data such as P-PRINT and HIST-PRINT is saved in the host machine, it is collectively exported to SST or a USB flash drive.

NOTE:

- Service print data cannot be output when an error has occurred.
- When connecting a USB flash drive that runs on external power, start the machine with the power is turned ON in advance. A USB flash drive connected after the machine has been started cannot be recognized.

How to obtain the report data	Location
"Moving the file in service mode" on page 1570	USB flash drive
"Moving the file in download mode" on page 1571	USB flash drive
"How to Export Service Print File to a PC Using SST" on page 1572	PC

Service Print and Data File Name Supported for File Output

Service Mode	Content
COPIER > Function > MISC-P > P-PRINT	Output of service mode setting values
COPIER > Function > MISC-P > HIST-PRT	Output of jam and error history
COPIER > Function > MISC-P > USER-PRT	Output of Settings/Registration menu setting values list
COPIER > Function > MISC-P > D-PRINT	Output of service mode (DISPLAY)
COPIER > Function > MISC-P > ENV-PRT	Output of the temperature and humidity inside the machine/surface temperature of the Fixing Roller as a log
COPIER > Function > MISC-P > PJH-P-1	Output of details on print job history (100 jobs)
COPIER > Function > MISC-P > PJH-P-2	Output of details on print job history (all jobs)
COPIER > Function > MISC-P > USBH-PRT	Output of USB device information report
COPIER > Function > MISC-P > TNRB-RPT	Output of the Toner Container ID report

NOTE:

When each service mode is individually executed, the report corresponding to the service mode as of the time of execution is output.

■ Moving the file in service mode

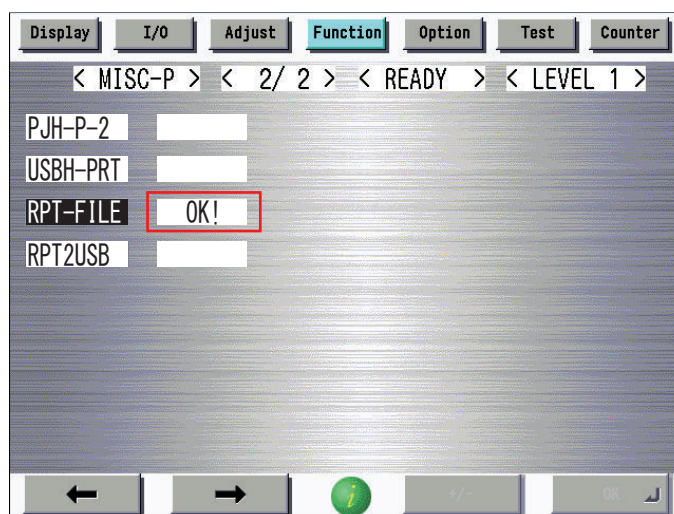
Preparation

The following item needs to be prepared to export the service print file to a USB flash drive.

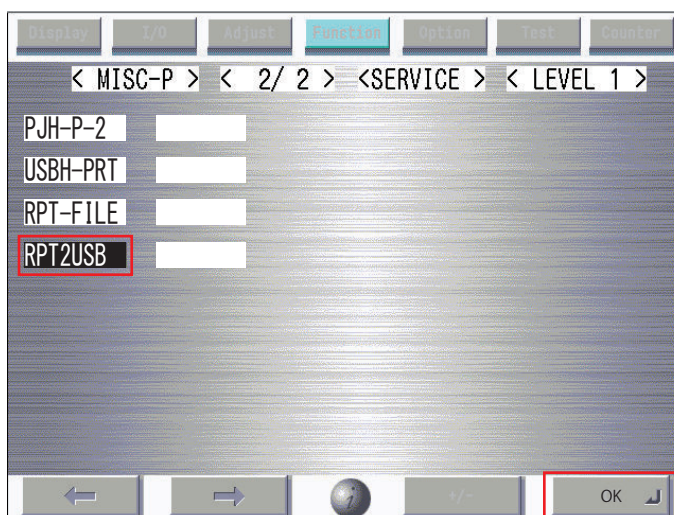
- USB flash drive (FAT32 format file system that is not locked with a password. To display the USB menu, the said model's firmware must already be registered.)

Overall flow

1. Selecting RPT-FILE
Select service mode > Copier > Function > MISC-P > RPT-FILE; and then press OK.
2. Generating report file
After the "ACTIVE" blinks for 3 to 4 minutes, generation of a report file is complete as "OK!" is displayed.



3. Connect the USB flash drive storage device to the USB port.
4. Select service mode > Copier > Function > MISC-P > RPT2USB; and then press OK.

**NOTE:**

- If the downloaded file is opened as plain text, the paragraphs are misaligned, which makes it difficult to read the data.
- When the file is dragged to WordPad, an image similar to the image output on paper may be displayed in some cases.

■ Moving the file in download mode

Preparation

The following item needs to be prepared to export the service print file to a USB flash drive.

- USB flash drive (FAT32 format file system that is not locked with a password. To display the USB menu, the said model's firmware must already be registered.)

Overall flow

1. Selecting RPT-FILE
Select service mode > Copier > Function > MISC-P > RPT-FILE; and then press OK.
2. Generating report file
After the "ACTIVE" blinks for 3 to 4 minutes, generation of a report file is complete as "OK!" is displayed.



3. Execute Download mode > [5]: Download File > [4]: ServicePrint Download.

```

[[[[[[[ Download File Menu (USB) ]]]]]]]
-----
[1]: SUBLOG Download
[4]: ServicePrint Download
[C]: Return to Main Menu

[Reset]: Start shutdown sequence

/[4] has been selected. Execute?/
- (OK) : 0 / (CANCEL) : Any other keys -

```

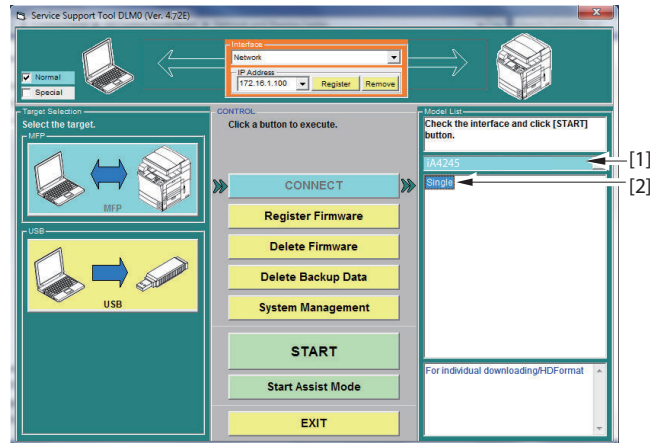


リムーバブルディスク (F:) > IAC3330 > QUC00005 > SP201505211916L				
フォルダー				
	名前	更新日時	種類	サイズ
	D-PRINT-RPT.TXT	2015/05/21 19:16	テキスト ドキュ...	12 KB
	ENV-PRT-RPT.TXT	2015/05/21 19:16	テキスト ドキュ...	3 KB
	HIST-PRT-RPT.TXT	2015/05/21 19:16	テキスト ドキュ...	13 KB
	KEY-HIST-RPT.TXT	2015/05/21 19:16	テキスト ドキュ...	1 KB
	PJH-P-1-RPT.TXT	2015/05/21 19:16	テキスト ドキュ...	1 KB
	PJH-P-2-RPT.TXT	2015/05/21 19:16	テキスト ドキュ...	1 KB
	P-PRINT-RPT.TXT	2015/05/21 19:16	テキスト ドキュ...	85 KB
	TNRB-RPT.TXT	2015/05/21 19:16	テキスト ドキュ...	1 KB
	USBH_PRT-RPT.TXT	2015/05/21 19:16	テキスト ドキュ...	1 KB
	USER-PRT-RPT.TXT	2015/05/21 19:16	テキスト ドキュ...	7 KB

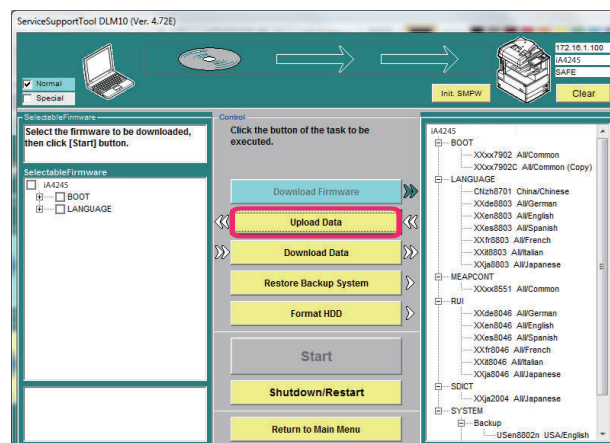
■ How to Export Service Print File to a PC Using SST

The procedure for exporting the service print file to a PC using SST will now be described. (SST described in the procedure is Ver 4.72.)

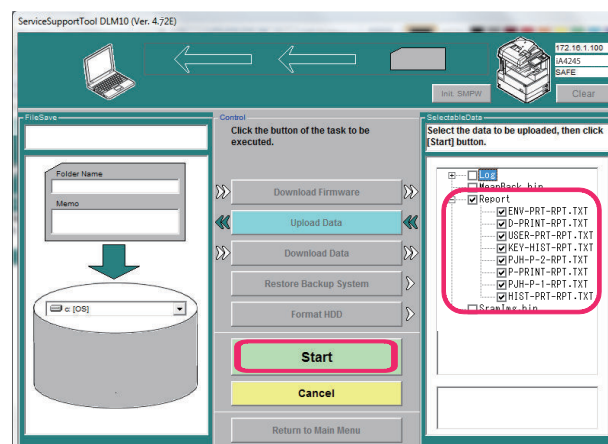
1. Start the SST.
2. Select the model [1] to be connected and the information file for separate download [2] ([Single]). Then, check the network settings and click the "Start" button.



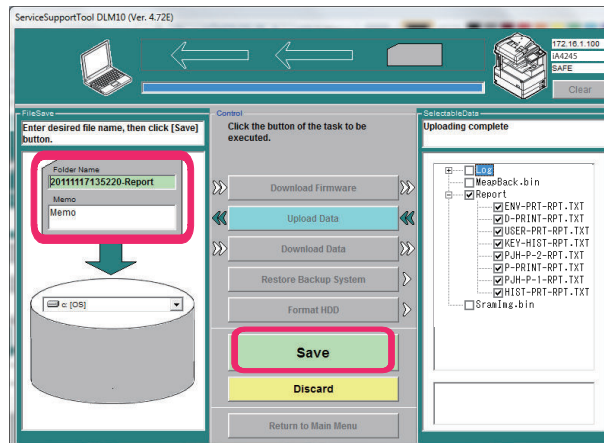
3. Click the [Upload Data] button.



4. Select [Report] and click the [Start] button.



5. Specify the folder name to be saved and enter comments if necessary. Then click the [Store] button.



6. Click the [OK] button.

COPIER (Service mode for printer)

DISPLAY (State display mode)

■ VERSION

COPIER (Service mode for printer) > DISPLAY (State display mode) > VERSION

DC-CON	1	Display of DCON firmware version
Detail		To display the firmware version of DC Controller PCB.
Use Case		When upgrading the firmware
Adj/Set/Operate Method		N/A (Display only)
Display/Adj/Set Range		00.01 to 99.99
R-CON	1	Display of RCON firmware version
Detail		To display the firmware version of Reader Controller PCB.
Use Case		When upgrading the firmware
Adj/Set/Operate Method		N/A (Display only)
Display/Adj/Set Range		00.01 to 99.99
PANEL	1	Dspl of Control Panel CPU PCB ROM ver
Detail		To display the ROM version of Control Panel CPU PCB.
Use Case		When upgrading the firmware
Adj/Set/Operate Method		N/A (Display only)
Display/Adj/Set Range		00.01 to 99.99
SORTER	1	Dspl of FIN-CONT (Main) firmware version
Detail		To display the firmware version of Finisher Controller PCB (Main).
Use Case		When upgrading the firmware
Adj/Set/Operate Method		N/A (Display only)
Display/Adj/Set Range		00.01 to 99.99
SDL-STCH	1	Dspl of Saddle Sttch Ctrollr PCB ROM ver
Detail		To display the ROM version of the Saddle Stitcher Controller PCB.
Use Case		When upgrading the firmware
Adj/Set/Operate Method		N/A (Display only)
Display/Adj/Set Range		00.01 to 99.99
MN-CONT	1	Display of MNCON firmware version
Detail		To display the firmware version of Main Controller PCB.
Use Case		When upgrading the firmware
Adj/Set/Operate Method		N/A (Display only)
Display/Adj/Set Range		00.01 to 99.99
RIP1	1	Display of RIP1 software version
Detail		To display the software version to be downloaded to RIP1 (PS/PCL Expansion Accelerator Board).
Use Case		When upgrading the firmware
Adj/Set/Operate Method		N/A (Display only)
Display/Adj/Set Range		00.01 to 99.99

COPIER (Service mode for printer) > DISPLAY (State display mode) > VERSION

DIAG-DVC	1	Dspl of self diagnosis device ROM ver
Detail		To display the ROM version of self diagnosis device.
Use Case		When upgrading the firmware
Adj/Set/Operate Method		N/A (Display only)
Display/Adj/Set Range		00.01 to 99.99
PUNCH	1	Display of Finisher Inner Punch Unit
Detail		To display the version of Finisher Inner Puncher Unit.
Use Case		When upgrading the firmware
Adj/Set/Operate Method		N/A (Display only)
Display/Adj/Set Range		00.01 to 99.99
LANG-FR	1	Display of French language file version
Detail		To display the version of French language file.
Use Case		When upgrading the firmware
Adj/Set/Operate Method		N/A (Display only)
Display/Adj/Set Range		00.01 to 99.99
LANG-DE	1	Display of German language file version
Detail		To display the version of German language file.
Use Case		When upgrading the firmware
Adj/Set/Operate Method		N/A (Display only)
Display/Adj/Set Range		00.01 to 99.99
LANG-IT	1	Display of Italian language file version
Detail		To display the version of Italian language file.
Use Case		When upgrading the firmware
Adj/Set/Operate Method		N/A (Display only)
Display/Adj/Set Range		00.01 to 99.99
LANG-CS	2	Display of Czech language file version
Detail		To display the version of Czech language file.
Use Case		When upgrading the firmware
Adj/Set/Operate Method		N/A (Display only)
Display/Adj/Set Range		00.01 to 99.99
LANG-DA	2	Display of Danish language file version
Detail		To display the version of Danish language file.
Use Case		When upgrading the firmware
Adj/Set/Operate Method		N/A (Display only)
Display/Adj/Set Range		00.01 to 99.99
LANG-EL	2	Display of Greek language file version
Detail		To display the version of Greek language file.
Use Case		When upgrading the firmware
Adj/Set/Operate Method		N/A (Display only)
Display/Adj/Set Range		00.01 to 99.99
LANG-ES	1	Display of Spanish language file version
Detail		To display the version of Spanish language file.
Use Case		When upgrading the firmware
Adj/Set/Operate Method		N/A (Display only)
Display/Adj/Set Range		00.01 to 99.99

COPIER (Service mode for printer) > DISPLAY (State display mode) > VERSION

LANG-ET	2	Display of Estonian language file ver
Detail		To display the version of Estonian language file.
Use Case		When upgrading the firmware
Adj/Set/Operate Method		N/A (Display only)
Display/Adj/Set Range		00.01 to 99.99
LANG-FI	2	Display of Finnish language file version
Detail		To display the version of Finnish language file.
Use Case		When upgrading the firmware
Adj/Set/Operate Method		N/A (Display only)
Display/Adj/Set Range		00.01 to 99.99
LANG-HU	2	Display of Hungarian language file ver
Detail		To display the version of Hungarian language file.
Use Case		When upgrading the firmware
Adj/Set/Operate Method		N/A (Display only)
Display/Adj/Set Range		00.01 to 99.99
LANG-KO	2	Display of Korean language file version
Detail		To display the version of Korean language file.
Use Case		When upgrading the firmware
Adj/Set/Operate Method		N/A (Display only)
Display/Adj/Set Range		00.01 to 99.99
LANG-NL	2	Display of Dutch language file version
Detail		To display the version of Dutch language file.
Use Case		When upgrading the firmware
Adj/Set/Operate Method		N/A (Display only)
Display/Adj/Set Range		00.01 to 99.99
LANG-NO	2	Display of Norwegian language file ver
Detail		To display the version of Norwegian language file.
Use Case		When upgrading the firmware
Adj/Set/Operate Method		N/A (Display only)
Display/Adj/Set Range		00.01 to 99.99
LANG-PL	2	Display of Polish language file version
Detail		To display the version of Polish language file.
Use Case		When upgrading the firmware
Adj/Set/Operate Method		N/A (Display only)
Display/Adj/Set Range		00.01 to 99.99
LANG-PT	2	Display of Portuguese language file ver
Detail		To display the version of Portuguese language file.
Use Case		When upgrading the firmware
Adj/Set/Operate Method		N/A (Display only)
Display/Adj/Set Range		00.01 to 99.99
LANG-RU	2	Display of Russian language file version
Detail		To display the version of Russian language file.
Use Case		When upgrading the firmware
Adj/Set/Operate Method		N/A (Display only)
Display/Adj/Set Range		00.01 to 99.99

COPIER (Service mode for printer) > DISPLAY (State display mode) > VERSION

LANG-SL	2	Display of Slovenian language file ver
Detail		To display the version of Slovenian language file.
Use Case		When upgrading the firmware
Adj/Set/Operate Method		N/A (Display only)
Display/Adj/Set Range		00.01 to 99.99
LANG-SV	2	Display of Swedish language file version
Detail		To display the version of Swedish language file.
Use Case		When upgrading the firmware
Adj/Set/Operate Method		N/A (Display only)
Display/Adj/Set Range		00.01 to 99.99
LANG-TW	2	Dspl of Chinese language file ver: trad
Detail		To display the version of Chinese language file (traditional).
Use Case		When upgrading the firmware
Adj/Set/Operate Method		N/A (Display only)
Display/Adj/Set Range		00.01 to 99.99
LANG-ZH	2	Dspl of Chinese language file ver: simpl
Detail		To display the version of Chinese language file (simplified).
Use Case		When upgrading the firmware
Adj/Set/Operate Method		N/A (Display only)
Display/Adj/Set Range		00.01 to 99.99
LANG-BU	2	Display of Bulgarian language file ver
Detail		To display the version of Bulgarian language file.
Use Case		When upgrading the firmware
Adj/Set/Operate Method		N/A (Display only)
Display/Adj/Set Range		00.01 to 99.99
LANG-CR	2	Display of Croatian language file ver
Detail		To display the version of Croatian language file.
Use Case		When upgrading the firmware
Adj/Set/Operate Method		N/A (Display only)
Display/Adj/Set Range		00.01 to 99.99
LANG-RM	2	Display of Romanian language file ver
Detail		To display the version of Romanian language file.
Use Case		When upgrading the firmware
Adj/Set/Operate Method		N/A (Display only)
Display/Adj/Set Range		00.01 to 99.99
LANG-SK	2	Display of Slovak language file version
Detail		To display the version of Slovak language file.
Use Case		When upgrading the firmware
Adj/Set/Operate Method		N/A (Display only)
Display/Adj/Set Range		00.01 to 99.99
LANG-TK	2	Display of Turkish language file version
Detail		To display the version of Turkish language file.
Use Case		When upgrading the firmware
Adj/Set/Operate Method		N/A (Display only)
Display/Adj/Set Range		00.01 to 99.99

COPIER (Service mode for printer) > DISPLAY (State display mode) > VERSION

LANG-CA	2	Display of Catalan language file version
Detail		To display the version of Catalan language file.
Use Case		When upgrading the firmware
Adj/Set/Operate Method		N/A (Display only)
Display/Adj/Set Range		00.01 to 99.99
MEDIA-JA	2	Dspl of Japanese media information ver
Detail		To display the version of Japanese media information.
Use Case		When upgrading the firmware
Adj/Set/Operate Method		N/A (Display only)
Display/Adj/Set Range		00.01 to 99.99
MEDIA-EN	2	Dspl of English media information ver
Detail		To display the version of English media information.
Use Case		When upgrading the firmware
Adj/Set/Operate Method		N/A (Display only)
Display/Adj/Set Range		00.01 to 99.99
MEDIA-DE	2	Dspl of German media information version
Detail		To display the version of German media information.
Use Case		When upgrading the firmware
Adj/Set/Operate Method		N/A (Display only)
Display/Adj/Set Range		00.01 to 99.99
MEDIA-IT	2	Dspl of Italian media information ver
Detail		To display the version of Italian media information.
Use Case		When upgrading the firmware
Adj/Set/Operate Method		N/A (Display only)
Display/Adj/Set Range		00.01 to 99.99
MEDIA-FR	2	Dspl of French media information version
Detail		To display the version of French media information.
Use Case		When upgrading the firmware
Adj/Set/Operate Method		N/A (Display only)
Display/Adj/Set Range		00.01 to 99.99
MEDIA-ZH	2	Dspl of Chinese media info ver: smpl
Detail		To display the version of Chinese media information (simplified).
Use Case		When upgrading the firmware
Adj/Set/Operate Method		N/A (Display only)
Display/Adj/Set Range		00.01 to 99.99
MEDIA-SK	2	Dspl of Slovak media information version
Detail		To display the version of Slovak media information.
Use Case		When upgrading the firmware
Adj/Set/Operate Method		N/A (Display only)
Display/Adj/Set Range		00.01 to 99.99
MEDIA-TK	2	Dspl of Turkish media information ver
Detail		To display the version of Turkish media information.
Use Case		When upgrading the firmware
Adj/Set/Operate Method		N/A (Display only)
Display/Adj/Set Range		00.01 to 99.99

COPIER (Service mode for printer) > DISPLAY (State display mode) > VERSION

MEDIA-CS	2	Dspl of Czech media information version
Detail		To display the version of Czech media information.
Use Case		When upgrading the firmware
Adj/Set/Operate Method		N/A (Display only)
Display/Adj/Set Range		00.01 to 99.99
MEDIA-EL	2	Dspl of Greek media information version
Detail		To display the version of Greek media information.
Use Case		When upgrading the firmware
Adj/Set/Operate Method		N/A (Display only)
Display/Adj/Set Range		00.01 to 99.99
MEDIA-ES	2	Dspl of Spanish media information ver
Detail		To display the version of Spanish media information.
Use Case		When upgrading the firmware
Adj/Set/Operate Method		N/A (Display only)
Display/Adj/Set Range		00.01 to 99.99
MEDIA-ET	2	Dspl of Estonian media information ver
Detail		To display the version of Estonian media information.
Use Case		When upgrading the firmware
Adj/Set/Operate Method		N/A (Display only)
Display/Adj/Set Range		00.01 to 99.99
MEDIA-FI	2	Dspl of Finnish media information ver
Detail		To display the version of Finnish media information.
Use Case		When upgrading the firmware
Adj/Set/Operate Method		N/A (Display only)
Display/Adj/Set Range		00.01 to 99.99
MEDIA-HU	2	Dspl of Hungarian media information ver
Detail		To display the version of Hungarian media information.
Use Case		When upgrading the firmware
Adj/Set/Operate Method		N/A (Display only)
Display/Adj/Set Range		00.01 to 99.99
MEDIA-KO	2	Dspl of Korean media information version
Detail		To display the version of Korean media information.
Use Case		When upgrading the firmware
Adj/Set/Operate Method		N/A (Display only)
Display/Adj/Set Range		00.01 to 99.99
MEDIA-NL	2	Dspl of Dutch media information version
Detail		To display the version of Dutch media information.
Use Case		When upgrading the firmware
Adj/Set/Operate Method		N/A (Display only)
Display/Adj/Set Range		00.01 to 99.99
MEDIA-NO	2	Dspl of Norwegian media information ver
Detail		To display the version of Norwegian media information.
Use Case		When upgrading the firmware
Adj/Set/Operate Method		N/A (Display only)
Display/Adj/Set Range		00.01 to 99.99

COPIER (Service mode for printer) > DISPLAY (State display mode) > VERSION

MEDIA-PL	2	Dspl of Polish media information version
Detail		To display the version of Polish media information.
Use Case		When upgrading the firmware
Adj/Set/Operate Method		N/A (Display only)
Display/Adj/Set Range		00.01 to 99.99
MEDIA-PT	2	Dspl of Portuguese media information ver
Detail		To display the version of Portuguese media information.
Use Case		When upgrading the firmware
Adj/Set/Operate Method		N/A (Display only)
Display/Adj/Set Range		00.01 to 99.99
MEDIA-RU	2	Dspl of Russian media information ver
Detail		To display the version of Russian media information.
Use Case		When upgrading the firmware
Adj/Set/Operate Method		N/A (Display only)
Display/Adj/Set Range		00.01 to 99.99
MEDIA-SL	2	Dspl of Slovenian media information ver
Detail		To display the version of Slovenian media information.
Use Case		When upgrading the firmware
Adj/Set/Operate Method		N/A (Display only)
Display/Adj/Set Range		00.01 to 99.99
MEDIA-SV	2	Dspl of Swedish media information ver
Detail		To display the version of Swedish media information.
Use Case		When upgrading the firmware
Adj/Set/Operate Method		N/A (Display only)
Display/Adj/Set Range		00.01 to 99.99
MEDIA-TW	2	Dspl of Chinese media info version:trad
Detail		To display the version of Chinese media information (traditional).
Use Case		When upgrading the firmware
Adj/Set/Operate Method		N/A (Display only)
Display/Adj/Set Range		00.01 to 99.99
MEDIA-BU	2	Dspl of Bulgarian media information ver
Detail		To display the version of Bulgarian media information.
Use Case		When upgrading the firmware
Adj/Set/Operate Method		N/A (Display only)
Display/Adj/Set Range		00.01 to 99.99
MEDIA-CR	2	Dspl of Croatian media information ver
Detail		To display the version of Croatian media information.
Use Case		When upgrading the firmware
Adj/Set/Operate Method		N/A (Display only)
Display/Adj/Set Range		00.01 to 99.99
MEDIA-RM	2	Dspl of Romanian media information ver
Detail		To display the version of Romanian media information.
Use Case		When upgrading the firmware
Adj/Set/Operate Method		N/A (Display only)
Display/Adj/Set Range		00.01 to 99.99

COPIER (Service mode for printer) > DISPLAY (State display mode) > VERSION

MEDIA-CA	2	Dspl of Catalan media information ver
Detail		To display the version of Catalan media information.
Use Case		When upgrading the firmware
Adj/Set/Operate Method		N/A (Display only)
Display/Adj/Set Range		00.01 to 99.99
FAX1	1	Display of 1-line FAX PCB ROM version
Detail		To display the ROM version of 1-line FAX PCB. Nothing is displayed if the PCB is not connected.
Use Case		When upgrading the firmware
Adj/Set/Operate Method		N/A (Display only)
Display/Adj/Set Range		ASCII character string (21 digits)
FAX2/3/4	1	Dspl of 2/3/4-line FAX PCB ROM version
Detail		To display the ROM version of 2/3/4-line FAX PCB. Nothing is displayed if the PCB is not connected.
Use Case		When checking the version
Adj/Set/Operate Method		N/A (Display only)
Display/Adj/Set Range		ASCII character string (21 digits)
IOCS	1	Display of IOCS version
Detail		To display the IOCS version.
Use Case		When upgrading the firmware
Adj/Set/Operate Method		N/A (Display only)
Display/Adj/Set Range		00.01 to 99.99
TRIM	1	Display of Trimmer ROM version
Detail		To display the ROM version of Trimmer.
Use Case		When upgrading the firmware
Adj/Set/Operate Method		N/A (Display only)
Display/Adj/Set Range		00.01 to 99.99
FOLD	1	Dspl of Paper Folding Unit ROM version
Detail		To display the ROM version of Paper Folding Unit.
Use Case		When upgrading the firmware
Adj/Set/Operate Method		N/A (Display only)
Display/Adj/Set Range		00.01 to 99.99
INS	1	Display of Inserter ROM version
Detail		To display the ROM version of Inserter.
Use Case		When upgrading the firmware
Adj/Set/Operate Method		N/A (Display only)
Display/Adj/Set Range		00.01 to 99.99
INS-IF	1	Dspl of Inserter Relay PCB ROM version
Detail		To display the ROM version of Inserter Relay PCB.
Use Case		When upgrading the firmware
Adj/Set/Operate Method		N/A (Display only)
Display/Adj/Set Range		00.01 to 99.99

COPIER (Service mode for printer) > DISPLAY (State display mode) > VERSION

PUNCH-IF	1	Dspl of Multi-hole Puncher IFU ROM ver
Detail		To display the ROM version of Interface Unit for Multi-hole Puncher.
Use Case		When upgrading the firmware
Adj/Set/Operate Method		N/A (Display only)
Display/Adj/Set Range		00.01 to 99.99
Supplement/Memo		Product name of P-Puncher: Multi Function Professional Puncher-A1
S-LNG-JP	1	Dspl of service mode Japanese file ver
Detail		To display the version of Japanese language file in service mode.
Use Case		When upgrading the firmware
Adj/Set/Operate Method		N/A (Display only)
Display/Adj/Set Range		00.01 to 99.99
S-LNG-EN	1	Dspl of service mode English file ver
Detail		To display the version of English language file in service mode.
Use Case		When upgrading the firmware
Adj/Set/Operate Method		N/A (Display only)
Display/Adj/Set Range		00.01 to 99.99
S-LNG-FR	1	Dspl of service mode French file version
Detail		To display the version of French language file in service mode.
Use Case		When upgrading the firmware
Adj/Set/Operate Method		N/A (Display only)
Display/Adj/Set Range		00.01 to 99.99
S-LNG-IT	1	Dspl of service mode Italian file ver
Detail		To display the version of Italian language file in service mode.
Use Case		When upgrading the firmware
Adj/Set/Operate Method		N/A (Display only)
Display/Adj/Set Range		00.01 to 99.99
S-LNG-GR	1	Dspl of service mode German file version
Detail		To display the version of German language file in service mode.
Use Case		When upgrading the firmware
Adj/Set/Operate Method		N/A (Display only)
Display/Adj/Set Range		00.01 to 99.99
S-LNG-SP	1	Dspl of service mode Spanish file ver
Detail		To display the version of Spanish language file in service mode.
Use Case		When upgrading the firmware
Adj/Set/Operate Method		N/A (Display only)
Display/Adj/Set Range		00.01 to 99.99
LS-ROM-V	2	Dspl of Laser Scanner Unit EEPROM ver
Detail		To display the EEPROM version of Laser Scanner Unit.
Use Case		At trouble analysis
Adj/Set/Operate Method		N/A (Display only)
Display/Adj/Set Range		001 to 999

COPIER (Service mode for printer) > DISPLAY (State display mode) > VERSION

LS-UNT-V	2	Dspl of Laser Scanner Unit version
Detail	To display the version of Laser Scanner Unit.	
Use Case	At trouble analysis	
Adj/Set/Operate Method	N/A (Display only)	
Display/Adj/Set Range	001 to 999	
LS-SRL	2	Dspl of serial No. of Laser Scanner Unit
Detail	To display the serial number of Laser Scanner Unit.	
Use Case	At trouble analysis	
Adj/Set/Operate Method	N/A (Display only)	
Display/Adj/Set Range	00000001 to 99999999	
BCT	1	Display of self diagnosis tool version
Detail	To display the version of self diagnosis tool.	
Use Case	When upgrading the firmware	
Adj/Set/Operate Method	N/A (Display only)	
Display/Adj/Set Range	00.01 to 99.99	
LANG-TH	2	Display of Thai language file version
Detail	To display the version of Thai language file.	
Use Case	When upgrading the firmware	
Adj/Set/Operate Method	N/A (Display only)	
Display/Adj/Set Range	00.01 to 99.99	
LANG-VN	2	Display of Vietnamese language file ver
Detail	To display the version of Vietnamese language file.	
Use Case	When upgrading the firmware	
Adj/Set/Operate Method	N/A (Display only)	
Display/Adj/Set Range	00.01 to 99.99	
LANG-AR	2	Dspl of Arabic language file ver
Detail	To display the version of Arabic language file.	
Use Case	When upgrading the firmware	
Adj/Set/Operate Method	N/A (Display only)	
Display/Adj/Set Range	00.01 to 99.99	
LANG-MS	2	Dspl of Malay language file ver
Detail	To display the version of Malay language file.	
Use Case	When upgrading the firmware	
Adj/Set/Operate Method	N/A (Display only)	
Display/Adj/Set Range	00.01 to 99.99	
LANG-HI	2	Dspl of Hindi language file ver
Detail	To display the version of Hindi language file.	
Use Case	When upgrading the firmware	
Adj/Set/Operate Method	N/A (Display only)	
Display/Adj/Set Range	00.01 to 99.99	
LANG-EU	2	Dspl of Euskera language file ver
Detail	To display the version of Euskera language file.	
Use Case	When upgrading the firmware	
Adj/Set/Operate Method	N/A (Display only)	
Display/Adj/Set Range	00.01 to 99.99	

COPIER (Service mode for printer) > DISPLAY (State display mode) > VERSION

D-OVLP	1	Dspl Double Feed Detection Kit version
Detail		To display the version of Double Feed Detection Kit (option).
Use Case		When upgrading the firmware
Adj/Set/Operate Method		N/A (Display only)
Display/Adj/Set Range		00.01 to 99.99
SORT-SLV	1	Dspl of FIN-CONT (Sub) firmware version
Detail		To display the firmware version of Finisher Controller PCB (Sub).
Use Case		When upgrading the firmware
Adj/Set/Operate Method		N/A (Display only)
Display/Adj/Set Range		00.01 to 99.99
PUNCH-CM	1	Comctn area firm ver: Multi Func P-Punch
Detail		To display the firmware version of the communication area on the Main PCB of the Multi Function Professional Puncher.
Use Case		When upgrading the firmware
Adj/Set/Operate Method		N/A (Display only)
Display/Adj/Set Range		00.01 to 99.99
Supplement/Memo		Product name of P-Puncher: Multi Function Professional Puncher-A1
PUNCH-MN	1	Control area firm ver:Multi Func P-Punch
Detail		To display the firmware version of the control area on the Main PCB of the Multi Function Professional Puncher.
Use Case		When upgrading the firmware
Adj/Set/Operate Method		N/A (Display only)
Display/Adj/Set Range		00.01 to 99.99
Supplement/Memo		Product name of P-Puncher: Multi Function Professional Puncher-A1
CONT-PF	1	Display of Controller firmware version
Detail		To display the platform version of the controller.
Use Case		When checking the platform version at upgrade/problem occurrence
Adj/Set/Operate Method		N/A (Display only)
Display/Adj/Set Range		00.01 to 99.99
LANG-HE	2	Display of Hebrew language file version
Detail		To display the version of Hebrew language file.
Use Case		When upgrading the firmware
Adj/Set/Operate Method		N/A (Display only)
Display/Adj/Set Range		00.01 to 99.99
LANG-LT	2	Dspl of Lithuanian language file version
Detail		To display the version of Lithuanian language file.
Use Case		When upgrading the firmware
Adj/Set/Operate Method		N/A (Display only)
Display/Adj/Set Range		00.01 to 99.99
LANG-LV	2	Display of Latvian language file version
Detail		To display the version of Latvian language file.
Use Case		When upgrading the firmware
Adj/Set/Operate Method		N/A (Display only)
Display/Adj/Set Range		00.01 to 99.99

COPIER (Service mode for printer) > DISPLAY (State display mode) > VERSION

JOGGER	1	Display of Finisher Jogger Kit
Detail		To display the version of Finisher Jogger Kit.
Use Case		When upgrading the firmware
Adj/Set/Operate Method		N/A (Display only)
Display/Adj/Set Range		00.01 to 99.99
PUNCH2CM	1	Comctn area firm ver: Puncher2
Detail		To display the firmware version of the communication area on the Main PCB of the Multi Function Professional Puncher.
Use Case		When upgrading the firmware
Adj/Set/Operate Method		N/A (Display only)
Display/Adj/Set Range		00.01 to 99.99
PUNCH2MN	1	Control area firm ver:Puncher2
Detail		To display the firmware version of the control area on the Main PCB of the Multi Function Professional Puncher.
Use Case		When upgrading the firmware
Adj/Set/Operate Method		N/A (Display only)
Display/Adj/Set Range		00.01 to 99.99
TRIM3	1	Display of Trimmer ROM version
Detail		To display the ROM version of Trimmer.
Use Case		When upgrading the firmware
Adj/Set/Operate Method		N/A (Display only)
Display/Adj/Set Range		00.01 to 99.99
LANG-UK	2	Dspl of Ukrainian language file ver
Detail		To display the Ukrainian language file version
Use Case		When the firmware is upgraded
Adj/Set/Operate Method		None (display only)
Display/Adj/Set Range		00.00 to 99.99
LANG-MI	2	Dspl of Maori language file ver
Detail		To display the Maori language file version
Use Case		When the firmware is upgraded
Adj/Set/Operate Method		None (display only)
Display/Adj/Set Range		00.00 to 99.99
SORTER2	1	Dspl of FIN-CONT (Main) firmware version
Detail		To display the firmware version of Finisher Controller PCB (Main).
Use Case		When upgrading the firmware
Adj/Set/Operate Method		N/A (Display only)
Display/Adj/Set Range		00.01 to 99.99
SORT-SL2	1	Display of FIN-CONT firmware version
Detail		To display the firmware version of Finisher Controller PCB.
Use Case		When upgrading the firmware
Adj/Set/Operate Method		N/A (Display only)
Display/Adj/Set Range		00.01 to 99.99

COPIER (Service mode for printer) > DISPLAY (State display mode) > VERSION

SDL-STC2	1	Dspl of Saddle Sttch Ctrllr PCB ROM ver
Detail	To display the ROM version of the Saddle Stitcher Controller PCB.	
Use Case	When upgrading the firmware	
Adj/Set/Operate Method	N/A (Display only)	
Display/Adj/Set Range	00.01 to 99.99	

■ USER

COPIER (Service mode for printer) > DISPLAY (State display mode) > USER

ADFTYPE	1	Display of DADF type
Detail	To display the type of the DADF currently installed.	
Use Case	When replacing the DADF	
Adj/Set/Operate Method	N/A (Display only)	
Display/Adj/Set Range	0 to 2 0: Reverse type, 1: 1-path type, 2: Not installed (Copyboard model)	
Related Service Mode	COPIER> OPTION> CUSTOM> SCANTYPE	
SER-NAME	1	Dspl firmware registration series name
Detail	Display firmware registration series name	
Use Case	To check the folder name for firmware registration in USB flash drive	
Adj/Set/Operate Method	N/A (Display only)	

■ ACC-ST5

COPIER (Service mode for printer) > DISPLAY (State display mode) > ACC-ST5

FEEDER	1	Display of DADF connection state
Detail	To display the connecting state of DADF.	
Use Case	When checking the connection between the machine and DADF	
Adj/Set/Operate Method	N/A (Display only)	
Display/Adj/Set Range	0 to 1 0: Not connected, 1: Connected	
SORTER	1	Connect state of Finisher-related option
Detail	To display the connection state of Finisher-related options.	
Use Case	When checking the connection of Finisher-related options	
Adj/Set/Operate Method	N/A (Display only)	
Display/Adj/Set Range	Left column (connection state of Finisher-related options): 1 to 5 1: Without Saddle 2: With Saddle, without Folding Unit 3: With Saddle and Inserter, without Folding Unit 4: With Saddle and Folding Unit, without Inserter 5: With Saddle, Inserter and Folding Unit Right column (connection state of Finisher-belonged Puncher): 0 to 4 0: No hole, 1: 2-hole, 2/4-hole switching, 2: 3-hole, 2/3-hole, 2/3-hole switching, 3: 4-hole, 4: 4-hole (SW)	

COPIER (Service mode for printer) > DISPLAY (State display mode) > ACC-ST5

DECK	1	Dspl of Paper Deck connection state
Detail	To display the connecting state of the Paper Deck.	
Use Case	When checking the connection between the machine and the Paper Decks	
Adj/Set/Operate Method	N/A (Display only)	
Display/Adj/Set Range	0 to 8 0: Not connected 1: Connected (small) 2: Connected (large) (Display is hidden on this machine.) 3: POD Deck Lite (with Multi-purpose Tray) 4: POD Deck Lite (without Multi-purpose Tray) 5: Multi-purpose Tray only 6: POD deck 7: 2-POD deck connected (Display is hidden on this machine.) 8: 3-POD deck connected (Display is hidden on this machine.)	
CARD	1	Dspl of connection state of Card Reader
Detail	To display the connecting state of Card Reader.	
Use Case	When checking the connection between the machine and the Card Reader	
Adj/Set/Operate Method	N/A (Display only)	
Display/Adj/Set Range	0 to 1 0: No card is inserted while the Card Reader is connected. (Copy is not available.) 1: Card Reader is not connected, or card is inserted while the Card Reader is connected. (Copy is available.)	
DATA-CON	1	Dspl of NE Controller connection state
Detail	To display the connecting state of NE Controller.	
Use Case	When checking the connection between the machine and the NE Controller	
Adj/Set/Operate Method	N/A (Display only)	
Display/Adj/Set Range	0 to 1 0: Not connected, 1: Connected	
RAM	1	Dspl MNCON PCB 1 img proc memory cpcty
Detail	To display the memory capacity for image processing (DDR2-SDRAM) on the Main Controller PCB 1.	
Use Case	When checking the memory capacity of the machine	
Adj/Set/Operate Method	N/A (Display only)	
Unit	MB	
COINROBO	1	Dspl of Coin Manager connection state
Detail	To display the connecting state of the Coin Manager.	
Use Case	When checking the connection between the machine and the Coin Manager	
Adj/Set/Operate Method	N/A (Display only)	
Display/Adj/Set Range	0 to 1 0: Not connected, 1: Connected	
NETWARE	1	Install state dspl of NetWare firmware
Detail	To display the installation state of the NetWare firmware.	
Use Case	When checking whether NetWare firmware is installed to the machine	
Adj/Set/Operate Method	N/A (Display only)	
Display/Adj/Set Range	0 to 1 0: Not installed, 1: Installed	

COPIER (Service mode for printer) > DISPLAY (State display mode) > ACC-ST5

TRIM-CN	1	Display of Trimmer connection state
Detail	To display the connecting state of Trimmer.	
Use Case	When checking the connection between the machine and Trimmer	
Adj/Set/Operate Method	N/A (Display only)	
Display/Adj/Set Range	0 to 1 0: Not connected, 1: Connected	
HDD	1	Display of HDD model name
Detail	To display the model name of HDD.	
Use Case	When checking the model name of HDD used on the machine	
Adj/Set/Operate Method	N/A (Display only)	
PCI1	1	Display of PCI1-connected PCB name
Detail	To display the name of the PCB that is connected to PCI1.	
Use Case	When checking the name of the PCB that is connected to PCI1	
Adj/Set/Operate Method	N/A (Display only)	
Display/Adj/Set Range	-: No PCB connected Voice Board: Voice PCB 3DES Board: Encryption PCB 1Gbit-Board: Giga Ethernet PCB	
IA-RAM	1	Dspl MNCON PCB 1 control memory capacity
Detail	To display the memory capacity for controller control (DDR2-SDRAM) on the Main Controller PCB 1.	
Use Case	When checking the memory capacity of the Main Controller PCB	
Adj/Set/Operate Method	N/A (Display only)	
Unit	MB	

■ ANALOG

COPIER (Service mode for printer) > DISPLAY (State display mode) > ANALOG

TEMP	1	Display of inside temperature
Detail	To display the temperature inside the machine detected by Environment Sensor.	
Use Case	When checking the temperature inside the machine	
Adj/Set/Operate Method	N/A (Display only)	
Display/Adj/Set Range	0 to 60	
Unit	deg C	
Appropriate Target Value	20 - 27	
HUM	1	Display of inside humidity
Detail	To display the humidity inside the machine detected by Environment Sensor.	
Use Case	When checking the humidity inside the machine	
Adj/Set/Operate Method	N/A (Display only)	
Display/Adj/Set Range	0 to 100	
Unit	%	
Appropriate Target Value	30 - 70	

COPIER (Service mode for printer) > DISPLAY (State display mode) > ANALOG

ABS-HUM	1	Display of inside moisture content
Detail	To display the absolute moisture content inside the machine detected by Environment Sensor.	
Use Case	When checking the moisture content inside the machine	
Adj/Set/Operate Method	N/A (Display only)	
Display/Adj/Set Range	0 to 100	
Unit	g/m3	
Appropriate Target Value	0 - 22	
FIX-U	1	Dsplt of Fixing Roller center temperature
Detail	To display the center temperature of the Fixing Roller detected by the Fixing Main Thermistor.	
Use Case	When checking the temperature at the center of Fixing Roller	
Adj/Set/Operate Method	N/A (Display only)	
Display/Adj/Set Range	0 to 999	
Unit	deg C	
FIX-UE	1	Dsplt of Fixing Roller edge temperature
Detail	To display the edge temperature of the Fixing Roller detected by the Fixing Sub Thermistor 1. Fixing Sub Thermistor 1 is located in the rear nip inlet side of Fixing Roller.	
Use Case	When checking the edge temperature of the Fixing Roller	
Adj/Set/Operate Method	N/A (Display only)	
Display/Adj/Set Range	0 to 999	
Unit	deg C	
FIX-UE2	1	Dsplt of Fixing Roller edge temperature 2
Detail	To display the edge temperature of the Fixing Roller detected by the Fixing Sub Thermistor 2. Fixing Sub Thermistor 2 is located in the rear nip outlet side of Fixing Roller.	
Use Case	When checking the edge temperature of the Fixing Roller	
Adj/Set/Operate Method	N/A (Display only)	
Display/Adj/Set Range	0 to 999	
Unit	deg C	
PDK-TEMP	1	Dsplt of POD Deck compartment temp
Detail	To display the compartment temperature of POD Deck Lite. It may be out of order if the indicated temperature is greatly different from the machine right after power-on.	
Adj/Set/Operate Method	N/A (Display only)	
Display/Adj/Set Range	0 to 60	
Unit	deg C	
Related Service Mode	COPIER> DISPLAY> ANALOG> TEMP, PDK-HUM	
PDK-HUM	1	Dsplt of POD Deck compartment humidity
Detail	To display the compartment humidity of POD Deck Lite. It may be out of order if the indicated humidity is greatly different from the machine right after power-on.	
Adj/Set/Operate Method	N/A (Display only)	
Display/Adj/Set Range	0 to 100	
Unit	%	
Related Service Mode	COPIER> DISPLAY> ANALOG> HUM, PDK-TEMP	

■ CST-STS

COPIER (Service mode for printer) > DISPLAY (State display mode) > CST-STS

DK1-FGD	2	For R&D
Amount of Change per Unit	1	
DK1-FGU	2	For R&D
Amount of Change per Unit	1	
DK1-HADV	2	For R&D
Amount of Change per Unit	1	

■ HV-STS

COPIER (Service mode for printer) > DISPLAY (State display mode) > HV-STS

PRIMARY	1	Display of primary charging current
Detail	To display the current that is applied to the Primacy Charging Assembly at the latest. The result set in COPIER> ADJUST> HV-PRI> PRIMARY is reflected.	
Use Case	When checking ON/OFF of potential control	
Adj/Set/Operate Method	N/A (Display only)	
Display/Adj/Set Range	0 to 1600	
Unit	uA	
Related Service Mode	COPIER> ADJUST> HV-PRI> PRIMARY	
PRI-GRID	1	Dspl of Primary Charging Ass'y grid bias
Detail	To display the grid bias voltage that is applied to the Primacy Charging Assembly at the latest. The result set in COPIER> ADJUST> HV-PRI> PRI-GRID is reflected.	
Use Case	When checking ON/OFF of potential control	
Adj/Set/Operate Method	N/A (Display only)	
Display/Adj/Set Range	500 to 900	
Unit	V	
Related Service Mode	COPIER> ADJUST> HV-PRI> PRI-GRID	
PRE-TR	1	Dspl of pre-transfer charge DC current
Detail	To display the DC component of current that is applied to the Pre-transfer Charging Assembly at the latest.	
Use Case	For checking	
Adj/Set/Operate Method	N/A (Display only)	
Display/Adj/Set Range	-650 to 0	
Unit	uA	
TR	1	Dspl of trns current: Plain, 1st side
Detail	To display the current flow to the Transfer Roller for the 1st side of the latest plain paper.	
Use Case	For checking	
Adj/Set/Operate Method	N/A (Display only)	
Unit	uA	
BIAS	1	Dspl of developing DC bias setting VL
Detail	To display the setting value of developing DC bias.	
Use Case	For checking	
Adj/Set/Operate Method	N/A (Display only)	
Unit	V	

COPIER (Service mode for printer) > DISPLAY (State display mode) > HV-STS

TR-V	1	Dspl of ATVC detection voltage value
Detail		To display the ATVC detection voltage value.
Use Case		For checking
Adj/Set/Operate Method		N/A (Display only)
Unit		V
TR-LV-I	1	Dspl ppr lead edge trns bias outpt crnt
Detail		To display the current value in the paper leading edge position at transfer bias output.
Use Case		For checking
Adj/Set/Operate Method		N/A (Display only)
Display/Adj/Set Range		0 to 100
Unit		uA
TR-LV-T	1	Dspl ppr lead edge trns bias output tmng
Detail		To display the transfer bias output timing in the paper leading edge position.
Use Case		For checking
Adj/Set/Operate Method		N/A (Display only)
Display/Adj/Set Range		-50 to 50
Unit		mm

■ CCD

COPIER (Service mode for printer) > DISPLAY (State display mode) > CCD

TARGET-B	2	Shading target value (B)
Detail		To display the shading target value of Blue. Continuous display of 0 (minimum) or FFFF (maximum) is considered a failure of the Reader Controller PCB.
Use Case		- When replacing the Reader Controller PCB - At scanned image failure
Adj/Set/Operate Method		N/A (Display only)
Display/Adj/Set Range		0 to FFFF
Appropriate Target Value		512 - 2047
TARGET-G	2	Shading target value (G)
Detail		To display the shading target value of Green. Continuous display of 0 (minimum) or 65535 (maximum) is considered as a failure of the Reader Controller PCB.
Use Case		- When replacing the Reader Controller PCB - At scanned image failure
Adj/Set/Operate Method		N/A (Display only)
Display/Adj/Set Range		0 to FFFF
Appropriate Target Value		512 - 2047
TARGET-R	2	Shading target value (R)
Detail		To display the shading target value of Red. Continuous display of 0 (minimum) or 65535 (maximum) is considered as a failure of the Reader Controller PCB.
Use Case		- When replacing the Reader Controller PCB - At scanned image failure
Adj/Set/Operate Method		N/A (Display only)
Display/Adj/Set Range		0 to FFFF
Appropriate Target Value		512 - 2047

COPIER (Service mode for printer) > DISPLAY (State display mode) > CCD

LAMP-BW	2	Dspl LED light intnsty adj VL:B&W, front
Detail	To display the LED light intensity adjustment value of Scanner Unit (for front side) in B&W scanning mode.	
Use Case	When an image failure occurs at front side reading in black mode	
Adj/Set/Operate Method	N/A (Display only)	
Display/Adj/Set Range	0 to FFFF	
Appropriate Target Value	100 - 275	
Supplement/Memo	LED cannot be replaced individually. Replace the Scanner Unit.	
LAMP-CL	2	Dspl LED light intnsty adj VL:clr, front
Detail	To display the LED light intensity adjustment value of Scanner Unit (for front side) in color scanning mode.	
Use Case	When an image failure occurs at front side reading in color mode	
Adj/Set/Operate Method	N/A (Display only)	
Display/Adj/Set Range	0 to FFFF	
Appropriate Target Value	100 - 275	
Supplement/Memo	LED cannot be replaced individually. Replace the Scanner Unit.	
LAMP2-BW	2	Dspl LED light intnsty adj VL: B&W, back
Detail	To display the LED light intensity adjustment value of Scanner Unit (for back side) in B&W scanning mode.	
Use Case	When an image failure occurs at back side reading in black mode	
Adj/Set/Operate Method	N/A (Display only)	
Display/Adj/Set Range	0 to FFFF	
Appropriate Target Value	100 - 275	
Supplement/Memo	LED cannot be replaced individually. Replace the Scanner Unit.	
LAMP2-CL	2	Dspl LED light intnsty adj VL: clr, back
Detail	To display the LED light intensity adjustment value of Scanner Unit (for back side) in color scanning mode.	
Use Case	When an image failure occurs at back side reading in color mode	
Adj/Set/Operate Method	N/A (Display only)	
Display/Adj/Set Range	0 to FFFF	
Appropriate Target Value	100 - 275	
Supplement/Memo	LED cannot be replaced individually. Replace the Scanner Unit.	

■ DPOT

COPIER (Service mode for printer) > DISPLAY (State display mode) > DPOT

DPOT-K	1	Display of Bk Drum surface potential
Detail	To display the current surface potential Vd on the Bk Photosensitive Drum that is specified as a result of the potential control. The value after the calculation of potential offset is displayed. If the offset value is not adjusted, negative value may be detected during printing.	
Use Case	When checking whether the surface potential of the drum is the cause of density failure or fogging	
Adj/Set/Operate Method	N/A (Display only)	
Display/Adj/Set Range	-30 to 600	
Unit	V	
Amount of Change per Unit	1	

COPIER (Service mode for printer) > DISPLAY (State display mode) > DPOT

VL1T	1	Dspl of bright area target potential VL
Detail		To display the bright area target potential value.
Adj/Set/Operate Method		N/A (Display only)
Unit		V
VL1M	1	Dspl bright area measured potential VL
Detail		To display the bright area measured potential value.
Adj/Set/Operate Method		N/A (Display only)
Unit		V
Amount of Change per Unit		1
VDT	1	Dspl of dark area target potential VL
Detail		To display the dark area target potential value.
Adj/Set/Operate Method		N/A (Display only)
Unit		V
Amount of Change per Unit		1
VDM	1	Dspl of dark area measured potential VL
Detail		To display the dark area measured potential value.
Adj/Set/Operate Method		N/A (Display only)
Unit		V
Amount of Change per Unit		1
BIAS-C	2	Dspl dev bias potential control result
Detail		To display the developing bias potential control result.
Adj/Set/Operate Method		N/A (Display only)
Unit		V
Amount of Change per Unit		1
LPOWER-C	2	Output laser intnsty potntl ctrl result
Detail		To display the output laser intensity potential control result.
Adj/Set/Operate Method		N/A (Display only)
Display/Adj/Set Range		0 to 255
PRIM-C	2	Dspl pry chg current potntl ctrl result
Detail		To display the potential control result of primary charging current.
Adj/Set/Operate Method		N/A (Display only)
Unit		uA
Related Service Mode		COPIER> ADJUST> HV-PRI> PRI-GRID
Amount of Change per Unit		1
VLT-L	1	Bright area target potential VL: thin
Detail		To display the bright area target potential VL with thin paper.
Use Case		At the occurrence of an image density failure
Adj/Set/Operate Method		N/A (Display only)
Display/Adj/Set Range		50 to 500
Unit		V

COPIER (Service mode for printer) > DISPLAY (State display mode) > DPOT

VLT-H1	1	Bright area tgt potential VL:pln3/hvy1-4
Detail		To display the bright area target potential VL with plain paper 3 and heavy paper 1 to 4.
Use Case		At occurrence of an image density failure
Adj/Set/Operate Method		N/A (Display only)
Display/Adj/Set Range		50 to 500
Unit		V
VLT-H2	1	Bright area target potential VL: hvy 5,6
Detail		To display the bright area target potential VL with heavy paper 5 and 6.
Use Case		At occurrence of an image density failure
Adj/Set/Operate Method		N/A (Display only)
Display/Adj/Set Range		50 to 500
Unit		V

■ DENS

COPIER (Service mode for printer) > DISPLAY (State display mode) > DENS

DMAX-STS	1	Display of D-max control execution state
Detail		To display the D-max control execution state.
Use Case		- At periodical maintenance - When a density failure occurs - When an alarm or error occurs
Adj/Set/Operate Method		N/A (Display only)
Display/Adj/Set Range		0 to 2 0: During execution 1: D-max control is not reflected due to failure in Patch Sensor output value. (Only potential control is executed.) 2: Not executed (D-max control is OFF with DMAX-SW, DMAXS-SW).
Appropriate Target Value		0
Related Service Mode		COPIER> OPTION> IMG-MCON> DMAX-SW COPIER> OPTION> IMG-DEV> DMAXS-SW
DMAX-N	1	Dspl developing contrast by D-max ctrl
Detail		To display the developing contrast Vcont determined by D-max control.
Use Case		When identifying the cause at the occurrence of the maximum density failure or gradation failure
Adj/Set/Operate Method		N/A (Display only)
Display/Adj/Set Range		50 to 300
Unit		V
Appropriate Target Value		90 - 248
DMAX-N-L	2	Dspl density/target VL at D-max control
Detail		To display the list of D-max control Vcont, patch detection density and target density value at the latest. This list consists of maximum Vcont during D-max control and patch detection density (DENS) 1 to 5.
Use Case		When identifying the cause at the occurrence of the maximum density failure or gradation failure
Adj/Set/Operate Method		N/A (Display only)
Display/Adj/Set Range		Vcont: 50 to 300 Patch detection density: 0 to 1023
Unit		V
Appropriate Target Value		Vcont: 150 - 250 Patch detection density: 500 - 1023
Related Service Mode		COPIER> DISPLAY> DENS> DMAX-N

COPIER (Service mode for printer) > DISPLAY (State display mode) > DENS

P-LED	2	Patch sensor LED light correction result
Detail		Displaying the LED light intensity correction result (DA value) of the patch sensor The correction result is used for D-max control or D-half control.
Use Case		When identifying the cause at the occurrence of the maximum density failure or gradation failure
Adj/Set/Operate Method		N/A (Display only)
Display/Adj/Set Range		0 to 255
Appropriate Target Value		35 - 96
Related Service Mode		COPIER> FUNCTION> MISC-P> P-LED
P-B-AVE	2	ETB background dtct result average VL
Detail		To display the average value of ETB background detection result by Patch Sensor. Detection result is used for D-max control and D-half control.
Use Case		When identifying the cause at the occurrence of the maximum density failure or gradation failure
Adj/Set/Operate Method		N/A (Display only)
Display/Adj/Set Range		0 to 1023
Appropriate Target Value		650 - 850
Related Service Mode		COPIER> DISPLAY> DENS> P-B-MAX/MIN
P-B-MAX	2	ETB background dtct result maximum VL
Detail		To display the maximum value of ETB background detection result by Patch Sensor. Detection result is used for D-max control and D-half control.
Use Case		When identifying the cause at the occurrence of the maximum density failure or gradation failure
Adj/Set/Operate Method		N/A (Display only)
Display/Adj/Set Range		0 to 1023
Appropriate Target Value		650 - 900
Related Service Mode		COPIER> DISPLAY> DENS> P-B-AVE/MIN
P-B-MIN	2	ETB background dtct result minimum VL
Detail		To display the minimum value of ETB background detection result by Patch Sensor. Detection result is used for D-max control and D-half control.
Use Case		When identifying the cause at the occurrence of the maximum density failure or gradation failure
Adj/Set/Operate Method		N/A (Display only)
Display/Adj/Set Range		0 to 1023
Appropriate Target Value		600 - 850
Related Service Mode		COPIER> DISPLAY> DENS> P-B-AVE/MAX

■ MISC

COPIER (Service mode for printer) > DISPLAY (State display mode) > MISC

LPOWER	2	Display of laser light intensity
Detail		To display the laser power setting value during image formation in real time.
Use Case		At occurrence of an image failure
Adj/Set/Operate Method		N/A (Display only)
Display/Adj/Set Range		0 to 255
SD-INFO	2	For R&D

COPIER (Service mode for printer) > DISPLAY (State display mode) > MISC

STC-REC	1	Check High Consumption Alarm Send Status
Detail		To express whether High Consumption Alarm is sent or not with 0 and 1.
Use Case		- When checking whether High Consumption Alarm is sent or not
Adj/Set/Operate Method		Display only
Caution		The value returns to 0 only in the following cases: - When performing COPIER > FUNCTION > CLEAR > CNT-DCON - When performing "Initialize All Data/Settings" - When the DC Controller is replaced
Display/Adj/Set Range		0 to 1 0: Transmission disabled, 1: Transmission enabled 1st column: Toner (Y) 2nd column: Toner (M) 3rd column: Toner (C) 4th column: Toner (K) 5th column: Waste Toner Container 6th column: Fixing Web 7th to 8th column: Spare
Default Value		0

■ 2D-SHADE

COPIER (Service mode for printer) > DISPLAY (State display mode) > 2D-SHADE

2D-STS	1	Display of 2D shading ON/OFF
Detail		To display ON/OFF of 2D shading. When 0 is displayed although 1 or 2 is set with COPIER> OPTION> IMG-LSR> 2D-SHADE, check the Drum Lot number with DRM-LOT. If no number has been registered, execute COPIER> FUNCTION> 2D-SHADE> 2D-READ.
Use Case		When uneven image occurs
Adj/Set/Operate Method		N/A (Display only)
Display/Adj/Set Range		0 to 1 0: OFF, 1: ON
Related Service Mode		COPIER> DISPLAY> 2D-SHADE> DRM-LOT COPIER> FUNCTION> 2D-SHADE> 2D-READ COPIER> OPTION> IMG-LSR> 2D-SHADE
DRM-LOT	2	Display of Drum Lot number
Detail		To display the Photosensitive Drum Lot number (10 digits) read at power-on. Lot number is stored in ROM for 2D shading. Check that the displayed value is matched with the Lot number in the seal affixed on the Photosensitive Drum.
Use Case		When uneven image occurs
Adj/Set/Operate Method		N/A (Display only)
Display/Adj/Set Range		10-digit alphanumerics
Related Service Mode		COPIER> DISPLAY> 2D-SHADE> 2D-STS
CHK-SUM	1	Display of checksum calculation result
Detail		To display the checksum calculation result at power-on. Calculation result is stored in ROM for 2D shading. When the calculation result is NG, ROM for 2D shading has a failure, so replace this ROM.
Use Case		When uneven image occurs
Adj/Set/Operate Method		N/A (Display only)
Display/Adj/Set Range		0 to 1 0: at normal state, 1: at failure occurrence



This item is not used because it is intended for R&D.
The I/O information can be found in service mode > SITUATION > Sensor Check.

ADJUST (Adjustment mode)

AE

COPIER (Service mode for printer) > ADJUST (Adjustment mode) > AE

AE-TBL	1	Adj of text density at image density adj
Detail		To adjust text density according to the adjusted image density. As the greater value is set, text gets darker.
Use Case		When clearing the RAM data of the Reader Controller PCB
Adj/Set/Operate Method		1) Enter the setting value, and then press OK key. 2) Turn OFF/ON the main power switch.
Caution		When clearing the RAM data of the Reader Controller PCB, enter the value of service label.
Display/Adj/Set Range		1 to 9
Default Value		5

ADJ-XY

COPIER (Service mode for printer) > ADJUST (Adjustment mode) > ADJ-XY

ADJ-X	1	Adj start pstn in book mode: vert scan
Detail		To adjust the image reading start position (image leading edge position) in the vertical scanning direction at copyboard reading. When replacing the Reader Controller PCB/clearing RAM data, enter the value of service label. Decrease the value when the non-image width is larger than the standard value. Increase the value when out of original area is copied. As the value is incremented by 1, the image position is moved to the trailing edge side by 0.1 mm.
Use Case		When replacing the Reader Controller PCB/clearing RAM data
Adj/Set/Operate Method		1) Enter the setting value (switch negative/positive by +/- key) and press OK key. 2) Turn OFF/ON the main power switch.
Display/Adj/Set Range		-50 to 50
Default Value		0
Amount of Change per Unit		0.1
ADJ-Y	1	Adj start pstn in book mode: horz scan
Detail		To adjust the image reading start position in the horizontal scanning direction at copyboard reading. When replacing the Reader Controller PCB/clearing RAM data, enter the value of service label. Decrease the value when the non-image width is larger than the standard value. Increase the value when out of original area is copied. As the value is incremented by 1, the image position is moved to the rear side by 0.1 mm.
Use Case		When replacing the Reader Controller PCB/clearing RAM data
Adj/Set/Operate Method		1) Enter the setting value (switch negative/positive by +/- key) and press OK key. 2) Turn OFF/ON the main power switch.
Caution		After the setting value is changed, write the changed value in the service label.
Display/Adj/Set Range		-35 to 35
Default Value		0
Amount of Change per Unit		0.1

COPIER (Service mode for printer) > ADJUST (Adjustment mode) > ADJ-XY

ADJ-S	1	Adjustment of Reader shading position
Detail	To adjust the Scanner Unit (for front side) position in feed direction when reading the White Plate on the left edge of the Copyboard Glass. When replacing the Scanner Unit, execute RDSHDPOS and write the value of this item in the service label. When clearing the Reader-related RAM data, enter the value of service label. As the value is incremented by 1, the reading position moves to the trailing edge side by 0.1 mm.	
Use Case	- When black lines/white lines appear - When replacing the Scanner Unit (for front side) - When clearing the Reader-related RAM data	
Adj/Set/Operate Method	1) Enter the setting value (switch negative/positive by +/- key) and press OK key. 2) Turn OFF/ON the main power switch.	
Caution	After the setting value is changed, write the changed value in the service label.	
Display/Adj/Set Range	-100 to 100	
Default Value	0	
Related Service Mode	COPIER> FUNCTION> INSTALL> RDSHDPOS	
Amount of Change per Unit	0.1	
ADJ-Y-DF	1	Adj start pstn:DADF mode, horz scan, frt
Detail	To adjust the front side image reading start position in horizontal scanning direction at DADF reading. When replacing the Reader Controller PCB/clearing RAM data, enter the value of service label. As the value is incremented by 1, the image position is moved to the rear side by 0.1 mm.	
Use Case	When replacing the Reader Controller PCB/clearing RAM data	
Adj/Set/Operate Method	1) Enter the setting value (switch negative/positive by +/- key) and press OK key. 2) Turn OFF/ON the main power switch.	
Caution	After the setting value is changed, write the changed value in the service label.	
Display/Adj/Set Range	-35 to 35	
Unit	mm	
Default Value	0	
Amount of Change per Unit	0.1	
STRD-POS	1	Adj read pstn in DADF mode: front side
Detail	To adjust the reading position at DADF reading (front side). When replacing the Reader Controller PCB/clearing RAM data, enter the value of service label.	
Use Case	When replacing the Reader Controller PCB/clearing RAM data	
Adj/Set/Operate Method	1) Enter the setting value (switch negative/positive by +/- key) and press OK key. 2) Turn OFF/ON the main power switch.	
Caution	After the setting value is changed, write the changed value in the service label.	
Display/Adj/Set Range	-100 to 35	
Unit	mm	
Default Value	0	
Related Service Mode	COPIER> FUNCTION> INSTALL> STRD-POS	
Amount of Change per Unit	0.1	

COPIER (Service mode for printer) > ADJUST (Adjustment mode) > ADJ-XY

ADJ-X-MG	1	Fine adj img ratio: book mode, vert scan
Detail	To make a fine adjustment of image magnification ratio in vertical scanning direction at copyboard reading. When replacing the Reader Controller PCB/clearing RAM data, enter the value of service label. As the value is changed by 1, the image magnification ratio is changed by 0.01 %. +: Enlarge -: Reduce	
Use Case	When replacing the Reader Controller PCB/clearing RAM data	
Adj/Set/Operate Method	1) Enter the setting value (switch negative/positive by +/- key) and press OK key. 2) Turn OFF/ON the main power switch.	
Caution	After the setting value is changed, write the changed value in the service label.	
Display/Adj/Set Range	-50 to 50	
Unit	%	
Default Value	0	
Amount of Change per Unit	0.01	
ADJY-DF2	1	Adj start pstn:DADF mode, horz scan, bck
Detail	To adjust the back side image reading start position in horizontal scanning direction at DADF reading. When replacing the Reader Controller PCB/clearing RAM data, enter the value of service label. As the value is incremented by 1, the image position is moved to the rear side by 0.1 mm.	
Use Case	When replacing the Reader Controller PCB/clearing RAM data	
Adj/Set/Operate Method	1) Enter the setting value (switch negative/positive by +/- key) and press OK key. 2) Turn OFF/ON the main power switch.	
Caution	After the setting value is changed, write the changed value in the service label.	
Display/Adj/Set Range	-35 to 35	
Unit	mm	
Default Value	0	
Amount of Change per Unit	0.1	

■ CCD

COPIER (Service mode for printer) > ADJUST (Adjustment mode) > CCD

W-PLT-X	1	Stdrd White Plt white lvl data (X) entry
Detail	To enter the white level data (X) for the Standard White Plate. When replacing the Reader Controller PCB/clearing RAM data/replacing the Copyboard Glass, enter the value of barcode label which is affixed on the glass.	
Use Case	- When replacing the Reader Controller PCB/clearing RAM data - When replacing the Copyboard Glass	
Adj/Set/Operate Method	1) Enter the setting value, and then press OK key. 2) Turn OFF/ON the main power switch.	
Display/Adj/Set Range	1 to 9999	
Default Value	8271	
Related Service Mode	COPIER> ADJUST> CCD> W-PLT-Y/Z	
Amount of Change per Unit	1	

COPIER (Service mode for printer) > ADJUST (Adjustment mode) > CCD

W-PLT-Y	1	Stdrd White Plt white lvl data (Y) entry
Detail	To enter the white level data (Y) for the Standard White Plate. When replacing the Reader Controller PCB/clearing RAM data/replacing the Copyboard Glass, enter the value of barcode label which is affixed on the glass.	
Use Case	- When replacing the Reader Controller PCB/clearing RAM data - When replacing the Copyboard Glass	
Adj/Set/Operate Method	1) Enter the setting value, and then press OK key. 2) Turn OFF/ON the main power switch.	
Display/Adj/Set Range	1 to 9999	
Default Value	8735	
Related Service Mode	COPIER> ADJUST> CCD> W-PLT-X/Z	
Amount of Change per Unit	1	
W-PLT-Z	1	Stdrd White Plt white lvl data (Z) entry
Detail	To enter the white level data (Z) for the Standard White Plate. When replacing the Reader Controller PCB/clearing RAM data/replacing the Copyboard Glass, enter the value of barcode label which is affixed on the glass.	
Use Case	- When replacing the Reader Controller PCB/clearing RAM data - When replacing the Copyboard Glass	
Adj/Set/Operate Method	1) Enter the setting value, and then press OK key. 2) Turn OFF/ON the main power switch.	
Display/Adj/Set Range	1 to 9999	
Default Value	9418	
Related Service Mode	COPIER> ADJUST> CCD> W-PLT-X/Y	
Amount of Change per Unit	1	
SH-TRGT	1	Shading target VL (B&W) entry: Copyboard
Detail	To enter the B&W shading target value in copyboard reading mode. When replacing the Reader Controller PCB, enter the value of service label. When replacing the Scanner Unit, execute COPIER> FUNCTION> CCD> DF-WLVL3, and write the value which is automatically set in the service label.	
Use Case	- When replacing the Reader Controller PCB/clearing RAM data - When replacing the Scanner Unit	
Adj/Set/Operate Method	1) Enter the setting value, and then press OK key. 2) Turn OFF/ON the main power switch.	
Caution	After the setting value is changed, write the changed value in the service label.	
Display/Adj/Set Range	1 to 2047	
Default Value	1126	
Amount of Change per Unit	1	

COPIER (Service mode for printer) > ADJUST (Adjustment mode) > CCD

100-RG	1	Img Sensr RG color displace crrect: front
Detail	To correct the color displacement between R and G lines in vertical scanning direction due to the Scanner Unit (for front side). When replacing the Reader Controller PCB/clearing RAM data, enter the value of service label.	
Use Case	When replacing the Reader Controller PCB/clearing RAM data	
Adj/Set/Operate Method	1) Enter the setting value (switch negative/positive by +/- key) and press OK key. 2) Turn OFF/ON the main power switch.	
Caution	After the setting value is changed, write the changed value in the service label.	
Display/Adj/Set Range	-256 to 256	
Unit	line	
Default Value	0	
Amount of Change per Unit	0.001	
100-GB	1	Img Sensr GB color displace crrect: front
Detail	To correct the color displacement between G and B lines in vertical scanning direction due to the Scanner Unit (for front side). When replacing the Reader Controller PCB/clearing RAM data, enter the value of service label.	
Use Case	When replacing the Reader Controller PCB/clearing RAM data	
Adj/Set/Operate Method	1) Enter the setting value (switch negative/positive by +/- key) and press OK key. 2) Turn OFF/ON the main power switch.	
Caution	After the setting value is changed, write the changed value in the service label.	
Display/Adj/Set Range	-256 to 256	
Unit	line	
Default Value	0	
Amount of Change per Unit	0.001	
DFTAR-R	1	Shading target VL (R) entry: front side
Detail	To enter the shading target value of Red on the front side at DADF reading. When replacing the Reader Controller PCB, enter the value of service label. When replacing the Copyboard Glass/Scanner Unit (for front side), execute COPIER> FUNCTION> CCD> DF-WLV1, DF-WLV2 and write the value which is automatically set in the service label.	
Use Case	- When replacing the Reader Controller PCB/clearing RAM data - When replacing the Copyboard Glass/Scanner Unit (for front side)	
Adj/Set/Operate Method	1) Enter the setting value, and then press OK key. 2) Turn OFF/ON the main power switch.	
Display/Adj/Set Range	1 to 2047	
Default Value	1159	
Related Service Mode	COPIER> FUNCTION> CCD> DF-WLV1, DF-WLV2	
Amount of Change per Unit	1	

COPIER (Service mode for printer) > ADJUST (Adjustment mode) > CCD

DFTAR-G	1	Shading target VL (G) entry: front side
Detail	To enter the shading target value of Green on the front side at DADF reading. When replacing the Reader Controller PCB, enter the value of service label. When replacing the Copyboard Glass/Scanner Unit (for front side), execute COPIER> FUNCTION> CCD> DF-WLVL1, DF-WLVL2 and write the value which is automatically set in the service label.	
Use Case	- When replacing the Reader Controller PCB/clearing RAM data - When replacing the Copyboard Glass/Scanner Unit (for front side)	
Adj/Set/Operate Method	1) Enter the setting value, and then press OK key. 2) Turn OFF/ON the main power switch.	
Display/Adj/Set Range	1 to 2047	
Default Value	1189	
Related Service Mode	COPIER> FUNCTION> CCD> DF-WLVL1, DF-WLVL2	
Amount of Change per Unit	1	
DFTAR-B	1	Shading target VL (B) entry: front side
Detail	To enter the shading target value of Blue on the front side at DADF reading. When replacing the Reader Controller PCB, enter the value of service label. When replacing the Copyboard Glass/Scanner Unit (for front side), execute COPIER> FUNCTION> CCD> DF-WLVL1, DF-WLVL2 and write the value which is automatically set in the service label.	
Use Case	- When replacing the Reader Controller PCB/clearing RAM data - When replacing the Copyboard Glass/Scanner Unit (for front side)	
Adj/Set/Operate Method	1) Enter the setting value, and then press OK key. 2) Turn OFF/ON the main power switch.	
Display/Adj/Set Range	1 to 2047	
Default Value	1209	
Related Service Mode	COPIER> FUNCTION> CCD> DF-WLVL1, DF-WLVL2	
Amount of Change per Unit	1	
100DF2GB	2	Img Sensr GB color displace crct: back
Detail	To correct the color displacement between G and B lines in vertical scanning direction due to the Scanner Unit (for back side). When replacing the Reader Controller PCB/clearing RAM data, enter the value of service label.	
Use Case	When replacing the Reader Controller PCB/clearing RAM data	
Adj/Set/Operate Method	1) Enter the setting value (switch negative/positive by +/- key) and press OK key. 2) Turn OFF/ON the main power switch.	
Display/Adj/Set Range	-256 to 256	
Unit	line	
Default Value	0	
Amount of Change per Unit	0.001	

COPIER (Service mode for printer) > ADJUST (Adjustment mode) > CCD

100DF2RG	2	Img Sensr RG color displace crrect: back
Detail	To correct the color displacement between R and G lines in vertical scanning direction due to the Scanner Unit (for back side). When replacing the Reader Controller PCB/clearing RAM data, enter the value of service label.	
Use Case	When replacing the Reader Controller PCB/clearing RAM data	
Adj/Set/Operate Method	1) Enter the setting value (switch negative/positive by +/- key) and press OK key. 2) Turn OFF/ON the main power switch.	
Display/Adj/Set Range	-256 to 256	
Unit	line	
Default Value	0	
Amount of Change per Unit	0.001	
DFCH2R2	1	Complex chart No.2 data (R) entry: front
Detail	To derive the front/back side linearity, enter the Red data on the front side of No.2 image in DADF complex chart. Enter the value of service label on the Reader.	
Use Case	When replacing the Reader Controller PCB/clearing RAM data	
Adj/Set/Operate Method	1) Enter the setting value, and then press OK key. 2) Turn OFF/ON the main power switch.	
Display/Adj/Set Range	1 to 2550	
Default Value	2000	
Amount of Change per Unit	1	
DFCH2R10	1	Complex chart No.10 data (R) entry:front
Detail	To derive the front/back side linearity, enter the Red data on the front side of No.10 image in DADF complex chart. Enter the value of service label on the Reader.	
Use Case	When replacing the Reader Controller PCB/clearing RAM data	
Adj/Set/Operate Method	1) Enter the setting value, and then press OK key. 2) Turn OFF/ON the main power switch.	
Display/Adj/Set Range	0 to 2550	
Default Value	0	
Amount of Change per Unit	1	
DFCH2B2	1	Complex chart No.2 data (B) entry: front
Detail	To derive the front/back side linearity, enter the Blue data on the front side of No.2 image in DADF complex chart. Enter the value of service label on the Reader.	
Use Case	When replacing the Reader Controller PCB/clearing RAM data	
Adj/Set/Operate Method	1) Enter the setting value, and then press OK key. 2) Turn OFF/ON the main power switch.	
Display/Adj/Set Range	1 to 2550	
Default Value	2000	
Amount of Change per Unit	1	

COPIER (Service mode for printer) > ADJUST (Adjustment mode) > CCD

DFCH2B10	1	Complex chart No.10 data (B) entry:front
Detail	To derive the front/back side linearity, enter the Blue data on the front side of No.10 image in DADF complex chart. Enter the value of service label on the Reader.	
Use Case	When replacing the Reader Controller PCB/clearing RAM data	
Adj/Set/Operate Method	1) Enter the setting value, and then press OK key. 2) Turn OFF/ON the main power switch.	
Display/Adj/Set Range	0 to 2550	
Default Value	0	
Amount of Change per Unit	1	
DFCH2G2	1	Complex chart No.2 data (G) entry: front
Detail	To derive the front/back side linearity, enter the Green data on the front side of No.2 image in DADF complex chart. Enter the value of service label on the Reader.	
Use Case	When replacing the Reader Controller PCB/clearing RAM data	
Adj/Set/Operate Method	1) Enter the setting value, and then press OK key. 2) Turn OFF/ON the main power switch.	
Display/Adj/Set Range	1 to 2550	
Default Value	2000	
Amount of Change per Unit	1	
DFCH2G10	1	Complex chart No.10 data (G) entry:front
Detail	To derive the front/back side linearity, enter the Green data on the front side of No.10 image in DADF complex chart. Enter the value of service label on the Reader.	
Use Case	When replacing the Reader Controller PCB/clearing RAM data	
Adj/Set/Operate Method	1) Enter the setting value, and then press OK key. 2) Turn OFF/ON the main power switch.	
Display/Adj/Set Range	0 to 2550	
Default Value	0	
Amount of Change per Unit	1	
DFCH-R2	1	Complex chart No.2 data (R) entry: back
Detail	To derive the front/back side linearity, enter the Red data on the back side of No.2 image in DADF complex chart. Enter the value of service label on the Reader.	
Use Case	When replacing the Reader Controller PCB/clearing RAM data	
Adj/Set/Operate Method	1) Enter the setting value, and then press OK key. 2) Turn OFF/ON the main power switch.	
Display/Adj/Set Range	1 to 2550	
Default Value	2000	
Related Service Mode	COPIER> ADJUST> CCD> DFCH-R10, DFCH-B2, DFCH-B10, DFCH-G2, DFCH-G10 COPIER> FUNCTION> CCD> DF-LNR	
Amount of Change per Unit	1	

COPIER (Service mode for printer) > ADJUST (Adjustment mode) > CCD

DFCH-R10	1	Complex chart No.10 data (R) entry: back
Detail	To derive the front/back side linearity, enter the Red data on the back side of No.10 image in DADF complex chart. Enter the value of service label on the Reader.	
Use Case	When replacing the Reader Controller PCB/clearing RAM data	
Adj/Set/Operate Method	1) Enter the setting value, and then press OK key. 2) Turn OFF/ON the main power switch.	
Display/Adj/Set Range	0 to 2550	
Default Value	0	
Related Service Mode	COPIER> ADJUST> CCD> DFCH-R2, DFCH-B2, DFCH-B10, DFCH-G2, DFCH-G10 COPIER> FUNCTION> CCD> DF-LNR	
Amount of Change per Unit	1	
DFCH-B2	1	Complex chart No.2 data (B) entry: back
Detail	To derive the front/back side linearity, enter the Blue data on the back side of No.2 image in DADF complex chart. Enter the value of service label on the Reader.	
Use Case	When replacing the Reader Controller PCB/clearing RAM data	
Adj/Set/Operate Method	1) Enter the setting value, and then press OK key. 2) Turn OFF/ON the main power switch.	
Display/Adj/Set Range	1 to 2550	
Default Value	2000	
Related Service Mode	COPIER> ADJUST> CCD> DFCH-R10, DFCH-B2, DFCH-B10, DFCH-G2, DFCH-G10 COPIER> FUNCTION> CCD> DF-LNR	
Amount of Change per Unit	1	
DFCH-B10	1	Complex chart No.10 data (B) entry: back
Detail	To derive the front/back side linearity, enter the Blue data on the back side of No.10 image in DADF complex chart. Enter the value of service label on the Reader.	
Use Case	When replacing the Reader Controller PCB/clearing RAM data	
Adj/Set/Operate Method	1) Enter the setting value, and then press OK key. 2) Turn OFF/ON the main power switch.	
Display/Adj/Set Range	0 to 2550	
Default Value	0	
Related Service Mode	COPIER> ADJUST> CCD> DFCH-R2, DFCH-B2, DFCH-B10, DFCH-G2, DFCH-G10 COPIER> FUNCTION> CCD> DF-LNR	
Amount of Change per Unit	1	

COPIER (Service mode for printer) > ADJUST (Adjustment mode) > CCD

DFCH-G2	1	Complex chart No.2 data (G) entry: back
Detail	To derive the front/back side linearity, enter the Green data on the back side of No.2 image in DADF complex chart. Enter the value of service label on the Reader.	
Use Case	When replacing the Reader Controller PCB/clearing RAM data	
Adj/Set/Operate Method	1) Enter the setting value, and then press OK key. 2) Turn OFF/ON the main power switch.	
Display/Adj/Set Range	1 to 2550	
Default Value	2000	
Related Service Mode	COPIER> ADJUST> CCD> DFCH-R10, DFCH-B2, DFCH-B10, DFCH-G2, DFCH-G10 COPIER> FUNCTION> CCD> DF-LNR	
Amount of Change per Unit	1	
DFCH-G10	1	Complex chart No.10 data (G) entry: back
Detail	To derive the front/back side linearity, enter the Green data on the back side of No.10 image in DADF complex chart. Enter the value of service label on the Reader.	
Use Case	When replacing the Reader Controller PCB/clearing RAM data	
Adj/Set/Operate Method	1) Enter the setting value, and then press OK key. 2) Turn OFF/ON the main power switch.	
Display/Adj/Set Range	0 to 2550	
Default Value	0	
Related Service Mode	COPIER> ADJUST> CCD> DFCH-R2, DFCH-B2, DFCH-B10, DFCH-G2, DFCH-G10 COPIER> FUNCTION> CCD> DF-LNR	
Amount of Change per Unit	1	
DFCH2K2	1	Complex chart No.2 data (B&W) entr: frt
Detail	To derive the front/back side linearity, enter the B&W data on the front side of No.2 image in DADF complex chart. Enter the value of service label on the Reader.	
Use Case	When replacing the Reader Controller PCB/clearing RAM data	
Adj/Set/Operate Method	1) Enter the setting value, and then press OK key. 2) Turn OFF/ON the main power switch.	
Display/Adj/Set Range	1 to 2550	
Default Value	2000	
Amount of Change per Unit	1	
DFCH2K10	1	Complex chart No.10 data (B&W) entr: frt
Detail	To derive the front/back side linearity, enter the B&W data on the front side of No.10 image in DADF complex chart. Enter the value of service label on the Reader.	
Use Case	When replacing the Reader Controller PCB/clearing RAM data	
Adj/Set/Operate Method	1) Enter the setting value, and then press OK key. 2) Turn OFF/ON the main power switch.	
Display/Adj/Set Range	0 to 2550	
Default Value	0	
Amount of Change per Unit	1	

COPIER (Service mode for printer) > ADJUST (Adjustment mode) > CCD

DFCH-K2	1	Complex chart No.2 data (B&W) entr: bck
Detail	To derive the front/back side linearity, enter the B&W data on the back side of No.2 image in DADF complex chart. Enter the value of service label on the Reader.	
Use Case	When replacing the Reader Controller PCB/clearing RAM data	
Adj/Set/Operate Method	1) Enter the setting value, and then press OK key. 2) Turn OFF/ON the main power switch.	
Display/Adj/Set Range	1 to 2550	
Default Value	2000	
Related Service Mode	COPIER> ADJUST> CCD> DFCH-R2, DFCH-R10, DFCH-B2, DFCH-B10, DFCH-G2, DFCH-G10, DFCH-K10 COPIER> FUNCTION> CCD> DF-LNR	
Amount of Change per Unit	1	
DFCH-K10	1	Complex chart No.10 data (B&W) entr: bck
Detail	To derive the front/back side linearity, enter the B&W data on the back side of No.10 image in DADF complex chart. Enter the value of service label on the Reader.	
Use Case	When replacing the Reader Controller PCB/clearing RAM data	
Adj/Set/Operate Method	1) Enter the setting value, and then press OK key. 2) Turn OFF/ON the main power switch.	
Display/Adj/Set Range	0 to 2550	
Default Value	0	
Related Service Mode	COPIER> ADJUST> CCD> DFCH-R2, DFCH-R10, DFCH-B2, DFCH-B10, DFCH-G2, DFCH-G10, DFCH-K2 COPIER> FUNCTION> CCD> DF-LNR	
Amount of Change per Unit	1	
DFTAR-BW	1	Shading target VL (B&W) entry: front
Detail	To enter the B&W shading target value on the front side at DADF reading. When replacing the Reader Controller PCB, enter the value of service label. When replacing the Copyboard Glass/Scanner Unit (for front side), execute COPIER> FUNCTION> CCD> DF-WLVL3, DF-WLVL4 and write the value which is automatically set in the service label.	
Use Case	- When replacing the Reader Controller PCB/clearing RAM data - When replacing the Copyboard Glass/Scanner Unit (for front side)	
Adj/Set/Operate Method	1) Enter the setting value, and then press OK key. 2) Turn OFF/ON the main power switch.	
Display/Adj/Set Range	1 to 2047	
Default Value	1209	
Related Service Mode	COPIER> FUNCTION> CCD> DF-WLVL3, DF-WLVL4	
Amount of Change per Unit	1	

COPIER (Service mode for printer) > ADJUST (Adjustment mode) > CCD

DFTBK-G	1	Shading target VL (G) entry: back side
Detail	To enter the shading target value of Green on the back side at DADF reading. When replacing the Reader Controller PCB, enter the value of service label. When replacing the Copyboard Glass/Scanner Unit (for back side), execute COPIER> FUNCTION> CCD> DF-WLVL1, DF-WLVL2 and write the value which is automatically set in the service label.	
Use Case	- When replacing the Reader Controller PCB/clearing RAM data - When replacing the Scanner Unit (for back side)	
Adj/Set/Operate Method	1) Enter the setting value, and then press OK key. 2) Turn OFF/ON the main power switch.	
Display/Adj/Set Range	700 to 1400	
Default Value	1136	
Related Service Mode	COPIER> FUNCTION> CCD> DF-WLVL1, DF-WLVL2	
Amount of Change per Unit	1	
DFTBK-B	1	Shading target VL (B) entry: back side
Detail	To enter the shading target value of Blue on the back side at DADF reading. When replacing the Reader Controller PCB, enter the value of service label. When replacing the Copyboard Glass/Scanner Unit (for back side), execute COPIER> FUNCTION> CCD> DF-WLVL1, DF-WLVL2 and write the value which is automatically set in the service label.	
Use Case	- When replacing the Reader Controller PCB/clearing RAM data - When replacing the Scanner Unit (for back side)	
Adj/Set/Operate Method	1) Enter the setting value, and then press OK key. 2) Turn OFF/ON the main power switch.	
Display/Adj/Set Range	700 to 1400	
Default Value	1126	
Related Service Mode	COPIER> FUNCTION> CCD> DF-WLVL1, DF-WLVL2	
Amount of Change per Unit	1	
DFTBK-R	1	Shading target VL (R) entry: back side
Detail	To enter the shading target value of Red on the back side at DADF reading. When replacing the Reader Controller PCB, enter the value of service label. When replacing the Copyboard Glass/Scanner Unit (for back side), execute COPIER> FUNCTION> CCD> DF-WLVL1, DF-WLVL2 and write the value which is automatically set in the service label.	
Use Case	- When replacing the Reader Controller PCB/clearing RAM data - When replacing the Scanner Unit (for back side)	
Adj/Set/Operate Method	1) Enter the setting value, and then press OK key. 2) Turn OFF/ON the main power switch.	
Display/Adj/Set Range	700 to 1400	
Default Value	1156	
Related Service Mode	COPIER> FUNCTION> CCD> DF-WLVL1, DF-WLVL2	
Amount of Change per Unit	1	

COPIER (Service mode for printer) > ADJUST (Adjustment mode) > CCD

DFTBK-BW	1	Shading target VL (B&W) entry: back
Detail	To enter the B&W shading target value on the back side at DADF reading. When replacing the Reader Controller PCB, enter the value of service label. When replacing the Copyboard Glass/Scanner Unit (for back side), execute COPIER> FUNCTION> CCD> DF-WLVL3, DF-WLVL4 and write the value which is automatically set in the service label.	
Use Case	- When replacing the Reader Controller PCB/clearing RAM data - When replacing the Copyboard Glass/Scanner Unit (for back side)	
Adj/Set/Operate Method	1) Enter the setting value, and then press OK key. 2) Turn OFF/ON the main power switch.	
Display/Adj/Set Range	700 to 1400	
Default Value	1126	
Related Service Mode	COPIER> FUNCTION> CCD> DF-WLVL3, DF-WLVL4	
Amount of Change per Unit	1	

■ LASER

COPIER (Service mode for printer) > ADJUST (Adjustment mode) > LASER

PVE-OFST	1	Adj of write start position of laser
Detail	To adjust the image position by changing the laser emitting position. When replacing the DC Controller PCB/clearing RAM data, enter the value of service label. As the value is incremented by 1, the image moves by 0.1mm. +: Toward rear -: Toward front	
Use Case	When adjusting image position	
Adj/Set/Operate Method	Enter the setting value (switch negative/positive by -/+ key) and press OK key.	
Caution	Use this only when replacing the DC Controller PCB/Laser Scanner Unit. When adjusting the image write start position, use COPIER> ADJUST> FEED-ADJ> ADJ-C1/C2/C3/C4/MF/DK. If it is not sufficient enough, execute mechanical adjustment.	
Display/Adj/Set Range	-300 to 300	
Unit	mm	
Default Value	0	
Related Service Mode	COPIER> ADJUST> FEED-ADJ> ADJ-C1, ADJ-C2, ADJ-C3, ADJ-C4, ADJ-MF, ADJ-DK	
Amount of Change per Unit	0.1	
POWER	1	Adj laser power at no potential control
Detail	To adjust the laser power when the potential control is not performed.	
Display/Adj/Set Range	0 to 255	
Default Value	0	
Related Service Mode	COPIER> OPTION> FNC-SW> PO-CNT COPIER> OPTION> TEMPO> F-POT-SW	

■ IMG-REG

COPIER (Service mode for printer) > ADJUST (Adjustment mode) > IMG-REG

MAG-H-K	1	Fine adj of magnification: horz scan
Detail		To make a fine adjustment of image magnification in horizontal scanning direction by adjusting the rotation speed of the Polygon Mirror/modulating clock. Convert the magnification measurement line length of PG for image position adjustment into a percentage, and enter the amount of change in percentage. As the value is incremented by 1, the image magnification changes by 0.01%. +: Enlarge -: Reduce
Use Case		- When checking image at initial installation - At check operation when replacing the Laser Scanner Unit - When adjustment is requested by a user
Adj/Set/Operate Method		Enter the setting value (switch negative/positive by +/- key) and press OK key.
Caution		Do not use this at the normal service.
Display/Adj/Set Range		-100 to 100
Unit		%
Default Value		0
Amount of Change per Unit		0.01
MAG-V	1	For R&D
Amount of Change per Unit		0.01

■ DEVELOP

COPIER (Service mode for printer) > ADJUST (Adjustment mode) > DEVELOP

BIAS	1	Adjustment of developing bias
Detail		To adjust the developing bias when the potential control is not performed.
Use Case		When potential control is not performed
Adj/Set/Operate Method		1) Enter the setting value, and then press OK key. 2) Turn OFF/ON the main power switch.
Display/Adj/Set Range		0 to 600
Unit		V
Default Value		180
Amount of Change per Unit		1
FRQ-DEV	2	Setting of developing bias frequency
Detail		To set the frequency of developing bias. Increase the value when fogging occurs.
Use Case		When fogging occurs
Adj/Set/Operate Method		Enter the setting value and press OK key.
Display/Adj/Set Range		-2 to 3 -2 to -1: Not used, 0: 2.7kHz, 1: 3.0kHz, 2: 3.2kHz, 3: 3.5kHz
Default Value		0

■ DENS

COPIER (Service mode for printer) > ADJUST (Adjustment mode) > DENS

DENS-ADJ	1	Density correction of copy image
Detail		To correct the density of copy image by changing the F-value table. When replacing the DC Controller PCB/clearing RAM data, enter the value of service label. Blurring is alleviated when the value is increased, and fogging is alleviated when the value is decreased.
Use Case		When fogging or blurring at high density area occurs with a copy image
Adj/Set/Operate Method		Enter the setting value, and then press OK key.
Caution		Density of printer output image cannot be corrected.
Display/Adj/Set Range		1 to 9
Default Value		5
Supplement/Memo		F-value table: shows the relationship between original density and image density.
P-OFFSET	1	Display/adj of patch detection offset VL
Detail		To display/adjust the patch detection offset value used by the Patch Sensor.
Use Case		- When density of solid area is out of the specified range although there is no failure at high voltage or the Developing Assembly - When density of solid area is out of the specified range at Sensor replacement or after a long use
Adj/Set/Operate Method		1) Check whether density varies due to the Patch Sensor (high voltage, etc.) 2) Enter the setting value, and then press OK key. 3) Execute D-max control manually. 4) Check density on solid area with 17 gradations.
Display/Adj/Set Range		0 to 255
Default Value		64
Related Service Mode		COPIER> FUNCTION> MISC-P> DMAX-N
P-DHALF	1	Fine adj D-half Imnce dens convs table
Detail		To make a fine adjustment of the luminance density conversion table used for D-half control (display/adjustment).
Use Case		- When halftone density of solid area is out of the specified range although there is no failure at high voltage or the Developing Assembly - When density of solid area is within the specified range but halftone density of solid area is out of the specified range at sensor replacement or after a long use
Adj/Set/Operate Method		1) Check whether halftone density varies due to the Patch Sensor (high voltage, etc.) 2) Check that the density of solid area is within the specified range. 3) Enter the setting value (switch negative/positive by +/- key) and press OK key. 4) Execute D-half control. 5) Check the halftone density with the chart pointed out by the user.
Caution		D-half control is enabled only for COPY/AdobePS&PDF/EFI.
Display/Adj/Set Range		-16 to 16
Default Value		0

COPIER (Service mode for printer) > ADJUST (Adjustment mode) > DENS

P-B-TGT	2	Fine adj LED intnsty tgt VL:D-max/D-half
Detail		To make a fine adjustment of the target value for the LED light intensity adjustment used for D-max control and D-half control (display/adjustment). Decrease the value if the intensity of LED is too strong, and increase the value if the intensity is too weak.
Use Case		When continuing to use on a temporary basis regardless unevenness of the ITB, soiled sensor, life of sensor, etc.
Adj/Set/Operate Method		1) Check whether density varies due to the Patch Sensor (high voltage, etc.) 2) Check that the result of LED light intensity correction is out of the specified range. 3) Enter the setting value, and then press OK key. 4) Execute D-max control manually. 5) Check density on solid area with 17 gradations.
Display/Adj/Set Range		0 to 1023
Default Value		796
Related Service Mode		COPIER> DISPLAY> DENS> P-LED, P-B-AVE
DMAX-N-T	2	Fine adj of density target VL for D-max
Detail		To make a fine adjustment of density target value used for D-max control. (display/adjustment).
Use Case		When adjusting the density (In principle, density is adjusted with P-OFFSE value)
Adj/Set/Operate Method		1) Check whether density varies due to the Patch Sensor (high voltage, etc.) 2) Enter the setting value, and then press OK key. 3) Execute D-max control manually. 4) Check density on solid area with 17 gradations.
Display/Adj/Set Range		0 to 1023
Default Value		895
Related Service Mode		COPIER> FUNCTION> MISC-P> DMAX-N COPIER> DISPLAY> DENS> DMAX-N COPIER> ADJUST> DENS> P-OFFSET

■ BLANK

COPIER (Service mode for printer) > ADJUST (Adjustment mode) > BLANK

BLANK-T	1	Adjustment of leading edge margin
Detail		To adjust the margin on the leading edge of paper. As the value is incremented by 1, the margin is increased toward the center of the paper by 1 pixel (0.0212 mm).
Use Case		- When reducing the margin upon user's request - When enlarging the margin for transfer separation/fixing separation
Adj/Set/Operate Method		Enter the setting value, and then press OK key.
Display/Adj/Set Range		0 to 1000
Unit		pixel
Default Value		118
Amount of Change per Unit		1

COPIER (Service mode for printer) > ADJUST (Adjustment mode) > BLANK

BLANK-L	1	Adjustment of left edge margin
Detail	To adjust the margin on the left edge of paper. As the value is incremented by 1, the margin is increased toward the center of the paper by 1 pixel (0.0212 mm).	
Use Case	- When reducing the margin upon user's request - When enlarging the margin for transfer separation/fixing separation	
Adj/Set/Operate Method	Enter the setting value, and then press OK key.	
Display/Adj/Set Range	0 to 1000	
Unit	pixel	
Default Value	118	
Amount of Change per Unit	1	
BLANK-R	1	Adjustment of right edge margin
Detail	To adjust the margin on the right edge of paper. As the value is incremented by 1, the margin is increased toward the center of the paper by 1 pixel (0.0212 mm).	
Use Case	- When reducing the margin upon user's request - When enlarging the margin for transfer separation/fixing separation	
Adj/Set/Operate Method	Enter the setting value, and then press OK key.	
Display/Adj/Set Range	0 to 1000	
Unit	pixel	
Default Value	118	
Amount of Change per Unit	1	
BLANK-B	1	Adjustment of trailing edge margin
Detail	To adjust the margin on the trailing edge of paper. As the value is incremented by 1, the margin is increased toward the center of the paper by 1 pixel (0.0212 mm).	
Use Case	- When reducing the margin upon user's request - When enlarging the margin for transfer separation/fixing separation	
Adj/Set/Operate Method	Enter the setting value, and then press OK key.	
Display/Adj/Set Range	0 to 1000	
Unit	pixel	
Default Value	118	
Amount of Change per Unit	1	

■ V-CONT

COPIER (Service mode for printer) > ADJUST (Adjustment mode) > V-CONT

EPOTOFST	1	Manual entry of Potential Sensor offset
Detail	To set the offset auto adjustment value of Potential Sensor manually. As the value is incremented by 1, the offset value changes by 0.8 V. +: Identified as the lower potential than the detected one -: Identified as the higher potential than the detected one	
Use Case	When an error is displayed by executing OFST (auto offset adjustment) at the replacement of Potential Sensor (When the value out of specified range is set due to Potential Sensor disconnection/connection failure/installation failure), restore to the factory setting values. 1) To stop the error, set 933 (V) in EPOTOFST. 2) Check around the Potential Sensor. If there is an error, address it and if not, go to the step 3). 3) Enter the value of service label. 4) If image fogging or the like occurs, increase the value by 10V increment.	
Adj/Set/Operate Method	Enter the setting value, and then press OK key.	
Display/Adj/Set Range	765 to 1000	
Unit	V	
Default Value	0	
Related Service Mode	COPIER> FUNCTION> DPC> OFST	
Amount of Change per Unit	0.8	
VL-OFST	1	Bright area tgt potential ofst VL entry
Detail	To set the offset auto adjustment value of bright area target potential VL manually. As the value is incremented by 1, the offset value changes by 1V. +: Increase -: Decrease	
Use Case	When replacing the DC Controller PCB/clearing RAM data	
Adj/Set/Operate Method	Enter the setting value (switch negative/positive by -/+ key) and press OK key.	
Display/Adj/Set Range	-30 to 30	
Unit	V	
Default Value	0	
Amount of Change per Unit	1	
VD-OFST	1	Dark area tgt potential ofst VL entry
Detail	To set the offset auto adjustment value of dark area target potential VL manually. As the value is incremented by 1, the offset value changes by 1V. +: Increase -: Decrease	
Use Case	When replacing the DC Controller PCB/clearing RAM data	
Adj/Set/Operate Method	Enter the setting value (switch negative/positive by -/+ key) and press OK key.	
Display/Adj/Set Range	-30 to 30	
Unit	V	
Default Value	0	
Amount of Change per Unit	1	

COPIER (Service mode for printer) > ADJUST (Adjustment mode) > V-CONT

DE-OFST	1	Copy image Vdc offset value entry
Detail	To set the Vdc offset auto adjustment value for potential control of copy image manually. As the value is incremented by 1, the offset value changes by 1V. +: Increase -: Decrease	
Adj/Set/Operate Method	Enter the setting value (switch negative/positive by -/+ key) and press OK key.	
Display/Adj/Set Range	-50 to 50	
Unit	V	
Default Value	0	
Amount of Change per Unit	1	
VCONT-1	1	Dev contrast crrect potntl:first time/day
Detail	To make a fine adjustment of correction potential of developing contrast target potential Vcont for the first time of the day.	
Use Case	When image density for the first time of the day is low	
Adj/Set/Operate Method	Enter the setting value, and then press OK key.	
Display/Adj/Set Range	0 to 10	
Unit	V	
Default Value	0	
Amount of Change per Unit	1	
VL-OF-L	2	Bright area target potential:thin
Detail	To make a fine adjustment of bright area target potential VL with thin paper.	
Use Case	When an image density failure occurs with thin paper	
Adj/Set/Operate Method	Enter the setting value (switch negative/positive by -/+ key) and press OK key.	
Display/Adj/Set Range	-200 to 200	
Unit	V	
Default Value	20	
Amount of Change per Unit	1	
SMR-IPRV	2	Smeared image control batch settings
Detail	To set the service modes necessary for smeared image control (toner scattering) collectively. When 1 is set, offset value of each service mode is set. - COPIER> ADJUST> HV-TR> P-TR-OF1 to 6 (Environment: 4, feed mode: 7, offset value of pre-transfer charging current: +10) - COPIER> ADJUST> V-CONT> VL-OFST (Offset value of bright area target potential: 30) - COPIER> ADJUST> V-CONT> VD-OFST (Offset value of dark area target potential: -30) When 0 is set, each offset value returns to 0 (default).	
Use Case	When a smeared image occurs	
Adj/Set/Operate Method	1) Enter the setting value, and then press OK key. 2) Turn OFF/ON the main power switch. 3) Execute auto gradation adjustment (full adjustment).	
Caution	When the numerical value of the item (P-TR-OF1 to 6, VL-OFST, VD-OFDT) in which the offset value is collectively set is changed, SMR-IPRV becomes from 1 to 0. This will only appear as 0, and the settings will be retained.	
Display/Adj/Set Range	0 to 1 0: OFF, 1: ON	
Default Value	0	
Related Service Mode	COPIER> ADJUST> HV-TR> P-TR-OF1 - 6 COPIER> ADJUST> V-CONT> VL-OFST, VD-OFST	

■ PASCAL

COPIER (Service mode for printer) > ADJUST (Adjustment mode) > PASCAL

OFST-P-Y	1	Y density adj at test print reading
Detail	To adjust the offset of Y-color test print reading signal at auto gradation adjustment (full adjustment). When replacing the Reader Controller PCB/clearing RAM data, enter the value of service label. As the value is larger, the image after adjustment gets darker.	
Use Case	When replacing the Reader Controller PCB/clearing RAM data	
Adj/Set/Operate Method	1) Enter the setting value (switch negative/positive by +/- key) and press OK key. 2) Turn OFF/ON the main power switch.	
Display/Adj/Set Range	-128 to 128	
Default Value	According to the adjustment value of the Reader at factory shipment	
Amount of Change per Unit	1	
OFST-P-M	1	M density adj at test print reading
Detail	To adjust the offset of M-color test print reading signal at auto gradation adjustment (full adjustment). When replacing the Reader Controller PCB/clearing RAM data, enter the value of service label. As the value is larger, the image after adjustment gets darker.	
Use Case	When replacing the Reader Controller PCB/clearing RAM data	
Adj/Set/Operate Method	1) Enter the setting value (switch negative/positive by +/- key) and press OK key. 2) Turn OFF/ON the main power switch.	
Caution	After the setting value is changed, write the changed value in the service label.	
Display/Adj/Set Range	-128 to 128	
Default Value	According to the adjustment value of the Reader at factory shipment	
Amount of Change per Unit	1	
OFST-P-C	1	C density adj at test print reading
Detail	To adjust the offset of C-color test print reading signal at auto gradation adjustment (full adjustment). When replacing the Reader Controller PCB/clearing RAM data, enter the value of service label. As the value is larger, the image after adjustment gets darker.	
Use Case	When replacing the Reader Controller PCB/clearing RAM data	
Adj/Set/Operate Method	1) Enter the setting value (switch negative/positive by +/- key) and press OK key. 2) Turn OFF/ON the main power switch.	
Caution	After the setting value is changed, write the changed value in the service label.	
Display/Adj/Set Range	-128 to 128	
Default Value	According to the adjustment value of the Reader at factory shipment	
Amount of Change per Unit	1	

COPIER (Service mode for printer) > ADJUST (Adjustment mode) > PASCAL

OFST-P-K	1	Bk density adj at test print reading
Detail		To adjust the offset of Bk-color test print reading signal at auto gradation adjustment (full adjustment). When replacing the Reader Controller PCB/clearing RAM data, enter the value of service label. As the value is larger, the image after adjustment gets darker.
Use Case		When replacing the Reader Controller PCB/clearing RAM data
Adj/Set/Operate Method		1) Enter the setting value (switch negative/positive by +/- key) and press OK key. 2) Turn OFF/ON the main power switch.
Caution		After the setting value is changed, write the changed value in the service label.
Display/Adj/Set Range		-128 to 128
Default Value		According to the adjustment value of the Reader at factory shipment
Amount of Change per Unit		1

■ HV-PRI

COPIER (Service mode for printer) > ADJUST (Adjustment mode) > HV-PRI

PRIMARY	1	Adjustment of primary charging current
Detail		To adjust the primary charging current flows to the Primary Charging Assembly when potential control is OFF. When potential control is turned OFF, the specified primary charging current is output.
Use Case		- When outputting image while potential control is OFF - When changing the primary charging current and then checking the high voltage output
Adj/Set/Operate Method		Enter the setting value, and then press OK key.
Display/Adj/Set Range		0 to 1600
Unit		uA
Default Value		1000
Related Service Mode		COPIER> OPTION> FNC-SW> PO-CNT
Amount of Change per Unit		1

PRI-GRID	1	Adjustment of Pry Chg Ass'y grid bias
Detail		To adjust the grid voltage of the Primary Charging Assembly at potential control. Adjust the offset value for the voltage table that changes according to the durability. When an image failure occurs due to the soiled Primary Charging Wire, set a negative value. If the value in COPIER> DISPLAY> DPOT> PRIM-C is 1550 (micro A) or higher when E061-0101 (potential control error) occurs, set a positive value.
Use Case		- When an image failure occurs due to the soiled Primary Charging Wire - When E061-0101 occurs
Adj/Set/Operate Method		Enter the setting value (switch negative/positive by +/- key) and press OK key.
Display/Adj/Set Range		-50 to 220
Unit		V
Default Value		0
Related Service Mode		COPIER> DISPLAY> DPOT> PRIM-C
Amount of Change per Unit		1

■ HV-TR

COPIER (Service mode for printer) > ADJUST (Adjustment mode) > HV-TR

TR-OFS1	2	Adj trns tgt crrnt offset:plain1,2/color
Detail	To adjust the offset value of the target current of the Transfer Roller for plain paper 1, 2/colored paper. Enter the offset value in the right column. The left 2 columns are not used.	
Use Case	When transfer failure occurs	
Adj/Set/Operate Method	Enter the setting value (switch negative/positive by -/+ key) and press OK key.	
Display/Adj/Set Range	-10 to 10	
Unit	uA	
Default Value	0	
Related Service Mode	COPIER> ADJUST> HV-TR> TR-OFS2 - 6	
Amount of Change per Unit	5	
TR-OFS2	2	Adj trns tgt crrnt offset: pln3/hvy1-4
Detail	To adjust the offset value of the target current of the Transfer Roller for plain paper 3 and heavy paper 1 to 4. Enter the offset value in the right column. The left 2 columns are not used.	
Use Case	When transfer failure occurs	
Adj/Set/Operate Method	Enter the setting value (switch negative/positive by -/+ key) and press OK key.	
Display/Adj/Set Range	-10 to 10	
Unit	uA	
Default Value	0	
Related Service Mode	COPIER> ADJUST> HV-TR> TR-OFS1, 3 - 8	
Amount of Change per Unit	5	
TR-OFS3	2	Adj trns tgt crrnt offset: heavy 5, 6
Detail	To adjust the offset value of the target current of the Transfer Roller for heavy paper 5 and 6. Enter the offset value in the right column. The left 2 columns are not used.	
Use Case	When transfer failure occurs	
Adj/Set/Operate Method	Enter the setting value (switch negative/positive by -/+ key) and press OK key.	
Display/Adj/Set Range	-10 to 10	
Unit	uA	
Default Value	0	
Related Service Mode	COPIER> ADJUST> HV-TR> TR-OFS1, 2, 4 - 6	
Amount of Change per Unit	5	
TR-OFS4	2	Adj transfer tgt current offset: Thin
Detail	To adjust the offset value of the target current of the Transfer Roller for thin paper. Enter the offset value in the right column. The left 2 columns are not used.	
Use Case	When transfer failure occurs	
Adj/Set/Operate Method	Enter the setting value (switch negative/positive by -/+ key) and press OK key.	
Display/Adj/Set Range	-10 to 10	
Unit	uA	
Default Value	0	
Related Service Mode	COPIER> ADJUST> HV-TR> TR-OFS1 - 3, 5 - 6	
Amount of Change per Unit	5	

COPIER (Service mode for printer) > ADJUST (Adjustment mode) > HV-TR

TR-OFS5	2	Adj trns tgt crrent offset: Spec ppr, 1st
Detail	To adjust the offset value of the target current of the Transfer Roller when feeding 1st side of the specified paper. Enter the offset value in the right column. The left 2 columns are not used. Set the paper type with TR-SP1.	
Use Case	When transfer failure occurs	
Adj/Set/Operate Method	Enter the setting value (switch negative/positive by -/+ key) and press OK key.	
Display/Adj/Set Range	-10 to 10	
Unit	uA	
Default Value	0	
Related Service Mode	COPIER> ADJUST> HV-TR> TR-OFS1 - 4, 6, TR-SP1	
Amount of Change per Unit	5	
TR-OFS6	2	Adj trns tgt crrent offset: Spec ppr, 2nd
Detail	To adjust the offset value of the target current of the Transfer Roller when feeding 2nd side of the specified paper. Enter the offset value in the right column. The left 2 columns are not used. Set the paper type with TR-SP2.	
Use Case	When transfer failure occurs	
Adj/Set/Operate Method	Enter the setting value (switch negative/positive by -/+ key) and press OK key.	
Display/Adj/Set Range	-10 to 10	
Unit	uA	
Default Value	0	
Related Service Mode	COPIER> ADJUST> HV-TR> TR-OFS1 - 5, TR-SP2	
Amount of Change per Unit	5	
TR-L-OF1	2	Adj lead edge trns tgt crrent ofst:Plain
Detail	To adjust the leading edge transfer target current and the offset value of leading edge transfer bias output timing for plain paper.	
Use Case	When a drum separation failure occurs	
Adj/Set/Operate Method	Enter the setting value (switch negative/positive by -/+ key) and press OK key.	
Display/Adj/Set Range	Leading edge transfer target current offset value: -2 to 10 Offset value of leading edge transfer bias output timing: 0 to 20	
Unit	uA	
Default Value	0	
Related Service Mode	COPIER> ADJUST> HV-TR> TR-L-OF2 - 6	
Amount of Change per Unit	5	
TR-L-OF2	2	Adj lead edge trns tgt crrent:pln3/hvy1-4
Detail	To adjust the leading edge transfer target current and the offset value of leading edge transfer bias output timing for plain paper 3 and heavy paper 1 to 4.	
Use Case	When a drum separation failure occurs	
Adj/Set/Operate Method	Enter the setting value (switch negative/positive by -/+ key) and press OK key.	
Display/Adj/Set Range	Leading edge transfer target current offset value: -2 to 10 Offset value of leading edge transfer bias output timing: 0 to 20	
Unit	uA	
Default Value	0	
Related Service Mode	COPIER> ADJUST> HV-TR> TR-L-OF1, 3 - 6	
Amount of Change per Unit	5	

COPIER (Service mode for printer) > ADJUST (Adjustment mode) > HV-TR

TR-L-OF3	2	Adj lead edge trns tgt crnt ofst:hvy5,6
Detail	To adjust the leading edge transfer target current and the offset value of leading edge transfer bias output timing for heavy paper 5 and 6.	
Use Case	When a drum separation failure occurs	
Adj/Set/Operate Method	Enter the setting value (switch negative/positive by -/+ key) and press OK key.	
Display/Adj/Set Range	Leading edge transfer target current offset value: -2 to 10 Offset value of leading edge transfer bias output timing: 0 to 20	
Unit	uA	
Default Value	0	
Related Service Mode	COPIER> ADJUST> HV-TR> TR-L-OF1, 2, 4 - 6	
Amount of Change per Unit	5	
TR-L-OF4	2	Adj lead edge trns tgt crnt ofst: Thin
Detail	To adjust the leading edge transfer target current and the offset value of leading edge transfer bias output timing for thin paper.	
Use Case	When a drum separation failure occurs	
Adj/Set/Operate Method	Enter the setting value (switch negative/positive by -/+ key) and press OK key.	
Display/Adj/Set Range	Leading edge transfer target current offset value: -2 to 10 Offset value of leading edge transfer bias output timing: 0 to 20	
Unit	uA	
Default Value	0	
Related Service Mode	COPIER> ADJUST> HV-TR> TR-L-OF1 - 3, 5 - 6	
Amount of Change per Unit	5	
TR-L-OF5	2	Adj lead edg trn tgt crnt ofst:Spec,1st
Detail	To adjust the leading edge transfer target current and the offset value of leading edge transfer bias output timing when feeding 1st side of the specified paper. Set the paper type with TR-L-SP1.	
Use Case	When a drum separation failure occurs	
Adj/Set/Operate Method	Enter the setting value (switch negative/positive by -/+ key) and press OK key.	
Display/Adj/Set Range	Leading edge transfer target current offset value: -2 to 10 Offset value of leading edge transfer bias output timing: 0 to 20	
Unit	uA	
Default Value	0	
Related Service Mode	COPIER> ADJUST> HV-TR> TR-L-OF1 - 4, 6, TR-L-SP1	
Amount of Change per Unit	5	
TR-L-OF6	2	Adj lead edg trn tgt crnt ofst:Spec,2nd
Detail	To adjust the leading edge transfer target current and the offset value of leading edge transfer bias output timing when feeding 2nd side of the specified paper. Set the paper type with TR-L-SP2.	
Use Case	When a drum separation failure occurs	
Adj/Set/Operate Method	Enter the setting value (switch negative/positive by -/+ key) and press OK key.	
Display/Adj/Set Range	Leading edge transfer target current offset value: -2 to 10 Offset value of leading edge transfer bias output timing: 0 to 20	
Unit	uA	
Default Value	0	
Related Service Mode	COPIER> ADJUST> HV-TR> TR-L-OF1 - 5, TR-L-SP2	
Amount of Change per Unit	5	

COPIER (Service mode for printer) > ADJUST (Adjustment mode) > HV-TR

P-TR-OF1	2	Adj pre-trn chg crnt ofst: pln1,2/color
Detail	To adjust the offset value of the pre-transfer charging current for plain paper 1, 2/colored paper. Enter the offset value in the right column. The left 2 columns are not used.	
Use Case	When transfer failure occurs	
Adj/Set/Operate Method	Enter the setting value (switch negative/positive by -/+ key) and press OK key.	
Display/Adj/Set Range	-10 to 10	
Unit	uA	
Default Value	0	
Related Service Mode	COPIER> ADJUST> HV-TR> P-TR-OF2 - 6	
Amount of Change per Unit	10	
P-TR-OF2	2	Adj pre-trn chg crnt ofst: pln3/hvy1-4
Detail	To adjust the offset value of the pre-transfer charging current for plain paper 3 and heavy paper 1 to 4. Enter the offset value in the right column. The left 2 columns are not used.	
Use Case	When transfer failure occurs	
Adj/Set/Operate Method	Enter the setting value (switch negative/positive by -/+ key) and press OK key.	
Display/Adj/Set Range	-10 to 10	
Unit	uA	
Default Value	0	
Related Service Mode	COPIER> ADJUST> HV-TR> P-TR-OF1, 3 - 6	
Amount of Change per Unit	10	
P-TR-OF3	2	Adj pre-trn charge crnt ofst: heavy 5,6
Detail	To adjust the offset value of the pre-transfer charging current for heavy paper 5 and 6. Enter the offset value in the right column. The left 2 columns are not used.	
Use Case	When transfer failure occurs	
Adj/Set/Operate Method	Enter the setting value (switch negative/positive by -/+ key) and press OK key.	
Display/Adj/Set Range	-10 to 10	
Unit	uA	
Default Value	0	
Related Service Mode	COPIER> ADJUST> HV-TR> P-TR-OF1, 2, 4 - 6	
Amount of Change per Unit	10	
P-TR-OF4	2	Adj of pre-trn charge crnt ofst: Thin
Detail	To adjust the offset value of the pre-transfer charging current for thin paper. Enter the offset value in the right column. The left 2 columns are not used.	
Use Case	When transfer failure occurs	
Adj/Set/Operate Method	Enter the setting value (switch negative/positive by -/+ key) and press OK key.	
Display/Adj/Set Range	-10 to 10	
Unit	uA	
Default Value	0	
Related Service Mode	COPIER> ADJUST> HV-TR> P-TR-OF1 - 3, 5 - 6	
Amount of Change per Unit	10	

COPIER (Service mode for printer) > ADJUST (Adjustment mode) > HV-TR

P-TR-OF5	2	Adj pre-trn chg crnt ofst: Spec ppr,1st
Detail	To adjust the offset value of the pre-transfer charging current when feeding 1st side of the specified paper. Enter the offset value in the right column. The left 2 columns are not used. Set the paper type with P-TR-SP1.	
Use Case	When transfer failure occurs	
Adj/Set/Operate Method	Enter the setting value (switch negative/positive by +/- key) and press OK key.	
Display/Adj/Set Range	-10 to 10	
Unit	uA	
Default Value	0	
Related Service Mode	COPIER> ADJUST> HV-TR> P-TR-OF1 - 4, 6, P-TR-SP1	
Amount of Change per Unit	10	
P-TR-OF6	2	Adj pre-trn chg crnt ofst: Spec ppr,2nd
Detail	To adjust the offset value of the pre-transfer charging current when feeding 2nd side of the specified paper. Enter the offset value in the right column. The left 2 columns are not used. Set the paper type with P-TR-SP2.	
Use Case	When transfer failure occurs	
Adj/Set/Operate Method	Enter the setting value (switch negative/positive by +/- key) and press OK key.	
Display/Adj/Set Range	-10 to 10	
Unit	uA	
Default Value	0	
Related Service Mode	COPIER> ADJUST> HV-TR> P-TR-OF1 - 5, P-TR-SP2	
Amount of Change per Unit	10	
TR-SP1	2	Set ppr type(1st) for trns tgt crnt adj
Detail	To set the paper type (1st side) which the target current of the Transfer Roller is adjusted. Set the offset value of the current with TR-OFS5.	
Use Case	When transfer failure occurs	
Adj/Set/Operate Method	Enter the setting value, and then press OK key.	
Display/Adj/Set Range	0 to 10 0: No specification, 1: Transparency, 2: Postcard, 3: Tracing paper, 4: Bond paper, 5: Labels, 6: Recycled paper, 7: Not used, 8: Punched paper, 9: Tab paper, 10: Letterhead	
Default Value	0	
Related Service Mode	COPIER> ADJUST> HV-TR> TR-OFS5	
TR-SP2	2	Set ppr type(2nd) for trns tgt crnt adj
Detail	To set the paper type (2nd side) which the target current of the Transfer Roller is adjusted. Set the offset value of the current with TR-OFS6.	
Use Case	When transfer failure occurs	
Adj/Set/Operate Method	Enter the setting value, and then press OK key.	
Display/Adj/Set Range	0 to 10 0: No specification, 1: Transparency, 2: Postcard, 3: Tracing paper, 4: Bond paper, 5: Labels, 6: Recycled paper, 7: Not used, 8: Punched paper, 9: Tab paper, 10: Letterhead	
Default Value	0	
Related Service Mode	COPIER> ADJUST> HV-TR> TR-OFS6	

COPIER (Service mode for printer) > ADJUST (Adjustment mode) > HV-TR

TR-L-SP1	2	Set ppr(1st): lead edg trn tgt crnt adj
Detail		To set the paper type (1st side) which the leading edge transfer target current and the leading edge transfer bias output timing are adjusted. Set the offset values with TR-L-OF5.
Use Case		When a drum separation failure occurs
Adj/Set/Operate Method		Enter the setting value, and then press OK key.
Display/Adj/Set Range		0 to 10 0: No specification, 1: Transparency, 2: Postcard, 3: Tracing paper, 4: Bond paper, 5: Labels, 6: Recycled paper, 7: Plain paper/Colored paper, 8: Punched paper, 9: Tab paper, 10: Letterhead
Default Value		0
Related Service Mode		COPIER> ADJUST> HV-TR> TR-L-OF5
TR-L-SP2	2	Set ppr(2nd): lead edg trn tgt crnt adj
Detail		To set the paper type (2nd side) which the leading edge transfer target current and the leading edge transfer bias output timing are adjusted. Set the offset values with TR-L-OF6.
Use Case		When a drum separation failure occurs
Adj/Set/Operate Method		Enter the setting value, and then press OK key.
Display/Adj/Set Range		0 to 10 0: No specification, 1: Transparency, 2: Postcard, 3: Tracing paper, 4: Bond paper, 5: Labels, 6: Recycled paper, 7: Plain paper/Colored paper, 8: Punched paper, 9: Tab paper, 10: Letterhead
Default Value		0
Related Service Mode		COPIER> ADJUST> HV-TR> TR-L-OF6
P-TR-SP1	2	Set ppr type(1st) for pre-trns chg crnt
Detail		To set the paper type (1st side) which the pre-transfer charging current is adjusted. Set the offset value of the current with P-TR-OF5.
Use Case		When transfer failure occurs
Adj/Set/Operate Method		Enter the setting value, and then press OK key.
Display/Adj/Set Range		0 to 10 0: No specification, 1: Transparency, 2: Postcard, 3: Tracing paper, 4: Bond paper, 5: Labels, 6: Recycled paper, 7: Not used, 8: Punched paper, 9: Tab paper, 10: Letterhead
Default Value		0
Related Service Mode		COPIER> ADJUST> HV-TR> P-TR-OF5
P-TR-SP2	2	Set ppr type(2nd) for pre-trns chg crnt
Detail		To set the paper type (2nd side) which the pre-transfer charging current is adjusted. Set the offset value of the current with P-TR-OF6.
Use Case		When transfer failure occurs
Adj/Set/Operate Method		Enter the setting value, and then press OK key.
Display/Adj/Set Range		0 to 10 0: No specification, 1: Transparency, 2: Postcard, 3: Tracing paper, 4: Bond paper, 5: Labels, 6: Recycled paper, 7: Not used, 8: Punched paper, 9: Tab paper, 10: Letterhead
Default Value		0
Related Service Mode		COPIER> ADJUST> HV-TR> P-TR-OF6

■ FEED-ADJ

COPIER (Service mode for printer) > ADJUST (Adjustment mode) > FEED-ADJ

REGIST	1	Adj register start timing: </=90g/m2, 1st
Detail	<p>To adjust the leading edge margin by changing the timing to turn ON the Registration Motor when feeding the 1st side of paper which paper weight is 90 g/m2 or less (excluding transparency and clear film).</p> <p>As the value is incremented by 1, the margin on the leading edge of paper is increased by 0.1 mm.</p> <p>+: Top margin becomes smaller. (An image moves upward.)</p> <p>-: Top margin becomes larger. (An image moves downward.)</p> <p>When replacing the DC Controller PCB/clearing RAM data, enter the value of service label.</p>	
Use Case	When replacing the DC Controller PCB/clearing RAM data	
Adj/Set/Operate Method	Enter the setting value (switch negative/positive by +/- key) and press OK key.	
Display/Adj/Set Range	-50 to 50	
Unit	mm	
Default Value	0	
Amount of Change per Unit	0.1	
ADJ-C1	1	Right Deck write start pstn in horz scan
Detail	<p>To adjust the image write start position in the horizontal scanning direction when feeding paper from the Right Deck.</p> <p>As the value is incremented by 1, the margin on the left edge of paper is increased by 0.1 mm.</p> <p>+: Left margin becomes larger. (An image moves to the right.)</p> <p>-: Left margin becomes smaller. (An image moves to the left.)</p> <p>When replacing the DC Controller PCB/clearing RAM data, enter the value of service label.</p>	
Use Case	When replacing the DC Controller PCB/clearing RAM data	
Adj/Set/Operate Method	Enter the setting value (switch negative/positive by +/- key) and press OK key.	
Caution	If write start position cannot be adjusted in service mode, execute mechanical adjustment.	
Display/Adj/Set Range	-20 to 20	
Unit	mm	
Default Value	0	
Amount of Change per Unit	0.1	
ADJ-C2	1	Left Deck write start pstn in horz scan
Detail	<p>To adjust the image write start position in the horizontal scanning direction when feeding paper from the Left Deck.</p> <p>As the value is incremented by 1, the margin on the left edge of paper is increased by 0.1 mm.</p> <p>+: Left margin becomes larger. (An image moves to the right.)</p> <p>-: Left margin becomes smaller. (An image moves to the left.)</p> <p>When replacing the DC Controller PCB/clearing RAM data, enter the value of service label.</p>	
Use Case	When replacing the DC Controller PCB/clearing RAM data	
Adj/Set/Operate Method	Enter the setting value (switch negative/positive by +/- key) and press OK key.	
Caution	If write start position cannot be adjusted in service mode, execute mechanical adjustment.	
Display/Adj/Set Range	-20 to 20	
Unit	mm	
Default Value	0	
Amount of Change per Unit	0.1	

COPIER (Service mode for printer) > ADJUST (Adjustment mode) > FEED-ADJ

ADJ-C3	1	Cassette 3 write start pstn in horz scan
Detail	To adjust the image write start position in the horizontal scanning direction when feeding paper from the Cassette 3. As the value is incremented by 1, the margin on the left edge of paper is increased by 0.1 mm. +: Left margin becomes larger. (An image moves to the right.) -: Left margin becomes smaller. (An image moves to the left.) When replacing the DC Controller PCB/clearing RAM data, enter the value of service label.	
Use Case	When replacing the DC Controller PCB/clearing RAM data	
Adj/Set/Operate Method	Enter the setting value (switch negative/positive by +/- key) and press OK key.	
Caution	If write start position cannot be adjusted in service mode, execute mechanical adjustment.	
Display/Adj/Set Range	-20 to 20	
Unit	mm	
Default Value	0	
Amount of Change per Unit	0.1	
ADJ-C4	1	Cassette 4 write start pstn in horz scan
Detail	To adjust the image write start position in the horizontal scanning direction when feeding paper from the Cassette 4. As the value is incremented by 1, the margin on the left edge of paper is increased by 0.1 mm. +: Left margin becomes larger. (An image moves to the right.) -: Left margin becomes smaller. (An image moves to the left.) When replacing the DC Controller PCB/clearing RAM data, enter the value of service label.	
Use Case	When replacing the DC Controller PCB/clearing RAM data	
Adj/Set/Operate Method	Enter the setting value (switch negative/positive by +/- key) and press OK key.	
Caution	If write start position cannot be adjusted in service mode, execute mechanical adjustment.	
Display/Adj/Set Range	-20 to 20	
Unit	mm	
Default Value	0	
Amount of Change per Unit	0.1	
ADJ-MF	1	Write start pstn in horz scan: MP Tray
Detail	To adjust the image write start position in the horizontal scanning direction when feeding paper from the Multi-purpose Tray. As the value is incremented by 1, the margin on the left edge of paper is increased by 0.1 mm. +: Left margin becomes larger. (An image moves to the right.) -: Left margin becomes smaller. (An image moves to the left.) When replacing the DC Controller PCB/clearing RAM data, enter the value of service label.	
Use Case	When replacing the DC Controller PCB/clearing RAM data	
Adj/Set/Operate Method	Enter the setting value (switch negative/positive by +/- key) and press OK key.	
Caution	If write start position cannot be adjusted in service mode, execute mechanical adjustment.	
Display/Adj/Set Range	-20 to 20	
Unit	mm	
Default Value	0	
Amount of Change per Unit	0.1	

COPIER (Service mode for printer) > ADJUST (Adjustment mode) > FEED-ADJ

ADJ-DK	1	Write start pstn in horz scan:Deck/POD D
Detail	<p>To adjust the image write start position in the horizontal scanning direction when feeding paper from the Paper Deck/ POD Deck Lite.</p> <p>As the value is incremented by 1, the margin on the left edge of paper is increased by 0.1 mm. +: Left margin becomes larger. (An image moves to the right.) -: Left margin becomes smaller. (An image moves to the left.)</p> <p>When replacing the DC Controller PCB/clearing RAM data, enter the value of service label.</p>	
Use Case	When replacing the DC Controller PCB/clearing RAM data	
Adj/Set/Operate Method	Enter the setting value (switch negative/positive by +/- key) and press OK key.	
Caution	If write start position cannot be adjusted in service mode, execute mechanical adjustment.	
Display/Adj/Set Range	-20 to 20	
Unit	mm	
Default Value	0	
Amount of Change per Unit	0.1	
ADJ-REFE	1	Write start pstn in horz scan: 2nd side
Detail	<p>To adjust the image write start position on the second side in the horizontal scanning direction. The image write start position is set in the relative amount against the first side regardless of the paper pickup cassette/tray/deck.</p> <p>As the value is incremented by 1, the margin on the left edge of paper is increased by 0.1 mm. +: Left margin becomes larger. (An image moves to the right.) -: Left margin becomes smaller. (An image moves to the left.)</p> <p>When replacing the DC Controller PCB/clearing RAM data, enter the value of service label.</p>	
Use Case	When replacing the DC Controller PCB/clearing RAM data	
Adj/Set/Operate Method	Enter the setting value (switch negative/positive by +/- key) and press OK key.	
Display/Adj/Set Range	-50 to 50	
Unit	mm	
Default Value	0	
Amount of Change per Unit	0.1	
RG-MF	1	Adj register start tmg:</=90g/m2,MP Tray
Detail	<p>To adjust the leading edge margin by changing the timing to turn ON the Registration Motor when feeding paper which paper weight is 90 g/m2 or less (excluding transparency and clear film) from the Multi-purpose Tray.</p> <p>As the value is incremented by 1, the margin on the leading edge of paper is increased by 0.1 mm. +: Top margin becomes smaller. (An image moves upward.) -: Top margin becomes larger. (An image moves downward.)</p>	
Adj/Set/Operate Method	Enter the setting value (switch negative/positive by +/- key) and press OK key.	
Display/Adj/Set Range	-50 to 50	
Default Value	0	
Amount of Change per Unit	0.1	

COPIER (Service mode for printer) > ADJUST (Adjustment mode) > FEED-ADJ

REG-THCK	1	Adj register start timing: >/= 91g/m2
Detail	To adjust the leading edge margin by changing the timing to turn ON the Registration Motor when feeding paper which paper weight is 91 g/m2 or more (excluding transparency and clear film). As the value is incremented by 1, the margin on the leading edge of paper is increased by 0.1 mm. +: Top margin becomes smaller. (An image moves upward.) -: Top margin becomes larger. (An image moves downward.)	
Adj/Set/Operate Method	Enter the setting value (switch negative/positive by -/+ key) and press OK key.	
Display/Adj/Set Range	-50 to 50	
Default Value	0	
Amount of Change per Unit	0.1	
REG-OHT	1	Adj register start tmng:trnsp, clear film
Detail	To adjust the leading edge margin by changing the timing to turn ON the Registration Motor when feeding transparency/clear film. As the value is incremented by 1, the margin on the leading edge of paper is increased by 0.1 mm. +: Top margin becomes smaller. (An image moves upward.) -: Top margin becomes larger. (An image moves downward.)	
Adj/Set/Operate Method	Enter the setting value (switch negative/positive by -/+ key) and press OK key.	
Display/Adj/Set Range	-50 to 50	
Default Value	0	
Amount of Change per Unit	0.1	
REG-DUP1	1	Adj register start timing:</=90g/m2, 2nd
Detail	To adjust the leading edge margin by changing the timing to turn ON the Registration Motor when feeding the 2nd side of paper which paper weight is 90 g/m2 or less. As the value is incremented by 1, the margin on the leading edge of paper is increased by 0.1 mm. +: Top margin becomes smaller. (An image moves upward.) -: Top margin becomes larger. (An image moves downward.)	
Use Case	When adjusting the leading edge margin	
Adj/Set/Operate Method	Enter the setting value (switch negative/positive by -/+ key) and press OK key.	
Display/Adj/Set Range	-50 to 50	
Default Value	0	
Amount of Change per Unit	0.1	
REG-DUP2	1	Adj register start timing:>/=91g/m2, 2nd
Detail	To adjust the leading edge margin by changing the timing to turn ON the Registration Motor when feeding the 2nd side of paper which paper weight is 91 g/m2 or more. As the value is incremented by 1, the margin on the leading edge of paper is increased by 0.1 mm. +: Top margin becomes smaller. (An image moves upward.) -: Top margin becomes larger. (An image moves downward.)	
Use Case	When adjusting the leading edge margin	
Adj/Set/Operate Method	Enter the setting value (switch negative/positive by -/+ key) and press OK key.	
Display/Adj/Set Range	-50 to 50	
Default Value	0	
Amount of Change per Unit	0.1	

COPIER (Service mode for printer) > ADJUST (Adjustment mode) > FEED-ADJ

LP-FEED1	1	Adj pre-rgst arch amnt: casstt,</=90g/m2
Detail	To adjust the arch amount before registration when feeding paper which paper weight is 90 g/m2 or less from a cassette. As the value is incremented by 1, the pre-registration arch amount changes by 0.1 mm. +: Increase -: Decrease	
Adj/Set/Operate Method	Enter the setting value (switch negative/positive by -/+ key) and press OK key.	
Display/Adj/Set Range	-50 to 50	
Unit	mm	
Default Value	0	
Amount of Change per Unit	0.1	
LP-FEED2	1	Adj pre-rgst arch amnt: casstt,>/=91g/m2
Detail	To adjust the arch amount before registration when feeding paper which paper weight is 91 g/m2 or more from a cassette. As the value is incremented by 1, the pre-registration arch amount changes by 0.1 mm. +: Increase -: Decrease	
Adj/Set/Operate Method	Enter the setting value (switch negative/positive by -/+ key) and press OK key.	
Display/Adj/Set Range	-50 to 50	
Unit	mm	
Default Value	0	
Amount of Change per Unit	0.1	
LP-MULT1	1	Adj pre-rgst arch amnt:MP Tray,</=90g/m2
Detail	To adjust the arch amount before registration when feeding paper which paper weight is 90 g/m2 or less from the Multi-purpose Tray. As the value is incremented by 1, the pre-registration arch amount changes by 0.1 mm. +: Increase -: Decrease	
Adj/Set/Operate Method	Enter the setting value (switch negative/positive by -/+ key) and press OK key.	
Display/Adj/Set Range	-50 to 50	
Unit	mm	
Default Value	0	
Amount of Change per Unit	0.1	
LP-MULT2	1	Adj pre-rgst arch amnt:MP Tray,>/=91g/m2
Detail	To adjust the arch amount before registration when feeding paper which paper weight is 91 g/m2 or more from the Multi-purpose Tray. As the value is incremented by 1, the pre-registration arch amount changes by 0.1 mm. +: Increase -: Decrease	
Adj/Set/Operate Method	Enter the setting value (switch negative/positive by -/+ key) and press OK key.	
Display/Adj/Set Range	-50 to 50	
Unit	mm	
Default Value	0	
Amount of Change per Unit	0.1	

COPIER (Service mode for printer) > ADJUST (Adjustment mode) > FEED-ADJ

LP-DUP1	1	Adj pre-rgst arch amnt: 2-side,</=90g/m2
Detail	To adjust the arch amount before registration when feeding paper which paper weight is 90 g/m2 or less in duplex mode. As the value is incremented by 1, the pre-registration arch amount changes by 0.1 mm. +: Increase -: Decrease	
Adj/Set/Operate Method	Enter the setting value (switch negative/positive by -/+ key) and press OK key.	
Display/Adj/Set Range	-50 to 50	
Unit	mm	
Default Value	0	
Amount of Change per Unit	0.1	
LP-DUP2	1	Adj pre-rgst arch amnt: 2-side,>/=91g/m2
Detail	To adjust the arch amount before registration when feeding paper which paper weight is 91 g/m2 or more in duplex mode. As the value is incremented by 1, the pre-registration arch amount changes by 0.1 mm. +: Increase -: Decrease	
Adj/Set/Operate Method	Enter the setting value (switch negative/positive by -/+ key) and press OK key.	
Display/Adj/Set Range	-50 to 50	
Unit	mm	
Default Value	0	
Amount of Change per Unit	0.1	
REG-SPD	1	Speed adj Registration Motor:1/1 speed
Detail	To adjust 1/1 speed of the Registration Motor. +: The speed is increased. -: The speed is decreased.	
Use Case	- At occurrence of an image failure - When the leading edge margin becomes larger due to wear of the Registration Roller	
Adj/Set/Operate Method	Enter the setting value (switch negative/positive by -/+ key) and press OK key.	
Display/Adj/Set Range	-50 to 50	
Default Value	0	
TBLT-SPD	1	Fine adjustment of ETB speed
Detail	To make a fine adjustment of the ETB speed. +: The speed is increased. -: The speed is decreased. When the speed is changed, image magnification in the vertical scanning direction is changed.	
Use Case	When image magnification is changed due to replacement of ETB, etc.	
Adj/Set/Operate Method	Enter the setting value (switch negative/positive by -/+ key) and press OK key.	
Display/Adj/Set Range	-200 to 200	
Unit	mm	
Default Value	0	
Amount of Change per Unit	0.1	

COPIER (Service mode for printer) > ADJUST (Adjustment mode) > FEED-ADJ

LP-DK	1	Adj pre-rgst arch amount: 1st side, Deck
Detail		To adjust the arch amount before registration for the 1st side of paper when feeding paper from POD Deck Lite/Paper Deck Unit. As the value is changed by 1, the arch amount is changed by 0.1 mm. +: Increase -: Decrease
Use Case		When skew occurs on the 1st side at the time of picking up paper from POD Deck Lite/Paper Deck Unit
Adj/Set/Operate Method		Enter the setting value (switch negative/positive by +/- key) and press OK key.
Caution		If the value is too large, paper wrinkles or paper bending may occur.
Display/Adj/Set Range		-50 to 50
Unit		mm
Default Value		0
Amount of Change per Unit		0.1
DK1-PKLV	2	Adjustment of paper surface height: Deck
Detail		To adjust the pickup position of the POD Deck Lite/Paper Deck Unit. As the value is changed by 1, the pickup position is moved by 1 mm. +: Move up -: Move down Increase the value when a pickup failure occurs, and decrease the value when double feed occurs.
Use Case		- When a pickup failure occurs - When double feed occurs
Adj/Set/Operate Method		Enter the setting value (switch negative/positive by +/- key) and press OK key.
Caution		If the value is too large, double feed may occur. If the value is too small, a pickup failure may occur.
Display/Adj/Set Range		-10 to 10 -10 to -1: Move down by 1 mm, 0: 0 mm, 1: Move up by 1 mm, 2 to 10: Move up by 2 mm
Unit		mm
Default Value		0
Amount of Change per Unit		1

■ CST-ADJ

COPIER (Service mode for printer) > ADJUST (Adjustment mode) > CST-ADJ

MF-A4R	1	Adj of MP Tray A4R paper width
Detail		To adjust the width of A4R paper in the Multi-purpose Tray. When replacing the DC Controller PCB/clearing RAM data, enter the value of service label. When replacing the Multi-purpose Tray Paper Width Detection PCB or registering a new value, execute COPIER> FUNCTION> CST> A4R.
Use Case		- When replacing the DC Controller PCB/clearing RAM data - When replacing the Multi-purpose Tray Paper Width Detection PCB or registering a new value
Adj/Set/Operate Method		Enter the setting value, and then press OK key.
Caution		After the setting value is changed, write the changed value in the service label.
Display/Adj/Set Range		0 to 255
Related Service Mode		COPIER> FUNCTION> CST> A4R

COPIER (Service mode for printer) > ADJUST (Adjustment mode) > CST-ADJ

MF-A6R	1	Adj of MP Tray A6R paper width
Detail	To adjust the width of A6R paper in the Multi-purpose Tray. When replacing the DC Controller PCB/clearing RAM data, enter the value of service label. When replacing the Multi-purpose Tray Paper Width Detection PCB or registering a new value, execute COPIER> FUNCTION> CST> A6R.	
Use Case	- When replacing the DC Controller PCB/clearing RAM data - When replacing the Multi-purpose Tray Paper Width Detection PCB or registering a new value	
Adj/Set/Operate Method	Enter the setting value, and then press OK key.	
Caution	After the setting value is changed, write the changed value in the service label.	
Display/Adj/Set Range	0 to 255	
Related Service Mode	COPIER> FUNCTION> CST> A6R	
MF-A4	1	Adj of MP Tray A4 paper width
Detail	To adjust the width of A4 paper in the Multi-purpose Tray. When replacing the DC Controller PCB/clearing RAM data, enter the value of service label. When replacing the Multi-purpose Tray Paper Width Detection PCB or registering a new value, execute COPIER> FUNCTION> CST> A4.	
Use Case	- When replacing the DC Controller PCB/clearing RAM data - When replacing the Multi-purpose Tray Paper Width Detection PCB or registering a new value	
Adj/Set/Operate Method	Enter the setting value, and then press OK key.	
Caution	After the setting value is changed, write the changed value in the service label.	
Display/Adj/Set Range	0 to 255	
Related Service Mode	COPIER> FUNCTION> CST> A4	
PDK-A4	1	Adj of POD Deck Lite A4 paper width
Detail	To adjust the width of A4 paper in the POD Deck Lite. When replacing the DC Controller PCB/clearing RAM data, enter the value of service label. When replacing the Paper Width Sensor PCB or registering a new value, execute COPIER> FUNCTION> CST> PDK-A4.	
Use Case	- When replacing the DC Controller PCB/clearing RAM data - When replacing the Paper Width Sensor PCB or registering a new value	
Adj/Set/Operate Method	1) Enter the setting value, and then press OK key. 2) Turn OFF/ON the main power switch.	
Caution	After the setting value is changed, write the changed value in the service label.	
Display/Adj/Set Range	0 to 1023	
Default Value	0	
Related Service Mode	COPIER> FUNCTION> CST> PDK-A4	
PDK-A5R	1	Adj of POD Deck Lite A5R paper width
Detail	To adjust the width of A5R paper in the POD Deck Lite. When replacing the DC Controller PCB/clearing RAM data, enter the value of service label. When replacing the Paper Width Sensor PCB or registering a new value, execute COPIER> FUNCTION> CST> PDK-A5R.	
Use Case	- When replacing the DC Controller PCB/clearing RAM data - When replacing the Paper Width Sensor PCB or registering a new value	
Adj/Set/Operate Method	1) Enter the setting value, and then press OK key. 2) Turn OFF/ON the main power switch.	
Caution	After the setting value is changed, write the changed value in the service label.	
Display/Adj/Set Range	0 to 1023	
Default Value	0	
Related Service Mode	COPIER> FUNCTION> CST> PDK-A5R	

■ MISC

COPIER (Service mode for printer) > ADJUST (Adjustment mode) > MISC

SEG-ADJ	1	Set criteria for text/photo: front side
Detail		To set the judgment level of text/photo original in Text/Photo/Map mode. As the value is increased, the original tends to be detected as a photo document, and as the value is decreased, the original tends to be detected as a text document.
Use Case		When adjusting the classification level of text and photo in Text/Photo/Map mode
Adj/Set/Operate Method		1) Enter the setting value (switch negative/positive by +/- key) and press OK key. 2) Turn OFF/ON the main power switch.
Display/Adj/Set Range		-4 to 4
Default Value		0
K-ADJ	1	Set criteria for black text: front side
Detail		To set the judgment level of black characters at text processing. As the value is increased, the text tends to be detected as black.
Use Case		When preferring the text to be judged as black
Adj/Set/Operate Method		1) Enter the setting value (switch negative/positive by +/- key) and press OK key. 2) Turn OFF/ON the main power switch.
Display/Adj/Set Range		-3 to 3
Default Value		0
ACS-ADJ	1	Set criteria for B&W/color in ACS:front
Detail		To set the judgment level of B&W/color original in ACS mode. As the value is increased, the original tends to be detected as a B&W document, and as the value is decreased, the original tends to be detected as a color document.
Use Case		When adjusting the color detection level in ACS mode
Adj/Set/Operate Method		1) Enter the setting value (switch negative/positive by +/- key) and press OK key. 2) Turn OFF/ON the main power switch.
Display/Adj/Set Range		-3 to 3
Default Value		0
ACS-EN	2	Set judgment area in ACS mode:front side
Detail		To set the judgment area in ACS mode. As the greater value is set, the judgment area is widened.
Use Case		When adjusting the judgment area in ACS mode
Adj/Set/Operate Method		1) Enter the setting value (switch negative/positive by +/- key) and press OK key. 2) Turn OFF/ON the main power switch.
Display/Adj/Set Range		-2 to 2
Default Value		1
ACS-CNT	2	Set judgment pixel count area in ACS:front
Detail		To set the area which counts the pixel to judge the color presence in ACS mode. As the greater value is set, the judgment area is widened.
Use Case		When adjusting the area which counts the pixel to judge the color presence in ACS mode
Adj/Set/Operate Method		1) Enter the setting value (switch negative/positive by +/- key) and press OK key. 2) Turn OFF/ON the main power switch.
Display/Adj/Set Range		-2 to 2
Default Value		0

COPIER (Service mode for printer) > ADJUST (Adjustment mode) > MISC

ACS-EN2	2	Set ACS mode jdgmt area in DADF mode
Detail	To set the judgment area in ACS mode at DADF reading. As the greater value is set, the judgment area is widened.	
Use Case	When adjusting the judgment area in ACS mode at DADF reading	
Adj/Set/Operate Method	1) Enter the setting value (switch negative/positive by +/- key) and press OK key. 2) Turn OFF/ON the main power switch.	
Display/Adj/Set Range	-2 to 2	
Default Value	1	
ACS-CNT2	2	Set ACS jdgmt pixel count area in DADF
Detail	To set the area which counts the pixel to judge the color presence in ACS mode at DADF reading. As the greater value is set, the judgment area is widened.	
Use Case	When adjusting the area which counts the pixel to judge the color presence in ACS mode at DADF reading	
Adj/Set/Operate Method	1) Enter the setting value (switch negative/positive by +/- key) and press OK key. 2) Turn OFF/ON the main power switch.	
Display/Adj/Set Range	-2 to 2	
Default Value	0	
SEG-ADJ3	1	Set criteria for text/photo: back side
Detail	To set the judgment level of text/photo original in Text/Photo/Map mode (back side at duplex reading with 1 path). As the value is increased, the original tends to be detected as a photo document, and as the value is decreased, the original tends to be detected as a text document.	
Use Case	When adjusting the classification level of text and photo in Text/Photo/Map mode (back side at duplex reading with 1 path)	
Adj/Set/Operate Method	1) Enter the setting value (switch negative/positive by +/- key) and press OK key. 2) Turn OFF/ON the main power switch.	
Display/Adj/Set Range	-4 to 4	
Default Value	0	
K-ADJ3	1	Set criteria for black text: back side
Detail	To set the judgment level of black characters at text processing (back side at duplex reading with 1 path). As the value is increased, the text tends to be detected as black.	
Use Case	When preferring the text to be judged as black (back side at duplex reading with 1 path)	
Adj/Set/Operate Method	1) Enter the setting value (switch negative/positive by +/- key) and press OK key. 2) Turn OFF/ON the main power switch.	
Display/Adj/Set Range	-3 to 3	
Default Value	0	
ACS-ADJ3	1	Set ACS B&W/color jdgmt stdrd:back side
Detail	To set the judgment level of B&W/color original in ACS mode (back side at duplex reading with 1 path). As the value is increased, the original tends to be detected as a B&W document, and as the value is decreased, the original tends to be detected as a color document.	
Use Case	When adjusting the color detection level in ACS mode (back side at duplex reading with 1 path)	
Adj/Set/Operate Method	1) Enter the setting value (switch negative/positive by +/- key) and press OK key. 2) Turn OFF/ON the main power switch.	
Display/Adj/Set Range	-3 to 3	
Default Value	0	

COPIER (Service mode for printer) > ADJUST (Adjustment mode) > MISC

ACS-EN3	2	Set of ACS mode jdgmt area: back side
Detail	To set the judgment area in ACS mode (back side at duplex reading with 1 path). As the greater value is set, the judgment area is widened.	
Use Case	When adjusting the judgment area in ACS mode (back side at duplex reading with 1 path)	
Adj/Set/Operate Method	1) Enter the setting value (switch negative/positive by +/- key) and press OK key. 2) Turn OFF/ON the main power switch.	
Display/Adj/Set Range	-2 to 2	
Default Value	1	
ACS-CNT3	2	ACS mode jdgmt pixel count area: back
Detail	To set the area which counts the pixel to judge the color presence in ACS mode (back side at duplex reading with 1 path). As the greater value is set, the judgment area is widen.	
Use Case	When adjusting the area which counts the pixel to judge the color presence in ACS mode (back side at duplex reading with 1 path)	
Adj/Set/Operate Method	1) Enter the setting value (switch negative/positive by +/- key) and press OK key. 2) Turn OFF/ON the main power switch.	
Display/Adj/Set Range	-2 to 2	
Default Value	0	
TBSIS-WB	2	Setting of blank band ejection time
Detail	To set the blank band ejection time. As the value is incremented by 1, the ejection time changes by 0.1 second. +: Increase -: Decrease	
Use Case	When an image failure (streaks of uneven density) occurs	
Adj/Set/Operate Method	Enter the setting value (switch negative/positive by +/- key) and press OK key.	
Caution	When a positive value is set, the ejection time increases.	
Display/Adj/Set Range	0 to 100	
Unit	sec	
Default Value	0	
Amount of Change per Unit	0.1	
HP-OFST	1	Setting of 2D shading drum HP offset
Detail	To set the home position of Photosensitive Drum in the vertical scanning direction at 2D shading. As the value is incremented by 1, the home position moves by 10 mm.	
Use Case	When adjusting the home position of the Photosensitive Drum at the replacement of the drum	
Adj/Set/Operate Method	Enter the setting value (switch negative/positive by +/- key) and press OK key.	
Display/Adj/Set Range	-5 to 5	
Unit	mm	
Default Value	0	
Amount of Change per Unit	10	

■ EXP-LED

COPIER (Service mode for printer) > ADJUST (Adjustment mode) > EXP-LED

PR-EXP	2	Setting of Pre-exposure LED current
Detail		To set the current of the Cleaning Pre-exposure LED. Increase the value when taking a measure for drum ghost. Decrease the value when potential is not applied well.
Use Case		- When drum ghost is significant (drum pitch is not correct) - When potential is not applied well
Adj/Set/Operate Method		1) Enter the setting value, and then press OK key. 2) Turn OFF/ON the main power switch.
Display/Adj/Set Range		110 to 233
Unit		mA
Default Value		213
Amount of Change per Unit		0.4

FUNCTION (Operation / inspection mode)

■ INSTALL

COPIER (Service mode for printer) > FUNCTION (Operation / inspection mode) > INSTALL

TONER-S	1	Toner supply to Developing Assembly
Detail		To execute a series of operation necessary for supplying toner to the Developing Assembly/Toner Supply area (drive the Developing Cylinder, Toner Stirring/Feed Member, Photosensitive Drum and ETB, and output developing bias) as a whole. After counting down from 600 seconds, it is automatically stopped.
Use Case		- At installation - When replacing the Developing Assembly - When replacing toner in the Developing Assembly
Adj/Set/Operate Method		1) Select the items. "Check the Developer" is displayed. 2) Check connection, and then press OK key. It automatically stops after 10 minutes.
Caution		- Although "Check the Developer" is displayed when selecting the item, be sure to check the connection between the Developing Assembly and connector in advance. - The operation can be stopped manually with OK key when a failure occurs.
Display/Adj/Set Range		During operation: xxx second (remaining time), When operation finished normally: END
Default Value		600
Required Time		13 min
STRD-POS	1	Auto adj frt side read pstn: stream read
Detail		To automatically adjust the Scanner Unit (for front side) position in feed direction when stream reading original with DADF. The adjustment result is reflected to COPIER> ADJUST> ADJ-XY> STRD-POS.
Use Case		At DADF installation/uninstallation
Adj/Set/Operate Method		1) Set a paper for stream reading position adjustment, and then close the DADF. 2) Select the item, and then press OK key. The operation automatically stops after the adjustment. 3) Write the value displayed by COPIER> ADJUST> ADJ-XY> STRD-POS in the service label.
Caution		Write the adjusted value in the service label.
Display/Adj/Set Range		At normal termination: OK!, At abnormal termination: NG!
Related Service Mode		COPIER> ADJUST> ADJ-XY> STRD-POS
Supplement/Memo		For the details of paper for stream reading position adjustment, refer to the Service Manual.

COPIER (Service mode for printer) > FUNCTION (Operation / inspection mode) > INSTALL

CARD	1	Card number setting
Detail		To set the card number to be used for Card Reader. A series of numbers from the entered number to the number of cards specified by CARD-RNG can be used.
Use Case		- At installation of the Card Reader - After replacement of the HDD
Adj/Set/Operate Method		1) Enter the number, and then press OK key. 2) Turn OFF/ON the main power switch.
Caution		The card management information (department ID and password) is initialized.
Display/Adj/Set Range		1 to 2001
Default Value		1
Related Service Mode		COPIER> OPTION> FNC-SW> CARD-RNG
E-RDS	1	ON/OFF of Embedded-RDS
Detail		To set whether to use the E-RDS.
Use Case		When using Embedded-RDS
Adj/Set/Operate Method		1) Enter the setting value, and then press OK key. 2) Turn OFF/ON the main power switch.
Caution		Be sure to use E-RDS, RGW-PORT, COM-TEST, COM-LOG and RGW-ADR as a set.
Display/Adj/Set Range		0 to 1 0: Not used, 1: Used (All the counter information is sent.)
Default Value		It differs according to the location.
Related Service Mode		COPIER> FUNCTION> INSTALL> RGW-PORT, COM-TEST, COM-LOG, RGW-ADR COPIER> FUNCTION> CLEAR> ERDS-DAT
Supplement/Memo		Embedded-RDS: Function to send device information such as the device counter, failure, and consumables to the sales company's server via SOAP protocol
RGW-PORT	1	Set port number of Sales Co's server
Detail		To set the port number of the sales company's server to be used for Embedded-RDS.
Use Case		When using Embedded-RDS
Adj/Set/Operate Method		1) Enter the setting value, and then press OK key. 2) Turn OFF/ON the main power switch.
Caution		Be sure to use E-RDS, RGW-PORT, COM-TEST, COM-LOG and RGW-ADR as a set.
Display/Adj/Set Range		1 to 65535
Default Value		443
Related Service Mode		COPIER> FUNCTION> INSTALL> E-RDS, COM-TEST, COM-LOG, RGW-ADR
Supplement/Memo		Embedded-RDS: Function to send device information such as the device counter, failure, and consumables to the sales company's server via SOAP protocol
COM-TEST	1	Dspl connect result w/ Sales Co's server
Detail		To display the result of the connection test with the sales company's server.
Use Case		When using Embedded-RDS
Adj/Set/Operate Method		Select the item, and then press OK key.
Caution		Be sure to use E-RDS, RGW-PORT, COM-TEST, COM-LOG and RGW-ADR as a set.
Display/Adj/Set Range		During operation: ACTIVE, When connection is completed: OK, When connection is failed: NG
Related Service Mode		COPIER> FUNCTION> INSTALL> E-RDS, RGW-PORT, COM-LOG, RGW-ADR
Supplement/Memo		Embedded-RDS: Function to send device information such as the device counter, failure, and consumables to the sales company's server via SOAP protocol

COPIER (Service mode for printer) > FUNCTION (Operation / inspection mode) > INSTALL

COM-LOG	1	Dspl connect error w/ Sales Co's server
Detail		To display error information when the connection with the sales company's server failed.
Use Case		When using Embedded-RDS
Adj/Set/Operate Method		N/A (Display only)
Caution		Be sure to use E-RDS, RGW-PORT, COM-TEST, COM-LOG and RGW-ADR as a set.
Display/Adj/Set Range		Year, date, time, error code, error detail information (maximum 128 characters)
Related Service Mode		COPIER> FUNCTION> INSTALL> E-RDS, RGW-PORT, COM-TEST, RGW-ADR
Supplement/Memo		Embedded-RDS: Function to send device information such as the device counter, failure, and consumables to the sales company's server via SOAP protocol
RGW-ADR	1	URL setting of Sales Company's server
Detail		To set the URL of the sales company's server to be used for Embedded-RDS.
Use Case		When using Embedded-RDS
Adj/Set/Operate Method		1) Select the URL. 2) Enter the URL, and then press OK key. 3) Turn OFF/ON the main power switch.
Caution		- Do not use Shift-JIS character strings. - Be sure to use E-RDS, RGW-PORT, COM-TEST, COM-LOG and RGW-ADR as a set.
Display/Adj/Set Range		URL
Default Value		https://b01.ugwdevice.net/ugw/agentif010
Related Service Mode		COPIER> FUNCTION> INSTALL> E-RDS, RGW-PORT, COM-TEST, COM-LOG
Supplement/Memo		Embedded-RDS: Function to send device information such as the device counter, failure, and consumables to the sales company's server via SOAP protocol
CNT-DATE	1	Set counter send start date to SC server
Detail		To set the year, month, date, hour and minute to send counter information to the sales company's server. This is displayed only when the Embedded-RDS third-party extended function is available.
Use Case		When the non-Canon-made extension function of the Embedded-RDS is available
Adj/Set/Operate Method		1) Enter the setting value, and then press OK key. 2) Turn OFF/ON the main power switch.
Display/Adj/Set Range		YYYYMMDDHHMM (12 digits) YYYY: Year, MM: Month, DD: Date, HH: Hour, MM: Minute
Default Value		000000000000
Supplement/Memo		Embedded-RDS: Function to send device information such as the device counter, failure, and consumables to the sales company's server via SOAP protocol
CNT-INTV	1	Set counter send interval to SC server
Detail		To set the interval of sending counter information to the sales company's server in a unit of one hour. This is displayed only when the Embedded-RDS third-party extended function is available.
Use Case		When using the Embedded-RDS third-party extended function
Adj/Set/Operate Method		1) Enter the setting value, and then press OK key. 2) Turn OFF/ON the main power switch.
Display/Adj/Set Range		1 to 168 (=1 week)
Unit		hour
Default Value		24
Supplement/Memo		Embedded-RDS: Function to send device information such as the device counter, failure, and consumables to the sales company's server via SOAP protocol
Amount of Change per Unit		1

COPIER (Service mode for printer) > FUNCTION (Operation / inspection mode) > INSTALL

CDS-CTL	1	Set country/area when using CDS
Detail	To set country/region to enable CDS. In principle, the default value is the same as that of CONFIG. If the value differs from the country/region of the vice-company of sales, change the setting.	
Use Case	When enabling CDS	
Adj/Set/Operate Method	1) Select the item, and then press OK key. 2) Turn OFF/ON the main power switch.	
Caution	If the setting value is not configured to be the same as the country/region of the vice-company of sales, the necessary firmware may not be able to be downloaded.	
Display/Adj/Set Range	JP: Japan, US: USA, GB: Great Britain, FR: France, DE: Germany, IT: Italy, AU: Australia, SG: Singapore, NL: Netherlands, KR: Korea, CN: China, TW: Taiwan, ES: Spain, SE: Sweden, PT: Portugal, NO: Norway, DK: Denmark, FI: Finland, PL: Poland, HU: Hungary, CZ: Czech Republic, SI: Slovenia, GR: Greece, EE: Estonia, RU: Russia, SK: Slovakia, RO: Romania, HR: Croatia, BG: Bulgaria, TR: Turkey, TH: Thailand, VN: Vietnam, AR: Argentina, IN: India, CA: Canada, LA: Latin America, HK: Hong Kong	
Default Value	It differs according to the location.	
Related Service Mode	COPIER> OPTION> FNC-SW> CONFIG	
Supplement/Memo	CDS: Contents Delivery System	
DRM-INIT	1	Initialization of Photosensitive Drum
Detail	To initialize Photosensitive Drum. Clear drum counter (PT-DRM), Drum Lot number, and checksum stored in the DC Controller.	
Use Case	After replacement of the Photosensitive Drum	
Adj/Set/Operate Method	Select the item, and then press OK key.	
Display/Adj/Set Range	During operation: ACTIVE, At normal termination: OK, At abnormal termination: NG	
Related Service Mode	COPIER> COUNTER> LF> K-DRM-LF COPIER> DISPLAY> 2D-SHADE> CHK-SUM, DRM-LOT	
RDSHDPOS	1	Auto adj of Reader shading position
Detail	To automatically adjust the Scanner Unit (for front side) position in feed direction when reading the White Plate on the left edge of the Copyboard Glass. The adjustment result is reflected to ADJ-S.	
Use Case	When replacing the Scanner Unit (for front side)	
Adj/Set/Operate Method	Select the item, and then press OK key.	
Display/Adj/Set Range	At start of operation: START, During operation: ACTIVE, When operation finished normally: OK!	
Required Time	10 sec	
Related Service Mode	COPIER> ADJUST> ADJ-XY> ADJ-S	
Supplement/Memo	Shading: It determines the white color reference by reading the White Plate.	
BIT-SVC	1	OFF/ON of Web service of E-RDS
Detail	*Operation on this item is restricted by the setting of [Restrict Service Representation Access]. To set ON/OFF of Web service function of E-RDS. When OFF is selected, authentication information cannot be obtained from E-RDS.	
Use Case	Upon user's request	
Adj/Set/Operate Method	1) Enter the setting value, and then press OK key. 2) Turn OFF/ON the main power switch.	
Display/Adj/Set Range	0 to 1 0: OFF, 1: ON	
Default Value	1	

COPIER (Service mode for printer) > FUNCTION (Operation / inspection mode) > INSTALL

DEV-G-R	2	Exe ghost alleviate mode:Dev Ass'y rplce
Detail	To execute the processing to remove unnecessary toner from the Photosensitive Drum when ghost occurs at replacement of the Developing Assembly. The effect to be obtained will not change even if this item is executed three times or more.	
Use Case	When ghost occurs at replacement of the Developing Assembly with a new one	
Adj/Set/Operate Method	1) Set A4/LTR size paper on the Multi-purpose Tray. 2) Select the item, and then press OK key.	
Caution	<ul style="list-style-type: none"> - When executing this item, toner for 1200 sheets at 5% image ratio is consumed. Be sure to get approval from the user in advance by explaining that toner consumption is increased and it takes 17 minutes. - Be sure to disconnect the network cable and telephone cord. Otherwise, this item will not be executed. - Although this item cannot be executed without placing paper, no paper will be consumed. - When Front Cover open/no toner/waste toner full is detected while this item is in process, the process is canceled. Once the process is canceled, cancel "local print" of "job" on the Status Monitor/Cancel screen. If it is not canceled, the process that is resumed after recovery will be printed/delivered as an actual job (wasting of paper). - After execution, make a copy to check the effect. If no effect is obtained, replace the Developing Assembly. 	
Display/Adj/Set Range	During operation: ACTIVE, At normal termination: OK, At abnormal termination: NG	
Required Time	17 min	
NFC-USE	1	ON/OFF of NFC option
Detail	To set whether to enable the installed NFC option. Set 1 when using the NFC option. [Use NFC Card Emulation] is displayed in [Settings/Registration].	
Use Case	When installing the NFC option	
Adj/Set/Operate Method	1) Enter the setting value, and then press OK key. 2) Turn OFF/ON the main power switch.	
Display/Adj/Set Range	0 to 1 0: OFF, 1: ON	
Default Value	0	
Additional Functions Mode	Management Settings> Device Management> Use NFC Card Emulation	
BLE-USE	1	ON/OFF of BLE module option
Detail	To set whether to enable the installed BLE module option. Set 1 when using the BLE module option. The BLE setting screen is displayed in [Settings/Registration].	
Use Case	When installing the BLE module option	
Adj/Set/Operate Method	1) Enter the setting value, and then press OK key. 2) Turn OFF/ON the main power switch.	
Caution	Do not set 1 when the BLE module option is not installed.	
Display/Adj/Set Range	0 to 1 0: OFF, 1: ON	
Default Value	0	
INSTDTST	1	Batch set installation date info: YMDHN
Detail	Information on the current date and time is entered collectively in YMDHN of INSTDT by pressing INSTDTST.	
Use Case	At installation	
Adj/Set/Operate Method	Select the item, and then press OK key.	
Related Service Mode	COPIER>OPTION>USER>INSTDT-Y COPIER>OPTION>USER>INSTDT-M COPIER>OPTION>USER>INSTDT-D COPIER>OPTION>USER>INSTDT-H COPIER>OPTION>USER>INSTDT-N	

COPIER (Service mode for printer) > FUNCTION (Operation / inspection mode) > INSTALL

FAX-USE	1	Enable/disable FAX function
Detail	*Operation on this item is restricted by the setting of [Restrict Service Representation Access]. To switch enable/disable of the FAX function of a device mounted with a FAX Board.	
Use Case	When disabling the FAX function of a device mounted with a FAX Board	
Adj/Set/Operate Method	1) Enter the setting value, and then press OK key. 2) Turn ON/OFF the Main Power.	
Display/Adj/Set Range	0 to 1 0: OFF, 1: ON	
Default Value	1	
SUB-IF	1	Set for line connecting to cloud service
Detail	To select the network line connecting to the Canon cloud service	
Use Case	When the Canon cloud service is used with a sub line	
Adj/Set/Operate Method	1) Select either [Wired LAN+Wireless LAN] or [Wired LAN+Wired LAN] when selecting interface 2) Configure the network setting for the sub line 3) Select 1 for this setting 4) Turn the main power OFF, and then ON	
Display/Adj/Set Range	0 to 1 0: Main line, 1: Sub line	
Default Value	0	

■ CCD

COPIER (Service mode for printer) > FUNCTION (Operation / inspection mode) > CCD

DF-WLVL1	1	White level adj in book mode: color
Detail	To adjust the white level for copyboard scanning automatically by setting the paper which is usually used by the user on the Copyboard Glass.	
Use Case	- When replacing the Copyboard Glass - When replacing the Scanner Unit - When replacing the Reader Controller PCB/clearing RAM data	
Adj/Set/Operate Method	1) Set a paper on the Copyboard Glass. 2) Select the item, and then press OK key.	
Caution	Be sure to execute DF-WLVL2 in a row.	
Display/Adj/Set Range	During operation: ACTIVE, When operation finished normally: OK!	
Related Service Mode	COPIER> FUNCTION> CCD> DF-WLVL2	
DF-WLVL2	1	White level adj: stream reading, color
Detail	To automatically adjust the white level for stream reading by placing the paper which is usually used by the user on the DADF.	
Use Case	- When replacing the Copyboard Glass - When replacing the Scanner Unit - When replacing the Reader Controller PCB/clearing RAM data	
Adj/Set/Operate Method	1) Set paper on the DADF. 2) Select the item, and then press OK key.	
Caution	Be sure to execute this item after DF-WLVL1.	
Display/Adj/Set Range	During operation: ACTIVE, When operation finished normally: OK!	
Related Service Mode	COPIER> FUNCTION> CCD> DF-WLVL1	

COPIER (Service mode for printer) > FUNCTION (Operation / inspection mode) > CCD

DF-LNR	1	Deriving of DADF front/back linearity
Detail		To derive the front/back side linearity in DADF mode based on the scanning data which has been backed up at factory.
Use Case		When replacing the Reader Controller PCB/clearing RAM data
Adj/Set/Operate Method		1) Enter the value of the reader's service label. COPIER> ADJUST> CCD> DFCH-R2, DFCH-G2, DFCH-B2, DFCH-K2, DFCH-R10, DFCH-G10, DFCH-B10, DFCH-K10, DFCH2R2, DFCH2G2, DFCH2B2, DFCH2K2, DFCH2R10, DFCH2G10, DFCH2B10, DFCH2K10 2) Select the item, and then press OK key.
Display/Adj/Set Range		During operation: ACTIVE, When operation finished normally: OK!
Related Service Mode		COPIER> ADJUST> CCD> DFCH-R2/R10/G2/G10/B2/B10/K2/K10, DFCH2R2/10, DFCH2G2/10, DFCH2B2/10, DFCH2K2/10
DF-WLVL3	1	White level adj in book mode: B&W
Detail		To adjust the white level for copyboard scanning automatically by setting a paper which is usually used by the user on the Copyboard Glass.
Use Case		- When replacing the Copyboard Glass - When replacing the Scanner Unit - When replacing the Reader Controller PCB/clearing RAM data
Adj/Set/Operate Method		1) Set a paper on the Copyboard Glass. 2) Select the item, and then press OK key.
Caution		Be sure to execute DF-WLVL4 in a row.
Display/Adj/Set Range		During operation: ACTIVE, When operation finished normally: OK!
Related Service Mode		COPIER> FUNCTION> CCD> DF-WLVL4
DF-WLVL4	1	White level adj: stream reading, B&W
Detail		To automatically adjust the white level for stream reading by placing the paper which is usually used by the user on the DADF.
Use Case		- When replacing the Copyboard Glass - When replacing the Scanner Unit - When replacing the Reader Controller PCB/clearing RAM data
Adj/Set/Operate Method		1) Set paper on the DADF. 2) Select the item, and then press OK key.
Caution		Be sure to execute this item after DF-WLVL3.
Display/Adj/Set Range		During operation: ACTIVE, When operation finished normally: OK!
Related Service Mode		COPIER> FUNCTION> CCD> DF-WLVL3
BW-TGT	1	Set of B&W shading target value
Detail		After the white level data (X/Y/Z) for the Standard White Plate is set, read the Standard White Plate and set the black and white shading target value.
Use Case		When replacing the Copyboard Glass/Scanner Unit
Adj/Set/Operate Method		Select the item, and then press OK key.
Caution		Be sure to execute this item after execution of COPIER> ADJUST> CCD>W-PLT-X, W-PLT-Y, W-PLT-Z.
Related Service Mode		COPIER> ADJUST> CCD> W-PLT-X/Y/Z, SH-TRGT

COPIER (Service mode for printer) > FUNCTION (Operation / inspection mode) > CCD

LMPADJ	1	Adj light intensity of Scanner Unit LED
Detail	To adjust the light intensity of Scanner Unit's LED lamp and store adjustment result. Using the stored value helps cut startup time.	
Use Case	- When replacing the Scanner Unit - When replacing the Main Controller PCB	
Adj/Set/Operate Method	1) Close the ADF or Copyboard. 2) Select the item, and then press OK key.	
Caution	Execute this mode with the ADF or Copyboard closed. Adjustment fails if executed with them open.	
Display/Adj/Set Range	- Operation in process: ACTIVE - Proper completion: OK! - Abnormal termination: NG!	
Related Service Mode	COPIER > DISPLAY > CCD > LAMP-BW COPIER > DISPLAY > CCD > LAMP-CL COPIER > DISPLAY > CCD > LAMP2-BW COPIER > DISPLAY > CCD > LAMP2-CL	

■ DENS

COPIER (Service mode for printer) > FUNCTION (Operation / inspection mode) > DENS

DEV-AGG	1	Exe of dev unevenness elimination mode
Detail	To stir toner when uneven developing occurs, execute image formation with solid white without feeding. Because the Drum Cleaning Blade is flipped when only solid white images are formed, form solid black images periodically. Although the operation takes approx. 10 minutes in the initial settings, the duration of execution (number of times) can be changed with AGG-SW.	
Use Case	When unevenness occurs right after executing TONER-S	
Adj/Set/Operate Method	Select the item, and then press OK key.	
Caution	If using frequently, the Drum Cleaning Blade might be flipped.	
Related Service Mode	COPIER> FUNCTION> INSTALL> TONER-S COPIER> FUNCTION> DENS> AGG-SW	
AGG-SW	1	Set dev unevenness elimination mod times
Detail	To set the number of times to execute the developing unevenness elimination mode. As the value is incremented by 1, the duration of execution is increased by approx. 5 minutes. +: Increase (When eliminating developing unevenness surely) -: Decrease (When shortening the duration of execution) Although the operation is executed successively for the specified numbers, unevenness can be resolved by executing it approx. 4 times (approx. 20 minutes).	
Use Case	When changing the number of times to execute the developing unevenness elimination mode	
Adj/Set/Operate Method	Enter the value, and then press OK key.	
Display/Adj/Set Range	0 to 5	
Unit	time	
Default Value	2	
Related Service Mode	COPIER> FUNCTION> DENS> DEV-AGG	
Amount of Change per Unit	1	

■ DPC

COPIER (Service mode for printer) > FUNCTION (Operation / inspection mode) > DPC

DPC	1	Execution of potential control
Detail		To execute potential control for the Photosensitive Drum manually. (It is usually executed automatically.)
Use Case		When checking potential control operation
Adj/Set/Operate Method		1) Select the item, and then press OK key. 2) Turn OFF/ON the main power switch.
Required Time		10 sec
OFST	1	Potential adjustment of Potential Sensor
Detail		To adjust the detection potential offset value of the Potential Sensor automatically.
Use Case		- When replacing the Potential Sensor - At diagnosis for a failure of the Potential Sensor
Adj/Set/Operate Method		Select the item, and then press OK key.
Caution		An error is displayed when open circuit/connection failure/installation failure occurs to the Potential Sensor at the time of replacement. In this case, manually set the value to 0 V in EPOTOFST and then make an adjustment.
Required Time		4 sec
Related Service Mode		COPIER> ADJUST> V-CONT> EPOTOFST
DPC2	1	Execution of potential control
Detail		To execute potential control for the Photosensitive Drum manually (without restarting the host machine).
Use Case		When checking potential control operation
Adj/Set/Operate Method		1) Select the item, and then press OK key. After 10 seconds, potential control is completed. 2) Turn OFF/ON the main power switch.
Caution		The result of potential control is reflected after turning OFF/ON the power.
Required Time		10 sec

■ CST

COPIER (Service mode for printer) > FUNCTION (Operation / inspection mode) > CST

MF-A4R	1	Reg Multi-purpose Tray A4R stdrd width
Detail		To register the standard value of A4R paper width (210mm) on the Multi-purpose Tray. Make a fine adjustment by COPIER> ADJUST> CST-ADJ> MF-A4R.
Adj/Set/Operate Method		1) Set A4R paper on the Multi-purpose Tray, and set the guide so that it fits the paper width. 2) Select the item, and then press OK key. The value is registered after automatic adjustment.
Caution		After execution, check the registered value by COPIER> ADJUST> CST-ADJ> MF-A4R, and write it down on the service label.
Related Service Mode		COPIER> ADJUST> CST-ADJ> MF-A4R
MF-A6R	1	Reg Multi-purpose Tray A6R stdrd width
Detail		To register the standard value of A6R paper width (105 mm) on the Multi-purpose Tray. Make a fine adjustment by COPIER> ADJUST> CST-ADJ> MF-A6R.
Adj/Set/Operate Method		1) Set A6R paper on the Multi-purpose Tray, and set the guide so that it fits the paper width. 2) Select the item, and then press OK key. The value is registered after automatic adjustment.
Caution		After execution, check the registered value by COPIER> ADJUST> CST-ADJ> MF-A6R, and write it down on the service label.
Related Service Mode		COPIER> ADJUST> CST-ADJ> MF-A6R

COPIER (Service mode for printer) > FUNCTION (Operation / inspection mode) > CST

MF-A4	1	Reg Multi-purpose Tray A4 standard width
Detail		To register the standard value of A4 paper width (297 mm) on the Multi-purpose Tray. Make a fine adjustment by COPIER> ADJUST> CST-ADJ> MF-A4.
Adj/Set/Operate Method		1) Set A4 paper on the Multi-purpose Tray, and set the guide so that it fits the paper width. 2) Select the item, and then press OK key. The value is registered after automatic adjustment.
Caution		After execution, check the registered value by COPIER> ADJUST> CST-ADJ> MF-A4, and write it down on the service label.
Related Service Mode		COPIER> ADJUST> CST-ADJ> MF-A4
DK1-FCK	1	Checking of Deck individual delivery
Detail		To check whether individual delivery from a deck that is isolated from the host machine can be performed. If it operates normally, only a sheet of paper is delivered.
Use Case		When identifying the cause (pickup failure, skew feed, etc.)
Adj/Set/Operate Method		1) Check that paper is placed in a deck. 2) Isolate the deck from the host machine. 3) Display this item on the Control Panel. 4) While bringing the Feed Lower Guide into contact with the Pullout Roller by hand, press OK key.
Caution		- Isolate the deck before execution. - Execute this item while lifting the Feed Lower Guide of the deck by hand and bringing it into contact with the Deck Pullout Roller. If they are not in contact with each other, paper will not be delivered completely.
Display/Adj/Set Range		During operation: ACTIVE, When operation finished normally: OK!
DK1-INT1	1	Initialization at Deck parts replacement
Detail		To execute initialization of POD Deck Lite at parts replacement. By executing this item, the lifter moves up from the lower limit position and stops when the Paper Surface Sensor detects paper top face. The travel distance is reflected to the paper level detection control.
Use Case		When replacing the Pickup Unit/PCB/compartment
Adj/Set/Operate Method		Select the item, and then press OK key.
Caution		Execute this item while there is no paper in a deck and the lifter is in stopped state.
Display/Adj/Set Range		During operation: ACTIVE, When operation finished normally: OK!
Required Time		30 sec
DK1-SPAD	1	Setting of Deck Lifter stop position
Detail		To set stop position of the lifter when opening the compartment of the POD Deck Lite/Paper Deck Unit. When 0 is set, the lifter moves down to the lower limit position when the compartment is opened. When 1 is set, the lifer moves up to the pickup position and then the compartment opens. The height of the Pre-separation Plate can be adjusted. Even 1 is set, the value is returned to 0 when the compartment is opened.
Use Case		When adjusting pre-separation position after replacing the Pickup Unit/compartment
Adj/Set/Operate Method		Enter the setting value, and then press OK key.
Caution		Set 0 for DK1-PKLV before execution.
Display/Adj/Set Range		0 to 1 0: Stop at lower limit position (normal), 1: Stop at pickup position
Default Value		0
Related Service Mode		COPIER> ADJUST> FEED-ADJ> DK1-PKLV

COPIER (Service mode for printer) > FUNCTION (Operation / inspection mode) > CST

PDK-A4	1	Rgst POD Deck Lite A4 standard width
Detail		To register the standard value of A4 paper width (297 mm) on the POD Deck Lite. Make a fine adjustment by COPIER> ADJUST> CST-ADJ> PDK-A4.
Use Case		- When replacing the DC Controller PCB/clearing RAM data - When replacing the Paper Width Sensor PCB or registering a new value
Adj/Set/Operate Method		1) Set A4 paper on the POD Deck Lite, and set the guide so that it fits the paper width. 2) Select the item, and then press OK key. The value is registered after automatic adjustment.
Caution		After execution, check the registered value by COPIER> ADJUST> CST-ADJ> PDK-A4, and write it down on the service label.
Display/Adj/Set Range		0 to 1023
Default Value		0
Related Service Mode		COPIER> ADJUST> CST-ADJ> PDK-A4
PDK-A5R	1	Rgst POD Deck Lite A5R standard width
Detail		To register the standard value of A5R paper width (148.5 mm) on the POD Deck Lite. Make a fine adjustment by COPIER> ADJUST> CST-ADJ> PDK-A5R.
Use Case		- When replacing the DC Controller PCB/clearing RAM data - When replacing the Paper Width Sensor PCB or registering a new value
Adj/Set/Operate Method		1) Set A5R paper on the POD Deck Lite, and set the guide so that it fits the paper width. 2) Select the item, and then press OK key. The value is registered after automatic adjustment.
Caution		After execution, check the registered value by COPIER> ADJUST> CST-ADJ> PDK-A5R, and write it down on the service label.
Display/Adj/Set Range		0 to 1023
Default Value		0
Related Service Mode		COPIER> ADJUST> CST-ADJ> PDK-A5R
DK1-LIFT	1	Drive of Deck Lifter Motor
Detail		To drive the Lifter Motor of the POD Deck Lite/Paper Deck Unit. When descent timeout alarm (04-1537) occurs, the lifter wire may be wound in the opposite direction. The Lifter Motor is driven for approximately 5 seconds to wind the wire correctly.
Use Case		At recovery from descent timeout alarm
Adj/Set/Operate Method		1) Close the compartment. 2) Select the item, and then press OK key.
Display/Adj/Set Range		During operation: ACTIVE, When operation finished normally: OK!
Required Time		5 sec

■ CLEANING

COPIER (Service mode for printer) > FUNCTION (Operation / inspection mode) > CLEANING

TBLT-CLN	1	ETB cleaning
Detail		To execute three idle rotations of the ETB and clean the ETB. Disengage the Photosensitive Drum and Transfer Roller from the ETB.
Use Case		When ETB cleaning failure/stain on the back of paper occurs
Adj/Set/Operate Method		Select the item, and then press OK key.
Display/Adj/Set Range		During operation: ACTIVE, When operation finished normally: OK!

COPIER (Service mode for printer) > FUNCTION (Operation / inspection mode) > CLEANING

WIRE-CLN	1	Cleaning of all Charging Wires
Detail		To clean the Charging Wires of Primary Charging Assembly and Pre-transfer Charging Assembly simultaneously (5-reciprocation). Polish new Charging Wires to remove foreign matters or protrusions.
Use Case		- When replacing the Primary Charging Assembly/Pre-transfer Charging Assembly - When replacing the Charging Wire - When vertical lines occur on an image
Adj/Set/Operate Method		Select the item, and then press OK key.
Display/Adj/Set Range		During operation: ACTIVE, When operation finished normally: OK!
WIRE-EX	1	Check cleaning operation of all Chg Wir
Detail		To clean the Charging Wires of Primary Charging Assembly and Pre-transfer Charging Assembly simultaneously (1-reciprocation). Check the reciprocation operation of the Wire Cleaner.
Use Case		When checking operation of the Primary Charging Wire Cleaning Motor after removing and then installing the Primary Charging Assembly at working around the Process area
Adj/Set/Operate Method		Select the item, and then press OK key.
Display/Adj/Set Range		During operation: ACTIVE, When operation finished normally: OK!
Required Time		30 sec

■ FIXING

COPIER (Service mode for printer) > FUNCTION (Operation / inspection mode) > FIXING

NIP-CHK	1	Check of fixing nip width
Detail		To check whether the fixing nip width is appropriate by printing. If it is not appropriate, a fixing failure may occur.
Use Case		- When replacing the fixing-related parts (Fixing Roller, Pressure Roller) - When a fixing failure occurs
Adj/Set/Operate Method		1) Print approx. 20 sheets of A4 size paper. 2) Set A4 size plain paper/recycled paper on the Multi-purpose Tray. 3) Select the item, and then press OK key. A sheet is stopped once in a state held by the Fixing Nip area, and is delivered approx. 20 seconds later. 4) Measure the nip width of delivered sheet. If the nip widths are as follow it is judged as normal: 7.0 to 8.0 mm at the center, and difference between front and rear is within 0.5mm. If there is an error, execute step 5. 5) Check the Fixing Roller, Pressure Roller, and Fixing Lower Unit, and replace damaged part.
Related Service Mode		COPIER> TEST> PG> TYPE

■ PANEL

COPIER (Service mode for printer) > FUNCTION (Operation / inspection mode) > PANEL

LCD-CHK	1	Check of LCD Panel dot missing
Detail		To check whether there is a missing dot on the LCD Panel of the Control Panel.
Use Case		When replacing the LCD Panel
Adj/Set/Operate Method		1) Select the item, and then press OK key. 2) Check that the LCD Panel lights up in the order of white, black, red, green and blue. 3) Press STOP key or touch the screen to terminate checking.

COPIER (Service mode for printer) > FUNCTION (Operation / inspection mode) > PANEL

LED-CHK	1	Check of Control Panel LED
Detail		To check whether the LED on the Control Panel lights up.
Use Case		When replacing the LCD Panel
Adj/Set/Operate Method		1) Select the item, and then press OK key. 2) Check that the LED lights up in the order. 3) Use LED-OFF to terminate checking.
Related Service Mode		COPIER> FUNCTION> PANEL> LED-OFF
LED-OFF	1	End check of Control Panel LED
Detail		To terminate the check of LED on the Control Panel.
Use Case		During execution of LED-CHK
Adj/Set/Operate Method		Select the item, and then press OK key.
Related Service Mode		COPIER> FUNCTION> PANEL> LED-CHK
KEY-CHK	1	Check of key entry
Detail		To check the key input on the Control Panel.
Use Case		When replacing the LCD Panel
Adj/Set/Operate Method		1) Select the item and press the key on the Control Panel. 2) Check that the input value is displayed. 3) Cancel the selection to terminate checking.
TOUCHCHK	1	Adj of coordinate pstn of Touch Panel
Detail		To adjust the coordinate position on the Touch Panel of the Control Panel.
Use Case		When replacing the LCD Panel
Adj/Set/Operate Method		1) Select the item, and then press OK key. 2) Press the nine "+" keys in sequence.

■ PART-CHK

COPIER (Service mode for printer) > FUNCTION (Operation / inspection mode) > PART-CHK

CL	1	Specification of operation Clutch
Detail		To specify the Clutch to operate.
Use Case		When replacing the Clutch/checking the operation
Adj/Set/Operate Method		Enter the setting value, and then press OK key.
Display/Adj/Set Range		1 to 6 1: Developing Clutch (CL1) 2: Magnet Roller Clutch (CL5) 3 to 6: Not used
Default Value		0
Related Service Mode		COPIER> FUNCTION> PART-CHK> CL-ON
CL-ON	1	Operation check of Clutch
Detail		To start operation check of the Clutch specified by CL. The operation stops after "ON for 0.5 sec" => "OFF for 10 sec" => "ON for 0.5 sec" => "OFF for 10 sec" => "ON for 0.5 sec".
Use Case		When replacing the Clutch/checking the operation
Adj/Set/Operate Method		Select the item, and then press OK key.
Display/Adj/Set Range		During operation: ACTIVE, When operation finished normally: OK!
Required Time		22 sec
Related Service Mode		COPIER> FUNCTION> PART-CHK> CL

COPIER (Service mode for printer) > FUNCTION (Operation / inspection mode) > PART-CHK

MTR	1	Specification of operation Motor
	Detail	To specify the Motor to operate.
	Use Case	When replacing the Motor/checking the operation
	Adj/Set/Operate Method	Enter the setting value, and then press OK key.
	Display/Adj/Set Range	1 to 17 1: Not used 2: Toner Feed Motor (M28) 3: Delivery Motor (M13) 4: Reverse Motor (M14) 5: Side Registration Motor (M16) 6: Duplex Feed Right Motor (M18) 7: Duplex Feed Left Motor (M19) 8: Vertical Path Upper Motor (M26) 9: Vertical Path Lower Motor (M27) 10: Vertical Path Middle Motor (M31) 11: Duplex Feed Merging Motor (M32) 12: Multi-purpose Tray Registration Front Motor (M33) 13: Registration Motor (M34) 14: ETB Motor (M43) 15: (POD Deck Lite/Paper Deck Unit) Deck Pickup Motor (M1) 16: (POD Deck Lite/Paper Deck Unit) Deck Pull-out Motor (M2) 17: Fixing Motor (M03)
	Default Value	1
	Related Service Mode	COPIER> FUNCTION> PART-CHK> MTR-ON
MTR-ON	1	Operation check of Motor
	Detail	To start operation check of the Motor specified by MTR. The operation automatically stops after operation of 30 seconds.
	Use Case	When replacing the Motor/checking the operation
	Adj/Set/Operate Method	Select the item, and then press OK key.
	Display/Adj/Set Range	During operation: ACTIVE, When operation finished normally: OK!
	Required Time	30 sec
	Related Service Mode	COPIER> FUNCTION> PART-CHK> MTR
SL	1	Specification of operation Solenoid
	Detail	To specify the Solenoid to operate.
	Use Case	When replacing the Solenoid/checking the operation
	Adj/Set/Operate Method	Enter the setting value, and then press OK key.
	Display/Adj/Set Range	1 to 11 1: Multi Middle Plate Release Solenoid (SL2) 2: Cassette 3 Pickup Solenoid (SL3) 3: Cassette 4 Pickup Solenoid (SL4) 4: Reverse Upper Flapper Solenoid (SL5) 5: Right Deck Pickup Solenoid (SL6) 6: Left Deck Pickup Solenoid (SL7) 7: Left Deck Merging Solenoid (SL11) 8: Fixing Cleaning Web Drive Solenoid (SL9) 9: Patch Sensor Shutter Solenoid (SL10) 10: Reverse Detachment Solenoid (SL12) 11: (POD Deck Lite/Paper Deck Unit) Deck Pickup Release Solenoid
	Default Value	1
	Related Service Mode	COPIER> FUNCTION> PART-CHK> SL-ON

COPIER (Service mode for printer) > FUNCTION (Operation / inspection mode) > PART-CHK

SL-ON	1	Operation check of Solenoid
Detail		To start operation check for the Solenoid specified by SL. The operation stops after "ON for 0.5 sec" => "OFF for 10 sec" => "ON for 0.5 sec" => "OFF for 10 sec" => "ON for 0.5 sec".
Use Case		When replacing the Solenoid/checking the operation
Adj/Set/Operate Method		Select the item, and then press OK key.
Display/Adj/Set Range		During operation: ACTIVE, When operation finished normally: OK!
Required Time		1 min
Related Service Mode		COPIER> FUNCTION> PART-CHK> SL
D-FDS	1	Operation check of Double Feed Sensor
Detail		To start operation check of the Double Feed Sensor. When D-FDS-SW is set to 1 after the Double Feed Detection Kit (option) installed, an error (E850/E890) occurs if the Double Feed Sensor cannot be recognized.
Use Case		When checking whether the Double Feed Sensor is recognized (an error does not occur) while the Double Feed Detection Kit is installed
Adj/Set/Operate Method		Select the item, and then press OK key.
Caution		Be sure to execute this item when D-FDS-SW is set to 1.
Display/Adj/Set Range		During operation: ACTIVE, When operation finished normally: OK!, When D-FDS-SW is 0: NG
Related Service Mode		COPIER> OPTION> FNC-SW> D-FDS-SW
FIN-CL	1	Specification of operation clutch:Fin-W
Detail		To specify the clutch for the finisher to operate.
Use Case		When replacing the clutch/checking the operation
Adj/Set/Operate Method		Enter the setting value, and then press OK key.
Display/Adj/Set Range		101: Saddle Folding Roller Disengagement Clutch (CL101)
Default Value		1
Related Service Mode		COPIER> FUNCTION> PART-CHK> FINCL-ON
Supplement/Memo		Product name of Fin-W: Staple Finisher-W1PRO, Booklet Finisher-W1 PRO
FINCL-ON	1	Operation check of Clutch: Fin-W
Detail		To start operation check for the Clutch specified by FIN-CL.
Use Case		When replacing the clutch/checking the operation
Adj/Set/Operate Method		Select the item, and then press OK key.
Display/Adj/Set Range		During operation: ACTIVE, At normal termination: OK, At abnormal termination: NG
Related Service Mode		COPIER> FUNCTION> PART-CHK> FIN-CL
Supplement/Memo		Product name of Fin-W: Staple Finisher-W1PRO, Booklet Finisher-W1 PRO
FIN-FAN	1	Specification of operation fan: Fin-W
Detail		To specify the fan to operate.
Use Case		When replacing the fan/checking the operation
Adj/Set/Operate Method		Enter the setting value, and then press OK key.
Display/Adj/Set Range		1 to 6 1: Power Cooling Fan 1 (FM1), 2 to 4: Not used, 5: Upper Delivery Fan (FM5), 6: Lower Delivery Fan (FM6)
Default Value		1
Related Service Mode		COPIER> FUNCTION> PART-CHK> FINFANON
Supplement/Memo		Product name of Fin-W: Staple Finisher-W1PRO, Booklet Finisher-W1 PRO

COPIER (Service mode for printer) > FUNCTION (Operation / inspection mode) > PART-CHK

FINFANON	1	Operation check of fan: Fin-W
Detail		To start operation check for the Fan specified by FIN-FAN.
Use Case		When replacing the fan/checking the operation
Adj/Set/Operate Method		Select the item, and then press OK key.
Display/Adj/Set Range		During operation: ACTIVE, At normal termination: OK, At abnormal termination: NG
Related Service Mode		COPIER> FUNCTION> PART-CHK> FIN-FAN
Supplement/Memo		Product name of Fin-W: Staple Finisher-W1PRO, Booklet Finisher-W1 PRO
FIN-MTR	1	Specification of operation motor: Fin-W
Detail		To specify the motor to operate.
Use Case		When replacing the motor/checking the operation
Adj/Set/Operate Method		Enter the setting value, and then press OK key.
Caution		1 to 209 1: Inlet Feed Motor (M1), 2: Shift Feed Motor (M2), 3: Buffer Front Feed Motor (M3), 4: Buffer Motor (M4), 5: Delivery Motor (M5), 6: Horizontal Registration Detection Unit Move Motor (M6), 7: Horizontal Registration Shift Motor (M7), 8: Feed Roller Disengage Motor (M8) 9: Front Alignment Motor (M9), 10: Rear Alignment Motor (M10), 11: Processing Stopper Move Motor (M11), 12: Assist Motor (M12), 13: Stack Delivery Auxiliary Tray Motor (M13), 14: Paddle Rotation Motor (M14), 15: Paddle Lift Motor (M15), 16: Paper Trailing Edge Drop Motor (M16), 17: Feed Belt Move Motor (M17), 18: Swing Guide Motor (M18), 19: Stack Delivery Motor (M19), 20: Upper Guide Motor (M20), 21: Staple Move Motor (M21) 22: Tray A Lift Motor (M22), 23: Tray B Lift Motor (M23) 24: Punch Motor (M24) 25: Not used 26: Processing Feed Motor (M26), 27: Inlet Roller Disengage Motor (M27), 28: Delivery Angle Adjustment Motor (M28) 29 to 100: Not used
Display/Adj/Set Range		101: Saddle Feed Motor (M101), 102: Saddle Alignment Guide Motor (M102), 103: Saddle Lead Edge Stopper Motor (M103), 104: Saddle Roller Guide Motor (M104), 105: Saddle Paper Push-On Plate Motor (M105), 106: Saddle Fold/Feeder Motor (M106), 107: Saddle Delivery Belt Motor (M107), 108: Saddle Press Motor (M108), 109: Not used, 110: Saddle Trailing Edge Holding Motor (M110), 111: Saddle Trailing Edge Moving Motor (M111), 112: Saddle Alignment Roller Motor (M112), 113: Saddle Tapping Motor (M113), 114: Saddle Lead-in Roller Disengage Motor (M114), 115: Saddle Clamp Motor (M115) 116 to 200: Not used 201: Stack Retainer Motor (M201) 202: Upper Neat Stack Unit Front Alignment Motor (M202), 203: Upper Neat Stack Unit Rear Alignment Motor (M203), 204: Upper Neat Stack Unit Alignment Plate Lifting Motor (M204) 205: Lower Neat Stack Unit Front Alignment Motor (M205), 206: Lower Neat Stack Unit Rear Alignment Motor (M206), 207: Lower Neat Stack Unit Alignment Plate Lifting Motor (M207), 208: Lower Neat Stack Unit Return Roller Lifting Motor (M208), 209: Upper Neat Stack Unit Return Roller Lifting Motor (M209)
Default Value		1
Related Service Mode		COPIER> FUNCTION> PART-CHK> FINMTRON
Supplement/Memo		Product name of Fin-W: Staple Finisher-W1PRO, Booklet Finisher-W1 PRO
FINMTRON	1	Operation check of motor: Fin-W
Detail		To start operation check of the motor specified by FIN-MTR.
Use Case		When replacing the motor/checking the operation
Adj/Set/Operate Method		Select the item, and then press OK key.
Display/Adj/Set Range		During operation: ACTIVE, At normal termination: OK, At abnormal termination: NG
Related Service Mode		COPIER> FUNCTION> PART-CHK> FIN-MTR
Supplement/Memo		Product name of Fin-W: Staple Finisher-W1PRO, Booklet Finisher-W1 PRO

COPIER (Service mode for printer) > FUNCTION (Operation / inspection mode) > PART-CHK

FIN-SL	1	Specify operation solenoid: Fin-W
Detail		To specify the solenoid for the finisher to operate.
Use Case		When replacing the solenoid/checking the operation
Adj/Set/Operate Method		Enter the setting value, and then press OK key.
Display/Adj/Set Range		1 to 105 1: Buffer Path Switch Solenoid (SL1), 2: Upper Path Switch Solenoid (SL2), 3: Saddle Path Switch Solenoid (SL3) 4 to 9: Not used 10: Assist Roller Disengagement Solenoid 1 (SL10), 11: Assist Roller Disengagement Solenoid 2 (SL11) 12 to 102: Not used 103: Alignment Roller Disengage Solenoid (upper) (SL103), 104: Alignment Roller Disengage Solenoid (lower) (SL104) 105: Lead Edge Gripper Solenoid (SL105)
Default Value		1
Related Service Mode		COPIER> FUNCTION> PART-CHK> FINSL-ON
Supplement/Memo		Product name of Fin-W: Staple Finisher-W1PRO, Booklet Finisher-W1 PRO
FINSL-ON	1	Operation check of solenoid: Fin-W
Detail		To start operation check for the Solenoid specified by FIN-SL.
Use Case		When replacing the solenoid/checking the operation
Adj/Set/Operate Method		Select the item, and then press OK key.
Display/Adj/Set Range		During operation: ACTIVE, At normal termination: OK, At abnormal termination: NG
Related Service Mode		COPIER> FUNCTION> PART-CHK> FIN-SL
Supplement/Memo		Product name of Fin-W: Staple Finisher-W1PRO, Booklet Finisher-W1 PRO
FN2-CL	1	Specify of oprtn Clutch: Fin-X
Detail		To specify the Clutch to operate.
Use Case		When replacing the Clutch/checking the operation
Adj/Set/Operate Method		Enter the setting value, and then press OK key.
Display/Adj/Set Range		1: Shutter Clutch (CL102)
Default Value		1
Related Service Mode		COPIER> FUNCTION> PART-CHK> FN2CL-ON
Supplement/Memo		Product name of Fin-X: Staple Finisher-X1, Booklet Finisher-X1
FN2CL-ON	1	Operation check of Clutch: Fin-X
Detail		To start operation check for the Clutch specified by FN2-CL. After the clutch operates for the specified period of time (10 to 30 seconds), it automatically stops.
Use Case		When replacing the Clutch/checking the operation
Adj/Set/Operate Method		Select the item, and then press OK key.
Caution		- When the job starts during the operation of the clutch, the finisher sequence error jam occurs. - When the error avoidance jam occurs during the operation of the clutch, the jam becomes the error immediately.
Display/Adj/Set Range		During operation: ACTIVE, At normal termination: OK, At abnormal termination: NG
Related Service Mode		COPIER> FUNCTION> PART-CHK> FN2-CL
Supplement/Memo		Product name of Fin-X: Staple Finisher-X1, Booklet Finisher-X1

COPIER (Service mode for printer) > FUNCTION (Operation / inspection mode) > PART-CHK

FN2-FAN	1	Specify of oprtn Fan: Fin-X
Detail		To specify the Fan to operate.
Use Case		When replacing the Fan/checking the operation
Adj/Set/Operate Method		Enter the setting value, and then press OK key.
Display/Adj/Set Range		1 to 2 1: Power Supply Fan (FAN101) 2: Heat Exhaust Fan (FAN102)
Default Value		1
Related Service Mode		COPIER> FUNCTION> PART-CHK> FN2FANON
Supplement/Memo		Product name of Fin-X: Staple Finisher-X1, Booklet Finisher-X1
FN2FANON	1	Operation check of Fan: Fin-X
Detail		To start operation check of the fan specified by FN2-FAN. After the fan operates for the specified period of time (10 to 30 seconds), it automatically stops.
Use Case		When replacing the Fan/checking the operation
Adj/Set/Operate Method		Select the item, and then press OK key.
Display/Adj/Set Range		During operation: ACTIVE, At normal termination: OK, At abnormal termination: NG
Related Service Mode		COPIER> FUNCTION> PART-CHK> FN2-FAN
Supplement/Memo		Product name of Fin-X: Staple Finisher-X1, Booklet Finisher-X1

COPIER (Service mode for printer) > FUNCTION (Operation / inspection mode) > PART-CHK

FN2-MTR	1	Specification of oprtn Motor: Fin-X
Detail		To specify the Motor to operate.
Use Case		When replacing the Motor/checking the operation
Adj/Set/Operate Method		Enter the setting value, and then press OK key.
Caution		When setting the staple motor or the saddle stitcher motor, remove each staple cartridge. When the staple cartridge is installed, the motor is not driven.
Display/Adj/Set Range	1 to 37	1: Feed Motor (M101) 2: Stack Delivery Upper Motor (M104) 3: Front Align Motor (M108) 4: Stapler Shift Motor (M107) 5: Tray 1 Shift Motor (M105) 6: Staple Motor (M115) 7: Swing Guide Motor (M110) 8: Buffer Feed Motor (M102) 9: Tray 2 Shift Motor (M106) 10: Feed Roller Disengage/Buffer Flapper Motor (M119) 11: Stacking Tray Paper Retainer Motor (M114) 12: Tray Auxiliary Guide Motor (M120) 13: Paper Trailing Edge Pushing Guide Motor (M113) 14: Gripper Motor (M117) 15: Gripper Base Motor (M116) 16: Paper Return Guide Roller Motor (M121) 17: Paper Return Guide Motor (M112) 18: Processing Tray Paper Retainer Motor (M118) 19: Punch Motor (M102) 20: Punch Slide Motor (M101) 21: Rear Align Motor (M109) 22: Stack Delivery Lower/Shutter Motor (M122) 23: Not used 24: Not used 25: Inlet Feed Motor (M200) 26: Saddle Feed Motor (M201) 27: Saddle Align Roller Motor (M212) 28: Saddle Align Guide Motor (M202) 29: Saddle Lead Edge Stopper Motor (M203) 30: Saddle Roller Guide Motor (M204) 31: Saddle Trailing Edge Retainer Motor (M210) 32: Saddle Trailing Edge Moving Motor (M211) 33: Saddle Tapping Motor (M213) 34: Saddle Pull Roller Disengage Motor (M214) 35: Saddle Stitcher Motor (M209) 36: Saddle Folding/Feed Motor (M206) 37: Saddle Paper Pushing Plate Motor (M205)
Related Service Mode		COPIER> FUNCTION> PART-CHK> FN2MTRON
Supplement/Memo		Product name of Fin-X: Staple Finisher-X1, Booklet Finisher-X1

COPIER (Service mode for printer) > FUNCTION (Operation / inspection mode) > PART-CHK

FN2MTRON	1	Operation check of motor: Fin-X
Detail		To start operation check of the motor specified by FN2-MTR. After the motor operates for the specified period of time (10 to 30 seconds), it automatically stops.
Use Case		When replacing the Motor/checking the operation
Adj/Set/Operate Method		Select the item, and then press OK key.
Caution		- When the job starts during the operation of the motor, the finisher sequence error jam occurs. - When the error avoidance jam occurs during the operation of the motor, the jam becomes the error immediately.
Display/Adj/Set Range		During operation: ACTIVE, At normal termination: OK, At abnormal termination: NG
Related Service Mode		COPIER> FUNCTION> PART-CHK> FN2-MTR
Supplement/Memo		Product name of Fin-X: Staple Finisher-X1, Booklet Finisher-X1
FN2-SL	1	Specification of oprtn solenoid: Fin-X
Detail		To specify the Solenoid to operate.
Use Case		When replacing the Solenoid/checking the operation
Adj/Set/Operate Method		Enter the setting value, and then press OK key.
Display/Adj/Set Range		1 to 5 1: Swing Guide Solenoid (SL101) 2: Saddle Inlet Flapper Solenoid (SL206) 3: Saddle Lead Edge Stopper Solenoid (SL205) 4: Saddle Alignment Roller Disengage Solenoid (Upper) (SL203) 5: Saddle Alignment Roller Disengage Solenoid (Lower) (SL204)
Default Value		1
Related Service Mode		COPIER> FUNCTION> PART-CHK> FN2SL-ON
Supplement/Memo		Product name of Fin-X: Staple Finisher-X1, Booklet Finisher-X1
FN2SL-ON	1	Operation check of solenoid: Fin-X
Detail		To start operation check for the Solenoid specified by FN2-SL. After the solenoid operates for the specified period of time (10 to 30 seconds), it automatically stops.
Use Case		When replacing the Solenoid/checking the operation
Adj/Set/Operate Method		Select the item, and then press OK key.
Display/Adj/Set Range		During operation: ACTIVE, At normal termination: OK, At abnormal termination: NG
Related Service Mode		COPIER> FUNCTION> PART-CHK> FN2-SL
Supplement/Memo		Product name of Fin-X: Staple Finisher-X1, Booklet Finisher-X1
FN3-CL	1	Specify of oprtn Clutch: Fin-AC
Detail		To specify the Clutch to operate.
Use Case		When replacing the Clutch/checking the operation
Adj/Set/Operate Method		Enter the setting value, and then press OK key.
Display/Adj/Set Range		1 to 3 1: Lower Stack Delivery Roller Clutch (CL102) 2: Escape Feed Clutch (CL101) 3: Paddle Clutch (CL103)
Related Service Mode		COPIER> FUNCTION> PART-CHK> FN3CL-ON
Supplement/Memo		Product name of Fin-AC: Staple Finisher-AC1, Booklet Finisher-AC1

COPIER (Service mode for printer) > FUNCTION (Operation / inspection mode) > PART-CHK

FN3CL-ON	1	Operation check of Clutch: Fin-AC
Detail		To start operation check for the Clutch specified by FN3-CL. After the clutch operates for the specified period of time (10 to 30 seconds), it automatically stops.
Use Case		When replacing the Clutch/checking the operation
Adj/Set/Operate Method		Select the item, and then press OK key.
Caution		- When the job starts during the operation of the clutch, the finisher sequence error jam occurs. - When the error avoidance jam occurs during the operation of the clutch, the jam becomes the error immediately.
Display/Adj/Set Range		During operation: ACTIVE, At normal termination: OK, At abnormal termination: NG
Related Service Mode		COPIER> FUNCTION> PART-CHK> FN3-CL
Supplement/Memo		Product name of Fin-AC: Staple Finisher-AC1, Booklet Finisher-AC1

COPIER (Service mode for printer) > FUNCTION (Operation / inspection mode) > PART-CHK

FN3-MTR	1	Specification of oprtn Motor: Fin-AC
Detail		To specify the Motor to operate.
Use Case		When replacing the Motor/checking the operation
Adj/Set/Operate Method		Enter the setting value, and then press OK key.
Caution		When setting the staple motor or the saddle stitcher motor, remove each staple cartridge. When the staple cartridge is installed, the motor is not driven.
Display/Adj/Set Range		1 to 39 1: Inlet Feed Motor(M101) 2: Pre-processing/Buffer Motor(M102) 3: Stack Delivery/Paddle Motor(M103) 4: Escape Feed Motor(M117) 5: Paper End Pushing Guide Motor(M112) 6: Stapler Shift Motor(M114) 7: Stack Tray Shift Motor(M105) 8: Swing Guide Motor(M110) 9: Front Alignment Motor(M107) 10: Rear Alignment Motor(M108) 11: Return Roller Lift Motor(M111) 12: Flapper Motor(M104) 13: Upper Escape Delivery Shift Motor(M119) 14: Paper End Assist Motor(M113) 15: Escape Flapper Motor(M118) 16: Lower Escape Delivery Shift Motor(M106) 17: Tray Auxiliary Guide Motor(M109) 18: Not Used 19: Staple Motor(M115) 20: Staple-free Binding Motor(M116) 21: Saddle Feed/Paddle Motor(M201) 22: Saddle Delivery Motor(M207) 23: Saddle Switching Lever Motor(M202) 24: Saddle Stitcher Motor(M208) 25: Saddle Paper End Stopper Motor(M206) 26: Saddle Gripper Motor(M205) 27: Saddle Alignment Motor(M203) 28: Saddle Paper Pushing Plate/Folding Motor(M204) 29: Punch Motor(M301) 30: Punch Shift Motor(M302) 31 to 33: Not Used 34: Paper Retainer Lever Motor(M209) 35: Neat Front Alignment Motor(M1) 36: Neat Rear Alignment Motor(M2) 37: Neat Alignment Plate Lift Motor(M5) 38: Neat Paddle Rotation Motor(M4) 39: Neat Paddle Lift Motor(M3)
Related Service Mode		COPIER> FUNCTION> PART-CHK> FN3MTRON
Supplement/Memo		Product name of Fin-AC: Staple Finisher-AC1, Booklet Finisher-AC1

COPIER (Service mode for printer) > FUNCTION (Operation / inspection mode) > PART-CHK

FN3MTRON	1	Operation check of motor: Fin-AC
Detail		To start operation check of the motor specified by FN3-MTR. After the motor operates for the specified period of time (10 to 30 seconds), it automatically stops.
Use Case		When replacing the Motor/checking the operation
Adj/Set/Operate Method		Select the item, and then press OK key.
Caution		- When the job starts during the operation of the motor, the finisher sequence error jam occurs. - When the error avoidance jam occurs during the operation of the motor, the jam becomes the error immediately.
Display/Adj/Set Range		During operation: ACTIVE, At normal termination: OK, At abnormal termination: NG
Related Service Mode		COPIER> FUNCTION> PART-CHK> FN3-MTR
Supplement/Memo		Product name of Fin-AC: Staple Finisher-AC1, Booklet Finisher-AC1
INS-CL	1	Specification of operation clutch: INS
Detail		To specify the clutch for the inserter to operate.
Use Case		When replacing the clutch/checking the operation
Adj/Set/Operate Method		Enter the setting value, and then press OK key.
Display/Adj/Set Range		1 to 2 1: Upper Tray Registration Clutch, 2: Lower Tray Registration Clutch
Default Value		1
Related Service Mode		COPIER> FUNCTION> PART-CHK> INSCL-ON
Supplement/Memo		Product name of INS: Document Insertion Unit-N1
INSCL-ON	1	Operation check of clutch: INS
Detail		To start operation check of the clutch for the inserter specified by INS-CL. After the clutch operates for the specified period of time (10 to 30 seconds), it automatically stops.
Use Case		When replacing the clutch/checking the operation
Adj/Set/Operate Method		Select the item, and then press OK key.
Display/Adj/Set Range		During operation: ACTIVE, At normal termination: OK, At abnormal termination: NG
Related Service Mode		COPIER> FUNCTION> PART-CHK> INS-CL
Supplement/Memo		Product name of INS: Document Insertion Unit-N1
INS-MTR	1	Specification of operation motor: INS
Detail		To specify the motor for the inserter to operate.
Use Case		When replacing the motor/checking the operation
Adj/Set/Operate Method		Enter the setting value, and then press OK key.
Display/Adj/Set Range		1 to 6 1: Entrance Motor 1, 2: Drive Switchover Motor, 3: Upper Tray Lift Motor, 4: Lower Tray Lift Motor, 5: Tray Pickup Motor, 6: Reverse Motor
Default Value		1
Related Service Mode		COPIER> FUNCTION> PART-CHK> INSMTRON
Supplement/Memo		Product name of INS: Document Insertion Unit-N1
INSMTRON	1	Operation check of motor: INS
Detail		To start operation check of the motor for the inserter specified by INS-MTR. After the motor operates for the specified period of time (10 to 30 seconds), it automatically stops.
Use Case		When replacing the motor/checking the operation
Adj/Set/Operate Method		Select the item, and then press OK key.
Display/Adj/Set Range		During operation: ACTIVE, At normal termination: OK, At abnormal termination: NG
Related Service Mode		COPIER> FUNCTION> PART-CHK> INS-MTR
Supplement/Memo		Product name of INS: Document Insertion Unit-N1

COPIER (Service mode for printer) > FUNCTION (Operation / inspection mode) > PART-CHK

INS-SL	1	Specification of operation solenoid: INS
Detail		To specify the solenoid for the inserter to operate.
Use Case		When replacing the solenoid/checking the operation
Adj/Set/Operate Method		Enter the setting value, and then press OK key.
Display/Adj/Set Range		1: Reversal Solenoid
Default Value		1
Related Service Mode		COPIER> FUNCTION> PART-CHK> INSSL-ON
Supplement/Memo		Product name of INS: Document Insertion Unit-N1
INSSL-ON	1	Operation check of solenoid: INS
Detail		To start operation check of the solenoid for the inserter specified by INS-SL. After the solenoid operates for the specified period of time (10 to 30 seconds), it automatically stops.
Use Case		When replacing the solenoid/checking the operation
Adj/Set/Operate Method		Select the item, and then press OK key.
Display/Adj/Set Range		During operation: ACTIVE, At normal termination: OK, At abnormal termination: NG
Related Service Mode		COPIER> FUNCTION> PART-CHK> INS-SL
Supplement/Memo		Product name of INS: Document Insertion Unit-N1
PFU-CL	1	Specification of operation clutch: PFU
Detail		To specify the clutch for the Paper Folding Unit to operate.
Use Case		When replacing the clutch/checking the operation
Adj/Set/Operate Method		Enter the setting value, and then press OK key.
Display/Adj/Set Range		1 to 2 1: Fold Adjustment Feed Clutch, 2: Fold Adjustment Back Clutch
Default Value		1
Related Service Mode		COPIER> FUNCTION> PART-CHK> PFUCL-ON
Supplement/Memo		Product name of PFU: Paper Folding Unit-J1
PFUCL-ON	1	Operation check of clutch: PFU
Detail		To start operation check of the clutch for the Paper Folding Unit specified by PFU-CL. After the clutch operates for the specified period of time (10 to 30 seconds), it automatically stops.
Use Case		When replacing the clutch/checking the operation
Adj/Set/Operate Method		Select the item, and then press OK key.
Display/Adj/Set Range		During operation: ACTIVE, At normal termination: OK, At abnormal termination: NG
Related Service Mode		COPIER> FUNCTION> PART-CHK> PFU-CL
Supplement/Memo		Product name of PFU: Paper Folding Unit-J1
PFU-MTR	1	Specification of operation motor: PFU
Detail		To specify the motor for the Paper Folding Unit to operate.
Use Case		When replacing the motor/checking the operation
Adj/Set/Operate Method		Enter the setting value, and then press OK key.
Display/Adj/Set Range		1 to 10 1: Entrance Motor 1, 2: Entrance Motor 2, 3: Exit Motor 1, 4: Exit Motor 2, 5: C-fold Stopper Motor, 6: Fold Position Adjustment Motor, 7: Leading Edge Press Guide Motor, 8: Upper Stopper Motor, 9: Fold Feed Motor, 10: Fold Tray Motor
Default Value		1
Related Service Mode		COPIER> FUNCTION> PART-CHK> PFUMTRON
Supplement/Memo		Product name of PFU: Paper Folding Unit-J1

COPIER (Service mode for printer) > FUNCTION (Operation / inspection mode) > PART-CHK

PFUMTRON	1	Operation check of motor: PFU
Detail		To start operation check of the motor for the Paper Folding Unit specified by PFU-MTR. After the motor operates for the specified period of time (10 to 30 seconds), it automatically stops.
Use Case		When replacing the motor/checking the operation
Adj/Set/Operate Method		Select the item, and then press OK key.
Display/Adj/Set Range		During operation: ACTIVE, At normal termination: OK, At abnormal termination: NG
Related Service Mode		COPIER> FUNCTION> PART-CHK> PFU-MTR
Supplement/Memo		Product name of PFU: Paper Folding Unit-J1
PFU-SL	1	Specification of operation solenoid: PFU
Detail		To specify the solenoid for the Paper Folding Unit to operate.
Use Case		When replacing the solenoid/checking the operation
Adj/Set/Operate Method		Enter the setting value, and then press OK key.
Display/Adj/Set Range		1 to 4 1: Folding/Straight Branching Flapper Solenoid, 2: Release Timing Solenoid, 3: C-fold Stopper Solenoid, 4: Flapper Solenoid
Default Value		1
Related Service Mode		COPIER> FUNCTION> PART-CHK> PFUSL-ON
Supplement/Memo		Product name of PFU: Paper Folding Unit-J1
PFUSL-ON	1	Operation check of solenoid: PFU
Detail		To start operation check of the solenoid for the Paper Folding Unit specified by PFU-SL. After the solenoid operates for the specified period of time (10 to 30 seconds), it automatically stops.
Use Case		When replacing the solenoid/checking the operation
Adj/Set/Operate Method		Select the item, and then press OK key.
Display/Adj/Set Range		During operation: ACTIVE, At normal termination: OK, At abnormal termination: NG
Related Service Mode		COPIER> FUNCTION> PART-CHK> PFU-SL
Supplement/Memo		Product name of PFU: Paper Folding Unit-J1
TRM-FAN	1	Specification of operation fan:Bklt Trim
Detail		To specify the fan for the Booklet Trimmer to operate.
Use Case		When replacing the fan/checking the operation
Adj/Set/Operate Method		Enter the setting value, and then press OK key.
Caution		This item is enabled only when the Booklet Trimmer is connected.
Display/Adj/Set Range		1 to 9 1: Blower Fan 2 to 9: Not use
Default Value		1
Related Service Mode		COPIER> FUNCTION> PART-CHK> TRMFANON
TRMFANON	1	Operation check of fan: Booklet Trimmer
Detail		To start operation check of the fan for the Booklet Trimmer specified by TRM-FAN.
Use Case		When replacing the fan/checking the operation
Adj/Set/Operate Method		Select the item, and then press OK key.
Caution		This item is enabled only when the Booklet Trimmer is connected.
Display/Adj/Set Range		During operation: ACTIVE, When operation finished normally: OK!
Related Service Mode		COPIER> FUNCTION> PART-CHK> TRM-FAN

COPIER (Service mode for printer) > FUNCTION (Operation / inspection mode) > PART-CHK

TRM-MTR	1	Specification of oprtn motor: Bklt Trim
Detail		To specify the motor for the Booklet Trimmer to operate.
Use Case		When replacing the motor/checking the operation
Adj/Set/Operate Method		Enter the setting value, and then press OK key.
Display/Adj/Set Range		1 to 10 1: Infeed Belt Motor (M01), 2: Transport Hook Motor (M02), 3: Top-bottom Guide Motor (M03), 4: Trim Section Transport Motor (M04), 5: Knife Motor (M05), 6: Stopper Move Motor (M06), 7: Stopper Open/Close Motor (M07), 8: Delivery Roller Motor (M08), 9: Conveyor Belt Motor (M09), 10: Main Drive Motor (M10)
Default Value		1
Related Service Mode		COPIER> FUNCTION> PART-CHK> TRMMTRON
TRMMTRON	1	Operation check of motor:Booklet Trimmer
Detail		To start operation check of the motor for the Booklet Trimmer specified by TRM-MTR.
Use Case		When replacing the motor/checking the operation
Adj/Set/Operate Method		Select the item, and then press OK key.
Display/Adj/Set Range		During operation: ACTIVE, At normal termination: OK, At abnormal termination: NG
Related Service Mode		COPIER> FUNCTION> PART-CHK> TRM-MTR
PCH-MTR	1	Specification of operation motor:P-Punch
Detail		To specify the motor for the Professional Puncher to operate.
Use Case		When replacing the motor/checking the operation
Adj/Set/Operate Method		Enter the setting value, and then press OK key.
Display/Adj/Set Range		1 to 8 1: Entrance Motor (M1), 2: Accel Motor (M2), 3: Front/Left Stepper Motor (M3), 4: Rear/Right Stepper Motor (M4), 5: Alignment Stepper Motor (M5), 6: Exit Motor (M6), 7: Decel Motor (M7), 8: Bypass Motor (M8)
Default Value		1
Related Service Mode		COPIER> FUNCTION> PART-CHK> PCHMTRON
Supplement/Memo		Product name of P-Puncher: Multi Function Professional Puncher-A1
PCHMTRON	1	Operation check of motor: P-Puncher
Detail		To start operation check of the motor for the Professional Puncher specified by PCH-MTR.
Use Case		When replacing the motor/checking the operation
Adj/Set/Operate Method		Select the item, and then press OK key.
Display/Adj/Set Range		During operation: ACTIVE, At normal termination: OK, At abnormal termination: NG
Related Service Mode		COPIER> FUNCTION> PART-CHK> PCH-MTR
Supplement/Memo		Product name of P-Puncher: Multi Function Professional Puncher-A1
PCH-SL	1	Specification of oprtn solenoid: P-Punch
Detail		To specify the solenoid for the Professional Puncher to operate.
Use Case		When replacing the solenoid/checking the operation
Adj/Set/Operate Method		Enter the setting value, and then press OK key.
Display/Adj/Set Range		1 to 8 1: Divert Solenoid (SOL1), 2: Punch Clutch Solenoid (SOL2), 3: Entrance Idler Solenoid 1 (SOL3), 4: Entrance Idler Solenoid 2 (SOL4), 5: Accel Idler Solenoid (SOL5), 6: Exit Idler Solenoid 1 (SOL6), 7: Exit Idler Solenoid 2 (SOL7), 8: Exit Idler Solenoid 3 (SOL8)
Default Value		1
Related Service Mode		COPIER> FUNCTION> PART-CHK> PCHSL-ON
Supplement/Memo		Product name of P-Puncher: Multi Function Professional Puncher-A1

COPIER (Service mode for printer) > FUNCTION (Operation / inspection mode) > PART-CHK

PCHSL-ON	1	Operation check of solenoid: P-Puncher
Detail		To start operation check of the solenoid for the Professional Puncher specified by PCH-SL.
Use Case		When replacing the solenoid/checking the operation
Adj/Set/Operate Method		Select the item, and then press OK key.
Display/Adj/Set Range		During operation: ACTIVE, At normal termination: OK, At abnormal termination: NG
Related Service Mode		COPIER> FUNCTION> PART-CHK> PCH-SL
Supplement/Memo		Product name of P-Puncher: Multi Function Professional Puncher-A1

■ CLEAR

COPIER (Service mode for printer) > FUNCTION (Operation / inspection mode) > CLEAR

ERR	1	Clear of error code
Detail		To clear the specific error code.
Use Case		At error occurrence
Adj/Set/Operate Method		1) Select the item, and then press OK key. 2) Turn OFF/ON the main power switch.
DC-CON	1	RAM clear of DC Controller PCB
Detail		To clear the RAM data of the DC Controller PCB. Not clear the counter.
Use Case		When clearing RAM data of the DC Controller PCB
Adj/Set/Operate Method		1) Select the item, and then press OK key. 2) Turn OFF/ON the main power switch.
Caution		- Output the service mode setting values by P-PRINT before execution. After execution, enter necessary setting values. - The RAM data is cleared After the main power switch is turned OFF/ON.
Related Service Mode		COPIER> FUNCTION> MISC-P> P-PRINT
R-CON	1	RAM clear of Reader Controller PCB
Detail		To clear the RAM data of the Reader Controller PCB.
Use Case		When clearing RAM data of the Reader Controller PCB
Adj/Set/Operate Method		1) Select the item, and then press OK key. 2) Turn OFF/ON the main power switch.
Caution		- Output the service mode setting values by P-PRINT before execution. After execution, enter necessary setting values. - The RAM data is cleared after the main power switch is turned OFF/ON.
Related Service Mode		COPIER> FUNCTION> MISC-P> P-PRINT
JAM-HIST	1	Clear of jam history
Detail		To clear the jam history.
Use Case		When clearing the jam history
Adj/Set/Operate Method		Select the item, and then press OK key.
Related Service Mode		COPIER> DISPLAY> JAM
ERR-HIST	1	Clear of error code history
Detail		To clear the error code history.
Use Case		When clearing the error code history
Adj/Set/Operate Method		Select the item, and then press OK key.
Related Service Mode		COPIER> DISPLAY> ERR

COPIER (Service mode for printer) > FUNCTION (Operation / inspection mode) > CLEAR

PWD-CLR	1	Clear of system administrator password
Detail		* Operation on this item is restricted by the setting of [Restrict Service Representation Access]. To clear the password of the system administrator set in [Settings/Registration].
Use Case		When clearing the password of the system administrator
Adj/Set/Operate Method		Select the item, and then press OK key.
ADRS-BK	1	Clear of address book
Detail		*Operation on this item is restricted by the setting of [Restrict Service Representation Access]. To clear the address book data.
Use Case		When clearing the address book data
Adj/Set/Operate Method		1) Select the item, and then press OK key. 2) Turn OFF/ON the main power switch.
Caution		The address book data is cleared after the main power switch is turned OFF/ON.
CNT-MCON	1	Clear of Main Controller service counter
Detail		To clear the service counter counted by the Main Controller PCB.
Use Case		When clearing the service counter counted by the Main Controller PCB
Adj/Set/Operate Method		Select the item, and then press OK key.
Related Service Mode		COPIER> COUNTER
Supplement/Memo		See COUNTER for the target counter.
CNT-DCON	1	For R&D
MMI	1	Clear Settings/Registration setting VL
Detail		*Operation on this item is restricted by the setting of [Restrict Service Representation Access]. To clear the Settings/Registration setting values. - Preferences (excluding values for Paper Type Management Settings) - Adjustment/Maintenance - Function Settings - Set Destination (excluding Address Lists) - Management Settings (excluding Department ID Management)
Use Case		When clearing various setting values of [Settings/Registration]
Adj/Set/Operate Method		1) Select the item, and then press OK key. 2) Turn OFF/ON the main power switch.
Caution		- The setting value is cleared after the main power switch is turned OFF/ON. - If this item is executed while a login application other than User Authentication is running, it switched to User Authentication after reboot. Set the login application using SMS as needed.
Supplement/Memo		SMS (Service Management Service): An application for management which can be used on remote UI.
MN-CON	1	Deletion of setting values
Detail		*Operation on this item is restricted by the setting of [Restrict Service Representation Access]. To delete the setting values of address lists, forwarding settings, Settings/Registration and service mode. For details, refer to "Backup Data List" in the Service Manual.
Use Case		When initializing the setting values
Adj/Set/Operate Method		1) Select the item, and then press OK key. The machine is automatically rebooted. 2) Turn OFF/ON the main power switch.
Caution		- Output the service mode setting values by P-PRINT before execution. After execution, enter necessary setting value. - RAM data is cleared after the main power switch is turned OFF/ON.
Related Service Mode		COPIER> FUNCTION> MISC-P> P-PRINT

COPIER (Service mode for printer) > FUNCTION (Operation / inspection mode) > CLEAR

CARD	1	Clear of card ID-related data
Detail		*Operation on this item is restricted by the setting of [Restrict Service Representation Access]. To clear the data related to the card ID (department).
Use Case		When clearing the data related to the card ID
Adj/Set/Operate Method		1) Select the item, and then press OK key. 2) Turn OFF/ON the main power switch.
Caution		The value is cleared after the main power switch is turned OFF/ON.
ALARM	1	Clear of alarm log
Detail		To clear alarm log.
Use Case		When clearing alarm log
Adj/Set/Operate Method		1) Select the item, and then press OK key. 2) Turn OFF/ON the main power switch.
Caution		The alarm log is cleared after the main power switch is turned OFF/ON.
Related Service Mode		COPIER> DISPLAY> ALARM-2
CA-KEY	2	Deletion of CA certificate and key pair
Detail		*Operation on this item is restricted by the setting of [Restrict Service Representation Access]. To simultaneously delete the CA certificate and key pair which are additionally registered by the user.
Use Case		When a service person replaces/discards the device
Adj/Set/Operate Method		1) Select the item, and then press OK key. 2) Check that OK is displayed. 3) Turn OFF/ON the main power switch.
Caution		- Unless this item is executed at the time of replacement/discard of the device, the CA certificate and key pair which are additionally registered by the user remain in the HDD, which is a problem in terms of security. - Do not execute this item carelessly because the CA certificate and key pair which are additionally registered are deleted when it is executed. If they are deleted mistakenly, they need to be again registered by the user. If no CA certificate and key pair are additionally registered, the machine condition becomes the same as the one at the time of factory shipment. - When NG is displayed in 2), there is a possibility that deletion was not executed. In this case, surely execute the deletion by initializing the HDD, etc.
Display/Adj/Set Range		At normal termination: OK!, At abnormal termination: NG!
Supplement/Memo		- The CA certificate is used in the MEAP application with E-RDS and SSL client connection, and the key pair is used in the SSL function of IPP, RUI and MEAP. - When the main power switch is turned OFF/ON, the CA certificate and key pair which were registered at the time of factory shipment are decompressed from the archive, and become available in the E-RDS/SSL function.
ERDS-DAT	1	Initialization of E-RDS SRAM data
Detail		To initialize the "internal setting values" of the Embedded-RDS stored in the SRAM. "Internal setting values" are ON/OFF of E-RDS, server's port number, server's SOAP URL, and communication schedule with the server (how often the data is acquired), etc. The value set by COPIER> FUNCTION> INSTALL> E-RDS, RGW-PORT, RGW-ADR, COM-LOG is cleared.
Use Case		When clear the SRAM of the "internal setting values".
Adj/Set/Operate Method		Select the item, and then press OK key.
Display/Adj/Set Range		At normal termination: OK!, At abnormal termination: NG!
Related Service Mode		COPIER> FUNCTION> INSTALL> E-RDS, RGW-PORT, RGW-ADR, COM-LOG
USBM-CLR	1	Initialize USB MEAP priority rgst info
Detail		To initialize the registered ID data retained in the OS field by calling the API provided by the OS.
Use Case		When a failure occurs in USB MEAP priority registration
Adj/Set/Operate Method		Select the item, and then press OK key.

COPIER (Service mode for printer) > FUNCTION (Operation / inspection mode) > CLEAR

JV-CACHE	1	Cache clear of JAVA application
Detail		*Operation on this item is restricted by the setting of [Restrict Service Representation Access]. To clear the cache information used by JAVA application.
Use Case		When initializing the JAVA application
Adj/Set/Operate Method		Select the item, and then press OK key.
TR-BLT	1	Clearing Transfer Belt parts counter
Detail		To clear ETB parts counter when replacing to a new Transfer Belt (ETB).
Use Case		When replacing to a new ETB
Adj/Set/Operate Method		Select the item, and then press OK key.
Related Service Mode		COPIER> COUNTER> DRBL-1> TR-BLT
GRD-CRNT	1	Init of Primary Charging Wire current VL
Detail		To initialize the current value of the Primary Charging Wire by initializing the voltage value of the grid wire. The current value of the Primary Charging Wire is linked with the usage status; thus, execute initialization at the time of replacement.
Use Case		When replacing the Primary Charging Wire
Adj/Set/Operate Method		Select the item, and then press OK key.
LANG-CLR	2	Uninstallation of language files
Detail		To uninstall the language files other than Japanese and English files installed in HDD. When installing a new language file while the maximum number of language files (11 files) have been already installed, an existing language file needs to be uninstalled.
Use Case		When deleting/switching language files
Adj/Set/Operate Method		1) Select the item, and then press OK key. 2) Download the firmware in which the necessary language files are included using SST or a USB flash drive.
Caution		A language file is not uninstalled unless the downloaded language files are installed by SST or a USB flash drive after the execution of this item. If installation is not executed, uninstallation will be canceled. (Status of the machine remains the same as it was before execution.)
Supplement/Memo		- After the execution, language displayed on the screen becomes English. Switch the language as needed. - There are 9 language files (JEFIGSCKT) installed at the time of shipment.
FIN-MCON	1	Clearing Finisher delvry destination set
Detail		To clear the setting of Delivery Tray of the Finisher specified in [Settings/Registration] (Function Settings> Common> Paper Output Settings> Output Tray Settings). Since the delivery destination settings are stored in the DC Controller PCB in the machine, malfunction occurs when replacing the Finisher with another type of it without clearing the settings. If the type of Finishers is the same, there is no need to clear the settings.
Use Case		When the Finisher is replaced with a different model in the field
Adj/Set/Operate Method		1) Select the item, and then press OK key. 2) Turn OFF/ON the main power switch.
Additional Functions Mode		Function Settings> Common> Paper Output Settings> Output Tray Settings
PLPW-CLR	2	Clear security policy setting password
Detail		*Operation on this item is restricted by the setting of [Restrict Service Representation Access]. To clear the password of the security administrator set in the security policy settings.
Use Case		When clearing the password of the security administrator
Adj/Set/Operate Method		Select the item, and then press OK key.

COPIER (Service mode for printer) > FUNCTION (Operation / inspection mode) > CLEAR

JV-TYPE	1	Specification of MEAP cache clear target
Detail		*Operation on this item is restricted by the setting of [Restrict Service Representation Access]. To specify the MEAP cache area to be cleared. The target area is divided into the 4 parts: - A jar file of MEAP application bundled as standard - Data of the application mentioned above - A jar file of MEAP application installed additionally - Data of the application mentioned above When JV-CACHE is executed, the area specified with this item is cleared. For details, refer to the Service Manual.
Use Case		When analyzing the cause of a problem due to MEAP application
Adj/Set/Operate Method		Enter the setting value, and then press OK key.
Display/Adj/Set Range		0 to 4 0: Entire MEAP cache area 1: A jar file of MEAP application bundled as standard 2: A jar file and data of MEAP application bundled as standard 3: Data of MEAP application which has been installed additionally 4: A jar file and data of MEAP application which has been installed additionally
Related Service Mode		COPIER> FUNCTION> CLEAR> JV-CACHE
Supplement/Memo		MEAP applications bundled as standard: system application, built-in login application MEAP applications installed additionally: non-Canon-made login application, general application, etc.
DK-RCV	1	Clearing of deck alarm
Detail		To clear the descent timeout alarm (04-1537) occurred in the POD Deck Lite/Paper Deck Unit.
Use Case		At recovery from descent timeout alarm
Adj/Set/Operate Method		1) Select the item, and then press OK key. 2) Turn OFF/ON the main power switch.
CUSTOM2	2	[For customization]
CNT-RCON	1	For R&D
KEY-HCD	2	For R&D
TPM-DA	2	For R&D

■ MISC-R

COPIER (Service mode for printer) > FUNCTION (Operation / inspection mode) > MISC-R

SCANLAMP	1	Lighting check of Scanner Unit (frt) LED
Detail		To light up the Scanning Lamp for 3 seconds under the White Plate and the Copyboard Glass respectively.
Use Case		When replacing the LED of the Scanner Unit
Adj/Set/Operate Method		Select the item, and then press OK key.
Display/Adj/Set Range		During operation: ACTIVE, When operation finished normally: OK!
SCANLMP2	1	Lighting check of Scanner Unit (bck) LED
Detail		To light up the LED of the Scanner Unit (for back side) for 3 sec. Check whether there is a missing block or no lighting in LED.
Use Case		When replacing the LED of the Scanner Unit
Adj/Set/Operate Method		Select the item, and then press OK key.
Display/Adj/Set Range		During operation: ACTIVE, When operation finished normally: OK!

COPIER (Service mode for printer) > FUNCTION (Operation / inspection mode) > MISC-R

RD-SHPOS	2	Moving to Reader Scanner Unit fix pstn
Detail		To move the Reader Scanner Unit to the position where it is secured in when moving. When moving the Reader after installation, the Reader Scanner Unit may move and get damage. By moving the Scanner Unit to the specified position and securing it in place with a screw before moving, damage can be prevented.
Use Case		When moving the Reader after installation
Adj/Set/Operate Method		Select the item, and then press OK key.
Caution		Be sure to move the Scanner Unit to the fixing position and secure it in place with a screw when moving the Reader after installation. Otherwise, the Scanner Unit may get damage.
Display/Adj/Set Range		During operation: ACTIVE, When operation finished normally: OK!

■ MISC-P

COPIER (Service mode for printer) > FUNCTION (Operation / inspection mode) > MISC-P

P-PRINT	1	Output of service mode setting values
Detail		To output the service mode setting values. Text data is saved in HDD as a file (P-PRINT-RPT.TXT).
Use Case		Before executing the CLEAR service mode, etc.
Adj/Set/Operate Method		Select the item, and then press OK key.
Caution		Be sure to use A4/LTR size plain paper/recycled paper.
Display/Adj/Set Range		During operation: ACTIVE, When operation finished normally: OK!
Related Service Mode		COPIER> FUNCTION> MISC-P> RPT-FILE
HIST-PRT	1	Output of jam and error logs
Detail		To output the jam log and error log. Text data is saved in HDD as a file (HIST-PRT-RPT.TXT).
Use Case		When outputting the jam/error log
Adj/Set/Operate Method		Select the item, and then press OK key.
Caution		Be sure to use A4/LTR size plain paper/recycled paper.
Display/Adj/Set Range		During operation: ACTIVE, When operation finished normally: OK!
Related Service Mode		COPIER> FUNCTION> MISC-P> RPT-FILE
TRS-DATA	2	Moving memory reception data to Inbox
Detail		*Operation on this item is restricted by the setting of [Restrict Service Representation Access]. To move the data received in memory to Inbox.
Use Case		When moving the data received in memory to Inbox
Adj/Set/Operate Method		1) Select the item, and then press OK key. 2) Turn OFF/ON the main power switch.
Additional Functions Mode		Fax/I-Fax Inbox> Memory RX Inbox
USER-PRT	1	Settings/Registration menu list output
Detail		To output Settings/Registration menu list. Text data is saved in HDD as a file (USER-PRT-RPT.TXT).
Use Case		When outputting Settings/Registration menu list.
Adj/Set/Operate Method		Select the item, and then press OK key.
Caution		Be sure to use A4/LTR size plain paper/recycled paper.
Display/Adj/Set Range		During operation: ACTIVE, When operation finished normally: OK!
Related Service Mode		COPIER> FUNCTION> MISC-P> RPT-FILE
Supplement/Memo		It takes approximately 3 seconds before output starts.

COPIER (Service mode for printer) > FUNCTION (Operation / inspection mode) > MISC-P

LBL-PRNT	1	Output of service label
Detail		To print the service label.
Use Case		When printing the service label
Adj/Set/Operate Method		1) Place A4/LTR paper in Right Deck. 2) Select the item, and then press OK key.
Caution		Be sure to use A4/LTR size plain paper/recycled paper.
Required Time		55 sec
Supplement/Memo		It takes approximately 15 seconds before printing starts.
PRE-EXP	1	Light-up of Pre-exposure LED
Detail		To light up the Cleaning Pre-exposure LED. Open the Front Cover, and check that the LEDs light up visually. It automatically stops after all light up.
Use Case		When checking that the Pre-exposure LEDs light up
Adj/Set/Operate Method		Select the item, and then press OK key.
Caution		Drum memory may occur, so be sure not to execute this item frequently.
Display/Adj/Set Range		During operation: ACTIVE, When operation finished normally: OK!
Required Time		30 sec
Supplement/Memo		The required time is a rough standard, and it may take a shorter time.
ENV-PRT	1	Outpt inside temp&hmdy/Fix Rol temp log
Detail		To output data of the temperature and humidity inside the machine/surface temperature of the Fixing Roller as a log. Text data is saved in HDD as a file (ENV-PRT-RPT.TXT).
Use Case		When figuring out the past temperature inside the machine/fixing temperature information at problem analysis
Adj/Set/Operate Method		Select the item, and then press OK key.
Caution		Be sure to use A4/LTR size plain paper/recycled paper.
Display/Adj/Set Range		During operation: ACTIVE, When operation finished normally: OK!
Related Service Mode		COPIER> FUNCTION> MISC-P> RPT-FILE
PJH-P-1	1	Outpt print job log detail info:100 jobs
Detail		*Operation on this item is restricted by the setting of [Restrict Service Representation Access]. To output the print job logs of the latest 100 jobs with detailed information. In the case of less than 100 jobs, the logs of all print jobs are output. Text data is saved in HDD as a file (PJH-P-1-RPT.TXT).
Use Case		When outputting the print job logs with detailed information
Adj/Set/Operate Method		Select the item, and then press OK key.
Caution		Be sure to use A4/LTR size plain paper/recycled paper.
Display/Adj/Set Range		During operation: ACTIVE, When operation finished normally: OK!
Related Service Mode		COPIER> FUNCTION> MISC-P> RPT-FILE
Supplement/Memo		Output the print job logs with detailed information which are not displayed/output in the job log screen under "System Monitor>Print>Log>Printer" and in the report of the print job log.

COPIER (Service mode for printer) > FUNCTION (Operation / inspection mode) > MISC-P

PJH-P-2	1	Output print job log detail info:all jobs
Detail		*Operation on this item is restricted by the setting of [Restrict Service Representation Access]. To output all print job logs stored in the machine with detailed information (for maximum 5000 jobs). The difference between PJH-P-1 and this item is only the number of jobs output. Text data is saved in HDD as a file (PJH-P-2-RPT.TXT).
Use Case		When printing the print job history with detailed information
Adj/Set/Operate Method		Select the item, and then press OK key.
Caution		Be sure to use A4/LTR size plain paper/recycled paper.
Display/Adj/Set Range		During operation: ACTIVE, When operation finished normally: OK!
Related Service Mode		COPIER> FUNCTION> MISC-P> RPT-FILE
Supplement/Memo		Output the print job logs with detailed information which are not displayed/output in the job log screen under "System Monitor>Print>Log>Printer" and in the report of the print job log.
WB	2	Reverse toner forcible eject: blank band
Detail		To eject the reverse toner forcibly. After execution, it automatically stops.
Use Case		When operating in a high duty and low humidity environment for a long time (executed by administrator)
Adj/Set/Operate Method		Select the item, and then press OK key.
Display/Adj/Set Range		During operation: ACTIVE, At normal termination: OK, At abnormal termination: NG
Required Time		9 sec
Supplement/Memo		The required time is a rough standard, and it may take a shorter time.
BB	1	Toner forcible eject (black band)
Detail		Forcibly discharge low-charge toner, and send it to the drum cleaner unit. The operation automatically stops after execution.
Use Case		When operating the machine in low-duty and high-humidity environment for a long period of time (implemented by the administrator)
Adj/Set/Operate Method		Select the item, and then press OK key.
Display/Adj/Set Range		During operation: ACTIVE, At normal termination: OK, At abnormal termination: NG
Required Time		60 sec
DMAX-N	1	Execute plain paper group D-max control
Detail		To execute D-max control for plain paper group manually. (It is usually executed automatically.) The result is displayed in COPIER> DISPLAY> DENS> DMAX-N.
Use Case		When checking single-part operation at replacement or cleaning of the Patch Sensor
Adj/Set/Operate Method		Select the item, and then press OK key.
Caution		Be sure to execute this item after P-LED and P-BASE.
Display/Adj/Set Range		During operation: ACTIVE, At normal termination: OK, At abnormal termination: NG
Required Time		30 sec
Related Service Mode		COPIER> DISPLAY> DENS> DMAX-N
Supplement/Memo		The required time is a rough standard, and it may take a shorter time.
P-BASE	2	Detection of background by Patch Sensor
Detail		To detect the ETB background by the Patch Sensor. (It is usually executed automatically.) The result is displayed in COPIER> DISPLAY> DENS> P-B-AVE, P-B-MAX, P-B-MIN.
Use Case		When checking single-part operation at replacement or cleaning of the Patch Sensor/ETB
Adj/Set/Operate Method		Select the item, and then press OK key.
Caution		Be sure to execute this item after P-LED.
Display/Adj/Set Range		During operation: ACTIVE, At normal termination: OK, At abnormal termination: NG
Required Time		2 sec
Related Service Mode		COPIER> DISPLAY> DENS> P-B-AVE/MAX/MIN

COPIER (Service mode for printer) > FUNCTION (Operation / inspection mode) > MISC-P

P-LED	2	Adj of Patch Sensor light intensity
Detail	To adjust light intensity of the Patch Sensor. (It is usually executed automatically.) The result is displayed in COPIER> DISPLAY> DENS> P-LED.	
Use Case	When checking single-part operation at replacement or cleaning of the Patch Sensor	
Adj/Set/Operate Method	Select the item, and then press OK key.	
Display/Adj/Set Range	During operation: ACTIVE, At normal termination: OK, At abnormal termination: NG	
Required Time	2 sec	
Related Service Mode	COPIER> DISPLAY> DENS> P-LED	
USBH-PRT	1	Output of USB device information report
Detail	To output information of the connected USB device in the form of a report. Text data is saved in HDD as a file (USBH-PRT-RPT.TXT).	
Use Case	When outputting information of the USB device in the form of a report	
Adj/Set/Operate Method	Select the item, and then press OK key.	
Caution	Be sure to use A4/LTR size plain paper/recycled paper.	
Display/Adj/Set Range	During operation: ACTIVE, When operation finished normally: OK!	
Related Service Mode	COPIER> FUNCTION> MISC-P> RPT-FILE	
DV-RT	1	Idle rotation of Developing Assembly
Detail	To execute idle rotation of the Developing Assembly. Duration can be set by COPIER> OPTION> IMG-DEV>DV-RT-LG.	
Use Case	When small vertical lines occurs on an image	
Adj/Set/Operate Method	Select the item, and then press OK key.	
Caution	If using frequently, deterioration of developer or toner scattering might occur.	
Display/Adj/Set Range	During operation: ACTIVE, At normal termination: OK, At abnormal termination: NG	
Related Service Mode	COPIER> OPTION> IMG-DEV> DV-RT-LG	
RPT-FILE	1	Output of report print file
Detail	To save various service reports in HDD as a file. The files can be obtained using PC to which SST has been installed or USB flash drive after starting the machine in download mode.	
Use Case	When obtaining the service report as a file instead of printing the report out	
Adj/Set/Operate Method	Select the item, and then press OK key.	
Supplement/Memo	File size: Approx. 1 MB at a maximum	
RPT2USB	1	Write serv rpt file to USB flash drive
Detail	To store the report file of service mode saved in HDD by RPT-FILE to a USB flash drive.	
Use Case	When storing the report file of service mode to a USB flash drive	
Adj/Set/Operate Method	Select the item, and then press OK key.	
Related Service Mode	COPIER> FUNCTION> MISC-P> RPT-FILE	
ACCPST	1	Acceptance of delivery option config
Detail	To make the host machine recognize the delivery option being connected. Execute this item when the connected delivery option is removed. In a case where an option is added, it is recognized automatically; therefore, there is no need to execute this item.	
Use Case	When the connected delivery option is removed	
Adj/Set/Operate Method	Select the item, and then press OK key.	
Caution	Unless this item is executed after removal of delivery option, a message indicating that the equipment cannot be recognized appears every time the power is turned ON.	
Display/Adj/Set Range	During operation: ACTIVE, At normal termination: OK, At abnormal termination: NG	

■ SENS-ADJ

COPIER (Service mode for printer) > FUNCTION (Operation / inspection mode) > SENS-ADJ

STCK-LMT	2	[Not used]
-----------------	----------	-------------------

■ SYSTEM

COPIER (Service mode for printer) > FUNCTION (Operation / inspection mode) > SYSTEM

DOWNLOAD	1	Shift to download mode
Detail		To make the machine enter the download mode and wait for a command. Perform downloading by SST or a USB flash drive.
Use Case		At upgrade
Adj/Set/Operate Method		1) Select the item, and then press OK key. 2) Perform downloading by SST or a USB flash drive.
Caution		Do not turn OFF/ON the power during downloading.
Supplement/Memo		SST: Service Support Tool
CHK-TYPE	1	Spec HD-CLEAR/HD-CHECK exe partition No.
Detail		To specify the partition number of the HDD to execute HD-CLEAR/HD-CHECK.
Use Case		When executing HD-CLEAR/HD-CHECK
Adj/Set/Operate Method		Enter the setting value, and then press OK key.
Display/Adj/Set Range		0 to 65535 0: All partitions (only the areas where the operation can be executed) 1: PDL-related file storage area 2: Image data storage area 3: MEAP-related area 4: Not used 5 and 6: Image data storage area 7: General application temporary area (temporary file) 8: General application-related area 9: PDL spool data (temporary file) 10: SEND-related area 11: Update-related area 12: License-related area 13: System area 14: SWAP (temporary file/memory alternative area) 15 to 16: Not used 17: Debug log area 18: Advanced Box image data storage area 19: Print data storage area 20 to 65535: Not used * When 4, 12, 13, 15 or 16 is set, nothing is cleared even if HD-CLEAR is executed. * For 2, 5 and 6, HD-CLEAR/HD-CHECK is executed to all of the areas by selecting one of them. * By selecting 8, HD-CLEAR/HD-CHECK is also executed to 7, 9, 11 and 17.
Default Value		0
Related Service Mode		COPIER> FUNCTION> SYSTEM> HD-CLEAR, HD-CHECK
HD-CHECK	1	File system check of specified partition
Detail		To execute system check of the partition specified by CHK-TYPE at the next startup.
Use Case		When E602/E614 error (file corruption, etc.) occurs
Adj/Set/Operate Method		Enter 1, and then press OK key.
Caution		Be sure to execute this item after CHK-TYPE.
Display/Adj/Set Range		0 to 1 0: Not executed, 1: Executed at next startup
Default Value		0
Related Service Mode		COPIER> FUNCTION> SYSTEM> CHK-TYPE

COPIER (Service mode for printer) > FUNCTION (Operation / inspection mode) > SYSTEM

HD-CLEAR	1	Initialization of specified partition
Detail		*Operation on this item is restricted by the setting of [Restrict Service Representation Access]. To initialize the partition specified by CHK-TYPE at next startup.
Use Case		When E602/E614 error (file corruption, etc.) occurs
Adj/Set/Operate Method		Enter 1, and then press OK key.
Caution		Be sure to execute this item after CHK-TYPE.
Display/Adj/Set Range		0 to 1 0: Not executed, 1: Executed at next startup
Default Value		0
Related Service Mode		COPIER> FUNCTION> SYSTEM> CHK-TYPE
DSRAMBUP	2	Backup of DC Controller PCB SRAM
Detail		To back up the setting data in SRAM of the DC Controller PCB.
Use Case		When replacing the DC Controller PCB for troubleshooting at the time of trouble occurrence
Adj/Set/Operate Method		Select the item, and then press OK key.
Caution		During operation, the setting data changes by manual or automatic adjustment. When backup data which has been left for a long period of time is restored, it is overwritten with new setting data and the old data is deleted.
Related Service Mode		COPIER> FUNCTION> SYSTEM> DSRAMRES
DSRAMRES	2	Restore of DC Controller PCB SRAM
Detail		To restore the setting data which has been backed up in SRAM of the DC Controller PCB.
Use Case		When replacing the DC Controller PCB for troubleshooting at the time of trouble occurrence
Adj/Set/Operate Method		Select the item, and then press OK key.
Caution		During operation, the setting data changes by manual or automatic adjustment. When backup data which has been left for a long period of time is restored, it is overwritten with new setting data and the old data is deleted.
Related Service Mode		COPIER> FUNCTION> SYSTEM> DSRAMBUP
RSRAMBUP	2	Backup of Reader Controller PCB SRAM
Detail		To back up the setting data in SRAM of the Reader Controller PCB.
Use Case		When replacing the Reader Controller PCB for troubleshooting at the time of trouble occurrence
Adj/Set/Operate Method		Select the item, and then press OK key.
Caution		During operation, the setting data changes by manual or automatic adjustment. When backup data which has been left for a long period of time is restored, it is overwritten with new setting data and the old data is deleted.
Related Service Mode		COPIER> FUNCTION> SYSTEM> RSRAMRES
RSRAMRES	2	Restore of Reader Controller PCB SRAM
Detail		To restore the setting data which has been backed up in SRAM of the Reader Controller PCB.
Use Case		When replacing the Reader Controller PCB for troubleshooting at the time of trouble occurrence
Adj/Set/Operate Method		1) Select the item, and then press OK key. 2) Turn OFF/ON the main power switch.
Caution		During operation, the setting data changes by manual or automatic adjustment. When backup data which has been left for a long period of time is restored, it is overwritten with new setting data and the old data is deleted.
Related Service Mode		COPIER> FUNCTION> SYSTEM> RSRAMBUP
R-REBOOT	1	Reboot of host machine (Remote)
Detail		To reboot the host machine.
Use Case		When the reboot is carried out with the remote control by VNC
Adj/Set/Operate Method		Select the item, and then press OK key.

COPIER (Service mode for printer) > FUNCTION (Operation / inspection mode) > SYSTEM

FIXIP	1	Start of fixed IP mode
Detail		IP address is set to "172.16.1.100". In an environment where wired LAN (main) and wireless LAN (sub) are used, the IP address of wired LAN becomes the fixed IP. During the fixed IP mode, "FIXIP" is displayed on the upper left of the screen.
Use Case		When preferring to use the network settings with the fixed IP address "172.16.1.100"
Adj/Set/Operate Method		Select the item, and then press OK key.
Caution		- It is necessary to turn OFF/ON the power to recover from the fixed IP mode. - Whether to use RUI or not when the fixed IP mode is enabled follows the setting of "Management Settings> License/Other> Remote UI."

■ 2D-SHADE

COPIER (Service mode for printer) > FUNCTION (Operation / inspection mode) > 2D-SHADE

M-LINE1	2	2D shading horizontal scan 1 correction
Detail		To set the correction value of the horizontal scanning direction 1 at 2D shading.
Adj/Set/Operate Method		1) Enter the value, and then press OK key. 2) Turn OFF/ON the main power switch.
Display/Adj/Set Range		0 to 255
Related Service Mode		COPIER> OPTION> IMG-LSR> 2D-SHADE COPIER> FUNCTION> 2D-SHADE> M-LINE2
M-LINE2	2	2D shading horizontal scan 2 correction
Detail		To set the correction value of the horizontal scanning direction 2 at 2D shading.
Adj/Set/Operate Method		1) Enter the value, and then press OK key. 2) Turn OFF/ON the main power switch.
Display/Adj/Set Range		0 to 255
Related Service Mode		COPIER> OPTION> IMG-LSR> 2D-SHADE COPIER> FUNCTION> 2D-SHADE> M-LINE1
Supplement/Memo		The right column is not used.
S-LINE1	2	2D shading vertical scan 1 correction
Detail		To display the correction value of the vertical scanning direction 1 at 2D shading.
Adj/Set/Operate Method		N/A (Display only)
Display/Adj/Set Range		0 to 255
Related Service Mode		COPIER> OPTION> IMG-LSR> 2D-SHADE COPIER> FUNCTION> 2D-SHADE> S-LINE2 - LINE4
S-LINE2	2	2D shading vertical scan 2 correction
Detail		To display the correction value of the vertical scanning direction 2 at 2D shading.
Adj/Set/Operate Method		N/A (Display only)
Display/Adj/Set Range		0 to 255
Related Service Mode		COPIER> OPTION> IMG-LSR> 2D-SHADE COPIER> FUNCTION> 2D-SHADE> S-LINE1/LINE3/LINE4
S-LINE3	2	2D shading vertical scan 3 correction
Detail		To display the correction value of the vertical scanning direction 3 at 2D shading.
Adj/Set/Operate Method		N/A (Display only)
Display/Adj/Set Range		0 to 255
Related Service Mode		COPIER> OPTION> IMG-LSR> 2D-SHADE COPIER> FUNCTION> 2D-SHADE> S-LINE1/LINE2/LINE4

COPIER (Service mode for printer) > FUNCTION (Operation / inspection mode) > 2D-SHADE

S-LINE4	2	2D shading vertical scan 4 correction
Detail	To display the correction value of the vertical scanning direction 4 at 2D shading.	
Adj/Set/Operate Method	N/A (Display only)	
Display/Adj/Set Range	0 to 255	
Related Service Mode	COPIER> OPTION> IMG-LSR> 2D-SHADE COPIER> FUNCTION> 2D-SHADE> S-LINE1/LINE2/LINE3	
SHD-P1	1	2D shading pattern 1 output
Detail	To output pattern 1 for 2D shading.	
Use Case	When checking 2D shading profile visually and entering manually	
Adj/Set/Operate Method	Select the item, and then press OK key.	
Related Service Mode	COPIER> OPTION> IMG-LSR> 2D-SHADE COPIER> FUNCTION> 2D-SHADE> SHD-P2/P3	
SHD-P2	1	2D shading pattern 2 output
Detail	To output pattern 2 for 2D shading.	
Use Case	When checking 2D shading profile visually and entering manually	
Adj/Set/Operate Method	Select the item, and then press OK key.	
Related Service Mode	COPIER> OPTION> IMG-LSR> 2D-SHADE COPIER> FUNCTION> 2D-SHADE> SHD-P1/P3	
SHD-P3	1	2D shading pattern 3 output
Detail	To output pattern 3 for 2D shading.	
Use Case	When checking 2D shading profile visually and entering manually	
Adj/Set/Operate Method	Select the item, and then press OK key.	
Related Service Mode	COPIER> OPTION> IMG-LSR> 2D-SHADE COPIER> FUNCTION> 2D-SHADE> SHD-P1/P2	
2D-READ	1	Read 2D shading ROM
Detail	To read 2D shading ROM data. To check ROM for 2D shading, compare the calculated checksum and checksum of ROM. When they are matched, the checksum and Drum Lot number are stored in the DC Controller. When they are not matched, it is judged as an alarm.	
Use Case	After executing initialization of Drum at Drum replacement	
Adj/Set/Operate Method	Select the item, and then press OK key.	
Display/Adj/Set Range	During operation: ACTIVE, At normal termination: OK, At abnormal termination: NG	
Related Service Mode	COPIER> DISPLAY> 2D-SHADE> 2D-STS COPIER> OPTION> IMG-LSR> 2D-SHADE	

COPIER (Service mode for printer) > FUNCTION (Operation / inspection mode) > 2D-SHADE

2D-SET	2	Btch set of low dens prev: frt/rear side
Detail	<p>To execute a series of settings/operations to improve low density at the front/rear side. Conventionally, measures against low density at the front/rear side due to individual difference of the Photosensitive Drum have been taken by combining the following service modes.</p> <p>COPIER> OPTION> IMG-LSR> 2D-SHADE COPIER> FUNCTION> DPC> DPC COPIER> FUNCTION> 2D-SHADE> M-LINE1/2</p> <p>With this item, these service modes are set/executed collectively so the results equivalent to those obtained by executing them manually can be obtained easily.</p> <p>Set 1 for low density at the front side, 2 for low density at the rear side, and 3 for low density at both sides. In each case, density is increased for a certain level. If further adjustment is required, it is necessary to make adjustment with conventional procedure.</p> <p>When 0 is set, all the settings of service modes are returned to the default.</p>	
Use Case	When low density at the front/rear side occurs at an early stage	
Adj/Set/Operate Method	<p>1) Enter the setting value, and then press OK key.</p> <p>2) Turn OFF/ON the main power switch.</p>	
Caution	<p>- The setting is reflected after turning OFF/ON the power.</p> <p>- If adjustment is made with M-LINE1/2 after setting this item to 1, 2 or 3, the value 0 is displayed to indicate the setting of this item is changed. However, it does not mean that the setting is returned to the default. When returning the setting to the default, enter 0.</p> <p>- Make the setting again after replacing the Photosensitive Drum because the sensitivity is different between the old and new drums.</p>	
Display/Adj/Set Range	<p>0 to 3</p> <p>0: Set 2D shading to OFF, and return all of the setting values to the default values</p> <p>1: Increase the density at the front side only</p> <p>2: Increase the density at the rear side only</p> <p>3: Increase the density on both sides</p>	
Default Value	0	
Related Service Mode	<p>COPIER> OPTION> IMG-LSR> 2D-SHADE COPIER> FUNCTION> DPC> DPC COPIER> FUNCTION> 2D-SHADE> M-LINE1/LINE2</p>	

■ DBG-LOG

COPIER (Service mode for printer) > FUNCTION (Operation / inspection mode) > DBG-LOG

LOG2USB	2	Storage of debug log to USB memory
Detail	<p>To store a set of debug logs to the USB flash drive at the error occurrence. A type of log to be collected is set in LOG-TRIG.</p> <p>If there is a debug log which has been automatically saved, it is archived at this time. Required time differs according to the device conditions and volume of log data.</p>	
Use Case	When analyzing the cause of a problem	
Adj/Set/Operate Method	<p>1) Install the USB flash drive.</p> <p>2) Select the item, and then press OK key.</p>	
Caution	<p>- Wait until the machine recognizes the USB memory (approx. 10 sec.).</p> <p>- During the data transfer ("ACTIVE" display), do not turn OFF the power/remove the USB memory/ use the screen for operations.</p>	
Display/Adj/Set Range	During operation: ACTIVE, At normal termination: OK, At abnormal termination: NG	
Related Service Mode	COPIER> FUNCTION> DBG-LOG> LOG-TRIG	
LOG2SRVR	2	For R&D

COPIER (Service mode for printer) > FUNCTION (Operation / inspection mode) > DBG-LOG

LOG-TRIG	2	Set of debug log storage condition
Detail		To set the conditions (timing, types, etc.) to automatically store the debug logs (stored as an archive file). By reading the operation setting file of the setting value from the Main Controller, the conditions written in the file are set. When setting a new condition is necessary, read the operation setting file provided by R&D from the USB memory.
Use Case		- When changing the conditions of debug log to automatically store - When setting a new condition
Adj/Set/Operate Method		Enter the setting value, and then press OK key.
Display/Adj/Set Range		0 to 99999
Related Service Mode		COPIER> FUNCTION> DBG-LOG> LOG2USB, LOG2SRVR
HIT-STS	2	Display of debug log state
Detail		To display whether archive file of the debug log which is matched with the conditions set in LOG-TRIG exists or not.
Use Case		When checking the debug log automatically saved
Adj/Set/Operate Method		N/A (Display only)
Display/Adj/Set Range		0 to 1 0: No log is available, 1: Log is available
Related Service Mode		COPIER> FUNCTION> DBG-LOG> LOG-TRIG
SYSLOG	2	For R&D
DEFAULT	2	Reset of debug log setting
Detail		To clear all debug log settings and return to the state before debug log collection operation.
Use Case		- When returning the device in which analyzing the cause of a problem was completed - When resetting the debug log settings
Adj/Set/Operate Method		Select the item, and then press OK key.
LOG-DEL	2	Clearing of debug logs
Detail		To delete the debug log file. The debug log setting is not reset.
Use Case		When clearing the debug log
Adj/Set/Operate Method		Select the item, and then press OK key.
HIT-STS2	2	For R&D

OPTION (Specification setting mode)

■ FNC-SW

COPIER (Service mode for printer) > OPTION (Specification setting mode) > FNC-SW

PO-CNT	1	ON/OFF of potential control function
Detail		To set ON/OFF of potential control function.
Use Case		When replacing the Potential Sensor
Adj/Set/Operate Method		1) Enter the setting value, and then press OK key. 2) Turn OFF/ON the main power switch.
Caution		Be sure to set the value back to 1 (ON) after servicing.
Display/Adj/Set Range		0 to 1 0: OFF, 1: ON
Default Value		1

COPIER (Service mode for printer) > OPTION (Specification setting mode) > FNC-SW

PO-CNTMD	2	Set potential control execution timing
Detail	To set the combination of timing to execute the potential control.	
Use Case	When productivity is decreased at execution of potential control	
Adj/Set/Operate Method	Enter the setting value, and then press OK key.	
Display/Adj/Set Range	0 to 2 0: - At warm-up rotation performed first time for the day in an HH environment - At last rotation in the case that a job right after startup first time for the day takes 10 minutes or longer - At last rotation after 1500 sheets since the last potential control - At last rotation of the first job after 90 minutes since the last potential control - At warm-up rotation of the first job after 10 minutes since the startup first time for the day (30 seconds) 1: - At warm-up rotation performed first time for the day in an HH environment - At last rotation in the case that a job right after startup first time for the day takes 10 minutes or longer - At last rotation after 1500 sheets since the last potential control - At warm-up rotation of the first job after 10 minutes since the startup first time for the day (30 seconds) 2: - At warm-up rotation performed first time for the day in an HH environment - At last rotation after 1500 sheets since the last potential control	
Default Value	0	
MODEL-SZ	1	Fixed magnifictn & DADF orgnl dtct size
Detail	To set the fixed magnification ratio display and the original detection size with DADF. It is set automatically at the time of installation of the Reader according to the location.	
Use Case	Upon user's request	
Adj/Set/Operate Method	1) Enter the setting value, and then press OK key. 2) Turn OFF/ON the main power switch.	
Display/Adj/Set Range	0 to 3 0: AB configuration (6R5E) for Japan, 1: Inch configuration (5R4E) for North/Middle/South America, 2: A configuration (3R3E) for Europe, 3: AB/Inch configuration (6R5E) for Asia, Oceania, South America	
Default Value	It differs according to the location.	
SCANSLCT	2	ON/OFF of scan area calculate function
Detail	To set ON/OFF of the function to calculate scanning area from the specified paper size. When the paper size is larger than the original size, selecting ON reduces productivity because the scanning area gets larger.	
Use Case	When matching the scanning area with the paper size	
Adj/Set/Operate Method	1) Enter the setting value, and then press OK key. 2) Turn OFF/ON the main power switch.	
Display/Adj/Set Range	0 to 1 0: OFF (calculated from the detected original size) 1: ON (calculated from the specified paper size)	
Default Value	0	
DH-SW	2	For R&D

COPIER (Service mode for printer) > OPTION (Specification setting mode) > FNC-SW

SENS-CNF	2	Setting of original detection size
Detail	To set original detection size according to AB configuration/Inch configuration. Set 0 for AB configuration machine, and set 1 for Inch configuration machine.	
Use Case	When replacing the Reader Controller PCB/clearing RAM data	
Adj/Set/Operate Method	1) Enter the setting value, and then press OK key. 2) Turn OFF/ON the main power switch.	
Display/Adj/Set Range	0 to 1 0: AB configuration, 1: Inch configuration	
Default Value	0	
CONFIG	1	Set country/area/lang/location/ppr size
Detail	To set the country/region, language, location, paper size configuration for multiple system software in HDD.	
Use Case	Upon user's request	
Adj/Set/Operate Method	1) Select the setting item. 2) Switch with +/- key, and then press OK key. 3) Turn OFF/ON the main power switch.	
Display/Adj/Set Range	XX YY.ZZ.AA XX: Country/region JP: Japan, US: USA, GB: Great Britain, FR: France, DE: Germany, IT: Italy, AU: Australia, SG: Singapore, NL: Netherlands, KR: Korea, CN: China, TW: Taiwan, ES: Spain, SE: Sweden, PT: Portugal, NO: Norway, DK: Denmark, FI: Finland, PL: Poland, HU: Hungary, CZ: Czech Republic, SI: Slovenia, GR: Greece, EE: Estonia, RU: Russia, SK: Slovakia, RO: Romania, HR: Croatia, BG: Bulgaria, TR: Turkey, TH: Thailand, VN: Vietnam, AR: Argentina, IN: India YY: Language (Fixed; e.g. ja: Japanese) ZZ: Location (Fixed; e.g. 00: CANON) AA: Paper size configuration (00: AB configuration, 01: Inch configuration, 02: A configuration, 03: Inch/AB configuration)	
Default Value	It differs according to the location.	
Related Service Mode	COPIER> OPTION> FNC-SW> MODEL-SZ	
W/SCNR	1	Setting of Reader Unit installation
Detail	To set installation of the Reader Unit. When the Reader Unit is detected at startup of the machine, "1: Installed" is set automatically.	
Use Case	When installing/removing the Reader Unit	
Adj/Set/Operate Method	1) Enter the setting value, and then press OK key. 2) Turn OFF/ON the main power switch.	
Display/Adj/Set Range	0 to 1 0: Not installed, 1: Installed	
Default Value	0 (Printer model)/1 (Copier model)	
ORG-LGL	2	Special ppr size set at stream read: LGL
Detail	To set the size of special paper (LGL configuration) that cannot be recognized at stream reading.	
Use Case	- Upon user's request - When picking up special paper size original from DADF	
Adj/Set/Operate Method	1) Enter the setting value, and then press OK key. 2) Turn OFF/ON the main power switch.	
Display/Adj/Set Range	0 to 12 0: LEGAL-R, 1: FOOLSCAP-R/FOLIO-R, 2: OFICIO-R, 3: Not used, 4: Australian FOOLSCAP-R, 5: Ecuador OFICIO-R, 6: Bolivia OFICIO-R, 7: Argentine OFICIO-R, 8: Not used, 9: Government LEGAL-R, 10: Mexico OFICIO-R, 11: F4A, 12: India LEGAL-R	
Default Value	0	

COPIER (Service mode for printer) > OPTION (Specification setting mode) > FNC-SW

ORG-LTR	2	Special ppr size set at stream read: LTR
Detail		To set the size of special paper (LTR configuration) that cannot be recognized at stream reading.
Use Case		- Upon user's request - When picking up special paper size original from DADF
Adj/Set/Operate Method		1) Enter the setting value, and then press OK key. 2) Turn OFF/ON the main power switch.
Display/Adj/Set Range		0 to 3 0: LETTER, 1: EXECUTIVE, 2: Argentine LETTER, 3: Government LETTER
Default Value		0
ORG-LTRR	2	Special ppr size set at stream read:LTRR
Detail		To set the size of special paper (LTRR configuration) that cannot be recognized in stream reading mode.
Use Case		- Upon user's request - When picking up special paper size original from DADF
Adj/Set/Operate Method		1) Enter the setting value, and then press OK key. 2) Turn OFF/ON the main power switch.
Display/Adj/Set Range		0 to 5 0: LTR-R, 1: G-LTR-R, 2: A-LTR-R, 3: EXECUTIVE-R, 4: OFICIO-R, 5: Ecuador OFICIO-R
Default Value		0
ORG-LDR	2	Special ppr size set at stream read: LDR
Detail		To set the size of special paper (LDR configuration) that cannot be recognized at stream reading.
Use Case		- Upon user's request - When picking up special paper size original from DADF
Adj/Set/Operate Method		1) Enter the setting value, and then press OK key. 2) Turn OFF/ON the main power switch.
Display/Adj/Set Range		0 to 1 0: LEDGER-R, 1: Argentine LETTER
Default Value		0
ORG-B5	2	Special ppr size set at stream read: B5
Detail		To set the size of special paper (B5) that cannot be recognized at stream reading.
Use Case		- Upon user's request - When picking up special paper size original from DADF
Adj/Set/Operate Method		1) Enter the setting value, and then press OK key. 2) Turn OFF/ON the main power switch.
Display/Adj/Set Range		0 to 1 0: B5, 1: Korean government office paper
Default Value		0
INTROT-1	1	Set last rotation auto adj exe interval
Detail		To set the paper interval to execute D-max/D-half control at last rotation. As the value is incremented by 1, the interval is increased by 500 sheets.
Use Case		When matching the use environment of the user
Adj/Set/Operate Method		1) Enter the setting value, and then press OK key. 2) Turn OFF/ON the main power switch.
Caution		Increasing the number of sheets (widening the interval) causes higher frequency of image failure.
Display/Adj/Set Range		1 to 255
Unit		sheet
Default Value		12
Amount of Change per Unit		500

COPIER (Service mode for printer) > OPTION (Specification setting mode) > FNC-SW

DMAX-SW	1	ON/OFF of D-max control for pln group
Detail	To set ON/OFF of D-max control for plain paper group. When 1 to 3 is set, the control is executed at last rotation/first startup for the day. When 0 is set, it is controlled only with EPC using environment Vcont and Vback. (Conventional B&W machine control)	
Use Case	When D-max-related failure occurs/when identifying the cause of D-max-related failure	
Adj/Set/Operate Method	1) Enter the setting value, and then press OK key. 2) Turn OFF/ON the main power switch.	
Display/Adj/Set Range	0 to 3 0: OFF, 1: At last rotation, 2: At first startup for the day, 3: At last rotation + At first startup for the day	
Default Value	1	
MODELSZ2	2	Ppr size dtct global support in bookmode
Detail	To set whether to enable global support of original size detection at Copyboard reading.	
Use Case	Upon user's request (original consists of mixed media (AB/Inch configuration))	
Adj/Set/Operate Method	1) Enter the setting value, and then press OK key. 2) Turn OFF/ON the main power switch.	
Caution	The Document Size Sensor (Photo Sensor) is additionally required to correctly detect the document size when the original consists of mixed media (AB/Inch configuration).	
Display/Adj/Set Range	0 to 1 0: Detected with detection size according to location, 1: Detected with AB/Inch mixed media.	
Default Value	0	
SVMD-ENT	2	Setting of entry method to service mode
Detail	To set the way to get in service mode to prevent information leak.	
Use Case	As needed	
Adj/Set/Operate Method	1) Enter the setting value, and then press OK key. 2) Turn OFF/ON the main power switch.	
Display/Adj/Set Range	0 to 1 0: Factory default 1: [Settings/Registration] - Pressing [4] and [9] at the same time - [Settings/Registration]	
Default Value	0	
KSIZE-SW	2	Setting of K-size paper support
Detail	To set detection/display of K-size paper (for China). When MODEL-SZ is 0, this setting is enabled.	
Use Case	When using K size paper	
Adj/Set/Operate Method	1) Enter the setting value, and then press OK key. 2) Turn OFF/ON the main power switch.	
Display/Adj/Set Range	0 to 1 0: Not supported, 1: Supported	
Default Value	It differs according to the location.	
Related Service Mode	COPIER> OPTION> FNC-SW> MODEL-SZ	
Supplement/Memo	8K paper: 270 x 390 mm, 16K paper: 270 x 195 mm	

COPIER (Service mode for printer) > OPTION (Specification setting mode) > FNC-SW

ORG-A4R	2	Special ppr size set at stream read: A4R
Detail	To set the size of special paper (A4R) that cannot be recognized at stream reading. When picking up A4R size original from the DADF of the Inch/AB configuration models, the size is converted into the specified size so that an image can be formed properly.	
Use Case	- Upon user's request - When picking up special paper size original from DADF	
Adj/Set/Operate Method	1) Enter the setting value, and then press OK key. 2) Turn OFF/ON the main power switch.	
Display/Adj/Set Range	0 to 1 0: A4R, 1: FOLIO-R	
Default Value	0	
PDF-RDCT	2	PDF reduction set at forwarding
Detail	To set whether to reduce the image for transmission when converting the image received by I-Fax into PDF for e-mail/file transmission.	
Use Case	Upon user's request	
Adj/Set/Operate Method	1) Enter the setting value, and then press OK key. 2) Turn OFF/ON the main power switch.	
Display/Adj/Set Range	0 to 1 0: Following the current setting, 1: Image reduction	
Default Value	0	
SJB-UNW	2	Reserve upper limit of secured print job
Detail	*Operation on this item is restricted by the setting of [Restrict Service Representation Access]. To set the upper limit for the number of reserved jobs in secured print job.	
Use Case	Upon user's request	
Adj/Set/Operate Method	1) Enter the setting value, and then press OK key. 2) Turn OFF/ON the main power switch.	
Display/Adj/Set Range	0 to 2 0: 50 jobs, 1: 90 jobs, 2: No limit	
Default Value	1	
CARD-RNG	2	Card number setting (department number)
Detail	To set the number of cards (departments) that can be used with the Card Reader.	
Use Case	When setting the number of cards (departments)	
Adj/Set/Operate Method	1) Enter the setting value, and then press OK key. 2) Turn OFF/ON the main power switch.	
Display/Adj/Set Range	1 to 1000	
Default Value	1000	
SJOB-CL	1	Set of scan job canceling by logout
Detail	*Operation on this item is restricted by the setting of [Restrict Service Representation Access]. To set whether to cancel the scan job in operation by logout of the user.	
Use Case	Upon user's request	
Adj/Set/Operate Method	1) Enter the setting value, and then press OK key. 2) Turn OFF/ON the main power switch.	
Caution	The job with scanning completed cannot be canceled.	
Display/Adj/Set Range	0 to 2 0: Cancel only scan job in waiting state, 1: Cancel all scan jobs, 2: Not canceled	
Default Value	0	
Supplement/Memo	Scan job: A job after the scanning operation is completed.	

COPIER (Service mode for printer) > OPTION (Specification setting mode) > FNC-SW

MIBCOUNT	2	Scope range set of Charge Counter MIB
Detail		To set the range of counter information that can be obtained as MIB (Management Information Base).
Adj/Set/Operate Method		1) Enter the setting value, and then press OK key. 2) Turn OFF/ON the main power switch.
Display/Adj/Set Range		0 to 2 0: All charge counters are obtained, 1: Only displayed counter* is obtained, 2: All charge counters are not obtained * : Counter specified by the following: COPIER> OPTION> USER> COUNTER 1 to 6
Default Value		0
Related Service Mode		COPIER> OPTION> USER> COUNTER1 - COUNTER6
CNTR-SW	1	Init of parts counter replacement timing
Detail		To return the estimated life of parts counter to the initial value. If either "00000000" or a value before the specification change is displayed in the estimated life value of the parts counter, set 0 after upgrading of the firmware.
Use Case		- When either "00000000" or a value before the specification change is displayed in the estimated life value of the parts counter - When changing the state back to the initial state after entering the estimated life value manually
Adj/Set/Operate Method		1) Enter 0, and then press OK key. 2) Turn OFF/ON the main power switch.
Display/Adj/Set Range		0: Returned to the initial value
Default Value		0
W/RAID	1	Set of HDD Mirroring Kit installation
Detail		To set installation condition of HDD Mirroring Kit. Select "1: Installed" when installing the HDD Mirroring Kit. Select "0: Not installed" when removing the HDD Mirroring Kit.
Use Case		When installing/removing HDD Mirroring Kit
Adj/Set/Operate Method		1) Enter the setting value, and then press OK key. 2) Turn OFF/ON the main power switch.
Display/Adj/Set Range		0 to 1 0: Not installed, 1: Installed
Default Value		0
PSWD-SW	1	Password type set to enter service mode
Detail		To set the type of password that is required to enter when getting into service mode. 2 types are available: one for "service technician" and the other for "system administrator + service technician". When selecting the type for "system administrator + service technician", enter the password for service technician after the password entry by the user's system administrator.
Use Case		Upon request from the user who concerns security
Adj/Set/Operate Method		1) Enter the setting value, and then press OK key. 2) Turn OFF/ON the main power switch.
Display/Adj/Set Range		0 to 2 0: No password, 1: Service technician, 2: System administrator + service technician
Default Value		0

COPIER (Service mode for printer) > OPTION (Specification setting mode) > FNC-SW

SM-PSWD	2	Password setting for service technician
Detail	To set password for service technician that is used when getting into service mode.	
Use Case	When password is required to get into service mode	
Adj/Set/Operate Method	1) Enter the setting value, and then press OK key. 2) Turn OFF/ON the main power switch.	
Caution	Be sure to select 1 or 2 with PSWD-SW in advance.	
Display/Adj/Set Range	1 to 99999999	
Default Value	11111111	
Related Service Mode	COPIER> OPTION> FNC-SW> PSWD-SW	
RPT2SIDE	1	Set of report 1-sided/2-sided output
Detail	To set whether to use 1-sided or 2-sided for report output of service mode.	
Use Case	When making 1-sided report output	
Adj/Set/Operate Method	1) Enter the setting value, and then press OK key. 2) Turn OFF/ON the main power switch.	
Display/Adj/Set Range	0 to 1 0: 1-sided, 1: 2-sided	
Default Value	1	
Related Service Mode	COPIER> FUNCTION> MISC-P> P-PRINT	
STND-PNL	2	Set Upright Control Panel installation
Detail	To set whether the Upright Control Panel is installed. When the Upright Control Panel is installed, set 1.	
Use Case	At installation of the Upright Control Panel	
Adj/Set/Operate Method	Enter the setting value, and then press OK key.	
Display/Adj/Set Range	0 to 1 0: Not installed, 1: Installed	
Default Value	It differs according to the location.	
INVALPDL	1	Disable of PDL license
Detail	*Operation on this item is restricted by the setting of [Restrict Service Representation Access]. To disable the registered PDL license. When "1: Disabled" is set, PDL is disabled even if a PDL license is registered. This is set to the machines installed at convenience stores, which do not allow PDL to be used.	
Use Case	When prohibiting the use of PDL	
Adj/Set/Operate Method	1) Enter the setting value, and then press OK key. 2) Turn OFF/ON the main power switch.	
Display/Adj/Set Range	0 to 1 0: Registered PDL license is enabled, 1: Disabled	
Default Value	0	

COPIER (Service mode for printer) > OPTION (Specification setting mode) > FNC-SW

CDS-FIRM	1	Set to allow firmware update by admin
Detail	<p>* Operation on this item is restricted by the setting of [Restrict Service Representation Access]. To set whether to allow the user (administrator) to perform firmware update linked with CDS and collection of log files.</p> <p>When 1 is set, [Distribution Update] is added to remote UI, and [Firmware Update] is added to [Register/Update Software] of local UI. Log files can be collected from remote UI.</p>	
Use Case	When allowing the administrator to update the firmware	
Adj/Set/Operate Method	<p>1) Enter the setting value, and then press OK key.</p> <p>2) Turn OFF/ON the main power switch.</p>	
Caution	Do not use it for purposes other than collecting log files. Be sure to return the value to 0 after use.	
Display/Adj/Set Range	0 to 1 0: Disabled, 1: Enabled	
Default Value	It differs according to the location.	
Related Service Mode	COPIER> OPTION> FNC-SW> LCDSFLG	
Additional Functions Mode	Management Settings> License/Other> Register/Update Software	
Supplement/Memo	CDS: Contents Delivery System	
CDS-MEAP	1	Set to allow MEAP installation by admin
Detail	<p>* Operation on this item is restricted by the setting of [Restrict Service Representation Access]. To set whether to allow the user (administrator) to install MEAP applications from CDS and enable iR options.</p> <p>When 1 is set, Updater can be activated from [Settings/Registration].</p>	
Use Case	When allowing the administrator to install MEAP applications and enable iR options from CDS	
Adj/Set/Operate Method	<p>1) Enter the setting value, and then press OK key.</p> <p>2) Turn OFF/ON the main power switch.</p>	
Display/Adj/Set Range	0 to 1 0: Disabled, 1: Enabled	
Default Value	1	
Supplement/Memo	CDS: Contents Delivery System	
CDS-UGW	1	Set to allow firmware update from UGW
Detail	<p>*Operation on this item is restricted by the setting of [Restrict Service Representation Access]. To set whether to permit update of the firmware from the UGW server.</p> <p>When "1: Enabled" is set, Updater accepts the operation from the UGW server in cooperation with CDS.</p>	
Use Case	When allowing update of the firmware from the UGW server	
Adj/Set/Operate Method	<p>1) Enter the setting value, and then press OK key.</p> <p>2) Turn OFF/ON the main power switch.</p>	
Display/Adj/Set Range	0 to 1 0: Disabled, 1: Enabled	
Default Value	It differs according to the location.	
Supplement/Memo	CDS: Contents Delivery System	

COPIER (Service mode for printer) > OPTION (Specification setting mode) > FNC-SW

LOCLFIRM	1	Set to allow firmware update by file
Detail	*Operation on this item is restricted by the setting of [Restrict Service Representation Access]. To set whether to permit the user (administrator) to update the firmware from the remote UI using a local file. This update is executed as a measure for vulnerability in emergency situations.	
Use Case	When allowing the administrator to update the firmware using a file	
Adj/Set/Operate Method	1) Enter the setting value, and then press OK key. 2) Turn OFF/ON the main power switch.	
Display/Adj/Set Range	0 to 1 0: Disabled, 1: Enabled	
Default Value	1	
T-RUN-LV	1	No.of keep print at Toner Cntner rplce
Detail	To set the number of prints to be kept from the indication of Toner Container replacement until job is interrupted. The time to keep printing varies depending on image ratio and productivity.	
Use Case	When preferring to shorten the time from replacement of the Toner Container to the recovery	
Adj/Set/Operate Method	Enter the setting value, and then press OK key.	
Display/Adj/Set Range	0 to 1 0: Approx. 900 sheets, 1: Approx. 140 sheets (A4, 5% image ratio)	
Default Value	0	
BXNUPLOG	2	[Not used]
SDLMTWRN	1	Cpcty warn dspl ON/OFF: E-mail/I-Fax TX
Detail	To set whether to display the warning message when sending data that exceeds the upper limit value for the transmission data size via E-mail/I-Fax.	
Use Case	For customization	
Adj/Set/Operate Method	Enter the setting value, and then press OK key.	
Display/Adj/Set Range	0 to 1 0: OFF, 1: ON	
Default Value	0	
Additional Functions Mode	Function Settings> Send> E-Mail/I-Fax Settings> Maximum Data Size for Sending	
FAX-INT	2	Set FAX RX print interruption oprtn mode
Detail	To set the mode performing interruption operation of FAX reception print automatically.	
Use Case	Upon user's request	
Adj/Set/Operate Method	1) Enter the setting value, and then press OK key. 2) Turn OFF/ON the main power switch.	
Caution	- Do not set this item while charge management (charging by Coin Manager, a device alone, etc.) is used. - During an ongoing job for which delivery setting (offset, stapling, etc.) is made, interruption operation is performed between sets.	
Display/Adj/Set Range	0 to 1 0: Normal, 1: Interruption operation mode	
Default Value	0	

COPIER (Service mode for printer) > OPTION (Specification setting mode) > FNC-SW

CDS-LVUP	1	Set to allow CDS periodical update
Detail	<p>*Operation on this item is restricted by the setting of [Restrict Service Representation Access]. To set whether to allow the user (administrator) to perform periodical update linked with CDS. When 1 is set, setting of periodical update can be made in Settings/Registration menu/via remote UI.</p> <p>When 2 is set, setting of periodical update can be made on the Updater screen in service mode.</p>	
Use Case	When allowing the user/service technician to perform periodical update	
Adj/Set/Operate Method	<p>1) Enter the setting value, and then press OK key.</p> <p>2) Turn OFF/ON the main power switch.</p>	
Display/Adj/Set Range	<p>0 to 2</p> <p>0: Prohibited periodical update</p> <p>1: Display the periodical update setting screen in Settings/Registration menu/on remote UI</p> <p>2: Display the periodical update setting screen on the Updater in service mode</p>	
Default Value	It differs according to the location.	
Related Service Mode	Updater	
Additional Functions Mode	Management Settings> License/Other> Register/Update Software> Periodical Update	
Supplement/Memo	CDS: Contents Delivery System	
AMSOFFSW	1	Enabling of AMS mode
Detail	<p>*Operation on this item is restricted by the setting of [Restrict Service Representation Access]. To enable the AMS mode.</p> <p>When 0 is set, the AMS mode is enabled. The AMS mode is automatically enabled when the following 2 conditions are satisfied.</p> <ul style="list-style-type: none"> - AMS license for an iR option is installed. - AMS-supported Login application (User Authentication, etc.) is activated. 	
Use Case	When enabling AMS mode	
Adj/Set/Operate Method	<p>1) Check that AMS-supported Login application is activated.</p> <p>2) Enter 0, and then press OK key.</p> <p>3) Turn OFF/ON the main power switch.</p> <p>4) Check that [Role Management] is displayed on remote UI.</p>	
Display/Adj/Set Range	<p>0 to 1</p> <p>0: AMS mode enabled, 1: AMS mode disabled</p>	
Default Value	1	
Related Service Mode	COPIER> OPTION> LCNS-TR> ST-AMS	
Additional Functions Mode	(Remote UI) User Management> Authentication Management> Role Management	
Supplement/Memo	<p>AMS: Access Management System</p> <p>In AMS mode, [Role Management] is displayed on remote UI.</p>	
UA-OFFSW	1	ON/OFF of unified auth function
Detail	<p>*Operation on this item is restricted by the setting of [Restrict Service Representation Access]. To set ON/OFF of the Unified Authentication function.</p> <p>Set 0 when not preferring to use the Unified Authentication function because of security concern.</p>	
Use Case	Upon user's request (not to use the Unified Authentication function)	
Adj/Set/Operate Method	<p>1) Enter the setting value, and then press OK key.</p> <p>2) Turn OFF/ON the main power switch.</p>	
Display/Adj/Set Range	<p>0 to 1</p> <p>0: ON, 1: OFF</p>	
Default Value	0	
Supplement/Memo	Unified Authentication: A function with which it is considered that login authentication under it is performed by logging in it using SSO-H.	

COPIER (Service mode for printer) > OPTION (Specification setting mode) > FNC-SW

MIB-NVTA	1	RFC-compatible character stringMIB write
Detail	As default, MIB object which NVT-ASCII can be written exists in order to link with local UI entry value. This violates RFC order, so a problem like garbled 2-byte characters may occur in the SNMP monitoring system, such as other vendor's MPS. Whether to allow writing of non-RFC-compatible character strings in MIB can be set using this item. When 1 is set, only the character strings which are strictly compatible with RFC are written. (Writing operation is executed from the SNMP manager.) It is not linked with local UI.	
Use Case	Upon user's request (to operate with RFC-compatible system)	
Adj/Set/Operate Method	1) Enter the setting value, and then press OK key. 2) Turn OFF/ON the main power switch.	
Display/Adj/Set Range	0 to 3 0: Compatible in a conventional manner, 1: RFC-compatible, 2 to 3: Not used	
Default Value	0	
Supplement/Memo	RFC: Document of internet-related technical standards NVT-ASCII: Network Virtual Terminal-ASCII	
MIB-EXT	1	For R&D
SVC-RUI	1	Enabling of remote UI func for servicing
Detail	To set whether to enable the remote UI function for servicing (not provided to end users). When 0 is set, the remote UI function is disabled. When setting a value other than 0, the remote UI function is enabled and its value will be used as the password to use the function.	
Use Case	When preferring to use the import function of background image file of main menu/custom menu	
Adj/Set/Operate Method	Enter the setting value (other than 0), and then press OK key.	
Display/Adj/Set Range	0 to 65535	
Default Value	0	
LCDSFLG	1	Enabling of local CDS server
Detail	To set whether to use the local CDS server. When CDS-FIRM is 1, this setting is enabled.	
Use Case	When using the local CDS server	
Adj/Set/Operate Method	Enter the setting value, and then press OK key.	
Display/Adj/Set Range	0 to 1 0: Disabled, 1: Enabled	
Default Value	0	
Related Service Mode	COPIER> OPTION> FNC-SW> CDS-FIRM	
Additional Functions Mode	Management Settings> License/Other> Register/Update Software> Software Management Settings> Connection Server Settings	
Supplement/Memo	When local CDS is used, iW EMC/MC device firmware update plug-in is required.	

COPIER (Service mode for printer) > OPTION (Specification setting mode) > FNC-SW

BXSHIFT	1	Setting of binding at 0mm binding margin
Detail	To set whether to judge the job as a job "without binding" when storing a PDL job in Inbox while the binding margin is set to "0". By setting the binding margin to 0 mm while "0" is set, the job is processed as "without binding". "Booklet" in "Options" on the Inbox screen can be also used. When "1" is set, it is judged as "with binding" even the binding margin is 0 mm so "Booklet", which has an exclusive relationship with "binding", cannot be used.	
Use Case	Upon user's request	
Adj/Set/Operate Method	1) Enter the setting value, and then press OK key. 2) Turn OFF/ON the main power switch.	
Caution	When storing a PDL job in Mail Box while 1 is set, "Booklet" in "Options" on the Mail Box screen cannot be used.	
Display/Adj/Set Range	0 to 1 0: Without binding, 1: With binding	
Default Value	0	
SELF-CHK	2	For R&D
HOME-SW	1	Set screen displayed with Main Menu key
Detail	To set whether to display the main menu screen or the screen registered as the startup screen when pressing Main Menu key.	
Use Case	Upon user's request (to change the startup screen)	
Adj/Set/Operate Method	Enter the setting value, and then press OK key.	
Display/Adj/Set Range	0 to 1 0: Main Menu screen, 1: Screen registered as the startup screen	
Default Value	0	
NO-LGOUT	1	Display/hide of logout button
Detail	*Operation on this item is restricted by the setting of [Restrict Service Representation Access]. To set whether to display or hide [Logout] button. When 0 is set, [Logout] button is displayed on the screen, and logout with the ID key is enabled. (Normal) When 1 is set, [Logout] button is not displayed, and logout with the ID key is disabled.	
Use Case	Upon user's request (for customization, etc.)	
Adj/Set/Operate Method	1) Enter the setting value, and then press OK key. 2) Turn OFF/ON the main power switch.	
Display/Adj/Set Range	0 to 1 0: Display, 1: Hide	
Default Value	0	
JM-ERR-D	2	Set of error display of 0CAx jam (DCON)
Detail	To set whether to display "0CAx" jam as the error "E996-0CAx". In the case of a jam, log cannot be obtained depending on the timing. By selecting 1 when the jam "0CAx" occurs, it is displayed as the error "E996-0CAx" so that the log can be obtained.	
Use Case	When obtaining a log at the occurrence of 0CAx jam	
Adj/Set/Operate Method	Enter the setting value, and then press OK key.	
Display/Adj/Set Range	0 to 1 0: Display as a jam, 1: Display as an error	
Default Value	0	
Related Service Mode	COPIER> OPTION> FNC-SW> JM-ERR-R	

COPIER (Service mode for printer) > OPTION (Specification setting mode) > FNC-SW

JM-ERR-R	2	Enable to obtain the log for 0071 jam
Detail	To set whether to display 0071 jam as the error "E996-0071". In the case of a jam, a log may not be able to be obtained depending on the timing. By selecting 1 when the 0071 jam occurs, it is displayed as an error so that a log can be obtained.	
Use Case	When obtaining a log at the occurrence of 0071 jam	
Adj/Set/Operate Method	Enter the setting value, and then press OK key.	
Display/Adj/Set Range	0 to 1 0: Display as a jam, 1: Display as an error	
Default Value	0	
Related Service Mode	COPIER> OPTION> FNC-SW> JM-ERR-D	
ASLPMAX	1	Set auto sleep shift time maximum value
Detail	Set auto sleep shift time maximum value.	
Use Case	Upon user's request	
Adj/Set/Operate Method	Enter the setting value, and then press OK key.	
Display/Adj/Set Range	0 to 1 0: 240minutes, 1: 120 minutes	
Default Value	It differs according to the location.	
SEND-SPD	2	ON/OFF of SEND operation speed-up
Detail	To set whether to speed up the SEND operation. Usually, speed of SEND/XBOX is increased by performing image conversion during SEND and Scan. Reading speed may decrease when scanning large size color original at high resolution or when competing operation occurs with another job during scanning. Set 1 to keep the speed. When failure with MEAP application occurs, set 1.	
Use Case	- When reading speed is decreased during SEND and Scan - When failure with MEAP application occurs	
Adj/Set/Operate Method	1) Enter the setting value, and then press OK key. 2) Turn OFF/ON the main power switch.	
Display/Adj/Set Range	0 to 1 0: ON, 1: OFF	
Default Value	0	

COPIER (Service mode for printer) > OPTION (Specification setting mode) > FNC-SW

VER-CHNG	2	Setting of firmware update operation
Detail	To set how to update firmware of PCB/option which has been installed/replaced by comparing the version of it with the version stored in the Flash PCB of the Main Controller. If combination of firmware versions of PCB/option stored in the Main Controller and the version in PCB/option after installation/replacement is not appropriate (operation with the combination of firmware versions has not yet been checked), failure where analysis is difficult may occur. It is possible to check the firmware versions at the start of the machine, and automatically write the firmware stored in the Main Controller in PCB/option collectively as needed. When 0 is set, versions are not checked and firmware update is not performed. Therefore, it is necessary to manually update the versions using a USB memory/SST. When 1 is set, firmware is updated if the version in PCB/option is old. However, it is not updated if the version is new or old and new versions are mixed. When 2 is set, a compatible firmware (the version where operation has been checked) is written from the Main Controller regardless of whether the version in PCB/option is old or new.	
Use Case	When installing/replacing PCB/option having firmware	
Adj/Set/Operate Method	1) Enter the setting value, and then press OK key. 2) Turn OFF/ON the main power switch.	
Display/Adj/Set Range	0 to 2 0: Keep the current firmware version. 1: Update the firmware if the version in PCB/option is older than that stored in the Main controller. If the version is new or old and new versions are mixed, firmware is not updated. 2: Update the firmware regardless of whether the version is old or new if the version in PCB/option differs from that stored in the Main Controller.	
Default Value	1	
Supplement/Memo	When updating the firmware, the main menu is displayed on the Control Panel at startup and then a message prompting to update firmware is displayed. By pressing [Update], the machine reboots immediately and firmware is updated. By pressing [Skip], it returns to the main menu. The message is displayed again at next startup.	
CE-SW	1	[Reserve]
S-TRAY	2	Presence/absence of Shift Tray
Detail	To set whether the Shift Tray is installed or not. When it is installed, set 1.	
Use Case	When installing the Shift Tray	
Adj/Set/Operate Method	1) Enter the setting value, and then press OK key. 2) Turn OFF/ON the main power switch.	
Display/Adj/Set Range	0 to 1 0: Not installed, 1: Installed	
Default Value	0	
D-FDS-SW	2	ON/OFF of double feed detection
Detail	To set whether to enable the double feed detection function. Set 1 when the Double Feed Detection Kit (option) is installed.	
Use Case	When installing the Double Feed Detection Kit	
Adj/Set/Operate Method	Enter the setting value, and then press OK key.	
Caution	When 1 is set, be sure to check the operation with D-FDS. If the Double Feed Sensor cannot be recognized, an error (E196) occurs.	
Display/Adj/Set Range	0 to 1 0: OFF, 1: ON	
Default Value	0	
Related Service Mode	COPIER> FUNCTION> PART-CHK> D-FDS	

COPIER (Service mode for printer) > OPTION (Specification setting mode) > FNC-SW

PICLOGIN	1	ON/OFF of Picture Login display
Detail	To set whether to display [Picture Login] in [Settings/Registration].	
Use Case	When switching the Picture Login function	
Adj/Set/Operate Method	1) Enter the setting value, and then press OK key. 2) Turn OFF/ON the main power switch.	
Display/Adj/Set Range	0 to 1 0: OFF, 1: ON	
Default Value	1	
Additional Functions Mode	Management Settings> User Management> Authentication Management> Use User Authentication> Picture Login	
FL-START	2	[For customization]
RCONTRY	2	Set process at RCON communication error
Detail	To set the processing to be executed at occurrence of RCON communication error. Normally, recovery is performed without displaying an error. A log is not collected. Set 1 when recovery processing is performed frequently. An error is displayed and a log for analysis can be collected.	
Use Case	When recovery processing due to RCON communication error is performed frequently	
Adj/Set/Operate Method	1) Enter the setting value, and then press OK key. 2) Turn OFF/ON the main power switch.	
Display/Adj/Set Range	0 to 1 0: Perform recovery without collecting a log, 1: Collect a log and display an error	
Default Value	0	
3RDP-MSG	2	ON/OFF pop-up screen dspI after upgrade
Detail	To set whether to display the screen to prompt the user to "Third-Party Software" at the first startup after upgrading due to change in the platform version.	
Use Case	There will be no occasion to use this item intentionally.	
Adj/Set/Operate Method	1) Enter the setting value, and then press OK key. 2) Turn OFF/ON the main power switch.	
Caution	Even if 0 is set, the screen is displayed if CDS-LVUP is set to 0.	
Display/Adj/Set Range	0 to 1 0: Hide, 1: Display	
Default Value	0	
Related Service Mode	COPIER> OPTION> FNC-SW> CDS-LVUP	
SZ-MODE	1	For R&D

■ DSPLY-SW

COPIER (Service mode for printer) > OPTION (Specification setting mode) > DSPLY-SW

UI-COPY	2	ON/OFF of copy screen display
Detail	To set whether to display or hide the copy function.	
Use Case	Upon user's request	
Adj/Set/Operate Method	1) Enter the setting value, and then press OK key. 2) Turn OFF/ON the main power switch.	
Display/Adj/Set Range	0 to 1 0: Hide, 1: Display	
Default Value	1	

COPIER (Service mode for printer) > OPTION (Specification setting mode) > DSPLY-SW

UI-BOX	2	ON/OFF of Inbox screen display
Detail	*Operation on this item is restricted by the setting of [Restrict Service Representation Access]. To set whether to display the Inbox function. The setting values "1" and "2" of this item are linked with the values "ON" and "OFF" of [Mail Box] in [Settings/Registration] respectively. The setting is reflected after turning OFF/ON the power.	
Use Case	Upon user's request	
Adj/Set/Operate Method	1) Enter the setting value, and then press OK key. 2) Turn OFF/ON the main power switch.	
Display/Adj/Set Range	1 to 2 1: Inbox function is active 2: Inbox function is active (with limitation; Storing is available with PDL to Inbox despite no display on the Control Panel/remote UI)	
Default Value	1	
Additional Functions Mode	Preferences> Display Settings> Store Location Display Settings> Mail Box	
UI-SEND	2	ON/OFF of Send screen display
Detail	To set whether to display or hide the SEND function.	
Use Case	Upon user's request	
Adj/Set/Operate Method	1) Enter the setting value, and then press OK key. 2) Turn OFF/ON the main power switch.	
Display/Adj/Set Range	0 to 1 0: Hide, 1: Display	
Default Value	1	
UI-FAX	2	ON/OFF of fax screen display
Detail	To set whether to display or hide the FAX function.	
Use Case	Upon user's request	
Adj/Set/Operate Method	1) Enter the setting value, and then press OK key. 2) Turn OFF/ON the main power switch.	
Display/Adj/Set Range	0 to 1 0: Hide, 1: Display	
Default Value	1	
NWERR-SW	2	OFF/ON of network-related error display
Detail	To set OFF/ON of network-related error message display. When setting "0: OFF" while the machine is not connected to network, the error message "Check the network connection." is not displayed.	
Use Case	When using the machine as a copy machine	
Adj/Set/Operate Method	1) Enter the setting value, and then press OK key. 2) Turn OFF/ON the main power switch.	
Display/Adj/Set Range	0 to 1 0: OFF, 1: ON	
Default Value	0 (Copier model)/1 (Printer model)	

COPIER (Service mode for printer) > OPTION (Specification setting mode) > DSPLY-SW

UI-PRINT	2	Set of secured print-related UI display
Detail	To set whether to display UI related to secured print.	
Use Case	Upon user's request	
Adj/Set/Operate Method	1) Enter the setting value, and then press OK key. 2) Turn OFF/ON the main power switch.	
Display/Adj/Set Range	0 to 2 0: Hide all UIs related to secured print 1: Display all UIs related to secured print 2: Hide Secured Print button in the main menu and the simple authentication settings in [Settings/Registration]	
Default Value	0	
IMGC-ADJ	1	ON/OFF of img adj item dspl in [Set/Reg]
Detail	To set whether to display the item relating to image adjustment in [Settings/Registration]. When 1 is set, detailed image adjustment procedure will be displayed only for the paper duplicated in Preferences> Paper Settings> Paper Type Management Settings.	
Use Case	As needed	
Adj/Set/Operate Method	1) Enter the setting value, and then press OK key. 2) Turn OFF/ON the main power switch.	
Display/Adj/Set Range	0 to 1 0: Hide, 1: Display	
Default Value	0	
Additional Functions Mode	Preferences> Paper Settings> Set Paper Type Management	
UI-RSCAN	2	ON/OFF of remote scan screen display
Detail	To set whether to display the remote scan screen on the Control Panel.	
Use Case	Upon user's request	
Adj/Set/Operate Method	1) Enter the setting value, and then press OK key. 2) Turn OFF/ON the main power switch.	
Display/Adj/Set Range	0 to 1 0: OFF, 1: ON	
Default Value	1	
UI-WEB	2	ON/OFF of Web browser screen display
Detail	To set whether to display or hide the Web browser screen.	
Use Case	Upon user's request	
Adj/Set/Operate Method	1) Enter the setting value, and then press OK key. 2) Turn OFF/ON the main power switch.	
Display/Adj/Set Range	0 to 1 0: Hide, 1: Display	
Default Value	1	

COPIER (Service mode for printer) > OPTION (Specification setting mode) > DSPLY-SW

UI-HOLD	2	ON/OFF of hold job screen display
Detail	To set whether to display the hold job screen on the Control Panel.	
Use Case	Upon user's request	
Adj/Set/Operate Method	1) Enter the setting value, and then press OK key. 2) Turn OFF/ON the main power switch.	
Display/Adj/Set Range	0 to 3 0: Hide (when POD function is OFF and JAL is OFF) 1: Display (when POD function is ON and JAL is OFF) 2: Hide (when POD function is OFF and JAL is ON) 3: Hide (when POD function is ON and JAL is ON)	
Default Value	1	
Supplement/Memo	POD function: JDF + HOLD functions JAL function: A function to save the print result as a thumbnail.	
RMT-CNSL	1	Allow console application connection
Detail	To set whether to allow connection from a console application (RemoteConsole). When 1 is set, logs of MEAP application can be collected via the console application activated on a PC.	
Use Case	When collecting logs of MEAP application	
Adj/Set/Operate Method	1) Enter the setting value, and then press OK key. 2) Turn OFF/ON the main power switch.	
Display/Adj/Set Range	0 to 1 0: OFF, 1: ON	
Default Value	0	
UI-SBOX	2	ON/OFF of Advanced Box screen display
Detail	*Operation on this item is restricted by the setting of [Restrict Service Representation Access]. To set ON/OFF of the Advanced Box screen on the Control Panel. The setting values 0 (OFF) and 1 (ON) are linked with OFF and ON of [Advanced Box/Network] in [Settings/Registration] respectively. The setting is reflected after turning OFF/ON the power.	
Use Case	When not displaying the Advanced Box screen on the Control Panel	
Adj/Set/Operate Method	1) Enter the setting value, and then press OK key. 2) Turn OFF/ON the main power switch.	
Display/Adj/Set Range	0 to 1 0: OFF, 1: ON	
Default Value	It differs according to the location.	
Additional Functions Mode	Preferences> Display Settings> Store Location Display Settings> Advanced Box/Network	
UI-MEM	2	ON/OFF of memory media screen display
Detail	*Operation on this item is restricted by the setting of [Restrict Service Representation Access]. To set ON/OFF of the memory media screen display on the Control Panel. The setting values 0 (OFF) and 1 (ON) are linked with OFF and ON of [Memory Media] in [Settings/Registration] respectively. The setting is reflected after turning OFF/ON the power.	
Use Case	When not displaying the memory media screen on the Control Panel	
Adj/Set/Operate Method	1) Enter the setting value, and then press OK key. 2) Turn OFF/ON the main power switch.	
Display/Adj/Set Range	0 to 1 0: OFF, 1: ON	
Default Value	1	
Additional Functions Mode	Preferences> Display Settings> Store Location Display Settings> Memory Media	

COPIER (Service mode for printer) > OPTION (Specification setting mode) > DSPLY-SW

UI-NAVI	2	ON/OFF of Tutorial display
Detail		To set whether to display or hide "Introduction to Useful Features" in the main menu.
Use Case		Upon user's request
Adj/Set/Operate Method		1) Enter the setting value, and then press OK key. 2) Turn OFF/ON the main power switch.
Display/Adj/Set Range		0 to 1 0: Hide, 1: Display
Default Value		1
SCT-BTN	1	Set No. of shortcut buttons upper limit
Detail		To set an upper limit on the number of shortcut buttons that appear at the top of the Control Panel screen. The setting is enabled for the Upright Control Panel only.
Use Case		Upon user's request
Adj/Set/Operate Method		1) Enter the setting value, and then press OK key. 2) Turn OFF/ON the main power switch.
Caution		- In case of the Flat Control Panel, the setting is disabled. (Four shortcut buttons are always displayed.) - When 1 is set, the number of shortcut buttons that can be set increases from 2 to 4. However, the buttons become small in width, and the number of characters that can be displayed decreases. Depending on the MEAP application allocated to the shortcut button, the character strings displayed may not be fully displayed. Since the character strings displayed on the shortcut button are specified by the MEAP application, they cannot be changed. Therefore, if the number of characters are too many, foregoing symptom occurs. To prevent the symptom, a measure such as decreasing the number of characters on the MEAP application side needs to be taken.
Display/Adj/Set Range		0 to 1 0: 2 buttons, 1: 4 buttons
Default Value		0
Supplement/Memo		The settings for shortcut buttons are made in [Top Buttons Settings] which is displayed by pressing Advanced Menu button in upper right of the screen.
SDTM-DSP	1	ON/OFF of auto shutdown shift time dspI
Detail		To set whether to display [Auto Shutdown Time] in [Settings/Registration].
Use Case		Upon user's request
Adj/Set/Operate Method		Enter the setting value, and then press OK key.
Caution		When 0 is set, automatic shutdown is not executed.
Display/Adj/Set Range		0 to 1 0: OFF, 1: ON
Default Value		It differs according to the location.
Additional Functions Mode		Preferences> Timer/Energy Settings> Auto Shutdown Time
UI-PPA	2	ON/OFF of PPA screen display
Detail		To set whether to display PPA-related information on the Control Panel or remote UI. The setting is linked with LGCY-SCP. When LGCY-SCP is set to 0, the setting of this item becomes 1. When LGCY-SCP is set to 1, the setting of this item becomes 0.
Use Case		When not displaying PPA-related information on the screen
Adj/Set/Operate Method		1) Enter the setting value, and then press OK key. 2) Turn OFF/ON the main power switch.
Display/Adj/Set Range		0 to 1 0: OFF, 1: ON
Default Value		0 (non PPA-installed machine)/1 (PPA-installed machine)
Related Service Mode		COPIER> OPTION> USER> LGCY-SCP
Supplement/Memo		PPA (Personal Print Application): A function to hold print job. It contains the secured print function.

COPIER (Service mode for printer) > OPTION (Specification setting mode) > DSPLY-SW

CE-DSP	2	[Reserve]
LOCAL-SZ	1	ON/OFF area-spec stdrd size ppr set scrn
Detail	To set whether to display the area-specific standard size paper on the paper settings screen in [Settings/Registration]. When 1 is set, paper type (FOOLSCAP, OFICIO, etc.) can be set on the paper settings screen for each paper source.	
Use Case	Upon user's request	
Adj/Set/Operate Method	Enter the setting value, and then press OK key.	
Display/Adj/Set Range	0 to 1 0: OFF, 1: ON	
Default Value	It differs according to the location.	
Additional Functions Mode	Preferences> Paper Settings> Paper Settings	
DIE-DSP	2	ON/OFF die total counter dspl: P-Puncher
Detail	To set whether to display the total counter of die on the Professional Puncher on the "Consumables" screen.	
Use Case	Upon user's request	
Adj/Set/Operate Method	Enter the setting value, and then press OK key.	
Display/Adj/Set Range	0 to 1 0: OFF, 1: ON	
Default Value	0	
Supplement/Memo	Product name of P-Puncher: Multi Function Professional Puncher-A1	
OIL-DSP	2	ON/OFF die lubricant warn dspl:P-Puncher
Detail	To set whether to display the Professional Puncher die lubrication warning message and the warning deletion screen. When 1 is set, the die lubrication warning message is displayed on the status line of the Control Panel after performing the specified number of punches. In addition, [Initialize After Puncher Unit Die Lubrication] is displayed in [Settings/Registration]. By executing this item after lubrication, the lubrication counter is initialized and the die lubrication warning message is cleared. Set 0 when lubrication is performed regularly because of no need for warning. In this case, both the die lubrication warning message and the warning deletion screen are not displayed.	
Use Case	Upon user's request (no need for warning of lubrication)	
Adj/Set/Operate Method	1) Enter the setting value, and then press OK key. 2) Turn OFF/ON the main power switch.	
Display/Adj/Set Range	0 to 1 0: OFF, 1: ON	
Default Value	1	
Related Service Mode	COPIER> COUNTER> DRBL-2> OIL-DIE	
Additional Functions Mode	Adjustment/Maintenance> Maintenance> Initialize After Replacing Parts> Initialize After Puncher Unit Die Lubrication	
Supplement/Memo	Product name of P-Puncher: Multi Function Professional Puncher-A1	
SND-NAME	1	Setting of [Scan and Send] button name
Detail	To set the name of [Scan and Send] button displayed in the main menu.	
Use Case	Upon user's request	
Adj/Set/Operate Method	1) Enter the setting value, and then press OK key. 2) Turn OFF/ON the main power switch.	
Display/Adj/Set Range	0 to 2 0: [Scan and Send], 1: [Scan], 2: [Scan]	
Default Value	0	

COPIER (Service mode for printer) > OPTION (Specification setting mode) > DSPLY-SW

PCMP-DSP	1	Set copy cmpl scrn dspl:chg w/devc alone
Detail		To set whether to display the screen indicating completion of copying at the time of charging with a device alone. When 0 is set, a message "Copying is complete. Do you want to start the job again with the same settings?" is not displayed in a pop-up screen. When COIN is 4, this setting is enabled.
Use Case		Upon user's request
Adj/Set/Operate Method		Enter the setting value, and then press OK key.
Display/Adj/Set Range		0 to 1 0: OFF, 1: ON
Default Value		1
Related Service Mode		COPIER> OPTION> ACC> COIN
ERR-DISP	2	[For customization]
SVC-ACA	1	Display of ACA installation button
Detail		To set whether to display the [Install Auto Configuration Agent] button on the CDS Updater screen (user mode/service mode).
Use Case		When switching to install/not to install the ACA via network
Adj/Set/Operate Method		Enter the setting value, and then press OK key.
Display/Adj/Set Range		0 to 2 0: Hide (Hide user mode/service mode) 1: Display only service mode (Hide user mode) 2: Display all (Display user mode/service mode)
Default Value		It differs according to the location.
Related Service Mode		Service Mode > Updater
Additional Functions Mode		Management Settings> License/Other> Register/Update Software
Supplement/Memo		ACA : Auto Configuration Agent
SVC-SRA	1	Display/hide of DBS installation button
Detail		To set whether to display the [Install Data Backup Service] button on the CDS Updater screen (user mode/service mode).
Use Case		When switching to install/not to install the Data Backup Service via network
Adj/Set/Operate Method		1) Enter the setting value, and then press OK key. 2) Turn OFF/ON the main power switch.
Caution		Depending on the setting value, display when entering from Settings/Registration and that from service mode differ.
Display/Adj/Set Range		0 to 2 0: Hide (Hide user mode/service mode) 1: Display only service mode (Hide user mode) 2: Display all (Display user mode/service mode)
Default Value		It differs according to the location.
Related Service Mode		Service Mode> Updater> Install Data Backup Service
Additional Functions Mode		Management Settings> License/Other> Register/Update Software> Install Data Backup Service

COPIER (Service mode for printer) > OPTION (Specification setting mode) > DSPLY-SW

LF-DSP-S	2	Set Display/Hide Life VL in Service Mode
Detail	To set whether to display Life Value and Replacement Life Value on the service mode counter screen. If this option is set to 1, Life Value is displayed in the third column and Replacement Life Value in the fourth column of all items under COPIER > COUNTER > LIFE.	
Use Case	When displaying Live Value and Replacement Life Value	
Adj/Set/Operate Method	Enter the setting value, and then press OK key.	
Caution	Change the setting in accordance with the instruction of the sales company HQ.	
Display/Adj/Set Range	0 to 1 0: Hide, 1: Display	
Default Value	The value differs according to the location.	
Related Service Mode	COPIER > COUNTER > LIFE	
LF-DSP-U	2	Dspy/hide Chk Consumable State/Days Left
Detail	To set whether to display the "Status" and "Number of Days Left" in Status Monitor/Cancel > Consmbls./Others > Check Consumables.	
Use Case	When switching display/hide the Status and Number of Days Left.	
Adj/Set/Operate Method	Enter the setting value, and then press OK key.	
Caution	Change the setting in accordance with the instruction of the sales company HQ.	
Display/Adj/Set Range	0 to 1 0: Hide, 1: Display	
Default Value	The value differs according to the location.	
Additional Functions Mode	Status Monitor/Cancel > Consmbls./Others > Consumables	
ERRL-DSP	1	For R&D
JLG-UD-D	1	[For customization]
UFOS-DSP	1	Display/hide of uniFLOW Setup
Detail	Service mode to switch to display or hide [uniFLOW Setup].	
Use Case	When to switch to display or hide [uniFLOW Setup]	
Adj/Set/Operate Method	1) Enter the setting value, and then press OK key. 2) Turn OFF/ON the main power switch.	
Display/Adj/Set Range	0 to 1 0: Hide, 1: Display	
Default Value	It differs according to the location.	
Additional Functions Mode	Main Menu > uniFLOW Setup	
Supplement/Memo	uniFLOW : The name of the product destined for China is "mdsFLOW".	
SVC-DAT	1	For R&D

■ NETWORK

COPIER (Service mode for printer) > OPTION (Specification setting mode) > NETWORK

IFAX-LIM	2	No. of max print lines at IFAX reception
Detail	To set the maximum number of lines for e-mail text to be printed when receiving IFAX. Setting of this item can prevent endless printing of the attached file data in the case of receiving an error e-mail or failure in interpretation of the context. Selecting 0 prints the header/footer in 1 sheet when receiving e-mail text without attached file.	
Use Case	When preventing endless print in the case of failure in reception	
Adj/Set/Operate Method	1) Enter the setting value, and then press OK key. 2) Turn OFF/ON the main power switch.	
Display/Adj/Set Range	0 to 999 0: E-mail text not printed, 999: Unlimited	
Default Value	500	
SMTPTXPN	2	Setting of SMTP TX port number
Detail	*Operation on this item is restricted by the setting of [Restrict Service Representation Access]. To set SMTP transmission port number.	
Use Case	Upon user's request	
Adj/Set/Operate Method	1) Enter the setting value, and then press OK key. 2) Turn OFF/ON the main power switch.	
Display/Adj/Set Range	0 to 65535	
Default Value	25	
SMPTRXPN	2	Setting of SMTP reception port number
Detail	*Operation on this item is restricted by the setting of [Restrict Service Representation Access]. To set SMTP reception port number.	
Use Case	Upon user's request	
Adj/Set/Operate Method	1) Enter the setting value, and then press OK key. 2) Turn OFF/ON the main power switch.	
Display/Adj/Set Range	0 to 65535	
Default Value	25	
POP3PN	2	Setting of POP3 reception port number
Detail	*Operation on this item is restricted by the setting of [Restrict Service Representation Access]. To set POP3 reception port number.	
Use Case	Upon user's request	
Adj/Set/Operate Method	1) Enter the setting value, and then press OK key. 2) Turn OFF/ON the main power switch.	
Display/Adj/Set Range	0 to 65535	
Default Value	110	
FTPTXPN	1	Specification of SEND port (FTP) number
Detail	*Operation on this item is restricted by the setting of [Restrict Service Representation Access]. To specify address port (FTP) number for SEND.	
Use Case	Upon user's request	
Adj/Set/Operate Method	1) Enter the setting value, and then press OK key. 2) Turn OFF/ON the main power switch.	
Display/Adj/Set Range	0 to 65535	
Default Value	21	

COPIER (Service mode for printer) > OPTION (Specification setting mode) > NETWORK

NW-SPEED	2	Setting of network data transfer speed
Detail	To set the data transfer speed when the service network is connected. When downloading the firmware through network, use 0 in the normal operation. When fixed to 100Base-TX/10Base-T for any reason, change the setting.	
Use Case	When fixing the communication speed	
Adj/Set/Operate Method	1) Enter the setting value, and then press OK key. 2) Turn OFF/ON the main power switch.	
Display/Adj/Set Range	0 to 2 0: Auto, 1: 100Base-TX, 2: 10Base-T	
Default Value	0	
STS-PORT	2	[Not used]
CMD-PORT	2	ON/OFF TOTasync command comctn port
Detail	*Operation on this item is restricted by the setting of [Restrict Service Representation Access]. To set ON/OFF for asynchronous command communication port with T.O.T. Select "1: ON" in the case of connecting the PC and the machine with the cross cable while Service NAVI is used.	
Adj/Set/Operate Method	1) Enter the setting value, and then press OK key. 2) Turn OFF/ON the main power switch.	
Display/Adj/Set Range	0 to 1 0: OFF, 1: ON	
Default Value	0	
Related Service Mode	COPIER> OPTION> NETWORK> STS-PORT	
Supplement/Memo	T.O.T (TUIF over TCP): Communication protocol to be used for communication with the built-in application (UI) and the internal application such as COPY/ SEND/ BOX, etc. (Canon's own protocol).	
NS-CMD5	2	Limit CRAM-MD5 auth method at SMTP auth
Detail	*Operation on this item is restricted by the setting of [Restrict Service Representation Access]. To restrict use of CRAM-MD5 authentication method at the time of SMTP authentication.	
Use Case	Upon user's request	
Adj/Set/Operate Method	1) Enter the setting value, and then press OK key. 2) Turn OFF/ON the main power switch.	
Display/Adj/Set Range	0 to 1 0: SMTP server-dependent, 1: Not used	
Default Value	0	
Supplement/Memo	SMTP authentication: Protocol in which user authentication function is added to SMTP, which is the protocol to be used for e-mail transmission. At the time of e-mail transmission, this protocol executes authentication of the user account and the password between the SMTP server and the user to approve e-mail transmission only when it's authenticated.	
NS-GSAPI	2	Limit GSSAPI auth method at SMTP auth
Detail	*Operation on this item is restricted by the setting of [Restrict Service Representation Access]. To restrict use of GSSAPI authentication method at the time of SMTP authentication.	
Use Case	Upon user's request	
Adj/Set/Operate Method	1) Enter the setting value, and then press OK key. 2) Turn OFF/ON the main power switch.	
Display/Adj/Set Range	0 to 1 0: SMTP server-dependent, 1: Not used	
Default Value	0	
Supplement/Memo	SMTP authentication: Protocol in which user authentication function is added to SMTP, which is the protocol to be used for e-mail transmission. At the time of e-mail transmission, this protocol executes authentication of the user account and the password between the SMTP server and the user to approve e-mail transmission only when it's authenticated.	

COPIER (Service mode for printer) > OPTION (Specification setting mode) > NETWORK

NS-NTLM	2	Limit NTLM auth method at SMTP auth
Detail	*Operation on this item is restricted by the setting of [Restrict Service Representation Access]. To restrict use of NTLM authentication method at the time of SMTP authentication.	
Use Case	Upon user's request	
Adj/Set/Operate Method	1) Enter the setting value, and then press OK key. 2) Turn OFF/ON the main power switch.	
Display/Adj/Set Range	0 to 1 0: SMTP server-dependent, 1: Not used	
Default Value	0	
Supplement/Memo	SMTP authentication: Protocol in which user authentication function is added to SMTP, which is the protocol to be used for e-mail transmission. At the time of e-mail transmission, this protocol executes authentication of the user account and the password between the SMTP server and the user to approve e-mail transmission only when it's authenticated.	
NS-PLNWS	2	Limit plaintext auth at SMTP auth encry
Detail	*Operation on this item is restricted by the setting of [Restrict Service Representation Access]. To restrict use of PLAIN/LOGIN authentication, which is plaintext, at the time of SMTP authentication under the environment where the communication packet is encrypted.	
Use Case	Upon user's request	
Adj/Set/Operate Method	1) Enter the setting value, and then press OK key. 2) Turn OFF/ON the main power switch.	
Display/Adj/Set Range	0 to 1 0: SMTP server-dependent, 1: Not used	
Default Value	0	
Supplement/Memo	SMTP authentication: Protocol in which user authentication function is added to SMTP, which is the protocol to be used for e-mail transmission. At the time of e-mail transmission, this protocol executes authentication of the user account and the password between the SMTP server and the user to approve e-mail transmission only when it's authenticated.	
NS-PLN	2	Limit plaintext auth at SMTPauth noency
Detail	*Operation on this item is restricted by the setting of [Restrict Service Representation Access]. To restrict use of PLAIN/LOGIN authentication, which is plaintext, at the time of SMTP authentication under the environment where the communication packet is not encrypted.	
Use Case	Upon user's request	
Adj/Set/Operate Method	1) Enter the setting value, and then press OK key. 2) Turn OFF/ON the main power switch.	
Display/Adj/Set Range	0 to 1 0: SMTP server-dependent, 1: Not used	
Default Value	0	
Supplement/Memo	SMTP authentication: Protocol in which user authentication function is added to SMTP, which is the protocol to be used for e-mail transmission. At the time of e-mail transmission, this protocol executes authentication of the user account and the password between the SMTP server and the user to approve e-mail transmission only when it's authenticated.	

COPIER (Service mode for printer) > OPTION (Specification setting mode) > NETWORK

NS-LGN	2	Limit LOGIN authentication at SMTP auth
Detail		*Operation on this item is restricted by the setting of [Restrict Service Representation Access]. To restrict use of LOGIN authentication at the time of SMTP authentication.
Use Case		Upon user's request
Adj/Set/Operate Method		1) Enter the setting value, and then press OK key. 2) Turn OFF/ON the main power switch.
Display/Adj/Set Range		0 to 1 0: SMTP server-dependent, 1: Not used
Default Value		0
Supplement/Memo		SMTP authentication: Protocol in which user authentication function is added to SMTP, which is the protocol to be used for e-mail transmission. At the time of e-mail transmission, this protocol executes authentication of the user account and the password between the SMTP server and the user to approve e-mail transmission only when it's authenticated.
MEAP-PN	2	HTTP port No.setting of MEAP application
Detail		*Operation on this item is restricted by the setting of [Restrict Service Representation Access]. To set HTTP port number of MEAP application.
Use Case		Upon user's request
Adj/Set/Operate Method		1) Enter the setting value, and then press OK key. 2) Turn OFF/ON the main power switch.
Caution		Do not specify port 8080 when the Print Server is connected. Otherwise, you cannot browse the device RUI in which MEAP authentication application is running (Port 8080 is reserved for redirection of EFI Controller to the iR side.)
Display/Adj/Set Range		1 to 65535
Default Value		8000
RMT-LGIN	2	Set to allow remote login to SSH server
Detail		To set whether to allow remote login from the remote host (SSH client: DA) to debug console of the SSH server.
Use Case		As needed (This mode is used for the Japanese models only and not used with overseas models (outside Japan)).
Adj/Set/Operate Method		1) Enter the setting value, and then press OK key. 2) Turn OFF/ON the main power switch.
Display/Adj/Set Range		0 to 1 0: Disabled, 1: Enabled
Default Value		1
Supplement/Memo		DA: Digital Accessory
CHNG-STS	2	Set of TOT status connection port number
Detail		To set the port number for status connection with T.O.T.
Use Case		When the Service NAVI is used
Adj/Set/Operate Method		1) Enter the setting value, and then press OK key. 2) Turn OFF/ON the main power switch.
Display/Adj/Set Range		1 to 65535
Default Value		20010
Related Service Mode		COPIER> OPTION> NETWORK> STS-PORT

COPIER (Service mode for printer) > OPTION (Specification setting mode) > NETWORK

CHNG-CMD	2	Set of TOT command connection port No.
Detail		To set the port number for command connection with T.O.T.
Use Case		When the Service NAVI is used
Adj/Set/Operate Method		1) Enter the setting value, and then press OK key. 2) Turn OFF/ON the main power switch.
Display/Adj/Set Range		1 to 65535
Default Value		20000
Related Service Mode		COPIER> OPTION> NETWORK> CMD-PORT
MEAP-SSL	2	HTTPS port setting of MEAP
Detail		*Operation on this item is restricted by the setting of [Restrict Service Representation Access]. To set the port of HTTPS server in the case of using SSL with HTTP of MEAP.
Use Case		When specifying the setting of HTTPS port for MEAP
Adj/Set/Operate Method		1) Enter the setting value, and then press OK key. 2) Turn OFF/ON the main power switch.
Display/Adj/Set Range		0 to 65535
Default Value		8443
LPD-PORT	2	Setting of LPD port number
Detail		*Operation on this item is restricted by the setting of [Restrict Service Representation Access]. To set the LPD port number.
Use Case		Upon user's request
Adj/Set/Operate Method		1) Enter the setting value, and then press OK key. 2) Turn OFF/ON the main power switch.
Display/Adj/Set Range		1 to 65535
Default Value		515
Supplement/Memo		LPD port: Network port for TCP/IP communication when making prints through network.
WUEN-LIV	2	Recovery time setting after sleep notice
Detail		To set the time from the sleep start from network without job assignment until the mode is shifted to the sleep mode.
Use Case		When setting the startup time after sleep notification
Adj/Set/Operate Method		1) Enter the setting value, and then press OK key. 2) Turn OFF/ON the main power switch.
Display/Adj/Set Range		10 to 600
Unit		sec
Default Value		15

COPIER (Service mode for printer) > OPTION (Specification setting mode) > NETWORK

IFX-CHIG	1	Set operation by IFAX recv mail content
Detail	To set the number of characters for the IFAX received mail content, so that the mail is not printed/forwarded when the characters in the text is less than the number of specified characters. This machine can output blank paper because some senders send e-mail text consists of linefeed codes only. In such case, specify 2 (number of characters) so that there will be no output of blank paper. In the case of specifying any number other than 0, header/footer is printed/forwarded in 1 sheet only if the e-mail (body) text is less than the specified value while no TIFF file is attached. As the value is incremented by 1, the number of target characters in e-mail body text is increased by 1 character.	
Use Case	When reducing print of blank paper due to e-mail received by IFAX	
Adj/Set/Operate Method	1) Enter the setting value, and then press OK key. 2) Turn OFF/ON the main power switch.	
Caution	Be sure to get approval from the user by telling that there will be no print of e-mail (body) text if the number of characters is less than the specified value.	
Display/Adj/Set Range	0 to 999 0: E-mail (body) text is not ignored.	
Unit	char	
Default Value	0	
Supplement/Memo	1 Japanese Kanji character is calculated as 2 bytes, and the control codes (such as linefeed code, etc) are included in the number of characters.	
DNSTRANS	1	Setting of DNS query priority protocol
Detail	*Operation on this item is restricted by the setting of [Restrict Service Representation Access]. To set priority of the protocol (IPv4/IPv6) for DNS query. In the case of using both IPv6 and IPv4 while the DNS server supports IPv4, it takes time because of timeout when executing DNS query with priority on IPv6. Giving priority on query by IPv4 can shorten the time.	
Use Case	When it takes time to execute DNS query with priority on IPv6 because the DNS server supports IPv4	
Adj/Set/Operate Method	1) Enter the setting value, and then press OK key. 2) Turn OFF/ON the main power switch.	
Display/Adj/Set Range	0 to 1 0: IPv4, 1: IPv6	
Default Value	1	
PROXYRES	2	Setting of proxy response to Windows
Detail	*Operation on this item is restricted by the setting of [Restrict Service Representation Access]. To set whether to provide proxy response or return the device status when an inquiry is received via Windows while the device is in sleep mode.	
Use Case	When executing status response for query from Windows correctly	
Adj/Set/Operate Method	1) Enter the setting value, and then press OK key. 2) Turn OFF/ON the main power switch.	
Display/Adj/Set Range	0 to 1 0: No proxy response, 1: Proxy response	
Default Value	1	
WOLTRANS	1	ON/OFF sleep recover by packet reception
Detail	*Operation on this item is restricted by the setting of [Restrict Service Representation Access]. To set whether to recover from deep sleep when receiving unicast packets to the machine (excluding proxy response).	
Adj/Set/Operate Method	1) Enter the setting value, and then press OK key. 2) Turn OFF/ON the main power switch.	
Display/Adj/Set Range	1 to 2 1: ON, 2: OFF	
Default Value	1	

COPIER (Service mode for printer) > OPTION (Specification setting mode) > NETWORK

802XTOUT	1	Set of IEEE802.1X authentication timeout
Detail	*Operation on this item is restricted by the setting of [Restrict Service Representation Access]. To set timeout value for IEEE802.1X authentication. If the device executes 802.1X authentication, change the wait time for response from the authentication server.	
Use Case	When response from the authentication server is slow/fast	
Adj/Set/Operate Method	1) Enter the setting value, and then press OK key. 2) Turn OFF/ON the main power switch.	
Display/Adj/Set Range	10 to 120	
Unit	sec	
Default Value	30	
SPDALDEL	2	Initialization of SPD value
Detail	*Operation on this item is restricted by the setting of [Restrict Service Representation Access]. To initialize all the SPD values that are under management. SPD values can be initialized without clearing SRAM.	
Adj/Set/Operate Method	1) Enter the setting value, and then press OK key. 2) Turn OFF/ON the main power switch.	
Display/Adj/Set Range	0 to 1 0: OFF, 1: ON	
Default Value	0	
Supplement/Memo	SPD: Database that manages SA (Security Association). SPD value is managed when IPSec Board is used. Normally, SRAM needs to be cleared in the case of mismatch in SPD value.	
NCONF-SW	1	ON/OFF of Network Configurator function
Detail	*Operation on this item is restricted by the setting of [Restrict Service Representation Access]. To set ON/OFF of Network Configurator function. If the user does not use the function, select OFF to prevent remote attack through network.	
Use Case	Upon user's request	
Adj/Set/Operate Method	1) Enter the setting value, and then press OK key. 2) Turn OFF/ON the main power switch.	
Display/Adj/Set Range	0 to 1 0: OFF, 1: ON	
Default Value	1	
Supplement/Memo	Network Configurator function is a function to be used for communication with NetSpot Device Installer, etc., and the network setting can be changed from the remote.	
AFS-JOB	1	Set of FAX server job reception port
Detail	*Operation on this item is restricted by the setting of [Restrict Service Representation Access]. To set the reception port of the fax server to which a fax client sends jobs.	
Use Case	When changing the job reception port of the fax server	
Adj/Set/Operate Method	1) Enter the setting value, and then press OK key. 2) Turn OFF/ON the main power switch.	
Display/Adj/Set Range	0 to 65535	
Default Value	20317	
Related Service Mode	COPIER> OPTION> NETWORK> AFC-EVNT	

COPIER (Service mode for printer) > OPTION (Specification setting mode) > NETWORK

AFC-EVNT	1	Set of FAX client event reception port
Detail		*Operation on this item is restricted by the setting of [Restrict Service Representation Access]. To set the event notification reception port of a fax client.
Use Case		When changing the event notification reception port of a fax client
Adj/Set/Operate Method		1) Enter the setting value, and then press OK key. 2) Turn OFF/ON the main power switch.
Display/Adj/Set Range		0 to 65535
Default Value		29400
Related Service Mode		COPIER> OPTION> NETWORK> AFS-JOB
ILOGMODE	1	Setting of filter log target packet
Detail		*Operation on this item is restricted by the setting of [Restrict Service Representation Access]. To set the target packet to be recorded in the filter log. Usually, only the unicast packets to the machine are recorded in the filter log by PFW (personal firewall). When 1 is set, address filter is enabled for all protocols so all packets are recorded in the filter log. However, logs of multicast/broadcast packets sent from a harmless device or an address that are subject to rejection and have no direct relation to the machine are also recorded, and consequently the number of logs is increased.
Use Case		Upon user's request (to collect all filter logs)
Adj/Set/Operate Method		1) Enter the setting value, and then press OK key. 2) Turn OFF/ON the main power switch.
Caution		When 1 is set, the number of logs is increased because logs of packets which have no direct relation to the machine are recorded.
Display/Adj/Set Range		0 to 1 0: Unicast packets to the machine only, 1: All packets
Default Value		0
ILOGKEEP	1	Set of IP address block log hold time
Detail		*Operation on this item is restricted by the setting of [Restrict Service Representation Access]. To set the retention time from the log time of IP block. When access is made again from a same IP address which was blocked before, if it is within the retention time of the previous log, its log is not recorded. If access is frequently made from a same IP address, the log record of the UI might be filled with its logs. If the user considers that a single log for a same IP address is enough, set the longer retention time.
Use Case		Upon user's request
Adj/Set/Operate Method		1) Enter the setting value, and then press OK key. 2) Turn OFF/ON the main power switch.
Display/Adj/Set Range		0 to 48 0: 1 minute (special mode) 1 to 48: 1 hour to 48 hours
Default Value		1
IPTBROAD	1	Set to allow broad/multicast TX
Detail		*Operation on this item is restricted by the setting of [Restrict Service Representation Access]. To set whether to permit transmission of broadcast packets and multicast packets. Transmission of broadcast packets and multicast packets is permitted without specifying an exception address. It is permitted within the device even if it is rejected in the default setting of the IPv4/v6 transmission filter. Set "1: Disabled" when the user does not want to send them.
Use Case		Upon user's request
Adj/Set/Operate Method		Enter the setting value, and then press OK key.
Display/Adj/Set Range		0 to 5 0: Enabled, 1: Disabled, 2 to 5: Not used
Default Value		0

COPIER (Service mode for printer) > OPTION (Specification setting mode) > NETWORK

PFWFTPRT	1	Set of RST reply at IP filter FTP SEND
Detail	*Operation on this item is restricted by the setting of [Restrict Service Representation Access]. When FTP SEND is executed using an IP filter by which packets from a specific remote PC are rejected, SYN is returned to the port 113 if the PC supports authentication of the FTP port 113. However, since the IP filter blocks the packets, the block logs are increased and the performance is lowered. When 1 is set, RST is returned to the port 113 without blocking packets.	
Use Case	When executing FTP SEND against the OS which supports authentication of the FTP port 113 while the IP filter is enabled	
Adj/Set/Operate Method	Enter the setting value, and then press OK key.	
Display/Adj/Set Range	0 to 1 0: OFF, 1: ON	
Default Value	0	
DDNSINTV	1	Set of DDNS periodical update interval
Detail	DNS registration is executed only once at start-up with the current iR, so the registered contents are deleted in an environment where the DNS server settings are deleted at intervals. To set the interval of DDNS periodical update for not deleting the registered contents.	
Use Case	When the DNS server settings are deleted at intervals	
Adj/Set/Operate Method	Enter the setting value, and then press OK key.	
Display/Adj/Set Range	0 to 48 0: No periodical update, 1: 1-hour interval, 2: 2-hour interval, ..., 47: 47-hour interval, 48: 48-hour interval	
Unit	hour	
Default Value	24	
SIPAUDIO	2	Set of SIP session establishment order
Detail	To set whether to establish audio session or T.38 session first with SIP. Usually, audio session followed by T.38 session is established when using IPFAX in an intranet environment. However, this order is not specified by the standard. Set 1 when connecting the SIP server or terminal where the session starts with T.38 session.	
Use Case	When connecting the SIP server or terminal where the session starts with T.38 session	
Adj/Set/Operate Method	Enter the setting value, and then press OK key.	
Caution	When 1 is set, IPFAX fails with the destination where the session starts with audio session.	
Display/Adj/Set Range	0 to 1 0: audio, 1: T.38	
Default Value	0	
Supplement/Memo	SIP: Session Initiation Protocol	
SIPINOUT	2	Set of internal/external number to URI
Detail	To set whether to store the external number or the internal number in From URI when using NGN.	
Use Case	When a call cannot be made with external number while using NGN	
Adj/Set/Operate Method	1) Enter the setting value, and then press OK key. 2) Turn OFF/ON the main power switch.	
Display/Adj/Set Range	0 to 1 0: External number, 1: Internal number	
Default Value	0	
Supplement/Memo	NGN: Next Generation Network URI: Uniform Resource Identifier	

COPIER (Service mode for printer) > OPTION (Specification setting mode) > NETWORK

SIPREGPR	2	Setting of registrar server use protocol
Detail	To set the protocol used for communication with registrar server. Although the protocol that is the same as the one for proxy server is usually used, another protocol can be used in accordance with user and environment.	
Use Case	Upon user's request (to use a protocol different from the one for proxy server)	
Adj/Set/Operate Method	Enter the setting value, and then press OK key.	
Display/Adj/Set Range	0 to 3 0: Protocol set in Settings/Registration menu, 1: UDP, 2: TCP, 3: SSL	
Default Value	0	
Additional Functions Mode	Preferences> Network> TCP/IP Settings> SIP Settings> Intranet Settings	
VLAN-SW	2	ON/OFF VLAN participation packets send
Detail	To set whether to send packets for participating in dynamic VLAN at link-up.	
Use Case	When participating in dynamic VLAN	
Adj/Set/Operate Method	Enter the setting value, and then press OK key.	
Display/Adj/Set Range	0 to 1 0: OFF, 1: ON	
Default Value	0	
Supplement/Memo	<ul style="list-style-type: none"> - VLAN (Virtual LAN): A method for realizing grouping of terminals depending on the hub, switch connection port, MAC address, protocol, etc. - At link-up: At startup, when LAN cable is connected, when recovering from deep sleep, when pressing the button to reflect the setting (dynamic update) - If IP address of the machine has not been set, an IP address is assigned after participating in VLAN. 	
FTPMODE	1	Set of FTP print default operation mode
Detail	To set the default operation mode of FTP print. Switch the default operation mode between ASCII mode and BIN mode in accordance with user's environment.	
Use Case	At installation	
Adj/Set/Operate Method	1) Enter the setting value, and then press OK key. 2) Turn OFF/ON the main power switch.	
Display/Adj/Set Range	0 to 1 0: ASCII mode, 1: BIN mode	
Default Value	0	
SSLMODE	2	Setting of HTTP/HTTPS port open/close
Detail	<p>*Operation on this item is restricted by the setting of [Restrict Service Representation Access]. To set whether to open or close HTTP/HTTPS port. When 1 is set while [Use HTTP] is ON and [Use TLS] is OFF in Settings/Registration menu, HTTP port is opened whereas HTTPS port is closed. When 2 is set while both [Use HTTP] and [Use TLS] are ON in Settings/Registration menu, HTTP port is closed whereas HTTPS port is opened.</p>	
Use Case	When limiting the port to open because of security concern	
Adj/Set/Operate Method	1) Enter the setting value, and then press OK key. 2) Turn OFF/ON the main power switch.	
Display/Adj/Set Range	0 to 2 0: Normal, 1: Open HTTP port (80/8000) only, 2: Open HTTPS port (443/8443) only	
Default Value	0	
Additional Functions Mode	Preferences> Network> TCP/IP Settings> Use HTTP Management Settings> License/Other> MEAP Settings> Use TLS	

COPIER (Service mode for printer) > OPTION (Specification setting mode) > NETWORK

SSLSTRNG	2	Allow weak encryption algorithm for SSL
Detail	To set whether to allow using weak encryption algorithm for SSL. When 1 is set, weak encryption algorithm cannot be used.	
Use Case	When prohibiting weak encryption algorithm because of security concern	
Adj/Set/Operate Method	1) Enter the setting value, and then press OK key. 2) Turn OFF/ON the main power switch.	
Display/Adj/Set Range	0 to 1 0: Normal mode, 1: Secure mode (Not used TLS_RSA_WITH_RC4_128_SHA, TLS_RSA_WITH_RC4_128_MD5)	
Default Value	1	
NW-WAIT	2	Set connect wait at deep sleep recovery
Detail	To set whether to send wakeup notice after the time set in Settings/Registration menu has elapsed when recovering from deep sleep. When 0 is set, wakeup notice is sent after "Waiting Time for Connection at Startup" has elapsed. When 1 is set, wakeup notice is sent when the machine becomes ready for communication.	
Use Case	When a failure of the device management tool occurs	
Adj/Set/Operate Method	1) Enter the setting value, and then press OK key. 2) Turn OFF/ON the main power switch.	
Display/Adj/Set Range	0 to 1 0: Wait, 1: Not wait	
Default Value	0	
Additional Functions Mode	Preferences> Network> Waiting Time for Connection at Startup	
WLAN-USE	2	Setting of wireless LAN invalidation
Detail	To set whether to disable the wireless LAN. Bringing in and installation of the wireless LAN equipment may be prohibited depending on user. In such case, set 0 to prevent the wireless LAN to be used. When 0 is set, [Wireless Connection Settings] is not displayed in [Settings/Registration].	
Use Case	When bringing in and installation of the wireless LAN equipment is prohibited	
Adj/Set/Operate Method	1) Enter the setting value, and then press OK key. 2) Turn OFF/ON the main power switch.	
Display/Adj/Set Range	0 to 1 0: Disabled, 1: Enabled	
Default Value	1	
Additional Functions Mode	Preferences> Network> Wireless Connection Settings	
WLANPORT	2	Set of port filter at wireless LAN side
Detail	*Operation on this item is restricted by the setting of [Restrict Service Representation Access]. To set whether to open all ports at the wireless LAN side. When 0 is set, only the specific port is opened (filter is enabled). Set 1 when using an application which uses a port other than the specific port. All ports are opened (filter is disabled).	
Use Case	Upon user's request	
Adj/Set/Operate Method	1) Enter the setting value, and then press OK key. 2) Turn OFF/ON the main power switch.	
Display/Adj/Set Range	0 to 1 0: Open the specific port, 1: Open all ports	
Default Value	0	
RAW-PORT	2	[For customization]

COPIER (Service mode for printer) > OPTION (Specification setting mode) > NETWORK

LINKWAKE	2	Set of deep sleep recovery at link-up
Detail		To set whether to recover from deep sleep when link-up (disconnection and then connection of LAN cable) is detected. Set 0 if the closest hub or switch chatters at link-up. It can prevent recovery from deep sleep triggered by chattering.
Use Case		When the machine recovers from deep sleep due to chattering of the closest hub or switch
Adj/Set/Operate Method		1) Enter the setting value, and then press OK key. 2) Turn OFF/ON the main power switch.
Display/Adj/Set Range		0 to 1 0: Not recovered, 1: Recovered
Default Value		1
WIFIRFCH	2	For R&D
Amount of Change per Unit		1
BLEPOWER	2	Set of Bluetooth radio field strength
Detail		To set the radio field strength for transmission over BLE (Bluetooth Low Energy). As the value is changed by 1, the radio field strength is changed by 1 dBm.
Use Case		When radio field strength of BLE is not appropriate
Adj/Set/Operate Method		1) Enter the setting value (switch negative/positive by +/- key) and press OK key. 2) Turn OFF/ON the main power switch.
Caution		Do not change the setting in Singapore. It is prohibited by law.
Display/Adj/Set Range		-10 to -1 (-10 to -1 dBm)
Default Value		-5
WSMC-USE	2	[Not used]
WSMC-RST	2	[Not used]
INTENT	2	For R&D

■ ENV-SET

COPIER (Service mode for printer) > OPTION (Specification setting mode) > ENV-SET

ENVP-INT	1	Temp, humid/Fix Roll temp log get cycle
Detail		To set the cycle to obtain log of the temperature and humidity inside the machine or the surface temperature of the Fixing Roller. As the value is incremented by 1, the cycle is increased by 1 minute. Obtained log can be displayed by selecting the following: COPIER > DISPLAY > ENVRNT
Use Case		At trouble analysis
Adj/Set/Operate Method		1) Enter the setting value, and then press OK key. 2) Turn OFF/ON the main power switch.
Caution		Be sure to set "High" for [Sleep Mode Energy Use] in [Settings/Registration] before collecting logs, and change the value back to its original setting after log collection.
Display/Adj/Set Range		0 to 480
Unit		min
Default Value		60
Related Service Mode		COPIER> DISPLAY> ENVRNT
Additional Functions Mode		Preferences> Timer/Energy Settings> Sleep Mode Energy Use
Amount of Change per Unit		1

COPIER (Service mode for printer) > OPTION (Specification setting mode) > ENV-SET

DRY-CISU	1	ON/OFF of condensation prevention mode
Detail	To set ON/OFF of condensation prevention mode. Set 1 when an image failure or E225 occurs due to condensation in the Scanner Unit. From the next startup, the Scanner Unit (for front side) stops the fan for 15 sec and the Scanner Unit (for back side) lights LED for 30 sec.	
Use Case	When droplets appear on the Scanner Unit due to condensation and image failure or E225 occurs	
Adj/Set/Operate Method	1) Enter the setting value, and then press OK key. 2) Turn OFF/ON the main power switch.	
Display/Adj/Set Range	0 to 1 0: OFF (Normal mode), 1: ON (Condensation prevention mode)	
Default Value	0	

■ CLEANING

COPIER (Service mode for printer) > OPTION (Specification setting mode) > CLEANING

W-CLN-P	2	Set last rotn Pmry Charge Wir cln intvl
Detail	To set the offset value of the paper interval for automatic cleaning of the Primary Charging Wire. Default is 2000 sheets, and the paper interval can be changed within the range between 1000 and 5000 sheets.	
Use Case	Upon user's request	
Adj/Set/Operate Method	Enter the setting value (switch negative/positive by -/+ key) and press OK key.	
Display/Adj/Set Range	-1000 to 3000	
Unit	sheet	
Default Value	0 (2000 sheets)	

CLN-SW	1	ON/OFF of cleaning black band sequence
Detail	To set ON/OFF of black band sequence for cleaning. When printing a low duty image while toner ejection operation at low duty image is set to OFF, amount of toner supply to the Cleaning Blade is decreased extremely. Toner is supplied to the edge of Cleaning Blade if the sequence is executed. The execution of sequence is synchronized with the Primary Charging Wire cleaning timing. When setting CLN-SW to 2 and setting CLN-ADJ to 0, the setting value "7" of environment control for each process speed is executed. When setting CLN-SW to 2 and setting CLN-ADJ to other than 0, operation is accorded with the setting value of CLN-ADJ. When setting CLN-SW to 0, operation is not executed regardless of the CLN-ADJ setting.	
Use Case	When amount of toner supply to the Cleaning Blade is decreased extremely	
Adj/Set/Operate Method	Enter the setting value, and then press OK key.	
Display/Adj/Set Range	0 to 2 0: OFF, 1: Based on environment control, 2: ON	
Default Value	1	
Related Service Mode	COPIER> OPTION> CLEANING> CLN-ADJ	

CLN-ADJ	1	Set black band length for cleaning
Detail	To set black band length for cleaning. When setting CLN-SW to 2 and setting CLN-ADJ to other than 0, operation is accorded with the setting value of CLN-ADJ. When setting CLN-SW to 0, operation is not executed regardless of the CLN-ADJ setting.	
Use Case	When amount of toner supply to the Cleaning Blade is decreased extremely	
Adj/Set/Operate Method	Enter the setting value, and then press OK key.	
Display/Adj/Set Range	0 to 4 0: Based on environment control, 1: 1000 mm, 2: 2098 mm, 3: 3548 mm, 4: 5000 mm	
Default Value	0	
Related Service Mode	COPIER> OPTION> CLEANING> CLN-SW	

■ FEED-SW

COPIER (Service mode for printer) > OPTION (Specification setting mode) > FEED-SW

TRY-CHG	2	Set Delivery Tray destn for next job:Fin
Detail	To set which tray of the finisher the next job is delivered to. When 0 is set, paper is delivered to the Priority Tray unless the Priority Tray is full. When 1 is set, paper is delivered to the tray to which the previous job is delivered. When the tray is full, paper is delivered to an empty tray.	
Use Case	Upon user's request	
Adj/Set/Operate Method	1) Enter the setting value, and then press OK key. 2) Turn OFF/ON the main power switch.	
Display/Adj/Set Range	0 to 1 0: Deliver to the Priority Tray, 1: Deliver followed by the previous job	
Default Value	0	
INSRT-SW	1	[Not used]
DK2-TURN	1	ON/OFF of L-Deck Pckup Rol little rotn
Detail	To set whether to rotate the Left Deck Pickup Roller a little after completion of job or at the time of warm-up rotation. If the Pickup Deck has not been used for a long time, a part of the Separation Roller engaged with the Pickup Roller becomes worn and the roller stops rotation. As a result of that, jam may occur. When 1 is set, the Pickup Roller rotates 75mm after completion of job so that wear of the Separation Roller can be reduced. As the usage is extended or at the operation performed first time for the day in a low temperature environment, the Separation Roller is not rotated in response to rotation of the Pickup Roller. As a result of that, jam may occur. When 2 is set, the Pickup Roller rotates 75mm at warm-up rotation.	
Use Case	When pickup jam occurs with the following conditions - Pickup Deck has not been used for a long time - The usage is extended - At the operation performed first time for the day in a low temperature environment	
Adj/Set/Operate Method	Enter the setting value, and then press OK key.	
Caution	When ON is set, papers sticking out of the Receptacle may get stuck at the time of opening and closing the deck.	
Display/Adj/Set Range	0 to 3 0: OFF, 1: ON after a job, 2: ON at warm-up rotation, 3: ON after a job and at warm-up rotation	
Default Value	0	
Related Service Mode	COPIER> OPTION> FEED-SW> DK1-TURN, DK3-TURN, DK4-TURN, DK5-TURN	

COPIER (Service mode for printer) > OPTION (Specification setting mode) > FEED-SW

DK3-TURN	1	ON/OFF of Casstt3 Pckup Rol little rotn
Detail	<p>To set whether to rotate the Cassette 3 Pickup Roller a little after completion of job or at the time of warm-up rotation.</p> <p>If the Pickup Cassette has not been used for a long time, a part of the Separation Roller engaged with the Pickup Roller becomes worn and the roller stops rotation. As a result of that, jam may occur. When 1 is set, the Pickup Roller rotates 75mm after completion of job so that wear of the Separation Roller can be reduced.</p> <p>As the usage is extended or at the operation performed first time for the day in a low temperature environment, the Separation Roller is not rotated in response to rotation of the Pickup Roller. As a result of that, jam may occur. When 2 is set, the Pickup Roller rotates 75mm at warm-up rotation.</p>	
Use Case	<p>When pickup jam occurs with the following conditions</p> <ul style="list-style-type: none"> - Pickup Cassette has not been used for a long time - The usage is extended - At the operation performed first time for the day in a low temperature environment 	
Adj/Set/Operate Method	Enter the setting value, and then press OK key.	
Caution	When ON is set, papers sticking out of the Receptacle may get stuck at the time of opening and closing the Cassette.	
Display/Adj/Set Range	0 to 3 0: OFF, 1: ON after a job, 2: ON at warm-up rotation, 3: ON after a job and at warm-up rotation	
Default Value	0	
Related Service Mode	COPIER> OPTION> FEED-SW> DK1-TURN, DK2-TURN, DK4-TURN, DK5-TURN	
DK4-TURN	1	ON/OFF of Casstt4 Pckup Rol little rotn
Detail	<p>To set whether to rotate the Cassette 4 Pickup Roller a little after completion of job or at the time of warm-up rotation.</p> <p>If the Pickup Cassette has not been used for a long time, a part of the Separation Roller engaged with the Pickup Roller becomes worn and the roller stops rotation. As a result of that, jam may occur. When 1 is set, the Pickup Roller rotates 75mm after completion of job so that wear of the Separation Roller can be reduced.</p> <p>As the usage is extended or at the operation performed first time for the day in a low temperature environment, the Separation Roller is not rotated in response to rotation of the Pickup Roller. As a result of that, jam may occur. When 2 is set, the Pickup Roller rotates 75mm at warm-up rotation.</p>	
Use Case	<p>When pickup jam occurs with the following conditions</p> <ul style="list-style-type: none"> - Pickup Cassette has not been used for a long time - The usage is extended - At the operation performed first time for the day in a low temperature environment 	
Adj/Set/Operate Method	Enter the setting value, and then press OK key.	
Caution	When ON is set, papers sticking out of the Receptacle may get stuck at the time of opening and closing the Cassette.	
Display/Adj/Set Range	0 to 3 0: OFF, 1: ON after a job, 2: ON at warm-up rotation, 3: ON after a job and at warm-up rotation	
Default Value	0	
Related Service Mode	COPIER> OPTION> FEED-SW> DK1-TURN, DK2-TURN, DK3-TURN, DK5-TURN	

COPIER (Service mode for printer) > OPTION (Specification setting mode) > FEED-SW

DK1-TURN	1	ON/OFF of R-Deck Pckup Rol little rotn
Detail	<p>To set whether to rotate the Right Deck Pickup Roller a little after completion of job or at the time of warm-up rotation.</p> <p>If the Pickup Deck has not been used for a long time, a part of the Separation Roller engaged with the Pickup Roller becomes worn and the roller stops rotation. As a result of that, jam may occur. When 1 is set, the Pickup Roller rotates 75mm after completion of job so that wear of the Separation Roller can be reduced.</p> <p>As the usage is extended or at the operation performed first time for the day in a low temperature environment, the Separation Roller is not rotated in response to rotation of the Pickup Roller. As a result of that, jam may occur. When 2 is set, the Pickup Roller rotates 75mm at warm-up rotation.</p>	
Use Case	<p>When pickup jam occurs with the following conditions</p> <ul style="list-style-type: none"> - Pickup Deck has not been used for a long time - The usage is extended - At the operation performed first time for the day in a low temperature environment 	
Adj/Set/Operate Method	Enter the setting value, and then press OK key.	
Caution	When ON is set, papers sticking out of the Receptacle may get stuck at the time of opening and closing the deck.	
Display/Adj/Set Range	0 to 3 0: OFF, 1: ON after a job, 2: ON at warm-up rotation, 3: ON after a job and at warm-up rotation	
Default Value	0	
Related Service Mode	COPIER> OPTION> FEED-SW> DK2-TURN, DK3-TURN, DK4-TURN, DK5-TURN	
DK5-TURN	1	ON/OFF of OP-Deck Pckup Rol little rotn
Detail	<p>To set whether to rotate the Option Deck Pickup Roller a little after completion of job or at the time of warm-up rotation.</p> <p>If the Pickup Deck has not been used for a long time, a part of the Separation Roller engaged with the Pickup Roller becomes worn and the roller stops rotation. As a result of that, jam may occur. When 1 is set, the Pickup Roller rotates 75mm after completion of job so that wear of the Separation Roller can be reduced.</p> <p>As the usage is extended or at the operation performed first time for the day in a low temperature environment, the Separation Roller is not rotated in response to rotation of the Pickup Roller. As a result of that, jam may occur. When 2 is set, the Pickup Roller rotates 75mm at warm-up rotation.</p>	
Use Case	<p>When pickup jam occurs with the following conditions</p> <ul style="list-style-type: none"> - Pickup Deck has not been used for a long time - The usage is extended - At the operation performed first time for the day in a low temperature environment 	
Adj/Set/Operate Method	Enter the setting value, and then press OK key.	
Caution	When ON is set, papers sticking out of the Receptacle may get stuck at the time of opening and closing the deck.	
Display/Adj/Set Range	0 to 3 0: OFF, 1: ON after a job, 2: ON at warm-up rotation, 3: ON after a job and at warm-up rotation	
Default Value	0	
Related Service Mode	COPIER> OPTION> FEED-SW> DK1-TURN, DK2-TURN, DK3-TURN, DK4-TURN	

COPIER (Service mode for printer) > OPTION (Specification setting mode) > FEED-SW

DK1-AIR	1	ON/OFF of POD Deck Lite air assist
Detail	<p>To set ON/OFF of the POD Deck Lite air assist.</p> <p>In the initial settings, the air assist is OFF for plain paper, and ON for coated paper and heavy paper.</p> <p>When do ON with constant air capacity in all paper, set the value to 1. When the transfer failure occurs with coated paper, heavy paper, etc., set the value to 2. When a jam or double feed error frequently occurs with paper of the air assist off, set the value to 3 and usually set air capacity of each paper class in an user mode.</p>	
Use Case	<p>- When a jam or double feed error frequently occurs with plain paper or heavy paper 1</p> <p>- When the transfer performance is low with coated paper, texture paper, etc.</p>	
Adj/Set/Operate Method	<p>Enter the setting value, and then press OK key.</p> <p>-When do set air capacity in an user mode</p> <p>1)Perform service mode item. COPIER > OPTION > DSPLY-SW > IMGC-ADJ</p> <p>2)Turn OFF/ON the main power switch.</p> <p>3)Reproduce object media using the user mode.</p> <p>4)Select the reproduce media setup.</p> <p>5)Select the adjustment for paper flotation fan level, and set the value.</p> <p>6)Set the reproduce media of the object deck.</p>	
Caution	<p>When set the value 3, an air capacity control is necessary in an user mode.</p>	
Display/Adj/Set Range	<p>0 to 3</p> <p>0 : Initial setting</p> <p>1 : Air assist ON (Constant air capacity in all paper)</p> <p>2 : Air assist OFF (All paper)</p> <p>3 : Air assist ON (Paper classification setting)</p>	
Default Value	0	
Related Service Mode	COPIER> OPTION> DSPLY-SW> IMGC-ADJ	
Additional Functions Mode	Preference> Paper Settings> Set Paper Type Management	
Supplement/Memo	<p>When set the value 3, The media which were air assist OFF get possible to set the following air capacity in the adjustment for paper flotation fan level.</p> <p>-5 to 0 : 0%</p> <p>+1 : 20%</p> <p>+2 : 24%</p> <p>+3 : 28%</p> <p>+4 : 32%</p> <p>+5 : 36%</p>	
TFL-RTC	1	Set delvry dest at rcvry after tray full
Detail	<p>To select the delivery destination for a job with multiple pages after recovering the Delivery Tray that reaches the full level.</p> <p>When 0 is set, a job is output from the delivery destination again from which the last job was delivered.</p> <p>When 1 is set, a job is output from the delivery destination which priority is set as high at "Output Tray Settings" in [Settings/Registration].</p>	
Use Case	<p>When changing the delivery tray</p>	
Adj/Set/Operate Method	<p>1) Enter the setting value, and then press OK key.</p> <p>2) Turn OFF/ON the main power switch.</p>	
Display/Adj/Set Range	<p>0 to 1</p> <p>0: Output from the tray from which the last job was output, 1: Output from the delivery destination which priority is high among the delivery trays</p>	
Default Value	0	
Additional Functions Mode	Function Settings> Common> Paper Output Settings> Output Tray Settings	

COPIER (Service mode for printer) > OPTION (Specification setting mode) > FEED-SW

DK1-ALVD	2	Deck Air Float Fan airflow amnt: dwstm
Detail		To adjust the airflow amount of the Air Flootation Fan (Downstream) of the POD Deck Lite. When making an adjustment, be sure to adjust the setting of DK1-ALVU.
Use Case		When double-feed occurs.
Adj/Set/Operate Method		Enter the setting value (switch negative/positive by +/- key) and press OK key.
Caution		If the value is large, uneven transfer may occur. If the value is small, double feed may occur.
Display/Adj/Set Range		-10 to 10
Default Value		0
Related Service Mode		COPIER> OPTION> FEED-SW> DK1-ALVU
DK1-ALVU	2	Deck Air Float Fan airflow amnt:upstream
Detail		To adjust the airflow amount of the Air Flootation Fan (Upstream) of the POD Deck Lite. When making an adjustment, be sure to adjust the setting of DK1-ALVD.
Use Case		When double-feed occurs.
Adj/Set/Operate Method		Enter the setting value (switch negative/positive by +/- key) and press OK key.
Caution		If the value is large, uneven transfer may occur. If the value is small, double feed may occur.
Display/Adj/Set Range		-10 to 10
Default Value		0
Related Service Mode		COPIER> OPTION> FEED-SW> DK1-ALVD
DK1-LDWN	2	Set ppr surface level down: Deck standby
Detail		To set whether to lower the paper surface level in the POD Deck Lite or Paper Deck Unit below pickup position during standby. When a trace which looks like that the Pickup Roller had contact with a paper occurs, set 1. It returns to pickup position at the time of starting a job.
Use Case		When trace of the Pickup Roller appears on transparency or the 1st sheet of coated paper in an LL environment
Adj/Set/Operate Method		Enter the setting value, and then press OK key.
Caution		When 1 is set, FCOT becomes longer.
Display/Adj/Set Range		0 to 1 0: Normal (Pickup Roller is in contact), 1: Paper surface level moves down
Default Value		0
DK1-PSP	2	Setting of Deck Pickup Roller eng/diseng
Detail		To set whether to disengage the Pickup Roller of the POD Deck Lite or Paper Deck Unit every time paper is picked up. When 0 is set, it is disengaged only for heavy paper (151 g/m2 or more), coated paper and transparency. When 1 is set, it is disengaged regardless of the paper type.
Use Case		When trace of the Pickup Roller appears on the 2nd sheet and later
Adj/Set/Operate Method		Enter the setting value, and then press OK key.
Caution		If the machine is continued to be used while the setting value is 1, the life of the solenoid becomes shorter.
Display/Adj/Set Range		0 to 1 0: Disengaged only for heavy paper (151 g/m2 or more), coated paper and transparency 1: Disengaged regardless of the paper type
Default Value		0

COPIER (Service mode for printer) > OPTION (Specification setting mode) > FEED-SW

PDK-REST	1	Set Deck ppr lvl thrshld: prdctvty prrty
Detail		To set the threshold value for paper level to be determined as "no paper" in the Deck. As the value is increased, papers remaining in the Deck at the time of switching paper source by auto cassette change decrease. However, in some cases, the machine keeps pickup operation until paper runs out. As a result of that, adjustment needs to be made so productivity may decrease. Therefore, thickness of paper needs to be taken into consideration when making the setting. In case of heavy paper, keep the setting value as 0. In case of thin paper, set a relatively large value.
Use Case		Upon user's request (to use up paper in the Deck)
Adj/Set/Operate Method		Enter the setting value, and then press OK key.
Caution		As the value is increased, the machine keeps pickup operation until paper runs out so productivity may be decreased.
Display/Adj/Set Range		0 to 5 0: Maximum paper level, ... 5: Minimum paper level
Default Value		0
TRY-FUFD	1	ON/OFF 1-page print job face down output
Detail		To set whether to output a 1-page print job to the Copy Tray face down. Normally, a multiple-page print job is output face down, whereas a 1-page print job is output face up. When 0 is set, face down output is executed even for a 1-page print job.
Use Case		Upon user's request
Adj/Set/Operate Method		Enter the setting value, and then press OK key.
Caution		The setting is not applied to the following cases: - When the output destination is not the Copy Tray - A print job with multiple pages - A job that the delivery side is specified or fixed - A copy job
Display/Adj/Set Range		0 to 1 0: OFF (face down), 1: ON (face up)
Default Value		1

■ IMG-RDR

COPIER (Service mode for printer) > OPTION (Specification setting mode) > IMG-RDR

DFDST-L1	1	Adj img crrect level: stream read, front
Detail	<p>To set whether to perform image correction between originals in the Scanner Unit (for front side) at stream reading based on the result of dust detection.</p> <p>Set one of 1 to 255 when black lines appear. Dust detection is performed and image is corrected as needed.</p> <p>Set 0 if a fine image portion is unclear as a result of dust detection correction control. In that case, dust detection is not performed.</p>	
Use Case	<ul style="list-style-type: none"> - When black line occurs due to dust - Upon user's request 	
Adj/Set/Operate Method	<ol style="list-style-type: none"> 1) Enter the setting value, and then press OK key. 2) Turn OFF/ON the main power switch. 	
Caution	<ul style="list-style-type: none"> - If the value is too large, a fine image portion may be unclear. If the value is too small, black lines may appear on the image. - When setting DFDST-L2 to "0", DFDST-L1 will also be "0" automatically (image correction is not performed). - When setting DFDST-L1 to "0", DFDST-L2 will also be "0" automatically (dust detection is not performed). 	
Display/Adj/Set Range	<p>0 to 255</p> <p>0: OFF, 1 to 255: ON</p>	
Default Value	170	
Related Service Mode	COPIER> OPTION> IMG-RDR> DFDST-L2	
Supplement/Memo	Black lines may appear on the image if there is dust. With dust detection correction control, the image is corrected to prevent black lines once dust is detected.	
DFDST-L2	1	Adj dust dtct level: stream read, front
Detail	<p>To adjust dust detection level for dust avoidance control that is executed in the Scanner Unit (for front side) at start of the first stream reading after power-on.</p> <p>Decrease the value in the case of frequent display of cleaning instruction at the time of dust detection. As the value is smaller, dust is less likely to be detected. When 0 is set, the cleaning instruction is not displayed.</p> <p>Increase the value when black lines appear. As the value is larger, the small dust is more likely to be detected.</p>	
Use Case	<ul style="list-style-type: none"> - When black line occurs due to dust - Upon user's request 	
Adj/Set/Operate Method	<ol style="list-style-type: none"> 1) Enter the setting value, and then press OK key. 2) Turn OFF/ON the main power switch. 	
Caution	<ul style="list-style-type: none"> - If the value is too large, the cleaning instruction screen may appear frequently because even fine dust that will not appear on the image may be detected. - When setting DFDST-L2 to "0", DFDST-L1 will also be "0" automatically (image correction is not performed). - When setting DFDST-L1 to "0", DFDST-L2 will also be "0" automatically (dust detection is not performed). 	
Display/Adj/Set Range	<p>0 to 255</p> <p>0: OFF, 1 to 255: ON</p>	
Default Value	170	
Related Service Mode	COPIER> OPTION> IMG-RDR> DFDST-L1	
Supplement/Memo	Black lines may appear on the image if there is dust. With dust detection correction control, the image is corrected to prevent black lines once dust is detected.	

COPIER (Service mode for printer) > OPTION (Specification setting mode) > IMG-RDR

ABC-MODE	1	Adj sface digital ABC bckgd dens reduct
Detail		To adjust the background density reduction setting level of front side digital ABC (Auto Background Control) at B&W mode.
Adj/Set/Operate Method		Enter the setting value (switch negative/positive by -/+ key) and press OK key.
Display/Adj/Set Range		-1 to 4 -1: Setting of the direction which the background reduction is less (For photo original and complex form original) 0: Default 1 to 3: Setting of the direction which the background reduction is more 4: Background density reduction according to the density in the 5 mm portion of the image leading edge
Default Value		0
Supplement/Memo		Auto Background Control: A control to make the background color of the original close to white with the image processing when reading the image on front side with the Scanner Unit (paper front).
ABC-MD2	1	Adj back digital ABC bckgd dens reduct
Detail		To adjust the background density reduction setting level of back side digital ABC (Auto Background Control) at B&W mode.
Adj/Set/Operate Method		Enter the setting value (switch negative/positive by -/+ key) and press OK key.
Display/Adj/Set Range		-1 to 4 -1: Setting of the direction which the background reduction is less (For photo original and complex form original) 0: Default 1 to 3: Setting of the direction which the background reduction is more 4: Background density reduction according to the density in the 5 mm portion of the image leading edge
Default Value		0
Supplement/Memo		Auto Background Control: A control to make the background color of the original close to white with the image processing when reading the image on back side with the Scanner Unit (paper back).
DF2DSTL1	1	ON/OFF img crrect: stream, back, 1-path
Detail		To set whether to perform image correction between originals in the Scanner Unit (for back side) at stream reading with DADF (1-path model) based on the result of dust detection. Set one of 1 to 255 when black lines appear. Dust detection is performed and image is corrected as needed. Set 0 if a fine image portion is unclear as a result of dust detection correction control. In that case, dust detection is not performed.
Use Case		- When black line occurs due to dust - Upon user's request
Adj/Set/Operate Method		1) Enter the setting value, and then press OK key. 2) Turn OFF/ON the main power switch.
Caution		- If the value is too large, a fine image portion may be unclear. On the contrary, if the value is too small, black lines may appear on the image. - When setting DF2DSTL2 to "0", DF2DSTL1 will also be "0" automatically (image correction is not performed). - When setting DF2DSTL1 to "0", DF2DSTL2 will also be "0" automatically (dust detection is not performed).
Display/Adj/Set Range		0 to 255 0: OFF, 1 to 255: ON
Default Value		170
Supplement/Memo		Black lines may appear on the image if there is dust. With dust detection correction control, the image is corrected to prevent black lines once dust is detected.

COPIER (Service mode for printer) > OPTION (Specification setting mode) > IMG-RDR

DF2DSTL2	1	Adj dust dtct level:stream, back, 1-path
Detail		To adjust dust detection level for dust avoidance control that is executed in the Scanner Unit (for back side) at the first stream reading with DADF (1-path model) after power-on. Decrease the value in the case of frequent display of cleaning instruction at the time of dust detection. As the value is smaller, dust is less likely to be detected. When 0 is set, the cleaning instruction is not displayed. Increase the value when black lines appear. As the value is larger, the small dust is more likely to be detected.
Use Case		- When black line occurs due to dust - Upon user's request
Adj/Set/Operate Method		1) Enter the setting value, and then press OK key. 2) Turn OFF/ON the main power switch.
Caution		If the value is too large, the cleaning instruction screen may appear frequently because even fine dust that will not appear on the image may be detected. - When setting DF2DSTL2 to "0", DF2DSTL1 will also be "0" automatically (image correction is not performed). - When setting DF2DSTL1 to "0", DF2DSTL2 will also be "0" automatically (dust detection is not performed).
Display/Adj/Set Range		0 to 255 0: OFF, 1 to 255: ON
Default Value		170
Supplement/Memo		Black lines may appear on the image if there is dust. With dust detection correction control, the image is corrected to prevent black lines once dust is detected.

■ IMG-MCON

COPIER (Service mode for printer) > OPTION (Specification setting mode) > IMG-MCON

PASCAL	1	Set of auto gradation adjustment data
Detail		To set the gradation adjustment data that is used at image formation. When 0 is set, the initial LUT is used. When 1 is set, the gradation adjustment data gamma LUT that is generated by auto gradation adjustment (full/quick adjustment) control is used.
Use Case		When PASCAL-related failure occurs/when identifying the cause of PASCAL-related failure
Adj/Set/Operate Method		1) Enter the setting value, and then press OK key. 2) Turn OFF/ON the main power switch.
Display/Adj/Set Range		0 to 3 0: Initial LUT, 1: Auto gradation adjustment data, 2 to 3: Not used
Default Value		1
SHARP	2	Setting of sharpness level of image
Detail		To set the setting level (center value) of sharpness of image. As the value is increased, the image tends to be sharp, and as the value is decreased, image tends to be soft.
Use Case		Upon user's request
Adj/Set/Operate Method		1) Enter the setting value, and then press OK key. 2) Turn OFF/ON the main power switch.
Display/Adj/Set Range		1 to 5
Default Value		3

COPIER (Service mode for printer) > OPTION (Specification setting mode) > IMG-MCON

DRM-H-SW	2	ON/OFF of Drum Heater
Detail	To set ON/OFF control of the Drum Heater at power-off/at sleep.	
Adj/Set/Operate Method	1) Enter the setting value, and then press OK key. 2) Turn OFF/ON the main power switch.	
Display/Adj/Set Range	0 to 2 0: ON/OFF depending on the environment condition, 1: ON, 2: OFF	
Default Value	0	
SCR-SLCT	2	Halftone process in Photo Printout mode
Detail	To set halftone process (error diffusion, 2 screen types) in Photo Printout mode when making a copy. When moire occurs on a copy image, set 0 (suitable for character reproduction). When halftone dots are rough, set 2.	
Use Case	When moire image or rough dots occurs on copy image	
Adj/Set/Operate Method	1) Enter the setting value, and then press OK key. 2) Turn OFF/ON the main power switch.	
Display/Adj/Set Range	0 to 2 0: Error diffusion, 1: Low screen ruling, 2: High screen ruling	
Default Value	1	
Additional Functions Mode	Function Settings> Copy> Photo Printout Mode	
TMC-SLCT	2	Setting of error diffusion coefficient
Detail	To set coefficient to be used for error diffusion process. Specify according to the level of granularity and dot stability.	
Adj/Set/Operate Method	1) Enter the setting value, and then press OK key. 2) Turn OFF/ON the main power switch.	
Display/Adj/Set Range	0 to 2 0: Small granularity/low dot stability 1: Small granularity/low dot stability (color mode), Large granularity/high dot stability (B&W mode) 2: Large granularity/high dot stability	
Default Value	2	
REDU-CNT	2	Set toner deposit amount limit at clr adj
Detail	To set whether to limit the toner deposit amount at color adjustment (color balance, fine adjustment of density). When 0 is set, the color adjustment value is reflected to an image precisely, but toner scattering in the transfer section and fixing section or paper wrapping in the fixing section may occur.	
Use Case	- Upon user's request - When reflecting the color adjustment value to an image precisely	
Adj/Set/Operate Method	1) Enter the setting value, and then press OK key. 2) Turn OFF/ON the main power switch.	
Caution	When 0 is set, toner scattering in the Transfer Assembly and Fixing Assembly might occur, and paper might wind around the Fixing Assembly.	
Display/Adj/Set Range	0 to 1 0: Toner deposit amount is not limited. 1: Toner deposit amount is limited to the specified amount.	
Default Value	1	

COPIER (Service mode for printer) > OPTION (Specification setting mode) > IMG-MCON

VP-ART	2	Setting of line art processing
Detail	<p>To set outline processing for line art on scalable PDF.</p> <p>In the outline processing, a binary image outline is extracted in the field which is recognized as line art, and is converted into vector data.</p> <p>Specify whether to convert the binary image outline into vector data or to recognize it as one line (as a thin line). For the thin line, the line width can be specified.</p> <p>Change this value when you want to obtain an output of a wide-width line as one line rather than as an outline (when you want to prioritize edit operation as a line rather than image quality).</p>	
Use Case	Upon user's request	
Adj/Set/Operate Method	<p>1) Enter the setting value, and then press OK key.</p> <p>2) Turn OFF/ON the main power switch.</p>	
Display/Adj/Set Range	0 to 99	
Default Value	1	
VP-TXT	2	Setting of character vectorization
Detail	<p>To set vector conversion processing for text on scalable PDF.</p> <p>In the vector conversion processing, a binary image outline is extracted in the field which is recognized as text, and is converted into vector data.</p> <p>In regular vector conversion, function approximation is not used for small text because the image quality is not changed.</p> <p>When the value is changed, function approximation processing is executed for small text, which realizes smooth text although the image quality is changed.</p> <p>Change this value when you want to prioritize smoothness in small text.</p>	
Use Case	Upon user's request	
Adj/Set/Operate Method	<p>1) Enter the setting value, and then press OK key.</p> <p>2) Turn OFF/ON the main power switch.</p>	
Display/Adj/Set Range	0 to 99	
Default Value	1	
C-PDL-T	2	Setting of PDL gradation reference
Detail	<p>To set whether gradation or density to be prioritized as the gradation reference for PDL.</p> <p>With priority on gradation (% of halftone dots), gradation is matched with original on the shadow area although the maximum density decreases. With priority on density, density is always matched with original.</p>	
Use Case	Upon user's request	
Adj/Set/Operate Method	Enter the setting value, and then press OK key.	
Display/Adj/Set Range	0 to 1 0: Priority on gradation (% of halftone dots), 1: Priority on density	
Default Value	0	
Supplement/Memo	Abbreviation of CAL_PDL_Target	
C-S-C-D	2	High density end edge crrct ON/OFF: copy
Detail	<p>To set ON/OFF of high density trailing edge correction function at copy.</p> <p>With CAL of COPY, high density trailing edge correction function is ON in normal operation; however, set OFF as needed.</p>	
Use Case	<p>ON: When reducing jagged line and jagged outline of text</p> <p>OFF: When matching density with original on high density area, or when prioritizing density and gradation</p>	
Adj/Set/Operate Method	Enter the setting value, and then press OK key.	
Display/Adj/Set Range	0 to 1 0: OFF, 1: ON	
Default Value	1	
Supplement/Memo	Abbreviation of CAL_Shadow_COPY_Density. When adjusting the input signal 255 to low in the case that the density of solid area is too high, jaggy (jagged effect of halftone) may occur to text, etc. By entering the input signal 255 as solid, occurrence of jaggy can be prevented.	

COPIER (Service mode for printer) > OPTION (Specification setting mode) > IMG-MCON

LIN-OFST	1	Set special paper added dot amnt offset
Detail	To set the offset amount of dots added to vertical/horizontal direction when lines on special paper are thinner than those on plain paper. When printing special paper, compared to plain paper, the amount of dots specified with this item is added. As the value is larger, lines become thicker. When WDREDUCT is 0, this setting is enabled.	
Use Case	When the line width of special paper is thinner than the one of plain paper	
Adj/Set/Operate Method	Enter the setting value, and then press OK key.	
Display/Adj/Set Range	0 to 4	
Default Value	1	
Related Service Mode	COPIER> OPTION> IMG-MCON> WDREDUCT	
EP-CONT	1	ON/OFF wht dot remov/set thin line width
Detail	To set ON/OFF of white dots removal and line width of thin line by ON/OFF of laser light modulation and changing the amount of exposure. Normally, white dots are removed, but they may be removed too much, causing a failure (unsmooth gradation, etc.). When -2 is set, white dots are not removed, so the cause whether it is due to image processing or engine can be identified. When widening a thin line , set 1. When narrowing a thin line , set -1.	
Use Case	When a failure (unsmooth gradation, etc.) occurs	
Adj/Set/Operate Method	1) Enter the setting value (switch negative/positive by +/- key) and press OK key. 2) Turn OFF/ON the main power switch. 3) Execute auto gradation adjustment (full adjustment).	
Display/Adj/Set Range	-2 to 1 -2: Narrow the line width, white dots removal OFF -1: Narrow the line width, white dots removal ON 0: Normal line width, white dots removal ON 1: Widen the line width, white dots removal ON	
Unit	um	
Default Value	0	
Additional Functions Mode	Adjustment/Maintenance> Adjust Image Quality> Auto Adjust Gradation > Full Adjust	
DOTSCT	2	Set high dens area white dot reduct mode
Detail	To set the mode to reduce white dots occur in the high density area with 600 dpi. Set 2 when white dots occur at regular intervals in the high density area. Set 0 when degree of gradation in the high density area is decreased due to parts life or environment.	
Use Case	- When white dots occur at regular intervals in the high density area - When the degree of gradation is decreased because colors in the high density area become darker	
Adj/Set/Operate Method	Enter the setting value, and then press OK key.	
Caution	- It is enabled only for PDL job. - When 0 is set, white dots may be significant. - When 2 is set, gradation in the high density area may become not noticeable.	
Display/Adj/Set Range	0 to 2 0: OFF, 1: ON (Weak), 2: ON (Strong)	
Default Value	1	

COPIER (Service mode for printer) > OPTION (Specification setting mode) > IMG-MCON

SP-GRAD	2	ON/OFF of special gradation processing
Detail	To set whether to make the density gradation characteristics of halftone the same as that of conventional machines.	
Use Case	When making the density gradation characteristic the same as that of conventional machines	
Adj/Set/Operate Method	Enter the setting value, and then press OK key.	
Display/Adj/Set Range	0 to 1 0: ON, 1: OFF	
Default Value	1	
BIN-SEL	2	For R&D

■ IMG-LSR

COPIER (Service mode for printer) > OPTION (Specification setting mode) > IMG-LSR

LAPC-SW	2	ON/OFF of ini rotn/last rotn APC crct
Detail	To set ON/OFF of laser APC correction executed at initial rotation and last rotation.	
Use Case	Upon user's request	
Adj/Set/Operate Method	1) Enter the setting value, and then press OK key. 2) Turn OFF/ON the main power switch.	
Display/Adj/Set Range	0 to 1 0: OFF, 1: ON	
Default Value	1	
2D-SHADE	1	ON/OFF of 2D shading
Detail	To set ON/OFF of 2D shading.	
Use Case	- When uneven image occurs - When low edge density occurs	
Adj/Set/Operate Method	1) Enter the setting value, and then press OK key. 2) Turn OFF/ON the main power switch.	
Caution	When ON is set, the Drum Heater is turned ON at power-off and during sleep so power consumption is increased.	
Display/Adj/Set Range	0 to 2 0: OFF, 1: ON (VD), 2: ON (VL)	
Default Value	0	
Related Service Mode	COPIER> DISPLAY> 2D-SHADE> 2D-ST5	

■ IMG-DEV

COPIER (Service mode for printer) > OPTION (Specification setting mode) > IMG-DEV

DRM-IDL	1	Set first idle rotn time in NL Ev
Detail	To set the duration of idle rotation to be performed first time for the day in an NL (normal temperature/low humidity) environment.	
Use Case	When image density for the first time of the day is low	
Adj/Set/Operate Method	1) Enter the setting value, and then press OK key. 2) Turn OFF/ON the main power switch.	
Display/Adj/Set Range	0 to 20 0: OFF, 1: 30 sec, 2: 60 sec, ..., 19: 570 sec, 20: 600 sec	
Unit	sec	
Default Value	1	
Related Service Mode	COPIER> OPTION> IMG-DEV> DRM-IDL2, DRM-IDL3	
Amount of Change per Unit	30	

COPIER (Service mode for printer) > OPTION (Specification setting mode) > IMG-DEV

DV-RT-LG	1	Set Developing Assembly idle rotn time
Detail		To set the duration of idle rotation of the Developing Assembly by COPIER> FUNCTION> MISC-P> DV-RT. As the value is incremented by 1, the duration is increased by 1 minute. +: Increase -: Decrease
Use Case		When an image failure is not alleviated by executing idle rotation
Adj/Set/Operate Method		Enter the setting value, and then press OK key.
Caution		If the duration is long, deterioration of developer or toner scattering might occur.
Display/Adj/Set Range		1 to 20
Unit		min
Default Value		5
Related Service Mode		COPIER> FUNCTION> MISC-P> DV-RT
Amount of Change per Unit		1
ADJ-VPPN	1	Adjustment of developing bias Vpp
Detail		To adjust Vpp of the developing AC bias. The initial value is 1.5 kV, and as the value is decreased by 1, Vpp is decreased by 0.1 kV (density and fogging increase). Decrease the value when fogging or bias leak occurs, and increase the value when the density is low or white spots occur.
Use Case		When fogging, bias leak, low density, or white spots occur
Adj/Set/Operate Method		Enter the setting value (switch negative/positive by -/+ key) and press OK key.
Display/Adj/Set Range		-4 to 2
Unit		V
Default Value		0
Amount of Change per Unit		100
PG-DMAX	2	Setting of patch image in D-max control
Detail		To set the patch image formed by D-max control. When increasing the target density, accuracy of patch image reading improves by setting 1.
Use Case		When increasing the target density
Adj/Set/Operate Method		Enter the setting value, and then press OK key.
Display/Adj/Set Range		0 to 1 0: Solid patch, 1: Shadow patch
Default Value		0
DRM-IDL2	1	Set first idle rotn time in NN Ev
Detail		To set the duration of idle rotation to be performed first time for the day in an NN (normal temperature/normal humidity) environment.
Use Case		When image density for the first time of the day is low
Adj/Set/Operate Method		Enter the setting value, and then press OK key.
Display/Adj/Set Range		0 to 20 0: OFF, 1: 30 sec, 2: 60 sec, ..., 19: 570 sec, 20: 600 sec
Unit		sec
Default Value		1
Related Service Mode		COPIER> OPTION> IMG-DEV> DRM-IDL, DRM-IDL3
Amount of Change per Unit		30

COPIER (Service mode for printer) > OPTION (Specification setting mode) > IMG-DEV

ATM	2	Set of highland ev voltg reduction mode
Detail		To set the highland environment voltage reduction mode in the case that leak occurs at a high latitude. When 1 is set, high voltage settings for the Primary Charging Assembly, Pre-transfer Charging Assembly and developing bias are decreased so that leak can be prevented.
Use Case		When leak occurs at high latitude
Adj/Set/Operate Method		Enter the setting value, and then press OK key.
Display/Adj/Set Range		0 to 1 0: Normal, 1: Voltage reduction mode
Default Value		0
LWDTY-SW	1	ON/OFF of low duty ejection
Detail		To set ON/OFF of low duty ejection control. When 1 is set, developer is ejected at the time of last rotation/during a job.
Use Case		Upon user's request (Reduction of toner consumption)
Adj/Set/Operate Method		Enter the setting value, and then press OK key.
Caution		Be sure to get approval from the user by telling possibility that the image density may be lowered due to deterioration of developer when setting 0.
Display/Adj/Set Range		0 to 1 0: OFF, 1: ON
Default Value		1
Related Service Mode		COPIER> OPTION> IMG-DEV> LWDTYADJ
LWDTYADJ	1	Set low duty ejection threshold value
Detail		To set offset of image density which becomes the threshold value for the low duty ejection control. The threshold value which becomes a reference differs depending on the environment (temperature and humidity). When a positive value is entered, the interval of low duty ejection control becomes shorter. Lowering of image density can be prevented, but replacement timing of the Waste Toner Container becomes early due to the increase of toner consumption.
Use Case		When density is lowered at the time of continuous output of low duty image
Adj/Set/Operate Method		Enter the setting value (switch negative/positive by +/- key) and press OK key.
Display/Adj/Set Range		-50 to 50
Unit		%
Default Value		0
Related Service Mode		COPIER> OPTION> IMG-DEV> LWDTY-SW
BB-CNT	1	Set Bk band output intvl: Cleaning Blade
Detail		To set the paper interval to output black band for preventing flip of the Cleaning Blade. As the value is changed by 1, the interval (the number of sheets) is changed by 100 sheets. When a negative value is entered, the interval to output black band becomes shorter. The possibility that the Cleaning Blade may be flipped is decreased, but replacement timing of the Waste Toner Container becomes early due to the increase of toner consumption.
Use Case		When flip of the Cleaning Blade occurs
Adj/Set/Operate Method		Enter the setting value (switch negative/positive by +/- key) and press OK key.
Display/Adj/Set Range		-15 to 15
Unit		sheet
Default Value		0
Amount of Change per Unit		100

COPIER (Service mode for printer) > OPTION (Specification setting mode) > IMG-DEV

PRI-SHUT	1	Set Pry/Pre-trn Chg Shutter close timing
Detail	<p>To set the time from when the Photosensitive Drum stops to when the Primary/Pre-transfer Charging Shutter is closed.</p> <p>With the Primary/Pre-transfer Charging Shutter control, the Primary/Pre-transfer Charging Shutter is closed after 255 to 300 minutes* from the stop of the Photosensitive Drum to prevent image smear due to nitrogen oxide.</p> <p>* It differs according to the environment (moisture content).</p> <p>Decrease the value to close the shutter earlier when image smear occurs first time for the day. As the value is changed by 1, the time is changed by 30 minutes.</p> <p>Depending on the value, the shutter is closed before the machine shifts to sleep mode, so that the first copy time becomes longer for the time to open the shutter again (approx. 13 seconds). As the value is reduced, the life of the Primary/Pre-transfer Charging Wire Cleaning Pad is shortened because cleaning of the Charging Wire is performed every time the shutter is closed.</p>	
Use Case	When image smear occurs	
Adj/Set/Operate Method	Enter the setting value (switch negative/positive by +/- key) and press OK key.	
Caution	<p>- If the shutter is closed before the machine shifts to sleep mode, the first copy time becomes longer for the time to open it again.</p> <p>- As the value is reduced, the life of the Primary/Pre-transfer Charging Wire Cleaning Pad is shortened.</p>	
Display/Adj/Set Range	-7 to 0	
Unit	min	
Default Value	0	
Amount of Change per Unit	30	
TBLTCLSW	1	Setting of ETB cleaning timing
Detail	<p>To set the timing to execute ETB cleaning control.</p> <p>When 1 or 2 is set, it is also executed at the time of the Charging Wire cleaning.</p> <p>As the value is increased, the soiling of the back side of paper is decreased, but the life of the ETB is shortened and productivity is decreased.</p>	
Use Case	When the back side of paper is soiled	
Adj/Set/Operate Method	Enter the setting value, and then press OK key.	
Caution	As the number of times of ETB cleaning is increased, the life of the ETB is shortened and productivity is decreased.	
Display/Adj/Set Range	0 to 2 0: OFF 1: At last rotation + At Charging Wire cleaning 2: At last rotation + At initial rotation + At Charging Wire cleaning	
Default Value	1	
Related Service Mode	COPIER> OPTION> IMG-DEV> TBLTBIS+, TBLTBIS-, TBLTTMS	

COPIER (Service mode for printer) > OPTION (Specification setting mode) > IMG-DEV

TBLTBIS+	1	Setting of ETB cleaning bias (+)
Detail	To set the transfer current value to apply cleaning bias(+) at the time of ETB cleaning. As the value is increased, the soiling of the back side of paper is decreased, but the life of the ETB is shortened. Compared with TBLTCLSW, productivity can be sustained, but the life of the ETB is shortened further.	
Use Case	When the back side of paper is soiled	
Adj/Set/Operate Method	Enter the setting value (switch negative/positive by +/- key) and press OK key.	
Caution	As the greater value is set, the life of the ETB is shortened.	
Display/Adj/Set Range	-10 to 10	
Unit	uA	
Default Value	0	
Related Service Mode	COPIER> OPTION> IMG-DEV> TBLTCLSW, TBLTBIS-, TBLTTMS	
Amount of Change per Unit	10	
TBLTBIS-	1	Setting of ETB cleaning bias (-)
Detail	To set the transfer current value to apply cleaning bias (-) at the time of ETB cleaning.	
Use Case	When the back side of paper is soiled	
Adj/Set/Operate Method	Enter the setting value, and then press OK key.	
Display/Adj/Set Range	0 to 5	
Unit	uA	
Default Value	0	
Related Service Mode	COPIER> OPTION> IMG-DEV> TBLTCLSW, TBLTBISP, TBLTTMS	
Amount of Change per Unit	10	
TBLTTMS	1	Set ETB cleaning bias application times
Detail	To set the number of times to apply cleaning bias at the time of ETB cleaning. Apply positive (+) and negative (-) cleaning bias alternately. As the value is increased, the soiling of the back side of paper is decreased, but the life of the ETB is shortened and productivity is decreased.	
Use Case	When the back side of paper is soiled	
Adj/Set/Operate Method	Enter the setting value, and then press OK key.	
Caution	As the greater value is set, the life of the ETB is shortened and productivity is decreased.	
Display/Adj/Set Range	1 to 10	
Unit	time	
Default Value	2	
Related Service Mode	COPIER> OPTION> IMG-DEV> TBLTCLSW, TBLTBISP, TBLTBIS-	
DRM-IDL3	1	Set first idle rotn time in HH Ev
Detail	To set the idle rotation time to be performed first time for the day in an HH (high temperature and high humidity) environment.	
Use Case	When image density for the first time of the day is low	
Adj/Set/Operate Method	Enter the setting value, and then press OK key.	
Display/Adj/Set Range	0 to 20 0: OFF, 1: 60 sec, 2: 90 sec, ..., 19: 600 sec, 20: 630 sec	
Unit	sec	
Default Value	1	
Related Service Mode	COPIER> OPTION> IMG-DEV> DRM-IDL, DRM-IDL2	
Amount of Change per Unit	30	

■ IMG-FIX

COPIER (Service mode for printer) > OPTION (Specification setting mode) > IMG-FIX

FIX-CLN	1	Set fixing cleaning execution interval
Detail	To set the number of sheets as the intervals to execute fixing cleaning. By performing idle rotation of the Fixing Assembly for 5 seconds every time a specified number of sheets are fed, remove soil adhered on the Pressure Roller. Set 1 when an image failure occurs. If it is not alleviated, set 2 or 3. Because idle rotation is executed by interrupting an ongoing job, as the short execution interval is set, productivity decreases.	
Use Case	When an image failure due to the Pressure Roller occurs	
Adj/Set/Operate Method	Enter the setting value, and then press OK key.	
Caution	As the short execution interval is set, productivity decreases.	
Display/Adj/Set Range	0 to 3 0: OFF, 1: 500 sheets, 2: 300 sheets, 3: 150 sheets	
Default Value	0	
FIX-TEMP	1	Set fixing/productivity: Heavy paper
Detail	To set priority between productivity and fixing by changing temperature at which down sequence is applied to Heavy paper. When 2 is set, fixing has priority over productivity because the machine is likely to go into the down sequence. When 0 is set, productivity has priority over fixing.	
Use Case	When changing priority between fixing and productivity for Heavy paper	
Adj/Set/Operate Method	Enter the setting value, and then press OK key.	
Display/Adj/Set Range	0 to 2 0: Priority on productivity (-5 degC), 1: Normal, 2: Priority on fixing (+5 degC)	
Unit	deg C	
Default Value	1	
FSPD-S1	2	Setting of fixing improvement mode
Detail	To set whether to start the machine in fixing improvement mode. When 1 to 4 is set, duration of warm-up is increased for the specified time to increase the temperature of the Fixing Assembly.	
Adj/Set/Operate Method	1) Enter the setting value, and then press OK key. 2) Turn OFF/ON the main power switch.	
Display/Adj/Set Range	0 to 4 0: 0 second, 1: 30 seconds, 2: 60 seconds, 3: 90 seconds, 4: 120 seconds	
Default Value	0	
CBLTINVL	1	Setting of Fixing Web Solenoid ON times
Detail	To set frequency to turn ON the Fixing Cleaning Web Drive Solenoid. If an image failure occurs due to the soiled Pressure Roller, set 1. If an image failure occurs due to the soiled Separation Claw, set 2. If the life of Fixing Cleaning Web is shorter than the target (500,000 sheets) (in case of much take-up amount of web), set 3.	
Use Case	- When an image failure due to the soiled Pressure Roller/Separation Claw occurs - When the life of Fixing Cleaning Web is too short	
Adj/Set/Operate Method	1) Enter the setting value, and then press OK key. 2) Turn OFF/ON the main power switch.	
Display/Adj/Set Range	0 to 3 0: Normal, 1: 1.5 times of normal *, 2: 0.5 times of normal, 3: 0.75 times of normal *: Only for paper which length in feed direction is 236.0 mm or less or 364.0 mm or longer	
Default Value	0	

COPIER (Service mode for printer) > OPTION (Specification setting mode) > IMG-FIX

TMP-TBL2	1	Set fixing control temp table: Thin
Detail		To set the control temperature table of the Fixing Roller for 52 to 63g/m2 size paper.
Use Case		When alleviating the curl
Adj/Set/Operate Method		Enter the setting value (switch negative/positive by +/- key) and press OK key.
Display/Adj/Set Range		-5 to 2 -5 to -1: -5 deg C, 0: 0 deg C, 1 to 2: +5 deg C
Unit		deg C
Default Value		0
TMP-TBL3	1	Set fixing control temp table
Detail		To set the control temperature table of the Fixing Roller for 91 to 256g/m2 size paper.
Use Case		When alleviating the curl
Adj/Set/Operate Method		1) Enter the setting value (switch negative/positive by +/- key) and press OK key. 2) Turn OFF/ON the main power switch.
Display/Adj/Set Range		-5 to 2 -5 to -2: -10 deg C, -1: -5 deg C, 0 to 2: 0 deg C
Unit		deg C
Default Value		0
TMP-TBL4	1	Set fixing control temp table: Bond
Detail		To set the control temperature table of the Fixing Roller for bond paper.
Use Case		When alleviating the curl
Adj/Set/Operate Method		Enter the setting value (switch negative/positive by +/- key) and press OK key.
Display/Adj/Set Range		-5 to 2 -5 to -1: -5 deg C, 0 to 2: 0 deg C
Unit		deg C
Default Value		0
RAG-CONT	1	Set fix smeared image ctrl mode level
Detail		To set level of the mode (skipping) to control smeared image caused by fixing area.
Use Case		When a smeared image occurs
Adj/Set/Operate Method		1) Enter the setting value, and then press OK key. 2) Turn OFF/ON the main power switch.
Caution		Set RAG-SW to 1 to 3 to enable skipping.
Display/Adj/Set Range		0 to 3 0: No skipping, 1: Small skipping, 2: Medium skipping, 3: Large skipping
Default Value		0
Related Service Mode		COPIER> OPTION> IMG-FIX> RAG-SW
RAG-SW	1	ON/OFF of fixing burst prevention mode
Detail		To set ON/OFF of fixing burst prevention mode (skipping) to prevent line burst. Select "1: ON" in the case all horizontal lines are burst. Set ON according to paper type in the case the degree of line burst differs depending on media.
Use Case		When horizontal lines burst
Adj/Set/Operate Method		Enter the setting value, and then press OK key.
Caution		Set RAG-CONT to 1 to 3 to enable skipping.
Display/Adj/Set Range		0 to 1 0: OFF, 1: ON
Default Value		0
Related Service Mode		COPIER> OPTION> IMG-FIX> RAG-CONT

COPIER (Service mode for printer) > OPTION (Specification setting mode) > IMG-FIX

FIX-DWN	2	Set prdctvty reduct mode: small size
Detail	To set the speed ratio in the case of reducing productivity when feeding small size paper.	
Use Case	When an image failure (crepe mark) occurs	
Adj/Set/Operate Method	Enter the setting value (switch negative/positive by +/- key) and press OK key.	
Display/Adj/Set Range	-3 to 0 -3: 40%, -2: 60%, -1: 80%, 0: 100%	
Default Value	0	
Supplement/Memo	Small size paper: Paper width is 257 mm or less.	
FIX-RT	2	Set idle rotation time at last rotation
Detail	To set the idle rotation time at last rotation executed after completion of job using paper which width is B4 (257 mm) or less.	
Use Case	When an image failure (crepe mark) occurs	
Adj/Set/Operate Method	Enter the setting value, and then press OK key.	
Display/Adj/Set Range	0 to 3 0: No idle rotation, 1: 10 seconds, 2: 20 seconds, 3: 30 seconds	
Default Value	0	
MIX-WAIT	1	Set of fixing wait mode at mixed paper
Detail	To set the fixing wait mode when plain paper and heavy paper are mixed. When 0 is set, fixing mode for heavy paper is also used for plain paper while papers are mixed. When switching from plain paper to heavy paper, the machine does not wait until the fixing temperature rises. When 1 is set, the machine waits because the fixing temperature for plain paper is switched to the one for heavy paper. Fixing is improved, but productivity decreases.	
Use Case	When fixing is deteriorated while plain paper and heavy paper are mixed	
Adj/Set/Operate Method	Enter the setting value, and then press OK key.	
Caution	When 1 is set, productivity decreases.	
Display/Adj/Set Range	0 to 3 0: Fixing temperature is not switched according to paper type, 2: Fixing temperature is switched, 2 to 3: Spare	
Default Value	0	
P-BETWN	1	Setting of paper interval: 2-sided mode
Detail	To set the paper interval at 2-sided mode. Use this item when uneven gloss occurs at intervals of the Fixing Roller circumference (126 mm) on 1st side of 2-sided print. When 1 is set, 150 mm or less paper interval at 2-sided mode becomes 150 mm or more. Uneven gloss can be alleviated, but productivity decreases.	
Use Case	When uneven gloss occurs on 1st side of 2-sided print	
Adj/Set/Operate Method	Enter the setting value, and then press OK key.	
Caution	When 1 is set, productivity decreases.	
Display/Adj/Set Range	0 to 1 0: Normal, 1: Widening paper interval	
Default Value	0	

COPIER (Service mode for printer) > OPTION (Specification setting mode) > IMG-FIX

FIX-TMP2	1	Set fixing/productivity: Plain paper A3+
Detail	To set priority between productivity and fixing by changing temperature at which down sequence is applied to plain paper A3-Extension (13"x19"). When 1 is set, fixing has priority over productivity because the machine is likely to go into the down sequence. When -1 is set, productivity has priority over fixing.	
Use Case	When changing priority between fixing and productivity for plain paper A3-Extension (13"x19")	
Adj/Set/Operate Method	Enter the setting value (switch negative/positive by +/- key) and press OK key.	
Display/Adj/Set Range	-1 to 1 -1: Priority on productivity (-3 degC), 0: Normal, 1: Priority on fixing (+3 degC)	
Unit	deg C	
Default Value	0	
Supplement/Memo	Extra-long size paper: Paper larger than LDR (431.8 mm)	
FIX-TMP3	1	Set fixing/productivity: Spcl ppr A3+
Detail	To set priority between productivity and fixing by changing temperature at which down sequence is applied to special paper A3-Extension (13"x19"). When 1 is set, fixing has priority over productivity because the machine is likely to go into the down sequence. When -1 is set, productivity has priority over fixing.	
Use Case	When changing priority between fixing and productivity for special paper A3-Extension (13"x19")	
Adj/Set/Operate Method	Enter the setting value (switch negative/positive by +/- key) and press OK key.	
Display/Adj/Set Range	-1 to 1 -1: Priority on productivity (-3 degC), 0: Normal, 1: Priority on fixing (+3 degC)	
Unit	deg C	
Default Value	0	
Supplement/Memo	Extra-long size paper: Paper larger than LDR (431.8 mm)	
FX-IMGLV	2	Set img qlty/prdctvty lvl:Qlty Prtty
Detail	To set image quality/productivity level when "Quality Priority" is set. When "Quality Priority" is selected in [Productivity/Image Quality Priority for Thin/Plain Paper], productivity may be extremely decreased to prevent occurrence of image with crepe mark. When 0 is set, image quality is slightly decreased compared with its of normal Quality Priority mode, but productivity improves (suitable for text document). When 1 is set, image quality is prioritized so image with crepe mark does not occur but productivity decreases (suitable for photo document). This setting is enabled when "Quality Priority" is set in [Settings/Registration].	
Use Case	Upon user's request (Alleviation of image with crepe mark)	
Adj/Set/Operate Method	Enter the setting value, and then press OK key.	
Caution	Be sure to get approval from the user by telling that the productivity decreases to improve image quality.	
Display/Adj/Set Range	0 to 1 0: Text document mode, 1: Photo document mode	
Default Value	0	
Additional Functions Mode	Function Settings> Common> Print Settings> Thin/Plain Paper Printing Priority Settings	

COPIER (Service mode for printer) > OPTION (Specification setting mode) > IMG-FIX

FX-WNKL	2	Setting of paper wrinkle prevention mode
Detail	<p>To set paper wrinkle prevention mode.</p> <p>If the edge temperature of the Fixing Roller is lower than the center temperature, feeding speed at the center of a paper becomes faster than the speed at the edge so paper wrinkle occurs. Normally, when printing to paper larger than A3 or LDR size paper at the start of printing in a high humidity environment, control temperature is increased by performing idle rotation. Paper wrinkle which occurs at this time can be decreased, but first copy time becomes longer. In other cases, idle rotation is not performed.</p> <p>When paper wrinkle occurs with A3/LDR or larger size paper in a normal humidity/high humidity environment, set 2. If paper wrinkle is not alleviated with 2, set 3. (First copy time becomes longer.)</p> <p>When paper wrinkle occurs with B4 or larger size paper in all environments, set 4. If it is not alleviated with 4, set 5 or 6. (As the value is larger, first copy time becomes longer.)</p>	
Use Case	<ul style="list-style-type: none"> - When paper wrinkles occur - Upon user's request (shorten the first copy time) 	
Adj/Set/Operate Method	Enter the setting value, and then press OK key.	
Caution	When 2 to 6 is set, the first copy time becomes longer.	
Display/Adj/Set Range	0 to 6 0: OFF, 1: Normal, 2: Level 1, 3: Level 2, 4: Level 3, 5: Level 4, 6: Level 5	
Default Value	1	
FIX-TMP4	1	Set fixing/productivity: Plain paper
Detail	<p>To set priority between productivity and fixing by changing temperature at which down sequence is applied to plain paper (64 to 90g/m²).</p> <p>When a positive value is set, fixing has priority over productivity because the machine is likely to go into the down sequence.</p> <p>When a negative value is set, productivity has priority over fixing.</p>	
Use Case	<ul style="list-style-type: none"> - When fixing failure occurs on plain paper - When productivity is decreased due to down sequence 	
Adj/Set/Operate Method	Enter the setting value (switch negative/positive by +/- key) and press OK key.	
Display/Adj/Set Range	-2 to 2 -2: -6 deg C, -1: -3 deg C, 0: 0 deg C, 1: +3 deg C, 2: +6 deg C	
Unit	deg C	
Default Value	0	

COPIER (Service mode for printer) > OPTION (Specification setting mode) > IMG-FIX

WEB-LIFE	1	Set Fixing Web level alarm notice timing
Detail	To set the timing to notify the Web absence alarm according to the time required for replacement of the Fixing Cleaning Web. The maximum output number until the error message appears after the Fixing Cleaning Web absence alarm is 97875 sheets (on a A4 size conversion basis). If a large volume of papers is output after the appearance of the alarm message, the machine may stop due to an error before replacing the Web. If 0 is set, an alarm is notified when the Fixing Cleaning Web Level Sensor detects "Web absence" as usual. If the value is between 1 and 7, an alarm is notified when the Fixing Cleaning Web Drive Solenoid counter reaches the specified value. As the value is incremented by 1, the threshold of the counter is increased by 50,000 sheets (on a A4 size conversion basis).	
Use Case	When changing the timing to notify the Web absence alarm according to the output status	
Adj/Set/Operate Method	Enter the setting value, and then press OK key.	
Caution	Depending on the setting value of COPIER> OPTION> IMG-FIX> CBLTINVL, the number of estimated prints to display an alarm differs.	
Display/Adj/Set Range	0 to 7 0: Detection by the sensor, 1: Count of 500,000 sheets (on a A4 size conversion basis), 2: 550,000 sheets, 3: 600,000 sheets, 4: 650,000 sheets, 5: 700,000 sheets, 6: 750,000 sheets, 7: 800,000 sheets	
Default Value	0	
Related Service Mode	COPIER> OPTION> IMG-FIX> CBLTINVL	

■ CUSTOM

COPIER (Service mode for printer) > OPTION (Specification setting mode) > CUSTOM

TEMP-TBL	1	Set fixing control temp table: Plain
Detail	To set the control temperature table of the Fixing Roller for 64 to 90 g/m2 size paper.	
Use Case	When alleviating the curl	
Adj/Set/Operate Method	Enter the setting value (switch negative/positive by -/+ key) and press OK key.	
Display/Adj/Set Range	-5 to 2 -5 to -1: -5 deg C, 0 to 2: 0 deg C	
Unit	deg C	
Default Value	0	
SC-L-CNT	1	Set large paper jdgmt reference at scan
Detail	To set the judgment reference of the scan counter as to which to use B4 or LTR to determine large size. The threshold is determined by the combination with the setting of B4-L-CNT. SC-L-CNT=0, B4-L-CNT=0: paper exceeding B4 is determined as large size, paper with B4 or smaller is determined as small size. SC-L-CNT=0, B4-L-CNT=1: paper with B4 or larger is determined as large size, paper smaller than B4 is determined as small size.	
Use Case	As needed	
Adj/Set/Operate Method	1) Enter the setting value, and then press OK key. 2) Turn OFF/ON the main power switch.	
Display/Adj/Set Range	0 to 1 0: B4 size, 1: LTR size	
Default Value	0	
Related Service Mode	COPIER> OPTION> USER> B4-L-CNT	

COPIER (Service mode for printer) > OPTION (Specification setting mode) > CUSTOM

FACT-DEF	2	Set batch chng of factory setting values
Detail		To set the batch change of factory setting values for customization.
Display/Adj/Set Range		0 to 1
Default Value		0
MAILYEAR	2	Set auto add to e-mail Subject/File name
Detail		To set whether to add date, time and split number automatically to the end of a character string of e-mail Subject/File name.
Use Case		Upon user's request
Adj/Set/Operate Method		1) Enter the setting value, and then press OK key. 2) Turn OFF/ON the main power switch.
Display/Adj/Set Range		0 to 1 0: Following the current setting, 1: Adding
Default Value		0
SCANTYPE	1	Switching of DADF + Reader type
Detail		To switch the type of DADF + Reader to a different type.
Use Case		At installation
Adj/Set/Operate Method		1) Enter the setting value, and then press OK key. 2) Turn OFF/ON the main power switch.
Display/Adj/Set Range		0 to 1 0: DADF (reverse model) + Reader, 1: DADF (1-path model) + Reader
Default Value		1
PDLEVCT1	2	Set event skipping at continuous PDL job
Detail		To set event skipping at continuous PDL job. During continuous operation, processing performance may be decreased due to other events generated by the event in operation. In this case, decrease of processing performance can be prevented by skipping the amount of event. Processing performance: No event skipping < Subject of skipping 1
Use Case		Upon user's request
Adj/Set/Operate Method		1) Enter the setting value, and then press OK key. 2) Turn OFF/ON the main power switch.
Display/Adj/Set Range		0 to 1 0: No event skipping, 1: Subject of skipping 1
Default Value		1
ABK-TOOL	1	Allow access from address book mntc tool
Detail		*Operation on this item is restricted by the setting of [Restrict Service Representation Access]. To set whether to accept import from the address book maintenance tool.
Use Case		When executing import from the address book maintenance tool
Adj/Set/Operate Method		1) Enter the setting value, and then press OK key. 2) Turn OFF/ON the main power switch.
Display/Adj/Set Range		0 to 1 0: Disabled, 1: Enabled
Default Value		0
Supplement/Memo		Address book maintenance tool: Tool provided from CMJ.

COPIER (Service mode for printer) > OPTION (Specification setting mode) > CUSTOM

DEV-SP1	2	Device special settings 1
Detail	To execute the device special settings 1.	
Adj/Set/Operate Method	1) Enter the setting value, and then press OK key. 2) Turn OFF/ON the main power switch.	
Caution	Change the setting value in accordance with the instructions from the Quality Support Division.	
Display/Adj/Set Range	00000000 to 11111111	
Default Value	00000000	
DEV-SP2	2	Device special settings 2
Detail	To execute the device special settings 2.	
Adj/Set/Operate Method	1) Enter the setting value, and then press OK key. 2) Turn OFF/ON the main power switch.	
Caution	Change the setting value in accordance with the instructions from the Quality Support Division.	
Display/Adj/Set Range	00000000 to 11111111	
Default Value	00000000	
DEV-SP3	2	Device special settings 3
Detail	To execute the device special settings 3.	
Adj/Set/Operate Method	1) Enter the setting value, and then press OK key. 2) Turn OFF/ON the main power switch.	
Caution	Change the setting value in accordance with the instructions from the Quality Support Division.	
Display/Adj/Set Range	00000000 to 11111111	
Default Value	00000000	
DEV-SP4	2	Device special settings 4
Detail	To execute the device special settings 4.	
Adj/Set/Operate Method	1) Enter the setting value, and then press OK key. 2) Turn OFF/ON the main power switch.	
Caution	Change the setting value in accordance with the instructions from the Quality Support Division.	
Display/Adj/Set Range	00000000 to 11111111	
Default Value	00000000	
DEV-SP5	2	Device special settings 5
Detail	To execute the device special settings 5.	
Adj/Set/Operate Method	1) Enter the setting value, and then press OK key. 2) Turn OFF/ON the main power switch.	
Caution	Change the setting value in accordance with the instructions from the Quality Support Division.	
Display/Adj/Set Range	00000000 to 11111111	
Default Value	00000000	
DEV-SP6	2	Device special settings 6
Detail	To execute the device special settings 6.	
Adj/Set/Operate Method	1) Enter the setting value, and then press OK key. 2) Turn OFF/ON the main power switch.	
Caution	Change the setting value in accordance with the instructions from the Quality Support Division.	
Display/Adj/Set Range	00000000 to 11111111	
Default Value	00000000	

COPIER (Service mode for printer) > OPTION (Specification setting mode) > CUSTOM

DEV-SP7	2	Device special settings 7
Detail	To execute the device special settings 7.	
Adj/Set/Operate Method	1) Enter the setting value, and then press OK key. 2) Turn OFF/ON the main power switch.	
Caution	Change the setting value in accordance with the instructions from the Quality Support Division.	
Display/Adj/Set Range	00000000 to 11111111	
Default Value	00000000	
DEV-SP8	2	Device special settings 8
Detail	To execute the device special settings 8.	
Adj/Set/Operate Method	1) Enter the setting value, and then press OK key. 2) Turn OFF/ON the main power switch.	
Caution	Change the setting value in accordance with the instructions from the Quality Support Division.	
Display/Adj/Set Range	00000000 to 11111111	
Default Value	00000000	
AC-FREQ	2	Setting of frequency of AC power
Detail	Although power frequency is judged for power control with the machine, it might be judged incorrectly depending on power circumstance at the installation location. At left side column, the power frequency (50 Hz/60 Hz) which the DC Controller judged at power-on is displayed. In the case that the power frequency is not matched with the one at the installation location, set the AC power frequency at right side column.	
Use Case	When the breaker is frequently tripped during operation	
Adj/Set/Operate Method	1) Select the right side column. 2) Enter the setting value, and then press OK key.	
Display/Adj/Set Range	Left side: 1 to 2 1: 50 Hz, 2: 60 Hz Right side: 0 to 2 0: Judged frequency is used, 1: 50 Hz, 2: 60 Hz	
Default Value	0	
DFEJCLED	1	ON/OFF of DADF Original Output Indicator
Detail	To set whether to light up the Original Output Indicator of the DADF.	
Use Case	Upon user's request (The Original Output Indicator is too bright.)	
Adj/Set/Operate Method	Enter the setting value, and then press OK key.	
Display/Adj/Set Range	0 to 1 0: ON, 1: OFF	
Default Value	0	
RDEV-SP1	2	RCON device special settings 1
Detail	To execute the device special setting.	
Use Case	For customization	
Adj/Set/Operate Method	1) Enter the setting value, and then press OK key. 2) Turn OFF/ON the main power switch.	
Caution	Use this mode only when specific instructions are given.	
Display/Adj/Set Range	00000000 to 11111111	
Default Value	0	

COPIER (Service mode for printer) > OPTION (Specification setting mode) > CUSTOM

RDEV-SP2	2	RCON device special settings 2
Detail	To execute the device special setting.	
Use Case	For customization	
Adj/Set/Operate Method	1) Enter the setting value, and then press OK key. 2) Turn OFF/ON the main power switch.	
Caution	Use this mode only when specific instructions are given.	
Display/Adj/Set Range	00000000 to 11111111	
Default Value	0	
RDEV-SP3	2	RCON device special settings 3
Detail	To execute the device special setting.	
Use Case	For customization	
Adj/Set/Operate Method	1) Enter the setting value, and then press OK key. 2) Turn OFF/ON the main power switch.	
Caution	Use this mode only when specific instructions are given.	
Display/Adj/Set Range	00000000 to 11111111	
Default Value	0	
RDEV-SP4	2	RCON device special settings 4
Detail	To execute the device special setting.	
Use Case	For customization	
Adj/Set/Operate Method	1) Enter the setting value, and then press OK key. 2) Turn OFF/ON the main power switch.	
Caution	Use this mode only when specific instructions are given.	
Display/Adj/Set Range	00000000 to 11111111	
Default Value	0	
RDEV-SP5	2	RCON device special settings 5
Detail	To execute the device special setting.	
Use Case	For customization	
Adj/Set/Operate Method	1) Enter the setting value, and then press OK key. 2) Turn OFF/ON the main power switch.	
Caution	Use this mode only when specific instructions are given.	
Display/Adj/Set Range	00000000 to 11111111	
Default Value	0	
RDEV-SP6	2	RCON device special settings 6
Detail	To execute the device special setting.	
Use Case	For customization	
Adj/Set/Operate Method	1) Enter the setting value, and then press OK key. 2) Turn OFF/ON the main power switch.	
Caution	Use this mode only when specific instructions are given.	
Display/Adj/Set Range	00000000 to 11111111	
Default Value	0	

COPIER (Service mode for printer) > OPTION (Specification setting mode) > CUSTOM

RDEV-SP7	2	RCON device special settings 7
Detail		To execute the device special setting.
Use Case		For customization
Adj/Set/Operate Method		1) Enter the setting value, and then press OK key. 2) Turn OFF/ON the main power switch.
Caution		Use this mode only when specific instructions are given.
Display/Adj/Set Range		00000000 to 11111111
Default Value		0
RDEV-SP8	2	RCON device special settings 8
Detail		To execute the device special setting.
Use Case		For customization
Adj/Set/Operate Method		1) Enter the setting value, and then press OK key. 2) Turn OFF/ON the main power switch.
Caution		Use this mode only when specific instructions are given.
Display/Adj/Set Range		00000000 to 11111111
Default Value		0
PD-SPCL	2	[Not used]
PAP-TYPE	2	[For customization]
DCM-EXCL	1	[For customization]
FPOT-MD	2	[For customization]
MEDIA-EX	2	Display/hide of coated paper
Detail		To switch display/hide of coated paper. When 1 is set, coated paper is displayed in Paper Settings.
Use Case		When using coated paper
Adj/Set/Operate Method		Enter the setting value, and then press OK key.
Caution		Be sure to check in advance that there is no problem like jams with the paper to be used.
Display/Adj/Set Range		0 to 1 0: Hide, 1: Display
Default Value		0

■ USER

COPIER (Service mode for printer) > OPTION (Specification setting mode) > USER

COPY-LIM	1	Setting of upper limit for copy
Detail		To set the upper limit value for copy.
Use Case		Upon user's request
Adj/Set/Operate Method		1) Enter the setting value, and then press OK key. 2) Turn OFF/ON the main power switch.
Display/Adj/Set Range		1 to 9999
Default Value		9999

COPIER (Service mode for printer) > OPTION (Specification setting mode) > USER

SLEEP	1	Setting of auto sleep function
Detail		To set ON/OFF of auto sleep function.
Use Case		Upon user's request
Adj/Set/Operate Method		1) Enter the setting value, and then press OK key. 2) Turn OFF/ON the main power switch.
Display/Adj/Set Range		0 to 1 0: OFF, 1: ON
Default Value		1
Additional Functions Mode		Preferences> Timer/Energy Settings> Auto Sleep Time
Supplement/Memo		The time to shift to the sleep mode can be set in Settings/Registration> Preferences> Timer/Energy Settings> Auto Sleep Time.
SIZE-DET	2	ON/OFF of original size detect function
Detail		To set ON/OFF of original size detection function.
Use Case		Upon user's request (The LED is too bright, etc.)
Adj/Set/Operate Method		1) Enter the setting value, and then press OK key. 2) Turn OFF/ON the main power switch.
Display/Adj/Set Range		0 to 1 0: OFF, 1: ON
Default Value		1
COUNTER1	1	Display of software counter 1
Detail		To display counter type for software counter 1 on the Counter Check screen.
Use Case		Upon user/dealer's request
Adj/Set/Operate Method		N/A (Display only)
Caution		Display only. No change is available.
Default Value		It differs according to the location.
COUNTER2	1	Setting of software counter 2
Detail		To set counter type for software counter 2 on the Counter Check screen.
Use Case		Upon user/dealer's request
Adj/Set/Operate Method		1) Enter the setting value, and then press OK key. 2) Turn OFF/ON the main power switch.
Display/Adj/Set Range		0 to 999 0: No registration
Default Value		It differs according to the location.
COUNTER3	1	Setting of software counter 3
Detail		To set counter type for software counter 3 on the Counter Check screen.
Use Case		Upon user/dealer's request
Adj/Set/Operate Method		1) Enter the setting value, and then press OK key. 2) Turn OFF/ON the main power switch.
Display/Adj/Set Range		0 to 999 0: No registration
Default Value		It differs according to the location.

COPIER (Service mode for printer) > OPTION (Specification setting mode) > USER

COUNTER4	1	Setting of software counter 4
Detail	To set counter type for software counter 4 on the Counter Check screen.	
Use Case	Upon user/dealer's request	
Adj/Set/Operate Method	1) Enter the setting value, and then press OK key. 2) Turn OFF/ON the main power switch.	
Display/Adj/Set Range	0 to 999 0: No registration	
Default Value	It differs according to the location.	
COUNTER5	1	Setting of software counter 5
Detail	To set counter type for software counter 5 on the Counter Check screen.	
Use Case	Upon user/dealer's request	
Adj/Set/Operate Method	1) Enter the setting value, and then press OK key. 2) Turn OFF/ON the main power switch.	
Display/Adj/Set Range	0 to 999 0: No registration	
Default Value	0	
COUNTER6	1	Setting of software counter 6
Detail	To set counter type for software counter 6 on the Counter Check screen.	
Use Case	Upon user/dealer's request	
Adj/Set/Operate Method	1) Enter the setting value, and then press OK key. 2) Turn OFF/ON the main power switch.	
Display/Adj/Set Range	0 to 999 0: No registration	
Default Value	0	
DATE-DSP	2	Setting of data/time display format
Detail	*Operation on this item is restricted by the setting of [Restrict Service Representation Access]. To set date/time display format according to the country or region. After the display format is set with this mode, the order of date is reflected to the followings: Preferences > Timer/Energy Settings > Date/Time Settings, and report output.	
Use Case	Upon user's request	
Adj/Set/Operate Method	1) Enter the setting value, and then press OK key. 2) Turn OFF/ON the main power switch.	
Display/Adj/Set Range	0 to 2 0: YYMM/DD, 1: DD/MMYY, 2: MM/DD/YY	
Default Value	It differs according to the location.	
Additional Functions Mode	Preferences> Timer/Energy Settings> Date/Time Settings	
MB-CCV	2	Control card usage limit for Mail Box
Detail	*Operation on this item is restricted by the setting of [Restrict Service Representation Access]. To restrict use of control card for Mail Box.	
Use Case	Upon user's request	
Adj/Set/Operate Method	1) Enter the setting value, and then press OK key. 2) Turn OFF/ON the main power switch.	
Display/Adj/Set Range	0 to 1 0: Unlimited, 1: Limited	
Default Value	1	

COPIER (Service mode for printer) > OPTION (Specification setting mode) > USER

CONTROL	1	Charge setting of PDL job
Detail		*Operation on this item is restricted by the setting of [Restrict Service Representation Access]. To set charge count transmission of PDL job to the connecting charging management device (Coin Manager or non-Canon-made control card).
Use Case		Upon user's request
Adj/Set/Operate Method		1) Enter the setting value, and then press OK key. 2) Turn OFF/ON the main power switch.
Display/Adj/Set Range		0 to 1 0: No charge, 1: Charge
Default Value		0
Related Service Mode		COPIER> OPTION> ACC> COIN
B4-L-CNT	1	Count setting of B4 size
Detail		To set B4 count with software counter 1 to 8 as to whether B4 is counted as large size or small size. Selecting 1 counts B4 or larger size paper as large size while paper smaller than B4 size as small size.
Use Case		Upon user's request
Adj/Set/Operate Method		1) Enter the setting value, and then press OK key. 2) Turn OFF/ON the main power switch.
Display/Adj/Set Range		0 to 1 0: Small size, 1: Large size
Default Value		0
Related Service Mode		COPIER> OPTION> CUSTOM> SC-L-CNT
MF-LG-ST	2	ON/OFF of long original mode display
Detail		To set whether to display or hide the [Long Original] button. When 1 is set, [Long Original] button is displayed in Copy > Options screen and the long strip paper becomes available.
Use Case		Upon user's request (use of long strip original or long strip paper)
Adj/Set/Operate Method		1) Enter the setting value, and then press OK key. 2) Turn OFF/ON the main power switch.
Display/Adj/Set Range		0 to 1 0: Hide, 1: Display
Default Value		0
Additional Functions Mode		Copy> Options
CNT-DISP	2	Display/hide of serial No.
Detail		To set whether to display or hide the serial No. on the Counter Check screen.
Use Case		When setting to display/hide serial No. on the Counter Check screen.
Adj/Set/Operate Method		1) Enter the setting value, and then press OK key. 2) Turn OFF/ON the main power switch.
Display/Adj/Set Range		0 to 1 0: OFF, 1: ON
Default Value		0

COPIER (Service mode for printer) > OPTION (Specification setting mode) > USER

PH-D-SEL	2	Set dither matrix at screen processing
Detail	To set the screen dither matrix to be used for halftoning processing at the time of copy output, B&W Inbox scan output and B&W SEND output. When moire occurs frequently, set to "0: 134 lines". When the setting is changed, the number of PG lines to be output at PASCAL control is also changed.	
Use Case	When moire frequently occurs at the time of copy output, B&W Inbox scan output and B&W SEND output. Especially when moire frequently occurs in the halftone density area of photo and image gradation areas	
Adj/Set/Operate Method	1) Enter the setting value, and then press OK key. 2) Turn OFF/ON the main power switch.	
Display/Adj/Set Range	0 to 1 0: 134 lines, 1: 141 lines	
Default Value	1	
Related Service Mode	COPIER> OPTION> USER> PH-D-SL2	
COPY-JOB	1	Setting of copy job reservation
Detail	To set to enable/disable copy job reservation when the Card Reader/Coin Manager is used.	
Use Case	Upon user's request	
Adj/Set/Operate Method	1) Enter the setting value, and then press OK key. 2) Turn OFF/ON the main power switch.	
Display/Adj/Set Range	0 to 1 0: Enabled, 1: Disabled	
Default Value	0	
OP-SZ-DT	2	Orgnl size dtct ON/OFF at copyboard open
Detail	To set ON/OFF of original size detection while the Copyboard is opened. When "0: OFF" is set, enter original size manually from the Control Panel. When "1: ON" is set, original size is detected automatically.	
Adj/Set/Operate Method	1) Enter the setting value, and then press OK key. 2) Turn OFF/ON the main power switch.	
Display/Adj/Set Range	0 to 1 0: OFF, 1: ON	
Default Value	0	
NW-SCAN	2	Setting of network scan function usage
Detail	*Operation on this item is restricted by the setting of [Restrict Service Representation Access]. To set to enable/disable use of network scan function.	
Use Case	Upon user's request	
Adj/Set/Operate Method	1) Enter the setting value, and then press OK key. 2) Turn OFF/ON the main power switch.	
Caution	- Do not change this mode in Japan. - For PS/PCL machines for overseas (outside Japan), fix the setting value as "1: Enabled". For others, permit the use.	
Display/Adj/Set Range	0 to 1 0: Disabled, 1: Enabled	

COPIER (Service mode for printer) > OPTION (Specification setting mode) > USER

JOB-INVL	2	Job intvl setting at interruption copy
Detail	To set output interval between jobs at the time of interruption copy. Sorting is difficult after interruption copy because of the continuous output of the next job. Paper interval becomes longer when starting pickup for the next job after the last sheet of the previous job is delivered.	
Use Case	Upon user's request	
Adj/Set/Operate Method	1) Enter the setting value, and then press OK key. 2) Turn OFF/ON the main power switch.	
Display/Adj/Set Range	0 to 2 0: Continuous output of the interruption copy and the next job 1: Starting pickup for the next job after the interruption copy is delivered all. 2: Starting pickup for the next job after the previous job is delivered all. (For all jobs)	
Default Value	0	
TAB-ROT	1	Set of landscape img rotn at PDL:tab ppr
Detail	To set whether to rotate landscape image by 180 degrees when PDL print is made on tab paper. When 1 is set, image is rotated.	
Use Case	Upon user's request	
Adj/Set/Operate Method	1) Enter the setting value, and then press OK key. 2) Turn OFF/ON the main power switch.	
Display/Adj/Set Range	0 to 1 0: Not rotated, 1: Rotated	
Default Value	0	
PR-PSESW	1	ON/OFF Pause All Print Jobs button dsp
Detail	To set whether to display [Pause All Print Jobs] button on the Status Monitor/Cancel screen.	
Use Case	- Upon user's request - When promptly stopping the print job in operation or under reservation	
Adj/Set/Operate Method	1) Enter the setting value, and then press OK key. 2) Turn OFF/ON the main power switch.	
Display/Adj/Set Range	0 to 1 0: OFF, 1: ON	
Default Value	1	
IDPRN-SW	1	Charge target job set of dept mngm cntr
Detail	*Operation on this item is restricted by the setting of [Restrict Service Representation Access]. To set the job type that advances the department management counter.	
Use Case	Upon user's request	
Adj/Set/Operate Method	1) Enter the setting value, and then press OK key. 2) Turn OFF/ON the main power switch.	
Display/Adj/Set Range	0 to 1 0: PRINT category: BoxPrint, ReportPrint, PDLPrint COPY category: COPY 1: PRINT category: ReportPrint, PDLPrint COPY category: COPY, BoxPrint	
Default Value	0	

COPIER (Service mode for printer) > OPTION (Specification setting mode) > USER

PCL-COPY	2	Set of PCL COPIES command control method
Detail		To set the binder control method of COPIES command with PCL. Select whether to use the control method of Canon-made PCL or use the same control method of non-Canon-made PCL.
Use Case		Upon user's request
Adj/Set/Operate Method		1) Enter the setting value, and then press OK key. 2) Turn OFF/ON the main power switch.
Display/Adj/Set Range		0 to 65535 0: Control method of Canon-made PCL (following the value of COPIES command that is specified for each page to control on a page basis) 1: Control method of non-Canon-made PCL (handling the value of COPIES command, which is specified for page 1 at the time of Collate mode, as bind figure while the value of COPIES command for the next page or later is invalid. Same control applies as Canon-made PCL at the time of non-sorted mode) 2 to 65535: For future use
Default Value		0
CNT-SW	1	Set default dspl items on charge counter
Detail		To set default display items of the charge counter on the Counter Check screen. For details of each type, refer to the Service Manual.
Use Case		Upon user's request
Adj/Set/Operate Method		1) Enter the setting value, and then press OK key. 2) Turn OFF/ON the main power switch.
Caution		Do not use this mode overseas (outside Japan).
Display/Adj/Set Range		0 to 2 Typical combinations of locations are shown below. For other combinations, refer to the Service Manual. For Japan 0: Counter 1 - Total 1: 101 1: Counter 1 - Total 2: 102, Counter 2 - Copy (Total 2): 202, Counter 3 - Total A2: 127 2: Not used For UL 0: Counter 1 - Total 1: 101, Counter 2 - Total (Large): 103, Counter 3 - Copy (Total 1): 201, Counter 4 - Copy (Large): 203 1: Counter 1 - Total 2: 102, Counter 2 - Copy (Total 2): 202 2: Not used
Default Value		0
TAB-ACC	1	ON/OFF of auto cst change for tab ppr
Detail		To set to enable/disable auto cassette change when tab paper runs out.
Use Case		Upon user's request
Adj/Set/Operate Method		1) Enter the setting value, and then press OK key. 2) Turn OFF/ON the main power switch.
Caution		Be sure to instruct the user to thoroughly comply the following: - Use tab paper with the same number of tabs. - Set tab paper. Be sure to comply the above; otherwise, proper print is not available and it can cause soil inside the machine because of toner.
Display/Adj/Set Range		0 to 1 0: OFF, 1: ON
Default Value		0

COPIER (Service mode for printer) > OPTION (Specification setting mode) > USER

BCNT-AST	1	Set of box print charge target job
Detail		*Operation on this item is restricted by the setting of [Restrict Service Representation Access]. To set the job type that advances the count in box print with NE Controller (ASSIST).
Use Case		When switching the job type that is subject to counting of the box print with NE Controller
Adj/Set/Operate Method		1) Enter the setting value, and then press OK key. 2) Turn OFF/ON the main power switch.
Display/Adj/Set Range		0 to 1 0: PDL job, 1: Copy job
Default Value		0
PRJOB-CP	2	Set count TX at RX/report print
Detail		To set to enable/disable a page-basis count pulse transmission to the charging management device at the time of reception print or report print.
Use Case		Upon user's request
Adj/Set/Operate Method		1) Enter the setting value, and then press OK key. 2) Turn OFF/ON the main power switch.
Display/Adj/Set Range		0 to 1 0: No transmission, 1: Transmission
Default Value		0
Supplement/Memo		Charging management device: Coin Manager, Non-Canon-made control card
DOC-REM	1	Display/hide of original removal message
Detail		To set whether to display or hide the message to remove original when scanning with DADF without opening/closing DADF after scanning with the Copyboard.
Use Case		Upon user's request
Adj/Set/Operate Method		1) Enter the setting value, and then press OK key. 2) Turn OFF/ON the main power switch.
Display/Adj/Set Range		0 to 1 0: Hide, 1: Display
Default Value		0
DPT-ID-7	2	Password entry set at dept ID reg/auth
Detail		*Operation on this item is restricted by the setting of [Restrict Service Representation Access]. To set whether to require a password entry at the time of registration/authentication of department ID. With the setting to require entry, entry of 7-digit password is required as well as entry of department ID.
Use Case		Upon user's request
Adj/Set/Operate Method		1) Enter the setting value, and then press OK key. 2) Turn OFF/ON the main power switch.
Display/Adj/Set Range		0 to 1 0: Department ID only, 1: 7-digit (password) entry
Default Value		0
RUI-RJT	2	Connct set at invalid auth from remoteUI
Detail		*Operation on this item is restricted by the setting of [Restrict Service Representation Access]. To set to disconnect HTTP port when the machine receives invalid authentication from remote UI 3 times.
Use Case		Upon user's request
Adj/Set/Operate Method		1) Enter the setting value, and then press OK key. 2) Turn OFF/ON the main power switch.
Display/Adj/Set Range		0 to 1 0: Continued connection, 1: Disconnected
Default Value		0

COPIER (Service mode for printer) > OPTION (Specification setting mode) > USER

FREG-SW	2	ON/OFF MEAP counter free reg area dspl
Detail	To set whether to display or hide the free register area of MEAP counter for SEND	
Use Case	At trouble analysis	
Adj/Set/Operate Method	1) Enter the setting value, and then press OK key. 2) Turn OFF/ON the main power switch.	
Caution	Take necessary action in accordance with the instructions from the Quality Support Division.	
Display/Adj/Set Range	0 to 1 0: Hide, 1: Display	
Default Value	0	
Supplement/Memo	Individual count-up (counter advance) of MEAP application is available in the free register area of MEAP counter.	
IFAX-SZL	2	Set of I-Fax transmission size limit
Detail	To set for restricting data size at the time of I-Fax transmission that does not go through the server. With the setting to restrict the data size, it is to be #830 error in the case of sending data that exceeds the upper limit value. In the case that the data goes through the server, the size of transmission data is always restricted.	
Use Case	Upon user's request	
Adj/Set/Operate Method	1) Enter the setting value, and then press OK key. 2) Turn OFF/ON the main power switch.	
Display/Adj/Set Range	0 to 1 0: Limited, 1: Not limited (Restriction applies when data goes through the server.)	
Default Value	1	
Additional Functions Mode	Function Settings> Send> E-Mail/I-Fax Settings> Maximum Data Size for Sending	
Supplement/Memo	Set the upper limit value for transmission data size in Settings/Registration menu.	
IFAX-PGD	2	Set page split TX at IFax Simple mode TX
Detail	To set whether to perform split-data transmission on a page basis in the case that the transmission size in I-Fax Simple mode exceeds the upper limit value.	
Use Case	Upon user's request	
Adj/Set/Operate Method	1) Enter the setting value, and then press OK key. 2) Turn OFF/ON the main power switch.	
Caution	In the case to enable split-data transmission, be sure to get approval from the user by explaining the following: - No guarantee for page order on the reception side - There is a possibility of interruption of other received jobs between pages.	
Display/Adj/Set Range	0 to 1 0: Disabled, 1: Enabled	
Default Value	0	
Additional Functions Mode	Function Settings> Send> E-Mail/I-Fax Settings> Maximum Data Size for Sending	
Supplement/Memo	Set the upper limit value for transmission data size in Settings/Registration menu.	

COPIER (Service mode for printer) > OPTION (Specification setting mode) > USER

MEAPSAFE	2	Setting of MEAP safe mode
Detail	*Operation on this item is restricted by the setting of [Restrict Service Representation Access]. To set safe mode for MEAP platform. MPSF is displayed on the Control Panel in safe mode. In safe mode, MEAP application is stopped while just the system application, which starts with initial state, is activated. Logs for cause analysis of MEAP failure can be obtained.	
Use Case	Perform system recovery processing when MEAP platform fails to be activated due to resource confliction between MEAP applications, service registration or use order.	
Adj/Set/Operate Method	1) Enter the setting value, and then press OK key. 2) Turn OFF/ON the main power switch.	
Display/Adj/Set Range	0 to 1 0: Normal mode, 1: Safe mode	
Default Value	0	
AFN-PSWD	2	Setting of Set/Reg menu access limit
Detail	*Operation on this item is restricted by the setting of [Restrict Service Representation Access]. To set restriction on accessing Settings/Registration menu by entering password. With the setting to enable this mode, password entry of system administrator is required after pressing Settings/Registration key.	
Use Case	Upon user's request	
Adj/Set/Operate Method	1) Enter the setting value, and then press OK key. 2) Turn OFF/ON the main power switch.	
Display/Adj/Set Range	0 to 1 0: Password is not required, 1: Password is required	
Default Value	0	
PTJAM-RC	2	Auto reprint setting at PDL print jam
Detail	To set to automatically restart printing after jam recovery that occurs with PDL print.	
Use Case	Upon user's request	
Adj/Set/Operate Method	1) Enter the setting value, and then press OK key. 2) Turn OFF/ON the main power switch.	
Display/Adj/Set Range	0 to 1 0: Not automatically reprinted, 1: Automatically reprinted	
Default Value	1	
PDL-NCSW	2	Card mngm setting for PDL print job
Detail	*Operation on this item is restricted by the setting of [Restrict Service Representation Access]. To set to make PDL print job to be subject to card management by the Card Reader. With the setting to enable this mode, PDL print is available only when the card ID of the card inserted to the Card Reader matches the department ID.	
Use Case	Upon user's request	
Adj/Set/Operate Method	1) Enter the setting value, and then press OK key. 2) Turn OFF/ON the main power switch.	
Display/Adj/Set Range	0 to 1 0: PDL print is available with no card inserted. 1: PDL print is available only when the card ID matches the department ID in the case that the card is inserted.	
Default Value	0	

COPIER (Service mode for printer) > OPTION (Specification setting mode) > USER

PS-MODE	2	Setting of PS print line drawing
Detail	To set the image processing at PS print. Set 8 when line width differs depending on the drawing position although the same line width is set.	
Use Case	Use case When right and left ruled lines are different in width	
Adj/Set/Operate Method	1) Enter the setting value, and then press OK key. 2) Turn OFF/ON the main power switch.	
Display/Adj/Set Range	0 to 65535 0 to 7: Spare 8: Strokeadjustment is enabled. 9 to 65535: Spare	
Default Value	0	
CNCT-RLZ	2	Setting of connection serialize function
Detail	Connection serialize is a function to assure job grouping function of imageWARE Output Manager Select Edition V1.0. The setting to enable this mode can avoid job rearrangement because the machine does not receive job data from other connection until it completes job data reception from the current connection.	
Use Case	Upon user's request	
Adj/Set/Operate Method	1) Enter the setting value, and then press OK key. 2) Turn OFF/ON the main power switch.	
Display/Adj/Set Range	0 to 1 0: OFF, 1: ON	
Default Value	0	
Supplement/Memo	Connection: Connection to be established through network between multiple hosts (PC, etc). Job grouping function: A function of imageWARE Output Manager Select Edition V1.0. This is to prevent job interruption from other PC by group job (sending multiple jobs in 1 session at job transmission).	
JA-FUNC	2	Display of job archive function ON/OFF
Detail	To display ON/OFF of job archive function. Make the setting with the MEAP program which supports job archiving.	
Use Case	When using the job archive function	
Adj/Set/Operate Method	N/A (Display only)	
Caution	Setting cannot be made with this item.	
Display/Adj/Set Range	0 to 1 0: OFF, 1: ON	
Default Value	0	
JA-JOB	2	Display of job archive target job
Detail	To display the job type subject to job archive. When the job archive function is ON, archive operation is executed when executing the target job. Make the setting with the MEAP program which supports job archiving.	
Use Case	When using the job archive function	
Adj/Set/Operate Method	N/A (Display only)	
Caution	Setting cannot be made with this item.	
Display/Adj/Set Range	0: N/A, 3: Limited to FAX/IFAX, 0xFFFFFFFF: All jobs	
Default Value	0	
Related Service Mode	COPIER> OPTION> USER> JA-FUNC	

COPIER (Service mode for printer) > OPTION (Specification setting mode) > USER

JA-RESTR	2	Display of job archive restriction items
Detail	To display restriction items for job archive specification. When the job archive function is ON, follow the setting to execute operation to restrict specification. Make the setting with the MEAP program which supports job archiving.	
Use Case	When using the job archive function	
Adj/Set/Operate Method	N/A (Display only)	
Caution	Setting cannot be made with this item.	
Display/Adj/Set Range	0 to 1 0: OFF, 1: ON 32 specification restrictions with Bit definition Bit0: Function to obtain image file (0: OFF, 1: ON) Bit1: Function to compose form registration (0: OFF, 1: ON) Bit2: Function to edit document (0: OFF, 1: ON)	
Default Value	0	
Related Service Mode	COPIER> OPTION> USER> JA-FUNC	
LDAP-SW	1	Retrieval condition set for LDAP server
Detail	To set the condition to search e-mail address, etc. from LDAP server.	
Use Case	When specifying condition to search e-mail address, etc. from LDAP server	
Adj/Set/Operate Method	1) Enter the setting value, and then press OK key. 2) Turn OFF/ON the main power switch.	
Display/Adj/Set Range	0 to 5 0: Includes the next, 1: Not include the next, 2: Equivalent to the next, 3: Not equivalent to the next, 4: Starts with the next, 5: Finishes with the next	
Default Value	4	
Supplement/Memo	LDAP (Lightweight Directory Access Protocol): Registering LDAP server enables to search e-mail address, etc. from LDAP server and the result can be registered in the Address Book, etc. Registration is available by the following: Set Destination > Register LDAP Server	
FROM-OF	1	Deletion of mail sender's address
Detail	*Operation on this item is restricted by the setting of [Restrict Service Representation Access]. To set whether to delete the sender's address (From) at the time of e-mail transmission.	
Use Case	Upon user's request	
Adj/Set/Operate Method	1) Enter the setting value, and then press OK key. 2) Turn OFF/ON the main power switch.	
Display/Adj/Set Range	0 to 1 0: Retained, 1: Deleted	
Default Value	0	
FILE-OF	1	Set file transmission to entered address
Detail	*Operation on this item is restricted by the setting of [Restrict Service Representation Access]. To set whether to allow file transmission to a newly entered address. When 1 is set, file transmission is not available by entering the address because "File" is not displayed on the transmission screen. The addresses already registered in the Address Book can be used.	
Use Case	Upon user's request	
Adj/Set/Operate Method	1) Enter the setting value, and then press OK key. 2) Turn OFF/ON the main power switch.	
Caution	To restrict addresses for transmission, be sure to manually delete them because the addresses registered in the Address Book can be used.	
Display/Adj/Set Range	0 to 1 0: Enabled, 1: Disabled	
Default Value	0	

COPIER (Service mode for printer) > OPTION (Specification setting mode) > USER

MAIL-OF	1	Setting of e-mail TX to entered address
Detail		*Operation on this item is restricted by the setting of [Restrict Service Representation Access]. To set whether to allow e-mail transmission to a newly entered address. When 1 is set, e-mail transmission is not available by entering the address because "E-mail" is not displayed on the transmission screen. The addresses already registered in the Address Book can be used.
Use Case		Upon user's request
Adj/Set/Operate Method		1) Enter the setting value, and then press OK key. 2) Turn OFF/ON the main power switch.
Caution		To restrict addresses for transmission, be sure to manually delete them because the addresses registered in the Address Book can be used.
Display/Adj/Set Range		0 to 1 0: Allowed, 1: Prohibited
Default Value		0
IFAX-OF	1	Setting of I-Fax TX to entered address
Detail		* Operation on this item is restricted by the setting of [Restrict Service Representation Access]. To set whether to allow I-Fax transmission to a newly entered address. When 1 is set, I-Fax transmission is not available by entering the address because "I-Fax" is not displayed on the transmission screen. The addresses already registered in the Address Book can be used.
Use Case		Upon user's request
Adj/Set/Operate Method		1) Enter the setting value, and then press OK key. 2) Turn OFF/ON the main power switch.
Caution		To restrict addresses for transmission, be sure to manually delete them because the addresses registered in the Address Book can be used.
Display/Adj/Set Range		0 to 1 0: Enabled, 1: Disabled
Default Value		0
LDAP-DEF	1	Initial condtn set of LDAP server search
Detail		To set initial condition for search target attribute that is specified at the time of LDAP server Details search.
Use Case		Upon user's request
Adj/Set/Operate Method		1) Enter the setting value, and then press OK key. 2) Turn OFF/ON the main power switch.
Display/Adj/Set Range		0 to 6 0: Name, 1: E-mail, 2: FAX, 3: Organization, 4: Organization unit, 5: No registration 1 (any setting), 6: No registration 2 (any setting)
Default Value		0
Related Service Mode		COPIER> OPTION> USER> LDAP-SW

COPIER (Service mode for printer) > OPTION (Specification setting mode) > USER

FREE-DSP	2	ON/OFF of charge disable screen
Detail	To set whether to display or hide the "Use Charge Management" screen for switching between charge and no charge. The hardware switch for switching charge/no charge in the Coin Manager enables the mode in which all the services are available for free (store manager mode) by temporarily canceling the charging system. Even without the hardware switch, the mode can be switched with the software switch when it is set to display the "Use Charge Management" screen in [Settings/Registration].	
Use Case	When enabling all the services to be provided for free by temporarily canceling the charging system	
Adj/Set/Operate Method	1) Enter the setting value, and then press OK key. 2) Turn OFF/ON the main power switch.	
Display/Adj/Set Range	0 to 1 0: Hide, 1: Display	
Default Value	0	
Additional Functions Mode	Management Settings> Charge Management> Use Charge Management	
TNRB-SW	2	Display/hide of Toner Container counter
Detail	To set whether to display the Toner Container counter on the Counter Check screen.	
Use Case	When showing the Toner Container counter to the user	
Adj/Set/Operate Method	1) Enter the setting value, and then press OK key. 2) Turn OFF/ON the main power switch.	
Display/Adj/Set Range	0 to 1 0: Hide, 1: Display	
Default Value	It differs according to the location.	
Supplement/Memo	60s: The number of premature replacements of the Toner Container 70s: The number of installations of a new Toner Container 80s: The number of installations of a new Toner Container + the number of premature replacements 180s: The number of installations of unidentified Toner Container	
DK1-ASST	1	Set of POD Deck Lite Air Heater control
Detail	To set the condition to turn ON the Air Heater at the POD Deck Lite in accordance with media/environment. When the media is switched from non-coated paper to coated paper, pickup operation does not start until the temperature of the Air Heater reaches the specified temperature; thus, waiting time occurs. When 1 is set, the Air Heater is turned ON for coated paper only. When the use environment is near the threshold for turning ON/OFF the Air Heater, switching occurs frequently, which increases the wait time. When 2 is set, the heater is always ON regardless of media and environment.	
Use Case	Upon user's request (to shorten the waiting time)	
Adj/Set/Operate Method	Enter the setting value, and then press OK key.	
Caution	Be sure to get approval from the user in advance by explaining that there is a possibility that transfer performance may decrease in a low humidity environment when 2 is set.	
Display/Adj/Set Range	0 to 2 0: ON/OFF depending on the media/environment condition 1: ON for coated paper only 2: Always ON (No environment/media-dependant)	
Default Value	0	

COPIER (Service mode for printer) > OPTION (Specification setting mode) > USER

USBH-DSP	2	ON/OFF of USB host use display
Detail	To set whether to display "Preferences > External Interface > USB Settings > Use USB Host". By selecting "1: Display", whether to use USB host on USB Settings screen can be selected.	
Use Case	When switching to display or hide "Use USB Host" on USB Settings screen	
Adj/Set/Operate Method	1) Enter the setting value, and then press OK key. 2) Turn OFF/ON the main power switch.	
Display/Adj/Set Range	0 to 1 0: Hide, 1: Display	
Default Value	0	
Additional Functions Mode	Preferences> External Interface> USB Settings> Use USB Host	
USBM-DSP	2	ON/OFF USB ex-mem device MEAP driver use
Detail	To set whether to display [Use MEAP Driver for USB Storage Device] in [Settings/Registration]. When 0 is set, the item is not displayed so that the user administrator cannot change the setting.	
Use Case	When not allowing the user administrator to select whether to use the MEAP driver	
Adj/Set/Operate Method	1) Enter the setting value, and then press OK key. 2) Turn OFF/ON the main power switch.	
Caution	When setting 0, be sure to make the setting after the specified setting is completed.	
Display/Adj/Set Range	0 to 1 0: OFF, 1: ON	
Default Value	1	
Additional Functions Mode	Preferences> External Interface> USB Settings> Use MEAP Driver for USB External Device	
USBI-DSP	2	ON/OFF USB input device MEAP driver use
Detail	To set whether to display [Use MEAP Driver for USB Input Device] in [Settings/Registration]. When 0 is set, the item is not displayed so that the user administrator cannot change the setting.	
Use Case	When not allowing the user administrator to select whether to use the MEAP driver	
Adj/Set/Operate Method	1) Enter the setting value, and then press OK key. 2) Turn OFF/ON the main power switch.	
Caution	When setting 0, be sure to make the setting after the specified setting is completed.	
Display/Adj/Set Range	0 to 1 0: OFF, 1: ON	
Default Value	1	
Additional Functions Mode	Preferences> External Interface> USB Settings> Use MEAP Driver for USB Input Device	
CTCHKDSP	1	Display/hide of counter print
Detail	To set whether to display or hide "Print List" on the Counter Check screen. Model name, model number information, counter check date and counter information can be output as a total count management report.	
Use Case	Upon user's request	
Adj/Set/Operate Method	1) Enter the setting value, and then press OK key. 2) Turn OFF/ON the main power switch.	
Display/Adj/Set Range	0 to 1 0: Hide, 1: Display	
Default Value	1	

COPIER (Service mode for printer) > OPTION (Specification setting mode) > USER

DFLT-ADJ	1	Tgt Auto Adj Gradation initial dspl set
Detail		To set the initial display of the target full adjustment/quick adjustment items on [Auto Adjust Gradation] in [Settings/Registration]. This setting is enabled when EFI Controller is connected or only on the copy model which Adobe PS/PDF is available. When 0 is set, the target adjustment item is not displayed. When 1 to 3 is set, the target adjustment items (Copy/Printer/Both) are displayed and one of them is selected.
Use Case		When switching the initial display at the time of Auto Adjust Gradation
Adj/Set/Operate Method		1) Enter the setting value, and then press OK key. 2) Turn OFF/ON the main power switch.
Display/Adj/Set Range		0 to 3 0: Adjustment item is not displayed. 1: "Copy" in the target adjustment items is selected. 2: "Printer" in the target adjustment items is selected. 3: "Both" in the target adjustment items is selected.
Default Value		0
Additional Functions Mode		Adjustment/Maintenance> Adjust Image Quality> Auto Adjust Gradation
USBR-DSP	2	ON/OFF USB infrared devc MEAP driver use
Detail		To set whether to display "Use MEAP Driver for USB Infrared Device" in [Settings/Registration]. When 1 is set, whether to use MEAP driver can be selected on USB Settings screen.
Use Case		When allowing the user administrator to select whether to use the MEAP driver
Adj/Set/Operate Method		1) Enter the setting value, and then press OK key. 2) Turn OFF/ON the main power switch.
Display/Adj/Set Range		0 to 1 0: OFF, 1: ON
Default Value		0
Additional Functions Mode		Preferences> External Interface> USB Settings> Use MEAP Driver for USB Infrared Device
POL-SCAN	1	ON/OFF Rights Management Server set dspl
Detail		When "1: Display" is set, the Rights Management Server function screen is displayed. While the Rights Management Server function is a standard feature, it is possible to hide if not necessary.
Use Case		Upon user's request
Adj/Set/Operate Method		1) Enter the setting value, and then press OK key. 2) Turn OFF/ON the main power switch.
Display/Adj/Set Range		0 to 1 0: Hide, 1: Display
Default Value		It differs according to the location.

COPIER (Service mode for printer) > OPTION (Specification setting mode) > USER

PH-D-SL2	2	Set halftone process in text/photo mode
Detail	<p>When copying or B&W scanning to Inbox in text/photo mode, halftone processing of the image which reproduces gradation of text and photo judgment areas can be specified with this setting. Set to 1 when jaggy occurs or request to use the same halftoning method (text area) as conventional one is raised.</p> <p>Set to 2 when moire occurs frequently or request to use the same halftoning method as conventional B&W MFP method is raised.</p> <p>Even 0 is set, TBIC is used for text judgment area and low screen ruling for photo judgment area at the time of B&W Inbox scan.</p> <p>The setting is disabled when the B&W Inbox scanning density is set to auto.</p>	
Use Case	<p>- When jaggy occurs on the edge of text or thin lines at copy output. Especially when jaggy occurs in the text or thin lines (text in halftone dots) of the area where gradation in the halftone density is expressed like photo, graphics, etc.</p> <p>- When moire occurs frequently at the time of copy or B&W Inbox scan Especially when moire frequently occurs in the area where gradation in the halftone density is expressed like photo, graphics, etc. and this symptom is not alleviated with PH-D-SEL or sharpness adjustment</p> <p>- When receiving a request to use the same halftoning method (text area) as the conventional one (model with image area separation method) at copy output</p> <p>- When receiving a request to use the same halftoning method (both text and photo areas) as the conventional B&W MFP method at the time of copy or B&W Inbox output</p>	
Adj/Set/Operate Method	<p>1) Enter the setting value, and then press OK key.</p> <p>2) Turn OFF/ON the main power switch.</p>	
Display/Adj/Set Range	<p>0 to 2</p> <p>0: Low screen ruling (134 lines) is used for photo judgment area and high screen ruling (141 lines) for text judgment area.</p> <p>1: Low screen ruling is used for photo judgment area and TBIC for text judgment area.</p> <p>2: TBIC is used for both photo and text judgment areas.</p>	
Default Value	0	
Related Service Mode	COPIER> OPTION> USER> PH-D-SEL	
W-TN-DSP	1	ON/OFF of Wst Toner Cont rplce procedure
Detail	<p>To set whether to display the replacement procedure on the Control Panel when the Waste Toner Container is full.</p> <p>Set 0 when a service technician replaces the Waste Toner Container. In this case, the replacement procedure is not displayed.</p> <p>Set 1 when the user performs the replacement. The animation showing the replacement procedure is displayed.</p>	
Use Case	When the user replaces the Waste Toner Container	
Adj/Set/Operate Method	Enter the setting value, and then press OK key.	
Display/Adj/Set Range	<p>0 to 1</p> <p>0: OFF, 1: ON</p>	
Default Value	0	
SCAN-RSL	2	Setting of scanned image resolution
Detail	To set the resolution of image which is generated by scan processing.	
Use Case	When the scan processing performance with 1200 dpi is low	
Adj/Set/Operate Method	<p>1) Enter the setting value, and then press OK key.</p> <p>2) Turn OFF/ON the main power switch.</p>	
Display/Adj/Set Range	<p>0 to 1</p> <p>0: 600 dpi, 1: 1200 dpi</p>	
Default Value	0	

COPIER (Service mode for printer) > OPTION (Specification setting mode) > USER

JA-SBOX	2	Setting of linking with Advanced Box: SAM
Detail		*Operation on this item is restricted by the setting of [Restrict Service Representation Access]. To set the link with Advanced Box when iW SAM is enabled. When 1 is set, linking with Advanced Box is enabled.
Use Case		When the operation restriction is cleared at the time of iW SAM
Adj/Set/Operate Method		1) Enter the setting value, and then press OK key. 2) Turn OFF/ON the main power switch.
Display/Adj/Set Range		0 to 1 0: Disabled, 1: Enabled
Default Value		0
JA-DFAX	2	Setting of direct fax transmission: SAM
Detail		*Operation on this item is restricted by the setting of [Restrict Service Representation Access]. To set the direct fax transmission when iW SAM is enabled. When 1 is set, the direct fax transmission is enabled.
Use Case		When the operation restriction is cleared at the time of iW SAM
Adj/Set/Operate Method		1) Enter the setting value, and then press OK key. 2) Turn OFF/ON the main power switch.
Display/Adj/Set Range		0 to 1 0: Disabled, 1: Enabled
Default Value		0
JA-REP	2	Setting of TX Report with image: SAM
Detail		*Operation on this item is restricted by the setting of [Restrict Service Representation Access]. To set the TX Report with image when iW SAM is enabled. When 1 is set, the TX Report with image is enabled.
Use Case		When the operation restriction is cleared at the time of iW SAM
Adj/Set/Operate Method		1) Enter the setting value, and then press OK key. 2) Turn OFF/ON the main power switch.
Display/Adj/Set Range		0 to 1 0: Disabled, 1: Enabled
Default Value		0
JA-FREP	2	Setting of Fax TX Report with image: SAM
Detail		*Operation on this item is restricted by the setting of [Restrict Service Representation Access]. To set the Fax TX Report with image when iW SAM is enabled. When 1 is set, the Fax TX Report with image is enabled.
Use Case		When the operation restriction is cleared at the time of iW SAM
Adj/Set/Operate Method		1) Enter the setting value, and then press OK key. 2) Turn OFF/ON the main power switch.
Display/Adj/Set Range		0 to 1 0: Disabled, 1: Enabled
Default Value		0
JA-BOX	2	Setting of Inbox document operation: SAM
Detail		*Operation on this item is restricted by the setting of [Restrict Service Representation Access]. To set the operation for Inbox document at the time of iW SAM When 1 is set, the Inbox document can be operated.
Use Case		When the operation restriction is cleared at the time of iW SAM
Adj/Set/Operate Method		1) Enter the setting value, and then press OK key. 2) Turn OFF/ON the main power switch.
Display/Adj/Set Range		0 to 1 0: Disabled, 1: Enabled
Default Value		0

COPIER (Service mode for printer) > OPTION (Specification setting mode) > USER

JA-FORM	2	Setting of image composition: SAM
Detail		*Operation on this item is restricted by the setting of [Restrict Service Representation Access]. To set the image composition when iW SAM is enabled. When 1 is set, the image composition is enabled.
Use Case		When the operation restriction is cleared at the time of iW SAM
Adj/Set/Operate Method		1) Enter the setting value, and then press OK key. 2) Turn OFF/ON the main power switch.
Display/Adj/Set Range		0 to 1 0: Disabled, 1: Enabled
Default Value		0
JA-PREV	2	Setting of preview page deletion: SAM
Detail		*Operation on this item is restricted by the setting of [Restrict Service Representation Access]. To set whether a page is deleted from the scan preview screen at the time of iW SAM When 1 is set, a page is deleted from the scan preview screen.
Use Case		When the operation restriction is cleared at the time of iW SAM
Adj/Set/Operate Method		1) Enter the setting value, and then press OK key. 2) Turn OFF/ON the main power switch.
Display/Adj/Set Range		0 to 1 0: Disabled, 1: Enabled
Default Value		0
JA-PULL	2	Setting of network scan: SAM
Detail		*Operation on this item is restricted by the setting of [Restrict Service Representation Access]. To set the network scan when iW SAM is enabled. When 1 is set, the network scan is enabled.
Use Case		When the operation restriction is cleared at the time of iW SAM
Adj/Set/Operate Method		1) Enter the setting value, and then press OK key. 2) Turn OFF/ON the main power switch.
Display/Adj/Set Range		0 to 1 0: Disabled, 1: Enabled
Default Value		0
JA-PDLB	2	Set of printer driver multi box save: SAM
Detail		*Operation on this item is restricted by the setting of [Restrict Service Representation Access]. To set whether a document can be simultaneously saved to multiple Inboxes from the printer driver at the time of iW SAM. When 1 is set, a document can be saved to multiple Inboxes from the printer driver.
Use Case		When the operation restriction is cleared at the time of iW SAM
Adj/Set/Operate Method		1) Enter the setting value, and then press OK key. 2) Turn OFF/ON the main power switch.
Display/Adj/Set Range		0 to 1 0: Disabled, 1: Enabled
Default Value		0
JA-JOBK	2	Setting of job merge allowance: SAM
Detail		*Operation on this item is restricted by the setting of [Restrict Service Representation Access]. To set whether merging jobs is allowed when iW SAM is enabled. When 1 is set, jobs can be merged.
Use Case		When the operation restriction is cleared at the time of iW SAM
Adj/Set/Operate Method		1) Enter the setting value, and then press OK key. 2) Turn OFF/ON the main power switch.
Display/Adj/Set Range		0 to 1 0: Disabled, 1: Enabled
Default Value		0

COPIER (Service mode for printer) > OPTION (Specification setting mode) > USER

JA-JDF	2	Setting of JDF: SAM
Detail	*Operation on this item is restricted by the setting of [Restrict Service Representation Access]. To set the use of JDF when iW SAM is enabled. When 1 is set, JDF can be used.	
Use Case	When the operation restriction is cleared at the time of iW SAM	
Adj/Set/Operate Method	1) Enter the setting value, and then press OK key. 2) Turn OFF/ON the main power switch.	
Display/Adj/Set Range	0 to 1 0: Disabled, 1: Enabled	
Default Value	0	
JA-RUI	2	Setting of Inbox document access: SAM
Detail	*Operation on this item is restricted by the setting of [Restrict Service Representation Access]. To set the Inbox document access from remote UI at the time of iW SAM. When 1 is set, accessing to the Inbox document from remote UI is enabled.	
Use Case	When the operation restriction is cleared at the time of iW SAM	
Adj/Set/Operate Method	1) Enter the setting value, and then press OK key. 2) Turn OFF/ON the main power switch.	
Display/Adj/Set Range	0 to 1 0: Disabled, 1: Enabled	
Default Value	0	
JA-WEB	2	Setting of Inbox document upload: SAM
Detail	*Operation on this item is restricted by the setting of [Restrict Service Representation Access]. To set the Inbox document upload with the Web browser at the time of iW SAM. When 1 is set uploading to the Inbox document with the Web Browser is enabled.	
Use Case	When the operation restriction is cleared at the time of iW SAM	
Adj/Set/Operate Method	1) Enter the setting value, and then press OK key. 2) Turn OFF/ON the main power switch.	
Display/Adj/Set Range	0 to 1 0: Disabled, 1: Enabled	
Default Value	0	
EXP-CRYP	1	Confndtial encrypt ON/OFF:add book expprt
Detail	* Operation on this item is restricted by the setting of [Restrict Service Representation Access]. To set whether to encrypt the confidential part (password part) in the Address Book when exporting the address book and device settings via remote UI. When 0 is set, the confidential part in the address book is exported without encryption.	
Use Case	When there is a need to export password without encryption because of operation and tool	
Adj/Set/Operate Method	1) Enter the setting value, and then press OK key. 2) Turn OFF/ON the main power switch.	
Caution	Be sure not to allow the user to execute export without encryption because of security concern.	
Display/Adj/Set Range	0 to 1 0: OFF, 1: ON	
Default Value	1	

COPIER (Service mode for printer) > OPTION (Specification setting mode) > USER

THK1-DSP	1	Prdctvty/align priority set dspl: Fin-X1
Detail		To set whether to display "Finisher Output Priority Settings (Heavy 1-4)" in [Settings/Registration] when the Finisher-X1 is connected.
Use Case		When the user sets productivity/alignment priority of Finisher
Adj/Set/Operate Method		1) Enter the setting value, and then press OK key. 2) Turn OFF/ON the main power switch.
Caution		Be sure to receive approval from the user in advance after explaining that there is a possibility that stacking condition may decrease by giving priority on productivity.
Display/Adj/Set Range		0 to 1 0: OFF, 1: ON
Default Value		0
Related Service Mode		SORTER> OPTION> BUFF-THK
Additional Functions Mode		Adjustment/Maintenance> Adjust Action
SMD-EXPT	1	Setting of export target data: remote UI
Detail		To set whether to export "service mode data" from remote UI. When 1 is set, "service mode data" is displayed as the target data of export on remote UI. When installing more than 1 machine at the same time, the same service mode data can be registered.
Use Case		When installing more than 1 machine at the same time
Adj/Set/Operate Method		1) Enter the setting value, and then press OK key. 2) Turn OFF/ON the main power switch.
Display/Adj/Set Range		0 to 1 0: Hide, 1: Display
Default Value		0
Supplement/Memo		If selecting "service mode data" as the target data of export on remote UI after setting SMD-EXPT to 1, service mode data can be exported.
SNDSTREN	1	Set of setting delete aftr scan and send
Detail		To set whether to delete the transmission settings except for the address after transmission from the "Scan and Send" screen.
Use Case		Upon user's request
Adj/Set/Operate Method		1) Enter the setting value, and then press OK key. 2) Turn OFF/ON the main power switch.
Display/Adj/Set Range		0 to 5 0: Deleted 1: Retained only the transmission setting 2: Retained the transmission setting and address * 3: Retained only address * 4: Retained the transmission setting and address 5: Retained only address * The setting for Options > Job Done Notice > Attach TX Image is not retained.
Default Value		It differs according to the location.

COPIER (Service mode for printer) > OPTION (Specification setting mode) > USER

FAXSTREN	1	Set of setting delete aftr fax transmit
Detail		To set whether to delete the transmission settings except for the address after transmission from the "Fax" screen.
Use Case		Upon user's request
Adj/Set/Operate Method		1) Enter the setting value, and then press OK key. 2) Turn OFF/ON the main power switch.
Display/Adj/Set Range		0 to 2 0: Delete 1: Retain * 2: Retain * The setting for Options > Job Done Notice > Attach TX Image is not retained.
Default Value		It differs according to the location.
SJ-UNMSK	2	ON/OFF secured job masking cancellation
Detail		*Operation on this item is restricted by the setting of [Restrict Service Representation Access]. To set whether to mask other people's secured jobs. When 0 is set, operation of other people's secured jobs is not possible because they are masked. When COIN is set to 6 or 7 (charge mode: Type-C), set 1. Masking is canceled and other people's secured jobs can be operated. It is enabled at MEAP authentication.
Use Case		When operating secured jobs in charge mode Type-C
Adj/Set/Operate Method		1) Enter the setting value, and then press OK key. 2) Turn OFF/ON the main power switch.
Display/Adj/Set Range		0 to 1 0: OFF (Masking enabled), 1: ON (Masking canceled)
Default Value		0
Related Service Mode		COPIER> OPTION> ACC> COIN
SJ-CLMSK	2	ON/OFF secured job stop button display
Detail		*Operation on this item is restricted by the setting of [Restrict Service Representation Access]. To set whether to display the button to stop a secured job. When 0 is set, the stop button is displayed. When COIN is set to 6 or 7 (charge mode: Type-C), set 1. Since the stop button is not displayed, the secured job cannot be stopped.
Use Case		When prohibiting to stop the secured job in charge mode Type-C
Adj/Set/Operate Method		1) Enter the setting value, and then press OK key. 2) Turn OFF/ON the main power switch.
Display/Adj/Set Range		0 to 1 0: OFF (Display), 1: ON (Hide)
Default Value		0
Related Service Mode		COPIER> OPTION> ACC> COIN
PRTDP-SW	1	Set delivery side for 1-page job:2-sided
Detail		To set whether to deliver paper face-up or face-down when printing only 1 page although 2-sided print is set. When 0 is set, paper is delivered face-down like 1-sided job. (Paper does not pass through the Duplex Path.) When 1 is set, paper is delivered face-up via the Duplex Path. Paper feed distance becomes longer so productivity is decreased.
Use Case		When changing the delivery side of 1-page print although 2-sided print is set
Adj/Set/Operate Method		1) Enter the setting value, and then press OK key. 2) Turn OFF/ON the main power switch.
Display/Adj/Set Range		0 to 1 0: Face-down delivery, 1: Face-up delivery
Default Value		0

COPIER (Service mode for printer) > OPTION (Specification setting mode) > USER

PDFD-MSW	2	Set output paper size: direct print PDF
Detail	To set output paper size at direct print PDF. Usually, the region defined by MediaBox is output. However, in some cases, the region defined (trimmed) by CropBox is judged as output paper size depending on PDF file. Set 1 when output result differs from what is defined at direct print PDF.	
Use Case	When preferring to output a PDF file with paper which size is defined by CropBox while the sizes of MediaBox and CropBox are different	
Adj/Set/Operate Method	Enter the setting value, and then press OK key.	
Display/Adj/Set Range	0 to 1 0: MediaBox (Normal), 1: CropBox	
Default Value	0	
SFT-OUT	2	Setting of offset priority delivery
Detail	To set whether to deliver a job where offset and collate/offset group is set to the delivery destination with offset function. When 0 is set, a job is delivered to the delivery destination set in [Settings/Registration] even though the offset function is not available. When 1 is set, a job is delivered to the delivery destination with offset function even though a delivery destination without offset function is set in [Settings/Registration].	
Use Case	When preferring to deliver a job to the delivery destination with offset function	
Adj/Set/Operate Method	1) Enter the setting value, and then press OK key. 2) Turn OFF/ON the main power switch.	
Display/Adj/Set Range	0 to 1 0: Based on Output Tray Settings, 1: Priority on job settings (deliver to a delivery destination where offset is possible)	
Default Value	1	
Additional Functions Mode	Function Settings> Common> Paper Output Settings> Output Tray Settings	
LGCY-SCP	2	Setting of PPA/secured print switch
Detail	*Operation on this item is restricted by the setting of [Restrict Service Representation Access]. To set whether to use the PPA function or the conventional secured print function. Set 0 when using the PPA function. The conventional secured print function is disabled. Set 1 when using the conventional secured print function (when the EFI Controller is connected, etc.). The PPA function is disabled. When IMG-CONT is set to 3 or 4 for connecting the EFI Controller, the setting of this item becomes 1. When this item is set to 0, the setting of UI-PPA becomes 1. When this item is set to 1, the setting of UI-PPA becomes 0.	
Use Case	When using the conventional secured print function (when the EFI Controller is connected, etc.)	
Adj/Set/Operate Method	1) Enter the setting value, and then press OK key. 2) Turn OFF/ON the main power switch.	
Caution	The PPA function cannot be used when the EFI Controller is connected.	
Display/Adj/Set Range	0 to 1 0: Use the PPA function, 1: Use the conventional secured print function	
Default Value	0	
Related Service Mode	COPIER> OPTION> DSPLY-SW> UI-PPA COPIER> OPTION> INT-FACE> IMG-CONT	
Supplement/Memo	PPA (Personal Print Application): A function to hold print job. It contains the function of secured print.	

COPIER (Service mode for printer) > OPTION (Specification setting mode) > USER

FLM-DSPL	2	ON/OFF of Clear Film usage
Detail	To set whether to use the Clear Film. When 1 is set, "Clear Film" is displayed on the paper type screen so it can be registered as the paper to be used.	
Use Case	When using large size transparency or special film	
Adj/Set/Operate Method	1) Enter the setting value, and then press OK key. 2) Turn OFF/ON the main power switch.	
Caution	- Since the clear film is not defined in the specifications, image quality is not guaranteed even though it can be fed. - After the setting is made, check image quality and get approval from the user. If there is an error, set the value back to 0.	
Display/Adj/Set Range	0 to 1 0: OFF, 1: ON	
Default Value	0	
Additional Functions Mode	Preferences> Paper Settings> Paper Settings> Set > Detailed Settings > Clear Film	
CNT-PRT	2	ON/OFF of parts counter report output
Detail	To set whether to print parts counter values on the counter report.	
Use Case	When grasping the estimated life of parts while the monitoring service function is not used	
Adj/Set/Operate Method	1) Enter the setting value, and then press OK key. 2) Turn OFF/ON the main power switch.	
Display/Adj/Set Range	0 to 1 0: OFF (Not print), 1: ON (Print)	
Default Value	It differs according to the location.	
Additional Functions Mode	Check Counter> Print List	
JA-WIFI	2	Setting of SAM Wi-Fi direct print
Detail	*Operation on this item is restricted by the setting of [Restrict Service Representation Access]. To set whether to allow Wi-Fi direct print when iW SAM is enabled. Wi-Fi direct print cannot be used when iW SAM is enabled. However, when 1 is set, it can be used.	
Use Case	When the operation restriction is cleared at the time of iW SAM	
Adj/Set/Operate Method	1) Enter the setting value, and then press OK key. 2) Turn OFF/ON the main power switch.	
Display/Adj/Set Range	0 to 1 0: Disabled, 1: Enabled	
Default Value	0	
C-P-SIZE	2	[For customization]
MF-FEED	1	Manual restart w/OK key: no ppr on MP Tr
Detail	If the following three conditions are satisfied, pickup is not restarted automatically when placing paper on the Multi-purpose Tray. 1. The setting of "Preferences> Paper Settings> Multi-Purpose Tray Defaults" is "Fixed". 2. The job type is PDL. 3. The setting value of this service mode is 1. 4. Paper is placed at occurrence of no paper on the Multi-Purpose Tray.	
Use Case	Upon user's request. Use this item for customization for Aeon during application of service mode.	
Adj/Set/Operate Method	Enter the setting value, and then press OK key.	
Display/Adj/Set Range	0 to 1 0: OFF, 1: ON	
Default Value	0	
Additional Functions Mode	Preferences> Paper Settings> Multi-Purpose Tray Defaults	

COPIER (Service mode for printer) > OPTION (Specification setting mode) > USER

INSTDT-Y	1	Register installation date info: year
Detail		To set the information on the installation date (year).
Use Case		- At installation - When replacing the HDD
Adj/Set/Operate Method		Enter the setting value, and then press OK key.
Display/Adj/Set Range		0 to 2038
Default Value		0
Related Service Mode		COPIER>FUNCTION>INSTALL>INSTDTST
INSTDT-M	1	Register installation date info: month
Detail		To set the information on the installation date (month).
Use Case		- At installation - When replacing the HDD
Adj/Set/Operate Method		Enter the setting value, and then press OK key.
Display/Adj/Set Range		0 to 12
Default Value		0
Related Service Mode		COPIER>FUNCTION>INSTALL>INSTDTST
INSTDT-D	1	Register installation date info: day
Detail		To set the information on the installation date (day).
Use Case		- At installation - When replacing the HDD
Adj/Set/Operate Method		Enter the setting value, and then press OK key.
Display/Adj/Set Range		0 to 31
Default Value		0
Related Service Mode		COPIER>FUNCTION>INSTALL>INSTDTST
INSTDT-H	1	Register installation date info: hour
Detail		To set the information on the installation date (hour).
Use Case		- At installation - When replacing the HDD
Adj/Set/Operate Method		Enter the setting value, and then press OK key.
Display/Adj/Set Range		0 to 23
Default Value		0
Related Service Mode		COPIER>FUNCTION>INSTALL>INSTDTST
INSTDT-N	1	Register installation date info: minute
Detail		To set the information on the installation date (minute).
Use Case		- At installation - When replacing the HDD
Adj/Set/Operate Method		Enter the setting value, and then press OK key.
Display/Adj/Set Range		0 to 59
Default Value		0
Related Service Mode		COPIER>FUNCTION>INSTALL>INSTDTST

COPIER (Service mode for printer) > OPTION (Specification setting mode) > USER

STOP-USE	1	ON/OFF of Stop key function
Detail		To switch ON and OFF of the Stop key function. When Stop key is pressed, all print jobs are paused.
Use Case		When switching to use/not use Stop key according to the customer
Adj/Set/Operate Method		1) Enter the setting value, and then press OK key. 2) Turn OFF/ON the main power switch.
Caution		Be sure to explain to the customer in advance that all print jobs are paused when Stop key is pressed.
Display/Adj/Set Range		0 to 1 0: OFF, 1: ON
Default Value		1
LASTREST	1	Set remaining consumables display specs
Detail		To switch the percentage of increments in which the remaining level of consumables is shown at their near end.
Use Case		When the remaining level of toner or waste toner is suddenly displayed as 0%
Adj/Set/Operate Method		1) Enter the setting value, and then press OK key. 2) Turn ON/OFF the Main Power.
Caution		The default value is properly set according to the country and the model, and thus should not be normally changed unless requested.
Display/Adj/Set Range		0 to 1 0: 5%, 1: 1%
Default Value		The value differs according to the location.
Additional Functions Mode		Status Monitor/Cancel > Consmbpls./Others > Consumables
SZCHKSW	2	For R&D
PP-DFTSW	1	Chg the default settings for a pln ppr
Detail		Set the default settings for a plain paper when setting changes to the plain paper either 1 or 2 or 3.
Use Case		In case the default for a plain paper is needed to be changed to a value other than the machine setting value.
Adj/Set/Operate Method		1) Enter the setting value, and then press OK key. 2) Turn OFF/ON the main power switch.
Caution		Inputting for all destination is possible on display, however, it activates for China only.
Display/Adj/Set Range		0 - 3 0:Default 1:Plain Paper 1 2:Plain Paper 2 3:Plain Paper 3
Default Value		0

■ CST

COPIER (Service mode for printer) > OPTION (Specification setting mode) > CST

P-SZ-C1	1	Setting of Right Deck paper size
Detail		To set the paper size used in the Right Deck.
Use Case		Upon user's request
Adj/Set/Operate Method		Enter the setting value, and then press OK key.
Caution		Be sure to match with the hardware setting size.
Display/Adj/Set Range		0 to 2 0: A4, 1: B5, 2: LTR
Default Value		0

COPIER (Service mode for printer) > OPTION (Specification setting mode) > CST

P-SZ-C2	1	Setting of Left Deck paper size
Detail		To set the paper size used in the Left Deck.
Use Case		Upon user's request
Adj/Set/Operate Method		Enter the setting value, and then press OK key.
Caution		Be sure to match with the hardware setting size.
Display/Adj/Set Range		0 to 2 0: A4, 1: B5, 2: LTR
Default Value		0

■ ACC

COPIER (Service mode for printer) > OPTION (Specification setting mode) > ACC

COIN	1	Setting of charge management
Detail		*Operation on this item is restricted by the setting of [Restrict Service Representation Access]. To set charging management method.
Use Case		At installation of Coin Manager
Adj/Set/Operate Method		1) Enter the setting value, and then press OK key. 2) Turn OFF/ON the main power switch.
Caution		Following items are automatically specified when changing the value to 3 (from 0 to 2). The change will not be returned even if changing back the value to 0 to 2 (from 3) once the mode has been changed. - COPIER> OPTION> USER> CONTROL=1 - COPIER> OPTION> NETWORK> DA-CNCT=1 - COPIER> OPTION> DSPLY-SW> UI-BOX, UI-SEND, UI-FAX=0 - Function Settings > Send > E-Mail/I-Fax Settings > Communication Settings > SMTP Receive, POP=OFF - Preferences> Network > TCP/IP Settings > DNS Settings > FTP Print Settings > Use FTP Printing=OFF - Preferences> Network > TCP/IP Settings > DNS Settings > IPP Print Settings > Use IPP Printing=ON
Display/Adj/Set Range		0 to 7 0: No charge 1: Charge with Coin Manager 2: Charge with remote counter 3: Charge with DA (only in Japan) 4: Charge with this machine itself 5: Not used 6: External charge mode 6 7: External charge mode 7
Default Value		0
Related Service Mode		COPIER> OPTION> USER> CONTROL COPIER> OPTION> FNC-SW> DA-CNCT COPIER> OPTION> DSPLY-SW> UI-BOX, UI-SEND, UI-FAX COPIER> OPTION> ACC> PDL-THR
Additional Functions Mode		Function Settings> Send> E-Mail/I-Fax Settings> Communication Settings Preferences> Network> TCP/IP Settings> DNS Settings> FTP Print Settings, IPP Print Settings
Supplement/Memo		Control card can be used with "No charge". DA: Digital Accessory
DK-P	1	Setting of Paper Deck paper size
Detail		To set the paper size used in the Paper Deck.
Adj/Set/Operate Method		Enter the setting value, and then press OK key.
Display/Adj/Set Range		0 to 2 0: A4, 1: B5, 2: LTR
Default Value		It differs according to the location.

COPIER (Service mode for printer) > OPTION (Specification setting mode) > ACC

CARD-SW	1	Screen set when Coin Manager connected
Detail		To set coin or card that the user is urged to insert on the Control Panel when the Coin Manager is connected.
Use Case		Upon user's request
Adj/Set/Operate Method		Enter the setting value, and then press OK key.
Display/Adj/Set Range		0 to 3 0: Card, 1: certification by external device, 2: Coin and card, 3: Card
CC-SPSW	2	Support setting of control card I/F
Detail		To set support level for control card (CCIV/CCV) interface.
Use Case		Upon user's request (when connecting to the external counter management system using the control card interface)
Adj/Set/Operate Method		1) Enter the setting value, and then press OK key. 2) Turn OFF/ON the main power switch.
Display/Adj/Set Range		0 to 1 0: No support, 1: Support
Default Value		0
UNIT-PRC	2	Setting of Coin Manager currency unit
Detail		To set currency unit to be handled with Coin Manager
Use Case		At installation of Coin Manager
Adj/Set/Operate Method		1) Enter the setting value, and then press OK key. 2) Turn OFF/ON the main power switch.
Display/Adj/Set Range		0 to 6 0: Japanese yen, 1: Euro, 2: Pound, 3: Swiss Franc, 4: Dollar, 5: No currency unit (no fractional unit), 6: No currency unit (with fractional unit)
Default Value		0
MIN-PRC	1	Set of Coin Manager minimum price
Detail		To set the minimum amount to be handled with Coin Manager. Enter 10 when specifying 10 Japanese yen as the minimum amount to be handled with the Coin Manager that supports Japanese yen. In the case to specify 1 to 4 (Euro/Pound/Swiss Franc/Dollar) by going through the following: COPIER> OPTION> ACC > UNIT-PRC, entry is in fractional unit. Entry of 50 indicates 50 cents (\$ 0.50).
Use Case		At installation of Coin Manager
Adj/Set/Operate Method		1) Enter the setting value, and then press OK key. 2) Turn OFF/ON the main power switch.
Caution		This mode is enabled when selecting 4 for the following: COPIER> OPTION> ACC> COIN.
Display/Adj/Set Range		0 to 9999
Default Value		10
Related Service Mode		COPIER> OPTION> ACC> COIN, UNIT-PRC
Supplement/Memo		When a value smaller than the minimum amount is entered in Settings/Registration menu as the charging amount, it causes an error.

COPIER (Service mode for printer) > OPTION (Specification setting mode) > ACC

MAX-PRC	1	Set of Coin Manager maximum price
Detail		To set the maximum amount to be handled with Coin Manager. Enter 8800 when specifying 8800 Japanese yen as the maximum amount to be handled with the Coin Manager that supports Japanese yen.
Use Case		At installation of Coin Manager
Adj/Set/Operate Method		1) Enter the setting value, and then press OK key. 2) Turn OFF/ON the main power switch.
Caution		This mode is enabled when selecting 4 for the following: COPIER> OPTION> ACC> COIN.
Display/Adj/Set Range		0 to 9999
Default Value		8800
Related Service Mode		COPIER> OPTION> ACC> COIN, UNIT-PRC
Supplement/Memo		When a value larger than the maximum amount is entered in Settings/Registration menu as the charging amount, it causes an error.
MIC-TUN	1	Manual adj of voice recognize microphone
Detail		To manually adjust the voice receiving level (sensitivity) of the connected voice recognition microphone. Microphone sensitivity is automatically tuned in [Settings/Registration]; however, adjust it manually as needed.
Use Case		When the sensitivity of microphone is not improved by auto tuning
Adj/Set/Operate Method		1) Enter the setting value, and then press OK key. 2) Turn OFF/ON the main power switch.
Display/Adj/Set Range		0 to 255
Default Value		128
Additional Functions Mode		Preferences> Accessibility> Voice Navigation Settings> Tune Microphone
SRL-SPSW	1	Setting of Serial I/F Kit support
Detail		To set the support level of the Serial Interface Kit. To keep processing performance of printer engine, select "1: Priority on speed". To correctly stop the output by the upper limit number of sheets, select "2: Priority on upper limit number of sheets".
Use Case		At installation of Serial Interface Kit
Adj/Set/Operate Method		1) Enter the setting value, and then press OK key. 2) Turn OFF/ON the main power switch.
Caution		With priority on speed, output cannot be correctly stopped by the upper limit number of sheets. With priority on the upper limit number of sheets, processing performance of the printer engine is decreased depending on pickup location.
Display/Adj/Set Range		0 to 2 0: No support, 1: Priority on speed, 2: Priority on upper limit number of sheets
Default Value		0
PDL-THR	2	ON/OFF PDL print: external charge mode
Detail		*Operation on this item is restricted by the setting of [Restrict Service Representation Access]. To set whether to execute normal PDL print when COIN is set to external charge mode 6/7.
Use Case		When executing normal PDL print in external charge mode
Adj/Set/Operate Method		1) Enter the setting value, and then press OK key. 2) Turn OFF/ON the main power switch.
Display/Adj/Set Range		0 to 1 0: OFF, 1: ON
Default Value		0
Related Service Mode		COPIER> OPTION> ACC> COIN

COPIER (Service mode for printer) > OPTION (Specification setting mode) > ACC

CR-TYPE	1	Setting of Card Reader
Detail	To set the model of the Card Reader. Set 1 in the case of connecting the Card Reader-C1. It operates even 0 is set, but recognition rate decreases.	
Use Case	When connecting the Card Reader-C1	
Adj/Set/Operate Method	1) Enter the setting value, and then press OK key. 2) Turn OFF/ON the main power switch.	
Display/Adj/Set Range	0 to 1 0: Card Reader-F1, 1: Card Reader-C1	
Default Value	0	
MEAP-SRL	1	Set to allow serial comctn from MEAP app
Detail	*Operation on this item is restricted by the setting of [Restrict Service Representation Access]. To set whether to allow serial communication of MEAP application. When 1 is set, serial communication of the machine is stopped and only the serial communication with MEAP application is available.	
Use Case	When performing serial communication from MEAP application	
Adj/Set/Operate Method	1) Enter the setting value, and then press OK key. 2) Turn OFF/ON the main power switch.	
Display/Adj/Set Range	0 to 1 0: Prohibited, 1: Allowed	
Default Value	0	
CV-CSZ	1	Set outpt info notice:chg w/device alone
Detail	To set whether to notify the Coin Manager of color mode and paper size at the time of charging with a device alone.	
Use Case	When Coin Manager (CV3) is connected	
Adj/Set/Operate Method	Enter the setting value, and then press OK key.	
Caution	Set 0 when a coin manager other than CV3 is connected. When 1 is set, an error occurs.	
Display/Adj/Set Range	0 to 1 0: OFF, 1: ON	
Default Value	0	
COIN-AUT	1	ON/OFF of charge/no charge mixed setting
Detail	* Operation on this item is restricted by the setting of [Restrict Service Representation Access]. To set whether to switch charge/no charge according to the authentication setting in an environment where both charged and no charged users exist. When this item is set to 1 while the setting value of COIN is 4, the initial screen where the user can select charge/no charge can be set. Selecting "Charge" on the initial screen displays the copy screen, and selecting "No Charge" displays the main menu after authentication.	
Use Case	At installation of Coin Manager	
Adj/Set/Operate Method	1) Enter the setting value, and then press OK key. 2) Turn OFF/ON the main power switch.	
Caution	When setting 1, be sure to set COIN to 4 in advance. If COIN-AUT is set first, it is necessary to make the settings in the following order again: COIN and then COIN-AUT.	
Display/Adj/Set Range	0 to 1 0: OFF, 1: ON	
Default Value	0	
Related Service Mode	COPIER> OPTION> ACC> COIN COPIER> OPTION> DSPLY-SW> UI-BOX/SEND/FAX	
Additional Functions Mode	Preferences > Display Settings > Default Screen after Startup/Restoration	

■ INT-FACE

COPIER (Service mode for printer) > OPTION (Specification setting mode) > INT-FACE

IMG-CONT	1	Connection setting of print server
Detail	To set connection with print server. When Secure print is set to 3 or 4, Conventional secured print function becomes effective(LGCY-SCP becomes 1). When Conventional secured print function becomes effective, Forced Hold Printing becomes invalid(UI-PPA become 0). If IMG-CONT is changed back from 3 or 4 to 0, LGCY-SCP do not link with each other.	
Use Case	At installation/Removal	
Adj/Set/Operate Method	1) Enter the setting value, and then press OK key. 2) Turn OFF/ON the main power switch.	
Display/Adj/Set Range	0 to 4 0: Print server not yet connected (normal), 1, 2: Not used, 3: Print server (color machine) connected, 4: Print server (B&W machine) connected	
Default Value	0	
Related Service Mode	COPIER> OPTION> USER> LGCY-SCP COPIER> OPTION> DSPLY-SW> UI-PPA	
Supplement/Memo	PPA (Personal Print Application): A function to Forced Hold Printing. It contains the function of secured print.	
NWCT-TM	2	Timeout setting of network connection
Detail	*Operation on this item is restricted by the setting of [Restrict Service Representation Access]. To set the time to keep network connection between this machine and the PC application (keep-alive setting). As the value is incremented by 1, the time is increased by 1 minute.	
Adj/Set/Operate Method	1) Enter the setting value, and then press OK key. 2) Turn OFF/ON the main power switch.	
Display/Adj/Set Range	1 to 5	
Unit	min	
Default Value	5	
Supplement/Memo	Expected PC application: Network print application, E-mail function, cascade copy, MEAP network application, etc.	
CNT-TYPE	1	Display of print server ID
Detail	To display the ID of the print server being recognized by the machine.	
Use Case	At installation of print server	
Adj/Set/Operate Method	N/A (Display only)	
Display/Adj/Set Range	1 to 999 1: Not yet connected, 400 to 499: EFI print server, 600 to 699: Creo print server, 700 to 799: Oce print server	
Default Value	1	
VTRNS-TO	2	For R&D
Amount of Change per Unit	1	

COPIER (Service mode for printer) > OPTION (Specification setting mode) > INT-FACE

ERRHNDL	2	Set PS Cont-related error recover proc
Detail		To set the recovery process of the host machine and the PS Controller when a PS Controller-related error occurs. When 0 is set, print server error (E677-0080) is displayed on the Control Panel of the host machine. When 1 is set, the host machine automatically executes recovery process. Print server error is not displayed and received jobs are canceled. The PS Controller is automatically rebooted. This setting is enabled only when the PS Controller is connected.
Use Case		Upon user's request (automatic recovery at occurrence of E677-0080)
Adj/Set/Operate Method		1) Enter the setting value, and then press OK key. 2) Turn OFF/ON the main power switch.
Caution		Be sure to get approval from the user in advance by telling that jobs received by the host machine are canceled when a PS Controller-related error occurs so missing of jobs or pages may occur.
Display/Adj/Set Range		0 to 9 0: Display the error only 1: Cancel the received jobs and the PS Controller is rebooted 2 to 9: Not used
Default Value		0
Supplement/Memo		Even if 1 is set, E677-0080 is displayed if automatic recovery fails.

■ TEMPO

COPIER (Service mode for printer) > OPTION (Specification setting mode) > TEMPO

F-POT-SW	2	Setting at Potential Sensor failure
Detail		To set the control at the Potential Sensor failure. If the potential control, D-max control, etc. are executed at the Potential Sensor failure, an image failure or error occurs. When 0 is set, the potential control and D-max become OFF, so the device can be run temporarily although the Potential Sensor failure occurs. Use the item as a temporary measure when it takes time until replacing the Potential Sensor.
Use Case		When replacing the Potential Sensor
Adj/Set/Operate Method		1) Enter the setting value, and then press OK key. 2) Turn OFF/ON the main power switch.
Caution		Be sure to set the value back to 1 (ON) after replacing.
Display/Adj/Set Range		0 to 1 0: OFF, 1: ON
Default Value		0
Related Service Mode		COPIER> OPTION> FNC-SW> PO-CNT
F-HUM-SW	2	ON/OFF of humidity manual entry
Detail		To set whether to enable F-HUM-D setting when an error (failure) in the Environment Sensor occurs. When 1 is set, the F-HUM-D setting is enabled. Use the item as a temporary measure until replacing the Environment Sensor.
Use Case		When an error (failure) in the Environment Sensor occurs
Adj/Set/Operate Method		Enter the setting value, and then press OK key.
Display/Adj/Set Range		0 to 1 0: OFF, 1: ON
Default Value		0
Related Service Mode		COPIER> OPTION> TEMPO> F-HUM-D

COPIER (Service mode for printer) > OPTION (Specification setting mode) > TEMPO

F-HUM-D	2	Manual entry of humidity
Detail		Enter the humidity at the installation location manually when an error in the Environment Sensor occurs. When F-HUM-SW is 1, this setting is enabled.
Adj/Set/Operate Method		Enter the setting value, and then press OK key.
Display/Adj/Set Range		30 to 99
Unit		%
Default Value		35
Related Service Mode		COPIER> OPTION> TEMPO> F-HUM-SW
Amount of Change per Unit		1

■ LCNS-TR

COPIER (Service mode for printer) > OPTION (Specification setting mode) > LCNS-TR

ST-SEND	2	Installation state dspl of SEND function
Detail		To display installation state of SEND function when disabling and then transferring the license.
Use Case		When checking whether SEND function is installed
Adj/Set/Operate Method		1) Select ST-SEND. 2) Enter 0, and then press OK key. When installation has been completed, the transfer license key is displayed under TR-SEND.
Display/Adj/Set Range		When operation finished normally: OK!
Default Value		According to the setting at shipment
TR-SEND	2	Trns license key dspl of SEND function
Detail		To display transfer license key to use SEND function when disabling and then transferring the license.
Use Case		- When replacing HDD - When replacing the device
Adj/Set/Operate Method		1) Select ST-SEND. 2) Enter 0, and then press OK key. The transfer license key is displayed under TR-SEND.
Display/Adj/Set Range		24 digits
ST-ENPDF	2	Install state dspl of Encryption PDF
Detail		To display installation state of encrypted PDF transmission function when disabling and then transferring the license.
Use Case		When checking whether Encryption PDF is installed
Adj/Set/Operate Method		1) Select ST-ENPDF. 2) Enter 0, and then press OK key. When installation has been completed, the transfer license key is displayed under TR-ENPDF.
Display/Adj/Set Range		When operation finished normally: OK!
Default Value		According to the setting at shipment
TR-ENPDF	2	Trns license key dspl of Encryption PDF
Detail		To display transfer license key to use Encryption PDF when disabling and then transferring the license.
Use Case		- When replacing HDD - When replacing the device
Adj/Set/Operate Method		1) Select ST-ENPDF. 2) Enter 0, and then press OK key. The transfer license key is displayed under TR-ENPDF.
Caution		This mode is enabled when SEND function is installed.
Display/Adj/Set Range		24 digits

COPIER (Service mode for printer) > OPTION (Specification setting mode) > LCNS-TR

ST-SPDF	2	Install state dspl of Searchable PDF
Detail		To display installation state of Searchable PDF when disabling and then transferring the license.
Use Case		When checking whether Searchable PDF is installed
Adj/Set/Operate Method		1) Select ST-SPDF. 2) Enter 0, and then press OK key. When installation has been completed, the transfer license key is displayed under TR-SPDF.
Display/Adj/Set Range		When operation finished normally: OK!
Default Value		According to the setting at shipment
TR-SPDF	2	Trns license key dspl of Searchable PDF
Detail		To display transfer license key to use Searchable PDF when disabling and then transferring the license.
Use Case		- When replacing HDD - When replacing the device
Adj/Set/Operate Method		1) Select ST-SPDF. 2) Enter 0, and then press OK key. The transfer license key is displayed under TR-SPDF.
Caution		This mode is enabled when SEND function is installed.
Display/Adj/Set Range		24 digits
ST-EXPDF	2	Instal state of Encry PDF + Searchbl PDF
Detail		To display installation state of encrypted PDF + searchable PDF when disabling and then transferring the license.
Use Case		When checking whether Encryption PDF + Searchable PDF is installed
Adj/Set/Operate Method		1) Select ST-EXPDF. 2) Enter 0, and then press OK key. When installation has been completed, the transfer license key is displayed under TR-EXPDF.
Display/Adj/Set Range		When operation finished normally: OK!
Default Value		According to the setting at shipment
TR-EXPDF	2	Trns lcns key of Encry PDF+Searchbl PDF
Detail		To display transfer license key to use Encryption PDF + Searchable PDF when disabling and then transferring the license.
Use Case		- When replacing HDD - When replacing the device
Adj/Set/Operate Method		1) Select ST-EXPDF. 2) Enter 0, and then press OK key. The transfer license key is displayed under TR-EXPDF.
Caution		This mode is enabled when SEND function is installed for Japan.
Display/Adj/Set Range		24 digits
ST-PDFDR	2	Install state dspl of Direct Print PDF
Detail		To display installation state of Direct Print PDF when disabling and then transferring the license.
Use Case		When checking whether Direct Print PDF is installed
Adj/Set/Operate Method		1) Select ST-PDFDR. 2) Enter 0, and then press OK key. When installation has been completed, the transfer license key is displayed under TR-PDFDR.
Display/Adj/Set Range		When operation finished normally: OK!
Default Value		According to the setting at shipment

COPIER (Service mode for printer) > OPTION (Specification setting mode) > LCNS-TR

TR-PDFDR	2	Trns lcns key dspl of Direct Print PDF
Detail		To display transfer license key to use Direct Print PDF when disabling and then transferring the license.
Use Case		- When replacing HDD - When replacing the device
Adj/Set/Operate Method		1) Select ST-PDFDR. 2) Enter 0, and then press OK key. The transfer license key is displayed under TR-PDFDR.
Display/Adj/Set Range		24 digits
ST-SCR	2	Install state dspl of Encry Secure Print
Detail		To display installation state of Encrypted Secure Print when disabling and then transferring the license.
Use Case		When checking whether Encrypted Secure Print is installed
Adj/Set/Operate Method		1) Select ST-SCR. 2) Enter 0, and then press OK key. When installation has been completed, the transfer license key is displayed under TR-SCR.
Display/Adj/Set Range		When operation finished normally: OK!
Default Value		According to the setting at shipment
TR-SCR	2	Trns license key dspl: Encry Secure Pnt
Detail		To display transfer license key to use Encrypted Secure Print when disabling and then transferring the license.
Use Case		- When replacing HDD - When replacing the device
Adj/Set/Operate Method		1) Select ST-SCR. 2) Enter 0, and then press OK key. The transfer license key is displayed under TR-SCR.
Caution		This mode is enabled when there is "3DES+USH-H" Board.
Display/Adj/Set Range		24 digits
ST-HDCLR	2	Installation state display of Data Erase
Detail		To display installation state of Data Erase (for old model) when transfer is disabled.
Use Case		When checking whether Data Erase (for old model) is installed
Adj/Set/Operate Method		1) Select ST-HDCLR. 2) Enter 0, and then press OK key. When installation has been completed, the transfer license key is displayed under TR-HDCLR.
Display/Adj/Set Range		When operation finished normally: OK!
Default Value		0
TR-HDCLR	2	Transfer license key dspl of Data Erase
Detail		To display transfer license key to use Data Erase (for old model) when transfer is disabled.
Use Case		- When replacing HDD - When replacing the device
Adj/Set/Operate Method		1) Select ST-HDCLR. 2) Enter 0, and then press OK key. The transfer license key is displayed under TR-HDCLR.
Caution		This mode is enabled when there is "3DES+USH-H" Board.
Display/Adj/Set Range		24 digits

COPIER (Service mode for printer) > OPTION (Specification setting mode) > LCNS-TR

ST-BRDIM	2	Install state dspl: PCL Barcode Printing
Detail		To display installation state of BarDIMM when disabling and then transferring the license.
Use Case		When checking whether Barcode Printing for PCL is installed
Adj/Set/Operate Method		1) Select ST-BRDIM. 2) Enter 0, and then press OK key. When installation has been completed, the transfer license key is displayed under TR-BRDIM.
Display/Adj/Set Range		When operation finished normally: OK!
Default Value		According to the setting at shipment
TR-BRDIM	2	Trns lcns key dspl: PCL Barcode Printing
Detail		To display transfer license key to use Barcode Printing for PCL when disabling and then transferring the license.
Use Case		- When replacing HDD - When replacing the device
Adj/Set/Operate Method		1) Select ST-BRDIM. 2) Enter 0, and then press OK key. The transfer license key is displayed under TR-BRDIM.
Display/Adj/Set Range		24 digits
ST-VNC	2	Install state dspl of Remote Oprtr Soft
Detail		To display installation state of Remote Operators Software when disabling and then transferring the license.
Use Case		When checking whether Remote Operators Software is installed
Adj/Set/Operate Method		1) Select ST-VNC. 2) Enter 0, and then press OK key. When installation has been completed, the transfer license key is displayed under TR-VNC.
Display/Adj/Set Range		When operation finished normally: OK!
Default Value		According to the setting at shipment
TR-VNC	2	Trns lcns dspl of Remote Operators Soft
Detail		To display transfer license key to use Remote Operators Software when disabling and then transferring the license.
Use Case		- When replacing HDD - When replacing the device
Adj/Set/Operate Method		1) Select ST-VNC. 2) Enter 0, and then press OK key. The transfer license key is displayed under TR-VNC.
Display/Adj/Set Range		24 digits
ST-WEB	2	Install state dspl: Web Access Software
Detail		To display installation state of Web Access Software when disabling and then transferring the license.
Use Case		When checking whether Web Access Software is installed
Adj/Set/Operate Method		1) Select ST-WEB. 2) Enter 0, and then press OK key. When installation has been completed, the transfer license key is displayed under TR-WEB.
Display/Adj/Set Range		When operation finished normally: OK!
Default Value		According to the setting at shipment

COPIER (Service mode for printer) > OPTION (Specification setting mode) > LCNS-TR

TR-WEB	2	Trns license key dspl of Web Access Soft
Detail		To display transfer license key to use Web Access Software when disabling and then transferring the license.
Use Case		- When replacing HDD - When replacing the device
Adj/Set/Operate Method		1) Select ST-WEB. 2) Enter 0, and then press OK key. The transfer license key is displayed under TR-WEB.
Display/Adj/Set Range		24 digits
ST-HRPDF	2	Install state dspl of High Compress PDF
Detail		To display installation state of High Compression PDF when disabling and then transferring the license.
Use Case		When checking whether High Compression PDF is installed
Adj/Set/Operate Method		1) Select ST-HRPDF. 2) Enter 0, and then press OK key. When installation has been completed, the transfer license key is displayed under TR-HRPDF.
Display/Adj/Set Range		When operation finished normally: OK!
Default Value		According to the setting at shipment
TR-HRPDF	2	Trns lcns key dspl of High Compress PDF
Detail		To display transfer license key to use High Compression PDF when disabling and then transferring the license.
Use Case		- When replacing HDD - When replacing the device
Adj/Set/Operate Method		1) Select ST-HRPDF. 2) Enter 0, and then press OK key. The transfer license key is displayed under TR-HRPDF.
Display/Adj/Set Range		24 digits
ST-TRSND	2	Install state dspl: Trial SEND function
Detail		To display installation state of Trial SEND function when disabling and then transferring the license.
Use Case		When checking whether Trial SEND function is installed
Adj/Set/Operate Method		1) Select ST-TRSND. 2) Enter 0, and then press OK key. When installation has been completed, the transfer license key is displayed under TR-TRSND.
Display/Adj/Set Range		When operation finished normally: OK!
Default Value		According to the setting at shipment
TR-TRSND	2	Trns lcns key dspl: Trial SEND function
Detail		To display transfer license key to use Trial SEND function when disabling and then transferring the license.
Use Case		- When replacing HDD - When replacing the device
Adj/Set/Operate Method		1) Select ST-TRSND. 2) Enter 0, and then press OK key. The transfer license key is displayed under TR-TRSND.
Display/Adj/Set Range		24 digits

COPIER (Service mode for printer) > OPTION (Specification setting mode) > LCNS-TR

ST-WTMRK	2	Install state dspl of Secure Watermark
Detail		To display installation state of Secure Watermark when disabling and then transferring the license.
Use Case		When checking whether Secure Watermark is installed
Adj/Set/Operate Method		1) Select ST-WTMRK. 2) Enter 0, and then press OK key. When installation has been completed, the transfer license key is displayed under TR-WTMRK.
Display/Adj/Set Range		When operation finished normally: OK!
Default Value		According to the setting at shipment
TR-WTMRK	2	Trns license key dspl: Secure Watermark
Detail		To display transfer license key to use Secure Watermark when disabling and then transferring the license.
Use Case		- When replacing HDD - When replacing the device
Adj/Set/Operate Method		1) Select ST-WTMRK. 2) Enter 0, and then press OK key. The transfer license key is displayed under TR-WTMRK.
Display/Adj/Set Range		24 digits
ST-TSPDF	2	Install state dspl of Time Stamp PDF: JP
Detail		To display installation state of Time Stamp PDF (JP only) when disabling and then transferring the license.
Use Case		When checking whether Time Stamp PDF (JP only) is installed
Adj/Set/Operate Method		1) Select ST-TSPDF. 2) Enter 0, and then press OK key. When installation has been completed, the transfer license key is displayed under TR-TSPDF.
Display/Adj/Set Range		When operation finished normally: OK!
Default Value		According to the setting at shipment
TR-TSPDF	2	Trns lcns key dspl of Time Stamp PDF: JP
Detail		To display transfer license key to use Time Stamp PDF (JP only) when disabling and then transferring the license.
Use Case		- When replacing HDD - When replacing the device
Adj/Set/Operate Method		1) Select ST-TSPDF. 2) Enter 0, and then press OK key. The transfer license key is displayed under TR-TSPDF.
Caution		This mode is enabled when SEND function is installed.
Display/Adj/Set Range		24 digits
ST-USPDF	2	Install state dspl of Dgtl User Sign PDF
Detail		To display installation state of Digital User Signature PDF when disabling and then transferring the license.
Use Case		When checking whether Digital User Signature PDF is installed
Adj/Set/Operate Method		1) Select ST-USPDF. 2) Enter 0, and then press OK key. When installation has been completed, the transfer license key is displayed under TR-USPDF.
Display/Adj/Set Range		When operation finished normally: OK!
Default Value		0

COPIER (Service mode for printer) > OPTION (Specification setting mode) > LCNS-TR

TR-USPDF	2	Trns lcns key dspl of Dgtl User Sign PDF
Detail	To display transfer license key to use Digital User Signature PDF when disabling and then transferring the license.	
Use Case	- When replacing HDD - When replacing the device	
Adj/Set/Operate Method	1) Select ST-USPDF. 2) Enter 0, and then press OK key. The transfer license key is displayed under TR-USPDF.	
Caution	This mode is enabled when SEND function is installed.	
Display/Adj/Set Range	24 digits	
ST-DVPDF	2	Install state dspl of Device Sign PDF
Detail	To display installation state of device signature PDF transmission function when disabling and then transferring the license.	
Use Case	When checking whether Device Signature PDF is installed	
Adj/Set/Operate Method	1) Select ST-DVPDF. 2) Enter 0, and then press OK key. When installation has been completed, the transfer license key is displayed under TR-DVPDF.	
Display/Adj/Set Range	When operation finished normally: OK!	
Default Value	According to the setting at shipment	
TR-DVPDF	2	Trns lcns key dspl of Device Sign PDF
Detail	To display transfer license key to use Device Signature PDF when disabling and then transferring the license.	
Use Case	- When replacing HDD - When replacing the device	
Adj/Set/Operate Method	1) Select ST-DVPDF. 2) Enter 0, and then press OK key. The transfer license key is displayed under TR-DVPDF.	
Caution	This mode is enabled when SEND function is installed.	
Display/Adj/Set Range	24 digits	
ST-SCPDF	2	Install state dspl of Trace & Smooth PDF
Detail	To display installation state of Trace & Smooth PDF when disabling and then transferring the license.	
Use Case	When checking whether Trace & Smooth PDF is installed	
Adj/Set/Operate Method	1) Select ST-SCPDF. 2) Enter 0, and then press OK key. When installation has been completed, the transfer license key is displayed under TR-SCPDF.	
Display/Adj/Set Range	When operation finished normally: OK!	
Default Value	According to the setting at shipment	
TR-SCPDF	2	Trns lcns key dspl of Trace & Smooth PDF
Detail	To display transfer license key to use Trace & Smooth PDF when disabling and then transferring the license.	
Use Case	- When replacing HDD - When replacing the device	
Adj/Set/Operate Method	1) Select ST-SCPDF. 2) Enter 0, and then press OK key. The transfer license key is displayed under TR-SCPDF.	
Caution	This mode is enabled when SEND function is installed.	
Display/Adj/Set Range	24 digits	

COPIER (Service mode for printer) > OPTION (Specification setting mode) > LCNS-TR

ST-AMS	2	Install state dspl of Access Mngm System
Detail		To display installation state of Access Management System when disabling and then transferring the license.
Use Case		When checking whether Access Management System is installed
Adj/Set/Operate Method		1) Select ST-AMS. 2) Enter 0, and then press OK key. When installation has been completed, the transfer license key is displayed under TR-AMS.
Display/Adj/Set Range		When operation finished normally: OK!
Default Value		According to the setting at shipment
TR-AMS	2	Trns lcns key dspl of Access Mngm System
Detail		To display transfer license key to use Access Management System when disabling and then transferring the license.
Use Case		- When replacing HDD - When replacing the device
Adj/Set/Operate Method		1) Select ST-AMS. 2) Enter 0, and then press OK key. The transfer license key is displayed under TR-AMS.
Display/Adj/Set Range		24 digits
ST-ERDS	2	Install state dspl: E-RDS 3rd Pty Expnsn
Detail		To display installation state of monitoring service function when disabling and then transferring the license.
Use Case		When checking whether E-RDS non-Canon-made extension function is installed
Adj/Set/Operate Method		1) Select ST-ERDS. 2) Enter 0, and then press OK key. When installation has been completed, the transfer license key is displayed under TR-ERDS.
Display/Adj/Set Range		When operation finished normally: OK!
Default Value		According to the setting at shipment
Supplement/Memo		Monitoring service function: A function to send charge counter to the non-Canon-made charge server.
TR-ERDS	2	Trns lcns key dspl: E-RDS 3rd Pty Expnsn
Detail		To display transfer license key to use E-RDS non-Canon-made extension function when disabling and then transferring the license.
Use Case		- When replacing HDD - When replacing the device
Adj/Set/Operate Method		1) Select ST-ERDS. 2) Enter 0, and then press OK key. The transfer license key is displayed under TR-ERDS.
Display/Adj/Set Range		24 digits
Supplement/Memo		Monitoring service function: A function to send charge counter to the non-Canon-made charge server.
ST-PS	2	Install state display of PS function
Detail		To display installation state of PS function when disabling and then transferring the license.
Use Case		When checking whether PS function is installed
Adj/Set/Operate Method		1) Select ST-PS. 2) Enter 0, and then press OK key. When installation has been completed, the transfer license key is displayed under TR-PS.
Display/Adj/Set Range		When operation finished normally: OK!
Default Value		According to the setting at shipment

COPIER (Service mode for printer) > OPTION (Specification setting mode) > LCNS-TR

TR-PS	2	Transfer license key dspl of PS function
Detail		To display transfer license key to use PS function when disabling and then transferring the license.
Use Case		- When replacing HDD - When replacing the device
Adj/Set/Operate Method		1) Select ST-PS. 2) Enter 0, and then press OK key. The transfer license key is displayed under TR-PS.
Display/Adj/Set Range		24 digits
ST-PCL	2	Install state display of PCL function
Detail		To display installation state of PCL function when disabling and then transferring the license.
Use Case		When checking whether PCL function is installed
Adj/Set/Operate Method		1) Select ST-PCL. 2) Enter 0, and then press OK key. When installation has been completed, the transfer license key is displayed under TR-PCL.
Display/Adj/Set Range		When operation finished normally: OK!
Default Value		According to the setting at shipment
TR-PCL	2	Transfer license key dspl: PCL function
Detail		To display transfer license key to use PCL function when disabling and then transferring the license.
Use Case		- When replacing HDD - When replacing the device
Adj/Set/Operate Method		1) Select ST-PCL. 2) Enter 0, and then press OK key. The transfer license key is displayed under TR-PCL.
Display/Adj/Set Range		24 digits
ST-PSLI5	2	Install state dspl: PS/LIPS4/LIPS LX: JP
Detail		To display installation state of PS/LIPS4/LIPS LX function (JP only) when disabling and then transferring the license.
Use Case		When checking whether PS/LIPS4/LIPS LX function (JP only) is installed
Adj/Set/Operate Method		1) Select ST-PSLI5. 2) Enter 0, and then press OK key. When installation has been completed, the transfer license key is displayed under TR-PSLI5.
Display/Adj/Set Range		When operation finished normally: OK!
Default Value		0
TR-PSLI5	2	Trns lcns key dspl: PS/LIPS4/LIPS LX: JP
Detail		To display transfer license key to use PS/LIPS4/LIPS LX function (JP only) when disabling and then transferring the license.
Use Case		- When replacing HDD - When replacing the device
Adj/Set/Operate Method		1) Select ST-PSLI5. 2) Enter 0, and then press OK key. The transfer license key is displayed under TR-PSLI5.
Display/Adj/Set Range		24 digits

COPIER (Service mode for printer) > OPTION (Specification setting mode) > LCNS-TR

ST-LIPS5	2	Install state dspl:LIPS LX/LIPS4 func:JP
Detail		To display installation state of LIPS LX/LIPS4 function (JP only) when disabling and then transferring the license.
Use Case		When checking whether LIPS LX/LIPS4 function (JP only) is installed
Adj/Set/Operate Method		1) Select ST-LIPS5. 2) Enter 0, and then press OK key. When installation has been completed, the transfer license key is displayed under TR-LIPS5.
Display/Adj/Set Range		When operation finished normally: OK!
Default Value		According to the setting at shipment
TR-LIPS5	2	Trns lcns key dspl:LIPS LX/LIPS4 func:JP
Detail		To display transfer license key to use LIPS LX/LIPS4 function (JP only) when disabling and then transferring the license.
Use Case		- When replacing HDD - When replacing the device
Adj/Set/Operate Method		1) Select ST-LIPS5. 2) Enter 0, and then press OK key. The transfer license key is displayed under TR-LIPS5.
Display/Adj/Set Range		24 digits
ST-LIPS4	2	Install state display of LIPS4 func: JP
Detail		To display installation state of LIPS4 function (JP only) when disabling and then transferring the license.
Use Case		When checking whether LIPS4 function (JP only) is installed
Adj/Set/Operate Method		1) Select ST-LIPS4. 2) Enter 0, and then press OK key. When installation has been completed, the transfer license key is displayed under TR-LIPS4.
Display/Adj/Set Range		When operation finished normally: OK!
Default Value		According to the setting at shipment
TR-LIPS4	2	Trns license key dspl of LIPS4 func: JP
Detail		To display transfer license key to use LIPS4 function (JP only) when disabling and then transferring the license.
Use Case		- When replacing HDD - When replacing the device
Adj/Set/Operate Method		1) Select ST-LIPS4. 2) Enter 0, and then press OK key. The transfer license key is displayed under TR-LIPS4.
Display/Adj/Set Range		24 digits
ST-PSPCL	2	Install state dspl of PS/PCL function
Detail		To display installation state of PS/PCL function when disabling and then transferring the license.
Use Case		When checking whether PS/PCL function is installed
Adj/Set/Operate Method		1) Select ST-PSPCL. 2) Enter 0, and then press OK key. When installation has been completed, the transfer license key is displayed under TR-PSPCL.
Display/Adj/Set Range		When operation finished normally: OK!
Default Value		According to the setting at shipment

COPIER (Service mode for printer) > OPTION (Specification setting mode) > LCNS-TR

TR-PSPCL	2	Transfer license key dspl of PS/PCL func
Detail		To display transfer license key to use PS/PCL function when disabling and then transferring the license.
Use Case		- When replacing HDD - When replacing the device
Adj/Set/Operate Method		1) Select ST-PSPCL. 2) Enter 0, and then press OK key. The transfer license key is displayed under TR-PSPCL.
Display/Adj/Set Range		24 digits
ST-PCLUF	2	Install state dspl: PCL/UFR II function
Detail		To display installation state of PCL/UFR II function when disabling and then transferring the license.
Use Case		When checking whether PCL/UFR II function is installed
Adj/Set/Operate Method		1) Select ST-PCLUF. 2) Enter 0, and then press OK key. When installation has been completed, the transfer license key is displayed under TR-PCLUF.
Display/Adj/Set Range		When operation finished normally: OK!
Default Value		According to the setting at shipment
TR-PCLUF	2	Trns license key dspl of PCL/UFR II func
Detail		To display transfer license key to use PCL/UFR II function when disabling and then transferring the license.
Use Case		- When replacing HDD - When replacing the device
Adj/Set/Operate Method		1) Select ST-PCLUF. 2) Enter 0, and then press OK key. The transfer license key is displayed under TR-PCLUF.
Display/Adj/Set Range		24 digits
ST-PSLIP	2	Install state dspl of PS/LIPS4 func: JP
Detail		To display installation state of PS/LIPS4 function (JP only) when disabling and then transferring the license.
Use Case		When checking whether PS/LIPS4 function (JP only) is installed
Adj/Set/Operate Method		1) Select ST-PSLIP. 2) Enter 0, and then press OK key. When installation has been completed, the transfer license key is displayed under TR-PSLIP.
Display/Adj/Set Range		When operation finished normally: OK!
Default Value		According to the setting at shipment
TR-PSLIP	2	Trns license key dspl: PS/LIPS4 func:JP
Detail		To display transfer license key to use PS/LIPS4 function (JP only) when disabling and then transferring the license.
Use Case		- When replacing HDD - When replacing the device
Adj/Set/Operate Method		1) Select ST-PSLIP. 2) Enter 0, and then press OK key. The transfer license key is displayed under TR-PSLIP.
Display/Adj/Set Range		24 digits

COPIER (Service mode for printer) > OPTION (Specification setting mode) > LCNS-TR

ST-PSPCU	2	Install state dspl of PS/PCL/UFR II func
Detail		To display installation state of PS/PCL/UFR II function when disabling and then transferring the license.
Use Case		When checking whether PS/PCL/UFR II function is installed
Adj/Set/Operate Method		1) Select ST-PSPCU. 2) Enter 0, and then press OK key. When installation has been completed, the transfer license key is displayed under TR-PSPCU.
Display/Adj/Set Range		When operation finished normally: OK!
Default Value		According to the setting at shipment
TR-PSPCU	2	Trns lcns key dspl of PS/PCL/UFR II func
Detail		To display transfer license key to use PS/PCL/UFR II function when disabling and then transferring the license.
Use Case		- When replacing HDD - When replacing the device
Adj/Set/Operate Method		1) Select ST-PSPCU. 2) Enter 0, and then press OK key. The transfer license key is displayed under TR-PSPCU.
Display/Adj/Set Range		24 digits
ST-LXUFR	2	Install state display of UFR II function
Detail		To display installation state of UFR II function when disabling and then transferring the license.
Use Case		When checking whether UFR II function is installed
Adj/Set/Operate Method		1) Select ST-LXUFR. 2) Enter 0, and then press OK key. When installation has been completed, the transfer license key is displayed under TR-LXUFR.
Display/Adj/Set Range		When operation finished normally: OK!
Default Value		According to the setting at shipment
TR-LXUFR	2	Trns license key dspl of UFR II function
Detail		To display transfer license key to use UFR II function when disabling and then transferring the license.
Use Case		- When replacing HDD - When replacing the device
Adj/Set/Operate Method		1) Select ST-LXUFR. 2) Enter 0, and then press OK key. The transfer license key is displayed under TR-LXUFR.
Display/Adj/Set Range		24 digits
ST-HDCR2	2	Install state dspl:HDD Init All Data/Set
Detail		To display installation state of HDD Initialize All Data/Settings when disabling and then transferring the license.
Use Case		When checking whether HDD Initialize All Data/Settings is installed
Adj/Set/Operate Method		1) Select ST-HDCR2. 2) Enter 0, and then press OK key. When installation has been completed, the transfer license key is displayed under TR-HDCR2.
Display/Adj/Set Range		When operation finished normally: OK!
Default Value		0

COPIER (Service mode for printer) > OPTION (Specification setting mode) > LCNS-TR

TR-HDCR2	2	Trns lcns key dspl:HDD Init All Data/Set
Detail		To display transfer license key to use HDD Initialize All Data/Settings when disabling and then transferring the license.
Use Case		- When replacing HDD - When replacing the device
Adj/Set/Operate Method		1) Select ST-HDCR2. 2) Enter 0, and then press OK key. The transfer license key is displayed under TR-HDCR2.
Display/Adj/Set Range		24 digits
ST-JBLK	2	Install state dspl of Document Scan Lock
Detail		To display installation state of Document Scan Lock when disabling and then transferring the license.
Use Case		When checking whether Document Scan Lock is installed
Adj/Set/Operate Method		1) Select ST-JBLK. 2) Enter 0, and then press OK key. When installation has been completed, the transfer license key is displayed under TR-JBLK.
Display/Adj/Set Range		When operation finished normally: OK!
Default Value		0
TR-JBLK	2	Trns lcns key dspl of Document Scan Lock
Detail		To display transfer license key to use Document Scan Lock when disabling and then transferring the license.
Use Case		- When replacing HDD - When replacing the device
Adj/Set/Operate Method		1) Select ST-JBLK. 2) Enter 0, and then press OK key. The transfer license key is displayed under TR-JBLK.
Display/Adj/Set Range		24 digits
ST-AFAX	2	Installation state display of Remote Fax
Detail		To display installation state of remote fax client function when disabling and then transferring the license.
Use Case		When checking whether Remote Fax is installed
Adj/Set/Operate Method		1) Select ST-AFAX. 2) Enter 0, and then press OK key. When installation has been completed, the transfer license key is displayed under TR-AFAX.
Display/Adj/Set Range		When operation finished normally: OK!
Default Value		According to the setting at shipment
TR-AFAX	2	Transfer license key dspl of Remote Fax
Detail		To display transfer license key to use Remote Fax when disabling and then transferring the license.
Use Case		- When replacing HDD - When replacing the device
Adj/Set/Operate Method		1) Select ST-AFAX. 2) Enter 0, and then press OK key. The transfer license key is displayed under TR-AFAX.
Display/Adj/Set Range		24 digits

COPIER (Service mode for printer) > OPTION (Specification setting mode) > LCNS-TR

ST-POPDF	2	Install state display of PDF w/ Policy
Detail		To display installation state of PDF function with Policy when transfer is disabled.
Use Case		When checking whether PDF function with Policy is installed
Adj/Set/Operate Method		1) Select ST-POPDF. 2) Enter 0, and then press OK key. When installation has been completed, the transfer license key is displayed under TR-POPDF.
Display/Adj/Set Range		When operation finished normally: OK!
Default Value		0
TR-POPDF	2	Trns lcns key display of PDF w/ Policy
Detail		To display transfer license key to use PDF function with Policy when transfer is disabled.
Use Case		- When replacing HDD - When replacing the device
Adj/Set/Operate Method		1) Select ST-POPDF. 2) Enter 0, and then press OK key. The transfer license key is displayed under TR-POPDF.
Display/Adj/Set Range		24 digits
ST-REPDF	2	Install state dspl:Reader Extensions PDF
Detail		To display installation state of Reader Extensions PDF when disabling and then transferring the license.
Use Case		When checking whether Reader Extensions PDF is installed
Adj/Set/Operate Method		1) Select ST-REPDF. 2) Enter 0, and then press OK key. When installation has been completed, the transfer license key is displayed under TR-REPDF.
Display/Adj/Set Range		When operation finished normally: OK!
Default Value		According to the setting at shipment
TR-REPDF	2	Trns lcns key dspl:Reader Extensions PDF
Detail		To display transfer license key to use Reader Extensions PDF when disabling and then transferring the license.
Use Case		- When replacing HDD - When replacing the device
Adj/Set/Operate Method		1) Select ST-REPDF. 2) Enter 0, and then press OK key. The transfer license key is displayed under TR-REPDF.
Display/Adj/Set Range		24 digits
ST-OOXML	2	Install state display of Office Open XML
Detail		To display installation state of Office Open XML when disabling and then transferring the license.
Use Case		When checking whether Office Open XML is installed
Adj/Set/Operate Method		1) Select ST-OOXML. 2) Enter 0, and then press OK key. When installation has been completed, the transfer license key is displayed under TR-OOXML.
Display/Adj/Set Range		When operation finished normally: OK!
Default Value		According to the setting at shipment

COPIER (Service mode for printer) > OPTION (Specification setting mode) > LCNS-TR

TR-OOXML	2	Trns lcns key display of Office Open XML
Detail		To display transfer license key to use Office Open XML when disabling and then transferring the license.
Use Case		- When replacing HDD - When replacing the device
Adj/Set/Operate Method		1) Select ST-OOXML. 2) Enter 0, and then press OK key. The transfer license key is displayed under TR-OOXML.
Display/Adj/Set Range		24 digits
ST-XPS	2	Install state dspl of Direct Print XPS
Detail		To display installation state of Direct Print XPS when disabling and then transferring the license.
Use Case		When checking whether Direct Print XPS is installed
Adj/Set/Operate Method		1) Select ST-XPS. 2) Enter 0, and then press OK key. When installation has been completed, the transfer license key is displayed under TR-XPS.
Display/Adj/Set Range		When operation finished normally: OK!
Default Value		According to the setting at shipment
TR-XPS	2	Trns lcns key dspl of Direct Print XPS
Detail		To display transfer license key to use Direct Print XPS when disabling and then transferring the license.
Use Case		- When replacing HDD - When replacing the device
Adj/Set/Operate Method		1) Select ST-XPS. 2) Enter 0, and then press OK key. The transfer license key is displayed under TR-XPS.
Display/Adj/Set Range		24 digits
ST-2600	2	Instal state dspl: IEEE2600.1 scrty func
Detail		To display installation state of security function of IEEE2600.1 when disabling and then transferring the license.
Use Case		When checking whether the IEEE2600.1 security function is installed
Adj/Set/Operate Method		1) Select ST-2600. 2) Enter 0, and then press OK key. When installation has been completed, the transfer license key is displayed under TR-2600.
Display/Adj/Set Range		When operation finished normally: OK!
Default Value		According to the setting at shipment
TR-2600	2	Trn lcns key dspl: IEEE2600.1 scrty func
Detail		To display transfer license key to use IEEE2600.1 security function when disabling and then transferring the license.
Use Case		- When replacing HDD - When replacing the device
Adj/Set/Operate Method		1) Select ST-2600. 2) Enter 0, and then press OK key. The transfer license key is displayed under TR-2600.
Display/Adj/Set Range		24 digits

COPIER (Service mode for printer) > OPTION (Specification setting mode) > LCNS-TR

ST-OPFNT	2	Install state display of PCL Font Set
Detail		To display installation state of PCL Font Set when disabling and then transferring the license.
Use Case		When checking whether PCL Font Set is installed
Adj/Set/Operate Method		1) Select ST-OPFNT. 2) Enter 0, and then press OK key. When installation has been completed, the transfer license key is displayed under TR-OPFNT.
Display/Adj/Set Range		When operation finished normally: OK!
Default Value		According to the setting at shipment
TR-OPFNT	2	Trns license key display of PCL Font Set
Detail		To display transfer license key to use the PCL Font Set when disabling and then transferring the license.
Use Case		- When replacing HDD - When replacing the device
Adj/Set/Operate Method		1) Select ST-OPFNT. 2) Enter 0, and then press OK key. The transfer license key is displayed under TR-OPFNT.
Display/Adj/Set Range		24 digits
ST-NCAPT	2	Install state display of NetCap function
Detail		To display installation state of network packet capture function when disabling and then transferring the license.
Use Case		When checking whether network packet capture function is installed
Adj/Set/Operate Method		1) Select ST-NCAPT. 2) Enter 0, and then press OK key. When installation has been completed, the transfer license key is displayed under TR-NCAPT.
Display/Adj/Set Range		When operation finished normally: OK!
Default Value		0
TR-NCAPT	2	Transfer license key dsply of NetCap func
Detail		To display transfer license key to use the network packet capture function when disabling and then transferring the license.
Use Case		- When replacing HDD - When replacing the device
Adj/Set/Operate Method		1) Select ST-NCAPT. 2) Enter 0, and then press OK key. The transfer license key is displayed under TR-NCAPT.
Display/Adj/Set Range		24 digits
ST-IPFAX	2	Installation state display of IPFAX
Detail		To display installation state of IPFAX when disabling and then transferring the license.
Use Case		When checking whether IPFAX is installed
Adj/Set/Operate Method		1) Select ST-IPFAX. 2) Enter 0, and then press OK key. When installation has been completed, the transfer license key is displayed under TR-IPFAX.
Display/Adj/Set Range		When operation finished normally: OK!
Default Value		According to the setting at shipment

COPIER (Service mode for printer) > OPTION (Specification setting mode) > LCNS-TR

TR-IPFAX	2	Transfer license key dspl of IPFAX
Detail		To display transfer license key to use IPFAX when disabling and then transferring the license.
Use Case		- When replacing HDD - When replacing the device
Adj/Set/Operate Method		1) Select ST-IPFAX. 2) Enter 0, and then press OK key. The transfer license key is displayed under TR-IPFAX.
Display/Adj/Set Range		24 digits
ST-U-RDS	2	Install state display of E-RDS function
Detail		To display installation state of Embedded-RDS function when disabling and then transferring the license.
Use Case		When checking whether Embedded-RDS function is installed
Adj/Set/Operate Method		1) Select ST-U-RDS. 2) Enter 0, and then press OK key. When installation has been completed, the transfer license key is displayed under TR-U-RDS.
Display/Adj/Set Range		When operation finished normally: OK!
Default Value		According to the setting at shipment
Related Service Mode		COPIER> FUNCTION> INSTALL> E-RDS
TR-U-RDS	2	Trns license key dspl of E-RDS function
Detail		To display transfer license key to use Embedded-RDS function when disabling and then transferring the license.
Use Case		- When replacing the HDD - When replacing the device
Adj/Set/Operate Method		1) Select ST-U-RDS. 2) Enter 0, and then press OK key. The transfer license key is displayed under TR-U-RDS.
Display/Adj/Set Range		24 digits
ST-SMLG	2	Install state dspl of picture login func
Detail		To display installation state of picture login function when disabling and then transferring the license.
Use Case		When checking whether picture login function is installed
Adj/Set/Operate Method		1) Select ST-SMLG. 2) Enter 0, and then press OK key. When installation has been completed, the transfer license key is displayed under TR-SMLG.
Display/Adj/Set Range		When operation finished normally: OK!
Default Value		According to the setting at shipment
TR-SMLG	2	Trns lcns key dspl: picture login func
Detail		To display transfer license key to use picture login function when disabling and then transferring the license.
Use Case		- When replacing HDD - When replacing the device
Adj/Set/Operate Method		1) Select ST-SMLG. 2) Enter 0, and then press OK key. The transfer license key is displayed under TR-SMLG.
Display/Adj/Set Range		24 digits

COPIER (Service mode for printer) > OPTION (Specification setting mode) > LCNS-TR

ST-TCFNT	2	Inst state dspl:PCL Asian Font, trad CHI
Detail		To display installation state of PCL Asian Font (traditional Chinese) when disabling and then transfer the license.
Use Case		When checking whether PCL Asian Font (traditional Chinese) is installed
Adj/Set/Operate Method		1) Select ST-TCFNT. 2) Enter 0, and then press OK key. When installation has been completed, the transfer license key is displayed under TR-TCFNT.
Caution		When replacing the HDD, check that "PCL Traditional Chinese Fonts" and "PCL Traditional Chinese Fonts (HKSCS)" are installed with [Font List] in [Settings/Registration].
Display/Adj/Set Range		When operation finished normally: OK!
Default Value		According to the setting at shipment
Additional Functions Mode		Function Settings> Printer> Output Report> PCL> Font List
TR-TCFNT	2	Trn lic key dspl:PCL Asian Font,trad CHI
Detail		To display transfer license key to use PCL Asian Font (traditional Chinese) when disabling and then transferring the license.
Use Case		- When replacing HDD - When replacing the device
Adj/Set/Operate Method		1) Select ST-TCFNT. 2) Enter 0, and then press OK key. The transfer license key is displayed under TR-TCFNT.
Display/Adj/Set Range		24 digits
Additional Functions Mode		Function Settings> Printer> Output Report> PCL> Font List
TR-FRWEB	2	Trn lcns key dspl:Web Access SW,free ver
Detail		To display transfer license key to use the free version of Web Access Software when disabling and then transferring the license of it.
Use Case		- When replacing HDD - When replacing the device
Adj/Set/Operate Method		1) Select ST-FRWEB. 2) Enter 0, and then press OK key. The transfer license key is displayed under TR-FRWEB.
Display/Adj/Set Range		24 digits
ST-FRWEB	2	Instl state dspl:Web Access SW, free ver
Detail		To display installation state of the free version of Web Access Software when disabling and then transferring the license of it.
Use Case		When checking whether the free version of Web Access Software is installed
Adj/Set/Operate Method		1) Select ST-FRWEB. 2) Enter 0, and then press OK key. When installation has been completed, the transfer license key is displayed under TR-FRWEB.
Display/Adj/Set Range		When operation finished normally: OK!
Default Value		According to the setting at shipment
ST-HCD	2	Inst state dspl: IEEE2600 Security Kit
Detail		To display installation state of Security Kit for IEEE2600 when disabling and then transferring the license.
Use Case		When checking whether the Security Kit for IEEE2600 is installed
Adj/Set/Operate Method		1) Select ST-HCD. 2) Enter 0, and then press OK key. When installation has been completed, the transfer license key is displayed under TR-HCD.
Display/Adj/Set Range		When operation finished normally: OK!
Default Value		According to the setting at shipment

COPIER (Service mode for printer) > OPTION (Specification setting mode) > LCNS-TR

TR-HCD	2	Trn lcns key dspl: IEEE2600 Security Kit
Detail		To display transfer license key to use the Security Kit for IEEE2600 when disabling and then transferring the license of it.
Use Case		- When replacing HDD - When replacing the device
Adj/Set/Operate Method		1) Select ST-HCD. 2) Enter 0, and then press OK key. The transfer license key is displayed under TR-HCD.
Display/Adj/Set Range		24 digits
Default Value		0
ST-MECWL	2	Inst state dspl: McAfee whitelist func
Detail		To display installation state of McAfee whitelisting function when disabling the function and transferring the license.
Use Case		When checking whether McAfee whitelisting function is installed.
Adj/Set/Operate Method		1) Select ST-MECWL. 2) Enter 0, and then press OK key. When installation has been completed, the transfer license key is displayed under TR-MECWL.
Display/Adj/Set Range		When operation finished normally: OK!
Supplement/Memo		McAfee and the McAfee logo are trademarks or registered trademarks of McAfee, LLC or its subsidiaries in the United States and other countries. All other trademarks and registered trademarks are the property of their respective manufacturers. Copyright(c)2018 McAfee LLC
TR-MECWL	2	Trn lcns key dspl: McAfee whitelist func
Detail		To display transfer license key to use McAfee whitelisting function when disabling and then transferring the license of it.
Use Case		- When replacing the HDD - When replacing the device
Adj/Set/Operate Method		1) Select ST-MECWL. 2) Enter 0, and then press OK key. The transfer license key is displayed under TR-MECWL.
Display/Adj/Set Range		24 digits
Supplement/Memo		McAfee and the McAfee logo are trademarks or registered trademarks of McAfee, LLC or its subsidiaries in the United States and other countries. All other trademarks and registered trademarks are the property of their respective manufacturers. Copyright(c)2018 McAfee LLC

■ CUSTOM2

COPIER (Service mode for printer) > OPTION (Specification setting mode) > CUSTOM2

SP-B01	2	[For customization]
SP-B02	2	[For customization]
SP-B03	2	[For customization]
SP-B04	2	[For customization]
SP-B05	2	[For customization]
SP-B06	2	[For customization]
SP-B07	2	[For customization]
SP-B08	2	[For customization]
SP-B09	2	[For customization]
SP-B10	2	[For customization]
SP-B11	2	[For customization]
SP-B12	2	[For customization]

COPIER (Service mode for printer) > OPTION (Specification setting mode) > CUSTOM2

SP-B13	2	[For customization]
SP-B14	2	[For customization]
SP-B15	2	[For customization]
SP-B16	2	[For customization]
SP-B17	2	[For customization]
SP-B18	2	[For customization]
SP-B19	2	[For customization]
SP-B20	2	[For customization]
SP-B21	2	[For customization]
SP-B22	2	[For customization]
SP-B23	2	[For customization]
SP-B24	2	[For customization]
SP-B25	2	[For customization]
SP-B26	2	[For customization]
SP-B27	2	[For customization]
SP-B28	2	[For customization]
SP-B29	2	[For customization]
SP-B30	2	[For customization]
SP-B31	2	[For customization]
SP-B32	2	[For customization]
SP-B33	2	[For customization]
SP-B34	2	[For customization]
SP-B35	2	[For customization]
SP-B36	2	[For customization]
SP-B37	2	[For customization]
SP-B38	2	[For customization]
SP-B39	2	[For customization]
SP-B40	2	[For customization]
SP-B41	2	[For customization]
SP-B42	2	[For customization]
SP-B43	2	[For customization]
SP-B44	2	[For customization]
SP-B45	2	[For customization]
SP-B46	2	[For customization]
SP-B47	2	[For customization]
SP-B48	2	[For customization]
SP-B49	2	[For customization]
SP-B50	2	[For customization]
SP-B51	2	[For customization]
SP-B52	2	[For customization]
SP-B53	2	[For customization]

COPIER (Service mode for printer) > OPTION (Specification setting mode) > CUSTOM2

SP-B54	2	[For customization]
SP-B55	2	[For customization]
SP-B56	2	[For customization]
SP-B57	2	[For customization]
SP-B58	2	[For customization]
SP-B59	2	[For customization]
SP-B60	2	[For customization]
SP-B61	2	[For customization]
SP-B62	2	[For customization]
SP-B63	2	[For customization]
SP-B64	2	[For customization]
SP-B65	2	[For customization]
SP-B66	2	[For customization]
SP-B67	2	[For customization]
SP-B68	2	[For customization]
SP-B69	2	[For customization]
SP-B70	2	[For customization]
SP-B71	2	[For customization]
SP-B72	2	[For customization]
SP-B73	2	[For customization]
SP-B74	2	[For customization]
SP-B75	2	[For customization]
SP-B76	2	[For customization]
SP-B77	2	[For customization]
SP-B78	2	[For customization]
SP-B79	2	[For customization]
SP-B80	2	[For customization]
SP-V01	2	[For customization]
SP-V02	2	[For customization]
SP-V03	2	[For customization]
SP-V04	2	[For customization]
SP-V05	2	[For customization]
SP-V06	2	[For customization]
SP-V07	2	[For customization]
SP-V08	2	[For customization]
SP-V09	2	[For customization]
SP-V10	2	[For customization]
SP-V11	2	[For customization]
SP-V12	2	[For customization]
SP-V13	2	[For customization]
SP-V14	2	[For customization]

COPIER (Service mode for printer) > OPTION (Specification setting mode) > CUSTOM2

SP-V15	2	[For customization]
SP-V16	2	[For customization]
SP-V17	2	[For customization]
SP-V18	2	[For customization]
SP-V19	2	[For customization]
SP-V20	2	[For customization]
SP-V21	2	[For customization]
SP-V22	2	[For customization]
SP-V23	2	[For customization]
SP-V24	2	[For customization]
SP-V25	2	[For customization]
SP-V26	2	[For customization]
SP-V27	2	[For customization]
SP-V28	2	[For customization]
SP-V29	2	[For customization]
SP-V30	2	[For customization]
SP-V31	2	[For customization]
SP-V32	2	[For customization]
SP-V33	2	[For customization]
SP-V34	2	[For customization]
SP-V35	2	[For customization]
SP-V36	2	[For customization]
SP-V37	2	[For customization]
SP-V38	2	[For customization]
SP-V39	2	[For customization]
SP-V40	2	[For customization]
SP-V41	2	[For customization]
SP-V42	2	[For customization]
SP-V43	2	[For customization]
SP-V44	2	[For customization]
SP-V45	2	[For customization]
SP-V46	2	[For customization]
SP-V47	2	[For customization]
SP-V48	2	[For customization]
SP-V49	2	[For customization]
SP-V50	2	[For customization]
SP-V51	2	[For customization]
SP-V52	2	[For customization]
SP-V53	2	[For customization]
SP-V54	2	[For customization]
SP-V55	2	[For customization]

COPIER (Service mode for printer) > OPTION (Specification setting mode) > CUSTOM2

SP-V56	2	[For customization]
SP-V57	2	[For customization]
SP-V58	2	[For customization]
SP-V59	2	[For customization]
SP-V60	2	[For customization]
SP-V61	2	[For customization]
SP-V62	2	[For customization]
SP-V63	2	[For customization]
SP-V64	2	[For customization]
SP-V65	2	[For customization]
SP-V66	2	[For customization]
SP-V67	2	[For customization]
SP-V68	2	[For customization]
SP-V69	2	[For customization]
SP-V70	2	[For customization]
SP-V71	2	[For customization]
SP-V72	2	[For customization]
SP-V73	2	[For customization]
SP-V74	2	[For customization]
SP-V75	2	[For customization]
SP-V76	2	[For customization]
SP-V77	2	[For customization]
SP-V78	2	[For customization]
SP-V79	2	[For customization]
SP-V80	2	[For customization]

■ PM-PRE-M

COPIER (Service mode for printer) > OPTION (Specification setting mode) > PM-PRE-M

TONER-K	1	Dspl/hide Toner (Bk) preparation warning
Detail		To switch between display/hide the preparation warning on the Control Panel Status Bar.
Use Case		In the case of displaying the warning when consumables/consumable parts are not automatically delivered
Adj/Set/Operate Method		Enter the setting value, and then press OK key.
Display/Adj/Set Range		0 to 1 0: Hide, 1: Display
Default Value		The value differs according to the location.
WST-TNR	1	Display/hide Wst Tonr Cont prep warning
Detail		To switch between display/hide the preparation warning on the Control Panel Status Bar.
Use Case		In the case of displaying the warning when consumables/consumable parts are not automatically delivered
Adj/Set/Operate Method		Enter the setting value, and then press OK key.
Display/Adj/Set Range		0 to 1 0: Hide, 1: Display
Default Value		The value differs according to the location.

■ PM-U-DSP

COPIER (Service mode for printer) > OPTION (Specification setting mode) > PM-U-DSP

PT-DRM	1	Display/hide Drum-U (Bk) consumable scrn
Detail		To switch between display/hide the status and the number of days left on the consumables screen.
Use Case		When switching the display on the consumables screen
Adj/Set/Operate Method		Enter the setting value, and then press OK key.
Display/Adj/Set Range		0 to 1 0: Hide, 1: Display
Default Value		The value differs according to the location.
Additional Functions Mode		Status Monitor > Consmbls/Others > Consumables
FX-REP	1	Dspl/hide Fixing Ass'y Consumables scrn
Detail		To switch between display/hide the status and the number of days left on the consumables screen.
Use Case		When switching the display on the consumables screen
Adj/Set/Operate Method		Enter the setting value, and then press OK key.
Display/Adj/Set Range		0 to 1 0: Hide, 1: Display
Default Value		The value differs according to the location.
Additional Functions Mode		Status Monitor > Consmbls/Others > Consumables

■ PM-MSG-D

COPIER (Service mode for printer) > OPTION (Specification setting mode) > PM-MSG-D

TONER-K	1	Set days left before Toner(Bk) prep warn
Detail		To set the timing (number of days left) at which the preparation warning will be displayed.
Use Case		When changing the timing (number of days left) at which the preparation warning will be displayed
Adj/Set/Operate Method		Enter the setting value, and then press OK key.
Caution		Change the setting in accordance with the instruction of the sales company HQ.
Display/Adj/Set Range		0 to 365
Default Value		The value differs according to the location.
WST-TNR	1	Set days left bef Wst Tnr Cont prep warn
Detail		To set the timing (number of days left) at which the preparation warning will be displayed.
Use Case		When changing the timing (number of days left) at which the preparation warning will be displayed
Adj/Set/Operate Method		Enter the setting value, and then press OK key.
Caution		Change the setting in accordance with the instruction of the sales company HQ.
Display/Adj/Set Range		0 to 365
Default Value		The value differs according to the location.

■ PM-DLV-D

COPIER (Service mode for printer) > OPTION (Specification setting mode) > PM-DLV-D

TONER-K	1	Set Toner (Bk) prior alarm notice timing
Detail		To set the number of days left before the prior notification alarm will be notified.
Use Case		When changing the timing to notify the prior notification alarm
Adj/Set/Operate Method		Enter the setting value, and then press OK key.
Display/Adj/Set Range		-1 to 365 -1: The alarm not issued
Default Value		It differs according to the location.

COPIER (Service mode for printer) > OPTION (Specification setting mode) > PM-DLV-D

WST-TNR	1	Set Wst Tonr Cont prior alarm notice tmng
Detail		To set the number of days left before the prior notification alarm will be notified.
Use Case		When changing the timing to notify the prior notification alarm
Adj/Set/Operate Method		Enter the setting value, and then press OK key.
Display/Adj/Set Range		-1 to 365 -1: The alarm not issued
Default Value		It differs according to the location.
PT-DRM	1	Set Drum-U(Bk) prior alarm notice timing
Detail		To set the number of days left before the prior notification alarm will be notified.
Use Case		When changing the timing to notify the prior notification alarm
Adj/Set/Operate Method		Enter the setting value, and then press OK key.
Display/Adj/Set Range		-1 to 365 -1: The alarm not issued
Default Value		It differs according to the location.
CLN-BLD	1	Set D-CIn Blade Prior alarm notice tmng
Detail		To set the number of days left before the prior notification alarm will be notified.
Use Case		When changing the timing to notify the prior notification alarm
Adj/Set/Operate Method		Enter the setting value, and then press OK key.
Display/Adj/Set Range		-1 to 365 -1: The alarm not issued
Default Value		It differs according to the location.
DV-UNT-K	1	Set Dev Cylinder prior alarm notice tmng
Detail		To set the number of days left before the prior notification alarm will be notified.
Use Case		When changing the timing to notify the prior notification alarm
Adj/Set/Operate Method		Enter the setting value, and then press OK key.
Display/Adj/Set Range		-1 to 365 -1: The alarm not issued
Default Value		It differs according to the location.
TR-BLT	1	Set ETB prior notice alarm notice timing
Detail		To set the number of days left before the prior notification alarm will be notified.
Use Case		When changing the timing to notify the prior notification alarm
Adj/Set/Operate Method		Enter the setting value, and then press OK key.
Display/Adj/Set Range		-1 to 365 -1: The alarm not issued
Default Value		It differs according to the location.
TR-ROLL	1	Set Transfer Roller prior alm notice tmng
Detail		To set the number of days left before the prior notification alarm will be notified.
Use Case		When changing the timing to notify the prior notification alarm
Adj/Set/Operate Method		Enter the setting value, and then press OK key.
Display/Adj/Set Range		-1 to 365 -1: The alarm not issued
Default Value		It differs according to the location.

COPIER (Service mode for printer) > OPTION (Specification setting mode) > PM-DLV-D

T-CLN-BD	1	Set ETB Cleaning Blade prior alm ntc tmg
Detail		To set the number of days left before the prior notification alarm will be notified.
Use Case		When changing the timing to notify the prior notification alarm
Adj/Set/Operate Method		Enter the setting value, and then press OK key.
Display/Adj/Set Range		-1 to 365 -1: The alarm not issued
Default Value		It differs according to the location.
T-CN-BRU	1	Set Brush Roller prior alm notice timing
Detail		To set the number of days left before the prior notification alarm will be notified.
Use Case		When changing the timing to notify the prior notification alarm
Adj/Set/Operate Method		Enter the setting value, and then press OK key.
Display/Adj/Set Range		-1 to 365 -1: The alarm not issued
Default Value		It differs according to the location.
FX-UP-RL	1	Set Fixing Roller prior alarm notice tmg
Detail		To set the number of days left before the prior notification alarm will be notified.
Use Case		When changing the timing to notify the prior notification alarm
Adj/Set/Operate Method		Enter the setting value, and then press OK key.
Display/Adj/Set Range		-1 to 365 -1: The alarm not issued
Default Value		It differs according to the location.
FX-LW-RL	1	Set Pressure Roller prior alarm ntc tmg
Detail		To set the number of days left before the prior notification alarm will be notified.
Use Case		When changing the timing to notify the prior notification alarm
Adj/Set/Operate Method		Enter the setting value, and then press OK key.
Display/Adj/Set Range		-1 to 365 -1: The alarm not issued
Default Value		It differs according to the location.
FX-WEB1	1	Set Fixing Web prior alarm notice timing
Detail		To set the number of days left before the prior notification alarm will be notified.
Use Case		When changing the timing to notify the prior notification alarm
Adj/Set/Operate Method		Enter the setting value, and then press OK key.
Display/Adj/Set Range		-1 to 365 -1: The alarm not issued
Default Value		It differs according to the location.

TEST (Print test mode)

■ PG

COPIER (Service mode for printer) > TEST (Print test mode) > PG

TYPE	1	Test print
Detail		To execute the test print.
Use Case		At trouble analysis
Adj/Set/Operate Method		1) Enter the setting value, and then press OK key. 2) Press Start key. Test print is executed.
Caution		Be sure to return the value to 0 after the test print output.
Display/Adj/Set Range		0 to 50 0: Normal print 1: Grid 2: 17 gradations Tbic rank 2 3: 17 gradations 600 dpi (134-line screen or 141-line screen) 4: Solid white 5: Halftone (density: 80H, Tbic rank 2, without image correction) 6: Halftone (density: 80H, 134-line screen or 141-line screen, without image correction) 7: Solid black 8: Horizontal line (4 dots, 27 spaces) 9: Horizontal line (6 dots, 50 spaces) 10: Horizontal line (2 dots, 3 spaces) 11: Halftone (density: 60H, Tbic rank 2, without image correction) 12: Halftone (density: 80H, 134-line screen or 141-line screen, without image correction) 13: Halftone (density: 30H, Tbic rank 2, without image correction) 14: Halftone (density: 30H, 134-line screen or 141-line screen, without image correction) 15 to 50: For development
Default Value		0
TXPH	1	Setting of test print image mode
Detail		To set the image mode at the time of test print output. This mode is enabled for test print only.
Use Case		At trouble analysis
Adj/Set/Operate Method		Enter the setting value, and then press OK key.
Display/Adj/Set Range		0 to 6 0: Error diffusion 1: Low screen ruling (approx. 133 to 190 lines) 2: High screen ruling (approx. 200 to 268 lines) 3: Copy screen (approx. 220 lines) 4: REOS screen (no screen structure) 5: Error diffusion (with trailing edge adjustment) 6: High screen ruling (with trailing edge adjustment)
Default Value		0
DENS-K	1	Adj of Bk color density at test print
Detail		To adjust Bk color density when performing test print (TYPE=5). As the greater value is set, the image gets darker.
Use Case		At test print (TYPE=5)
Adj/Set/Operate Method		Enter the setting value, and then press OK key.
Display/Adj/Set Range		0 to 255
Default Value		128

COPIER (Service mode for printer) > TEST (Print test mode) > PG

PG-PICK	1	Setting of test print Pickup Cassette
Detail	To set the Pickup Cassette for test print output.	
Use Case	- At trouble analysis - At test print output	
Adj/Set/Operate Method	Enter the setting value, and then press OK key.	
Display/Adj/Set Range	1 to 8 1: Cassette 1 (Right Deck), 2: Cassette 2 (Left Deck), 3: Cassette 3 (Option Cassette 2), 4: Cassette 4 (Option Cassette 2), 5: Multi-purpose Tray, 6: Paper Deck, 7 to 8: Not used	
2-SIDE	1	Setting of PG 2-sided mode
Detail	To set 1-sided/2-sided print for PG output.	
Use Case	At trouble analysis	
Adj/Set/Operate Method	Enter the setting value, and then press OK key.	
Display/Adj/Set Range	0 to 1 0: 1-sided, 1: 2-sided	
Default Value	0	
PG-QTY	1	Setting of PG output quantity
Detail	To set the number of sheets for PG output.	
Use Case	At trouble analysis	
Adj/Set/Operate Method	Enter the setting value, and then press OK key.	
Display/Adj/Set Range	1 to 999	
Unit	sheet	
Default Value	1	
Amount of Change per Unit	1	
FINISH	1	Accessory processing function test print
Detail	To execute the test print relating to accessory processing function.	
Use Case	When checking operation of accessory processing function	
Adj/Set/Operate Method	1) Enter the number of sheets for PG-QTY, and then press OK key. 2) Enter the setting value, and then press OK key. 3) Press Start button. The machine outputs a test print.	
Display/Adj/Set Range	0 to 99 0: N/A 1: Staple (front) *1 2: Staple (2 points) *1 3: Staple (rear) *1 4: Booklet (saddle stitch) *1 5: Z-fold (single sleeve) *1 6: 2-fold *2 7: C-fold *2 8: V-fold *1 9: 4-fold *2 10: Z-fold (out-3-fold) *2 11: Punch (Inner Puncher) *3 12: Multiple-hole punch *4 14: Trimming (Booklet Trimmer) 16: Staple free stapling*1 17 to 99: Spare (for future use) *1 Finisher, *2 Multi-folding machine, *3 Inner Puncher, *4 Multiple-hole Puncher	
Default Value	0	
Related Service Mode	COPIER> TEST> PG> PG-QTY	

■ NETWORK

COPIER (Service mode for printer) > TEST (Print test mode) > NETWORK

PING	1	Network connection check
Detail		To check connection between this machine and TCP/IP network.
Use Case		- When checking network connection at the time of installation - At network connection failure
Adj/Set/Operate Method		1) Turn OFF the main power switch. 2) Connect the network cable to this machine, and then turn ON the main power switch. 3) Inform the system administrator at user's site that installation of this machine is complete, and ask for network setting. 4) Ask the system administrator to check the network connection, and check the remote host address of PING transmission target. 5) Select the item and enter the remote host address, and then press OK key and Start key. OK: Connection is normal. Checking procedure is complete. NG: Connection failed. Go to step 6) if the cable connection is OK. In case of cable connection failure, connect again and then go to step 5). 6) Select the item and enter loopback address, and then press OK key and Start key. OK: TCP/IP setting of this machine is normal. Go to step 7) to check NIC. NG: TCP/IP setting of this machine has failure. Go to step 3) to check the setting again. 7) Select the item and enter the local host address, and then press OK key. OK: Network setting of this machine and NIC are normal. Inform the system administrator that the trouble is due to network environment and ask for countermeasure. NG: Connection failure/fault with NIC. Check connection of NIC/ replace NIC.
Display/Adj/Set Range		0.0.0.0 to 255.255.255.255 At normal state: OK At failure occurrence: NG
Supplement/Memo		- Remote host address: IP address of PC terminal in network. - Loopback address: 127.0.0.1. Checking TCP/IP of this machine is available because the signal is returned before NIC. - NIC: Network interface - Local host address: IP address of this machine
IPV6-ADR	1	Setting of PING send address (IPv6)
Detail		To set the IPv6 address to send PING. When PING is sent to this address by COPIER> TEST> NETWORK> PING-IP6, the network connection condition in the IPv6 environment can be checked.
Adj/Set/Operate Method		Enter the setting value, and then press OK key.
Caution		- Enter a consistent character string as an address of IPv6. - Enter an address within 39 characters including hexadecimal numbers (0-9, a-f) and a separator (:).
Related Service Mode		COPIER> TEST> NETWORK> PING-IP6
PING-IP6	1	PING transmission to IPv6 address
Detail		To send PING to the address specified by IPV6-ADR. The network connection condition in the IPv6 environment can be checked.
Adj/Set/Operate Method		Select the item, and then press OK key.
Related Service Mode		COPIER> TEST> NETWORK> IPV6-ADR

■ NET-CAP

COPIER (Service mode for printer) > TEST (Print test mode) > NET-CAP

CAPOFFON	2	ON/OFF of NetCap function
Detail	To set ON/OFF of network packet capture function.	
Adj/Set/Operate Method	Enter the setting value, and then press OK key.	
Display/Adj/Set Range	0 to 1 0: OFF, 1: ON	
Default Value	0	
Related Service Mode	COPIER> TEST> NET-CAP	
Additional Functions Mode	Store Network Packet Log	
STT-STP	2	Start and stop of network packet capture
Detail	To start and stop network packet capture.	
Adj/Set/Operate Method	Enter the setting value, and then press OK key.	
Display/Adj/Set Range	0 to 1 0: Stop, 1: Start	
Default Value	0	
Related Service Mode	COPIER> TEST> NET-CAP	
Additional Functions Mode	Store Network Packet Log	
CAPSTATE	2	State display of network packet capture
Detail	To display the state of network packet capture.	
Adj/Set/Operate Method	N/A (Display only)	
Related Service Mode	COPIER> TEST> NET-CAP	
Additional Functions Mode	Store Network Packet Log	
PONSTART	2	Set network packet capture start timing
Detail	To set whether to perform network packet capture from power-on.	
Adj/Set/Operate Method	1) Enter the setting value, and then press OK key. 2) Turn OFF/ON the main power switch.	
Display/Adj/Set Range	0 to 1 0: OFF, 1: ON	
Default Value	0	
Related Service Mode	COPIER> TEST> NET-CAP	
Additional Functions Mode	Store Network Packet Log	
OVERWRIT	2	Setting of NetCap data overwriting
Detail	To set whether to finish network capturing or overwrite when HDD becomes full.	
Adj/Set/Operate Method	1) Enter the setting value, and then press OK key. 2) Turn OFF/ON the main power switch.	
Display/Adj/Set Range	0 to 1 0: No overwriting (finish network packet capture), 1: Overwriting	
Default Value	1	
Related Service Mode	COPIER> TEST> NET-CAP	
Additional Functions Mode	Store Network Packet Log	

COPIER (Service mode for printer) > TEST (Print test mode) > NET-CAP

PAYLOAD	2	Set network packet capture data save
Detail		To set whether to discard payload when saving the captured packet data.
Adj/Set/Operate Method		1) Enter the setting value, and then press OK key. 2) Turn OFF/ON the main power switch.
Display/Adj/Set Range		0 to 1 0: Save captured packet data as is, 1: Discard payload and save the packet data
Default Value		0
Related Service Mode		COPIER> TEST> NET-CAP
Additional Functions Mode		Store Network Packet Log
FILE-CLR	2	Deletion of network packet capture data
Detail		To delete the captured packet data.
Adj/Set/Operate Method		1) Enter the setting value, and then press OK key. 2) Turn OFF/ON the main power switch.
SIMPFILT	2	Settings of packet data filtering
Detail		To set whether to perform filtering when capturing packet data. When 0 is set, filtering is not performed (All the data are captured.) When 1 is set, packet data is captured only when the receiver's or sender's address coincides with the Mac address of this machine.
Use Case		At problem analysis (at packet data analysis)
Adj/Set/Operate Method		1) Enter the setting value, and then press OK key. 2) Turn OFF/ON the main power switch.
Display/Adj/Set Range		0 to 1 0: Not filtered, 1: Filtered
ENCDATA	2	Setting of packet data encryption
Detail		To set whether to encrypt the packet data when writing the captured packet data to the USB memory.
Use Case		- At problem analysis (at packet data analysis) - When improving security of written packet data
Adj/Set/Operate Method		1) Enter the setting value, and then press OK key. 2) Turn OFF/ON the main power switch.
Caution		This setting is enabled only when writing data to the USB memory. Even when the packet data is loaded using SST, the file is specified, therefore the setting is disabled.
Display/Adj/Set Range		0 to 2 0: Encrypted (encrypted file) 1: Not encrypted (plain text file) 2: Encrypted (encrypted file + plain text file)
Default Value		0
CAPIF	2	Setting of network packet capture target
Detail		To set the network interface to capture the packet data. Make this setting before starting network packet capture.
Use Case		When changing the target of network packet capture
Adj/Set/Operate Method		Enter the setting value, and then press OK key.
Display/Adj/Set Range		1 to 6 1: Local loopback, 2: Wired LAN, 3: Wireless LAN, 4: Wireless Soft AP mode, 5: Wi-Fi direct 6: Wired LAN (Sub-Line)
Default Value		2
Related Service Mode		COPIER> TEST> NET-CAP

■ P-STOP

COPIER (Service mode for printer) > TEST (Print test mode) > P-STOP

PRINTER	1	Forcible stop of paper feed
Detail		To forcibly stop paper for the next job at the specified position (only once). Leading edge of paper stops at the specified position so that the cause of a problem can be identified. When the operation is stopped forcibly, jam code "AAxx" is displayed. When a normal jam occurs at a position other than the specified position or paper is delivered without being forcibly stopped, this setting is automatically cleared.
Use Case		- When bent paper/skew/wrinkles occur - When jam occurs frequently
Adj/Set/Operate Method		1) Enter the setting value, and then press OK key. 2) Execute a job (copy/test print). Paper stops at the specified position.
Caution		- Remove the paper being stopped with the normal jam removal procedure. After jam removal, the job is automatically recovered. - Display of standard jam code indicates that a jam occurs somewhere other than the specified position. Setting of forcible stop is enabled until paper stops at the specified position. - The setting is disabled for job where paper does not pass through the specified position. - Unfixed toner may be adhered on paper depending on the stop position. Thus, handle it with care.
Display/Adj/Set Range		0 to 255 0: OFF 1: Outlet of the Right Deck Pickup Assembly 2: Outlet of the Left Deck Pickup Assembly 3: Outlet of the Cassette 3 Pickup Assembly 4: Outlet of the Cassette 4 Pickup Assembly 5: Outlet of the Pickup Option Deck 6: Vertical Path Assembly (Lower) 7: Vertical Path Assembly (Middle) 8: Vertical Path Assembly (Upper) 20: Outlet of the Vertical Path Assembly, 21: Outlet of the Vertical Path Assembly (2nd side) 22: Inlet of the Registration Assembly, 23: Inlet of the Registration Assembly (2nd side) 30: Inlet of the Fixing Assembly, 31: Inlet of the Fixing Assembly (2nd side) 40: Delivery outlet, 41: Delivery outlet (2nd side) 70: Inlet of the Reverse Assembly 71: Duplex reverse point (before reverse), 72: Duplex reverse point (at reverse) 73: Inlet of the Duplex Feed Unit 74: Duplex Feed Unit (before merging) 75: Duplex Feed Unit (after merging) 76: Outlet of the Duplex Feed Unit 99: Inlet of the Fixing Assembly (1st side, when checking image) * Any value other than those mentioned above: Not used * If image and paper is A3/LDR size, not only paper but also image on the Photosensitive Drum can be checked.
Default Value		0

COUNTER (Counter mode)

■ TOTAL

COPIER (Service mode for printer) > COUNTER (Counter mode) > TOTAL

SERVICE1	1	Service-purposed total counter 1
Detail		To count up when the printout is delivered outside the machine. Large size: 1, Small size: 1 A blank sheet is not counted.
Display/Adj/Set Range		0 to 99999999

COPIER (Service mode for printer) > COUNTER (Counter mode) > TOTAL

SERVICE2	1	Service-purposed total counter 2
	Detail	To count up when the printout is delivered outside the machine. Large size: 2, Small size: 1 A blank sheet is not counted.
	Display/Adj/Set Range	0 to 99999999
COPY	1	Total copy counter
	Detail	To count up when the printout is delivered outside the machine. Large size: 1, Small size: 1 A blank sheet is not counted.
	Display/Adj/Set Range	0 to 99999999
PDL-PRT	1	PDL print counter
	Detail	To count up when the printout is delivered outside the machine according to the charge counter at PDL print. Large size: 1, Small size: 1 A blank sheet is not counted.
	Display/Adj/Set Range	0 to 99999999
FAX-PRT	1	FAX reception print counter
	Detail	To count up when the printout is delivered outside the machine according to the charge counter at FAX reception. Large size: 1, Small size: 1 A blank sheet is not counted.
	Display/Adj/Set Range	0 to 99999999
RMT-PRT	1	Remote print counter
	Detail	To count up when the printout is delivered outside the machine/when the 2-sided printout is stacked according to the charge counter at remote print. Large size: 1, Small size: 1 A blank sheet is not counted.
	Display/Adj/Set Range	0 to 99999999
BOX-PRT	1	Inbox print counter
	Detail	To count up when the printout is delivered outside the machine according to the charge counter at Inbox print. Large size: 1, Small size: 1 A blank sheet is not counted.
	Display/Adj/Set Range	0 to 99999999
RPT-PRT	1	Report print counter
	Detail	To count up when the printout is delivered outside the machine according to the charge counter at report print. Large size: 1, Small size: 1 A blank sheet is not counted.
	Display/Adj/Set Range	0 to 99999999
2-SIDE	1	2-sided copy/print counter
	Detail	To count up the number of 2-sided copies/prints when the copy/printout is delivered outside the machine according to the charge counter. Large size: 1, Small size: 1 A blank sheet is not counted.
	Display/Adj/Set Range	0 to 99999999

COPIER (Service mode for printer) > COUNTER (Counter mode) > TOTAL

SCAN	1	Scan counter
Detail	To count the number of scan operations according to the charge counter when the scanning operation is complete. Large size: 1, small size: 1	
Display/Adj/Set Range	0 to 99999999	

■ PICK-UP

COPIER (Service mode for printer) > COUNTER (Counter mode) > PICK-UP

C1	1	Cassette 1 pickup total counter
Detail	Small size: 1	
Unit	sheet	
C2	1	Cassette 2 pickup total counter
Detail	Small size: 1	
Unit	sheet	
C3	1	Cassette 3 pickup total counter
Detail	Total pickup counter value of the Cassette 3 Large size: 1, Small size: 1	
Unit	sheet	
C4	1	Cassette 4 pickup total counter
Detail	Total pickup counter value of the Cassette 4 Large size: 1, Small size: 1	
Unit	sheet	
MF	1	Multi-purpose Tray pickup total counter
Detail	Total pickup counter value of the Multi-purpose Tray Large size: 1, Small size: 1	
Unit	sheet	
DK	1	Deck pickup total counter
Detail	Total pickup counter value of the POD Deck Lite/Paper Deck Unit Large size: 1, Small size: 1	
Unit	sheet	
2-SIDE	1	2-sided pickup total counter
Detail	Total pickup counter value of 2-sided print Large size: 1, Small size: 1	
Unit	sheet	

■ FEEDER

COPIER (Service mode for printer) > COUNTER (Counter mode) > FEEDER

FEED	1	DADF original pickup total counter
Detail	DADF original pickup total counter	
Use Case	When checking the total counter of original pickup by DADF	
Display/Adj/Set Range	0 to 99999999	
Unit	sheet	
Default Value	0	

COPIER (Service mode for printer) > COUNTER (Counter mode) > FEEDER

L-FEED	1	DADF large size pickup total counter
Detail	DADF large size pickup total counter	
Use Case	When checking the total counter of large size pickup by DADF	
Display/Adj/Set Range	0 to 99999999	
Unit	sheet	
Default Value	0	
S-FEED	1	DADF small size pickup total counter
Detail	DADF small size pickup total counter	
Use Case	When checking the total counter of small size pickup by DADF	
Display/Adj/Set Range	0 to 99999999	
Unit	sheet	
Default Value	0	
DFOP-CNT	1	DADF hinge open/close counter
Detail	DADF hinge open/close counter	
Use Case	When checking the DADF hinge open/close counter	
Display/Adj/Set Range	0 to 99999999	
Unit	sheet	
Default Value	0	

■ JAM

COPIER (Service mode for printer) > COUNTER (Counter mode) > JAM

TOTAL	1	Host machine total jam counter
Detail	Host machine total jam counter	
Use Case	When checking the total jam counter of the host machine	
Unit	time	
FEEDER	1	Feeder total jam counter
Detail	Feeder total jam counter	
Use Case	When checking the total jam counter of feeder	
Unit	time	
SORTER	1	Finisher total jam counter
Detail	Finisher total jam counter	
Use Case	When checking the total jam counter of finisher	
Unit	time	
2-SIDE	1	Duplex Unit jam counter
Detail	Duplex Unit jam counter	
Use Case	When checking the jam counter of Duplex Unit	
Adj/Set/Operate Method	To clear the counter value: Select the item, and then press Clear key.	
Unit	time	
MF	1	Multi-purpose Tray jam counter
Detail	Multi-purpose Tray jam counter	
Use Case	When checking the jam counter of Multi-purpose Tray	
Unit	time	

COPIER (Service mode for printer) > COUNTER (Counter mode) > JAM

C1	1	Right Deck jam counter
Detail		Right Deck jam counter
Use Case		When checking the jam counter of machine's Right Deck
Unit		time
C2	1	Left Deck jam counter
Detail		Left Deck jam counter
Use Case		When checking the jam counter of machine's Left Deck
Unit		time
C3	1	Cassette 3 pickup jam counter
Detail		Cassette 3 pickup jam counter
Use Case		When checking the jam counter of machine's Cassette 3
Unit		time
C4	1	Cassette 4 pickup jam counter
Detail		Cassette 4 pickup jam counter
Use Case		When checking the jam counter of machine's Cassette 4
Unit		time
DK	1	Pickup decks jam counter
Detail		Pickup decks jam counter
Use Case		When checking the jam counter of all pickup decks
Adj/Set/Operate Method		To clear the counter value: Select the item, and then press Clear key.
Unit		time
INS1	1	Inserter Tray pickup jam counter
Detail		Pickup jam counter value of the Inserter Tray In the case of the Inserter, the Upper Tray is the target for advancing the counter.
Use Case		When checking the pickup jam counter
Adj/Set/Operate Method		To clear the counter value: Select the item, and then press Clear key.
Display/Adj/Set Range		0 to 99999999
Unit		time
Default Value		0
INS2	1	Inserter Lower Tray pickup jam counter
Detail		Pickup jam counter value of the Lower Tray of the Inserter
Use Case		When checking the pickup jam counter
Adj/Set/Operate Method		To clear the counter value: Select the item, and then press Clear key.
Display/Adj/Set Range		0 to 99999999
Unit		time
Default Value		0

■ MISC

COPIER (Service mode for printer) > COUNTER (Counter mode) > MISC

FIX-WEB	1	Fixing Cleaning Web counter
Detail		The number of Fixing Cleaning Web Drive Solenoid (SL9) operations executed after the Fixing Cleaning Web Level Sensor (PS45) is ON. When the counter reaches 65250, E005-0001 occurs.
Use Case		At the time of Fixing Cleaning Web level detection/replacement
Adj/Set/Operate Method		To clear the counter value: Select the item, and then press Clear key.
Caution		Clear the counter value after replacement.
Unit		time
T-SPLY-K	1	Toner supply counter
Detail		Number of toner supply blocks. Counted for every one rotation of Toner Feed Screw.
Use Case		When checking the usage status of toner
Unit		block
ALLPW-ON	1	Number of DCON PCB power-on times
Detail		Number of power-on times (Non-all-night Power Unit). To count up when power is turned ON (Non-all-night Power Unit).
Use Case		When checking the usage status of the product
Unit		time
Default Value		0
Amount of Change per Unit		1
HDD-ON	1	Number of HDD start-up times
Detail		To count up at HDD start-up.
Use Case		When checking the usage status of the product
Unit		time
Default Value		0
Amount of Change per Unit		1
SWG-RL	1	For R&D
Default Value		0
Amount of Change per Unit		1
FIN-RBLT	1	For R&D
Amount of Change per Unit		1

COPIER (Service mode for printer) > COUNTER (Counter mode) > MISC

NEAT-PDL	1	Neat Paddle prts cntr: Fin-AC1
Detail	Neat Paddle 1st line: Total counter value from the previous replacement 2nd line: Estimated life	
Use Case	Neat Paddle 1st line: Total counter value from the previous replacement 2nd line: Estimated life	
Adj/Set/Operate Method	To clear the counter value: Select the item, and then press Clear key. To change the estimated life: Select the item, enter the value, and then press OK key.	
Caution	Clear the counter value after replacement.	
Display/Adj/Set Range	0 to 3600000	
Unit	sheet	
Default Value	0	

■ JOB

COPIER (Service mode for printer) > COUNTER (Counter mode) > JOB

DVPAPLEN	1	For R&D
DVRUNLEN	1	For R&D

■ PRDC-1

COPIER (Service mode for printer) > COUNTER (Counter mode) > PRDC-1

PRM-WIRE	1	Primary Charging Wire parts counter
Detail	Primary Charging Wire 1st line: Total counter value from the previous replacement 2nd line: Estimated life value	
Use Case	When checking the consumption level of parts/replacing the parts	
Adj/Set/Operate Method	To clear the counter value: Select the item, and then press Clear key. To change the estimated life: Select the item, enter the value, and then press OK key.	
Caution	Clear the counter value after replacement.	
Display/Adj/Set Range	0 to 99999999	
Default Value	0	
Supplement/Memo	This is commonly used as operator maintenance parts counter.	
PO-WIRE	1	Pre-transfer Charging Wire parts cntr
Detail	Pre-transfer Charging Wire 1st line: Total counter value from the previous replacement 2nd line: Estimated life value	
Use Case	When checking the consumption level of parts/replacing the parts	
Adj/Set/Operate Method	To clear the counter value: Select the item, and then press Clear key. To change the estimated life: Select the item, enter the value, and then press OK key.	
Caution	Clear the counter value after replacement.	
Display/Adj/Set Range	0 to 99999999	
Default Value	0	

COPIER (Service mode for printer) > COUNTER (Counter mode) > PRDC-1

PRM-CLN	1	Primary Charge Wire Clean Pad prts cntr
Detail		Primary Charging Wire Cleaning Pad 1, 2 1st line: Total counter value from the previous replacement 2nd line: Estimated life
Use Case		When checking the consumption level of parts/replacing the parts
Adj/Set/Operate Method		To clear the counter value: Select the item, and then press Clear key. To change the estimated life: Select the item, enter the value, and then press OK key.
Caution		Clear the counter value after replacement.
Display/Adj/Set Range		0 to 99999999
Default Value		0
PO-CLN	1	Pre-trn Charge Wire Clean Pad prts cntr
Detail		Pre-transfer Charging Wire Cleaning Pad 1, 2 1st line: Total counter value from the previous replacement 2nd line: Estimated life
Use Case		When checking the consumption level of parts/replacing the parts
Adj/Set/Operate Method		To clear the counter value: Select the item, and then press Clear key. To change the estimated life: Select the item, enter the value, and then press OK key.
Caution		Clear the counter value after replacement.
Display/Adj/Set Range		0 to 99999999
Default Value		0
FIX-TH1	1	Fixing Main Thermistor parts counter
Detail		Fixing Main Thermistor 1st line: Total counter value from the previous replacement 2nd line: Estimated life value
Use Case		When checking the consumption level of parts/replacing the parts
Adj/Set/Operate Method		To clear the counter value: Select the item, and then press Clear key. To change the estimated life: Select the item, enter the value, and then press OK key.
Caution		Clear the counter value after replacement.
Display/Adj/Set Range		0 to 99999999
Default Value		0
FIX-TH2	1	Fixing Sub Thermistor parts counter
Detail		Fixing Sub Thermistor 1, 2 1st line: Total counter value from the previous replacement 2nd line: Estimated life
Use Case		When checking the consumption level of parts/replacing the parts
Adj/Set/Operate Method		To clear the counter value: Select the item, and then press Clear key. To change the estimated life: Select the item, enter the value, and then press OK key.
Caution		Clear the counter value after replacement.
Display/Adj/Set Range		0 to 99999999
Default Value		0
OZ-FIL1	1	Ozone Filter parts counter
Detail		Ozone Filter 1st line: Total counter value from the previous replacement 2nd line: Estimated life value
Use Case		When checking the consumption level of parts/replacing the parts
Adj/Set/Operate Method		To clear the counter value: Select the item, and then press Clear key. To change the estimated life: Select the item, enter the value, and then press OK key.
Caution		Clear the counter value after replacement.
Display/Adj/Set Range		0 to 99999999
Default Value		0

COPIER (Service mode for printer) > COUNTER (Counter mode) > PRDC-1

AR-FIL1	1	Primary Suction Air Filter prts cntr
Detail	Dustproof Filter 1st line: Total counter value from the previous replacement 2nd line: Estimated life value	
Use Case	When checking the consumption level of parts/replacing the parts	
Adj/Set/Operate Method	To clear the counter value: Select the item, and then press Clear key. To change the estimated life: Select the item, enter the value, and then press OK key.	
Caution	Clear the counter value after replacement.	
Display/Adj/Set Range	0 to 99999999	
Default Value	0	
Supplement/Memo	This is commonly used as operator maintenance parts counter.	

■ DRBL-1

COPIER (Service mode for printer) > COUNTER (Counter mode) > DRBL-1

PRM-UNIT	1	Primary Charging Assembly parts counter
Detail	Primary Charging Assembly 1st line: Total counter value from the previous replacement 2nd line: Estimated life value	
Use Case	When checking the consumption level of parts/replacing the parts	
Adj/Set/Operate Method	To clear the counter value: Select the item, and then press Clear key. To change the estimated life: Select the item, enter the value, and then press OK key.	
Caution	Clear the counter value after replacement.	
Display/Adj/Set Range	0 to 99999999	
Default Value	0	
PO-UNIT	1	Pre-transfer Charging Ass'y parts cntr
Detail	Pre-transfer Charging Assembly 1st line: Total counter value from the previous replacement 2nd line: Estimated life value	
Use Case	When checking the consumption level of parts/replacing the parts	
Adj/Set/Operate Method	To clear the counter value: Select the item, and then press Clear key. To change the estimated life: Select the item, enter the value, and then press OK key.	
Caution	Clear the counter value after replacement.	
Display/Adj/Set Range	0 to 99999999	
Default Value	0	
T-CLN-BD	1	ETB Cleaning Blade parts counter
Detail	ETB Cleaning Blade 1st line: Total counter value from the previous replacement 2nd line: Estimated life value	
Use Case	When checking the consumption level of parts/replacing the parts	
Adj/Set/Operate Method	To clear the counter value: Select the item, and then press Clear key. To change the estimated life: Select the item, enter the value, and then press OK key.	
Caution	Clear the counter value after replacement.	
Display/Adj/Set Range	0 to 99999999	
Default Value	0	

COPIER (Service mode for printer) > COUNTER (Counter mode) > DRBL-1

T-CN-BRU	1	Brush Roller parts counter
Detail	Brush Roller 1st line: Total counter value from the previous replacement 2nd line: Estimated life value	
Use Case	When checking the consumption level of parts/replacing the parts	
Adj/Set/Operate Method	To clear the counter value: Select the item, and then press Clear key. To change the estimated life: Select the item, enter the value, and then press OK key.	
Caution	Clear the counter value after replacement.	
Display/Adj/Set Range	0 to 99999999	
Default Value	0	
TR-BLT	1	ETB parts counter
Detail	ETB 1st line: Total counter value from the previous replacement 2nd line: Estimated life value	
Use Case	When checking the consumption level of parts/replacing the parts	
Adj/Set/Operate Method	To clear the counter value: Select the item, and then press Clear key. To change the estimated life: Select the item, enter the value, and then press OK key.	
Caution	Clear the counter value after replacement.	
Display/Adj/Set Range	0 to 99999999	
Unit	sheet	
Default Value	0	
Related Service Mode	COPIER> FUNCTION> CLEAR> TR-BLT	
TR-ROLL	1	Transfer Roller parts counter
Detail	Transfer Roller 1st line: Total counter value from the previous replacement 2nd line: Estimated life value	
Use Case	When checking the consumption level of parts/replacing the parts	
Adj/Set/Operate Method	To clear the counter value: Select the item, and then press Clear key. To change the estimated life: Select the item, enter the value, and then press OK key.	
Caution	Clear the counter value after replacement.	
Display/Adj/Set Range	0 to 99999999	
Default Value	0	
Supplement/Memo	This is commonly used as operator maintenance parts counter.	
PT-DRM	1	Photosensitive Drum parts counter
Detail	Photosensitive Drum 1st line: Total counter value from the previous replacement 2nd line: Estimated life value	
Use Case	When checking the consumption level of parts/replacing the parts	
Adj/Set/Operate Method	To clear the counter value: Select the item, and then press Clear key. To change the estimated life: Select the item, enter the value, and then press OK key.	
Caution	Clear the counter value after replacement.	
Display/Adj/Set Range	0 to 99999999	
Default Value	0	

COPIER (Service mode for printer) > COUNTER (Counter mode) > DRBL-1

CLN-BLD	1	Drum Cleaning Blade parts counter
Detail	Drum Cleaning Blade 1st line: Total counter value from the previous replacement 2nd line: Estimated life value	
Use Case	When checking the consumption level of parts/replacing the parts	
Adj/Set/Operate Method	To clear the counter value: Select the item, and then press Clear key. To change the estimated life: Select the item, enter the value, and then press OK key.	
Caution	Clear the counter value after replacement.	
Display/Adj/Set Range	0 to 99999999	
Default Value	0	
SP-CLAW	1	Drum Separation Claw parts counter
Detail	Drum Separation Claw 1st line: Total counter value from the previous replacement 2nd line: Estimated life value	
Use Case	When checking the consumption level of parts/replacing the parts	
Adj/Set/Operate Method	To clear the counter value: Select the item, and then press Clear key. To change the estimated life: Select the item, enter the value, and then press OK key.	
Caution	Clear the counter value after replacement.	
Display/Adj/Set Range	0 to 99999999	
Default Value	0	
BS-SL-F	1	Drum Front Side Seal parts counter
Detail	Drum Front Side Seal 1st line: Total counter value from the previous replacement 2nd line: Estimated life value	
Use Case	When checking the consumption level of parts/replacing the parts	
Adj/Set/Operate Method	To clear the counter value: Select the item, and then press Clear key. To change the estimated life: Select the item, enter the value, and then press OK key.	
Caution	Clear the counter value after replacement.	
Display/Adj/Set Range	0 to 99999999	
Default Value	0	
BS-SL-R	1	Drum Rear Side Seal parts counter
Detail	Drum Rear Side Seal 1st line: Total counter value from the previous replacement 2nd line: Estimated life value	
Use Case	When checking the consumption level of parts/replacing the parts	
Adj/Set/Operate Method	To clear the counter value: Select the item, and then press Clear key. To change the estimated life: Select the item, enter the value, and then press OK key.	
Caution	Clear the counter value after replacement.	
Display/Adj/Set Range	0 to 99999999	
Default Value	0	
DV-UNT-K	1	Developing Unit (Bk) parts counter
Detail	Developing Unit (Bk) 1st line: Total counter value from the previous replacement 2nd line: Estimated life value	
Use Case	When checking the consumption level of parts/replacing the parts	
Adj/Set/Operate Method	To clear the counter value: Select the item, and then press Clear key. To change the estimated life value: Select the item, enter the value, and then press OK key.	
Display/Adj/Set Range	0 to 99999999	
Unit	sheet	
Default Value	0	

COPIER (Service mode for printer) > COUNTER (Counter mode) > DRBL-1

C1-PU-RL	1	Right Deck Pickup Roller parts counter
Detail	Right Deck Pickup Roller 1st line: Total counter value from the previous replacement 2nd line: Estimated life value	
Use Case	When checking the consumption level of parts/replacing the parts	
Adj/Set/Operate Method	To clear the counter value: Select the item, and then press Clear key. To change the estimated life: Select the item, enter the value, and then press OK key.	
Caution	Clear the counter value after replacement.	
Display/Adj/Set Range	0 to 99999999	
Unit	sheet	
Default Value	0	
C1-SP-RL	1	Right Deck Separation Roller parts cntr
Detail	Right Deck Separation Roller 1st line: Total counter value from the previous replacement 2nd line: Estimated life value	
Use Case	When checking the consumption level of parts/replacing the parts	
Adj/Set/Operate Method	To clear the counter value: Select the item, and then press Clear key. To change the estimated life: Select the item, enter the value, and then press OK key.	
Caution	Clear the counter value after replacement.	
Display/Adj/Set Range	0 to 99999999	
Unit	sheet	
Default Value	0	
C1-FD-RL	1	Right Deck Feed Roller parts counter
Detail	Right Deck Feed Roller 1st line: Total counter value from the previous replacement 2nd line: Estimated life value	
Use Case	When checking the consumption level of parts/replacing the parts	
Adj/Set/Operate Method	To clear the counter value: Select the item, and then press Clear key. To change the estimated life: Select the item, enter the value, and then press OK key.	
Caution	Clear the counter value after replacement.	
Display/Adj/Set Range	0 to 99999999	
Unit	sheet	
Default Value	0	
C2-PU-RL	1	Left Deck Pickup Roller parts counter
Detail	Left Deck Pickup Roller 1st line: Total counter value from the previous replacement 2nd line: Estimated life value	
Use Case	When checking the consumption level of parts/replacing the parts	
Adj/Set/Operate Method	To clear the counter value: Select the item, and then press Clear key. To change the estimated life: Select the item, enter the value, and then press OK key.	
Caution	Clear the counter value after replacement.	
Display/Adj/Set Range	0 to 99999999	
Unit	sheet	
Default Value	0	

COPIER (Service mode for printer) > COUNTER (Counter mode) > DRBL-1

C2-SP-RL	1	Left Deck Separation Roller prts counter
Detail	Left Deck Separation Roller 1st line: Total counter value from the previous replacement 2nd line: Estimated life value	
Use Case	When checking the consumption level of parts/replacing the parts	
Adj/Set/Operate Method	To clear the counter value: Select the item, and then press Clear key. To change the estimated life: Select the item, enter the value, and then press OK key.	
Caution	Clear the counter value after replacement.	
Display/Adj/Set Range	0 to 99999999	
Unit	sheet	
Default Value	0	
C2-FD-RL	1	Left Deck Feed Roller parts counter
Detail	Left Deck Feed Roller 1st line: Total counter value from the previous replacement 2nd line: Estimated life value	
Use Case	When checking the consumption level of parts/replacing the parts	
Adj/Set/Operate Method	To clear the counter value: Select the item, and then press Clear key. To change the estimated life: Select the item, enter the value, and then press OK key.	
Caution	Clear the counter value after replacement.	
Display/Adj/Set Range	0 to 99999999	
Unit	sheet	
Default Value	0	
C3-PU-RL	1	Cassette 3 Pickup Roller parts counter
Detail	Cassette 3 Pickup Roller 1st line: Total counter value from the previous replacement 2nd line: Estimated life value	
Use Case	When checking the consumption level of parts/replacing the parts	
Adj/Set/Operate Method	To clear the counter value: Select the item, and then press Clear key. To change the estimated life: Select the item, enter the value, and then press OK key.	
Caution	Clear the counter value after replacement.	
Display/Adj/Set Range	0 to 99999999	
Default Value	0	
C3-SP-RL	1	Cassette 3 Separation Roller parts cntr
Detail	Cassette 3 Separation Roller 1st line: Total counter value from the previous replacement 2nd line: Estimated life value	
Use Case	When checking the consumption level of parts/replacing the parts	
Adj/Set/Operate Method	To clear the counter value: Select the item, and then press Clear key. To change the estimated life: Select the item, enter the value, and then press OK key.	
Caution	Clear the counter value after replacement.	
Display/Adj/Set Range	0 to 99999999	
Default Value	0	

COPIER (Service mode for printer) > COUNTER (Counter mode) > DRBL-1

C3-FD-RL	1	Cassette 3 Feed Roller parts counter
Detail	Cassette 3 Feed Roller 1st line: Total counter value from the previous replacement 2nd line: Estimated life value	
Use Case	When checking the consumption level of parts/replacing the parts	
Adj/Set/Operate Method	To clear the counter value: Select the item, and then press Clear key. To change the estimated life: Select the item, enter the value, and then press OK key.	
Caution	Clear the counter value after replacement.	
Display/Adj/Set Range	0 to 99999999	
Default Value	0	
C4-PU-RL	1	Cassette 4 Pickup Roller parts counter
Detail	Cassette 4 Pickup Roller 1st line: Total counter value from the previous replacement 2nd line: Estimated life value	
Use Case	When checking the consumption level of parts/replacing the parts	
Adj/Set/Operate Method	To clear the counter value: Select the item, and then press Clear key. To change the estimated life: Select the item, enter the value, and then press OK key.	
Caution	Clear the counter value after replacement.	
Display/Adj/Set Range	0 to 99999999	
Default Value	0	
C4-SP-RL	1	Cassette 4 Separation Roller parts cnter
Detail	Cassette 4 Separation Roller 1st line: Total counter value from the previous replacement 2nd line: Estimated life value	
Use Case	When checking the consumption level of parts/replacing the parts	
Adj/Set/Operate Method	To clear the counter value: Select the item, and then press Clear key. To change the estimated life: Select the item, enter the value, and then press OK key.	
Caution	Clear the counter value after replacement.	
Display/Adj/Set Range	0 to 99999999	
Default Value	0	
C4-FD-RL	1	Cassette 4 Feed Roller parts counter
Detail	Cassette 4 Feed Roller 1st line: Total counter value from the previous replacement 2nd line: Estimated life value	
Use Case	When checking the consumption level of parts/replacing the parts	
Adj/Set/Operate Method	To clear the counter value: Select the item, and then press Clear key. To change the estimated life: Select the item, enter the value, and then press OK key.	
Caution	Clear the counter value after replacement.	
Display/Adj/Set Range	0 to 99999999	
Default Value	0	

COPIER (Service mode for printer) > COUNTER (Counter mode) > DRBL-1

M-SP-RL	1	Multi-purpose Tray Sprtn Roll prts cntr
Detail	Multi-purpose Tray Separation Roller 1st line: Total counter value from the previous replacement 2nd line: Estimated life value	
Use Case	When checking the consumption level of parts/replacing the parts	
Adj/Set/Operate Method	To clear the counter value: Select the item, and then press Clear key. To change the estimated life: Select the item, enter the value, and then press OK key.	
Caution	Clear the counter value after replacement.	
Display/Adj/Set Range	0 to 99999999	
Unit	sheet	
Default Value	0	
M-FD-RL	1	Multi-purpose Tray Feed Roll prts cntr
Detail	Multi-purpose Tray Feed Roller 1st line: Total counter value from the previous replacement 2nd line: Estimated life value	
Use Case	When checking the consumption level of parts/replacing the parts	
Adj/Set/Operate Method	To clear the counter value: Select the item, and then press Clear key. To change the estimated life: Select the item, enter the value, and then press OK key.	
Caution	Clear the counter value after replacement.	
Display/Adj/Set Range	0 to 99999999	
Unit	sheet	
Default Value	0	
FX-UP-RL	1	Fixing Roller parts counter
Detail	Fixing Roller 1st line: Total counter value from the previous replacement 2nd line: Estimated life value	
Use Case	When checking the consumption level of parts/replacing the parts	
Adj/Set/Operate Method	To clear the counter value: Select the item, and then press Clear key. To change the estimated life: Select the item, enter the value, and then press OK key.	
Caution	Clear the counter value after replacement.	
Display/Adj/Set Range	0 to 99999999	
Default Value	0	
FX-LW-RL	1	Pressure Roller Unit parts counter
Detail	Pressure Roller Unit 1st line: Total counter value from the previous replacement 2nd line: Estimated life value	
Use Case	When checking the consumption level of parts/replacing the parts	
Adj/Set/Operate Method	To clear the counter value: Select the item, and then press Clear key. To change the estimated life: Select the item, enter the value, and then press OK key.	
Caution	Clear the counter value after replacement.	
Display/Adj/Set Range	0 to 99999999	
Default Value	0	

COPIER (Service mode for printer) > COUNTER (Counter mode) > DRBL-1

FX-IN-BS	1	Fixing Roller Insulating Bush parts cntr
Detail	Fixing Roller Insulating Bush 1st line: Total counter value from the previous replacement 2nd line: Estimated life value	
Use Case	When checking the consumption level of parts/replacing the parts	
Adj/Set/Operate Method	To clear the counter value: Select the item, and then press Clear key. To change the estimated life: Select the item, enter the value, and then press OK key.	
Caution	Clear the counter value after replacement.	
Display/Adj/Set Range	0 to 99999999	
Default Value	0	
FX-L-STC	1	Press Roller Static Eliminator prts cntr
Detail	Pressure Roller Static Eliminator (Front/Rear) 1st line: Total counter value from the previous replacement 2nd line: Estimated life value	
Use Case	When checking the consumption level of parts/replacing the parts	
Adj/Set/Operate Method	To clear the counter value: Select the item, and then press Clear key. To change the estimated life: Select the item, enter the value, and then press OK key.	
Caution	Clear the counter value after replacement.	
Display/Adj/Set Range	0 to 99999999	
Default Value	0	
DLV-UCLW	1	Upper Separation Claw parts counter
Detail	Upper Separation Claw 1st line: Total counter value from the previous replacement 2nd line: Estimated life value	
Use Case	When checking the consumption level of parts/replacing the parts	
Adj/Set/Operate Method	To clear the counter value: Select the item, and then press Clear key. To change the estimated life: Select the item, enter the value, and then press OK key.	
Caution	Clear the counter value after replacement.	
Display/Adj/Set Range	0 to 99999999	
Default Value	0	
WST-TNR	1	Waste Toner Container parts counter
Detail	1st line: Total counter value from the previous replacement 2nd line: Estimated life	
Use Case	When checking the consumption level of parts/replacing the parts	
Adj/Set/Operate Method	To clear the counter value: Select the item, and then press Clear key. To change the estimated life: Select the item, enter the value, and then press OK key.	
Caution	Clear the counter value after replacement.	
Display/Adj/Set Range	0 to 99999999	
Unit	image	
Default Value	0	
Amount of Change per Unit	1	

COPIER (Service mode for printer) > COUNTER (Counter mode) > DRBL-1

FX-RTNR	1	Fixing Roller Thrust Stopper parts cntr
Detail		Fixing Roller Thrust Retainer 1st line: Total counter value from the previous replacement 2nd line: Estimated life value
Use Case		When checking the consumption level of parts/replacing the parts
Adj/Set/Operate Method		To clear the counter value: Select the item, and then press Clear key. To change the estimated life: Select the item, enter the value, and then press OK key.
Caution		Clear the counter value after replacement.
Display/Adj/Set Range		0 to 99999999
Default Value		0
EXP-SCR1	1	Pre-exposure Scraper parts counter
Detail		Pre-exposure Scraper 1st line: Total counter value from the previous replacement 2nd line: Estimated life value
Use Case		When checking the consumption level of parts/replacing the parts
Adj/Set/Operate Method		To clear the counter value: Select the item, and then press Clear key. To change the estimated life: Select the item, enter the value, and then press OK key.
Caution		Clear the counter value after replacement.
Display/Adj/Set Range		0 to 99999999
Default Value		0
FX-WEB1	1	Fixing Web fed sheet cntr: accumulated
Detail		To set the accumulated number of fed sheets (converted on the basis of small size, including at the time of cleaning) as the number of take-ups of the Fixing Web. 1st line: Total counter value from the previous replacement 2nd line: Estimated life value By pressing Clear key when replacing the Fixing Web/Fixing Assembly, the numbers of fed sheets are reset.
Use Case		When checking the consumption level of parts/replacing the parts
Adj/Set/Operate Method		To clear the counter value: Select the item, and then press Clear key. To change the estimated life value: Select the item, enter the value, and then press OK key.
Caution		Clear the counter value after replacement.
Display/Adj/Set Range		0 to 99999999
Unit		sheet
Default Value		0
Amount of Change per Unit		1

■ DRBL-2

COPIER (Service mode for printer) > COUNTER (Counter mode) > DRBL-2

DF-PU-RL	1	Pickup Roller parts counter: All Reader
Detail		1st line: Total counter value from the previous replacement 2nd line: Estimated life
Use Case		When checking the consumption level of parts/replacing the parts
Adj/Set/Operate Method		To clear the counter value: Select the item, and then press Clear key. To change the estimated life: Select the item, enter the value, and then press OK key.
Caution		Clear the counter value after replacement.
Display/Adj/Set Range		0 to 99999999
Unit		sheet
Default Value		0
Supplement/Memo		Regardless of the read mode (1-sided/2-sided), the counter is advanced every time a sheet is fed.
Amount of Change per Unit		1
DF-SP-RL	1	Separation Roller parts counter: DADF
Detail		1st line: Total counter value from the previous replacement 2nd line: Estimated life
Use Case		When checking the consumption level of parts/replacing the parts
Adj/Set/Operate Method		To clear the counter value: Select the item, and then press Clear key. To change the estimated life: Select the item, enter the value, and then press OK key.
Caution		Clear the counter value after replacement.
Display/Adj/Set Range		0 to 99999999
Unit		sheet
Default Value		0
Supplement/Memo		Regardless of the read mode (1-sided/2-sided), the counter is advanced every time a sheet is fed.
Amount of Change per Unit		1
STAMP	1	Stamp parts counter: DADF
Detail		To display the estimated life and parts counter of DADF stamp. 1st line: Total counter value from the previous replacement 2nd line: Estimated life to be entered by operator
Use Case		At replacement
Adj/Set/Operate Method		To clear the counter value: Select the item, and then press Clear key. To change the estimated life: Select the item, enter the value, and then press OK key.
Caution		Clear the counter value after replacement.
Display/Adj/Set Range		0 to 99999999
Unit		sheet
Default Value		0
Amount of Change per Unit		1

COPIER (Service mode for printer) > COUNTER (Counter mode) > DRBL-2

PD-PU-RL	1	Pickup Roller parts counter: Deck
Detail		Pickup Roller (Front/Rear) of Paper Deck/POD Deck Lite 1st line: Total counter value from the previous replacement 2nd line: Estimated life
Use Case		When checking the consumption level of parts/replacing the parts
Adj/Set/Operate Method		To clear the counter value: Select the item, and then press Clear key. To change the estimated life: Select the item, enter the value, and then press OK key.
Caution		Clear the counter value after replacement.
Display/Adj/Set Range		0 to 99999999
Unit		sheet
Default Value		0
Amount of Change per Unit		1
PD-SP-RL	1	Separation Roller parts counter: Deck
Detail		Separation Roller of Paper Deck/POD Deck Lite 1st line: Total counter value from the previous replacement 2nd line: Estimated life
Use Case		When checking the consumption level of parts/replacing the parts
Adj/Set/Operate Method		To clear the counter value: Select the item, and then press Clear key. To change the estimated life: Select the item, enter the value, and then press OK key.
Caution		Clear the counter value after replacement.
Display/Adj/Set Range		0 to 99999999
Unit		sheet
Default Value		0
Amount of Change per Unit		1
PD-FD-RL	1	Feed Roller parts counter: Deck
Detail		Feed Roller of Paper Deck/POD Deck Lite 1st line: Total counter value from the previous replacement 2nd line: Estimated life
Use Case		When checking the consumption level of parts/replacing the parts
Adj/Set/Operate Method		To clear the counter value: Select the item, and then press Clear key. To change the estimated life: Select the item, enter the value, and then press OK key.
Caution		Clear the counter value after replacement.
Display/Adj/Set Range		0 to 99999999
Unit		sheet
Default Value		0
Amount of Change per Unit		1

COPIER (Service mode for printer) > COUNTER (Counter mode) > DRBL-2

FIN-STPR	1	Stapler parts counter: Fin-X/AC
Detail		Stapler Unit 1st line: Total counter value from the previous replacement 2nd line: Estimated life value
Use Case		When checking the consumption level of parts/replacing the parts
Adj/Set/Operate Method		To clear the counter value: Select the item, and then press Clear key. To change the estimated life: Select the item, enter the value, and then press OK key.
Caution		Clear the counter value after replacement.
Display/Adj/Set Range		0 to 99999999
Unit		time
Default Value		0
Amount of Change per Unit		1
SDL-STPL	1	Saddle stitcher parts counter: Fin-X/W
Detail		Saddle stitcher unit 1st line: total counter value from the previous replacement 2nd line: estimated life
Use Case		When checking the consumption level of parts/replacing the parts
Adj/Set/Operate Method		To clear the counter value: Select the item, and then press Clear key. To change the estimated life: Select the item, enter the value, and then press OK key.
Caution		Clear the counter value after replacement.
Display/Adj/Set Range		0 to 99999999
Unit		time
Default Value		0
Amount of Change per Unit		1
PUNCH	1	Punch Unit parts counter: Fin-W/X/AC
Detail		Punch Unit 1st line: Total counter value from the previous replacement 2nd line: Estimated life value
Use Case		When checking the consumption level of parts/replacing the parts
Adj/Set/Operate Method		To clear the counter value: Select the item, and then press Clear key. To change the estimated life: Select the item, enter the value, and then press OK key.
Caution		Clear the counter value after replacement.
Display/Adj/Set Range		0 to 99999999
Unit		time
Default Value		0
Amount of Change per Unit		1

COPIER (Service mode for printer) > COUNTER (Counter mode) > DRBL-2

SORT-2	1	Feed Belt parts counter: Fin-W
Detail		Feed Belt 1st line: total counter value from the previous replacement 2nd line: estimated life
Use Case		When checking the consumption level of parts/replacing the parts
Adj/Set/Operate Method		To clear the counter value: Select the item, and then press Clear key. To change the estimated life: Select the item, enter the value, and then press OK key.
Caution		Clear the counter value after replacement.
Display/Adj/Set Range		0 to 99999999
Unit		sheet
Default Value		0
Amount of Change per Unit		1
SDL-RL	1	Sddl Disengagement Rol prts cntr: Fin-W1
Detail		Saddle Disengagement Roller 1st line: total counter value from the previous replacement 2nd line: estimated life
Use Case		When checking the consumption level of parts/replacing the parts
Adj/Set/Operate Method		To clear the counter value: Select the item, and then press Clear key. To change the estimated life: Select the item, enter the value, and then press OK key.
Caution		Clear the counter value after replacement.
Display/Adj/Set Range		0 to 99999999
Unit		sheet
Default Value		0
Amount of Change per Unit		1
IS-P-RL1	1	Upper Tray Pickup Roller parts cntr: INS
Detail		Upper Tray Pickup/Separation/Feed Roller 1st line: Total counter value from the previous replacement 2nd line: Estimated life
Use Case		When checking the consumption level of parts/replacing the parts
Adj/Set/Operate Method		To clear the counter value: Select the item, and then press Clear key. To change the estimated life: Select the item, enter the value, and then press OK key.
Caution		Clear the counter value after replacement.
Display/Adj/Set Range		0 to 99999999
Unit		sheet
Default Value		0
Amount of Change per Unit		1

COPIER (Service mode for printer) > COUNTER (Counter mode) > DRBL-2

IS-TQLM1	1	Upper Tray Torque Limiter prts cntr: INS
Detail	Upper Tray Torque Limiter 1st line: Total counter value from the previous replacement 2nd line: Estimated life	
Use Case	When checking the consumption level of parts/replacing the parts	
Adj/Set/Operate Method	To clear the counter value: Select the item, and then press Clear key. To change the estimated life: Select the item, enter the value, and then press OK key.	
Caution	Clear the counter value after replacement.	
Display/Adj/Set Range	0 to 99999999	
Unit	sheet	
Default Value	0	
Amount of Change per Unit	1	
IS-P-RL2	1	Lower Tray Pickup Roller parts cntr: INS
Detail	Lower Tray Pickup/Separation/Feed Roller 1st line: Total counter value from the previous replacement 2nd line: Estimated life	
Use Case	When checking the consumption level of parts/replacing the parts	
Adj/Set/Operate Method	To clear the counter value: Select the item, and then press Clear key. To change the estimated life: Select the item, enter the value, and then press OK key.	
Caution	Clear the counter value after replacement.	
Display/Adj/Set Range	0 to 99999999	
Unit	sheet	
Default Value	0	
Amount of Change per Unit	1	
IS-TQLM2	1	Lower Tray Torque Limiter prts cntr: INS
Detail	Lower Tray Torque Limiter 1st line: Total counter value from the previous replacement 2nd line: Estimated life	
Use Case	When checking the consumption level of parts/replacing the parts	
Adj/Set/Operate Method	To clear the counter value: Select the item, and then press Clear key. To change the estimated life: Select the item, enter the value, and then press OK key.	
Caution	Clear the counter value after replacement.	
Display/Adj/Set Range	0 to 99999999	
Unit	sheet	
Default Value	0	
Amount of Change per Unit	1	

COPIER (Service mode for printer) > COUNTER (Counter mode) > DRBL-2

SDL-JRL	1	Saddle Align Roller parts counter:Fin-W
Detail		Saddle Alignment Roller 1st line: total counter value from the previous replacement 2nd line: estimated life
Use Case		When checking the consumption level of parts/replacing the parts
Adj/Set/Operate Method		To clear the counter value: Select the item, and then press Clear key. To change the estimated life: Select the item, enter the value, and then press OK key.
Caution		Clear the counter value after replacement.
Display/Adj/Set Range		0 to 99999999
Unit		sheet
Default Value		0
Amount of Change per Unit		1
BEHLTQLM	1	Torque Limt parts cntr: Fin-X
Detail		Process Tray Torque Limiter (Tray 1/2 Paper Retainer) 1st line: Total counter value from the previous replacement 2nd line: Estimated life
Use Case		When checking the consumption level of parts/replacing the parts
Adj/Set/Operate Method		To clear the counter value: Select the item, and then press Clear key. To change the estimated life: Select the item, enter the value, and then press OK key.
Caution		Clear the counter value after replacement.
Display/Adj/Set Range		0 to 99999999
Unit		sheet
Default Value		0
Amount of Change per Unit		1
SWG-RL	1	Paper Return Roll prts cntr: Fin-X
Detail		Process Tray Paper Return Roller (Front/Rear) 1st line: Total counter value from the previous replacement 2nd line: Estimated life
Use Case		When checking the consumption level of parts/replacing the parts
Adj/Set/Operate Method		To clear the counter value: Select the item, and then press Clear key. To change the estimated life: Select the item, enter the value, and then press OK key.
Caution		Clear the counter value after replacement.
Display/Adj/Set Range		0 to 99999999
Unit		sheet
Default Value		0
Amount of Change per Unit		1

COPIER (Service mode for printer) > COUNTER (Counter mode) > DRBL-2

SWG-DL-1	1	Stck Dvry Upper Roll prts cntr: Fin-X
Detail	Swing Guide Assembly Stack Delivery Upper Roller (Front/Rear) 1st line: Total counter value from the previous replacement 2nd line: Estimated life	
Use Case	When checking the consumption level of parts/replacing the parts	
Adj/Set/Operate Method	To clear the counter value: Select the item, and then press Clear key. To change the estimated life: Select the item, enter the value, and then press OK key.	
Caution	Clear the counter value after replacement.	
Display/Adj/Set Range	0 to 99999999	
Unit	sheet	
Default Value	0	
Amount of Change per Unit	1	
SWG-DL-2	1	Stck Dvry Upper Roll prts cntr: Fin-X
Detail	Swing Guide Assembly Stack Delivery Upper Roller (Center) 1st line: Total counter value from the previous replacement 2nd line: Estimated life	
Use Case	When checking the consumption level of parts/replacing the parts	
Adj/Set/Operate Method	To clear the counter value: Select the item, and then press Clear key. To change the estimated life: Select the item, enter the value, and then press OK key.	
Caution	Clear the counter value after replacement.	
Display/Adj/Set Range	0 to 99999999	
Unit	sheet	
Default Value	0	
Amount of Change per Unit	1	
SHT-TQLM	1	Shutter Torque Limiter prts cntr: Fin-X
Detail	Grate-shaped Upper Guide Shutter Torque Limiter 1st line: Total counter value from the previous replacement 2nd line: Estimated life	
Use Case	When checking the consumption level of parts/replacing the parts	
Adj/Set/Operate Method	To clear the counter value: Select the item, and then press Clear key. To change the estimated life: Select the item, enter the value, and then press OK key.	
Caution	Clear the counter value after replacement.	
Display/Adj/Set Range	0 to 99999999	
Unit	sheet	
Default Value	0	
Amount of Change per Unit	1	

COPIER (Service mode for printer) > COUNTER (Counter mode) > DRBL-2

SWG-TQLM	1	Ppr Holding Torq Limt prts cntr: Fin-X
Detail	Process Tray Assembly Paper Holding Torque Limiter 1st line: Total counter value from the previous replacement 2nd line: Estimated life	
Use Case	When checking the consumption level of parts/replacing the parts	
Adj/Set/Operate Method	To clear the counter value: Select the item, and then press Clear key. To change the estimated life: Select the item, enter the value, and then press OK key.	
Caution	Clear the counter value after replacement.	
Display/Adj/Set Range	0 to 99999999	
Unit	sheet	
Default Value	0	
Amount of Change per Unit	1	
SUB-TQLM	1	Sub Guide Torque Limt prts cntr: Fin-X
Detail	Process Tray Assembly Sub Guide Torque Limiter 1st line: Total counter value from the previous replacement 2nd line: Estimated life	
Use Case	When checking the consumption level of parts/replacing the parts	
Adj/Set/Operate Method	To clear the counter value: Select the item, and then press Clear key. To change the estimated life: Select the item, enter the value, and then press OK key.	
Caution	Clear the counter value after replacement.	
Display/Adj/Set Range	0 to 99999999	
Unit	sheet	
Default Value	0	
Amount of Change per Unit	1	
TRY-TQLM	1	Tray Torque Limiter prts cntr: Fin-X/AC
Detail	Tray 1 Torque Limiter (Fin-X)/Stack Tray Torque Limiter (Fin-AC) 1st line: Total counter value from the previous replacement 2nd line: Estimated life value	
Use Case	When checking the consumption level of parts/replacing the parts	
Adj/Set/Operate Method	To clear the counter value: Select the item, and then press Clear key. To change the estimated life: Select the item, enter the value, and then press OK key.	
Caution	Clear the counter value after replacement.	
Display/Adj/Set Range	0 to 99999999	
Unit	sheet	
Default Value	0	
Amount of Change per Unit	1	

COPIER (Service mode for printer) > COUNTER (Counter mode) > DRBL-2

TR2-TQLM	1	Tray 2 Torque Limiter prts cntr: Fin-X
Detail		Tray 2 Torque Limiter 1st line: Total counter value from the previous replacement 2nd line: Estimated life
Use Case		When checking the consumption level of parts/replacing the parts
Adj/Set/Operate Method		To clear the counter value: Select the item, and then press Clear key. To change the estimated life: Select the item, enter the value, and then press OK key.
Caution		Clear the counter value after replacement.
Display/Adj/Set Range		0 to 99999999
Unit		sheet
Default Value		0
Amount of Change per Unit		1
TRM-CUT	1	Cutter Unit parts counter: Fin-X
Detail		Cutter Unit parts counter 1st line: Total counter value from the previous replacement 2nd line: Estimated life
Use Case		When checking the consumption level of parts/replacing the parts
Adj/Set/Operate Method		To clear the counter value: Select the item, and then press Clear key. To change the estimated life: Select the item, enter the value, and then press OK key.
Caution		Clear the counter value after replacement.
Display/Adj/Set Range		0 to 99999999
Unit		time
Default Value		0
Amount of Change per Unit		1
SWG-SL	1	Swing Solenoid parts counter: Fin-X
Detail		Swing Guide Assembly Swing Guide Solenoid 1st line: Total counter value from the previous replacement 2nd line: Estimated life
Use Case		When checking the consumption level of parts/replacing the parts
Adj/Set/Operate Method		To clear the counter value: Select the item, and then press Clear key. To change the estimated life: Select the item, enter the value, and then press OK key.
Caution		Clear the counter value after replacement.
Display/Adj/Set Range		0 to 99999999
Unit		sheet
Default Value		0
Amount of Change per Unit		1

COPIER (Service mode for printer) > COUNTER (Counter mode) > DRBL-2

FN-PDL-U	1	Neat Paddle (Upper) prts cntr: Fin-W
Detail		Neat Paddle (Upper) 1st line: Total counter value from the previous replacement 2nd line: Estimated life
Use Case		When checking the consumption level of parts/replacing the parts
Adj/Set/Operate Method		To clear the counter value: Select the item, and then press Clear key. To change the estimated life: Select the item, enter the value, and then press OK key.
Caution		Clear the counter value after replacement.
Display/Adj/Set Range		0 to 99999999
Unit		sheet
Default Value		0
Amount of Change per Unit		1
FN-PDL-L	1	Neat Paddle (Lower) prts cntr: Fin-W
Detail		1st line: Total counter value from the previous replacement 2nd line: Estimated life
Use Case		When checking the consumption level of parts/replacing the parts
Adj/Set/Operate Method		To clear the counter value: Select the item, and then press Clear key. To change the estimated life: Select the item, enter the value, and then press OK key.
Caution		Clear the counter value after replacement.
Display/Adj/Set Range		0 to 99999999
Unit		sheet
Default Value		0
Amount of Change per Unit		1
FIN-MPDL	1	Paddle parts counter: Fin-AC
Detail		Paddle 1st line: Total counter value from the previous replacement 2nd line: Estimated life value
Use Case		When checking the consumption level of parts/replacing the parts
Adj/Set/Operate Method		To clear the counter value: Select the item, and then press Clear key. To change the estimated life: Select the item, enter the value, and then press OK key.
Caution		Clear the counter value after replacement.
Display/Adj/Set Range		0 to 99999999
Unit		time
Default Value		0
Amount of Change per Unit		1

COPIER (Service mode for printer) > COUNTER (Counter mode) > DRBL-2

FR-STPL	1	Stpl-free Binding Unit prts cntr: Fin-AC
Detail	Staple-free Binding Unit 1st line: Total counter value from the previous replacement 2nd line: Estimated life value	
Use Case	When checking the consumption level of parts/replacing the parts	
Adj/Set/Operate Method	To clear the counter value: Select the item, and then press Clear key. To change the estimated life: Select the item, enter the value, and then press OK key.	
Caution	Clear the counter value after replacement.	
Display/Adj/Set Range	0 to 99999999	
Unit	time	
Default Value	0	
Amount of Change per Unit	1	
OIL-DIE	1	Lubrication counter: P-Puncher
Detail	1st line: Total counter value from the previous lubrication 2nd line: Estimated life value	
Use Case	When checking the consumption level of parts/at lubrication	
Adj/Set/Operate Method	To clear the counter value: Select the item, and then press Clear key. To change the estimated life: Select the item, enter the value, and then press OK key.	
Caution	Clear the counter value after lubrication.	
Display/Adj/Set Range	0 to 99999999	
Unit	time	
Supplement/Memo	Product name of P-Puncher: Multi Function Professional Puncher-A1	
Amount of Change per Unit	1	
SDL-STP	1	Saddle Stitcher parts counter: Fin-AC
Detail	Saddle Stitcher Unit 1st line: Total counter value from the previous replacement 2nd line: Estimated life value	
Use Case	When checking the consumption level of parts/replacing the parts	
Adj/Set/Operate Method	To clear the counter value: Select the item, and then press Clear key. To change the estimated life: Select the item, enter the value, and then press OK key.	
Caution	Clear the counter value after replacement.	
Display/Adj/Set Range	0 to 99999999	
Unit	time	
Default Value	0	
Amount of Change per Unit	1	
HOLD-LVR	1	Paper Retainer Lever cntr: Fin-AC
Detail	1st line: Total counter value from the previous replacement 2nd line: Estimated life	
Use Case	When checking the consumption level of parts/replacing the parts	
Adj/Set/Operate Method	To clear the counter value: Select the item, and then press Clear key. To change the estimated life: Select the item, enter the value, and then press OK key.	
Caution	Clear the counter value after replacement.	
Display/Adj/Set Range	0 to 99999999	
Default Value	0	

■ H-DBL-A1

COPIER (Service mode for printer) > COUNTER (Counter mode) > H-DBL-A1

FIN-CMN1	1	Common fd path fed sht cntr(-12M):Fin-W1
Detail		Buffer upper cover unit, Buffer roller 1, Buffer roller 2, Buffer roller3, Pre-buffer feed roller, Side registration detection unit, Drive detection unit, Inlet feed roller, Shift unit 1st line: total counter value from the previous replacement 2nd line: Estimated life
Use Case		When checking the consumption level of parts/replacing the parts
Adj/Set/Operate Method		To clear the counter value: Select the item, and then press Clear key. To change the estimated life: Select the item, enter the value, and then press OK key.
Caution		Clear the counter value after replacement.
Display/Adj/Set Range		0 to 99999999
Unit		sheet
Default Value		0
FIN-UP1	1	Sht cntr:Uppr path delvry(to 12M):Fin-W1
Detail		Upper delivery roller 1st line: total counter value from the previous replacement 2nd line: Estimated life
Use Case		When checking the consumption level of parts/replacing the parts
Adj/Set/Operate Method		To clear the counter value: Select the item, and then press Clear key. To change the estimated life: Select the item, enter the value, and then press OK key.
Caution		Clear the counter value after replacement.
Display/Adj/Set Range		0 to 99999999
Unit		sheet
Default Value		0
FIN-DWN1	1	Sht cntr:Lowr path delvry(to 12M):Fin-W1
Detail		Stack delivery roller 1st line: total counter value from the previous replacement 2nd line: Estimated life
Use Case		When checking the consumption level of parts/replacing the parts
Adj/Set/Operate Method		To clear the counter value: Select the item, and then press Clear key. To change the estimated life: Select the item, enter the value, and then press OK key.
Caution		Clear the counter value after replacement.
Display/Adj/Set Range		0 to 99999999
Unit		sheet
Default Value		0
FIN-PRC1	1	Sheet counter:Saddle feed(to 12M):Fin-W1
Detail		Process unit, Process upper guide unit 1st line: total counter value from the previous replacement 2nd line: Estimated life
Use Case		When checking the consumption level of parts/replacing the parts
Adj/Set/Operate Method		To clear the counter value: Select the item, and then press Clear key. To change the estimated life: Select the item, enter the value, and then press OK key.
Caution		Clear the counter value after replacement.
Display/Adj/Set Range		0 to 99999999
Unit		sheet
Default Value		0

COPIER (Service mode for printer) > COUNTER (Counter mode) > H-DBL-A1

FIN-SDL1	1	Sheet counter:Saddle feed(to 12M):Fin-W1
Detail	Saddle unit, Conveyer unit 1st line: total counter value from the previous replacement 2nd line: Estimated life	
Use Case	When checking the consumption level of parts/replacing the parts	
Adj/Set/Operate Method	To clear the counter value: Select the item, and then press Clear key. To change the estimated life: Select the item, enter the value, and then press OK key.	
Caution	Clear the counter value after replacement.	
Display/Adj/Set Range	0 to 99999999	
Unit	sheet	
Default Value	0	
PF-FLD	1	Folding feed area parts counter: PFU
Detail	1st line: total counter value from the previous replacement 2nd line: Estimated life	
Use Case	When checking the consumption level of parts/replacing the parts	
Adj/Set/Operate Method	To clear the counter value: Select the item, and then press Clear key. To change the estimated life: Select the item, enter the value, and then press OK key.	
Caution	Clear the counter value after replacement.	
Display/Adj/Set Range	0 to 99999999	
Unit	sheet	
Default Value	0	
Amount of Change per Unit	1	
PF-TRY	1	Fold Tray feed area parts counter: PFU
Detail	1st line: total counter value from the previous replacement 2nd line: Estimated life	
Use Case	When checking the consumption level of parts/replacing the parts	
Adj/Set/Operate Method	To clear the counter value: Select the item, and then press Clear key. To change the estimated life: Select the item, enter the value, and then press OK key.	
Caution	Clear the counter value after replacement.	
Display/Adj/Set Range	0 to 99999999	
Unit	sheet	
Default Value	0	
Amount of Change per Unit	1	

■ SORTER

COPIER (Service mode for printer) > COUNTER (Counter mode) > SORTER

DIESET1	1	Total punch No. of die set 1: P-Puncher
Detail	Total punch number of die set 1 on Professional Puncher.	
Use Case	When checking the usage status of each die set	
Unit	time	
Default Value	0	
Supplement/Memo	Product name of P-Puncher: Multi Function Professional Puncher-A1	
Amount of Change per Unit	1	

COPIER (Service mode for printer) > COUNTER (Counter mode) > SORTER

DIESET2	1	Total punch No. of die set 2: P-Puncher
Detail		Total punch number of die set 2 on Professional Puncher.
Use Case		When checking the usage status of each die set
Unit		time
Default Value		0
Supplement/Memo		Product name of P-Puncher: Multi Function Professional Puncher-A1
Amount of Change per Unit		1
DIESET3	1	Total punch No. of die set 3: P-Puncher
Detail		Total punch number of die set 3 on Professional Puncher.
Use Case		When checking the usage status of each die set
Unit		time
Default Value		0
Supplement/Memo		Product name of P-Puncher: Multi Function Professional Puncher-A1
Amount of Change per Unit		1
DIESET4	1	Total punch No. of die set 4: P-Puncher
Detail		Total punch number of die set 4 on Professional Puncher.
Use Case		When checking the usage status of each die set
Unit		time
Default Value		0
Supplement/Memo		Product name of P-Puncher: Multi Function Professional Puncher-A1
Amount of Change per Unit		1
DIESET5	1	Total punch No. of die set 5: P-Puncher
Detail		Total punch number of die set 5 on Professional Puncher.
Use Case		When checking the usage status of each die set
Unit		time
Default Value		0
Supplement/Memo		Product name of P-Puncher: Multi Function Professional Puncher-A1
Amount of Change per Unit		1
DIESET6	1	Total punch No. of die set 6: P-Puncher
Detail		Total punch number of die set 6 on Professional Puncher.
Use Case		When checking the usage status of each die set
Unit		time
Default Value		0
Supplement/Memo		Product name of P-Puncher: Multi Function Professional Puncher-A1
Amount of Change per Unit		1
DIESET7	1	Total punch No. of die set 7: P-Puncher
Detail		Total punch number of die set 7 on Professional Puncher.
Use Case		When checking the usage status of each die set
Unit		time
Default Value		0
Supplement/Memo		Product name of P-Puncher: Multi Function Professional Puncher-A1
Amount of Change per Unit		1

COPIER (Service mode for printer) > COUNTER (Counter mode) > SORTER

DIESET8	1	Total punch No. of die set 8: P-Puncher
Detail		Total punch number of die set 8 on Professional Puncher.
Use Case		When checking the usage status of each die set
Unit		time
Default Value		0
Supplement/Memo		Product name of P-Puncher: Multi Function Professional Puncher-A1
Amount of Change per Unit		1
DIESET9	1	Total punch No. of die set 9: P-Puncher
Detail		Total punch number of die set 9 on Professional Puncher.
Use Case		When checking the usage status of each die set
Unit		time
Default Value		0
Supplement/Memo		Product name of P-Puncher: Multi Function Professional Puncher-A1
Amount of Change per Unit		1
DIESET10	1	Total punch No. of die set 10: P-Puncher
Detail		Total punch number of die set 10 on Professional Puncher.
Use Case		When checking the usage status of each die set
Unit		time
Default Value		0
Supplement/Memo		Product name of P-Puncher: Multi Function Professional Puncher-A1
Amount of Change per Unit		1
DIESET11	1	Total punch No. of die set 11: P-Puncher
Detail		Total punch number of die set 11 on Professional Puncher.
Use Case		When checking the usage status of each die set
Unit		time
Default Value		0
Supplement/Memo		Product name of P-Puncher: Multi Function Professional Puncher-A1
Amount of Change per Unit		1
DIESET12	1	Total punch No. of die set 12: P-Puncher
Detail		Total punch number of die set 12 on Professional Puncher.
Use Case		When checking the usage status of each die set
Unit		time
Default Value		0
Supplement/Memo		Product name of P-Puncher: Multi Function Professional Puncher-A1
Amount of Change per Unit		1
DIESET13	1	Total punch No. of die set 13: P-Puncher
Detail		Total punch number of die set 13 on Professional Puncher.
Use Case		When checking the usage status of each die set
Unit		time
Default Value		0
Supplement/Memo		Product name of P-Puncher: Multi Function Professional Puncher-A1
Amount of Change per Unit		1

COPIER (Service mode for printer) > COUNTER (Counter mode) > SORTER

DIESET14	1	Total punch No. of die set 14: P-Puncher
Detail		Total punch number of die set 14 on Professional Puncher.
Use Case		When checking the usage status of each die set
Unit		time
Default Value		0
Supplement/Memo		Product name of P-Puncher: Multi Function Professional Puncher-A1
Amount of Change per Unit		1
DIESET15	1	Total punch No. of die set 15: P-Puncher
Detail		Total punch number of die set 15 on Professional Puncher.
Use Case		When checking the usage status of each die set
Unit		time
Default Value		0
Supplement/Memo		Product name of P-Puncher: Multi Function Professional Puncher-A1
Amount of Change per Unit		1
DIESET16	1	Total punch No. of die set 16: P-Puncher
Detail		Total punch number of die set 16 on Professional Puncher.
Use Case		When checking the usage status of each die set
Unit		time
Default Value		0
Supplement/Memo		Product name of P-Puncher: Multi Function Professional Puncher-A1
Amount of Change per Unit		1
DIESET17	1	Total punch No. of die set 17: P-Puncher
Detail		Total punch number of die set 17 on Professional Puncher.
Use Case		When checking the usage status of each die set
Unit		time
Default Value		0
Supplement/Memo		Product name of P-Puncher: Multi Function Professional Puncher-A1
Amount of Change per Unit		1
DIESET18	1	Total punch No. of die set 18: P-Puncher
Detail		Total punch number of die set 18 on Professional Puncher.
Use Case		When checking the usage status of each die set
Unit		time
Default Value		0
Supplement/Memo		Product name of P-Puncher: Multi Function Professional Puncher-A1
Amount of Change per Unit		1
DIESET19	1	Total punch No. of die set 19: P-Puncher
Detail		Total punch number of die set 19 on Professional Puncher.
Use Case		When checking the usage status of each die set
Unit		time
Default Value		0
Supplement/Memo		Product name of P-Puncher: Multi Function Professional Puncher-A1
Amount of Change per Unit		1

COPIER (Service mode for printer) > COUNTER (Counter mode) > SORTER

DIESET20	1	Total punch No. of die set 20: P-Puncher
Detail		Total punch number of die set 20 on Professional Puncher.
Use Case		When checking the usage status of each die set
Unit		time
Default Value		0
Supplement/Memo		Product name of P-Puncher: Multi Function Professional Puncher-A1
Amount of Change per Unit		1
DIESET21	1	Total punch No. of die set 21: P-Puncher
Detail		Total punch number of die set 21 on Professional Puncher.
Use Case		When checking the usage status of each die set
Unit		time
Default Value		0
Supplement/Memo		Product name of P-Puncher: Multi Function Professional Puncher-A1
Amount of Change per Unit		1
DIESET22	1	Total punch No. of die set 22: P-Puncher
Detail		Total punch number of die set 22 on Professional Puncher.
Use Case		When checking the usage status of each die set
Unit		time
Default Value		0
Supplement/Memo		Product name of P-Puncher: Multi Function Professional Puncher-A1
Amount of Change per Unit		1
DIESET23	1	Total punch No. of die set 23: P-Puncher
Detail		Total punch number of die set 23 on Professional Puncher.
Use Case		When checking the usage status of each die set
Unit		time
Default Value		0
Supplement/Memo		Product name of P-Puncher: Multi Function Professional Puncher-A1
Amount of Change per Unit		1
DIESET24	1	Total punch No. of die set 24: P-Puncher
Detail		Total punch number of die set 24 on Professional Puncher.
Use Case		When checking the usage status of each die set
Unit		time
Default Value		0
Supplement/Memo		Product name of P-Puncher: Multi Function Professional Puncher-A1
Amount of Change per Unit		1
DIESET25	1	Total punch No. of die set 25: P-Puncher
Detail		Total punch number of die set 25 on Professional Puncher.
Use Case		When checking the usage status of each die set
Unit		time
Default Value		0
Supplement/Memo		Product name of P-Puncher: Multi Function Professional Puncher-A1
Amount of Change per Unit		1

COPIER (Service mode for printer) > COUNTER (Counter mode) > SORTER

DIESET26	1	Total punch No. of die set 26: P-Puncher
Detail		Total punch number of die set 26 on Professional Puncher.
Use Case		When checking the usage status of each die set
Unit		time
Default Value		0
Supplement/Memo		Product name of P-Puncher: Multi Function Professional Puncher-A1
Amount of Change per Unit		1
DIESET27	1	Total punch No. of die set 27: P-Puncher
Detail		Total punch number of die set 27 on Professional Puncher.
Use Case		When checking the usage status of each die set
Unit		time
Default Value		0
Supplement/Memo		Product name of P-Puncher: Multi Function Professional Puncher-A1
Amount of Change per Unit		1
DIESET28	1	Total punch No. of die set 28: P-Puncher
Detail		Total punch number of die set 28 on Professional Puncher.
Use Case		When checking the usage status of each die set
Unit		time
Default Value		0
Supplement/Memo		Product name of P-Puncher: Multi Function Professional Puncher-A1
Amount of Change per Unit		1
DIESET29	1	Total punch No. of die set 29: P-Puncher
Detail		Total punch number of die set 29 on Professional Puncher.
Use Case		When checking the usage status of each die set
Unit		time
Default Value		0
Supplement/Memo		Product name of P-Puncher: Multi Function Professional Puncher-A1
Amount of Change per Unit		1
DIESET30	1	Total punch No. of die set 30: P-Puncher
Detail		Total punch number of die set 30 on Professional Puncher.
Use Case		When checking the usage status of each die set
Unit		time
Default Value		0
Supplement/Memo		Product name of P-Puncher: Multi Function Professional Puncher-A1
Amount of Change per Unit		1
DIESET31	1	Total punch No. of die set 31: P-Puncher
Detail		Total punch number of die set 31 on Professional Puncher.
Use Case		When checking the usage status of each die set
Unit		time
Default Value		0
Supplement/Memo		Product name of P-Puncher: Multi Function Professional Puncher-A1
Amount of Change per Unit		1

COPIER (Service mode for printer) > COUNTER (Counter mode) > SORTER

DIESET32	1	Total punch No. of die set 32: P-Puncher
Detail		Total punch number of die set 32 on Professional Puncher.
Use Case		When checking the usage status of each die set
Unit		time
Default Value		0
Supplement/Memo		Product name of P-Puncher: Multi Function Professional Puncher-A1
Amount of Change per Unit		1
DIESET33	1	Total punch No. of die set 33: P-Puncher
Detail		Total punch number of die set 33 on Professional Puncher.
Use Case		When checking the usage status of each die set
Unit		time
Default Value		0
Supplement/Memo		Product name of P-Puncher: Multi Function Professional Puncher-A1
Amount of Change per Unit		1
DIESET34	1	Total punch No. of die set 34: P-Puncher
Detail		Total punch number of die set 34 on Professional Puncher.
Use Case		When checking the usage status of each die set
Unit		time
Default Value		0
Supplement/Memo		Product name of P-Puncher: Multi Function Professional Puncher-A1
Amount of Change per Unit		1
DIESET35	1	Total punch No. of die set 35: P-Puncher
Detail		Total punch number of die set 35 on Professional Puncher.
Use Case		When checking the usage status of each die set
Unit		time
Default Value		0
Supplement/Memo		Product name of P-Puncher: Multi Function Professional Puncher-A1
Amount of Change per Unit		1
DIESET36	1	Total punch No. of die set 36: P-Puncher
Detail		Total punch number of die set 36 on Professional Puncher.
Use Case		When checking the usage status of each die set
Unit		time
Default Value		0
Supplement/Memo		Product name of P-Puncher: Multi Function Professional Puncher-A1
Amount of Change per Unit		1
DIESET37	1	Total punch No. of die set 37: P-Puncher
Detail		Total punch number of die set 37 on Professional Puncher.
Use Case		When checking the usage status of each die set
Unit		time
Default Value		0
Supplement/Memo		Product name of P-Puncher: Multi Function Professional Puncher-A1
Amount of Change per Unit		1

COPIER (Service mode for printer) > COUNTER (Counter mode) > SORTER

DIESET38	1	Total punch No. of die set 38: P-Puncher
Detail		Total punch number of die set 38 on Professional Puncher.
Use Case		When checking the usage status of each die set
Unit		time
Default Value		0
Supplement/Memo		Product name of P-Puncher: Multi Function Professional Puncher-A1
Amount of Change per Unit		1
DIESET39	1	Total punch No. of die set 39: P-Puncher
Detail		Total punch number of die set 39 on Professional Puncher.
Use Case		When checking the usage status of each die set
Unit		time
Default Value		0
Supplement/Memo		Product name of P-Puncher: Multi Function Professional Puncher-A1
Amount of Change per Unit		1
DIESET40	1	Total punch No. of die set 40: P-Puncher
Detail		Total punch number of die set 40 on Professional Puncher.
Use Case		When checking the usage status of each die set
Unit		time
Default Value		0
Supplement/Memo		Product name of P-Puncher: Multi Function Professional Puncher-A1
Amount of Change per Unit		1
DIESET41	1	Total punch No. of die set 41: P-Puncher
Detail		Total punch number of die set 41 on Professional Puncher.
Use Case		When checking the usage status of each die set
Unit		time
Default Value		0
Supplement/Memo		Product name of P-Puncher: Multi Function Professional Puncher-A1
Amount of Change per Unit		1
DIESET42	1	Total punch No. of die set 42: P-Puncher
Detail		Total punch number of die set 42 on Professional Puncher.
Use Case		When checking the usage status of each die set
Unit		time
Default Value		0
Supplement/Memo		Product name of P-Puncher: Multi Function Professional Puncher-A1
Amount of Change per Unit		1
DIESET43	1	Total punch No. of die set 43: P-Puncher
Detail		Total punch number of die set 43 on Professional Puncher.
Use Case		When checking the usage status of each die set
Unit		time
Default Value		0
Supplement/Memo		Product name of P-Puncher: Multi Function Professional Puncher-A1
Amount of Change per Unit		1

COPIER (Service mode for printer) > COUNTER (Counter mode) > SORTER

DIESET44	1	Total punch No. of die set 44: P-Puncher
Detail		Total punch number of die set 44 on Professional Puncher.
Use Case		When checking the usage status of each die set
Unit		time
Default Value		0
Supplement/Memo		Product name of P-Puncher: Multi Function Professional Puncher-A1
Amount of Change per Unit		1
DIESET45	1	Total punch No. of die set 45: P-Puncher
Detail		Total punch number of die set 45 on Professional Puncher.
Use Case		When checking the usage status of each die set
Unit		time
Default Value		0
Supplement/Memo		Product name of P-Puncher: Multi Function Professional Puncher-A1
Amount of Change per Unit		1
DIESET46	1	Total punch No. of die set 46: P-Puncher
Detail		Total punch number of die set 46 on Professional Puncher.
Use Case		When checking the usage status of each die set
Unit		time
Default Value		0
Supplement/Memo		Product name of P-Puncher: Multi Function Professional Puncher-A1
Amount of Change per Unit		1
DIESET47	1	Total punch No. of die set 47: P-Puncher
Detail		Total punch number of die set 47 on Professional Puncher.
Use Case		When checking the usage status of each die set
Unit		time
Default Value		0
Supplement/Memo		Product name of P-Puncher: Multi Function Professional Puncher-A1
Amount of Change per Unit		1
DIESET48	1	Total punch No. of die set 48: P-Puncher
Detail		Total punch number of die set 48 on Professional Puncher.
Use Case		When checking the usage status of each die set
Unit		time
Default Value		0
Supplement/Memo		Product name of P-Puncher: Multi Function Professional Puncher-A1
Amount of Change per Unit		1
DIESET49	1	Total punch No. of die set 49: P-Puncher
Detail		Total punch number of die set 49 on Professional Puncher.
Use Case		When checking the usage status of each die set
Unit		time
Default Value		0
Supplement/Memo		Product name of P-Puncher: Multi Function Professional Puncher-A1
Amount of Change per Unit		1

COPIER (Service mode for printer) > COUNTER (Counter mode) > SORTER

DIESET50	1	Total punch No. of die set 50: P-Puncher
Detail		Total punch number of die set 50 on Professional Puncher.
Use Case		When checking the usage status of each die set
Unit		time
Default Value		0
Supplement/Memo		Product name of P-Puncher: Multi Function Professional Puncher-A1
Amount of Change per Unit		1
DIESET51	1	Total punch No. of die set 51: P-Puncher
Detail		Total punch number of die set 51 on Professional Puncher.
Use Case		When checking the usage status of each die set
Unit		time
Default Value		0
Supplement/Memo		Product name of P-Puncher: Multi Function Professional Puncher-A1
Amount of Change per Unit		1
DIESET52	1	Total punch No. of die set 52: P-Puncher
Detail		Total punch number of die set 52 on Professional Puncher.
Use Case		When checking the usage status of each die set
Unit		time
Default Value		0
Supplement/Memo		Product name of P-Puncher: Multi Function Professional Puncher-A1
Amount of Change per Unit		1
DIESET53	1	Total punch No. of die set 53: P-Puncher
Detail		Total punch number of die set 53 on Professional Puncher.
Use Case		When checking the usage status of each die set
Unit		time
Default Value		0
Supplement/Memo		Product name of P-Puncher: Multi Function Professional Puncher-A1
Amount of Change per Unit		1
DIESET54	1	Total punch No. of die set 54: P-Puncher
Detail		Total punch number of die set 54 on Professional Puncher.
Use Case		When checking the usage status of each die set
Unit		time
Default Value		0
Supplement/Memo		Product name of P-Puncher: Multi Function Professional Puncher-A1
Amount of Change per Unit		1
DIESET55	1	Total punch No. of die set 55: P-Puncher
Detail		Total punch number of die set 55 on Professional Puncher.
Use Case		When checking the usage status of each die set
Unit		time
Default Value		0
Supplement/Memo		Product name of P-Puncher: Multi Function Professional Puncher-A1
Amount of Change per Unit		1

COPIER (Service mode for printer) > COUNTER (Counter mode) > SORTER

DIESET56	1	Total punch No. of die set 56: P-Puncher
Detail		Total punch number of die set 56 on Professional Puncher.
Use Case		When checking the usage status of each die set
Unit		time
Default Value		0
Supplement/Memo		Product name of P-Puncher: Multi Function Professional Puncher-A1
Amount of Change per Unit		1
DIESET57	1	Total punch No. of die set 57: P-Puncher
Detail		Total punch number of die set 57 on Professional Puncher.
Use Case		When checking the usage status of each die set
Unit		time
Default Value		0
Supplement/Memo		Product name of P-Puncher: Multi Function Professional Puncher-A1
Amount of Change per Unit		1
DIESET58	1	Total punch No. of die set 58: P-Puncher
Detail		Total punch number of die set 58 on Professional Puncher.
Use Case		When checking the usage status of each die set
Unit		time
Default Value		0
Supplement/Memo		Product name of P-Puncher: Multi Function Professional Puncher-A1
Amount of Change per Unit		1
DIESET59	1	Total punch No. of die set 59: P-Puncher
Detail		Total punch number of die set 59 on Professional Puncher.
Use Case		When checking the usage status of each die set
Unit		time
Default Value		0
Supplement/Memo		Product name of P-Puncher: Multi Function Professional Puncher-A1
Amount of Change per Unit		1
DIESET60	1	Total punch No. of die set 60: P-Puncher
Detail		Total punch number of die set 60 on Professional Puncher.
Use Case		When checking the usage status of each die set
Unit		time
Default Value		0
Supplement/Memo		Product name of P-Puncher: Multi Function Professional Puncher-A1
Amount of Change per Unit		1
DIESET61	1	Total punch No. of die set 61: P-Puncher
Detail		Total punch number of die set 61 on Professional Puncher.
Use Case		When checking the usage status of each die set
Unit		time
Default Value		0
Supplement/Memo		Product name of P-Puncher: Multi Function Professional Puncher-A1
Amount of Change per Unit		1

COPIER (Service mode for printer) > COUNTER (Counter mode) > SORTER

DIESET62	1	Total punch No. of die set 62: P-Puncher
Detail		Total punch number of die set 62 on Professional Puncher.
Use Case		When checking the usage status of each die set
Unit		time
Default Value		0
Supplement/Memo		Product name of P-Puncher: Multi Function Professional Puncher-A1
Amount of Change per Unit		1
DIESET63	1	Total punch No. of die set 63: P-Puncher
Detail		Total punch number of die set 63 on Professional Puncher.
Use Case		When checking the usage status of each die set
Unit		time
Default Value		0
Supplement/Memo		Product name of P-Puncher: Multi Function Professional Puncher-A1
Amount of Change per Unit		1
DIESET64	1	Total punch No. of die set 64: P-Puncher
Detail		Total punch number of die set 64 on Professional Puncher.
Use Case		When checking the usage status of each die set
Unit		time
Default Value		0
Supplement/Memo		Product name of P-Puncher: Multi Function Professional Puncher-A1
Amount of Change per Unit		1
FIN-DWN	1	Sheet counter of lower delivery: Fin-W1
Detail		Counter to indicate the number of sheet that are delivered to the lower tray of the stacker
Use Case		When checking the usage status
Unit		sheet
Default Value		0
Amount of Change per Unit		1
FIN-SDL	1	Sheet counter of saddle feed: Fin-W1
Detail		Counter to indicate the number of sheets that go through the saddle assembly of the finisher
Use Case		When checking the usage status
Unit		sheet
Default Value		0
Amount of Change per Unit		1
FIN-UP	1	Sheet counter of upper delivery: Fin-W1
Detail		Counter to indicate the number of sheet that are delivered to the upper tray of the finisher
Use Case		When checking the usage status
Unit		sheet
Default Value		0
Amount of Change per Unit		1

COPIER (Service mode for printer) > COUNTER (Counter mode) > SORTER

FIN-CMN	1	Sheet counter of common feed path:Fin-W1
Detail		Counter to indicate the number of sheets that go through the common feed path of the finisher
Use Case		When checking the usage status
Unit		sheet
Default Value		0
Amount of Change per Unit		1
FIN-PRC	1	Sheet counter of process delivery:Fin-W1
Detail		Counter to indicate the number of sheet that are delivered at the middle process of the finisher
Use Case		When checking the usage status
Unit		sheet
Default Value		0
Amount of Change per Unit		1

■ H-DBL-A2

COPIER (Service mode for printer) > COUNTER (Counter mode) > H-DBL-A2

FIN-CMN2	1	Sht cntr of cmmn feed pth(to 24M):Fin-W1
Detail		Inlet roller feed motor 1st line: total counter value from the previous replacement 2nd line: Estimated life
Use Case		When checking the consumption level of parts/replacing the parts
Adj/Set/Operate Method		To clear the counter value: Select the item, and then press Clear key. To change the estimated life: Select the item, enter the value, and then press OK key.
Caution		Clear the counter value after replacement.
Display/Adj/Set Range		0 to 99999999
Unit		sheet
Default Value		0
Amount of Change per Unit		1
FIN-PRC2	1	ST cntr of prcss tray dlvy(to 24M):Fn-W1
Detail		Trailing edge drop motor 1st line: total counter value from the previous replacement 2nd line: Estimated life
Use Case		When checking the consumption level of parts/replacing the parts
Adj/Set/Operate Method		To clear the counter value: Select the item, and then press Clear key. To change the estimated life: Select the item, enter the value, and then press OK key.
Caution		Clear the counter value after replacement.
Display/Adj/Set Range		0 to 99999999
Unit		sheet
Default Value		0
Amount of Change per Unit		1

COPIER (Service mode for printer) > COUNTER (Counter mode) > H-DBL-A2

MP-PUNIT	1	Punch Unit parts counter: P-Puncher
Detail		1st line: Total counter value from the previous replacement 2nd line: Estimated life
Use Case		When checking the consumption level of parts/replacing the parts
Adj/Set/Operate Method		To clear the counter value: Select the item, and then press Clear key. To change the estimated life: Select the item, enter the value, and then press OK key.
Caution		Clear the counter value after replacement.
Display/Adj/Set Range		0 to 99999999
Unit		sheet
Supplement/Memo		Product name of P-Puncher: Multi Function Professional Puncher-A1
Amount of Change per Unit		1

■ H-DBL-A3

COPIER (Service mode for printer) > COUNTER (Counter mode) > H-DBL-A3

FIN-CMN3	1	ST cntr of cmmn path feed(to 36M):Fin-W1
Detail		Buffer motor, Pre-buffer feed motor, Side registration shift motor, Delivery motor 1st line: total counter value from the previous replacement 2nd line: Estimated life
Use Case		When checking the consumption level of parts/replacing the parts
Adj/Set/Operate Method		To clear the counter value: Select the item, and then press Clear key. To change the estimated life: Select the item, enter the value, and then press OK key.
Caution		Clear the counter value after replacement.
Display/Adj/Set Range		0 to 99999999
Unit		sheet
Default Value		0
Amount of Change per Unit		1

FIN-PRC3	1	STcntr of prcss tray dlrvy(to 36M):Fn-W1
Detail		Process delivery motor 1st line: total counter value from the previous replacement 2nd line: Estimated life
Use Case		When checking the consumption level of parts/replacing the parts
Adj/Set/Operate Method		To clear the counter value: Select the item, and then press Clear key. To change the estimated life: Select the item, enter the value, and then press OK key.
Caution		Clear the counter value after replacement.
Display/Adj/Set Range		0 to 99999999
Unit		sheet
Default Value		0
Amount of Change per Unit		1

COPIER (Service mode for printer) > COUNTER (Counter mode) > H-DBL-A3

IS-ENT	1	Thru-path init fd area parts counter:INS
Detail		1st line: total counter value from the previous replacement 2nd line: Estimated life
Use Case		When checking the consumption level of parts/replacing the parts
Adj/Set/Operate Method		To clear the counter value: Select the item, and then press Clear key. To change the estimated life: Select the item, enter the value, and then press OK key.
Caution		Clear the counter value after replacement.
Display/Adj/Set Range		0 to 99999999
Unit		sheet
Default Value		0
Amount of Change per Unit		1
IS-FD1	1	Upper Tray feed area parts counter: INS
Detail		1st line: total counter value from the previous replacement 2nd line: Estimated life
Use Case		When checking the consumption level of parts/replacing the parts
Adj/Set/Operate Method		To clear the counter value: Select the item, and then press Clear key. To change the estimated life: Select the item, enter the value, and then press OK key.
Caution		Clear the counter value after replacement.
Display/Adj/Set Range		0 to 99999999
Unit		sheet
Default Value		0
Amount of Change per Unit		1
PF-ENT	1	Thru-path init fd area parts counter:PFU
Detail		1st line: total counter value from the previous replacement 2nd line: Estimated life
Use Case		When checking the consumption level of parts/replacing the parts
Adj/Set/Operate Method		To clear the counter value: Select the item, and then press Clear key. To change the estimated life: Select the item, enter the value, and then press OK key.
Caution		Clear the counter value after replacement.
Display/Adj/Set Range		0 to 99999999
Unit		sheet
Default Value		0
Amount of Change per Unit		1
PF-CNT	1	Thru-path center fd area prts cntr: PFU
Detail		1st line: total counter value from the previous replacement 2nd line: Estimated life
Use Case		When checking the consumption level of parts/replacing the parts
Adj/Set/Operate Method		To clear the counter value: Select the item, and then press Clear key. To change the estimated life: Select the item, enter the value, and then press OK key.
Caution		Clear the counter value after replacement.
Display/Adj/Set Range		0 to 99999999
Unit		sheet
Default Value		0
Amount of Change per Unit		1

COPIER (Service mode for printer) > COUNTER (Counter mode) > H-DBL-A3

IS-FD2	1	Lower Tray feed area parts counter: INS
Detail		1st line: total counter value from the previous replacement 2nd line: Estimated life
Use Case		When checking the consumption level of parts/replacing the parts
Adj/Set/Operate Method		To clear the counter value: Select the item, and then press Clear key. To change the estimated life: Select the item, enter the value, and then press OK key.
Caution		Clear the counter value after replacement.
Display/Adj/Set Range		0 to 99999999
Unit		sheet
Default Value		0
Amount of Change per Unit		1
PF-EXT	1	Thru-path out fd area parts counter: PFU
Detail		1st line: total counter value from the previous replacement 2nd line: Estimated life
Use Case		When checking the consumption level of parts/replacing the parts
Adj/Set/Operate Method		To clear the counter value: Select the item, and then press Clear key. To change the estimated life: Select the item, enter the value, and then press OK key.
Caution		Clear the counter value after replacement.
Display/Adj/Set Range		0 to 99999999
Unit		sheet
Default Value		0
Amount of Change per Unit		1
IS-EXT	1	Thru-path out fd area parts counter: INS
Detail		1st line: total counter value from the previous replacement 2nd line: Estimated life
Use Case		When checking the consumption level of parts/replacing the parts
Adj/Set/Operate Method		To clear the counter value: Select the item, and then press Clear key. To change the estimated life: Select the item, enter the value, and then press OK key.
Caution		Clear the counter value after replacement.
Display/Adj/Set Range		0 to 99999999
Unit		sheet
Default Value		0
Amount of Change per Unit		1
IS-CNT	1	Thru-path center fd area prts cntr: INS
Detail		1st line: total counter value from the previous replacement 2nd line: Estimated life
Use Case		When checking the consumption level of parts/replacing the parts
Adj/Set/Operate Method		To clear the counter value: Select the item, and then press Clear key. To change the estimated life: Select the item, enter the value, and then press OK key.
Caution		Clear the counter value after replacement.
Display/Adj/Set Range		0 to 99999999
Unit		sheet
Default Value		0
Amount of Change per Unit		1

■ MISC2

COPIER (Service mode for printer) > COUNTER (Counter mode) > MISC2

APW-TIME	2	For R&D
CPW-TIME	2	For R&D
BAT-TIME	2	For R&D
FUSE-CNT	2	For R&D
SPW-TIME	2	For R&D

■ LIFE

COPIER (Service mode for printer) > COUNTER (Counter mode) > LIFE

TONER-K	1	Toner (Bk): Life VL and No. of days left
Detail	To display the life value and the number of days left of Toner (Bk).The 3rd and 4th columns may be hidden depending on the country. 1st column: Operation Life Value 2nd column: Number of Days Left 3rd column: Life Value 4th column: Replacement Life Value	
Use Case	When checking Life VL/No. of days left	
Display/Adj/Set Range	1st column: 0 to 999 (%) 2nd column: 0 to 999 (days) 3rd column: 0 to 999 (%) 4th column: 50 to 999 (%)	
Supplement/Memo	Operation Life Value: Wear level value relative to Replacement Life Value (%) Operation Life Value = Life Value/Replacement Life Value x 100 Number of Days Left: Expected number of days until the part reaches its end of life Replacement Life Value: Target replacement life value	
WST-TNR	1	Waste Toner Container:Life VL/days left
Detail	To display the life value and the number of days left of Waste Toner Container. The 3rd and 4th columns may be hidden depending on the country. 1st column: Operation Life Value 2nd column: Number of Days Left 3rd column: Life Value 4th column: Replacement Life Value	
Use Case	When checking Life VL/No. of days left	
Adj/Set/Operate Method	To reset Operation Life Value/Number of Days Left/Life Value: Select the item, and then press Clear key.	
Caution	- Clear the counters if the waste toner container is replaced when the Preparing Waste Toner Container warning or Waste Toner Full message is not displayed. - Operation Life Value/Number of Days Left/Life Value can be reset also by clearing the counters in COPIER> COUNTER> DRBL-1> WST-TNR.	
Display/Adj/Set Range	1st column: 0 to 999 (%) 2nd column: 0 to 999 (days) 3rd column: 0 to 999 (%) 4th column: 50 to 999 (%)	
Supplement/Memo	Operation Life Value: Wear level value relative to Replacement Life Value (%) Operation Life Value = Life Value/Replacement Life Value x 100 Number of Days Left: Expected number of days until the part reaches its end of life Replacement Life Value: Target replacement life value	

COPIER (Service mode for printer) > COUNTER (Counter mode) > LIFE

PT-DRM	1	Drum Unit (Bk): Life VL/No. of days
Detail		To display the life value and the number of days left of Drum Unit (Bk).The 3rd and 4th columns may be hidden depending on the country. 1st column: Operation Life Value 2nd column: Number of Days Left 3rd column: Life Value 4th column: Replacement Life Value
Use Case		- When checking Life VL/No. of days left of the part - At parts replacement
Adj/Set/Operate Method		To change the Replacement Life Value: Select the item, enter the value, and then press OK key. To reset Operation Life Value/Number of Days Left/Life Value: Select the item, and then press Clear key.
Caution		- Be sure to reset Operation Life Value/Number of Days Left/Life Value after replacing the part. - Operation Life Value/Number of Days Left/Life Value can also be reset by clearing the parts counter.
Display/Adj/Set Range		1st column: 0 to 999 (%) 2nd column: 0 to 999 (days) 3rd column: 0 to 999 (%) 4th column: 50 to 999 (%)
Supplement/Memo		Operation Life Value: Wear level value relative to Replacement Life Value (%) Operation Life Value = Life Value/Replacement Life Value x 100 Number of Days Left: Expected number of days until the part reaches its end of life Replacement Life Value: Target replacement life value
PRM-WIRE	1	Primary Charging Wire: Life VL/days left
Detail		To display the life value and the number of days left of the Primary Charging Wire. The 3rd and 4th columns may be hidden depending on the country. 1st column: Operation Life Value 2nd column: Number of Days Left 3rd column: Life Value 4th column: Replacement Life Value
Use Case		- When checking Life VL/No. of days left of the part - At parts replacement
Adj/Set/Operate Method		To change the Replacement Life Value: Select the item, enter the value, and then press OK key. To reset Operation Life Value/Number of Days Left/Life Value: Select the item, and then press Clear key.
Caution		- Be sure to reset Operation Life Value/Number of Days Left/Life Value after replacing the part. - Operation Life Value/Number of Days Left/Life Value can also be reset by clearing the parts counter.
Display/Adj/Set Range		1st column: 0 to 999 (%) 2nd column: 0 to 999 (days) 3rd column: 0 to 999 (%) 4th column: 50 to 999 (%)
Supplement/Memo		Operation Life Value: Wear level value relative to Replacement Life Value (%) Operation Life Value = Life Value/Replacement Life Value x 100 Number of Days Left: Expected number of days until the part reaches its end of life Replacement Life Value: Target replacement life value

COPIER (Service mode for printer) > COUNTER (Counter mode) > LIFE

PRM-CLN	1	Pry Chg Wire Cln Pad: Life VL/days left
Detail		To display the life value and the number of days left of the Primary Charging Wire Cleaning Pad. The 3rd and 4th columns may be hidden depending on the country. 1st column: Operation Life Value 2nd column: Number of Days Left 3rd column: Life Value 4th column: Replacement Life Value
Use Case		- When checking Life VL/No. of days left of the part - At parts replacement
Adj/Set/Operate Method		To change the Replacement Life Value: Select the item, enter the value, and then press OK key. To reset Operation Life Value/Number of Days Left/Life Value: Select the item, and then press Clear key.
Caution		- Be sure to reset Operation Life Value/Number of Days Left/Life Value after replacing the part. - Operation Life Value/Number of Days Left/Life Value can also be reset by clearing the parts counter.
Display/Adj/Set Range		1st column: 0 to 999 (%) 2nd column: 0 to 999 (days) 3rd column: 0 to 999 (%) 4th column: 50 to 999 (%)
Supplement/Memo		Operation Life Value: Wear level value relative to Replacement Life Value (%) Operation Life Value = Life Value/Replacement Life Value x 100 Number of Days Left: Expected number of days until the part reaches its end of life Replacement Life Value: Target replacement life value
PRM-UNIT	1	P-Chg Ass'y: Life VL/days left
Detail		To display the life value and the number of days left of the Primary Charging Assembly. The 3rd and 4th columns may be hidden depending on the country. 1st column: Operation Life Value 2nd column: Number of Days Left 3rd column: Life Value 4th column: Replacement Life Value
Use Case		- When checking Life VL/No. of days left of the part - At parts replacement
Adj/Set/Operate Method		To change the Replacement Life Value: Select the item, enter the value, and then press OK key. To reset Operation Life Value/Number of Days Left/Life Value: Select the item, and then press Clear key.
Caution		- Be sure to reset Operation Life Value/Number of Days Left/Life Value after replacing the part. - Operation Life Value/Number of Days Left/Life Value can also be reset by clearing the parts counter.
Display/Adj/Set Range		1st column: 0 to 999 (%) 2nd column: 0 to 999 (days) 3rd column: 0 to 999 (%) 4th column: 50 to 999 (%)
Supplement/Memo		Operation Life Value: Wear level value relative to Replacement Life Value (%) Operation Life Value = Life Value/Replacement Life Value x 100 Number of Days Left: Expected number of days until the part reaches its end of life Replacement Life Value: Target replacement life value

COPIER (Service mode for printer) > COUNTER (Counter mode) > LIFE

CLN-BLD	1	D-CIn Blade:Life VL and No. of days left
Detail		To display the life value and the number of days left of the Drum Cleaning Blade. The 3rd and 4th columns may be hidden depending on the country. 1st column: Operation Life Value 2nd column: Number of Days Left 3rd column: Life Value 4th column: Replacement Life Value
Use Case		- When checking Life VL/No. of days left of the part - At parts replacement
Adj/Set/Operate Method		To change the Replacement Life Value: Select the item, enter the value, and then press OK key. To reset Operation Life Value/Number of Days Left/Life Value: Select the item, and then press Clear key.
Caution		- Be sure to reset Operation Life Value/Number of Days Left/Life Value after replacing the part. - Operation Life Value/Number of Days Left/Life Value can also be reset by clearing the parts counter.
Display/Adj/Set Range		1st column: 0 to 999 (%) 2nd column: 0 to 999 (days) 3rd column: 0 to 999 (%) 4th column: 50 to 999 (%)
Supplement/Memo		Operation Life Value: Wear level value relative to Replacement Life Value (%) Operation Life Value = Life Value/Replacement Life Value x 100 Number of Days Left: Expected number of days until the part reaches its end of life Replacement Life Value: Target replacement life value
BS-SL-F	1	D-CIn Ass'y Side Seal F:Life VL/days left
Detail		To display the life value and the number of days left of the Drum Cleaner Assembly Side Seal Front. The 3rd and 4th columns may be hidden depending on the country. 1st column: Operation Life Value 2nd column: Number of Days Left 3rd column: Life Value 4th column: Replacement Life Value
Use Case		- When checking Life VL/No. of days left of the part - At parts replacement
Adj/Set/Operate Method		To change the Replacement Life Value: Select the item, enter the value, and then press OK key. To reset Operation Life Value/Number of Days Left/Life Value: Select the item, and then press Clear key.
Caution		- Be sure to reset Operation Life Value/Number of Days Left/Life Value after replacing the part. - Operation Life Value/Number of Days Left/Life Value can also be reset by clearing the parts counter.
Display/Adj/Set Range		1st column: 0 to 999 (%) 2nd column: 0 to 999 (days) 3rd column: 0 to 999 (%) 4th column: 50 to 999 (%)
Supplement/Memo		Operation Life Value: Wear level value relative to Replacement Life Value (%) Operation Life Value = Life Value/Replacement Life Value x 100 Number of Days Left: Expected number of days until the part reaches its end of life Replacement Life Value: Target replacement life value

COPIER (Service mode for printer) > COUNTER (Counter mode) > LIFE

BS-SL-R	1	D-Cln Ass'y Side Seal R:Life VL/days left
Detail		To display the life value and the number of days left of the Drum Cleaner Assembly Side Seal Rear. The 3rd and 4th columns may be hidden depending on the country. 1st column: Operation Life Value 2nd column: Number of Days Left 3rd column: Life Value 4th column: Replacement Life Value
Use Case		- When checking Life VL/No. of days left of the part - At parts replacement
Adj/Set/Operate Method		To change the Replacement Life Value: Select the item, enter the value, and then press OK key. To reset Operation Life Value/Number of Days Left/Life Value: Select the item, and then press Clear key.
Caution		- Be sure to reset Operation Life Value/Number of Days Left/Life Value after replacing the part. - Operation Life Value/Number of Days Left/Life Value can also be reset by clearing the parts counter.
Display/Adj/Set Range		1st column: 0 to 999 (%) 2nd column: 0 to 999 (days) 3rd column: 0 to 999 (%) 4th column: 50 to 999 (%)
Supplement/Memo		Operation Life Value: Wear level value relative to Replacement Life Value (%) Operation Life Value = Life Value/Replacement Life Value x 100 Number of Days Left: Expected number of days until the part reaches its end of life Replacement Life Value: Target replacement life value
SP-CLAW	1	Drum Sepn Claw:Life VL/No. of days left
Detail		To display the life value and the number of days left of the Drum Separation Claw. The 3rd and 4th columns may be hidden depending on the country. 1st column: Operation Life Value 2nd column: Number of Days Left 3rd column: Life Value 4th column: Replacement Life Value
Use Case		- When checking Life VL/No. of days left of the part - At parts replacement
Adj/Set/Operate Method		To change the Replacement Life Value: Select the item, enter the value, and then press OK key. To reset Operation Life Value/Number of Days Left/Life Value: Select the item, and then press Clear key.
Caution		- Be sure to reset Operation Life Value/Number of Days Left/Life Value after replacing the part. - Operation Life Value/Number of Days Left/Life Value can also be reset by clearing the parts counter.
Display/Adj/Set Range		1st column: 0 to 999 (%) 2nd column: 0 to 999 (days) 3rd column: 0 to 999 (%) 4th column: 50 to 999 (%)
Supplement/Memo		Operation Life Value: Wear level value relative to Replacement Life Value (%) Operation Life Value = Life Value/Replacement Life Value x 100 Number of Days Left: Expected number of days until the part reaches its end of life Replacement Life Value: Target replacement life value

COPIER (Service mode for printer) > COUNTER (Counter mode) > LIFE

EXP-SCRP	1	Pre-exp Scraper:Life VL/No. of days left
Detail	To display the life value and the number of days left of the Pre-exposure Scraper. The 3rd and 4th columns may be hidden depending on the country. 1st column: Operation Life Value 2nd column: Number of Days Left 3rd column: Life Value 4th column: Replacement Life Value	
Use Case	- When checking Life VL/No. of days left of the part - At parts replacement	
Adj/Set/Operate Method	To change the Replacement Life Value: Select the item, enter the value, and then press OK key. To reset Operation Life Value/Number of Days Left/Life Value: Select the item, and then press Clear key.	
Caution	- Be sure to reset Operation Life Value/Number of Days Left/Life Value after replacing the part. - Operation Life Value/Number of Days Left/Life Value can also be reset by clearing the parts counter.	
Display/Adj/Set Range	1st column: 0 to 999 (%) 2nd column: 0 to 999 (days) 3rd column: 0 to 999 (%) 4th column: 50 to 999 (%)	
Supplement/Memo	Operation Life Value: Wear level value relative to Replacement Life Value (%) Operation Life Value = Life Value/Replacement Life Value x 100 Number of Days Left: Expected number of days until the part reaches its end of life Replacement Life Value: Target replacement life value	
DV-UNT-K	1	Dev Ass'y (Bk):Life VL/No. of days left
Detail	To display the life value and the number of days left of the Developing Assembly (Bk). The 3rd and 4th columns may be hidden depending on the country. 1st column: Operation Life Value 2nd column: Number of Days Left 3rd column: Life Value 4th column: Replacement Life Value	
Use Case	- When checking Life VL/No. of days left of the part - At parts replacement	
Adj/Set/Operate Method	To change the Replacement Life Value: Select the item, enter the value, and then press OK key. Operation Life Value/Number of Days Left/Life Value: Display only	
Caution	Operation Life Value, Number of Days Left and Life Value are reset automatically execute operation for initial installation of the Developing Unit.	
Display/Adj/Set Range	1st column: 0 to 999 (%) 2nd column: 0 to 999 (days) 3rd column: 0 to 999 (%) 4th column: 50 to 999 (%)	
Supplement/Memo	Operation Life Value: Wear level value relative to Replacement Life Value (%) Operation Life Value = Life Value/Replacement Life Value x 100 Number of Days Left: Expected number of days until the part reaches its end of life Replacement Life Value: Target replacement life value	

COPIER (Service mode for printer) > COUNTER (Counter mode) > LIFE

TR-BLT	1	ETB:Life VL and No. of days left
Detail	To display the life value and the number of days left of the ETB.	The 3rd and 4th columns may be hidden depending on the country. 1st column: Operation Life Value 2nd column: Number of Days Left 3rd column: Life Value 4th column: Replacement Life Value
Use Case	- When checking Life VL/No. of days left of the part - At parts replacement	
Adj/Set/Operate Method	To change the Replacement Life Value: Select the item, enter the value, and then press OK key. To reset Operation Life Value/Number of Days Left/Life Value: Select the item, and then press Clear key.	
Caution	- Be sure to reset Operation Life Value/Number of Days Left/Life Value after replacing the part. - Operation Life Value/Number of Days Left/Life Value can also be reset by clearing the parts counter.	
Display/Adj/Set Range	1st column: 0 to 999 (%) 2nd column: 0 to 999 (days) 3rd column: 0 to 999 (%) 4th column: 50 to 999 (%)	
Supplement/Memo	Operation Life Value: Wear level value relative to Replacement Life Value (%) Operation Life Value = Life Value/Replacement Life Value x 100 Number of Days Left: Expected number of days until the part reaches its end of life Replacement Life Value: Target replacement life value	
TR-ROLL	1	Transfer Roller:Life VL/No. of days left
Detail	To display the life value and the number of days left of the Transfer Roller.	The 3rd and 4th columns may be hidden depending on the country. 1st column: Operation Life Value 2nd column: Number of Days Left 3rd column: Life Value 4th column: Replacement Life Value
Use Case	- When checking Life VL/No. of days left of the part - At parts replacement	
Adj/Set/Operate Method	To change the Replacement Life Value: Select the item, enter the value, and then press OK key. To reset Operation Life Value/Number of Days Left/Life Value: Select the item, and then press Clear key.	
Caution	- Be sure to reset Operation Life Value/Number of Days Left/Life Value after replacing the part. - Operation Life Value/Number of Days Left/Life Value can also be reset by clearing the parts counter.	
Display/Adj/Set Range	1st column: 0 to 999 (%) 2nd column: 0 to 999 (days) 3rd column: 0 to 999 (%) 4th column: 50 to 999 (%)	
Supplement/Memo	Operation Life Value: Wear level value relative to Replacement Life Value (%) Operation Life Value = Life Value/Replacement Life Value x 100 Number of Days Left: Expected number of days until the part reaches its end of life Replacement Life Value: Target replacement life value	

COPIER (Service mode for printer) > COUNTER (Counter mode) > LIFE

T-CLN-BD	1	ETB CIn Blade:Life VL/No. of days left
Detail	To display the life value and the number of days left of the ETB Cleaning Blade. The 3rd and 4th columns may be hidden depending on the country. 1st column: Operation Life Value 2nd column: Number of Days Left 3rd column: Life Value 4th column: Replacement Life Value	
Use Case	- When checking Life VL/No. of days left of the part - At parts replacement	
Adj/Set/Operate Method	To change the Replacement Life Value: Select the item, enter the value, and then press OK key. To reset Operation Life Value/Number of Days Left/Life Value: Select the item, and then press Clear key.	
Caution	- Be sure to reset Operation Life Value/Number of Days Left/Life Value after replacing the part. - Operation Life Value/Number of Days Left/Life Value can also be reset by clearing the parts counter.	
Display/Adj/Set Range	1st column: 0 to 999 (%) 2nd column: 0 to 999 (days) 3rd column: 0 to 999 (%) 4th column: 50 to 999 (%)	
Supplement/Memo	Operation Life Value: Wear level value relative to Replacement Life Value (%) $\text{Operation Life Value} = \frac{\text{Life Value}}{\text{Replacement Life Value}} \times 100$ Number of Days Left: Expected number of days until the part reaches its end of life Replacement Life Value: Target replacement life value	
T-CN-BRU	1	Brush Roller:Life VL/No. of days left
Detail	To display the life value and the number of days left of the Brush Roller. The 3rd and 4th columns may be hidden depending on the country. 1st column: Operation Life Value 2nd column: Number of Days Left 3rd column: Life Value 4th column: Replacement Life Value	
Use Case	- When checking Life VL/No. of days left of the part - At parts replacement	
Adj/Set/Operate Method	To change the Replacement Life Value: Select the item, enter the value, and then press OK key. To reset Operation Life Value/Number of Days Left/Life Value: Select the item, and then press Clear key.	
Caution	- Be sure to reset Operation Life Value/Number of Days Left/Life Value after replacing the part. - Operation Life Value/Number of Days Left/Life Value can also be reset by clearing the parts counter.	
Display/Adj/Set Range	1st column: 0 to 999 (%) 2nd column: 0 to 999 (days) 3rd column: 0 to 999 (%) 4th column: 50 to 999 (%)	
Supplement/Memo	Operation Life Value: Wear level value relative to Replacement Life Value (%) $\text{Operation Life Value} = \frac{\text{Life Value}}{\text{Replacement Life Value}} \times 100$ Number of Days Left: Expected number of days until the part reaches its end of life Replacement Life Value: Target replacement life value	

COPIER (Service mode for printer) > COUNTER (Counter mode) > LIFE

PO-WIRE	1	P-trs Chg Ass'y:Life VL/No. of days left
Detail		To display the life value and the number of days left of the Pre-transfer Charging Assembly. The 3rd and 4th columns may be hidden depending on the country. 1st column: Operation Life Value 2nd column: Number of Days Left 3rd column: Life Value 4th column: Replacement Life Value
Use Case		- When checking Life VL/No. of days left of the part - At parts replacement
Adj/Set/Operate Method		To change the Replacement Life Value: Select the item, enter the value, and then press OK key. To reset Operation Life Value/Number of Days Left/Life Value: Select the item, and then press Clear key.
Caution		- Be sure to reset Operation Life Value/Number of Days Left/Life Value after replacing the part. - Operation Life Value/Number of Days Left/Life Value can also be reset by clearing the parts counter.
Display/Adj/Set Range		1st column: 0 to 999 (%) 2nd column: 0 to 999 (days) 3rd column: 0 to 999 (%) 4th column: 50 to 999 (%)
Supplement/Memo		Operation Life Value: Wear level value relative to Replacement Life Value (%) Operation Life Value = Life Value/Replacement Life Value x 100 Number of Days Left: Expected number of days until the part reaches its end of life Replacement Life Value: Target replacement life value
PO-CLN	1	P-trs Chg Wire Cln Pad:Life VL/days left
Detail		To display the life value and the number of days left of the Pre-transfer Charging Assembly Cleaning Pad. The 3rd and 4th columns may be hidden depending on the country. 1st column: Operation Life Value 2nd column: Number of Days Left 3rd column: Life Value 4th column: Replacement Life Value
Use Case		- When checking Life VL/No. of days left of the part - At parts replacement
Adj/Set/Operate Method		To change the Replacement Life Value: Select the item, enter the value, and then press OK key. To reset Operation Life Value/Number of Days Left/Life Value: Select the item, and then press Clear key.
Caution		- Be sure to reset Operation Life Value/Number of Days Left/Life Value after replacing the part. - Operation Life Value/Number of Days Left/Life Value can also be reset by clearing the parts counter.
Display/Adj/Set Range		1st column: 0 to 999 (%) 2nd column: 0 to 999 (days) 3rd column: 0 to 999 (%) 4th column: 50 to 999 (%)
Supplement/Memo		Operation Life Value: Wear level value relative to Replacement Life Value (%) Operation Life Value = Life Value/Replacement Life Value x 100 Number of Days Left: Expected number of days until the part reaches its end of life Replacement Life Value: Target replacement life value

COPIER (Service mode for printer) > COUNTER (Counter mode) > LIFE

PO-UNIT	1	P-trs Chg Ass'y:Life VL/No. of days left
Detail		To display the life value and the number of days left of the Pre-transfer Charging Assembly. The 3rd and 4th columns may be hidden depending on the country. 1st column: Operation Life Value 2nd column: Number of Days Left 3rd column: Life Value 4th column: Replacement Life Value
Use Case		- When checking Life VL/No. of days left of the part - At parts replacement
Adj/Set/Operate Method		To change the Replacement Life Value: Select the item, enter the value, and then press OK key. To reset Operation Life Value/Number of Days Left/Life Value: Select the item, and then press Clear key.
Caution		- Be sure to reset Operation Life Value/Number of Days Left/Life Value after replacing the part. - Operation Life Value/Number of Days Left/Life Value can also be reset by clearing the parts counter.
Display/Adj/Set Range		1st column: 0 to 999 (%) 2nd column: 0 to 999 (days) 3rd column: 0 to 999 (%) 4th column: 50 to 999 (%)
Supplement/Memo		Operation Life Value: Wear level value relative to Replacement Life Value (%) Operation Life Value = Life Value/Replacement Life Value x 100 Number of Days Left: Expected number of days until the part reaches its end of life Replacement Life Value: Target replacement life value
FX-UP-RL	1	Fixing Roller: Life VL/No. of days left
Detail		To display the life value and the number of days left of the Fixing Roller. The 3rd and 4th columns may be hidden depending on the country. 1st column: Operation Life Value 2nd column: Number of Days Left 3rd column: Life Value 4th column: Replacement Life Value
Use Case		- When checking Life VL/No. of days left of the part - At parts replacement
Adj/Set/Operate Method		To change the Replacement Life Value: Select the item, enter the value, and then press OK key. To reset Operation Life Value/Number of Days Left/Life Value: Select the item, and then press Clear key.
Caution		- Be sure to reset Operation Life Value/Number of Days Left/Life Value after replacing the part. - Operation Life Value/Number of Days Left/Life Value can also be reset by clearing the parts counter.
Display/Adj/Set Range		1st column: 0 to 999 (%) 2nd column: 0 to 999 (days) 3rd column: 0 to 999 (%) 4th column: 50 to 999 (%)
Supplement/Memo		Operation Life Value: Wear level value relative to Replacement Life Value (%) Operation Life Value = Life Value/Replacement Life Value x 100 Number of Days Left: Expected number of days until the part reaches its end of life Replacement Life Value: Target replacement life value

COPIER (Service mode for printer) > COUNTER (Counter mode) > LIFE

FIX-TH1	1	Fixing Main Thermistor:Life VL/days left
Detail		To display the life value and the number of days left of the Fixing Main Thermistor. The 3rd and 4th columns may be hidden depending on the country. 1st column: Operation Life Value 2nd column: Number of Days Left 3rd column: Life Value 4th column: Replacement Life Value
Use Case		- When checking Life VL/No. of days left of the part - At parts replacement
Adj/Set/Operate Method		To change the Replacement Life Value: Select the item, enter the value, and then press OK key. To reset Operation Life Value/Number of Days Left/Life Value: Select the item, and then press Clear key.
Caution		- Be sure to reset Operation Life Value/Number of Days Left/Life Value after replacing the part. - Operation Life Value/Number of Days Left/Life Value can also be reset by clearing the parts counter.
Display/Adj/Set Range		1st column: 0 to 999 (%) 2nd column: 0 to 999 (days) 3rd column: 0 to 999 (%) 4th column: 50 to 999 (%)
Supplement/Memo		Operation Life Value: Wear level value relative to Replacement Life Value (%) Operation Life Value = Life Value/Replacement Life Value x 100 Number of Days Left: Expected number of days until the part reaches its end of life Replacement Life Value: Target replacement life value
FIX-TH2	1	Fixing Sub Thermistor:Life VL/days left
Detail		To display the life value and the number of days left of the Fixing Sub Assembly. The 3rd and 4th columns may be hidden depending on the country. 1st column: Operation Life Value 2nd column: Number of Days Left 3rd column: Life Value 4th column: Replacement Life Value
Use Case		- When checking Life VL/No. of days left of the part - At parts replacement
Adj/Set/Operate Method		To change the Replacement Life Value: Select the item, enter the value, and then press OK key. To reset Operation Life Value/Number of Days Left/Life Value: Select the item, and then press Clear key.
Caution		- Be sure to reset Operation Life Value/Number of Days Left/Life Value after replacing the part. - Operation Life Value/Number of Days Left/Life Value can also be reset by clearing the parts counter.
Display/Adj/Set Range		1st column: 0 to 999 (%) 2nd column: 0 to 999 (days) 3rd column: 0 to 999 (%) 4th column: 50 to 999 (%)
Supplement/Memo		Operation Life Value: Wear level value relative to Replacement Life Value (%) Operation Life Value = Life Value/Replacement Life Value x 100 Number of Days Left: Expected number of days until the part reaches its end of life Replacement Life Value: Target replacement life value

COPIER (Service mode for printer) > COUNTER (Counter mode) > LIFE

FX-IN-BS	1	Fixing Rol InsIt Bush: Life VL/days left
Detail	<p>To display the life value and the number of days left of the Fixing Roller Insulating Bush. The 3rd and 4th columns may be hidden depending on the country.</p> <p>1st column: Operation Life Value 2nd column: Number of Days Left 3rd column: Life Value 4th column: Replacement Life Value</p>	
Use Case	<p>- When checking Life VL/No. of days left of the part - At parts replacement</p>	
Adj/Set/Operate Method	<p>To change the Replacement Life Value: Select the item, enter the value, and then press OK key. To reset Operation Life Value/Number of Days Left/Life Value: Select the item, and then press Clear key.</p>	
Caution	<p>- Be sure to reset Operation Life Value/Number of Days Left/Life Value after replacing the part. - Operation Life Value/Number of Days Left/Life Value can also be reset by clearing the parts counter.</p>	
Display/Adj/Set Range	<p>1st column: 0 to 999 (%) 2nd column: 0 to 999 (days) 3rd column: 0 to 999 (%) 4th column: 50 to 999 (%)</p>	
Supplement/Memo	<p>Operation Life Value: Wear level value relative to Replacement Life Value (%) Operation Life Value = Life Value/Replacement Life Value x 100 Number of Days Left: Expected number of days until the part reaches its end of life Replacement Life Value: Target replacement life value</p>	
FX-RTNR	1	Fix Rol Thrust Rtnr: Life VL/days left
Detail	<p>To display the life value and the number of days left of the Fixing Roller Thrust Retainer. The 3rd and 4th columns may be hidden depending on the country.</p> <p>1st column: Operation Life Value 2nd column: Number of Days Left 3rd column: Life Value 4th column: Replacement Life Value</p>	
Use Case	<p>- When checking Life VL/No. of days left of the part - At parts replacement</p>	
Adj/Set/Operate Method	<p>To change the Replacement Life Value: Select the item, enter the value, and then press OK key. To reset Operation Life Value/Number of Days Left/Life Value: Select the item, and then press Clear key.</p>	
Caution	<p>- Be sure to reset Operation Life Value/Number of Days Left/Life Value after replacing the part. - Operation Life Value/Number of Days Left/Life Value can also be reset by clearing the parts counter.</p>	
Display/Adj/Set Range	<p>1st column: 0 to 999 (%) 2nd column: 0 to 999 (days) 3rd column: 0 to 999 (%) 4th column: 50 to 999 (%)</p>	
Supplement/Memo	<p>Operation Life Value: Wear level value relative to Replacement Life Value (%) Operation Life Value = Life Value/Replacement Life Value x 100 Number of Days Left: Expected number of days until the part reaches its end of life Replacement Life Value: Target replacement life value</p>	

COPIER (Service mode for printer) > COUNTER (Counter mode) > LIFE

FX-LW-RL	1	Pressure Roller:Life VL/No. of days left
Detail	<p>To display the life value and the number of days left of the Pressure Roller. The 3rd and 4th columns may be hidden depending on the country.</p> <p>1st column: Operation Life Value 2nd column: Number of Days Left 3rd column: Life Value 4th column: Replacement Life Value</p>	
Use Case	<p>- When checking Life VL/No. of days left of the part - At parts replacement</p>	
Adj/Set/Operate Method	<p>To change the Replacement Life Value: Select the item, enter the value, and then press OK key. To reset Operation Life Value/Number of Days Left/Life Value: Select the item, and then press Clear key.</p>	
Caution	<p>- Be sure to reset Operation Life Value/Number of Days Left/Life Value after replacing the part. - Operation Life Value/Number of Days Left/Life Value can also be reset by clearing the parts counter.</p>	
Display/Adj/Set Range	<p>1st column: 0 to 999 (%) 2nd column: 0 to 999 (days) 3rd column: 0 to 999 (%) 4th column: 50 to 999 (%)</p>	
Supplement/Memo	<p>Operation Life Value: Wear level value relative to Replacement Life Value (%) Operation Life Value = Life Value/Replacement Life Value x 100 Number of Days Left: Expected number of days until the part reaches its end of life Replacement Life Value: Target replacement life value</p>	
FX-L-STC	1	Pres Roller Sttc Elim: Life VL/days left
Detail	<p>To display the life value and the number of days left of the Pressure Roller Static Eliminator. The 3rd and 4th columns may be hidden depending on the country.</p> <p>1st column: Operation Life Value 2nd column: Number of Days Left 3rd column: Life Value 4th column: Replacement Life Value</p>	
Use Case	<p>- When checking Life VL/No. of days left of the part - At parts replacement</p>	
Adj/Set/Operate Method	<p>To change the Replacement Life Value: Select the item, enter the value, and then press OK key. To reset Operation Life Value/Number of Days Left/Life Value: Select the item, and then press Clear key.</p>	
Caution	<p>- Be sure to reset Operation Life Value/Number of Days Left/Life Value after replacing the part. - Operation Life Value/Number of Days Left/Life Value can also be reset by clearing the parts counter.</p>	
Display/Adj/Set Range	<p>1st column: 0 to 999 (%) 2nd column: 0 to 999 (days) 3rd column: 0 to 999 (%) 4th column: 50 to 999 (%)</p>	
Supplement/Memo	<p>Operation Life Value: Wear level value relative to Replacement Life Value (%) Operation Life Value = Life Value/Replacement Life Value x 100 Number of Days Left: Expected number of days until the part reaches its end of life Replacement Life Value: Target replacement life value</p>	

COPIER (Service mode for printer) > COUNTER (Counter mode) > LIFE

FX-WEB1	1	Fixing Web: Life VL and No. of days left
Detail	<p>To display the life value and the number of days left of the Fixing Web. The 3rd and 4th columns may be hidden depending on the country. 1st column: Operation Life Value 2nd column: Number of Days Left 3rd column: Life Value 4th column: Replacement Life Value</p>	
Use Case	<p>- When checking Life VL/No. of days left of the part - At parts replacement</p>	
Adj/Set/Operate Method	<p>To reset Operation Life Value/Number of Days Left/Life Value: Select the item, and then press Clear key.</p>	
Caution	<p>- Be sure to reset Operation Life Value/Number of Days Left/Life Value after replacing the part. - Operation Life Value/Number of Days Left/Life Value can also be reset by clearing the parts counter.</p>	
Display/Adj/Set Range	<p>1st column: 0 to 999 (%) 2nd column: 0 to 999 (days) 3rd column: 0 to 999 (%) 4th column: 50 to 999 (%)</p>	
Supplement/Memo	<p>Operation Life Value: Wear level value relative to Replacement Life Value (%) Operation Life Value = Life Value/Replacement Life Value x 100 Number of Days Left: Expected number of days until the part reaches its end of life Replacement Life Value: Target replacement life value</p>	
C1-PU-RL	1	R-Deck Pickup Rol: Life VL/No. days left
Detail	<p>To display the life value and the number of days left of the Right Deck Pickup Roller. The 3rd and 4th columns may be hidden depending on the country. 1st column: Operation Life Value 2nd column: Number of Days Left 3rd column: Life Value 4th column: Replacement Life Value</p>	
Use Case	<p>- When checking Life VL/No. of days left of the part - At parts replacement</p>	
Adj/Set/Operate Method	<p>To change the Replacement Life Value: Select the item, enter the value, and then press OK key. To reset Operation Life Value/Number of Days Left/Life Value: Select the item, and then press Clear key.</p>	
Caution	<p>- Be sure to reset Operation Life Value/Number of Days Left/Life Value after replacing the part. - Operation Life Value/Number of Days Left/Life Value can also be reset by clearing the parts counter.</p>	
Display/Adj/Set Range	<p>1st column: 0 to 999 (%) 2nd column: 0 to 999 (days) 3rd column: 0 to 999 (%) 4th column: 50 to 999 (%)</p>	
Supplement/Memo	<p>Operation Life Value: Wear level value relative to Replacement Life Value (%) Operation Life Value = Life Value/Replacement Life Value x 100 Number of Days Left: Expected number of days until the part reaches its end of life Replacement Life Value: Target replacement life value</p>	

COPIER (Service mode for printer) > COUNTER (Counter mode) > LIFE

C1-FD-RL	1	R-Deck Feed Roll: Life VL/No. days left
Detail	To display the life value and the number of days left of the Right Deck Feed Roller. The 3rd and 4th columns may be hidden depending on the country. 1st column: Operation Life Value 2nd column: Number of Days Left 3rd column: Life Value 4th column: Replacement Life Value	
Use Case	- When checking Life VL/No. of days left of the part - At parts replacement	
Adj/Set/Operate Method	To change the Replacement Life Value: Select the item, enter the value, and then press OK key. To reset Operation Life Value/Number of Days Left/Life Value: Select the item, and then press Clear key.	
Caution	- Be sure to reset Operation Life Value/Number of Days Left/Life Value after replacing the part. - Operation Life Value/Number of Days Left/Life Value can also be reset by clearing the parts counter.	
Display/Adj/Set Range	1st column: 0 to 999 (%) 2nd column: 0 to 999 (days) 3rd column: 0 to 999 (%) 4th column: 50 to 999 (%)	
Supplement/Memo	Operation Life Value: Wear level value relative to Replacement Life Value (%) Operation Life Value = Life Value/Replacement Life Value x 100 Number of Days Left: Expected number of days until the part reaches its end of life Replacement Life Value: Target replacement life value	
C1-SP-RL	1	R-Deck Sepn Roll: Life VL/No. days left
Detail	To display the life value and the number of days left of the Right Deck Separation Roller. The 3rd and 4th columns may be hidden depending on the country. 1st column: Operation Life Value 2nd column: Number of Days Left 3rd column: Life Value 4th column: Replacement Life Value	
Use Case	- When checking Life VL/No. of days left of the part - At parts replacement	
Adj/Set/Operate Method	To change the Replacement Life Value: Select the item, enter the value, and then press OK key. To reset Operation Life Value/Number of Days Left/Life Value: Select the item, and then press Clear key.	
Caution	- Be sure to reset Operation Life Value/Number of Days Left/Life Value after replacing the part. - Operation Life Value/Number of Days Left/Life Value can also be reset by clearing the parts counter.	
Display/Adj/Set Range	1st column: 0 to 999 (%) 2nd column: 0 to 999 (days) 3rd column: 0 to 999 (%) 4th column: 50 to 999 (%)	
Supplement/Memo	Operation Life Value: Wear level value relative to Replacement Life Value (%) Operation Life Value = Life Value/Replacement Life Value x 100 Number of Days Left: Expected number of days until the part reaches its end of life Replacement Life Value: Target replacement life value	

COPIER (Service mode for printer) > COUNTER (Counter mode) > LIFE

C2-PU-RL	1	L-Deck Pickup Rol: Life VL/No. days left
Detail	<p>To display the life value and the number of days left of the Left Deck Pickup Roller. The 3rd and 4th columns may be hidden depending on the country.</p> <p>1st column: Operation Life Value 2nd column: Number of Days Left 3rd column: Life Value 4th column: Replacement Life Value</p>	
Use Case	<p>- When checking Life VL/No. of days left of the part - At parts replacement</p>	
Adj/Set/Operate Method	<p>To change the Replacement Life Value: Select the item, enter the value, and then press OK key. To reset Operation Life Value/Number of Days Left/Life Value: Select the item, and then press Clear key.</p>	
Caution	<p>- Be sure to reset Operation Life Value/Number of Days Left/Life Value after replacing the part. - Operation Life Value/Number of Days Left/Life Value can also be reset by clearing the parts counter.</p>	
Display/Adj/Set Range	<p>1st column: 0 to 999 (%) 2nd column: 0 to 999 (days) 3rd column: 0 to 999 (%) 4th column: 50 to 999 (%)</p>	
Supplement/Memo	<p>Operation Life Value: Wear level value relative to Replacement Life Value (%) Operation Life Value = Life Value/Replacement Life Value x 100 Number of Days Left: Expected number of days until the part reaches its end of life Replacement Life Value: Target replacement life value</p>	
C2-FD-RL	1	L-Deck Feed Roll: Life VL/No. days left
Detail	<p>To display the life value and the number of days left of the Left Deck Feed Roller. The 3rd and 4th columns may be hidden depending on the country.</p> <p>1st column: Operation Life Value 2nd column: Number of Days Left 3rd column: Life Value 4th column: Replacement Life Value</p>	
Use Case	<p>- When checking Life VL/No. of days left of the part - At parts replacement</p>	
Adj/Set/Operate Method	<p>To change the Replacement Life Value: Select the item, enter the value, and then press OK key. To reset Operation Life Value/Number of Days Left/Life Value: Select the item, and then press Clear key.</p>	
Caution	<p>- Be sure to reset Operation Life Value/Number of Days Left/Life Value after replacing the part. - Operation Life Value/Number of Days Left/Life Value can also be reset by clearing the parts counter.</p>	
Display/Adj/Set Range	<p>1st column: 0 to 999 (%) 2nd column: 0 to 999 (days) 3rd column: 0 to 999 (%) 4th column: 50 to 999 (%)</p>	
Supplement/Memo	<p>Operation Life Value: Wear level value relative to Replacement Life Value (%) Operation Life Value = Life Value/Replacement Life Value x 100 Number of Days Left: Expected number of days until the part reaches its end of life Replacement Life Value: Target replacement life value</p>	

COPIER (Service mode for printer) > COUNTER (Counter mode) > LIFE

C2-SP-RL	1	L-Deck Sepn Roll: Life VL/No. days left
Detail	To display the life value and the number of days left of the Left Deck Separation Roller. The 3rd and 4th columns may be hidden depending on the country. 1st column: Operation Life Value 2nd column: Number of Days Left 3rd column: Life Value 4th column: Replacement Life Value	
Use Case	- When checking Life VL/No. of days left of the part - At parts replacement	
Adj/Set/Operate Method	To change the Replacement Life Value: Select the item, enter the value, and then press OK key. To reset Operation Life Value/Number of Days Left/Life Value: Select the item, and then press Clear key.	
Caution	- Be sure to reset Operation Life Value/Number of Days Left/Life Value after replacing the part. - Operation Life Value/Number of Days Left/Life Value can also be reset by clearing the parts counter.	
Display/Adj/Set Range	1st column: 0 to 999 (%) 2nd column: 0 to 999 (days) 3rd column: 0 to 999 (%) 4th column: 50 to 999 (%)	
Supplement/Memo	Operation Life Value: Wear level value relative to Replacement Life Value (%) Operation Life Value = Life Value/Replacement Life Value x 100 Number of Days Left: Expected number of days until the part reaches its end of life Replacement Life Value: Target replacement life value	
C3-PU-RL	1	Cst3 Pckup Rol: Life VL/No. of days left
Detail	To display the life value and the number of days left of the Cassette 3 Pickup Roller. The 3rd and 4th columns may be hidden depending on the country. 1st column: Operation Life Value 2nd column: Number of Days Left 3rd column: Life Value 4th column: Replacement Life Value	
Use Case	- When checking Life VL/No. of days left of the part - At parts replacement	
Adj/Set/Operate Method	To change the Replacement Life Value: Select the item, enter the value, and then press OK key. To reset Operation Life Value/Number of Days Left/Life Value: Select the item, and then press Clear key.	
Caution	- Be sure to reset Operation Life Value/Number of Days Left/Life Value after replacing the part. - Operation Life Value/Number of Days Left/Life Value can also be reset by clearing the parts counter.	
Display/Adj/Set Range	1st column: 0 to 999 (%) 2nd column: 0 to 999 (days) 3rd column: 0 to 999 (%) 4th column: 50 to 999 (%)	
Supplement/Memo	Operation Life Value: Wear level value relative to Replacement Life Value (%) Operation Life Value = Life Value/Replacement Life Value x 100 Number of Days Left: Expected number of days until the part reaches its end of life Replacement Life Value: Target replacement life value	

COPIER (Service mode for printer) > COUNTER (Counter mode) > LIFE

C3-SP-RL	1	Cst3 Sepn Roll: Life VL/No. of days left
Detail	<p>To display the life value and the number of days left of the Cassette 3 Separation Roller. The 3rd and 4th columns may be hidden depending on the country.</p> <p>1st column: Operation Life Value 2nd column: Number of Days Left 3rd column: Life Value 4th column: Replacement Life Value</p>	
Use Case	<p>- When checking Life VL/No. of days left of the part - At parts replacement</p>	
Adj/Set/Operate Method	<p>To change the Replacement Life Value: Select the item, enter the value, and then press OK key. To reset Operation Life Value/Number of Days Left/Life Value: Select the item, and then press Clear key.</p>	
Caution	<p>- Be sure to reset Operation Life Value/Number of Days Left/Life Value after replacing the part. - Operation Life Value/Number of Days Left/Life Value can also be reset by clearing the parts counter.</p>	
Display/Adj/Set Range	<p>1st column: 0 to 999 (%) 2nd column: 0 to 999 (days) 3rd column: 0 to 999 (%) 4th column: 50 to 999 (%)</p>	
Supplement/Memo	<p>Operation Life Value: Wear level value relative to Replacement Life Value (%) $\text{Operation Life Value} = \frac{\text{Life Value}}{\text{Replacement Life Value}} \times 100$ Number of Days Left: Expected number of days until the part reaches its end of life Replacement Life Value: Target replacement life value</p>	
C3-FD-RL	1	Cst3 Feed Roll: Life VL/No. of days left
Detail	<p>To display the life value and the number of days left of the Cassette 3 Feed Roller. The 3rd and 4th columns may be hidden depending on the country.</p> <p>1st column: Operation Life Value 2nd column: Number of Days Left 3rd column: Life Value 4th column: Replacement Life Value</p>	
Use Case	<p>- When checking Life VL/No. of days left of the part - At parts replacement</p>	
Adj/Set/Operate Method	<p>To change the Replacement Life Value: Select the item, enter the value, and then press OK key. To reset Operation Life Value/Number of Days Left/Life Value: Select the item, and then press Clear key.</p>	
Caution	<p>- Be sure to reset Operation Life Value/Number of Days Left/Life Value after replacing the part. - Operation Life Value/Number of Days Left/Life Value can also be reset by clearing the parts counter.</p>	
Display/Adj/Set Range	<p>1st column: 0 to 999 (%) 2nd column: 0 to 999 (days) 3rd column: 0 to 999 (%) 4th column: 50 to 999 (%)</p>	
Supplement/Memo	<p>Operation Life Value: Wear level value relative to Replacement Life Value (%) $\text{Operation Life Value} = \frac{\text{Life Value}}{\text{Replacement Life Value}} \times 100$ Number of Days Left: Expected number of days until the part reaches its end of life Replacement Life Value: Target replacement life value</p>	

COPIER (Service mode for printer) > COUNTER (Counter mode) > LIFE

C4-PU-RL	1	Cst4 Pckup Rol: Life VL/No. of days left
Detail	<p>To display the life value and the number of days left of the Cassette 4 Pickup Roller. The 3rd and 4th columns may be hidden depending on the country.</p> <p>1st column: Operation Life Value 2nd column: Number of Days Left 3rd column: Life Value 4th column: Replacement Life Value</p>	
Use Case	<p>- When checking Life VL/No. of days left of the part - At parts replacement</p>	
Adj/Set/Operate Method	<p>To change the Replacement Life Value: Select the item, enter the value, and then press OK key. To reset Operation Life Value/Number of Days Left/Life Value: Select the item, and then press Clear key.</p>	
Caution	<p>- Be sure to reset Operation Life Value/Number of Days Left/Life Value after replacing the part. - Operation Life Value/Number of Days Left/Life Value can also be reset by clearing the parts counter.</p>	
Display/Adj/Set Range	<p>1st column: 0 to 999 (%) 2nd column: 0 to 999 (days) 3rd column: 0 to 999 (%) 4th column: 50 to 999 (%)</p>	
Supplement/Memo	<p>Operation Life Value: Wear level value relative to Replacement Life Value (%) Operation Life Value = Life Value/Replacement Life Value x 100 Number of Days Left: Expected number of days until the part reaches its end of life Replacement Life Value: Target replacement life value</p>	
C4-FD-RL	1	Cst4 Feed Roll: Life VL/No. of days left
Detail	<p>To display the life value and the number of days left of the Cassette 4 Feed Roller. The 3rd and 4th columns may be hidden depending on the country.</p> <p>1st column: Operation Life Value 2nd column: Number of Days Left 3rd column: Life Value 4th column: Replacement Life Value</p>	
Use Case	<p>- When checking Life VL/No. of days left of the part - At parts replacement</p>	
Adj/Set/Operate Method	<p>To change the Replacement Life Value: Select the item, enter the value, and then press OK key. To reset Operation Life Value/Number of Days Left/Life Value: Select the item, and then press Clear key.</p>	
Caution	<p>- Be sure to reset Operation Life Value/Number of Days Left/Life Value after replacing the part. - Operation Life Value/Number of Days Left/Life Value can also be reset by clearing the parts counter.</p>	
Display/Adj/Set Range	<p>1st column: 0 to 999 (%) 2nd column: 0 to 999 (days) 3rd column: 0 to 999 (%) 4th column: 50 to 999 (%)</p>	
Supplement/Memo	<p>Operation Life Value: Wear level value relative to Replacement Life Value (%) Operation Life Value = Life Value/Replacement Life Value x 100 Number of Days Left: Expected number of days until the part reaches its end of life Replacement Life Value: Target replacement life value</p>	

COPIER (Service mode for printer) > COUNTER (Counter mode) > LIFE

C4-SP-RL	1	Cst4 Sepn Roll: Life VL/No. of days left
Detail	<p>To display the life value and the number of days left of the Cassette 4 Separation Roller. The 3rd and 4th columns may be hidden depending on the country.</p> <p>1st column: Operation Life Value 2nd column: Number of Days Left 3rd column: Life Value 4th column: Replacement Life Value</p>	
Use Case	<p>- When checking Life VL/No. of days left of the part - At parts replacement</p>	
Adj/Set/Operate Method	<p>To change the Replacement Life Value: Select the item, enter the value, and then press OK key. To reset Operation Life Value/Number of Days Left/Life Value: Select the item, and then press Clear key.</p>	
Caution	<p>- Be sure to reset Operation Life Value/Number of Days Left/Life Value after replacing the part. - Operation Life Value/Number of Days Left/Life Value can also be reset by clearing the parts counter.</p>	
Display/Adj/Set Range	<p>1st column: 0 to 999 (%) 2nd column: 0 to 999 (days) 3rd column: 0 to 999 (%) 4th column: 50 to 999 (%)</p>	
Supplement/Memo	<p>Operation Life Value: Wear level value relative to Replacement Life Value (%) $\text{Operation Life Value} = \frac{\text{Life Value}}{\text{Replacement Life Value}} \times 100$ Number of Days Left: Expected number of days until the part reaches its end of life Replacement Life Value: Target replacement life value</p>	
M-FD-RL	1	MP Tray Fd Rol: Life VL/No of days left
Detail	<p>To display the life value and the number of days left of the Multi-purpose Tray Feed Roller. The 3rd and 4th columns may be hidden depending on the country.</p> <p>1st column: Operation Life Value 2nd column: Number of Days Left 3rd column: Life Value 4th column: Replacement Life Value</p>	
Use Case	<p>- When checking Life VL/No. of days left of the part - At parts replacement</p>	
Adj/Set/Operate Method	<p>To change the Replacement Life Value: Select the item, enter the value, and then press OK key. To reset Operation Life Value/Number of Days Left/Life Value: Select the item, and then press Clear key.</p>	
Caution	<p>- Be sure to reset Operation Life Value/Number of Days Left/Life Value after replacing the part. - Operation Life Value/Number of Days Left/Life Value can also be reset by clearing the parts counter.</p>	
Display/Adj/Set Range	<p>1st column: 0 to 999 (%) 2nd column: 0 to 999 (days) 3rd column: 0 to 999 (%) 4th column: 50 to 999 (%)</p>	
Supplement/Memo	<p>Operation Life Value: Wear level value relative to Replacement Life Value (%) $\text{Operation Life Value} = \frac{\text{Life Value}}{\text{Replacement Life Value}} \times 100$ Number of Days Left: Expected number of days until the part reaches its end of life Replacement Life Value: Target replacement life value</p>	

COPIER (Service mode for printer) > COUNTER (Counter mode) > LIFE

M-SP-RL	1	MP Tray Sepn Rol:Life VL/No of days left
Detail	<p>To display the life value and the number of days left of the Multi-purpose Tray Separation Roller. The 3rd and 4th columns may be hidden depending on the country.</p> <p>1st column: Operation Life Value 2nd column: Number of Days Left 3rd column: Life Value 4th column: Replacement Life Value</p>	
Use Case	<p>- When checking Life VL/No. of days left of the part - At parts replacement</p>	
Adj/Set/Operate Method	<p>To change the Replacement Life Value: Select the item, enter the value, and then press OK key. To reset Operation Life Value/Number of Days Left/Life Value: Select the item, and then press Clear key.</p>	
Caution	<p>- Be sure to reset Operation Life Value/Number of Days Left/Life Value after replacing the part. - Operation Life Value/Number of Days Left/Life Value can also be reset by clearing the parts counter.</p>	
Display/Adj/Set Range	<p>1st column: 0 to 999 (%) 2nd column: 0 to 999 (days) 3rd column: 0 to 999 (%) 4th column: 50 to 999 (%)</p>	
Supplement/Memo	<p>Operation Life Value: Wear level value relative to Replacement Life Value (%) $\text{Operation Life Value} = \frac{\text{Life Value}}{\text{Replacement Life Value}} \times 100$ Number of Days Left: Expected number of days until the part reaches its end of life Replacement Life Value: Target replacement life value</p>	
DLV-UCLW	1	Upper Sepn Claw:Life VL/No. of days left
Detail	<p>To display the life value and the number of days left of the Upper Separation Claw. The 3rd and 4th columns may be hidden depending on the country.</p> <p>1st column: Operation Life Value 2nd column: Number of Days Left 3rd column: Life Value 4th column: Replacement Life Value</p>	
Use Case	<p>- When checking Life VL/No. of days left of the part - At parts replacement</p>	
Adj/Set/Operate Method	<p>To change the Replacement Life Value: Select the item, enter the value, and then press OK key. To reset Operation Life Value/Number of Days Left/Life Value: Select the item, and then press Clear key.</p>	
Caution	<p>- Be sure to reset Operation Life Value/Number of Days Left/Life Value after replacing the part. - Operation Life Value/Number of Days Left/Life Value can also be reset by clearing the parts counter.</p>	
Display/Adj/Set Range	<p>1st column: 0 to 999 (%) 2nd column: 0 to 999 (days) 3rd column: 0 to 999 (%) 4th column: 50 to 999 (%)</p>	
Supplement/Memo	<p>Operation Life Value: Wear level value relative to Replacement Life Value (%) $\text{Operation Life Value} = \frac{\text{Life Value}}{\text{Replacement Life Value}} \times 100$ Number of Days Left: Expected number of days until the part reaches its end of life Replacement Life Value: Target replacement life value</p>	

COPIER (Service mode for printer) > COUNTER (Counter mode) > LIFE

OZ-FIL1	1	Ozone Filter: Life VL/No. of days left
Detail		To display the life value and the number of days left of the Ozone Filter. The 3rd and 4th columns may be hidden depending on the country. 1st column: Operation Life Value 2nd column: Number of Days Left 3rd column: Life Value 4th column: Replacement Life Value
Use Case		- When checking Life VL/No. of days left of the part - At parts replacement
Adj/Set/Operate Method		To change the Replacement Life Value: Select the item, enter the value, and then press OK key. To reset Operation Life Value/Number of Days Left/Life Value: Select the item, and then press Clear key.
Caution		- Be sure to reset Operation Life Value/Number of Days Left/Life Value after replacing the part. - Operation Life Value/Number of Days Left/Life Value can also be reset by clearing the parts counter.
Display/Adj/Set Range		1st column: 0 to 999 (%) 2nd column: 0 to 999 (days) 3rd column: 0 to 999 (%) 4th column: 50 to 999 (%)
Supplement/Memo		Operation Life Value: Wear level value relative to Replacement Life Value (%) Operation Life Value = Life Value/Replacement Life Value x 100 Number of Days Left: Expected number of days until the part reaches its end of life Replacement Life Value: Target replacement life value
AR-FIL1	1	Dustproof Fit: Life VL/No. of days left
Detail		To display the life value and the number of days left of the Dustproof Filter. The 3rd and 4th columns may be hidden depending on the country. 1st column: Operation Life Value 2nd column: Number of Days Left 3rd column: Life Value 4th column: Replacement Life Value
Use Case		- When checking Life VL/No. of days left of the part - At parts replacement
Adj/Set/Operate Method		To change the Replacement Life Value: Select the item, enter the value, and then press OK key. To reset Operation Life Value/Number of Days Left/Life Value: Select the item, and then press Clear key.
Caution		- Be sure to reset Operation Life Value/Number of Days Left/Life Value after replacing the part. - Operation Life Value/Number of Days Left/Life Value can also be reset by clearing the parts counter.
Display/Adj/Set Range		1st column: 0 to 999 (%) 2nd column: 0 to 999 (days) 3rd column: 0 to 999 (%) 4th column: 50 to 999 (%)
Supplement/Memo		Operation Life Value: Wear level value relative to Replacement Life Value (%) Operation Life Value = Life Value/Replacement Life Value x 100 Number of Days Left: Expected number of days until the part reaches its end of life Replacement Life Value: Target replacement life value

COPIER (Service mode for printer) > COUNTER (Counter mode) > LIFE

DF-PU-RL	1	Pickup Roller (DADF): Life VL/days left
Detail	<p>To display the life value and the number of days left of the Pickup Roller (DADF). The 3rd and 4th columns may be hidden depending on the country.</p> <p>1st column: Operation Life Value 2nd column: Number of Days Left 3rd column: Life Value 4th column: Replacement Life Value</p>	
Use Case	<p>- When checking Life VL/No. of days left of the part - At parts replacement</p>	
Adj/Set/Operate Method	<p>To change the Replacement Life Value: Select the item, enter the value, and then press OK key. To reset Operation Life Value/Number of Days Left/Life Value: Select the item, and then press Clear key.</p>	
Caution	<p>- Be sure to reset Operation Life Value/Number of Days Left/Life Value after replacing the part. - Operation Life Value/Number of Days Left/Life Value can also be reset by clearing the parts counter.</p>	
Display/Adj/Set Range	<p>1st column: 0 to 999 (%) 2nd column: 0 to 999 (days) 3rd column: 0 to 999 (%) 4th column: 50 to 999 (%)</p>	
Supplement/Memo	<p>Operation Life Value: Wear level value relative to Replacement Life Value (%) $\text{Operation Life Value} = \text{Life Value} / \text{Replacement Life Value} \times 102$ Number of Days Left: Expected number of days until the part reaches its end of life Replacement Life Value: Target re</p>	
DF-SP-RL	1	Separation Rol (DADF): Life VL/days left
Detail	<p>To display the life value and the number of days left of the Separation Roller (DADF). The 3rd and 4th columns may be hidden depending on the country.</p> <p>1st column: Operation Life Value 2nd column: Number of Days Left 3rd column: Life Value 4th column: Replacement Life Value</p>	
Use Case	<p>- When checking Life VL/No. of days left of the part - At parts replacement</p>	
Adj/Set/Operate Method	<p>To change the Replacement Life Value: Select the item, enter the value, and then press OK key. To reset Operation Life Value/Number of Days Left/Life Value: Select the item, and then press Clear key.</p>	
Caution	<p>- Be sure to reset Operation Life Value/Number of Days Left/Life Value after replacing the part. - Operation Life Value/Number of Days Left/Life Value can also be reset by clearing the parts counter.</p>	
Display/Adj/Set Range	<p>1st column: 0 to 999 (%) 2nd column: 0 to 999 (days) 3rd column: 0 to 999 (%) 4th column: 50 to 999 (%)</p>	
Supplement/Memo	<p>Operation Life Value: Wear level value relative to Replacement Life Value (%) $\text{Operation Life Value} = \text{Life Value} / \text{Replacement Life Value} \times 114$ Number of Days Left: Expected number of days until the part reaches its end of life Replacement Life Value: Target re</p>	

COPIER (Service mode for printer) > COUNTER (Counter mode) > LIFE

PD-PU-RL	1	Pickup Roller (Deck): Life VL/days left
Detail	To display the life value and the number of days left of the Pickup Roller (Deck). The 3rd and 4th columns may be hidden depending on the country. 1st column: Operation Life Value 2nd column: Number of Days Left 3rd column: Life Value 4th column: Replacement Life Value	
Use Case	- When checking Life VL/No. of days left of the part - At parts replacement	
Adj/Set/Operate Method	To change the Replacement Life Value: Select the item, enter the value, and then press OK key. To reset Operation Life Value/Number of Days Left/Life Value: Select the item, and then press Clear key.	
Caution	- Be sure to reset Operation Life Value/Number of Days Left/Life Value after replacing the part. - Operation Life Value/Number of Days Left/Life Value can also be reset by clearing the parts counter.	
Display/Adj/Set Range	1st column: 0 to 999 (%) 2nd column: 0 to 999 (days) 3rd column: 0 to 999 (%) 4th column: 50 to 999 (%)	
Supplement/Memo	Operation Life Value: Wear level value relative to Replacement Life Value (%) Operation Life Value = Life Value/Replacement Life Value x 136 Number of Days Left: Expected number of days until the part reaches its end of life Replacement Life Value: Target re	
PD-SP-RL	1	Sprtn Roll Part (Deck):Life VL/days left
Detail	To display the life value and the number of days left of the Separation Roller of Paper Deck/POD Deck Lite. The 3rd and 4th columns may be hidden depending on the country. 1st column: Operation Life Value 2nd column: Number of Days Left 3rd column: Life Value 4th column: Replacement Life Value	
Use Case	- When checking Life VL/No. of days left of the part - At parts replacement	
Adj/Set/Operate Method	To change the Replacement Life Value: Select the item, enter the value, and then press OK key. To reset Operation Life Value/Number of Days Left/Life Value: Select the item, and then press Clear key.	
Caution	- Be sure to reset Operation Life Value/Number of Days Left/Life Value after replacing the part. - Operation Life Value/Number of Days Left/Life Value can also be reset by clearing the parts counter.	
Display/Adj/Set Range	1st column: 0 to 999 (%) 2nd column: 0 to 999 (days) 3rd column: 0 to 999 (%) 4th column: 50 to 999 (%)	
Supplement/Memo	Operation Life Value: Wear level value relative to Replacement Life Value (%) Operation Life Value = Life Value/Replacement Life Value x 141 Number of Days Left: Expected number of days until the part reaches its end of life Replacement Life Value: Target re	

COPIER (Service mode for printer) > COUNTER (Counter mode) > LIFE

PD-FD-RL	1	Feed Roller (Deck): Life VL/days left
Detail	<p>To display the life value and the number of days left of the Feed Roller of Paper Deck/POD Deck Lite.</p> <p>The 3rd and 4th columns may be hidden depending on the country.</p> <p>1st column: Operation Life Value 2nd column: Number of Days Left 3rd column: Life Value 4th column: Replacement Life Value</p>	
Use Case	<p>- When checking Life VL/No. of days left of the part - At parts replacement</p>	
Adj/Set/Operate Method	<p>To change the Replacement Life Value: Select the item, enter the value, and then press OK key. To reset Operation Life Value/Number of Days Left/Life Value: Select the item, and then press Clear key.</p>	
Caution	<p>- Be sure to reset Operation Life Value/Number of Days Left/Life Value after replacing the part. - Operation Life Value/Number of Days Left/Life Value can also be reset by clearing the parts counter.</p>	
Display/Adj/Set Range	<p>1st column: 0 to 999 (%) 2nd column: 0 to 999 (days) 3rd column: 0 to 999 (%) 4th column: 50 to 999 (%)</p>	
Supplement/Memo	<p>Operation Life Value: Wear level value relative to Replacement Life Value (%) $\text{Operation Life Value} = \text{Life Value} / \text{Replacement Life Value} \times 151$ Number of Days Left: Expected number of days until the part reaches its end of life Replacement Life Value: Target re</p>	
FIN-STPR	1	Stapler : Life VL/No. of days left
Detail	<p>To display the life value and the number of days left of the Stapler Unit (Fin-X/AC).</p> <p>The 3rd and 4th columns may be hidden depending on the country.</p> <p>1st column: Operation Life Value 2nd column: Number of Days Left 3rd column: Life Value 4th column: Replacement Life Value</p>	
Use Case	<p>- When checking Life VL/No. of days left of the part - At parts replacement</p>	
Adj/Set/Operate Method	<p>To change the Replacement Life Value: Select the item, enter the value, and then press OK key. To reset Operation Life Value/Number of Days Left/Life Value: Select the item, and then press Clear key.</p>	
Caution	<p>- Be sure to reset Operation Life Value/Number of Days Left/Life Value after replacing the part. - Operation Life Value/Number of Days Left/Life Value can also be reset by clearing the parts counter.</p>	
Display/Adj/Set Range	<p>1st column: 0 to 999 (%) 2nd column: 0 to 999 (days) 3rd column: 0 to 999 (%) 4th column: 50 to 999 (%)</p>	
Supplement/Memo	<p>Operation Life Value: Wear level value relative to Replacement Life Value (%) $\text{Operation Life Value} = \text{Life Value} / \text{Replacement Life Value} \times 100$ Number of Days Left: Expected number of days until the part reaches its end of life Replacement Life Value: Target replacement life value</p>	

COPIER (Service mode for printer) > COUNTER (Counter mode) > LIFE

SDL-STP	1	Saddle Stitcher : Life VL/No. of days
Detail		To display the life value and the number of days left of the Saddle stitcher unit (Fin-AC). The 3rd and 4th columns may be hidden depending on the country. 1st column: Operation Life Value 2nd column: Number of Days Left 3rd column: Life Value 4th column: Replacement Life Value
Use Case		- When checking Life VL/No. of days left of the part - At parts replacement
Adj/Set/Operate Method		To change the Replacement Life Value: Select the item, enter the value, and then press OK key. To reset Operation Life Value/Number of Days Left/Life Value: Select the item, and then press Clear key.
Caution		- Be sure to reset Operation Life Value/Number of Days Left/Life Value after replacing the part. - Operation Life Value/Number of Days Left/Life Value can also be reset by clearing the parts counter.
Display/Adj/Set Range		1st column: 0 to 999 (%) 2nd column: 0 to 999 (days) 3rd column: 0 to 999 (%) 4th column: 50 to 999 (%)
Supplement/Memo		Operation Life Value: Wear level value relative to Replacement Life Value (%) Operation Life Value = Life Value/Replacement Life Value x 100 Number of Days Left: Expected number of days until the part reaches its end of life Replacement Life Value: Target replacement life value
SDL-STPL	1	Saddle Stitcher : Life VL/No. of days
Detail		To display the life value and the number of days left of the Saddle stitcher unit (Fin-X). The 3rd and 4th columns may be hidden depending on the country. 1st column: Operation Life Value 2nd column: Number of Days Left 3rd column: Life Value 4th column: Replacement Life Value
Use Case		- When checking Life VL/No. of days left of the part - At parts replacement
Adj/Set/Operate Method		To change the Replacement Life Value: Select the item, enter the value, and then press OK key. To reset Operation Life Value/Number of Days Left/Life Value: Select the item, and then press Clear key.
Caution		- Be sure to reset Operation Life Value/Number of Days Left/Life Value after replacing the part. - Operation Life Value/Number of Days Left/Life Value can also be reset by clearing the parts counter.
Display/Adj/Set Range		1st column: 0 to 999 (%) 2nd column: 0 to 999 (days) 3rd column: 0 to 999 (%) 4th column: 50 to 999 (%)
Supplement/Memo		Operation Life Value: Wear level value relative to Replacement Life Value (%) Operation Life Value = Life Value/Replacement Life Value x 100 Number of Days Left: Expected number of days until the part reaches its end of life Replacement Life Value: Target replacement life value

COPIER (Service mode for printer) > COUNTER (Counter mode) > LIFE

FR-STPL	1	Stpl-free Binding: Life VL/No. of days
Detail		To display the life value and the number of days left of the Stpl-free Binding. The 3rd and 4th columns may be hidden depending on the country. 1st column: Operation Life Value 2nd column: Number of Days Left 3rd column: Life Value 4th column: Replacement Life Value
Use Case		- When checking Life VL/No. of days left of the part - At parts replacement
Adj/Set/Operate Method		To change the Replacement Life Value: Select the item, enter the value, and then press OK key. To reset Operation Life Value/Number of Days Left/Life Value: Select the item, and then press Clear key.
Caution		- Be sure to reset Operation Life Value/Number of Days Left/Life Value after replacing the part. - Operation Life Value/Number of Days Left/Life Value can also be reset by clearing the parts counter.
Display/Adj/Set Range		1st column: 0 to 999 (%) 2nd column: 0 to 999 (days) 3rd column: 0 to 999 (%) 4th column: 50 to 999 (%)
Supplement/Memo		Operation Life Value: Wear level value relative to Replacement Life Value (%) Operation Life Value = Life Value/Replacement Life Value x 100 Number of Days Left: Expected number of days until the part reaches its end of life Replacement Life Value: Target replacement life value
BEHLTQLM	1	Torque Limter: Life VL/No. of days left
Detail		To display the life value and the number of days left of the Process Tray Torque Limter (Tray 1/2 Paper Retainer). The 3rd and 4th columns may be hidden depending on the country. 1st column: Operation Life Value 2nd column: Number of Days Left 3rd column: Life Value 4th column: Replacement Life Value
Use Case		- When checking Life VL/No. of days left of the part - At parts replacement
Adj/Set/Operate Method		To change the Replacement Life Value: Select the item, enter the value, and then press OK key. To reset Operation Life Value/Number of Days Left/Life Value: Select the item, and then press Clear key.
Caution		- Be sure to reset Operation Life Value/Number of Days Left/Life Value after replacing the part. - Operation Life Value/Number of Days Left/Life Value can also be reset by clearing the parts counter.
Display/Adj/Set Range		1st column: 0 to 999 (%) 2nd column: 0 to 999 (days) 3rd column: 0 to 999 (%) 4th column: 50 to 999 (%)
Supplement/Memo		Operation Life Value: Wear level value relative to Replacement Life Value (%) Operation Life Value = Life Value/Replacement Life Value x 100 Number of Days Left: Expected number of days until the part reaches its end of life Replacement Life Value: Target replacement life value

COPIER (Service mode for printer) > COUNTER (Counter mode) > LIFE

SHT-TQLM	1	Shutter Torque Limt: Life VL/days left
Detail		To display the life value and the number of days left of the Grate-shaped Upper Guide Shutter Torque Limiter. The 3rd and 4th columns may be hidden depending on the country. 1st column: Operation Life Value 2nd column: Number of Days Left 3rd column: Life Value 4th column: Replacement Life Value
Use Case		- When checking Life VL/No. of days left of the part - At parts replacement
Adj/Set/Operate Method		To change the Replacement Life Value: Select the item, enter the value, and then press OK key. To reset Operation Life Value/Number of Days Left/Life Value: Select the item, and then press Clear key.
Caution		- Be sure to reset Operation Life Value/Number of Days Left/Life Value after replacing the part. - Operation Life Value/Number of Days Left/Life Value can also be reset by clearing the parts counter.
Display/Adj/Set Range		1st column: 0 to 999 (%) 2nd column: 0 to 999 (days) 3rd column: 0 to 999 (%) 4th column: 50 to 999 (%)
Supplement/Memo		Operation Life Value: Wear level value relative to Replacement Life Value (%) Operation Life Value = Life Value/Replacement Life Value x 100 Number of Days Left: Expected number of days until the part reaches its end of life Replacement Life Value: Target replacement life value
SUB-TQLM	1	Sub Guide Torque Limt: Life VL/days left
Detail		To display the life value and the number of days left of the Process Tray Assembly Sub Guide Torque Limiter. The 3rd and 4th columns may be hidden depending on the country. 1st column: Operation Life Value 2nd column: Number of Days Left 3rd column: Life Value 4th column: Replacement Life Value
Use Case		- When checking Life VL/No. of days left of the part - At parts replacement
Adj/Set/Operate Method		To change the Replacement Life Value: Select the item, enter the value, and then press OK key. To reset Operation Life Value/Number of Days Left/Life Value: Select the item, and then press Clear key.
Caution		- Be sure to reset Operation Life Value/Number of Days Left/Life Value after replacing the part. - Operation Life Value/Number of Days Left/Life Value can also be reset by clearing the parts counter.
Display/Adj/Set Range		1st column: 0 to 999 (%) 2nd column: 0 to 999 (days) 3rd column: 0 to 999 (%) 4th column: 50 to 999 (%)
Supplement/Memo		Operation Life Value: Wear level value relative to Replacement Life Value (%) Operation Life Value = Life Value/Replacement Life Value x 100 Number of Days Left: Expected number of days until the part reaches its end of life Replacement Life Value: Target replacement life value

COPIER (Service mode for printer) > COUNTER (Counter mode) > LIFE

SWG-TQLM	1	Ppr Holding Torq Limt: Life VL/days left
Detail		To display the life value and the number of days left of the Process Tray Assembly Paper Holding Torque Limiter. The 3rd and 4th columns may be hidden depending on the country. 1st column: Operation Life Value 2nd column: Number of Days Left 3rd column: Life Value 4th column: Replacement Life Value
Use Case		- When checking Life VL/No. of days left of the part - At parts replacement
Adj/Set/Operate Method		To change the Replacement Life Value: Select the item, enter the value, and then press OK key. To reset Operation Life Value/Number of Days Left/Life Value: Select the item, and then press Clear key.
Caution		- Be sure to reset Operation Life Value/Number of Days Left/Life Value after replacing the part. - Operation Life Value/Number of Days Left/Life Value can also be reset by clearing the parts counter.
Display/Adj/Set Range		1st column: 0 to 999 (%) 2nd column: 0 to 999 (days) 3rd column: 0 to 999 (%) 4th column: 50 to 999 (%)
Supplement/Memo		Operation Life Value: Wear level value relative to Replacement Life Value (%) Operation Life Value = Life Value/Replacement Life Value x 100 Number of Days Left: Expected number of days until the part reaches its end of life Replacement Life Value: Target replacement life value
TR2-TQLM	1	Tray 2 Torque Limiter: Life VL/days left
Detail		To display the life value and the number of days left of the Tray 2 Torque Limiter. The 3rd and 4th columns may be hidden depending on the country. 1st column: Operation Life Value 2nd column: Number of Days Left 3rd column: Life Value 4th column: Replacement Life Value
Use Case		- When checking Life VL/No. of days left of the part - At parts replacement
Adj/Set/Operate Method		To change the Replacement Life Value: Select the item, enter the value, and then press OK key. To reset Operation Life Value/Number of Days Left/Life Value: Select the item, and then press Clear key.
Caution		- Be sure to reset Operation Life Value/Number of Days Left/Life Value after replacing the part. - Operation Life Value/Number of Days Left/Life Value can also be reset by clearing the parts counter.
Display/Adj/Set Range		1st column: 0 to 999 (%) 2nd column: 0 to 999 (days) 3rd column: 0 to 999 (%) 4th column: 50 to 999 (%)
Supplement/Memo		Operation Life Value: Wear level value relative to Replacement Life Value (%) Operation Life Value = Life Value/Replacement Life Value x 100 Number of Days Left: Expected number of days until the part reaches its end of life Replacement Life Value: Target replacement life value

COPIER (Service mode for printer) > COUNTER (Counter mode) > LIFE

TRY-TQLM	1	Tray Torque Limiter: Life VL/No. of days
Detail		To display the life value and the number of days left of the Tray 1 Torque Limiter (Fin-X)/Stack Tray Torque Limiter (Fin-AC). The 3rd and 4th columns may be hidden depending on the country. 1st column: Operation Life Value 2nd column: Number of Days Left 3rd column: Life Value 4th column: Replacement Life Value
Use Case		- When checking Life VL/No. of days left of the part - At parts replacement
Adj/Set/Operate Method		To change the Replacement Life Value: Select the item, enter the value, and then press OK key. To reset Operation Life Value/Number of Days Left/Life Value: Select the item, and then press Clear key.
Caution		- Be sure to reset Operation Life Value/Number of Days Left/Life Value after replacing the part. - Operation Life Value/Number of Days Left/Life Value can also be reset by clearing the parts counter.
Display/Adj/Set Range		1st column: 0 to 999 (%) 2nd column: 0 to 999 (days) 3rd column: 0 to 999 (%) 4th column: 50 to 999 (%)
Supplement/Memo		Operation Life Value: Wear level value relative to Replacement Life Value (%) Operation Life Value = Life Value/Replacement Life Value x 100 Number of Days Left: Expected number of days until the part reaches its end of life Replacement Life Value: Target replacement life value
FIN-MPDL	1	Paddle: Life VL/No. of days left
Detail		To display the life value and the number of days left of the Paddle. The 3rd and 4th columns may be hidden depending on the country. 1st column: Operation Life Value 2nd column: Number of Days Left 3rd column: Life Value 4th column: Replacement Life Value
Use Case		- When checking Life VL/No. of days left of the part - At parts replacement
Adj/Set/Operate Method		To change the Replacement Life Value: Select the item, enter the value, and then press OK key. To reset Operation Life Value/Number of Days Left/Life Value: Select the item, and then press Clear key.
Caution		- Be sure to reset Operation Life Value/Number of Days Left/Life Value after replacing the part. - Operation Life Value/Number of Days Left/Life Value can also be reset by clearing the parts counter.
Display/Adj/Set Range		1st column: 0 to 999 (%) 2nd column: 0 to 999 (days) 3rd column: 0 to 999 (%) 4th column: 50 to 999 (%)
Supplement/Memo		Operation Life Value: Wear level value relative to Replacement Life Value (%) Operation Life Value = Life Value/Replacement Life Value x 100 Number of Days Left: Expected number of days until the part reaches its end of life Replacement Life Value: Target replacement life value

COPIER (Service mode for printer) > COUNTER (Counter mode) > LIFE

FN-PDL-U	1	Neat Paddle Up: Life VL/No. of days left
Detail	<p>To display the life value and the number of days left of the Neat Paddle (Upper). The 3rd and 4th columns may be hidden depending on the country. 1st column: Operation Life Value 2nd column: Number of Days Left 3rd column: Life Value 4th column: Replacement Life Value</p>	
Use Case	<p>- When checking Life VL/No. of days left of the part - At parts replacement</p>	
Adj/Set/Operate Method	<p>To change the Replacement Life Value: Select the item, enter the value, and then press OK key. To reset Operation Life Value/Number of Days Left/Life Value: Select the item, and then press Clear key.</p>	
Caution	<p>- Be sure to reset Operation Life Value/Number of Days Left/Life Value after replacing the part. - Operation Life Value/Number of Days Left/Life Value can also be reset by clearing the parts counter.</p>	
Display/Adj/Set Range	<p>1st column: 0 to 999 (%) 2nd column: 0 to 999 (days) 3rd column: 0 to 999 (%) 4th column: 50 to 999 (%)</p>	
Supplement/Memo	<p>Operation Life Value: Wear level value relative to Replacement Life Value (%) Operation Life Value = Life Value/Replacement Life Value x 100 Number of Days Left: Expected number of days until the part reaches its end of life Replacement Life Value: Target replacement life value</p>	
FN-PDL-L	1	Neat Paddle Lw: Life VL/No. of days left
Detail	<p>To display the life value and the number of days left of the Neat Paddle (Lower). The 3rd and 4th columns may be hidden depending on the country. 1st column: Operation Life Value 2nd column: Number of Days Left 3rd column: Life Value 4th column: Replacement Life Value</p>	
Use Case	<p>- When checking Life VL/No. of days left of the part - At parts replacement</p>	
Adj/Set/Operate Method	<p>To change the Replacement Life Value: Select the item, enter the value, and then press OK key. To reset Operation Life Value/Number of Days Left/Life Value: Select the item, and then press Clear key.</p>	
Caution	<p>- Be sure to reset Operation Life Value/Number of Days Left/Life Value after replacing the part. - Operation Life Value/Number of Days Left/Life Value can also be reset by clearing the parts counter.</p>	
Display/Adj/Set Range	<p>1st column: 0 to 999 (%) 2nd column: 0 to 999 (days) 3rd column: 0 to 999 (%) 4th column: 50 to 999 (%)</p>	
Supplement/Memo	<p>Operation Life Value: Wear level value relative to Replacement Life Value (%) Operation Life Value = Life Value/Replacement Life Value x 100 Number of Days Left: Expected number of days until the part reaches its end of life Replacement Life Value: Target replacement life value</p>	

COPIER (Service mode for printer) > COUNTER (Counter mode) > LIFE

SDL-JRL	1	Sddl Alignment RI: Life VL/No. days left
Detail		To display the life value and the number of days left of the Saddle Alignment Roller. The 3rd and 4th columns may be hidden depending on the country. 1st column: Operation Life Value 2nd column: Number of Days Left 3rd column: Life Value 4th column: Replacement Life Value
Use Case		- When checking Life VL/No. of days left of the part - At parts replacement
Adj/Set/Operate Method		To change the Replacement Life Value: Select the item, enter the value, and then press OK key. To reset Operation Life Value/Number of Days Left/Life Value: Select the item, and then press Clear key.
Caution		- Be sure to reset Operation Life Value/Number of Days Left/Life Value after replacing the part. - Operation Life Value/Number of Days Left/Life Value can also be reset by clearing the parts counter.
Display/Adj/Set Range		1st column: 0 to 999 (%) 2nd column: 0 to 999 (days) 3rd column: 0 to 999 (%) 4th column: 50 to 999 (%)
Supplement/Memo		Operation Life Value: Wear level value relative to Replacement Life Value (%) Operation Life Value = Life Value/Replacement Life Value x 100 Number of Days Left: Expected number of days until the part reaches its end of life Replacement Life Value: Target replacement life value
SDL-RL	1	Sddl Disengage RI: Life VL/No. days left
Detail		To display the life value and the number of days left of the Saddle Disengagement Roller. The 3rd and 4th columns may be hidden depending on the country. 1st column: Operation Life Value 2nd column: Number of Days Left 3rd column: Life Value 4th column: Replacement Life Value
Use Case		- When checking Life VL/No. of days left of the part - At parts replacement
Adj/Set/Operate Method		To change the Replacement Life Value: Select the item, enter the value, and then press OK key. To reset Operation Life Value/Number of Days Left/Life Value: Select the item, and then press Clear key.
Caution		- Be sure to reset Operation Life Value/Number of Days Left/Life Value after replacing the part. - Operation Life Value/Number of Days Left/Life Value can also be reset by clearing the parts counter.
Display/Adj/Set Range		1st column: 0 to 999 (%) 2nd column: 0 to 999 (days) 3rd column: 0 to 999 (%) 4th column: 50 to 999 (%)
Supplement/Memo		Operation Life Value: Wear level value relative to Replacement Life Value (%) Operation Life Value = Life Value/Replacement Life Value x 100 Number of Days Left: Expected number of days until the part reaches its end of life Replacement Life Value: Target replacement life value

COPIER (Service mode for printer) > COUNTER (Counter mode) > LIFE

SWG-DL-1	1	Stck Dvry Upper Roll: Life VL/days left
Detail		To display the life value and the number of days left of the Swing Guide Assembly Stack Delivery Upper Roller (Front/Rear). The 3rd and 4th columns may be hidden depending on the country. 1st column: Operation Life Value 2nd column: Number of Days Left 3rd column: Life Value 4th column: Replacement Life Value
Use Case		- When checking Life VL/No. of days left of the part - At parts replacement
Adj/Set/Operate Method		To change the Replacement Life Value: Select the item, enter the value, and then press OK key. To reset Operation Life Value/Number of Days Left/Life Value: Select the item, and then press Clear key.
Caution		- Be sure to reset Operation Life Value/Number of Days Left/Life Value after replacing the part. - Operation Life Value/Number of Days Left/Life Value can also be reset by clearing the parts counter.
Display/Adj/Set Range		1st column: 0 to 999 (%) 2nd column: 0 to 999 (days) 3rd column: 0 to 999 (%) 4th column: 50 to 999 (%)
Supplement/Memo		Operation Life Value: Wear level value relative to Replacement Life Value (%) Operation Life Value = Life Value/Replacement Life Value x 100 Number of Days Left: Expected number of days until the part reaches its end of life Replacement Life Value: Target replacement life value
SWG-DL-2	1	Stck Dvry Upper Roll: Life VL/days left
Detail		To display the life value and the number of days left of the Swing Guide Assembly Stack Delivery Upper Roller (Center). The 3rd and 4th columns may be hidden depending on the country. 1st column: Operation Life Value 2nd column: Number of Days Left 3rd column: Life Value 4th column: Replacement Life Value
Use Case		- When checking Life VL/No. of days left of the part - At parts replacement
Adj/Set/Operate Method		To change the Replacement Life Value: Select the item, enter the value, and then press OK key. To reset Operation Life Value/Number of Days Left/Life Value: Select the item, and then press Clear key.
Caution		- Be sure to reset Operation Life Value/Number of Days Left/Life Value after replacing the part. - Operation Life Value/Number of Days Left/Life Value can also be reset by clearing the parts counter.
Display/Adj/Set Range		1st column: 0 to 999 (%) 2nd column: 0 to 999 (days) 3rd column: 0 to 999 (%) 4th column: 50 to 999 (%)
Supplement/Memo		Operation Life Value: Wear level value relative to Replacement Life Value (%) Operation Life Value = Life Value/Replacement Life Value x 100 Number of Days Left: Expected number of days until the part reaches its end of life Replacement Life Value: Target replacement life value

COPIER (Service mode for printer) > COUNTER (Counter mode) > LIFE

SWG-RL	1	Paper Return Roll: Life VL/No. of days
Detail	<p>To display the life value and the number of days left of the Process Tray Paper Return Roller (Front/Rear).</p> <p>The 3rd and 4th columns may be hidden depending on the country.</p> <p>1st column: Operation Life Value 2nd column: Number of Days Left 3rd column: Life Value 4th column: Replacement Life Value</p>	
Use Case	<p>- When checking Life VL/No. of days left of the part - At parts replacement</p>	
Adj/Set/Operate Method	<p>To change the Replacement Life Value: Select the item, enter the value, and then press OK key. To reset Operation Life Value/Number of Days Left/Life Value: Select the item, and then press Clear key.</p>	
Caution	<p>- Be sure to reset Operation Life Value/Number of Days Left/Life Value after replacing the part. - Operation Life Value/Number of Days Left/Life Value can also be reset by clearing the parts counter.</p>	
Display/Adj/Set Range	<p>1st column: 0 to 999 (%) 2nd column: 0 to 999 (days) 3rd column: 0 to 999 (%) 4th column: 50 to 999 (%)</p>	
Supplement/Memo	<p>Operation Life Value: Wear level value relative to Replacement Life Value (%) Operation Life Value = Life Value/Replacement Life Value x 100 Number of Days Left: Expected number of days until the part reaches its end of life Replacement Life Value: Target replacement life value</p>	
TRM-CUT	1	Cutter Unit: Life VL/No. of days left
Detail	<p>To display the life value and the number of days left of the Cutter Unit.</p> <p>The 3rd and 4th columns may be hidden depending on the country.</p> <p>1st column: Operation Life Value 2nd column: Number of Days Left 3rd column: Life Value 4th column: Replacement Life Value</p>	
Use Case	<p>- When checking Life VL/No. of days left of the part - At parts replacement</p>	
Adj/Set/Operate Method	<p>To change the Replacement Life Value: Select the item, enter the value, and then press OK key. To reset Operation Life Value/Number of Days Left/Life Value: Select the item, and then press Clear key.</p>	
Caution	<p>- Be sure to reset Operation Life Value/Number of Days Left/Life Value after replacing the part. - Operation Life Value/Number of Days Left/Life Value can also be reset by clearing the parts counter.</p>	
Display/Adj/Set Range	<p>1st column: 0 to 999 (%) 2nd column: 0 to 999 (days) 3rd column: 0 to 999 (%) 4th column: 50 to 999 (%)</p>	
Supplement/Memo	<p>Operation Life Value: Wear level value relative to Replacement Life Value (%) Operation Life Value = Life Value/Replacement Life Value x 100 Number of Days Left: Expected number of days until the part reaches its end of life Replacement Life Value: Target replacement life value</p>	

COPIER (Service mode for printer) > COUNTER (Counter mode) > LIFE

SWG-SL	1	Swing Solenoid :Life VL/days left
Detail		To display the life value and the number of days left of the Swing Guide Assembly Swing Guide Solenoid . The 3rd and 4th columns may be hidden depending on the country. 1st column: Operation Life Value 2nd column: Number of Days Left 3rd column: Life Value 4th column: Replacement Life Value
Use Case		- When checking Life VL/No. of days left of the part - At parts replacement
Adj/Set/Operate Method		To change the Replacement Life Value: Select the item, enter the value, and then press OK key. To reset Operation Life Value/Number of Days Left/Life Value: Select the item, and then press Clear key.
Caution		- Be sure to reset Operation Life Value/Number of Days Left/Life Value after replacing the part. - Operation Life Value/Number of Days Left/Life Value can also be reset by clearing the parts counter.
Display/Adj/Set Range		1st column: 0 to 999 (%) 2nd column: 0 to 999 (days) 3rd column: 0 to 999 (%) 4th column: 50 to 999 (%)
Supplement/Memo		Operation Life Value: Wear level value relative to Replacement Life Value (%) Operation Life Value = Life Value/Replacement Life Value x 100 Number of Days Left: Expected number of days until the part reaches its end of life Replacement Life Value: Target replacement life value
PUNCH	1	Punch Unit: Life VL/No. of days left
Detail		To display the life value and the number of days left of the Punch Unit. The 3rd and 4th columns may be hidden depending on the country. 1st column: Operation Life Value 2nd column: Number of Days Left 3rd column: Life Value 4th column: Replacement Life Value
Use Case		- When checking Life VL/No. of days left of the part - At parts replacement
Adj/Set/Operate Method		To change the Replacement Life Value: Select the item, enter the value, and then press OK key. To reset Operation Life Value/Number of Days Left/Life Value: Select the item, and then press Clear key.
Caution		- Be sure to reset Operation Life Value/Number of Days Left/Life Value after replacing the part. - Operation Life Value/Number of Days Left/Life Value can also be reset by clearing the parts counter.
Display/Adj/Set Range		1st column: 0 to 999 (%) 2nd column: 0 to 999 (days) 3rd column: 0 to 999 (%) 4th column: 50 to 999 (%)
Supplement/Memo		Operation Life Value: Wear level value relative to Replacement Life Value (%) Operation Life Value = Life Value/Replacement Life Value x 100 Number of Days Left: Expected number of days until the part reaches its end of life Replacement Life Value: Target replacement life value

COPIER (Service mode for printer) > COUNTER (Counter mode) > LIFE

SORT-2	1	Feed Belt: Life VL/No. of days left
Detail		To display the life value and the number of days left of the Feed Belt. The 3rd and 4th columns may be hidden depending on the country. 1st column: Operation Life Value 2nd column: Number of Days Left 3rd column: Life Value 4th column: Replacement Life Value
Use Case		- When checking Life VL/No. of days left of the part - At parts replacement
Adj/Set/Operate Method		To change the Replacement Life Value: Select the item, enter the value, and then press OK key. To reset Operation Life Value/Number of Days Left/Life Value: Select the item, and then press Clear key.
Caution		- Be sure to reset Operation Life Value/Number of Days Left/Life Value after replacing the part. - Operation Life Value/Number of Days Left/Life Value can also be reset by clearing the parts counter.
Display/Adj/Set Range		1st column: 0 to 999 (%) 2nd column: 0 to 999 (days) 3rd column: 0 to 999 (%) 4th column: 50 to 999 (%)
Supplement/Memo		Operation Life Value: Wear level value relative to Replacement Life Value (%) Operation Life Value = Life Value/Replacement Life Value x 100 Number of Days Left: Expected number of days until the part reaches its end of life Replacement Life Value: Target replacement life value
HOLD-LVR	1	Paper Retainer Lever: Life VL/days left
Detail		To display the life value and the number of days left of the Paper Retainer Lever. The 3rd and 4th columns may be hidden depending on the country. 1st column: Operation Life Value 2nd column: Number of Days Left 3rd column: Life Value 4th column: Replacement Life Value
Use Case		- When checking Life VL/No. of days left of the part - At parts replacement
Adj/Set/Operate Method		To change the Replacement Life Value: Select the item, enter the value, and then press OK key. To reset Operation Life Value/Number of Days Left/Life Value: Select the item, and then press Clear key.
Caution		- Be sure to reset Operation Life Value/Number of Days Left/Life Value after replacing the part. - Operation Life Value/Number of Days Left/Life Value can also be reset by clearing the parts counter.
Display/Adj/Set Range		1st column: 0 to 999 (%) 2nd column: 0 to 999 (days) 3rd column: 0 to 999 (%) 4th column: 50 to 999 (%)
Supplement/Memo		Operation Life Value: Wear level value relative to Replacement Life Value (%) Operation Life Value = Life Value/Replacement Life Value x 100 Number of Days Left: Expected number of days until the part reaches its end of life Replacement Life Value: Target replacement life value

COPIER (Service mode for printer) > COUNTER (Counter mode) > LIFE

IS-TQLM1	1	Torque Limiter: Life VL/No. of days left
Detail	<p>To display the life value and the number of days left of the Upper Tray Torque Limiter. The 3rd and 4th columns may be hidden depending on the country.</p> <p>1st column: Operation Life Value 2nd column: Number of Days Left 3rd column: Life Value 4th column: Replacement Life Value</p>	
Use Case	<p>- When checking Life VL/No. of days left of the part - At parts replacement</p>	
Adj/Set/Operate Method	<p>To change the Replacement Life Value: Select the item, enter the value, and then press OK key. To reset Operation Life Value/Number of Days Left/Life Value: Select the item, and then press Clear key.</p>	
Caution	<p>- Be sure to reset Operation Life Value/Number of Days Left/Life Value after replacing the part. - Operation Life Value/Number of Days Left/Life Value can also be reset by clearing the parts counter.</p>	
Display/Adj/Set Range	<p>1st column: 0 to 999 (%) 2nd column: 0 to 999 (days) 3rd column: 0 to 999 (%) 4th column: 50 to 999 (%)</p>	
Supplement/Memo	<p>Operation Life Value: Wear level value relative to Replacement Life Value (%) $\text{Operation Life Value} = \frac{\text{Life Value}}{\text{Replacement Life Value}} \times 100$ Number of Days Left: Expected number of days until the part reaches its end of life Replacement Life Value: Target replacement life value</p>	
IS-TQLM2	1	Low Tray Torq Limit: Life VL/No. of days
Detail	<p>To display the life value and the number of days left of the Lower Tray Torque Limiter. The 3rd and 4th columns may be hidden depending on the country.</p> <p>1st column: Operation Life Value 2nd column: Number of Days Left 3rd column: Life Value 4th column: Replacement Life Value</p>	
Use Case	<p>- When checking Life VL/No. of days left of the part - At parts replacement</p>	
Adj/Set/Operate Method	<p>To change the Replacement Life Value: Select the item, enter the value, and then press OK key. To reset Operation Life Value/Number of Days Left/Life Value: Select the item, and then press Clear key.</p>	
Caution	<p>- Be sure to reset Operation Life Value/Number of Days Left/Life Value after replacing the part. - Operation Life Value/Number of Days Left/Life Value can also be reset by clearing the parts counter.</p>	
Display/Adj/Set Range	<p>1st column: 0 to 999 (%) 2nd column: 0 to 999 (days) 3rd column: 0 to 999 (%) 4th column: 50 to 999 (%)</p>	
Supplement/Memo	<p>Operation Life Value: Wear level value relative to Replacement Life Value (%) $\text{Operation Life Value} = \frac{\text{Life Value}}{\text{Replacement Life Value}} \times 100$ Number of Days Left: Expected number of days until the part reaches its end of life Replacement Life Value: Target replacement life value</p>	

COPIER (Service mode for printer) > COUNTER (Counter mode) > LIFE

IS-P-RL1	1	Pick RI (INS, PF/INS): Life VL/days left
Detail	To display the life value and the number of days left of the Upper Tray Pickup/Separation/Feed Roller (Document Insertion Unit-N1). The 3rd and 4th columns may be hidden depending on the country. 1st column: Operation Life Value 2nd column: Number of Days Left 3rd column: Life Value 4th column: Replacement Life Value	
Use Case	- When checking Life VL/No. of days left of the part - At parts replacement	
Adj/Set/Operate Method	To change the Replacement Life Value: Select the item, enter the value, and then press OK key. To reset Operation Life Value/Number of Days Left/Life Value: Select the item, and then press Clear key.	
Caution	- Be sure to reset Operation Life Value/Number of Days Left/Life Value after replacing the part. - Operation Life Value/Number of Days Left/Life Value can also be reset by clearing the parts counter.	
Display/Adj/Set Range	1st column: 0 to 999 (%) 2nd column: 0 to 999 (days) 3rd column: 0 to 999 (%) 4th column: 50 to 999 (%)	
Supplement/Memo	Operation Life Value: Wear level value relative to Replacement Life Value (%) Operation Life Value = Life Value/Replacement Life Value x 100 Number of Days Left: Expected number of days until the part reaches its end of life Replacement Life Value: Target replacement life value	
IS-P-RL2	1	Lower Tray Pickup RI: Life VL/days left
Detail	To display the life value and the number of days left of the Lower Tray Pickup/Separation/Feed Roller. The 3rd and 4th columns may be hidden depending on the country. 1st column: Operation Life Value 2nd column: Number of Days Left 3rd column: Life Value 4th column: Replacement Life Value	
Use Case	- When checking Life VL/No. of days left of the part - At parts replacement	
Adj/Set/Operate Method	To change the Replacement Life Value: Select the item, enter the value, and then press OK key. To reset Operation Life Value/Number of Days Left/Life Value: Select the item, and then press Clear key.	
Caution	- Be sure to reset Operation Life Value/Number of Days Left/Life Value after replacing the part. - Operation Life Value/Number of Days Left/Life Value can also be reset by clearing the parts counter.	
Display/Adj/Set Range	1st column: 0 to 999 (%) 2nd column: 0 to 999 (days) 3rd column: 0 to 999 (%) 4th column: 50 to 999 (%)	
Supplement/Memo	Operation Life Value: Wear level value relative to Replacement Life Value (%) Operation Life Value = Life Value/Replacement Life Value x 100 Number of Days Left: Expected number of days until the part reaches its end of life Replacement Life Value: Target replacement life value	

FEEDER (ADF service mode)

DISPLAY (State display mode)

FEEDER (ADF service mode) > DISPLAY (State display mode)

FEEDSIZE	1	Dspl orgnl size detected by DADF
Detail		To display the original size detected by the DADF.
Use Case		When checking the paper size recognized by the device after scanning
Adj/Set/Operate Method		N/A (Display only)
TRY-WIDE	1	Distance of Original Width Detect Slider
Detail		To display the distance between the Original Width Detection Sliders.
Use Case		At incorrect detection of original size
Adj/Set/Operate Method		N/A (Display only)
Display/Adj/Set Range		0 to 2970
Unit		mm
Amount of Change per Unit		1

ADJUST (Adjustment mode)

FEEDER (ADF service mode) > ADJUST (Adjustment mode)

DOCST	1	Adj of DADF img lead edge margin: front
Detail		To adjust the leading edge margin on the front side at DADF reading. Execute this item when the output image after DADF installation is displaced. When replacing the Reader Controller PCB/clearing RAM data, enter the value of service label. As the value is incremented by 1, the margin is reduced by 0.1 mm. (The image moves upward.)
Use Case		- When installing DADF - When replacing the Reader Controller PCB/clearing RAM data
Adj/Set/Operate Method		Enter the setting value (switch negative/positive by +/- key) and press OK key.
Display/Adj/Set Range		-50 to 50
Unit		mm
Default Value		0
Amount of Change per Unit		0.1
LA-SPEED	1	Fine adj img ratio: DADF,vert scan,front
Detail		To make a fine adjustment of the front side image magnification ratio in vertical scanning direction at DADF reading. As the value is incremented by 1, the image is reduced by 0.1% in vertical scanning direction. (The feeding speed increases, and the image is reduced.)
Use Case		- When installing DADF - When replacing the Reader Controller PCB/clearing RAM data
Adj/Set/Operate Method		Enter the setting value (switch negative/positive by +/- key) and press OK key.
Display/Adj/Set Range		-30 to 30
Unit		%
Default Value		0
Amount of Change per Unit		0.1

FEEDER (ADF service mode) > ADJUST (Adjustment mode)

DOCST2	1	Adj of DADF img lead edge margin: back
Detail	To adjust the leading edge margin on the back side at DADF reading. Execute this item when the output image after DADF installation is displaced. When replacing the Reader Controller PCB/clearing RAM data, enter the value of service label. As the value is incremented by 1, the margin is reduced by 0.1 mm. (The image moves upward.)	
Use Case	- When installing DADF - When replacing the Reader Controller PCB/clearing RAM data	
Adj/Set/Operate Method	Enter the setting value (switch negative/positive by +/- key) and press OK key.	
Display/Adj/Set Range	-50 to 50	
Unit	mm	
Default Value	0	
Amount of Change per Unit	0.1	
LA-SPD2	1	Fine adj img ratio: DADF,vert scan,back
Detail	To make a fine adjustment of the back side image magnification ratio in vertical scanning direction at DADF reading. As the value is incremented by 1, the image is reduced by 0.01% in vertical scanning direction. (The feeding speed increases, and the image is reduced.)	
Use Case	- When installing DADF - When replacing the Reader Controller PCB/clearing RAM data	
Adj/Set/Operate Method	Enter the setting value (switch negative/positive by +/- key) and press OK key.	
Display/Adj/Set Range	-200 to 200 (-2.00 to 2.00%)	
Unit	%	
Default Value	0	
Amount of Change per Unit	0.01	
ADJMCSN1	1	Fine adj img ratio:2-sided,horz scan,frt
Detail	To make a fine adjustment of the front side image magnification ratio in horizontal scanning direction at DADF 2-sided reading. As the value is incremented by 1, the image is enlarged by 0.1% in horizontal scanning direction.	
Use Case	When image magnification ratio on the front side and back side are different at 2-sided reading	
Adj/Set/Operate Method	Enter the setting value (switch negative/positive by +/- key) and press OK key.	
Display/Adj/Set Range	-10 to 10	
Unit	%	
Default Value	0	
Amount of Change per Unit	0.1	
ADJMCSN2	1	Fine adj img ratio:2-sided,horz scan,bck
Detail	To make a fine adjustment of the back side image magnification ratio in horizontal scanning direction at DADF 2-sided reading. As the value is incremented by 1, the image is enlarged by 0.1% in horizontal scanning direction.	
Use Case	When image magnification ratio on the front side and back side are different at 2-sided reading	
Adj/Set/Operate Method	Enter the setting value (switch negative/positive by +/- key) and press OK key.	
Display/Adj/Set Range	-10 to 10	
Unit	%	
Default Value	0	
Amount of Change per Unit	0.1	

FEEDER (ADF service mode) > ADJUST (Adjustment mode)

ADJ-T1	1	Adj of DADF img lead edge margin: front
Detail	To adjust the leading edge margin of image after skew correction (front side). When the value is increased by 1, leading edge margin is increased by 0.1 mm. When the value is decreased by 1, leading edge margin is decreased by 0.1 mm.	
Use Case	When adjusting the leading edge margin	
Adj/Set/Operate Method	Enter the setting value, and then press OK key.	
Caution	Setting the value too high or too low may cause cropped image.	
Display/Adj/Set Range	-15 to 15	
Unit	mm	
Default Value	0	
Amount of Change per Unit	0.1	
ADJ-T2	1	Adj of DADF img lead edge margin: back
Detail	To adjust the leading edge margin of image after skew correction (back side). When the value is increased by 1, leading edge margin is increased by 0.1 mm. When the value is decreased by 1, leading edge margin is decreased by 0.1 mm.	
Use Case	When adjusting the leading edge margin	
Adj/Set/Operate Method	Enter the setting value, and then press OK key.	
Caution	Setting the value too high or too low may cause cropped image.	
Display/Adj/Set Range	-15 to 15	
Unit	mm	
Default Value	0	
Amount of Change per Unit	0.1	
ADJ-L1	1	Adj of DADF img left edge margin: front
Detail	To adjust the left edge margin of image after skew correction (on front side). When the value is increased by 1, left edge margin is increased by 0.1 mm. When the value is decreased by 1, left edge margin is decreased by 0.1 mm.	
Use Case	When adjusting the position of scanned image's left edge	
Adj/Set/Operate Method	Enter the setting value, and then press OK key.	
Caution	Setting the value too high or too low may cause cropped image.	
Display/Adj/Set Range	-30 to 30	
Unit	mm	
Default Value	0	
Amount of Change per Unit	0.1	
ADJ-L2	1	Adj of DADF img left edge margin: back
Detail	To adjust the left edge margin of image after skew correction (on back side). When the value is increased by 1, left edge margin is increased by 0.1 mm. When the value is decreased by 1, left edge margin is decreased by 0.1 mm.	
Use Case	When adjusting the position of scanned image's left edge	
Adj/Set/Operate Method	Enter the setting value, and then press OK key.	
Caution	Setting the value too high or too low may cause cropped image.	
Display/Adj/Set Range	-30 to 30	
Unit	mm	
Default Value	0	
Amount of Change per Unit	0.1	

FEEDER (ADF service mode) > ADJUST (Adjustment mode)

ADJ-PAR1	1	Parallelogram crrect for DADF read: front
Detail		To perform parallelogram correction on image after skew correction (front side). When the value is increased by 1, image is corrected clockwise by 0.01 degree. When the value is decreased by 1, image is corrected counterclockwise by 0.01 degree.
Use Case		When scanned image is parallelogram-shaped
Adj/Set/Operate Method		Enter the setting value, and then press OK key.
Caution		Setting the value too high or too low may cause cropped image.
Display/Adj/Set Range		-30 to 30
Default Value		0
ADJ-PAR2	1	Parallelogram crrect for DADF read: back
Detail		To perform parallelogram correction on image after skew correction (back side). When the value is increased by 1, image is corrected clockwise by 0.01 degree. When the value is decreased by 1, image is corrected counterclockwise by 0.01 degree.
Use Case		When scanned image is parallelogram-shaped
Adj/Set/Operate Method		Enter the setting value, and then press OK key.
Caution		Setting the value too high or too low may cause cropped image.
Display/Adj/Set Range		-30 to 30
Default Value		0
ADJ-ROT1	1	Angle correction for DADF reading: front
Detail		To correct rotation angle on image after skew correction (front side). When the value is increased by 1, image is corrected clockwise by 0.01 degree. When the value is decreased by 1, image is corrected counterclockwise by 0.01 degree.
Use Case		When scanned image is missing part of its trailing edge
Adj/Set/Operate Method		Enter the setting value, and then press OK key.
Caution		Setting the value too high or too low may cause cropped image.
Display/Adj/Set Range		-300 to 300
Default Value		0
ADJ-ROT2	1	Angle correction for DADF reading: back
Detail		To correct rotation angle on image after skew correction (back side). When the value is increased by 1, image is corrected clockwise by 0.01 degree. When the value is decreased by 1, image is corrected counterclockwise by 0.01 degree.
Use Case		When scanned image is missing part of its trailing edge
Adj/Set/Operate Method		Enter the setting value, and then press OK key.
Caution		Setting the value too high or too low may cause cropped image.
Display/Adj/Set Range		-300 to 300
Default Value		0
ADJ-DT	1	Skew adj val: bck lead edge register dif
Detail		To correct the skew difference of the front and back by correcting the difference of leading edge registration.
Use Case		- When writing the values on the service label after executing ADJ-SKW. - When clearing RAM data of the Reader / replacing the Reader Controller PCB
Adj/Set/Operate Method		Enter the setting value, and then press OK key.
Caution		Do not change the adjustment values of this mode for image position adjustment.
Display/Adj/Set Range		-255 to 255
Default Value		0
Related Service Mode		FEEDER->FUNCTION->ADJ-SKW

FEEDER (ADF service mode) > ADJUST (Adjustment mode)

ADJ-DL	1	Skew adj val: bck left edge register dif
Detail		To correct the skew difference of the front and back by correcting the difference of left edge registration.
Use Case		- When writing the values on the service label after executing ADJ-SKW. - When clearing RAM data of the Reader / replacing the Reader Controller PCB
Adj/Set/Operate Method		Enter the setting value, and then press OK key.
Caution		Do not change the adjustment values of this mode for image position adjustment.
Display/Adj/Set Range		-255 to 255
Default Value		0
Related Service Mode		FEEDER->FUNCTION->ADJ-SKW
ADJ-DROT	1	Skew adj value: back, angle difference
Detail		To correct the skew difference of the front and back by correcting the difference of angles.
Use Case		- When writing the values on the service label after executing ADJ-SKW. - When clearing RAM data of the Reader / replacing the Reader Controller PCB
Adj/Set/Operate Method		Enter the setting value, and then press OK key.
Caution		Do not change the adjustment values of this mode for image position adjustment.
Display/Adj/Set Range		-255 to 255
Default Value		0
Related Service Mode		FEEDER->FUNCTION->ADJ-SKW
LA-SPDT1	1	Fine adj img ro: DADF,vert scan,frt,hvy
Detail		To make a fine adjustment of the front side image magnification ratio in vertical scanning direction at DADF reading (when feeding heavy paper). As value is incremented by 1, image shrinks by 0.01%. As value is decreased by 1, image expands by 0.01%.
Use Case		- When installing the DADF - When replacing the Reader Controller PCB/clearing RAM data
Adj/Set/Operate Method		Enter the setting value (switch positive/negative by +/- key) and press OK key.
Display/Adj/Set Range		-200 to 200
Unit		%
Default Value		0
LA-SPDT2	1	Fine adj img ro: DADF,vert scan,back,hvy
Detail		To make a fine adjustment of the back side image magnification ratio in vertical scanning direction at DADF reading (when feeding heavy paper). As value is incremented by 1, image shrinks by 0.01%. As value is decreased by 1, image expands by 0.01%.
Use Case		- When installing the DADF - When replacing the Reader Controller PCB/clearing RAM data
Adj/Set/Operate Method		Enter the setting value (switch positive/negative by +/- key) and press OK key.
Display/Adj/Set Range		-200 to 200
Unit		%
Default Value		0

FUNCTION (Operation / inspection mode)

FEEDER (ADF service mode) > FUNCTION (Operation / inspection mode)

MTR-CHK	1	Specification of DADF operation motor
Detail		To specify the motor of DADF to operate. The motor is activated by MTR-ON.
Use Case		At operation check
Adj/Set/Operate Method		Enter the setting value, and then press OK key.
Display/Adj/Set Range		0 to 3 0: Pickup Motor (M401) 1: Pullout Motor (M402) 2: Read Motor (M403) 3: Delivery Motor (M404)
Related Service Mode		FEEDER> FUNCTION> MTR-ON
TRY-A4	1	Adj of DADF Tray width detect ref 1: A4
Detail		To automatically adjust the paper width detection reference point 1 for the DADF Original Pickup Tray. (A4)
Use Case		- When replacing the ADF Original Pickup Tray - When replacing the Reader Controller PCB/clearing RAM data
Adj/Set/Operate Method		Select the item, and then press OK key.
TRY-A5R	1	Adj of DADF Tray width detect ref 2: A5R
Detail		To automatically adjust the paper width detection reference point 2 for the DADF Original Pickup Tray. (A5R)
Use Case		- When replacing the ADF Original Pickup Tray - When replacing the Reader Controller PCB/clearing RAM data
Adj/Set/Operate Method		Select the item, and then press OK key.
TRY-LTR	1	Adj of DADF Tray width detect ref 1: LTR
Detail		To automatically adjust the paper width detection reference point 1 for the DADF Original Pickup Tray. (LTR)
Use Case		- When replacing the ADF Original Pickup Tray - When replacing the Reader Controller PCB/clearing RAM data
Adj/Set/Operate Method		Select the item, and then press OK key.
TRY-LTRR	1	Adj of DADF Tray width detect ref2: LTRR
Detail		To automatically adjust the paper width detection reference point 2 for the DADF Original Pickup Tray. (LTRR)
Use Case		- When replacing the ADF Original Pickup Tray - When replacing the Reader Controller PCB/clearing RAM data
Adj/Set/Operate Method		Select the item, and then press OK key.
FEED-CHK	1	Specify DADF individual feed operation
Detail		To specify the feed mode for DADF. Feed operation is activated by FEED-ON.
Use Case		At operation check
Adj/Set/Operate Method		Enter the setting value, and then press OK key.
Display/Adj/Set Range		0 to 2 0: 1-sided pickup/delivery operation, 1: Not used, 2: 1-sided pickup/delivery operation (with stamp)
Related Service Mode		FEEDER> FUNCTION> FEED-ON

FEEDER (ADF service mode) > FUNCTION (Operation / inspection mode)

SL-CHK	1	Specification of DADF operation solenoid
Detail		To specify the solenoid of DADF to operate. The solenoid is activated by SL-ON.
Use Case		At operation check
Adj/Set/Operate Method		Enter the setting value, and then press OK key.
Display/Adj/Set Range		0: Stamp Solenoid
Related Service Mode		FEEDER> FUNCTION> SL-ON
SL-ON	1	Operation check of DADF solenoid
Detail		To start operation check of the solenoid specified by SL-CHK.
Use Case		At operation check
Adj/Set/Operate Method		1) Select the item, and then press OK key. It is driven for approximately 5 seconds and is automatically stopped. 2) Press OK key. The operation check is completed.
Caution		Be sure to press the OK key again after execution. The operation automatically stops after approximately 5 seconds, but is not completed unless the OK key is pressed (STOP is not displayed).
Related Service Mode		FEEDER> FUNCTION> SL-CHK
MTR-ON	1	Operation check of DADF motor
Detail		To start operation check of the motor specified by MTR-CHK.
Use Case		At operation check
Adj/Set/Operate Method		1) Select the item, and then press OK key. It is driven for approximately 5 seconds and is automatically stopped. 2) Press OK key. The operation check is completed.
Caution		Be sure to press the OK key again after execution. The operation automatically stops after approximately 5 seconds, but is not completed unless the OK key is pressed (STOP is not displayed).
Related Service Mode		FEEDER> FUNCTION> MTR-CHK
ROLL-CLN	1	Rotation of DADF rollers
Detail		To rotate the rollers of DADF for cleaning. Check the rollers with lint-free paper moistened with alcohol while they are rotating.
Use Case		When cleaning the rollers
Adj/Set/Operate Method		1) Select the item, and then press OK key. 2) Clean the rotating rollers with lint-free paper moistened with alcohol. 3) Press OK key. The rollers stop.
FEED-ON	1	Operation check of DADF individual feed
Detail		To start operation check of the feed mode specified by FEED-CHK.
Use Case		At operation check
Adj/Set/Operate Method		Select the item, and then press OK key.
Related Service Mode		FEEDER> FUNCTION> FEED-CHK

FEEDER (ADF service mode) > FUNCTION (Operation / inspection mode)

TRY-A4R	1	Auto-adj DADF Tr ppr wid dtct ref (A4R)
Detail		To automatically adjust the paper width detection reference for the DADF Original Pickup Tray (A4R).
Use Case		- When replacing the ADF Original Pickup Tray - When replacing the Reader Controller PCB/clearing RAM data
Adj/Set/Operate Method		1) Place an A4R-size original on the ADF tray and adjust the tray to the original's width. 2) Select the item, and then press OK key.
Caution		If configured with an original that is not either A4R- or A5-size placed, the size detection on the ADF tray does not detect paper size properly.
Display/Adj/Set Range		0 to 9999
TRY-STMR	1	Auto-adj DADF Tr ppr wid dtct ref STMR
Detail		To automatically adjust the paper width detection reference for the DADF Original Pickup Tray (STMR).
Use Case		- When replacing the ADF Original Pickup Tray - When replacing the Reader Controller PCB/clearing RAM data
Adj/Set/Operate Method		1) Place an STMR-size original on the ADF tray and adjust the tray to the original's width. 2) Select the item, and then press OK key.
Caution		If configured with a non-STMR-size original placed, the size detection on the ADF tray does not detect paper size properly.
Display/Adj/Set Range		0 to 9999
ADJ-SKW	1	Skew adj: frt / bck diff correct adjust
Detail		To correct the skew difference of the front and back by extracting the difference and calculate the correction value.
Use Case		- When replacing the Scanner Unit (Paper Front) - When replacing the Scanner Unit (Paper Back) - When replacing the Scanner Glass (Paper Back) - When installing the 1-path DADF
Adj/Set/Operate Method		1) Place the adjustment chart, included in the package of the unit, on the ADF Document Pickup Tray. 2) Write the following adjusted values on the service label after executing the modes. FEEDER > ADJUST > ADJ-DT FEEDER > ADJUST > ADJ-DL FEEDER > ADJUST > ADJ-DROT
Caution		- Do not open/close the ADF during the setup operation. - If this adjustment chart is not used, "NG" is displayed.
Display/Adj/Set Range		Operating: ACTIVE, Terminated normally: OK, Terminated abnormally: NG

OPTION (Specification setting mode)

FEEDER (ADF service mode) > OPTION (Specification setting mode)

SIZE-SW	1	ON/OFF of mixed paper detection: AB/Inch
Detail		To set whether to detect mixed media detection: AB configuration and Inch configuration.
Use Case		When mixing AB and Inch configuration sizes original
Adj/Set/Operate Method		Enter the setting value, and then press OK key.
Display/Adj/Set Range		0 to 1 0: OFF, 1: ON
Default Value		0

FEEDER (ADF service mode) > OPTION (Specification setting mode)

R-ATM	1	Set DADF double feed dtct highland mode
Detail		To set the Double Feed Sensor of the DADF to the highland mode. Set 1 if the installation site is above the altitude of 2000 meters.
Use Case		When the installation site is above the altitude of 2000 meters at installation
Adj/Set/Operate Method		Enter the setting value, and then press OK key.
Display/Adj/Set Range		0 to 1 0: Normal, 1: Highland mode
Default Value		0
R-OVLPLV	2	Set DADF double feed dtct threshold VL
Detail		To set the threshold value at which the Double Feed Sensor of the DADF judges whether papers are double fed. Decrease the value if single feed of paper is incorrectly detected as double feed. Increase the value if double feed of paper is incorrectly detected as single feed.
Use Case		When double feed is incorrectly detected with special paper not defined in the specifications
Adj/Set/Operate Method		Enter the setting value (switch negative/positive by +/- key) and press OK key.
Caution		In the case of highlands, be sure to set R-ATM in advance.
Display/Adj/Set Range		-3 to 3
Default Value		0
Related Service Mode		FEEDER> OPTION> R-ATM
DF-STPL	1	For R&D
SKW-SW	1	Sw skew correct func for ADF stream read
Detail		To enable/disable the ADF skew correction function for ADF stream reading.
Use Case		When one wishes to examine an image printed with the ADF skew correction function disabled
Adj/Set/Operate Method		1) Enter the setting value, and then press OK key. 2) Perform image adjustment. 3) Turn OFF/ON the main power switch.
Caution		Tuning the main power switch OFF/ON automatically sets the value to 0.
Display/Adj/Set Range		0 to 1 0: Enable, 1: Disable
Default Value		0

SORTER (Service mode for delivery options)

ADJUST (Adjustment mode)

SORTER (Service mode for delivery options) > ADJUST (Adjustment mode)

PNCH-Y	1	Adj Punch hole horz reg: Fin-X/AC/W
Detail		To adjust the punch hole position of the Puncher Unit in horizontal registration direction. As the value is changed by 1, the punch hole shifts by 0.1 mm (Fin-X/AC)/0.45 mm (Fin-W). Fin-W/X: +: Toward front -: Toward rear Fin-AC: +: Toward rear -: Toward front
Use Case		When the punch hole is misaligned in the horizontal registration direction
Adj/Set/Operate Method		Enter the setting value (switch negative/positive by -/+ key) and press OK key.
Caution		Fin-AC: When the setting of "PUN-Y-SW" is 0, the adjustable range is from -3 to 15.
Display/Adj/Set Range		Fin-X: -15 to 15 Fin-AC: -25 to 25 Fin-W: -5 to 5
Unit		mm
Default Value		0
Related Service Mode		Fin-AC: SORTER> OPTION> PUN-Y-SW
Amount of Change per Unit		Fin-X1/V1:0.1, FinW1:0.45
PF-A3Z1	1	Adj of A3 Z-fold position (1st): PFU
Detail		To adjust the 1st fold position of A3 paper Z-fold position on Paper Folding Unit. As the value is changed by 1, the fold position is moved by 0.1 mm.
Use Case		When the fold position adjustment in Settings/Registration menu is inadequate
Adj/Set/Operate Method		Enter the setting value (switch negative/positive by -/+ key) and press OK key.
Display/Adj/Set Range		-128 to 127
Unit		mm
Default Value		0
Additional Functions Mode		Adjustment/Maintenance> Adjust Action> Adjust Fold Position> Adjust Z-Fold Position
Amount of Change per Unit		0.1
PF-A3Z2	1	Adj of A3 Z-fold position (2nd): PFU
Detail		To adjust the 2nd fold position of A3 paper Z-fold position on Paper Folding Unit. As the value is changed by 1, the fold position is moved by 0.1 mm.
Use Case		When the fold position adjustment in Settings/Registration menu is inadequate
Adj/Set/Operate Method		Enter the setting value (switch negative/positive by -/+ key) and press OK key.
Display/Adj/Set Range		-128 to 127
Unit		mm
Default Value		0
Additional Functions Mode		Adjustment/Maintenance> Adjust Action> Adjust Fold Position> Adjust Z-Fold Position
Amount of Change per Unit		0.1

SORTER (Service mode for delivery options) > ADJUST (Adjustment mode)

PF-B4Z1	1	Adj of B4 Z-fold position (1st): PFU
Detail		To adjust the 1st fold position of B4 paper Z-fold position on Paper Folding Unit. As the value is changed by 1, the fold position is moved by 0.1 mm.
Use Case		When the fold position adjustment in Settings/Registration menu is inadequate
Adj/Set/Operate Method		Enter the setting value (switch negative/positive by +/- key) and press OK key.
Display/Adj/Set Range		-128 to 127
Unit		mm
Default Value		0
Additional Functions Mode		Adjustment/Maintenance> Adjust Action> Adjust Fold Position> Adjust Z-Fold Position
Amount of Change per Unit		0.1
PF-B4Z2	1	Adj of B4 Z-fold position (2nd): PFU
Detail		To adjust the 2nd fold position of B4 paper Z-fold position on Paper Folding Unit. As the value is changed by 1, the fold position is moved by 0.1 mm.
Use Case		When the fold position adjustment in Settings/Registration menu is inadequate
Adj/Set/Operate Method		Enter the setting value (switch negative/positive by +/- key) and press OK key.
Display/Adj/Set Range		-128 to 127
Unit		mm
Default Value		0
Additional Functions Mode		Adjustment/Maintenance> Adjust Action> Adjust Fold Position> Adjust Z-Fold Position
Amount of Change per Unit		0.1
PF-A4RZ1	1	Adj of A4R Z-fold position (1st): PFU
Detail		To adjust the 1st fold position of A4R paper Z-fold position on Paper Folding Unit. As the value is changed by 1, the fold position is moved by 0.1 mm.
Use Case		When the fold position adjustment in Settings/Registration menu is inadequate
Adj/Set/Operate Method		Enter the setting value (switch negative/positive by +/- key) and press OK key.
Display/Adj/Set Range		-128 to 127
Unit		mm
Default Value		0
Additional Functions Mode		Adjustment/Maintenance> Adjust Action> Adjust Fold Position> Adjust Z-Fold Position
Amount of Change per Unit		0.1
PF-A4RZ2	1	Adj of A4R Z-fold position (2nd): PFU
Detail		To adjust the 2nd fold position of A4R paper Z-fold position on Paper Folding Unit. As the value is changed by 1, the fold position is moved by 0.1 mm.
Use Case		When the fold position adjustment in Settings/Registration menu is inadequate
Adj/Set/Operate Method		Enter the setting value (switch negative/positive by +/- key) and press OK key.
Display/Adj/Set Range		-128 to 127
Unit		mm
Default Value		0
Additional Functions Mode		Adjustment/Maintenance> Adjust Action> Adjust Fold Position> Adjust Z-Fold Position
Amount of Change per Unit		0.1

SORTER (Service mode for delivery options) > ADJUST (Adjustment mode)

PF-LDRZ1	1	Adj of LDR Z-fold position (1st): PFU
Detail		To adjust the 1st fold position of LDR paper Z-fold position on Paper Folding Unit. As the value is changed by 1, the fold position is moved by 0.1 mm.
Use Case		When the fold position adjustment in Settings/Registration menu is inadequate
Adj/Set/Operate Method		Enter the setting value (switch negative/positive by +/- key) and press OK key.
Display/Adj/Set Range		-128 to 127
Unit		mm
Default Value		0
Additional Functions Mode		Adjustment/Maintenance> Adjust Action> Adjust Fold Position> Adjust Z-Fold Position
Amount of Change per Unit		0.1
PF-LDRZ2	1	Adj of LDR Z-fold position (2nd): PFU
Detail		To adjust the 2nd fold position of LDR paper Z-fold position on Paper Folding Unit. As the value is changed by 1, the fold position is moved by 0.1 mm.
Use Case		When the fold position adjustment in Settings/Registration menu is inadequate
Adj/Set/Operate Method		Enter the setting value (switch negative/positive by +/- key) and press OK key.
Display/Adj/Set Range		-128 to 127
Unit		mm
Default Value		0
Additional Functions Mode		Adjustment/Maintenance> Adjust Action> Adjust Fold Position> Adjust Z-Fold Position
Amount of Change per Unit		0.1
PF-LGLZ1	1	Adj of LGL Z-fold position (1st): PFU
Detail		To adjust the 1st fold position of LGL paper Z-fold position on Paper Folding Unit. As the value is changed by 1, the fold position is moved by 0.1 mm.
Use Case		When the fold position adjustment in Settings/Registration menu is inadequate
Adj/Set/Operate Method		Enter the setting value (switch negative/positive by +/- key) and press OK key.
Display/Adj/Set Range		-128 to 127
Unit		mm
Default Value		0
Additional Functions Mode		Adjustment/Maintenance> Adjust Action> Adjust Fold Position> Adjust Z-Fold Position
Amount of Change per Unit		0.1
PF-LGLZ2	1	Adj of LGL Z-fold position (2nd): PFU
Detail		To adjust the 2nd fold position of LGL paper Z-fold position on Paper Folding Unit. As the value is changed by 1, the fold position is moved by 0.1 mm.
Use Case		When the fold position adjustment in Settings/Registration menu is inadequate
Adj/Set/Operate Method		Enter the setting value (switch negative/positive by +/- key) and press OK key.
Display/Adj/Set Range		-128 to 127
Unit		mm
Default Value		0
Additional Functions Mode		Adjustment/Maintenance> Adjust Action> Adjust Fold Position> Adjust Z-Fold Position
Amount of Change per Unit		0.1

SORTER (Service mode for delivery options) > ADJUST (Adjustment mode)

PFLTRRZ1	1	Adj of LTRR Z-fold position (1st): PFU
Detail		To adjust the 1st fold position of LTRR paper Z-fold position on Paper Folding Unit. As the value is changed by 1, the fold position is moved by 0.1 mm.
Use Case		When the fold position adjustment in Settings/Registration menu is inadequate
Adj/Set/Operate Method		Enter the setting value (switch negative/positive by +/- key) and press OK key.
Display/Adj/Set Range		-128 to 127
Unit		mm
Default Value		0
Additional Functions Mode		Adjustment/Maintenance> Adjust Action> Adjust Fold Position> Adjust Z-Fold Position
Amount of Change per Unit		0.1
PFLTRRZ2	1	Adj of LTRR Z-fold position (2nd): PFU
Detail		To adjust the 2nd fold position of LTRR paper Z-fold position on Paper Folding Unit. As the value is changed by 1, the fold position is moved by 0.1 mm.
Use Case		When the fold position adjustment in Settings/Registration menu is inadequate
Adj/Set/Operate Method		Enter the setting value (switch negative/positive by +/- key) and press OK key.
Display/Adj/Set Range		-128 to 127
Unit		mm
Default Value		0
Additional Functions Mode		Adjustment/Maintenance> Adjust Action> Adjust Fold Position> Adjust Z-Fold Position
Amount of Change per Unit		0.1
PF-A4RC1	1	Adj of A4R C-fold position (1st): PFU
Detail		To adjust the 1st fold position of A4R paper C-fold position on Paper Folding Unit. As the value is changed by 1, the fold position is moved by 0.1 mm.
Use Case		When the fold position adjustment in Settings/Registration menu is inadequate
Adj/Set/Operate Method		Enter the setting value (switch negative/positive by +/- key) and press OK key.
Display/Adj/Set Range		-70 to 127
Unit		mm
Default Value		0
Additional Functions Mode		Adjustment/Maintenance> Adjust Action> Adjust Fold Position> Adjust C-Fold Position
Amount of Change per Unit		0.1
PF-A4RC2	1	Adj of A4R C-fold position (2nd): PFU
Detail		To adjust the 2nd fold position of A4R paper C-fold position on Paper Folding Unit. As the value is changed by 1, the fold position is moved by 0.1 mm.
Use Case		When the fold position adjustment in Settings/Registration menu is inadequate
Adj/Set/Operate Method		Enter the setting value (switch negative/positive by +/- key) and press OK key.
Display/Adj/Set Range		-128 to 70
Unit		mm
Default Value		0
Additional Functions Mode		Adjustment/Maintenance> Adjust Action> Adjust Fold Position> Adjust C-Fold Position
Amount of Change per Unit		0.1

SORTER (Service mode for delivery options) > ADJUST (Adjustment mode)

PFLTRRC1	1	Adj of LTRR C-fold position (1st): PFU
Detail	To adjust the 1st fold position of LTRR paper C-fold position on Paper Folding Unit. As the value is changed by 1, the fold position is moved by 0.1 mm.	
Use Case	When the fold position adjustment in Settings/Registration menu is inadequate	
Adj/Set/Operate Method	Enter the setting value (switch negative/positive by +/- key) and press OK key.	
Display/Adj/Set Range	-70 to 127	
Unit	mm	
Default Value	0	
Additional Functions Mode	Adjustment/Maintenance> Adjust Action> Adjust Fold Position> Adjust C-Fold Position	
Amount of Change per Unit	0.1	
PFLTRRC2	1	Adj of LTRR C-fold position (2nd): PFU
Detail	To adjust the 2nd fold position of LTRR paper C-fold position on Paper Folding Unit. As the value is changed by 1, the fold position is moved by 0.1 mm.	
Use Case	When the fold position adjustment in Settings/Registration menu is inadequate	
Adj/Set/Operate Method	Enter the setting value (switch negative/positive by +/- key) and press OK key.	
Display/Adj/Set Range	-128 to 70	
Unit	mm	
Default Value	0	
Additional Functions Mode	Adjustment/Maintenance> Adjust Action> Adjust Fold Position> Adjust C-Fold Position	
Amount of Change per Unit	0.1	
PF-A4R31	1	Adj of A4R out-3-fold position(1st): PFU
Detail	To adjust the 1st fold position of A4R paper out-3-fold position on Paper Folding Unit. As the value is changed by 1, the fold position is moved by 0.1 mm.	
Use Case	When the fold position adjustment in Settings/Registration menu is inadequate	
Adj/Set/Operate Method	Enter the setting value (switch negative/positive by +/- key) and press OK key.	
Display/Adj/Set Range	-128 to 120	
Unit	mm	
Default Value	0	
Additional Functions Mode	Adjustment/Maintenance> Adjust Action> Adjust Fold Position> Adjust Accordion Z-Fold Position	
Amount of Change per Unit	0.1	
PF-A4R32	1	Adj of A4R out-3-fold position(2nd): PFU
Detail	To adjust the 2nd fold position of A4R paper out-3-fold position on Paper Folding Unit. As the value is changed by 1, the fold position is moved by 0.1 mm.	
Use Case	When the fold position adjustment in Settings/Registration menu is inadequate	
Adj/Set/Operate Method	Enter the setting value (switch negative/positive by +/- key) and press OK key.	
Display/Adj/Set Range	-120 to 127	
Unit	mm	
Default Value	0	
Additional Functions Mode	Adjustment/Maintenance> Adjust Action> Adjust Fold Position> Adjust Accordion Z-Fold Position	
Amount of Change per Unit	0.1	

SORTER (Service mode for delivery options) > ADJUST (Adjustment mode)

PFLTRR31	1	Adj of LTRR out-3-fold position(1st):PFU
Detail		To adjust the 1st fold position of LTRR paper out-3-fold position on Paper Folding Unit. As the value is changed by 1, the fold position is moved by 0.1 mm.
Use Case		When the fold position adjustment in Settings/Registration menu is inadequate
Adj/Set/Operate Method		Enter the setting value (switch negative/positive by +/- key) and press OK key.
Display/Adj/Set Range		-128 to 120
Unit		mm
Default Value		0
Additional Functions Mode		Adjustment/Maintenance> Adjust Action> Adjust Fold Position> Adjust Accordion Z-Fold Position
Amount of Change per Unit		0.1
PFLTRR32	1	Adj of LTRR out-3-fold position(2nd):PFU
Detail		To adjust the 2nd fold position of LTRR paper out-3-fold position on Paper Folding Unit. As the value is changed by 1, the fold position is moved by 0.1 mm.
Use Case		When the fold position adjustment in Settings/Registration menu is inadequate
Adj/Set/Operate Method		Enter the setting value (switch negative/positive by +/- key) and press OK key.
Display/Adj/Set Range		-120 to 127
Unit		mm
Default Value		0
Additional Functions Mode		Adjustment/Maintenance> Adjust Action> Adjust Fold Position> Adjust Accordion Z-Fold Position
Amount of Change per Unit		0.1
PF-A4R41	1	Adj of A4R 4-fold position (1st): PFU
Detail		To adjust the 1st fold position of A4R paper 4-fold position on Paper Folding Unit. As the value is changed by 1, the fold position is moved by 0.1 mm.
Use Case		When the fold position adjustment in Settings/Registration menu is inadequate
Adj/Set/Operate Method		Enter the setting value (switch negative/positive by +/- key) and press OK key.
Display/Adj/Set Range		-128 to 120
Unit		mm
Default Value		0
Additional Functions Mode		Adjustment/Maintenance> Adjust Action> Adjust Fold Position> Adjust Double Parallel Fold Position
Amount of Change per Unit		0.1
PF-A4R42	1	Adj of A4R 4-fold position (2nd): PFU
Detail		To adjust the 2nd fold position of A4R paper 4-fold position on Paper Folding Unit. As the value is changed by 1, the fold position is moved by 0.1 mm.
Use Case		When the fold position adjustment in Settings/Registration menu is inadequate
Adj/Set/Operate Method		Enter the setting value (switch negative/positive by +/- key) and press OK key.
Display/Adj/Set Range		-128 to 55
Unit		mm
Default Value		0
Additional Functions Mode		Adjustment/Maintenance> Adjust Action> Adjust Fold Position> Adjust Double Parallel Fold Position
Amount of Change per Unit		0.1

SORTER (Service mode for delivery options) > ADJUST (Adjustment mode)

PFLTRR41	1	Adj of LTRR 4-fold position (1st): PFU
Detail		To adjust the 1st fold position of LTRR paper 4-fold position on Paper Folding Unit. As the value is changed by 1, the fold position is moved by 0.1 mm.
Use Case		When the fold position adjustment in Settings/Registration menu is inadequate
Adj/Set/Operate Method		Enter the setting value (switch negative/positive by +/- key) and press OK key.
Display/Adj/Set Range		-128 to 120
Unit		mm
Default Value		0
Additional Functions Mode		Adjustment/Maintenance> Adjust Action> Adjust Fold Position> Adjust Double Parallel Fold Position
Amount of Change per Unit		0.1
PFLTRR42	1	Adj of LTRR 4-fold position (2nd): PFU
Detail		To adjust the 2nd fold position of LTRR paper 4-fold position on Paper Folding Unit. As the value is changed by 1, the fold position is moved by 0.1 mm.
Use Case		When the fold position adjustment in Settings/Registration menu is inadequate
Adj/Set/Operate Method		Enter the setting value (switch negative/positive by +/- key) and press OK key.
Display/Adj/Set Range		-128 to 55
Unit		mm
Default Value		0
Additional Functions Mode		Adjustment/Maintenance> Adjust Action > Adjust Fold Position> Adjust Double Parallel Fold Position
Amount of Change per Unit		0.1
PF-A4R21	1	Adjustment of A4R 2-fold position: PFU
Detail		To adjust the 1st fold position of A4R paper 2-fold position on Paper Folding Unit. As the value is changed by 1, the fold position is moved by 0.1 mm.
Use Case		When the fold position adjustment in Settings/Registration menu is inadequate
Adj/Set/Operate Method		Enter the setting value (switch negative/positive by +/- key) and press OK key.
Display/Adj/Set Range		-128 to 55
Unit		mm
Default Value		0
Additional Functions Mode		Adjustment/Maintenance> Adjust Action> Adjust Fold Position> Adjust Half Fold Position
Amount of Change per Unit		0.1
PFLTRR21	1	Adjustment of LTRR 2-fold position: PFU
Detail		To adjust the 1st fold position of LTRR paper 2-fold position on Paper Folding Unit. As the value is changed by 1, the fold position is moved by 0.1 mm.
Use Case		When the fold position adjustment in Settings/Registration menu is inadequate
Adj/Set/Operate Method		Enter the setting value (switch negative/positive by +/- key) and press OK key.
Display/Adj/Set Range		-128 to 55
Unit		mm
Default Value		0
Additional Functions Mode		Adjustment/Maintenance> Adjust Action> Adjust Fold Position> Adjust Half Fold Position
Amount of Change per Unit		0.1

SORTER (Service mode for delivery options) > ADJUST (Adjustment mode)

PRCS-ALG	1	Adj Proc Tray Align Plate width: Fin-X
Detail	To adjust the width of Alignment Plate on Finisher Process Tray Assembly. As the value is incremented by 1, the width of Alignment Plate is increased by 0.1mm. +: Increase (narrow) -: Decrease (widen) The adjustment value is reflected for SORTER> ADJUST> ST-ALG1/ST-ALG2.	
Use Case	When the paper displacement occurs on paper stack	
Adj/Set/Operate Method	Enter the setting value, and then press OK key.	
Display/Adj/Set Range	-50 to 50	
Unit	mm	
Default Value	0	
Related Service Mode	SORTER> ADJUST> ST-ALG1/ST-ALG2	
Amount of Change per Unit	0.1	
STP-F1	1	Adj Front 1-staple position: Fin-X/AC
Detail	Fin-X: To adjust the A4R/LGL/LTRR paper front 1-staple position on Finisher. As the value is changed by 1, the staple position shifts by 0.1mm. +: Toward rear -: Toward front Fin-AC: To adjust the front 1-staple position on Finisher. As the value is changed by 1, the staple position shifts by 0.1mm. +: Toward rear -: Toward front	
Use Case	Fin-X: When the A4R/LGL/LTRR paper front staple position is displaced Fin-AC: When the front staple position is displaced	
Adj/Set/Operate Method	Enter the setting value, and then press OK key.	
Display/Adj/Set Range	Fin-X: -50 to 50 Fin-AC: -30 to 30	
Unit	mm	
Default Value	0	
Amount of Change per Unit	0.1	
STP-F2	1	Front 1-staple position(half): Fin-X
Detail	To adjust the A3/B4/A4/B5/LDR/LTR/EXEC/8K/16K paper front 1-staple position on Finisher. As the value is incremented by 1, the staple position moves by 0.1mm. +: Toward rear -: Toward front	
Use Case	When the A3/B4/A4/B5/LDR/LTR/EXEC/8K/16K paper front staple position is displaced	
Adj/Set/Operate Method	Enter the setting value, and then press OK key.	
Display/Adj/Set Range	-50 to 50	
Unit	mm	
Default Value	0	
Amount of Change per Unit	0.1	

SORTER (Service mode for delivery options) > ADJUST (Adjustment mode)

STP-R1	1	Adj Rear 1-staple position: Fin-X/AC
Detail	Fin-X: To adjust the A4R/LGL/LTRR paper rear 1-staple position on Finisher. As the value is changed by 1, the staple position shifts by 0.1mm. +: Toward rear -: Toward front Fin-AC: To adjust the rear 1-staple position on Finisher. As the value is changed by 1, the staple position shifts by 0.1mm. +: Toward rear -: Toward front	
Use Case	Fin-X: When the A4R/LGL/LTRR paper rear staple position is displaced Fin-AC: When the rear staple position is displaced	
Adj/Set/Operate Method	Enter the setting value, and then press OK key.	
Display/Adj/Set Range	Fin-X: -50 to 50 Fin-AC: -30 to 30	
Unit	mm	
Default Value	0	
Amount of Change per Unit	0.1	
STP-R2	1	Rear 1-staple position (half): Fin-X
Detail	To adjust the A3/B4/A4/B5/LDR/LTR/EXEC/8K/16K paper rear 1-staple position on Finisher. As the value is incremented by 1, the staple position moves by 0.1mm. +: Toward rear -: Toward front	
Use Case	When the A3/B4/A4/B5/LDR/LTR/EXEC/8K/16K paper rear staple position is displaced	
Adj/Set/Operate Method	Enter the setting value, and then press OK key.	
Display/Adj/Set Range	-50 to 50	
Unit	mm	
Default Value	0	
Amount of Change per Unit	0.1	
STP-2P	1	Adj Front/Rear 2-staple pstn: Fin-X/AC
Detail	To adjust the front/rear 2-staple position on Finisher. As the value is changed by 1, the staple position shifts by 0.1mm. +: Toward rear -: Toward front	
Use Case	When the front/rear 2-staple position is displaced	
Adj/Set/Operate Method	Enter the setting value, and then press OK key.	
Display/Adj/Set Range	Fin-X: -50 to 50 Fin-AC: -30 to 30	
Unit	mm	
Default Value	0	
Amount of Change per Unit	0.1	

SORTER (Service mode for delivery options) > ADJUST (Adjustment mode)

BFF-SFT	1	Adj Buffer ppr displc:1-2 sht, Fin-X/AC
Detail	To adjust the paper displacement amount on Finisher Buffer Assembly. As the value is changed by 1, the paper position shifts by 0.1mm. Fin-X: +: The 2nd sheet of buffered paper shifts toward the delivery side for the 1st sheet -: The 2nd sheet of buffered paper shifts toward the inlet side for the 1st sheet Fin-AC: +: The 1st sheet of buffered paper shifts toward the inlet side for the 2nd sheet of paper -: The 1st sheet of buffered paper shifts toward the delivery side for the 2nd sheet of paper	
Use Case	Fin-X: When the paper displacement occurs on the 1st to 2nd sheets of the 2nd sets (B5/A4/LTR) and later Fin-AC: When the paper displacement occurs on the 1st to 2nd sheets of buffered paper	
Adj/Set/Operate Method	Enter the setting value, and then press OK key.	
Display/Adj/Set Range	Fin-X: -50 to 50 Fin-AC: -60 to 60	
Unit	mm	
Default Value	0	
Amount of Change per Unit	0.1	
PNCH-X	1	Adj Punch hole pstn in fd way: Fin-X/AC
Detail	To adjust the punch hole position on puncher unit in feed direction. As the value is changed by 1, the punch hole shifts by 0.1mm. +: Toward delivery direction -: Toward inlet direction	
Use Case	When the punch hole is displaced in feed direction	
Adj/Set/Operate Method	Enter the setting value, and then press OK key.	
Caution	Fin-X: When setting the punch mode to the precision priority, this adjustment can be executed only the delivery direction (+ side). Fin-AC: When setting the punch mode to the precision priority, this adjustment cannot be executed.	
Display/Adj/Set Range	-20 to 20	
Unit	mm	
Default Value	0	
Related Service Mode	SORTER> OPTION> PUCH-SW	
Additional Functions Mode	Adjustment/Maintenance> Adjust Action> Switch Finisher Puncher Mode	
Amount of Change per Unit	0.1	

SORTER (Service mode for delivery options) > ADJUST (Adjustment mode)

TRM-RG1	1	Skew adjust (small size): Fin-X
Detail	To adjust the skew of half-folded paper stack, which length is A4(210mm) or shorter, on Finisher Trimmer As the value is incremented by 1, the paper stack stop position moves by 0.1mm. +: Toward delivery direction -: Toward inlet direction	
Use Case	When the skew occurs on half-folded paper stack which length is A4(210mm) or shorter	
Adj/Set/Operate Method	Enter the setting value, and then press OK key.	
Display/Adj/Set Range	-50 to 50	
Unit	mm	
Default Value	0	
Amount of Change per Unit	0.1	
TRM-RG2	1	Skew adjust (large size): Fin-X
Detail	To adjust the skew of half-folded paper stack, which length is more than A4(210mm), on Finisher Trimmer As the value is incremented by 1, the paper stack stop position moves by 0.1mm. +: Toward delivery direction -: Toward inlet direction	
Use Case	When the skew occurs on half-folded paper stack which length is more than A4(210mm)	
Adj/Set/Operate Method	Enter the setting value, and then press OK key.	
Display/Adj/Set Range	-50 to 50	
Unit	mm	
Default Value	0	
Amount of Change per Unit	0.1	
TRM-CUT1	1	Trimming pstn adj (small size): Fin-X
Detail	To adjust the trimming position of half-folded paper stack, which length is A4(210mm) or shorter, on Finisher Trimmer As the value is incremented by 1, the paper stack cut position moves by 0.1mm. +: Toward staple direction -: Toward opposite direction of staple	
Use Case	When the trimming position displaced on half-folded paper stack which length is A4(210mm) or shorter	
Adj/Set/Operate Method	Enter the setting value, and then press OK key.	
Display/Adj/Set Range	-50 to 50	
Unit	mm	
Default Value	0	
Amount of Change per Unit	0.1	

SORTER (Service mode for delivery options) > ADJUST (Adjustment mode)

TRM-CUT2	1	Trimming pstin adj (large size): Fin-X
Detail	To adjust the trimming position of half-folded paper stack, which length is more than A4(210mm), on Finisher Trimmer As the value is incremented by 1, the paper stack trimming position moves by 0.1mm. +: Toward staple direction -: Toward opposite direction of staple	
Use Case	When the trimming position displaced on half-folded paper stack which length is more than A4(210mm)	
Adj/Set/Operate Method	Enter the setting value, and then press OK key.	
Display/Adj/Set Range	-50 to 50	
Unit	mm	
Default Value	0	
Amount of Change per Unit	0.1	
BFF-SFT2	1	Adj Buffer ppr displc:2-3 sht, Fin-X/AC
Detail	To adjust the paper displacement amount on Finisher Buffer Assembly. As the value is changed by 1, the paper position shifts by 0.1mm. Fin-X: +: The 3rd sheet of buffered paper shifts toward the delivery side for the 2nd sheet +: The 3rd sheet of buffered paper shifts toward the inlet side for the 2nd sheet Fin-AC: +: The 2nd sheet of buffered paper shifts toward the inlet side for the 3rd sheet of paper -: The 2nd sheet of buffered paper shifts toward the delivery side for the 3rd sheet of paper	
Use Case	Fin-X: When the paper displacement occurs on the 2nd to 3rd sheets of the 2nd sets (B5/A4/LTR) and later Fin-AC: When the paper displacement occurs on the 2nd to 3rd sheets of buffered paper	
Adj/Set/Operate Method	Enter the setting value, and then press OK key.	
Display/Adj/Set Range	Fin-X: -50 to 50 Fin-AC: -60 to 60	
Unit	mm	
Default Value	0	
Amount of Change per Unit	0.1	

SORTER (Service mode for delivery options) > ADJUST (Adjustment mode)

SDL-STP	1	Adj Saddle Sttch stpl pstn: Fin-X/AC
Detail	Fin-X:	To adjust the staple position of Saddle Stitcher. As the value is changed by 1, the staple position shifts by 0.1mm. +: The staple position shifts downward -: The staple position shifts upward
	Fin-AC:	To adjust the staple position of Saddle Stitcher. As the value is changed by 1, the staple position shifts by 0.1mm. +: The staple position shifts toward the left at open page of the book -: The staple position shifts toward the right at open page of the book
Use Case		When the staple position of the Saddle Stitcher is displaced
Adj/Set/Operate Method		Enter the setting value, and then press OK key.
Display/Adj/Set Range		-20 to 20
Unit		mm
Default Value		0
Supplement/Memo	Fin-AC:	Because the staple position of the thin paper is changed by this adjustment at the same time, perform the adjustment of SDL-STP2 as needed after performing this adjustment if the staple position of the thin paper has been adjusted by SDL-STP2.
Amount of Change per Unit		0.1
SDL-FLD	1	Adj Saddle Sttch fold pstn: Fin-X/AC
Detail	Fin-X:	To adjust the fold position of Saddle Stitcher. As the value is changed by 1, the fold position shifts by 0.1 mm. +: The undersurface of the spread becomes longer -: The top surface of the spread becomes longer
	Fin-AC:	To adjust the fold position of Saddle Stitcher. As the value is changed by 1, the fold position shifts by 0.1 mm. +: The fold position shifts toward the left at open page of the book -: The fold position shifts toward the right at open page of the book
Use Case		When the fold position of the Saddle Stitcher is displaced
Adj/Set/Operate Method		Enter the setting value, and then press OK key.
Display/Adj/Set Range		-20 to 20
Unit		mm
Default Value		0
Supplement/Memo	Fin-AC:	Because the fold position of the thin paper is changed by this adjustment at the same time, perform the adjustment of SDL-FLD2 as needed after performing this adjustment if the fold position of the thin paper has been adjusted by SDL-FLD2.
Amount of Change per Unit		0.1

SORTER (Service mode for delivery options) > ADJUST (Adjustment mode)

SDL-ALG	1	Adj of Saddle Sttch align wid: Fin-X/AC
Detail	To adjust the alignment width of Saddle Stitcher. Fin-X: As the value is changed by 1, the alignment width changes by 0.2 mm. Fin-AC: As the value is changed by 1, the alignment width changes by 0.1 mm. +: The width of the alignment plate becomes narrow. -: The width of the alignment plate becomes wide.	
Use Case	When the misalignment occurs within a paper stack on the Saddle Stitcher	
Adj/Set/Operate Method	Enter the setting value, and then press OK key.	
Display/Adj/Set Range	-20 to 20	
Unit	mm	
Default Value	0	
Amount of Change per Unit	0.2 (Fin-X1)/0.1 (Fin-V1)	
SDL-RLPT	1	Adj Sddl Diseng Roll diseng amnt: Fin-X
Detail	To adjust the disengagement amount of Saddle Stitcher Disengagement Roller. As the value is incremented by 1, the disengagement amount is increased by 0.3 mm. +: Increase (widen) -: Decrease (narrow) Adjustment error gets considerably increased as Disengagement Roller swings in a circular orbit when the setting value is "10" or more/ "-10" or less.	
Use Case	When the feed failure (with thin paper, etc.) occurs on the Saddle Stitcher	
Adj/Set/Operate Method	Enter the setting value, and then press OK key.	
Display/Adj/Set Range	-15 to 15	
Unit	mm	
Default Value	0	
Amount of Change per Unit	0.3	
SDL-RLFD	1	Adj Sddl Diseng Roller feed amnt: Fin-X
Detail	To adjust the feed amount from the 11th sheet to the 15th sheet of Saddle Stitcher Disengagement Roller. As the value is incremented by 1, the contact time is increased by 20 msec. +: Increase -: Decrease	
Use Case	When the feed failure (with thin paper, etc.) occurs on the Saddle Stitcher	
Adj/Set/Operate Method	Enter the setting value, and then press OK key.	
Display/Adj/Set Range	-5 to 5	
Unit	msec	
Default Value	0	
Amount of Change per Unit	20	

SORTER (Service mode for delivery options) > ADJUST (Adjustment mode)

BFR-UPA4	1	Adj Stck Dvry Upr Rol rise tmg:A4,Fin-X
Detail	To adjust the Stack Delivery Upper Roller rise timing when A4 size paper is waited in the buffer path. As the value is incremented by 1, the rise timing becomes early by 1 msec.	
Use Case	When an alignment failure occurs because the Stack Delivery Upper Roller feeds A4 size buffer paper to the Process Tray too much	
Adj/Set/Operate Method	Enter the setting value, and then press OK key.	
Display/Adj/Set Range	0 to 50	
Unit	msec	
Default Value	0	
Supplement/Memo	Setting value is effective upto "18". Values in "19"- "50" do not become effective while setting.	
Amount of Change per Unit	1	
BFR-UPB5	1	Adj Stck Dvry Upr Rol rise tmg:B5,Fin-X
Detail	To adjust the Stack Delivery Upper Roller rise timing when B5 size paper is waited in the buffer path. As the value is incremented by 1, the rise timing becomes early by 1 msec.	
Use Case	When Stack Delivery Upper Roller is driven for too much time and B5 size buffer paper is excessively conveyed to Processing Tray resulting in the misalignment	
Adj/Set/Operate Method	Enter the setting value, and then press OK key.	
Display/Adj/Set Range	0 to 50	
Unit	msec	
Default Value	0	
Supplement/Memo	Setting value is effective upto "18". Values in "19"- "50" do not become effective while setting.	
Amount of Change per Unit	1	
BFR-UPLT	1	Adj Stck Dvry U-Roll rise tmg:LTR,Fin-X
Detail	To adjust the Stack Delivery Upper Roller rise timing when LTR size paper is waited in the buffer path. As the value is incremented by 1, the rise timing becomes early by 1 msec.	
Use Case	When an alignment failure occurs because the Stack Delivery Upper Roller feeds letter size buffer paper to the Process Tray too much	
Adj/Set/Operate Method	Enter the setting value, and then press OK key.	
Display/Adj/Set Range	0 to 50	
Unit	msec	
Default Value	0	
Supplement/Memo	Setting value is effective upto "18". Values in "19"- "50" do not become effective while setting.	
Amount of Change per Unit	1	
RTR-DWA4	1	Adj Rtn Roll fall tmg for A4:Fin-X
Detail	To adjust the Paper Return Roller fall timing when A4 size paper is waited in the buffer path. As the value is incremented by 1, the fall timing becomes early by 1msec.	
Use Case	When Upper Stack Delivery Roller is driven for too much time and A4 size buffer paper is excessively conveyed to Processing Tray resulting in the misalignment	
Adj/Set/Operate Method	Enter the setting value, and then press OK key.	
Display/Adj/Set Range	-21 to 41	
Unit	msec	
Default Value	0	
Amount of Change per Unit	1	

SORTER (Service mode for delivery options) > ADJUST (Adjustment mode)

RTR-DWB5	1	Adj Rtn Roll fall tmng for B5: Fin-X
Detail	To adjust the Paper Return Roller fall timing when B5 size paper is waited in the buffer path. As the value is incremented by 1, the fall timing becomes early by 1msec.	
Use Case	When Upper Stack Delivery Roller is driven for too much time and B5 size buffer paper is excessively conveyed to Processing Tray resulting in the misalignment	
Adj/Set/Operate Method	Enter the setting value, and then press OK key.	
Display/Adj/Set Range	-21 to 41	
Unit	msec	
Default Value	0	
Amount of Change per Unit	1	
RTR-DWLT	1	Adj Rtn Roll fall tmng for LTR: Fin-X
Detail	To adjust the Paper Return Roller fall timing when LTR size paper is waited in the buffer path. As the value is incremented by 1, the fall timing becomes early by 1msec.	
Use Case	When Upper Stack Delivery Roller is driven for too much time and LTR size buffer paper is excessively conveyed to Processing Tray resulting in the misalignment	
Adj/Set/Operate Method	Enter the setting value, and then press OK key.	
Display/Adj/Set Range	-21 to 41	
Unit	msec	
Default Value	0	
Amount of Change per Unit	1	
BF-SB-A4	1	Adj switchback position for A4: Fin-X
Detail	To adjust the paper switchback position when A4 size paper is waited in the buffer path. As the value is incremented by 1, the switchback amount is increased by 0.1mm.	
Use Case	When Upper Stack Delivery Roller is driven for too much time and A4 size buffer paper is excessively conveyed to Processing Tray resulting in the misalignment	
Adj/Set/Operate Method	Enter the setting value, and then press OK key.	
Display/Adj/Set Range	0 to 50	
Unit	mm	
Default Value	0	
Amount of Change per Unit	0.1	
BF-SB-B5	1	Adj switchback position for B5: Fin-X
Detail	To adjust the paper switchback position when B5 size paper is waited in the buffer path. As the value is incremented by 1, the switchback amount is increased by 0.1mm.	
Use Case	When Upper Stack Delivery Roller is driven for too much time and B5 size buffer paper is excessively conveyed to Processing Tray resulting in the misalignment	
Adj/Set/Operate Method	Enter the setting value, and then press OK key.	
Display/Adj/Set Range	0 to 50	
Unit	mm	
Default Value	0	
Amount of Change per Unit	0.1	

SORTER (Service mode for delivery options) > ADJUST (Adjustment mode)

BF-SB-LT	1	Adj swback position for LTR: Fin-X
Detail		To adjust the paper switchback position when LTR size paper is waited in the buffer path. As the value is incremented by 1, the switchback amount is increased by 0.1mm.
Use Case		When Upper Stack Delivery Roller is driven for too much time and LTR size buffer paper is excessively conveyed to Processing Tray resulting in the misalignment
Adj/Set/Operate Method		Enter the setting value, and then press OK key.
Display/Adj/Set Range		0 to 50
Unit		mm
Default Value		0
Amount of Change per Unit		0.1
RTR-UPA4	1	Adj Rtn Roll rise angl for A4: Fin-X
Detail		To adjust the Paper Return Roller rise angle when processing is performed to A4 size paper. As the value is incremented by 1, the roller rise angle is increased by 1 degree.
Use Case		When poor alignment occurs as A4 size buffer paper is conveyed to Processing Tray and the height of Upper Stack Delivery Roller is wrong in its parking position
Adj/Set/Operate Method		Enter the setting value, and then press OK key.
Display/Adj/Set Range		1 to 44
Default Value		22
Amount of Change per Unit		1
RTR-UPB5	1	Adj Rtn Roll rise angl for B5: Fin-X
Detail		To adjust the Paper Return Roller rise angle when processing is performed to B5 size paper. As the value is incremented by 1, the roller rise angle is increased by 1 degree.
Use Case		When poor alignment occurs as B5 size buffer paper is conveyed to Processing Tray and the height of Upper Stack Delivery Roller is wrong in its parking position
Adj/Set/Operate Method		Enter the setting value, and then press OK key.
Display/Adj/Set Range		1 to 44
Default Value		22
Amount of Change per Unit		1
RTR-UPLT	1	Adj Rtn Rol rise angl forLTR: Fin-X
Detail		To adjust the Paper Return Roller rise angle when processing is performed to LTR size paper. As the value is incremented by 1, the roller rise angle is increased by 1 degree.
Use Case		When poor alignment occurs as LTR size buffer paper is conveyed to Processing Tray and the height of Upper Stack Delivery Roller is wrong in its parking position
Adj/Set/Operate Method		Enter the setting value, and then press OK key.
Display/Adj/Set Range		1 to 44
Default Value		22
Amount of Change per Unit		1

SORTER (Service mode for delivery options) > ADJUST (Adjustment mode)

PUNCH-SB	1	Adj Punch Mode ppr swback amnt: Fin-X
Detail	To adjust the paper switchback amount in the high accuracy punch mode of Finisher. As the value is incremented by 1, the switchback amount is increased by 1mm.	
Use Case	When the punch accuracy deteriorates in the paper feed direction	
Adj/Set/Operate Method	Enter the setting value, and then press OK key.	
Display/Adj/Set Range	0 to 4	
Unit	mm	
Default Value	0	
Amount of Change per Unit	1	
ST-ALG1	1	Adj Stacker A4 align pstn: Fin-X/AC
Detail	To adjust the A4 size paper alignment position of the Processing Tray. As the value is changed by 1, the position of the alignment plate moves by 0.1 mm. Fin-X: +: Outward (The width of the alignment plates becomes wide.) -: Inward (The width of the alignment plates becomes narrow.) The adjustment value is reflected for SORTER> ADJUST> PRCS-ALG/ST-ALG2. Fin-AC: +: Inward (The width of the alignment plates becomes narrow.) -: Outward (The width of the alignment plates becomes wide.)	
Use Case	When misalignment occurs in A4 size paper	
Adj/Set/Operate Method	1) Enter the setting value, and then press OK key. 2) The alignment plate moves to position of the A4 width. 3) Set the A4 paper on the processing tray. 4) Enter the setting value, and then press OK key. 5) Check the adjustment movement of the alignment plate. 6) Repeat steps 4) and 5) and adjust alignment width. 7) After completion of the adjustment, remove paper on the processing tray.	
Display/Adj/Set Range	-50 to 50	
Unit	mm	
Default Value	0	
Related Service Mode	Fin-X: SORTER> ADJUST> PRCS-ALG/ST-ALG2	
Amount of Change per Unit	0.1	

SORTER (Service mode for delivery options) > ADJUST (Adjustment mode)

ST-ALG2	1	Adj Stacker LTR align pstn: Fin-X/AC
Detail	To adjust the LTR size paper alignment position of the Processing Tray. As the value is changed by 1, the position of the alignment plate moves by 0.1 mm. Fin-X: +: Outward (The width of the alignment plates becomes wide.) -: Inward (The width of the alignment plates becomes narrow.) The adjustment value is reflected for SORTER> ADJUST> PRCS-ALG/ST-ALG1. Fin-AC: +: Inward (The width of the alignment plates becomes narrow.) -: Outward (The width of the alignment plates becomes wide.)	
Use Case	When misalignment occurs in LTR size paper	
Adj/Set/Operate Method	1) Enter the setting value, and then press OK key. 2) The alignment plate moves to position of the LTR width. 3) Set the LTR paper on the processing tray. 4) Enter the setting value, and then press OK key. 5) Check the adjustment movement of the alignment plate. 6) Repeat steps 4) and 5) and adjust alignment width. 7) After completion of the adjustment, remove paper on the processing tray.	
Display/Adj/Set Range	-50 to 50	
Unit	mm	
Default Value	0	
Related Service Mode	Fin-X: SORTER> ADJUST> PRCS-ALG/ST-ALG1	
Amount of Change per Unit	0.1	
SW-UP-RL	1	Adj of Swing Unit height: Fin-AC
Detail	To adjust the height of the Swing Unit. As the value is changed by 1, the height of the swing unit changes by angle of 0.1 degree. +: Downward -: Upward	
Use Case	When misalignment occurs by failure of the paper feeding to processing tray	
Adj/Set/Operate Method	Enter the setting value, and then press OK key.	
Display/Adj/Set Range	-30 to 30	
Default Value	0	
Amount of Change per Unit	0.1	
DW-CL	1	Set of dwnwrld curl alleviatn mod: Fin-X
Detail	Set 1 when a stacking failure occurs due to downward curl on the paper delivered to the tray. When 1 is set, the delivery speed by the gripper slows down.	
Use Case	When a stacking failure due to downward curl on the paper occurs	
Adj/Set/Operate Method	Enter the setting value, and then press OK key.	
Caution	When 1 is set, productivity decreases.	
Display/Adj/Set Range	0 to 1 0: OFF, 1: ON	
Default Value	0	
PRT-DWN	1	[Not used]
Amount of Change per Unit	1	

SORTER (Service mode for delivery options) > ADJUST (Adjustment mode)

PF-LGL41	1	Adj of LGL 4-fold position (1st): PFU
Detail		To adjust the 1st fold position of LGL paper 4-fold position on Paper Folding Unit. As the value is incremented by 1, the fold position moves by 0.1 mm.
Use Case		When the fold position adjustment in Settings/Registration menu is inadequate
Adj/Set/Operate Method		Enter the setting value (switch negative/positive by +/- key) and press OK key.
Display/Adj/Set Range		-128 to 120
Unit		mm
Default Value		0
Additional Functions Mode		Adjustment/Maintenance> Adjust Action> Adjust Fold Position> Adjust Double Parallel Fold Position
Amount of Change per Unit		0.1
PF-LGL42	1	Adj of LGL 4-fold position (2nd): PFU
Detail		To adjust the 2nd fold position of LGL paper 4-fold position on Paper Folding Unit. As the value is incremented by 1, the fold position moves by 0.1 mm.
Use Case		When the fold position adjustment in Settings/Registration menu is inadequate
Adj/Set/Operate Method		Enter the setting value (switch negative/positive by +/- key) and press OK key.
Display/Adj/Set Range		-128 to 127
Unit		mm
Default Value		0
Additional Functions Mode		Adjustment/Maintenance> Adjust Action> Adjust Fold Position> Adjust Double Parallel Fold Position
Amount of Change per Unit		0.1
PNC-SBTN	1	Thin swbck amnt: Hi accurcy punch:Fin-X
Detail		To adjust the switchback amount of thin paper (59g/m2 or less) in the high accuracy punch mode of the finisher. As the value is incremented by 1, the switchback amount is increased by 1mm.
Use Case		When the punch accuracy of thin paper (59g/m2 or less) is low in feed direction
Adj/Set/Operate Method		Enter the setting value, and then press OK key.
Display/Adj/Set Range		0 to 4
Unit		mm
Default Value		1
Amount of Change per Unit		1
SBFD-SPL	1	Adj small plain ppr swback pstn: Fin-X
Detail		To adjust the switchback position when stacking small size plain papers on the Process Tray. As the value is incremented by 1, the switchback amount is increased by 1mm.
Use Case		When alignment condition of small size plain paper is poor in feed direction
Adj/Set/Operate Method		Enter the setting value, and then press OK key.
Display/Adj/Set Range		-10 to 10
Unit		mm
Default Value		0
Amount of Change per Unit		1

SORTER (Service mode for delivery options) > ADJUST (Adjustment mode)

SBFD-LPL	1	Adj large plain ppr swback pstn: Fin-X
Detail		To adjust the switchback position when stacking large size plain papers on the Process Tray. As the value is incremented by 1, the switchback amount is increased by 1mm.
Use Case		When alignment condition of large size plain paper is poor in feed direction
Adj/Set/Operate Method		Enter the setting value, and then press OK key.
Display/Adj/Set Range		-10 to 10
Unit		mm
Default Value		0
Amount of Change per Unit		1
SBFD-SHV	1	Adj small heavy ppr swback pstn: Fin-X
Detail		To adjust the switchback position when stacking small size heavy papers on the Process Tray. As the value is incremented by 1, the switchback amount is increased by 1mm.
Use Case		When alignment condition of small size heavy paper is poor in feed direction
Adj/Set/Operate Method		Enter the setting value, and then press OK key.
Display/Adj/Set Range		-10 to 10
Unit		mm
Default Value		0
Amount of Change per Unit		1
SBFD-LHV	1	Adj large heavy ppr swback pstn: Fin-X
Detail		To adjust the switchback position when stacking large size heavy papers on the Process Tray. As the value is incremented by 1, the switchback amount is increased by 1mm.
Use Case		When alignment condition of large size heavy paper is poor in feed direction
Adj/Set/Operate Method		Enter the setting value, and then press OK key.
Display/Adj/Set Range		-10 to 10
Unit		mm
Default Value		0
Amount of Change per Unit		1
SBFD-STN	1	Adj small thin ppr swback pstn: Fin-X
Detail		To adjust the switchback position when stacking small size thin papers (59 g/m ² or less) on the Process Tray. As the value is incremented by 1, the switchback amount is increased by 1mm.
Use Case		When alignment condition of small size thin paper is poor in feed direction
Adj/Set/Operate Method		Enter the setting value, and then press OK key.
Display/Adj/Set Range		-10 to 10
Unit		mm
Default Value		0
Amount of Change per Unit		1

SORTER (Service mode for delivery options) > ADJUST (Adjustment mode)

SBFD-LTN	1	Adj large thin ppr swback pstn: Fin-X
Detail		To adjust the switchback position when stacking large size thin papers (59 g/m ² or less) on the Process Tray. As the value is incremented by 1, the switchback amount is increased by 1mm.
Use Case		When alignment condition of large size thin paper is poor in feed direction
Adj/Set/Operate Method		Enter the setting value, and then press OK key.
Display/Adj/Set Range		-10 to 10
Unit		mm
Default Value		0
Amount of Change per Unit		1
SBFD-SCT	1	Adj small coated ppr swback pstn: Fin-X
Detail		To adjust the switchback position when stacking small size coated papers on the Process Tray. As the value is incremented by 1, the switchback amount is increased by 1mm.
Use Case		When alignment condition of small size coated paper is poor in feed direction
Adj/Set/Operate Method		Enter the setting value, and then press OK key.
Display/Adj/Set Range		-10 to 10
Unit		mm
Default Value		0
Amount of Change per Unit		1
SBFD-LCT	1	Adj large coated ppr swback pstn: Fin-X
Detail		To adjust the switchback position when stacking large size coated papers on the Process Tray. As the value is incremented by 1, the switchback amount is increased by 1mm.
Use Case		When alignment condition of large size coated paper is poor in feed direction
Adj/Set/Operate Method		Enter the setting value, and then press OK key.
Display/Adj/Set Range		-10 to 10
Unit		mm
Default Value		0
Amount of Change per Unit		1
NST-SPD	1	Adj dvry speed at non-collate: Fin-X/AC
Detail		To adjust the delivery speed to the stack tray at non-collated mode. Fin-X: As the value is changed by 1, the delivery speed changes by 20 mm/sec. To slow down when the delivered paper is thrown too much and speed up when the delivered paper leans over the delivery area Fin-AC: As the value is changed by 1, the delivery speed changes by 10 mm/sec.
Use Case		When the paper stacking at non-collated mode is misalignment
Adj/Set/Operate Method		Enter the setting value, and then press OK key.
Display/Adj/Set Range		Fin-X: -5 to 5 Fin-AC: -10 to 10
Unit		mm/s
Default Value		0
Amount of Change per Unit		20 (Fin-X1)/10 (Fin-V1)

SORTER (Service mode for delivery options) > ADJUST (Adjustment mode)

NST-SPTN	1	Adj thin ppr dvry SPD:non-collate,Fin-X
Detail	To adjust the delivery speed of thin paper (59g/m2 or less) in non-collate mode. As the value is incremented by 1, the delivery speed is increased by 20 mm/sec. To slow down when the delivered paper is thrown too much and speed up when the delivered paper leans over the delivery area	
Use Case	When the stacking condition of thin paper (59g/m2 or less) in non-collate mode is misalignment	
Adj/Set/Operate Method	Enter the setting value, and then press OK key.	
Display/Adj/Set Range	-5 to 5	
Unit	mm/s	
Default Value	0	
Amount of Change per Unit	20	
RTNRL-SP	1	Adj Return Roller rotation speed: Fin-X
Detail	To adjust the Paper Return Roller rotation speed. As the value is incremented by 1, the delivery speed is increased by 50 mm/sec.	
Use Case	When poor alignment occurs as buffer paper is conveyed to Processing Tray and hit Processing Stopper with wrong speed	
Adj/Set/Operate Method	Enter the setting value, and then press OK key.	
Display/Adj/Set Range	-6 to 0	
Unit	mm/s	
Default Value	0	
Amount of Change per Unit	50	
SW-ADJ	1	Adjustment of Swing Guide height: Fin-X
Detail	To adjust the height of the Swing Guide at the time of nip. As the value is incremented by 1, the height of the Swing Guide changes by 0.23 mm. +: Height is increased -: Height is decreased	
Use Case	When an image is scratched at the Swing Guide due to friction of papers	
Adj/Set/Operate Method	Enter the setting value, and then press OK key.	
Display/Adj/Set Range	-10 to 10	
Unit	mm	
Default Value	0	
Amount of Change per Unit	0.23	
GRP-ALG	1	Adj of Gripper standby point: Fin-X
Detail	To adjust the timing that the Gripper grabs a paper stack by changing the standby point of the Gripper. As the value is incremented by 1, the standby position moves by 0.12 mm. +: Timing becomes earlier -: Timing is delayed	
Use Case	When poor alignment occurs on Delivery Tray as Gripper does not grip a paper stack and throws it away	
Adj/Set/Operate Method	Enter the setting value, and then press OK key.	
Display/Adj/Set Range	-40 to 40	
Unit	mm	
Default Value	0	
Amount of Change per Unit	0.12	

SORTER (Service mode for delivery options) > ADJUST (Adjustment mode)

PRTN-ALG	1	Adj Paper Retainer fall amount: Fin-X
Detail	To adjust the fall amount of the Paper Retainer. As the value is incremented by 1, the fall amount is increased by 0.65 degree. +: Move down -: Move up	
Use Case	When adjusting the position the Paper Retainer moves down to the Processing Tray. Except when buffered paper is fed.	
Adj/Set/Operate Method	Enter the setting value, and then press OK key.	
Display/Adj/Set Range	-34 to 14	
Default Value	0	
Amount of Change per Unit	0.65	
BFF-SFT3	1	Buffer ppr displace amount adj 3: Fin-X
Detail	To adjust the paper displacement amount on the 3rd and 4th sheets on Finisher Buffer Assembly. As the value is incremented by 1, the paper position moves by 0.1 mm. +: The 4th sheet of buffered paper shifts toward the delivery side for the 3rd sheet -: The 4th sheet of buffered paper shifts toward the inlet side for the 3rd sheet	
Use Case	When the paper displacement occurs on the 3rd to 4th sheets of the 2nd sets (B5/A4/LTR) and later	
Adj/Set/Operate Method	Enter the setting value, and then press OK key.	
Display/Adj/Set Range	-50 to 50	
Unit	mm	
Default Value	0	
Amount of Change per Unit	0.1	
BFF-SFT4	1	Buffer ppr displace amount adj 4: Fin-X
Detail	To adjust the paper displacement amount on the 4th and 5th sheets on Finisher Buffer Assembly. As the value is incremented by 1, the paper position moves by 0.1 mm. +: The 5th sheet of buffered paper shifts toward the delivery side for the 4th sheet -: The 5th sheet of buffered paper shifts toward the inlet side for the 4th sheet	
Use Case	When the paper displacement occurs on the 4th to 5th sheets of the 2nd sets (B5/A4/LTR) and later	
Adj/Set/Operate Method	Enter the setting value, and then press OK key.	
Display/Adj/Set Range	-50 to 50	
Unit	mm	
Default Value	0	
Amount of Change per Unit	0.1	
FR-ST-PS	1	Adj Staple-free Binding pressure: Fin-AC
Detail	To adjust the binding pressure at the staple-free binding mode. As the value is changed by 1, the binding pressure changes by 1 mNm. +: Increased -: Decreased	
Use Case	Upon user's request (When changing the binding pressure)	
Adj/Set/Operate Method	Enter the setting value, and then press OK key.	
Caution	The life of staple-free binding unit becomes shorter when increasing the setting value.	
Display/Adj/Set Range	-15 to 15	
Unit	mNm	
Default Value	0	
Amount of Change per Unit	1	

SORTER (Service mode for delivery options) > ADJUST (Adjustment mode)

FR-STP-Y	1	Adj Stpl-free Bind pstn (F/R way):Fin-AC
Detail		To adjust the binding position for front/rear direction at the staple-free binding mode. As the value is changed by 1, the binding position shifts by 0.1 mm. +: Toward rear -: Toward front
Use Case		When the binding position in front/rear direction is displaced at the staple-free binding mode
Adj/Set/Operate Method		Enter the setting value, and then press OK key.
Display/Adj/Set Range		-20 to 15
Unit		mm
Default Value		0
Amount of Change per Unit		0.1
RBLT-PRS	1	Adj Return Belt height 1:Fin-AC
Detail		To adjust the height of the Return Belt when stacking the 65 sheets on the processing tray. As the value is changed by 1, the height of the return belt changes by angle of 0.1 degree. +: Downward -: Upward When replacing the Finisher Controller PCB/clearing the RAM data of the Finisher Controller PCB, enter the value of service label.
Use Case		When the paper alignment position is displaced. When replacing the Finisher Controller PCB/clearing the RAM data of the Finisher Controller PCB.
Adj/Set/Operate Method		Enter the setting value (switch negative/positive by +/- key) and press OK key.
Caution		The height of Return Belt of the stacking 1 sheet adjust in the RBLT-PS3. The height of Return Belt at the stacking 2 to 64 sheets alignment on the processing tray is the total of setting values of RBLT-PRS and PBLT-PS3, After the setting value is changed, write the changed value in the service label.
Display/Adj/Set Range		-50 to 100
Default Value		0
Related Service Mode		SORTER> ADJUST> RBLT-PS2,RBLT-PS3
Supplement/Memo		The height of Return Belt when stacking the first sheet of paper or buffering the paper: The height of Return Belt is double of the setting value. (Escape position of Return Belt) The height of Return Belt when stacking the sheet of paper except for first sheet: The height of Return Belt is the setting value. (Paper feed position of Return Belt)
Amount of Change per Unit		0.1
MSTP-2P	1	Adj manual staple position: Fin-AC
Detail		To adjust the staple position for front/rear direction at the manual staple mode. As the value is changed by 1, the staple position shifts by 0.1 mm. +: Toward rear -: Toward front
Use Case		When the staple position for front/rear direction is displaced at the manual staple mode
Adj/Set/Operate Method		Enter the setting value, and then press OK key.
Display/Adj/Set Range		-20 to 30
Unit		mm
Default Value		0
Amount of Change per Unit		0.1

SORTER (Service mode for delivery options) > ADJUST (Adjustment mode)

CENT-ALG	1	Adj align plates ctr stdrd pstn: Fin-AC
Detail	To adjust the center standard position of the alignment plates. As the value is changed by 1, the center standard position of the alignment plates shifts by 0.1 mm. +: Toward rear -: Toward front	
Use Case	- When the center standard position of the alignment plates is misaligned - When the paper alignment position is displaced	
Adj/Set/Operate Method	Enter the setting value, and then press OK key.	
Caution	Do not use this at the normal service work to influence the alignment operation greatly. Adjust the alignment width with ST-ALG1/ST-ALG2 normally.	
Display/Adj/Set Range	-50 to 50	
Unit	mm	
Default Value	0	
Related Service Mode	SORTER> ADJUST> ST-ALG1/ST-ALG2	
Amount of Change per Unit	0.1	
SDL-STP2	1	Adj Saddle Sttch stpl pstn: Thin, Fin-AC
Detail	To adjust the staple position of Saddle Stitcher (when using the thin paper; the paper that the paper weight is less than 64 g/m ²). As the value is incremented by 1, the staple position moves by 0.1mm. +: The staple position moves toward the left at open page of the book -: The staple position moves toward the right at open page of the book	
Use Case	When the staple position of the Saddle Stitcher is displaced with the thin paper	
Adj/Set/Operate Method	Enter the setting value, and then press OK key.	
Display/Adj/Set Range	-20 to 20	
Unit	mm	
Default Value	0	
Supplement/Memo	Perform this adjustment after performing the adjustment of SDL-STP. Because the staple position of the thin paper is adjusted by the total setting values of SDL-STP and SDL-STP2, the actual adjustment of the staple position is performed in the staple position adjustable range (-20 to 20) even if entering the setting value beyond the mechanical staple position adjustable range.	
Amount of Change per Unit	0.1	
SDL-FLD2	1	Adj Saddle Sttch fold pstn: Thin, Fin-AC
Detail	To adjust the fold position of Saddle Stitcher (when using the thin paper; the paper that the paper weight is less than 64 g/m ²). As the value is incremented by 1, the fold position moves by 0.1 mm. +: The fold position moves toward the left at open page of the book -: The fold position moves toward the right at open page of the book	
Use Case	When the fold position of the Saddle Stitcher is displaced with the thin paper	
Adj/Set/Operate Method	Enter the setting value, and then press OK key.	
Display/Adj/Set Range	-20 to 20	
Unit	mm	
Default Value	0	
Supplement/Memo	Perform this adjustment after performing the adjustment of SDL-FLD. Because the fold position of the thin paper is adjusted by the total setting values of SDL-FLD and SDL-FLD2, the actual adjustment of the fold position is performed in the fold position adjustable range (-20 to 20) even if entering the setting value beyond the mechanical fold position adjustable range.	
Amount of Change per Unit	0.1	

SORTER (Service mode for delivery options) > ADJUST (Adjustment mode)

ESC1-SPD	1	Adj Low Escape Tr delivery speed: Fin-AC
Detail	To adjust the delivery speed to the lower escape tray. As the value is changed by 1, the delivery speed to the lower escape tray changes by 10 mm/sec.	
Use Case	When the paper stacking to the lower escape tray is misalignment	
Adj/Set/Operate Method	Enter the setting value, and then press OK key.	
Display/Adj/Set Range	-10 to 0	
Unit	mm/s	
Default Value	0	
Amount of Change per Unit	10	
ESC2-SPD	1	Adj Upr Escape Tr delivery speed: Fin-AC
Detail	To adjust the delivery speed to the upper escape tray. As the value is changed by 1, the delivery speed to the upper escape tray changes by 10 mm/sec.	
Use Case	When the paper stacking to the upper escape tray is misalignment	
Adj/Set/Operate Method	Enter the setting value, and then press OK key.	
Display/Adj/Set Range	-10 to 10	
Unit	mm/s	
Default Value	0	
Amount of Change per Unit	10	
SFT-SPD	1	Adj dvry speed at collate mode: Fin-AC
Detail	To adjust the delivery speed to the stack tray at collate mode. As the value is changed by 1, the delivery speed changes by 10 mm/sec.	
Use Case	When the paper stacking on stack tray at collate mode is misalignment	
Adj/Set/Operate Method	Enter the setting value, and then press OK key.	
Caution	- When the value is decreased, the productivity is decreased. - When the buffer operation is performed, delivery speed does not change. (The buffer operation is the operation to deliver the stacking paper on the processing tray.) The ON/OFF of buffer operation is set by BUFF-SW.	
Display/Adj/Set Range	-5 to 5	
Unit	mm/s	
Default Value	0	
Related Service Mode	SORTER> OPTION> BUFF-SW	
Amount of Change per Unit	10	
STP-SPD	1	Adj dvry speed at staple mode: Fin-AC
Detail	To adjust the delivery speed to the stack tray at staple mode or staple-free binding mode. As the value is changed by 1, the delivery speed changes by 10 mm/sec.	
Use Case	When the paper stacking at staple mode or staple-free binding mode is misalignment	
Adj/Set/Operate Method	Enter the setting value, and then press OK key.	
Caution	- When the value is decreased, the productivity is decreased. - When the buffer operation is performed, delivery speed does not change. (The buffer operation is the operation to deliver the stacking paper on the processing tray.) The ON/OFF of buffer operation is set by BUFF-SW.	
Display/Adj/Set Range	-5 to 5	
Unit	mm/s	
Default Value	0	
Related Service Mode	SORTER> OPTION> BUFF-SW	
Amount of Change per Unit	10	

SORTER (Service mode for delivery options) > ADJUST (Adjustment mode)

RBLT-PS2	1	Adj of Return Belt height 2:Fin-AC
Detail	To adjust the height of the Return Belt when aligning the paper on the processing tray. As the value is changed by 1, the height of the return belt changes by angle of 0.1 degree. +: Downward -: Upward When replacing the Finisher Controller PCB/clearing the RAM data of the Finisher Controller PCB, enter the value of service label.	
Use Case	When the misalignment of paper stack occurs during alignment operation on the processing tray. When replacing the Finisher Controller PCB/clearing the RAM data of the Finisher Controller PCB.	
Adj/Set/Operate Method	Enter the setting value, and then press OK key.	
Caution	The height of Return Belt during the paper alignment on the processing tray is the total of setting values of RBLT-PRS2 and PBLT-PS3, so adjust again the setting value of RBLT-PS2 if necessary when changing the setting value of RBLT-PRS3. After the setting value is changed, write the changed value in the service label.	
Display/Adj/Set Range	-30 to 30	
Default Value	0	
Related Service Mode	SORTER> ADJUST> RBLT-PRS,RBLT-PS3	
Supplement/Memo	Perform this adjustment after executing adjustment of RBLT-PRS.	
Amount of Change per Unit	0.1	
RBLT-PS3	1	Adj of Return Belt height 3:Fin-AC
Detail	To adjust the height of the Return Belt when stacking the 1 sheet on the processing tray. As the value is changed by 1, the height of the return belt changes by angle of 0.1 degree. +: Downward -: Upward When replacing the Finisher Controller PCB/clearing the RAM data of the Finisher Controller PCB, enter the value of service label.	
Use Case	When the paper alignment position is displaced. When replacing the Finisher Controller PCB/clearing the RAM data of the Finisher Controller PCB.	
Adj/Set/Operate Method	Enter the setting value (switch negative/positive by -/+ key) and press OK key.	
Caution	The height of Return Belt of the stacking 65 sheets adjust in the RBLT-PRS. The height of Return Belt at the stacking 2 to 64 sheets alignment on the processing tray is the total of setting values of RBLT-PRS and RBLT-PS3. So adjust again the setting value of RBLT-PS2 if necessary when changing the setting value of RBLT-PS3. After the setting value is changed, write the changed value in the service label.	
Display/Adj/Set Range	-50 to 100	
Default Value	0	
Related Service Mode	SORTER> ADJUST> RBLT-PRS,RBLT-PS2	
Amount of Change per Unit	0.1	
IS1-VLM	1	Read U-Tr ppr lvl ref pstn adj VL (INS)
Detail	To read the adjustment value for the paper level detection reference position of the Inserter Upper Tray. The adjustment value read after completion of adjustment should be within the range from 188 to 200. An adjustment value not falling within the range limits indicates that the tray paper level detection position has not been adjusted.	
Use Case	When checking the adjustment value for the paper level detection reference position of the Inserter Lower Tray	
Adj/Set/Operate Method	Display only	
Display/Adj/Set Range	0 to 255	
Appropriate Target Value	188 to 200	
Default Value	0	

SORTER (Service mode for delivery options) > ADJUST (Adjustment mode)

IS2-VLM	1	Dspl L-Tr ppr lvl ref pstn adj VL (INS)
Detail	To read the adjustment value for the paper level detection reference position of the Inserter Lower Tray. The adjustment value read after completion of adjustment should be within the range from 188 to 200. An adjustment value not falling within the range limits indicates that the tray paper level detection position has not been adjusted.	
Use Case	When checking the adjustment value for the paper level detection reference position of the Inserter Lower Tray	
Adj/Set/Operate Method	Display only	
Display/Adj/Set Range	0 to 255	
Appropriate Target Value	188 to 200	
Default Value	0	
NT-BF-HT	1	Neat align plate acpt pstn: Fin-AC
Detail	To adjust the paper acceptance position of the neat alignment plate. As the value is changed by 1, the acceptance position height of the neat alignment plate is changed by 0.674 degree. +: Move down -: Move up	
Use Case	When the leading edge of the buffer paper is trapped on the alignment plate	
Adj/Set/Operate Method	Enter the setting value (switch negative/positive by -/+ key) and press OK key.	
Caution	After the setting value is changed, write the changed value in the service label.	
Display/Adj/Set Range	-16 to 16	
Default Value	0	
Amount of Change per Unit	0.674	
NEAT-R	1	Neat rear align plate pstn: Fin-AC
Detail	To adjust the rear alignment plate position of the neat alignment unit. As the value is incremented by 1, the rear alignment plate position moves by 0.208mm. +: Inward (The width of the alignment plate becomes narrower.) -: Outward (The width of the alignment plate becomes wider.)	
Use Case	When replacing the Neat controller PCB	
Adj/Set/Operate Method	Enter the setting value (switch negative/positive by -/+ key) and press OK key.	
Caution	- Do not use this at the normal service work to influence the alignment operation greatly. - Adjust the alignment width with "Adjustment/Maintenance> Adjust Action> Finisher Tray C Alignment Adjustment" normally. - After the setting value is changed, write the changed value in the service label.	
Display/Adj/Set Range	-10 to 10	
Unit	mm	
Default Value	0	
Additional Functions Mode	Adjustment/Maintenance> Adjust Action> Finisher Tray C Alignment Adjustment	
Amount of Change per Unit	0.208	

SORTER (Service mode for delivery options) > ADJUST (Adjustment mode)

NEAT-F	1	Neat front align plate pstn: Fin-AC
Detail	To adjust the front alignment plate position of the neat alignment unit. As the value is incremented by 1, the front alignment plate position moves by 0.208mm. +: Inward (The width of the alignment plate becomes narrower.) -: Outward (The width of the alignment plate becomes wider.)	
Use Case	When replacing the Neat controller PCB	
Adj/Set/Operate Method	Enter the setting value (switch negative/positive by -/+ key) and press OK key.	
Caution	- Do not use this at the normal service work to influence the alignment operation greatly. - Adjust the alignment width with "Adjustment/Maintenance> Adjust Action> Finisher Tray C Alignment Adjustment" normally. - After the setting value is changed, write the changed value in the service label.	
Display/Adj/Set Range	-10 to 10	
Unit	mm	
Default Value	0	
Additional Functions Mode	Adjustment/Maintenance> Adjust Action> Finisher Tray C Alignment Adjustment	
Amount of Change per Unit	0.208	
NEAT-HGT	1	Neat align plate height: Fin-AC
Detail	To adjust the height of the alignment plate at the neat alignment position. As the value is changed by 1, the height of the alignment plate is changed by 0.674 degree. +: Move down -: Move up	
Use Case	When the alignment plate does not hit the paper stack on the stack tray at the neat alignment	
Adj/Set/Operate Method	Enter the setting value (switch negative/positive by -/+ key) and press OK key.	
Caution	Be careful not to interfere with the stack tray of the home position position.	
Display/Adj/Set Range	-4 to 4	
Default Value	0	
Amount of Change per Unit	0.674	
NEAT-PDL	1	Neat paddle height: Fin-AC
Detail	To adjust the height of the neat paddle. As the value is changed by 1, the height of the Neat Paddle is changed by 0.690 degree. +: Move down -: Move up	
Use Case	When improving the paper alignment of the feed direction at stacking the paper on the stack tray	
Adj/Set/Operate Method	Enter the setting value (switch negative/positive by -/+ key) and press OK key.	
Caution	After the setting value is changed, write the changed value in the service label.	
Display/Adj/Set Range	-25 to 25	
Default Value	0	
Amount of Change per Unit	0.69	

SORTER (Service mode for delivery options) > ADJUST (Adjustment mode)

NEAT-Y	1	Neat align plate ctr stdrd pstn: Fin-AC
Detail		To adjust the center reference position of the neat alignment plate. As the value is changed by 1, the center reference position of the alignment plate is moved by 0.1 mm. +: Toward rear -: Toward front
Use Case		- When the center standard position of the alignment plates is misaligned - When the paper alignment position is displaced
Adj/Set/Operate Method		Enter the setting value (switch negative/positive by +/- key) and press OK key.
Display/Adj/Set Range		-20 to 20
Unit		mm
Default Value		0
Additional Functions Mode		Adjustment/Maintenance> Adjust Action> Finisher Tray C Alignment Adjustment
Amount of Change per Unit		0.1

FUNCTION (Operation / inspection mode)

SORTER (Service mode for delivery options) > FUNCTION (Operation / inspection mode)

FN-SENS1	1	Adj Punch Horz Rgst Sensor: Fin-X/AC
Detail		To automatically adjust the output of the Horizontal Registration Sensor 1 to 5 of the Puncher Unit in sequence. Horizontal Registration Sensor 1: A3/A4, 2: LDR/LTR, 3: B4/B5, 4: A4R/LTRR/LGL, 5: B5R
Use Case		Fin-X: - When installing/replacing the Puncher Unit - When replacing the Punch Side Registration Sensor - When replacing the Finisher Controller PCB Fin-AC: - When installing/replacing the Puncher Unit - When replacing the Punch Side Registration Sensor
Adj/Set/Operate Method		Select the item, and then press OK key.
Caution		If paper blocks light to the sensor, the adjustment result ends in NG.
Display/Adj/Set Range		During operation: ACTIVE, At normal termination: OK, At abnormal termination: NG
FN-SENS2	1	Adj Punch Waste Full Sensor: Fin-X/AC
Detail		To automatically adjust the output of Punch Waste Full Sensor (Punch Waste Full Detection PCB) of the Puncher Unit.
Use Case		Fin-X: - When installing/replacing the Puncher Unit - When replacing the Punch Waste Full Detection PCB - When replacing the Finisher Controller PCB Fin-AC: - When installing/replacing the Puncher Unit - When replacing the Punch Waste Full Sensor
Adj/Set/Operate Method		Select the item, and then press OK key.
Caution		If paper blocks light to the sensor, the adjustment result ends in NG.
Display/Adj/Set Range		During operation: ACTIVE, At normal termination: OK, At abnormal termination: NG

SORTER (Service mode for delivery options) > FUNCTION (Operation / inspection mode)

FIN-BK-R	1	Finisher backup data saving: Fin-W/X/AC
Detail		To read the backup data from Finisher Controller PCB and save in HDD.
Use Case		When replacing the Finisher Controller PCB
Adj/Set/Operate Method		1) Select the item, and then press OK key. 2) Turn OFF/ON the main power switch.
Display/Adj/Set Range		During operation: ACTIVE, At normal termination: OK, At abnormal termination: NG
Related Service Mode		SORTER> FUNCTION> FIN-BK-W
FLD-BK-W	1	Controller PCB backup data write: PFU
Detail		To write the backup data saved in HDD to the Paper Folding Unit Controller PCB of the Paper Folding Unit.
Use Case		When replacing the Paper Folding Unit Controller PCB of the Paper Folding Unit
Adj/Set/Operate Method		1) Select the item, and then press OK key. 2) Turn OFF/ON the main power switch.
Display/Adj/Set Range		During operation: ACTIVE, At normal termination: OK, At abnormal termination: NG
Related Service Mode		SORTER> FUNCTION> FLD-BK-R
PIU-BK-R	1	Controller PCB backup data read: IFU
Detail		To read the backup data from the Interface Board PCB of the Multi Function Professional Puncher and save in HDD.
Use Case		When replacing the Interface Board PCB of the Multi Function Professional Puncher
Adj/Set/Operate Method		Select the item, and then press OK key.
Display/Adj/Set Range		During operation: ACTIVE, At normal termination: OK, At abnormal termination: NG
Related Service Mode		SORTER> FUNCTION> PIU-BK-W
INS-BK-R	1	Insertor backup data reading: INS-N1
Detail		To read the backup data from the Insertion Unit Controller PCB of the Insertor and save in HDD.
Use Case		When replacing the Insertion Unit Controller PCB of the Insertor
Adj/Set/Operate Method		1) Select the item, and then press OK key. 2) Turn OFF/ON the main power switch.
Display/Adj/Set Range		During operation: ACTIVE, At normal termination: OK, At abnormal termination: NG
Related Service Mode		SORTER> FUNCTION> INS-BK-W
FIN-BK-W	1	Finisher backup data writing:Fin-W/X/AC
Detail		To write the backup data saved in HDD to the Finisher Controller PCB.
Use Case		When replacing the Finisher Controller PCB
Adj/Set/Operate Method		1) Select the item, and then press OK key. 2) Turn OFF/ON the main power switch.
Display/Adj/Set Range		During operation: ACTIVE, At normal termination: OK, At abnormal termination: NG
Related Service Mode		SORTER> FUNCTION> FIN-BK-R
FLD-BK-R	1	Controller PCB backup data read: PFU
Detail		To read the backup data from the Paper Folding Unit Controller PCB of the Paper Folding Unit and save in HDD.
Use Case		When replacing the Paper Folding Unit Controller PCB of the Paper Folding Unit
Adj/Set/Operate Method		1) Select the item, and then press OK key. 2) Turn OFF/ON the main power switch.
Display/Adj/Set Range		During operation: ACTIVE, At normal termination: OK, At abnormal termination: NG
Related Service Mode		SORTER> FUNCTION> FLD-BK-W

SORTER (Service mode for delivery options) > FUNCTION (Operation / inspection mode)

INS-BK-W	1	Inserter backup data writing: INS-N1
Detail		To write the backup data saved in HDD to Insertion Unit Controller PCB of the Inserter.
Use Case		When replacing the Insertion Unit Controller PCB of the Inserter
Adj/Set/Operate Method		1) Select the item, and then press OK key. 2) Turn OFF/ON the main power switch.
Display/Adj/Set Range		During operation: ACTIVE, At normal termination: OK, At abnormal termination: NG
Related Service Mode		SORTER> FUNCTION> INS-BK-R
PIU-BK-W	1	Controller PCB backup data write: IFU
Detail		To write the backup data saved in HDD to the Interface Board PCB of the Multi Function Professional Puncher.
Use Case		When replacing the Interface Board PCB of the Multi Function Professional Puncher
Adj/Set/Operate Method		Select the item, and then press OK key.
Display/Adj/Set Range		During operation: ACTIVE, At normal termination: OK, At abnormal termination: NG
Related Service Mode		SORTER> FUNCTION> PIU-BK-R
VR1-A4R	1	Adj Upper Tray Width Sensor: A4R, INS-N1
Detail		To automatically adjust the minimum paper width (A4R) of the Inserter Upper Tray.
Use Case		When the size mismatch jam occurs at the time of pickup from the Inserter Upper Tray
Adj/Set/Operate Method		1) Place A4R paper on the Inserter Upper Tray and align it with the width of the Slide Guide. 2) Select the item, and then press OK key.
Caution		When not executing VR1-A4, be sure to execute VR1-A4 continuously.
Display/Adj/Set Range		During operation: ACTIVE, At normal termination: OK, At abnormal termination: NG
Related Service Mode		SORTER> FUNCTION> VR1-A4
VR1-A4	1	Adj Upper Tray Width Sensor: A4, INS-N1
Detail		To automatically adjust the maximum paper width (A4) of the Inserter Upper Tray.
Use Case		When the size mismatch jam occurs at the time of pickup from the Inserter Upper Tray
Adj/Set/Operate Method		1) Place A4 paper on the Inserter Upper Tray and align it with the width of the Slide Guide. 2) Select the item, and then press OK key.
Caution		When not executing VR1-A4R, be sure to execute VR1-A4R continuously.
Display/Adj/Set Range		During operation: ACTIVE, At normal termination: OK, At abnormal termination: NG
Related Service Mode		SORTER> FUNCTION> VR1-A4R
VR1-LTRR	1	Adj Upper Tray Width Sensor:LTRR, INS-N1
Detail		To automatically adjust the minimum paper width (LTRR) of the Inserter Upper Tray.
Use Case		When the size mismatch jam occurs at the time of pickup from the Inserter Upper Tray
Adj/Set/Operate Method		1) Place LTRR paper on the Inserter Upper Tray and align it with the width of the Slide Guide. 2) Select the item, and then press OK key.
Caution		When not executing VR1-LTR, be sure to execute VR1-LTR continuously.
Display/Adj/Set Range		During operation: ACTIVE, At normal termination: OK, At abnormal termination: NG
Related Service Mode		SORTER> FUNCTION> VR1-LTR
VR1-LTR	1	Adj Upper Tray Width Sensor: LTR, INS-N1
Detail		To automatically adjust the maximum paper width (LTR) of the Inserter Upper Tray.
Use Case		When the size mismatch jam occurs at the time of pickup from the Inserter Upper Tray
Adj/Set/Operate Method		1) Place LTR paper on the Inserter Upper Tray and align it with the width of the Slide Guide. 2) Select the item, and then press OK key.
Caution		When not executing VR1-LTRR, be sure to execute VR1-LTRR continuously.
Display/Adj/Set Range		During operation: ACTIVE, At normal termination: OK, At abnormal termination: NG
Related Service Mode		SORTER> FUNCTION> VR1-LTRR

SORTER (Service mode for delivery options) > FUNCTION (Operation / inspection mode)

VR2-A4R	1	Adj Lower Tray Width Sensor: A4R, INS-N1
Detail		To automatically adjust the minimum paper width (A4R) of the Inserter Lower Tray.
Use Case		When the size mismatch jam occurs at the time of pickup from the Inserter Lower Tray
Adj/Set/Operate Method		1) Place A4R paper on the Inserter Lower Tray and align it with the width of the Slide Guide. 2) Select the item, and then press OK key.
Caution		When not executing VR2-A4, be sure to execute VR2-A4 continuously.
Display/Adj/Set Range		During operation: ACTIVE, At normal termination: OK, At abnormal termination: NG
Related Service Mode		SORTER> FUNCTION> VR2-A4
VR2-A4	1	Adj Lower Tray Width Sensor: A4, INS-N1
Detail		To automatically adjust the maximum paper width (A4) of the Inserter Lower Tray.
Use Case		When the size mismatch jam occurs at the time of pickup from the Inserter Lower Tray
Adj/Set/Operate Method		1) Place A4 paper on the Inserter Lower Tray and align it with the width of the Slide Guide. 2) Select the item, and then press OK key.
Caution		When not executing VR2-A4R, be sure to execute VR2-A4R continuously.
Display/Adj/Set Range		During operation: ACTIVE, At normal termination: OK, At abnormal termination: NG
Related Service Mode		SORTER> FUNCTION> VR2-A4R
VR2-LTRR	1	Adj Lower Tray Width Sensor:LTRR, INS-N1
Detail		To automatically adjust the minimum paper width (LTRR) of the Inserter Lower Tray.
Use Case		When the size mismatch jam occurs at the time of pickup from the Inserter Lower Tray
Adj/Set/Operate Method		1) Place LTRR paper on the Inserter Lower Tray and align it with the width of the Slide Guide. 2) Select the item, and then press OK key.
Caution		When not executing VR2-LTR, be sure to execute VR2-LTR continuously.
Display/Adj/Set Range		During operation: ACTIVE, At normal termination: OK, At abnormal termination: NG
Related Service Mode		SORTER> FUNCTION> VR2-LTR
VR2-LTR	1	Adj Lower Tray Width Sensor: LTR, INS-N1
Detail		To automatically adjust the maximum paper width (LTR) of the Inserter Lower Tray.
Use Case		When the size mismatch jam occurs at the time of pickup from the Inserter Lower Tray
Adj/Set/Operate Method		1) Place LTR paper on the Inserter Lower Tray and align it with the width of the Slide Guide. 2) Select the item, and then press OK key.
Caution		When not executing VR2-LTRR, be sure to execute VR2-LTRR continuously.
Display/Adj/Set Range		During operation: ACTIVE, At normal termination: OK, At abnormal termination: NG
Related Service Mode		SORTER> FUNCTION> VR2-LTRR
FIN-CON	1	Controller PCB RAM clear: Fin-X/AC
Detail		To execute the RAM clear of the Finisher Controller PCB to delete all the adjustment contents (excluding counter information).
Use Case		When clearing RAM data of the Finisher Controller PCB
Adj/Set/Operate Method		1) Select the item, and then press OK key. 2) Turn OFF/ON the main power switch.
Caution		- Output the service mode setting values by P-PRINT before execution. After execution, enter necessary setting value. - RAM data is cleared after the main power switch is turned OFF/ON.
Display/Adj/Set Range		During operation: ACTIVE, At normal termination: OK, At abnormal termination: NG
Related Service Mode		COPIER> FUNCTION> MISC-P> P-PRINT
Supplement/Memo		The adjustment values stored to the puncher controller PCB does not cleared.

SORTER (Service mode for delivery options) > FUNCTION (Operation / inspection mode)

PF-CON	1	Controller PCB RAM clear: PFU
Detail		To clear RAM data of the Paper Folding Unit Controller PCB on the Paper Folding Unit. All the adjustment contents (excluding counter values) are deleted.
Use Case		When clearing RAM data of the Paper Folding Unit Controller PCB on Paper Folding Unit
Adj/Set/Operate Method		Select the item, and then press OK key.
Caution		Output the service mode setting values by P-PRINT before execution. After execution, enter necessary setting value.
Display/Adj/Set Range		During operation: ACTIVE, At normal termination: OK, At abnormal termination: NG
Related Service Mode		COPIER> FUNCTION> MISC-P> P-PRINT
PF-SENS1	1	Adj Slowdown Timing Sensor output: PFU
Detail		Slowdown Timing Sensor To adjust the output of Slowdown Timing Sensor on the Paper Folding Unit automatically.
Use Case		- When replacing the Slowdown Timing Sensor - When replacing the Paper Folding Unit Controller PCB of the Paper Folding Unit
Adj/Set/Operate Method		Select the item, and then press OK key.
Display/Adj/Set Range		During operation: ACTIVE, At normal termination: OK, At abnormal termination: NG
PF-SENS2	1	Adj Release Timing Sensor output: PFU
Detail		Release Timing Sensor To adjust the output of Release Timing Sensor on the Paper Folding Unit automatically.
Use Case		- When replacing the Release Timing Sensor - When replacing the Paper Folding Unit Controller PCB of the Paper Folding Unit
Adj/Set/Operate Method		Select the item, and then press OK key.
Display/Adj/Set Range		During operation: ACTIVE, At normal termination: OK, At abnormal termination: NG
PF-SENS3	1	Adj Fold Position Sensor output: PFU
Detail		Fold Position Sensor To adjust the output of Fold Position Sensor on the Paper Folding Unit automatically.
Use Case		- When replacing the Fold Position Sensor - When replacing the Paper Folding Unit Controller PCB of the Paper Folding Unit
Adj/Set/Operate Method		Select the item, and then press OK key.
Display/Adj/Set Range		During operation: ACTIVE, At normal termination: OK, At abnormal termination: NG
PF-SENS4	1	Adj Upper Stopper Ppr Sensor output: PFU
Detail		Upper Stopper Paper Sensor To adjust the output of Upper Stopper Paper Sensor on the Paper Folding Unit automatically.
Use Case		- When replacing the Upper Stopper Path Sensor - When replacing the Paper Folding Unit Controller PCB of the Paper Folding Unit
Adj/Set/Operate Method		Select the item, and then press OK key.
Display/Adj/Set Range		During operation: ACTIVE, At normal termination: OK, At abnormal termination: NG
TRM-SENS	1	Adj of Trimmr Dust Sensor output: Fin-X
Detail		To adjust the output of Saddle Dust Sensor on Saddle Unit automatically.
Use Case		- When installing the Trimmer - When replacing the Trimmer Dust Sensor - When replacing the Saddle Controller PCB
Adj/Set/Operate Method		Select the item, and then press OK key.
Display/Adj/Set Range		During operation: ACTIVE, At normal termination: OK, At abnormal termination: NG

SORTER (Service mode for delivery options) > FUNCTION (Operation / inspection mode)

IS-CON	1	Insertion Unit Controller PCB RAM clear
Detail		To clear RAM data of the Insertion Unit Controller PCB of the Inserter. All the adjustment contents (excluding counter values) are deleted.
Use Case		When clearing RAM data of the Insertion Unit Controller PCB of Inserter
Adj/Set/Operate Method		1) Select the item, and then press OK key. 2) Turn OFF/ON the main power switch.
Caution		After execution, perform adjustment of the Tray Width Sensor.
Display/Adj/Set Range		During operation: ACTIVE, At normal termination: OK, At abnormal termination: NG
CNT-FCON	1	For R&D
CNT-ICON	1	For R&D
CNT-PCON	1	For R&D
FR-ST-RP	1	Ppr dust remov at stpl-free bind: Fin-AC
Detail		To remove the paper dust from the staple-free binding unit, the staple-free binding operation repeatedly is executed 30 times without paper. When this mode is executed, the performance of the staple-free binding unit recovers.
Use Case		When the performance of the staple-free binding unit deteriorates
Adj/Set/Operate Method		Select the item, and then press OK key.
Caution		- The part counter value of the staple-free binding operation increases. - When the job starts during the operation of this mode, the finisher sequence error jam occurs. - When the error avoidance jam occurs during the operation of this mode, the jam becomes the error immediately.
Display/Adj/Set Range		During operation: ACTIVE, At normal termination: OK, At abnormal termination: NG
Supplement/Memo		The removed paper dust accumulates on the lower frame under the paper path, so it does not influence to the performance of the machine.
PUN-BK-R	1	Puncher backup data saving: Fin-AC
Detail		To read the backup data from Puncher Controller PCB and save in HDD.
Use Case		When replacing the Puncher Controller PCB
Adj/Set/Operate Method		1) Select the item, and then press OK key. 2) Turn OFF/ON the main power switch.
Caution		Be sure to read the data before writing.
Display/Adj/Set Range		During operation: ACTIVE, At normal termination: OK, At abnormal termination: NG
Related Service Mode		SORTER> FUNCTION> PUN-BK-W
PUN-BK-W	1	Puncher backup data writing: Fin-AC
Detail		To write the backup data saved in HDD to Puncher Controller PCB.
Use Case		When replacing the Puncher Controller PCB
Adj/Set/Operate Method		1) Select the item, and then press OK key. 2) Turn OFF/ON the main power switch.
Caution		Be sure to read the data before writing.
Display/Adj/Set Range		During operation: ACTIVE, At normal termination: OK, At abnormal termination: NG
Related Service Mode		SORTER> FUNCTION> PUN-BK-R
EMSG-CLR	1	Fin limited function mssg clear: Fin-AC
Detail		To clear the message that displayed on the control panel when the function of the staple-free binding is limited. The staple-free binding alarm is cleared.
Use Case		When clearing the message related to limited functions mode that is displayed after troubleshooting of finisher is performed
Adj/Set/Operate Method		Select the item, and then press OK key.
Caution		Only the messages related to staple free stapling can be cleared.
Display/Adj/Set Range		At normal termination: OK!, At abnormal termination: NG!

SORTER (Service mode for delivery options) > FUNCTION (Operation / inspection mode)

IS1-VLM	1	Adj Upr-tray ppr lvl dtct ref pstn (INS)
Detail		To automatically adjust the reference position for paper level detection of Inserter Upper Tray.
Use Case		When improving the paper level detection accuracy of Inserter Upper Tray
Adj/Set/Operate Method		1) Remove the paper on the Inserter Upper Tray 2) Select the item, and then press OK key
Display/Adj/Set Range		Operated: ACTIVE, Terminated normally, Terminated abnormally: NG
IS2-VLM	1	Adj Low-tray ppr lvl dtct ref pstn (INS)
Detail		To automatically adjust the reference position for paper level detection of Inserter Lower Tray.
Use Case		When improving the paper level detection accuracy of Inserter Lower Tray
Adj/Set/Operate Method		1) Remove the paper on the Inserter Lower Tray 2) Select the item, and then press OK key
Display/Adj/Set Range		Operated: ACTIVE, Terminated normally, Terminated abnormally: NG
NT-BK-W	1	Jogger kit backup data writing: Fin-AC
Detail		To write the backup data saved in HDD to Neat Controller PCB.
Use Case		When replacing the Neat Controller PCB
Adj/Set/Operate Method		1) Select the item, and then press OK key. 2) Turn OFF/ON the main power switch.
Display/Adj/Set Range		During operation: ACTIVE, At normal termination: OK, At abnormal termination: NG
Related Service Mode		SORTER> FUNCTION> NT-BK-R
NT-BK-R	1	Jogger kit backup data saving: Fin-AC
Detail		To read the backup data from Neat Controller PCB and save in HDD.
Use Case		When replacing the Neat Controller PCB
Adj/Set/Operate Method		1) Select the item, and then press OK key. 2) Turn OFF/ON the main power switch.
Display/Adj/Set Range		During operation: ACTIVE, At normal termination: OK, At abnormal termination: NG
Related Service Mode		SORTER> FUNCTION> NT-BK-W
PNCH-INT	1	Init punch mtr stop pstn; Fin-AC
Detail		To execute initialization Initialization of punch motor stop reference value.
Use Case		When replacing the punch motor/gear/belt/sensor flag
Adj/Set/Operate Method		1) Select the item, and then press OK key. 2) Turn OFF/ON the main power switch.
Display/Adj/Set Range		During operation: ACTIVE, At normal termination: OK, At abnormal termination: NG

OPTION (Specification setting mode)

SORTER (Service mode for delivery options) > OPTION (Specification setting mode)

MD-SPRTN	1	Restricted operation at Finisher error
Detail	To set whether to stop the machine when an error occurs at Finisher. The result set in [Limited Functions Mode] in [Settings/Registration] is displayed. Set 0 when canceling restriction on operations. When switching whether to restrict operations for each function, make the setting in [Limited Functions Mode].	
Use Case	When canceling restriction on operations of the finisher	
Adj/Set/Operate Method	1) Enter the setting value, and then press OK key. 2) Turn OFF/ON the main power switch.	
Caution	Do not set any value other than 0.	
Display/Adj/Set Range	0 to 255 0: Normal 1: Function restriction 2 to 255: Not use	
Default Value	0	
Additional Functions Mode	Management Settings> Device Management> Limited Functions Mode	
SDL-PRS	1	Set Saddle Stitcher press oprtn: Fin-W
Detail	To set press operation of the Saddle Stitcher. Use this item when a saddle stitched booklet is swollen. If wrinkles occur, make the setting not to perform press operation.	
Use Case	- When wrinkles occur due to press operation in the case that the machine is installed in a high humidity environment or thin paper is used - When saddle stitched booklet is swollen due to poor folding accuracy	
Adj/Set/Operate Method	Enter the setting value, and then press OK key.	
Caution	If wrinkles occur due to press operation, do not execute the operation.	
Display/Adj/Set Range	0 to 5 0: Normal 1: Without press operation 2: Not used 3: Extend press operation time (enabled for booklet with 21 sheets or more) 4: With forcible press operation (enabled for booklet with 9 sheets or less) 5: Without intermittent feed	
Default Value	0	

SORTER (Service mode for delivery options) > OPTION (Specification setting mode)

BUFF-SW	1	Set of fin buffer opertn: Fin-W/X/AC
Detail		To set ON/OFF of buffer operation in the Finisher. Fin-W: Set 1 to 4 when misalignment occurs. When 1 is set, buffer operation is not performed for all jobs. Alignment performance is improved, but productivity is decreased. When 2 is set, buffer operation is not performed only for non-binding job. Since buffer operation is performed for binding jobs, productivity is improved, but alignment performance is decreased. When 3 is set, buffer operation is not performed only for binding jobs. When 4 is set, it is not performed only for binding jobs with coated papers. This item can be also set with DIP switch of the Finisher (with common setting range and setting value). The latest setting value is enabled regardless of service mode/DIP switch. Fin-AC: To prohibit buffer operation performed to increase productivity at collating, stapling and staple-free stapling. Fin-X: When 1 is set, buffer operation is prohibited in staple mode. However, productivity decreases.
Use Case		Fin-W: When misalignment of paper stack occurs (misalignment of 3 sheets at the lowest part of the stack in case of the side stitch, and 3 sheets at the middle of the stack in case of saddle stitch) Fin-AC: When misalignment occurs with paper stack delivered to the Process Tray with buffer operation Fin-X: When misalignment of buffer paper occurs
Adj/Set/Operate Method		Fin-W: 1) Enter the setting value, and then press OK key. 2) Turn OFF/ON the main power switch. Fin-X/AC: Enter the setting value, and then press OK key.
Caution		When the buffer operation is set to OFF, productivity is decreased.
Display/Adj/Set Range		Fin-W: 0 to 4 0: ON, 1: OFF, 2: OFF for non-binding job only, 3: OFF for binding job only, 4: OFF for binding job with coated paper only Fin-AC: 0 to 2 0: ON, 1: OFF, 2: ON only at collating Fin-X: 0 to 1 0: ON, 1: OFF
Default Value		0
TRY-EJCT	1	Delivery control for thin paper: Fin-W
Detail		To set the delivery control (delivery speed) for thin paper. When this setting is made, delivery control for thin paper is applied to all jobs regardless of media. When 1 is set, lifting amount of tray is changed at Lower Tray delivery. When 2 is set, delivery speed is reduced at Upper/Lower Tray delivery. This item can be also set with DIP switch of the Finisher (with common setting range and setting value). The latest setting is enabled regardless of service mode/DIP switch.
Use Case		When the stack failure of thin paper occurs.
Adj/Set/Operate Method		Enter the setting value, and then press OK key.
Display/Adj/Set Range		0 to 1 0: Normal operation, 1: Change the lifting amount of the Lower Tray
Default Value		0

SORTER (Service mode for delivery options) > OPTION (Specification setting mode)

PN-SKEW	1	Position accuracy of punch hole: Fin-W
Detail		To set the accuracy of punch hole when the punch hole is displaced due to paper skew.
Use Case		If the punch hole is displaced by 2 mm (approx) or more and also skew appears on the paper fed to the finisher.
Adj/Set/Operate Method		Enter the setting value, and then press OK key.
Caution		As the greater value is set, skew is corrected more accurately; however, productivity is decreased.
Display/Adj/Set Range		0 to 2 0: Normal mode, 1: skew tolerance increase mode, 2: skew tolerance decrease mode
Default Value		0
CURL-SW	1	Set of curl mode: Fin-W
Detail		To set the delivery speed according to the curl direction (upward/downward curl). To improve the stack failure due to paper curl. The item can be also set with DIP switch of the Finisher (with common setting range and setting value). The latest setting value is enabled regardless of service mode/DIP switch.
Use Case		When stack failure occurs due to paper curl.
Adj/Set/Operate Method		1) Enter the setting value, and then press OK key. 2) Turn OFF/ON the main power switch.
Display/Adj/Set Range		0 to 2 0: Normal operation 1: Upward curl mode setting (accelerate the delivery speed at upper delivery/lower delivery) 2: Downward curl mode setting (decelerate the delivery speed at lower delivery)
Default Value		0
TRY-OVER	1	Setting of tray stack limit: Fin-W
Detail		To set whether to limit the stack capacity of the Upper/Lower Tray. When 1 is set, paper can be stacked beyond the maximum stack capacity. This setting is enabled only when the high volume stack mode is set to ON in Settings/Registration.
Use Case		When stacking the paper beyond the maximum stack capacity of the Tray.
Adj/Set/Operate Method		Enter the setting value, and then press OK key.
Caution		When 1 is set, stacking performance decreases.
Display/Adj/Set Range		0 to 1 0: Normal operation, 1: Clearing limit of stack capacity
Default Value		0
Additional Functions Mode		Function Settings> Common> Paper Output Settings> High Volume Stack Mode
TRM-LMT	1	Set fore edg min trim amnt limit: Fin-X
Detail		According to the number of paper stack and the grammage, whether to set the limit of fore-edge minimum trimming amount of the booklet trimmer.
Use Case		When the fore-edge trimming amount is set to small on the thick paper stack and if trimming failure occurs.
Adj/Set/Operate Method		1) Enter the setting value, and then press OK key. 2) Turn OFF/ON the main power switch.
Caution		The actual trimming amount may be larger than the setting value.
Display/Adj/Set Range		0 to 1 0: Fixed (normal), 1: limited
Default Value		0

SORTER (Service mode for delivery options) > OPTION (Specification setting mode)

PUCH-SW	1	Hi-prdctvty/accrcy punch mod: Fin-X/AC
Detail		To switch the high-productivity punch mode or high-accuracy punch mode of Finisher.
Use Case		When switching the high-productivity punch mode or high-accuracy punch mode
Adj/Set/Operate Method		Select the item, and then press OK key.
Display/Adj/Set Range		0 to 1 0: high-accuracy, 1: high-productivity
Default Value		0
Additional Functions Mode		Adjustment/Maintenance> Adjust Action> Switch Finisher Puncher Mode
Supplement/Memo		The settings of this service mode and the "Switch Finisher Puncher Mode" of the "Settings/Registration" change at the same time.
ALG-IMPR	1	Set Finisher alignment mode: Fin-X
Detail		To set when misalignment occurs at the time of paper feed in the processing tray because the nip pressure of the stack delivery roller is weak.
Use Case		When misalignment occurs in the processing tray at the staple mode on plain paper of small size
Adj/Set/Operate Method		Enter the setting value, and then press OK key.
Display/Adj/Set Range		0 to 20 0: Increase the nip pressure from 50th sheet at 1-sided/2-sided printing. 1: Increase the nip pressure from 30th sheet at 2-sided printing. 2: Increase the nip pressure from 30th sheet at 1-sided/2-sided printing. 3: Increase the nip pressure from the first sheet at 1-sided/2-sided printing. 4: Increase the nip pressure from 50th sheet at 1-sided/2-sided printing. Increase the feed amount to the Process Tray by 3 mm from the first sheet. 5: Increase the nip pressure from 30th sheet at 1-sided/2-sided printing. Increase the feed amount to the Process Tray by 3 mm from the first sheet. 6: Increase the nip pressure from 30th sheet at 2-sided printing. Increase the feed amount to the Process Tray by 3 mm from the first sheet. 7: Increase the nip pressure from the first sheet at 1-sided/2-sided printing. Increase the feed amount to the Process Tray by 3 mm from the first sheet. 8: Increase the nip pressure from 50th sheet at 1-sided/2-sided printing. Increase the feed amount to the Process Tray by 6 mm from the first sheet. 9: Increase the nip pressure from 30th sheet at 1-sided/2-sided printing. Increase the feed amount to the Process Tray by 6 mm from the first sheet. 10: Increase the nip pressure from 30th sheet at 2-sided printing. Increase the feed amount to the Process Tray by 6 mm from the first sheet. 11: Increase the nip pressure from the first sheet at 1-sided/2-sided printing. Increase the feed amount to the Process Tray by 6 mm from the first sheet. 12 to 20: Not used
Default Value		0

SORTER (Service mode for delivery options) > OPTION (Specification setting mode)

1SHT-SRT	1	Set 1-sheet offset+collate: Fin-X/AC
Detail		To set ON/OFF of offset and collate for 1-sheet document. Fin-X: When 1 is set, delivery to the Stack Tray with offset and collate for 1-sheet document is enabled, but the stacking performance is decreased. Fin-AC: When 1 is set, delivery to the Stack Tray with offset and collate for 1-sheet document is disabled.
Use Case		Fin-X: When preferring to execute offset and collate for 1-sheet document Fin-AC: Upon user's request
Adj/Set/Operate Method		Enter the setting value, and then press OK key.
Caution		The stacking condition decreases when the collated delivery operation for a sheet of paper enables. A sheet of paper is delivered by non-sort decreases when the collated delivery operation for a sheet of paper disables.
Display/Adj/Set Range		0 to 1 Fin-X: 0: OFF, 1: ON Fin-AC: 0: ON, 1: OFF
Default Value		0
Additional Functions Mode		Setting/Registration> Function Settings> Common> Paper Output Settings> Offset Jobs
Supplement/Memo		The collated delivery operation for a sheet of paper works in the following condition. The setting of a sheet of paper and a copy This service mode is ON. The job from a printer driver Oddset jobs is ON.
SD-LMTLS	1	Sddl delivery limitless oprtn: Fin-X
Detail		To set ON/OFF of the Finisher Saddle Assembly limitless delivery operation. When 1 is set, "stack over" does not occur and saddle operation can be performed continuously, but the stacking condition decreases.
Use Case		When preferring to perform saddle operation continuously
Adj/Set/Operate Method		Enter the setting value, and then press OK key.
Caution		When limitless operation is set to ON, the saddle stacking condition decreases.
Display/Adj/Set Range		0 to 1 0: OFF, 1: ON
Default Value		0

SORTER (Service mode for delivery options) > OPTION (Specification setting mode)

SD-STCNB	1	Sddl delivery stack quantity: Fin-X
Detail		To increase the number of sets to be stacked to the Saddle Finisher. When 1 is set, the number of sets to be stacked to the Saddle Finisher is increased.
Use Case		When preferring to increase the number of sets to be stacked to the Saddle Finisher
Adj/Set/Operate Method		Enter the setting value, and then press OK key.
Display/Adj/Set Range		0 to 1 0: Common to small/large sizes 17 to 20 sheets booklet: 5 sets, 11 to 16 sheets booklet: 10 sets, 6 to 10 sheets booklet: 15 sets, 1 to 5 sheets booklet: 25 sets 1: <Small size> 17 to 20 sheets booklet: 20 sets, 11 to 16 sheets booklet: 30 sets, 6 to 10 sheets booklet: 40 sets, 1 to 5 sheets booklet: 50 sets <Large size> 17 to 20 sheets booklet: 10 sets, 11 to 16 sheets booklet: 20 sets, 6 to 10 sheets booklet: 30 sets, 1 to 5 sheets booklet: 40 sets
Default Value		0
BUFF-THK	1	Set buffer oprtn for heavy paper: Fin-X
Detail		To set ON/OFF of buffer operation for heavy paper (181 to 220 g/m ²). When 1 is set, productivity of collate and staple mode of Finisher is increased, but stacking performance may be decreased.
Use Case		When improving productivity of collate and staple mode for heavy paper (181 to 220 g/m ²)
Adj/Set/Operate Method		Enter the setting value, and then press OK key.
Caution		When improving productivity, the stacking condition may decrease.
Display/Adj/Set Range		0 to 1 0: OFF, 1: ON
Default Value		0
Related Service Mode		SORTER> OPTION> PRD-PRTY
PRCS-SP1	1	For R&D
PRCS-SP2	1	Set stack SPD at heavy ppr staple:Fin-X
Detail		Speed is normally decreased when stacking heavy paper (181 g/m ² or more) on the Process Tray of the Finisher. When 1 is set, stacking speed in staple mode does not decrease so that productivity is increased, but stacking performance may be decreased.
Use Case		When increasing productivity in staple mode for heavy paper (181 g/m ² or more)
Adj/Set/Operate Method		Enter the setting value, and then press OK key.
Caution		When improving productivity, the stacking condition may decrease.
Display/Adj/Set Range		0 to 1 0: Speed is decreased, 1: Speed is not decreased
Default Value		0
Related Service Mode		SORTER> OPTION> PRD-PRTY
BUFF-MX1	1	For R&D

SORTER (Service mode for delivery options) > OPTION (Specification setting mode)

BUFF-MX2	1	Set buffer at mix weight staple: Fin-X
Detail		To set ON/OFF of buffer operation when mixing papers which weights are different. When 1 is set, productivity of staple mode of Finisher is improved, but the stacking condition decreases.
Use Case		When improving productivity of staple mode in the case of mixing papers which weights are different
Adj/Set/Operate Method		Enter the setting value, and then press OK key.
Caution		When improving productivity, the stacking condition may decrease.
Display/Adj/Set Range		0 to 1 0: OFF, 1: ON
Default Value		0
Related Service Mode		SORTER> OPTION> PRD-PRTY
PRCS-MX1	1	Set stck SPD at mix ppr type sort:Fin-X
Detail		The speed is decreased when stacking papers on the Finisher Process Tray in the case of mixing papers which the paper types (paper weight or paper material) differ. When 1 is set, the stacking speed at sort mode does not decrease and productivity is improved, but the stacking condition may decrease.
Use Case		When improving productivity of sort mode in the case of mixing papers which the paper types differ
Adj/Set/Operate Method		Enter the setting value, and then press OK key.
Caution		When improving productivity, the stacking condition may decrease.
Display/Adj/Set Range		0 to 1 0: Speed is decreased, 1: Speed is not decreased
Default Value		0
PRCS-MX2	1	Stck SPD at mix ppr sort/staple:Fin-X
Detail		The speed is decreased when stacking papers on the Finisher Process Tray in the case of mixing papers which the paper types (paper weight or paper material) differ. When 1 is set, the stacking speed at sort and staple mode does not decrease and productivity is improved, but the stacking condition may decrease.
Use Case		When improving productivity of sort and staple mode in the case of mixing papers which paper types differ
Adj/Set/Operate Method		Enter the setting value, and then press OK key.
Caution		When improving productivity, the stacking condition may decrease.
Display/Adj/Set Range		0 to 1 0: Speed is decreased, 1: Speed is not decreased
Default Value		0
Related Service Mode		SORTER> OPTION> PRD-PRTY
BUF-THK1	1	Set No. of bffr for pln3/hvy ppr: Fin-X
Detail		To set the number of plain paper 3 (91 to 105 g/m ²) and heavy paper 1 to 4 (106 to 180 g/m ²) for buffer. When 1 is set, productivity of staple mode of Finisher is improved.
Use Case		When prioritizing productivity of staple mode of Finisher using plain paper 3 and heavy paper 1 to 4
Adj/Set/Operate Method		Enter the setting value, and then press OK key.
Display/Adj/Set Range		0 to 1 0: 2 sheets, 1: 3 sheets
Default Value		0
Related Service Mode		SORTER> OPTION> PRD-PRTY

SORTER (Service mode for delivery options) > OPTION (Specification setting mode)

PRD-PRTY	1	Prdctvty prrty btch at sort/stpl: Fin-X
Detail		To simultaneously set productivity priority for BUFF-THK, PRCS-SP2, BUFF-MX2, PRCS-MX2, and BUF-THK1. But each setting value does not change. When 1 is set, productivity of sort and staple mode of Finisher's corresponding items is improved.
Use Case		When prioritizing productivity of sort and staple mode of Finisher
Adj/Set/Operate Method		Enter the setting value, and then press OK key.
Display/Adj/Set Range		0 to 1 0: Normal mode, 1: Productivity priority mode
Default Value		0
Related Service Mode		SORTER> OPTION> BUFF-THK/MX2, PRCS-SP2/MX2, BUF-THK1
FIN-SP1	2	Finisher special setting 1: Fin-W/V
Detail		To execute the Finisher special settings 1.
Adj/Set/Operate Method		1) Enter the setting value, and then press OK key. 2) Turn OFF/ON the main power switch.
Caution		Take necessary action in accordance with the instructions from the Quality Support Division.
Display/Adj/Set Range		00000000 to 11111111
Default Value		00000000
FIN-SP2	2	Finisher special settings 2: Fin-W/V
Detail		To execute the Finisher special settings 2.
Adj/Set/Operate Method		1) Enter the setting value, and then press OK key. 2) Turn OFF/ON the main power switch.
Caution		Take necessary action in accordance with the instructions from the Quality Support Division.
Display/Adj/Set Range		00000000 to 11111111
Default Value		00000000
SLD-BCK	1	Setting of bleed-thru prev mode: Fin-X
Detail		When the back of the coated paper as the cover is soiled, set 1/2. Value "1" is set as usual. Setting value will be changed to "2"when the alignment in Processing Tray is poor with the value "1".
Use Case		When the back of paper is soiled while coated paper is used as cover
Adj/Set/Operate Method		Enter the setting value, and then press OK key.
Display/Adj/Set Range		0 to 2 0: OFF 1: Receive buffer paper by lifting the Paper Return Roller 2: Receive buffer paper by lowering the Paper Return Roller
Default Value		0
NSRT-STC	1	Set stack improve mode: non-sort, Fin-AC
Detail		To set stack improvement mode when non-collate is set to the Stack Tray (Tray C). When 1 is set, paper stack is delivered at the center reference via the Process Tray even if it is non-collate mode so the stacking condition can be improved.
Use Case		When the stacking condition is low while non-collate is set to the Stack Tray (Tray C)
Adj/Set/Operate Method		Enter the setting value, and then press OK key.
Caution		When 1 is set: - Productivity is decreased. - In the case of the paper type or the paper size that cannot feed via a processing tray , paper is delivered by non-sort.
Display/Adj/Set Range		0 to 1 0: OFF, 1: ON
Default Value		0

SORTER (Service mode for delivery options) > OPTION (Specification setting mode)

STP-MAX	1	Set max No. of sht for staple: Fin-W
Detail		To set the maximum number of sheets to be stapled in the Finisher.
Use Case		- Upon user's request (to increase the number of sheets to be stapled) - When decreasing the number of sheets to be stapled at the time of staple failure occurrence due to the paper type or use environment
Adj/Set/Operate Method		1) Enter the setting value, and then press OK key. 2) Turn OFF/ON the main power switch.
Caution		If the setting value is larger than the default (upper limit on the specification), staple failure may occur.
Display/Adj/Set Range		2 to 200
Default Value		100
SDL-MAX	1	Set max No. of sht for staple: Fin-W
Detail		To set the maximum number of sheets to be stapled in the Saddle Finisher.
Use Case		- Upon user's request (to increase the number of sheets to be stapled) - When decreasing the number of sheets to be stapled at the time of staple failure occurrence due to the paper type or use environment
Adj/Set/Operate Method		1) Enter the setting value, and then press OK key. 2) Turn OFF/ON the main power switch.
Caution		If the setting value is larger than the default (upper limit on the specification), staple failure may occur.
Display/Adj/Set Range		2 to 50
Default Value		25
VFLD-MAX	1	Set Saddle V-fold max No. of sht: Fin-W
Detail		To set the maximum number of sheets to be folded in V-shape in the Saddle.
Use Case		Upon user's request (to increase the number of sheets to be folded in V-shape in the Saddle)
Adj/Set/Operate Method		Enter the setting value, and then press OK key.
Caution		If the setting value is larger than the default (upper limit on the specification), Saddle V-fold failure may occur.
Display/Adj/Set Range		1 to 50
Default Value		5
NEAT-MIX	1	ON/OFF mixed ppr width at delvry: Fin-W
Detail		To set whether to switch the delivery destination of papers whose widths are different. When 1 is set, papers whose widths are different are delivered to different trays. If all trays are in use, message prompting to remove papers appears.
Use Case		When not mixing papers whose widths are different on a tray
Adj/Set/Operate Method		Enter the setting value, and then press OK key.
Display/Adj/Set Range		0 to 1 0: Permit mixed paper, 1: Switch the delivery destination
Default Value		0

SORTER (Service mode for delivery options) > OPTION (Specification setting mode)

NEAT-SW	1	Ppr align cndtn:ppr dvry: Fin-W/AC
Detail	Fin-W: To set the conditions for performing paper alignment when delivering papers which widths are different. When the specified condition (paper type) is satisfied while NEAT-MIX is 1, paper alignment is performed. Fin-AC: To set the conditions for performing the neat alignment at the paper delivery.	
Use Case	Fin-W: When performing paper alignment with a specific paper type (neat alignment) Fin-AC: When the neat alignment is not performed	
Adj/Set/Operate Method	Enter the setting value, and then press OK key.	
Display/Adj/Set Range	Fin-W: 0 to 2 0: When paper widths are different, when offsetting 6 or more sheets of Z-fold paper, when offsetting certain custom paper 1: When paper widths are different 2: Always Fin-AC: 0 to 1 0: The neat alignment is not performed when the original consists of mixed width. 1: The neat alignment is not performed.	
Default Value	0	
Related Service Mode	Fin-W: SORTER> OPTION> NEAT-MIX	
TRM-CNT	1	Set of number of trim: Fore Edge Trimmer
Detail	To set the number of trimming by the Fore Edge Trimmer.	
Use Case	When preferring to perform trimming precisely	
Adj/Set/Operate Method	Enter the setting value, and then press OK key.	
Caution	In case of performing trimming twice, productivity may decrease.	
Display/Adj/Set Range	0 to 2 0: 1 time, 1: 2 times (1 time if productivity decreases), 2: 2 times	
Default Value	0	
THN-SW	1	Dvry Tr thn ppr stk cpcty incr: Fin-X
Detail	To set whether to increase the stack capacity for thin paper on the Delivery Tray. - When not collating small size thin paper When 1 is set, the stack capacity is changed from the number of large size sheets to be stacked to the number of small size sheets (approx. 2400 sheets) to be stacked.	
Use Case	Upon user's request (to increase the stack capacity of thin paper)	
Adj/Set/Operate Method	Enter the setting value, and then press OK key.	
Display/Adj/Set Range	0 to 1 0: OFF, 1: ON	
Default Value	0	
THN-STK	1	Set thin ppr stack mthd:Low Tray, Fin-W
Detail	To set the method for stacking thin papers on the Lower Tray. When 1 is set, the method is changed from normal delivery to the delivery method with which papers are delivered as a paper stack so stacking condition improves.	
Use Case	Upon user's request (to improve stacking condition of thin papers on the Lower Tray)	
Adj/Set/Operate Method	Enter the setting value, and then press OK key.	
Display/Adj/Set Range	0 to 1 0: Normal delivery method, 1: Stack delivery method	
Default Value	0	

SORTER (Service mode for delivery options) > OPTION (Specification setting mode)

MSTP-TMG	1	Set of manual staple timing: Fin-AC
Detail	To set the duration of time before executing automatic stapling at manual staple mode. As the value is changed by 1, the time is changed by 1 second. +: Timing is delayed -: Timing becomes earlier	
Use Case	Upon user's request	
Adj/Set/Operate Method	Enter the setting value, and then press OK key.	
Display/Adj/Set Range	1 to 5	
Unit	sec	
Default Value	3	
Additional Functions Mode	Adjustment/Maintenance> Adjust Action> Time Until Stapling Starts in Stapler Mode	
Supplement/Memo	The settings of this service mode and the "Time Until Stapling Starts in Stapler Mode" of the "Settings/Registration" change at the same time.	
Amount of Change per Unit	1	
PUN-Y-SW	1	Setting of punch horz reg oprtn: Fin-AC
Detail	To set whether or not to perform the horizontal registration operation of puncher unit for matching with the center of the paper.	
Use Case	When the adjustable range of the punch hole horizontal registration adjustment (PNCH-Y) is enlarged.	
Adj/Set/Operate Method	Enter the setting value, and then press OK key.	
Caution	When a punch hole position precision improvement mode was set, this mode is given priority to.	
Display/Adj/Set Range	0 to 1 0: The horizontal registration operation is performed. 1: The horizontal registration operation is not performed. (fixed in the center position)	
Default Value	0	
Related Service Mode	SORTER> ADJUST> PNCH-Y SORTER> OPTION> PNCH-SW3	
PNCH-SW2	1	Setting of punch hole spec: Fin-AC
Detail	To set the punch hole specification of puncher unit.	
Use Case	When replacing the Puncher Unit	
Adj/Set/Operate Method	1) Enter the setting value, and then press OK key. 2) Turn OFF/ON the main power switch.	
Display/Adj/Set Range	0: 2/4 holes puncher unit 1: 2/3 holes puncher unit 2: SWE 4 holes puncher unit	
Default Value	0	
PNCH-SW3	1	Set punch hole hi precision mode: Fin-AC
Detail	To set ON/OFF of the mode to improve the precision of the punch hole position. When 1 is set, the punch hole position is decided by the paper trailing edge standard.	
Use Case	When the position of the punch hole is misaligned	
Adj/Set/Operate Method	Enter the setting value, and then press OK key.	
Caution	- When ON is set, productivity is decreased. - This mode is enabled only when precision priority is set for punch mode.	
Display/Adj/Set Range	0 to 1 0: OFF, 1: ON	
Default Value	0	
Related Service Mode	SORTER> OPTION> PUCH-SW, PUN-Y-SW	
Additional Functions Mode	Adjustment/Maintenance> Adjust Action> Switch Finisher Puncher Mode	

SORTER (Service mode for delivery options) > OPTION (Specification setting mode)

SFT-CHNG	1	Set dvry number of stck ppr: Fin-AC
Detail	To change the number of small size papers to be delivered as a stack in offset and collate mode. When 1 is set, the number of sheets to be delivered as a stack in offset and collate mode is changed from 5 sheets to 2 sheets.(However, it is not changed when delivering paper with a weight of 91 g/m2 or more or tab paper.)	
Use Case	When improving stacking performance at the time of offsetting and collating paper other than paper with a weight of 91 g/m2 or more and tab paper	
Adj/Set/Operate Method	Enter the setting value, and then press OK key.	
Display/Adj/Set Range	0 to 1 0: OFF, 1: ON	
Default Value	1	
STP-ALG	1	Set align plate oprtn at stpl mod:Fin-AC
Detail	To set the operation of alignment plates at staple mode and staple-free binding mode. Set to 1 when the alignment operation by the alignment plates is changed from one time to two times at the staple mode and staple-free binding mode.	
Use Case	When improving the alignment (front/rear) of the paper at staple mode	
Adj/Set/Operate Method	Enter the setting value, and then press OK key.	
Caution	When setting to ON, productivity is decreased.	
Display/Adj/Set Range	0 to 1 0: OFF, 1: ON	
Default Value	0	
SDL-ALG	1	Set paddle oprtn in sddl unit: Fin-AC
Detail	To set the paddle operation when stacking the paper in the saddle stitcher unit. Set to 1 when the paddle operation of the last stack paper in the saddle stitcher unit is changed from one rotation to two rotations.	
Use Case	When improving the paper alignment of the feed direction at stacking the paper in the saddle stitcher unit	
Adj/Set/Operate Method	Enter the setting value, and then press OK key.	
Caution	When setting to ON, productivity is decreased.	
Display/Adj/Set Range	0 to 1 0: OFF, 1: ON	
Default Value	0	
SDL-FLD	1	Set number of saddle folds: Fin-X
Detail	To set the number of saddle folds by the Saddle Stitcher. Set 1 when the crease is soiled caused by saddle folding. Set 2 when the crease is weak.	
Use Case	- When the crease is soiled - When the crease is weak	
Adj/Set/Operate Method	1) Enter the setting value, and then press OK key. 2) Turn OFF/ON the main power switch.	
Display/Adj/Set Range	0 to 2 0: 1 time or 2 times (by combination of the paper size and the number of sheets), 1: 1 time, 2: 2 times	
Default Value	0	

SORTER (Service mode for delivery options) > OPTION (Specification setting mode)

TRY-STP	1	Stpl/fold stck limit clear: Fin-W/X/AC
Detail		To set whether to limit the stack capacity of the stapled copies/folded sheets. When clearing the limit, the tray height limit is applied instead.
Use Case		When stacking papers beyond the maximum number of stapled copies/folded sheets
Adj/Set/Operate Method		Enter the setting value, and then press OK key.
Caution		When the stacking limit is cleared, stacking capacity increases, but stacking performance decreases.
Display/Adj/Set Range		0 to 3 0: Normal specification 1: Clear the limit of stack capacity of the stapled copies, and apply the tray height limit 2: Clear the limit of stack capacity of the folded sheets, and apply the tray height limit 3: Clear the limit of stack capacity of both the stapled copies and folded sheets, and apply the tray height limit
Default Value		0
TRY-LMT	1	Set stack limit of stack tray: Fin-AC
Detail		To set whether to limit the stack capacity of the stack tray. Set to 1 when the stack capacity of the stack tray for the small size paper except the thin paper and coated paper is changed from about 3,000 sheets to about 2,000 sheets.
Use Case		When the stacking performance decreases by the curled paper during stacking a large amount of the small size paper except the thin paper and coated paper
Adj/Set/Operate Method		Enter the setting value, and then press OK key.
Display/Adj/Set Range		0 to 1 0: OFF, 1: ON
Default Value		0
NEAT-CRL	1	Set curl at the neat stck prrty: Fin-AC
Detail		To set the paper curl type while NEAT-ALN is 1. When 1 or 2 is set, the operation is changed as shown below. - The timing of the paddle descent and alignment start become late. - The neat alignment movement is changed from one time to two times
Use Case		When the delivered paper is excessive curl and the paper alignment is poor
Adj/Set/Operate Method		Enter the setting value, and then press OK key.
Caution		When 1 or 2 is set, productivity is decreased
Display/Adj/Set Range		0 to 2 0: No curl 1: Upward curl 2: Downward curl
Default Value		0
Related Service Mode		SORTER > OPTION > NEAT-ALN
Additional Functions Mode		Adjustment/Maintenance> Adjust Action> Finisher Output Priority Settings

SORTER (Service mode for delivery options) > OPTION (Specification setting mode)

NEAT-ALN	1	Set of neat stack priority mode: Fin-AC
Detail	To set ON/OFF of neat stack accuracy priority mode As the value is changed by 1, the stack accuracy improves to reduce the number of sheets in the paper stack at the stack delivery.	
Use Case	When the stack accuracy is prioritized	
Adj/Set/Operate Method	Enter the setting value and press OK key.	
Caution	When 1 is set, productivity is decreased.	
Display/Adj/Set Range	0 to 1 0: Productivity priority 1: Alignment priority	
Default Value	0	
Additional Functions Mode	Adjustment/Maintenance> Adjust Action> Finisher Output Priority Settings	

BOARD (Option board setting mode)

OPTION (Specification setting mode)

BOARD (Option board setting mode) > OPTION (Specification setting mode)

MENU-1	2	Hide/dspl of printer set menu level 1
Detail	To set whether to display or hide the level 1 of printer setting menu.	
Use Case	Upon user's request	
Adj/Set/Operate Method	1) Enter the setting value, and then press OK key. 2) Turn OFF/ON the main power switch.	
Display/Adj/Set Range	0 to 1 0: Hide, 1: Display	
Default Value	0	
MENU-2	2	Hide/dspl of printer set menu level 2
Detail	To set whether to display or hide the level 2 of printer setting menu.	
Use Case	Upon user's request	
Adj/Set/Operate Method	1) Enter the setting value, and then press OK key. 2) Turn OFF/ON the main power switch.	
Display/Adj/Set Range	0 to 1 0: Hide, 1: Display	
Default Value	0	
MENU-3	2	Hide/dspl of printer set menu level 3
Detail	To set whether to display or hide the level 3 of printer setting menu.	
Use Case	Upon user's request	
Adj/Set/Operate Method	1) Enter the setting value, and then press OK key. 2) Turn OFF/ON the main power switch.	
Display/Adj/Set Range	0 to 1 0: Hide, 1: Display	
Default Value	0	
MENU-4	2	Hide/dspl of printer set menu level 4
Detail	To set whether to display or hide the level 4 of printer setting menu.	
Use Case	Upon user's request	
Adj/Set/Operate Method	1) Enter the setting value, and then press OK key. 2) Turn OFF/ON the main power switch.	
Display/Adj/Set Range	0 to 1 0: Hide, 1: Display	
Default Value	0	

FAX (Service Mode for FAX)

Overview

■ Configuration of the Service Mode

Service mode is divided into the following 10 items (#1 to #10).

Item	Name	Description
#1 SSSW	Service software switch	This can be used to conduct the registration/settings relating to basic functions of the fax, such as error management, echo prevention and prevention of communication problems.
#2 MENU	Menu switch setting	This can be used to conduct the registration/settings relating to the required functions at installation, such as NL equalizer, transmission level.
#3 NUMERIC Param.	Setting of numeric parameters	This can be used to enter numeric parameters.
#4 NCU	(Adjustment by a service technician is not possible.)	The values of this item are collectively set based on the setting of #5 TYPE.
#5 TYPE	Country/region setting	If the item "STANDARD" displayed on the display is set, #4 NCU data is collectively set to comply with the communication standards in Japan.
#6 IPFAX	Communication settings of IPFAX	If the license option for IPFAX has been enabled, IPFAX is displayed.
#7 PRINT	Printer function setting	This can be used to conduct the registration/settings relating to the printer basic service functions, such as size reduction conditions for received images.
#8 CLEAR	Data initialization mode setting	This item is to initialize each data.
#9 TEST	Test Mode	To execute various tests.
#10 REPORT	Service Report	To execute report print.

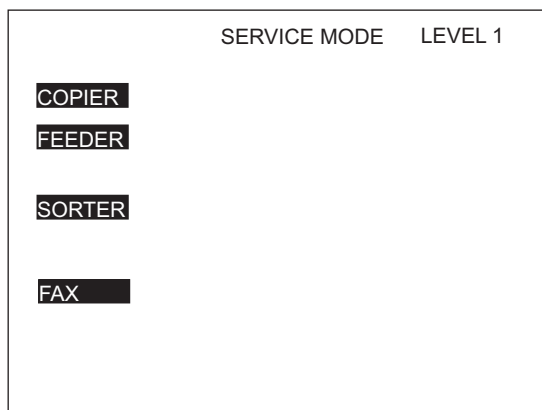
CAUTION:

If a 2nd line fax option is installed, IPFAX cannot be used.

■ Operation method

1. Enter service mode.

2. When the connected options (FEEDER, SORTER, FAX, BOARD) are displayed, select FAX and enter service mode of this board.



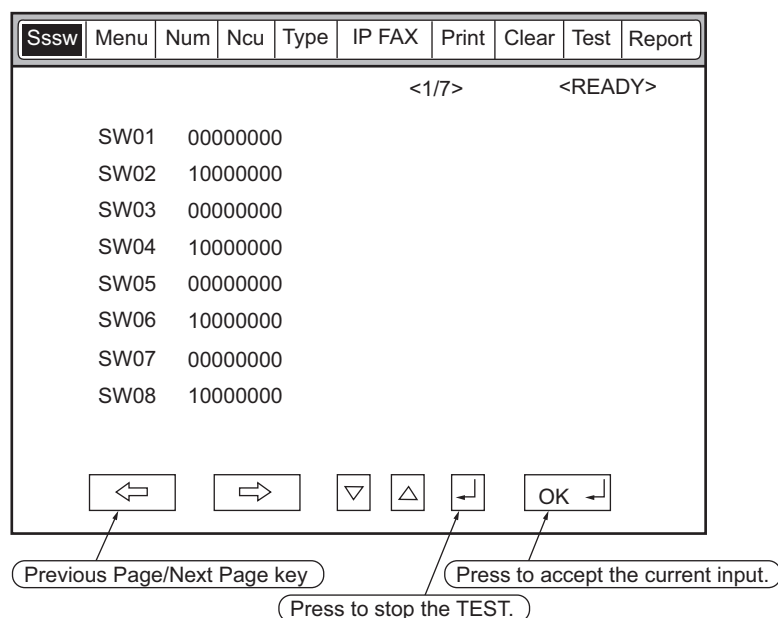
COPIER: Service mode of the connected equipment

FEEDER: Service mode of the ADF (*)

SORTER: Service mode of the Finisher (*)

FAX: Service mode of the fax (*)

The following explains the operation method using the #1 SSSW screen as an example. The meaning of the keys and operations are common for all screens.



- When changing the setting of the bit switch, directly press the bit (numeric value) you want to change.
- To enter a numeric value, use the numeric keypad.
- When confirming a change in a numeric value or when executing an item, press the [OK] key.
- To return to the previous layer, use the [Reset] key.

CAUTION:

When changing the service mode settings, turn OFF and then ON the power.

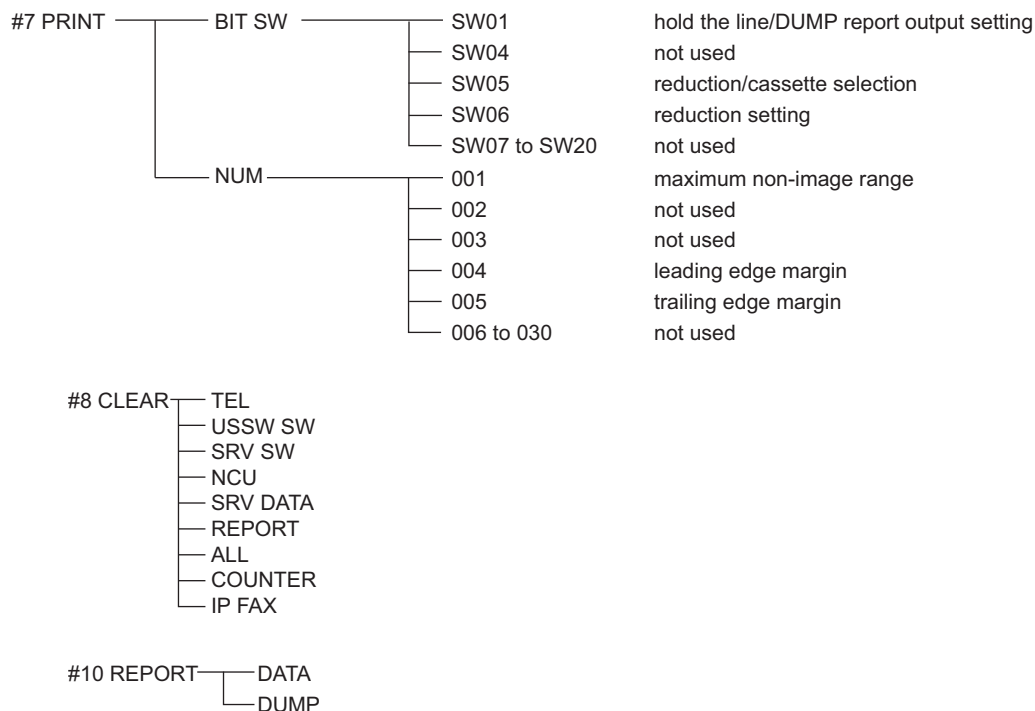
The details of settings in service mode are stored in the storage of the host machine. The settings for this board are enabled by loading the settings stored in the storage of the host machine to the G3 Fax Control PCB when the main power is turned ON. Therefore, be sure to turn OFF and then ON the power when the settings have been changed.

■ Menu List

#1 SSSW	SW01	error management
	SW02	Not used
	SW03	set remedy against echo
	SW04	set remedy against communication error
	SW05	set standard function <DIS signal>
	SW06 to SW08	Not used
	SW09	set communication result display
	SW10 to SW11	Not used
	SW12	set page timer
	SW13	Display of the screen Settings
	SW14	Inch/mm resolution settings
	SW15	Not used
	SW17	Transmission level setting of modem
	SW18	The control of IP supported communication setting
	SW19 to SW21	Not used
	SW22	Settings of archive send function
	SW23 to SW24	Not used
	SW25	set report display function
	SW26	set transmission function
	SW27	Not used
	SW28	set V. 8/V. 34
	SW29	Not used
	SW30	Dial tone detection method switching
	SW31 to SW50	Not used

#2 MENU	001 to 004	Not used
	005	NL equalizer
	006	line monitor
	007	transmission level (ATT)
	008	V.34 modulation speed upper limit
	009	V.34 data speed upper limit
	010 to 020	Not used

#3 NUM	001	not used
	002	RTN transmission condition (1)
	003	RTN transmission condition (2)
	004	RTN transmission condition (3)
	005	NCC pause time (before ID code)
	006	NCC pause time (after ID code)
	007	pre-pulse time at time of call
	008	not used
	009	number of characters in telephone numbers between transmitting and receiving parties.
	010	line connection identification time
	011	T.30 T1 timer (for reception)
	012	not used
	013	T.30 EOL timer
	014	not used
	015	hooking detection time
	016	Time until a temporary response is obtained when switching FAX/TEL
	017	Pseudo RBT signal pattern ON time
	018	Pseudo RBT signal pattern ON time (short)
	019	Pseudo RBT signal pattern OFF time (long)
	020	Pseudo CI signal pattern ON time
	021	Pseudo CI signal pattern OFF time (short)
	022	Pseudo CI signal pattern OFF (long)
	023	CNG detection level when switching FAX/TEL
	024	Pseudo RBT transmission level when switching FAX/TEL
	025	CNG monitoring time when the answering phone connection function is set
	026	Silent detection level when the answering phone connection function is set
	027	preamble detection time for V.21 low-speed flag
	028	Off-hook PCB duty settings
	029-80	not used



Setting of Bit Switch (SSSW)

Bit Switch Composition

The registration/setup items of the switch are set according to the positions of its 8 bits; the bit switch shown on the display is as follows, each bit being either 0 or 1:

	Bit 7									Bit 0
SW01	0	0	0	0	0	0	0	0	0	0

CAUTION:

Do not change service data identified as "not used"; they are set as initial settings.

Sssw	Menu	Num	Ncu	Type	IP FAX	Print	Clear	Test	Report
					<1/7>	<READY>			
SW01	0	0	0	0	0	0	0	0	0
SW02	1	0	0	0	0	0	0	0	0
SW03	0	0	0	0	0	0	0	0	0
SW04	1	0	0	0	0	0	0	0	0
SW05	0	0	0	0	0	0	0	0	0
SW06	1	0	0	0	0	0	0	0	0
SW07	0	0	0	0	0	0	0	0	0
SW08	1	0	0	0	0	0	0	0	0

←
→
▽
△
↩
OK ↩

• SSSW-SW01

Functional Construction

Bit	Function	1	0
0	Error codes for service technician	Output	Do not output
1	Error dump list	Output	Do not output
2	Not used	-	-
3	Not used	-	-
4	Display service error codes in the ##300 series	Display	Do not display
5	Increase the capacity of SUBLOG for USBFAX2	Increase	Do not increase
6	Not used	-	-
7	Cancel prohibition of user setting collectively	Cancel	Do not cancel

Details of Bit 0

Select whether to output service error codes.

When "Output" is selected, service error codes will be on the display and on the report.

Detailed Discussions of Bit 1

Select whether to output error dump list.

When "Output" is selected, the error transmission report and the reception result report at the time of occurrence of an error are output with the error dump list attached.

Detailed Discussions of Bit 4

Select whether to display service error codes in the ##300 series.

Detailed Discussions of Bit 5

Select whether to increase the log storage area when firmware automatic update function of USBFAX2 (a modem with Silicone Labs modem mounted version) is used.

Detailed Discussions of Bit 7

Select whether to collectively cancel the prohibition of user settings.

• SSSW-SW02

Functional Construction

Bit	Function	1	0
0	Not used	-	-
1	Not used	-	-
2	Not used	-	-
3	Not used	-	-
4	To prohibit control channel retrain during V.34	Prohibit	Do not prohibit
5	Not used	-	-
6	Not used	-	-
7	F-NET service without ring tone	Supported	Not supported

Detailed Discussions of Bit 4

Select whether to prohibit the control channel retrain during V.34.

Detailed Discussions of Bit 7

Select whether to support F-NET (fax communication network) service without a ring tone.

If "Supported" is selected, fax document will be automatically received without a ring tone when FC signal (1300 Hz tonal signal) from F-NET is detected.

• SSSW-SW03

Functional Construction

Bit	Function	1	0
0	Not used	-	-
1	Echo protect tone at high speed transmission	Send	Do not send

Bit	Function	1	0
2	Not used	-	-
3	Not used	-	-
4	Transmission mode: International transmission (1)	Yes	No
5	Transmission mode: International transmission (3)	Yes	No
6	Send mode	International transmission (3)	International transmission (2)
7	Tonal signal before sending CED signal	Send	Do not send

Detailed Discussions of Bit 1

Use it to enable/disable sending an echo protect tone for a high-speed transmission V.29 modem signal (transmission speed at 9600 or 7200 bps).

If errors occur frequently at time of sending fax because of the condition of the line, select "Send". Selecting "send" sends non-modulated carrier for about 200 ms as the synchronous signal before sending images.

NOTE:

Error codes caused by line condition when sending fax
##100, ##104, ##281, ##282, ##283, ##750, ##755, ##760, ##765

Detailed Discussions of Bits 4, 5 and 6

Transmission mode: Selected to use whether international transmission (1), international transmission (2) or international transmission (3).

Use these switches or the dial registration to select a transmission mode if errors occur frequently at time when sending fax overseas.

NOTE:

Error codes caused by echoes at time of sending fax
#005, ##100, ##101, ##102, ##104, ##201, ##280, ##281, ##283, ##284, ##750, ##760, ##765, ##774, ##779, ##784, ##794

Settings using the Dial Registration (user level):

Select "international transmission (1)" when making an entry in the address book. If errors persist, select "international transmission (2)" and then "international transmission (3)".

Transmission mode selected using One-Touch Dial function or the Speed Dial function will be given priority over the setting made by the service soft switch.

An international transmission mode may be selected using the keypad if a mode has been selected using this switch; for settings, see the following table:

Transmission mode	Bit7	Bit6	Bit5	Bit4	Bit3	Bit2	Bit1	Bit0
International transmission (1)	*	0	0	1	-	-	*	-
International transmission (2)	*	0	1	0	-	-	*	-
International transmission (3)	*	1	1	0	-	-	*	-

International transmission (1): Selected to ignore the first DIS signal from the other party.

International transmission (2): Selected to transmit a 1850-Hz total signal when transmitting the DIS signal.

International transmission (3): Selected to transmit a 1650-Hz total signal when transmitting the DIS signal.

Detailed Discussions of Bit 7

Select whether to enable/disable sending of a 1080-Hz tonal signal before sending CED signal.

Select "Send" if errors occur frequently because of an echo when reception is from overseas.

NOTE:

Error codes caused by echoes at the time of reception
#005, ##101, ##106, ##107, ##114, ##200, ##201, ##790

• SSSW-SW04

Functional Construction

Bit	Function	1	0
0	LC monitoring	Monitor	Do not monitor
1	Check the CI signal frequency	Check	Do not checked
2	Final flag sequences of the procedure signal	2 pcs	1 piece
3	Reception mode after sending CFR signal	High speed	High speed/low speed
4	Time to ignore low-speed signals after sending CFR signal	1500 msec	700 msec
5	Check the CS signal frequency (when PBX is set)	Check	Do not check
6	CNG signal at the time of manual sending	Send	Do not send
7	CED signal at the time of manual reception	Send	Do not send

Detailed Discussions of Bit 1

Select whether to check the CI signal frequency.

Detailed Discussions of Bit 2

Select the number of the final flag sequences with the procedure signal (300 bps transmission speed).
Select "2" when the other party's machine does not properly receive the procedure signal sent by this machine.

NOTE:

Error codes occurring at the time of sending fax

##100, ##280, ##281, ##750, ##753, ##754, ##755, ##758, ##759, ##760, ##763, ##764, ##765, ##768, ##769, ##770, ##773, ##775, ##778, ##780, ##783, ##785, ##788

Detailed Discussions of Bit 3

Select a reception mode after sending CFR signal.

Select "High speed" in the case of frequent errors caused by line condition at the time of reception. Simultaneously, turn "OFF" the "ECM reception" of the user data.

NOTE:

Error codes caused by line condition at the time of reception

##107, ##114, ##201

Be sure to change bit 4 before changing this bit; if errors still occur, change this bit.

When 'high speed' is selected, only high-speed signals (images) will be received after sending the CFR signal.

Detailed Discussions of Bit 4

Select the time length during which low-speed signals are ignored after sending the CFR signal.

Select "1500 msec" when reception of image signal is difficult because the line condition is not good.

Detailed Discussions of Bit 5

Select whether to check the CI signal frequency when PBX is set.

Detailed Discussions of Bit 6

Select whether to send CNG signal at the time of manual sending.

If error occurs frequently at manual sending when the destination device that has FAX/TEL switch mode does not change to the fax mode, select "Send".

Detailed Discussions of Bit 7

Select whether to send CED signal at the time of manual reception.

Select "Send" when the other party's machine does not start sending although manual reception is executed.

• SSSW-SW05

Functional Construction

Bit	Function	1	0
0	Not used	-	-
1	To execute mm/inch conversion (text mode).	Yes	No
2	Not used	-	-

Bit	Function	1	0
3	To send bit 33 or later of DIS signal.	Prohibit	Do not prohibit
4	Record paper length to be declared by DIS signal	A4/B4 size	Any size
5	Not used	-	-
6	Not used	-	-
7	Not used	-	-

Detailed Discussions of Bit 1

Execute mm/inch conversion for the image scanned in text mode.

Detailed Discussions of Bit 3

Select whether to send bit 33 or later of DIS signal.

CAUTION:

If "Prohibit" is selected, the super-fine reception from other brand printers or memory box function will be disabled.

Detailed Discussions of Bit 4

Select whether the paper to be declared by DIS signal is a cut paper.

Select "A4/B4 size" if dividing the original at the sending machine side at the time of receiving a long original.

NOTE:

Depending on the model of sending machine, long originals may not be divided.

• SSSW-SW09

Functional Construction

Bit	Function	1	0
0	Communication result at normal completion	Display	Do not display
1	Communication result at completion with an error	Display	Do not display
2	Not used	-	-
3	Not used	-	-
4	Not used	-	-
5	Not used	-	-
6	Not used	-	-
7	Not used	-	-

Detailed Discussions of Bit 0 and 1

Select whether to continue displaying the communication result on the Control Panel at normal completion and/or at completion with an error.

• SSSW-SW12

Functional Construction

Bit	Function	1	0
0	Timeout period for sending 1 page (sending)	1	0
1	Timeout period for sending 1 page (sending)	1	0
2	Timeout period for sending 1 page (HT sending)	1	0
3	Timeout period for sending 1 page (HT sending)	1	0
4	Timeout period for sending 1 page (reception)	1	0
5	Timeout period for sending 1 page (reception)	1	0
6	Not used	-	-
7	Page timer settings for sending/receiving	Set	Do not set

This machine stops communication when sending/receiving per original page takes 32 minutes or longer. When setting the timer different from the above, see the following to set the most appropriate time length.

When 'Do not set' is selected using bit 7, the timeout length per page for all modes will depend on the setting of bit 0 and bit 1.

Timeout period at the time of sending/receiving

Timeout period	Bit7	Bit6	Bit5	Bit4	Bit3	Bit2	Bit1	Bit0
8 min.	0	*	*	*	*	*	0	0
16 min.	0	*	*	*	*	*	0	1
32 min.	0	*	*	*	*	*	1	0
64 min.	0	*	*	*	*	*	1	1

Timeout period at the time of sending (in text mode)

Timeout period	Bit7	Bit6	Bit5	Bit4	Bit3	Bit2	Bit1	Bit0
8 min.	1	*	*	*	*	*	0	0
16 min.	1	*	*	*	*	*	0	1
32 min.	1	*	*	*	*	*	1	0
64 min.	1	*	*	*	*	*	1	1

Timeout period at the time of sending (in text mode)

Timeout period	Bit7	Bit6	Bit5	Bit4	Bit3	Bit2	Bit1	Bit0
8 min.	1	*	*	*	0	0	*	*
16 min.	1	*	*	*	0	1	*	*
32 min.	1	*	*	*	1	0	*	*
64 min.	1	*	*	*	1	1	*	*

Timeout period at the time of reception

Timeout Period	Bit7	Bit6	Bit5	Bit4	Bit3	Bit2	Bit1	Bit0
8 min.	1	*	0	0	*	*	*	*
16 min.	1	*	0	1	*	*	*	*
32 min.	1	*	1	0	*	*	*	*
64 min.	1	*	1	1	*	*	*	*

• SSSW-SW13

Functional Construction

Bit	Function	1	0
0	Not used	-	-
1	Not used	-	-
2	Not used	-	-
3	Display Modem Dial-in/My Number Setting screen	Yes	No
4	Display Number Display Setting screen	Yes	No
5	Not used	-	-
6	Not used	-	-
7	Not used	-	-

Detailed Discussions of Bit 3

To set whether to display Modem Dial-in Setting screen and My Number Setting screen.

NOTE:

Turn OFF and then ON the power of the host machine after the setting.

Detailed Discussions of Bit 4

To set whether to enable the display of Number Display Setting screen.

NOTE:

Turn OFF and then ON the power of the host machine after the setting.

• SSSW-SW14

Functional Construction

Bit	Function	1	0
0	Not used	-	-
1	Not used	-	-
2	Not used	-	-
3	Not used	-	-
4	inch-configuration resolution declaration	Yes	No
5	Not used	-	-
6	Not used	-	-
7	Not used	-	-

Detailed Discussions of Bit 4

At the time of G3 communication, select whether to declare inch-configuration resolution to the other party's machine. if 'declare' is selected, the machine will indicate that it reads and records at an inch-configuration resolution using the DIS, DCS, or DTC signal.

• SSSW-SW17

Functional Construction

Bit	Function	1	0
0	Not used	-	-
1	To select the transmission level of the modem	0 to 15	8 to 15
2	Not used	-	-
3	Not used	-	-
4	Not used	-	-
5	Not used	-	-
6	Not used	-	-
7	Not used	-	-

Detailed Discussions of Bit 1

Select the transmission level of the modem.

• SSSW-SW18

Functional Construction

Bit	Function	1	0
0	Not used	-	-
1	Not used	-	-
2	Prohibition of the control of IP supported communication	Yes	No
3	Number of command retransmission (V1.7 or earlier)	6 times	3 times
4	Request retransmission of all frames after frame loss at JBIG reception	Yes	No
5	Not used	-	-
6	Not used	-	-
7	Not used	-	-

Detailed Discussions of Bit 2

Set whether to prohibit the control of IP supported communication

1: Yes

0: No

Detailed Discussions of Bit 3

Number of command retransmission

1: 6 times

0: 3 times

Detailed Discussions of Bit 4

Set whether to request retransmission of all frames after frame loss at JBIG reception

1: Yes

0: No

• SSSW-SW22

Functional Construction

Bit	Function	1	0
0	Backup when an archive transmission error occurs	Use	Do not use
1	Not used	-	-
2	Not used	-	-
3	Prohibit manual polling operation	-	-
4	Not used	-	-
5	Not used	-	-
6	Archive transmission function	Enabled	Disabled
7	Not used	-	-

Detailed Discussions of Bit0

Select whether to back up data when a communication error occurs during archive transmission.

This function is available on the Platform Version 3.6 or later.

Detailed Discussions of Bit3

Set whether to prohibit of manual polling operation

Detailed Discussions of Bit 6

Set whether to send the sent images to the destination specified by the forwarding function.

• SSSW-SW23

Functional Construction

Bit	Function	1	0
0	Not used	-	-
1	Not used	-	-
2	Prohibit to rotate A4 or larger paper in portrait position by 180 degrees	-	-
3	Not used	-	-
4	Not used	-	-
5	Not used	-	-
6	Not used	-	-
7	Not used	-	-

Detailed Discussion of Bit 2

Set whether to add header with or without rotating the image by 180 degrees when A4 or larger paper is placed in the feeder in portrait position (R position).

1: Yes

0: No

• SSSW-SW25

Functional Construction

Bit	Function	1	0
0	Sender's phone number indicated in the report	Receiver's number	Caller's number
1	Not used	-	-

Bit	Function	1	0
2	Not used	-	-
3	Not used	-	-
4	Not used	-	-
5	Firmware automatic update (USB Fax)	Prohibit	Do not prohibited
6	Not used	-	-
7	Not used	-	-

Detailed Discussions of Bit 0

Select a phone number to be indicated on the report after transmission is completed.

Caller's number: To display the caller's phone number on the report

Receiver's number: To indicate the phone number (CSI signal data) sent from the other party's machine on the report

Detailed Discussions of Bit 5

Select whether to prohibit the firmware automatic update for USB Fax.

• SSSW-SW26

Functional Construction

Bit	Function	1	0
0	Not used	-	-
1	Not used	-	-
2	Check the sequential broadcast.	Check	Do not check
3	Not used	-	-
4	Not used	-	-
5	Redial function when transmission error occurs	Use	Do not use
6	Not used	-	-
7	Error report when sending process is canceled	Do not output	Output

Detailed Discussions of Bit 2

Select whether to display a confirmation message when entering destination for the sequential broadcast in order to prevent the user from broadcasting by mistake.

Detailed Discussions of Bit 5

Select whether to use the redial function when outgoing transmission error occurs.

Detailed Discussions of Bit 7

Select whether to output an error report when the [Stop] key is pressed to cancel sending.

• SSSW-SW28

Functional Configuration

Bit	Function	1	0
0	V.8 procedure at the caller side	No	Yes
1	V.8 procedure at the receiver side	No	Yes
2	V.8 late start at the caller side	No	Yes
3	V.8 late start at the receiver side	No	Yes
4	Fallback from the V.34 receiver side	Prohibit	Do not prohibit
5	Not used	-	-
6	Not used	-	-
7	Not used	-	-

Detailed Discussions of Bit 0

Select whether to execute V.8 procedure when making a call.

"No": V.8 procedure is not executed even if V.8 procedure is received from the receiver side, and the procedure starts from V.21.

Detailed Discussions of Bit 1

Select whether to execute V.8 procedure when receiving a call.

"No": V.8 procedure is not executed, and the procedure starts from V.21.

Detailed Discussions of Bit 2

Select whether to execute V.8 procedure when ANSam signal from the receiver side cannot be recognized at the time of making a call and V.8 procedure is declared by DIS signal from the receiver side.

"Yes": CI signal is sent in response to the DIS signal of the receiver side to execute the V.8 procedure.

"No": CI signal is not sent in response to the DIS signal of the receiver side, and the V.21 procedure is executed.

In the case of manual transmission, there will be no V.8 late start regardless of this setting.

Detailed Discussions of Bit 3

Select whether to declare the existence of the V.8 procedure with the DIS signal that is transmitted after the ANSam signal in case that the ANSam signal at the reception is not recognized at the caller side.

"Yes": V.8 procedure is declared by DIS signal and V.8 procedure is executed after CI signal is sent from the caller side.

"No": V.8 procedure is not declared by DIS signal, and V.21 procedure is executed.

In the case of manual transmission, there will be no V.8 late start regardless of this setting.

Detailed Discussions of Bit 4

Select whether to prohibit fallback from the V.34 receiver side.

"Prohibit": There will be no fallback from the receiver side.

• SSSW-SW30

Functional Construction

Bit	Function	1	0
0	Not used	-	-
1	Not used	-	-
2	Not used	-	-
3	Not used	-	-
4	Not used	-	-
5	Switching the dial tone detection method	-	New detection method
6	Flow control between pages	Control	Do not control
7	Not used	-	-

Detailed Discussions of Bit 5

Switch the detection method when executing the dial tone detection at the time of calling.

0: New detection method (default)

1: Not used

Detailed Discussions of Bit 6

Select whether to execute flow control between pages.

• SSSW-SW50

Functional Construction

Bit	Function	1	0
0	Transmission number restriction: Function to prevent no external access code *2	ON: Enable	OFF: Disable
1	Transmission number restriction: Extension allowance, prohibition *2	Prohibited	Allow
2	Transmission number restriction: Add "0" to the first digit of external access code *2	Yes	No
3	Operate as the client of a fax server *1 *a	Yes	No
4	Display the send job stop confirmation screen when pressing Stop key *2	No	Yes
5	Send jobs that are targeted to stop when pressing Stop key *2	Ongoing send job	Incomplete send job
6	not used	-	-
7	not used	-	-

*1: Supported by the platform version 306 or later

*2: Supported by the platform version 307 or later

*a: Enabled only for USA

Details of Bit 0

To prevent incorrectly sending fax due to forgetting to use the external access number, "0", this function displays a pop-up warning window and prevents sending and returns to the status before pressing Start button by pressing [OK] after setting the fax number in [Fax] or [Scan and Send] and pressing Start button if the set telephone number does not start with "00". This function is supported even if the machine is operating in the fax server mode.

- 0: ON: Disable
- 1: OFF: Enable

CAUTION:

- If using this function, enter the telephone number from the area code.
- This function applies to the fax destination telephone number of "Address List", "One-touch" and "Numeric Keypad input".
However, the warning is not displayed with "sending from Mail Box" and "manual sending".
- A warning is displayed when sending IP fax but it is not displayed when sending PC fax.
- A warning is not displayed when forwarding transmission.
- If any registered number matches to the condition for displaying a warning, the warning is displayed with "sequential broadcast" and "group sending".
- "*" and "#" are also processed as a number.

NOTE:

Example of sending fax to 03-1234-5678

- The machine accepts sending fax with "0 (external access code) + 03 1234 5678 (telephone number)".
- The machine displays a warning and stops sending with "(no external access code) + 03 1234 5678 (telephone number)".
- If the external access code is other than "0", it can be changed from the following service mode.

Service Mode > FAX > NUM > 080

Change the default setting of 080 from "0" to the external access code used in the installation environment.

Details of Bit 1

This is set to allow or prohibit transmission to the extension line.

This is enabled only if Bit 0 (function to prevent no external access code) is "1" (ON: Enable).

If transmission to the extension line is allowed, all telephone numbers not starting with the external access code are allowed. For example, if the external access code is "0", any number starting with "00" as starting 2 digits and number of the extension line are allowed. This means numbers starting with "01" to "09" are prohibited and other numbers are allowed.

If transmission to the extension line is prohibited, only allow the telephone number starting with the external access code + area code "0". For example, if the external access code is "0", allow only numbers starting with "00" as starting 2 digits.

Prohibit all extension numbers. This means only numbers starting with "00" are allowed and other numbers are prohibited.

- 0: Allow
- 1: Prohibit

Details of Bit 2

This is the switch to add "0" to the beginning of external access code (default "0") set by the NUM switch 080.

The NUM switch can be used to set "0" and "1" but not "00" and "01" as the external access code.

This switch is used to solve this issue. In the above example, set this setting to "add" and then set the NUM switch 080 to "0" and "1" to set the external access code of "00" and "01".

- 0: No
- 1: Yes

CAUTION:

- This automatically adds the external access number to the destination telephone number for sending fax registered by Address List, One-touch and entering by the Numeric Keypad excluding Direct Send and Send from Mail Box.
- This should be set only in the network environment that sends fax by adding the external access code.
- Do not add the external access code to the telephone number for fax send destination as the external access code is automatically added.

Details of Bit 3

This switch operates the machine as the client of fax server.

- 0: No
- 1: Yes

- 1:
To make monitoring tone of the phone line from the speaker from the start of communication until the completion.
- 2:
Not used
- 3 (OFF):
There will be no monitoring tone of the phone line from the speaker.

007: ATT transmission level

Set the transmission level (ATT).

Increase the transmission level (make it closer to 8) in the case of frequent errors caused by line status at the time of communication.

NOTE:

Error codes caused by line status at the time of transmission

##100, ##101, ##102, ##104, ##201, ##280, ##281, ##282, ##283, ##284, ##750, ##752, ##754, ##755, ##757, ##759, ##760, ##762, ##764, ##765, ##767, ##769, ##770, ##772, ##774, ##775, ##777, ##779, ##780, ##782, ##784, ##785, ##787, ##789

Error codes caused by line status at the time of reception

##103, ##106, ##107, ##201, ##793

008: Upper limit for V.34 modulation speed

Select the upper limit of the modulation speed (baud rate) in the V.34 primary channel.

When 4 (2743 baud) is selected, the communication is actually performed at 2400 baud.

009: Upper limit of V.34 data speed

Select an upper limit of data transmission speed in the V.34 primary channel in the range between 2.4k and 33.6kbps at 2400bps intervals (0: 2.4 kbps to 13: 33.6 kbps).

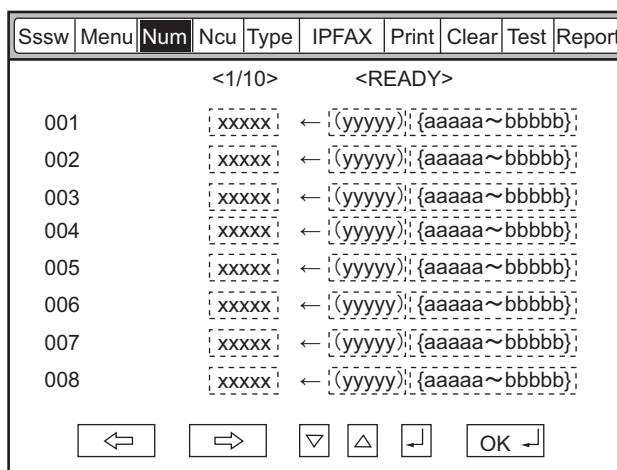
010: Pseudo CI signal frequency

Set pseudo CI signal frequency.

Depending on the type of external phones, there is no ring tone when the FAX/TEL switching function is working. Change the pseudo CI signal frequency when there is no ring tone.

Setting of Numeric Parameter (NUMERIC Param.)

■ Configuration of Numeric Parameters



No.	Function	Setting range	Default value
002	RTN transmission condition (1)	1 to 99%	10
003	RTN transmission condition (2)	2 to 99 times	15
004	RTN transmission condition (3)	1 to 99 lines	12
005	NCC pause time (before ID code)	1 to 60 sec	4
006	NCC pause time (after ID code)	1 to 60 sec	4
007	Prepose time at the time of making a call	0 to 9999 (x 10 ms)	0

No.	Function	Setting range	Default value
009	Comparing the number of digits between the sender's telephone number and the receiver's telephone number	0 to 20 digits	0
010	Line connection identification time	0 to 9999 (x 10 ms)	5500
011	T.30 T1 timer (for reception)	0 to 9999 (x 10 ms)	3500
013	T.30 EOL timer	500 to 3000 (x 10 ms)	1300
015	Hooking detection time	0 to 999	120
016	Time until a temporary response is obtained when switching FAX/TEL	0 to 9	4
017	Pseudo RBT signal pattern ON time	0 to 999	100
018	Pseudo RBT signal pattern OFF time (short)	0 to 999	0
019	Pseudo RBT signal pattern OFF time (long)	0 to 999	200
020	Pseudo CI signal pattern ON time	0 to 999	100
021	Pseudo CI signal pattern OFF time (short)	0 to 999	0
022	Pseudo CI signal pattern OFF time (long)	0 to 999	200
023	CNG detection level when switching FAX/TEL	0 to 7	4
024	Pseudo RBT transmission level when switching FAX/TEL	10 to 20 (TYPE = STANDARD)	20
025	CNG monitoring time when the answering phone connection function is set		
026	Silent detection level when the answering phone connection function is set		
027	V.21 low-speed flag preamble detection time	20 (-10 ms)	0
028	Off-hook PCB duty settings	1 to 99%	0 (50%)
080	Transmission number restriction: Outside line transmission number *1	0 to 9999	0

*1 : Supported on the platform version 307 or later

002: RTN transmission condition (1)/003: RTN transmission condition (2)/004: RTN transmission condition (3)

Set the RTN signal transmission condition.

In the case of frequent errors caused by RTN signal transmission at the time of reception, increase the parameters to loosen the RTN signal transmission condition.

NOTE:

Error codes caused by RTN signal transmission at the time of reception

##104, ##107, ##114, ##201

RTN signal transmission condition (1) is the ratio of error lines for the total number of lines per page of the received image.

RTN signal transmission condition (2) is the reference value (*2) of burst error (*1).

RTN signal transmission condition (3) is the number of errors that fail to meet the reference value of burst error.

*1: Burst error (transmission errors with several continued lines)

*2: Reference value (When "15" is set, transmission error with 15 consecutive lines is recognized as a burst error.)

When any of the above conditions is detected during reception of image signals, RTN signal is sent after reception of the procedure signal from the sending machine. Increasing such parameter sends less RTN signal.

005: NCC pause time (before ID code)

Set the pause time to be automatically entered between the access code and ID code when dialing on NCC (New Common Carrier) line.

006: NCC pause time (after ID code)

Set the pause time to be automatically entered between the ID code and the other party's telephone number when dialing on NCC (New Common Carrier) line.

007: Prepose time at the time of making a call

When automatically making a call, set the time from closing a line to making a call.

009: Comparing the number of digits between the sender's telephone number and the receiver's telephone number

Set the TSI comparing the number of digits (last XX digits) when matching telephone numbers.

010: Line connection identification time

Set the line connection identification time.

Increase this parameter in the case of frequent errors caused by line connection status at the time of communication.

NOTE:

Error codes caused by line connection status

##005, ##018

The line connection identification time is the duration from when the dial signal is transmitted until the line is disconnected at the sending side, or from when DIS signal is transmitted until the line is disconnected at the reception side.

011: T.30 T1 timer (for reception)

Set T1 timer at the time of reception (wait time until receiving the meaningful signal after DIS transmission).

013: T.30 EOL timer

Set the receivable 1 line transmission time.

In the case of a long line data length (e.g.: computer FAX), extend the transmission time to prevent reception errors.

015: Hooking detection time

Set the hooking detection time.

016: Time until the primary response is obtained when switching FAX/TEL

Set the time from when capturing the line until transmission of pseudo RBT at FAX/TEL switching function operation.

017: Pseudo RBT signal pattern ON time/ 018: Pseudo RBT signal pattern OFF time (short)/ 019: Pseudo RBT signal pattern OFF time (long)

Set the pattern of pseudo RBT signal to be sent at Fax/Tel switching function operation.

020: Pseudo CI signal pattern ON time/ 021: Pseudo CI signal pattern OFF time (short)/ 022: Pseudo CI signal pattern OFF time (long)

Set the pattern of pseudo CI signal to be sent at Fax/Tel switching function operation.

023: CNG detection level when switching FAX/TEL

Set the CNG detection level at Fax/Tel switching function operation.

024: Pseudo RBT transmission level when switching FAX/TEL

Set the transmission level of pseudo RBT at Fax/Tel switching function operation.

025: CNG monitoring time when the answering phone connection function is set**027: V21 low-speed flag preamble detection time**

Set the period of time for judge detection of V.21 low-speed command preamble.

Continuous detection for the fixed period of time leads to command analysis.

028: Off-hook PCB duty settings

Set the Off-hook PCB duty setting.

When 0 or a value that is 100 or more is entered, the duty becomes 50%.

080: Transmission number restriction: Outside line transmission number

This sets the number permitted to dial to the outside line.

Only the outside line transmission by the set number is permitted and other numbers are prohibited from transmission.

Setting of Destination (TYPE)

■ Overview

When the type shown on the display is set, all the service data is set to match each country/region domestic telecommunication standards.

Setting of Printer Functions (PRINTER)

■ Setting of Bit Switch (SSSW)

● SSSW-SW01

Functional Construction

Bit	Function	1	0
0	Not used	-	-
1	Not used	-	-
2	Not used	-	-
3	Not used	-	-
4	Not used	-	-
5	Not used	-	-
6	Hold the line (when error code occurs)	Hold	Do not hold
7	Output a print log when DUMP report is output	Output	Do not output

Detailed Discussions of Bit 6

Select whether to hold the line when an error code occurs.

However, in the case of vertical scanning prioritized recording, even when 0 is set for Bit 1 and Bit 0, the priority order will be Letter -> A4 -> Legal.

Detailed Discussions of Bit 7

Select whether to output a print log at the time of the DUMP report output.

● SSSW-SW05

Functional Construction

Bit	Function	1	0
0	Letter priority	Set	Do not set
1	Legal priority	Set	Do not set
2	Not used	-	-
3	Not used	-	-
4	Not used	-	-
5	To prohibit reduced size printing (A4)	Prohibited	Not prohibited
6	To prohibit reduced size printing (A4)	Prohibited	Not prohibited
7	Vertical scanning prioritized recording	Set	Do not set

Detailed Discussions of Bit 0 and 1

When an image which can be printed in 100% magnification and with the same number of divided pages on any of A4, letter and legal is received, set which paper is prioritized for printing.

With the settings of Bit 0 and Bit 1, the priority order of the recording paper is shown in the following table.

Bit 1	Bit 0	Priority order of the recording paper
0	0	A4 -> Letter -> Legal
0	1	Letter -> A4 -> Legal
1	0	Legal -> Letter -> A4
1	1	Letter -> Legal -> A4

However, in the case of vertical scanning prioritized recording, the priority order will be Letter -> A4 -> Legal even when 0 is set for Bit 1 and Bit 0.

Detailed Discussions of Bit 5 and 6

Select whether to enable reduced size printing for A4 or LTR.

Detailed Discussions of Bit 7

Set whether to set vertical scanning prioritized recording.

Set:

If B4 recording paper and A4 recording paper are set and an A4 extra-long image (*) is received, printing will be on the B4 recording paper.

Do not set:

If B5 horizontal recording paper and A4 recording paper are set and a B4 image is received, printing will be by division and on B5 horizontal recording paper.

*: Image B4 or shorter and that cannot be printed on A4 recording paper.

• SSSW-SW06

Functional Construction

Bit	Function	1	0
0	Not used	-	-
1	Not used	-	-
2	Not used	-	-
3	Not used	-	-
4	Not used	-	-
5	Reduced printing from A4 to B5	Enable	Disable
6	Not used	-	-
7	Not used	-	-

Detailed Discussions of Bit 5

Set whether to execute the reduction print that forcibly reduces the received A4 size document into the B5 size. This function is invalid when outputting the report.

■ Setting of Numeric Parameter (NUMERIC Param.)

• Numerical Parameter Composition

No.	Function	Setting range	Initial setting	Unit
01	Missing areas of printing image when receiving image with longer length than standard	0 to 9999	12	1 mm
04	Leading edge blank area	0 to 9999	3	1 mm
05	Trailing edge blank area	0 to 9999	3	1 mm

<001: printing upon reception of extra-length image>

Use it to set the range of the image to be removed from when printing an extra-length received image.

Lower the parameter to decrease the range if the trailing edge of the received image must be retained (as when it is longer than the effective recording length).

<004: leading edge margin>

Use it to set the leading-edge margin for the effective recording length.

<005: trailing edge margin>

Use it to set the trailing-edge margin for the effective recording length.

IPFAX Setting

■ IPFAX

● BASIC N

Bit	Function	Setting range
2	Session control reception timeout (sec.)	0 to 9999 (0*)
20	Reception start delay time (sec.)	0 to 9999 (0*)
21	BYE sending delay time at transmission (x10 msec.)	0 to 9999 (0*)
22	BYE receiving delay time at transmission (x10 msec.)	0 to 9999 (0*)

● NETA NUM

Bit	Function	Setting range
1	T0 timer(Timer C) for IPFAX(sec.)	0 to 9999 (55*)

● NETC NUM

Bit	Function	Setting range
1	SW for adjusting the speed at VoIPGW transmission [%]	0 to 9999* However, the value is fixed in the case of ECM, and is corrected by adding 5 %.
2	VoIPGW buffer size [byte]	0 to 9999* However, when the value is 0, it is internally interpreted as 200.
3	Packet division size [byte]	0 to 9999* However, when the value is 0, it is internally interpreted as 66.
4	Number of VoIPGW buffer reset frames at ECM * At ECM transmission, when frames of the number of this NUM value have been transmitted, the next frames will be transmitted after the VoIPGW buffer becomes empty.	0 to 9999* However, when the value is 0, it is internally interpreted as 16.

● T.38 Bit Setting

SW01

Bit	Function	Setting range	
		1	0
1	German mode is effective during T.38 communication.	Effective	Invalid *
2	T.38 significant bit of DIS (bit123) is ignored. (When this SW is effective, the other party's machine is regarded as IPFAX even if DIS bit123 is 0.)	Ignore	Not ignore
3	Transmission ECM = OFF setting	Effective	Invalid *
4	Reception ECM = OFF setting	Effective	Invalid *

● T.38 NUM Setting

Bit	Function	Setting range
1	High-speed flag sending time of ECM mode for IPFAX (x10 msec.).	0 to 9999 (0*)
2	WAIT time from the close of T.38 to the close of SIP: Unit; second (However, the setting becomes 2 seconds even if the setting is changed to 2 or more.).	0 to 9999 (1*)

Using Test Mode

1. Press the desired item to highlight; then, press the OK key to bring up its screen.

The following table shows text mode items that are valid and invalid when a fax board is installed:

Yes: may be used

-: not used

Level 1	Level 2	Fax Board present
MODEM	RELAY-1	Yes
	RELAY-2	-
	FREQ	Yes
	G3TX	Yes
	DTMFTX	Yes
	TONERX	-
	V34G3TX	Yes
FACULTY	G3 4800TX	Yes
	SPEAKER	-
	DETECT1	-
	DETECT2	-
	DETECT3	-
	VOICETX	-
DATA SET		-
ISDNMOD		-
ISDNMOD2		-

CAUTION:

Do not use items in the table identified as "-."

■ MODEM Test

● Relay Test (RELAY-1)


Use it to see if the individual relays on the NCU board go on and off as expected.







Sssw	Menu	Num	Ncu	Type	IP FAX	Print	Clear	Test	Report
<MODEM>	<RELAY-1>	<1/1>	<READY>						
CML	OFF								
P	OFF								
S	OFF								
H	OFF								
D	OFF								
R	OFF								

Using Text Mode

1. From the relays indicated on the screen, select the one you want to test; then, turn it off or on using the Up/Down key. (Some of the relays may not actually exist on the NCU board.)

• Frequency Test (FREQ)


Of the items indicated below, press one; in response, the DC circuit will be closed and the selected frequency will be transmitted using the tone transmission function of the modem. You can also monitor the transmission signal by listening to the sound generated by the speaker. To stop the operation and end test mode, press the  key.







Ssw	Menu	Num	Ncu	Type	IP FAX	Print	Clear	Test	Report
				<MODEM>	<FREQ>	<1/1>	<READY>		
RBT									
462Hz									
1100Hz									
1300Hz									
1500Hz									
1650Hz									
1850Hz									
2100Hz									
									

CAUTION:

'RBT' is not currently supported.

• G3 Signal Transmission Test (G3 Tx)

Of the items indicated below, press one. In response, the DC circuit will be closed and the selected frequency will be transmitted using the G3 signal transmission function of the modem. You can also monitor the transmission signal by listening to the sound generated by the speaker. To stop the operation and end test mode, press the  key.

Ssw	Menu	Num	Ncu	Type	IP FAX	Print	Clear	Test	Report
				<MODEM>	<G3TX>	<1/2>	<READY>		
300bps									
2400bps									
4800bps									
7200bps									
9600bps									
TC7200									
TC9600									
12000bps									
									

Sssw	Menu	Num	Ncu	Type	IP FAX	Print	Clear	Test	Report
<MODEM>	<G3TX>	<2/2>	<READY>						
	14400bps								
	300-ALL0								
	300-ALL1								
	300-1:1								
	300-1:4								
	300-4:1								

CAUTION:

'300-ALL0' through '300-4:1' are not currently supported.

• DTMF Transmission Test

Of the items indicated below, press one; in response, the DC circuit will be closed and the selected DTMF signal will be transmitted using the DTMF transmission function of the modem. You can also monitor the transmission signal by listening to the speaker. To stop the operation and to end test mode, press the key.

Sssw	Menu	Num	Ncu	Type	IP FAX	Print	Clear	Test	Report
<MODEM>	<DTMFTX>	<1/1>	<READY>						
	LONG	0 1 2 3 4 5 6 7 8 9 * #							

Using Text Mode

1. From the items indicated on the screen, select the item you want to test; then, press the key on keypad that corresponds to the DTMF signal to test.

CAUTION:

'SHORT' is not currently supported.

• V.34 G3 Signal Transmission Test (V34G3Tx)

Select the transmission speed you want to test, and then select a modulation speed (baud rate); in response, the V.34 G3 transmission signal will be transmitted to the telephone line terminal and the speaker. To stop the operation and to end test mode, press the key.

Sssw	Menu	Num	Ncu	Type	IP FAX	Print	Clear	Test	Report
<MODEM>		<V34G3TX>		<1/1>		<READY>			
SPEED		33600bps							
3429baud									
3200baud									
3000baud									
2800baud									
2743baud									
2400baud									
←		→		▽		△		↵	
OK ↵									

Using Text Mode

1. Select 'SPEED', and then select the speed you want to test using the Up/Down key.
2. Select the baud rate you want to test.

■ Function Test

● 4800-bps Signal Transmission Test

The DC circuit will be closed, and a 4800-bps signal will be transmitted using the 4800-bps signal transmission function of the modem. You can also monitor the transmission signal by listening to the speaker. To stop the operation and end test mode, press the ↵ key.

Sssw	Menu	Num	Ncu	Type	IP FAX	Print	Clear	Test	Report
<FACULTY>		<G34800TX>		<1/1>		<READY>			
G34800TX									
←		→		▽		△		↵	
OK ↵									

● Service Report (REPORT)

■ System Data List

Use it to check the settings associated with the service soft switch and service parameters.

```

2003 09/02 TUE 12:00 FAX
*****
*** SYSTEM DATA LIST ***
*****
SERIAL NO          XXXXXXXX
#1 SSSW
SW01      .....  00000000
SW02      .....  10000000
SW03      .....  00000000
SW04      .....  10000000
SW05      .....  00000000
SW06      .....  10000000
SW07      .....  00000000
SW08      .....  00000000
SW09      .....  00000000
SW10      .....  00000000
SW11      .....  00000000
SW12      .....  00000011
SW13      .....  00000000
SW14      .....  00000000
SW15      .....  00000000
SW16      .....  00000000
SW17      .....  00000000
SW18      .....  00000000
SW19      .....  00011000
SW20      .....  00000000
SW21      .....  00000000
SW22      .....  00000000
SW23      .....  00000000
SW24      .....  00000000
SW25      .....  00000000
SW26      .....  00100000
SW27      .....  00000000
SW28      .....  00000000
SW29      .....  00000000
SW30      .....  00000000
SW31      .....  00000000
SW32      .....  00000000
SW33      .....  00000000
SW34      .....  00000000
SW35      .....  00000000
SW36      .....  00000000
SW37      .....  00000000
SW38      .....  00000000
SW39      .....  00000000
SW40      .....  00000000
SW41      .....  00000000
SW42      .....  00000000
SW43      .....  00000000
SW44      .....  00000000
SW45      .....  00000000
SW46      .....  00000000
SW47      .....  00000000
SW48      .....  00000000
SW49      .....  00000000
SW50      .....  00000000
#2 MENU
01:      .....  0
02:      .....  0
03:      .....  0
04:      .....  0
05:      .....  0
06:      .....  0
07:      .....  10
08:      .....  0
09:      .....  0
10:      .....  2
    
```

System Dump List

NOTE:

A system dump list is generated when you execute the following in service mode: FAX > Report > DUMP.

Use it to check the history of communications, both successful and error.

```

2013 04/05 FRI 12:00 FAX
*****
*** SYSTEM DUMP LIST ***
*****
SERIAL NO          XXXXXXXX
CLEAR DATE          2013 02/03 FRI 13:37
*1 TX = 1298
*2 A4 = 1302 B4 = 49 A3 = 27 LTR = 0 LGL = 0
*1 RX = 1572
*2 A4 = 1581 B4 = 59 A3 = 59 LTR = 0 LGL = 0
*3 NWSPD = 0
*3 33600 = 1 31200 = 0 28800 = 2986 26400 = 0 24000 = 0
21600 = 0 19200 = 0 16800 = 0 14400 = 0 12000 = 0
9600 = 0 7200 = 0 4800 = 0 2400 = 0
14400 = 83 12000 = 1 TC9600 = 0 TC7200 = 0
14400 = 0 14400 = 0
*4 9600 = 2 7200 = 0 4800 = 4 2400 = 0
STD = 60 FINE = 2839 SUPER = 107 ULTRA = 71
*5 MH = 7 MR = 32 MMR = 9 JBIG = 3029 JPEG = 0
*6 G3 = 37 ECM = 3040 G4 = 0 IPECM = 0 IPG3 = 0
*7 #000 0 0 0 0 0 0 0 0 0
0 0 0 0 0 0 0 0 0
0 0 0 2 0 0 0 0 0
0 0 0 0 0 0 0 0 0
0 0 0 0 0 0 0 0 0
0 0 0 0 0 0 0 0 0
0 0 0 0 0 0 0 0 0
0 0 0 0 0 0 0 0 0
0 0 0 0 0 0 0 0 0
0 0 0 0 0 0 0 0 0
0 0 0 0 0 0 0 0 0
0 0 0 0 0 0 0 0 0
0 0 0 0 22 0 0 0 0
0 0 0 0 0 0 0 0 0
    
```


2003 09/02 TUE 12:00 FAX

0001

```

*****
*** FAX ERROR TX REPORT ***
*****
TX FUNCTION WAS NOT COMPLETED

JOB NO.                1269
DESTINATION ADDRESS    12345678
PSWDSUBADDRESS
DESTINATION ID
ST. TIME              09/02 09:00
USAGE T              01'50
PGS.                 1
RESULT               NG
                   1      ##750
    
```

```

START TIME          09/02 09:00
OTHER PARTY        12345678
MAKER CODE         10001000
MACHINE CODE       0100001 00000000
RCV VS FRAME       E0 81 85 D4 90 7E 00 00
SYMBOL RATE        3429 baud
DATA RATE          28800 bps [V.34]
TX LVL REDUCTION   0
ERR ABCODE         92
ERR SECTXB         8A
ERR SECRXB         80
    
```

```

Rx : (bit 1 ) 00000100 01110111 01011111 00100011 00000001 10101001 00000001 (bit 56)
      (bit 57) 00000001 00000001 00000100 00000000 00000000 (bit 96)
Tx : (bit 1 ) 00000000 01000010 00011111 00100001 00000001 00000001 00000001 (bit 56)
      (bit 57) 00000001 00000001 00000100 00000000 00000000 (bit 96)
    
```

Rx : NSF CSI DIS	CFR	MCF	MCF
Tx : NSS TSI DCS	PIX-288 PPS-NUL	PIX-288 PPS-NUL	PIX-288 PPS-NUL
Rx : MCF	MCF	MCF	
Tx :	PIX-288 PPS-NUL	PIX-288 PPS-EOP	DCN

10

Installation

How to Utilize This Installation

Procedure.....	1976
Checking before Installation.....	1977
Installation of Host Machine.....	1980
When Relocating the Machine.....	2022
Printer Cover-H2.....	2031
NFC Kit-E1/E2.....	2042
Connection Kit-A2/A3 for Bluetooth LE.....	2061
Numeric Keypad-A1/A2.....	2071
Reader Heater-P1.....	2077
Paper Deck Heater Unit-A1.....	2089
Utility Tray-B1.....	2097
Copy Card Reader-F1.....	2101
Serial Interface Kit-K3 / Copy Control Interface Kit-A1.....	2111
Voice Operation Kit-D1.....	2117
Voice Guidance Kit-G1.....	2126
HDD-related Option.....	2133
Super G3 FAX Board-AS1.....	2153
Super G3 FAX Board-AS2.....	2159
Super G3 2nd Line Fax Board-AS1	2164
Super G3 2nd Line Fax Board-AS2	2176

Super G3 3rd/4th Line Fax Board-AS1.....	2187
Super G3 3rd4th Line Fax Board-AS2.....	2194

How to Utilize This Installation Procedure







Description on the Parts Included in the Package







The parts with a diagonal line in the contents list will not be used.

Symbols

The frequently-performed operations are described with symbols in this procedure.

Screw

		 1x	 1x	 1x	 1x
Packaged Item	Unused Parts	Install	Remove	Tighten	Loosen

Harness (Common for Guides and Clamps)		Connector		Power Cord	
 1x	 1x	 1x	 1x		
Install	Remove	Connect	Disconnect	Connect	Disconnect

Power

						
ON	OFF	Check the sound	Check visually	Check	Push	Cleaning

Checking before Installation

Following shows requirements for the installation site. Therefore, it is desirable to see the installation site in advance before bringing in the machine to the user's site.

Checking the Power Supply

1. **Be sure to connect the power plug exclusively to an outlet that compiles with the following.**
 - USA : 110-127V +/-10%, 60Hz, 16A
 - EUR/Asia/Oceania/China/Korea : 220-240V +/-10%, 50/60Hz, 10A
 - TW : 110-120V +/-10%, 60Hz, 16A
2. **Install this machine near the power outlet and leave sufficient space around the power plug so that it can be unplugged easily in an emergency.**

Checking the Installation Environment

1. The environment of the installation site must be in the range as shown below. Avoid installation near the faucet, water boiler, humidifier or refrigerator.
Guaranteed range for operation/image Temperature: 10.0 to 30.0 deg C, Humidity: 20 to 80%
2. The machine must not be installed near a source of fire or in an area subject to dust or ammonium gas. If the area is exposed to direct rays of the sun, provide curtains to the window.
3. Be sure to provide adequate ventilation of the room to keep the work environment comfortable. Room odor can be bothering when running the machine for a long time in a poorly-ventilated room although the ozone amount generated while running this equipment does not harm human health.

Points to Note at Installation Work

Take note of the following points when installing the host machine.

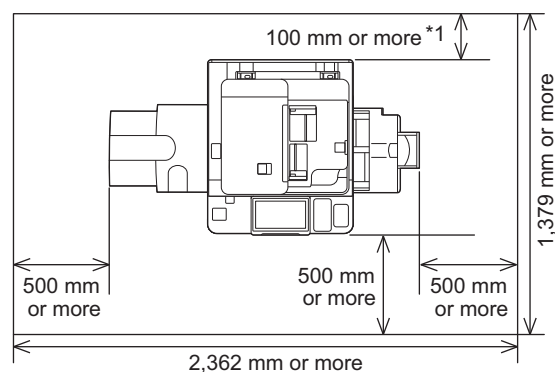
1. **Moving the host machine from a cool place to a warm place can generate condensation, causing moisture beads on the metal surface. Using the host machine while the machine is condensed can cause image failure. Therefore, when moving the machine from a cool place to a warm place to install, unpack the host machine and leave it for 2 hours or more before the installation work so that the machine becomes used to the room temperature.**
2. **Be sure to work with a group of 4 or more people to install the host machine.**

Points to Note When Moving This Host Machine

- When moving this host machine after having unpacked it, be careful by placing a plate, etc. on areas with steps to prevent the casters from hitting those steps. If the casters hit a step, the casters or the base plate may be deformed.
- Keep the fixation members and screws that were removed during unpacking or installation as they may be used to transport the machine for relocation or repair.

Checking Installation Space

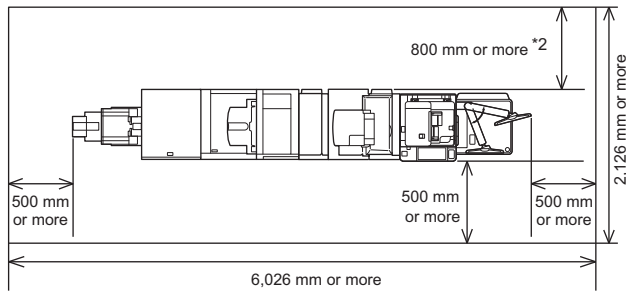
1. **The foot of this equipment should be in contact with the floor. This equipment should be kept on the level.**
2. **The machine must be away from the wall by 100 mm or more to secure a sufficient space to operate the machine.**
 - When the Copy Tray-R2 is attached:



NOTE:

*1 Make sure to provide at least 800 mm of space if you install one or more of the following: Booklet Trimmer-F1, Paper Folding Unit-J1, Multi Function Professional Puncher-B1, or Document Insertion Unit-N1.

- When the Booklet Trimmer-F1, Booklet Finisher-W1 PRO, Paper Folding Unit-J1, Multi Function Professional Puncher-B1, Document Insertion Unit-N1, POD Deck Lite-C1, and Upright Control Panel-J1 are attached:

**NOTE:**

*2 Make sure to provide at least 100 mm of space if none of the Booklet Trimmer-F1, Paper Folding Unit-J1, Multi Function Professional Puncher-B1, or Document Insertion Unit-N1 is installed.

- To install the host machine, install it in a well-ventilated place. Especially when there are multiple host machines, be sure to locate the machine where the machine is free from direct exhaust of other machines. Be sure to keep the machine away from the air-inlet duct which is used for ventilation of the room.

Table of Options Combination

NOTE:

Following table shows the combination of options to be installed at the right side of the host machine. Refer to the table below to install the options described in the table. Be sure to check the combination before the installation work.

	Utility Tray	Voice Operation Kit	Voice Guidance Kit	Copy Card Reader
Utility Tray	-	No	No	Yes
Voice Operation Kit	No	-	No	Yes
Voice Guidance Kit	No	No	-	Yes
Copy Card Reader	Yes	Yes	Yes	-

Yes: installation is available, No: installation is not available

Order to Install the Host machine and the Options

NOTE:

In the case of installing the host machine and the other options at the same time, follow the order as described below to install the options first so that the installation operability is improved.

- Checking before Installation
- Unpacking
- Checking the Contents
- 光学系の設置(Only for Machines Equipped with the Image Reader Unit)
- Installation of the Printer Cover (Only for Machines Equipped with the Printer Cover)
- Installation of the Covers
- Installation of the Developing Assembly
- Installation of the Pickup Assembly
- Installing the Fixing Assembly
- Installation of Toner Container
- Installing the Exhaust Filter
- Setting the Environment Heater Switch
- Turning ON the Main Power <Registering the Speed License>
- Host Machine Settings (Start Setup Guide)
- Registration of Installation Date Information
- Installation of the Host machine
- Other Installation Work
- Affixing the Labels on the Reader Assembly (Only for Machines Equipped with the Image Reader Unit)
- Storing the Cleaning Cloth (Only for Machines Equipped with the Image Reader Unit)
- Checking the K paper settings (Only for CHINA)
- Setting the Deck
- Setting the Paper Cassette
- Image Position Adjustment
- Image Position Adjustment (Single Pass ADF)
- Checking the Network Connection
- Network Troubleshooting

27. Installing the Card Reader

NOTE:

When installing the IC Card Reader and the Numeric Keypad at the same time, be sure to install the Numeric Keypad first.

28. Operation when using uniFLOW Online

Installation of Host Machine

NOTE:

The pictures and illustrations used may be different from the product in front of you, but the procedure is the same.

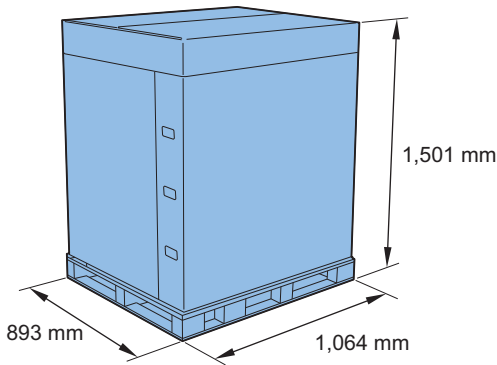
Unpacking

CAUTION:

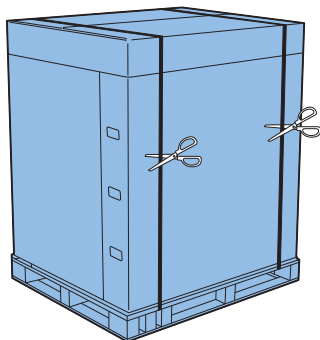
- The host machine weighs about 219 kg (including the DADF). For safety, be sure to work carefully to move and install the machine.
- Be sure to work with a group of 4 or more people to install the host machine.

NOTE:

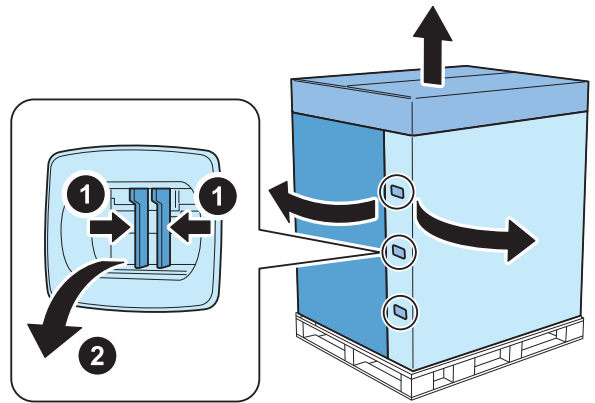
The dimension of the host machine and the transport container is as shown in the figure. Be sure to secure a space to unpack, and then start the installation work.



1. Cut the polyester packing band.



2. Unpack the host machine.



3. Bring down the Package Box from the pallet.

4. Pull the plastic bag all the way down.

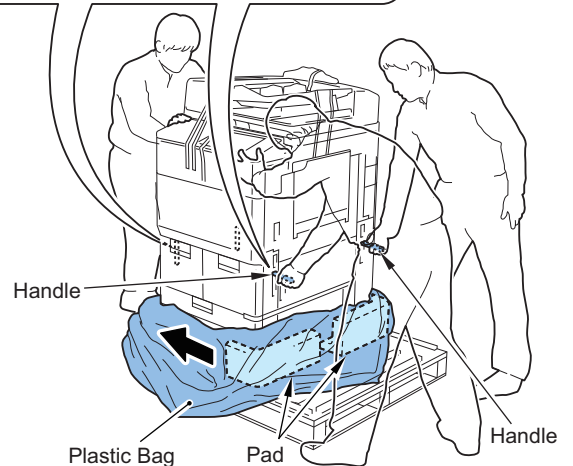
5. Open 4 Handle Covers.

Hold the handles at the right side of the host machine and lift the host machine to remove the pad. Put the plastic bag aside in the direction of the arrow.

- 1 Claw each

CAUTION:

Be sure not to lift the host machine too much. Otherwise, it will lose the balance.

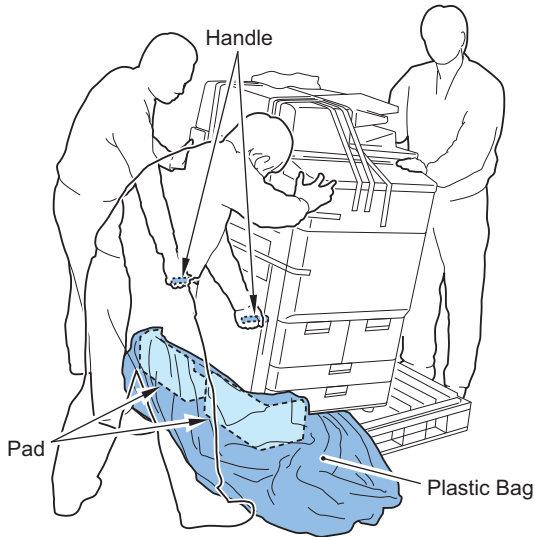




6. Hold the handles at the left side of the host machine and lift the host machine to remove the pad and the plastic bag.

CAUTION:

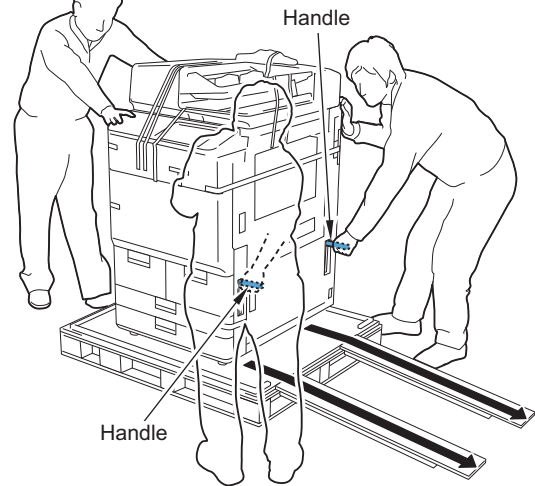
Be sure not to lift the host machine too much. Otherwise, it will lose the balance.



9. Hold the handles at the right side of the host machine, and then, while supporting the corner of the host machine, fit the casters to the center of the Slope Plate to slowly bring the machine down.

CAUTION:

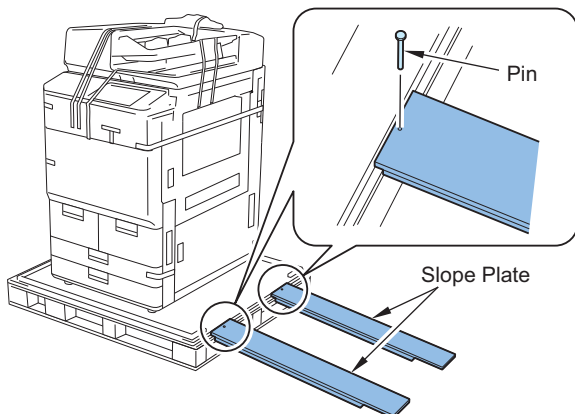
Be careful not to make the casters off from the Slope Plate.



7. Take out the 2 Slope Plates stored at the right side of the Pallet and remove the 2 pins which are secured at the back of the Slope Plate with tape.



8. Turn around the 2 Slope Plates to install as shown in the figure, and then fit the pin-holes of the pallet with the pin-holes of the Slope Plates to put the 2 pins into the holes.



10. Close 4 Handle Covers.

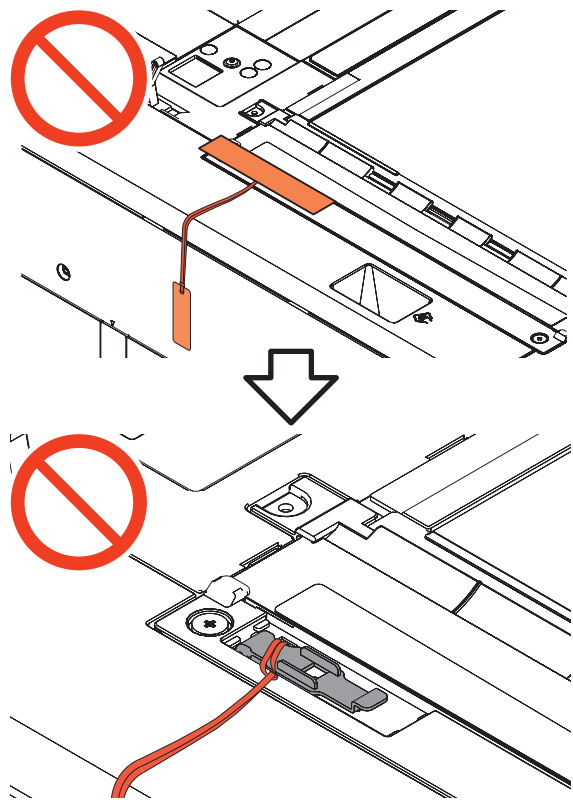


11. Remove tapes on the exterior surface of the host machine.

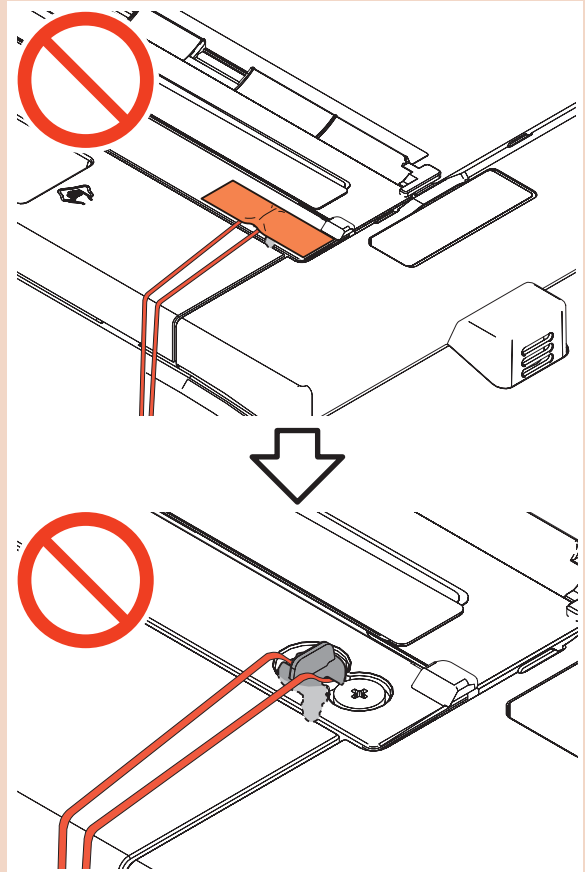
CAUTION:

Do not remove the Scanner Fixation Member until you proceed to "Installing the Scanner (Only for Machines Equipped with the Image Reader Unit)" on page 1985. (Only for machines equipped with the Image Reader Unit.)

< Rear side >



< Front side >



NOTE:

- When the tape is removed from the Image Reader Unit, the DADF will open. Do not close it in this step.
- Do not remove 5 tapes for tags and a tape for the Filter Cover at this step. These tapes will be removed later on.

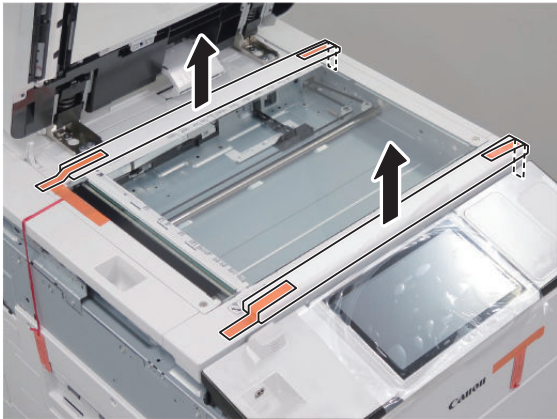




12. Open the DADF and remove tapes on the exterior surface of the host machine. (Only for machines equipped with the Image Reader Unit.)

NOTE:

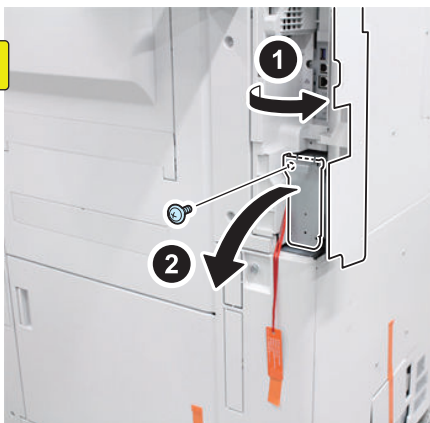
Remove the Scanner Fixation Member and the Scanner Fixation Screw when you proceed to "Installing the Scanner (Only for Machines Equipped with the Image Reader Unit)" on page 1985.



13. Close the DADF. (Only for machines equipped with the Image Reader Unit.)



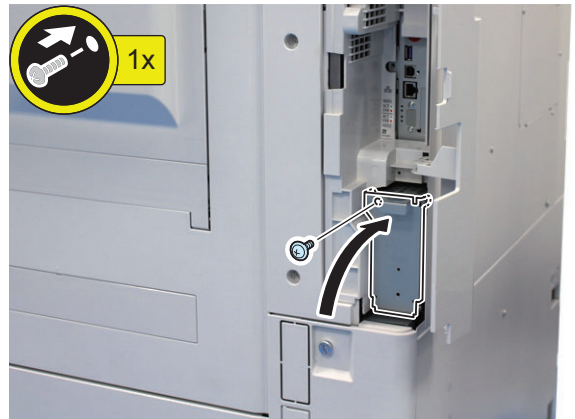
14. Open the Right Rear Cover 1, and Open the HDD Lid.
• 1 Screw



15. Remove the tape securing the tag and remove the package material.


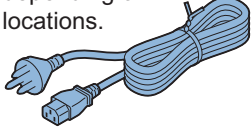

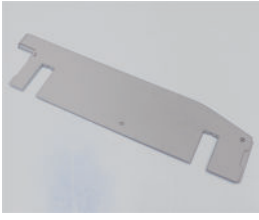


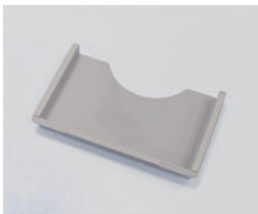


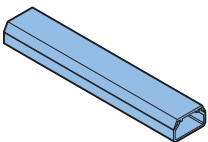
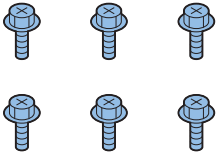

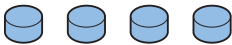


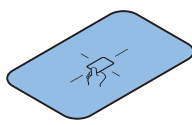
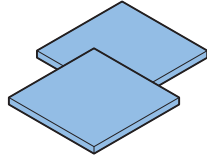
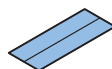


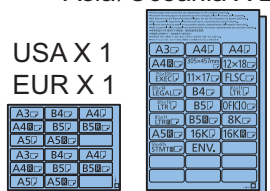




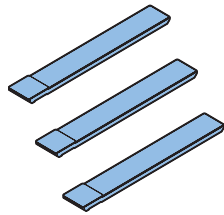
16. Close the HDD Lid.
• 1 Screw



17. Close the Right Rear Cover 1.

Checking the Contents

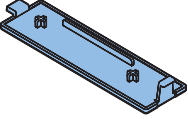

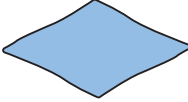

<input type="checkbox"/> [1] Developing Assembly X 1 	<input type="checkbox"/> [2] Power Code X 1 220-240V region only. The connector has a different shape depending on locations. 
<input type="checkbox"/> [3] Exhaust Filter X 1 	<input type="checkbox"/> [4] Left Upper Cover X 1 
<input type="checkbox"/> [5] Right Upper Cover X 1 	<input type="checkbox"/> [6] Upper Rear Cover X 1 
<input type="checkbox"/> [7] Service Book Holder X 1 	<input type="checkbox"/> [8] Finisher Connector Cover X 2 
<input type="checkbox"/> [9] Cleaning Tool X 1 	<input type="checkbox"/> [10] Cord Guide X 1 
<input type="checkbox"/> [11] Screw (RS Tightening ; M4x10) X 6 	<input type="checkbox"/> [12] Screw (Binding; M4x6) X 1  <input type="checkbox"/> [13] Rubber Cap X 4 

<input type="checkbox"/> [14] IC Card Reader Sheet X 1 	<input type="checkbox"/> [15] Cushion X 2 
<input type="checkbox"/> [16] Double-sided Tape X 1 	<input type="checkbox"/> [17] Wire Saddle X 1 
<input type="checkbox"/> [18] Paper Size Label (Deck) X 1 	<input type="checkbox"/> [19] Paper Size Label (Cassette) Asia/Oceania X 2 USA X 1 EUR X 1 
<input type="checkbox"/> [20] JAM Label X1 	<input type="checkbox"/> [21] Control Panel Language Label X 1 Only for Asia/Oceania Used for Korea 
<input type="checkbox"/> [22] Connection Seal (Front) X 1 	<input type="checkbox"/> [23] Connection Seal (Middle) X 1 
<input type="checkbox"/> [24] Name Plate X 3 	

NOTE:

- [16]: Use this if necessary when installing the IC Card Reader.
- [19]: Number of labels attached to the sheet varies according to location/area.
- [21]: Give this to the user as the user may affix it if necessary (See the User's Guide for the procedure).

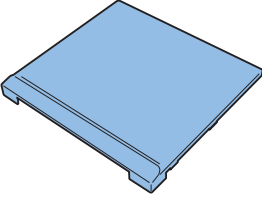
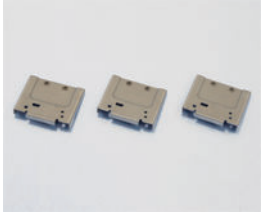


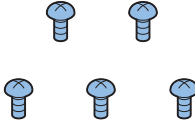
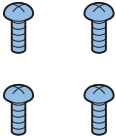

■ Parts Included in the Package of Models with the Image Reader Unit

<input type="checkbox"/> [1] Reader Left Upper Cover X 1 	<input type="checkbox"/> [2] Rubber Cap X 1 
<input type="checkbox"/> [3] Cleaning Cloth X 1 	<input type="checkbox"/> [4] Copy Prohibition Label USA X 1 EUR X 1 

NOTE:

[4]: Number of labels attached to the sheet varies according to location/area.

■ Printer Cover (Only for Machines Equipped with the Printer Cover)

<input type="checkbox"/> [1] Printer Cover X 1 	<input type="checkbox"/> [2] Right Cover Support Plate X 3 
<input type="checkbox"/> [3] Reader Fixation Plate L X 1 	<input type="checkbox"/> [4] Reader Fixation Plate R X 1 
<input type="checkbox"/> [5] Screw (Binding; M4x6) X 5 	<input type="checkbox"/> [6] Screw (P Tightening; M4x10) X 4 
<input type="checkbox"/> [7] Screw (TP; M4x8) X 1 	

● Installation Procedure

■ Installing the Scanner (Only for Machines Equipped with the Image Reader Unit)

NOTE:

- Because the Scanner Fixation Member will be needed when moving the machine, be sure to keep it in a safe place.
- When moving the machine, be sure to execute following service mode (Lv.2), remove the Reader Left Upper, and then install the Scanner Fixation Member. (For details, refer to "When Relocating the Machine".)

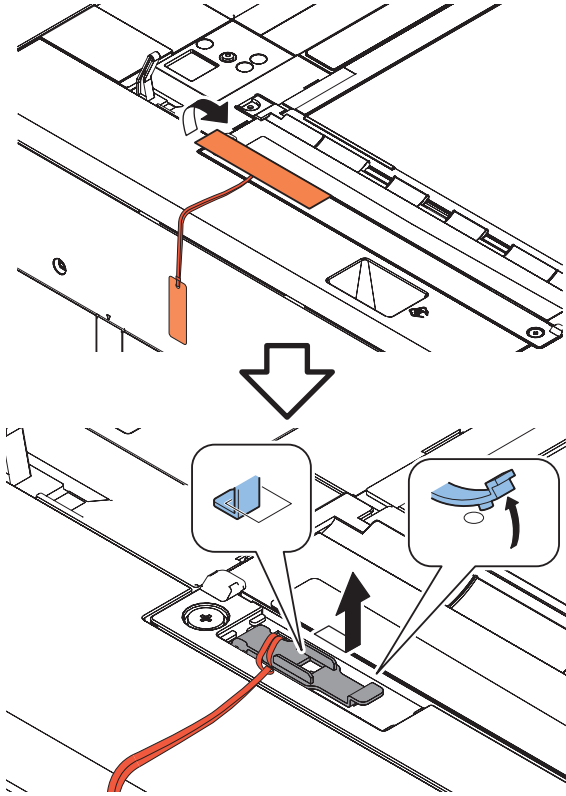
COPIER > FUNCTION > MISC-R > RD-SHPOS



1. Peel the tape off and remove the Scanner Fixation Member (rear side).

NOTE:

Be sure to keep the Scanner Fixation Member in a safe place for moving the machine.

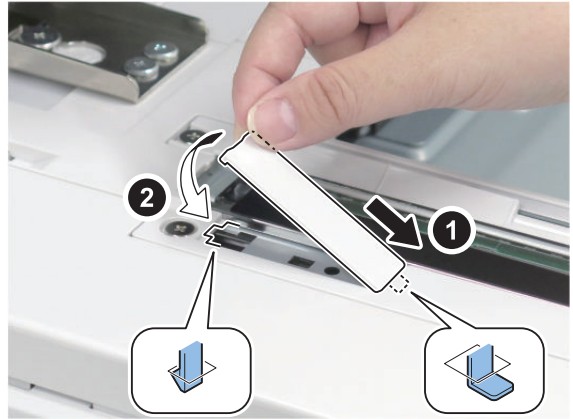
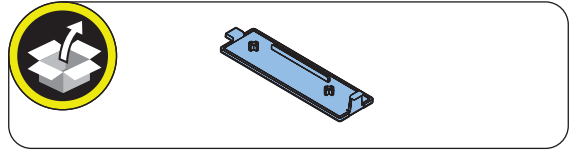


NOTE:

The removed Scanner Fixation Member will be stored in step 7.



2. Install the Reader Left Upper Cover.

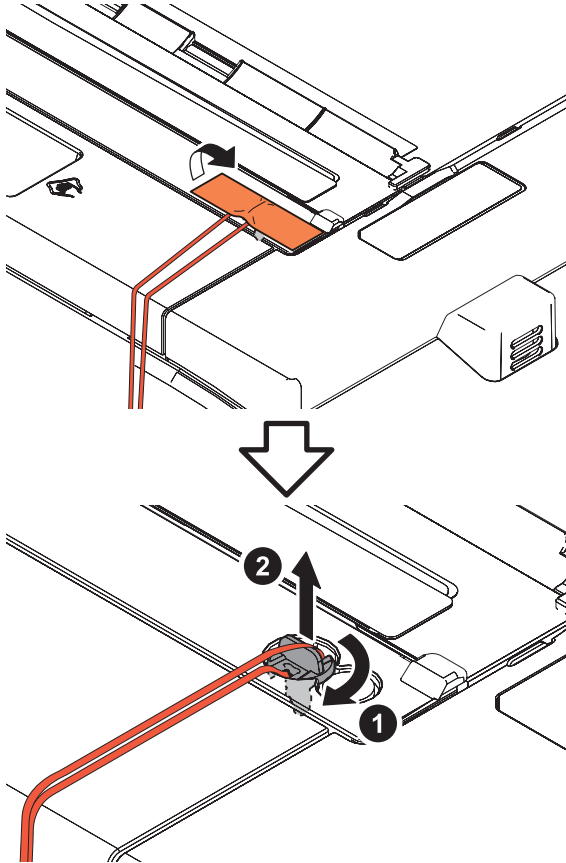




3. Peel the tape off and remove the Scanner Fixation Member (front side).

NOTE:

Be sure to keep the Scanner Fixation Member in a safe place for moving the machine.

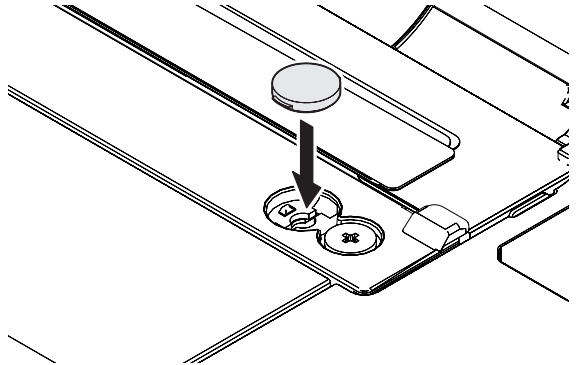
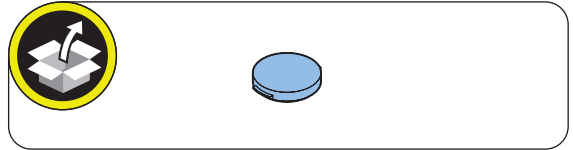


NOTE:

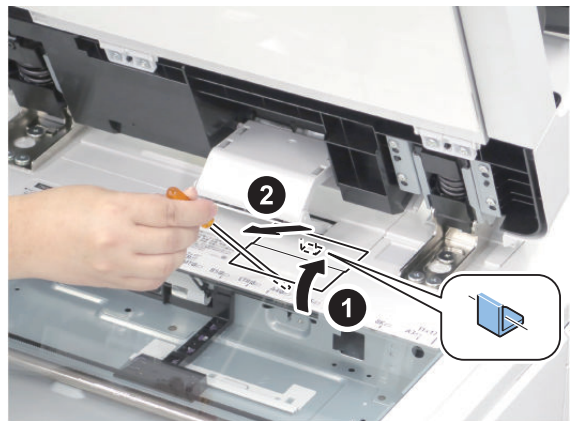
The removed Scanner Fixation Member will be stored in step 8.



4. Install the Rubber Cap.



5. Remove the Maintenance Cover (Upper).

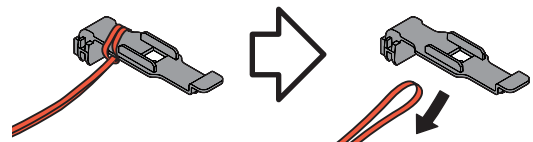


NOTE:

The removed cover will be used in step 7.

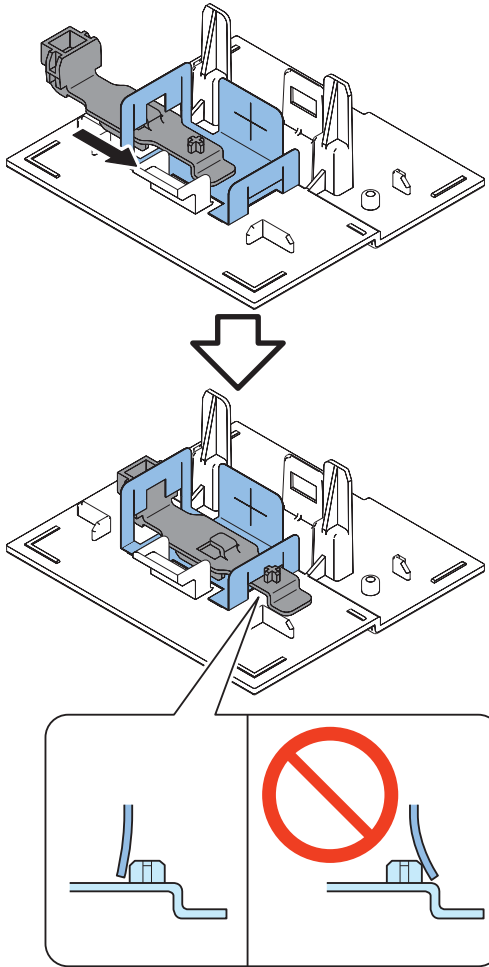


6. Remove the strap with a tag from the removed Scanner Fixation Member.

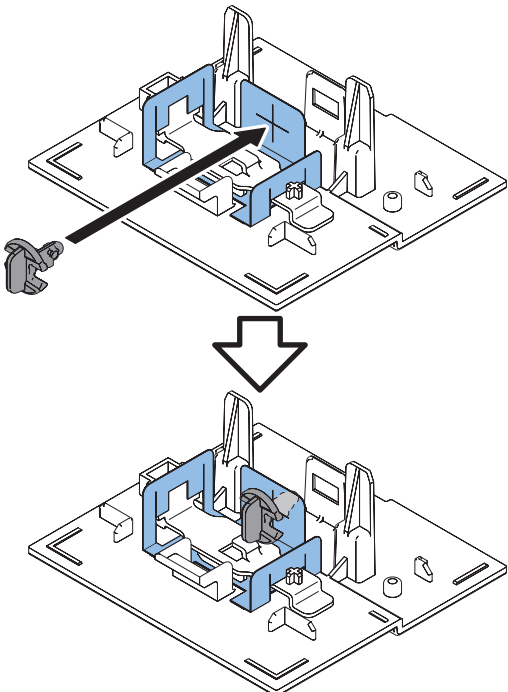




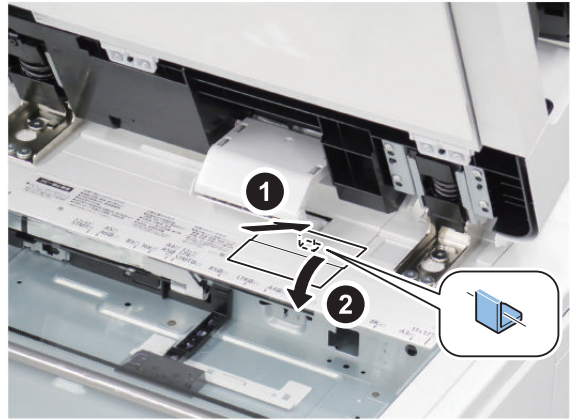
7. Store the Scanner Fixation Member.



8. Store the Scanner Fixation Member.



9. Install the Maintenance Cover (Upper).

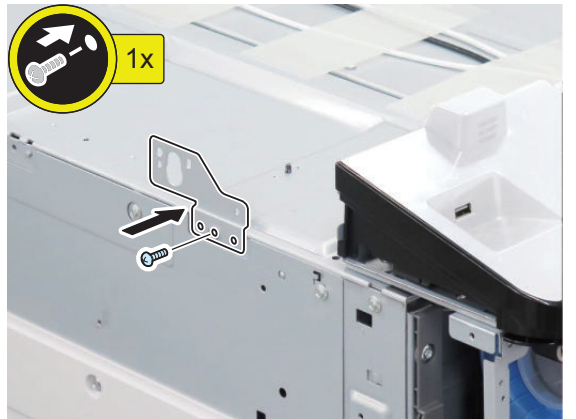
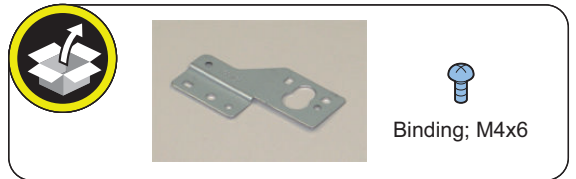


■ Installation of the Printer Cover (Only for Machines Equipped with the Printer Cover)



1. Install the Reader Fixation Plate L.

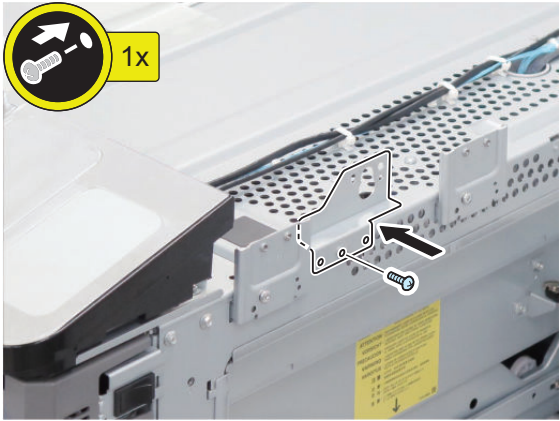
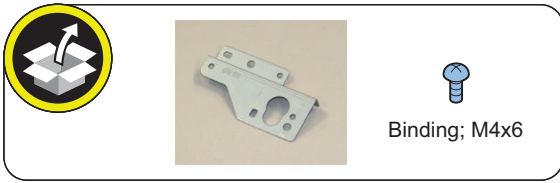
- 2 Bosses
- 1 Screw (Binding: M4x6)





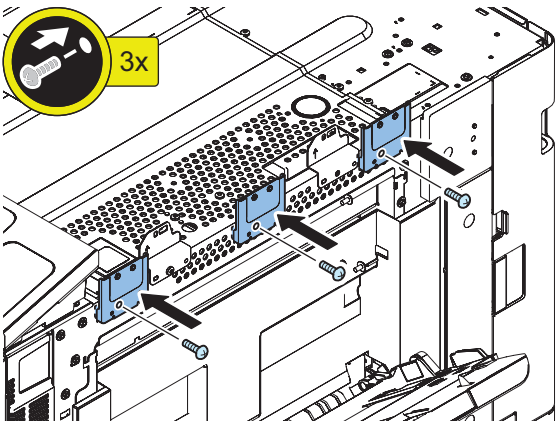
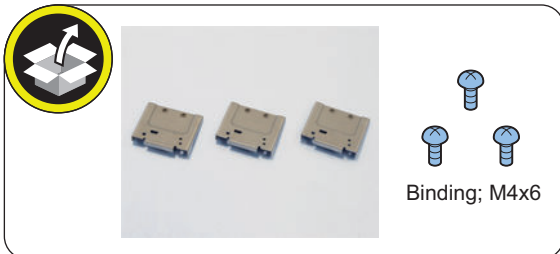
2. Open the Multi-purpose Tray, and install the Reader Fixation Plate R.

- 2 Bosses
- 1 Screw (Binding: M4x6)



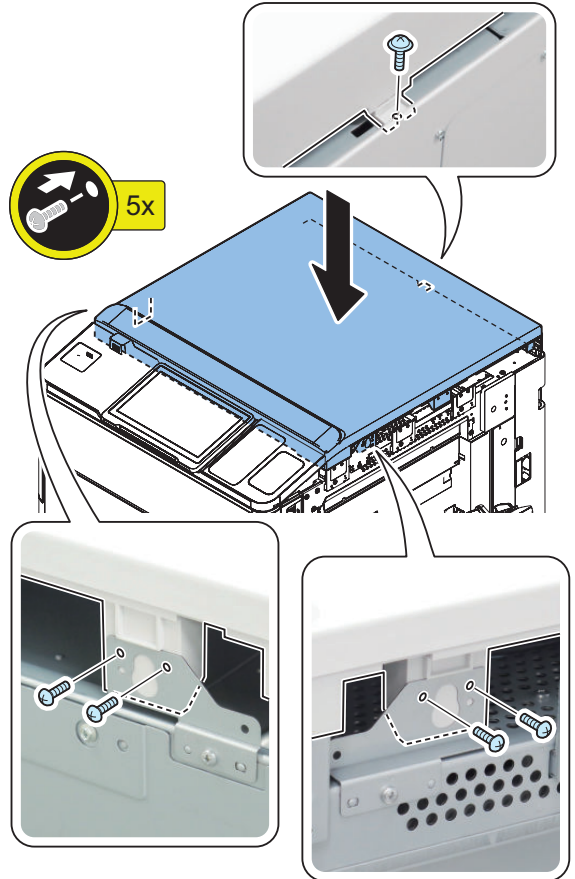
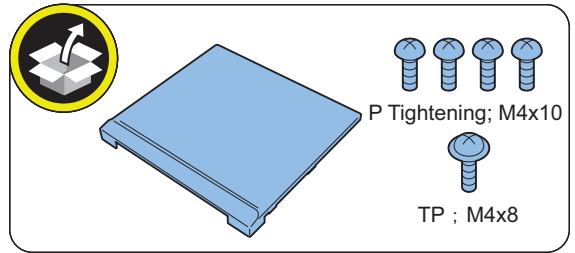
3. Install the 3 Right Cover Support Plates.

- 2 Hooks each
- 1 Screw each (Binding: M4x6)



4. Install the Printer Cover.

- 4 Screws (P Tightening; M4x10)
- 1 Screw (TP: M4x8)



5. Close the Multi-purpose Tray.

■ Installation of the Covers

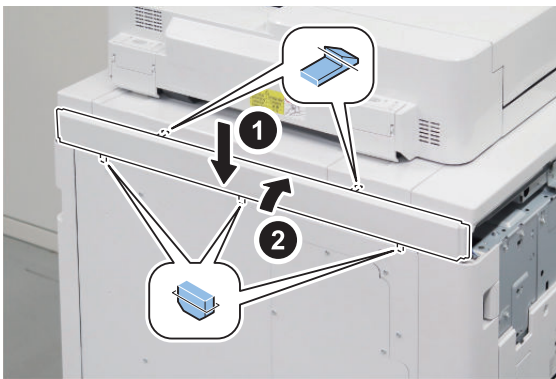
NOTE:

The installation procedure is the same between the Flat Control Panel model and the Upright Control Panel model.



1. Install the Upper Rear Cover.

- 3 Protrusions
- 2 Claws

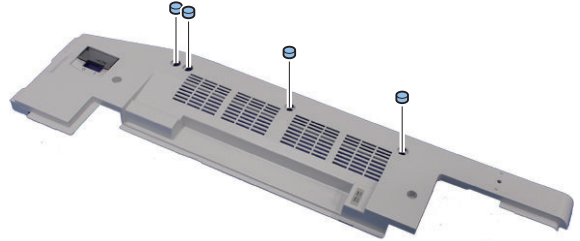
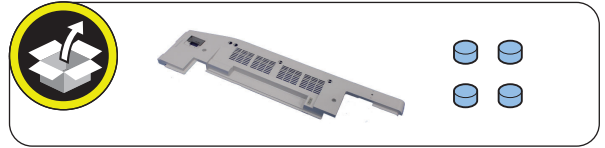


2. Open the covers.

- Toner Replacement Cover
- Right Cover
- Right Rear Cover 1

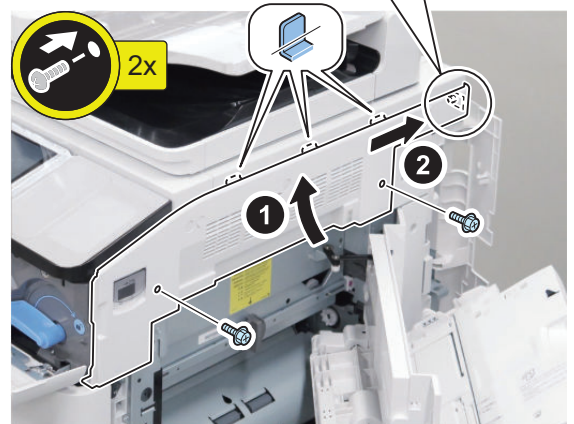
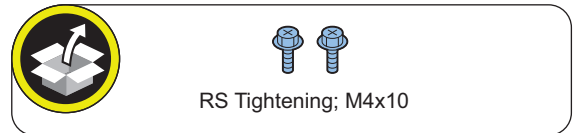


3. Install the 4 Rubber Caps to the Right Upper Cover.



4. Install the Right Upper Cover by fitting its hole onto the boss of the Upper Rear Cover.

- 3 Protrusions
- 2 Screws (RS Tightening; M4x10)

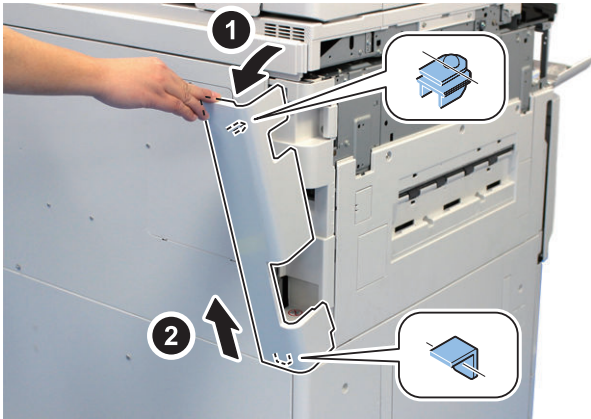


5. Close the Right Cover and Right Rear Cover 1.



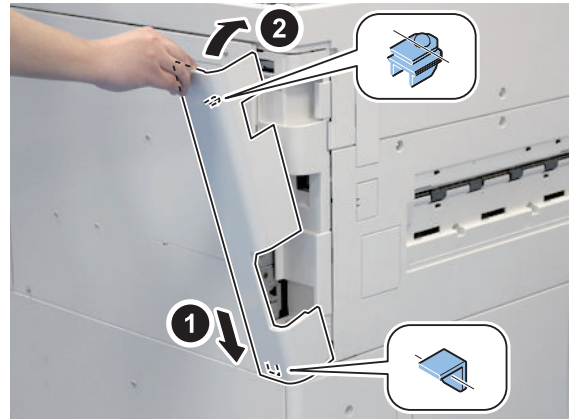
6. Remove the Left Rear Cover.

- 1 Claw
- 1 Hook



8. Install the Left Rear Cover.

- 1 Hook
- 1 Claw

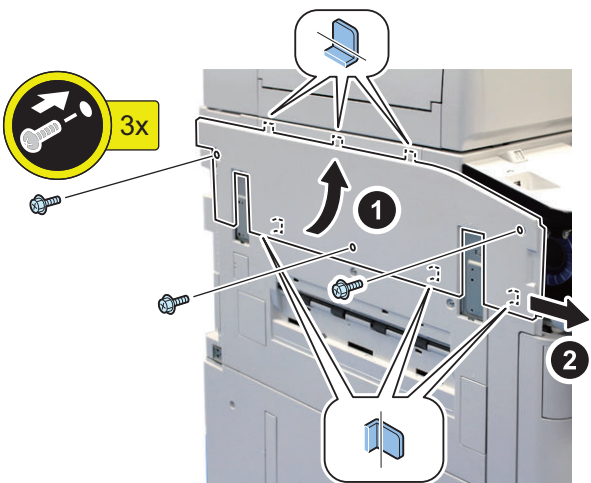
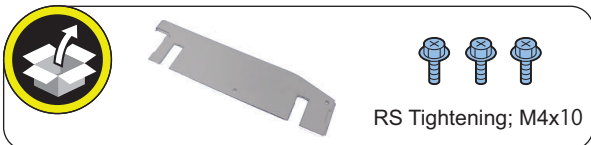


7. Install the Left Upper Cover in the direction of the arrow.

- 3 Protrusions
- 3 Hooks
- 3 Screws (RS Tightening; M4x10)

CAUTION:

When installing the Left Upper Cover, be careful not to secure it while it is being slid fully toward the front. Otherwise, the Left Upper Cover may interfere with the Toner Replacement Cover and the magnet cannot work.



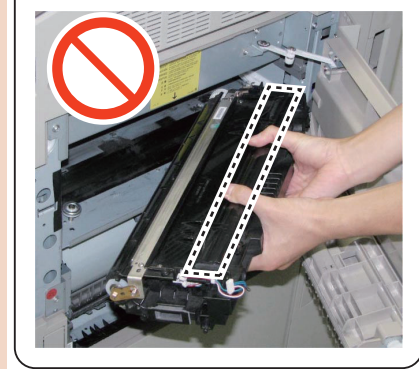
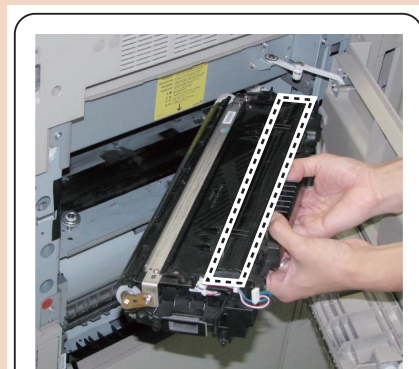
9. Close the Toner Replacement Cover.

■ Installation of the Developing Assembly

CAUTION:

How to Hold the Developing Assembly

- When holding the Developing Assembly, be sure to hold the handle of the Developing Assembly as shown in the figure.
- Do not touch the shutter area of the Developing Assembly. The shutter area is slippery, so it may cause a fall of the assembly.



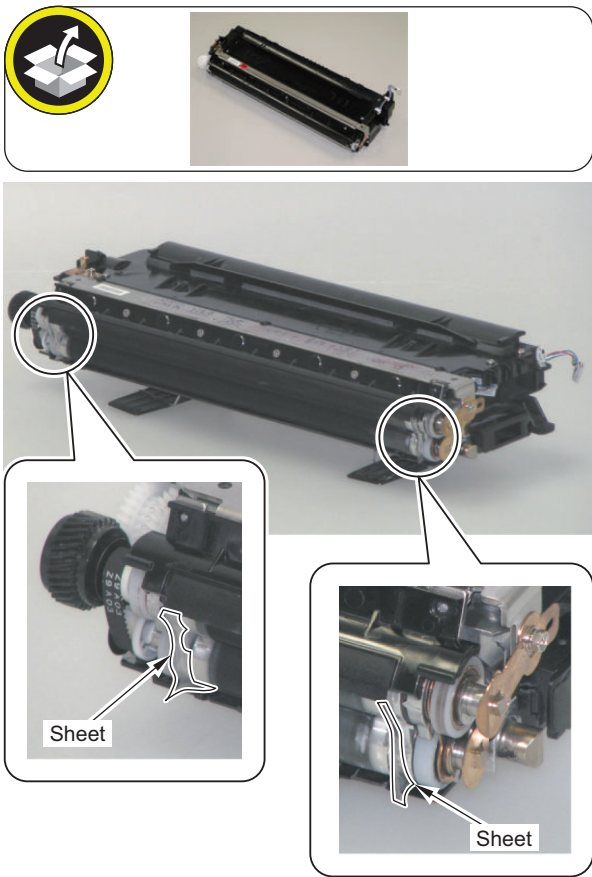


1. Unpack the Developing Assembly.

CAUTION:

Points to Caution when Installing the Developing Assembly

Be sure not to remove the Toner Blocking Sheet by mistake.



2. Remove the package materials.



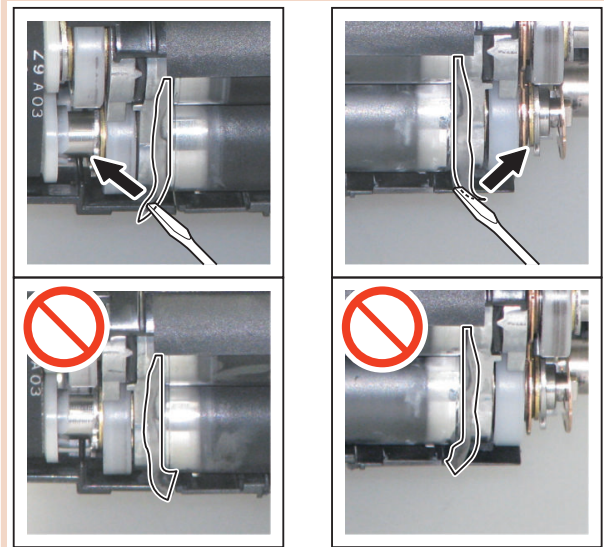
CAUTION:

Checking and Adjusting the Direction of the Toner Blocking Sheet

Be sure to check the direction of the Toner Blocking Sheet before installing the Developing Assembly to the host machine.

If the Toner Blocking Sheet turns inward, image error due to toner scattering will occur, so adjust it to turn outward with a flat-blade screwdriver.

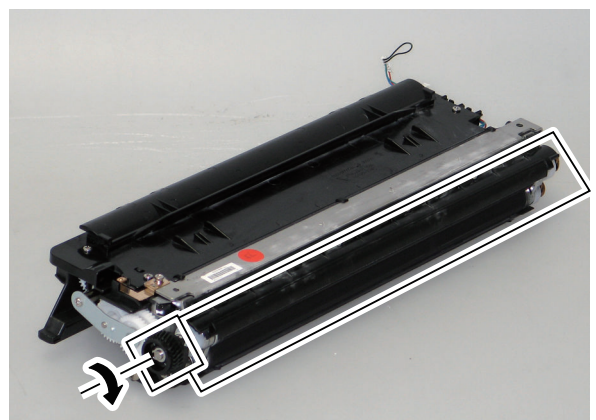
Be careful not to damage the Developing Assembly when adjusting the sheet.



3. Check if there are any scratches on the cylinder while rotating the gear manually in the direction of the arrow.

CAUTION:

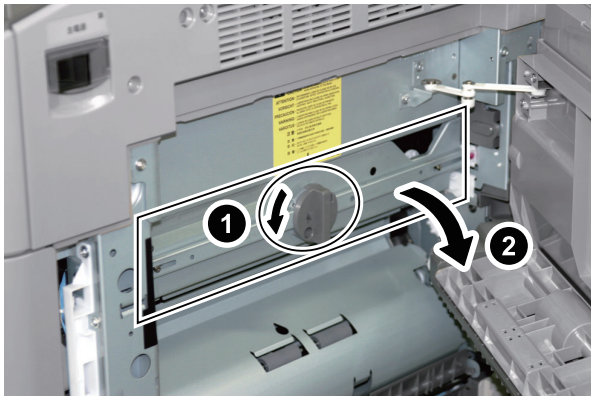
- Do not damage and touch the cylinder.
- Do not turn the gear inversely.



4. Open the Right Cover.

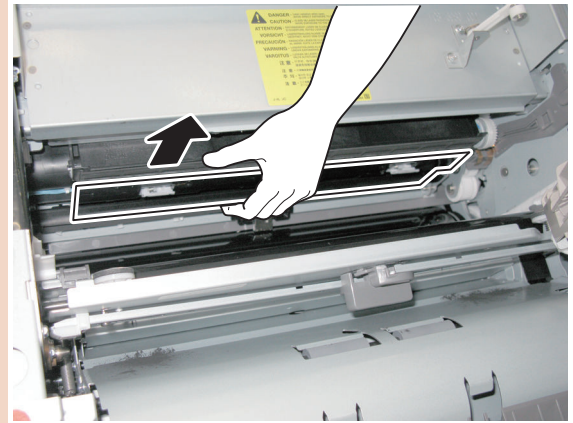


5. Turn the Lock Lever, and open the Developing Assembly Pressure Cover.



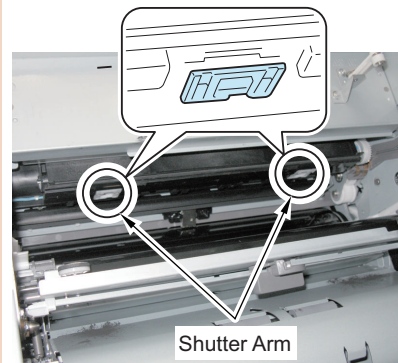
CAUTION:

- Before installing the Developing Assembly, be sure to check that the Buffer Shutter is not opened.
- If forcedly inserting the Developing Assembly while the Buffer Shutter is open, the Buffer Shutter may get damage. When the Buffer Shutter is open, be sure to close it by pulling it toward the front.

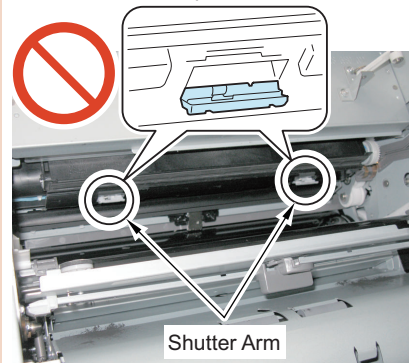


- Whether the Developing Assembly is installed properly can be checked with the Shutter Arm.

<Buffer Shutter is closed>

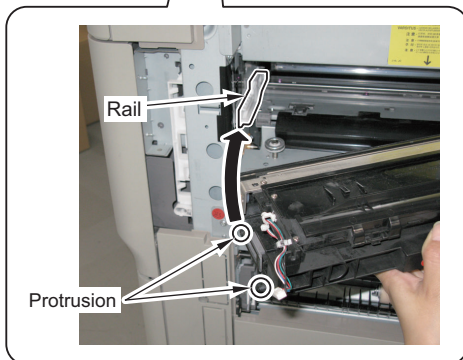
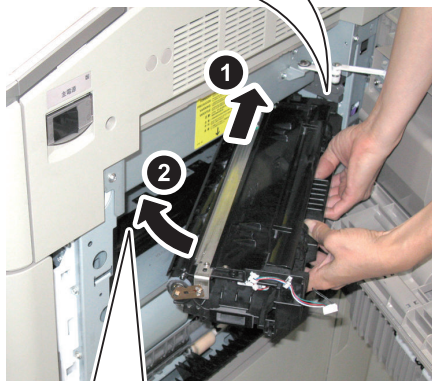
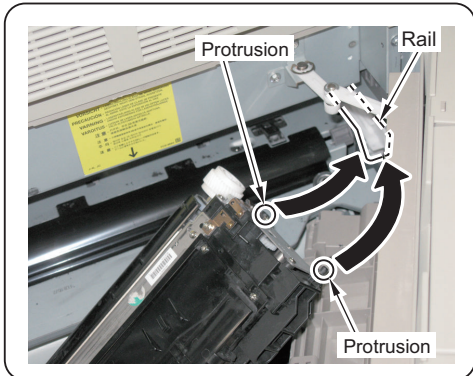


<Buffer Shutter is open>

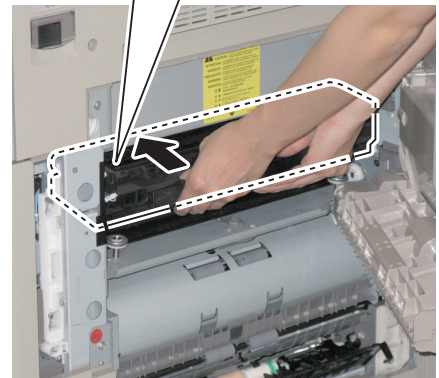
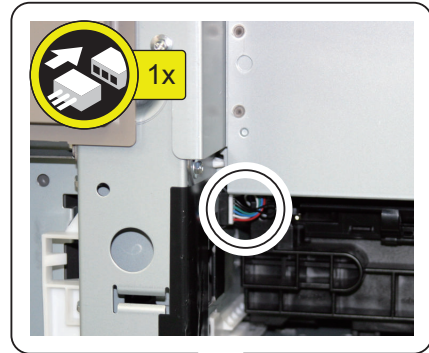




6. Hold the Developing Assembly as shown in the figure, and align the protrusions at both sides of the assembly with the rails on the host machine.
- 2 Protrusions each



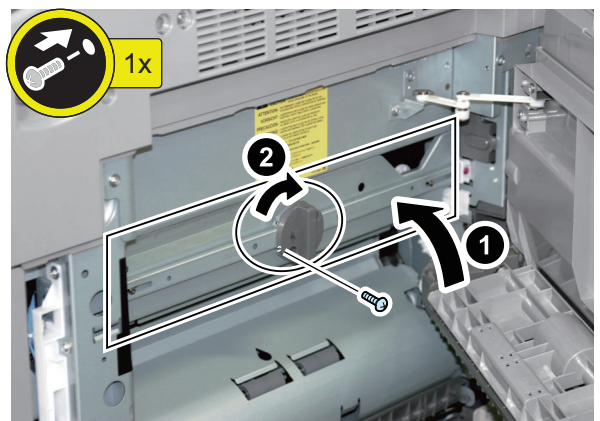
7. Along the rails, insert the Developing Assembly horizontally.
- 1 Connector



8. Close the Developing Assembly Pressure Cover and return the Lock Lever to the original position. Secure with the Screw (Binding; M4x6).



 Binding; M4x6



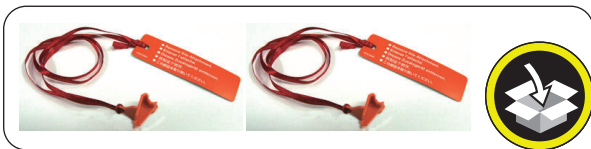
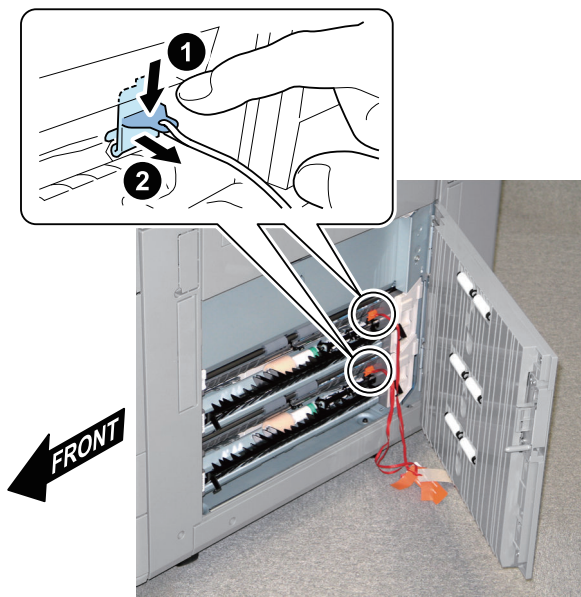
9. Close the Right Cover.

■ Installation of the Pickup Assembly

-
- 1. Remove tapes securing tags from the Vertical Path Cover.

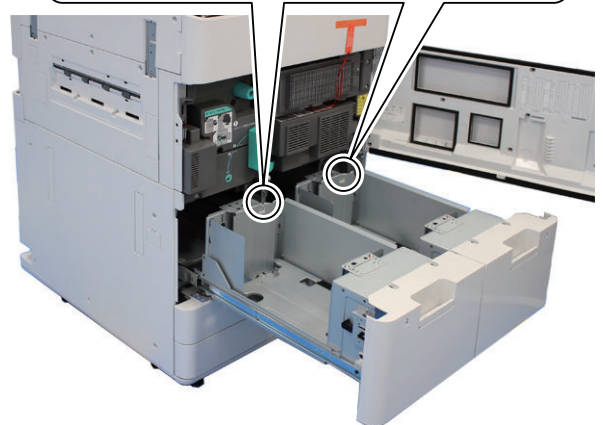
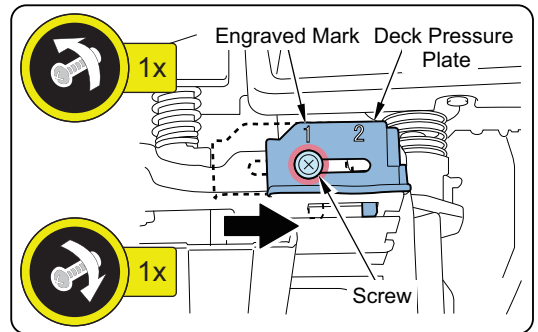


-
- 2. Open the Vertical Path Cover and remove 2 Pressure Release Spacers at pickup slot for each cassette.



-
- 3. Close the Vertical Path Cover.
-
- 4. Open the Front Cover.
-
- 5. Open the Left and Right Decks, and remove the tape.

-
- 6. Loosen the screw and slide the Deck Pressure Plate in the direction of the arrow. Check that the screw position is at the engraved mark '1', and then tighten the screw.



-
- 7. Close the Left and Right Decks.

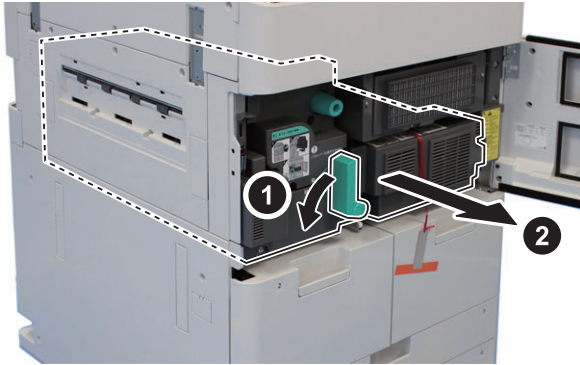
■ Installing the Fixing Assembly

-
- 1. Remove the tapes.



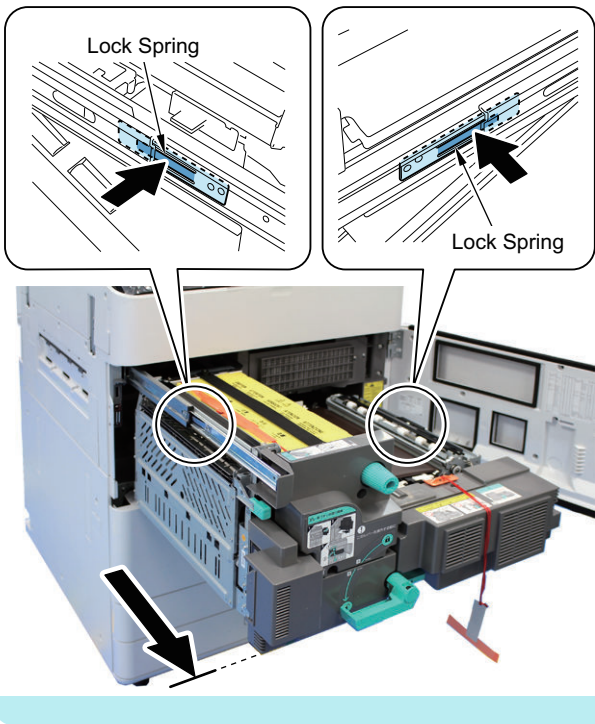


2. Turn the Fixing Feed Unit Release Lever in the direction of the arrow and pull the Fixing Feed Unit all the way out.

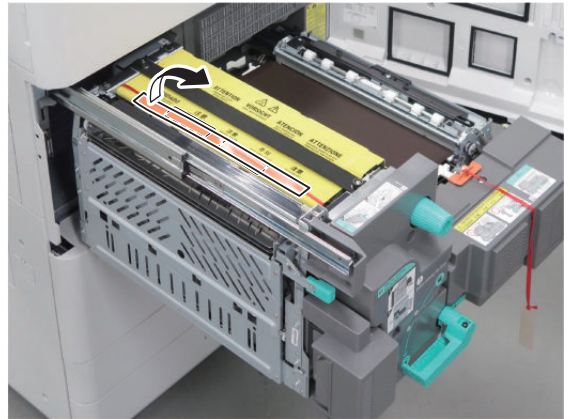


NOTE:

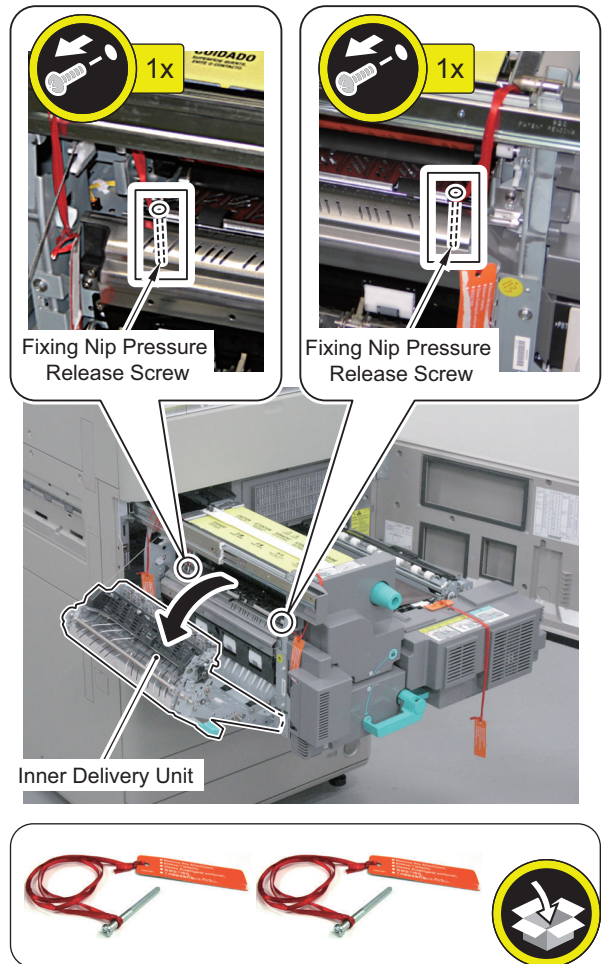
In the case that the Fixing Nip Pressure Release Screw is hard to be removed, release the lock by pressing the Lock Springs at both rails, and pull out the Fixing Feed Unit further until it stops.



3. Remove the tape securing a tag on the Fixing Upper Cover.



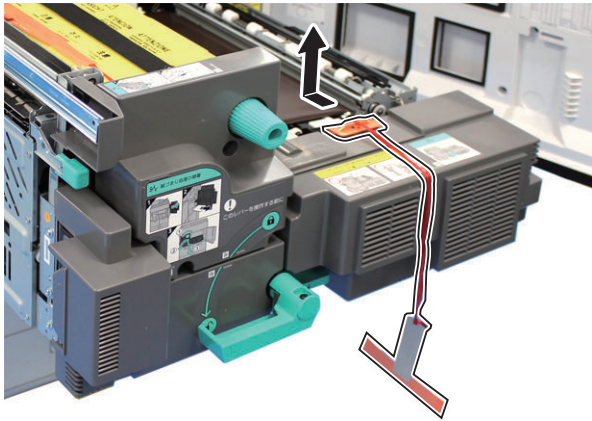
4. Open the Inner Delivery Unit, and remove the 2 Fixing Nip Pressure Release Screws.



5. Close the Inner Delivery Unit.



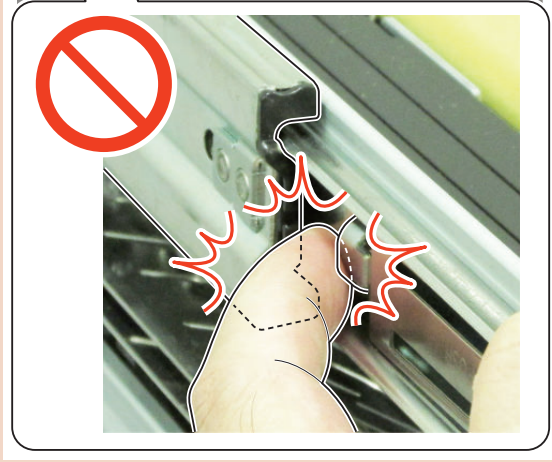
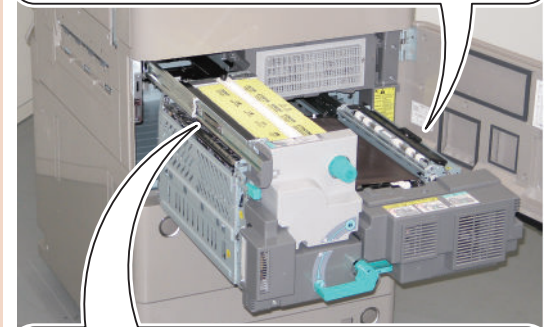
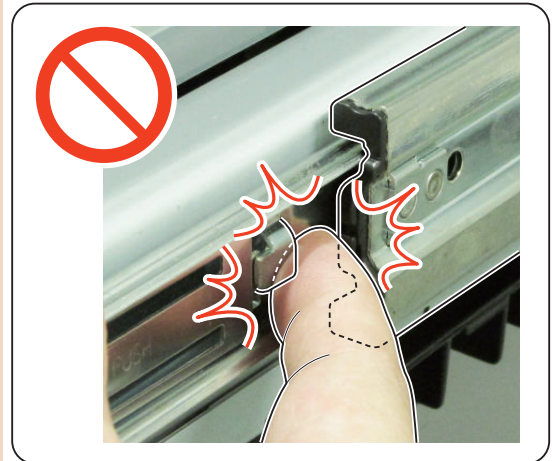
6. Remove the ETB Spacer.



7. Return the Fixing Feed Unit and lock the Fixing Feed Unit Release Lever.

NOTE:
In the case of pulling out the Fixing Feed Unit further, be sure to return the Fixing Feed Unit while releasing the Lock Spring.

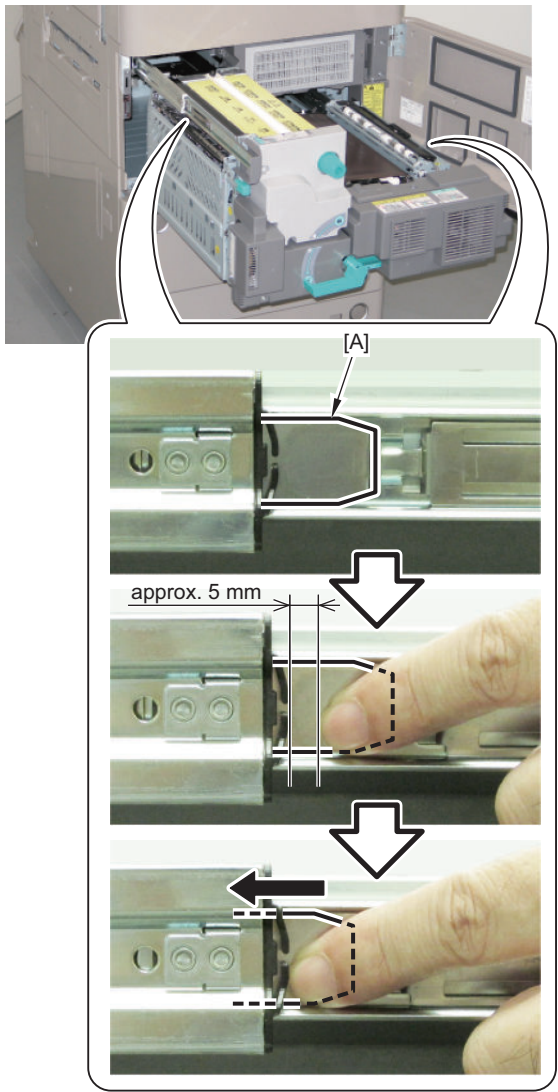
CAUTION:
Points to Note when Inserting the Fixing Feed Unit
While pressing the Release Springs, slowly push the Fixing Feed Unit in so that the fingers do not get caught.



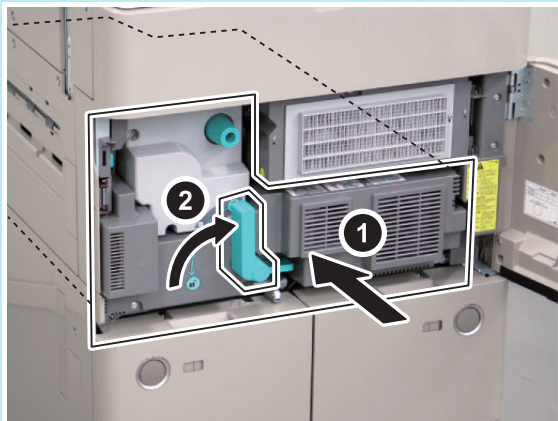
NOTE:

How to push the Fixing Feed Unit

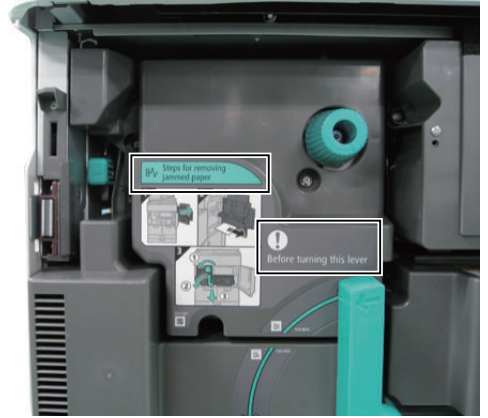
1. Release the Release Springs [A] on the side of either rail.
Slowly push the Fixing Feed Unit in by approximately 5 mm while keeping it level.



2. Take the fingers off the Release Springs and slowly push the Fixing Feed Unit in to the end.



8. Affix the Jam Label of the appropriate language over the existing label on the Fixing Front Cover.



9. Close the Front Cover.

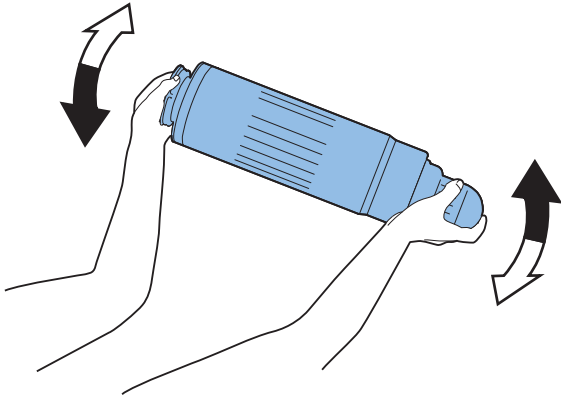
■ **Installation of Toner Container**

1. Open the Toner Replacement Cover, and turn the Lock Lever in the direction of the arrow to release.





2. Unpack the Toner Container and shake it approx. 10 times horizontally.



3. Remove the cap of the Toner Container.



4. Set the Toner Container to the host machine, and turn the Lock Lever in the direction of the arrow to secure the Toner Container in place.

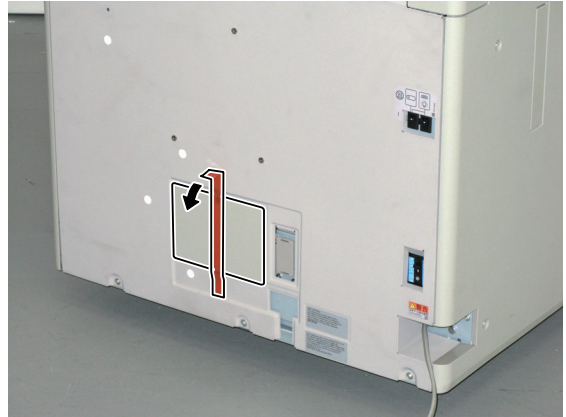


5. Close the Toner Replacement Cover.

■ Installing the Exhaust Filter



1. Remove the tape, and remove the Filter Cover.



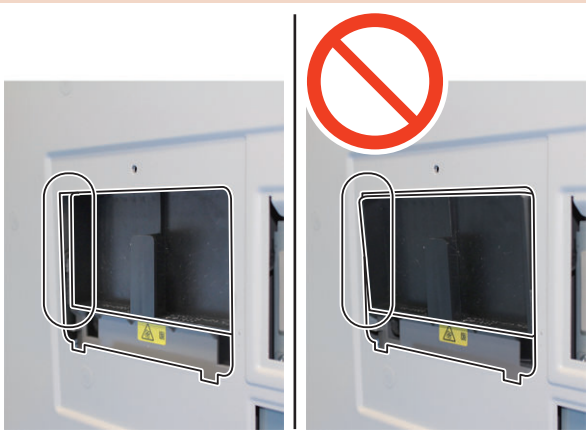


2. Hold the Exhaust Filter as shown in the figure, and install it to the Main Body.



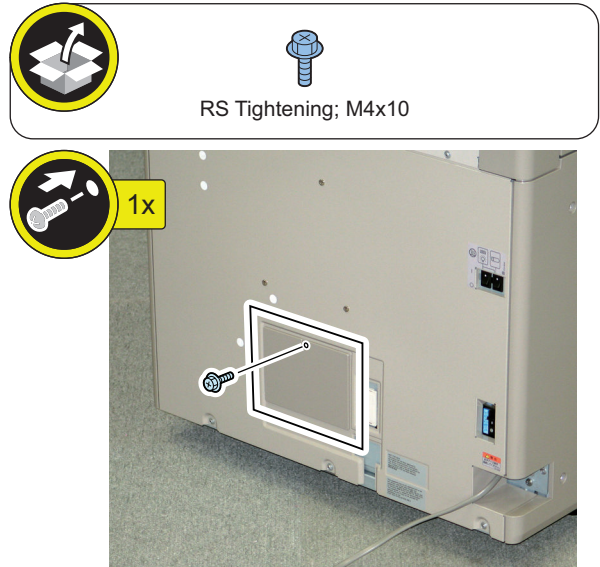
CAUTION:

When installing the Exhaust Filter, be sure to install it straight. If it is installed askew, the Filter Cover does not fit properly.



3. Install the Filter Cover.

- Screw (RS Tightening; M4x10)



■ **Setting the Environment Heater Switch**

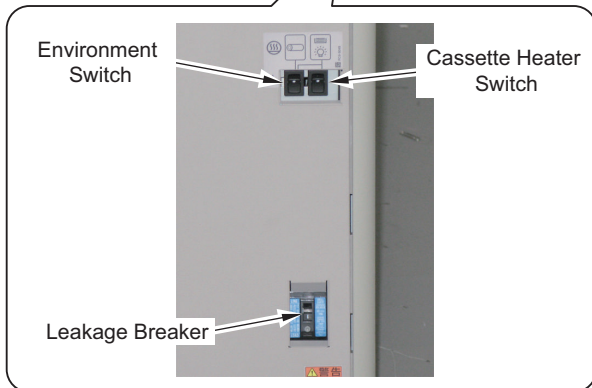
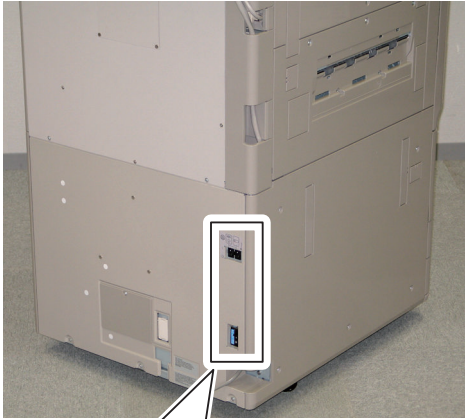


1. Check that the Leakage Breaker is ON.

- Turn ON the Environment Heater Switch and the Cassette Heater Switch in accordance with the installation environment.

NOTE:

In the case of high humidity environment, turn ON the Environment Heater Switch.



■ Turning ON the Main Power <Registering the Speed License>

CAUTION:

- Before performing this procedure, it is necessary to obtain the license key of the speed license.
- With this product, license of engine speed needs to be entered depending on location or model.
- Since the automatic adjustment of the ADF reading position will be executed when the main power is turned ON for the first time, remove all objects on the copyboard glass and close the ADF.



- Remove the protection sheet on the control panel.
- Connect the power plug of the host machine to the power outlet.
- Turn ON the main power switch.

- An error message "E612-0007" is displayed.
- Enter service mode.
- Press [SPEED LICENSE].

CAUTION:

Check that the serial number of the machine at acquisition of the license and the serial number displayed on the license No. input screen are the same.

- Enter the license number and press [Start]. Then, "OK" is displayed.
- Turn OFF/ON the main power switch.

NOTE:

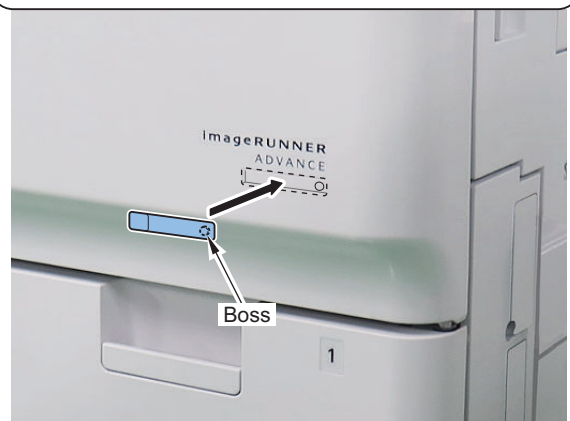
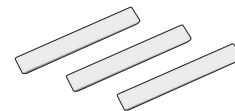
Turning OFF the Main Power

- Open the Switch Cover and turn OFF the main power switch.
- Check that the control panel display and the main power lamp are OFF, and then disconnect the power plug.

- Install the Name Plate of the product according to the speed license.

CAUTION:

Be sure to bring back the unused Name Plates.



<In the Case of Printer Model>

- A message is displayed prompting to check that the Reader Unit Cable is connected properly.
- Select the following service mode and enter "0" to the setting value.
COPIER > OPTION > FNC-SW > W/SCNR
- Exit the Service Mode.
- Turn OFF and then ON the main power switch.

■ Host Machine Settings (Start Setup Guide)

The Setup Guide screen appears when the main power is turned ON after registration of the speed license. Follow the instructions displayed on the Touch Panel Display to configure the settings of the host machine.

CAUTION:

- Some of the settings can be skipped without entering the command. To configure skipped settings, configure the settings one by one after exiting Setup Guide.
- Setup Guide can be started again from [Settings/Registration]. ([Settings/Registration] > [Management Settings] > [License/Other] > [Start Setup Guide])
- If the host machine is turned OFF during the registration using the Setup Guide, the Setup Guide is automatically started by turning ON the host machine.
- Once registration using the Setup Guide is completed, the Setup Guide is not automatically started by turning ON the host machine.

CAUTION:

Register the information of paper loaded during installation of the host machine.

Be sure to register the correct paper type. Especially in the case of special paper types such as heavy paper, registering a wrong paper type may result in image failure, and when the Fixing Assembly becomes soiled or paper wraparound occurs, repair by a service technician becomes necessary.

NOTE:

Following works can be performed while toner mixing is executed.

- "Securing the Host Machine" on page 2002
- "Other Installation Work" on page 2003
- "Affixing the Labels on the Reader Assembly (Only for Machines Equipped with the Image Reader Unit)" on page 2004
- "Setting the Deck" on page 590
- "Setting the Paper Cassette" on page 2006

● Informing the System Administrator That Installation Is Complete

When the installation is completed, ask the system administrator to change the password.

Also ask the system administrator to keep the changed password in a safeplace to prevent leakage.

■ Registration of Installation Date Information

CAUTION:

Be sure that [Date/Time Settings] is completed. (There are items in Setup Guide.)



1. Enter the following service mode, and execute "Batch Set Installation Date Info".

COPIER > FUNCTION > INSTALL > INSTDTST

NOTE:

- Year, month, day, hour, and minute can be edited individually in the following service modes.
COPIER > OPTION > USER > INSTDT-Y
COPIER > OPTION > USER > INSTDT-M
COPIER > OPTION > USER > INSTDT-D
COPIER > OPTION > USER > INSTDT-H
COPIER > OPTION > USER > INSTDT-N
- The default value of each service mode is "0".
- When "0" is set for each service mode, "Device Installation Date" on the counter report will be blank.

2. Exit service mode.

3. Output the counter report, and check that the installation date information is registered.

- [Counter/Device Information] key > [Print List] > [Yes]

2017 08/30 WED 09:40		0001
***** *** Counter Report *** *****		
Device Installation Date	2017/08/09 07:56	
Counter Check Date	2017/08/30 09:40	
Model	IR-ADV	
Serial Number	UN000938	

■ Securing the Host Machine



1. Confirm the position to install the Host Machine and turn the 2 adjusters with your hand until they closely contact the floor.

NOTE:

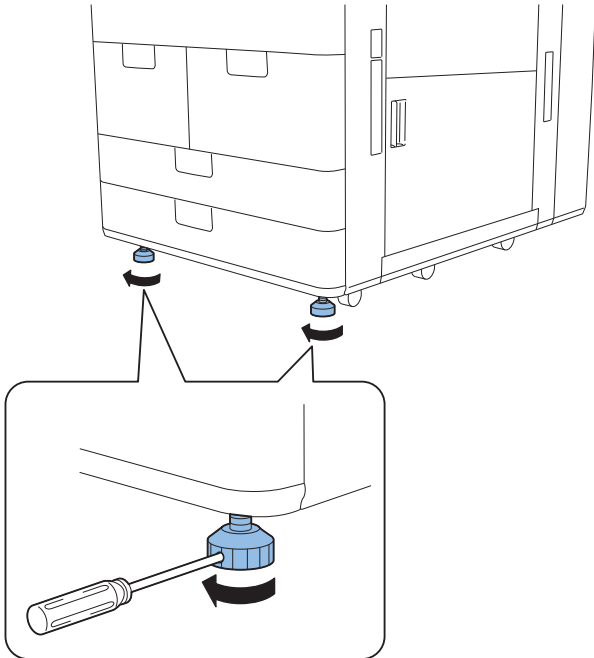
If you failed to turn the adjusters with your hand, use a screwdriver so that they can be turned by your hand.



2. Use a screwdriver to turn the adjusters in the direction of the arrow to make them secured.

NOTE:

Securing of the adjuster is not earthquake resistant.

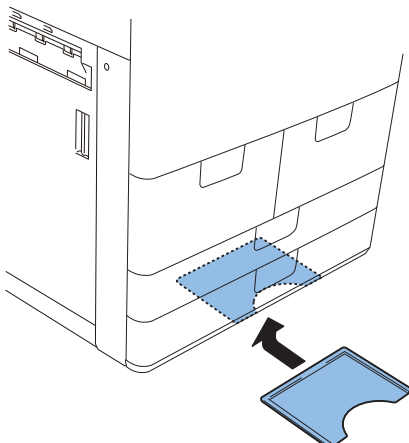
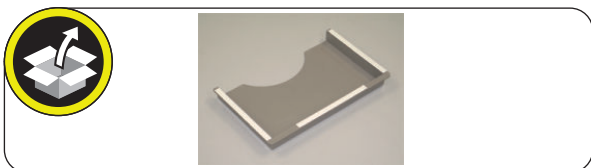


■ **Other Installation Work**

● **Service Book Holder**



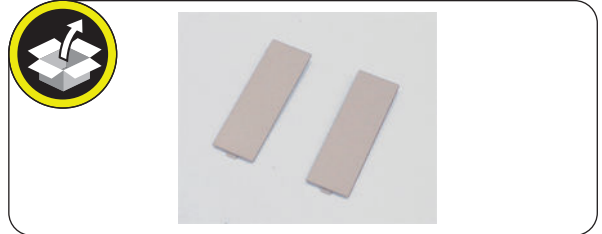
1. Remove the double-sided tape on back side of the Service Book Holder, and affix the holder on the Base Plate of the host machine.



● **Finisher Connector Cover**



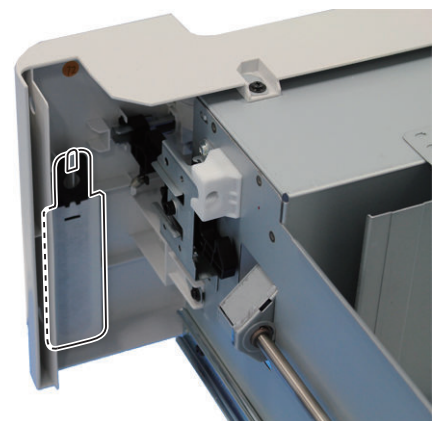
1. Install the 2 Finisher Connector Covers to the left side of the host machine.
 - 1 Protrusion each
 - 1 Claw each



● **Cleaning Tool**



1. Store the cleaning tool on the inside of the Right Deck to use for maintenance. (Hook it on the back side of the Deck Cover.)



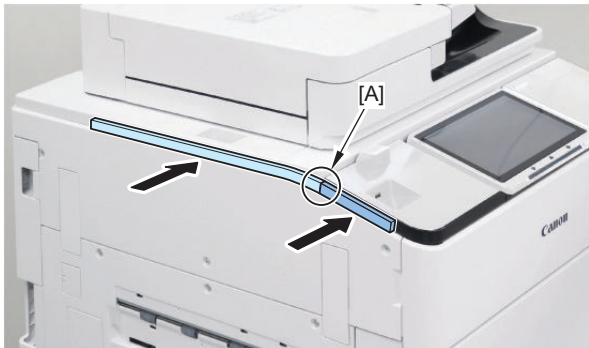
● Connection Seal

□

1. Affix the Connection Seal (Front) and the Connection Seal (Middle) to the position on the left side of the host machine as shown in the figure. (When connecting delivery options)

CAUTION:

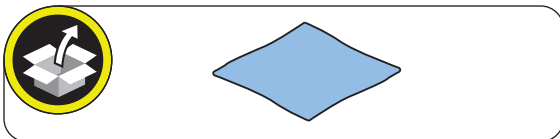
Be sure that there is no gap between [A] the Connection Seal (Front) and the Connection Seal (Middle).



● Storing the Cleaning Cloth (Only for Machines Equipped with the Image Reader Unit)

□

1. Place the Cleaning Cloth in the space shown in the figure.



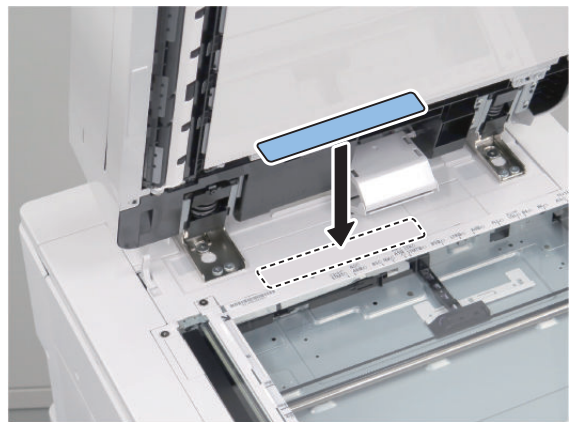
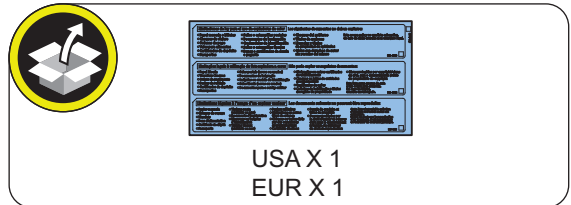
■ Affixing the Labels on the Reader Assembly (Only for Machines Equipped with the Image Reader Unit)

□

1. Open the DADF.

□

2. Affix the Copy Prohibition Label of the appropriate language at the places shown in the figure below.



□

3. Close the DADF.

■ Checking the K paper settings (Only for CHINA)

□

Check the following service mode, and change the setting value if different.

1. Enter service mode.
2. Check that the setting value of COPIER > OPTION > FNC-SW > MODEL-SZ is "0".
3. Enter service mode (Lv.2).
4. Check that the setting value of COPIER > OPTION > FNC-SW > SENS-CNF is "0".
5. Check that the setting value of COPIER > OPTION > FNC-SW > MODELSZ2 is "0".
6. Check that the setting value of COPIER > OPTION > FNC-SW > KSIZE-SW is "1".
7. When having changed the setting, turn OFF and then ON the main power to enable the setting value.

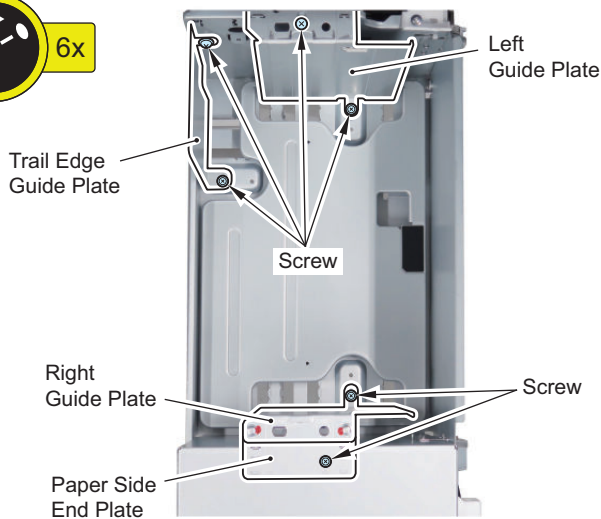
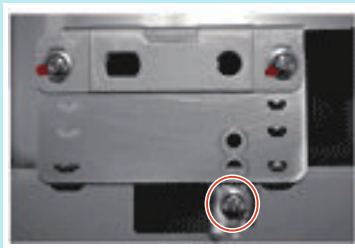
■ Setting the Deck

-
- 1. Pull out the Left and the Right Decks to the front.
-
- 2. Remove the 4 screws fixing the Trailing Edge Guide Plate, Left Guide Plate, Right Guide Plate, and Paper Side End Plate in place, and fix each of the Guide Plates at user's desired size.

NOTE:

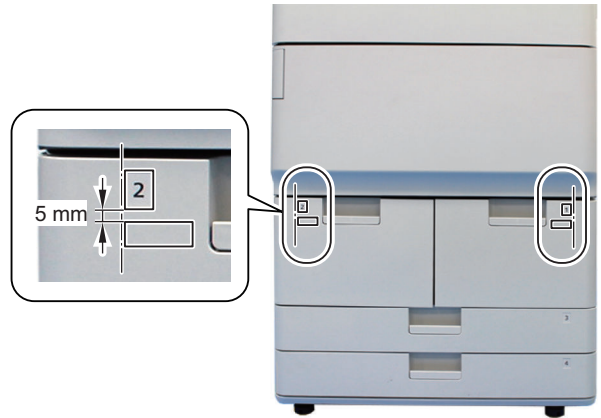
Setting the Paper Side End Plate

- Be sure to align the Paper Side End Plate with the position according to the size requested by the user, and secure the screw.
- When B5 size is set, the Paper Size End Plate cannot be fixed to the deck with the screw. In order to prevent the screw from being lost, be sure to secure the screw to the deck as shown below.



-
- 3. Put the specified size of papers in the Left/Right Deck, and push the Left/Right Deck in.

-
- 4. Affix Paper Size Labels (for Deck) according to the paper size, with the edge of each label aligned with the edge of the cassette number label. Approx. 5 mm away from the number label.



-
- NOTE:**
If Setup Guide is running, skip this procedure.

5. Register the type of paper loaded in the paper source.

1. Select the [Settings/Registration] > [Preferences] > [Paper Settings] > [Paper Settings].
2. Select the paper source where paper is loaded, and press [Set].
3. Select the paper type same as that of the loaded paper, and press [OK] > [OK].

NOTE:

If the corresponding paper type is not displayed on the simple settings screen, press [Detailed Settings] and make a selection on the detailed settings screen. If the type of loaded paper is not displayed on the detailed settings screen, you can register it.

NOTE:

If Setup Guide is running, perform the following works after Setup Guide ends.



6. When the size has been changed, register the paper size for the Left and Right Deck in the service mode.

Right Deck :

COPIER > OPTION > CST > P-SZ-C1

Left Deck :

COPIER > OPTION > CST > P-SZ-C2



7. Exit from the service mode.

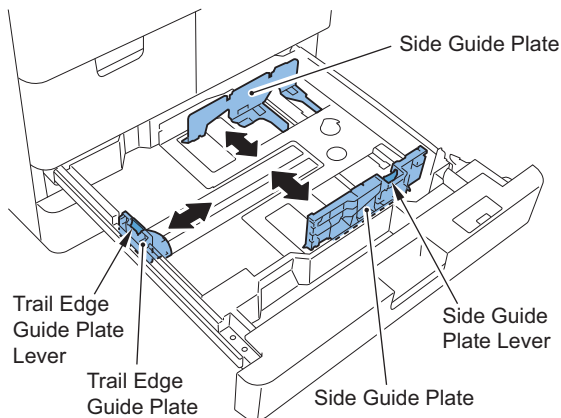
■ Setting the Paper Cassette



1. Pull out the Cassette to the front.



2. Hold the lever of the Side Guide Plate, and adjust the plate to the specified size. Adjust the Trailing Edge Guide Plate in the same way.



3. Set paper, and push the Cassette.



4. Set another cassette as well.

NOTE:

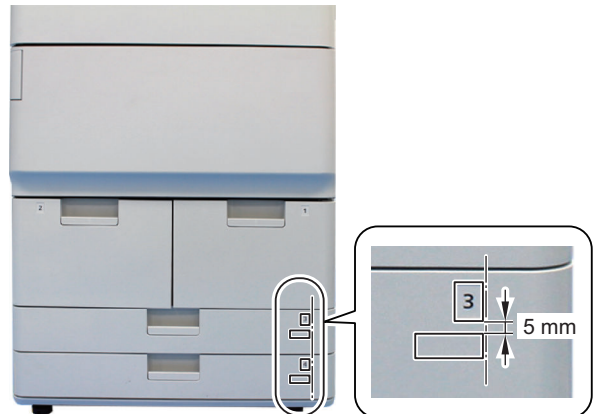
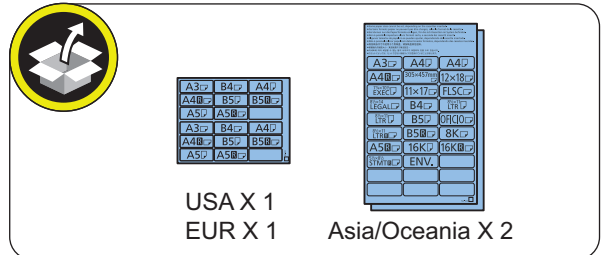
Paper size is set to be automatically recognized.



5. Affix Paper Size Labels (for Cassette) according to the paper size, with the right edge aligned with the right edge of the number label, approx. 5 mm away from the number label.

NOTE:

- Be sure to check with the user whether or not to affix the Paper Size Label, and then affix it at the recommended position.
- Keep the Paper Size Labels as they will be used when changing the paper size.



NOTE:

If Setup Guide is running, skip this procedure.

6. Register the type of paper loaded in the paper source.

1. Select the [Settings/Registration] > [Preferences] > [Paper Settings] > [Paper Settings].
2. Select the paper source where paper is loaded, and press [Set].
3. Select the paper type same as that of the loaded paper, and press [OK] > [OK].

NOTE:

If the corresponding paper type is not displayed on the simple settings screen, press [Detailed Settings] and make a selection on the detailed settings screen. If the type of loaded paper is not displayed on the detailed settings screen, you can register it.

■ Image Position Adjustment

● Left Edge Margin Adjustment (1st side)



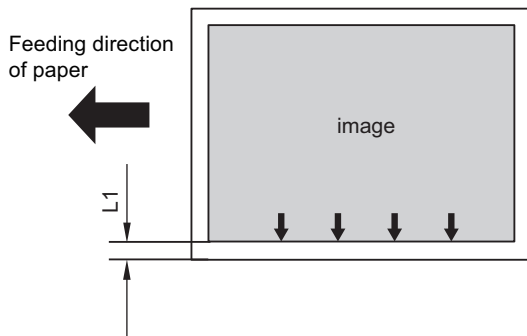
1. After setting the service mode as follow, press the **Start key** and output a test print from each cassette and Deck.

COPIER > TEST > PG > TYPE = 5

COPIER > TEST > PG > PG-PICK = 1/2/3/4



2. Check that the left edge margin of the image (L1) is within 2.5 +/- 1.5mm. When the result is out of the specified range, perform adjustment by following the following procedure.



3. Adjust the image position in service mode.

NOTE:

<Setting Range>

-20 to 20 (0.1 mm per unit)

As the value is incremented by 1, the left edge margin is increased by 0.1mm.

Right Deck:

COPIER > ADJUST > FEED-ADJ > ADJ-C1

Left Deck:

COPIER > ADJUST > FEED-ADJ > ADJ-C2

Cassette3:

COPIER > ADJUST > FEED-ADJ > ADJ-C3

Cassette4:

COPIER > ADJUST > FEED-ADJ > ADJ-C4



4. When the setting value was changed in step 3, write down the new numerical value in the service label.



5. Exit from the service mode.



6. Perform printing again from the cassette/deck, and check that the left edge margin (L1) of the image is within 2.5 +/- 1.5 mm.

NOTE:

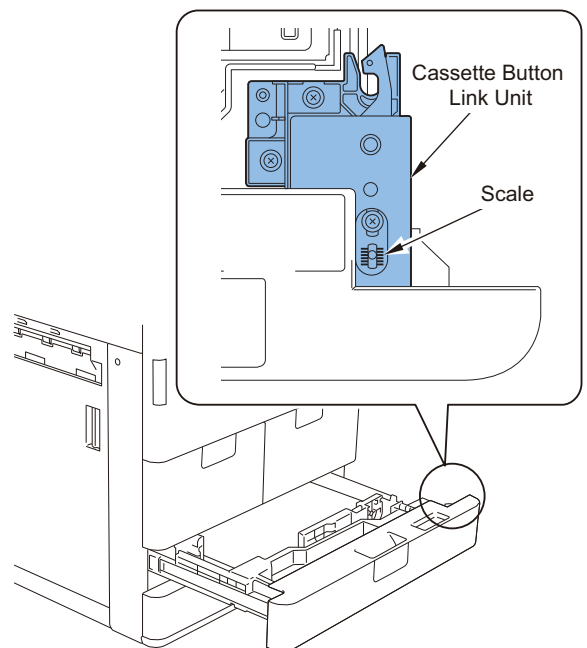
If the adjustment cannot be made with the setting value of -20 to 20 (adjustment amount: -2.0 to 2.0mm), execute step 7 and later steps.



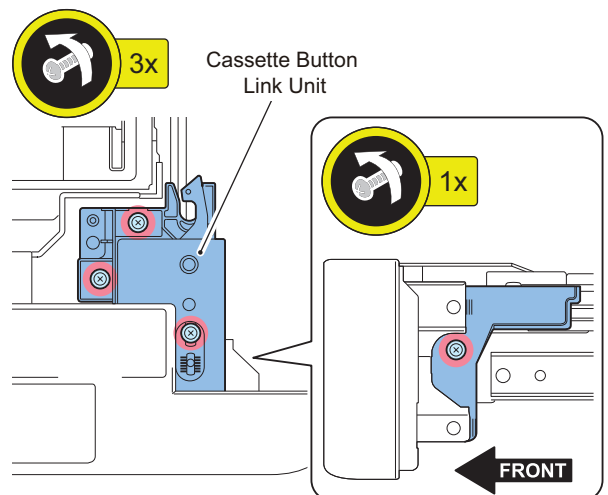
7. Pull out the Cassette.



8. Check the Cassette position by the scale of the Cassette Button Link Unit.



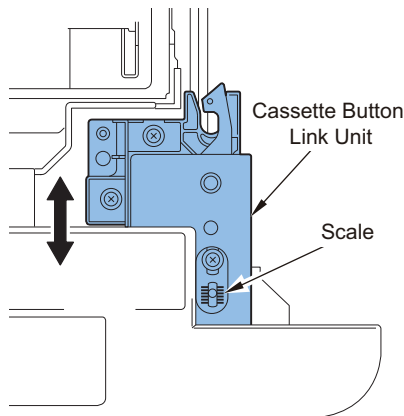
9. Loosen the 4 screws of the Cassette Button Link Unit.



-
10. According to the scale in which the position was checked in step 8, adjust the position of the Cassette Button Link Button.

NOTE:

- In the case of larger margin at the rear side, move the Cassette Button Link Unit to the rear side.
- In the case of larger margin at the front side, move the Cassette Button Link Unit to the front side.

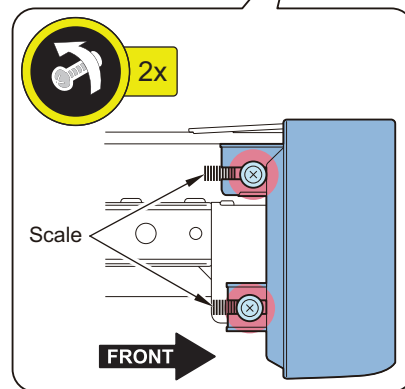
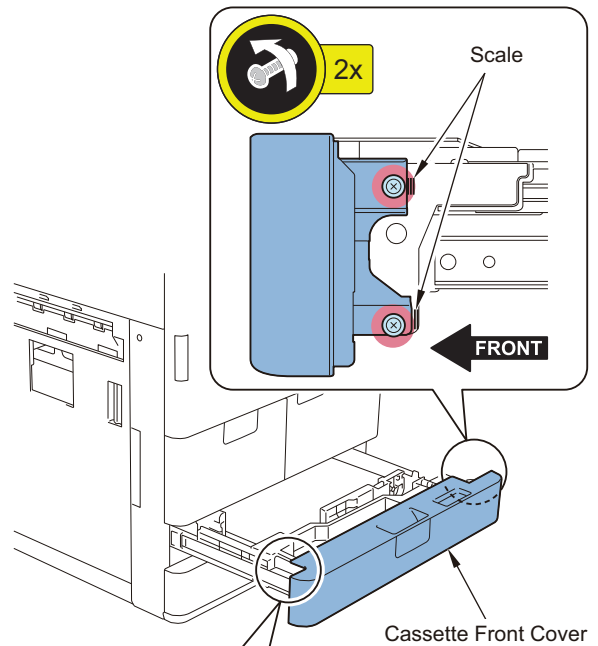


-
11. Tighten the 4 screws (which have been loosened in step 9).

NOTE:

If you are concerned with alignment of the Cassette Front Cover, perform steps 12 to 14 to make an adjustment as necessary.

-
12. Loosen the 4 screws and adjust the position of the Cassette Front Cover by referring to the scale.



-
14. Once the position of the Cassette Front Cover is confirmed, tighten the 4 screws (which have been loosened in step 12).
-
15. Perform printing again from the cassette/deck, and check that the left edge margin (L1) of the image is within 2.5 +/- 1.5mm.

NOTE:

When a mechanical adjustment was made, be sure to execute the service mode again.

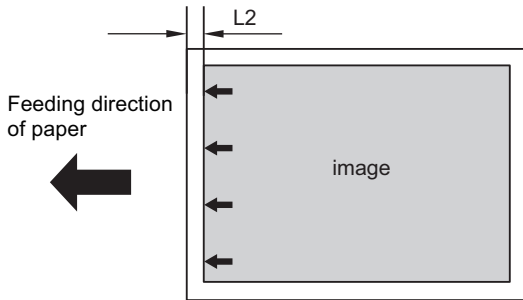
• Leading Edge Margin Adjustment (1st side)

NOTE:

By executing the margin adjustment for the Cassette 3, the adjustment is applied to all source of paper.

1. After setting the service mode as follow, press the Start key and output a test print from Cassette 3.
 COPIER > TEST > PG > TYPE = 5
 COPIER > TEST > PG > PG-PICK = 3

2. Check that the leading edge margin of the image (L2) is within 2.5 +1.5/-0.5 mm. When the result is out of the specified range, perform adjustment by following the following procedure.



3. Adjust the image position in service mode.

NOTE:
 <Setting Range>
 -50 to 50 (0.1 mm per unit)
 As the value is incremented by 1, the leading edge margin is decreased by 0.1mm.

COPIER > ADJUST > FEED-ADJ > REGIST

4. Perform printing again from the cassette 3, and check that the leading edge margin (L2) of the image is within 2.5 +1.5/-0.5 mm.

5. When the setting value was changed in step 3, write down the new numerical value in the service label.

6. Exit from the service mode.

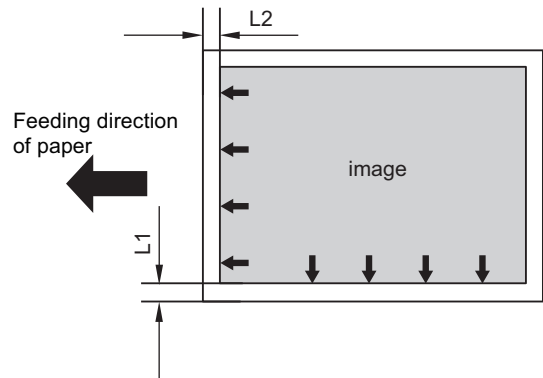
• Left Edge/Leading Edge Margin Adjustment (2nd side)

NOTE:
 By executing the margin adjustment for the Cassette 3, the adjustment is applied to all source of paper.

1. After setting the service mode as follow, press the Start key and output a test print from Cassette 3.
 COPIER > TEST > PG > TYPE = 5
 COPIER > TEST > PG > 2-SIDE = 1
 COPIER > TEST > PG > PG-PICK = 3

2. Check that the left edge margin (L1) and leading edge margin (L2) are within the range indicated below. When the result is out of the specified range, perform adjustment by following the following procedure.

- left edge margin L1: 2.5 +/-1.5 mm
- leading edge margin L2 : 2.5 +1.5/-0.5 mm



3. Adjust the image position in service mode.
 <left edge margin>

NOTE:
 <Setting Range>
 -50 to 50 (0.1 mm per unit)
 As the value is incremented by 1, the left edge margin is increased by 0.1mm.

COPIER > ADJUST > FEED-ADJ > ADJ-REFE
 <leading edge margin>

NOTE:
 <Setting Range>
 -50 to 50 (0.1 mm per unit)
 As the value is incremented by 1, the leading edge margin is decreased by 0.1mm.

COPIER > ADJUST > FEED-ADJ > REG-DUP1

4. Perform printing again from the cassette 3, and check that the left edge margin (L1) and leading edge margin (L2) of the image are within the range indicated below.
- left edge margin L1: 2.5 +/-1.5 mm
 - leading edge margin L2 : 2.5 +1.5/-0.5 mm



5. When the setting value was changed in step 3, write down the new numerical value in the service label.



6. Exit from the service mode.

• Left Edge/Leading Edge Margin Adjustment of Multi-purpose Pickup Tray



1. After setting the service mode as follow, press the Start key and output a test print from Multi-purpose Pickup Tray.

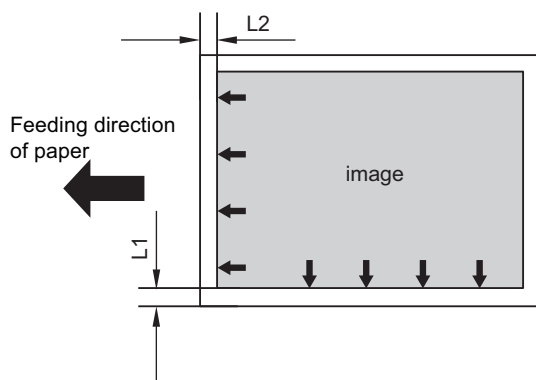
COPIER > TEST > PG > TYPE = 5

COPIER > TEST > PG > PG-PICK = 5



2. Check that the left edge margin (L1) and leading edge margin (L2) are within the range indicated below. When the result is out of the specified range, perform adjustment by following the following procedure.

- left edge margin L1: 2.5 +/-1.5 mm
- leading edge margin L2: 2.5 +1.5/-0.5 mm



3. Adjust the image position in service mode.

<left edge margin>

NOTE:

<Setting Range>

-20 to 20 (0.1 mm per unit)

As the value is incremented by 1, the left edge margin is increased by 0.1mm.

COPIER > ADJUST > FEED-ADJ > ADJ-MF

<leading edge margin>

NOTE:

<Setting Range>

-50 to 50 (0.1 mm per unit)

As the value is incremented by 1, the leading edge margin is decreased by 0.1mm.

COPIER > ADJUST > FEED-ADJ > RG-MF



4. When the setting value was changed in step 3, write down the new numerical value in the service label.



5. Exit from the service mode.



6. Perform printing again from the Multi-purpose Pickup Tray, and check that the left edge margin (L1) and leading edge margin (L2) of the image are within the range indicated below.

- left edge margin L1: 2.5 +/-1.5 mm
- leading edge margin L2: 2.5 +1.5/-0.5 mm

NOTE:

In the case of left edge margin: If the adjustment cannot be made with the setting value of -20 to 20 (adjustment amount: -2.0 to 2.0mm), execute step 7 and later steps.

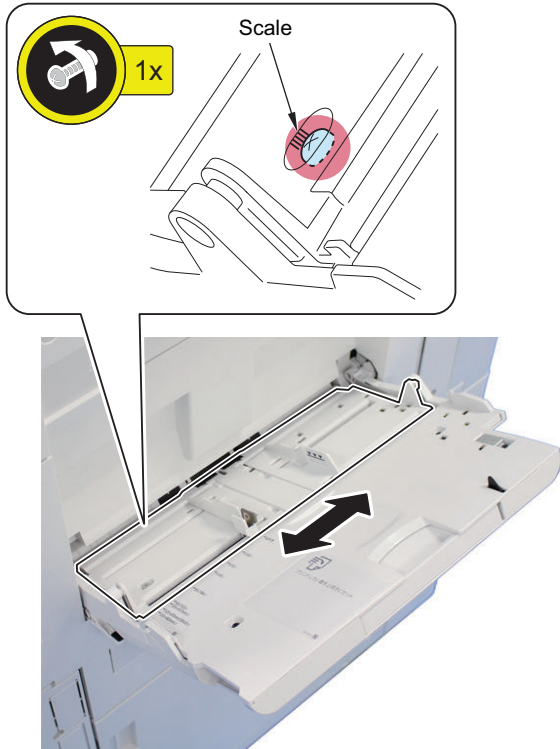


7. Open the Multi-purpose Pickup Tray.



8. Loosen the screw and adjust the position of the Slide Guide by referring to the scale.

- In the case of larger margin at the rear side, move the Slide Guide to the front side.
- In the case of larger margin at the front side, move the Slide Guide to the rear side.



9. Tighten the screw loosened in step 8.



10. Perform printing again from the Multi-purpose Pickup Tray, and check that the left edge margin (L1) and leading edge margin (L2) of the image are within the range indicated below.

- left edge margin L1: 2.5 +/-1.5 mm
- leading edge margin L2: 2.5 +1.5/-0.5 mm

NOTE:

When a mechanical adjustment was made, be sure to execute the service mode again.

■ Image Position Adjustment (Single Pass ADF)

● Checking the Skew

Check the image at ADF stream reading with using the "Test Charts for Image Position Adjustment". If any adjustments have been made, perform all of the following "Adjustment Procedure". If it is confirmed that there is no problem, proceed to "Network Connectivity Check".

1. Adjustment of the White Plate
2. Height Adjustment

3. Light intensity adjustment
4. Automatic Adjustment of the Stream Reading Position (Automatic Adjustment of the Reading Position at ADF Reading)
5. White Level Adjustment
6. Front/Back Side Difference Correction Adjustment

NOTE:

Even if the above adjustment is performed, if a fixed skew or image shift occurs, the image is manually adjusted according to the state of the printed image

- Adjustment of leading edge margin of the scanned image for the corrected image Amount of Change per:0.1mm
FEEDER > ADJUST > ADJ-T1 (front side)
FEEDER > ADJUST > ADJ-T2 (back side)
- Adjustment of the left edge margin of the scanned image for the corrected image Amount of Change per:0.1mm
FEEDER > ADJUST > ADJ-L1 (front side)
FEEDER > ADJUST > ADJ-L2 (back side)
- Angle correction of the corrected image Amount of Change per:0.01 degree
FEEDER > ADJUST > ADJ-ROT1 (front side)
FEEDER > ADJUST > ADJ-ROT2 (back side)
- Parallelogram correction amount for corrected image Amount of Change per:0.01 degree
FEEDER > ADJUST > ADJ-PAR1 (front side)
FEEDER > ADJUST > ADJ-PAR2 (back side)

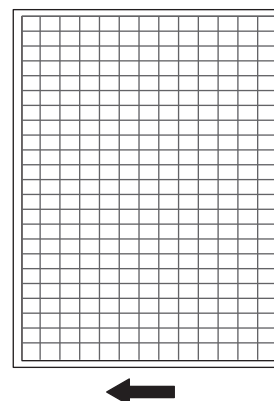
Refer to the following Service Manual

- Adjustment > Original Feed System (Single Pass ADF) > Skew Adjustment (at Stream Scanning of Originals)

Creating the Test Charts for Image Position Adjustment

CAUTION:

Create the test charts for image position adjustment after completing adjustments on the printer side.



1. After setting the service modes as follows, press the Start key to output the test chart.

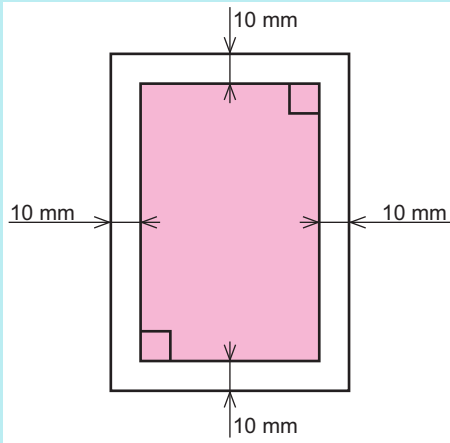
- COPIER > TEST > PG > TYPE = 1 or 6
- COPIER > TEST > PG > PG-PICK = To set the Pickup Cassette for test print output.

NOTE:

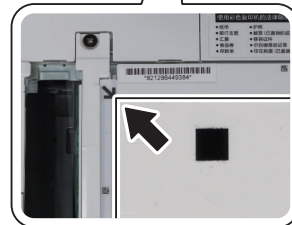
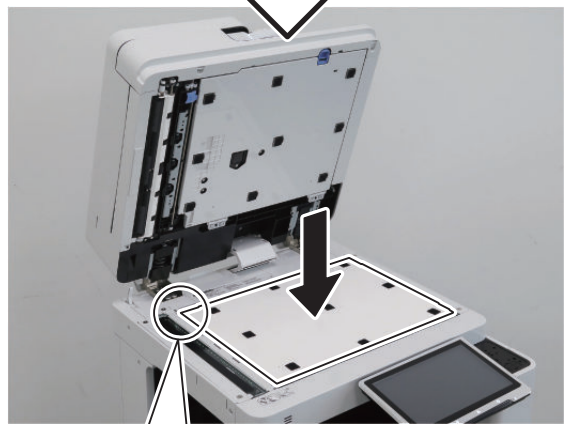
Pressing "i" (Information Button) displays the TYPE number.

NOTE:

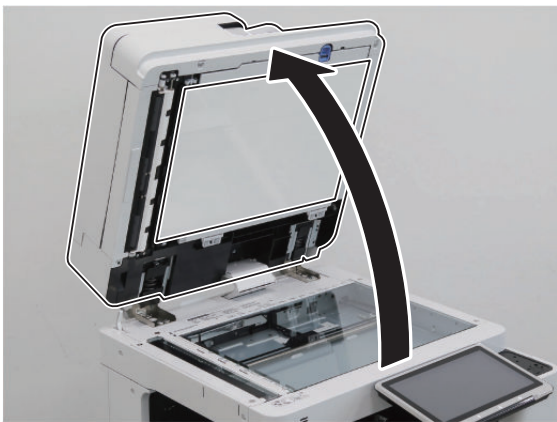
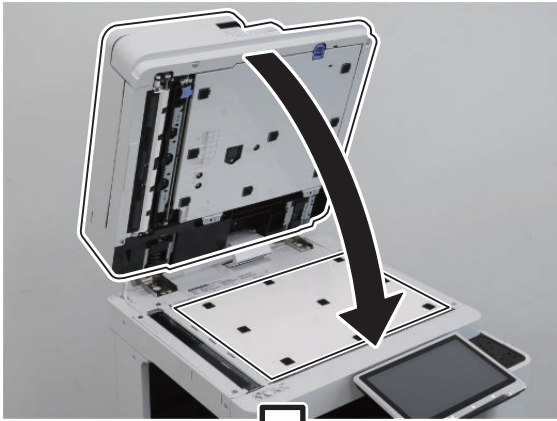
- If the specified test chart cannot be output, draw a test chart on A3 or LDR paper with a rectangle whose four corners are 10 mm smaller than the paper.
- To draw characters and marks so that you can see the direction of the copied image.

**Adjustment of the White Plate**

□
1.



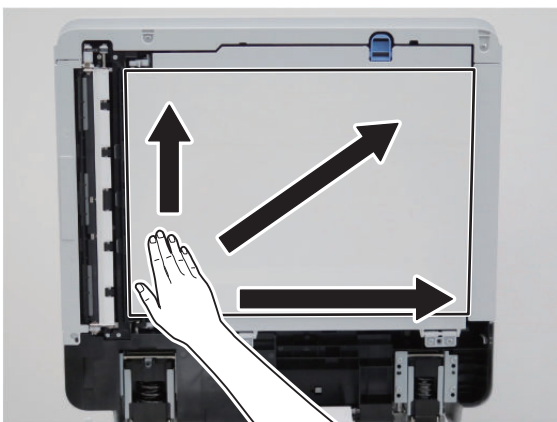
□
2.



□
3.

CAUTION:

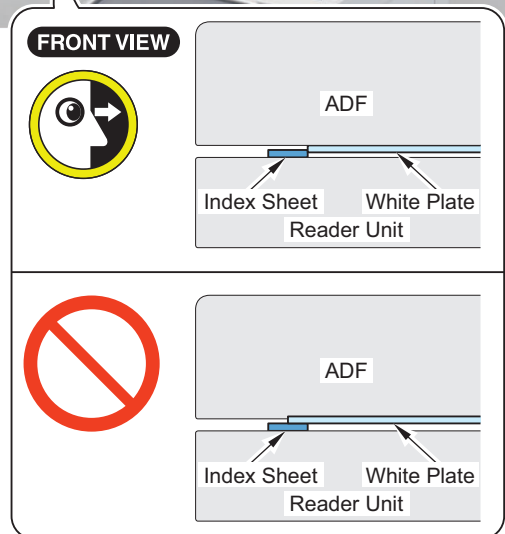
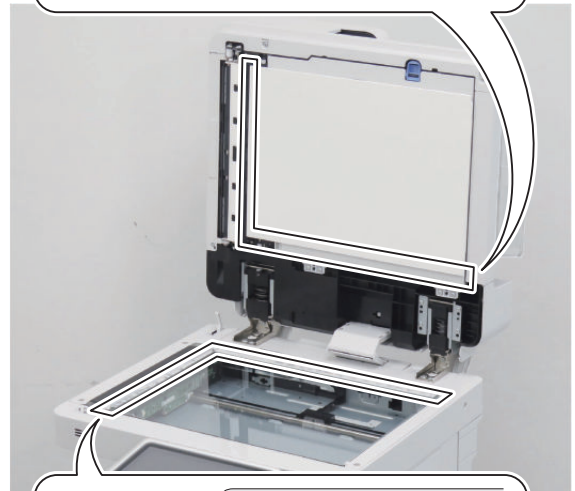
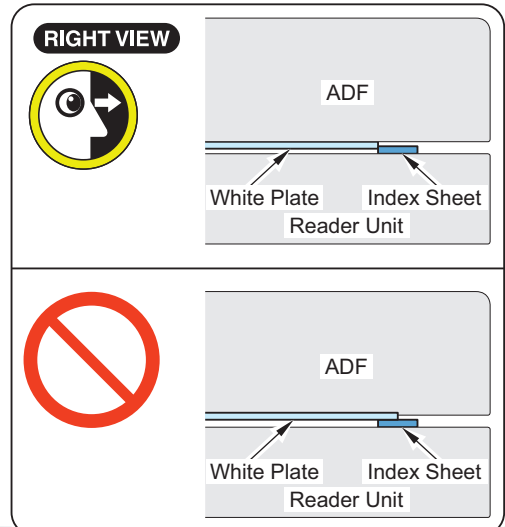
If the White Plate is pressed downward, it is placed on the Index Sheet, so be sure to press it upward.



□
4.

NOTE:

- Be sure that there is no gap (for reference, 0.3 mm or less) between the White Plate and the Index Sheet.
- Check that the White Plate is not placed on the Index Sheet.



Checking the Height

Height Check Sheet Preparation or Creation

1. Prepare the check sheet used for height adjustment.



NOTE:

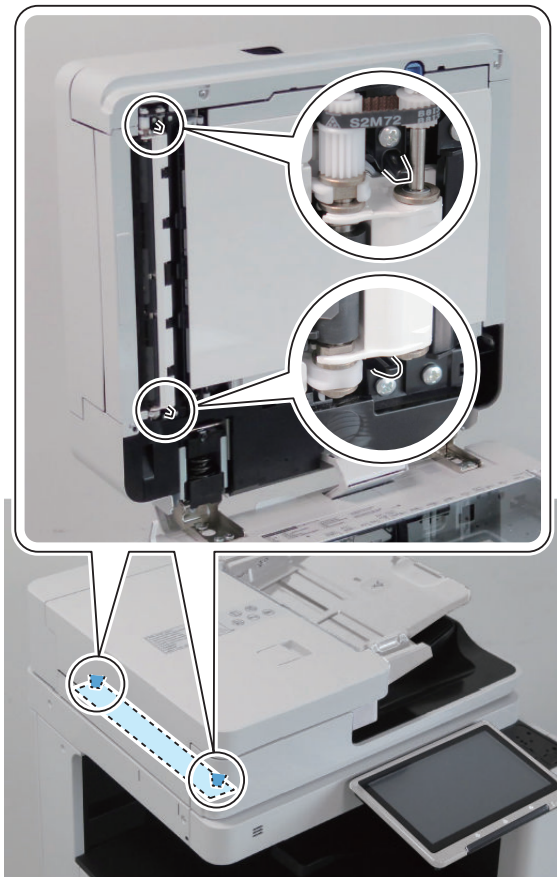
Points to Note when Creating the Check Sheet

- Output with A4 (paper size) or LTR (paper size)
- Use plain paper 1 to 3 (64 to 105 g/m2) (Paper Type).

Height Adjustment

Checking the Height

1. Check that the 2 Height Adjustment Bosses at the left front side and the left rear side are in contact with the Stream Reading Glass.

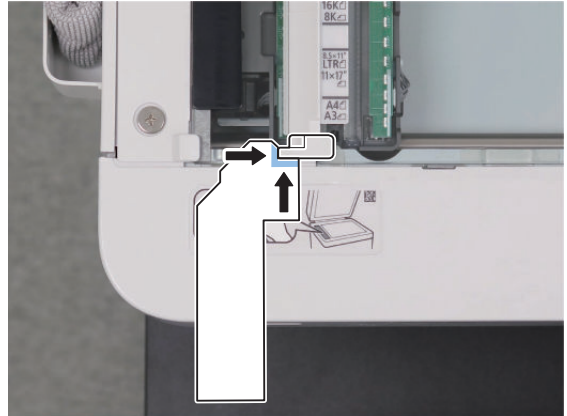


2. If they are not in contact, perform the height adjustment. If it cannot be visually checked, perform "Checking the Height of the Height Adjustment Boss".

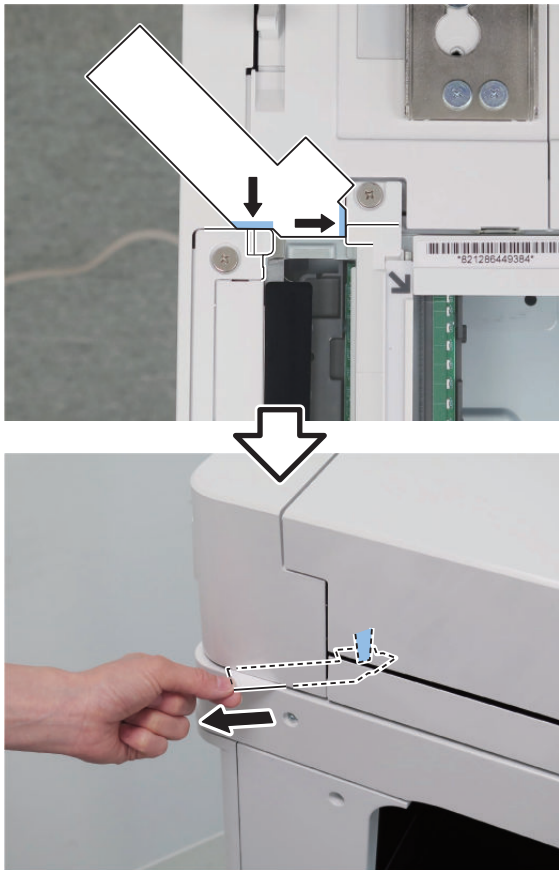
Checking the Height of the Height Adjustment Boss

1. Put a sheet of paper on the place where the protrusions touch the Stream Reading Glass, and check whether there is any resistance of the paper when closing the ADF.

<The Left Front Side>



<The Left Rear Side>



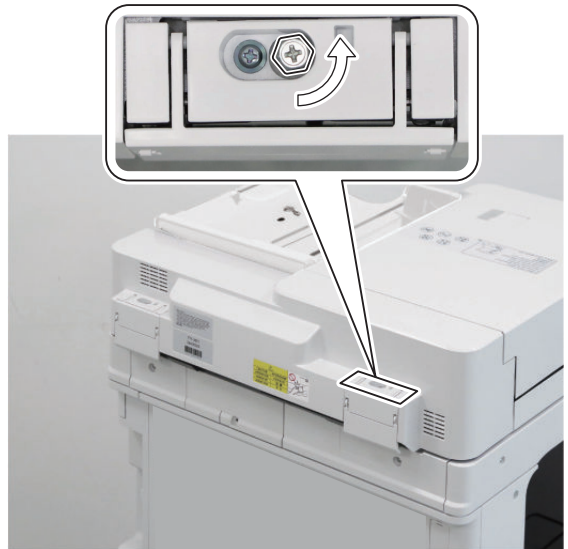
2. If there is no resistance, perform the height adjustment.

Height Adjustment Procedure

- 1. Adjust by turning the Fixation Screw on the upper side of Hinge.
 - If both front and rear side (or only front side) are not installed properly: Turn the Right Hinge Fixation Screw clockwise (black arrow) to correctly locate it at the front.



- If the rear side is not installed properly: Turn the Left Hinge Fixation Screw counterclockwise (white arrow).



2. Check the height again and see if it is at an appropriate height.

Light intensity adjustment

NOTE:

- This mode automatically performs adjustment.
- If "NG" is displayed after executing this mode, check that PCB and each connector are properly connected.



1. Execute the following service mode with the ADF closed.

COPIER > FUNCTION > CCD > LMPADJ

Automatic Adjustment of the Stream Reading Position (Automatic Adjustment of the Reading Position at ADF Reading)

NOTE:

- If the DADF is opened during adjustment, restart the adjustment.
- Enter the value after adjustment on the Service Label (on the back of the Reader Front Cover or Printer Front Cover). (The adjustment result is reflected to COPIER > ADJUST > ADJ-XY > STRD-POS.)
COPIER > ADJUST > ADJ-XY > STRD-POS



1. Execute the following service mode item.

COPIER > FUNCTION > INSTALL > STRD-POS

NOTE:

If "NG" is displayed after executing this mode, execute "Right Angle Adjustment (Slant Adjustment)" on the service manual.

2. Turn OFF/ON the main power of the Host Machine.

White Level Adjustment



1. Place a sheet of blank A4 or LTR size paper on the Copyboard Glass and close the ADF.

CAUTION:

When executing the white level adjustment using paper with smaller width, adjustment may not be executed properly.

2. Execute the service mode item.
COPIER > FUNCTION > CCD > DF-WLV1
3. Remove the blank paper from the Copyboard Glass, and place it on the Document Pickup Tray of ADF.
4. Execute the service mode item.
COPIER > FUNCTION > CCD > DF-WLV2
5. Place the blank paper on the Copyboard Glass again and close the ADF.
6. Execute the service mode item.
COPIER > FUNCTION > CCD > DF-WLV3
7. Remove the blank paper from the Copy Board Glass, and place it on the Document Pickup Tray of ADF.

8. Execute the service mode item.

COPIER > FUNCTION > CCD > DF-WLV4

Front/Back Side Difference Correction Adjustment

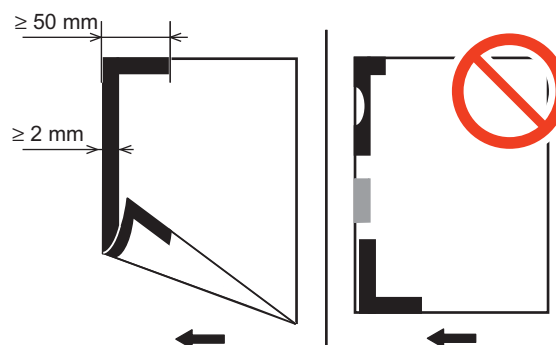
Automatic Front/Back Side Difference Correction Adjustment

NOTE:

If the chart in the following state is used, skew detection may not be possible and correction may not be possible.

- The painted part is not long enough.
- The painted part is chipped.
- The color is light.
- The edges are not painted.
- Broken/torn/chipped.
- Translucent, thin paper manuscript is used.
- The area painted black is not dry enough.

1. Use a chart of a service parts of a Automatic Front/Back Side Difference Correction Adjustment, or using A4 or LTR paper, the leading edge and the side edge of the front/back side in the feeding direction are painted black with magic, and a chart for Automatic Front/Back Side Difference Correction Adjustment is prepared.



2. Set the value of the service mode to "0" below.

- FEEDER > ADJUST > ADJ-T2/L2/ROT2 = 0

NOTE:

- The ADJ-T2/L2/ROT2 is an item for manually fine-adjusting the skew in the case that a deviation remains in the position of the back image to which the skew is automatically corrected after the Automatic Front/Back Side Difference Correction Adjustment.
- "0" is the value at the time of shipment from the factory. By resetting to the initial state, there is no unintended deviation due to manual correction with respect to the back surface image in which skew correction is automatically performed, so that a constant accuracy is guaranteed.

3. Set the document tray so that the black-painted portion becomes the leading edge in the feeding direction.

4. Automatic Front/Back Side Difference Correction Adjustment is performed in the following service mode.

- FEEDER > FUNCTION > ADJ-SKW

NOTE:

If "NG" is displayed after executing this mode, execute "Right Angle Adjustment (Slant Adjustment)" on the service manual.

5. Write the adjusted values below on the service label.

- FEEDER > ADJUST > ADJ-DT
- FEEDER > ADJUST > ADJ-DL
- FEEDER > ADJUST > ADJ-DROT

■ Checking the Network Connection

● Overview

If the user's network environment is TCP/IP, use the Ping function to check that the network setting is properly performed.

● Checking the Network Connection

CAUTION:

Be sure to use the network cable with Category 5e or higher. In addition, a sealed type (STP cable) is recommended.

Using the non-shield type can affect the peripheral electrical equipment through the network cable.

1. Turn OFF the main power switch.
2. Connect the network cable to the Host Machine and turn ON the main power switch.
3. Remove the cover of the Cord Guide.
4. Remove the release paper, and affix the Cord Guide to the area indicated in the figure.



5. Put the network cable through the Cord Guide, and install the cover of the Cord Guide.



6. Inform the system administrator at the installation site that installation of the Host Machine is complete, and then, ask for the network setting.

NOTE:

Network setting cannot be executed unless logging in as an administrator.

Factory default password is as follows.

- System administration division ID: Administrator
- System administration password: 7654321

CAUTION:

To perform the network setting, the following Additional Functions items must be set "ON".

- [Settings/Registration] > [Preferences] > [Network] > [Confirm Network Connection Setting Changes]
- [Settings/Registration] > [Preferences] > [Network] > [TCP/IP Settings] > [IPv4 settings] > [Use IPv4]

7. Turn OFF and then ON the main power.

● Operation Procedure Using Ping

1. Select the following: [Settings/Registration] > [Preferences] > [Network] > [TCP/IP Settings] > [IPv4 settings] > [PING command]
2. Enter the IP address with the numeric keypad on the Control Panel and press "Execute" key. "Response from the host" is displayed if Ping command is succeeded while "no response from the host" is displayed if failed.

● Checking by the Remote Host Address

Using the remote host address to execute Ping can check whether connection to the network is enabled or not.

Remote host address: IP address of PC terminal connected/running on TCP/IP network environment that connects to this equipment.

1. Inform the system administrator about checking of the network connection using Ping.
2. Confirm the remote host address with the system administrator.
3. Enter the remote host address to Ping.
 - The network is properly connected if the message say "Response from the host".
 - The network is not properly connected if the message say "No response from the host", therefore, execute the following troubleshooting.

■ Network Troubleshooting

● Checking Connection of the Network Cable

To check whether the network cable is properly connected to the LAN Port.

● Operation Procedure Using Ping

1. Ask the network administrator at the user's site to write down the IP address of the PC that is connected to the network.
2. [Settings/Registration] > [Preferences] > [Network] > [TCP/IP Settings] > [IPv4 settings] > [Ping Command]; and enter the IP address of the PC with the numeric keypad and press Execute key.
 - The network is properly connected if the message say "Response from the host".
 - If the message say "No response from the host", check the following.

● Checking the Network Setting of the Host Machine

Check if the IP address specified in the Host Machine is correct.

1. Select the following: [Settings/Registration] > [Preferences] > [Network] > [TCP/IP Settings] > [IPv4 settings] > [IP address setting]; and write down the address in the IP address field.
2. Select the following: [Settings/Registration] > [Preferences] > [Network] > [TCP/IP Settings] > [IPv4

settings] > [Ping Command]; and enter the IP address.

- The IP address specified in the Host Machine is correct if the message say "Response from the host".
- If "No response from the host." is displayed, check if the IP address information set for the system administrator is correct.

NOTE:

When setting the address by manually input, set the Subnet Mask by following the instruction of the administrator.

● Checking Network Function on the Main Controller

Perform checking by the loopback address.

1. Select the following: [Settings/Registration] > [Preferences] > [Network] > [TCP/IP Settings] > [IPv4 settings] > [Ping Command]; and enter the IP address, "127.0.0.1" with the numeric keypad and enter Execute key.
 - The network function of the Main Controller is working properly if the message say "Response from the host".
 - If the message say "No response from the host", the network function of the Main Controller is faulty.
2. Replace with a Main Controller that works properly, and then check connection.

■ Installing the IC Card Reader

NOTE:

- When installing the IC Card Reader, the IC Card Reader (sales company's option) is required.
- Use the shorter cable of the IC Card Reader.
- When installing the IC Card Reader and Numeric Keypad at the same time, install the Numeric Keypad first.

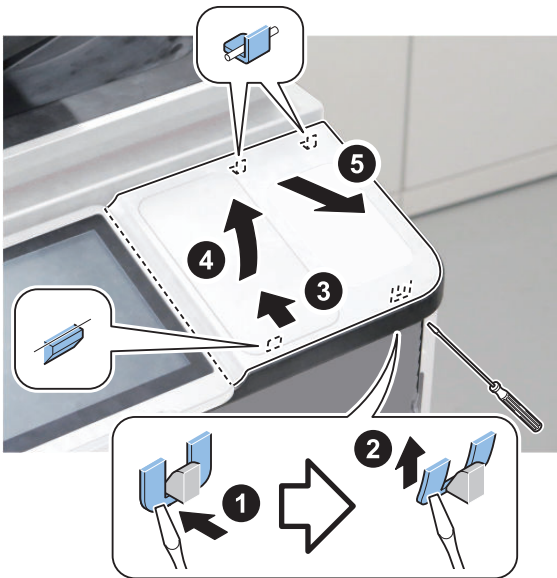


1. ■ If the main power switch of the host machine is ON, turn it OFF.

□
2.

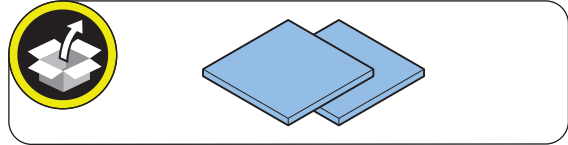


□
3.

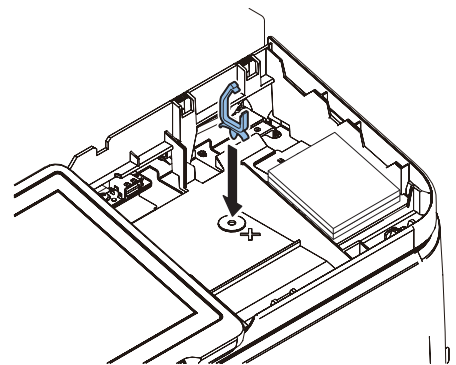
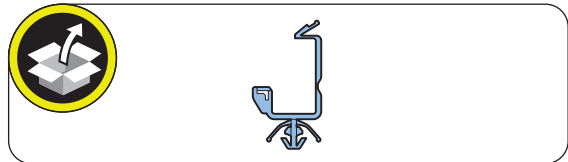


□
4.

NOTE:
Be sure to change the number of cushions according to the thickness of the Card Reader.
If it makes the Control Panel Upper Right Cover difficult to install, using one or no cushions is allowed.



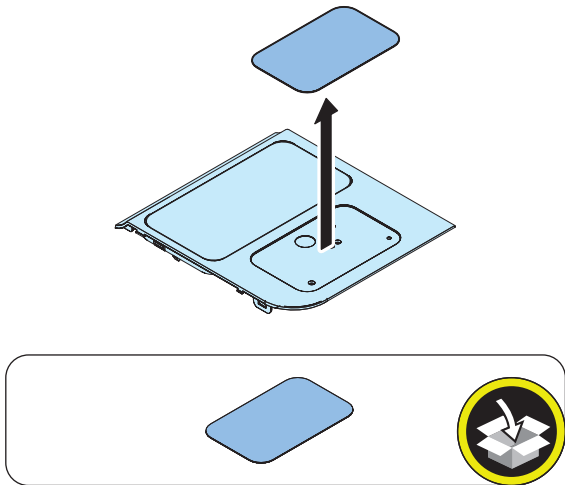
□
5.



6.

NOTE:

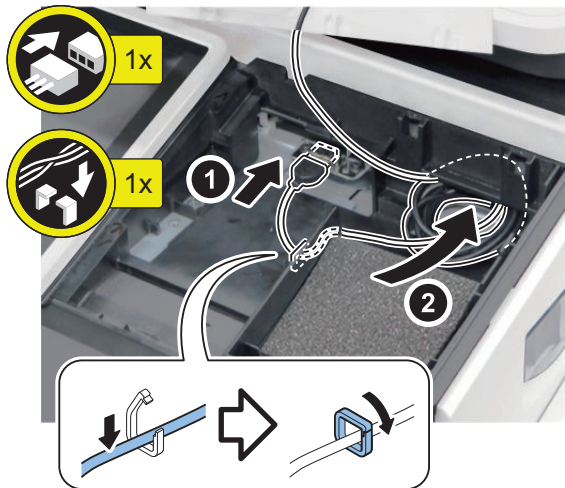
If any paste is remaining on the removed surface, clean with alcohol (to prevent the non-level surface from forming when affixing the Device Port Sheet).



7.

NOTE:

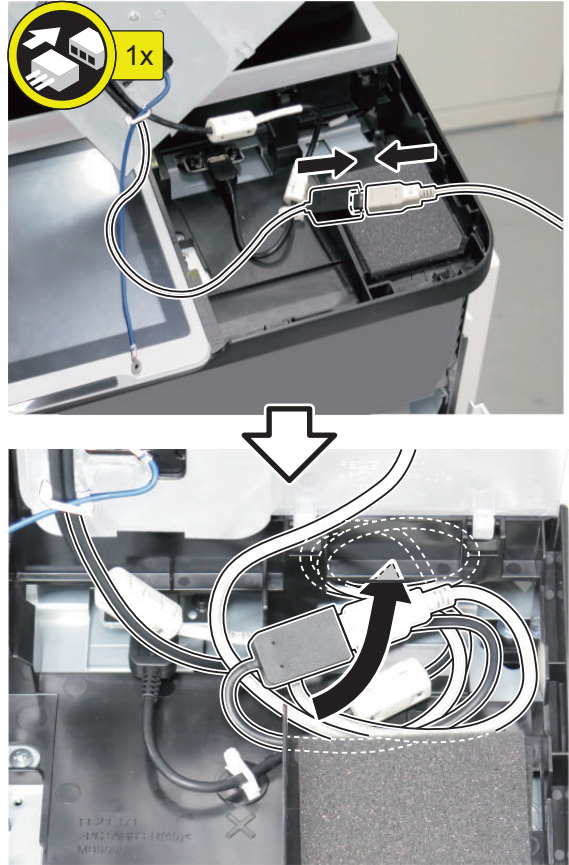
Store the excess length of the cable in the position as shown in the figure.



< When installing with the Numeric Keypad at the same time >

NOTE:

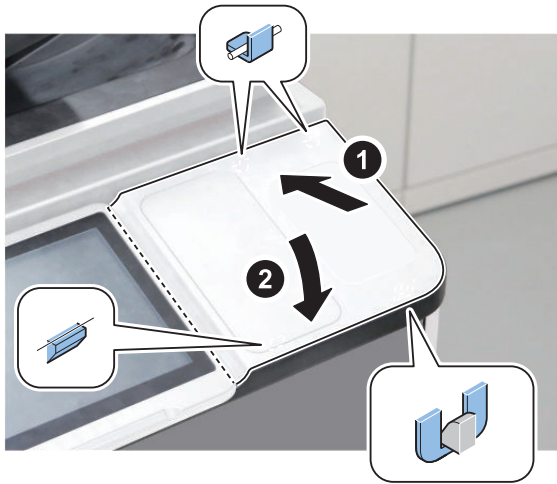
Store the excess length of the cable in the position as shown in the figure.



8.



□
9.



□
12. Connect the power plug to the outlet.

13. Turn ON the main power switch.

■ Operation when using uniFLOW Online

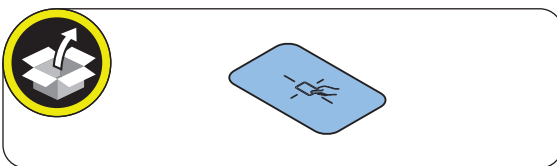
When using uniFLOW Online*, follow the setup procedures on the uniFLOW* Online First Steps Guide (http://www.nt-ware.com/uFO_FS).

* China version of "uniFLOW" is called "mdsFLOW".

□
10.



□
11.



When Relocating the Machine

Points to Note When Relocating the Host Machine

It is basically based on delivery of pre-installed host machines to shops. In the case of relocation from a low humidity environment (an air-conditioned room) to a high humidity environment (high-temperature high-humidity open air), be careful of condensation.

Overview

Works before Relocation

- Image check
- Move the Scanner Unit (service mode).
- Detach the options.
- Works inside the Decks
- Fix the Scanner Unit.
- Fix the covers of the DADF.
- Clean the area around the hopper.
- Clean the area around the Registration Assembly.
- Clean the Pre-transfer Charging Assembly.
- Clean the Developing Assembly.

Works after Relocation

- Check for any toner scattering.
- Image check

Works during Relocation

When relocating an installed host machine to another location, the following works need to be performed.



1. From the following service mode, print 2 sheets each of TYPE 4, TYPE 6, and TYPE 7 in a large size, and check that there is nothing wrong with the image.
COPIER > TEST > PG > TYPE



2. From the following service mode (Lv.2), move the Scanner Unit to the position to secure.
COPIER > FUNCTION > MISC-R > RD-SHPOS

CAUTION:

If the Reader is moved after installation, the Scanner Unit of Reader may move and become damaged. Damage can be prevented by moving the Scanner Unit to the specified location and securing it before moving. If the machine is moved with the ADF Reading Glass stopped at a position other than the specified position, the Glass Holder of the ADF may be scraped and the Reading Glass may be soiled, resulting in lined images. In order to prevent it, execute the foregoing service mode to move the ADF Reading Glass to the specified position.

If the Reader Scanner Unit is manually moved back to the fixation position, the ADF Reading Glass does not move along with the Reader Scanner Unit. Be sure to use service mode to move it.



3. Turn OFF the main power switch.



4. Check that the display in the Control Panel and the lamp of the main power are turned off, then disconnect the power plug. Disconnect the Grounding Wire if it is connected.



5. Detach the options.

Works inside the Decks

Lower lifters inside the Pickup Decks and cassettes.



1. Pull out all Pickup Decks and cassettes.



2. Confirm that lifters are lowered and close all Pickup Decks and cassettes.

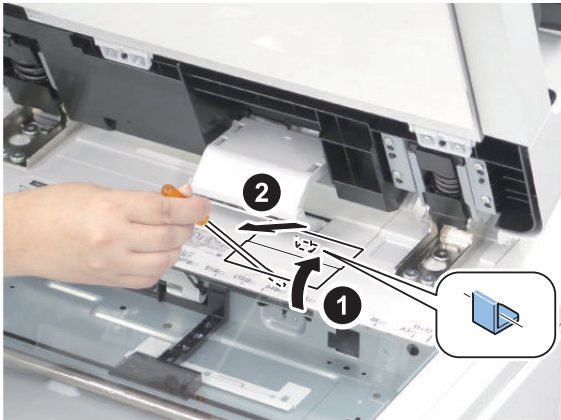
CAUTION:

- Make sure to turn the Main Power OFF and then perform these procedures. If the Main Power is ON, lifters may rise again after closing Pickup Decks and cassettes.
- If the machine is moved with lifters raised, the Lifter Drive Gear may be damaged due to the shaking.

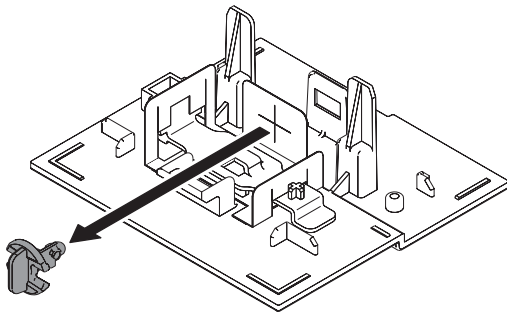
■ Fixing the Reader Unit



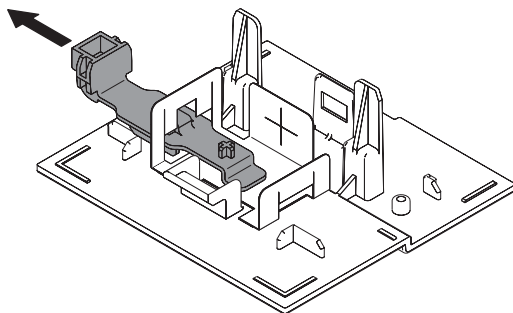
1. Open the DADF, and remove the Maintenance Cover (Upper).



2. Remove the Scanner Fixation Member from the Maintenance Cover (Upper).



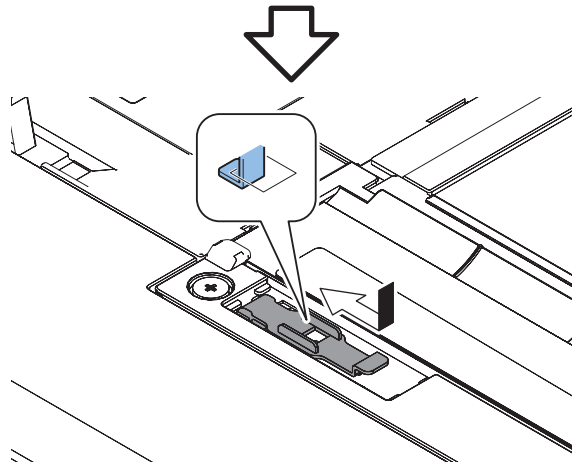
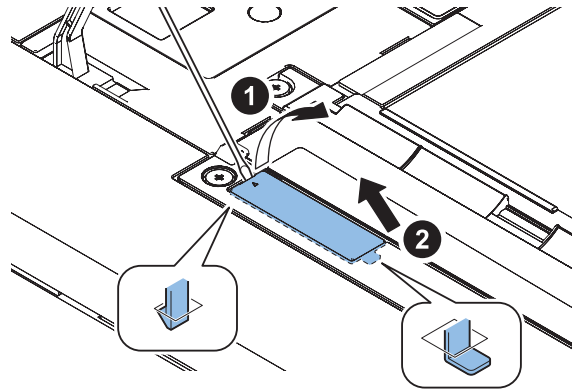
3. Remove the Scanner Fixation Member from the Maintenance Cover (Upper).



4. Remove the Reader Left Upper Cover and install the Scanner Fixation Member.

NOTE:

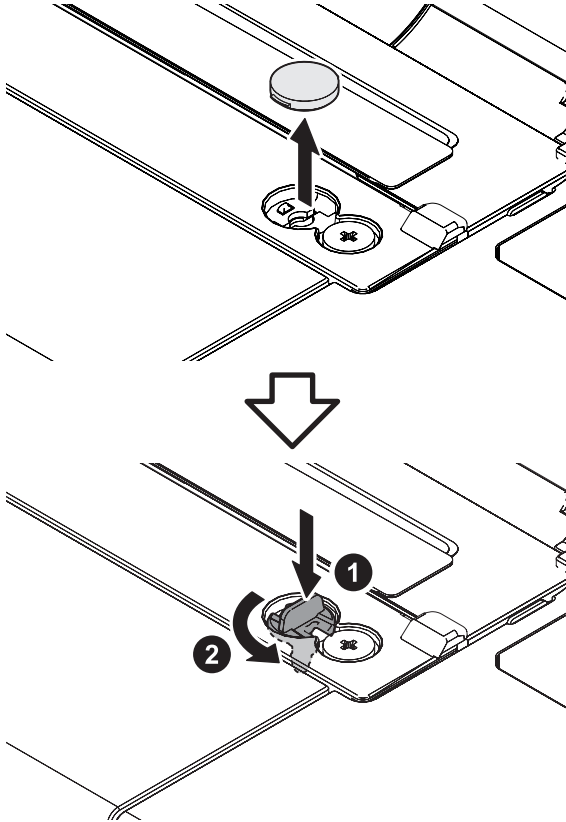
Make sure to keep the Reader Left Upper Cover as it will be used again.



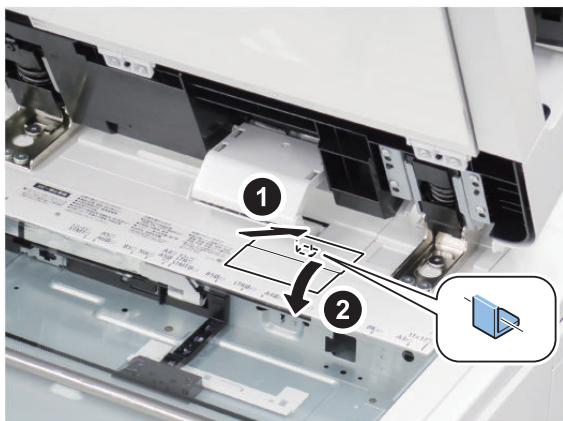
- 5. Remove the Rubber Cap and install the Scanner Fixation Member.
- 9. Secure the followings with tape to prevent them from opening during delivery.
 - DADF
 - Feeder Cover
 - Document Pickup Tray

NOTE:

Make sure to keep the Rubber Cap as it will be used again.



- 6. Install the Maintenance Cover (Upper).



- 7. Put cushioning material (plastic packing material with air bubbles, etc.) between the DADF and the reader.
- 8. Close the DADF.

■ Cleaning of the Area around the Hopper

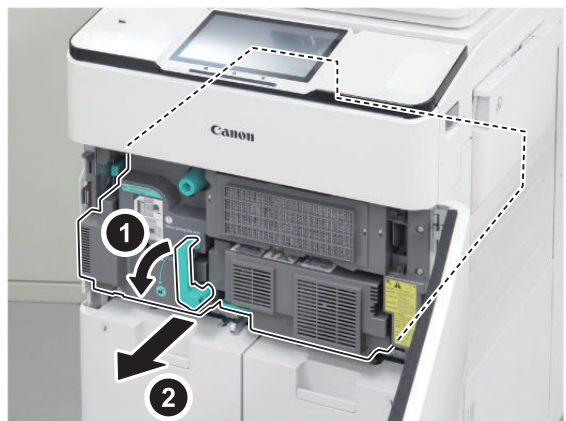
- 1. Open the Toner Exchange Cover and remove toner from the area around the hopper.



- 2. Close the Toner Exchange Cover.

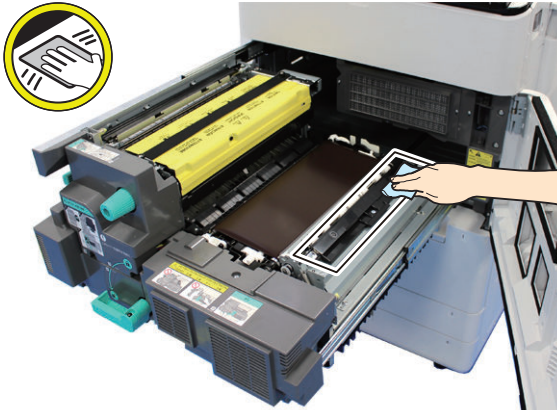
■ Registration Assembly Cleaning Procedure

- 1. Open the Front Cover.
- 2. Turn the Fixing Feed Unit Pressure Release Lever in the direction of the arrow to pull out the Fixing Feed Unit.





3. Clean the top surface of the Registration Assembly with lint-free paper moistened with alcohol.

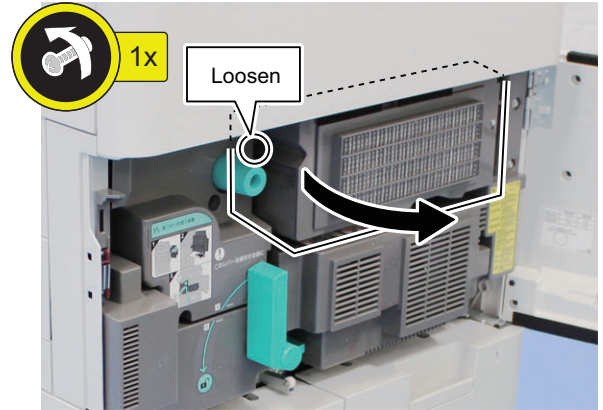


4. Return the Fixing Feed Unit to its original position.

■ Pre-transfer Charging Assembly Cleaning Procedure



1. Open the Inner Cover.
 - 1 Screw (to loosen)



CAUTION:

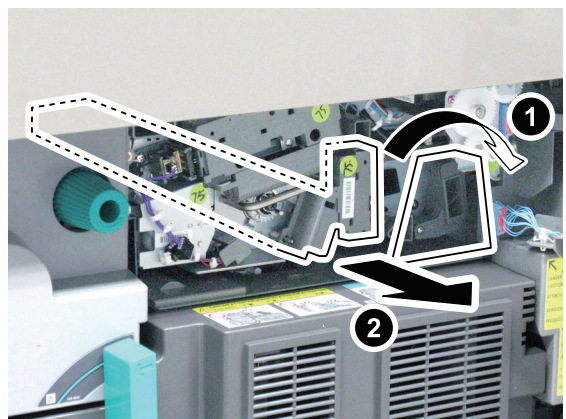
When removing the Primary Charging Assembly and the Pre-transfer Charging Assembly, go through the following procedure while the Charging Shutter is open.

- At sleep mode, press the Power Switch on the Control Panel, check that the machine is in standby condition, turn OFF the Main Power, and then perform removing.
- In the case that the condition of the Charging Shutter (open/close) is unknown while the power of the host machine is OFF, turn ON the power, check that the machine is in standby condition, turn OFF the Main Power, and then perform removing.

If the above operations are not performed, it may be possible to remove the assembly while the Charging Shutter is closed, which may damage the drum or the shutter.

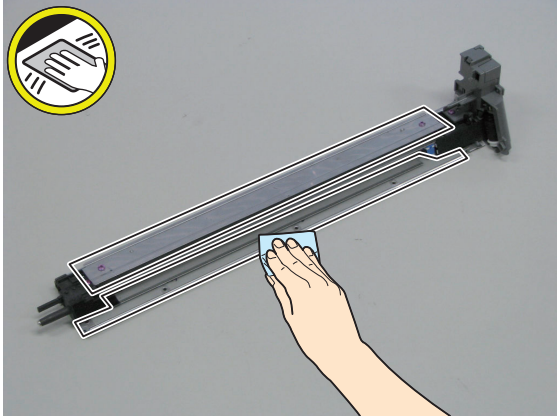


2. Turn the Lock Lever in the direction of the arrow to pull out the Pre-transfer Charging Assembly.

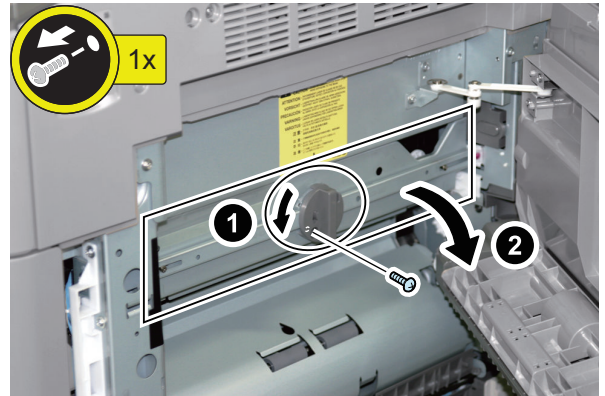




3. Clean the top surface of the Pre-transfer Charging Assembly and the Transfer Inlet Guide with lint-free paper moistened with alcohol.



3. Turn the Lock Lever, and open the Developing Assembly Pressure Cover.
 - 1 Screw

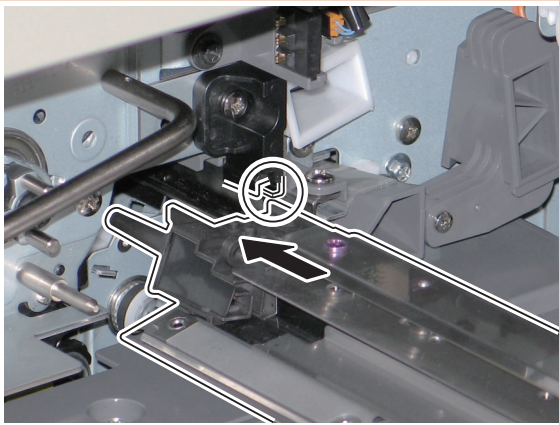


4. Return the Pre-transfer Charging Assembly to its original position.

CAUTION:

Points to Caution at Installation

Be sure to fit the Transfer Charging Assembly to the groove on the host machine and install it horizontally.



5. Close the Inner Cover. (1 Screw)



6. Close the Front Cover.

■ Developing Assembly Cleaning Procedure



1. Place paper underneath the Developing Assembly.

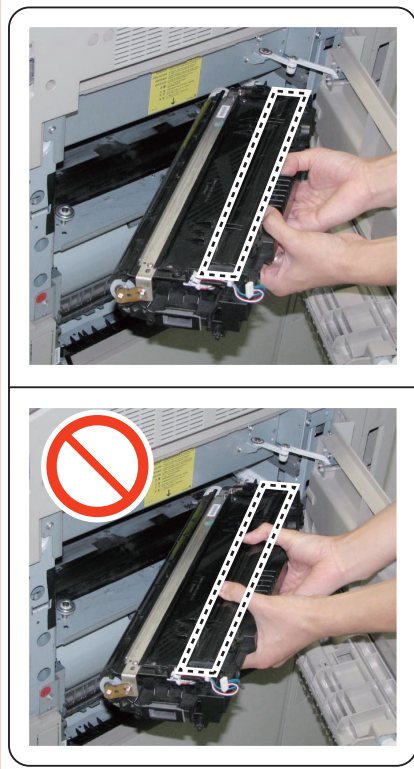


2. Open the Right Cover.

CAUTION:

How to Hold the Developing Assembly

- When holding the Developing Assembly, be sure to hold the handle of the Developing Assembly as shown in the figure.
- Do not touch the shutter area of the Developing Assembly. The shutter area is slippery, so it may cause a fall of the assembly.

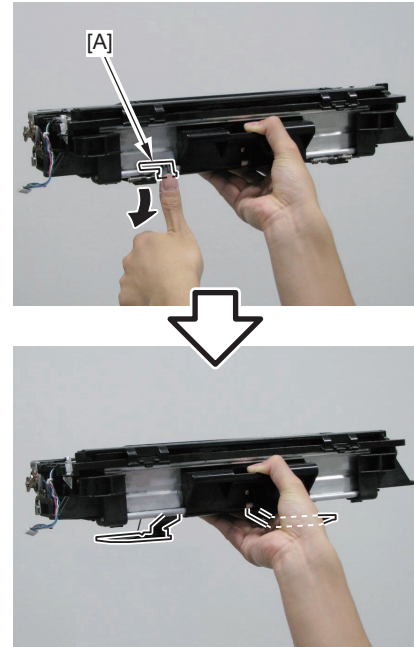


□

5. Push the [A] part of the Developing Assembly and extend the legs from the assembly.

CAUTION:

If the Developing Assembly is placed without extending the legs, it may cause the developing error due to scratches on the assembly.

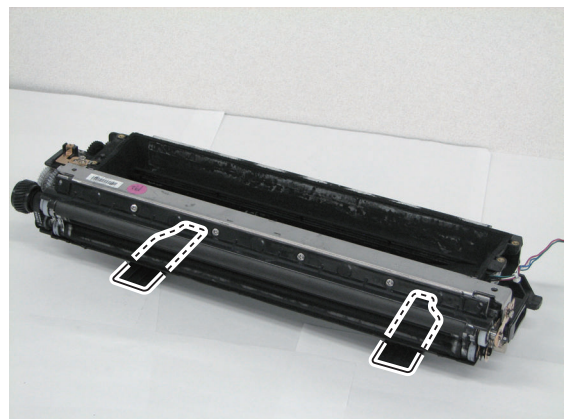


□

6. Place the Developing Assembly.

NOTE:

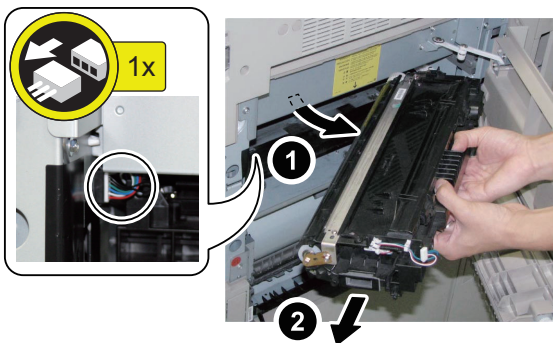
When the Developing Assembly is put on the floor or the desk, be sure to place paper underneath to work on the Developing Assembly.



□

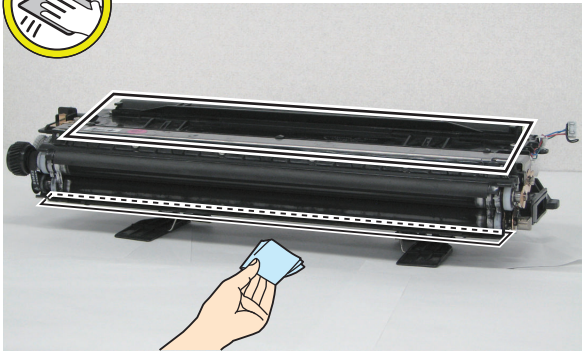
4. Remove the Developing Assembly by following the Rail.

- 1 Connector



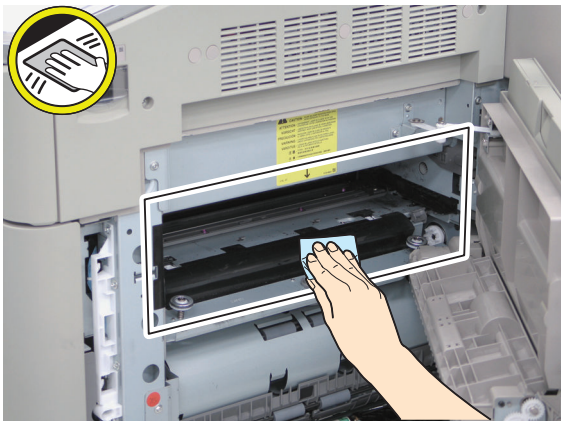
□

- 7. Clean the top surface of the Developer Container and the lower side of the Developing Assembly with lint-free paper moistened with alcohol.



□

- 8. Clean the location where the Developing Assembly is going to be installed inside the host machine if necessary.



□

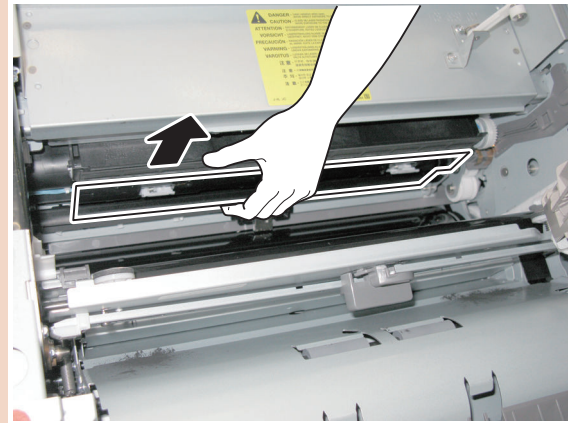
- 9. Return the legs to its original position.

CAUTION:

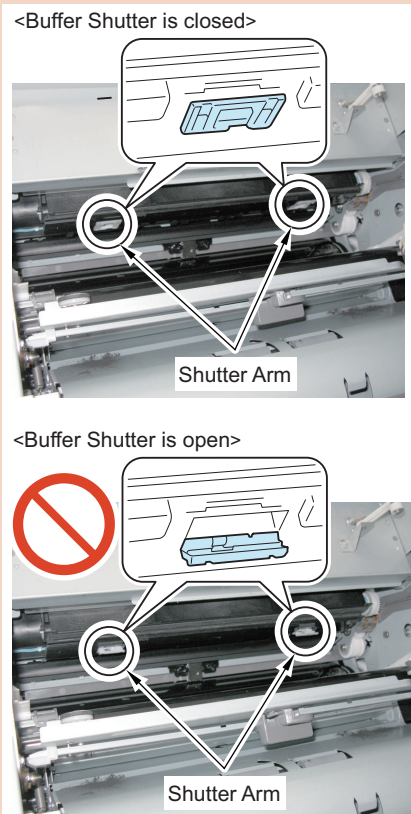
Points to Caution when Installing the Developing Assembly

Before installing the Developing Assembly, check that the Buffer Shutter is not open.

If the Developing Assembly is forcibly installed while the Buffer Shutter is open, the shutter may get damage. When the Buffer Shutter is open, pull out the shutter to the front and then close it.



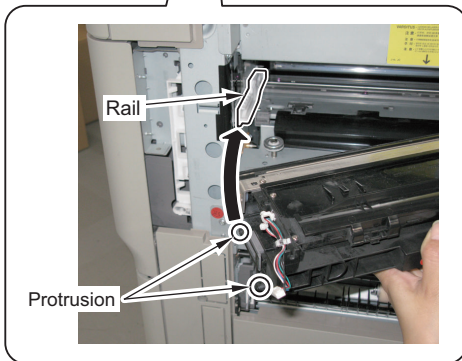
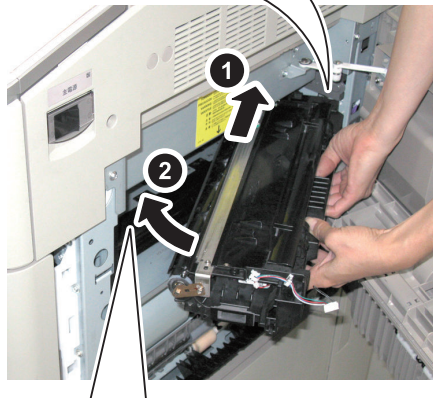
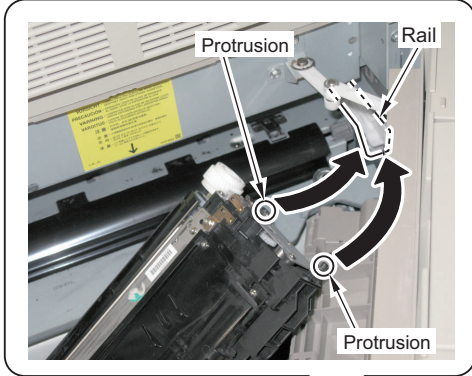
Whether the shutter is open or not can be checked with the Shutter Arm.



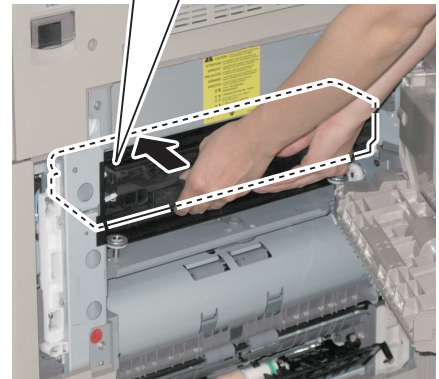
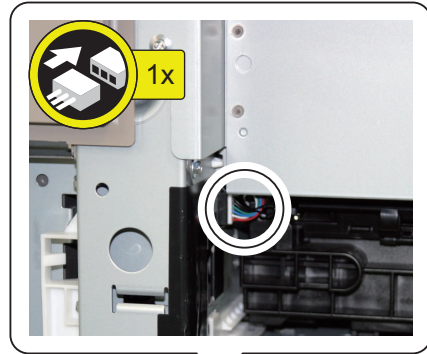


10. Return the Developing Assembly to its original position.

1. As shown in the figure, hold the Developing Assembly and fit the protrusions at right and left sides of the Developing Assembly to the rail of the host machine.



2. Install the Developing Assembly horizontally by following the rail. (1 Connector)



11. Close the Developing Assembly Pressure Cover. (1 Screw)



12. Close the Right Cover.



13. Lift the 2 adjusters of the host machine off the floor by turning the adjusters with a screwdriver.

Works after Relocation



1. Check that there is no toner scattering in the area where you cleaned before relocation. If there is any toner scattering, wipe off the toner. The procedure is the same with "Works before Relocation".
 - Hopper
 - Registration Assembly
 - Pre-transfer Charging Assembly
 - Developing Assembly



2. Remove the packing materials you put before relocation.



- 3. By following the steps 1 to 6 of "Fixing the Reader Unit" in reverse order, remove the Scanner System Fixation Member and return the Reader Left Upper Cover, Rubber Cap and Maintenance Cover (Upper) to their original position.**



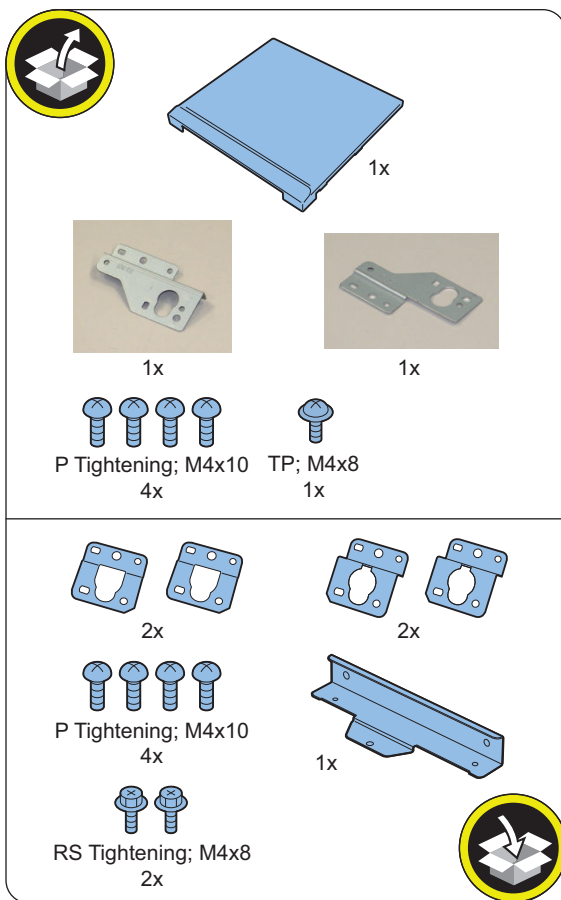
- 4. After turning ON the power, print 2 sheets each of TYPE 4, TYPE 6, and TYPE 7 in a large size, and check that there is nothing wrong with the image.**

Printer Cover-H2

Points to Note before Installation

- After installation of the Printer Cover, be sure to change the setting of the following service mode to "0" before turning OFF the power of the host machine. Otherwise, an error may occur when turning ON the power.
COPIER > OPTION > FNC-SW > W/SCNR
- The pictures and illustrations used may be different from the product in front of you, but the procedure is the same.

Checking the Contents



Essential Items to Be Performed Before Installation

- Turn OFF the main power of the host machine, and disconnect the power plug from the outlet.

⚠ WARNING:

- If performing work without disconnecting the power plug of the host machine, it may cause electrical shock.
- If disconnecting the power plug without turning OFF the main power, it may cause damage of the machine.

- When turning OFF the main power, follow the below procedure.
 1. Turn OFF the main power switch of the host machine.
 2. The display in the Control Panel and the lamp of the main power are turned off.

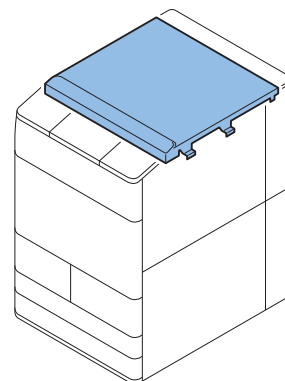
Points to Note When Turning ON/OFF the Main Power

The following message is displayed.

1. When a message prompting to turn OFF and then ON the main power appears, turn OFF and then ON the main power switch.
2. If a message prompting the user to update the version appears, press [Update] to automatically update the version of this equipment.

If [Skip] is selected, a message prompting the user to update the version will appear every time the host machine is started. In the service mode (Lv. 2) shown below, it is possible to set not to display the message.
COPIER > OPTION > FNC-SW > VER-CHNG

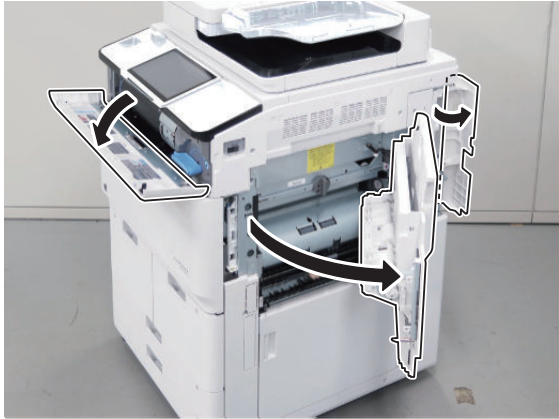
Installation Outline Drawing



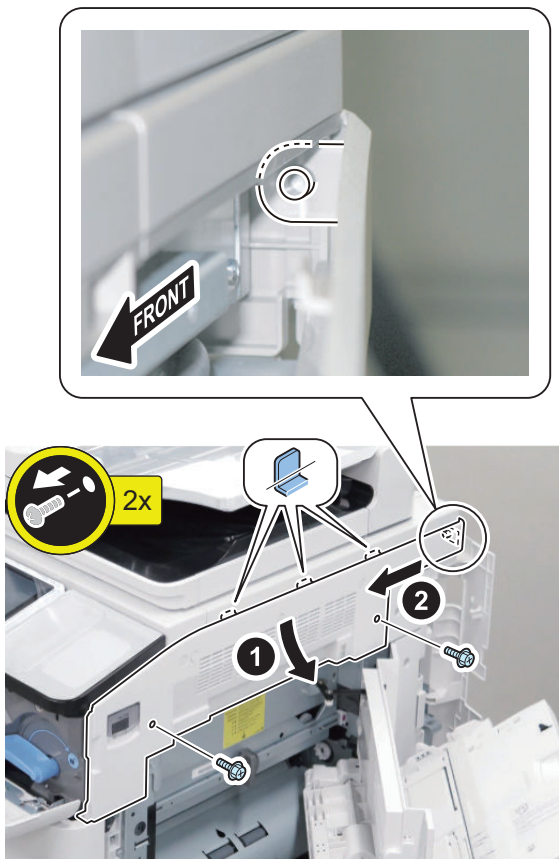
Installation Procedure

Removing the Covers

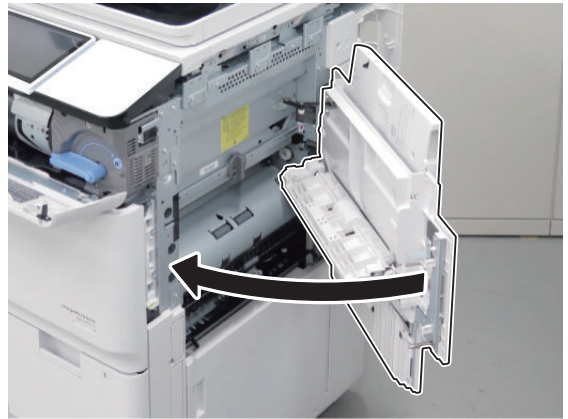
1.



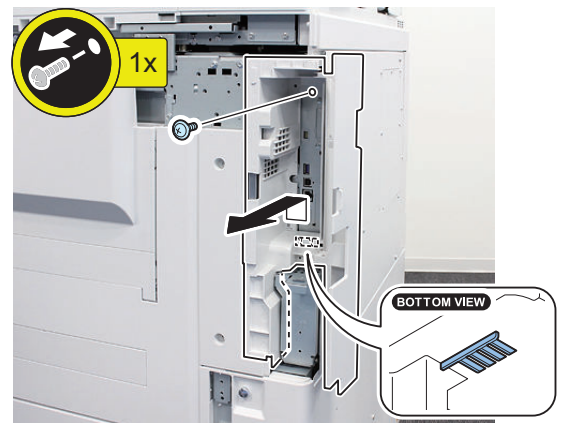
2.



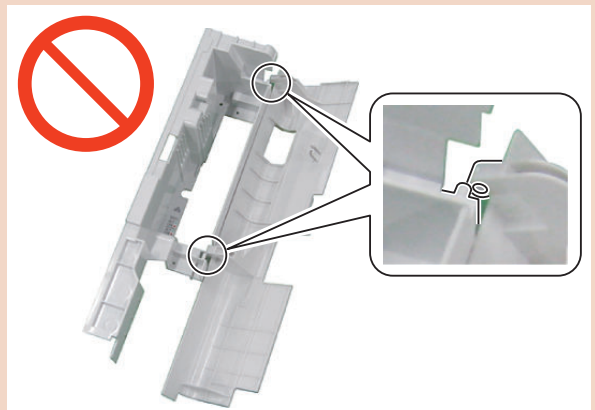
3.



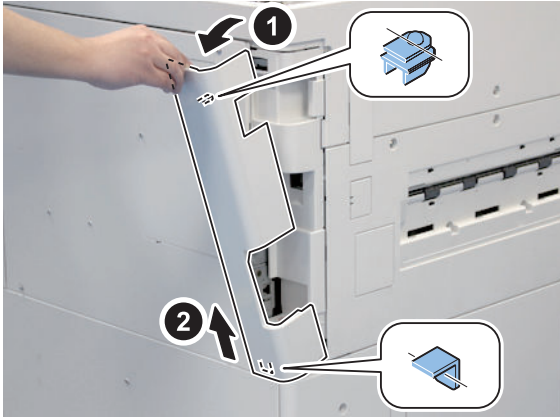
4.



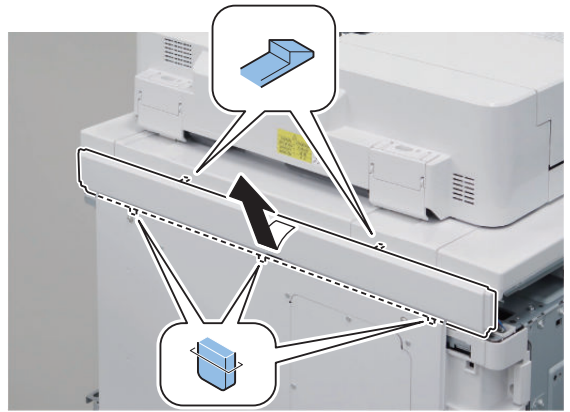
CAUTION:
Be careful not to let the 2 bosses of the Side Cover come off from the 2 mounting holes of the Right Rear Cover 1.



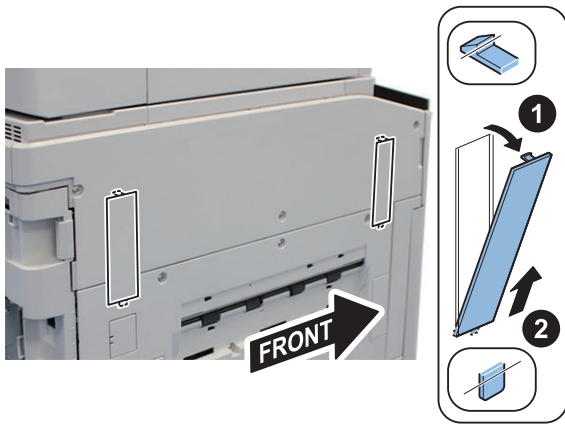
□
5.



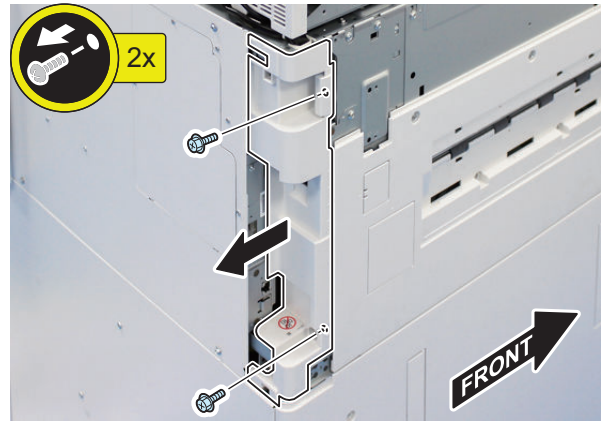
□
8.



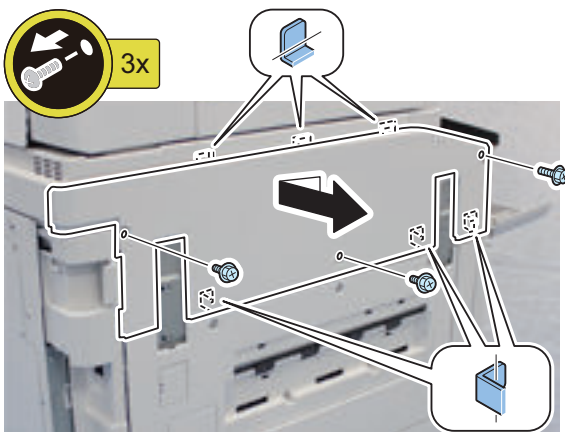
□
6.



□
9.



□
7.



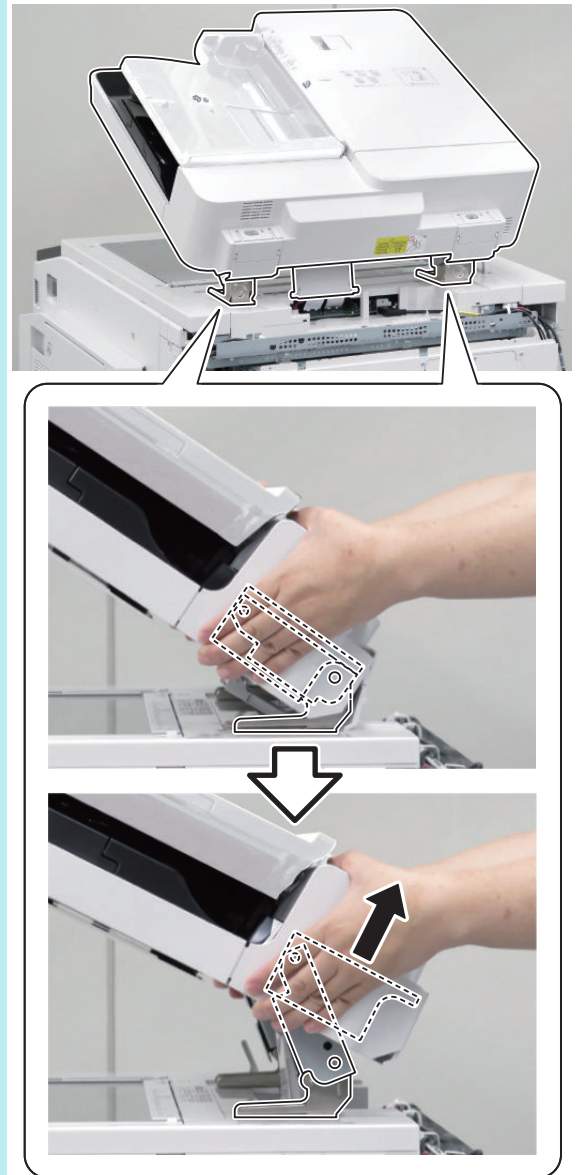
■ Removing the ADF

□
1.

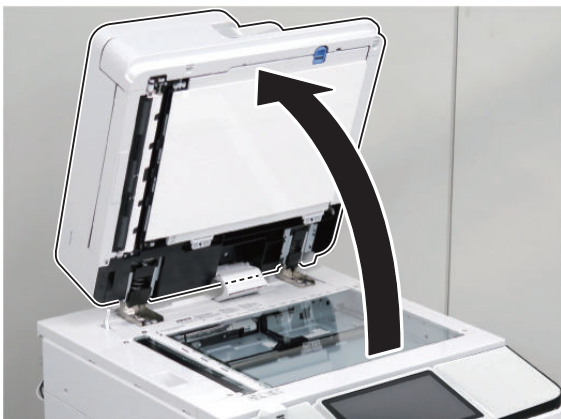


NOTE:

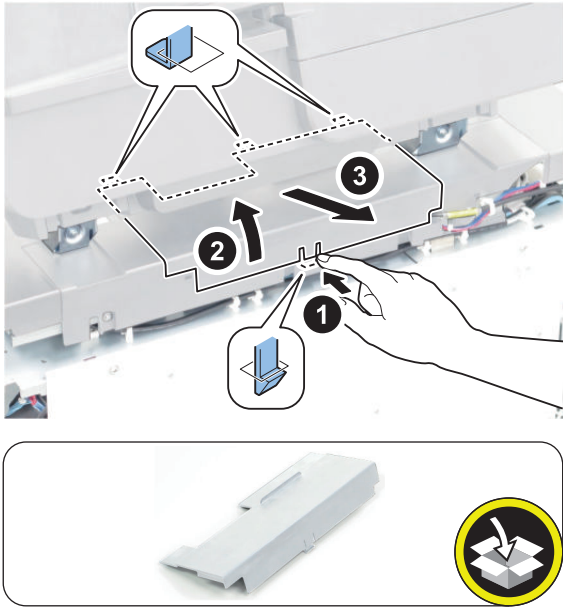
When performing following procedures, using ADF in the book mode as necessary makes the work easy. The book mode is released by opening the ADF.



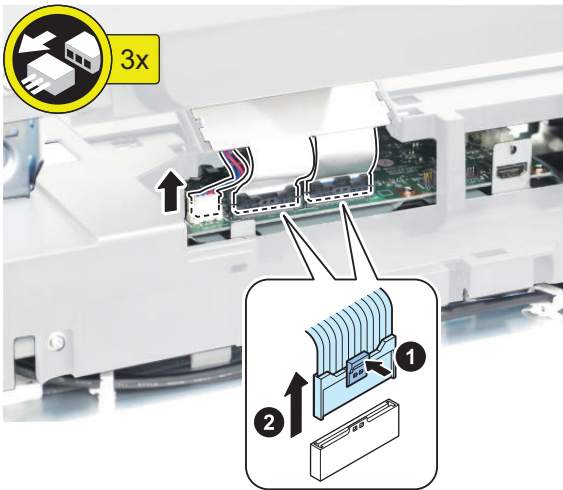
□
2.



□
3.



□
4.

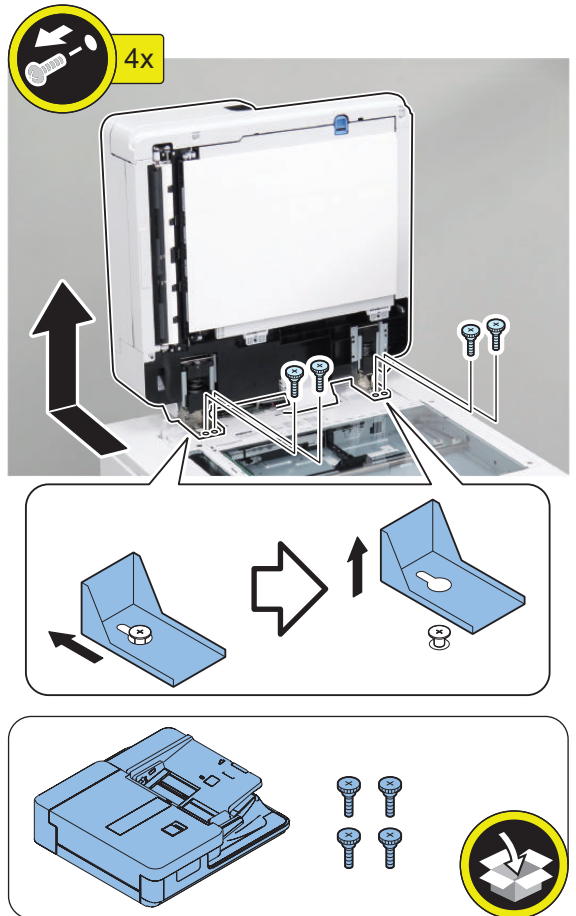


□
5.



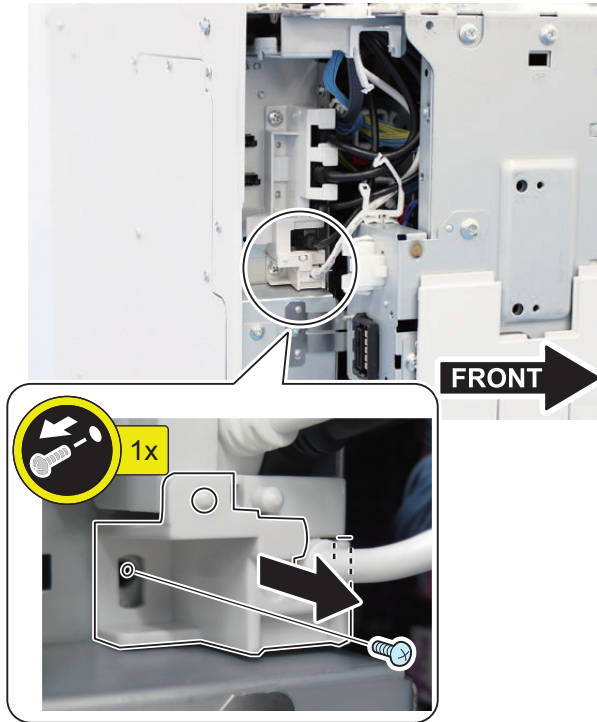
□
6.

⚠ CAUTION:
Be careful not to drop the ADF.

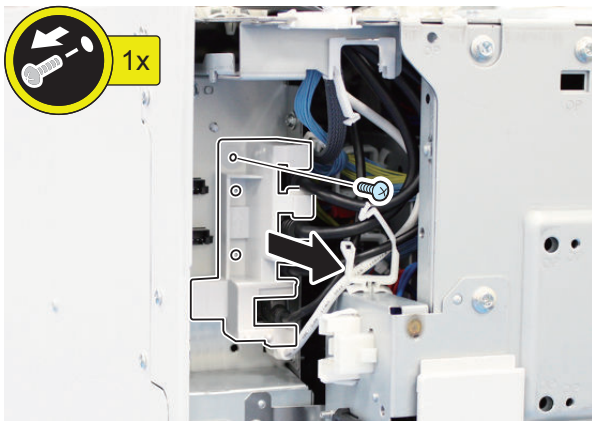


■ Removing the Reader Unit

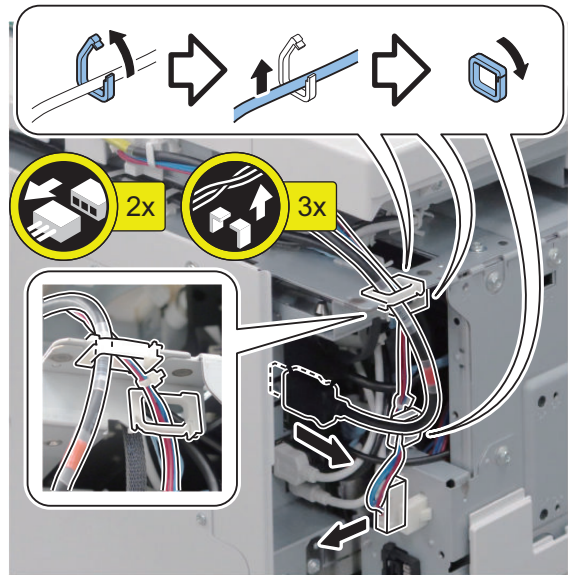
□
1.



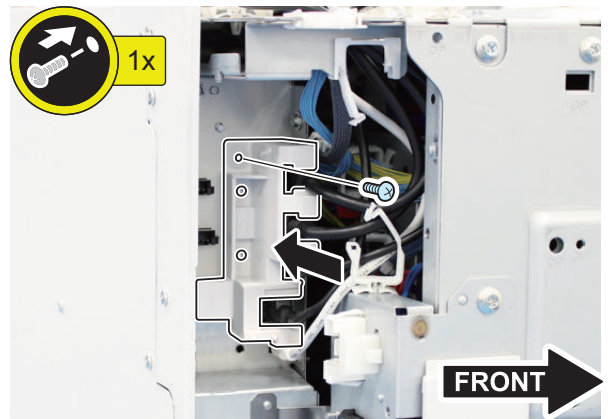
□
2.



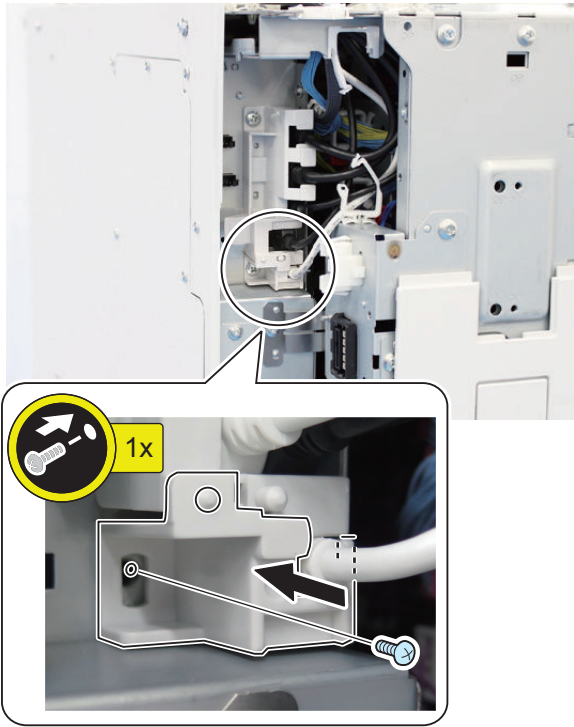
□
3.



□
4.



□
5.

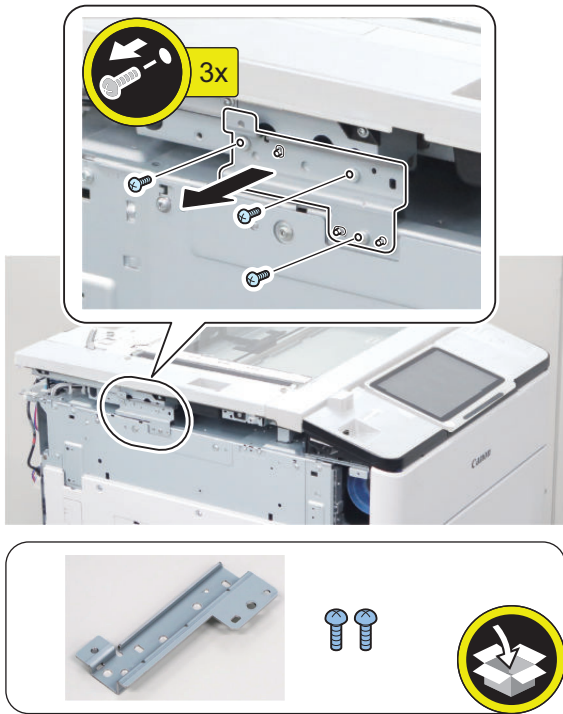


□
6.



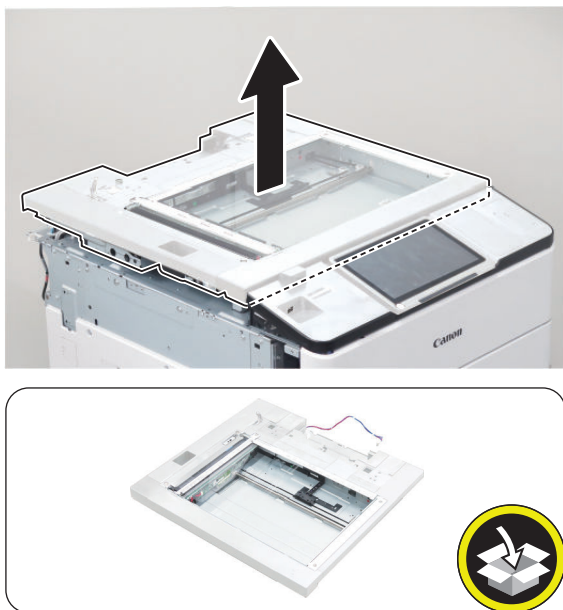
NOTE:
Removed screw will be used in step 1 of "Installing the Printer Cover".

□
7.



NOTE:
Removed screw will be used in step 2 of "Installing the Printer Cover".

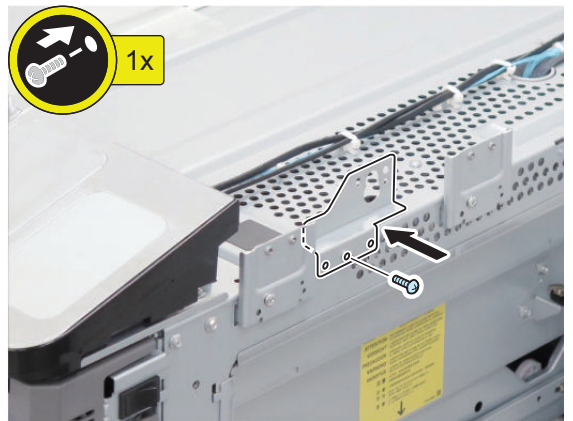
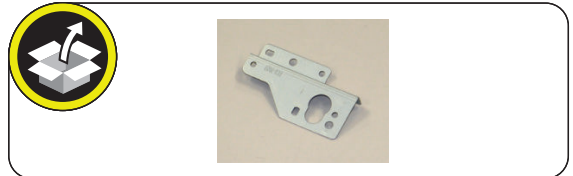
□
8.



■ Installing the Printer Cover

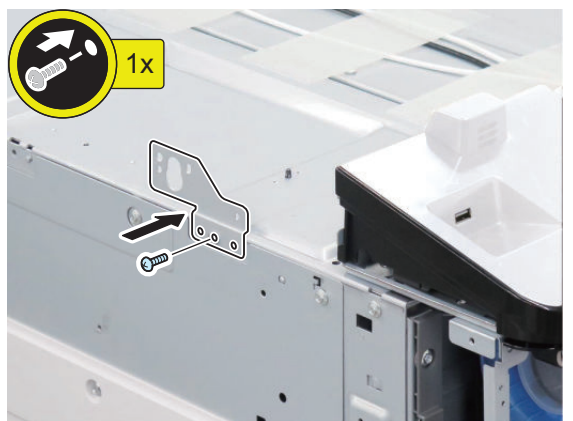
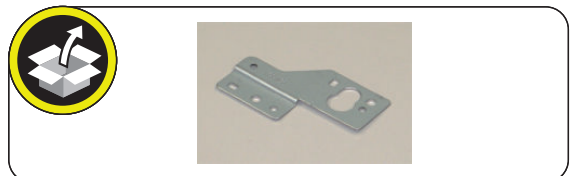
□
1.

NOTE:
Use screw removed in step 6 of "Removing the Reader Unit".

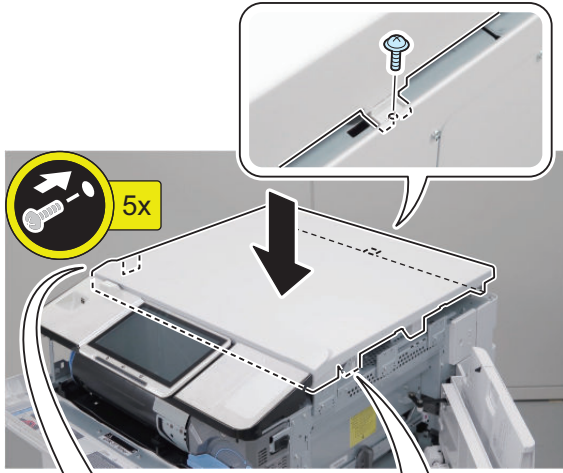
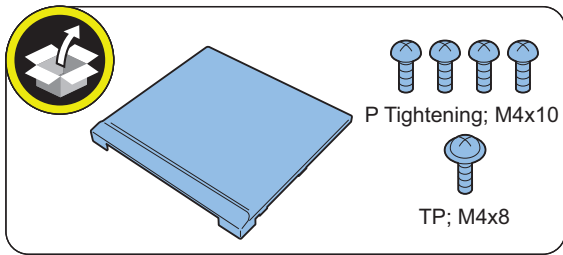


□
2.

NOTE:
Use screw removed in step 7 of "Removing the Reader Unit".

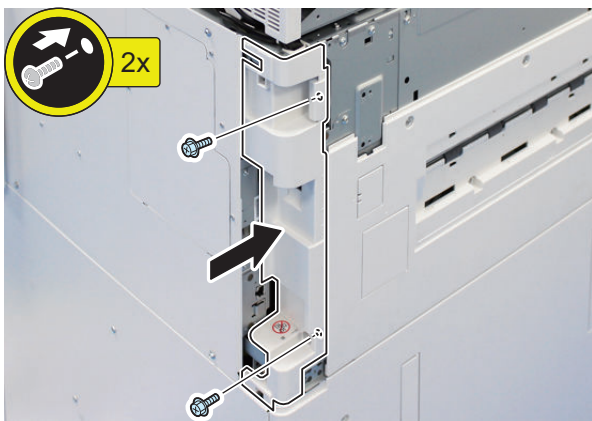


3.

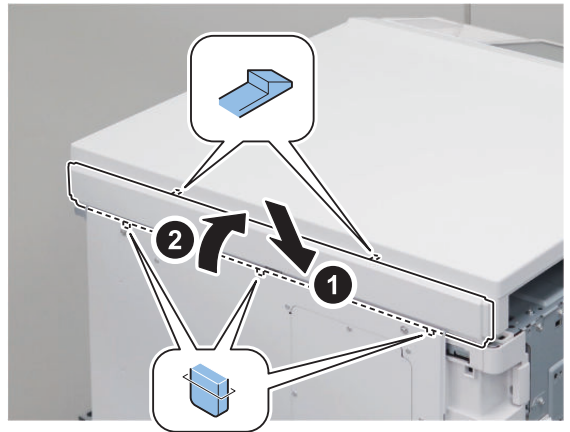


■ Installing the Covers

1.

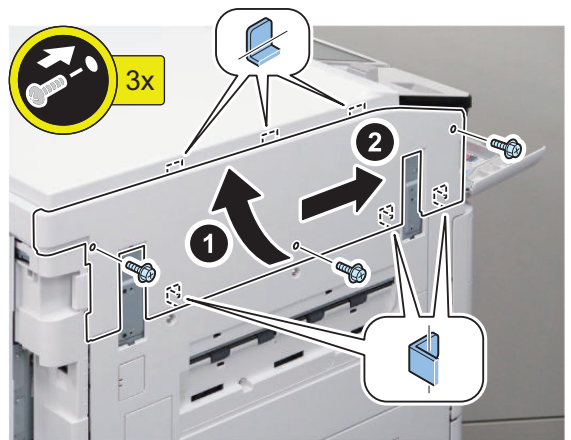


2.

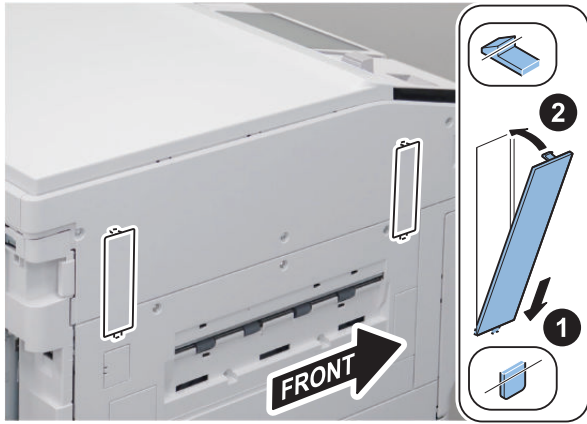


3.

CAUTION:
When installing the Left Upper Cover, be careful not to secure it while it is being slid fully toward the front. Otherwise, the Left Upper Cover may interfere with the Toner Replacement Cover and the magnet cannot work.



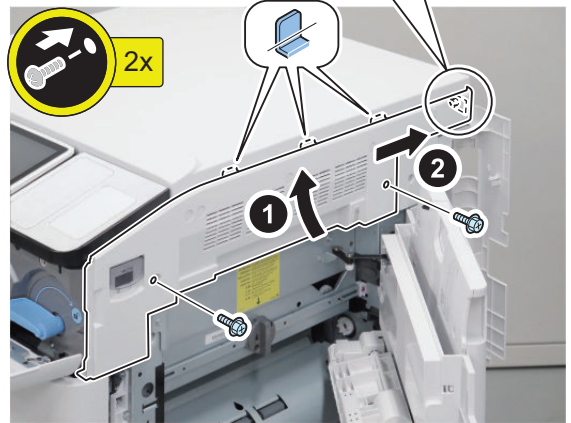
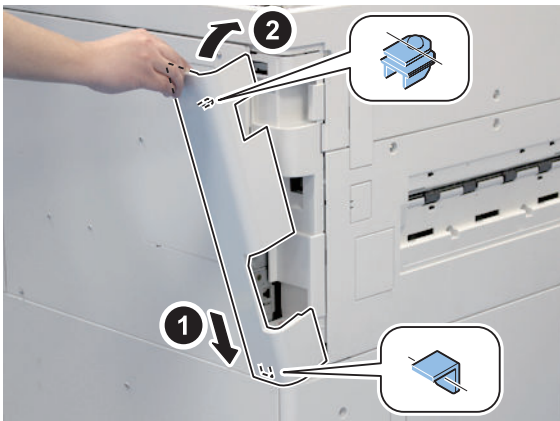
4.



7.

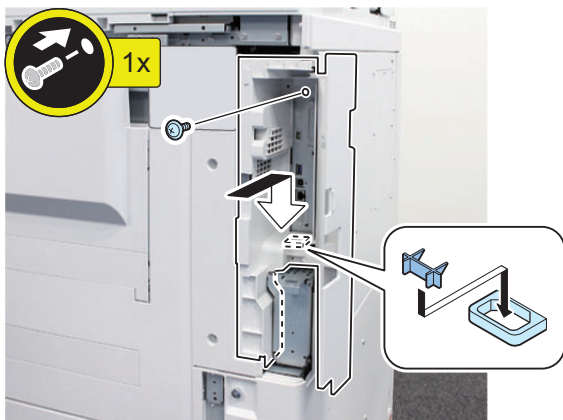


5.



8.

6.



Operation Check

□

1. Connect the power plug of the host machine to the outlet.

2. Turn ON the main power switch.**CAUTION:**

If "E732-0023" is displayed after turning ON the main power switch, turn OFF and then ON the main power switch, and then perform the following steps.

- 3. A message is displayed prompting to check that the Reader Unit Cable is connected properly.**
- 4. Select "0" for the following service mode.**
 - COPIER > OPTION > FNC-SW > W/SCNR
- 5. Get out from service mode.**
- 6. Turn OFF and then ON the main power switch.**

Auto Adjust Gradation



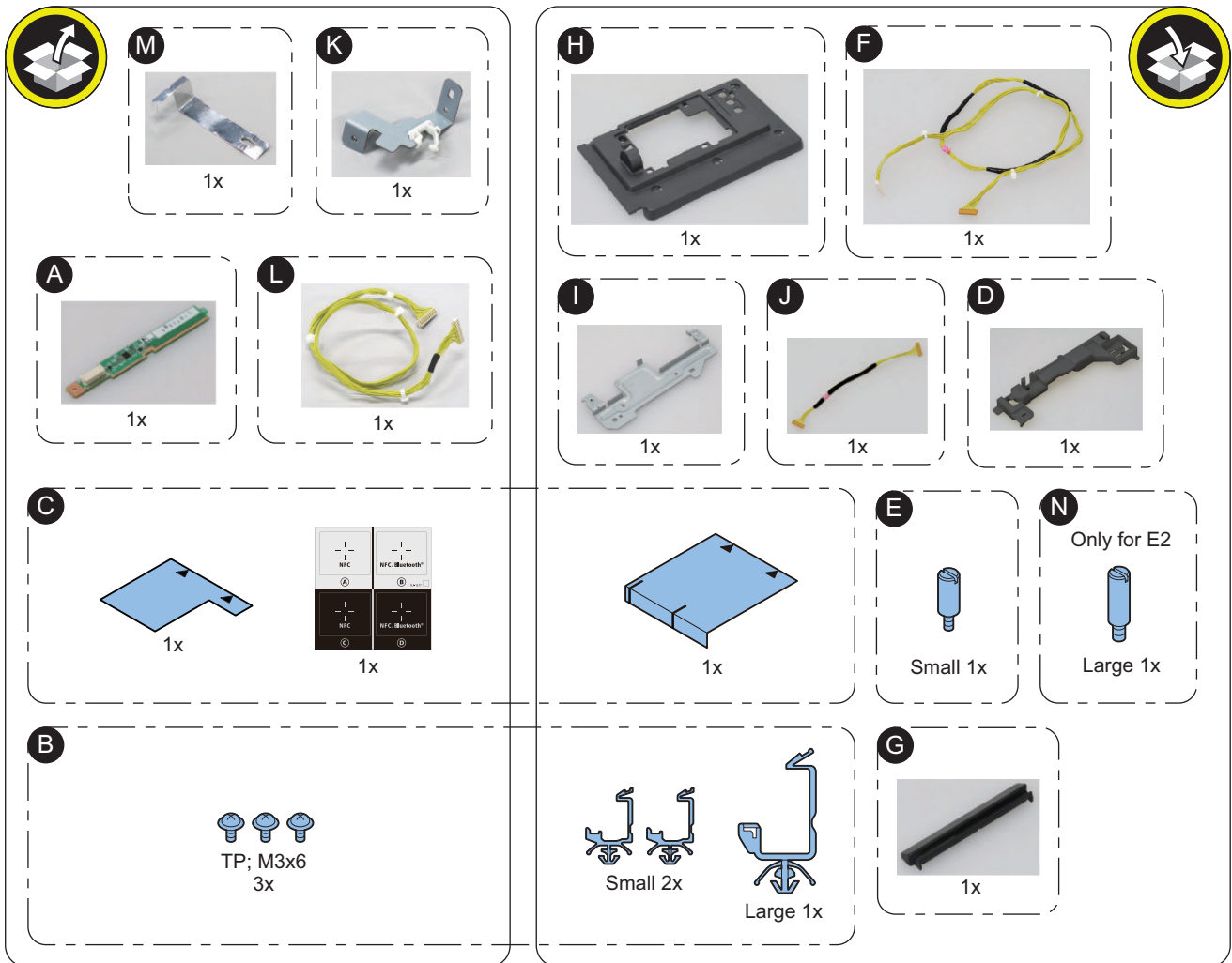
- 1. Set A3, A4, 11x17, or LTR size papers in a cassette.**
- 2. Select [Settings/Registration] > [Adjustment / Maintenance] > [Adjust Image Quality] > [Auto Adjust Gradation], and execute the item.**

NFC Kit-E1/E2

Points to Note before Installation

The pictures and illustrations used may be different from the product in front of you, but the procedure is the same.

Checking the Contents



< Others >

- Guides are included

Essential Items to Be Performed Before Installation

- Turn OFF the main power of the host machine, and disconnect the power plug from the outlet.

⚠ WARNING:

- If performing work without disconnecting the power plug of the host machine, it may cause electrical shock.
- If disconnecting the power plug without turning OFF the main power, it may cause damage of the machine.

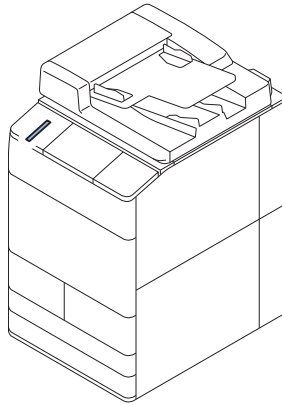
- When turning OFF the main power, follow the below procedure.
 1. Turn OFF the main power switch of the host machine.
 2. The display in the Control Panel and the lamp of the main power are turned off.

● Points to Note When Turning ON/OFF the Main Power

The following message is displayed.

1. When a message prompting to turn OFF and then ON the main power appears, turn OFF and then ON the main power switch.
2. If a message prompting the user to update the version appears, press [Update] to automatically update the version of this equipment.
If [Skip] is selected, a message prompting the user to update the version will appear every time the host machine is started. In the service mode (Lv. 2) shown below, it is possible to set not to display the message.
COPIER > OPTION > FNC-SW > VER-CHNG

● Installation Outline Drawing



● Installation Procedure

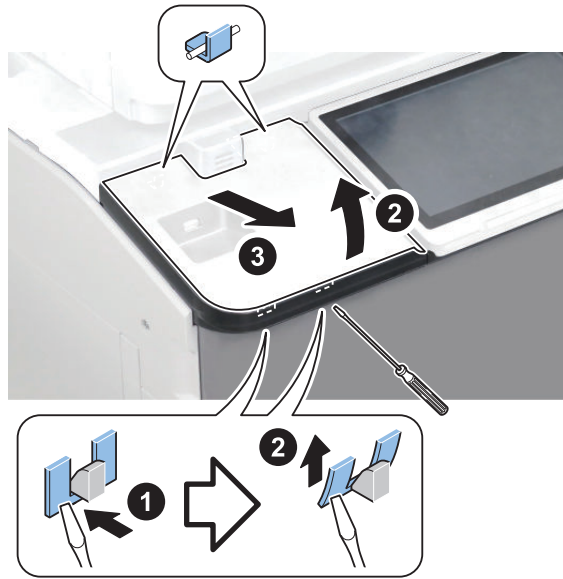
■ Installing the NFC PCB

□

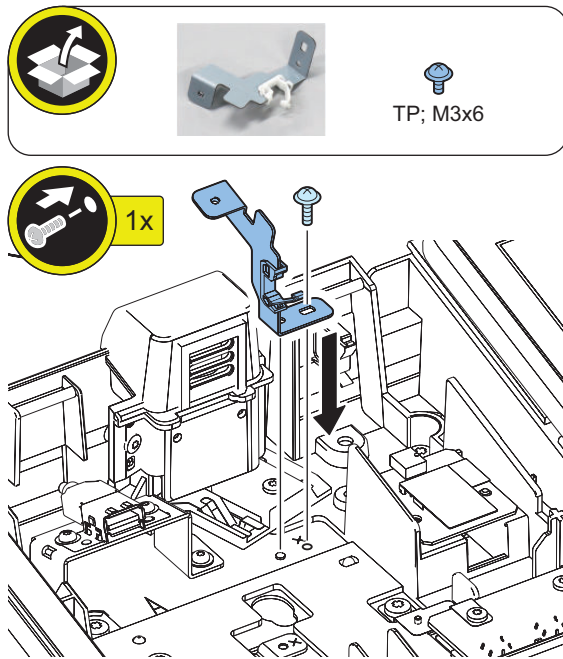
1.



□
2.

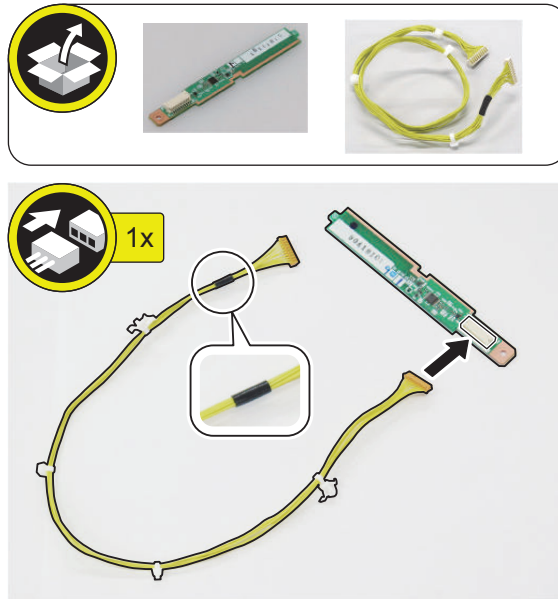


□
3.

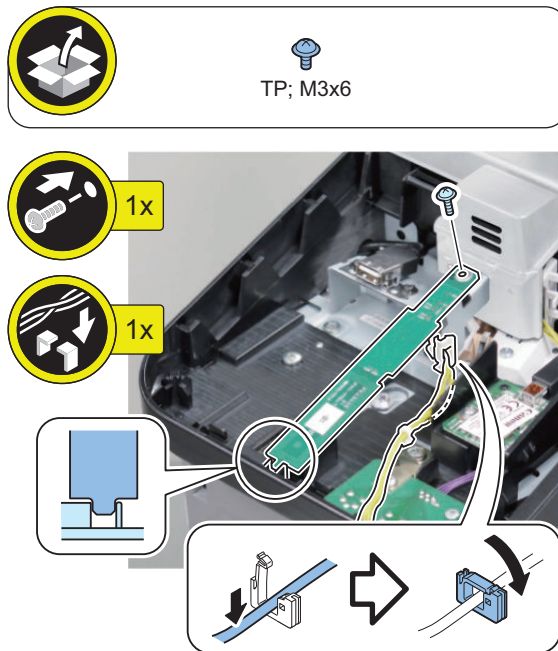


□
4.

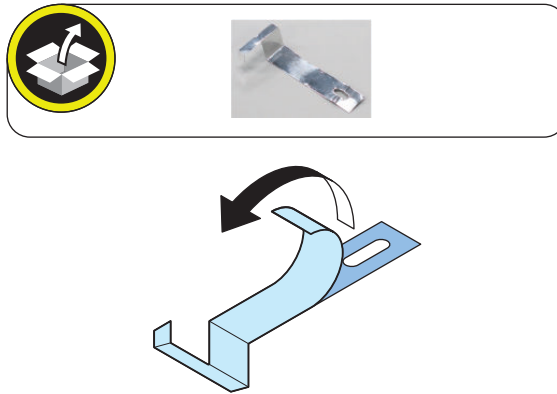
CAUTION:
Connect the cable end which is not wrapped with black tape.



□
5.



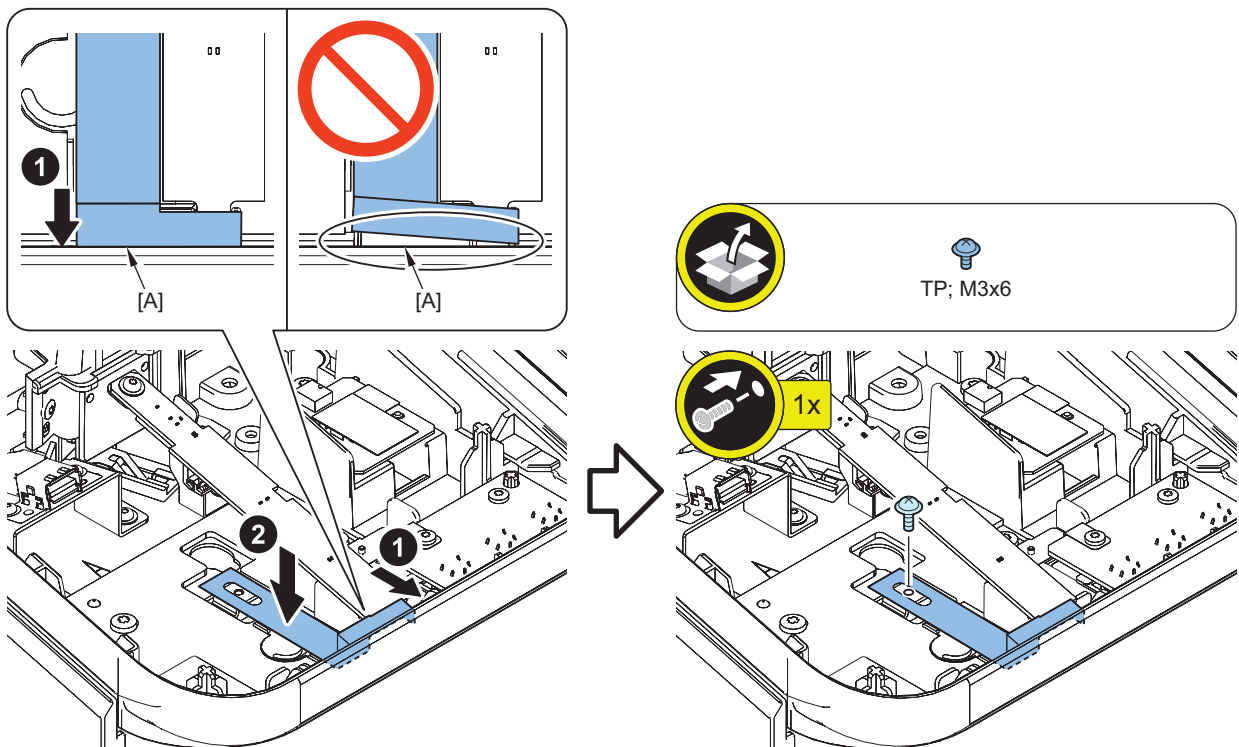
□
6.



□
7.

CAUTION:

Make sure to affix the shield sheet flat against the cover wall [A] without a gap between the shield sheet and the cover. Static electricity from the gap in the Control Panel Left Upper Cover may cause damage to the NFC PCB.

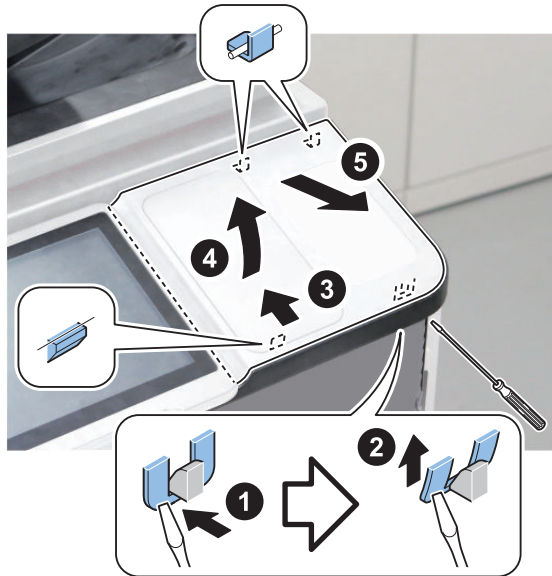


□
8. Next, proceed to the installation procedure for the target parts.

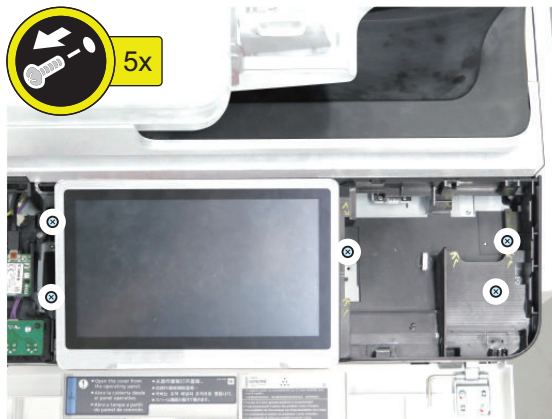
- “Connecting the NFC Cable (for the Flat Control Panel)” on page 2047
- “Connecting the NFC Cable (for the Upright Control Panel)” on page 2052

■ Connecting the NFC Cable (for the Flat Control Panel)

□
1.



□
2.



NOTE:

The removed screw will be used in step 10.

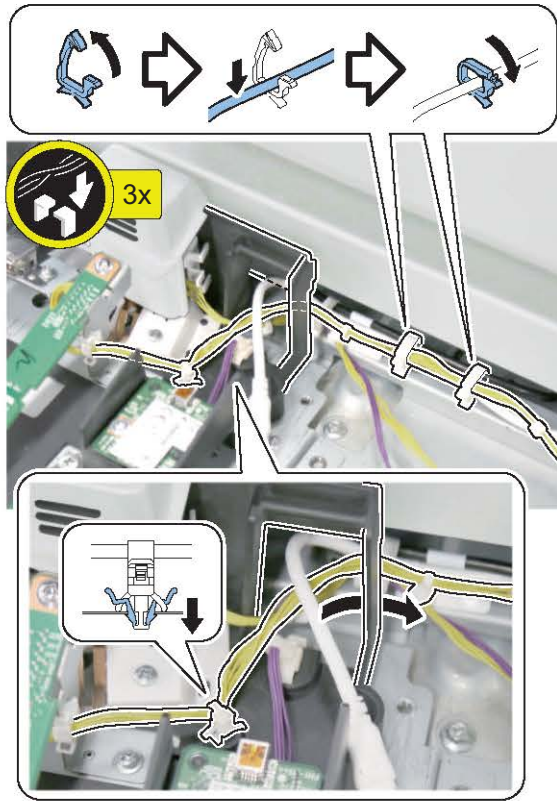
□
3.



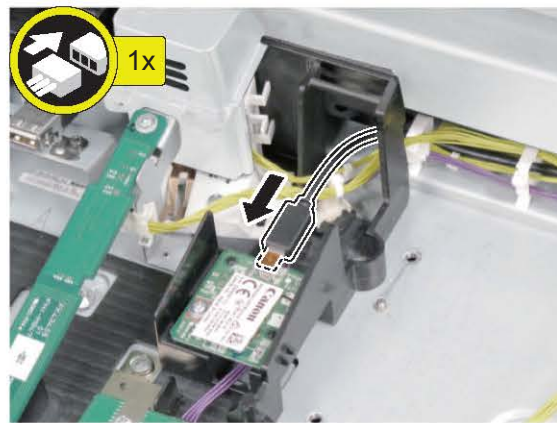
□
4.



□
5.



□
6.



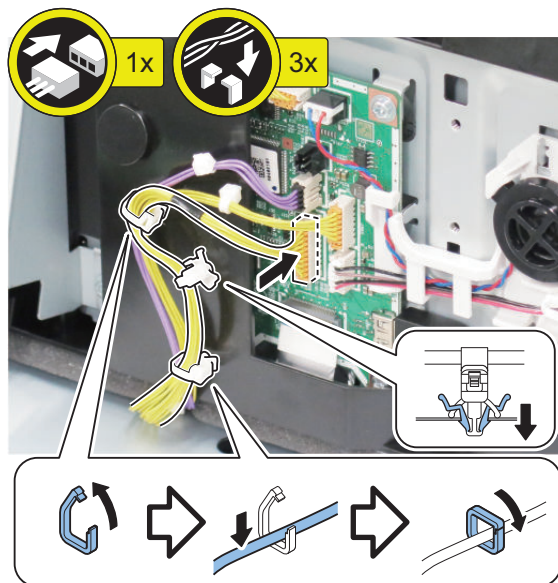
□
7.



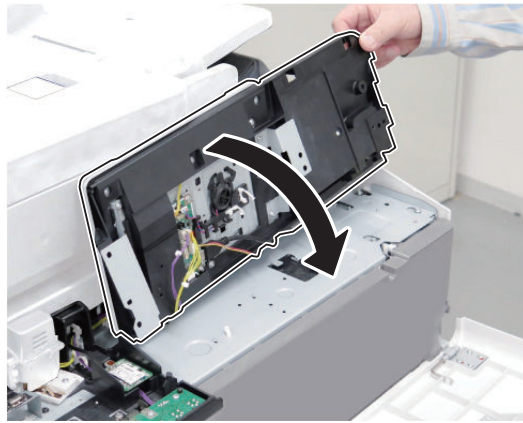
□
8.

CAUTION:

Make sure to check if any connectors are disconnected by pushing again all the connectors connected to the Flat Control Panel Unit.

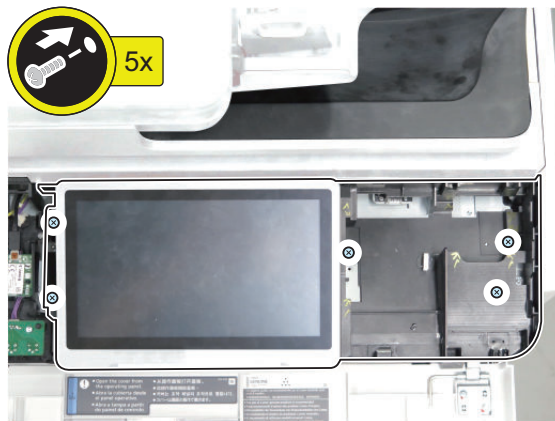


□
9.

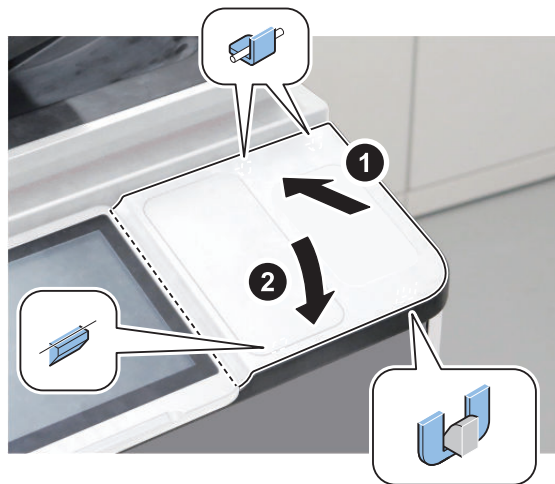


□
10.

NOTE:
Use the screws removed in step 2.



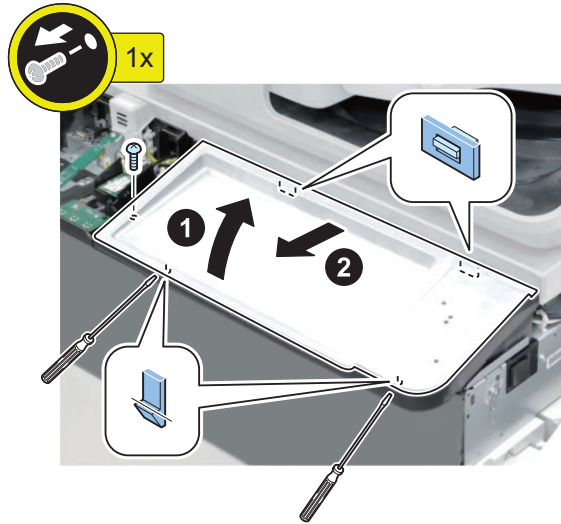
□
11.



□
12. Next, proceed to “Affixing the NFC Labels” on page 2057.

■ **Connecting the NFC Cable (for the Upright Control Panel)**

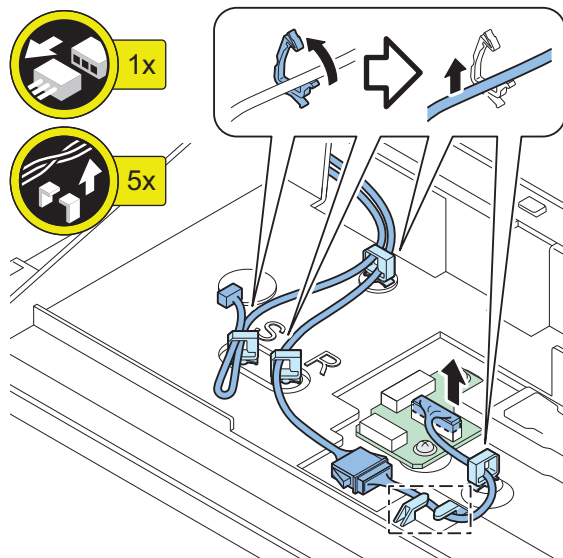
□
1.



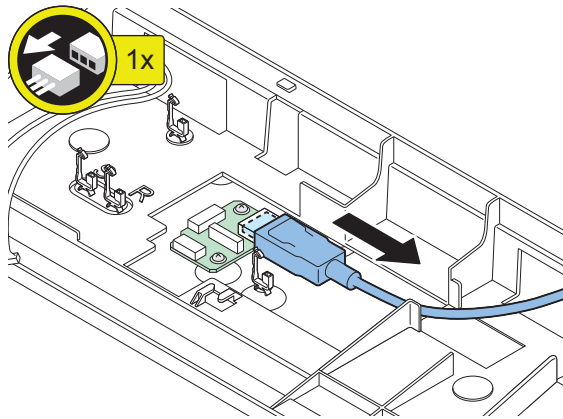
NOTE:

The removed screw will be used in step 11.

□
2.



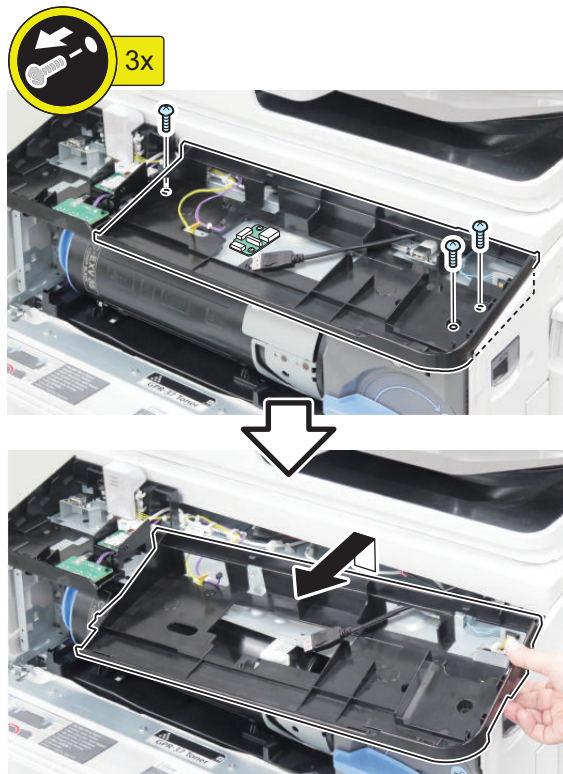
□
3.



□
4.

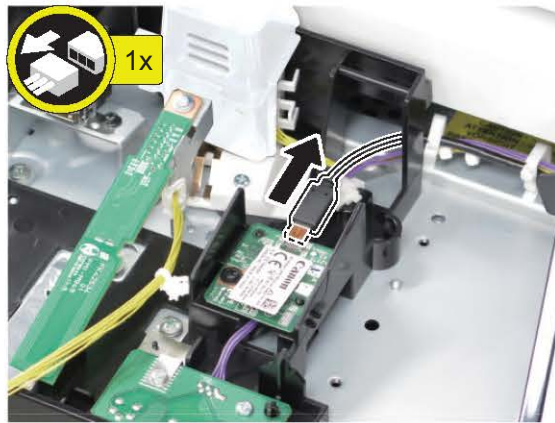
NOTE:

Slightly pull the Front Tray Lower Unit without pulling out the cables that pass through it.

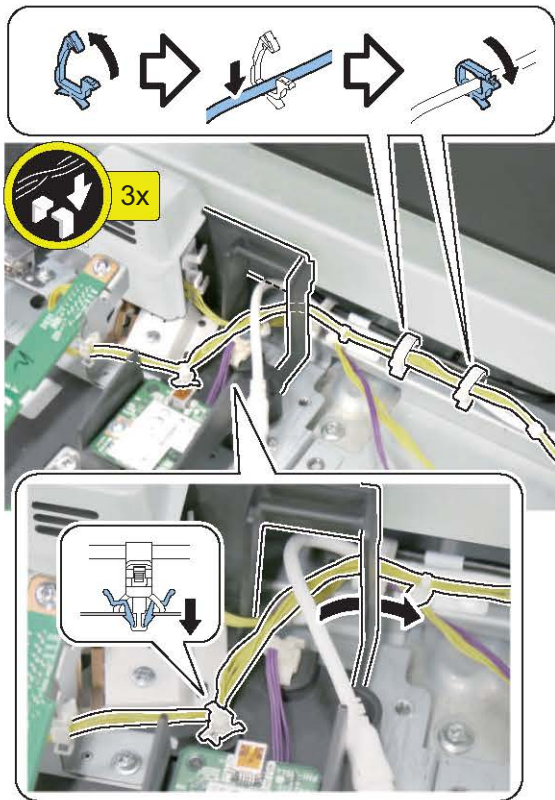
**NOTE:**

The removed screw will be used in step 8.

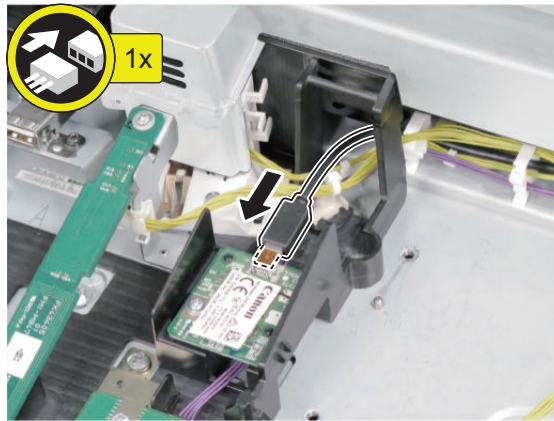
□
5.



□
6.

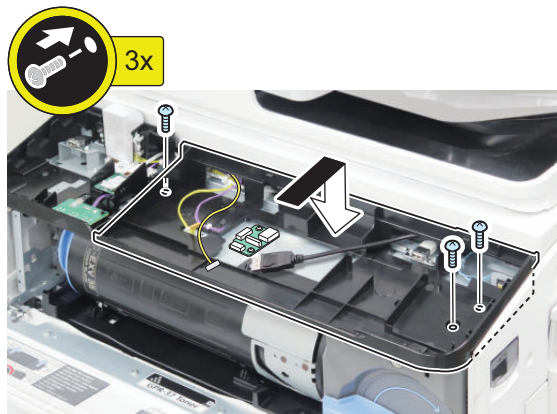


□
7.

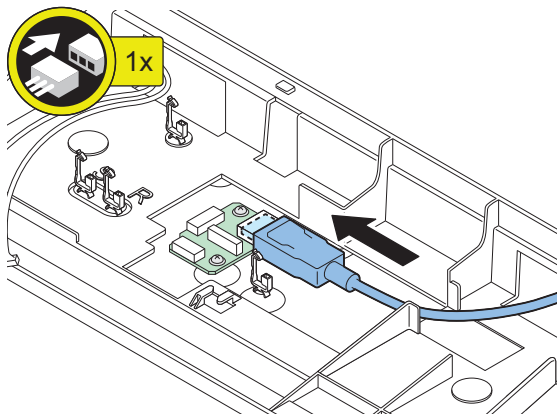


□
8.

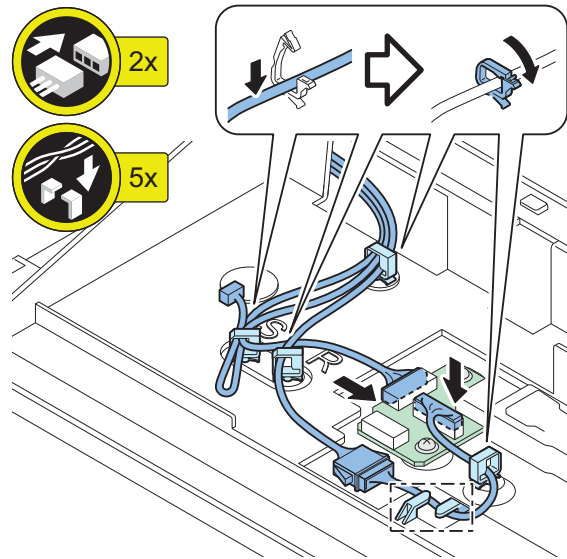
NOTE:
Use the screws removed in step 4.



□
9.

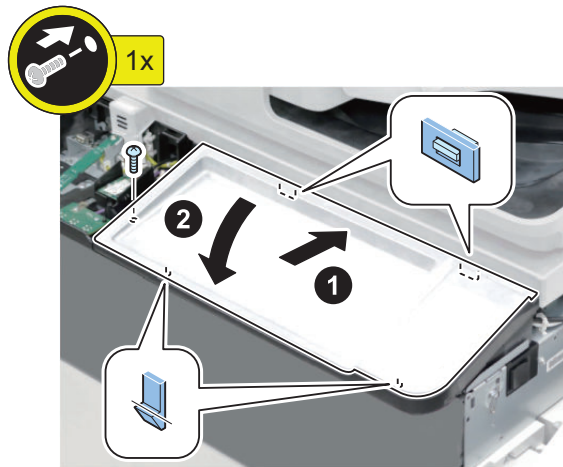


□
10.



□
11.

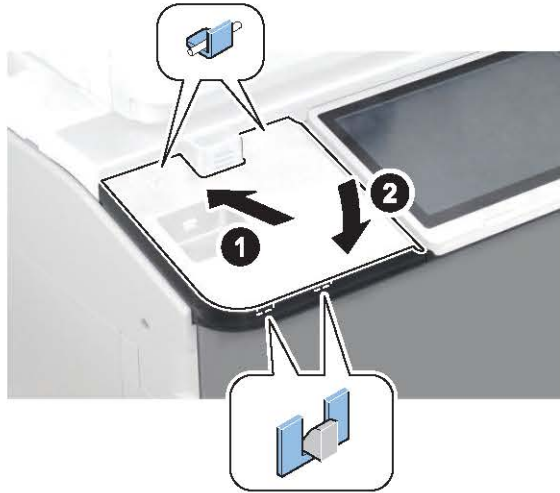
NOTE:
Use the screws removed in step 1.



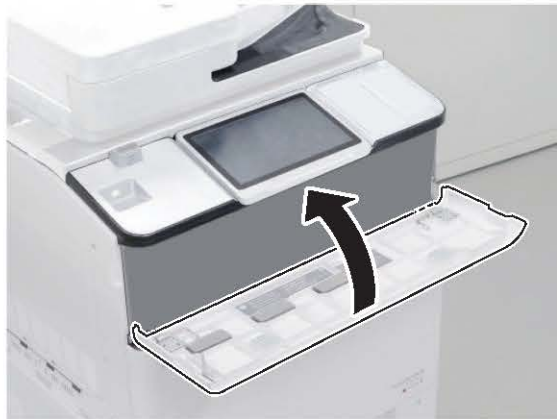
□
12. Next, proceed to [“Affixing the NFC Labels”](#) on page 2057.

■ Affixing the NFC Labels

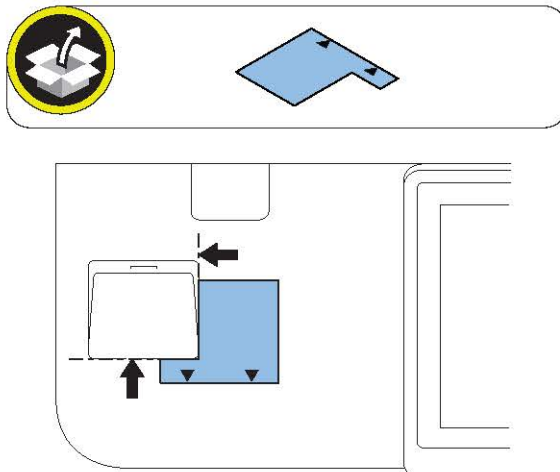
□
1.



□
2.

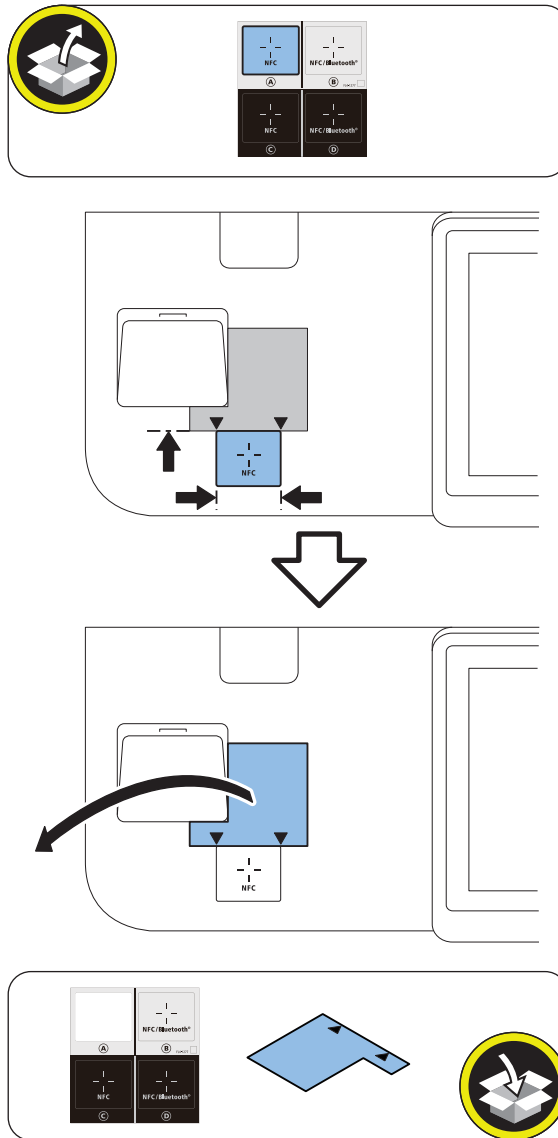


□
3.



□
4.

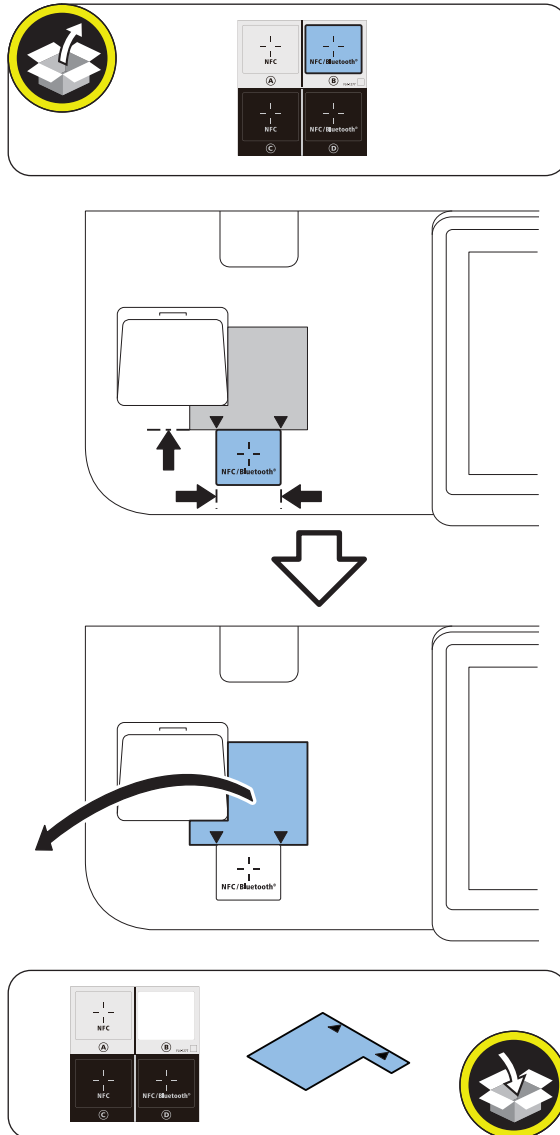
< When installing with the NFC Kit >



< When installing with the Connection Kit-A2 for Bluetooth LE at the same time >

NOTE:

If "Bluetooth" Label is already affixed there, remove the label and wipe off the glue with alcohol.



■ Setting after Installation



1. Connect the power plug of the host machine to the outlet.
2. Turn ON the main power switch.
3. Enter service mode and set the value to "1".
COPIER > FUNCTION > INSTALL > NFC-USE

NOTE:

When [System Manager Information Settings] is set, it is required to log in as a system manager in accordance with instructions of the user administrator.

4. Select [Settings/Registration] > [Management Settings] > [Device Management] > [Use NFC Card Emulation], and set the item to "ON".
5. Turn OFF and then ON the main power switch.

6. When a message prompting the version update is displayed, press [Update] and automatically update the version of this equipment.

CAUTION:

It may take time to display the update screen. (Approx. 1 to 2 min.) During this time, do not operate the screen.

7. Check the end of the following service mode.

COPIER > DISPLAY > VERSION > PANEL

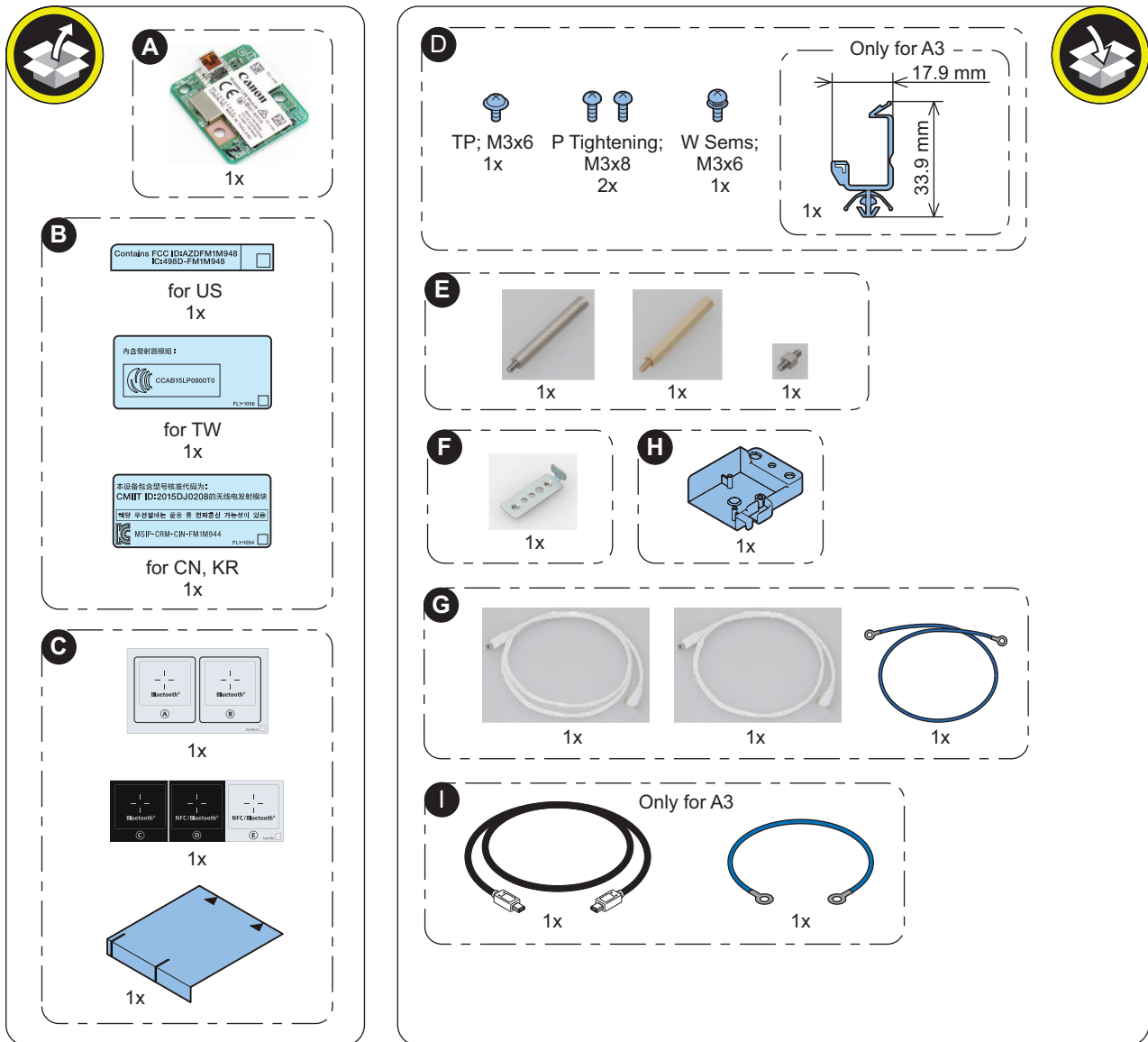
- If the end is an even number (e.g. 01.26): NFC is not installed.
- If the end is an odd number (e.g. 01.27): NFC is installed.

Connection Kit-A2/A3 for Bluetooth LE

Points to Note before Installation

The pictures and illustrations used may be different from the product in front of you, but the procedure is the same.

Checking the Contents



Essential Items to Be Performed Before Installation

- Turn OFF the main power of the host machine, and disconnect the power plug from the outlet.

⚠ WARNING:

- If performing work without disconnecting the power plug of the host machine, it may cause electrical shock.
- If disconnecting the power plug without turning OFF the main power, it may cause damage of the machine.

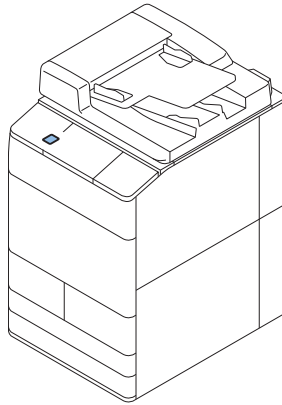
- When turning OFF the main power, follow the below procedure.
 1. Turn OFF the main power switch of the host machine.
 2. The display in the Control Panel and the lamp of the main power are turned off.

Points to Note When Turning ON/OFF the Main Power

The following message is displayed.

1. When a message prompting to turn OFF and then ON the main power appears, turn OFF and then ON the main power switch.
2. If a message prompting the user to update the version appears, press [Update] to automatically update the version of this equipment.
If [Skip] is selected, a message prompting the user to update the version will appear every time the host machine is started. In the service mode (Lv. 2) shown below, it is possible to set not to display the message.
COPIER > OPTION > FNC-SW > VER-CHNG

Installation Outline Drawing

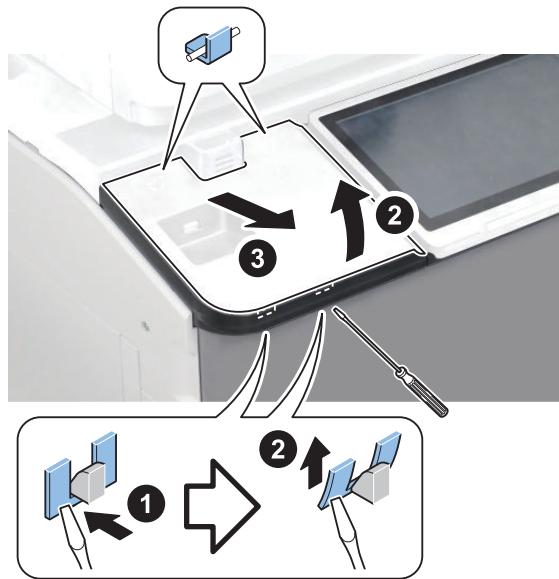


Installation Procedure

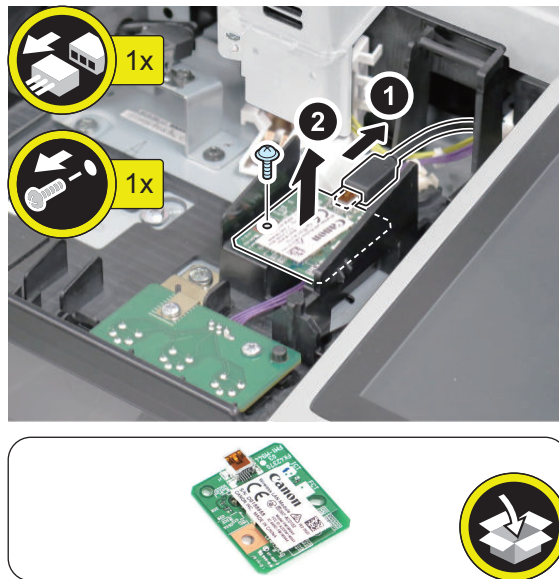
1.



□
2.



□
3.

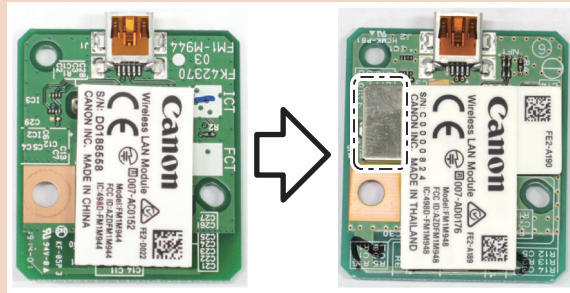


NOTE:

The removed screw will be used in a next step.

CAUTION:

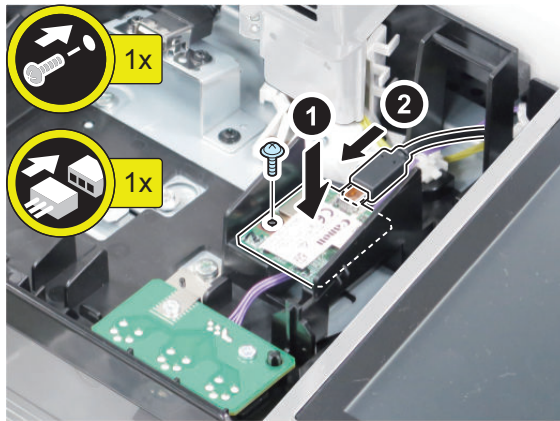
Replace the removed Wi-Fi PCB with the optional Bluetooth PCB. Be sure to mount the correct one.



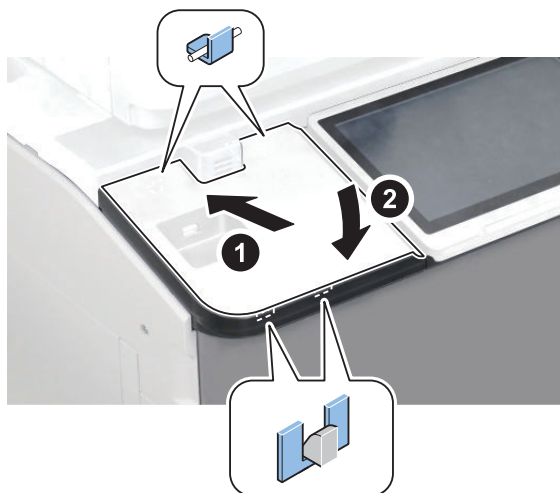
□
4.

NOTE:

Use the screw removed in the previous step.



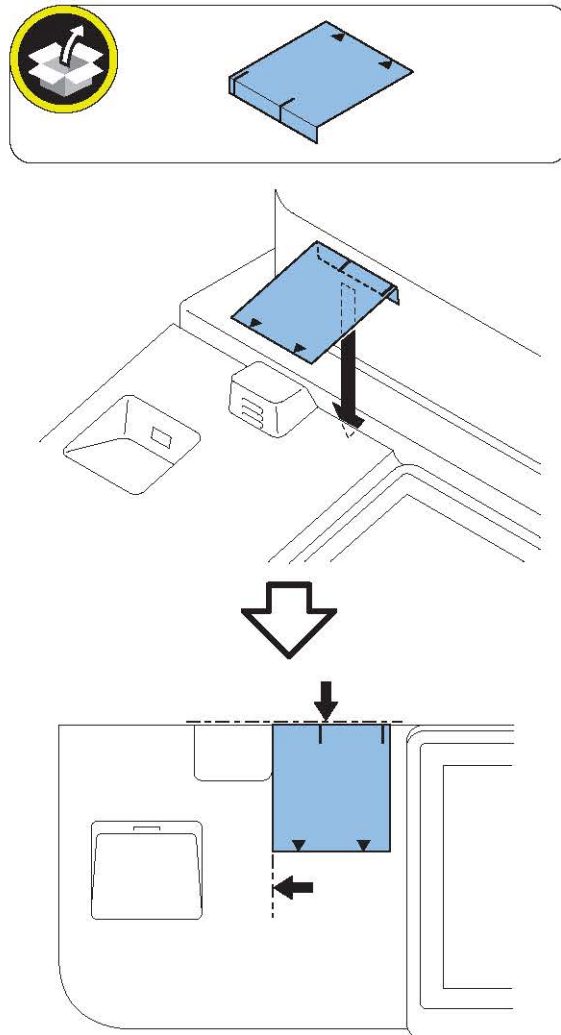
□
5.



□
6.

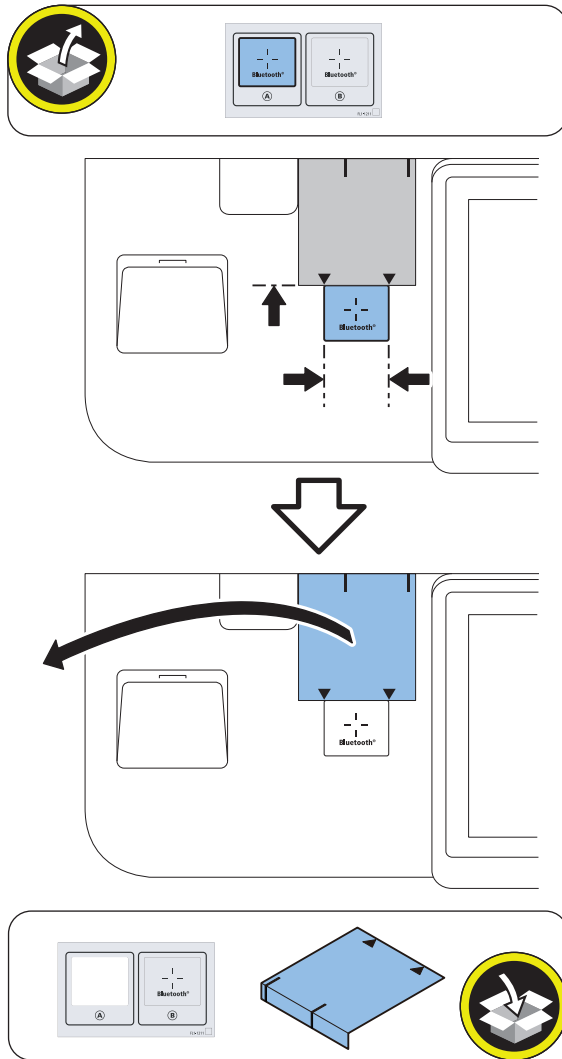


□
7.



□
8.

< When installing with the Connection Kit-A2 for Bluetooth LE >

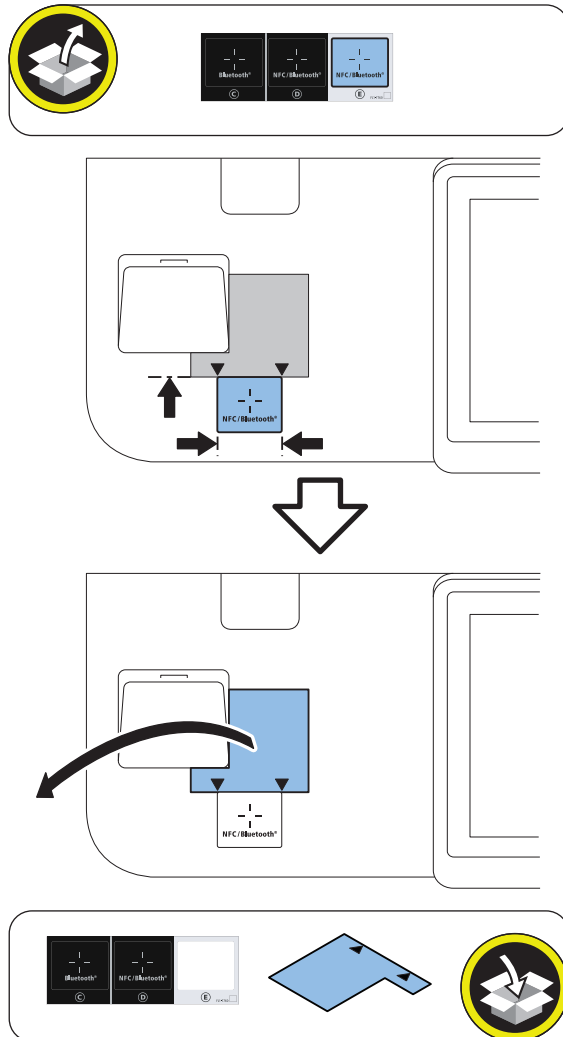


< When installing with the NFC Kit at the same time >

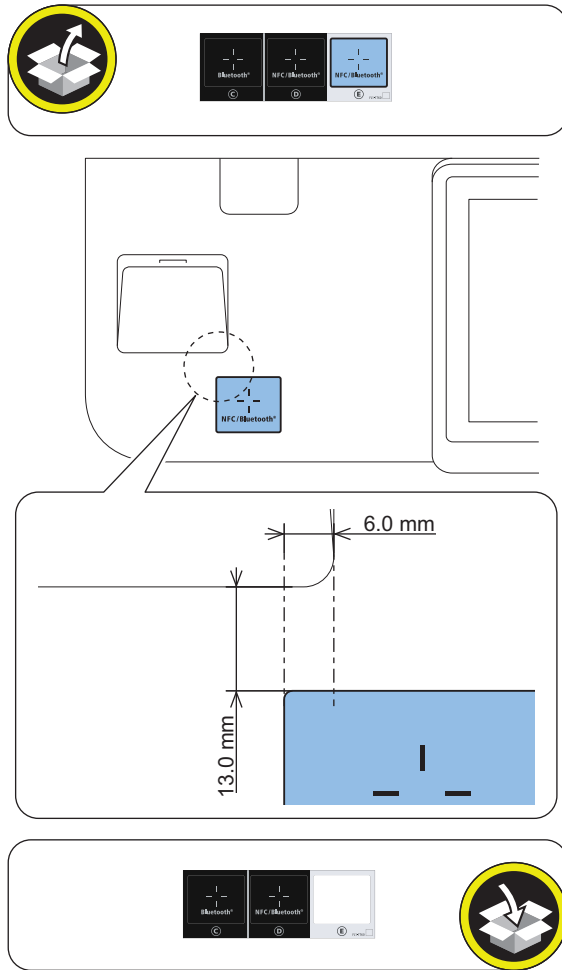
NOTE:

If "Bluetooth" Label is already affixed there, remove the label and wipe off the glue with alcohol before affixing the new label.

- When the Target Sheet for the NFC Kit is available



- When the Target Sheet for the NFC Kit is not available



■ Affixing the Wireless LAN Approval Label

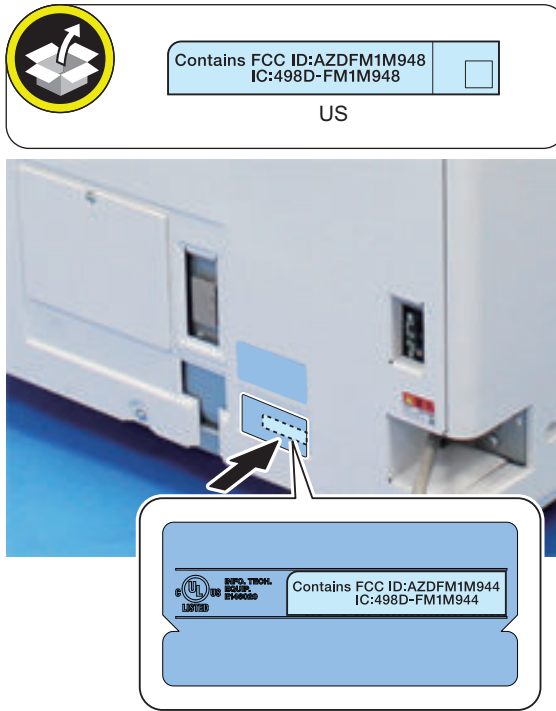
□
1.

NOTE:

In countries other than the following countries, it is not necessary to affix the Approval Label.

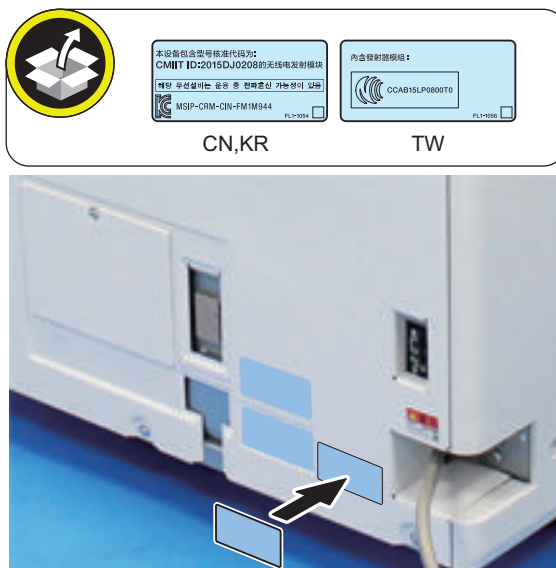
< For US >

Affix it over the number on the Wireless LAN Approval Label.



< For CN, KR, and TW >

Affix it over the Wireless LAN Approval Label.



Setting after Installation



1. **Connect the power plug of the host machine to the outlet.**
2. **Turn ON the main power switch.**
3. **In the following Service Mode, set the value to "1."**
COPIER > FUNCTION > INSTALL > BLE-USE

NOTE:

When [System Manager Information Settings] is set, it is required to log in as a system manager in accordance with instructions of the user administrator.

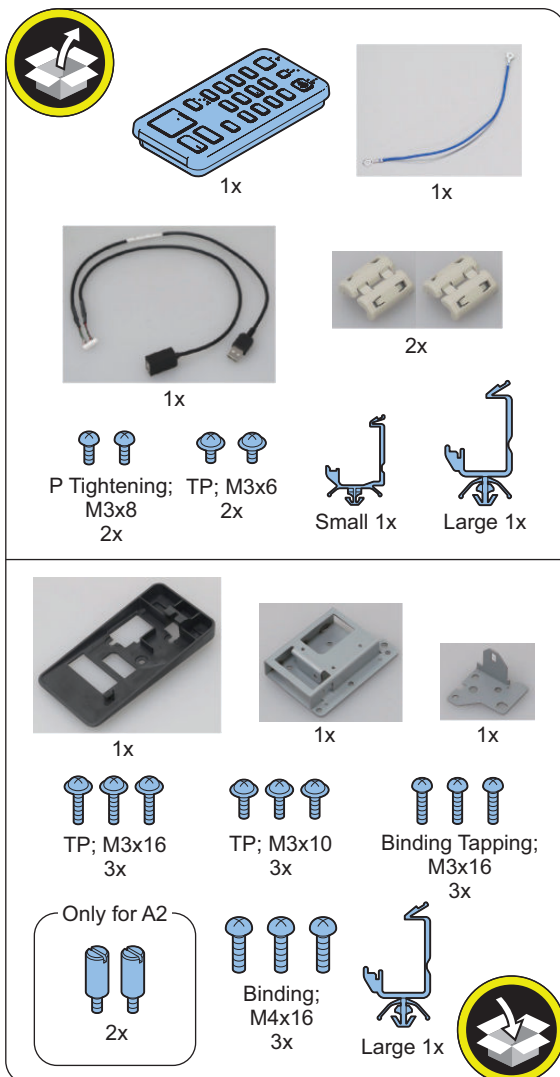
4. **Select [Settings/Registration] > [Preferences] > [Network] > [Confirm Network Connection Setting Changes], and set the item [ON].**
5. **Select [Settings/Registration] > [Preferences] > [Network] > [Bluetooth Settings] > [Use Bluetooth] > [ON].**
6. **The message "Perform Apply Setting Changes from Settings/Registration" appears in the Touch Panel Display.**
7. **Perform "Apply Setting Changes."**
Press [Settings/Registration] > [Yes].

Numeric Keypad-A1/A2

Points to Note before Installation

- When installing the Numeric Keypad and the IC Card Reader at the same time, be sure to install the Numeric Keypad first.
- The pictures and illustrations used may be different from the product in front of you, but the procedure is the same.

Checking the Contents



Essential Items to Be Performed Before Installation

- Turn OFF the main power of the host machine, and disconnect the power plug from the outlet.

⚠ WARNING:

- If performing work without disconnecting the power plug of the host machine, it may cause electrical shock.
- If disconnecting the power plug without turning OFF the main power, it may cause damage of the machine.

- When turning OFF the main power, follow the below procedure.
 1. Turn OFF the main power switch of the host machine.
 2. The display in the Control Panel and the lamp of the main power are turned off.

Points to Note When Turning ON/OFF the Main Power

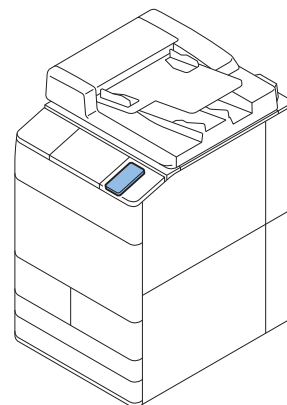
The following message is displayed.

1. When a message prompting to turn OFF and then ON the main power appears, turn OFF and then ON the main power switch.
2. If a message prompting the user to update the version appears, press [Update] to automatically update the version of this equipment.

If [Skip] is selected, a message prompting the user to update the version will appear every time the host machine is started. In the service mode (Lv. 2) shown below, it is possible to set not to display the message.

COPIER > OPTION > FNC-SW > VER-CHNG

Installation Outline Drawing

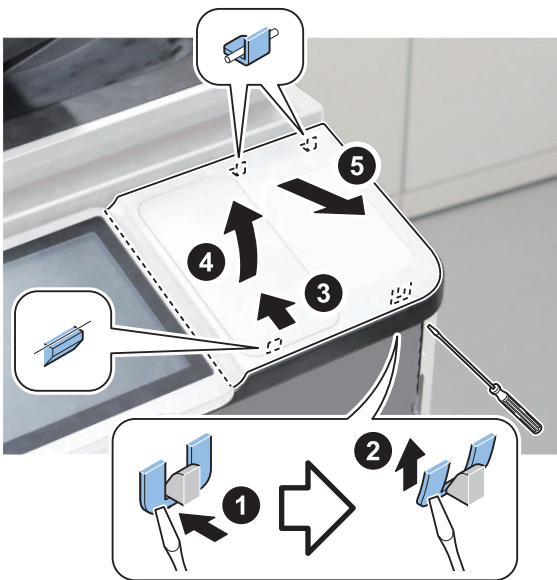


Installation Procedure

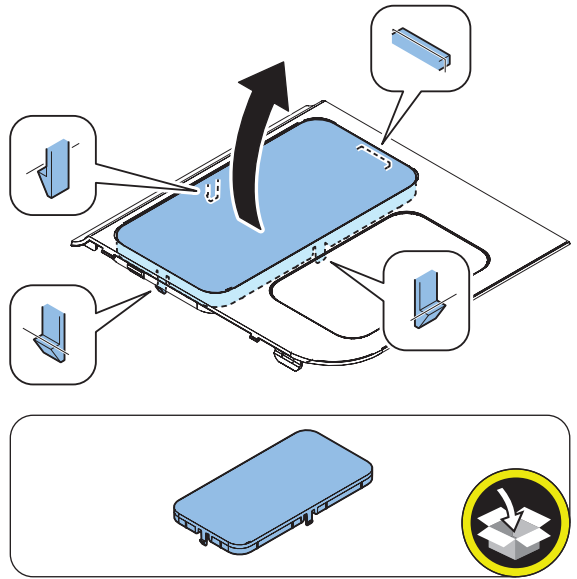
1.



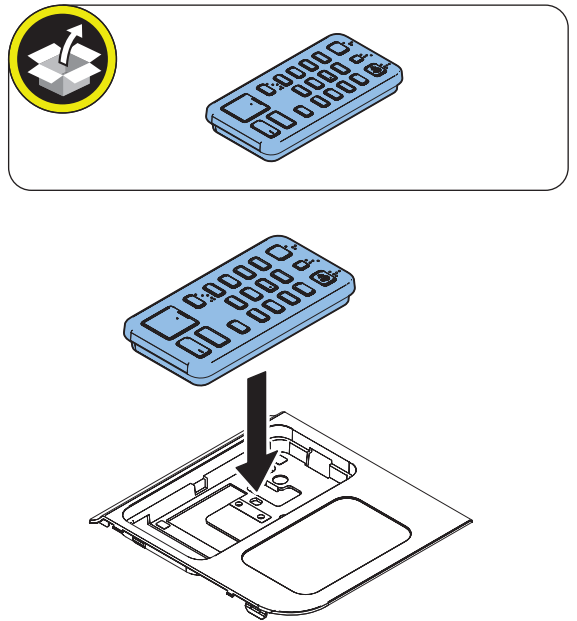
2.



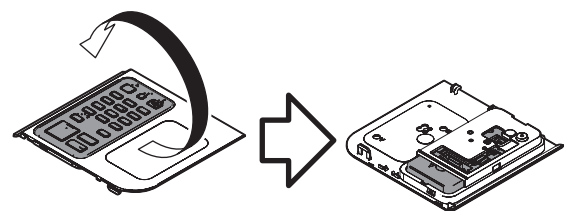
3.



4.



5.



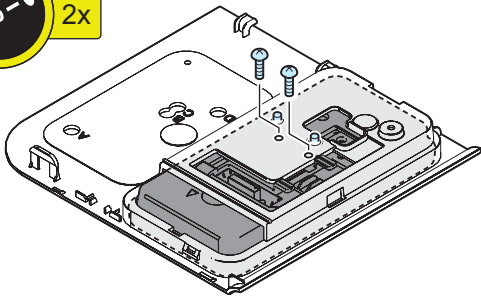
□
6.

CAUTION:

Be sure to check that the 2 bosses are fitted securely. Installing the Control Panel Right Upper Cover while the bosses are not fitted securely will cause rattling.



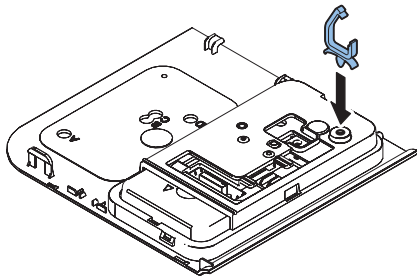
P Tightening; M3x8



□
7.



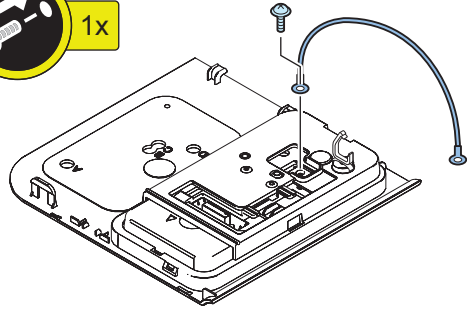
Small



□
8.



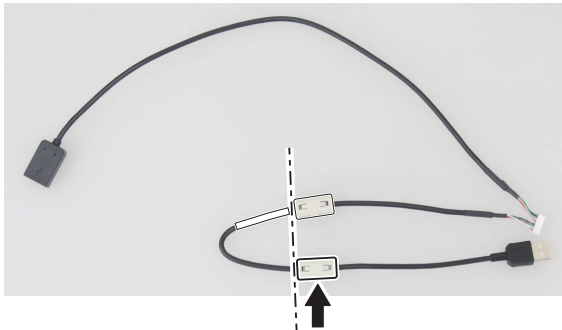
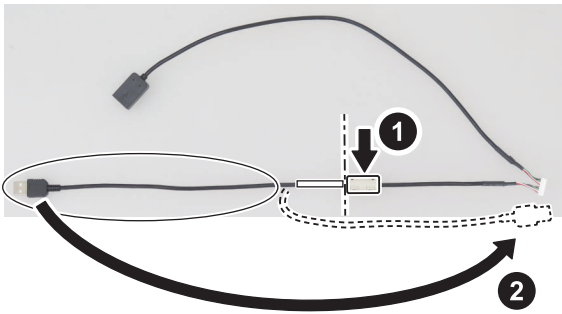
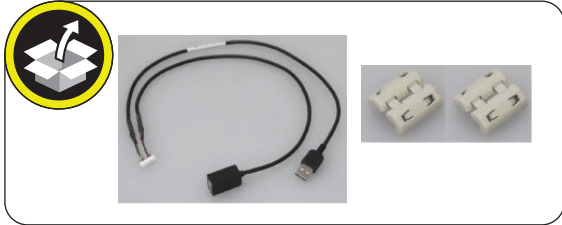
TP; M3x6



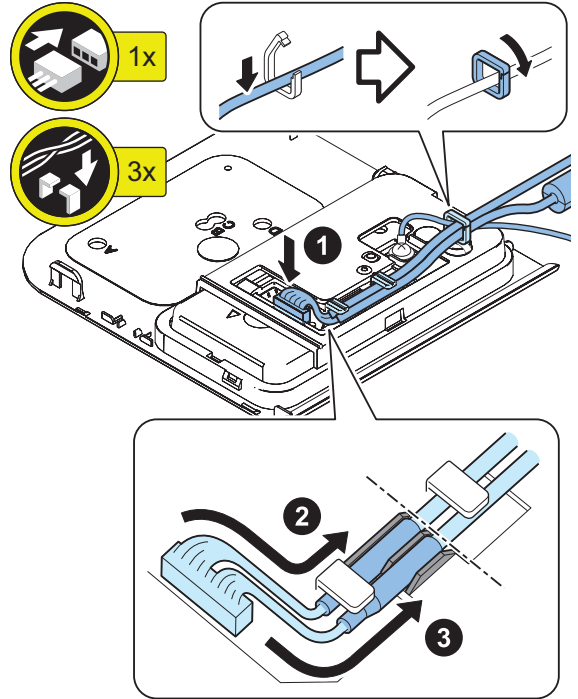
9.

NOTE:

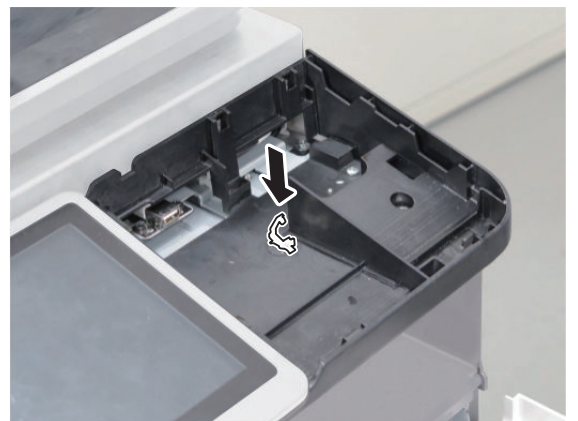
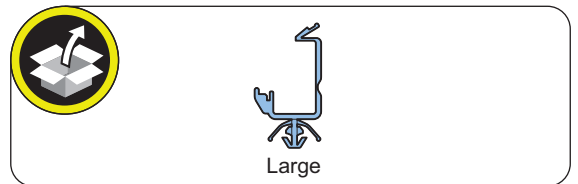
Attach the first core along with the white tape affixed to the Numeric Keypad cable. Fold the cable as shown in the figure, and attach the second core in a line-symmetric position with respect to the core attached first.



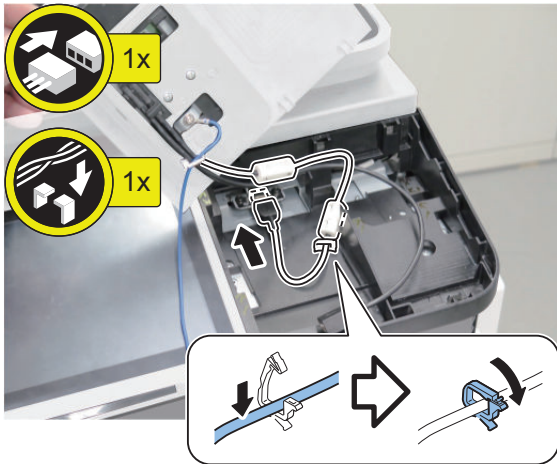
10.



11.



□
12.

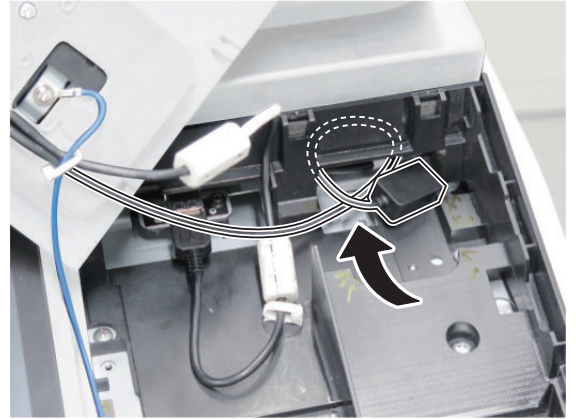


□
13.

< When installing the Numeric Keypad only >

NOTE:

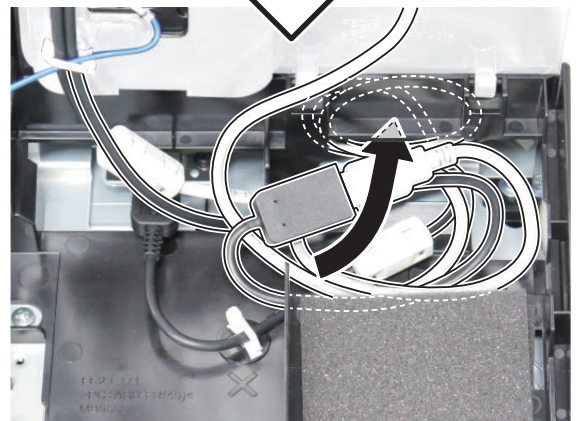
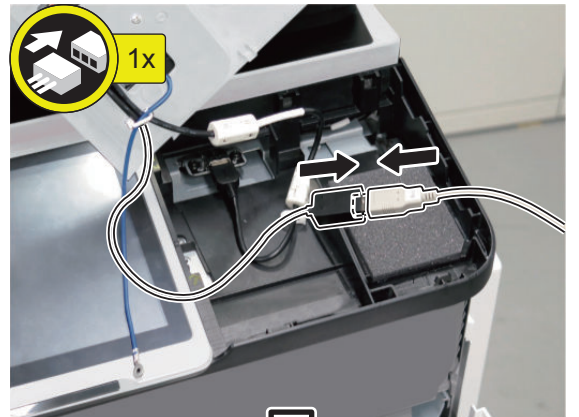
Store the excess length of the cable in the position as shown in the figure.



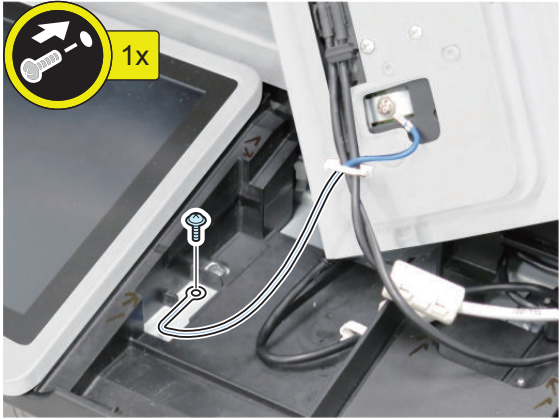
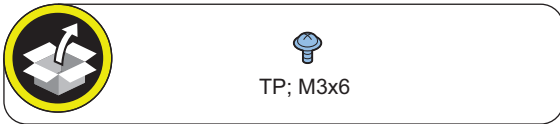
< When installing with the IC Card Reader at the same time >

NOTE:

Store the excess length of the cable in the position as shown in the figure.



□
14.



□
16.



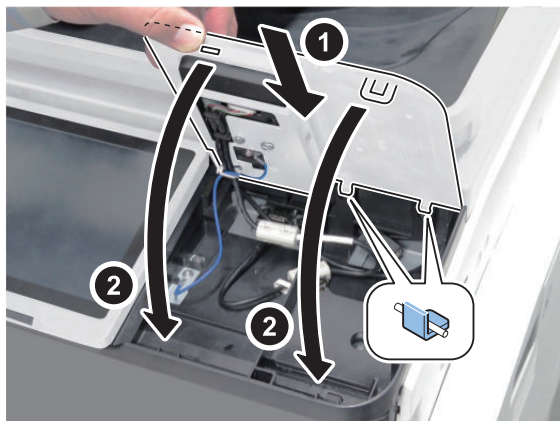
□
15.

CAUTION:
Place the Core in the position as shown in the figure.



□
17. Connect the power plug to the outlet.

18. Turn ON the main power switch.

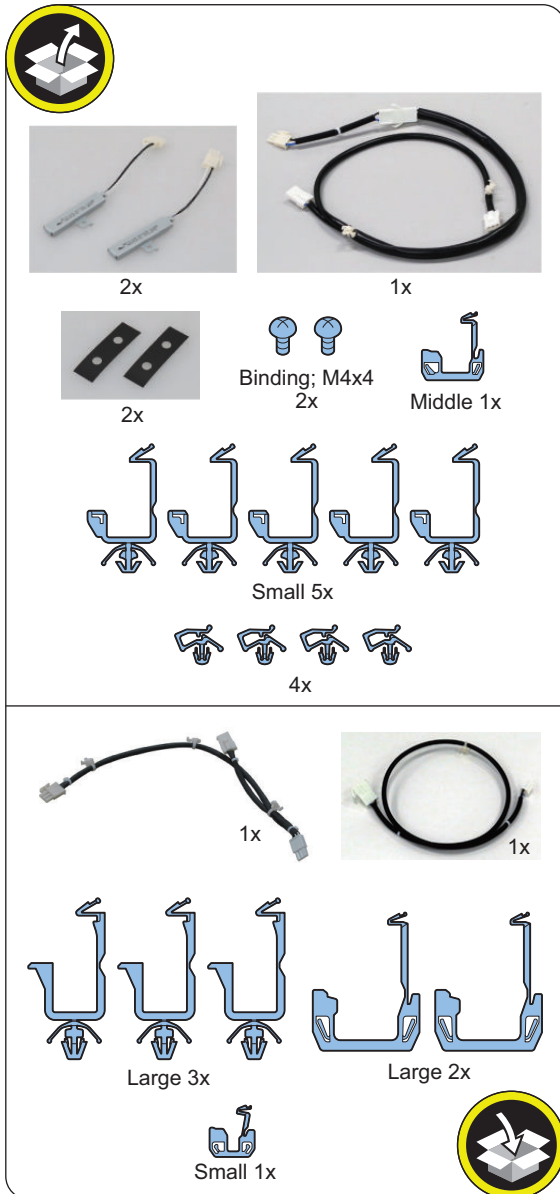


Reader Heater-P1

Points to Note before Installation

The pictures and illustrations used may be different from the product in front of you, but the procedure is the same.

Checking the Contents



Essential Items to Be Performed Before Installation

- Turn OFF the main power of the host machine, and disconnect the power plug from the outlet.

WARNING:

- If performing work without disconnecting the power plug of the host machine, it may cause electrical shock.
- If disconnecting the power plug without turning OFF the main power, it may cause damage of the machine.

- When turning OFF the main power, follow the below procedure.
 1. Turn OFF the main power switch of the host machine.
 2. The display in the Control Panel and the lamp of the main power are turned off.

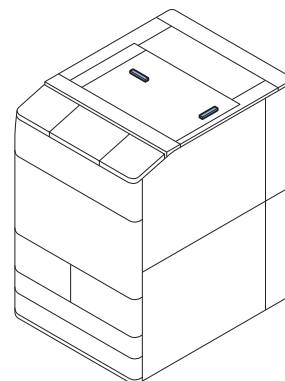
Points to Note When Turning ON/OFF the Main Power

The following message is displayed.

1. When a message prompting to turn OFF and then ON the main power appears, turn OFF and then ON the main power switch.
2. If a message prompting the user to update the version appears, press [Update] to automatically update the version of this equipment.

If [Skip] is selected, a message prompting the user to update the version will appear every time the host machine is started. In the service mode (Lv. 2) shown below, it is possible to set not to display the message.
COPIER > OPTION > FNC-SW > VER-CHNG

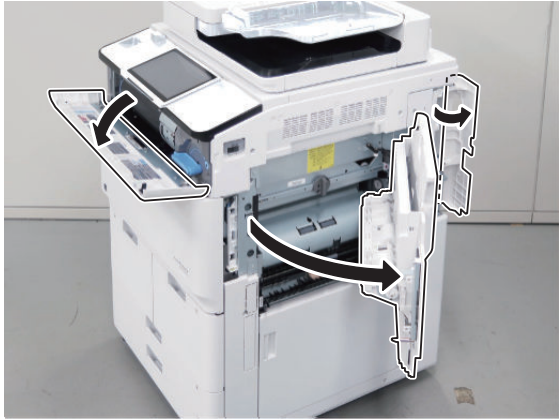
Installation Outline Drawing



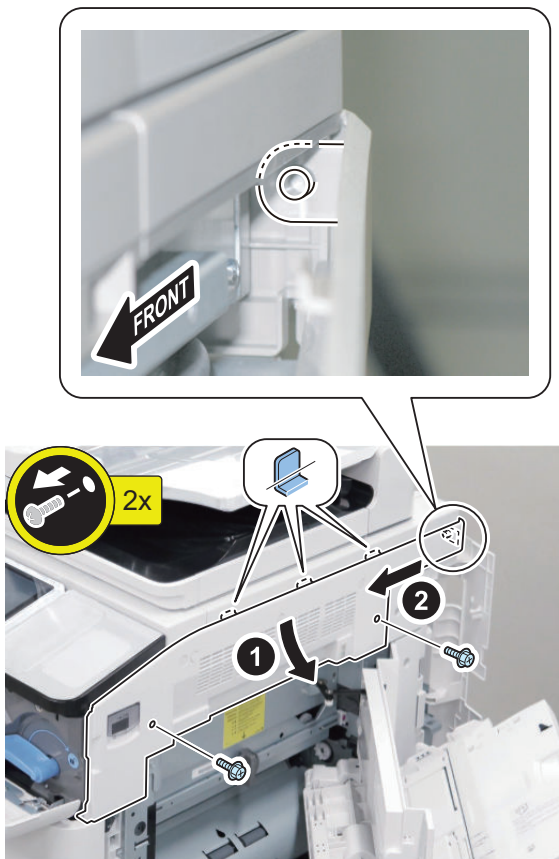
Installation Procedure

Installing the Covers

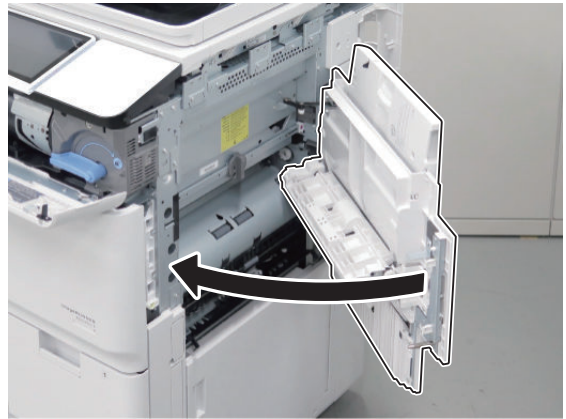
1.



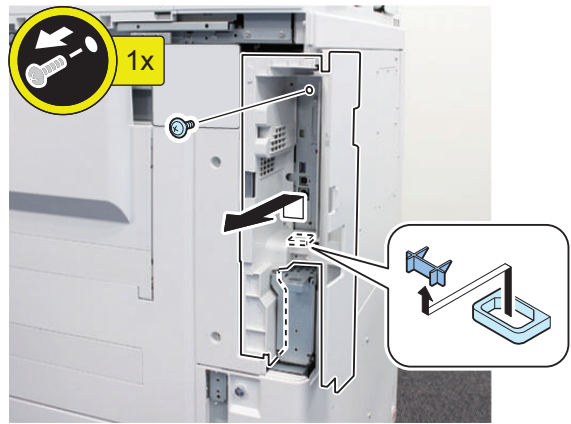
2.



3.

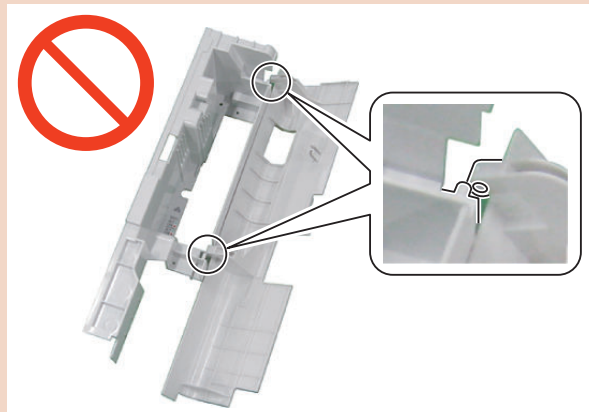


4.

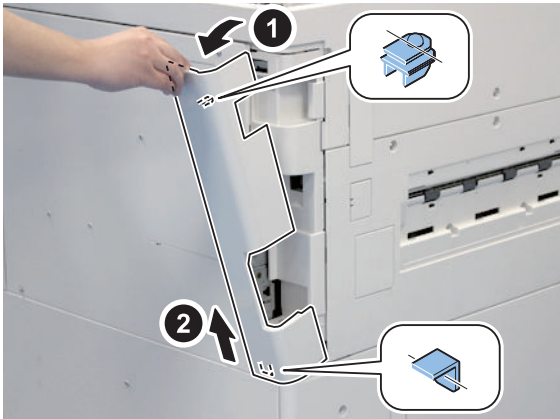


CAUTION:

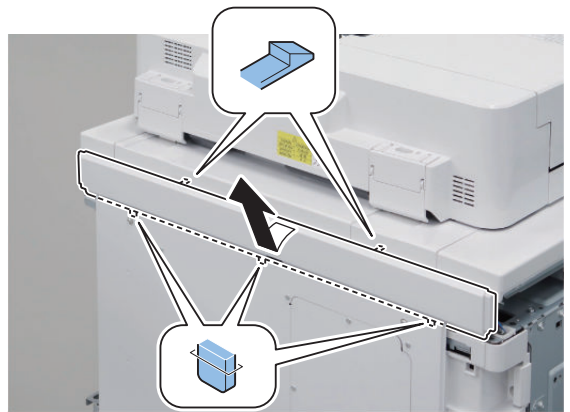
When installing the Left Upper Cover, be careful not to secure it while it is being slid fully toward the front. Otherwise, the Left Upper Cover may interfere with the Toner Replacement Cover and the magnet cannot work.



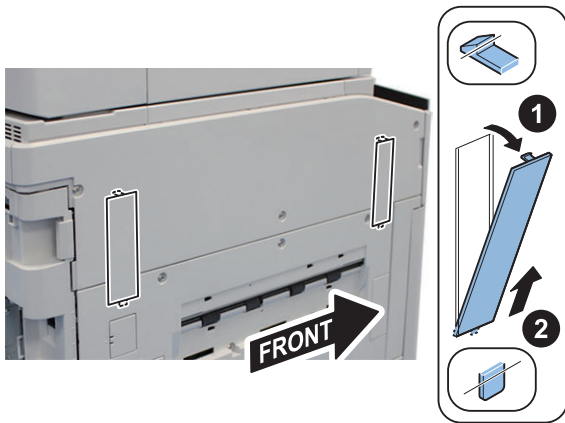
□
5.



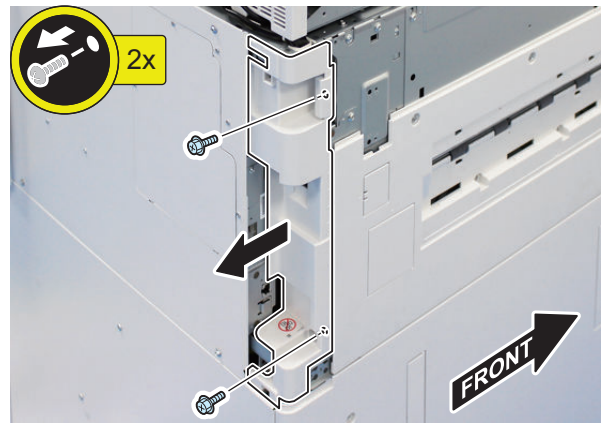
□
8.



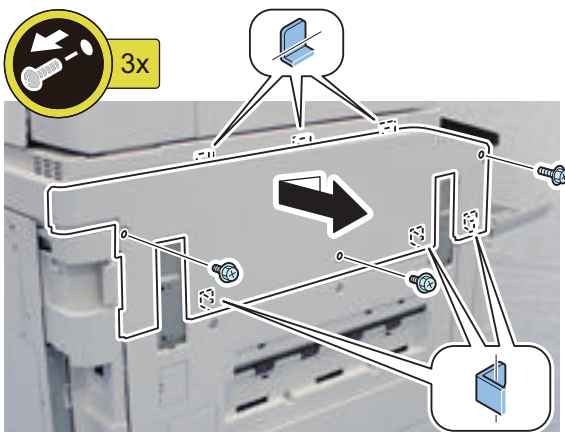
□
6.



□
9.

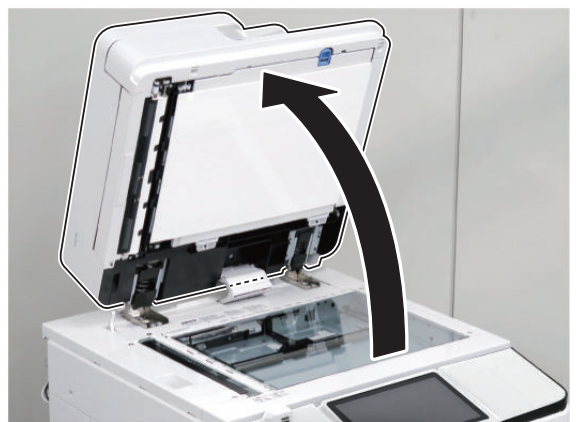


□
7.

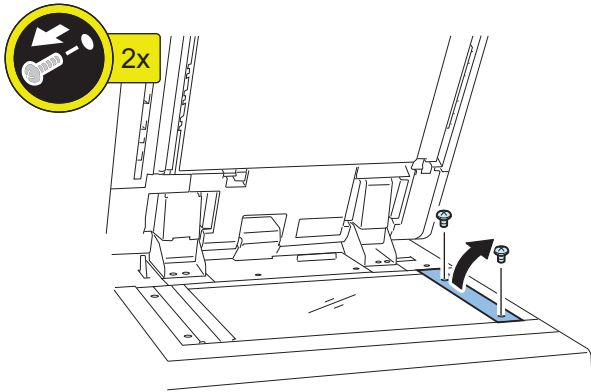


■ Installing the Reader Heater

□
1.



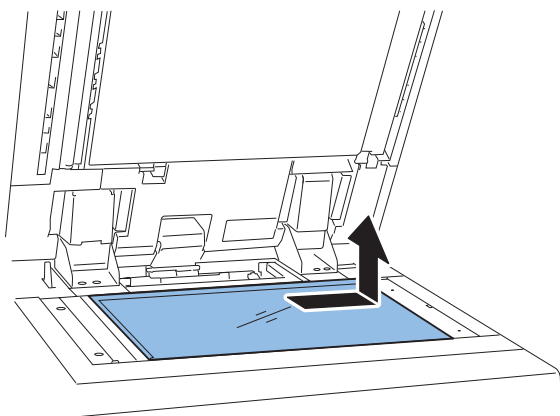
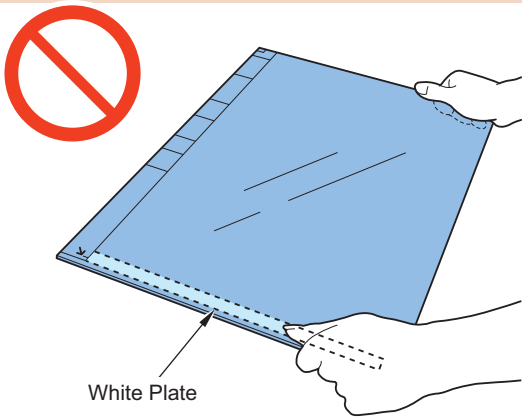
□
2.



□
3.

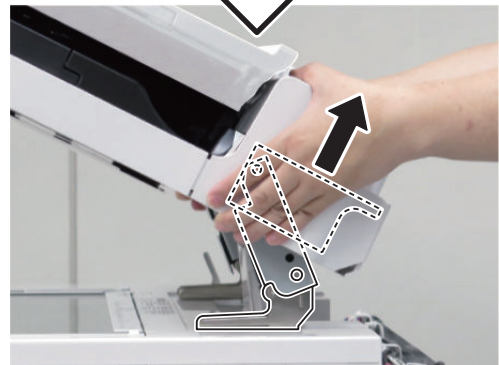
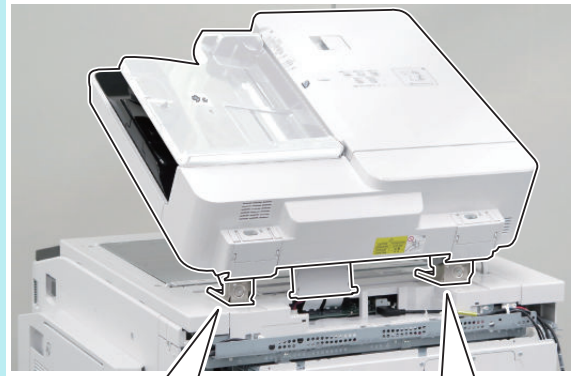
CAUTION:

- Soiling on the glass surface and the White Plate affects reading. When removing or installing the Copyboard Glass, be sure not to touch the glass surface and the White Plate.
- If soiling is attached, clean it with lint-free paper.

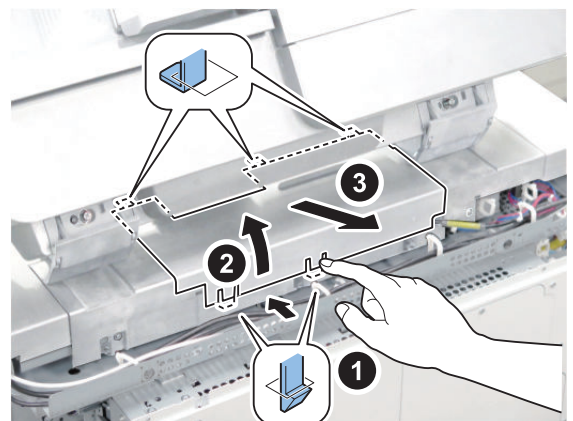


NOTE:

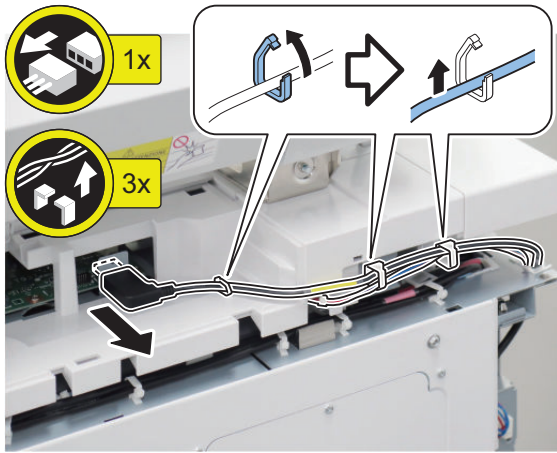
When performing following procedures, using ADF in the book mode as necessary makes the work easy. The book mode is released by opening the ADF.



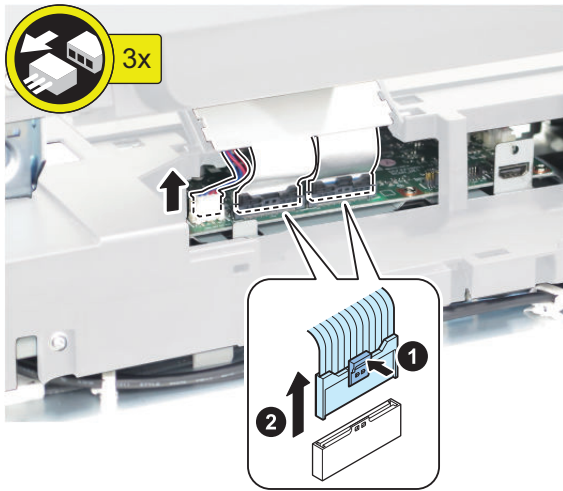
□
4.



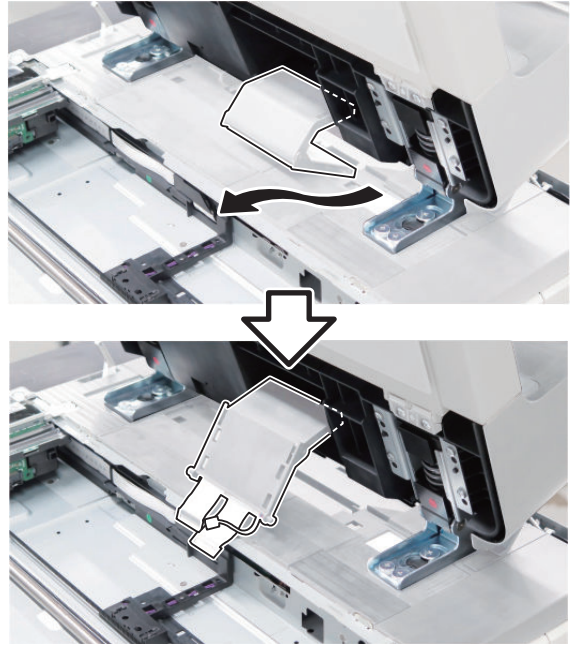
□
5.



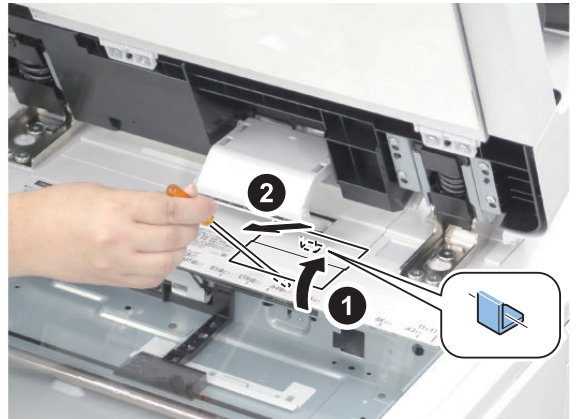
□
6.



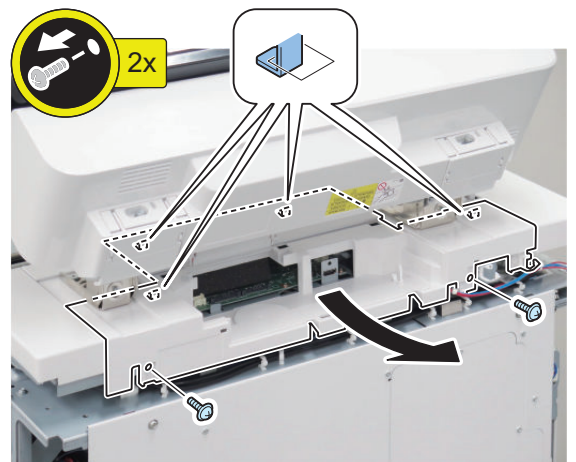
□
7.



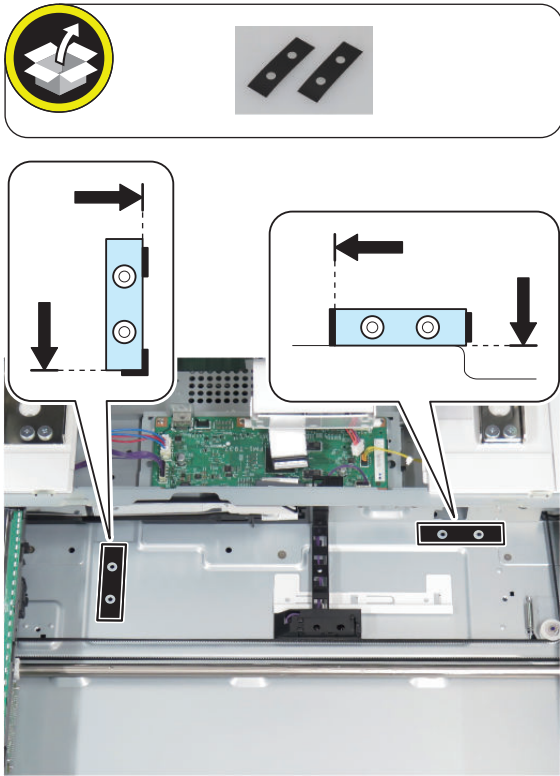
□
8.



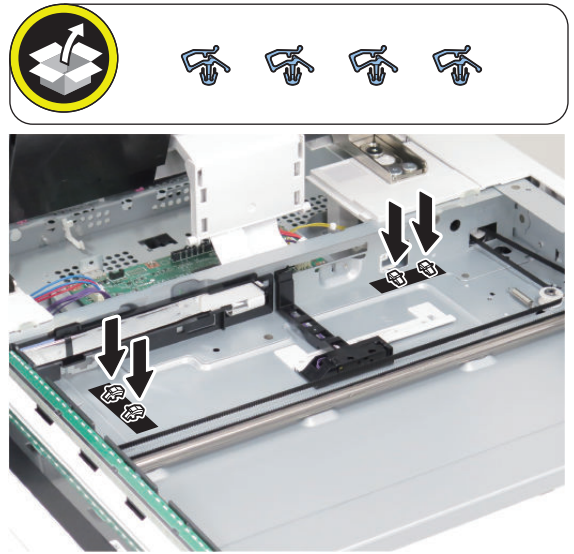
□
9.



10.



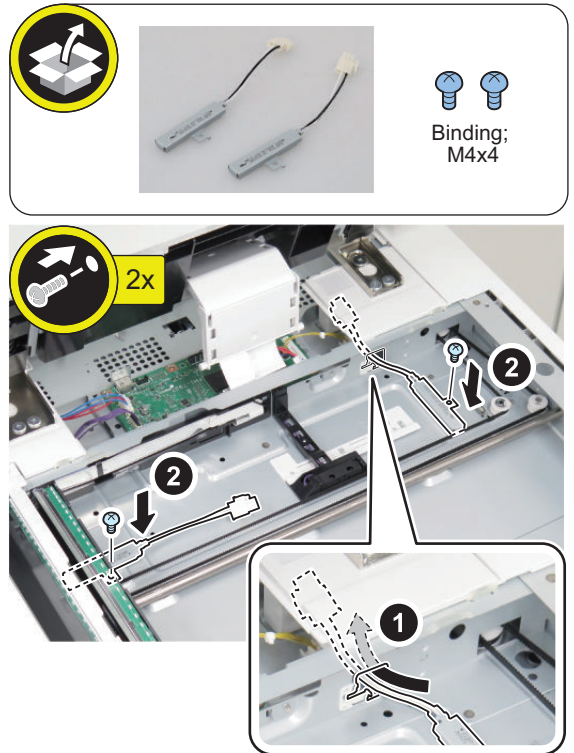
12.



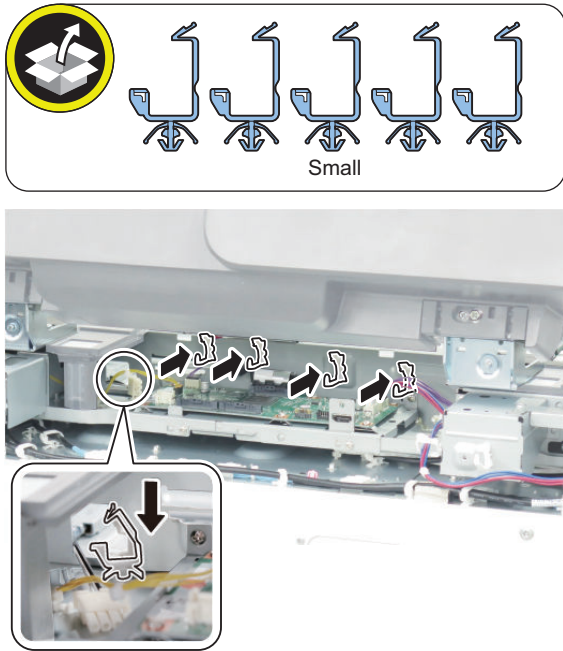
11.



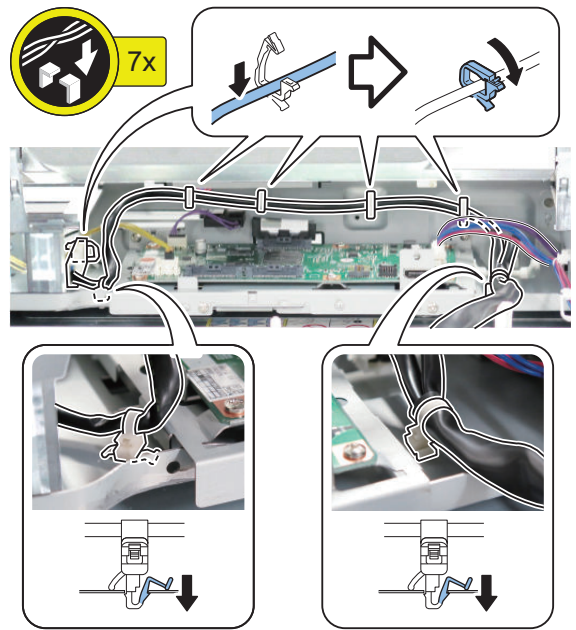
13.



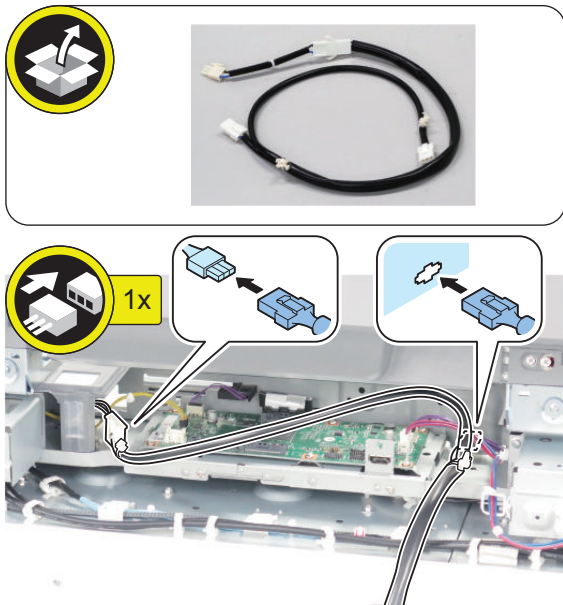
□
14.



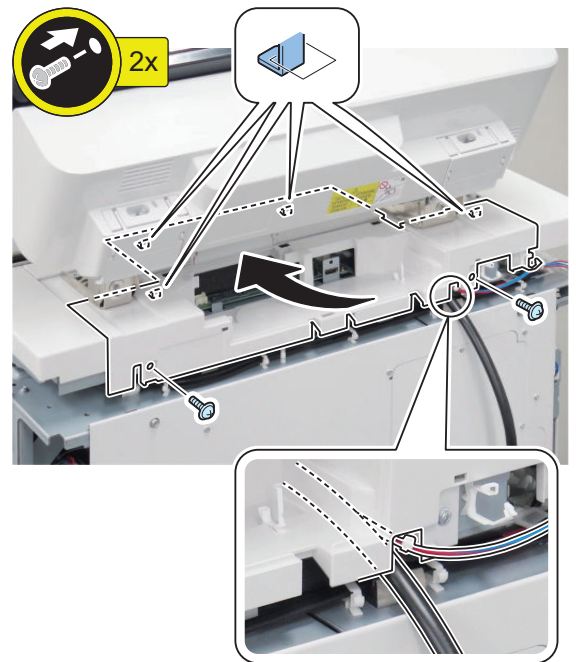
□
16.



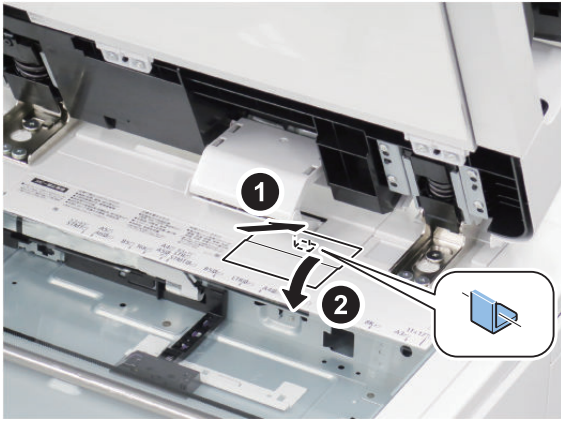
□
15.



□
17.



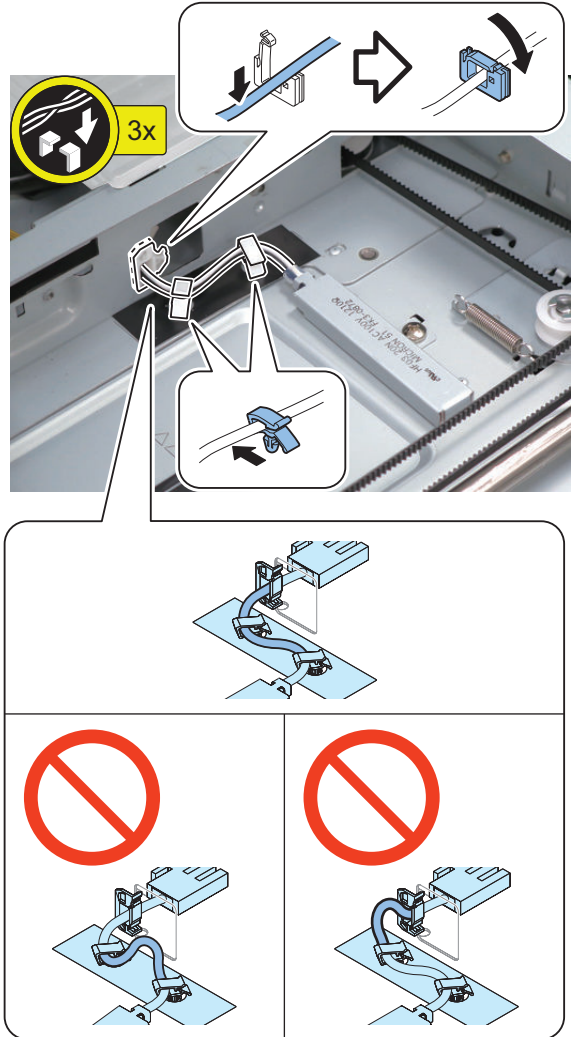
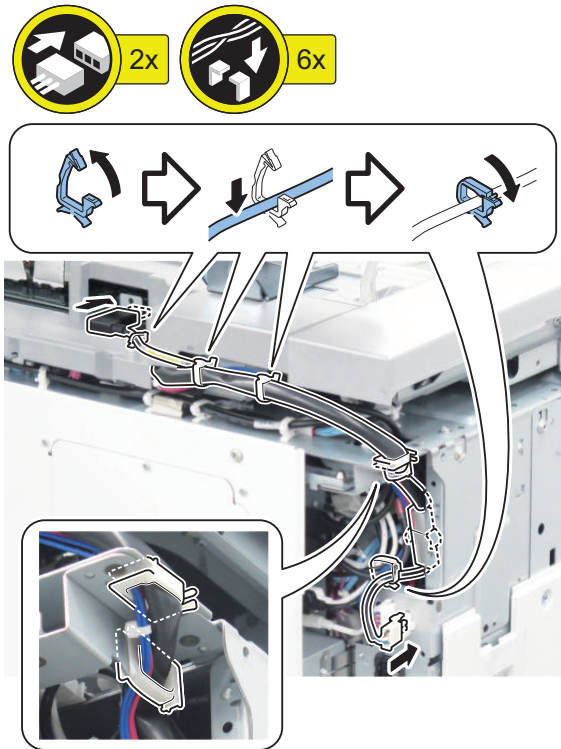
□
18.



□
20.

CAUTION:
Be sure to hold down the Reader Heater Harness because it may interfere with moving of the Scanner Box if it is not connected properly.

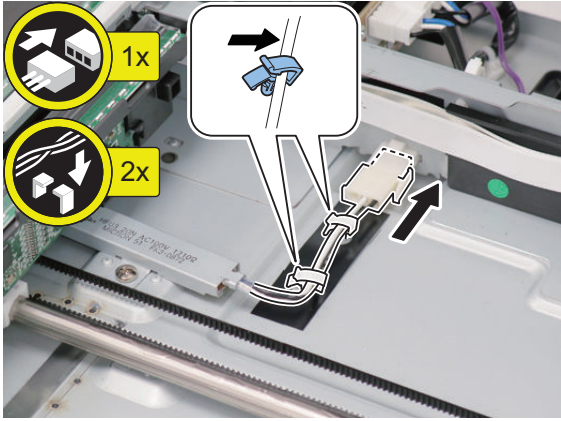
□
19.



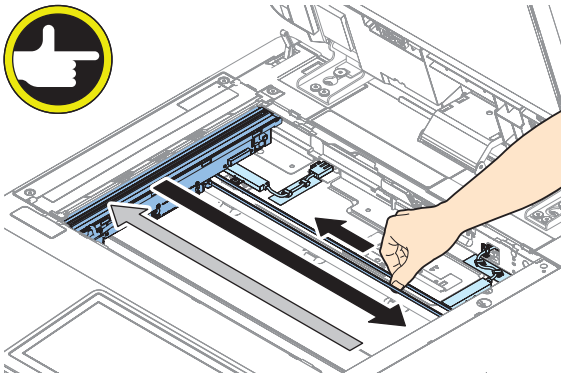
□
21.

CAUTION:

Be sure to hold down the Reader Heater Harness because it may interfere with moving of the Scanner Box if it is not connected properly.

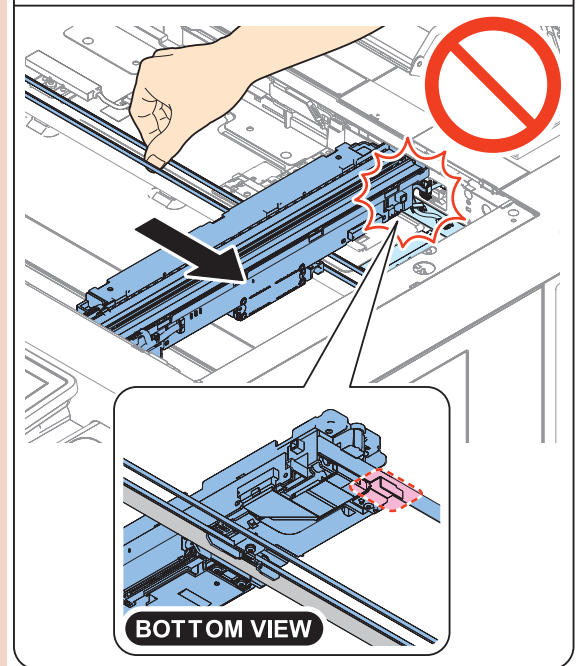
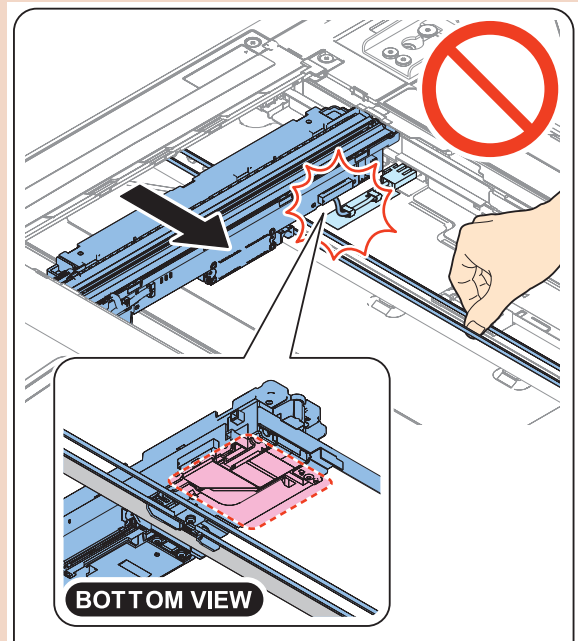


□
22.

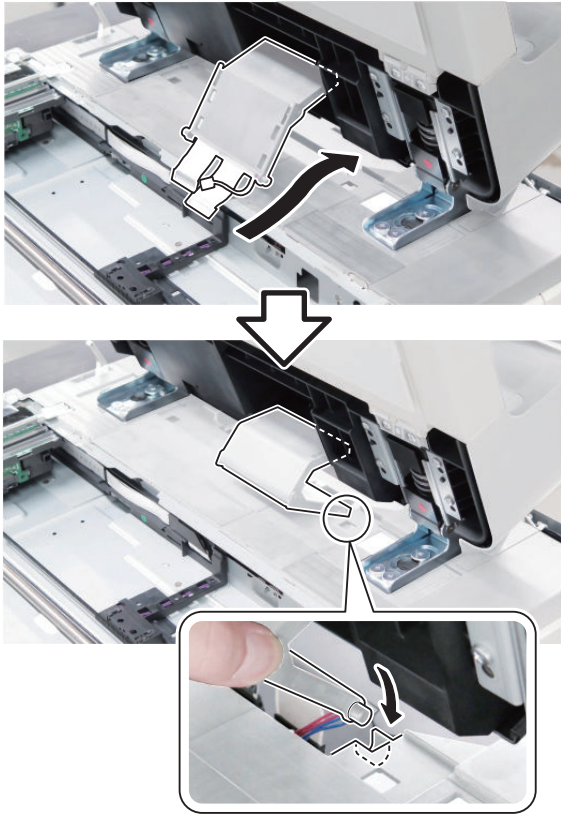


CAUTION:

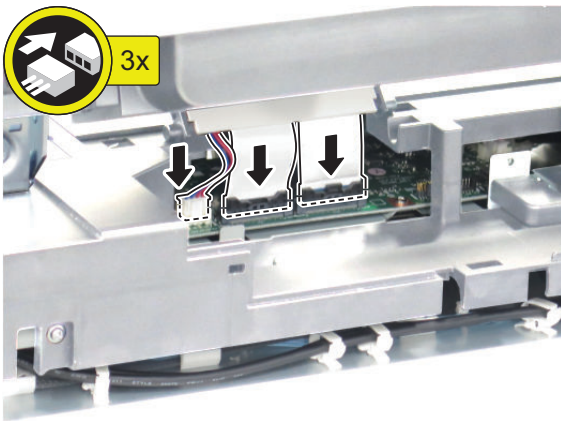
Move the Scanner Box to the right edge, and check if the underside of the Scanner Box and the HP Sensor Flag Plate do not interfere with the Reader Heater harness.



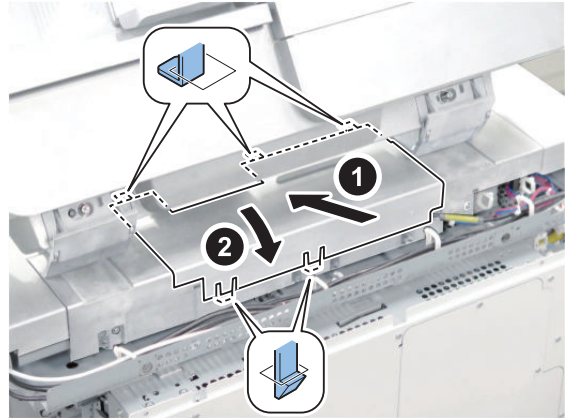
□
23.



□
24.



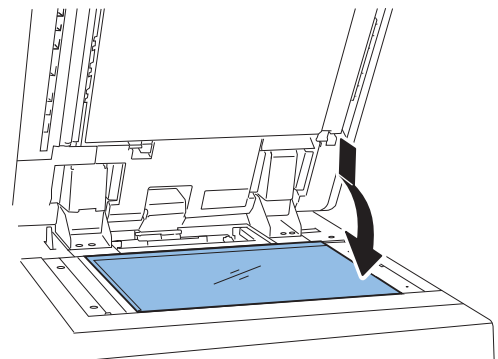
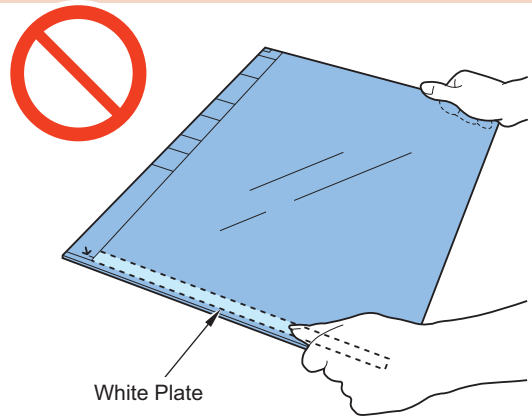
□
25.



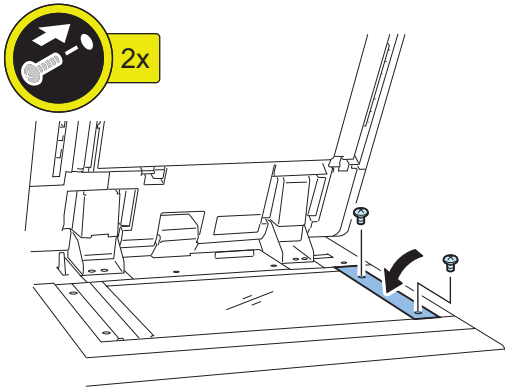
□
26.

CAUTION:

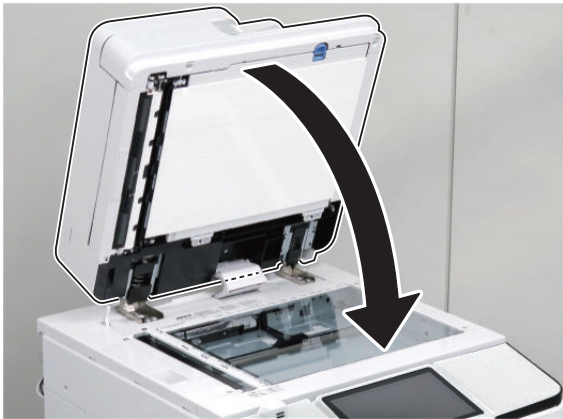
- Soiling on the glass surface and the White Plate affects reading. When removing or installing the Copyboard Glass, be sure not to touch the glass surface and the White Plate.
- If soiling is attached, clean it with lint-free paper.



□
27.

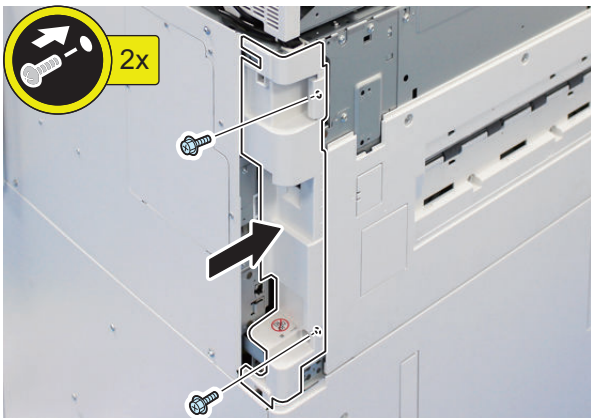


□
28.

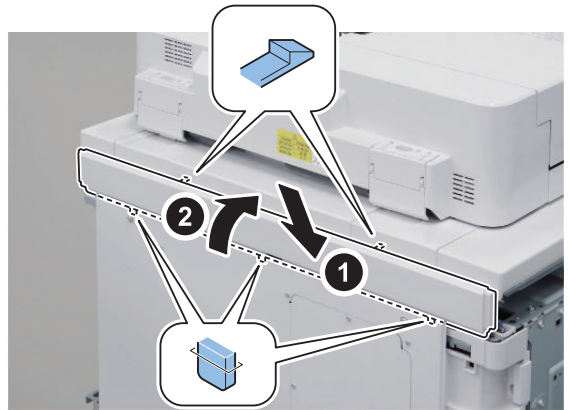


■ Installing the Covers

□
1.

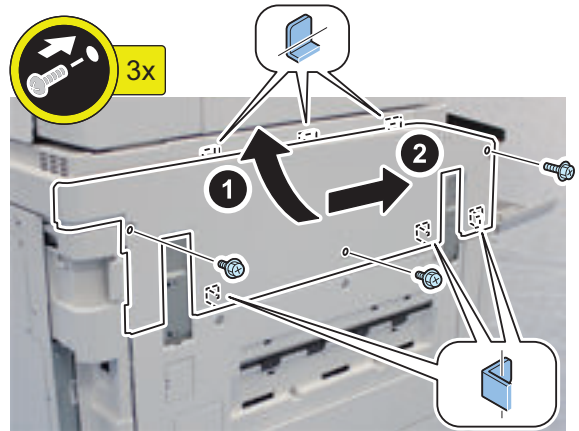


□
2.

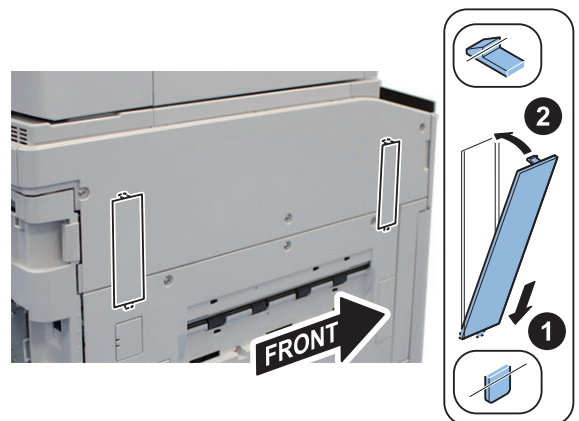


□
3.

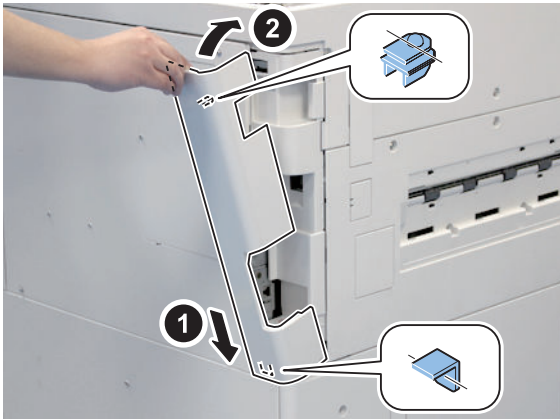
CAUTION:
When installing the Left Upper Cover, be careful not to secure it while it is being slid fully toward the front. Otherwise, the Left Upper Cover may interfere with the Toner Replacement Cover and the magnet cannot work.



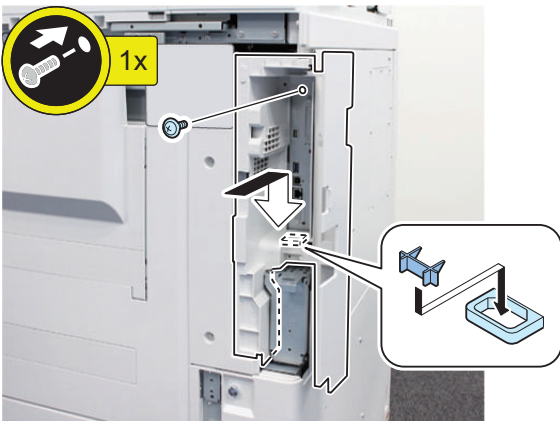
□
4.



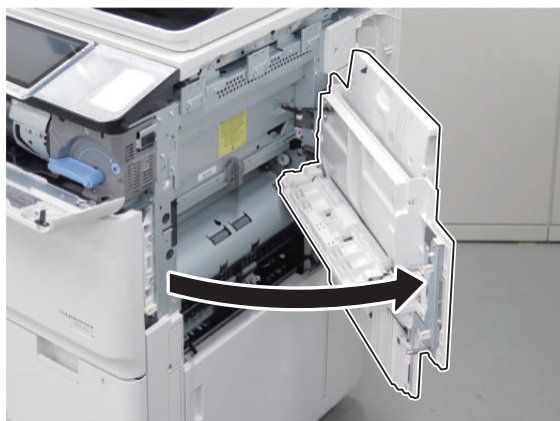
5.



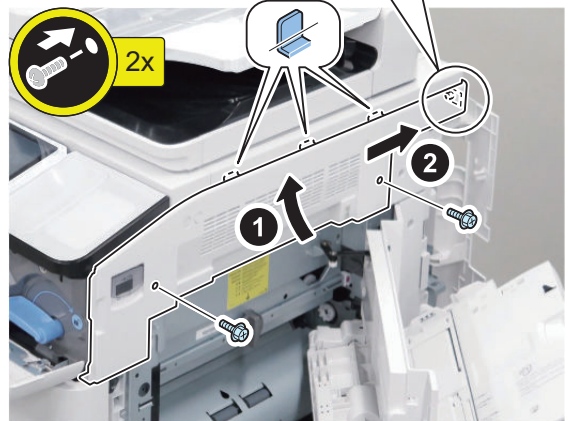
6.



7.



8.



9.



10. Turn ON the Environment Heater Switch.

11. Connect the power plug to the outlet.

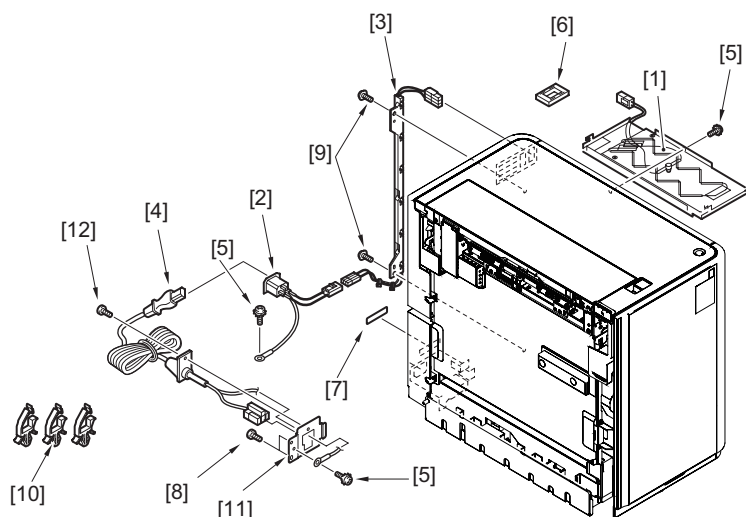
12. Turn ON the main power switch.

Paper Deck Heater Unit-A1

Checking the Supplied Parts

NOTE:

Each part of the Paper Deck Heater Unit-A1 for the Paper Deck is supplied as a service part according to the location, so prepare the following parts. Also, use the appropriate Paper Deck Heater Unit for each country.



Item	Parts Name	Parts Number	Q'ty
[1]	Heater unit	FG6-9650 (100V) FG6-9651 (230V)	1pc.
[2]	AC input connector	FG6-1117	1pc.
[3]	Relay harness unit	FG6-2957	1pc.
[4]	AC cable	FK3-0630 (100V) FK3-0631 (230V)	1pc.
[5]	Screw (Toothed washer; M4x6)	XB2-7400-607	3pcs.
*[6]	Cable protection bushing	WT2-5098	1pc.
[7]	Power supply label	FS6-8478 (100V) FS6-8725 (230V)	1pc.
[8]	Screw (Binding; M4x4)	XB1-2400-409	2pcs.
[9]	Screw (RS Tightening; M4x8)	XA9-0732-010	2pcs.
[10]	Wire saddle	WT2-5730	3pcs.
[11]	Cord mount	FC7-5473	1pc.
[12]	Screw with flat spring (M4x10)	XB2-8401-007	1pc.

*As for the change of the part number, please refer to the latest parts catalog.

*[6] Cable protection bushing is not used for the installation.

<Others>

Including guides

Essential Items to Be Performed Before Installation

- Turn OFF the main power of the host machine, and disconnect the power plug from the outlet.

⚠ WARNING:

- If performing work without disconnecting the power plug of the host machine, it may cause electrical shock.
- If disconnecting the power plug without turning OFF the main power, it may cause damage of the machine.

- When turning OFF the main power, follow the below procedure.
 1. Turn OFF the main power switch of the host machine.
 2. The display in the Control Panel and the lamp of the main power are turned off.

Points to Note When Turning ON/OFF the Main Power

The following message is displayed.

1. When a message prompting to turn OFF and then ON the main power appears, turn OFF and then ON the main power switch.
2. If a message prompting the user to update the version appears, press [Update] to automatically update the version of this equipment.

If [Skip] is selected, a message prompting the user to update the version will appear every time the host machine is started. In the service mode (Lv. 2) shown below, it is possible to set not to display the message.
COPIER > OPTION > FNC-SW > VER-CHNG

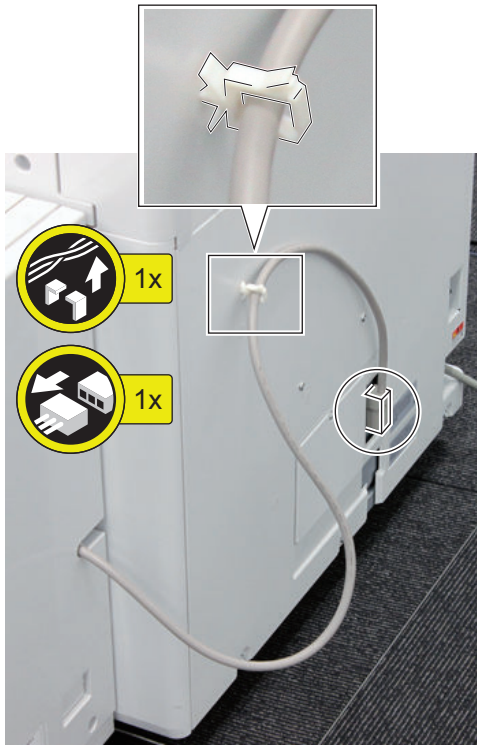
Installation Procedure

■ Preparation of the Paper Deck

□

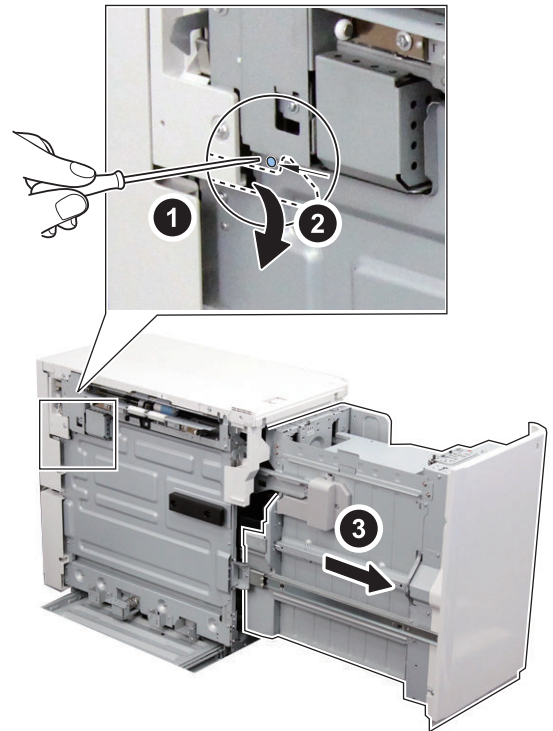
1. Remove the lattice connector from the host machine.

- 1 Wire saddle
- 1 Connector



□

2. Insert screwdrivers into the hole at rear left side of the compartment and then release the lever to open it.



□

3. Remove the right cover.

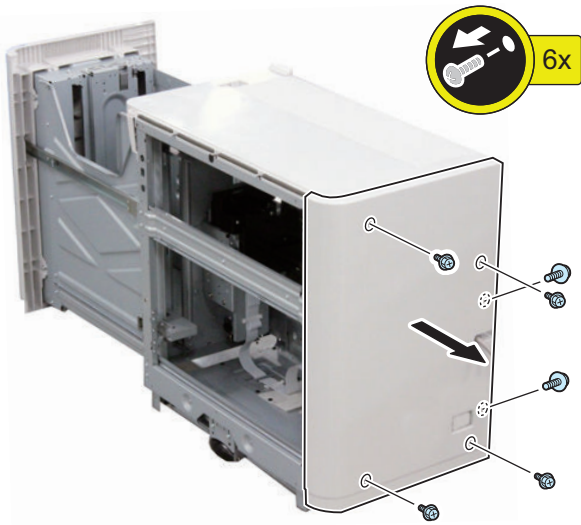
- 5 Screws





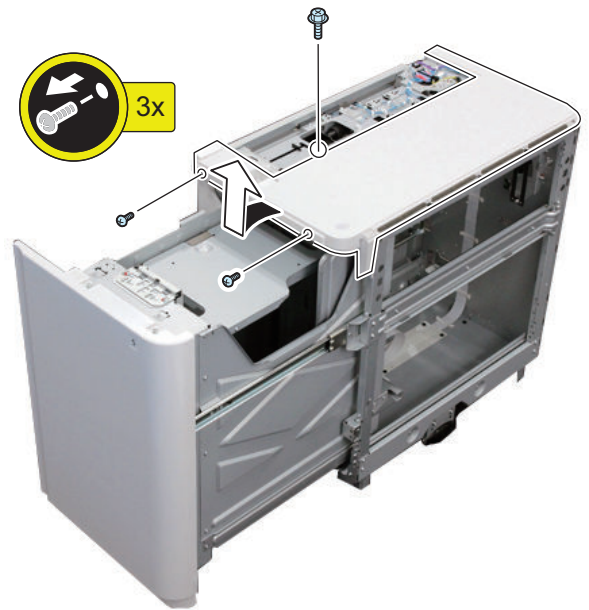
4. Remove the rear cover.

- 6 Screws

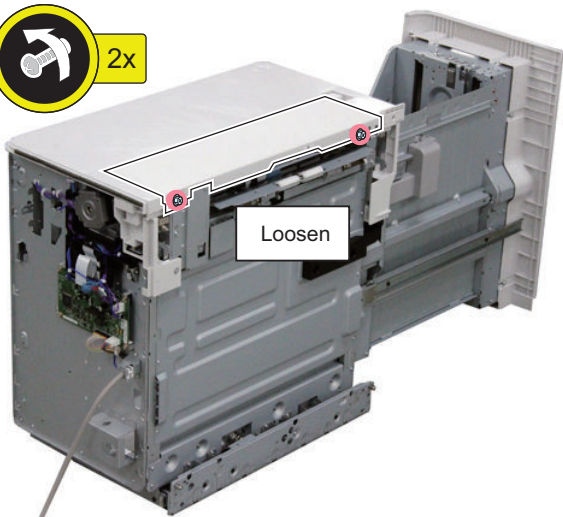


6. Remove the upper cover.

- 3 Screws

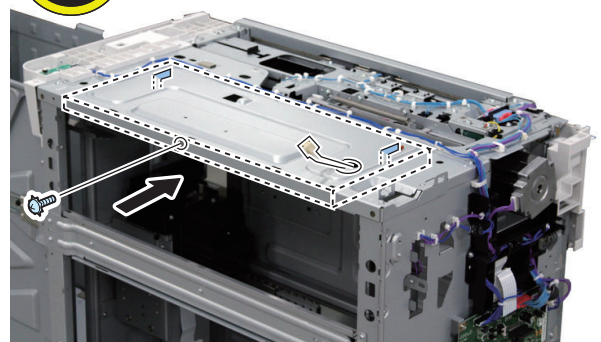
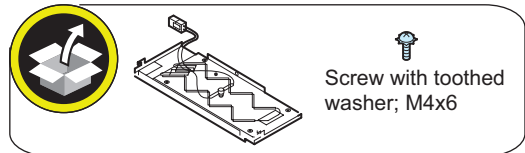


5. Remove the left upper cover.



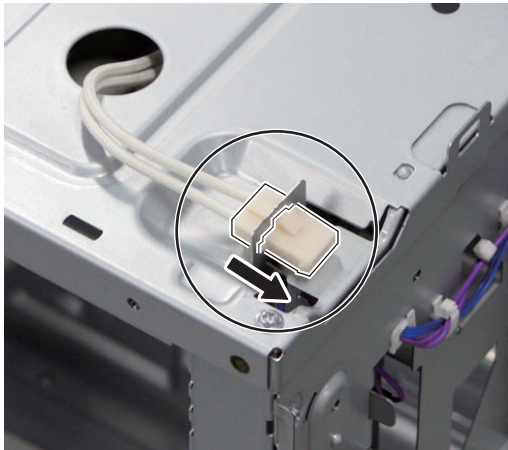
7. Put the connector through the hole in the top plate and then fix the heater unit in the Paper Deck Unit.

- 2 Hooks
- 1 Screw (Toothed washer; M4x6)



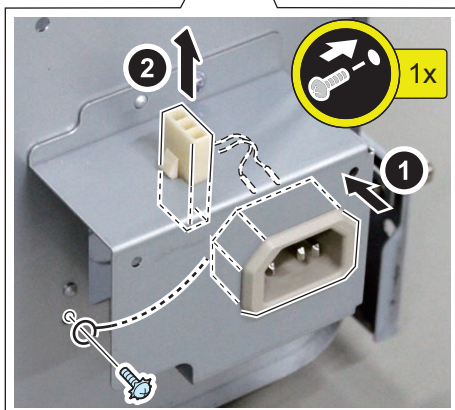
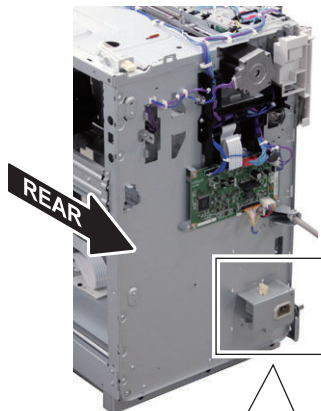
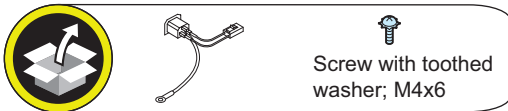


8. Insert the connector of the heater to the panel mount part.



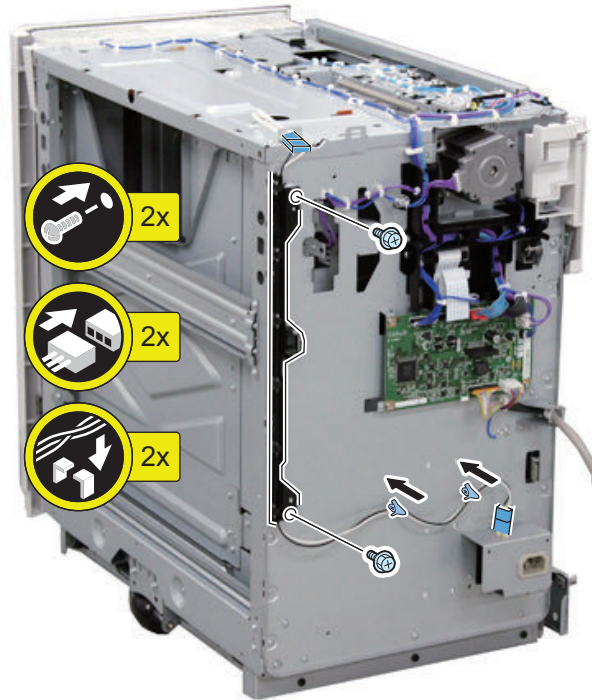
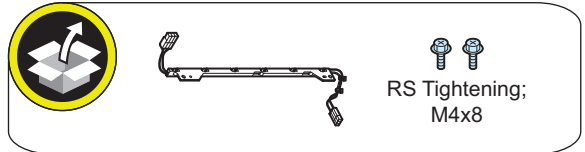
9. Insert the supplied AC input connector and then fix the ground cable.

- 1 Screw (Toothed washer; M4x6)



10. Install the relay harness unit on the rear side panel of the Paper Deck Unit.

- 2 Screws (RS Tightening; M4x8)
- 2 Connectors
- 2 Snap bands



11. Re-attach the external covers.

■ Preparation of the Host Machine



1. Remove the left rear cover.





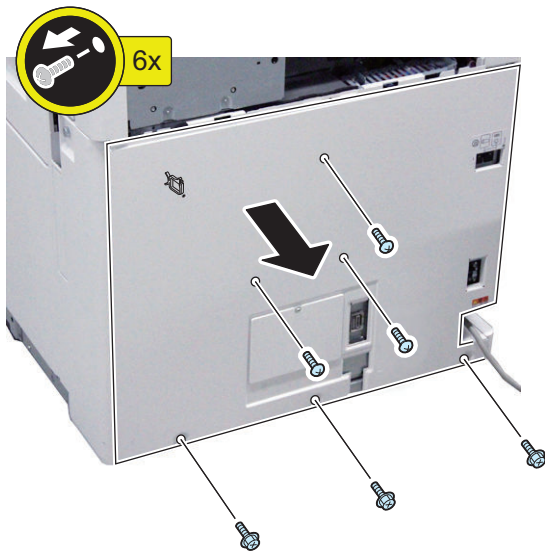
2. Remove the rear upper cover.

- 4 Screws



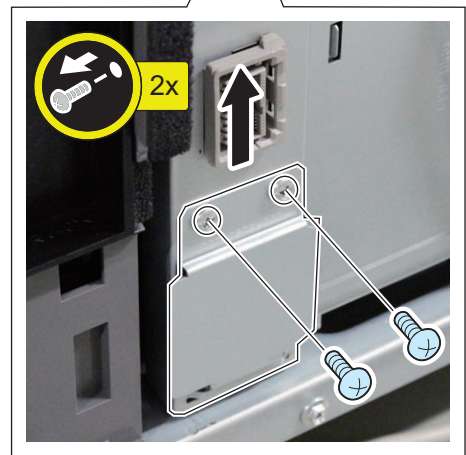
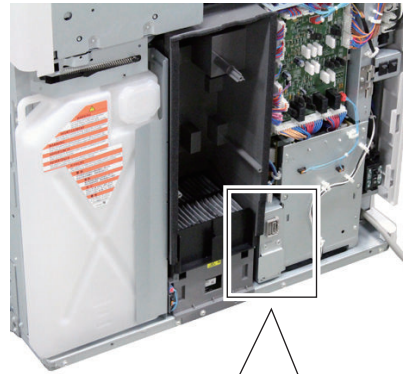
3. Remove the rear lower cover.

- 6 Screws



4. Remove the blindfold plate (the removed cover and screws are not used).

- 2 Screws

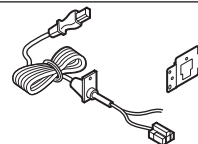


Binding; M4x10

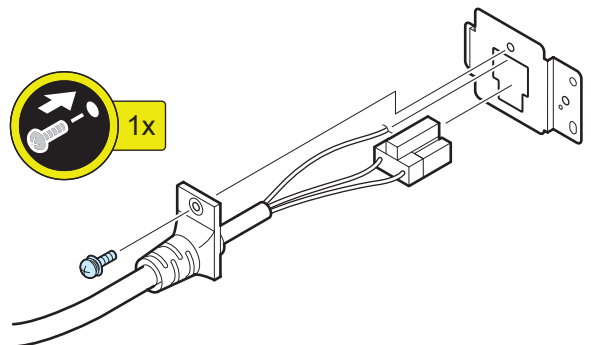


5. Insert the AC cord into the hole of the cord mount and fix it.

- 1 Screw (Flat spring; M4x10)



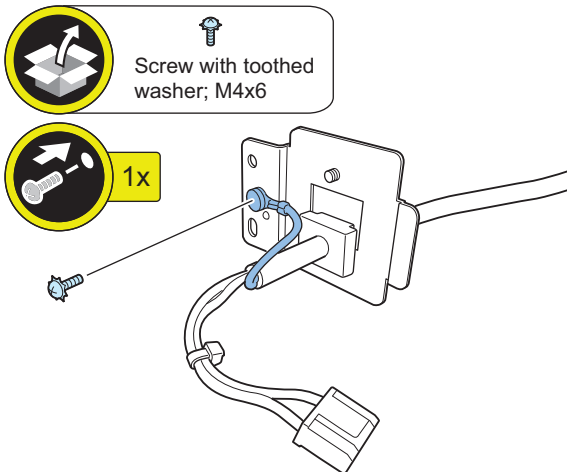
Screw with flat spring; M4x10





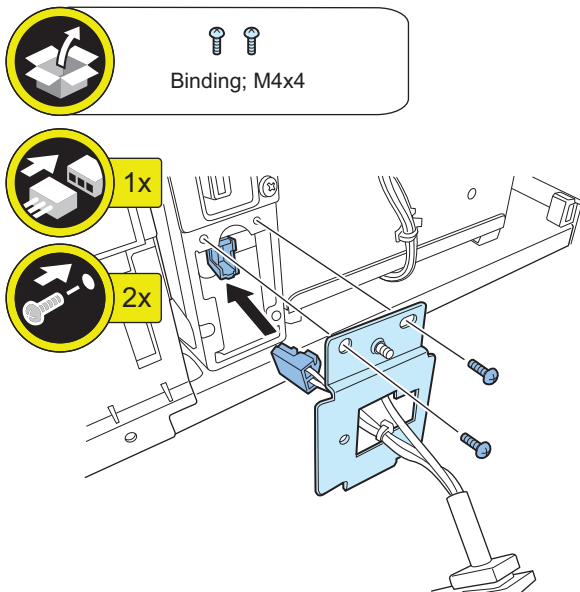
6. Fix the ground cable to the cord mount.

- 1 Screw (Toothed washer; M4x6)



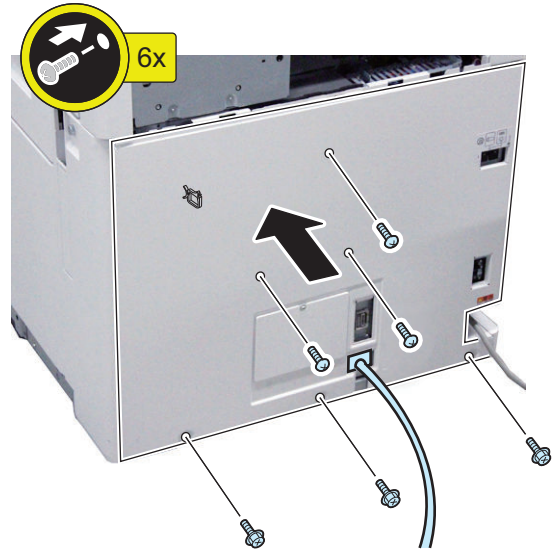
7. Connect the AC cable to the host machine and then fix it.

- 2 Screws (Binding; M4x4)



8. Attach the rear lower cover.

- 3 Screws (RS Tightening; M4x10)
- 3 Screws (P Tightening; M4x10)



■ Connection with the Host Machine

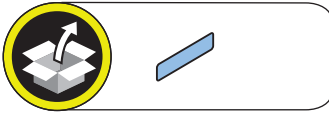


1. Cut the blindfold cover of the AC input from rear side of the Paper Deck Unit.





2. Paste the power supply label.

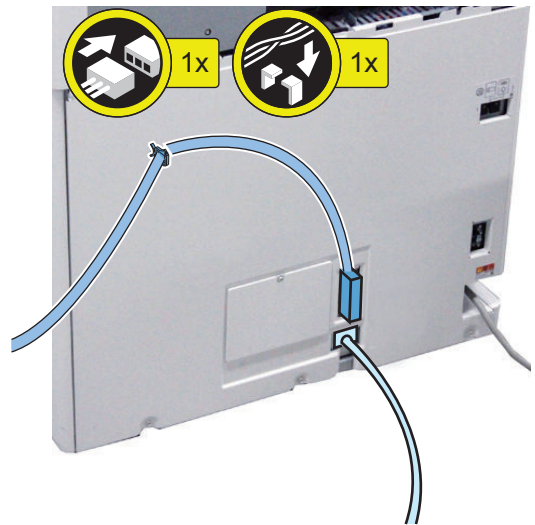


3. Connect the Paper Deck Unit with the host machine.

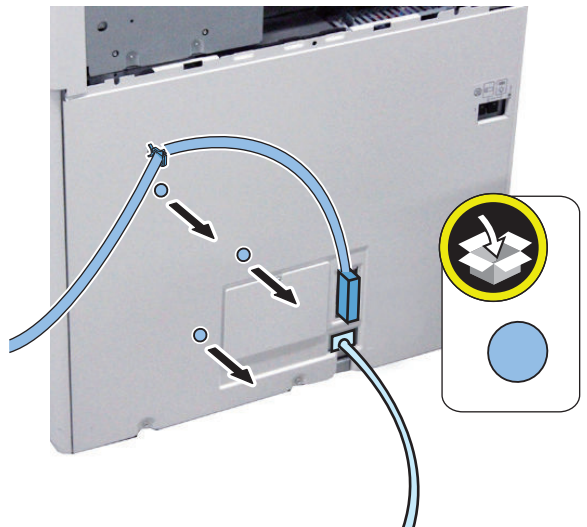


4. Connect the lattice connector of the Paper Deck Unit to the host machine and the fix it with the wire saddle.

- 1 Wire saddle



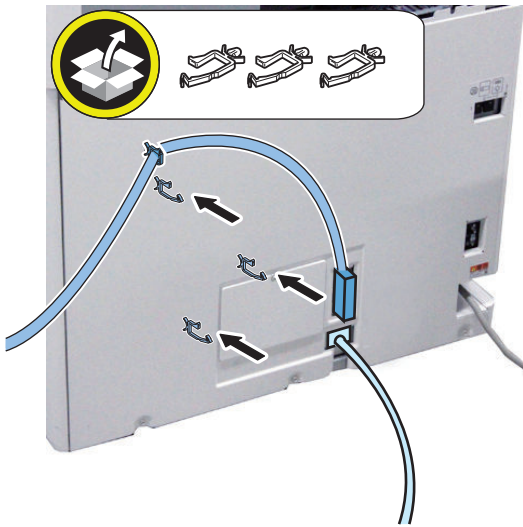
5. Remove the blindfold seals (the removed seals are not used).





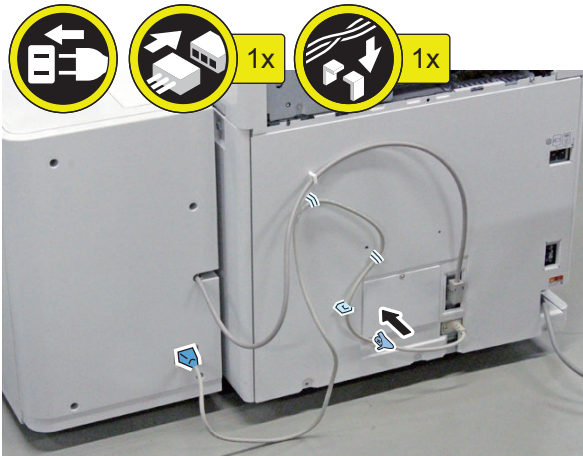
6. Attach the wire saddles.

- 3 Wire saddles



7. Connect the AC cable to the Paper Deck Unit and then fix it as shown in the figure.

- 1 Snap band
- 3 Wire saddles



Utility Tray-B1

Points to Note at Installation

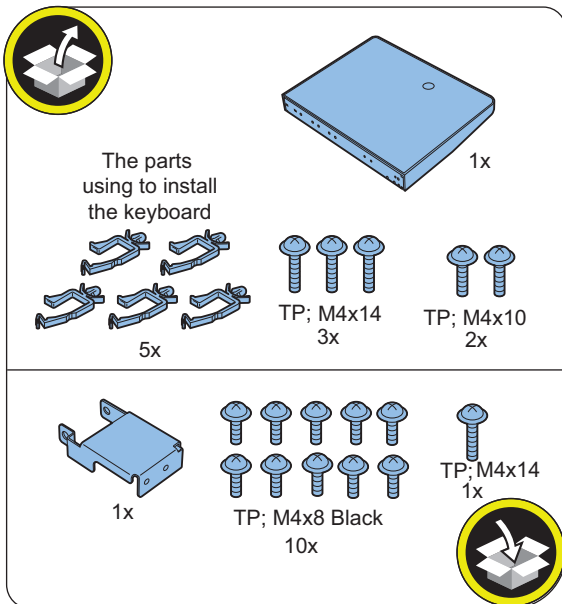
- The pictures and illustrations used may be different from the product in front of you, but the procedure is the same.
- Refer to "Table of Options Combination" when installing this equipment before operation.

Table of Options Combination

	Voice Operation	Voice Guidance Kit	Copy Card Reader
Utility Tray	No	No	Yes

Yes: Available, No: Unavailable

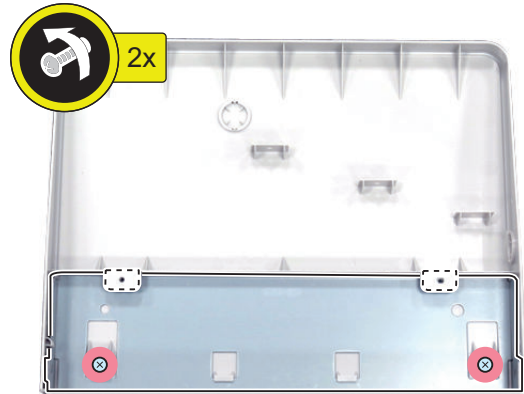
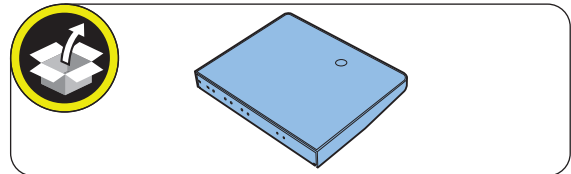
Checking the Contents



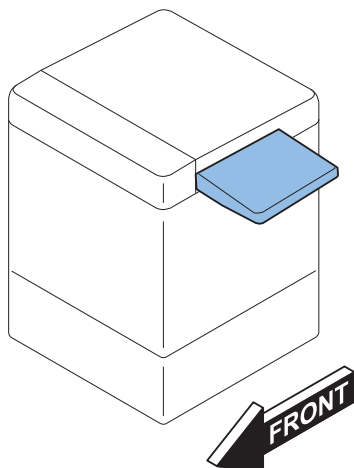
Installation Procedure

1. Remove packing tapes.

2.

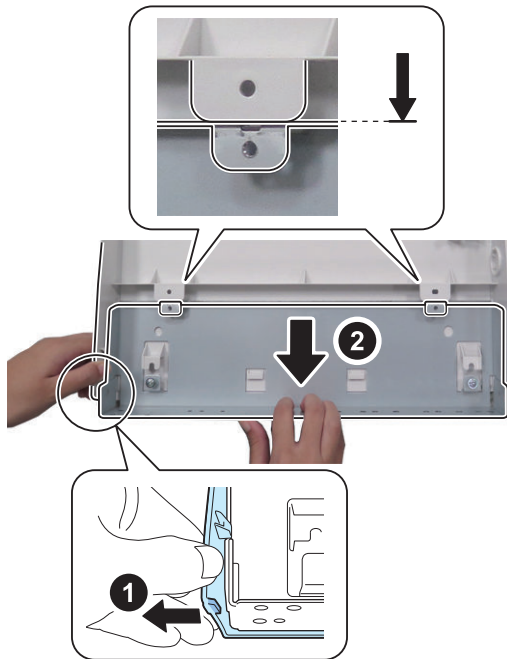
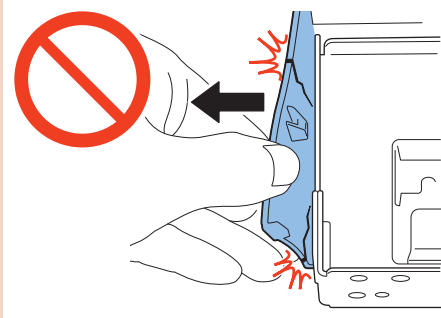


Installation Outline Drawing



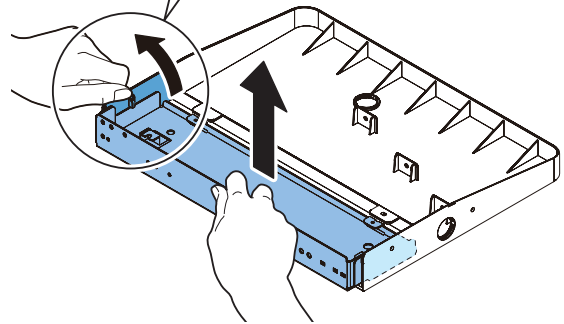
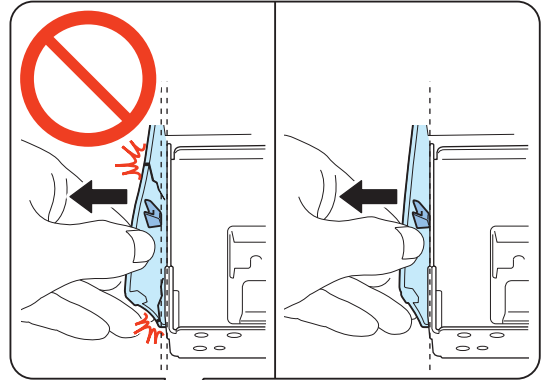
□
3.

CAUTION:
To avoid damage, do not pull the Utility Tray too much.

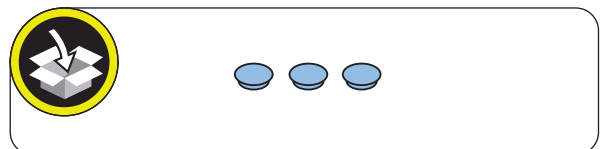


□
4.

CAUTION:
To avoid damage, do not pull the Utility Tray too much.



□
5.

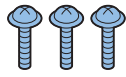
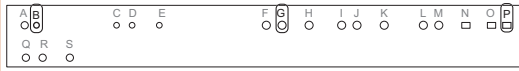


6.

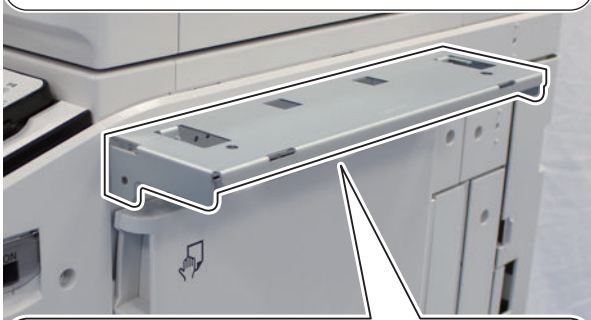
CAUTION:

Points to Note at Installation

If the holes are marked as shown below, align the holes marked with B, G and P with the holes in the host machine

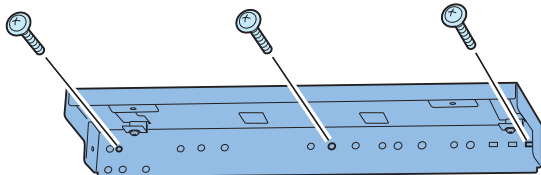


TP ; M4x14



3x

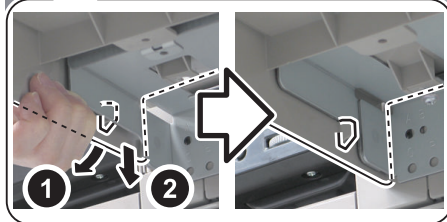
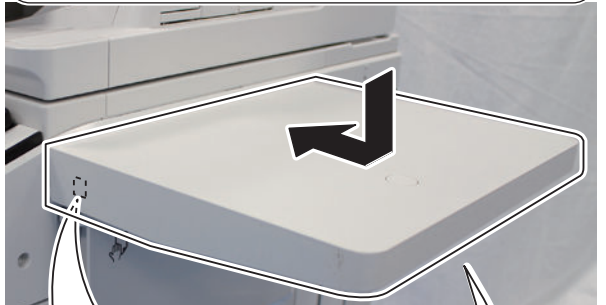
BOTTOM VIEW



7.



TP ; M4x10

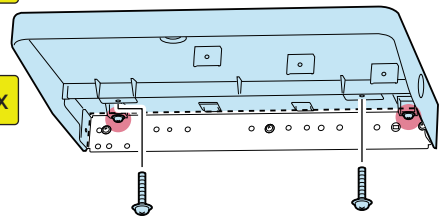


2x

BOTTOM VIEW

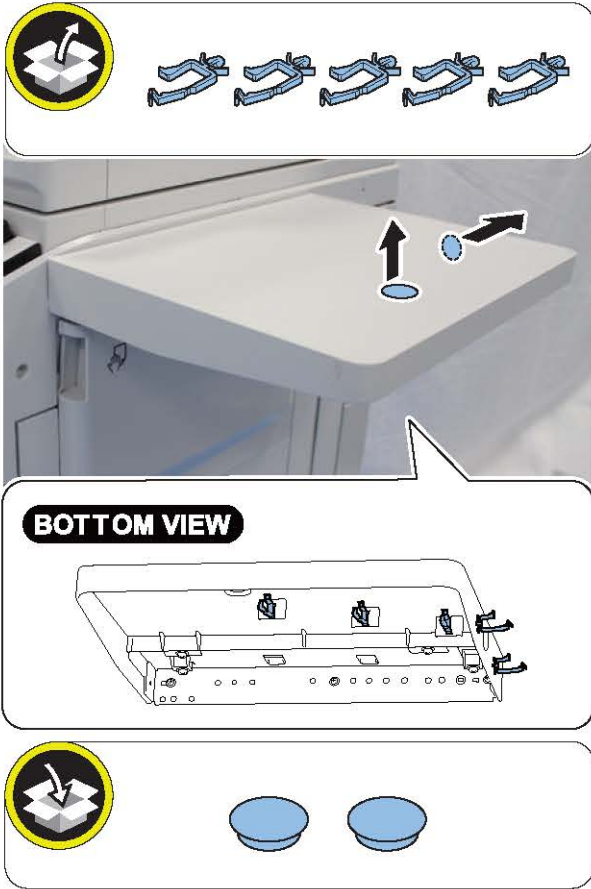


2x



■ When Installing the USB Keyboard

□
1.



Copy Card Reader-F1

Points to Note at Installation

- To install this equipment, the Copy Card Reader Attachment is required.
- After installing the Copy Card Reader, input the card number to be used in service mode. Otherwise the card cannot be recognized even though it is inserted. COPIER > FUNCTION > INSTALL > CARD
- When installing this equipment, be sure to install it by referring to "Table of Options Combination".
- The pictures and illustrations used may be different from the product in front of you, but the procedure is the same.

Table of Options Combination

	Utility Tray	Voice Operation	Voice Guidance Kit	Serial Interface Kit	Copy Control Interface Kit
Copy Card Reader	Yes	Yes	Yes	No	No

Yes: Available, No: Unavailable

Essential Items to Be Performed Before Installation

- Turn OFF the main power of the host machine, and disconnect the power plug from the outlet.

⚠ WARNING:

- If performing work without disconnecting the power plug of the host machine, it may cause electrical shock.
- If disconnecting the power plug without turning OFF the main power, it may cause damage of the machine.

- When turning OFF the main power, follow the below procedure.
 1. Turn OFF the main power switch of the host machine.
 2. The display in the Control Panel and the lamp of the main power are turned off.

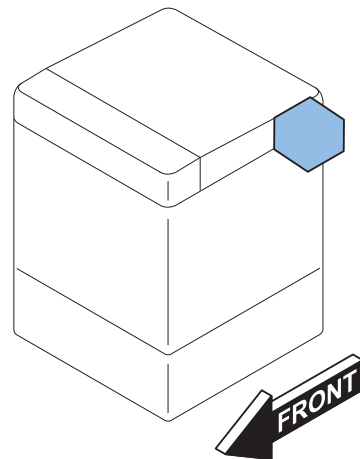
Points to Note When Turning ON/OFF the Main Power

The following message is displayed.

1. When a message prompting to turn OFF and then ON the main power appears, turn OFF and then ON the main power switch.
2. If a message prompting the user to update the version appears, press [Update] to automatically update the version of this equipment.




If [Skip] is selected, a message prompting the user to update the version will appear every time the host machine is started. In the service mode (Lv. 2) shown below, it is possible to set not to display the message. COPIER > OPTION > FNC-SW > VER-CHNG

Installation Outline Drawing

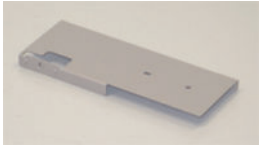

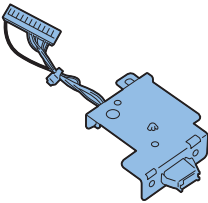
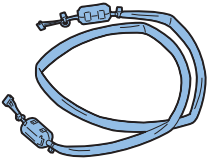


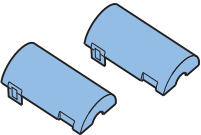
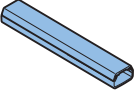
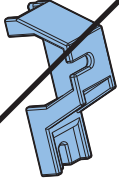










Checking the Contents

<Copy Card Reader-F1>

<input type="checkbox"/> [1] Card Reader Unit X 1 	<input type="checkbox"/> [2] Toothed washer X 1 
<input type="checkbox"/> [3] Screw (RS tight; M4x10) X 1 	

<Copy Card Reader Attachment- A4>

<input type="checkbox"/> [1] Card Reader Mounting Plate X 1 Used only for the Upright Control Panel 	<input type="checkbox"/> [2] Card Reader Mounting Plate X 1 Used only for the Flat Control Panel 
<input type="checkbox"/> [3] Card Reader Relay Unit X 1 	<input type="checkbox"/> [4] Card Reader External Relay Harness X 1 
<input type="checkbox"/> [5] Connector Cover1 X 1 	<input type="checkbox"/> [6] Connector Cover2 X 1 
<input type="checkbox"/> [7] Connector Case X 2 	<input type="checkbox"/> [8] Cord Guide X 1 
<input type="checkbox"/> [9] Connector Cover X 1 	<input type="checkbox"/> [10] PCB Spacer X 1 

<input type="checkbox"/> [11] Screw (Binding; M3x6) X 1 	<input type="checkbox"/> [12] Screw (TP; M4x12) X 1 Used only for the Upright Control Panel 
<input type="checkbox"/> [13] Screw (RS tight; M4x8) X 1 Used only for the Upright Control Panel 	<input type="checkbox"/> [14] Screw (Binding; M4x20) X 1 Used only for the Flat Control Panel 
<input type="checkbox"/> [15] Screw (Binding; M4x6) X 1 Used only for the Flat Control Panel 	<input type="checkbox"/> [16] Relay Harness X 1 
<input type="checkbox"/> [17] Screw (TP; M3x6) X 1 	

Installation Procedure

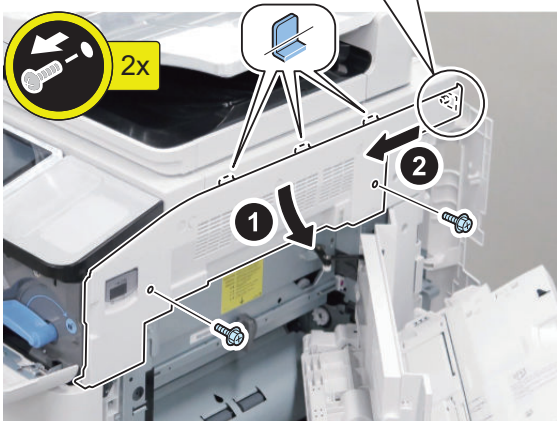
■ Installing the Card Reader Mounting Plate <in the case of the Flat Control Panel >



1. Open the Toner Replacement Cover, Right Cover, and Right Rear Cover 1.



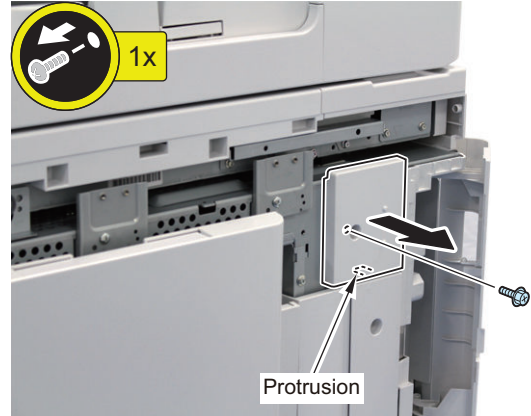
2. Remove the Right Upper Cover.
 - 2 Screws
 - 3 Protrusions
 - 1 Boss



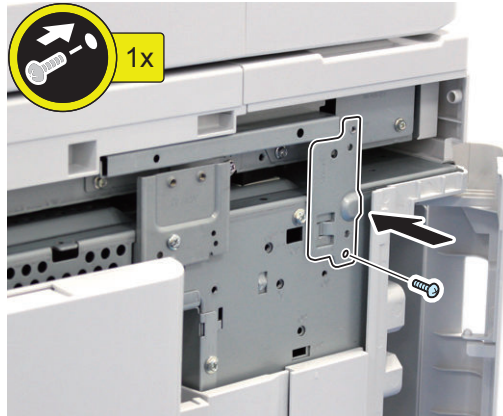
3. Close the Right Cover.



4. Remove the Right Rear Cover 2.
 - 1 Screw
 - 1 Protrusion



5. Install the Card Reader Mounting Plate.
 - 1 Screw (Binding; M4x6)



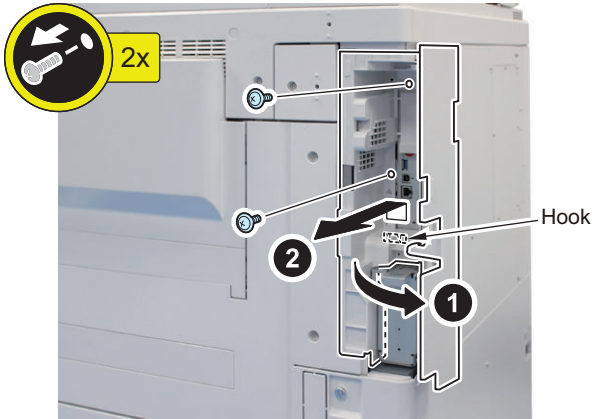
6. Install the Right Rear Cover 2 (1 Screw).
7. Open the Right Cover, and then install the Right Upper Cover (2 Screws).
8. Close the Right Cover and Toner Replacement Cover.

■ Installing the Card Reader



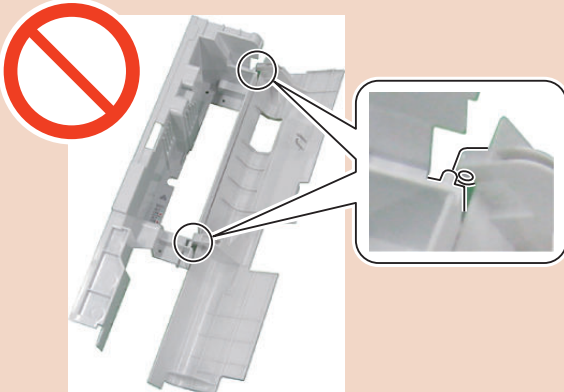
1. Remove the Side Cover.

- 2 Screws
- 1 Hook



CAUTION:

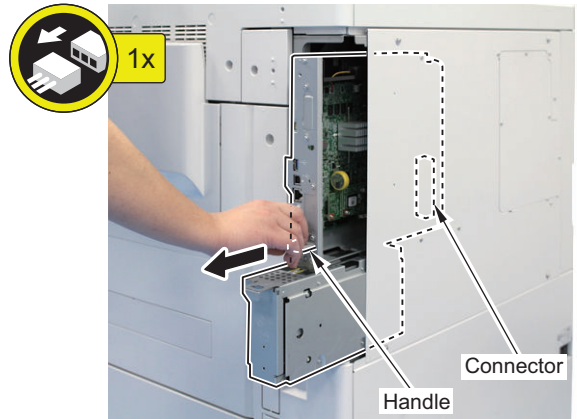
Be careful not to let the 2 bosses of the Side Cover come off from the 2 mounting holes of the Right Rear Cover 1.



2. Hold the handle to remove the Main Controller PCB

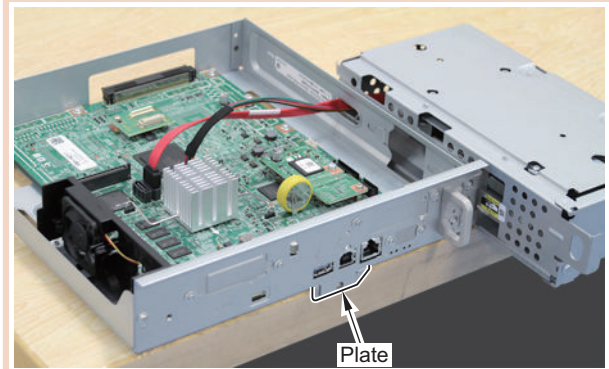
1.

- 1 Connector



CAUTION:

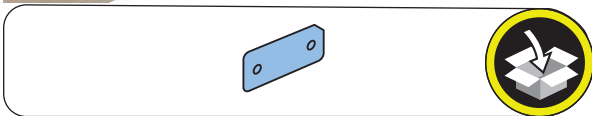
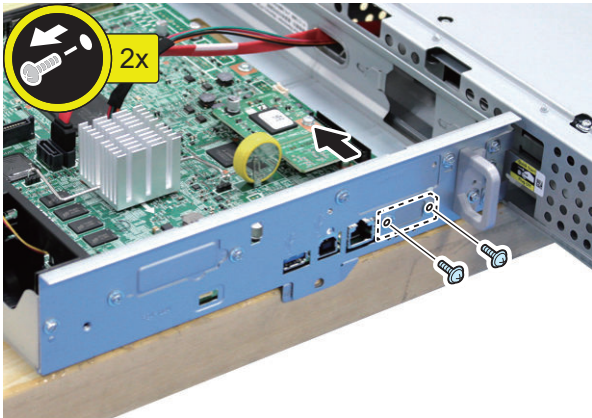
Be sure to place the removed Main Controller PCB 1 flatly. Reason: Due to the protruded plate, the PCB may be deformed if work is performed while it is placed at an angle.



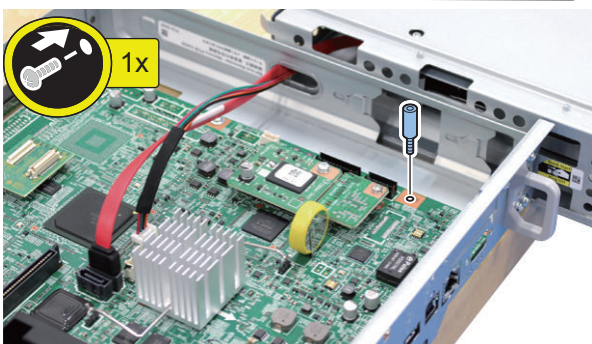
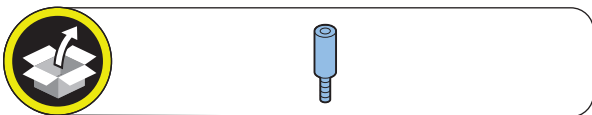
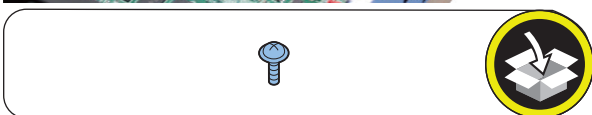
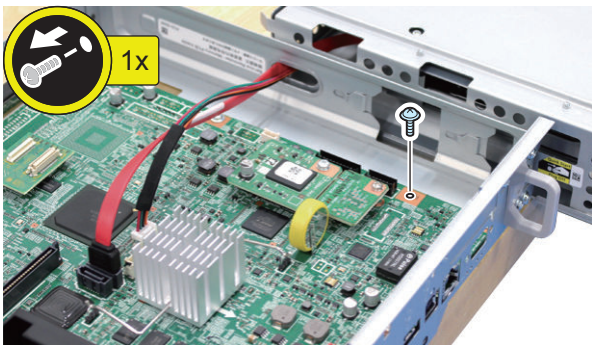


3. Remove the Face Cover. (The removed Face Cover will not be used.)

- 2 Screws (The removed screws will be used in step 5)

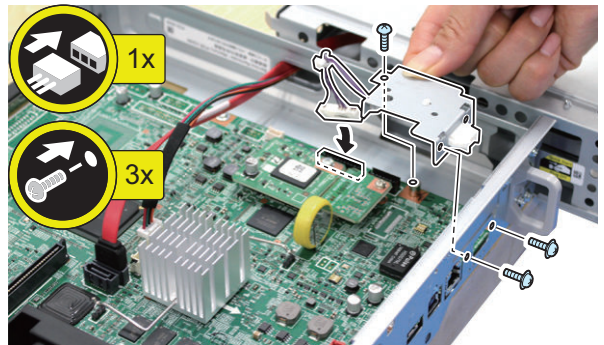
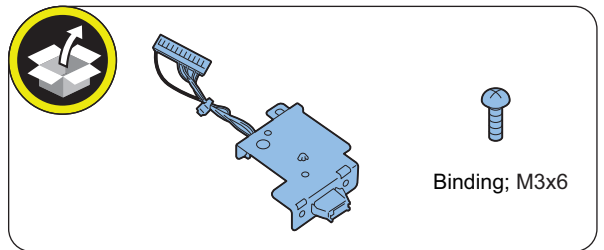


4. Remove the screw, and install the PCB Spacer. (The removed screws will not be used.)



5. Install the Card Reader Reply Unit.

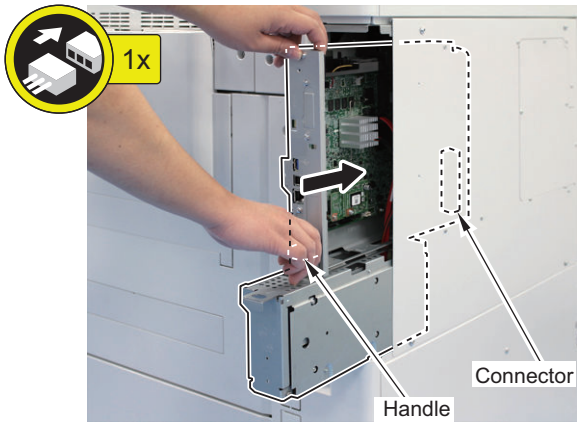
- 1 Connector
- 2 Screws (Use the screws removed in step 3.)
- 1 Screw (Binding; M3x6)





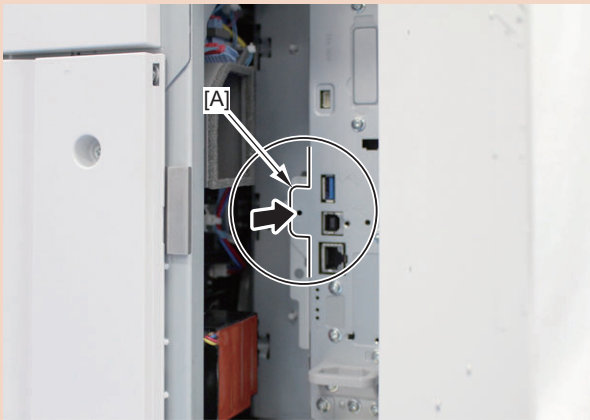
6. Insert the Main Controller PCB 1 until it stops.

- 1 Connector

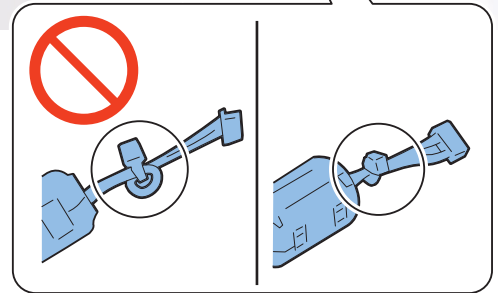
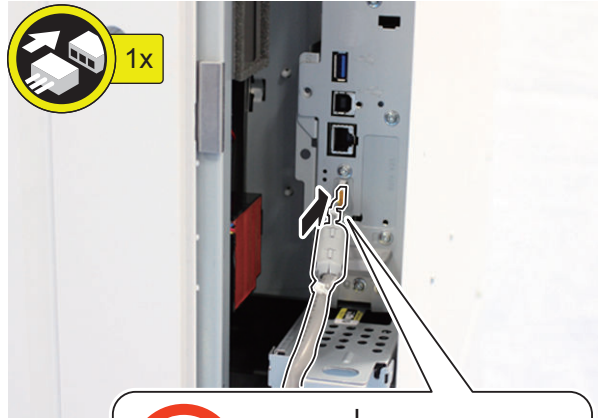
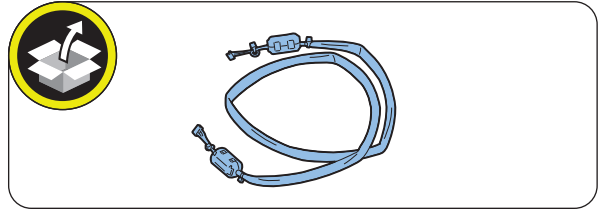


CAUTION:

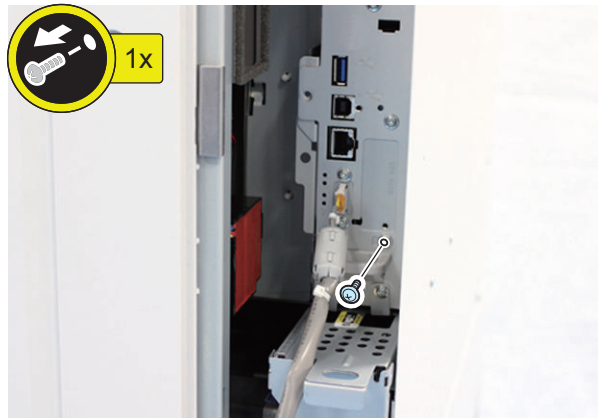
Be sure to push [A] part hard to install it, otherwise the connector may not be connected properly.



7. Connect the Card Reader External Relay Harness.



8. Remove the Screw (The removed screws will be used at next step.)



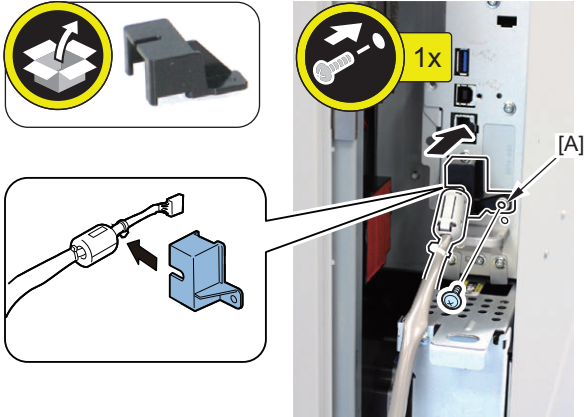


9. Install the Connector Cover to the Card Reader External Relay Harness.

- 1 Screw (Use the screw removed at previous step.)

CAUTION:

- Install the screw to the [A] part.
- When installing the Connector Cover, be sure to place the tie-wrap on the Card Reader External Relay Harness on the inside of the Connector Cover.

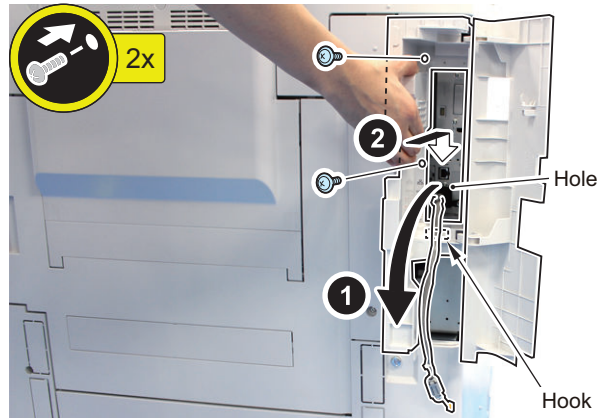
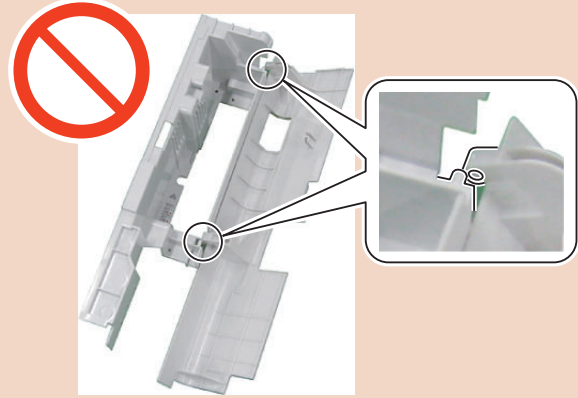


10. Install the Side Cover by putting the Card Reader External Relay Harness through a hole of the cover.

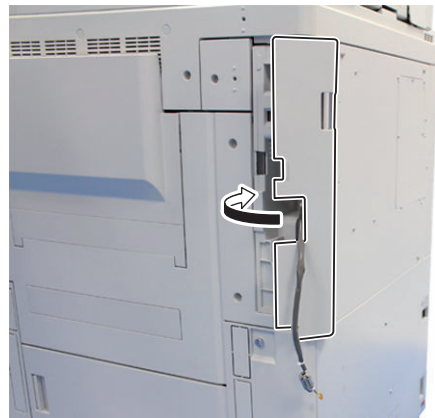
- 1 Hook
- 2 Screws

CAUTION:

Be careful not to let the 2 bosses of the Side Cover come off from the 2 mounting holes of the Right Rear Cover 1



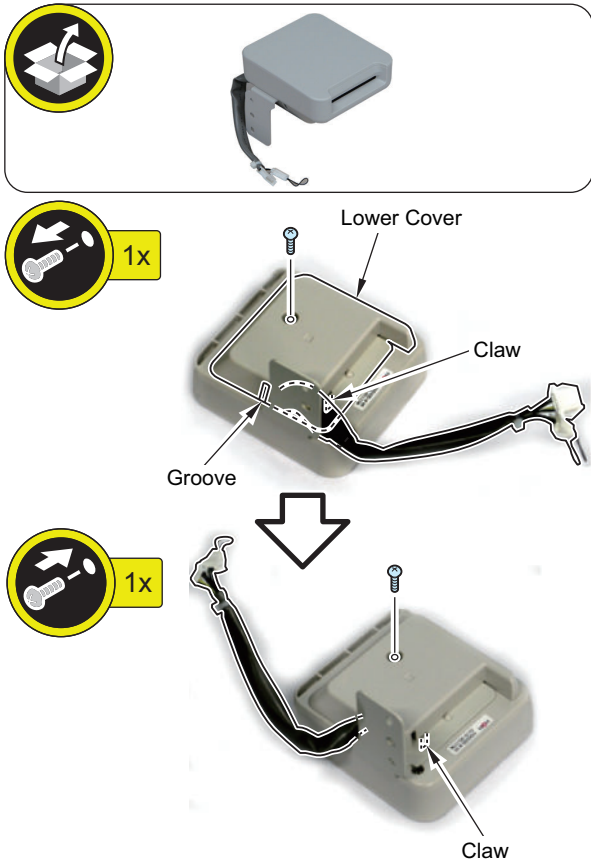
11. Close the Right Rear Cover 1.



□

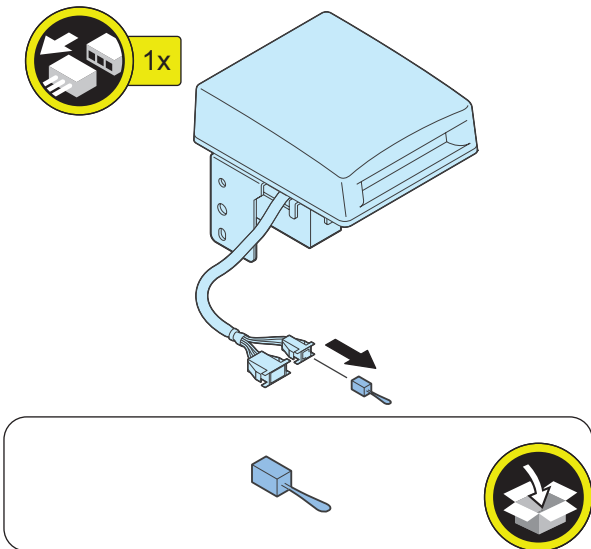
12. Remove the Lower Cover of the Card Reader Unit, and change the position of the cable.

- 1 Claw
- 1 Screw



□

13. Disconnect the Short Connector on the Card Reader. (The removed Short Connector will not be used.)



□

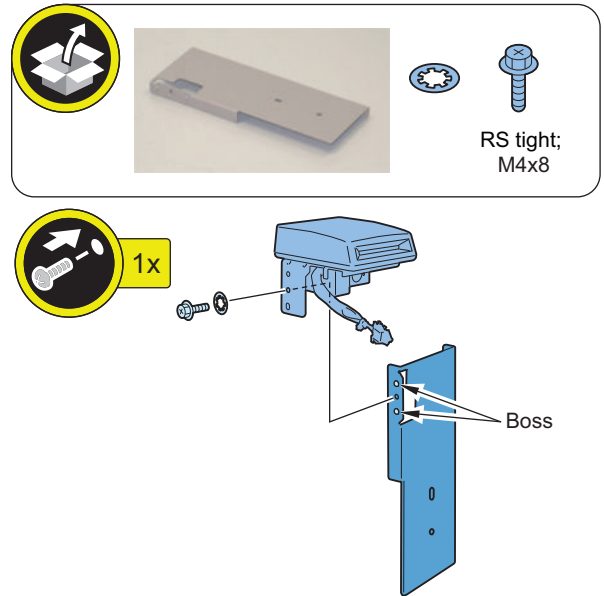
14. Install the Card Reader.

<In the Case of Upright Control Panel>

□

14-1. Install the Card Reader to the Card Reader Mounting Plate.

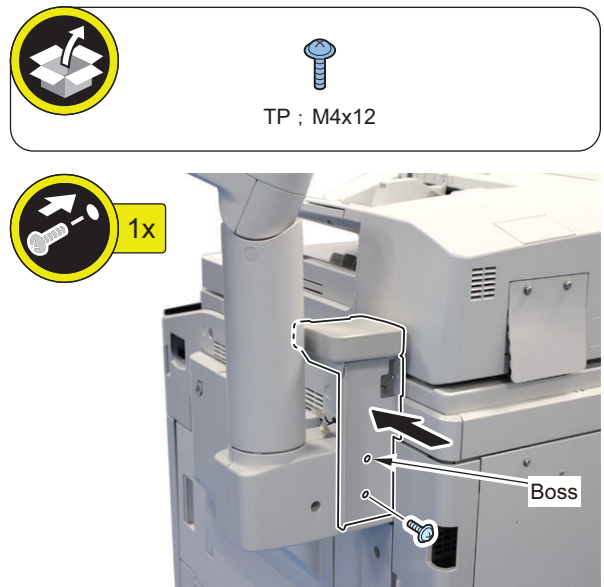
- 2 Bosses
- 1 Toothed Washer
- 1 Screw (RS Tightening; M4x8)



□

14-2. Install the Card Reader Unit assembled in step 14-1.

- 1 Boss
- 1 Screw (TP; M4x12)

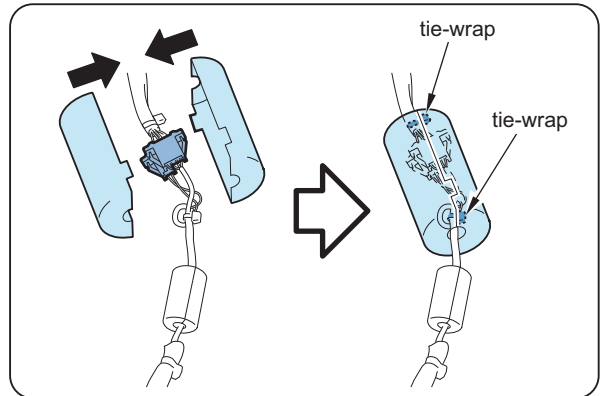
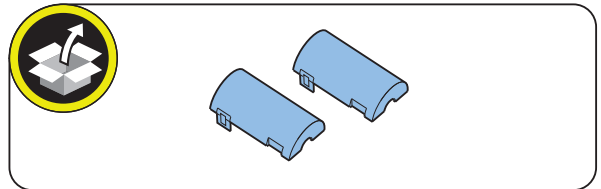
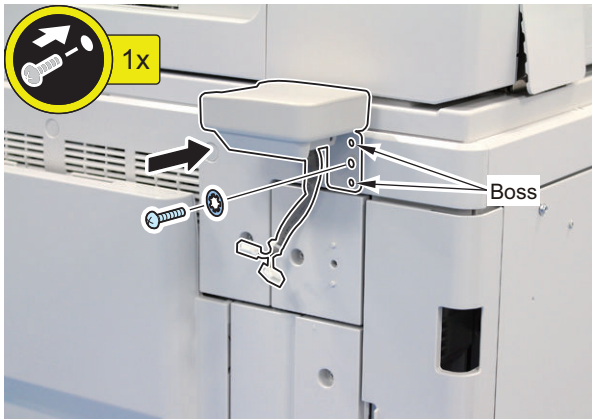
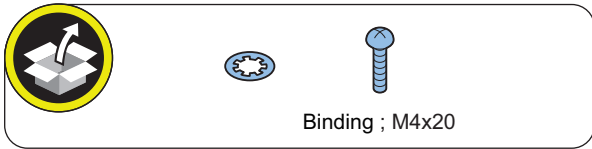


<In the Case of Flat Control Panel>

□

14-1. Install the Card Reader.

- 2 Bosses
- 1 Toothed Washer
- 1 Screw (Binding; M4x20)



- 15. If the Upright Control Panel is installed, put the connector of the Card Reader Unit through the hole on the Card Reader Mounting Plate.

NOTE:

While pictures of the Upright Control Panel model are used for explaining the steps 16 and 17, the procedure is the same for the Flat Control Panel model.

- 16. Connect the connectors of the Card Reader Unit and the Card Reader External Relay Harness.



NOTE:

While pictures of the Flat Control Panel model are used for explaining the following steps, the procedure is the same for the Upright Control Panel model.

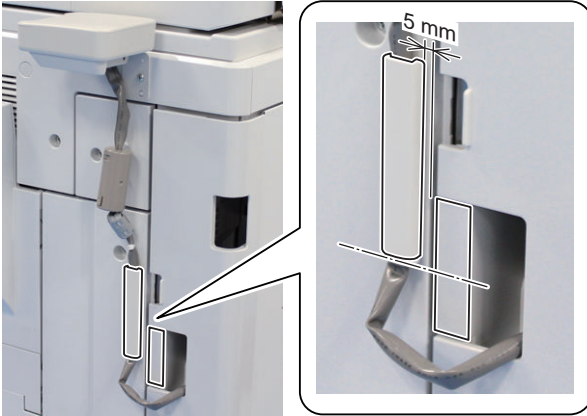
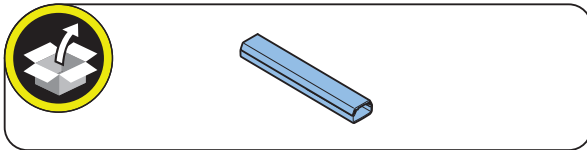
- 18. Remove the cover of Cord Guide, and affix it to the area indicated in the figure.

- 17. Install the Connector Case.

CAUTION:

When installing the Connector Cases, be sure to place the tie-wrap on the Card Reader External Relay Harness on the inside of the Connector Cases.

19. Put the Card Reader External Relay Harness through the Cord Guide, and install the cover of the Cord Guide.



20. Push the Card Reader External Relay Harness in the Right Rear Cover 1.



5. Use Service Mode to enter the minimum card number to be used by a user (1 to 2001).
COPIER > FUNCTION > INSTALL > CARD
Starting from the entered card number, the number of cards set in step 4 can be used.

6. Turn OFF and then ON the main power switch to enable the setting values.
7. Insert a card with a card number that has been registered, and check that the machine operates normally.

NOTE:

Perform the following operations to change the number of cards (departments) after it has been set. In such a case, counter information for each department is reset.

COPIER > FUNCTION > CLEAR > CARD

- Turn OFF and then ON the main power switch to enable the settings.
- After that, perform from step 3.

● Checking after Installation

1. Connect the power plug of the host machine to the power outlet.
2. Turn the main power switch ON.
3. Check the model of the Card Reader in service mode. (Default: 0 "Card Reader-F1")
COPIER > OPTION > ACC > CR-TYPE

4. Set the number of card (number of department ID) that can be used with the Card Reader in service mode.(Lv.2).
COPIER > OPTION > FNC-SW > CARD-RNG

Serial Interface Kit-K3 / Copy Control Interface Kit-A1

Points to Note at Installation

When installing this equipment, be sure to install it by referring to "Table of Options Combination".

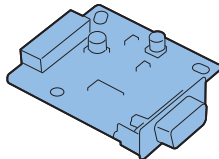
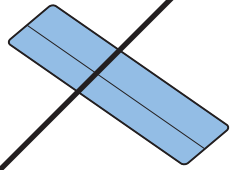
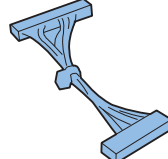
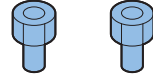



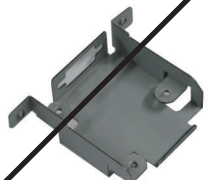
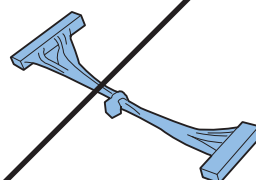

Table of Options Combination

	Serial Interface Kit	Copy Control Interface Kit	Voice Operation Kit	Voice Guidance Kit	Copy Card Reader
Serial Interface Kit	-	No	Yes	Yes	No
Copy Control Interface Kit	No	-	Yes	Yes	No

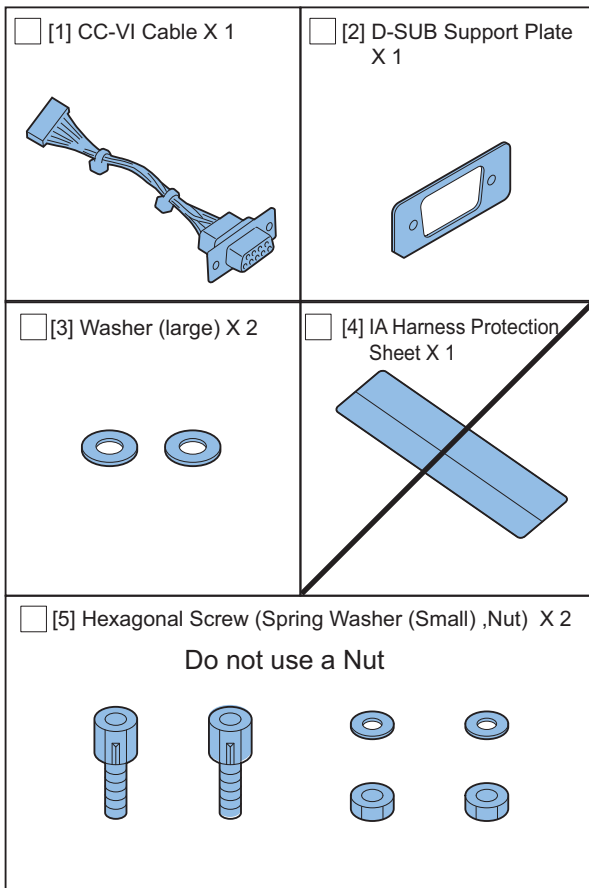
Yes: Available, No: Unavailable

Checking the Contents

<Serial Interface Kit-K3>

<input type="checkbox"/> [1] Serial RS Conversion Board X 1 	<input type="checkbox"/> [2] IA Harness Protection Sheet X 1 
<input type="checkbox"/> [3] RS Conversion Cable (Short) X 1 	<input type="checkbox"/> [4] Hexagonal Screw X 2 
<input type="checkbox"/> [5] Washer X 2 	<input type="checkbox"/> [6] PCB Spacer X 1 
<input type="checkbox"/> [7] Screw (TP; M3x6) X 3 	<input type="checkbox"/> [8] Support Plate X 1 
<input type="checkbox"/> [9] RS Conversion Cable (Long) X 1 	<input type="checkbox"/> [10] RS Conversion Cable X 1 

<Copy Control Interface Kit-A1>



Essential Items to Be Performed Before Installation

- Turn OFF the main power of the host machine, and disconnect the power plug from the outlet.

⚠ WARNING:

- If performing work without disconnecting the power plug of the host machine, it may cause electrical shock.
- If disconnecting the power plug without turning OFF the main power, it may cause damage of the machine.

- When turning OFF the main power, follow the below procedure.
 1. Turn OFF the main power switch of the host machine.
 2. The display in the Control Panel and the lamp of the main power are turned off.

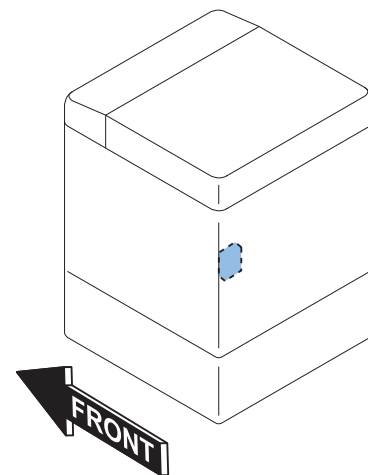
Points to Note When Turning ON/OFF the Main Power

The following message is displayed.

1. When a message prompting to turn OFF and then ON the main power appears, turn OFF and then ON the main power switch.
2. If a message prompting the user to update the version appears, press [Update] to automatically update the version of this equipment.

If [Skip] is selected, a message prompting the user to update the version will appear every time the host machine is started. In the service mode (Lv. 2) shown below, it is possible to set not to display the message.
COPIER > OPTION > FNC-SW > VER-CHNG

Installation Outline Drawing



Installation Procedure

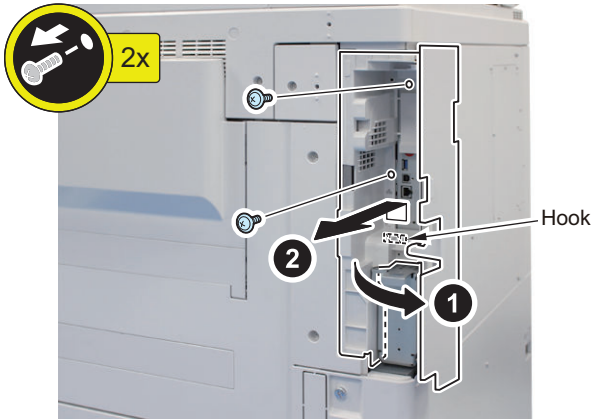
■ Removing the Main Controller PCB

1

□

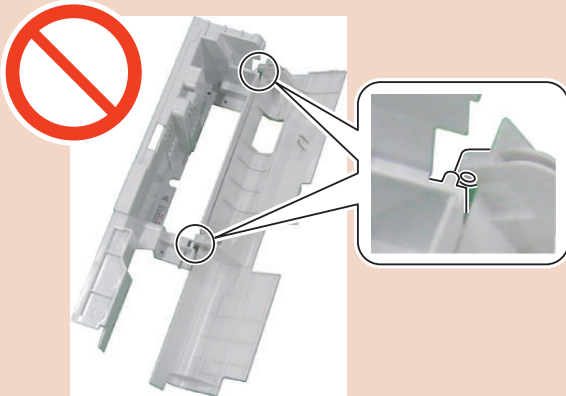
1. Open the Right Rear Cover 1, and remove the Side Cover.

- 2 Screws
- 1 Hook



CAUTION:

Be careful not to let the 2 bosses of the Side Cover come off from the 2 mounting holes of the Right Rear Cover 1.

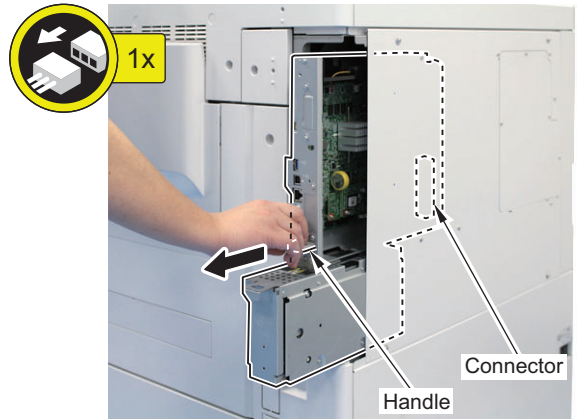


□

2. Hold the handle to remove the Main Controller PCB

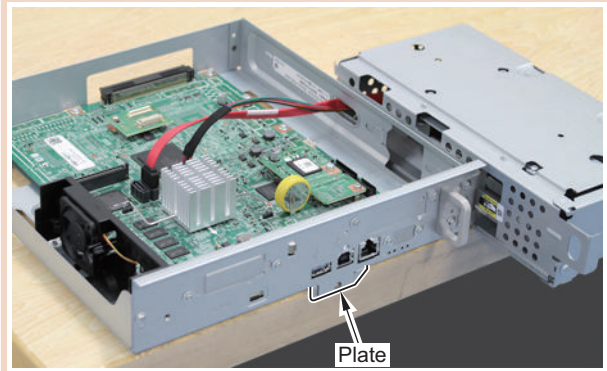
1.

- 1 Connector



CAUTION:

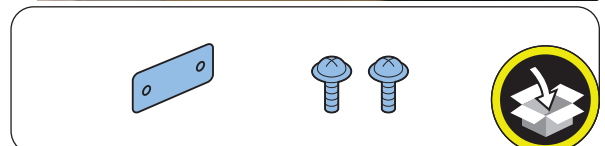
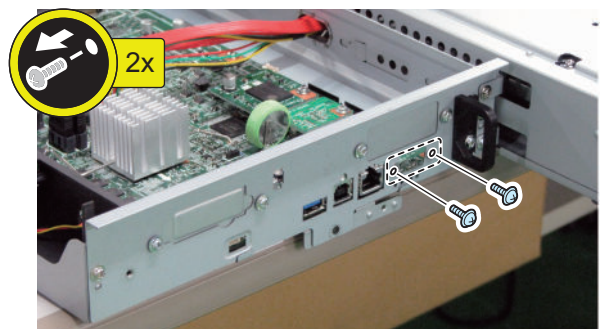
Be sure to place the removed Main Controller PCB 1 flatly. Reason: Due to the protruded plate, the PCB may be deformed if work is performed while it is placed at an angle.



□

3. Remove the face cover (The removed Face Cover will not be used).

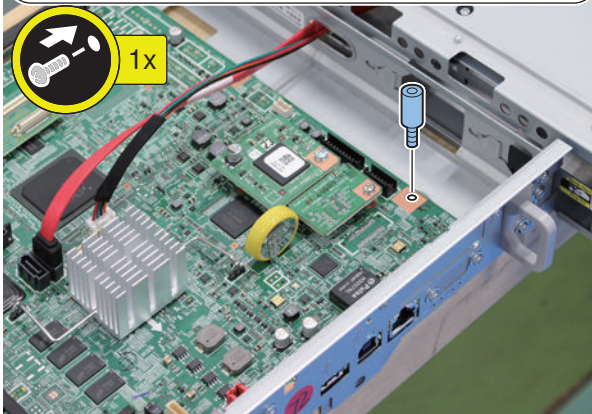
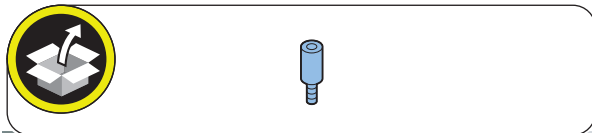
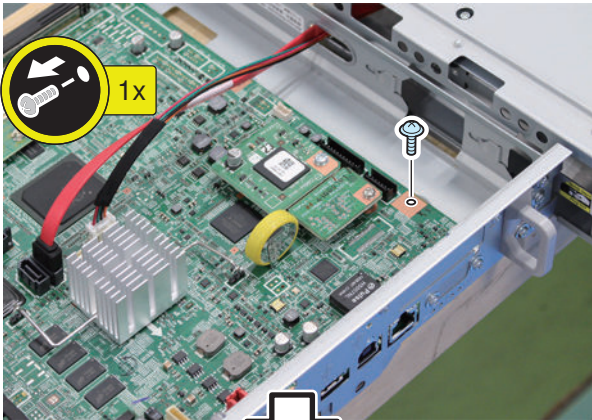
- 2 Screws



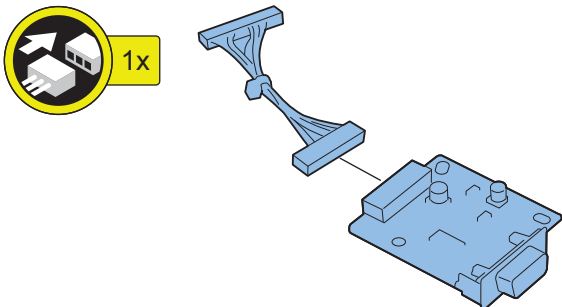
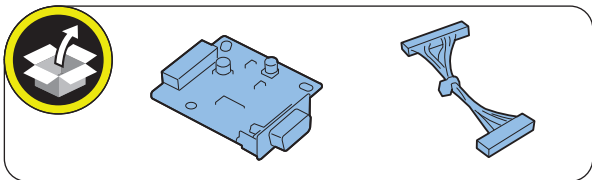
■ Installing the Serial Interface Kit



1. Remove the screw, and install the PCB Spacer (The removed screw will be used in step 3).

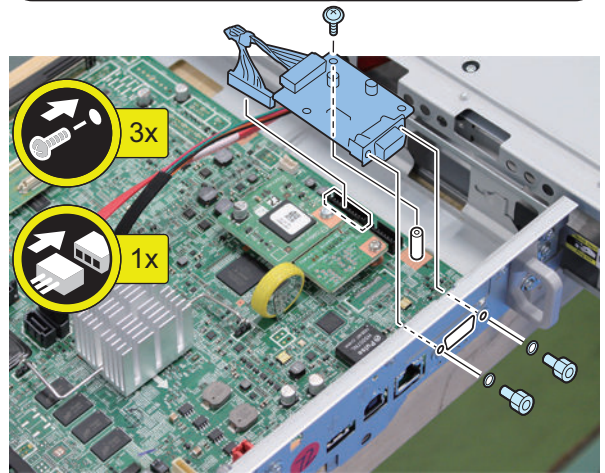
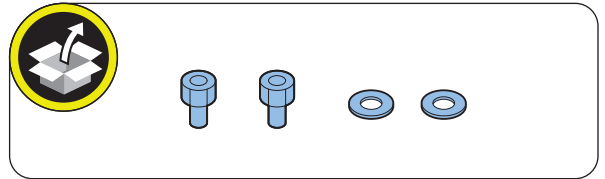


2. Connect the RS Conversion Cable (short) to the Serial RS Conversion Board.



3. Install the Serial RS Conversion Board.

- 1 Screw (Use the screw removed in step 1)
- 2 Washers
- 2 Hexagon Screws
- 1 Connector

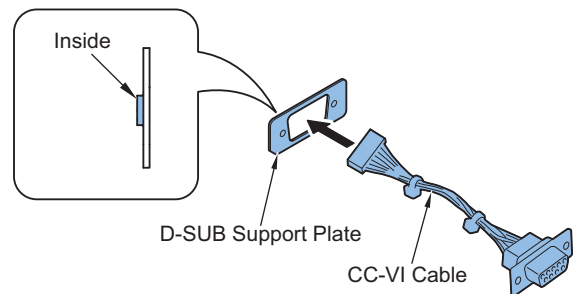
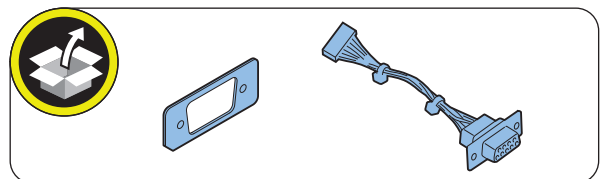


■ Installing the Copy Control interface Kit



1. Put the CC-VI Cable through the D-SUB Support Plate.

CAUTION:
Install the extruded side of the D-SUB Support Plate as shown in the figure.

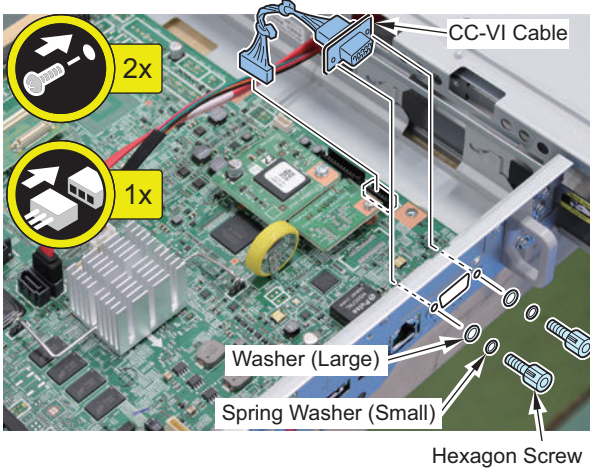
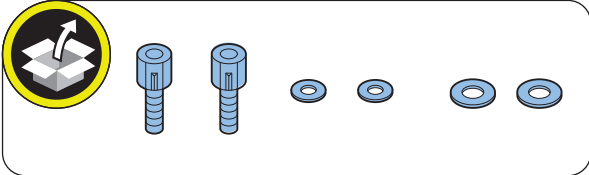




2. Connect the CC-VI Cable to the Main Controller PCB

1.

- 2 Hexagon Screws
- 2 Spring Washers (small)
- 2 Washers (Large)
- 1 Connector

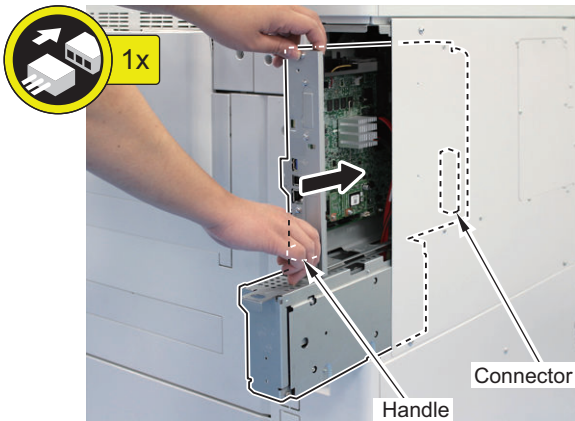


■ Installing the Main Controller PCB 1



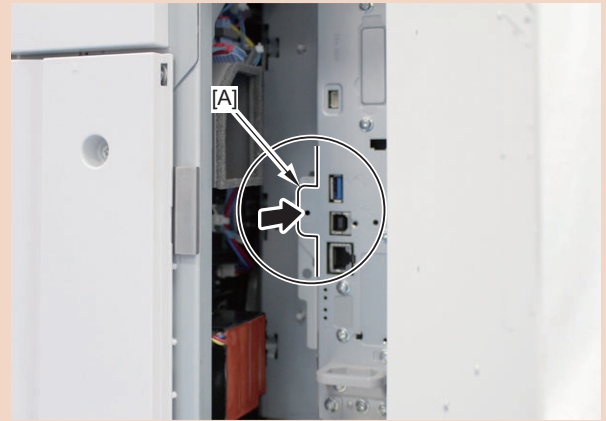
1. Insert the Main Controller PCB 1 until it stops.

- 1 Connector



CAUTION:

Be sure to push [A] part hard to install it, otherwise the connector may not be connected properly.

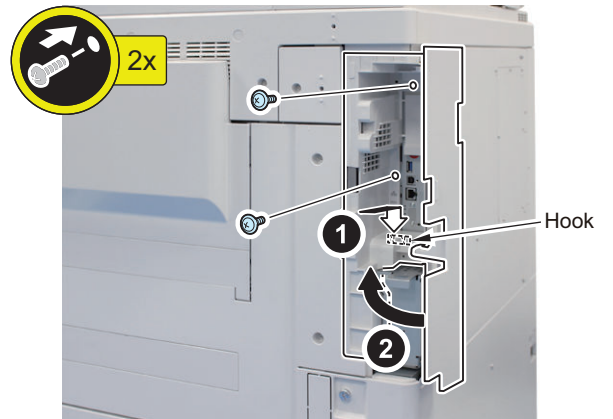
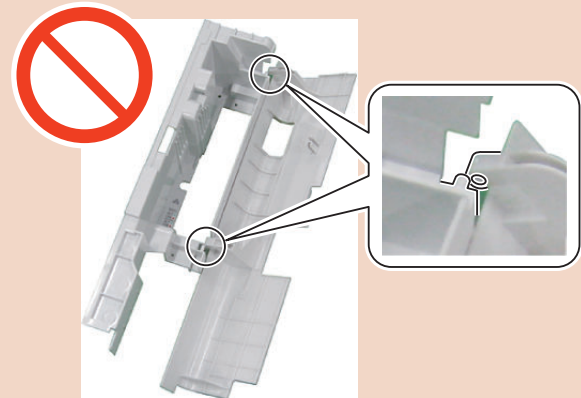


2. Install the Side Cover, and then Close the Right Rear Cover 1.

- 1 Hook
- 2 Screws

CAUTION:

Be careful not to let the 2 bosses of the Side Cover come off from the 2 mounting holes of the Right Rear Cover 1.





3. Connect the power plug of the host machine to the power outlet.
4. Turn the main power switch ON.

Voice Operation Kit-D1

Points to Note Before Installation


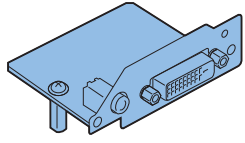
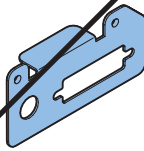
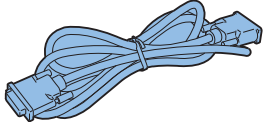
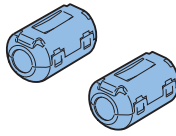
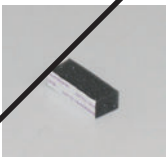
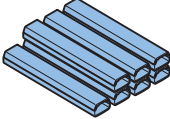

- The pictures and illustrations used may be different from the product in front of you, but the procedure is the same.
- When installing this equipment, the option Numeric Keypad is required. Refer to the Installation Procedure for the Numeric Keypad when installing the Numeric Keypad.
- Refer to "Combination of options" when installing this equipment before operation.

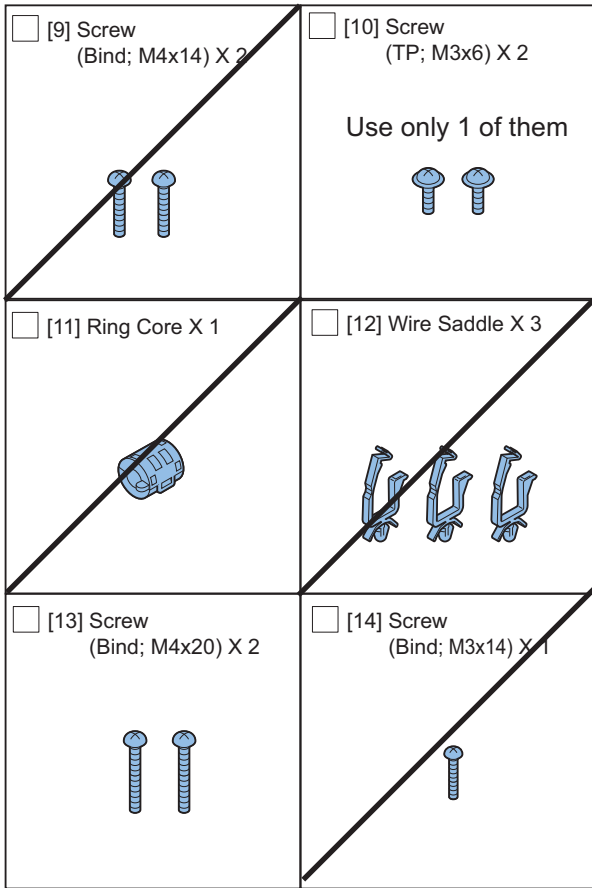
Table of Options Combination

	Copy Card Reader	Serial Inter-face Kit	Copy Control Interface Kit	Voice Guidance Kit	Utility Tray
Voice Operation Kit	Yes	Yes	Yes	No	No

Yes: Available, No: Unavailable

Checking the Contents

<input type="checkbox"/> [1] Speaker Unit X 1 	<input type="checkbox"/> [2] Voice Operation Board Unit X 1 
<input type="checkbox"/> [3] Support Plate X 1 	<input type="checkbox"/> [4] DVI Cable X 1 
<input type="checkbox"/> [5] Ring Core X 2 	<input type="checkbox"/> [6] Cable Face Seal X 1 
<input type="checkbox"/> [7] Cord Guide X 7 	<input type="checkbox"/> [8] Card Spacer X 1 



[7]: Use 6 of them for the Flat Control Panel model.
 [11]: This is used for the user installed option and should be handed over to the user.

<Others>

Including guides

Essential Items to Be Performed Before Installation

- Turn OFF the main power of the host machine, and disconnect the power plug from the outlet.

⚠ WARNING:

- If performing work without disconnecting the power plug of the host machine, it may cause electrical shock.
- If disconnecting the power plug without turning OFF the main power, it may cause damage of the machine.

- When turning OFF the main power, follow the below procedure.
 1. Turn OFF the main power switch of the host machine.
 2. The display in the Control Panel and the lamp of the main power are turned off.

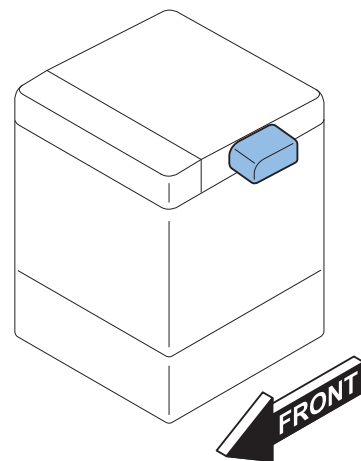
Points to Note When Turning ON/OFF the Main Power

The following message is displayed.

1. When a message prompting to turn OFF and then ON the main power appears, turn OFF and then ON the main power switch.
2. If a message prompting the user to update the version appears, press [Update] to automatically update the version of this equipment.

If [Skip] is selected, a message prompting the user to update the version will appear every time the host machine is started. In the service mode (Lv. 2) shown below, it is possible to set not to display the message.
 COPIER > OPTION > FNC-SW > VER-CHNG

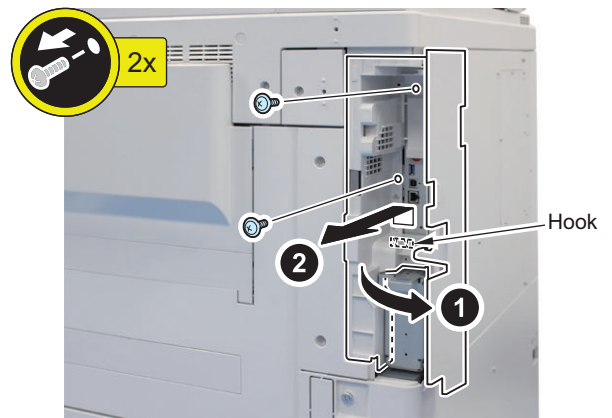
Installation Outline Drawing



Installation Procedure

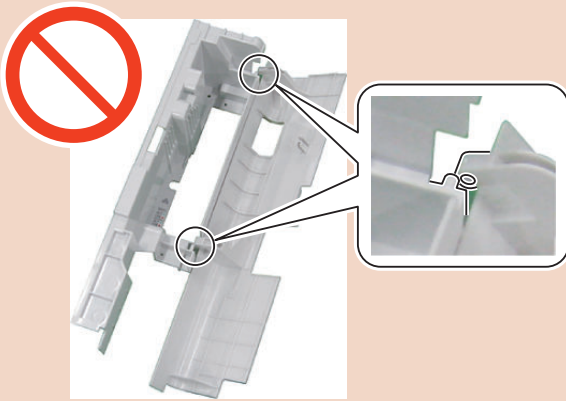
1. Open the Right Rear Cover 1, and then remove the Side Cover.

- 2 Screws
- 1 Hook



CAUTION:

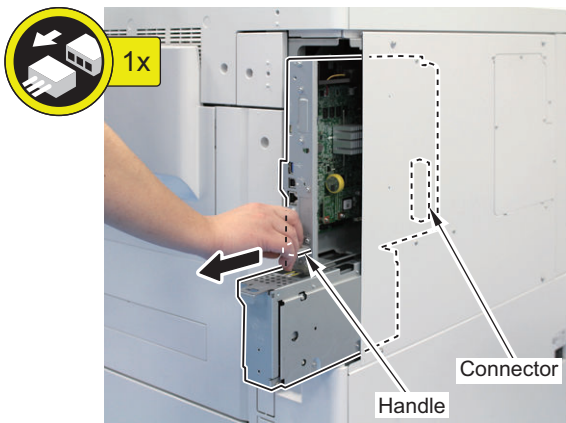
Be careful not to let the 2 bosses of the Side Cover come off from the 2 mounting holes of the Right Rear Cover 1.



□

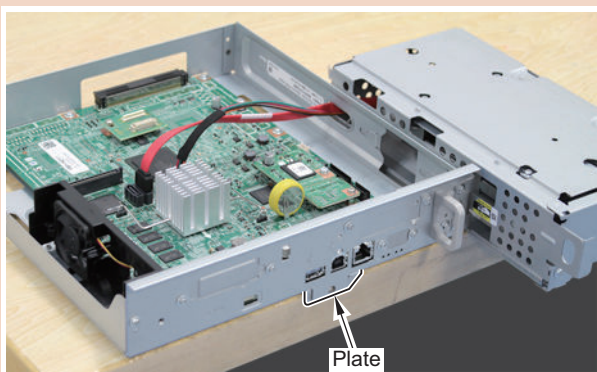
2. Hold the handle to remove the Main Controller PCB 1.

- 1 Connector



CAUTION:

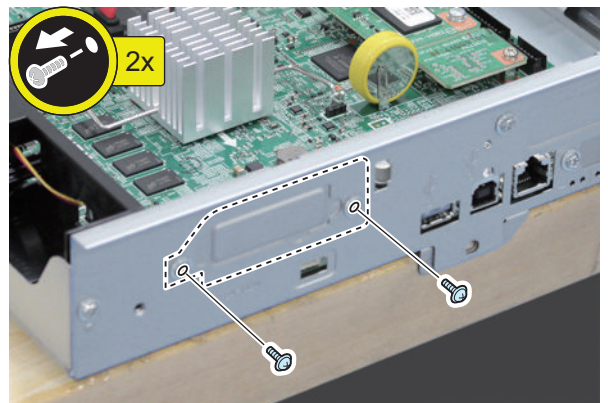
Be sure to place the removed Main Controller PCB 1 flatly. Reason: Due to the protruded plate, the PCB may be deformed if work is performed while it is placed at an angle.



□

3. Remove the Face Plate. (The removed Face Plate will not be used.)

- 2 Screws (The removed screws will be used at next step .)



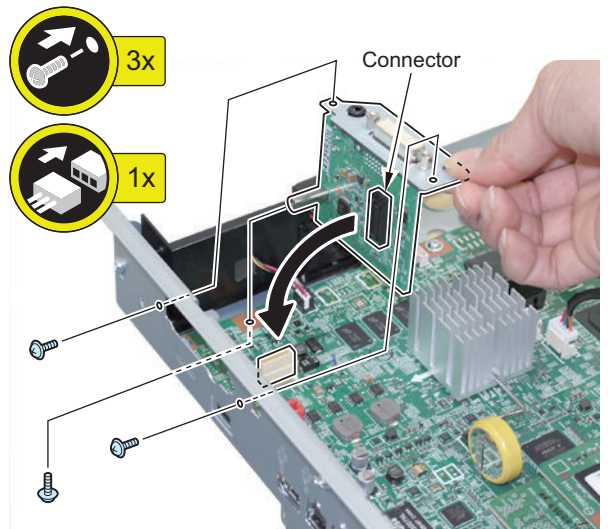
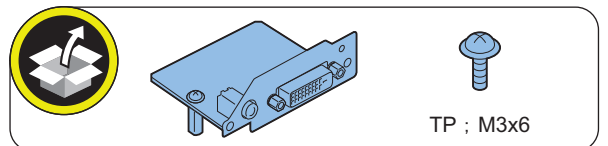
□

4. Install the Voice Operation Board Unit to the Main Controller PCB 1.

- 1 Connector
- 2 Screws (Use the screw removed at previous step)
- 1 Screw (TP; M3x6)

NOTE:

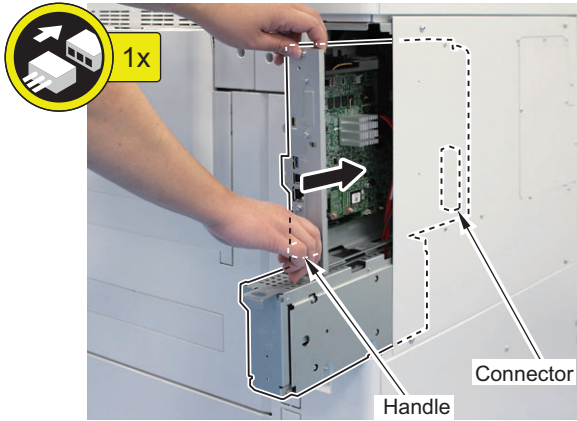
Check that the connector is connected properly.





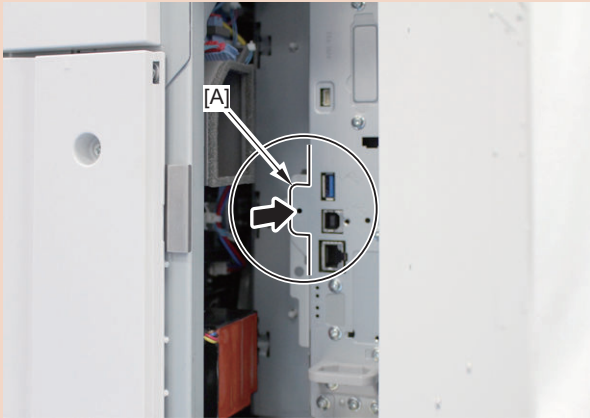
5. Insert the Main Controller PCB 1 until it stops.

- 1 Connector



CAUTION:

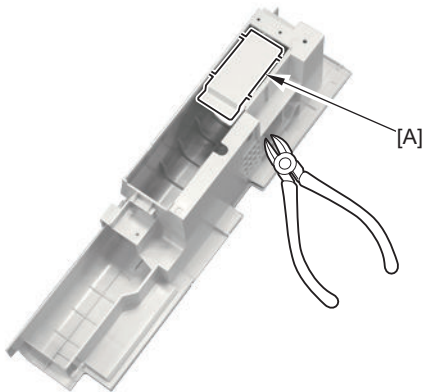
Be sure to push [A] part hard to install it, otherwise the connector may not be connected properly.



6. Be sure to push [A] part hard to install it, otherwise the connector may not be connected properly.

NOTE:

When cutting off the part, be sure not to make burrs .

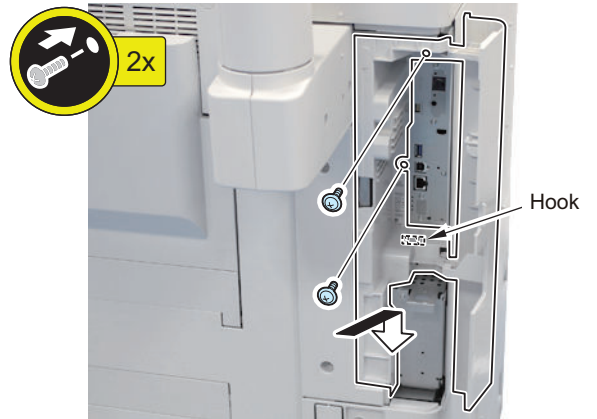
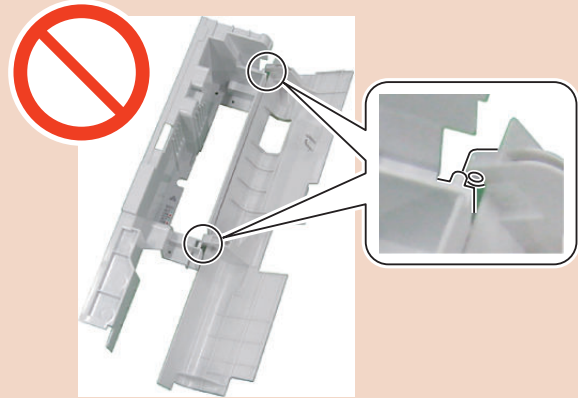


7. Install the Side Cover.

- 1 Hook
- 2 Screws

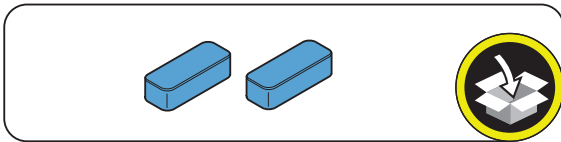
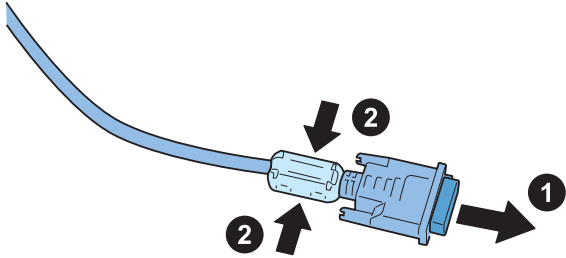
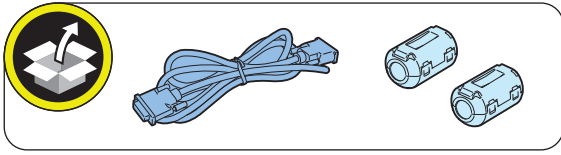
CAUTION:

Be careful not to let the 2 bosses of the Side Cover come off from the 2 mounting holes of the Right Rear Cover 1.

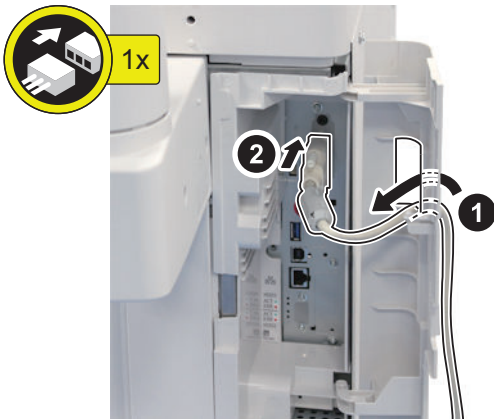




8. Attach the 2 Ring Cores to both ends of the DVI Cable and then remove caps from both ends.



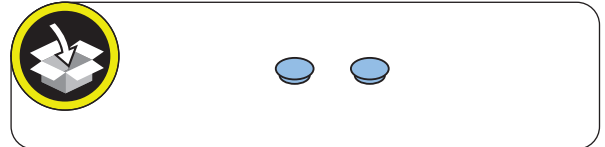
9. Pass the DVI Cable through the hole of the Side Cover, and connect the DVI Cable to the Voice Operation Board Unit.



10. Close the Right Rear Cover 1.



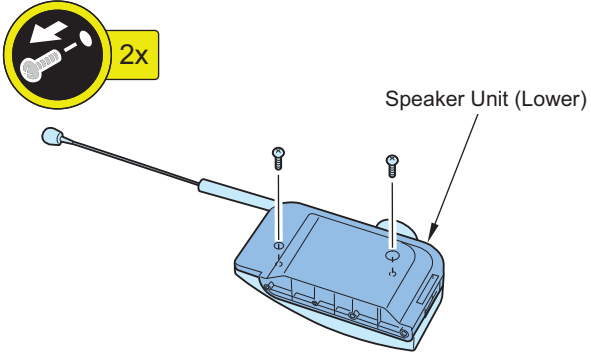
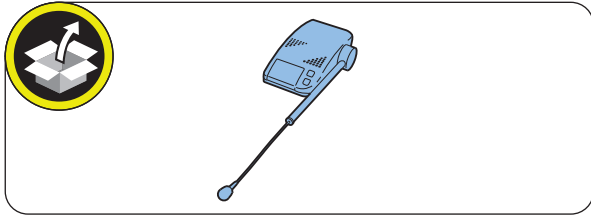
11. Remove the 2 Rubber Caps from the Right Upper Cover. (The removed Rubber Caps will not be used.)



□

12. Remove the Speaker Unit (Lower) from the Speaker Unit.

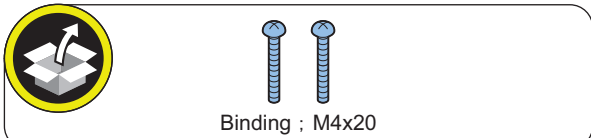
- 2 Screws (The removed screw will be used in step 14)



□

13. Install the Speaker Unit (Lower).

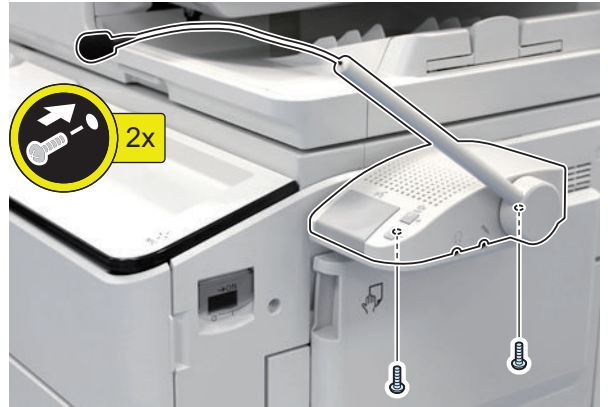
- 2 Screws (Binding; M4x20)



□

14. Install the Speaker Unit (Upper).

- 2 Screws (Use the screw removed in step 12.)



□

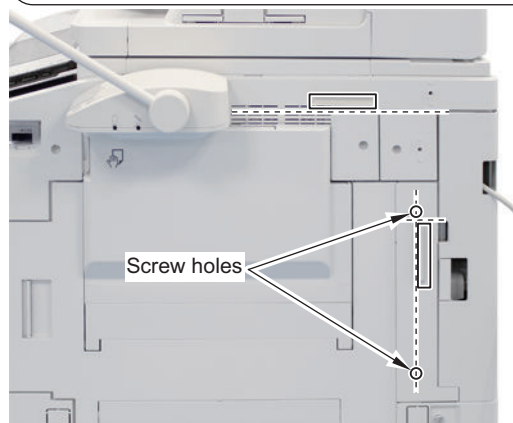
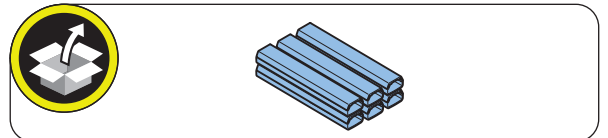
15. Remove the cover of Cord Guide, and affix it to the area indicated in the figure.

< In the Case of Flat Control Panel >

NOTE:

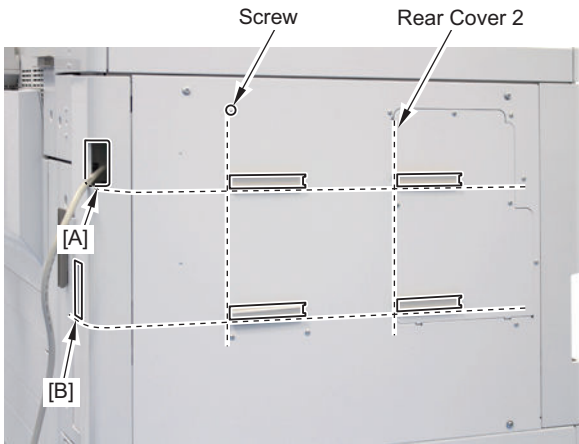
Even when this kit is used in combination with a Copy Card Reader, the positions to install the Cord Guides are the same.

- Use 6 Code Guides
< Right side >



<Rear side>

NOTE:
Be sure to affix them on the extension lines of [A] and [B].

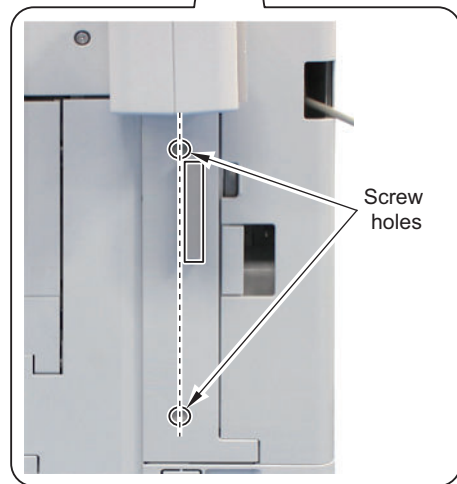
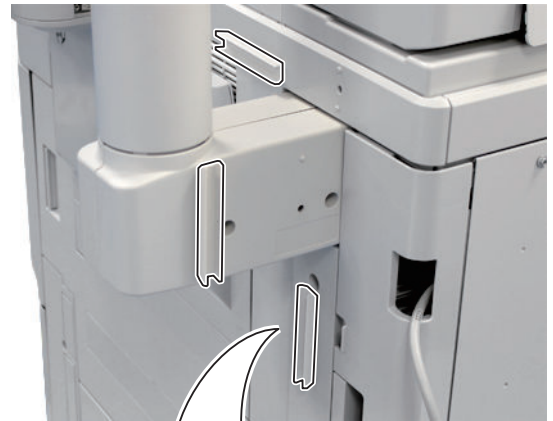
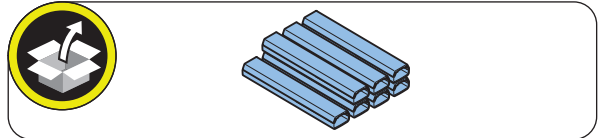


< In the Case of Upright Control Panel>

NOTE:
Even when this kit is used in combination with a Copy Card Reader, the positions to install the Cord Guides are the same.

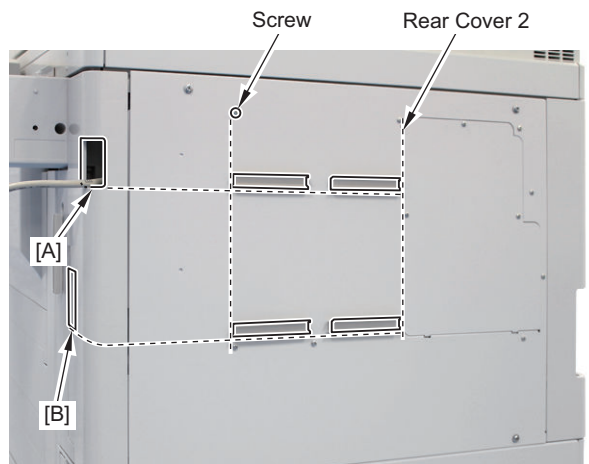
- Use 7 Cord Guides.

<Right side >



<Rear side >

NOTE:
[Be sure to affix them on the extension lines of [A] and [B].



16. Connect the DVI Cable to the Speaker Unit.

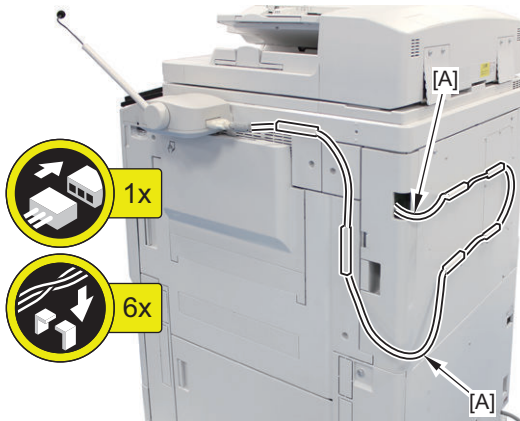
17. Put the Speaker Cable through the Cord Guide, and install the cover of the cord guide.

CAUTION:

Be sure to slack off [A] par for not interfering to open/close the Right Rear Cover¹.

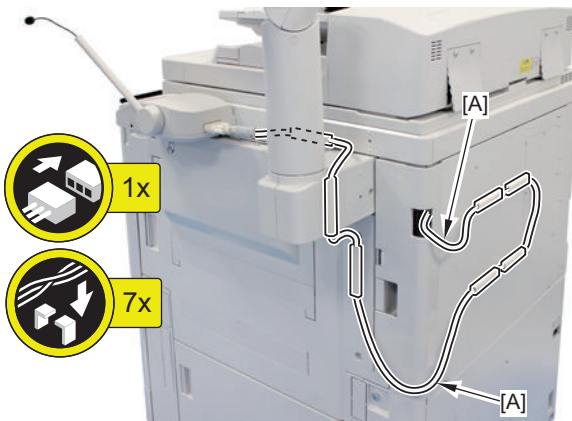
< In the Case of Flat Control Panel >

- Use 6 Cord Guides



< In the Case of Upright Control Panel >

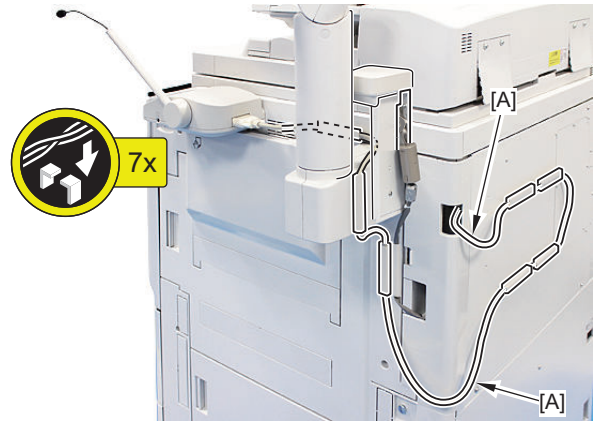
- Use 7 Cord Guides

**CAUTION:**

When using together with the Copy Card Reader

< In the Case of Upright Control Panel >

Be sure to pass the DVI cable between the Upright Arm and Card Reader Mounting Plate.



Checking after Installation

NOTE:

When changing the settings upon user's request, it is required to log in as a system manager in accordance with instructions from the user administrator.



1. Connect the power plug of the host machine to the outlet.
2. Turn ON the main power switch.
3. Select Settings/Registration > Preferences > Accessibility > Voice Navigation Settings > Use Voice Navigation, and check that the setting is ON.
4. Select Settings/Registration > Preferences > Accessibility > Voice Navigation Settings > Voice Navigation at Startup, and check that "Select Mode at Startup" is set.
5. Select Settings/Registration > Preferences > Accessibility > Voice Navigation Settings, and check that "Tune Microphone" is displayed.

Operation Check

■ When Starting to Use



1. Press the Guidance Start button or Voice Recognition button for 3 seconds or longer.

2. In "Select the Voice Navigation type." on the Control Panel screen, select "Manual + Vocal Mode", "Vocal Mode" or "Manual Mode", and press OK.
3. Once the indication on the screen is framed in red, the "Voice Operation Kit" becomes enabled.

NOTE:

When "Manual Mode" is selected in "Select the Voice Navigation type.", nothing happens by pressing the Voice Recognition button.

■ When Stopping to Use



1. Press the Guidance Start button or Voice Recognition button for 3 seconds or longer.

Voice Guidance Kit-G1

Points to Note at Installation

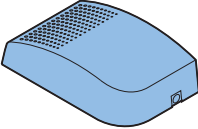
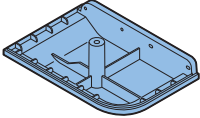
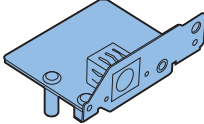
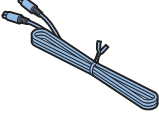
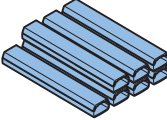
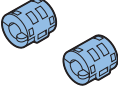

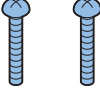
- The pictures and illustrations used may be different from the product in front of you, but the procedure is the same.
- When installing this equipment, the option Numeric Keypad is required. Refer to the Installation Procedure for the Numeric Keypad when installing the Numeric Keypad.
- When installing this equipment, be sure to install it by referring to "Table of Options Combination"

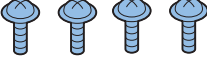


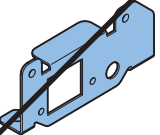
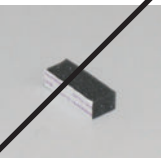

Table of Options Combination

	Copy Card Reader	Serial Interface Kit	Copy Control Interface Kit	Voice Operation Kit	Utility Tray
Voice Guidance Kit	Yes	Yes	Yes	No	No

Yes: Available, No: Unavailable

Checking the Contents

<input type="checkbox"/> [1] Speaker Unit (Upper) X 1 	<input type="checkbox"/> [2] Speaker Unit (Lower) X 1 
<input type="checkbox"/> [3] Voice Guidance Board Unit X 1 	<input type="checkbox"/> [4] Speaker Cable X 1 
<input type="checkbox"/> [5] Cord Guide X 7 Use 4 of them 	<input type="checkbox"/> [6] Ring Core X 2 
<input type="checkbox"/> [7] Screw (Binding ; M4x6) X 1 	<input type="checkbox"/> [8] Screw (Binding ; M4x20) X 2 

<input type="checkbox"/> [9] Screw (TP ; M3x6) X 4 Use 3 of them 	<input type="checkbox"/> [10] Screw (Binding ; M4x16) X 2 
<input type="checkbox"/> [11] Screw (Binding ; M3x16) X 1 	<input type="checkbox"/> [12] Voice Guidance Board Support Plate X 1 
<input type="checkbox"/> [13] Cable Face Seal X 1 	<input type="checkbox"/> [14] Card Spacer X 1 

<Others>
Including guides

Essential Items to Be Performed Before Installation

- Turn OFF the main power of the host machine, and disconnect the power plug from the outlet.

⚠ WARNING:

- If performing work without disconnecting the power plug of the host machine, it may cause electrical shock.
- If disconnecting the power plug without turning OFF the main power, it may cause damage of the machine.

- When turning OFF the main power, follow the below procedure.
 1. Turn OFF the main power switch of the host machine.
 2. The display in the Control Panel and the lamp of the main power are turned off.

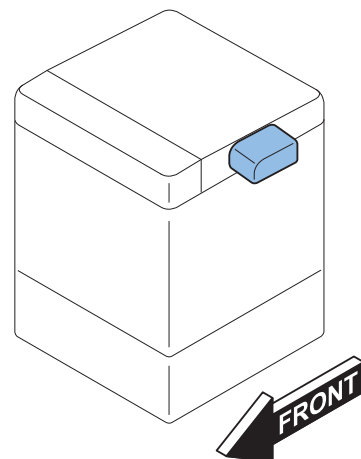
Points to Note When Turning ON/OFF the Main Power

The following message is displayed.

1. When a message prompting to turn OFF and then ON the main power appears, turn OFF and then ON the main power switch.
2. If a message prompting the user to update the version appears, press [Update] to automatically update the version of this equipment.

If [Skip] is selected, a message prompting the user to update the version will appear every time the host machine is started. In the service mode (Lv. 2) shown below, it is possible to set not to display the message.
COPIER > OPTION > FNC-SW > VER-CHNG

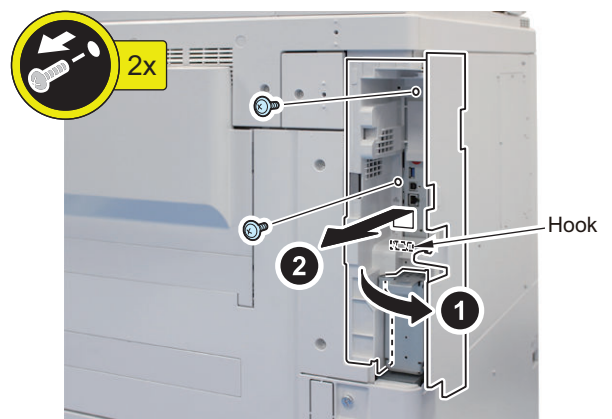
Installation Outline Drawing



Installation Procedure

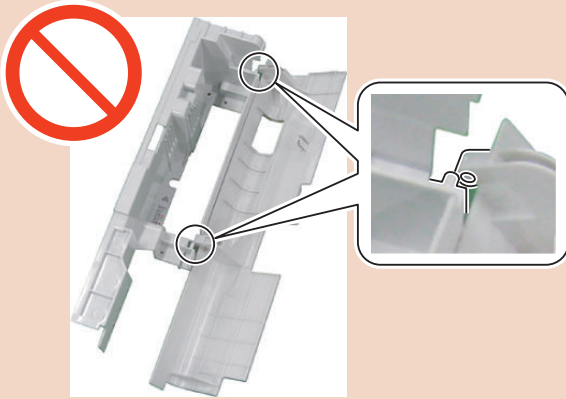
1. Open the Right Rear Cover 1, and remove the Side Cover.

- 2 Screws
- 1 Hook



CAUTION:

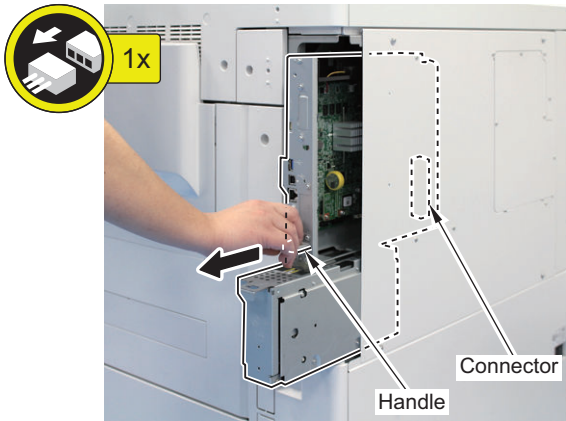
Be careful not to let the 2 bosses of the Side Cover come off from the 2 mounting holes of the Right Rear Cover 1.



□

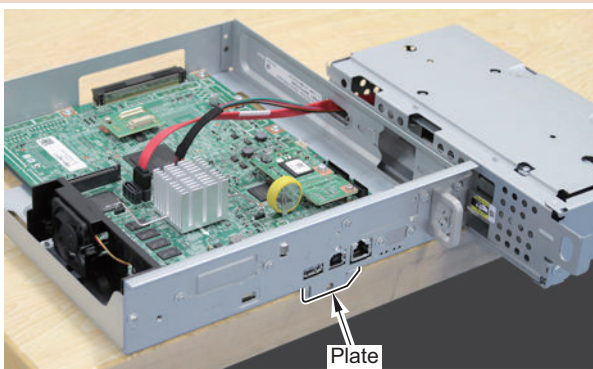
2. Hold the handle to remove the Main Controller.

- 1 Connector



CAUTION:

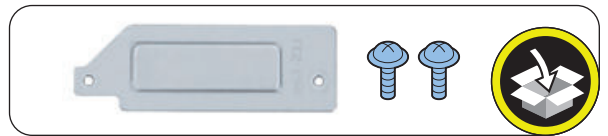
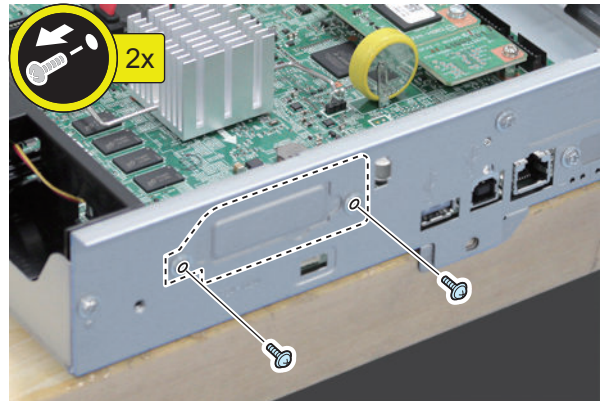
Be sure to place the removed Main Controller PCB 1 flatly. Reason: Due to the protruded plate, the PCB may be deformed if work is performed while it is placed at an angle.



□

3. Remove the Face Plate (The removed Face Plate and screws will not be used.)

- 2 screws

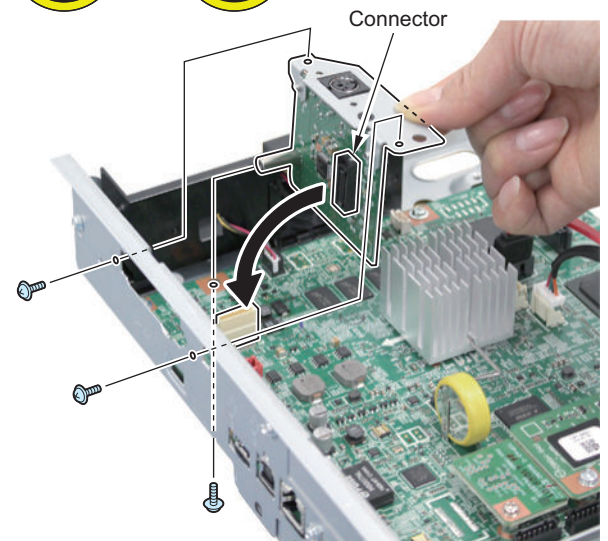
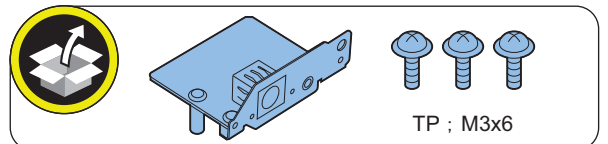


□

4. Install the Voice Guidance Board Unit to the Main Controller PCB 1.

- 1 Connector
- 3 Screws (TP; M3x6)

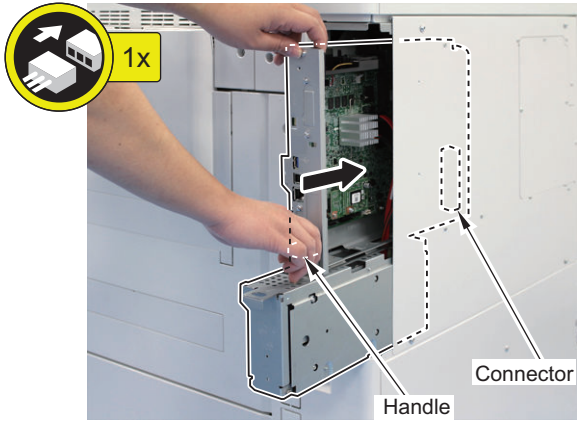
NOTE:
Check that the connector is connected properly.





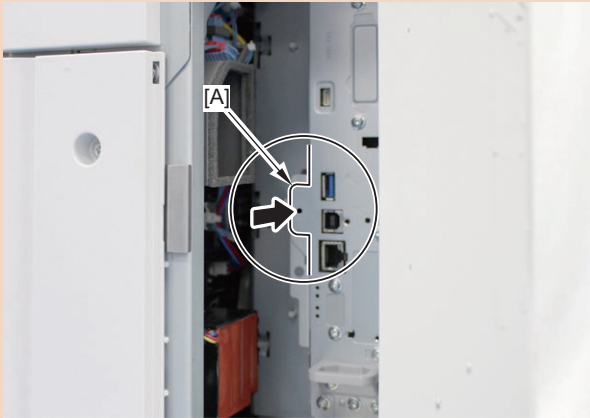
5. Insert the Main Controller PCB 1 until it stops.

- 1 Connector



CAUTION:

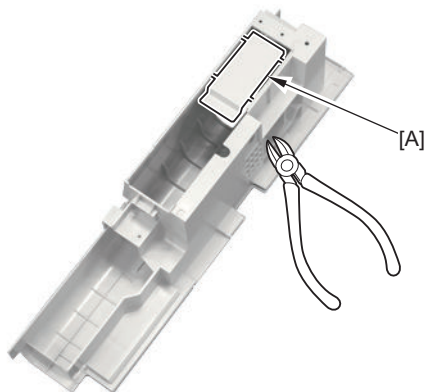
Be sure to push [A] part hard to install it, otherwise the connector may not be connected.



6. Cut off [A] part of the Side Cover with nippers.

NOTE:

When cutting off the part, be sure not to make burrs.

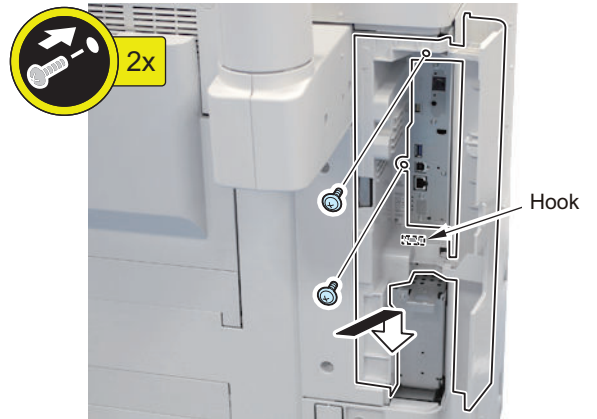
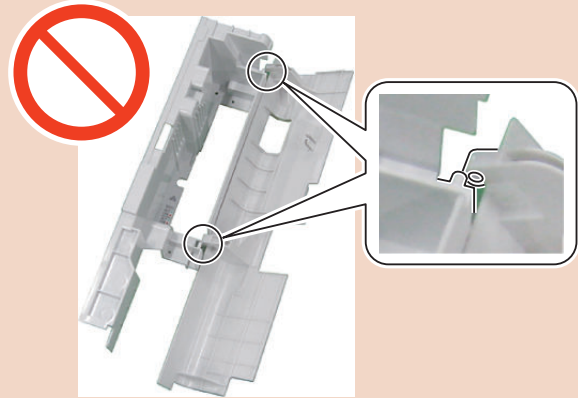


7. Install the Side Cover.

- 1 Hook
- 2 Screws

CAUTION:

Be careful not to let the 2 bosses of the Side Cover come off from the 2 mounting holes of the Right Rear Cover 1.

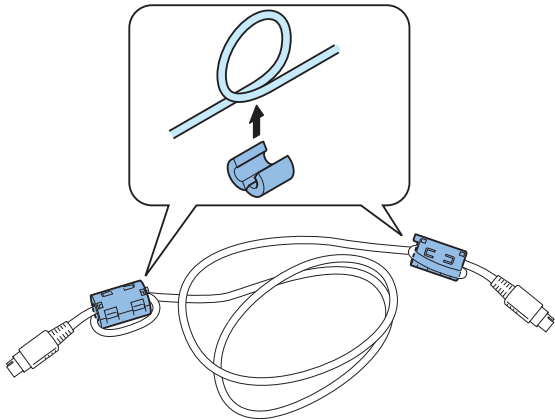
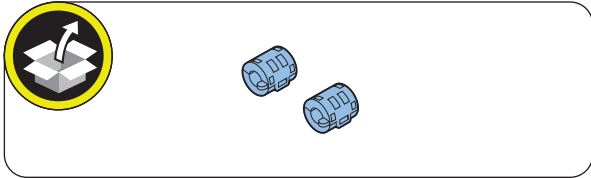




8. Attach the 2 Ring Cores to both ends of the Speaker Cable.

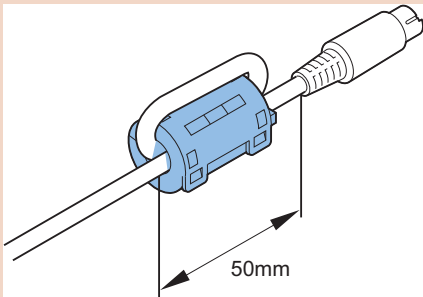
NOTE:

< In the Case of Upright Control Panel>
 <In the Case of Upright Control Panel> When installing the Card Reader at the same time, be sure to install a Ring Core only to one end of the Speaker Cable.

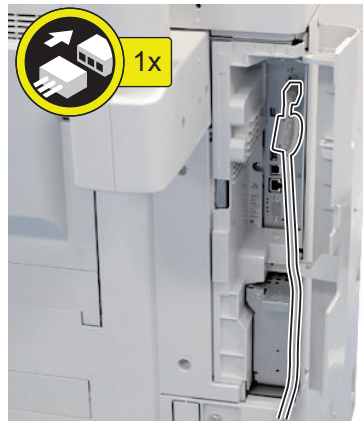


CAUTION:

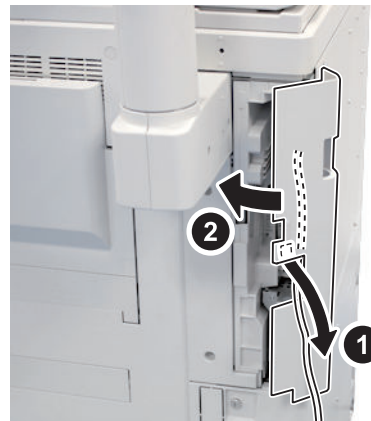
Be sure to attach the Ring Cores within 50mm from the end of the Speaker Cable.



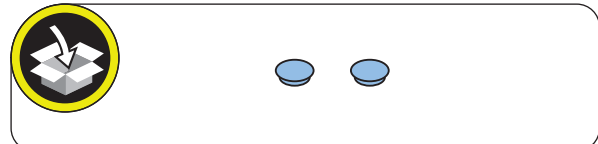
9. Connect the Speaker Cable to the Voice Guidance Board Unit.



10. Retrieve the Speaker Cable from the position shown in the figure, and close the Right Rear Cover 1.



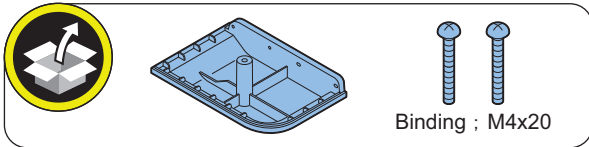
11. Remove the 2 Rubber Caps from the Right Upper Cover. (The removed Rubber Caps will not be used.)





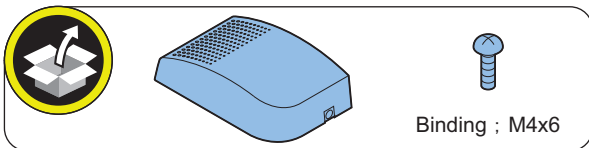
12. Install the Speaker Unit (Lower).

- 2 Screws (Binding; M4x20)



13. Install the Speaker Unit (Upper).

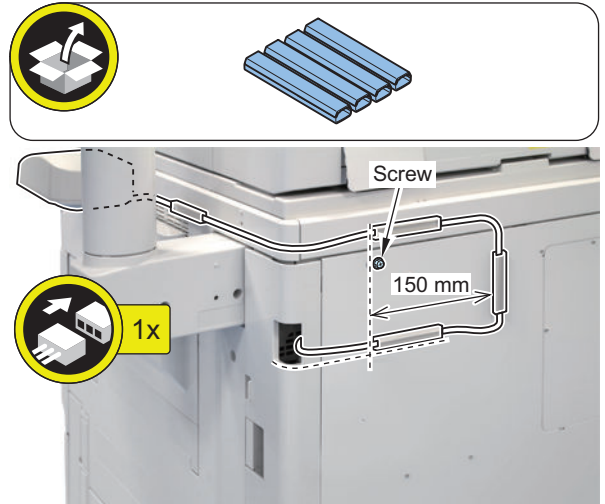
- 1 Screw (Binding; M4x6)



14. Connect the Speaker Cable to the Speaker Unit.

15. Remove the 4 covers from the Cord Guides, and affix them as shown in the figure.

16. Pass the Speaker Cable through the Cord Guides, and fit the 4 covers on the Cord Guides.

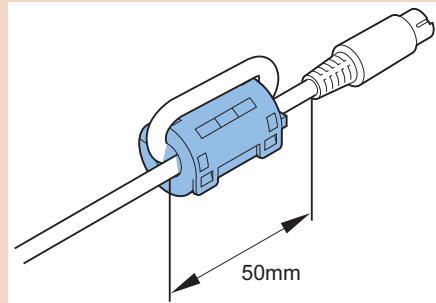


NOTE:
When using together with the Copy Card Reader

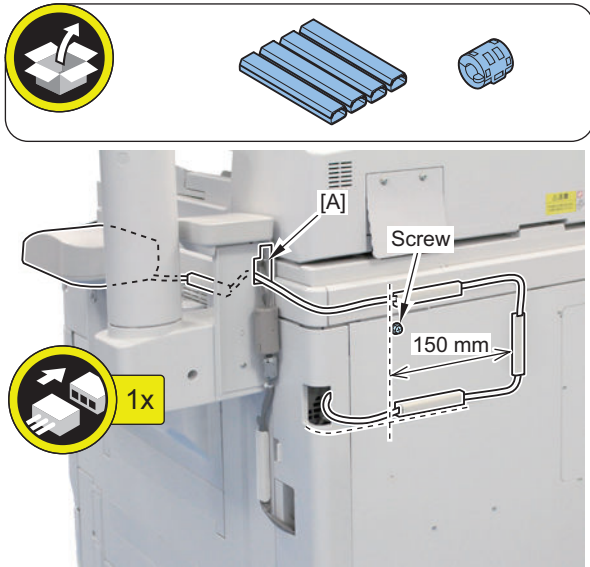
< In the Case of Upright Control Panel >

1. Pass the Speaker Cable through the [A] part, install the Ring Core to the cable, and then connect the cable to the Speaker Unit.

CAUTION:
Be sure to attach the Ring Cores within 50mm from the end of the Speaker Cable.

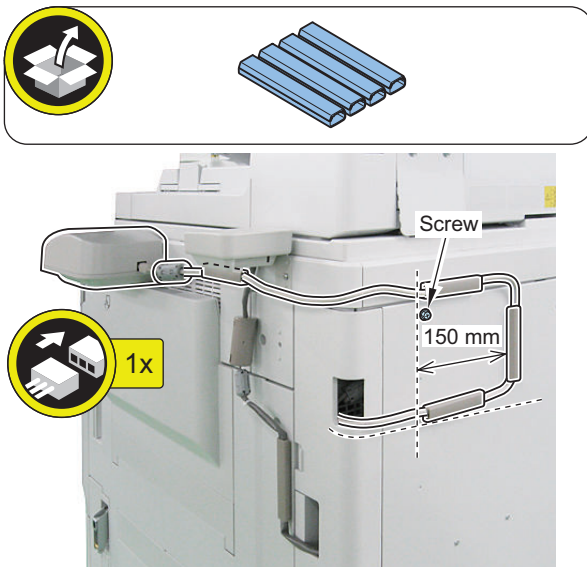


2. Remove the 4 covers from the Cord Guides, and affix them as shown in the figure.
3. Pass the Speaker Cable through the Cord Guides, and fit the 4 covers on the Cord Guides.



< In the Case of Flat Control Panel >

1. Connect the Speaker Cable to the Speaker Unit.
2. Remove the 4 covers from the Cord Guides, and affix them as shown in the figure.
3. Pass the Speaker Cable through the Cord Guides, and fit the 4 covers on the Cord Guides.



3. Select [Settings/Registration] > [Preferences] > [Accessibility] > [Voice Navigation Settings] > [Use Voice Navigation], and check that the setting is [ON].
4. Select [Settings/Registration] > [Preferences] > [Accessibility] > [Voice Navigation Settings] > [Voice Guide from Speakers], and check that the setting is ON.

Operation Check

NOTE:

Perform the following check from the Voice Recognition button on the numeric keypad.

■ When Using



1. Press the Voice Guidance Start button.
2. Once the indication on the screen is framed in red, the "Voice Guidance Kit" becomes enabled.

■ When Stopping to Use



1. Press the Voice Guidance Start button.

Checking after Installation

NOTE:

When changing the settings upon user's request, it is required to log in as a system manager in accordance with instructions from the user administrator.



1. Connect the power plug of the host machine to the power outlet.
2. Turn the main power switch ON.

HDD-related Option

Pre-checks

Points to Note at Installation

CAUTION:

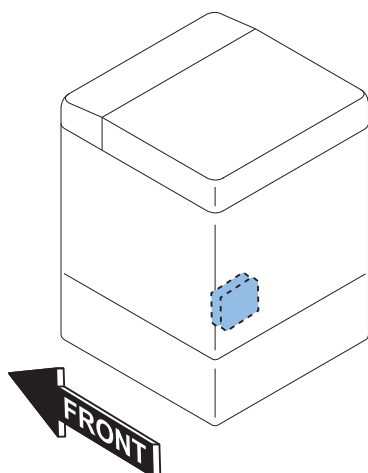
- For TYPE2 to TYPE3, be sure to perform the procedure of each TYPE after performing "Removing the HDD Box Unit" on page 2133.
- When using the mirroring function, be sure to install 2 HDDs of the same capacity.
- The HDD needs to be initialized after replacing the large capacity HDD.
- When replacing a HDD that contains user information with a high-capacity HDD (which is not an initial installation), backup and export of HDD data are necessary. For details, refer to "Backup Data" in the Service Manual.

When installing the HDD-related options (the following 3 products), refer to pages described below.

- 2.5inch/250GB HDD-N1
- 2.5inch/1TB HDD-P1
- HDD Mirroring Kit-J1

Title	Combination of Product
TYPE-1	"[TYPE-1] Option HDD (1TB)" on page 2136
TYPE-2	"Removing the HDD Box Unit" on page 2133 + "[TYPE-2] Standard HDD + Option HDD (250GB) + HDD Mirroring Kit" on page 2139
TYPE-3	"Removing the HDD Box Unit" on page 2133 + "[TYPE-3] 2 Option HDDs (1TB) + HDD Mirroring Kit" on page 2145

Installation Outline Drawing



Essential Items to Be Performed Before Installation

- Turn OFF the main power of the host machine, and disconnect the power plug from the outlet.

WARNING:

- If performing work without disconnecting the power plug of the host machine, it may cause electrical shock.
- If disconnecting the power plug without turning OFF the main power, it may cause damage of the machine.

- When turning OFF the main power, follow the below procedure.
 1. Turn OFF the main power switch of the host machine.
 2. The display in the Control Panel and the lamp of the main power are turned off.

Points to Note When Turning ON/OFF the Main Power

The following message is displayed.

1. When a message prompting to turn OFF and then ON the main power appears, turn OFF and then ON the main power switch.
2. If a message prompting the user to update the version appears, press [Update] to automatically update the version of this equipment.

If [Skip] is selected, a message prompting the user to update the version will appear every time the host machine is started. In the service mode (Lv. 2) shown below, it is possible to set not to display the message. COPIER > OPTION > FNC-SW > VER-CHNG

Removing the HDD Box Unit

CAUTION:

- For [TYPE-1 Option HDD (1TB)], this procedure is not necessary. For other TYPEs, be sure to proceed to each installation procedure after performing this procedure.
- The removed screws will be used again in the installation procedure of each TYPE.

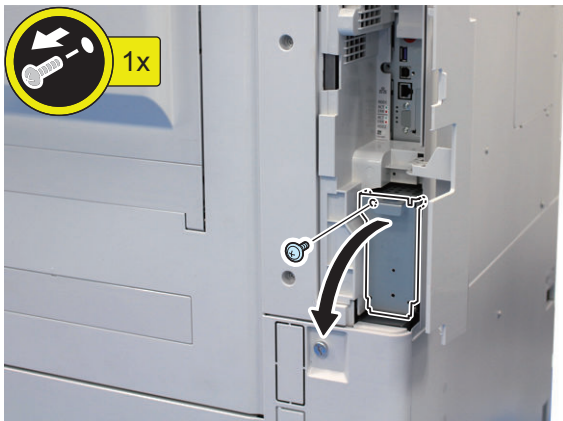


1. Open the Right Rear Cover 1.



2. Open the HDD Lid.

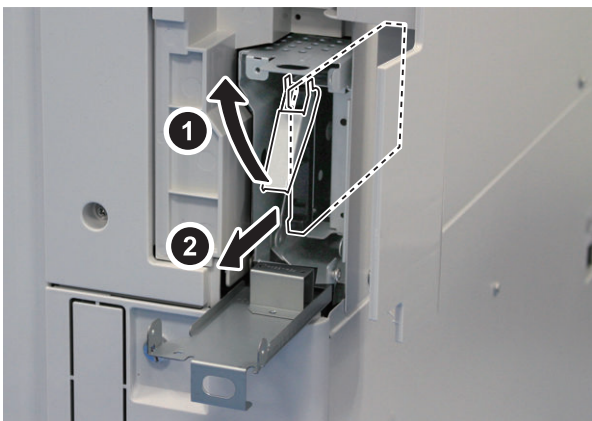
- 1 Screw



3. Remove the HDD.

NOTE:

When replacing with the Option HDD (1TB), the removed HDD will not be used.



4. Close the HDD Lid.

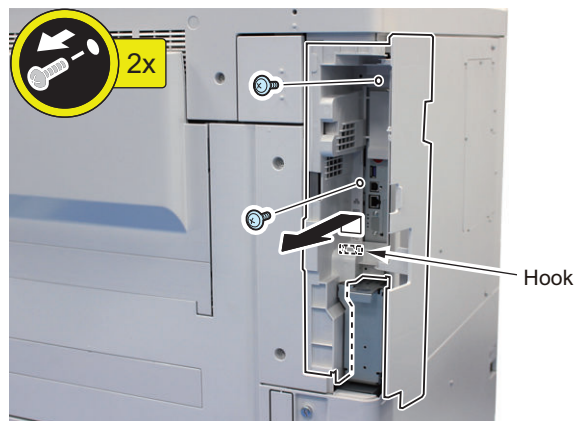
NOTE:

Do not tighten the screw here.



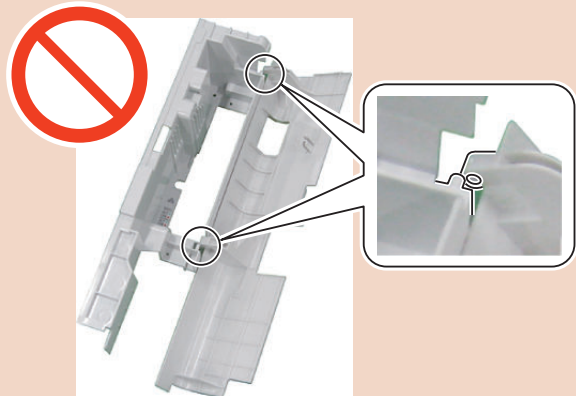
5. Remove the Side Cover.

- 2 Screws
- 1 Hook



CAUTION:

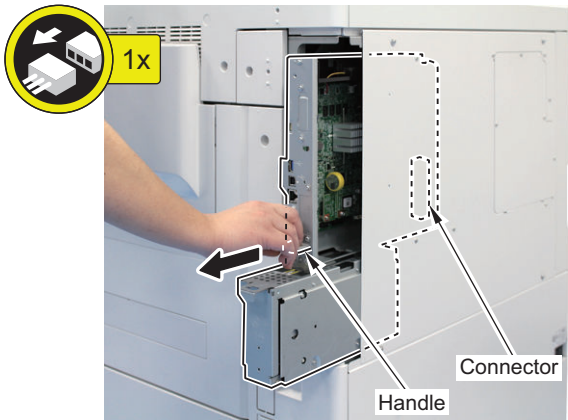
Be careful not to let the 2 bosses of the Side Cover come off from the 2 mounting holes of the Right Rear Cover 1.





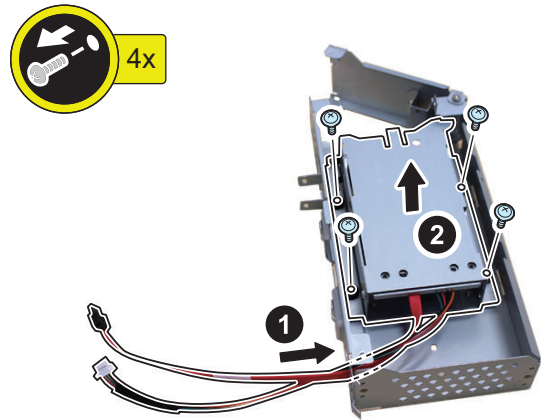
6. Hold the handle, and remove the Main Controller 1.

- 1 Connector



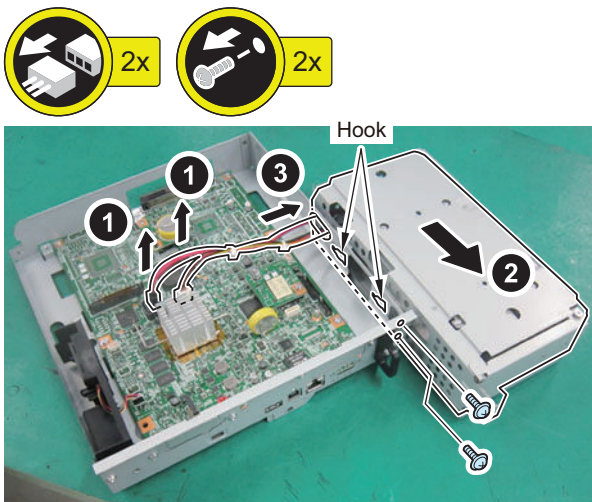
9. Remove the HDD Unit.

- 4 Screws



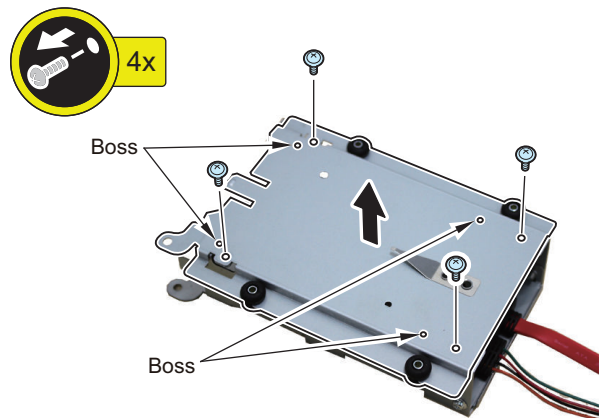
7. Remove the HDD Box Unit.

- 2 Connectors
- 2 Screws
- 2 Hooks



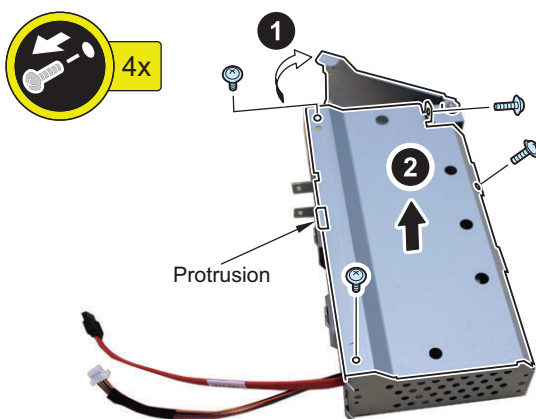
10. Remove the HDD Side Cover.

- 4 Screws
- 4 Bosses



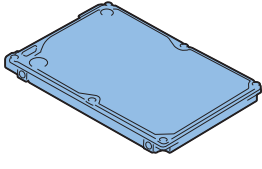
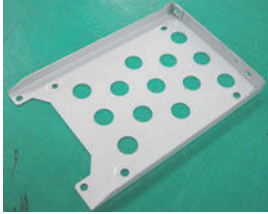


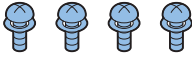

8. Open the HDD Lid, and remove the HDD Outside Cover.

- 4 Screws
- 1 Protrusion



[TYPE-1] Option HDD (1TB)

■ Checking the Contents

<input type="checkbox"/> [1] HDD X 1 	<input type="checkbox"/> [2] HDD Case X 1 
<input type="checkbox"/> [3] HDD Holder Hinge X 1 	<input type="checkbox"/> [4] HDD Case Hinge Base X 1 
<input type="checkbox"/> [5] Screw (Sems ; M3x4) X 4 	<input type="checkbox"/> [6] Screw (P Tightening ; M3x8) X 2 

■ Essential Items to Be Performed Before Installation

- Turn OFF the main power of the host machine, and disconnect the power plug from the outlet.

WARNING:

- If performing work without disconnecting the power plug of the host machine, it may cause electrical shock.
- If disconnecting the power plug without turning OFF the main power, it may cause damage of the machine.

- When turning OFF the main power, follow the below procedure.
 1. Turn OFF the main power switch of the host machine.
 2. The display in the Control Panel and the lamp of the main power are turned off.

■ Points to Note When Turning ON/OFF the Main Power

The following message is displayed.

1. When a message prompting to turn OFF and then ON the main power appears, turn OFF and then ON the main power switch.
2. If a message prompting the user to update the version appears, press [Update] to automatically update the version of this equipment.
If [Skip] is selected, a message prompting the user to update the version will appear every time the host machine is started. In the service mode (Lv. 2) shown below, it is possible to set not to display the message. COPIER > OPTION > FNC-SW > VER-CHNG

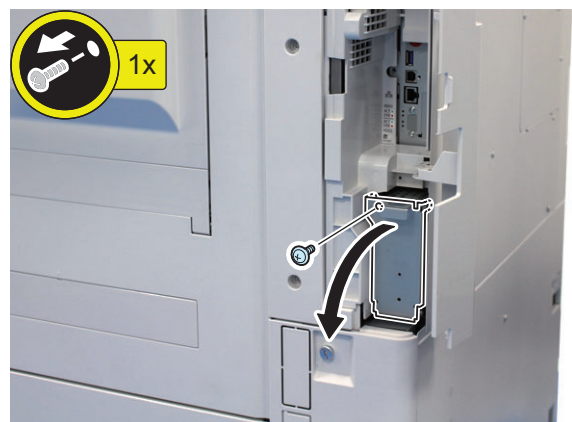
■ Installation Procedure

1. Open the Right Rear Cover 1.



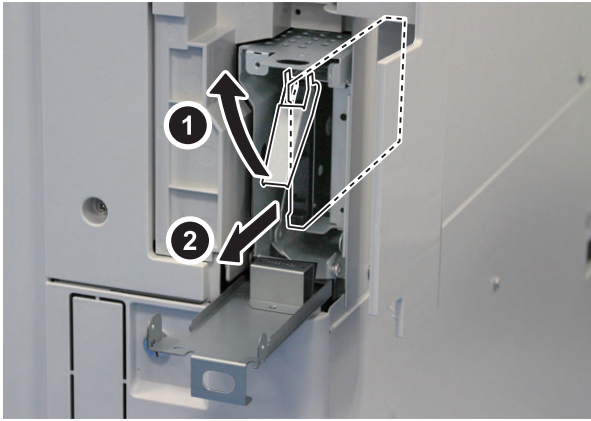
2. Open the HDD Lid.

- 1 Screw (will be used in step 7)



□

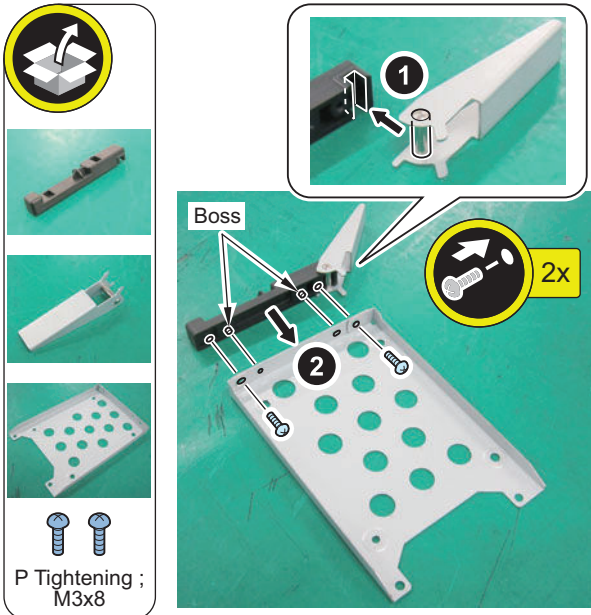
3. Remove the HDD. (The removed HDD will not be used.)



□

4. Fit the Hinge Pin of the HDD Holder Hinge with the groove of the HDD Case Hinge Base to install it to the HDD Case.

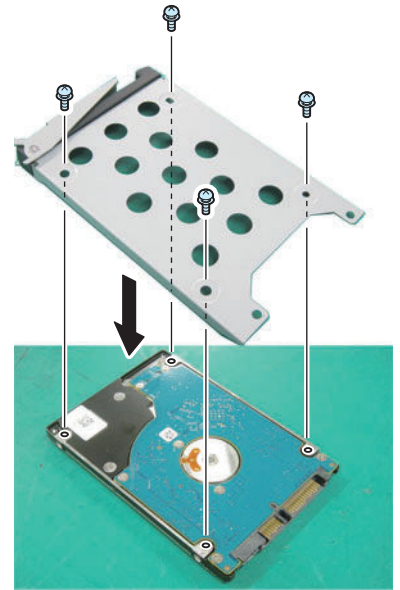
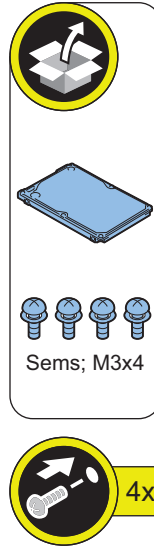
- 2 Bosses
- 2 Screws (P Tightening; M3x8)



□

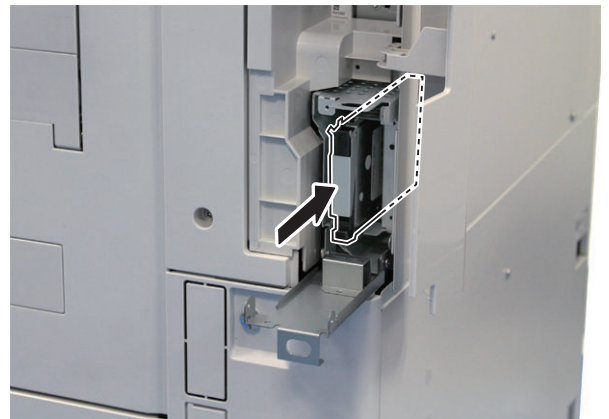
5. Install the assembled HDD Case to the HDD.

- 4 Screws (Sems; M3x4)



□

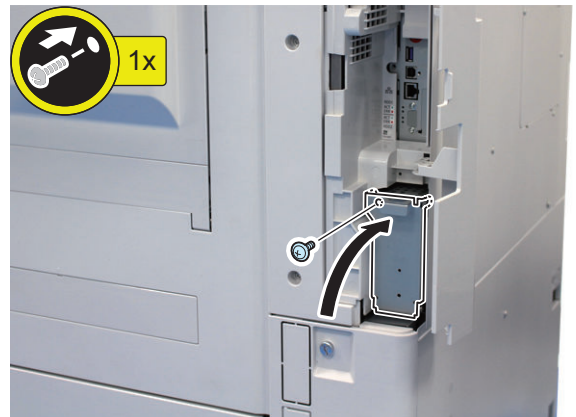
6. Install the Option HDD to the host machine.



□

7. Close the HDD Lid.

- 1 Screw (screws removed in step 2)





8. Close the Right Rear Cover 1.



■ HDD Initialization Procedure

1. Requirements

1. PC
Service Support Tool in the version that supports this host machine must be installed.
2. Cross Ethernet Cable (when SST is used)

2. Preparing for the Installation of the System Software of Host machine

1. If both PC and the machine are on, turn them off.
2. Connect the PC and the host machine using an Cross Ethernet cable. (when SST is used)
3. Turn on the PC.

3. Registering the system software

1. Insert the latest System Software into the PC using the SST.
2. Start the SST.
3. Click 'Register Firmware'.
4. Select the drive where the system software has been inserted, and click the [SEARCH] button.
5. Click the [REGISTER] button.
6. Click [OK].

4. Initializing HDD

<In case of SST>

1. Start the host machine with download mode in safe mode.
2. Start the SST.
3. Select the model. Then, select [Single] and click [Start].
4. Click [Format HDD].
5. Select [All], and click [Start].
6. Click [Execute Format].
7. The Format is executed.
8. Select [Shutdown/Restart], and click [Shutdown].
9. Click [OK]
10. The power of the host machine is turned OFF.
11. Terminate the SST.
12. Disconnect the Cross Ethernet Cable from the machine, and connect the user's network cable to the machine.

<In case of USB flash drive>

1. Connect the USB flash drive to the PC.
2. Start up SST, and click the USB icon displayed in the target selection screen.
3. Select the drive, the model series, and the version to be written to the USB flash drive, and click [Confirm].
4. Click [Start], and after the version has been written to the USB flash drive, click [OK] and then remove the USB flash drive.
5. Terminate the SST.
6. Connect the USB flash drive to the host machine, and start the host machine with download mode in safe mode.
7. When the USB menu is displayed, press keys on the Control Panel in the order shown below.
 - [4]: Clear/Format
 - [1]: Disk Format
 - [0]: OK
 - Press any keys.
 - [C]: Return to menu
 - [Reset] : Start shutdown sequence
 - [0]: OK (The power of the host machine is turned OFF automatically.)
8. Remove the USB flash drive.
9. Turn ON the main power switch.

■ Executing Auto Gradation Adjustment

When the high-capacity HDD is installed, the machine initializes its HDD, resetting the data used for auto gradation correction.

Therefore, execute full adjustment of auto gradation adjustment after installing the high-capacity HDD to enable proper images to be output.

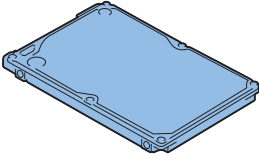
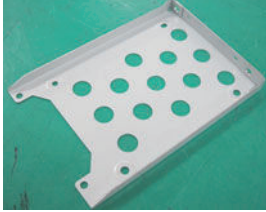


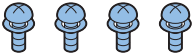

■ Execution of the Minimum Installation Work

Be sure to execute the minimum installation work in accordance with the Setup Guide because HDD is initialized when the high-capacity HDD is installed.

[TYPE-2] Standard HDD + Option HDD (250GB) + HDD Mirroring Kit

■ Checking the Contents

<Option HDD (250 GB)>

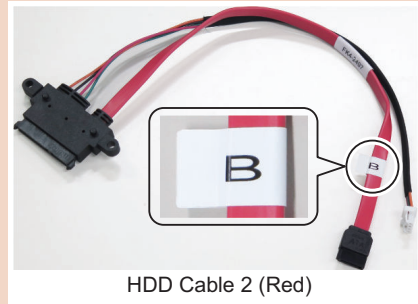
<input type="checkbox"/> [1] HDD X 1 	<input type="checkbox"/> [2] HDD Case X 1 
<input type="checkbox"/> [3] HDD Holder Hinge X 1 	<input type="checkbox"/> [4] HDD Case Hinge Base X 1 
<input type="checkbox"/> [5] Screw (Sems ; M3x4) X 4 	<input type="checkbox"/> [6] Screw (P Tightening ; M3x8) X 2 





<HDD Mirroring Kit>

CAUTION:

Although the red cable shown below may sometimes be supplied in lieu of the HDD Cable 2 (Blue), the procedure for connecting the red cable is the same as that for the blue cable.

When connecting the cable to the Controller PCB, make sure to first confirm that the sticker [B] is attached to the cable and then connect the cable to the Controller PCB.



<input type="checkbox"/> [1] HDD Cable 2 (Blue) X 1 	<input type="checkbox"/> [2] HDD Connector Support Plate X 1 
<input type="checkbox"/> [3] Screw (TP; M3x6) X 2 	<input type="checkbox"/> [4] Screw (TP; M3x8 Black) X 2 

<Others>

- Guides are included

■ Essential Items to Be Performed Before Installation

- Turn OFF the main power of the host machine, and disconnect the power plug from the outlet.

⚠ WARNING:

- If performing work without disconnecting the power plug of the host machine, it may cause electrical shock.
- If disconnecting the power plug without turning OFF the main power, it may cause damage of the machine.

- When turning OFF the main power, follow the below procedure.
 1. Turn OFF the main power switch of the host machine.
 2. The display in the Control Panel and the lamp of the main power are turned off.

■ Points to Note When Turning ON/OFF the Main Power

The following message is displayed.

1. When a message prompting to turn OFF and then ON the main power appears, turn OFF and then ON the main power switch.
2. If a message prompting the user to update the version appears, press [Update] to automatically update the version of this equipment.

If [Skip] is selected, a message prompting the user to update the version will appear every time the host machine is started. In the service mode (Lv. 2) shown below, it is possible to set not to display the message.
COPIER > OPTION > FNC-SW > VER-CHNG

■ Installation Procedure

CAUTION:

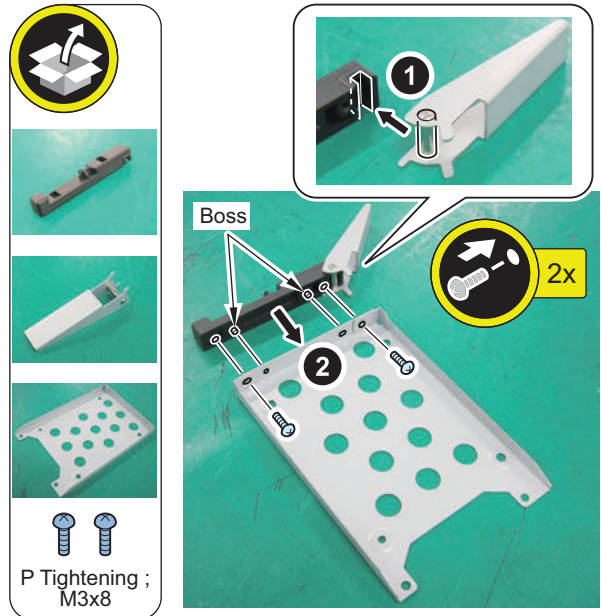
Be sure to perform "[Removing the HDD Box Unit](#)" on page 2133" before performing the following work.

● Assembling and Installing the Option



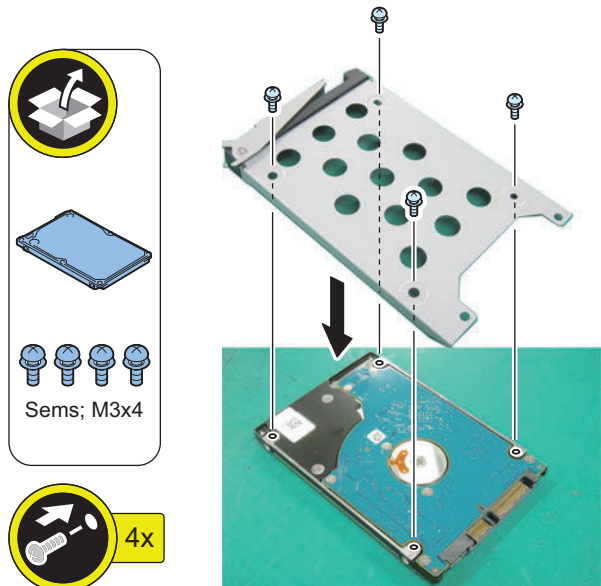
1. Fit the Hinge Pin of the HDD Holder Hinge with the groove of the HDD Case Hinge Base to install it to the HDD Case.

- 2 Bosses
- 2 Screws (P Tightening; M3x8)



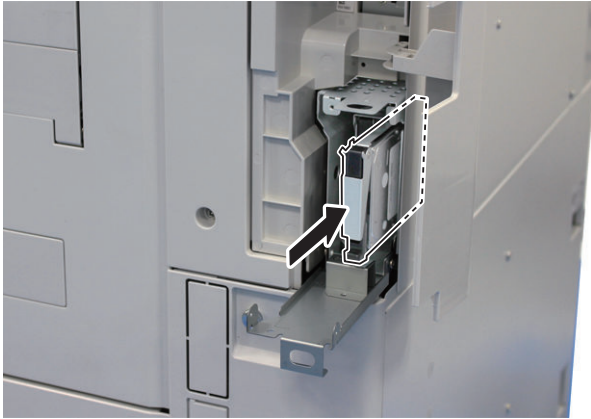
2. Install the assembled HDD Case to the HDD.

- 4 Screws (Sems; M3x4)



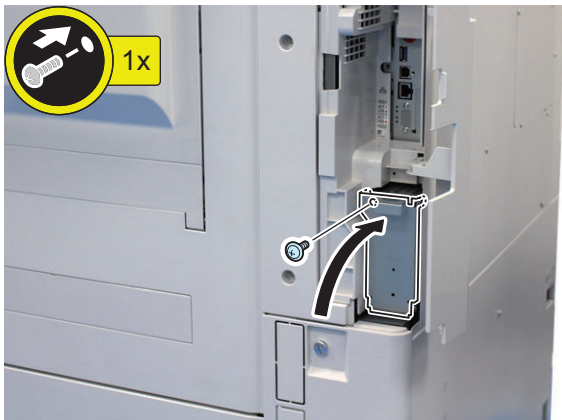


3. Install the Option HDD to the Slot 2 (Right).



4. Close the HDD Lid.

- 1 Screw (Use the removed screws)



5. Close the Right Rear Cover 1.

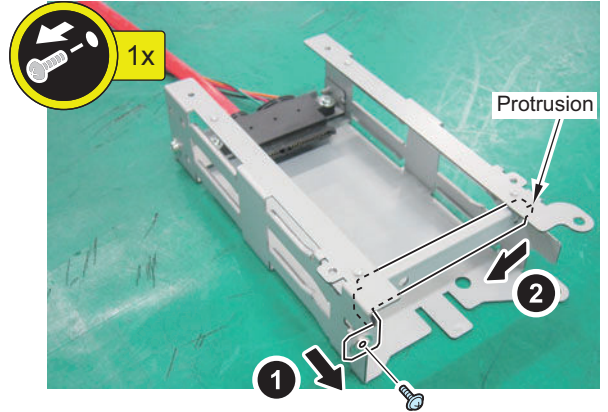


■ Installing the HDD Mirroring Kit



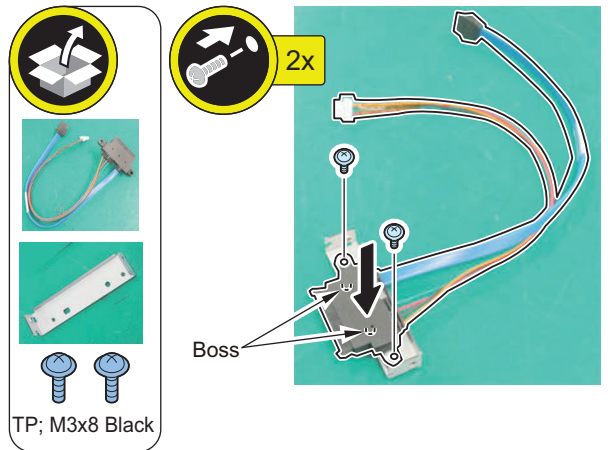
1. Remove the HDD Wrong Insertion Prevention Plate. (The removed parts will not be used.)

- 1 Screw
- 1 Protrusion



2. Assemble the HDD Cable 2 (Blue or Red) and the HDD Connector Support Plate.

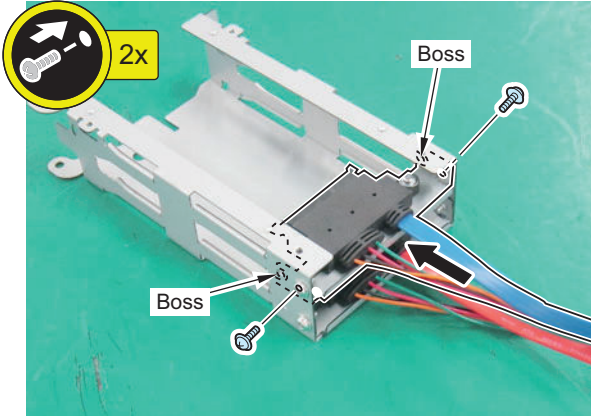
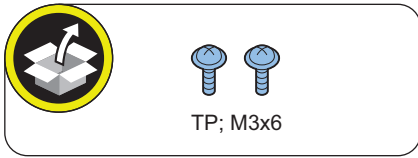
- 2 Bosses
- 2 Screws (TP; M3x8 Black)





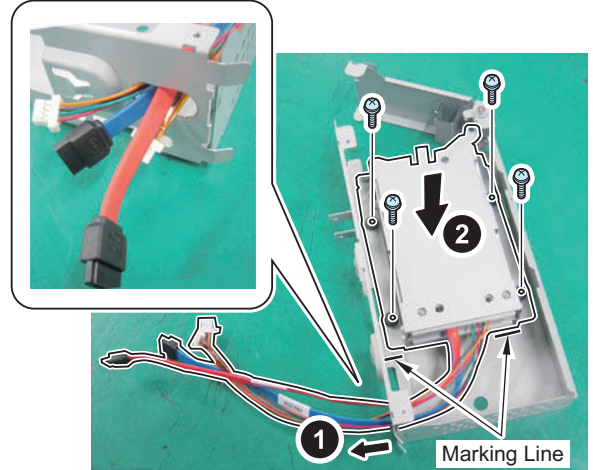
3. Install the assembled HDD Cable 2 Unit to the HDD Unit.

- 2 Bosses
- 2 Screws (TP; M3x6)



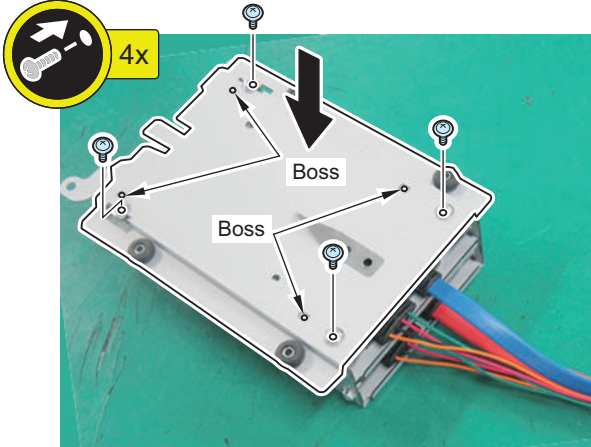
5. Put the 4 cables through the hole, and install the HDD Unit according to the marking lines.

- 4 Screws (Use the removed screws)



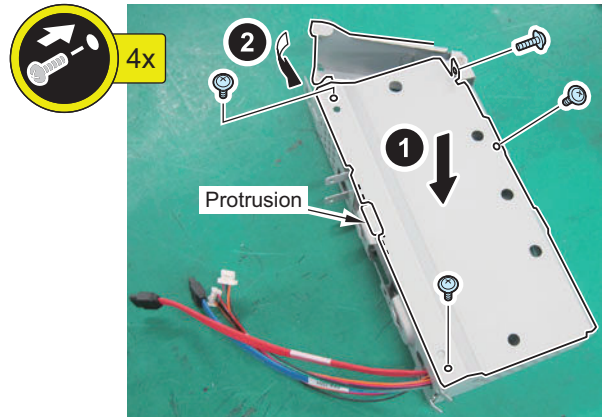
4. Installing the HDD Side Cover.

- 4 Bosses
- 4 Screws (Use the removed screws)



6. Install the HDD Outside Cover, and close the HDD Lid.

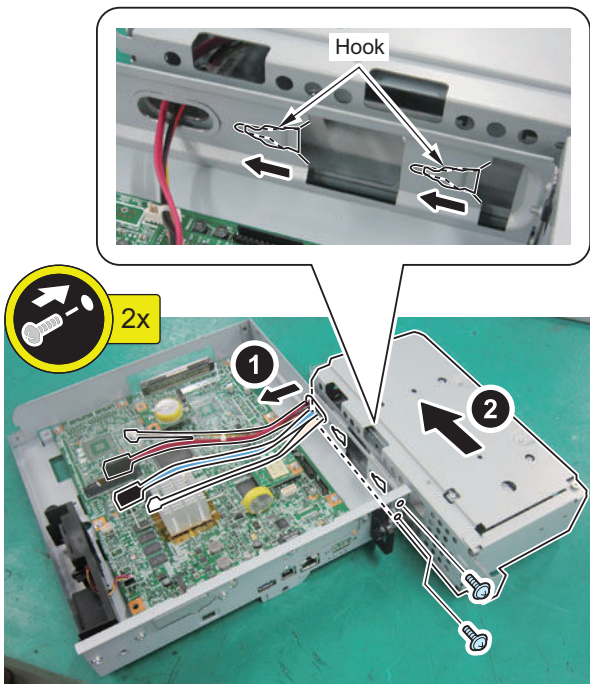
- 1 Protrusion
- 4 Screws (Use the removed screws)





7. Put the 4 cables through the hole, and install the HDD Box Unit.

- 2 Hooks
- 2 Screws (Use the removed screws)



CAUTION:

Be sure to connect the communication cable to the correct port. The HDD error occurs.

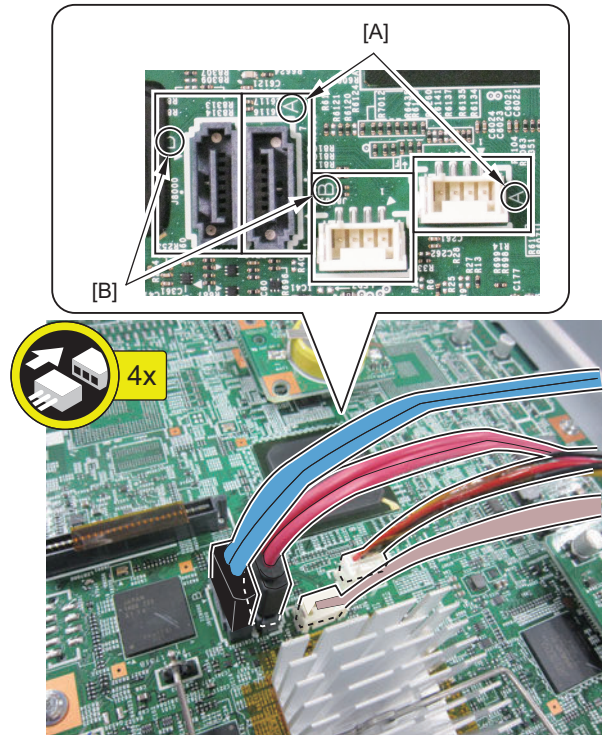
8. Connect the HDD Cable 1 (Red) to [A] on the Controller PCB.

- 2 Connectors

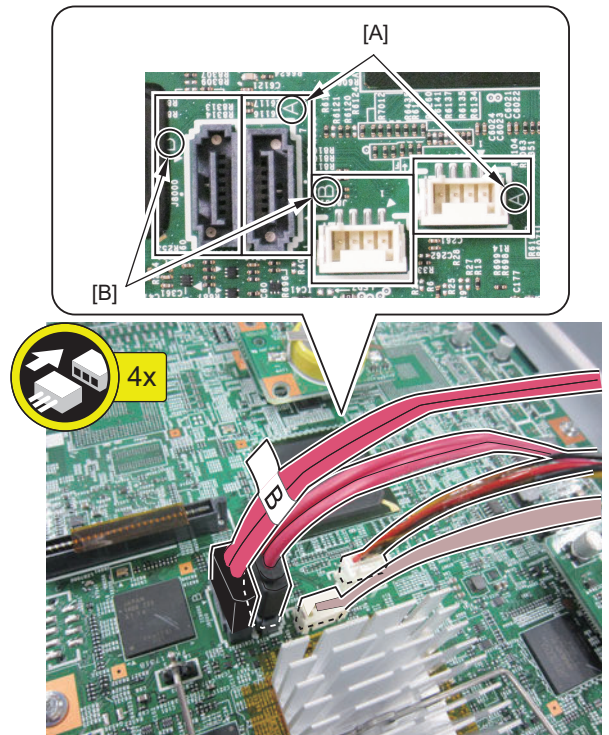
9. Connect the HDD Cable 2 (Blue) or the HDD Cable 2 (Red) with a sticker labeled [B] to [B] on the Controller PCB.

- 2 Connectors

< When using the HDD Cable 2 (Blue) >



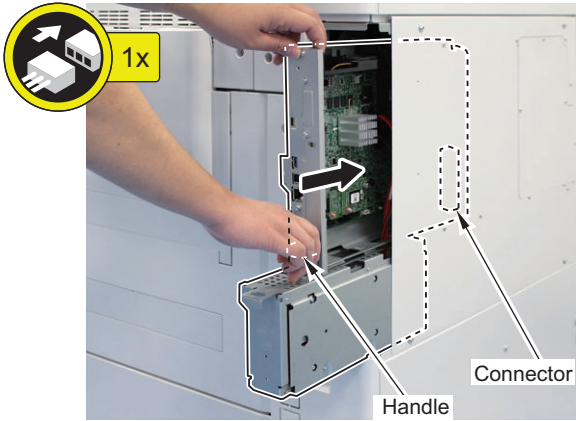
< When using the HDD Cable 2 (Red) >





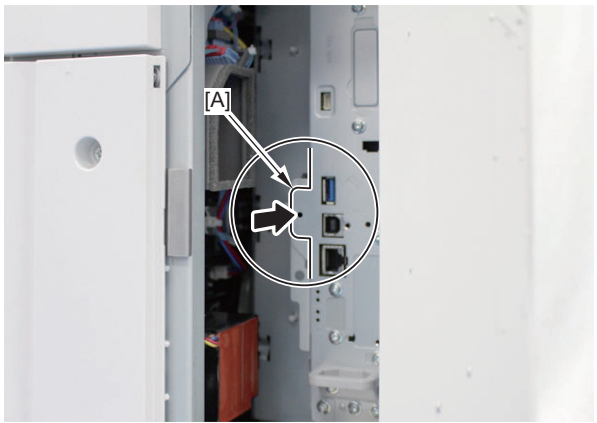
10. Insert the Main Controller PCB 1 until it stops.

- 1 Connector



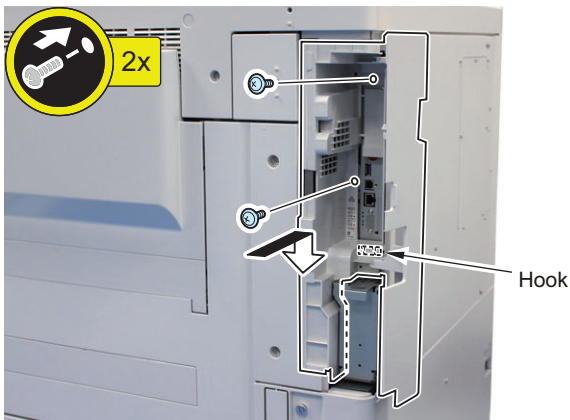
CAUTION:

Be sure to push [A] part hard to install it, otherwise the connector may not be connected properly.

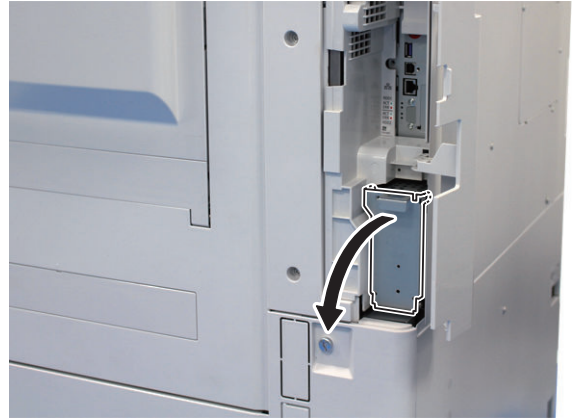


11. Install the Side Cover. Do not close the Right Rear Cover 1 yet here.

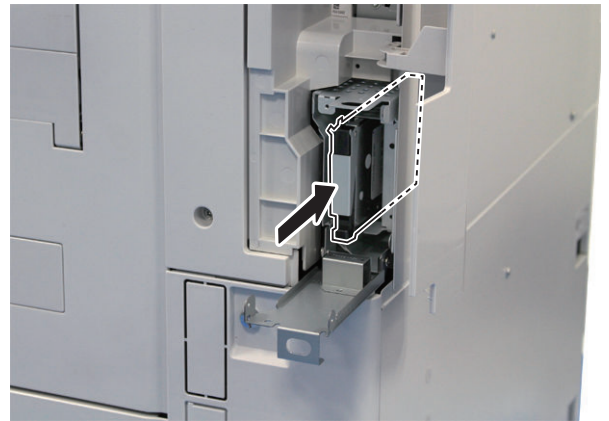
- 1 Hook
- 2 Screws



12. Open the HDD Lid.



13. Return the HDD removed from the host machine to the Slot 1 (Left).



■ Setting the Mirroring



1. Set the setting value for the mirroring to "1" in the following service mode.
COPIER > OPTION > FNC-SW > W/RAID
2. Turn OFF/ON the main power of the host machine to enable the setting value.
3. Make sure that the UI screen is activated correctly.
4. Open the Cover, and make sure that the LED blinks.

NOTE:

Rebuilding starts approximately after 3 minutes after turning OFF and then ON the power.

- HDD 1 (Slot 1): The green LED blinks.
- HDD 2 (Slot 2): The green and red LEDs blink.

CAUTION:

Rebuild process starts after setting "1" for W/RAID. If an error occurs during the rebuild process at the initial installation the hard disk needs to be replaced. (Call service rep.), reexecute the process with the following procedure.

1. Check that the lighting red LED is HDD2.
2. Select "0" for the following service mode.
COPIER > OPTION > FNC-SW > W/RAID
3. To enable the setting value, turn OFF/ON the Main Power Supply Switch of the host machine.
4. Select "1" for the following service mode.
COPIER > OPTION > FNC-SW > W/RAID
5. To enable the setting value, turn OFF/ON the Main Power Supply Switch of the host machine.

The foregoing procedure is limited to the rebuild process at the initial installation.

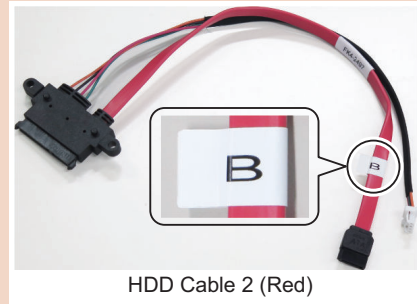
An error during the rebuild process that is executed during operation is not included in the consideration.

<HDD Mirroring Kit>

CAUTION:

Although the red cable shown below may sometimes be supplied in lieu of the HDD Cable 2 (Blue), the procedure for connecting the red cable is the same as that for the blue cable.

When connecting the cable to the Controller PCB, make sure to first confirm that the sticker [B] is attached to the cable and then connect the cable to the Controller PCB.

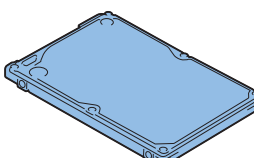
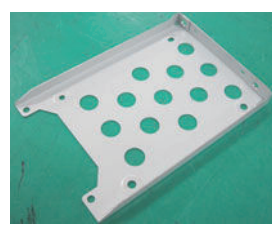


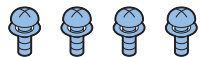







HDD Cable 2 (Red)

**[TYPE-3] 2 Option HDDs (1TB)
+ HDD Mirroring Kit**

■ Checking the Contents

<Option HDD (1TB)>

<input type="checkbox"/> [1] HDD X 1 	<input type="checkbox"/> [2] HDD Case X 1 
<input type="checkbox"/> [3] HDD Holder Hinge X 1 	<input type="checkbox"/> [4] HDD Case Hinge Base X 1 
<input type="checkbox"/> [5] Screw (Sems ; M3x4) X 4 	<input type="checkbox"/> [6] Screw (P Tightening ; M3x8) X 2 

<input type="checkbox"/> [1] HDD Cable 2 (Blue) X 1 	<input type="checkbox"/> [2] HDD Connector Support Plate X 1 
<input type="checkbox"/> [3] Screw (TP; M3x6) X 2 	<input type="checkbox"/> [4] Screw (TP; M3x8 Black) X 2 

<Others>

- Guides are included

■ Essential Items to Be Performed Before Installation

- Turn OFF the main power of the host machine, and disconnect the power plug from the outlet.

⚠ WARNING:

- If performing work without disconnecting the power plug of the host machine, it may cause electrical shock.
- If disconnecting the power plug without turning OFF the main power, it may cause damage of the machine.

- When turning OFF the main power, follow the below procedure.
 1. Turn OFF the main power switch of the host machine.
 2. The display in the Control Panel and the lamp of the main power are turned off.

■ Points to Note When Turning ON/OFF the Main Power

The following message is displayed.

1. When a message prompting to turn OFF and then ON the main power appears, turn OFF and then ON the main power switch.
2. If a message prompting the user to update the version appears, press [Update] to automatically update the version of this equipment.

If [Skip] is selected, a message prompting the user to update the version will appear every time the host machine is started. In the service mode (Lv. 2) shown below, it is possible to set not to display the message.
 COPIER > OPTION > FNC-SW > VER-CHNG

■ Installation Procedure

CAUTION:

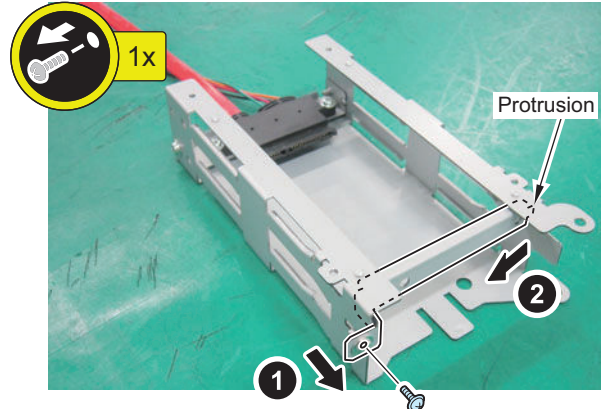
Be sure to perform "[Removing the HDD Box Unit](#)" on [page 2133](#)" before performing the following work.

● Installing the HDD Mirroring Kit



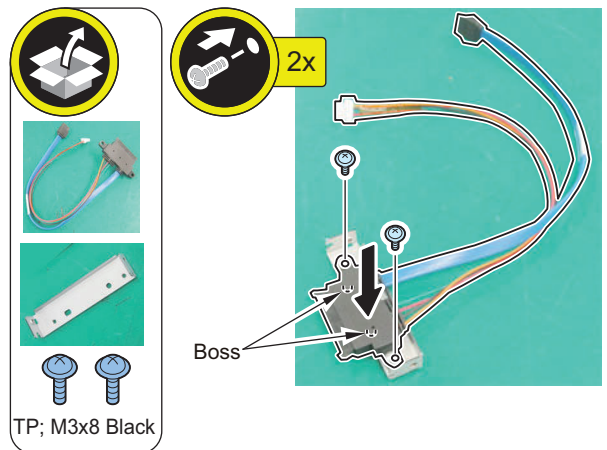
1. Remove the HDD Wrong Insertion Prevention Plate. (The removed parts will not be used.)

- 1 Screw
- 1 Protrusion



2. Assemble the HDD Cable 2 (Blue or Red) and the HDD Connector Support Plate.

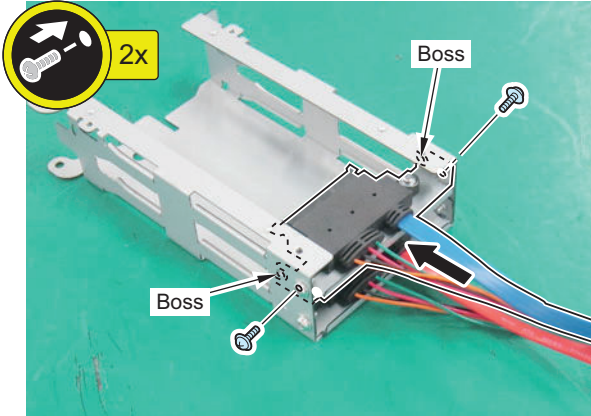
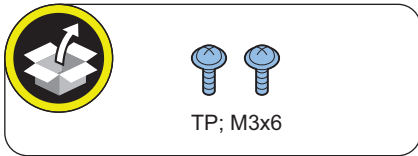
- 2 Bosses
- 2 Screws (TP; M3x8 Black)





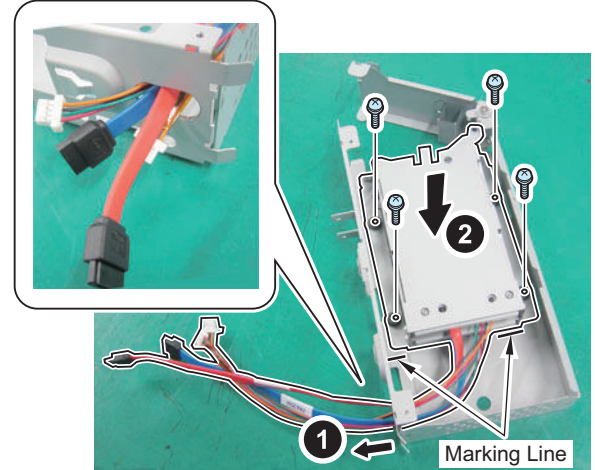
3. Install the assembled HDD Cable 2 Unit to the HDD Unit.

- 2 Bosses
- 2 Screws (TP; M3x6)



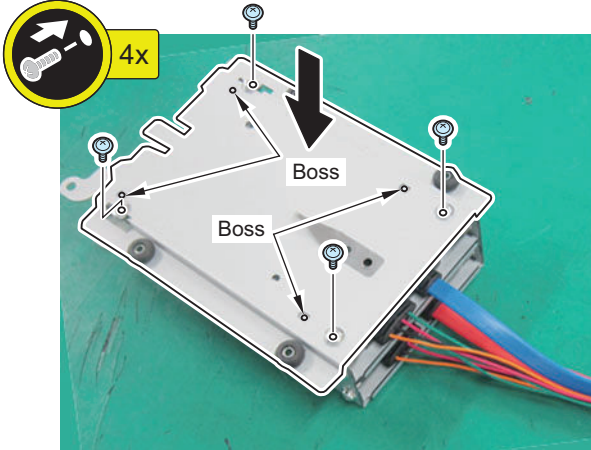
5. Put the 4 cables through the hole, and install the HDD Unit according to the marking lines.

- 4 Screws (Use the removed screws)



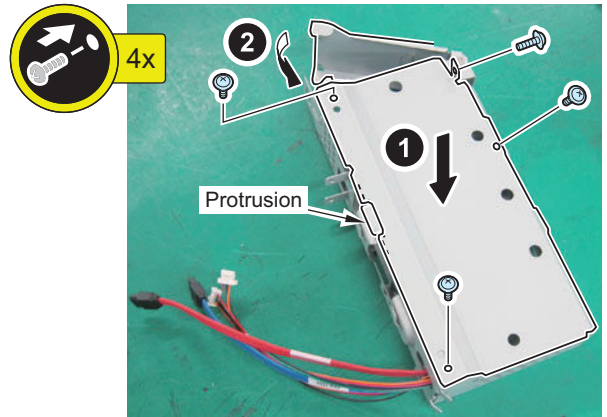
4. Install the HDD Side Cover.

- 4 Bosses
- 4 Screws (Use the removed screws)



6. Install the HDD Outside Cover, and close the HDD Lid.

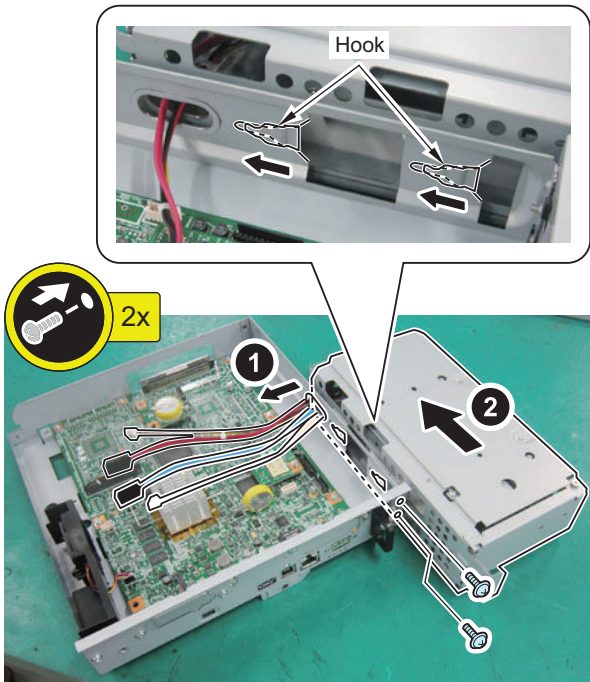
- 1 Protrusion
- 4 Screws (Use the removed screws)





7. Put the 4 cables through the hole, and install the HDD Box Unit.

- 2 Hooks
- 2 Screws (Use the removed screws)



CAUTION:
Be sure to connect the communication cable to the correct port. The HDD error occurs.

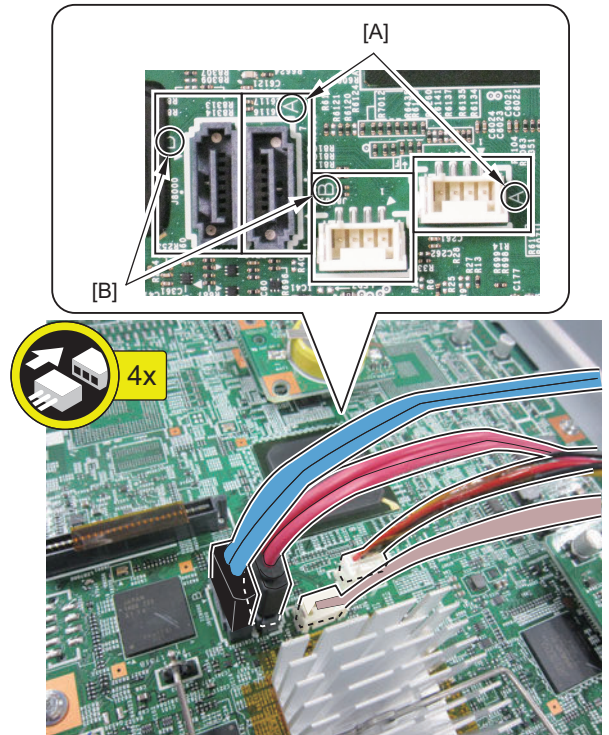
8. Connect the HDD Cable 1 (Red) to [A] on the Controller PCB.

- 2 Connectors

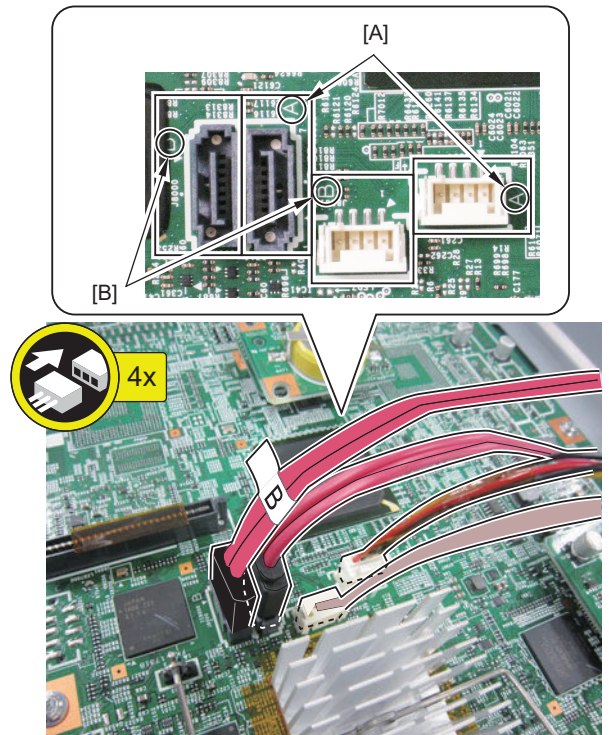
9. Connect the HDD Cable 2 (Blue) or the HDD Cable 2 (Red) with a sticker labeled [B] to [B] on the Controller PCB.

- 2 Connectors

< When using the HDD Cable 2 (Blue) >



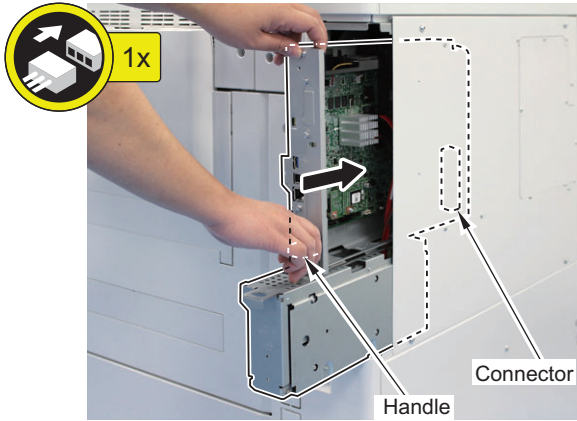
< When using the HDD Cable 2 (Red) >





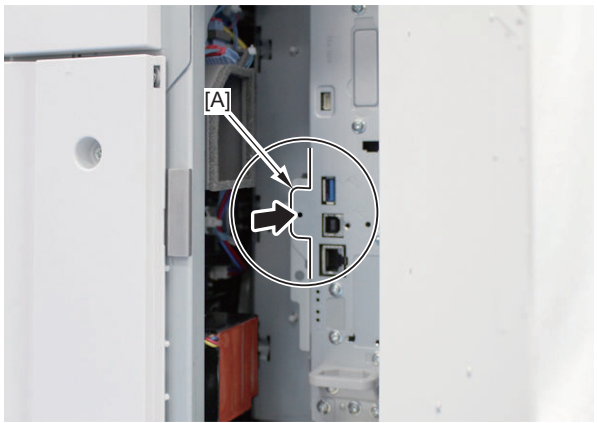
10. Insert the Main Controller PCB 1 until it stops.

- 1 Connector



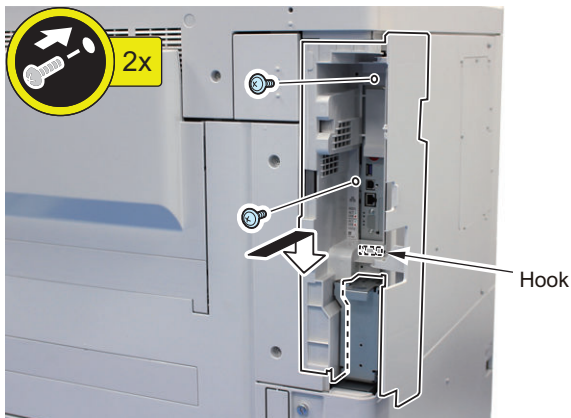
CAUTION:

Be sure to push [A] part hard to install it, otherwise the connector may not be connected properly.



11. Install the Side Cover. Do not close the Right Rear Cover 1 yet here.

- 1 Hook
- 2 Screws



12. Open the HDD Lid.

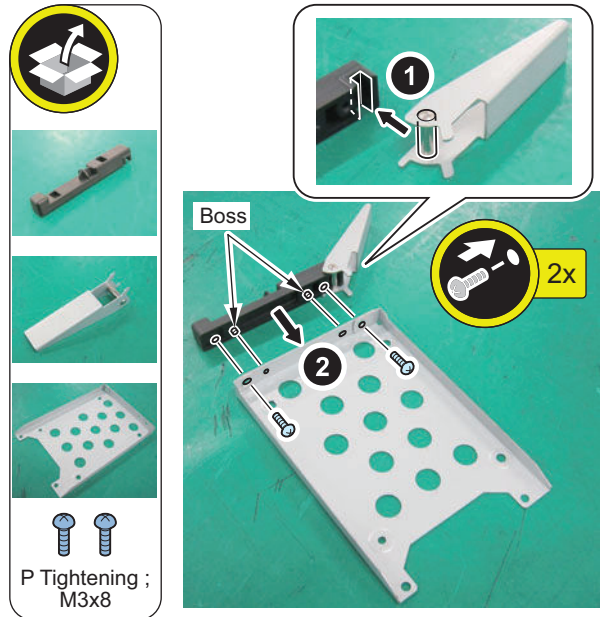


• Assembling and Installing the Option HDD



1. Fit the Hinge Pin of the HDD Holder Hinge with the groove of the HDD Case Hinge Base to install it to the HDD Case.

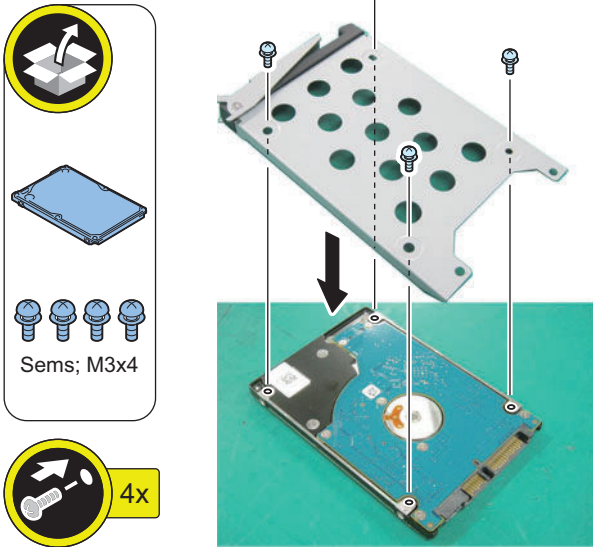
- 2 Bosses
- 2 Screws (P Tightening; M3x8)





2. Install the assembled HDD Case to the HDD.

- 4 Screws (Sems; M3x4)



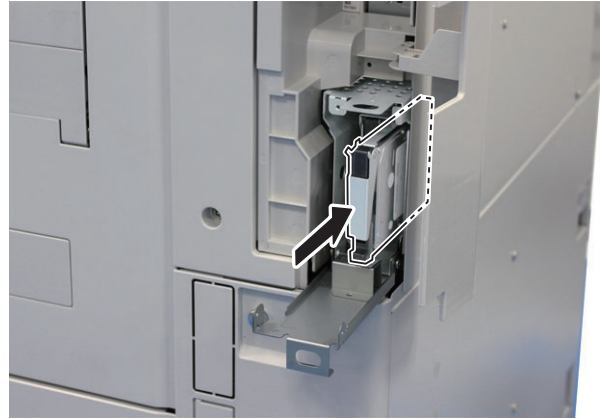
3. Install the First Option HDD to the Slot 1 (Left).



4. Assemble the Second Option HDD with same steps of Step 1 to Step 2.

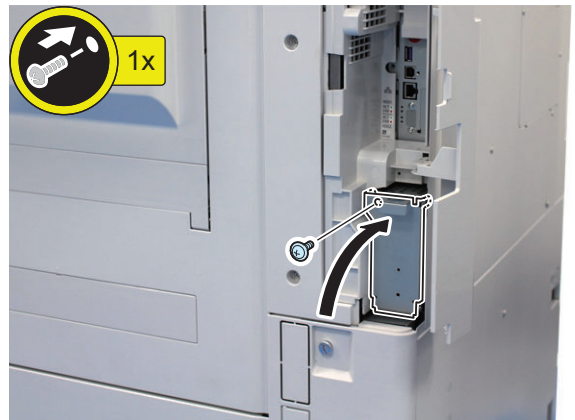


5. Install the Option HDD to the Slot 2 (Left).



6. Close the HDD Lid.

- 1 Screw (Use the removed screws)



7. Close the Right Rear Cover 1.



■ HDD Initialization Procedure

1. Requirements

1. PC
Service Support Tool in the version that supports this host machine must be installed.
2. Cross Ethernet Cable (when SST is used)

2. Preparing for the Installation of the System Software of Host machine

1. If both PC and the machine are on, turn them off.
2. Connect the PC and the host machine using an Cross Ethernet cable. (when SST is used)
3. Turn on the PC.

3. Registering the system software

1. Insert the latest System Software into the PC using the SST.
2. Start the SST.
3. Click 'Register Firmware'.
4. Select the drive where the system software has been inserted, and click the [SEARCH] button.
5. Click the [REGISTER] button.
6. Click [OK].

4. Initializing HDD

<In case of SST>

1. Start the host machine with download mode in safe mode.
2. Start the SST.
3. Select the model. Then, select [Single] and click [Start].
4. Click [Format HDD].
5. Select [All], and click [Start].
6. Click [Execute Format].
7. The Format is executed.
8. Select [Shutdown/Restart], and click [Shutdown].
9. Click [OK]
10. The power of the host machine is turned OFF.
11. Terminate the SST.
12. Disconnect the Cross Ethernet Cable from the machine, and connect the user's network cable to the machine.

<In case of USB flash drive>

1. Connect the USB flash drive to the PC.
2. Start up SST, and click the USB icon displayed in the target selection screen.
3. Select the drive, the model series, and the version to be written to the USB flash drive, and click [Confirm].
4. Click [Start], and after the version has been written to the USB flash drive, click [OK] and then remove the USB flash drive.
5. Terminate the SST.
6. Connect the USB flash drive to the host machine, and start the host machine with download mode in safe mode.
7. When the USB menu is displayed, press keys on the Control Panel in the order shown below.
 - [4]: Clear/Format
 - [1]: Disk Format
 - [0]: OK
 - Press any keys.
 - [C]: Return to menu
 - [Reset] : Start shutdown sequence
 - [0]: OK (The power of the host machine is turned OFF automatically.)
8. Remove the USB flash drive.
9. Turn ON the main power switch.

■ Setting the Mirroring



1. **Set the setting value for the mirroring to "1" in the following service mode.**
COPIER > OPTION > FNC-SW > W/RAID
2. **Turn OFF/ON the main power of the host machine to enable the setting value.**
3. **Make sure that the UI screen is activated correctly.**
4. **Open the Cover, and make sure that the LED blinks.**

NOTE:

Rebuilding starts approximately after 3 minutes after turning OFF and then ON the power.

- HDD 1 (Slot 1): The green LED blinks.
- HDD 2 (Slot 2): The green and red LEDs blink.

CAUTION:

Rebuild process starts after setting "1" for W/RAID. If an error occurs during the rebuild process at the initial installation the hard disk needs to be replaced. (Call service rep.), reexecute the process with the following procedure.

1. Check that the lighting red LED is HDD2.
2. Select "0" for the following service mode.
COPIER > OPTION > FNC-SW > W/RAID
3. To enable the setting value, turn OFF/ON the Main Power Supply Switch of the host machine.
4. Select "1" for the following service mode.
COPIER > OPTION > FNC-SW > W/RAID
5. To enable the setting value, turn OFF/ON the Main Power Supply Switch of the host machine.

The foregoing procedure is limited to the rebuild process at the initial installation.

An error during the rebuild process that is executed during operation is not included in the consideration.

■ Executing Auto Gradation Adjustment

When the high-capacity HDD is installed, the machine initializes its HDD, resetting the data used for auto gradation correction.

Therefore, execute full adjustment of auto gradation adjustment after installing the high-capacity HDD to enable proper images to be output.

■ Execution of the Minimum Installation Work

Be sure to execute the minimum installation work in accordance with the Setup Guide because HDD is initialized when the high-capacity HDD is installed.

Super G3 FAX Board-AS1

Product Name

Safety regulations require the product's name to be registered. In some regions where this product is sold, the following name may be registered instead.

- F632501

Points to Note at Installation

- When installing the Super G3 2nd Line Fax Board and this equipment at the same time, after checking "Checking the Contents", and install them following the Installation Procedure for Super G3 2nd Line Fax Board.
- For "Checking the Operation", refer to this document.

Essential Items to Be Performed Before Installation

- Turn OFF the main power of the host machine, and disconnect the power plug from the outlet.

⚠ WARNING:

- If performing work without disconnecting the power plug of the host machine, it may cause electrical shock.
- If disconnecting the power plug without turning OFF the main power, it may cause damage of the machine.

- When turning OFF the main power, follow the below procedure.
 1. Turn OFF the main power switch of the host machine.
 2. The display in the Control Panel and the lamp of the main power are turned off.

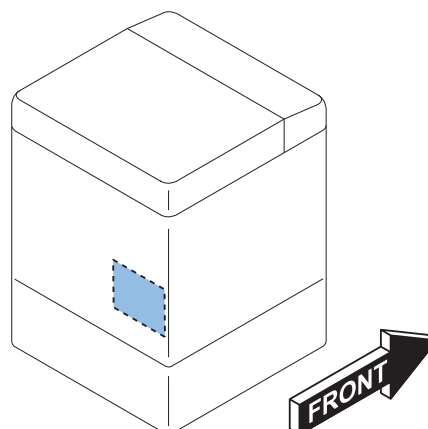
Points to Note When Turning ON/OFF the Main Power

The following message is displayed.



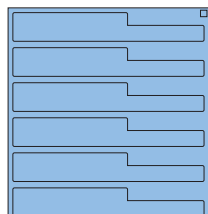

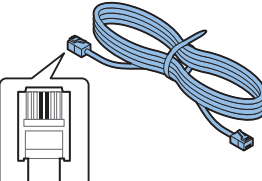
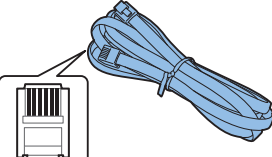
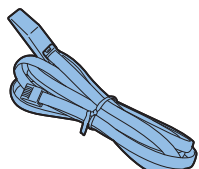
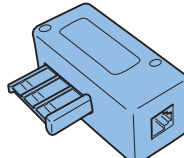
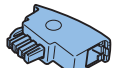
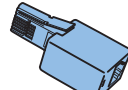

1. When a message prompting to turn OFF and then ON the main power appears, turn OFF and then ON the main power switch.
2. If a message prompting the user to update the version appears, press [Update] to automatically update the version of this equipment.

If [Skip] is selected, a message prompting the user to update the version will appear every time the host machine is started. In the service mode (Lv. 2) shown below, it is possible to set not to display the message.
 COPIER > OPTION > FNC-SW > VER-CHNG

Installation Outline Drawing



Checking the Contents

<input type="checkbox"/> [1] FAX Unit X 1 	<input type="checkbox"/> [2] Screw (TP; M3x4 Black) X 1 
<input type="checkbox"/> [3] Modular Label X 1 	<input type="checkbox"/> [4] Fax Approval Label X 1 Included for USA and Taiwan 
<input type="checkbox"/> [5] Telephone Cord (2 Contact type) X 1 	<input type="checkbox"/> [6] Telephone Cord (6 Contact type) (only for Europe) X 1 
<input type="checkbox"/> [7] PTT Cable (only for Asia) X 1 	<input type="checkbox"/> [8] PTT Plug (Only for France) X 1 
<input type="checkbox"/> [9] PTT Plug (Only for Germany) X 1 	<input type="checkbox"/> [10] PTT Plug (Only for U.K.) X 1 
<input type="checkbox"/> [11] Modular Cover (only for Europe) X 1 	

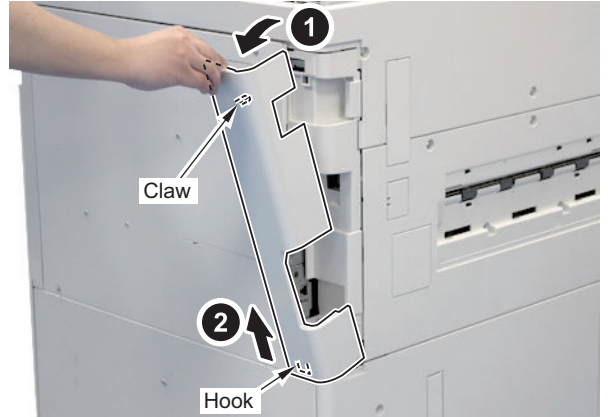
* These are not used with this machine.

< Others >
 • Including guides

Installation Procedure

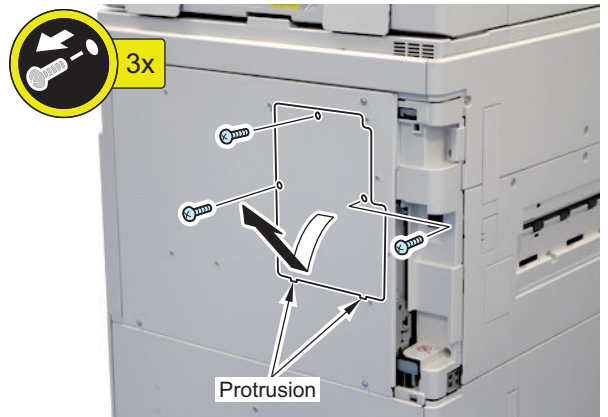
1. Remove the Left Rear Cover.

- 1 Claw
- 1 Hook



2. Remove the Rear Cover 2.

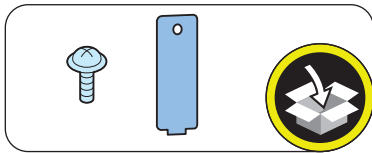
- 3 Screws
- 2 Protrusions





3. Remove the Face Cover. (The removed parts will not be used.)

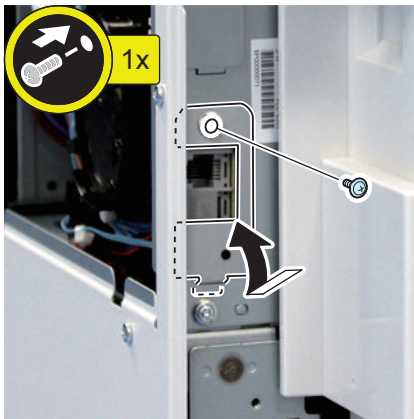
- 1 Screw (used in the next step only in EUR)
- 1 Protrusion



NOTE:
This step is only for Europe.

4. Install the Modular Cover.

- 1 Protrusion
- 1 Screw (use the screw removed in the previous step)

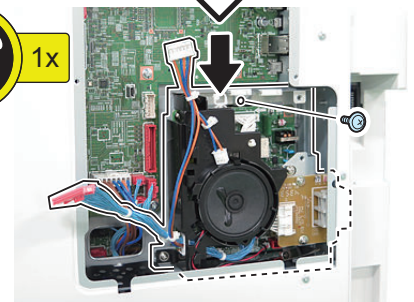
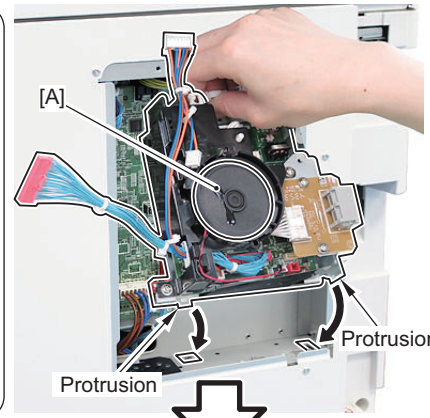
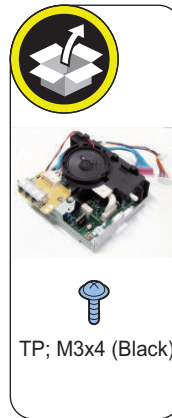


5. Remove the tape and, install the Fax Unit.

- 2 Protrusions
- 1 Screw (TP; M3x4: Black)

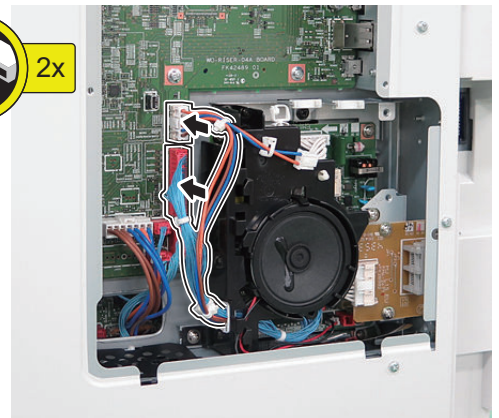
CAUTION:

- Be careful not to damage the [A] part of the speaker as the wiring may be broken.
- Be sure to tighten the screw while holding the FAX Unit.
- After tightening the screw of the FAX Unit, check for any backlash. If there is backlash, tighten the screw again with the protrusion precisely fitted.



6. Connect the 2 cables of the FAX Unit.

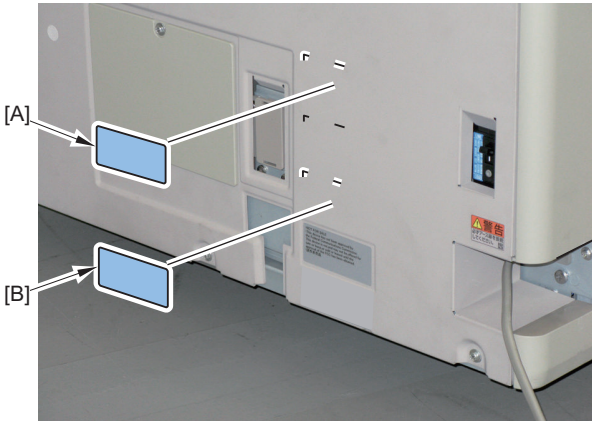
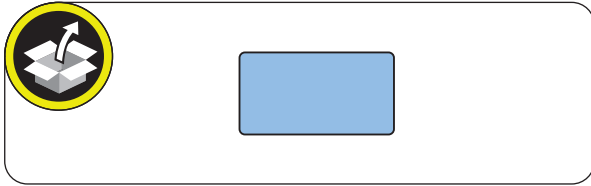
- 2 Connectors



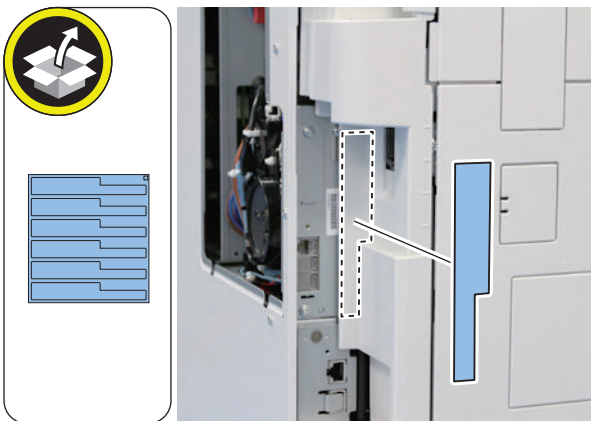


7. Affix the following FAX Approval Label.

- [A] For USA
- [B] For Taiwan



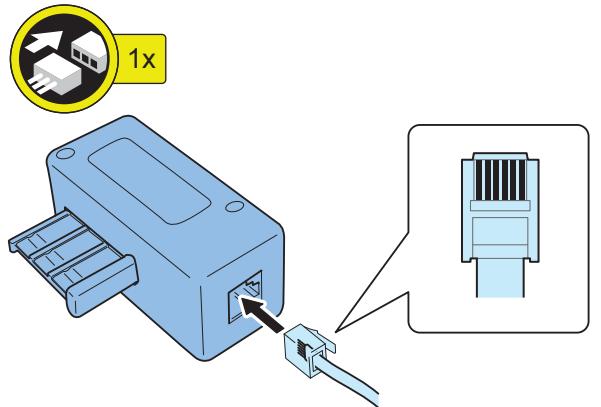
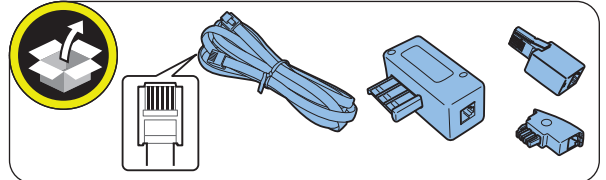
8. Affix the appropriate Modular Label to the place shown in the figure.



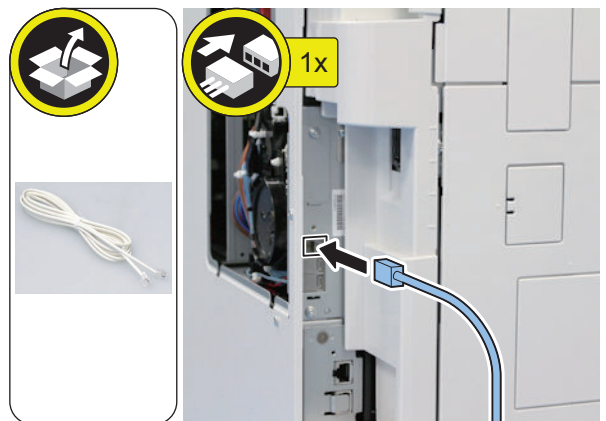
NOTE:

This step is only for Europe.
Do not connect the Telephone Cord (2 contact type) with the PTT Plug.

9. Connect the PTT Plug matched the field or area to the PTT Cable (6 contact type).



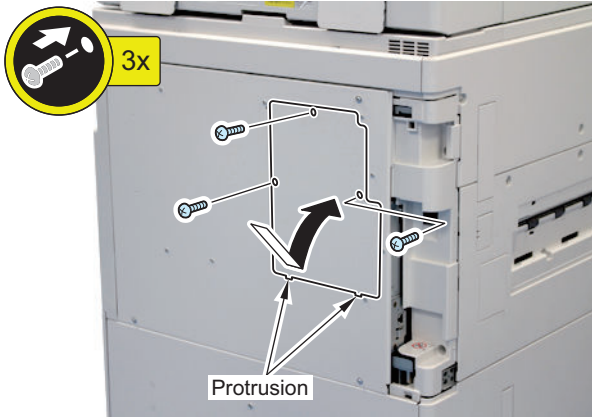
10. Connect the end of the PTT Cable or Telephone Cord to the modular jack on the Host machine, and connect the other end to the modular jack on the wall.





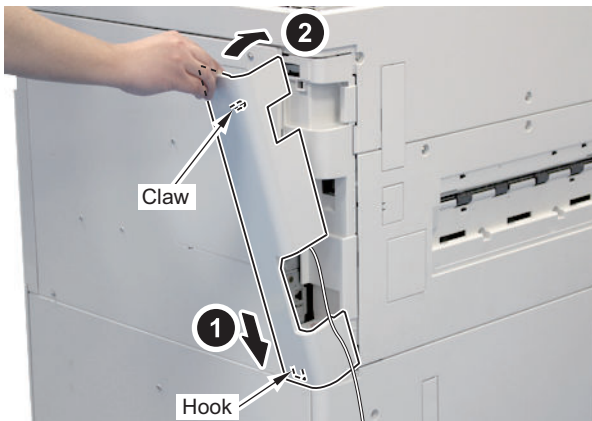
11. Install the Rear Cover 2.

- 2 Protrusions
- 3 Screws



12. Install the Left Rear Cover.

- 1 Hook
- 1 Claw



13. Connect the Power Plug to the outlet.

14. Turn ON the main power switch.

CAUTION:

If the machine does not recognize this equipment, unplug and then plug the power plug after turning OFF the main power switch, or turn OFF the main power switch and then turn it ON within 20 seconds. To avoid this symptom, unplug the power plug or turn the breaker OFF when installing.

This setting performs the parameter settings to match the communication specification of the country/region.



- 1. From the following service mode, set the TYPE of country/region to install this machine, and then press OK.**

FAX > TYPE > TYPE

- 2. Confirm that service mode parameter below is "0". In the case, parameter is "1", change to "0".**

COPIER > OPTION > DSPLY-SW > SDTM-DSP

NOTE:

To change parameter to "0" makes no show below [Settings/Registration > Preferences > Time/Energy Settings > Auto Shutdown Time] and auto shut down is not available.

- 3. Turn OFF/ON the main power switch to enable this setting.**

■ Basic Setting

NOTE:

- When "System Manager Information Settings" is set, be sure to follow the direction of user administrator in order to log in as an administrator.
- This setting can also be set from the Setup Guide ([Settings/Registration] > [Management Settings] > [License/Other] > [Start Setup Guide]).

In this section, make only minimum settings required for FAX communication.



- 1. Set the user telephone number.**

[Settings/Registration] > [Function Settings] > [Send] > [Fax Settings] > [Set Line] > [Line 1] > [Register Unit Telephone Number] > Enter the fax number > [OK]

- 2. Set Type of telephone line.**

[Settings/Registration] > [Function Settings] > [Send] > [Fax Settings] > [Set Line] > [Line 1] > [Select Line Type] > Select the line type to connect > [OK]

- 3. Turn OFF/ON the main power switch after setting the user telephone numbers and the type of telephone line.**

■ FAX Communication Test

Perform communication test to check if FAX function works correctly.



- 1. Switch the control panel display to Send/Fax display.**

● Checking the Operation

■ Type Setting

Select the country/region of the FAX Board in Service Mode:
FAX > Type > TYPE

- 2. Send the test document from this machine to another machine that can handle the communication test to check that this machine can send the data correctly.**
- 3. Send the test document from the target to this machine to check if the machine can receive the document properly.**

Super G3 FAX Board-AS2

Product Name

Safety regulations require the product's name to be registered. In some regions where this product is sold, the following name may be registered instead.

- F632501

Points to Note at Installation

- When installing the Super G3 2nd Line Fax Board and this equipment at the same time, after checking "Checking the Contents", and install them following the Installation Procedure for Super G3 2nd Line Fax Board.
- For "Checking the Operation", refer to this document.

Essential Items to Be Performed Before Installation

- Turn OFF the main power of the host machine, and disconnect the power plug from the outlet.

⚠ WARNING:

- If performing work without disconnecting the power plug of the host machine, it may cause electrical shock.
- If disconnecting the power plug without turning OFF the main power, it may cause damage of the machine.

- When turning OFF the main power, follow the below procedure.
 1. Turn OFF the main power switch of the host machine.
 2. The display in the Control Panel and the lamp of the main power are turned off.

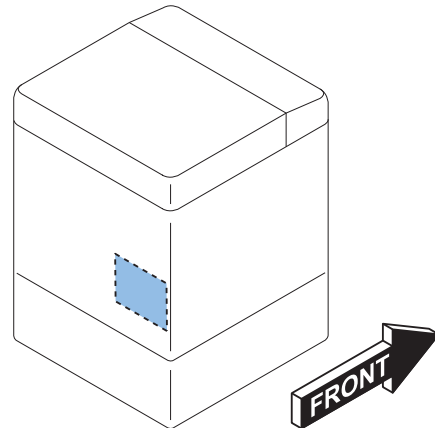
Points to Note When Turning ON/OFF the Main Power

The following message is displayed.



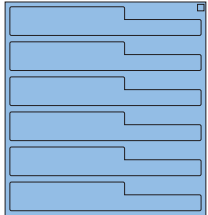

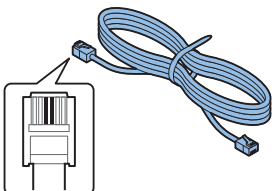
1. When a message prompting to turn OFF and then ON the main power appears, turn OFF and then ON the main power switch.
2. If a message prompting the user to update the version appears, press [Update] to automatically update the version of this equipment.

If [Skip] is selected, a message prompting the user to update the version will appear every time the host machine is started. In the service mode (Lv. 2) shown below, it is possible to set not to display the message.
COPIER > OPTION > FNC-SW > VER-CHNG

Installation Outline Drawing



Checking the Contents

<input type="checkbox"/> [1] FAX Unit X 1 	<input type="checkbox"/> [2] Screw (TP; M3x4 Black) X 1 
<input type="checkbox"/> [3] Modular Label X 1 	<input type="checkbox"/> [4] Fax Approval Label X 1 
<input type="checkbox"/> [5] Telephone Cord (2 Contact type) X 1 	

< Others >

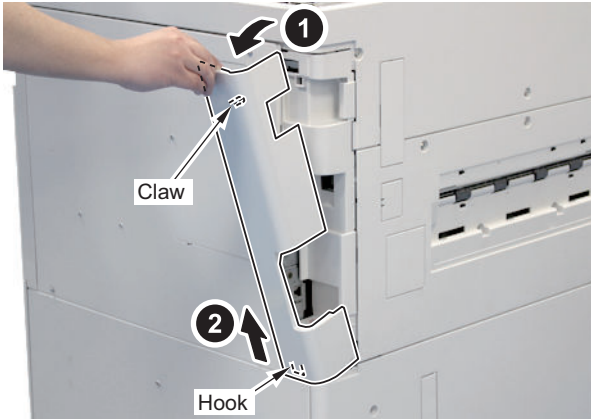
- Including guides

Installation Procedure



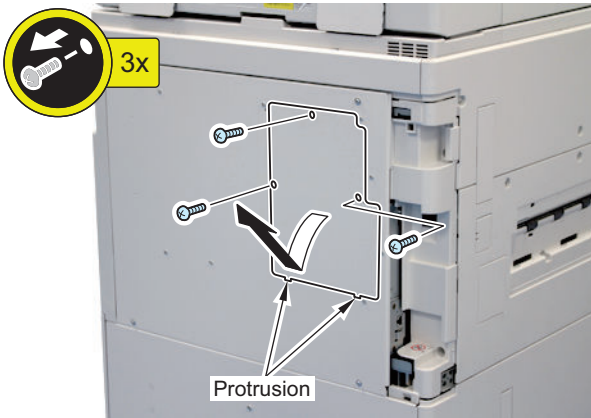
1. Remove the Left Rear Cover.

- 1 Claw
- 1 Hook



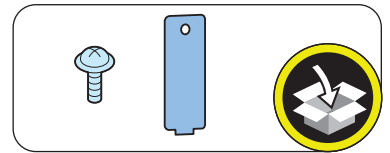
2. Remove the Rear Cover 2.

- 3 Screws
- 2 Protrusions



3. Remove the Face Cover. (The removed parts will not be used.)

- 1 Screw
- 1 Protrusion



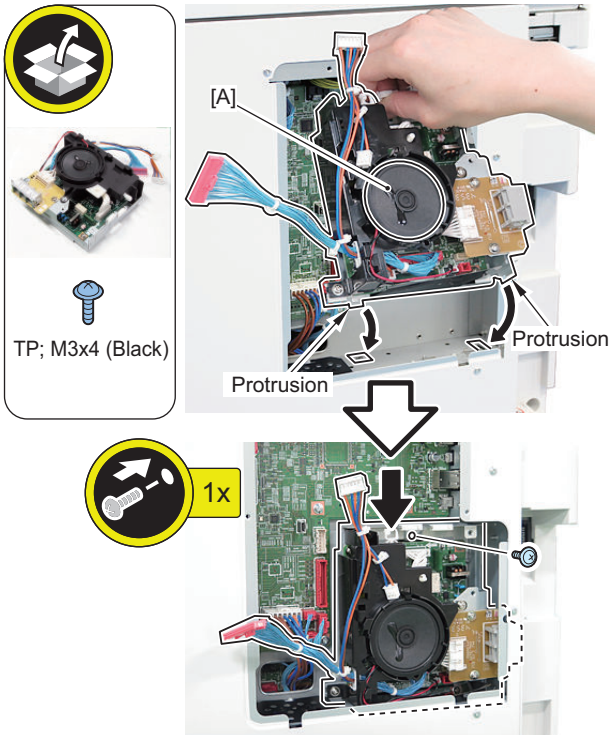


4. Remove the tape and, install the Fax Unit.

- 2 Protrusions
- 1 Screw (TP; M3x4: Black)

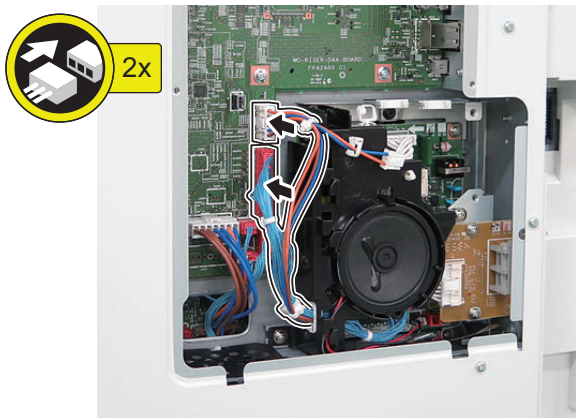
CAUTION:

- Be careful not to damage the [A] part of the speaker as the wiring may be broken.
- Be sure to tighten the screw while holding the FAX Unit.
- After tightening the screw of the FAX Unit, check for any backlash. If there is backlash, tighten the screw again with the protrusion precisely fitted.



5. Connect the 2 cables of the FAX Unit.

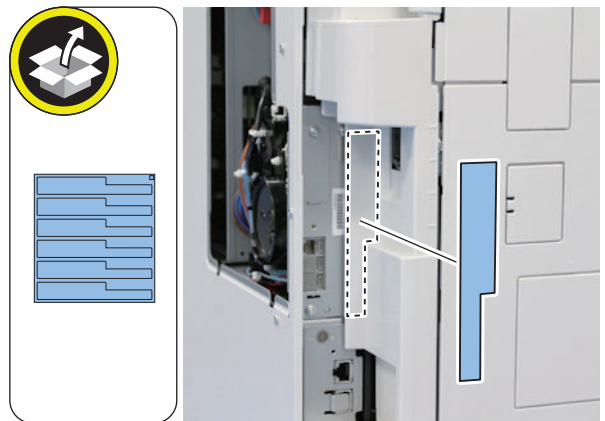
- 2 Connectors



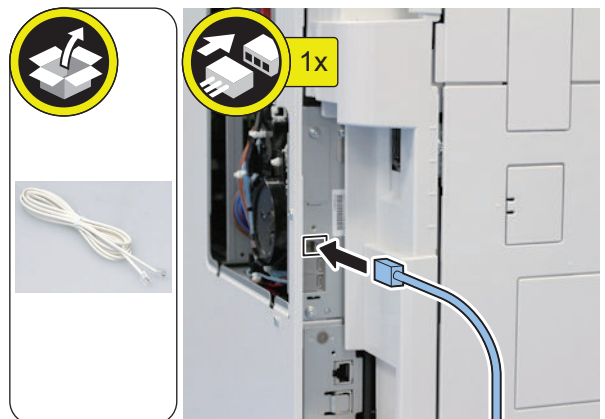
6. Affix the following FAX Approval Label.



7. Affix the appropriate Modular Label to the place shown in the figure.

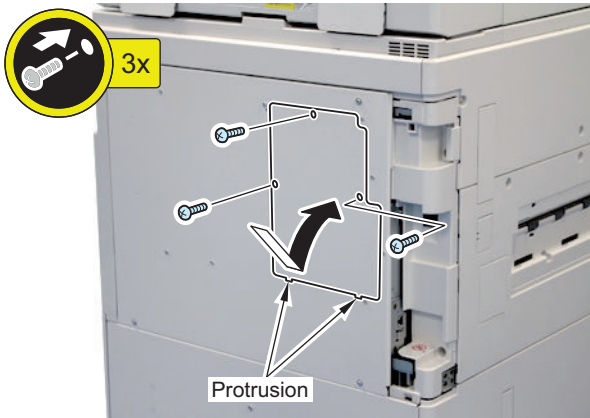


8. Connect the end of the Telephone Cord to the modular jack on the Host machine, and connect the other end to the modular jack on the wall.



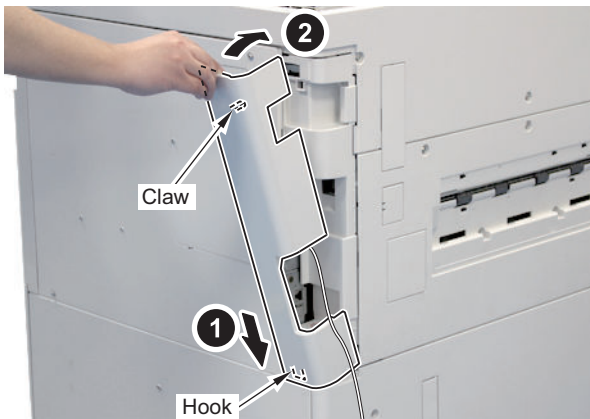
9. Install the Rear Cover 2.

- 2 Protrusions
- 3 Screws



10. Install the Left Rear Cover.

- 1 Hook
- 1 Claw



11. Connect the Power Plug to the outlet.

12. Turn ON the main power switch.

CAUTION:

If the machine does not recognize this equipment, unplug and then plug the power plug after turning OFF the main power switch, or turn OFF the main power switch and then turn it ON within 20 seconds. To avoid this symptom, unplug the power plug or turn the breaker OFF when installing.

Checking the Operation

■ Type Setting

Select the country/region of the FAX Board in Service Mode:
FAX > Type > TYPE

This setting performs the parameter settings to match the communication specification of the country/region.



1. From the following service mode, set the TYPE of country/region to install this machine, and then press OK.

FAX > TYPE > TYPE

2. Confirm that service mode parameter below is "0". In the case, parameter is "1", change to "0".

COPIER > OPTION > DSPLY-SW > SDTM-DSP

NOTE:

To change parameter to "0" makes no show below [Settings/Registration > Preferences > Time/Energy Settings > Auto Shutdown Time] and auto shut down is not available.

3. Turn OFF/ON the main power switch to enable this setting.

■ Basic Setting

NOTE:

- When "System Manager Information Settings" is set, be sure to follow the direction of user administrator in order to log in as an administrator.
- This setting can also be set from the Setup Guide ([Settings/Registration] > [Management Settings] > [License/Other] > [Start Setup Guide]).

In this section, make only minimum settings required for FAX communication.



1. Set the user telephone number.

[Settings/Registration] > [Function Settings] > [Send] > [Fax Settings] > [Set Line] > [Line 1] > [Register Unit Telephone Number] > Enter the fax number > [OK]

2. Set Type of telephone line.

[Settings/Registration] > [Function Settings] > [Send] > [Fax Settings] > [Set Line] > [Line 1] > [Select Line Type] > Select the line type to connect > [OK]

3. Turn OFF/ON the main power switch after setting the user telephone numbers and the type of telephone line.

■ FAX Communication Test

Perform communication test to check if FAX function works correctly.



1. Switch the control panel display to Send/Fax display.
2. Send the test document from this machine to another machine that can handle the communication test to check that this machine can send the data correctly.

3. Send the test document from the target to this machine to check if the machine can receive the document properly.

Super G3 2nd Line Fax Board-AS1

Product Name

Safety regulations require the product's name to be registered. In some regions where this product is sold, the following name may be registered instead.

- F632502

Points to Note at Installation

When installing the Super G3 FAX Board and this equipment at the same time, be sure to install them by referring to this document after checking "Checking the Contents" of Super G3 FAX Board.

Essential Items to Be Performed Before Installation

- Turn OFF the main power of the host machine, and disconnect the power plug from the outlet.

⚠ WARNING:

- If performing work without disconnecting the power plug of the host machine, it may cause electrical shock.
- If disconnecting the power plug without turning OFF the main power, it may cause damage of the machine.

- When turning OFF the main power, follow the below procedure.
 1. Turn OFF the main power switch of the host machine.
 2. The display in the Control Panel and the lamp of the main power are turned off.

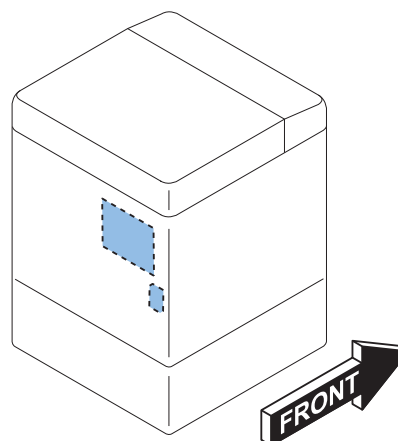
Points to Note When Turning ON/OFF the Main Power

The following message is displayed.


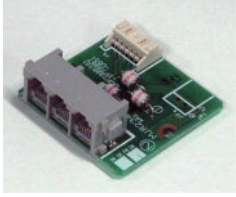



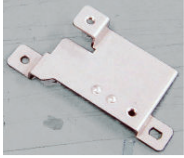



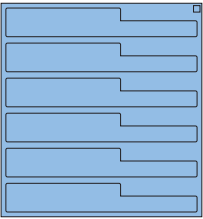
1. **When a message prompting to turn OFF and then ON the main power appears, turn OFF and then ON the main power switch.**
2. **If a message prompting the user to update the version appears, press [Update] to automatically update the version of this equipment.**


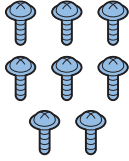


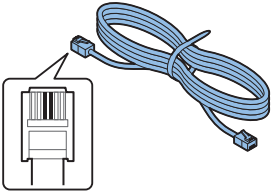
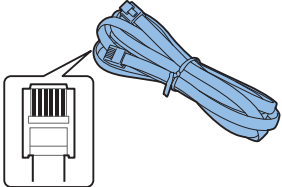
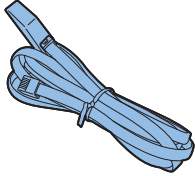
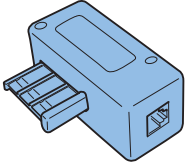
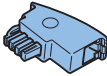
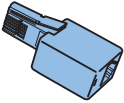
If [Skip] is selected, a message prompting the user to update the version will appear every time the host machine is started. In the service mode (Lv. 2) shown below, it is possible to set not to display the message.
COPIER > OPTION > FNC-SW > VER-CHNG

Installation Outline Drawing



Checking the Contents

<input type="checkbox"/> [1] G3FAX Expansion PCB X 1 	<input type="checkbox"/> [2] Modular PCB X 1 
<input type="checkbox"/> [3] USB Cable X 1 	<input type="checkbox"/> [4] Modular Cable X 1 
<input type="checkbox"/> [5] Signal Cable X 1 	<input type="checkbox"/> [6] FAX Shield Plate X 1 
<input type="checkbox"/> [7] FAX Board Fixed Plate X 1 	<input type="checkbox"/> [8] PCB Spacer (Long) X 3 
<input type="checkbox"/> [9] PCB Spacer (Short) X 1 	<input type="checkbox"/> [10] Modular Label X 1 

<input type="checkbox"/> [11] Dust Cover X 2 	<input type="checkbox"/> [12] Screw (TP; M3x4) X 8 
<input type="checkbox"/> [13] Screw (Binding; M4x4) X 1 	<input type="checkbox"/> [14] Fax Approval Label (only for Taiwan) X 1 
<input type="checkbox"/> [15] Telephone Cord (2 Contact type) X 1 	<input type="checkbox"/> [16] Telephone Cord (6 Contact type) (only for Europe) X 1 
<input type="checkbox"/> [17] PTT Cable (only for Asia) X 1 	<input type="checkbox"/> [18] PTT Plug (Only for France) X 1 
<input type="checkbox"/> [19] PTT Plug (Only for Germany) X 1 	<input type="checkbox"/> [20] PTT Plug (Only for U.K.) X 1 

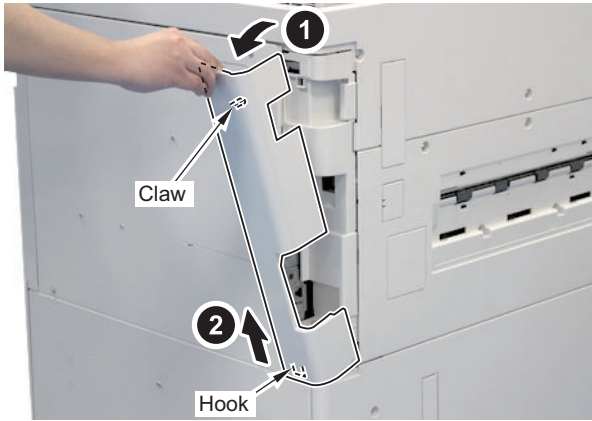
Installation Procedure

■ Preparation



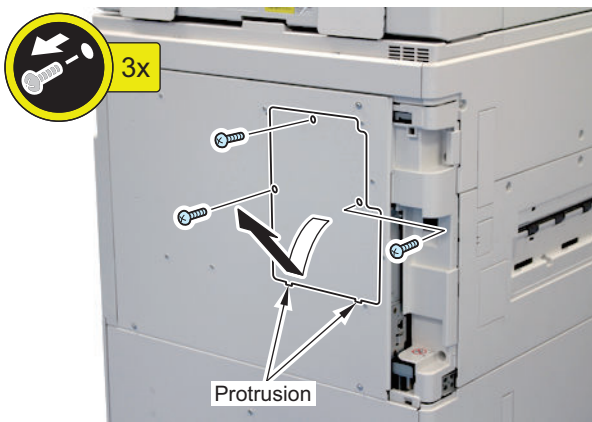
1. Remove the Left Rear Cover.

- 1 Claw
- 1 Hook



2. Remove the Rear Cover 2.

- 3 Screws
- 2 Protrusions

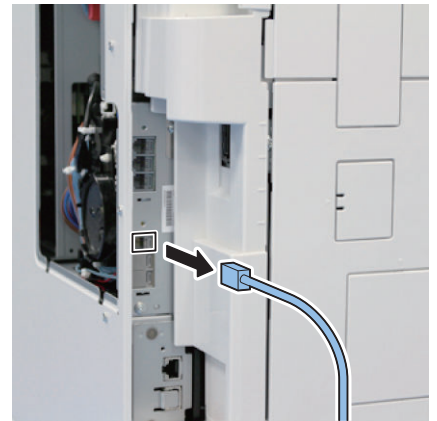


NOTE:

- When the Super G3 FAX Board is installed: Perform steps 3 and 4, and proceed to step 7.
- When installing the Super G3 FAX Board at the same time: Proceed to step 5.



3. Disconnect the Telephone Cord of the FAX (1-Line).

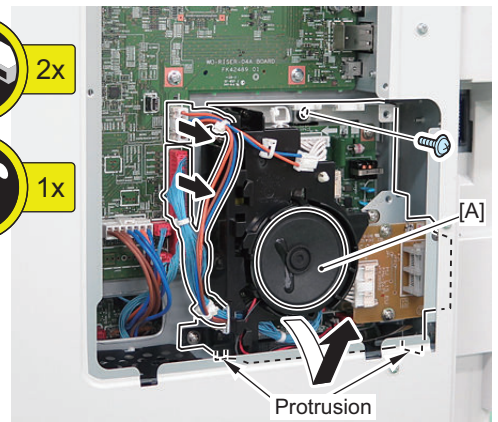


4. Remove the FAX Unit.

- 2 Connectors
- 1 Screw
- 2 Protrusions

CAUTION:

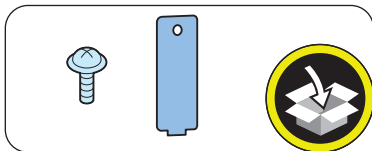
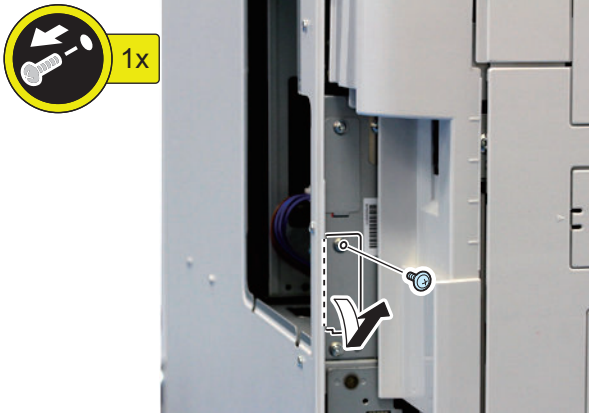
Be careful not to damage the [A] part of the speaker as the wiring may be open circuit.





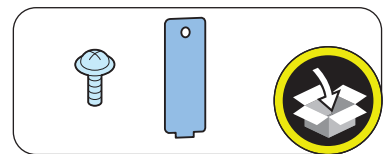
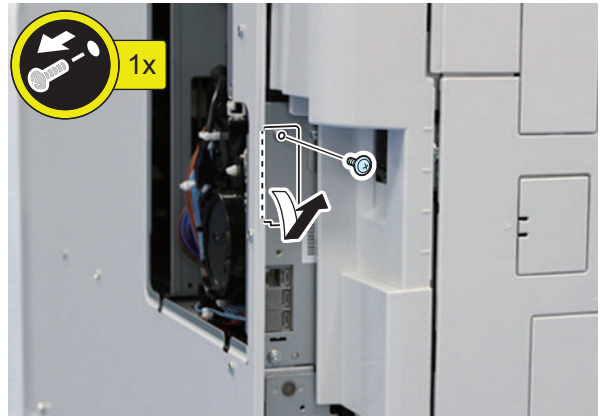
5. Remove the Face Cover of the FAX (1-Line). (The removed parts will not be used.)

- 1 Screw (used in the next step only in EUR)
- 1 Protrusion



7. Remove the Face Cover of the FAX (2-Line). (The removed parts will not be used.)

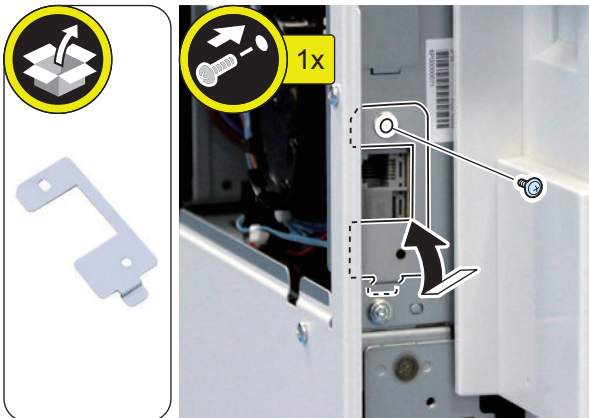
- 1 Screw
- 1 Protrusion



NOTE:
This step is only for Europe.

6. Install the Modular Cover.

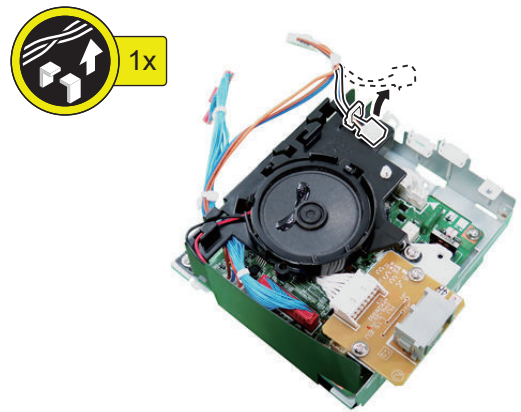
- 1 Protrusion
- 1 Screw (use the screw removed in the previous step)



■ Installing the Equipment



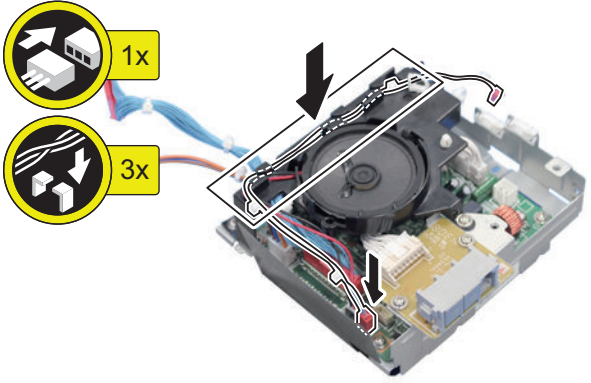
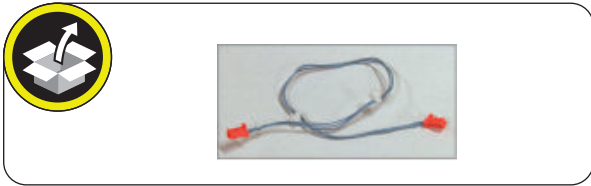
1. Free the Cable from the Wire Saddle.





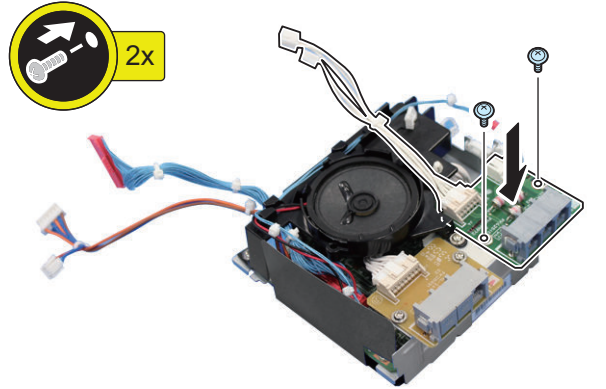
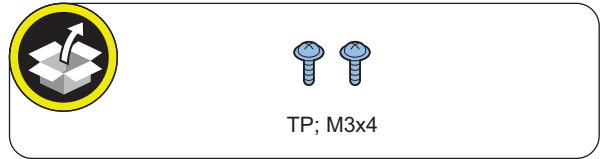
2. Install the Signal Cable to the FAX Unit.

- 3 Cable Guides

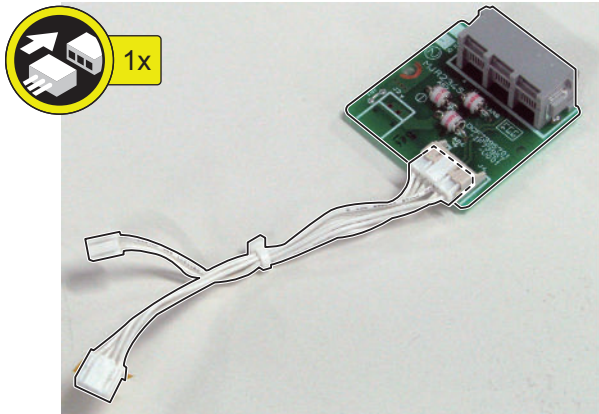
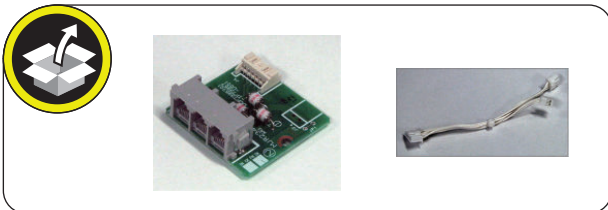


4. Install the Modular PCB to the FAX Unit.

- 2 Screws (TP; M3x4)



3. Install the Modular Cable to the Modular PCB.



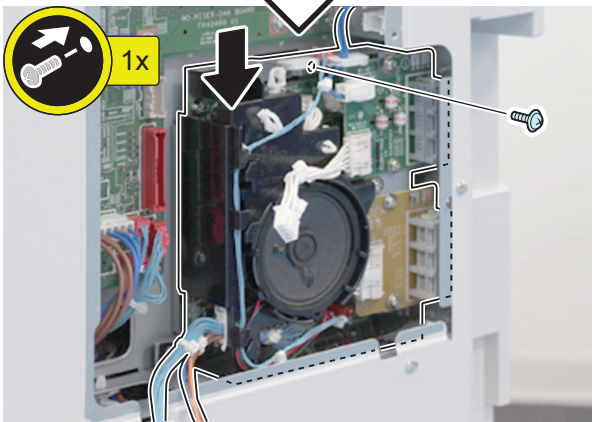
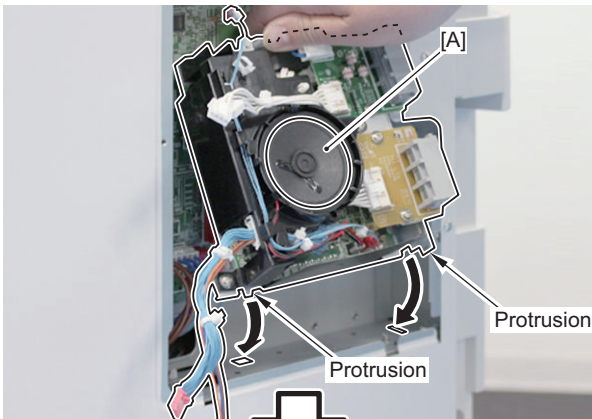


5. Install the FAX Unit to the Host Machine.

- 2 Protrusions
- 1 Screw (TP; M3x4 Black) (Use the removed screw or those included with the Super G3 FAX Board)

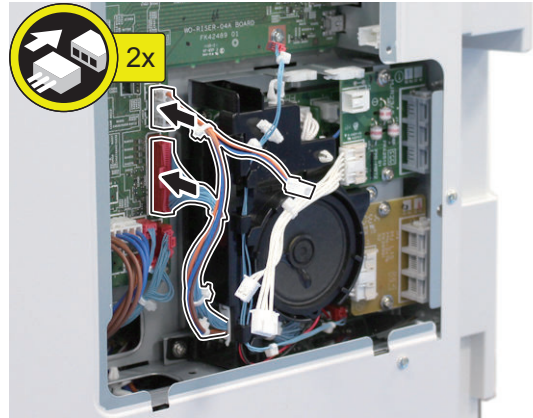
CAUTION:

- Be careful not to damage the [A] part of the speaker as the wiring may be broken.
- Be sure to tighten the screw while holding the FAX Unit.
- After tightening the screw of the FAX Unit, check for any backlash. If there is backlash, tighten the screw again with the protrusion precisely fitted.

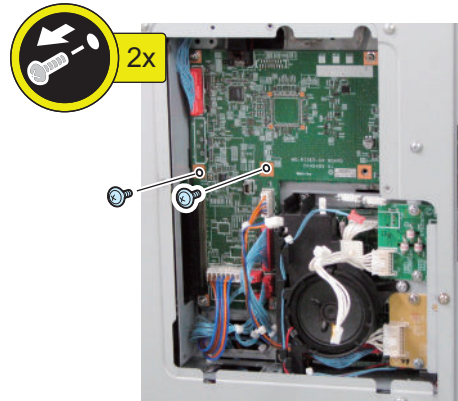


6. Install the 2 Cable of the FAX Unit.

- 2 Connectors

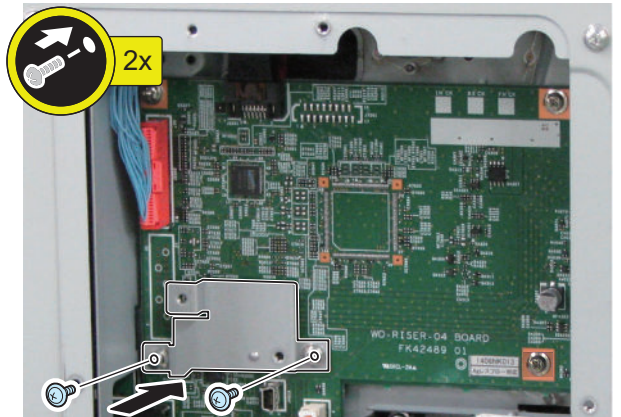
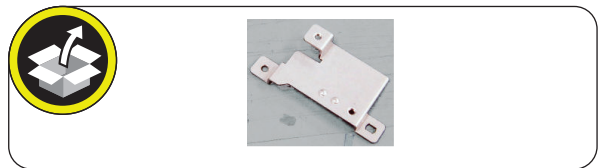


7. Remove the 2 Screws. (will be used in next step)



8. Install the FAX Shield Plate.

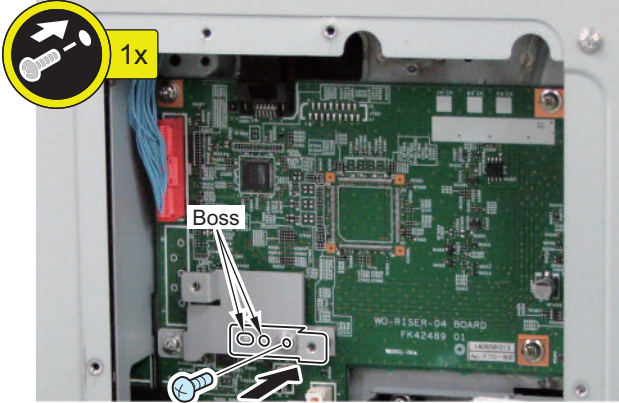
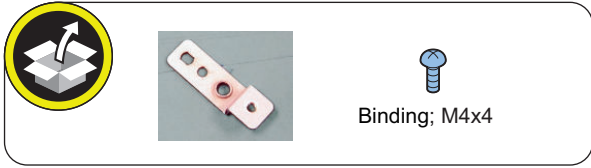
- 2 Screws (screws removed in the previous step)



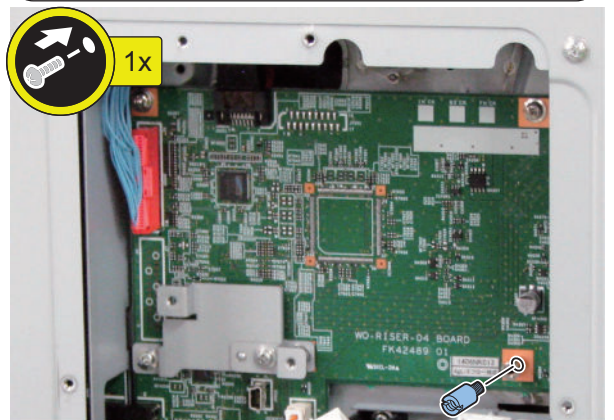
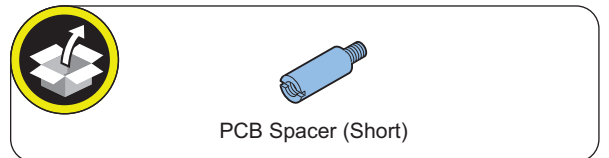
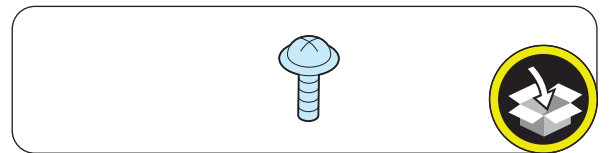
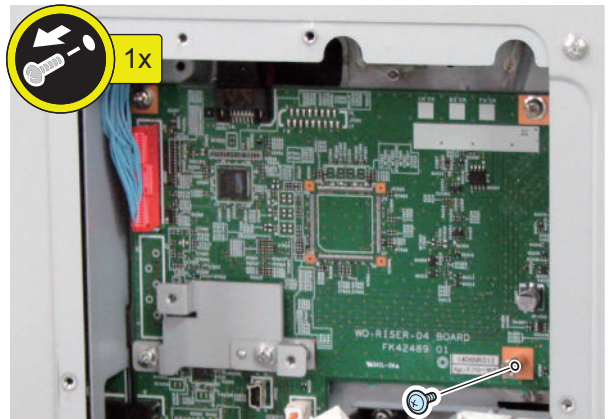


9. Install the FAX Board Fixed Plate.

- 2 Bosses
- 1 Screw (Binding; M4x4)

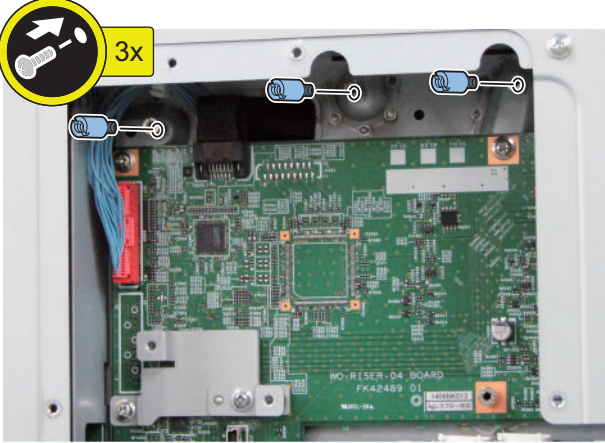
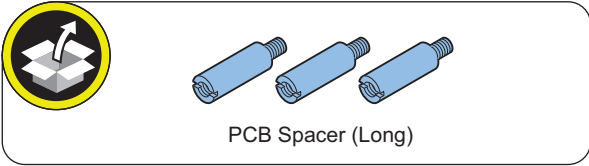


10. Remove the Screw and install the PCB Spacer (Short). (The removed screw will not be used.)





11. Install the 3 PCB Spacers (Long).

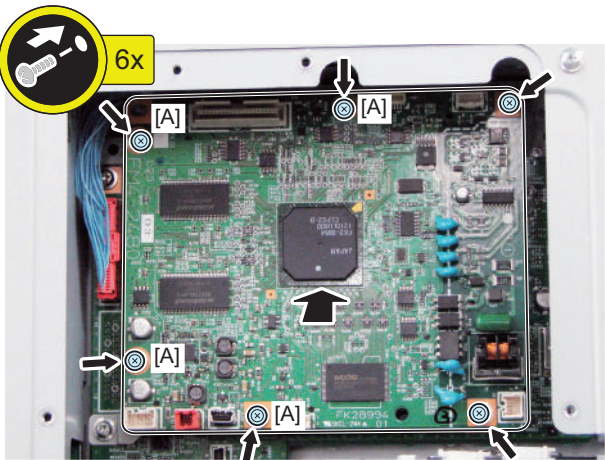
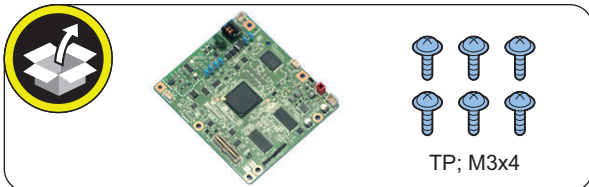


12. Install the G3FAX Expansion PCB.

- 6 Screws (TP; M3x4)

NOTE:

Because the 4 screws [A] need to be removed when installing the Super G3 3rd/4th Line Fax Board at the same time, it is efficient not to tighten them here.

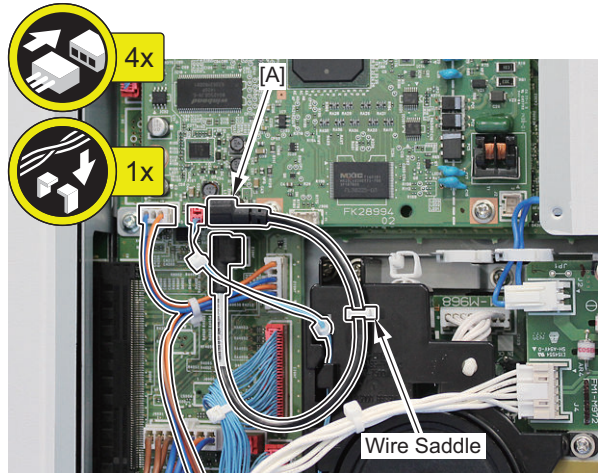


13. Install the Signal Cable, Power Supply Cable and USB Cable to the G3FAX Expansion PCB.

- 1 Wire Saddle

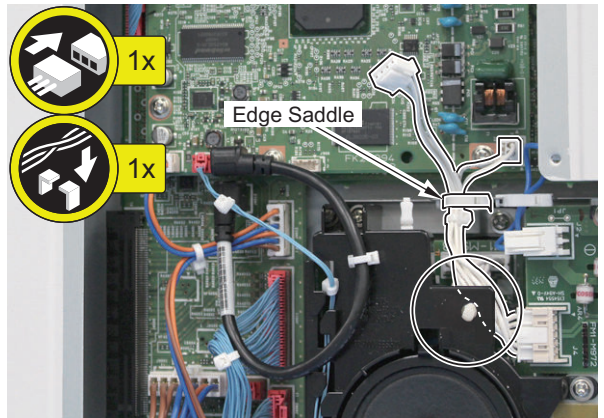
NOTE:

Because [A] of the USB Cable needs to be disconnected when installing the Super G3 3rd/4th Line Fax Board at the same time, it is efficient not to connect it here.



14. Pass the Modular Cable inside the Speaker Holder, and install the G3 FAX Control PCB.

- 1 Edge Saddle

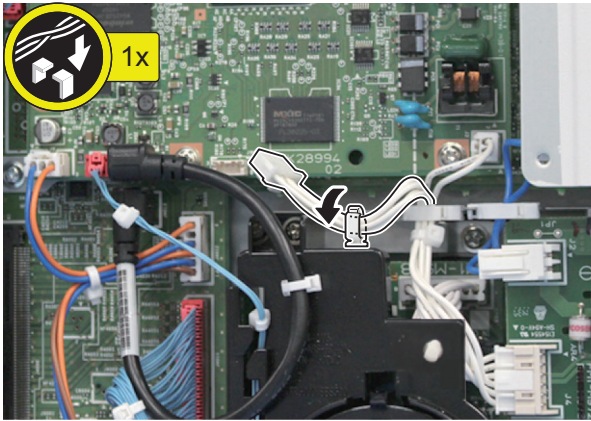


□

NOTE:

When installing the Super G3 3rd/4th Line Fax Board at the same time, the following step is not necessary.

15. Secure the cable with the Wire Saddle.



■ Subsequent Work

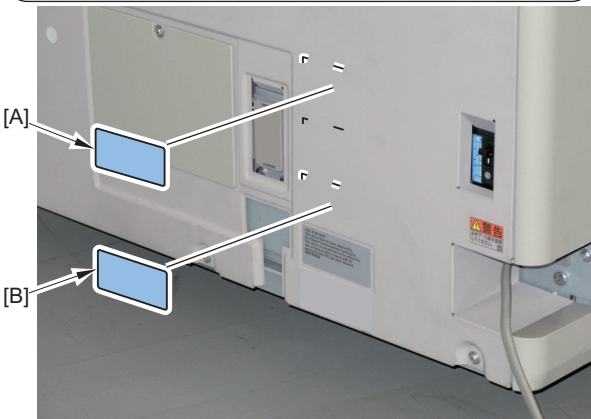
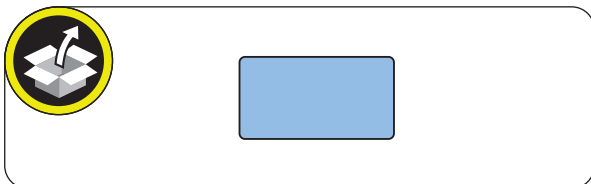
□

NOTE:

The following work is required only when installing the Super G3 FAX Board at the same time.

1. Affix the following FAX Approval Label.

- [A] For USA
- [B] For Taiwan

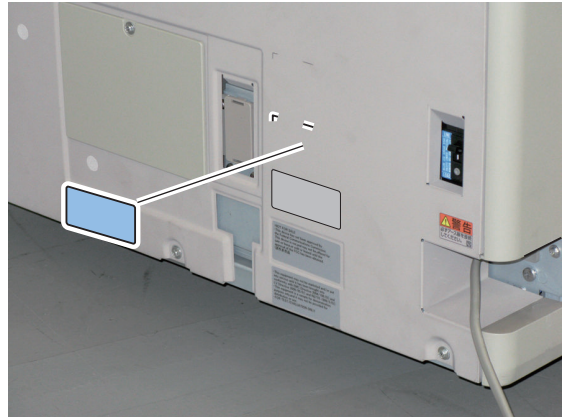
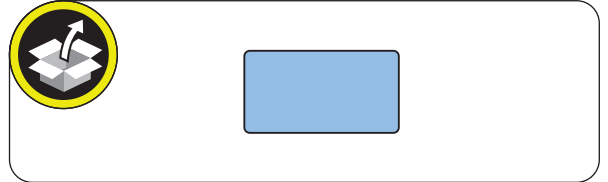


□

NOTE:

This step is only for Taiwan.

2. Affix the following FAX Approval Label.

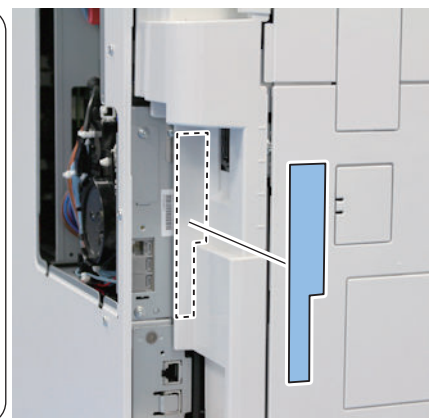
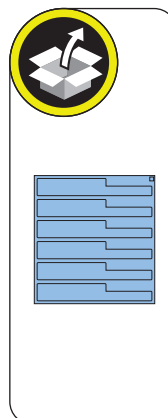


□

NOTE:

When installing the Super G3 3rd/4th Line Fax Board at the same time, the following step is not necessary.

3. Affix the appropriate Modular Label. If a label is already affixed, remove it and then affix the appropriate label.



□

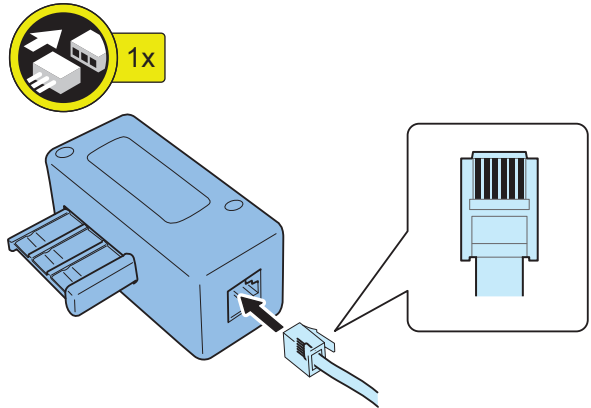
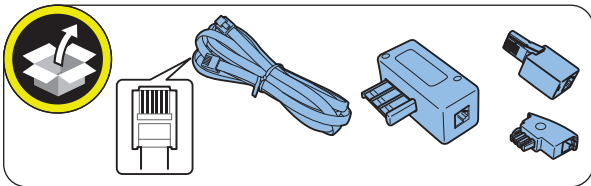
NOTE:

- This step is only for Europe.
- When installing the Super G3 FAX Board at the same time, assemble it by following the same procedure.

4. Connect the PTT Plug matched the field or area to the PTT Cable (6 contact type).

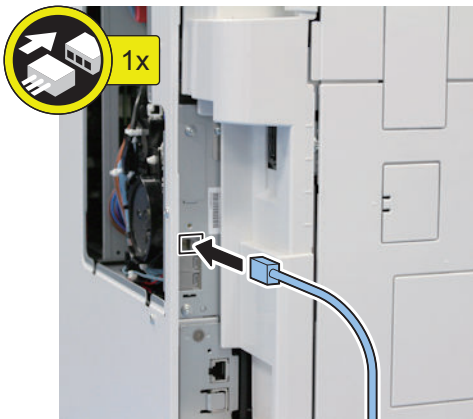
CAUTION:

Do not connect the Telephone Cord (2 contact type) with the PTT Plug.



□

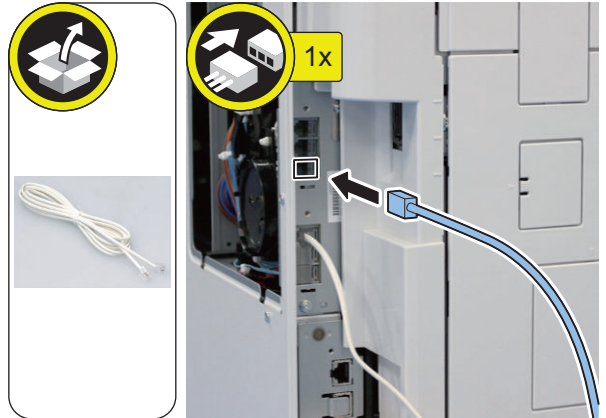
5. Connect the PTT Cable or Telephone Cord of the FAX (1-Line). When installing this equipment at the same time, connect the other end to the modular jack on the wall.



□

6. Connect the end of the PTT Cable or Telephone Cord to the modular jack on the Host machine, and

connect the other end to the modular jack on the wall.

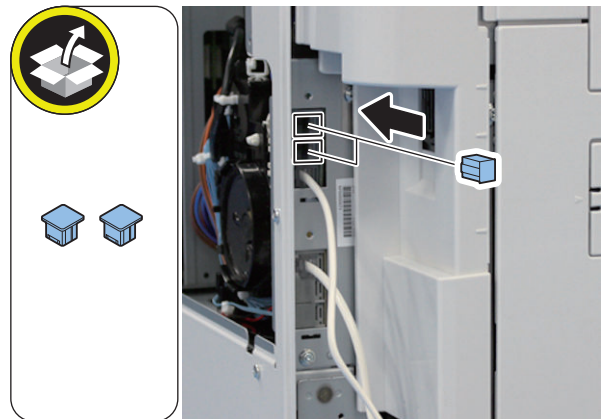


□

NOTE:

When installing the Super G3 3rd/4th Line Fax Board at the same time, the following step is not necessary.

7. Install the Dust Cover.

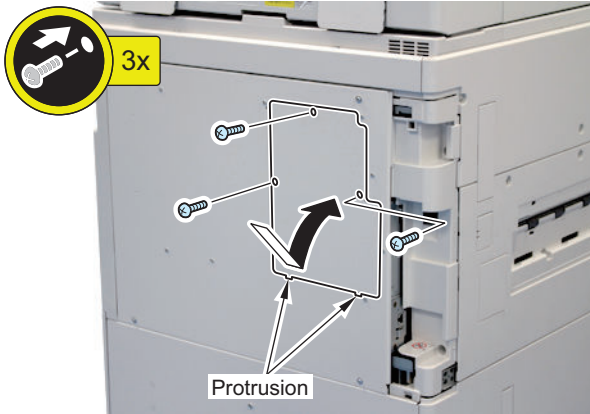


NOTE:

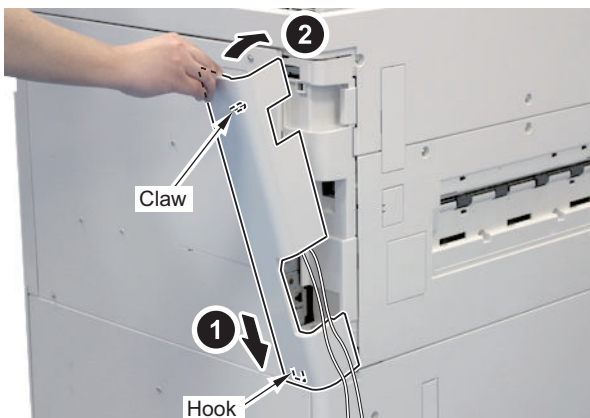
When performing the following steps, it is efficient to install the cover after installing the Super G3 3rd/4th Line Fax Board in case of installing the fax board at the same time.

**8. Install the Rear Cover 2.**

- 2 Protrusions
- 3 Screws

**9. Install the Left Rear Cover.**

- 1 Hook
- 1 Claw

**10. Connect the power plug to the outlet.****11. Turn ON the main power switch.****CAUTION:**

If the machine does not recognize this equipment, unplug and then plug the power plug after turning OFF the main power switch, or turn OFF the main power switch and then turn it ON within 20 seconds. To avoid this symptom, unplug the power plug or turn the breaker OFF when installing.

- 12. If a message prompting the user to update the version appears, press [Update] to automatically update the version of this equipment.**

NOTE:

If [Skip] is selected, a message prompting the user to update the version will appear every time the host machine is started.

In the service mode (Lev. 2) shown below, it is possible to set not to display the message.

COPIER > OPTION > FNC-SW > VER-CHNG

● Checking the Operation

■ Type Settings

Select the country/region of the FAX Board in Service Mode:
FAX > Type > TYPE

This setting performs the parameter settings to match the communication specification of the country/region.



- 1. From the following service mode, set the TYPE of country/region to install this machine, and then press OK.**

FAX > TYPE > TYPE

- 2. Confirm that service mode parameter below is "0". In the case, parameter is "1", change to "0".**

COPIER > OPTION > DSPLY-SW > SDTM-DSP

NOTE:

To change parameter to "0" makes no show below [Settings/Registration > Preferences > Time/Energy Settings > Auto Shutdown Time] and auto shut down is not available.

- 3. Turn OFF/ON the main power switch to enable this setting.**

■ Basic Settings

NOTE:

When "System Manager Information Settings" is set, be sure to follow the direction of user administrator in order to log in as an administrator.

In this section, make only minimum settings required for FAX communication.



- 1. Set the user telephone number.**

[Settings/Registration] > [Function Settings] > [Send] > [Fax Settings] > [Set Line] > [Line 2] > [Register Unit Telephone Number] > Enter FAX number > [OK]

2. Set the type of telephone line.

[Settings/Registration] > [Function Settings] > [Send] > [Fax Settings] > [Set Line] > [Line 2] > [Select Line Type] > Select the line type to connect > [OK]

3. Turn OFF/ON the main power switch after setting the user telephone numbers and the type of telephone line.**■ FAX Communication Test**

Perform communication test to check if FAX function works correctly.

**1. Switch the control panel display to Fax display.****2. Select the sending line.**

Press [Fax] > [Options] > [Select Line], select the added line, then press [OK] button.

3. Send and receive a test original between the equipment and a remote unit with which a communication test can be performed and check if it can be sent and receive correctly.

1. Press [Status Monitor/Cancel] > [Send] > [Job Log] and select [Fax] from pull down menu.
2. Press [Fax Activity Report] > [OutPut Normally] > [Start Printing].
3. The number printed following colon (:) in "COMM.MODE" field on FAX ACTIVITY REPORT TX/RX shows line type used for sending/receiving. E.g. "ECM:2" => Line 2

NOTE:

If E744-5000 error code (Fax software version mismatch error) occurred while sending or receiving fax, upgrade the firmware of 2-line Fax to the latest version.

Super G3 2nd Line Fax Board-AS2

Product Name

Safety regulations require the product's name to be registered. In some regions where this product is sold, the following name may be registered instead.

- F632502

Points to Note at Installation

When installing the Super G3 FAX Board and this equipment at the same time, be sure to install them by referring to this document after checking "Checking the Contents" of Super G3 FAX Board.

Essential Items to Be Performed Before Installation

- Turn OFF the main power of the host machine, and disconnect the power plug from the outlet.

⚠ WARNING:

- If performing work without disconnecting the power plug of the host machine, it may cause electrical shock.
- If disconnecting the power plug without turning OFF the main power, it may cause damage of the machine.

- When turning OFF the main power, follow the below procedure.
 1. Turn OFF the main power switch of the host machine.
 2. The display in the Control Panel and the lamp of the main power are turned off.

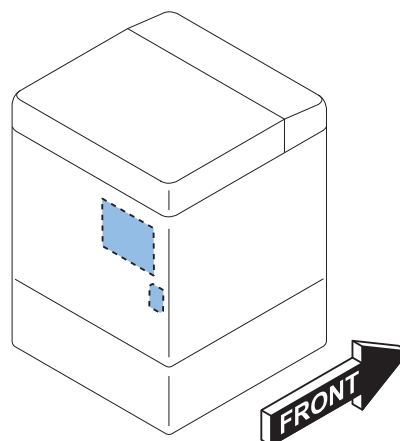
Points to Note When Turning ON/OFF the Main Power

The following message is displayed.


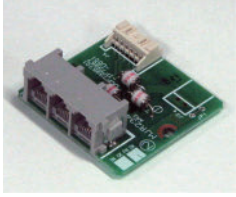



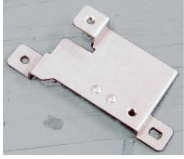



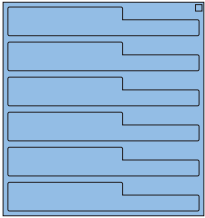
1. **When a message prompting to turn OFF and then ON the main power appears, turn OFF and then ON the main power switch.**
2. **If a message prompting the user to update the version appears, press [Update] to automatically update the version of this equipment.**


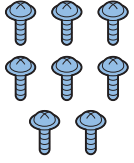

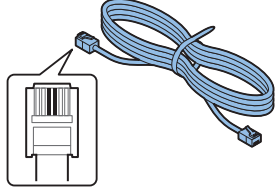
If [Skip] is selected, a message prompting the user to update the version will appear every time the host machine is started. In the service mode (Lv. 2) shown below, it is possible to set not to display the message.
COPIER > OPTION > FNC-SW > VER-CHNG

Installation Outline Drawing



Checking the Contents

<input type="checkbox"/> [1] G3FAX Expansion PCB X 1 	<input type="checkbox"/> [2] Modular PCB X 1 
<input type="checkbox"/> [3] USB Cable X 1 	<input type="checkbox"/> [4] Modular Cable X 1 
<input type="checkbox"/> [5] Signal Cable X 1 	<input type="checkbox"/> [6] FAX Shield Plate X 1 
<input type="checkbox"/> [7] FAX Board Fixed Plate X 1 	<input type="checkbox"/> [8] PCB Spacer (Long) X 3 
<input type="checkbox"/> [9] PCB Spacer (Short) X 1 	<input type="checkbox"/> [10] Modular Label X 1 

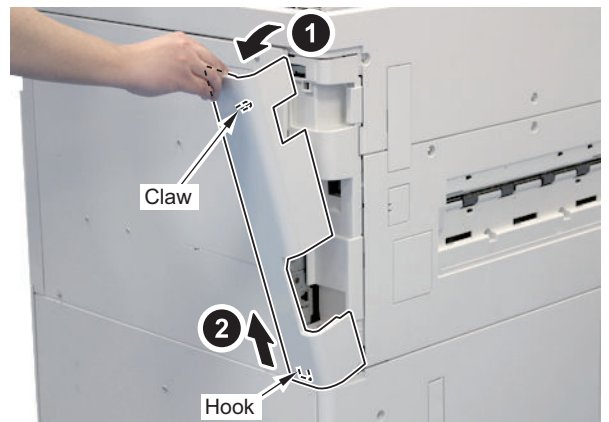
<input type="checkbox"/> [11] Dust Cover X 2 	<input type="checkbox"/> [12] Screw (TP; M3x4) X 8 
<input type="checkbox"/> [13] Screw (Binding; M4x4) X 1 	<input type="checkbox"/> [14] Telephone Cord (2 Contact type) X 1 

Installation Procedure

Preparation

1. Remove the Left Rear Cover.

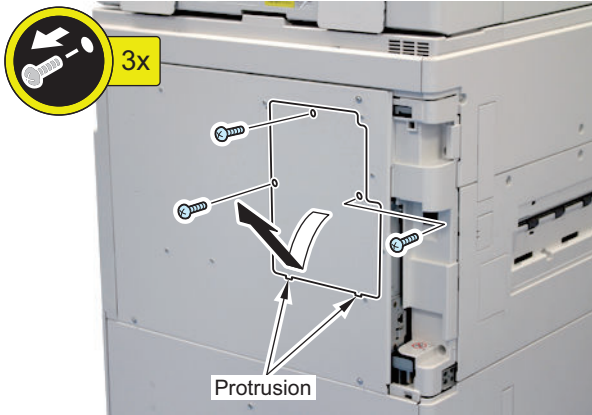
- 1 Claw
- 1 Hook





2. Remove the Rear Cover 2.

- 3 Screws
- 2 Protrusions

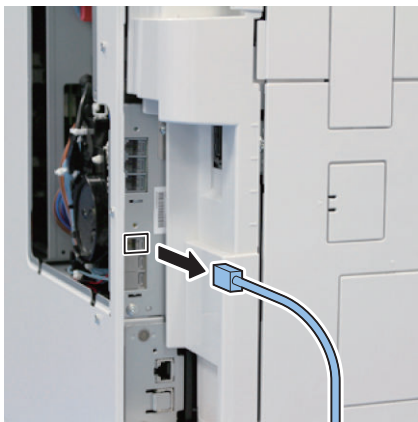


NOTE:

- When the Super G3 FAX Board is installed: Perform steps 3 and 4, and proceed to step 6.
- When installing the Super G3 FAX Board at the same time: Proceed to step 5.



3. Disconnect the Telephone Cord of the FAX (1-Line).

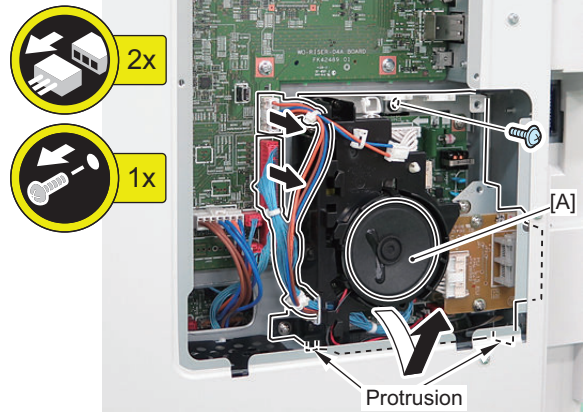


4. Remove the FAX Unit.

- 2 Connectors
- 1 Screw
- 2 Protrusions

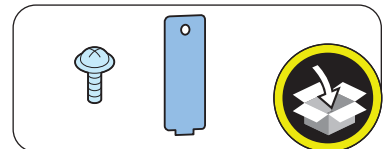
CAUTION:

Be careful not to damage the [A] part of the speaker as the wiring may be open circuit.



5. Remove the Face Cover of the FAX (1-Line). (The removed parts will not be used.)

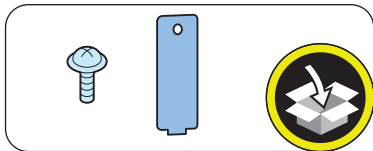
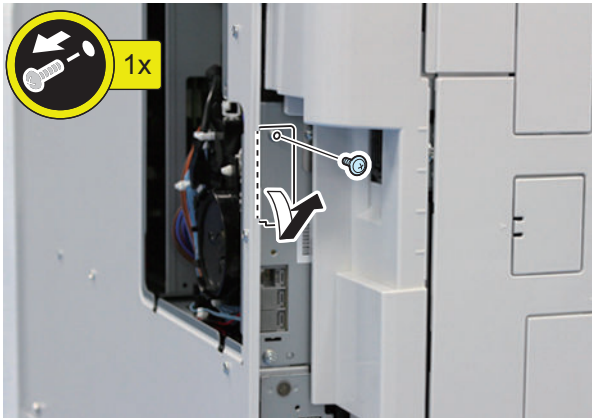
- 1 Screw
- 1 Protrusion





6. Remove the Face Cover of the FAX (2-Line). (The removed parts will not be used.)

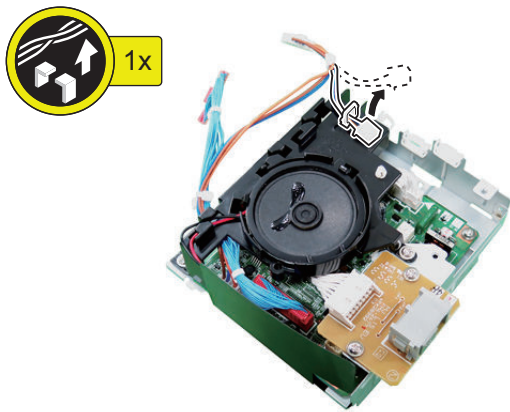
- 1 Screw
- 1 Protrusion



■ Installing the Equipment

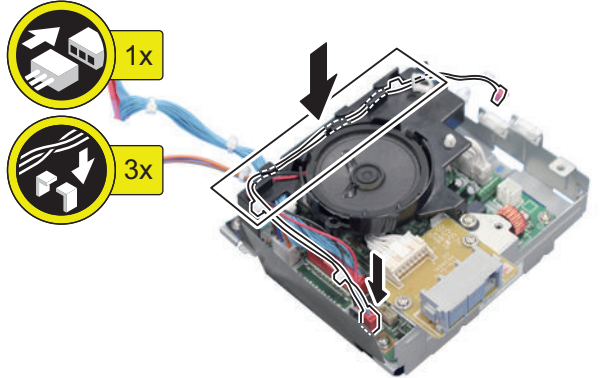
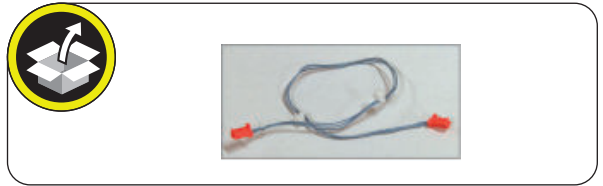


1. Free the Cable from the Wire Saddle.

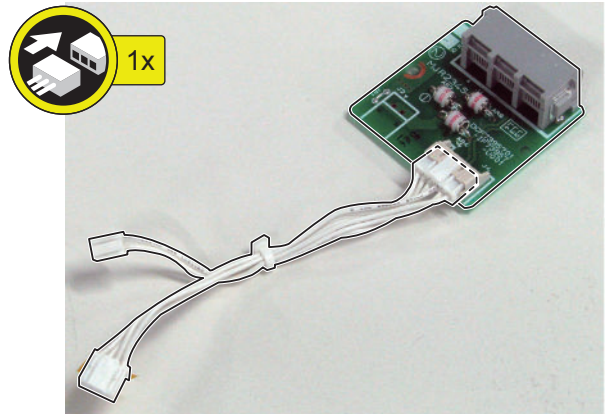
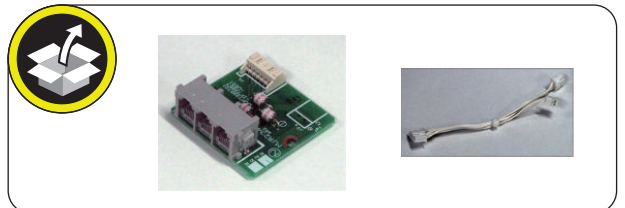


2. Install the Signal Cable to the FAX Unit.

- 3 Cable Guides



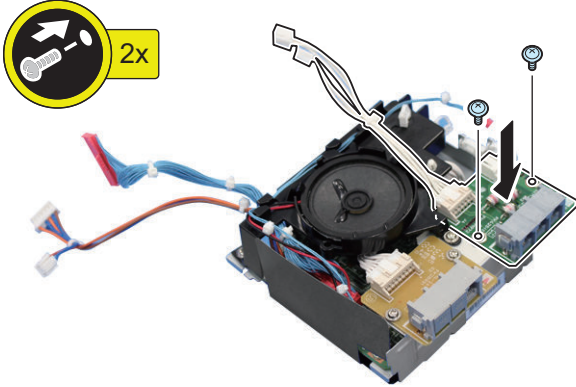
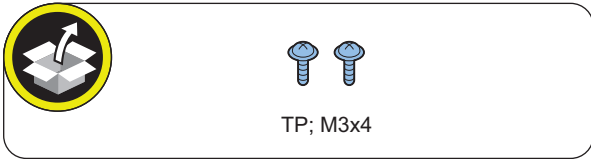
3. Install the Modular Cable to the Modular PCB.





4. Install the Modular PCB to the FAX Unit.

- 2 Screws (TP; M3x4)

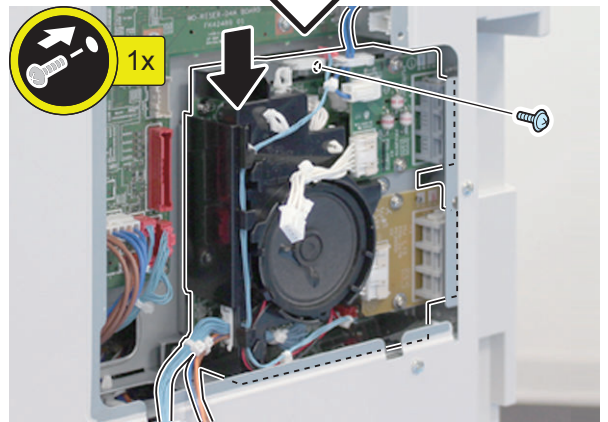
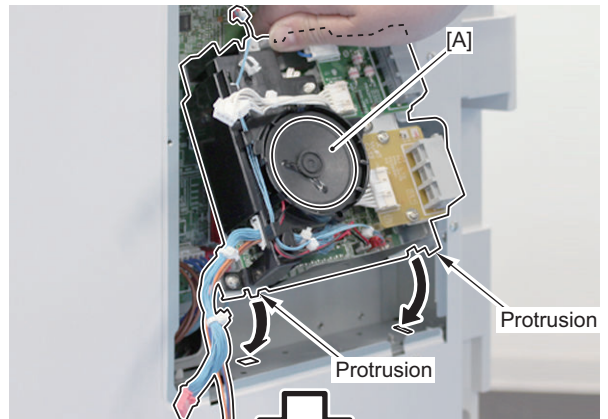


5. Install the FAX Unit to the Host Machine.

- 2 Protrusions
- 1 Screw (TP; M3x4 Black) (Use the removed screw or those included with the Super G3 FAX Board)

CAUTION:

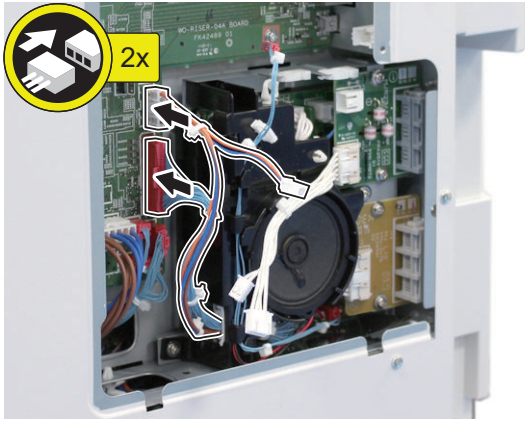
- Be careful not to damage the [A] part of the speaker as the wiring may be broken.
- Be sure to tighten the screw while holding the FAX Unit.
- After tightening the screw of the FAX Unit, check for any backlash. If there is backlash, tighten the screw again with the protrusion precisely fitted.



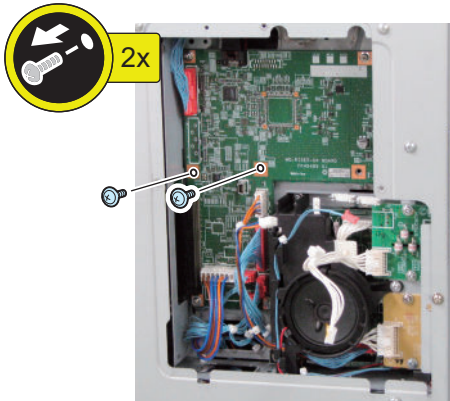


6. Install the 2 Cable of the FAX Unit.

- 2 Connectors

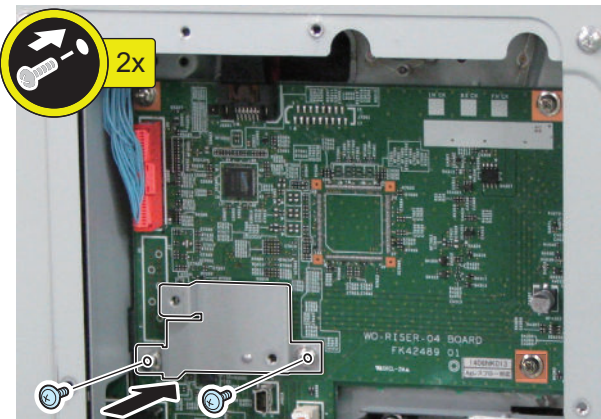
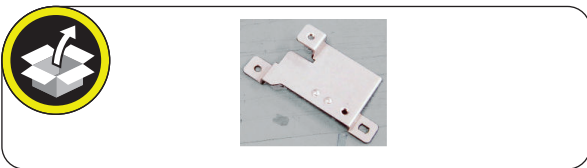


7. Remove the 2 Screws. (will be used in next step)



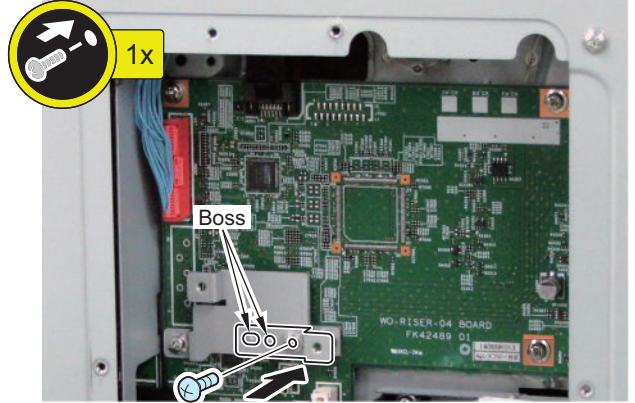
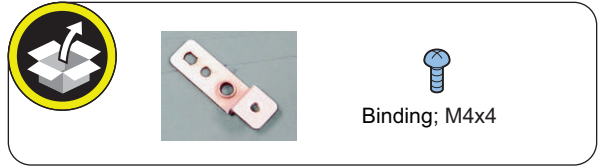
8. Install the FAX Shield Plate.

- 2 Screws (screws removed in the previous step)



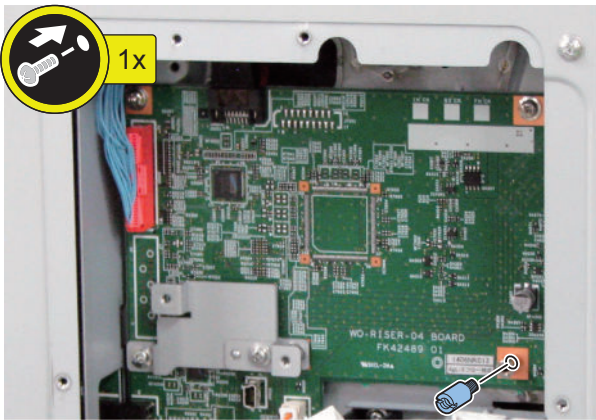
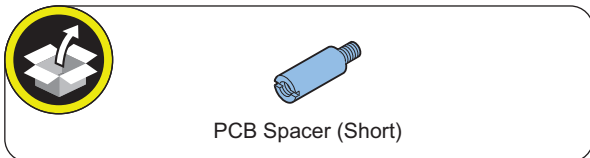
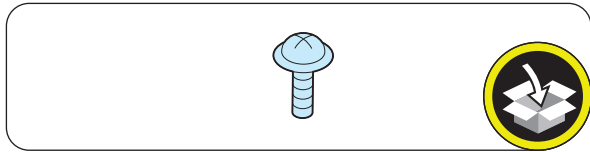
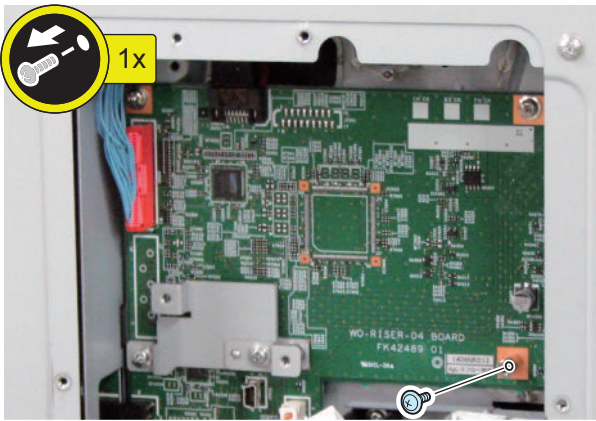
9. Install the FAX Board Fixed Plate.

- 2 Bosses
- 1 Screw (Binding; M4x4)

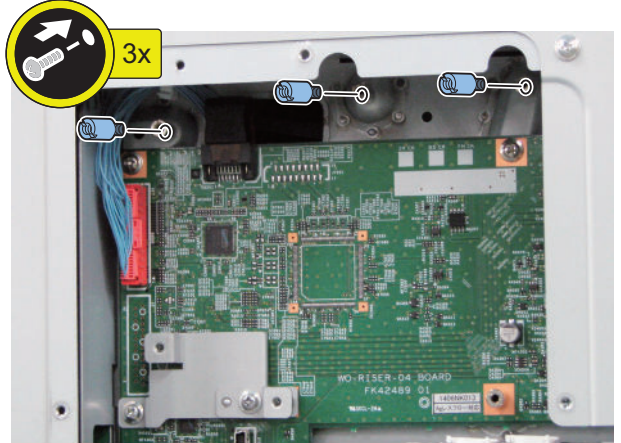
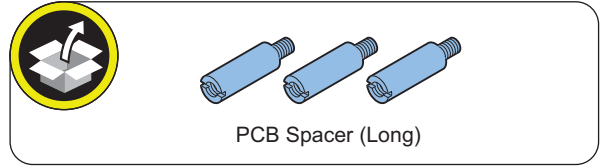




10. Remove the Screw and install the PCB Spacer (Short). (The removed screw will not be used.)



11. Install the 3 PCB Spacers (Long).

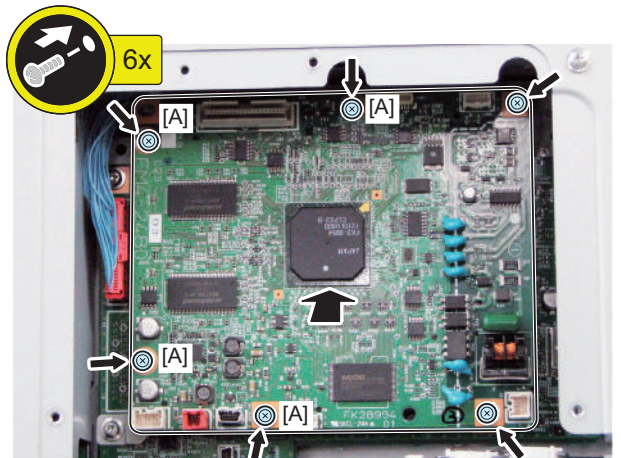
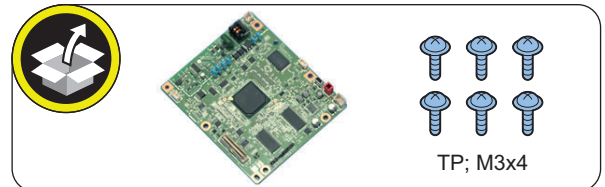


12. Install the G3FAX Expansion PCB.

- 6 Screws (TP; M3x4)

NOTE:

Because the 4 screws [A] need to be removed when installing the Super G3 3rd/4th Line Fax Board at the same time, it is efficient not to tighten them here.



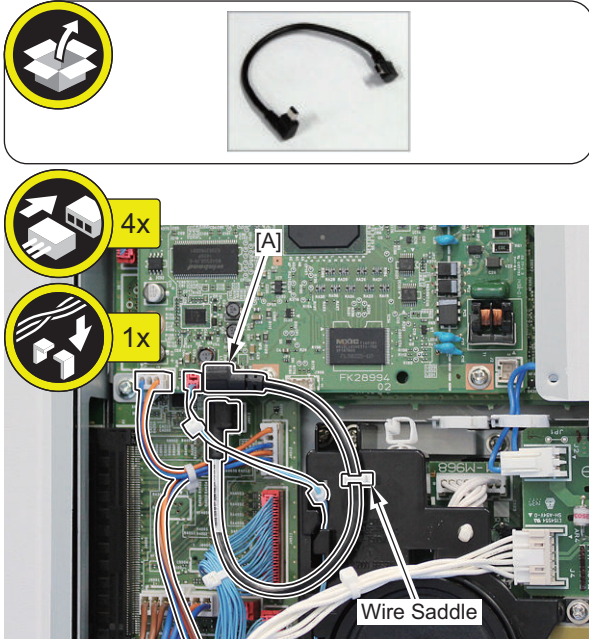


13. Install the Signal Cable, Power Supply Cable and USB Cable to the G3FAX Expansion PCB.

- 1 Wire Saddle

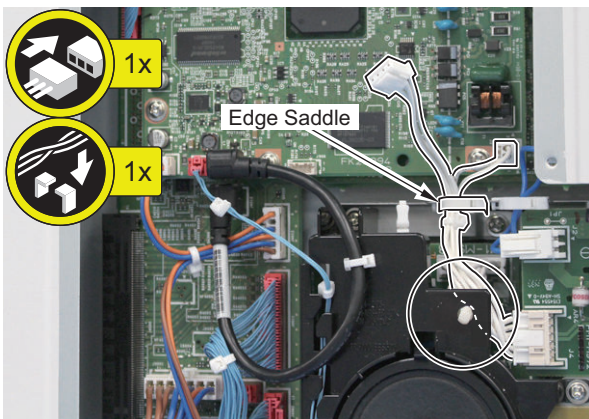
NOTE:

Because [A] of the USB Cable needs to be disconnected when installing the Super G3 3rd/4th Line Fax Board at the same time, it is efficient not to connect it here.



14. Pass the Modular Cable inside the Speaker Holder, and install the G3 FAX Control PCB.

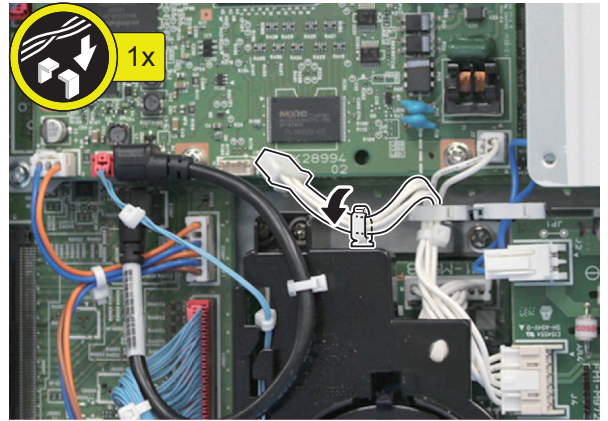
- 1 Edge Saddle



NOTE:

When installing the Super G3 3rd/4th Line Fax Board at the same time, the following step is not necessary.

15. Secure the cable with the Wire Saddle.



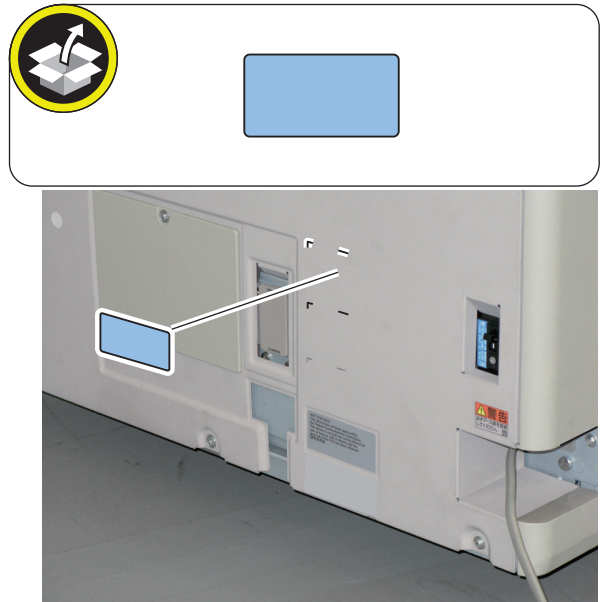
■ Subsequent Work



NOTE:

The following work is required only when installing the Super G3 FAX Board at the same time.

1. Affix the following FAX Approval Label.

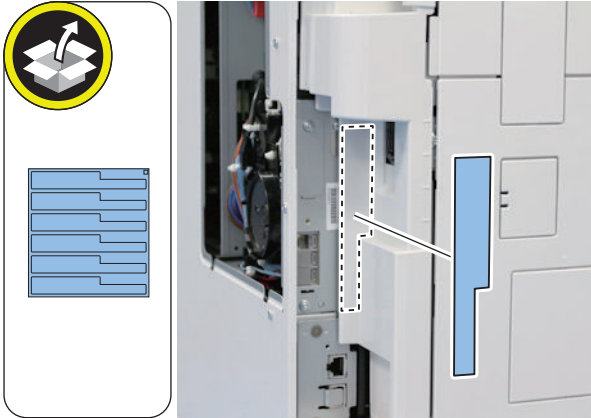


□

NOTE:

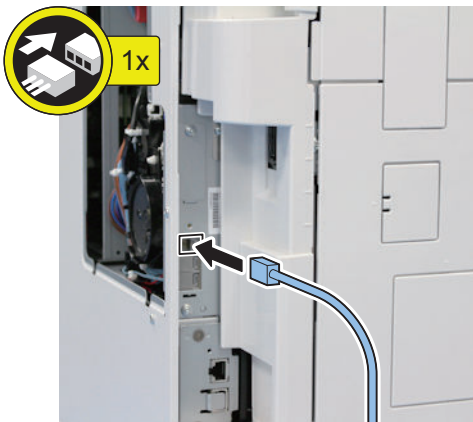
When installing the Super G3 3rd/4th Line Fax Board at the same time, the following step is not necessary.

2. Affix the appropriate Modular Label to the place shown in the figure.



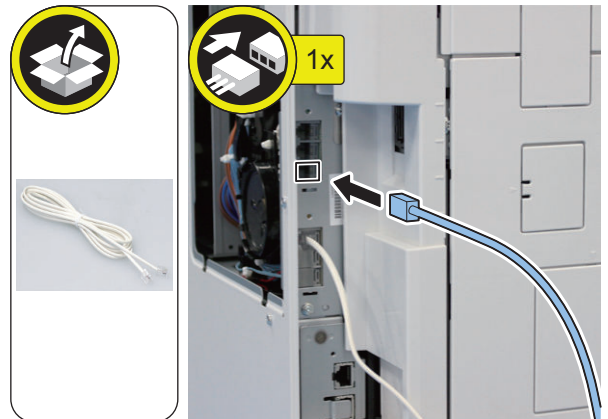
□

3. Connect the Telephone Cord of the FAX (1-Line). When installing this equipment at the same time, connect the other end to the modular jack on the wall.



□

4. Connect the end of the Telephone Cord to the modular jack on the Host machine, and connect the other end to the modular jack on the wall.

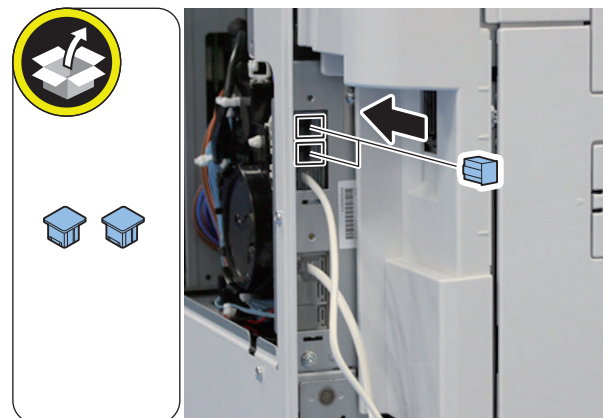


□

NOTE:

When installing the Super G3 3rd/4th Line Fax Board at the same time, the following step is not necessary.

5. Install the Dust Cover.

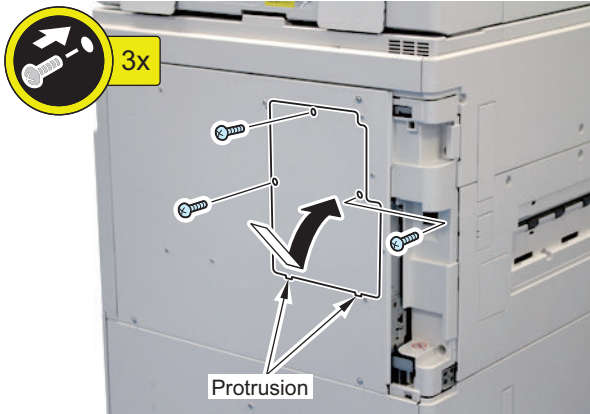


NOTE:

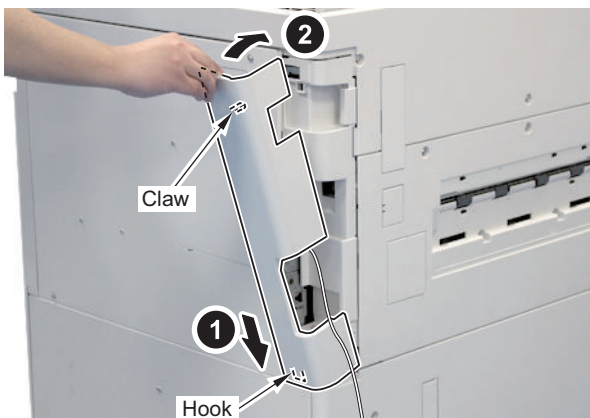
When performing the following steps, it is efficient to install the cover after installing the Super G3 3rd/4th Line Fax Board in case of installing the fax board at the same time.

**6. Install the Rear Cover 2.**

- 2 Protrusions
- 3 Screws

**7. Install the Left Rear Cover.**

- 1 Hook
- 1 Claw

**8. Connect the Power Plug to the outlet.****9. Turn ON the main power switch.****CAUTION:**

If the machine does not recognize this equipment, unplug and then plug the power plug after turning OFF the main power switch, or turn OFF the main power switch and then turn it ON within 20 seconds. To avoid this symptom, unplug the power plug or turn the breaker OFF when installing.

- 10. If a message prompting the user to update the version appears, press [Update] to automatically update the version of this equipment.**

NOTE:

If [Skip] is selected, a message prompting the user to update the version will appear every time the host machine is started.

In the service mode (Lv.2) shown below, it is possible to set not to display the message.

COPIER > OPTION > FNC-SW > VER-CHNG

Checking the Operation

Type Settings

Select the country/region of the FAX Board in Service Mode:
FAX > Type > TYPE

This setting performs the parameter settings to match the communication specification of the country/region.



- 1. From the following service mode, set the TYPE of country/region to install this machine, and then press OK.**

FAX > TYPE > TYPE

- 2. Confirm that service mode parameter below is "0". In the case, parameter is "1", change to "0".**

COPIER > OPTION > DSPLY-SW > SDTM-DSP

NOTE:

To change parameter to "0" makes no show below [Settings/Registration > Preferences > Time/Energy Settings > Auto Shutdown Time] and auto shut down is not available.

- 3. Turn OFF/ON the main power switch to enable this setting.**

Basic Settings

NOTE:

When "System Manager Information Settings" is set, be sure to follow the direction of user administrator in order to log in as an administrator.

In this section, make only minimum settings required for FAX communication.



- 1. Set the user telephone number.**

[Settings/Registration] > [Function Settings] > [Send] > [Fax Settings] > [Set Line] > [Line 2] > [Register Unit Telephone Number] > Enter FAX number > [OK]

2. Set the type of telephone line.

[Settings/Registration] > [Function Settings] > [Send] > [Fax Settings] > [Set Line] > [Line 2] > [Select Line Type] > Select the line type to connect > [OK]

3. Turn OFF/ON the main power switch after setting the user telephone numbers and the type of telephone line.**■ FAX Communication Test**

Perform communication test to check if FAX function works correctly.

**1. Switch the control panel display to Fax display.****2. Select the sending line.**

Press [Fax] > [Options] > [Select Line], select the added line, then press [OK] button.

3. Send and receive a test original between the equipment and a remote unit with which a communication test can be performed and check if it can be sent and receive correctly.

1. Press [Status Monitor/Cancel] > [Send] > [Job Log] and select [Fax] from pull down menu.
2. Press [Fax Activity Report] > [OutPut Normally] > [Start Printing].
3. The number printed following colon (:) in "COMM.MODE" field on FAX ACTIVITY REPORT TX/RX shows line type used for sending/receiving. E.g. "ECM:2" => Line 2

NOTE:

If E744-5000 error code (Fax software version mismatch error) occurred while sending or receiving fax, upgrade the firmware of 2-line Fax to the latest version.

Super G3 3rd/4th Line Fax Board-AS1

Product Name

Safety regulations require the product's name to be registered. In some regions where this product is sold, the following name may be registered instead.

- F632503

Points to Note at Installation

- Install this equipment after installing the Super G3 FAX Board and Super G3 2nd Line Fax Board.
- When installing Super G3 2nd Line Fax Board at the same time, start from "Installing the Equipment".
- When installing this equipment later, start from "Preparation".

Essential Items to Be Performed Before Installation

- Turn OFF the main power of the host machine, and disconnect the power plug from the outlet.

⚠ WARNING:

- If performing work without disconnecting the power plug of the host machine, it may cause electrical shock.
- If disconnecting the power plug without turning OFF the main power, it may cause damage of the machine.

- When turning OFF the main power, follow the below procedure.
 1. Turn OFF the main power switch of the host machine.
 2. The display in the Control Panel and the lamp of the main power are turned off.

Points to Note When Turning ON/OFF the Main Power

The following message is displayed.

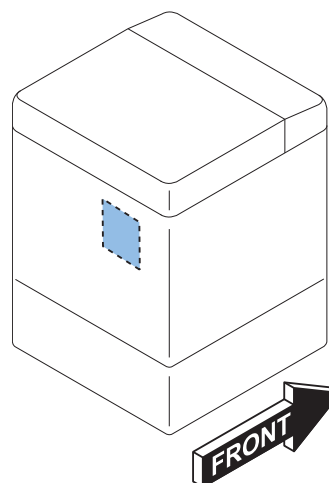
1. When a message prompting to turn OFF and then ON the main power appears, turn OFF and then ON the main power switch.

2. If a message prompting the user to update the version appears, press [Update] to automatically update the version of this equipment.

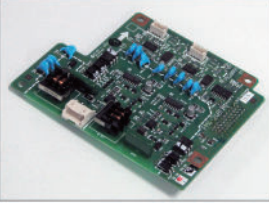
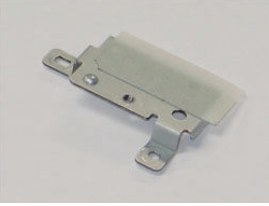

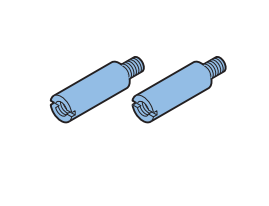
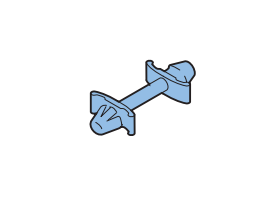
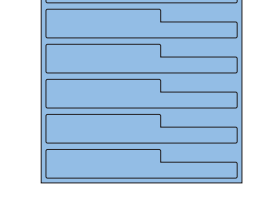
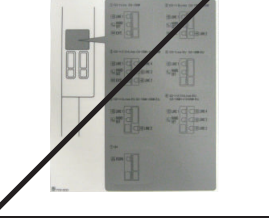
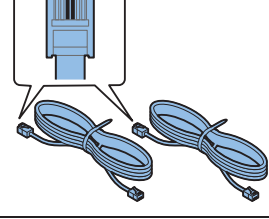
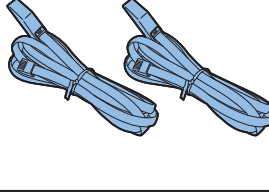
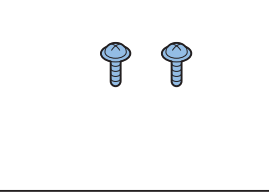
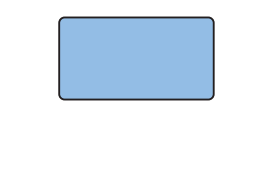
If [Skip] is selected, a message prompting the user to update the version will appear every time the host machine is started. In the service mode (Lv. 2) shown below, it is possible to set not to display the message.

COPIER > OPTION > FNC-SW > VER-CHNG

Installation Outline Drawing



Checking the Contents

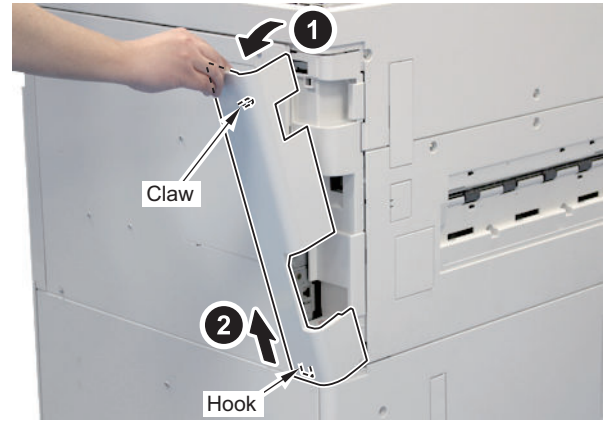
<input type="checkbox"/> [1] G3FAX Expansion PCB X 1 	<input type="checkbox"/> [2] FAX Shield Plate X 1 
<input type="checkbox"/> [3] FAX Board Fixed Plate X 1 	<input type="checkbox"/> [4] PCB Spacer X 2 
<input type="checkbox"/> [5] Resin Spacer X 1 	<input type="checkbox"/> [6] Modular Label X 1 
<input type="checkbox"/> [7] Modular Label X 1 	<input type="checkbox"/> [8] Telephone Cord X 2 
<input type="checkbox"/> [9] PTT Cable X 2 (only for Asia) 	<input type="checkbox"/> [10] Screw (TP; M3x4) X 2 
<input type="checkbox"/> [11] FAX Approval Label (only for Taiwan) X 1 	

Installation Procedure

Preparation

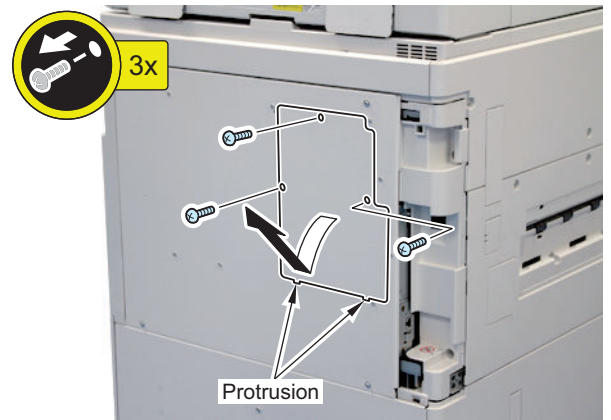
1. Remove the Left Rear Cover.

- 1 Claw
- 1 Hook

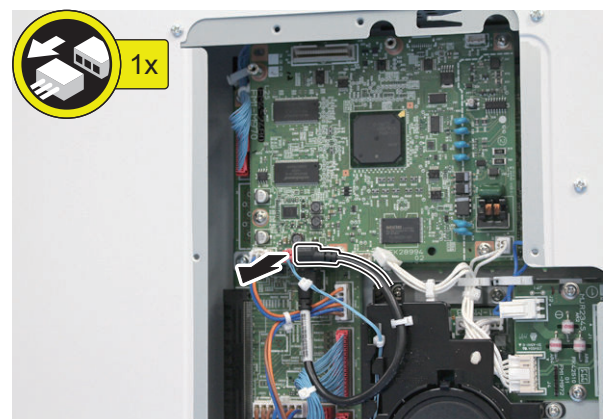


2. Remove the Rear Cover 2.

- 3 Screws
- 2 Protrusions

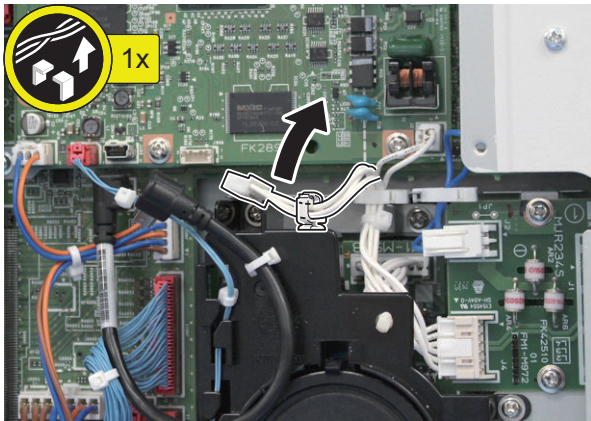


3. Disconnect the USB Cable of the G3FAX Expansion PCB side.

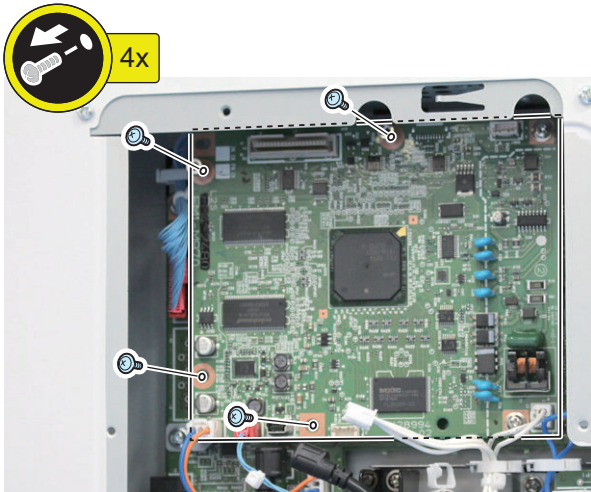




4. Free the Modular Cable from the Wire Saddle. (Close the Wire Saddle.)



5. Remove the 4 Screws. (will be used in Installing the Equipment)

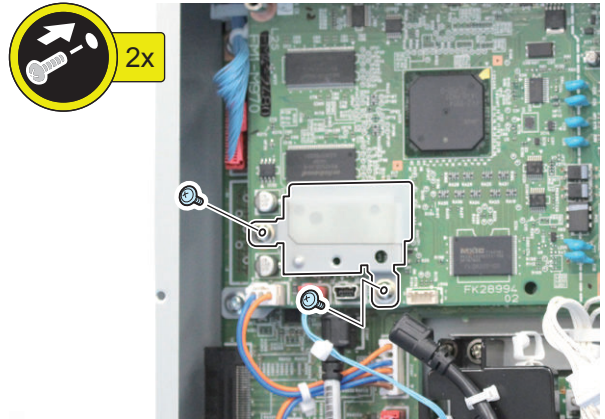
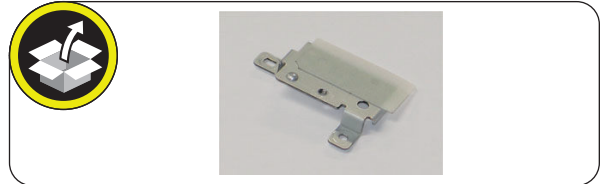


■ Installing the Equipment



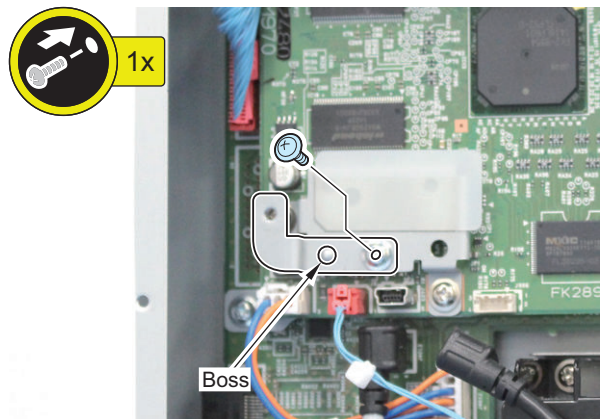
1. Install the FAX Shield Plate.

- 2 Screws (Use the removed screws or TP; M3x4 included with the FAX (2-Line))



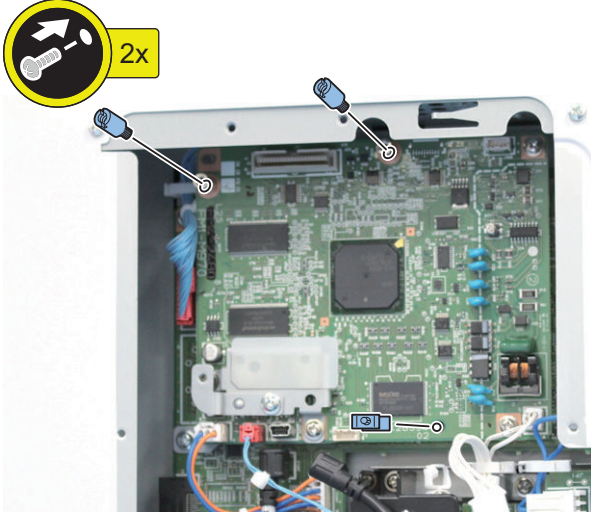
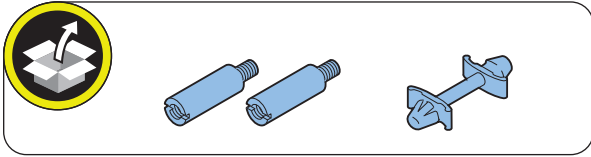
2. Install the FAX Board Fixed Plate.

- 1 Boss
- 1 Screw (TP; M3x4)



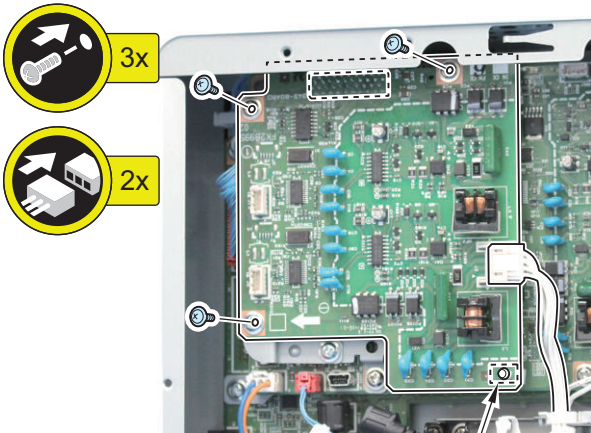
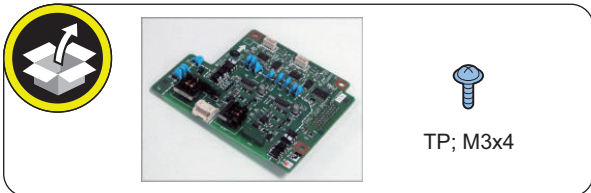


3. Install the 2 PCB Spacers and Resin Spacer.

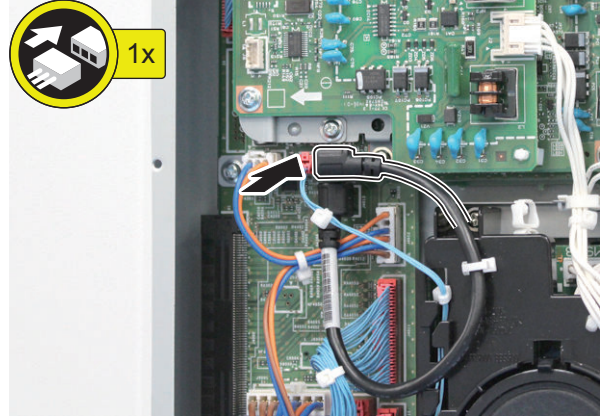


4. Install the G3FAX Expansion PCB.

- Upper Side: 2 Screws (Use the removed screws or TP; M3x4 included with the FAX (2-Line))
- Lower Side: 1 Screw (TP; M3x4)
- 1 Resin Spacer
- 2 Connectors



5. Connect the USB Cable.

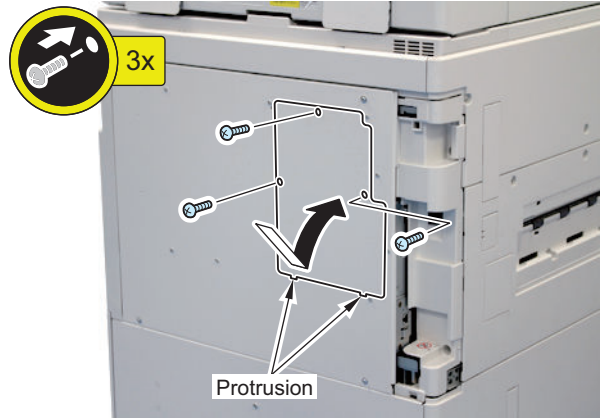


■ Subsequent Work



1. Install the Rear Cover 2.

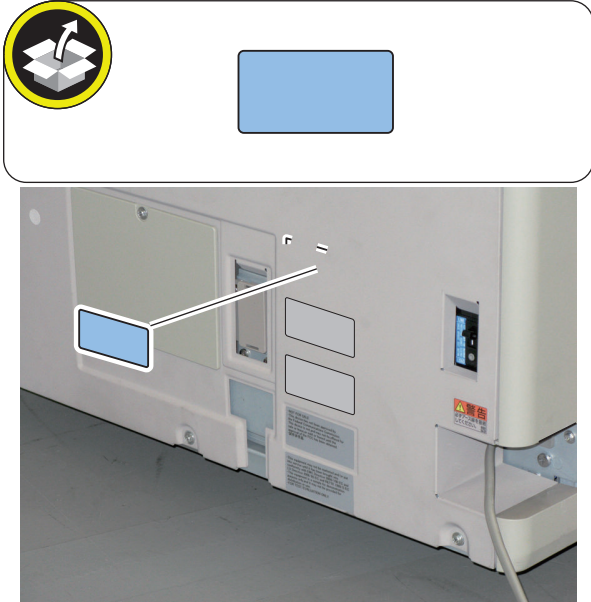
- 2 Protrusions
- 3 Screws



□

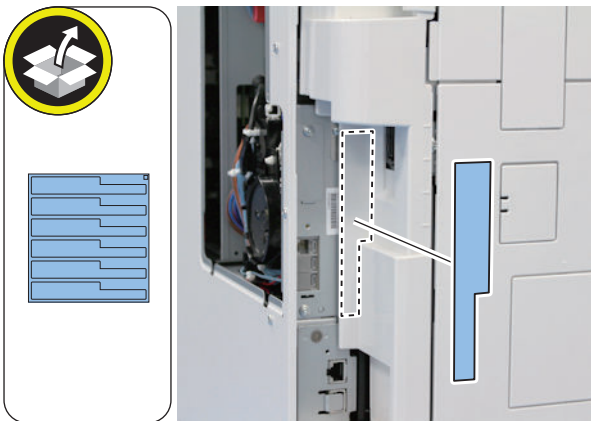
NOTE:
This step is only for Taiwan.

2. Affix the following FAX Approval Label.



□

3. Affix the appropriate Modular Label. If a label is already affixed, remove it and then affix the appropriate label.

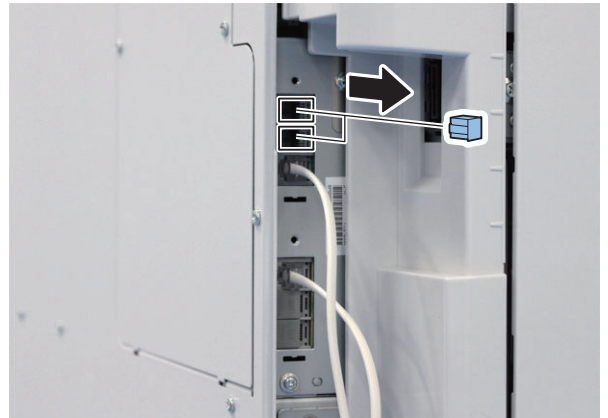


□

4. Remove the 2 Dust Covers if installed.

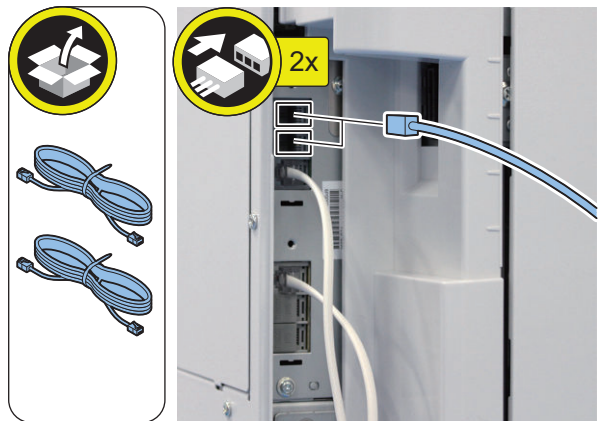
CAUTION:
Do not insert a screwdriver, etc. into the modular terminal.

NOTE:
Keep the removed Dust Cover.



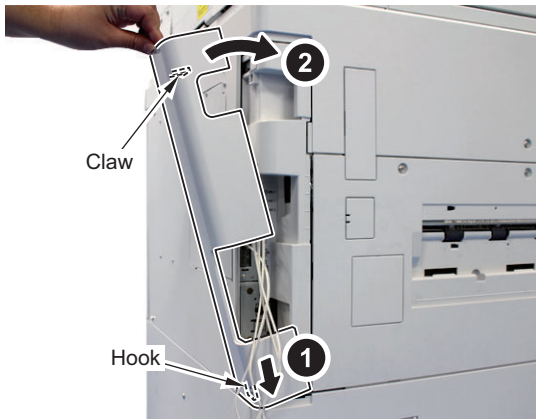
□

5. Connect one of the 2 Telephone Cords or the 2 PTT Cables to the modular jack on the host machine and the other cord to the modular jack on the wall.



**6. Install the Left Rear Cover.**

- 1 Hook
- 1 Claw

**7. Connect the power plug to the outlet.****8. Turn ON the main power switch.****CAUTION:**

If the machine does not recognize this equipment, unplug and then plug the power plug after turning OFF the main power switch, or turn OFF the main power switch and then turn it ON within 20 seconds.

To avoid this symptom, unplug the power plug or turn the breaker OFF when installing.

If the host machine still does not recognize this equipment after performing the foregoing remedy: In the case of installing the Super G3 Fax Board (1-Line) and the Super G3 2nd Line Fax Board at the same time, it is necessary to turn OFF and then ON the power three times in some cases (no message is displayed on the Control Panel).

Checking the Operation

■ Type Settings

Select the country/region of the FAX Board in Service Mode:
FAX > Type > TYPE

This setting performs the parameter settings to match the communication specification of the country/region.



1. From the following service mode, set the TYPE of country/region to install this machine, and then press OK.

- Service Mode > FAX > Type > TYPE

2. Confirm that service mode parameter below is "0". In the case, parameter is "1", change to "0".

- COPIER > OPTION > DSPLY-SW > SDTM-DSP

NOTE:

To change parameter to "0" makes no show below [Settings/Registration > Preferences > Time/Energy Settings > Auto Shutdown Time] and auto shut down is not available.

3. Turn OFF/ON the main power switch to enable this setting.

■ Basic Settings

NOTE:

When "System Manager Information Settings" is set, be sure to follow the direction of user administrator in order to log in as an administrator.

In this section, make only minimum settings required for FAX communication.



1. Set the user telephone number.

[Settings/Registration] > [Function Settings] > [Send] > [Fax Settings] > [Set Line] > [Line 3]/[Line 4] > [Register Unit Telephone Number] > Enter FAX number > [OK]

2. Set the type of telephone line.

[Settings/Registration] > [Function Settings] > [Send] > [Fax Settings] > [Set Line] > [Line 3]/[Line 4] > [Select Line Type] > Select the line type to connect > [OK]

3. Turn OFF/ON the main power switch after setting the user telephone numbers and the type of telephone line.

■ FAX Communication Test

Perform communication test to check if FAX function works correctly.



1. Switch the control panel display to Fax display.

2. Select the sending line.

Press [Fax] > [Options] > [Select Line], select the added line, then press [OK] button.

3. Send and receive a test original between the equipment and a remote unit with which a communication test can be performed and check if it can be sent and receive correctly.

1. Press [Status Monitor/Cancel] > [Send] > [Job Log] and select [Fax] from pull down menu.
2. Press [Fax Activity Report] > [OutPut Normally] > [Start Printing].

3. The number printed following colon (:) in "COMM.MODE" field on FAX ACTIVITY REPORT TX/RX shows line type used for sending/receiving. E.g. "ECM:3" => Line 3

Super G3 3rd/4th Line Fax Board-AS2

Product Name

Safety regulations require the product's name to be registered. In some regions where this product is sold, the following name may be registered instead.

- F632503

Points to Note at Installation

- Install this equipment after installing the Super G3 FAX Board and Super G3 2nd Line Fax Board.
- When installing Super G3 2nd Line Fax Board at the same time, start from "Installing the Equipment".
- When installing this equipment later, start from "Preparation".

Essential Items to Be Performed Before Installation

- Turn OFF the main power of the host machine, and disconnect the power plug from the outlet.

⚠ WARNING:

- If performing work without disconnecting the power plug of the host machine, it may cause electrical shock.
- If disconnecting the power plug without turning OFF the main power, it may cause damage of the machine.

- When turning OFF the main power, follow the below procedure.
 1. Turn OFF the main power switch of the host machine.
 2. The display in the Control Panel and the lamp of the main power are turned off.

Points to Note When Turning ON/OFF the Main Power

The following message is displayed.

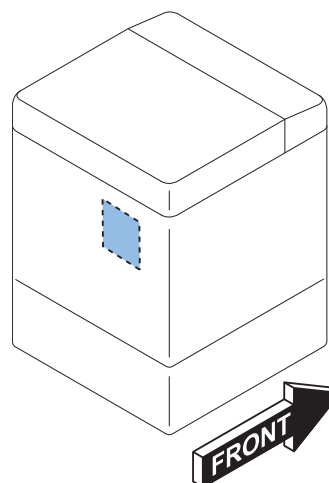
1. When a message prompting to turn OFF and then ON the main power appears, turn OFF and then ON the main power switch.

2. If a message prompting the user to update the version appears, press [Update] to automatically update the version of this equipment.

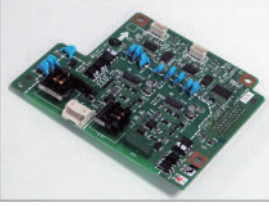
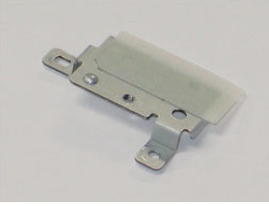

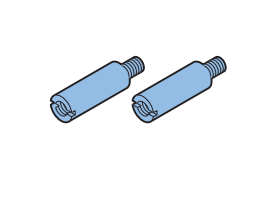
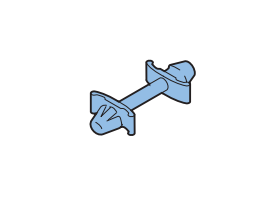
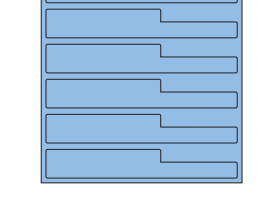
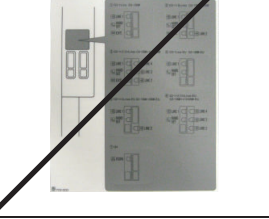
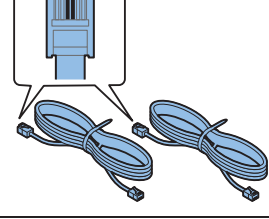
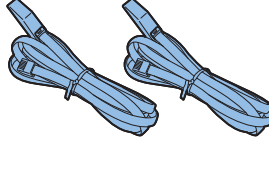
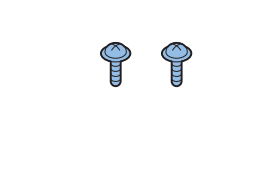
If [Skip] is selected, a message prompting the user to update the version will appear every time the host machine is started. In the service mode (Lv. 2) shown below, it is possible to set not to display the message.

COPIER > OPTION > FNC-SW > VER-CHNG

Installation Outline Drawing



Checking the Contents

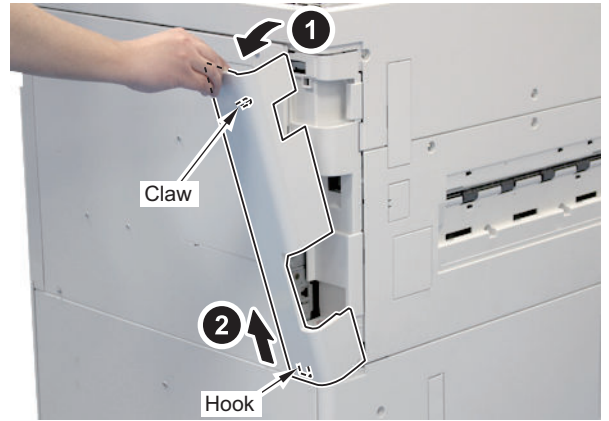
<input type="checkbox"/> [1] G3FAX Expansion PCB X 1 	<input type="checkbox"/> [2] FAX Shield Plate X 1 
<input type="checkbox"/> [3] FAX Board Fixed Plate X 1 	<input type="checkbox"/> [4] PCB Spacer X 2 
<input type="checkbox"/> [5] Resin Spacer X 1 	<input type="checkbox"/> [6] Modular Label X 1 
<input type="checkbox"/> [7] Modular Label X 1 	<input type="checkbox"/> [8] Telephone Cord X 2 
<input type="checkbox"/> [9] PTT Cable X 2 (only for Asia) 	<input type="checkbox"/> [10] Screw (TP; M3x4) X 2 

Installation Procedure

Preparation

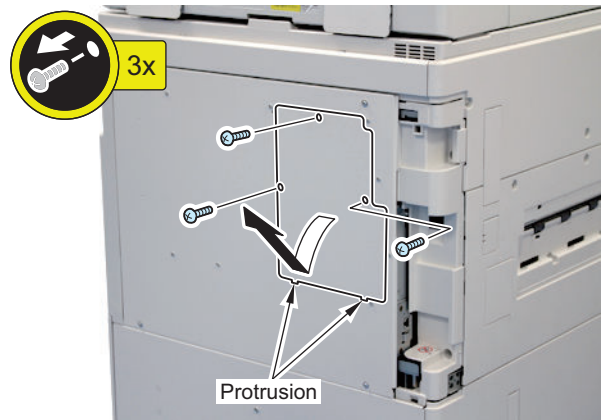
1. Remove the Left Rear Cover.

- 1 Claw
- 1 Hook

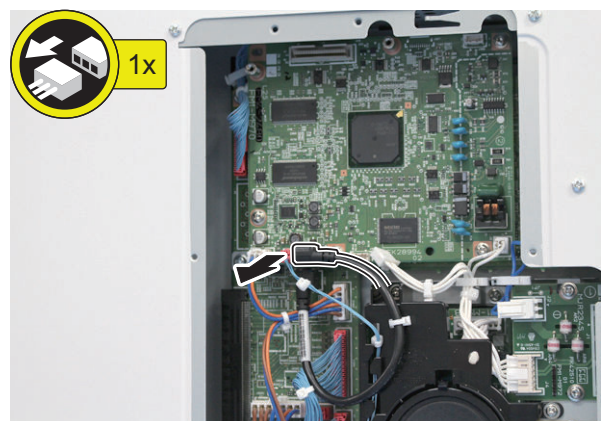


2. Remove the Rear Cover 2.

- 3 Screws
- 2 Protrusions

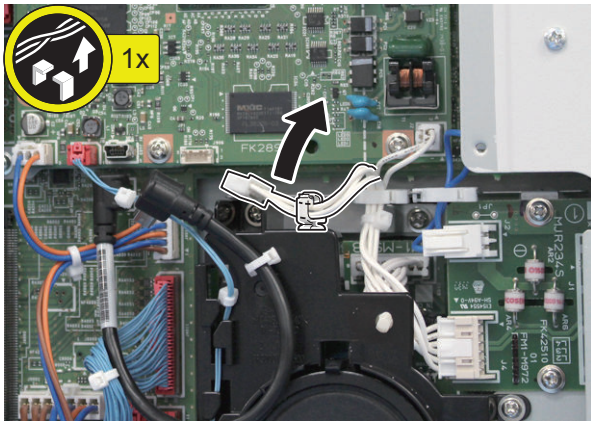


3. Disconnect the USB Cable of the G3FAX Expansion PCB side.

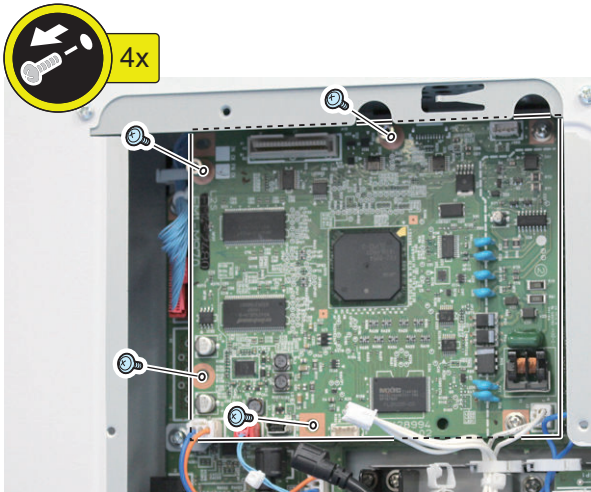




4. Free the Modular Cable from the Wire Saddle. (Close the Wire Saddle.)



5. Remove the 4 Screws. (will be used in Installing the Equipment)

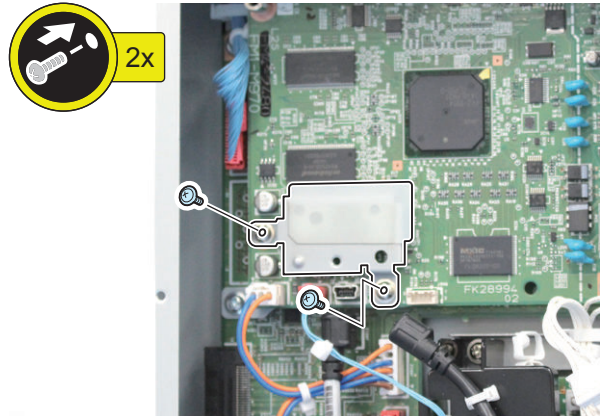
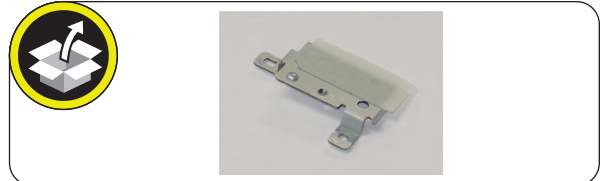


■ Installing the Equipment



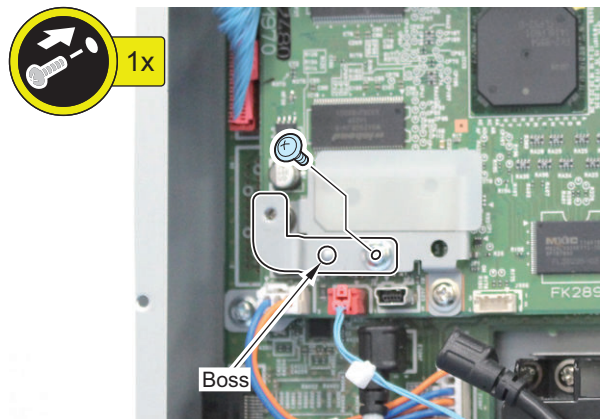
1. Install the FAX Shield Plate.

- 2 Screws (Use the removed screws or TP; M3x4 included with the FAX (2-Line))



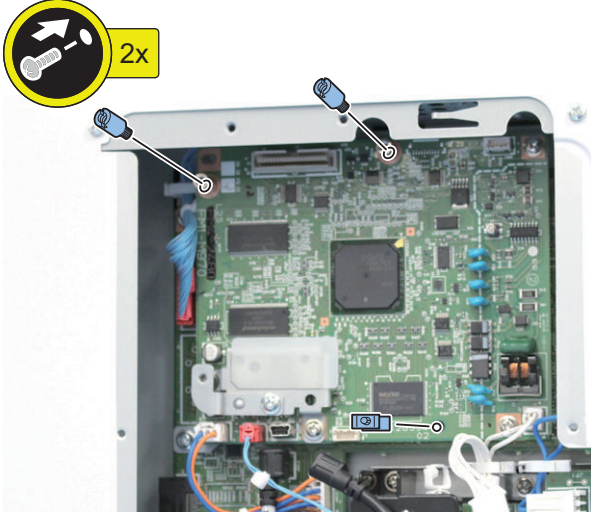
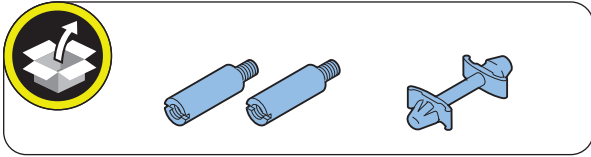
2. Install the FAX Board Fixed Plate.

- 1 Boss
- 1 Screw (TP; M3x4)



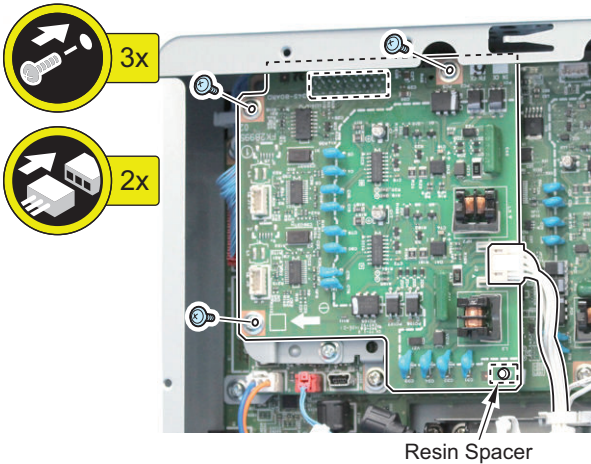
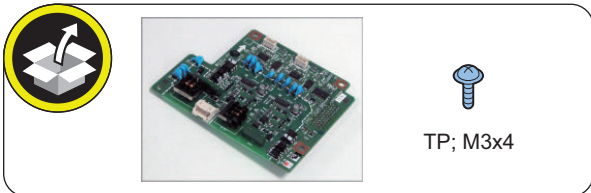


3. Install the 2 PCB Spacers and Resin Spacer.

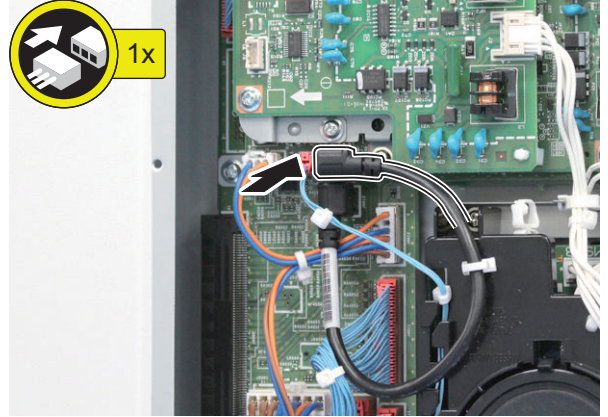


4. Install the G3FAX Expansion PCB.

- Upper Side: 2 Screws (Use the removed screws or TP; M3x4 included with the FAX (2-Line))
- Lower Side: 1 Screw (TP; M3x4)
- 1 Resin Spacer
- 2 Connectors



5. Connect the USB Cable.

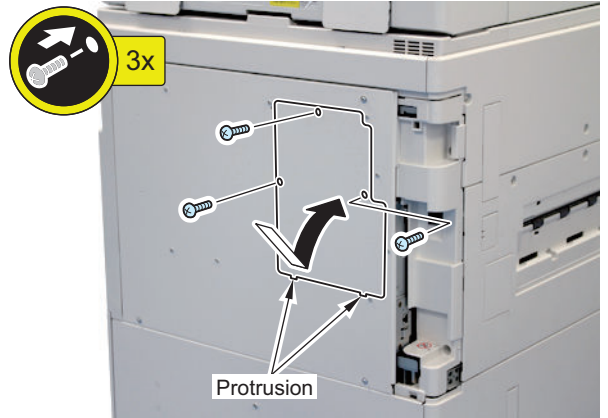


■ Subsequent Work

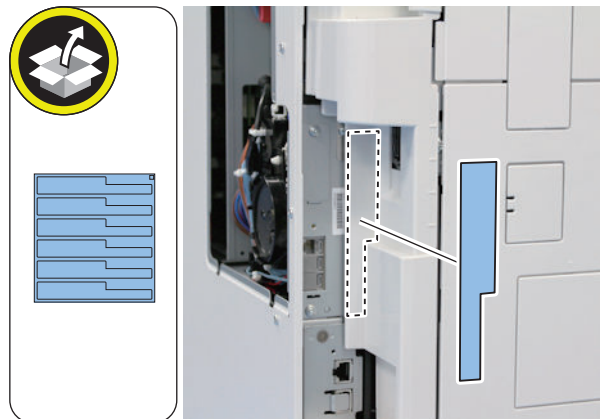


1. Install the Rear Cover 2.

- 2 Protrusions
- 3 Screws



2. Affix the appropriate Modular Label. If a label is already affixed, remove it and then affix the appropriate label.

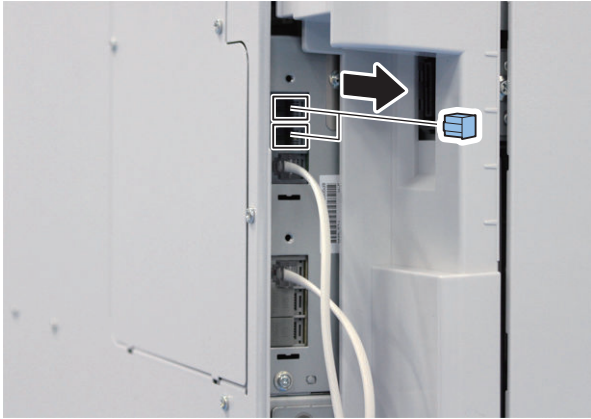


**3. Remove the 2 Dust Covers if installed.****CAUTION:**

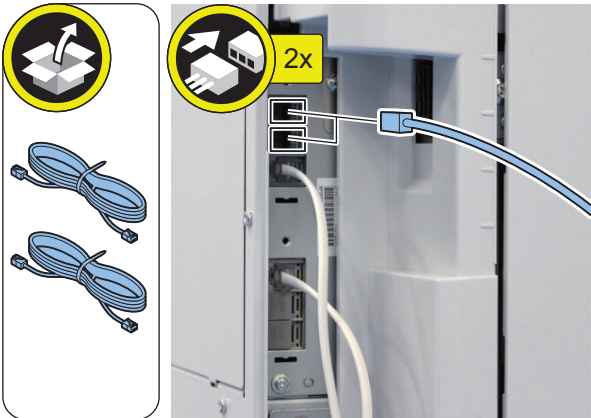
Do not insert a screwdriver, etc. into the modular terminal.

NOTE:

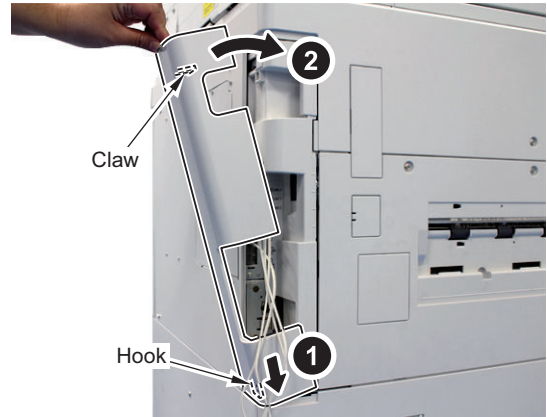
Keep the removed Dust Cover.



4. Connect one of the 2 Telephone Cords or the 2 PTT Cables to the modular jack on the host machine and the other cord to the modular jack on the wall.

**5. Install the Left Rear Cover.**

- 1 Hook
- 1 Claw

**6. Connect the power plug to the outlet.****7. Turn ON the main power switch.****CAUTION:**

If the machine does not recognize this equipment, unplug and then plug the power plug after turning OFF the main power switch, or turn OFF the main power switch and then turn it ON within 20 seconds.

To avoid this symptom, unplug the power plug or turn the breaker OFF when installing.

If the host machine still does not recognize this equipment after performing the foregoing remedy: In the case of installing the Super G3 Fax Board (1-Line) and the Super G3 2nd Line Fax Board at the same time, it is necessary to turn OFF and then ON the power three times in some cases (no message is displayed on the Control Panel).

Checking the Operation

■ Type Settings

Select the country/region of the FAX Board in Service Mode:
FAX > Type > TYPE

This setting performs the parameter settings to match the communication specification of the country/region.



1. From the following service mode, set the TYPE of country/region to install this machine, and then press OK.

- Service Mode > FAX > Type > TYPE

2. **Confirm that service mode parameter below is "0". In the case, parameter is "1", change to "0".**

- COPIER > OPTION > DSPLY-SW > SDTM-DSP

NOTE:

To change parameter to "0" makes no show below [Settings/Registration > Preferences > Time/Energy Settings > Auto Shutdown Time] and auto shut down is not available.

3. **Turn OFF/ON the main power switch to enable this setting.**

■ Basic Settings

NOTE:

When "System Manager Information Settings" is set, be sure to follow the direction of user administrator in order to log in as an administrator.

In this section, make only minimum settings required for FAX communication.



1. **Set the user telephone number.**

[Settings/Registration] > [Function Settings] > [Send] > [Fax Settings] > [Set Line] > [Line 3]/[Line 4] > [Register Unit Telephone Number] > Enter FAX number > [OK]

2. **Set the type of telephone line.**

[Settings/Registration] > [Function Settings] > [Send] > [Fax Settings] > [Set Line] > [Line 3]/[Line 4] > [Select Line Type] > Select the line type to connect > [OK]

3. **Turn OFF/ON the main power switch after setting the user telephone numbers and the type of telephone line.**

■ FAX Communication Test

Perform communication test to check if FAX function works correctly.



1. **Switch the control panel display to Fax display.**

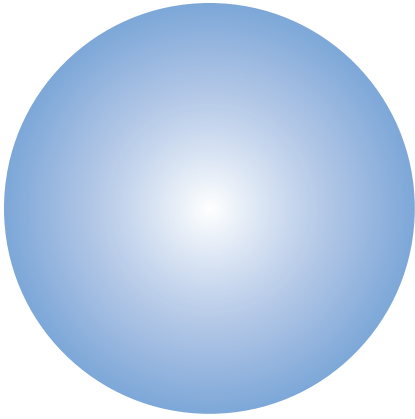
2. **Select the sending line.**

Press [Fax] > [Options] > [Select Line], select the added line, then press [OK] button.

3. **Send and receive a test original between the equipment and a remote unit with which a communication test can be performed and check if it can be sent and receive correctly.**

1. Press [Status Monitor/Cancel] > [Send] > [Job Log] and select [Fax] from pull down menu.
2. Press [Fax Activity Report] > [OutPut Normally] > [Start Printing].

3. The number printed following colon (:) in "COMM.MODE" field on FAX ACTIVITY REPORT TX/RX shows line type used for sending/receiving. E.g. "ECM:3" => Line 3



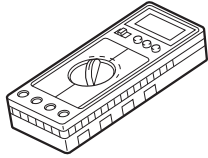
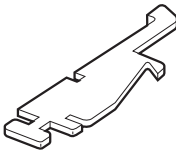
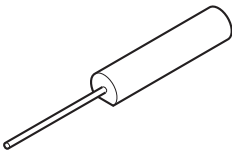
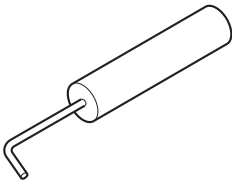
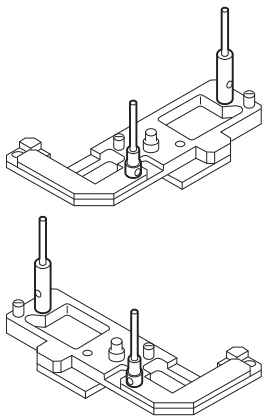
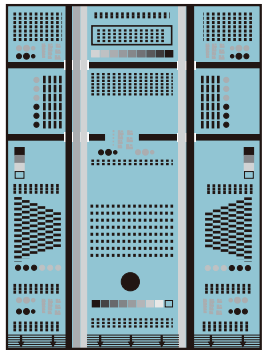
APPENDICES

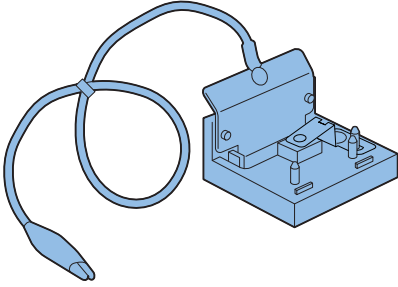
Service Tools.....	2201
General Circuit Diagram.....	2203
Detail of Storage partition.....	2233
Soft counter specifications.....	2235
Removal.....	2239
Target PCBs of Automatic Update..	2242
List of Service Modes That Can Be Restored.....	2243

Service Tools

Special Tools

In addition to the standard tools set, the following special tools are required when servicing the machine.

Tool name	Tool No	Category	Appearance	Remarks
Digital multimeter	FY9-2002	A		Used for electrical checks; for adjustment of laser power in combination with the laser power checker.
Cover switch	TKN-0093	A		
Tester extension pin	FY9-3038	A		Used as a probe extension when making electrical checks.
Tester extension pin(L-shaped)	FY9-3039	A		Used as a probe extension when making electrical checks.
Mirror positioning tool(front, rear)	FY9-3046-00 0	B		Used for positioning the mirror mount 1 and the mirror mount 2.
NA-3 Test Sheet	FY9-9196	A		Use for image adjustment / check

Tool name	Tool No	Category	Appearance	Remarks
Electrode for checking potential sensor	FY9-3059-00 0	B		Surface potential sensor for zero-level check

Reference: Category

A: Must be kept by each service engineer.

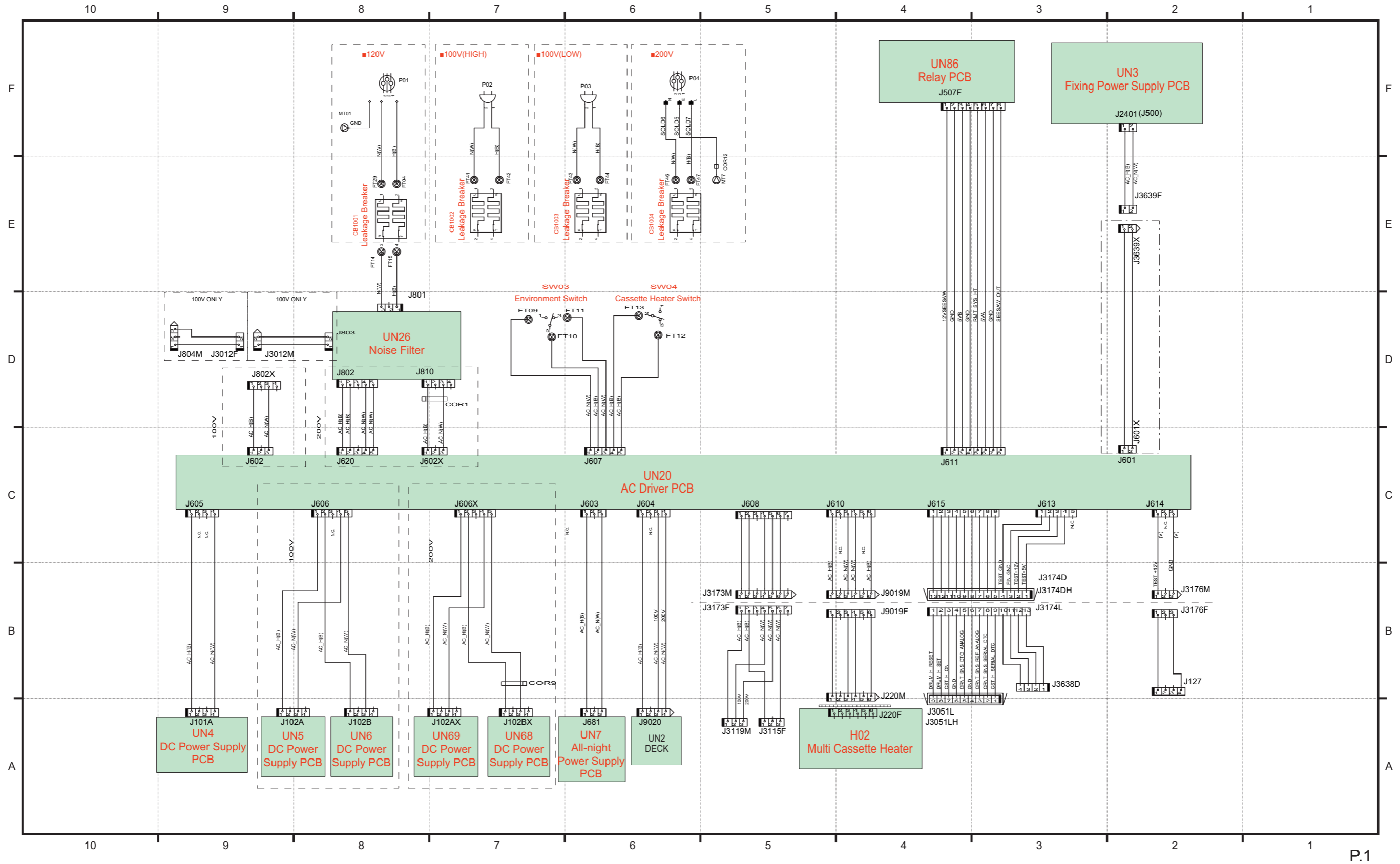
B: Must be kept by each group of about five engineers.

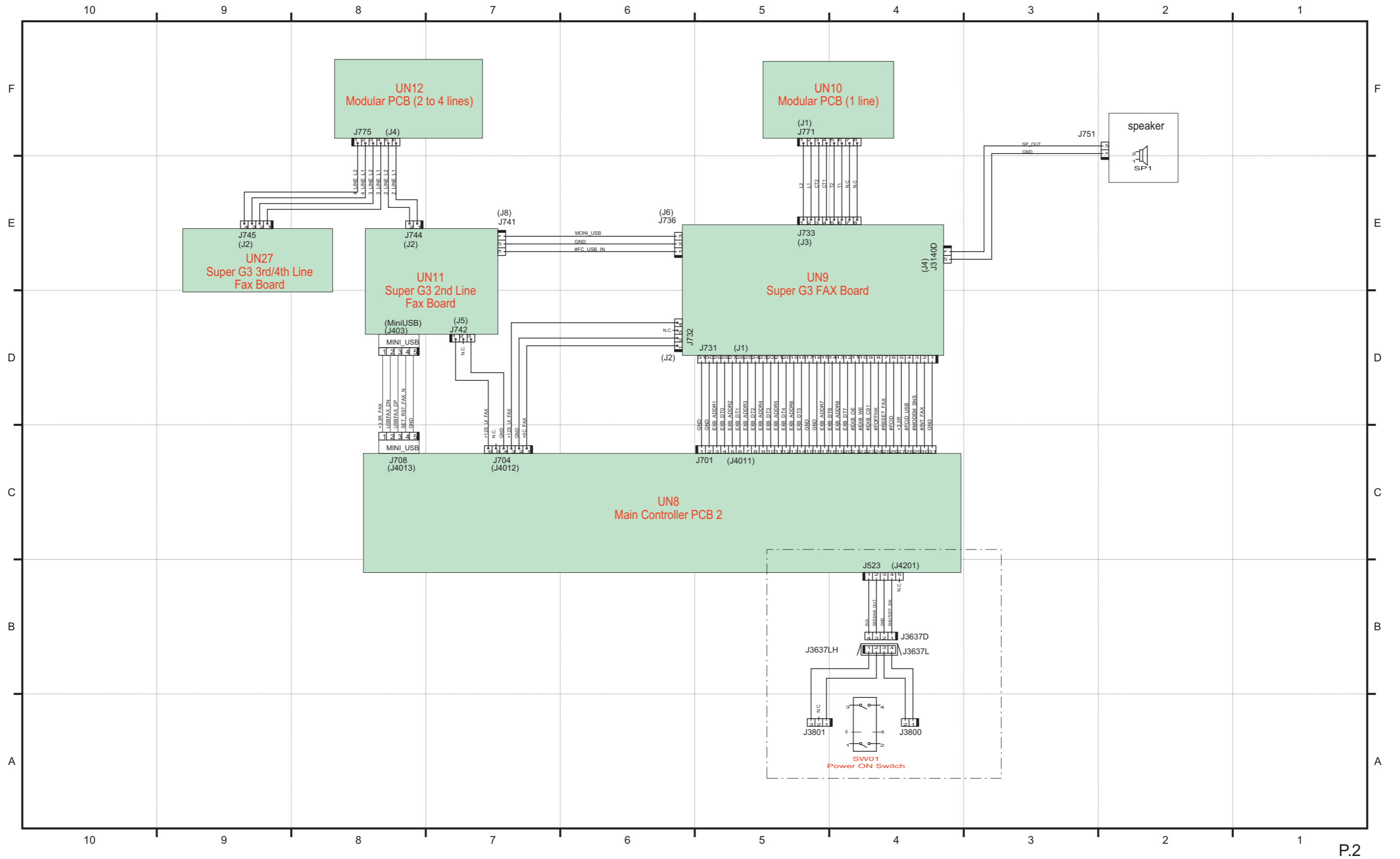
C: Must be kept by each workshop

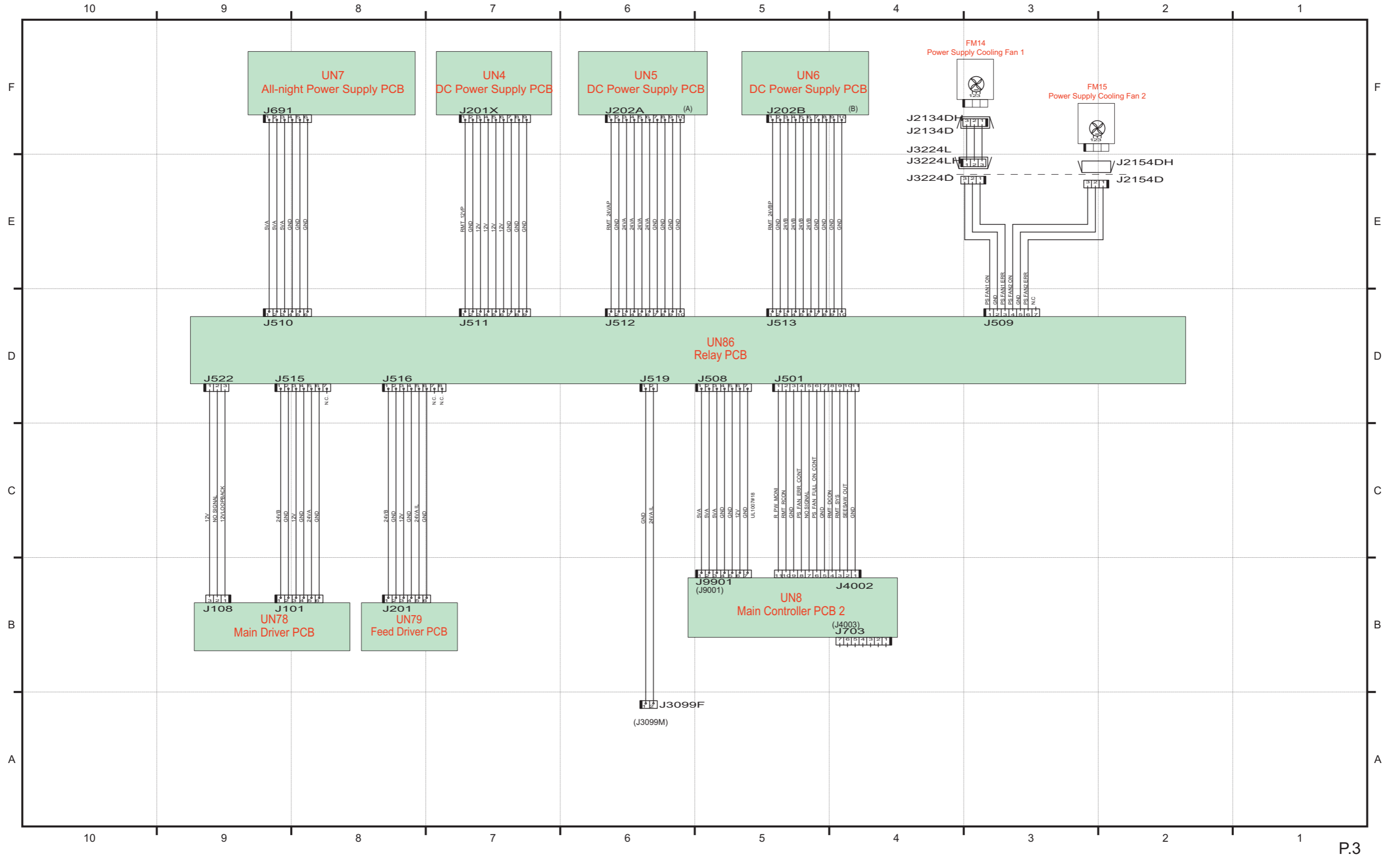
Solvent/Oil List

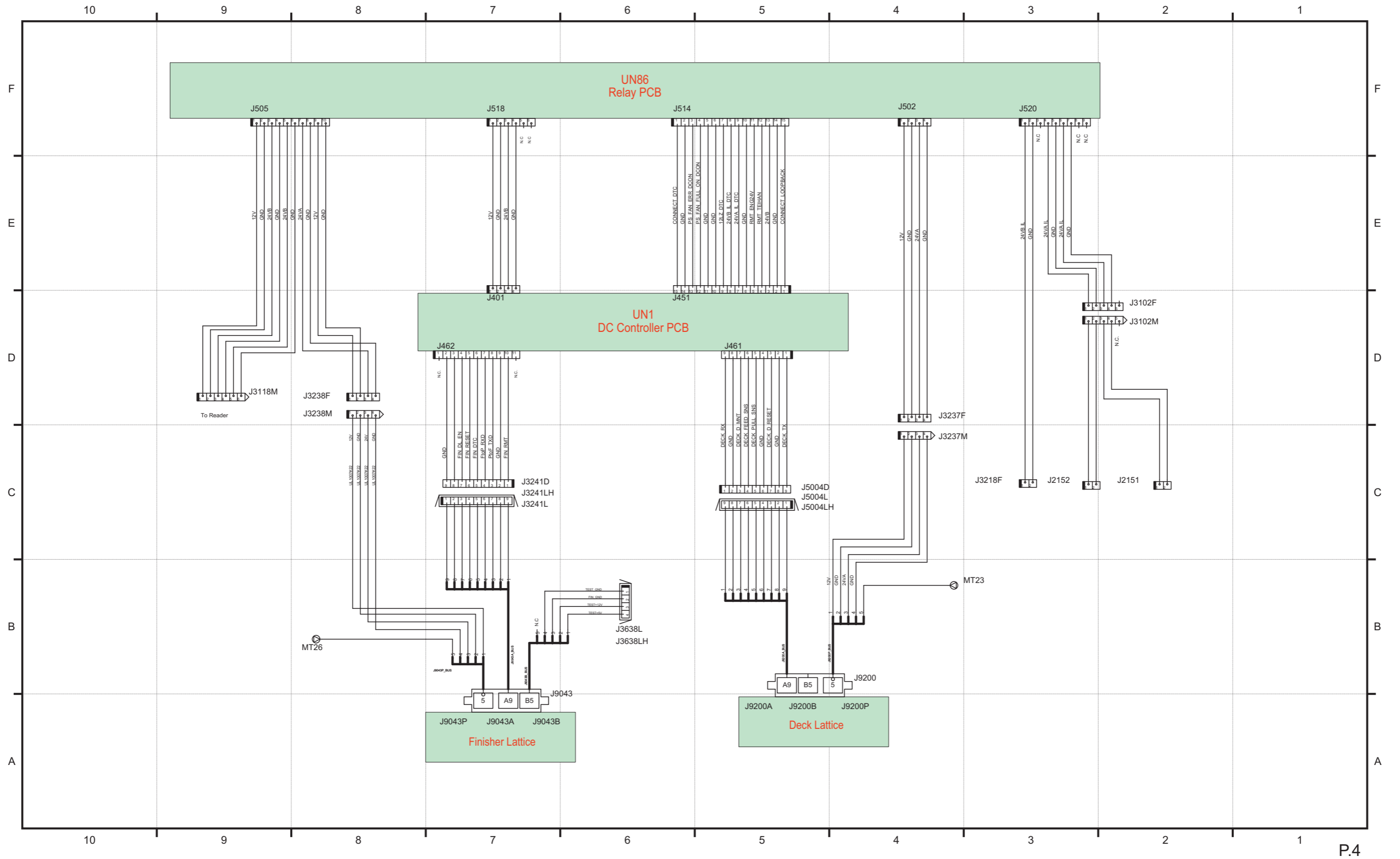
Solvent name	Location of use	Service parts number	Caution
Alcohol	External Covers, Control Panel, etc.	None (to be prepared by sales company)	Never put it close to fire
Super Lube Grease	Gears of the Fixing Assembly	FY9-6005	
Tospearl 240	Drum Cleaner Blade	FY9-6007	
MOLYKOTE EM-50L	Gears	HY9-0007	
Conductive grease	Drum Sliding Assembly	FY9-6008	
Drum cleaning powder	Cleaning of the Photosensitive Drum	FY9-6024	
Oil Glass Cleaner	Cleaning of the surface of the Stream Reading Glass	FY9-6035	
Cleaning cloth	Cleaning of the surface of the Stream Reading Glass	FC5-4430	

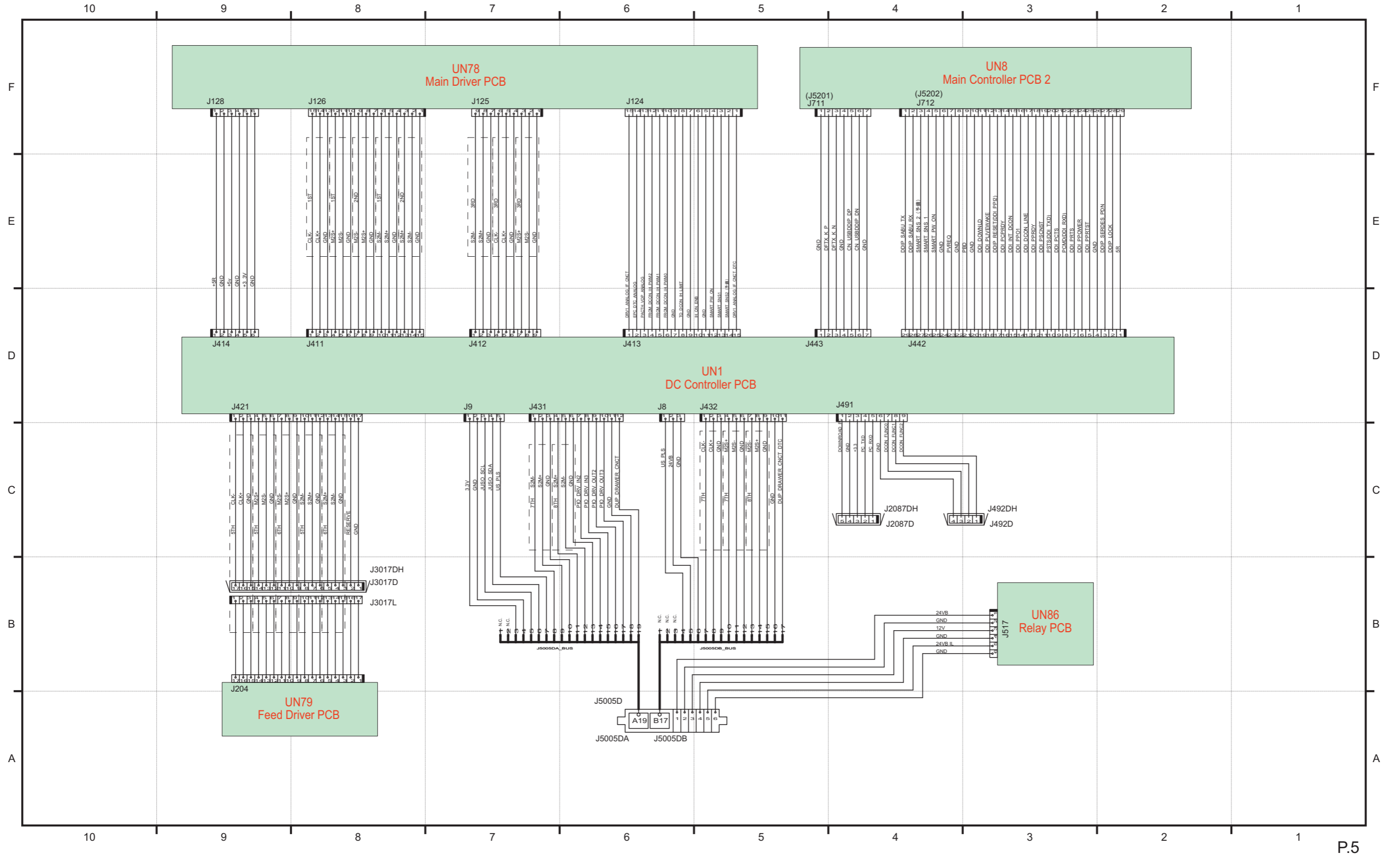
General Circuit Diagram

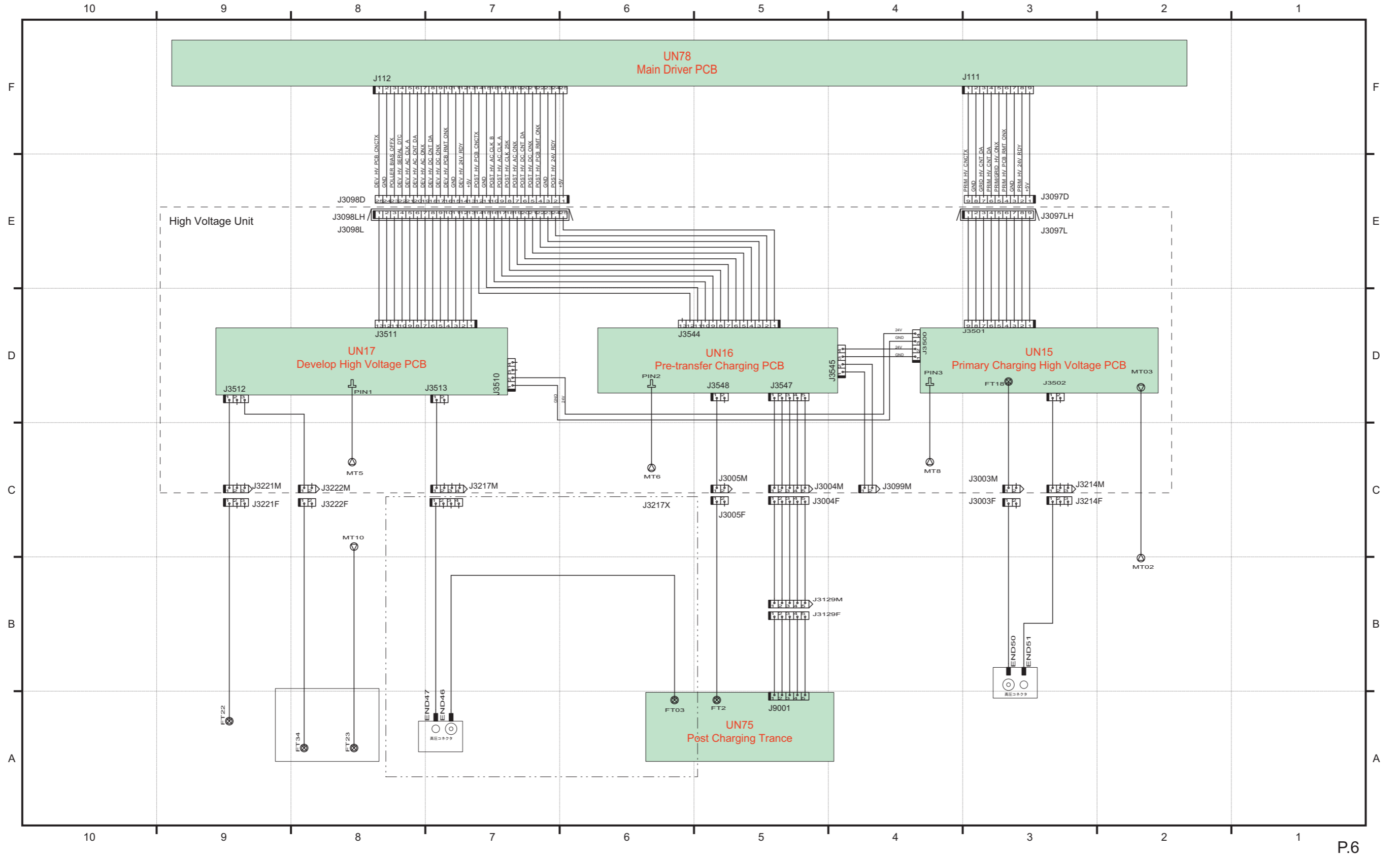


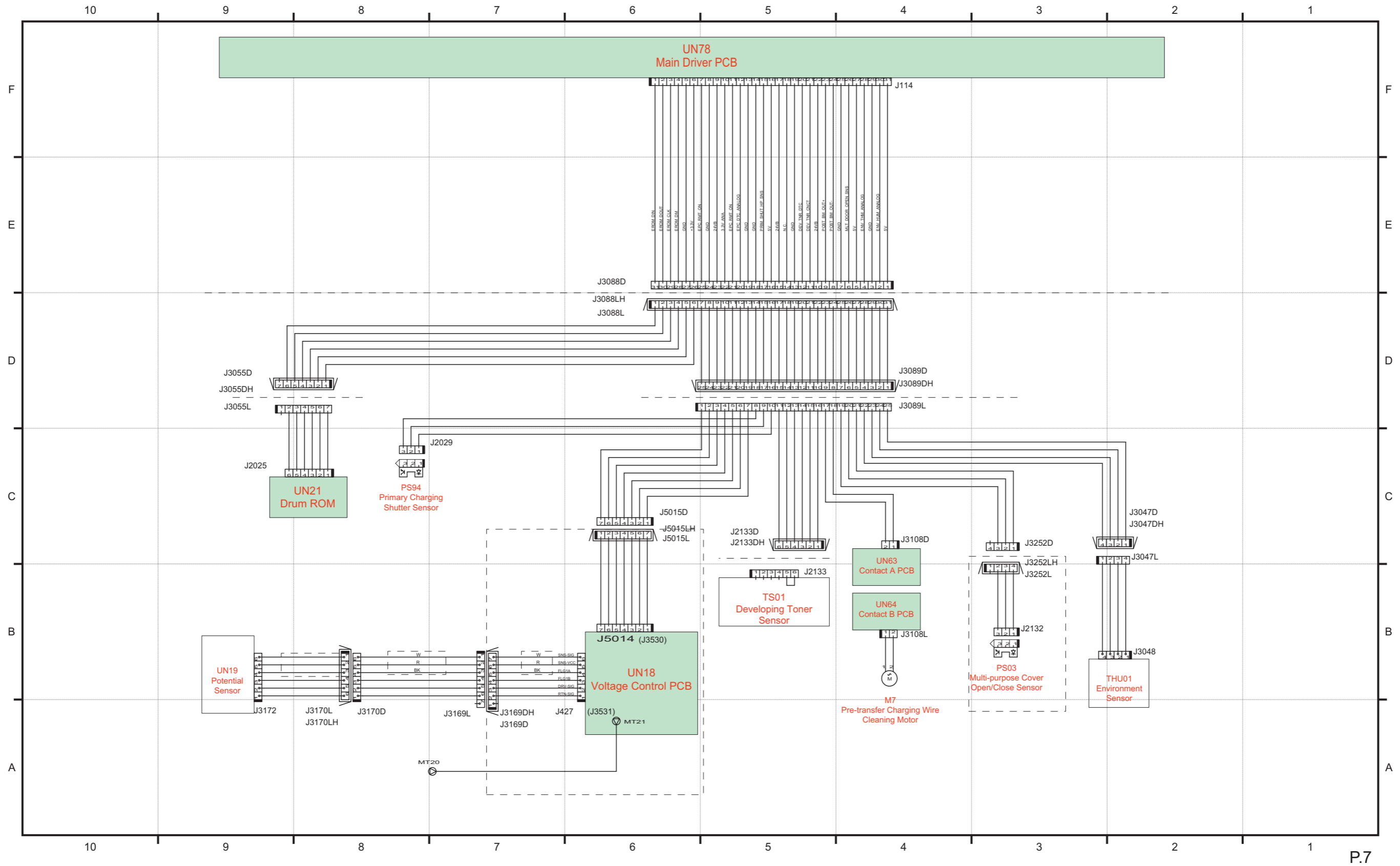


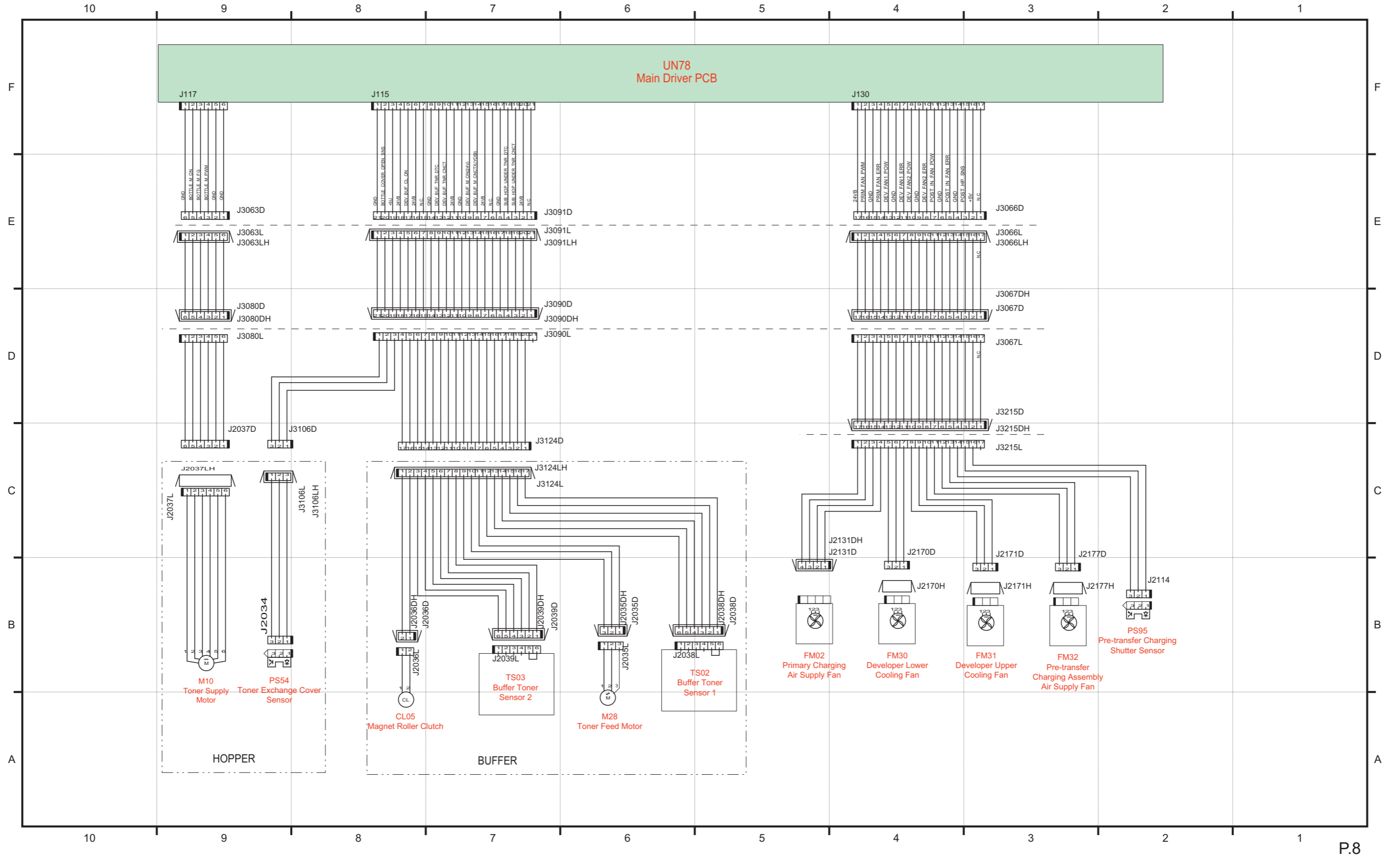


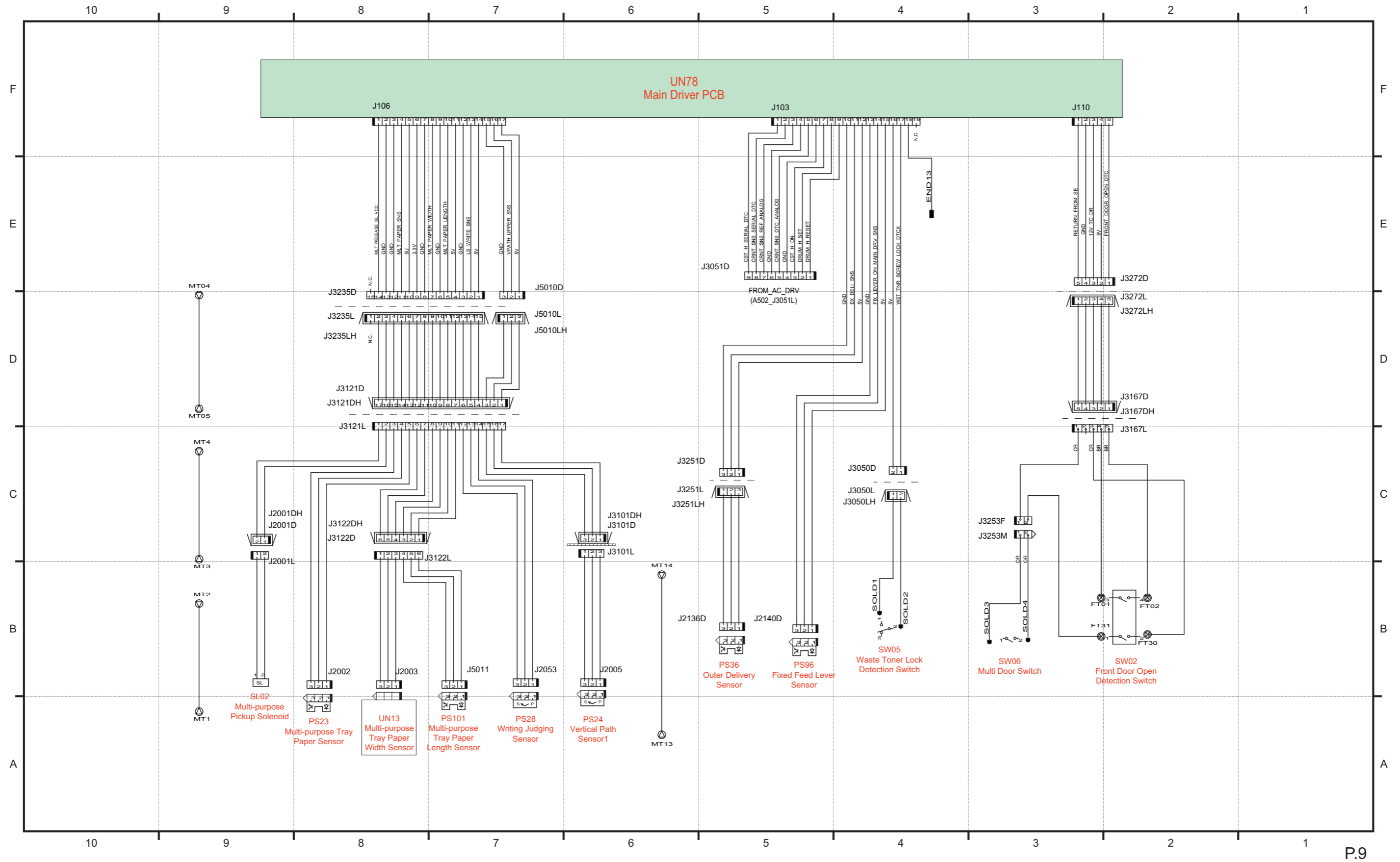


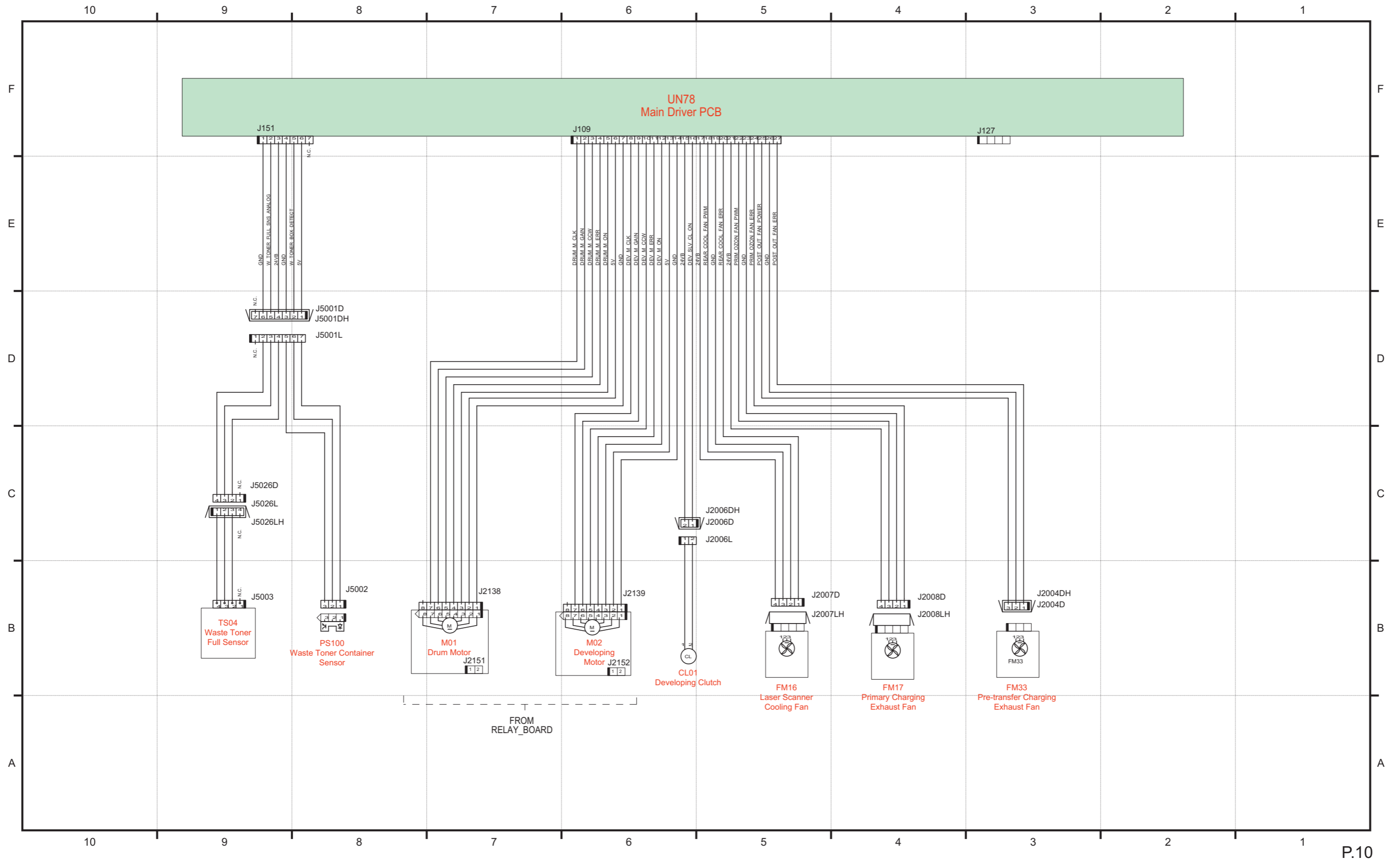


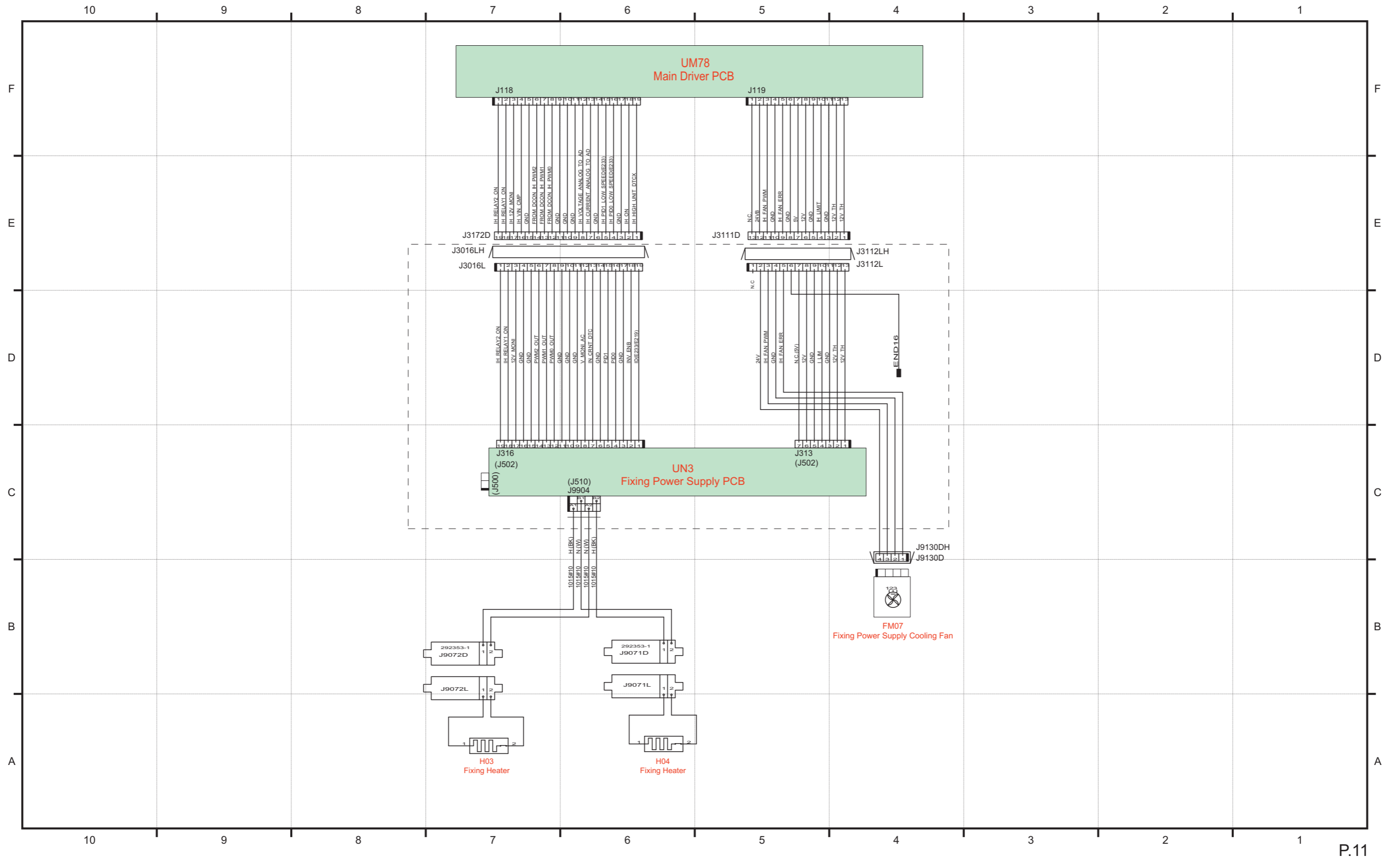


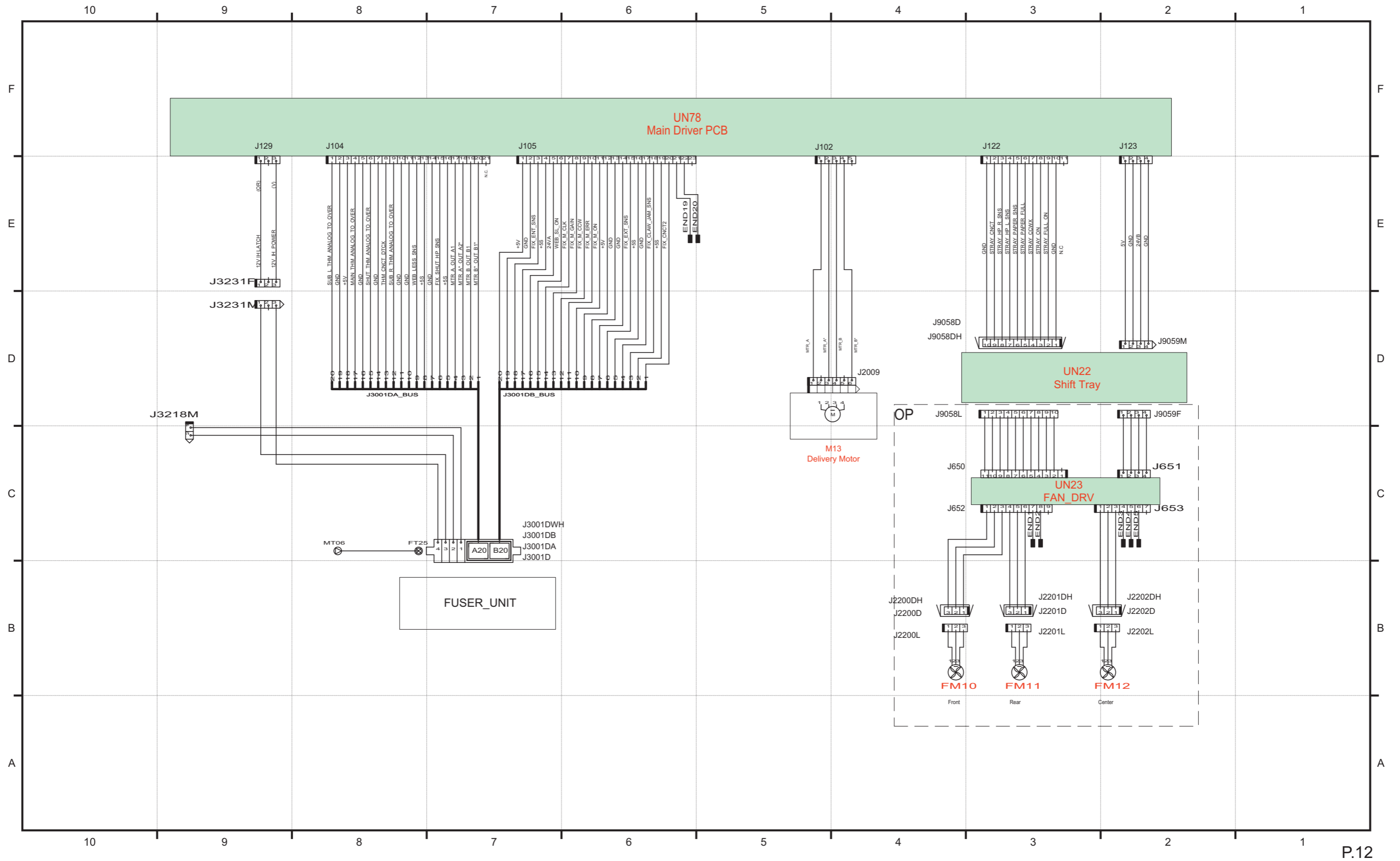


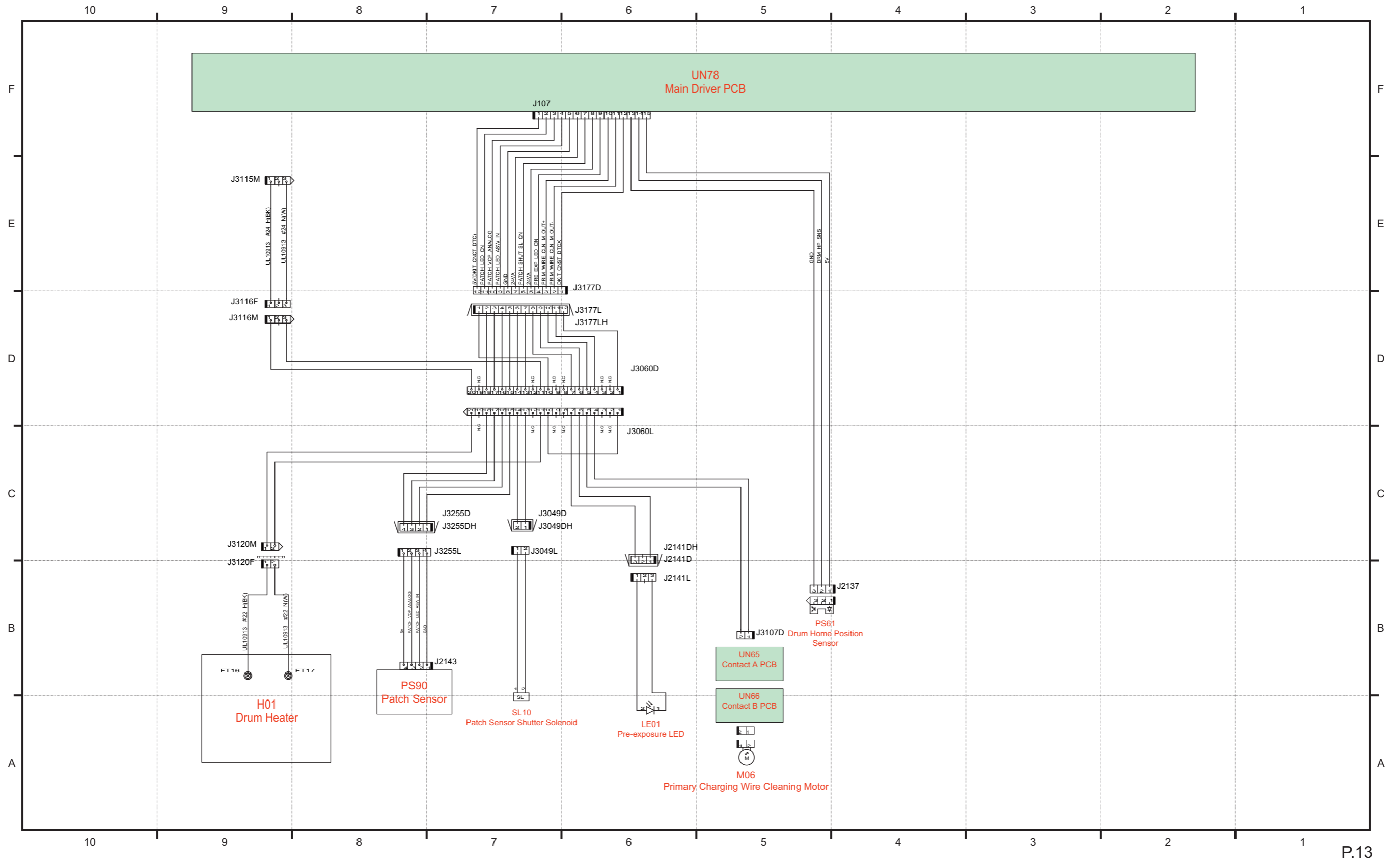


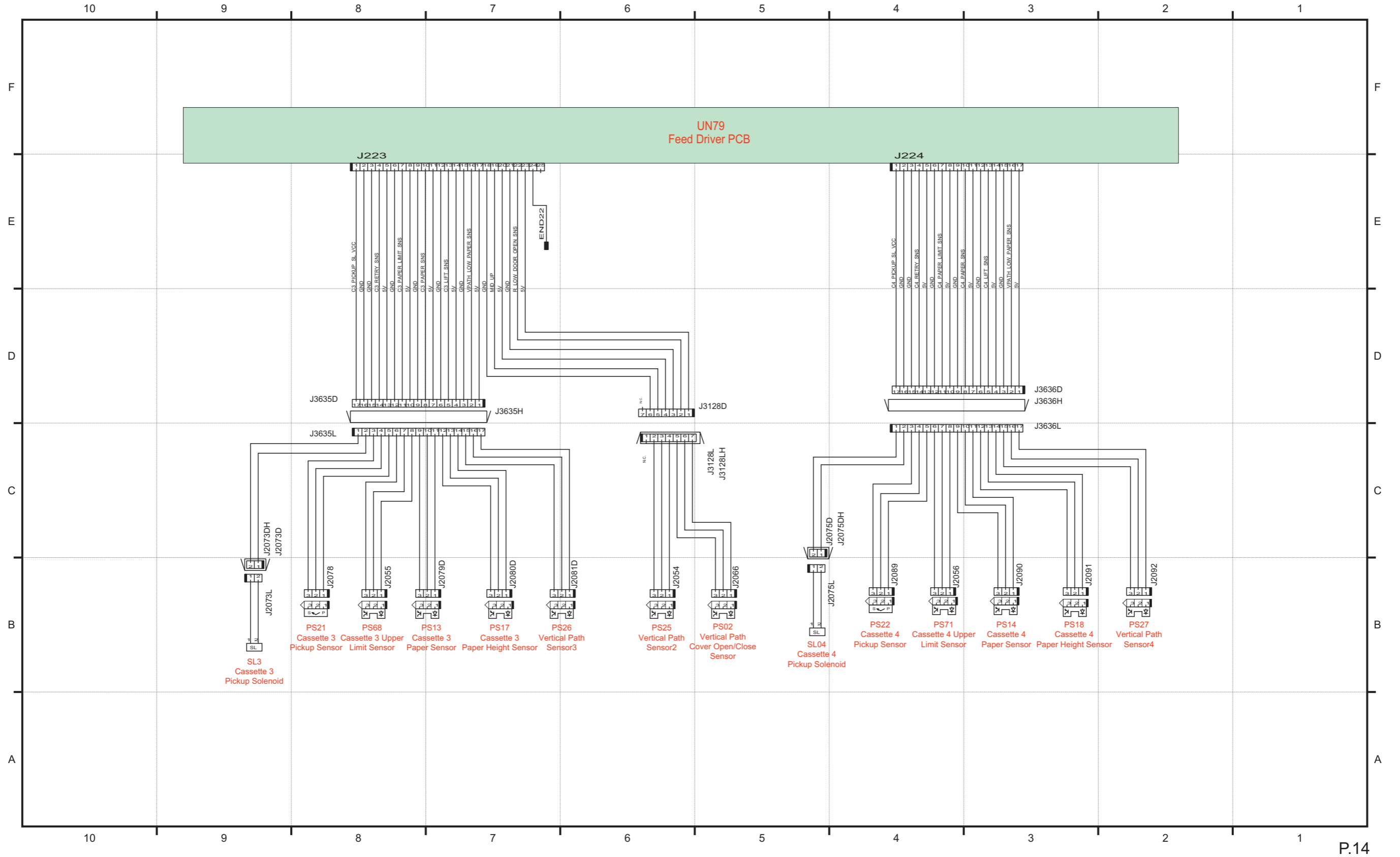


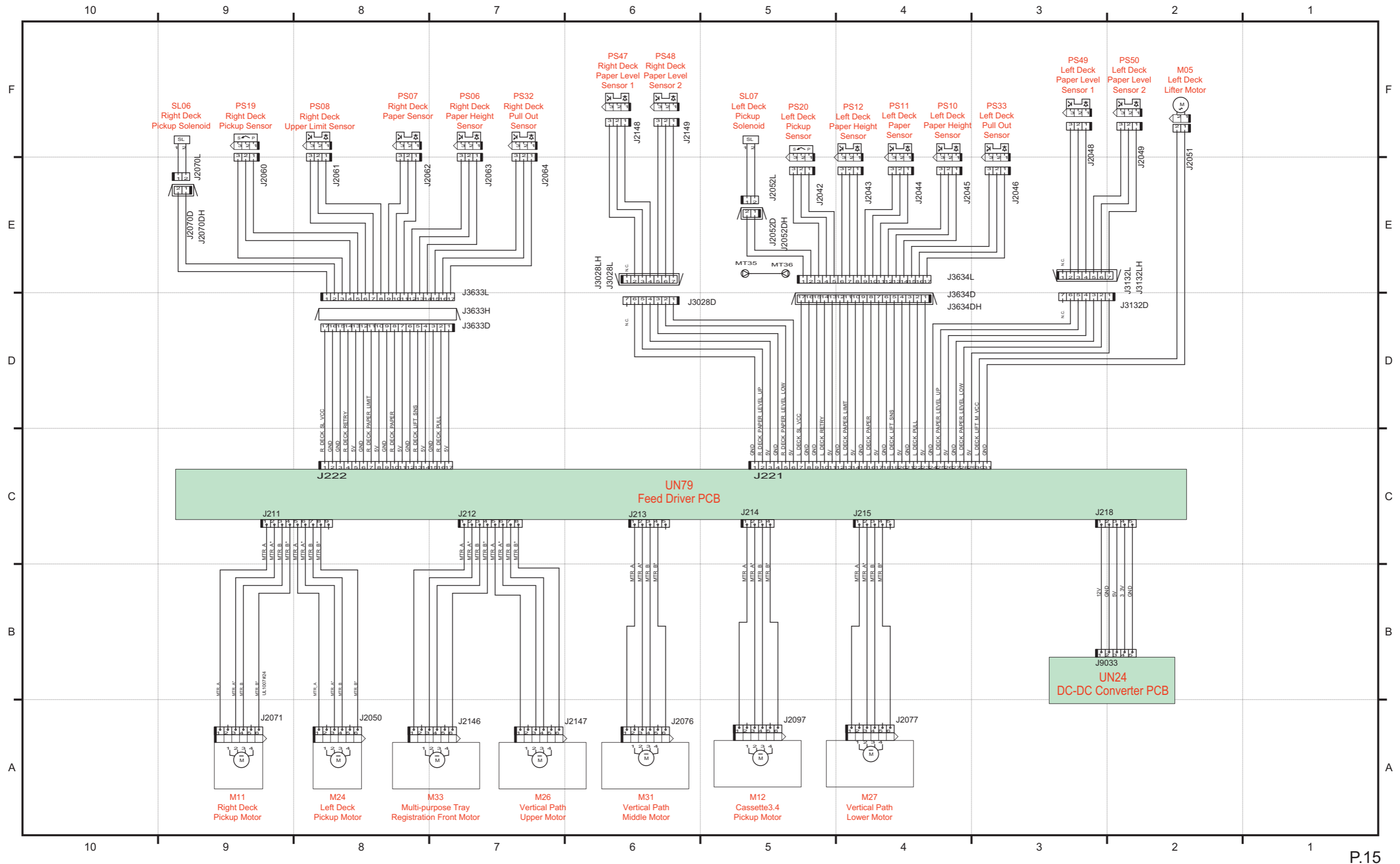


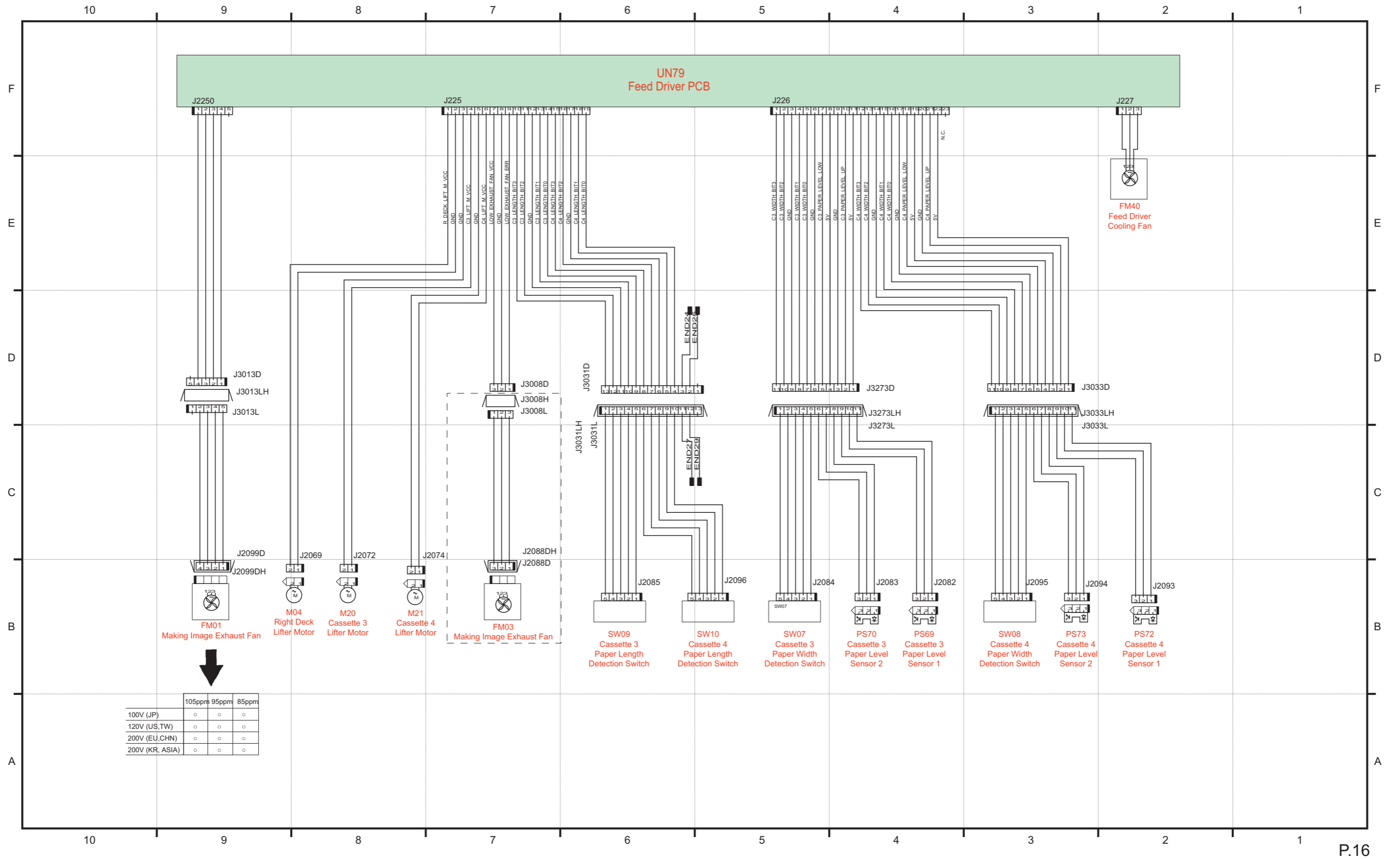


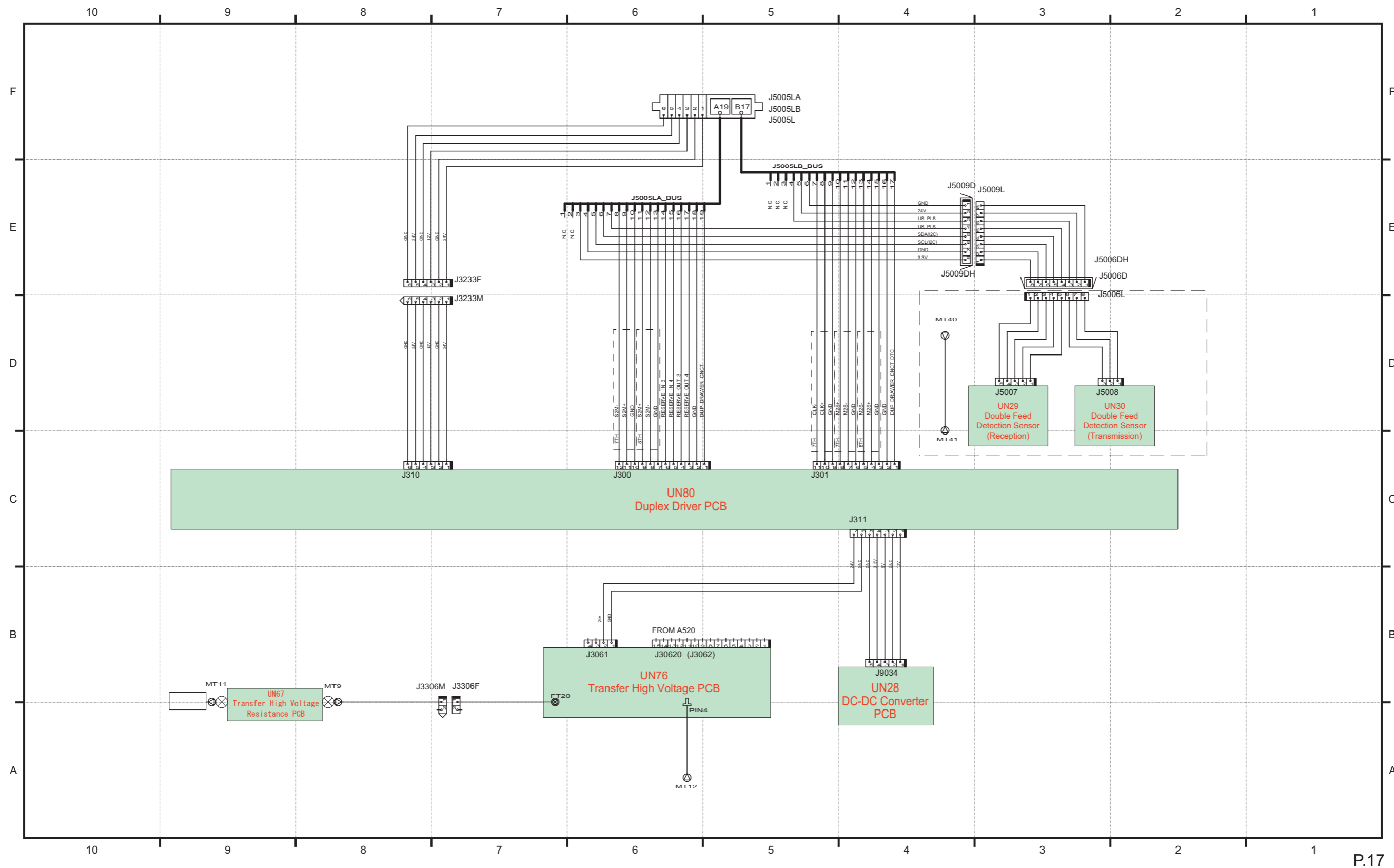


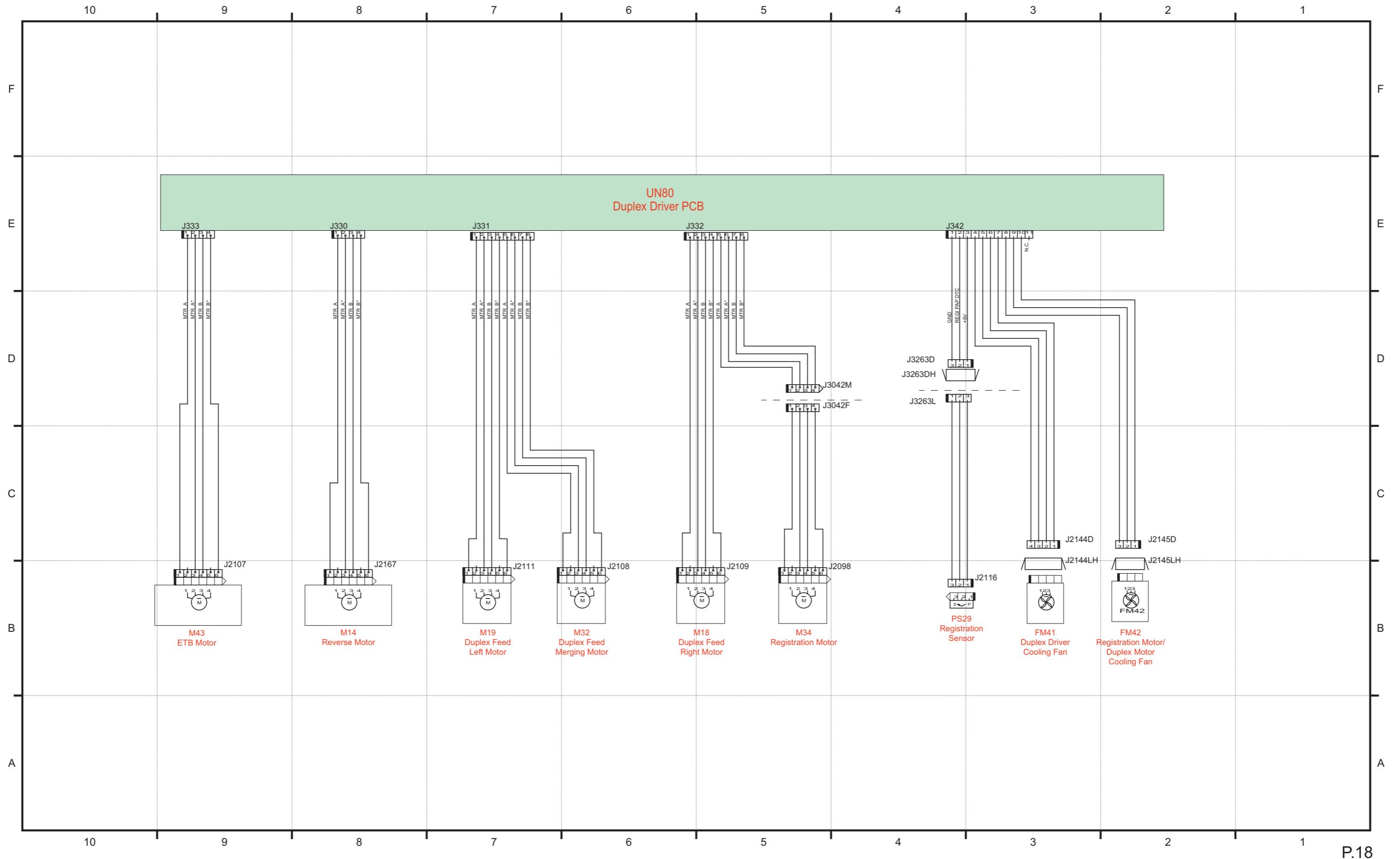


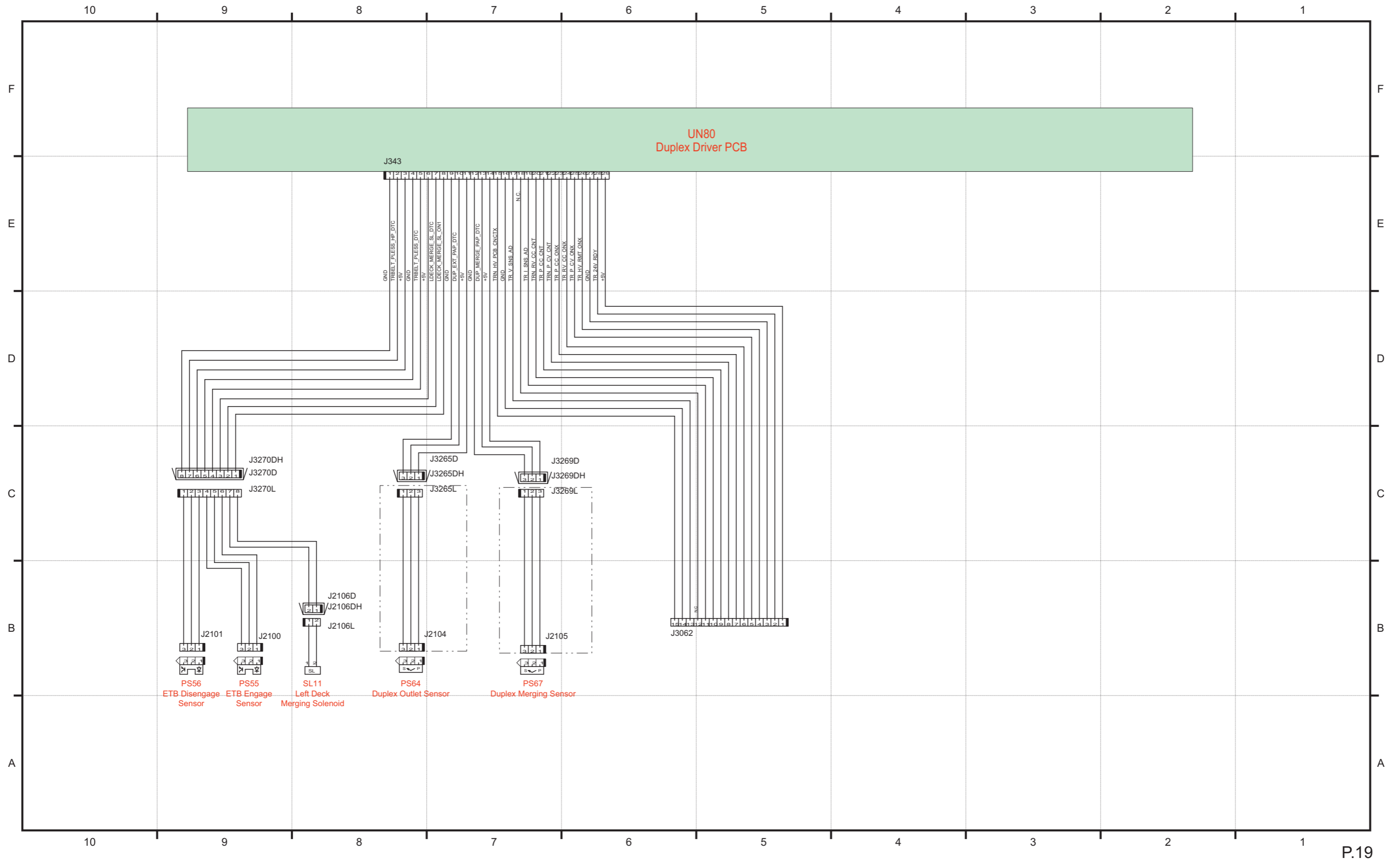


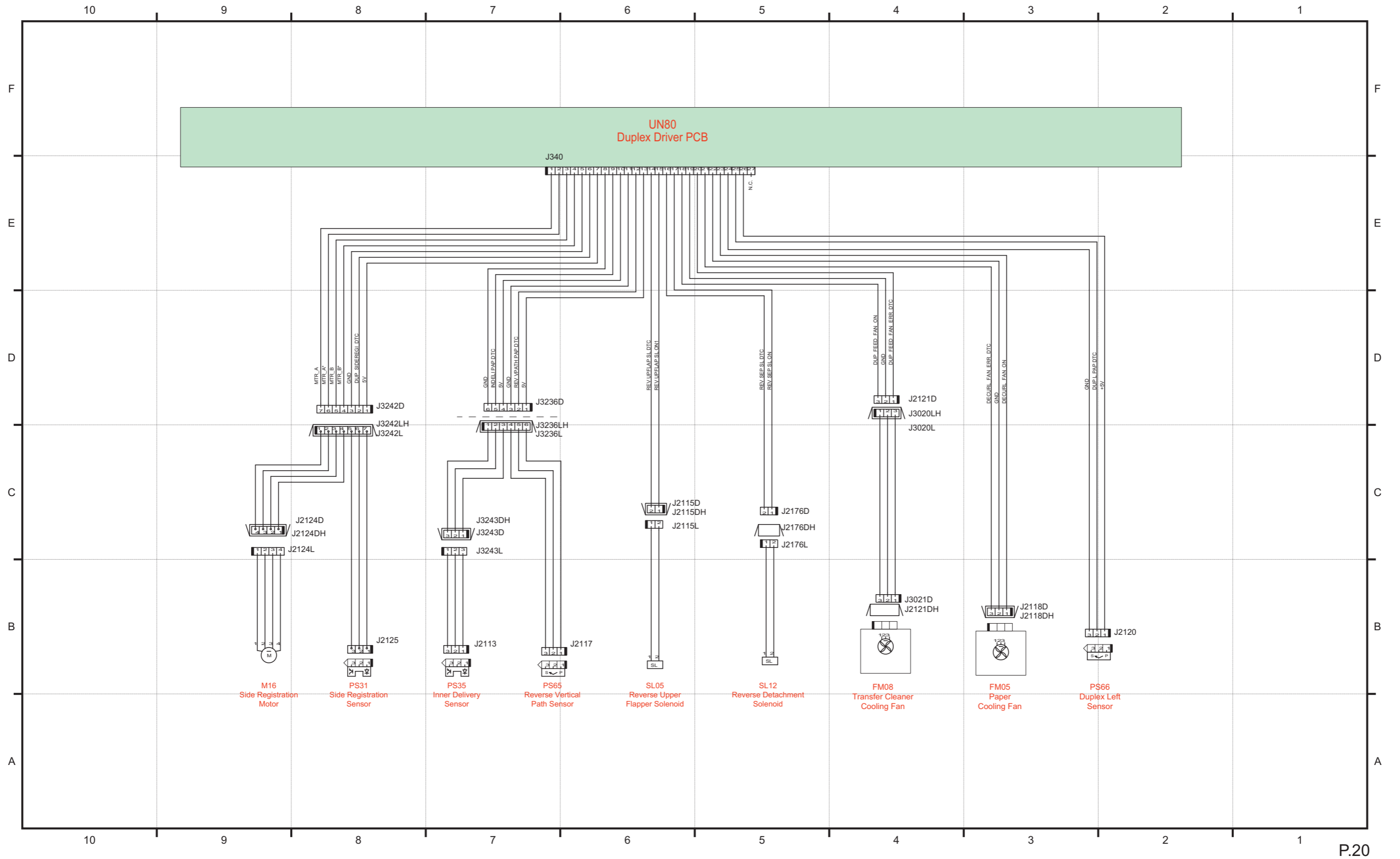


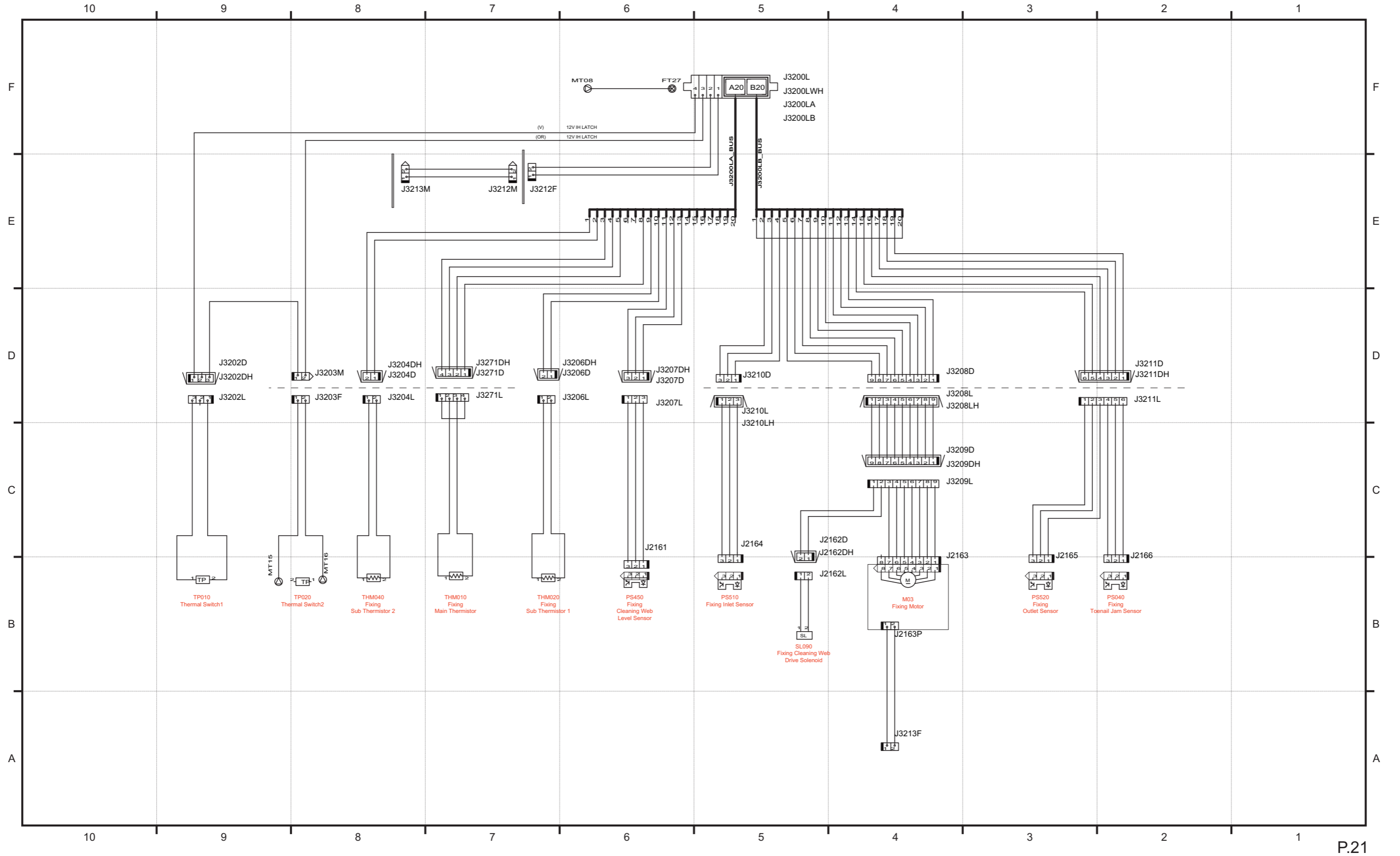


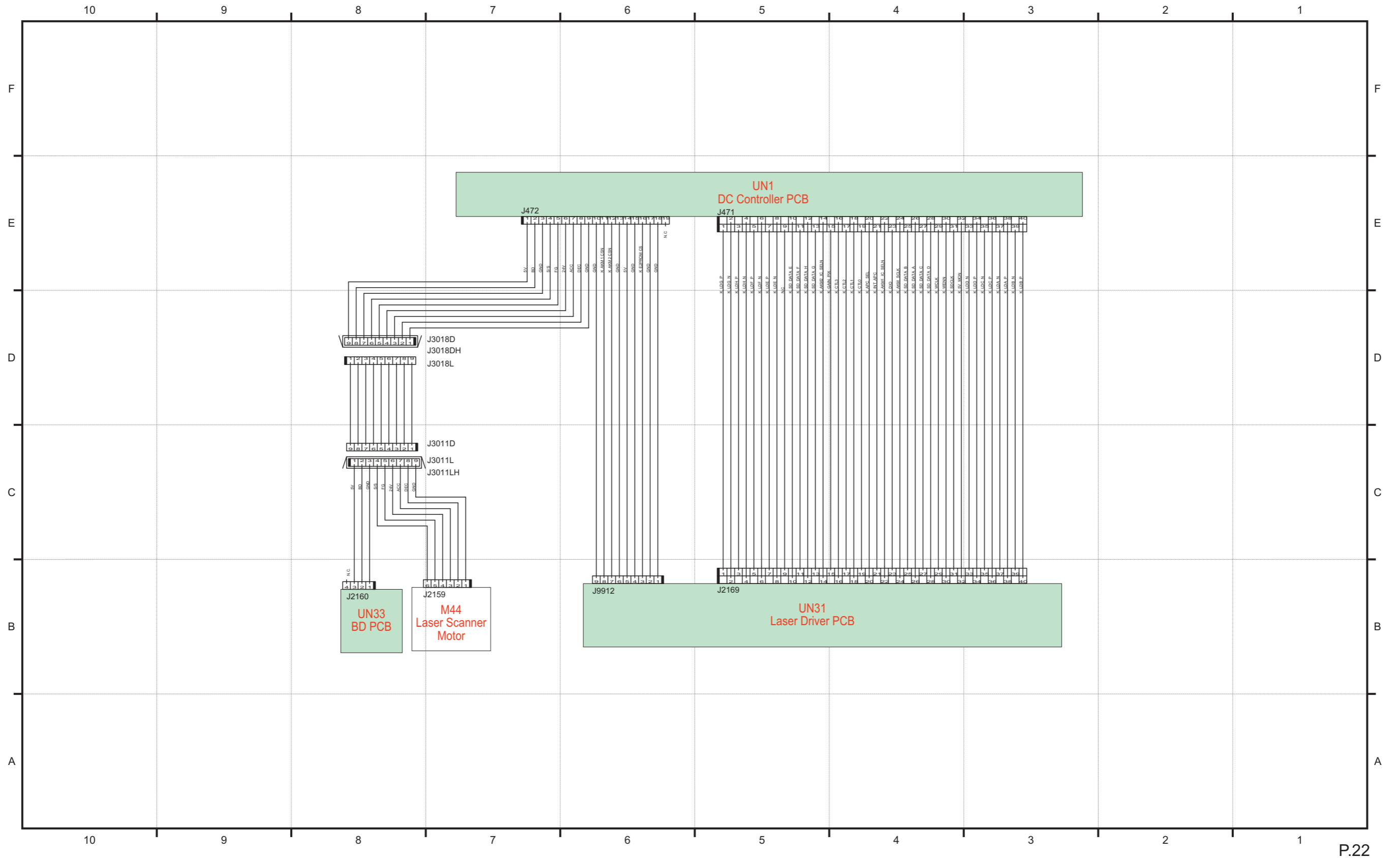


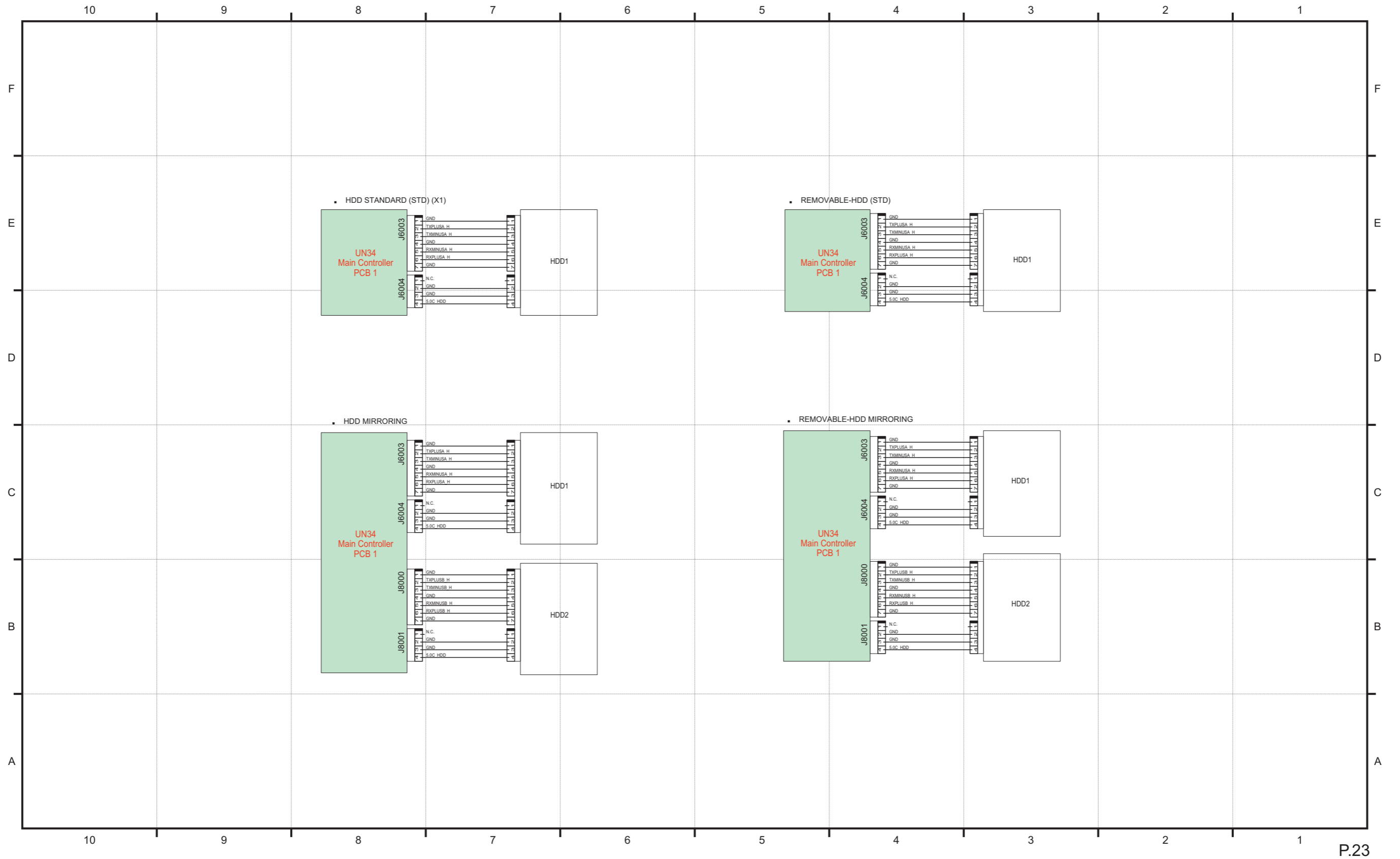


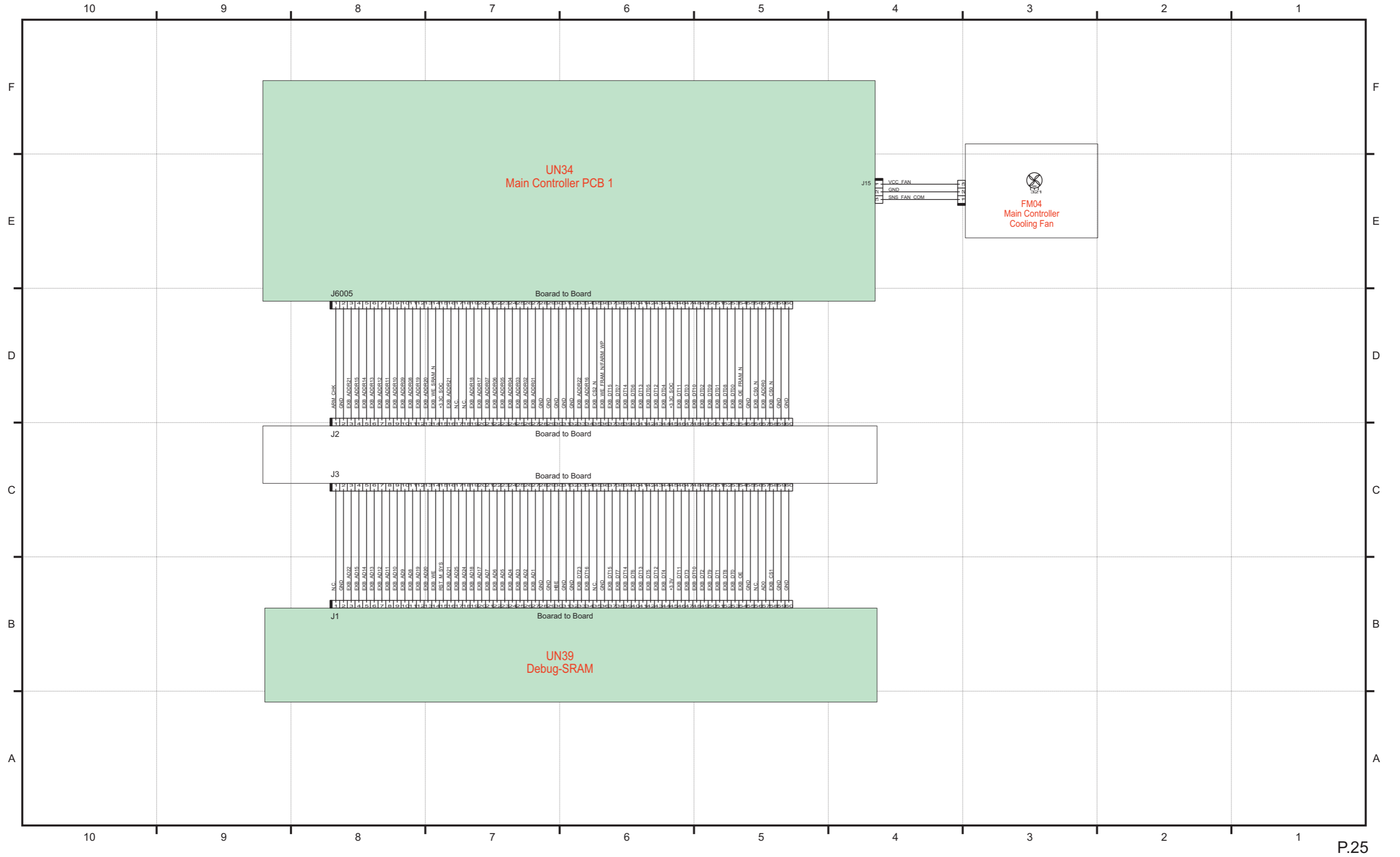


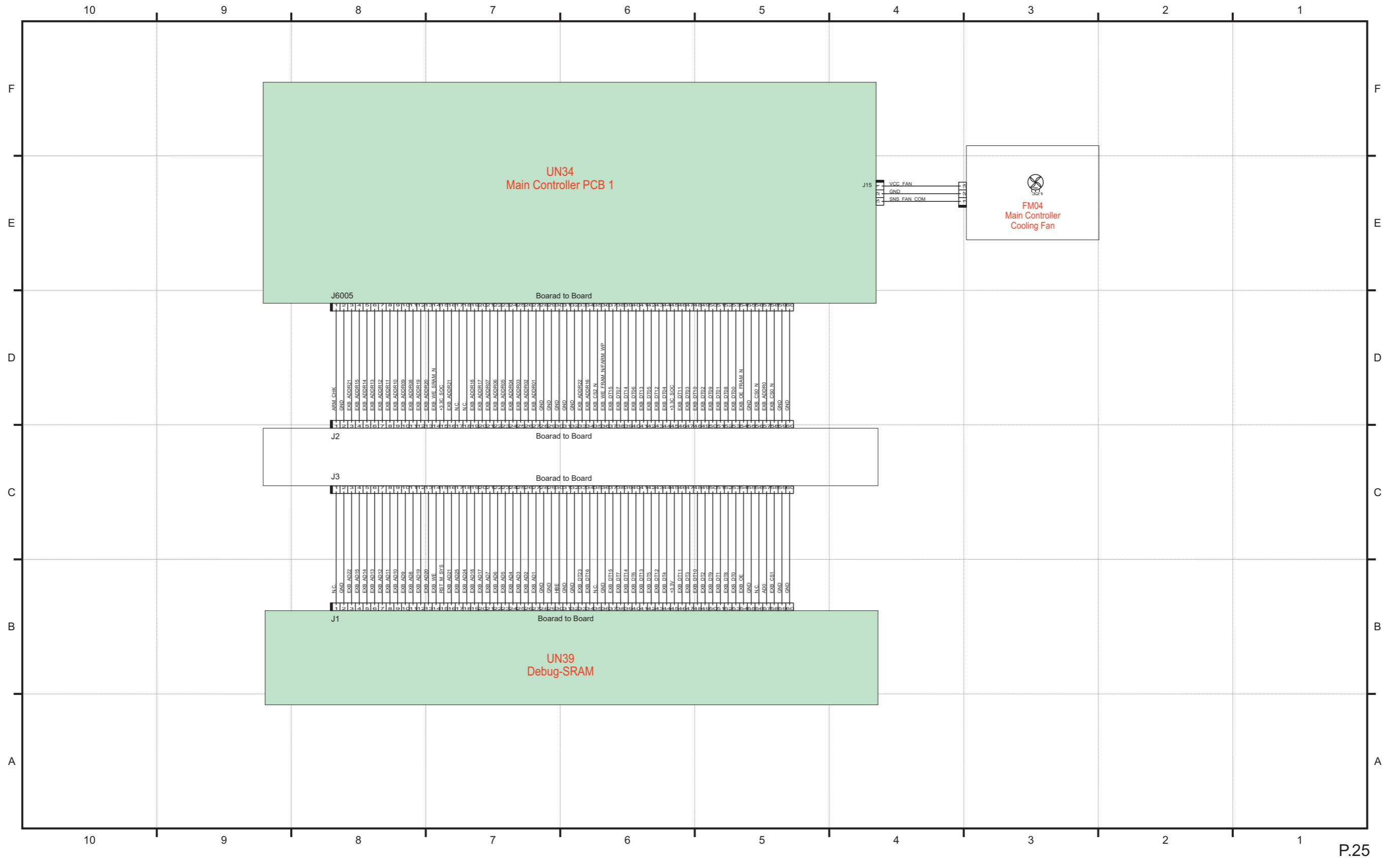


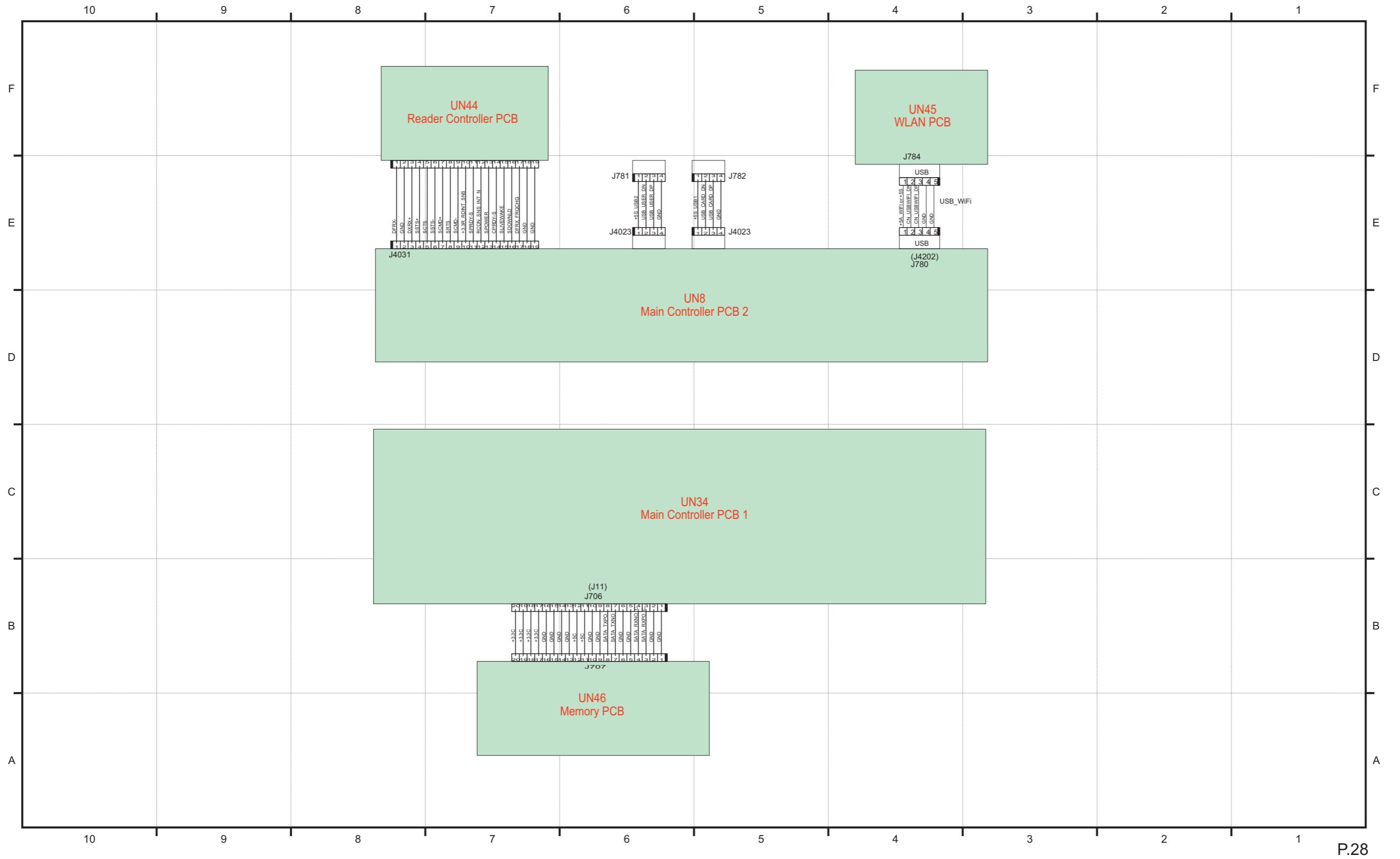


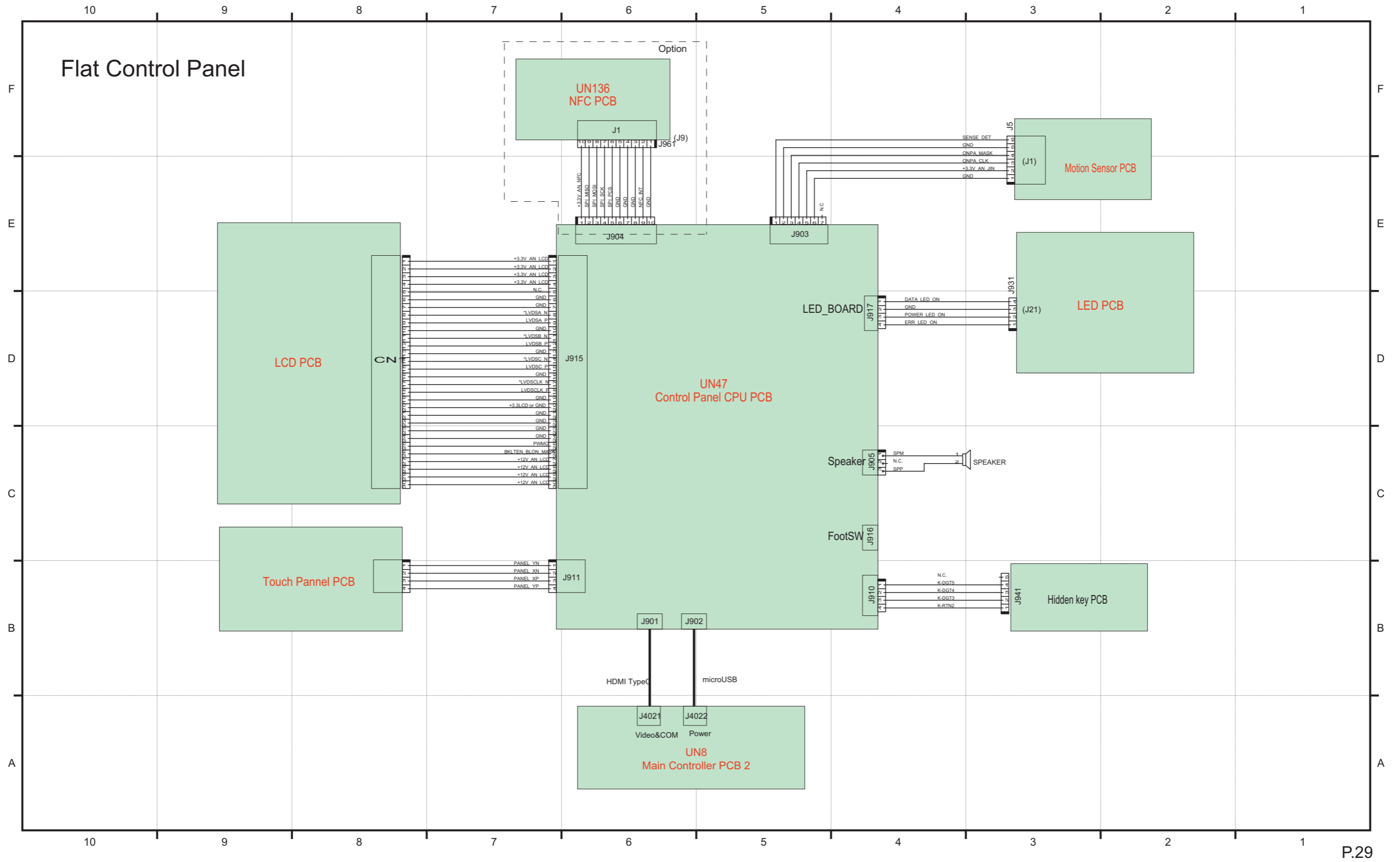


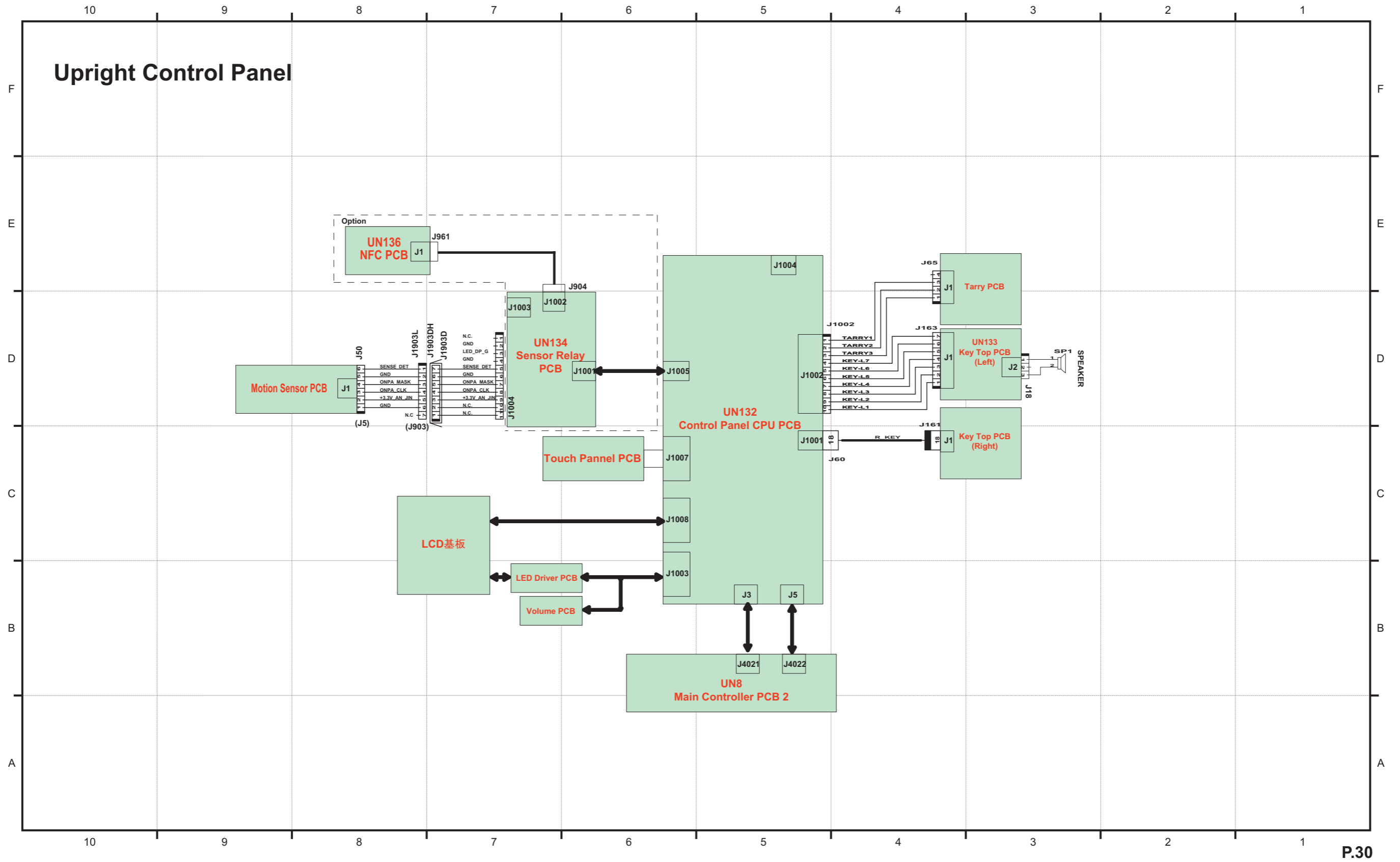












Detail of Storage partition

Partition name	CHK-TYPE	Description	Storage Format																			
			CHK_TYPE_0	CHK_TYPE_1	CHK_TYPE_2	CHK_TYPE_3	CHK_TYPE_4	CHK_TYPE_5	CHK_TYPE_6	CHK_TYPE_7	CHK_TYPE_8	CHK_TYPE_9	CHK_TYPE_10	CHK_TYPE_11	CHK_TYPE_12	CHK_TYPE_13	CHK_TYPE_14	CHK_TYPE_15	CHK_TYPE_16	CHK_TYPE_17	CHK_TYPE_18	CHK_TYPE_19
Storage																						
PDLDEV	1	PDL-related file storage area (font, registration form, color correction information file for ICCProfile-PDLfunction)	*1	*1																		
FSTDEV	2	Image data storage area (Box etc)	*1		*1			*1	*1													
APL_MEAP	3	MEAP	*1			*1																
-	4	Area that can be expanded																				
FSTCDEV	5	Image data storage area (for Job archive system)	*1		*1			*1	*1													
IMGMNG	6	Management data of image	*1		*1			*1	*1													
TMP_GEN	7	Storage area of universal data (temporary file)	*1							*1	*1											
APL_GEN	8	Storage area of universal data (Note: For details, see the following list.)	*1								*1											
TMP_PSS	9	PDL spool-related area	*1								*1	*1										
APL_SEND	10	Address book, Setting for Forwarding	*1									*1										
UPDATE	11	Update-related area	*1											*1								
APL_KEEP	12	MEAP stored data	*2													*2						
SYSDEV	13	The system-related area	*2														*2					
SWAP	14	SWAP (temporary file / memory alternative area)	*3															*3				
-	15	Area that can be expanded																				
-	16	-																				
DBG_LOG	17	Debug-related area	*1											*1							*1	
CRBDEV	18	Advanced Box area	*1																		*1	
PPADEV	19	Print Data	*1																			*1
SATA-FLASH																						
BOOT-DEV	1	Startup system area																				
SAFESYS	2	Safe startup system area																				
SYSDEV	3	Normal startup system area																				
-	4	Area that can be expanded																				
APL_GEN	5	Storage area of universal data (Note: For details, see the following list.)	*1											*1								
APL_KEEP	6	MEAP stored data																				
CON-FDEV	7	Setting value area	*1											*1								

*1: Both of HD-CHECK and HD-CLEAR can be executed

*2: HD-CHECK can be executed; HD-CLEAR cannot be executed

*3: HD-CHECK cannot be executed; HD-CLEAR can be executed

APL_GEN Details of universal data

Category	Data
Settings / Registration	Preferences
	Adjustment/Maintenance
	Function Settings
	Set Destination
	Management Settings
	Printer Settings
Setting items for each menu in Main Menu	Paper Information Settings
	Button settings in Main Menu
	Button settings on the top of the screen
	Wallpaper Setting for Main Menu
Setting for Advance Box	Other settings for Main Menu
Setting for Web Access	Registration information of Network Place
Setting for Universal Data	Web Access Setting information
	Unsent document (which is set timer transmission or reservation transmission)
	Job log information
	Key and server certificate which are registered in Management Settings>Device Settings>Certificate Setting
	Auto Adjust Gradation setting values

Soft counter specifications

The numbers entered for software counters are classified as follows:

No.	Counter Details
000 to 099	Remote copy
100 to 199	Total
200 to 299	Copy
300 to 399	Print
400 to 499	Copy and print
500 to 599	Scan
600 to 699	Box print
700 to 799	Reception print
800 to 899	Report print
900 to 999	Transmission

Meanings of symbols in tables

- 4C: Full Color
- Mono: Mono Color (Y,M,C / R,G,B / retro monochrome)
- Bk: Single black color
- L: Large size (larger than B4 size)
- S: Small size (smaller than B4 size)
- Numbers 1, 2 indicated under "Counter Details": Number of counts for large size paper
It can be changed by the service mode (COPIER > OPTION > USER > B4-L-CNT) so that the paper larger than B4 size can be counted as large size paper.
- Copy: Local copy + Remote Copy
- Copy A: Local copy + Remote Copy + Box Print
- Print: PDL print + report print + Box Print
- Print A: PDL print + report print
- Scan: Black and white scan + color scan

000 to 099

No.	Counter Details	No.	Counter Details
006	Remote Copy (mono color 1)	022	Remote Copy (mono color / Large / double sided)
007	Remote Copy (mono color 2)	023	Remote Copy (mono color / Small / double sided)
012	Remote Copy (mono color / Large)	071	Toner bottle counter black
013	Remote Copy (mono color / Small)		

100 to 199

No.	Counter Details	No.	Counter Details
101	Total 1	136	Total A (mono color / Large)
102	Total 2	137	Total A (mono color / Small)
103	Total (Large)	138	Total A1 (double sided)
104	Total (Small)	139	Total A2 (double sided)
108	Total (mono color 1)	140	Large A (double sided)
109	Total (mono color 2)	141	Small A (double sided)
112	Total (mono color / Large)	150	Total B1
113	Total (mono color / Small)	151	Total B2
114	Total 1 (double sided)	152	Total B (Large)
115	Total 2 (double sided)	153	Total B (Small)
116	Large (double sided)	156	Total B (mono color 1)
117	Small (double sided)	157	Total B (mono color 2)
126	Total A1	160	Total B (mono color / Large)
127	Total A2	161	Total B (mono color / Small)
128	Total A (Large)	162	Total B1 (double sided)
129	Total A (Small)	163	Total B2 (double sided)

No.	Counter Details	No.	Counter Details
132	Total A (mono color 1)	164	Large B (double sided)
133	Total A (mono color 2)	165	Small B (double sided)

200 to 299

No.	Counter Details	No.	Counter Details
201	Copy (Total 1)	222	Copy (mono color 2)
202	Copy (Total 2)	227	Copy (mono color / Large)
203	Copy (Large)	228	Copy (mono color / Small)
204	Copy (Small)	237	Copy (mono color / Large / double sided)
205	Copy A (Total 1)	238	Copy (mono color / Small / double sided)
206	Copy A (Total 2)	249	Copy A (mono color 1)
207	Copy A (Large)	250	Copy A (mono color 2)
208	Copy A (Small)	255	Copy A (mono color / Large)
209	Local copy(Total 1)	256	Copy A (mono color / Small)
210	Local copy(Total 2)	265	Copy A (mono color / Large / double sided)
211	Local copy(Large)	266	Copy A (mono color / Small / double sided)
212	Local copy(Small)	277	Local copy (mono color 1)
213	Remote Copy (Total 1)	278	Local copy (mono color 2)
214	Remote Copy (Total 2)	283	Local copy (mono color / Large)
215	Remote Copy (Large)	284	Local copy (mono color / Small)
216	Remote Copy (Small)	293	Local copy (mono color / Large / double sided)
221	Copy (mono color 1)	294	Local copy (mono color / Small / double sided)

300 to 399

No.	Counter Details	No.	Counter Details
301	Print (Total 1)	329	Print (mono color / Large / double sided)
302	Print (Total 2)	330	Print (mono color / Small / double sided)
303	Print (Large)	331	PDL Print (Total 1)
304	Print (Small)	332	PDL Print (Total 2)
305	Print A (Total 1)	333	PDL Print (Large)
306	Print A (Total 2)	334	PDL Print (Small)
307	Print A (Large)	339	PDL Print (mono color 1)
308	Print A (Small)	340	PDL Print (mono color 2)
313	Print (mono color 1)	345	PDL Print (mono color / Large)
314	Print (mono color 2)	346	PDL Print (mono color / Small)
319	Print (mono color / Large)	355	PDL Print (mono color / Large / double sided)
320	Print (mono color / Small)	356	PDL Print (mono color / Small / double sided)

400 to 499

No.	Counter Details	No.	Counter Details
403	Copy + Print (mono color / Large)	461	Long length Counter (Total)
404	Copy + Print (mono color / Small)	463	Long length Counter (Black and whiter)
405	Copy + Print (mono color 2)	466	Long length Counter (Total)
406	Copy + Print (mono color 1)	467	Long length Counter (Total)
411	Copy + Print (Large)	468	Long length Counter (Total)
412	Copy + Print (Small)	469	Long length Counter (Total)
413	Copy + Print (2)	470	Long length Counter (Total)
414	Copy + Print (1)	471	Long length Counter (Total)
421	Copy + Print (mono color / Large / double sided)	473	Long length Counter (Black and whiter)
422	Copy + Print (mono color / Small / double sided)		

500 to 599

No.	Counter Details	No.	Counter Details
501	Scan (Total 1)	507	Black and white Scan (Large)
502	Scan (Total 2)	508	Black and white Scan (Small)
503	Scan (Large)	509	Color Scan (Total 1)
504	Scan (Small)	510	Color Scan (Total 2)
505	Black and white Scan (Total 1)	511	Color Scan (Large)
506	Black and white Scan (Total 2)	512	Color Scan (Small)

600 to 699

No.	Counter Details	No.	Counter Details
601	Box Print (Total 1)	631	Memory media Print (Total 1)
602	Box Print (Total 2)	632	Memory media Print (Total 2)
603	Box Print (Large)	633	Memory media Print (Large)
604	Box Print (Small)	634	Memory media Print (Small)
609	Box Print (mono color 1)	639	Memory media Print (mono color 1)
610	Box Print (mono color 2)	640	Memory media Print (mono color 2)
615	Box Print (mono color / Large)	645	Memory media Print (mono color / Large)
616	Box Print (mono color / Small)	646	Memory media Print (mono color / Small)
625	Box Print (mono color / Large / double sided)	655	Memory media Print (mono color / Large / double sided)
626	Box Print (mono color / Small / double sided)	656	Memory media Print (mono color / Small / double sided)

700 to 799

No.	Counter Details	No.	Counter Details
701	Reception Print (Total 1)	743	Network Print (Total 1)
702	Reception Print (Total 2)	744	Network Print (Total 2)
703	Reception Print (Large)	745	Network Print (Large)
704	Reception Print (Small)	746	Network Print (Small)
709	Reception Print (mono color 1)	749	Network Print (mono color 1)
710	Reception Print (mono color 2)	750	Network Print (mono color 2)
715	Reception Print (mono color / Large)	753	Network Print (mono color / Large)
716	Reception Print (mono color / Small)	754	Network Print (mono color / Small)
725	Reception Print (mono color / Large / double sided)	757	Network Print (mono color / Large / double sided)
726	Reception Print (mono color / Small / double sided)	758	Network Print (mono color / Small / double sided)
727	Advanced Box Print (Total 1)	759	Mobile Print (Total 1)
728	Advanced Box Print (Total 2)	760	Mobile Print (Total 2)
729	Advanced Box Print (Large)	761	Mobile Print (Large)
730	Advanced Box Print (Small)	762	Mobile Print (Small)
733	Advanced Box Print (mono color 1)	765	Mobile Print (mono color 1)
734	Advanced Box Print (mono color 2)	766	Mobile Print (mono color 2)
737	Advanced Box Print (mono color / Large)	769	Mobile Print (mono color / Large)
738	Advanced Box Print (mono color / Small)	770	Mobile Print (mono color / Small)
741	Advanced Box Print (mono color / Large / double sided)	773	Mobile Print (mono color / Large / double sided)
742	Advanced Box Print (mono color / Small / double sided)	774	Mobile Print (mono color / Small / double sided)

800 to 899

No.	Counter Details	No.	Counter Details
801	Report Print (Total 1)	810	Report Print (mono color 2)
802	Report Print (Total 2)	815	Report Print (mono color / Large)
803	Report Print (Large)	816	Report Print (mono color / Small)
804	Report Print (Small)	825	Report Print (mono color / Large / double sided)
809	Report Print (mono color 1)	826	Report Print (mono color / Small / double sided)

900 to 999

No.	Counter Details	No.	Counter Details
915	Transmission scan total 2 (Color)	940	Remote Scan (Black and whiter)
916	Transmission scan total 2 (Black and whiter)	945	Transmission Scan / E-mail (Color)
917	Transmission scan total 3 (Color)	946	Transmission Scan / E-mail (Black and whiter)
918	Transmission scan total 3 (Black and whiter)	959	Media Scan (Color)
921	Transmission scan total 5 (Color)	960	Media Scan (Black and whiter)
922	Transmission scan total 5 (Black and whiter)	961	Application Scan (Total 1)
929	Transmission scan total 6 (Color)	962	Application Black and white Scan (Total 1)
930	Transmission scan total 6 (Black and whiter)	963	Application Color Scan (Total 1)
937	Box Scan (Color)	964	Super Box LocalScan (Color)
938	Box Scan (Black and whiter)	965	Super Box LocalScan (Black and whiter)
939	Remote Scan (Color)		

Removal

Overview

- User data kept by the machine contains address books and inbox documents that users can recognize.
- For security, the Settings/Registration menu for user is provided to delete data on FLASH PCB and perform overwrite deletion to render user data on Storage unrecoverable.
- Before the removal of machine, be sure to explain to the user that the above mode must be used to completely delete data. When performing the user operation as the substitute, make sure that the service staff executes this to prevent the information leak of user data.

■ Cancelling the Device Registration

If Data Backup Service is used, it is required to perform the following steps in the order.

1. **Stop using the Data Backup Service. (Operation on CBIO side)**
2. **Delete all the backup data. (Operation on CBIO side)**
3. **Cancel the device registration. (Operation on the device side)**

NOTE:

For the above-mentioned procedure, see the User's Guide for Data Backup Service or the Service Manual for the imageRUNNER ADVANCE system.

If the User's Guide is not available, see the technical documents published by each sales company.

CAUTION:

Be sure to cancel the device registration before deleting the user, because the device registration cannot be cancelled after deleting the user data.

■ User data deletion

- To delete user data, execute Settings/Registration > Management Settings > System Management > Initialize All Data/Settings. Performing Initialize All Data/Settings returns setting values of Settings/Registration menu to their factory defaults.
- Deletion Mode can be changed. Normally, "Once with 0 (Null) Data" can sufficiently delete data. Note that increasing the number of overwrite increases the time required for the deletion operation.

NOTE:

- When you perform Initialize All Data/Settings, license and data of MEAP application are initialized to the state same as when the HDD is replaced. If any MEAP application may be used by other users after the machine is removed, disable the MEAP application and uninstall it in advance.
- Performing Initialize All Data/Settings does not delete the license of the system option.

■ Deletion of Service Mode Settings

The user mode setting values may have been changed at the user's request. In that case, the service mode setting values should be changed back to the default values before removing the machine.

Work Procedure

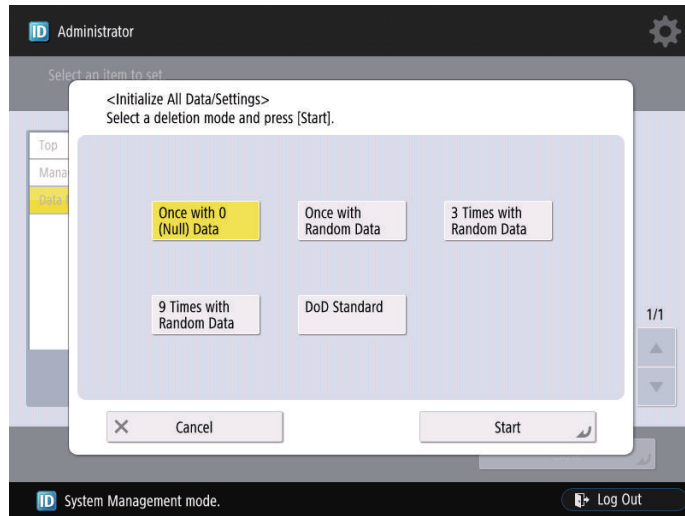
If the user uses MEAP applications, ask the user to uninstall the MEAP applications if necessary.

■ User data delete procedure

1. Settings/Registration > Management Settings > Data Management > Initialize All Data/Settings
2. Select a deletion mode.

3. Press [Start].

If the user has not given any instruction on which item in the deletion mode should be used, select the default "Once with 0 (Null) Data".



NOTE:

- When all the data are initialized, the user data on the HDD and the user data on the Flash PCB are deleted. For the items to be deleted, refer to the backup list.
- Performing "Initialize All Data" turns auto gradation adjustment values and TPM settings to OFF. Therefore, to enable normal operation the next time, the operation performed at installation is necessary.
- Performing Initialize All Data/Settings does not delete the license of the system option.

Report output upon completion of Initialize All Data/Settings

A report is output after "Initialize All Data/Settings" is completed.

Consider using this report to provide to user as a material to inform of work details when executing Initialize All Data/Settings upon user's request.

Operation after Initialize All Data/Settings

The machine is started normally at restart after Initialize All Data/Settings without displaying the message (Turn OFF the main power supply on the right side of the machine) on the screen to prompt shutdown.

The report is output after startup.

```

*****
*** System Information ***
*****

<< Initialize All Data/Settings Report >>

Serial Number          ZZZ99999
Device Name            iR-ADV XXXX (iAXXXX)

Overwrite Method for Deletion Mode  Once with Random Data (*1)

The following data stored in the device has been completely erased.

- Data stored in the temporary data area
- User generated data
- Settings under Settings/Registration (restored to factory defaults)
    
```

*1 display following one.
 "Once with 0 (Null) Data"
 "Once with Random Data"
 "3 Times with Random Data"
 "9 Times with Random Data"
 "DoD Standard"

Limitations

- The language of the report is only English, and cannot be changed.
- The report is output without fail (a function to select ON/OFF of report output is not provided).
- There is no second output of report when the machine is turned ON without paper.
- Only the output of this report remains in the job log.

■ Deletion of Service Mode Setting Values

Service Mode Lev1 > Function> CLEAR > MN-CONT



NOTE:

- When MN-CON clear is executed, the address book on the HDD is not deleted. As for the user data, initialize all the data.
- When MN-CON clear is executed, the password for the security policies will be deleted.

Target PCBs of Automatic Update

The following PCBs are mentioned in the System Service Manual as PCBs supported by the automatic update function.

List of Target PCBs of Automatic Update

Category	Target PCB	Service mode*
Main Unit	DC Controller PCB	DC-CON
	Reader Controller PCB	R-CON
Insertion Unit-N1	CAN transceiver PCB	INS-IF
	Insertion Controller PCB	INS
Multi Function Professional Puncher-B1	Multi Function Professional Puncher Controller PCB	PUNCH-IF
		PUNCH-CM
		PUNCH-MN
Paper Folding Unit-J1	Folder Controller PCB	FOLD
Staple Finisher-W1 PRO/ Booklet Finisher-W1 PRO	Finisher Controller PCB	SORTER
Booklet Trimmer-D1	Trimmer Controller PCB	TRIM
Staple Finisher-X1	Finisher Controller PCB	SORTER
Booklet Finisher-X1	Saddle Stitcher Controller PCB	SDL-STCH
Inner Booklet Trimmer-A1	Trimmer Controller PCB	TRIM
Staple Finisher-AC1	Finisher Controller PCB	SORTER
Booklet Finisher-AC1	Finisher Controller PCB	SORT-SLV
	Saddle Stitcher Controller PCB	SDL-STCH
2/3, 2/4, 4 Hole Puncher Unit-A1	Puncher Controller PCB	PUNCH

*: COPIER > DISPLAY > VERSION

List of Service Modes That Can Be Restored

The following items are restored when a DCM file obtained by using [Settings/Registration] > [Back Up/Restore] or [Backup/Restoration Using Service Mode] is exported.

Purpose for Using the Function

Case	Export/ Import	Use Case
A	Export from and import to the same device	<ul style="list-style-type: none"> Used as backup in preparation for a device failure Used as backup before changing settings
B	Export from and import to a different device of the same model	<ul style="list-style-type: none"> Collectively migrate data when replacing the host machine Copy the settings to multiple devices (during kitting)
C	Export from and import to a different model	<ul style="list-style-type: none"> Migrate the settings from the old model to the new model when replacing the host machine Migrate the settings of the base machine to a different model for a large-scale user

NOTE:

For the details of the function, refer to "Backup/Restoration" of the System Service Manual.

List of Service Modes That Can Be Restored

Initial screen	Main item	Intermediate item	Sub item	Case A	Case B	Case C
BOARD	OPTION	-	MENU-1	Restored	Restored	Restored
BOARD	OPTION	-	MENU-2	Restored	Restored	Restored
BOARD	OPTION	-	MENU-3	Restored	Restored	Restored
BOARD	OPTION	-	MENU-4	Restored	Restored	Restored
COPIER	ADJUST	ADJ-XY	ADJ-X	Restored	-	-
COPIER	ADJUST	ADJ-XY	ADJ-Y	Restored	-	-
COPIER	ADJUST	ADJ-XY	ADJ-Y-DF	Restored	-	-
COPIER	ADJUST	ADJ-XY	STRD-POS	Restored	-	-
COPIER	ADJUST	ADJ-XY	ADJ-X-MG	Restored	-	-
COPIER	ADJUST	ADJ-XY	ADJY-DF2	Restored	-	-
COPIER	ADJUST	AE	AE-TBL	Restored	-	-
COPIER	ADJUST	BLANK	BLANK-T	Restored	-	-
COPIER	ADJUST	BLANK	BLANK-L	Restored	-	-
COPIER	ADJUST	BLANK	BLANK-R	Restored	-	-
COPIER	ADJUST	BLANK	BLANK-B	Restored	-	-
COPIER	ADJUST	CCD	W-PLT-X	Restored	-	-
COPIER	ADJUST	CCD	W-PLT-Y	Restored	-	-
COPIER	ADJUST	CCD	W-PLT-Z	Restored	-	-
COPIER	ADJUST	CCD	SH-TRGT	Restored	-	-
COPIER	ADJUST	CCD	100-RG	Restored	-	-
COPIER	ADJUST	CCD	100-GB	Restored	-	-
COPIER	ADJUST	CCD	DFTAR-R	Restored	-	-
COPIER	ADJUST	CCD	DFTAR-G	Restored	-	-
COPIER	ADJUST	CCD	DFTAR-B	Restored	-	-
COPIER	ADJUST	CCD	MTF2-M1	Restored	-	-
COPIER	ADJUST	CCD	MTF2-M2	Restored	-	-
COPIER	ADJUST	CCD	MTF2-M3	Restored	-	-
COPIER	ADJUST	CCD	MTF2-M4	Restored	-	-
COPIER	ADJUST	CCD	MTF2-M5	Restored	-	-
COPIER	ADJUST	CCD	MTF2-M6	Restored	-	-
COPIER	ADJUST	CCD	MTF2-M7	Restored	-	-
COPIER	ADJUST	CCD	MTF2-M8	Restored	-	-

Initial screen	Main item	Intermediate item	Sub item	Case A	Case B	Case C
COPIER	ADJUST	CCD	MTF2-M9	Restored	-	-
COPIER	ADJUST	CCD	MTF2-S1	Restored	-	-
COPIER	ADJUST	CCD	MTF2-S2	Restored	-	-
COPIER	ADJUST	CCD	MTF2-S3	Restored	-	-
COPIER	ADJUST	CCD	MTF2-S4	Restored	-	-
COPIER	ADJUST	CCD	MTF2-S5	Restored	-	-
COPIER	ADJUST	CCD	MTF2-S6	Restored	-	-
COPIER	ADJUST	CCD	MTF2-S7	Restored	-	-
COPIER	ADJUST	CCD	MTF2-S8	Restored	-	-
COPIER	ADJUST	CCD	MTF2-S9	Restored	-	-
COPIER	ADJUST	CCD	100DF2GB	Restored	-	-
COPIER	ADJUST	CCD	100DF2RG	Restored	-	-
COPIER	ADJUST	CCD	DFCH2R2	Restored	-	-
COPIER	ADJUST	CCD	DFCH2R10	Restored	-	-
COPIER	ADJUST	CCD	DFCH2B2	Restored	-	-
COPIER	ADJUST	CCD	DFCH2B10	Restored	-	-
COPIER	ADJUST	CCD	DFCH2G2	Restored	-	-
COPIER	ADJUST	CCD	DFCH2G10	Restored	-	-
COPIER	ADJUST	CCD	MTF-M1	Restored	-	-
COPIER	ADJUST	CCD	MTF-M2	Restored	-	-
COPIER	ADJUST	CCD	MTF-M3	Restored	-	-
COPIER	ADJUST	CCD	MTF-M4	Restored	-	-
COPIER	ADJUST	CCD	MTF-M5	Restored	-	-
COPIER	ADJUST	CCD	MTF-M6	Restored	-	-
COPIER	ADJUST	CCD	MTF-M7	Restored	-	-
COPIER	ADJUST	CCD	MTF-M8	Restored	-	-
COPIER	ADJUST	CCD	MTF-M9	Restored	-	-
COPIER	ADJUST	CCD	MTF-S1	Restored	-	-
COPIER	ADJUST	CCD	MTF-S2	Restored	-	-
COPIER	ADJUST	CCD	MTF-S3	Restored	-	-
COPIER	ADJUST	CCD	MTF-S4	Restored	-	-
COPIER	ADJUST	CCD	MTF-S5	Restored	-	-
COPIER	ADJUST	CCD	MTF-S6	Restored	-	-
COPIER	ADJUST	CCD	MTF-S7	Restored	-	-
COPIER	ADJUST	CCD	MTF-S8	Restored	-	-
COPIER	ADJUST	CCD	MTF-S9	Restored	-	-
COPIER	ADJUST	CCD	DFCH-R2	Restored	-	-
COPIER	ADJUST	CCD	DFCH-R10	Restored	-	-
COPIER	ADJUST	CCD	DFCH-B2	Restored	-	-
COPIER	ADJUST	CCD	DFCH-B10	Restored	-	-
COPIER	ADJUST	CCD	DFCH-G2	Restored	-	-
COPIER	ADJUST	CCD	DFCH-G10	Restored	-	-
COPIER	ADJUST	CCD	MTF2-M10	Restored	-	-
COPIER	ADJUST	CCD	MTF2-M11	Restored	-	-
COPIER	ADJUST	CCD	MTF2-M12	Restored	-	-
COPIER	ADJUST	CCD	MTF2-S10	Restored	-	-
COPIER	ADJUST	CCD	MTF2-S11	Restored	-	-
COPIER	ADJUST	CCD	MTF2-S12	Restored	-	-
COPIER	ADJUST	CCD	MTF-M10	Restored	-	-
COPIER	ADJUST	CCD	MTF-M11	Restored	-	-
COPIER	ADJUST	CCD	MTF-M12	Restored	-	-
COPIER	ADJUST	CCD	MTF-S10	Restored	-	-
COPIER	ADJUST	CCD	MTF-S11	Restored	-	-

Initial screen	Main item	Intermediate item	Sub item	Case A	Case B	Case C
COPIER	ADJUST	CCD	MTF-S12	Restored	-	-
COPIER	ADJUST	CCD	DFCH2K2	Restored	-	-
COPIER	ADJUST	CCD	DFCH2K10	Restored	-	-
COPIER	ADJUST	CCD	DFCH-K2	Restored	-	-
COPIER	ADJUST	CCD	DFCH-K10	Restored	-	-
COPIER	ADJUST	CCD	DFTAR-BW	Restored	-	-
COPIER	ADJUST	CCD	DFTBK-G	Restored	-	-
COPIER	ADJUST	CCD	DFTBK-B	Restored	-	-
COPIER	ADJUST	CCD	DFTBK-R	Restored	-	-
COPIER	ADJUST	CCD	DFTBK-BW	Restored	-	-
COPIER	ADJUST	CST-ADJ	MF-A4R	Restored	-	-
COPIER	ADJUST	CST-ADJ	MF-A6R	Restored	-	-
COPIER	ADJUST	CST-ADJ	MF-A4	Restored	-	-
COPIER	ADJUST	CST-ADJ	PDK-A4	Restored	-	-
COPIER	ADJUST	CST-ADJ	PDK-A5R	Restored	-	-
COPIER	ADJUST	DENS	DENS-ADJ	Restored	-	-
COPIER	ADJUST	DENS	P-OFFSET	Restored	-	-
COPIER	ADJUST	DENS	P-DHALF	Restored	-	-
COPIER	ADJUST	DENS	P-B-TGT	Restored	-	-
COPIER	ADJUST	DENS	DMAX-N-T	Restored	-	-
COPIER	ADJUST	DEVELOP	BIAS	Restored	-	-
COPIER	ADJUST	DEVELOP	FRQ-DEV	Restored	-	-
COPIER	ADJUST	EXP-LED	PR-EXP	Restored	-	-
COPIER	ADJUST	FEED-ADJ	REGIST	Restored	-	-
COPIER	ADJUST	FEED-ADJ	ADJ-C1	Restored	-	-
COPIER	ADJUST	FEED-ADJ	ADJ-C2	Restored	-	-
COPIER	ADJUST	FEED-ADJ	ADJ-C3	Restored	-	-
COPIER	ADJUST	FEED-ADJ	ADJ-C4	Restored	-	-
COPIER	ADJUST	FEED-ADJ	ADJ-MF	Restored	-	-
COPIER	ADJUST	FEED-ADJ	ADJ-DK	Restored	-	-
COPIER	ADJUST	FEED-ADJ	ADJ-REFE	Restored	-	-
COPIER	ADJUST	FEED-ADJ	RG-MF	Restored	-	-
COPIER	ADJUST	FEED-ADJ	REG-THCK	Restored	-	-
COPIER	ADJUST	FEED-ADJ	REG-OHT	Restored	-	-
COPIER	ADJUST	FEED-ADJ	REG-DUP1	Restored	-	-
COPIER	ADJUST	FEED-ADJ	REG-DUP2	Restored	-	-
COPIER	ADJUST	FEED-ADJ	LP-FEED1	Restored	-	-
COPIER	ADJUST	FEED-ADJ	LP-MULT1	Restored	-	-
COPIER	ADJUST	FEED-ADJ	LP-DUP1	Restored	-	-
COPIER	ADJUST	FEED-ADJ	REG-SPD	Restored	-	-
COPIER	ADJUST	FEED-ADJ	LP-DK	Restored	-	-
COPIER	ADJUST	FEED-ADJ	DK1-PKLV	Restored	-	-
COPIER	ADJUST	HV-PRI	PRI-GRID	Restored	-	-
COPIER	ADJUST	HV-TR	TR-OFS1	Restored	-	-
COPIER	ADJUST	HV-TR	TR-OFS2	Restored	-	-
COPIER	ADJUST	HV-TR	TR-OFS3	Restored	-	-
COPIER	ADJUST	HV-TR	TR-OFS4	Restored	-	-
COPIER	ADJUST	HV-TR	TR-OFS5	Restored	-	-
COPIER	ADJUST	HV-TR	TR-OFS6	Restored	-	-
COPIER	ADJUST	HV-TR	TR-L-OF1	Restored	-	-
COPIER	ADJUST	HV-TR	TR-L-OF2	Restored	-	-
COPIER	ADJUST	HV-TR	TR-L-OF3	Restored	-	-
COPIER	ADJUST	HV-TR	TR-L-OF4	Restored	-	-

Initial screen	Main item	Intermediate item	Sub item	Case A	Case B	Case C
COPIER	ADJUST	HV-TR	TR-L-OF5	Restored	-	-
COPIER	ADJUST	HV-TR	TR-L-OF6	Restored	-	-
COPIER	ADJUST	HV-TR	P-TR-OF1	Restored	-	-
COPIER	ADJUST	HV-TR	P-TR-OF2	Restored	-	-
COPIER	ADJUST	HV-TR	P-TR-OF3	Restored	-	-
COPIER	ADJUST	HV-TR	P-TR-OF4	Restored	-	-
COPIER	ADJUST	HV-TR	P-TR-OF5	Restored	-	-
COPIER	ADJUST	HV-TR	P-TR-OF6	Restored	-	-
COPIER	ADJUST	HV-TR	TR-SP1	Restored	-	-
COPIER	ADJUST	HV-TR	TR-SP2	Restored	-	-
COPIER	ADJUST	HV-TR	TR-L-SP1	Restored	-	-
COPIER	ADJUST	HV-TR	TR-L-SP2	Restored	-	-
COPIER	ADJUST	HV-TR	P-TR-SP1	Restored	-	-
COPIER	ADJUST	HV-TR	P-TR-SP2	Restored	-	-
COPIER	ADJUST	IMG-REG	MAG-V	Restored	-	-
COPIER	ADJUST	LASER	PVE-OFST	Restored	-	-
COPIER	ADJUST	LASER	POWER	Restored	-	-
COPIER	ADJUST	MISC	SEG-ADJ	Restored	-	-
COPIER	ADJUST	MISC	K-ADJ	Restored	-	-
COPIER	ADJUST	MISC	ACS-ADJ	Restored	-	-
COPIER	ADJUST	MISC	ACS-EN	Restored	-	-
COPIER	ADJUST	MISC	ACS-CNT	Restored	-	-
COPIER	ADJUST	MISC	ACS-EN2	Restored	-	-
COPIER	ADJUST	MISC	ACS-CNT2	Restored	-	-
COPIER	ADJUST	MISC	SEG-ADJ3	Restored	-	-
COPIER	ADJUST	MISC	K-ADJ3	Restored	-	-
COPIER	ADJUST	MISC	ACS-ADJ3	Restored	-	-
COPIER	ADJUST	MISC	ACS-EN3	Restored	-	-
COPIER	ADJUST	MISC	ACS-CNT3	Restored	-	-
COPIER	ADJUST	MISC	TBSIS-WB	Restored	-	-
COPIER	ADJUST	MISC	HP-OFST	Restored	-	-
COPIER	ADJUST	PASCAL	OFST-P-Y	Restored	-	-
COPIER	ADJUST	PASCAL	OFST-P-M	Restored	-	-
COPIER	ADJUST	PASCAL	OFST-P-C	Restored	-	-
COPIER	ADJUST	PASCAL	OFST-P-K	Restored	-	-
COPIER	ADJUST	V-CONT	VL-OFST	Restored	-	-
COPIER	ADJUST	V-CONT	VD-OFST	Restored	-	-
COPIER	ADJUST	V-CONT	DE-OFST	Restored	-	-
COPIER	ADJUST	V-CONT	VCONT-1	Restored	-	-
COPIER	ADJUST	V-CONT	VL-OF-L	Restored	-	-
COPIER	FUNCTION	2D-SHADE	M-LINE1	Restored	-	-
COPIER	FUNCTION	2D-SHADE	M-LINE2	Restored	-	-
COPIER	FUNCTION	2D-SHADE	S-LINE1	Restored	-	-
COPIER	FUNCTION	2D-SHADE	S-LINE2	Restored	-	-
COPIER	FUNCTION	2D-SHADE	S-LINE3	Restored	-	-
COPIER	FUNCTION	2D-SHADE	S-LINE4	Restored	-	-
COPIER	FUNCTION	2D-SHADE	2D-SET	Restored	-	-
COPIER	FUNCTION	DENS	AGG-SW	Restored	-	-
COPIER	FUNCTION	INSTALL	E-RDS	Restored	Restored	Restored
COPIER	FUNCTION	INSTALL	RGW-PORT	Restored	Restored	Restored
COPIER	FUNCTION	INSTALL	RGW-ADR	Restored	Restored	Restored
COPIER	FUNCTION	INSTALL	CDS-CTL	Restored	Restored	Restored
COPIER	FUNCTION	INSTALL	BIT-SVC	Restored	Restored	Restored

Initial screen	Main item	Intermediate item	Sub item	Case A	Case B	Case C
COPIER	FUNCTION	INSTALL	NFC-USE	Restored	-	-
COPIER	FUNCTION	INSTALL	BLE-USE	Restored	-	-
COPIER	FUNCTION	INSTALL	FAX-USE	Restored	Restored	Restored
COPIER	OPTION	ACC	COIN	Restored	-	-
COPIER	OPTION	ACC	DK-P	Restored	-	-
COPIER	OPTION	ACC	CARD-SW	Restored	-	-
COPIER	OPTION	ACC	CC-SPSW	Restored	-	-
COPIER	OPTION	ACC	UNIT-PRC	Restored	-	-
COPIER	OPTION	ACC	MIN-PRC	Restored	-	-
COPIER	OPTION	ACC	MAX-PRC	Restored	-	-
COPIER	OPTION	ACC	MIC-TUN	Restored	-	-
COPIER	OPTION	ACC	SRL-SPSW	Restored	-	-
COPIER	OPTION	ACC	PDL-THR	Restored	-	-
COPIER	OPTION	ACC	CR-TYPE	Restored	-	-
COPIER	OPTION	ACC	MEAP-SRL	Restored	-	-
COPIER	OPTION	ACC	CV-CSZ	Restored	Restored	Restored
COPIER	OPTION	ACC	COIN-AUT	Restored	-	-
COPIER	OPTION	FNC-SW	PO-CNTMD	Restored	-	-
COPIER	OPTION	FNC-SW	MODEL-SZ	Restored	-	-
COPIER	OPTION	IMG-FIX	FIX-CLN	Restored	-	-
COPIER	OPTION	IMG-FIX	FIX-TEMP	Restored	-	-
COPIER	OPTION	IMG-FIX	FSPD-S1	Restored	-	-
COPIER	OPTION	FNC-SW	SCANSLCT	Restored	-	-
COPIER	OPTION	IMG-MCON	PASCAL	Restored	-	-
COPIER	OPTION	FNC-SW	DH-SW	Restored	-	-
COPIER	OPTION	IMG-DEV	DRM-IDL	Restored	Restored	Restored
COPIER	OPTION	FNC-SW	SENS-CNF	Restored	-	-
COPIER	OPTION	FNC-SW	CONFIG	Restored	-	-
COPIER	OPTION	IMG-MCON	SHARP	Restored	-	-
COPIER	OPTION	IMG-LSR	LAPC-SW	Restored	-	-
COPIER	OPTION	NETWORK	IFAX-LIM	Restored	Restored	Restored
COPIER	OPTION	CUSTOM	TEMP-TBL	Restored	-	-
COPIER	OPTION	FNC-SW	W/SCNR	Restored	-	-
COPIER	OPTION	IMG-MCON	DRM-H-SW	Restored	-	-
COPIER	OPTION	NETWORK	SMTPTXPN	Restored	Restored	Restored
COPIER	OPTION	NETWORK	SMTPRXPN	Restored	Restored	Restored
COPIER	OPTION	NETWORK	POP3PN	Restored	Restored	Restored
COPIER	OPTION	FNC-SW	ORG-LGL	Restored	-	-
COPIER	OPTION	FNC-SW	ORG-LTR	Restored	-	-
COPIER	OPTION	FNC-SW	ORG-B5	Restored	-	-
COPIER	OPTION	DSPLY-SW	UI-COPY	Restored	Restored	Restored
COPIER	OPTION	DSPLY-SW	UI-BOX	Restored	Restored	Restored
COPIER	OPTION	DSPLY-SW	UI-SEND	Restored	Restored	Restored
COPIER	OPTION	DSPLY-SW	UI-FAX	Restored	Restored	Restored
COPIER	OPTION	IMG-MCON	SCR-SLCT	Restored	-	-
COPIER	OPTION	IMG-MCON	TMC-SLCT	Restored	-	-
COPIER	OPTION	NETWORK	FTPTXPN	Restored	Restored	Restored
COPIER	OPTION	NETWORK	NW-SPEED	Restored	-	-
COPIER	OPTION	FNC-SW	INTROT-1	Restored	-	-
COPIER	OPTION	FNC-SW	DMAX-SW	Restored	-	-
COPIER	OPTION	FEED-SW	TRY-CHG	Restored	Restored	Restored
COPIER	OPTION	DSPLY-SW	NWERR-SW	Restored	Restored	Restored
COPIER	OPTION	NETWORK	STS-PORT	Restored	Restored	Restored

Initial screen	Main item	Intermediate item	Sub item	Case A	Case B	Case C
COPIER	OPTION	NETWORK	CMD-PORT	Restored	Restored	Restored
COPIER	OPTION	FNC-SW	MODELSZ2	Restored	-	-
COPIER	OPTION	IMG-RDR	DFDST-L1	Restored	-	-
COPIER	OPTION	IMG-RDR	DFDST-L2	Restored	-	-
COPIER	OPTION	NETWORK	NS-CMD5	Restored	Restored	Restored
COPIER	OPTION	NETWORK	NS-GSAPI	Restored	Restored	Restored
COPIER	OPTION	NETWORK	NS-NTLM	Restored	Restored	Restored
COPIER	OPTION	NETWORK	NS-PLNWS	Restored	Restored	Restored
COPIER	OPTION	NETWORK	NS-PLN	Restored	Restored	Restored
COPIER	OPTION	NETWORK	NS-LGN	Restored	Restored	Restored
COPIER	OPTION	NETWORK	MEAP-PN	Restored	Restored	Restored
COPIER	OPTION	FNC-SW	SVMD-ENT	Restored	Restored	Restored
COPIER	OPTION	ENV-SET	ENVP-INT	Restored	Restored	Restored
COPIER	OPTION	NETWORK	CHNG-STS	Restored	Restored	Restored
COPIER	OPTION	NETWORK	CHNG-CMD	Restored	Restored	Restored
COPIER	OPTION	IMG-DEV	DV-RT-LG	Restored	-	-
COPIER	OPTION	NETWORK	MEAP-SSL	Restored	Restored	Restored
COPIER	OPTION	CUSTOM	SC-L-CNT	Restored	-	-
COPIER	OPTION	IMG-FIX	CBLTINVL	Restored	-	-
COPIER	OPTION	FNC-SW	KSIZE-SW	Restored	-	-
COPIER	OPTION	NETWORK	LPD-PORT	Restored	Restored	Restored
COPIER	OPTION	FNC-SW	ORG-A4R	Restored	-	-
COPIER	OPTION	FNC-SW	PDF-RDCT	Restored	Restored	Restored
COPIER	OPTION	IMG-RDR	ABC-MODE	Restored	-	-
COPIER	OPTION	IMG-MCON	REDU-CNT	Restored	-	-
COPIER	OPTION	IMG-MCON	VP-ART	Restored	-	-
COPIER	OPTION	IMG-MCON	VP-TXT	Restored	-	-
COPIER	OPTION	DSPLY-SW	UI-PRINT	Restored	Restored	Restored
COPIER	OPTION	FNC-SW	SJB-UNW	Restored	Restored	Restored
COPIER	OPTION	DSPLY-SW	IMGC-ADJ	Restored	Restored	Restored
COPIER	OPTION	DSPLY-SW	UI-RSCAN	Restored	Restored	Restored
COPIER	OPTION	DSPLY-SW	UI-WEB	Restored	Restored	Restored
COPIER	OPTION	DSPLY-SW	UI-HOLD	Restored	Restored	Restored
COPIER	OPTION	FNC-SW	CARD-RNG	Restored	-	-
COPIER	OPTION	NETWORK	WUEN-LIV	Restored	Restored	Restored
COPIER	OPTION	CUSTOM	MAILYEAR	Restored	Restored	Restored
COPIER	OPTION	IMG-FIX	TMP-TBL2	Restored	-	-
COPIER	OPTION	IMG-FIX	TMP-TBL3	Restored	-	-
COPIER	OPTION	IMG-FIX	TMP-TBL4	Restored	-	-
COPIER	OPTION	FNC-SW	SJOB-CL	Restored	Restored	Restored
COPIER	OPTION	NETWORK	IFX-CHIG	Restored	Restored	Restored
COPIER	OPTION	IMG-FIX	RAG-CONT	Restored	-	-
COPIER	OPTION	NETWORK	DNSTRANS	Restored	Restored	Restored
COPIER	OPTION	IMG-RDR	ABC-MD2	Restored	-	-
COPIER	OPTION	FNC-SW	MIBCOUNT	Restored	Restored	Restored
COPIER	OPTION	ENV-SET	DRY-CISU	Restored	-	-
COPIER	OPTION	DSPLY-SW	RMT-CNSL	Restored	Restored	Restored
COPIER	OPTION	CUSTOM	PDLEVCT1	Restored	Restored	Restored
COPIER	OPTION	NETWORK	PROXYRES	Restored	Restored	Restored
COPIER	OPTION	NETWORK	WOLTRANS	Restored	Restored	Restored
COPIER	OPTION	IMG-RDR	DF2DSTL1	Restored	-	-
COPIER	OPTION	IMG-RDR	DF2DSTL2	Restored	-	-
COPIER	OPTION	NETWORK	802XTOUT	Restored	Restored	Restored

Initial screen	Main item	Intermediate item	Sub item	Case A	Case B	Case C
COPIER	OPTION	NETWORK	NCONF-SW	Restored	Restored	Restored
COPIER	OPTION	CUSTOM	ABK-TOOL	Restored	Restored	Restored
COPIER	OPTION	FNC-SW	W/RAID	Restored	-	-
COPIER	OPTION	FNC-SW	PSWD-SW	Restored	Restored	Restored
COPIER	OPTION	FNC-SW	SM-PSWD	Restored	Restored	Restored
COPIER	OPTION	IMG-MCON	C-PDL-T	Restored	-	-
COPIER	OPTION	IMG-MCON	C-S-P-D	Restored	-	-
COPIER	OPTION	IMG-MCON	C-S-C-D	Restored	-	-
COPIER	OPTION	IMG-DEV	ADJ-VPPN	Restored	-	-
COPIER	OPTION	IMG-FIX	RAG-SW	Restored	-	-
COPIER	OPTION	CUSTOM	DEV-SP1	Restored	-	-
COPIER	OPTION	CUSTOM	DEV-SP2	Restored	-	-
COPIER	OPTION	FNC-SW	RPT2SIDE	Restored	Restored	Restored
COPIER	OPTION	NETWORK	AFS-JOB	Restored	Restored	Restored
COPIER	OPTION	NETWORK	AFC-EVNT	Restored	Restored	Restored
COPIER	OPTION	DSPLY-SW	UI-SBOX	Restored	Restored	Restored
COPIER	OPTION	DSPLY-SW	UI-MEM	Restored	Restored	Restored
COPIER	OPTION	NETWORK	ILOGMODE	Restored	Restored	Restored
COPIER	OPTION	NETWORK	ILOGKEEP	Restored	Restored	Restored
COPIER	OPTION	DSPLY-SW	UI-NAVI	Restored	Restored	Restored
COPIER	OPTION	FNC-SW	STND-PNL	Restored	-	-
COPIER	OPTION	FNC-SW	INVALIDPDL	Restored	-	-
COPIER	OPTION	FNC-SW	CDS-FIRM	Restored	Restored	Restored
COPIER	OPTION	FNC-SW	CDS-MEAP	Restored	Restored	Restored
COPIER	OPTION	FNC-SW	CDS-UGW	Restored	Restored	Restored
COPIER	OPTION	FNC-SW	LOCLFIRM	Restored	Restored	Restored
COPIER	OPTION	CUSTOM	DEV-SP3	Restored	-	-
COPIER	OPTION	CUSTOM	DEV-SP4	Restored	-	-
COPIER	OPTION	CUSTOM	DEV-SP5	Restored	-	-
COPIER	OPTION	CUSTOM	DEV-SP6	Restored	-	-
COPIER	OPTION	CUSTOM	DEV-SP7	Restored	-	-
COPIER	OPTION	CUSTOM	DEV-SP8	Restored	-	-
COPIER	OPTION	NETWORK	IPTBROAD	Restored	Restored	Restored
COPIER	OPTION	FEED-SW	DK2-TURN	Restored	-	-
COPIER	OPTION	FEED-SW	DK3-TURN	Restored	-	-
COPIER	OPTION	FEED-SW	DK4-TURN	Restored	-	-
COPIER	OPTION	FEED-SW	DK1-TURN	Restored	-	-
COPIER	OPTION	FEED-SW	DK5-TURN	Restored	-	-
COPIER	OPTION	NETWORK	PFWFTPRT	Restored	Restored	Restored
COPIER	OPTION	IMG-DEV	PG-DMAX	Restored	-	-
COPIER	OPTION	CLEANING	CLN-SW	Restored	-	-
COPIER	OPTION	CLEANING	CLN-ADJ	Restored	-	-
COPIER	OPTION	IMG-FIX	FIX-DWN	Restored	-	-
COPIER	OPTION	IMG-FIX	FIX-RT	Restored	-	-
COPIER	OPTION	IMG-DEV	DRM-IDL2	Restored	-	-
COPIER	OPTION	CUSTOM	AC-FREQ	Restored	Restored	Restored
COPIER	OPTION	IMG-LSR	2D-SHADE	Restored	-	-
COPIER	OPTION	FNC-SW	T-RUN-LV	Restored	-	-
COPIER	OPTION	FEED-SW	DK1-AIR	Restored	-	-
COPIER	OPTION	FNC-SW	BXNUPLOG	Restored	Restored	Restored
COPIER	OPTION	IMG-MCON	LIN-OFST	Restored	-	-
COPIER	OPTION	FEED-SW	TFL-RTC	Restored	-	-
COPIER	OPTION	DSPLY-SW	UI-CUSTM	Restored	Restored	Restored

Initial screen	Main item	Intermediate item	Sub item	Case A	Case B	Case C
COPIER	OPTION	IMG-FIX	MIX-WAIT	Restored	-	-
COPIER	OPTION	IMG-FIX	P-BETWN	Restored	-	-
COPIER	OPTION	IMG-FIX	FIX-TMP2	Restored	-	-
COPIER	OPTION	IMG-FIX	FIX-TMP3	Restored	-	-
COPIER	OPTION	FNC-SW	SDLMTWRN	Restored	Restored	Restored
COPIER	OPTION	FNC-SW	JLK-PWSC	Restored	Restored	Restored
COPIER	OPTION	NETWORK	DDNSINTV	Restored	Restored	Restored
COPIER	OPTION	IMG-FIX	FX-IMGLV	Restored	-	-
COPIER	OPTION	IMG-FIX	FX-WNKL	Restored	-	-
COPIER	OPTION	FNC-SW	FAX-INT	Restored	Restored	Restored
COPIER	OPTION	IMG-DEV	ATM	Restored	-	-
COPIER	OPTION	FNC-SW	CDS-LVUP	Restored	Restored	Restored
COPIER	OPTION	IMG-MCON	EP-CONT	Restored	-	-
COPIER	OPTION	IMG-DEV	LWDTY-SW	Restored	-	-
COPIER	OPTION	IMG-DEV	LWDTYADJ	Restored	-	-
COPIER	OPTION	IMG-DEV	BB-CNT	Restored	-	-
COPIER	OPTION	IMG-DEV	PRI-SHUT	Restored	-	-
COPIER	OPTION	IMG-DEV	TBLTCLSW	Restored	-	-
COPIER	OPTION	IMG-DEV	TBLTBIS+	Restored	-	-
COPIER	OPTION	IMG-DEV	TBLTBIS-	Restored	-	-
COPIER	OPTION	IMG-DEV	TBLTTMS	Restored	-	-
COPIER	OPTION	IMG-FIX	FIX-TMP4	Restored	-	-
COPIER	OPTION	IMG-DEV	DRM-IDL3	Restored	-	-
COPIER	OPTION	FNC-SW	AMSOFFSW	Restored	Restored	Restored
COPIER	OPTION	FNC-SW	UA-OFFSW	Restored	Restored	Restored
COPIER	OPTION	FNC-SW	MIB-NVTA	Restored	-	-
COPIER	OPTION	FNC-SW	MIB-EXT	Restored	-	-
COPIER	OPTION	DSPLY-SW	SCT-BTN	Restored	Restored	Restored
COPIER	OPTION	CUSTOM	DFEJCLED	Restored	-	-
COPIER	OPTION	FNC-SW	SVC-RUI	Restored	-	-
COPIER	OPTION	FNC-SW	LCDSFLG	Restored	Restored	Restored
COPIER	OPTION	DSPLY-SW	SDTM-DSP	Restored	Restored	Restored
COPIER	OPTION	FNC-SW	BXSHIFT	Restored	Restored	Restored
COPIER	OPTION	FNC-SW	HOME-SW	Restored	Restored	Restored
COPIER	OPTION	FNC-SW	NO-LGOUT	Restored	Restored	Restored
COPIER	OPTION	FNC-SW	JM-ERR-D	Restored	-	-
COPIER	OPTION	FNC-SW	JM-ERR-R	Restored	-	-
COPIER	OPTION	NETWORK	SIPAUDIO	Restored	Restored	Restored
COPIER	OPTION	NETWORK	SIPINOUT	Restored	Restored	Restored
COPIER	OPTION	IMG-FIX	WEB-LIFE	Restored	-	-
COPIER	OPTION	NETWORK	SIPREGPR	Restored	Restored	Restored
COPIER	OPTION	FNC-SW	ASLPMAX	Restored	Restored	Restored
COPIER	OPTION	NETWORK	VLAN-SW	Restored	Restored	Restored
COPIER	OPTION	CUSTOM	PD-SPCL	Restored	-	-
COPIER	OPTION	FNC-SW	SEND-SPD	Restored	Restored	Restored
COPIER	OPTION	FNC-SW	VER-CHNG	Restored	Restored	Restored
COPIER	OPTION	NETWORK	FTPMODE	Restored	Restored	Restored
COPIER	OPTION	NETWORK	SSLMODE	Restored	Restored	Restored
COPIER	OPTION	NETWORK	SSLSTRNG	Restored	Restored	Restored
COPIER	OPTION	FEED-SW	DK1-ALVD	Restored	-	-
COPIER	OPTION	FEED-SW	DK1-ALVU	Restored	-	-
COPIER	OPTION	FEED-SW	DK1-LDWN	Restored	-	-
COPIER	OPTION	FEED-SW	DK1-PSP	Restored	-	-

Initial screen	Main item	Intermediate item	Sub item	Case A	Case B	Case C
COPIER	OPTION	FEED-SW	PDK-REST	Restored	-	-
COPIER	OPTION	DSPLY-SW	UI-PPA	Restored	Restored	Restored
COPIER	OPTION	NETWORK	NW-WAIT	Restored	Restored	Restored
COPIER	OPTION	NETWORK	WLAN-USE	Restored	Restored	Restored
COPIER	OPTION	DSPLY-SW	CE-DSP	Restored	-	-
COPIER	OPTION	IMG-MCON	DOTSCT	Restored	-	-
COPIER	OPTION	IMG-MCON	SP-GRAD	Restored	-	-
COPIER	OPTION	NETWORK	WLANPORT	Restored	Restored	Restored
COPIER	OPTION	DSPLY-SW	LOCAL-SZ	Restored	-	-
COPIER	OPTION	DSPLY-SW	DIE-DSP	Restored	Restored	Restored
COPIER	OPTION	CUSTOM	PAP-TYPE	Restored	Restored	Restored
COPIER	OPTION	FNC-SW	S-TRAY	Restored	-	-
COPIER	OPTION	FNC-SW	D-FDS-SW	Restored	-	-
COPIER	OPTION	NETWORK	RAW-PORT	Restored	Restored	Restored
COPIER	OPTION	DSPLY-SW	OIL-DSP	Restored	-	-
COPIER	OPTION	NETWORK	LINKWAKE	Restored	-	-
COPIER	OPTION	FNC-SW	PICLOGIN	Restored	-	-
COPIER	OPTION	CUSTOM	DCM-EXCL	Restored	Restored	Restored
COPIER	OPTION	DSPLY-SW	SND-NAME	Restored	Restored	Restored
COPIER	OPTION	DSPLY-SW	PCMP-DSP	Restored	Restored	Restored
COPIER	OPTION	FNC-SW	FL-START	Restored	Restored	Restored
COPIER	OPTION	CUSTOM	FPOT-MD	Restored	Restored	Restored
COPIER	OPTION	NETWORK	BLEPOWER	Restored	-	-
COPIER	OPTION	NETWORK	WSMC-USE	Restored	Restored	Restored
COPIER	OPTION	FEED-SW	TRY-FUFD	Restored	-	-
COPIER	OPTION	FNC-SW	3RDP-MSG	Restored	-	-
COPIER	OPTION	DSPLY-SW	ERR-DISP	Restored	Restored	Restored
COPIER	OPTION	DSPLY-SW	SVC-ACA	Restored	Restored	Restored
COPIER	OPTION	NETWORK	INTENT	Restored	-	-
COPIER	OPTION	IMG-MCON	BIN-SEL	Restored	-	-
COPIER	OPTION	DSPLY-SW	SVC-SRA	Restored	Restored	Restored
COPIER	OPTION	DSPLY-SW	LF-DSP-S	Restored	Restored	Restored
COPIER	OPTION	DSPLY-SW	LF-DSP-U	Restored	Restored	Restored
COPIER	OPTION	DSPLY-SW	ERRL-DSP	Restored	Restored	Restored
COPIER	OPTION	DSPLY-SW	JLG-UD-D	Restored	Restored	Restored
COPIER	OPTION	DSPLY-SW	UFOS-DSP	Restored	Restored	Restored
COPIER	OPTION	DSPLY-SW	SVC-DAT	Restored	Restored	Restored
COPIER	OPTION	CST	P-SZ-C1	Restored	Restored	Restored
COPIER	OPTION	CST	P-SZ-C2	Restored	Restored	Restored
COPIER	OPTION	CUSTOM2	SP-B01	Restored	Restored	Restored
COPIER	OPTION	CUSTOM2	SP-B02	Restored	Restored	Restored
COPIER	OPTION	CUSTOM2	SP-B03	Restored	Restored	Restored
COPIER	OPTION	CUSTOM2	SP-B04	Restored	Restored	Restored
COPIER	OPTION	CUSTOM2	SP-B05	Restored	Restored	Restored
COPIER	OPTION	CUSTOM2	SP-B06	Restored	Restored	Restored
COPIER	OPTION	CUSTOM2	SP-B07	Restored	Restored	Restored
COPIER	OPTION	CUSTOM2	SP-B08	Restored	Restored	Restored
COPIER	OPTION	CUSTOM2	SP-B09	Restored	Restored	Restored
COPIER	OPTION	CUSTOM2	SP-B10	Restored	Restored	Restored
COPIER	OPTION	CUSTOM2	SP-B11	Restored	Restored	Restored
COPIER	OPTION	CUSTOM2	SP-B12	Restored	Restored	Restored
COPIER	OPTION	CUSTOM2	SP-B13	Restored	Restored	Restored
COPIER	OPTION	CUSTOM2	SP-B14	Restored	Restored	Restored

Initial screen	Main item	Intermediate item	Sub item	Case A	Case B	Case C
COPIER	OPTION	CUSTOM2	SP-V41	Restored	Restored	Restored
COPIER	OPTION	CUSTOM2	SP-V42	Restored	Restored	Restored
COPIER	OPTION	CUSTOM2	SP-V43	Restored	Restored	Restored
COPIER	OPTION	CUSTOM2	SP-V44	Restored	Restored	Restored
COPIER	OPTION	CUSTOM2	SP-V45	Restored	Restored	Restored
COPIER	OPTION	CUSTOM2	SP-V46	Restored	Restored	Restored
COPIER	OPTION	CUSTOM2	SP-V47	Restored	Restored	Restored
COPIER	OPTION	CUSTOM2	SP-V48	Restored	Restored	Restored
COPIER	OPTION	CUSTOM2	SP-V49	Restored	Restored	Restored
COPIER	OPTION	CUSTOM2	SP-V50	Restored	Restored	Restored
COPIER	OPTION	CUSTOM2	SP-V51	Restored	Restored	Restored
COPIER	OPTION	CUSTOM2	SP-V52	Restored	Restored	Restored
COPIER	OPTION	CUSTOM2	SP-V53	Restored	Restored	Restored
COPIER	OPTION	CUSTOM2	SP-V54	Restored	Restored	Restored
COPIER	OPTION	CUSTOM2	SP-V55	Restored	Restored	Restored
COPIER	OPTION	CUSTOM2	SP-V56	Restored	Restored	Restored
COPIER	OPTION	CUSTOM2	SP-V57	Restored	Restored	Restored
COPIER	OPTION	CUSTOM2	SP-V58	Restored	Restored	Restored
COPIER	OPTION	CUSTOM2	SP-V59	Restored	Restored	Restored
COPIER	OPTION	CUSTOM2	SP-V60	Restored	Restored	Restored
COPIER	OPTION	CUSTOM2	SP-V61	Restored	Restored	Restored
COPIER	OPTION	CUSTOM2	SP-V62	Restored	Restored	Restored
COPIER	OPTION	CUSTOM2	SP-V63	Restored	Restored	Restored
COPIER	OPTION	CUSTOM2	SP-V64	Restored	Restored	Restored
COPIER	OPTION	CUSTOM2	SP-V65	Restored	Restored	Restored
COPIER	OPTION	CUSTOM2	SP-V66	Restored	Restored	Restored
COPIER	OPTION	CUSTOM2	SP-V67	Restored	Restored	Restored
COPIER	OPTION	CUSTOM2	SP-V68	Restored	Restored	Restored
COPIER	OPTION	CUSTOM2	SP-V69	Restored	Restored	Restored
COPIER	OPTION	CUSTOM2	SP-V70	Restored	Restored	Restored
COPIER	OPTION	CUSTOM2	SP-V71	Restored	Restored	Restored
COPIER	OPTION	CUSTOM2	SP-V72	Restored	Restored	Restored
COPIER	OPTION	CUSTOM2	SP-V73	Restored	Restored	Restored
COPIER	OPTION	CUSTOM2	SP-V74	Restored	Restored	Restored
COPIER	OPTION	CUSTOM2	SP-V75	Restored	Restored	Restored
COPIER	OPTION	CUSTOM2	SP-V76	Restored	Restored	Restored
COPIER	OPTION	CUSTOM2	SP-V77	Restored	Restored	Restored
COPIER	OPTION	CUSTOM2	SP-V78	Restored	Restored	Restored
COPIER	OPTION	CUSTOM2	SP-V79	Restored	Restored	Restored
COPIER	OPTION	CUSTOM2	SP-V80	Restored	Restored	Restored
COPIER	OPTION	INT-FACE	IMG-CONT	Restored	-	-
COPIER	OPTION	INT-FACE	NWCT-TM	Restored	-	-
COPIER	OPTION	INT-FACE	VTRNS-TO	Restored	-	-
COPIER	OPTION	INT-FACE	ERRHNDL	Restored	-	-
COPIER	OPTION	PM-DLV-D	TONER-K	Restored	Restored	Restored
COPIER	OPTION	PM-DLV-D	WST-TNR	Restored	Restored	Restored
COPIER	OPTION	PM-DLV-D	PT-DRM	Restored	Restored	Restored
COPIER	OPTION	PM-DLV-D	PRM-WIRE	Restored	Restored	Restored
COPIER	OPTION	PM-DLV-D	PRM-CLN	Restored	Restored	Restored
COPIER	OPTION	PM-DLV-D	PRM-UNIT	Restored	Restored	Restored
COPIER	OPTION	PM-DLV-D	CLN-BLD	Restored	Restored	Restored
COPIER	OPTION	PM-DLV-D	BS-SL-F	Restored	Restored	Restored
COPIER	OPTION	PM-DLV-D	BS-SL-R	Restored	Restored	Restored

Initial screen	Main item	Intermediate item	Sub item	Case A	Case B	Case C
COPIER	OPTION	PM-DLV-D	SP-CLAW	Restored	Restored	Restored
COPIER	OPTION	PM-DLV-D	EXP-SCRIP	Restored	Restored	Restored
COPIER	OPTION	PM-DLV-D	DV-UNT-K	Restored	Restored	Restored
COPIER	OPTION	PM-DLV-D	TR-BLT	Restored	Restored	Restored
COPIER	OPTION	PM-DLV-D	TR-ROLL	Restored	Restored	Restored
COPIER	OPTION	PM-DLV-D	T-CLN-BD	Restored	Restored	Restored
COPIER	OPTION	PM-DLV-D	T-CN-BRU	Restored	Restored	Restored
COPIER	OPTION	PM-DLV-D	PO-WIRE	Restored	Restored	Restored
COPIER	OPTION	PM-DLV-D	PO-CLN	Restored	Restored	Restored
COPIER	OPTION	PM-DLV-D	PO-UNIT	Restored	Restored	Restored
COPIER	OPTION	PM-DLV-D	FX-UP-RL	Restored	Restored	Restored
COPIER	OPTION	PM-DLV-D	FIX-TH1	Restored	Restored	Restored
COPIER	OPTION	PM-DLV-D	FIX-TH2	Restored	Restored	Restored
COPIER	OPTION	PM-DLV-D	FX-IN-BS	Restored	Restored	Restored
COPIER	OPTION	PM-DLV-D	FX-RTNR	Restored	Restored	Restored
COPIER	OPTION	PM-DLV-D	FX-LW-RL	Restored	Restored	Restored
COPIER	OPTION	PM-DLV-D	FX-L-STC	Restored	Restored	Restored
COPIER	OPTION	PM-DLV-D	FX-WEB1	Restored	Restored	Restored
COPIER	OPTION	PM-DLV-D	C1-PU-RL	Restored	Restored	Restored
COPIER	OPTION	PM-DLV-D	C1-FD-RL	Restored	Restored	Restored
COPIER	OPTION	PM-DLV-D	C1-SP-RL	Restored	Restored	Restored
COPIER	OPTION	PM-DLV-D	C2-PU-RL	Restored	Restored	Restored
COPIER	OPTION	PM-DLV-D	C2-FD-RL	Restored	Restored	Restored
COPIER	OPTION	PM-DLV-D	C2-SP-RL	Restored	Restored	Restored
COPIER	OPTION	PM-DLV-D	C3-PU-RL	Restored	Restored	Restored
COPIER	OPTION	PM-DLV-D	C3-SP-RL	Restored	Restored	Restored
COPIER	OPTION	PM-DLV-D	C3-FD-RL	Restored	Restored	Restored
COPIER	OPTION	PM-DLV-D	C4-PU-RL	Restored	Restored	Restored
COPIER	OPTION	PM-DLV-D	C4-FD-RL	Restored	Restored	Restored
COPIER	OPTION	PM-DLV-D	C4-SP-RL	Restored	Restored	Restored
COPIER	OPTION	PM-DLV-D	M-FD-RL	Restored	Restored	Restored
COPIER	OPTION	PM-DLV-D	M-SP-RL	Restored	Restored	Restored
COPIER	OPTION	PM-DLV-D	DLV-UCLW	Restored	Restored	Restored
COPIER	OPTION	PM-DLV-D	OZ-FIL1	Restored	Restored	Restored
COPIER	OPTION	PM-DLV-D	AR-FIL1	Restored	Restored	Restored
COPIER	OPTION	PM-DLV-D	DF-PU-RL	Restored	Restored	Restored
COPIER	OPTION	PM-DLV-D	DF-FD-RL	Restored	Restored	Restored
COPIER	OPTION	PM-DLV-D	DF-SP-RL	Restored	Restored	Restored
COPIER	OPTION	PM-DLV-D	LNT-TAP1	Restored	Restored	Restored
COPIER	OPTION	PM-DLV-D	LNT-TAP2	Restored	Restored	Restored
COPIER	OPTION	PM-DLV-D	PD-PU-RL	Restored	Restored	Restored
COPIER	OPTION	PM-DLV-D	PD-SP-RL	Restored	Restored	Restored
COPIER	OPTION	PM-DLV-D	PD-FD-RL	Restored	Restored	Restored
COPIER	OPTION	PM-MSG-D	TONER-K	Restored	Restored	Restored
COPIER	OPTION	PM-MSG-D	WST-TNR	Restored	Restored	Restored
COPIER	OPTION	PM-PRE-M	TONER-K	Restored	Restored	Restored
COPIER	OPTION	PM-PRE-M	WST-TNR	Restored	Restored	Restored
COPIER	OPTION	PM-U-DSP	PT-DRM	Restored	Restored	Restored
COPIER	OPTION	PM-U-DSP	FX-REP	Restored	Restored	Restored
COPIER	OPTION	USER	COPY-LIM	Restored	-	-
COPIER	OPTION	USER	SLEEP	Restored	Restored	Restored
COPIER	OPTION	USER	SIZE-DET	Restored	-	-
COPIER	OPTION	USER	COUNTER2	Restored	Restored	Restored

List of Service Modes That Can Be Restored

Initial screen	Main item	Intermediate item	Sub item	Case A	Case B	Case C
COPIER	OPTION	USER	COUNTER3	Restored	Restored	Restored
COPIER	OPTION	USER	COUNTER4	Restored	Restored	Restored
COPIER	OPTION	USER	COUNTER5	Restored	Restored	Restored
COPIER	OPTION	USER	COUNTER6	Restored	Restored	Restored
COPIER	OPTION	USER	DATE-DSP	Restored	Restored	Restored
COPIER	OPTION	USER	MB-CCV	Restored	-	-
COPIER	OPTION	USER	CONTROL	Restored	-	-
COPIER	OPTION	USER	B4-L-CNT	Restored	-	-
COPIER	OPTION	USER	MF-LG-ST	Restored	Restored	Restored
COPIER	OPTION	USER	CNT-DISP	Restored	Restored	Restored
COPIER	OPTION	USER	PH-D-SEL	Restored	-	-
COPIER	OPTION	USER	COPY-JOB	Restored	-	-
COPIER	OPTION	USER	OP-SZ-DT	Restored	-	-
COPIER	OPTION	USER	NW-SCAN	Restored	Restored	Restored
COPIER	OPTION	USER	JOB-INVL	Restored	Restored	Restored
COPIER	OPTION	USER	TAB-ROT	Restored	-	-
COPIER	OPTION	USER	PR-PSESW	Restored	Restored	Restored
COPIER	OPTION	USER	IDPRN-SW	Restored	-	-
COPIER	OPTION	USER	PCL-COPY	Restored	Restored	Restored
COPIER	OPTION	USER	CNT-SW	Restored	Restored	Restored
COPIER	OPTION	USER	TAB-ACC	Restored	Restored	Restored
COPIER	OPTION	USER	BCNT-AST	Restored	Restored	Restored
COPIER	OPTION	USER	PRJOB-CP	Restored	Restored	Restored
COPIER	OPTION	USER	DOC-REM	Restored	Restored	Restored
COPIER	OPTION	USER	DPT-ID-7	Restored	Restored	Restored
COPIER	OPTION	USER	RUI-RJT	Restored	Restored	Restored
COPIER	OPTION	USER	FREG-SW	Restored	Restored	Restored
COPIER	OPTION	USER	IFAX-SZL	Restored	Restored	Restored
COPIER	OPTION	USER	IFAX-PGD	Restored	Restored	Restored
COPIER	OPTION	USER	MEAPSAFE	Restored	-	-
COPIER	OPTION	USER	AFN-PSWD	Restored	Restored	Restored
COPIER	OPTION	USER	PTJAM-RC	Restored	Restored	Restored
COPIER	OPTION	USER	PDL-NCSW	Restored	-	-
COPIER	OPTION	USER	PS-MODE	Restored	Restored	Restored
COPIER	OPTION	USER	CNCT-RLZ	Restored	Restored	Restored
COPIER	OPTION	USER	LDAP-SW	Restored	Restored	Restored
COPIER	OPTION	USER	FROM-OF	Restored	Restored	Restored
COPIER	OPTION	USER	FILE-OF	Restored	Restored	Restored
COPIER	OPTION	USER	MAIL-OF	Restored	Restored	Restored
COPIER	OPTION	USER	IFAX-OF	Restored	Restored	Restored
COPIER	OPTION	USER	LDAP-DEF	Restored	Restored	Restored
COPIER	OPTION	USER	FREE-DSP	Restored	-	-
COPIER	OPTION	USER	TNRB-SW	Restored	Restored	Restored
COPIER	OPTION	USER	DK1-ASST	Restored	-	-
COPIER	OPTION	USER	USBH-DSP	Restored	Restored	Restored
COPIER	OPTION	USER	USBM-DSP	Restored	Restored	Restored
COPIER	OPTION	USER	USBI-DSP	Restored	Restored	Restored
COPIER	OPTION	USER	CTCHKDSP	Restored	Restored	Restored
COPIER	OPTION	USER	DFLT-ADJ	Restored	Restored	Restored
COPIER	OPTION	USER	USBR-DSP	Restored	Restored	Restored
COPIER	OPTION	USER	POL-SCAN	Restored	Restored	Restored
COPIER	OPTION	USER	PH-D-SL2	Restored	-	-
COPIER	OPTION	USER	W-TN-DSP	Restored	Restored	Restored

Initial screen	Main item	Intermediate item	Sub item	Case A	Case B	Case C
COPIER	OPTION	USER	SCAN-RSL	Restored	-	-
COPIER	OPTION	USER	JA-SBOX	Restored	Restored	Restored
COPIER	OPTION	USER	JA-DFAX	Restored	Restored	Restored
COPIER	OPTION	USER	JA-REP	Restored	Restored	Restored
COPIER	OPTION	USER	JA-FREP	Restored	Restored	Restored
COPIER	OPTION	USER	JA-BOX	Restored	Restored	Restored
COPIER	OPTION	USER	JA-FORM	Restored	Restored	Restored
COPIER	OPTION	USER	JA-PREV	Restored	Restored	Restored
COPIER	OPTION	USER	JA-PULL	Restored	Restored	Restored
COPIER	OPTION	USER	JA-PDLB	Restored	Restored	Restored
COPIER	OPTION	USER	JA-JOBK	Restored	Restored	Restored
COPIER	OPTION	USER	JA-JDF	Restored	Restored	Restored
COPIER	OPTION	USER	JA-RUI	Restored	Restored	Restored
COPIER	OPTION	USER	JA-WEB	Restored	Restored	Restored
COPIER	OPTION	USER	EXP-CRYP	Restored	Restored	Restored
COPIER	OPTION	USER	THK1-DSP	Restored	Restored	Restored
COPIER	OPTION	USER	SNDSTREN	Restored	Restored	Restored
COPIER	OPTION	USER	FAXSTREN	Restored	Restored	Restored
COPIER	OPTION	USER	SJ-UNMSK	Restored	Restored	Restored
COPIER	OPTION	USER	SJ-CLMSK	Restored	Restored	Restored
COPIER	OPTION	USER	PRTDP-SW	Restored	Restored	Restored
COPIER	OPTION	USER	PDFD-MSW	Restored	Restored	Restored
COPIER	OPTION	USER	SFT-OUT	Restored	Restored	Restored
COPIER	OPTION	USER	LGCY-SCP	Restored	Restored	Restored
COPIER	OPTION	USER	FLM-DSPL	Restored	-	-
COPIER	OPTION	USER	CNT-PRT	Restored	Restored	Restored
COPIER	OPTION	USER	C-P-SIZE	Restored	Restored	Restored
COPIER	OPTION	USER	MF-FEED	Restored	Restored	Restored
COPIER	OPTION	USER	INSTDT-Y	Restored	-	-
COPIER	OPTION	USER	INSTDT-M	Restored	-	-
COPIER	OPTION	USER	INSTDT-D	Restored	-	-
COPIER	OPTION	USER	INSTDT-H	Restored	-	-
COPIER	OPTION	USER	INSTDT-N	Restored	-	-
COPIER	OPTION	USER	STOP-USE	Restored	Restored	Restored
COPIER	OPTION	USER	LASTREST	Restored	Restored	Restored
COPIER	OPTION	USER	SZCHKSW	Restored	Restored	Restored
COPIER	TEST	NET-CAP	CAPIF	Restored	-	-
FEEDER	ADJUST	-	DOCST	Restored	-	-
FEEDER	ADJUST	-	LA-SPEED	Restored	-	-
FEEDER	ADJUST	-	DOCST2	Restored	-	-
FEEDER	ADJUST	-	LA-SPD2	Restored	-	-
FEEDER	ADJUST	-	ADJMSCN1	Restored	-	-
FEEDER	ADJUST	-	ADJMSCN2	Restored	-	-
FEEDER	OPTION	-	SIZE-SW	Restored	Restored	Restored
FEEDER	OPTION	-	R-ATM	Restored	-	-
FEEDER	OPTION	-	R-OVLPLV	Restored	-	-
SORTER	ADJUST	-	PNCH-Y	Restored	-	-
SORTER	ADJUST	-	PF-A3Z1	Restored	-	-
SORTER	ADJUST	-	PF-A3Z2	Restored	-	-
SORTER	ADJUST	-	PF-B4Z1	Restored	-	-
SORTER	ADJUST	-	PF-B4Z2	Restored	-	-
SORTER	ADJUST	-	PF-A4RZ1	Restored	-	-
SORTER	ADJUST	-	PF-A4RZ2	Restored	-	-

Initial screen	Main item	Intermediate item	Sub item	Case A	Case B	Case C
SORTER	ADJUST	-	PF-LDRZ1	Restored	-	-
SORTER	ADJUST	-	PF-LDRZ2	Restored	-	-
SORTER	ADJUST	-	PF-LGLZ1	Restored	-	-
SORTER	ADJUST	-	PF-LGLZ2	Restored	-	-
SORTER	ADJUST	-	PFLTRRZ1	Restored	-	-
SORTER	ADJUST	-	PFLTRRZ2	Restored	-	-
SORTER	ADJUST	-	PF-A4RC1	Restored	-	-
SORTER	ADJUST	-	PF-A4RC2	Restored	-	-
SORTER	ADJUST	-	PFLTRRC1	Restored	-	-
SORTER	ADJUST	-	PFLTRRC2	Restored	-	-
SORTER	ADJUST	-	PF-A4R31	Restored	-	-
SORTER	ADJUST	-	PF-A4R32	Restored	-	-
SORTER	ADJUST	-	PFLTRR31	Restored	-	-
SORTER	ADJUST	-	PFLTRR32	Restored	-	-
SORTER	ADJUST	-	PF-A4R41	Restored	-	-
SORTER	ADJUST	-	PF-A4R42	Restored	-	-
SORTER	ADJUST	-	PFLTRR41	Restored	-	-
SORTER	ADJUST	-	PFLTRR42	Restored	-	-
SORTER	ADJUST	-	PF-A4R21	Restored	-	-
SORTER	ADJUST	-	PFLTRR21	Restored	-	-
SORTER	ADJUST	-	PRCS-ALG	Restored	-	-
SORTER	ADJUST	-	STP-F1	Restored	-	-
SORTER	ADJUST	-	STP-F2	Restored	-	-
SORTER	ADJUST	-	STP-R1	Restored	-	-
SORTER	ADJUST	-	STP-R2	Restored	-	-
SORTER	ADJUST	-	STP-2P	Restored	-	-
SORTER	ADJUST	-	BFF-SFT	Restored	-	-
SORTER	ADJUST	-	PNCH-X	Restored	-	-
SORTER	ADJUST	-	TRM-RG1	Restored	-	-
SORTER	ADJUST	-	TRM-RG2	Restored	-	-
SORTER	ADJUST	-	TRM-CUT1	Restored	-	-
SORTER	ADJUST	-	TRM-CUT2	Restored	-	-
SORTER	ADJUST	-	BFF-SFT2	Restored	-	-
SORTER	ADJUST	-	SDL-STP	Restored	-	-
SORTER	ADJUST	-	SDL-FLD	Restored	-	-
SORTER	ADJUST	-	SDL-ALG	Restored	-	-
SORTER	ADJUST	-	SDL-RLPT	Restored	-	-
SORTER	ADJUST	-	SDL-RLFD	Restored	-	-
SORTER	ADJUST	-	BFR-UPA4	Restored	-	-
SORTER	ADJUST	-	BFR-UPB5	Restored	-	-
SORTER	ADJUST	-	BFR-UPLT	Restored	-	-
SORTER	ADJUST	-	RTR-DWA4	Restored	-	-
SORTER	ADJUST	-	RTR-DWB5	Restored	-	-
SORTER	ADJUST	-	RTR-DWLT	Restored	-	-
SORTER	ADJUST	-	BF-SB-A4	Restored	-	-
SORTER	ADJUST	-	BF-SB-B5	Restored	-	-
SORTER	ADJUST	-	BF-SB-LT	Restored	-	-
SORTER	ADJUST	-	RTR-UPA4	Restored	-	-
SORTER	ADJUST	-	RTR-UPB5	Restored	-	-
SORTER	ADJUST	-	RTR-UPLT	Restored	-	-
SORTER	ADJUST	-	PUNCH-SB	Restored	-	-
SORTER	ADJUST	-	ST-ALG1	Restored	-	-
SORTER	ADJUST	-	ST-ALG2	Restored	-	-

Initial screen	Main item	Intermediate item	Sub item	Case A	Case B	Case C
SORTER	ADJUST	-	SW-UP-RL	Restored	-	-
SORTER	ADJUST	-	DW-CL	Restored	-	-
SORTER	ADJUST	-	PRT-DWN	Restored	-	-
SORTER	ADJUST	-	PF-LGL41	Restored	-	-
SORTER	ADJUST	-	PF-LGL42	Restored	-	-
SORTER	ADJUST	-	PNC-SBTN	Restored	-	-
SORTER	ADJUST	-	SBFD-SPL	Restored	-	-
SORTER	ADJUST	-	SBFD-LPL	Restored	-	-
SORTER	ADJUST	-	SBFD-SHV	Restored	-	-
SORTER	ADJUST	-	SBFD-LHV	Restored	-	-
SORTER	ADJUST	-	SBFD-STN	Restored	-	-
SORTER	ADJUST	-	SBFD-LTN	Restored	-	-
SORTER	ADJUST	-	SBFD-SCT	Restored	-	-
SORTER	ADJUST	-	SBFD-LCT	Restored	-	-
SORTER	ADJUST	-	NST-SPD	Restored	-	-
SORTER	ADJUST	-	NST-SPTN	Restored	-	-
SORTER	ADJUST	-	RTNRL-SP	Restored	-	-
SORTER	ADJUST	-	SW-ADJ	Restored	-	-
SORTER	ADJUST	-	GRP-ALG	Restored	-	-
SORTER	ADJUST	-	PRTN-ALG	Restored	-	-
SORTER	ADJUST	-	BFF-SFT3	Restored	-	-
SORTER	ADJUST	-	BFF-SFT4	Restored	-	-
SORTER	ADJUST	-	FR-ST-PS	Restored	-	-
SORTER	ADJUST	-	FR-STP-Y	Restored	-	-
SORTER	ADJUST	-	RBLT-PRS	Restored	-	-
SORTER	ADJUST	-	MSTP-2P	Restored	-	-
SORTER	ADJUST	-	CENT-ALG	Restored	-	-
SORTER	ADJUST	-	SDL-STP2	Restored	-	-
SORTER	ADJUST	-	SDL-FLD2	Restored	-	-
SORTER	ADJUST	-	ESC1-SPD	Restored	-	-
SORTER	ADJUST	-	ESC2-SPD	Restored	-	-
SORTER	ADJUST	-	SFT-SPD	Restored	-	-
SORTER	ADJUST	-	STP-SPD	Restored	-	-
SORTER	ADJUST	-	RBLT-PS2	Restored	-	-
SORTER	ADJUST	-	RBLT-PS3	Restored	-	-
SORTER	OPTION	-	MD-SPRTN	Restored	-	-
SORTER	OPTION	-	SDL-PRS	Restored	-	-
SORTER	OPTION	-	BUFF-SW	Restored	-	-
SORTER	OPTION	-	TRY-EJCT	Restored	-	-
SORTER	OPTION	-	PN-SKEW	Restored	-	-
SORTER	OPTION	-	CURL-SW	Restored	-	-
SORTER	OPTION	-	TRY-OVER	Restored	-	-
SORTER	OPTION	-	TRM-LMT	Restored	-	-
SORTER	OPTION	-	PUCH-SW	Restored	-	-
SORTER	OPTION	-	ALG-IMPR	Restored	-	-
SORTER	OPTION	-	1SHT-SRT	Restored	-	-
SORTER	OPTION	-	SD-LMTLS	Restored	-	-
SORTER	OPTION	-	SD-STCNB	Restored	-	-
SORTER	OPTION	-	BUFF-THK	Restored	-	-
SORTER	OPTION	-	PRCS-SP1	Restored	-	-
SORTER	OPTION	-	PRCS-SP2	Restored	-	-
SORTER	OPTION	-	BUFF-MX1	Restored	-	-
SORTER	OPTION	-	BUFF-MX2	Restored	-	-

Initial screen	Main item	Intermediate item	Sub item	Case A	Case B	Case C
SORTER	OPTION	-	PRCS-MX1	Restored	-	-
SORTER	OPTION	-	PRCS-MX2	Restored	-	-
SORTER	OPTION	-	BUF-THK1	Restored	-	-
SORTER	OPTION	-	PRD-PRTY	Restored	-	-
SORTER	OPTION	-	SLD-BCK	Restored	-	-
SORTER	OPTION	-	NSRT-STC	Restored	-	-
SORTER	OPTION	-	STP-MAX	Restored	-	-
SORTER	OPTION	-	SDL-MAX	Restored	Restored	Restored
SORTER	OPTION	-	VFLD-MAX	Restored	Restored	Restored
SORTER	OPTION	-	NEAT-MIX	Restored	-	-
SORTER	OPTION	-	NEAT-SW	Restored	Restored	Restored
SORTER	OPTION	-	TRM-CNT	Restored	Restored	Restored
SORTER	OPTION	-	THN-SW	Restored	-	-
SORTER	OPTION	-	THN-STK	Restored	Restored	Restored
SORTER	OPTION	-	MSTP-TMG	Restored	Restored	Restored
SORTER	OPTION	-	PUN-Y-SW	Restored	-	-
SORTER	OPTION	-	PNCH-SW2	Restored	-	-
SORTER	OPTION	-	PNCH-SW3	Restored	-	-
SORTER	OPTION	-	SFT-CHNG	Restored	-	-
SORTER	OPTION	-	STP-ALG	Restored	-	-
SORTER	OPTION	-	SDL-ALG	Restored	-	-
SORTER	OPTION	-	SDL-FLD	Restored	-	-
SORTER	OPTION	-	TRY-STP	Restored	-	-
SORTER	OPTION	-	TRY-LMT	Restored	-	-