

imageRUNNER ADVANCE DX 6780i/6765i/6755i

INSTALLATION MANUAL



Canon

October 27, 2021
Rev. 2

Important Notices

Application

This manual has been issued by Canon Inc. for qualified persons to learn technical theory, installation, maintenance, and repair of products.

This manual covers all localities where the products are sold. For this reason, there may be information in this manual that does not apply to your locality.

Following "Trademarks" and "Copyright" are not applicable if they are not supported by laws and regulations in the country or region that this document and products are used in.

Corrections

This manual may contain technical inaccuracies or typographical errors due to improvements or changes in products.

When changes occur in applicable products or in the contents of this manual, Canon will release technical information as the need arises. In the event of major changes in the contents of this manual over a long or short period, Canon will issue a new edition of this manual.

Trademarks

The Bluetooth word mark and logos are registered trademarks owned by Bluetooth SIG, Inc. and any use of such marks by Canon is under license.

Mopria®, the Mopria® Logo and the Mopria® Alliance logo are registered trademarks and service marks of Mopria Alliance, Inc. in the United States and other countries. Unauthorized use is strictly prohibited.

Apple, AppleTalk, Bonjour, iPad, iPhone, iPod touch, Mac, OS X and Safari are trademarks of Apple Inc.

Microsoft, Windows, Windows Vista, Windows Server, Internet Explorer, Microsoft Edge, Excel and PowerPoint are either registered trademarks or trademarks of Microsoft Corporation in the United States and/or other countries.

Google Cloud Print, Google Chrome and Android are either registered trademarks or trademarks of Google Inc.

iHQC™ compression technology by I.R.I.S., copyright 2007-2015, All Rights Reserved.

PDF-iHQC™, XPS-iHQC™ technology by I.R.I.S., copyright 2007-2015, All rights Reserved.

Java is a registered trademark of Oracle and/or its affiliates.

Adobe is a registered trademark of Adobe Systems Incorporated.

Command WorkStation, EFI, Fiery, FreeForm, Spot-On, and WebTools are trademarks of Electronics For Imaging, Inc. and/or its wholly owned subsidiaries in the U.S. and/or certain other countries.

TORX® is a registered trademark of Acument Intellectual Properties, LLC in the United States.

Matrox is a registered trademark of Matrox Corporation in the Canada.

Other product names and other names in this document are generally registered trademarks or trademarks of the companies.

Copyright

The copyright of this document belongs to Canon Inc. This document may not be copied, reproduced or translated into another language, in whole or in part, without the prior consent of Canon Inc.
Copyright CANON INC. 2021

Caution

Use of this manual should be strictly supervised to avoid disclosure of confidential information.

Description on the parts included in the package

The parts with a diagonal line in the contents list will not be used.

Symbols

The frequently-performed operations are described with symbols in this procedure.

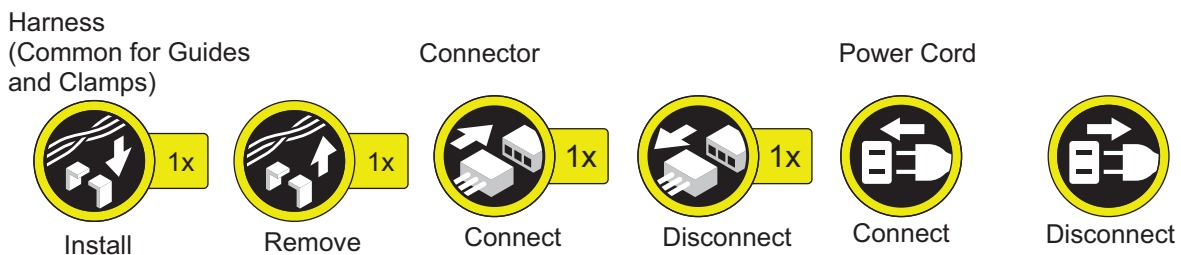
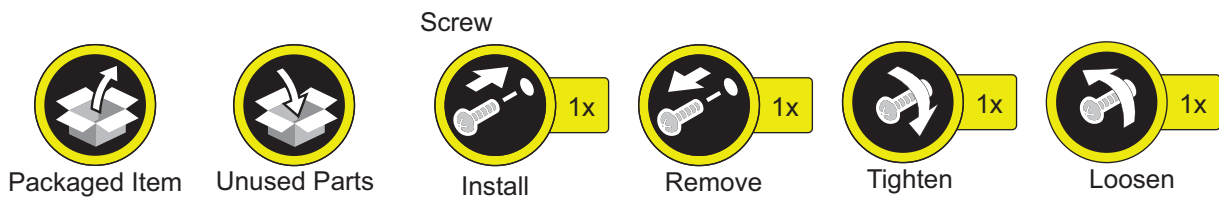

Contents

Safety Precautions.....	1
Toner Safety.....	2
About Toner.....	2
Handling Adhered Toner.....	2
Checking the Installation Environment.....	2
Checking the Installation Environment.....	2
Points to Note Before Servicing.....	2
Essential Items to Be Performed Before Installation.....	3
Checking Installation Space.....	3
illustrations.....	4
1. Product Lineup.....	5
Scanning System Options.....	6
Function Expansion System Options.....	7
Option Combination Table.....	8
Pickup/Delivery System Options.....	9
2. Host Machine.....	11
How to Utilize This Installation Procedure.....	12
Description on the Parts Included in the Package.....	12
Symbols.....	12
Checking before Installation.....	13
Checking the Power Supply.....	13
Checking the Installation Environment.....	13
Points to Note at Installation Work.....	13
Points to Note When Moving This Host Machine.....	13
Order to Install the Host machine and the Options.....	13
Installation of Host Machine.....	15
Unpacking.....	15
Checking the Contents.....	23
Installation Procedure.....	26
3. Image Reading System Options.....	91
Printer Cover-H2.....	92
Points to Note before Installation.....	92
Checking the Contents.....	92
Installation Outline Drawing.....	92
Installation Procedure.....	93
Operation Check.....	110
Reader Heater-P1.....	112
Points to Note before Installation.....	112
Checking the Contents.....	112
Installation Outline Drawing.....	113
Installation Procedure.....	113

4. Host Machine Options.....	136
Upright Control Panel-J1.....	137
Installation Procedure.....	137
Pre-checks.....	184
NFC Kit-E1/E2.....	188
Points to Note before Installation.....	188
Checking the Contents.....	188
Essential Items to Be Performed Before Installation.....	188
Points to Note When Turning ON/OFF the Main Power.....	189
Installation Outline Drawing.....	189
Installation Procedure.....	189
Connection Kit-A2/A3 for Bluetooth LE.....	207
Points to Note before Installation.....	207
Checking the Contents.....	207
Essential Items to Be Performed Before Installation.....	207
Points to Note When Turning ON/OFF the Main Power.....	208
Installation Outline Drawing.....	208
Installation Procedure.....	208
Setting after Installation.....	216
Numeric Keypad-A1/A2.....	217
Points to Note before Installation.....	217
Checking the Contents.....	217
Essential Items to Be Performed Before Installation.....	217
Points to Note When Turning ON/OFF the Main Power.....	218
Installation Outline Drawing.....	218
Installation Procedure.....	218
Utility Tray-B1.....	228
Points to Note at Installation.....	228
Checking the Contents.....	228
Installation Outline Drawing.....	228
Installation Procedure.....	229
Copy Card Reader-F1.....	235
Points to Note at Installation.....	235
Essential Items to Be Performed Before Installation.....	235
Points to Note When Turning ON/OFF the Main Power.....	235
Installation Outline Drawing.....	236
Checking the Contents.....	236
Installation Procedure.....	238
Checking after Installation.....	251
Serial Interface Kit-K3 / Copy Control Interface Kit-A1	252
Points to Note at Installation.....	252
Checking the Contents.....	252
Essential Items to Be Performed Before Installation.....	253
Points to Note When Turning ON/OFF the Main Power.....	253
Installation Outline Drawing.....	254
Installation Procedure.....	254
Voice Operation Kit-D1.....	261
Points to Note Before Installation.....	261
Checking the Contents.....	261
Essential Items to Be Performed Before Installation.....	262

Points to Note When Turning ON/OFF the Main Power.....	262
Installation Outline Drawing.....	263
Installation Procedure.....	263
Checking after Installation.....	274
Operation Check.....	274
Voice Guidance Kit-G1.....	275
Points to Note at Installation.....	275
Checking the Contents.....	275
Essential Items to Be Performed Before Installation.....	276
Points to Note When Turning ON/OFF the Main Power.....	276
Installation Outline Drawing.....	277
Installation Procedure.....	277
Checking after Installation.....	286
Operation Check.....	287
HDD-related Option.....	288
Pre-checks.....	288
Removing the HDD Box Unit.....	289
[TYPE-1] Option HDD (1TB).....	293
[TYPE-2] Standard HDD + Option HDD (250GB) + HDD Mirroring Kit.....	299
[TYPE-3] 2 Option HDDs (1TB) + HDD Mirroring Kit.....	310
Super G3 FAX Board-AS1.....	323
Product Name.....	323
Points to Note at Installation.....	323
Essential Items to Be Performed Before Installation.....	323
Points to Note When Turning ON/OFF the Main Power.....	323
Installation Outline Drawing.....	323
Checking the Contents.....	324
Installation Procedure.....	324
Checking the Operation.....	329
Super G3 FAX Board-AS2.....	331
Product Name.....	331
Points to Note at Installation.....	331
Essential Items to Be Performed Before Installation.....	331
Points to Note When Turning ON/OFF the Main Power.....	331
Installation Outline Drawing.....	331
Checking the Contents.....	332
Installation Procedure.....	332
Checking the Operation.....	336
Super G3 2nd Line Fax Board-AS1.....	338
Product Name.....	338
Points to Note at Installation.....	338
Essential Items to Be Performed Before Installation.....	338
Points to Note When Turning ON/OFF the Main Power.....	338
Installation Outline Drawing.....	338
Checking the Contents.....	339
Installation Procedure.....	341
Checking the Operation.....	357
Super G3 2nd Line Fax Board-AS2.....	359
Product Name.....	359
Points to Note at Installation.....	359
Essential Items to Be Performed Before Installation.....	359

Points to Note When Turning ON/OFF the Main Power..... 359

Installation Outline Drawing..... 359

Checking the Contents..... 360

Installation Procedure..... 361

Checking the Operation..... 376

Super G3 3rd/4th Line Fax Board-AS1..... 378

 Product Name..... 378

 Points to Note at Installation..... 378

 Essential Items to Be Performed Before Installation..... 378

 Points to Note When Turning ON/OFF the Main Power..... 378

 Installation Outline Drawing..... 379

 Checking the Contents..... 380

 Installation Procedure..... 381

 Checking the Operation..... 388

Super G3 3rd/4th Line Fax Board-AS2..... 390

 Product Name..... 390

 Points to Note at Installation..... 390

 Essential Items to Be Performed Before Installation..... 390

 Points to Note When Turning ON/OFF the Main Power..... 390

 Installation Outline Drawing..... 391

 Checking the Contents..... 392

 Installation Procedure..... 393

 Checking the Operation..... 399

5. Paper Feed Options..... 401

Paper Deck Unit-E1..... 402

 Checking before Installation..... 402

 Unpacking Procedure..... 402

 Checking the Contents..... 403

 Installation Procedure..... 404

 Checking after Installation..... 424

Paper Deck Heater Unit-A1..... 430

 Checking before Installation..... 430

 Checking the Supplied Parts..... 430

 Installation Procedure..... 431

 Checking after Installation..... 445

POD Deck Lite-C1..... 446

 Checking before Installation..... 446

 Unpacking..... 446

 Checking the Contents..... 447

 Installation Procedure..... 449

 Disposal Parts..... 469

 Paper Positioning Check/Adjustment Procedure..... 469

Paper Deck Heater Unit for POD Deck Lite-C1..... 474

 Checking the Parts to be Installed..... 474

 Removing from the Host Machine..... 474

 Installation Procedure..... 476

Cassette Heater Unit-38..... 483

 Checking the Contents..... 483

 Installation Outline Drawing..... 483

Essential Items to Be Performed Before Installation.....	483
Installation Procedure.....	483
6. Paper Output Options.....	490
Shift Tray-F1.....	491
Points to Note before Installation.....	491
Checking the Contents.....	491
Essential Items to Be Performed Before Installation.....	492
Points to Note When Turning ON/OFF the Main Power.....	492
Installation Outline Drawing.....	492
Installation Procedure.....	492
Checking after Installation.....	496
Document Insertion Unit-P1, Document Insertion/Folding Unit-J1.....	497
Checking Before Installation.....	497
Unpacking.....	497
Checking Bundled Components.....	505
Installation Procedure.....	506
Operation Checks.....	528
Adjusting the Height and Tilt.....	528
Staple Finisher-AC1/ Booklet Finisher-AC1.....	542
Checking before Installation.....	542
Unpacking.....	543
Checking the Contents.....	546
Installation Procedure.....	547
Affixing the Labels.....	558
Making Adjustments.....	562
Making Checks After Completion of Installation Work.....	576
Detaching from the Upstream Connection Machine.....	578
2/3 2/4 4 Hole Puncher Unit-A1.....	581
Checking Before Installation.....	581
Unpacking Procedure.....	581
Checking the Contents.....	583
Installation Procedure.....	583
Disposal Parts Check.....	598
Operation Check.....	598
Adjusting the Output Level of the Punch Waste Full Sensor.....	599
Checking and Adjusting the Punch Hole Position.....	600
Finisher Jogger Kit-A1.....	604
Checking Before Installation.....	604
Unpacking Procedure.....	604
Checking the Contents.....	605
Installation Procedure.....	606
Checking after Installation.....	614
Revision.....	616

Safety Precautions

Toner Safety.....	2
Checking the Installation Environment	2

Toner Safety

About Toner

Toner is a nontoxic matter composed of plastic, iron and a trace of pigments.

CAUTION:

Never throw toner in flames to avoid explosion.

Handling Adhered Toner

- Use dry tissue paper to wipe off toner adhered to skin or clothes and wash in water.
- Never use warm water for cleaning up toner to prevent toner particles from being gelated to soak into fibers permanently.
- Toner particles are reactive with vinyl polymers. Avoid contacting these materials.

Checking the Installation Environment

Checking the Installation Environment

1. The environment of the installation site must be in the range as shown below. Avoid installation near the faucet, water boiler, humidifier or refrigerator.
Guaranteed range for operation/image Temperature: 10.0 to 30.0 deg C, Humidity: 20 to 80%
2. The machine must not be installed near a source of fire or in an area subject to dust or ammonium gas.
If the area is exposed to direct rays of the sun, provide curtains to the window.
3. Be sure to provide adequate ventilation of the room to keep the work environment comfortable. Room odor can be bothering when running the machine for a long time in a poorly-ventilated room although the ozone amount generated while running this equipment does not harm human health.

Points to Note Before Servicing

- At servicing, be sure to turn OFF the power source according to the specified steps and disconnect the power plug.
- Be sure to disconnect the power plug on a regular basis and remove dust and dirt accumulated around the outlet with dry cloth.

CAUTION:

Leaving the power plug connected for a long time in an environment having a lot of dust, moisture, or oily smoke will cause a fire. (Because dust accumulated in the surrounding area will absorb moisture and cause an insulation failure)

- Be careful not to be injured by burrs of edges, sharp corners or protrusions.

CAUTION:

Hazardous area such as corners, edges, springs and other sharp sections may be remaining on products. Always be aware of the presence of hazardous area to avoid injury caused by contacting and/or striking those area, by not over-concentrating on service work.

Essential Items to Be Performed Before Installation

- Turn OFF the main power of the host machine, and disconnect the power plug from the outlet.

⚠ WARNING:

- If performing work without disconnecting the power plug of the host machine, it may cause electrical shock.
- If disconnecting the power plug without turning OFF the main power, it may cause damage of the machine.

- When turning OFF the main power, follow the below procedure.
 1. Turn OFF the main power switch of the host machine.
 2. The display in the Control Panel and the lamp of the main power are turned off.

Checking Installation Space

1. The foot of this equipment should be in contact with the floor. This equipment should be kept on the level.
2. The machine must be away from the wall by 100 mm or more to secure a sufficient space to operate the machine.
 - When the Copy Tray-R2 is attached:

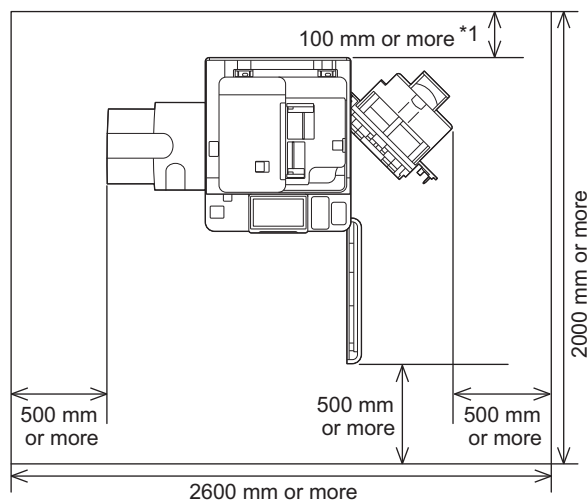

NOTE:

*1 Make sure to provide at least 800 mm of space if you install the Document Insertion/Folding Unit-J1.

- When the Booklet Finisher-AC1, Document Insertion/Folding Unit-J1, POD Deck Lite-C1, Upright Control Panel-J1 are attached:

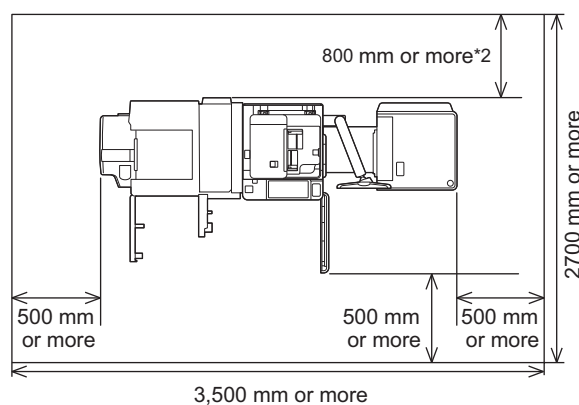

NOTE:

*2 Make sure to provide at least 100 mm of space if none of the Document Insertion/Folding Unit-J1 is installed.

3. To install the host machine, install it in a well-ventilated place. Especially when there are multiple host machines, be sure to locate the machine where the machine is free from direct exhaust of other machines. Be sure to keep the machine away from the air-inlet duct which is used for ventilation of the room.

illustrations

Although pictures or illustrations used for explanation may differ from the actual things, the procedure is the same.



Product Lineup

Scanning System Options.....	6
Function Expansion System Options	7
Pickup/Delivery System Options.....	9

Scanning System Options

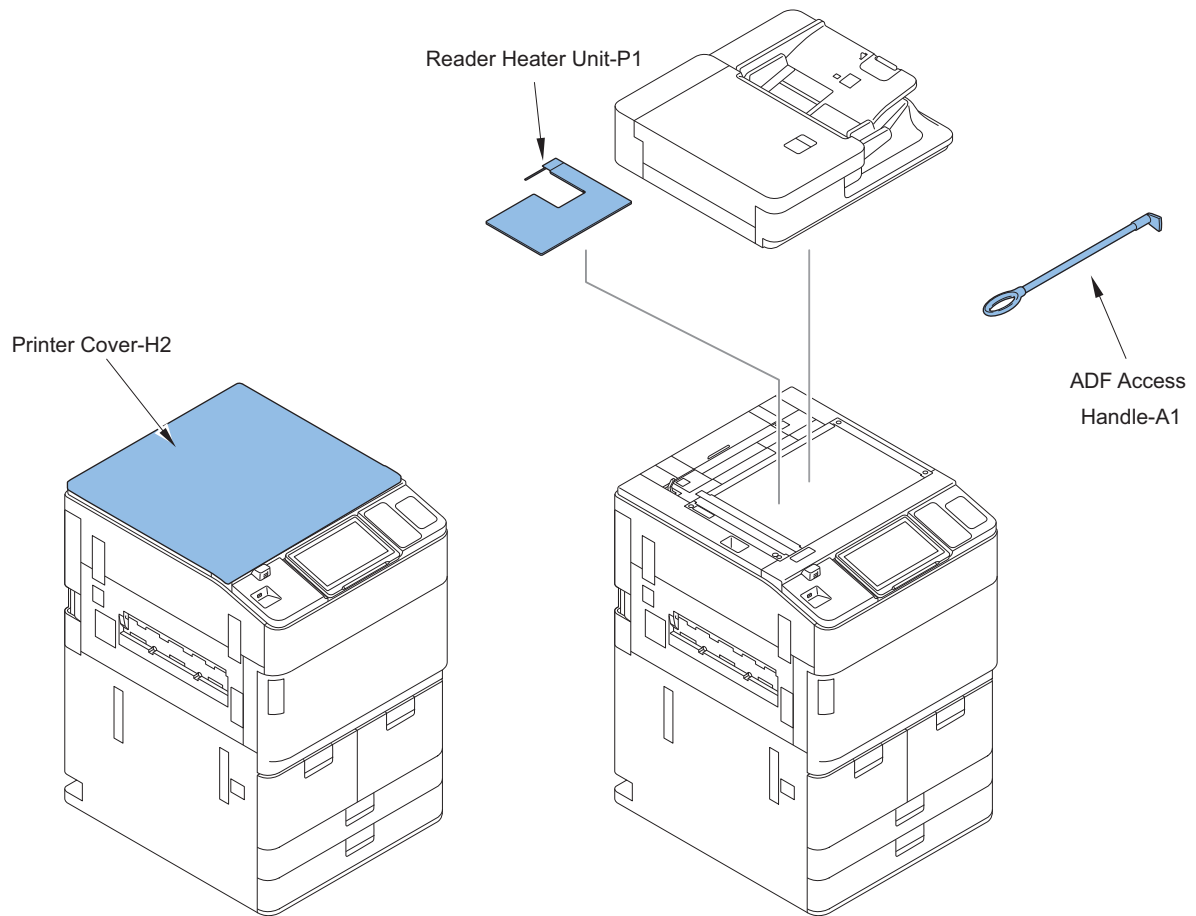

Required Options and Conditions

Product name	Required options, conditions, etc.
"Reader Heater-P1" on page 112	Option for Reader Unit
ADF Access Handle-A1	It is the handle to support opening and closing the Feeder.

Function Expansion System Options

Hardware Products

Product name	Required options, conditions, etc.
"Numeric Keypad-A1/A2" on page 217	No particular options and conditions are required.
"Upright Control Panel-J1" on page 137	No particular options and conditions are required.
"NFC Kit-E1/E2" on page 188	No particular options and conditions are required.
"Utility Tray-B1" on page 228	Using with Voice Guidance Kit-G1 and Voice Operation Kit-D1 is not available.
"Copy Card Reader-F1" on page 235	Copy Card Reader Installation Kit-A3 is required. Using with Serial Interface Kit-K2 and Copy Control Interface Kit-A1 is not available.
"Copy Card Reader-F1" on page 235	Required when Copy Card Reader-F1 is installed.
Card Set-A1 to A6	Copy Card Reader-F1 is required.
"Super G3 FAX Board-AS1" on page 323	No particular options and conditions are required.
"Super G3 FAX Board-AS2" on page 331	No particular options and conditions are required.
"Super G3 2nd Line Fax Board-AS1" on page 338	Super G3 FAX Board-AS1 is required.
"Super G3 2nd Line Fax Board-AS2" on page 359	Super G3 FAX Board-AS2 is required.
"Super G3 3rd/4th Line Fax Board-AS1" on page 378	Super G3 FAX Board-AS1 and Super G3 2nd Line Fax Board-AS1 is required.
"Super G3 3rd/4th Line Fax Board-AS2" on page 390	Super G3 FAX Board-AS2 and Super G3 2nd Line Fax Board-AS2 is required.
imagePASS-Y1 V1.1	No particular options and conditions are required.
"Voice Guidance Kit-G1" on page 275	Using with Utility Tray-B1 and Voice Operation Kit-D1 is not available.
"Voice Operation Kit-D1" on page 261	Using with Utility Tray-B1 and Voice Guidance Kit-G1 is not available.
"Serial Interface Kit-K3 / Copy Control Interface Kit-A1" on page 252	Required when the coin manager is connected. Using with Copy Card Reader-F1 and Copy Control Interface Kit-A1 is not available.
"Serial Interface Kit-K3 / Copy Control Interface Kit-A1" on page 252	Required when the coin manager is connected. Using with Copy Card Reader-F1 and Serial Interface Kit-K2 is not available.
"HDD-related Option" on page 288	This is used when the mirroring function is used with HDD Mirroring Kit-J1.
"HDD-related Option" on page 288	This is used when the mirroring function is used with HDD Mirroring Kit-J1.
"HDD-related Option" on page 288	When performing mirroring, either the Option HDD-N1 (250 GB) or the Option HDD-P1 (1 TB) is required.
"HDD-related Option" on page 288	No particular options and conditions are required.
iR-ADV Security Kit-AJ1 for IEEE 2600 Common Criteria Certification	
"Connection Kit-A2/A3 for Bluetooth LE" on page 207	
Power Supply Cable-U1	No particular options and conditions are required.

License Products

At the time of installation, obtain the license number according to the license certificate included and then enter the obtained license number from the Control Panel of the machine. The applicable functions are now enabled. There is no physical installation work at the time of installation.

Product name	Required options, conditions, etc.
Remote Fax Kit-A1	No particular options and conditions are required.
IP FAX Expansion Kit-B1	Using with Super G3 2nd Line Fax Board-AS1 or Super G3 3rd/4th Line Fax Board-AS1 is not available.
PCL Printer Kit-CH1	No particular options and conditions are required.
PCL International Font Set-A1	No particular options and conditions are required.
PCL Asian Font Set-A1	No particular options and conditions are required.
PS Printer Kit-BC1	No particular options and conditions are required.
PS Printer Kit-CH1	No particular options and conditions are required.
Barcode Printing Kit-D1	No particular options and conditions are required.
Picture Login-A1	No particular options and conditions are required.

Product name	Required options, conditions, etc.
Fiery Compose	No particular options and conditions are required.
Fiery Impose	No particular options and conditions are required.
Fiery Impose and Compose	No particular options and conditions are required.
Fiery imageViewer	No particular options and conditions are required.

Option Combination Table

NOTE:

- The following table shows the combination of options installed of the host machine. Before installing the options described in the table, refer to the table shown below to check the combination.

	Copy Card Reader	Voice Operation Kit	Voice Guidance Kit	Utility Tray	Serial Interface Kit	Copy Control Interface Kit
Copy Card Reader	-	Yes	Yes	Yes	No	No
Voice Operation Kit	Yes	-	No	No	Yes	Yes
Voice Guidance Kit	Yes	No	-	No	Yes	Yes
Utility Tray	Yes	No	No	-	Yes	Yes
Serial Interface Kit	No	Yes	Yes	Yes	-	No
Copy Control Interface Kit	No	Yes	Yes	Yes	No	-

Yes: Installable No: Not installable

Pickup/Delivery System Options

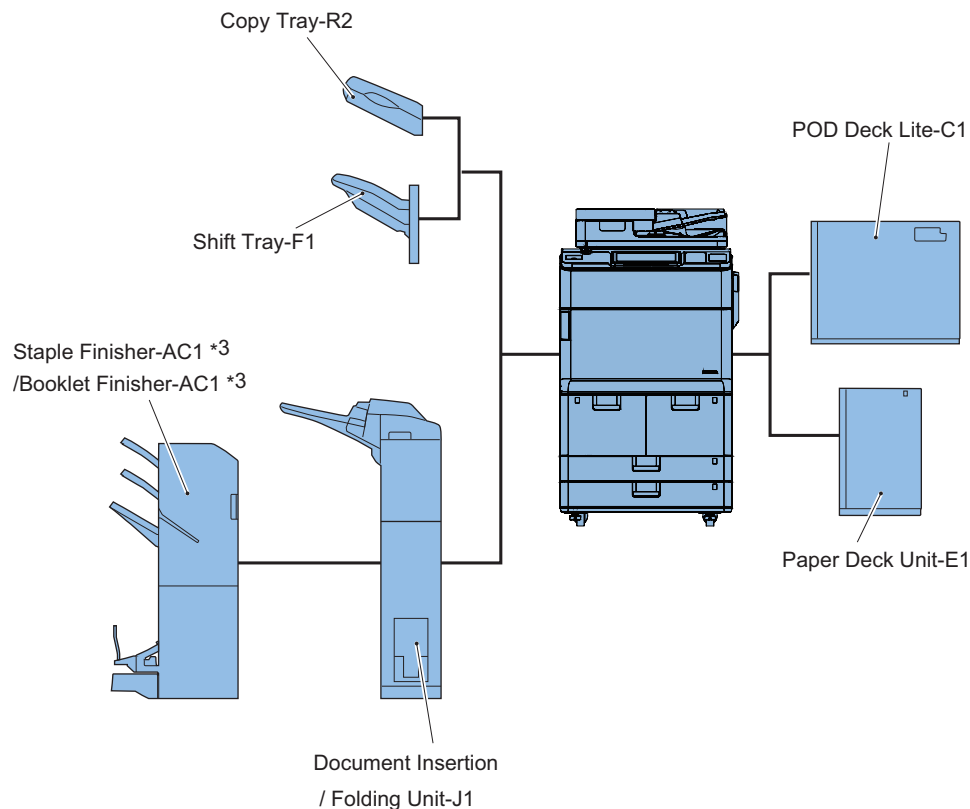

*1: 2/3, 2/4, 4 Hole Puncher Unit-A1 are available as an option.

Pickup System Required Options/Conditions

Pickup System Required Options/Conditions

Product name	Required options, conditions, etc.
"Paper Deck Unit-E1" on page 402	Using with POD Deck Lite-C1 is not available. Pickup method: retard method Pickup capacity: 3,500sheets (80 g/m ²) Paper type: thin paper, plain paper, heavy paper, color paper, recycled paper, bond paper, pre-punched paper, letterhead Paper size: A4, B5, LTR Paper weight: 52 to 256 g/m ² Double feed detection: not available
"POD Deck Lite-C1" on page 446	Using with Paper Deck Unit-E1 is not available. Pickup method: air separation method Pickup capacity: 3,500 sheets (80 g/m ²) Paper type: thin paper, plain paper, heavy paper, color paper, recycled paper, pre-punched paper, transparency, labels, tab paper, bond paper, letterhead, postcard Paper size: 13"x19" to A5R Paper weight: 52 to 256 g/m ² Double feed detection: not available
Tab Feeding Attachment Kit-B1	
"Cassette Heater Unit-38" on page 483	For cassette of main body
"Paper Deck Heater Unit-A1" on page 430	Option for Paper Deck Unit-E1
"Paper Deck Heater Unit for POD Deck Lite-C1" on page 474	Option for POD Deck Lite-C1

Pickup System Required Options/Conditions

Pickup System Required Options/Conditions

Product name	Required options, conditions, etc.
"Shift Tray-F1" on page 491	Using with delivery-related options is not available. Paper size: Paper available for the host machine Paper weight: 52 to 256 g/m ² Tray capacity: 500 sheets (64 g/m ²)
Copy Tray-R2	Using with delivery-related options is not available. Paper size: Paper available for the host machine Paper weight: 52 to 256 g/m ² Tray capacity: 250 sheets (64 g/m ²)
"Document Insertion Unit-P1, Document Insertion/Folding Unit-J1" on page 497	Staple Finisher/Booklet Finisher is required at the downstream side. Pickup capacity: 100 sheets x 1 bin Paper type: thin paper, plain paper, recycled paper, color paper, heavy paper, tab paper, bond paper, letterhead, coated paper Paper size: B5R to A3/11x17 Paper weight: 60 to 256 g/m ²
"Document Insertion Unit-P1, Document Insertion/Folding Unit-J1" on page 497	Folding Unit + Insertion Unit Staple Finisher/Booklet Finisher is required at the downstream side. Folding Unit Folding type: Z-Fold, C-Fold Paper type: thin paper, plain paper, recycled paper, color paper Paper size: Z fold (A3, B4, A4R/11 x 17, LGL, LTRR), C fold (A4R/LTRR) Paper weight: 60 to 105 g/m ² Insertion Unit Pickup capacity: 100 sheets x 1 bin Paper type: thin paper, plain paper, recycled paper, color paper, heavy paper, tab paper, bond paper, letterhead, coated paper Paper size: B5R to A3/11x17 Paper weight: 60 to 256 g/m ²
"Staple Finisher-AC1/ Booklet Finisher-AC1" on page 542	Using with Booklet Finisher-AC1 is not available. Paper weight: 52 to 256 g/m ² Maximum stacking capacity: 3,500 sheets (A4, B5, LTR) The number of sheets to be stitched: Staple: 65 sheets (A4, B5, LTR) Staple-Free Stapling: 4 sheets (81.4g/m ²) Manual Staple: 65 sheets (90g/m ²)
"Staple Finisher-AC1/ Booklet Finisher-AC1" on page 542	Using with Staple Finisher-AC1 is not available. Paper weight: 52 to 256 g/m ² Maximum stacking capacity: 3,500 sheets (A4, B5, LTR) The number of sheets to be stitched: Staple: 65 sheets (A4, B5, LTR) Staple-Free Stapling: 4 sheets (81.4g/m ²) Manual Staple: 65 sheets (90g/m ²) Saddle Stitch: 20 sheets/10 sets (81.4g/m ²)
"Finisher Jogger Kit-A1" on page 604	Booklet Finisher-AC1 and Staple Finisher-AC1 options
"2/3 2/4 4 Hole Puncher Unit-A1" on page 581	Booklet Finisher-AC1 and Staple Finisher-AC1 options Paper weight: 52 to 256 g/m ²
Staple Cartridge-X1	Plain Staple Cartridge Option for Booklet Finisher-AC1 and Staple Finisher-AC1
Staple Cartridge-Y1	Saddle Staple Cartridge Option for Booklet Finisher-AC1



Host Machine

How to Utilize This Installation Procedure.....	12
Checking before Installation.....	13
Installation of Host Machine.....	15

How to Utilize This Installation Procedure

Description on the Parts Included in the Package

The parts with a diagonal line in the contents list will not be used.

Symbols

The frequently-performed operations are described with symbols in this procedure.

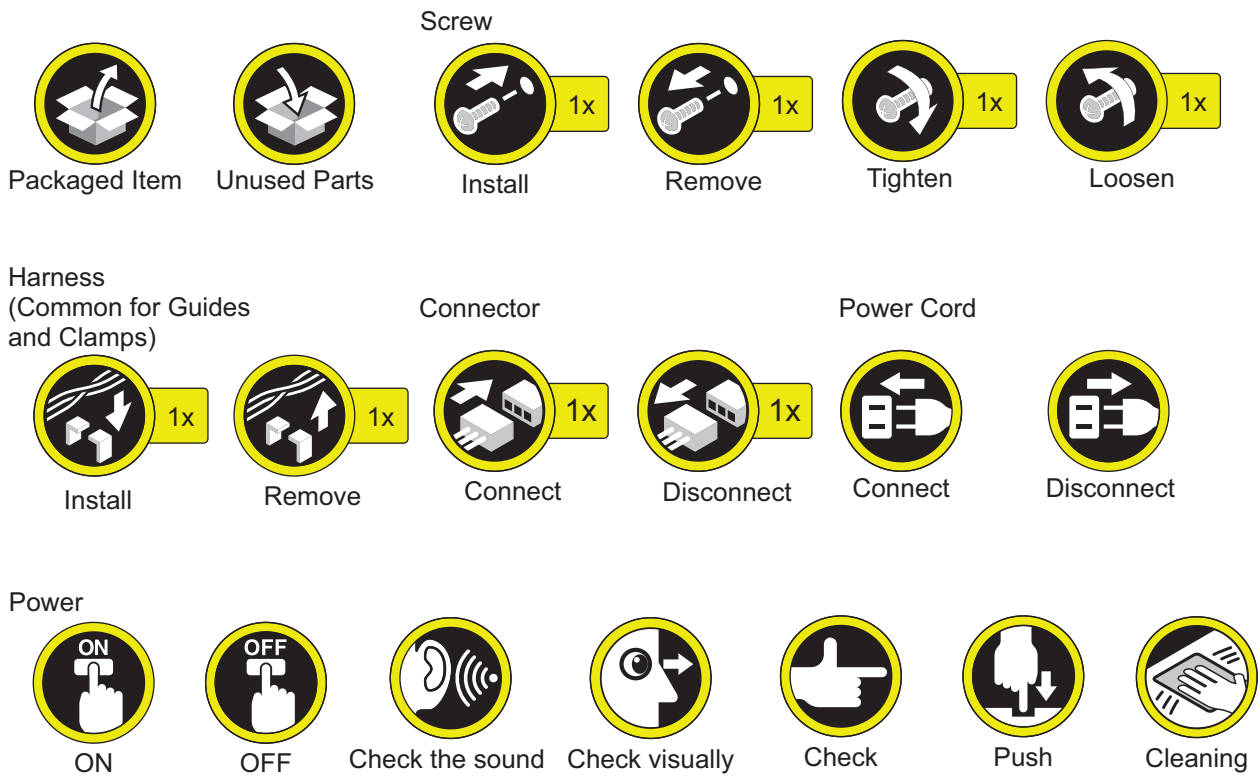

Checking before Installation

Following shows requirements for the installation site.

Therefore, it is desirable to see the installation site in advance before bringing in the machine to the user's site.

Checking the Power Supply

1. **Be sure to connect the power plug exclusively to an outlet that compiles with the following.**
 - USA : 110-127V +/-10%, 60Hz, 16A
 - EUR/Asia/Oceania/China/Korea : 220-240V +/-10%, 50/60Hz, 10A
 - TW : 110-120V +/-10%, 60Hz, 16A
2. **Install this machine near the power outlet and leave sufficient space around the power plug so that it can be unplugged easily in an emergency.**

Checking the Installation Environment

1. The environment of the installation site must be in the range as shown below. Avoid installation near the faucet, water boiler, humidifier or refrigerator.
Guaranteed range for operation/image Temperature: 10.0 to 30.0 deg C, Humidity: 20 to 80%
2. The machine must not be installed near a source of fire or in an area subject to dust or ammonium gas.
If the area is exposed to direct rays of the sun, provide curtains to the window.
3. Be sure to provide adequate ventilation of the room to keep the work environment comfortable. Room odor can be bothering when running the machine for a long time in a poorly-ventilated room although the ozone amount generated while running this equipment does not harm human health.

Points to Note at Installation Work

Take note of the following points when installing the host machine.

1. **Moving the host machine from a cool place to a warm place can generate condensation, causing moisture beads on the metal surface. Using the host machine while the machine is condensed can cause image failure. Therefore, when moving the machine from a cool place to a warm place to install, unpack the host machine and leave it for 2 hours or more before the installation work so that the machine becomes used to the room temperature.**
2. **Be sure to work with a group of 4 or more people to install the host machine.**

Points to Note When Moving This Host Machine

- When moving this host machine after having unpacked it, be careful by placing a plate, etc. on areas with steps to prevent the casters from hitting those steps.
If the casters hit a step, the casters or the base plate may be deformed.
- Keep the fixation members and screws that were removed during unpacking or installation as they may be used to transport the machine for relocation or repair.

Order to Install the Host machine and the Options

NOTE:

In the case of installing the host machine and the other options at the same time, follow the order as described below to install the options first so that the installation operability is improved.

1. **Checking before Installation**
2. **Unpacking**
3. **Checking the Contents**
4. **Installing the Scanner(Only for Machines Equipped with the Image Reader Unit)**

5. Installation of the Printer Cover (Only for Machines Equipped with the Printer Cover)
6. Installation of the Covers
7. Installation of the Developing Assembly
8. Installation of the Pickup Assembly
9. Installing the Fixing Assembly
10. Installation of Toner Container
11. Installing the Exhaust Filter
12. Setting the Environment Heater Switch
13. Turning ON the Main Power
14. Host Machine Settings (Start Setup Guide)
15. Registration of Installation Date Information
16. Installation of the Host machine
17. Other Installation Work
18. Affixing the Labels on the Reader Assembly (Only for Machines Equipped with the Image Reader Unit)
19. Storing the Cleaning Cloth (Only for Machines Equipped with the Image Reader Unit)
20. Checking the K paper settings (Only for CHINA)
21. Setting the Deck
22. Setting the Paper Cassette
23. Image Position Adjustment
24. Image Position Adjustment (Single Pass ADF)
25. Checking the Network Connection
26. Network Troubleshooting
27. Installing the Card Reader

NOTE:

When installing the IC Card Reader and the Numeric Keypad at the same time, be sure to install the Numeric Keypad first.

28. Operation when using uniFLOW Online

Installation of Host Machine

NOTE:

The pictures and illustrations used may be different from the product in front of you, but the procedure is the same.

Unpacking

CAUTION:

- The host machine weighs about 217 kg (including the DADF). For safety, be sure to work carefully to move and install the machine.
- Be sure to work with a group of 4 or more people to install the host machine.

NOTE:

The dimension of the host machine and the transport container is as shown in the figure. Be sure to secure a space to unpack, and then start the installation work.

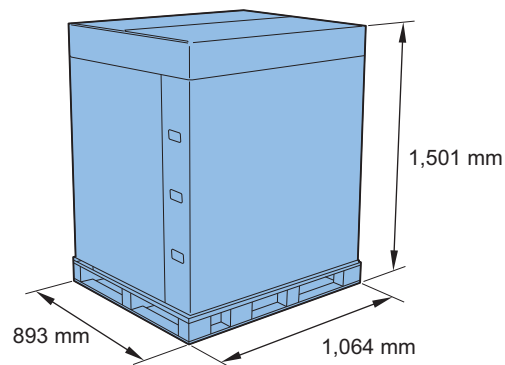

1. Cut the polyester packing band.

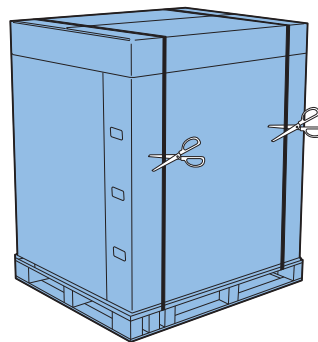

2. Unpack the host machine.

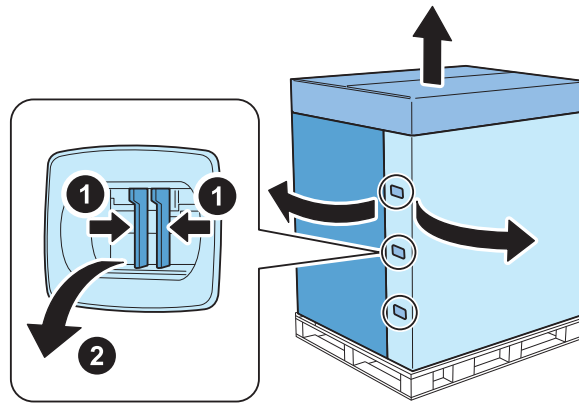

-
- 3. Bring down the Package Box from the pallet.
-
- 4. Pull the plastic bag all the way down.
-
- 5. Open 4 Handle Covers.
 - Hold the handles at the right side of the host machine and lift the host machine to remove the pad. Put the plastic bag aside in the direction of the arrow.
 - 1 Claw each

CAUTION:

Be sure not to lift the host machine too much. Otherwise, it will lose the balance.

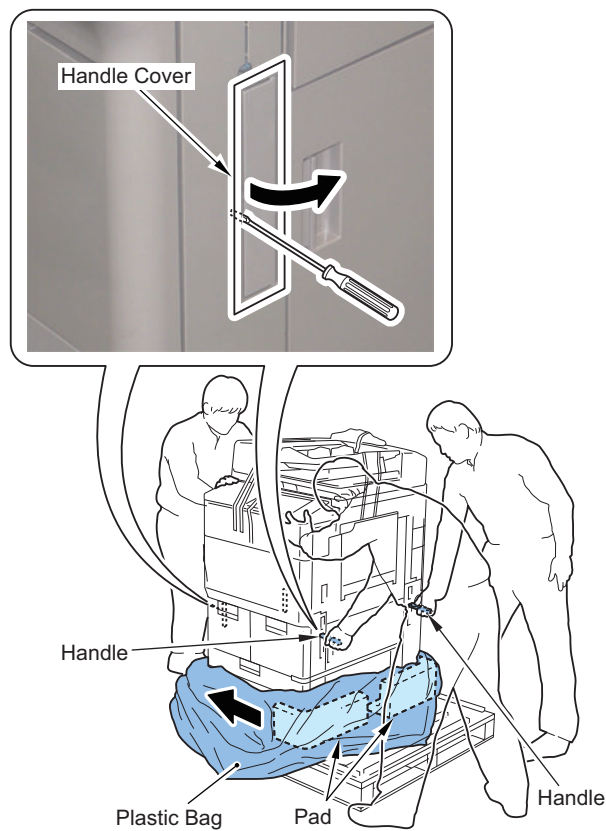



6. Hold the handles at the left side of the host machine and lift the host machine to remove the pad and the plastic bag.

CAUTION:

Be sure not to lift the host machine too much. Otherwise, it will lose the balance.

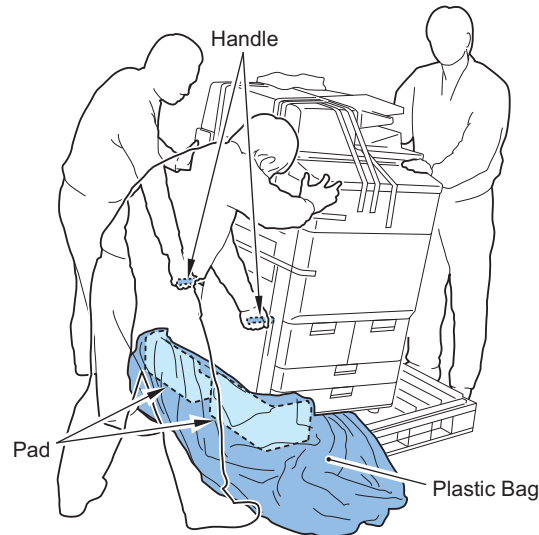

7. Take out the 2 Slope Plates stored at the right side of the Pallet and remove the 2 pins which are secured at the back of the Slope Plate with tape.



8. Turn around the 2 Slope Plates to install as shown in the figure, and then fit the pin-holes of the pallet with the pin-holes of the Slope Plates to put the 2 pins into the holes.

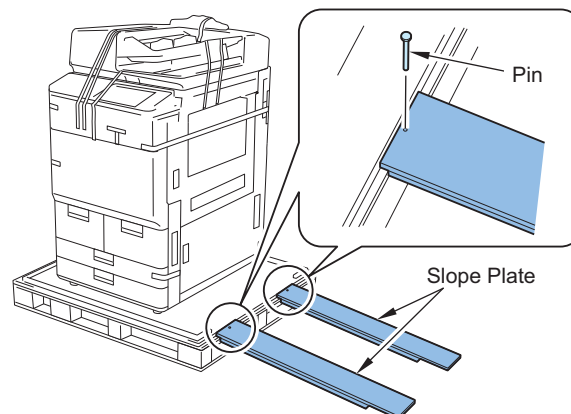



9. Hold the handles at the right side of the host machine, and then, while supporting the corner of the host machine, fit the casters to the center of the Slope Plate to slowly bring the machine down.

CAUTION:

Be careful not to make the casters off from the Slope Plate.

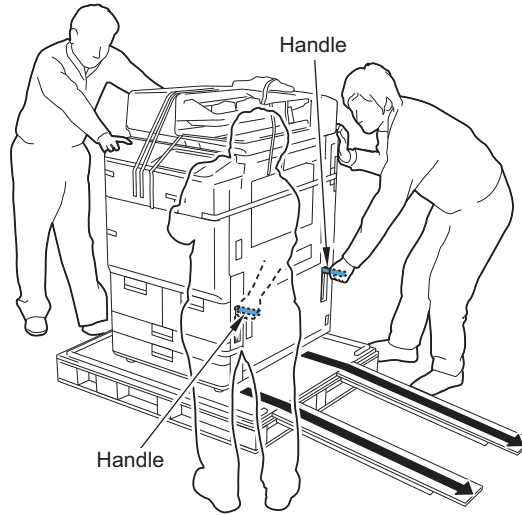

10. Close 4 Handle Covers.

**11. Remove tapes on the exterior surface of the host machine.****CAUTION:**

Do not remove the Scanner Fixation Member until you proceed to [“Installing the Scanner\(Only for Machines Equipped with the Image Reader Unit\)”](#) on page 26. (Only for machines equipped with the Image Reader Unit.)

< Rear side >

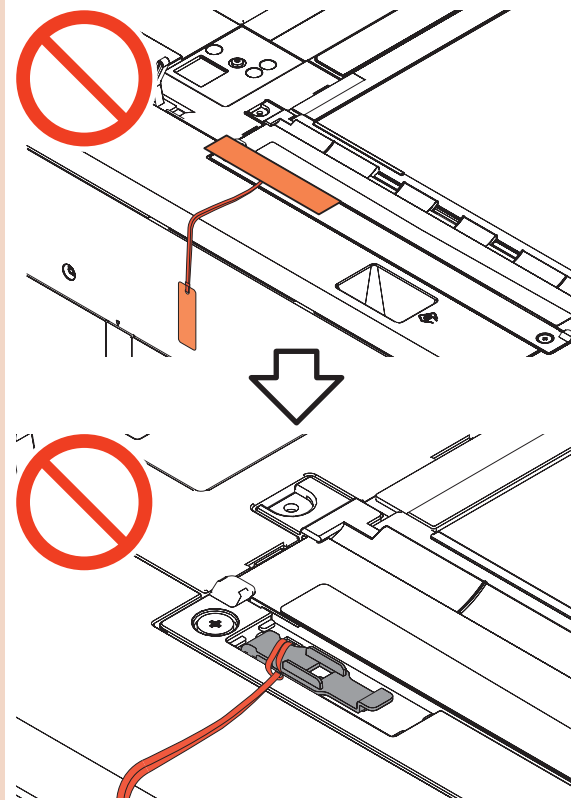

< Front side >

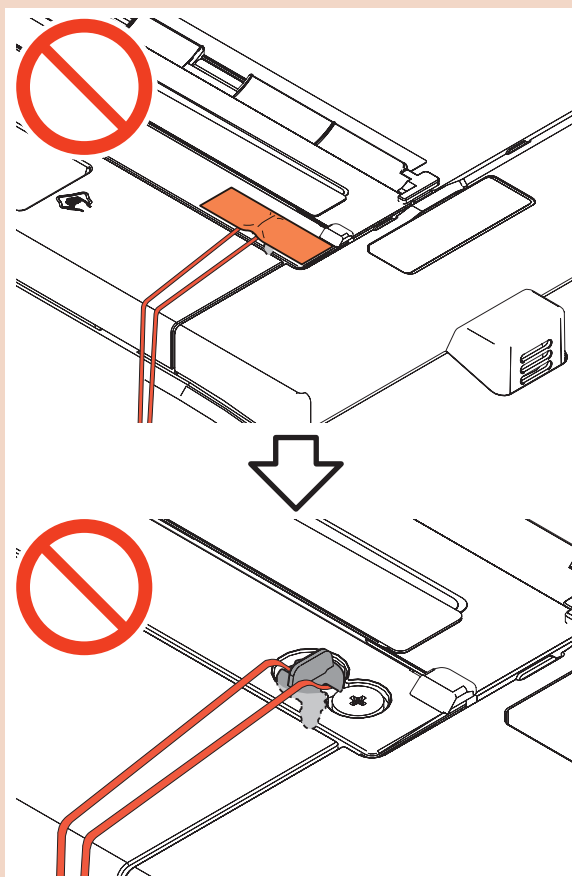
**NOTE:**

- When the tape is removed from the Image Reader Unit, the DADF will open. Do not close it in this step.
- Do not remove 5 tapes for tags and a tape for the Filter Cover at this step. These tapes will be removed later on.





12. Open the DADF and remove tapes on the exterior surface of the host machine. (Only for machines equipped with the Image Reader Unit.)

NOTE:

Remove the Scanner Fixation Member and the Scanner Fixation Screw when you proceed to “Installing the Scanner(Only for Machines Equipped with the Image Reader Unit)” on page 26.

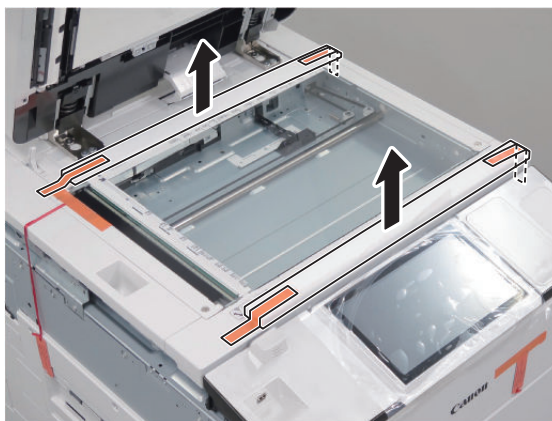

13. Close the DADF. (Only for machines equipped with the Image Reader Unit.)



14. Open the Right Rear Cover 1, and Open the HDD Lid.

- 1 Screw

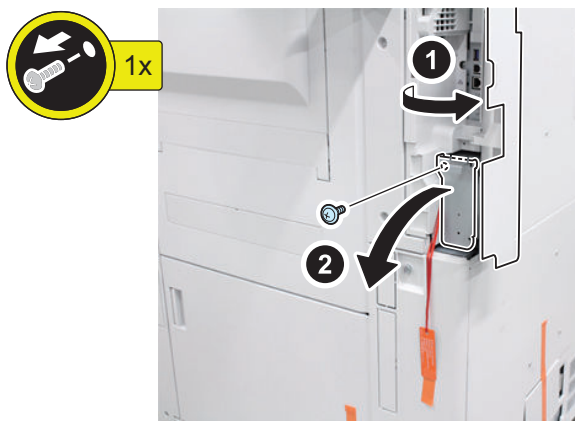



15. Remove the tape securing the tag and remove the package material.







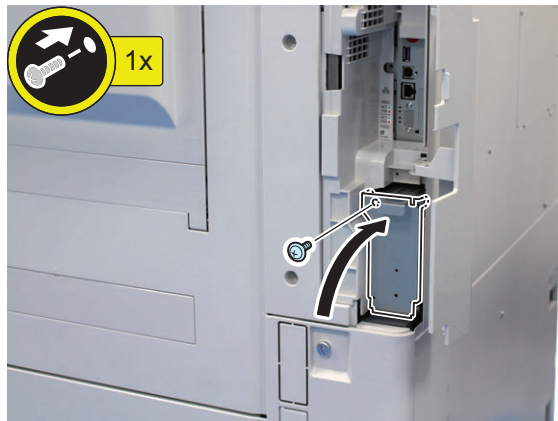



16. Close the HDD Lid.



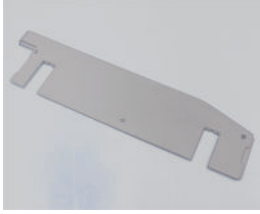

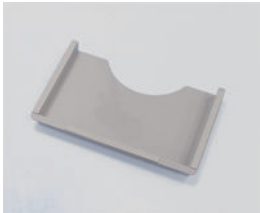
- 1 Screw

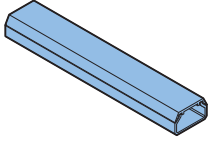
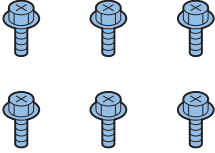

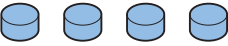
17. Close the Right Rear Cover 1.

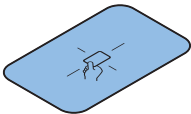
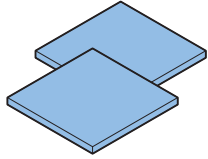
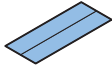
Checking the Contents

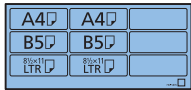
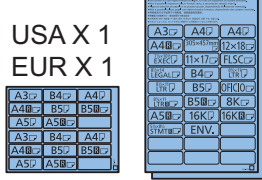

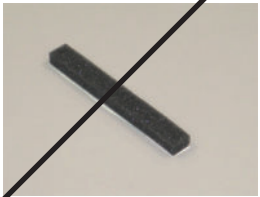
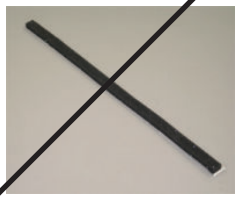
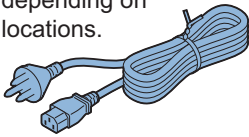

<input type="checkbox"/> [1] Developing Assembly X 1 	<input type="checkbox"/> [2] Toner Container X 1 Only for China, Korea and Taiwan 
<input type="checkbox"/> [3] Exhaust Filter X 1 	<input type="checkbox"/> [4] Left Upper Cover X 1 
<input type="checkbox"/> [5] Right Upper Cover X 1 	<input type="checkbox"/> [6] Upper Rear Cover X 1 
<input type="checkbox"/> [7] Service Book Holder X 1 	<input type="checkbox"/> [8] Finisher Connector Cover X 2 
<input type="checkbox"/> [9] Cleaning Tool X 1 	<input type="checkbox"/> [10] Cord Guide X 1 
<input type="checkbox"/> [11] Screw (RS Tightening ; M4x10) X 6 	<input type="checkbox"/> [12] Screw (Binding; M4x6) X 1  <input type="checkbox"/> [13] Rubber Cap X 4 

<input type="checkbox"/> [14] IC Card Reader Sheet X 1 	<input type="checkbox"/> [15] Cushion X 2 
<input type="checkbox"/> [16] Double-sided Tape X 1 	<input type="checkbox"/> [17] Wire Saddle X 1 
<input type="checkbox"/> [18] Paper Size Label (Deck) X 1 	<input type="checkbox"/> [19] Paper Size Label (Cassette) Asia/Oceania X 2 USA X 1 EUR X 1 
<input type="checkbox"/> [20] JAM Label X 1 	<input type="checkbox"/> [21] Control Panel Language Label X 1 Only for Asia/Oceania Used for Korea 
<input type="checkbox"/> [22] Connection Seal (Front) X 1 	<input type="checkbox"/> [23] Connection Seal (Middle) X 1 
<input type="checkbox"/> [24] Power Code X 1 220-240V region only. The connector has a different shape depending on locations. 	

NOTE:

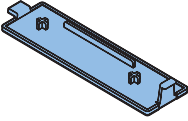
- [16]: Use this if necessary when installing the IC Card Reader.
- [19]: Number of labels attached to the sheet varies according to location/area.
- [21]: Give this to the user as the user may affix it if necessary (See the User's Guide for the procedure).
- [22], [23]: Included in the package of printer models for EUR and USA models (not used for this model).

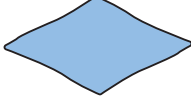



■ Parts Included in the Package of Models with the Image Reader Unit

<input type="checkbox"/> [1] Reader Left Upper Cover X 1 	<input type="checkbox"/> [2] Rubber Cap X 1 
<input type="checkbox"/> [3] Cleaning Cloth X 1 	<input type="checkbox"/> [4] Copy Prohibition Label USA X 1 EUR X 1 

NOTE:

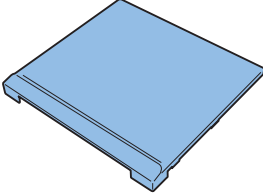
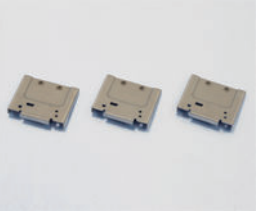
- [4]: Number of labels attached to the sheet varies according to location/area.

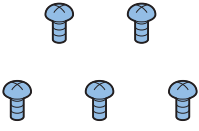
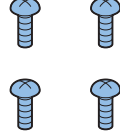
■ Printer Cover (Only for Machines Equipped with the Printer Cover)

<input type="checkbox"/> [1] Printer Cover X 1 	<input type="checkbox"/> [2] Right Cover Support Plate X 3 
<input type="checkbox"/> [3] Reader Fixation Plate L X 1 	<input type="checkbox"/> [4] Reader Fixation Plate R X 1 
<input type="checkbox"/> [5] Screw (Binding; M4x6) X 5 	<input type="checkbox"/> [6] Screw (P Tightening; M4x10) X 4 
<input type="checkbox"/> [7] Screw (TP; M4x8) X 1 	

● Installation Procedure

■ Installing the Scanner(Only for Machines Equipped with the Image Reader Unit)

NOTE:

- As the Scanner Fixation Member will be needed when moving the machine, be sure to keep it in a safe place.
- When moving the machine, be sure to execute following service mode (Lv.2), remove the Reader Left Upper, and then install the Scanner Fixation Member. (For details, refer to "When Relocating the Machine".)
COPIER > FUNCTION > MISC-R > RD-SHPOS



1. Open the ADF.

□
2.

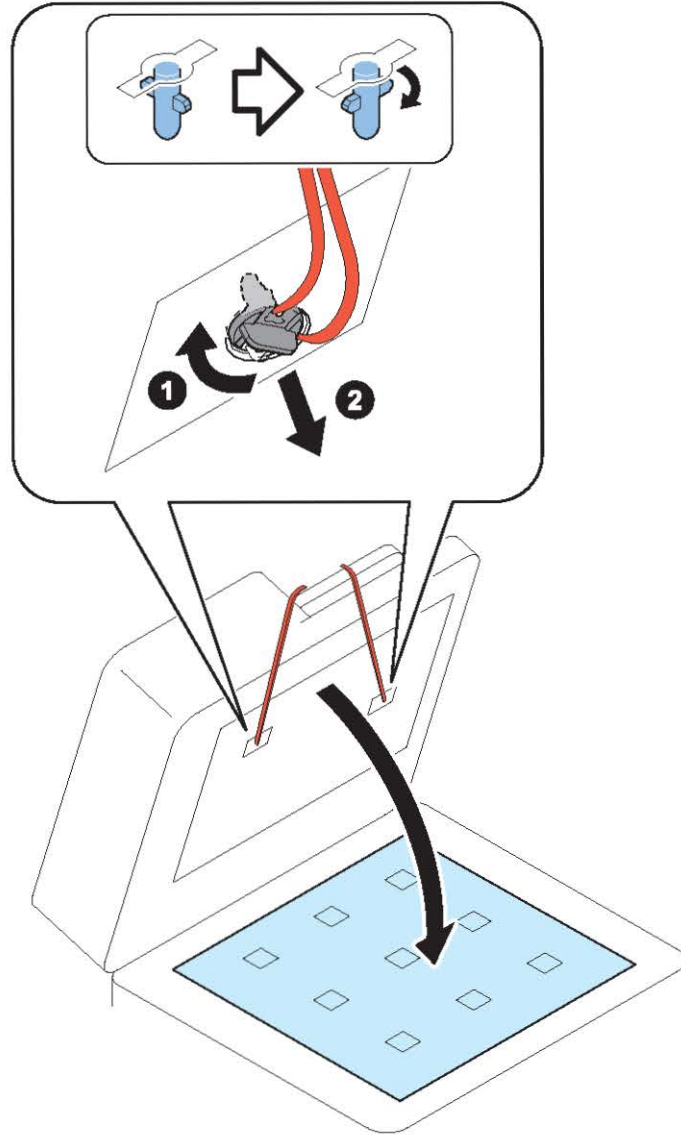



3.

NOTE:

Be sure to keep the Scanner Fixation Member in a safe place for moving the machine.

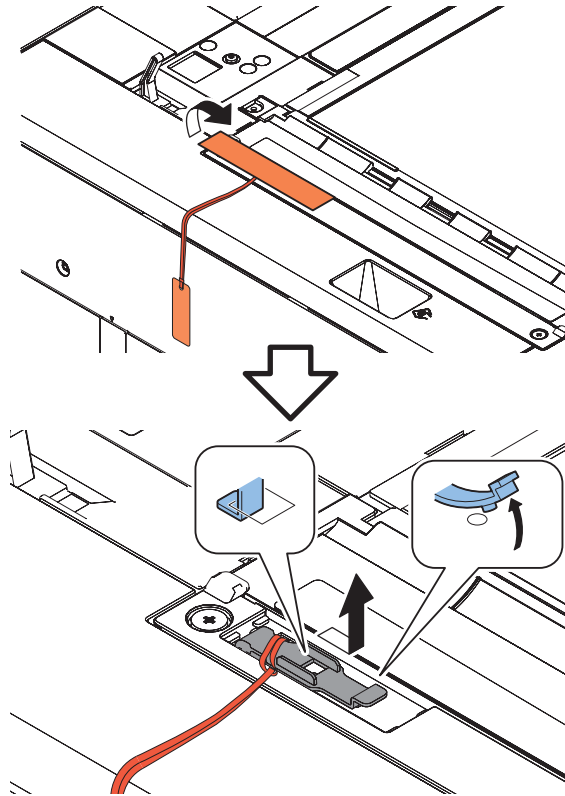

NOTE:

The removed Scanner Fixation Member will be stored in step 8.



4.

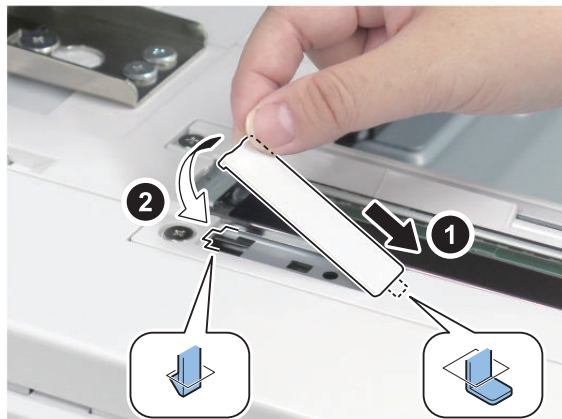
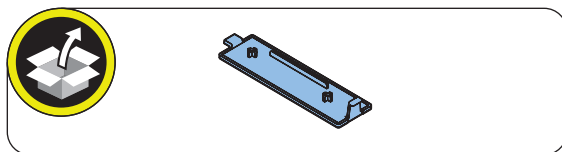



5.

NOTE:

Be sure to keep the Scanner Fixation Member in a safe place for moving the machine.

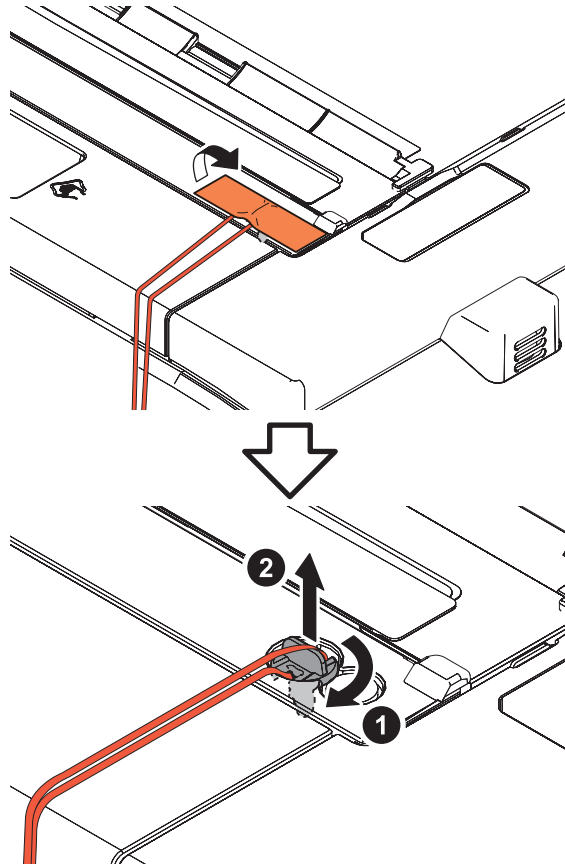

NOTE:

The removed Scanner Fixation Member will be stored in step 10.



6.

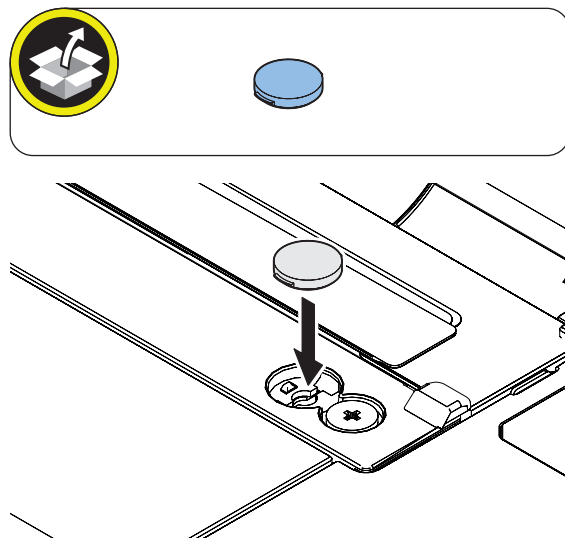



7.

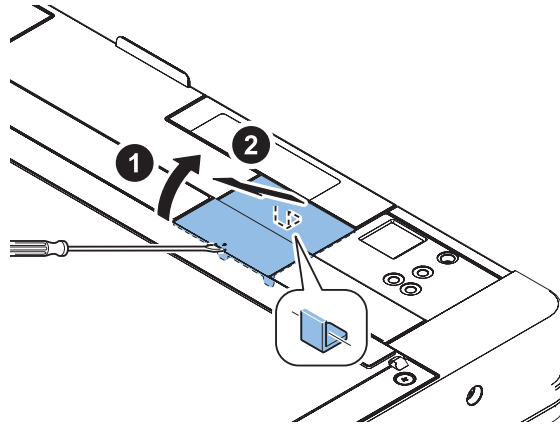

NOTE:

The removed Scanner Fixation Member will be stored in step 9.



8.

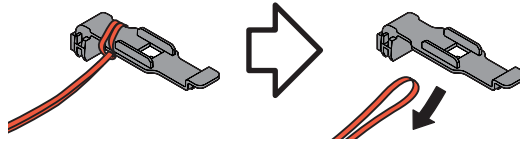

9.

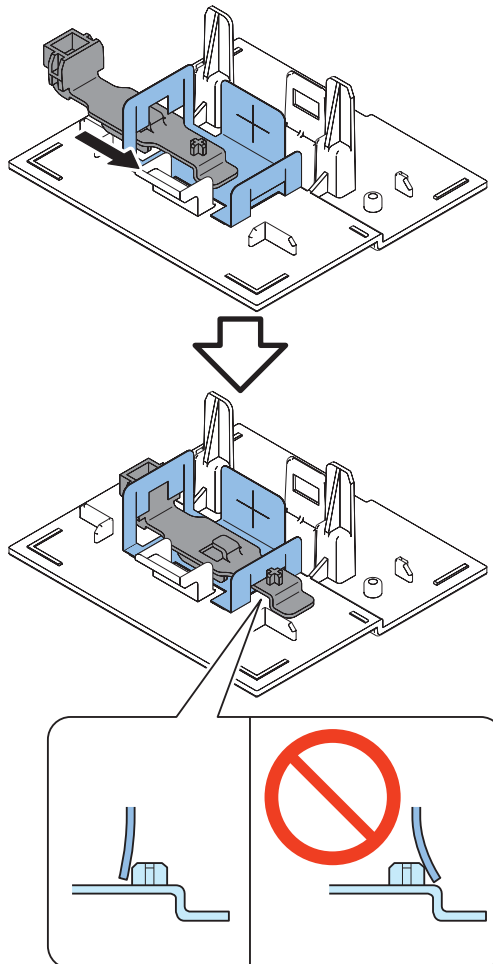



10.

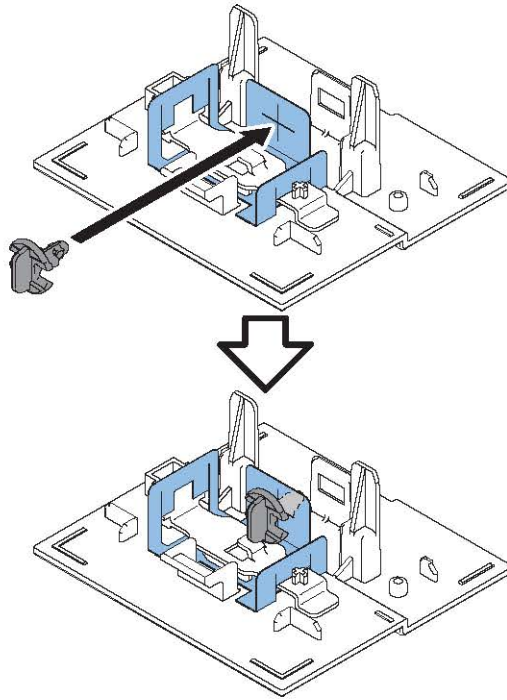

11.

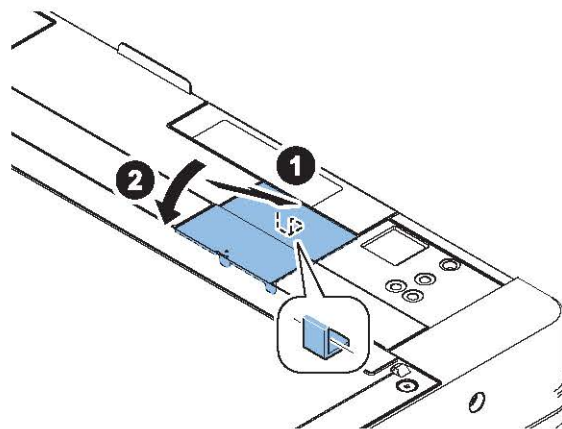

□
12.

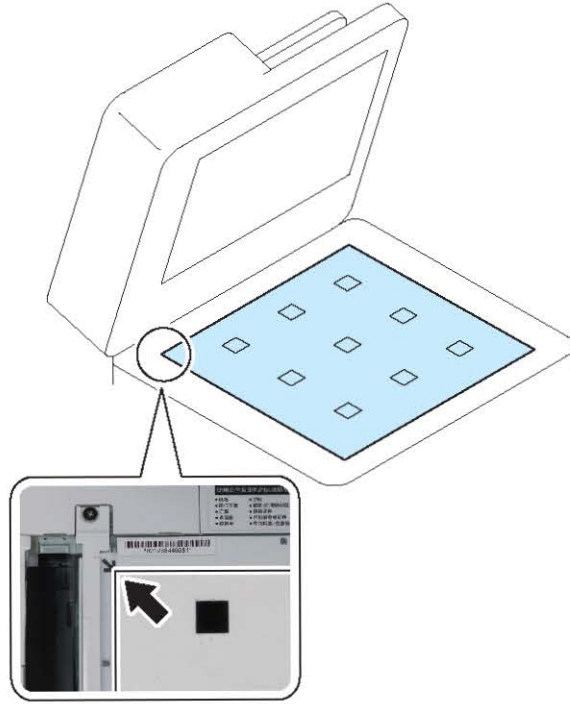

□
13.

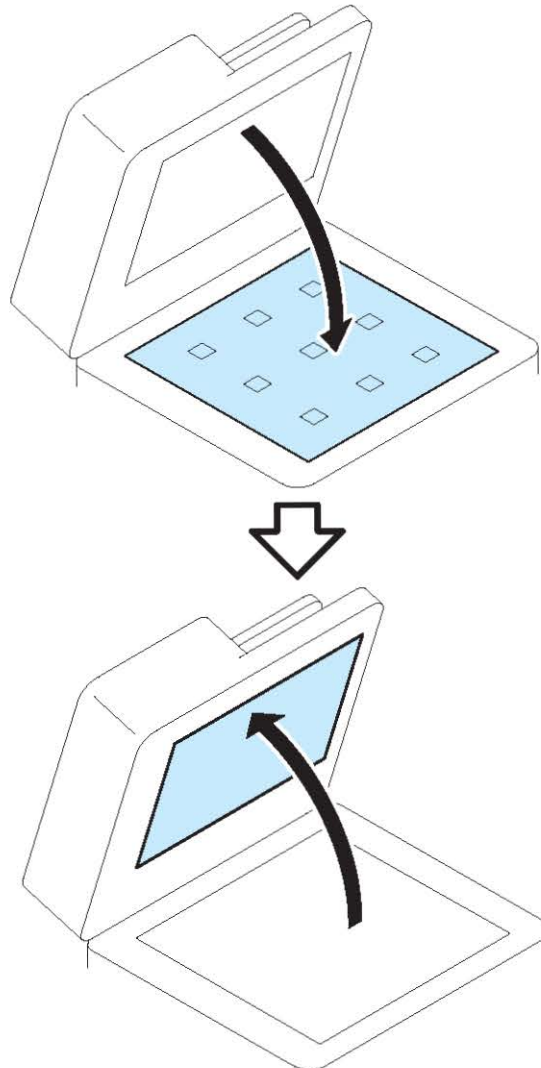



14.

CAUTION:

If the White Plate is pressed downward, it is placed on the Index Sheet, so be sure to press it upward.

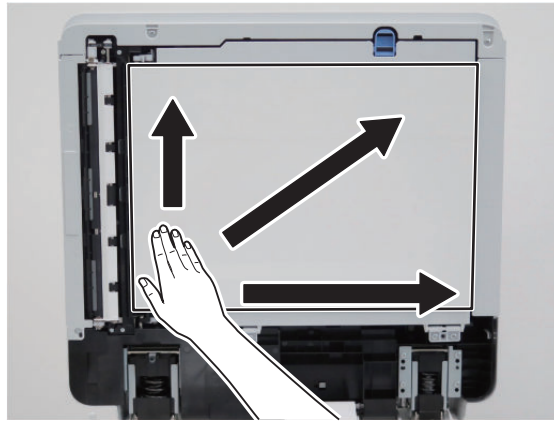

**15. Close the ADF.****NOTE:**

- Be sure that there is no gap (for reference, 0.3 mm or less) between the White Plate and the Index Sheet.
- Check that the White Plate is not placed on the Index Sheet.

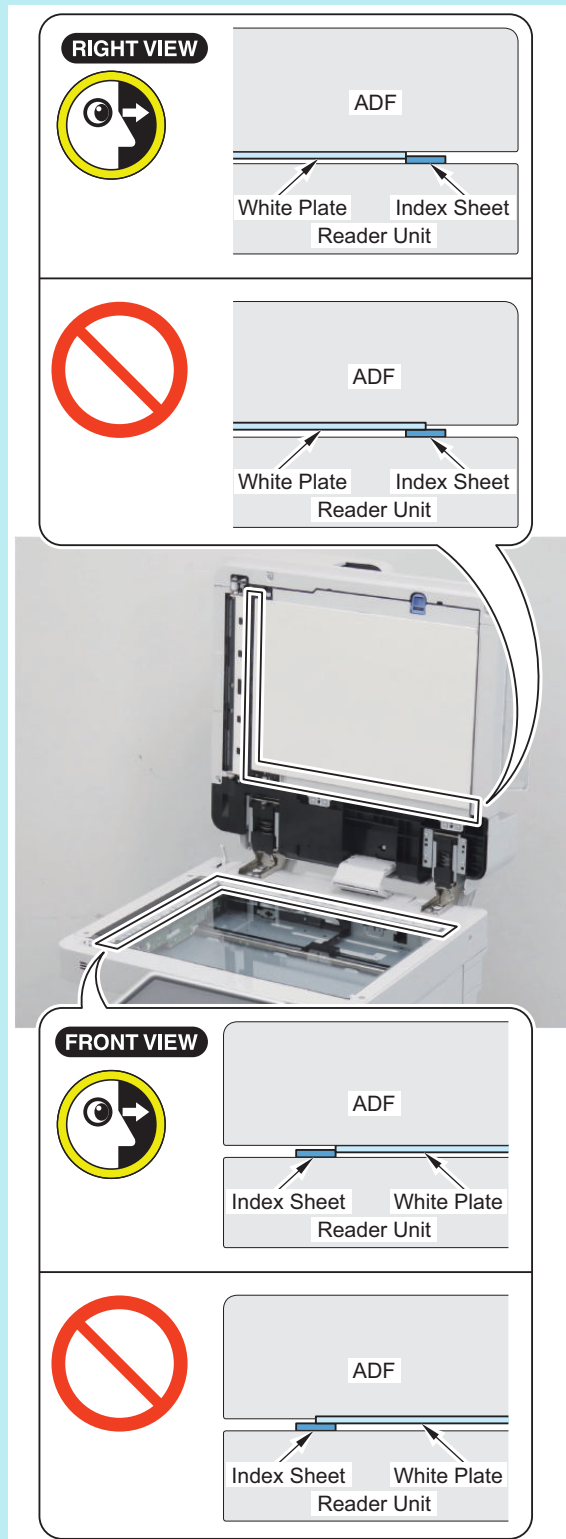

■ Installation of the Printer Cover (Only for Machines Equipped with the Printer Cover)



1. Install the Reader Fixation Plate L.

- 2 Bosses
- 1 Screw (Binding: M4x6)

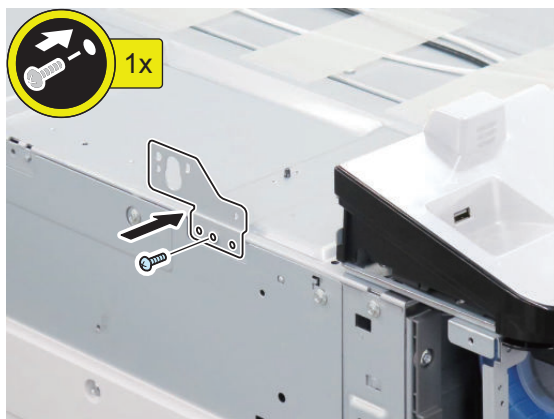
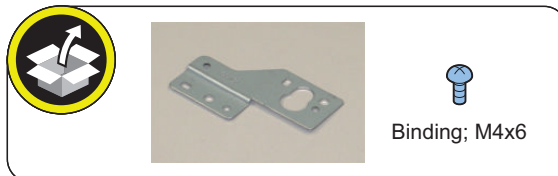

2. Open the Multi-purpose Tray, and install the Reader Fixation Plate R.

- 2 Bosses
- 1 Screw (Binding: M4x6)

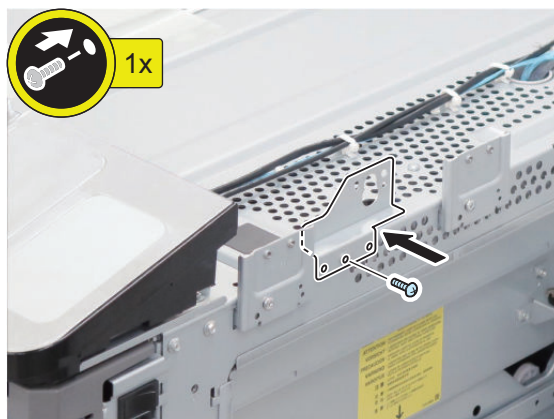
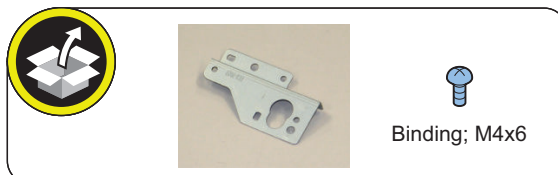



3. Install the 3 Right Cover Support Plates.

- 2 Hooks each
- 1 Screw each (Binding; M4x6)

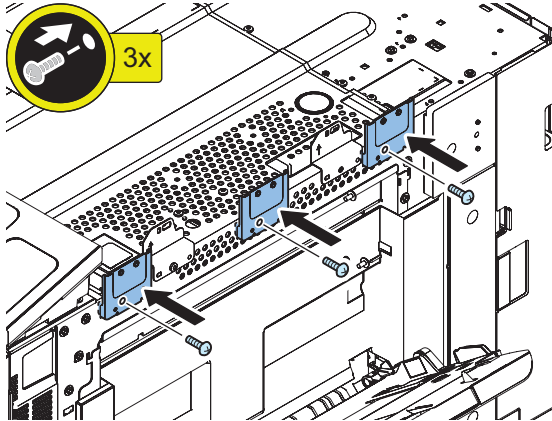
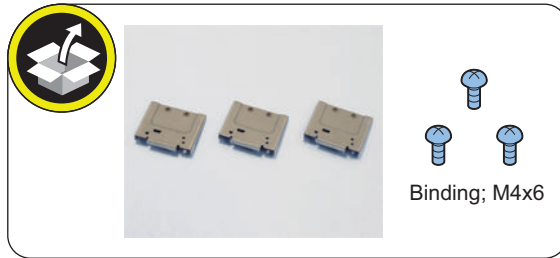



4. Install the Printer Cover.

- 4 Screws (P Tightening; M4x10)
- 1 Screw (TP: M4x8)

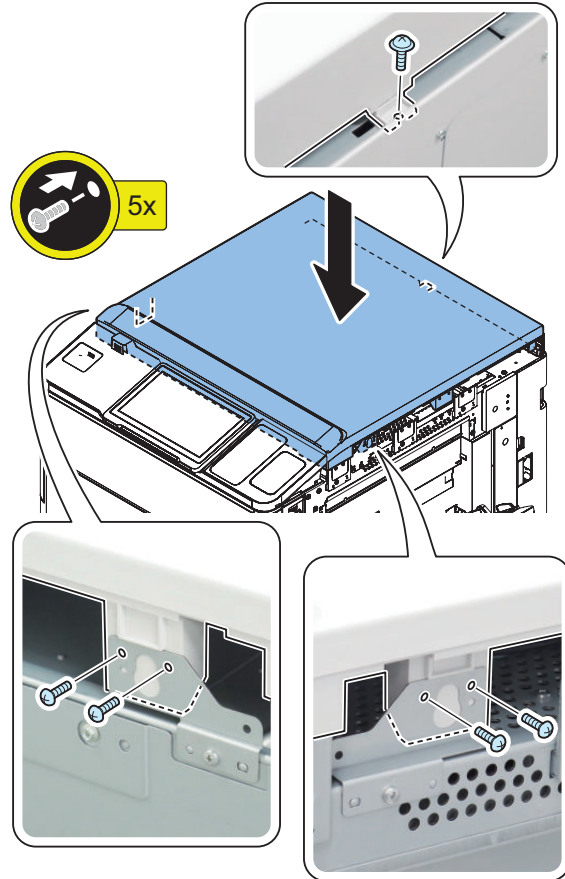
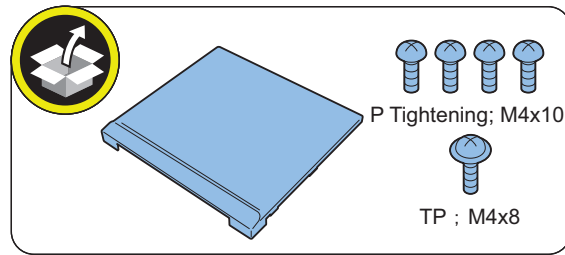

5. Close the Multi-purpose Tray.

■ Installation of the Covers

NOTE:

The installation procedure is the same between the Flat Control Panel model and the Upright Control Panel model.



1. Install the Upper Rear Cover.

- 3 Protrusions
- 2 Claws

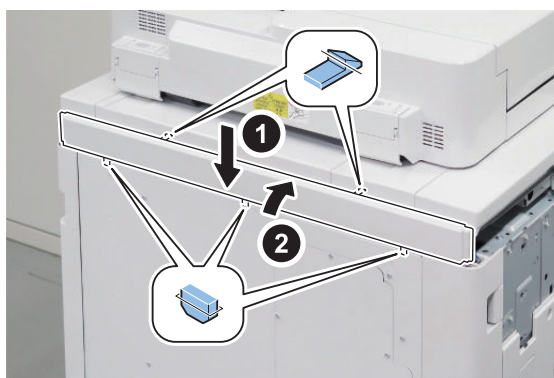

2. Open the covers.

- Toner Replacement Cover
- Right Cover
- Right Rear Cover 1





3. Install the 4 Rubber Caps to the Right Upper Cover.

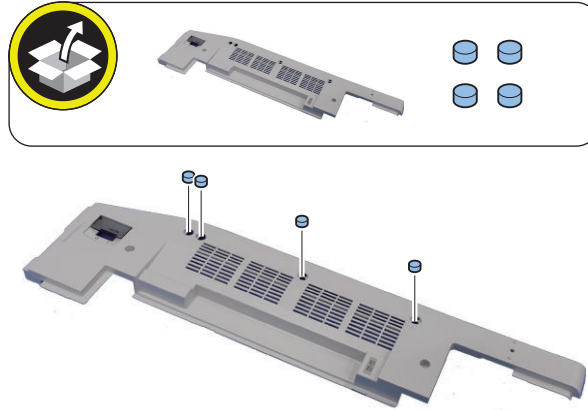

4. Install the Right Upper Cover by fitting its hole onto the boss of the Upper Rear Cover.

- 3 Protrusions
- 2 Screws (RS Tightening; M4x10)

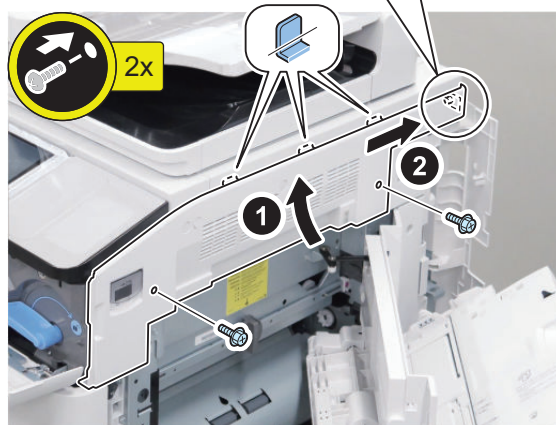
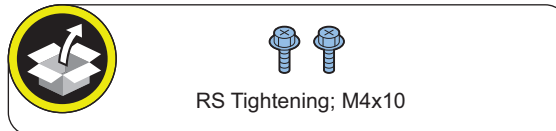

5. Close the Right Cover and Right Rear Cover 1.



6. Remove the Left Rear Cover.

- 1 Claw
- 1 Hook

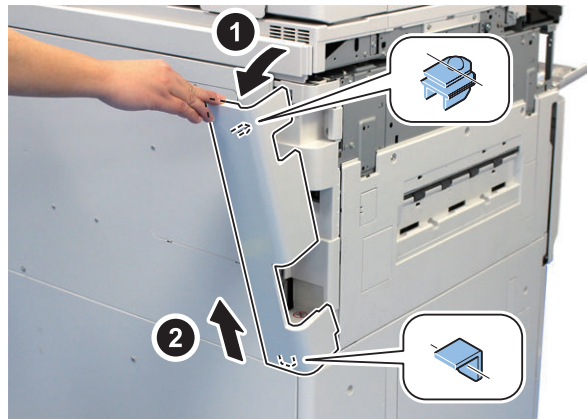

7. Install the Left Upper Cover in the direction of the arrow.

- 3 Protrusions
- 3 Hooks
- 3 Screws (RS Tightening; M4x10)

CAUTION:

When installing the Left Upper Cover, be careful not to secure it while it is being slid fully toward the front. Otherwise, the Left Upper Cover may interfere with the Toner Replacement Cover and the magnet cannot work.

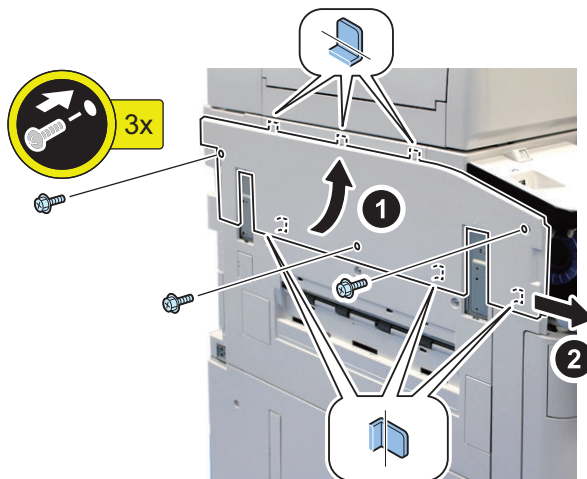
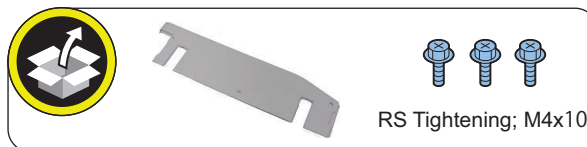



8. Install the Left Rear Cover.

- 1 Hook
- 1 Claw

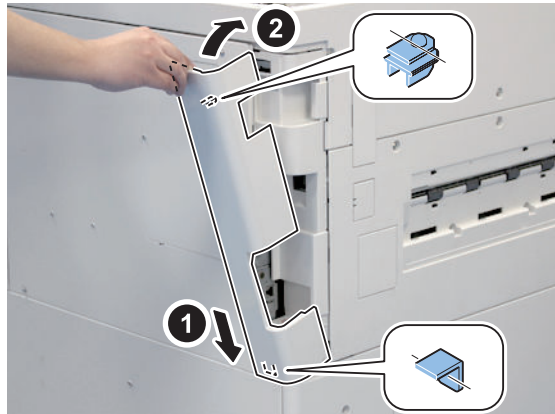

9. Close the Toner Replacement Cover.

■ Installation of the Developing Assembly

CAUTION:

How to Hold the Developing Assembly

- When holding the Developing Assembly, be sure to hold the handle of the Developing Assembly as shown in the figure.
- Do not touch the shutter area of the Developing Assembly. The shutter area is slippery, so it may cause a fall of the assembly.

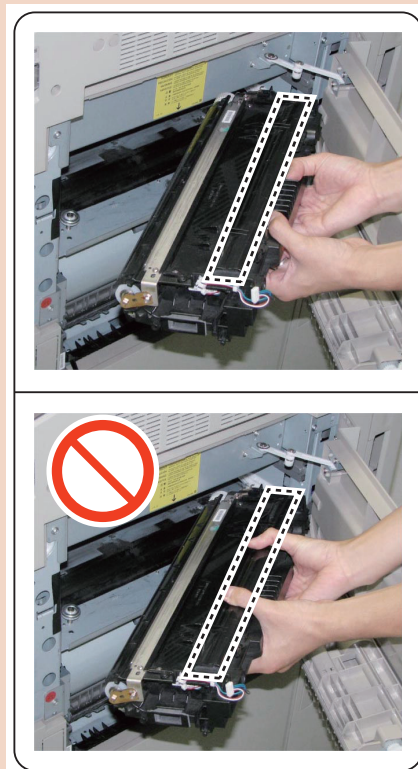

1. Unpack the Developing Assembly.



2. Check if there are any scratches on the cylinder while rotating the gear manually in the direction of the arrow.

CAUTION:

- Do not damage and touch the cylinder.
- Do not turn the gear inversely.



3. Open the Right Cover.



4. Turn the Lock Lever, and open the Developing Assembly Pressure Cover.

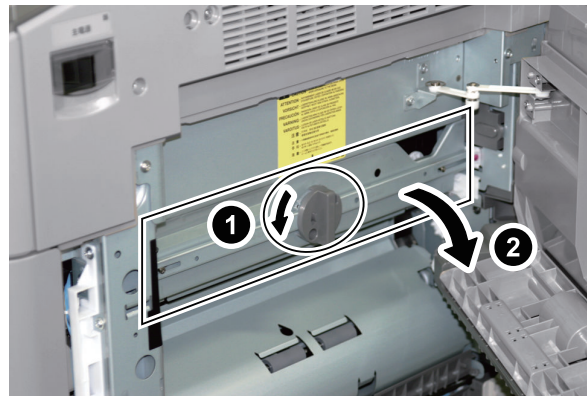

CAUTION:

- Before installing the Developing Assembly, be sure to check that the Buffer Shutter is not opened.
- If forcedly inserting the Developing Assembly while the Buffer Shutter is open, the Buffer Shutter may get damage. When the Buffer Shutter is open, be sure to close it by pulling it toward the front.

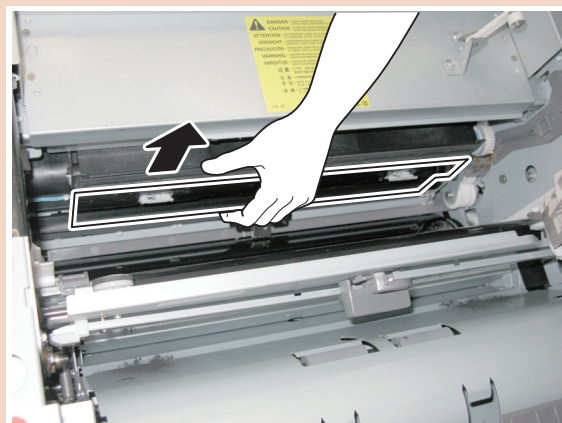

- Whether the Developing Assembly is installed properly can be checked with the Shutter Arm.

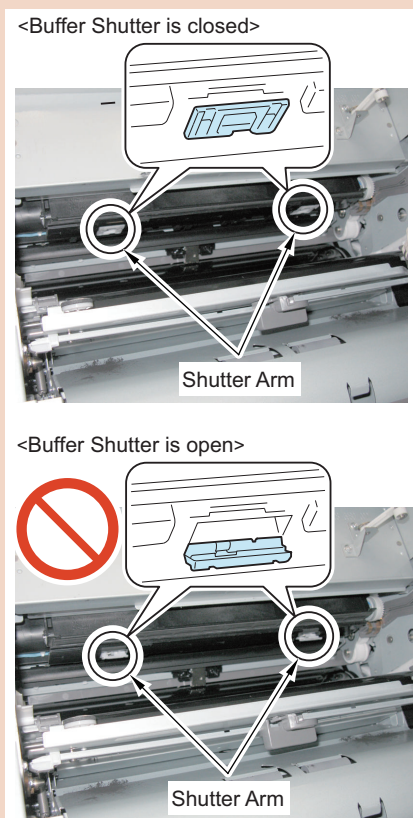



5. Hold the Developing Assembly as shown in the figure, and align the protrusions at both sides of the assembly with the rails on the host machine.

- 2 Protrusions each

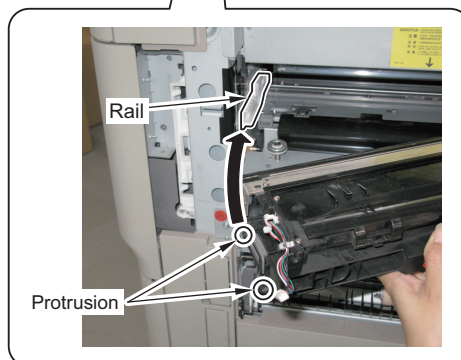
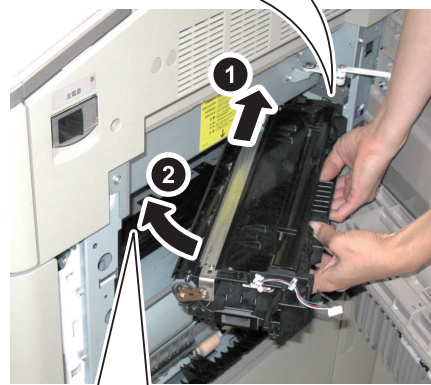
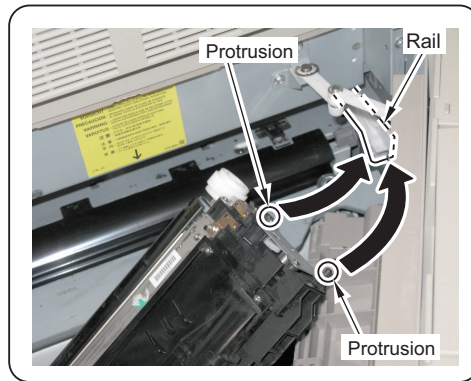



6. Along the rails, insert the Developing Assembly horizontally.

- 1 Connector

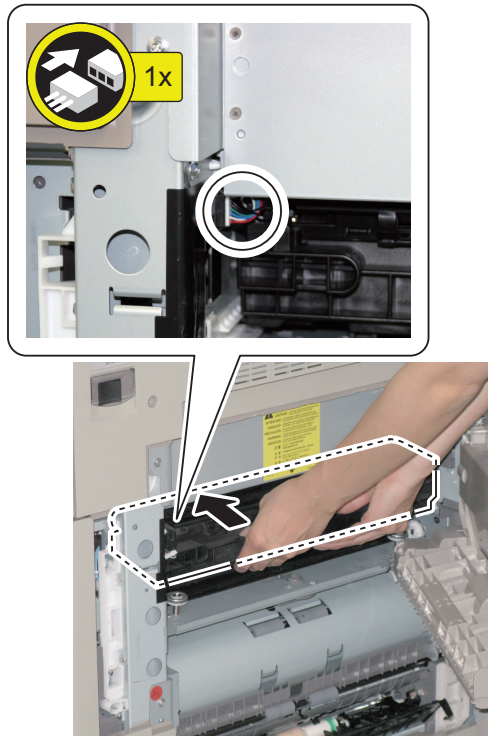

7. Close the Developing Assembly Pressure Cover and return the Lock Lever to the original position. Secure with the Screw (Binding; M4x6).

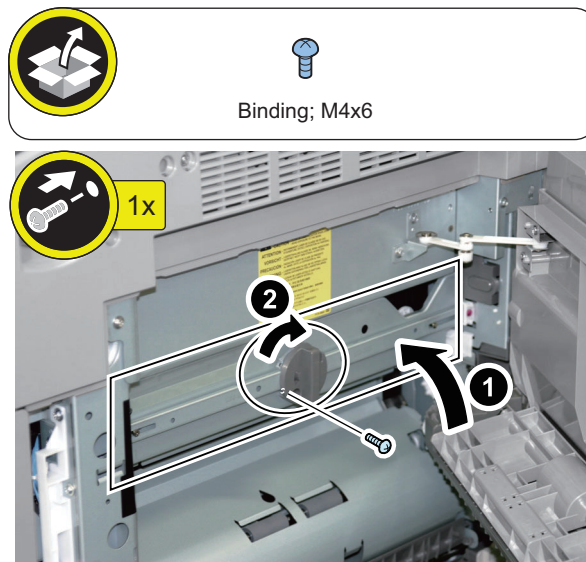

8. Close the Right Cover.

■ Installation of the Pickup Assembly



1. Remove tapes securing tags from the Vertical Path Cover.



2. Open the Vertical Path Cover and remove 2 Pressure Release Spacers at pickup slot for each cassette.

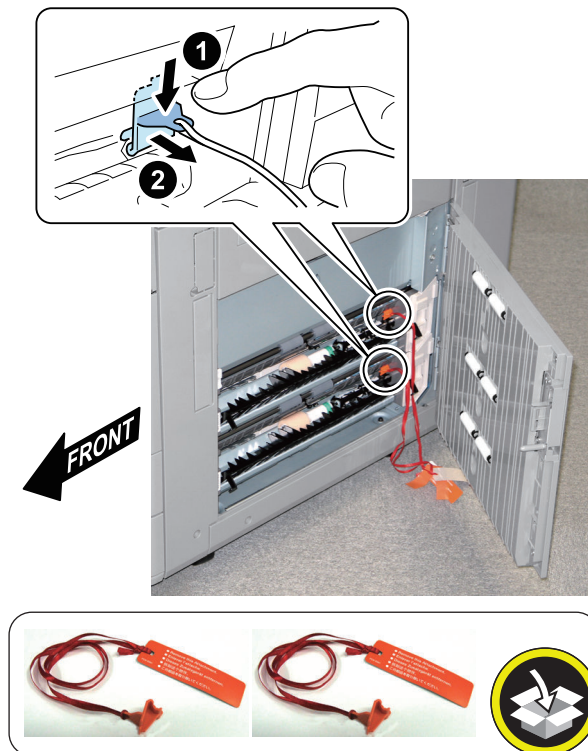

3. Close the Vertical Path Cover.



4. Open the Front Cover.



5. Open the Left and Right Decks, and remove the tape.



- Loosen the screw and slide the Deck Pressure Plate in the direction of the arrow. Check that the screw position is at the engraved mark '1', and then tighten the screw.

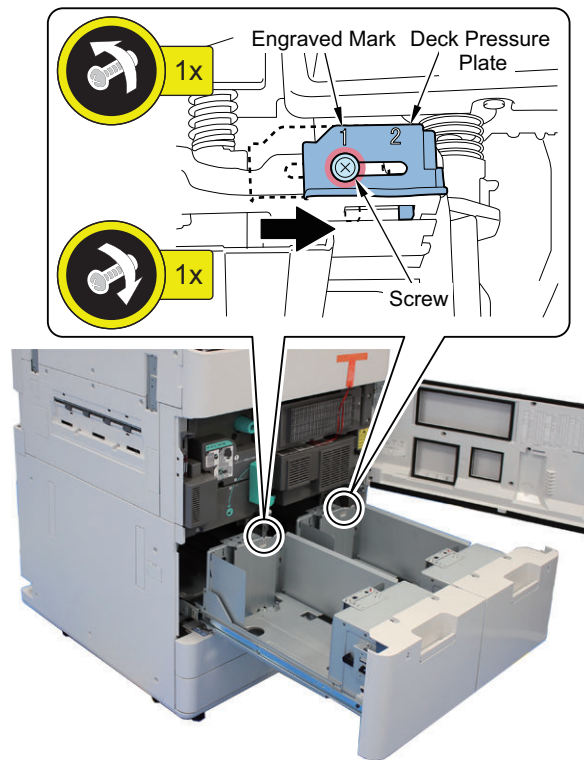

- Close the Left and Right Decks.

■ Installing the Fixing Assembly



- Remove the tapes.

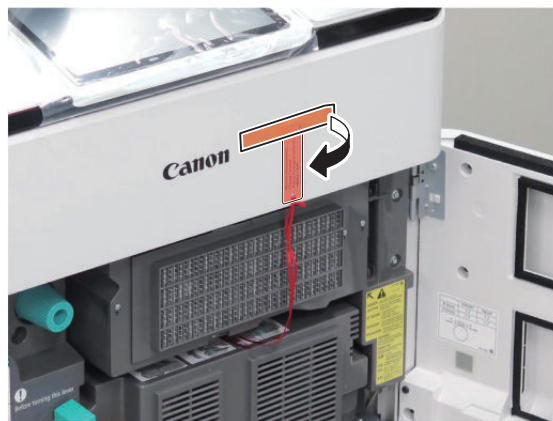

-
2. Turn the Fixing Feed Unit Release Lever in the direction of the arrow and pull the Fixing Feed Unit all the way out.

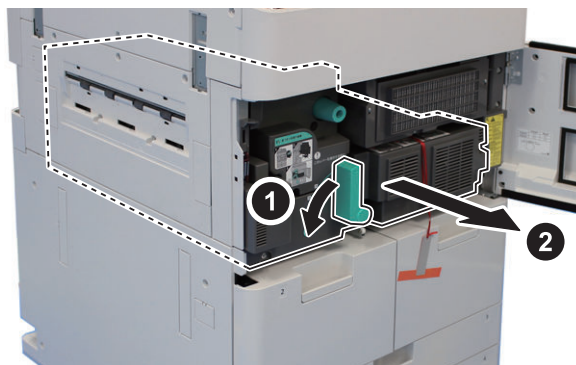
**NOTE:**

In the case that the Fixing Nip Pressure Release Screw is hard to be removed, release the lock by pressing the Lock Springs at both rails, and pull out the Fixing Feed Unit further until it stops.

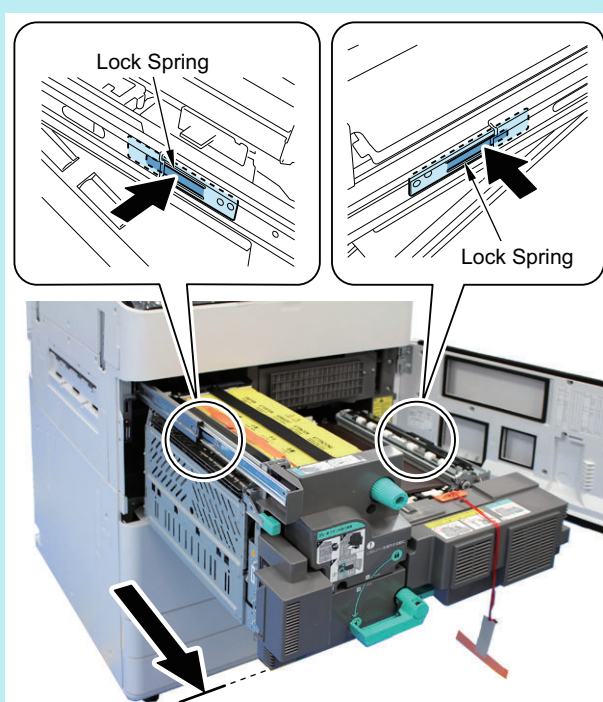

-
3. Remove the tape securing a tag on the Fixing Upper Cover.

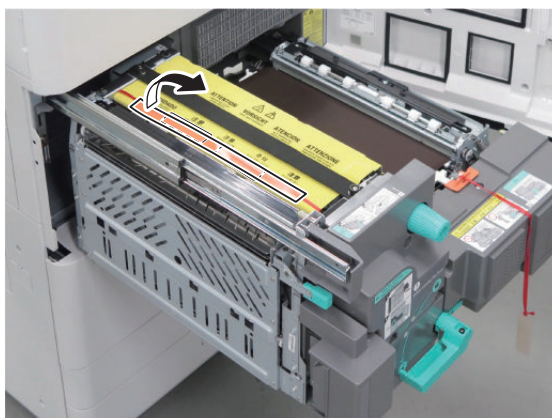



4. Open the Inner Delivery Unit, and remove the 2 Fixing Nip Pressure Release Screws.

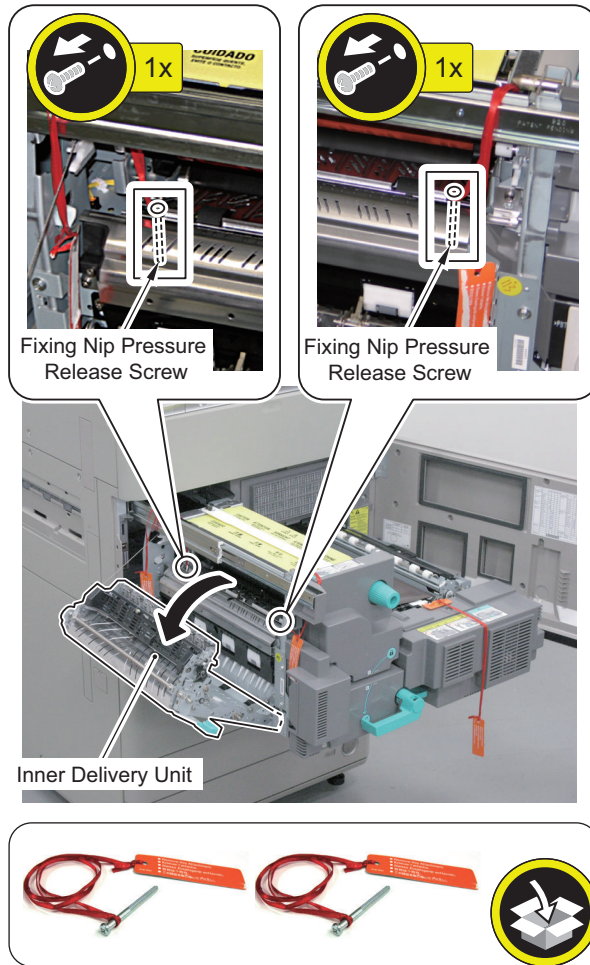

5. Close the Inner Delivery Unit.



6. Remove the ETB Spacer.

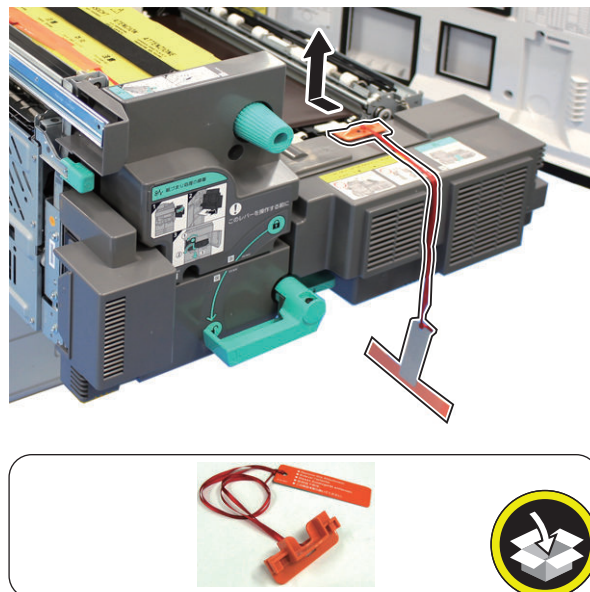



7. Return the Fixing Feed Unit and lock the Fixing Feed Unit Release Lever.

NOTE:

In the case of pulling out the Fixing Feed Unit further, be sure to return the Fixing Feed Unit while releasing the Lock Spring.

CAUTION:

Points to Note when Inserting the Fixing Feed Unit

While pressing the Release Springs, slowly push the Fixing Feed Unit in so that the fingers do not get caught.

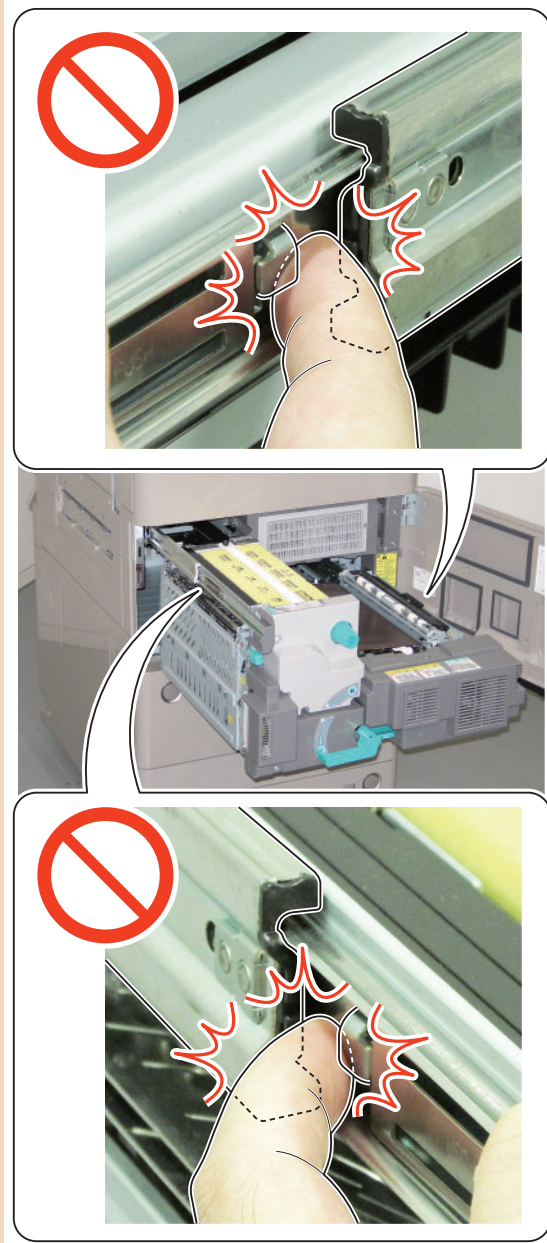

NOTE:

How to push the Fixing Feed Unit in

1. Release the Release Springs [A] on the side of either rail.
Slowly push the Fixing Feed Unit in by approximately 5 mm while keeping it level.

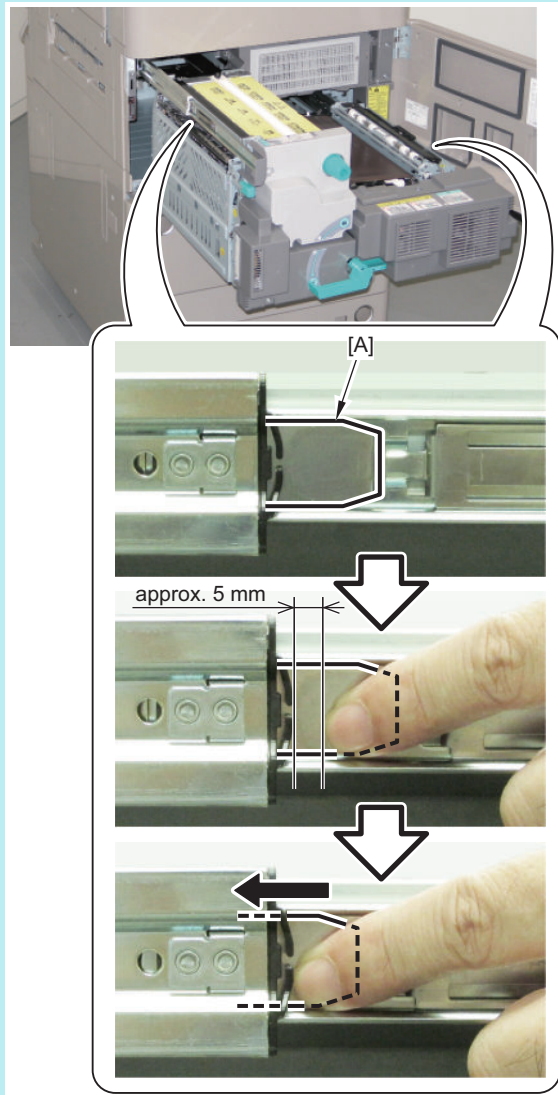

2. Take the fingers off the Release Springs and slowly push the Fixing Feed Unit in to the end.

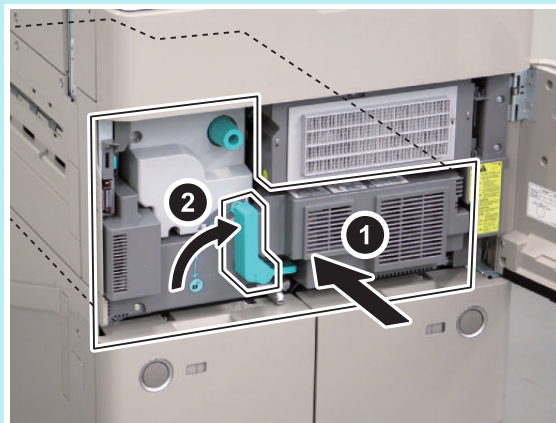



8. Affix the Jam Label of the appropriate language over the existing label on the Fixing Front Cover.

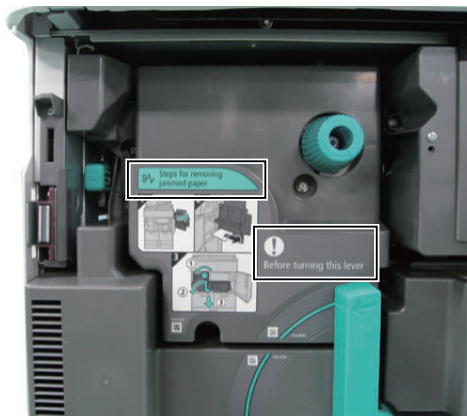

9. Close the Front Cover.

■ Installation of Toner Container



1. Open the Toner Replacement Cover, and turn the Lock Lever in the direction of the arrow to release.





2. **Unpack the Toner Container and shake it approx. 10 times horizontally.**

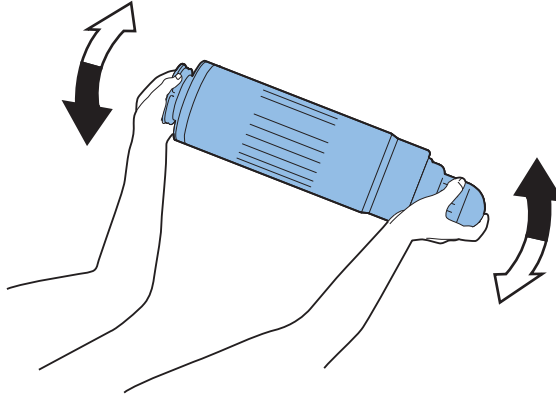

3. **Remove the cap of the Toner Container.**



4. **Set the Toner Container to the host machine, and turn the Lock Lever in the direction of the arrow to secure the Toner Container in place.**



5. **Close the Toner Replacement Cover.**

■ Installing the Exhaust Filter



1. Remove the tape, and remove the Filter Cover.

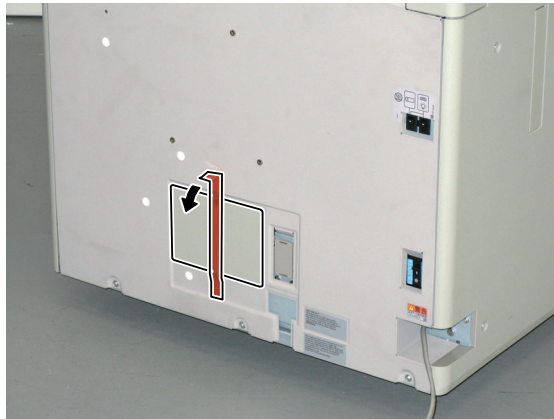

2. Hold the Exhaust Filter as shown in the figure, and install it to the Main Body.



CAUTION:

When installing the Exhaust Filter, be sure to install it straight. If it is installed askew, the Filter Cover does not fit properly.

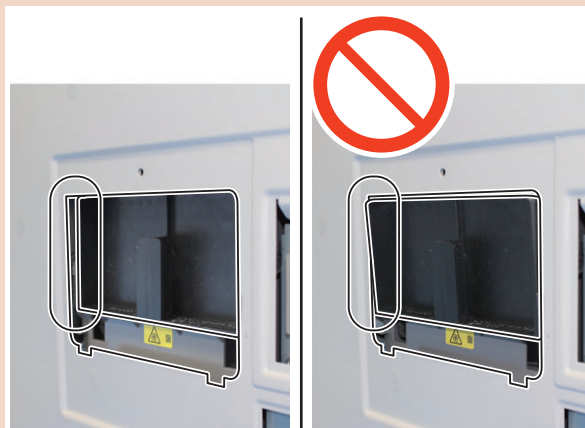



3. Install the Filter Cover.

- Screw (RS Tightening; M4x10)

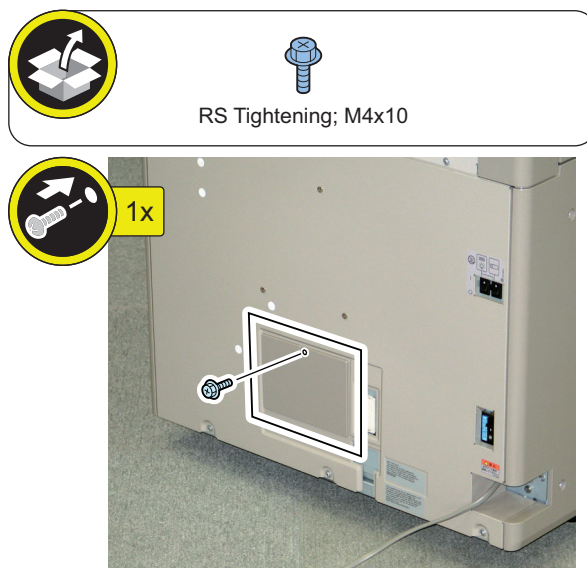

■ Setting the Environment Heater Switch



1. Check that the Leakage Breaker is ON.
2. Turn ON the Environment Heater Switch and the Cassette Heater Switch in accordance with the installation environment.

NOTE:

In the case of high humidity environment, turn ON the Environment Heater Switch.

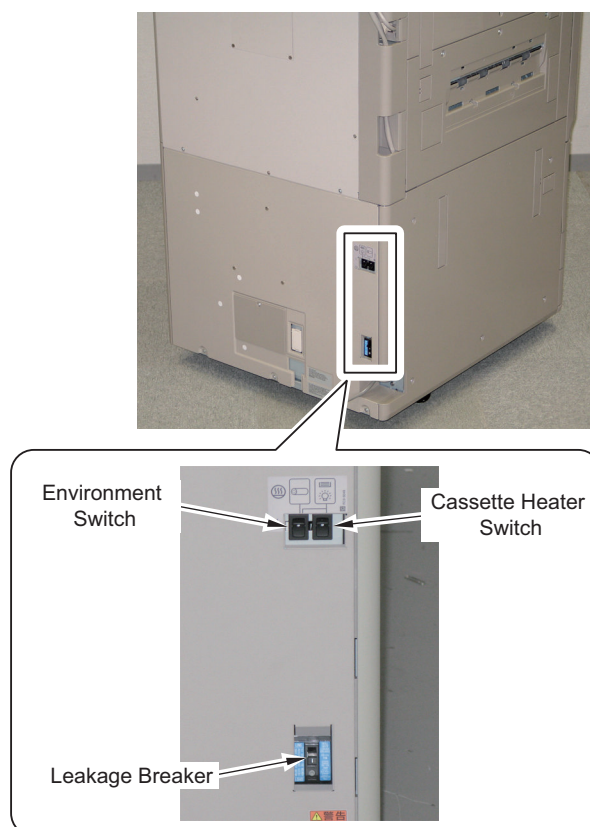

■ Turning ON the Main Power

CAUTION:

Since the automatic adjustment of the ADF reading position will be executed when the main power is turned ON for the first time, remove all objects on the copyboard glass and close the ADF.

1. Remove the protection sheet on the control panel.
2. Connect the power plug of the host machine to the power outlet.
3. Turn ON the main power switch.

<In the Case of Printer Model>

4. A message is displayed prompting to check that the Reader Unit Cable is connected properly.
5. Select the following service mode and enter "0" to the setting value.
COPIER > OPTION > FNC-SW > W/SCNR
6. Exit the Service Mode.

■ Host Machine Settings (Start Setup Guide)

The Setup Guide starts when the host machine is turned ON for the first startup. Follow the instructions displayed on the Touch Panel Display to configure the settings of the host machine.

CAUTION:

- Some of the settings can be skipped without entering the command. To configure skipped settings, configure the settings one by one after exiting Setup Guide.
- Setup Guide can be started again from [Settings/ Registration]. ([Settings/Registration] > [Management Settings] > [License/Other] > [Start Setup Guide])
- If the host machine is turned OFF during the registration using the Setup Guide, the Setup Guide is automatically started by turning ON the host machine.
- Once registration using the Setup Guide is completed, the Setup Guide is not automatically started by turning ON the host machine.

CAUTION:

Register the information of paper loaded during installation of the host machine.

Be sure to register the correct paper type. Especially in the case of special paper types such as heavy paper, registering a wrong paper type may result in image failure, and when the Fixing Assembly becomes soiled or paper wraparound occurs, repair by a service technician becomes necessary.

NOTE:

Following works can be performed while toner mixing is executed.

- "Securing the Host Machine" on page 57
- "Other Installation Work" on page 58
- "Affixing the Labels on the Reader Assembly (Only for Machines Equipped with the Image Reader Unit)" on page 60
- "Setting the Deck" on page 61
- "Setting the Paper Cassette" on page 63

● Informing the System Administrator That Installation Is Complete

When the installation is completed, ask the system administrator to change the password.

Also ask the system administrator to keep the changed password in a safeplace to prevent leakage.

■ Registration of Installation Date Information

CAUTION:

Be sure that [Date/Time Settings] is completed. (There are items in Setup Guide.)



1. Enter the following service mode, and execute "Batch Set Installation Date Info".

COPIER > FUNCTION > INSTALL > INSTDTST

NOTE:

- Year, month, day, hour, and minute can be edited individually in the following service modes.
COPIER > OPTION > USER > INSTDT-Y
COPIER > OPTION > USER > INSTDT-M
COPIER > OPTION > USER > INSTDT-D
COPIER > OPTION > USER > INSTDT-H
COPIER > OPTION > USER > INSTDT-N
- The default value of each service mode is "0".
- When "0" is set for each service mode, "Device Installation Date" on the counter report will be blank.

2. Exit service mode.

3. Output the counter report, and check that the installation date information is registered.
 - [Counter/Device Information] key > [Print List] > [Yes]

```

2017 08/30 WED 09:40
*****
*** Counter Report ***
*****
Device Installation Date 2017/08/09 07:56
Counter Check Date 2017/08/09 09:40
Model LR-ADV
Serial Number UXH00938
  
```

■ Securing the Host Machine



1. Confirm the position to install the Host Machine and turn the 2 adjusters with your hand until they closely contact the floor.

NOTE:

If you failed to turn the adjusters with your hand, use a screwdriver so that they can be turned by your hand.



2. Use a screwdriver to turn the adjusters in the direction of the arrow to make them secured.

NOTE:

Securing of the adjuster is not earthquake resistant.

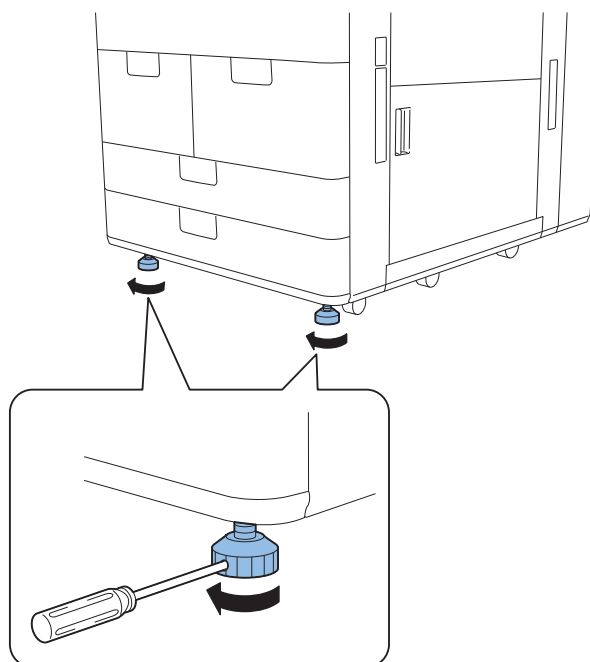

■ Other Installation Work

● Service Book Holder



1. Remove the double-sided tape on back side of the Service Book Holder, and affix the holder on the Base Plate of the host machine.

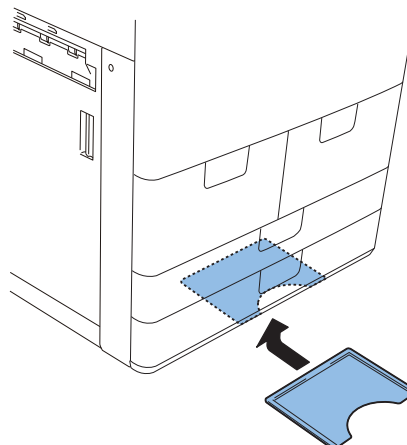
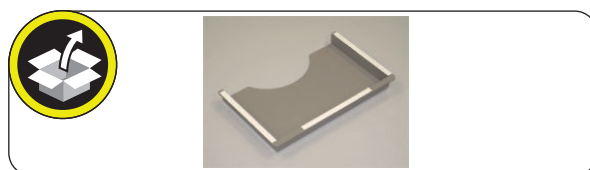

• Finisher Connector Cover



1. Install the 2 Finisher Connector Covers to the left side of the host machine.

- 1 Protrusion each
- 1 Claw each

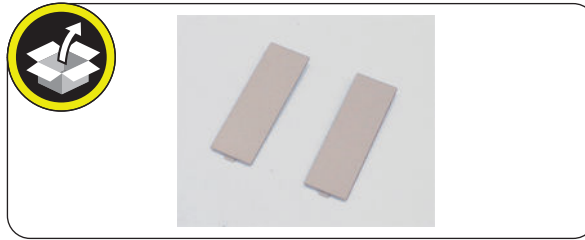

• Cleaning Tool



1. Store the cleaning tool on the inside of the Right Deck to use for maintenance. (Hook it on the back side of the Deck Cover.)

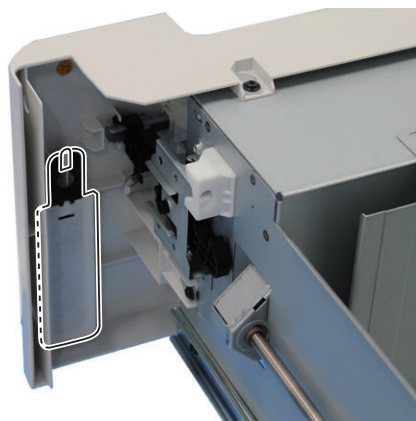

● **Storing the Cleaning Cloth (Only for Machines Equipped with the Image Reader Unit)**

1. Place the Cleaning Cloth in the space shown in the figure.



■ **Affixing the Labels on the Reader Assembly (Only for Machines Equipped with the Image Reader Unit)**

1. Open the DADF.

2. Affix the Copy Prohibition Label of the appropriate language at the places shown in the figure below.

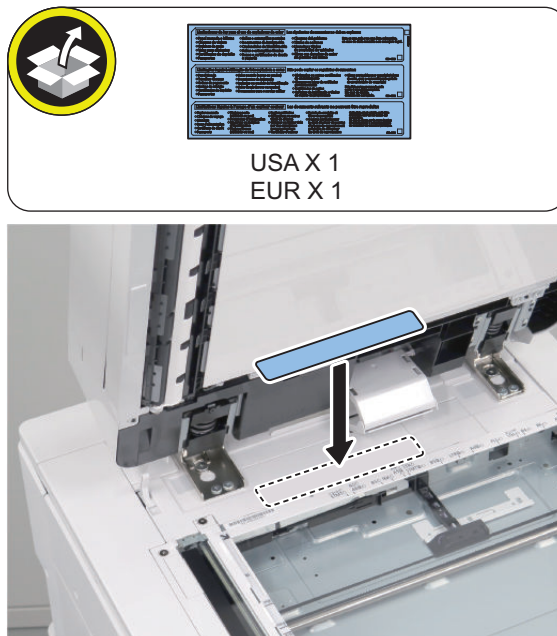

3. Close the DADF.

■ Checking the K paper settings (Only for CHINA)



Check the following service mode, and change the setting value if different.

1. Enter service mode.
2. Check that the setting value of COPIER > OPTION > FNC-SW > MODEL-SZ is "0".
3. Enter service mode (Lv.2).
4. Check that the setting value of COPIER > OPTION > FNC-SW > SENS-CNF is "0".
5. Check that the setting value of COPIER > OPTION > FNC-SW > MODELSZ2 is "0".
6. Check that the setting value of COPIER > OPTION > FNC-SW > KSIZE-SW is "1".
7. When having changed the setting, turn OFF and then ON the main power to enable the setting value.

■ Setting the Deck



1. Pull out the Left and the Right Decks to the front.



2. Remove the 4 screws fixing the Trailing Edge Guide Plate, Left Guide Plate, Right Guide Plate, and Paper Side End Plate in place, and fix each of the Guide Plates at user's desired size.

NOTE:

Setting the Paper Side End Plate

- Be sure to align the Paper Side End Plate with the position according to the size requested by the user, and secure the screw.
- When B5 size is set, the Paper Size End Plate cannot be fixed to the deck with the screw. In order to prevent the screw from being lost, be sure to secure the screw to the deck as shown below.

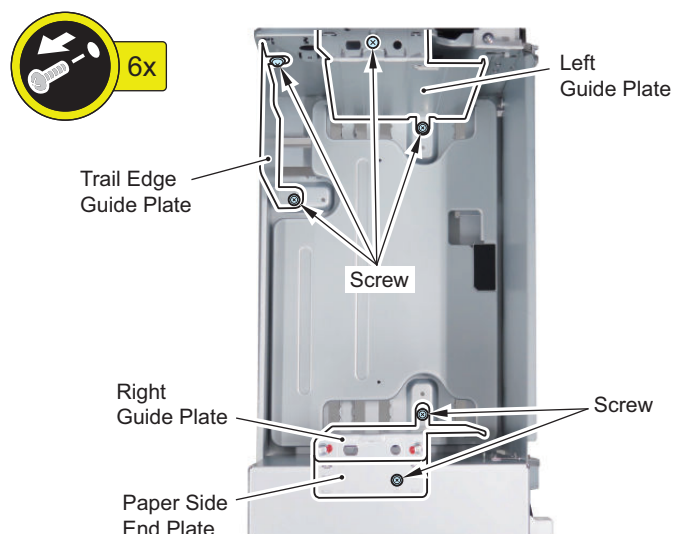

-
3. Put the specified size of papers in the Left/Right Deck, and push the Left/Right Deck in.
-
4. Affix Paper Size Labels (for Deck) according to the paper size, with the edge of each label aligned with the edge of the cassette number label. Approx. 5 mm away from the number label.

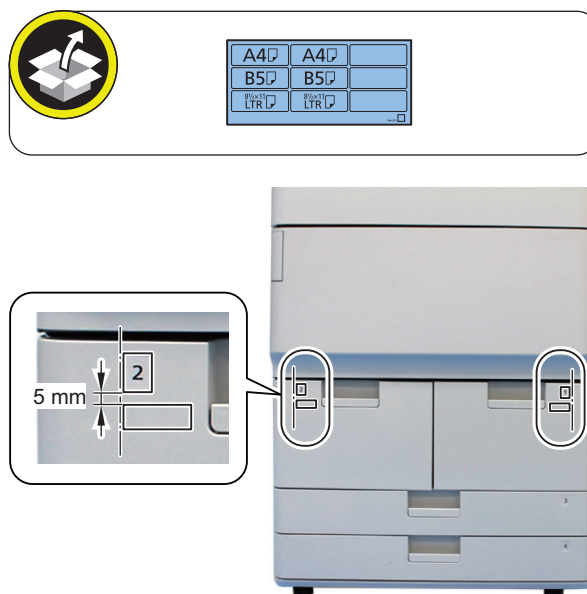

NOTE:

If Setup Guide is running, skip this procedure.

5. Register the type of paper loaded in the paper source.

1. Select the [Settings/Registration] > [Preferences] > [Paper Settings] > [Paper Settings].
2. Select the paper source where paper is loaded, and press [Set].
3. Select the paper type same as that of the loaded paper, and press [OK] > [OK].

NOTE:

If the corresponding paper type is not displayed on the simple settings screen, press [Detailed Settings] and make a selection on the detailed settings screen.

If the type of loaded paper is not displayed on the detailed settings screen, you can register it.

NOTE:

If Setup Guide is running, perform the following works after Setup Guide ends.

6. When the size has been changed, register the paper size for the Left and Right Deck in the service mode.

Right Deck :

COPIER > OPTION > CST > P-SZ-C1

Left Deck :

COPIER > OPTION > CST > P-SZ-C2

7. Exit from the service mode.

■ Setting the Paper Cassette

-
- 1. Pull out the Cassette to the front.
-
- 2. Hold the lever of the Side Guide Plate, and adjust the plate to the specified size. Adjust the Trailing Edge Guide Plate in the same way.

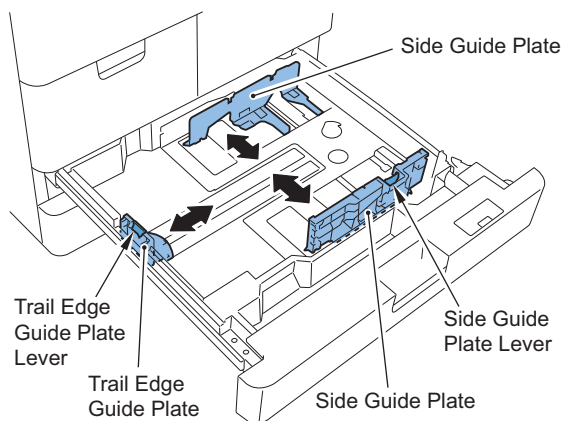

-
- 3. Set paper, and push the Cassette.
-
- 4. Set another cassette as well.

NOTE:

Paper size is set to be automatically recognized.



5. Affix Paper Size Labels (for Cassette) according to the paper size, with the right edge aligned with the right edge of the number label, approx. 5 mm away from the number label.

NOTE:

- Be sure to check with the user whether or not to affix the Paper Size Label, and then affix it at the recommended position.
- Keep the Paper Size Labels as they will be used when changing the paper size.

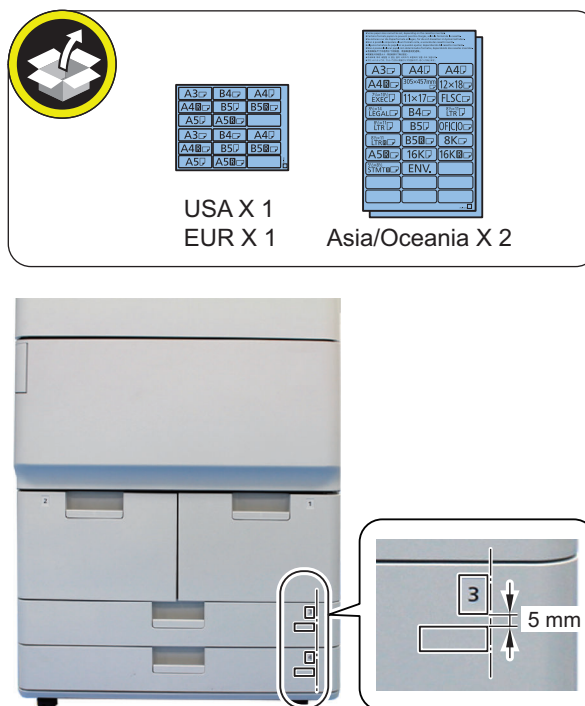
**NOTE:**

If Setup Guide is running, skip this procedure.

6. Register the type of paper loaded in the paper source.

1. Select the [Settings/Registration] > [Preferences] > [Paper Settings] > [Paper Settings].
2. Select the paper source where paper is loaded, and press [Set].
3. Select the paper type same as that of the loaded paper, and press [OK] > [OK].

NOTE:

If the corresponding paper type is not displayed on the simple settings screen, press [Detailed Settings] and make a selection on the detailed settings screen.

If the type of loaded paper is not displayed on the detailed settings screen, you can register it.

■ Image Position Adjustment

● Left Edge Margin Adjustment (1st side)



1. After setting the service mode as follow, press the Start key and output a test print from each cassette and Deck.

COPIER > TEST > PG > TYPE = 5

COPIER > TEST > PG > PG-PICK = 1/2/3/4



2. Check that the left edge margin of the image (L1) is within 2.5 +/- 1.5mm. When the result is out of the specified range, perform adjustment by following the following procedure.

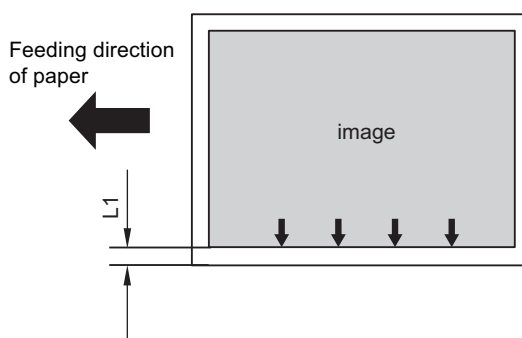

3. Adjust the image position in service mode.

NOTE:

<Setting Range>

-20 to 20 (0.1 mm per unit)

As the value is incremented by 1, the left edge margin is increased by 0.1mm.

Right Deck:

COPIER > ADJUST > FEED-ADJ > ADJ-C1

Left Deck:

COPIER > ADJUST > FEED-ADJ > ADJ-C2

Cassette3:

COPIER > ADJUST > FEED-ADJ > ADJ-C3

Cassette4:

COPIER > ADJUST > FEED-ADJ > ADJ-C4



4. When the setting value was changed in step 3, write down the new numerical value in the service label.



5. Exit from the service mode.



6. Perform printing again from the cassette/deck, and check that the left edge margin (L1) of the image is within 2.5 +/- 1.5 mm.

NOTE:

If the adjustment cannot be made with the setting value of -20 to 20 (adjustment amount: -2.0 to 2.0mm), execute step 7 and later steps.



7. Pull out the Cassette.



8. Check the Cassette position by the scale of the Cassette Button Link Unit.

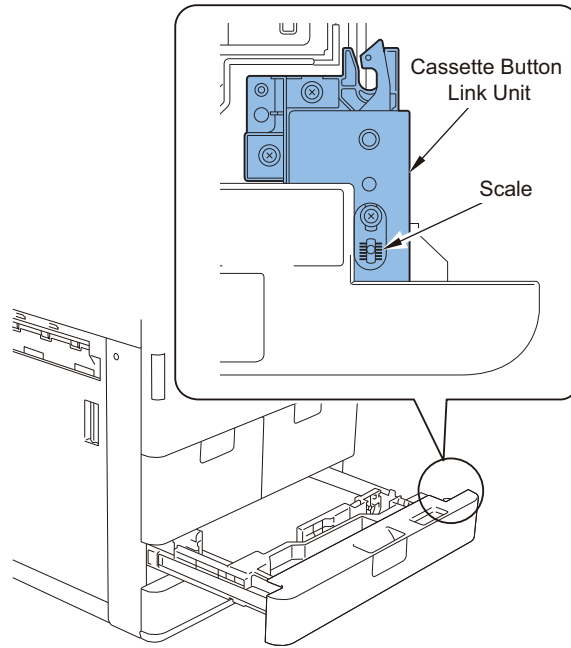

9. Loosen the 4 screws of the Cassette Button Link Unit.

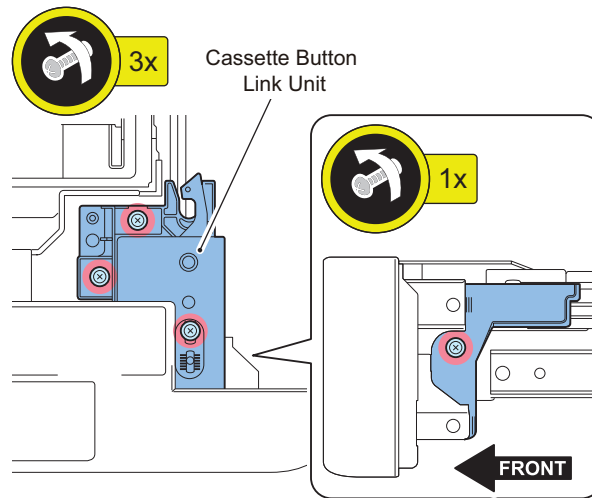



10. According to the scale in which the position was checked in step 8, adjust the position of the **Cassette Button Link Button**.

NOTE:

- In the case of larger margin at the rear side, move the Cassette Button Link Unit to the rear side.
- In the case of larger margin at the front side, move the Cassette Button Link Unit to the front side.

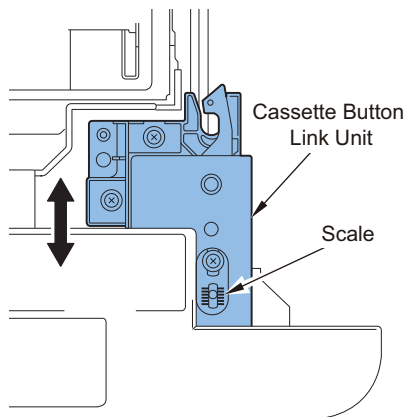

11. Tighten the 4 screws (which have been loosened in step 9).

NOTE:

If you are concerned with alignment of the Cassette Front Cover, perform steps 12 to 14 to make an adjustment as necessary.



12. Loosen the 4 screws and adjust the position of the Cassette Front Cover by referring to the scale.

13. When moving the Cassette Button Link Unit, adjust the left side of the Cassette Front Cover by shifting it with the same shifting amount of the unit.

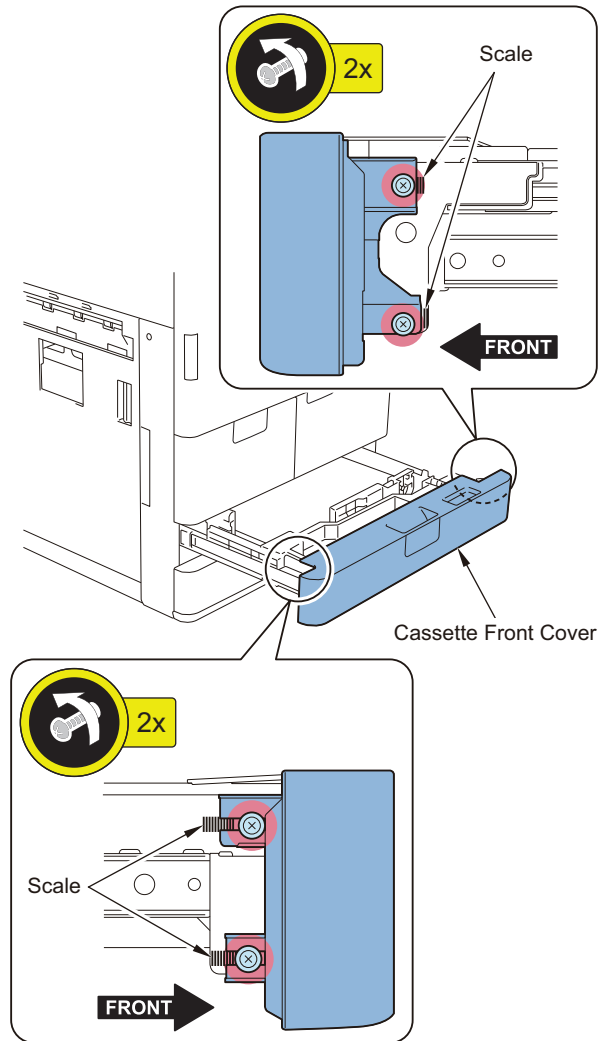

-
14. Once the position of the Cassette Front Cover is confirmed, tighten the 4 screws (which have been loosened in step 12).
-
15. Perform printing again from the cassette/deck, and check that the left edge margin (L1) of the image is within 2.5 +/- 1.5mm.

NOTE:

When a mechanical adjustment was made, be sure to execute the service mode again.

• Leading Edge Margin Adjustment (1st side)

NOTE:

By executing the margin adjustment for the Cassette 3, the adjustment is applied to all source of paper.

1. After setting the service mode as follow, press the Start key and output a test print from Cassette 3.

COPIER > TEST > PG > TYPE = 5

COPIER > TEST > PG > PG-PICK = 3

-
2. Check that the leading edge margin of the image (L2) is within $2.5 +1.5/-0.5$ mm. When the result is out of the specified range, perform adjustment by following the following procedure.

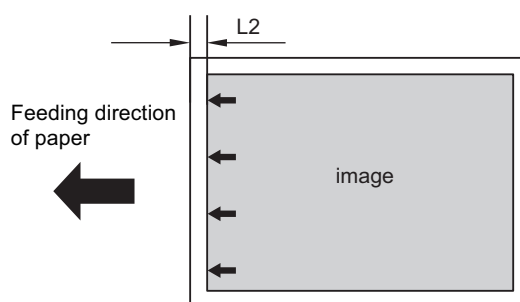

-
3. Adjust the image position in service mode.

NOTE:

<Setting Range>

-50 to 50 (0.1 mm per unit)

As the value is incremented by 1, the leading edge margin is decreased by 0.1mm.

COPIER > ADJUST > FEED-ADJ > REGIST

-
4. Perform printing again from the cassette 3, and check that the leading edge margin (L2) of the image is within $2.5 +1.5/-0.5$ mm.
-
5. When the setting value was changed in step 3, write down the new numerical value in the service label.
-
6. Exit from the service mode.

• Left Edge/Leading Edge Margin Adjustment (2nd side)

NOTE:

By executing the margin adjustment for the Cassette 3, the adjustment is applied to all source of paper.

-
1. After setting the service mode as follow, press the Start key and output a test print from Cassette 3.
- COPIER > TEST > PG > TYPE = 5
 COPIER > TEST > PG > 2-SIDE = 1
 COPIER > TEST > PG > PG-PICK = 3



2. Check that the left edge margin (L1) and leading edge margin (L2) are within the range indicated below. When the result is out of the specified range, perform adjustment by following the following procedure.

- left edge margin L1: 2.5 +/-1.5 mm
- leading edge margin L2 : 2.5 +1.5/-0.5 mm

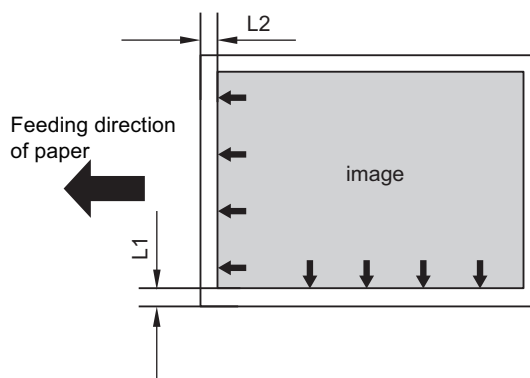

3. Adjust the image position in service mode.

<left edge margin>

NOTE:

<Setting Range>

-50 to 50 (0.1 mm per unit)

As the value is incremented by 1, the left edge margin is increased by 0.1mm.

COPIER > ADJUST > FEED-ADJ > ADJ-REFE

<left edge margin>

NOTE:

<Setting Range>

-50 to 50 (0.1 mm per unit)

As the value is incremented by 1, the leading edge margin is decreased by 0.1mm.

COPIER > ADJUST > FEED-ADJ > REG-DUP1



4. Perform printing again from the cassette 3, and check that the left edge margin (L1) and leading edge margin (L2) of the image are within the range indicated below.

- left edge margin L1: 2.5 +/-1.5 mm
- leading edge margin L2 : 2.5 +1.5/-0.5 mm



5. When the setting value was changed in step 3, write down the new numerical value in the service label.



6. Exit from the service mode.

• Left Edge/Leading Edge Margin Adjustment of Multi-purpose Pickup Tray



1. After setting the service mode as follow, press the Start key and output a test print from Multi-purpose Pickup Tray.

COPIER > TEST > PG > TYPE = 5

COPIER > TEST > PG > PG-PICK = 5

-
2. Check that the left edge margin (L1) and leading edge margin (L2) are within the range indicated below. When the result is out of the specified range, perform adjustment by following the following procedure.
- left edge margin L1: 2.5 +/-1.5 mm
 - leading edge margin L2: 2.5 +1.5/-0.5 mm

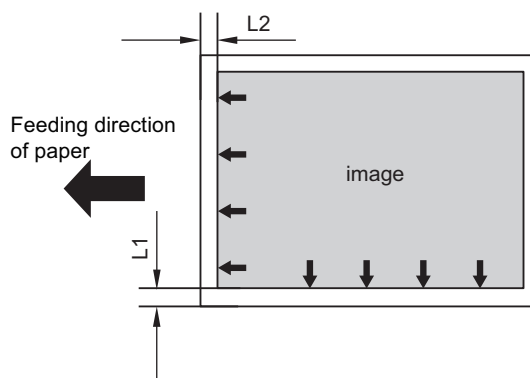

-
3. Adjust the image position in service mode.
<left edge margin>

NOTE:

<Setting Range>

-20 to 20 (0.1 mm per unit)

As the value is incremented by 1, the left edge margin is increased by 0.1mm.

COPIER > ADJUST > FEED-ADJ > ADJ-MF

<leading edge margin>

NOTE:

<Setting Range>

-50 to 50 (0.1 mm per unit)

As the value is incremented by 1, the leading edge margin is decreased by 0.1mm.

COPIER > ADJUST > FEED-ADJ > RG-MF

-
4. When the setting value was changed in step 3, write down the new numerical value in the service label.

-
5. Exit from the service mode.

-
6. Perform printing again from the Multi-purpose Pickup Tray, and check that the left edge margin (L1) and leading edge margin (L2) of the image are within the range indicated below.
- left edge margin L1: 2.5 +/-1.5 mm
 - leading edge margin L2: 2.5 +1.5/-0.5 mm

NOTE:

In the case of left edge margin: If the adjustment cannot be made with the setting value of -20 to 20 (adjustment amount: -2.0 to 2.0mm), execute step 7 and later steps.

-
7. Open the Multi-purpose Pickup Tray.

**8. Loosen the screw and adjust the position of the Slide Guide by referring to the scale.**

- In the case of larger margin at the rear side, move the Slide Guide to the front side.
- In the case of larger margin at the front side, move the Slide Guide to the rear side.

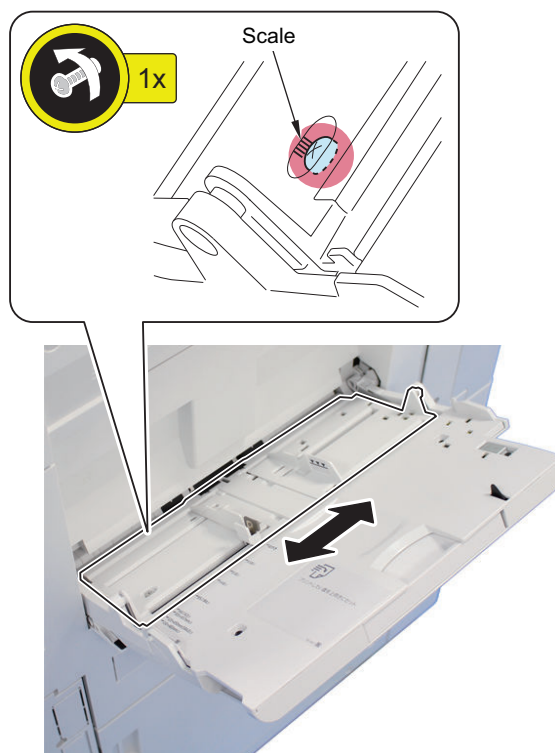
**9. Tighten the screw loosened in step 8.****10. Perform printing again from the Multi-purpose Pickup Tray, and check that the left edge margin (L1) and leading edge margin (L2) of the image are within the range indicated below.**

- left edge margin L1: 2.5 +/-1.5 mm
- leading edge margin L2: 2.5 +1.5/-0.5 mm

NOTE:

When a mechanical adjustment was made, be sure to execute the service mode again.

■ Image Position Adjustment (Single Pass ADF)

● Checking the Skew

Check the image at ADF stream reading with using the "Test Charts for Image Position Adjustment". If any adjustments have been made, perform all of the following "Adjustment Procedure". If it is confirmed that there is no problem, proceed to "Network Connectivity Check".

1. Adjustment of the White Plate
2. Height Adjustment
3. Light intensity adjustment
4. Automatic Adjustment of the Stream Reading Position (Automatic Adjustment of the Reading Position at ADF Reading)
5. White Level Adjustment
6. Front/Back Side Difference Correction Adjustment

NOTE:

Even if the above adjustment is performed, if a fixed skew or image shift occurs, the image is manually adjusted according to the state of the printed image

- Adjustment of leading edge margin of the scanned image for the corrected image Amount of Change per:0.1mm
FEEDER > ADJUST > ADJ-T1 (front side)
FEEDER > ADJUST > ADJ-T2 (back side)
- Adjustment of the left edge margin of the scanned image for the corrected image Amount of Change per:0.1mm
FEEDER > ADJUST > ADJ-L1 (front side)
FEEDER > ADJUST > ADJ-L2 (back side)
- Angle correction of the corrected image Amount of Change per:0.01 degree
FEEDER > ADJUST > ADJ-ROT1 (front side)
FEEDER > ADJUST > ADJ-ROT2 (back side)
- Parallelogram correction amount for corrected image Amount of Change per:0.01 degree
FEEDER > ADJUST > ADJ-PAR1 (front side)
FEEDER > ADJUST > ADJ-PAR2 (back side)

Refer to the following Service Manual

- Adjustment > Original Feed System (Single Pass ADF) > Skew Adjustment (at Stream Scanning of Originals)

Creating the Test Charts for Image Position Adjustment

CAUTION:

Create the test charts for image position adjustment after completing adjustments on the printer side.

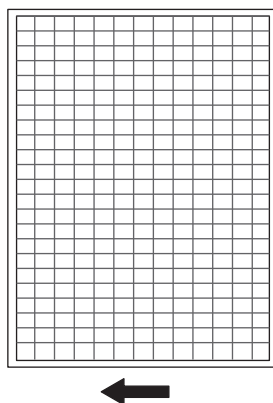

1. After setting the service modes as follows, press the Start key to output the test chart.

- COPIER > TEST > PG > TYPE = 6
- COPIER > TEST > PG > PG-PICK = To set the Pickup Cassette for test print output.

NOTE:

- If the specified test chart cannot be output, draw a test chart on A3 or LDR paper with a rectangle whose four corners are 10 mm smaller than the paper.
- To draw characters and marks so that you can see the direction of the copied image.

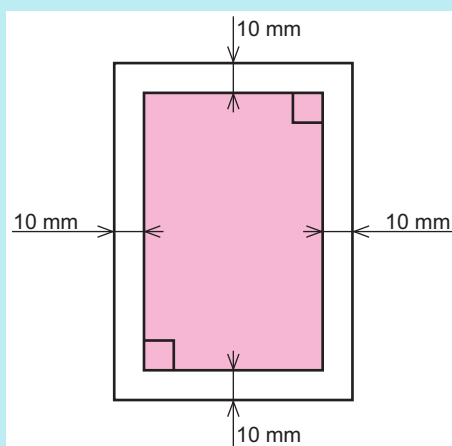

Adjustment of the White Plate

□
1.

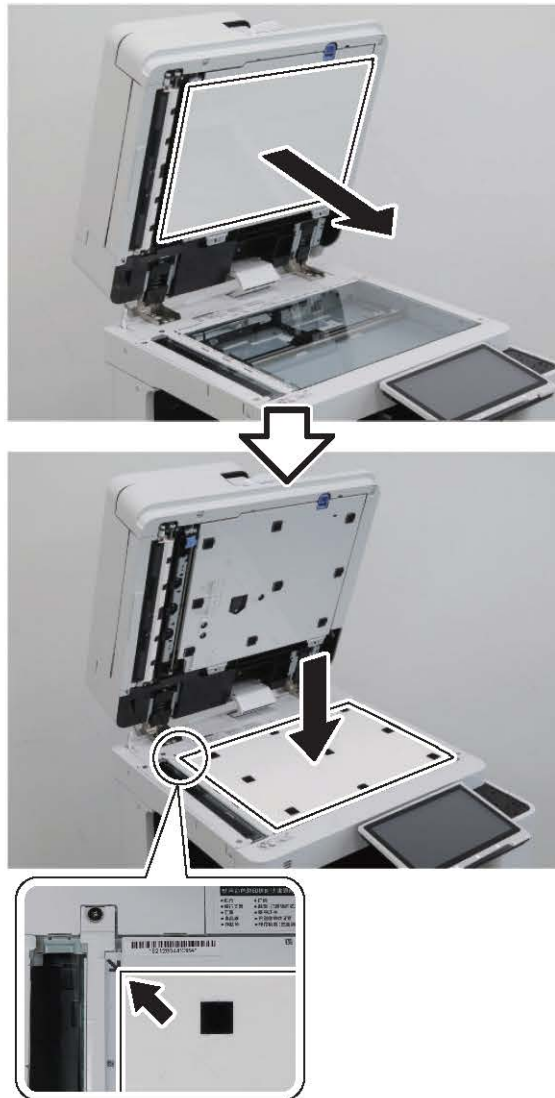

□
2.

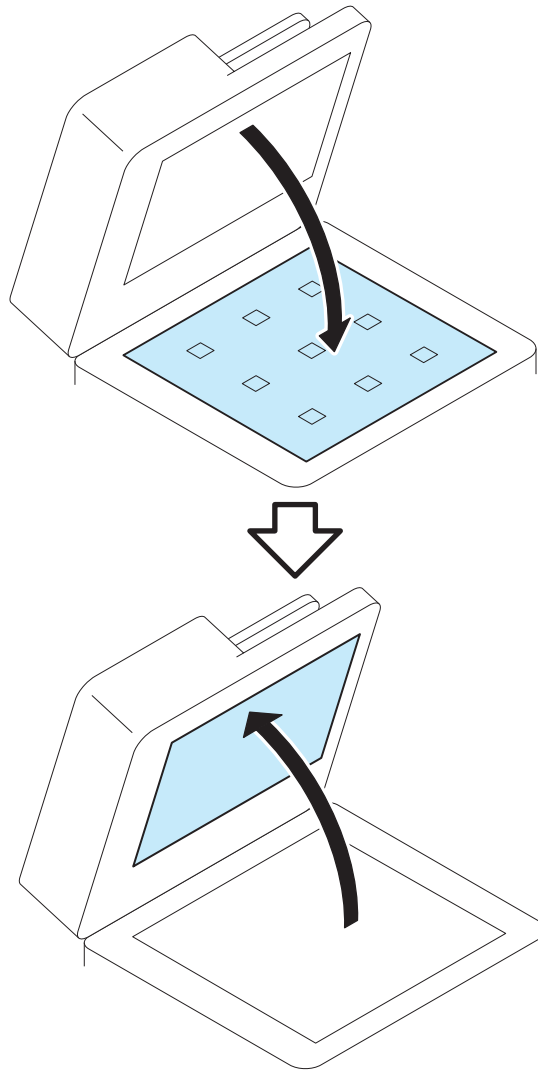

□
3.

CAUTION:

If the White Plate is pressed downward, it is placed on the Index Sheet, so be sure to press it upward.

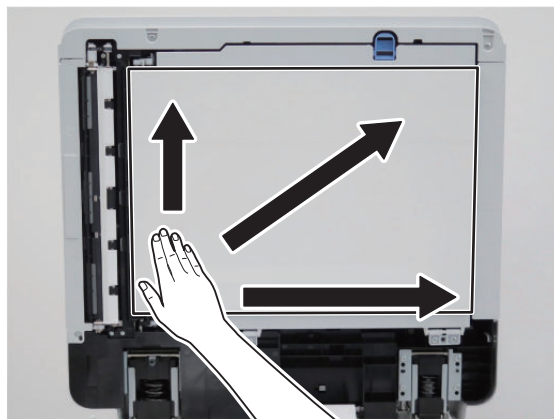

□
4.

NOTE:

- Be sure that there is no gap (for reference, 0.3 mm or less) between the White Plate and the Index Sheet.
- Check that the White Plate is not placed on the Index Sheet.

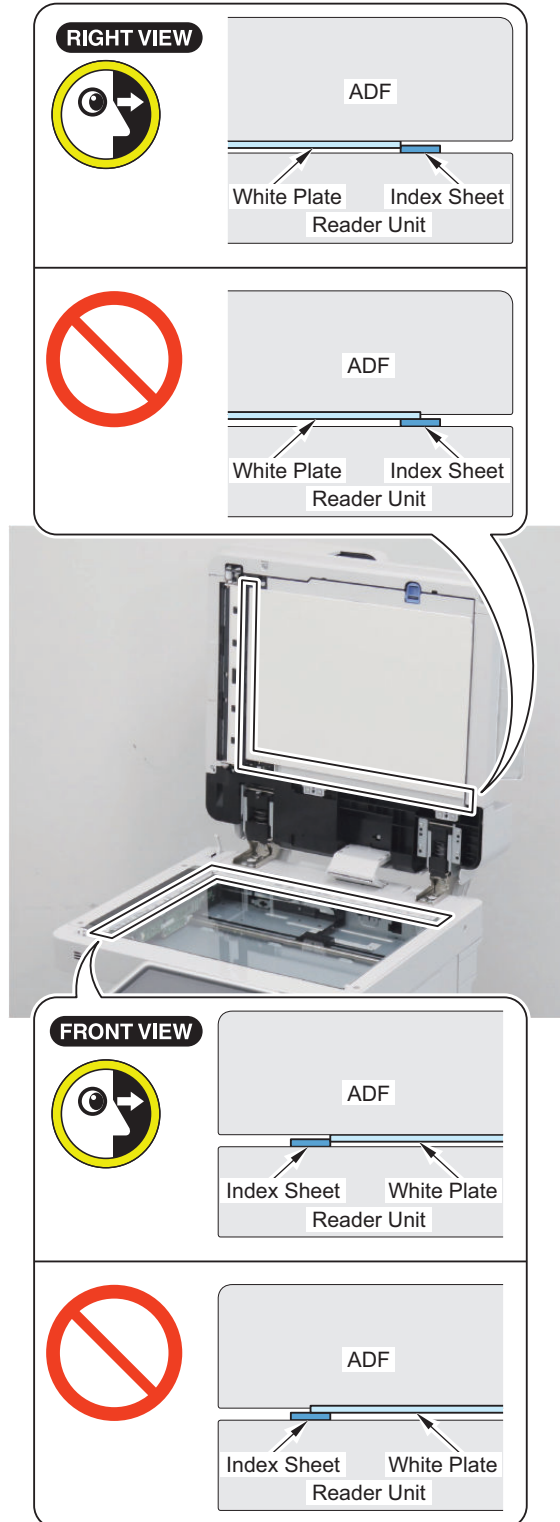

Checking the Height

Height Check Sheet Preparation or Creation

1. Prepare the check sheet used for height adjustment.

 Height check sheet

NOTE:

Points to Note when Creating the Check Sheet

- Output with A4 (paper size) or LTR (paper size).
- Use plain paper 1 to 3 (64 to 105 g/m²) (Paper Type).

Height Adjustment

Checking the Height

-
1. Check that the 2 Height Adjustment Bosses at the left front side and the left rear side are in contact with the Stream Reading Glass.

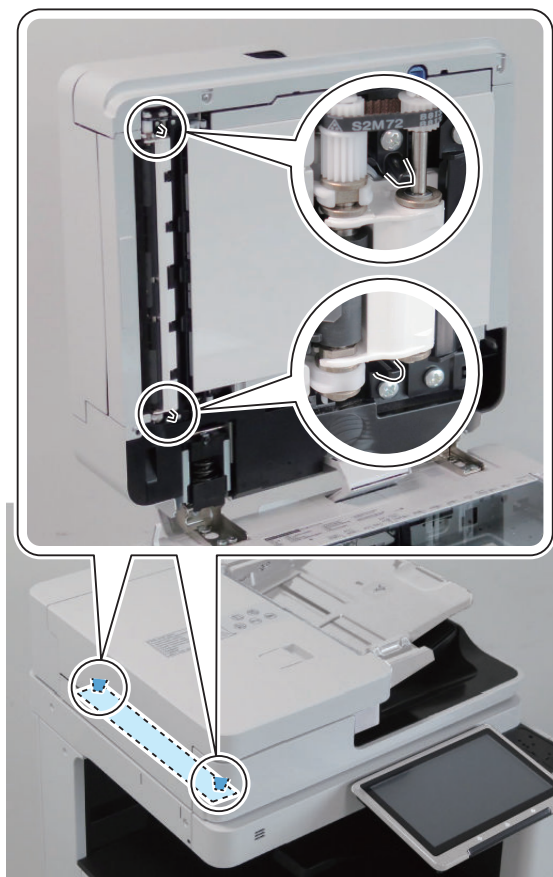

2. If they are not in contact, perform the height adjustment.
If it cannot be visually checked, perform "Checking the Height of the Height Adjustment Boss".

Checking the Height of the Height Adjustment Boss

- 1. Put a sheet of paper on the place where the protrusions touch the Stream Reading Glass, and check whether there is any resistance of the paper when closing the ADF.

<The Left Front Side>



<The Left Rear Side>

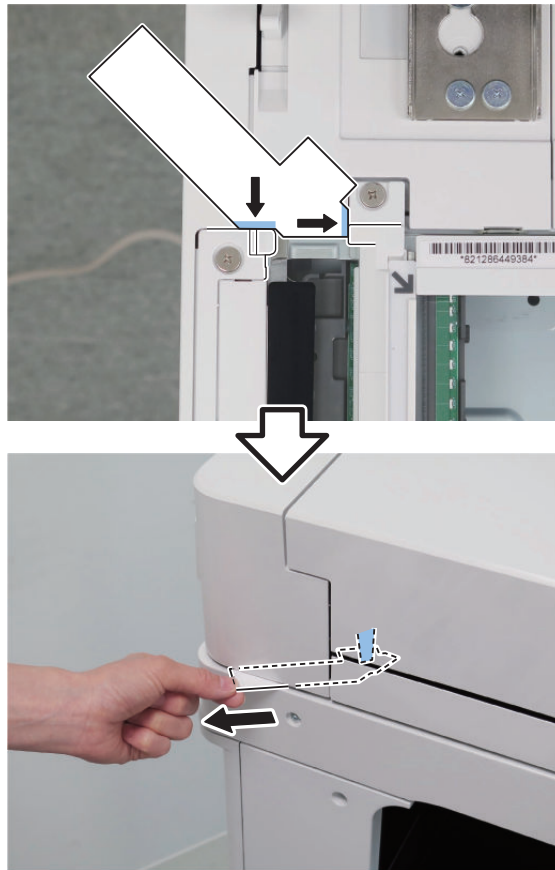

2. If there is no resistance, perform the height adjustment.

Height Adjustment Procedure

-
1. Adjust by turning the Fixation Screw on the upper side of Hinge.
 - If both front and rear side (or only front side) are not installed properly: Turn the Right Hinge Fixation Screw clockwise (black arrow) to correctly locate it at the front.



- If the rear side is not installed properly: Turn the Left Hinge Fixation Screw counterclockwise (white arrow).



2. Open th ADF fully and close the ADF and then, Check the height again and see if it is at an appropriate height.

Light intensity adjustment

NOTE:

- This mode automatically performs adjustment.
- If "NG" is displayed after executing this mode, check that PCB and each connector are properly connected.

□

1. **Execute the following service mode with the ADF closed.**
COPIER >FUNCTION >CCD > LMPADJ

Automatic Adjustment of the Stream Reading Position (Automatic Adjustment of the Reading Position at ADF Reading)

NOTE:

- If the DADF is opened during adjustment, restart the adjustment.
- Enter the value after adjustment on the Service Label (on the back of the Reader Front Cover or Printer Front Cover). The adjustment result is reflected to COPIER > ADJUST > ADJ-XY > STRD-POS.



1. Execute the following service mode.

COPIER > FUNCTION > INSTALL > STRD-POS

NOTE:

If "NG" is displayed after executing this mode, execute "Right Angle Adjustment (Slant Adjustment)" on the service manual.

White Level Adjustment



1. Place a sheet of blank A4 or LTR size paper on the Copyboard Glass and close the ADF.

CAUTION:

When executing the white level adjustment using paper with smaller width, adjustment may not be executed properly.

2. Execute the service mode item.

COPIER > FUNCTION > CCD > DF-WLVL1

3. Remove the blank paper from the Copyboard Glass, and place it on the Document Pickup Tray of ADF.

4. Execute the service mode item.

COPIER > FUNCTION > CCD > DF-WLVL2

5. Place the blank paper on the Copyboard Glass again and close the ADF.

6. Execute the service mode item.

COPIER > FUNCTION > CCD > DF-WLVL3

7. Remove the blank paper from the Copy Board Glass, and place it on the Document Pickup Tray of ADF.

8. Execute the service mode item.

COPIER > FUNCTION > CCD > DF-WLVL4

Front/Back Side Difference Correction Adjustment

Automatic Front/Back Side Difference Correction Adjustment

NOTE:

If the chart in the following state is used, skew detection may not be possible and correction may not be possible.

- The painted part is not long enough.
- The painted part is chipped.
- The color is light.
- The edges are not painted.
- Broken/torn/chipped.
- Translucent, thin paper manuscript is used.
- The area painted black is not dry enough.

1. Use a chart of a service parts of a Automatic Front/Back Side Difference Correction Adjustment, or using A4 or LTR paper, the leading edge and the side edge of the front/back side in the feeding direction are painted black with magic, and a chart for Automatic Front/Back Side Difference Correction Adjustment is prepared.

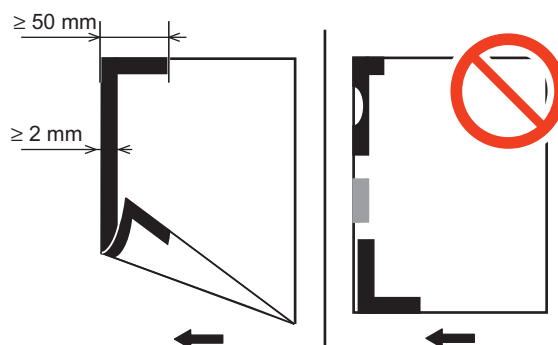

2. Set the value of the service mode to "0" below.

- FEEDER > ADJUST > ADJ-T2/L2/ROT2 = 0

NOTE:

- The ADJ-T2/L2/ROT2 is an item for manually fine-adjusting the skew in the case that a deviation remains in the position of the back image to which the skew is automatically corrected after the Automatic Front/Back Side Difference Correction Adjustment.
- "0" is the value at the time of shipment from the factory. By resetting to the initial state, there is no unintended deviation due to manual correction with respect to the back surface image in which skew correction is automatically performed, so that a constant accuracy is guaranteed.

3. Set the document tray so that the black-painted portion becomes the leading edge in the feeding direction.

4. Automatic Front/Back Side Difference Correction Adjustment is performed in the following service mode.

- FEEDER > FUNCTION > ADJ-SKW

NOTE:

If "NG" is displayed after executing this mode, execute "Right Angle Adjustment (Slant Adjustment)" on the service manual.

5. Write the adjusted values below on the service label.

- FEEDER > ADJUST > ADJ-DT
- FEEDER > ADJUST > ADJ-DL
- FEEDER > ADJUST > ADJ-DROT

■ Checking the Network Connection

● Overview

If the user's network environment is TCP/IP, use the Ping function to check that the network setting is properly performed.

● Checking the Network Connection

CAUTION:

Be sure to use the network cable with Category 5e or higher. In addition, a sealed type (STP cable) is recommended. Using the non-shield type can affect the peripheral electrical equipment through the network cable.

1. Turn OFF the main power switch.
2. Connect the network cable to the Host Machine and turn ON the main power switch.
3. Remove the cover of the Cord Guide.

4. Remove the release paper, and affix the Cord Guide to the area indicated in the figure.



5. Put the network cable through the Cord Guide, and install the cover of the Cord Guide.

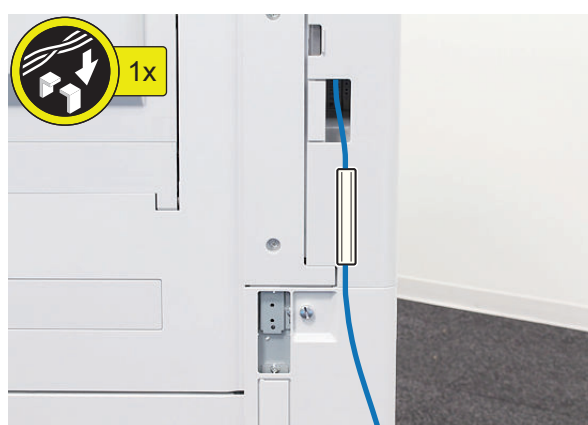

6. Inform the system administrator at the installation site that installation of the Host Machine is complete, and then, ask for the network setting.

NOTE:

Network setting cannot be executed unless logging in as an administrator.
Factory default password is as follows.

- System administration division ID: Administrator
- System administration password: 7654321

CAUTION:

To perform the network setting, the following Additional Functions items must be set "ON".

- [Settings/Registration] > [Preferences] > [Network] > [Confirm Network Connection Setting Changes]
- [Settings/Registration] > [Preferences] > [Network] > [TCP/IP Settings] > [IPv4 settings] > [Use IPv4]

7. Turn OFF and then ON the main power.

● **Operation Procedure Using Ping**

1. Select the following: [Settings/Registration] > [Preferences] > [Network] > [TCP/IP Settings] > [IPv4 settings] > [PING command]
2. Enter the IP address with the numeric keypad on the Control Panel and press "Execute" key. "Response from the host" is displayed if Ping command is succeeded while "no response from the host" is displayed if failed.

● Checking by the Remote Host Address

Using the remote host address to execute Ping can check whether connection to the network is enabled or not.

Remote host address: IP address of PC terminal connected/running on TCP/IP network environment that connects to this equipment.

1. Inform the system administrator about checking of the network connection using Ping.
2. Confirm the remote host address with the system administrator.
3. Enter the remote host address to Ping.
 - The network is properly connected if the message say "Response from the host".
 - The network is not properly connected if the message say "No response from the host", therefore, execute the following troubleshooting.

■ Network Troubleshooting

● Checking Connection of the Network Cable

To check whether the network cable is properly connected to the LAN Port.

● Operation Procedure Using Ping

1. Ask the network administrator at the user's site to write down the IP address of the PC that is connected to the network.
2. [Settings/Registration] > [Preferences] > [Network] > [TCP/IP Settings] > [IPv4 settings] > [Ping Command]; and enter the IP address of the PC with the numeric keypad and press Execute key.
 - The network is properly connected if the message say "Response from the host".
 - If the message say "No response from the host", check the following.

● Checking the Network Setting of the Host Machine

Check if the IP address specified in the Host Machine is correct.

1. Select the following: [Settings/Registration] > [Preferences] > [Network] > [TCP/IP Settings] > [IPv4 settings] > [IP address setting]; and write down the address in the IP address field.
2. Select the following: [Settings/Registration] > [Preferences] > [Network] > [TCP/IP Settings] > [IPv4 settings] > [Ping Command]; and enter the IP address.
 - The IP address specified in the Host Machine is correct if the message say "Response from the host".
 - If "No response from the host." is displayed, check if the IP address information set for the system administrator is correct.

NOTE:

When setting the address by manually input, set the Subnet Mask by following the instruction of the administrator.

● Checking Network Function on the Main Controller

Perform checking by the loopback address.

1. Select the following: [Settings/Registration] > [Preferences] > [Network] > [TCP/IP Settings] > [IPv4 settings] > [Ping Command]; and enter the IP address, "127.0.0.1" with the numeric keypad and enter Execute key.
 - The network function of the Main Controller is working properly if the message say "Response from the host".
 - If the message say "No response from the host", the network function of the Main Controller is faulty.
2. Replace with a Main Controller that works properly, and then check connection.

■ Installing the IC Card Reader

NOTE:

- When installing the IC Card Reader, the IC Card Reader (sales company's option) is required.
- Use the shorter cable of the IC Card Reader.
- When installing the IC Card Reader and Numeric Keypad at the same time, install the Numeric Keypad first.

□

1. If the main power switch of the host machine is ON, turn it OFF.

□

2.



□

3.

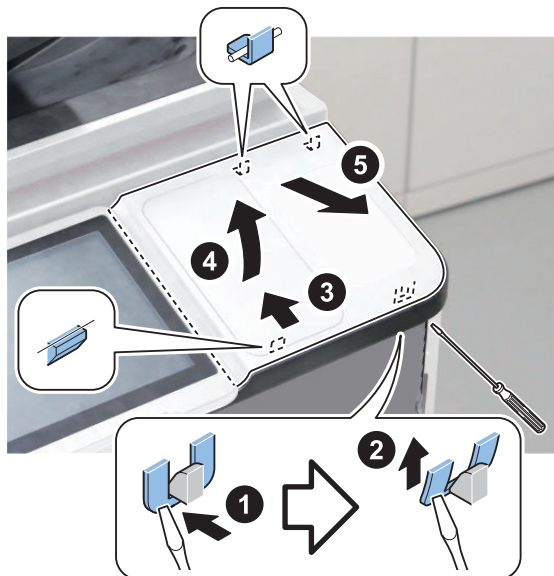

□
4.

NOTE:

Be sure to change the number of cushions according to the thickness of the Card Reader.
If it makes the Control Panel Upper Right Cover difficult to install, using one or no cushions is allowed.



□
5.

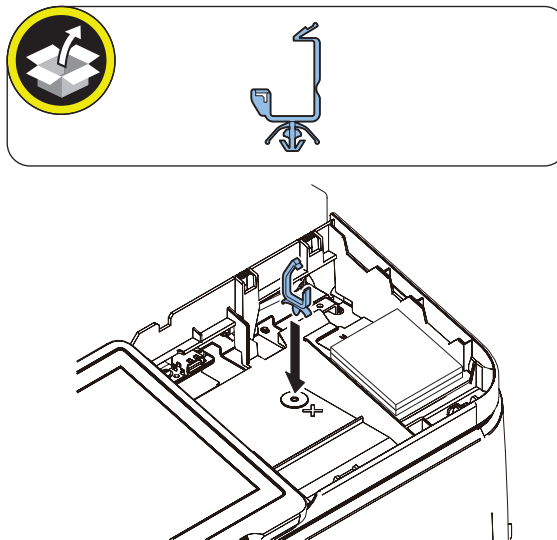

□
6.

NOTE:

If any paste is remaining on the removed surface, clean with alcohol (to prevent the non-level surface from forming when affixing the Device Port Sheet).

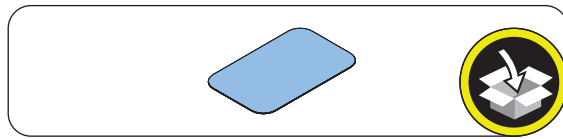
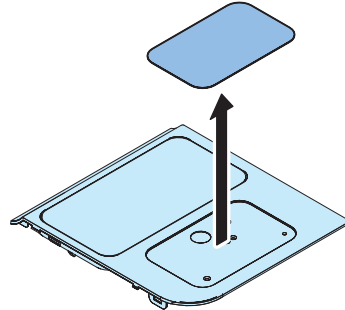

□
7.

NOTE:

Store the excess length of the cable in the position as shown in the figure.

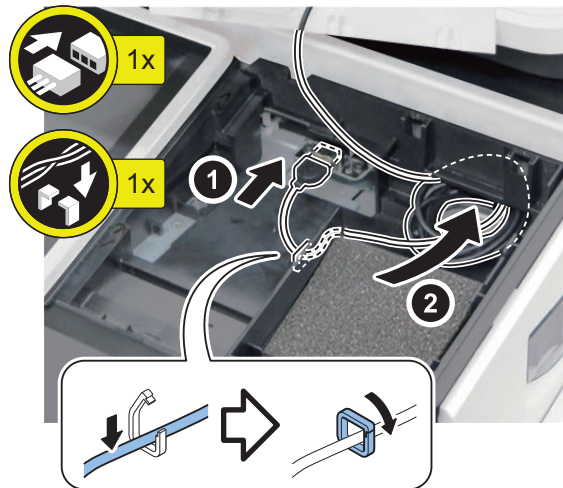

< When installing with the Numeric Keypad at the same time >

NOTE:
Store the excess length of the cable in the position as shown in the figure.

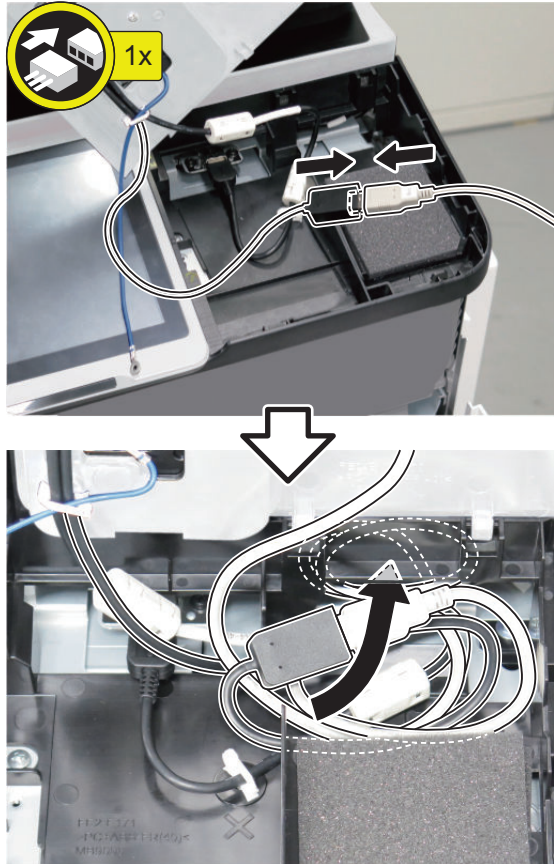

□
8.



□
9.

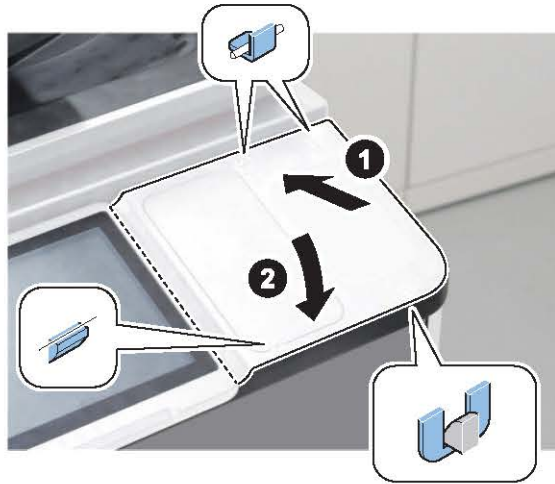

□
10.



□
11.

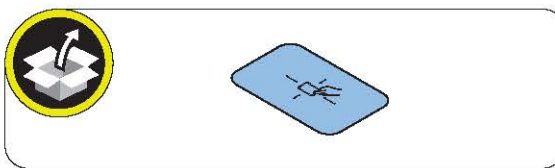



12. Connect the power plug to the outlet.

13. Turn ON the main power switch.

■ Operation when using uniFLOW Online

When using uniFLOW Online*, follow the setup procedures on the uniFLOW* Online First Steps Guide (http://www.nt-ware.com/uFO_FS).

* China version of "uniFLOW" is called "mdsFLOW".



Image Reading System Options

Printer Cover-H2.....	92
Reader Heater-P1.....	112

Printer Cover-H2

Points to Note before Installation

- After installation of the Printer Cover, be sure to change the setting of the following service mode to "0" before turning OFF the power of the host machine. Otherwise, an error may occur when turning ON the power.
COPIER > OPTION > FNC-SW > W/SCNR
- The pictures and illustrations used may be different from the product in front of you, but the procedure is the same.

Checking the Contents

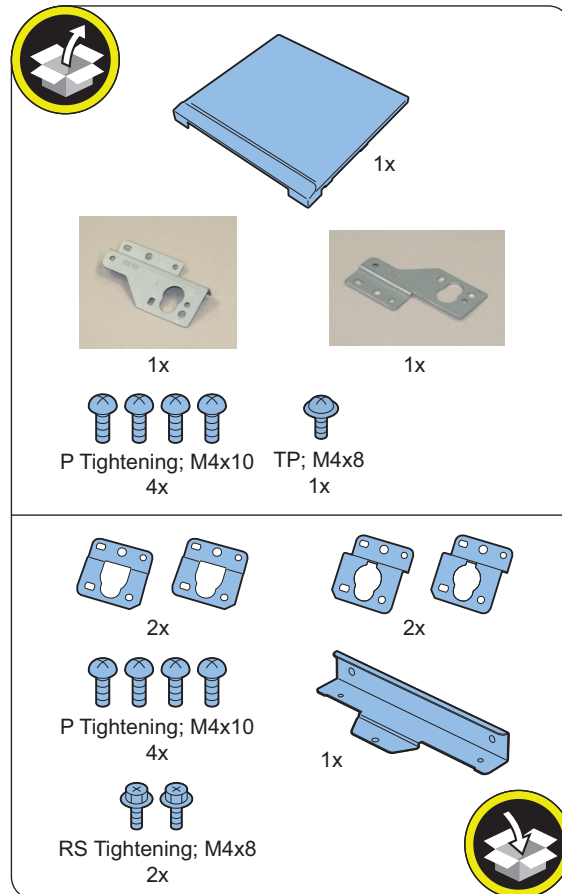

Installation Outline Drawing

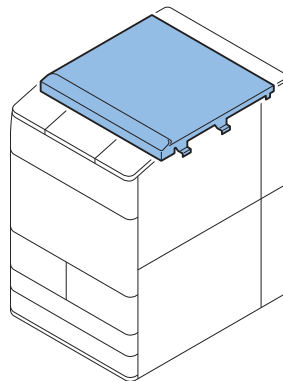

● Installation Procedure

■ Removing the Covers

□
1.

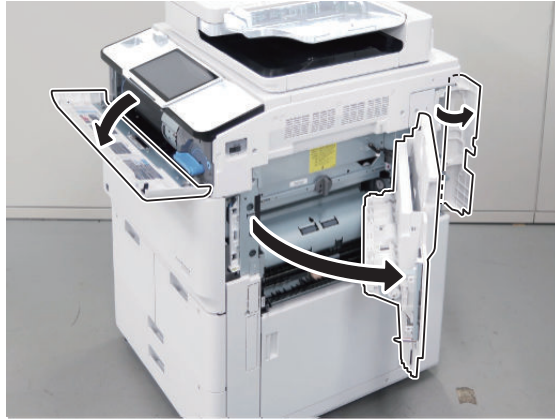

□
2.



□
3.

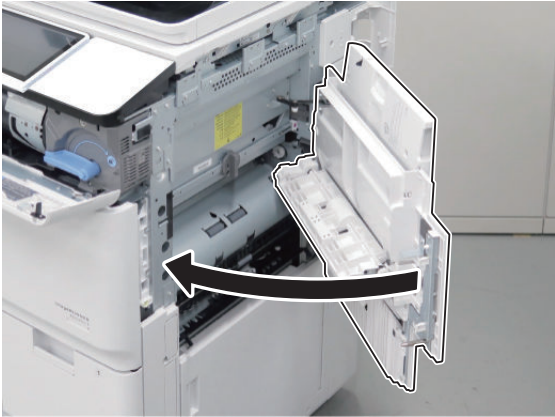

□
4.

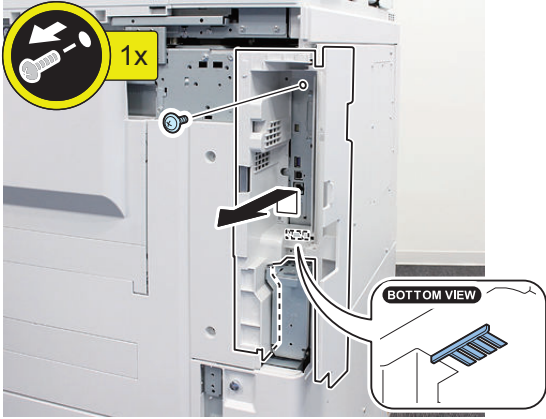

CAUTION:

Be careful not to let the 2 bosses of the Side Cover come off from the 2 mounting holes of the Right Rear Cover 1.

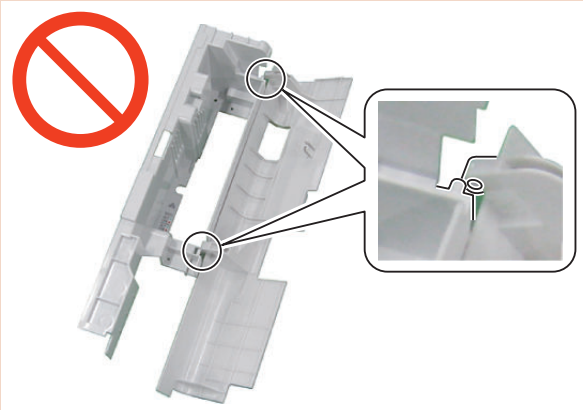

□
5.

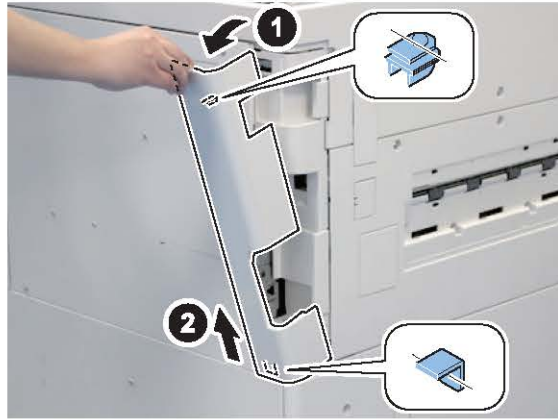

□
6.

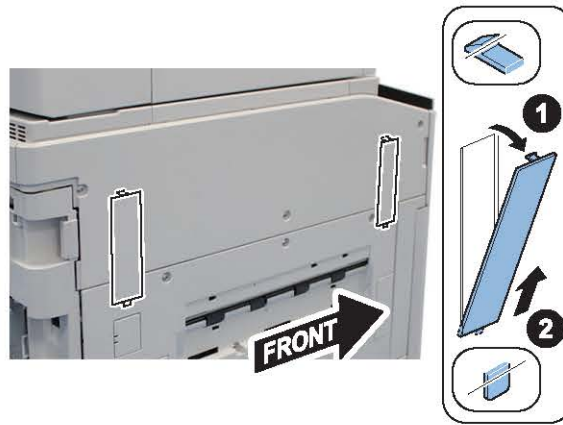

□
7.

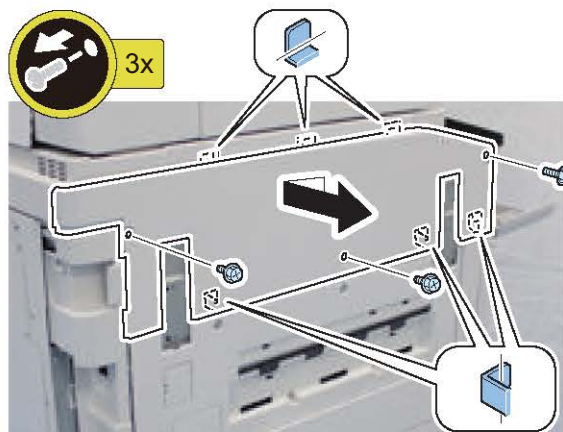

□
8.

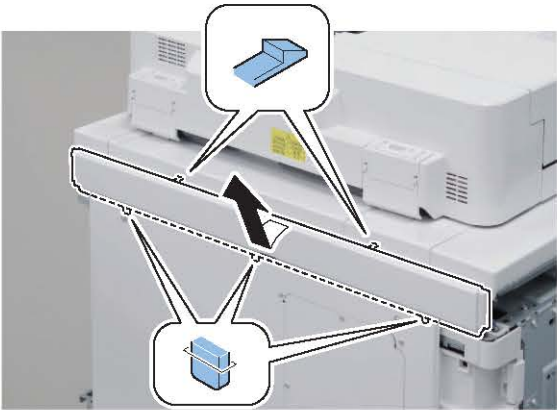

□
9.

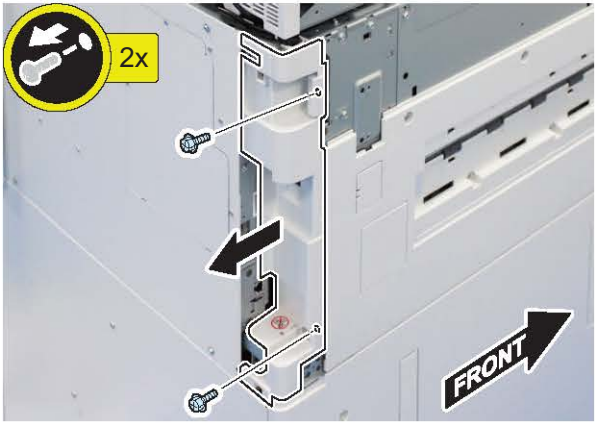

■ Removing the ADF

□
1.



□
2.



NOTE:

When performing following procedures, using ADF in the book mode as necessary makes the work easy.
The book mode is released by opening the ADF.

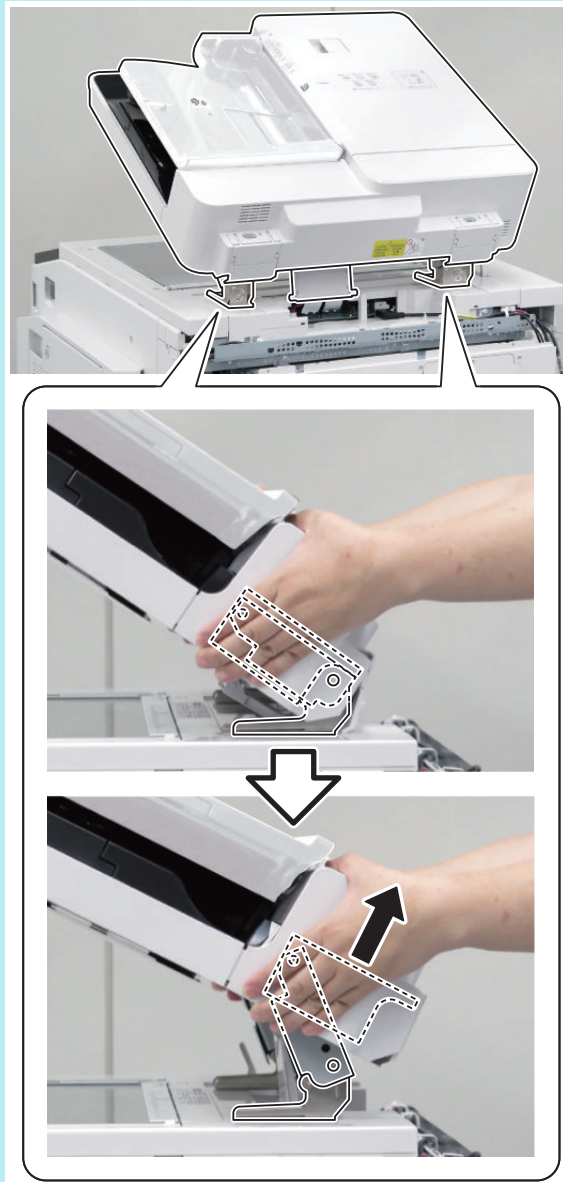

□
3.

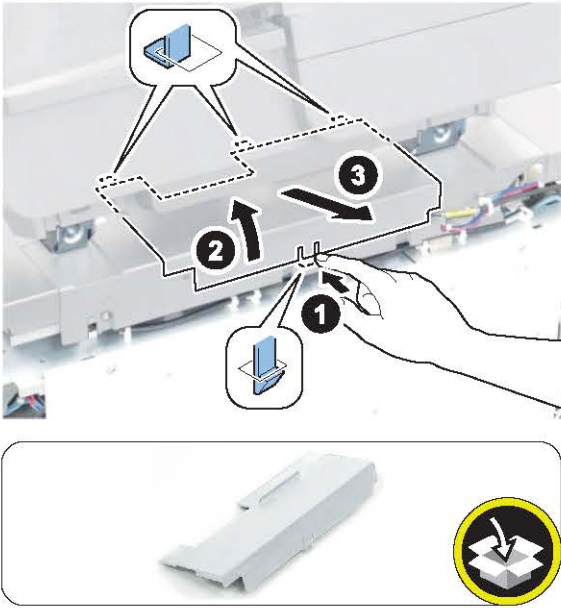

□
4.

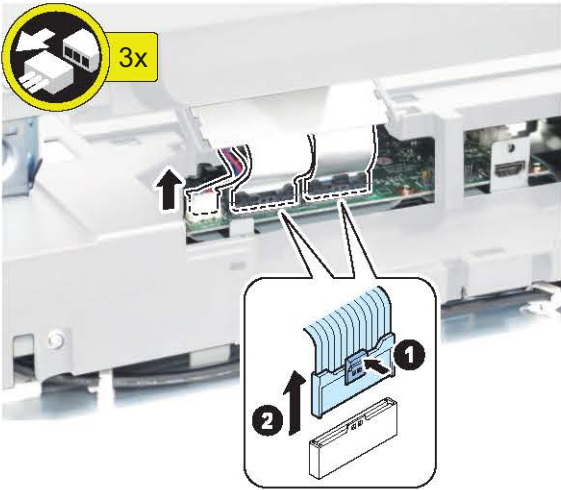

□
5.



□
6.

⚠ CAUTION:
Be careful not to drop the ADF.

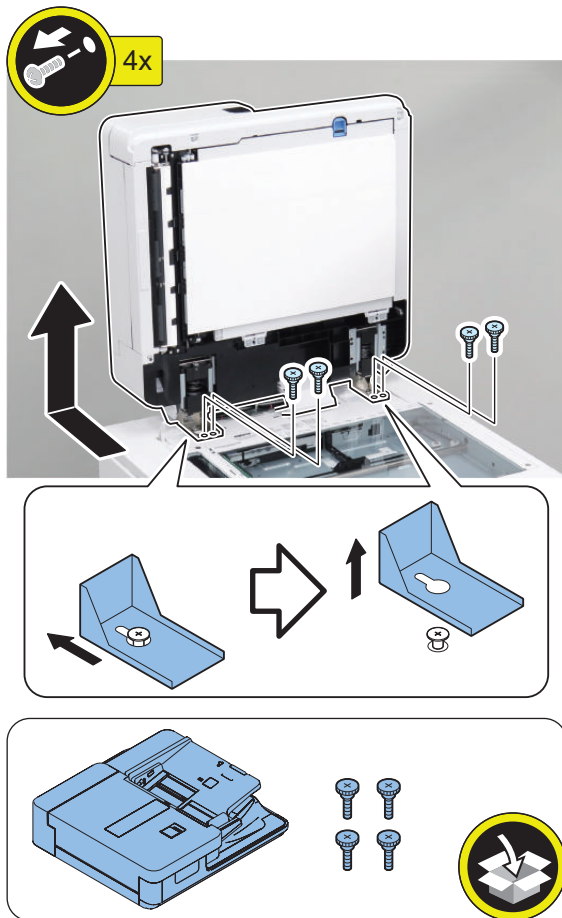

■ Removing the Reader Unit

□
1.

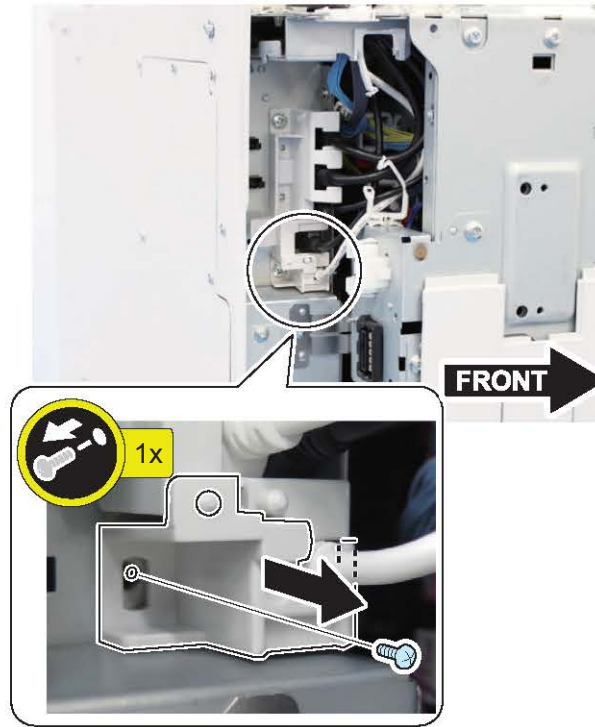

□
2.

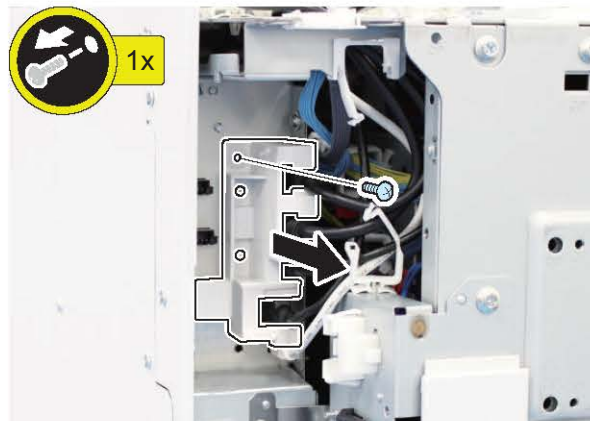

□
3.

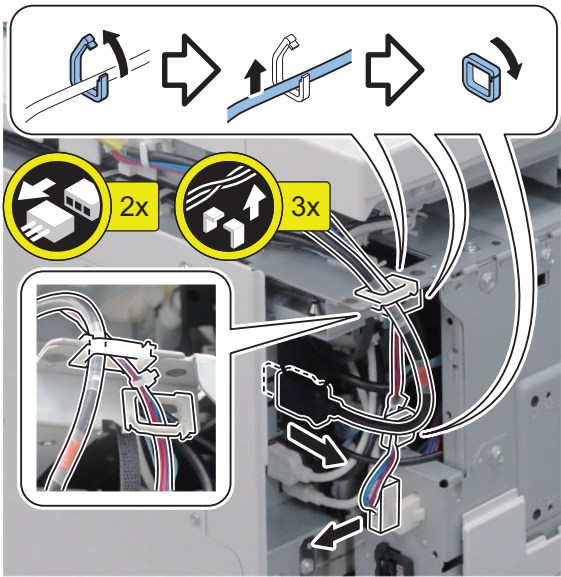

□
4.

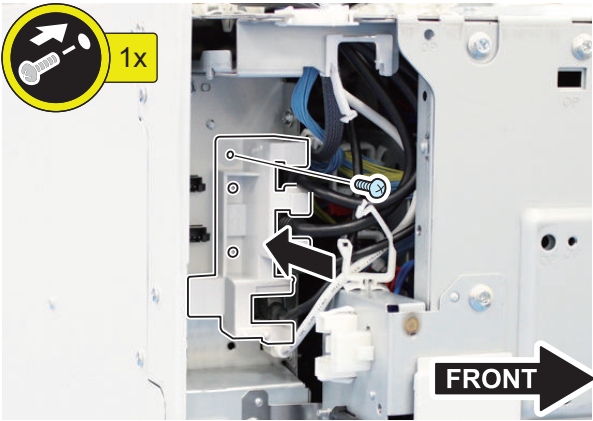

□
5.

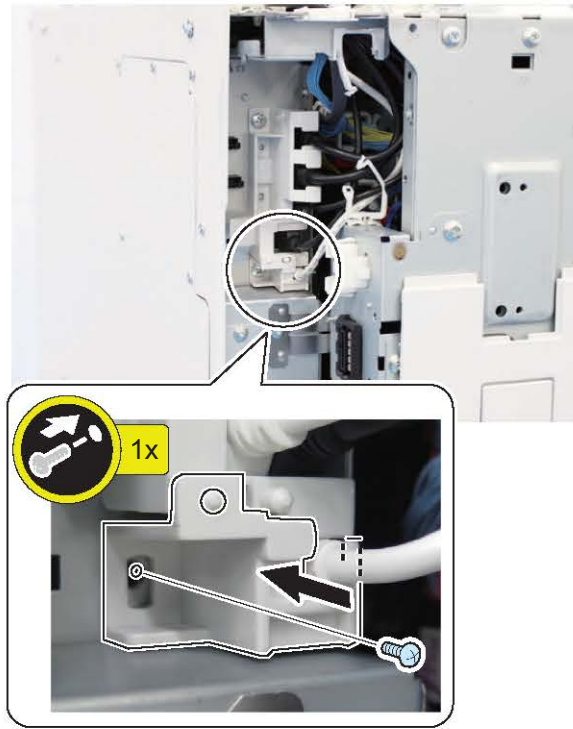

□
6.

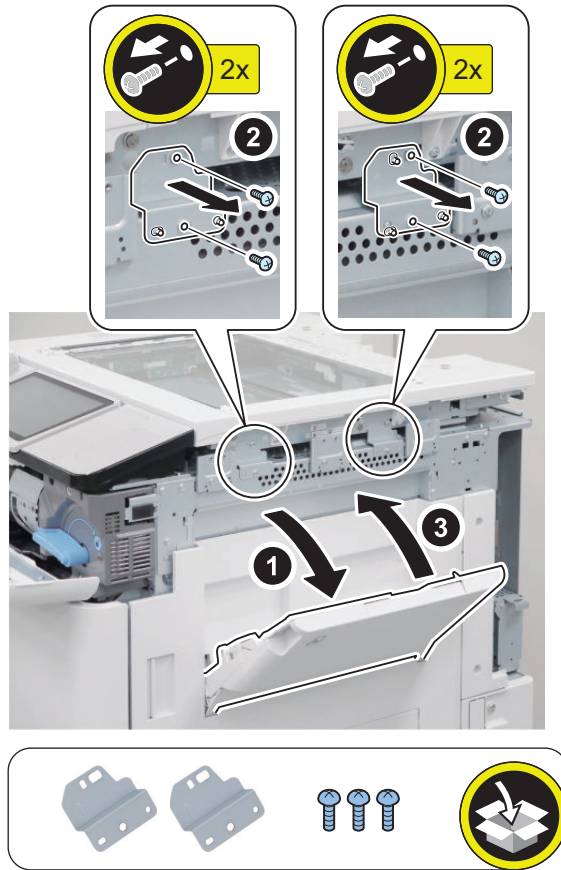

NOTE:
Removed screw will be used in step 1 of "Installing the Printer Cover".

□
7.

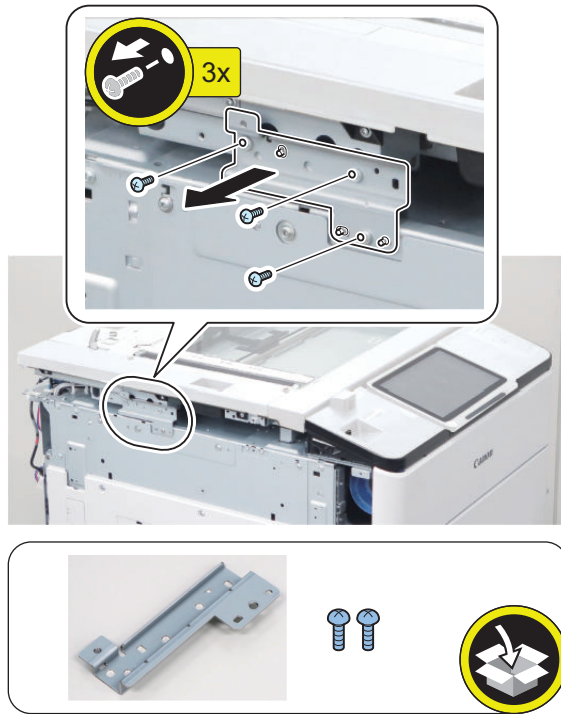

NOTE:
Removed screw will be used in step 2 of "Installing the Printer Cover".

□
8.



■ Installing the Printer Cover

□
1.

NOTE:

Use screw removed in step 6 of "Removing the Reader Unit".

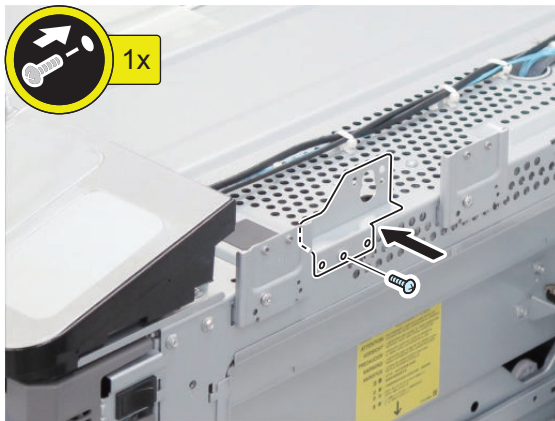

□
2.

NOTE:

Use screw removed in step 7 of "Removing the Reader Unit".

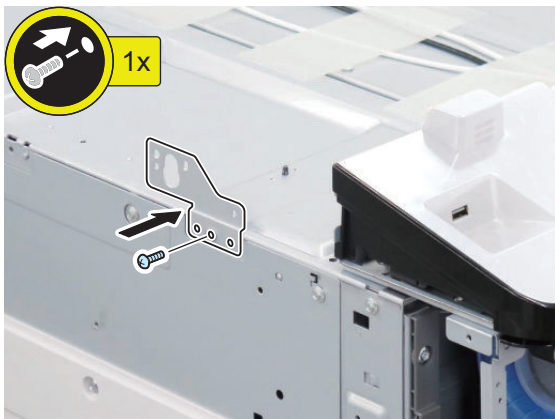
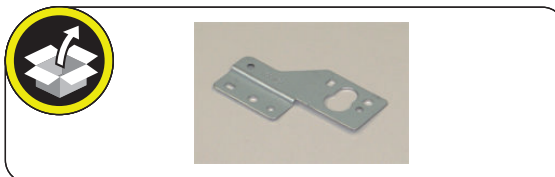

□
3.

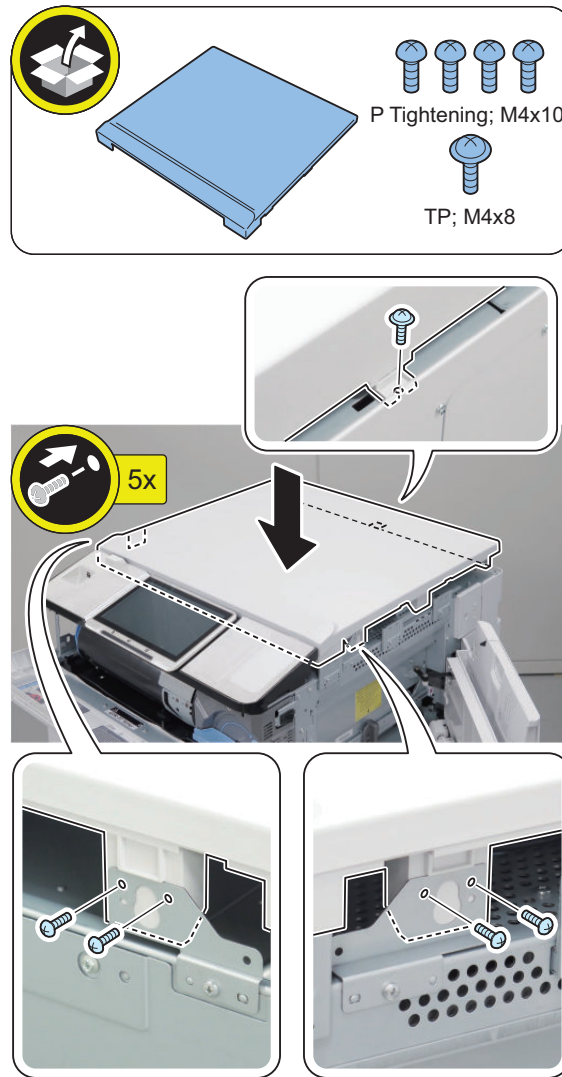

■ **Installing the Covers**

□
1.

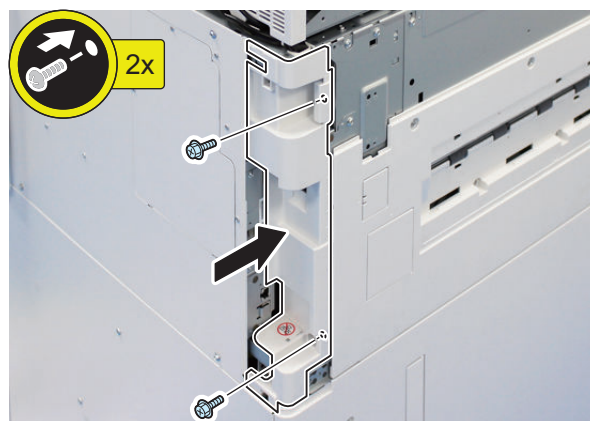

□
2.

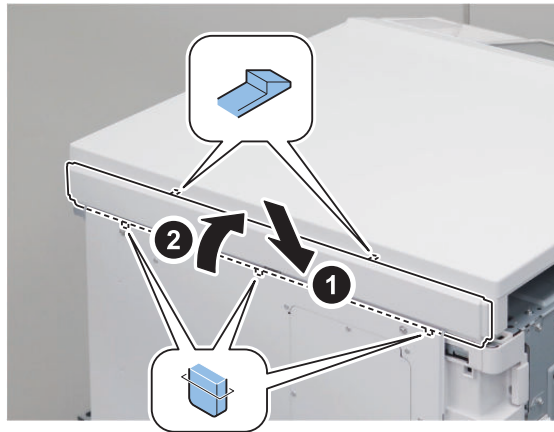

□
3.

CAUTION:

When installing the Left Upper Cover, be careful not to secure it while it is being slid fully toward the front. Otherwise, the Left Upper Cover may interfere with the Toner Replacement Cover and the magnet cannot work.

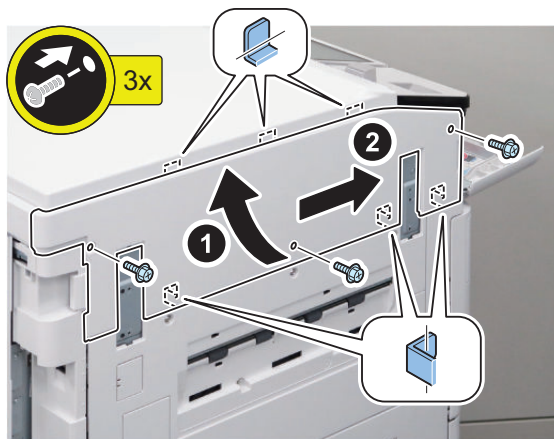

□
4.

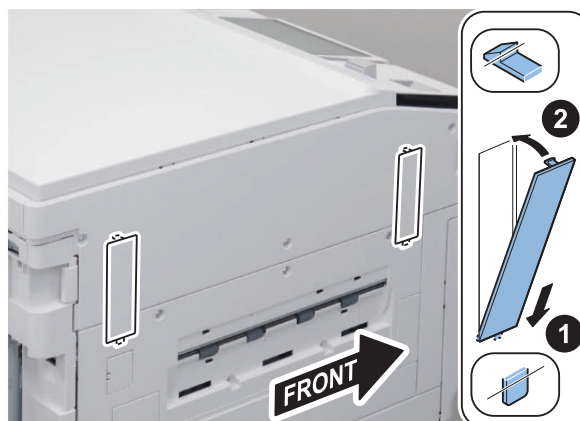

□
5.

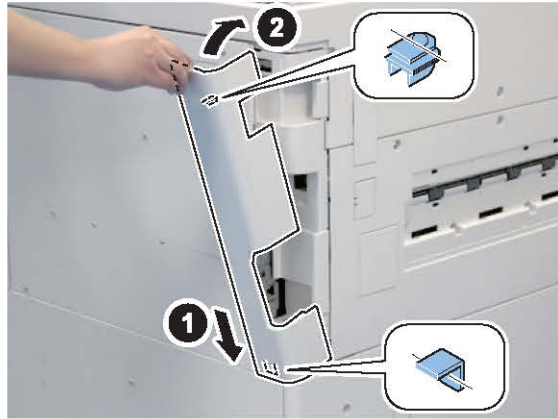

□
6.

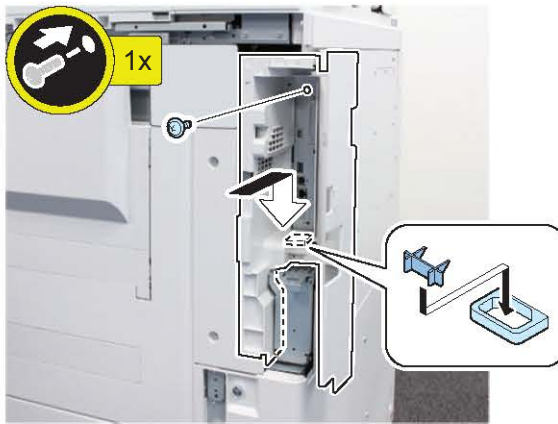

□
7.

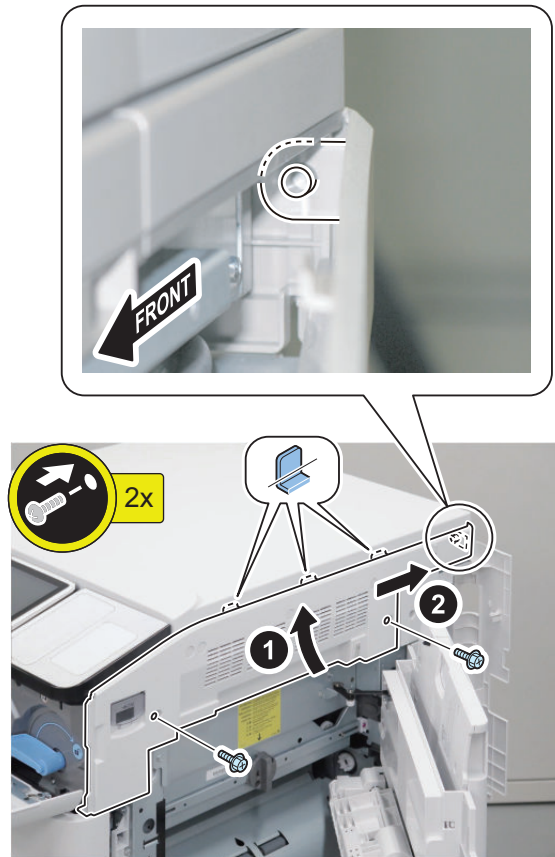

□
8.



Operation Check

-
1. Connect the power plug of the host machine to the outlet.

2. Turn ON the main power switch.

CAUTION:

If "E732-0023" is displayed after turning ON the main power switch, turn OFF and then ON the main power switch, and then perform the following steps.

3. A message is displayed prompting to check that the Reader Unit Cable is connected properly.

4. Select "0" for the following service mode.

- COPIER > OPTION > FNC-SW > W/SCNR

5. Get out from service mode.

6. Turn OFF and then ON the main power switch.

Reader Heater-P1

Points to Note before Installation

The pictures and illustrations used may be different from the product in front of you, but the procedure is the same.

Checking the Contents

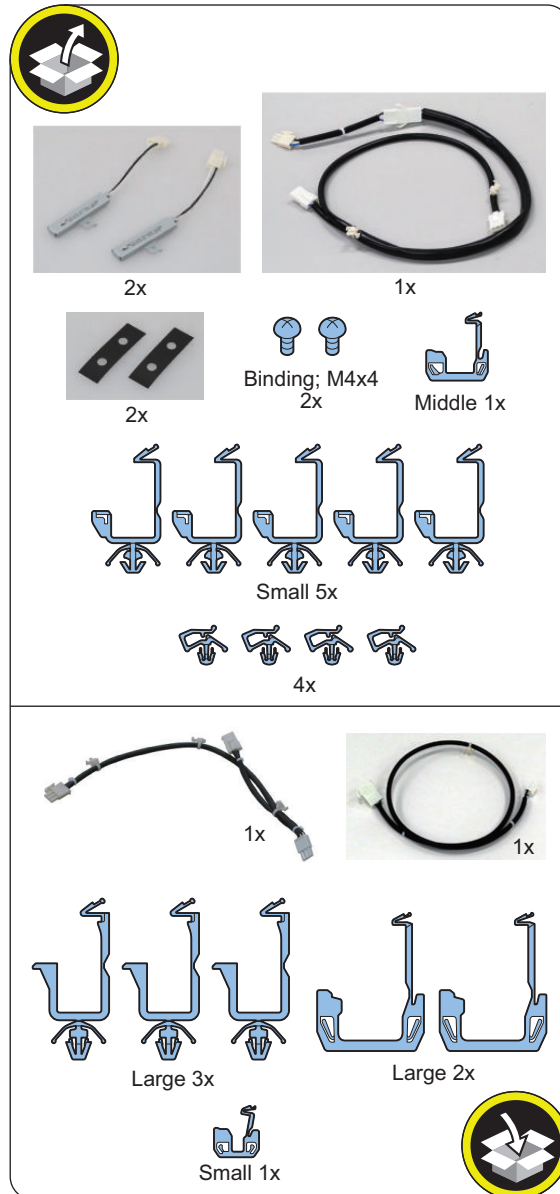

● Installation Outline Drawing

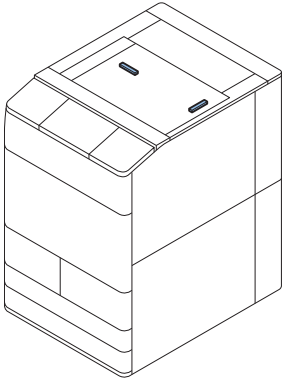

● Installation Procedure

■ Installing the Covers

□

1.



□
2.



□
3.

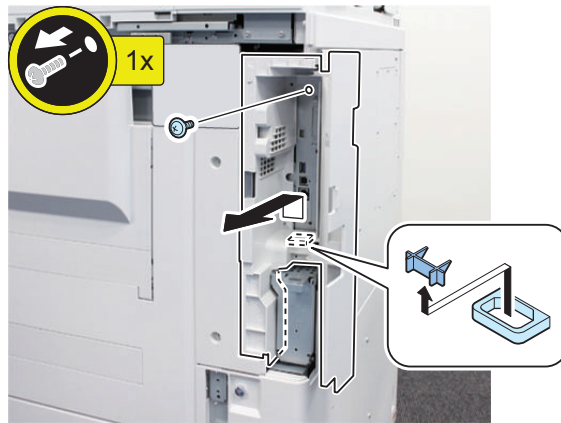

□
4.

**CAUTION:**

When installing the Left Upper Cover, be careful not to secure it while it is being slid fully toward the front. Otherwise, the Left Upper Cover may interfere with the Toner Replacement Cover and the magnet cannot work.

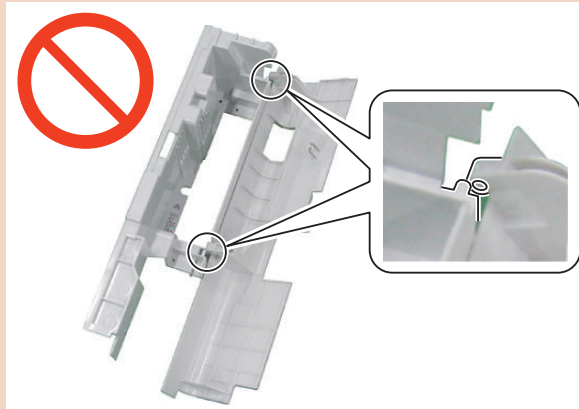

□
5.

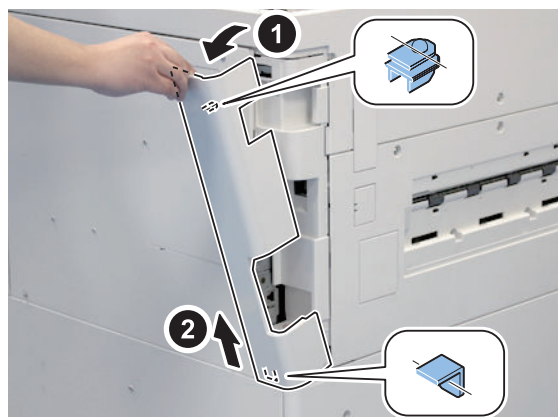

□
6.

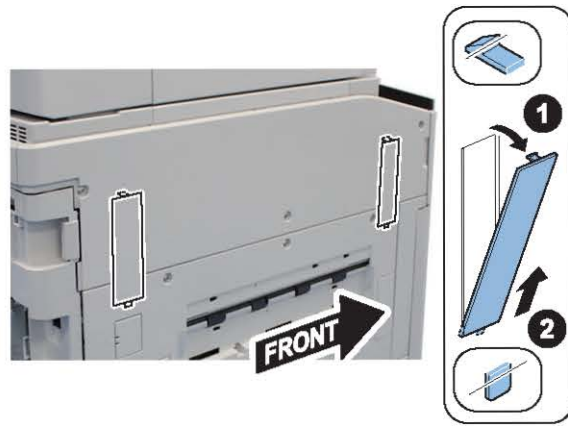

□
7.

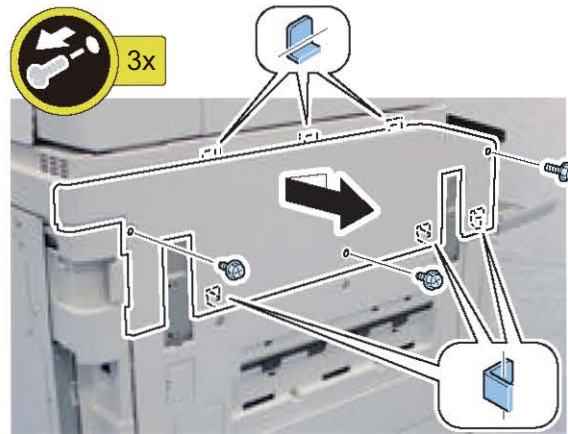

□
8.

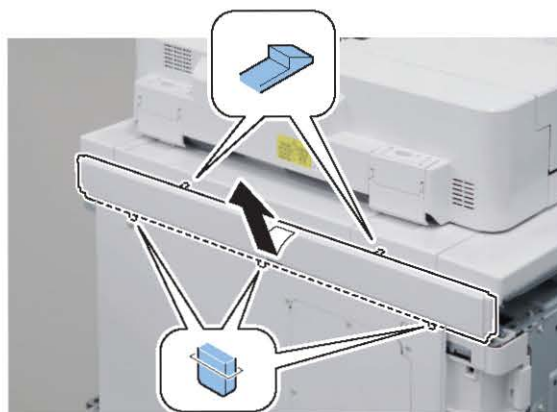

□
9.

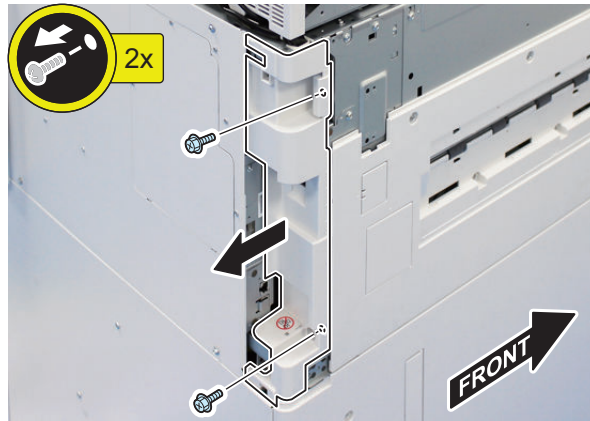

■ **Installing the Reader Heater**

□
1.

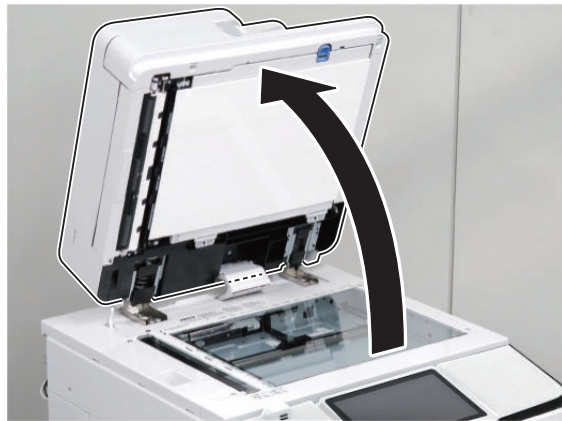

□
2.

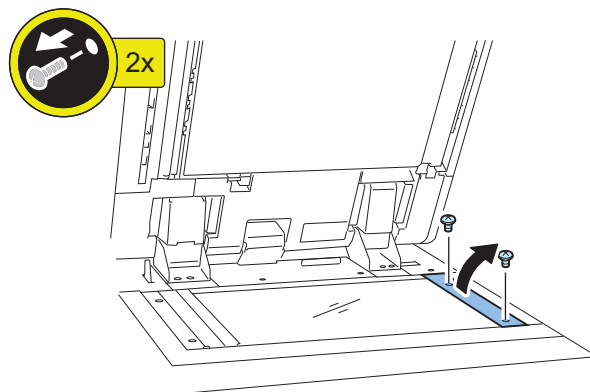

□
3.**CAUTION:**

- Soiling on the glass surface and the White Plate affects reading. When removing or installing the Copyboard Glass, be sure not to touch the glass surface and the White Plate.
- If soiling is attached, clean it with lint-free paper.

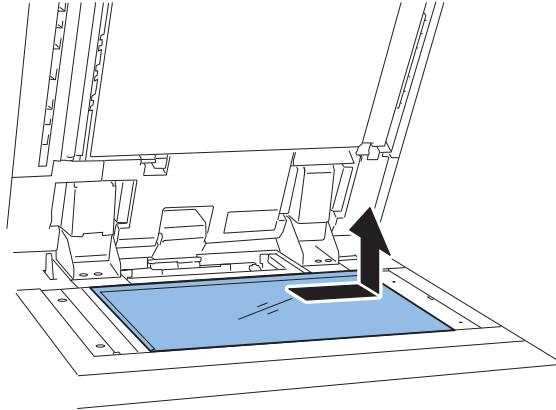
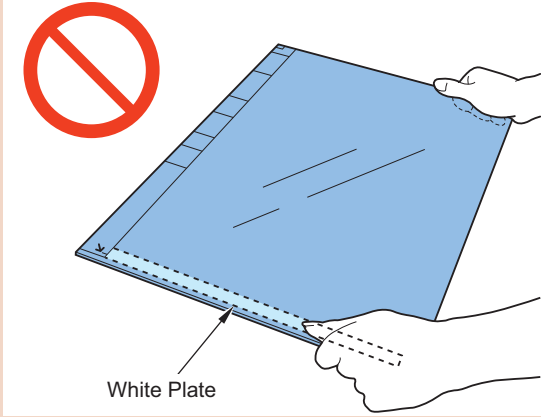

NOTE:

When performing following procedures, using ADF in the book mode as necessary makes the work easy.
The book mode is released by opening the ADF.

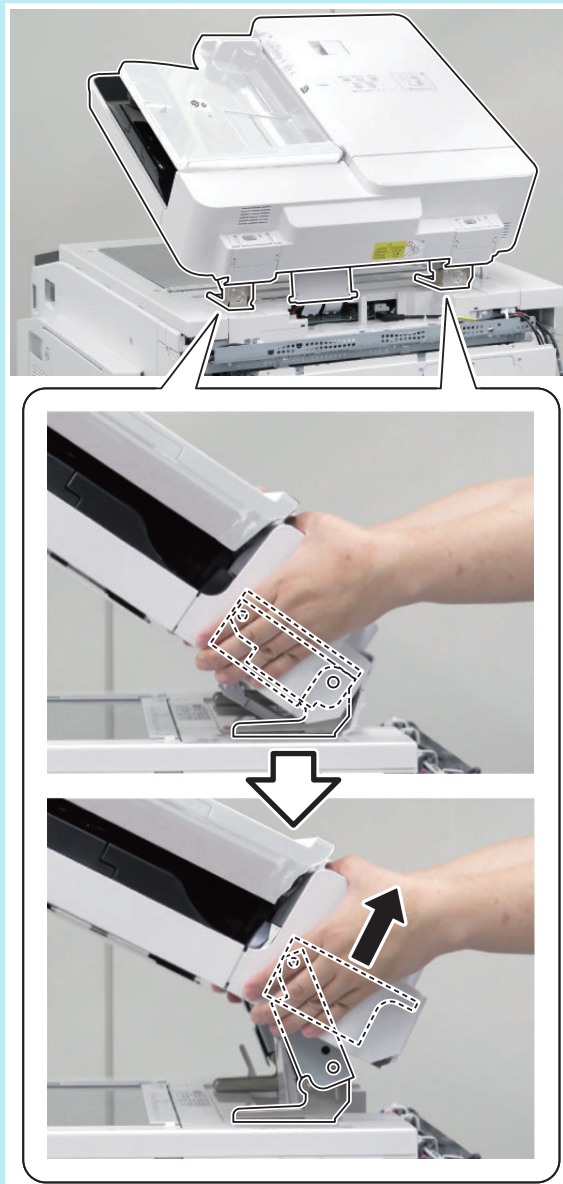

□
4.

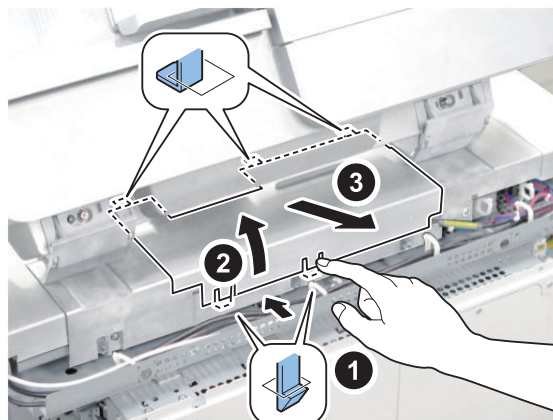

□
5.

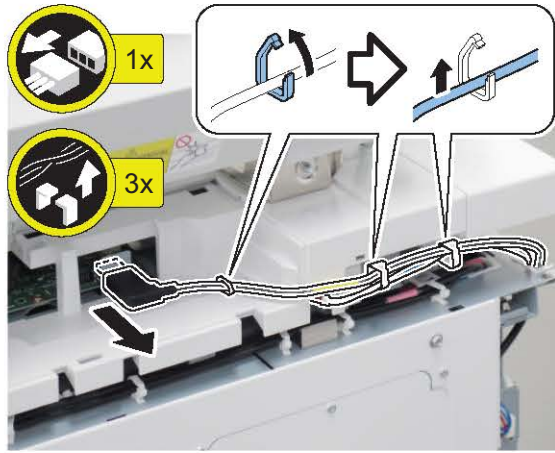

□
6.

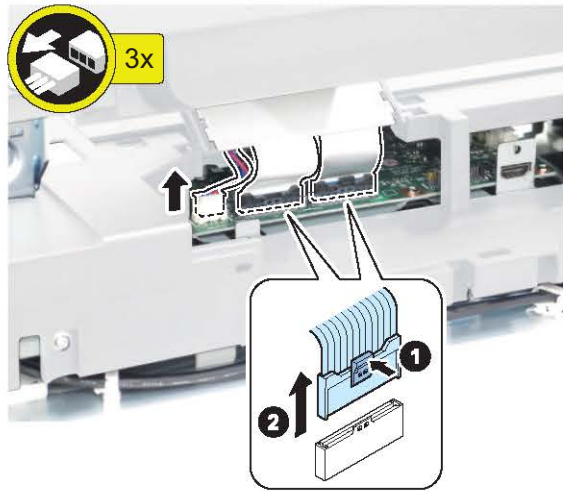

□
7.

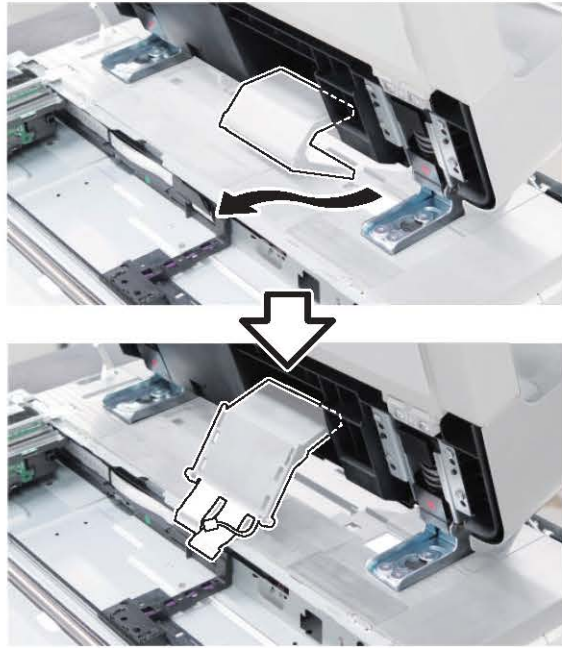

□
8.

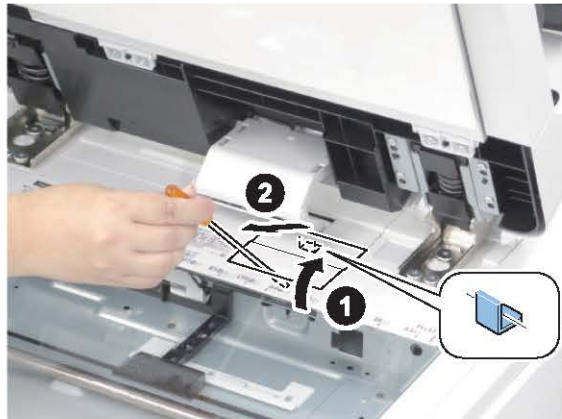

□
9.

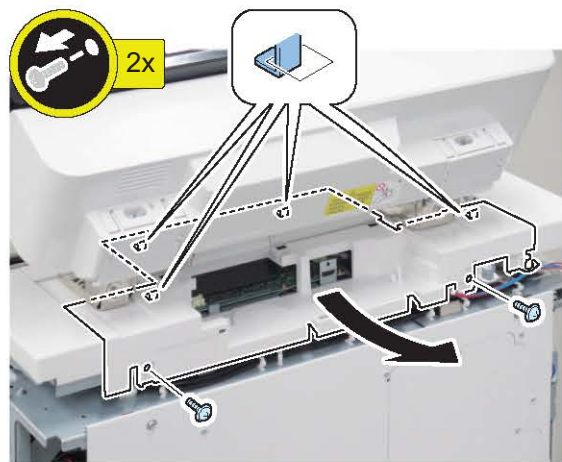

□
10.

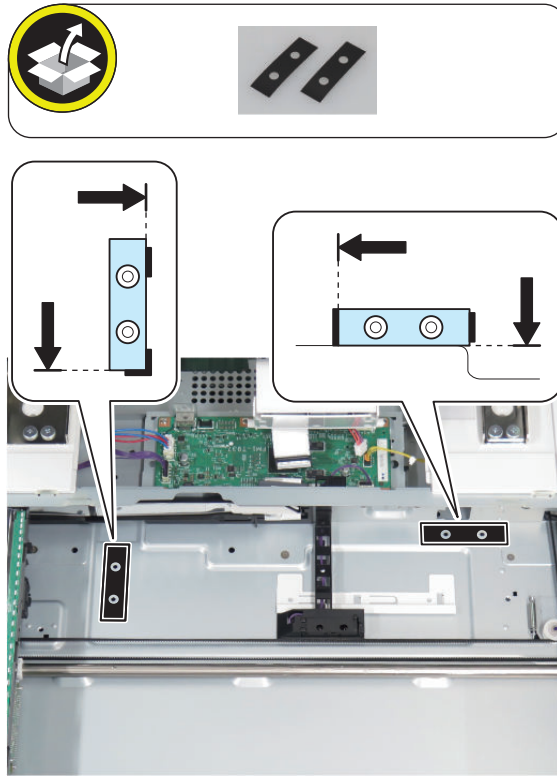

□
11.



□
12.

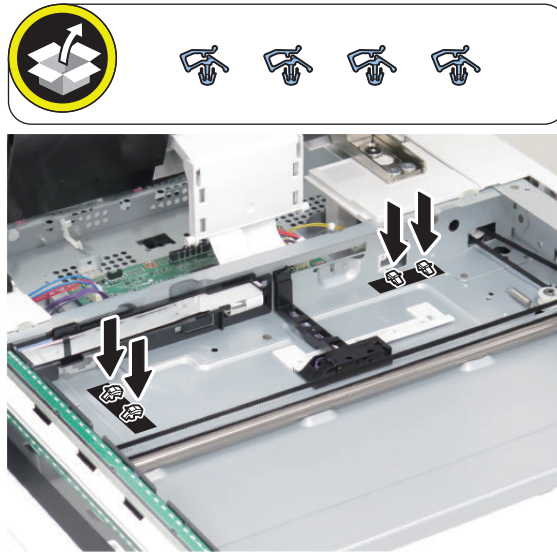

□
13.

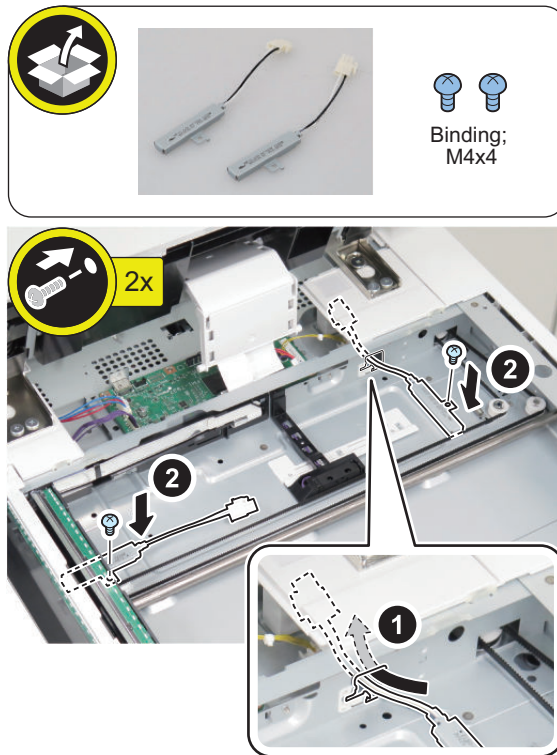

□
14.

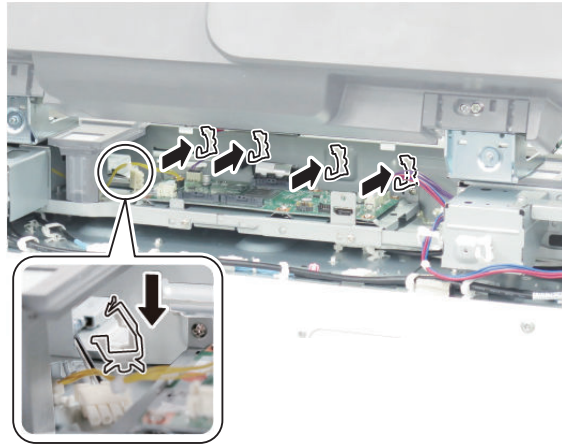
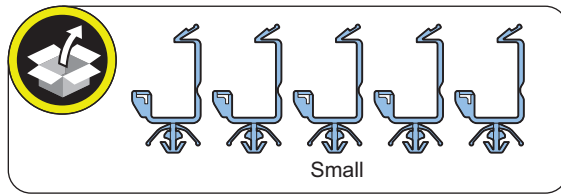

□
15.

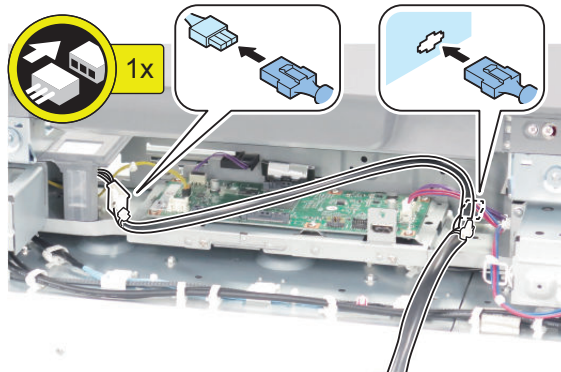
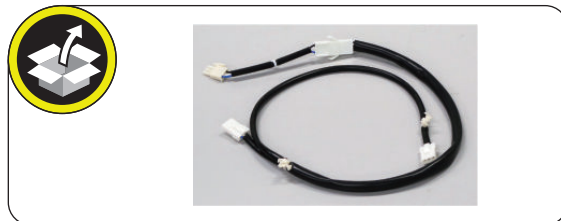

□
16.

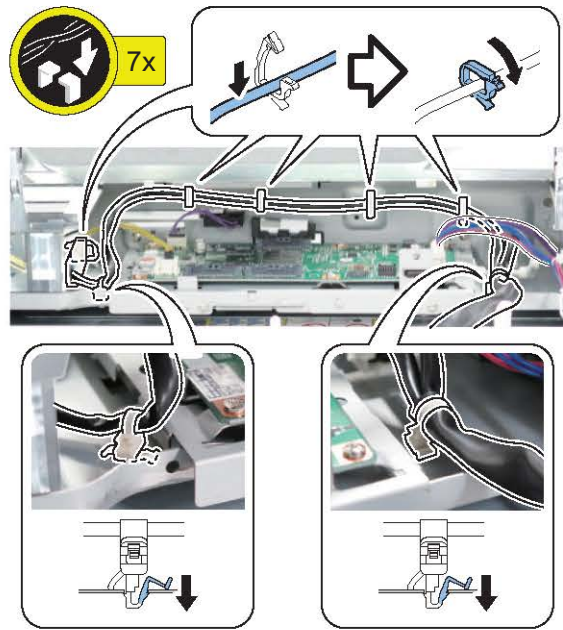

□
17.

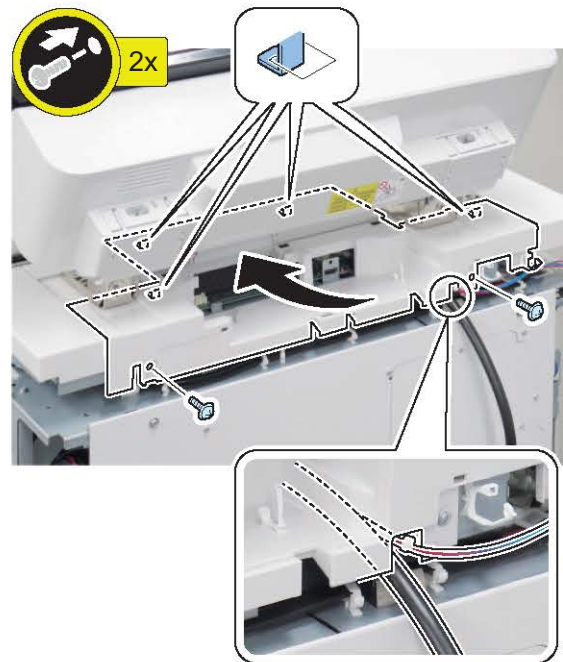

□
18.

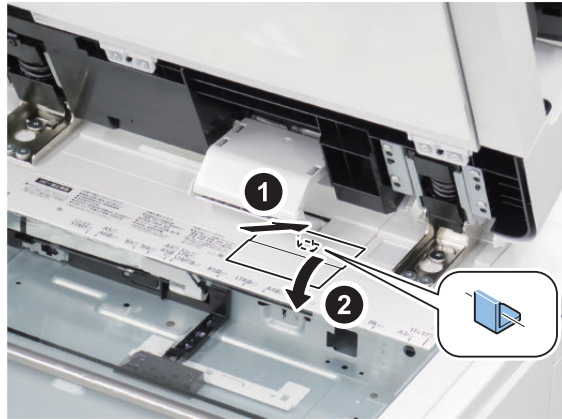

□
19.

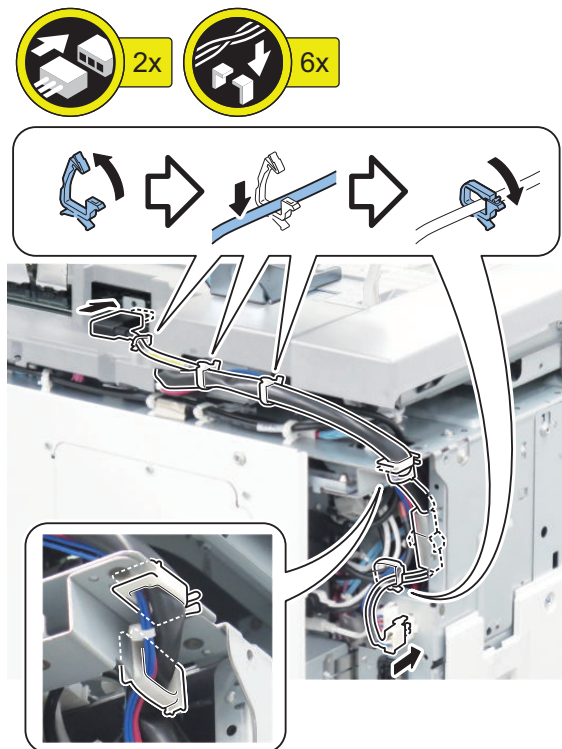

□
20.**CAUTION:**

Be sure to hold down the Reader Heater Harness because it may interfere with moving of the Scanner Box if it is not connected properly.

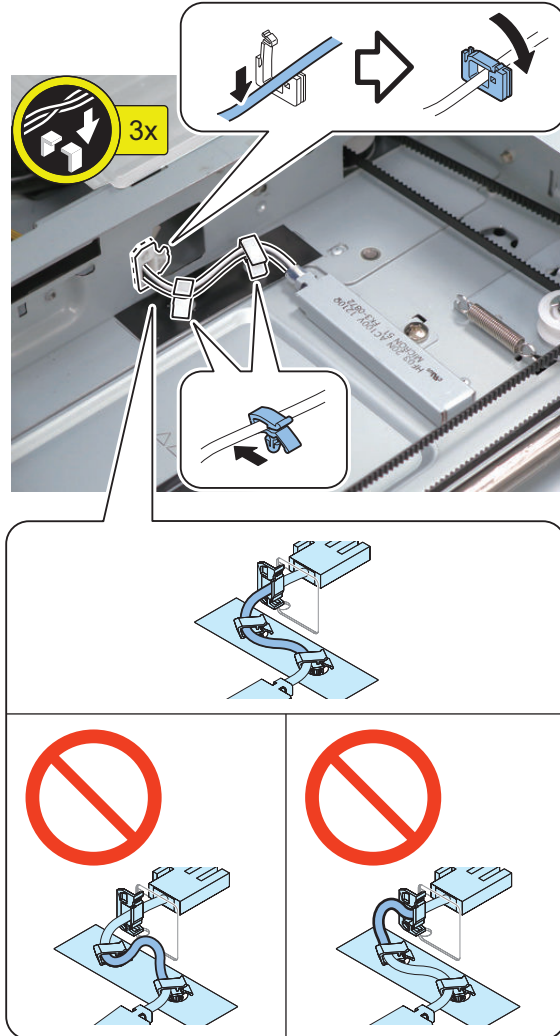

□
21.**CAUTION:**

Be sure to hold down the Reader Heater Harness because it may interfere with moving of the Scanner Box if it is not connected properly.

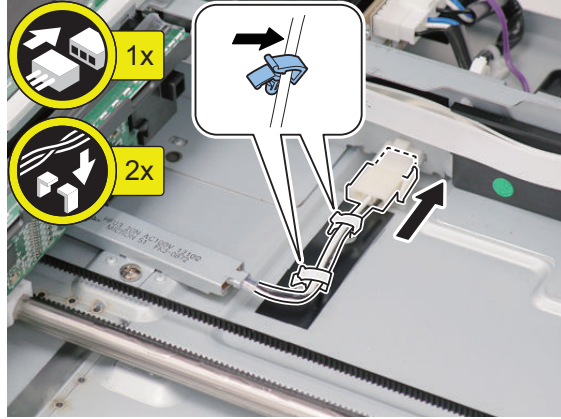
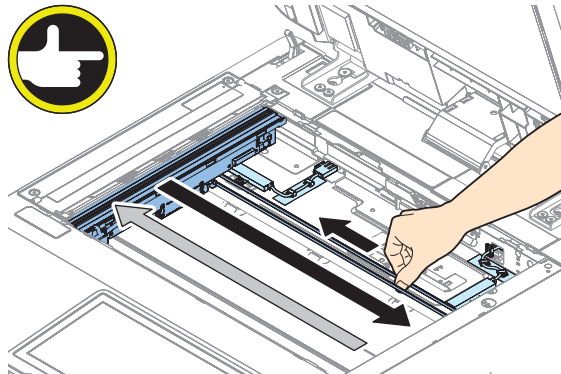
□
22.

CAUTION:

Move the Scanner Box to the right edge, and check if the underside of the Scanner Box and the HP Sensor Flag Plate do not interfere with the Reader Heater harness.

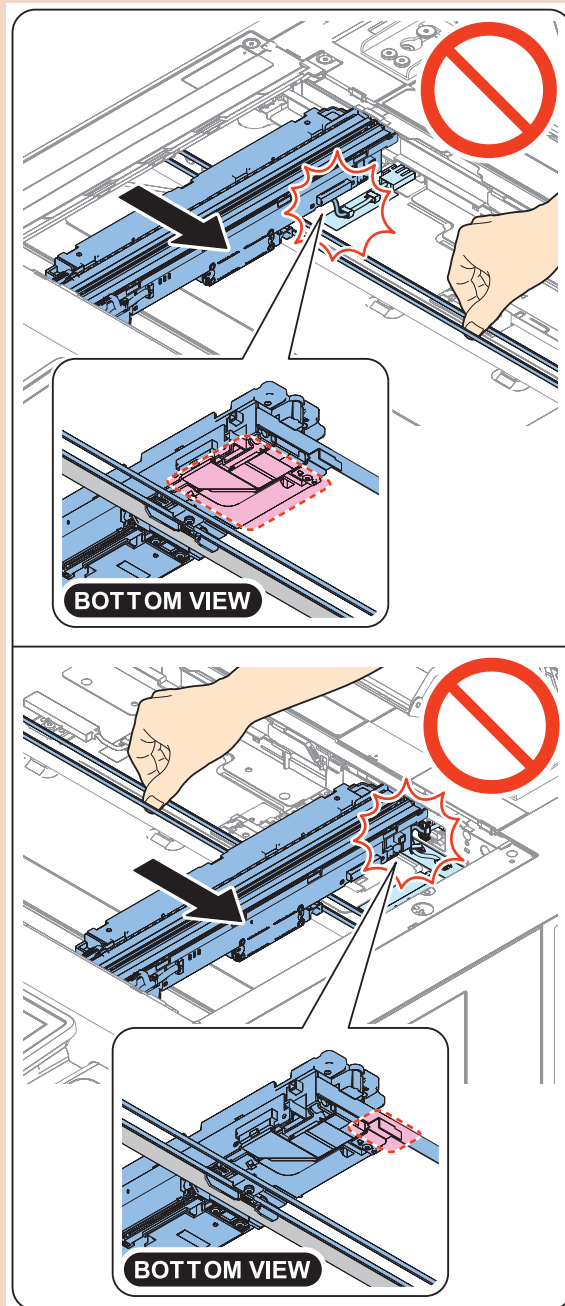

□
23.

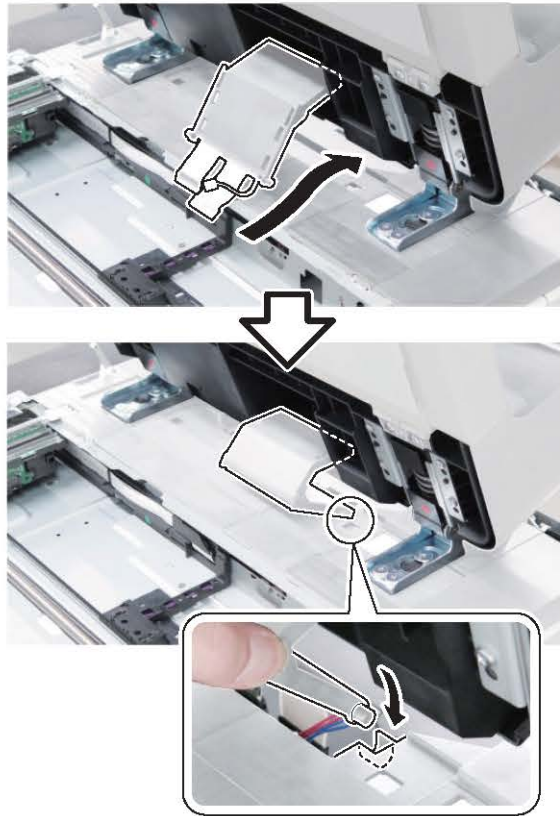

□
24.

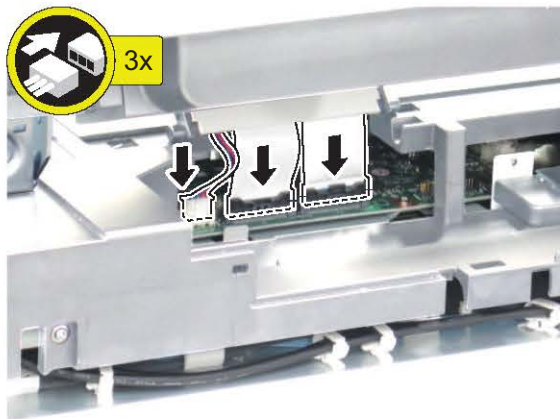

□
25.

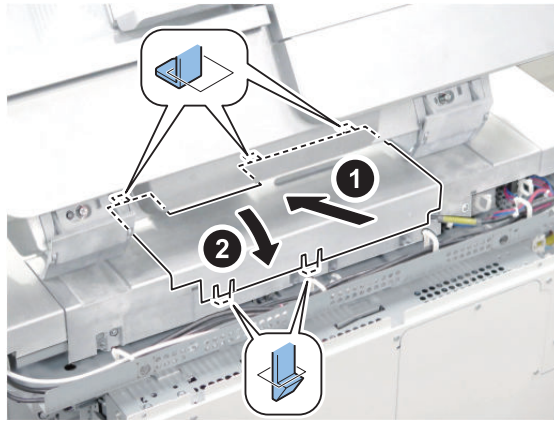

□
26.

CAUTION:

- Soiling on the glass surface and the White Plate affects reading. When removing or installing the Copyboard Glass, be sure not to touch the glass surface and the White Plate.
- If soiling is attached, clean it with lint-free paper.

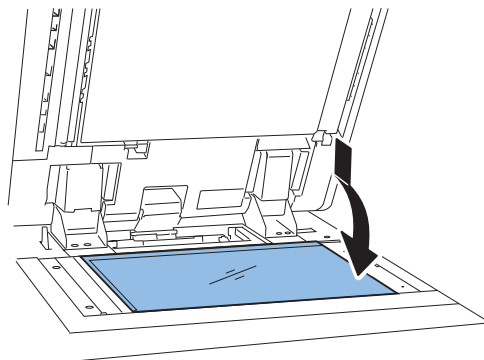
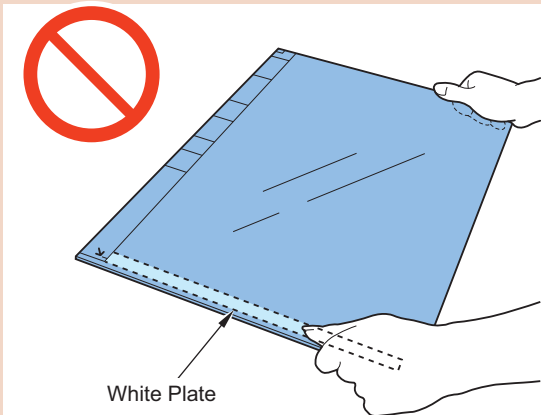

□
27.

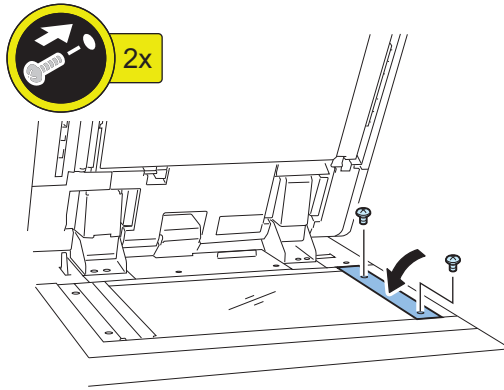

□
28.

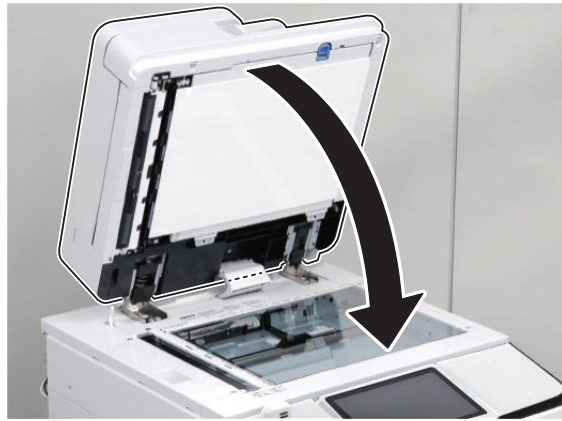

■ **Installing the Covers**

□
1.

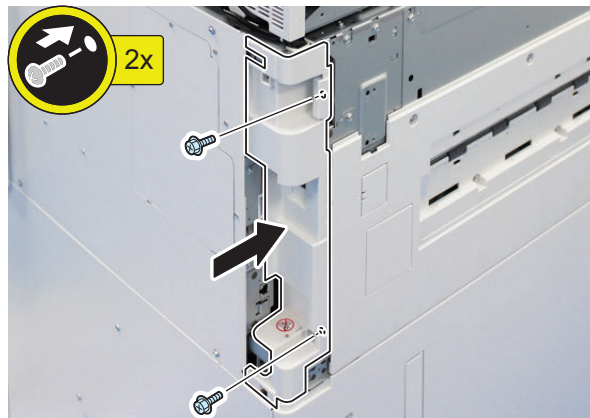

□
2.

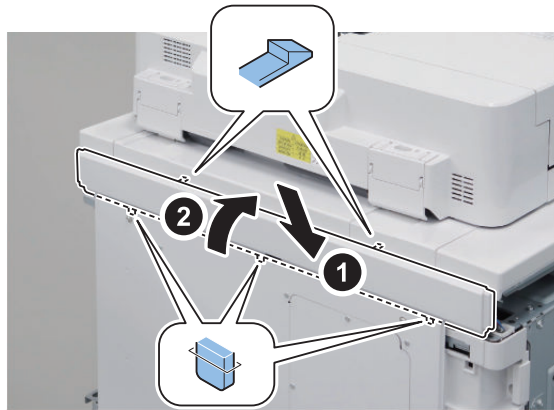

□
3.

CAUTION:

When installing the Left Upper Cover, be careful not to secure it while it is being slid fully toward the front. Otherwise, the Left Upper Cover may interfere with the Toner Replacement Cover and the magnet cannot work.

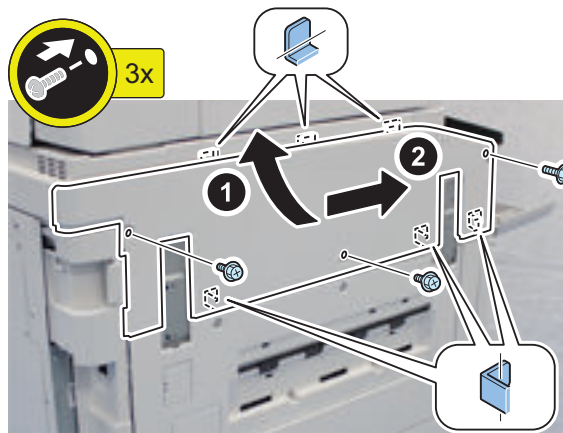

□
4.

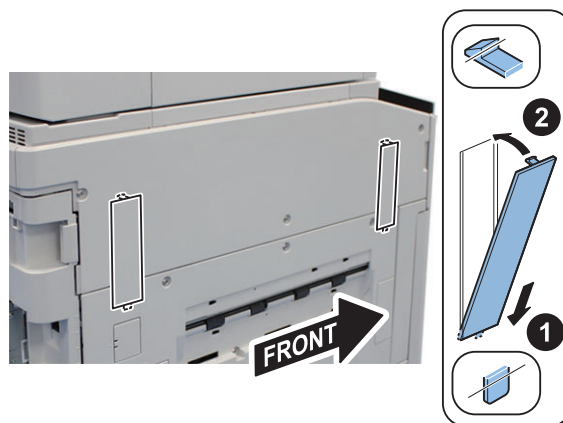

□
5.

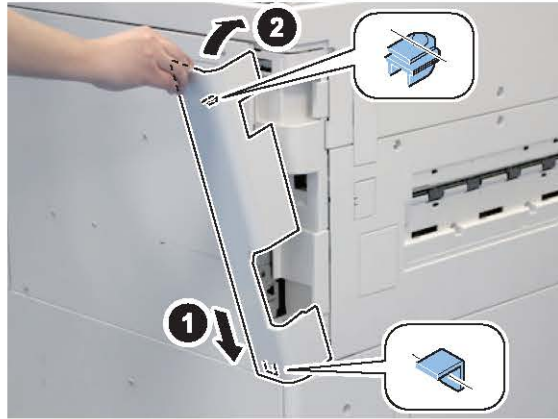

□
6.

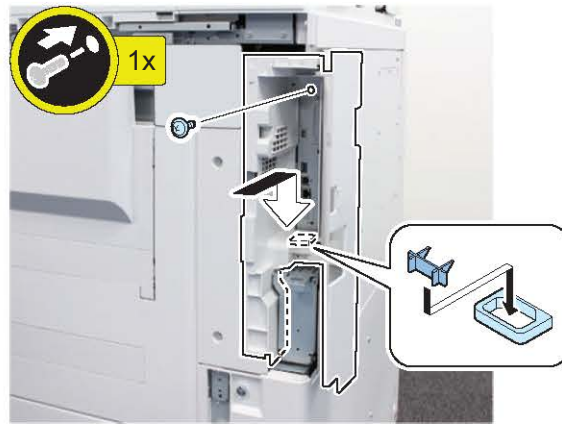

□
7.



□
8.

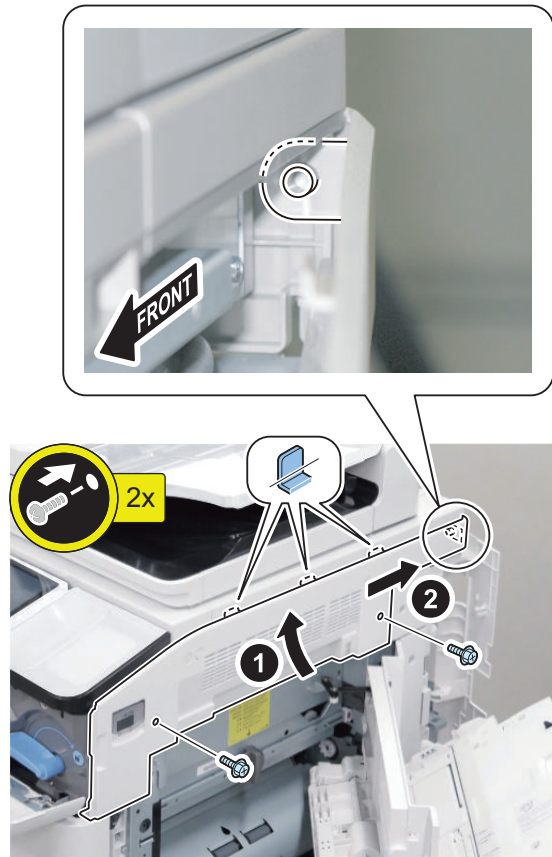

□
9.



□
10. Turn ON the Environment Heater Switch.

11. Connect the power plug to the outlet.

12. Turn ON the main power switch.

4

Host Machine Options

Upright Control Panel-J1.....	137
NFC Kit-E1/E2.....	188
Connection Kit-A2/A3 for Bluetooth LE.....	207
Numeric Keypad-A1/A2.....	217
Utility Tray-B1.....	228
Copy Card Reader-F1.....	235
Serial Interface Kit-K3 / Copy Control Interface Kit-A1	252
Voice Operation Kit-D1.....	261
Voice Guidance Kit-G1.....	275
HDD-related Option.....	288
Super G3 FAX Board-AS1.....	323
Super G3 FAX Board-AS2.....	331
Super G3 2nd Line Fax Board-AS1..	338
Super G3 2nd Line Fax Board-AS2..	359
Super G3 3rd/4th Line Fax Board-AS1	378
Super G3 3rd/4th Line Fax Board-AS2	390

Upright Control Panel-J1

● Installation Procedure

■ Removing the Covers

□

1.

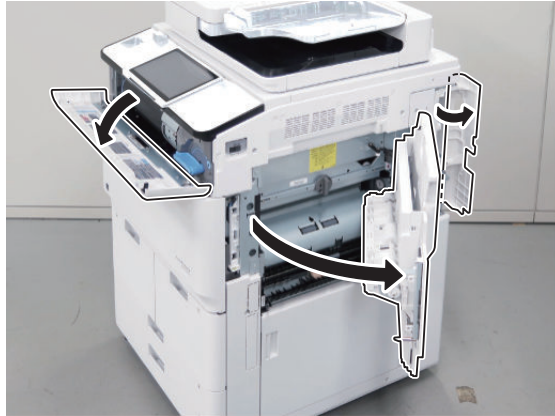

□

2.



□
3.

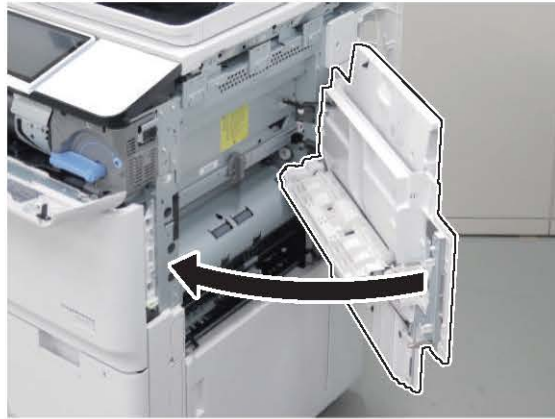

□
4.

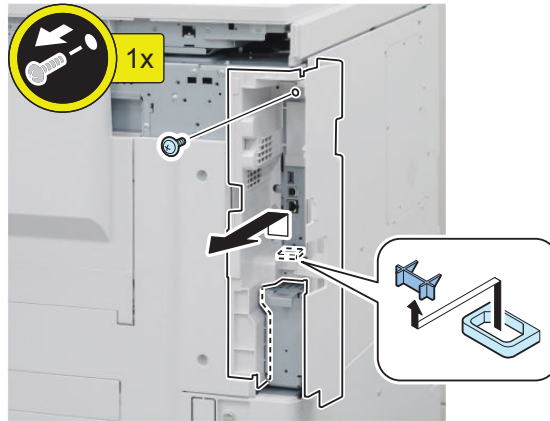

□
5.

**CAUTION:**

Be careful not to let the 2 bosses of the Side Cover come off from the 2 mounting holes of the Right Rear Cover 1.

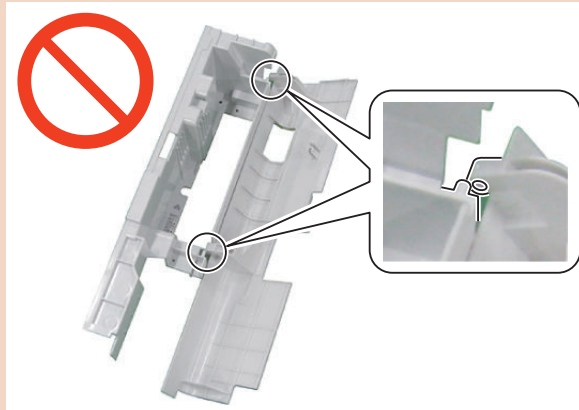

□
6.

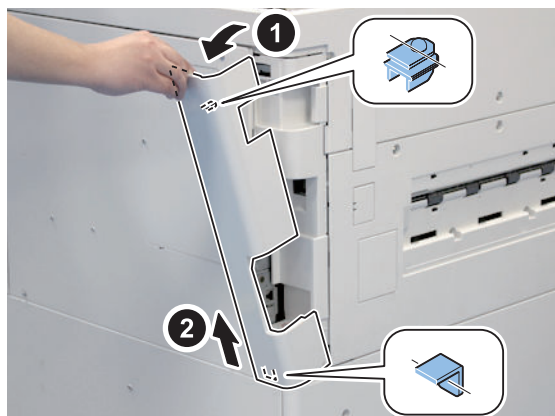

□
7.

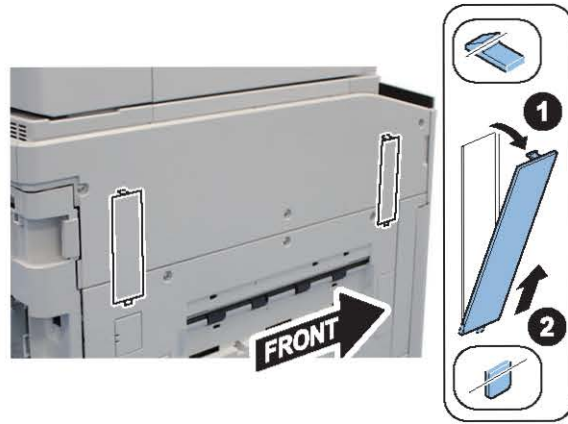

□
8.

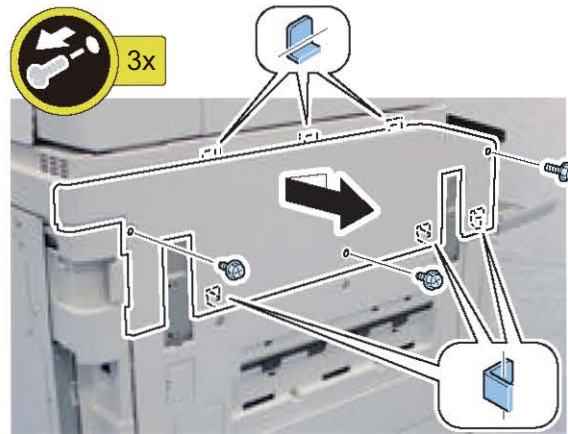

□
9.

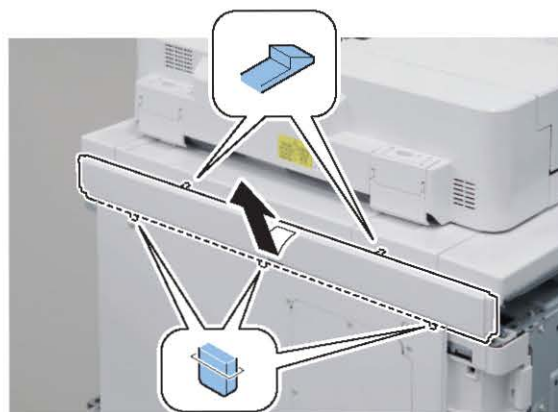

□
10.

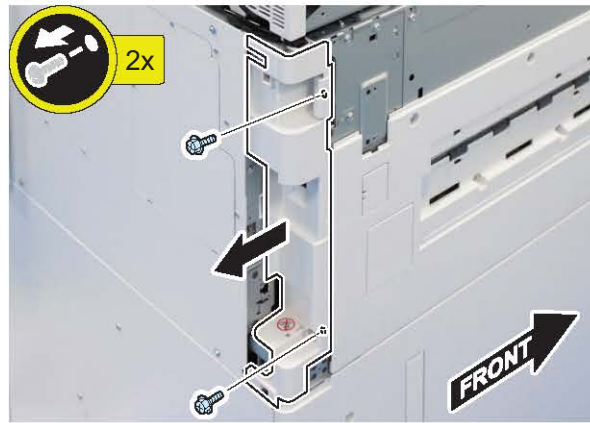

□
11.

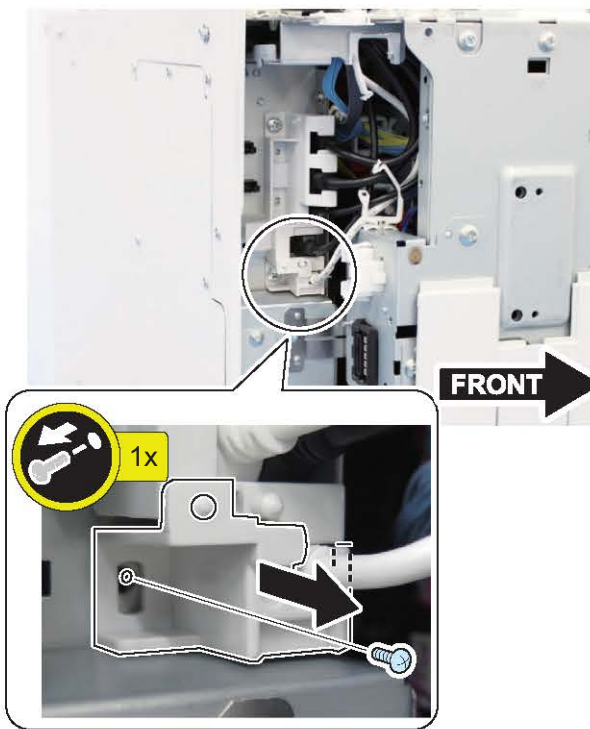

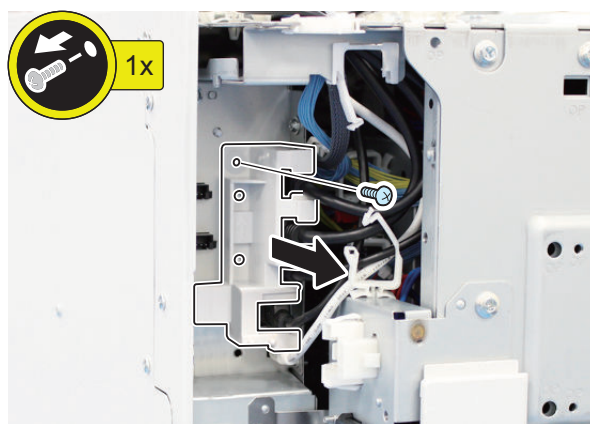
□
12.□
13. Remove the ADF and Reader Unit or the Printer Cover.

- When removing the ADF and Reader Unit: After performing the [“Removing the ADF”](#) on page 143, proceed to [“Removing the Reader Unit”](#) on page 146.
- When removing the Printer Cover: Perform to [“Removing the Printer Cover”](#) on page 148.

■ Removing the ADF

□
1.



□
2.



NOTE:

When performing following procedures, using ADF in the book mode as necessary makes the work easy.
The book mode is released by opening the ADF.

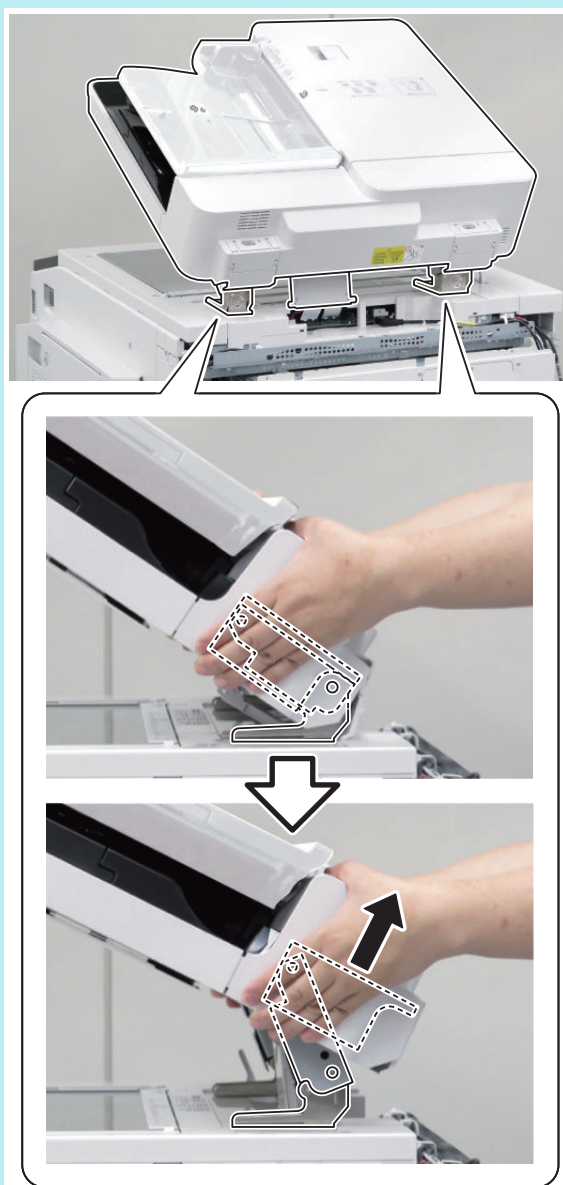

□
3.

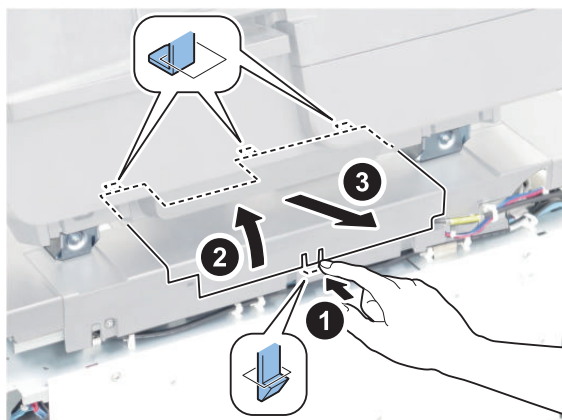

□
4.

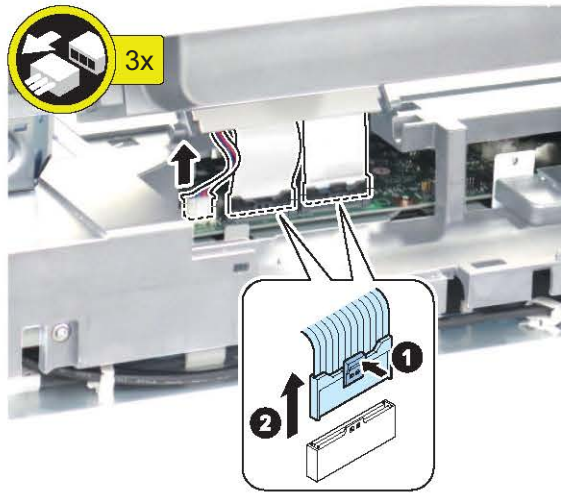

□
5.



□

6.

⚠ CAUTION:

Be careful not to drop the ADF.

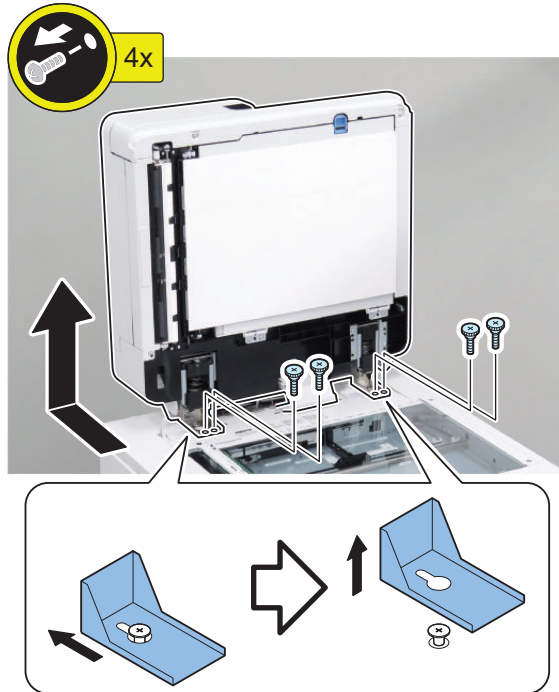

□

7. Next, perform [“Removing the Reader Unit”](#) on page 146.**■ Removing the Reader Unit**

□

1.

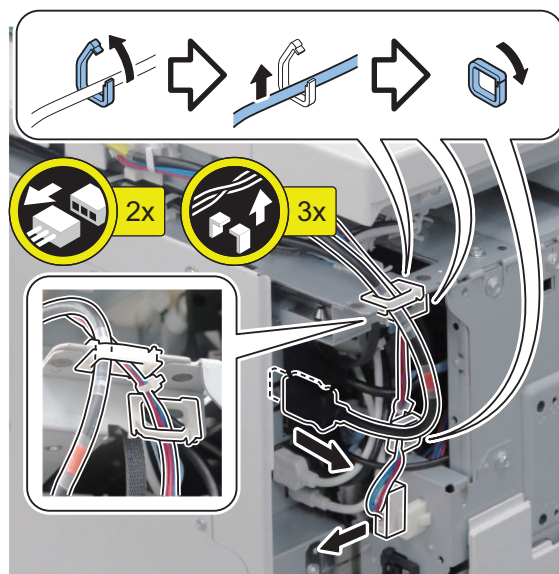

□
2.

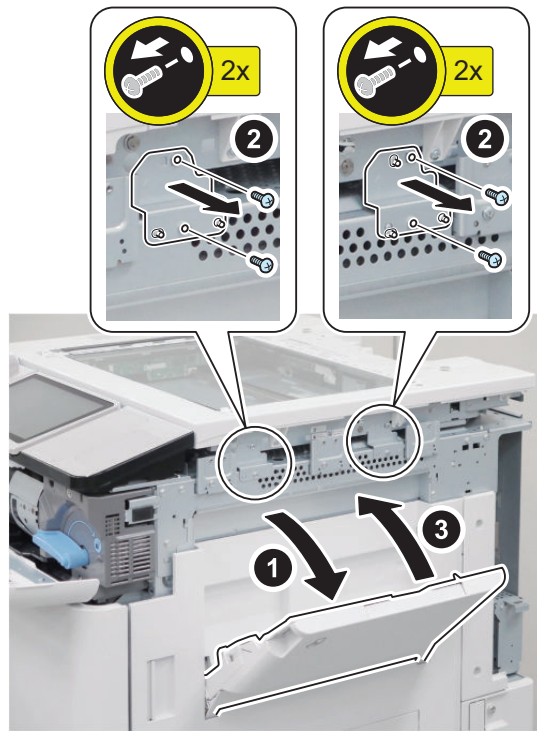

□
3.

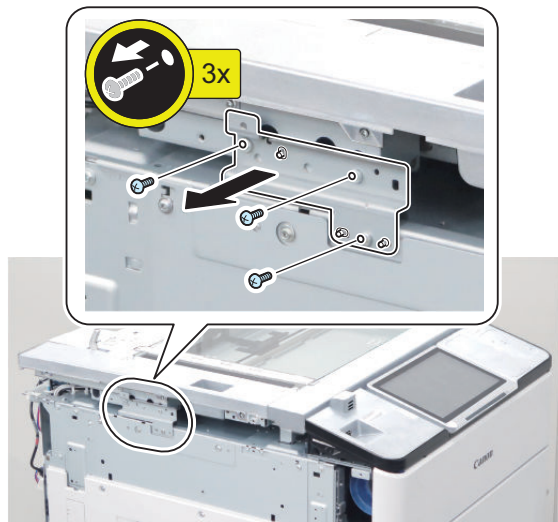

□
4.

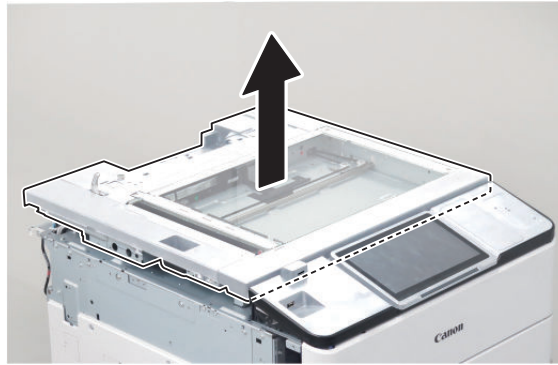

■ **Removing the Printer Cover**

□
1.

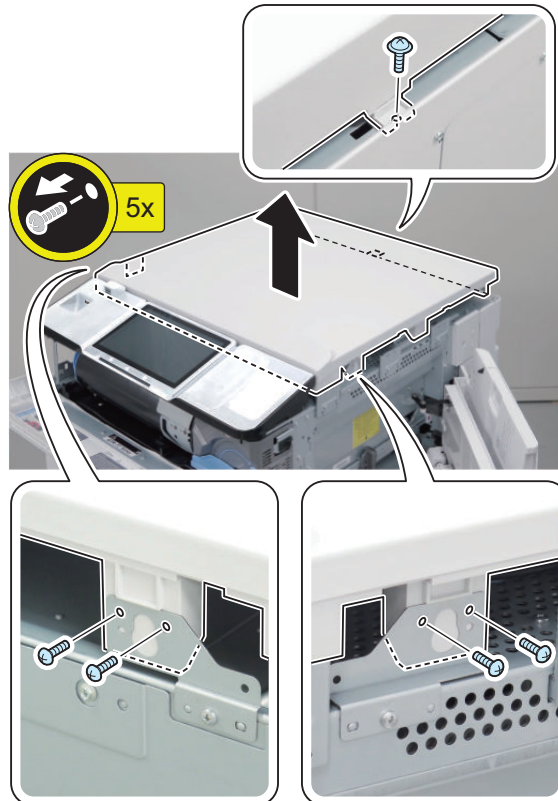

■ Removing the Flat Control Panel

□
1.

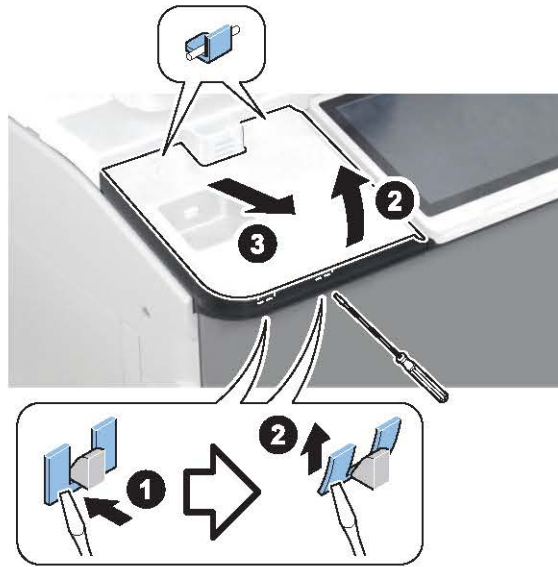

□
2.

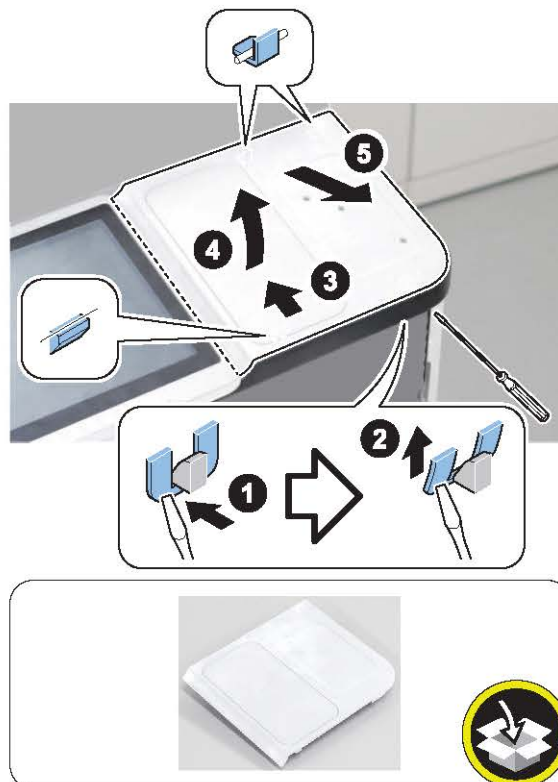

□
3.

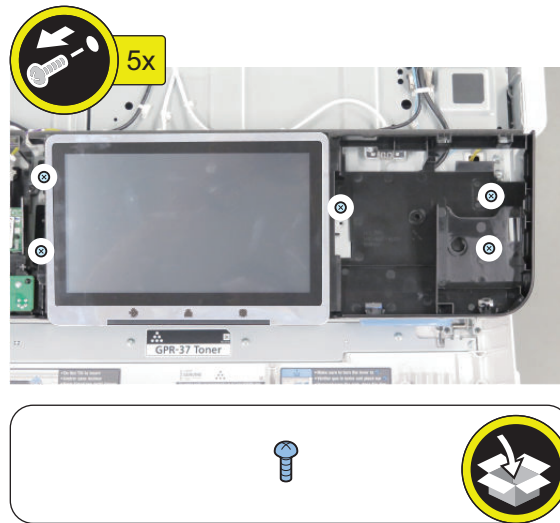

NOTE:

3 of removed screws will be used in step 8 and 1 will be used in step 13 of "Installing the Upright Arm".

□
4.

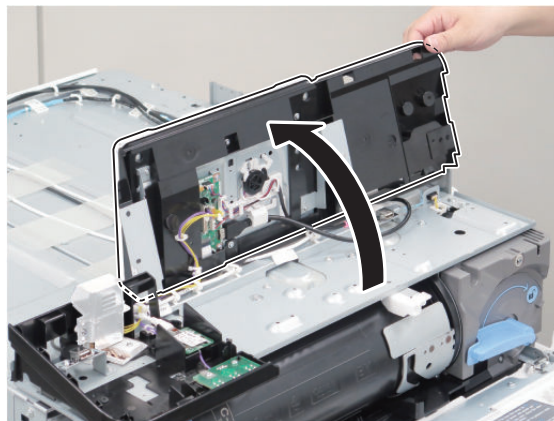

□
5.

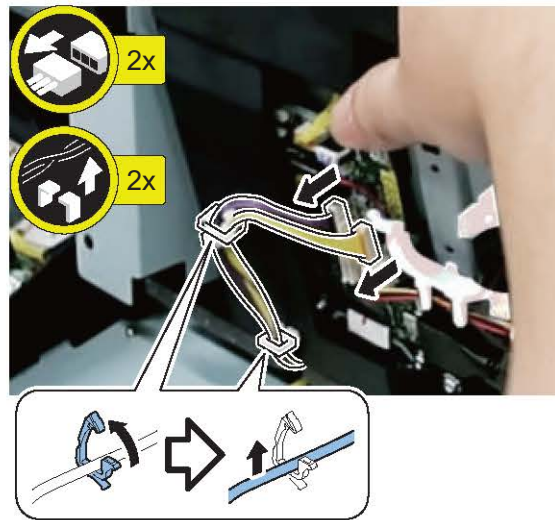

□
6.

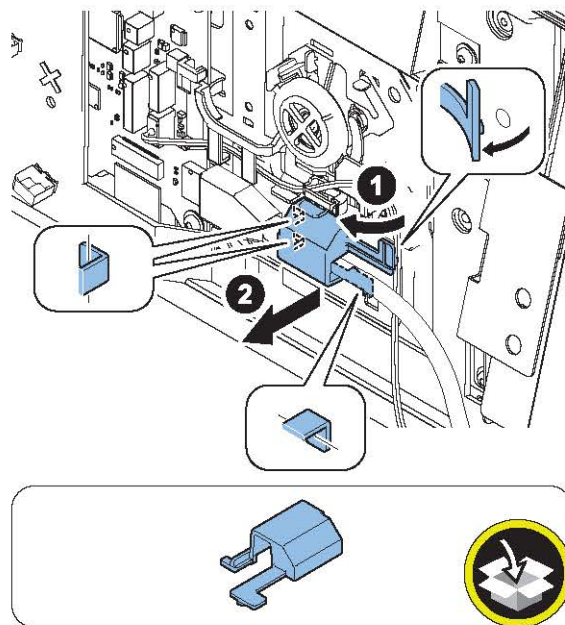

□
7.

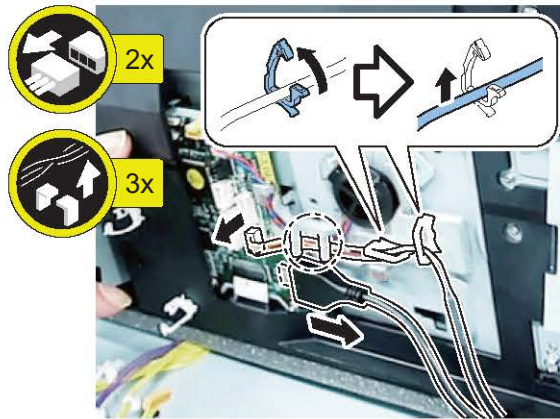

□
8.

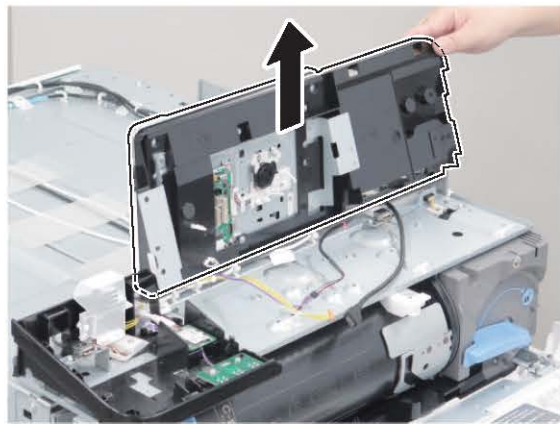

□
9.

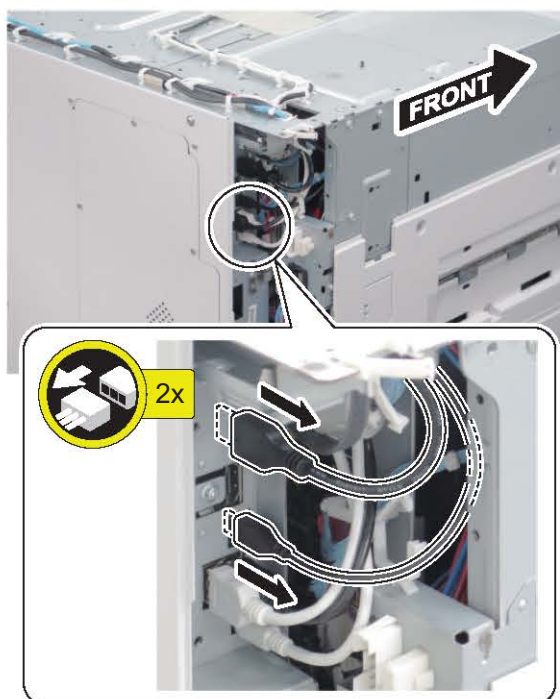

□
10.

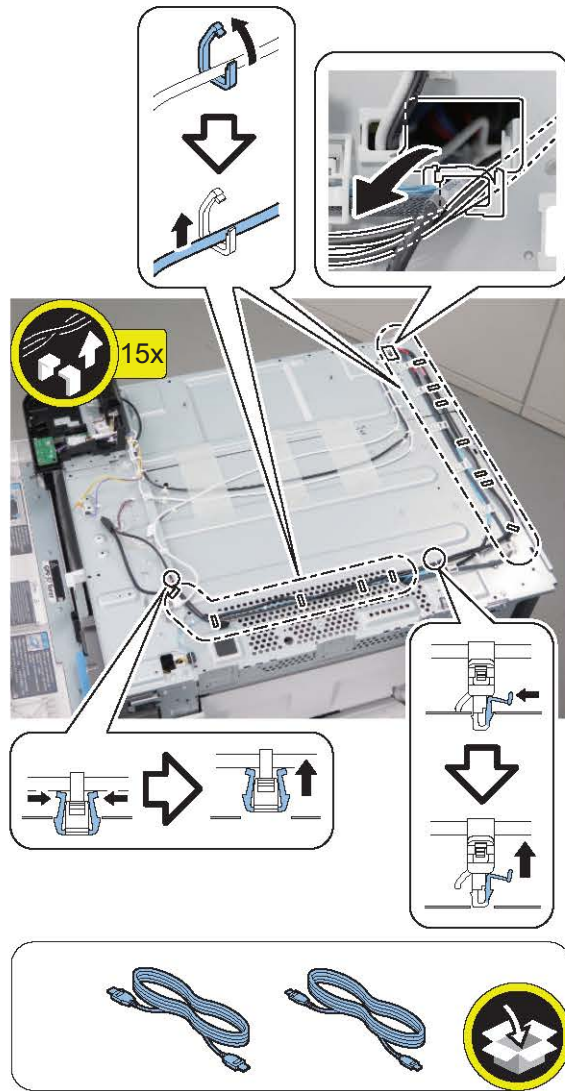

■ Installing the Upright Arm

□
1.

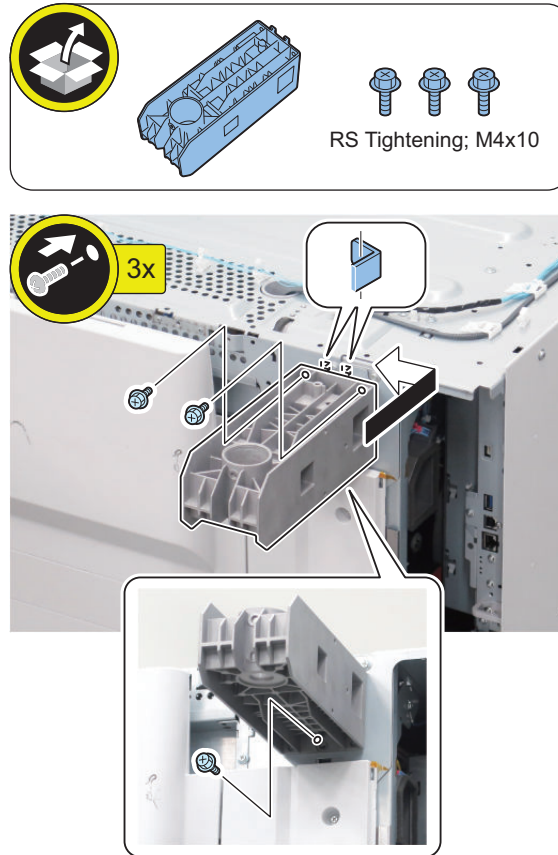

□
2.

NOTE:

Remove tapes, and insert the Upright Arm vertically into the round hole of the Frame Base.

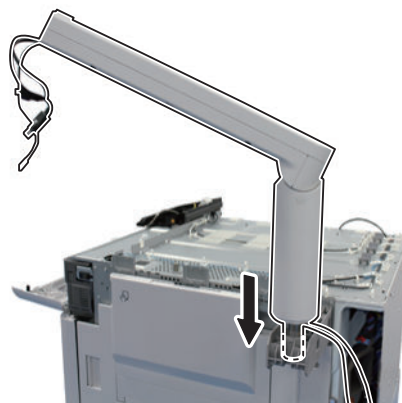

□
3.

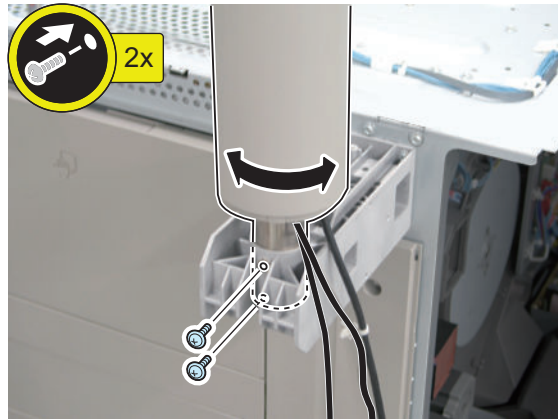
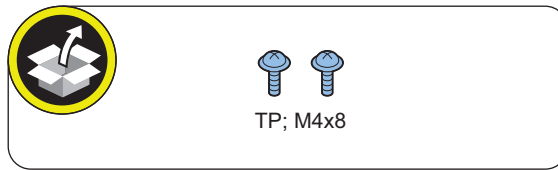

□
4.

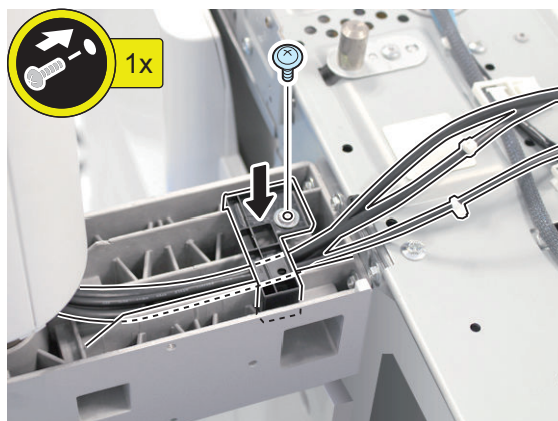

□
5.

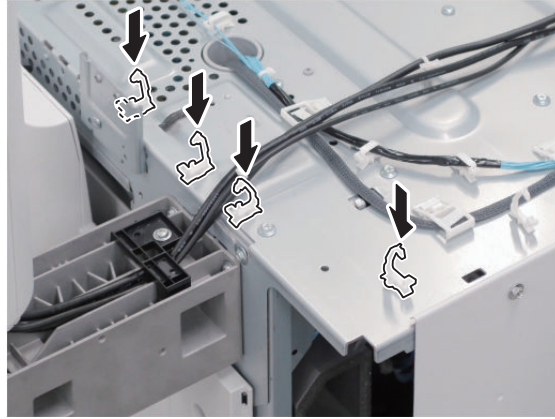
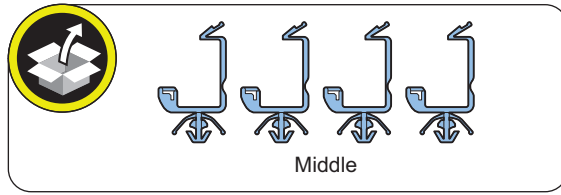

□
6.

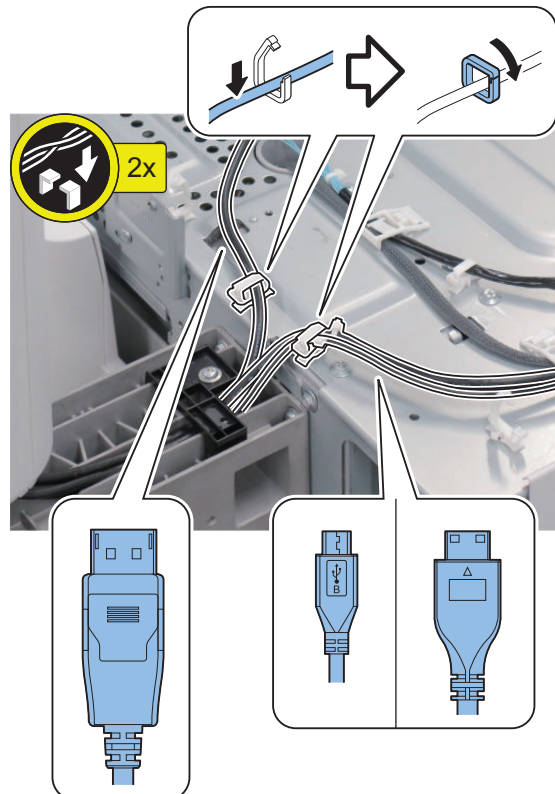

□
7.

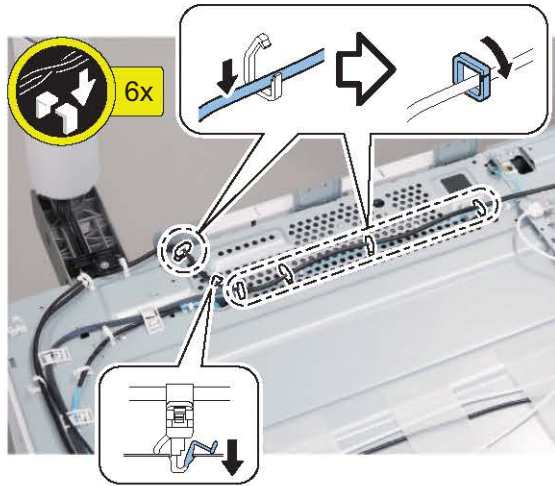

□
8.**NOTE:**

Use screws removed in step 3 of "Removing the Flat Control Panel".

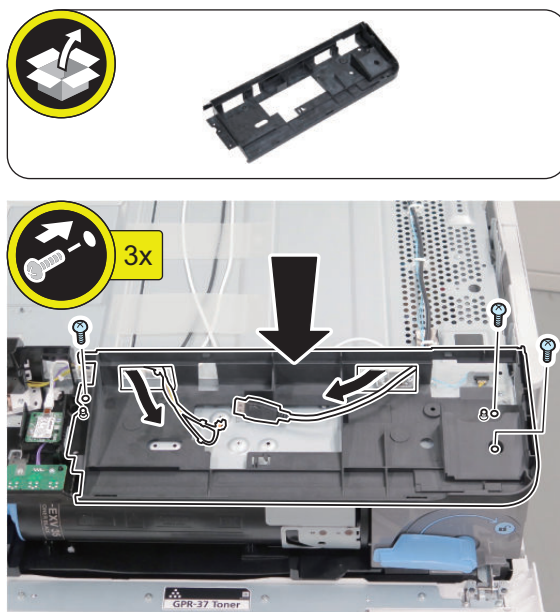
**NOTE:**

When the NFC Kit will be installed at the same time, make sure to pass the NFC Cable through together. (Refer to the Service Manual of host machine for the installation procedure.)

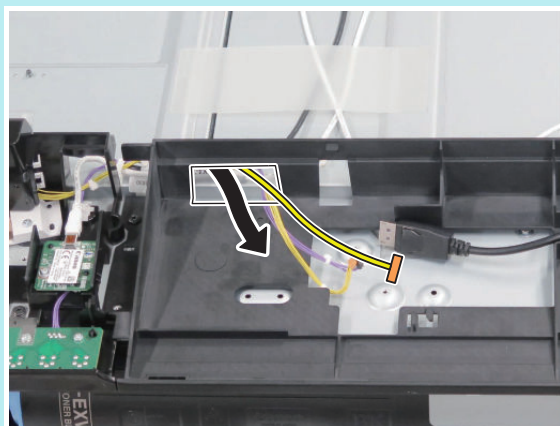

□
9.

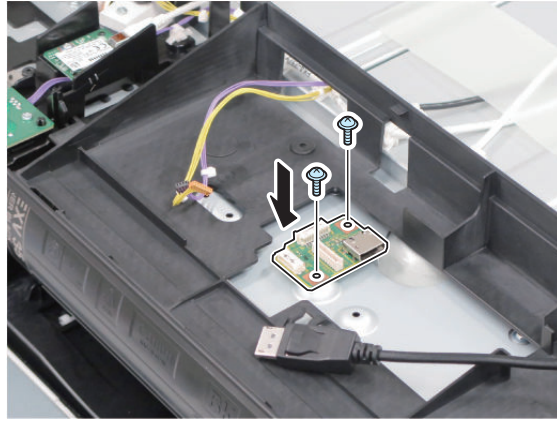
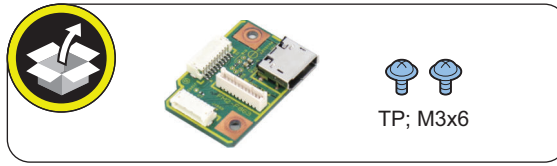

□
10.

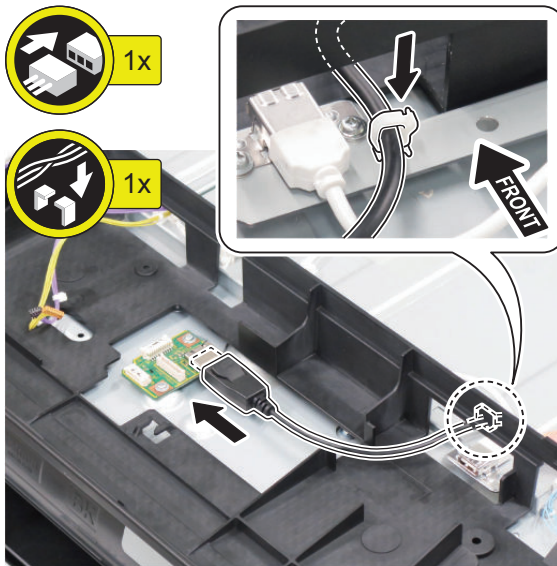

□
11.

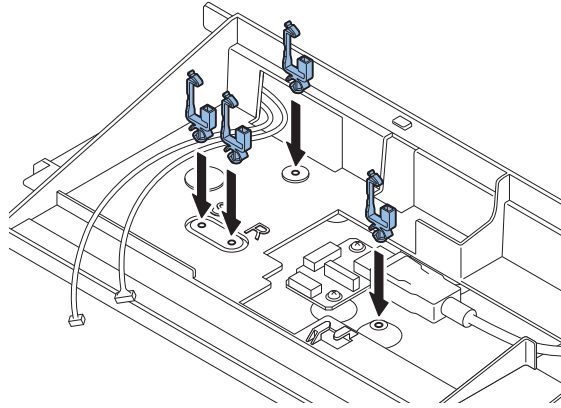
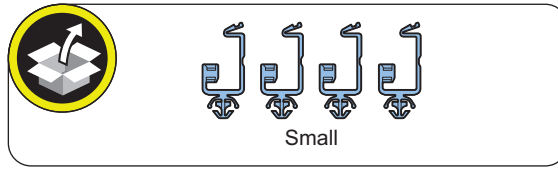

□
12.

NOTE:

Be careful to hold down the connector of Relay Cable so that it is securely fitted.

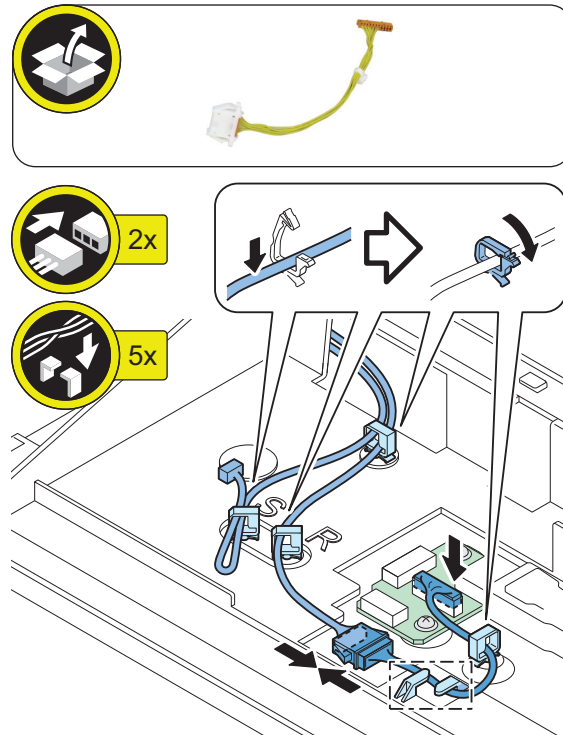
**NOTE:**

When the NFC Kit will be installed at the same time, make sure to connect the NFC Cable. (Refer to the Service Manual of host machine for the installation procedure.)

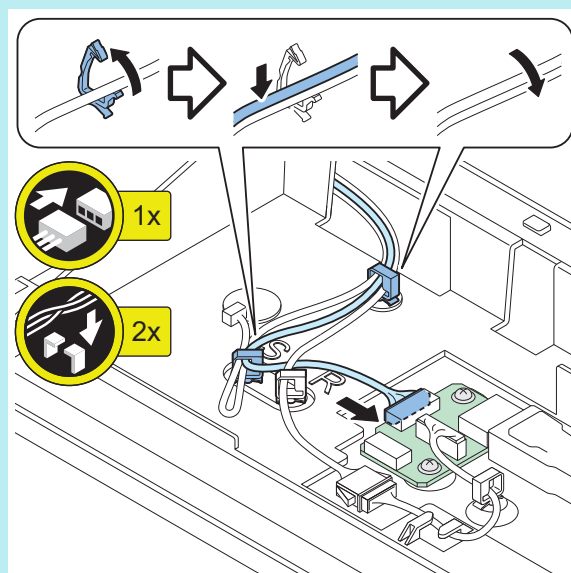

□
13.

NOTE:
Use screws removed in step 3 of "Removing the Flat Control Panel".

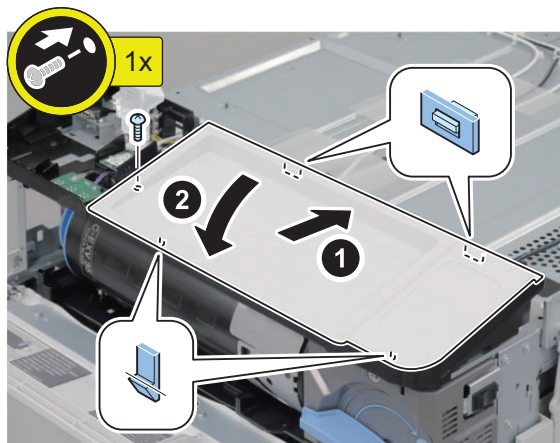
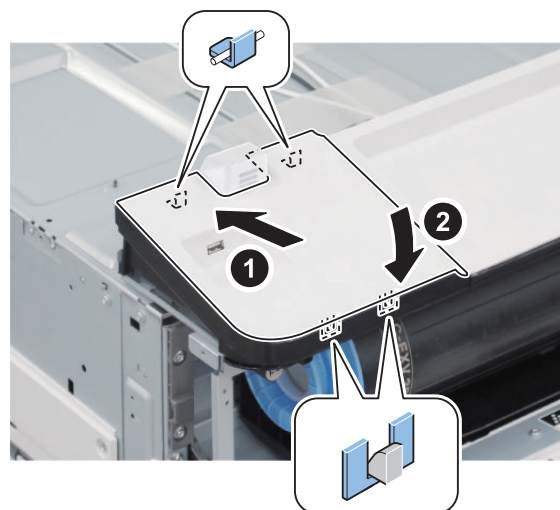
□
14.

□
15.

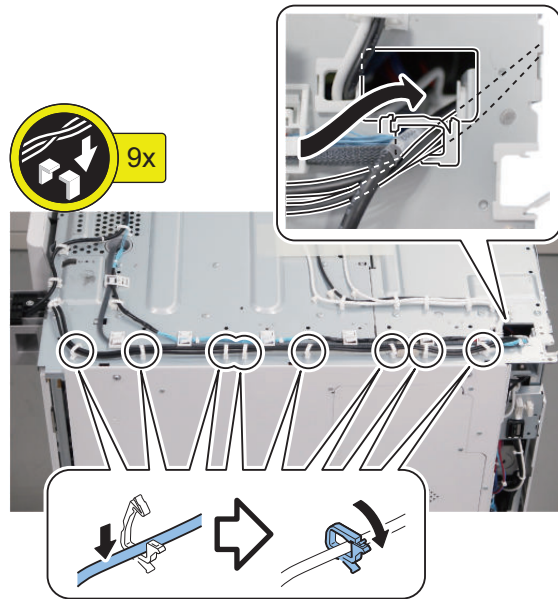

□
16.

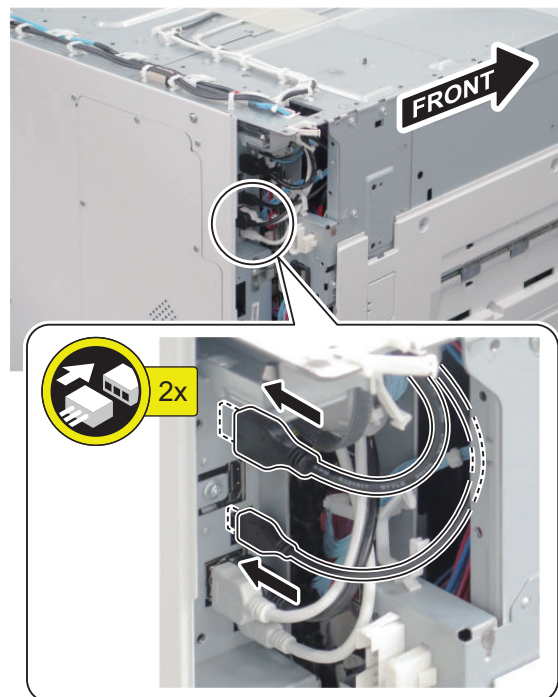

□
17. Install the removed Reader Unit and ADF or the Printer Cover.

- When installing the Reader Unit and ADF: After performing the [“Installing the Reader Unit” on page 164](#), proceed to [“Installing the ADF” on page 166](#).
- When installing the Printer Cover: Perform to [“Installing the Printer Cover ” on page 168](#).

■ Installing the Reader Unit

□
1.

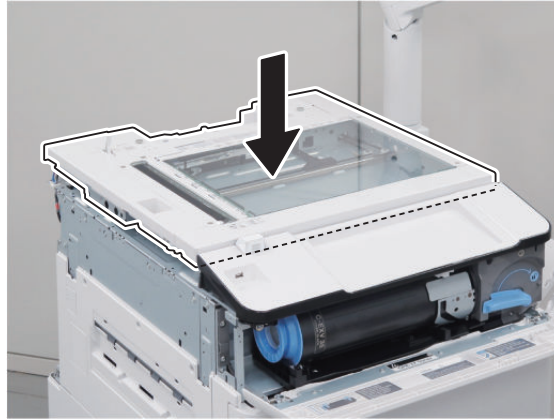

□
2.

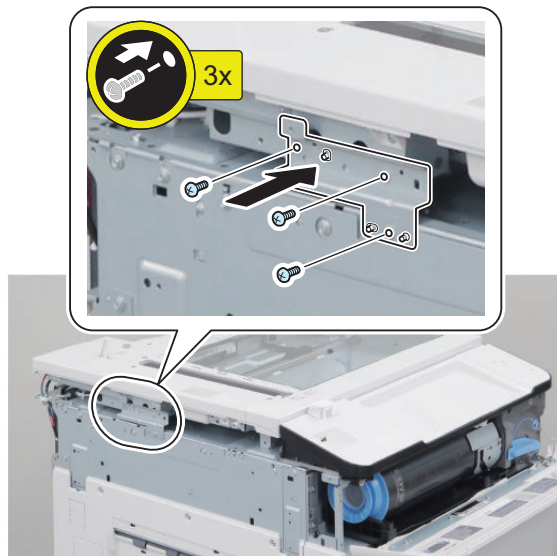

□
3.



□
4.

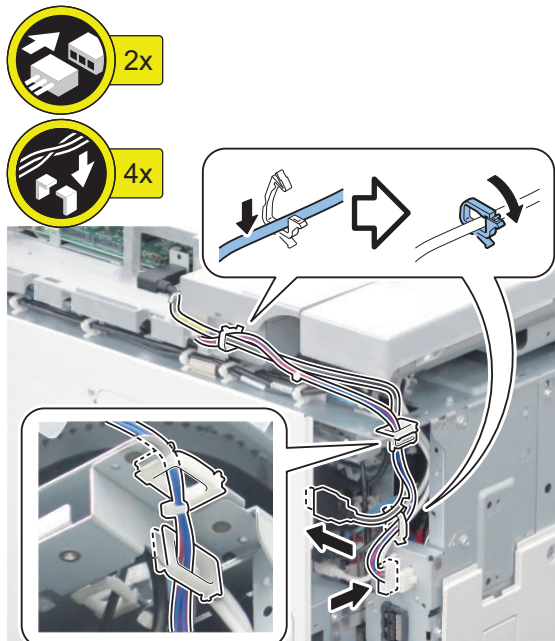

□
5. Next, perform **“Installing the ADF”** on page 166.

■ Installing the ADF

□
1.

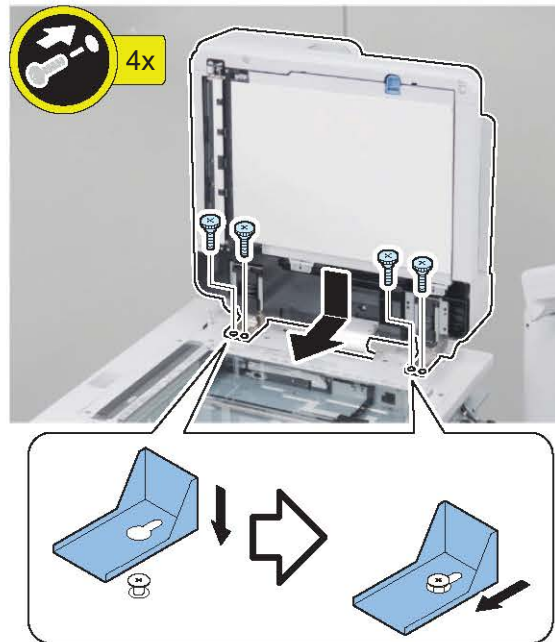

□
2.

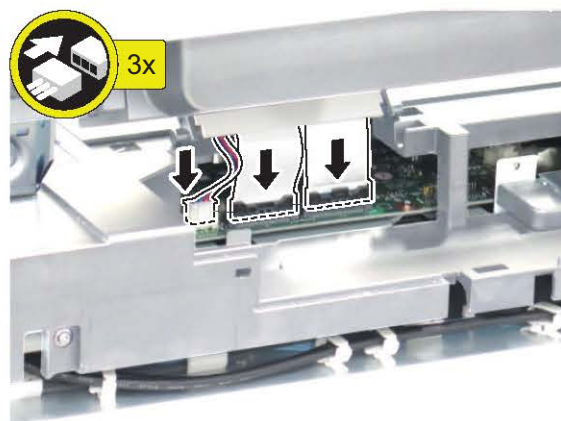

□
3.

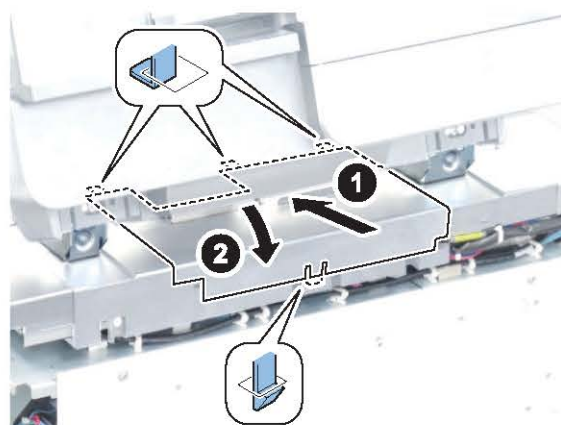

□
4.

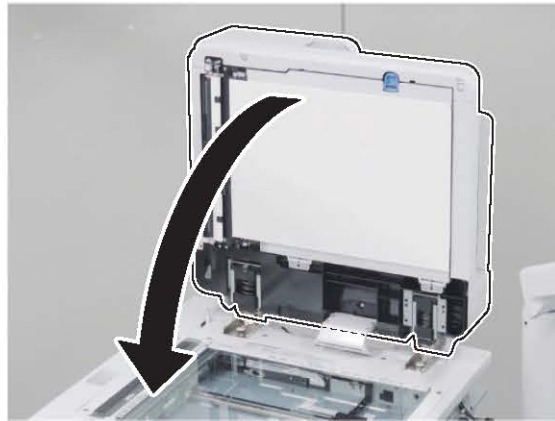

□
5.



■ Installing the Printer Cover

□
1.

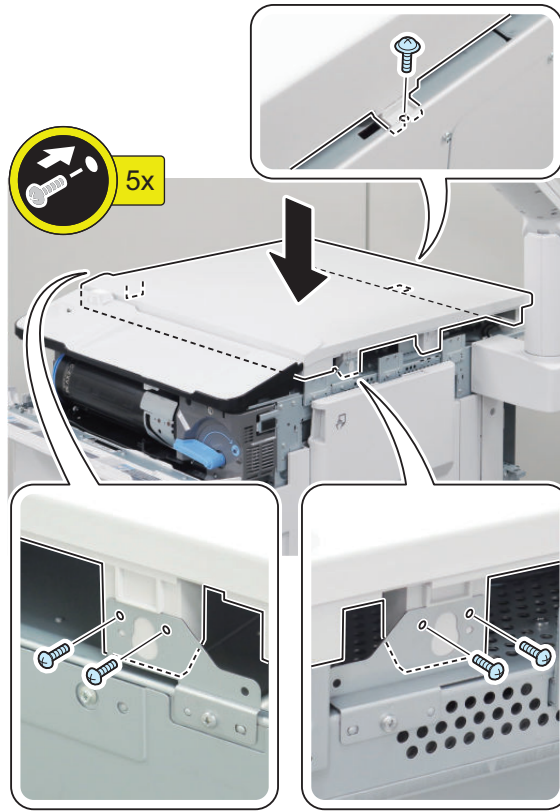

■ Installing the Covers

□
1.

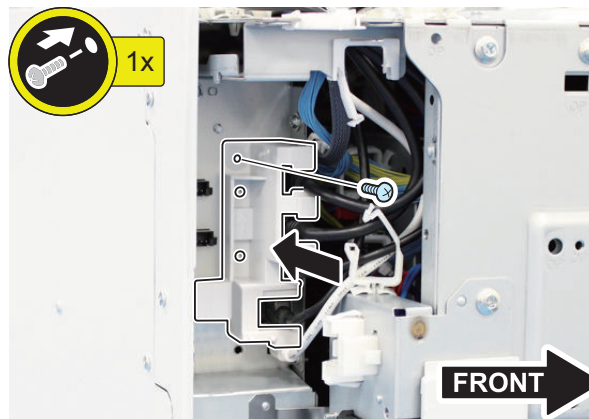

□
2.

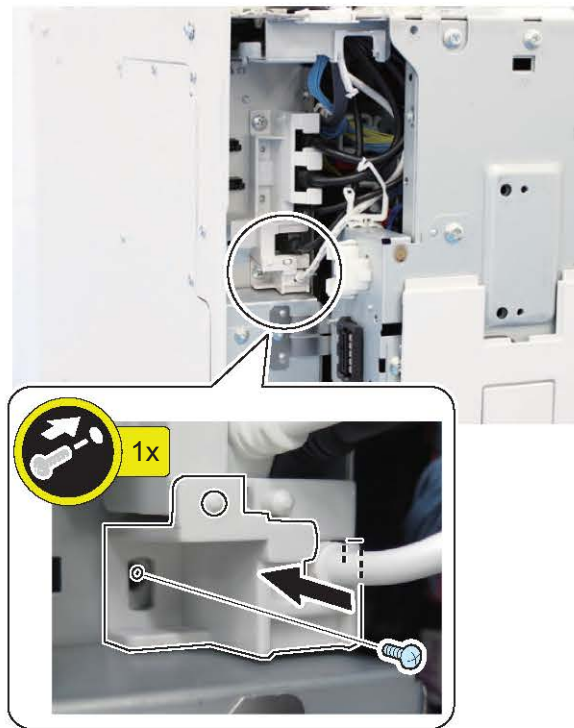

□
3.

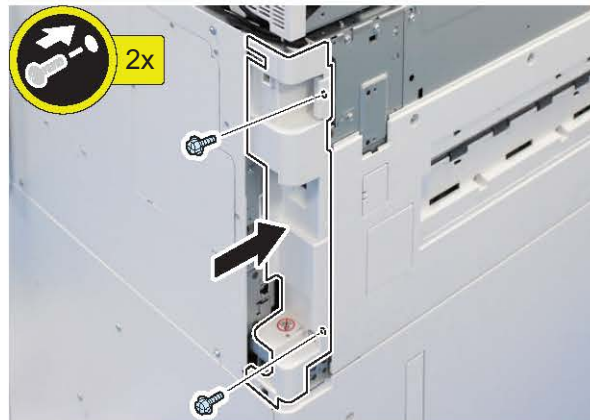

□
4.

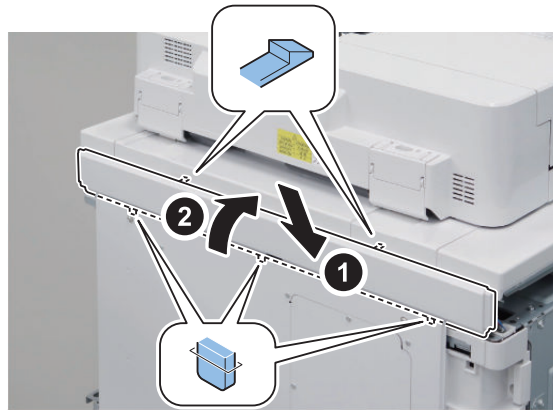

□
5.

CAUTION:

When installing the Left Upper Cover, be careful not to secure it while it is being slid fully toward the front. Otherwise, the Left Upper Cover may interfere with the Toner Replacement Cover and the magnet cannot work.

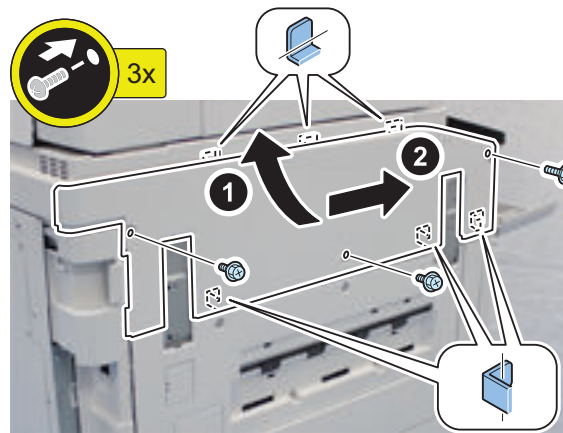

□
6.

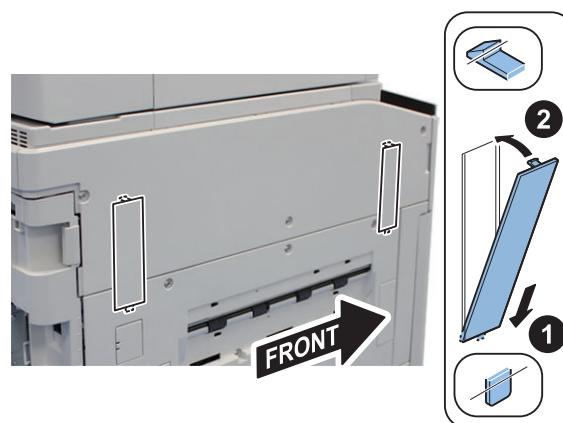

□
7.

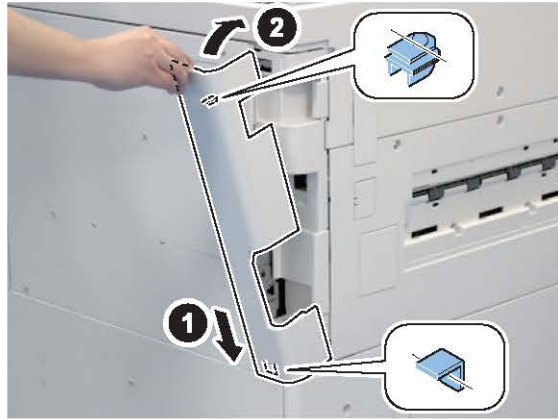

□
8.

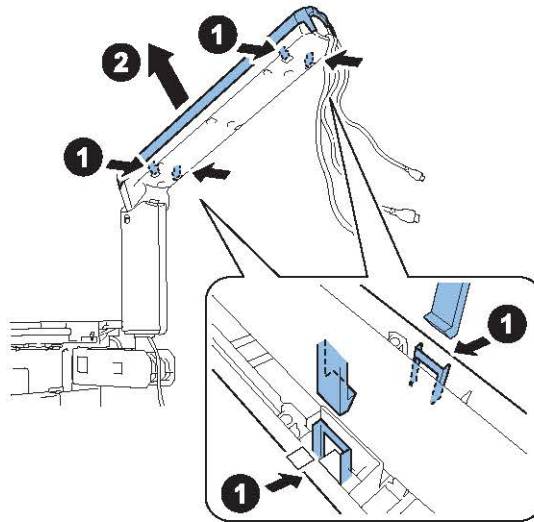

□
9.

CAUTION:

- Turn the Panel Base to make the protrusions [A] come to the upper side.
- Be sure to tighten the screws to secure the wire [B] simultaneously when installing the Panel Base.

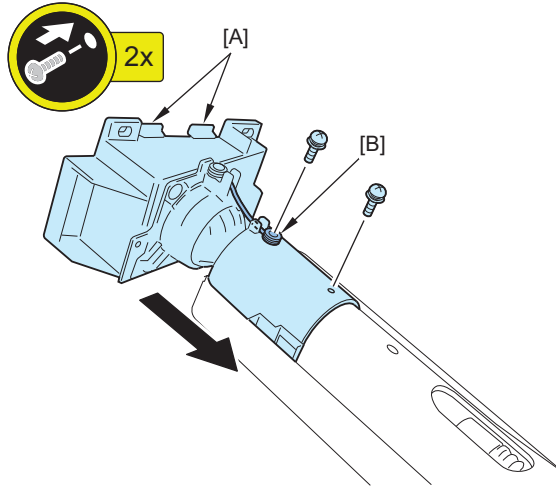
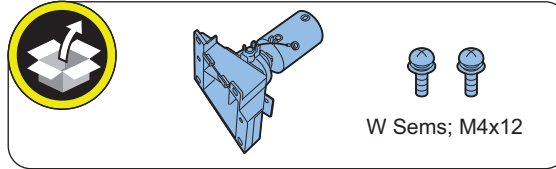

□
10.

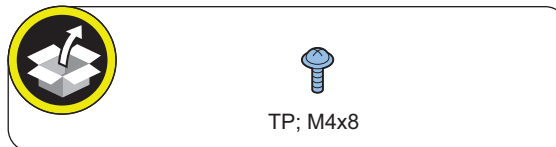

□
11.

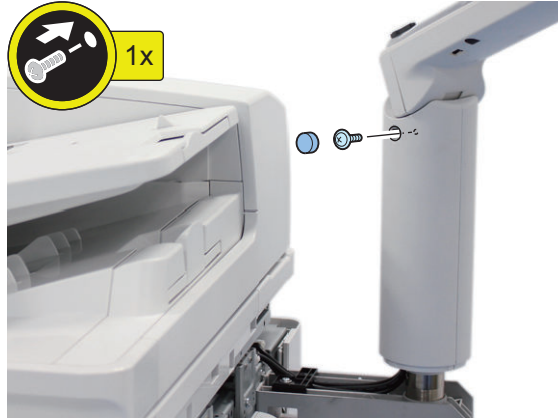
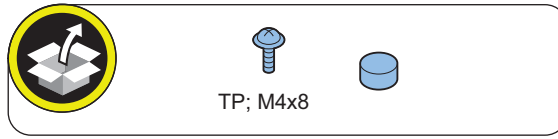

□
12.

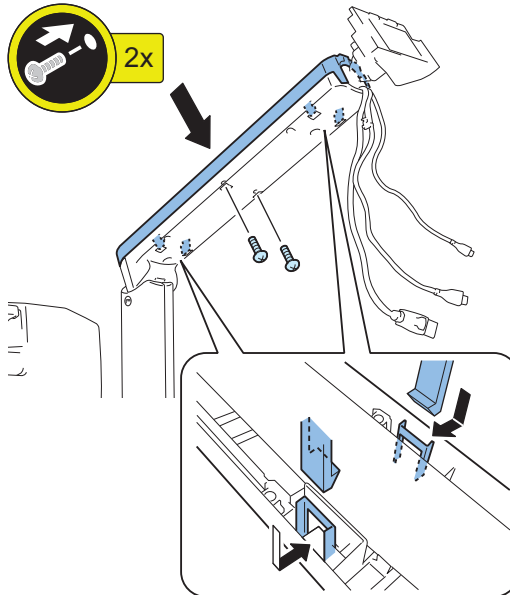
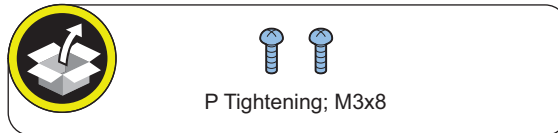

□
13.

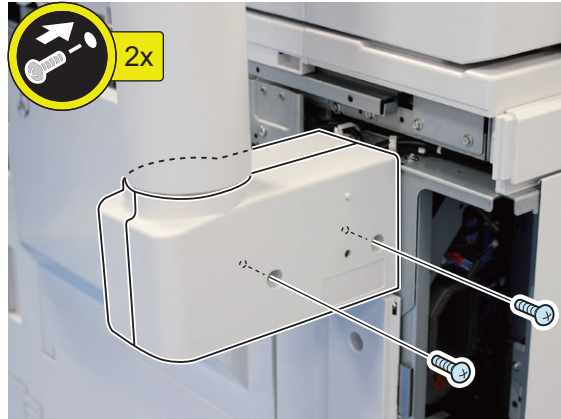
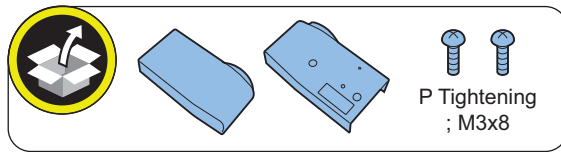

□
14.

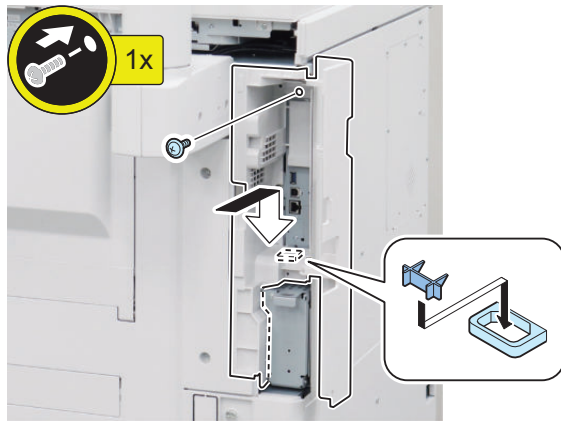

□
15.

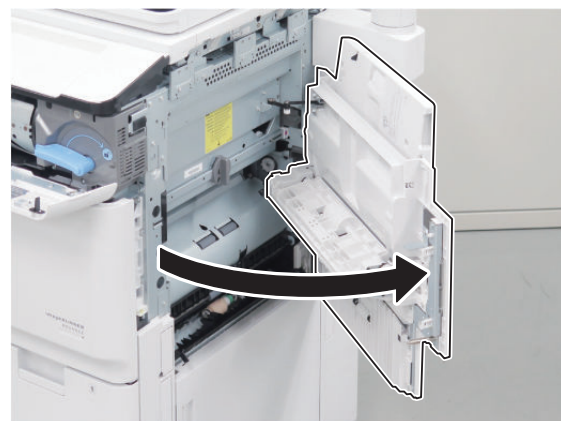

□
16.

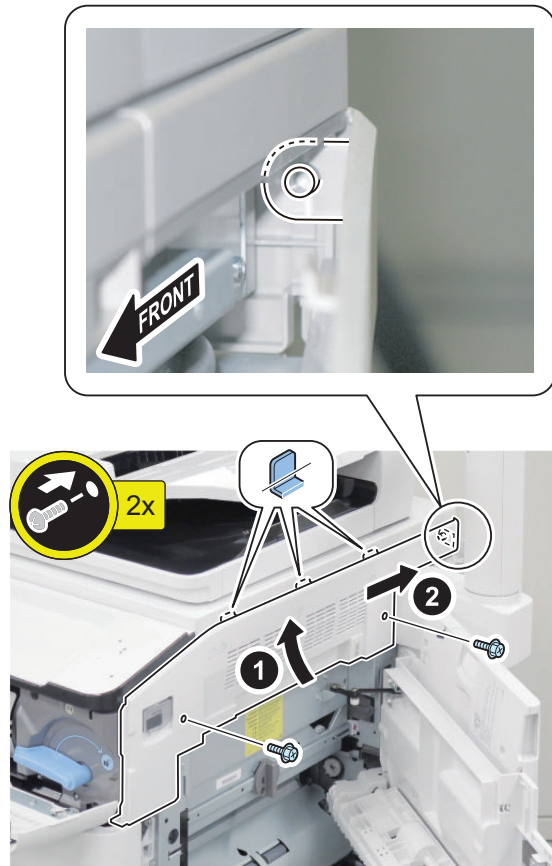

□
17.



■ Installing the Upright Control Panel

-
1. Remove the packing tape from the Upright Control Panel.

NOTE:

If the language of the Control Panel Sheet is not appropriate for the country, perform steps 2 to 11 and replace the Control Panel Sheet.

The sheet installed as standard is in English.

□
2.

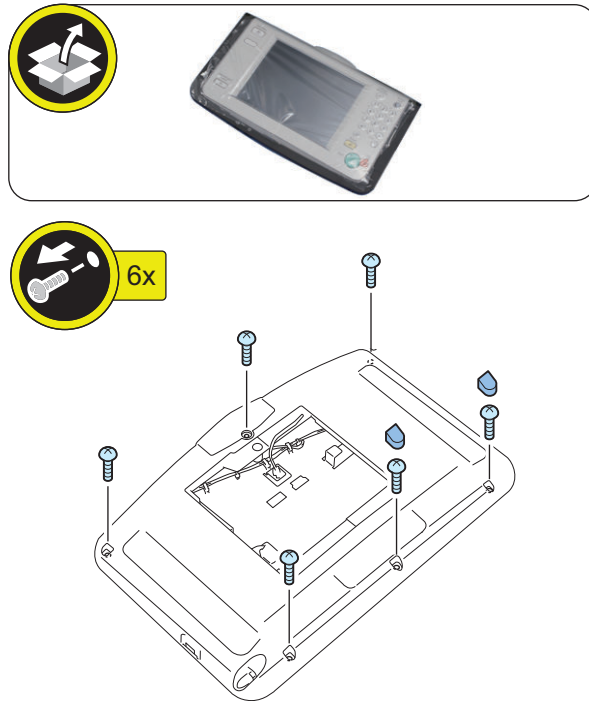

□
3. Remove the Protection Sheet from the Upright Control Panel.

□
4.

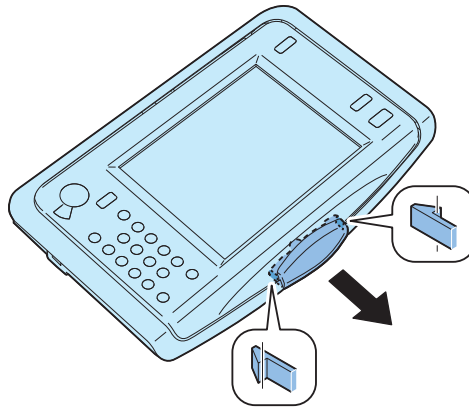

□
5.

CAUTION:
Disconnect the claws one by one in the direction of the arrow.

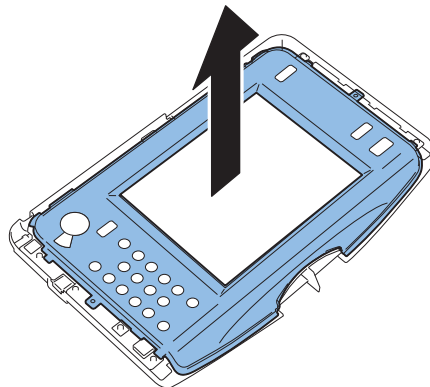
□
6.

□
7.**NOTE:**

Place the appropriate Control Panel Sheet on the Upright Control Panel, and remove the Protection Sheet from the Control Panel Sheet.

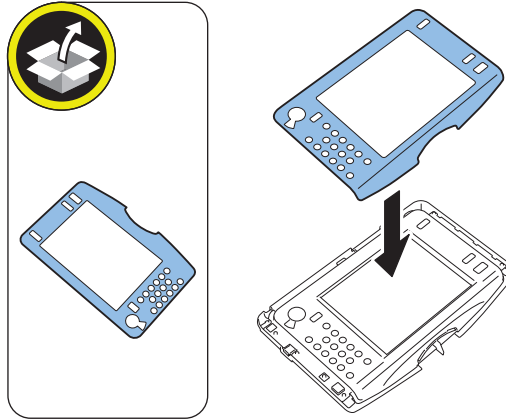
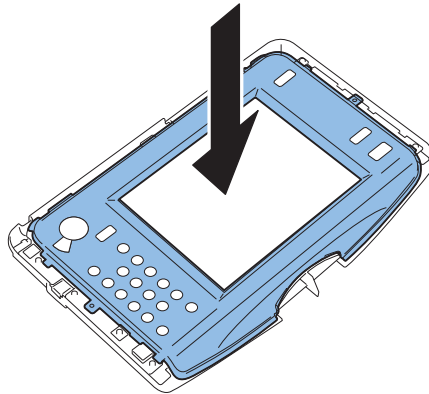
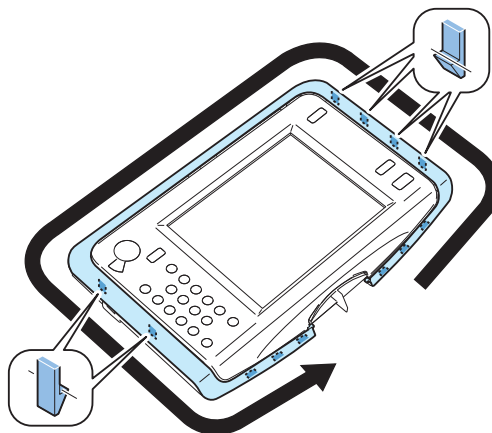
□
8.□
9.

□
10.

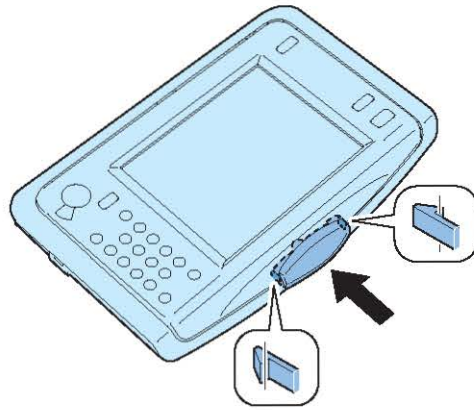

□
11.

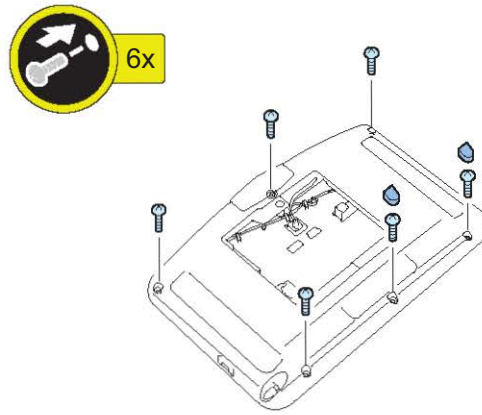

□
12.**NOTE:**

When installing the Upright Control Panel, be sure to tighten the screws from the upper part.

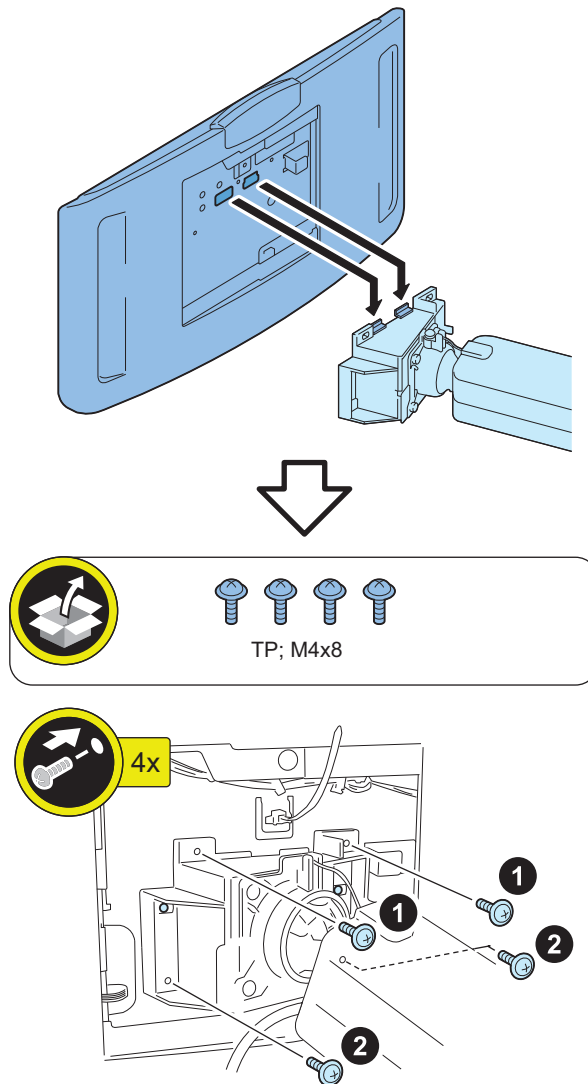

□
13.

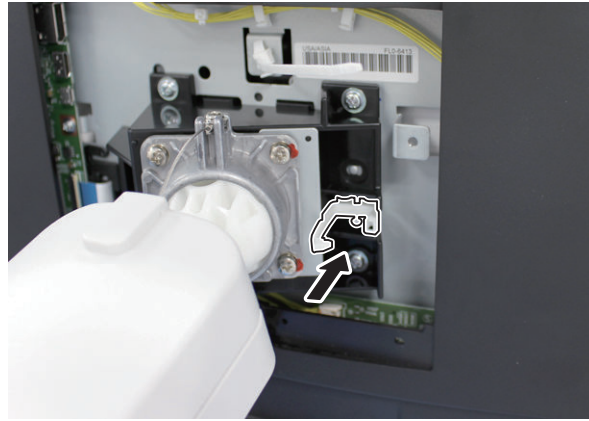
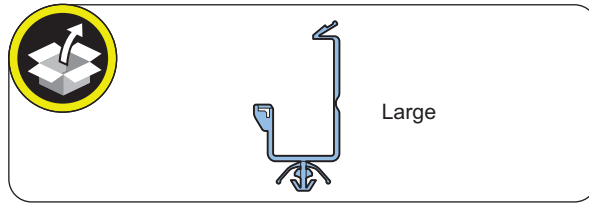

□
14.

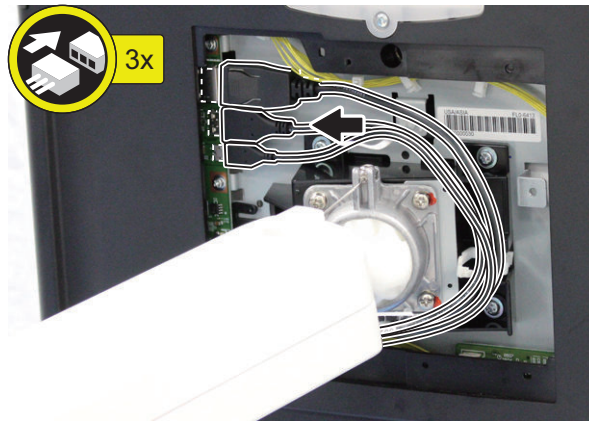

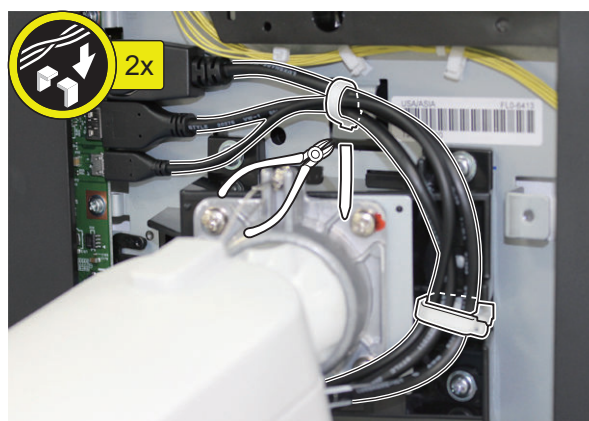
□
15.**CAUTION:**

- Check that the white tape of the Control Panel Cables is completely outside the Pipe Cover.
- If not, adjust the cables to positions where the white tape is outside the cover.



□
16.



□
17.



□
18. Connect the power plug to the outlet.



19. If the Protection Sheet has not been removed from the Control Panel, remove it.



20. Turn ON the main power switch. Check that the Upright Control Panel is displayed.



21. If a message prompting the user to update the version appears, press [Update] to automatically update the version of this equipment.

NOTE:

If [Skip] is selected, a message prompting the user to update the version will appear every time the host machine is started. In the service mode (Lv.2) shown below, it is possible to set not to display the message.

COPIER > OPTION > FNC-SW > VER-CHNG



22. Set the value of the following service mode (Lv.2) to "1".

COPIER > OPTION > FNC-SW > STND-PNL

NOTE:

By executing the above service mode, the following function can be changed.

- The animation of the host machine on the Control Panel screen can be switched from the Flat Control Panel to the Upright Control Panel.
- The [Timeline] button will be displayed on the main menu.



23. Turn OFF and then ON the main power switch to enable the setting value.

Pre-checks

■ Points to Note before Installation

The pictures and illustrations used may be different from the product in front of you, but the procedure is the same.

■ Checking the Contents

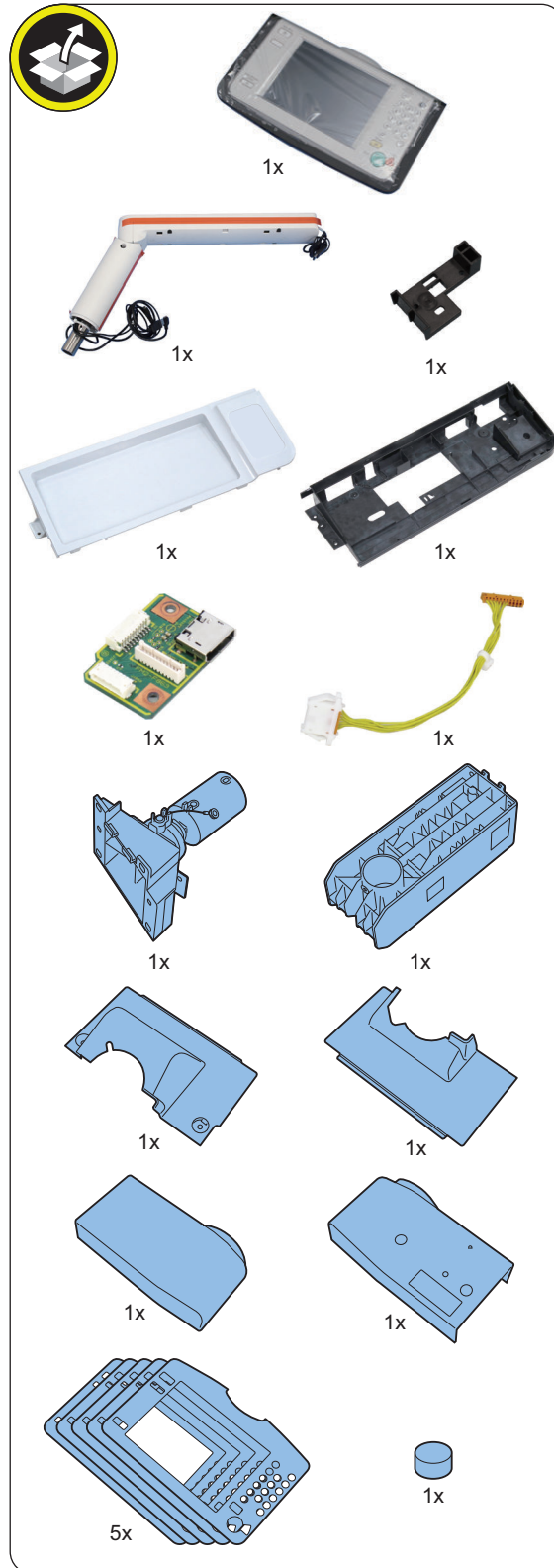

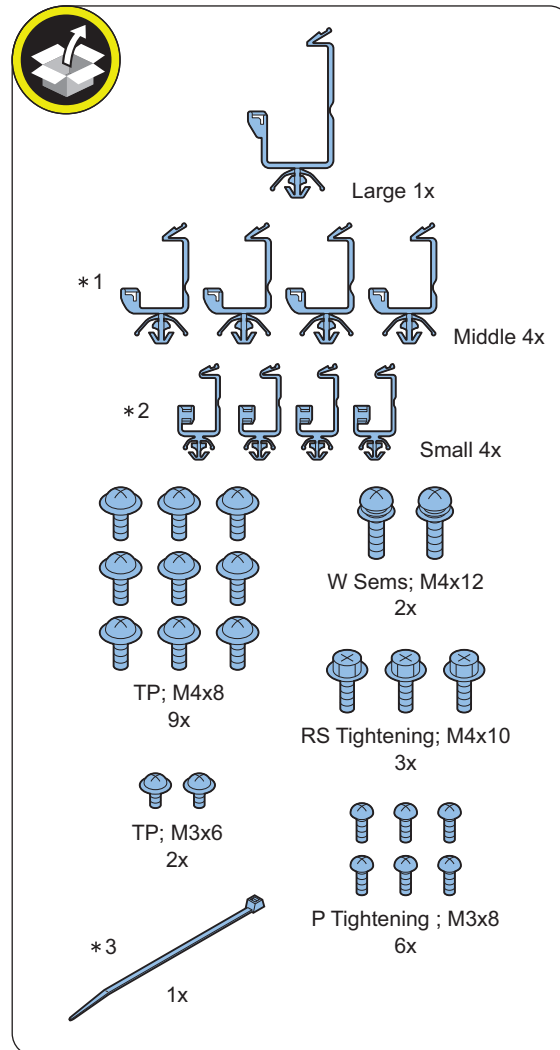

*1 : With the iR-ADV DX C7780/C7770/C7765 Series, 2 wire saddles (middle) are used.

*2 : With the iR-ADV DX C7780/C7770/C7765 Series, 3 wire saddles (middle) are used.

*3 : With the iR-ADV DX 8705/8795/8786 Series and the iR-ADV DX 6780/6765/6755 Series, the Harness Band is not used.

■ Essential Items to Be Performed Before Installation

- Turn OFF the main power of the host machine, and disconnect the power plug from the outlet.

⚠ WARNING:

- If performing work without disconnecting the power plug of the host machine, it may cause electrical shock.
- If disconnecting the power plug without turning OFF the main power, it may cause damage of the machine.

- When turning OFF the main power, follow the below procedure.
 1. Turn OFF the main power switch of the host machine.
 2. The display in the Control Panel and the lamp of the main power are turned off.

■ Points to Note When Turning ON/OFF the Main Power

The following message is displayed.

1. When a message prompting to turn OFF and then ON the main power appears, turn OFF and then ON the main power switch.
2. If a message prompting the user to update the version appears, press [Update] to automatically update the version of this equipment.

If [Skip] is selected, a message prompting the user to update the version will appear every time the host machine is started. In the service mode (Lv. 2) shown below, it is possible to set not to display the message.

COPIER > OPTION > FNC-SW > VER-CHNG

■ Installation Outline Drawing

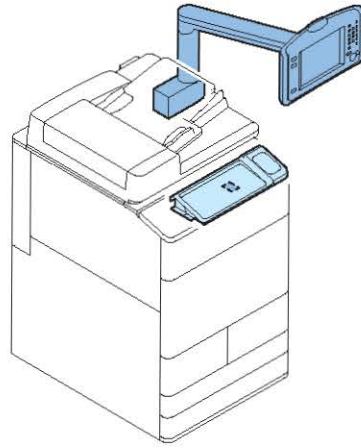

NFC Kit-E1/E2

Points to Note before Installation

The pictures and illustrations used may be different from the product in front of you, but the procedure is the same.

Checking the Contents

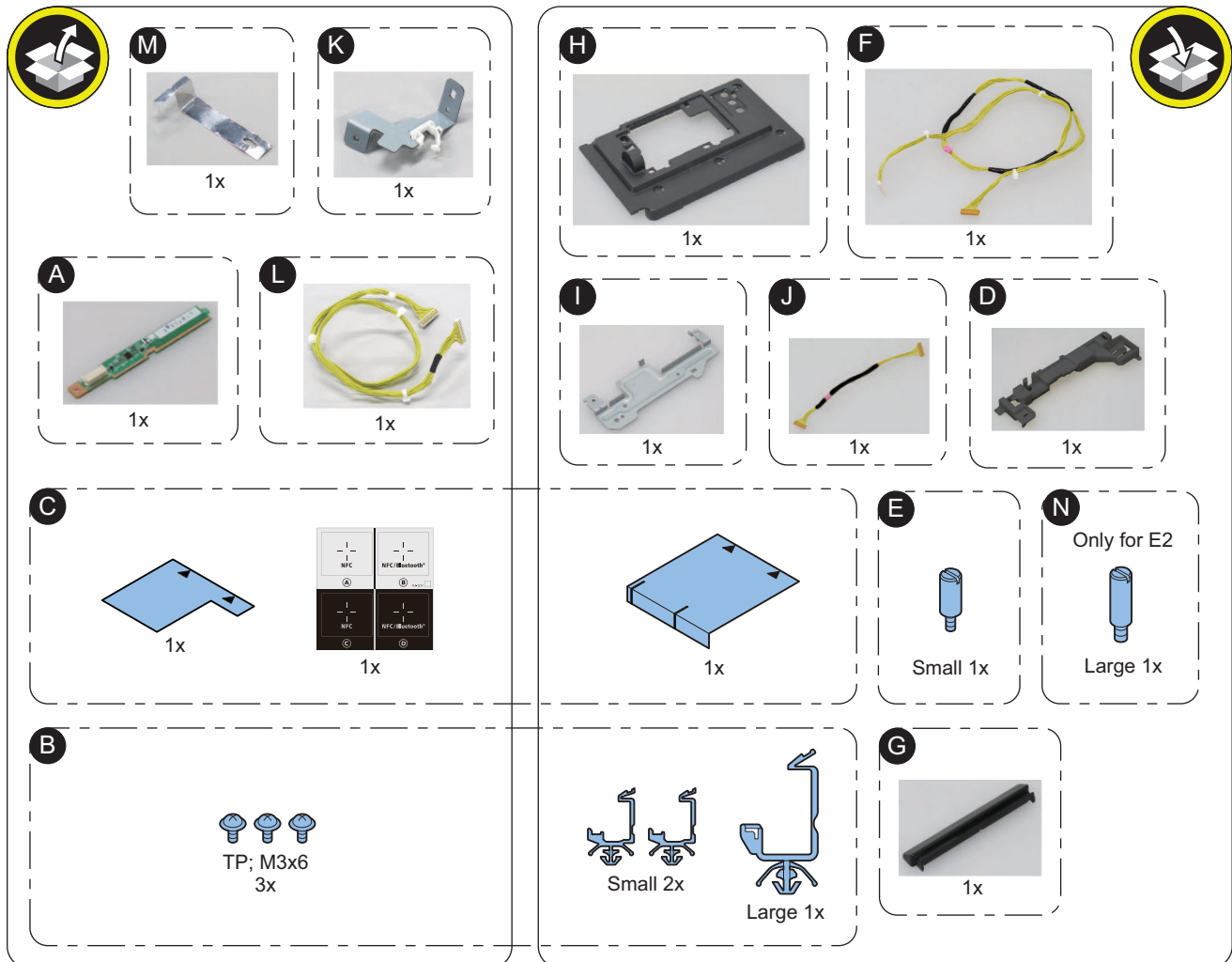

< Others >

- Guides are included

Essential Items to Be Performed Before Installation

- Turn OFF the main power of the host machine, and disconnect the power plug from the outlet.

⚠ WARNING:

- If performing work without disconnecting the power plug of the host machine, it may cause electrical shock.
- If disconnecting the power plug without turning OFF the main power, it may cause damage of the machine.

- When turning OFF the main power, follow the below procedure.
 1. Turn OFF the main power switch of the host machine.
 2. The display in the Control Panel and the lamp of the main power are turned off.

● Points to Note When Turning ON/OFF the Main Power

The following message is displayed.

1. When a message prompting to turn OFF and then ON the main power appears, turn OFF and then ON the main power switch.
2. If a message prompting the user to update the version appears, press [Update] to automatically update the version of this equipment.

If [Skip] is selected, a message prompting the user to update the version will appear every time the host machine is started. In the service mode (Lv. 2) shown below, it is possible to set not to display the message.
COPIER > OPTION > FNC-SW > VER-CHNG

● Installation Outline Drawing

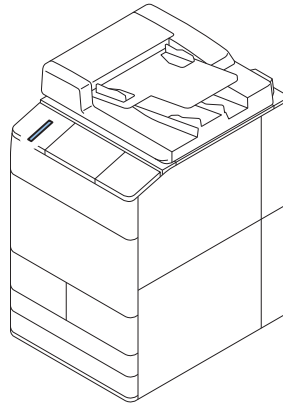

● Installation Procedure

■ Installing the NFC PCB

□

1.



□
2.

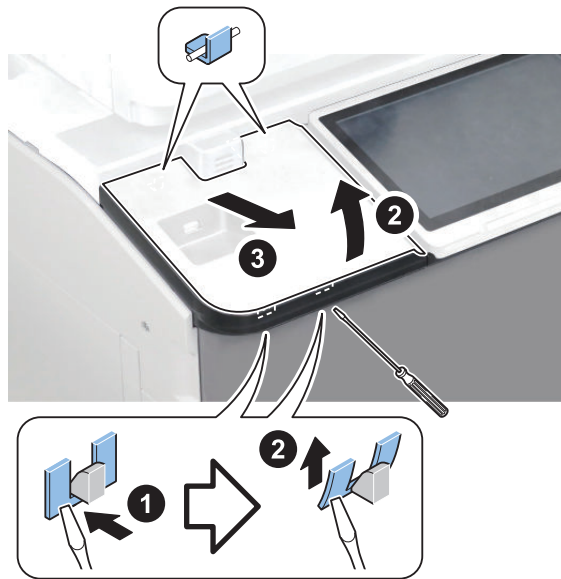

□
3.

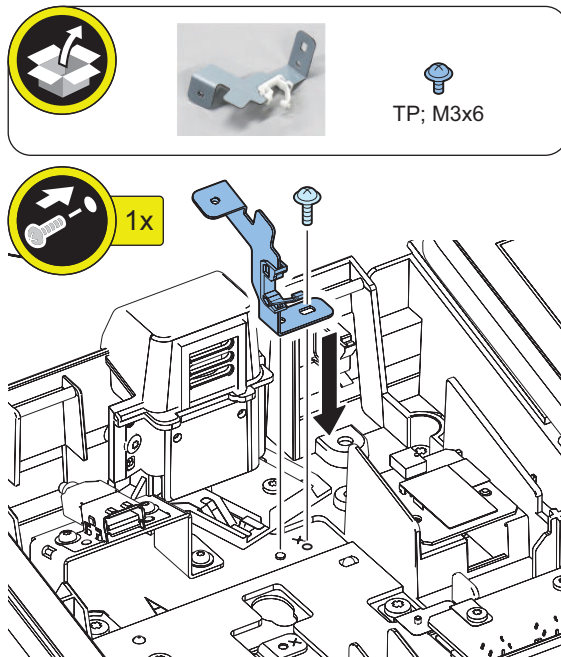

□
4.

CAUTION:
Connect the cable end which is not wrapped with black tape.

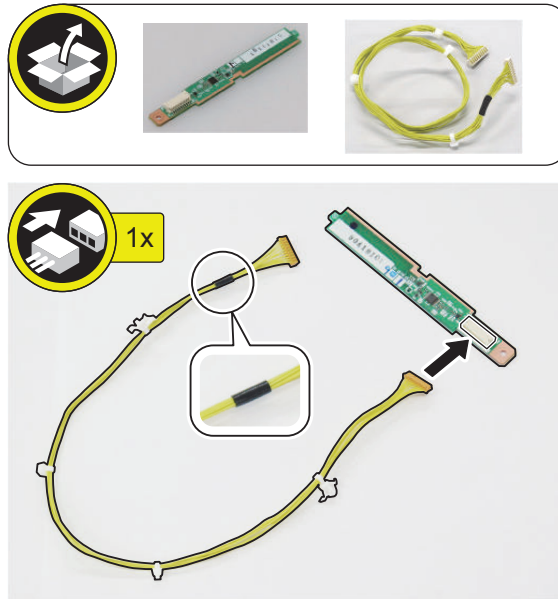

□
5.

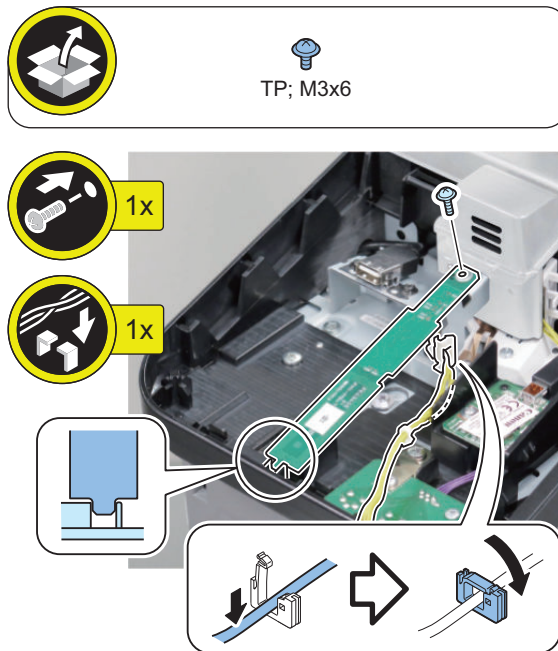

□
6.

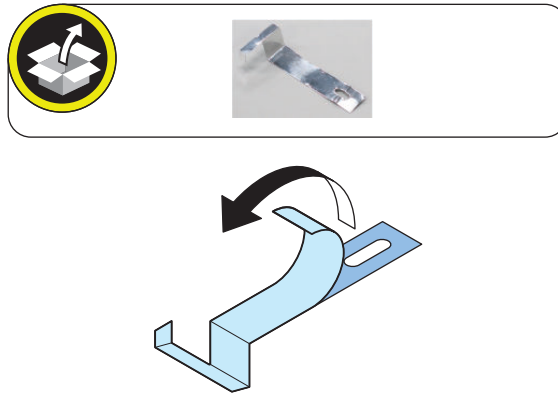

□
7.

CAUTION:

Make sure to affix the shield sheet flat against the cover wall [A] without a gap between the shield sheet and the cover. Static electricity from the gap in the Control Panel Left Upper Cover may cause damage to the NFC PCB.

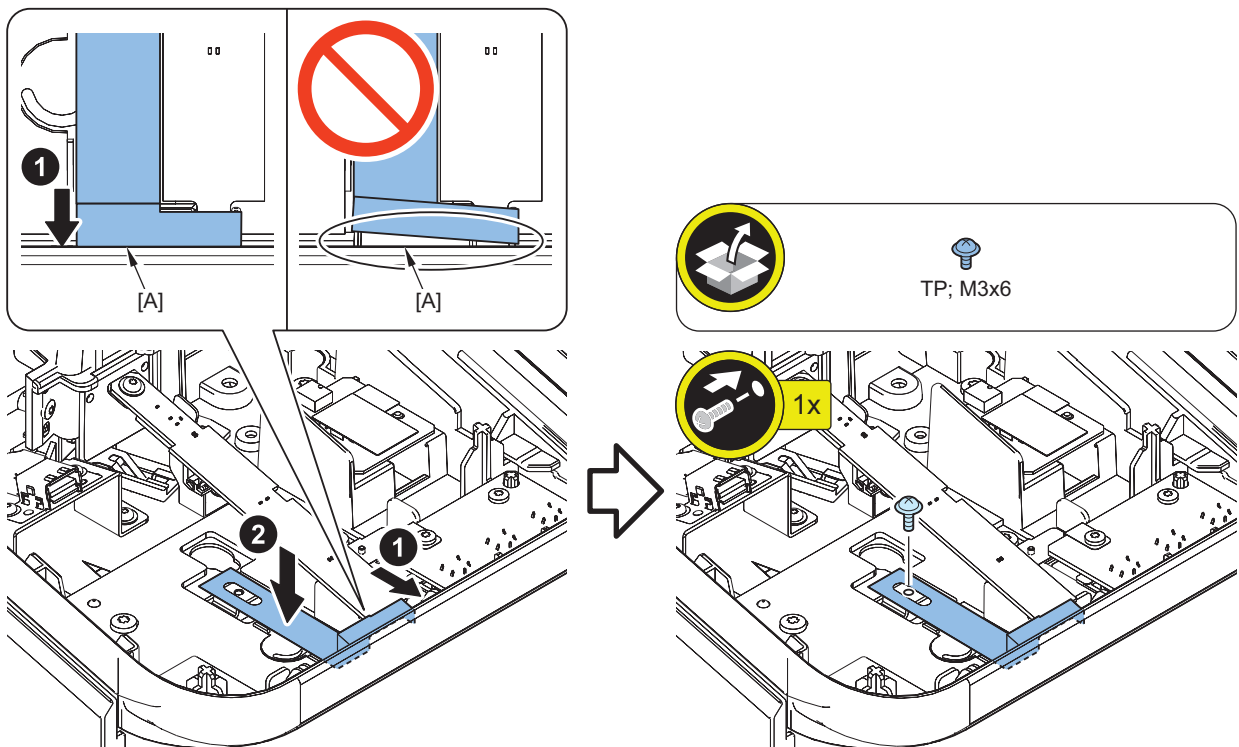

□
8. Next, proceed to the installation procedure for the target parts.

- “Connecting the NFC Cable (for the Flat Control Panel)” on page 193
- “Connecting the NFC Cable (for the Upright Control Panel)” on page 198

■ Connecting the NFC Cable (for the Flat Control Panel)

□
1.

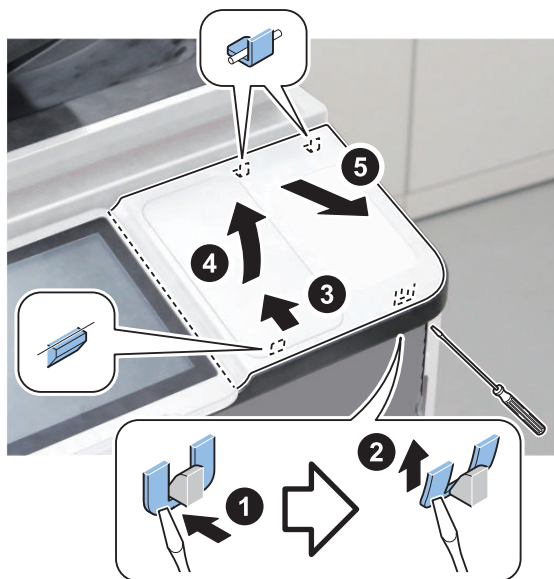

□
2.

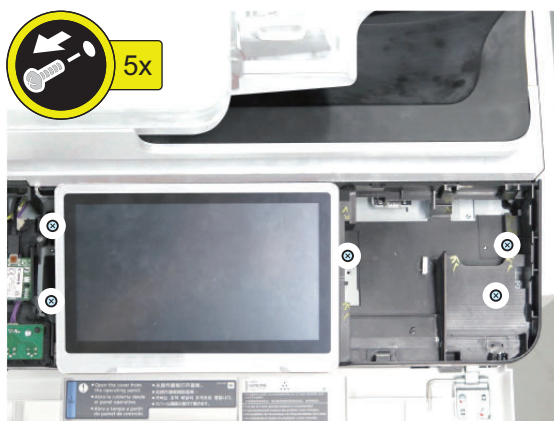

NOTE:

The removed screw will be used in step 10.

□
3.



□
4.



□
5.

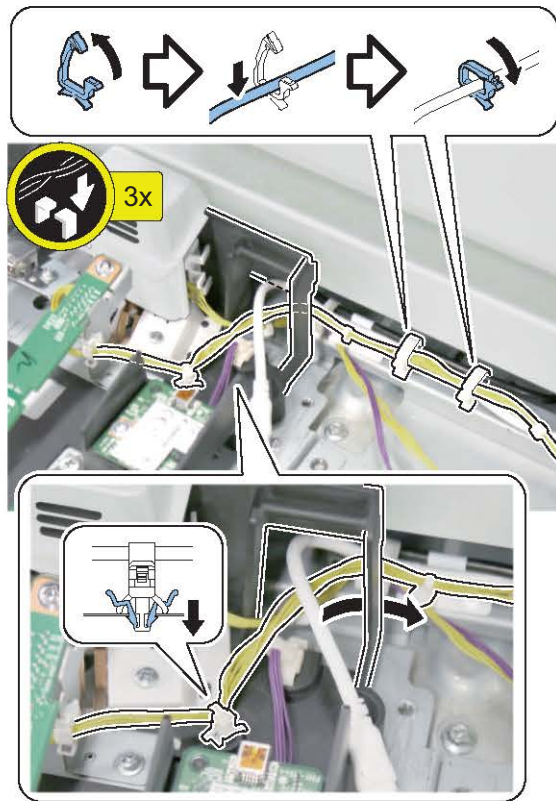

□
6.

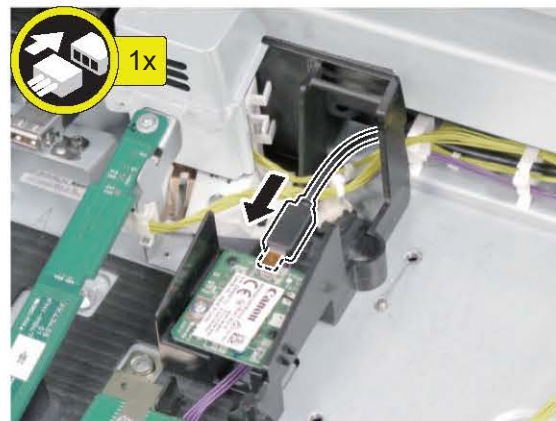

□
7.

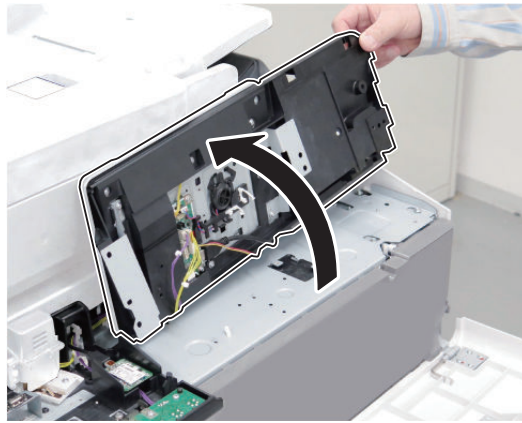

□
8.

CAUTION:

Make sure to check if any connectors are disconnected by pushing again all the connectors connected to the Flat Control Panel Unit.

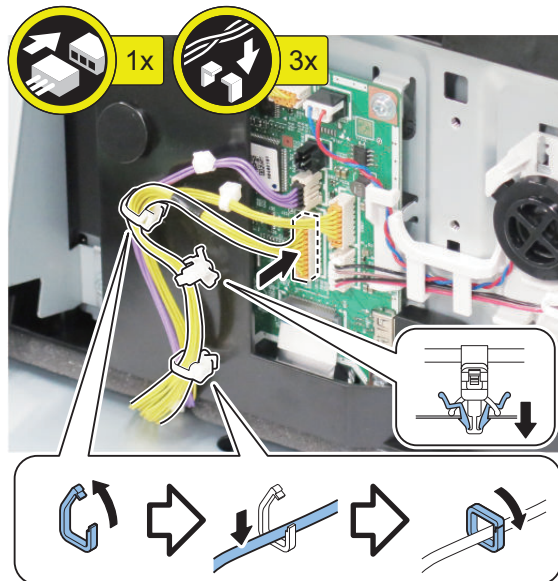

□
9.



□
10.

NOTE:
Use the screws removed in step 2.



□
11.

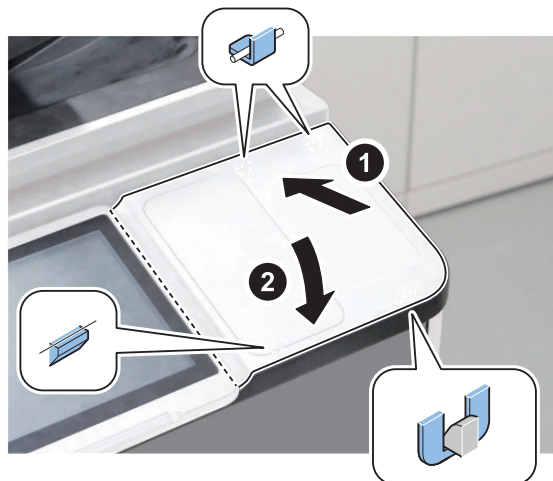

□
12. Next, proceed to “Affixing the NFC Labels” on page 203.

■ **Connecting the NFC Cable (for the Upright Control Panel)**

□
1.

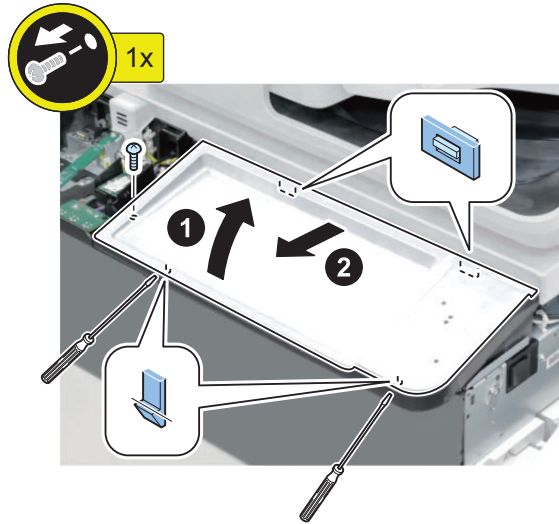

NOTE:

The removed screw will be used in step 11.

□
2.

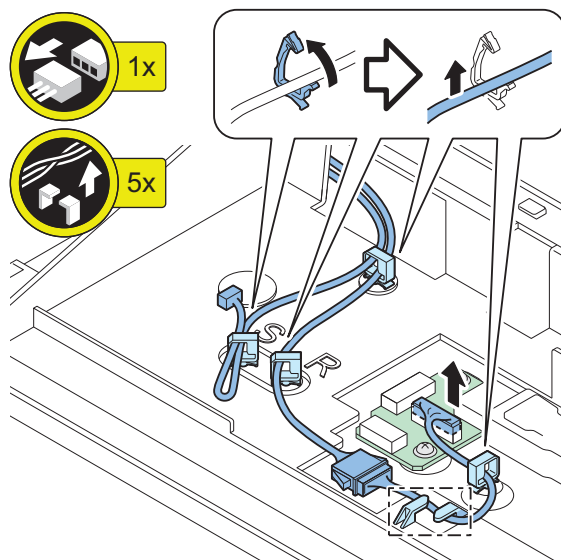

□
3.

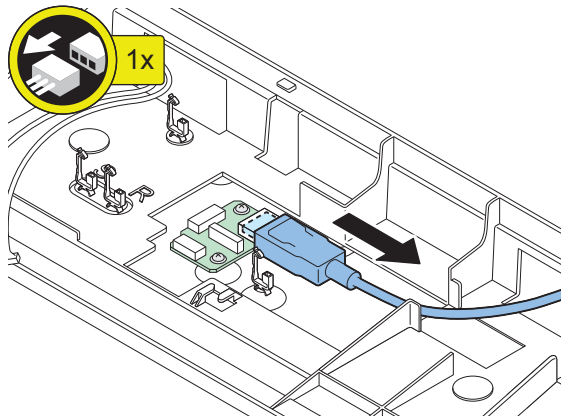

□
4.

NOTE:

Slightly pull the Front Tray Lower Unit without pulling out the cables that pass through it.

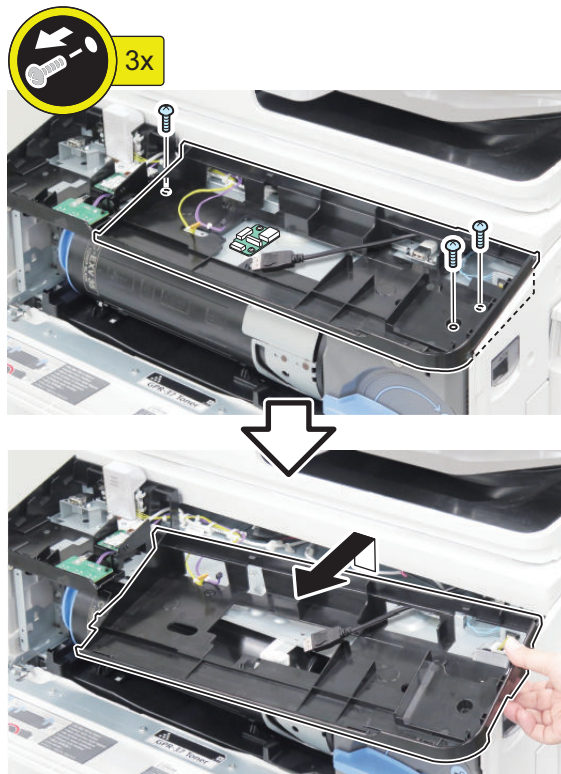
**NOTE:**

The removed screw will be used in step 8.

□
5.

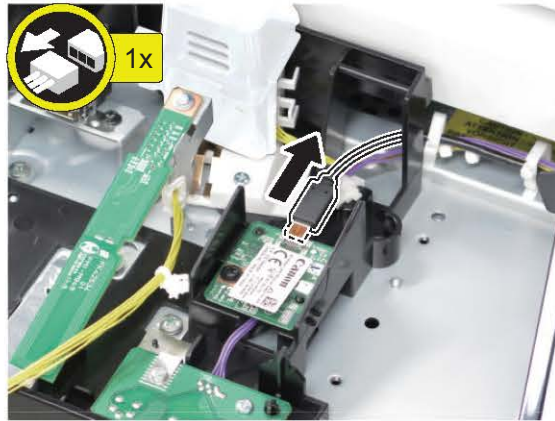

□
6.

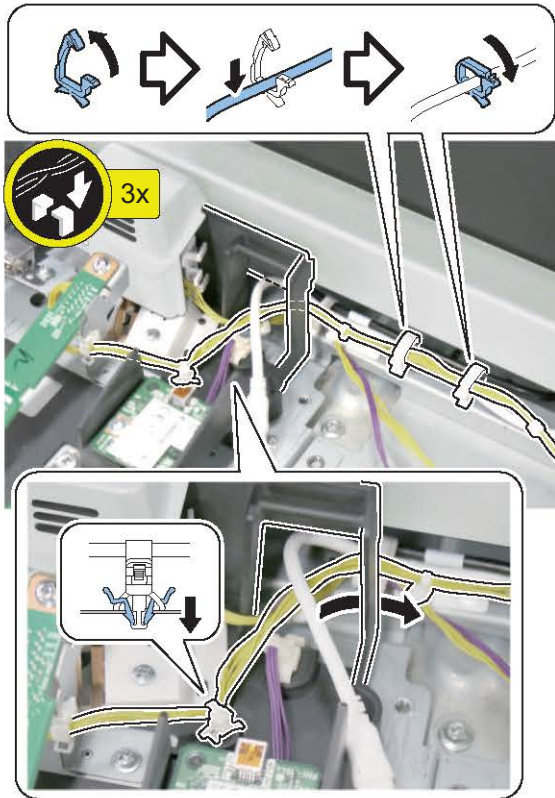

□
7.

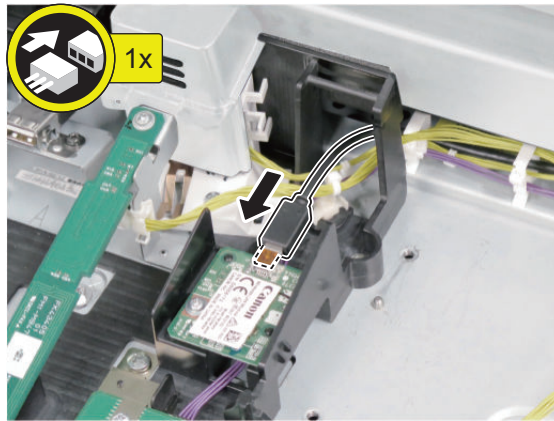

□
8.

NOTE:
Use the screws removed in step 4.

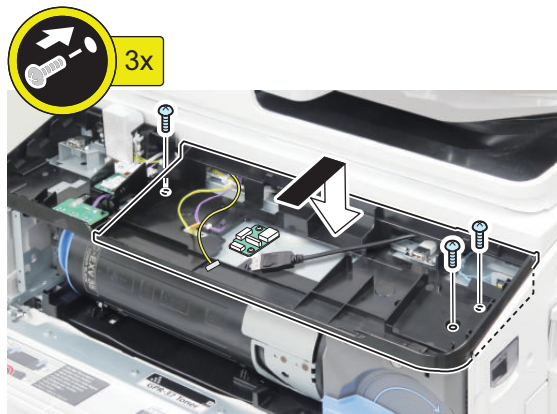

□
9.

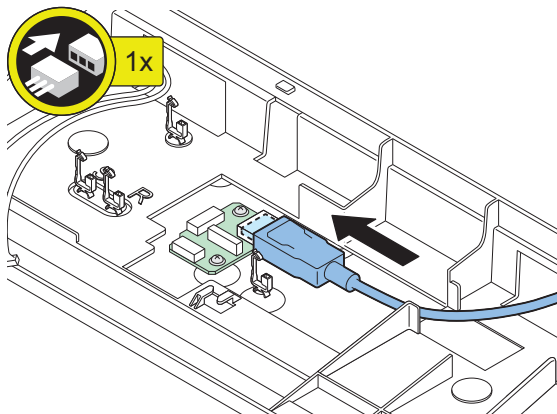

□
10.

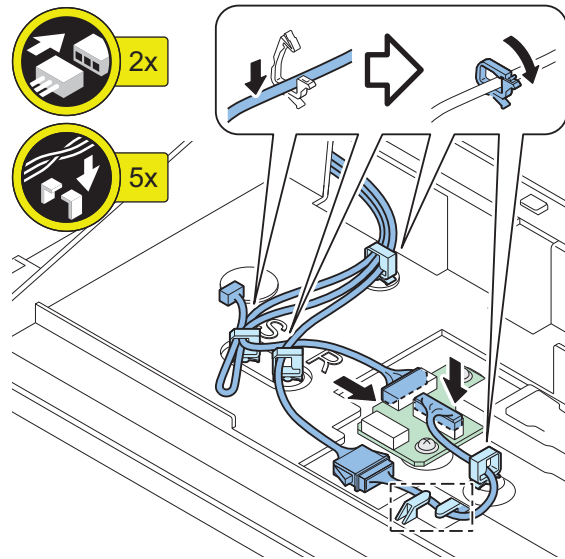

□
11.

NOTE:

Use the screws removed in step 1.

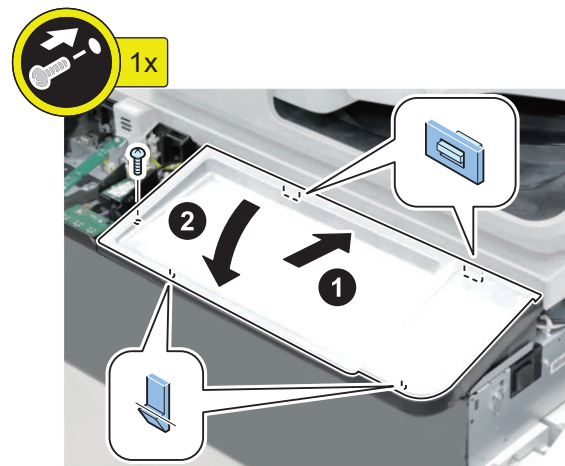

□
12. Next, proceed to [“Affixing the NFC Labels”](#) on page 203.

■ Affixing the NFC Labels

□
1.

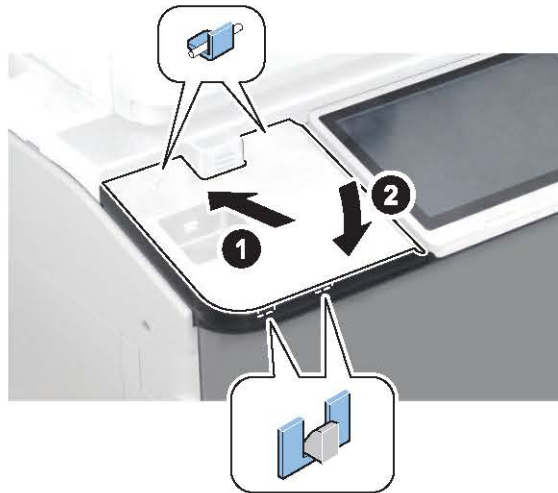

□
2.



□
3.

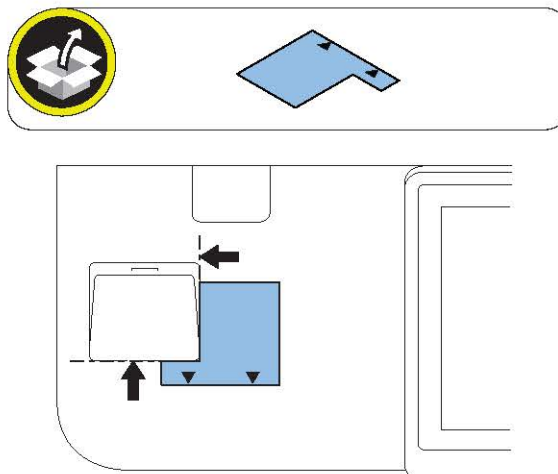

□
4.

< When installing with the NFC Kit >

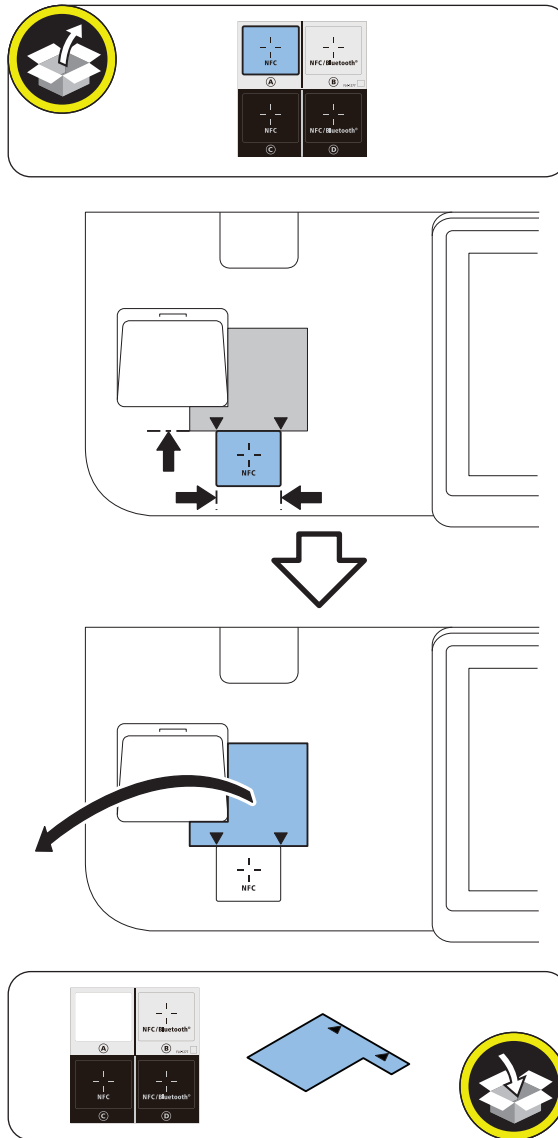

< When installing with the Connection Kit-A2 for Bluetooth LE at the same time >

NOTE:

If "Bluetooth" Label is already affixed there, remove the label and wipe off the glue with alcohol.

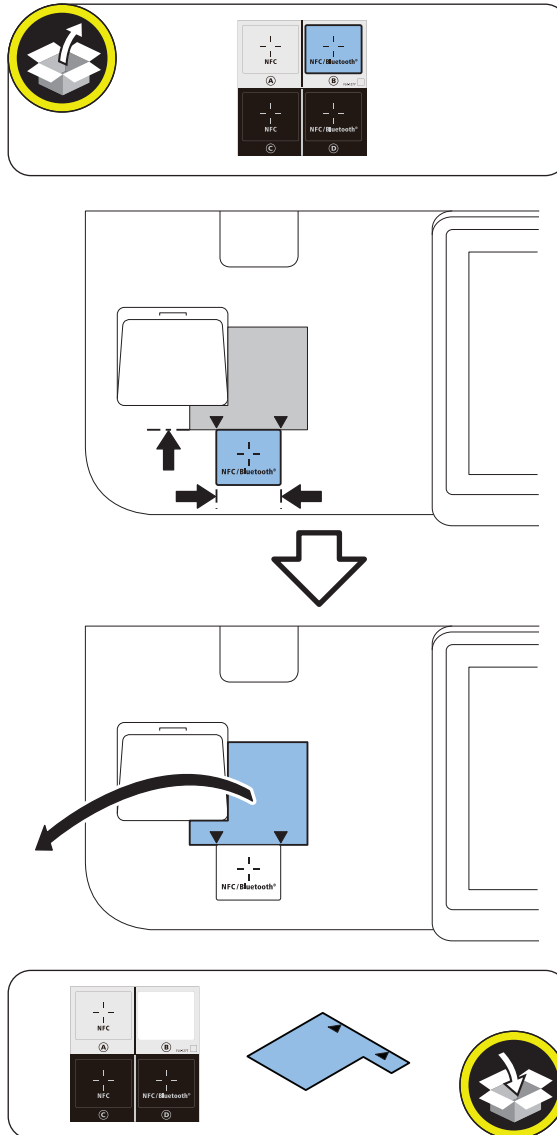

■ Setting after Installation



1. Connect the power plug of the host machine to the outlet.
2. Turn ON the main power switch.
3. Enter service mode and set the value to "1".
COPIER > FUNCTION > INSTALL > NFC-USE

NOTE:

When [System Manager Information Settings] is set, it is required to log in as a system manager in accordance with instructions of the user administrator.

4. Select [Settings/Registration] > [Management Settings] > [Device Management] > [Use NFC Card Emulation], and set the item to "ON".
5. Turn OFF and then ON the main power switch.

6. When a message prompting the version update is displayed, press [Update] and automatically update the version of this equipment.

CAUTION:

It may take time to display the update screen. (Approx. 1 to 2 min.) During this time, do not operate the screen.

7. Check the end of the following service mode.

COPIER > DISPLAY > VERSION > PANEL

- If the end is an even number (e.g. 01.26): NFC is not installed.
- If the end is an odd number (e.g. 01.27): NFC is installed.

Connection Kit-A2/A3 for Bluetooth LE

Points to Note before Installation

The pictures and illustrations used may be different from the product in front of you, but the procedure is the same.

Checking the Contents

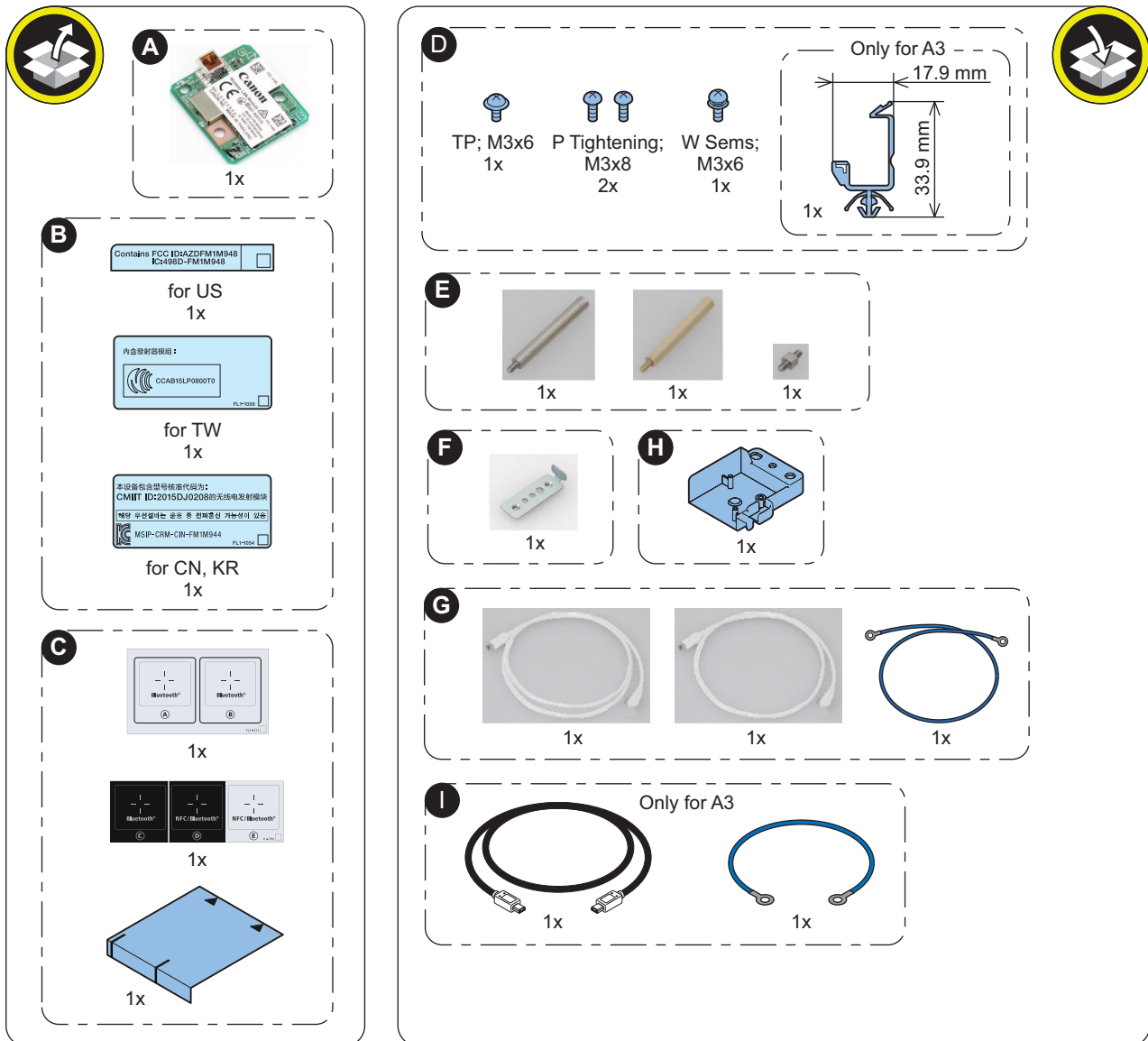

Essential Items to Be Performed Before Installation

- Turn OFF the main power of the host machine, and disconnect the power plug from the outlet.

⚠ WARNING:

- If performing work without disconnecting the power plug of the host machine, it may cause electrical shock.
- If disconnecting the power plug without turning OFF the main power, it may cause damage of the machine.

- When turning OFF the main power, follow the below procedure.
 1. Turn OFF the main power switch of the host machine.
 2. The display in the Control Panel and the lamp of the main power are turned off.

● Points to Note When Turning ON/OFF the Main Power

The following message is displayed.

1. When a message prompting to turn OFF and then ON the main power appears, turn OFF and then ON the main power switch.
2. If a message prompting the user to update the version appears, press [Update] to automatically update the version of this equipment.

If [Skip] is selected, a message prompting the user to update the version will appear every time the host machine is started. In the service mode (Lv. 2) shown below, it is possible to set not to display the message.

COPIER > OPTION > FNC-SW > VER-CHNG

● Installation Outline Drawing

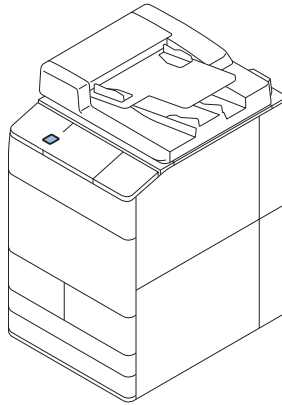

● Installation Procedure

□
1.



□
2.

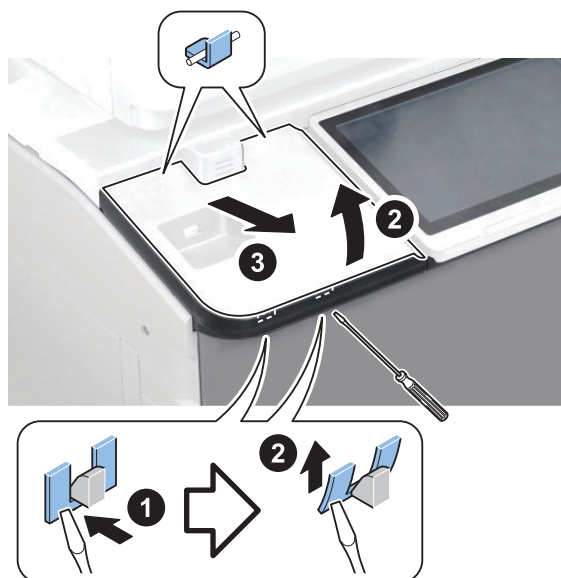

□
3.

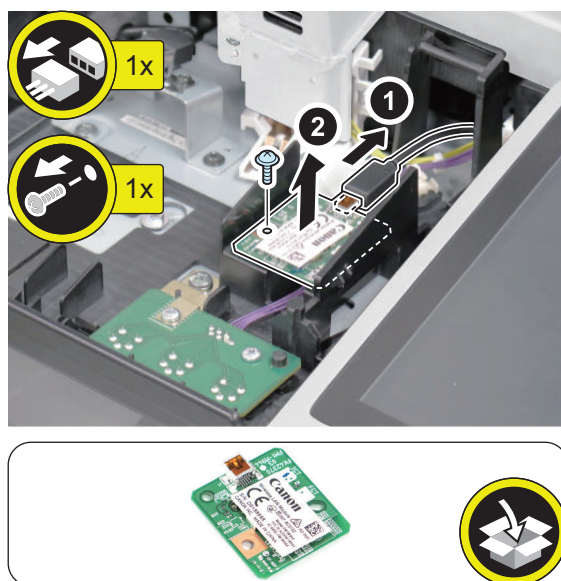

NOTE:
The removed screw will be used in a next step.

CAUTION:

Replace the removed Wi-Fi PCB with the optional Bluetooth PCB. Be sure to mount the correct one.

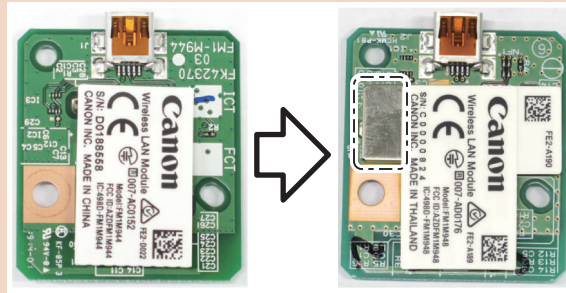

□
4.

NOTE:

Use the screw removed in the previous step.

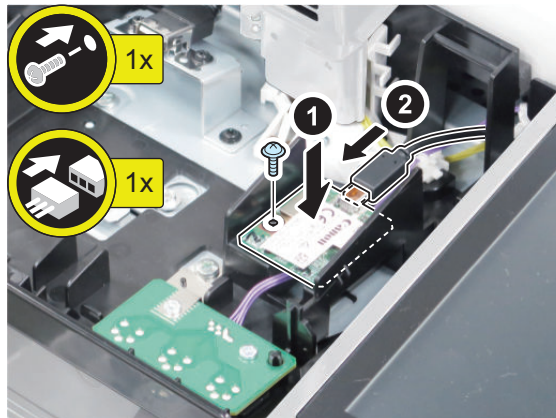

□
5.

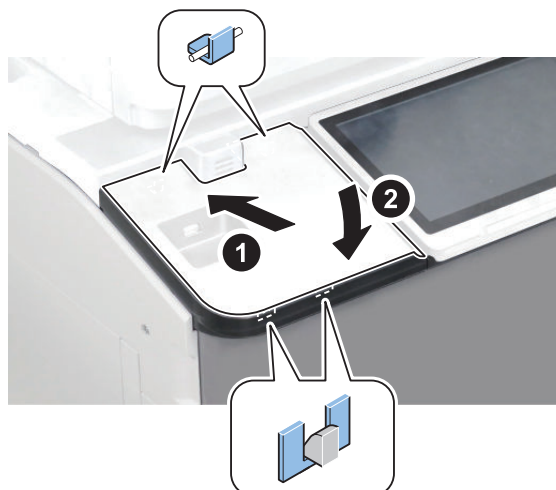

□
6.



□
7.

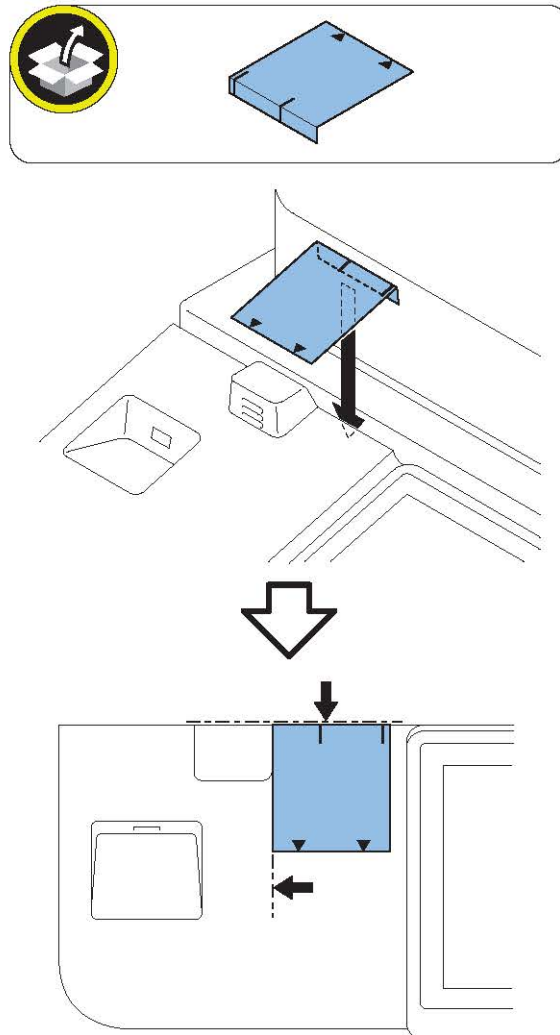

□
8.

< When installing with the Connection Kit-A2 for Bluetooth LE >

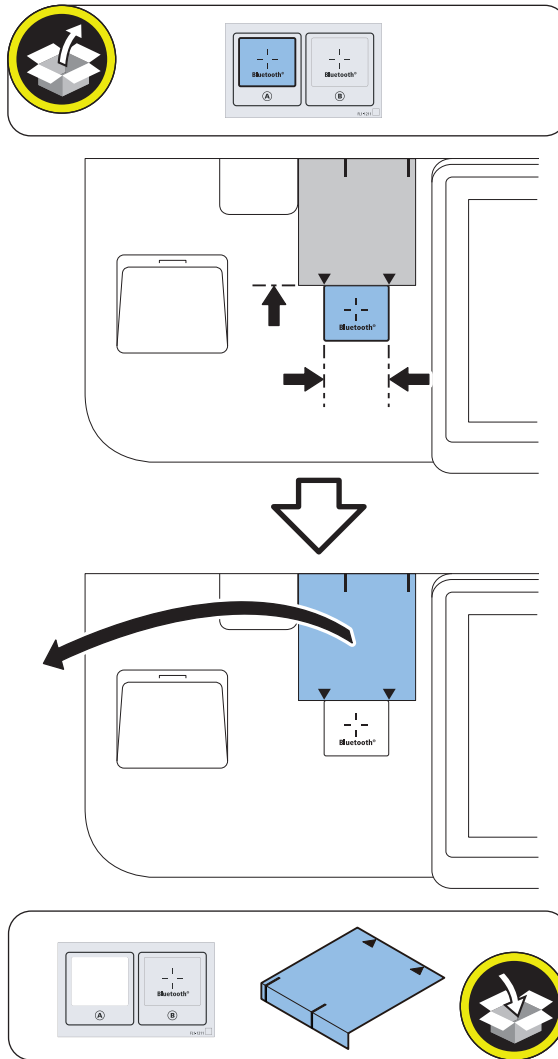

< When installing with the NFC Kit at the same time >

NOTE:

If "Bluetooth" Label is already affixed there, remove the label and wipe off the glue with alcohol before affixing the new label.

- When the Target Sheet for the NFC Kit is available

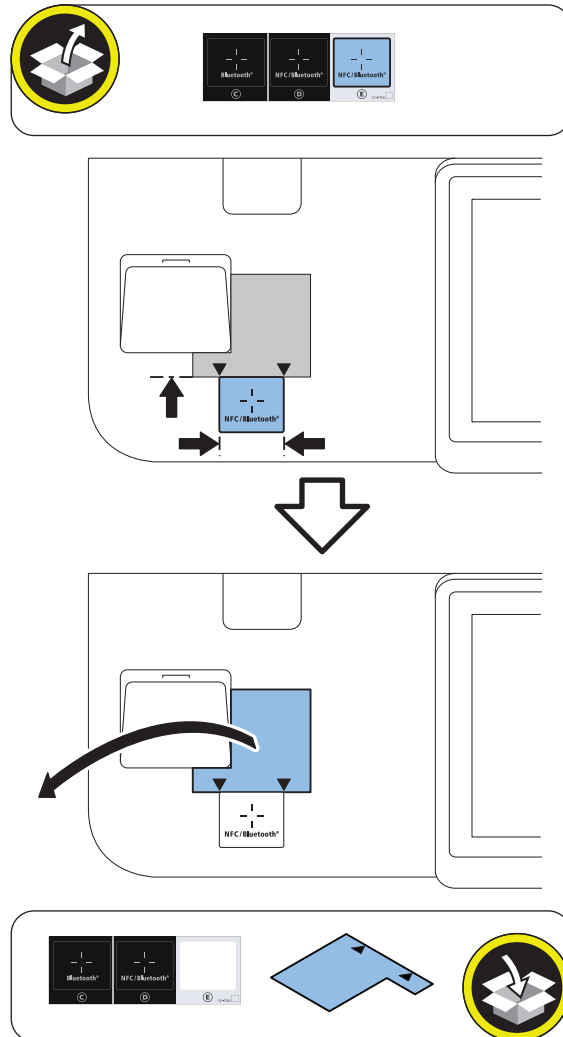

- When the Target Sheet for the NFC Kit is not available

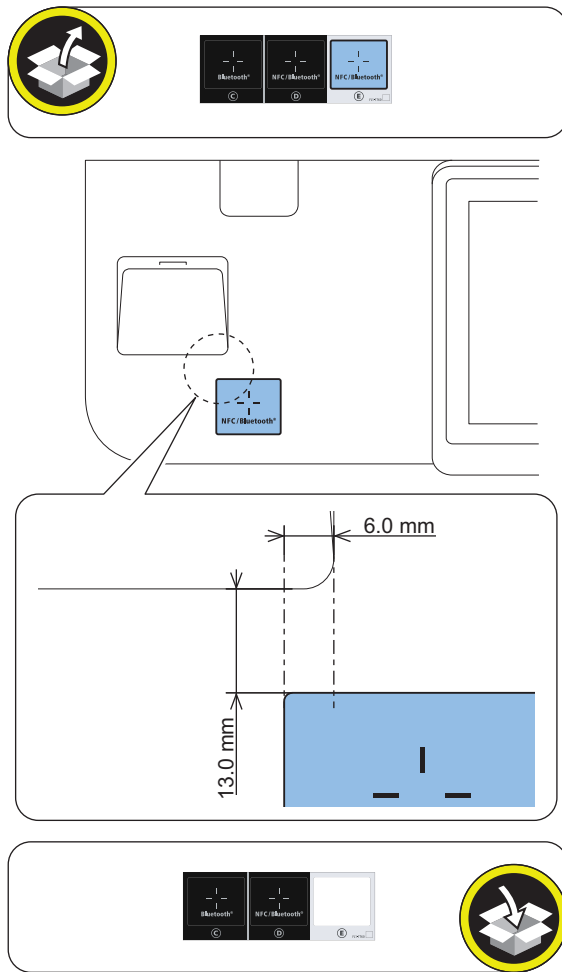

■ Affixing the Wireless LAN Approval Label

□
1.

NOTE:

In countries other than the following countries, it is not necessary to affix the Approval Label.

< For US >

Affix it over the number on the Wireless LAN Approval Label.

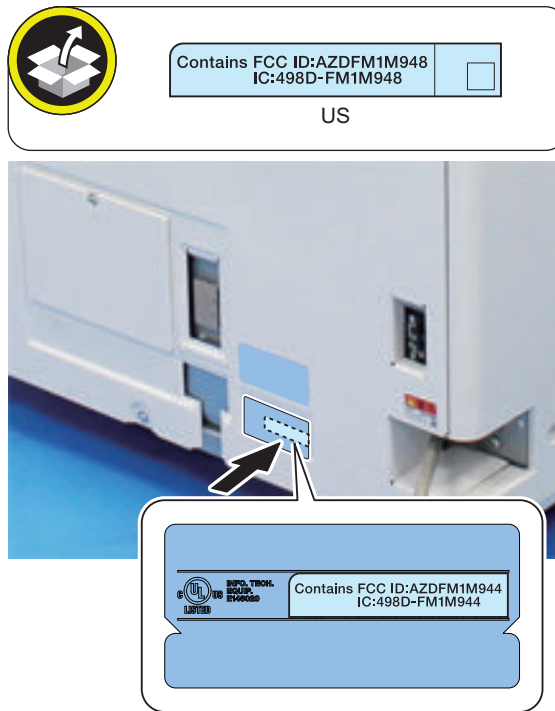

< For CN, KR, and TW >

Affix it over the Wireless LAN Approval Label.

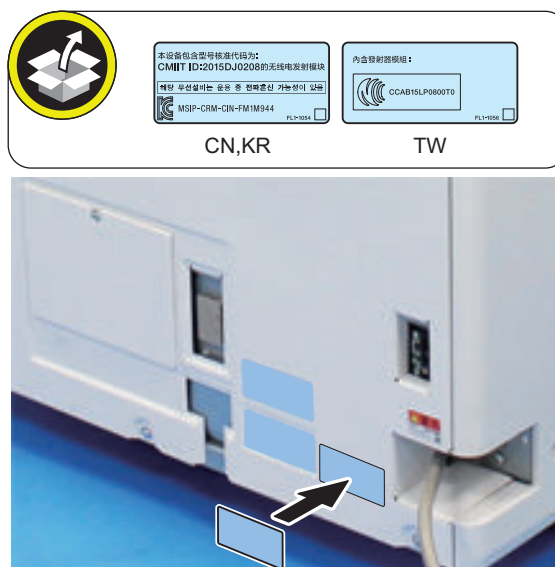

Setting after Installation



1. **Connect the power plug of the host machine to the outlet.**
2. **Turn ON the main power switch.**
3. **In the following Service Mode, set the value to "1."**
COPIER > FUNCTION > INSTALL > BLE-USE

NOTE:

When [System Manager Information Settings] is set, it is required to log in as a system manager in accordance with instructions of the user administrator.

4. **Select [Settings/Registration] > [Preferences] > [Network] > [Confirm Network Connection Setting Changes], and set the item [ON].**
5. **Select [Settings/Registration] > [Preferences] > [Network] > [Bluetooth Settings] > [Use Bluetooth] > [ON].**
6. **The message "Perform Apply Setting Changes from Settings/Registration" appears in the Touch Panel Display.**
7. **Perform "Apply Setting Changes."**
Press [Settings/Registration] > [Yes].

Numeric Keypad-A1/A2

Points to Note before Installation

- When installing the Numeric Keypad and the IC Card Reader at the same time, be sure to install the Numeric Keypad first.
- The pictures and illustrations used may be different from the product in front of you, but the procedure is the same.

Checking the Contents

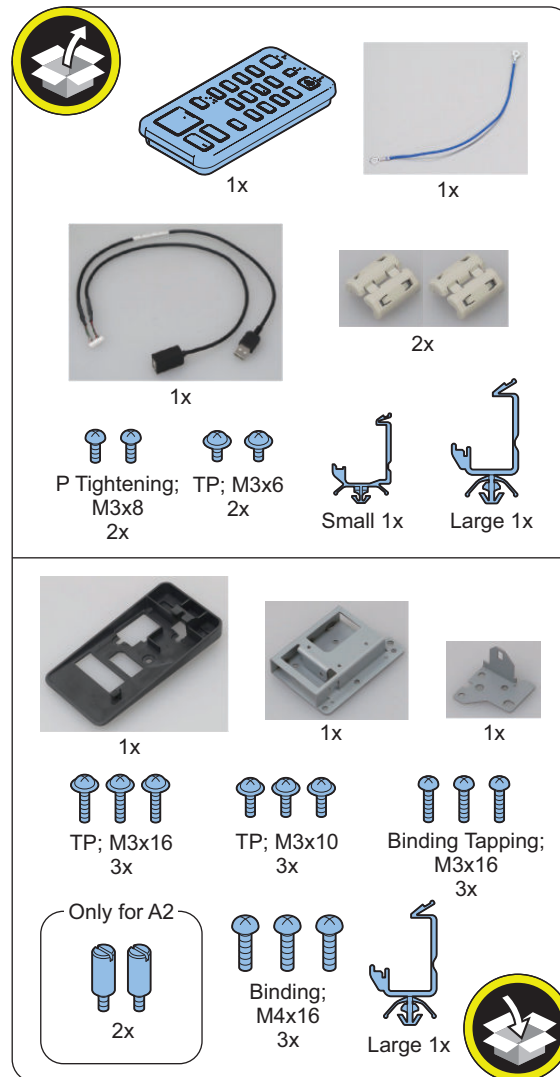

Essential Items to Be Performed Before Installation

- Turn OFF the main power of the host machine, and disconnect the power plug from the outlet.

⚠ WARNING:

- If performing work without disconnecting the power plug of the host machine, it may cause electrical shock.
- If disconnecting the power plug without turning OFF the main power, it may cause damage of the machine.

- When turning OFF the main power, follow the below procedure.
 1. Turn OFF the main power switch of the host machine.
 2. The display in the Control Panel and the lamp of the main power are turned off.

Points to Note When Turning ON/OFF the Main Power

The following message is displayed.

1. When a message prompting to turn OFF and then ON the main power appears, turn OFF and then ON the main power switch.
2. If a message prompting the user to update the version appears, press [Update] to automatically update the version of this equipment.

If [Skip] is selected, a message prompting the user to update the version will appear every time the host machine is started. In the service mode (Lv. 2) shown below, it is possible to set not to display the message.
COPIER > OPTION > FNC-SW > VER-CHNG

Installation Outline Drawing

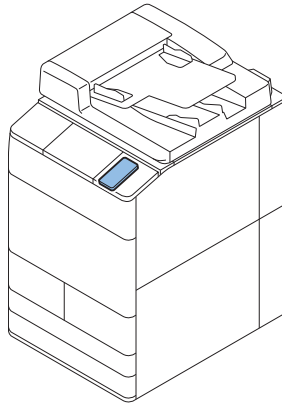

Installation Procedure

1.



□
2.

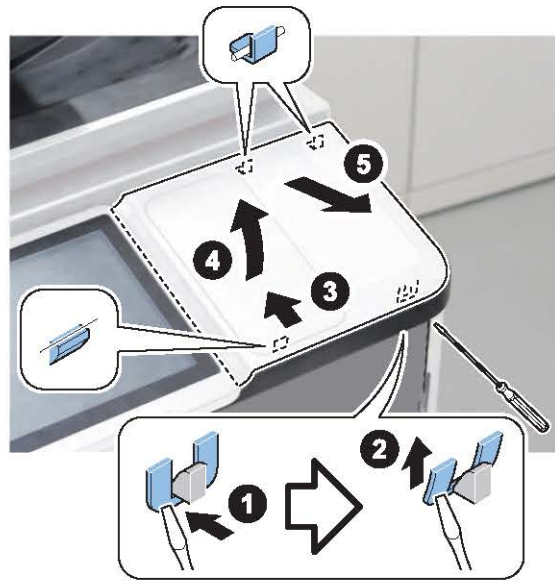

□
3.

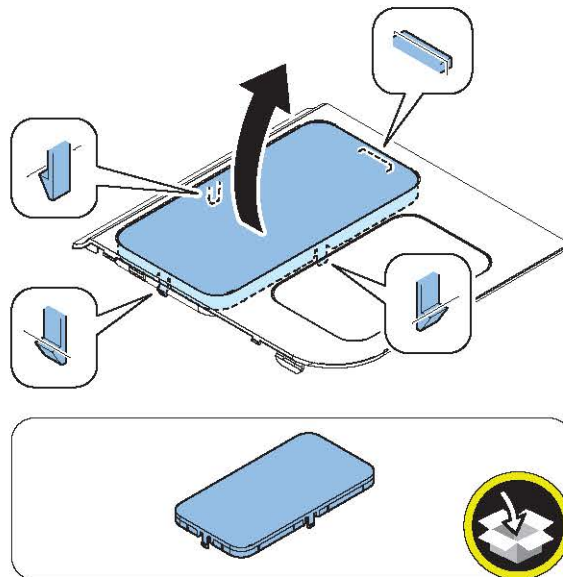

□
4.

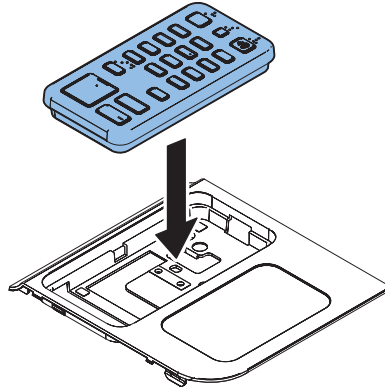
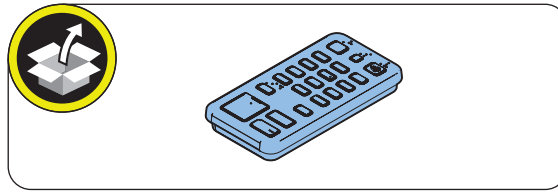

□
5.

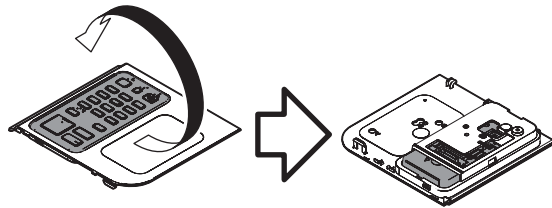

□
6.

CAUTION:

Be sure to check that the 2 bosses are fitted securely.

Installing the Control Panel Right Upper Cover while the bosses are not fitted securely will cause rattling.



P Tightening; M3x8

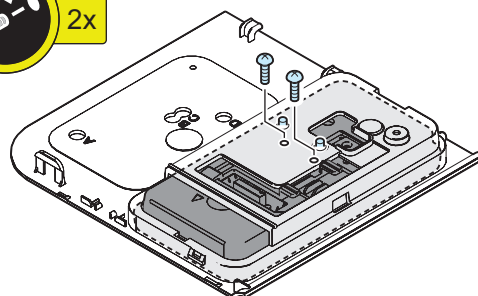

□
7.

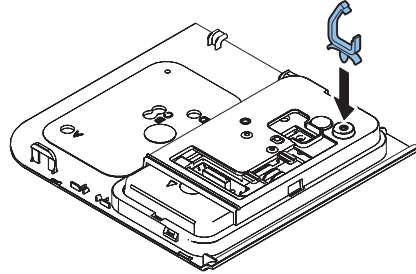
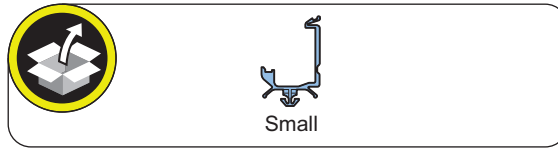

□
8.

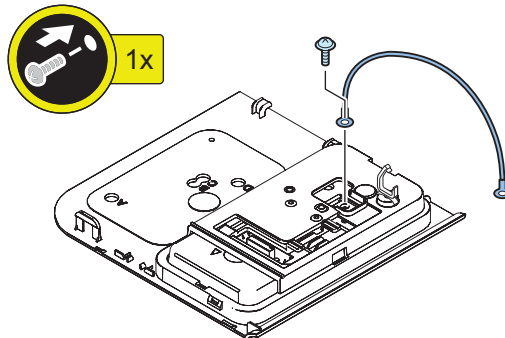

□
9.**NOTE:**

Attach the first core along with the white tape affixed to the Numeric Keypad cable. Fold the cable as shown in the figure, and attach the second core in a line-symmetric position with respect to the core attached first.

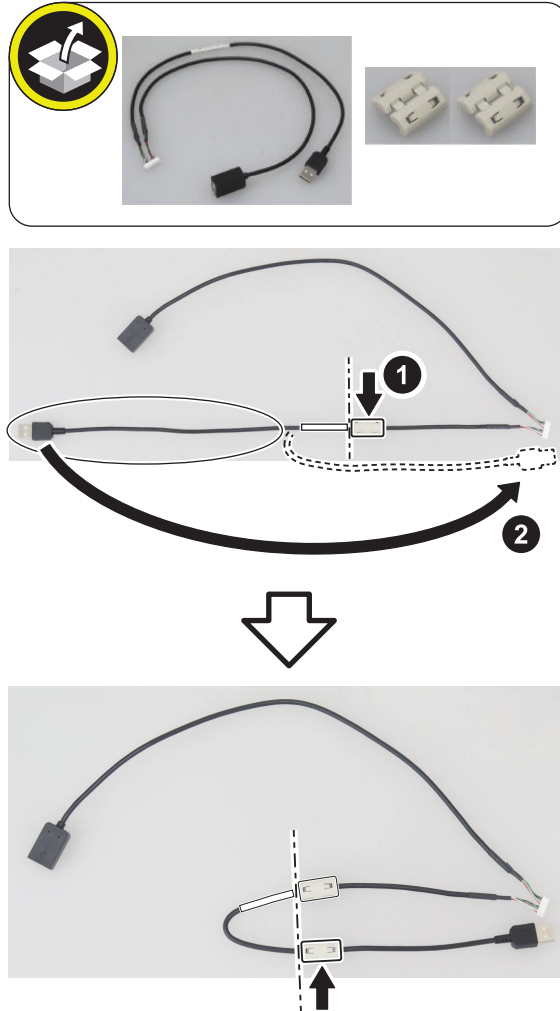

□
10.

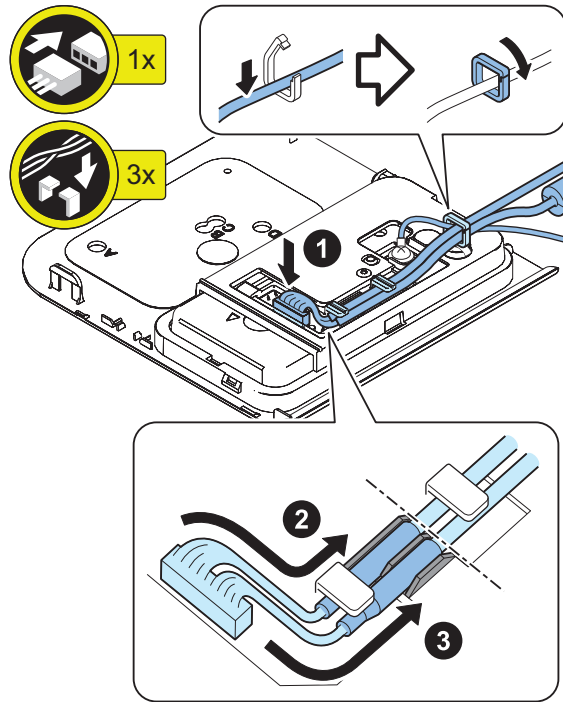

□
11.

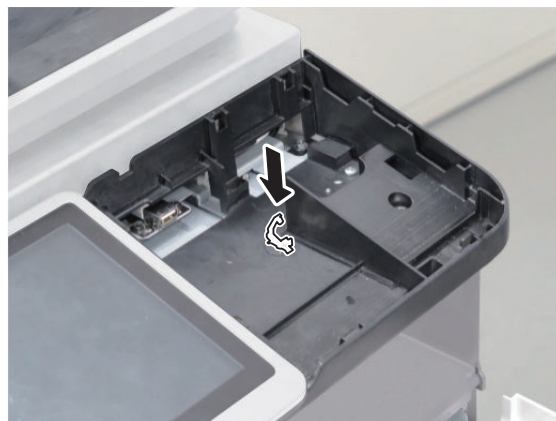
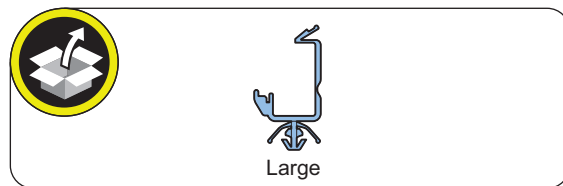

□
12.

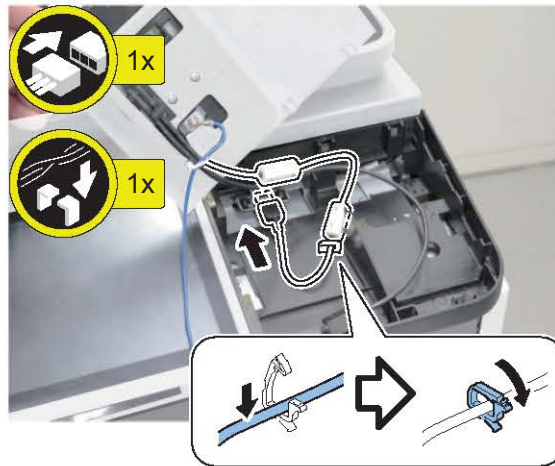

13.

< When installing the Numeric Keypad only >

NOTE:

Store the excess length of the cable in the position as shown in the figure.

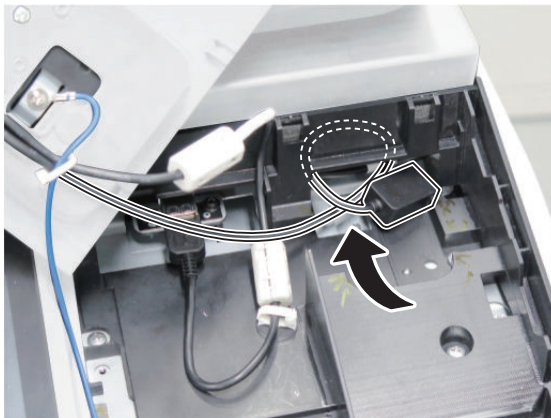

< When installing with the IC Card Reader at the same time >

NOTE:

Store the excess length of the cable in the position as shown in the figure.

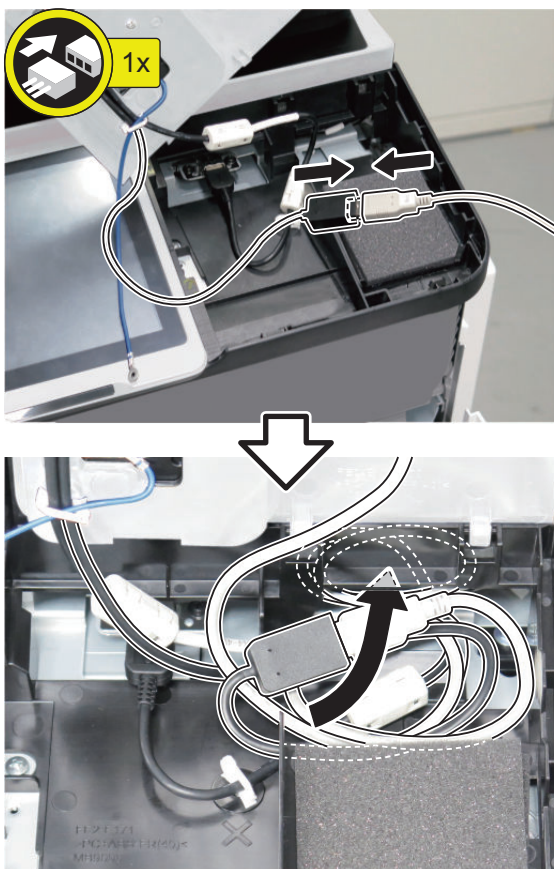

□
14.



□
15.

CAUTION:
Place the Core in the position as shown in the figure.

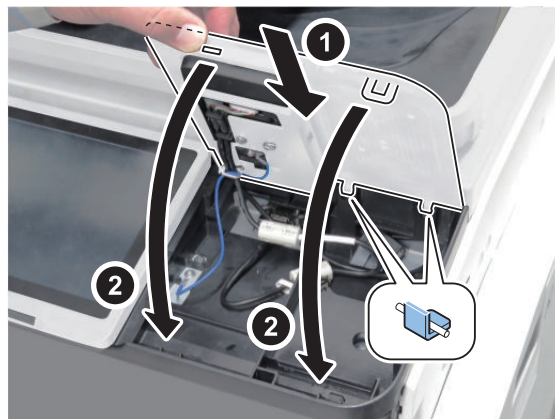

□
16.



□
17. Connect the power plug to the outlet.

18. Turn ON the main power switch.

Utility Tray-B1

Points to Note at Installation

- The pictures and illustrations used may be different from the product in front of you, but the procedure is the same.
- Refer to "Table of Options Combination" when installing this equipment before operation.

Table of Options Combination

	Voice Operation	Voice Guidance Kit	Copy Card Reader
Utility Tray	No	No	Yes

Yes: Available, No: Unavailable

Checking the Contents

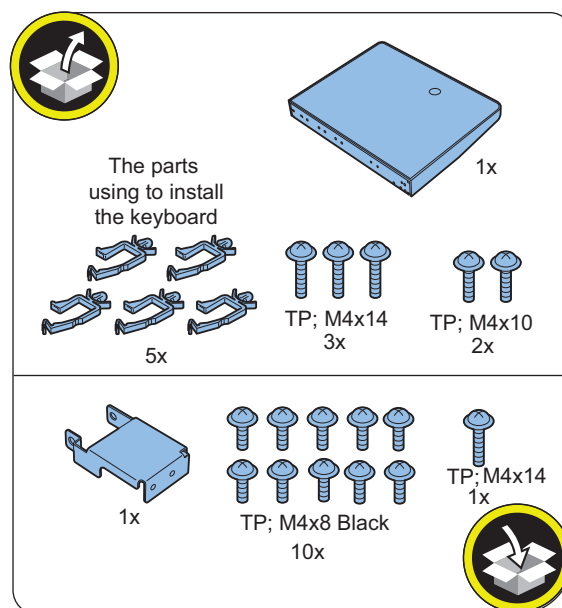

Installation Outline Drawing

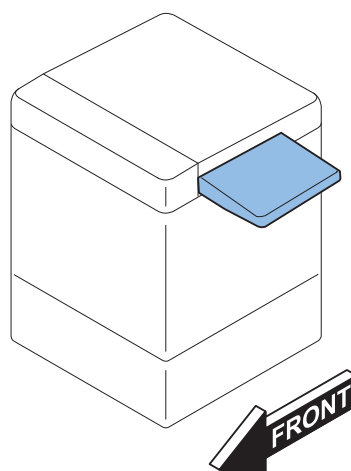

● Installation Procedure

□

1. Remove packing tapes.

□

2.

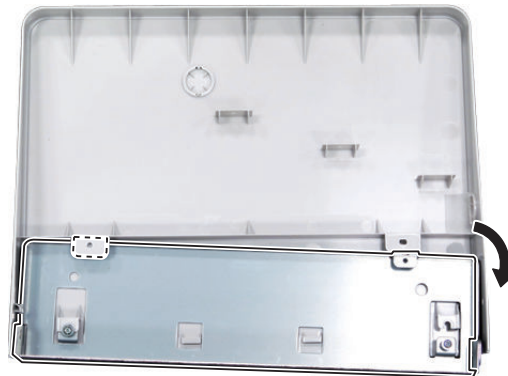
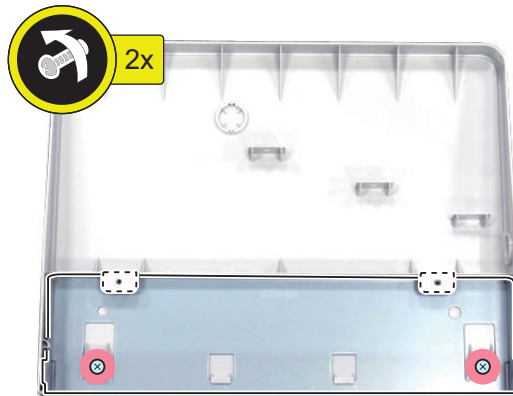
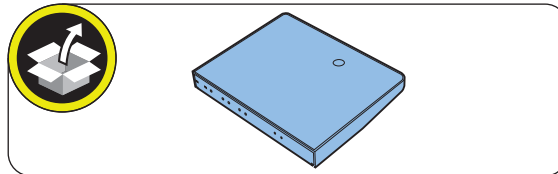

□
3.**CAUTION:**

To avoid damage, do not pull the Utility Tray too much.

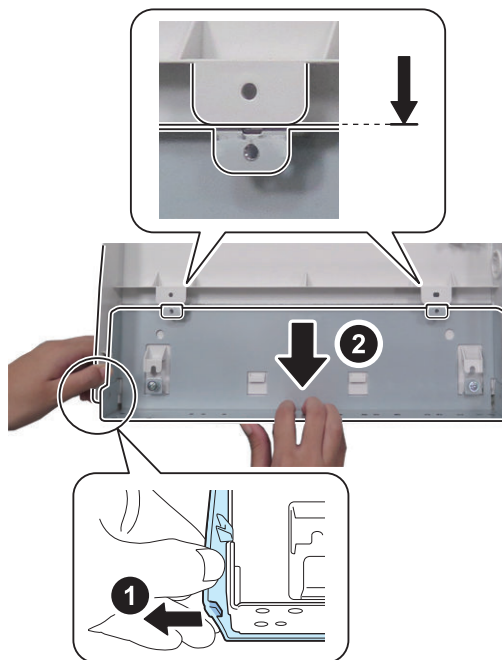
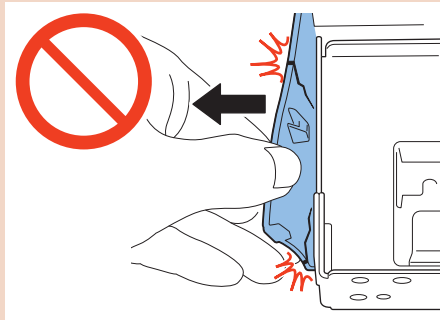

□
4.

CAUTION:
To avoid damage, do not pull the Utility Tray too much.

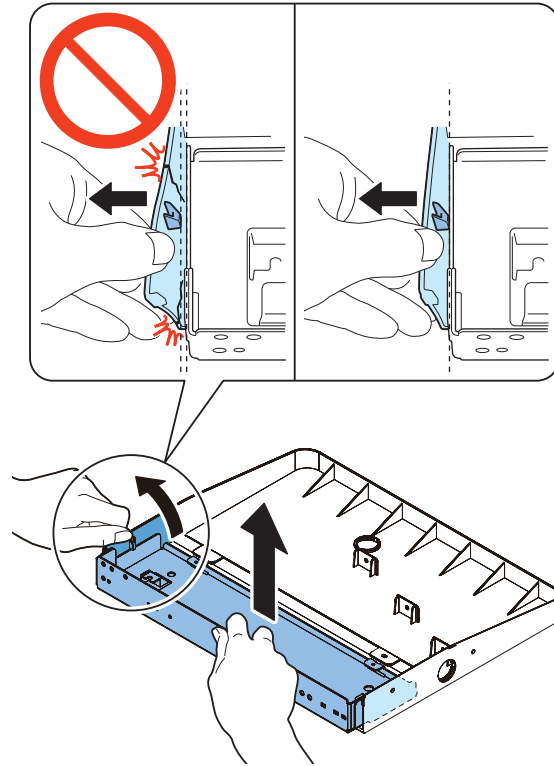

□
5.

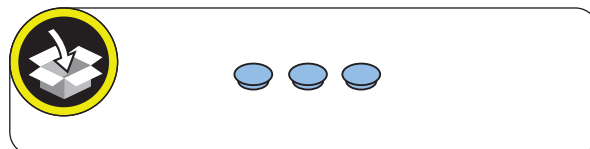

□
6.

CAUTION:

Points to Note at Installation

If the holes are marked as shown below, align the holes marked with B, G and P with the holes in the host machine

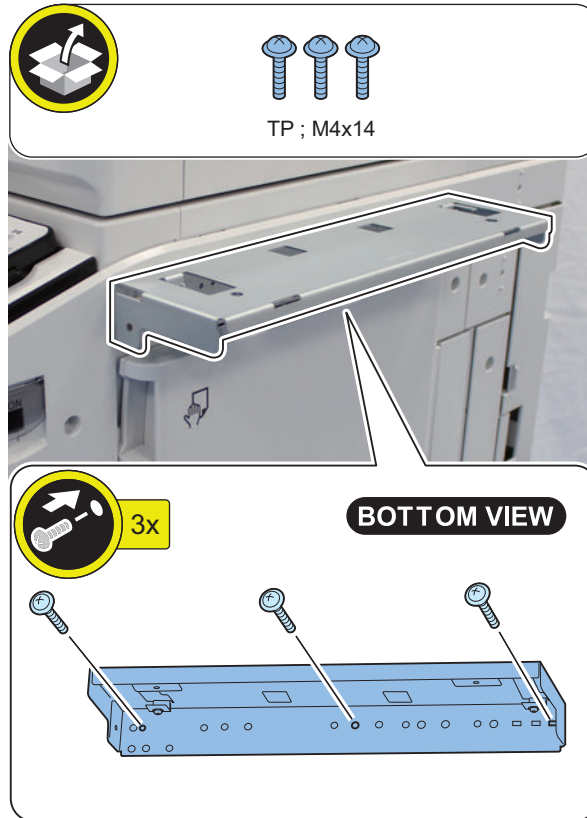
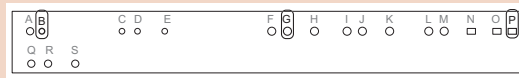

□
7.

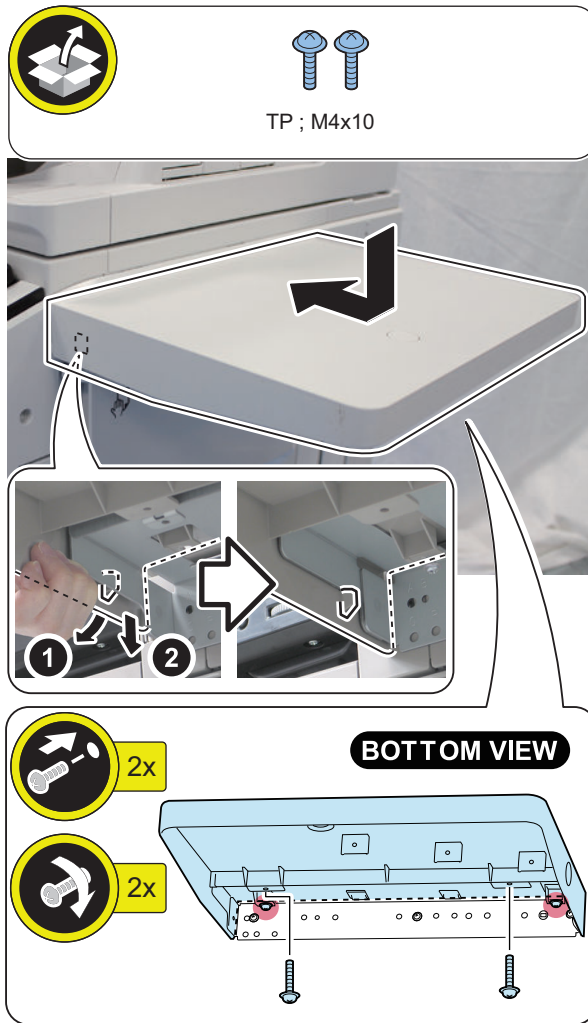

■ When Installing the USB Keyboard

□
1.

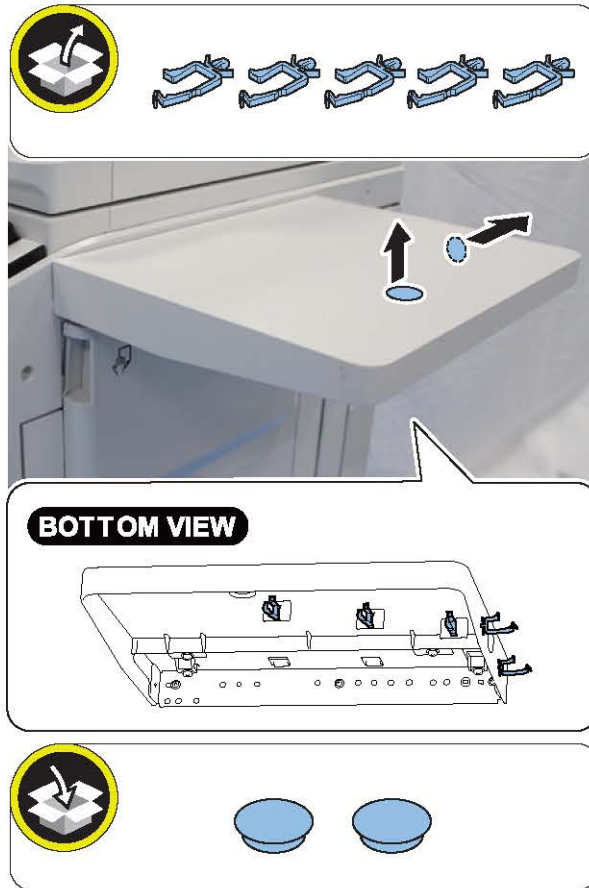

Copy Card Reader-F1

Points to Note at Installation

- To install this equipment, the Copy Card Reader Attachment is required.
- After installing the Copy Card Reader, input the card number to be used in service mode. Otherwise the card cannot be recognized even though it is inserted.
COPIER > FUNCTION > INSTALL > CARD
- When installing this equipment, be sure to install it by referring to "Table of Options Combination".
- The pictures and illustrations used may be different from the product in front of you, but the procedure is the same.

Table of Options Combination

	Utility Tray	Voice Operation	Voice Guidance Kit	Serial Interface Kit	Copy Control Interface Kit
Copy Card Reader	Yes	Yes	Yes	No	No

Yes: Available, No: Unavailable

Essential Items to Be Performed Before Installation

- Turn OFF the main power of the host machine, and disconnect the power plug from the outlet.

WARNING:

- If performing work without disconnecting the power plug of the host machine, it may cause electrical shock.
- If disconnecting the power plug without turning OFF the main power, it may cause damage of the machine.

- When turning OFF the main power, follow the below procedure.
 1. Turn OFF the main power switch of the host machine.
 2. The display in the Control Panel and the lamp of the main power are turned off.

Points to Note When Turning ON/OFF the Main Power

The following message is displayed.

1. When a message prompting to turn OFF and then ON the main power appears, turn OFF and then ON the main power switch.
2. If a message prompting the user to update the version appears, press [Update] to automatically update the version of this equipment.

If [Skip] is selected, a message prompting the user to update the version will appear every time the host machine is started. In the service mode (Lv. 2) shown below, it is possible to set not to display the message.

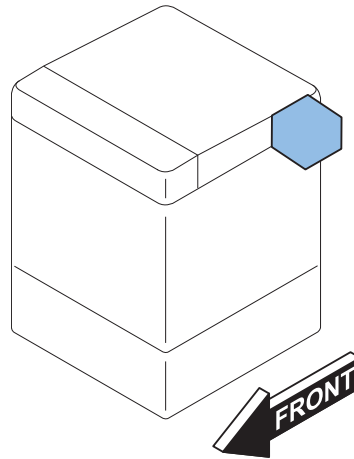

COPIER > OPTION > FNC-SW > VER-CHNG

Installation Outline Drawing











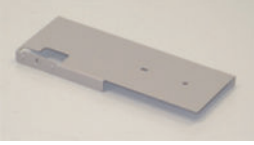

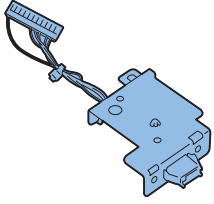
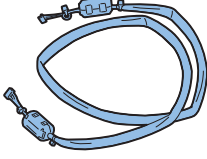

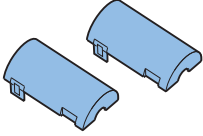
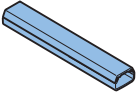
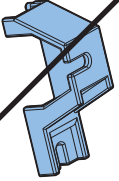
Checking the Contents

<Copy Card Reader-F1>

<input type="checkbox"/> [1] Card Reader Unit X 1 	<input type="checkbox"/> [2] Toothed washer X 1 
<input type="checkbox"/> [3] Screw (RS tight; M4x10) X 1 	

<Copy Card Reader Attachment- A4>

<input type="checkbox"/> [1] Card Reader Mounting Plate X 1 Used only for the Upright Control Panel 	<input type="checkbox"/> [2] Card Reader Mounting Plate X 1 Used only for the Flat Control Panel 
<input type="checkbox"/> [3] Card Reader Relay Unit X 1 	<input type="checkbox"/> [4] Card Reader External Relay Harness X 1 
<input type="checkbox"/> [5] Connector Cover1 X 1 	<input type="checkbox"/> [6] Connector Cover2 X 1 
<input type="checkbox"/> [7] Connector Case X 2 	<input type="checkbox"/> [8] Cord Guide X 1 
<input type="checkbox"/> [9] Connector Cover X 1 	<input type="checkbox"/> [10] PCB Spacer X 1 

<input type="checkbox"/> [11] Screw (Binding; M3x6) X 1 	<input type="checkbox"/> [12] Screw (TP; M4x12) X 1 Used only for the Upright Control Panel 
<input type="checkbox"/> [13] Screw (RS tight; M4x8) X 1 Used only for the Upright Control Panel 	<input type="checkbox"/> [14] Screw (Binding; M4x20) X 1 Used only for the Flat Control Panel 
<input type="checkbox"/> [15] Screw (Binding; M4x6) X 1 Used only for the Flat Control Panel 	<input type="checkbox"/> [16] Relay Harness X 1 
<input type="checkbox"/> [17] Screw(TP; M3x6) X 1 	

Installation Procedure

■ Installing the Card Reader Mounting Plate <in the case of the Flat Control Panel

>

1. Open the Toner Replacement Cover, Right Cover, and Right Rear Cover 1.





2. Remove the Right Upper Cover.

- 2 Screws
- 3 Protrusions
- 1 Boss

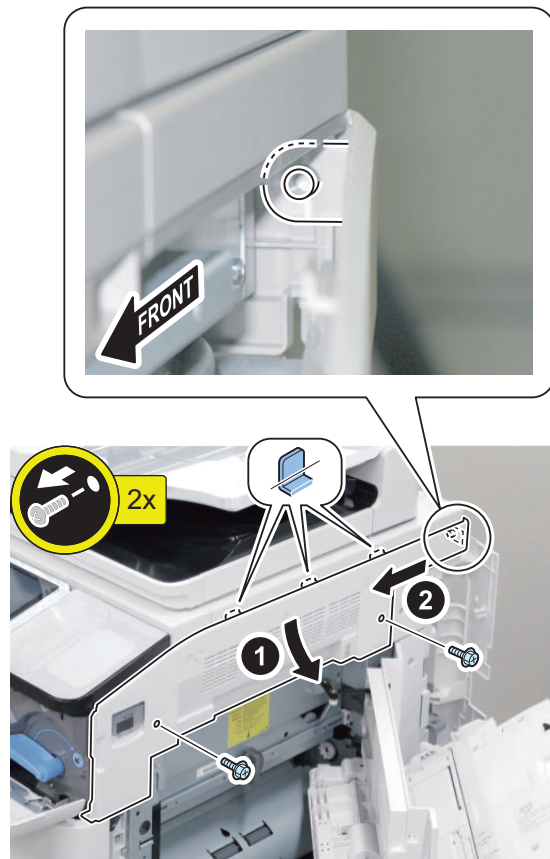

3. Close the Right Cover.



4. Remove the Right Rear Cover 2.

- 1 Screw
- 1 Protrusion

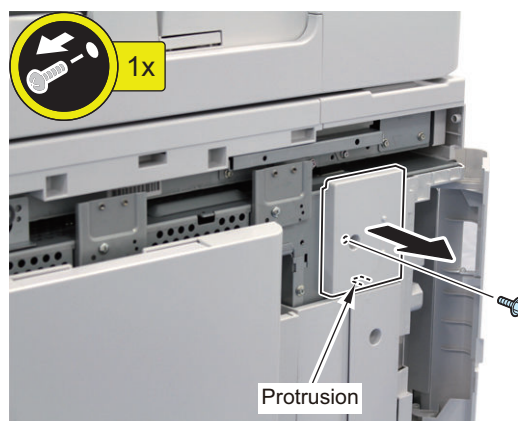



5. Install the Card Reader Mounting Plate.

- 1 Screw (Binding; M4x6)

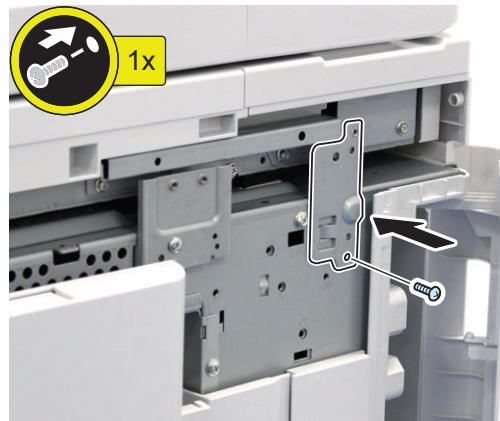
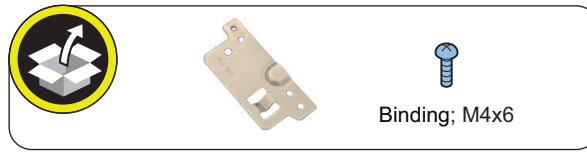

6. Install the Right Rear Cover 2 (1 Screw).

7. Open the Right Cover, and then install the Right Upper Cover (2 Screws).

8. Close the Right Cover and Toner Replacement Cover.

■ Installing the Card Reader



1. Remove the Side Cover.

- 2 Screws
- 1 Hook

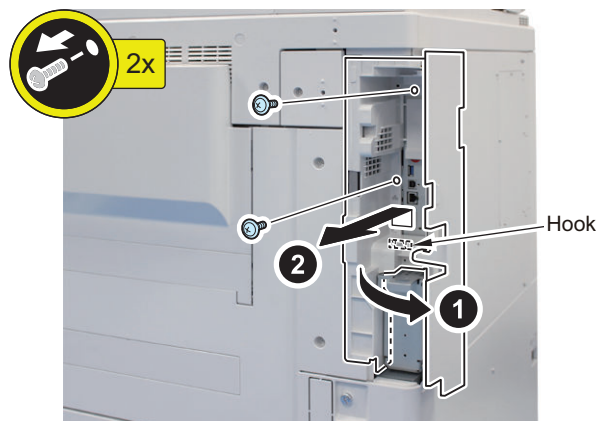

CAUTION:

Be careful not to let the 2 bosses of the Side Cover come off from the 2 mounting holes of the Right Rear Cover 1.

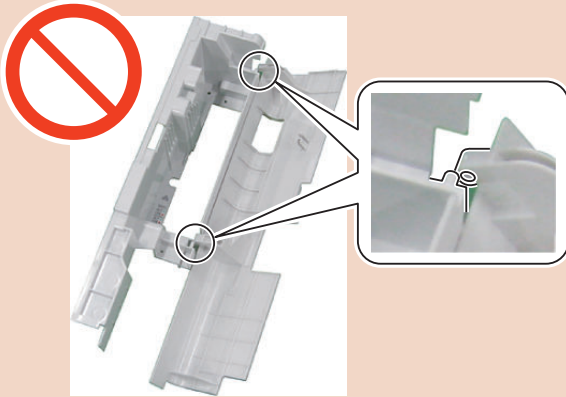

□

2. Hold the handle to remove the Main Controller PCB 1.

- 1 Connector

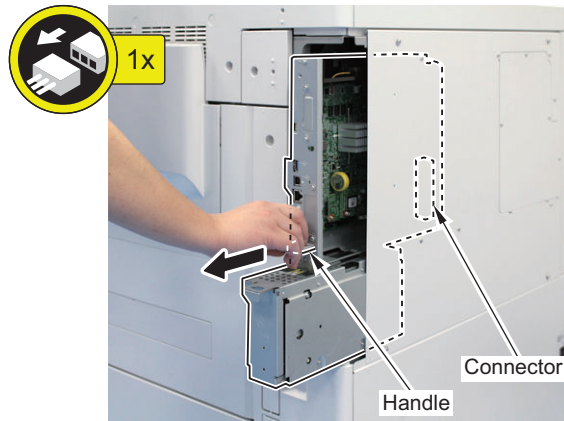
**CAUTION:**

Be sure to place the removed Main Controller PCB 1 flatly. Reason: Due to the protruded plate, the PCB may be deformed if work is performed while it is placed at an angle.

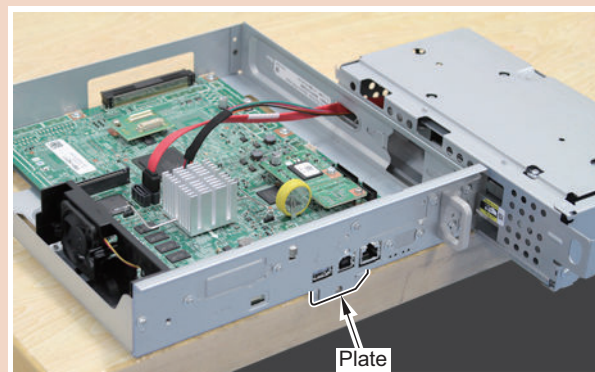



3. Remove the Face Cover. (The removed Face Cover will not be used.)

- 2 Screws(The removed screws will be used in step 5)

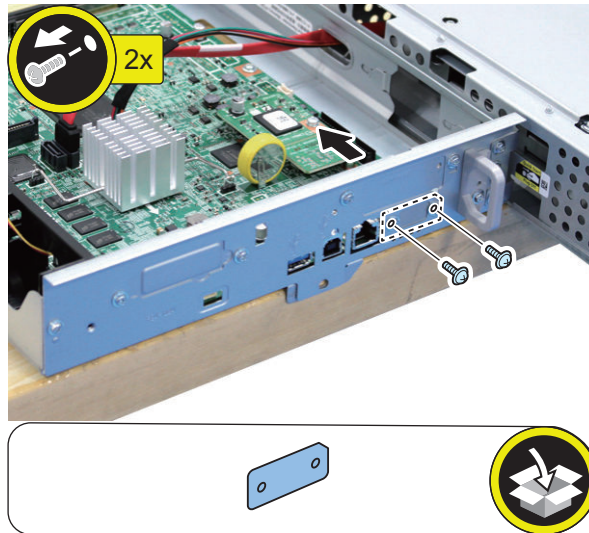

4. Remove the screw, and install the PCB Spacer. (The removed screws will not be used.)

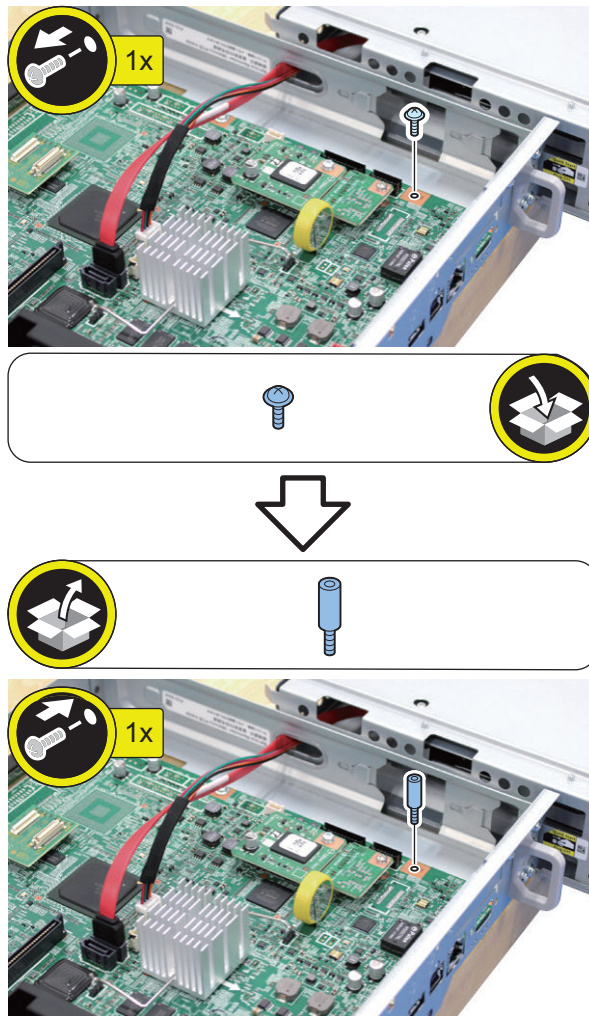



5. Install the Card Reader Reply Unit.

- 1 Connector
- 2 Screws (Use the screws removed in step 3.)
- 1 Screw (Binding; M3x6)

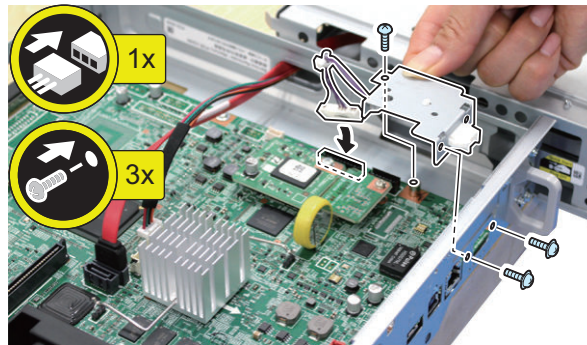
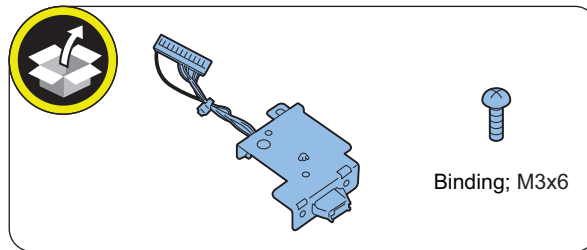

6. Insert the Main Controller PCB 1 until it stops.

- 1 Connector

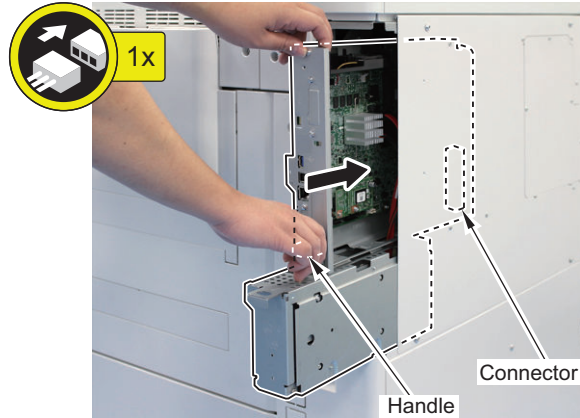

CAUTION:

Be sure to push [A] part hard to install it, otherwise the connector may not be connected properly.

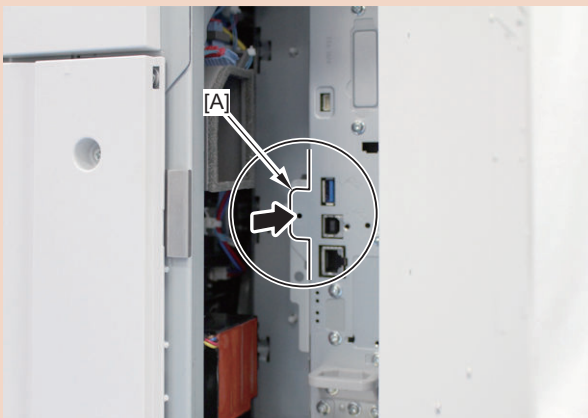



7. Connect the Card Reader External Relay Harness.

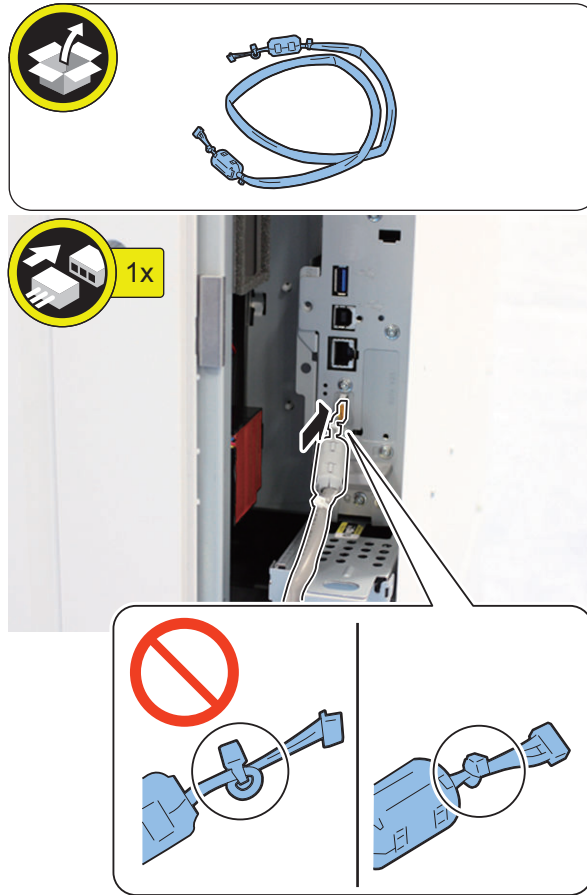

8. Remove the Screw (The removed screws will be used at next step.)





9. Install the Connector Cover to the Card Reader External Relay Harness.

- 1 Screw (Use the screw removed at previous step.)

CAUTION:

- Install the screw to the [A] part.
- When installing the Connector Cover, be sure to place the tie-wrap on the Card Reader External Relay Harness on the inside of the Connector Cover.

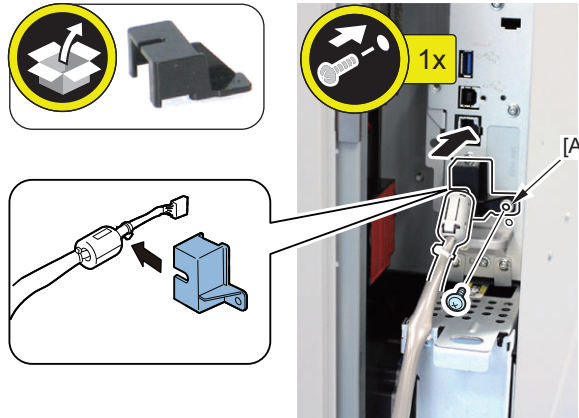

10. Install the Side Cover by putting the Card Reader External Relay Harness through a hole of the cover.

- 1 Hook
- 2 Screws

CAUTION:

Be careful not to let the 2 bosses of the Side Cover come off from the 2 mounting holes of the Right Rear Cover 1

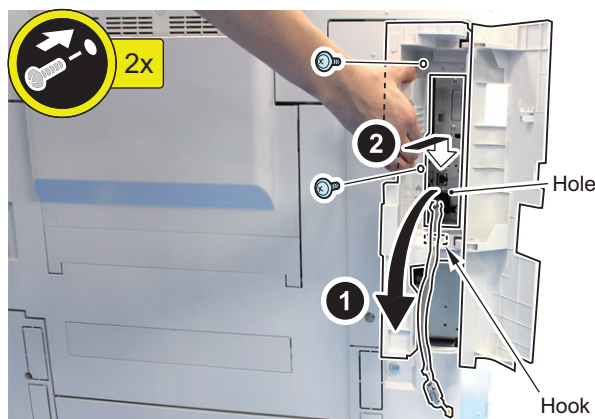
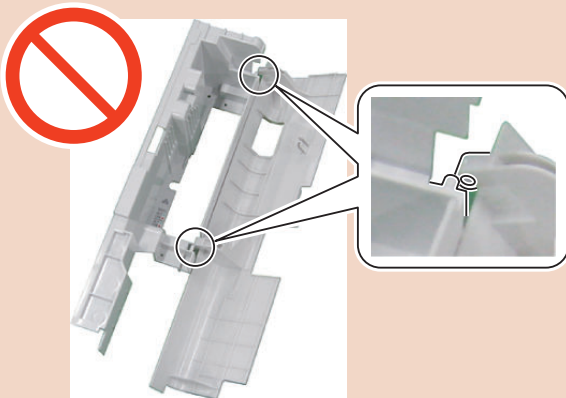



11. Close the Right Rear Cover 1.



12. Remove the Lower Cover of the Card Reader Unit, and change the position of the cable.

- 1 Claw
- 1 Screw

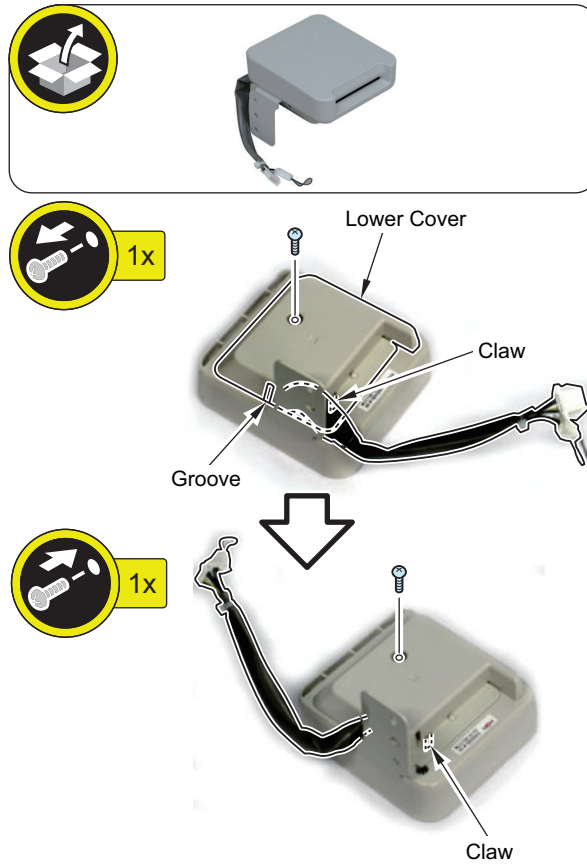



13. Disconnect the Short Connector on the Card Reader. (The removed Short Connector will not be used.)

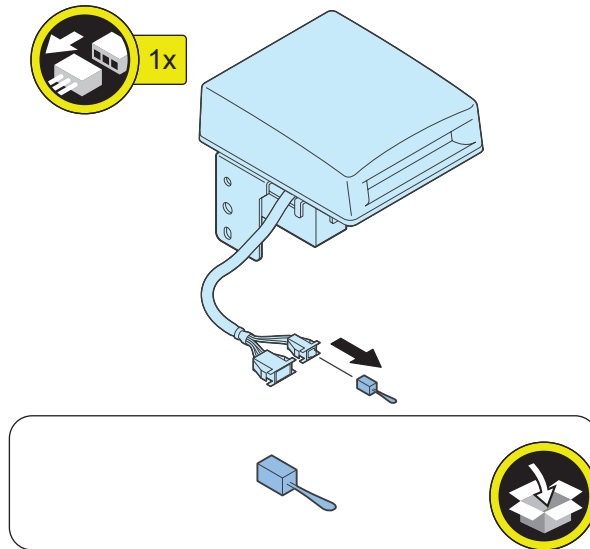



14. Install the Card Reader.

<In the Case of Upright Control Panel>



14-1. Install the Card Reader to the Card Reader Mounting Plate.

- 2 Bosses
- 1 Toothed Washer
- 1 Screw (RS Tightening; M4x8)

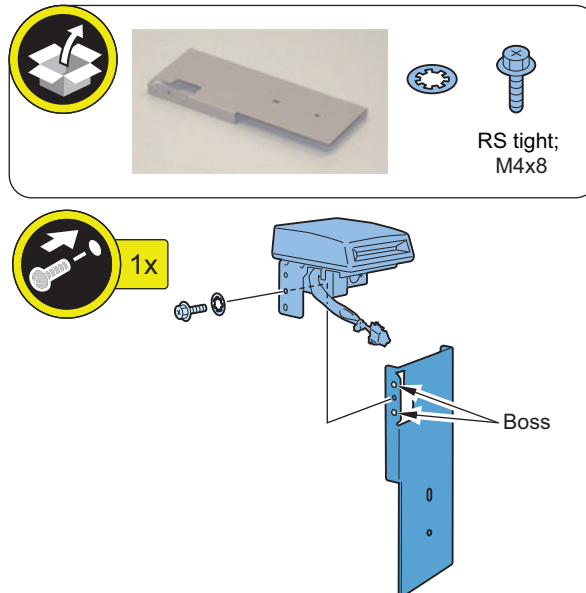

14-2. Install the Card Reader Unit assembled in step 14-1.

- 1 Boss
- 1 Screw (TP; M4x12)

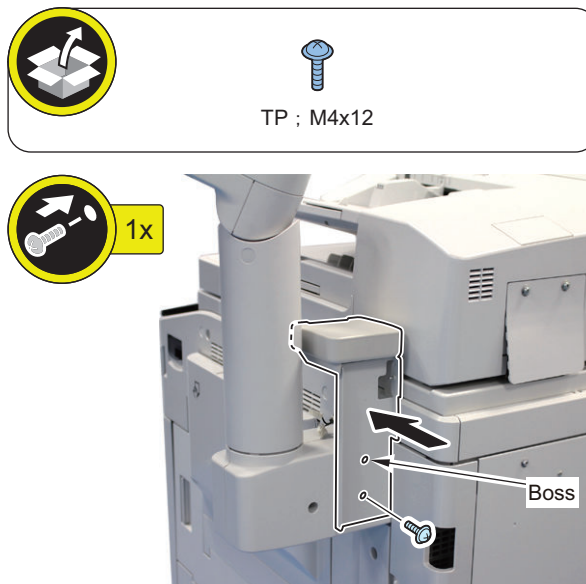

<In the Case of Flat Control Panel>



14-1. Install the Card Reader.

- 2 Bosses
- 1 Toothed Washer
- 1 Screw (Binding; M4x20)

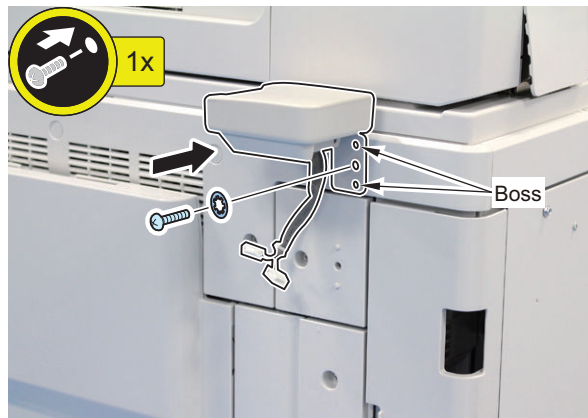
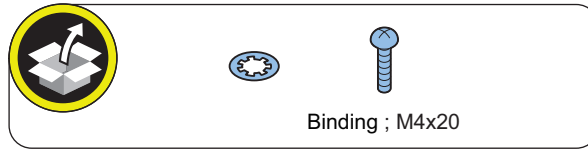

15. If the Upright Control Panel is installed, put the connector of the Card Reader Unit through the hole on the Card Reader Mounting Plate.

NOTE:

While pictures of the Upright Control Panel model are used for explaining the steps 16 and 17, the procedure is the same for the Flat Control Panel model.

16. Connect the connectors of the Card Reader Unit and the Card Reader External Relay Harness.



17. Install the Connector Case.

CAUTION:

When installing the Connector Cases, be sure to place the tie-wrap on the Card Reader External Relay Harness on the inside of the Connector Cases.

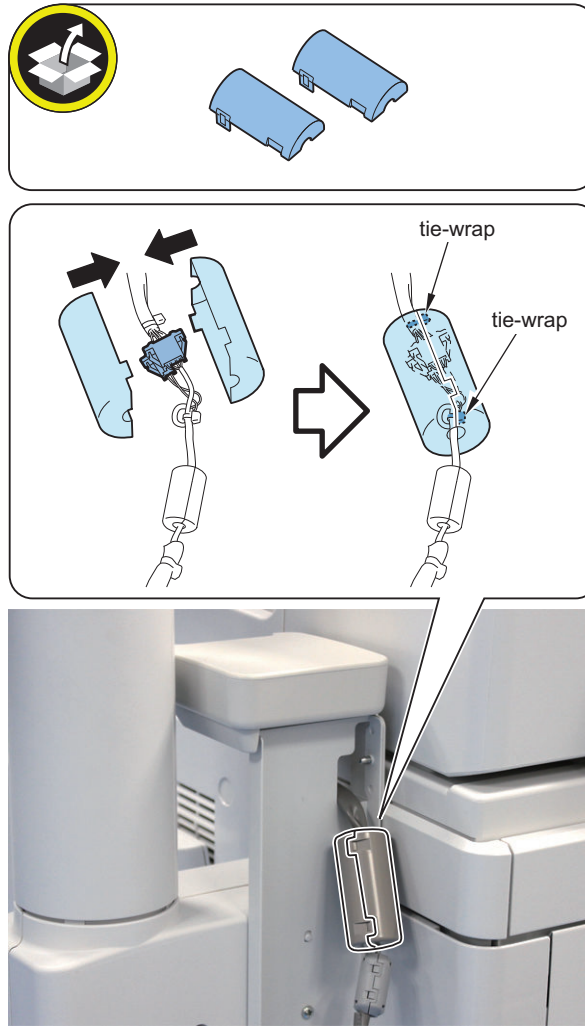

NOTE:

While pictures of the Flat Control Panel model are used for explaining the following steps, the procedure is the same for the Upright Control Panel model.

□

18. Remove the cover of Cord Guide, and affix it to the area indicated in the figure.

19. Put the Card Reader External Relay Harness through the Cord Guide, and install the cover of the Cord Guide.

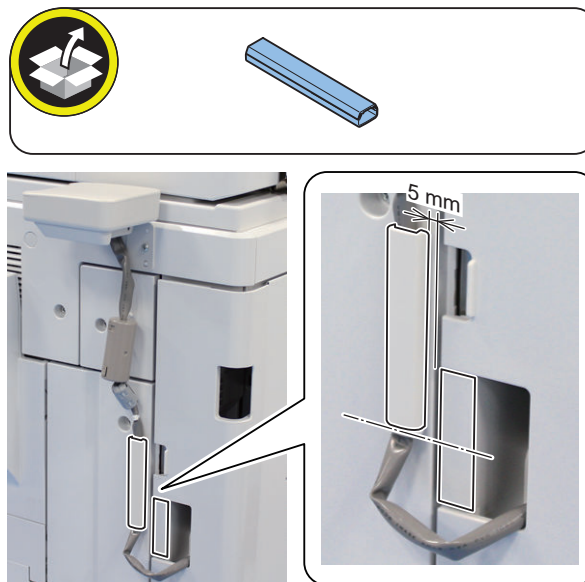

**20. Push the Card Reader External Relay Harness in the Right Rear Cover 1.**

Checking after Installation



1. **Connect the power plug of the host machine to the power outlet.**
2. **Turn the main power switch ON.**
3. **Check the model of the Card Reader in service mode. (Default: 0 "Card Reader-F1")**
COPIER > OPTION > ACC > CR-TYPE



4. **Set the number of card (number of department ID) that can be used with the Card Reader in service mode.(Lv.2).**
COPIER > OPTION > FNC-SW > CARD-RNG



5. **Use Service Mode to enter the minimum card number to be used by a user (1 to 2001).**
COPIER > FUNCTION > INSTALL > CARD
Starting from the entered card number, the number of cards set in step 4 can be used.



6. **Turn OFF and then ON the main power switch to enable the setting values.**
7. **Insert a card with a card number that has been registered, and check that the machine operates normally.**

NOTE:

Perform the following operations to change the number of cards (departments) after it has been set. In such a case, counter information for each department is reset.

COPIER > FUNCTION > CLEAR > CARD

- Turn OFF and then ON the main power switch to enable the settings.
- After that, perform from step 3.

Serial Interface Kit-K3 / Copy Control Interface Kit-A1

Points to Note at Installation

When installing this equipment, be sure to install it by referring to "Table of Options Combination".

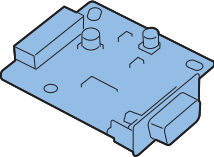
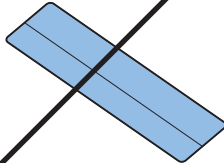
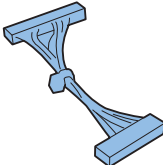
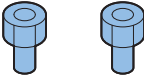



Table of Options Combination

	Serial Interface Kit	Copy Control Interface Kit	Voice Operation Kit	Voice Guidance Kit	Copy Card Reader
Serial Interface Kit	-	No	Yes	Yes	No
Copy Control Interface Kit	No	-	Yes	Yes	No

Yes: Available, No: Unavailable

Checking the Contents

<Serial Interface Kit-K3>

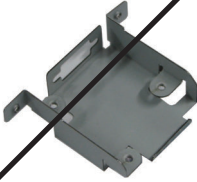
<input type="checkbox"/> [1] Serial RS Conversion Board X 1 	<input type="checkbox"/> [2] IA Harness Protection Sheet X 1 
<input type="checkbox"/> [3] RS Conversion Cable (Short) X 1 	<input type="checkbox"/> [4] Hexagonal Screw X 2 
<input type="checkbox"/> [5] Washer X 2 	<input type="checkbox"/> [6] PCB Spacer X 1 
<input type="checkbox"/> [7] Screw (TP; M3x6) X 3 	<input type="checkbox"/> [8] Support Plate X 1 

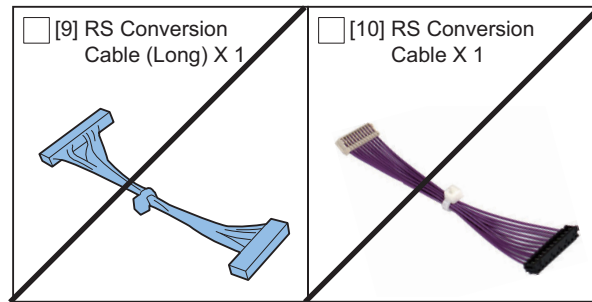

<Copy Control Interface Kit-A1>

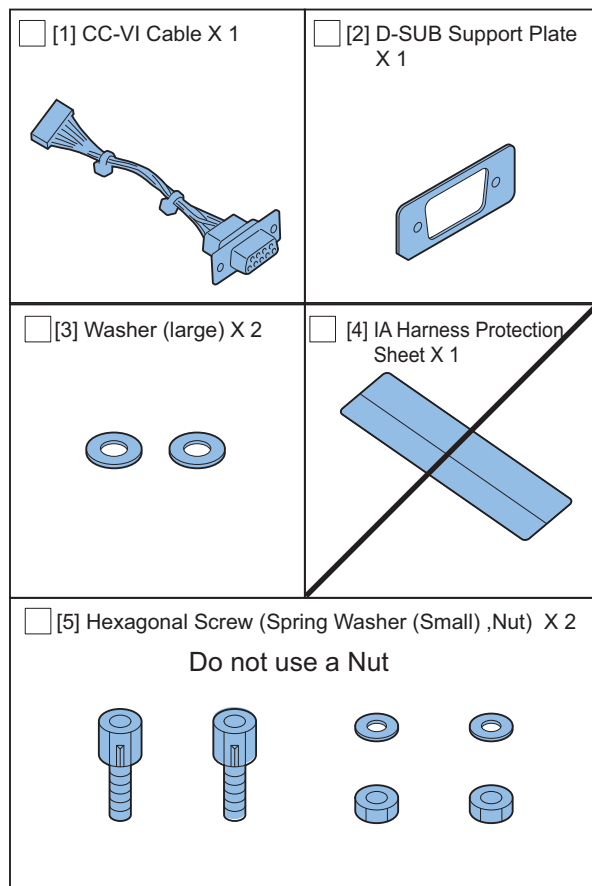

Essential Items to Be Performed Before Installation

- Turn OFF the main power of the host machine, and disconnect the power plug from the outlet.

⚠ WARNING:

- If performing work without disconnecting the power plug of the host machine, it may cause electrical shock.
- If disconnecting the power plug without turning OFF the main power, it may cause damage of the machine.

- When turning OFF the main power, follow the below procedure.
 1. Turn OFF the main power switch of the host machine.
 2. The display in the Control Panel and the lamp of the main power are turned off.

Points to Note When Turning ON/OFF the Main Power

The following message is displayed.

1. When a message prompting to turn OFF and then ON the main power appears, turn OFF and then ON the main power switch.

2. If a message prompting the user to update the version appears, press [Update] to automatically update the version of this equipment.

If [Skip] is selected, a message prompting the user to update the version will appear every time the host machine is started. In the service mode (Lv. 2) shown below, it is possible to set not to display the message.

COPIER > OPTION > FNC-SW > VER-CHNG

Installation Outline Drawing

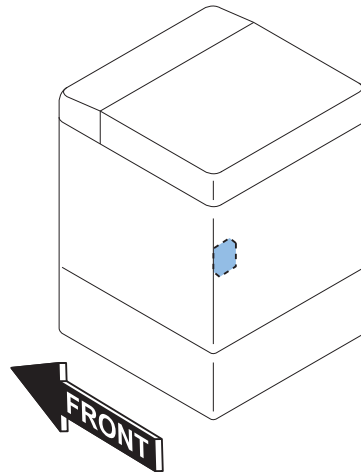

Installation Procedure

■ Removing the Main Controller PCB 1



1. Open the Right Rear Cover 1, and remove the Side Cover.

- 2 Scews
- 1 Hook

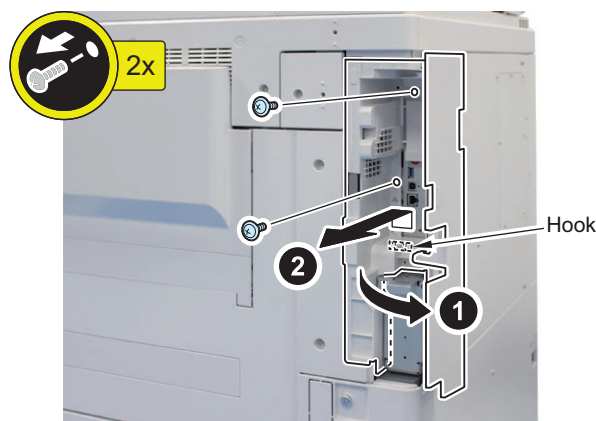

CAUTION:

Be careful not to let the 2 bosses of the Side Cover come off from the 2 mounting holes of the Right Rear Cover 1.

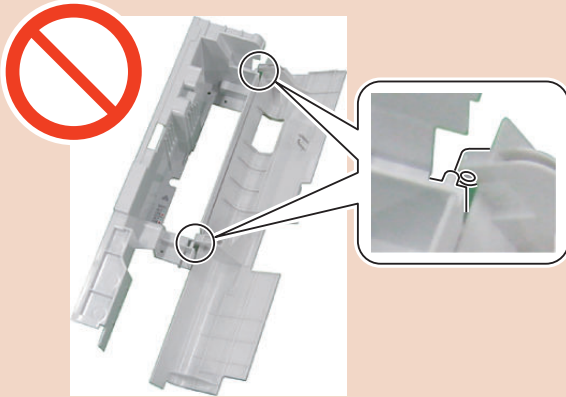

□

2. Hold the handle to remove the Main Controller PCB 1.

- 1 Connector

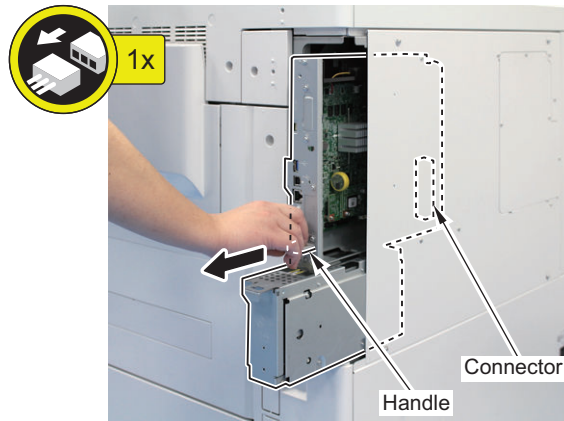
**CAUTION:**

Be sure to place the removed Main Controller PCB 1 flatly. Reason: Due to the protruded plate, the PCB may be deformed if work is performed while it is placed at an angle.

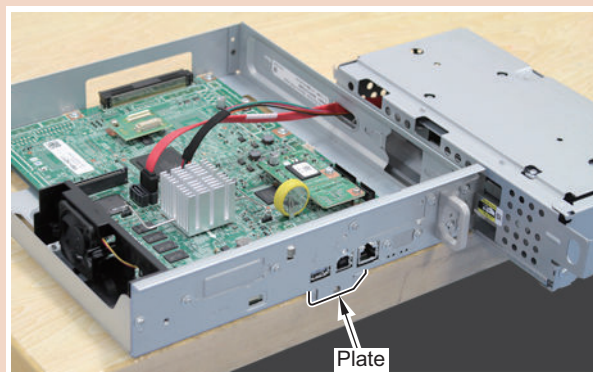

□

3. Remove the face cover (The removed Face Cover will not be used).

- 2 Screws

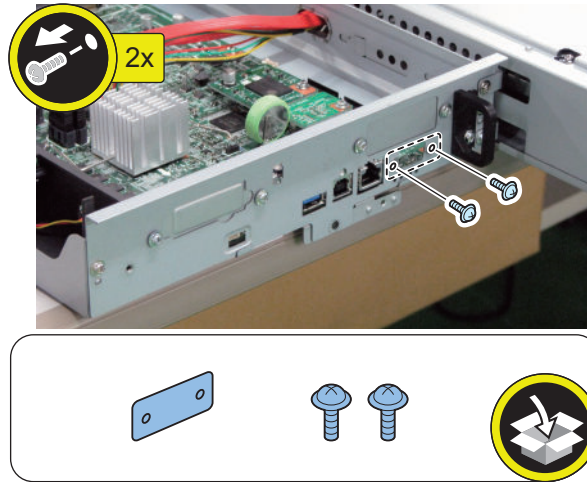

■ Installing the Serial Interface Kit

□

1. Remove the screw, and install the PCB Spacer (The removed screw will be used in step 3).

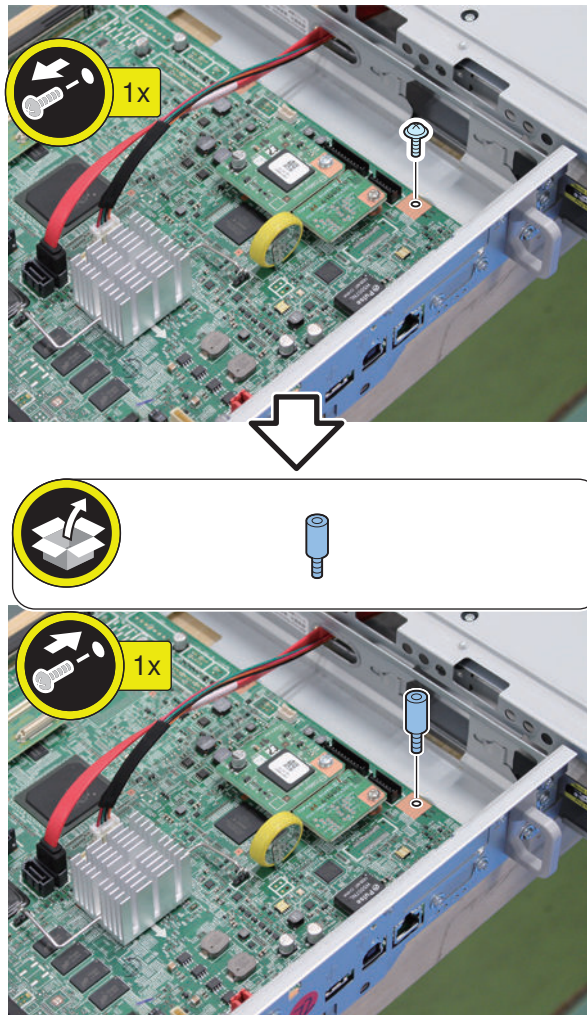



2. Connect the RS Conversion Cable (short) to the Serial RS Conversion Board.

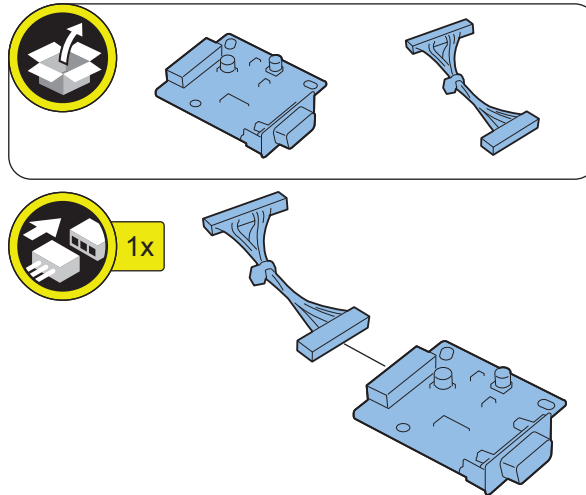

3. Install the Serial RS Conversion Board.

- 1 Screw (Use the screw removed in step1)
- 2 Washers
- 2 Hexagon Screws
- 1 Connector

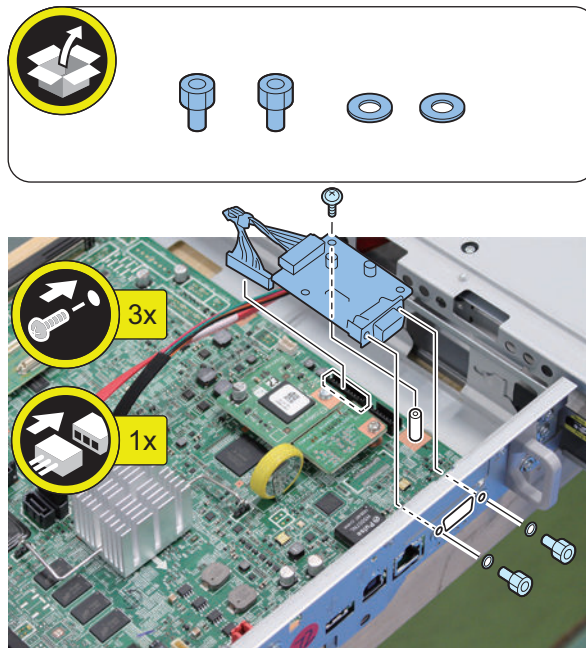

■ Installing the Copy Control interface Kit



1. Put the CC-VI Cable through the D-SUB Support Plate.

CAUTION:

Install the extruded side of the D-SUB Support Plate as shown in the figure.

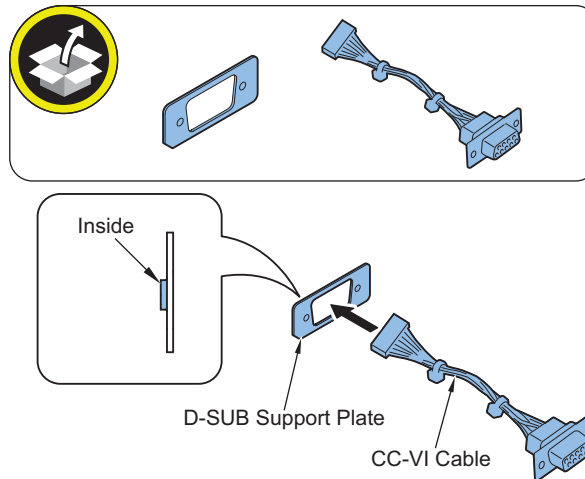

2. Connect the CC-VI Cable to the Main Controller PCB 1.

- 2 Hexagon Screws
- 2 Spring Washers (small)
- 2 Washers (Large)
- 1 Connector

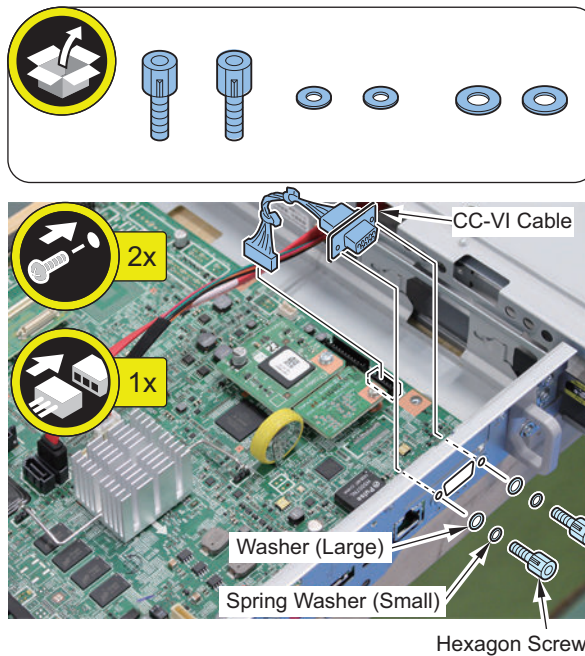

■ Installing the Main Controller PCB 1



1. Insert the Main Controller PCB 1 until it stops.

- 1 Connector

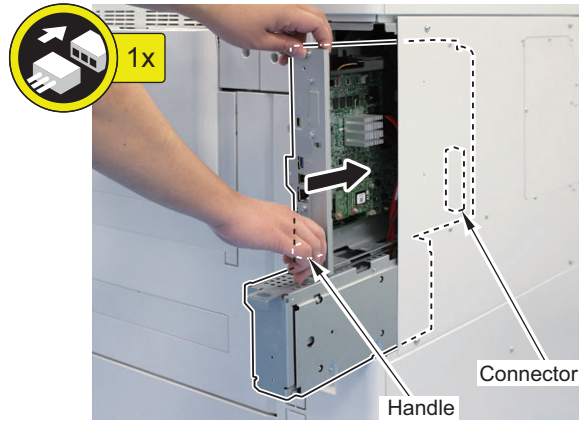

CAUTION:

Be sure to push [A] part hard to install it, otherwise the connector may not be connected properly.

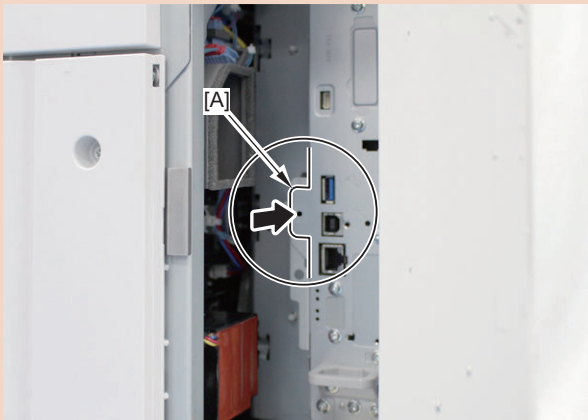



2. Install the Side Cover, and then Close the Right Rear Cover 1.

- 1 Hook
- 2 Screws

CAUTION:

Be careful not to let the 2 bosses of the Side Cover come off from the 2 mounting holes of the Right Rear Cover 1.

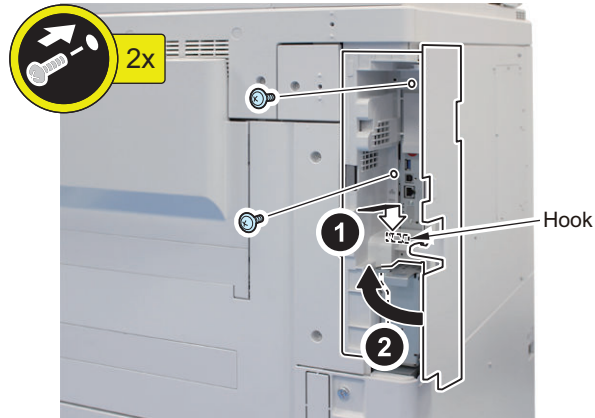
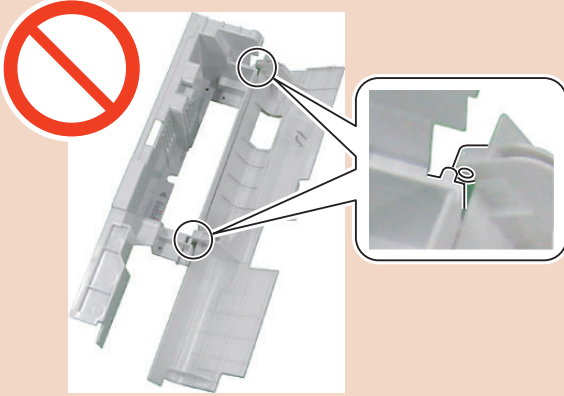

3. Connect the power plug of the host machine to the power outlet.

4. Turn the main power switch ON.

Voice Operation Kit-D1

Points to Note Before Installation



- The pictures and illustrations used may be different from the product in front of you, but the procedure is the same.
- When installing this equipment, the option Numeric Keypad is required. Refer to the Installation Procedure for the Numeric Keypad when installing the Numeric Keypad.
- Refer to "Combination of options" when installing this equipment before operation.

Table of Options Combination

	Copy Card Reader	Serial Interface Kit	Copy Control Interface Kit	Voice Guidance Kit	Utility Tray
Voice Operation Kit	Yes	Yes	Yes	No	No

Yes: Available, No: Unavailable

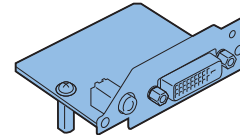
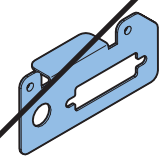
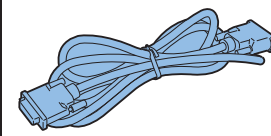
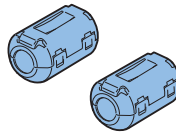
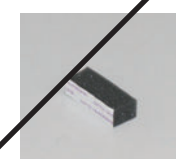
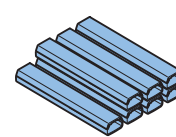
Checking the Contents

<input type="checkbox"/> [1] Speaker Unit X 1 	<input type="checkbox"/> [2] Voice Operation Board Unit X 1 
<input type="checkbox"/> [3] Support Plate X 1 	<input type="checkbox"/> [4] DVI Cable X 1 
<input type="checkbox"/> [5] Ring Core X 2 	<input type="checkbox"/> [6] Cable Face Seal X 1 
<input type="checkbox"/> [7] Cord Guide X 7 	<input type="checkbox"/> [8] Card Spacer X 1 

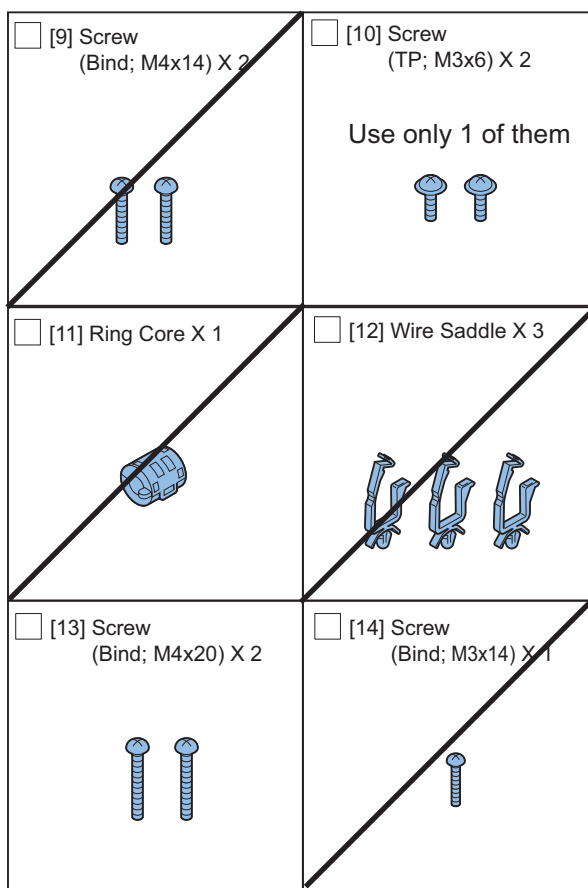

[7]: Use 6 of them for the Flat Control Panel model.

[11]: This is used for the user installed option and should be handed over to the user.

<Others>

Including guides

Essential Items to Be Performed Before Installation

- Turn OFF the main power of the host machine, and disconnect the power plug from the outlet.

⚠ WARNING:

- If performing work without disconnecting the power plug of the host machine, it may cause electrical shock.
- If disconnecting the power plug without turning OFF the main power, it may cause damage of the machine.

- When turning OFF the main power, follow the below procedure.
 1. Turn OFF the main power switch of the host machine.
 2. The display in the Control Panel and the lamp of the main power are turned off.

Points to Note When Turning ON/OFF the Main Power

The following message is displayed.

1. When a message prompting to turn OFF and then ON the main power appears, turn OFF and then ON the main power switch.
2. If a message prompting the user to update the version appears, press [Update] to automatically update the version of this equipment.

If [Skip] is selected, a message prompting the user to update the version will appear every time the host machine is started. In the service mode (Lv. 2) shown below, it is possible to set not to display the message.

COPIER > OPTION > FNC-SW > VER-CHNG

Installation Outline Drawing

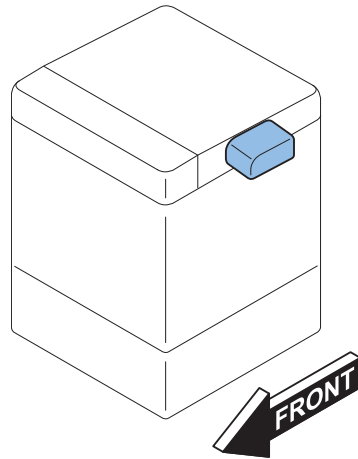

Installation Procedure



1. Open the Right Rear Cover 1, and then remove the Side Cover.

- 2 Screws
- 1 Hook

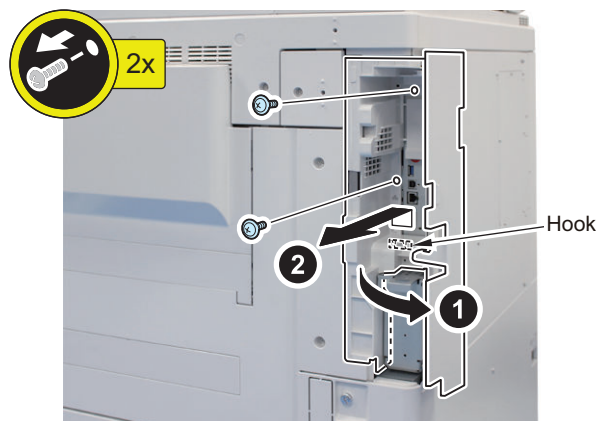

CAUTION:

Be careful not to let the 2 bosses of the Side Cover come off from the 2 mounting holes of the Right Rear Cover 1.

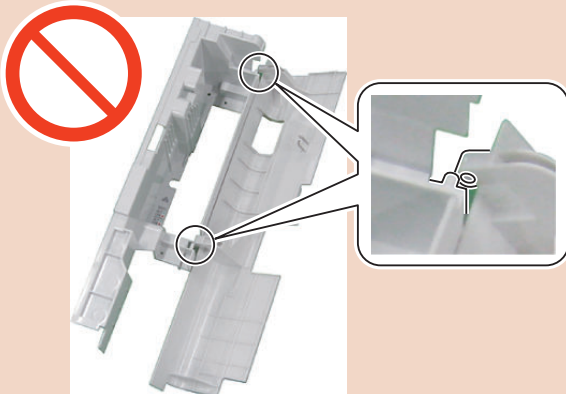



2. Hold the handle to remove the Main Controller PCB 1.

- 1 Connector

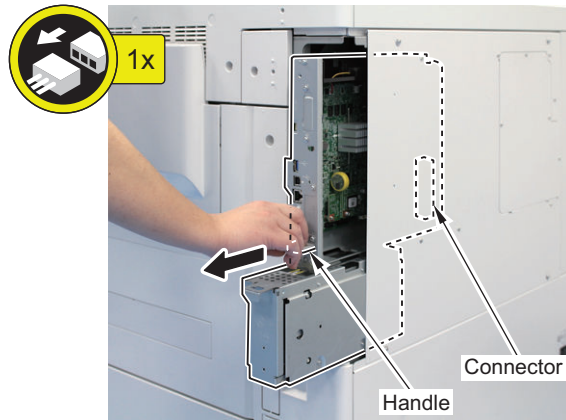

CAUTION:

Be sure to place the removed Main Controller PCB 1 flatly. Reason: Due to the protruded plate, the PCB may be deformed if work is performed while it is placed at an angle.

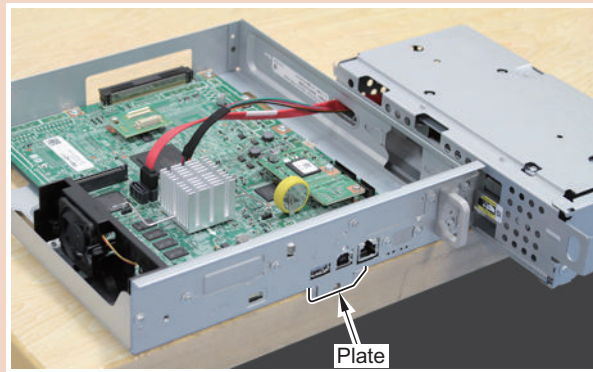

3. Remove the Face Plate. (The removed Face Plate will not be used.)

- 2 Screws (The removed screws will be used at next step .)

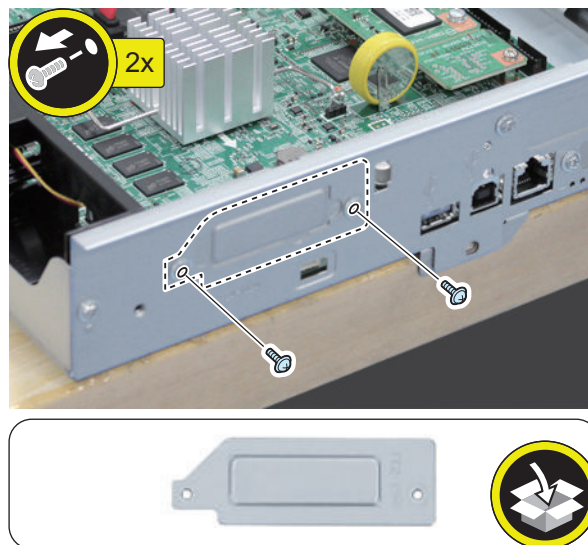



4. Install the Voice Operation Board Unit to the Main Controller PCB 1.

- 1 Connector
- 2 Screws (Use the screw removed at previous step)
- 1 Screw (TP; M3x6)

NOTE:

Check that the connector is connected properly.

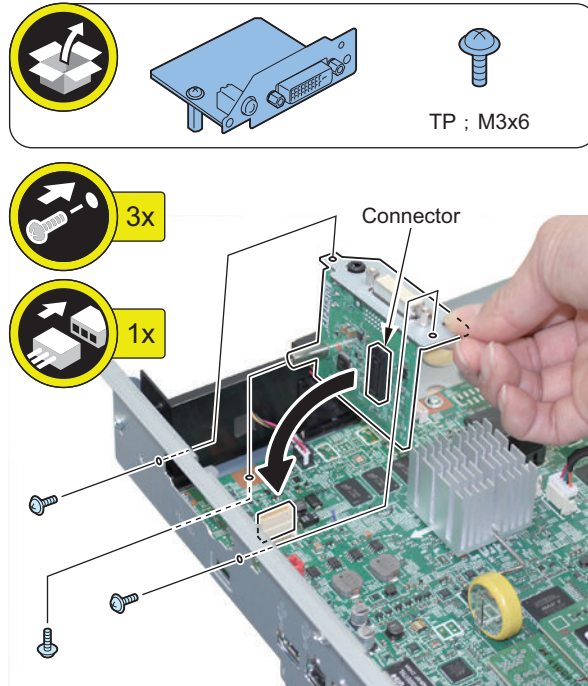



5. Insert the Main Controller PCB 1 until it stops.

- 1 Connector

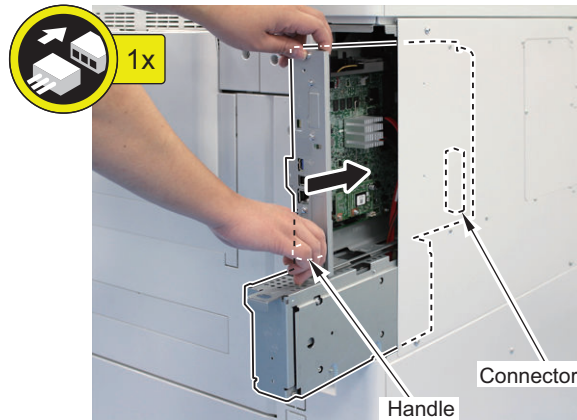

CAUTION:

Be sure to push [A] part hard to install it, otherwise the connector may not be connected properly.

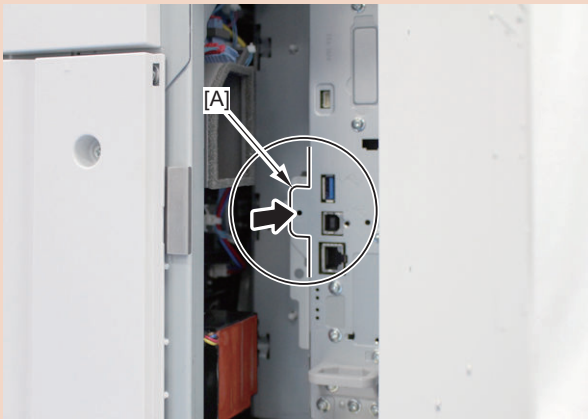

6. Be sure to push [A] part hard to install it, otherwise the connector may not be connected properly.

NOTE:

When cutting off the part, be sure not to make burrs .

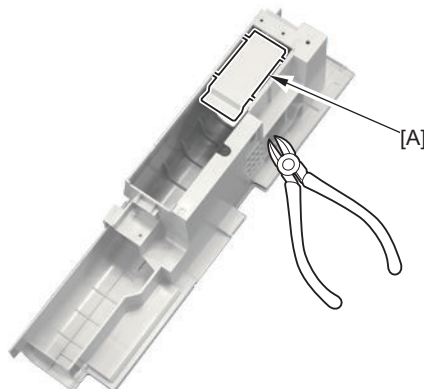



7. Install the Side Cover.

- 1 Hook
- 2 Screws

CAUTION:

Be careful not to let the 2 bosses of the Side Cover come off from the 2 mounting holes of the Right Rear Cover 1.

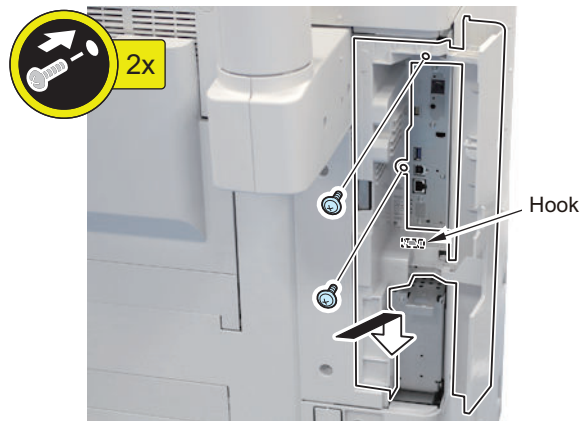
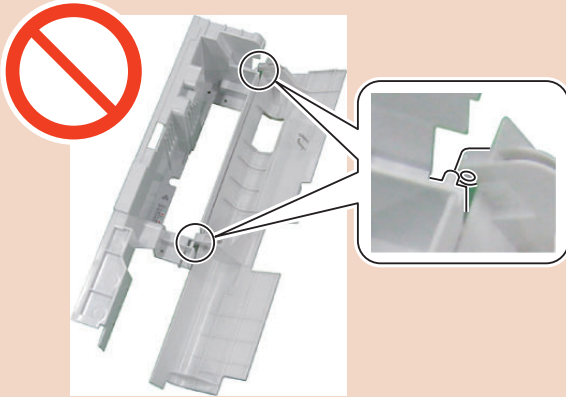

8. Attach the 2 Ring Cores to both ends of the DVI Cable and then remove caps from both ends.

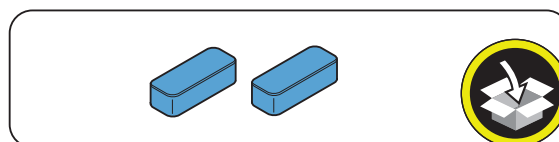
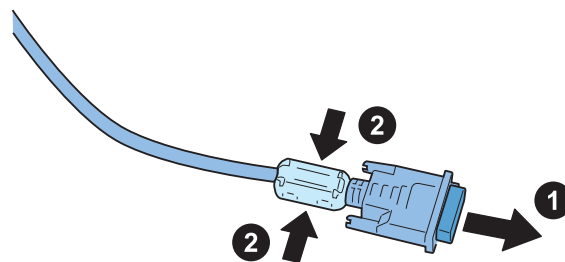
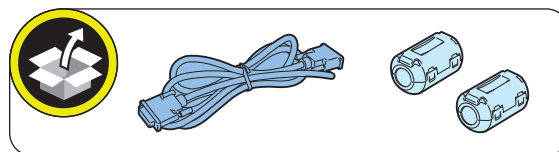

- 9. Pass the DVI Cable through the hole of the Side Cover, and connect the DVI Cable to the Voice Operation Board Unit.

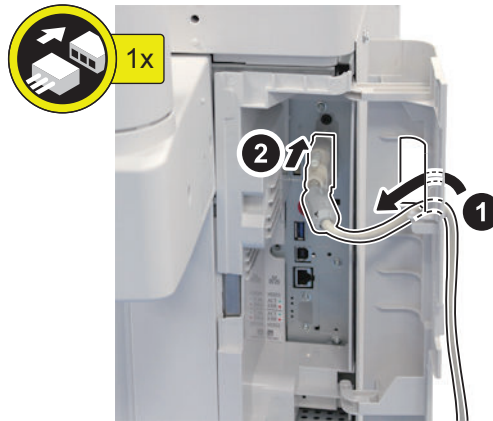

- 10. Close the Right Rear Cover 1.

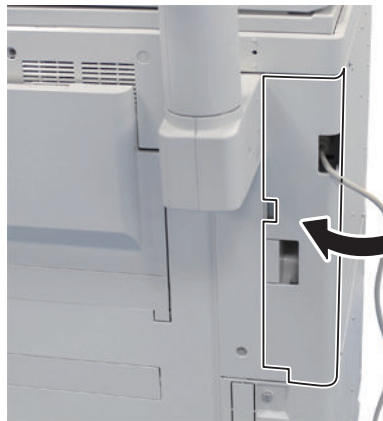

- 11. Remove the 2 Rubber Caps from the Right Upper Cover. (The removed Rubber Caps will not be used.)

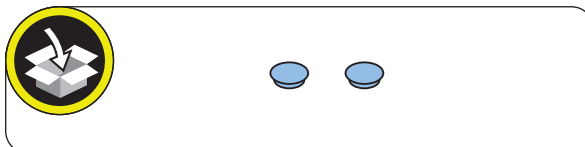

**12. Remove the Speaker Unit (Lower) from the Speaker Unit.**

- 2 Screws (The removed screw will be used in step 14)

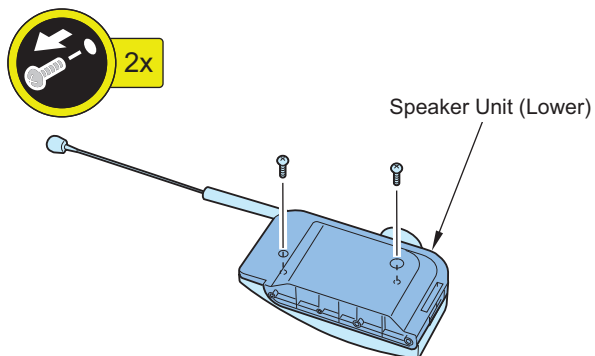
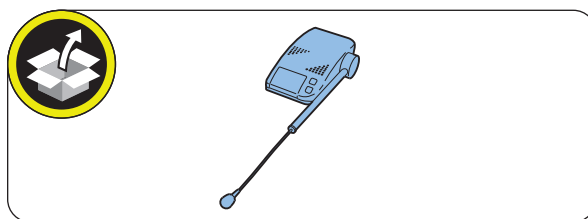
**13. Install the Speaker Unit (Lower).**

- 2 Screws (Binding; M4x20)

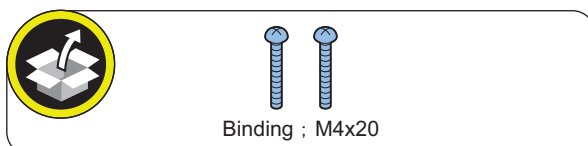



14. Install the Speaker Unit (Upper).

- 2 Screws (Use the screw removed in step 12.)

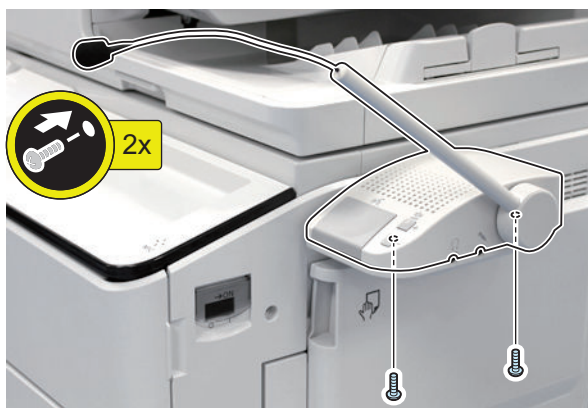

15. Remove the cover of Cord Guide, and affix it to the area indicated in the figure.

< In the Case of Flat Control Panel >

NOTE:

Even when this kit is used in combination with a Copy Card Reader, the positions to install the Cord Guides are the same.

- Use 6 Cord Guides

< Right side >

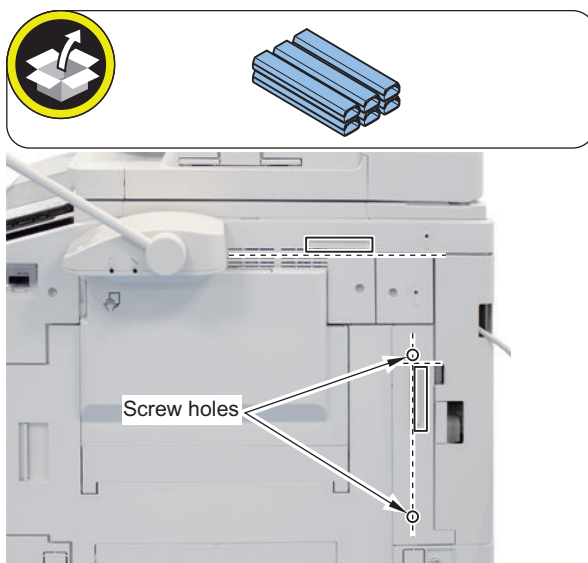

<Rear side>

NOTE:

Be sure to affix them on the extension lines of [A] and [B].

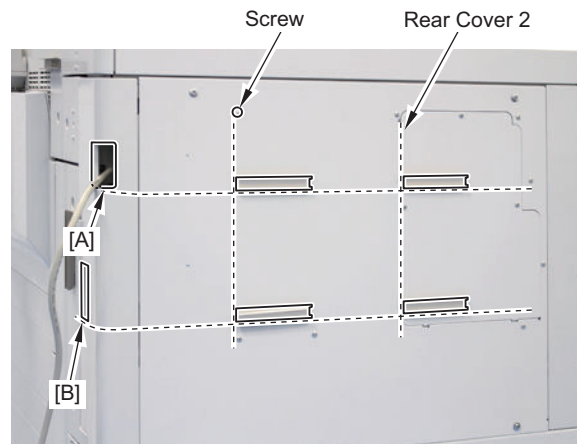

< In the Case of Upright Control Panel>

NOTE:

Even when this kit is used in combination with a Copy Card Reader, the positions to install the Cord Guides are the same.

- Use 7 Cord Guides.

<Right side >

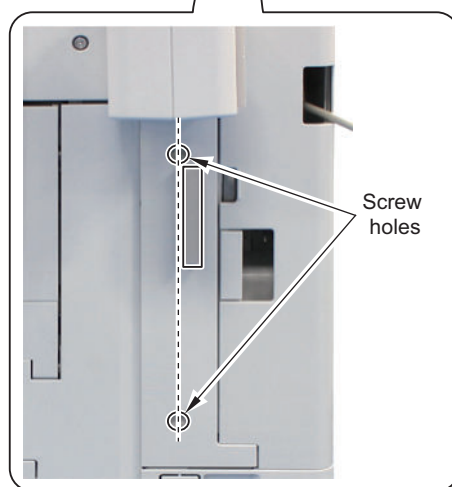
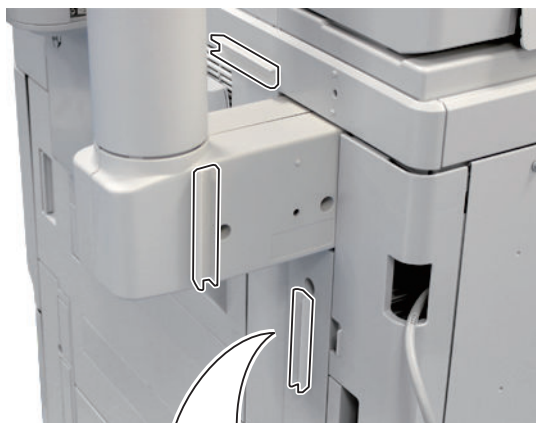
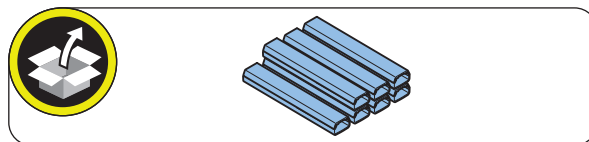

<Rear side >

NOTE:

[Be sure to affix them on the extension lines of [A] and [B].

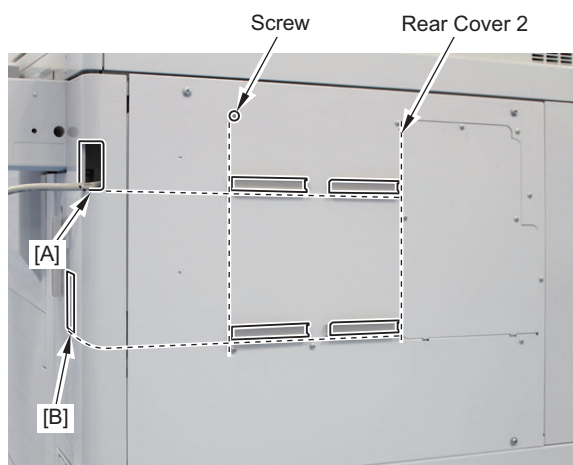

16. Connect the DVI Cable to the Speaker Unit.

17. Put the Speaker Cable through the Cord Guide, and install the cover of the cord guide.

CAUTION:

Be sure to slack off [A] par for not interfering to open/close the Right Rear Cover1.

< In the Case of Flat Control Panel >

- Use 6 Cord Guides

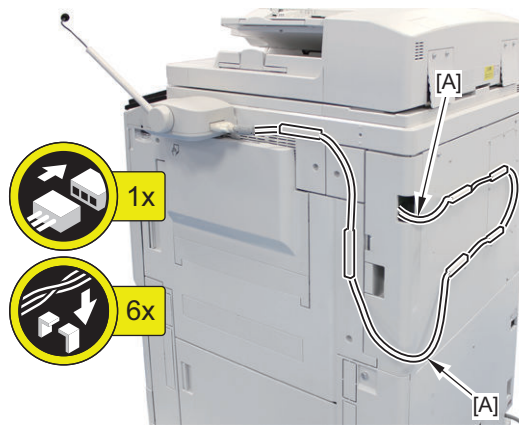

< In the Case of Upright Control Panel >

- Use 7 Cord Guides

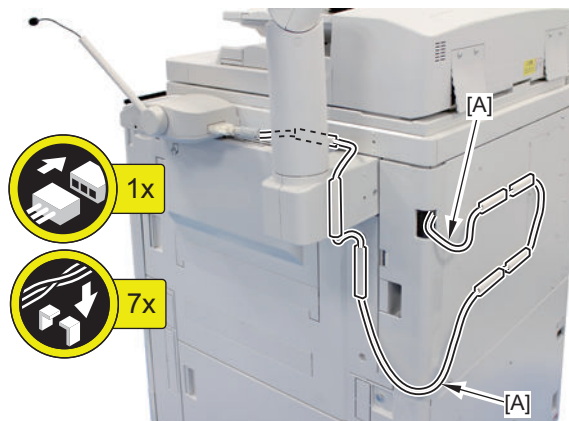

CAUTION:

When using together with the Copy Card Reader

< In the Case of Upright Control Panel >

Be sure to pass the DVI cable between the Upright Arm and Card Reader Mounting Plate.

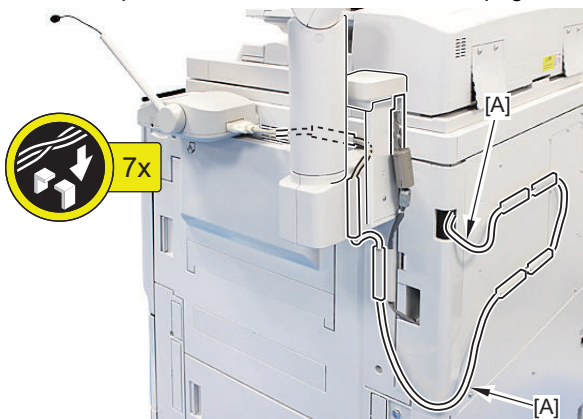

Checking after Installation

NOTE:

When changing the settings upon user's request, it is required to log in as a system manager in accordance with instructions from the user administrator.

-
1. **Connect the power plug of the host machine to the outlet.**
 2. **Turn ON the main power switch.**
 3. **Select Settings/Registration > Preferences > Accessibility > Voice Navigation Settings > Use Voice Navigation, and check that the setting is ON.**
 4. **Select Settings/Registration > Preferences > Accessibility > Voice Navigation Settings > Voice Navigation at Startup, and check that "Select Mode at Startup" is set.**
 5. **Select Settings/Registration > Preferences > Accessibility > Voice Navigation Settings, and check that "Tune Microphone" is displayed.**

Operation Check

■ When Starting to Use

-
1. **Press the Guidance Start button or Voice Recognition button for 3 seconds or longer.**
 2. **In "Select the Voice Navigation type." on the Control Panel screen, select "Manual + Vocal Mode", "Vocal Mode" or "Manual Mode", and press OK.**
 3. **Once the indication on the screen is framed in red, the "Voice Operation Kit" becomes enabled.**

NOTE:

When "Manual Mode" is selected in "Select the Voice Navigation type.", nothing happens by pressing the Voice Recognition button.

■ When Stopping to Use

-
1. **Press the Guidance Start button or Voice Recognition button for 3 seconds or longer.**

Voice Guidance Kit-G1

Points to Note at Installation



- The pictures and illustrations used may be different from the product in front of you, but the procedure is the same.
- When installing this equipment, the option Numeric Keypad is required. Refer to the Installation Procedure for the Numeric Keypad when installing the Numeric Keypad.
- When installing this equipment, be sure to install it by referring to "Table of Options Combination"

Table of Options Combination

	Copy Card Reader	Serial Interface Kit	Copy Control Interface Kit	Voice Operation Kit	Utility Tray
Voice Guidance Kit	Yes	Yes	Yes	No	No

Yes: Available, No: Unavailable

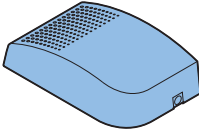
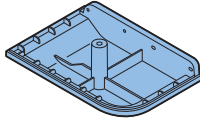
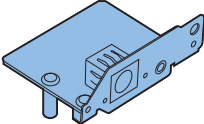
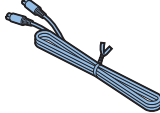
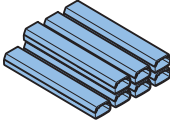
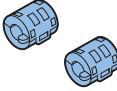
Checking the Contents

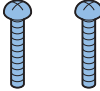
<input type="checkbox"/> [1] Speaker Unit (Upper) X 1 	<input type="checkbox"/> [2] Speaker Unit (Lower) X 1 
<input type="checkbox"/> [3] Voice Guidance Board Unit X 1 	<input type="checkbox"/> [4] Speaker Cable X 1 
<input type="checkbox"/> [5] Cord Guide X 7 Use 4 of them 	<input type="checkbox"/> [6] Ring Core X 2 
<input type="checkbox"/> [7] Screw (Binding ; M4x6) X 1 	<input type="checkbox"/> [8] Screw (Binding ; M4x20) X 2 

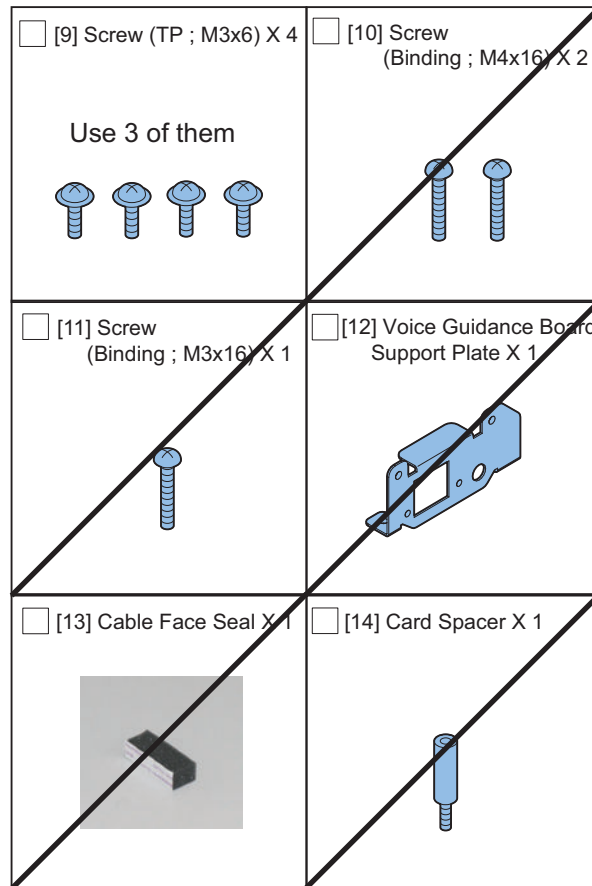

<Others>
Including guides

Essential Items to Be Performed Before Installation

- Turn OFF the main power of the host machine, and disconnect the power plug from the outlet.

⚠ WARNING:

- If performing work without disconnecting the power plug of the host machine, it may cause electrical shock.
- If disconnecting the power plug without turning OFF the main power, it may cause damage of the machine.

- When turning OFF the main power, follow the below procedure.
 1. Turn OFF the main power switch of the host machine.
 2. The display in the Control Panel and the lamp of the main power are turned off.

Points to Note When Turning ON/OFF the Main Power

The following message is displayed.

1. When a message prompting to turn OFF and then ON the main power appears, turn OFF and then ON the main power switch.
2. If a message prompting the user to update the version appears, press [Update] to automatically update the version of this equipment.

If [Skip] is selected, a message prompting the user to update the version will appear every time the host machine is started. In the service mode (Lv. 2) shown below, it is possible to set not to display the message.

COPIER > OPTION > FNC-SW > VER-CHNG

Installation Outline Drawing

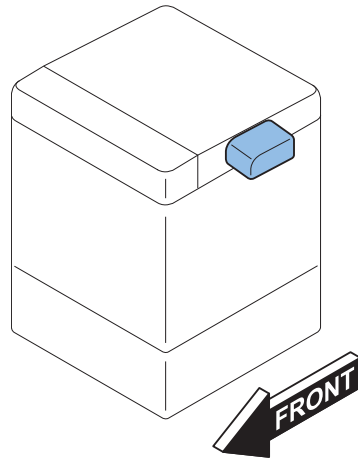

Installation Procedure



1. Open the Right Rear Cover 1, and remove the Side Cover.

- 2 Screws
- 1 Hook

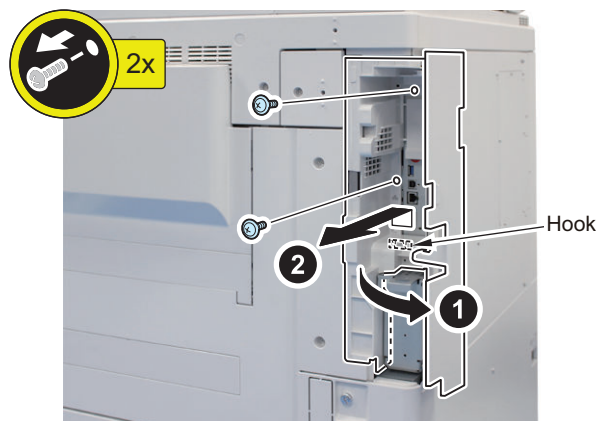

CAUTION:

Be careful not to let the 2 bosses of the Side Cover come off from the 2 mounting holes of the Right Rear Cover 1.

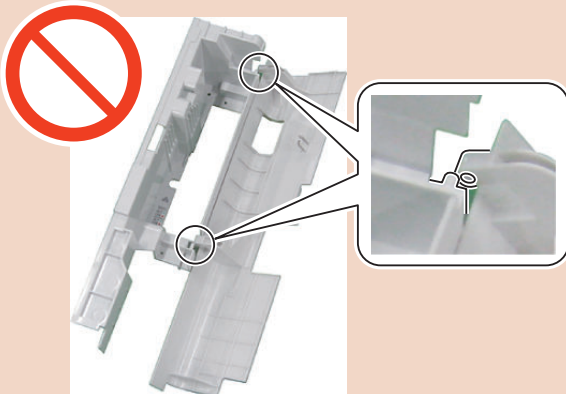



2. Hold the handle to remove the Main Controller.

- 1 Connector

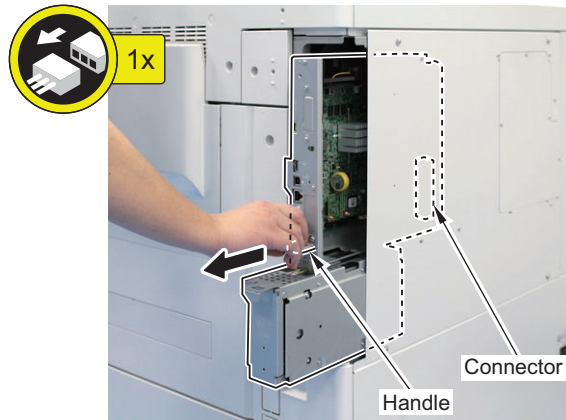

CAUTION:

Be sure to place the removed Main Controller PCB 1 flatly. Reason: Due to the protruded plate, the PCB may be deformed if work is performed while it is placed at an angle.

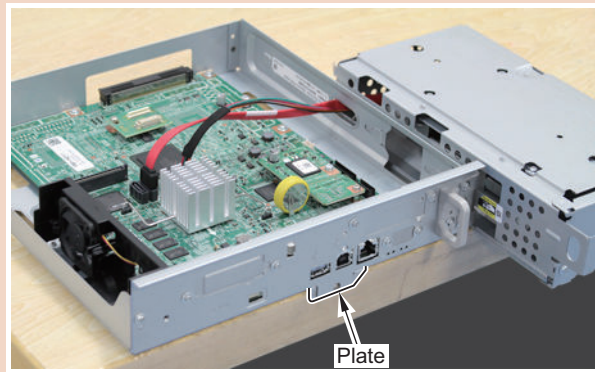

3. Remove the Face Plate (The removed Face Plate and screws will not be used.)

- 2 screws

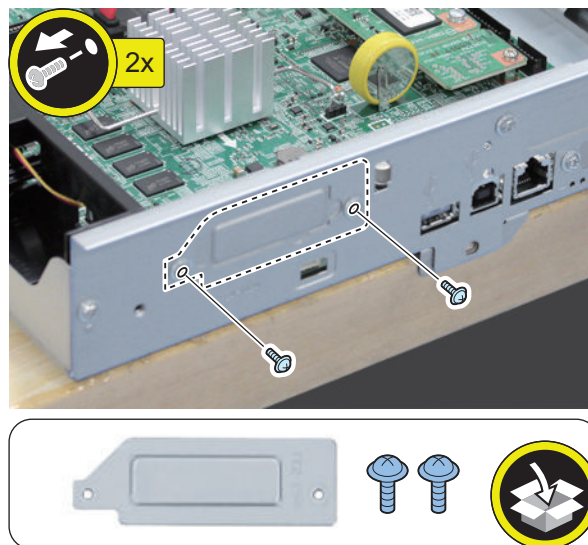

**4. Install the Voice Guidance Board Unit to the Main Controller PCB 1.**

- 1 Connector
- 3 Screws (TP; M3x6)

NOTE:

Check that the connector is connected properly.

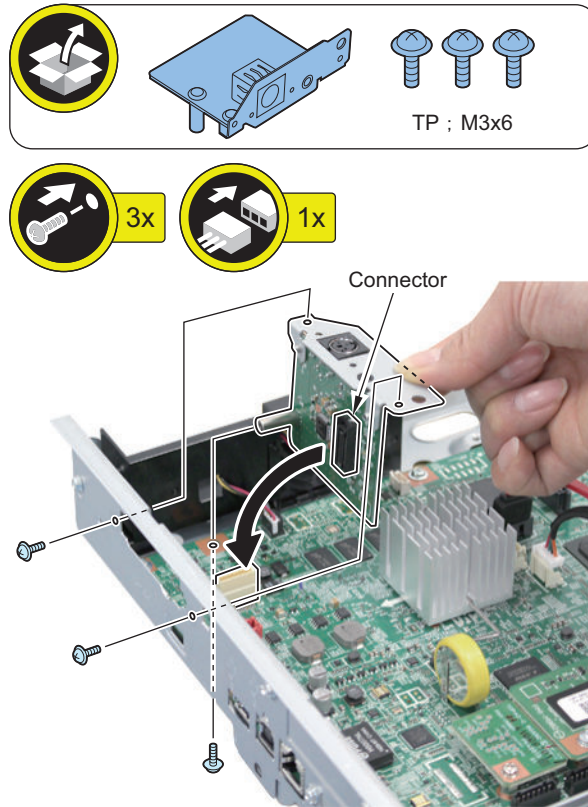



5. Insert the Main Controller PCB 1 until it stops.

- 1 Connector

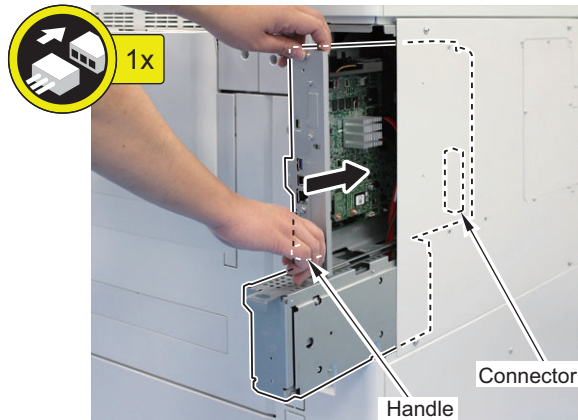

CAUTION:

Be sure to push [A] part hard to install it, otherwise the connector may not be connected.

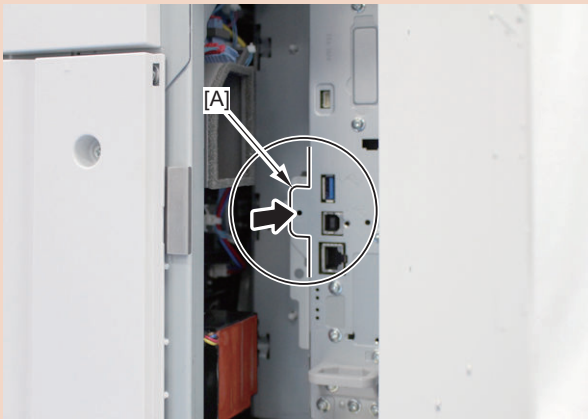

6. Cut off [A] part of the Side Cover with nippers.

NOTE:

When cutting off the part, be sure not to make burrs.

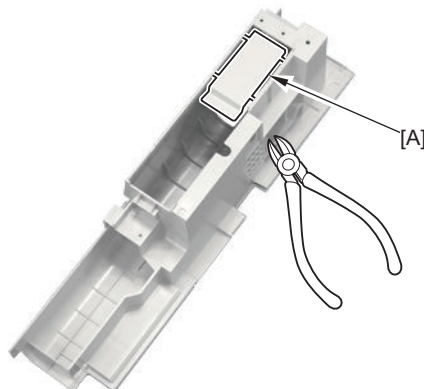



7. Install the Side Cover.

- 1 Hook
- 2 Screws

CAUTION:

Be careful not to let the 2 bosses of the Side Cover come off from the 2 mounting holes of the Right Rear Cover 1.

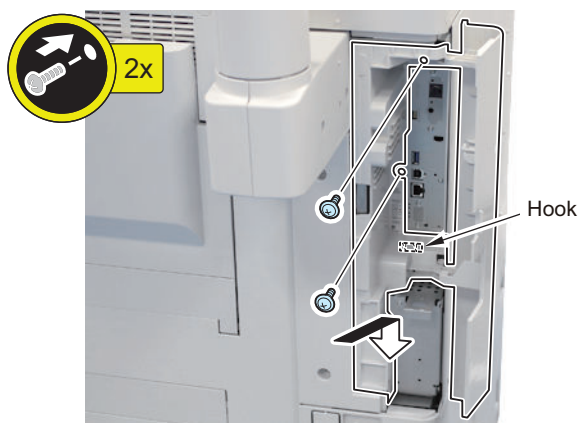
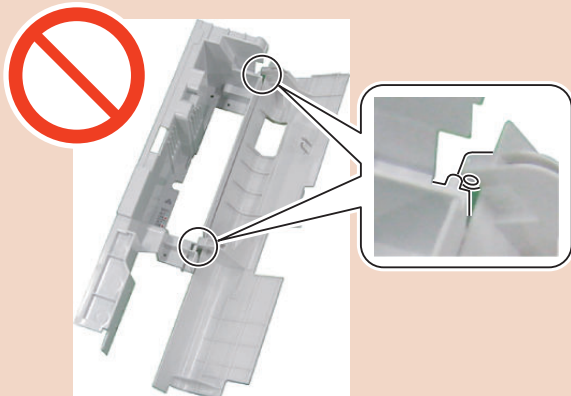



8. Attach the 2 Ring Cores to both ends of the Speaker Cable.

NOTE:

< In the Case of Upright Control Panel>

<In the Case of Upright Control Panel> When installing the Card Reader at the same time, be sure to install a Ring Core only to one end of the Speaker Cable.

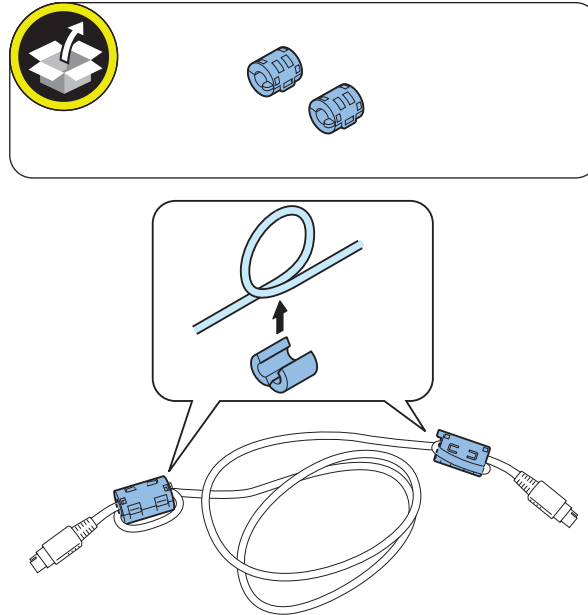

CAUTION:

Be sure to attach the Ring Cores within 50mm from the end of the Speaker Cable.

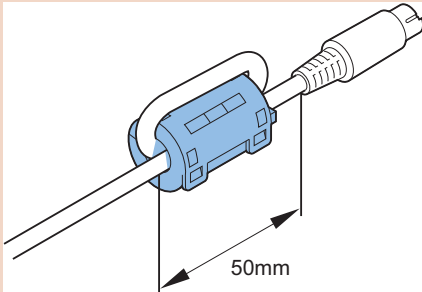

9. Connect the Speaker Cable to the Voice Guidance Board Unit.

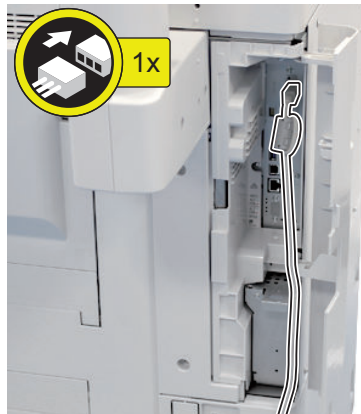



10. Retrieve the Speaker Cable from the position shown in the figure, and close the Right Rear Cover 1.

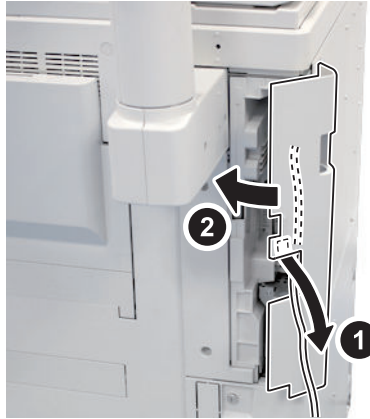

11. Remove the 2 Rubber Caps from the Right Upper Cover. (The removed Rubber Caps will not be used.)

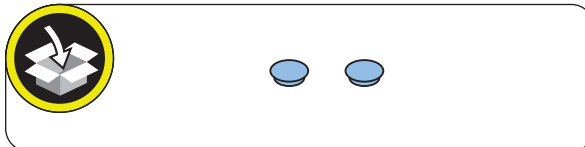



12. Install the Speaker Unit (Lower).

- 2 Screws (Binding; M4x20)

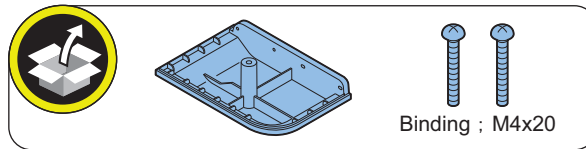

13. Install the Speaker Unit (Upper).

- 1 Screw (Binding; M4x6)

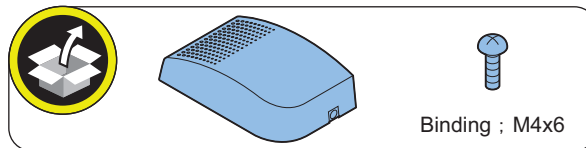

14. Connect the Speaker Cable to the Speaker Unit.

15. Remove the 4 covers from the Cord Guides, and affix them as shown in the figure.

16. Pass the Speaker Cable through the Cord Guides, and fit the 4 covers on the Cord Guides.

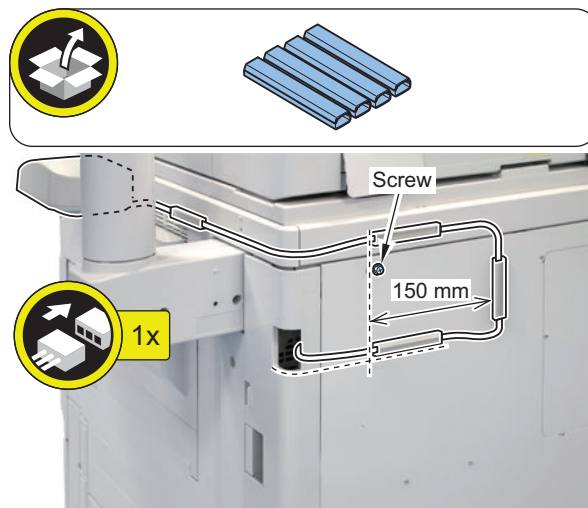

NOTE:

When using together with the Copy Card Reader

< In the Case of Upright Control Panel >

1. Pass the Speaker Cable through the [A] part, install the Ring Core to the cable, and then connect the cable to the Speaker Unit.

CAUTION:

Be sure to attach the Ring Cores within 50mm from the end of the Speaker Cable.

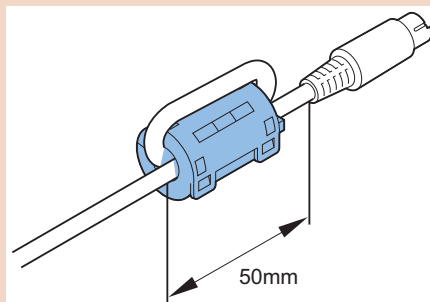

2. Remove the 4 covers from the Cord Guides, and affix them as shown in the figure.
3. Pass the Speaker Cable through the Cord Guides, and fit the 4 covers on the Cord Guides.

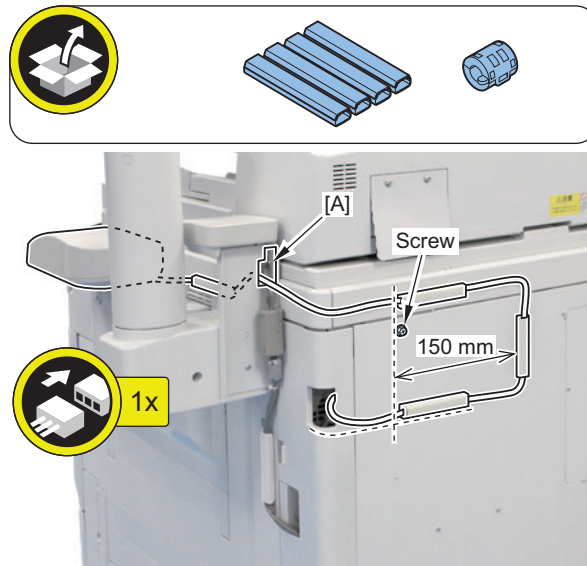

< In the Case of Flat Control Panel >

1. Connect the Speaker Cable to the Speaker Unit.
2. Remove the 4 covers from the Cord Guides, and affix them as shown in the figure.
3. Pass the Speaker Cable through the Cord Guides, and fit the 4 covers on the Cord Guides.

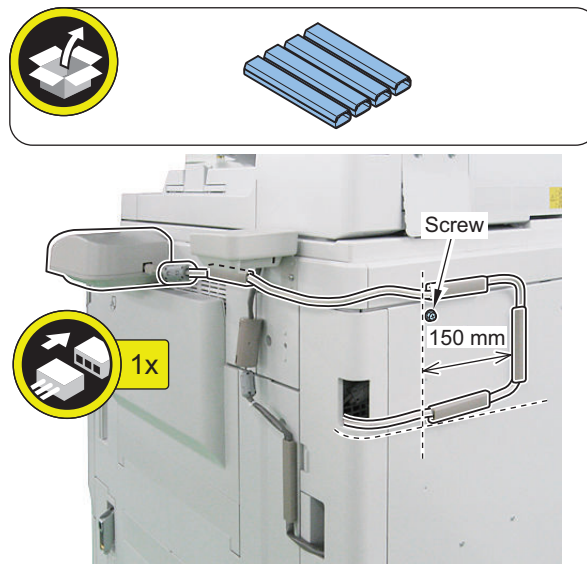

Checking after Installation

NOTE:

When changing the settings upon user's request, it is required to log in as a system manager in accordance with instructions from the user administrator.

-
1. Connect the power plug of the host machine to the power outlet.
 2. Turn the main power switch ON.
 3. Select [Settings/Registration] > [Preferences] > [Accessibility] > [Voice Navigation Settings] > [Use Voice Navigation], and check that the setting is [ON].
 4. Select [Settings/Registration] > [Preferences] > [Accessibility] > [Voice Navigation Settings] > [Voice Guide from Speakers], and check that the setting is ON.

Operation Check

NOTE:

Perform the following check from the Voice Recognition button on the numeric keypad.

■ When Using



1. Press the Voice Guidance Start button.
2. Once the indication on the screen is framed in red, the "Voice Guidance Kit" becomes enabled.

■ When Stopping to Use



1. Press the Voice Guidance Start button.

HDD-related Option

Pre-checks

Points to Note at Installation

CAUTION:

- For TYPE2 to TYPE3, be sure to perform the procedure of each TYPE after performing “[Removing the HDD Box Unit](#)” on page 289.
- When using the mirroring function, be sure to install 2 HDDs of the same capacity.
- The HDD needs to be initialized after replacing the large capacity HDD.
- When replacing a HDD that contains user information with a high-capacity HDD (which is not an initial installation), backup and export of HDD data are necessary. For details, refer to "Backup Data" in the Service Manual.

When installing the HDD-related options (the following 3 products), refer to pages described below.

- 2.5inch/250GB HDD-N1
- 2.5inch/1TB HDD-P1
- HDD Mirroring Kit-J1

Title	Combination of Product
TYPE-1	“ [TYPE-1] Option HDD (1TB) ” on page 293
TYPE-2	“ Removing the HDD Box Unit ” on page 289 + “ [TYPE-2] Standard HDD + Option HDD (250GB) + HDD Mirroring Kit ” on page 299
TYPE-3	“ Removing the HDD Box Unit ” on page 289 + “ [TYPE-3] 2 Option HDDs (1TB) + HDD Mirroring Kit ” on page 310

Installation Outline Drawing

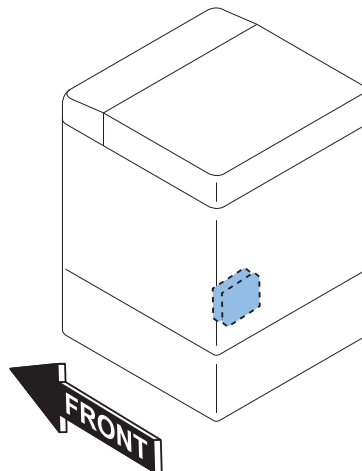

Essential Items to Be Performed Before Installation

- Turn OFF the main power of the host machine, and disconnect the power plug from the outlet.

⚠ WARNING:

- If performing work without disconnecting the power plug of the host machine, it may cause electrical shock.
- If disconnecting the power plug without turning OFF the main power, it may cause damage of the machine.

- When turning OFF the main power, follow the below procedure.
 1. Turn OFF the main power switch of the host machine.
 2. The display in the Control Panel and the lamp of the main power are turned off.

■ Points to Note When Turning ON/OFF the Main Power

The following message is displayed.

1. When a message prompting to turn OFF and then ON the main power appears, turn OFF and then ON the main power switch.
2. If a message prompting the user to update the version appears, press [Update] to automatically update the version of this equipment.

If [Skip] is selected, a message prompting the user to update the version will appear every time the host machine is started. In the service mode (Lv. 2) shown below, it is possible to set not to display the message.

COPIER > OPTION > FNC-SW > VER-CHNG

● Removing the HDD Box Unit

CAUTION:

- For [TYPE-1 Option HDD (1TB)], this procedure is not necessary. For other TYPES, be sure to proceed to each installation procedure after performing this procedure.
- The removed screws will be used again in the installation procedure of each TYPE.



1. Open the Right Rear Cover 1.



2. Open the HDD Lid.

- 1 Screw

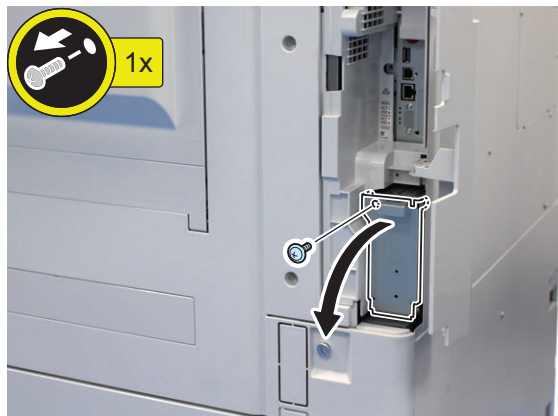



3. Remove the HDD.

NOTE:

When replacing with the Option HDD (1TB), the removed HDD will not be used.

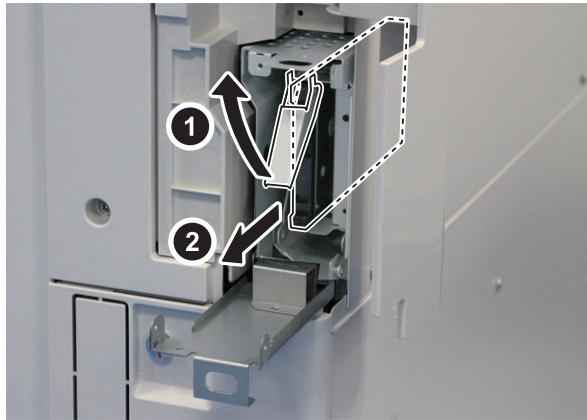

4. Close the HDD Lid.

NOTE:

Do not tighten the screw here.





5. Remove the Side Cover.

- 2 Screws
- 1 Hook

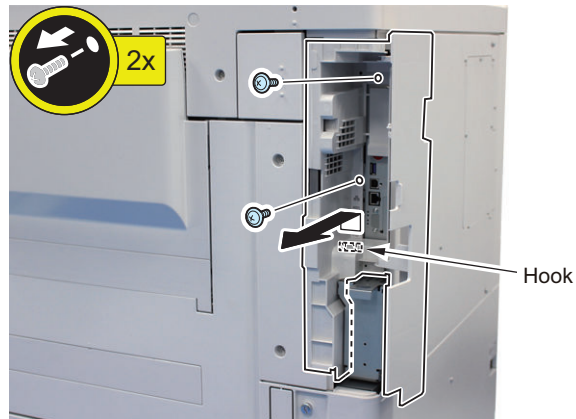

CAUTION:

Be careful not to let the 2 bosses of the Side Cover come off from the 2 mounting holes of the Right Rear Cover 1.

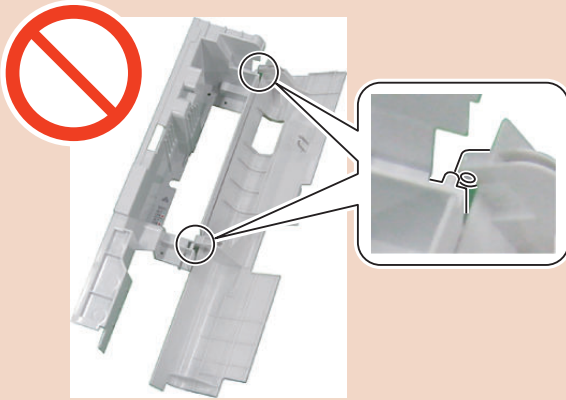

6. Hold the handle, and remove the Main Controller 1.

- 1 Connector

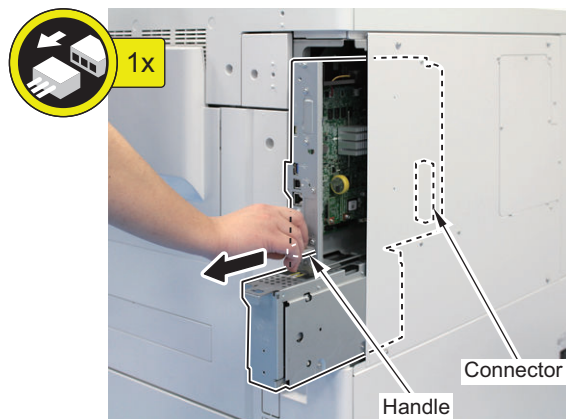



7. Remove the HDD Box Unit.

- 2 Connectors
- 2 Screws
- 2 Hooks

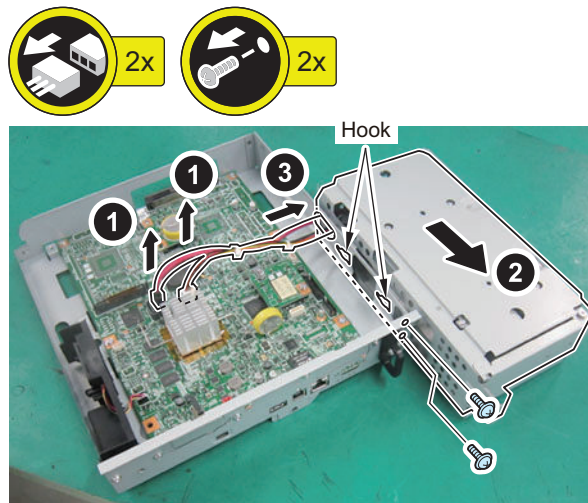

8. Open the HDD Lid, and remove the HDD Outside Cover.

- 4 Screws
- 1 Protrusion

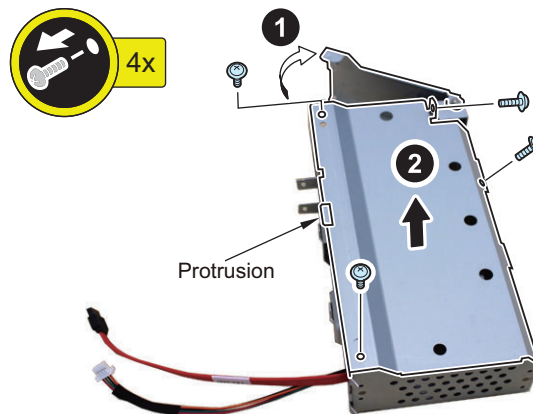

9. Remove the HDD Unit.

- 4 Screws

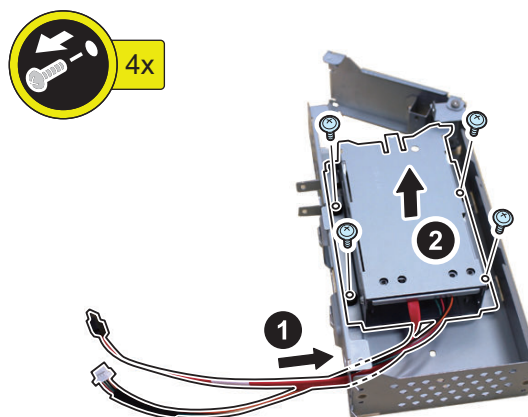



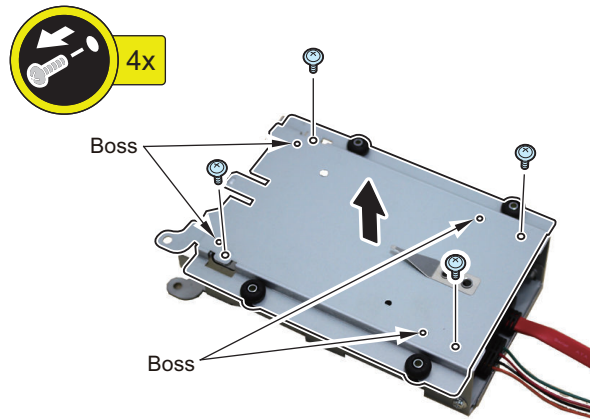

10. Remove the HDD Side Cover.

- 4 Screws
- 4 Bosses

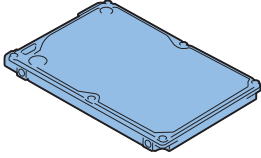
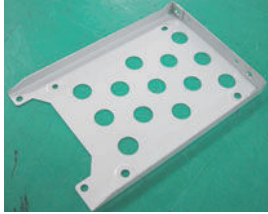

[TYPE-1] Option HDD (1TB)

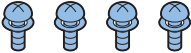
■ Checking the Contents

<input type="checkbox"/> [1] HDD X 1 	<input type="checkbox"/> [2] HDD Case X 1 
<input type="checkbox"/> [3] HDD Holder Hinge X 1 	<input type="checkbox"/> [4] HDD Case Hinge Base X 1 
<input type="checkbox"/> [5] Screw (Sems ; M3x4) X 4 	<input type="checkbox"/> [6] Screw (P Tightening ; M3x8) X 2 

■ Essential Items to Be Performed Before Installation

- Turn OFF the main power of the host machine, and disconnect the power plug from the outlet.

⚠ WARNING:

- If performing work without disconnecting the power plug of the host machine, it may cause electrical shock.
- If disconnecting the power plug without turning OFF the main power, it may cause damage of the machine.

- When turning OFF the main power, follow the below procedure.
 1. Turn OFF the main power switch of the host machine.
 2. The display in the Control Panel and the lamp of the main power are turned off.

■ Points to Note When Turning ON/OFF the Main Power

The following message is displayed.

1. When a message prompting to turn OFF and then ON the main power appears, turn OFF and then ON the main power switch.
2. If a message prompting the user to update the version appears, press [Update] to automatically update the version of this equipment.

If [Skip] is selected, a message prompting the user to update the version will appear every time the host machine is started. In the service mode (Lv. 2) shown below, it is possible to set not to display the message.

COPIER > OPTION > FNC-SW > VER-CHNG

■ Installation Procedure



1. Open the Right Rear Cover 1.





2. Open the HDD Lid.

- 1 Screw (will be used in step 7)

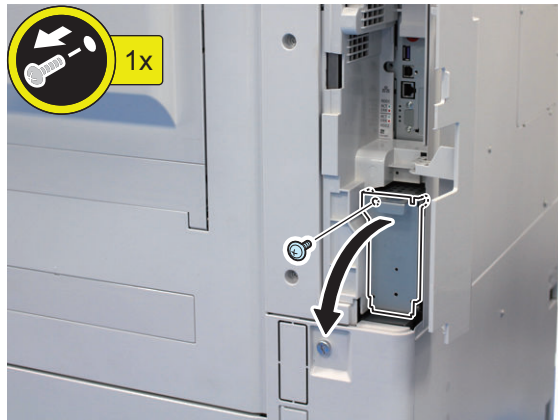

3. Remove the HDD. (The removed HDD will not be used.)

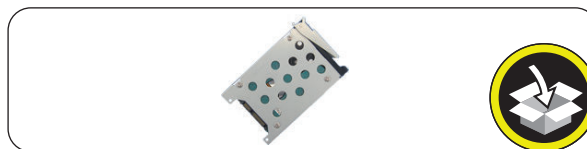
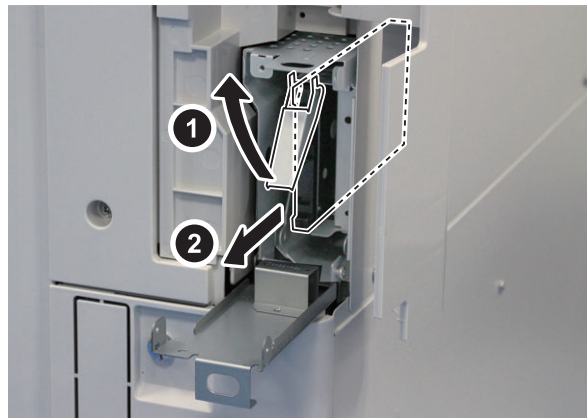



4. Fit the Hinge Pin of the HDD Holder Hinge with the groove of the HDD Case Hinge Base to install it to the HDD Case.

- 2 Bosses
- 2 Screws (P Tightening; M3x8)

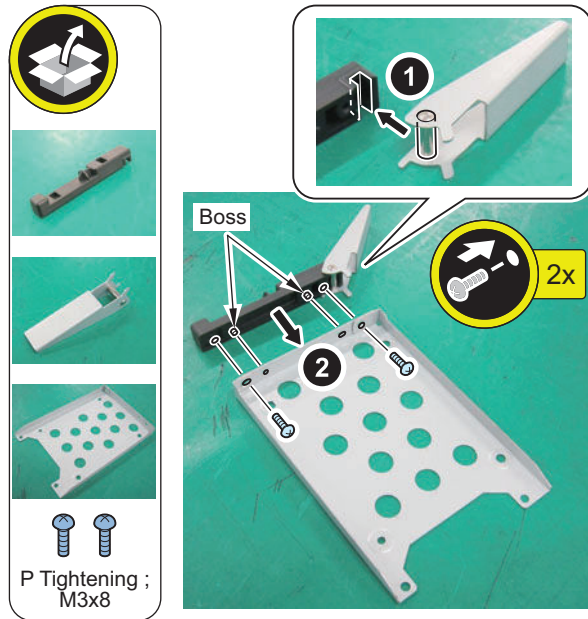

5. Install the assembled HDD Case to the HDD.

- 4 Screws (Sems; M3x4)

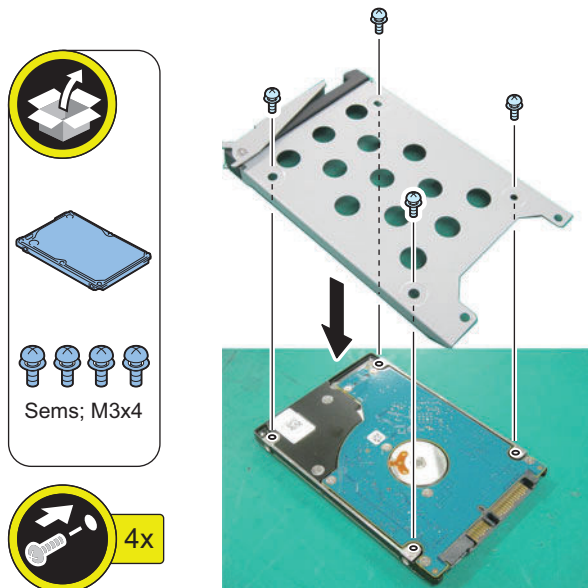



6. Install the Option HDD to the host machine.

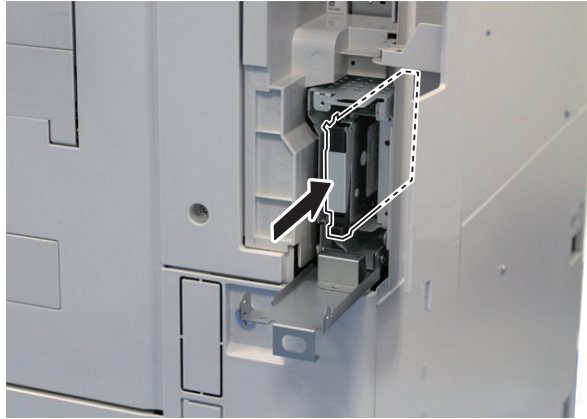

7. Close the HDD Lid.

- 1 Screw (screws removed in step 2)

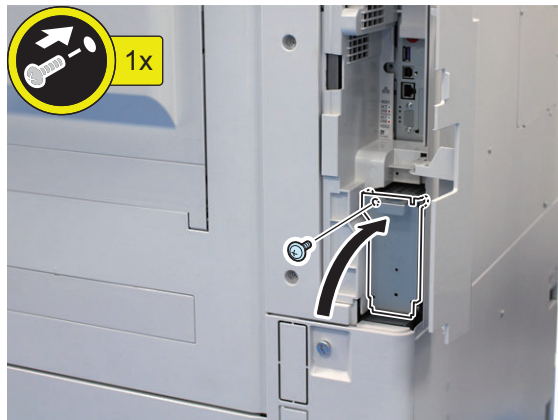

8. Close the Right Rear Cover 1.



■ HDD Initialization Procedure

1. Requirements

1. PC
Service Support Tool in the version that supports this host machine must be installed.
2. Cross Ethernet Cable (when SST is used)

2. Preparing for the Installation of the System Software of Host machine

1. If both PC and the machine are on, turn them off.
2. Connect the PC and the host machine using an Cross Ethernet cable. (when SST is used)
3. Turn on the PC.

3. Registering the system software

1. Insert the latest System Software into the PC using the SST.
2. Start the SST.
3. Click 'Register Firmware'.
4. Select the drive where the system software has been inserted, and click the [SEARCH] button.
5. Click the [REGISTER] button.
6. Click [OK].

4. Initializing HDD

<In case of SST>

1. Start the host machine with download mode in safe mode.
2. Start the SST.
3. Select the model. Then, select [Single] and click [Start].
4. Click [Format HDD].
5. Select [All], and click [Start].
6. Click [Execute Format].
7. The Format is executed.
8. Select [Shutdown/Restart], and click [Shutdown].
9. Click [OK]
10. The power of the host machine is turned OFF.
11. Terminate the SST.
12. Disconnect the Cross Ethernet Cable from the machine, and connect the user's network cable to the machine.

<In case of USB flash drive>

1. Connect the USB flash drive to the PC.
2. Start up SST, and click the USB icon displayed in the target selection screen.
3. Select the drive, the model series, and the version to be written to the USB flash drive, and click [Confirm].
4. Click [Start], and after the version has been written to the USB flash drive, click [OK] and then remove the USB flash drive.
5. Terminate the SST.
6. Connect the USB flash drive to the host machine, and start the host machine with download mode in safe mode.
7. When the USB menu is displayed, press keys on the Control Panel in the order shown below.
 - [4]: Clear/Format
 - [1]: Disk Format
 - [0]: OK
 - Press any keys.
 - [C]: Return to menu
 - [Reset] : Start shutdown sequence
 - [0]: OK (The power of the host machine is turned OFF automatically.)
8. Remove the USB flash drive.
9. Turn ON the main power switch.

■ Executing Auto Gradation Adjustment

When the high-capacity HDD is installed, the machine initializes its HDD, resetting the data used for auto gradation correction. Therefore, execute full adjustment of auto gradation adjustment after installing the high-capacity HDD to enable proper images to be output.







■ Execution of the Minimum Installation Work

Be sure to execute the minimum installation work in accordance with the Setup Guide because HDD is initialized when the high-capacity HDD is installed.

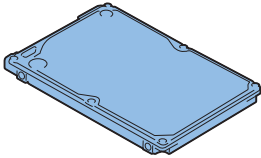
[TYPE-2] Standard HDD + Option HDD (250GB) + HDD Mirroring Kit

■ Checking the Contents

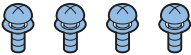
<Option HDD (250 GB)>

<input type="checkbox"/> [1] HDD X 1 	<input type="checkbox"/> [2] HDD Case X 1 
<input type="checkbox"/> [3] HDD Holder Hinge X 1 	<input type="checkbox"/> [4] HDD Case Hinge Base X 1 
<input type="checkbox"/> [5] Screw (Sems ; M3x4) X 4 	<input type="checkbox"/> [6] Screw (P Tightening ; M3x8) X 2 





<HDD Mirroring Kit>

CAUTION:

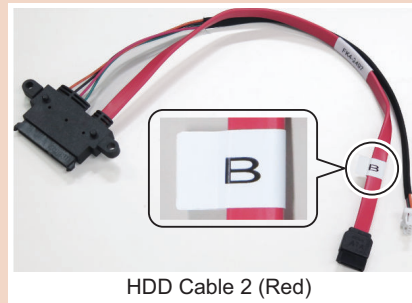
Although the red cable shown below may sometimes be supplied in lieu of the HDD Cable 2 (Blue), the procedure for connecting the red cable is the same as that for the blue cable.

When connecting the cable to the Controller PCB, make sure to first confirm that the sticker [B] is attached to the cable and then connect the cable to the Controller PCB.



<input type="checkbox"/> [1] HDD Cable 2 (Blue) X 1 	<input type="checkbox"/> [2] HDD Connector Support Plate X 1 
<input type="checkbox"/> [3] Screw (TP; M3x6) X 2 	<input type="checkbox"/> [4] Screw (TP; M3x8 Black) X 2 

<Others>

- Guides are included

■ Essential Items to Be Performed Before Installation

- Turn OFF the main power of the host machine, and disconnect the power plug from the outlet.

⚠ WARNING:

- If performing work without disconnecting the power plug of the host machine, it may cause electrical shock.
- If disconnecting the power plug without turning OFF the main power, it may cause damage of the machine.

- When turning OFF the main power, follow the below procedure.
 1. Turn OFF the main power switch of the host machine.
 2. The display in the Control Panel and the lamp of the main power are turned off.

■ Points to Note When Turning ON/OFF the Main Power

The following message is displayed.

1. When a message prompting to turn OFF and then ON the main power appears, turn OFF and then ON the main power switch.

2. If a message prompting the user to update the version appears, press [Update] to automatically update the version of this equipment.

If [Skip] is selected, a message prompting the user to update the version will appear every time the host machine is started. In the service mode (Lv. 2) shown below, it is possible to set not to display the message.

COPIER > OPTION > FNC-SW > VER-CHNG

■ Installation Procedure

CAUTION:

Be sure to perform "“Removing the HDD Box Unit” on page 289” before performing the following work.

● Assembling and Installing the Option



1. Fit the Hinge Pin of the HDD Holder Hinge with the groove of the HDD Case Hinge Base to install it to the HDD Case.

- 2 Bosses
- 2 Screws (P Tightening; M3x8)

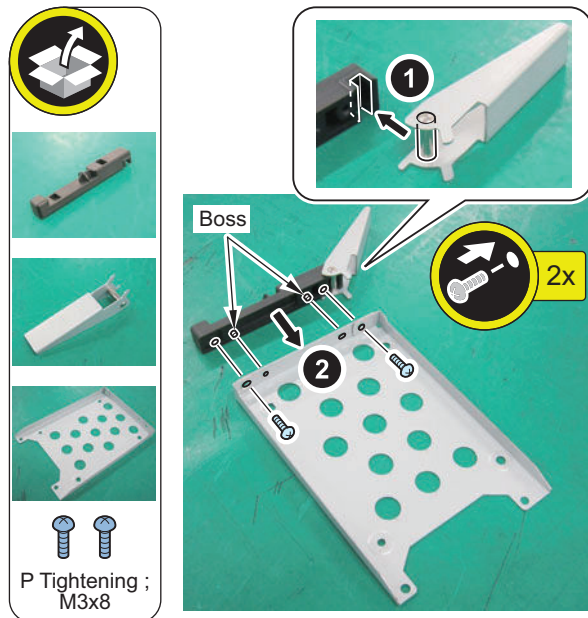



2. Install the assembled HDD Case to the HDD.

- 4 Screws (Sems; M3x4)

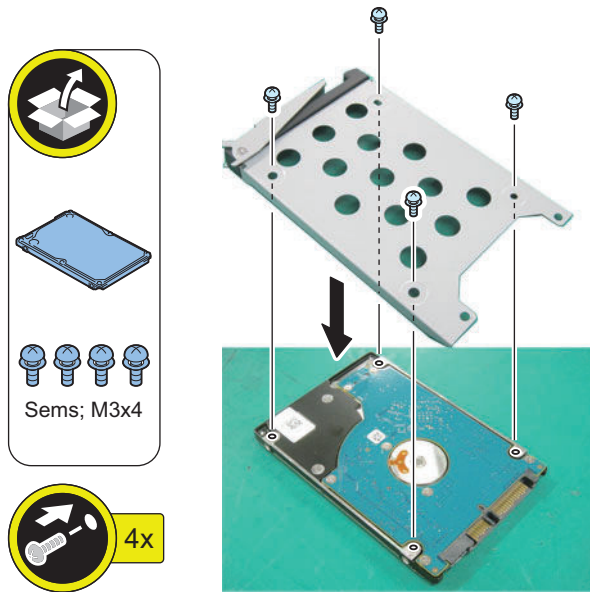

3. Install the Option HDD to the Slot 2 (Right).

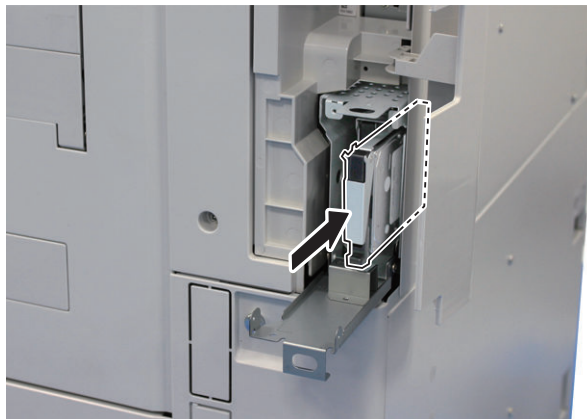

4. Close the HDD Lid.

- 1 Screw (Use the removed screws)

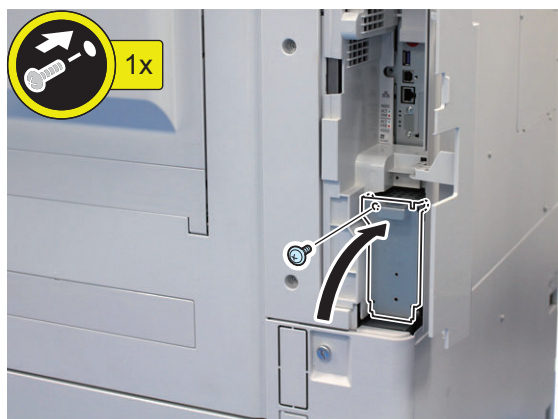

**5. Close the Right Rear Cover 1.****■ Installing the HDD Mirroring Kit****1. Remove the HDD Wrong Insertion Prevention Plate. (The removed parts will not be used.)**

- 1 Screw
- 1 Protrusion

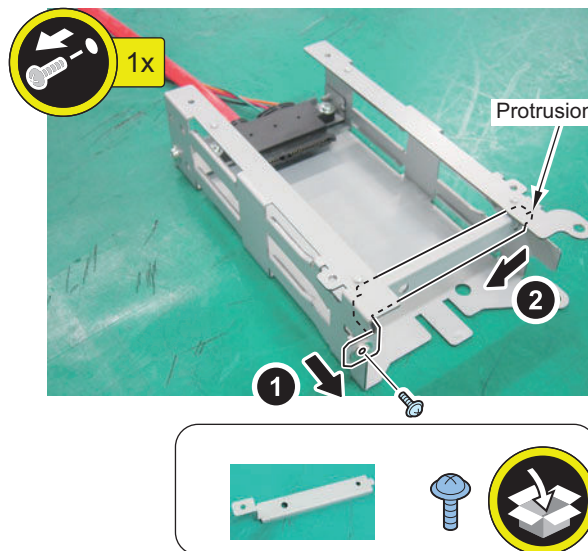



2. Assemble the HDD Cable 2 (Blue or Red) and the HDD Connector Support Plate.

- 2 Bosses
- 2 Screws (TP; M3x8 Black)

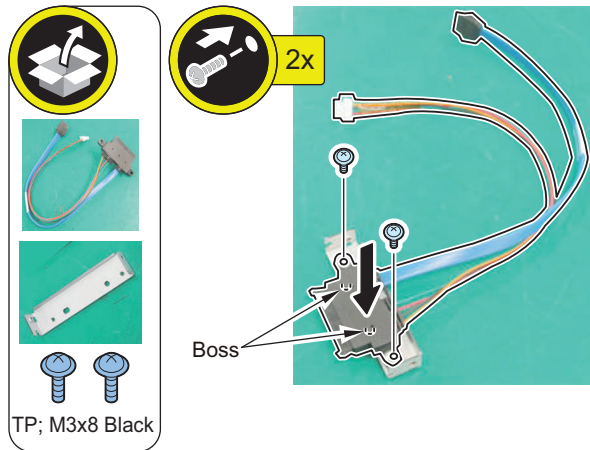

3. Install the assembled HDD Cable 2 Unit to the HDD Unit.

- 2 Bosses
- 2 Screws (TP; M3x6)

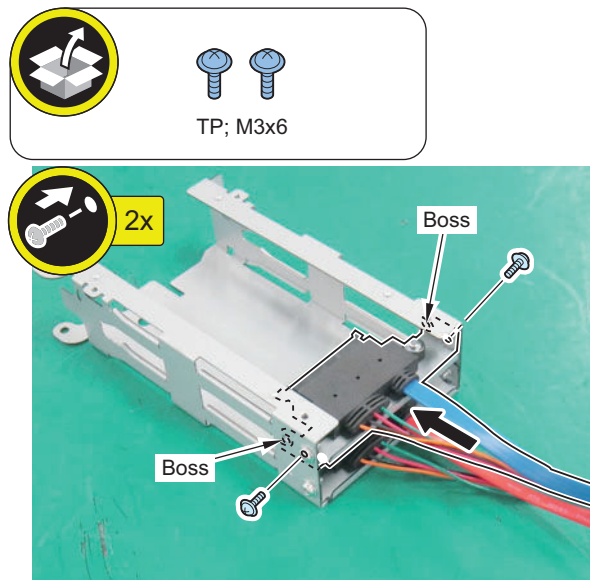

**4. Installing the HDD Side Cover.**

- 4 Bosses
- 4 Screws (Use the removed screws)

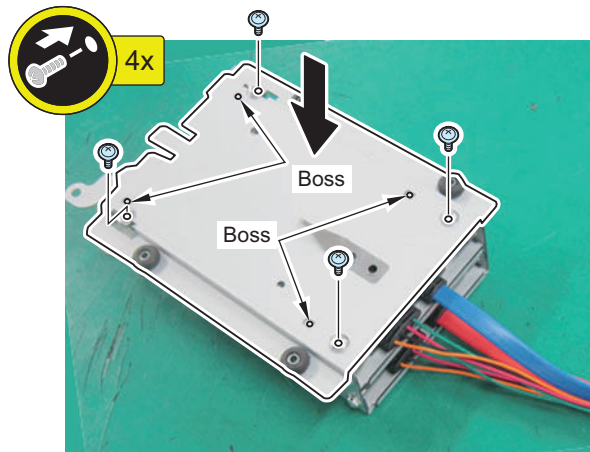
**5. Put the 4 cables through the hole, and install the HDD Unit according to the marking lines.**

- 4 Screws (Use the removed screws)

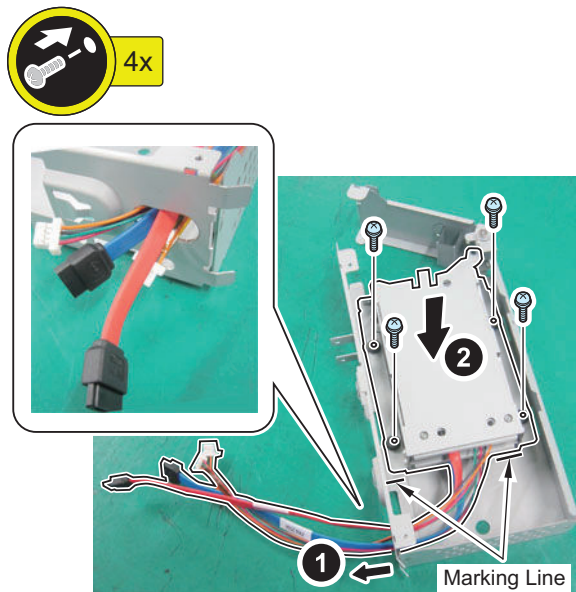



6. Install the HDD Outside Cover, and close the HDD Lid.

- 1 Protrusion
- 4 Screws (Use the removed screws)

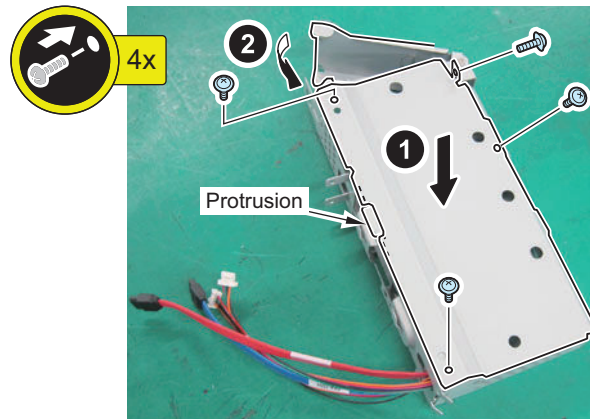

7. Put the 4 cables through the hole, and install the HDD Box Unit.

- 2 Hooks
- 2 Screws (Use the removed screws)

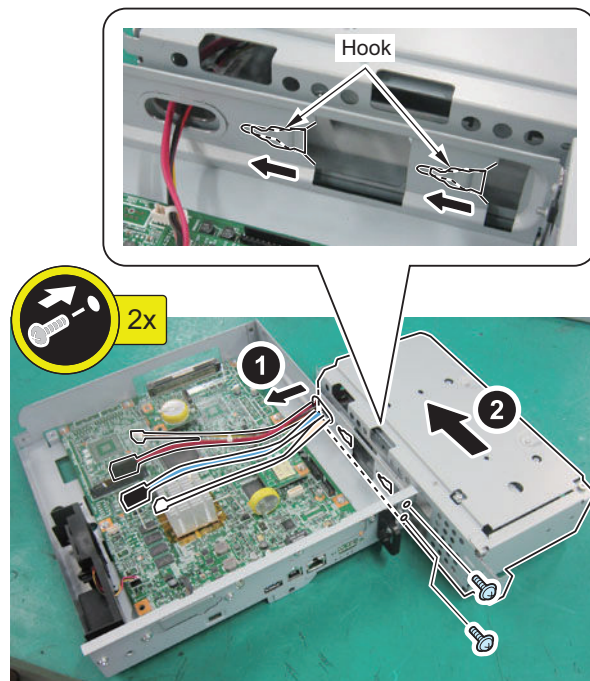

CAUTION:

Be sure to connect the communication cable to the correct port. The HDD error occurs.

8. Connect the HDD Cable 1 (Red) to [A] on the Controller PCB.

- 2 Connectors

9. Connect the HDD Cable 2 (Blue) or the HDD Cable 2 (Red) with a sticker labeled [B] to [B] on the Controller PCB.

- 2 Connectors

< When using the HDD Cable 2 (Blue) >

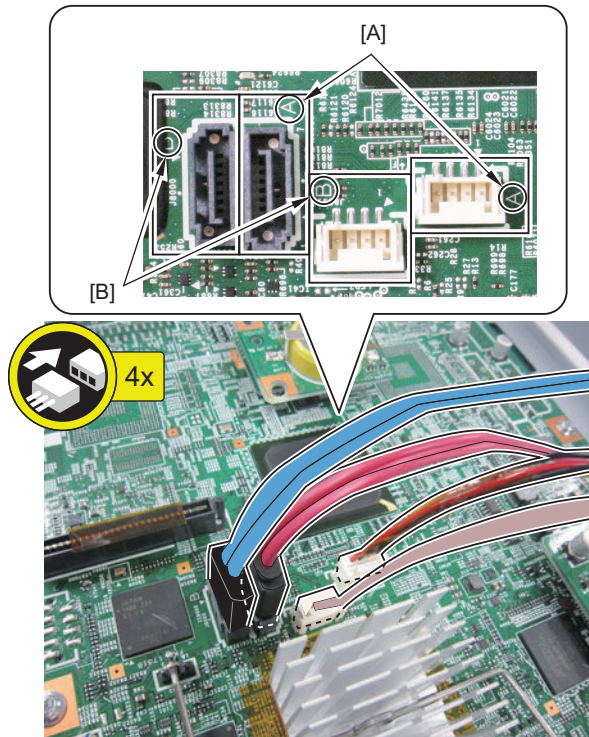

< When using the HDD Cable 2 (Red) >

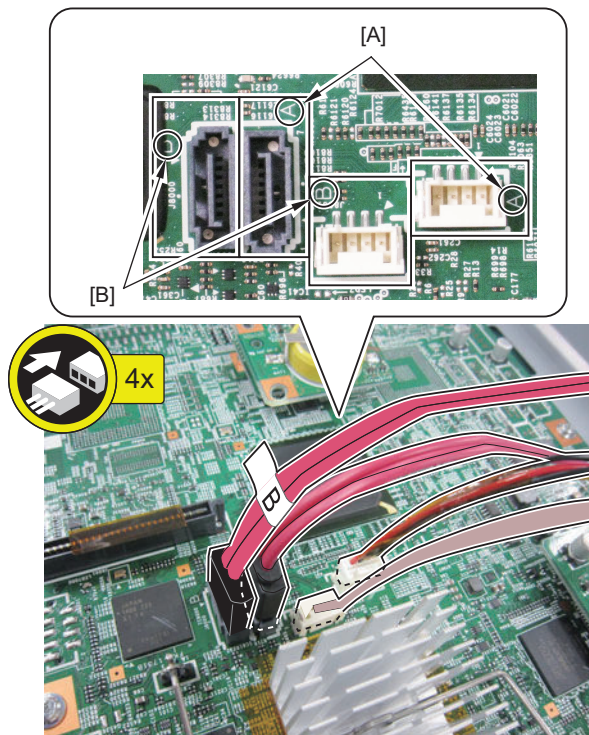



10. Insert the Main Controller PCB 1 until it stops.

- 1 Connector

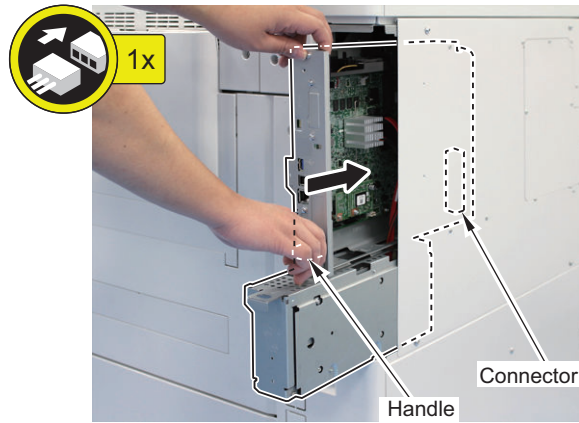

CAUTION:

Be sure to push [A] part hard to install it, otherwise the connector may not be connected properly.

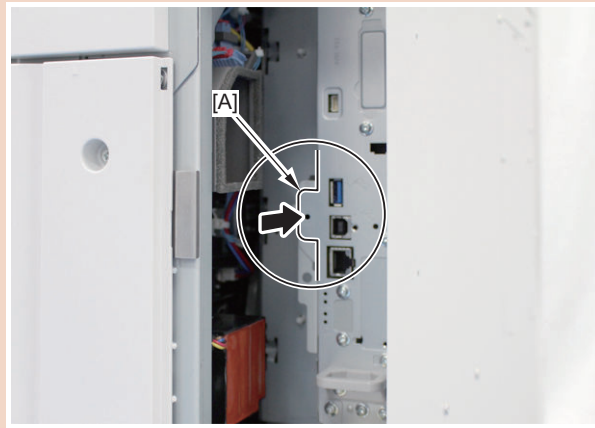

11. Install the Side Cover. Do not close the Right Rear Cover 1 yet here.

- 1 Hook
- 2 Screws

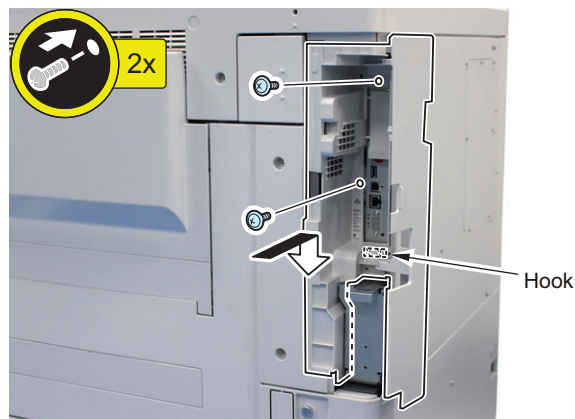



12. Open the HDD Lid.

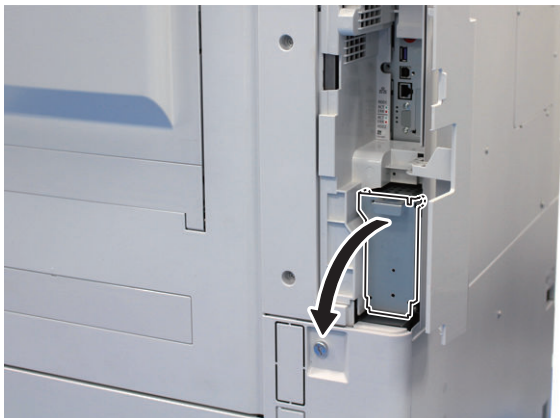

13. Return the HDD removed from the host machine to the Slot 1 (Left).

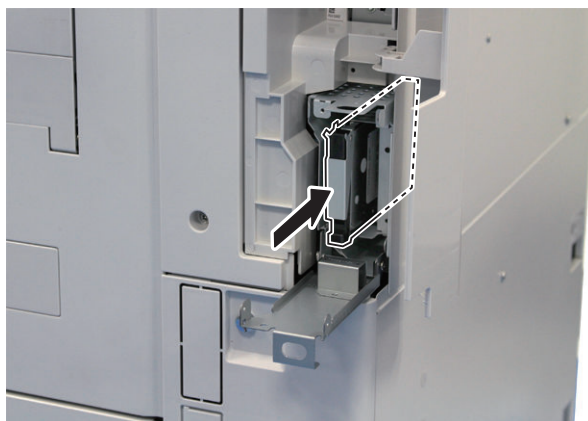

■ Setting the Mirroring



1. Set the setting value for the mirroring to "1" in the following service mode.
COPIER > OPTION > FNC-SW > W/RAID
2. Turn OFF/ON the main power of the host machine to enable the setting value.
3. Make sure that the UI screen is activated correctly.
4. Open the Cover, and make sure that the LED blinks.

NOTE:

Rebuilding starts approximately after 3 minutes after turning OFF and then ON the power.

- HDD 1 (Slot 1): The green LED blinks.
- HDD 2 (Slot 2): The green and red LEDs blink.

CAUTION:

Rebuild process starts after setting "1" for W/RAID.

If an error occurs during the rebuild process at the initial installation the hard disk needs to be replaced. (Call service rep.), reexecute the process with the following procedure.

1. Check that the lighting red LED is HDD2.
2. Select "0" for the following service mode.
COPIER > OPTION > FNC-SW > W/RAID
3. To enable the setting value, turn OFF/ON the Main Power Supply Switch of the host machine.
4. Select "1" for the following service mode.
COPIER > OPTION > FNC-SW > W/RAID
5. To enable the setting value, turn OFF/ON the Main Power Supply Switch of the host machine.







The foregoing procedure is limited to the rebuild process at the initial installation.

An error during the rebuild process that is executed during operation is not included in the consideration.

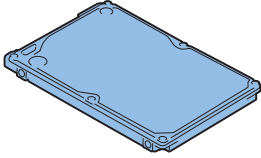
[TYPE-3] 2 Option HDDs (1TB) + HDD Mirroring Kit

■ Checking the Contents

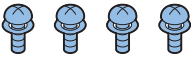
<Option HDD (1TB)>

<input type="checkbox"/> [1] HDD X 1 	<input type="checkbox"/> [2] HDD Case X 1 
<input type="checkbox"/> [3] HDD Holder Hinge X 1 	<input type="checkbox"/> [4] HDD Case Hinge Base X 1 
<input type="checkbox"/> [5] Screw (Sems ; M3x4) X 4 	<input type="checkbox"/> [6] Screw (P Tightening ; M3x8) X 2 





<HDD Mirroring Kit>

CAUTION:

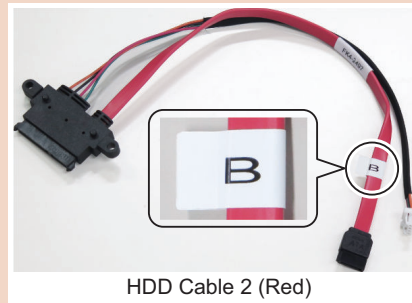
Although the red cable shown below may sometimes be supplied in lieu of the HDD Cable 2 (Blue), the procedure for connecting the red cable is the same as that for the blue cable.

When connecting the cable to the Controller PCB, make sure to first confirm that the sticker [B] is attached to the cable and then connect the cable to the Controller PCB.



<input type="checkbox"/> [1] HDD Cable 2 (Blue) X 1 	<input type="checkbox"/> [2] HDD Connector Support Plate X 1 
<input type="checkbox"/> [3] Screw (TP; M3x6) X 2 	<input type="checkbox"/> [4] Screw (TP; M3x8 Black) X 2 

<Others>

- Guides are included

■ Essential Items to Be Performed Before Installation

- Turn OFF the main power of the host machine, and disconnect the power plug from the outlet.

⚠ WARNING:

- If performing work without disconnecting the power plug of the host machine, it may cause electrical shock.
- If disconnecting the power plug without turning OFF the main power, it may cause damage of the machine.

- When turning OFF the main power, follow the below procedure.
 1. Turn OFF the main power switch of the host machine.
 2. The display in the Control Panel and the lamp of the main power are turned off.

■ Points to Note When Turning ON/OFF the Main Power

The following message is displayed.

1. When a message prompting to turn OFF and then ON the main power appears, turn OFF and then ON the main power switch.

2. If a message prompting the user to update the version appears, press [Update] to automatically update the version of this equipment.

If [Skip] is selected, a message prompting the user to update the version will appear every time the host machine is started. In the service mode (Lv. 2) shown below, it is possible to set not to display the message.

COPIER > OPTION > FNC-SW > VER-CHNG

■ Installation Procedure

CAUTION:

Be sure to perform "Removing the HDD Box Unit" on page 289" before performing the following work.

● Installing the HDD Mirroring Kit



1. Remove the HDD Wrong Insertion Prevention Plate. (The removed parts will not be used.)

- 1 Screw
- 1 Protrusion

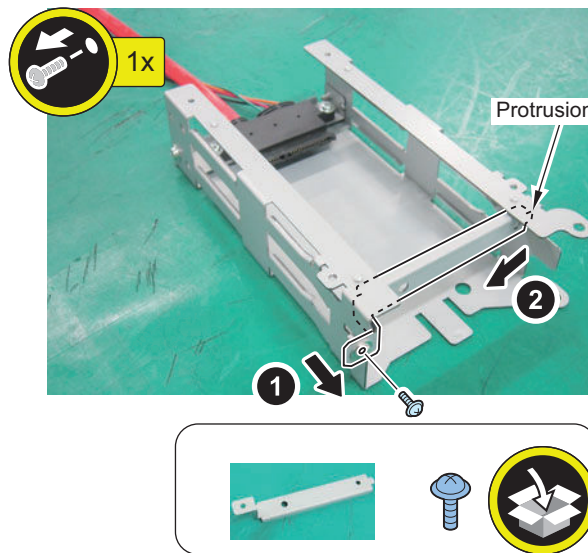

2. Assemble the HDD Cable 2 (Blue or Red) and the HDD Connector Support Plate.

- 2 Bosses
- 2 Screws (TP; M3x8 Black)

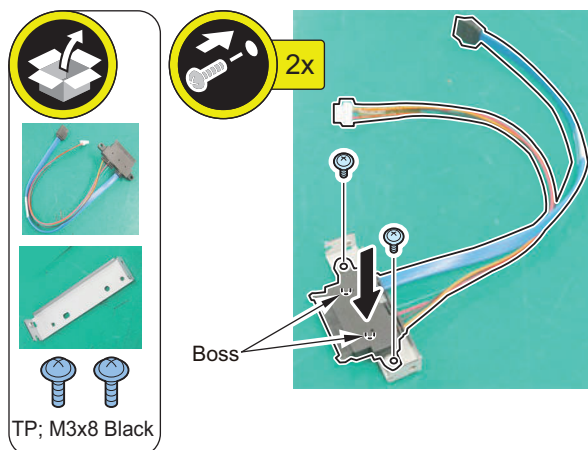

**3. Install the assembled HDD Cable 2 Unit to the HDD Unit.**

- 2 Bosses
- 2 Screws (TP; M3x6)

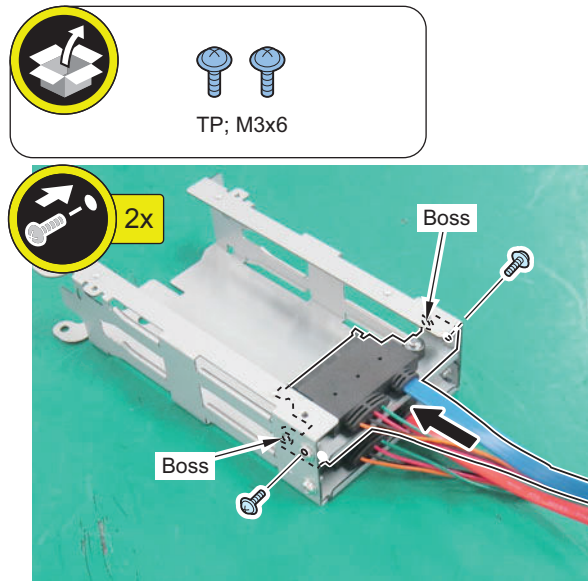
**4. Install the HDD Side Cover.**

- 4 Bosses
- 4 Screws (Use the removed screws)

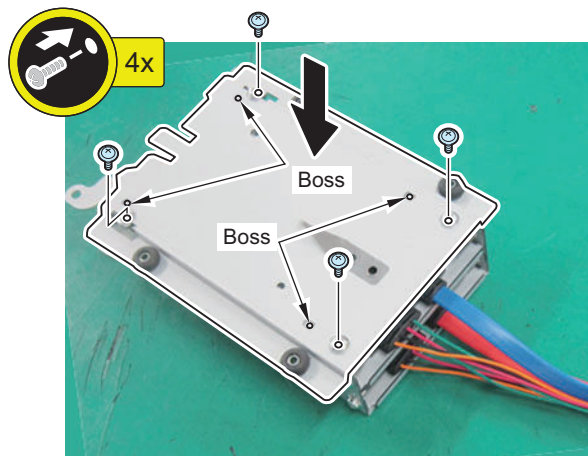

**5. Put the 4 cables through the hole, and install the HDD Unit according to the marking lines.**

- 4 Screws (Use the removed screws)

**6. Install the HDD Outside Cover, and close the HDD Lid.**

- 1 Protrusion
- 4 Screws (Use the removed screws)

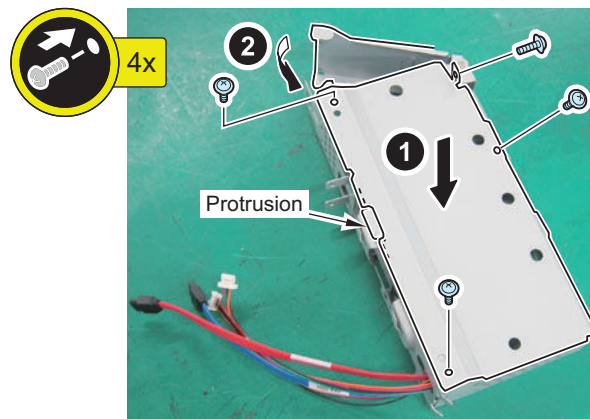



7. Put the 4 cables through the hole, and install the HDD Box Unit.

- 2 Hooks
- 2 Screws (Use the removed screws)

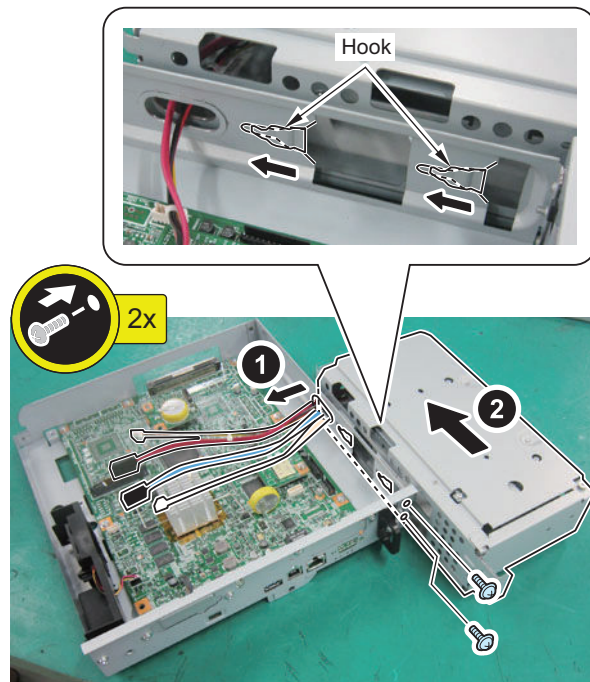

CAUTION:

Be sure to connect the communication cable to the correct port. The HDD error occurs.

8. Connect the HDD Cable 1 (Red) to [A] on the Controller PCB.

- 2 Connectors

9. Connect the HDD Cable 2 (Blue) or the HDD Cable 2 (Red) with a sticker labeled [B] to [B] on the Controller PCB.

- 2 Connectors

< When using the HDD Cable 2 (Blue) >

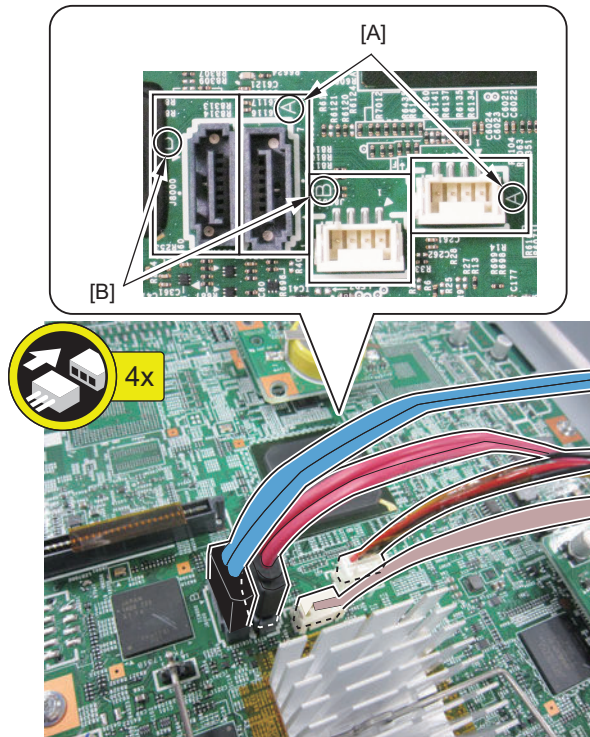

< When using the HDD Cable 2 (Red) >

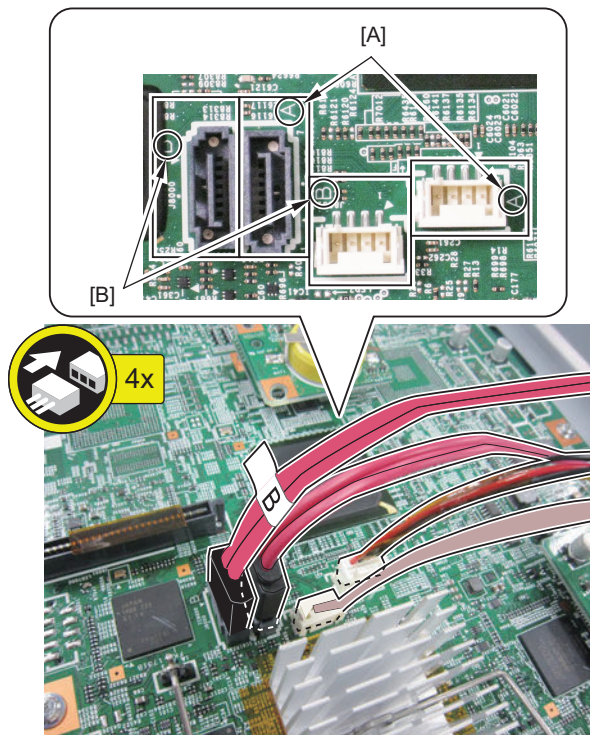



10. Insert the Main Controller PCB 1 until it stops.

- 1 Connector

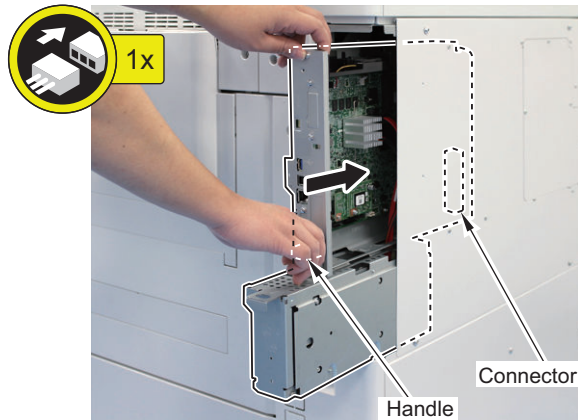

CAUTION:

Be sure to push [A] part hard to install it, otherwise the connector may not be connected properly.

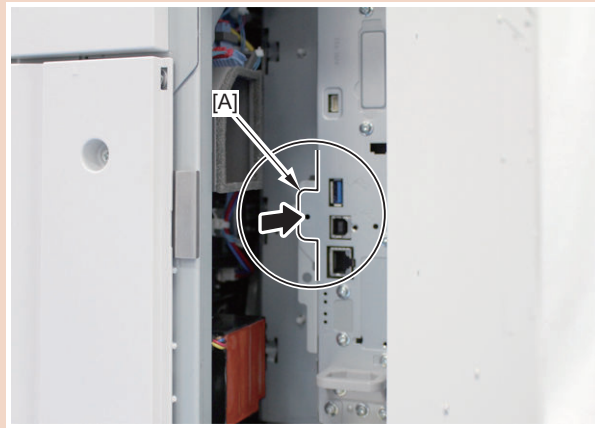

11. Install the Side Cover. Do not close the Right Rear Cover 1 yet here.

- 1 Hook
- 2 Screws

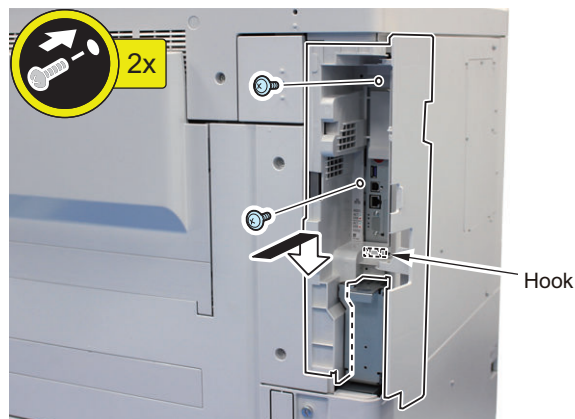



12. Open the HDD Lid.

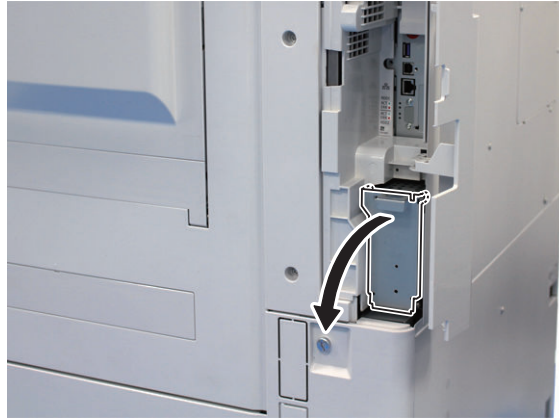

• Assembling and Installing the Option HDD



1. Fit the Hinge Pin of the HDD Holder Hinge with the groove of the HDD Case Hinge Base to install it to the HDD Case.

- 2 Bosses
- 2 Screws (P Tightening; M3x8)

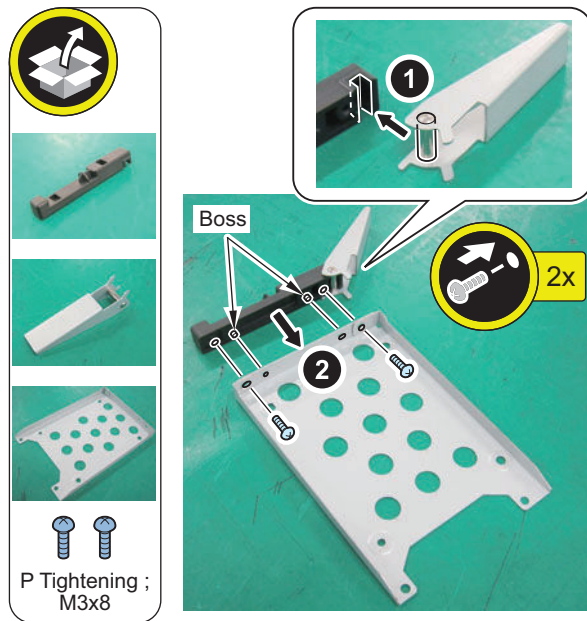



2. Install the assembled HDD Case to the HDD.

- 4 Screws (Sems; M3x4)

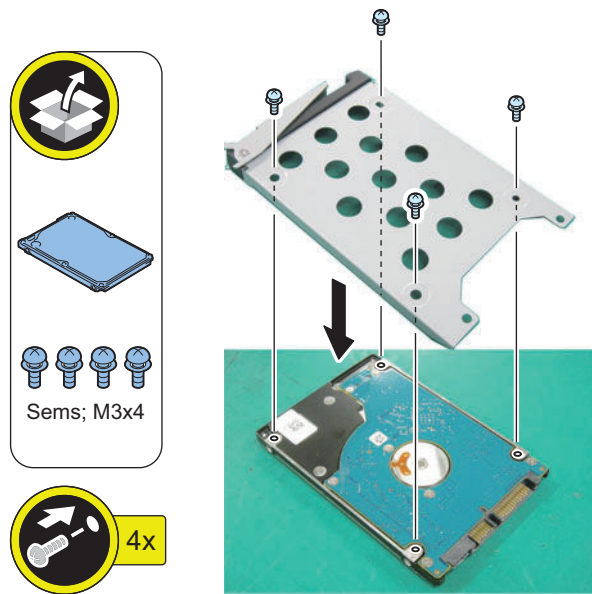

3. Install the First Option HDD to the Slot 1 (Left).

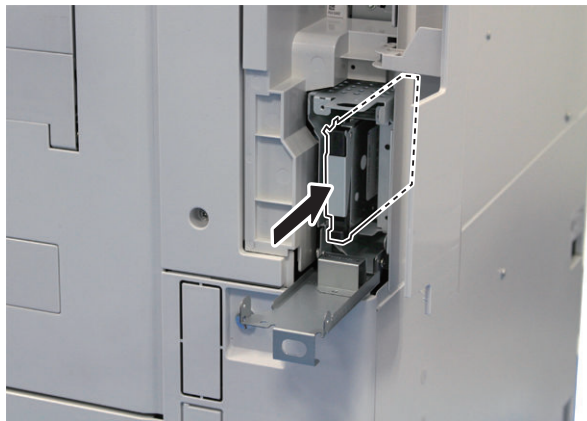

4. Assemble the Second Option HDD with same steps of Step 1 to Step 2.



5. Install the Option HDD to the Slot 2 (Left).

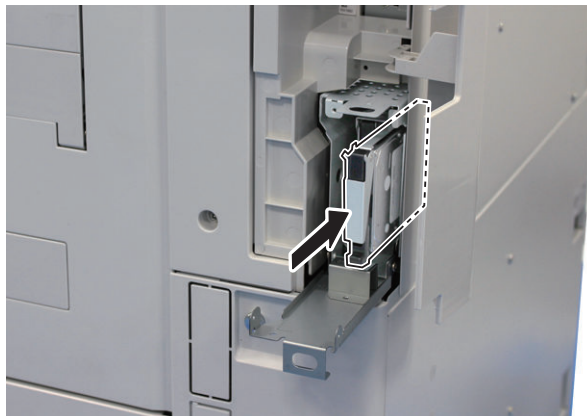



6. Close the HDD Lid.

- 1 Screw (Use the removed screws)

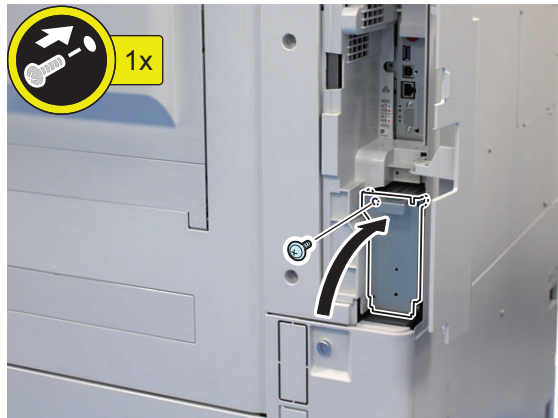

7. Close the Right Rear Cover 1.



■ HDD Initialization Procedure

1. Requirements

1. PC
Service Support Tool in the version that supports this host machine must be installed.
2. Cross Ethernet Cable (when SST is used)

2. Preparing for the Installation of the System Software of Host machine

1. If both PC and the machine are on, turn them off.
2. Connect the PC and the host machine using an Cross Ethernet cable. (when SST is used)
3. Turn on the PC.

3. Registering the system software

1. Insert the latest System Software into the PC using the SST.
2. Start the SST.
3. Click 'Register Firmware'.
4. Select the drive where the system software has been inserted, and click the [SEARCH] button.
5. Click the [REGISTER] button.
6. Click [OK].

4. Initializing HDD

<In case of SST>

1. Start the host machine with download mode in safe mode.
2. Start the SST.
3. Select the model. Then, select [Single] and click [Start].
4. Click [Format HDD].
5. Select [All], and click [Start].
6. Click [Execute Format].
7. The Format is executed.
8. Select [Shutdown/Restart], and click [Shutdown].
9. Click [OK]
10. The power of the host machine is turned OFF.
11. Terminate the SST.
12. Disconnect the Cross Ethernet Cable from the machine, and connect the user's network cable to the machine.

<In case of USB flash drive>

1. Connect the USB flash drive to the PC.
2. Start up SST, and click the USB icon displayed in the target selection screen.
3. Select the drive, the model series, and the version to be written to the USB flash drive, and click [Confirm].
4. Click [Start], and after the version has been written to the USB flash drive, click [OK] and then remove the USB flash drive.
5. Terminate the SST.
6. Connect the USB flash drive to the host machine, and start the host machine with download mode in safe mode.
7. When the USB menu is displayed, press keys on the Control Panel in the order shown below.
 - [4]: Clear/Format
 - [1]: Disk Format
 - [0]: OK
 - Press any keys.
 - [C]: Return to menu
 - [Reset] : Start shutdown sequence
 - [0]: OK (The power of the host machine is turned OFF automatically.)
8. Remove the USB flash drive.
9. Turn ON the main power switch.

■ Setting the Mirroring



1. **Set the setting value for the mirroring to "1" in the following service mode.**
COPIER > OPTION > FNC-SW > W/RAID
2. **Turn OFF/ON the main power of the host machine to enable the setting value.**
3. **Make sure that the UI screen is activated correctly.**
4. **Open the Cover, and make sure that the LED blinks.**

NOTE:

Rebuilding starts approximately after 3 minutes after turning OFF and then ON the power.

- HDD 1 (Slot 1): The green LED blinks.
- HDD 2 (Slot 2): The green and red LEDs blink.

CAUTION:

Rebuild process starts after setting "1" for W/RAID.

If an error occurs during the rebuild process at the initial installation the hard disk needs to be replaced. (Call service rep.), reexecute the process with the following procedure.

1. Check that the lighting red LED is HDD2.
2. Select "0" for the following service mode.
COPIER > OPTION > FNC-SW > W/RAID
3. To enable the setting value, turn OFF/ON the Main Power Supply Switch of the host machine.
4. Select "1" for the following service mode.
COPIER > OPTION > FNC-SW > W/RAID
5. To enable the setting value, turn OFF/ON the Main Power Supply Switch of the host machine.

The foregoing procedure is limited to the rebuild process at the initial installation.

An error during the rebuild process that is executed during operation is not included in the consideration.

■ Executing Auto Gradation Adjustment

When the high-capacity HDD is installed, the machine initializes its HDD, resetting the data used for auto gradation correction. Therefore, execute full adjustment of auto gradation adjustment after installing the high-capacity HDD to enable proper images to be output.

■ Execution of the Minimum Installation Work

Be sure to execute the minimum installation work in accordance with the Setup Guide because HDD is initialized when the high-capacity HDD is installed.

Super G3 FAX Board-AS1

Product Name

Safety regulations require the product's name to be registered. In some regions where this product is sold, the following name may be registered instead.

- F632501

Points to Note at Installation

- When installing the Super G3 2nd Line Fax Board and this equipment at the same time, after checking "Checking the Contents", and install them following the Installation Procedure for Super G3 2nd Line Fax Board.
- For "Checking the Operation", refer to this document.

Essential Items to Be Performed Before Installation

- Turn OFF the main power of the host machine, and disconnect the power plug from the outlet.

⚠ WARNING:

- If performing work without disconnecting the power plug of the host machine, it may cause electrical shock.
- If disconnecting the power plug without turning OFF the main power, it may cause damage of the machine.

- When turning OFF the main power, follow the below procedure.
 1. Turn OFF the main power switch of the host machine.
 2. The display in the Control Panel and the lamp of the main power are turned off.

Points to Note When Turning ON/OFF the Main Power

The following message is displayed.

1. When a message prompting to turn OFF and then ON the main power appears, turn OFF and then ON the main power switch.
2. If a message prompting the user to update the version appears, press [Update] to automatically update the version of this equipment.





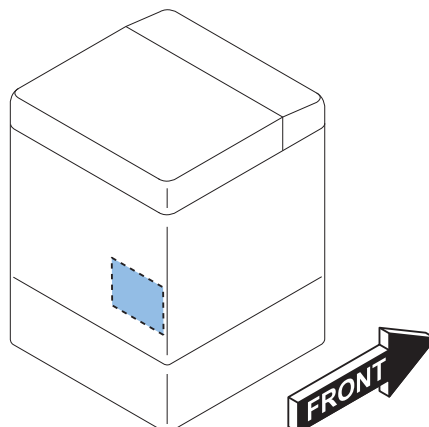

If [Skip] is selected, a message prompting the user to update the version will appear every time the host machine is started. In the service mode (Lv. 2) shown below, it is possible to set not to display the message.

COPIER > OPTION > FNC-SW > VER-CHNG

Installation Outline Drawing

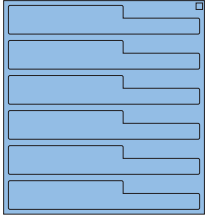

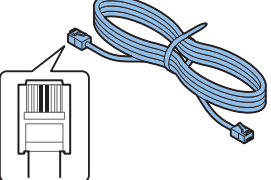
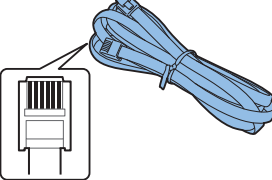
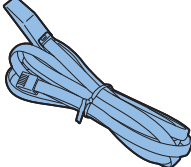
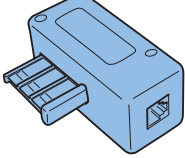
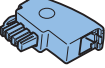
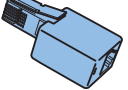
● Checking the Contents

<input type="checkbox"/> [1] FAX Unit X 1 	<input type="checkbox"/> [2] Screw (TP; M3x4 Black) X 1 	<input type="checkbox"/> [3] Modular Label X 1 	<input type="checkbox"/> [4] Fax Approval Label X 1 Included for USA and Taiwan 
<input type="checkbox"/> [5] Telephone Cord (2 Contact type) X 1 	<input type="checkbox"/> [6] Telephone Cord (6 Contact type) (only for Europe) X 1 	<input type="checkbox"/> [7] PTT Cable (only for Asia) X 1 	<input type="checkbox"/> [8] PTT Plug (Only for France) X 1 
<input type="checkbox"/> [9] PTT Plug (Only for Germany) X 1 	<input type="checkbox"/> [10] PTT Plug (Only for U.K.) X 1 	<input type="checkbox"/> [11] Modular Cover (only for Europe) X 1 	

<Others>

- Including guides

● Installation Procedure

1. Remove the Left Rear Cover.

- 1 Claw
- 1 Hook

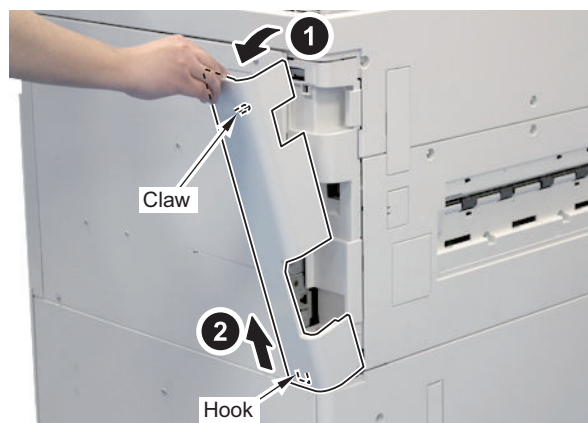

**2. Remove the Rear Cover 2.**

- 3 Screws
- 2 Protrusions

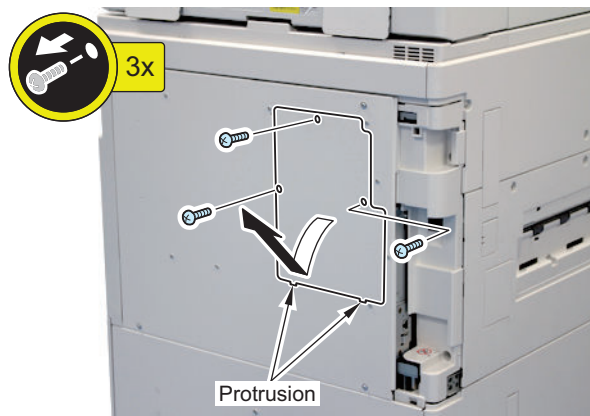
**3. Remove the Face Cover. (The removed parts will not be used.)**

- 1 Screw (used in the next step only in EUR)
- 1 Protrusion

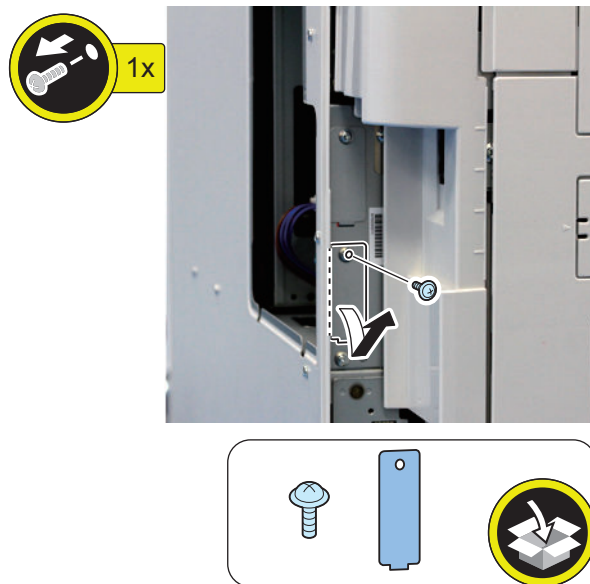

**NOTE:**

This step is only for Europe.

4. Install the Modular Cover.

- 1 Protrusion
- 1 Screw (use the screw removed in the previous step)

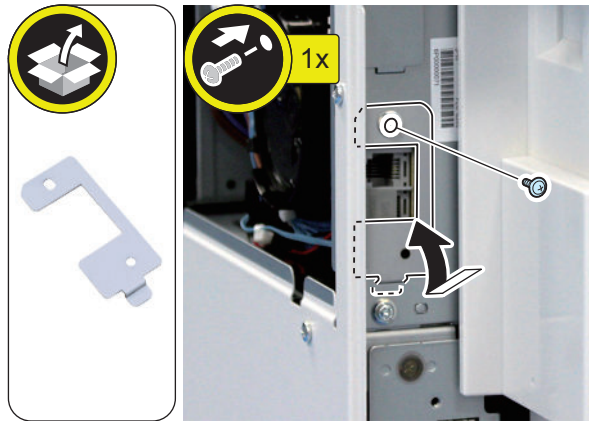
**5. Remove the tape and, install the Fax Unit.**

- 2 Protrusions
- 1 Screw (TP; M3x4; Black)

CAUTION:

- Be careful not to damage the [A] part of the speaker as the wiring may be broken.
- Be sure to tighten the screw while holding the FAX Unit.
- After tightening the screw of the FAX Unit, check for any backlash. If there is backlash, tighten the screw again with the protrusion precisely fitted.

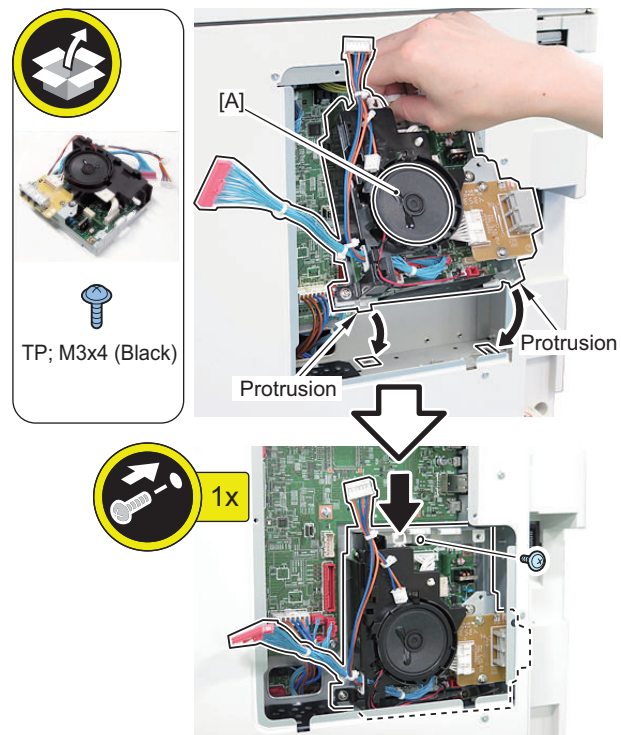



6. Connect the 2 cables of the FAX Unit.

- 2 Connectors

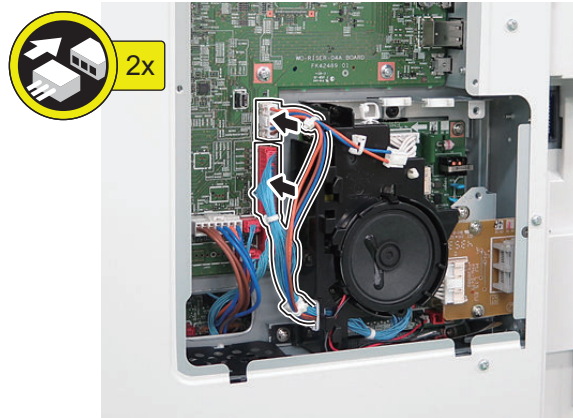

7. Affix the following FAX Approval Label.

- [A] For USA
- [B] For Taiwan

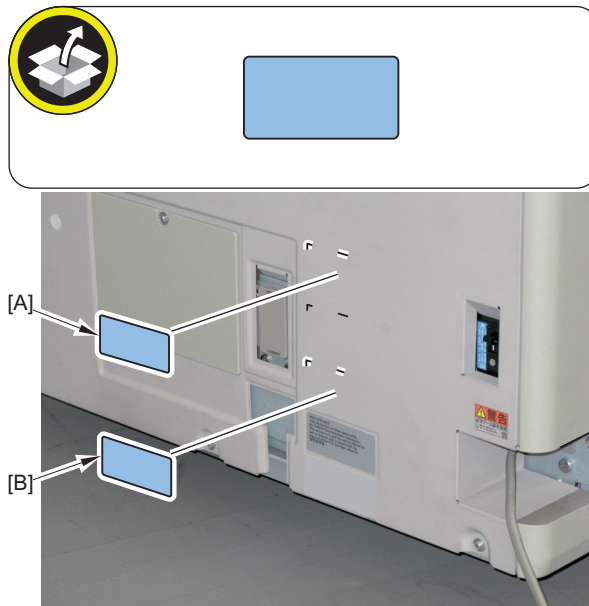

8. Affix the appropriate Modular Label to the place shown in the figure.

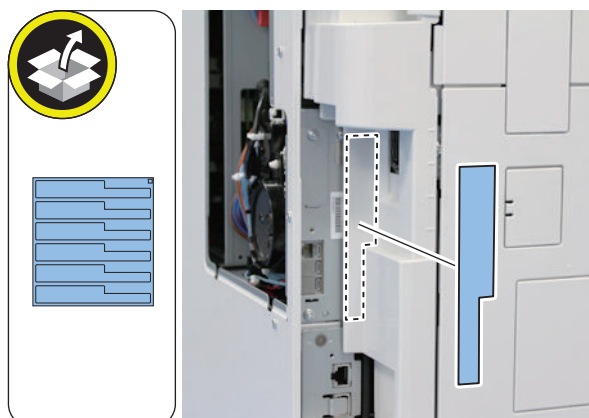

**NOTE:**

This step is only for Europe.

Do not connect the Telephone Cord (2 contact type) with the PTT Plug.

9. Connect the PTT Plug matched the field or area to the PTT Cable (6 contact type).

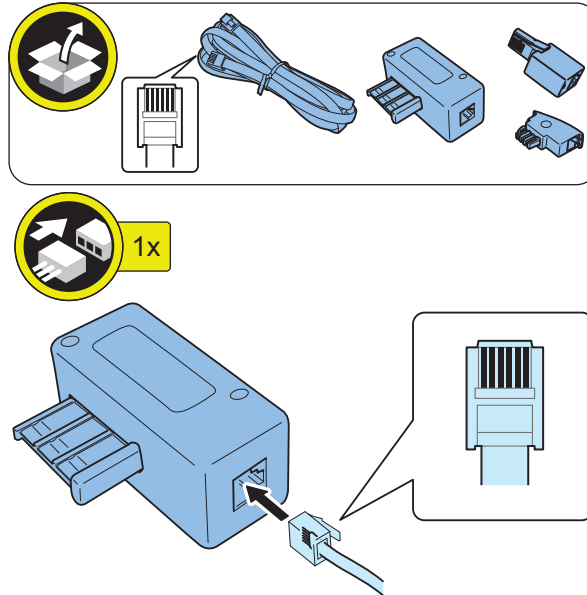

10. Connect the end of the PTT Cable or Telephone Cord to the modular jack on the Host machine, and connect the other end to the modular jack on the wall.

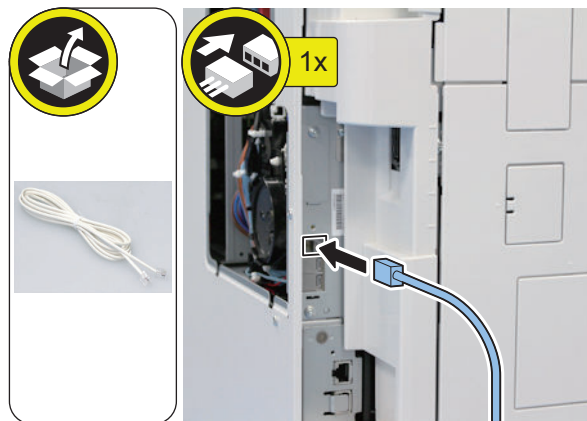

**11. Install the Rear Cover 2.**

- 2 Protrusions
- 3 Screws

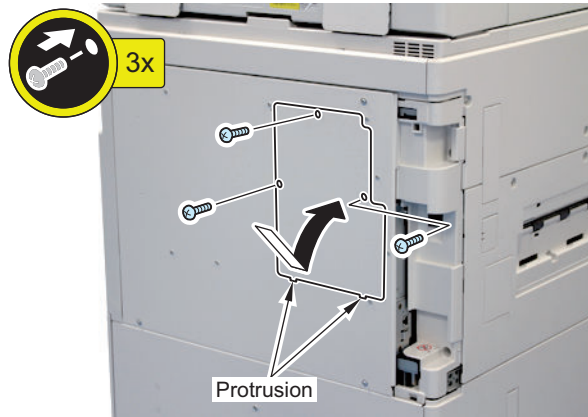
**12. Install the Left Rear Cover.**

- 1 Hook
- 1 Claw

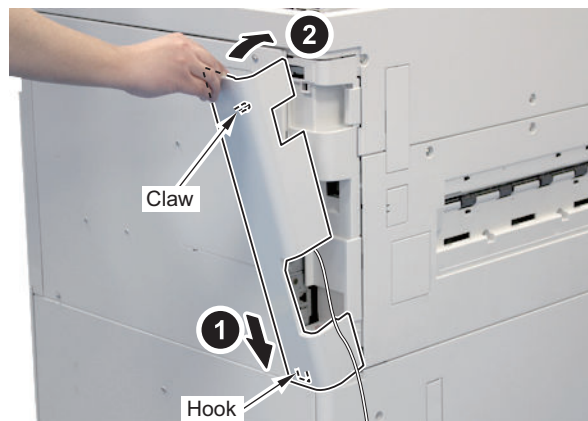
**13. Connect the Power Plug to the outlet.****14. Turn ON the main power switch.****CAUTION:**

If the machine does not recognize this equipment, unplug and then plug the power plug after turning OFF the main power switch, or turn OFF the main power switch and then turn it ON within 20 seconds. To avoid this symptom, unplug the power plug or turn the breaker OFF when installing.

Checking the Operation

■ Type Setting

Select the country/region of the FAX Board in Service Mode: FAX > Type > TYPE

This setting performs the parameter settings to match the communication specification of the country/region.



1. From the following service mode, set the TYPE of country/region to install this machine, and then press OK.

FAX > TYPE > TYPE

2. Confirm that service mode parameter below is "0". In the case, parameter is "1", change to "0".

COPIER > OPTION > DSPLY-SW > SDTM-DSP

NOTE:

To change parameter to "0" makes no show below [Settings/Registration > Preferences > Time/Energy Settings > Auto Shutdown Time] and auto shut down is not available.

3. Turn OFF/ON the main power switch to enable this setting.

■ Basic Setting

NOTE:

- When "System Manager Information Settings" is set, be sure to follow the direction of user administrator in order to log in as an administrator.
- This setting can also be set from the Setup Guide ([Settings/Registration] > [Management Settings] > [License/Other] > [Start Setup Guide]).

In this section, make only minimum settings required for FAX communication.



1. Set the user telephone number.

[Settings/Registration] > [Function Settings] > [Send] > [Fax Settings] > [Set Line] > [Line 1] > [Register Unit Telephone Number] > Enter the fax number > [OK]

2. Set Type of telephone line.

[Settings/Registration] > [Function Settings] > [Send] > [Fax Settings] > [Set Line] > [Line 1] > [Select Line Type] > Select the line type to connect > [OK]

3. Turn OFF/ON the main power switch after setting the user telephone numbers and the type of telephone line.

■ FAX Communication Test

Perform communication test to check if FAX function works correctly.



1. Switch the control panel display to Send/Fax display.
2. Send the test document from this machine to another machine that can handle the communication test to check that this machine can send the data correctly.
3. Send the test document from the target to this machine to check if the machine can receive the document properly.

Super G3 FAX Board-AS2

Product Name

Safety regulations require the product's name to be registered. In some regions where this product is sold, the following name may be registered instead.

- F632501

Points to Note at Installation

- When installing the Super G3 2nd Line Fax Board and this equipment at the same time, after checking "Checking the Contents", and install them following the Installation Procedure for Super G3 2nd Line Fax Board.
- For "Checking the Operation", refer to this document.

Essential Items to Be Performed Before Installation

- Turn OFF the main power of the host machine, and disconnect the power plug from the outlet.

⚠ WARNING:

- If performing work without disconnecting the power plug of the host machine, it may cause electrical shock.
- If disconnecting the power plug without turning OFF the main power, it may cause damage of the machine.

- When turning OFF the main power, follow the below procedure.
 1. Turn OFF the main power switch of the host machine.
 2. The display in the Control Panel and the lamp of the main power are turned off.

Points to Note When Turning ON/OFF the Main Power

The following message is displayed.

1. When a message prompting to turn OFF and then ON the main power appears, turn OFF and then ON the main power switch.
2. If a message prompting the user to update the version appears, press [Update] to automatically update the version of this equipment.



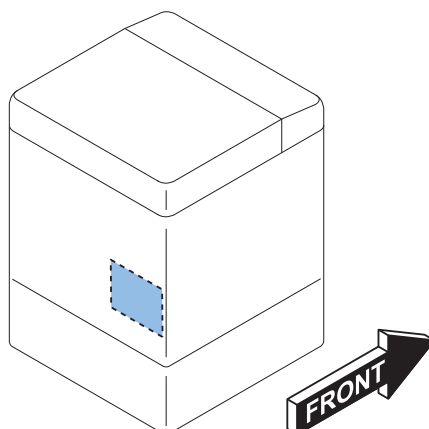

If [Skip] is selected, a message prompting the user to update the version will appear every time the host machine is started. In the service mode (Lv. 2) shown below, it is possible to set not to display the message.

COPIER > OPTION > FNC-SW > VER-CHNG

Installation Outline Drawing

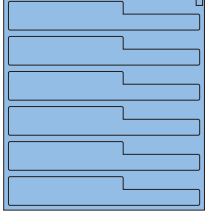

● Checking the Contents

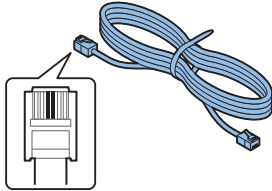
<input type="checkbox"/> [1] FAX Unit X 1 	<input type="checkbox"/> [2] Screw (TP; M3x4 Black) X 1 
<input type="checkbox"/> [3] Modular Label X 1 	<input type="checkbox"/> [4] Fax Approval Label X 1 
<input type="checkbox"/> [5] Telephone Cord (2 Contact type) X 1 	

< Others >

- Including guides

● Installation Procedure

1. Remove the Left Rear Cover.

- 1 Claw
- 1 Hook

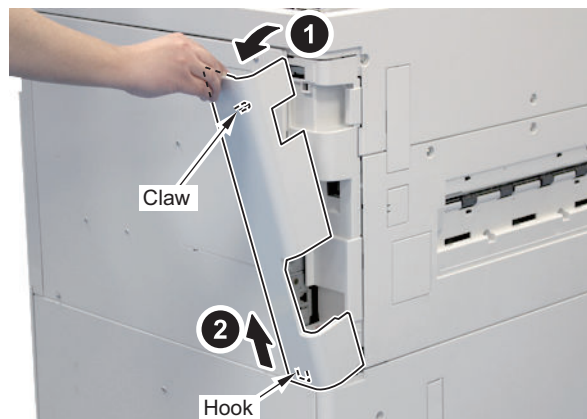

**2. Remove the Rear Cover 2.**

- 3 Screws
- 2 Protrusions

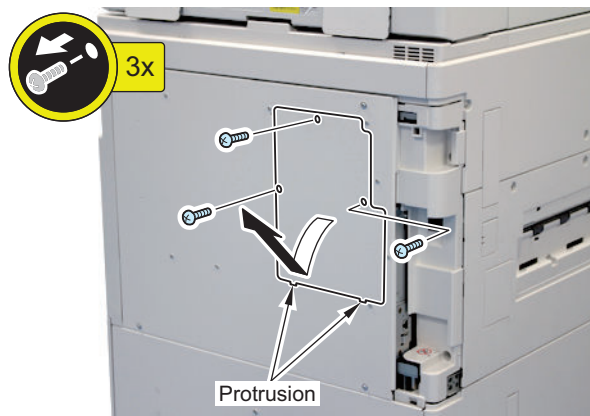
**3. Remove the Face Cover. (The removed parts will not be used.)**

- 1 Screw
- 1 Protrusion

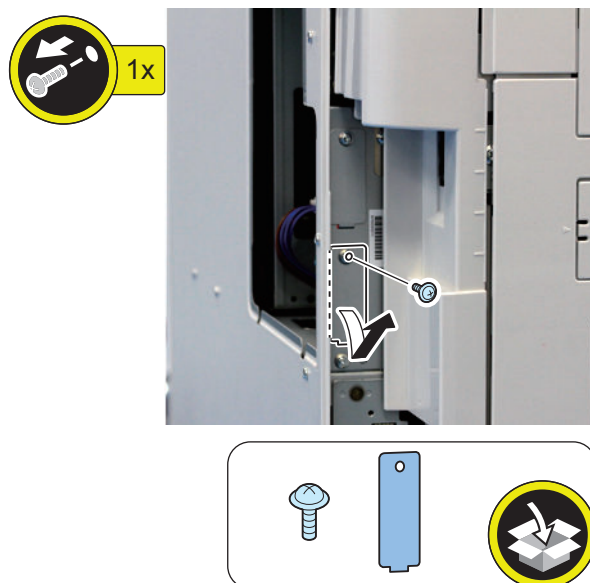



4. Remove the tape and, install the Fax Unit.

- 2 Protrusions
- 1 Screw (TP; M3x4: Black)

CAUTION:

- Be careful not to damage the [A] part of the speaker as the wiring may be broken.
- Be sure to tighten the screw while holding the FAX Unit.
- After tightening the screw of the FAX Unit, check for any backlash. If there is backlash, tighten the screw again with the protrusion precisely fitted.

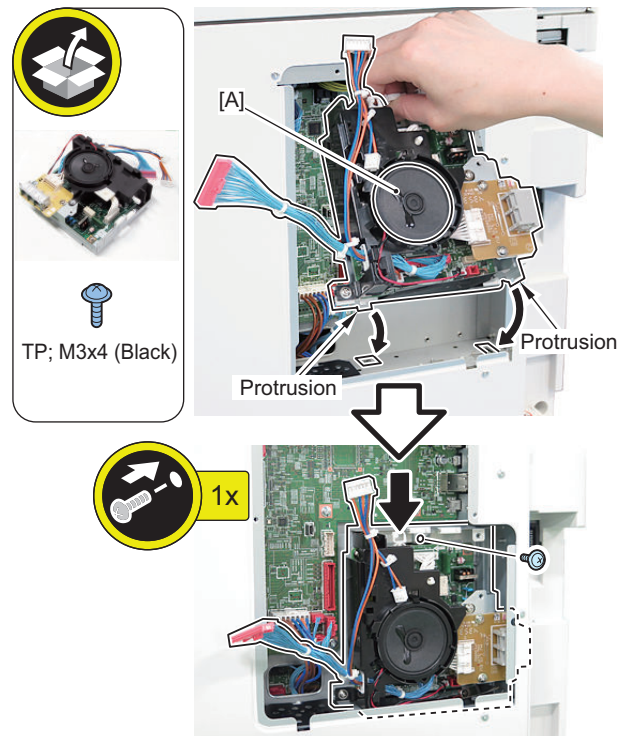

5. Connect the 2 cables of the FAX Unit.

- 2 Connectors

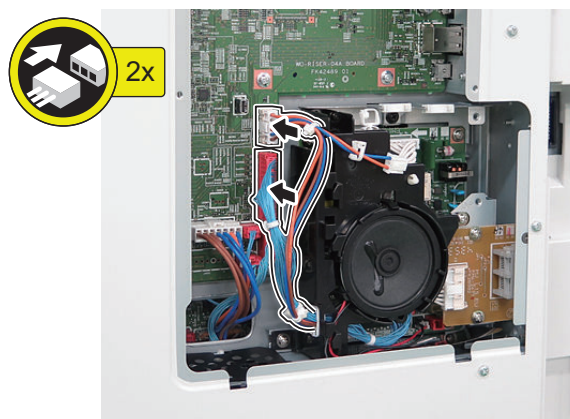



6. Affix the following FAX Approval Label.

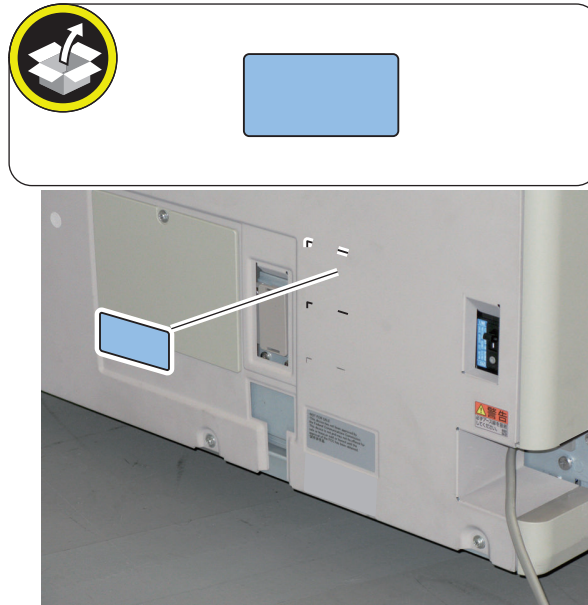

7. Affix the appropriate Modular Label to the place shown in the figure.

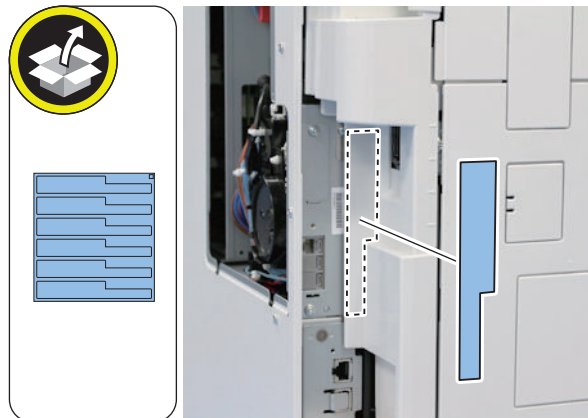

8. Connect the end of the Telephone Cord to the modular jack on the Host machine, and connect the other end to the modular jack on the wall.

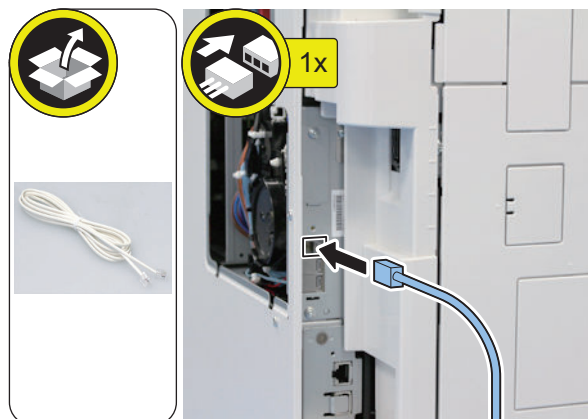

9. Install the Rear Cover 2.

- 2 Protrusions
- 3 Screws

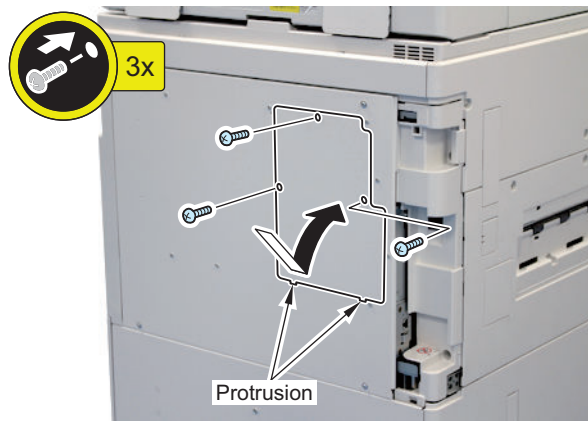
**10. Install the Left Rear Cover.**

- 1 Hook
- 1 Claw

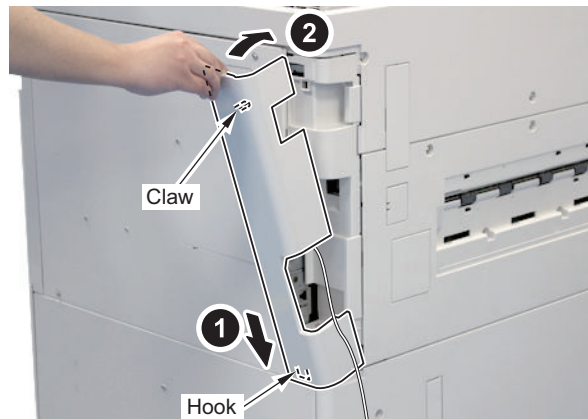
**11. Connect the Power Plug to the outlet.****12. Turn ON the main power switch.****CAUTION:**

If the machine does not recognize this equipment, unplug and then plug the power plug after turning OFF the main power switch, or turn OFF the main power switch and then turn it ON within 20 seconds.

To avoid this symptom, unplug the power plug or turn the breaker OFF when installing.

Checking the Operation

■ Type Setting

Select the country/region of the FAX Board in Service Mode: FAX > Type > TYPE

This setting performs the parameter settings to match the communication specification of the country/region.



1. From the following service mode, set the TYPE of country/region to install this machine, and then press OK.
FAX > TYPE > TYPE

2. Confirm that service mode parameter below is "0". In the case, parameter is "1", change to "0".

COPIER > OPTION > DSPLY-SW > SDTM-DSP

NOTE:

To change parameter to "0" makes no show below [Settings/Registration > Preferences > Time/Energy Settings > Auto Shutdown Time] and auto shut down is not available.

3. Turn OFF/ON the main power switch to enable this setting.

■ Basic Setting

NOTE:

- When "System Manager Information Settings" is set, be sure to follow the direction of user administrator in order to log in as an administrator.
- This setting can also be set from the Setup Guide ([Settings/Registration] > [Management Settings] > [License/Other] > [Start Setup Guide]).

In this section, make only minimum settings required for FAX communication.



1. Set the user telephone number.

[Settings/Registration] > [Function Settings] > [Send] > [Fax Settings] > [Set Line] > [Line 1] > [Register Unit Telephone Number] > Enter the fax number > [OK]

2. Set Type of telephone line.

[Settings/Registration] > [Function Settings] > [Send] > [Fax Settings] > [Set Line] > [Line 1] > [Select Line Type] > Select the line type to connect > [OK]

3. Turn OFF/ON the main power switch after setting the user telephone numbers and the type of telephone line.

■ FAX Communication Test

Perform communication test to check if FAX function works correctly.



1. Switch the control panel display to Send/Fax display.
2. Send the test document from this machine to another machine that can handle the communication test to check that this machine can send the data correctly.
3. Send the test document from the target to this machine to check if the machine can receive the document properly.

Super G3 2nd Line Fax Board-AS1

Product Name

Safety regulations require the product's name to be registered. In some regions where this product is sold, the following name may be registered instead.

- F632502

Points to Note at Installation

When installing the Super G3 FAX Board and this equipment at the same time, be sure to install them by referring to this document after checking "Checking the Contents" of Super G3 FAX Board.

Essential Items to Be Performed Before Installation

- Turn OFF the main power of the host machine, and disconnect the power plug from the outlet.

⚠ WARNING:

- If performing work without disconnecting the power plug of the host machine, it may cause electrical shock.
- If disconnecting the power plug without turning OFF the main power, it may cause damage of the machine.

- When turning OFF the main power, follow the below procedure.
 1. Turn OFF the main power switch of the host machine.
 2. The display in the Control Panel and the lamp of the main power are turned off.

Points to Note When Turning ON/OFF the Main Power

The following message is displayed.

1. When a message prompting to turn OFF and then ON the main power appears, turn OFF and then ON the main power switch.
2. If a message prompting the user to update the version appears, press [Update] to automatically update the version of this equipment.







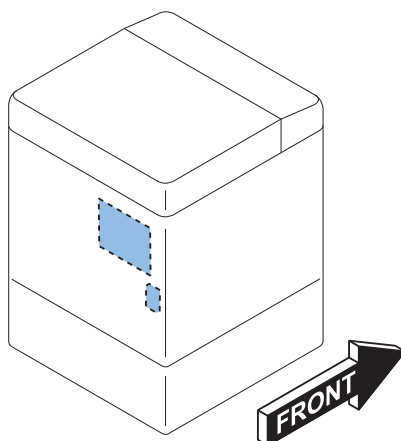

If [Skip] is selected, a message prompting the user to update the version will appear every time the host machine is started. In the service mode (Lv. 2) shown below, it is possible to set not to display the message.

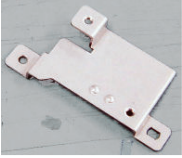

COPIER > OPTION > FNC-SW > VER-CHNG

Installation Outline Drawing

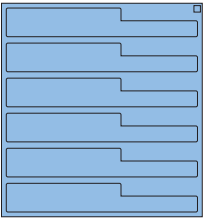

Checking the Contents

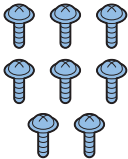
<input type="checkbox"/> [1] G3FAX Expansion PCB X 1 	<input type="checkbox"/> [2] Modular PCB X 1 
<input type="checkbox"/> [3] USB Cable X 1 	<input type="checkbox"/> [4] Modular Cable X 1 
<input type="checkbox"/> [5] Signal Cable X 1 	<input type="checkbox"/> [6] FAX Shield Plate X 1 
<input type="checkbox"/> [7] FAX Board Fixed Plate X 1 	<input type="checkbox"/> [8] PCB Spacer (Long) X 3 
<input type="checkbox"/> [9] PCB Spacer (Short) X 1 	<input type="checkbox"/> [10] Modular Label X 1 

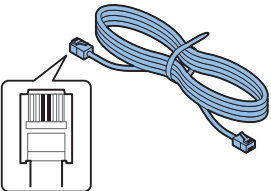
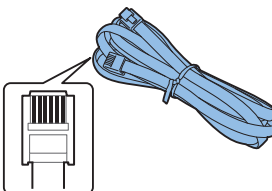
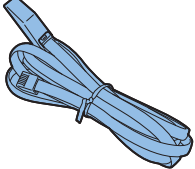
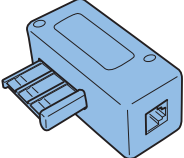
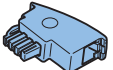
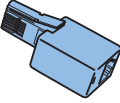
<input type="checkbox"/> [11] Dust Cover X 2 	<input type="checkbox"/> [12] Screw (TP; M3x4) X 8 
<input type="checkbox"/> [13] Screw (Binding; M4x4) X 1 	<input type="checkbox"/> [14] Fax Approval Label (only for Taiwan) X 1 
<input type="checkbox"/> [15] Telephone Cord (2 Contact type) X 1 	<input type="checkbox"/> [16] Telephone Cord (6 Contact type) (only for Europe) X 1 
<input type="checkbox"/> [17] PTT Cable (only for Asia) X 1 	<input type="checkbox"/> [18] PTT Plug (Only for France) X 1 
<input type="checkbox"/> [19] PTT Plug (Only for Germany) X 1 	<input type="checkbox"/> [20] PTT Plug (Only for U.K.) X 1 

Installation Procedure

■ Preparation



1. Remove the Left Rear Cover.

- 1 Claw
- 1 Hook

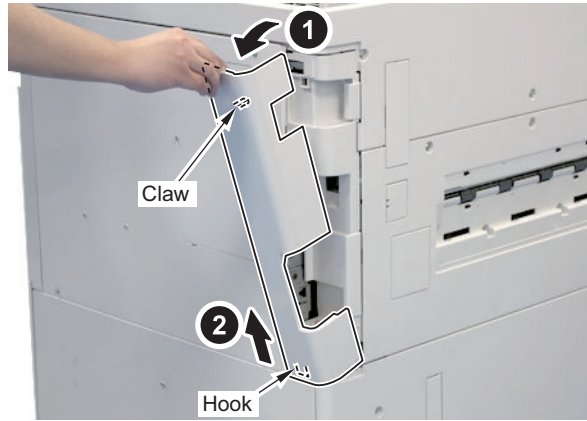

2. Remove the Rear Cover 2.

- 3 Screws
- 2 Protrusions

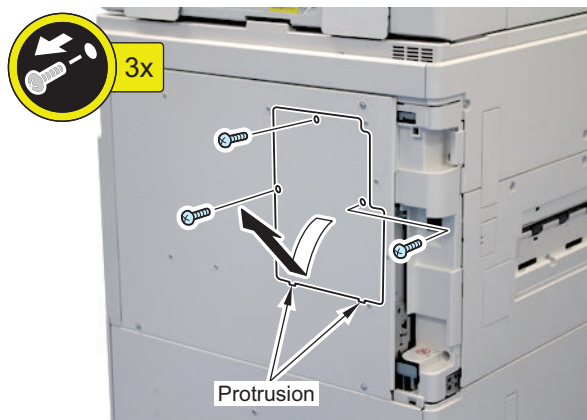

NOTE:

- When the Super G3 FAX Board is installed: Perform steps 3 and 4, and proceed to step 7.
- When installing the Super G3 FAX Board at the same time: Proceed to step 5.



3. Disconnect the Telephone Cord of the FAX (1-Line).

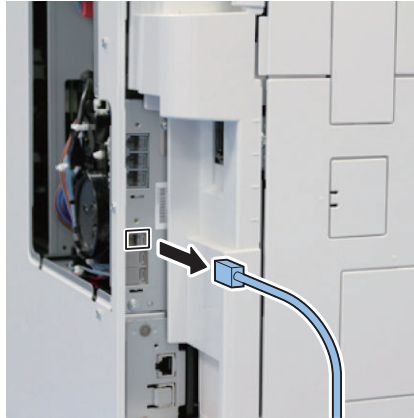

4. Remove the FAX Unit.

- 2 Connectors
- 1 Screw
- 2 Protrusions

CAUTION:

Be careful not to damage the [A] part of the speaker as the wiring may be open circuit.

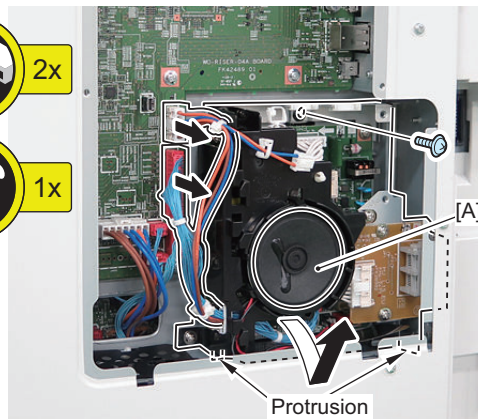
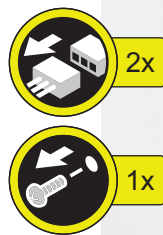

**5. Remove the Face Cover of the FAX (1-Line). (The removed parts will not be used.)**

- 1 Screw (used in the next step only in EUR)
- 1 Protrusion

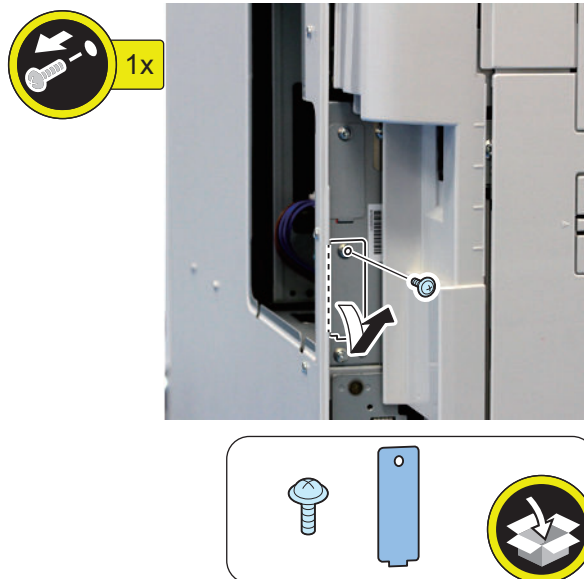
**NOTE:**

This step is only for Europe.

6. Install the Modular Cover.

- 1 Protrusion
- 1 Screw (use the screw removed in the previous step)

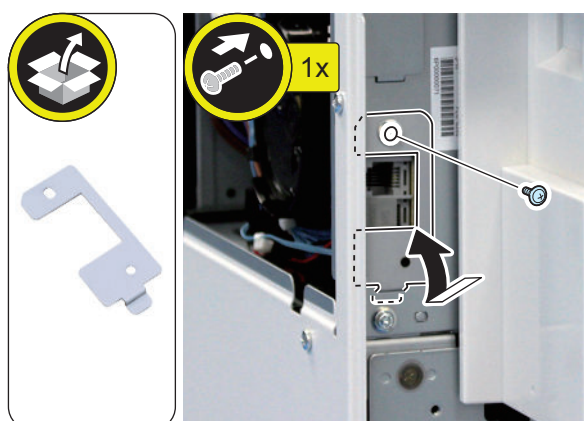

**7. Remove the Face Cover of the FAX (2-Line). (The removed parts will not be used.)**

- 1 Screw
- 1 Protrusion

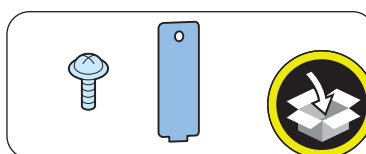
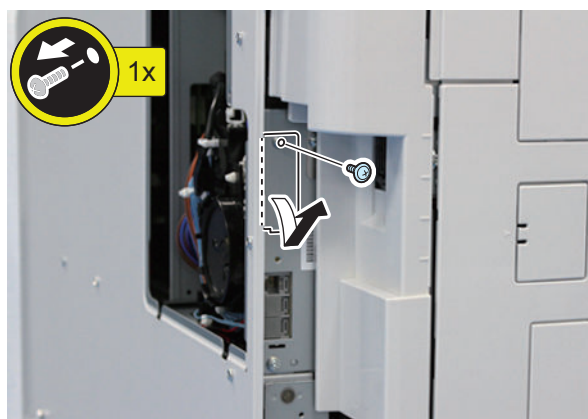
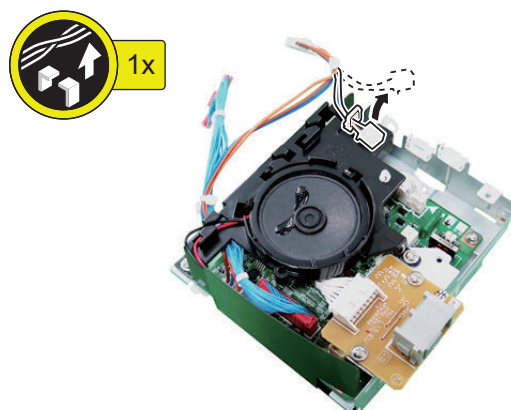
**■ Installing the Equipment****1. Free the Cable from the Wire Saddle.**



2. Install the Signal Cable to the FAX Unit.

- 3 Cable Guides

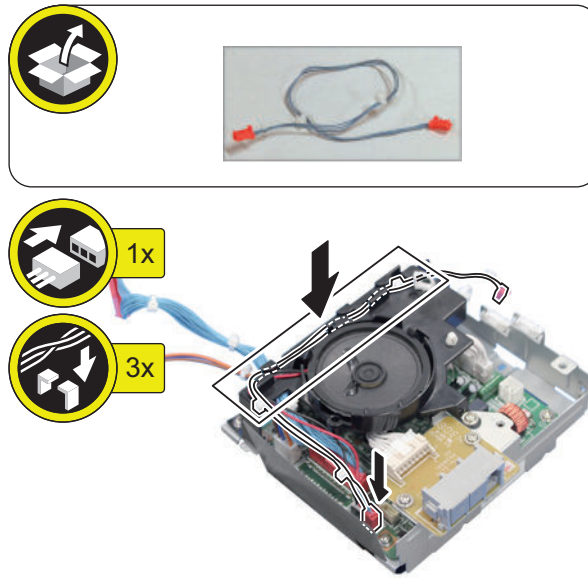

3. Install the Modular Cable to the Modular PCB.

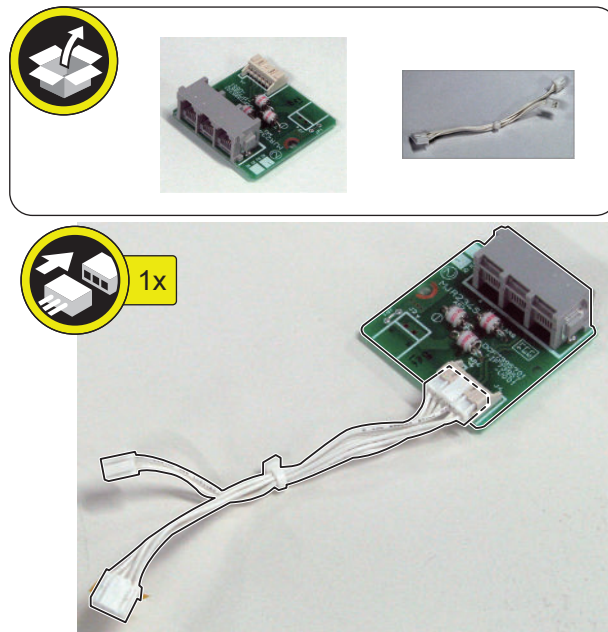



4. Install the Modular PCB to the FAX Unit.

- 2 Screws (TP; M3x4)

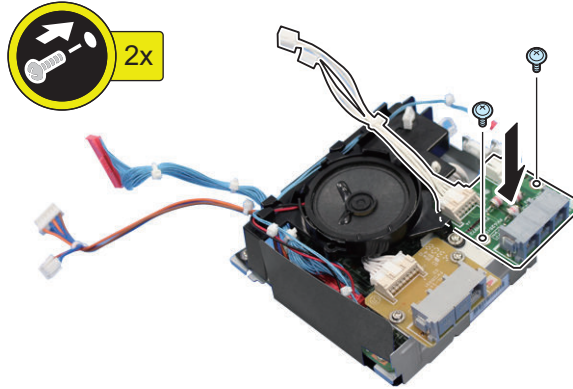
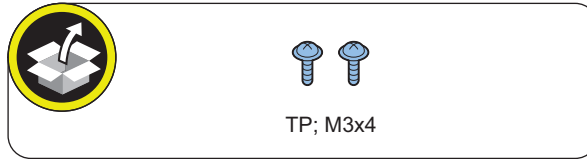



5. Install the FAX Unit to the Host Machine.

- 2 Protrusions
- 1 Screw (TP; M3x4 Black) (Use the removed screw or those included with the Super G3 FAX Board)

CAUTION:

- Be careful not to damage the [A] part of the speaker as the wiring may be broken.
- Be sure to tighten the screw while holding the FAX Unit.
- After tightening the screw of the FAX Unit, check for any backlash. If there is backlash, tighten the screw again with the protrusion precisely fitted.

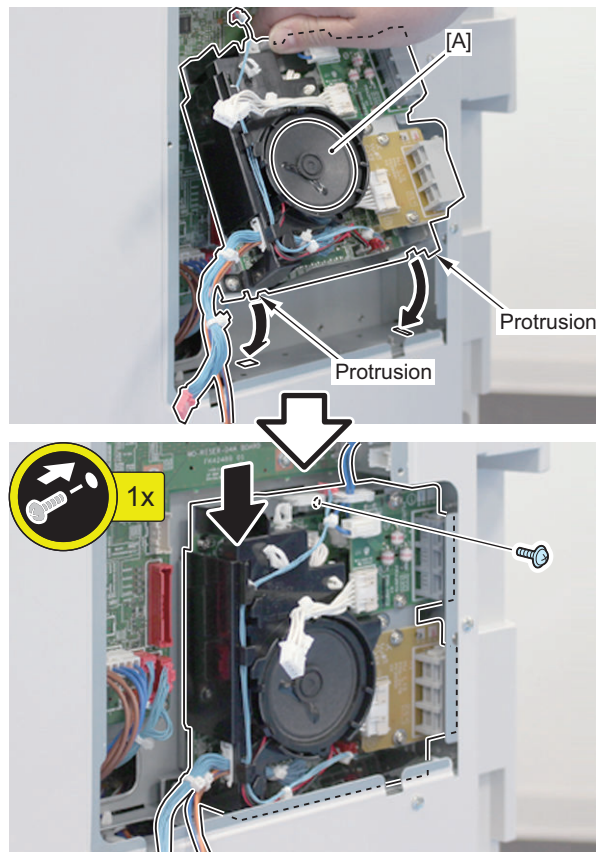

6. Install the 2 Cable of the FAX Unit.

- 2 Connectors

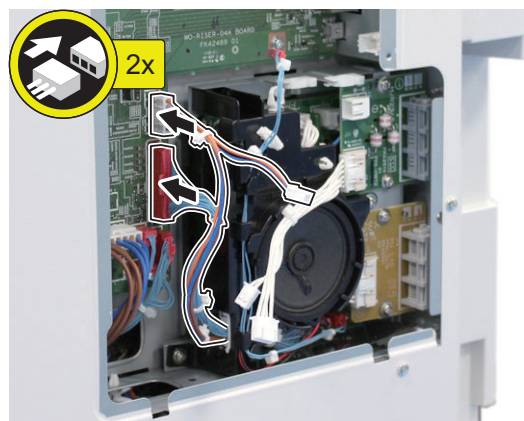



7. Remove the 2 Screws. (will be used in next step)

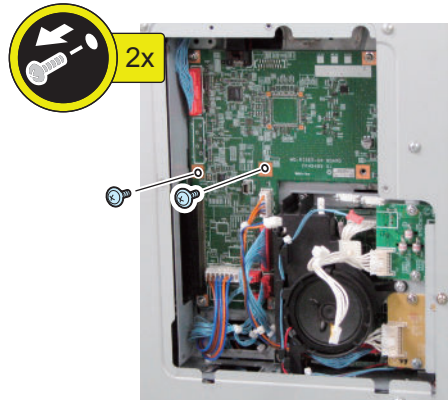

8. Install the FAX Shield Plate.

- 2 Screws (screws removed in the previous step)

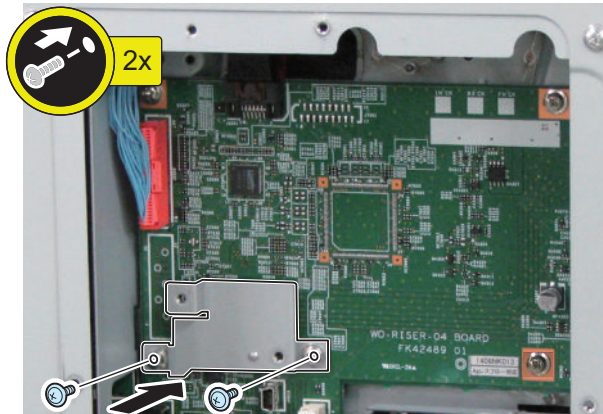
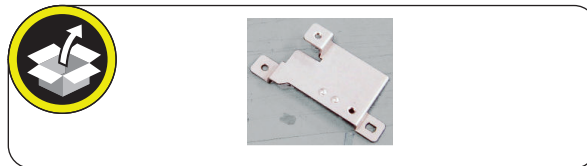



9. Install the FAX Board Fixed Plate.

- 2 Bosses
- 1 Screw (Binding; M4x4)

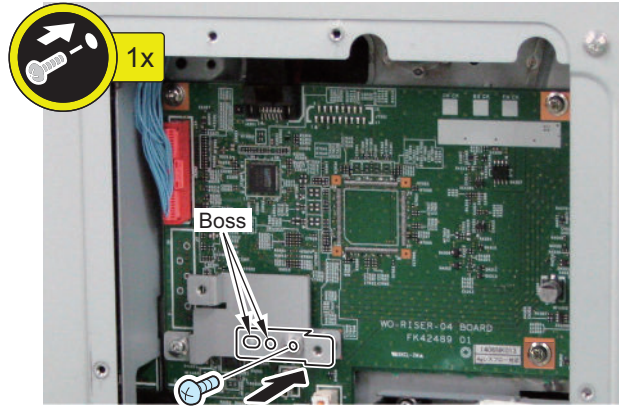



10. Remove the Screw and install the PCB Spacer (Short). (The removed screw will not be used.)

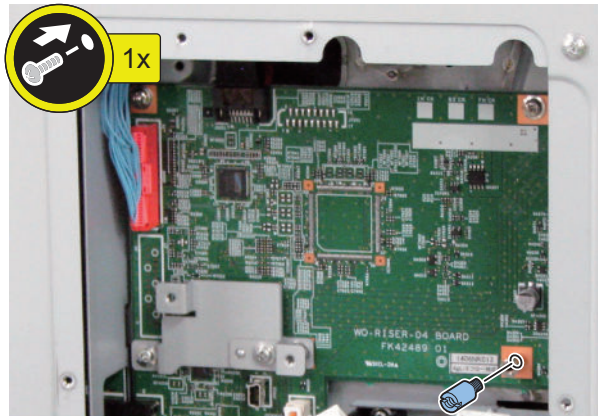
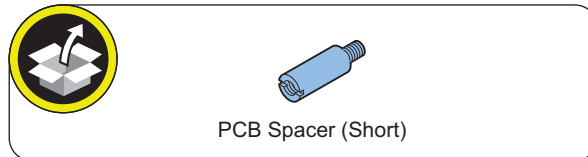
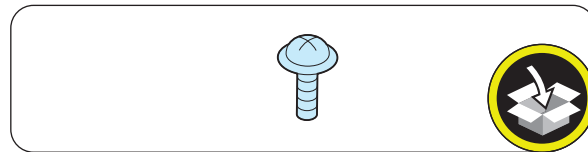
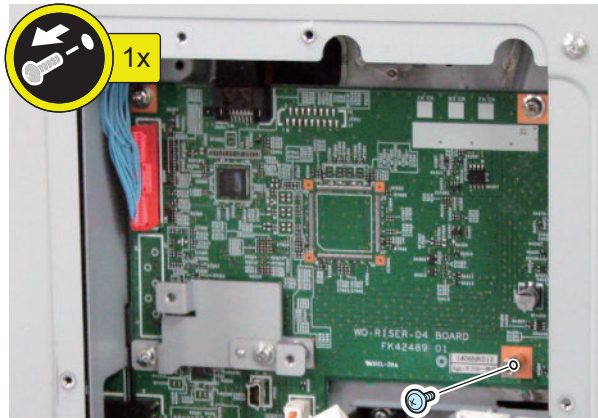



11. Install the 3 PCB Spacers (Long).

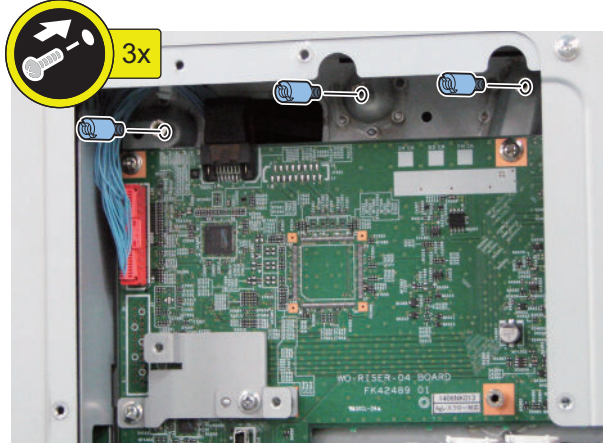
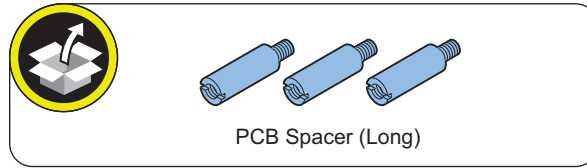

12. Install the G3FAX Expansion PCB.

- 6 Screws (TP; M3x4)

NOTE:

Because the 4 screws [A] need to be removed when installing the Super G3 3rd/4th Line Fax Board at the same time, it is efficient not to tighten them here.

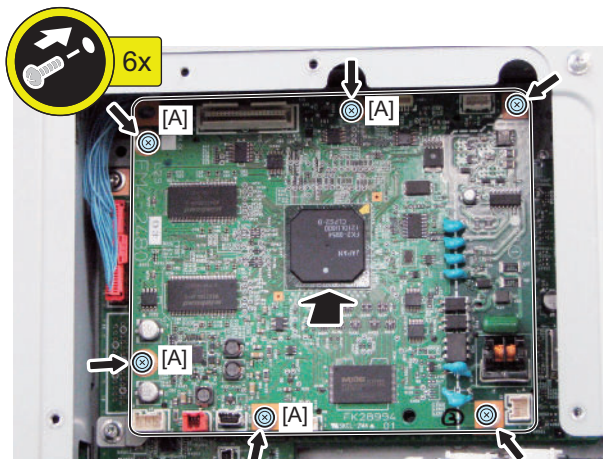
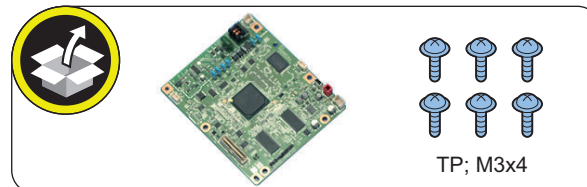



13. Install the Signal Cable, Power Supply Cable and USB Cable to the G3FAX Expansion PCB.

- 1 Wire Saddle

NOTE:

Because [A] of the USB Cable needs to be disconnected when installing the Super G3 3rd/4th Line Fax Board at the same time, it is efficient not to connect it here.

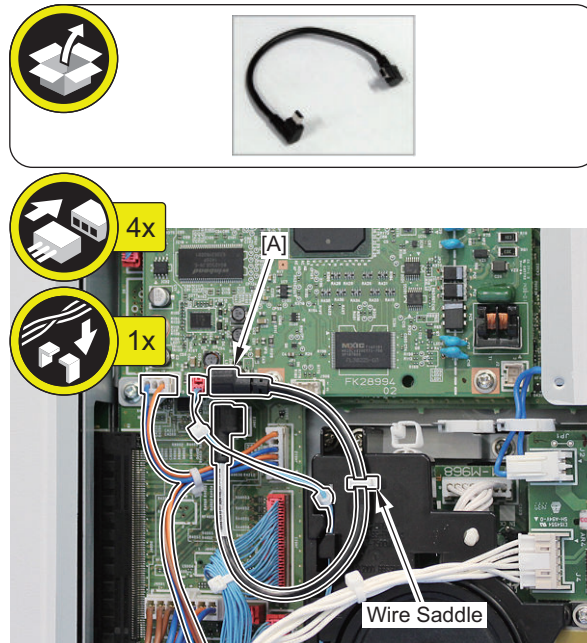

14. Pass the Modular Cable inside the Speaker Holder, and install the G3 FAX Control PCB.

- 1 Edge Saddle

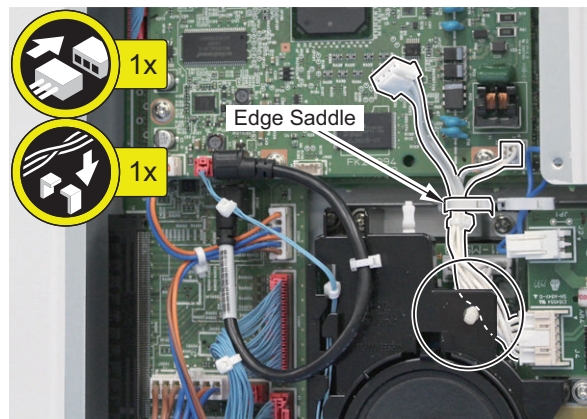

**NOTE:**

When installing the Super G3 3rd/4th Line Fax Board at the same time, the following step is not necessary.

15. Secure the cable with the Wire Saddle.

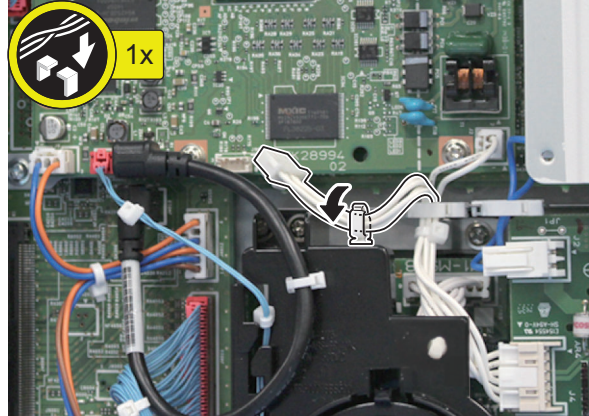

■ Subsequent Work

**NOTE:**

The following work is required only when installing the Super G3 FAX Board at the same time.

1. Affix the following FAX Approval Label.

- [A] For USA
- [B] For Taiwan

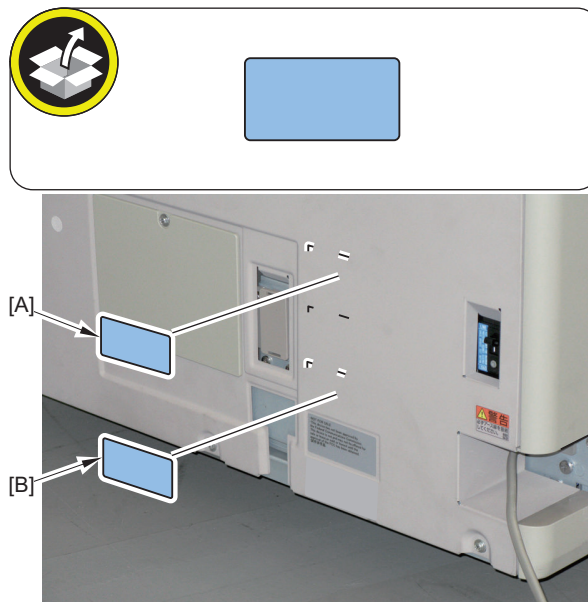



NOTE:
This step is only for Taiwan.

2. Affix the following FAX Approval Label.

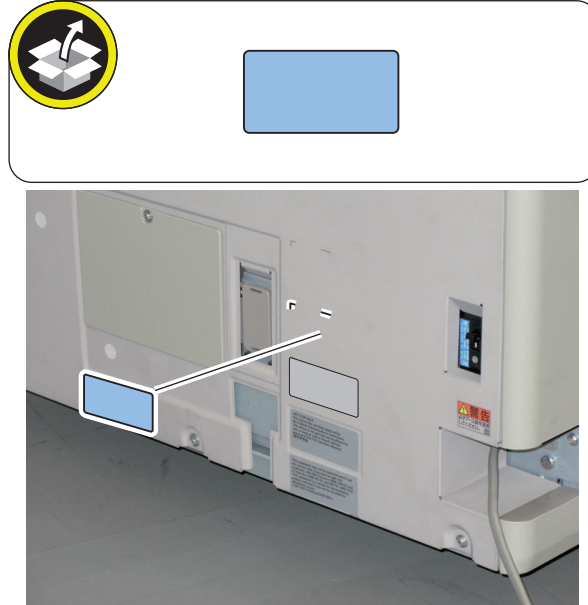

NOTE:
When installing the Super G3 3rd/4th Line Fax Board at the same time, the following step is not necessary.

3. Affix the appropriate Modular Label. If a label is already affixed, remove it and then affix the appropriate label.

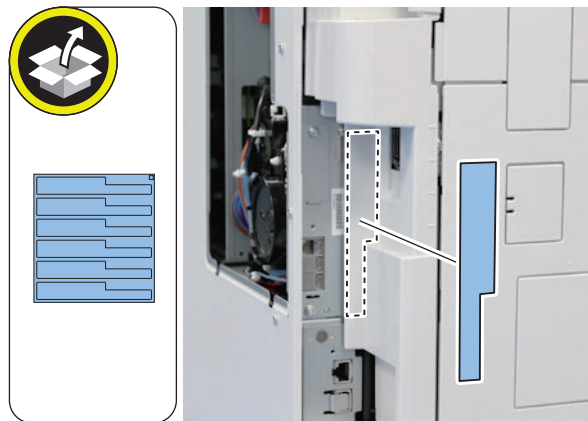

-
- 4. Connect the PTT Cable or Telephone Cord of the FAX (1-Line). When installing this equipment at the same time, connect the other end to the modular jack on the wall.

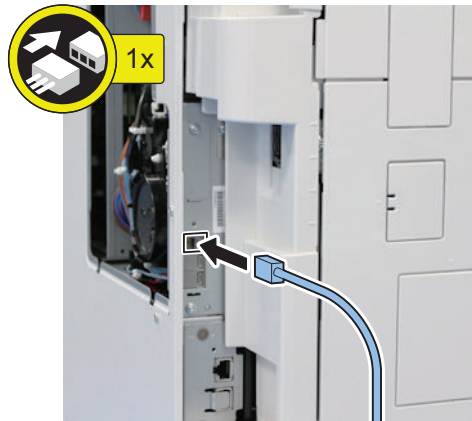

-
- 5. Connect the end of the PTT Cable or Telephone Cord to the modular jack on the Host machine, and connect the other end to the modular jack on the wall.

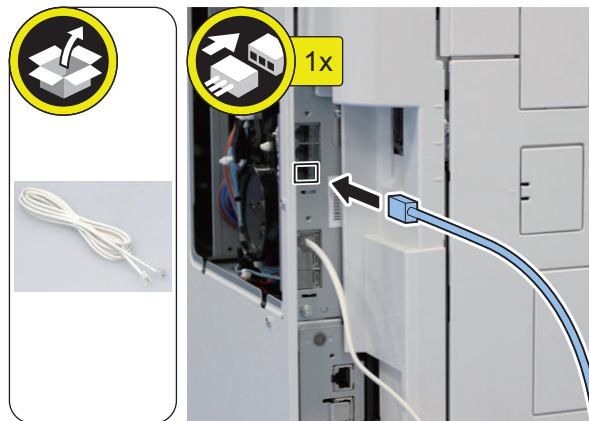

□

NOTE:
When installing the Super G3 3rd/4th Line Fax Board at the same time, the following step is not necessary.

- 6. Install the Dust Cover.

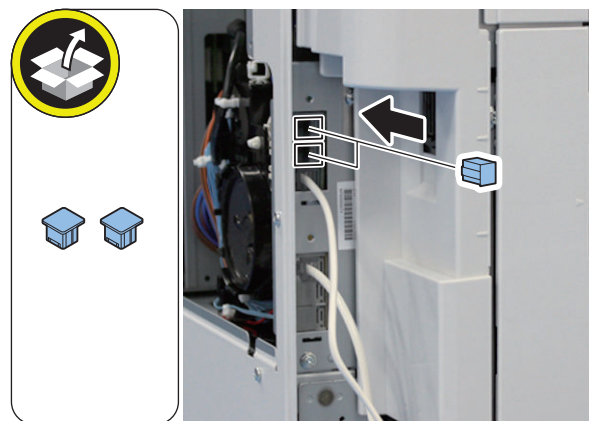

NOTE:

When performing the following steps, it is efficient to install the cover after installing the Super G3 3rd/4th Line Fax Board in case of installing the fax board at the same time.

**7. Install the Rear Cover 2.**

- 2 Protrusions
- 3 Screws

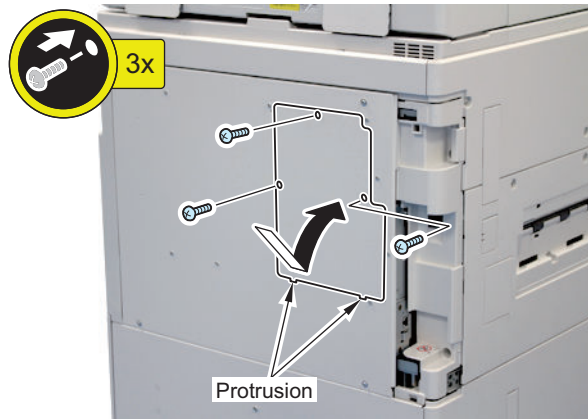
**8. Install the Left Rear Cover.**

- 1 Hook
- 1 Claw

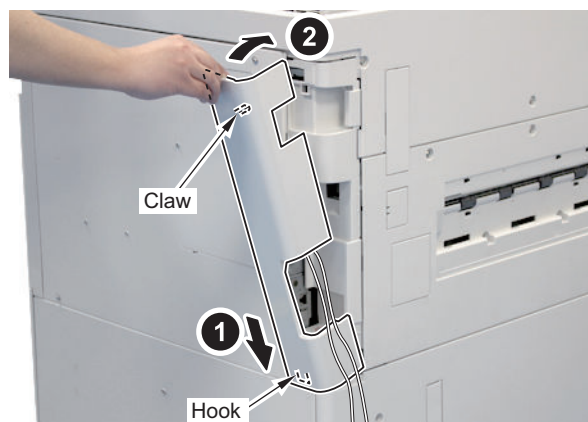
**9. Connect the power plug to the outlet.****10. Turn ON the main power switch.****CAUTION:**

If the machine does not recognize this equipment, unplug and then plug the power plug after turning OFF the main power switch, or turn OFF the main power switch and then turn it ON within 20 seconds.

To avoid this symptom, unplug the power plug or turn the breaker OFF when installing.

11. If a message prompting the user to update the version appears, press [Update] to automatically update the version of this equipment.

NOTE:

If [Skip] is selected, a message prompting the user to update the version will appear every time the host machine is started. In the service mode (Lev. 2) shown below, it is possible to set not to display the message.
COPIER > OPTION > FNC-SW > VER-CHNG

Checking the Operation

■ Type Settings

Select the country/region of the FAX Board in Service Mode: FAX > Type > TYPE

This setting performs the parameter settings to match the communication specification of the country/region.



1. From the following service mode, set the TYPE of country/region to install this machine, and then press OK.

FAX > TYPE > TYPE

2. Confirm that service mode parameter below is "0". In the case, parameter is "1", change to "0".

COPIER > OPTION > DSPLY-SW > SDTM-DSP

NOTE:

To change parameter to "0" makes no show below [Settings/Registration > Preferences > Time/Energy Settings > Auto Shutdown Time] and auto shut down is not available.

3. Turn OFF/ON the main power switch to enable this setting.

■ Basic Settings

NOTE:

When "System Manager Information Settings" is set, be sure to follow the direction of user administrator in order to log in as an administrator.

In this section, make only minimum settings required for FAX communication.



1. Set the user telephone number.

[Settings/Registration] > [Function Settings] > [Send] > [Fax Settings] > [Set Line] > [Line 2] > [Register Unit Telephone Number] > Enter FAX number > [OK]

2. Set the type of telephone line.

[Settings/Registration] > [Function Settings] > [Send] > [Fax Settings] > [Set Line] > [Line 2] > [Select Line Type] > Select the line type to connect > [OK]

3. Turn OFF/ON the main power switch after setting the user telephone numbers and the type of telephone line.

■ FAX Communication Test

Perform communication test to check if FAX function works correctly.



1. Switch the control panel display to Fax display.

2. Select the sending line.

Press [Fax] > [Options] > [Select Line], select the added line, then press [OK] button.

3. Send and receive a test original between the equipment and a remote unit with which a communication test can be performed and check if it can be sent and receive correctly.

1. Press [Status Monitor/Cancel] > [Send] > [Job Log] and select [Fax] from pull down menu.
2. Press [Fax Activity Report] > [OutPut Normally] > [Start Printing].
3. The number printed following colon (:) in "COMM.MODE" field on FAX ACTIVITY REPORT TX/RX shows line type used for sending/receiving.
E.g. "ECM:2" => Line 2

NOTE:

If E744-5000 error code (Fax software version mismatch error) occurred while sending or receiving fax, upgrade the firmware of 2-line Fax to the latest version.

Super G3 2nd Line Fax Board-AS2

Product Name

Safety regulations require the product's name to be registered. In some regions where this product is sold, the following name may be registered instead.

- F632502

Points to Note at Installation

When installing the Super G3 FAX Board and this equipment at the same time, be sure to install them by referring to this document after checking "Checking the Contents" of Super G3 FAX Board.

Essential Items to Be Performed Before Installation

- Turn OFF the main power of the host machine, and disconnect the power plug from the outlet.

⚠ WARNING:

- If performing work without disconnecting the power plug of the host machine, it may cause electrical shock.
- If disconnecting the power plug without turning OFF the main power, it may cause damage of the machine.

- When turning OFF the main power, follow the below procedure.
 1. Turn OFF the main power switch of the host machine.
 2. The display in the Control Panel and the lamp of the main power are turned off.

Points to Note When Turning ON/OFF the Main Power

The following message is displayed.

1. When a message prompting to turn OFF and then ON the main power appears, turn OFF and then ON the main power switch.
2. If a message prompting the user to update the version appears, press [Update] to automatically update the version of this equipment.







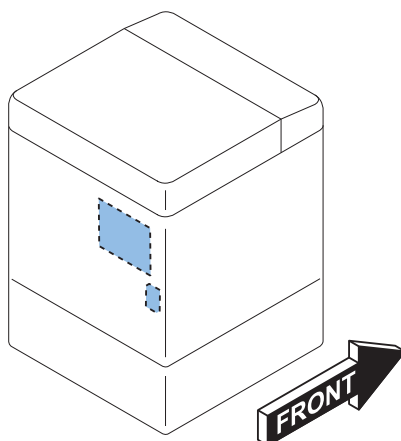

If [Skip] is selected, a message prompting the user to update the version will appear every time the host machine is started. In the service mode (Lv. 2) shown below, it is possible to set not to display the message.

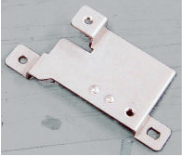

COPIER > OPTION > FNC-SW > VER-CHNG

Installation Outline Drawing

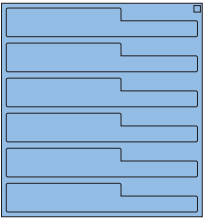

Checking the Contents

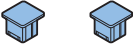
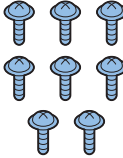
<input type="checkbox"/> [1] G3FAX Expansion PCB X 1 	<input type="checkbox"/> [2] Modular PCB X 1 
<input type="checkbox"/> [3] USB Cable X 1 	<input type="checkbox"/> [4] Modular Cable X 1 
<input type="checkbox"/> [5] Signal Cable X 1 	<input type="checkbox"/> [6] FAX Shield Plate X 1 
<input type="checkbox"/> [7] FAX Board Fixed Plate X 1 	<input type="checkbox"/> [8] PCB Spacer (Long) X 3 
<input type="checkbox"/> [9] PCB Spacer (Short) X 1 	<input type="checkbox"/> [10] Modular Label X 1 

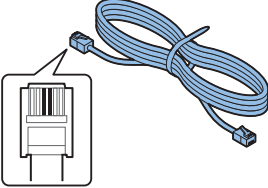
<input type="checkbox"/> [11] Dust Cover X 2 	<input type="checkbox"/> [12] Screw (TP; M3x4) X 8 
<input type="checkbox"/> [13] Screw (Binding; M4x4) X 1 	<input type="checkbox"/> [14] Telephone Cord (2 Contact type) X 1 

Installation Procedure

■ Preparation



1. Remove the Left Rear Cover.

- 1 Claw
- 1 Hook

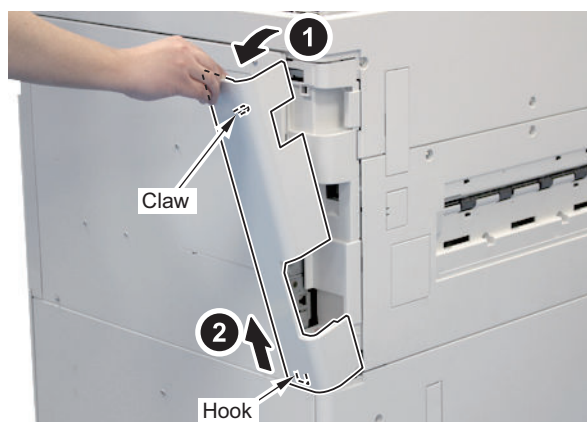

**2. Remove the Rear Cover 2.**

- 3 Screws
- 2 Protrusions

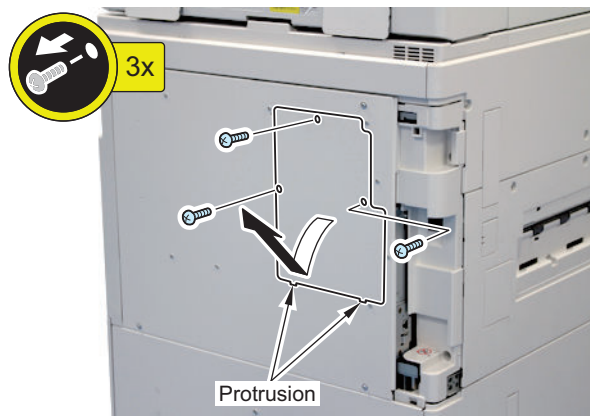
**NOTE:**

- When the Super G3 FAX Board is installed: Perform steps 3 and 4, and proceed to step 6.
- When installing the Super G3 FAX Board at the same time: Proceed to step 5.

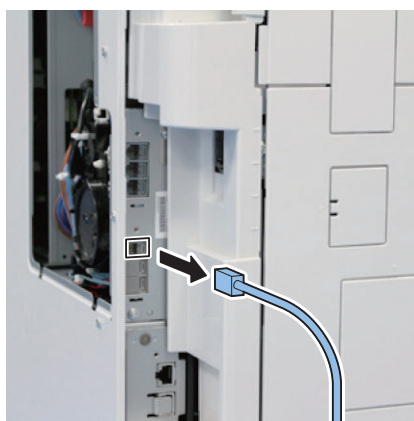
**3. Disconnect the Telephone Cord of the FAX (1-Line).**



4. Remove the FAX Unit.

- 2 Connectors
- 1 Screw
- 2 Protrusions

CAUTION:

Be careful not to damage the [A] part of the speaker as the wiring may be open circuit.

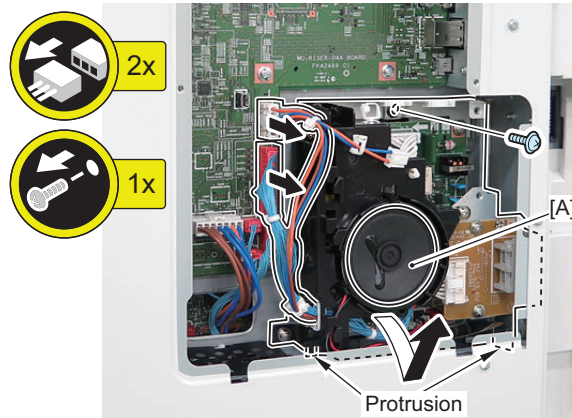

5. Remove the Face Cover of the FAX (1-Line). (The removed parts will not be used.)

- 1 Screw
- 1 Protrusion

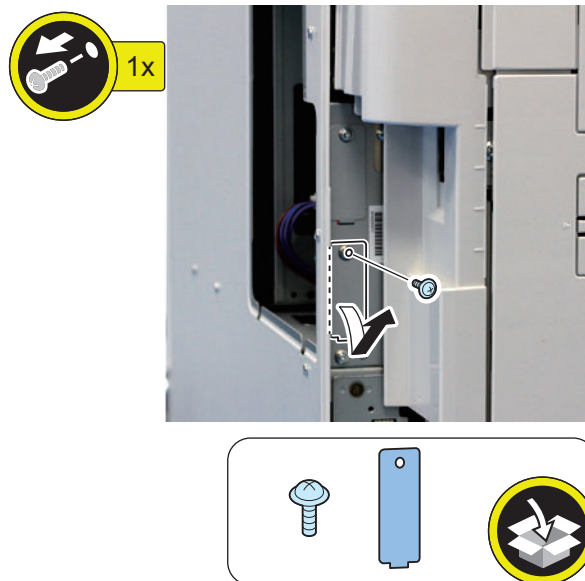

**6. Remove the Face Cover of the FAX (2-Line). (The removed parts will not be used.)**

- 1 Screw
- 1 Protrusion

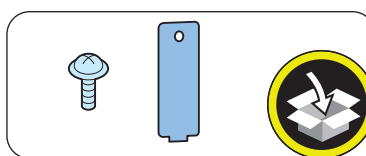
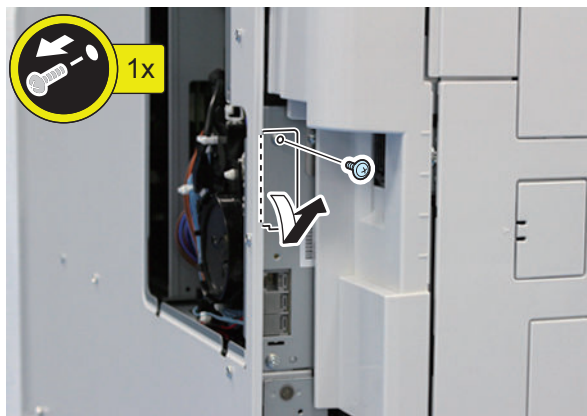
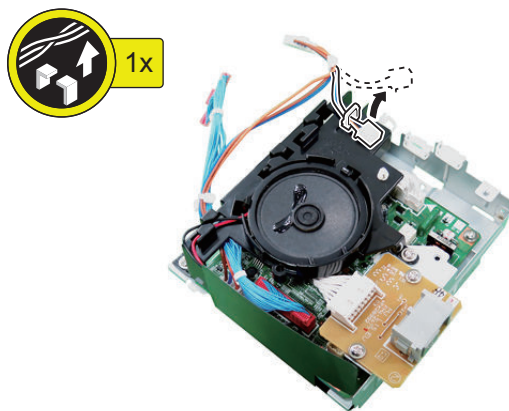
**■ Installing the Equipment****1. Free the Cable from the Wire Saddle.**



2. Install the Signal Cable to the FAX Unit.

- 3 Cable Guides

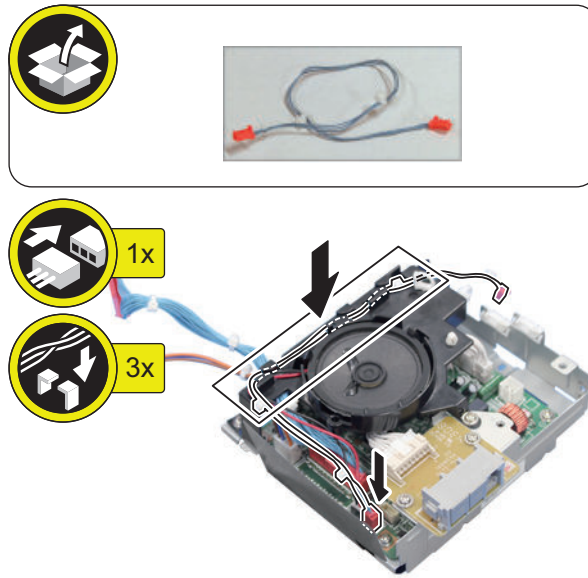

3. Install the Modular Cable to the Modular PCB.

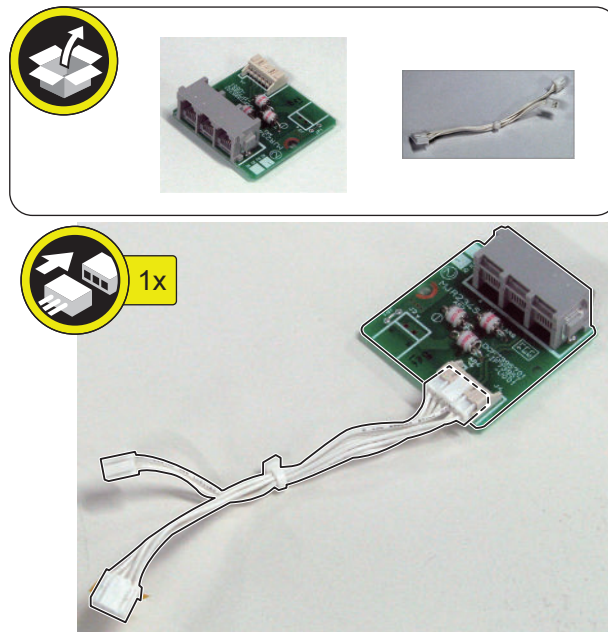



4. Install the Modular PCB to the FAX Unit.

- 2 Screws (TP; M3x4)

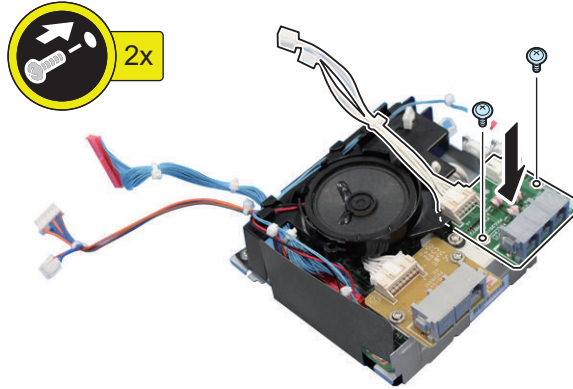
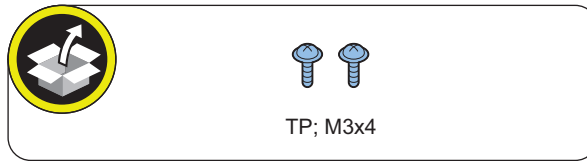



5. Install the FAX Unit to the Host Machine.

- 2 Protrusions
- 1 Screw (TP; M3x4 Black) (Use the removed screw or those included with the Super G3 FAX Board)

CAUTION:

- Be careful not to damage the [A] part of the speaker as the wiring may be broken.
- Be sure to tighten the screw while holding the FAX Unit.
- After tightening the screw of the FAX Unit, check for any backlash. If there is backlash, tighten the screw again with the protrusion precisely fitted.

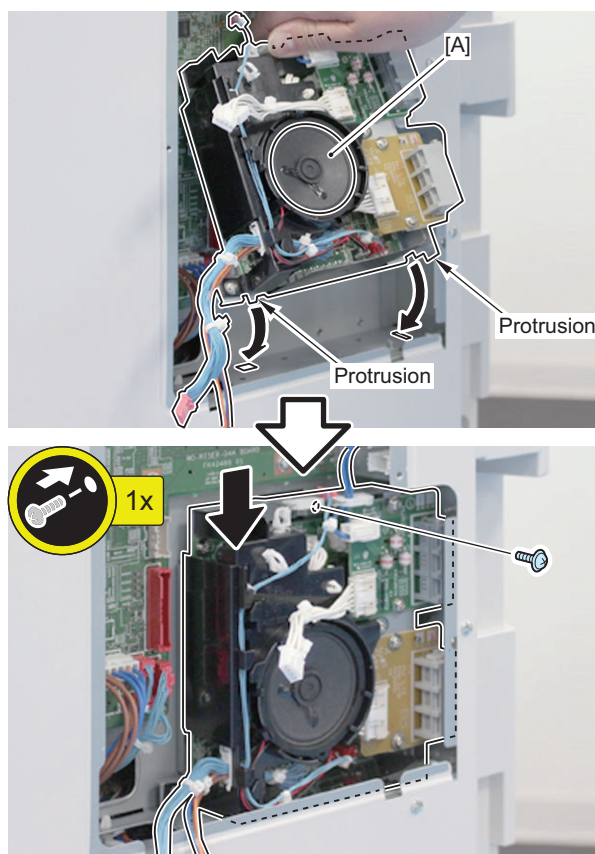

6. Install the 2 Cable of the FAX Unit.

- 2 Connectors

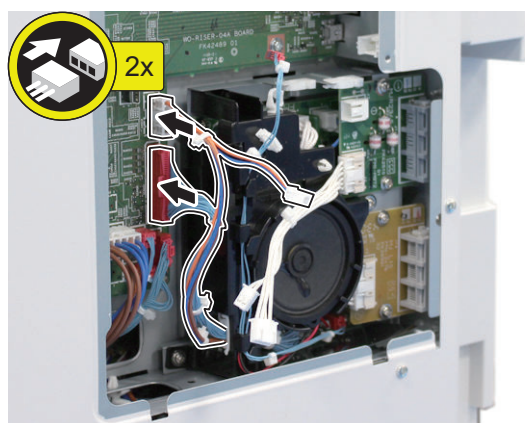



7. Remove the 2 Screws. (will be used in next step)

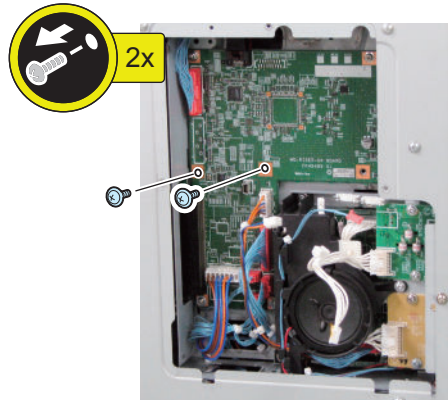

8. Install the FAX Shield Plate.

- 2 Screws (screws removed in the previous step)

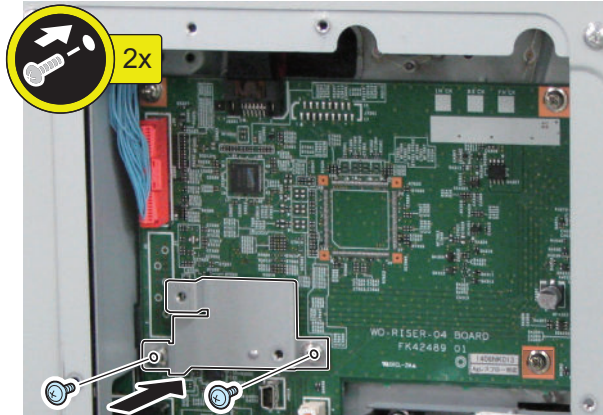
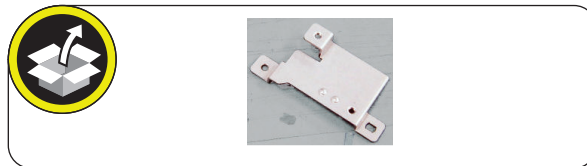



9. Install the FAX Board Fixed Plate.

- 2 Bosses
- 1 Screw (Binding; M4x4)

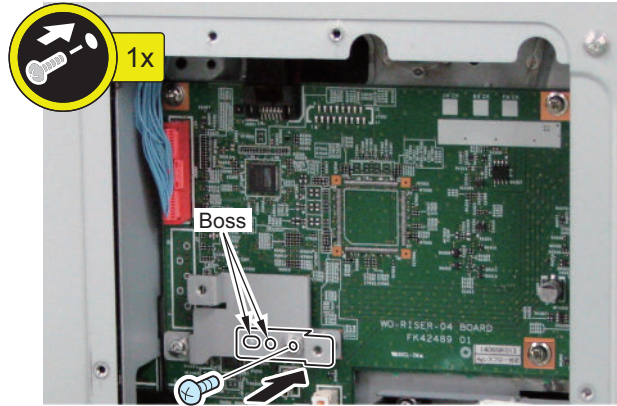



10. Remove the Screw and install the PCB Spacer (Short). (The removed screw will not be used.)

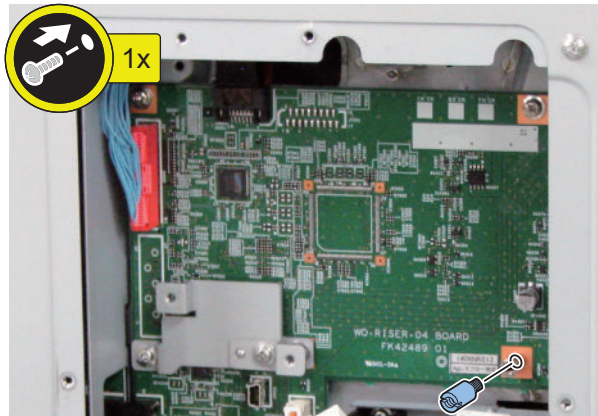
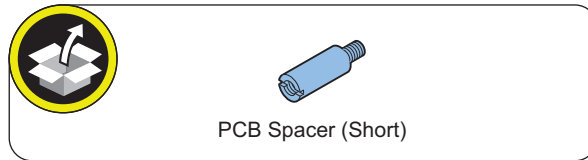
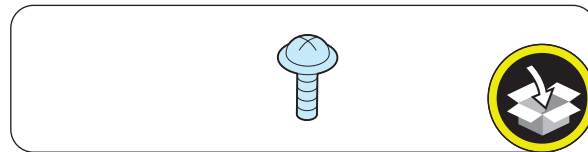
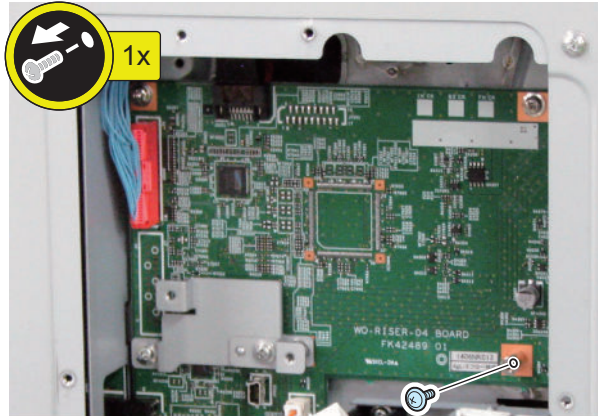



11. Install the 3 PCB Spacers (Long).

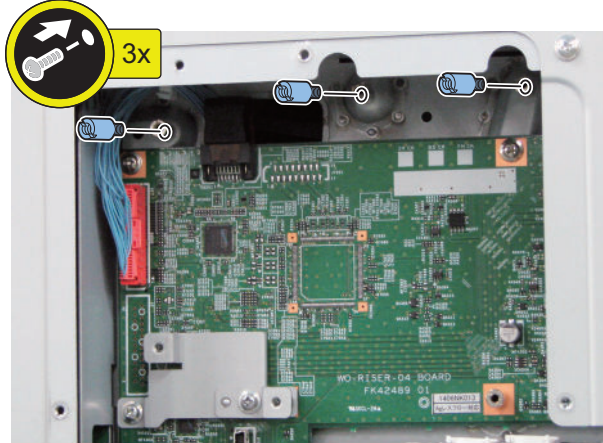
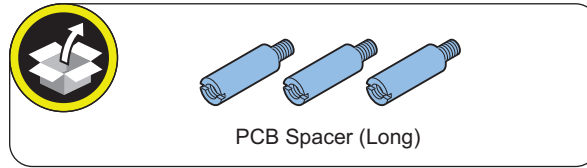

12. Install the G3FAX Expansion PCB.

- 6 Screws (TP; M3x4)

NOTE:

Because the 4 screws [A] need to be removed when installing the Super G3 3rd/4th Line Fax Board at the same time, it is efficient not to tighten them here.

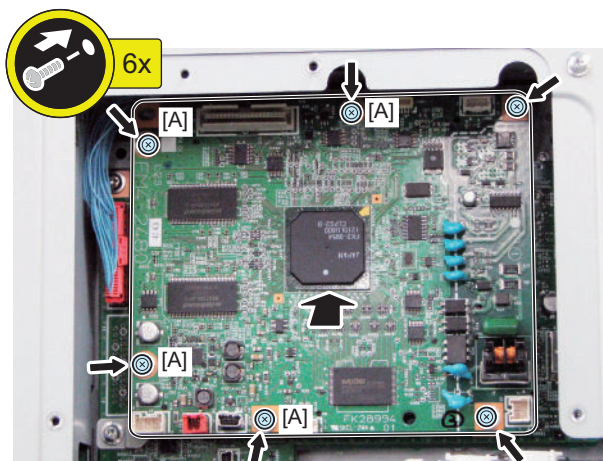
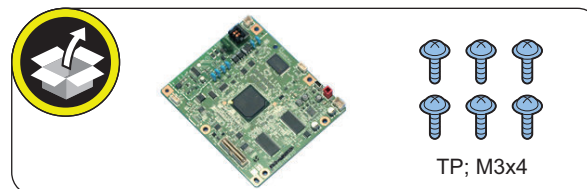



13. Install the Signal Cable, Power Supply Cable and USB Cable to the G3FAX Expansion PCB.

- 1 Wire Saddle

NOTE:

Because [A] of the USB Cable needs to be disconnected when installing the Super G3 3rd/4th Line Fax Board at the same time, it is efficient not to connect it here.

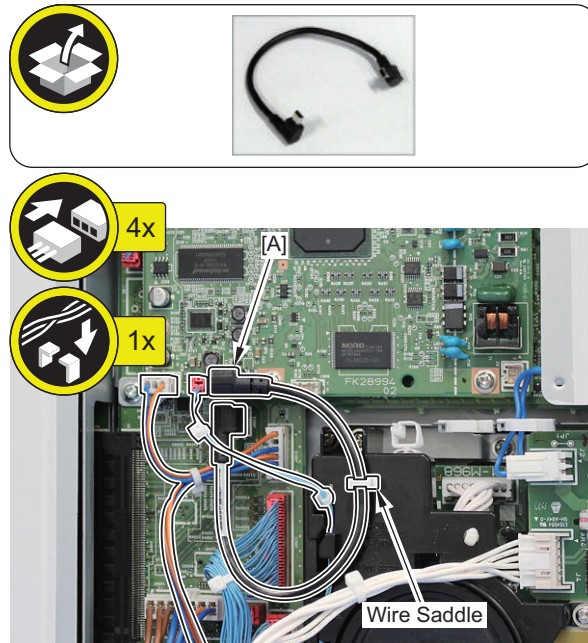

14. Pass the Modular Cable inside the Speaker Holder, and install the G3 FAX Control PCB.

- 1 Edge Saddle

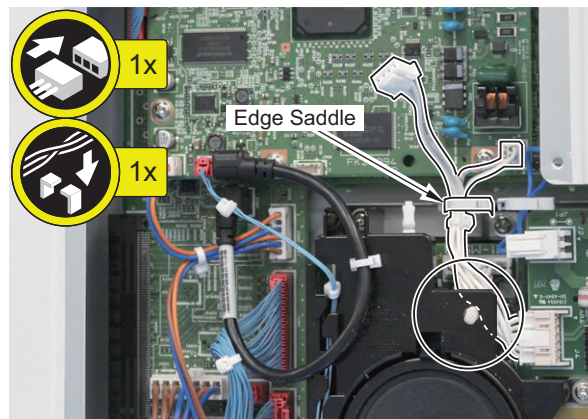



NOTE:

When installing the Super G3 3rd/4th Line Fax Board at the same time, the following step is not necessary.

15. Secure the cable with the Wire Saddle.

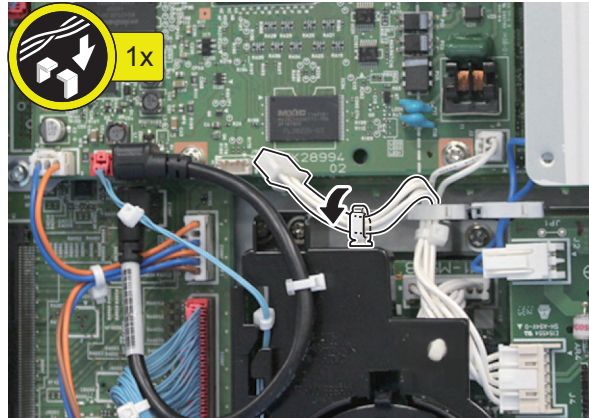

■ Subsequent Work



NOTE:

The following work is required only when installing the Super G3 FAX Board at the same time.

1. Affix the following FAX Approval Label.

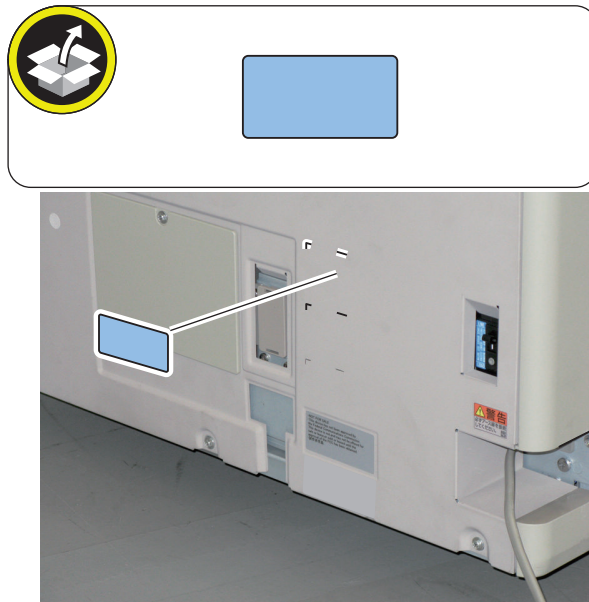



NOTE:

When installing the Super G3 3rd/4th Line Fax Board at the same time, the following step is not necessary.

2. Affix the appropriate Modular Label to the place shown in the figure.

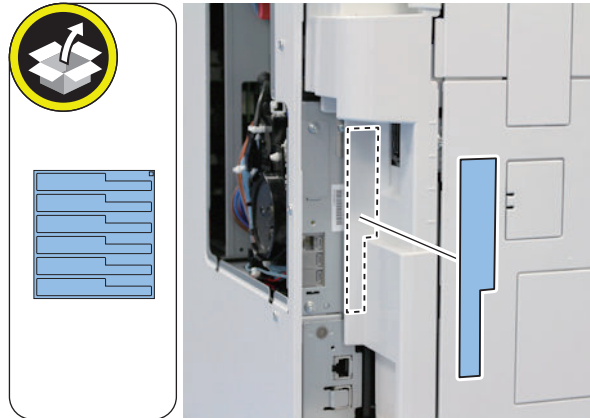

3. Connect the Telephone Cord of the FAX (1-Line). When installing this equipment at the same time, connect the other end to the modular jack on the wall.

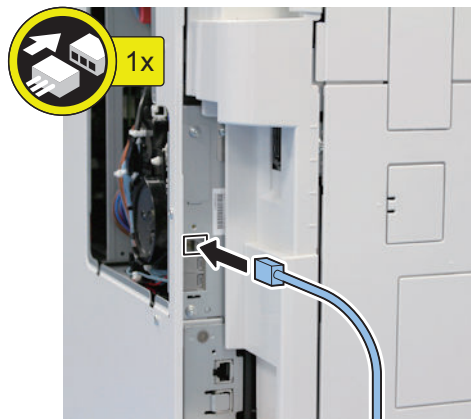

4. Connect the end of the Telephone Cord to the modular jack on the Host machine, and connect the other end to the modular jack on the wall.

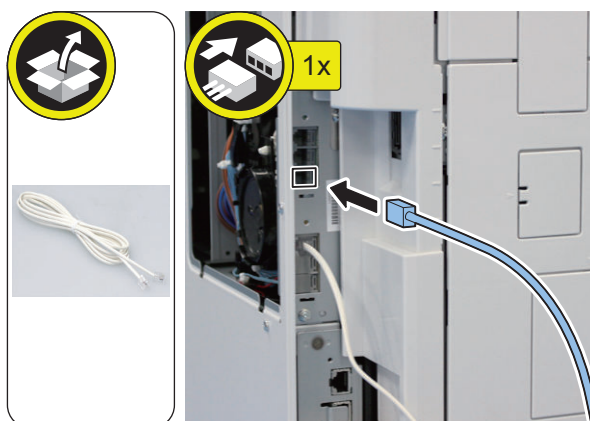

**NOTE:**

When installing the Super G3 3rd/4th Line Fax Board at the same time, the following step is not necessary.

5. Install the Dust Cover.

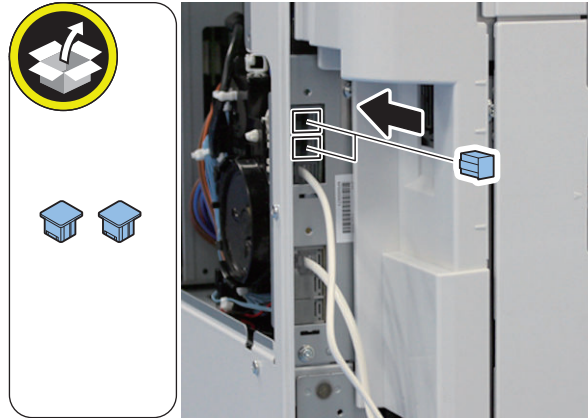
**NOTE:**

When performing the following steps, it is efficient to install the cover after installing the Super G3 3rd/4th Line Fax Board in case of installing the fax board at the same time.



6. Install the Rear Cover 2.

- 2 Protrusions
- 3 Screws

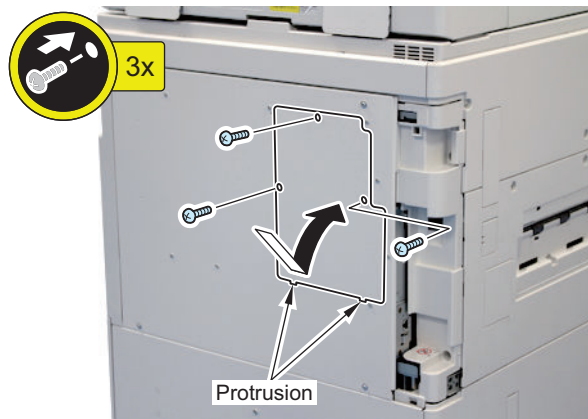

**7. Install the Left Rear Cover.**

- 1 Hook
- 1 Claw

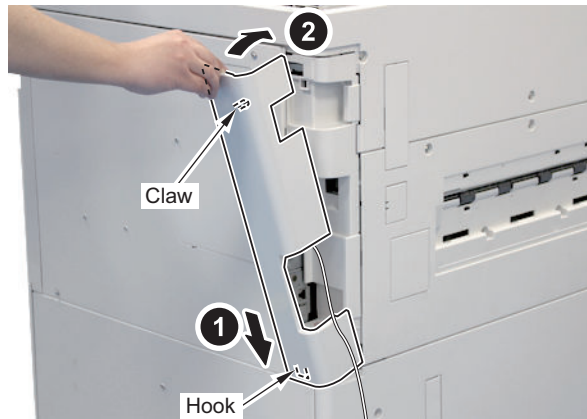
**8. Connect the Power Plug to the outlet.****9. Turn ON the main power switch.****CAUTION:**

If the machine does not recognize this equipment, unplug and then plug the power plug after turning OFF the main power switch, or turn OFF the main power switch and then turn it ON within 20 seconds.
To avoid this symptom, unplug the power plug or turn the breaker OFF when installing.

10. If a message prompting the user to update the version appears, press [Update] to automatically update the version of this equipment.**NOTE:**

If [Skip] is selected, a message prompting the user to update the version will appear every time the host machine is started.
In the service mode (Lv.2) shown below, it is possible to set not to display the message.

COPIER > OPTION > FNC-SW > VER-CHNG

Checking the Operation

■ Type Settings

Select the country/region of the FAX Board in Service Mode: FAX > Type > TYPE

This setting performs the parameter settings to match the communication specification of the country/region.

**1. From the following service mode, set the TYPE of country/region to install this machine, and then press OK.**

FAX > TYPE > TYPE

2. Confirm that service mode parameter below is "0". In the case, parameter is "1", change to "0".

COPIER > OPTION > DSPLY-SW > SDTM-DSP

NOTE:

To change parameter to "0" makes no show below [Settings/Registration > Preferences > Time/Energy Settings > Auto Shutdown Time] and auto shut down is not available.

3. Turn OFF/ON the main power switch to enable this setting.

■ Basic Settings

NOTE:

When "System Manager Information Settings" is set, be sure to follow the direction of user administrator in order to log in as an administrator.

In this section, make only minimum settings required for FAX communication.



1. Set the user telephone number.

[Settings/Registration] > [Function Settings] > [Send] > [Fax Settings] > [Set Line] > [Line 2] > [Register Unit Telephone Number] > Enter FAX number > [OK]

2. Set the type of telephone line.

[Settings/Registration] > [Function Settings] > [Send] > [Fax Settings] > [Set Line] > [Line 2] > [Select Line Type] > Select the line type to connect > [OK]

3. Turn OFF/ON the main power switch after setting the user telephone numbers and the type of telephone line.

■ FAX Communication Test

Perform communication test to check if FAX function works correctly.



1. Switch the control panel display to Fax display.

2. Select the sending line.

Press [Fax] > [Options] > [Select Line], select the added line, then press [OK] button.

3. Send and receive a test original between the equipment and a remote unit with which a communication test can be performed and check if it can be sent and receive correctly.

1. Press [Status Monitor/Cancel] > [Send] > [Job Log] and select [Fax] from pull down menu.

2. Press [Fax Activity Report] > [OutPut Normally] > [Start Printing].

3. The number printed following colon (:) in "COMM.MODE" field on FAX ACTIVITY REPORT TX/RX shows line type used for sending/receiving.

E.g. "ECM:2" => Line 2

NOTE:

If E744-5000 error code (Fax software version mismatch error) occurred while sending or receiving fax, upgrade the firmware of 2-line Fax to the latest version.

Super G3 3rd/4th Line Fax Board-AS1

Product Name

Safety regulations require the product's name to be registered. In some regions where this product is sold, the following name may be registered instead.

- F632503

Points to Note at Installation

- Install this equipment after installing the Super G3 FAX Board and Super G3 2nd Line Fax Board.
- When installing Super G3 2nd Line Fax Board at the same time, start from "Installing the Equipment".
- When installing this equipment later, start from "Preparation".

Essential Items to Be Performed Before Installation

- Turn OFF the main power of the host machine, and disconnect the power plug from the outlet.

WARNING:

- If performing work without disconnecting the power plug of the host machine, it may cause electrical shock.
- If disconnecting the power plug without turning OFF the main power, it may cause damage of the machine.

- When turning OFF the main power, follow the below procedure.
 1. Turn OFF the main power switch of the host machine.
 2. The display in the Control Panel and the lamp of the main power are turned off.

Points to Note When Turning ON/OFF the Main Power

The following message is displayed.

1. When a message prompting to turn OFF and then ON the main power appears, turn OFF and then ON the main power switch.
2. If a message prompting the user to update the version appears, press [Update] to automatically update the version of this equipment.



If [Skip] is selected, a message prompting the user to update the version will appear every time the host machine is started. In the service mode (Lv. 2) shown below, it is possible to set not to display the message.

COPIER > OPTION > FNC-SW > VER-CHNG

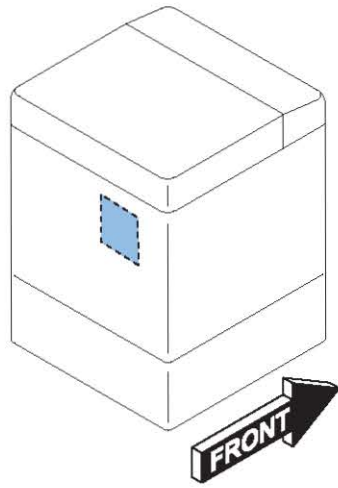
● Installation Outline Drawing

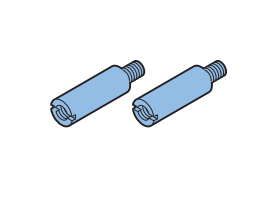
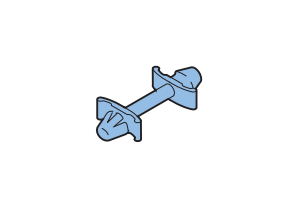
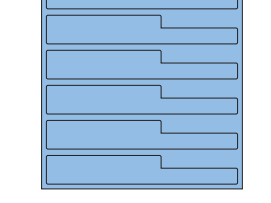
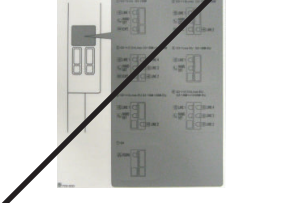
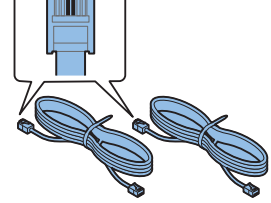
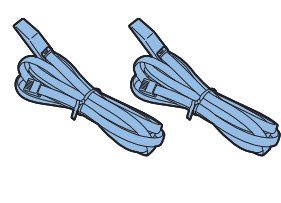
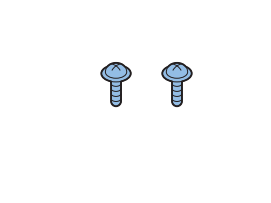
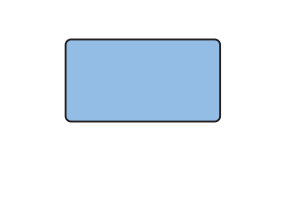

Checking the Contents

<input type="checkbox"/> [1] G3FAX Expansion PCB X 1 	<input type="checkbox"/> [2] FAX Shield Plate X 1 
<input type="checkbox"/> [3] FAX Board Fixed Plate X 1 	<input type="checkbox"/> [4] PCB Spacer X 2 
<input type="checkbox"/> [5] Resin Spacer X 1 	<input type="checkbox"/> [6] Modular Label X 1 
<input type="checkbox"/> [7] Modular Label X 1 	<input type="checkbox"/> [8] Telephone Cord X 2 
<input type="checkbox"/> [9] PTT Cable X 2 (only for Asia) 	<input type="checkbox"/> [10] Screw (TP; M3x4) X 2 
<input type="checkbox"/> [11] FAX Approval Label (only for Taiwan) X 1 	

Installation Procedure

■ Preparation



1. Remove the Left Rear Cover.

- 1 Claw
- 1 Hook

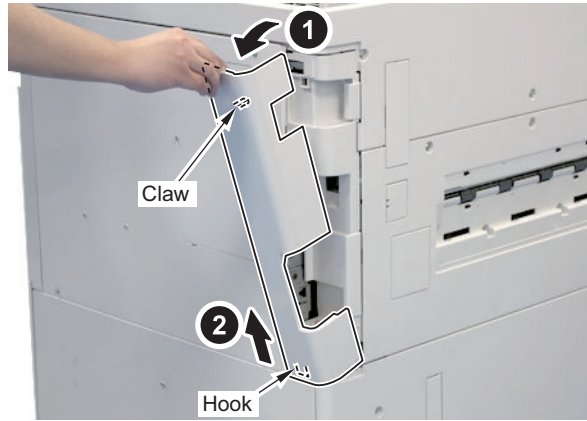

2. Remove the Rear Cover 2.

- 3 Screws
- 2 Protrusions

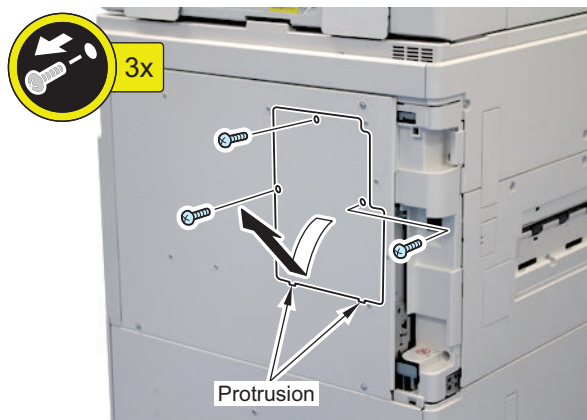

3. Disconnect the USB Cable of the G3FAX Expansion PCB side.

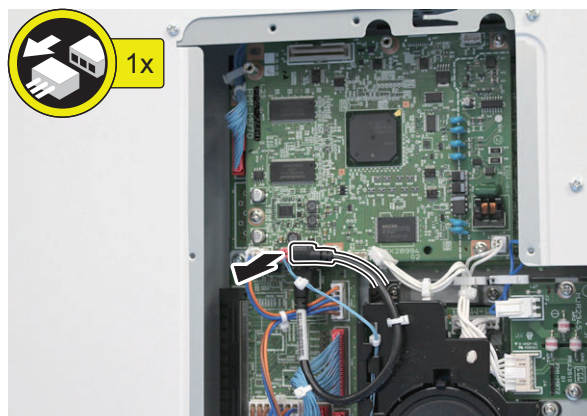

□

4. Free the Modular Cable from the Wire Saddle. (Close the Wire Saddle.)

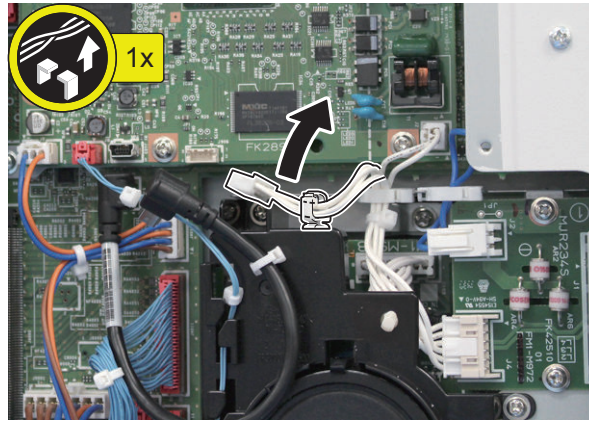

□

5. Remove the 4 Screws. (will be used in Installing the Equipment)

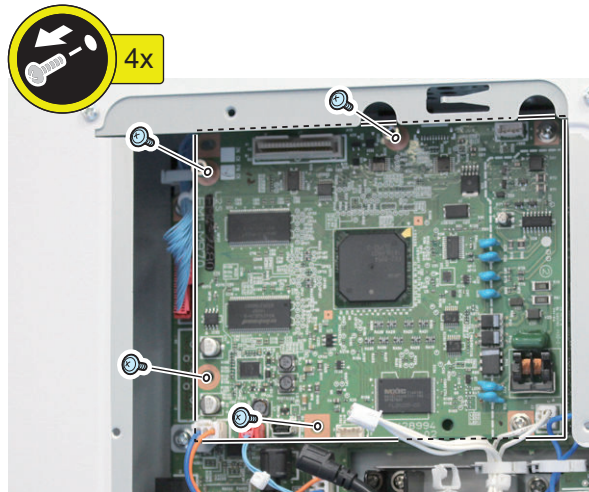

■ Installing the Equipment



1. Install the FAX Shield Plate.

- 2 Screws (Use the removed screws or TP; M3x4 included with the FAX (2-Line))

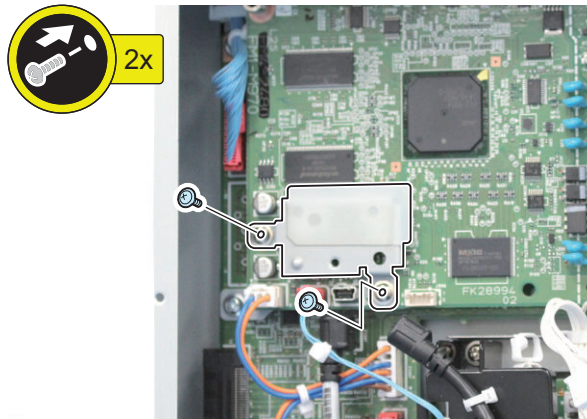
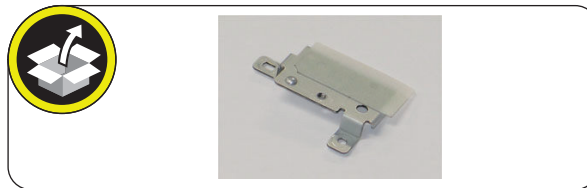

2. Install the FAX Board Fixed Plate.

- 1 Boss
- 1 Screw (TP; M3x4)

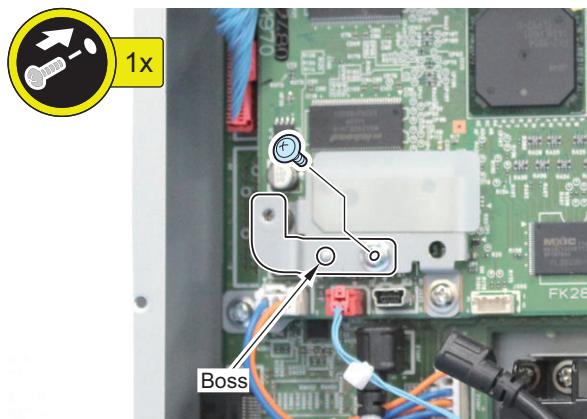



3. Install the 2 PCB Spacers and Resin Spacer.

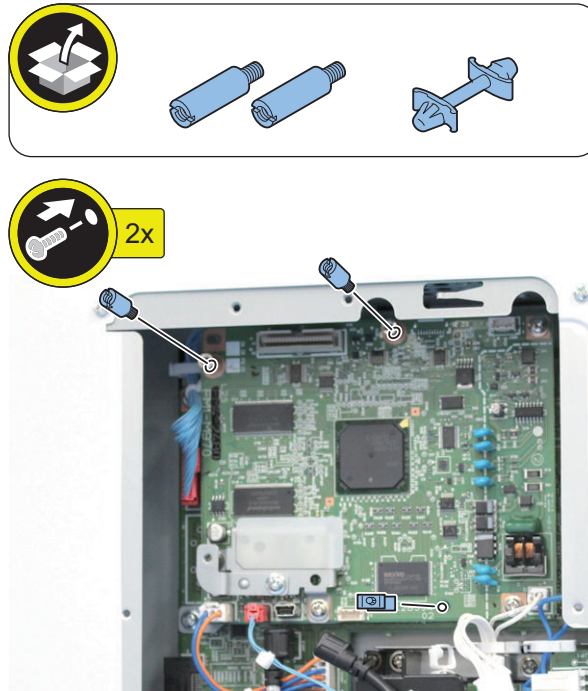

4. Install the G3FAX Expansion PCB.

- Upper Side: 2 Screws (Use the removed screws or TP; M3x4 included with the FAX (2-Line))
- Lower Side: 1 Screw (TP; M3x4)
- 1 Resin Spacer
- 2 Connectors

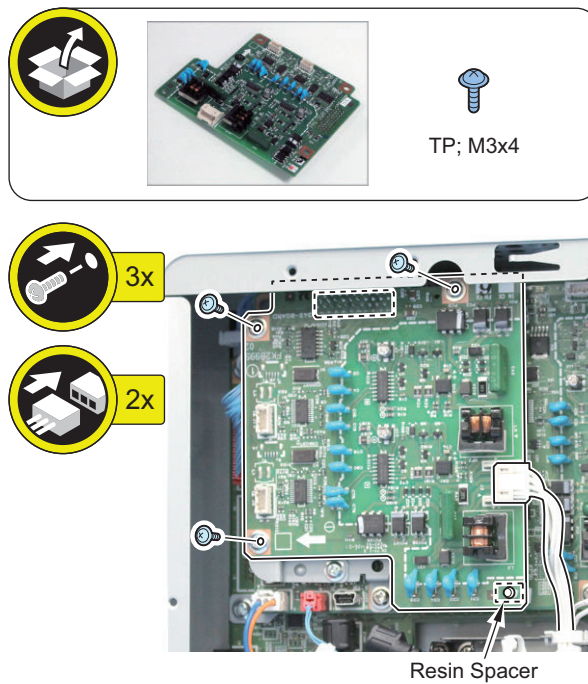



5. Connect the USB Cable.

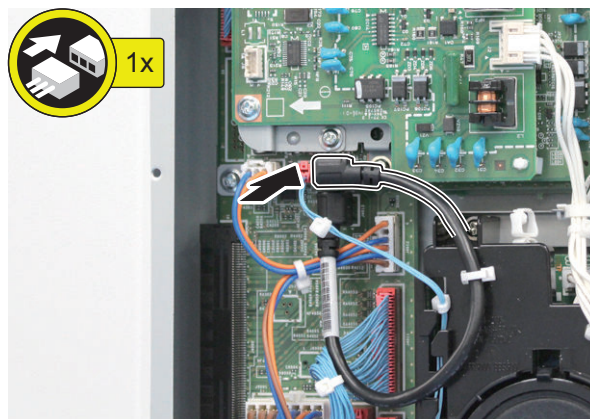

■ Subsequent Work



1. Install the Rear Cover 2.

- 2 Protrusions
- 3 Screws

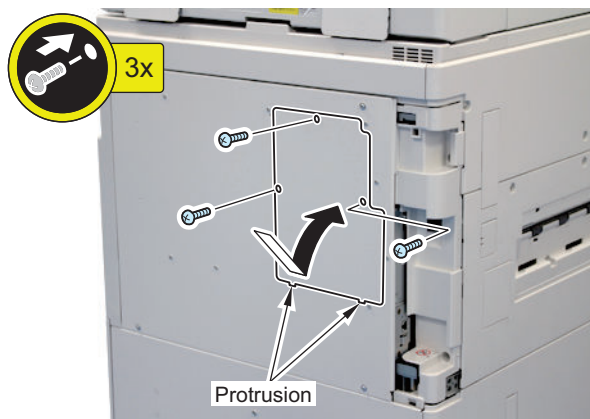



NOTE:
This step is only for Taiwan.

2. Affix the following FAX Approval Label.

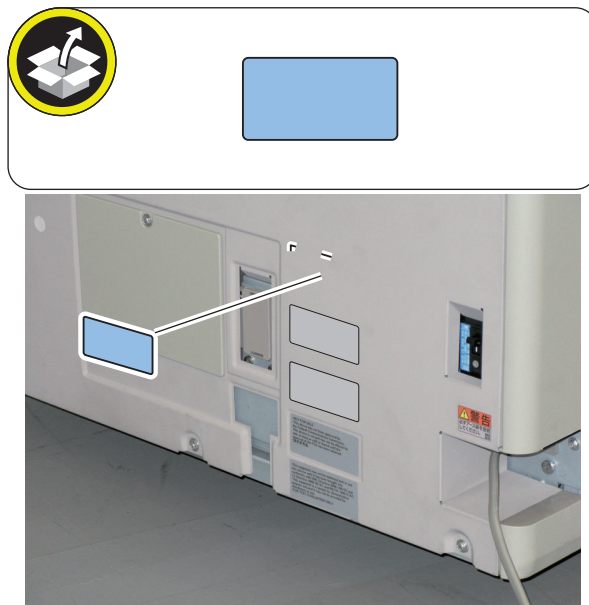

3. Affix the appropriate Modular Label. If a label is already affixed, remove it and then affix the appropriate label.

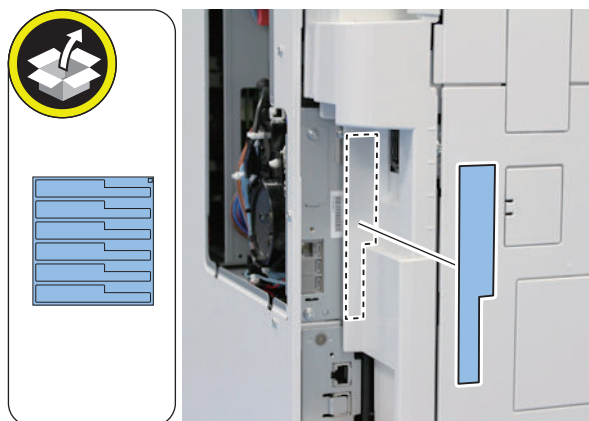

**4. Remove the 2 Dust Covers if installed.****CAUTION:**

Do not insert a screwdriver, etc. into the modular terminal.

NOTE:

Keep the removed Dust Cover.

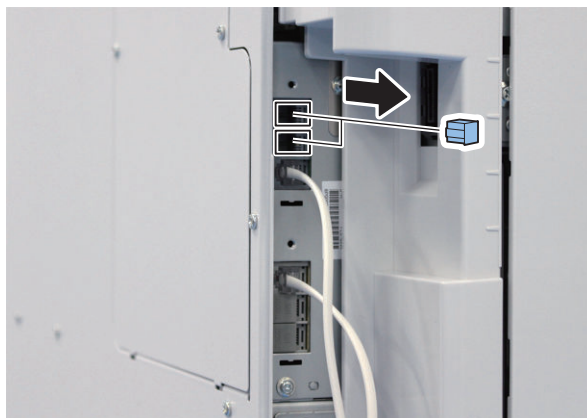
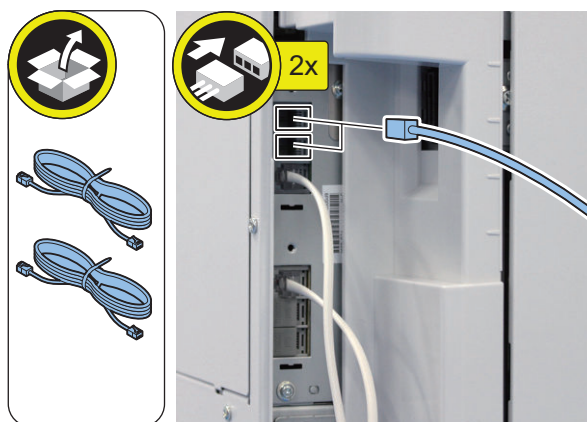
**5. Connect one of the 2 Telephone Cords or the 2 PTT Cables to the modular jack on the host machine and the other cord to the modular jack on the wall.**

**6. Install the Left Rear Cover.**

- 1 Hook
- 1 Claw

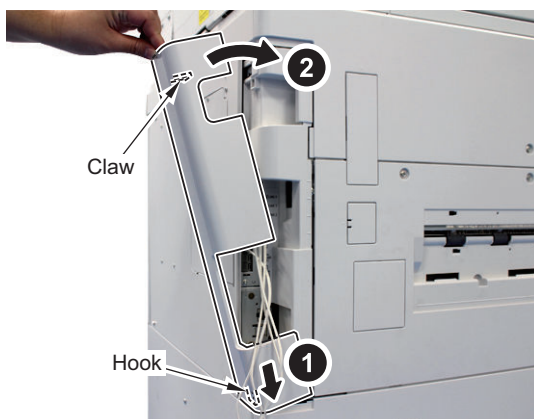
**7. Connect the power plug to the outlet.****8. Turn ON the main power switch.****CAUTION:**

If the machine does not recognize this equipment, unplug and then plug the power plug after turning OFF the main power switch, or turn OFF the main power switch and then turn it ON within 20 seconds.

To avoid this symptom, unplug the power plug or turn the breaker OFF when installing.

If the host machine still does not recognize this equipment after performing the foregoing remedy: In the case of installing the Super G3 Fax Board (1-Line) and the Super G3 2nd Line Fax Board at the same time, it is necessary to turn OFF and then ON the power three times in some cases (no message is displayed on the Control Panel).

Checking the Operation

■ Type Settings

Select the country/region of the FAX Board in Service Mode: FAX > Type > TYPE

This setting performs the parameter settings to match the communication specification of the country/region.

**1. From the following service mode, set the TYPE of country/region to install this machine, and then press OK.**

- Service Mode > FAX > Type > TYPE

2. Confirm that service mode parameter below is "0". In the case, parameter is "1", change to "0".

- COPIER > OPTION > DSPLY-SW > SDTM-DSP

NOTE:

To change parameter to "0" makes no show below [Settings/Registration > Preferences > Time/Energy Settings > Auto Shutdown Time] and auto shut down is not available.

3. Turn OFF/ON the main power switch to enable this setting.

■ Basic Settings

NOTE:

When "System Manager Information Settings" is set, be sure to follow the direction of user administrator in order to log in as an administrator.

In this section, make only minimum settings required for FAX communication.



1. Set the user telephone number.

[Settings/Registration] > [Function Settings] > [Send] > [Fax Settings] > [Set Line] > [Line 3]/[Line 4] > [Register Unit Telephone Number] > Enter FAX number > [OK]

2. Set the type of telephone line.

[Settings/Registration] > [Function Settings] > [Send] > [Fax Settings] > [Set Line] > [Line 3]/[Line 4] > [Select Line Type] > Select the line type to connect > [OK]

3. Turn OFF/ON the main power switch after setting the user telephone numbers and the type of telephone line.

■ FAX Communication Test

Perform communication test to check if FAX function works correctly.



1. Switch the control panel display to Fax display.

2. Select the sending line.

Press [Fax] > [Options] > [Select Line], select the added line, then press [OK] button.

3. Send and receive a test original between the equipment and a remote unit with which a communication test can be performed and check if it can be sent and receive correctly.

1. Press [Status Monitor/Cancel] > [Send] > [Job Log] and select [Fax] from pull down menu.

2. Press [Fax Activity Report] > [OutPut Normally] > [Start Printing].

3. The number printed following colon (:) in "COMM.MODE" field on FAX ACTIVITY REPORT TX/RX shows line type used for sending/receiving.

E.g. "ECM:3" => Line 3

Super G3 3rd/4th Line Fax Board-AS2

Product Name

Safety regulations require the product's name to be registered. In some regions where this product is sold, the following name may be registered instead.

- F632503

Points to Note at Installation

- Install this equipment after installing the Super G3 FAX Board and Super G3 2nd Line Fax Board.
- When installing Super G3 2nd Line Fax Board at the same time, start from "Installing the Equipment".
- When installing this equipment later, start from "Preparation".

Essential Items to Be Performed Before Installation

- Turn OFF the main power of the host machine, and disconnect the power plug from the outlet.

WARNING:

- If performing work without disconnecting the power plug of the host machine, it may cause electrical shock.
- If disconnecting the power plug without turning OFF the main power, it may cause damage of the machine.

- When turning OFF the main power, follow the below procedure.
 1. Turn OFF the main power switch of the host machine.
 2. The display in the Control Panel and the lamp of the main power are turned off.

Points to Note When Turning ON/OFF the Main Power

The following message is displayed.

1. When a message prompting to turn OFF and then ON the main power appears, turn OFF and then ON the main power switch.
2. If a message prompting the user to update the version appears, press [Update] to automatically update the version of this equipment.



If [Skip] is selected, a message prompting the user to update the version will appear every time the host machine is started. In the service mode (Lv. 2) shown below, it is possible to set not to display the message.

COPIER > OPTION > FNC-SW > VER-CHNG

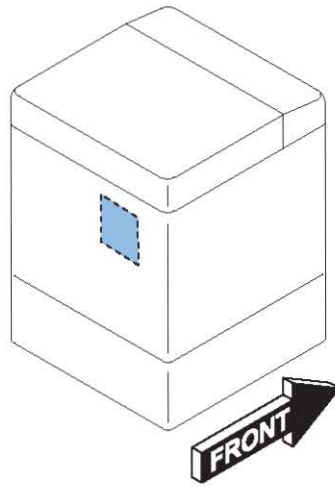
● Installation Outline Drawing

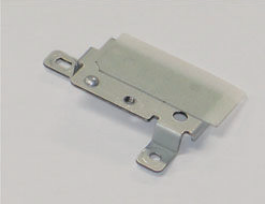

Checking the Contents

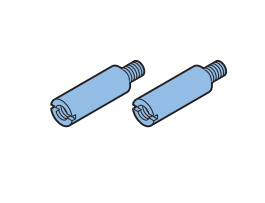
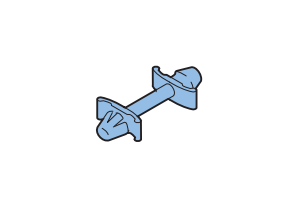
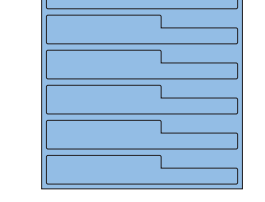
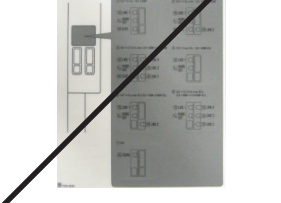
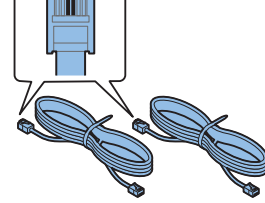
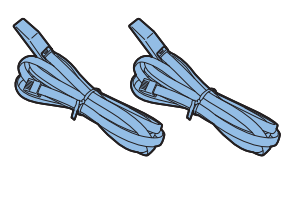
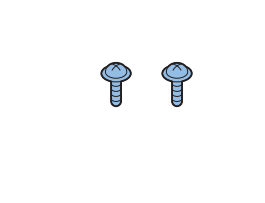
<input type="checkbox"/> [1] G3FAX Expansion PCB X 1 	<input type="checkbox"/> [2] FAX Shield Plate X 1 
<input type="checkbox"/> [3] FAX Board Fixed Plate X 1 	<input type="checkbox"/> [4] PCB Spacer X 2 
<input type="checkbox"/> [5] Resin Spacer X 1 	<input type="checkbox"/> [6] Modular Label X 1 
<input type="checkbox"/> [7] Modular Label X 1 	<input type="checkbox"/> [8] Telephone Cord X 2 
<input type="checkbox"/> [9] PTT Cable X 2 (only for Asia) 	<input type="checkbox"/> [10] Screw (TP; M3x4) X 2 

Installation Procedure

■ Preparation



1. Remove the Left Rear Cover.

- 1 Claw
- 1 Hook

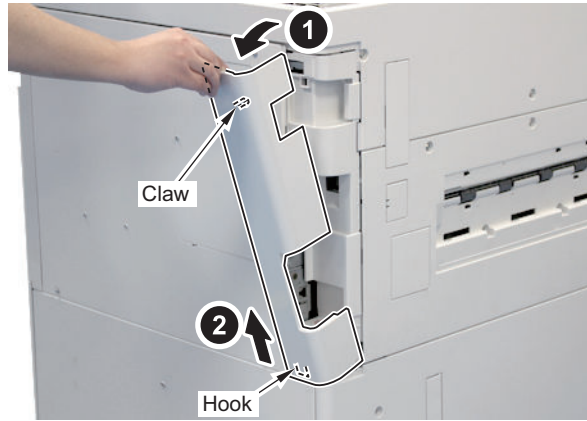

2. Remove the Rear Cover 2.

- 3 Screws
- 2 Protrusions

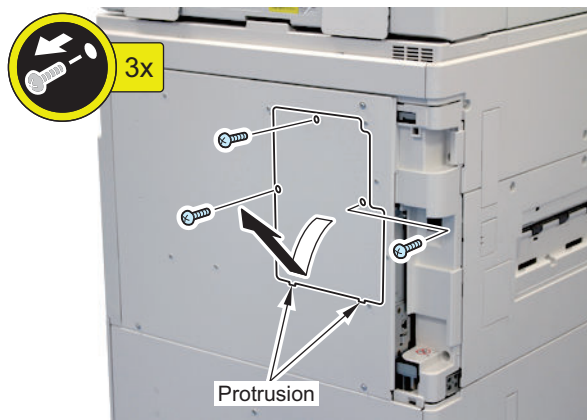

3. Disconnect the USB Cable of the G3FAX Expansion PCB side.

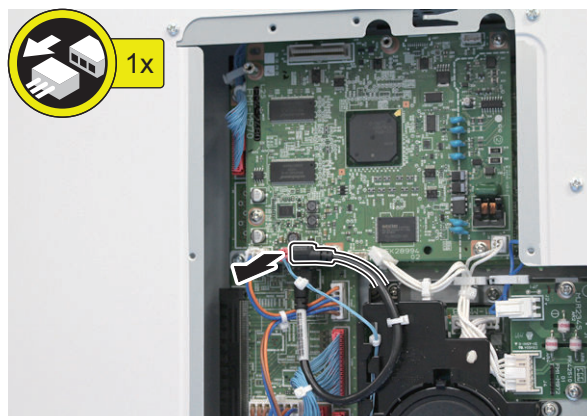

□

4. Free the Modular Cable from the Wire Saddle. (Close the Wire Saddle.)

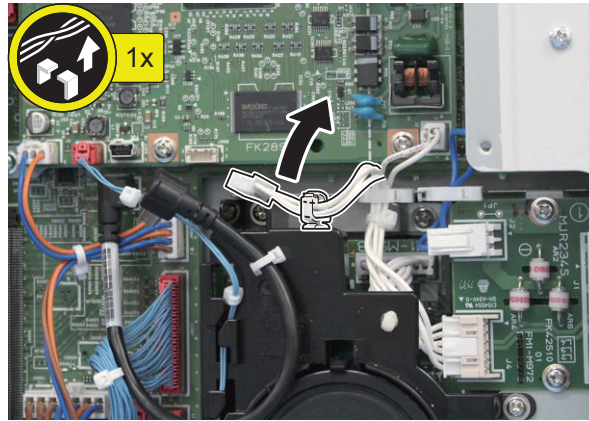

□

5. Remove the 4 Screws. (will be used in Installing the Equipment)

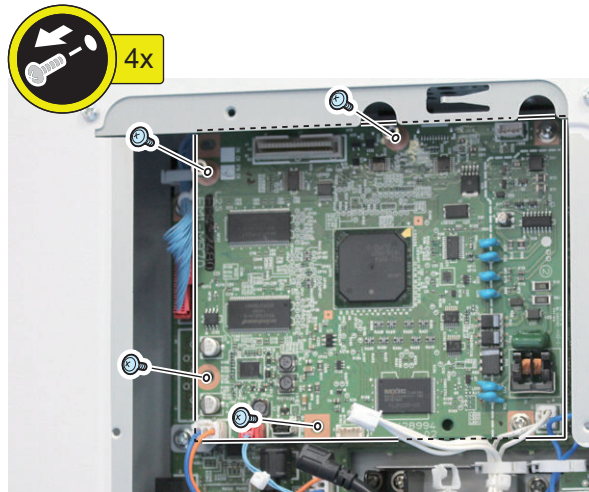

■ Installing the Equipment



1. Install the FAX Shield Plate.

- 2 Screws (Use the removed screws or TP; M3x4 included with the FAX (2-Line))

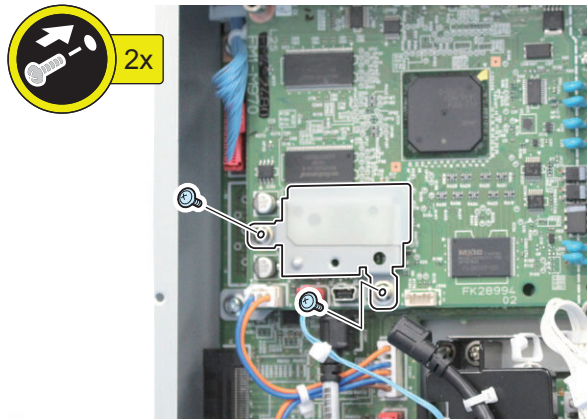
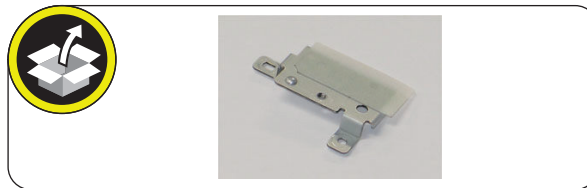

2. Install the FAX Board Fixed Plate.

- 1 Boss
- 1 Screw (TP; M3x4)

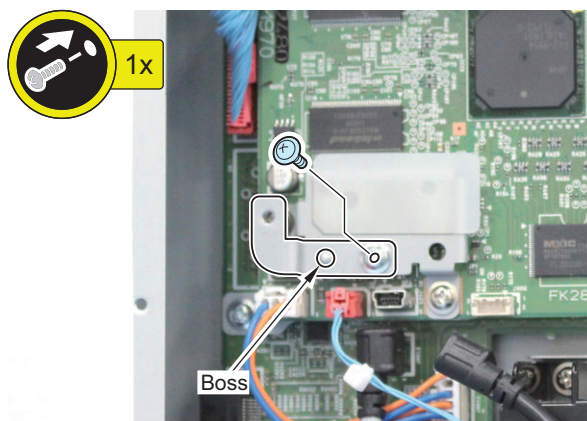



3. Install the 2 PCB Spacers and Resin Spacer.

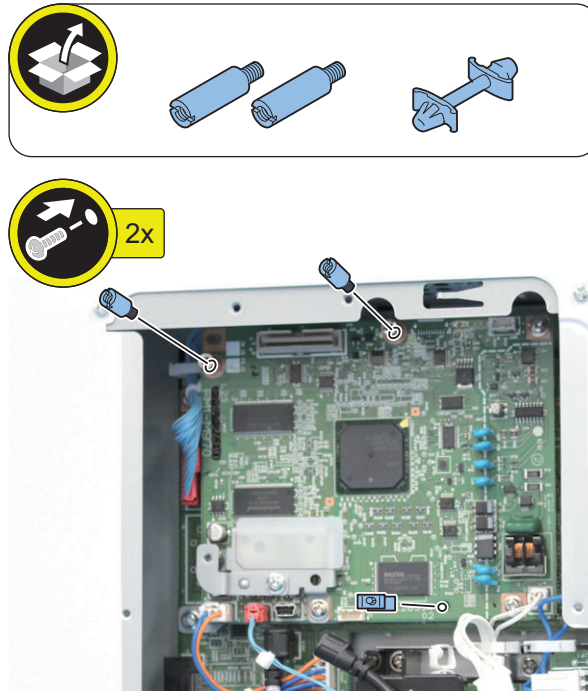

4. Install the G3FAX Expansion PCB.

- Upper Side: 2 Screws (Use the removed screws or TP; M3x4 included with the FAX (2-Line))
- Lower Side: 1 Screw (TP; M3x4)
- 1 Resin Spacer
- 2 Connectors

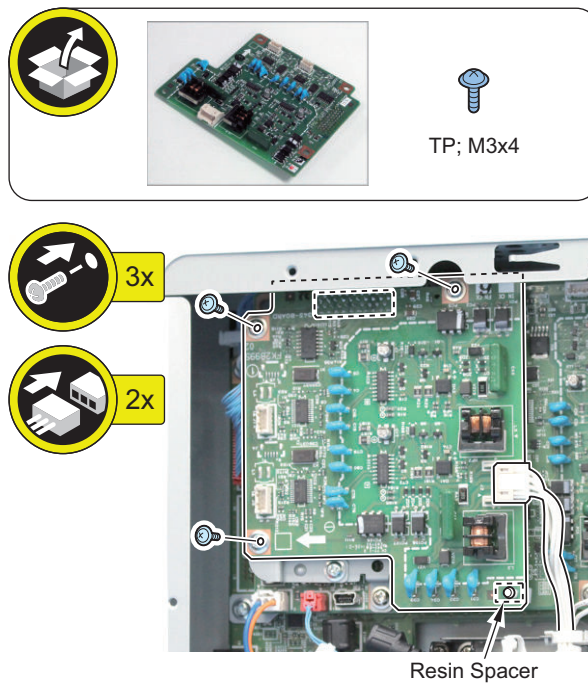



5. Connect the USB Cable.

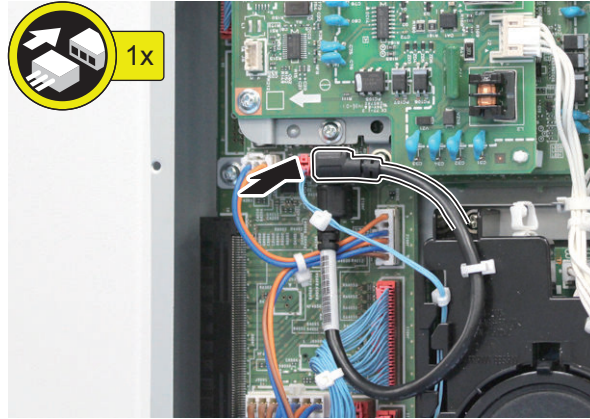

■ Subsequent Work



1. Install the Rear Cover 2.

- 2 Protrusions
- 3 Screws

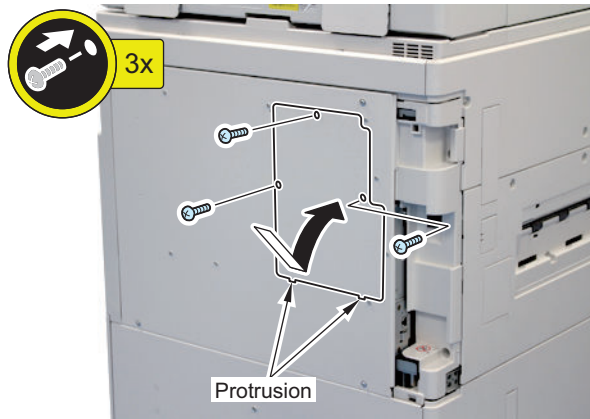

2. Affix the appropriate Modular Label. If a label is already affixed, remove it and then affix the appropriate label.

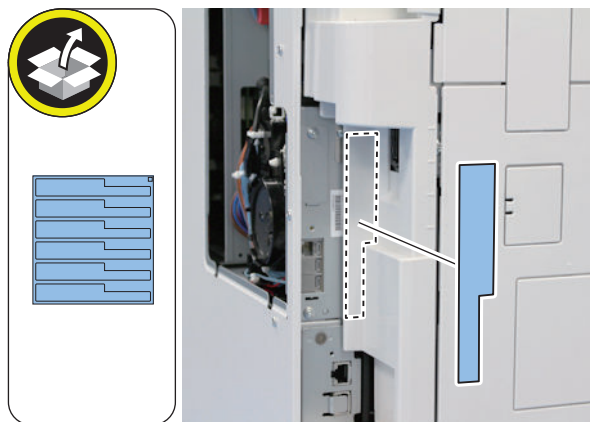

**3. Remove the 2 Dust Covers if installed.****CAUTION:**

Do not insert a screwdriver, etc. into the modular terminal.

NOTE:

Keep the removed Dust Cover.

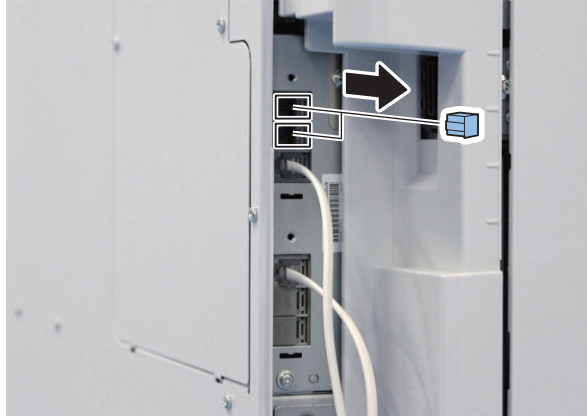
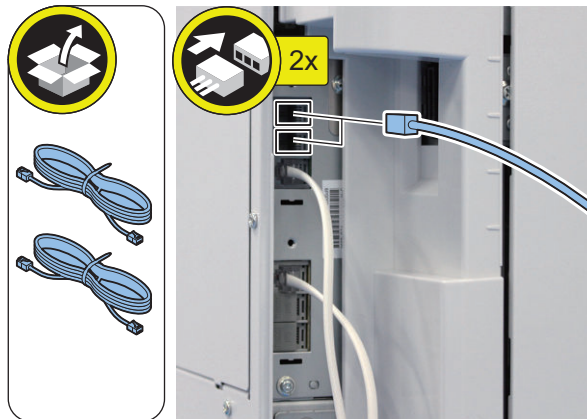
**4. Connect one of the 2 Telephone Cords or the 2 PTT Cables to the modular jack on the host machine and the other cord to the modular jack on the wall.**

**5. Install the Left Rear Cover.**

- 1 Hook
- 1 Claw

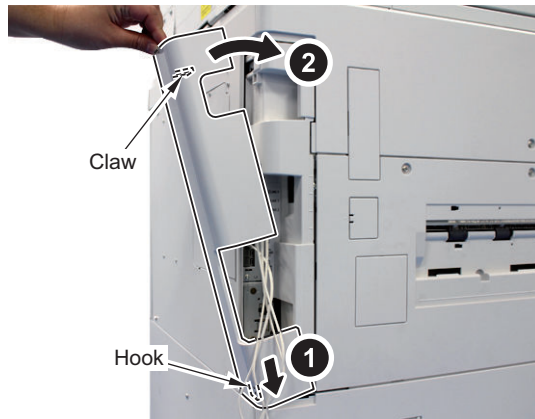
**6. Connect the power plug to the outlet.****7. Turn ON the main power switch.****CAUTION:**

If the machine does not recognize this equipment, unplug and then plug the power plug after turning OFF the main power switch, or turn OFF the main power switch and then turn it ON within 20 seconds.

To avoid this symptom, unplug the power plug or turn the breaker OFF when installing.

If the host machine still does not recognize this equipment after performing the foregoing remedy: In the case of installing the Super G3 Fax Board (1-Line) and the Super G3 2nd Line Fax Board at the same time, it is necessary to turn OFF and then ON the power three times in some cases (no message is displayed on the Control Panel).

Checking the Operation

■ Type Settings

Select the country/region of the FAX Board in Service Mode: FAX > Type > TYPE

This setting performs the parameter settings to match the communication specification of the country/region.

**1. From the following service mode, set the TYPE of country/region to install this machine, and then press OK.**

- Service Mode > FAX > Type > TYPE

2. Confirm that service mode parameter below is "0". In the case, parameter is "1", change to "0".

- COPIER > OPTION > DSPLY-SW > SDTM-DSP

NOTE:

To change parameter to "0" makes no show below [Settings/Registration > Preferences > Time/Energy Settings > Auto Shutdown Time] and auto shut down is not available.

3. Turn OFF/ON the main power switch to enable this setting.

■ Basic Settings

NOTE:

When "System Manager Information Settings" is set, be sure to follow the direction of user administrator in order to log in as an administrator.

In this section, make only minimum settings required for FAX communication.



1. Set the user telephone number.

[Settings/Registration] > [Function Settings] > [Send] > [Fax Settings] > [Set Line] > [Line 3]/[Line 4] > [Register Unit Telephone Number] > Enter FAX number > [OK]

2. Set the type of telephone line.

[Settings/Registration] > [Function Settings] > [Send] > [Fax Settings] > [Set Line] > [Line 3]/[Line 4] > [Select Line Type] > Select the line type to connect > [OK]

3. Turn OFF/ON the main power switch after setting the user telephone numbers and the type of telephone line.

■ FAX Communication Test

Perform communication test to check if FAX function works correctly.



1. Switch the control panel display to Fax display.

2. Select the sending line.

Press [Fax] > [Options] > [Select Line], select the added line, then press [OK] button.

3. Send and receive a test original between the equipment and a remote unit with which a communication test can be performed and check if it can be sent and receive correctly.

1. Press [Status Monitor/Cancel] > [Send] > [Job Log] and select [Fax] from pull down menu.

2. Press [Fax Activity Report] > [OutPut Normally] > [Start Printing].

3. The number printed following colon (:) in "COMM.MODE" field on FAX ACTIVITY REPORT TX/RX shows line type used for sending/receiving.

E.g. "ECM:3" => Line 3



Paper Feed Options

Paper Deck Unit-E1.....	402
Paper Deck Heater Unit-A1.....	430
POD Deck Lite-C1.....	446
Paper Deck Heater Unit for POD Deck Lite-C1.....	474
Cassette Heater Unit-38.....	483

Paper Deck Unit-E1

Checking before Installation

Requirements for the installation place are given below. It is recommended to look over the place to be used for installation before delivering the equipment to the user.

CAUTION:

- Install the host machine first and then install the Paper Deck.
- Do not carry the Paper Deck with the host machine is installed for prevention of breakage.

■ Points to Note on Installation

Exercise following caution for installation.

1. This equipment maximum 33 kg. When holding this equipment at the installation, be sure to perform the work in accordance with the standard to handle a heavy load in each country. In addition, be sure to keep the machine leveled when lifting it.
2. When moving this equipment after having unpacked it, be careful by placing a plate, etc. on areas with steps to prevent the casters from hitting those steps. If the casters hit a step, the casters or the base plate may be deformed.

■ Product Name

Safety regulations require the product's name to be registered. In some regions where this product is sold, the following names may be registered instead.

- F281210

Unpacking Procedure

NOTE:

Paper Deck is secured with packaging tapes and cushioning materials to protect it against vibration and shock during transport. Keep the removed all packaging tapes and cushioning materials for relocation.



1. Remove the cushioning materials.

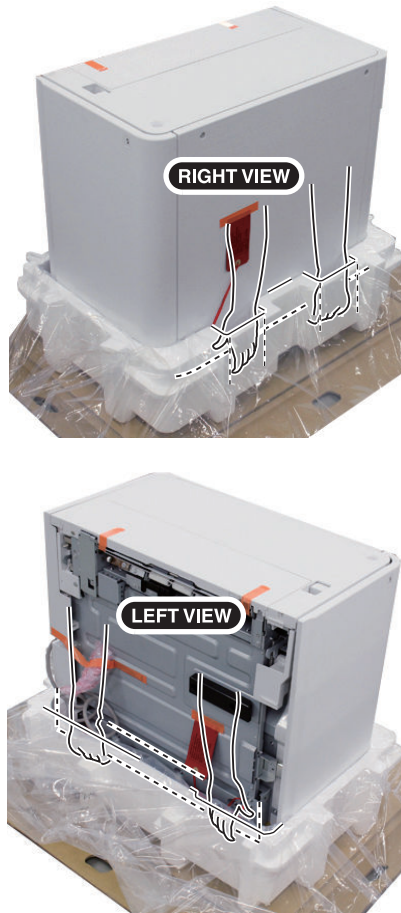

- 2. Open the plastic packing bag. Remove the Paper Deck from the pallet holding the parts as shown in the figure.



- 3. Remove the packaging tapes and the cushioning materials.

Checking the Contents

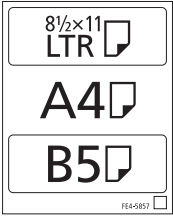
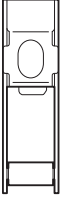
Check that none of the included parts is missing.

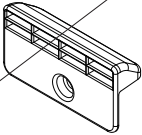
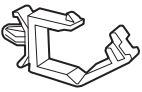
<p>□ [1] Paper Deck x1</p> 	<p>□ [2] Paper Size Label x1</p> 
<p>□ [3] Latch Plate x2</p> 	<p>□ [4] Screw (Binding;M4x5) x3</p> 
<p>□ [5] Screw (P Tightening;M3x8) x1</p> 	<p>□ [6] Door Stopper x1</p> 
<p>□ [7] Wire Saddle x1</p> 	

The parts [5], [6] are not used.

<Others>

- Other bundled items such as Installation Procedure, leaflets, etc.

Installation Procedure

CAUTION:

Check that the main power switch is OFF and the power plug is disconnected from the outlet.

NOTE:

Keep the removed fixing materials as they are used to transport for relocation.

■ Preparation of the Paper Deck Unit



1. Remove the screw from the base stay unit.

- 1 Screw

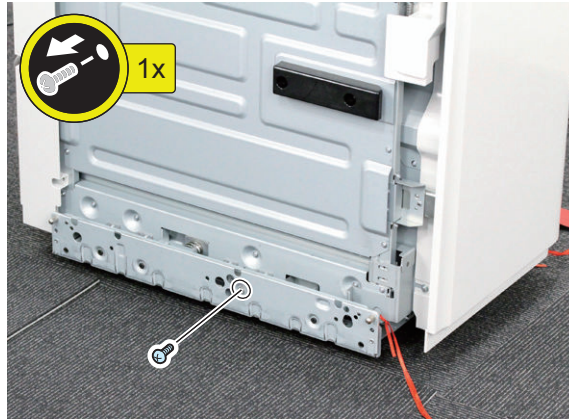



2. Push the Paper Deck Unit until it stops while holding the base stay unit and then attach the screw removed at procedure 2 as shown in the figure.

CAUTION:

Do not attach the screw removed at procedure 1 to the original position.

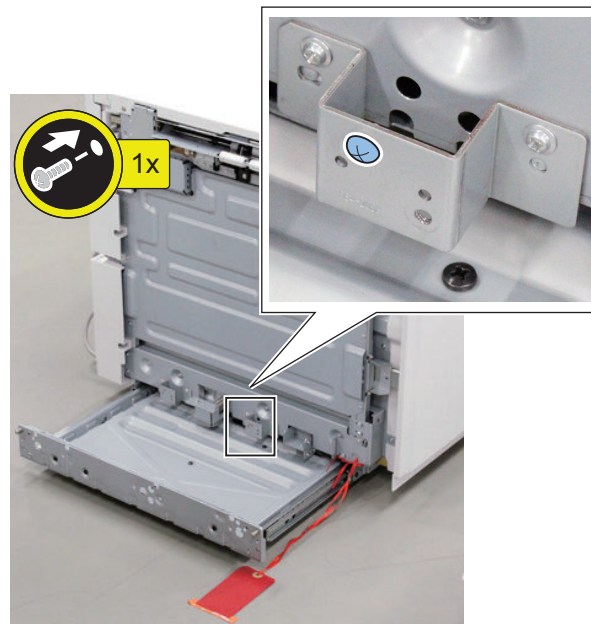
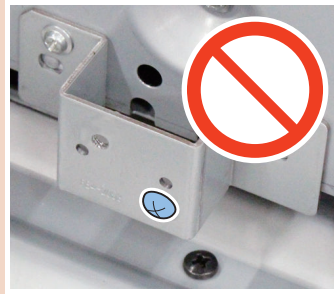
**NOTE:**

The screw is used to fix the base stay unit when the Paper Deck Unit is transported for relocation.



3. Remove the screws from bottom left side of the Paper Deck Unit (the removed screws are used at procedure 4, "Preparation of the Host Machine").

- 3 Screws

NOTE:

The fixing plate is removed at procedure 6, "Preparation of the Paper Deck Unit".

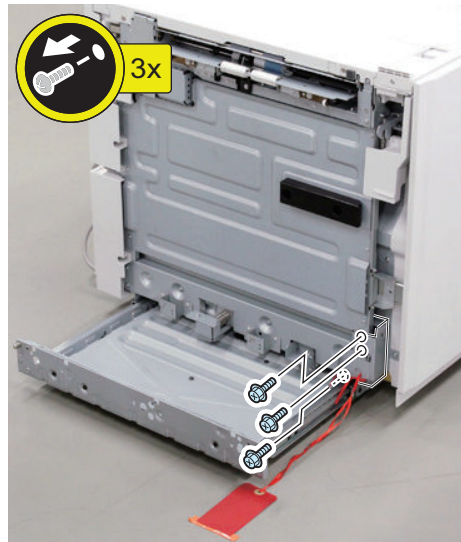

4. Remove the fixing plate from bottom right side of the compartment (the removed screw is used at procedure 4, "Preparation of the Host Machine").

- 1 Screw

NOTE:

The fixing plate is removed at procedure 7, "Preparation of the Paper Deck Unit".





5. Insert screwdrivers into the hole at rear left side of the compartment and then release the lever to open it.

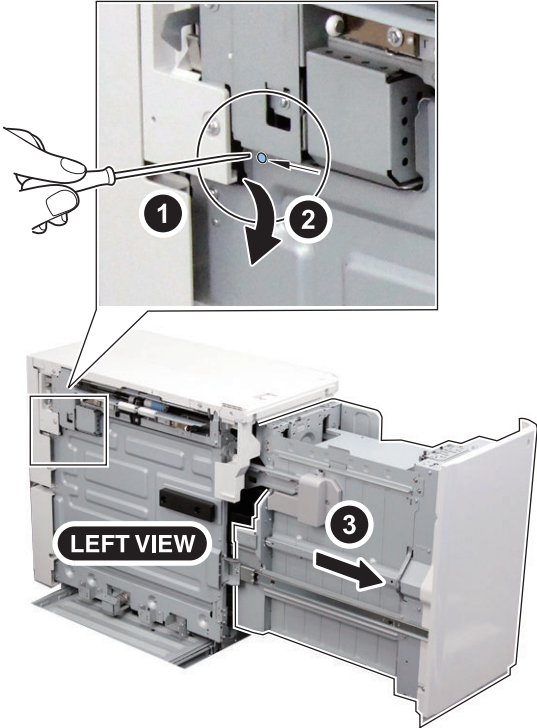

6. Remove the fixing plate and the cushioning material from bottom left side of the compartment (the removed screws are not used).
• 2 Screws

NOTE:
Do not forget to remove the cushioning material.

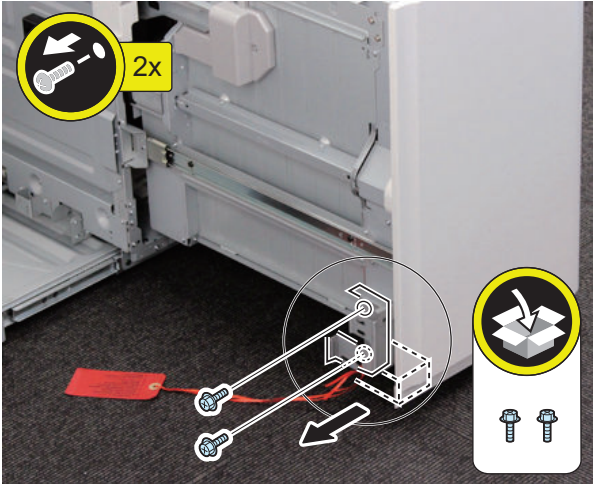



7. Remove the fixing plate and cushioning material from bottom right side of the compartment (the removed screw is not used).

- 1 Screw

NOTE:

Do not forget to remove the cushioning material.

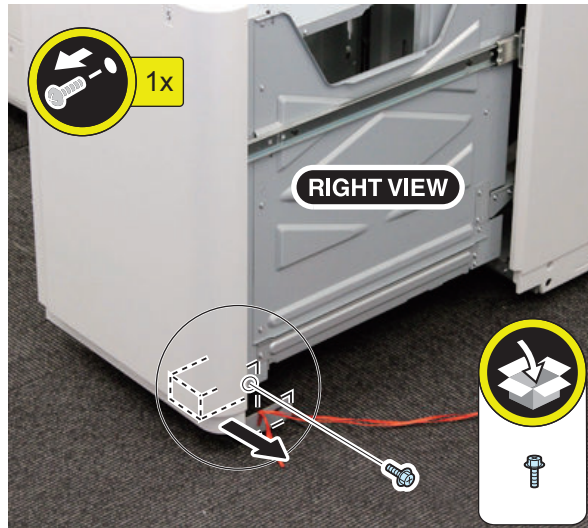

8. Remove the fixing sheet fixing the lifter plate (the removed screws are not used).

- 2 Screws

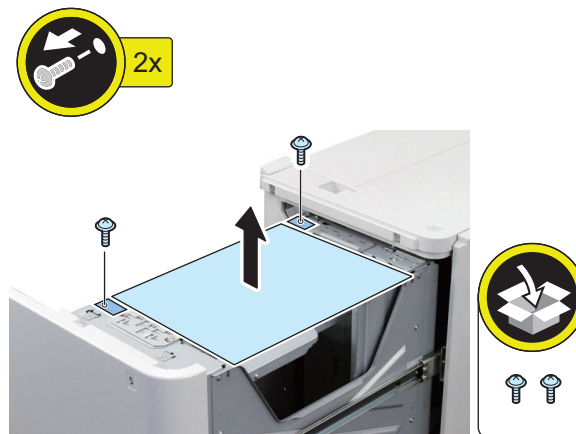

CAUTION:

Do not forget to remove the fixing sheet. The lifter wire may be broken without removing the above when the main power is turned ON.



9. Close the compartment.

■ Preparation of the Host Machine



1. Remove the feed cover (the removed cover is not used).



2. Remove the lower right cover (the removed cover and the screws are not used).
 - 2 Screws

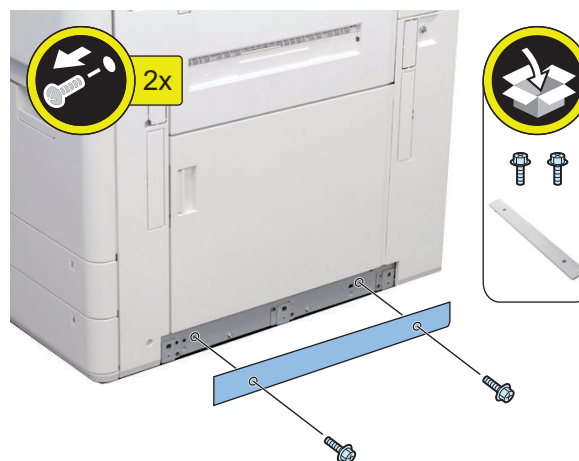



3. Cut the front and rear blinded covers with a side cutter.

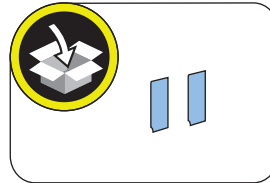
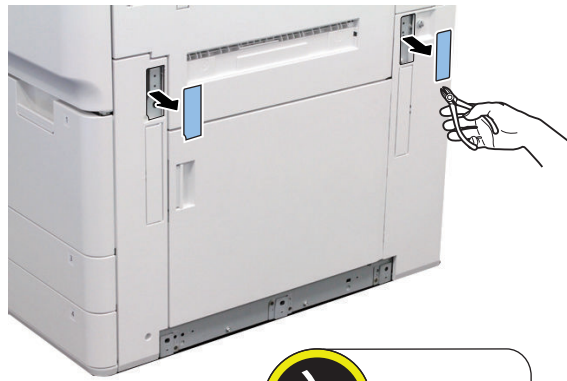

CAUTION:

Be sure to cut the cover properly so that no burr is formed.



4. Attach the latch plates (front and rear) to the host machine with screws removed at procedure 3, 4, "Preparation of the Paper Deck Unit".

CAUTION:

Attach the 2 latch plates in the center of the hole.

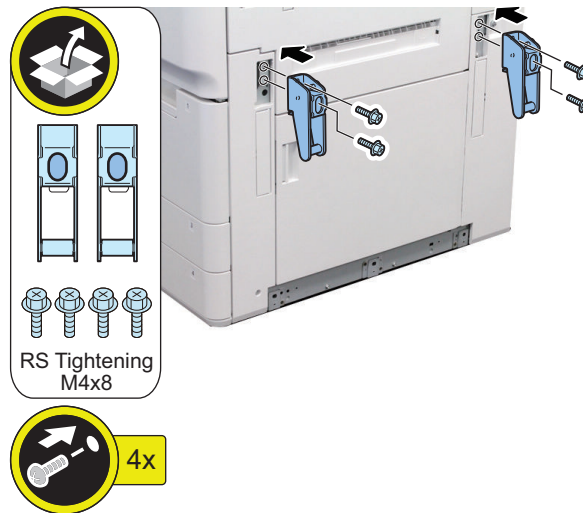
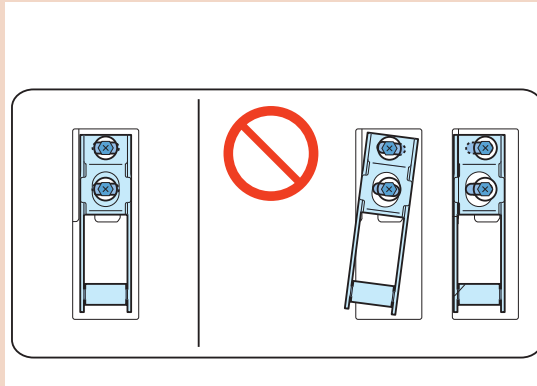



5. Remove the connector cover (the removed connector cover is not used).

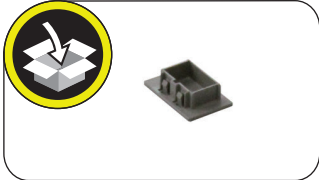
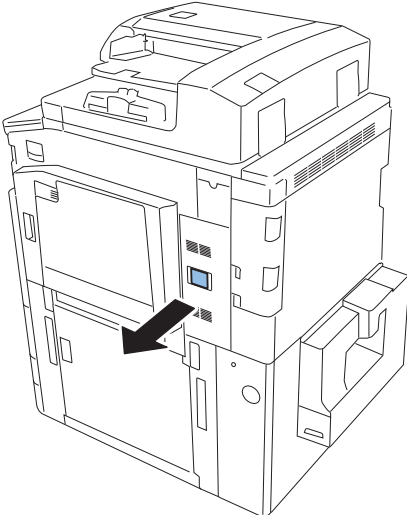

6. Remove the lower blindfold seal (the removed lower blindfold seal is not used).

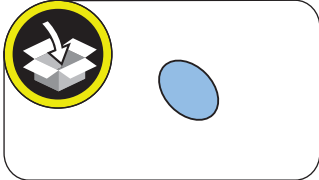
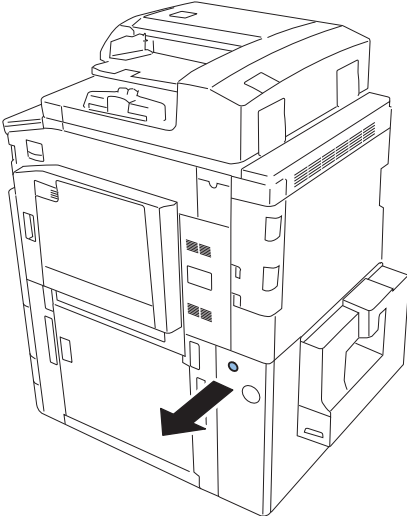



7. Attach the wire saddle to the host machine.

- 1 Wire saddle

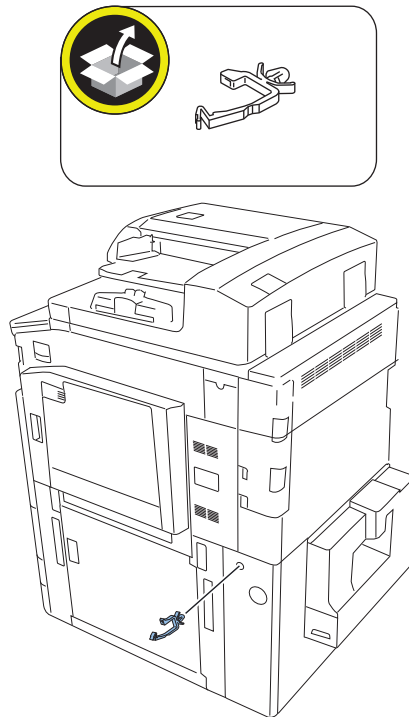

■ Connection with the Host Machine



1. Insert the positioning pins to the holes on the host machine and then fix the base stay unit.

- 3 Screws (Binding; M4x5)

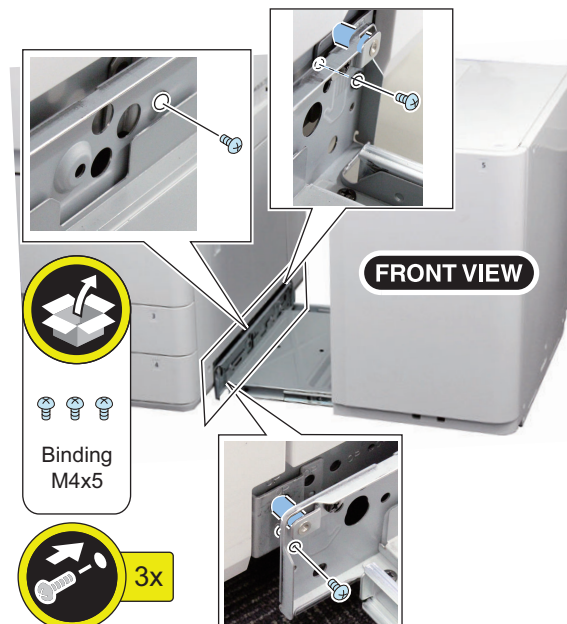

**2. Connect the Paper Deck Unit with the host machine.****NOTE:**

Do not nip the cable between the Paper Deck Unit and the host machine when connecting.

NOTE:

When it is difficult to insert the rear connection pin into the rear latch hole, loosen the 2 screws fixing the latch plate and then adjust the position of the latch plate to fit it. Check that the latch plate is not positioned at an angle when installing.

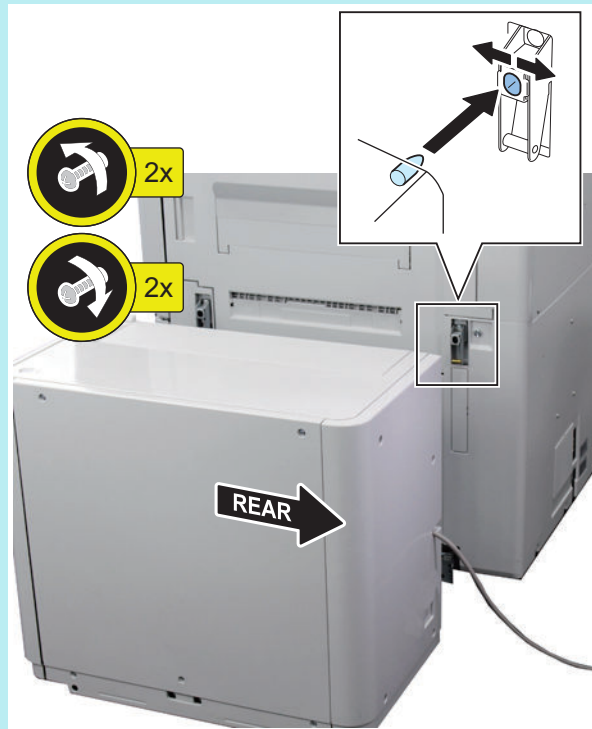



3. Loosen the 2 screws fixing the front bottom wheel to touch it to the floor.

- 2 Screws





4. Fasten the 2 screws loosened at procedure 3.

- 2 Screws

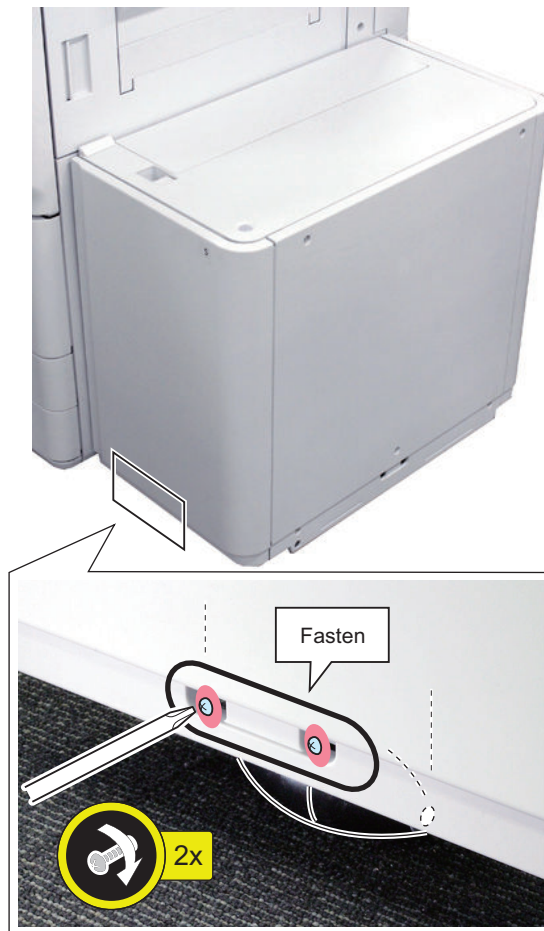



5. Loosen the 2 screws fixing the bottom right wheel to touch it to the floor.

- 2 Screws





6. Fasten the 2 screws loosened at procedure 5.

- 2 Screws

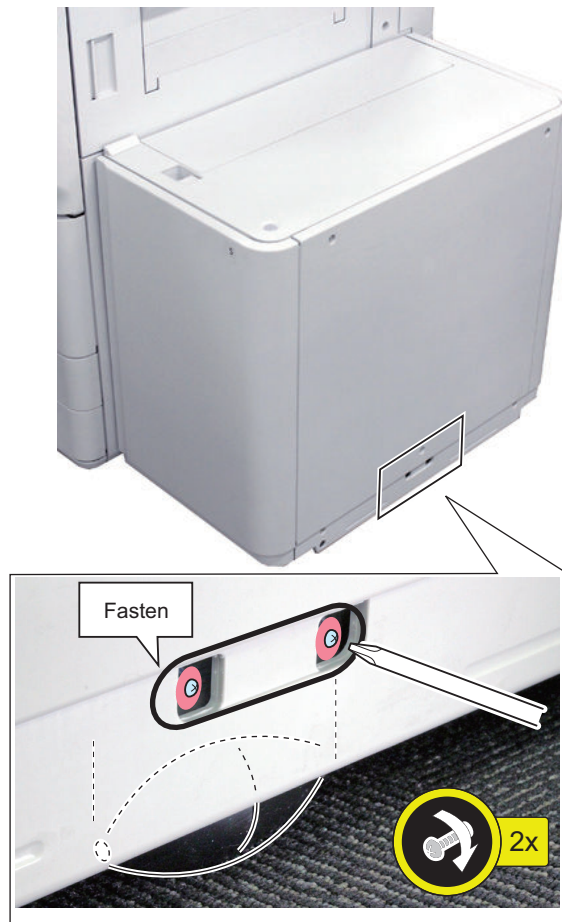

7. Connect the lattice connector of the Paper Deck Unit to the host machine and then fix it with the wire saddle.

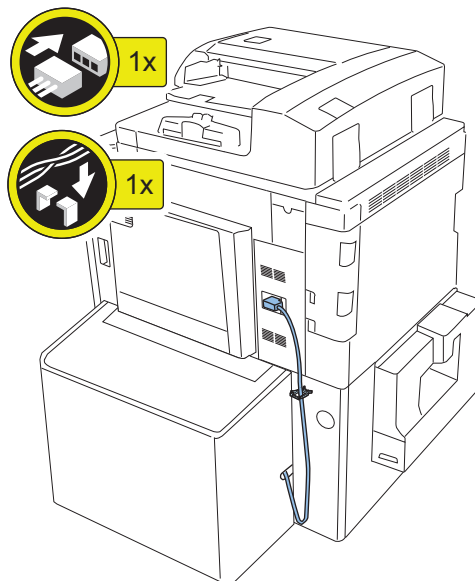



8. Paste the paper size label with a gap in 5mm from the cassette no. label while aligning right edge of the labels (the remaining labels are not used).

NOTE:

Keep the paper size label for use when paper size is changed.

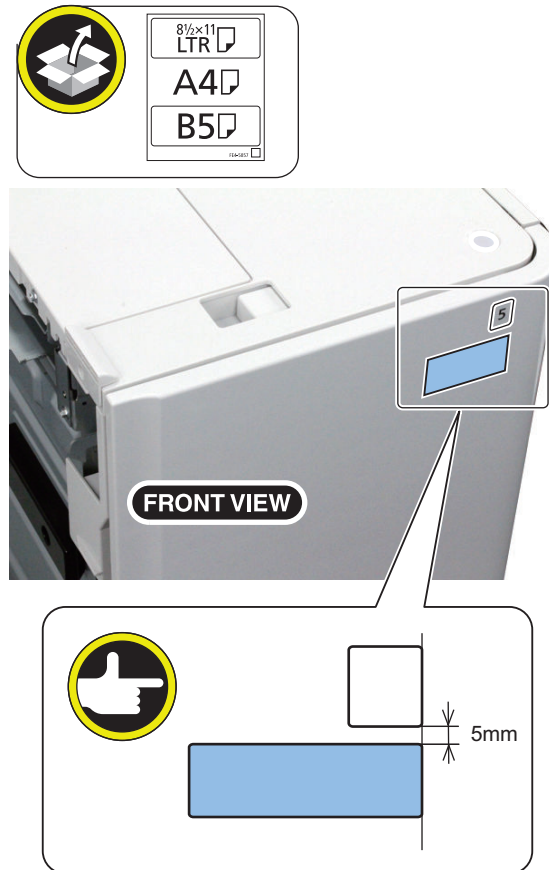

9. Turn ON the host machine.

■ Switching of the Paper Size



1. Press the open button to open the compartment.





2. Relocate the left/right edge guide plates at the specified paper size.

CAUTION:

Paper size is marked on both top and bottom of the compartment. Check that the marked paper size is the specified paper size when relocating the the left/right edge guide plates.

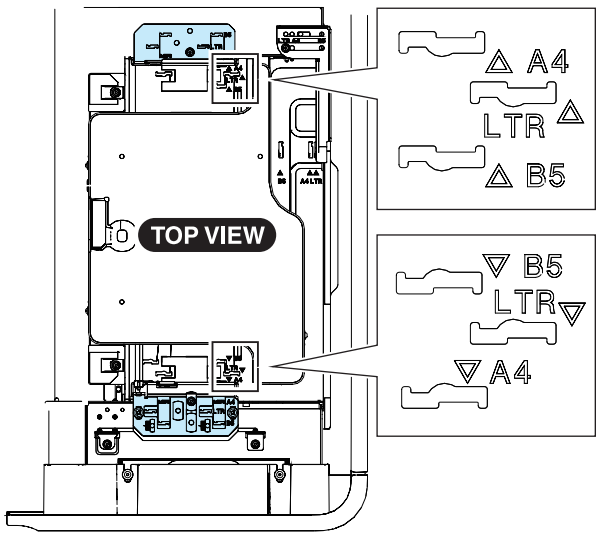



3. Relocate the rear edge guide plate at the specified paper size.

CAUTION:

Paper size is marked on both top and bottom of the compartment. Check that the marked paper size is the specified paper size when relocating the rear edge guide plate.

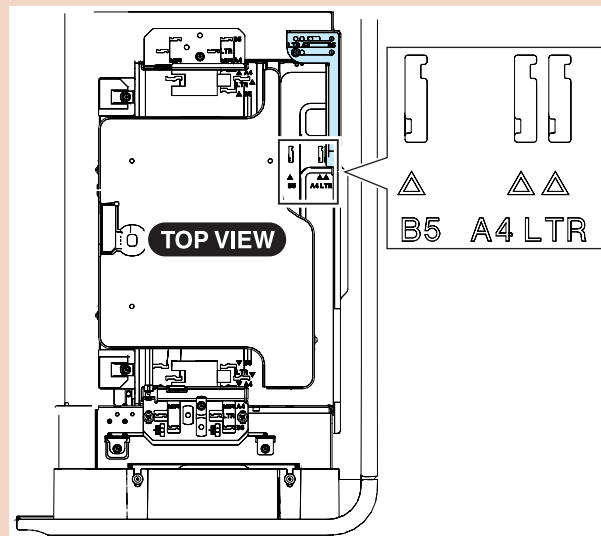

4. Set sheets of paper in the compartment and close it.



5. Set the paper size on the service mode.

(Lv.1) COPIER > OPTION > ACC > DK-P

- 0: A4
- 1: B5
- 2: LTR

Checking after Installation

■ Disposal Parts

1. Following disposal parts are remained after the installation procedure.

<input type="checkbox"/>	[1]	Screw (RS tightening; M4x8)	3pcs.
<input type="checkbox"/>	[2]	Screw (RS tightening; M4x10)	2pcs.
<input type="checkbox"/>	[3]	Screw (TP; M3x6)	2pcs.
<input type="checkbox"/>	[4]	Screw (P tightening; M3x8)	1pc.
<input type="checkbox"/>	[5]	Paper Size Label (remaining label)	1pc.
<input type="checkbox"/>	[6]	Blindfold Seal	1pc.
<input type="checkbox"/>	[7]	Door Stopprt	1pc.
<input type="checkbox"/>	[8]	Connector Cover	1pc.
<input type="checkbox"/>	[9]	Feed Cover	1pc.
<input type="checkbox"/>	[10]	Lower Right Cover	1pc.
<input type="checkbox"/>	[11]	Removed Face Cover	2pcs.

■ Paper Positioning Check /Adjustment Procedure

● Adjusting the Left Edge Margin(L1) of the Image

1. After setting the service modes (level 1) as follows, press the Start key and output a test print.

- COPIER > TEST > PG > TYPE = 5
- COPIER > TEST > PG > COLOR-M = 1
- COPIER > TEST > PG > COLOR-Y/C/K = 0

2. Print sheets of paper from POD Deck Lite and then check that L1 is 2.5+/-1.5mm.

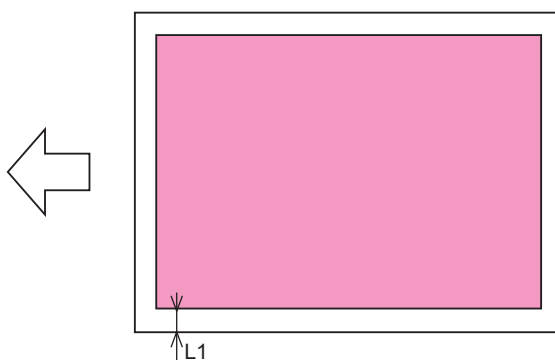

3. Execute manua adjustment as follows when it is out of standard.

• Adjustment Procedure (Manual)

1. Release the Paper Deck from the host machine and press the open button of the Paper Deck to open the compartment.



2. Loosen the 2 screws at the latch plate on left side of the compartment.
 - 2 Screws

NOTE:

The screws retaining the latch plate are locked with the paint to avoid loosening in transit. For the adjustment, loosen the paint-locked screws and change the latch plate position.

**3. Move the latch plate toward front [A] or rear [B] (1 scale = 1mm)**

- Move the latch plate to front [A] when L1 is large.
- Move the latch plate to rear [B] when L1 is small.

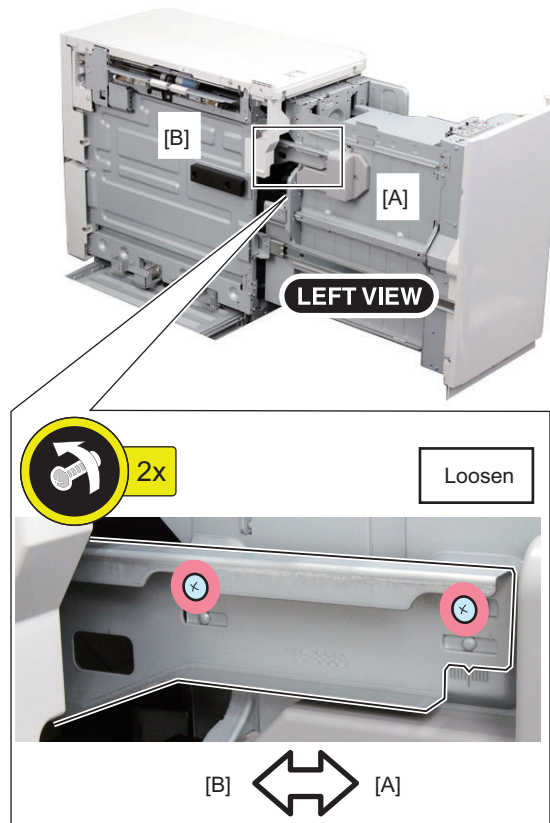

**4. Fasten the 2 screws loosened at procedure 2.**

- 2 Screws

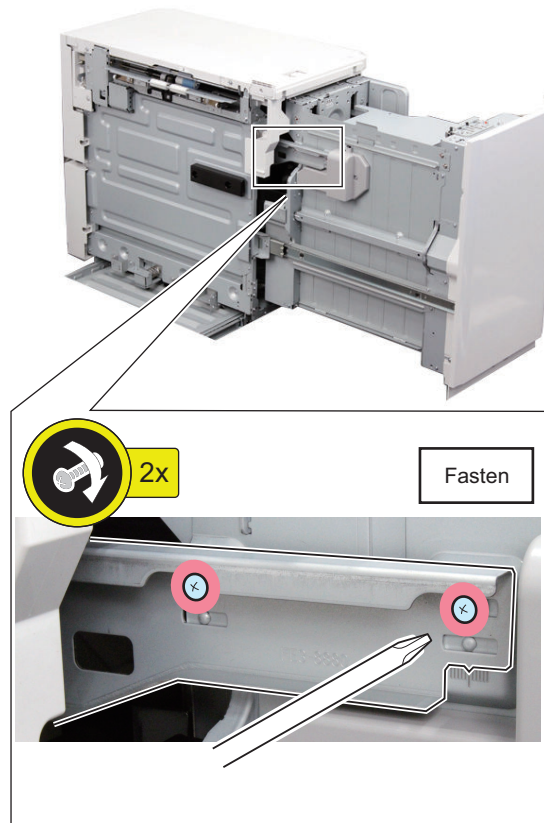
**5. Move the front cover fitting to the amount of the latch plate adjustment. Refer to the next item "Front Cover Positioning Adjustment" for detail.****6. Close the compartment and connect with the host machine.****7. Print sheet of paper from the Paper Deck. Check that L1 is 2.5+/-1.5mm. Re-adjust L1 in case that it is out of standard.**

• Front Cover Positioning Adjustment



1. Check that the gap between the front cover and the Paper Deck is as follows.

- Gap between the front cover and the right cover: $3\pm 1\text{mm}$
- Gap between the front cover and the upper cover: $4\pm 1\text{mm}$



NOTE:

Loosen the 6 screws on the front cover and then move it to adjust the gap within the standard.

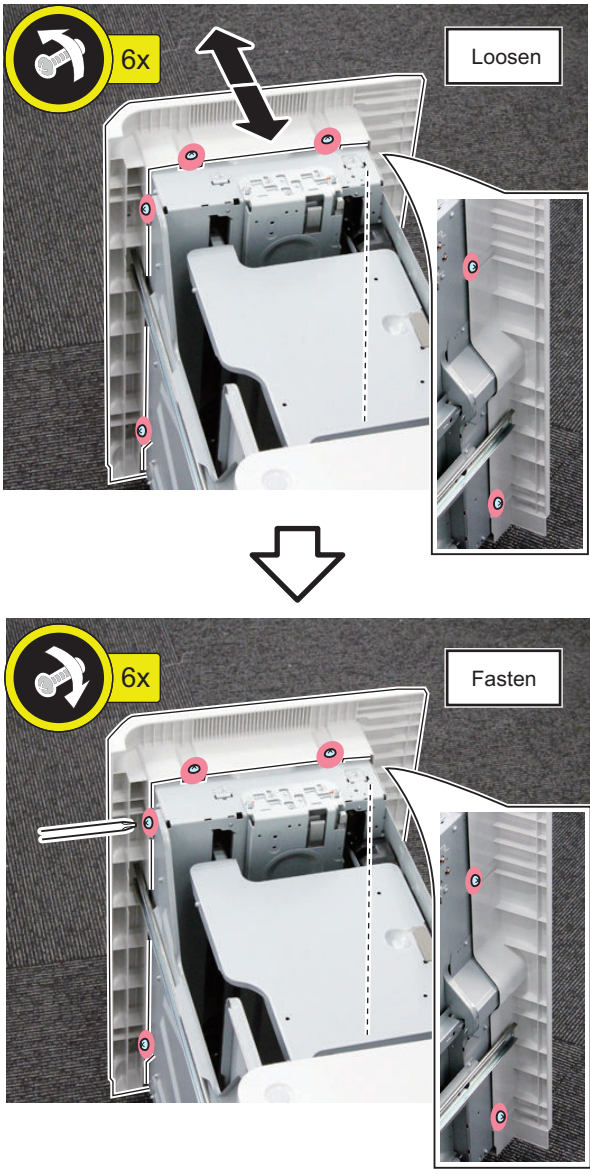

Paper Deck Heater Unit-A1

Checking before Installation

Requirements for the installation place are given below. It is recommended to look over the place to be used for installation before delivering the equipment to the user.

CAUTION:

- Install the host machine first and then install the Paper Deck Unit.
- Do not carry the Paper Deck Unit with the host machine is installed for prevention of breakage.

Checking the Supplied Parts

NOTE:

Each part of the Paper Deck Heater Unit-A1 for the Paper Deck is supplied as a service part according to the location, so prepare the following parts.

Also, use the appropriate Paper Deck Heater Unit for each country.

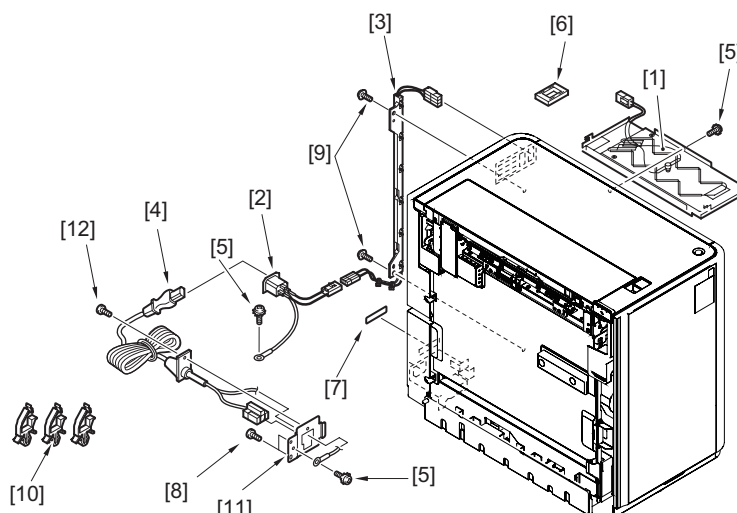

Item	Parts Name	Parts Number	Q'ty
[1]	Heater unit	FG6-9650 (100V) FG6-9651 (230V)	1pc.
[2]	AC input connector	FG6-1117	1pc.
[3]	Relay harness unit	FG6-2957	1pc.
[4]	AC cable	FK3-0630 (100V) FK3-0631 (230V)	1pc.
[5]	Screw (Toothed washer; M4x6)	XB2-7400-607	3pcs.
*[6]	Cable protection bushing	WT2-5098	1pc.
[7]	Power supply label	FS6-8478 (100V) FS6-8725 (230V)	1pc.
[8]	Screw (Binding; M4x4)	XB1-2400-409	2pcs.
[9]	Screw (RS Tightening; M4x8)	XA9-0732-010	2pcs.
[10]	Wire saddle	WT2-5730	3pcs.
[11]	Cord mount	FC7-5473	1pc.
[12]	Screw with flat spring (M4x10)	XB2-8401-007	1pc.

*As for the change of the part number, please refer to the latest parts catalog.

*[6] Cable protection bushing is not used for the installation.

<Others>

Including guides

Installation Procedure

■ Preparation of the Paper Deck Unit



1. Turn OFF the main power switch of the host machine.



2. Disconnect the lattice connector from the host machine and then release the cable from the wire saddle.

- 1 Wire Saddle
- 1 Connector

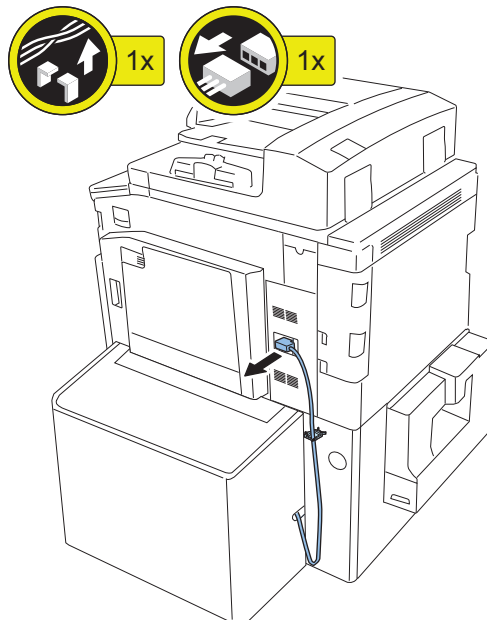

3. Pull the release lever and then withdraw the Paper Deck Unit until it stops.





4. Insert screwdrivers into the hole at rear left side of the compartment and then release the lever to open it.

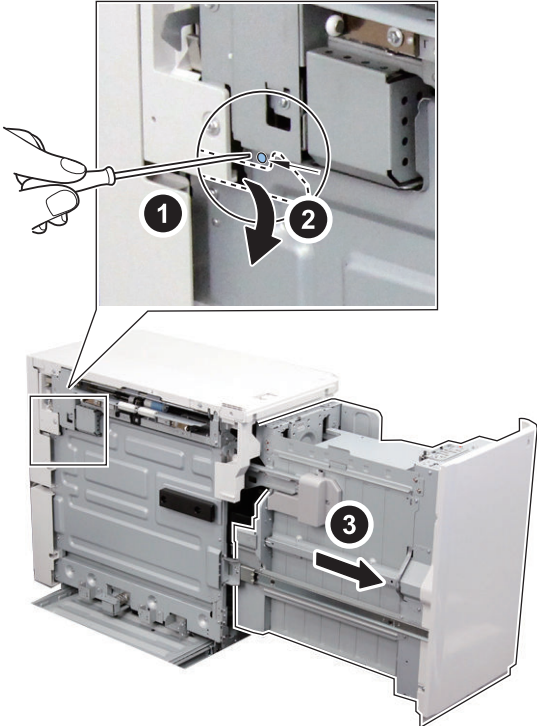

5. Remove the right cover.

- 5 Screws



□

- 6. Remove the rear cover.
 - 6 Screws

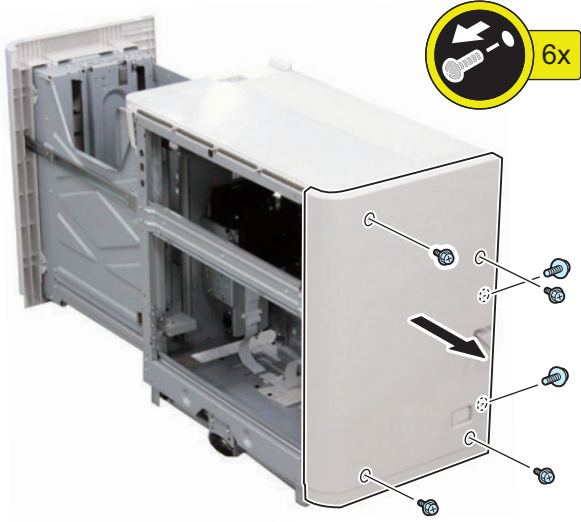

□

- 7. Cut the blindfold cover from the rear cover.

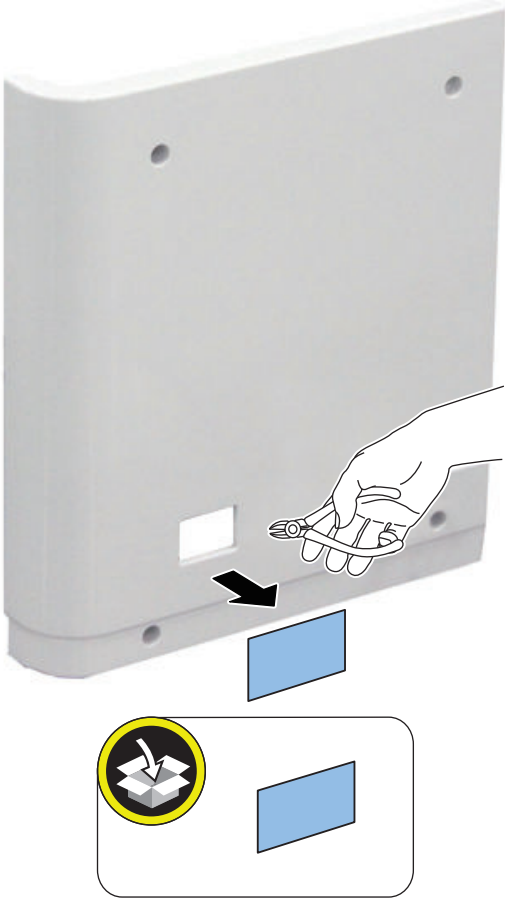



8. Loosen the 2 screws and then remove the upper left cover.

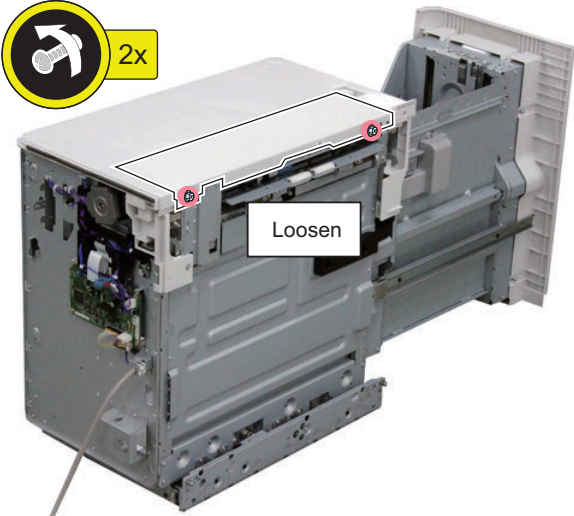

9. Remove the upper cover.
• 3 Screws



**10. Put the connector through the hole in the top plate and then fix the Heater Unit in the Paper Deck Unit.**

- 2 Hooks
- 1 Screw (Toothed washer; M4x6)

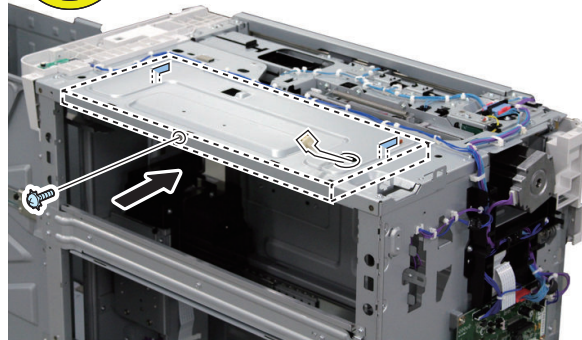
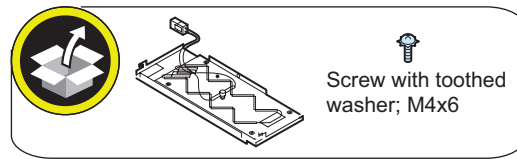
**11. Insert the connector of the Heater Unit to the panel mount part.**

□

12. Insert the AC input connector and then fix the ground cable.

- 1 Screw (Toothed washer; M4x6)

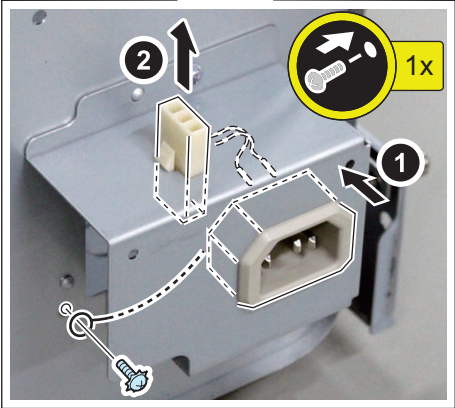
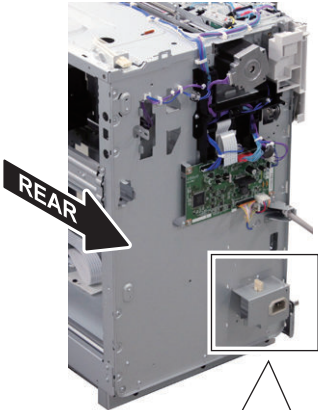



13. Install the relay harness unit on the rear side panel of the Paper Deck Unit.

- 2 Screws (RS Tightening; M4x8)
- 2 Connectors
- 2 Snap Fit

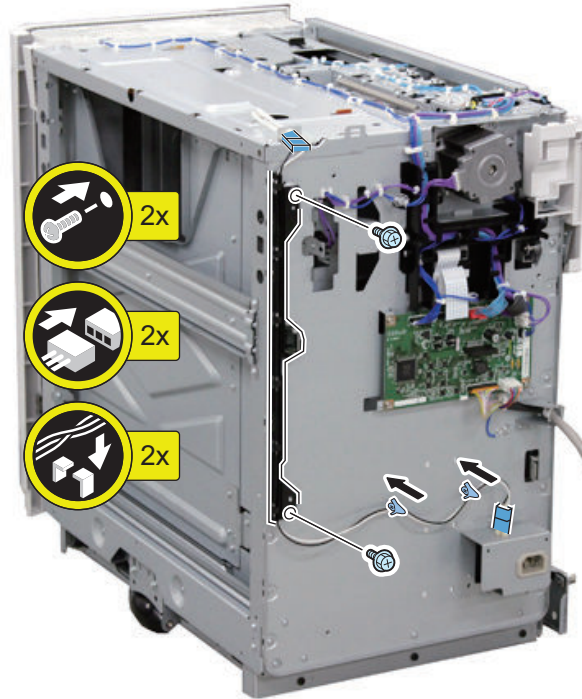
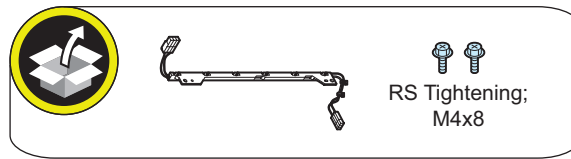

14. Re-attach the external covers.

■ Preparation of the Host Machine



1. Remove the 2 screws of the left lower cover.

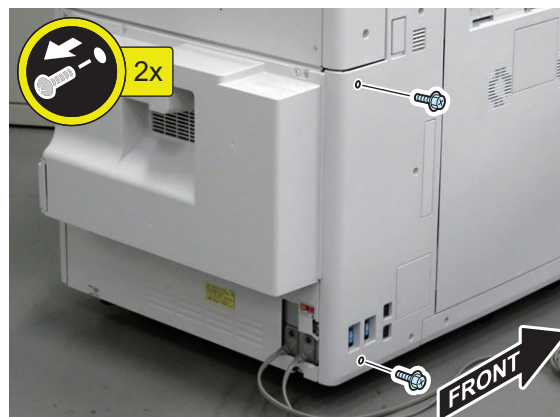

□

2. Hold and remove the rear lower cover unit.

- 4 Screws

CAUTION:

When disassembling, do not deform the grounding plate.

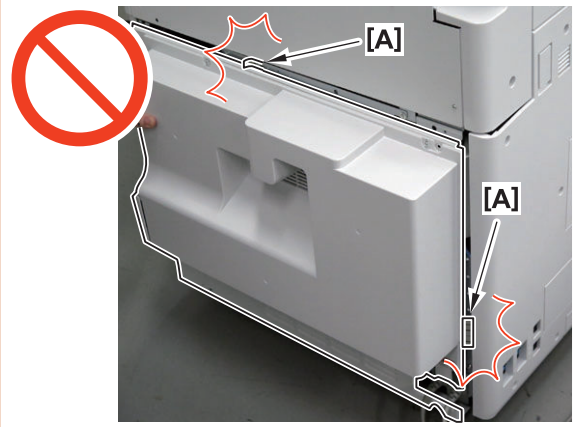



- 3. Remove the blindfold plate.
 - 2 Screws

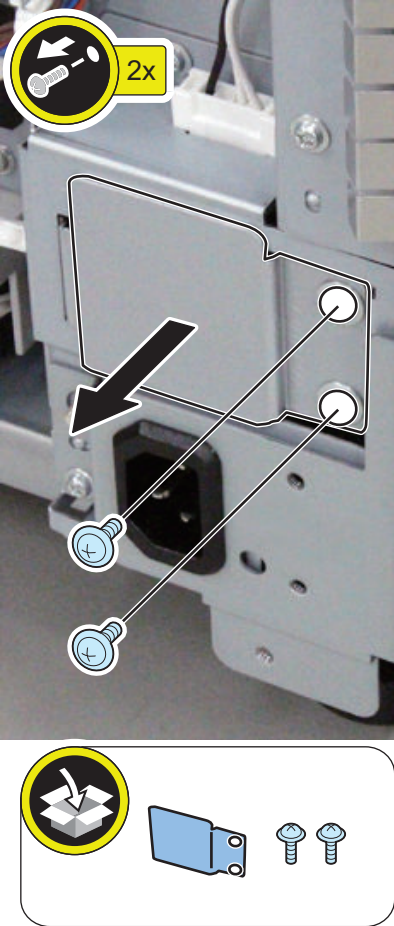

- 4. Insert the AC cord into the hole of the cord mount and fix it.
 - 1 Screw (Flat spring; M4x10)

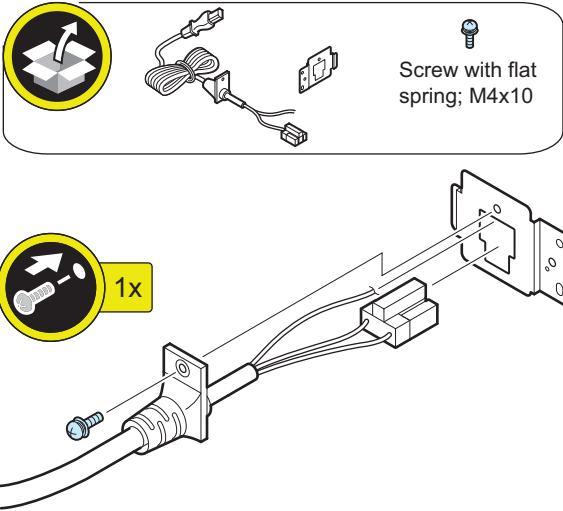



5. Fix the ground cable to the cord mount.

- 1 Screw (Toothed washer; M4x6)

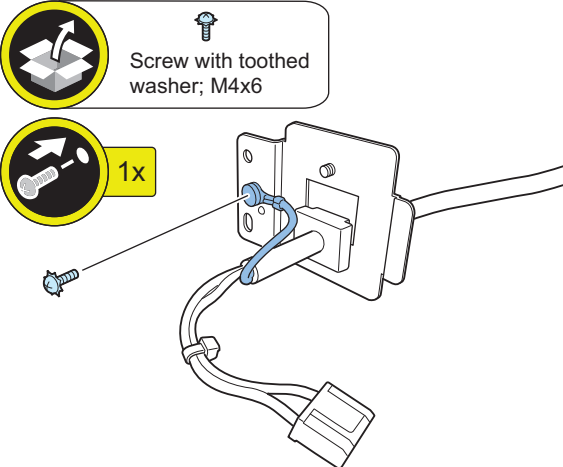

6. Connect the AC cable to the host machine and then fix it.

- 1 Connector
- 2 Screws (Binding; M4x4)

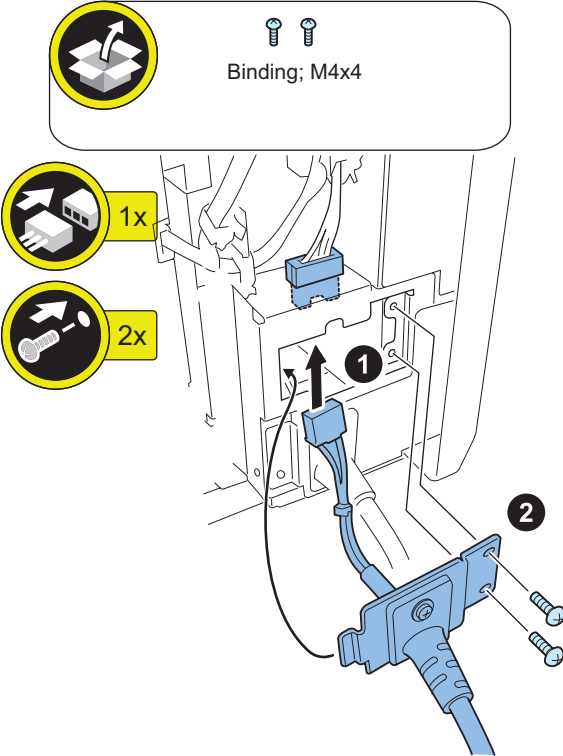



7. Attach the noise reduction cover and the lower rear cover.

- 4 Screws

CAUTION:

- When assembling, do not deform the grounding plate.

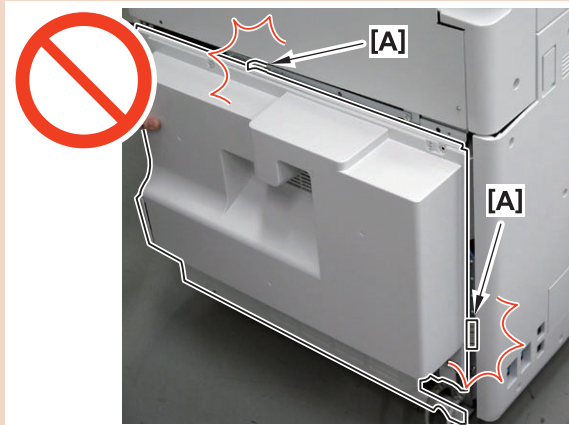

- When assembling, be sure to insert the edge [A] of the left lower cover in the groove [B] of the rear lower cover Unit.

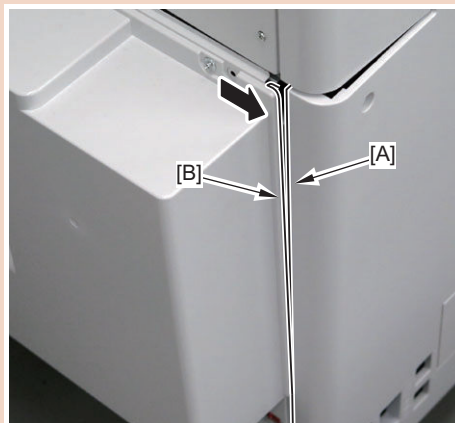

8. Attach the 2 screws of the left lower cover.

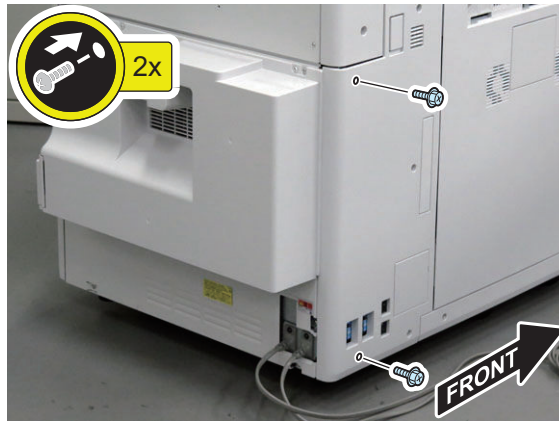

■ Connection with the Host Machine



1. Close the compartment and then connect the Paper Deck Unit with the host machine.



2. Paste the power supply label on the above the AC input connector.

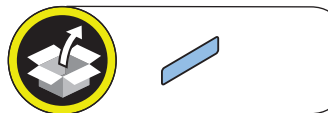

□

3. Connect the AC cable to the Paper Deck Unit.



□

4. Remove the 4 blindfold seals.

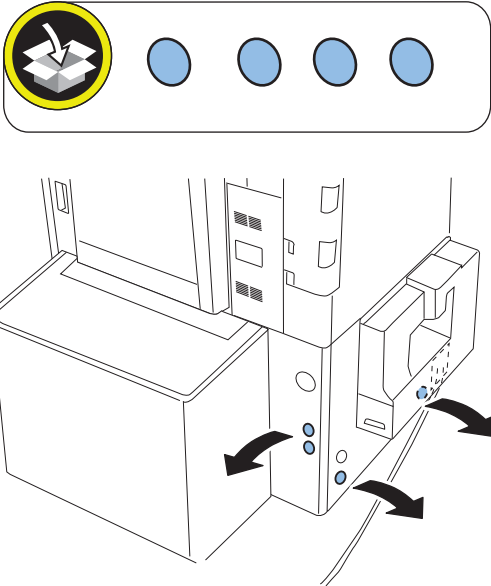



- 5. Attach the wire saddle.**
 - 3 Wire Saddles

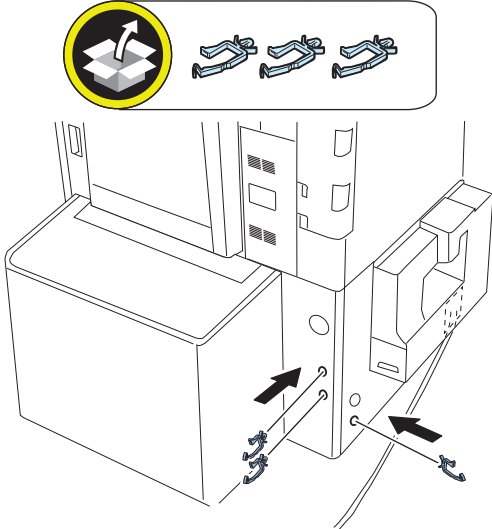

- 6. Fix the cable with the wire saddles and the snap fit.**
 - 3 Wire Saddles
 - 1 Snap Fit

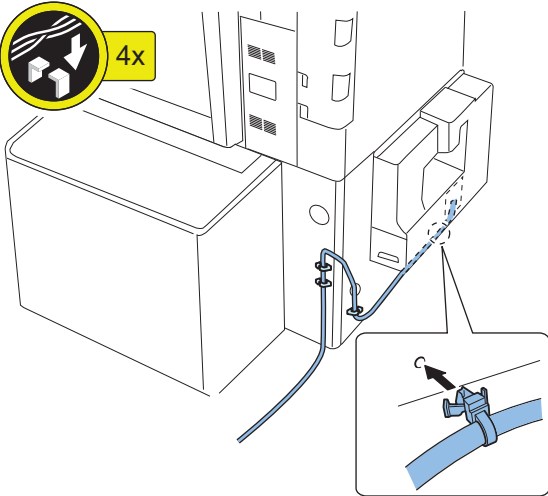



7. Connect the lattice connector of the Paper Deck to the host machine and then fix the cable with the wire saddle.

- 1 Connector
- 1 Wire Saddle

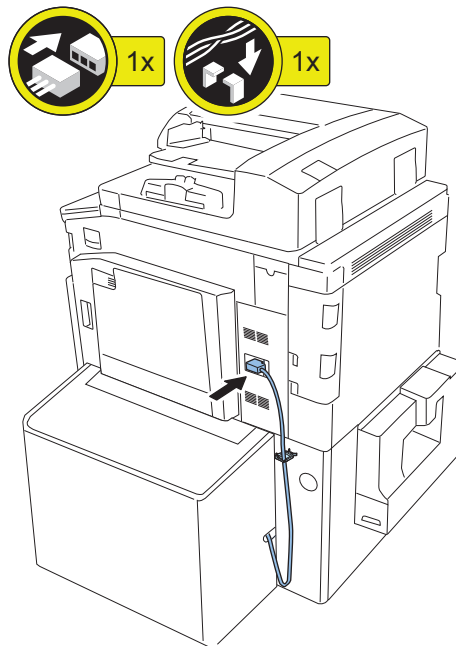

8. Turn ON the host machine.

Checking after Installation

■ Installation Procedure

1. Following disposal parts are remained after the installation procedure.

<input type="checkbox"/>	[1]	Cable Protection Bushing	1pc.
<input type="checkbox"/>	[2]	Screw (TP; M4x4)	2pcs.
<input type="checkbox"/>	[3]	Power Supply Label	1pc.
<input type="checkbox"/>	[4]	Blindfold Cover	1pc.
<input type="checkbox"/>	[5]	Blindfold Seal	4pcs.
<input type="checkbox"/>	[6]	Blindfold Plate	1pc.

POD Deck Lite-C1

Checking before Installation

Requirements for the installation place are shown below. It is recommended to look over the installation place before delivering the equipment to the user.

CAUTION:

- Install the host machine first and then install the POD Deck Lite.
- Do not carry the POD Deck Lite with the host machine installed for breakage prevention.

Points to Note on Installation

Exercise following caution for installation.

1. POD Deck Lite weighs maximum 67 kg. When holding the POD Deck Lite at the installation, be sure to perform the work in accordance with the standard to handle a heavy load in each country. In addition, be sure to keep the machine leveled when lifting it.
2. When moving this equipment after having unpacked it, be careful by placing a plate, etc. on areas with steps to prevent the casters from hitting those steps. If the casters hit a step, the casters or the base plate may be deformed.
3. The cassette heater switch is indicated by the heater symbol.

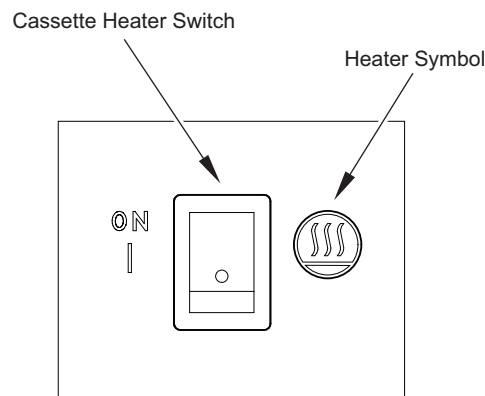

Checking the Power Supply

1. Check that this equipment is connectable to the outlet independently which supplies the rated voltage within +10/-15% at the specified ampere or higher.
2. When connecting the power plug of this equipment to an outlet, be sure to use an outlet of a system different from that of the host machine.
3. Install this equipment near the power outlet and leave sufficient space around the power plug so that it can be unplugged easily in an emergency.

Product Name

Safety regulations require the product's name to be registered. In some regions where this product is sold, the following names may be registered instead.

- F281020

Unpacking

Unpacking Procedure

NOTE:

POD Deck Lite is secured with packaging tapes and cushioning materials to protect it against vibration and shock during transportation. Remove all packaging tapes and cushioning materials following the unpacking procedure.



1. Open the box and remove the accessory box and cushioning materials.



2. Open the plastic packing bag. Remove the POD Deck Lite from the pallet.

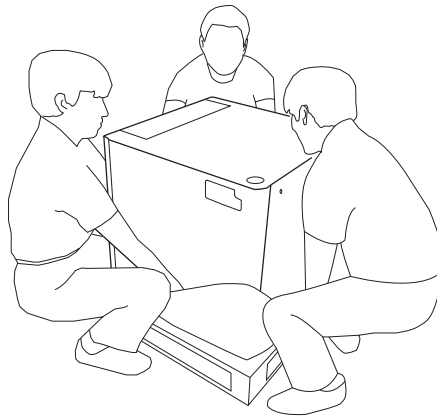

3. Remove the fixing plate and 2 tags (the removed tags, fixing plate and screws are not used).

- 2 Screws

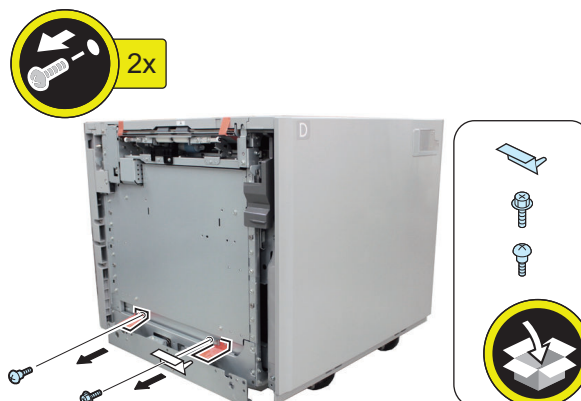







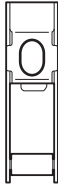

4. Remove all packaging tapes.

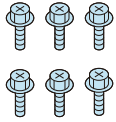
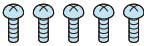
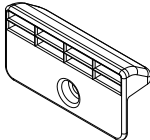
Checking the Contents

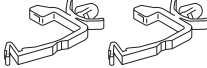
Check that none of the included parts is missing.

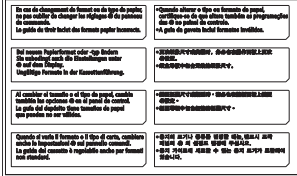
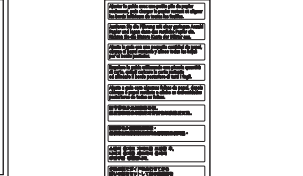
■ Contents

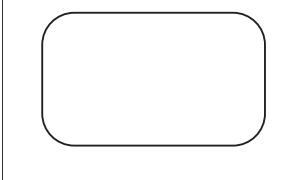
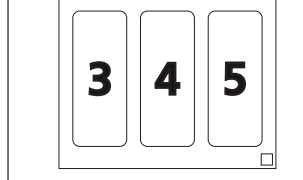
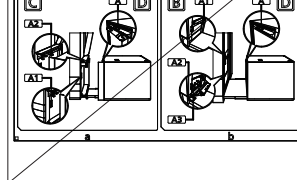
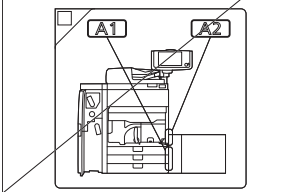
<p>□ [1] POD Deck Lite x1</p> 	<p>□ [2] Latch Plate x2</p>  <p>□ [4] Screw (P Tightening;M3x8) x1</p> 	
<p>□ [5] Screw (RS Tightening;M4x8) x6</p> 	<p>□ [6] Screw (Binding;M4x5) x5</p> <p>Use 3 of them</p> 	<p>□ [7] Door Stopper x1</p> 
<p>□ [8] Slope Guide x1</p> 	<p>□ [9] Wire Saddle x2</p> <p>Use 1 of them</p> 	

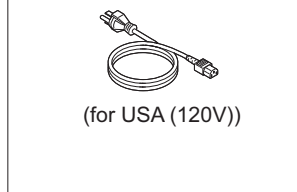
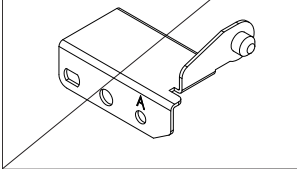
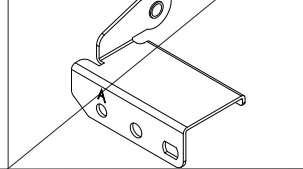
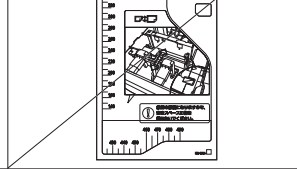
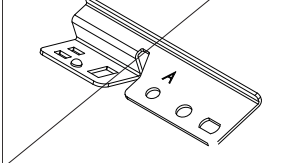
<p>□ [9] Foreign Language Label x1</p> 	<p>□ [10] Paper Size Overlay Label x1</p> 	<p>□ [11] Paper Size Label x1</p> 
<p>□ [12] Paper Size Plate x1</p> 	<p>□ [13] Cassette No. Label x1</p> 	<p>□ [14] Total Map Label x1</p> 
<p>□ [15] JAM Label x1</p> 	<p>□ [16] *1 Power Cord x3</p>  <p>(for Europe/Asia/Australia/Latin America (230V))</p>	<p>□ [17] *1 Power Cord x1</p>  <p>(for USA (120V))</p>
<p>□ [18] Feed Lower Guide Front Fixing Plate x1</p> 	<p>□ [19] Feed Lower Guide Rear Fixing Plate x1</p> 	<p>□ [20] Paper Size Sub label x1</p> 
<p>□ [21] Extraction Sensor Plate x1</p> 		

*1 : Use the appropriate power cord by location. Make sure not to leave unused power cords at the site.

<Others>

Other bundled items such as Installation Procedure, leaflets, etc.

Installation Procedure

NOTE:

Keep the removed fixing materials as they are used to transport for relocation.

■ Preparation of the Host Machine



1. Remove the feed cover.



2. Remove the lower right cover.
 - 2 Screws

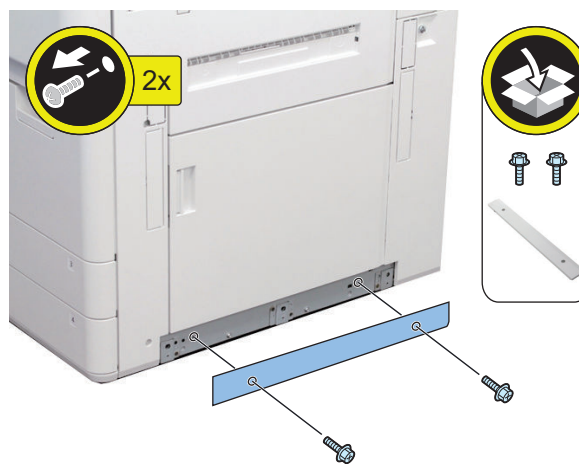



3. Cut the blindfold covers (front /rear) with a side cutter.



CAUTION:
Be sure to remove the face cover properly so that no burr is formed.



4. Attach the 2 latch plates to the host machine.
• 4 Screws (RS tightening; M4x8)

CAUTION:
Attach the 2 latch plates in the center of the hole.

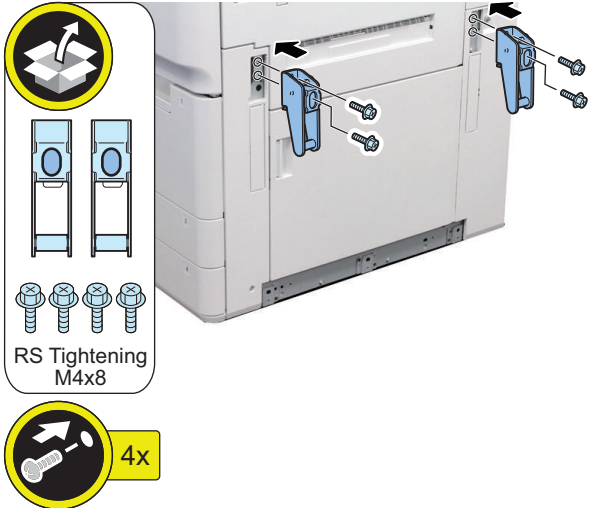
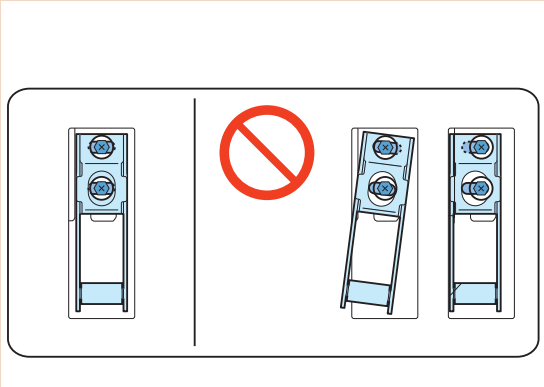



5. Remove the connector cover from rear of the host machine.



■ Preparation of the POD Deck Lite



- 1. Attach the door stopper.
 - 1 Screw (P tightening screw; M3x8)

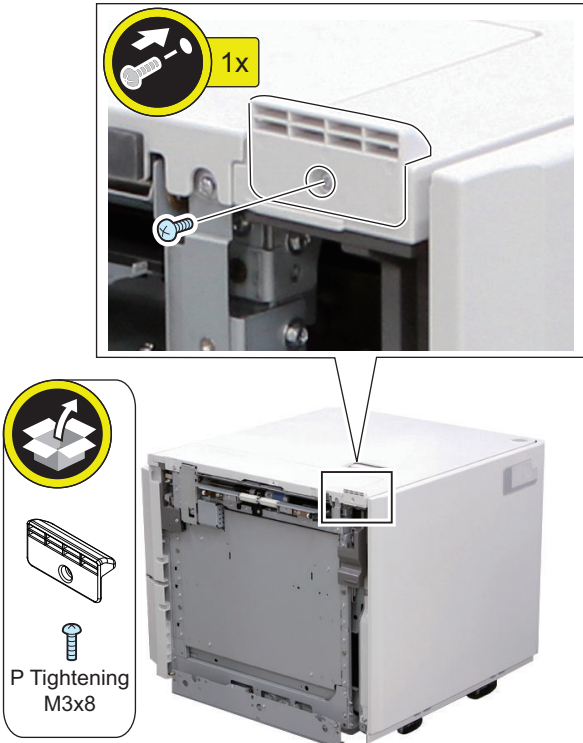

□

2. Attach the slope guide.

- 2 Screws (Binding screws; M4x5)

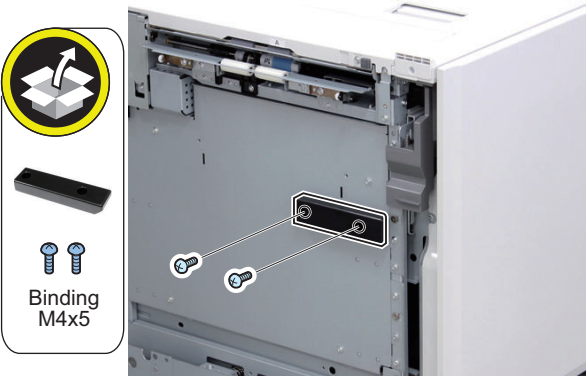

□

3. Remove the screw and spacer from the base stay unit. Push the POD Deck Lite until it stops while holding the base stay unit .





4. Fix the removed screw at procedure 3 to the original position.

NOTE:

The screw is used to fix the base stay unit when the POD Deck Lite is transported.

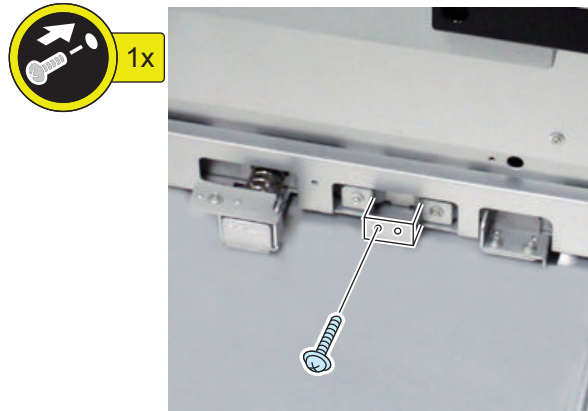

■ Connection with the Host Machine



1. Insert screwdrivers into the hole of the rear right side and then release the lever to open the compartment.

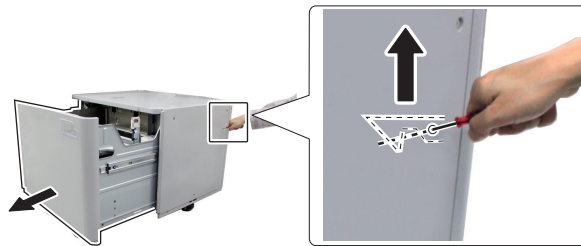

2. Open the compartment until it stops while releasing stoppers with pressing left and right latches.

⚠ CAUTION:

Be careful not to get your fingers caught.

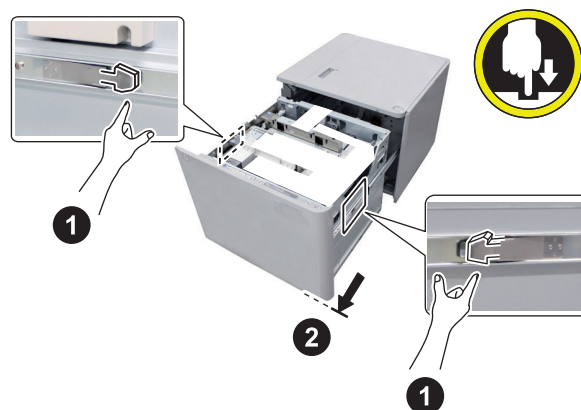



3. Remove the sheet and tapes from the compartment.

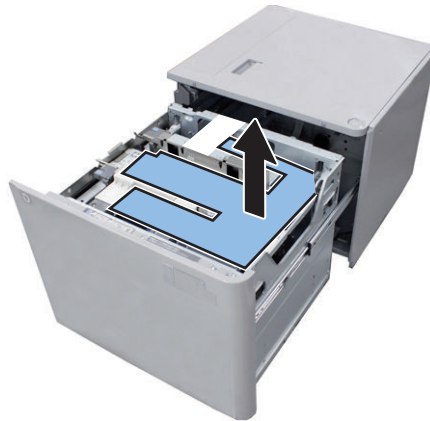

4. Remove the stay guide. Removed 1 screw and the stay guide are used at procedure 25.

- 3 Screws

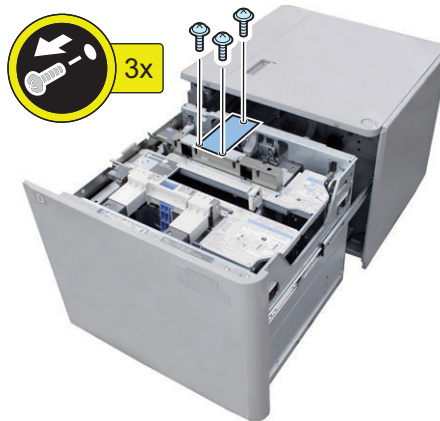

NOTE:

The removed screw is used to fix the stay guide plate when the POD Deck Lite is transported.



5. Fix the 2 screws removed at procedure 4 to the original position.

- 2 Screws (TP screws; M3x6)





6. Affix the foreign language label by language over the original label as shown in the figure.

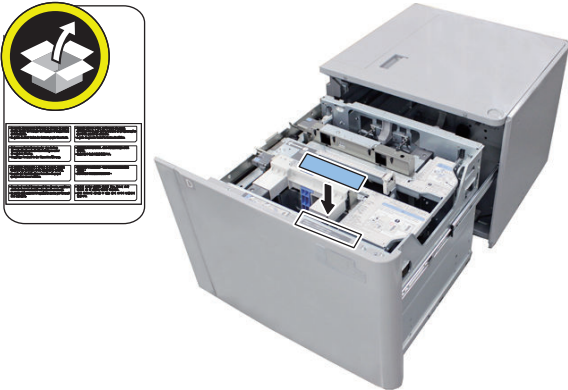

7. Affix the paper size overlay label over the original label by language as shown in the figure.

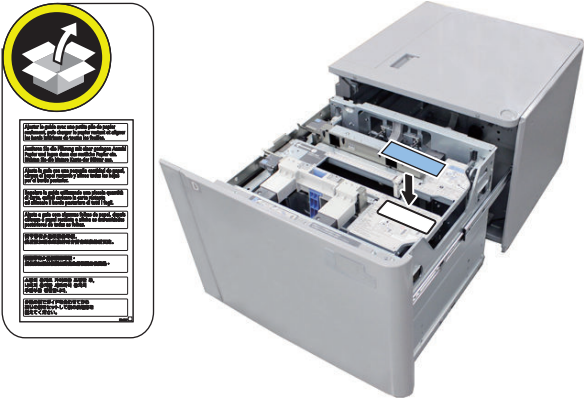

8. Close the compartment.

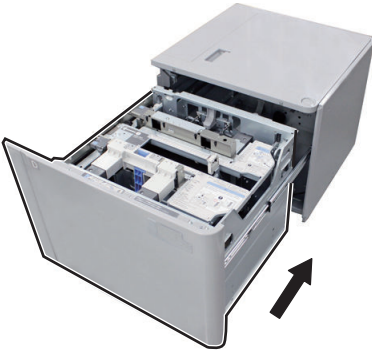



9. Insert the 2 positioning pins to the holes of the host machine and then fix the base stay.

- 3 Screws (Binding screws; M4x5)

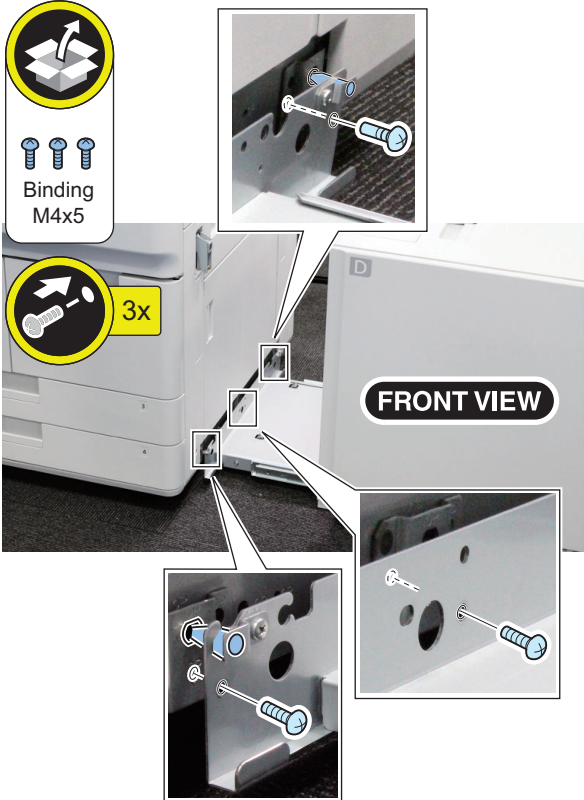

**10. Connect the POD Deck Lite with the host machine.****NOTE:**

- Do not nip the cable between the POD Deck Lite and the host machine when connecting.

NOTE:

- When inserting the rear connection pin into the rear latch hole is difficult, loosen the 2 screws fixing the latch plate and then adjust the position of the latch plate to fit it in. Check that the latch plate is not positioned at an angle when installing.

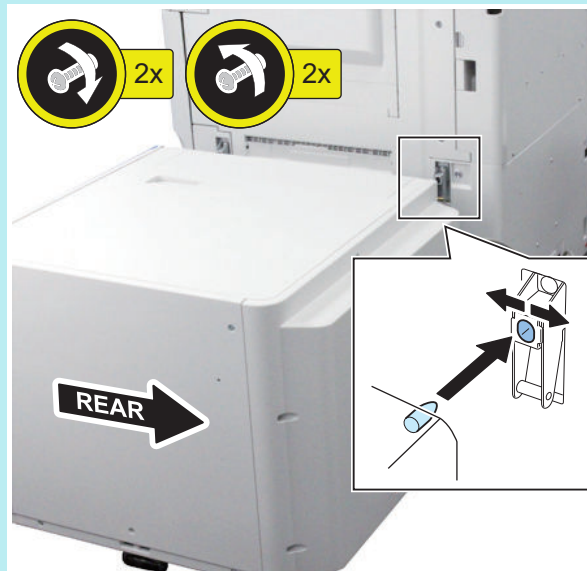



11. Loosen the 2 screws on the bottom right side wheel.

- 2 Screws

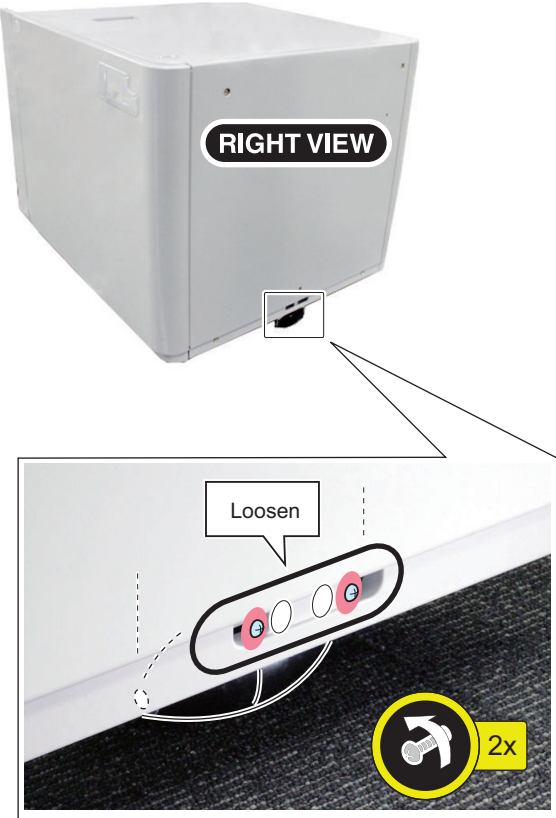



12. Match position(a) with position(b) by adjusting the height of the POD Deck Lite with the 2 adjusters.

- Position (a) : 2 fixing screw tapped holes (middle) of the POD Deck Lite.
- Position (b) : 2 fixing screw tapped holes (middle) of the bottom right side wheel.

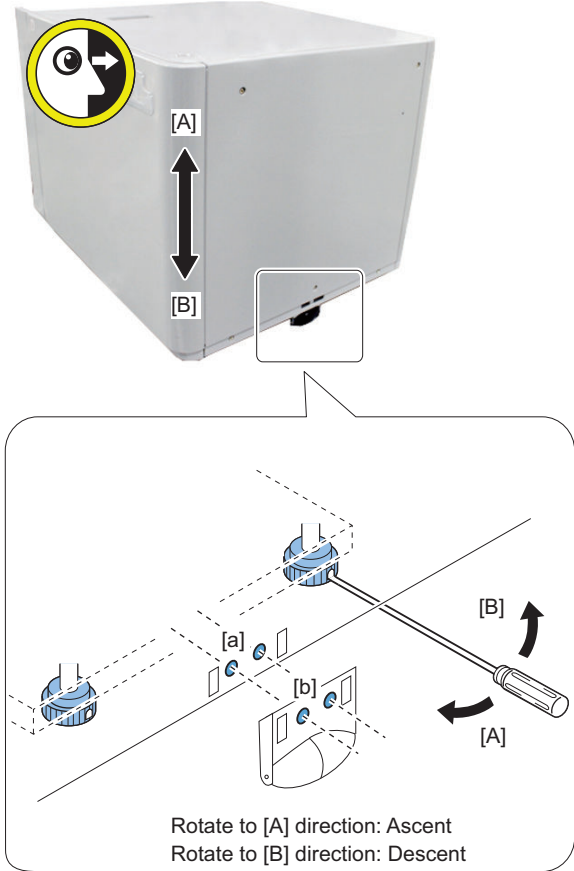



13. Fix the bottom right side wheel with Screw A and Screw B.

- Screw A: Supplied 2 Screws (RS tightening; M4x8)
- Screw B: 2 screws loosened at procedure 12

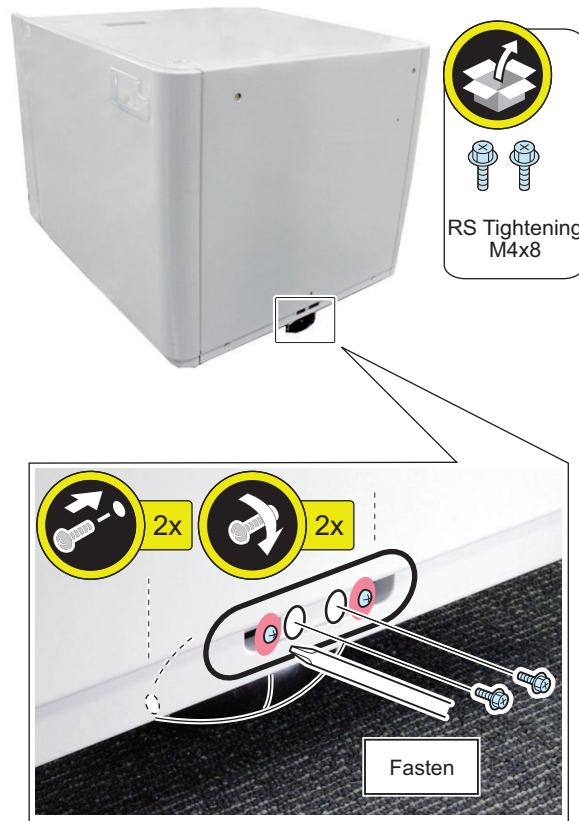

14. Loosen the 2 screws on the 2 front bottom wheels for each and touch them to the floor.

- 4 Screws

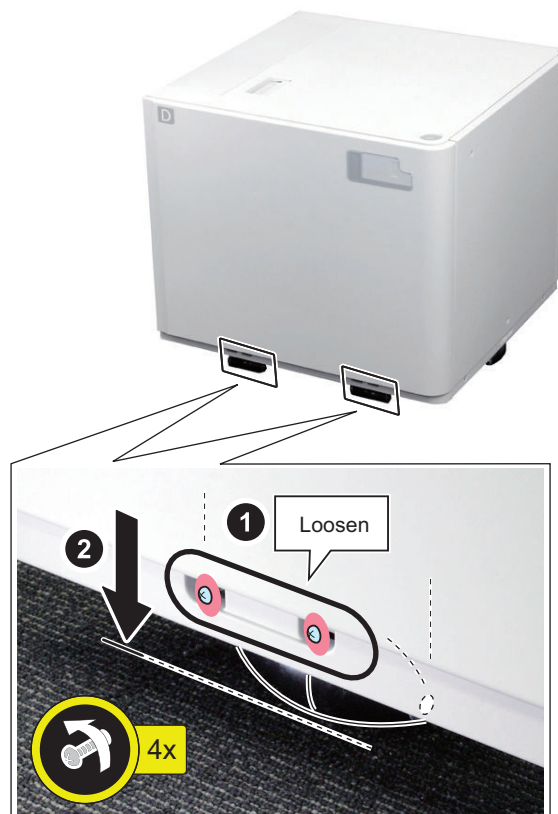



15. Fasten the 2 screws loosened at procedure 15.

- 4 Screws

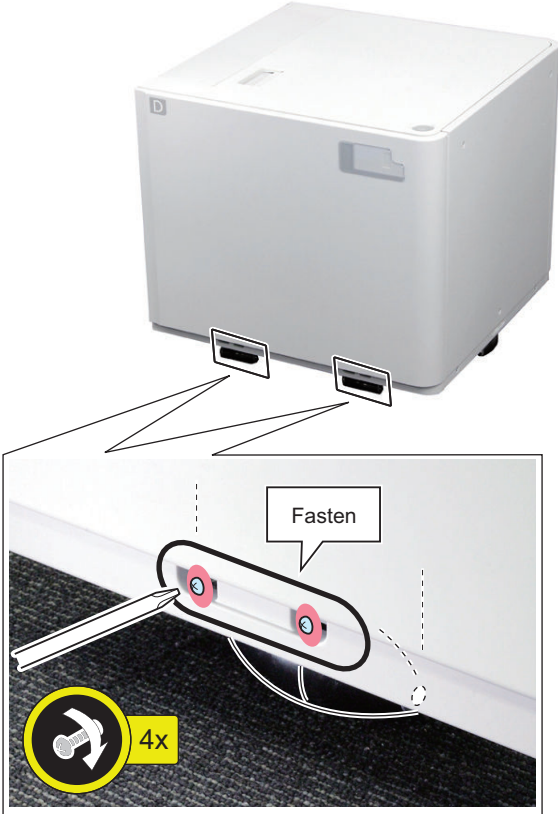

16. Adjust tilt with the 2 adjusters until a top gap [1] and a bottom gap [2] between the POD Deck Lite and the host machine are same width.

- Rotate to [A] direction: Ascent
- Rotate to [B] direction: Descent

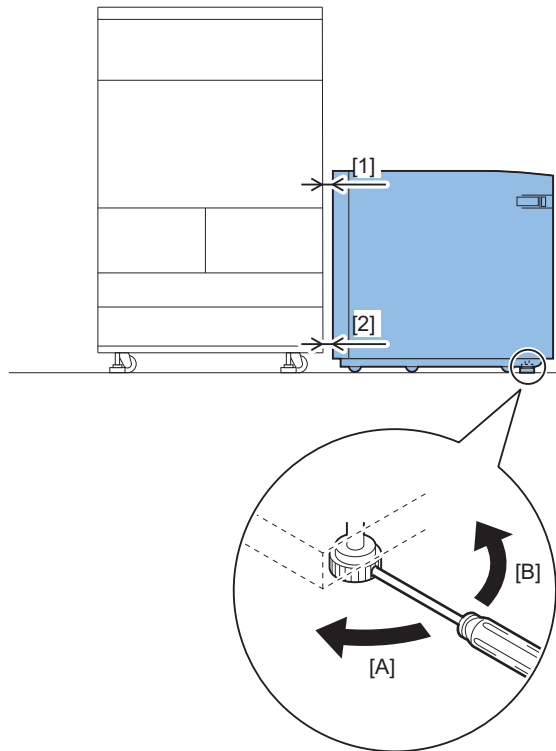

CAUTION:

- In case that the gap between the top [1] and the bottom [2] is not in parallel, connection may not be detected.
- Allowance gap range is that the bottom [2] is 2mm shorter than the top [1].
- When relocating the POD Deck Lite, re-adjust the gap in parallel.

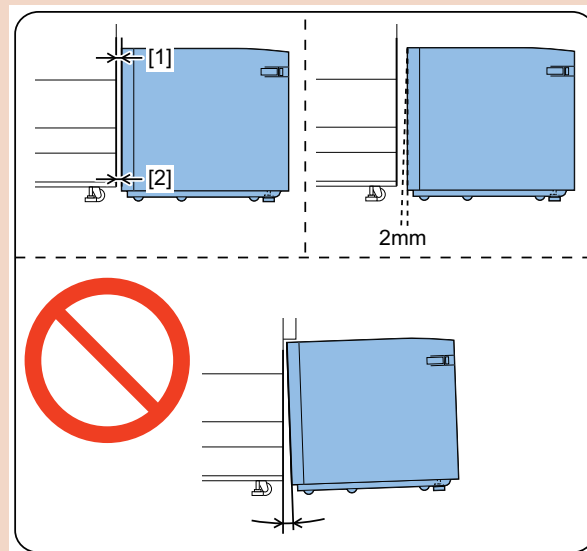



17. Attach the wire saddle to the hole on rear side of the POD Deck Lite and then clamp the cable with it.

- 1 Wire saddle

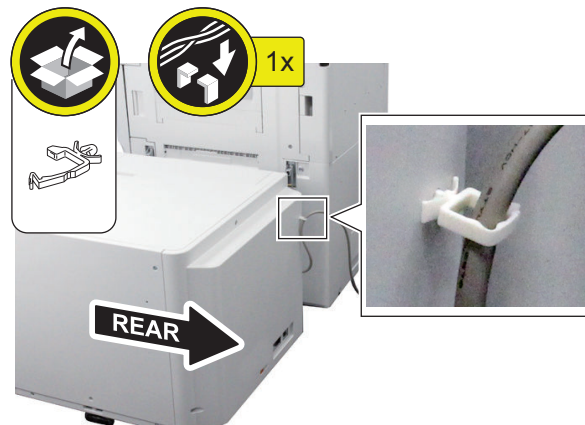

18. Connect the Interface Cable with the host machine.

CAUTION:

When connecting the Interface Cable, be sure to turn off the host machine and disconnect its power cable from the outlet. If you do not do so, electric shock can result.

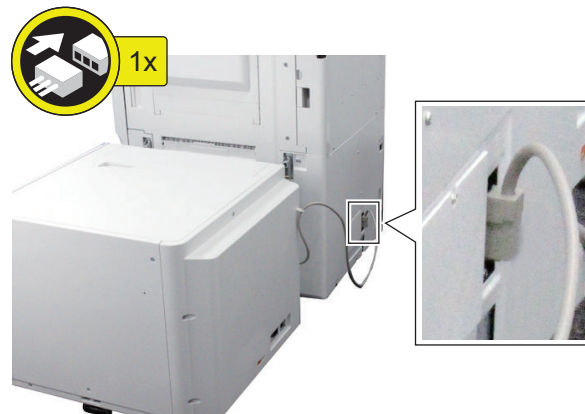

□

19. Connect the power cord to the inlet of the POD Deck Lite and then plug it to the external source.

⚠ CAUTION:

Make sure that the power cord is fully connected to the outlet. If the connection is incomplete, smoke or fire may occur.



□

20. Check that the circuit breaker is ON.



21. If the cassette heater is installed, turn ON the cassette heater in high humidity or low temperature environment.



22. Turn ON the main power on the host machine.

23. Press the open button of the POD Deck Lite to open the compartment.





24. Press the relay paper sensor until the lifter reaches to the bottom position.

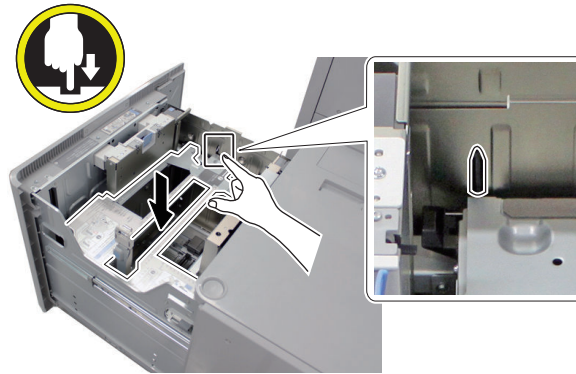

25. Fix the stay guide inside of the front frame with the screw removed at procedure 4.

- 1 Screw (TP; M3x6)

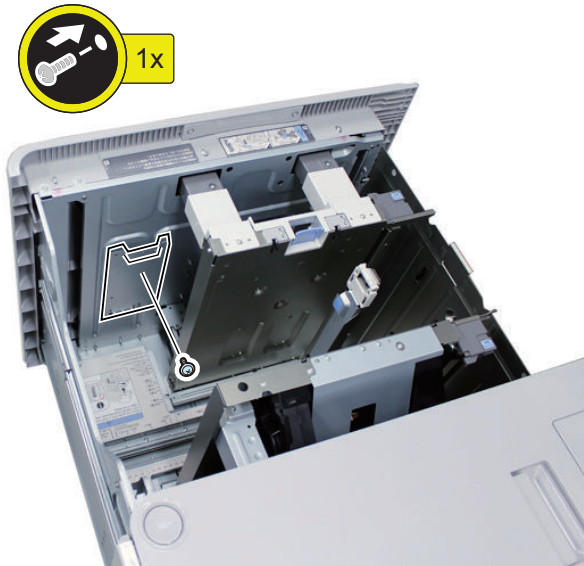

26. Set sheets of paper in the compartment and close it.

□

27. Affix the cassette No. label "5" .



□

28. Affix the paper size label on the size plate.

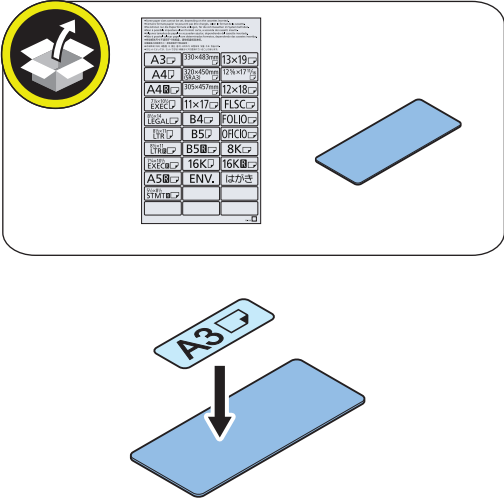

NOTE:

- Be sure to check with the user whether or not to affix the Paper Size Label, and then affix it.
- Keep the Paper Size Labels as they will be used when changing the paper size.

□

29. Insert the size plate prepared at procedure 29 to the media plate holder.



Disposal Parts

1. Following disposal parts are remained after the installation procedure.

<input type="checkbox"/>	[1]	Screw (RS Tightening;M4x8) 3pcs
<input type="checkbox"/>	[2]	Screw (Stepped Screw; M4x8) 1pc
<input type="checkbox"/>	[3]	Feed Cover 1pc
<input type="checkbox"/>	[4]	Lower Right Cover 1pc
<input type="checkbox"/>	[5]	Connector Cover 1pc
<input type="checkbox"/>	[6]	Blindfold Cover 2pcs
<input type="checkbox"/>	[7]	Total Map Label 1pc
<input type="checkbox"/>	[8]	Foreign Language Label 1pc
<input type="checkbox"/>	[9]	Cassette No. Label 1pc
<input type="checkbox"/>	[10]	Papaer Size Sub Label 1pc
<input type="checkbox"/>	[11]	JAM Label 1pc
<input type="checkbox"/>	[12]	Spacer 1pc
<input type="checkbox"/>	[13]	Extraction Sensor Plate 1pc
<input type="checkbox"/>	[14]	Feed Lower Guide Front Fixing Plate 1pc
<input type="checkbox"/>	[15]	Feed Lower Guide Rear Fixing Plate 1pc
<input type="checkbox"/>	[16]	Wire Saddle 1pc
<input type="checkbox"/>	[17]	Fixing Plate 1pc

Paper Positioning Check/Adjustment Procedure

■ Adjusting the Left Edge Margin(L1) of the Image

1. Print sheets of paper from the POD Deck Lite. Check that L1 is 2.5+/-1.5mm. Execute adjustment as follows when it is out of standard.

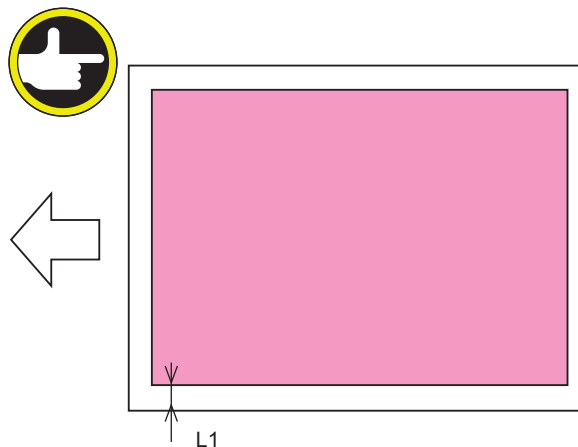

■ Adjustment Procedure(service mode)

1. Adjust the setting value on the following service mode.
(LV1) COPIER > ADJUST > FEED-ADJ > ADJ-DK

NOTE:

Setting range: -20 to 20 (0.1mm by 1 setting value)

L1 is increased 0.1mm by setting value 1.

+: L1 is increased (Image moves to the right).

-: L1 is decreased (Image moves to the left).

-
- 2. Exit service mode.
-
- 3. Print sheets of paper from POD Deck Lite and then check that L1 is 2.5+/-1.5mm. Execute manual adjustment as follows when it is out of standard.

■ Adjustment Procedure (manual)

-
- 1. Press the open button of the POD Deck Lite to open the compartment.



-
- 2. Open the compartment until it stops while releasing stoppers with pressing left and right latches.

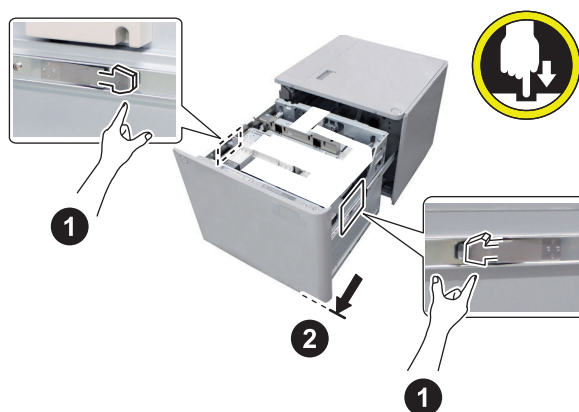



3. Loosen the 2 screws at the latch plate on the right side of the compartment.

- 2 Screws

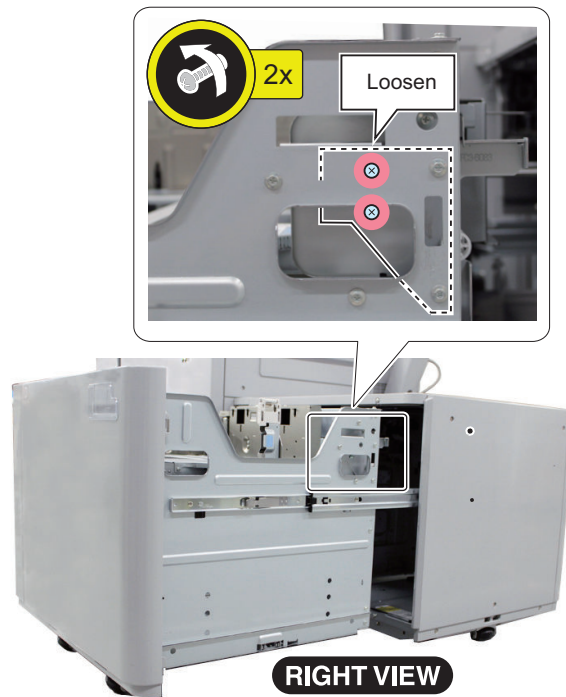

4. Move the latch plate toward front [A] or rear [B] (1 scale = 1mm) and then fasten the 2 screws. The adjusted value is used at procedure 6.

- When L1 is large, move the latch plate to front [A].
- When L1 is small, move the latch plate to rear [B].

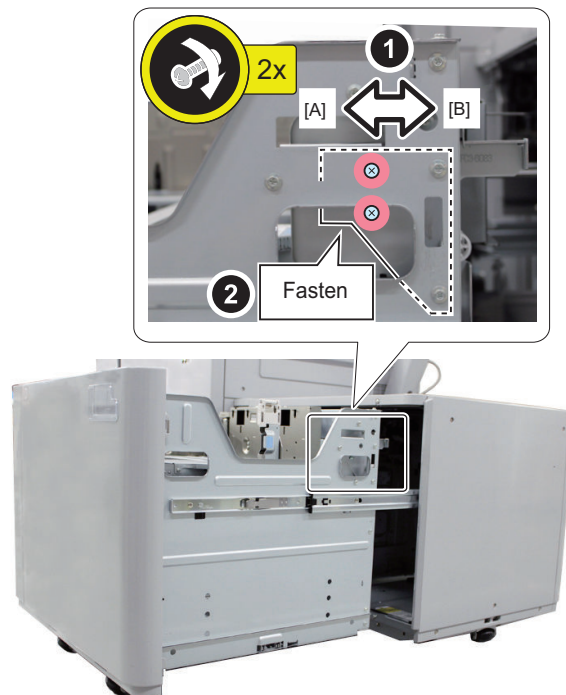



5. Loosen the 2 screws at the latch plate on the left side of the compartment.

- 2 Screws

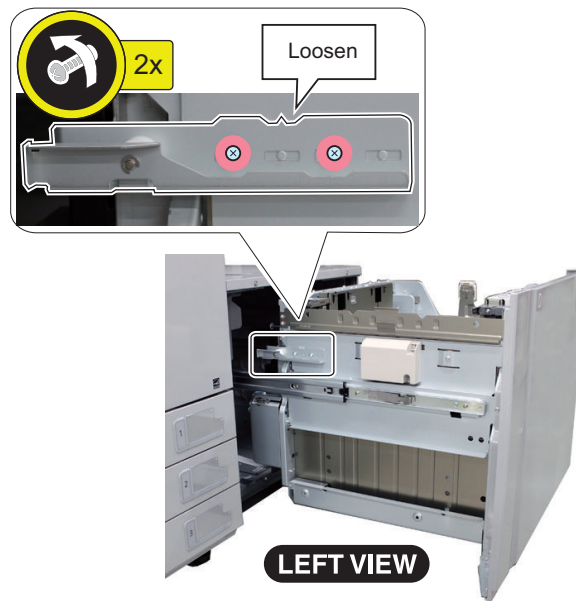

6. Move the latch plate in the same scale position as procedure 4 and then fasten the 2 screws (1 scale = 1mm).

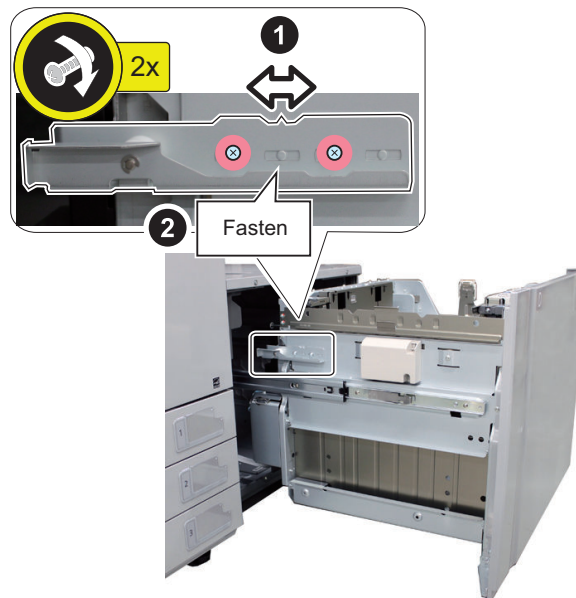

7. Move the front cover fitting to the amount of the latch plate adjustment. Refer to the next item "Front Cover Positioning Adjustment" for detail.



8. Close the compartment.



9. Print sheets of paper from the POD Deck Lite. Check that L1 is 2.5+/-1.5mm. Re-adjust L1 in case that it is out of standard.

■ Front Cover Positioning Adjustment



1. Check that the gap is 4 ± 1 mm between the front cover and upper cover, the front cover and right cover.



NOTE:

Loosen the 7 screws on the front cover to adjust the gap in 4 ± 1 mm.

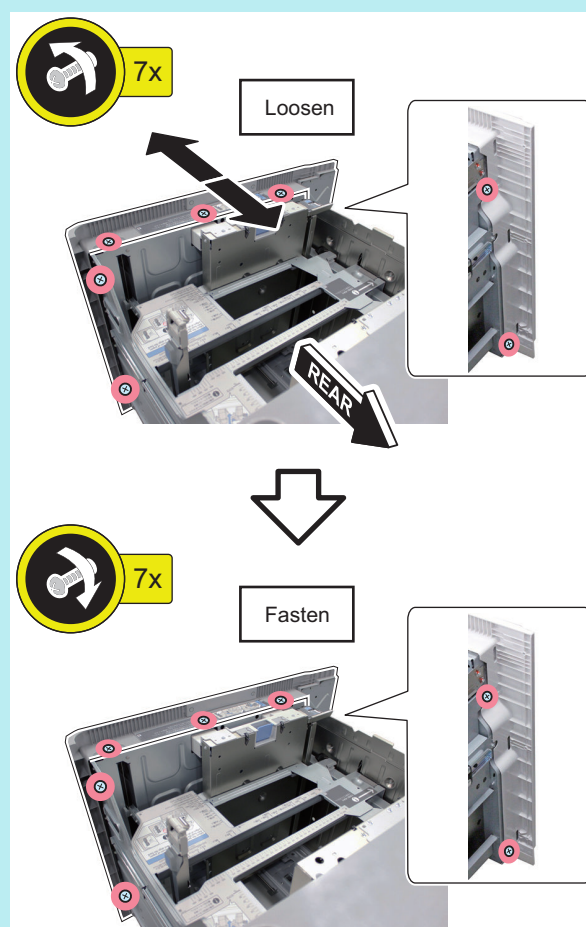

Paper Deck Heater Unit for POD Deck Lite-C1

Checking the Parts to be Installed

Each part of the Paper Deck Heater Unit for the Paper Deck is supplied as a service part, so prepare the following parts. Also, use the appropriate Paper Deck Heater Unit for each country.

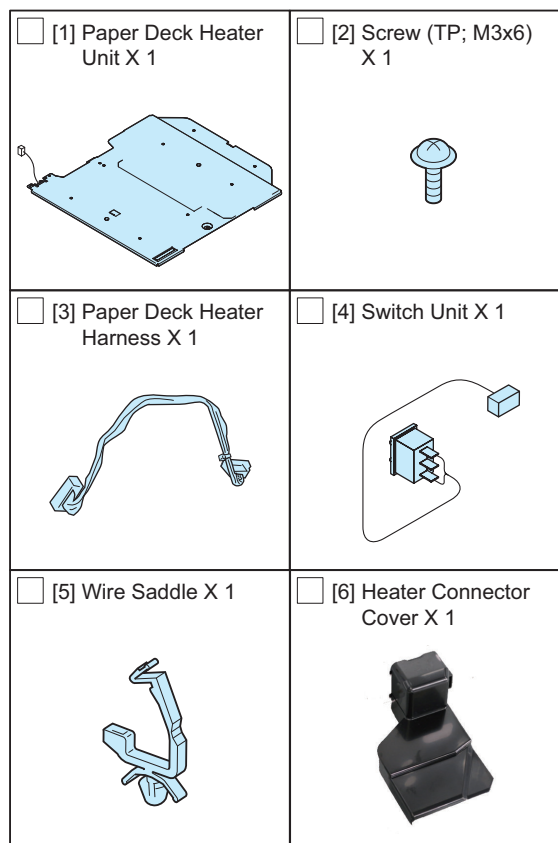

No	Parts name	Parts Number	Q'ty
[1]	Paper Deck Heater Unit	FM1-D634	1pc
[2]	Screw (TP ; M3x6)	XB6-7300-605	1pc
[3]	Paper Deck Heater Harness (120V)	FM1-E857	1pc
	Paper Deck Heater Harness (230V)	FM1-E858	1pc
[4]	Switch Unit	FM1-E859	1pc
[5]	Wire Saddle	WT2-6108	1pc
[6]	Heater Connector Cover	FE3-5299	1pc

*Check the parts numbers on the current parts catalogue as the above parts numbers may be changed.

Removing from the Host Machine

■ Removing from the Host Machine



1. Turn OFF the main power of the host machine.



2. Remove the power cord.

□

3. Remove the cable.

- 1 Wire saddle
- 1 Connector

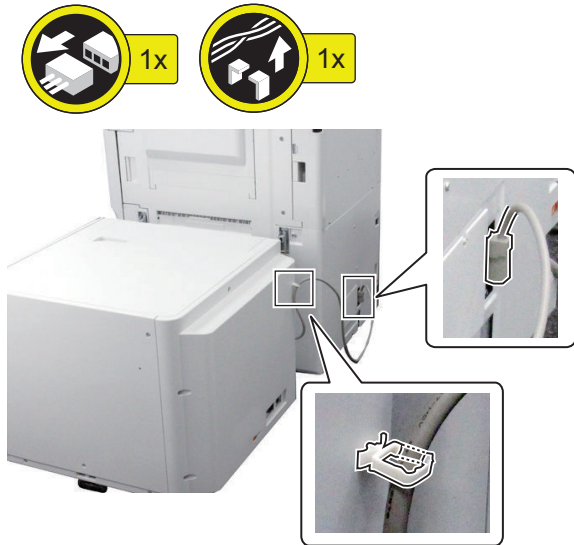

□

4. Slide the POD Deck Lite until it stops with holding the release lever.



Installation Procedure

- **1. Remove the Rear Cover.**
 - 5 Screws

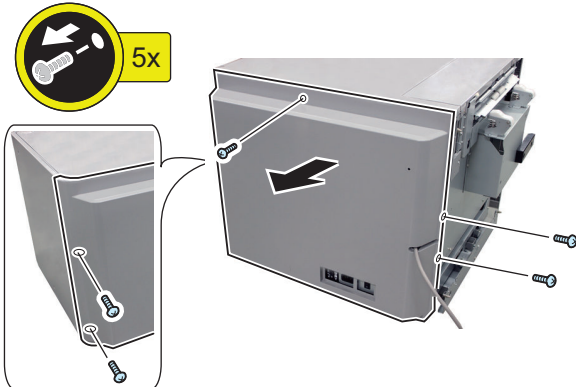

- **2. Open the Compartment while unlocking the release lever.**

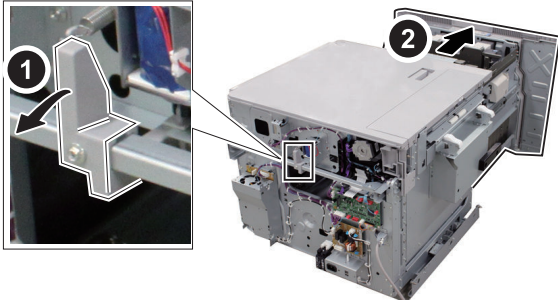

- **3. Remove the Right Cover.**
 - 5 Screws





4. Open the Compartment until it stops while releasing stoppers with pressing the left and right Latches.

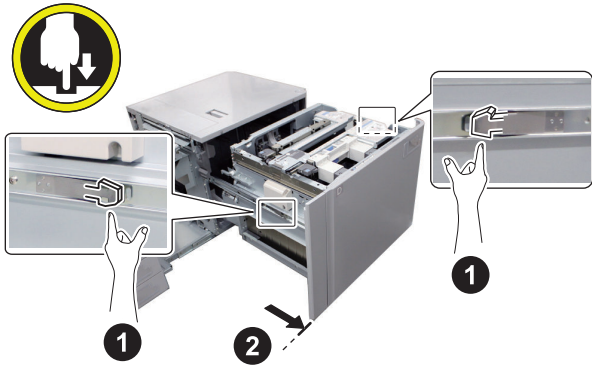

5. Install the Paper Deck Heater Unit.

- 3 Claws
- 1 Screw (TP; M3x6)

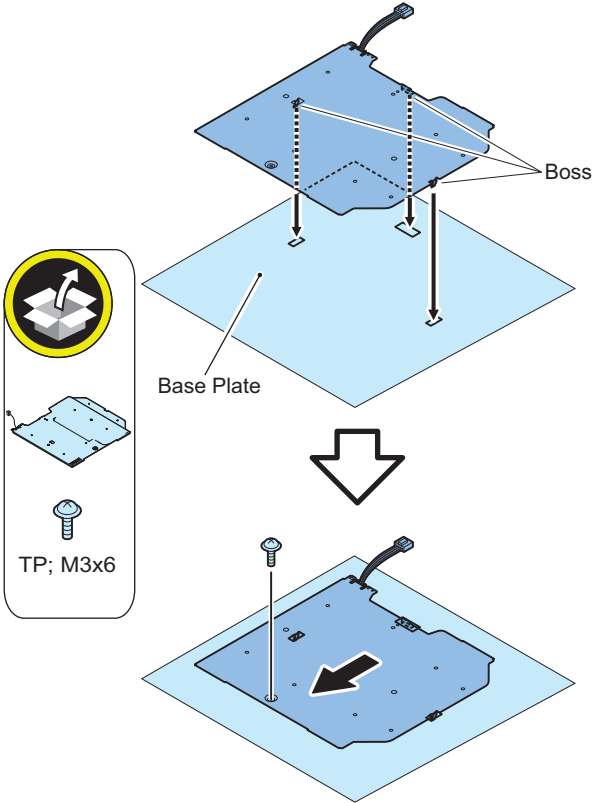



6. Connect the connector to the POD Deck Lite.

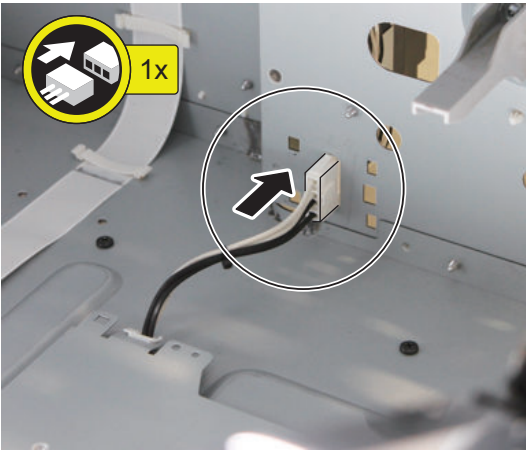

7. Install the Heater Connector Cover.

- 2 Protrusions
- 1 Claw

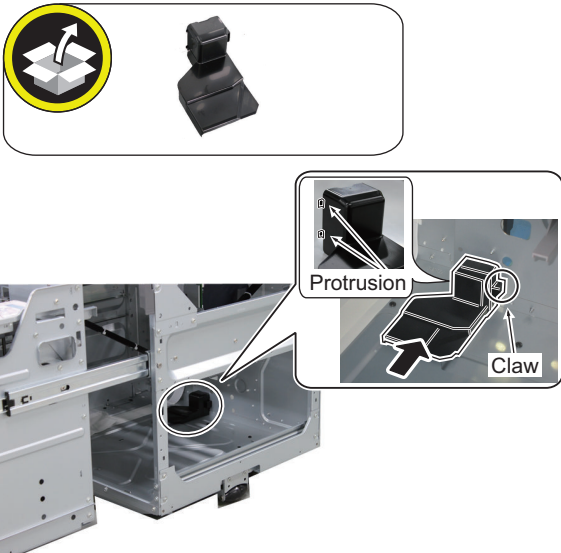

□

8. Install the Paper Deck Heater Harness.

- 3 Reuse bands
- 2 Connectors

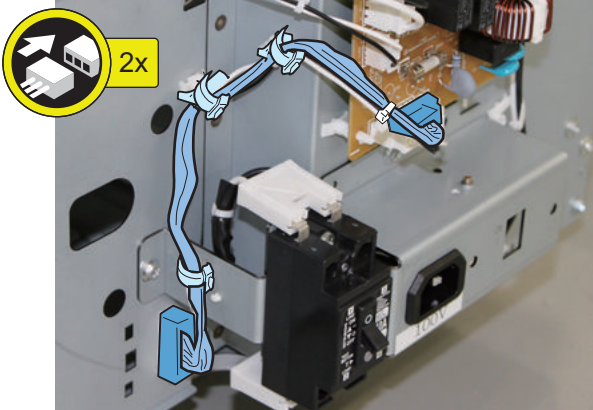
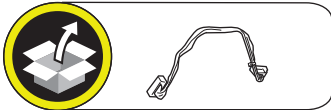

□

9. Install the Switch Unit.

NOTE:
When installing the Switch Unit, check that the Cassette Heater Switch is OFF.

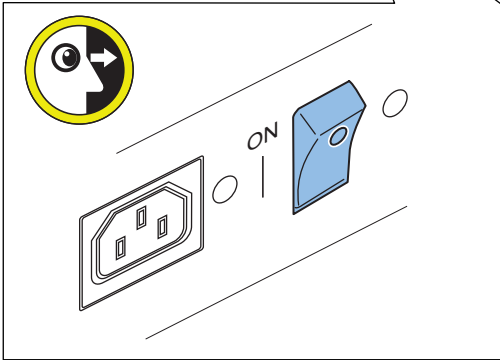
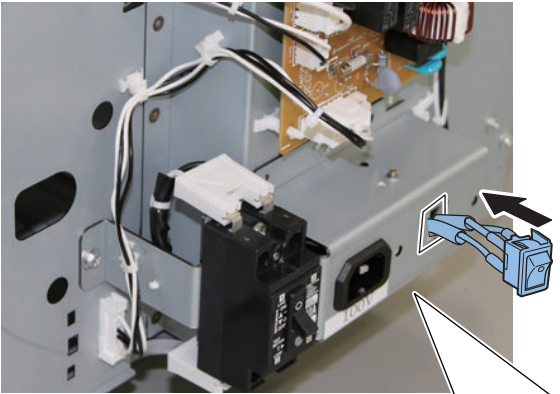
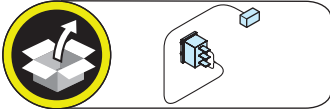



10. Attach the wire saddle.

- 1 Wire saddle

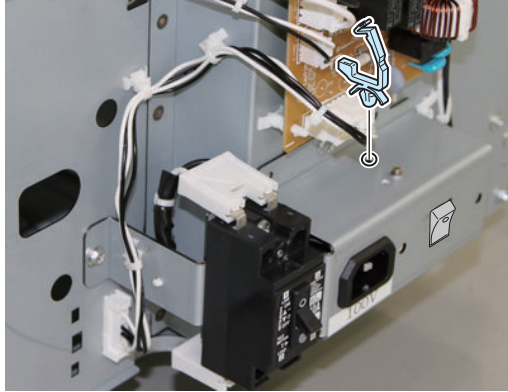
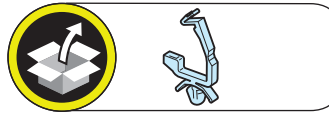

11. Fix the Switch Unit Harness as follows.

- 2 Wire saddles
- 1 Connector

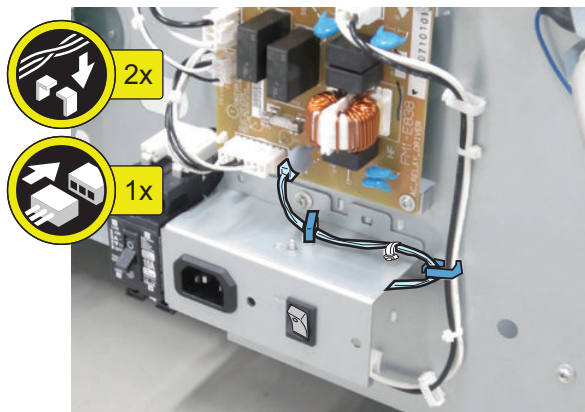

12. Attach the external covers.



13. Connect the POD Deck Lite with the host machine.



**14. Connect the cable.**

- 1 Wire saddle
- 1 Connector

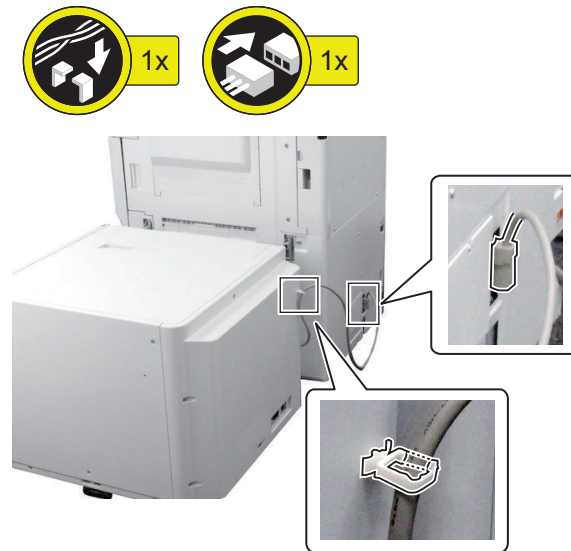
**15. Connect the power cord to the inlet of the POD Deck Lite and then plug it to the external source.****CAUTION:**

Make sure that the power cord is fully connected to the outlet. If the connection is incomplete, smoke or fire may occur.



16. Check that the circuit breaker is ON.



17. Turn ON the Cassette Heater Switch.



18. Turn ON the main power of the host machine.

Cassette Heater Unit-38

Checking the Contents

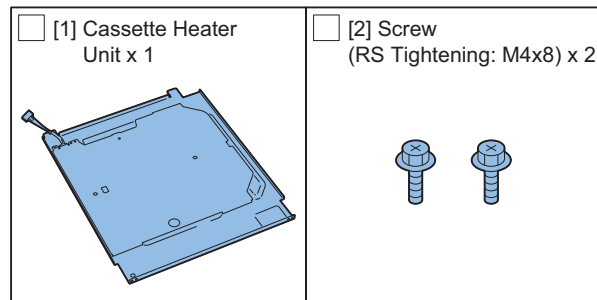

Installation Outline Drawing

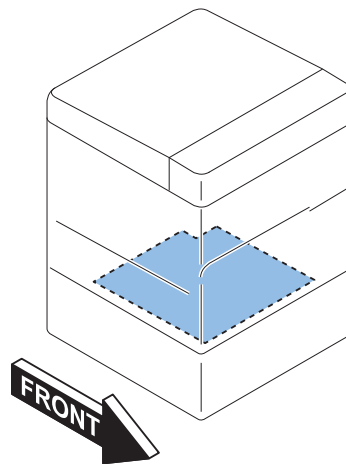

Essential Items to Be Performed Before Installation

- Turn OFF the main power of the host machine, and disconnect the power plug from the outlet.

⚠ WARNING:

- If performing work without disconnecting the power plug of the host machine, it may cause electrical shock.
- If disconnecting the power plug without turning OFF the main power, it may cause damage of the machine.

- When turning OFF the main power, follow the below procedure.
 1. Turn OFF the main power switch of the host machine.
 2. The display in the Control Panel and the lamp of the main power are turned off.

Installation Procedure

1. Open the Front Cover.



2. Pull out the Left Deck to remove.

- 2 Screws

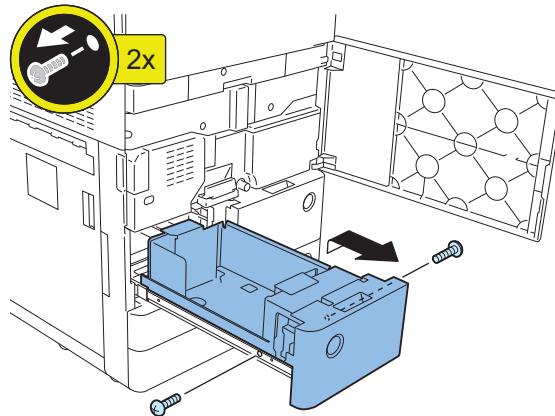

3. Put the 2 Rails in.

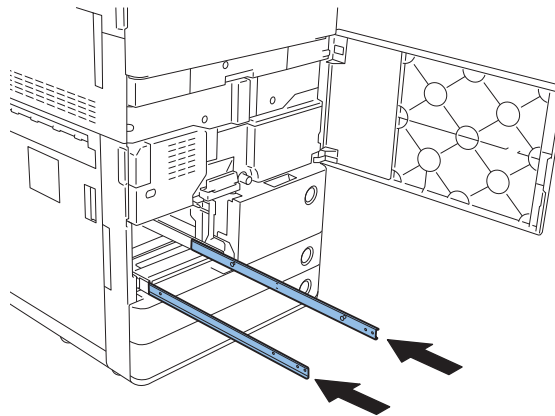

4. Pull out the Right Deck to remove the Left Deck in the same way.

5. Put the 2 Rails in.



6. Pull out Cassette 3 to remove.

- 4 Screws

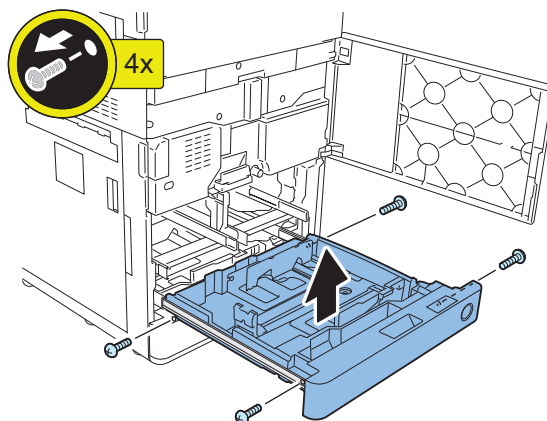



7. Put the 2 Rails in.

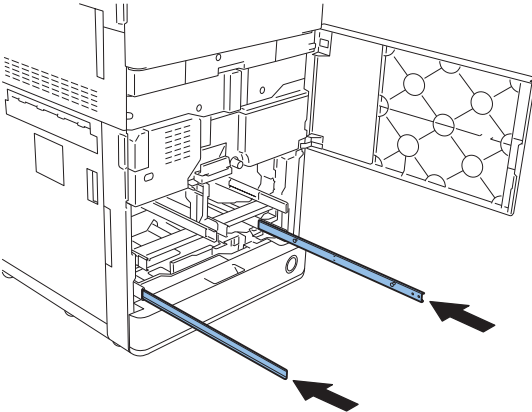

8. Remove the Connector Cover.

- 1 Claw
- 2 Protrusions

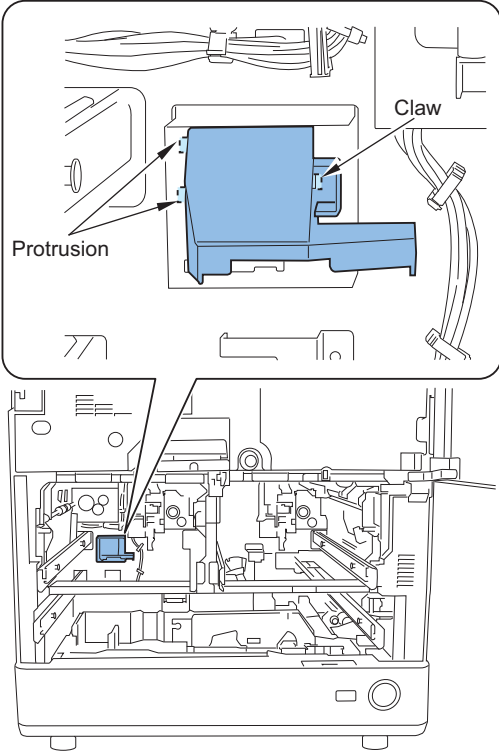

9. Remove tapes on the Cassette Heater Unit.



10. Fit the protrusions of the Cassette Heater Unit into the holes of the Host Machine.

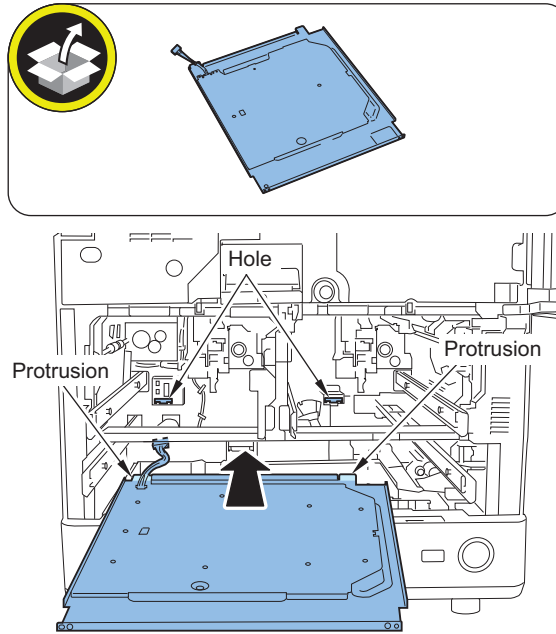

11. Fit the holes of the Cassette Heater Unit with the bosses of the Host Machine.

CAUTION:

When fitting the Cassette Heater Unit with the bosses, be sure to support the bottom side with your hand; otherwise, the Unit could fall if protrusions come out of the holes.

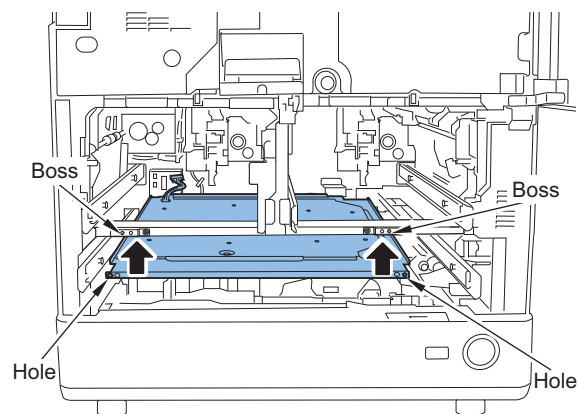



12. Install the Cassette Heater Unit.

- 2 Screws (RS Tightening; M4x8)

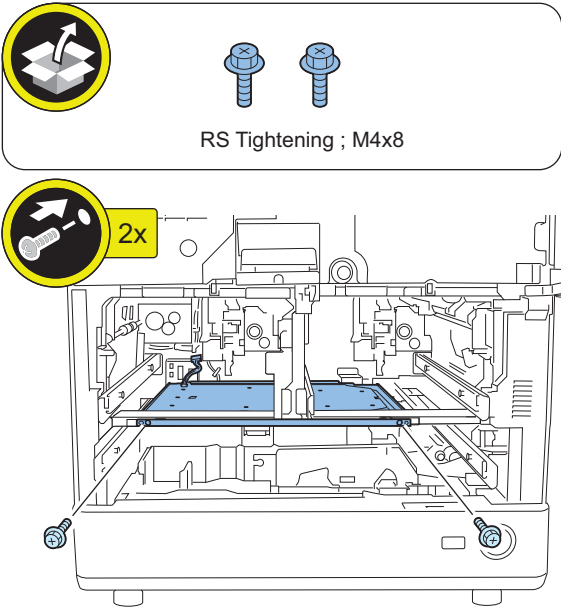

13. Install the Connector.

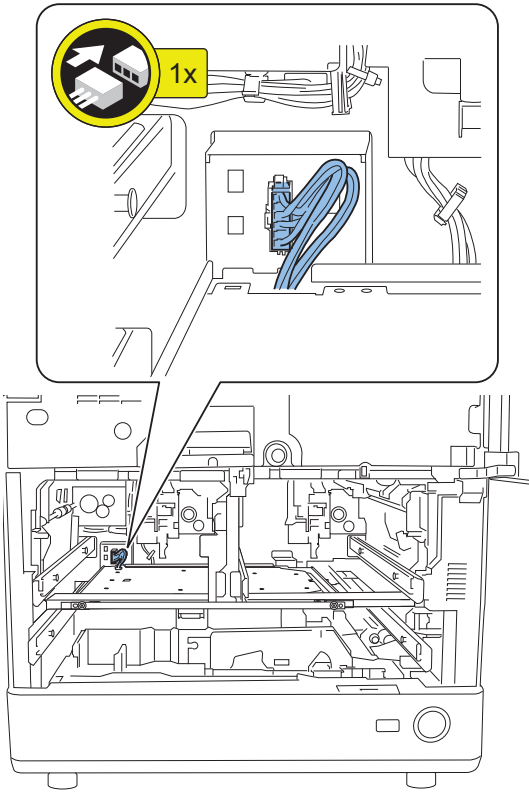

14. Install the Connector Cover.



15. Pull out the Rails at the installation area of Cassette 3. Fit the 4 pins on the Rails with the grooves of Cassette 3 to place Cassette 3 over the Rails.

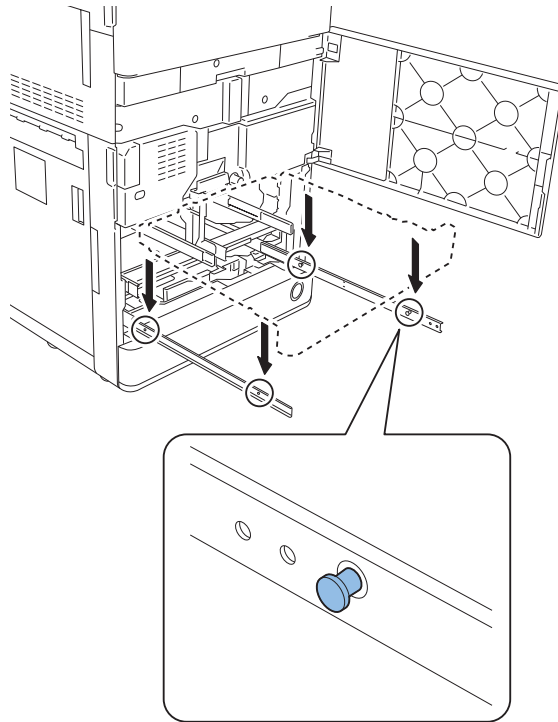

16. After having installed Cassette 3 with 4 screws, close Cassette 3.

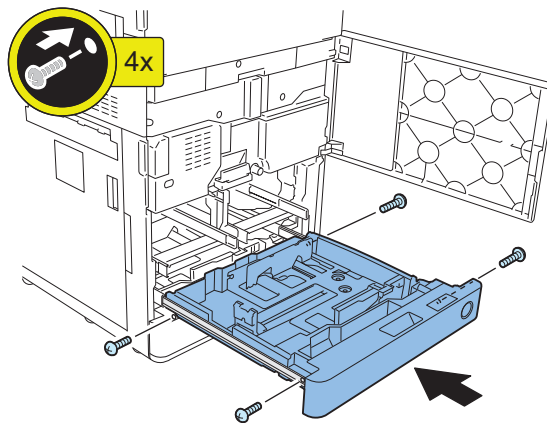



17. Pull out the Rails at the installation area of the Right Deck. Fit the 4 pins on the Rails with the grooves of the Right Deck to place the Right Deck over the Rails.

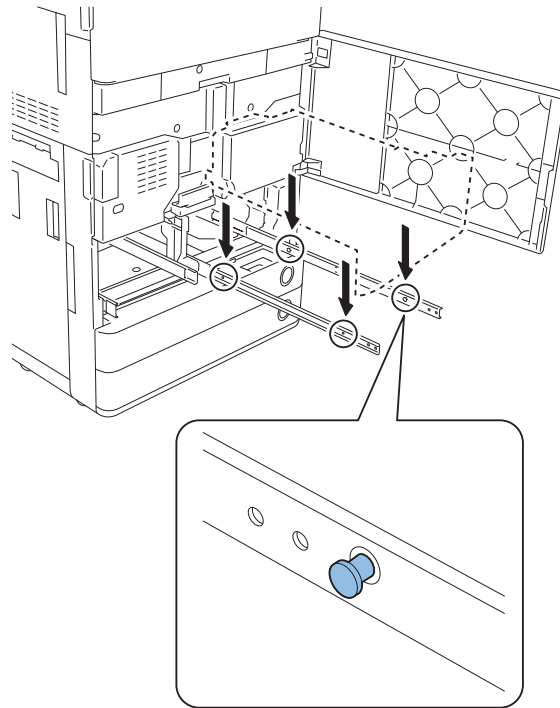

18. After having installed Right Deck with 2 screws, close the Right Deck.
19. Install the Left Deck in the same way as the Right Deck.
20. Close the Front Cover.
21. Turn on the Environment Heater Switch.
22. Connect the power plug to the outlet.
23. Turn ON the main power switch.



Paper Output Options











Shift Tray-F1.....	491
Document Insertion Unit-P1, Document Insertion/Folding Unit-J1	497
Staple Finisher-AC1/ Booklet Finisher- AC1.....	542
2/3 2/4 4 Hole Puncher Unit-A1.....	581
Finisher Jogger Kit-A1.....	604

Shift Tray-F1

Points to Note before Installation

The pictures and illustrations used may be different from the product in front of you, but the procedure is the same.

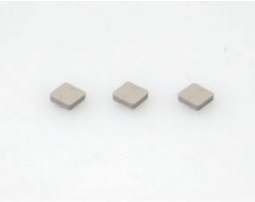
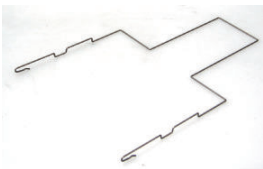
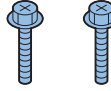
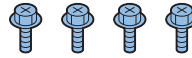
Checking the Contents

<input type="checkbox"/> [1] Shift Tray X 1 	<input type="checkbox"/> [2] Shift Drive Unit X 1 
<input type="checkbox"/> [3] Shift Tray Cover X 1 	<input type="checkbox"/> [4] Shift Tray Support Base X 1 
<input type="checkbox"/> [5] Reinforcing Plate X 1 	<input type="checkbox"/> [6] Shift Delivery Support Base (1) X 1 
<input type="checkbox"/> [7] Shift Delivery Support Base (2) X 1 	<input type="checkbox"/> [8] Face Cover X 1 
<input type="checkbox"/> [9] Rubber Cap X 3 	<input type="checkbox"/> [10] Shift Tray Shaft X 1 
<input type="checkbox"/> [11] Screw (RS Tightening; M4x20) X 2 	<input type="checkbox"/> [12] Screw (RS Tightening; M4x8) X 4  <input type="checkbox"/> [13] Screw (Binding; M4x6) X 2 

Essential Items to Be Performed Before Installation

- Turn OFF the main power of the host machine, and disconnect the power plug from the outlet.

⚠ WARNING:

- If performing work without disconnecting the power plug of the host machine, it may cause electrical shock.
- If disconnecting the power plug without turning OFF the main power, it may cause damage of the machine.

- When turning OFF the main power, follow the below procedure.
 1. Turn OFF the main power switch of the host machine.
 2. The display in the Control Panel and the lamp of the main power are turned off.

Points to Note When Turning ON/OFF the Main Power

The following message is displayed.

1. When a message prompting to turn OFF and then ON the main power appears, turn OFF and then ON the main power switch.
2. If a message prompting the user to update the version appears, press [Update] to automatically update the version of this equipment.

If [Skip] is selected, a message prompting the user to update the version will appear every time the host machine is started. In the service mode (Lv. 2) shown below, it is possible to set not to display the message.
COPIER > OPTION > FNC-SW > VER-CHNG

Installation Outline Drawing

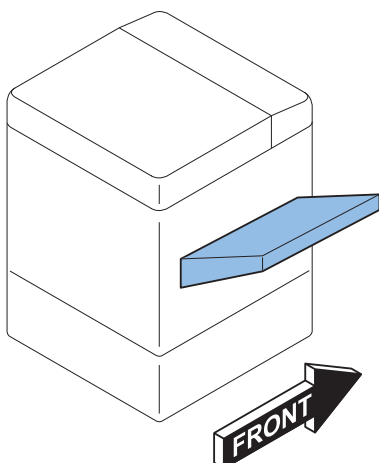

Installation Procedure



1. Remove the Left Rear Cover.

- 1 Claw
- 1 Hook

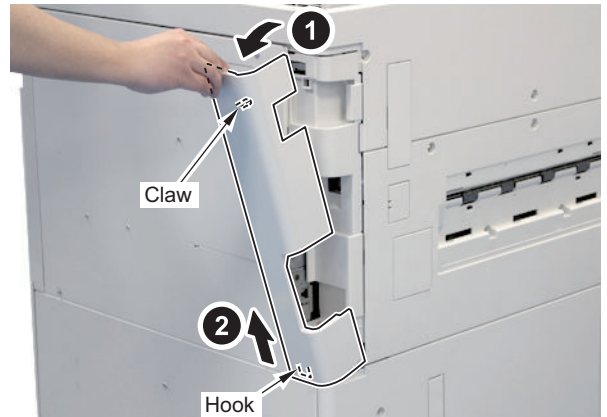

2. Open the Toner Replacement Cover.



3. Remove the 2 Finisher Connection Covers. (The removed Finisher Connection Cover will not be used.)

- 1 Claw for each
- 1 Protrusion for each

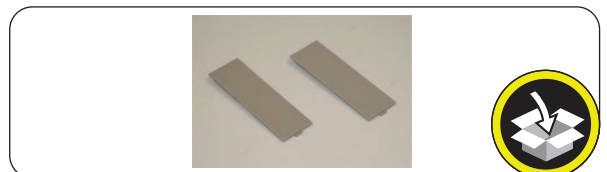
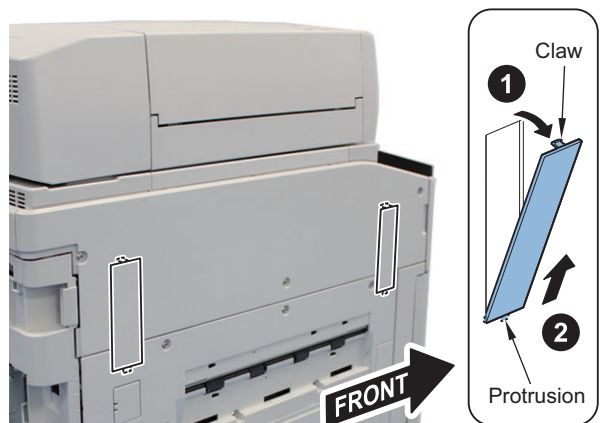



4. Remove the Left Upper Cover.

- 3 Screws
- 3 Hooks
- 3 Protrusions

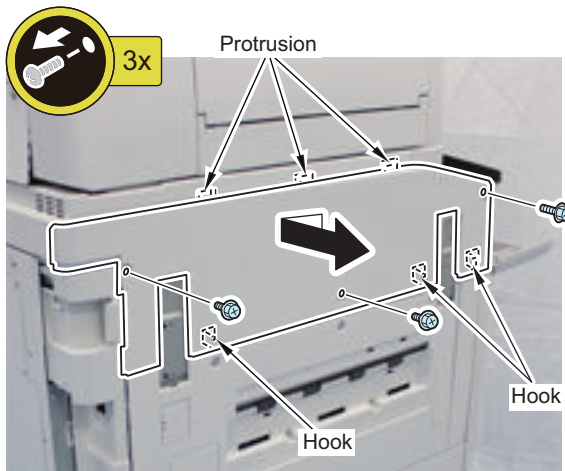

5. Remove the Delivery Cover.

- 5 Stepped Screws (The 3 removed Stepped Screws will be used in step 9.)
- 2 Hooks

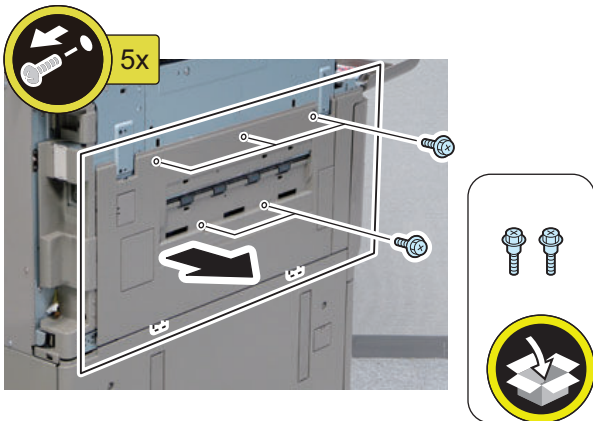

6. Remove the 2 screws, and install the Shift Delivery Support Base (1) using the removed screws.

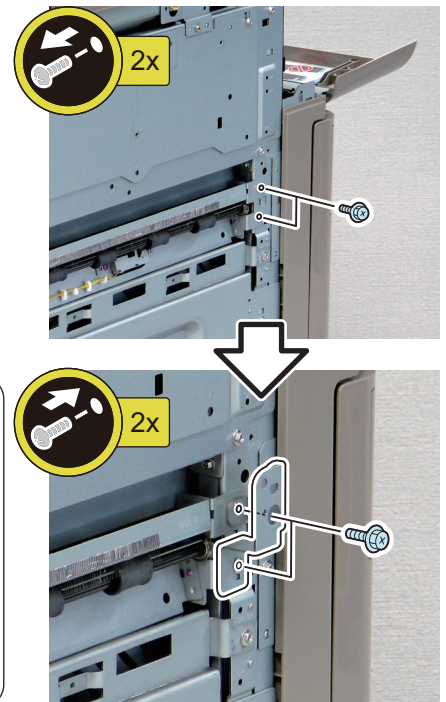



7. Remove the screw, and install the Shift Delivery Support Base (2) using the removed screw and the screw included in the package.

- 1 Screw (RS Tightening; M4x8)

CAUTION:

The 2 screws used are different in length. Be sure to install them to the correct positions.

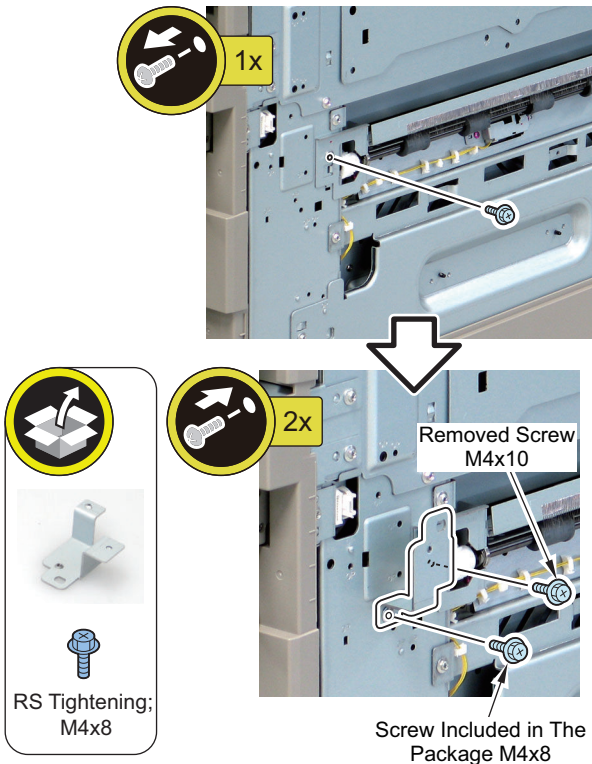

8. Install the Shift Tray Support Base.

- 2 Bosses
- 2 Screws (RS Tightening; M4x8)

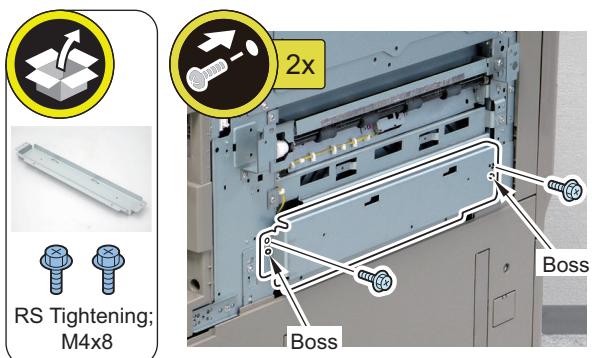

9. Install the Shift Tray Cover. Install the Shift Tray Cover.

- 2 Hooks
- 3 Stepped Screws (Use the screws removed in step 5.)

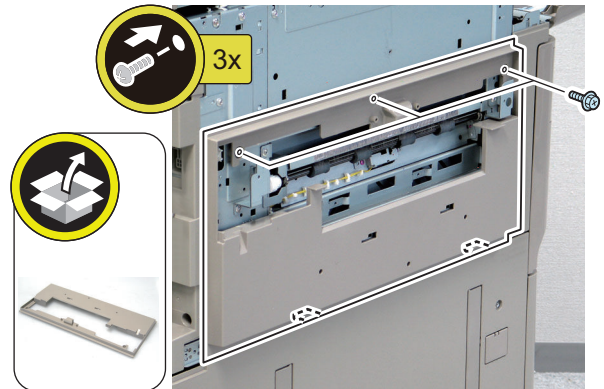

10. Remove the tapes, and install the Shift Tray Shaft.

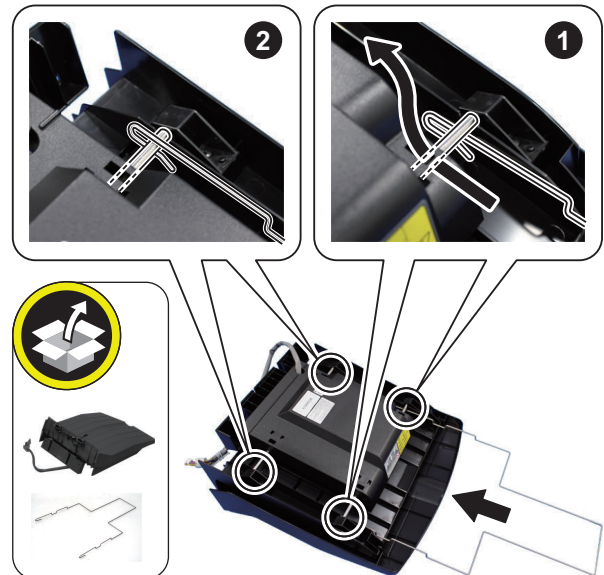

11. Install the Shift Tray.

- 2 Hooks

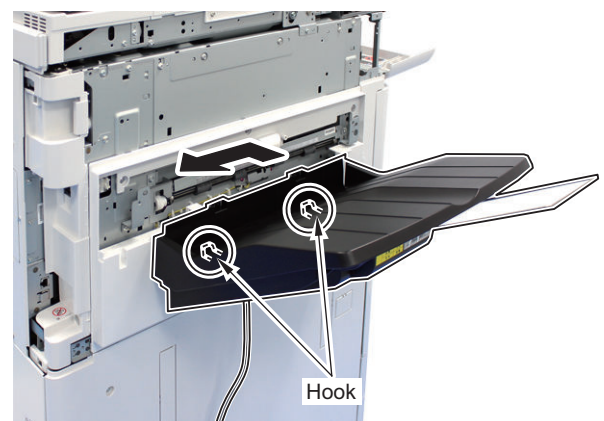



12. Install the Reinforcing Plate.

- 2 Screws (RS Tightening; M4x20)

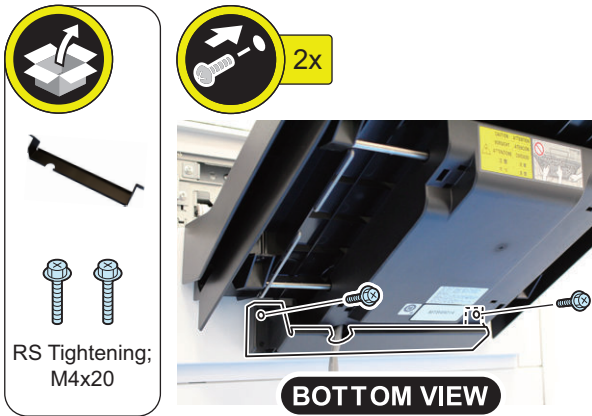

13. Install the Harness Fixing Plate attached to the end of the Shift Tray Cable.

- 1 Hook
- 1 Boss
- 1 Screw (RS Tightening; M4x8)
- 2 Connectors

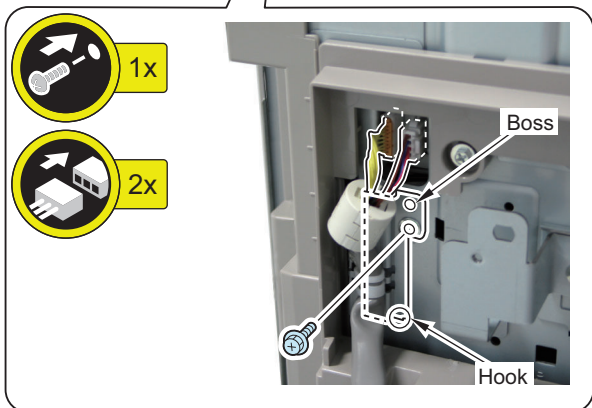
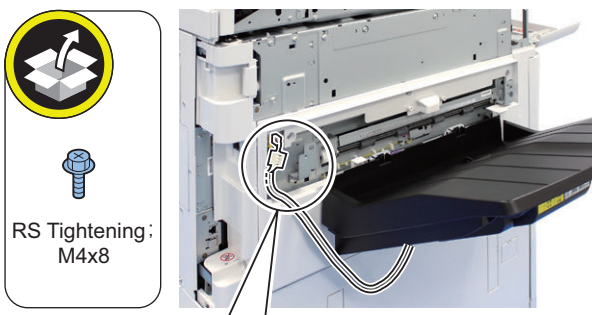

14. Remove the tapes, and install the Shift Drive Unit.

- 2 Screws (Binding; M4x6)
- 3 Rubber Caps

CAUTION:
Be sure to put the harness for connecting to the host machine into the groove when installing the unit.

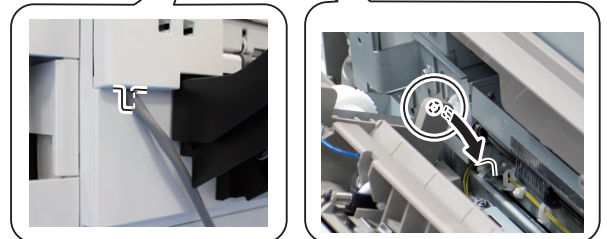
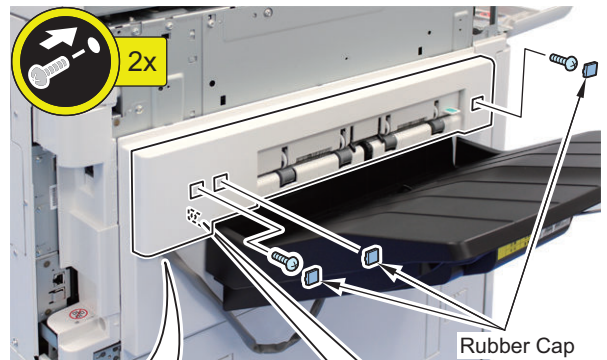
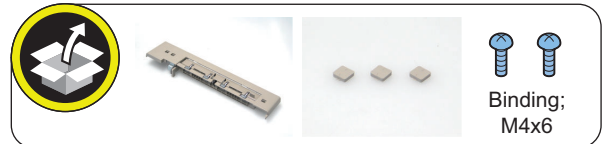

15. Install the Left Upper Cover.

- 3 Protrusions
- 3 Hooks
- 3 Screws

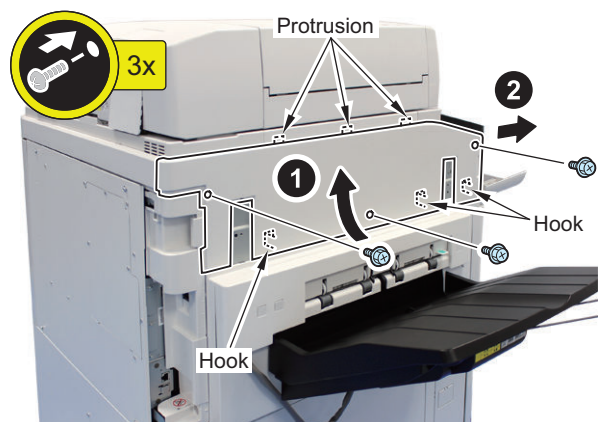



16. Using a flat-blade screwdriver, remove the Face Cover from the Delivery Cover removed in step 5 (the Delivery Cover will not be used).

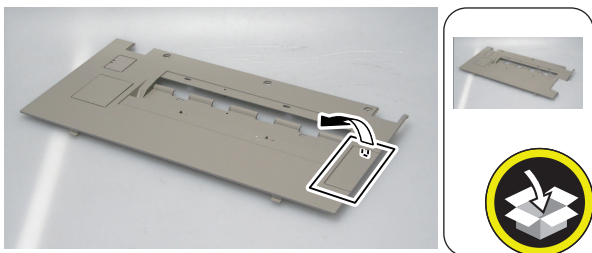

17. Install the Face Cover removed in the previous step and the Face Cover included in the package.

- 1 Protrusion for each
- 1 Claw for each



18. Close the Toner Replacement Cover.



19. Return the Left Rear Cover to their original position.

Checking after Installation



1. Connect the power plug of the host machine to the power outlet.
2. Turn ON the main power switch.
3. Press the counter check key on the control panel.
4. Press [Check Device Configuration].
5. Check that "Shift Tray-F1" is displayed in option field.

Document Insertion Unit-P1, Document Insertion/Folding Unit-J1

Checking Before Installation

The following conditions are required for the installation site. Therefore, it is recommended to see the installation site in advance before delivering this equipment to the user's site.

■ Checking the Power Supply

1. Check that this equipment is connectable to the outlet independently which supplies the rated voltage within +10/-15% at the specified ampere or higher.
2. When connecting the power plug of this equipment to an outlet, be sure to use an outlet of a system different from that of the host machine.
3. Install this equipment near the power outlet and leave sufficient space around the power plug so that it can be unplugged easily in an emergency.

■ Points to Note on installation

Exercise following caution for installation.

- This equipment is so heavy (Document Insertion Unit: approx. 40kg, Document Insertion/Folding Unit: approx. 76kg). Be sure to work in a group of 3 persons or more.
- When moving this equipment after having unpacked it, be careful by placing a plate, etc. on areas with steps to prevent the casters from hitting those steps. If the casters hit a step, the casters or the base plate may be deformed.

■ Product Name

Safety regulations require the product's name to be registered. In some regions where this product is sold, the following name may be registered instead.

Document Insertion Unit: F281300, Document Insertion/Folding Unit: F281310

Unpacking

■ Unpacking Procedure

NOTE:

The equipment is secured by tapes, cushioning and other materials to protect it from vibration and impact during transit. Remove all such tapes and cushioning materials as instructed below before installing the equipment. Keep all fixings in a safe place for later reuse in reshipping the equipment, as for relocation and repairs.



1. Take out the accessory box from the cushioning materials.

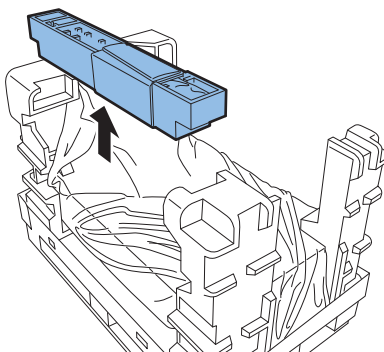

CAUTION:

Don't remove 4 cushioning materials because it may cause to deform this equipment. Otherwise, you would likely deform some areas of this equipment.

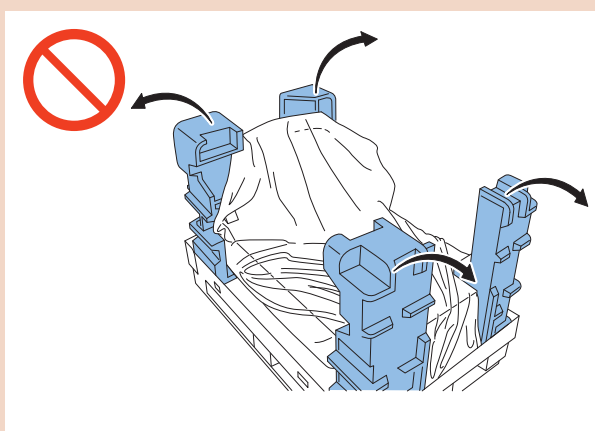

2. Lift the equipment together with the pallet.

CAUTION:

- Be sure not to have the equipment itself because it may cause to deform or damage the equipment. Do not hold the tray of the Inserter.
- This equipment is so heavy (Document Insertion Unit: approx. 40kg, Document Insertion/Folding Unit: approx. 76kg). Be sure to work in a group of 3 persons or more.

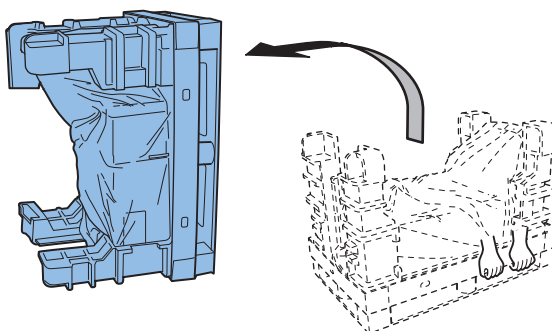



3. Remove the pallet and cushioning materials. Then, put the plastic cover down to the position shown.

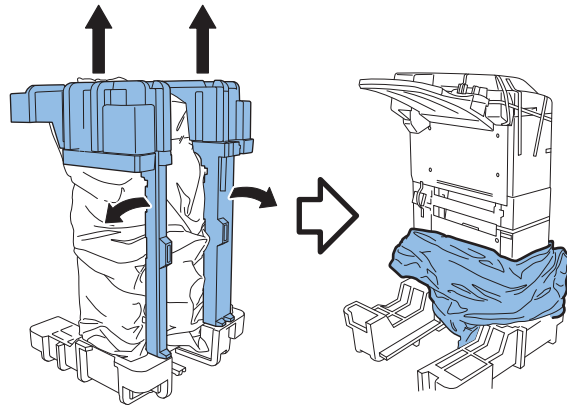

4. Lift the front and rear side lightly to remove the cushioning materials and plastic cover.

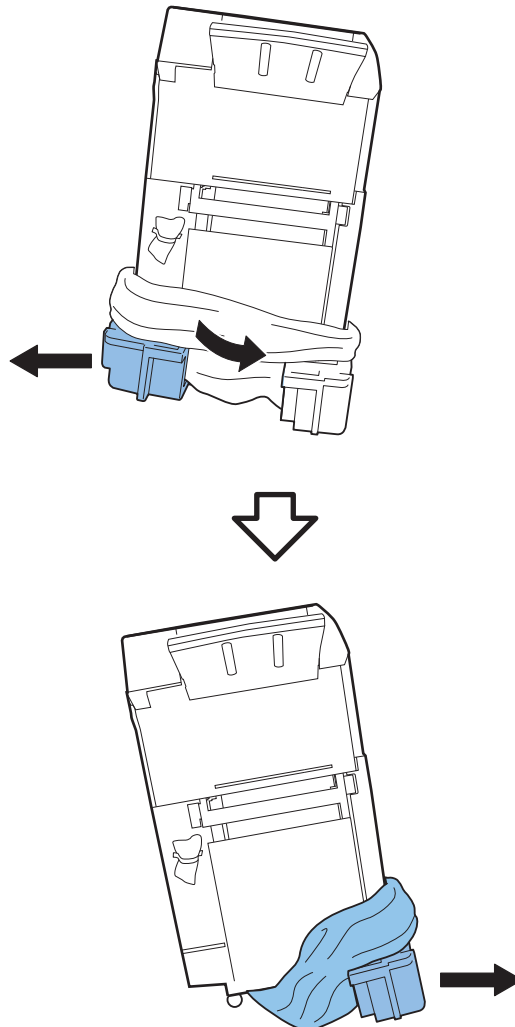

5. Remove the tapes used outside of this equipment.

NOTE:

In the case of the Document Insertion/Folding Unit, be sure not to remove the tapes from the Folder Unit because those are removed later.

■ Unpacking Procedure on the Folder Unit (for Document Insertion/Folding Unit)



1. Open the Front Upper Cover.

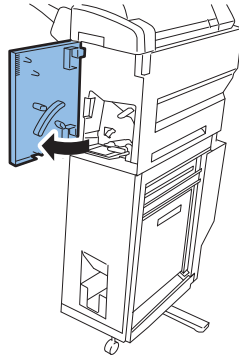

2. Holding the Jam Removal Lever, raise the Transfer Guide, and pull out the Folder Unit.

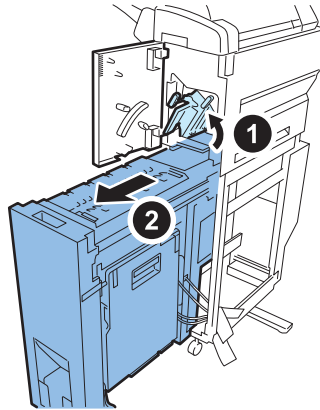



3. Remove all tapes from the Folder Unit and open the Folder Guide Plate (Right) fully (at two levels).

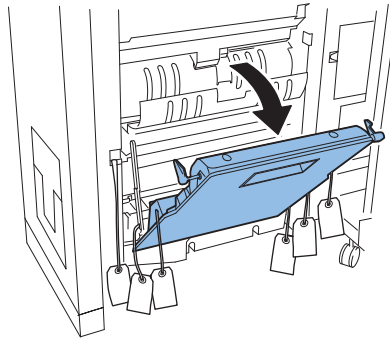

CAUTION:

The 2 screws (pointed by screwdrivers) at the front and rear are used to adjust the Folding Roller Pressure. Never loosen these screws.

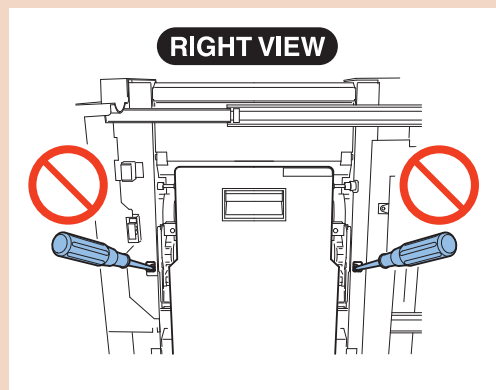

**4. Remove the 3 fixings on the front side of the folder unit.****CAUTION:**

The Folder Guide Plate (Right) must be opened fully when removing the fixings. Do not pull them out forcibly.

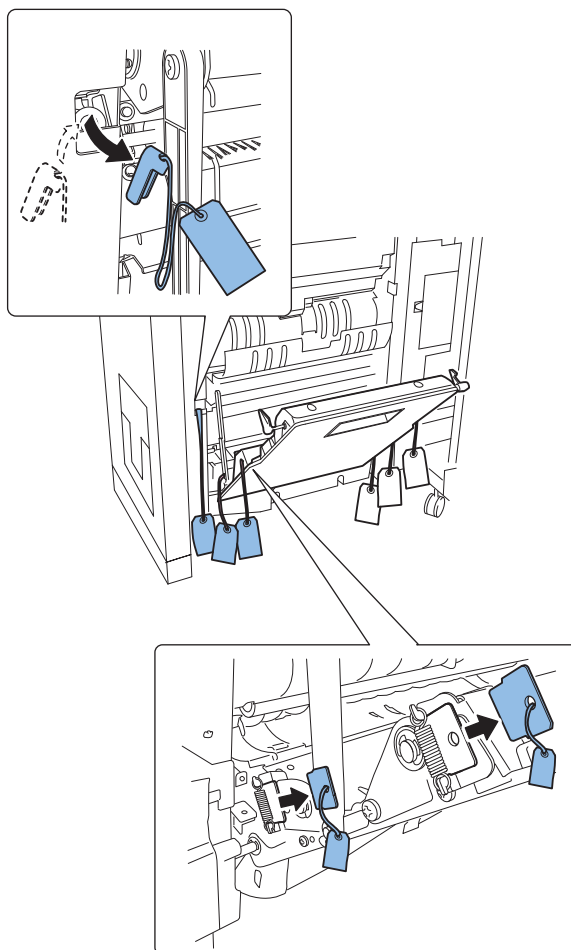

**5. Remove the 3 Fixings on the rear side of the folder unit.****CAUTION:**

The Folder Guide Plate (Right) must be opened fully when removing the Fixings. Do not pull them out forcibly.

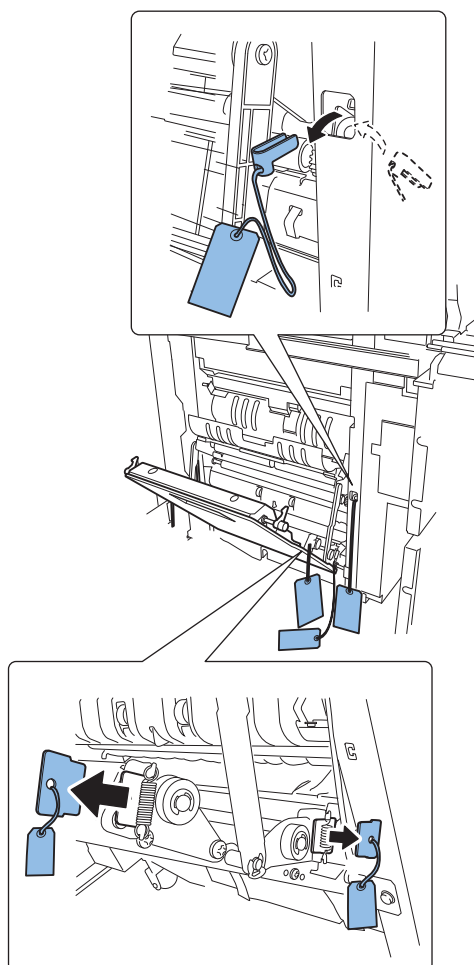



6. Close the Folder Guide Plate (Right) and return the Folder Unit to the original position. Then, holding the Jam Removal Lever, lower the Transfer Guide.

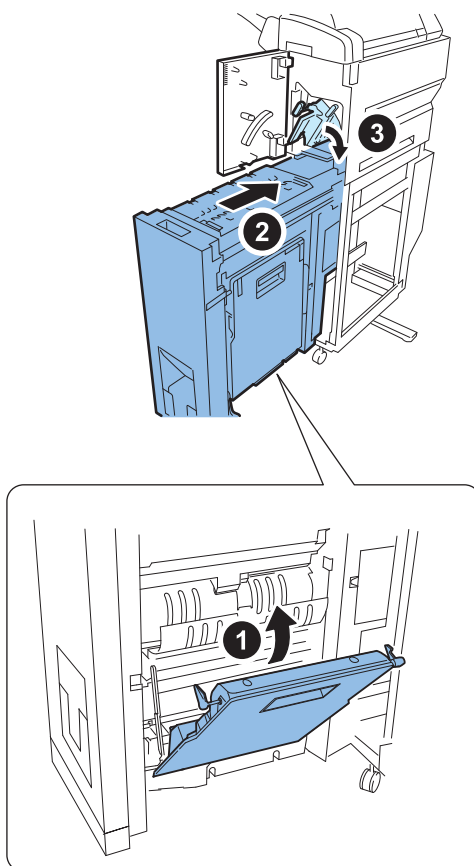

7. Close the Front Upper Cover.

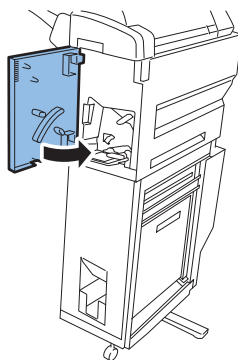

● Checking Bundled Components

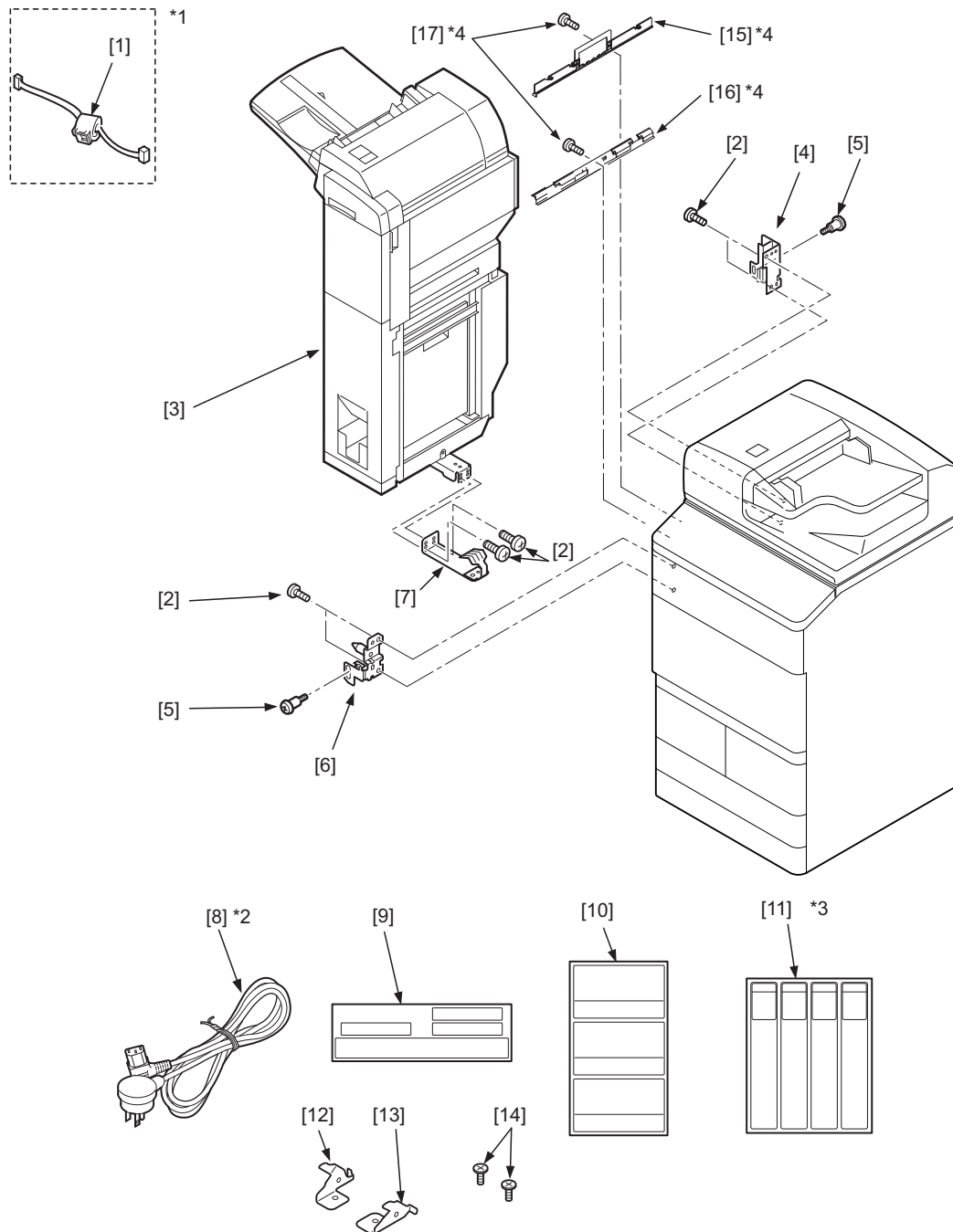

- [1] Relay Connector (for Finisher) 1pc. *1
- [2] Screw (Binding; M4x7) 6pcs.
- [3] Document Insertion Unit or Document Insertion/Folding Unit 1pc.
- [4] Fixing Plate (Rear) 1pc.
- [5] Screw (Stepped Screw; M4x5) 2pcs.
- [6] Fixing Plate (Front) 1pc.
- [7] Ground Plate Unit 1pc.
- [8] Power Cord 1pc. (for 120V model), 3pcs. (for 230V model) *2
- [9] Document Setting Label 1pc.
- [10] Document Prohibition Label 1pc.
- [11] Jam Removal Label 1pc. *3
- [12] Stopper (Rear) 1pc.
- [13] Stopper (Front) 1pc.
- [14] Screw (Flat Head Screw; M3x5) 2pcs.
- [15] Delivery Tray (U) 1pc. *4
- [16] Delivery Tray (L) 1pc. *4

[17] Screw (P Tightening; M4x12) 2pcs. *4

*1: Use the part [1] when connecting this equipment and the Finisher. (Refer to Finisher Installation Procedure.)

*2: The package may contain several power cords intended for use in Europe. Use the correct power cord to match the location/ area of installation. Make sure not to leave unused power cords at the site.

*3: The part [11] is supplied with the Document Insertion/Folding Unit only.

*4: The part [15], [16] and [17] are supplied with the Finisher.

Installation Procedure

■ Preparation of this Equipment

1. Mount the Ground Plate Unit.

- 2 Screws (Binding; M4x7)

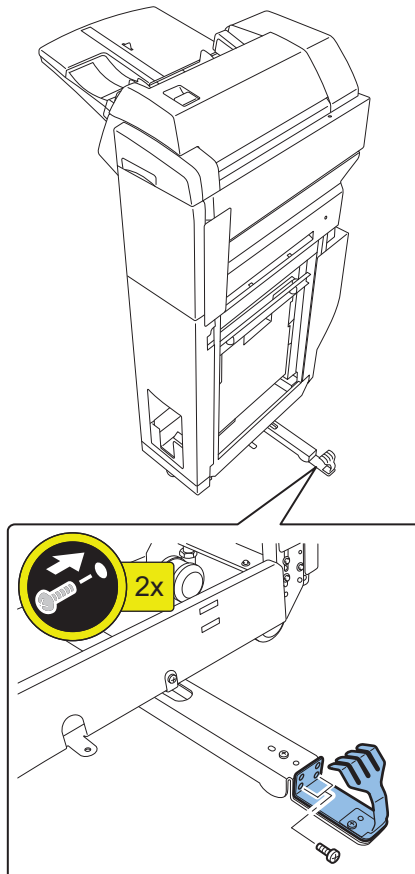

■ Preparing of the Host Machine



1. Remove the 2 covers. (Removed covers are not reused.)

- 2 Claws

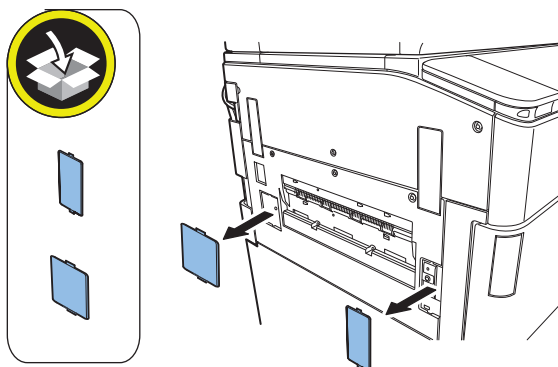

2. Install the Fixing Plates (Front/Rear).

- 4 Screws (Binding; M4x7)

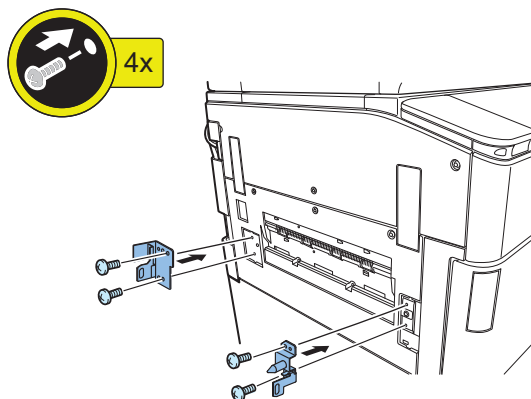
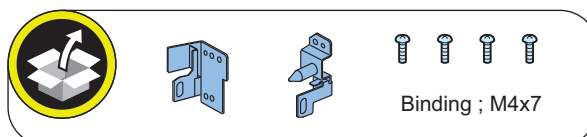

3. Mount the Delivery Tray (U) which is supplied with the Finisher.

- 3 Hooks
- 1 Screw (P Tightening; M4x12) (supplied with the Finisher)

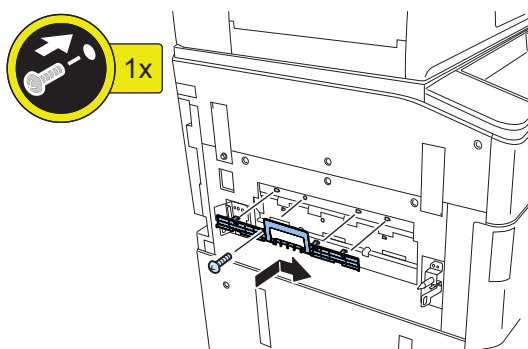

**4. Mount the Delivery Tray (L) which is supplied with the Finisher.**

- 2 Hooks
- 2 Screws (P Tightening; M4x12) (supplied with the Finisher)

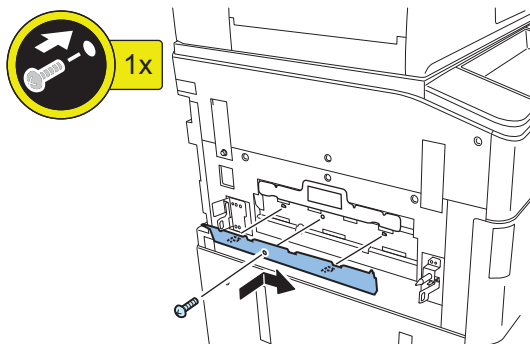
**5. Open the Feeder Cover, and then remove the screws.**

- 3 Screws

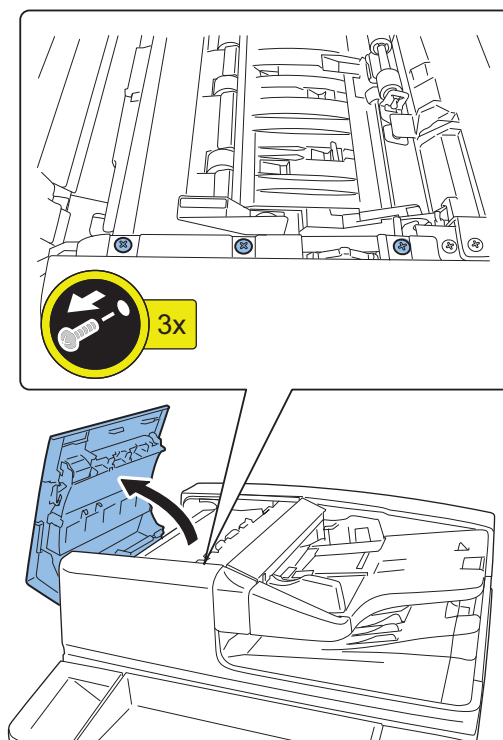
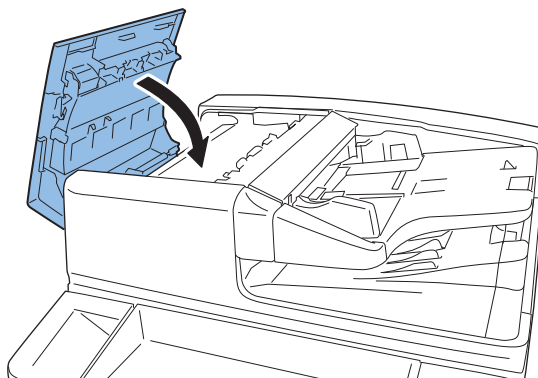
**6. Close the Feeder Cover.**

**7. Open the ADF, and then remove the ADF Front Cover.**

- 2 Screws [A] Binding [B] P Tightening
- 2 Claws

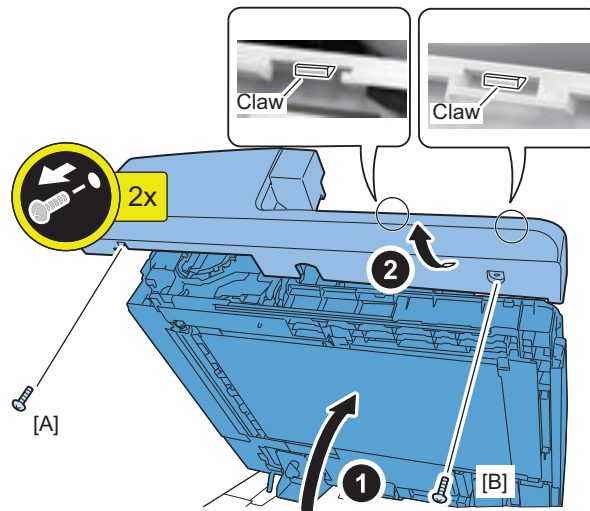
**8. Remove the ADF Left Lower Cover.**

- 2 Screws
- 3 Claws

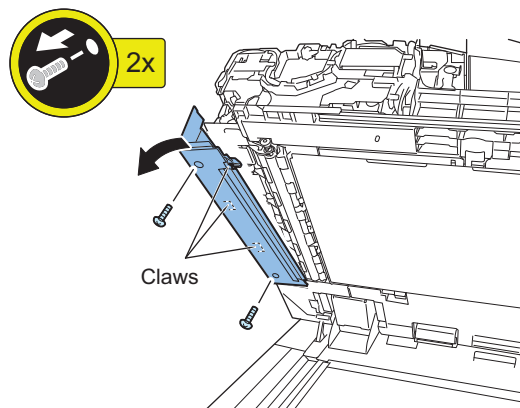



9. At the rear part of the ADF, install the Stopper (Rear).

- 1 Screw (Flat Head Screw; M3x5)

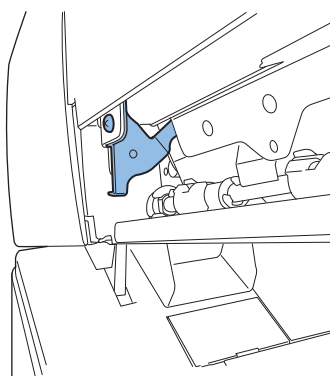
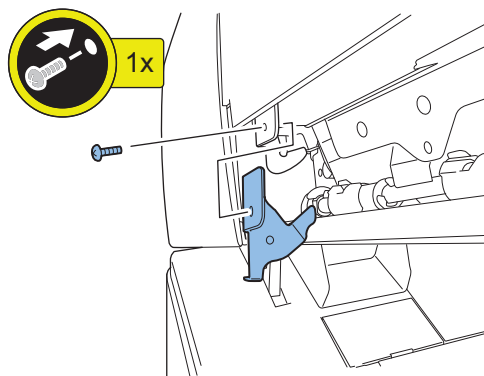
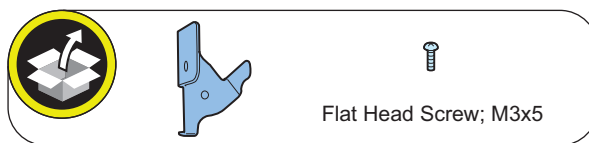

**10. At the front part of the ADF, install the Stopper (Front).**

- 1 Screw (Flat Head Screw; M3x5)

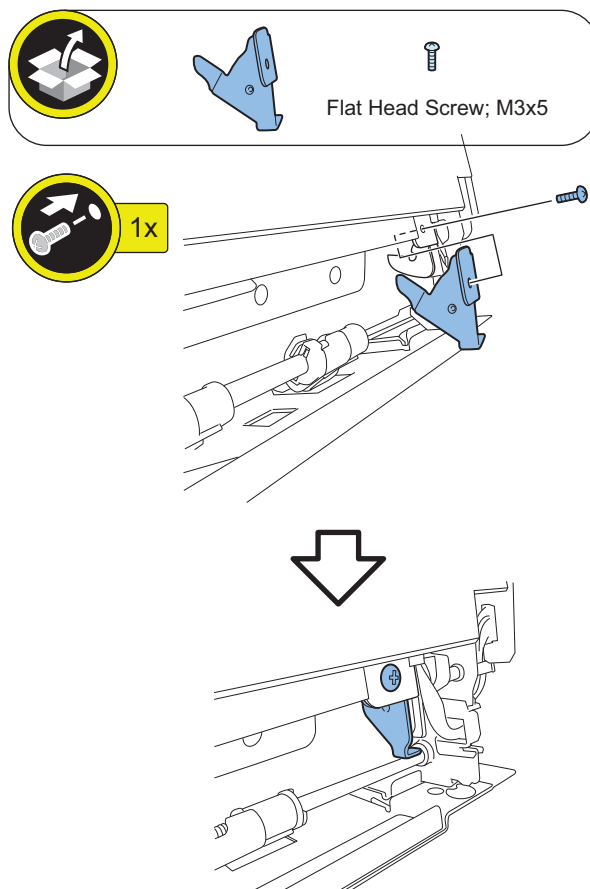
**11. Install the ADF Left Lower Cover.**

- 2 Screws
- 3 Claws

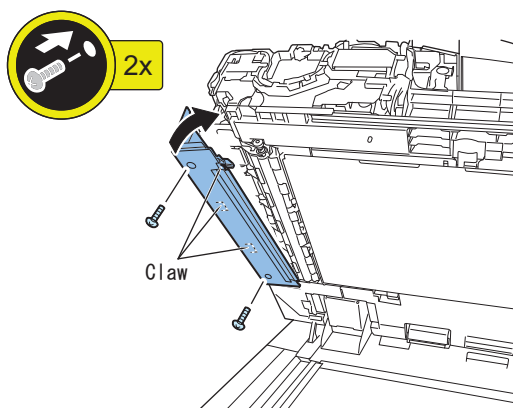



12. Install the ADF Front Cover, and then close the ADF.

- 2 Screws [A] Binding [B] P Tightening
- 2 Claws

NOTE:

When install the ADF Front Cover, be careful not to make a mistake in the screw to use.

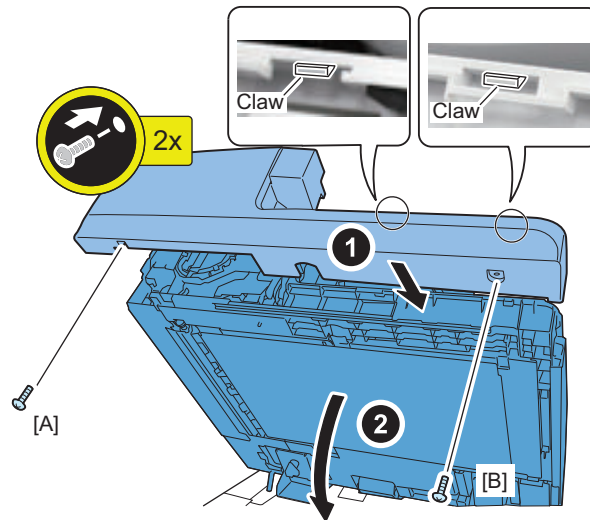

13. Open the Feeder Cover, and then install the screws.

- 3 Screws

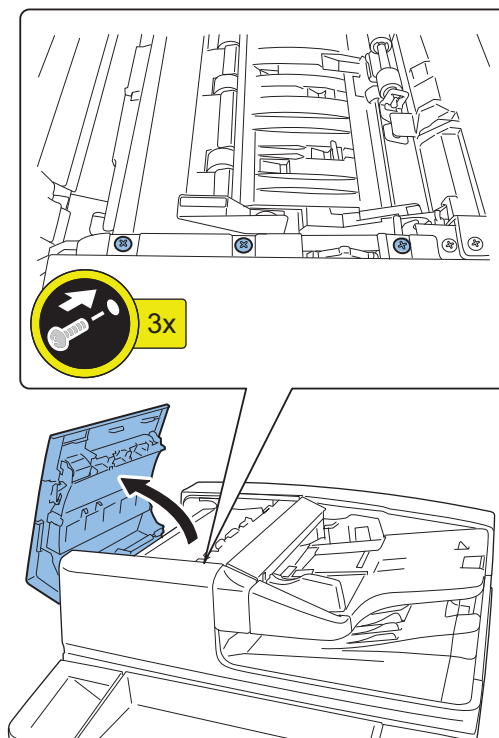



14. Close the Feeder Cover.

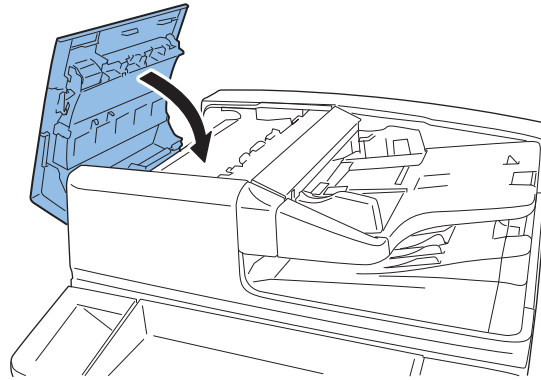

■ Connecting to the Host Machine (for Document Insertion Unit)



1. Fit the pin of the Fixing Plate (Front) on the Host Machine in the slot on this equipment.

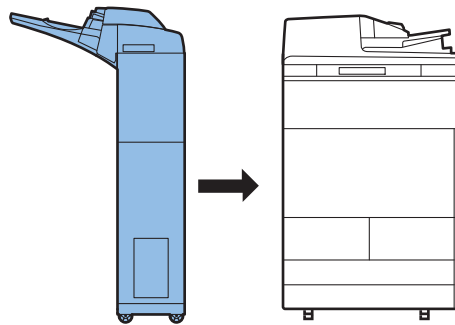

2. Open the Inserter Pickup Unit and the Front Upper Cover.

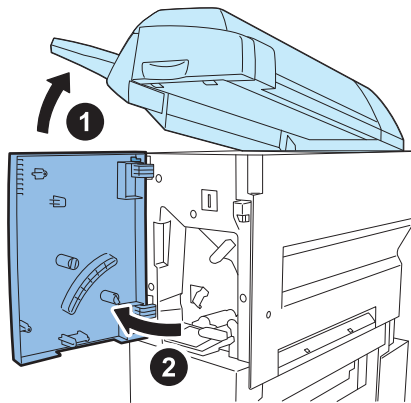



3. Remove the Front Upper Cover, and then holding the Jam Removal Lever, raise the Transfer Guide.

- 1 Clip

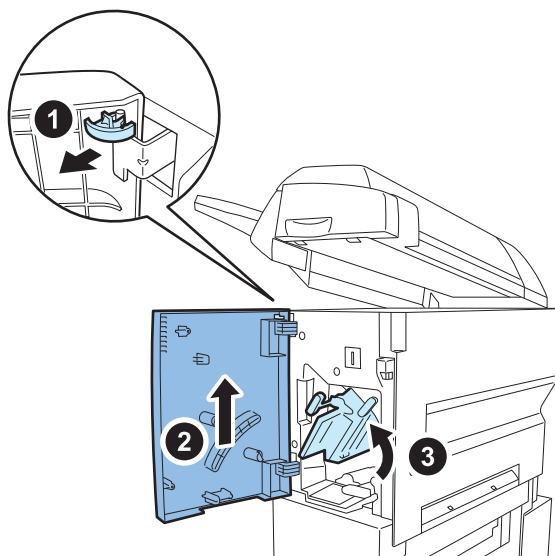

4. Remove the Front Lower Cover.

- 1 Screw

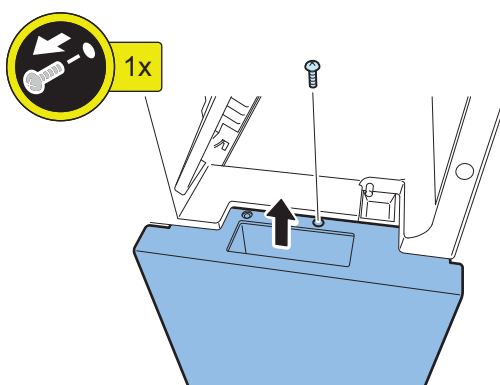



5. Check whether the screw hole is between the upper marking-off line and the lower marking-off line on the Fixing Plate (Front).

NOTE:

If the screw hole is not positioned between the marking-off lines, carry out the adjustment described in "Adjusting the Height and Tilt."

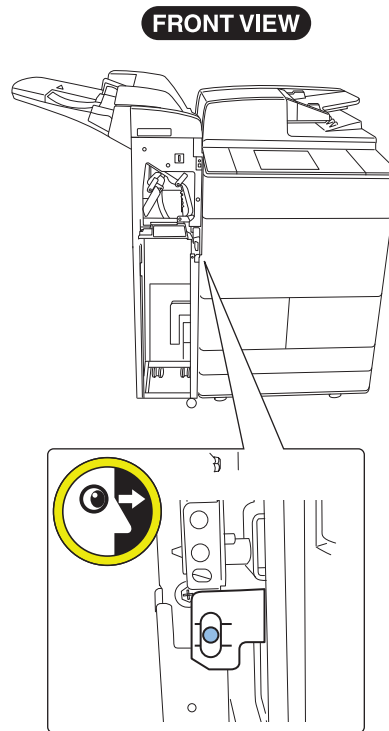



6. Check whether the screw hole is between the upper marking-off line and the lower marking-off line on the Fixing Plate (Rear).

NOTE:

If the screw hole is not positioned between the marking-off lines, carry out the adjustment described in "Adjusting the Height and Tilt."

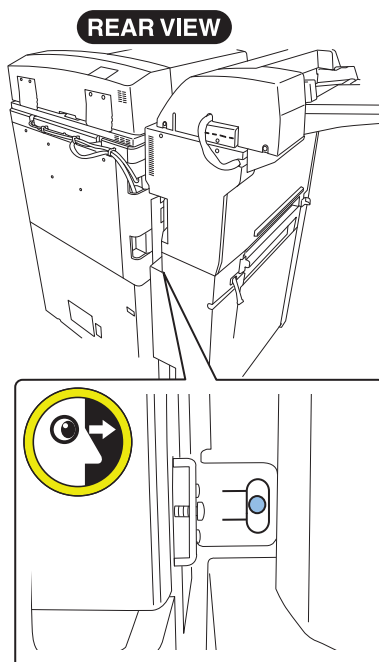

7. Fix the Fixing Plate (Rear) in place to this equipment.

- 1 Screw (Stepped Screw; M4x5)

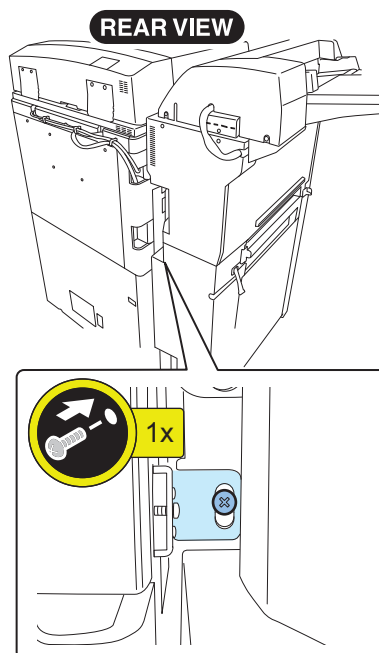
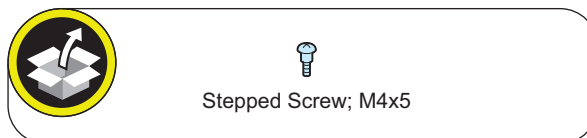



8. Fix the Fixing Plate (Front) in place to this equipment.

- 1 Screw (Stepped Screw; M4x5)



Stepped Screw; M4x5

FRONT VIEW

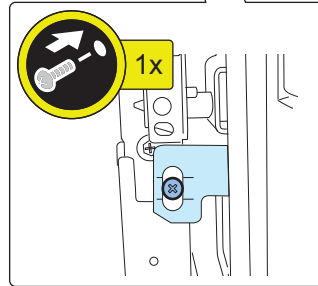
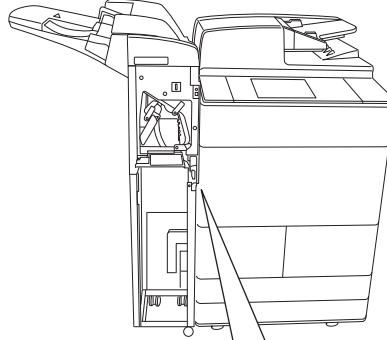



9. Attach the Front Lower Cover by engaging to the hook.

- 1 Screw

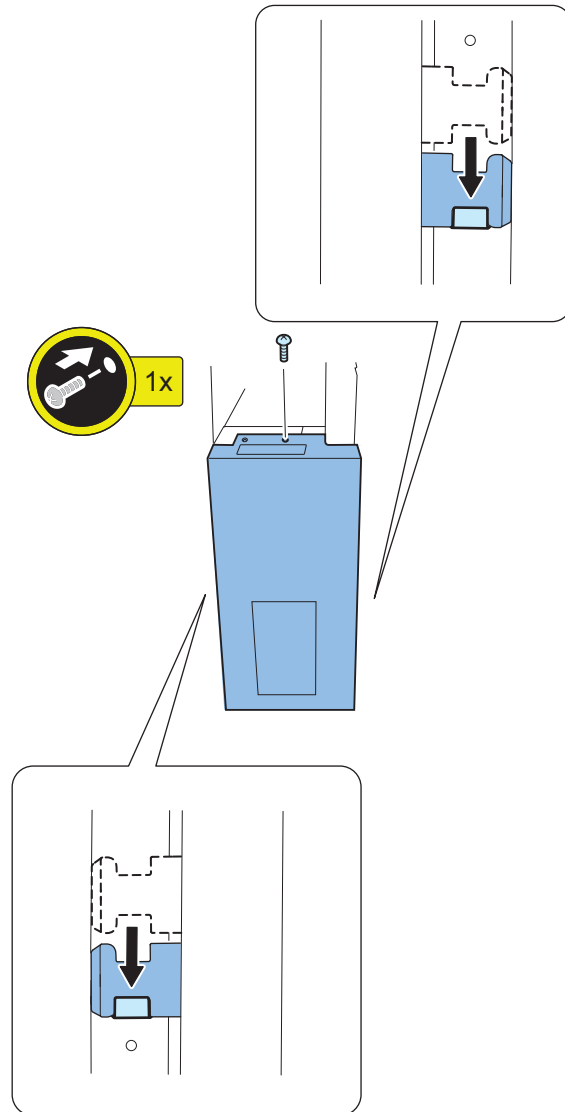



10. Holding the Jam Removal Lever, lower the Transfer Guide, and then install the Front Upper Cover.

- 1 Clip

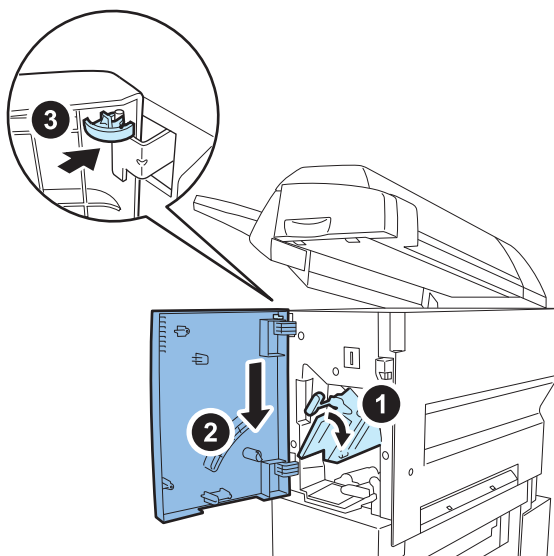

11. Close the Front Upper Cover and the Inserter Pickup Unit.

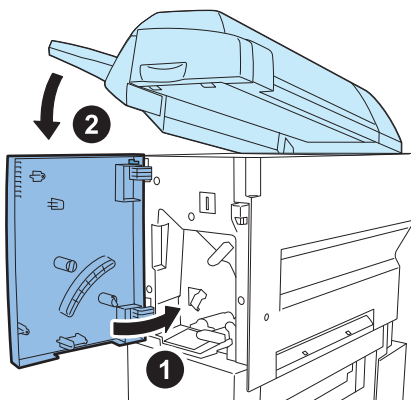

■ Connecting to the Host Machine (for Document Insertion/Folding Unit)



1. Fit the pin of the Fixing Plate (Front) on the Host Machine in the slot on this equipment.

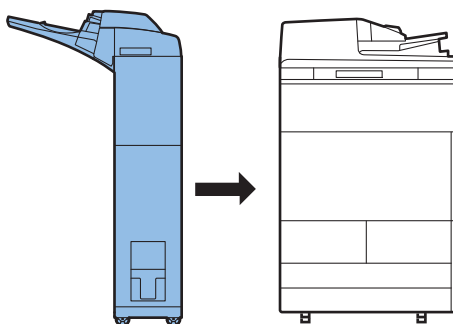



2. Open the Front Upper Cover.

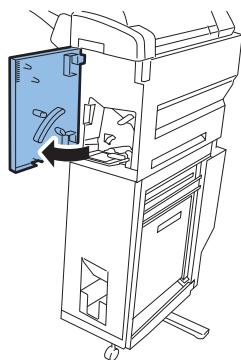

3. Holding the Jam Removal Lever, raise the Transfer Guide, and pull out the Folder Unit.

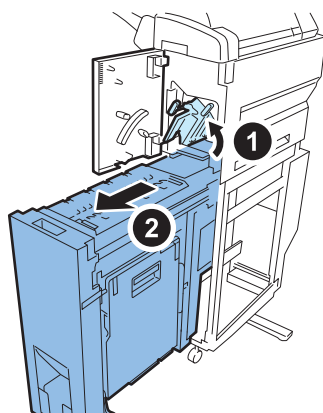



4. Check whether the screw hole is between the upper marking-off line and the lower marking-off line on the Fixing Plate (Front).

NOTE:

If the screw hole is not positioned between the marking-off lines, carry out the adjustment described in "Adjusting the Height and Tilt."

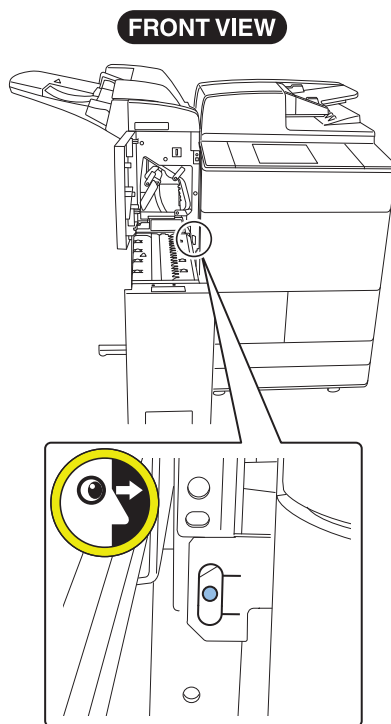



5. Check whether the screw hole is between the upper marking-off line and the lower marking-off line on the Fixing Plate (Rear).

NOTE:

If the screw hole is not positioned between the marking-off lines, carry out the adjustment described in "Adjusting the Height and Tilt."

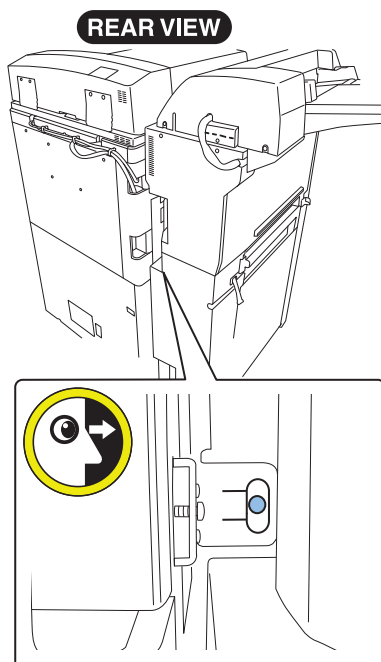

6. Fix the Fixing Plate (Rear) in place to this equipment.

- 1 Screw (Stepped Screw; M4x5)

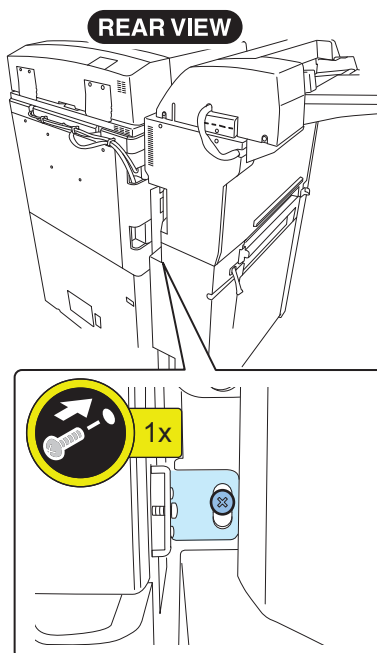
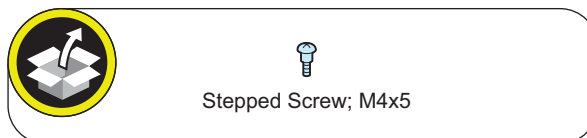

**7. Fix the Fixing Plate (Front) in place to this equipment.**

- 1 Screw (Stepped Screw; M4x5)

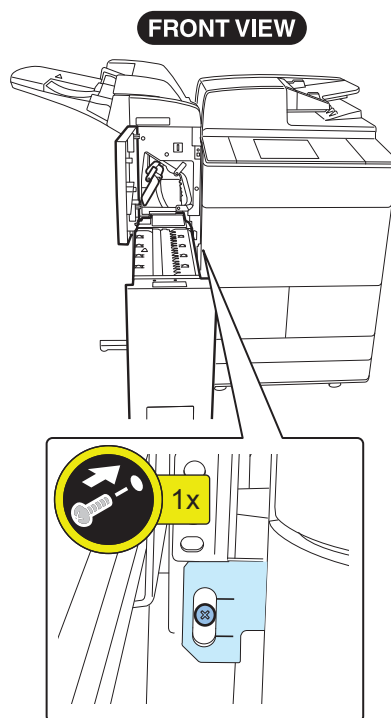
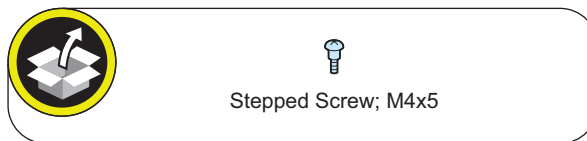
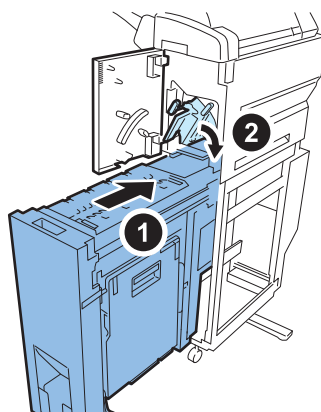
**8. Return the Folder Unit to the original position, and then holding the Jam Removal Lever, lower the Transfer Guide.**

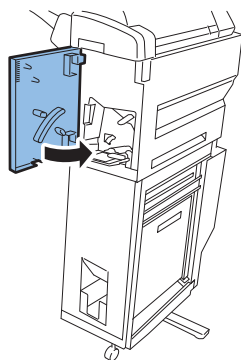
**9. Close the Front Upper Cover.****■ Connecting to the Power Cord****1. Insert the Power Cord into the equipment. Connect the plug end of the Power Cord into an external power outlet.****⚠ CAUTION:**

Make sure that the Power Cord is fully connected to the outlet. If the connection is not right, an accident causing the smoke or fire may occur.

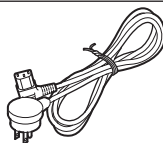
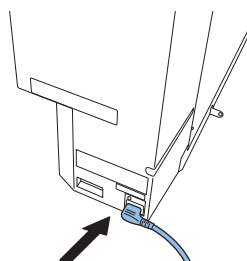
**REAR VIEW**

■ Attaching the Document Setting Label and Document Prohibition Label



1. Affix the Document Setting Label [1] and Document Prohibition Label [2] to the Inserter.

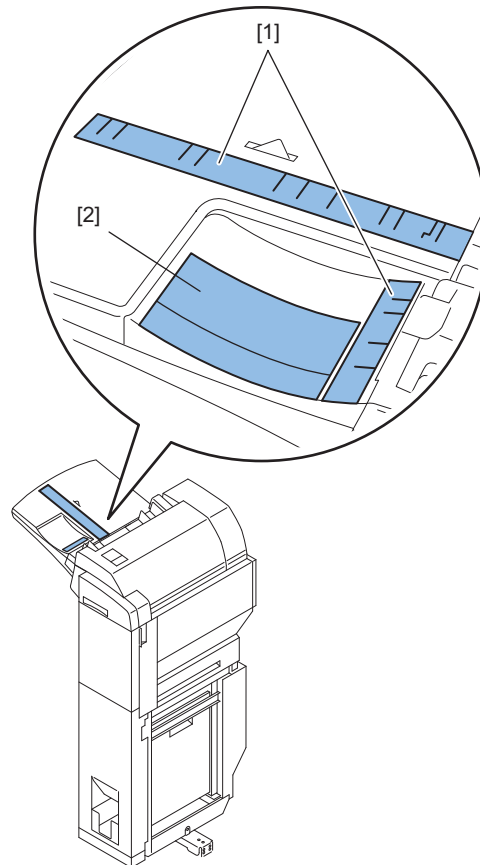
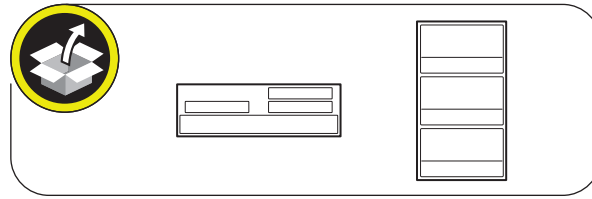

■ Attaching the Jam Removal Label (for Document Insertion/Folding Unit)



1. Open the Front Upper Cover.

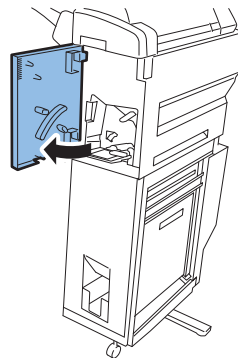



2. Holding the Jam Removal Lever, raise the Transfer Guide, and pull out the Folder Unit.

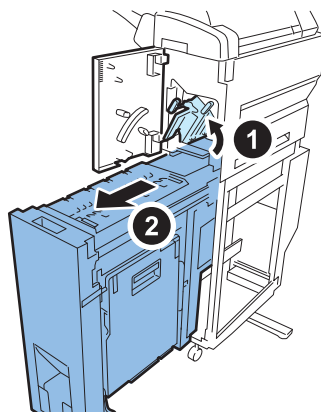

3. Open the Transfer Guide (Right), and then affix the Jam Removal Label.

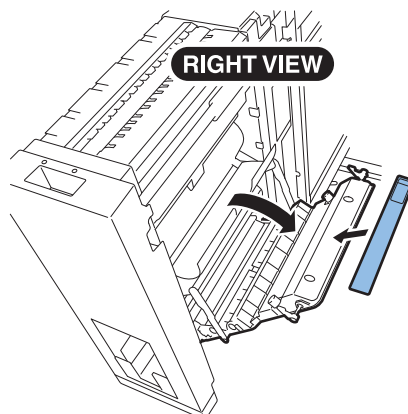
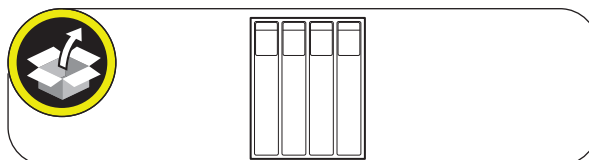

- 4. Close the Folder Guide Plate (Right) and return the Folder Unit to the original position. Holding the Jam Removal Lever, lower the Transfer Guide.

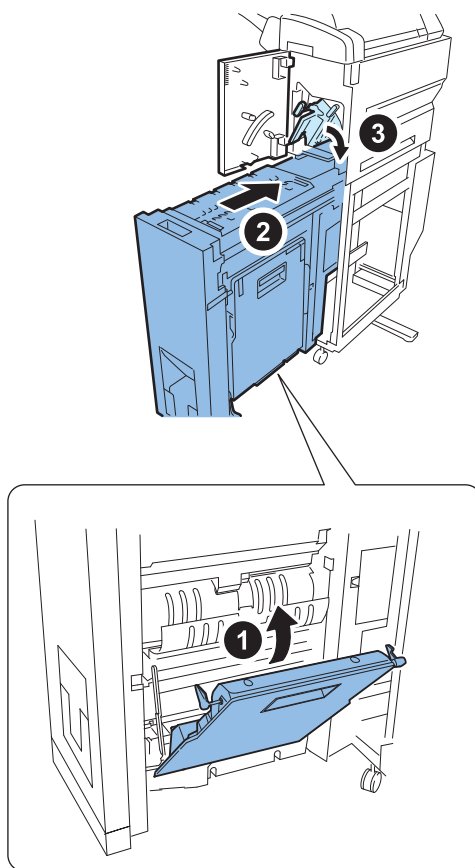

- 5. Close the Front Upper Cover.

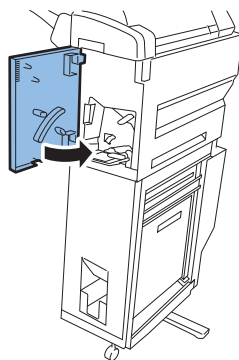

Operation Checks



1. After the completion of all installations, check that the Leakage Breaker is turned ON.

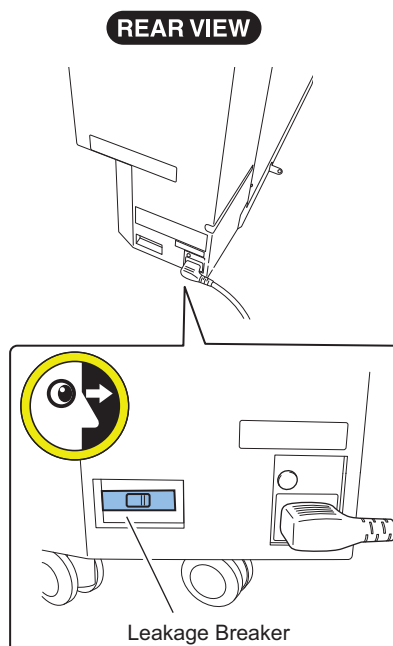

2. Turn on the Host Machine.



3. Confirm that the combination of the firmware version for the Host Machine and the equipment is appropriate.



4. Check the insertion operation from the tray.



5. Check the Z-folding, C-folding operation (Document Insertion/Folding Unit only).

Adjusting the Height and Tilt

CAUTION:

Depending on the condition of the floor of the site of installation, you may need to adjust the height and tilt of the equipment. Carry out the following procedure to adjust the height and tilt of the equipment.

■ Removing the Wrench (for the Document Insertion Unit)

If it is necessary to use the Wrench for “Adjusting the Heights and Tilt”, remove the Wrench according to the following procedures.



1. Remove the Wrench.

- 1 Screw

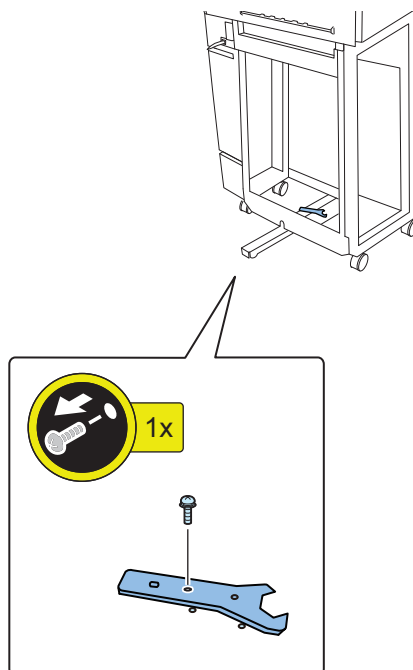

■ Removing the Wrench (for Document Insertion/Folding Unit)

If it is necessary to use the Wrench for “Adjusting the Heights and Tilt”, remove the Wrench according to the following procedures.



1. Disconnect this equipment from the Host Machine.

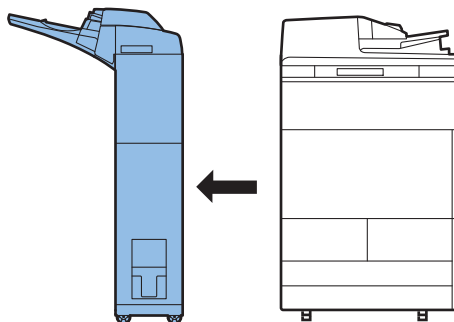

2. Open the Front Upper Cover.

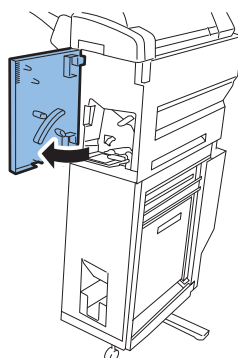



3. Holding the Jam Removal Lever, raise the Transfer Guide, and pull out the Folder Unit.

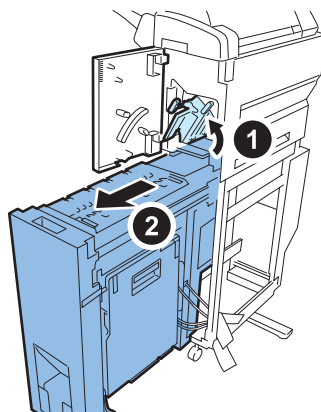

4. Remove the Wrench.

- 1 Screw

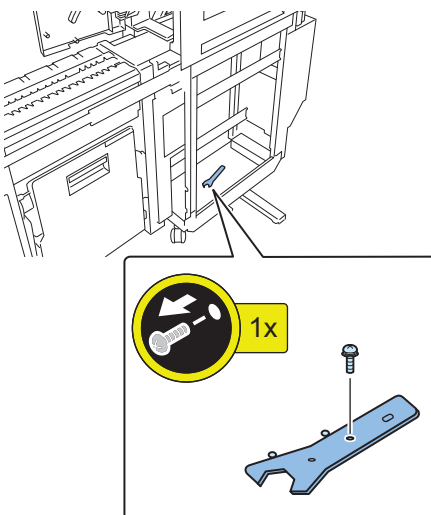

5. Return the Folder Unit to the original position, and then holding the Jam Removal Lever, lower the Transfer Guide.

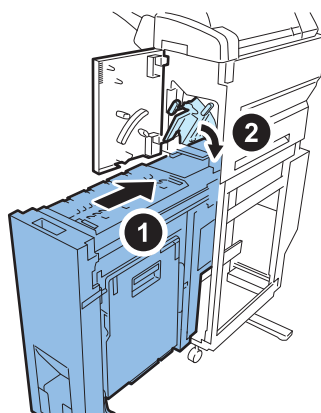



6. Close the Front Upper Cover.

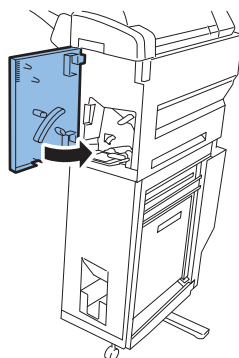

■ Adjusting the Height

CAUTION:

When have performed the procedure of "Adjusting the Height", be sure to perform the procedure of "Adjusting the Caster Roller Height of the Folding Unit". (Document Insertion/Folding Unit only)



1. Fit the pin of the Fixing Plate (Front) on the Host Machine in the slot on this equipment. (Document Insertion/Folding Unit only)

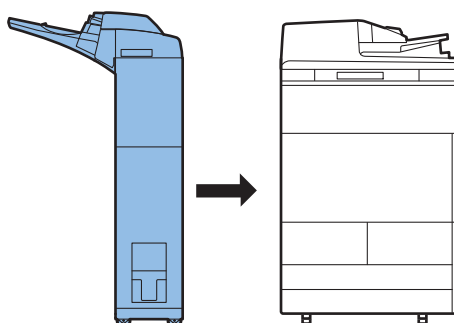

2. Open the Front Upper Cover. (Document Insertion/Folding Unit only)

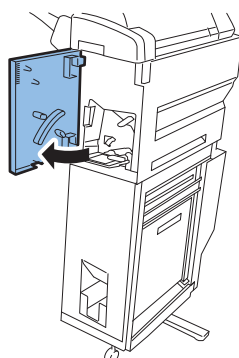



3. Holding the Jam Removal Lever, raise the Transfer Guide. (Document Insertion/Folding Unit only)

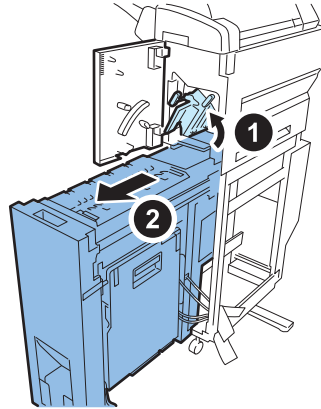

4. Loosen the nut [1] on the Caster of the front side (upstream equipment side). Then turn the nut [2] to adjust the height.

NOTE:

- Turn the nut [1] clockwise (direction of arrow [B]) to loosen.
- Turn the nut [2] counterclockwise (direction of arrow [A]) to reduce the height of the equipment and clockwise (direction of arrow [B]) to increase the height of the equipment.

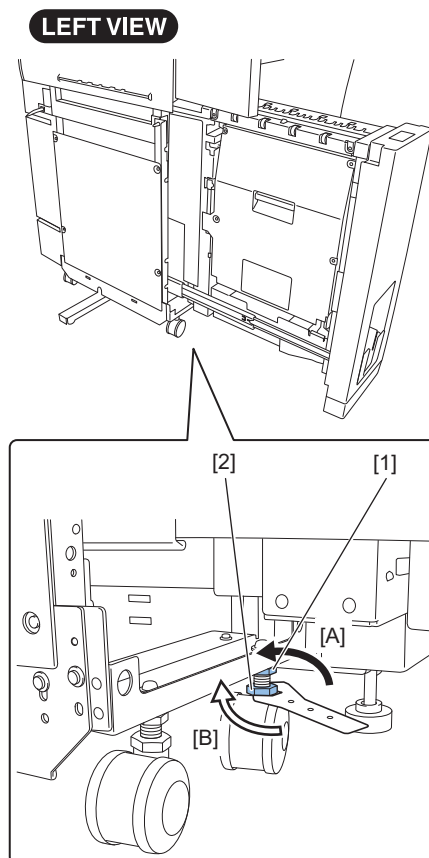



5. Loosen the nut [1] on the Caster of the rear side (upstream equipment side). Then turn the nut [2] to adjust the height.

NOTE:

- Turn the nut [1] clockwise (direction of arrow [B]) to loosen.
- Turn the nut [2] counterclockwise (direction of arrow [A]) to reduce the height of the equipment and clockwise (direction of arrow [B]) to increase the height of the equipment.

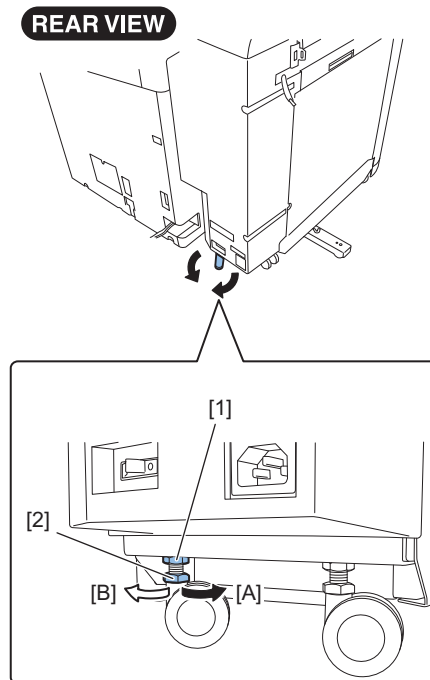

6. After adjustment, tighten the front and rear nuts [1] of the Caster (upstream equipment side).

■ Adjusting the Tilt



1. Loosen the nut [1] on the Caster of the front side (paper ejection side). Then turn the nut [2] to adjust the tilt.

NOTE:

- Turn the nut [1] clockwise (direction of arrow [B]) to loosen.
- Turn the nut [2] counterclockwise (direction of arrow [A]) to tilt toward the paper ejection side, and clockwise (direction of arrow [B]) to tilt toward the upstream equipment side.

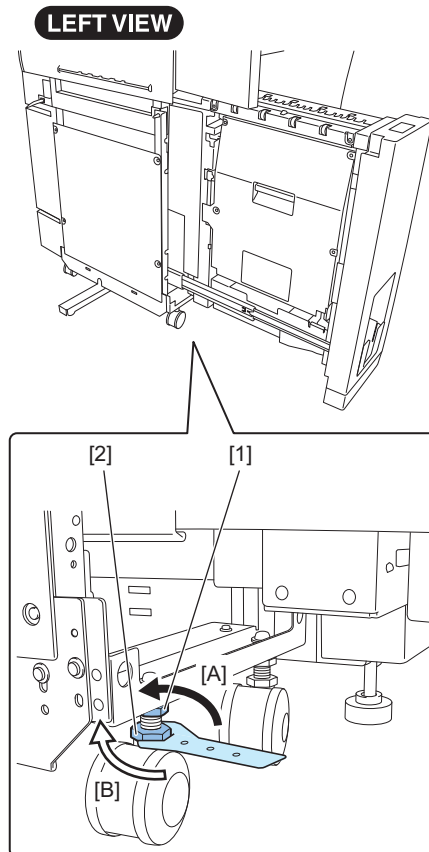



2. Loosen the nut [1] on the caster of the front side (rear side). Then turn the nut [2] to adjust the tilt.

NOTE:

- Turn the nut [1] clockwise (direction of arrow [B]) to loosen.
- Turn the nut [2] counterclockwise (direction of arrow [A]) to tilt toward the paper ejection side, and clockwise (direction of arrow [B]) to tilt toward the upstream equipment side.

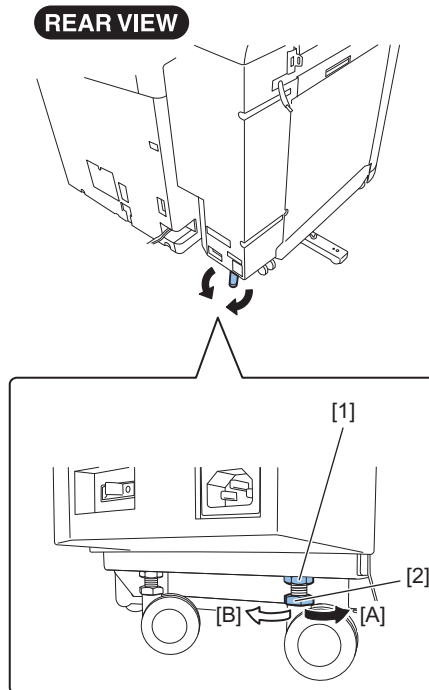

3. After adjustment, tighten the front and rear nuts [1] of the Caster (paper ejection side).

■ Adjusting the Caster Roller Height of the Folding Unit (for Document Insertion/ Folding Unit)



1. Remove the Folder Front Cover.

- 2 Screws

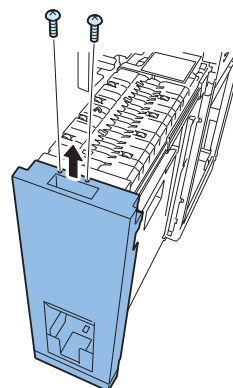

2. Return the Folder Unit to the original position.



3. Loosen the 2 screws of the Caster Roller.

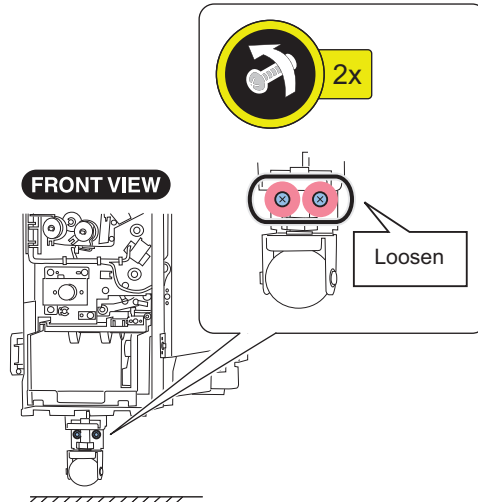

4. Adjust the height of the Caster Roller by turning the nut so that the space between the Caster Roller and the floor becomes about 1 mm.

NOTE:

Turn the nut [2] counterclockwise (direction of arrow [A]) to increase the height of the Caster Roller, and clockwise (direction of arrow [B]) to reduce the height of the Caster Roller.

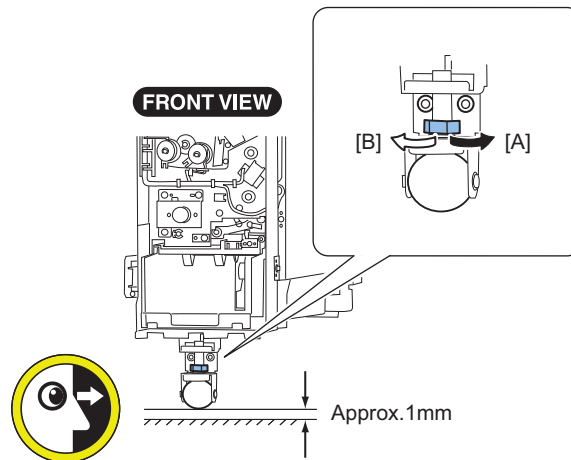



5. After adjustment, tighten the 2 screws of the Caster Roller.

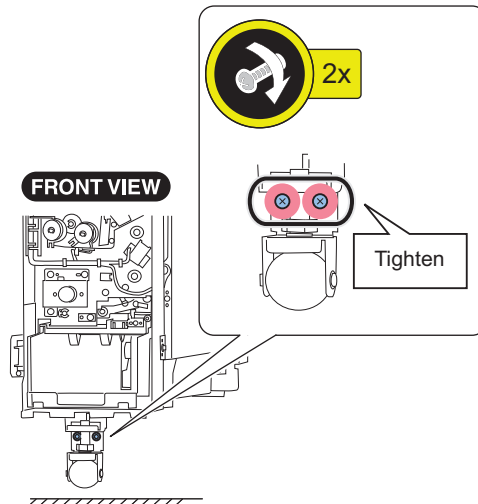

6. Pull out the Folder Unit, and then attach the Folder Unit Cover by engaging to the hook.

- 2 Screws (Binding ; M4x7)

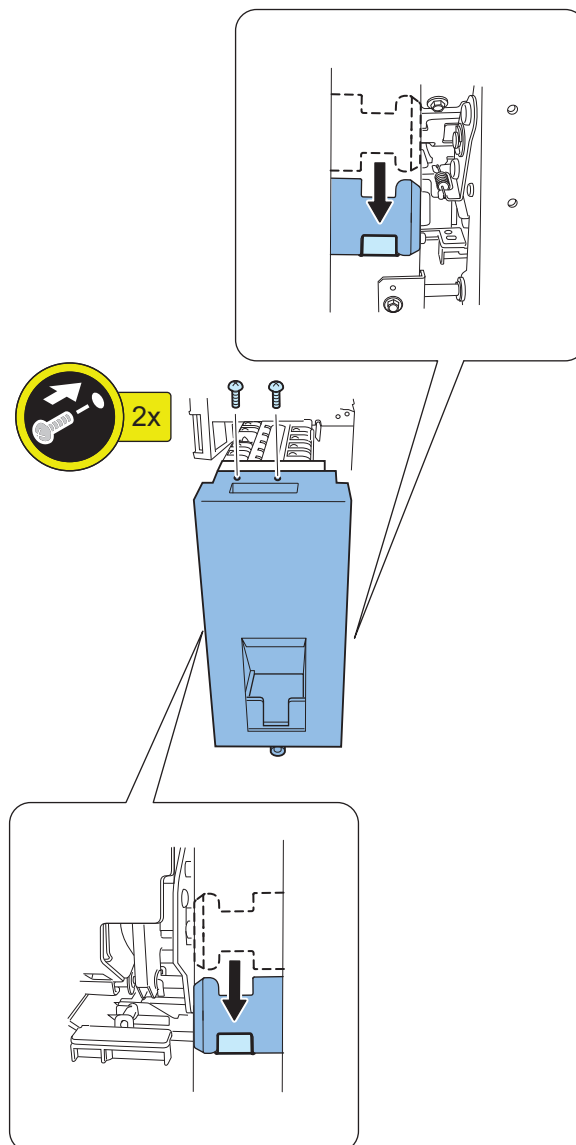



7. Return the Folder Unit to the original position, and then holding the Jam Removal Lever, lower the Transfer Guide.

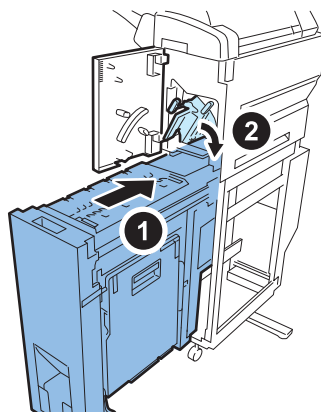

8. Close the Front Upper Cover.

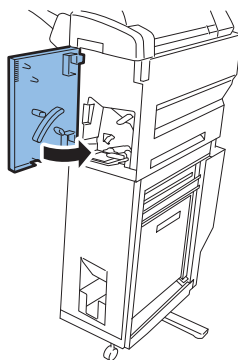

■ Storing the Wrench (for Document Insertion Unit)

NOTE:

After store the wrench, perform “Connecting to the Host Machine” procedure.



1. Store the wrench at the original position.

- 1 Screw (W Sems; M4x8)

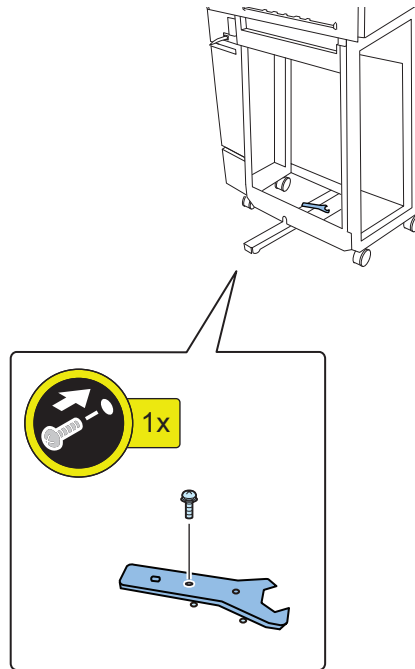

■ Storing the Wrench (for Document Insertion/Folding Unit)

NOTE:

After store the wrench, perform “Connecting to the Host Machine” procedure.



1. Disconnect this equipment from the Host Machine.

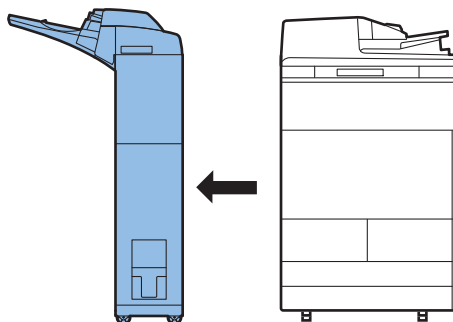



2. Open the Front Upper Cover.

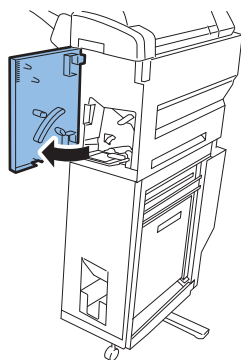

3. Holding the Jam Removal Lever, raise the Transfer Guide, and pull out the Folder Unit.

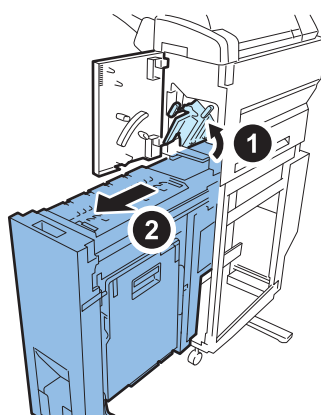

4. Store the wrench at the original position.

- 1 Screw (W Sems ; M4x8)

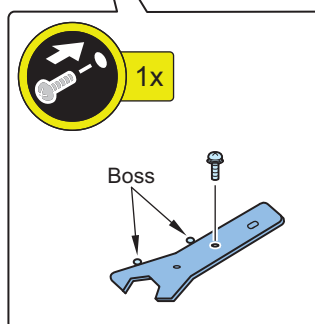
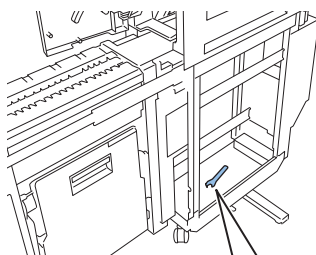



5. Return the Folder Unit to the original position, and then holding the Jam Removal Lever, lower the Transfer Guide.

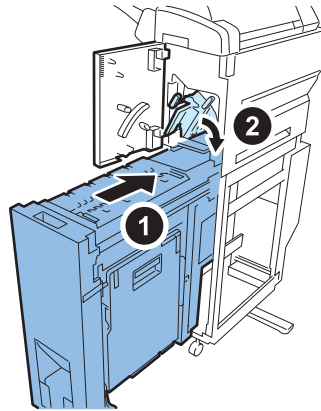

6. Close the Front Upper Cover.

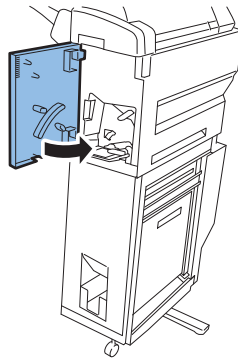

Staple Finisher-AC1/ Booklet Finisher-AC1

● Checking before Installation

The installation site must satisfy the conditions given below.

Therefore, it is recommended that the installation site be looked over before delivering this equipment to the customer.

CAUTION:

- Install the host machine first and then install this equipment.
- Do not carry this equipment with the host machine is installed for prevention of breakage.

■ Checking the Unpacking Space

Be sure to unpack this equipment according to the illustrations in a wide area where there is enough space around it.

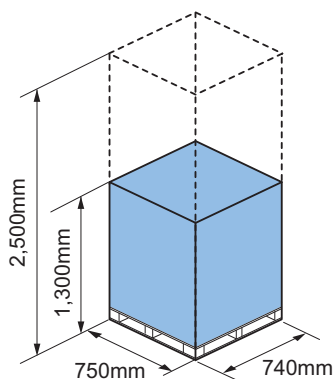

■ Points to Note on Installation

- Illustrations used in this procedure are those of the Booklet Finisher unless otherwise specified.
- Refer to "Order of Installation of Options" when installing this equipment.
- Since this machine is heavy (Staple Finisher: approx. 36kg, Booklet Finisher: approx. 60kg), 2 or more persons are required to install it. Be sure to perform the work in accordance with the standard to handle a heavy load in each country.
- When moving this equipment after having unpacked it, be careful by placing a plate, etc. on areas with steps to prevent the casters from hitting those steps. If the casters hit a step, the casters or the base plate may be deformed.

CAUTION:

When tightening the screws, do not tighten them too tightly. Otherwise, there is a risk of damage and deformation of screw holes.



■ Order of Installation of Options

When installing this equipment together with the other options, first install the host machine and then install options in the following order:

1. Document Insertion Unit or Document Insertion/ Folding Unit
2. Puncher Unit
3. Jogger Kit
4. Staple Finisher or Booklet Finisher (This equipment)
5. Long Sheet Tray

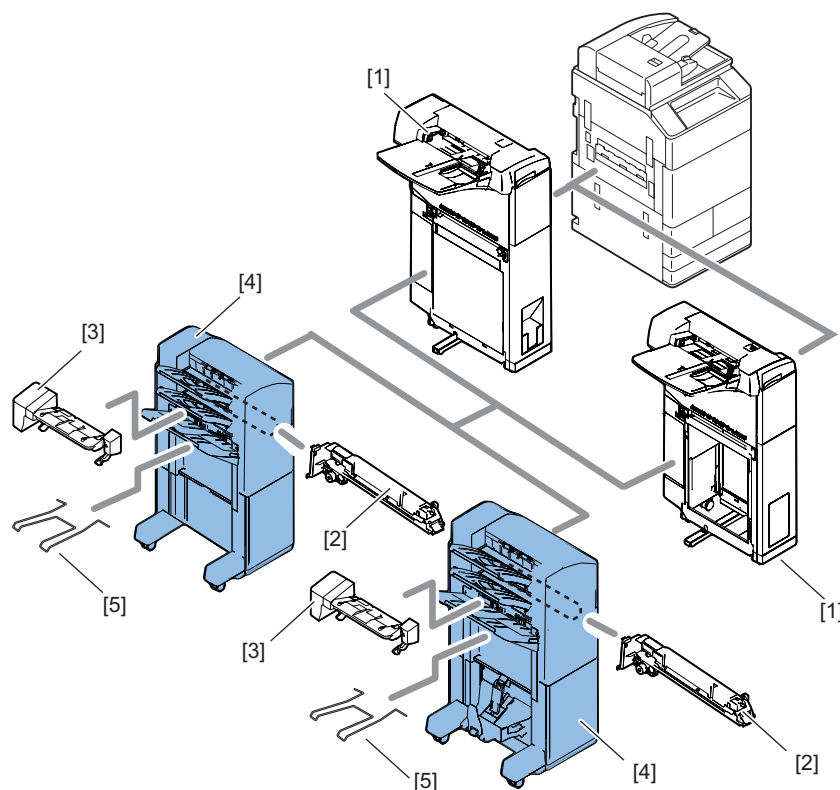

■ Product Name

Safety regulations require the product's name to be registered. In some regions where this product is sold, the following names may be registered instead.

- F281054
- F281059

● Unpacking

■ Unpacking Procedure

CAUTION:

This equipment is rather heavy. Be sure to work with a group of 2 or more people. Particularly when moving it over a step on the floor, be sure to take full care not to let it tumble over (Weight: Staple Finisher: approx. 36 kg, Booklet Finisher: approx. 60 kg).

NOTE:

This equipment is packed using tapes, fixings and cushioning materials to be protected against vibration and shock during transportation. Be sure to remove them before starting to install this equipment. It is a good idea to store away the removed fixings and cushioning materials for possible relocation of this equipment, e.g., to a new site or for repairs.

□
1.

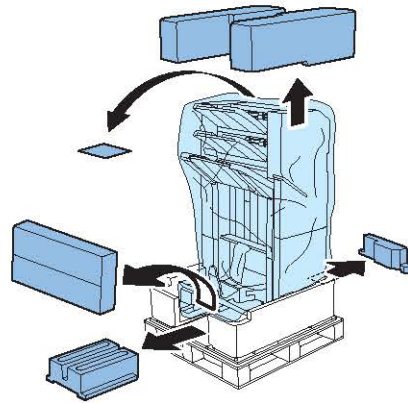

□
2.

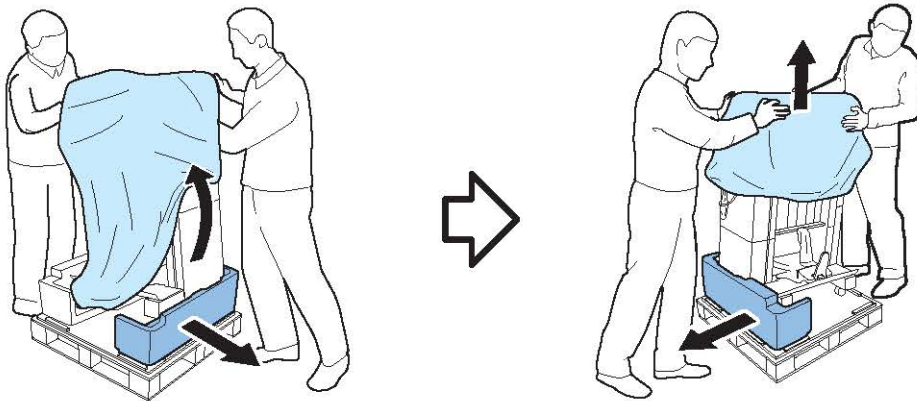

□
3. Hold the specified parts as shown and unload the finisher.

- For Staple Finisher

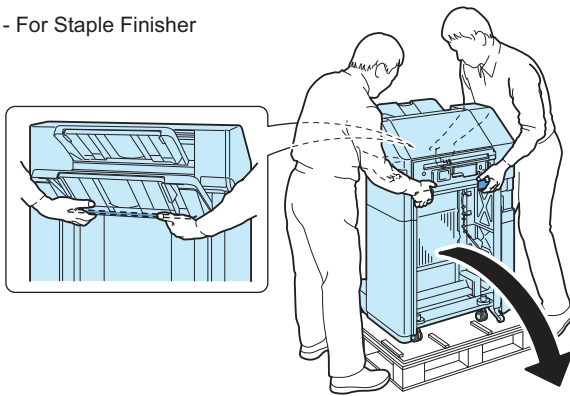

- For Booklet Finisher

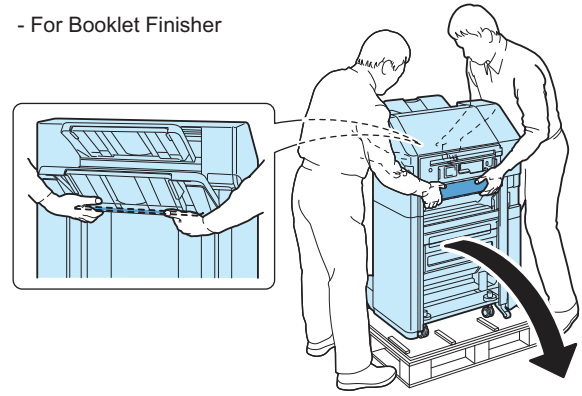

CAUTION:

Hold the specified parts as shown and do not hold the other parts to lift up the finisher.

- For Staple Finisher

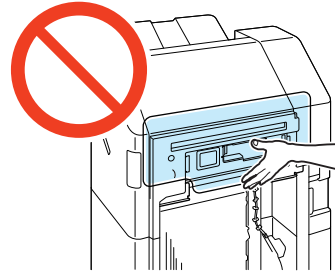
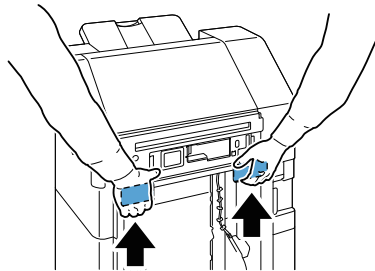

- For Booklet Finisher

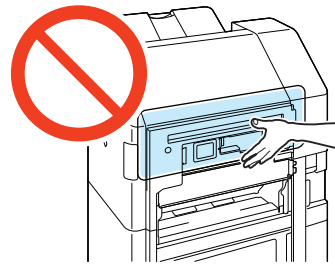
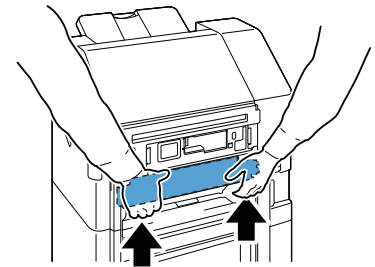

CAUTION:

Hold the metal part as shown and do not hold the other tray parts.

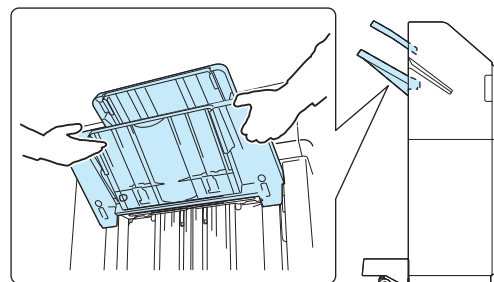
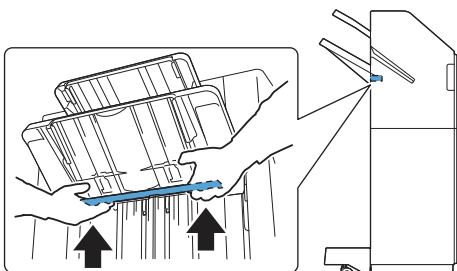

* Number of tray differs depending on the model type of finisher.

4. Remove all the tapes and cushioning materials outside this equipment.

5.

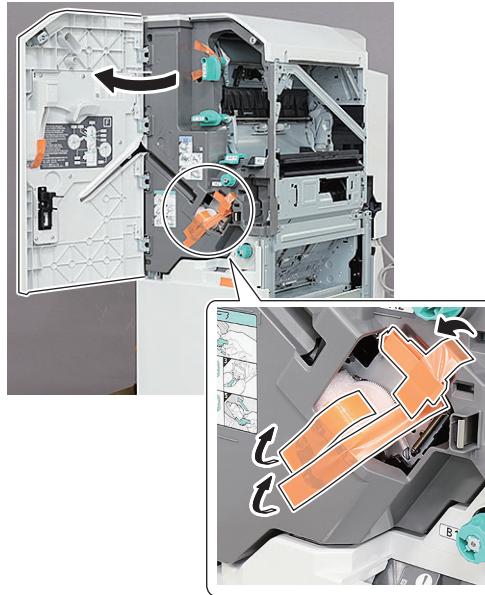

6.

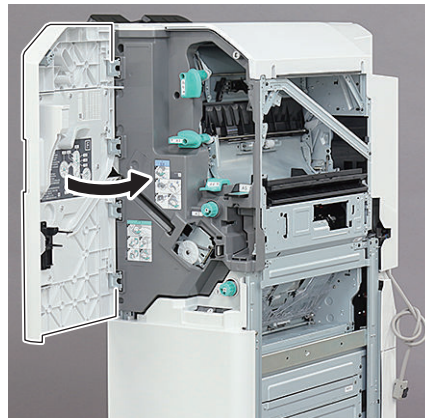

Checking the Contents

Check that none of the included parts is missing.

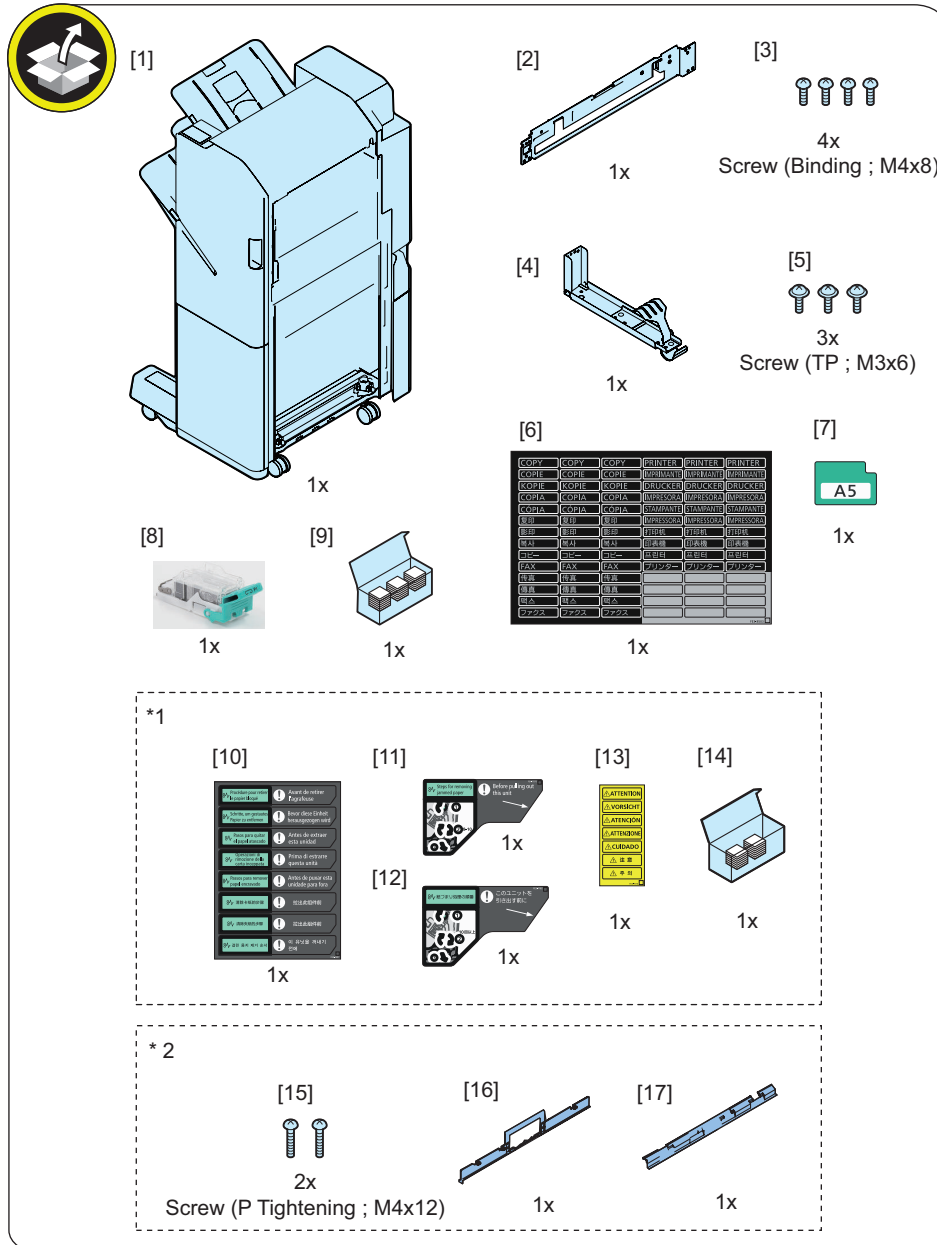

NOTE:

*1 : Booklet Finisher only

<Others>

Other bundled items such as Installation Procedure, leaflets, etc.

Installation Procedure

CAUTION:

Check that the main power switch is OFF and the power plug is disconnected from the outlet.

■ Connecting to the Host Machine

□
1.

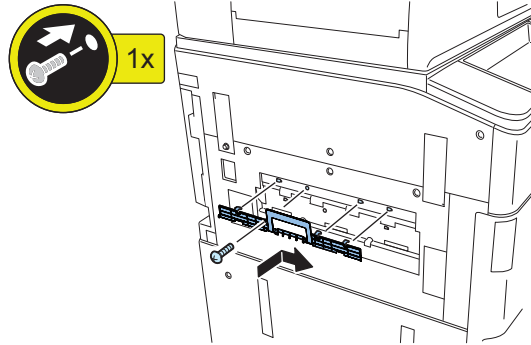
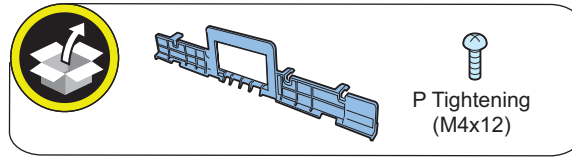

□
2.

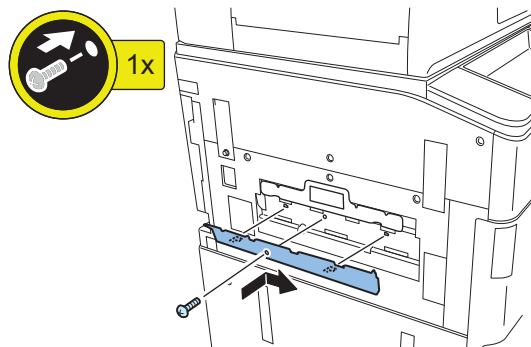
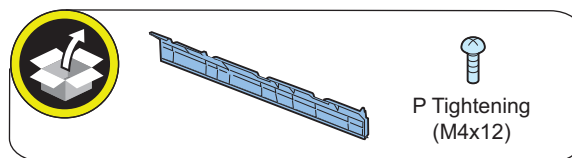

□
3.

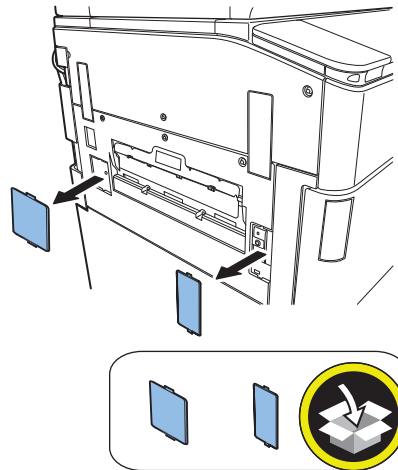

□
4.

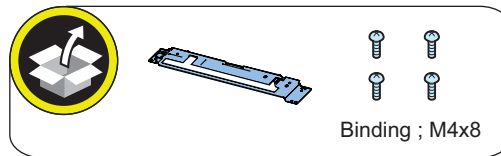

□
5.

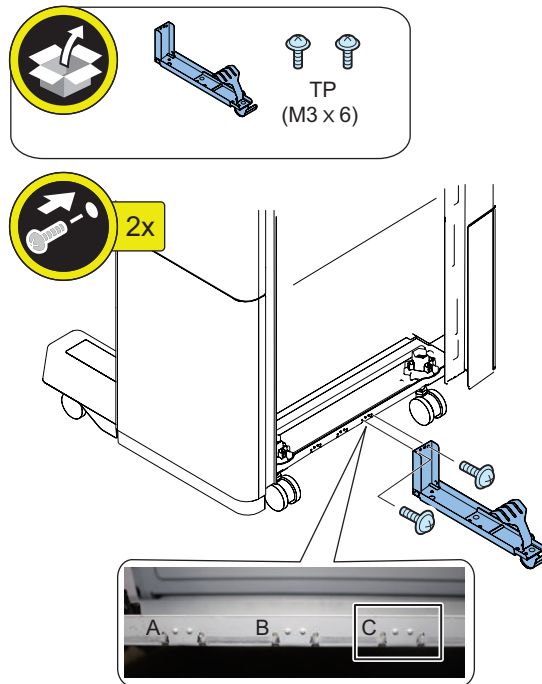

NOTE:
Install the Ground rail to the position [C].

■ **Connecting to the Document Insertion/ Folding Unit or Document Insertion Unit**

□
1.

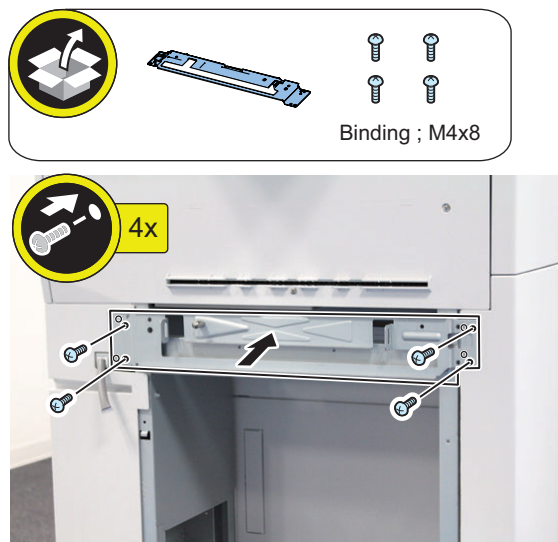

□
2.

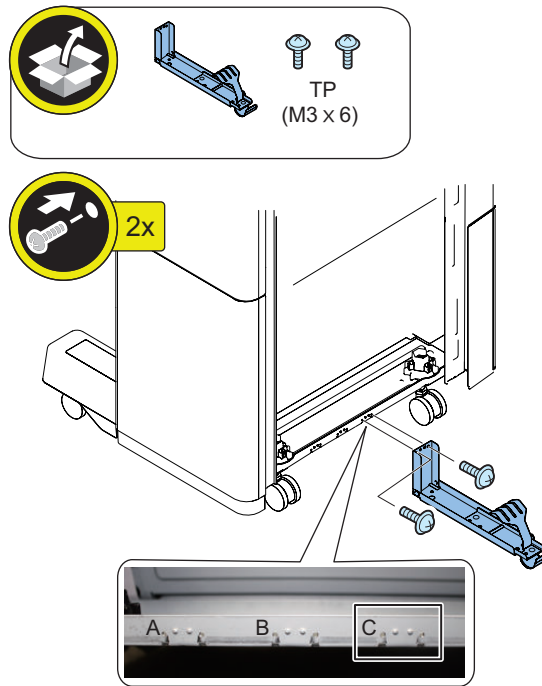

NOTE:
Install the Ground rail to the position [C].

□
3.

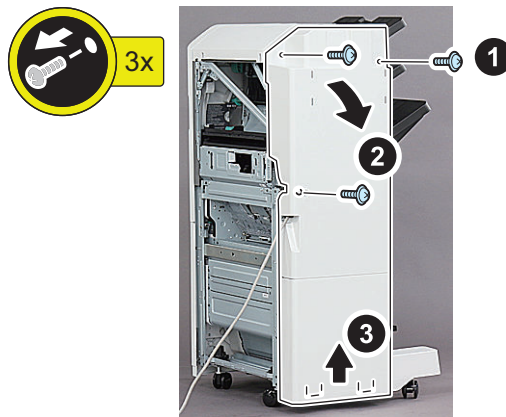



4. Install the Relay Connector supplied with the Document Insertion/ Folding Unit to the Finisher.

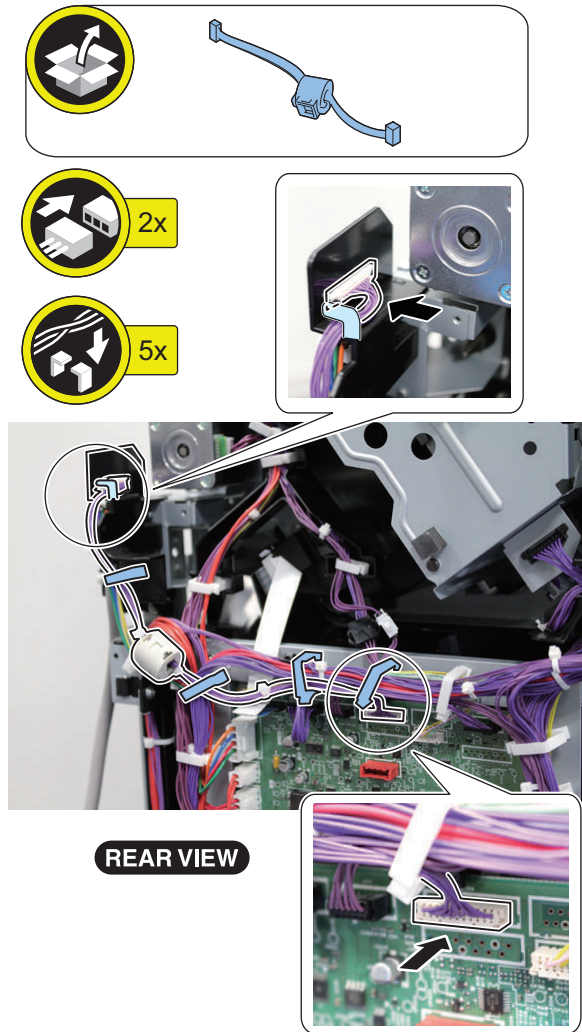

5.

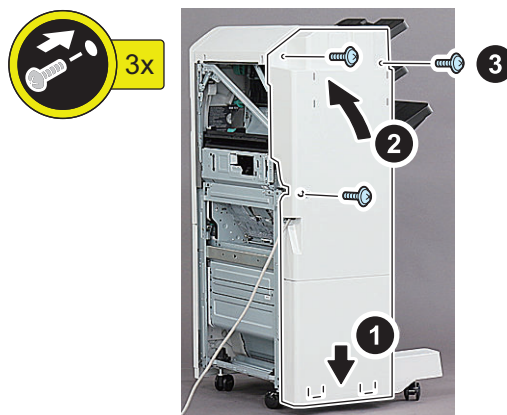

□

- 6.** Connect the Relay connector of the Document Insertion/ Folding Unit to the Finisher.



■ Connecting to the Upstream Connection Machine

□

- 1.** Check the height of the upstream connection machine and the Finisher.

Check that the hole of the connection plate is positioned between the marking-off lines of the Finisher.

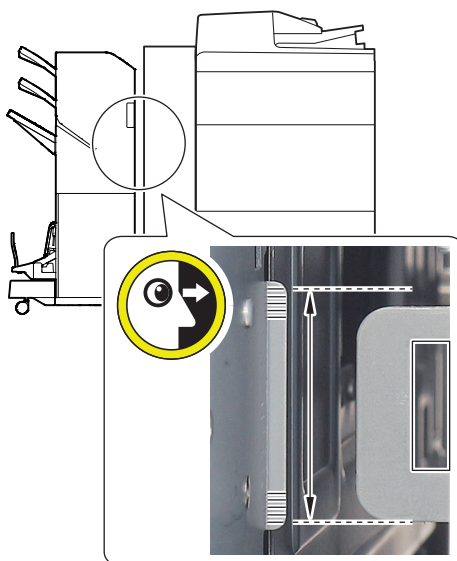

NOTE:

If the hole is not positioned between the marking-off lines, carry out the adjustment described in "Adjusting the Height."

□
2.

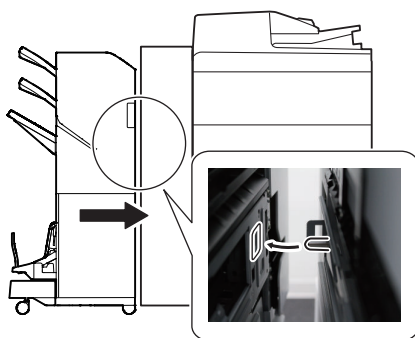

□
3.

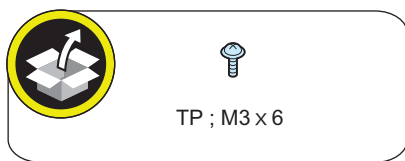



4. Pull out the Saddle Unit. (Booklet Finisher only)





- 5.** Loosen two screws, and then fix the Saddle Unit auxiliary caster so that its caster can touch floor. (Booklet Finisher only)



□

6. Put the Saddle Unit back. (Booklet Finisher only)



□

7.

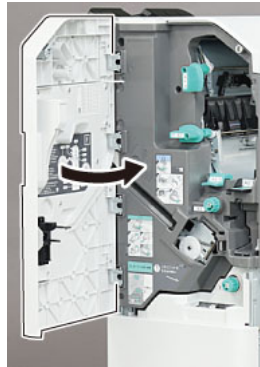

□

8.

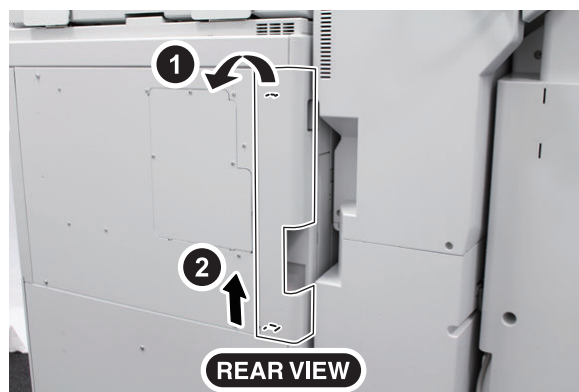

□
9.

⚠ CAUTION:

When connecting the interface cable, be sure to turn off the host machine and disconnect its power cable from the outlet. If you do not do so, electric shock can result.

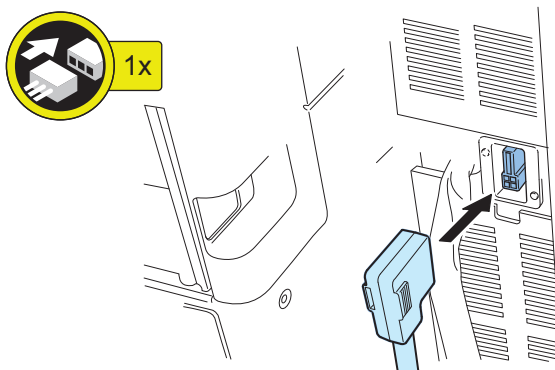

□
10.

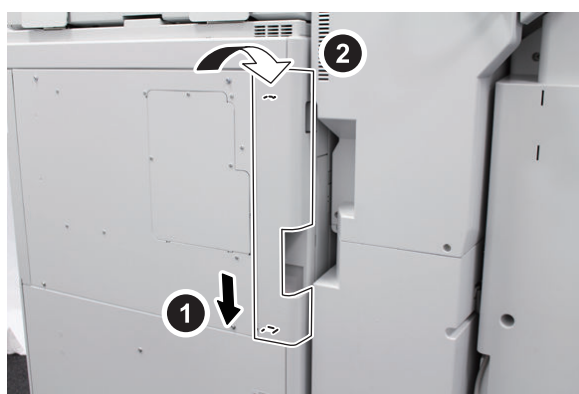

● Affixing the Labels

■ Affixing the Jam Label / Saddle Caution Label (Booklet Finisher only)

□
1.



□

2. Affix the label in the appropriate language.

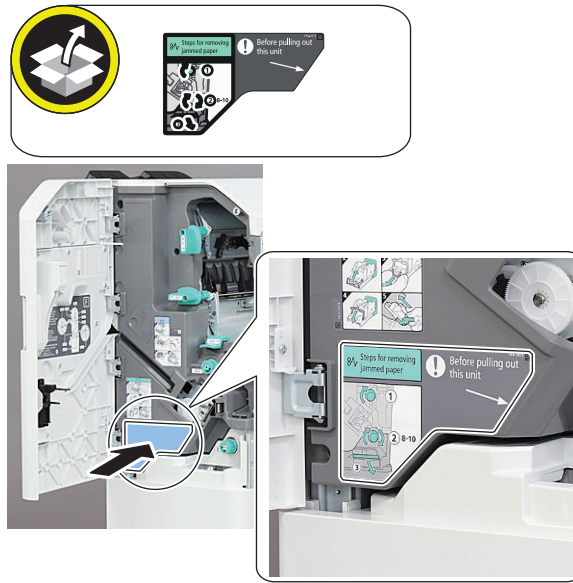

□

3. Affix the label in the appropriate language.

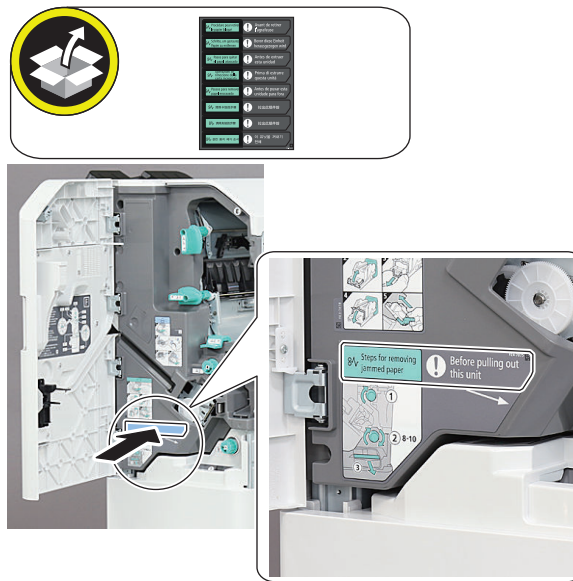



4. Affix the label in the appropriate language.

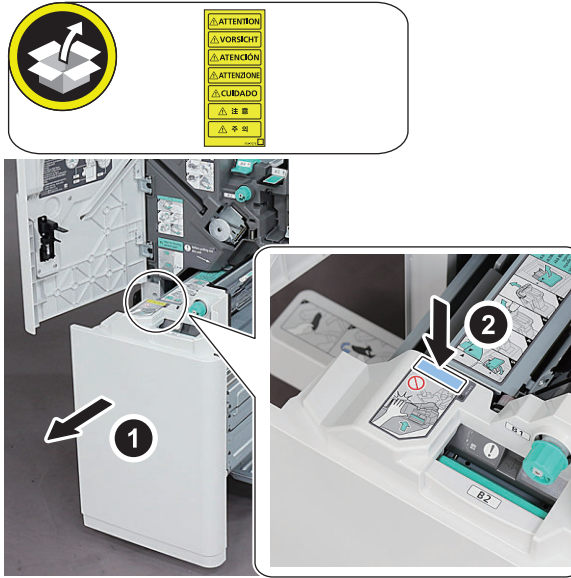

5.

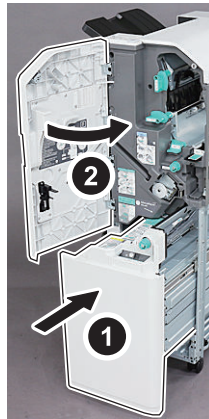

■ Affixing the Tray Labels



1. Affix the Tray labels which is specified by user.

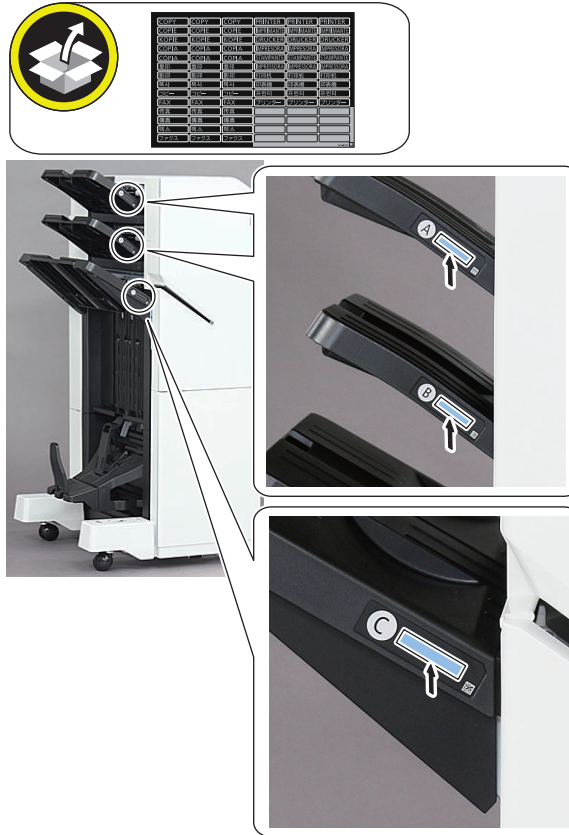

■ Affixing the Puncher Label. (When Installing Puncher Unit.)

□
1.

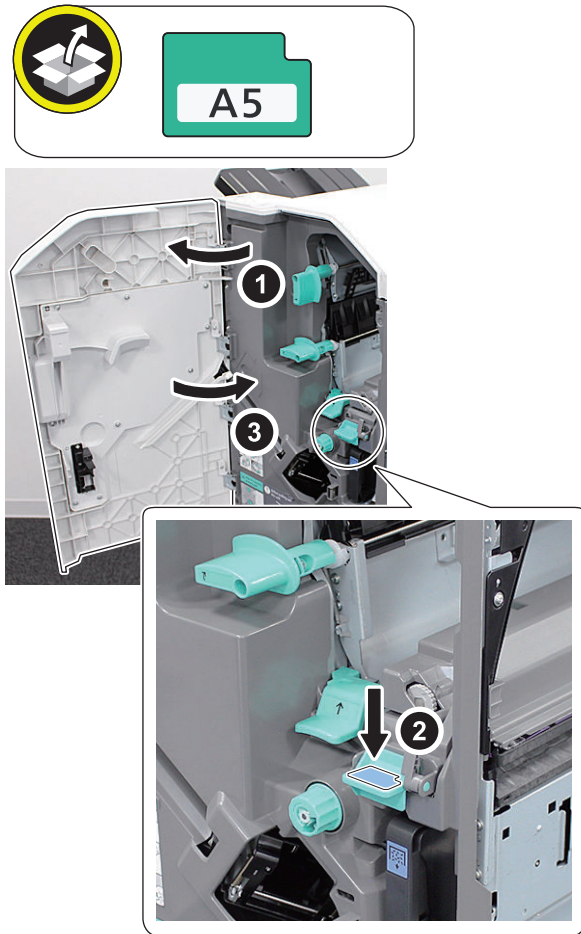

● Making Adjustments

The difference in height between the Finisher and the Host Machine and the tilt of the Finisher and the host machine need to be adjusted depending on the installation site floor condition. If the height or tilt is not adjusted properly, problems can occur (for example, a paper jam can occur frequently at the paper supply section of the Finisher). Check the height and tilt and adjust it as required. Be sure to adjust as necessary.

■ Checking the Height



1. Check that the hole of the connection guide plate is positioned between the marking-off lines of the Finisher.

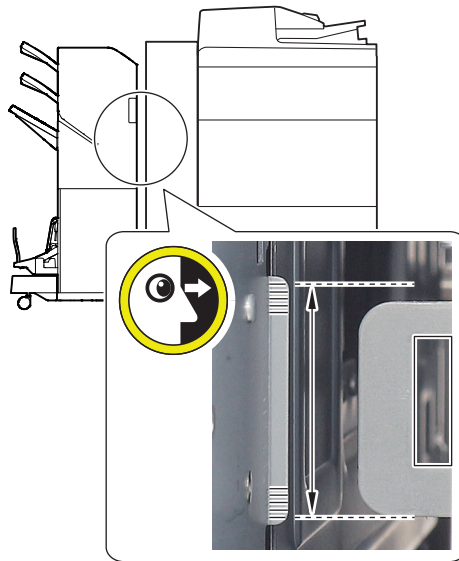

2. When the adjustment of height is necessary, make adjustment by referring the "Adjusting the Height".

NOTE:

When the adjustment of height is not necessary, proceed to the "Checking the Difference in Tilt".

■ Adjusting the Height



1. When it is fixed to the upstream connection machine, it is detached by approx. 150 mm.

⚠ CAUTION:

Be careful with the interface cable when detaching.

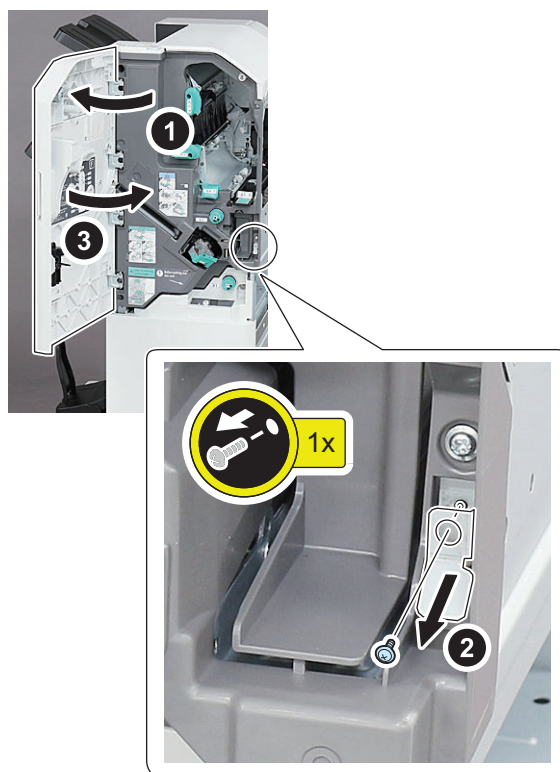

NOTE:

Disconnect the Relay connector when detaching the Finisher from the Document Insertion/ Folding Unit.





2. Remove the Caster covers (front/ rear).

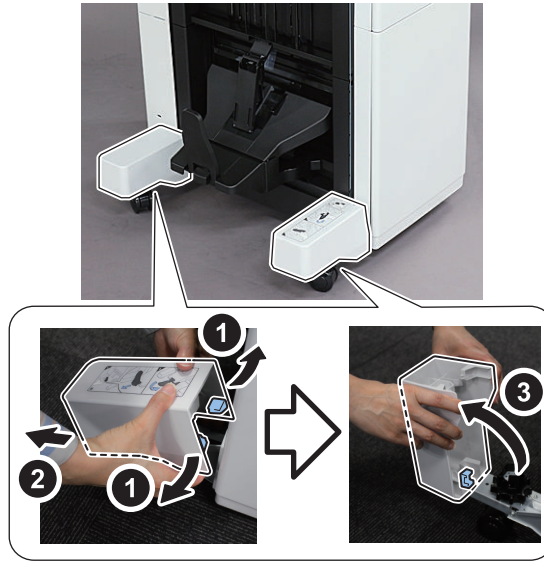

3. Turn the adjustment dial of the caster in the direction of the arrow by lifting the dial upward a little to adjust the height.

NOTE:

Adjust the height at 4 casters.

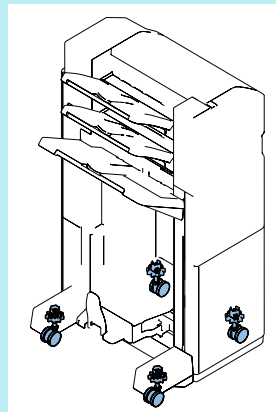

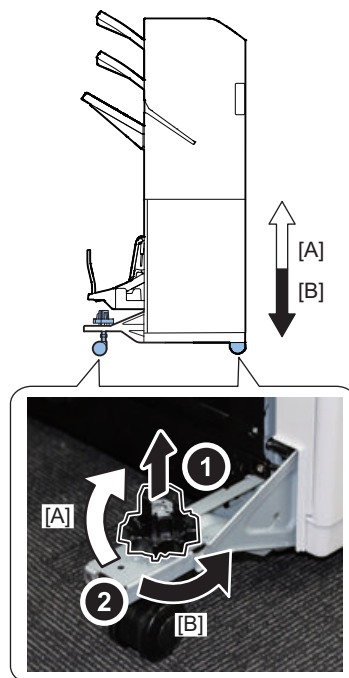

- To increase the height of the Finisher, turn the dial in the direction of arrow [A].
 - To decrease the height of the Finisher, turn the dial in the direction of arrow [B].
- A full turn of the adjustment dial changes the height of the Finisher by approx. 2.0 mm.

NOTE:

If the adjustment dial keeps lifting upward, lower the adjustment dial by releasing three claws. And be sure to insert the three pins of the adjustment dial to the hole of the caster support plate.

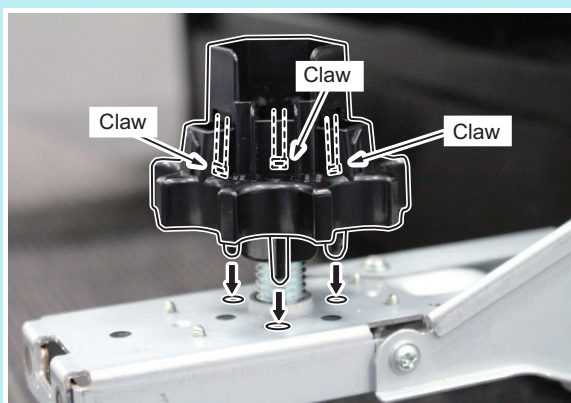



4. Install the Caster covers (Front / Rear).

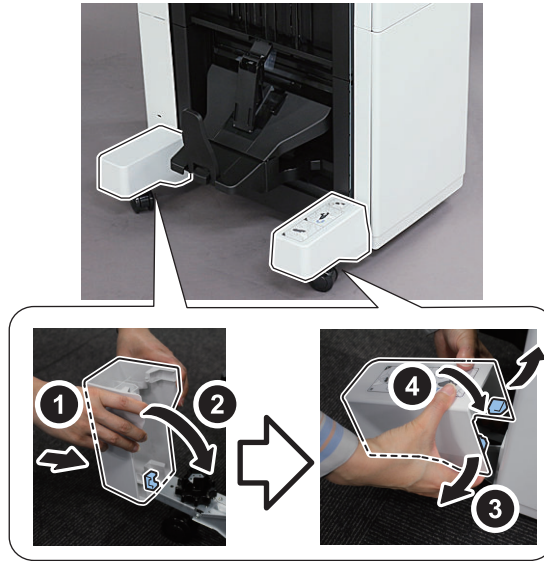

5. Install the Finisher to the upstream connection machine.

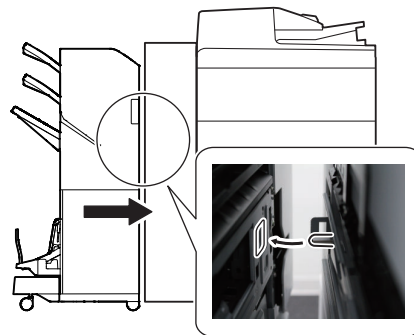

NOTE:

Connect the Relay connector when installing the Finisher to the Document Insertion/ Folding Unit.





6. Fix to the upstream connection machine.

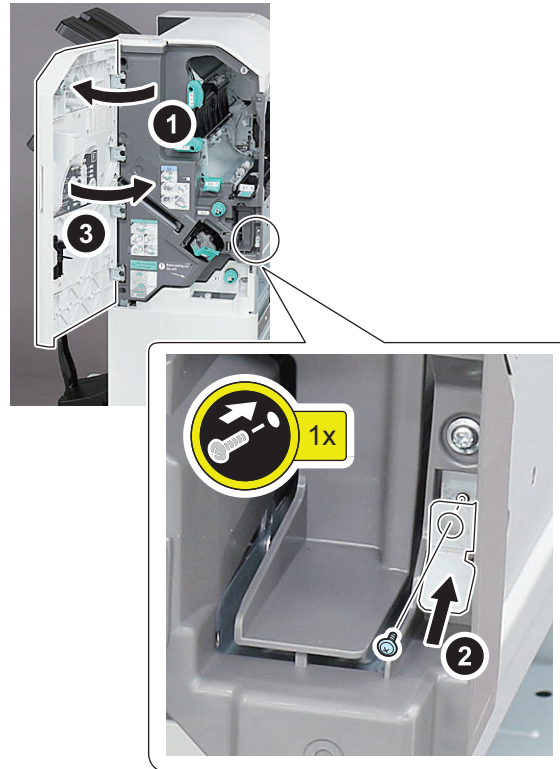

■ Checking the Difference in Tilt

Check the relational tilting amount of the Finisher and the upstream connection machine. Make sure that the gap between the right side of the Finisher and the left side of the upstream connection machine is within the standard shown in the figure. In the case the gaps are within the specification, this adjustment is not required.

● Connecting to the Host Machine

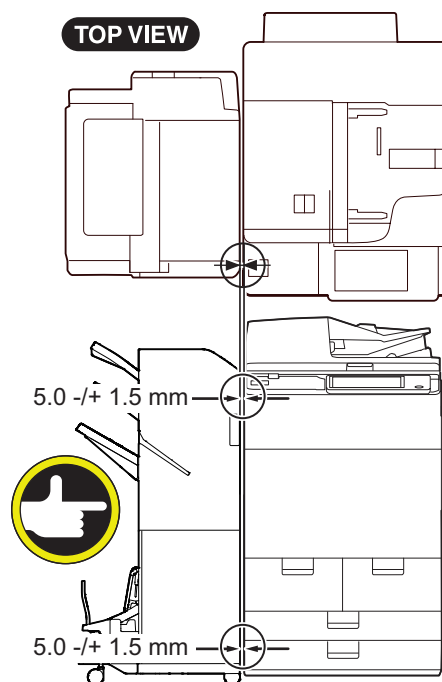

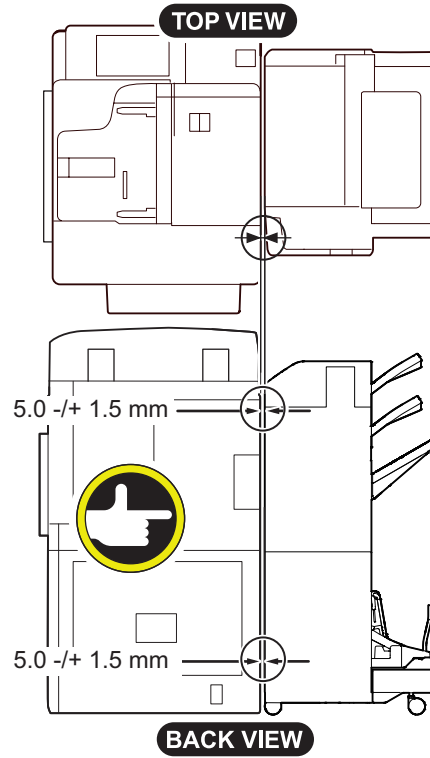

• Connecting to the Document Insertion/ Folding Unit or Document Insertion Unit

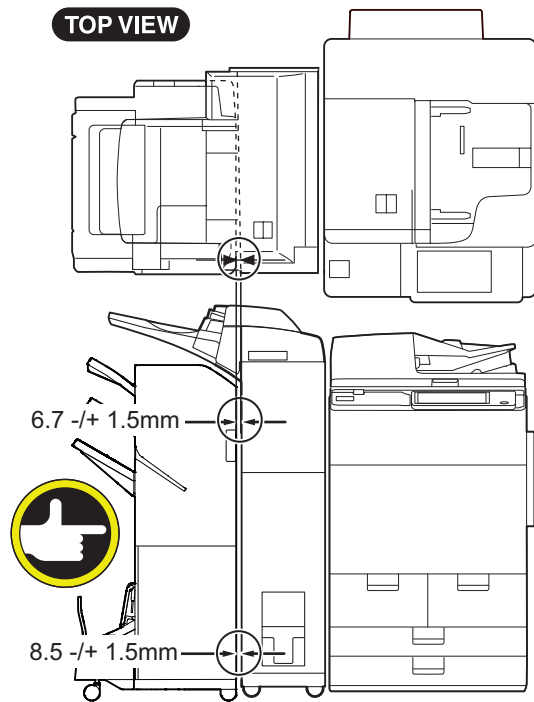

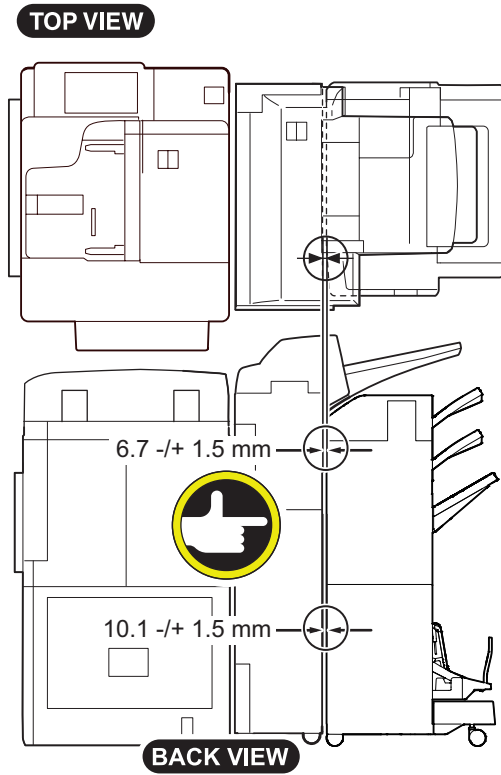

■ Adjusting the Tilt



1. When it is fixed to the upstream connection machine, it is detached by approx. 150 mm.

⚠ CAUTION:

Be careful with the interface cable when detaching.

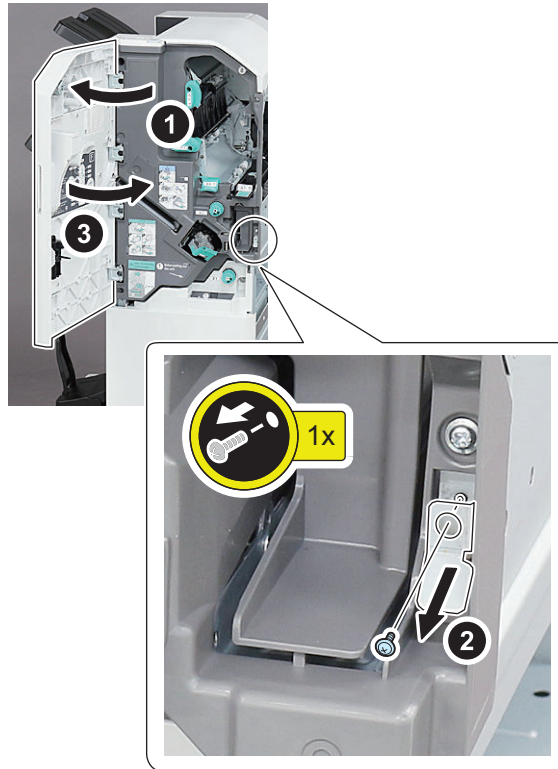

NOTE:

Disconnect the Relay connector when detaching the Finisher from the Document Insertion/ Folding Unit.





2. Remove the Caster Covers (Front/ Rear).

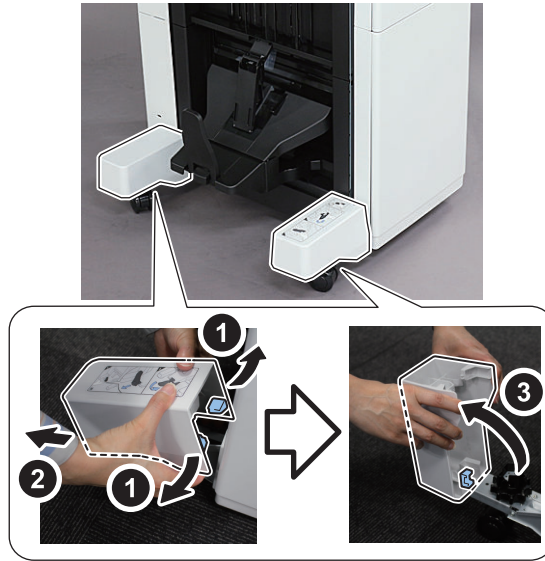



3. Turn the adjustment dial of the caster in the direction of the arrow by lifting the dial upward a little to adjust the tilt.

NOTE:

Adjust the tilt at 2 left casters.

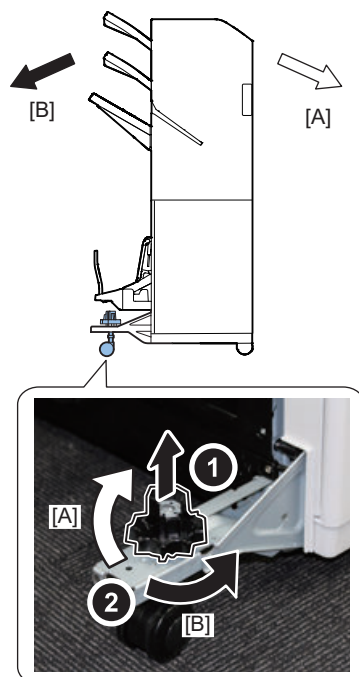
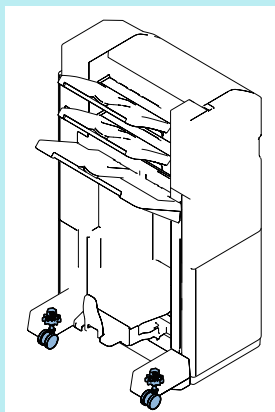

- To tilt the Finisher to the right, turn the dial in the direction of arrow [A].
- To tilt the Finisher to the left, turn the dial in the direction of arrow [B].

A full turn of the adjustment dial changes the height of the Finisher by approx. 2.0 mm.

NOTE:

If the adjustment dial keeps lifting upward, lower the adjustment dial by releasing three claws. And be sure to insert the three pins of the adjustment dial to the hole of the caster support plate.

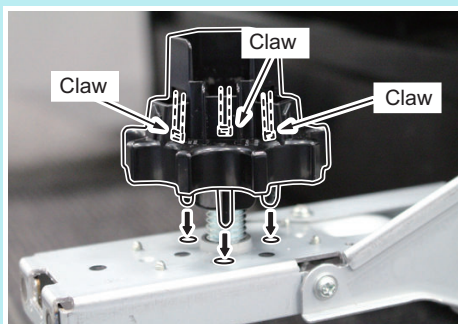
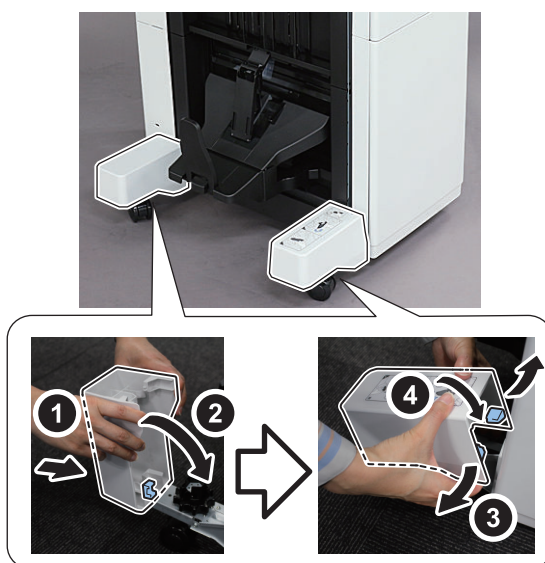
**4. Install the Caster covers (Front / Rear).**



5. Install the upstream connection machine.

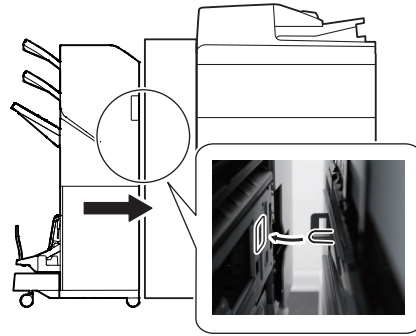

NOTE:

Connect the Relay connector when installing the Finisher to the Document Insertion/ Folding Unit.





6. Fix to the upstream connection machine.



Making Checks After Completion of Installation Work

■ Disposal Parts Check

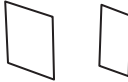
Following disposal parts are remained after completion of the installation work.

<input type="checkbox"/> [1]	 <p>2x Face Cover of the host machine</p>
<input type="checkbox"/> [2]	 <p>1x Puncher Label (When Puncher Unit is not installed)</p>

■ Operation Check

1. Turn ON the main power of the host machine.



2. Open the Front Cover, and then set the Staple Cartridge into the Stapler Unit.

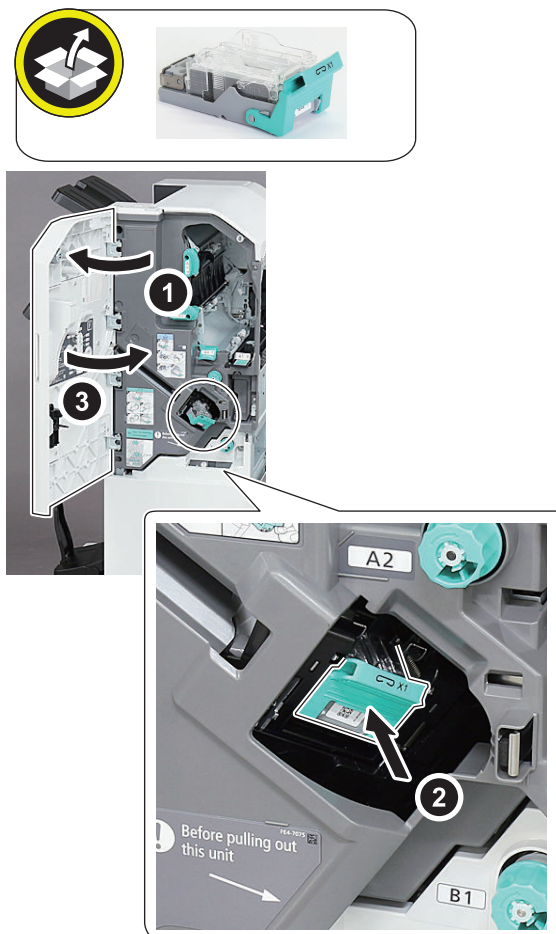

3. If a message prompting the user to update the version appears, press [Update] to automatically update the version of this equipment.

NOTE:

If [Skip] is selected, a message prompting the user to update the version will appear every time the host machine is started. In the service mode (Level 2) shown below, it is possible to set not to display the message.

(Lv.2) COPIER > OPTION > FNC-SW > VER-CHNG

-
4. Check the operation such as paper feed and stapling to make sure that problems such as a jam or malfunction do not occur.

CAUTION:

Staple-free binding unit might be out of its correct position due to a mechanical shock during transportation. When the staple-free binding unit is out of the correct position, a paper stack is clinched at wrong position in the staple-free binding mode.

To avoid the above, make copies in the following condition after the installation of the finisher and correct the position of the staple-free binding unit:

- Staple mode: Stapling at rear corner
- Paper size: LTR or A4
- Number of sheet: 2
- Copy quantity: 1

NOTE:

Mechanical drive of the staple-free binding unit is engaged with the stapler unit.

Making copies in the above condition will have the stapler unit returned to its home position and the staple-free binding unit stops at the correct position.

● Detaching from the Upstream Connection Machine

-
- 1.



□
2.

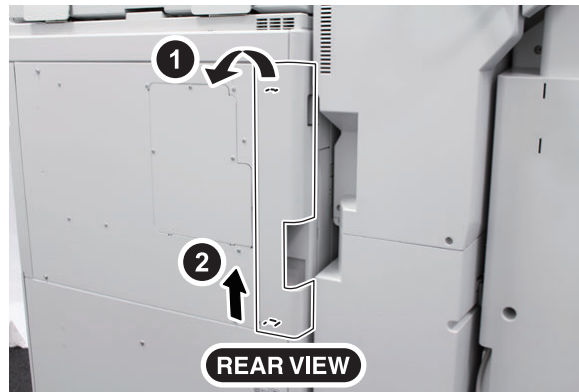

□
3.

⚠ CAUTION:

When disconnecting the Interface Cable, be sure to turn off the host machine and disconnect its power cable from the outlet.

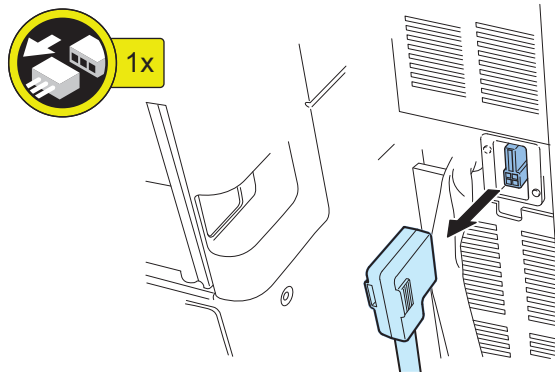

□
4.

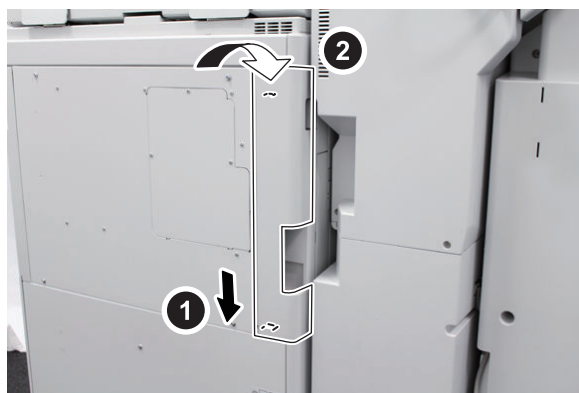

□

5. Disconnect the Relay connector when detaching the Finisher from the Document Insertion/ Folding Unit.



□

6.

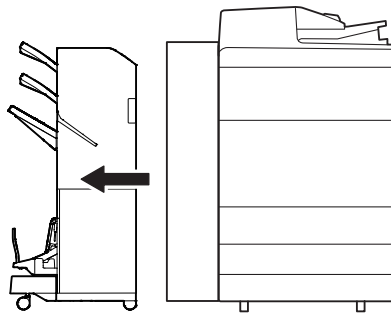

2/3 2/4 4 Hole Puncher Unit-A1

● Checking Before Installation

■ Checking Before Installation

When installing this Equipment together with the Finisher, install this Equipment before installing the Finisher to the Upstream Connection Machine.

■ Product Name

Safety regulations require the product's name to be registered. In some regions where this product is sold, the following name may be registered instead.

- F281060

■ Installation Outline Drawing

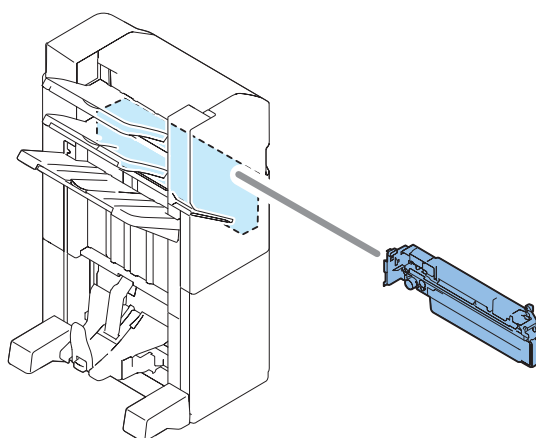

● Unpacking Procedure

- 1. Open the container box, and then take out the Punch Unit and the contents.
- 2. Remove all cushioning materials and tapes from outside of the Punch Unit.



3. Remove the 2 fixtures.







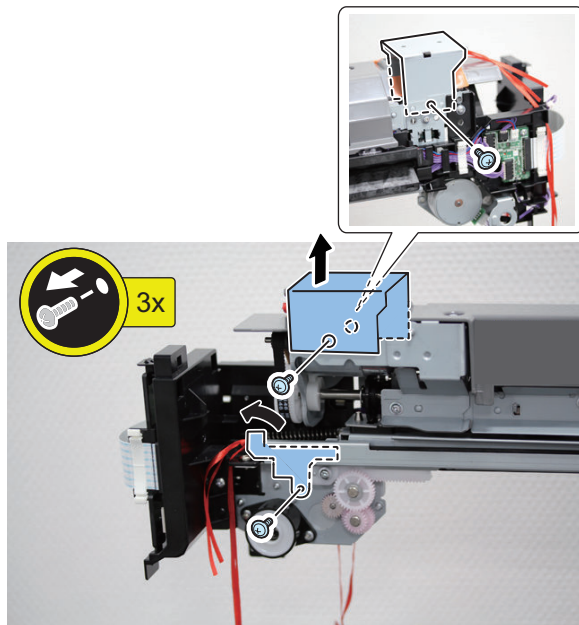

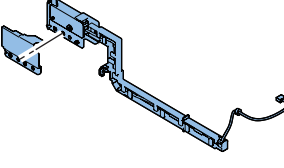

- 3 Screws

NOTE:

Removed screws are used in latter steps.

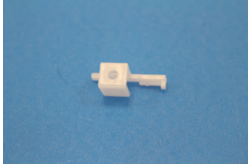

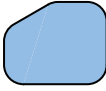
Checking the Contents

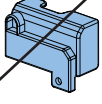
<input type="checkbox"/> [1] Punch Unit x1 	<input type="checkbox"/> [2] Punch Waste Tray x1 	<input type="checkbox"/> [3] Punch Waste Full Sensor Unit x1 
<input type="checkbox"/> [4] Punch Unit Open/ Close Guide x1 	<input type="checkbox"/> [5] Punch Unit Fixing Pin Holder x1 	<input type="checkbox"/> [6] Punch Unit Fixing Pin x1 
<input type="checkbox"/> [7] Punch Unit Positioning Guide x1 	<input type="checkbox"/> [8] Relay Harness x1 	<input type="checkbox"/> [9] Face Seal x1 
<input type="checkbox"/> [10] Rear Inner Cover (small) x1 	<input type="checkbox"/> [11] Screw (W Sems ; M3x6) x1 	<input type="checkbox"/> [12] Punch Front Cover x1 

- Part [12] is not used for installation.

<Others>

Other bundled items such as Installation Procedure, leaflets, etc.

Installation Procedure

⚠ CAUTION:

Make sure that the main power switch of the host machine is turned off and the power plug is disconnected from the outlet.

■ Installing the Punch Unit



1. Open the Front Cover of the Finisher.



2. Remove the Rear Cover of the Finisher.

- 3 Screws
- 3 Claws

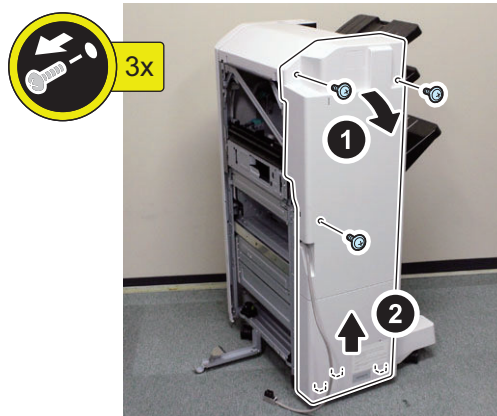



3. Remove the Rear Inner Cover.

- 1 Screw

NOTE:

Removed screw is used in the procedure later.

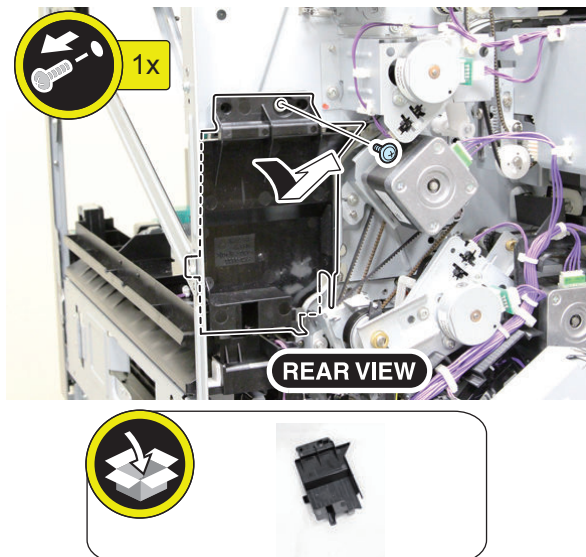



4. Remove the Inlet Feed Guide.

- 1 Screw
- 1 Connector
- 1 Wire saddle
- 2 Harness guides

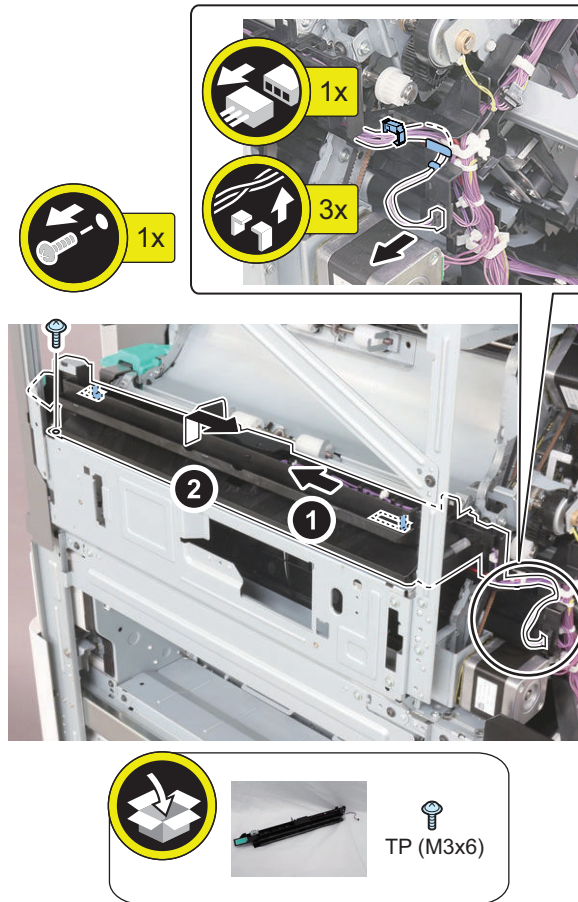



5. Install the Punch Unit Fixing Pin Holder.

- 1 Screw (TP ; M3x6)

NOTE:

Use the screw removed in Unpacking Procedure.

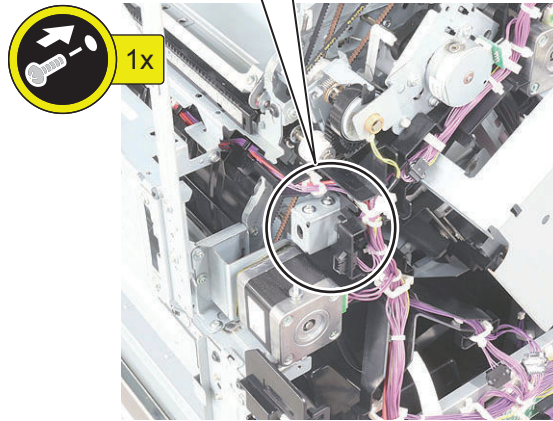
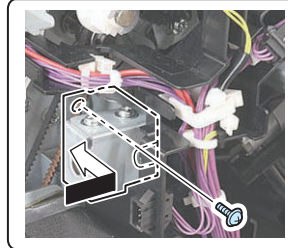



6. Remove the Magnet Unit.

- 1 Screw

NOTE:

Removed screw is used in the procedure later.

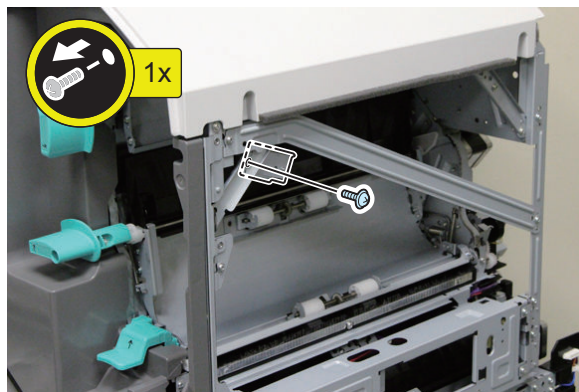

7. Remove a Screw.

NOTE:

Removed screw is used in the procedure later.

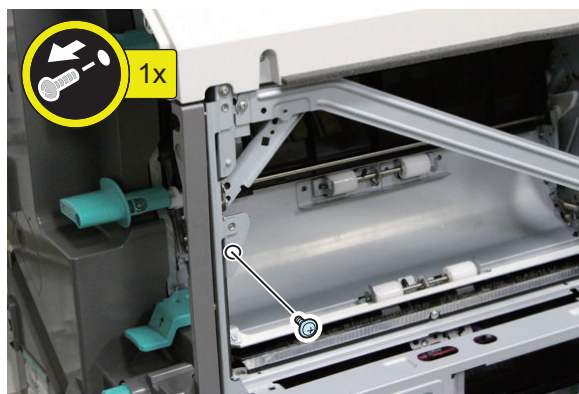

**8. Install the Punch Unit Open/Close Guide.**

- 2 Screws (TP ; M3x6)
- 1 Boss

NOTE:

Use screws removed in steps 6 and 7.

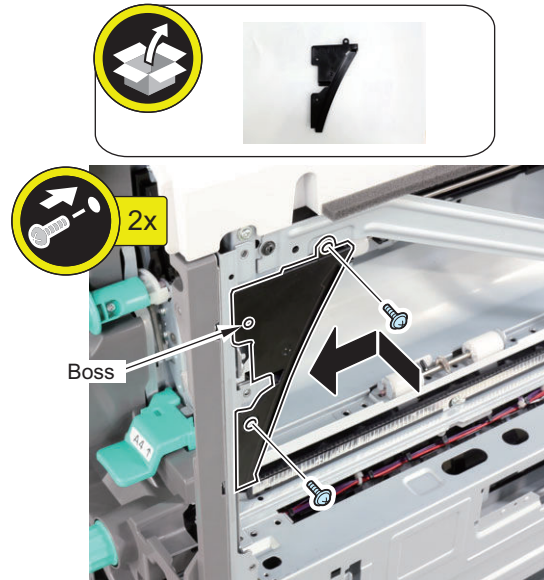



9. Install the Punch Waste Full Sensor Unit.

- 3 Hooks
- Sensor Cover
- 1 Screw (TP ; M3x6)

NOTE:

Use the screw removed in Unpacking Procedure.

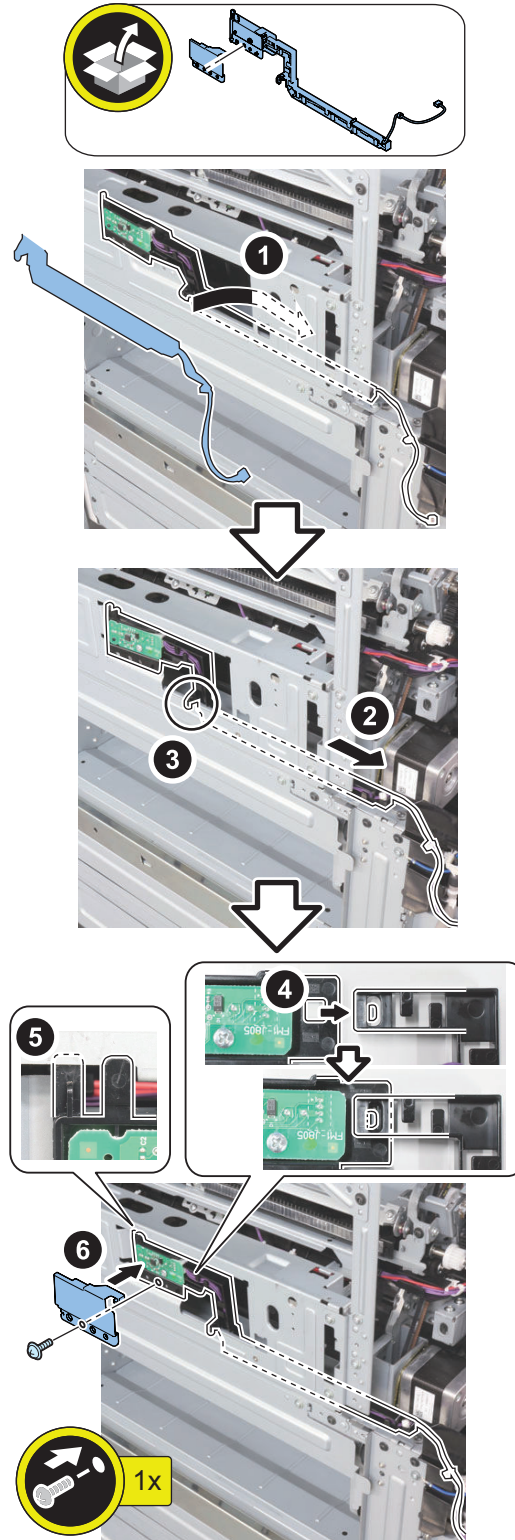



10. Cut out the face cover of the Inner Cover by using the side cutters.

CAUTION:

Be sure to remove the face cover properly so that no burr is formed.

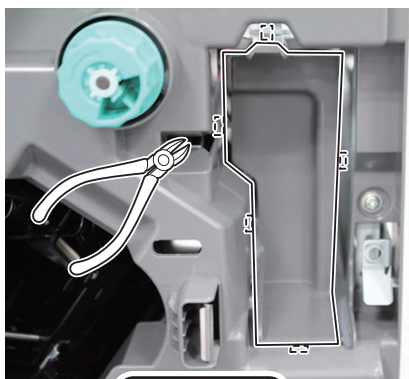

FRONT VIEW

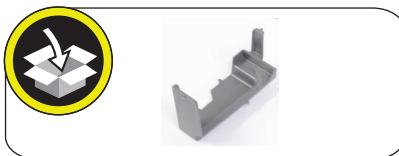

**11. Install the Punch Unit Positioning Guide so that the right edge of the guide can match the center of scale.**

- 1 Screw (TP ; M3x6)

NOTE:

Use the screw removed in Unpacking Procedure.

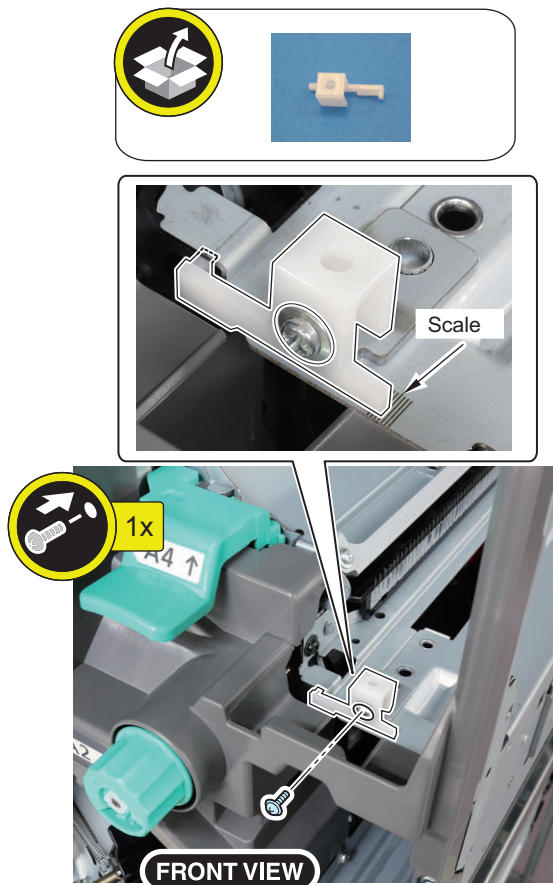



12. Affix the Face Seal to the Punch Unit.

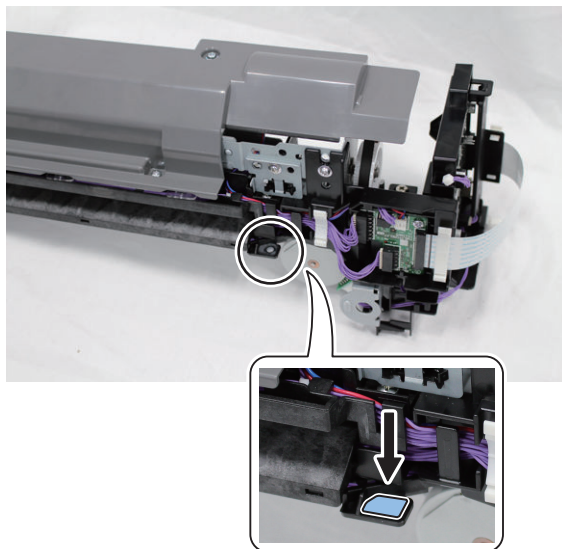
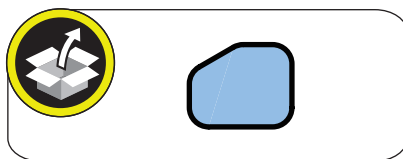



13. Install the Punch Unit from the back of the Finisher as shown in the figure.

CAUTION:

When having the Punch Unit, be careful not to have the PCB unit and its surrounding area.

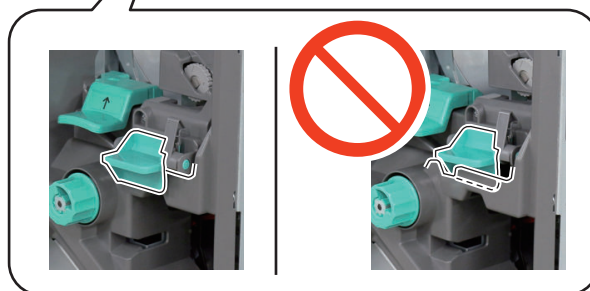
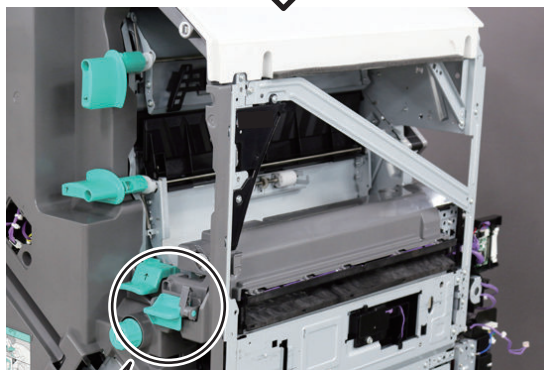



14. Install the Punch Unit Fixing Pin.

- 1 Screw (W Sems ; M3x6)

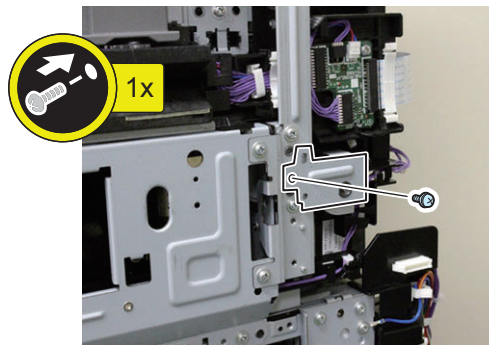
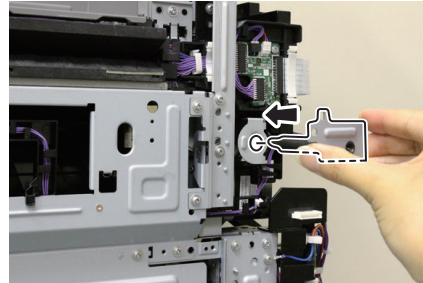

15. Connect the connector of the Punch Waste Full Sensor Unit to the Punch Unit.

- 4 Cable guides
- 1 Connector

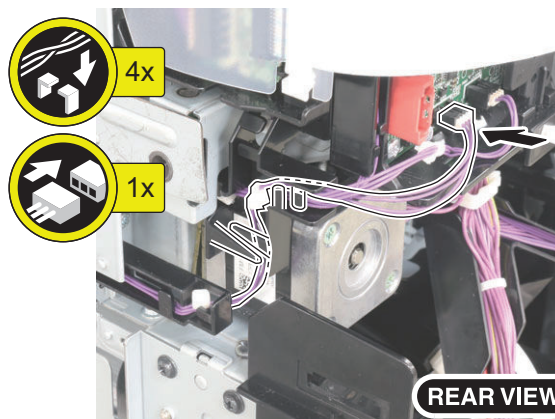



16. Connect the Relay Harness as shown in the figure.

- 2 Connectors
- 1 Reuse band
- 4 Wire saddles

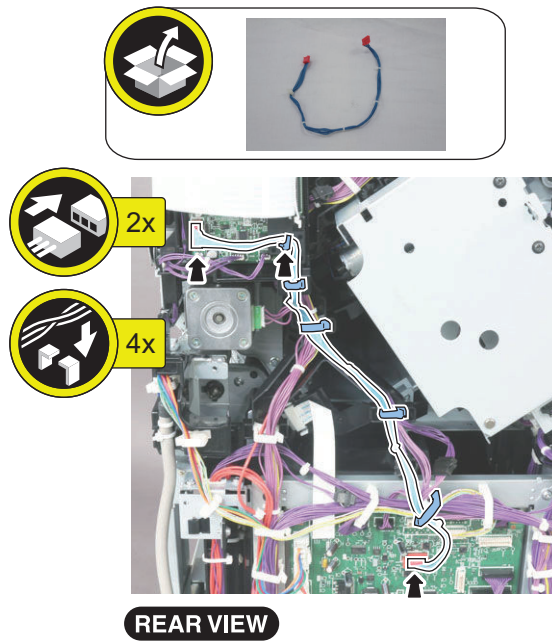

**17. Install the Rear Inner Cover (small).**

- 1 Screw (TP ; M3x6)
- 2 Bosses

NOTE:

Use the screw removed in step 3.

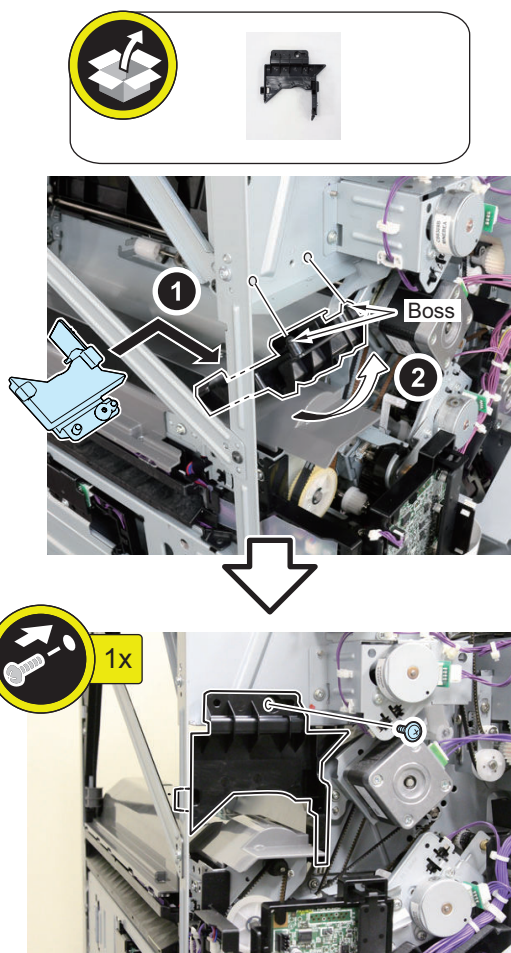
**18. Insert the Punch Waste Tray in the direction of the arrow from the front.**

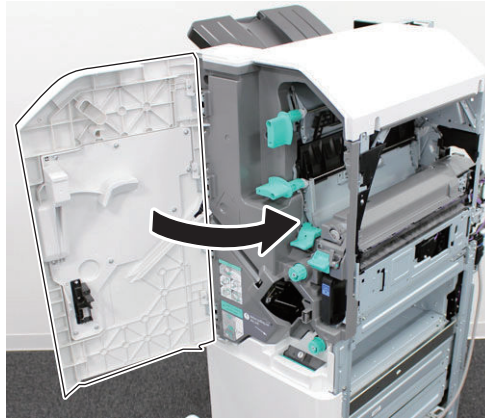
**19. Close the Front Cover of the Finisher.****20. Install the Rear Cover of the Finisher.**

- 3 Screws
- 3 Claws

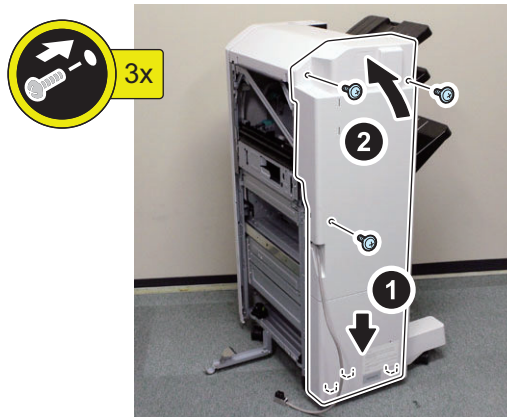
**21. Refer to the installation procedure of the Finisher to Install the Finisher in the Upstream Connection Machine.**

Disposal Parts Check

1. Following disposal parts are remained after completion of the installation work.

- [1] Inlet Feed Guide 1pc.
- [2] Rear Inner Cover 1pc.
- [3] Magnet Unit 1pc.
- [4] Screw (TP ; M3x6) 1pc.
- [5] Punch Cover (Front) 1pc.
- [6] Face Cover 1pc.

Operation Check

**1. Turn ON the main power of the Host Machine.**

-
2. If a message prompting the user to update the version appears, press [Update] to automatically update the version of this Equipment.

NOTE:

If [Skip] is selected, a message prompting the user to update the version will appear every time the Host Machine is started. In the service mode (Level 2) shown below, it is possible to set not to display the message.

(Level2) COPIER > OPTION > FNC-SW > VER-CHNG

-
3. Check the operation such as paper feed and punch operation to make sure that problems such as a jam or malfunction do not occur.

NOTE:

If the punch hole position of this Equipment needs to be adjusted, go to the "Checking and Adjusting the Punch Hole Position".

Adjusting the Output Level of the Punch Waste Full Sensor

After installing this Equipment, adjust the output level of the Punch Waste Full Sensor as follows.

-
1. Select the following item in the Service Mode and then press the OK button on the screen.
Service Mode (Level1) > SORTER > FUNCTION > FN-SENS2

-
2. When completing the output level adjustment successfully, the "OK" is indicated on the screen.

NOTE:

If the "NG" is indicated on the screen at the step 2, retry the adjustment by repeating the step 1. If the "NG" is indicated after retrying the adjustment, check whether there is not the malfunction in attachments and connections of the Punch Waste Full Sensor Unit and the surrounding area.

● Checking and Adjusting the Punch Hole Position

■ Checking the Punch Hole Position



1. Make a print with the punch mode and check whether the skew and side registration and the paper stop position are within the standard.

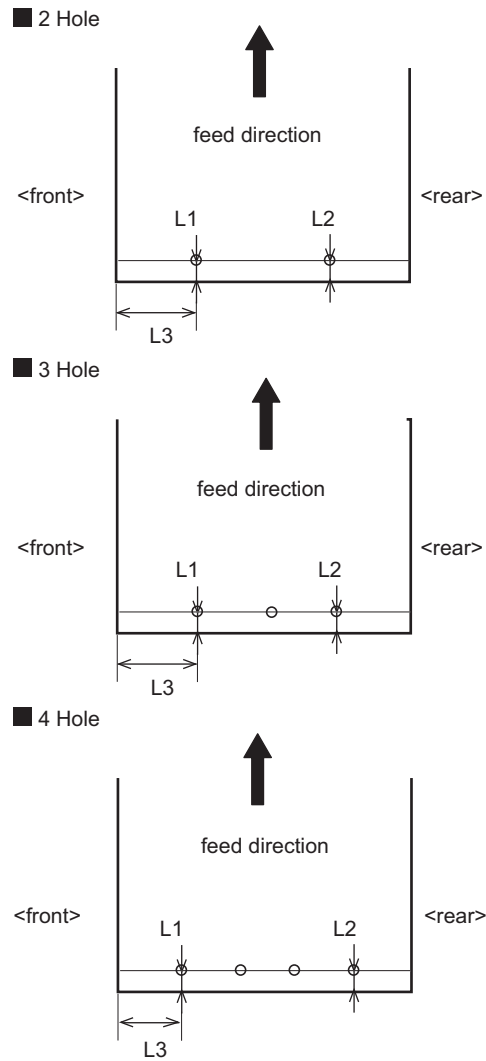

<Standard>

- 2/3 Hole Puncher Unit

L1 , L2	12 ± 1.5 mm
L3	2 holes : <ul style="list-style-type: none"> • 73 ± 1.5 mm (11"x17"/ LTRR) 3 holes : <ul style="list-style-type: none"> • 31.5 ± 1.5 mm (11"x17"/ LTR) • 40.5 ± 1.5 mm (A3/ A4)

- 2/4 Hole Puncher Unit

L1 , L2	12 ± 1.5 mm
L3	2 holes : <ul style="list-style-type: none"> • 108.5 ± 1.5 mm (A3/ A4) • 99.7 ± 1.5 mm (11"x17"/ LTR) 4 holes : <ul style="list-style-type: none"> • 28.5 ± 1.5 mm (A3/ A4) • 19.7 ± 1.5 mm (11"x17"/ LTR)

- 4 Hole Puncher Unit

L1 , L2	12 ± 1.5 mm
L3	<ul style="list-style-type: none"> • 92.5 ± 1.5 mm (A3/ A4) • 83.7 ± 1.5 mm (11"x17"/ LTR)

■ Skew Adjustment (Mechanical adjustment)

When the punch hole position is skew (when L1 is not equal to L2), make the adjustment according to the following procedure.

● Adjustment Procedure



1. Open the Front Cover of the Finisher.

-
2. Lift the Punch Unit. Loosen the screw fixing the Punch Unit Positioning Guide, and then move the guide to adjust by referring the scale. After adjusting, tighten the screw.

NOTE:

When $L1 > L2$: Move the guide to the right.
 When $L1 < L2$: Move the guide to the left.

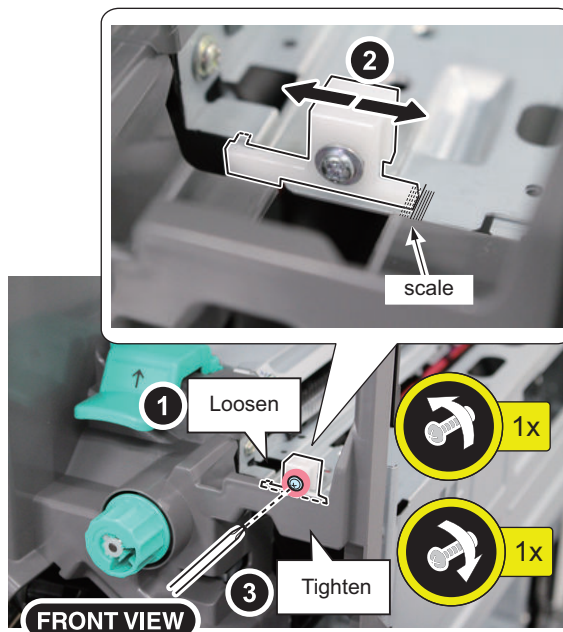

-
3. Lower the Punch Unit, and then close the Front Cover of the Finisher.

■ Side Registration Adjustment (Service mode adjustment)

When the side registration is not within the standard (when $L3$ is not within the standard), make the adjustment according to the following procedure.

-
1. Enter the following service mode to adjust the side registration.
 Service Mode (Level 1) > SORTER > ADJUST > PNCH-Y

NOTE:

When the setting value is increased by 1, $L3$ increases by 0.1mm.
 +: $L3$ increases. (The punch holes shift to the rear.)
 -: $L3$ decreases. (The punch holes shift to the front.)

-
2. Exit the service mode.

■ Paper Stop Position Adjustment (Service mode adjustment)



1. Enter the following service mode to adjust the paper stop position.

Service Mode (Level 1) > SORTER > ADJUST > PNCH-X

NOTE:

When the setting value is increased by 1, L1 and L2 increase by 0.1mm.

+: L1 and L2 increase. (The punch holes shift to the delivery direction.)

-: L1 and L2 decrease. (The punch holes shift to the inlet direction.)

-Settings/ Registration menu> Adjustment/ Maintenance> Adjust Action> Switch Finisher Puncher Mode



2. Exit the service mode.

Finisher Jogger Kit-A1

Checking Before Installation

The installation site must satisfy the conditions given below.

Therefore, it is recommended that the installation site be looked over before delivering this equipment to the customer.

■ Points to Note on Installation

- Refer to "Order of Installation of Options" when installing this equipment.
- This equipment weighs approx. 3 kg.

■ Order of Installation of Options

When installing this equipment together with the other options, first install the host machine and then install options in the following order:

1. Puncher Unit
2. Jogger Kit (This equipment)
3. Staple Finisher / Booklet Finisher
4. Long Sheet Tray

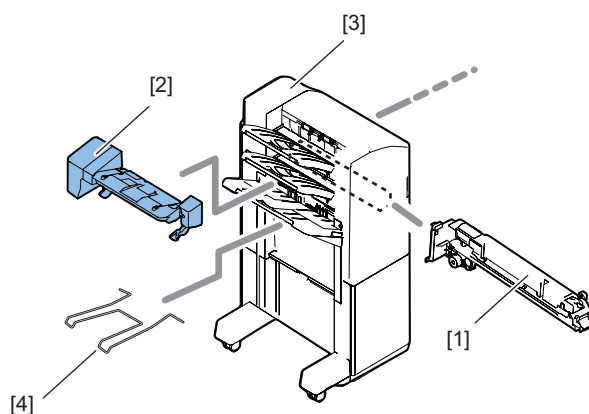

■ Product Name

Safety regulations require the product's name to be registered. In some regions where this product is sold, the following names may be registered instead.

- F281370

Unpacking Procedure

NOTE:

This equipment is packed using tapes, fixings and cushioning materials to be protected against vibration and shock during transportation.

Remove all such tapes and cushioning materials before installing this equipment.

□
1.

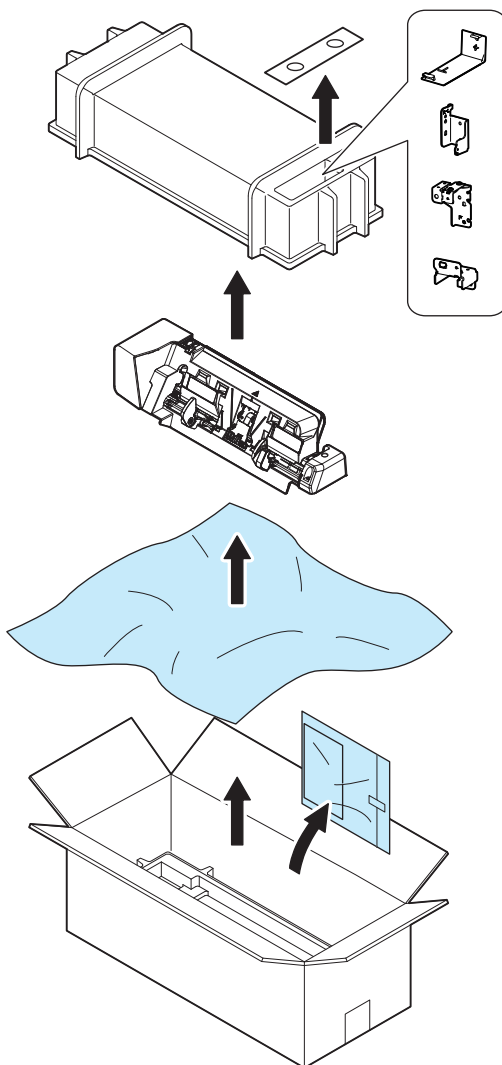

□
2. Remove all the tapes and cushioning materials outside this equipment.

Checking the Contents

Check that none of the included parts is missing.

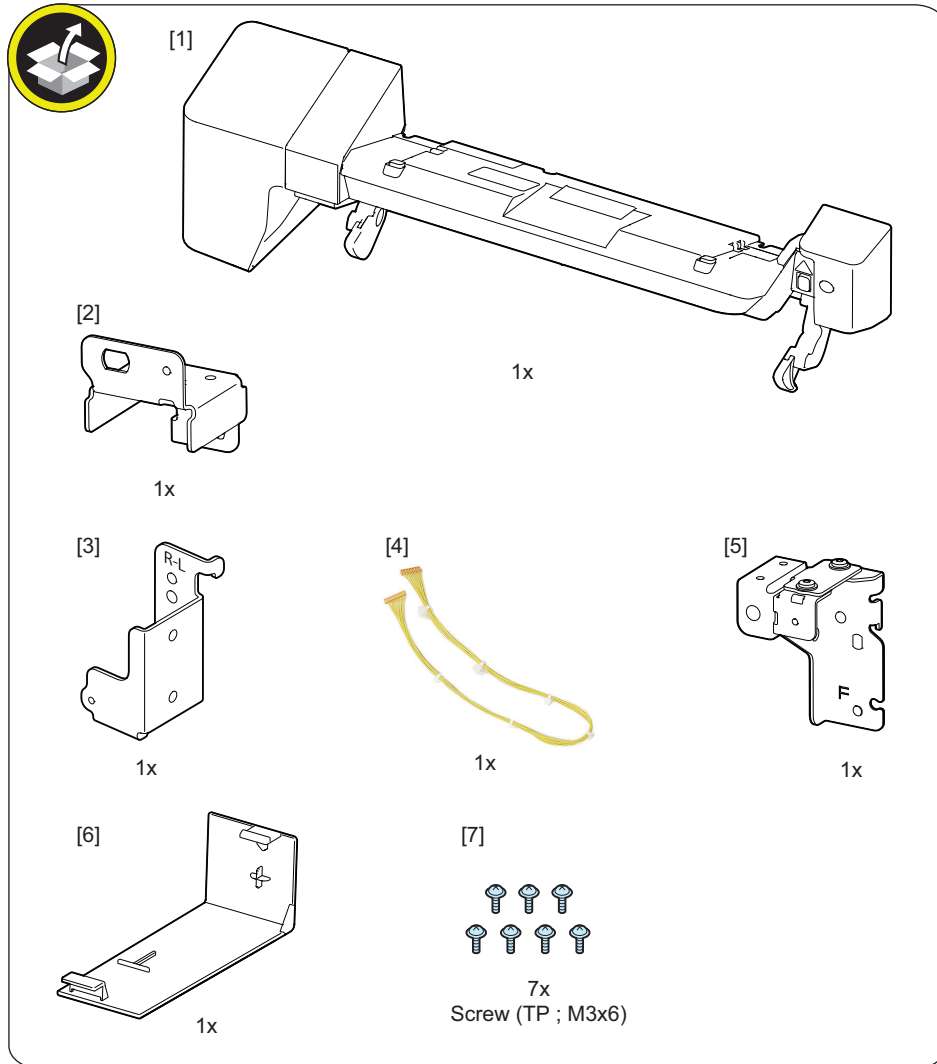

<Others>

Other bundled items such as Installation Procedure, leaflets, etc.

Installation Procedure

CAUTION:

Check that the main power switch is OFF and the power plug is disconnected from the outlet.

■ Preparing the Finisher for Installation

□
1.

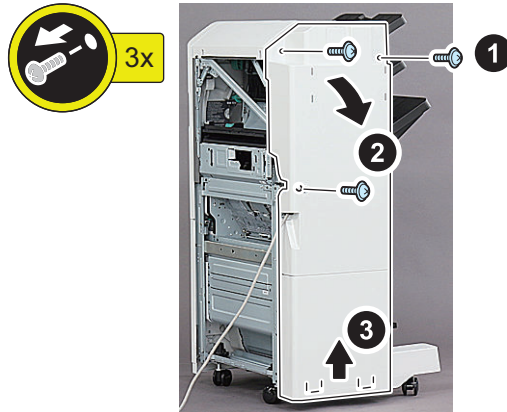

□
2. Disengage the ratchet gear to lower the Stack Tray by approx. 150mm for securing the room for the Jogger Kit.

CAUTION:

Hold the Stacking Tray by hand while disengaging the ratchet gear to avoid its free-fall.

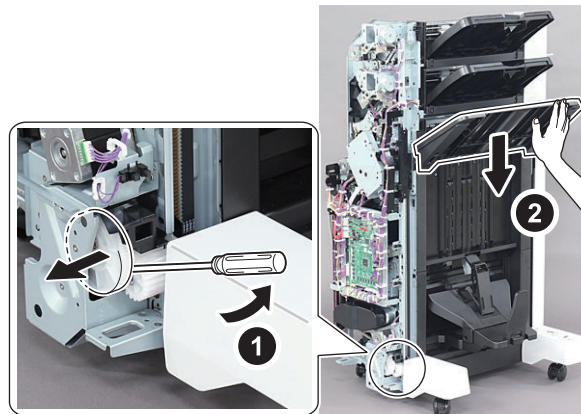

□
3.

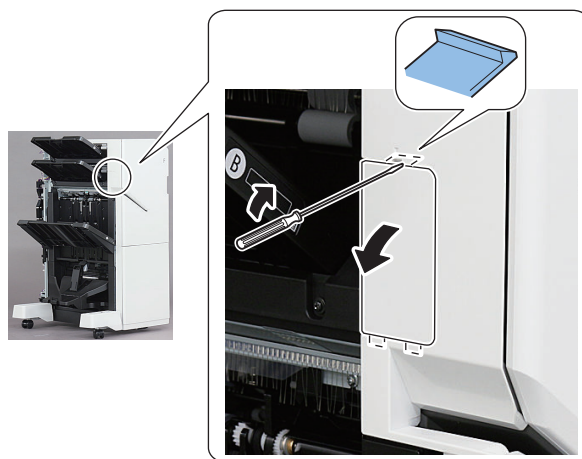

NOTE:
The removed face cover is stored in Rear Cover in a later step.

□
4.

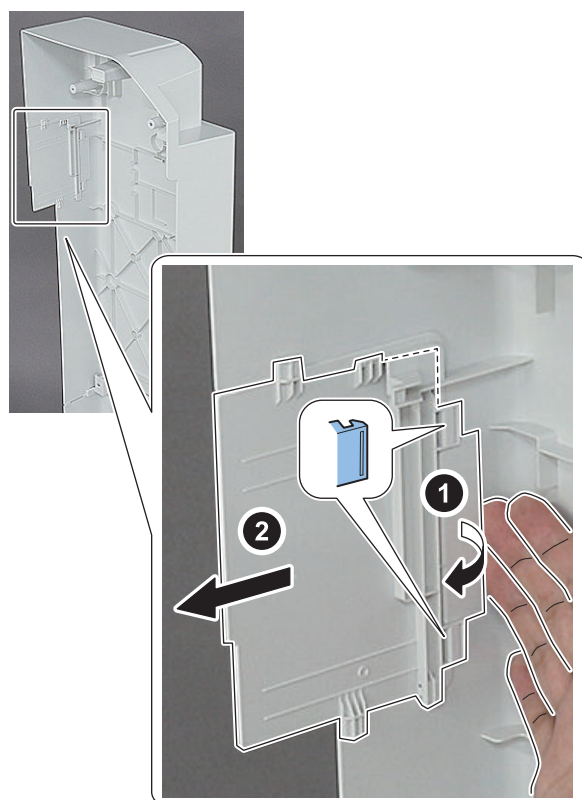

NOTE:
The removed face cover is stored in Rear Cover in a later step.

□

5. Store the removed face covers (2 pcs.) in the Rear Cover.

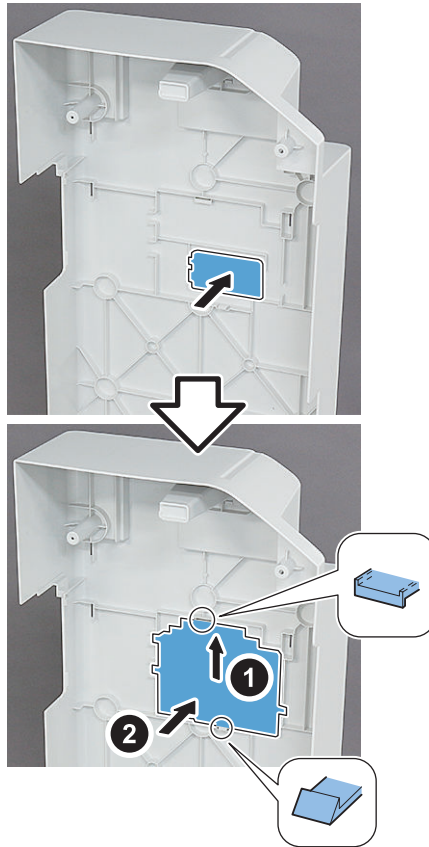

■ Installation Procedure

□

1.

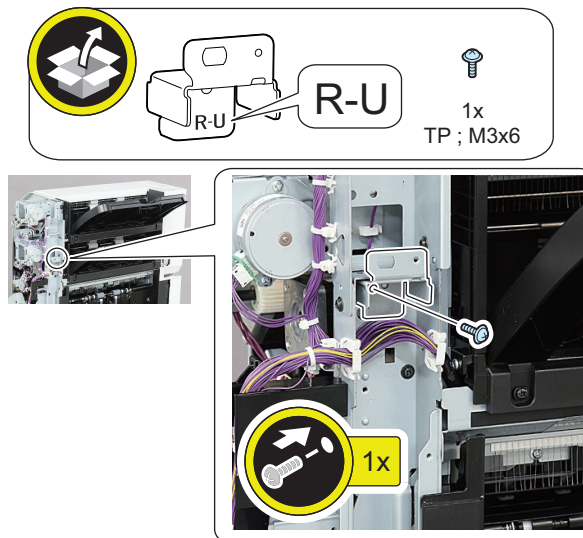

□
2.

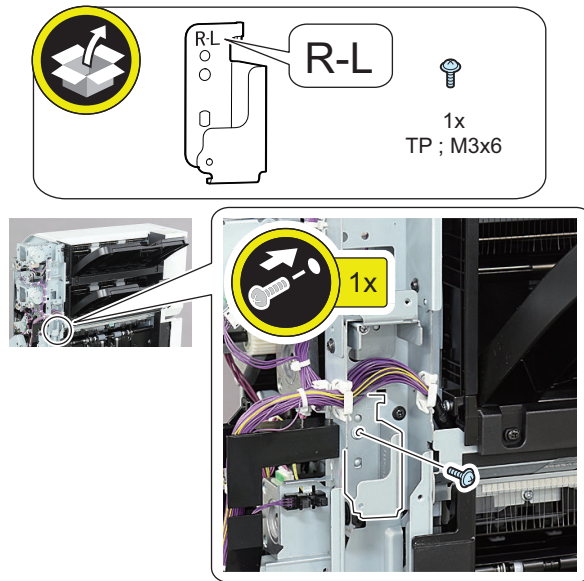

□
3.

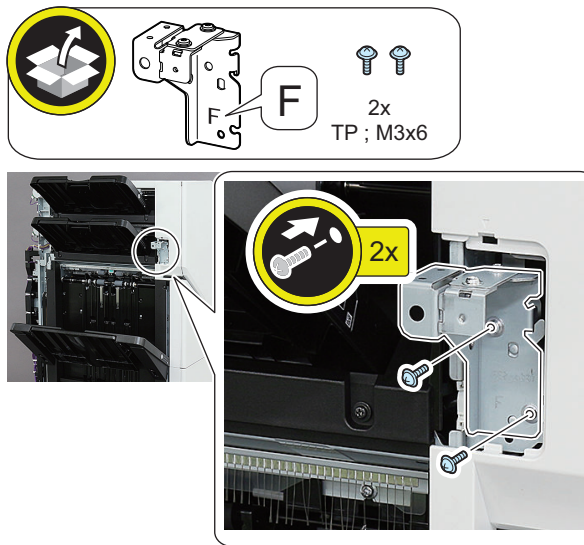



4. Place the Jogger Kit on Finisher.

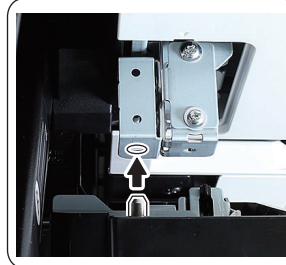
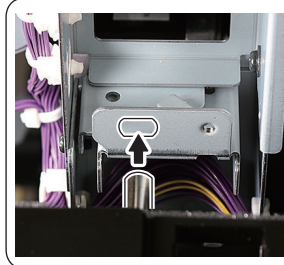
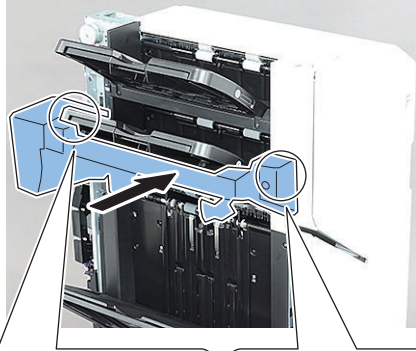
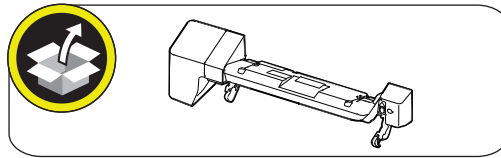

5.



3x
TP ; M3x6

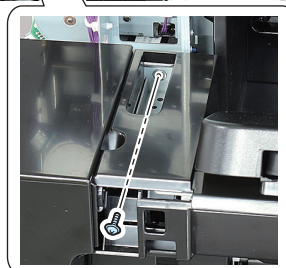
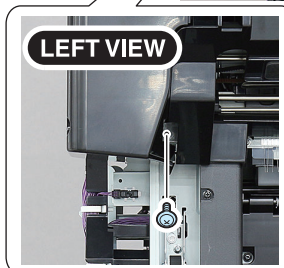
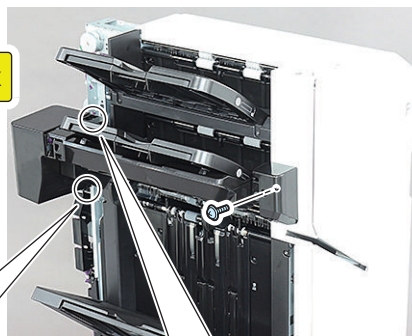

□
6.

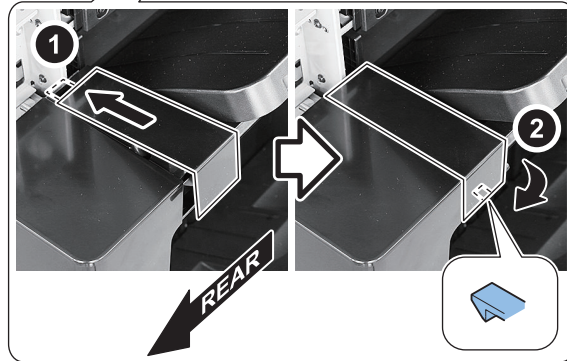
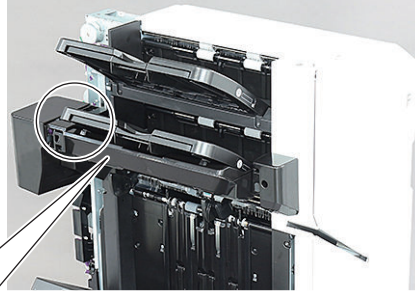
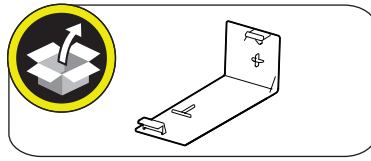

□
7.

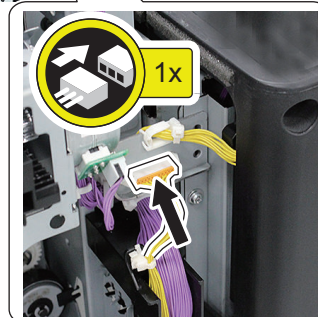
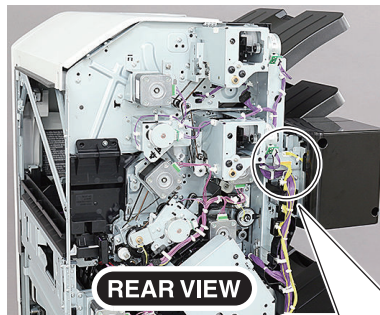
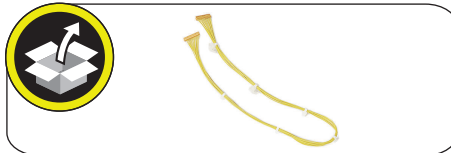

□
8.

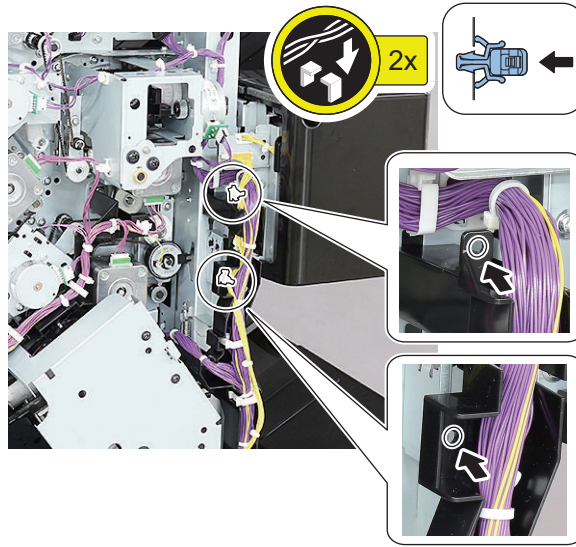

□
9.



10.

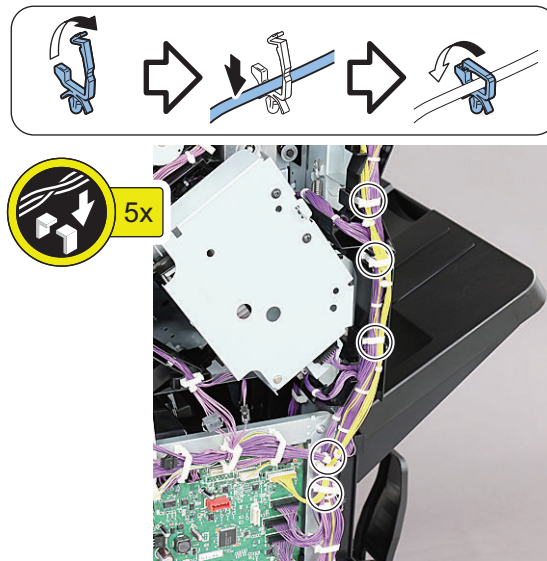

11.

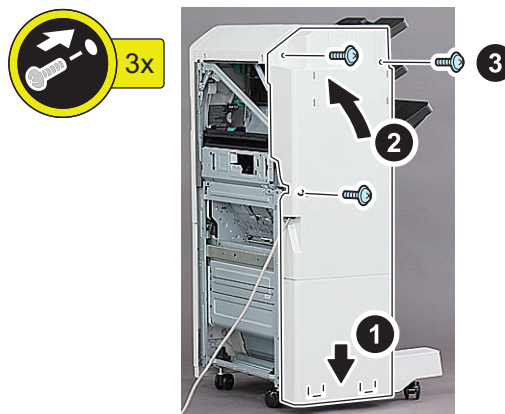

Checking after Installation

■ Disposal Parts Check

There are no parts left after installation work.

■ Operation Check

1. Install the Finisher.

2. Turn ON the main power of the host machine.



3. If a message prompting the user to update the version appears, press [Update] to automatically update the version of this equipment.

NOTE:

If [Skip] is selected, a message prompting the user to update the version will appear every time the host machine is started. In the service mode (Level 2) shown below, it is possible to set not to display the message.

(Lv.2) COPIER > OPTION > FNC-SW > VER-CHNG



4. Perform function checks for jogging operation, etc.

Revision

Rev	Chapter		Category	Product Name	Reference	Remarks
1.0	-	-	First Edition	Installation manual	-	-
2.0	2	Host Machine	Add Con- tents	Installing the Scanner	"Installing the Scanner(Only for Ma- chines Equipped with the Image Reader Unit) " on page 26	