

imagePROGRAF

PRO-2000

PRO-520

Parts Catalog

Revision 06

Canon

PC-16001-06

COPYRIGHT©2018 CANON INC. 102018

PREFACE

This Parts Catalog contains listings of parts used.

Diagrams are provided with the listings to aid the service technician in identifying clearly, the item to be ordered.

When ordering parts, consult this Parts Catalog for all of the information pertaining to each item.

このパーツカタログには、サービス部品の一覧を掲載しています。

また、サービステクニシャンが注文する部品を認識し易いように図解もあります。

部品を注文する際は、それぞれの部品に関する情報をこのパーツカタログでご確認ください。

COPYRIGHT (C) 2018 CANON INC.

Use of this manual should be strictly supervised to avoid disclosure of confidential information.

本マニュアルについては、機密保持等その取扱いには十分注意してください。

Contents

Numerical Index

Numerical Index.....	1-1
----------------------	-----

Parts Catalog

01	PRINTER & ACCESSORIES	2-1
02	TOP COVERS & SIDE COVERS	2-3
03	FRONT COVERS & REAR COVERS	2-5
04	ELECTRICAL PART	2-7
05	INK TANK & PURGE UNIT	2-9
06	CARRIAGE, TUBE UNIT & FILM STRIP	2-11
07	PINCH ROLLER, RELEASE LEVER & MIST FAN	2-13
08	ROLL COVERS	2-15
09	CUTTER & ACCESS COVER LOCK UNIT	2-17
10	PLATEN & FEED ROLLER	2-19
11	UPPER ROLL UNIT, SUCTION FAN & WASTE INK UNIT ..	2-21
12	STAND UNIT	2-23
13	TOOL	2-25
R1	LOWER ROLL UNIT (RIGHT)	2-27
R2	LOWER ROLL UNIT (LEFT)	2-29
R3	LOWER ROLL UNIT (MAIN)	2-31
ZZA	MECHANICAL STANDARD PARTS(HOW TO USE)	2-33
ZZB	MECHANICAL STANDARD PARTS(SCREWS)	2-34
ZZC	MECHANICAL STANDARD PARTS(BOLTS)	2-41
ZZD	MECHANICAL STANDARD PARTS(NUTS)	2-42
ZZE	MECHANICAL STANDARD PARTS(RETAINING RINGS) ..	2-43

Numerical Index

PRO-2000 / PRO-520

PARTS NUMBER	FIGURE & KEY NO.	PARTS NUMBER	FIGURE & KEY NO.	PARTS NUMBER	FIGURE & KEY NO.
AY3-4530-000	13 - 4	QD1-1788-000	R1 - 5	QD1-2420-000	06 - 7
AY3-4595-000	13 - 3	QD1-1789-000	R1 - 6	QD1-2429-000	08 - 10
AY3-4607-000	13 - 1	QD1-1790-000	R1 - 7	QD1-2431-000	08 - 12
AY3-4609-000	13 - 2	QD1-1791-000	R1 - 8	QD1-2435-000	08 - 13
CK-0541-000	13 - 5	QD1-1792-000	08 - 5	QD1-2436-000	08 - 11
NPN	01 - 1	QD1-1792-000	R2 - 2	QD1-2521-010	12 - 14
NPN	01 - 2	QD1-1795-000	R2 - 3	QD1-2522-000	12 - 1
NPN	01 - 2	QD1-1934-000	06 - 22	QD1-2528-000	12 - 17
NPN	01 - 2	QD1-1951-000	06 - 26	QD1-2529-000	12 - 16
NPN	01 - 2	QD1-1958-000	06 - 3	QD1-2545-000	06 - 30
NPN	01 - 2	QD1-1963-000	06 - 29	QD1-2548-000	09 - 7
NPN	01 - 2	QD1-1973-000	06 - 4	QD1-2549-000	02 - 27
NPN	01 - 2	QD1-1981-000	06 - 32	QD1-2550-000	02 - 28
NPN	01 - 2	QD1-1982-000	06 - 33	QD1-2553-000	03 - 7
NPN	01 - 2	QD1-1983-000	06 - 31	QD1-2557-000	02 - 25
NPN	01 - 2	QD1-2079-000	10 - 7	QD1-2562-000	03 - 8
NPN	01 - 2	QD1-2085-000	07 - 2	QD1-2579-000	05 - 3
NPN	01 - 2	QD1-2110-000	06 - 28	QD1-2588-000	R1 - 9
QC2-6710-000	13 - 6	QD1-2111-000	06 - 27	QD1-2593-000	R1 - 10
QC3-4923-000	06 - 25	QD1-2159-000	11 - 2	QD1-2595-000	R3 - 5
QC4-1522-000	07 - 1	QD1-2159-000	R3 - 3	QD1-2602-000	R3 - 6
QC4-8783-000	10 - 1	QD1-2160-000	11 - 3	QD1-2645-000	01 - 4
QC4-8784-000	10 - 2	QD1-2160-000	R3 - 4	QD1-2653-000	08 - 14
QC4-9195-000	01 - 3	QD1-2174-000	06 - 5	QD1-2656-000	R2 - 4
QC4-9300-000	12 - 10	QD1-2177-000	06 - 6	QD1-2695-000	03 - 18
QC4-9300-000	R3 - 22	QD1-2221-000	09 - 2	QD1-2702-000	10 - 9
QC4-9302-000	01 - 27	QD1-2222-000	09 - 3	QD1-2704-000	01 - 5
QC4-9303-000	12 - 11	QD1-2231-000	07 - 3	QD1-2705-000	01 - 6
QC5-1836-000	06 - 24	QD1-2233-000	07 - 4	QD1-2706-000	01 - 7
QC5-1874-000	06 - 1	QD1-2237-000	07 - 5	QD1-2709-000	08 - 15
QC5-1900-000	06 - 2	QD1-2239-000	08 - 6	QD1-2710-000	08 - 16
QC5-1993-000	05 - 1	QD1-2240-000	08 - 7	QD1-2712-000	07 - 7
QC5-8099-000	10 - 3	QD1-2241-000	08 - 8	QD1-2725-000	R1 - 11
QC5-8788-000	12 - 18	QD1-2244-000	10 - 8	QD1-2726-000	R1 - 12
QD1-1358-000	02 - 1	QD1-2280-000	07 - 6	QD1-2729-000	01 - 8
QD1-1359-000	02 - 2	QD1-2280-000	08 - 9	QD1-2736-000	12 - 2
QD1-1441-000	08 - 1	QD1-2317-000	03 - 1	QD1-2740-000	12 - 13
QD1-1441-000	09 - 1	QD1-2320-000	03 - 2	QD1-2746-000	01 - 26
QD1-1441-000	R1 - 1	QD1-2326-010	05 - 21	QD1-2747-000	01 - 9
QD1-1441-000	R2 - 1	QD1-2332-000	05 - 24	QD1-2752-000	02 - 8
QD1-1443-000	R1 - 2	QD1-2345-000	03 - 3	QD1-2768-000	03 - 9
QD1-1677-000	11 - 1	QD1-2348-000	05 - 2	QD1-2772-000	03 - 9
QD1-1677-000	R3 - 1	QD1-2349-000	03 - 4	QD1-2784-000	R2 - 5
QD1-1721-010	08 - 2	QD1-2358-000	02 - 4	QD1-2787-000	12 - 3
QD1-1722-000	08 - 3	QD1-2359-000	03 - 5	QD1-2801-000	10 - 10
QD1-1723-000	08 - 4	QD1-2360-000	02 - 5	QD1-2853-000	R2 - 6
QD1-1758-000	10 - 4	QD1-2366-000	02 - 6	QD1-2863-000	08 - 17
QD1-1760-000	10 - 5	QD1-2367-000	03 - 6	QD1-2867-000	08 - 18
QD1-1761-000	10 - 6	QD1-2398-000	02 - 7	QD1-2879-000	12 - 4
QD1-1781-000	R3 - 2	QD1-2408-000	09 - 4	QD1-2880-000	12 - 5
QD1-1785-000	R1 - 3	QD1-2411-000	09 - 5	QD1-2884-000	07 - 8
QD1-1787-000	R1 - 4	QD1-2416-000	09 - 6	QD1-2888-000	08 - 19

Numerical Index

PRO-2000 / PRO-520

PARTS NUMBER	FIGURE & KEY NO.	PARTS NUMBER	FIGURE & KEY NO.	PARTS NUMBER	FIGURE & KEY NO.
QD1-2893-000	02 - 9	QM4-4340-000	06 - 36	QM4-8662-000	06 - 15
QD1-2904-000	13 - 7	QM4-4341-000	06 - 9	QM4-8677-000	09 - 11
QD1-2912-000	02 - 3	QM4-4342-000	R3 - 10	QM4-8678-000	11 - 12
QK1-2868-000	06 - 8	QM4-4343-000	R3 - 11	QM4-8678-000	R2 - 12
QK2-0830-000	01 - 25	QM4-4350-000	02 - 12	QM4-8680-010	12 - 15
QK2-1472-000	04 - 11	QM4-4352-000	05 - 11	QM4-8692-000	02 - 19
QK2-1474-000	02 - 10	QM4-4353-000	12 - 7	QM4-8695-000	02 - 20
QK2-1476-000	R2 - 7	QM4-4356-010	12 - 8	QM4-8696-000	03 - 10
QK2-1484-000	09 - 8	QM4-4359-000	06 - 10	QM4-8697-000	03 - 11
QK2-1739-000	01 - 19	QM4-4362-000	06 - 11	QM4-8701-010	03 - 12
QK2-1741-000	01 - 20	QM4-4368-000	04 - 1	QM4-8702-010	03 - 13
QK2-1743-000	01 - 21	QM4-4379-000	06 - 13	QM4-8702-010	05 - 14
QK2-1745-000	01 - 22	QM4-4382-000	R2 - 11	QM4-8715-000	11 - 13
QK2-1747-000	01 - 23	QM4-4383-000	02 - 13	QM4-8715-000	R3 - 14
QK2-1749-000	01 - 24	QM4-4784-010	04 - 3	QM4-8718-000	11 - 14
QL2-8481-000	R1 - 21	QM4-4859-000	R3 - 12	QM4-8718-000	R3 - 15
QL2-8518-000	02 - 26	QM4-4860-000	R3 - 13	QM7-4756-000	04 - 4
QM4-4038-000	05 - 4	QM4-4863-000	07 - 13	QM7-4757-000	02 - 16
QM4-4191-000	06 - 34	QM4-4865-000	04 - 9	QM7-4761-000	05 - 15
QM4-4197-000	05 - 5	QM4-4867-000	04 - 10	QM7-4815-000	06 - 16
QM4-4198-000	05 - 6	QM4-4890-000	08 - 22	QM7-4821-000	04 - 12
QM4-4208-000	07 - 9	QM4-4892-000	08 - 23	QM7-4824-000	04 - 13
QM4-4217-000	09 - 9	QM4-4893-000	08 - 24	QM7-4826-000	04 - 14
QM4-4226-000	05 - 7	QM4-4897-000	R2 - 8	QM7-4828-000	10 - 19
QM4-4227-010	07 - 10	QM4-4898-000	R1 - 13	QM7-4829-000	07 - 14
QM4-4231-000	R2 - 9	QM4-4899-000	03 - 14	QM7-4831-000	09 - 12
QM4-4241-000	11 - 5	QM4-4900-000	02 - 14	QM7-4832-000	09 - 13
QM4-4242-000	11 - 6	QM4-4901-000	02 - 15	QM7-4834-000	05 - 16
QM4-4245-000	02 - 11	QM4-4904-000	09 - 10	QM7-4835-000	05 - 17
QM4-4249-010	11 - 7	QM4-4912-000	06 - 23	QM7-4845-000	05 - 18
QM4-4249-010	R3 - 8	QM4-4914-000	R1 - 14	QM7-4847-000	04 - 5
QM4-4252-000	07 - 11	QM4-4915-000	R1 - 15	QM7-4849-000	07 - 15
QM4-4253-000	07 - 12	QM4-4916-000	02 - 18	QM7-4857-000	11 - 19
QM4-4261-000	11 - 9	QM4-4923-010	05 - 22	QM7-4864-000	04 - 6
QM4-4269-000	10 - 14	QM4-4924-000	11 - 17	QM7-4867-000	04 - 15
QM4-4271-000	10 - 15	QM4-4925-000	11 - 18	QM7-4869-000	02 - 17
QM4-4272-000	10 - 16	QM4-4926-000	11 - 4	QM7-4871-000	R2 - 13
QM4-4277-000	10 - 17	QM4-4926-000	R3 - 7	QM7-4872-000	11 - 20
QM4-4287-000	05 - 8	QM4-4927-000	11 - 15	QM7-4872-000	R2 - 14
QM4-4288-000	10 - 18	QM4-4927-000	R3 - 16	QM7-4873-000	R2 - 15
QM4-4289-000	11 - 10	QM4-4928-000	11 - 16	QM7-4876-000	R3 - 18
QM4-4289-000	R3 - 9	QM4-4928-000	R3 - 17	QM7-4877-000	R1 - 16
QM4-4294-020	12 - 6	QM4-5388-000	10 - 12	QM7-4879-000	R3 - 19
QM4-4296-000	01 - 11	QM4-5389-000	10 - 13	QM7-4884-000	11 - 21
QM4-4297-000	01 - 12	QM4-5548-000	04 - 2	QM7-4884-000	R3 - 20
QM4-4298-000	01 - 13	QM4-5751-000	11 - 11	QU1-9070-000	06 - 17
QM4-4299-000	08 - 20	QM4-5850-000	06 - 12	WC4-5171-000	09 - 14
QM4-4299-000	R2 - 10	QM4-5861-000	11 - 8	WC4-5376-000	07 - 16
QM4-4301-000	08 - 21	QM4-6311-000	10 - 11	WG8-5677-000	10 - 20
QM4-4302-000	01 - 10	QM4-8637-000	06 - 14	WG8-5935-000	08 - 25
QM4-4316-040	05 - 9	QM4-8640-000	05 - 12	WG8-5935-000	09 - 15
QM4-4318-040	05 - 10	QM4-8641-000	05 - 13	WG8-5935-000	11 - 22

Numerical Index

PRO-2000 / PRO-520

PARTS NUMBER	FIGURE & KEY NO.	PARTS NUMBER	FIGURE & KEY NO.	PARTS NUMBER	FIGURE & KEY NO.
WG8-5935-000	R1 - 17	XD1-4200-402	04 - 21		
WG8-5935-000	R2 - 16	XD2-1100-322	01 - 15		
WG8-5935-000	R3 - 21	XD2-1100-322	R1 - 18		
WM2-5295-000	04 - 7	XD2-1100-642	01 - 16		
WP2-5410-000	04 - 8	XD3-2200-182	01 - 17		
WT2-5738-000	05 - 23	XG9-0793-000	01 - 18		
XA9-0732-000	02 - 21				
XA9-0732-000	03 - 15				
XA9-0732-000	04 - 16				
XA9-0732-000	05 - 19				
XA9-0732-000	07 - 17				
XA9-0732-000	08 - 26				
XA9-0732-000	09 - 16				
XA9-0732-000	10 - 21				
XA9-0732-000	11 - 23				
XA9-0732-000	R1 - 19				
XA9-0732-000	R2 - 17				
XA9-0732-000	R3 - 23				
XA9-0949-000	12 - 9				
XA9-1157-000	02 - 22				
XA9-1161-000	10 - 22				
XA9-1671-000	01 - 14				
XA9-1671-000	09 - 17				
XA9-1752-000	08 - 27				
XB1-2302-005	06 - 18				
XB1-2302-005	09 - 18				
XB1-2400-607	04 - 17				
XB1-2400-607	06 - 19				
XB2-8400-805	06 - 35				
XB2-8400-805	10 - 23				
XB4-7300-805	03 - 16				
XB4-7300-805	04 - 18				
XB4-7300-805	05 - 20				
XB4-7300-805	06 - 20				
XB4-7300-805	08 - 28				
XB4-7300-805	R1 - 20				
XB4-7301-209	06 - 21				
XB4-7401-005	02 - 23				
XB4-7401-005	03 - 17				
XB4-7401-005	08 - 29				
XB6-7300-405	02 - 24				
XB6-7300-405	08 - 30				
XB6-7300-405	09 - 19				
XB6-7300-605	04 - 19				
XB6-7300-605	08 - 31				
XB6-7300-605	R3 - 24				
XB6-7400-805	04 - 20				
XB6-7400-805	07 - 18				
XB6-7400-805	08 - 32				
XB6-7400-805	11 - 24				
XB7-1080-169	12 - 12				
XB7-1080-169	R3 - 25				

PRO-2000 / 520 (Parts Catalog)

PRO-2000 / 520

Q51-2607-000

Stand Unit / Basket Unit SD-21

Q55-3100-000

Roll Unit RU-21

Q55-3030-000

Contents

01	PRINTER & ACCESSORIES	2-1
02	TOP COVERS & SIDE COVERS	2-3
03	FRONT COVERS & REAR COVERS	2-5
04	ELECTRICAL PART	2-7
05	INK TANK & PURGE UNIT	2-9
06	CARRIAGE, TUBE UNIT & FILM STRIP	2-11
07	PINCH ROLLER, RELEASE LEVER & MIST FAN	2-13
08	ROLL COVERS	2-15
09	CUTTER & ACCESS COVER LOCK UNIT	2-17
10	PLATEN & FEED ROLLER	2-19
11	UPPER ROLL UNIT, SUCTION FAN & WASTE INK UNIT	2-21
12	STAND UNIT	2-23
13	TOOL	2-25
R1	LOWER ROLL UNIT (RIGHT)	2-27
R2	LOWER ROLL UNIT (LEFT)	2-29
R3	LOWER ROLL UNIT (MAIN)	2-31
ZZA	MECHANICAL STANDARD PARTS(HOW TO USE)	2-33
ZZB	MECHANICAL STANDARD PARTS(SCREWS)	2-34
ZZC	MECHANICAL STANDARD PARTS(BOLTS)	2-41
ZZD	MECHANICAL STANDARD PARTS(NUTS)	2-42
ZZE	MECHANICAL STANDARD PARTS(RETAINING RINGS)	2-43

Figure 01 PRINTER & ACCESSORIES

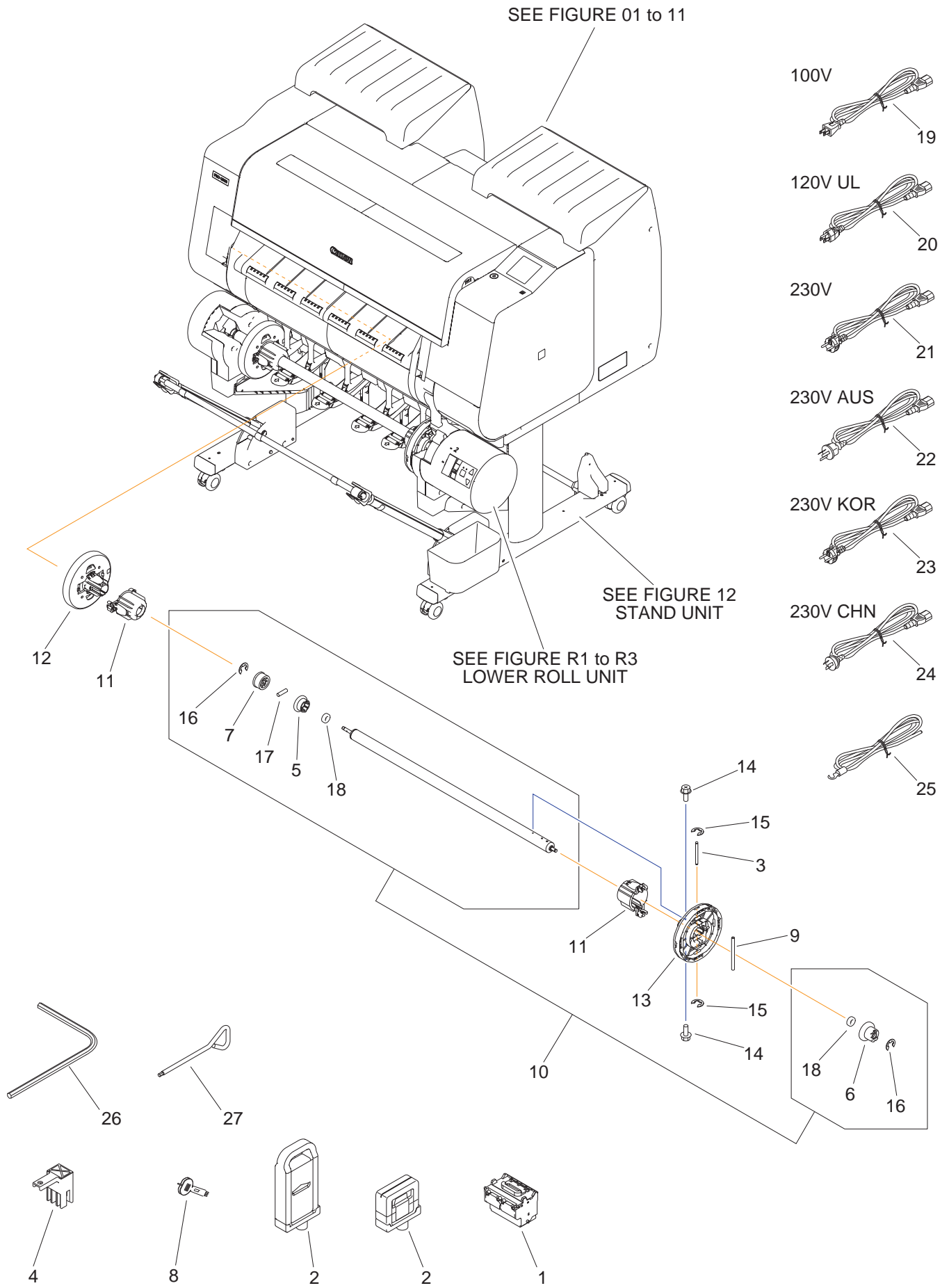

FIG	KEY	Part No.	DESCRIPTION	REMARKS	Q'ty
01	1	NPN	PRINT HEAD		RF
01	2	NPN	INK TANK (Y)		RF
01	2	NPN	INK TANK (M)		RF
01	2	NPN	INK TANK (C)		RF
01	2	NPN	INK TANK (PC)		RF
01	2	NPN	INK TANK (PM)		RF
01	2	NPN	INK TANK (GY)		RF
01	2	NPN	INK TANK (PBK)		RF
01	2	NPN	INK TANK (MBK)		RF
01	2	NPN	INK TANK (PGY)		RF
01	2	NPN	INK TANK (R)		RF
01	2	NPN	INK TANK (CO)		RF
01	2	NPN	INK TANK (B)		RF
01	3	QC4-9195-000	HOLD PIN4		1
01	4	QD1-2645-000	LOCK BELT		1
01	5	QD1-2704-000	HOLDER, SPOOL BEARING L		1
01	6	QD1-2705-000	HOLDER, SPOOL BEARING R		1
01	7	QD1-2706-000	GEAR, SPOOL		1
01	8	QD1-2729-000	PLATEN CLEANER BRUSH		1
01	9	QD1-2747-000	PIN, SPOOL		1
01	10	QM4-4302-000	SPOOL SHAFT UNIT		1
01	11	QM4-4296-000	SPOOL 3INCH ATTACHMENT UNIT		2
01	12	QM4-4297-000	SPOOL FLANGE UNIT L		1
01	13	QM4-4298-000	SPOOL FLANGE UNIT R		1
01	14	XA9-1671-000	SCREW, D, M3X8		2
01	15	XD2-1100-322	RETAINING RING (E-TYPE)		2
01	16	XD2-1100-642	RING, E		2
01	17	XD3-2200-182	PIN, DOWEL		1
01	18	XG9-0793-000	BEARING		2
01	19	QK2-1739-000	CORD, POWER	JPN	1
01	20	QK2-1741-000	CORD, POWER	USA	1
01	21	QK2-1743-000	CORD, POWER	EUR/SPL	1
01	22	QK2-1745-000	CORD, POWER	AUS	1
01	23	QK2-1747-000	CORD, POWER	KOR	1
01	24	QK2-1749-000	CORD, POWER	CHN	1
01	25	QK2-0830-000	CORD, GROUNDING	JPN	1
01	26	QD1-2746-000	HEXAGONAL WRENCH		1
01	27	QC4-9302-000	WRENCH, HEX KEY		1

Figure 02 TOP COVERS & SIDE COVERS

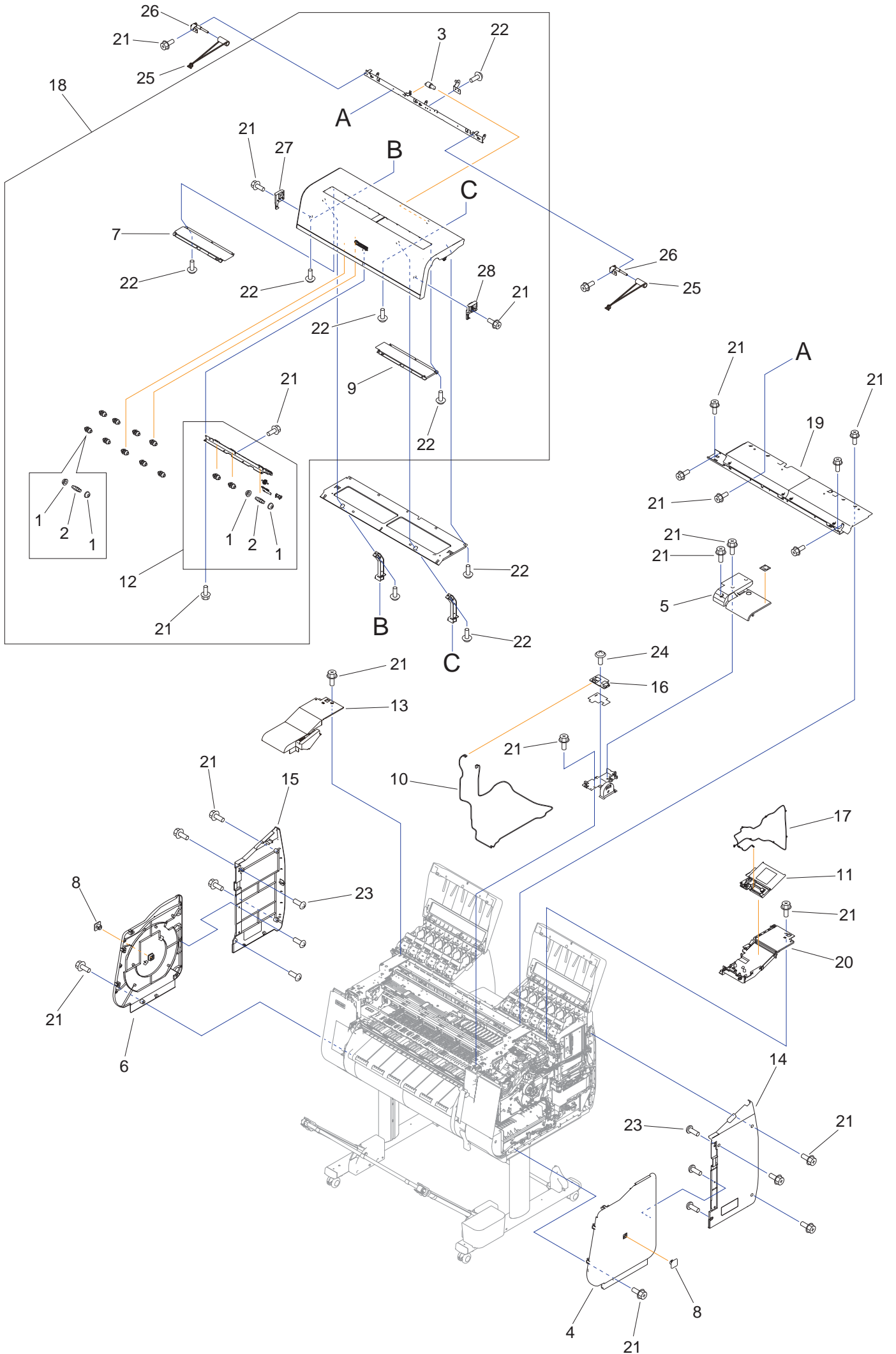

FIG	KEY	Part No.	DESCRIPTION	REMARKS	Q'ty
02	1	QD1-1358-000	ROLLER, PRESS		24
02	2	QD1-1359-000	SHAFT, PRESS ROLLER		12
02	3	QD1-2912-000	ROTARY DAMPER		1
02	4	QD1-2358-000	COVER, SIDE R A		1
02	5	QD1-2360-000	COVER, FRONT TOP R		1
02	6	QD1-2366-000	COVER, SIDE L A		1
02	7	QD1-2398-000	WINDOW		1
02	8	QD1-2752-000	CAP, SIDE COVER		2
02	9	QD1-2893-000	WINDOW R		1
02	10	QK2-1474-000	CABLE, USB RELAY		1
02	11	QM4-4245-000	OPERATION PANEL UNIT		1
02	12	QM4-4350-000	GUARD ACCESS COVER UNIT W/SPUR		1
02	13	QM4-4383-000	COVER UNIT, TOP L		1
02	14	QM4-4900-000	COVER UNIT, SIDE R B		1
02	15	QM4-4901-000	COVER UNIT, SIDE L B		1
02	16	QM7-4757-000	USB HOST PCB ASS'Y		1
02	17	QM7-4869-000	HARNESS ASS'Y, PANEL LVDS		1
02	18	QM4-4916-000	ACCESS COVER UNIT S		1
02	19	QM4-8692-000	COVER UNIT, BACK TOP CENTER		1
02	20	QM4-8695-000	COVER UNIT, BACK TOP R		1
02	21	XA9-0732-000	SCREW, RS, M4		AR
02	22	XA9-1157-000	SCREW, TAPPING, C. S. HEAD M4X10		AR
02	23	XB4-7401-005	SCREW, TP, TRUSS HEAD, M4X10		6
02	24	XB6-7300-405	SCREW, FLANGED PAN HEAD, M3X4		1
02	25	QD1-2557-000	SPRING, ACCESS COVER		2
02	26	QL2-8518-000	HINGE ASS'Y, ACCESS COVER SP		2
02	27	QD1-2549-000	LEVER, LOCK L		1
02	28	QD1-2550-000	LEVER, LOCK R		1

Figure 03 FRONT COVERS & REAR COVERS

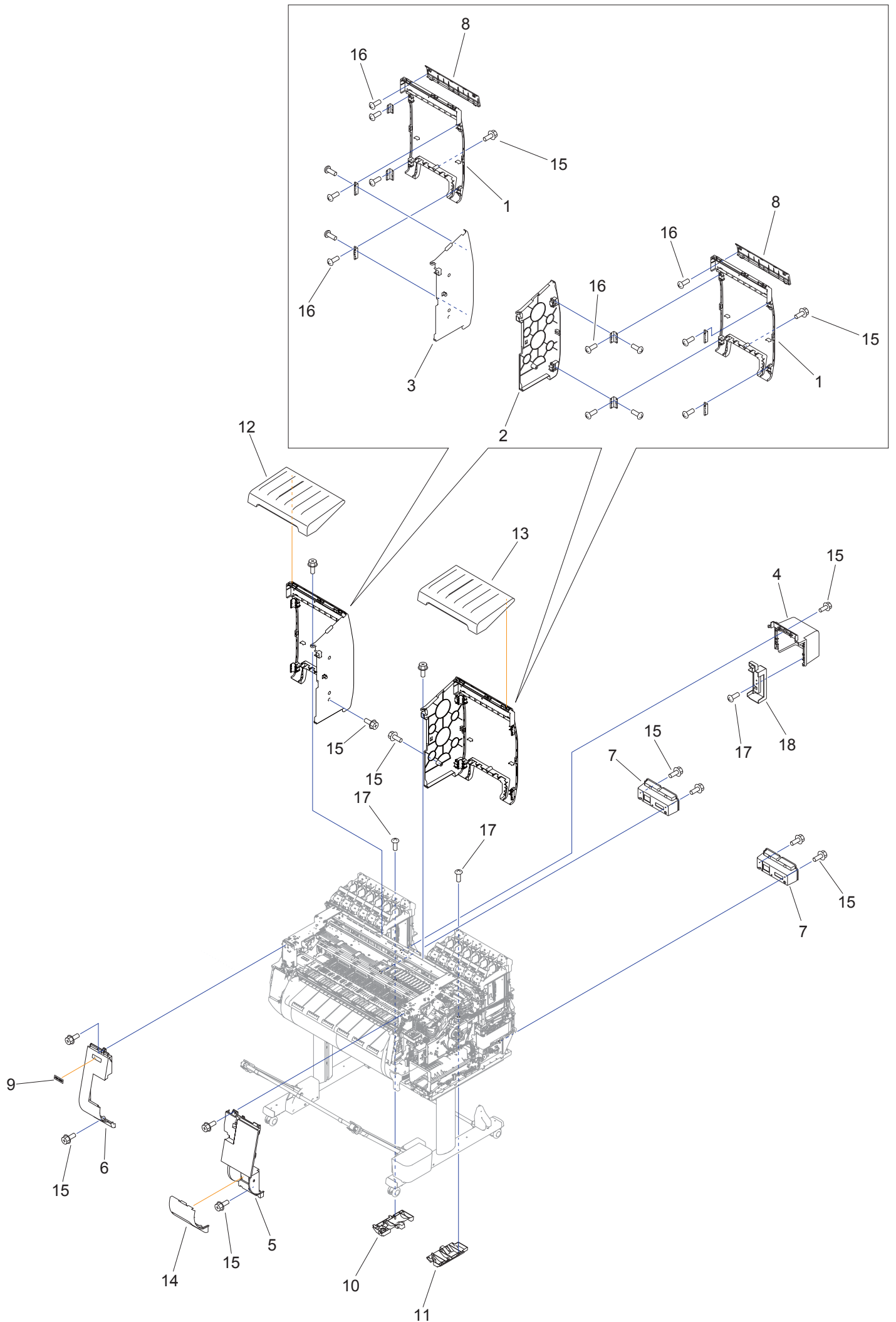

FIG	KEY	Part No.	DESCRIPTION	REMARKS	Q'ty
03	1	QD1-2317-000	COVER, INKTANK BACK		2
03	2	QD1-2320-000	COVER, INKTANK R INSIDE		1
03	3	QD1-2345-000	COVER, INKTANK L INSIDE		1
03	4	QD1-2349-000	COVER, MIST FAN		1
03	5	QD1-2359-000	COVER, FRONT R		1
03	6	QD1-2367-000	COVER, FRONT L		1
03	7	QD1-2553-000	HANDLE, INKTANK BACK		2
03	8	QD1-2562-000	COVER, INKTANK TOP BACK		2
03	9	QD1-2768-000	PRODUCT NAME PLATE	PRO-2000	1
03	9	QD1-2772-000	PRODUCT NAME PLATE	PRO-520	1
03	10	QM4-8696-000	INK SUPPLY MOUNT BASE UNIT L		1
03	11	QM4-8697-000	INK SUPPLY MOUNT BASE UNIT R		1
03	12	QM4-8701-010	COVER UNIT, INKTANK, TOP L		1
03	13	QM4-8702-010	COVER UNIT, INKTANK, TOP R		1
03	14	QM4-4899-000	COVER UNIT, MTC		1
03	15	XA9-0732-000	SCREW, RS, M4		27
03	16	XB4-7300-805	SCREW, TP, BH3X8, S		30
03	17	XB4-7401-005	SCREW, TP, TRUSS HEAD, M4X10		6
03	18	QD1-2695-000	COVER, BACK RIGHT		1

FIG	KEY	Part No.	DESCRIPTION	REMARKS	Q'ty
04	1	QM4-4368-000	I/F PCB UNIT		1
04	2	QM4-5548-000	POWER SUPPLY UNIT		1
04	3	QM4-4784-010	MAIN PCB UNIT		1
04	4	QM7-4756-000	BACKUP PCB UNIT		1
04	5	QM7-4847-000	HARNESS ASS'Y, R		1
04	6	QM7-4864-000	HARNESS ASS'Y, L		1
04	7	WM2-5295-000	HDD, ST320LT012		1
04	8	WP2-5410-000	SENSOR, HUMIDITY		1
04	9	QM4-4865-000	WIRELESS LAN PCB UNIT		1
04	10	QM4-4867-000	RELAY PCB UNIT, RU		1
04	11	QK2-1472-000	HDD CABLE ASS'Y		1
04	12	QM7-4821-000	HARNESS ASS'Y, POWER SUPPLY		1
04	13	QM7-4824-000	HARNESS ASS'Y, INLET RELAY		1
04	14	QM7-4826-000	INLET HARNESS UNIT		1
04	15	QM7-4867-000	HARNESS ASS'Y, RU RELAY		1
04	16	XA9-0732-000	SCREW, RS, M4		5
04	17	XB1-2400-607	SCREW, CROSS-RECESS, FCH		1
04	18	XB4-7300-805	SCREW, TP, BH3X8, S		1
04	19	XB6-7300-605	SCREW, TP, M3X6 (S)		18
04	20	XB6-7400-805	SCREW, FLANGED PAN HEAD, M4X8		5
04	21	XD1-4200-402	WASHER, TOOTHED LOCK, M4		1

Figure 05 INK TANK & PURGE UNIT

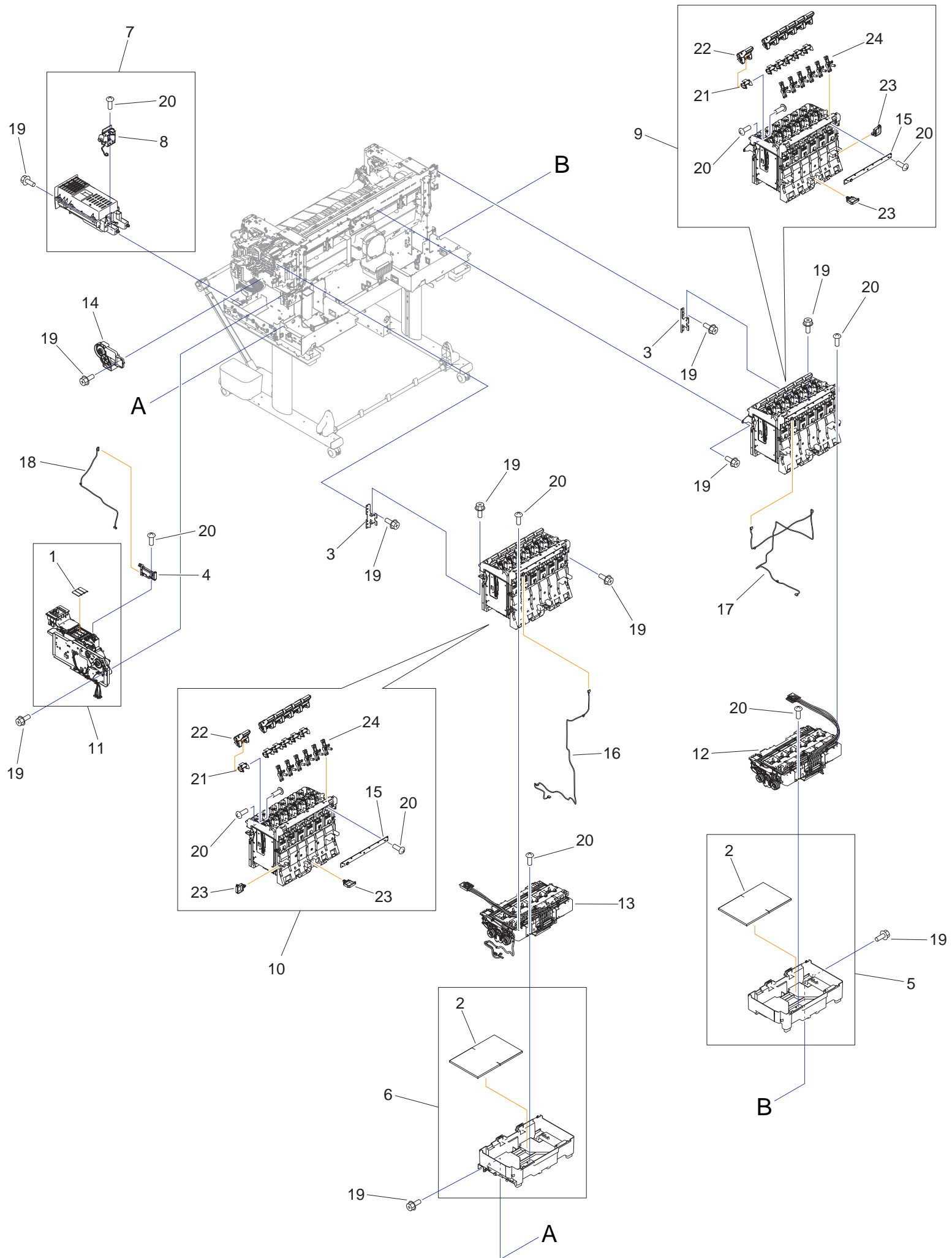

FIG	KEY	Part No.	DESCRIPTION	REMARKS	Q'ty
05	1	QC5-1993-000	ABSORBER, CAP		3
05	2	QD1-2348-000	ABSORBER, INK		2
05	3	QD1-2579-000	UPPER GUIDE, INK TANK		2
05	4	QM4-4038-000	HEAD MANAGEMENT SENSOR UNIT		1
05	5	QM4-4197-000	INK SUPPLY MOUNT UNIT L		1
05	6	QM4-4198-000	INK SUPPLY MOUNT UNIT R		1
05	7	QM4-4226-000	WASTE INK TANK UNIT		1
05	8	QM4-4287-000	ROM BOARD UNIT		1
05	9	QM4-4316-040	INK SUPPLY TANK HOLDER UNIT L		1
05	10	QM4-4318-040	INK SUPPLY TANK HOLDER UNIT R		1
05	11	QM4-4352-000	PURGE UNIT		1
05	12	QM4-8640-000	SUB INK TANK UNIT L		1
05	13	QM4-8641-000	SUB INK TANK UNIT R		1
05	14	QM4-8710-000	LIFT UNIT		1
05	15	QM7-4761-000	TANK LED PCB UNIT		2
05	16	QM7-4834-000	HARNESS ASS'Y, TANKLED R RLY		1
05	17	QM7-4835-000	HARNESS ASS'Y, TANKLED L RLY		1
05	18	QM7-4845-000	HARNESS ASS'Y, HEAD MANAGEMENT		1
05	19	XA9-0732-000	SCREW, RS, M4		13
05	20	XB4-7300-805	SCREW, TP, BH3X8, S		16
05	21	QD1-2326-010	LEVER, INK TANK		12
05	22	QM4-4923-010	HANDLE UNIT, INK TANK S		12
05	23	WT2-5738-000	CLAMP, CABLE		4
05	24	QD1-2332-000	EJECT LEVER, INK TANK		12

Figure 06 CARRIAGE, TUBE UNIT & FILM STRIP

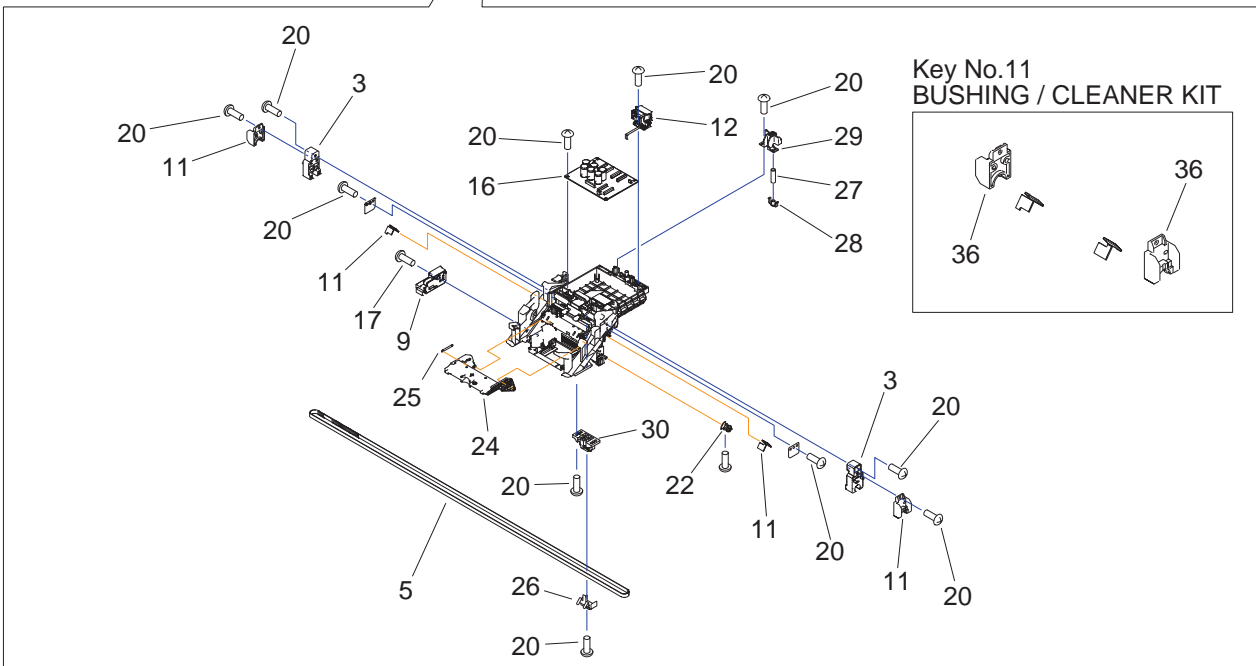
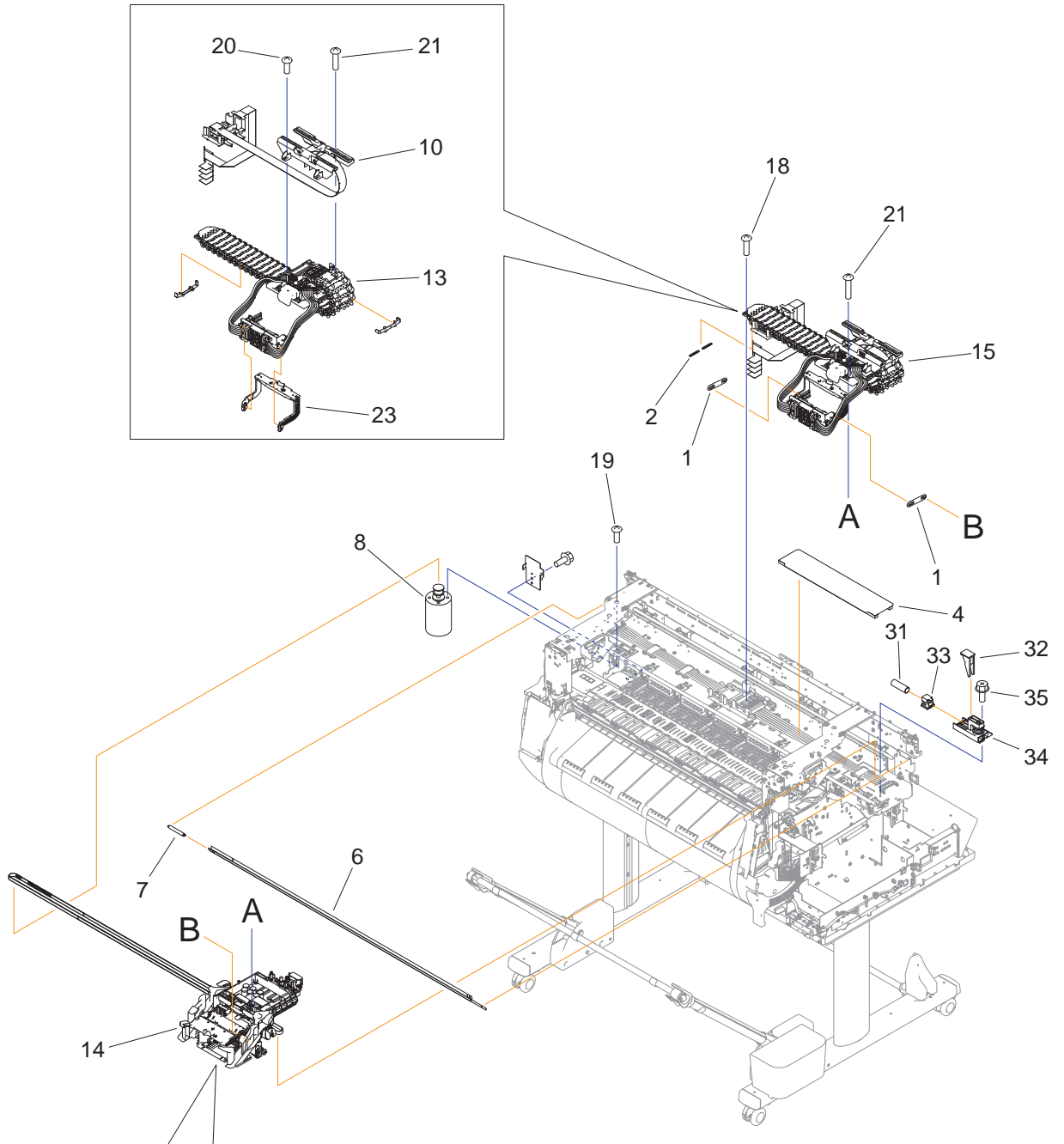

FIG	KEY	Part No.	DESCRIPTION	REMARKS	Q'ty
06	1	QC5-1874-000	ARM, LEVER LINK		2
06	2	QC5-1900-000	SIX-RING RUBBER CHAIN		2
06	3	QD1-1958-000	HOLDER, CARRIAGE UNIT		2
06	4	QD1-1973-000	SHEET DAMPER		1
06	5	QD1-2174-000	BELT, CARRIAGE		1
06	6	QD1-2177-000	FILM, TIMING SLIT STRIP		1
06	7	QD1-2420-000	SPRING, FILM STRIP		1
06	8	QK1-2868-000	MOTOR, DC, 47.8W		1
06	9	QM4-4341-000	MULTI SENSOR UNIT		1
06	10	QM4-4359-000	FLEXIBLE CABLE UNIT		1
06	11	QM4-4362-000	BUSHING / CLEANER KIT		1
06	12	QM4-5850-000	CARRIAGE ENCODER UNIT		1
06	13	QM4-4379-000	TUBE UNIT		1
06	14	QM4-8637-000	CARRIAGE UNIT		1
06	15	QM4-8662-000	INK TUBE UNIT		1
06	16	QM7-4815-000	CARRIAGE RELAY PCB UNIT		1
06	17	QU1-9070-000	SCREW, TP, M3 PAN HEAD, M2.6X8		1
06	18	XB1-2302-005	SCREW, MACH, TRUSS HEAD, M3X20		3
06	19	XB1-2400-607	SCREW, CROSS-RECESS, FCH		4
06	20	XB4-7300-805	SCREW, TP, BH3X8, S		AR
06	21	XB4-7301-209	SCREW, TP, M3X12		4
06	22	QD1-1934-000	COUPLING, CARRIAGE		1
06	23	QM4-4912-000	JOINT LEVER UNIT		1
06	24	QC5-1836-000	LEVER, HEAD SET		1
06	25	QC3-4923-000	SPRING, HEAD SET LEVER		1
06	26	QD1-1951-000	STOPPER, BELT, CR		1
06	27	QD1-2111-000	SPRING, SLIDER PRESSURE, CR		1
06	28	QD1-2110-000	HOLDER, SLIDER PRESSURE, CR		1
06	29	QD1-1963-000	STOPPER, SUB SLIDER, CR		1
06	30	QD1-2545-000	HOLDER, BELT, CR		1
06	31	QD1-1983-000	SPRING, IDLER PULLEY		1
06	32	QD1-1981-000	TENSIONER, IDLER PULLEY		1
06	33	QD1-1982-000	SLIDER, IDLER PULLEY		1
06	34	QM4-4191-000	IDLER PULLEY UNIT		1
06	35	XB2-8400-805	SCREW, W/SPRING WASHER, M4X8		1
06	36	QM4-4340-000	RAIL CLEANER UNIT		2

Figure 07 PINCH ROLLER, RELEASE LEVER & MIST FAN

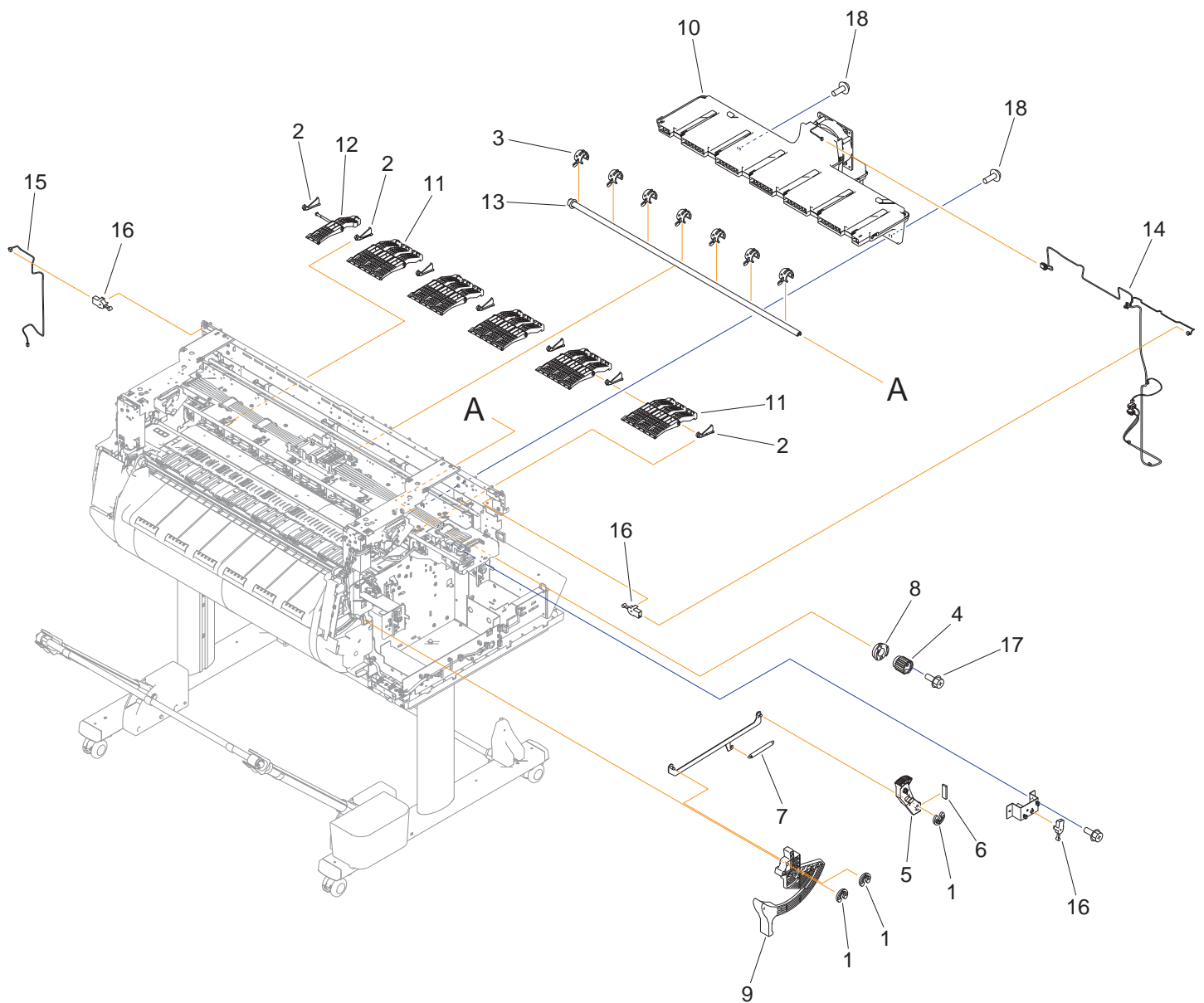

FIG	KEY	Part No.	DESCRIPTION	REMARKS	Q'ty
07	1	QC4-1522-000	E RING G17		3
07	2	QD1-2085-000	BUSH, ARM ROTARY SHAFT		7
07	3	QD1-2231-000	BUSHING, PRESSURE RELEASE		7
07	4	QD1-2233-000	GEAR, PRESSURE RELEASE		1
07	5	QD1-2237-000	GEAR, RELEASE LEVER		1
07	6	QD1-2280-000	PAD, RELEASE LEVER STOPPER		1
07	7	QD1-2712-000	SPRING, RELEASE LEVER		1
07	8	QD1-2884-000	BUSHING, PR RELEASE		1
07	9	QM4-4208-000	RELEASE LEVER UNIT		1
07	10	QM4-4227-010	MIST FAN DUCT UNIT 2		1
07	11	QM4-4252-000	PINCH ROLLER UNIT		5
07	12	QM4-4253-000	PINCH ROLLER UNIT L		1
07	13	QM4-4863-000	SHAFT PRESSURE RELEASE UNIT		1
07	14	QM7-4829-000	HARNESS ASS'Y, TANK CVR MFAN R		1
07	15	QM7-4849-000	HARNESS ASS'Y, TANK CVR L		1
07	16	WC4-5376-000	DETECT MICRO SWITCH		3
07	17	XA9-0732-000	SCREW, RS, M4		1
07	18	XB6-7400-805	SCREW, FLANGED PAN HEAD, M4X8		4

Figure 08 ROLL COVERS

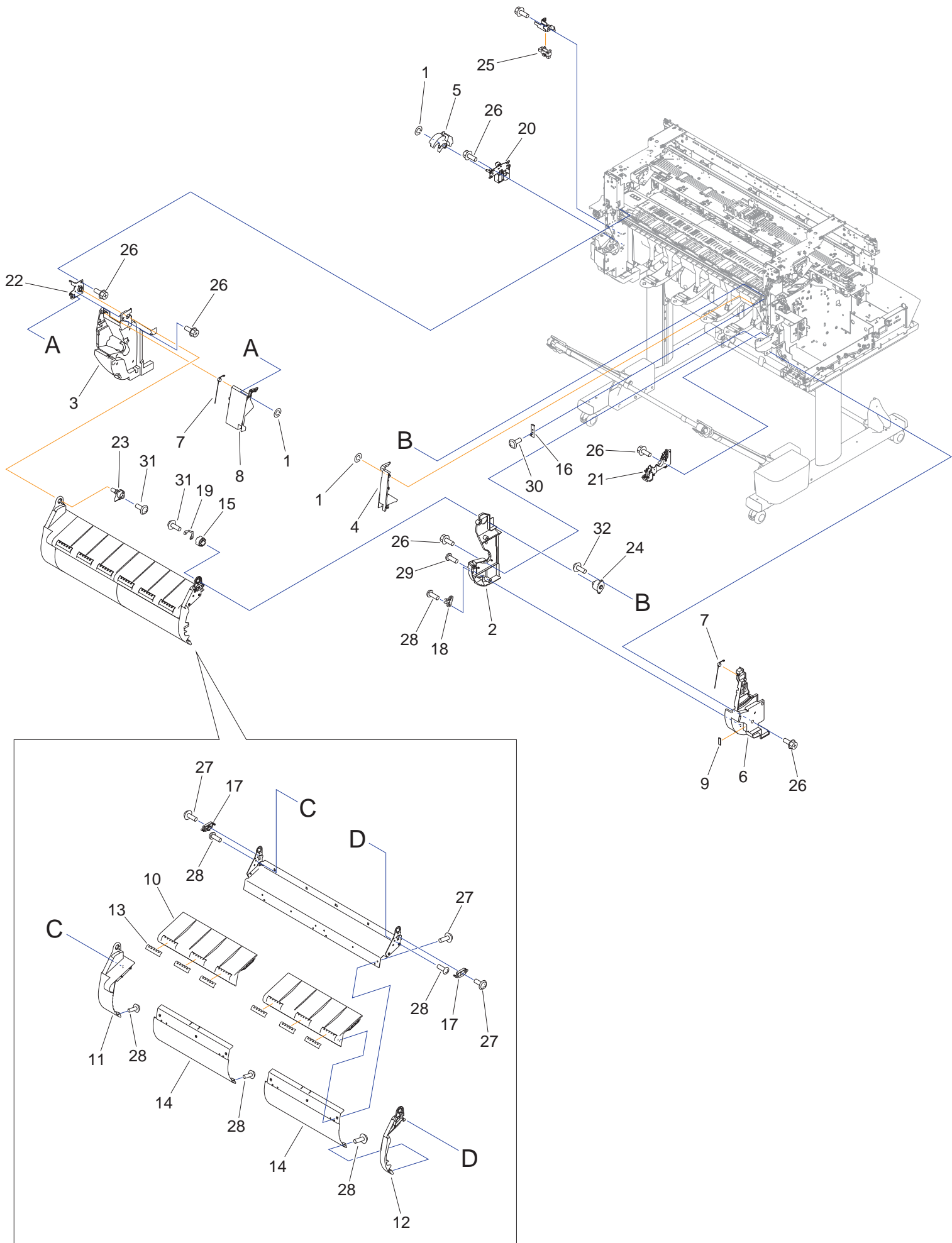

FIG	KEY	Part No.	DESCRIPTION	REMARKS	Q'ty
08	1	QD1-1441-000	CUT WASHER		3
08	2	QD1-1721-010	HOLDER, SPOOL SIDE R		1
08	3	QD1-1722-000	HOLDER, SPOOL SIDE L		1
08	4	QD1-1723-000	COVER, SPOOL R		1
08	5	QD1-1792-000	COVER, ROLL GEAR L		1
08	6	QD1-2239-000	CASE, SPOOL SIDE INNER R		1
08	7	QD1-2240-000	SPRING, SPOOL COVER		2
08	8	QD1-2241-000	COVER, SPOOL L		1
08	9	QD1-2280-000	PAD, RELEASE LEVER STOPPER		1
08	10	QD1-2429-000	COVER, ROLL TOP		2
08	11	QD1-2436-000	COVER, ROLL SIDE L		1
08	12	QD1-2431-000	COVER, ROLL SIDE R		1
08	13	QD1-2435-000	PAD, EJECT FRICTION		6
08	14	QD1-2653-000	COVER, ROLL FRONT		2
08	15	QD1-2709-000	CAP, ROLL COVER SHAFT		1
08	16	QD1-2710-000	SPRING, EJECT EARTH		1
08	17	QD1-2863-000	CAM, ROLL COVER SIDE		2
08	18	QD1-2867-000	CATCH, ROLL COVER		1
08	19	QD1-2888-000	SPRING, EARTH		1
08	20	QM4-4299-000	SPOOL LOCK UNIT		1
08	21	QM4-4301-000	SPOOL SENSOR UNIT		1
08	22	QM4-4890-000	PLATE UNIT, SPOOL SIDE SUPPORT		1
08	23	QM4-4892-000	BUSH UNIT, ROLL COVER L		1
08	24	QM4-4893-000	DAMPER UNIT, ROLL COVER R		1
08	25	WG8-5935-000	IC, PHOTO INTERRUPTER		1
08	26	XA9-0732-000	SCREW, RS, M4		18
08	27	XA9-1752-000	SCREW, TP, WASHER HEAD, M3X12		14
08	28	XB4-7300-805	SCREW, TP, BH3X8, S		8
08	29	XB4-7401-005	SCREW, TP, TRUSS HEAD, M4X10		2
08	30	XB6-7300-405	SCREW, FLANGED PAN HEAD, M3X4		1
08	31	XB6-7300-605	SCREW, TP, M3X6 (S)		3
08	32	XB6-7400-805	SCREW, FLANGED PAN HEAD, M4X8		2

FIG	KEY	Part No.	DESCRIPTION	REMARKS	Q'ty
09	1	QD1-1441-000	CUT WASHER		1
09	2	QD1-2221-000	COVER, HOME POSITION		1
09	3	QD1-2222-000	COVER, BACK POSITION		1
09	4	QD1-2408-000	LOCK LEVER, ACCESS COVER L		1
09	5	QD1-2411-000	SPRING, LOCK		1
09	6	QD1-2416-000	PLATE, SPRING SWITCH		2
09	7	QD1-2548-000	HOLDER, SWITCH		2
09	8	QK2-1484-000	SOLENOID		1
09	9	QM4-4217-000	ACCESS COVER LOCK UNIT R		1
09	10	QM4-4904-000	CUTTER BLADE UNIT	w/tool & instructions	1
09	11	QM4-8677-000	CUTTER MOTOR UNIT, W/ENCODER		1
09	12	QM7-4831-000	HARNESS ASS'Y, INTERLOCK SW		2
09	13	QM7-4832-000	HARNESS ASS'Y, RSIDE FRONT		1
09	14	WC4-5171-000	MICROSWITCH		2
09	15	WG8-5935-000	IC, PHOTO INTERRUPTER		1
09	16	XA9-0732-000	SCREW, RS, M4		AR
09	17	XA9-1671-000	SCREW, D, M3X8		6
09	18	XB1-2302-005	SCREW, MACH, TRUSS HEAD, M3X20		2
09	19	XB6-7300-405	SCREW, FLANGED PAN HEAD, M3X4		4

Figure 10 PLATEN & FEED ROLLER

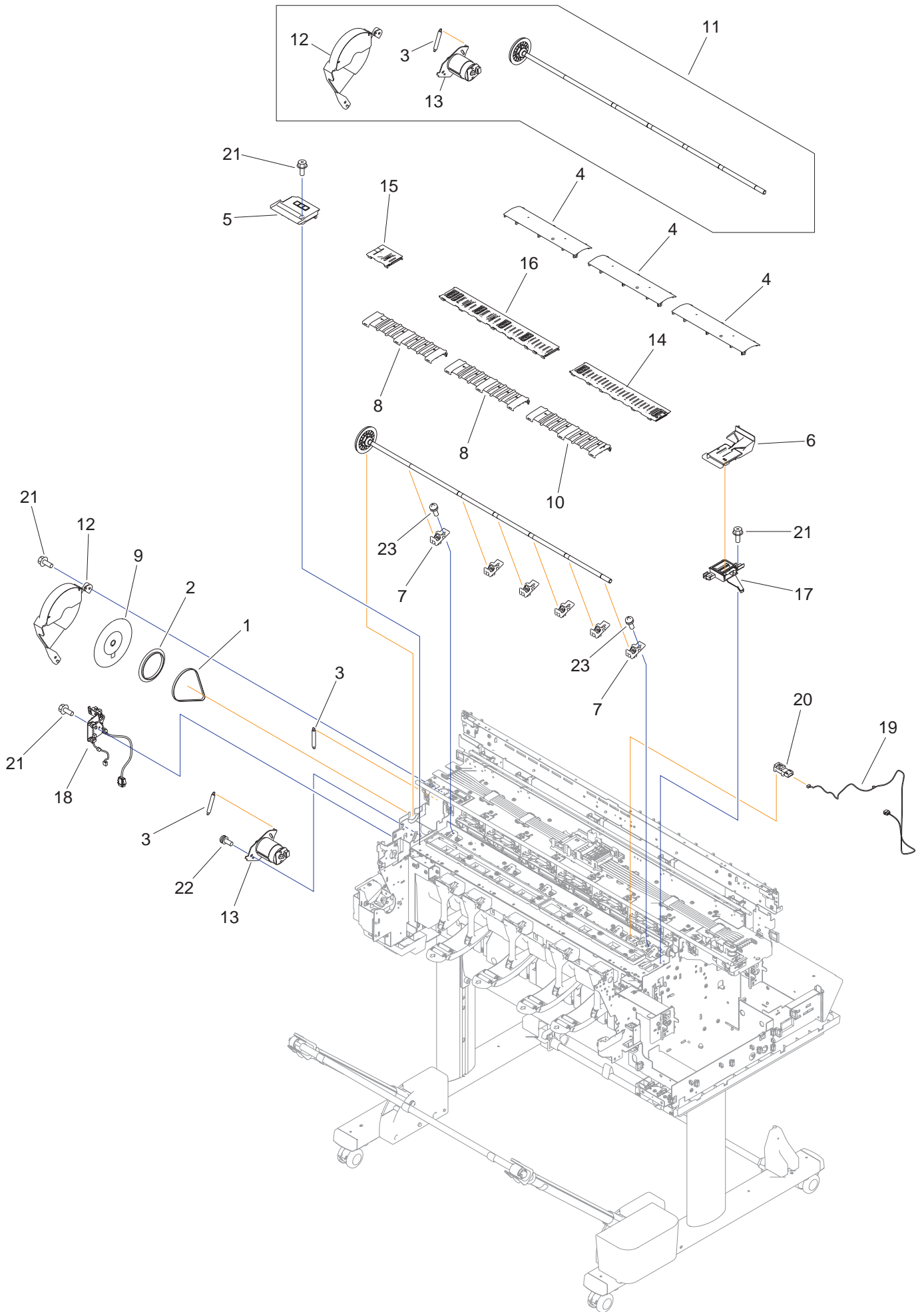

FIG	KEY	Part No.	DESCRIPTION	REMARKS	Q'ty
10	1	QC4-8783-000	BELT, PAPER TRANSPORT		1
10	2	QC4-8784-000	FLANGE, PULLEY		1
10	3	QC5-8099-000	SPRING, TENSION		2
10	4	QD1-1758-000	PLATEN, REAR		3
10	5	QD1-1760-000	AWAY PLATEN		1
10	6	QD1-1761-000	PLATEN, INK PRE EJECTION		1
10	7	QD1-2079-000	HOLDER, PAPER FEED ROLLER		6
10	8	QD1-2244-000	PLATEN, UNDER A		2
10	9	QD1-2702-000	FILM, TIMING SLIT DISK		1
10	10	QD1-2801-000	PLATEN, UNDER HOME		1
10	11	QM4-6311-000	PAPER FEED ROLLER UNIT		1
10	12	QM4-5388-000	CODEWHEEL COVER UNIT		1
10	13	QM4-5389-000	PAPER FEED MOTOR UNIT		1
10	14	QM4-4269-000	PLATEN UNIT, TOP A		1
10	15	QM4-4271-000	PLATEN UNIT, TOP AWAY		1
10	16	QM4-4272-000	PLATEN UNIT, TOP B		1
10	17	QM4-4277-000	PRE PRINTING PLATEN BASE ASS'Y		1
10	18	QM4-4288-000	PAPER FEED ENCODER UNIT		1
10	19	QM7-4828-000	HARNESS ASS'Y, LFPE SNS		1
10	20	WG8-5677-000	PHOTO INTERRUPTER		1
10	21	XA9-0732-000	SCREW, RS, M4		6
10	22	XA9-1161-000	SCREW, W/WASHER, M3X8		2
10	23	XB2-8400-805	SCREW, W/SPRING WASHER, M4X8		6

Figure 11 UPPER ROLL UNIT, SUCTION FAN & WASTE INK UNIT

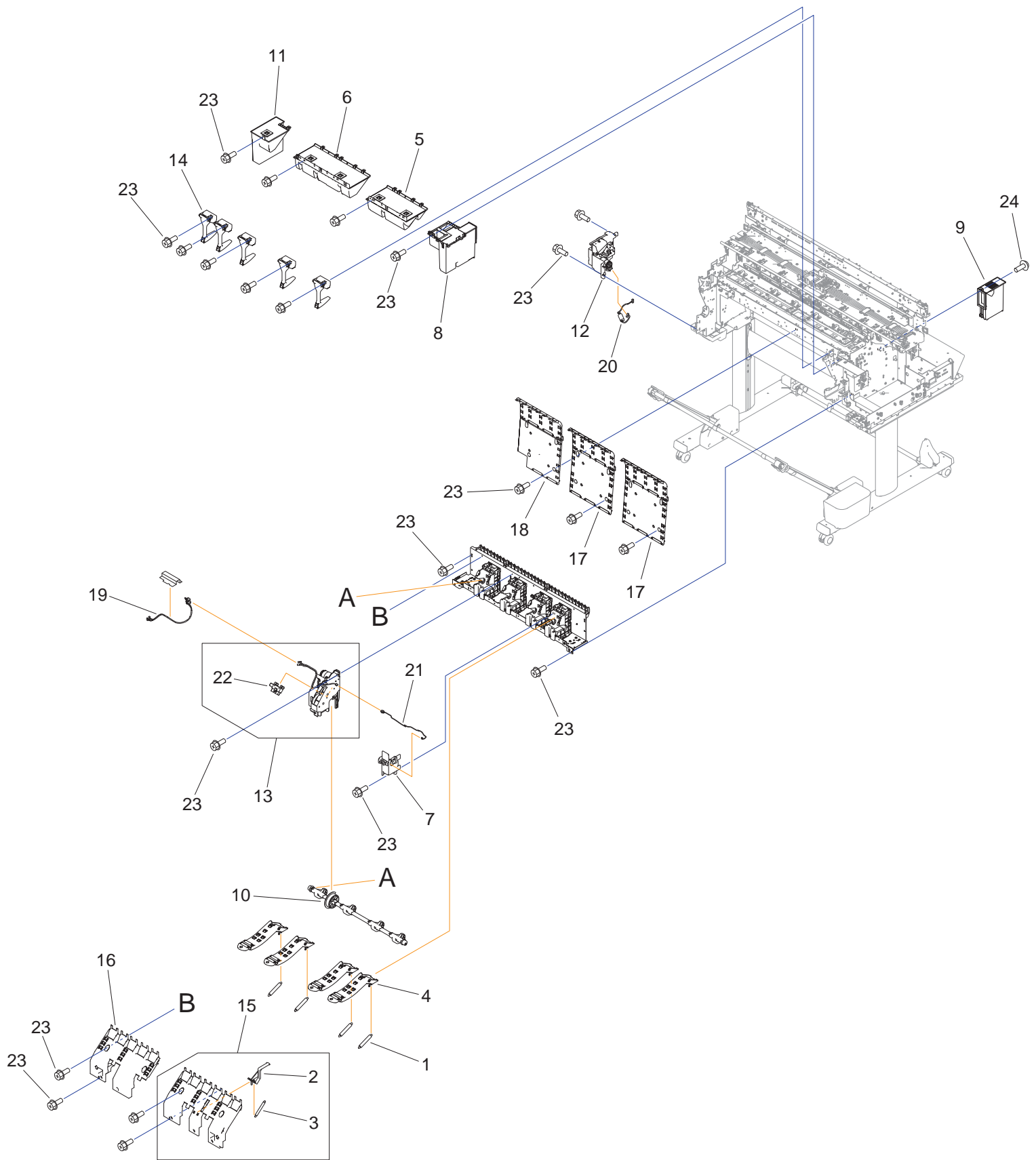

FIG	KEY	Part No.	DESCRIPTION	REMARKS	Q'ty
11	1	QD1-1677-000	SPRING, PAPER SET		4
11	2	QD1-2159-000	LEVER, PAPER FEED SENSOR		1
11	3	QD1-2160-000	SPRING, PAPER FEED SENSOR		1
11	4	QM4-4926-000	NIP ARM UNIT		4
11	5	QM4-4241-000	WASTE INK ABSORBER UNIT A		1
11	6	QM4-4242-000	WASTE INK ABSORBER UNIT B		1
11	7	QM4-4249-010	ROLL PAPER FEED SENSOR UNIT		1
11	8	QM4-5861-000	SUCTION FAN UNIT		1
11	9	QM4-4261-000	SUCTION FAN DUCT UNIT		1
11	10	QM4-4289-000	CAM SHAFT UNIT		1
11	11	QM4-5751-000	WASTE INK ABSORBER UNIT		1
11	12	QM4-8678-000	ACTIVE ROLL BRAKE UNIT		1
11	13	QM4-8715-000	DRIVE NIP ARM UNIT		1
11	14	QM4-8718-000	FLAPPER SEPARATE UNIT		5
11	15	QM4-4927-000	GUIDE UNIT, LOW A		1
11	16	QM4-4928-000	GUIDE UNIT, LOW B		1
11	17	QM4-4924-000	GUIDE UNIT, OUTSIDE A		2
11	18	QM4-4925-000	GUIDE UNIT, OUTSIDE B		1
11	19	QM7-4857-000	HARNESS ASS'Y, UP RLNIP RELAY		1
11	20	QM7-4872-000	HARNESS ASS'Y, ARB MOTOR		1
11	21	QM7-4884-000	HARNESS ASS'Y, RLNIP PF SNS		1
11	22	WG8-5935-000	IC, PHOTO INTERRUPTER		1
11	23	XA9-0732-000	SCREW, RS, M4		AR
11	24	XB6-7400-805	SCREW, FLANGED PAN HEAD, M4X8		1

FIG	KEY	Part No.	DESCRIPTION	REMARKS	Q'ty
12	1	QD1-2522-000	HOLDER, REAR ROD		2
12	2	QD1-2736-000	BOX		1
12	3	QD1-2787-000	CAP, STAND		4
12	4	QD1-2879-000	PLATE, CASTER		4
12	5	QD1-2880-000	CASTER, W/LOCK		4
12	6	QM4-4294-020	SIDE ROD UNIT		2
12	7	QM4-4353-000	REAR ROD UNIT		1
12	8	QM4-4356-010	TOP ROD UNIT		1
12	9	XA9-0949-000	SCREW, RS, M4X10		28
12	10	QC4-9300-000	SCREW, HEX SOCKET M4X10		9
12	11	QC4-9303-000	BOLT, HEXAGON BUTTON, M4X30		4
12	12	XB7-1080-169	SCREW, MACHINE M8X16		4
12	13	QD1-2740-000	CAP SUPPORT, TOP ROD L		1
12	14	QD1-2521-010	CAP, TOP ROD L		1
12	15	QM4-8680-010	BASKET ROLL UNIT		1
12	16	QD1-2529-000	ROD JOINT		1
12	17	QD1-2528-000	ROD END		1
12	18	QC5-8788-000	PTATE, LOCK		2

Figure 13 TOOL

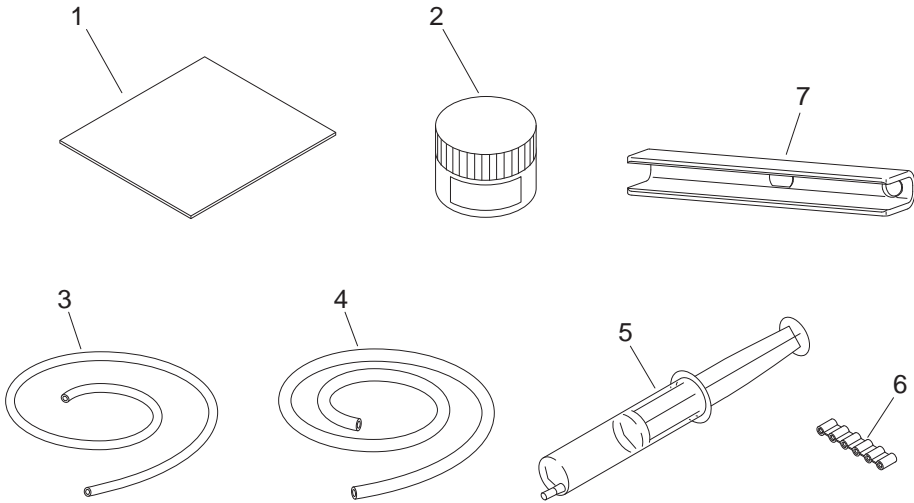

FIG	KEY	Part No.	DESCRIPTION	REMARKS	Q'ty
13	1	AY3-4607-000	PLATE, PURGE CHECK		1
13	2	AY3-4609-000	GREASE, FLOIL G-31KB		1
13	3	AY3-4595-000	TUBE, WASTE INK		1
13	4	AY3-4530-000	W-INK TUBE, BLACK		1
13	5	CK-0541-000	SYRINGE		1
13	6	QC2-6710-000	STOPPER		1
13	7	QD1-2904-000	TOOL, CUTTER SPACER		1

Figure R1 LOWER ROLL UNIT (RIGHT)

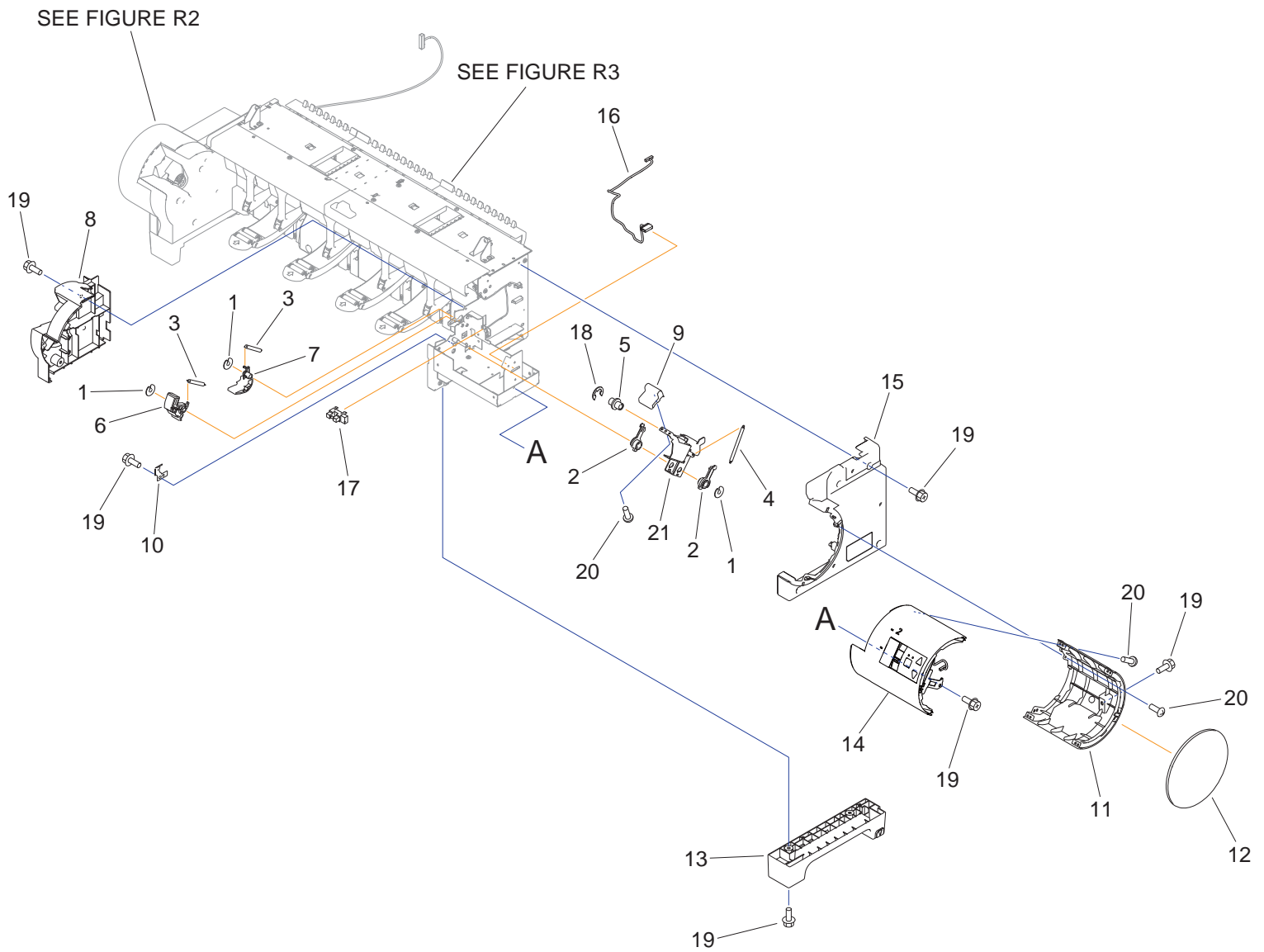

FIG	KEY	Part No.	DESCRIPTION	REMARKS	Q' ty
R1	1	QD1-1441-000	CUT WASHER		3
R1	2	QD1-1443-000	BUSHING, DRIVE		2
R1	3	QD1-1785-000	SPRING, LOCK A		2
R1	4	QD1-1787-000	SPRING, LOCK C		1
R1	5	QD1-1788-000	ROLLER, LOCK		1
R1	6	QD1-1789-000	LOCK LEVER A		1
R1	7	QD1-1790-000	LOCK LEVER B		1
R1	8	QD1-1791-000	HOLDER, SPOOL R		1
R1	9	QD1-2588-000	KNOB, OPERATION		1
R1	10	QD1-2593-000	PLATE, SPOOL GROUND		1
R1	11	QD1-2725-000	COVER, SIDE R REAR		1
R1	12	QD1-2726-000	COVER, SIDE R		1
R1	13	QM4-4898-000	HANDLE UNIT, LOWER SUPPORT R		1
R1	14	QM4-4914-000	OPERATION PANEL UNIT, RU		1
R1	15	QM4-4915-000	COVER UNIT, SIDE OUTER R		1
R1	16	QM7-4877-000	HARNESS ASS'Y, RU PANEL RLY		1
R1	17	WG8-5935-000	IC, PHOTO INTERRUPTER		1
R1	18	XD2-1100-322	RETAINING RING (E-TYPE)		1
R1	19	XA9-0732-000	SCREW, RS, M4		AR
R1	20	XB4-7300-805	SCREW, TP, BH3X8, S		7
R1	21	QL2-8481-000	LEVER ASS'Y, SPL LOCK R		1

Figure R2 LOWER ROLL UNIT (LEFT)

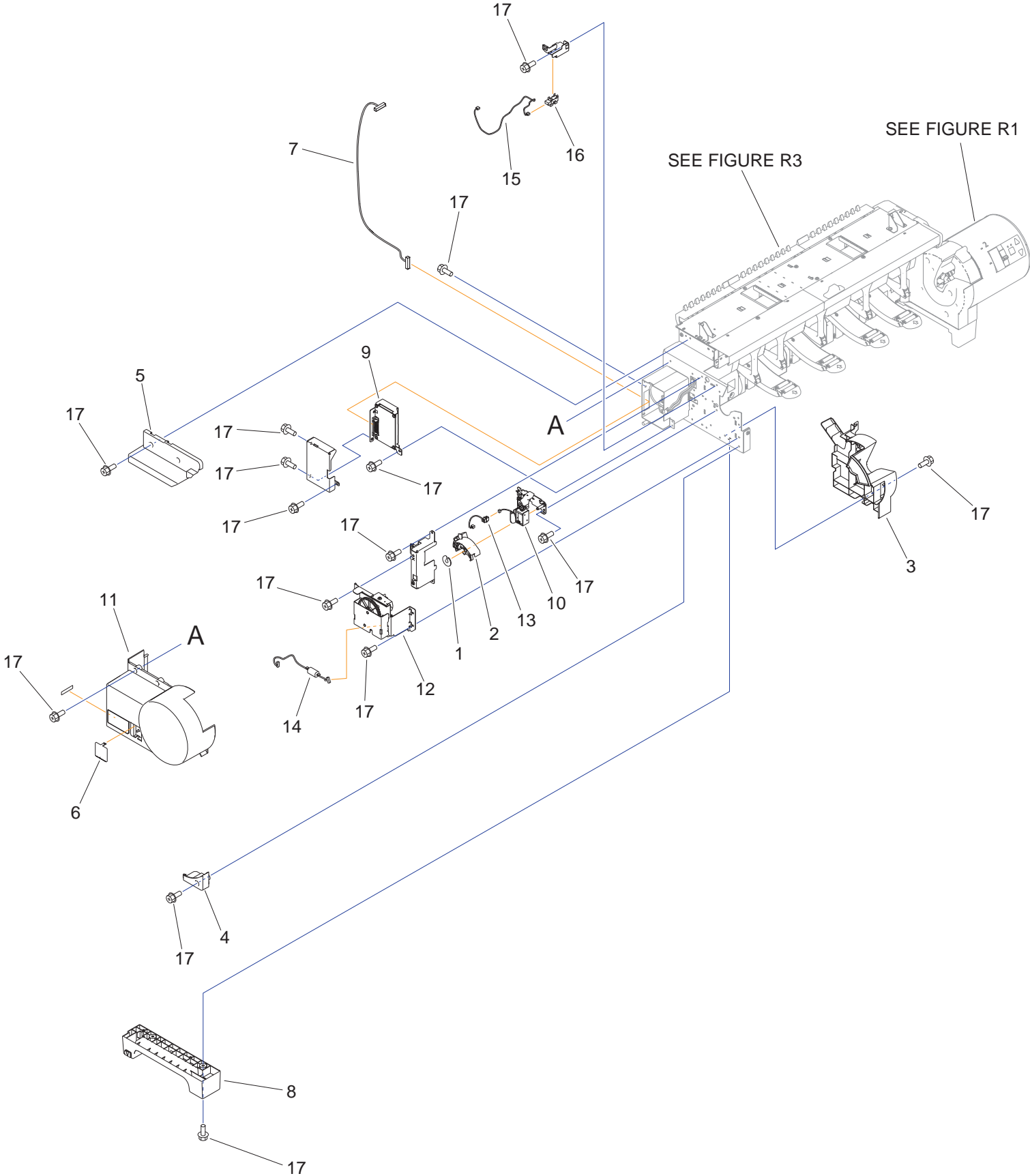

FIG	KEY	Part No.	DESCRIPTION	REMARKS	Q'ty
R2	1	QD1-1441-000	CUT WASHER		1
R2	2	QD1-1792-000	COVER, ROLL GEAR L		1
R2	3	QD1-1795-000	HOLDER, SPOOL L		1
R2	4	QD1-2656-000	COVER, SIDE L SUB		1
R2	5	QD1-2784-000	COVER, SIDE TOP L		1
R2	6	QD1-2853-000	CAP, COVER SIDE L		1
R2	7	QK2-1476-000	CABLE, ROLL UNIT		1
R2	8	QM4-4897-000	HANDLE UNIT, LOWER SUPPORT L		1
R2	9	QM4-4231-000	I/F PCB UNIT, RU		1
R2	10	QM4-4299-000	SPOOL LOCK UNIT		1
R2	11	QM4-4382-000	COVER UNIT, SIDE OUTER L		1
R2	12	QM4-8678-000	ACTIVE ROLL BRAKE UNIT		1
R2	13	QM7-4871-000	HARNESS ASS'Y, LO SPL SOL		1
R2	14	QM7-4872-000	HARNESS ASS'Y, ARB MOTOR		1
R2	15	QM7-4873-000	HARNESS ASS'Y, LO SPLSET L		1
R2	16	WG8-5935-000	IC, PHOTO INTERRUPTER		1
R2	17	XA9-0732-000	SCREW, RS, M4		AR

Figure R3 LOWER ROLL UNIT (MAIN)

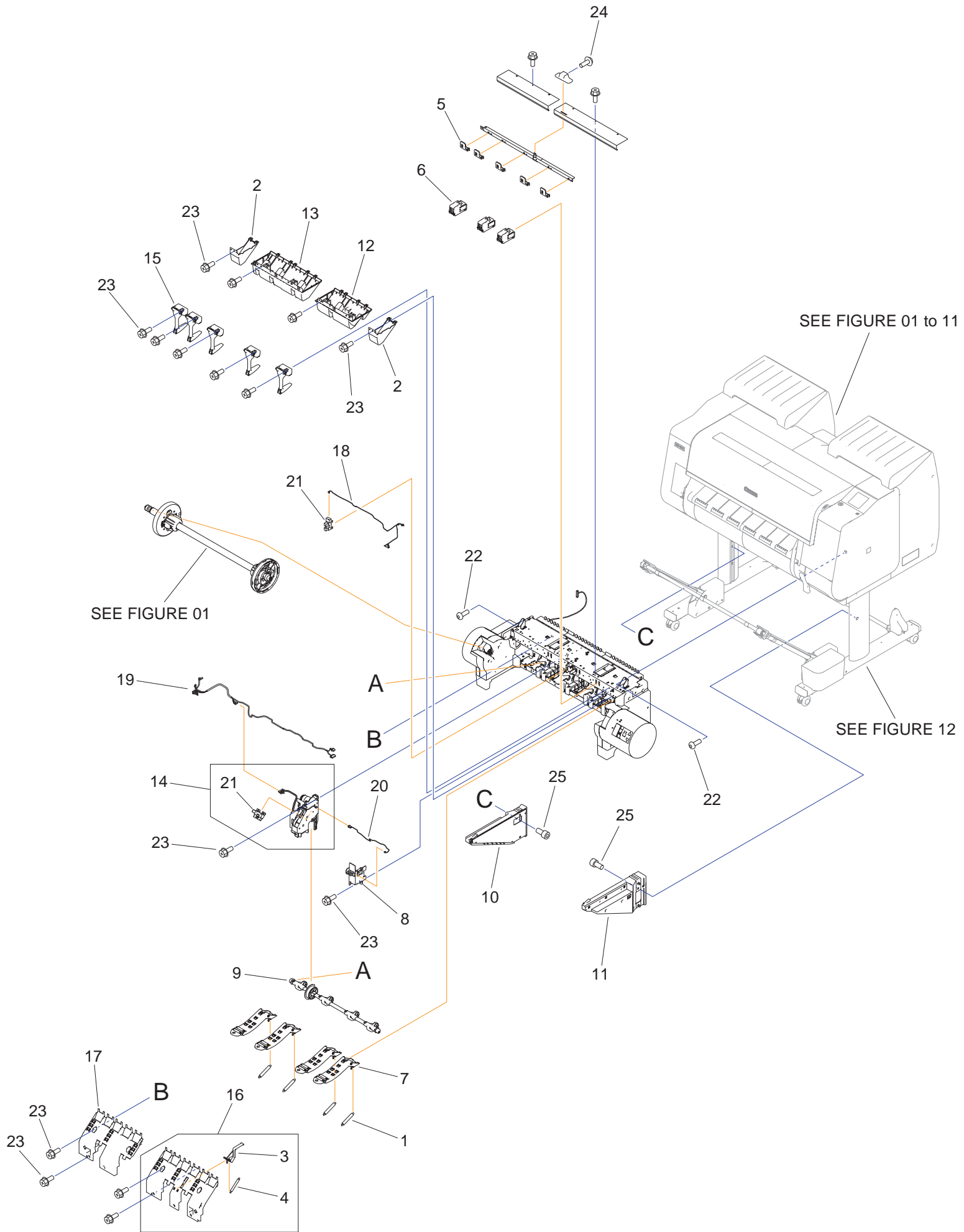

FIG	KEY	Part No.	DESCRIPTION	REMARKS	Q'ty
R3	1	QD1-1677-000	SPRING, PAPER SET		4
R3	2	QD1-1781-000	GUIDE, UPPER		2
R3	3	QD1-2159-000	LEVER, PAPER FEED SENSOR		1
R3	4	QD1-2160-000	SPRING, PAPER FEED SENSOR		1
R3	5	QD1-2595-000	CAM, FLAP SELEC		5
R3	6	QD1-2602-000	SUPPORT, FLAP SELEC		3
R3	7	QM4-4926-000	NIP ARM UNIT		4
R3	8	QM4-4249-010	ROLL PAPER FEED SENSOR UNIT		1
R3	9	QM4-4289-000	CAM SHAFT UNIT		1
R3	10	QM4-4342-000	RAIL UNIT L		1
R3	11	QM4-4343-000	RAIL UNIT R		1
R3	12	QM4-4859-000	PAPER GUIDE ROLLER UNIT, RU A		1
R3	13	QM4-4860-000	PAPER GUIDE ROLLER UNIT, RU B		1
R3	14	QM4-8715-000	DRIVE NIP ARM UNIT		1
R3	15	QM4-8718-000	FLAPPER SEPARATE UNIT		5
R3	16	QM4-4927-000	GUIDE UNIT, LOW A		1
R3	17	QM4-4928-000	GUIDE UNIT, LOW B		1
R3	18	QM7-4876-000	HARNESS ASS'Y, LO FLAP SPLSET		1
R3	19	QM7-4879-000	HARNESS ASS'Y, RU MAIN		1
R3	20	QM7-4884-000	HARNESS ASS'Y, RLNIP PF SNS		1
R3	21	WG8-5935-000	IC, PHOTO INTERRUPTER		2
R3	22	QC4-9300-000	SCREW, HEX SOCKET M4X10		2
R3	23	XA9-0732-000	SCREW, RS, M4		AR
R3	24	XB6-7300-605	SCREW, TP, M3X6 (S)		1
R3	25	XB7-1080-169	SCREW, MACHINE M8X16		2

Mechanical standard parts

機械標準部品

About a mechanical standard parts

A Mechanical standard parts is a mechanical part which not parts peculiar to a product. They are parts which are common to a Canon product and are used, such as a screw and a washer. The Fig No. and parts number of the mechanical standard parts are not listed in the product parts catalog. Refer to the parts catalog of mechanical standard parts when checking the parts number for screw or washer etc. and identify them by part shape or size.

機械標準部品とは

機械標準部品とは、製品特有の部品ではなく、ねじやワッシャなどキヤノン製品共通で使用されている機械部品(メカ部品)のことです。
製品のパーツカタログには、機械標準部品のFig No.や部品番号は記載しておりません。
ねじや、ワッシャ等の部品番号を調べる時は、機械標準部品のパーツカタログを参照し、部品の形状や大きさから判断し、使用している部品を調べてください。

Material and surface treatment of a mechanical standard parts

Material and surface treatment of mechanical standard parts are assigned commonly for each part. Refer to the Table 1 for the parts which material and surface treatment are assigned as numbers.

機械標準部品の材料および表面処理

機械標準部品の材料および表面処理については、各種部品共通で決められています。
材料および表面処理が番号で決められている部品については、表1を参照してください。

Table 1 Material and Surface treatment
表1 材料および表面処理

No. 番号	Material 材料	Surface treatment 表面処理	Color 色
1	Stainless steel ステンレス	Stainless steel black coloring (BC4) ステンレス黒着色(BC4)	Black 黒
2		not to be given なし	White 白
3	Brass 黄銅	Regular nickel plating (NL) 普通ニッケルメッキ(NL)	White 白
4		Black nickel plating (BN) 黒色ニッケルメッキ(BN)	Black 黒
5	Steel 鋼	White zinc trivalent chromate treating (ZC3) 白色亜鉛3価クロメート(ZC3)	White 白
6		Regular nickel chromium plating (NC) 普通ニッケルクロムメッキ(NC)	White 白
7		Regular nickel plating (NL) 普通ニッケルメッキ(NL)	White 白
8		Iron and steel phosphating (P1) 鉄鋼磷酸塩処理(P1)	Black 黒
9		Black zinc trivalent chromate treating (BZ3) 黒色亜鉛3価クロメート(BZ3)	Black 黒

1. Screws

ねじ

How to read Parts Numbers
部品番号の見方

Screws
ねじ

XB1-2400-609

Type No.
類別番号

Normal designation (d)
ねじの呼び(d)

Length (L)
ねじの長さ(L)

Material and Surface treatment

材料および表面処理

XB1-2 expresses Binding head machine screw.
XB1-2は、バインドねじを表す

40 expresses M4.0.
40は、M4.0を表す

0-60 expresses a length of 6.0mm.
0-60は、6.0mmの長さを表す

9 expresses Steel (Black zinc trivalent chromate treating) from Table 1.

9は、表1より鋼(黒色亜鉛3価クロメート)を表す

1-1. Cross Recessed Head Screws for Precision Equipments

精密機器用十字穴付き小ねじ

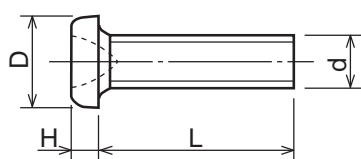

XA1-1, 6, 7

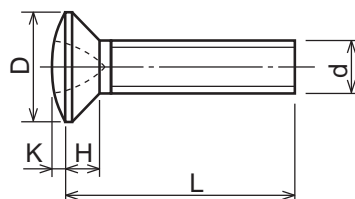

XA1-4

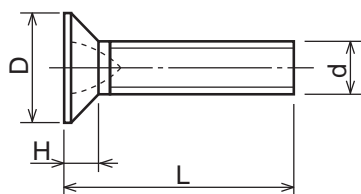

XA1-3

Type No. 類別番号	Type 類別	Head size (mm) 頭部寸法 (mm)						
		M1.4	M1.6	M1.7	M2	M2.5	M2.6	
XA1-1	Pan head Class 1 なべ1種	D	2	2.4	2.5	3	3.8	4
		H	0.5	0.55	0.5	0.6	0.9	0.8
XA1-3	Countersunk head Class 1 さら1種	D	2	2.4	2.5	3	3.8	4
		H	0.48	0.55	0.58	0.73	0.85	0.93
XA1-4	Oval countersunk head Class 1 丸さら1種	D	2	2.4	2.5	3	3.8	4
		H + K	0.68	0.8	0.88	1	1.25	1.3
XA1-6	Pan head Class 3 なべ3種	D	2.5	2.8	3	3.5	4.3	4.5
		H	0.8	0.85	0.9	1	1.3	1.2
XA1-7	Pan head Class 2 なべ2種	D	2.5	2.8	3	3.5	4.3	4.5
		H	0.5	0.55	0.5	0.6	0.9	0.8

1-2. Precision Tapping Screws
精密用タッピンねじ

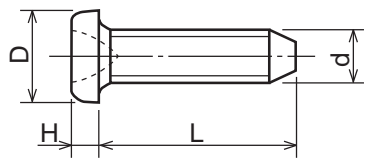

XA4-1, 2, 4

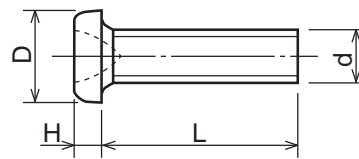

XA4-6, 7, 9

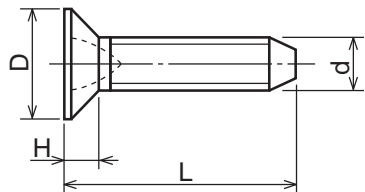

XA4-3

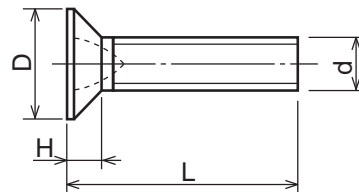

XA4-8

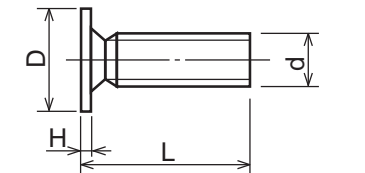

XA4-5

Type No. 類別番号	Type 類別
XA4-1	With tapered end pan head Class 1 絞り-なべ1種
XA4-2	With tapered end pan head Class 3 絞り-なべ3種
XA4-3	With tapered end countersunk head 絞り-さら
XA4-4	With tapered end pan head Class 2 絞り-なべ2種
XA4-5	With parallel end ultra thin head ストレート-超薄頭
XA4-6	With parallel end pan head Class 1 ストレート-なべ1種
XA4-7	With parallel end pan head Class 3 ストレート-なべ3種
XA4-8	With parallel end countersunk head ストレート-さら
XA4-9	With parallel end pan head Class 2 ストレート-なべ2種

		Head size (mm) 頭部寸法 (mm)					
		M1.4	M1.6	M1.7	M2	M2.5	M2.6
D	XA4-1	2	2.4	2.5	3	3.8	4
H	XA4-1	0.5	0.55	0.5	0.6	0.9	0.8
D	XA4-2	2.5	2.8	3	3.5	4.3	4.5
H	XA4-2	0.8	0.85	0.9	1	1.3	1.2
D	XA4-3	2	2.4	2.5	3	3.8	4
H	XA4-3	0.48	0.55	0.58	0.73	0.85	0.93
D	XA4-4	2.5	2.8	3	3.5	4.3	4.5
H	XA4-4	0.5	0.55	0.5	0.6	0.9	0.8
D	XA4-5	2.5	2.8	3	-	-	-
H	XA4-5	0.2	0.2	0.2	-	-	-
D	XA4-6	2	2.4	2.5	3	3.8	4
H	XA4-6	0.5	0.55	0.5	0.6	0.9	0.8
D	XA4-7	2.5	2.8	3	3.5	4.3	4.5
H	XA4-7	0.8	0.85	0.9	1	1.3	1.2
D	XA4-8	2	2.4	2.5	3	3.8	4
H	XA4-8	0.48	0.55	0.58	0.73	0.85	0.93
D	XA4-9	2.5	2.8	3	3.5	4.3	4.5
H	XA4-9	0.5	0.55	0.5	0.6	0.9	0.8

1-3. Cross Recessed Head Screws
 一般用十字穴付き小ねじ

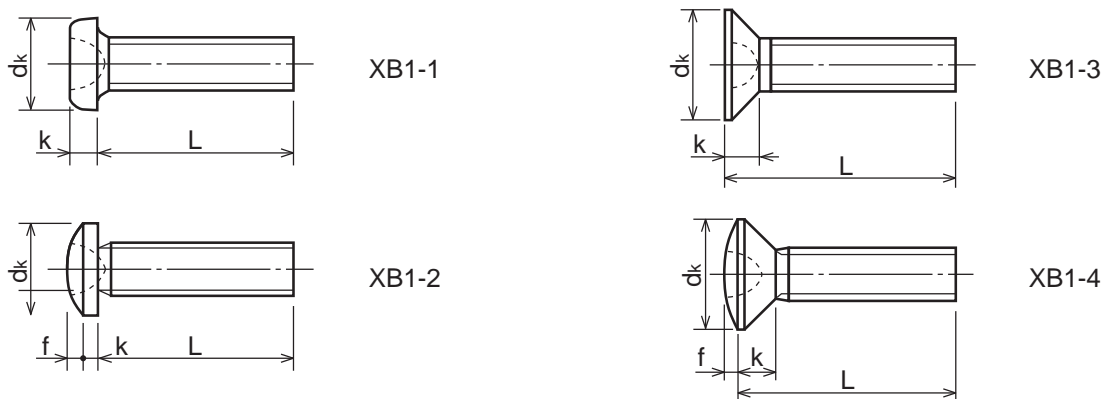

Type No. 類別番号	Type 類別
XB1-1	Pan head なべ
XB1-2	Binding head バインド
XB1-3	Countersunk head さら
XB1-4	Oval countersunk head 丸さら

		Head size (mm) 頭部寸法 (mm)					
		M2	M2.5	M2.6	M3	M4	M5
d_k	XB1-1	3.5	4.5	4.5	5.5	7	9
k	XB1-1	1.3	1.7	1.7	2	2.6	3.3
d_k	XB1-2	4.3	5.3	5.5	6.3	8.3	10.3
$k+f$	XB1-2	1.2	1.5	1.6	1.9	2.5	3.1
d_k	XB1-3	4	5	-	6	8	10
k	XB1-3	1.2	1.45	-	1.75	2.3	2.8
d_k	XB1-4	4	5	-	6	8	10
$k+f$	XB1-4	1.6	2	-	2.45	3.2	4
Screw part length ねじ部長さ b		8	12	12	12	16	20

1-4. Cross Recessed Head Screws with Captive Washer

座金組込み十字穴付き小ねじ

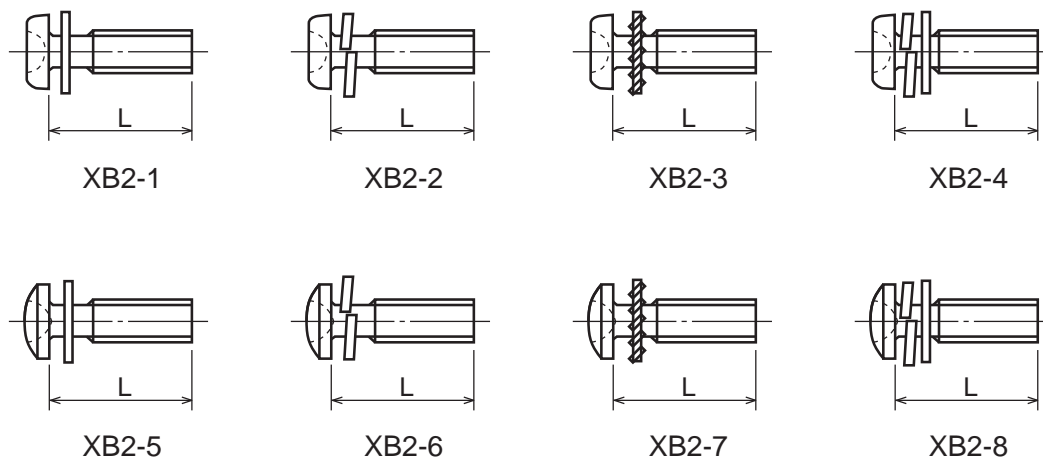

Type No. 類別番号	Type 類別
XB2-1	Pan head + Plain washer (circular bright) なべねじ+平座金
XB2-2	Pan head + Spring washer なべねじ+ばね座金
XB2-3	Pan head + Toothed lock washer なべねじ+歯付座金
XB2-4	Pan head + Spring washer and plain washer (circular bright) なべねじ+(ばね+平)座金
XB2-5	Binding head + Plain washer (circular bright) バインドねじ+平座金
XB2-6	Binding head + Spring washer バインドねじ+ばね座金
XB2-7	Binding head + Toothed lock washer バインドねじ+歯付座金
XB2-8	Binding head + Spring washer and plain washer (circular bright) バインドねじ+(ばね+平)座金

1-5. Hexagon Head Tapping Screws for Matallic Materials
 金属用六角タッピンねじ

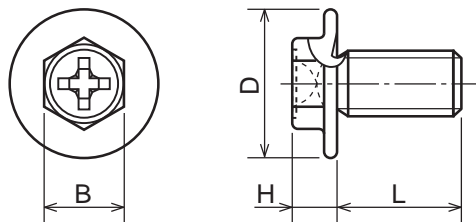

Type No. 類別番号	Type 類別	Head size (mm) 頭部寸法 (mm)		
		M3	M4	
XB3-6	For metallic materials 金属用タッピン	D	8	10
		B	5.5	5.5
XB3-7	For metallic materials with clawed 金属用タッピン-つめ付き	H XB3-6	3.1	3.1
		H XB3-7	3.2	3.2

1-6. Special Tapping Screws
 特殊タッピンねじ

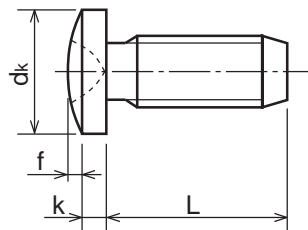

Type No. 類別番号	Type 類別	Head size (mm) 頭部寸法 (mm)		
		M3	M4	
XB4-5	Binding head バインド	dk	6.3	8.3
		k	1.3	1.7
		k+f	1.9	2.5

1-7. General Head Tapping Screws

一般用タッピンねじ

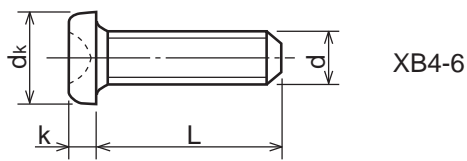

XB4-6

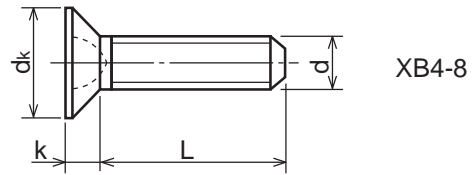

XB4-8

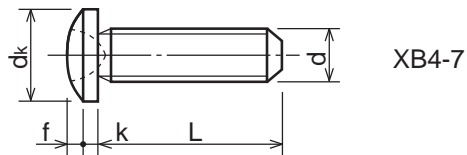

XB4-7

Type No. 類別番号	Type 類別
XB4-6	Pan head なべ
XB4-7	Binding head バインド
XB4-8	Countersunk head さら

		Head size (mm) 頭部寸法 (mm)					
		M2	M2.5	M2.6	M3	M4	M5
dk	XB4-6	3.5	4.5	4.5	5.5	7	9
k	XB4-6	1.3	1.7	1.7	2	2.6	3.3
dk	XB4-7	4.3	5.3	5.5	6.3	8.3	10.3
k+f	XB4-7	1.2	1.5	1.6	1.9	2.5	3.1
dk	XB4-8	4	5	5.2	6	8	10
k	XB4-8	1.2	1.45	1.5	1.75	2.3	2.8

1-8. Tapping Screws for Metallic Materials

金属用タッピンねじ

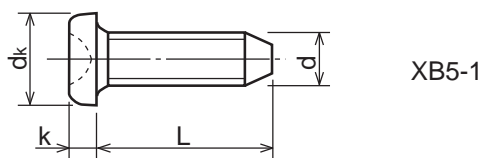

XB5-1

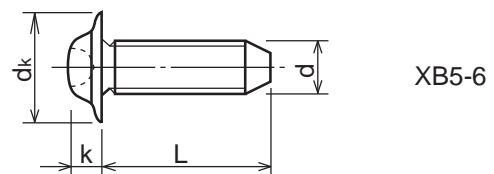

XB5-6

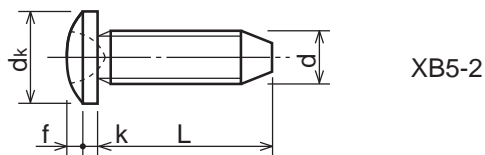

XB5-2

Type No. 類別番号	Type 類別
XB5-1	Pan head なべ
XB5-2	Binding head バインド
XB5-6	Flanged pan head つば付きなべ

		Head size (mm) 頭部寸法 (mm)				
		M2.5	M2.6	M3	M4	M5
dk	XB5-1	4.5	4.5	5.5	7	9
k	XB5-1	1.7	1.7	2	2.6	3.3
dk	XB5-2	5.5	5.5	6.3	8.3	10.3
k+f	XB5-2	1.6	1.6	1.9	2.5	3.1
dk	XB5-6	6.5	6.5	8	10	12
k	XB5-6	2.1	2.1	1.75	3.2	4

1-9. Hexagon Socket Set Screws

六角穴付き止めねじ

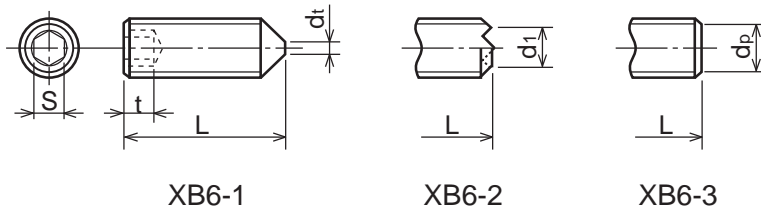

Type No. 類別番号	Type 類別	Head size (mm) 頭部寸法 (mm)							
		M1.6 M1.7	M2	M2.5 M2.6	M3	M5	M5	M6	
		S	0.7	0.9	1.3	1.5	2	2.5	3
		t	1.5	1.7	2	2	2.5	3	3.5
		$d_{t \max}$ XB6-1	0.4	0.5	0.65	0.75	1	1.25	1.5
		$d_{1 \max}$ XB6-2	-	1.2	1.5	1.7	2.2	2.8	3.3
		$d_{1 \min}$ XB6-2	-	1	1.2	1.4	1.9	2.4	2.9
		$d_{p \max}$ XB6-3	0.8	1	1.5	2	2.5	3.5	4
		$d_{p \min}$ XB6-3	0.55	0.75	1.25	1.75	2.25	3.2	3.7

1-10. Flanged Pan Head Machine Screws

つば付きなべ小ねじ

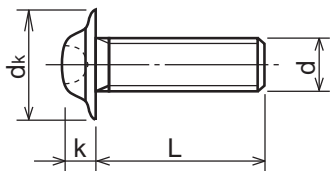

Type No. 類別番号	Type 類別	Head size (mm) 頭部寸法 (mm)					
		M2	M2.5 M2.6	M3	M5	M5	
		d_k	5	6.5	8	10	12
		k	1.7	2.1	2.5	3.2	4

2. Bolts (Socket head cap screw)

ボルト

How to read Parts Numbers

部品番号の見方

Bolt (Socket head cap screw)

ボルト

XB7-1080-409

Type No.
類別番号

Normal designation (d)
ねじの呼び(d)

Length (L)
ねじの長さ(L)

Material and Surface treatment

材料および表面処理

XB7-1 expresses Hexagon socket head cap screws.
XB7-1は、六角穴付きボルトを表す

080 expresses M8.0.
080は、M8.0を表す

40 expresses a length of 40mm.
40は、40mmの長さを表す

9 expresses Steel (Black zinc trivalent chromate treating) from Table 1.

9は、表1より鋼(黒色亜鉛3価クロメート)を表す

2-1. Hexagon socket head cap screws

六角穴付きボルト

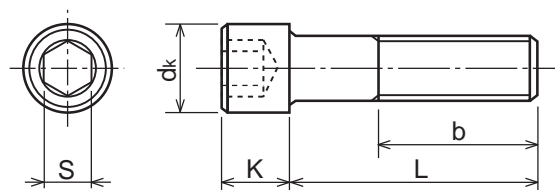

Type No. 類別番号	Type 類別
XB7-1	Hexagon socket head cap screws 六角穴付きボルト

	Head size (mm) 頭部寸法 (mm)						
	M3	M4	M5	M6	M8	M10	M12
S	2.5	3	4	5	6	8	10
dk	5.5	7	8.5	10	13	16	18
K	3	4	5	6	8	10	12
Screw part length ねじ部長さ b_{max}	18	20	22	24	28	32	36

3. Nuts
ナット

How to read Parts Numbers
部品番号の見方

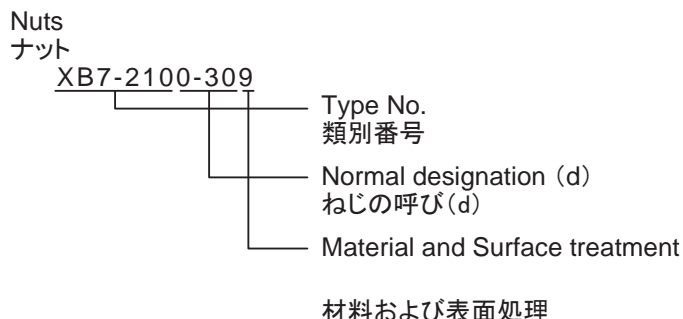

XB7-210 expresses Hexagon nut class 1.
XB7-210は、六角ナット1種を表す

0-30 expresses M3.0.
0-30は、M3.0を表す

9 expresses Steel (Black zinc trivalent chromate treating) from Table 1.
9は、表1より鋼(黒色亜鉛3価クロメート)を表す

3-1. Hexagon Nuts and Hexagon Thin Nuts
六角ナット

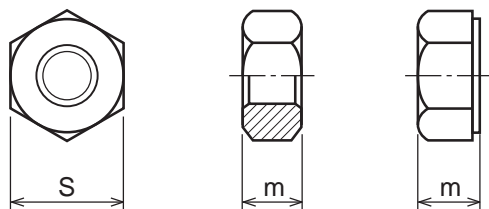

Type No. 類別番号	Type 類別
XB7-210	Hexagon nut Class 1 六角ナット-1種
XB7-220	Hexagon nut Class 3 六角ナット-3種
XB7-230	Hexagon nut Style 1 double chamfered 六角ナット-スタイル1-両面とり
XB7-231	Hexagon nut Style 1 washer faced 六角ナット-スタイル1-座付き
XB7-240	Hexagon nut Style 2 double chamfered 六角ナット-スタイル2-両面とり
XB7-241	Hexagon nut Style 2 washer faced 六角ナット-スタイル2-座付き
XB7-250	Hexagon nut 六角ナット
XB7-260	Hexagon thin nut double chamfered 六角低ナット-両面とり
XB7-270	Hexagon thin nut not chamfered 六角低ナット-面とり無し

S	Head size (mm) 頭部寸法 (mm)						
	M2	M2.5	M3	M4	M5	M6	M8
S	4	5	5.5	7	8	10	13
m XB7-210	1.6	2	2.4	3.2	4	5	6.5
m XB7-220	1.2	1.6	1.8	2.4	3.2	3.6	5
m XB7-230, 231	1.6	2	2.4	3.2	4.7	5.2	6.8
m XB7-240, 241	-	-	-	-	5.1	5.7	7.5
m XB7-250	-	-	-	-	5.6	6.1	7.9
m XB7-260	1.2	1.6	1.8	2.2	2.7	3.2	4
m XB7-270	1.2	1.6	1.8	2.2	2.7	3.2	4

5. Retaining Rings

止め輪

How to read Parts Numbers

Retaining Rings

止め輪

XD2-1100-202

Type No.
類別番号

Nominal designation
呼び

Material and Surface treatment
材料および表面処理

XD2-110 expresses retaining ring-E type (Type1).
XD2-110は、E形止め輪(1種)を表す

0-20 expresses a 020 of nominal designation.
(See Table 5)

0-20は、呼び020を表す(表5参照)

2 expresses Stainless steel (Surface treatment is not to be given) from Table 1.

2は、表1よりステンレス(表面処理なし)を表す

5-1. Retaining Rings - E type

E形止め輪

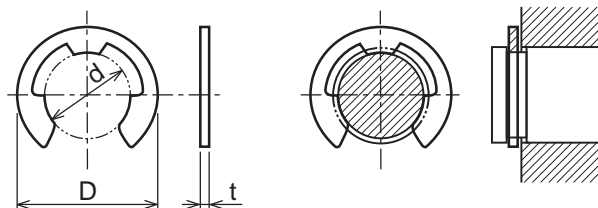

Type No. 類別番号	Type 類別
XD2-110	Retaining ring - E type (Type 1) E形止め輪(1種)
XD2-120	Retaining ring - E type (Type 2) E形止め輪(2種)

Table 5 表5

Type 種類	Nominal designation 呼び	d (mm)	D (mm)	t (mm)
Type 1 1種	007	0.65	2	0.2
	010	0.95	2.8	0.2
	013	1.25	3.3	0.3
	017	1.65	4.2	0.4
	020	1.95	4.6	0.5
	024	2.35	6	0.6
	028	2.74	6.5	0.6
	032	3.14	7.2	0.6
	037	3.64	8	0.7
	040	3.93	10	0.7
	042	4.13	10	0.7
	050	4.93	11	0.7
	058	5.73	12	0.7
	060	5.93	12.7	0.9
Type 2 2種	008	0.8	2	0.2
	012	1.2	3	0.3
	015	1.5	4	0.4
	020	2	5	0.4
	025	2.5	6	0.4
	030	3	7	0.6
	040	4	9	0.6
	050	5	11	0.6
	060	6	12	0.8
	070	7	14	0.8
	080	8	16	0.8
	090	9	18	0.8
100	10	20	1	

5-2. Grip Rings
グリップ止め輪

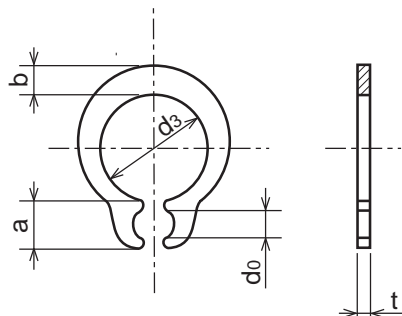

Table 5 表5

Nominal designation 呼び	d_3 (mm)	t (mm)	b (mm)	a (mm)	d_0 (mm)
020	1.9	0.5	1	1.8	0.8
025	2.35	0.5	1.2	1.9	0.9
030	2.85	0.6	1.4	1.9	0.9
035	3.3	0.6	1.6	2	0.9
040	3.8	0.8	1.8	2.8	1.2
045	4.25	0.8	2	2.9	1.3
050	4.75	0.8	2.2	2.9	1.3
060	5.7	1	2.4	3.1	1.4
070	6.7	1	2.7	3.3	1.4
080	7.7	1	3	3.5	1.4
090	8.65	1.2	3.3	4.7	1.5
100	9.65	1.2	3.5	4.7	2

Type No. 類別番号	Type 類別
XD2-210	Grip ring グリップ止め輪

5-3. Toothed Retaining Rings
歯付き形止め輪

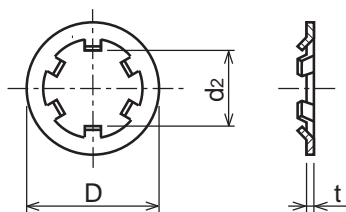

Table 5 表5

Nominal designation 呼び	d_2 (mm)	D (mm)	t (mm)	No of teeth 歯数
015	1.4	5.2	0.25	3
020	1.9	6	0.25	3
024	2.3	6.4	0.25	3
030	2.8	8	0.25	4
040	3.8	9	0.25	4
050	4.8	10	0.25	5
060	5.8	11	0.25	5
080	7.8	13	0.25	5
100	9.8	15.4	0.25	6

Type No. 類別番号	Type 類別
XD2-230	Toothed retaining ring 歯付き形止め輪

5-4. Retaining Rings - C Type

C形止め輪

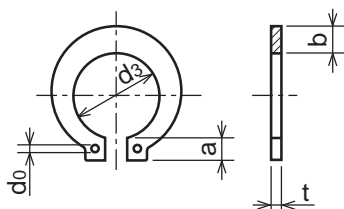

Type No. 類別番号	Type 類別
XD2-310	Retaining ring - C type for shaft C形止め輪 軸用

Table 5 表5

Nominal designation 呼び	d ₃ (mm)	t (mm)	b (mm)	a (mm)	d ₀ (mm)
010	9.3	1	1.6	3	1.2
012	11.1	1	1.8	3.2	1.5
014	12.9	1	2	3.4	1.7
015	13.8	1	2.1	3.5	1.7
016	14.7	1	2.2	3.6	1.7
017	15.7	1	2.2	3.7	1.7
018	16.5	1.2	2.6	3.8	1.7
020	18.5	1.2	2.7	3.9	2
022	20.5	1.2	2.7	4.1	2
025	23.2	1.2	3.1	4.3	2
028	25.9	1.5	3.1	4.6	2
030	27.9	1.5	3.5	4.8	2
032	29.6	1.5	3.5	5	2.5
035	32.2	1.5	4	5.4	2.5

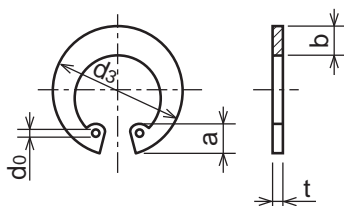

Type No. 類別番号	Type 類別
XD2-320	Retaining ring - C type for hole C形止め輪 穴用

Table 5 表5

Nominal designation 呼び	d ₃ (mm)	t (mm)	b (mm)	a (mm)	d ₀ (mm)
010	10.7	1	1.8	3.1	1.2
011	11.8	1	1.8	3.2	1.2
012	13	1	1.8	3.3	1.5
014	15.1	1	2	3.6	1.7
016	17.3	1	2	3.7	1.7
018	19.5	1	2.5	4	1.7
019	20.5	1	2.5	4	2
020	21.5	1	2.5	4	2
022	23.5	1	2.5	4.1	2
025	26.9	1.2	3	4.4	2
028	30.1	1.2	3	4.6	2
030	32.1	1.2	3	4.7	2
032	34.4	1.2	3.5	5.2	2.5
035	37.8	1.5	3.5	5.2	2.5
037	39.8	1.5	3.5	5.2	2.5
040	43.5	1.8	4	5.7	2.5
042	45.5	1.8	4	5.8	2.5
045	48.5	1.8	4.5	5.9	2.5
047	50.5	1.8	4.5	6.1	2.5
050	54.2	2	4.5	6.5	2.5
052	56.2	2	5.1	6.5	2.5
055	59.2	2	5.1	6.5	2.5
060	64.2	2	5.1	6.8	2.5
062	66.2	2	5.5	6.9	2.5
068	72.5	2.5	6	7.4	2.5
072	76.5	2.5	6.6	7.4	2.5
075	79.5	2.5	6.6	7.8	2.5
080	85.5	2.5	7	8	2.5
085	90.5	3	7	8	3
090	95.5	3	7.6	8.3	3
095	100.5	3	8	8.5	3

Prepared by
Inkjet Quality Assurance Center
インクジェット品質保証センター
CANON INC.

Canon