

DR-4010C

SERVICE MANUAL

FIRST EDITION

Canon

NOV. 2006

MY8-13AB-00D

COPYRIGHT © 2006 CANON ELECTRONICS INC.

Use of this manual should be strictly supervised to avoid disclosure of confidential information.

This Service Manual describes necessary basic information for field service and maintenance for maintaining the product quality and functions of this machine.

Contents

Chapter 1: General description

Product specifications, name of parts, operation method

Chapter 2: Functions and operation

Description of operation of machine system and electrical system by function

Chapter 3: Disassembly and reassembly

Disassembly method, reassembly method

Chapter 4: Installation and maintenance

Installation method, maintenance method

Chapter 5: Troubleshooting

Error display and troubleshooting

Appendix: General diagram etc.

Information in this manual is subject to change. Notification of such changes will be given in Service Information Bulletins.

Thoroughly read the information contained in this Service Manual and the Service Information Bulletins to gain a correct and deeper understanding of the machine. This is one way of fostering response for ensuring prolonged quality and function, and for investigating the cause of trouble during troubleshooting.

Quality Assurance Center
Canon Electronics Inc.

CONTENTS

CHAPTER 1 GENERAL DESCRIPTION

| | | |
|------|-----------------------------|------|
| I. | PRODUCT SPECIFICATIONS..... | 1-1 |
| 1. | Features | 1-1 |
| 2. | Specifications | 1-2 |
| 3. | Precautions | 1-7 |
| II. | NAME OF PARTS | 1-8 |
| 1. | Front Side..... | 1-8 |
| 2. | Operation Section | 1-8 |
| 3. | Rear Side | 1-9 |
| III. | USER OPERATION | 1-10 |
| 1. | Preparation..... | 1-10 |
| 2. | CapturePerfect 3.0..... | 1-11 |
| 3. | Job Function..... | 1-13 |
| 4. | Clearing Jam | 1-14 |

CHAPTER 2 FUNCTIONS & OPERATION

| | | |
|------|------------------------------------|------|
| I. | OUTLINE..... | 2-1 |
| 1. | Basic Configuration..... | 2-1 |
| 2. | Motor Drive..... | 2-2 |
| 3. | Electrical Circuits..... | 2-3 |
| 4. | Timing Chart..... | 2-4 |
| II. | READING SYSTEM | 2-5 |
| 1. | Outline | 2-5 |
| 2. | Reading Unit | 2-6 |
| 3. | Shading | 2-7 |
| 4. | CIS Position Correction..... | 2-9 |
| III. | FEED SYSTEM..... | 2-10 |
| 1. | Outline | 2-10 |
| 2. | Pickup Mechanism..... | 2-11 |
| 3. | Separation Mechanism | 2-12 |
| 4. | Straight Path..... | 2-13 |
| 5. | Feed Error Detection..... | 2-14 |
| IV. | CONTROL SYSTEM | 2-16 |
| 1. | Control PCB | 2-16 |
| 2. | Image Processing Control..... | 2-18 |
| V. | NEW IMAGE PROCESSING | 2-20 |
| 1. | Advanced Text Enhancement II | 2-20 |

| | | |
|-------|--|------|
| 2. | Prevent Bleed Through / Remove Background | 2-22 |
| 3. | Auto Image Type Detection..... | 2-23 |
| VI. | POWER SUPPLY | 2-24 |
| 1. | Power Supply | 2-24 |
| 2. | Protection Function | 2-25 |
| 3. | Power Saving Mode | 2-25 |
| VII. | ELECTRICAL PARTS LAYOUT | 2-26 |
| 1. | Upper Unit | 2-26 |
| 2. | Lower Unit | 2-27 |
| VIII. | PARTS LAYOUT ON EACH PCB..... | 2-28 |
| 1. | Control PCB | 2-28 |
| 2. | Sub PCB..... | 2-30 |
| 3. | Power Supply PCB..... | 2-31 |

CHAPTER 3 DISASSEMBLY & REASSEMBLY

| | | |
|------|-------------------------------------|------|
| I. | OUTLINE FLOWCHART | 3-1 |
| II. | EXTERNAL COVERS | 3-2 |
| 1. | Pickup Tray | 3-2 |
| 2. | Document Guides/Pickup Cover | 3-3 |
| 3. | Left Cover | 3-4 |
| 4. | Job Buttons/Light Guide..... | 3-5 |
| 5. | Right Cover | 3-5 |
| 6. | Front Cover | 3-6 |
| 7. | Eject Tray | 3-6 |
| 8. | Upper Cover..... | 3-7 |
| 9. | Rear Cover | 3-7 |
| 10. | Entrance Guide Cover..... | 3-8 |
| 11. | Entrance Guide Plate Upper | 3-8 |
| III. | FEED SYSTEM (ROLLERS, ETC.) | 3-9 |
| 1. | Roller Unit | 3-9 |
| 2. | Retard Roller | 3-9 |
| 3. | Registration Roller (Drive)..... | 3-9 |
| 4. | Reading Roller Front (Drive) | 3-10 |
| 5. | Reading Roller Rear (Drive)..... | 3-11 |
| 6. | Registration Roller (Follower)..... | 3-11 |
| 7. | Follower Roller Unit Front | 3-13 |

| | | |
|-----|-------------------------------------|------|
| 8. | Follower Roller Unit Rear | 3-13 |
| 9. | U-Turn Feed Roller (Drive) | 3-14 |
| 10. | U-Turn Eject Roller (Drive) | 3-14 |
| 11. | U-Turn Feed Roller (Follower)..... | 3-15 |
| 12. | U-Turn Eject Roller (Follower)..... | 3-16 |
| IV. | DRIVE SYSTEM (MOTOR, ETC.)..... | 3-17 |
| 1. | Main Motor..... | 3-17 |
| 2. | Shading Motor | 3-17 |
| 3. | Feed Clutch | 3-18 |
| 4. | Belt Left | 3-19 |
| 5. | Belt Right | 3-19 |
| 6. | Roller Unit Drive Shaft..... | 3-20 |
| 7. | Roller Unit Retaining Shaft | 3-20 |
| 8. | Retard Roller Drive Shaft..... | 3-21 |
| 9. | Retard Roller Retaining Shaft..... | 3-21 |
| V. | READING SYSTEM | 3-23 |
| 1. | Reading Unit (Upper) | 3-23 |
| 2. | Reading Unit (Lower) | 3-24 |
| 3. | Reading Glass (Upper)..... | 3-25 |
| 4. | Reading Glass (Lower)..... | 3-26 |
| VI. | ELECTRICAL SYSTEM (PCB, ETC.).... | 3-27 |
| 1. | Bottom Plate Unit..... | 3-27 |
| 2. | Control PCB..... | 3-28 |
| 3. | Power Supply PCB..... | 3-28 |
| 4. | Sub PCB..... | 3-29 |
| 5. | Ultrasonic PCB | 3-29 |
| 6. | Operation PCB | 3-30 |

CHAPTER 4 INSTALLATION & MAINTENANCE

| | | |
|----|-------------------------------------|-----|
| I. | INSTALLATION..... | 4-1 |
| 1. | Selection of Location | 4-1 |
| 2. | Checking Accessories | 4-2 |
| 3. | Protection Material Removal | 4-3 |
| 4. | Attaching the Roller Unit..... | 4-3 |
| 5. | Attaching the Retard Roller | 4-4 |
| 6. | Installing the Software | 4-6 |
| 7. | Connecting to the Computer | 4-7 |
| 8. | Power ON (scanner recognition)..... | 4-9 |
| 9. | Scanning..... | 4-9 |

| | | |
|------|----------------------------------|------|
| II. | PARTS REPLACEMENT | 4-11 |
| 1. | Periodically Replaced Parts..... | 4-11 |
| 2. | Consumable Parts | 4-11 |
| 3. | Major Parts List..... | 4-12 |
| III. | MAINTENANCE..... | 4-13 |
| 1. | User Maintenance | 4-13 |
| 2. | Service Maintenance | 4-14 |

CHAPTER 5 TROUBLESHOOTING

| | | |
|------|--|------|
| I. | ERROR DISPLAY | 5-1 |
| 1. | Power Indicator..... | 5-1 |
| 2. | Error Messages | 5-2 |
| II. | SERVICE MODE | 5-3 |
| 1. | Outline | 5-3 |
| 2. | Installation Procedure | 5-5 |
| 3. | Starting Up and Exiting Service Mode..... | 5-5 |
| 4. | All Adjustment..... | 5-6 |
| 5. | Individual Adjustments..... | 5-7 |
| 6. | Analog..... | 5-8 |
| 7. | Firm Load..... | 5-9 |
| 8. | About | 5-10 |
| 9. | Max Document Size | 5-10 |
| 10. | Dcon Check | 5-11 |
| 11. | Check Device..... | 5-13 |
| 12. | Sleep..... | 5-13 |
| 13. | SCSI Transfer | 5-14 |
| 14. | Counter..... | 5-14 |
| 15. | Mechanical Feed Mode | 5-15 |
| 16. | "About" Screen..... | 5-16 |
| III. | LIST OF FAILURES | 5-17 |
| 1. | Operation Failures | 5-17 |
| 2. | Images Failures | 5-17 |
| IV. | OPERATION TROUBLESHOOTING.... | 5-18 |
| 1. | No Power | 5-18 |
| 2. | Not Recognized by Computer | 5-19 |
| 3. | Scanning Does Not Start | 5-20 |
| 4. | Jam, Double Feed, Skew | 5-21 |
| 5. | Slow Scanning Speed..... | 5-22 |
| V. | IMAGE TROUBLESHOOTING | 5-23 |

| | |
|--|------|
| 1. Completely Black, Completely White, All Streaks | 5-24 |
| 2. Too Dark, Too Light | 5-25 |
| 3. Black Borders Around Image | 5-26 |
| 4. Image Skews..... | 5-26 |
| 5. Moire on Image | 5-26 |
| 6. Streaks and Spots on Image | 5-27 |
| 7. Outer Areas of Image Disappear | 5-27 |
| VI. AFTER REPLACING PARTS | 5-28 |
| 1. Control PCB | 5-28 |
| 2. Reading Unit | 5-28 |
| 3. Registration Related Parts | 5-28 |

APPENDIX

| | |
|--------------------------|-----|
| I. GENERAL DIAGRAM | A-1 |
|--------------------------|-----|

CHAPTER 1

GENERAL DESCRIPTION

| | | | |
|--------------------------------|-----|---------------------------|------|
| I. PRODUCT SPECIFICATIONS..... | 1-1 | III. USER OPERATION | 1-10 |
| II. NAME OF PARTS | 1-8 | | |

I. PRODUCT SPECIFICATIONS

1. Features

- 1) Compact design (small, light)
Dimensions (Tray closed): 318 (W) × 278 (D) × 187 (H) mm, Wight: 6.4 kg
- 2) High-speed scanning
Black and white, Grayscale, and Color: Simplex 42 ppm, Duplex 84 ipm (200 dpi, A4 size)
- 3) High-quality color
3-line 600dpi sensor (CIS), 3-D color correction
- 4) Dual-path mechanism (U-turn/Straight path)
- 5) New image processing
- 6) New shading mechanism
- 7) Ultrasonic sensor for double feed detection
- 8) Installation and replacing of rollers (consumable parts) by users

"Windows" is a trademark of Microsoft Corporation in the U.S. and other countries.
Other company names and product names mentioned in this document are registered trademarks or trademarks of the respective companies.

2. Specifications

1) Appearance/Installation

| No. | Item | Specifications |
|-----|---|--|
| 1 | Type | Desktop type sheet-fed scanner |
| 2 | Power supply rating | 1) 100V model: 100 VAC, 50/60 Hz, 25 W 2) 120V model: 120 VAC, 60 Hz, 0.5 A 3) 200V model: 220-240 VAC, 50/60 Hz, 0.3 A |
| 3 | Power consumption | 1) 100V model: Operating 25 W, Standby 3 W 2) 120V model: Operating 25 W, Standby 3 W 3) 200V model: Operating 24 W, Standby 3 W * Conforming to the International ENERGY STAR Program. |
| 4 | Operating environment | 10 to 32.5°C (50 to 90.5°F), 20 to 80%RH *No condensation allowed. |
| 5 | Noise | Operating: 68 dB or less, Standby: 40 dB or less *Sound power level |
| 6 | Dimensions *Details to be described later. | Tray closed: 318 (W) × 278(D) × 185.5 (H) mm Tray opened: 318 (W) × 595(D) × 225 (H) mm |
| 7 | Weight | Approx. 6.4 kg |
| 8 | Output interface | 1) USB2.0 (Hi-speed) 2) SCSI-III (Ultra-SCSI) |
| 9 | Expected product life (In-house information) | One of the following 2 items, whichever comes first. 1) 5 years 2) Sheets fed: 3,500,000 sheets (A4 copy paper) *There are parts needed to replace. *Duty cycle is 5,000 sheets/day. |
| 10 | Installation | By users |
| 11 | Bundle software | ISIS/TWAIN driver, CapturePerfect 3.0, Adobe Acrobat 7.0, Job Registration Tool, others |
| 12 | Consumable parts (commercial goods) | Roller unit/retard roller (exchange roller kit) |
| 13 | Option | Barcode reader (driver's option) |

Table 1-101

*Dimensions (unit: mm)

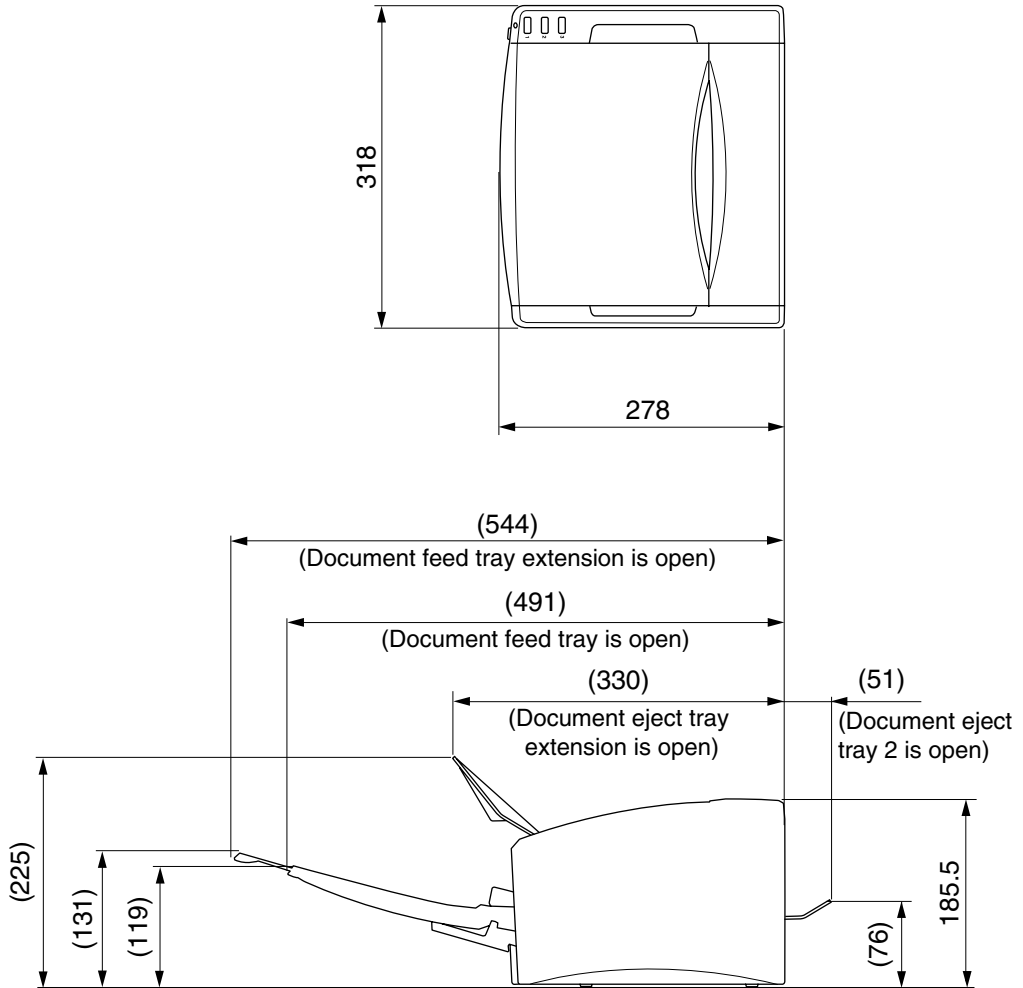

Figure 1-101

2) Document feed

| No. | Item | Specifications | | | |
|-----|--|---|---|--|-------|
| | | | U-turn path | Straight path | |
| 1 | Document size | | | | |
| | | 1) Width | 53 to 219 mm | | |
| | | 2) Length | 70 to 356 mm *Excluded long document mode. | | |
| 2 | Document weight (converted thickness) | 1) Separation pickup | 52 to 128 g/m ² (0.06 to 0.15 mm) | | |
| | | 2) Non-separation pickup | 42 to 164 g/m ² (0.05 to 0.20 mm) | 42 to 489 g/m ² (0.05 to 0.66 mm) *Excluded cards | |
| 3 | Long document mode | Length: 1000 mm max. Thickness: 0.20 mm or less *Image data size is 128 MB max. (Scanning conditions are limited.) *Feed function is not guaranteed. | | | |
| 4 | International standard card | Available at straight path with non-separation pickup only. Width: 53.9 mm, Length: 85.5 mm, Thickness: 0.76 mm *No embossing card is permitted. | | | |
| 5 | Folio | Size: A4 (LTR) or less at folded *Non-separation pickup is selected. | | | |
| 6 | Document limitation | 1) Pressure-sensitive paper: Can be fed with limitation of direction. 2) Carbon-backed paper: Cannot be fed. 3) Perforated paper for binder: Can be fed with limitation of holes. 4) Curled paper: Can be fed only if curl is 8 mm or less. 5) Creased paper: Can be fed, but crease must be straightened before being fed. | | | |
| 7 | Document storage | | U-turn path | Straight path | |
| | | 1) Pickup | 10 mm or less including curls, or 100 sheets with 80 g/m ² at max. | | |
| | | 2) Eject | 12 mm or less | 5 mm or less *Tray size limited | |
| | | 3) Eject direction | Face down | Face up | |
| 8 | Feed speed | Resolution | Binary | Grayscale | Color |
| | | 100/150/200/240/300 dpi | 289.8 mm/sec | | |
| | | 400/600 dpi (speed priority) | | | |
| | | 400/600 dpi (quality priority) | 135.0 mm/sec | | |

Table 1-102

3) Document reading *using bundle software CapturePerfect 3.0

| No. | Item | Specifications | | | | | |
|-----|---------------------------|---|----------------------------|---------|--------------------|--|--|
| 1 | Type of sensor | Color 3-line Contact Image Sensor (CIS) | | | | | |
| 2 | Sensor pixels | Density of pixels: 600 dpi, Effective pixels: 5577 × 3-line (236 mm) | | | | | |
| 3 | Light source | 3-color (RGB) LED R: 620 nm, G: 530 nm, B: 467 nm | | | | | |
| 4 | Reading side | Simplex/Duplex/Blank skip/Folio | | | | | |
| 5 | Reading size | 1) Typical: A4/A5/A5-R/A6/A6-R, B5/B6/B6-R, LGL/LTR 2) Auto size detection 3) Maximum size (236 × 355.6 mm) 4) User setting | | | | | |
| 6 | Output mode | 1) Binary (Black and white/Error diffusion/Advanced text enhancement/Advanced text enhancement II/High-speed text enhancement) 2) Grayscale (8 bits) 3) Color (24 bits) | | | | | |
| 7 | Output resolution | 100 × 100 dpi, 150 × 150 dpi, 200 × 200 dpi, 240 × 240 dpi, 300 × 300 dpi, 400 × 400 dpi (speed priority), 600 × 600 dpi (speed priority), 400 × 400 dpi (quality priority), 600 × 600 dpi (quality priority) | | | | | |
| 8 | Reading speed *A4 size | Mode (save type) | Resolution | Simplex | Duplex | | |
| | | Black and white (TIFF) | 200 dpi | 42 ppm | 84 ipm | | |
| | | | 300 dpi | | | | |
| | | | 400 dpi (speed priority) | 42 ppm | 42 ipm | | |
| | | | 600 dpi (speed priority) | | | | |
| | | | 400 dpi (quality priority) | 20 ppm | 24 ipm | | |
| | | | 600 dpi (quality priority) | | | | |
| | | Grayscale (JPEG) | 200 dpi | 42 ppm | 84 ipm | | |
| | | | 300 dpi | | | | |
| | | | 400 dpi (speed priority) | 42 ppm | 42 ipm | | |
| | | | 600 dpi (speed priority) | | | | |
| | | | 400 dpi (quality priority) | 20 ppm | 24 ipm | | |
| | | | 600 dpi (quality priority) | | | | |
| | | Color (JPEG) | 200 dpi | 42 ppm | 84 ipm | | |
| | | | 300 dpi | | | | |
| | | | 400 dpi (speed priority) | 42 ppm | 42 ipm | | |
| | | | 600 dpi (speed priority) | | | | |
| | | | 400 dpi (quality priority) | 20 ppm | -- (impossible) | | |
| | | | 600 dpi (quality priority) | | | | |
| | | * Settings of reading are default. The numbers above may differ depending on the computer, the function settings and other conditions. | | | | | |

Table 1-103

4) Image processing/Other functions *using bundle software CapturePerfect 3.0

| No. | Item | Specifications |
|-----|--------------------------|--|
| 1 | Brightness adjustment | 255 steps, back side individual setting |
| 2 | Auto-brightness | Available at black and white mode (ABC processing) |
| 3 | Contrast adjustment | 7 steps, back side individual setting |
| 4 | Gamma correction | Grayscale/R/B/G individual color, each side setting |
| 5 | Edge emphasis | 5 steps |
| 6 | Shading correction | Auto operation to get correction data at each batch |
| 7 | Color drop-out | Available: R/G/B, front/back side each *Custom color and color enhance modes are available also. |
| 8 | Skew correction (deskew) | Performed by image processing |
| 9 | Double feed detection | Length detection sensor, Ultrasonic sensor |
| 10 | New image processing | Advanced text enhancement II, Auto image type detection, Prevent bleed through/Remove background |
| 11 | Other image processing | Border removal, Punch hole removal, Image rotation, Text orientation recognition, Erase dot, Moire reduction, etc. |
| 12 | Job function | Save as file, Print, Attach to E-mail, Start, Stop, Launcher |
| 13 | Counter | Total scanning count (memorize in EEPROM on the scanner main body) |
| 14 | Operation buttons | Job buttons: 3 buttons (available registering the functions) |

Table 1-104

The specifications above are subject to change for improvement of the product.

3. Precautions

This section describes items that require particular care, for example, regarding human safety.

These precautions must be observed. The user should be explained the items that relate to user safety and instructed to take appropriate actions.

1) Power OFF in emergency

If such abnormal conditions as extraordinary noise, smoke, heat and odor occur, immediately switch the power OFF and unplug the power cord.

Be careful not to get clothing (ties, long hair, etc.) caught in the machine as it may cause injury. Should this occur, immediately unplug the power cord. Do not insert fingers in the feed section while moving the rollers.

2) Power OFF on disassembling

When disassembling and assembling are performed, switch the power OFF and unplug the power cord.

3) Prohibition of modify

This machine must not arbitrarily be modified or remade. If it is, use may be forcibly suspended.

To change the specifications or disassemble and reassemble this machine, follow the instructions described in this manual and the service information.

4) Electromagnetic wave interference

This machine complies with some standards regarding electromagnetic wave interference, such as VCCI and FCC. However, the user may have to take countermeasures if the machine causes electromagnetic wave interference.

5) "User Manual"

Read each "User Manual" thoroughly prior to use of this machine.

6) Disposal

Follow local regulations when disposing of the product and parts. This product is subject to the WEEE Directive in Europe.

II. NAME OF PARTS

1. Front Side

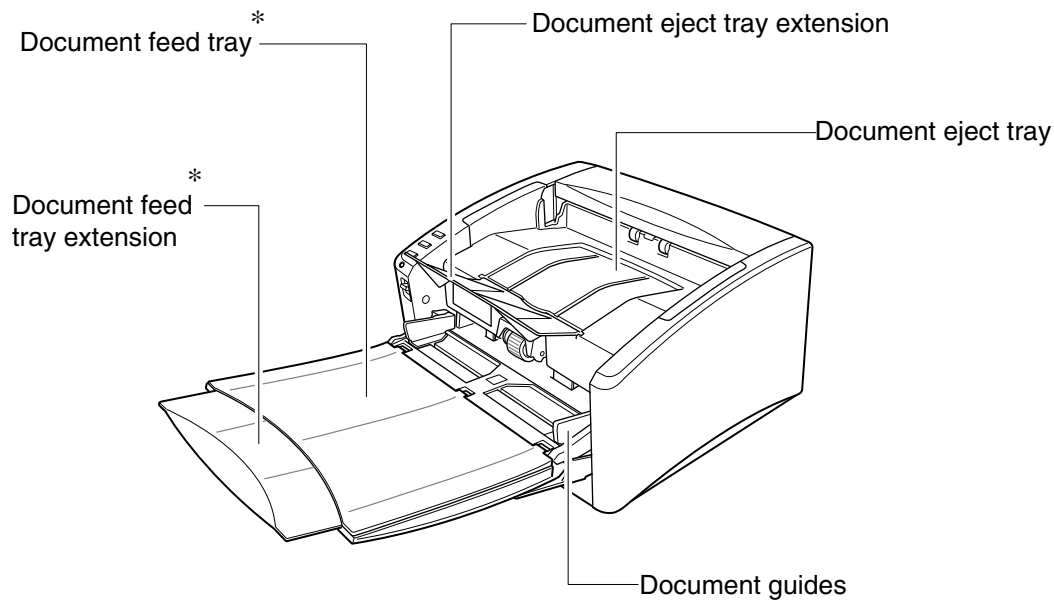

Figure 1-201

*: In this manual, the “document feed tray” may also be mentioned as the “pickup tray.”

2. Operation Section

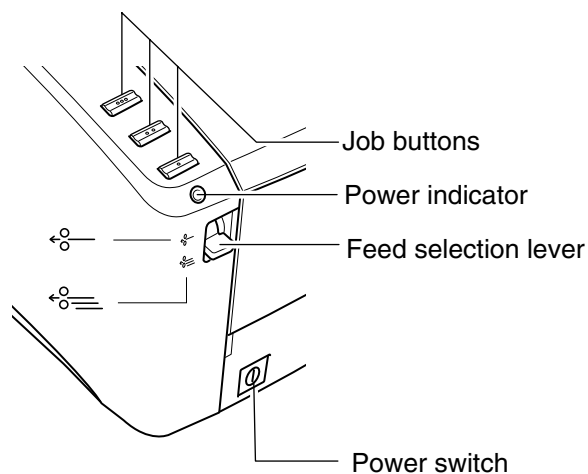

Figure 1-202

3. Rear Side

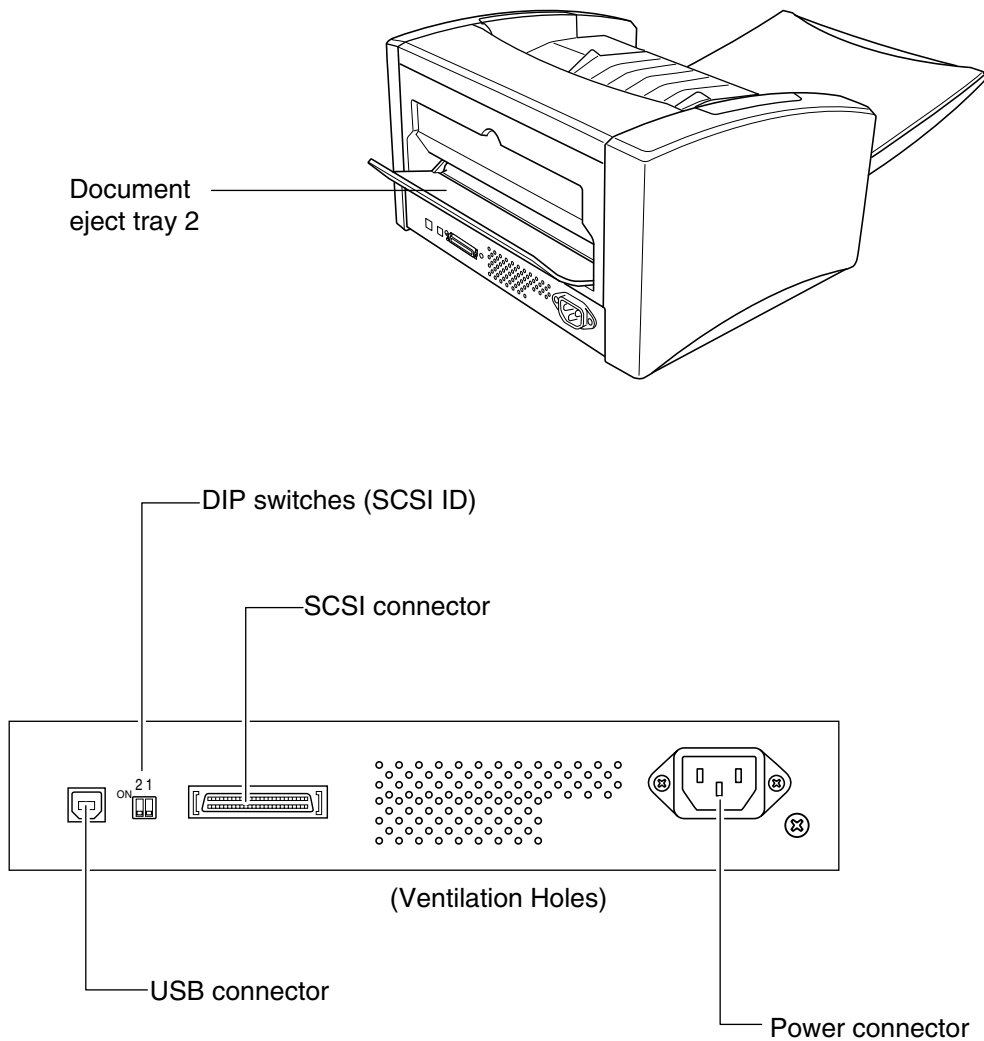

Figure 1-203

Note: Do not connect both the USB cable and the SCSI cable simultaneously. Do not obstruct the ventilation holes.

III. USER OPERATION

For details, refer to the “User Manual” of this machine and the software that is used.

For installation and maintenance, refer to “Chapter 4, INSTALLATION/MAINTENANCE.”

1. Preparation

1) Preparation of document feed tray and document eject tray

Make preparations of the document feed tray and the document eject tray as necessary for the document size and eject methods.

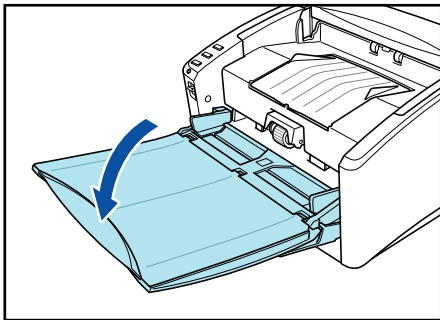

Figure 1-301

Note: Open document eject tray 2 on the rear side to use the straight path.

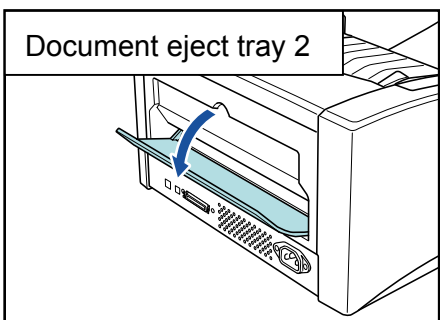

Figure 1-302

2) Setting of document

Align the document edges and then set the documents on the document feed tray.

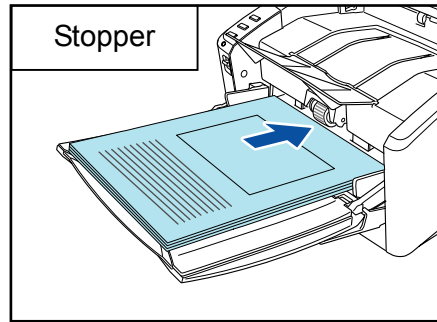

Figure 1-303

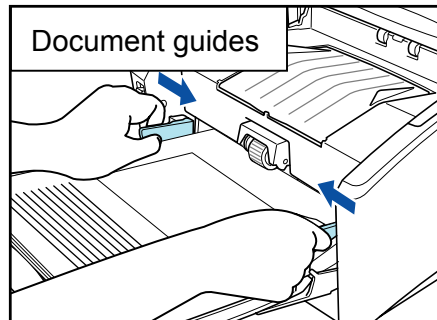

Figure 1-304

Note: With the feed selection lever, select either separation feed or non-separation feed. For the manual feed, set the lever to lower for non-separation feed.

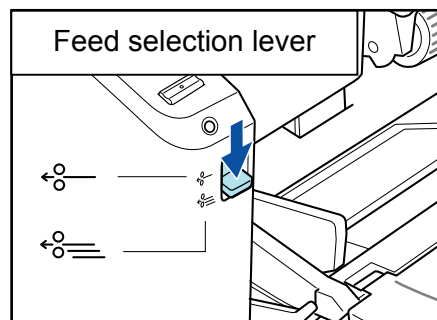

Figure 1-305

2. CapturePerfect 3.0

CapturePerfect 3.0 is an ISIS compatible application software package.

1) Start up CapturePerfect 3.0.

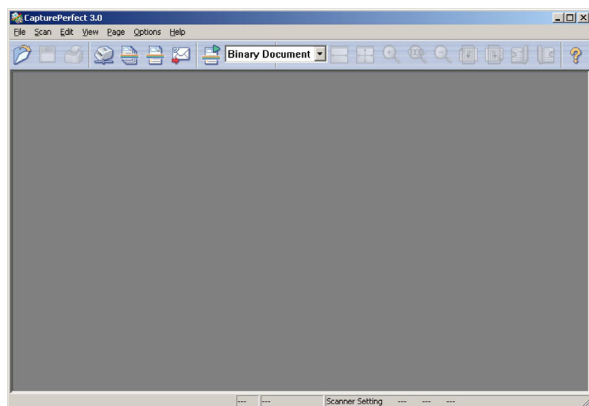

Figure 1-306

2) Select the scanner.

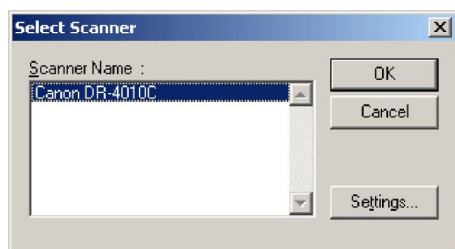

Figure 1-307

3) Select scanner settings.

This opens the ISIS driver setting dialog.

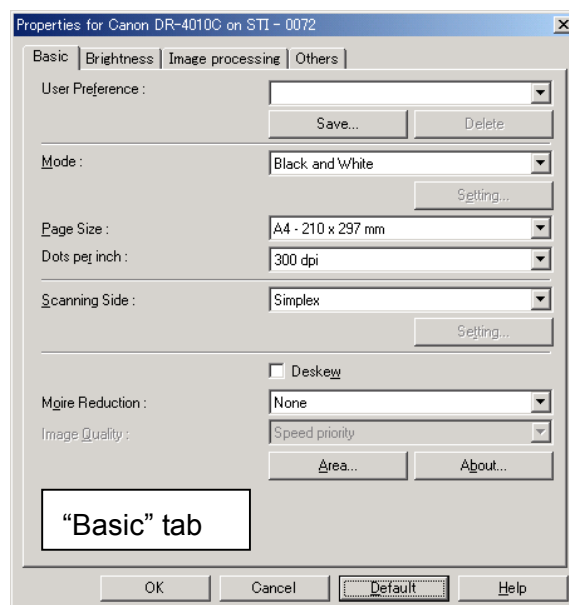

Figure 1-308

4) Set the reading conditions.

Refer to the User Manual for the details.

Note: Dialogs of the “Brightness,” “Image processing” and “Others” tabs other than the “Basic” tab are as shown below.

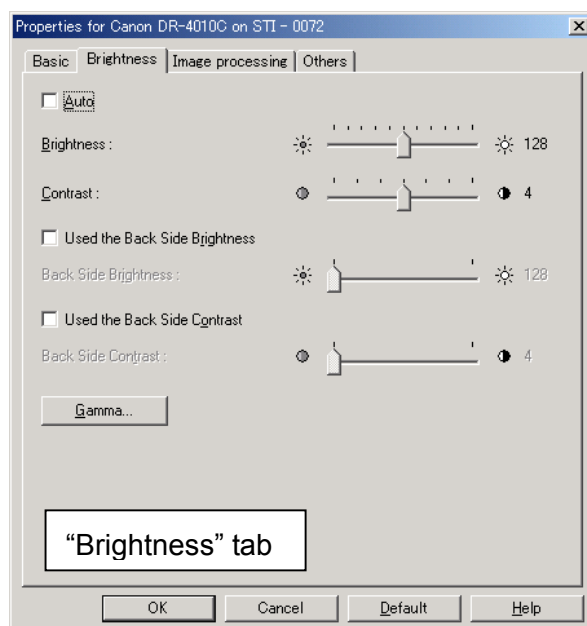

Figure 1-309

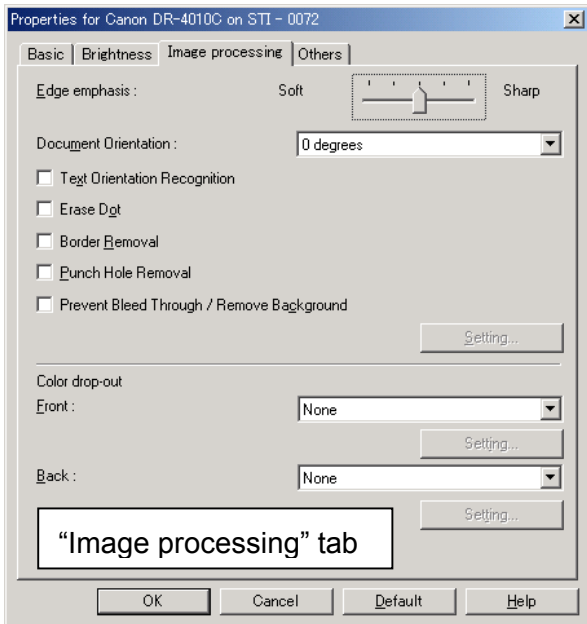

Figure 1-310

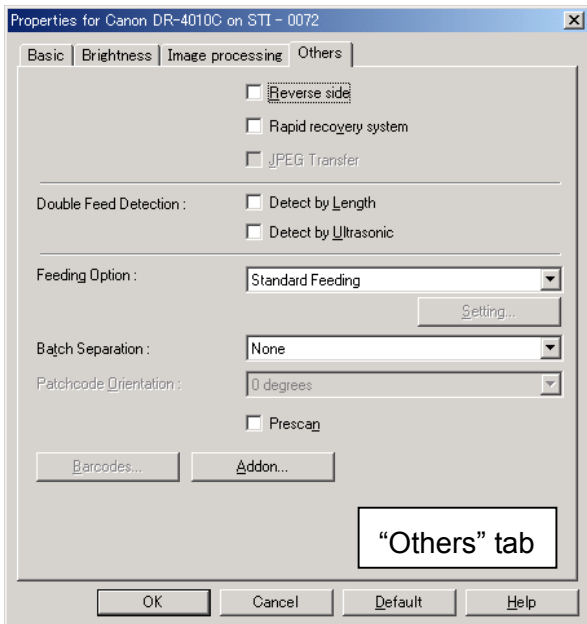

Figure 1-311

5) Ensure that the document is set correctly.

6) Select a scanning method.
Selecting "Scan Batch to File" opens the setting dialog.

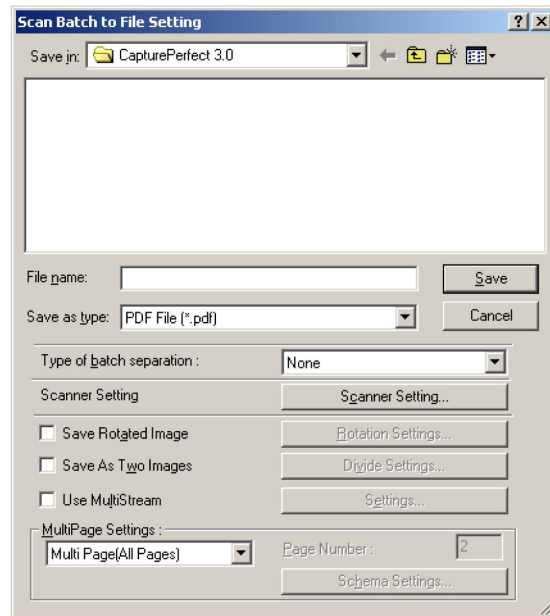

Figure 1-312

7) Specify the file name and format for saving images and then click "Save" to start scanning.

8) Close CapturePerfect 3.0 after scanning.

3. Job Function

With the job function of this machine, scanning can be performed simply by operation of the operation panel buttons. The operation panel has 3 job buttons. Desired 3 functions can be assigned to the job buttons out of 6 functions by the Job Registration Tool.

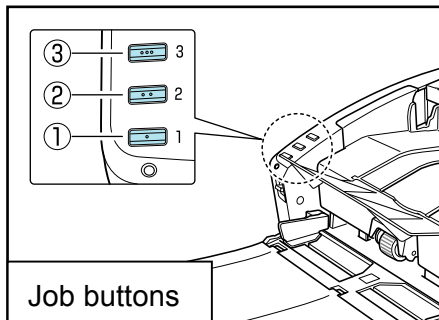

Figure 1-313



Figure 1-314

The Job Registration Tool is a TWAIN compatible application software package.

The following functions are assigned to each button at the factory as the default settings.

- Job button ①: Start
- Job button ②: Stop
- Job button ③: Save as file

The sequence of scanning by the job function is as shown below. Suppose that "Save as file" is assigned to job button ③.

- 1) Ensure that the document is correctly set.
- 2) Press job button ③ to execute the job.
The monitor appears and scanning starts.

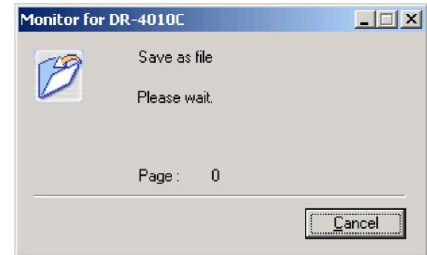

Figure 1-315

- 3) After all the documents are fed, the image data is sent. The monitor shows "Sending complete."

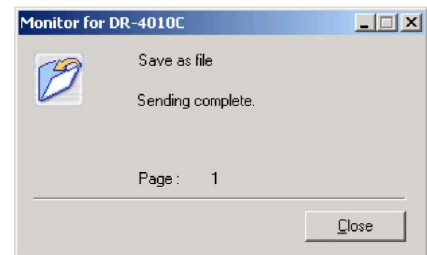

Figure 1-316

- 4) Click "Close" to close the monitor.

4. Clearing Jam

- 1) Remove a remaining document from the document eject tray and close the document eject tray extension.

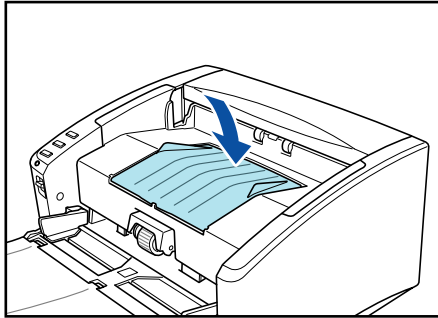

Figure 1-317

- 2) Slowly open the upper unit.

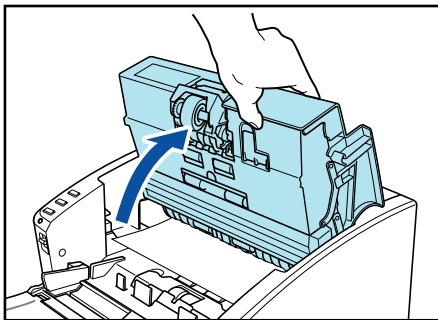

Figure 1-318

Note: When opening the upper unit, do not hold the roller unit in the center. The caution label is affixed on the left front of the upper unit.

- 3) Remove a jammed document.

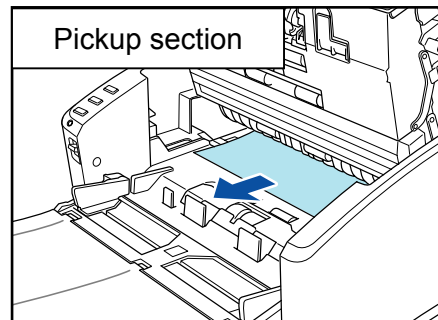

Figure 1-319

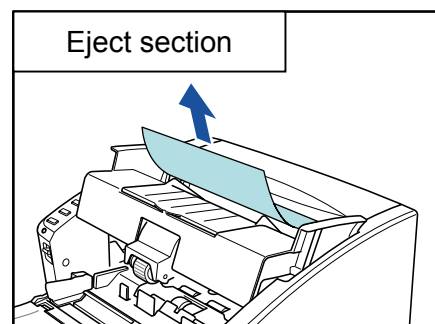

Figure 1-320

Note: Carefully remove a jammed document. Be careful not to wound yourself in the fingers by an edge of a sheet of paper for example. If a jammed document is torn off, be sure to remove the remaining part of the sheet.

- 4) Carefully close the upper unit. Press both sides of the unit with hands to firmly close it.

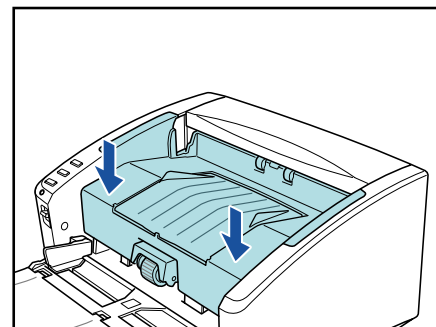

Figure 1-321

CHAPTER 2

FUNCTIONS & OPERATION

| | | | |
|--------------------------|------|-------------------------------------|------|
| I. OUTLINE..... | 2-1 | V. NEW IMAGE PROCESSING | 2-20 |
| II. READING SYSTEM | 2-5 | VI. POWER SUPPLY | 2-24 |
| III. FEED SYSTEM..... | 2-10 | VII. ELECTRICAL PARTS LAYOUT | 2-26 |
| IV. CONTROL SYSTEM | 2-16 | VIII. PARTS LAYOUT ON EACH PCB..... | 2-28 |

I. OUTLINE

1. Basic Configuration

Figure 2-101 shows the configuration of this machine.

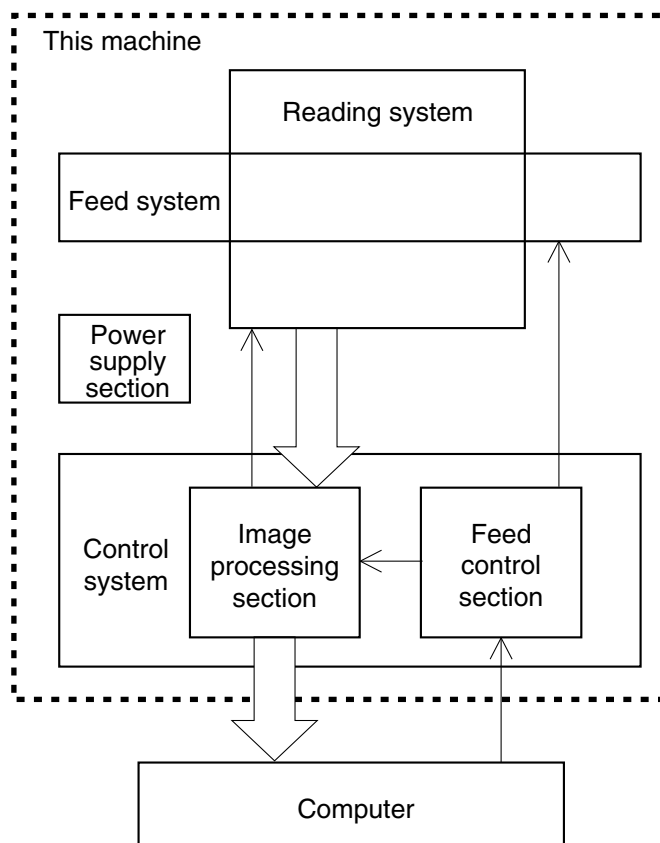

Figure 2-101

1) Reading system

This system reads image data from image sensors.

2) Feed system

This system performs from document pickup to document ejection.

3) Control system

This system is comprised of an image processing section and a feed control section.

The image processing section controls the reading system, processes the read image data, and outputs it to the computer. However, image data processing is also performed by the computer.

The feed control section controls the feed system.

4) Power supply section

This section converts the AC power supplied from external into the DC power and supplies it to the control PCB.

2. Motor Drive

This machine has a main motor (M1) for feeding the document. Additionally, it also has a shading motor (M2).

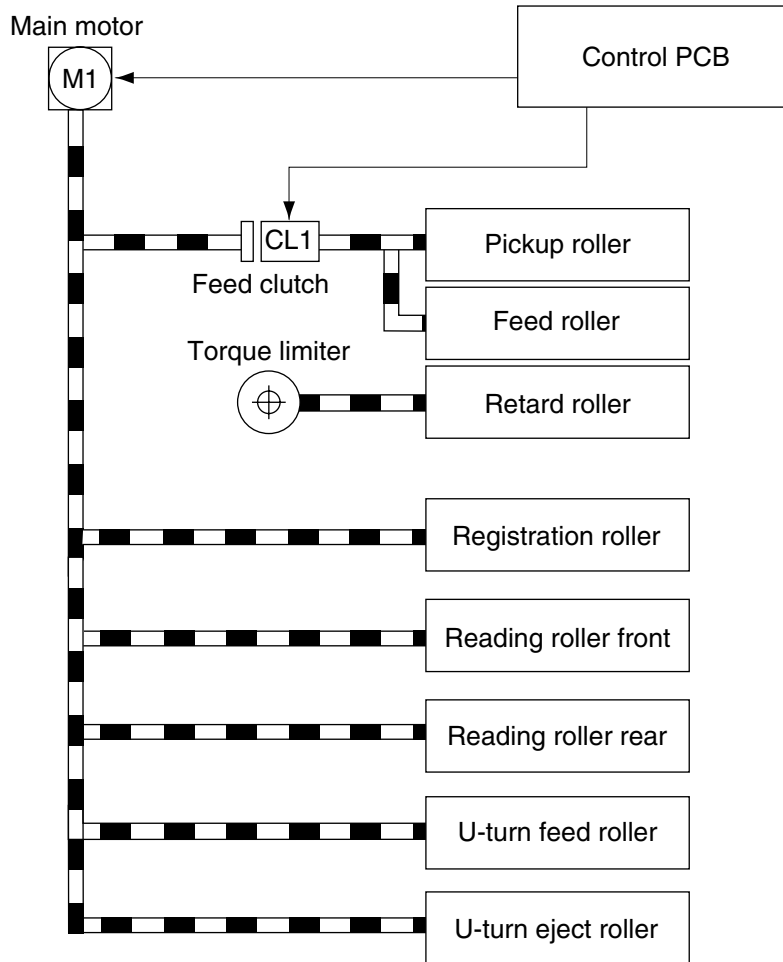

Figure 2-102

3. Electrical Circuits

Figure 2-103 shows an overview of the electrical circuits block diagram of this machine.

The control PCB, which is mounted on the lower part of the main body, controls the

other electrical circuits. The upper unit has a mounted sub PCB, which functions as a relay between the control PCB and the sensor signal, etc. in the upper unit.

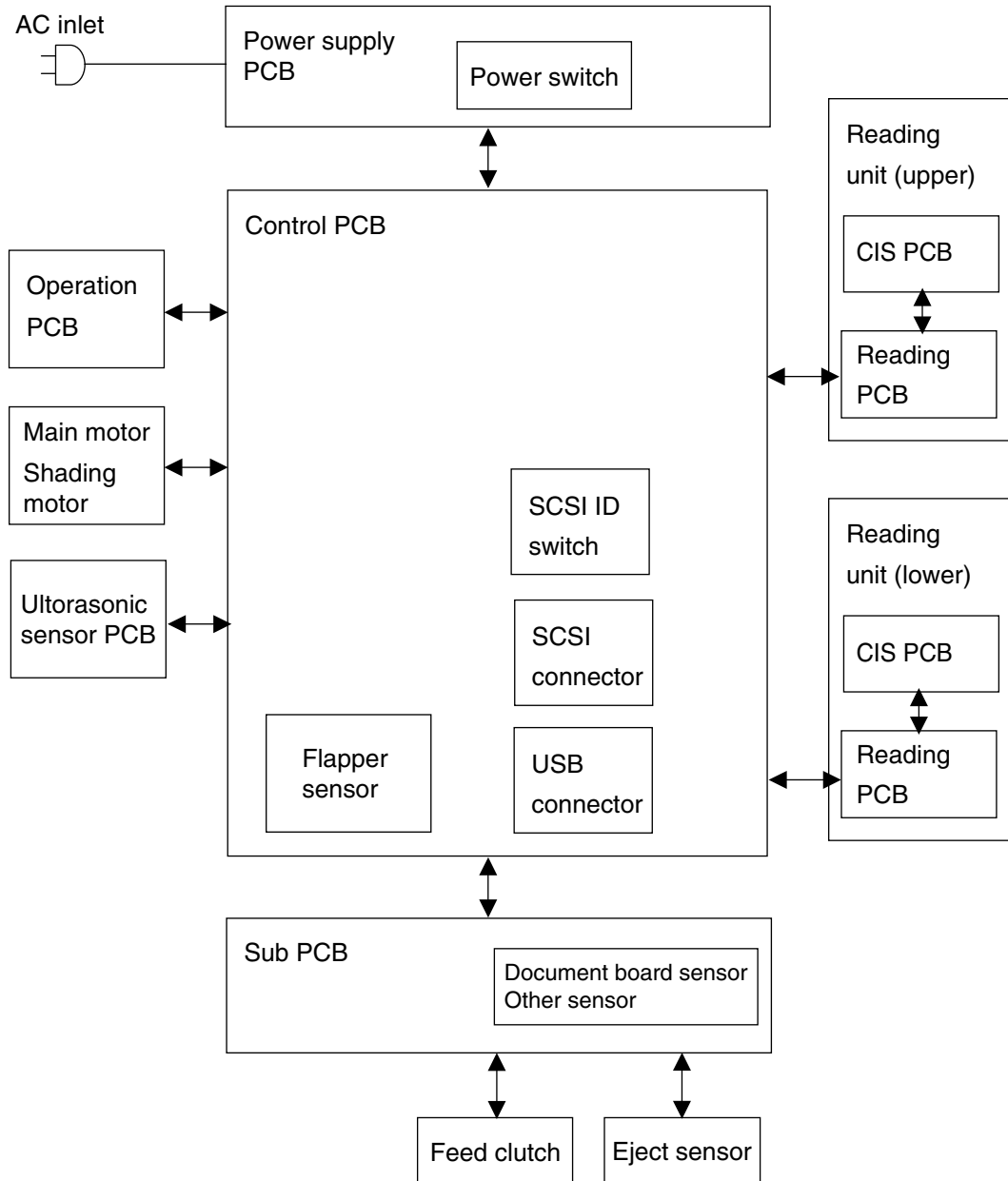

Figure 2-103

4. Timing Chart

Figure 2-104 shows the timing chart when you separately pickup 2 sheets of document by using a U-turn path without temporarily suspending the machine.

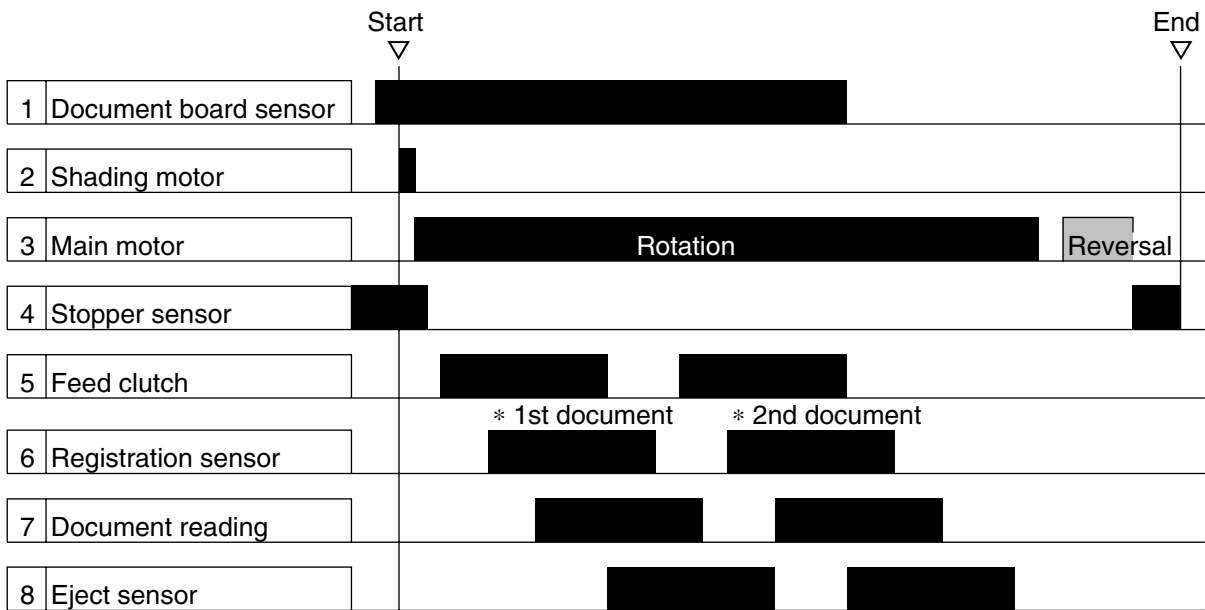

Figure 2-104

Once the machine starts scanning, it activates the shading motor, then the main motor. Operation of the main motor opens the stopper and lowers the roller unit. Thereafter the roller unit starts rotating to pick up the document.

II. READING SYSTEM

1. Outline

Figure 2-201 shows the configuration of the reading system.

The reading unit (upper) reads the front side of the documents and the reading unit (lower) reads the back side of the documents. This configuration enables the unit to read both the front and back sides of a document using a single scan.

The image data read are sent to the image processing section of the control PCB.

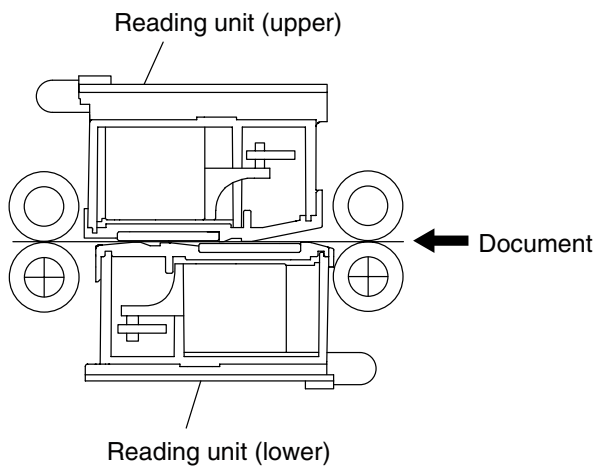

Figure 2-201

2. Reading Unit

Figure 2-202 shows a sectional view of the reading unit.

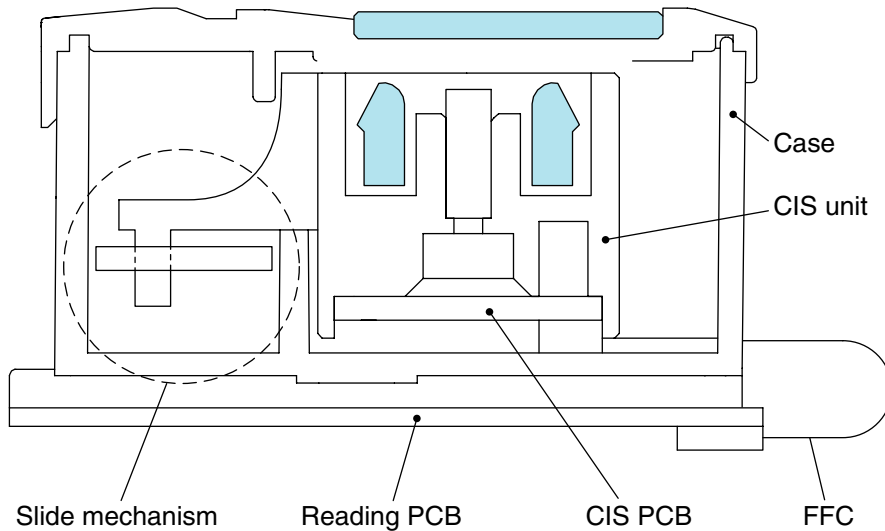

Figure 2-202

The reading unit consists of a CIS unit, a reading PCB, a reading glass assembly, an FFC, a case and a slide mechanism.

The CIS PCB in the CIS (Contact Image Sensor) unit has a light-receiving element having an optical resolution of 600 dpi. This light-receiving element is a 3-line CMOS image sensor with color filters for R, G and B. The number of effective pixels of each color is 5577 and its reading width is 236 mm.

As a 3-line type light-receiving element, it can light on the LEDs of the 3 colors at the same time for image reading, thus reducing color shift. In addition, it can prevent slow-down in reading in the color mode.

The lights from the LEDs illuminate the document through the light guides and the reading glass. The lights reflected from the document enter the image sensors through the lens arrays. The image sensors convert the lights to analog signals.

The analog signals are sent to the reading PCB, processed and transformed into digital signals. And then, they are sent to the control PCB.

Even if skewing occurs, the image missing area will be small since the effective length (236 mm) is long enough for A4 documents (210 mm) and LTR documents (215.9 mm).

3. Shading

This section explains the slide mechanism of the reading unit used to determine the shading correction value.

The CIS unit and its slide mechanism are mounted inside the reading unit. The CIS unit is positioned so that the background color should become black when the documents are read. Since the scanner needs to read a white reference data when determining the shading correction value, it shifts the CIS unit by about 5 mm. Figure 2-203 shows a sectional view of the reading

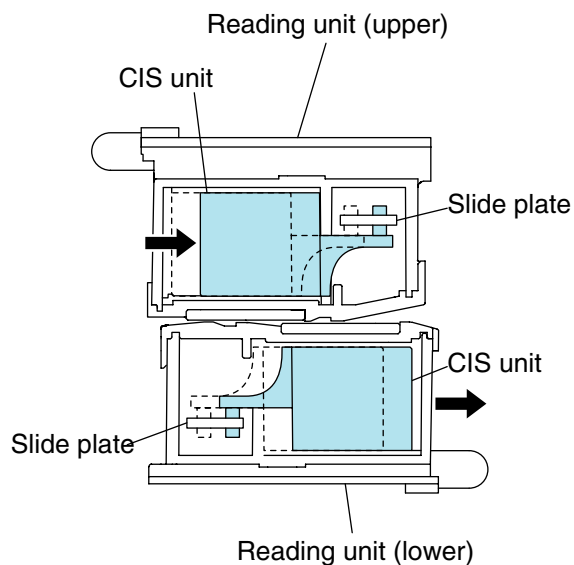

Figure 2-203

unit when the white reference is read and Figure 2-204 shows an enlarged view of the white reference area.

This machine does not use a conventional, white shading plate but instead has a white-printed area on the reading glass, which is covered with a protection sheet.

Therefore, the failures caused by the dirt and crack of the shading plate do not occur.

When the power is switched ON and when scanning starts, this machine slides the CIS unit and reads the white reference data to decide the shading correction value.

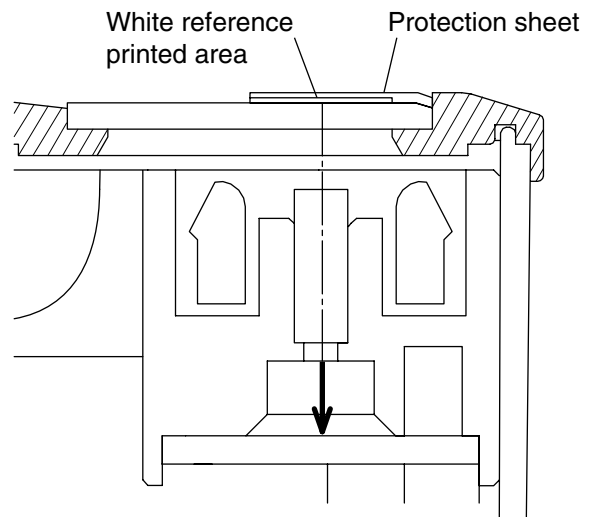

Figure 2-204

Figure 2-205 shows the slide plate part of the slide mechanism. The slide plate has 2 guide holes, in which the shafts from the CIS unit are inserted. When the slide plate moves vertically shown in the figure, the CIS unit shafts move along with the guide holes. This makes the CIS unit slide horizontally.

The section that drives the slide plate is shown in figure 2-206. The drive unit inserts the slide plate into the reading unit. The slide plate returns to its original position by a tension spring. Although the figure shows the reading unit (lower) only, the uniquely devised shape of the push plate allows the slide plates of both upper and lower reading units to move by one motor.

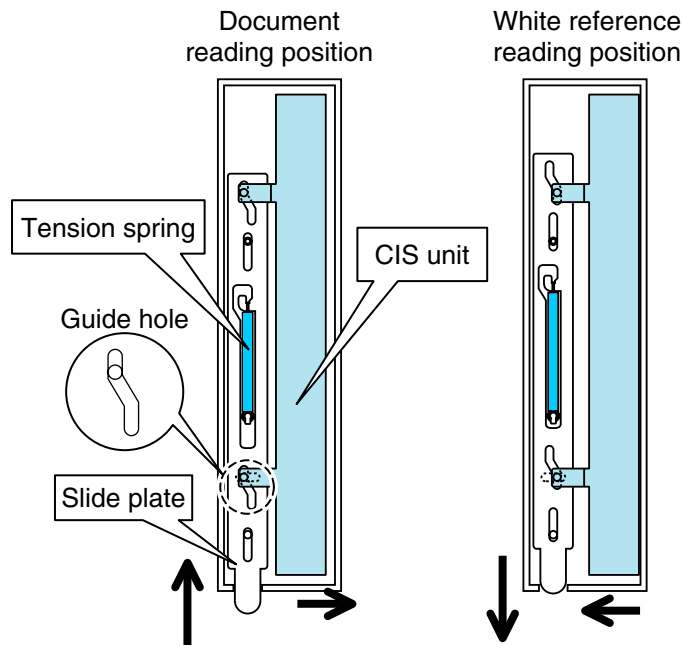

Figure 2-205

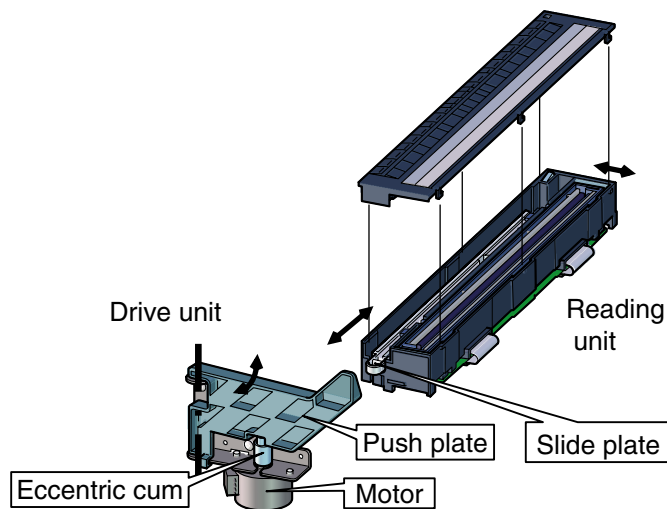

Figure 2-206

4. CIS Position Correction

The 3-line CIS is basically arranged at a pitch of 600 dpi (0.0423 mm) around R. (Figure 2-207)

Thus, RGB color shift can be prevented by correcting image data by considering the difference in the position of each line.

To correct position shift of 600dpi pitch, R data, G data before 2 lines and B data after 2 lines are joined to make one pixel data if R is used as reference.

$$L(n) \text{ data} = [R(n), G(n-2), B(n+2)]$$

This machine uses a reading PCB for rearrangement for this data.

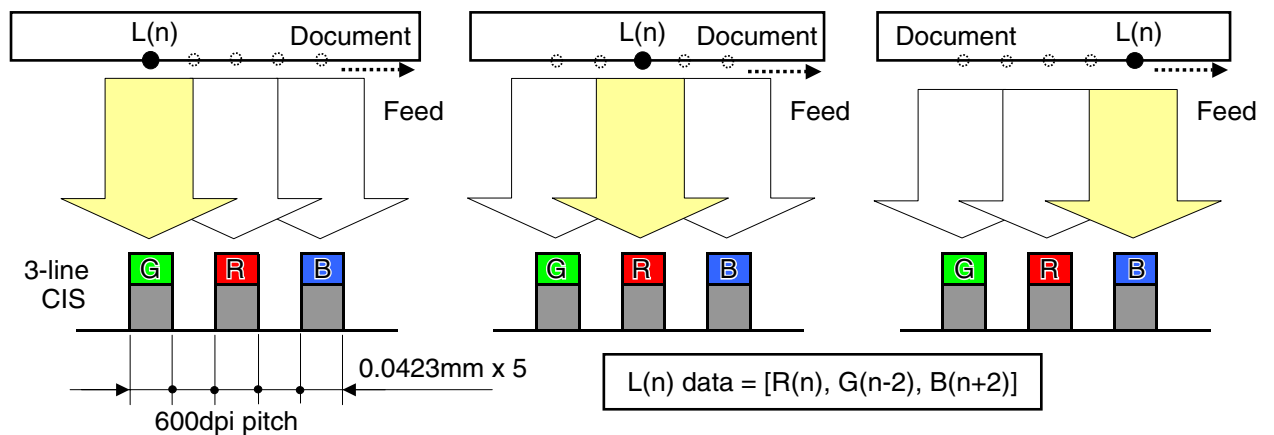

Figure 2-207

III. FEED SYSTEM

1. Outline

Figure 2-301 shows a sectional view of the feed system.

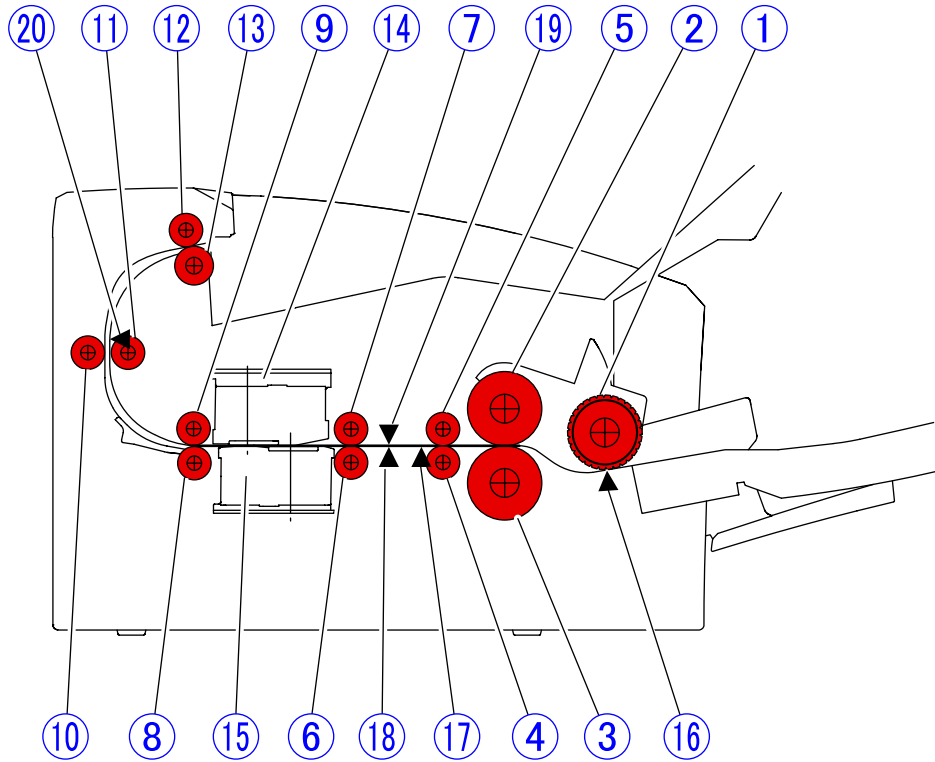

Figure 2-301

- | | |
|-----------------------------------|----------------------------------|
| ① Pickup roller | ⑪ U-turn feed roller (follower) |
| ② Feed roller | ⑫ U-turn eject roller (drive) |
| ③ Retard roller | ⑬ U-turn eject roller (follower) |
| ④ Registration roller (drive) | ⑭ Reading unit (upper) |
| ⑤ Registration roller (follower) | ⑮ Reading unit (lower) |
| ⑥ Reading roller front (drive) | ⑯ Document board sensor |
| ⑦ Reading roller front (follower) | ⑰ Registration sensor |
| ⑧ Reading roller rear (drive) | ⑱ Ultrasonic sensor (emitter) |
| ⑨ Reading roller rear (follower) | ⑲ Ultrasonic sensor (detector) |
| ⑩ U-turn feed roller (drive) | ⑳ Eject sensor |

2. Pickup Mechanism

This machine does not move the document board. Rather, it lowers the pickup roller and picks up the documents.

The surface from the document loading section to the separation section is designed as a slope, and documents are separated on the slope before they reach the separation section to prevent double feed.

The pickup section has a document stopper. This stopper limits the leading edge position of the documents when they are loaded, and the stopper lowers and starts the document pickup when a scan start instruction is given.

The main motor (M1) raises and lowers the stopper. The pickup roller goes up and down as the stopper is raised and lowered.

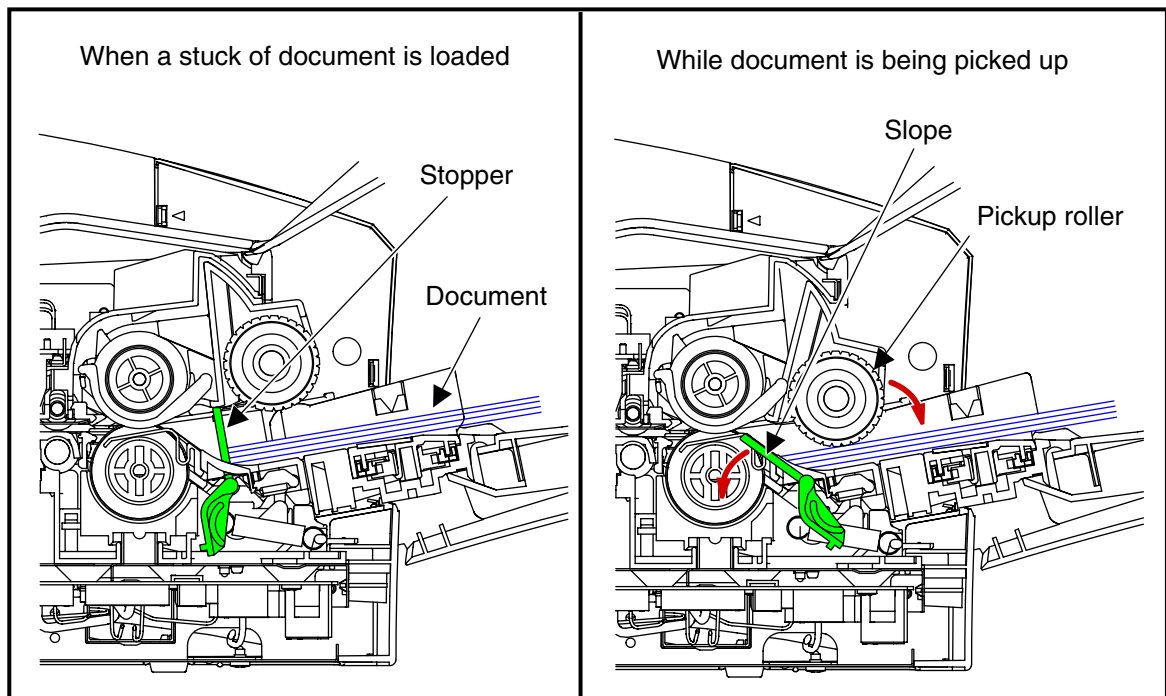

Figure 2-302

3. Separation Mechanism

Separation of this machine is performed by the retard roller.

Figure 2-303 shows the configuration of the separation mechanism.

Since the torque limiter is built in the retard roller, when the outside pressure on the roller exceeds the specified value into the feed direction, the roller begins to rotate in the same direction.

As shown in Figure 2-303-a, when overlapped documents enter into the clearance between the feed roller and the retard roller, the document in contact with the feed roller is fed in the feed direction, and the retard roller does not rotate so that the document in contact with the retard roller is not pushed in.

As shown in Figure 2-303-b, once a single document remains, the retard roller rotates in conjunction with the feed roller and the document to feed the document.

If non-separation is selected, the retard roller rotation becomes free and the separation function becomes invalid.

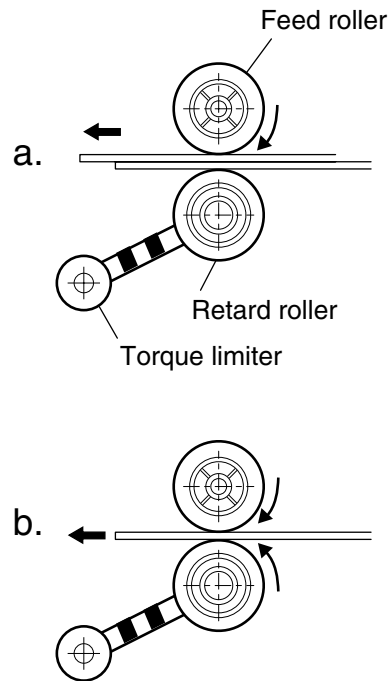

Figure 2-303

4. Straight Path

This machine has a straight path to feed the documents straightly and eject them to the opposite side of the document set, in addition to the U-shaped feed path (U-turn path).

The straight path is very useful when the thicker documents or cards are scanned. Thus, this machine is able to scan an international standard compliant card (vertical length: 53.9 mm, width: 85.5 mm, thickness: 0.76 mm) except for embossed cards.

If eject tray 2 on the rear side is opened, the internal flapper moves to close the U-turn path and open the straight path.

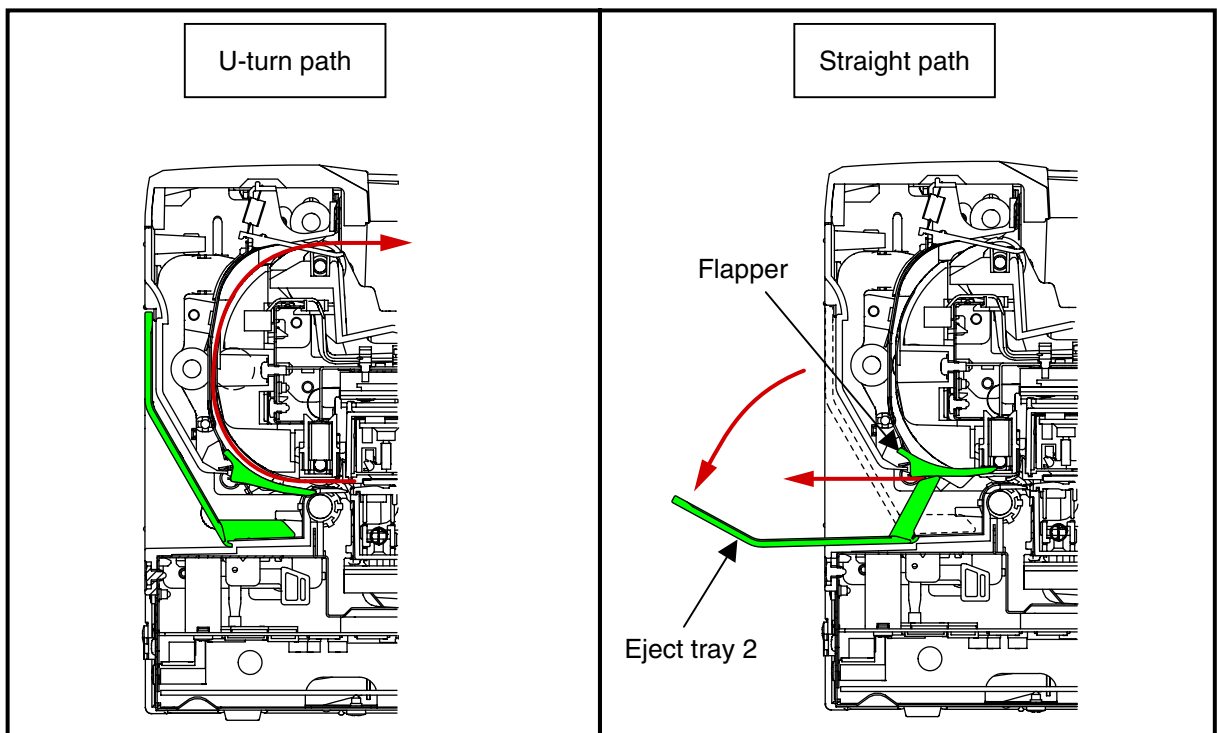

Figure 2-304

5. Feed Error Detection

1) Jam Detection

Document jams are detected by the registration sensor and the eject sensor. Note, however, that the eject sensor is ignored when the straight path is set.

a) Pickup Delay Jam (Pickup Error)

The leading edge of the document was not detected by the registration sensor within the specified time after the machine starts pickup.

b) Early Reach Jam

The leading edge of the following document was detected after the trailing edge of the document was detected by the registration sensor before the document has been fed for a specified length.

c) Residual Jam

The trailing edge of the document was not detected even though the document has been fed for the maximum specified length after the leading edge of the document was detected by the registration sensor.

d) Fast Feed Jam

The trailing edge of the document was detected after the leading edge of the document was detected by the registration sensor before the document has been fed for the minimum specified length.

e) Eject Delay Jam

The document was not detected by the eject sensor even though the document has been fed for the maximum specified length after the document was detected by the registration sensor.

f) Eject Residual Jam

The trailing edge of the document was

not detected even though the document has been fed for the document length detected by the registration sensor after the leading edge of the document was detected by the eject sensor.

g) Non-removal Jam

The next document pickup starts while the document is detected by the registration sensor or the eject sensor and still remains inside this machine.

2) Double Feed Detection

There are 2 document detection methods in this machine: the document length detection by the registration sensor and the document overlapping detection by the ultrasonic sensor.

The double feed detection by ultrasonic uses the ultrasonic drive sensor and the ultrasonic receive sensor.

The ultrasonic drive sensor transmits the ultrasonic and the ultrasonic receive sensor receives the ultrasonic signal to gain a specific signal level. When overlapping documents are fed, the signal level is different from when properly feeding a single document. This machine interprets this difference as a double feed.

Note: The double feed detection by ultrasonic may not work if the document overlapping width is 30 mm or less. Further, the machine does not execute the double feed detection for the area of 10 mm from the leading edge of the document.

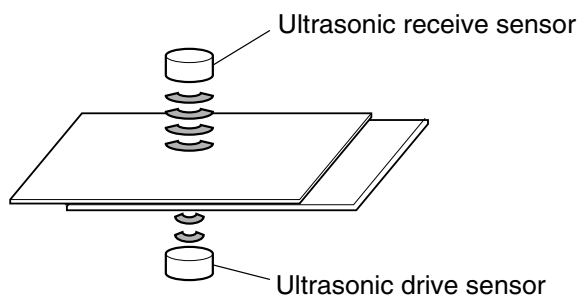

Figure 2-305

IV. CONTROL SYSTEM

1. Control PCB

Control of this machine is performed by the control PCB.

Figure 2-401 shows the block diagram of the control PCB, and Table 2-401 lists the main IC functions.

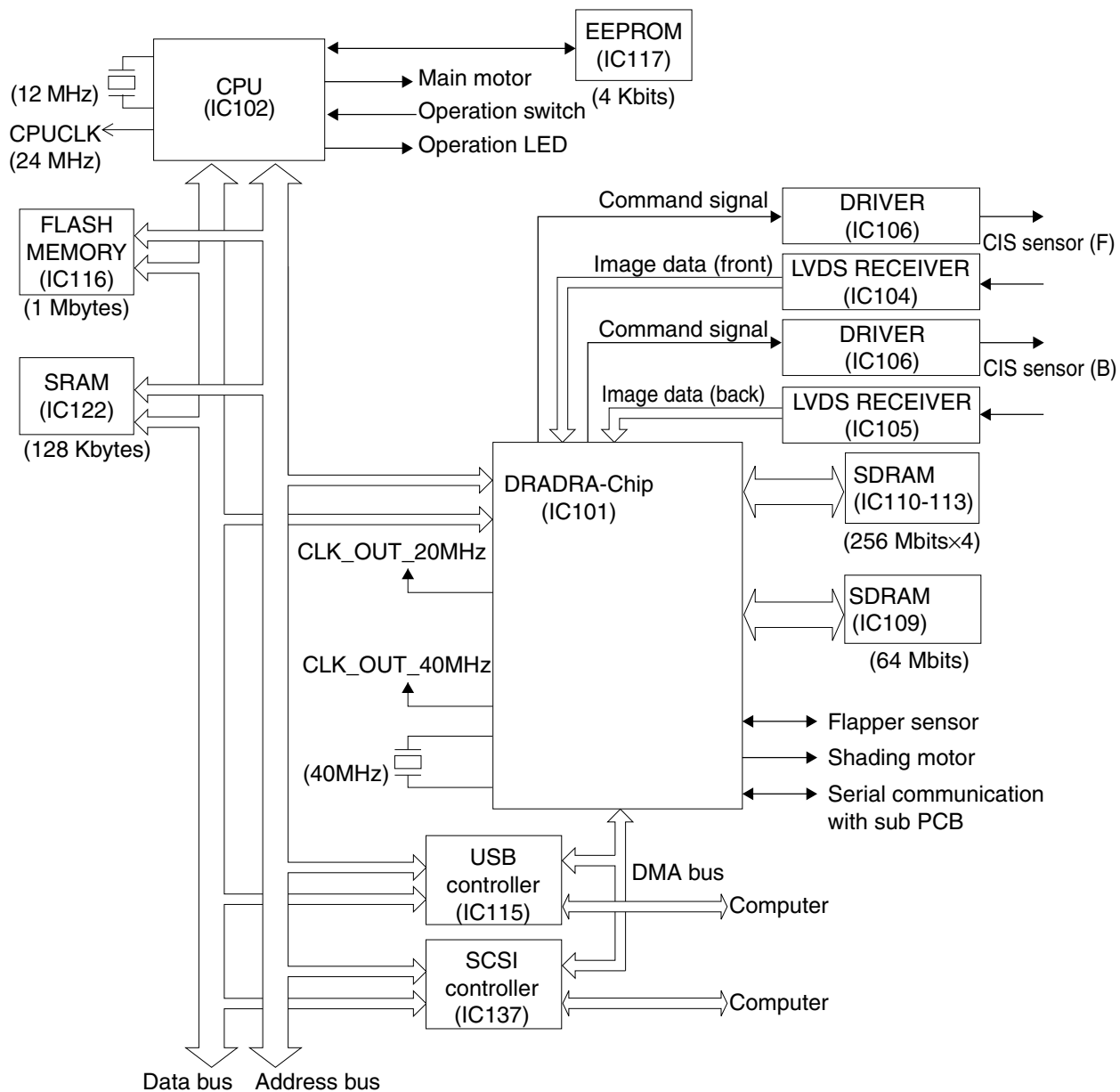

Figure 2-401

| No. | Name | Function |
|------------|-------------------------|---------------------------------------|
| IC101 | DRADRA-chip | Image processing |
| IC102 | CPU | Overall controls |
| IC104, 105 | LVDS receiver × 2 | Image data reception |
| IC106 | Driver | Command signal transmission |
| IC109 | SDRAM (64 Mbits) | JPEG module memory |
| IC110-113 | SDRAM (256 Mbits) × 4 | Image data storage (total 128 Mbytes) |
| IC115 | USB controller | USB control |
| IC116 | Flash memory (1 Mbytes) | Firmware and each parameter storage |
| IC117 | EEPROM (4 Kbits) | Each setting storage |
| IC122 | SRAM (128 Kbytes) | CPU work memory |
| IC137 | SCSI controller | SCSI control |

Table 2-401

2. Image Processing Control

Figure 2-402 shows the block diagram of the image processing in the main body.

The next section describes the principle of the image processing methods.

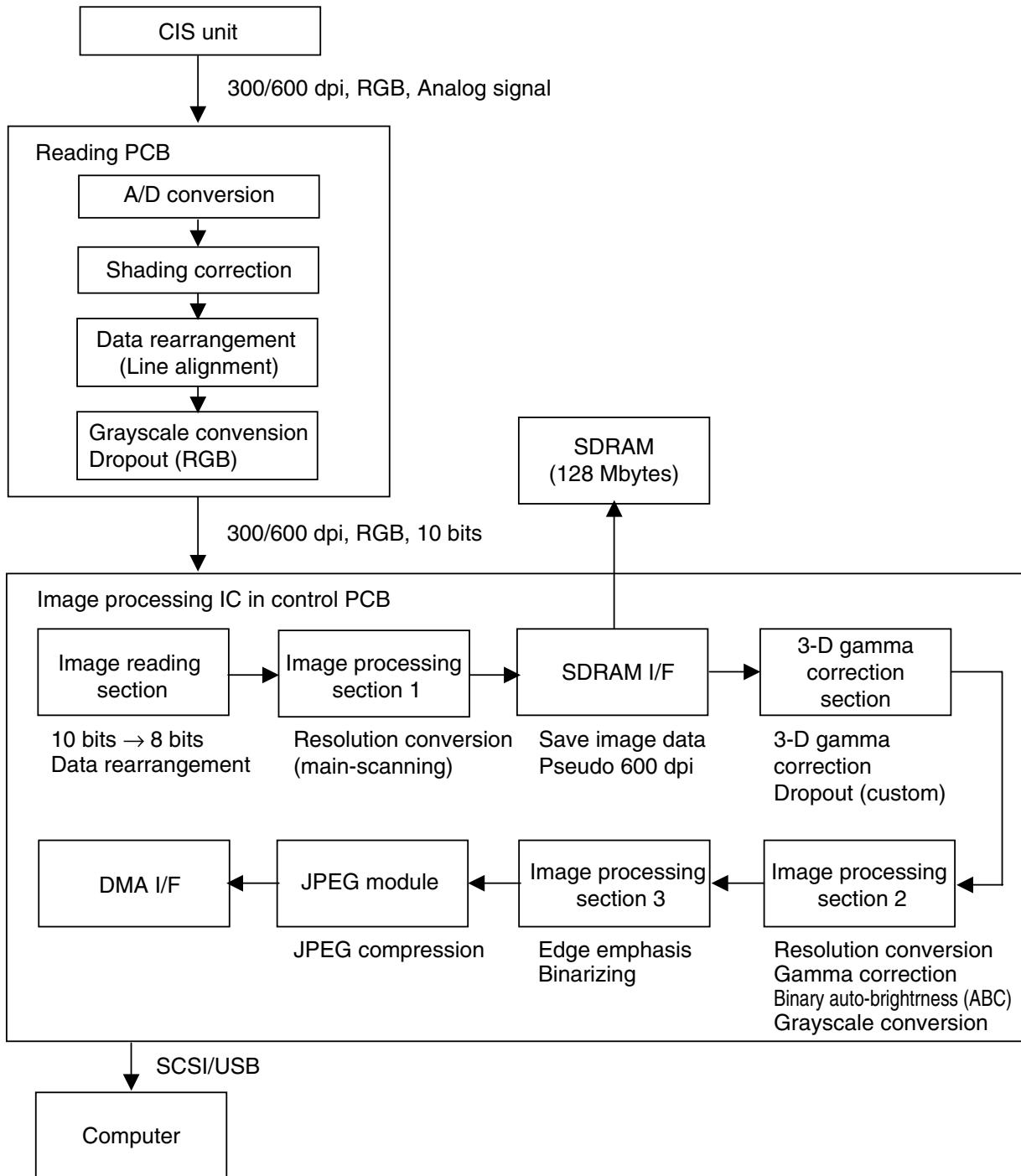

Figure 2-402

The RGB analog signals output from the CIS unit are input to the reading PCB.

After those signals are converted into the digital signals in the reading PCB, the dedicated image processing IC performs the shading correction and rearranges the order of the data to align 3 lines. The image data used at this time consist of 10bit digital signals.

According to the scanner settings, an optical resolution between 600 dpi and 300 dpi can be selected. In case that the resolution is set at 300 dpi or less, 300dpi data are output. The user selects either "Speed priority" or "Quality priority" for 400/600dpi. The machine processes the image by using the 300dpi data for "Speed priority" and the 600dpi data for "Quality priority."

The image data output from the reading PCB are input to the control PCB and processed by the dedicated image processing IC (DRADRA-chip).

Since the data are processed as 8 bits within the IC, they are converted from 10 bits to 8 bits at the image reading section. And, the image data is rearranged.

Image processing section 1 changes the resolution of the main-scanning direction in accordance with the scanner settings in order to convert the data into basic image data.

This machine is provided with the "MultiStream" function. Thus, the data can be converted into image data which meet 2 types of settings, simultaneously. The basic image data are stored in the SDRAM through the SDRAM interface. SDRAM is 128 Megabytes in capacity.

And then, the 3-D color space processing section performs the 3-D gamma correction to improve the quality of colors.

Image processing section 2 changes the resolution, performs the gamma correction (adjustment of brightness and contrast, and custom gamma correction), the binary auto-brightness adjustment (ABC), and the grayscale conversion.

Image processing section 3 handles the edge emphasis, binarizing (simple binarizing, error diffusion, and high-speed text enhancement).

In the JPEG module, the grayscale and color data can be compressed in JPEG format. When JPEG is selected, the image data size is reduced by compression within this machine so that it can be transferred to the computer in less time. As a result, more documents can be read in a given time.

Finally, processed image data are sent from the DMA I/F to the computer either through the SCSI or USB interface.

In case that the MultiStream is selected, the image data stored in the SDRAM are processed again in accordance with the secondary settings.

The other image processing (advanced text enhancement, auto-size detection, etc) are carried out inside the computer.

V. NEW IMAGE PROCESSING

1. Advanced Text Enhancement II

This scanner features a new, additional image processing method that differs from conventional text enhancement and is called “Advanced Text Enhancement II.” Using a different image processing method, Advanced Text Enhancement II achieves image processing results superior to conventional methods, including, for example, im-

proved character legibility for “documents with pale-colored characters and backgrounds”. However, the details of this image processing method cannot be disclosed.

The following figures show the mode-by-mode scanning results for 6 sample images having different backgrounds. The “Brightness” and the “Contrast” are set to their initial values.







| Original image (grayscale) Type of background | Advanced text enhancement | Advanced text enhancement II | High-speed text enhancement |
|--|--|---|--|
|  <p>Type A: White</p> |  |  |  |
|  <p>Type B: Deep gray (50%)</p> |  |  |  |
|  <p>Type C: Gray (25%)</p> |  |  |  |
|  <p>Type D: Mottle</p> |  |  |  |
|  <p>Type E: Characters</p> |  |  |  |
|  <p>Type F: Fine dots</p> |  |  |  |
| Remarks | In types B and C, the backgrounds disappear and the characters are easy to read. In type F, the deep background makes it difficult to read characters. | In types B, C and F, the backgrounds disappear and the characters are easy to read. In type E, the deep background makes it difficult to read characters. | In types B, C and F, the backgrounds disappear and the characters are easy to read. Though using a high speed, this mode may make black parts white. |

Figure 2-501

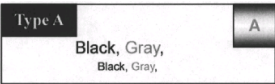
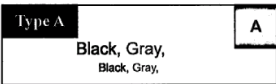
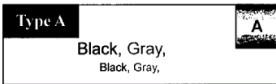
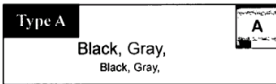
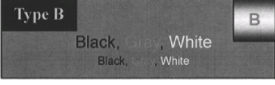
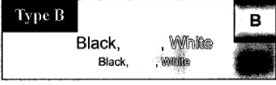
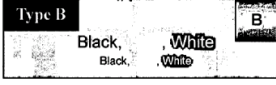
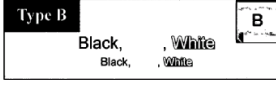
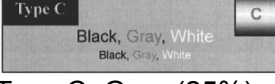
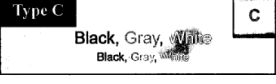
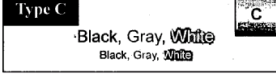
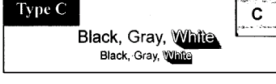
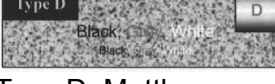



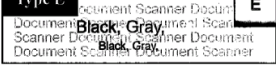

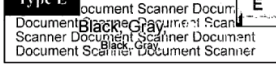
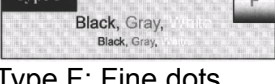
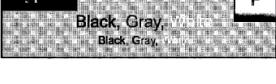
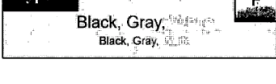
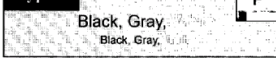
| Original image (grayscale) Type of background | Black and white | Black and white Auto brightness (ABC) | Error diffusion |
|--|--|--|--|
|  <p>Type A: White</p> |  |  |  |
|  <p>Type B: Deep gray (50%)</p> |  |  |  |
|  <p>Type C: Gray (25%)</p> |  |  |  |
|  <p>Type D: Mottle</p> |  |  |  |
|  <p>Type E: Characters</p> |  |  |  |
|  <p>Type F: Fine dots</p> |  |  |  |
| Remarks | Characters “Black” is impossible to read in types B and D and difficult to read in type C. | Characters in type C (gray) are easy to read. | This mode makes images similar to those in the grayscale mode but increases the file size. |

Figure 2-502

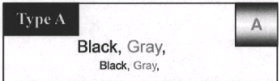
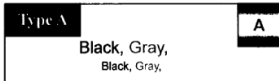
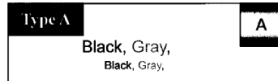
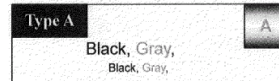
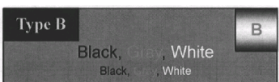
2. Prevent Bleed Through / Remove Background

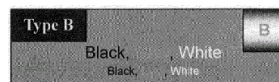
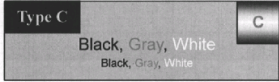
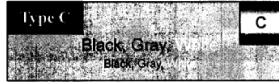
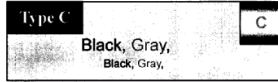
These image processing methods are used to prevent bleed-through, which results from scanning of a thin document and a document having a deeply colored backside, and to remove the background.

Different from the text enhancement modes that enhance the characters, these processing methods are based on a technique that judges faint-colored parts as

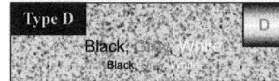
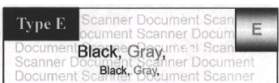
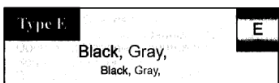
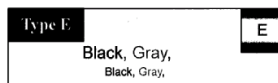
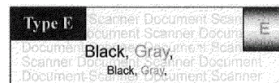
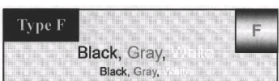
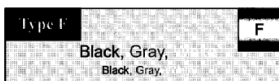
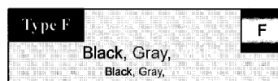
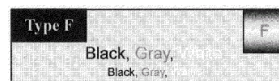
bleed-through and whitens them. However, the details of these image processing methods cannot be disclosed. These methods are effective in the color mode but cannot be used in conjunction with any of the text enhancement modes. Note, in addition, that these methods take relatively long times to process the images.

The following figure lists the scanning results of 3 sample images by the mode.

| Mode | Image 1 Bleed-through of characters | Image 2 Bleed-through of black area | Image 3 Gray background (15%) |
|---|---|--|---|
| Color (original image) | | | |
| Black and white | | | |
| Advanced text enhancement | | | |
| Advanced text enhancement II | | | |
| High-speed text enhancement | | | |
| Black and white + Prevent bleed through / Remove background | | | |
| Color + Prevent bleed through / Remove background | | | |
| Remarks | Effective in the bleed-through documents. Though other modes may bring good results for binary data, this processing is effective when color data are required. | | Effective in background removal of color documents as well. |

Figure 2-503

3. Auto Image Type Detection

When scanning a stack of documents consisting of color and monochrome documents, this image processing method automatically determines whether each document is color or monochrome and saves the data as either color data or binary data accordingly. This method can reduce the total file size compared with saving all the documents as color data.

When this mode is selected, the entire stack of documents is scanned in the color mode and the image data is sent to the computer. Then, the program in the computer judges whether each document is

color or monochrome. The user can adjust the color/monochrome discrimination conditions by changing the settings. The details of this image processing method cannot be disclosed.

When the program judges a document to be monochrome, one of the following binarizing methods can be selected; Black and White, Error Diffusion, Advanced Text Enhancement and Advanced Text Enhancement II.

Figure 2-504 shows the concept of this image processing method and Figure 2-505 shows the condition setting screen for the user.

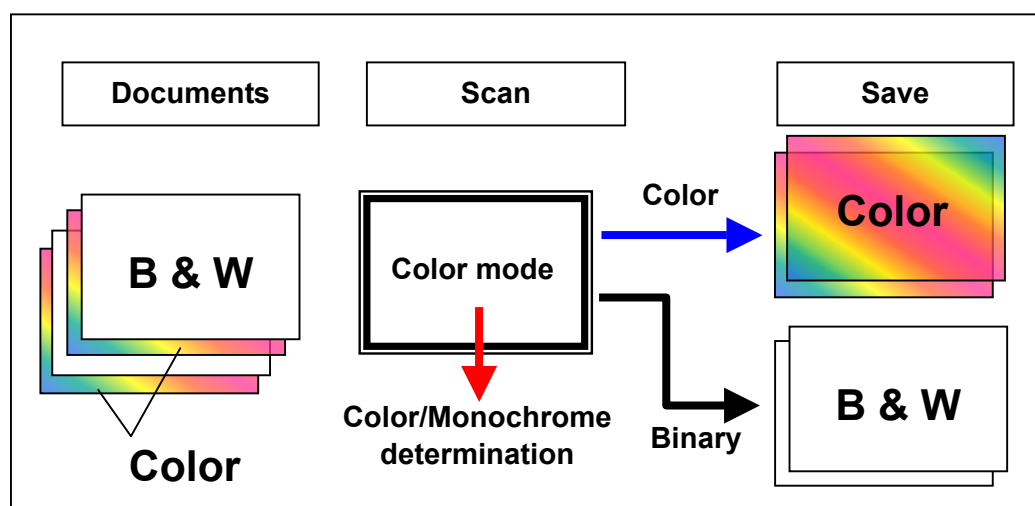

Figure 2-504

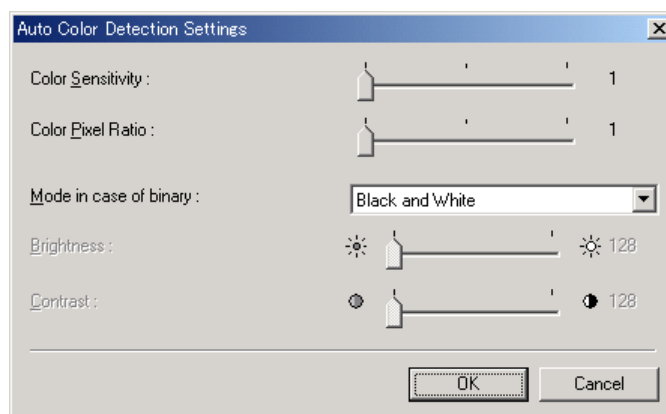

Figure 2-505

VI. POWER SUPPLY

1. Power Supply

The power supply PCBs of this machine use the dedicated parts for the 100V and 200V units. Figure 2-601 shows a block diagram of the power supply PCB.

AC power is supplied to the power supply PCB by turning ON the power switch.

The supplied AC power is converted by a rectifying bridge to unsmoothed UN100 to 240 V and converted to 24 VDC.

24 VDC is output from the power supply PCB to the control PCB. The necessary voltage are generated in the control PCB. Each PCB receives DC voltage from the control PCB.

Note:A suffix, "U," which is attached to voltage figures, means that those power supplies are turned OFF when the machine is placed in the sleep mode.

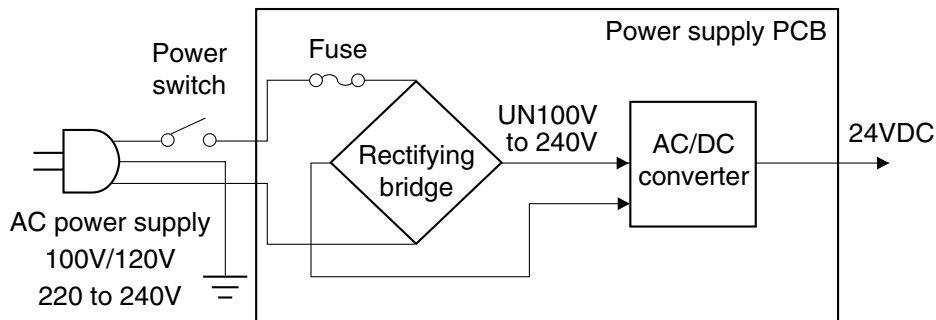

Figure 2-601

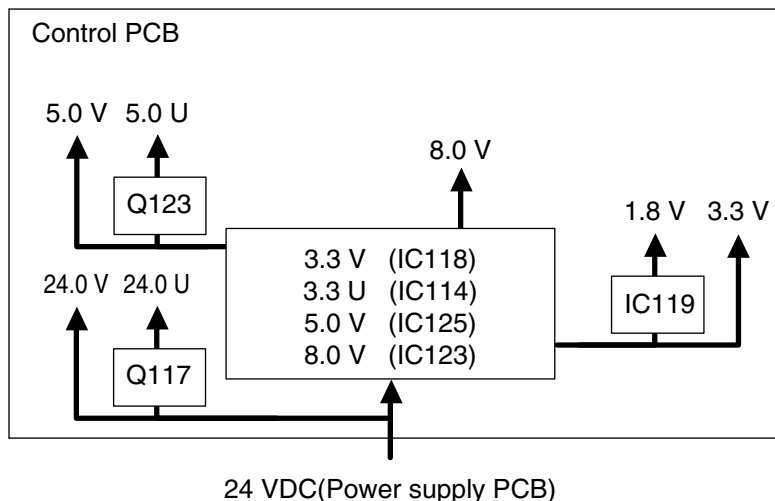

Figure 2-602

2. Protection Function

If the load is shorted and an excessive current flows, the protection function of the power supply PCB is activated and the output is stopped.

A fuse is used for protection on the power supply PCB and the control PCB. If an excessive current flows into the AC/DC converter, the fuse blows and stops the power supply to the PCB.

A fuse is also used for protection of the main motor. If an excessive current flows in the 24 V supplied to the motor, the fuse blows and stops the power supply to the motor.

If the upper unit is opened, the open sensor recognizes that it is opened, and the power to the main motor is cut.

3. Power Saving Mode

This machine will shift into the power saving mode if no button or no scan operation takes place for 10 seconds or more, when the power is ON or scanning ends. In the power saving mode, power consumption is minimized and the electrical circuits enter the sleep state. The CPU, however, does not shift into the sleep state.

The machine returns to the standby mode when any communication is carried out on the computer side or when any button on the operation panel is pressed.

This machine is compliant with the standards defined by International Energy Star Program.

VII. ELECTRICAL PARTS LAYOUT

1. Upper Unit

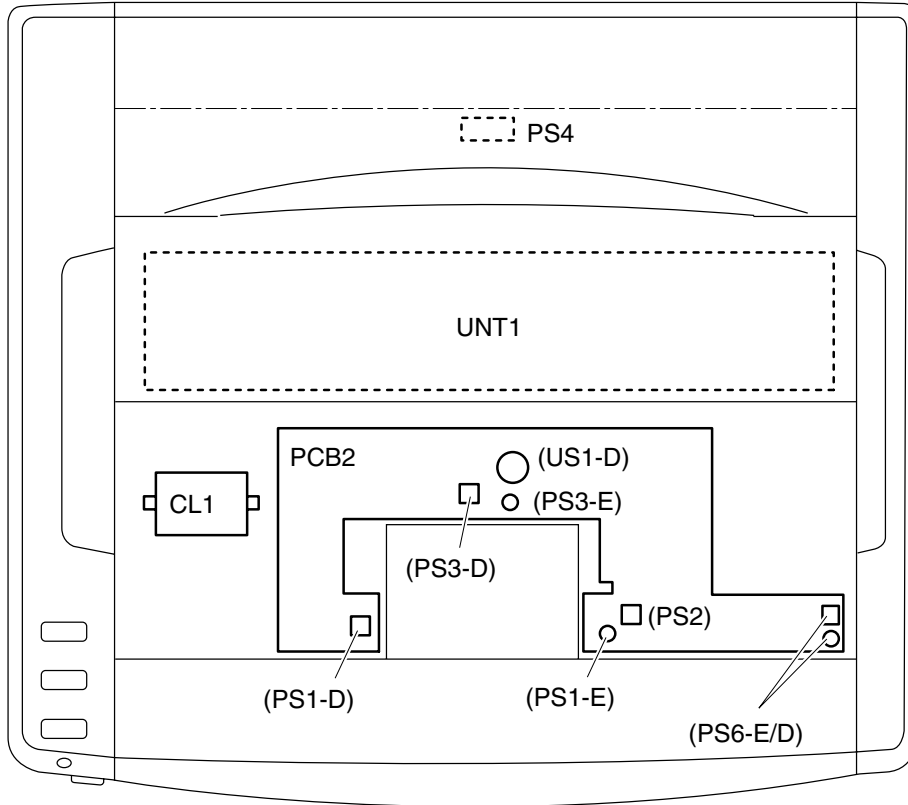

Figure 2-701

| Category | Name | Note | Symbol |
|----------|--|------|----------|
| Sensor | Document board sensor (Emitter/Detector) | Note | PS1-E/D |
| | Stopper sensor | Note | PS2 |
| | Registration sensor (Emitter/Detector) | Note | PS3- E/D |
| | Eject sensor | | PS4 |
| | Upper open sensor (Emitter/Detector) | Note | PS6- E/D |
| | Ultrasonic sensor (Detector) | Note | US1-D |
| Clutch | Feed clutch | | CL1 |
| PCB | Sub PCB | | PCB2 |
| Unit | Reading unit (upper) | | UNT1 |

Note:The document board/stopper/registration/upper open sensors and the ultrasonic sensor (Detector) are mounted on the sub PCB.

Table 2-701

2. Lower Unit

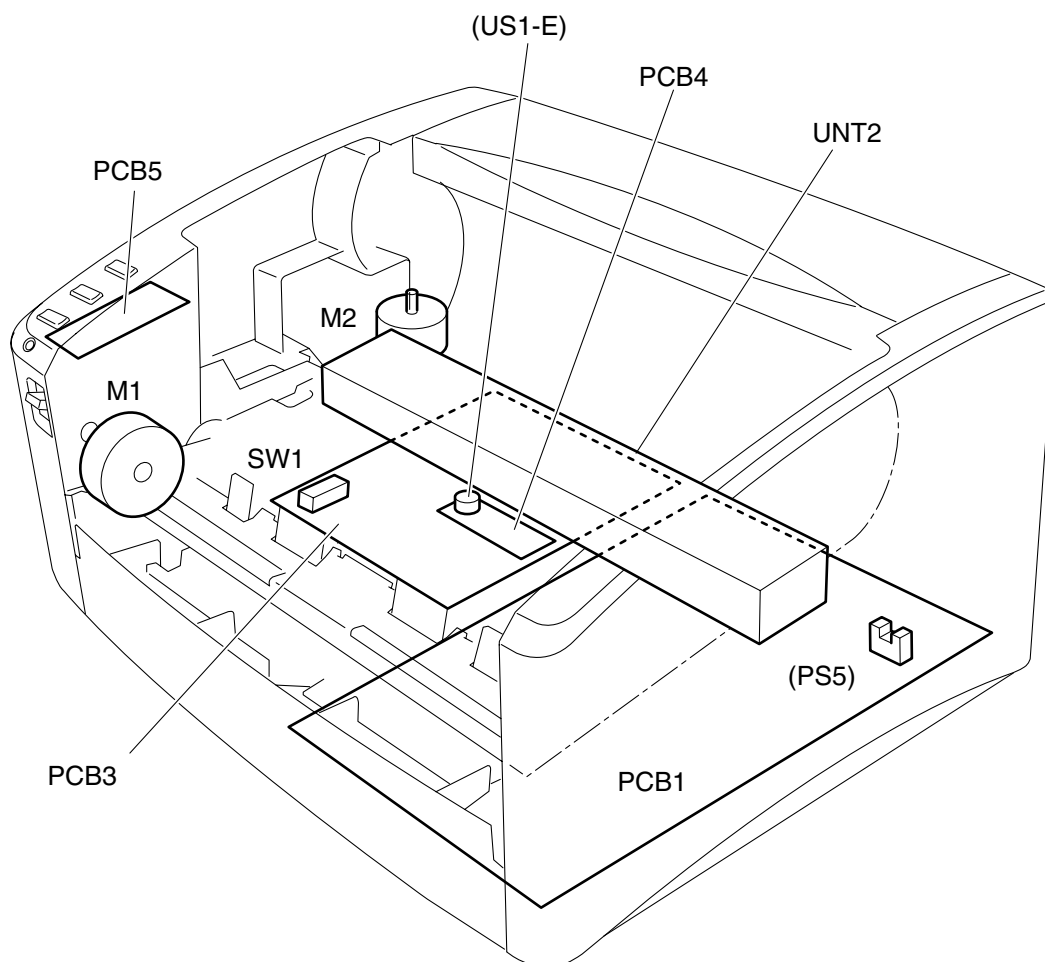

Figure 2-702

| Category | Name | Symbol |
|----------|-----------------------------|------------|
| Sensor | Flapper sensor | PS5 |
| | Ultrasonic sensor (Emitter) | Note US1-E |
| Motor | Main motor | M1 |
| | Shading motor | M2 |
| Switch | Power supply switch | SW1 |
| PCB | Control PCB | PCB1 |
| | Power supply PCB | PCB3 |
| | Ultrasonic sensor PCB | PCB4 |
| | Operation PCB | PCB5 |
| Unit | Reading unit (lower) | UNT2 |

Note: The ultrasonic sensor (Emitter) is mounted on the ultrasonic sensor PCB.

Table 2-702

VIII. PARTS LAYOUT ON EACH PCB

1. Control PCB

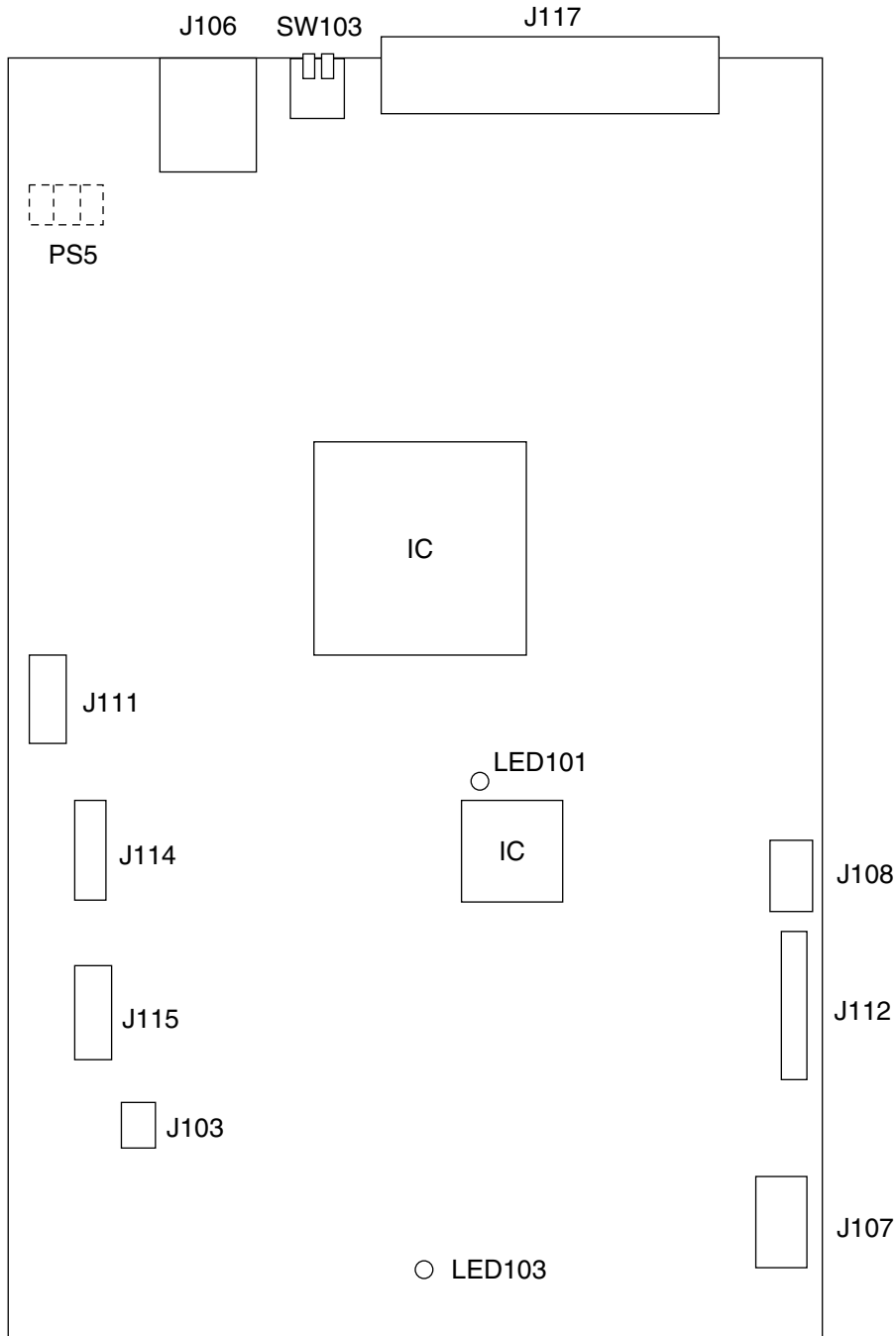

Figure 2-801

| Connector | | Description |
|-----------|-----|---------------------------|
| J103 | 3P | Ultrasonic sensor PCB |
| J106 | 4P | USB I/F |
| J107 | 4P | Power supply PCB |
| J108 | 5P | Shading motor |
| J112 | 16P | Main motor, operation PCB |
| J114 | 30P | Reading unit (upper) |
| J115 | 30P | Reading unit (lower) |
| J117 | 50P | SCSI I/F |

Table 2-801

| LED | Description |
|--------|-----------------------------------|
| LED101 | CPU normal operation: Flashing |
| LED103 | +24VDC supply: Lit |

Table 2-803

| Sensor | Description |
|--------|----------------|
| PS5 | Flapper sensor |

Table 2-804

| Switch | Description | | | | | | | | | | | | | | | |
|--------|--|-----|---|---|-----|-----|-----|-----|-----|----|-----|----|-----|-----|----|----|
| SW103 | <p>SCSI ID settings</p> <table border="1"> <tr> <td></td> <td>2</td> <td>1</td> </tr> <tr> <td>ID2</td> <td>OFF</td> <td>OFF</td> </tr> <tr> <td>ID3</td> <td>OFF</td> <td>ON</td> </tr> <tr> <td>ID4</td> <td>ON</td> <td>OFF</td> </tr> <tr> <td>ID5</td> <td>ON</td> <td>ON</td> </tr> </table> <p>Setting at shipping: ID2</p>  | | 2 | 1 | ID2 | OFF | OFF | ID3 | OFF | ON | ID4 | ON | OFF | ID5 | ON | ON |
| | 2 | 1 | | | | | | | | | | | | | | |
| ID2 | OFF | OFF | | | | | | | | | | | | | | |
| ID3 | OFF | ON | | | | | | | | | | | | | | |
| ID4 | ON | OFF | | | | | | | | | | | | | | |
| ID5 | ON | ON | | | | | | | | | | | | | | |

Table 2-802

2. Sub PCB

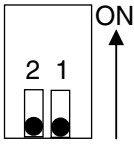
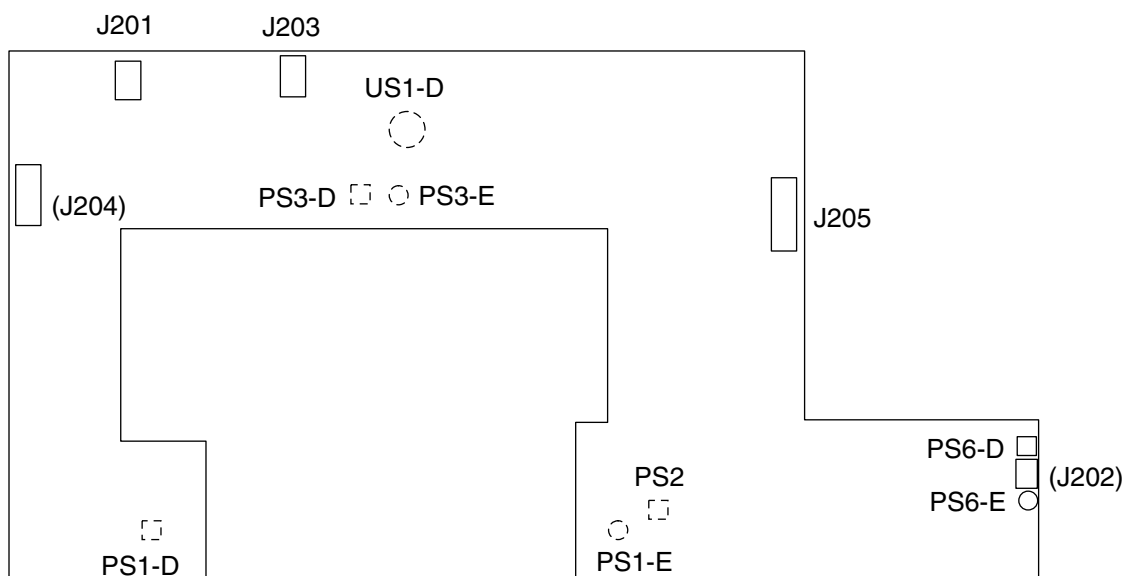

Figure 2-802

| Connector | | Description |
|-----------|----|----------------------|
| J201 | 2P | Feed clutch |
| (J202) | -- | (no connection) |
| J203 | 3P | Eject sensor |
| (J204) | -- | (for factory/design) |
| J205 | 7P | Control PCB |

Table 2-805

| Switch | Description |
|----------|--|
| PS-E/D | Document board sensor (Emitter/Detector) |
| PS2 | Stopper sensor |
| PS3- E/D | Registration sensor (Emitter/Detector) |
| PS6- E/D | Upper open sensor (Emitter/Detector) |
| US1-D | Ultrasonic sensor (Detector) |

Table 2-806

3. Power Supply PCB

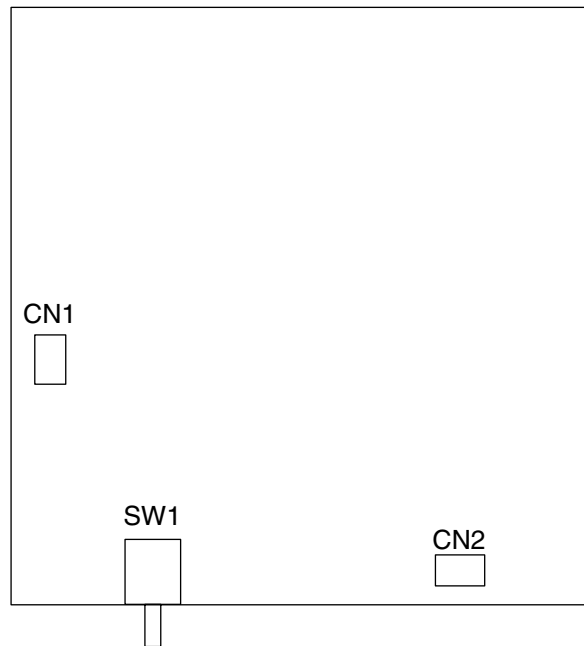

Figure 2-803

| Connector | | Description |
|-----------|----|---------------------------|
| CN1 | 2P | AC power supply input |
| CN2 | 4P | 24VDC power supply output |

Table 2-807

| Switch | Description |
|--------|---------------------|
| SW1 | Power supply ON/OFF |

Table 2-808

CHAPTER 3

DISASSEMBLY & REASSEMBLY

| | | | |
|--|-----|---|------|
| I. OUTLINE FLOWCHART | 3-1 | IV. DRIVE SYSTEM (MOTOR, ETC.)..... | 3-17 |
| II. EXTERNAL COVERS | 3-2 | V. READING SYSTEM | 3-23 |
| III. FEED SYSTEM (ROLLERS, ETC.) | 3-9 | VI. ELECTRICAL SYSTEM (PCB, ETC.) | 3-27 |

I. OUTLINE FLOWCHART

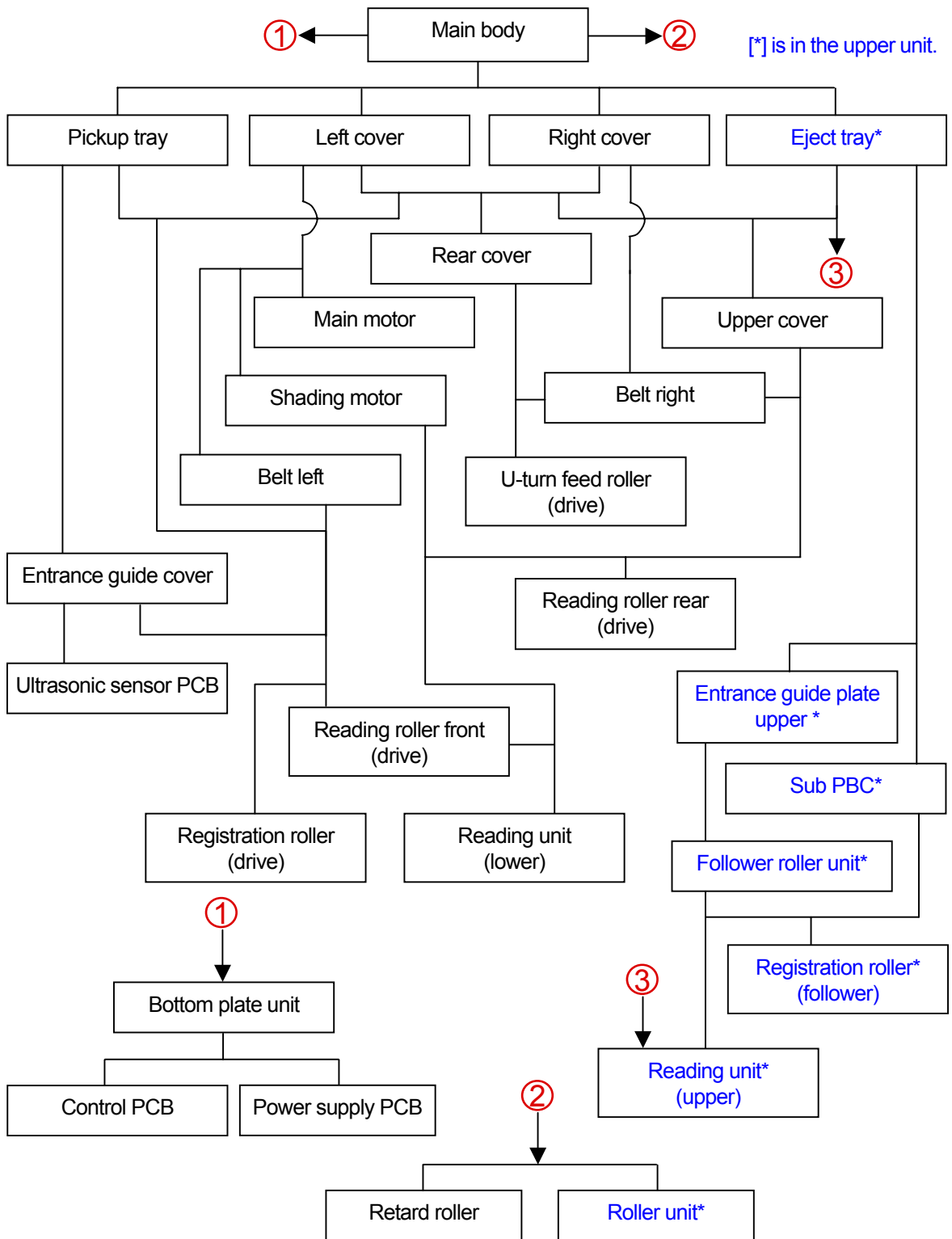

Figure 3-101

II. EXTERNAL COVERS

1. Pickup Tray

- 1) Open the pickup tray, then fully open the upper unit.
- 2) Bend the arms ① on both sides, unhook the fitting parts and upright the pickup tray ②.

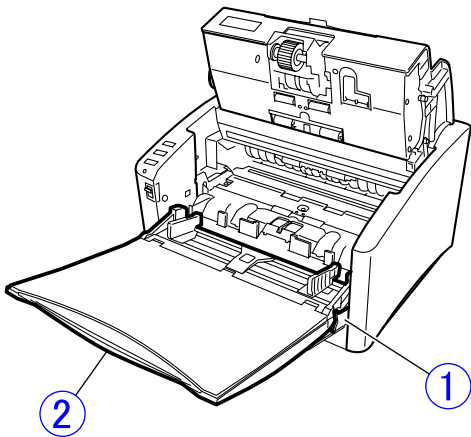

Figure 3-201

- 3) Pull the pickup tray ① upward and remove it.
The fitting parts can be removed when the pickup tray is fully closed.

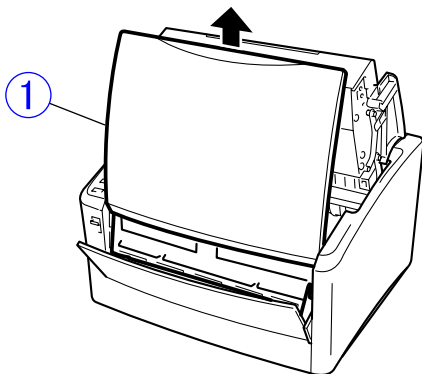

Figure 3-202

◆ Notes on assembling

Upright the pickup tray, hook the fitting parts ① on the right and the left, then open the pickup tray.

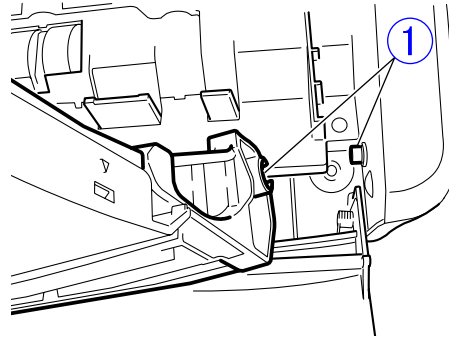

Figure 3-203

Note: Removing the pickup tray makes it easier to disassemble parts from this machine. The pickup tray may be removed even if the procedures do not indicate it.

2. Document Guides/Pickup Cover

1) Remove the pickup tray.

[\(Page 3-2\)](#)

2) Insert the tools in the openings ① and while unhooking the fitting parts, remove the document guides ②.

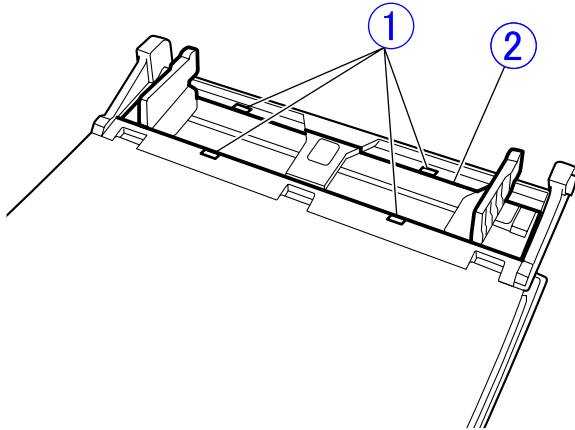

Figure 3-204

3) Insert the tools in the openings ① (2×2 places) on the right and the left, and while unhooking the fitting parts, remove the inner pickup cover ②.

Note: If it is difficult to remove the cover, additionally insert the tools in 2 openings ③ on the top to unhook the fitting parts.

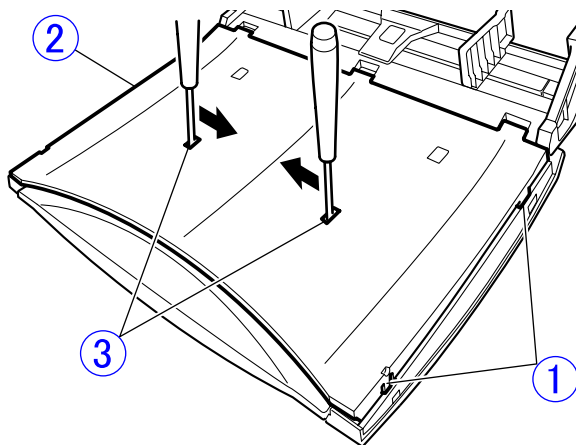

Figure 3-205

4) Remove the pickup tray extension ①. Slide the pickup cover ②, unhook the fitting parts ③ to remove the pickup cover.

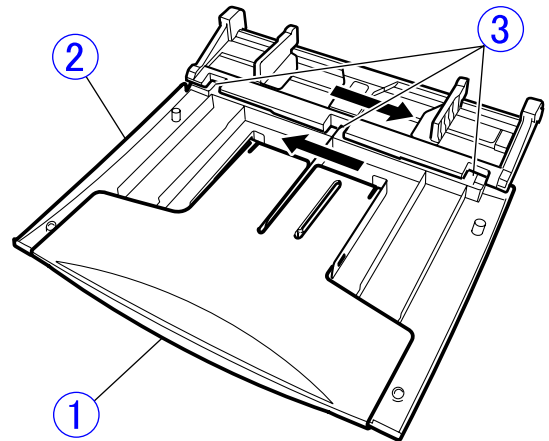

Figure 3-206

3. Left Cover

- 1) Remove the screw ① from the rear side, insert a tool in the opening ②, then remove the rear end of left cover ③ a little from the main body.

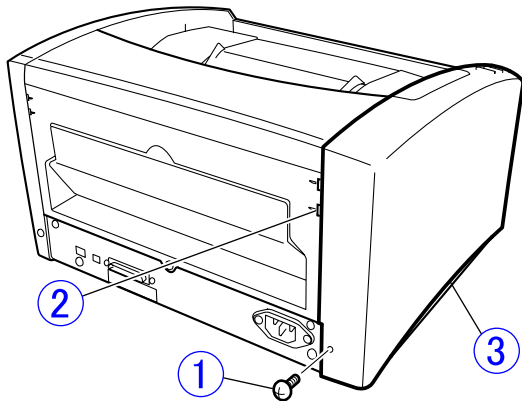

Figure 3-207

- 2) Insert a tool in the opening ①. While moving the tool in the direction indicated by the arrow to unhook the fitting parts inside, remove the front end of the left cover ② a little from the main body. Then remove the left cover entirely from the main body.

Note: Do not pull the left cover too much because the cables are connected.

There is a pair of fitting parts on the bottom. If this makes it difficult to remove the left cover, slide it downward when removing.

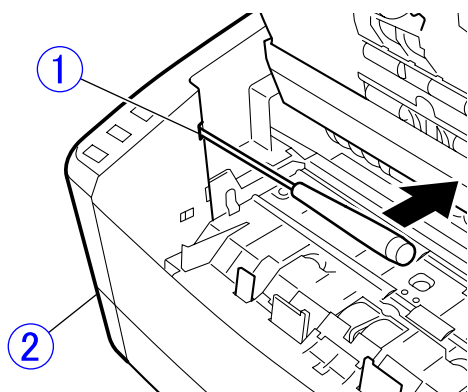

Figure 3-208

- 3) Remove the connector ①.

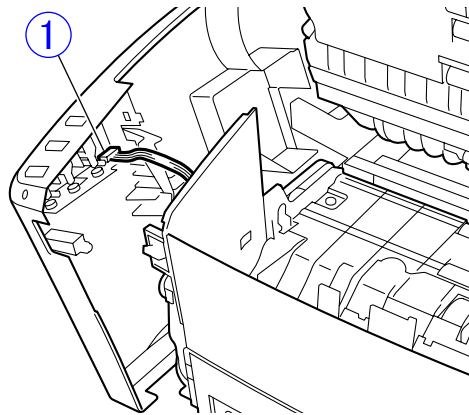

Figure 3-209

◆ Notes on assembling

When assembling, insert the bottom of the left cover in the bottom of the side panel first.

Do not allow parts to catch the cables.

4. Job Buttons/Light Guide

- 1) Remove the left cover.
(Page 3-4)
- 2) While unhooking the hook ①, pull out the operation PCB ②. Then remove the button parts (3 places) of the job buttons ③ from the holes of the left cover to remove them. In addition, press the light guide ④ from inside to outside to remove it.

Note: Do not damage the light guide.

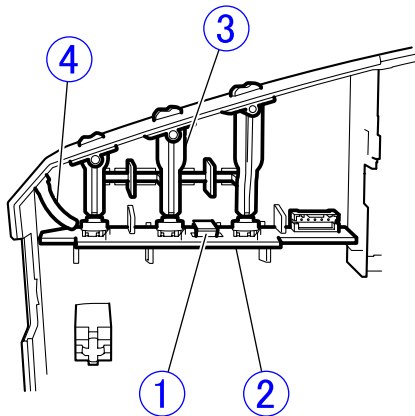

Figure 3-210

5. Right Cover

- 1) Remove the screw ① from the rear side, insert a tool in the opening ②, then remove the rear end of the right cover ③ a little from the main body.

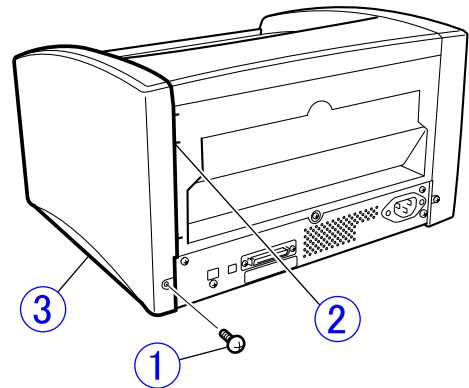

Figure 3-211

- 2) Insert a tool in the opening ①. While moving the tool in the direction indicated by the arrow to unhook the fitting parts inside, remove the front end of the right cover ② a little from the main body. Then remove the right cover entirely from the main body.

Note: There is a pair of fitting parts on the bottom. If this makes it difficult to remove the right cover, slide it downward when removing.

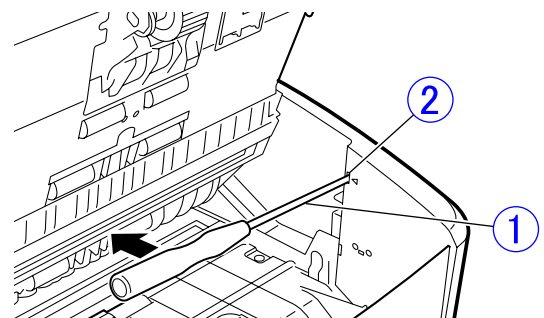

Figure 3-212

◆ Notes on assembling

When assembling, insert the bottom of the right cover in the bottom of the side panel first.

6. Front Cover

- 1) Remove the pickup tray.
(Page 3-2)
- 2) Remove the right cover.
(Page 3-5)
- 3) Remove the left cover.
(Page 3-4)
- 4) Unhook the hooks ① on the right and the left and remove the front cover ②.

Note: There is a hook inside in the center. If this makes it difficult to remove the front cover, unhook it, too.

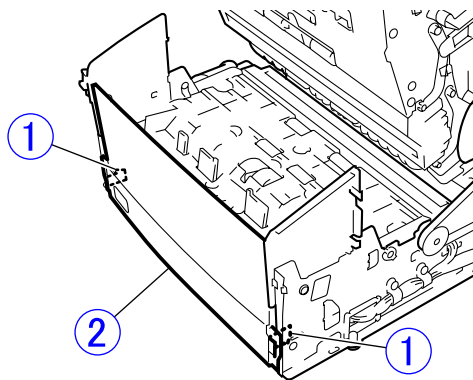

Figure 3-213

7. Eject Tray

- 1) Unhook hooks on the right and left ① (2×2 places), keep the upper unit open a little and draw the eject tray ② to the front to remove it.

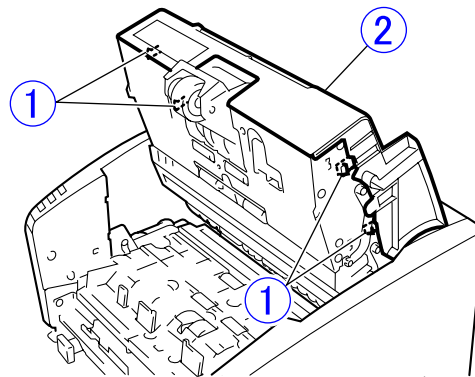

Figure 3-214

◆ Notes on assembling

When mounting the eject tray on the upper unit, place the arms ① on the right and the left, which support the reading unit, inside the eject tray guides ②.

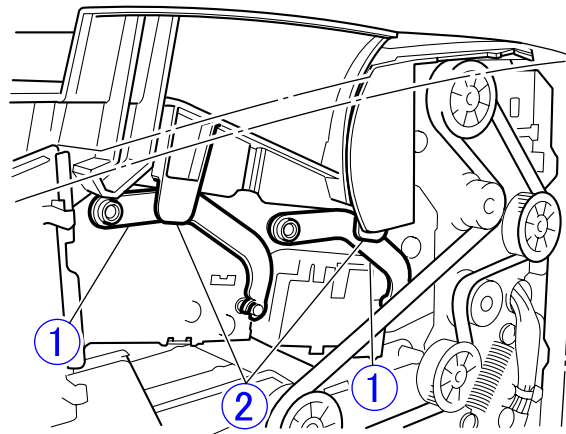

Figure 3-215

8. Upper Cover

- 1) Remove the right cover.
([Page 3-5](#))
- 2) Remove the left cover.
([Page 3-4](#))
- 3) Remove the eject tray.
([Page 3-6](#))
- 4) Remove the upper cover ①.

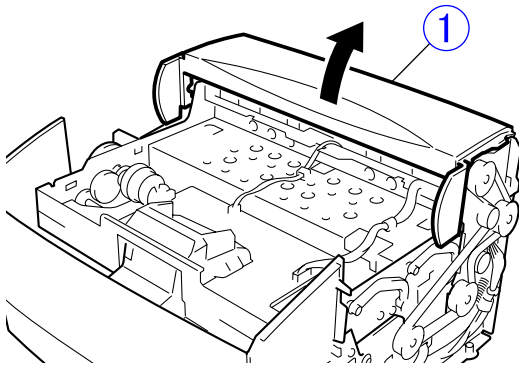

Figure 3-216

9. Rear Cover

- 1) Remove the right cover.
([Page 3-5](#))
- 2) Remove the left cover.
([Page 3-4](#))
- 3) Remove the screw ① and fully open eject tray 2 ②. While lifting the upper cover ③ a little, unhook the hooks ④ on the right and the left and remove the rear cover ⑤.

Note: Be sure to fully open eject tray 2. Otherwise the flapper may be damaged.

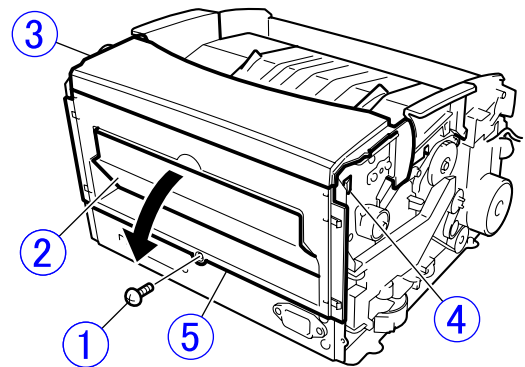

Figure 3-217

◆ Notes on assembling

Keep eject tray 2 closed when assembled. If it is open, the flapper lever on it may be damaged.

10. Entrance Guide Cover

- 1) Remove the pickup tray.
([Page 3-2](#))
- 2) Remove 4 shoulder screws ①, align the stoppers ② with their holes, then remove the entrance guide cover ③.

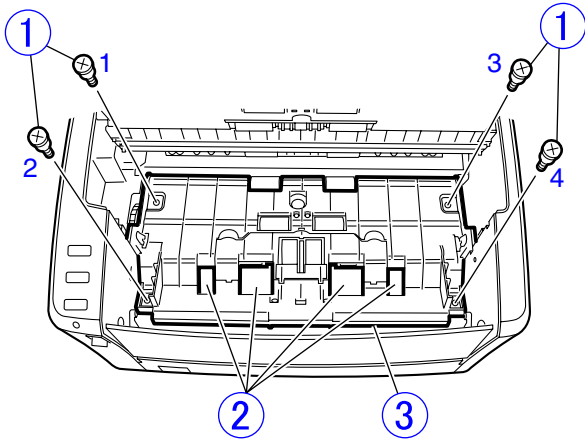

Figure 3-218

◆ Notes on assembling

Tighten the shoulder screws in the order of 1, 2, 3 and 4 as shown in the above figure. Tighten the left-side screws (oval holes) first to prevent bending.

11. Entrance Guide Plate Upper

- 1) Remove the roller unit.
- 2) Remove the eject tray.
([Page 3-6](#))
- 3) Remove 4 screws ① from the right and the left, unhook 2 pairs of fitting parts ②, then remove the entrance guide plate upper ③.

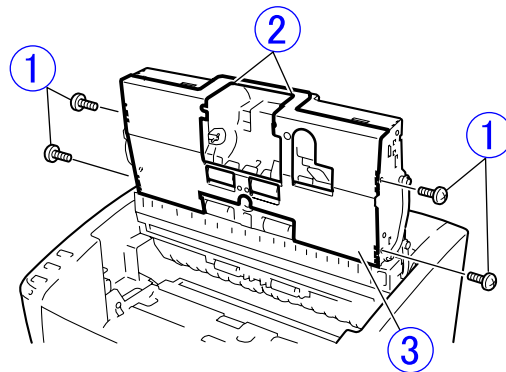

Figure 3-219

III. FEED SYSTEM (ROLLERS, ETC.)

1. Roller Unit

Refer to the "User Manual" or "Chapter 4, I-4. Attaching the Roller Unit."

[\(Page 4-3\)](#)

2. Retard Roller

Refer to the "User Manual" or "Chapter 4, I-5. Attaching the Retard Roller."

[\(Page 4-4\)](#)

3. Registration Roller (Drive)

- 1) Remove the pickup tray.
[\(Page 3-2\)](#)
- 2) Remove the right cover.
[\(Page 3-5\)](#)
- 3) Remove the left cover.
[\(Page 3-4\)](#)
- 4) Remove the entrance guide cover.
[\(Page 3-8\)](#)
- 5) Remove the belt left.
[\(Page 3-19\)](#)
- 6) Unhook 2 hooks of the left side gear ① and remove the gear. The internal pin is also removed at this time.

Note: Do not lose the pin.

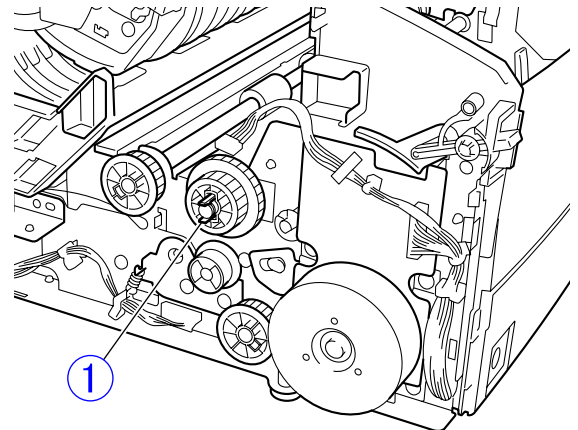

Figure 3-301

- 7) Remove the stopper ① from the right side. Remove the bearings ② from the right and the left and remove the registration roller ③.

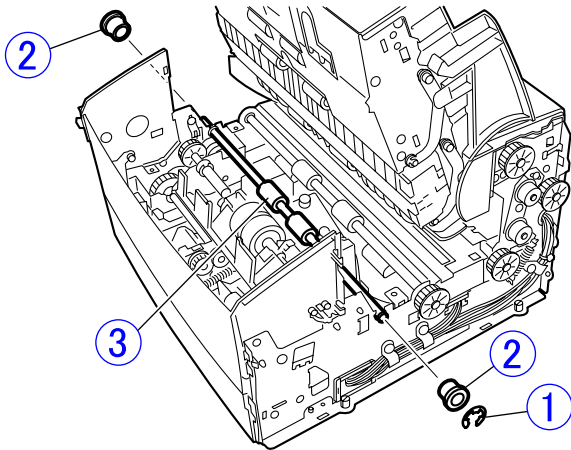

Figure 3-302

4. Reading Roller Front (Drive)

- 1) Referring to procedures 1 to 5 of "Registration Roller (Drive)," remove the belt left. [\(Page 3-9\)](#)
- 2) Remove the belt right. [\(Page 3-19\)](#)
- 3) Unhook the hooks on the right and left sides of the gear ① and remove the gear. The internal pin is also removed at this time.

Note: Do not lose the pin.

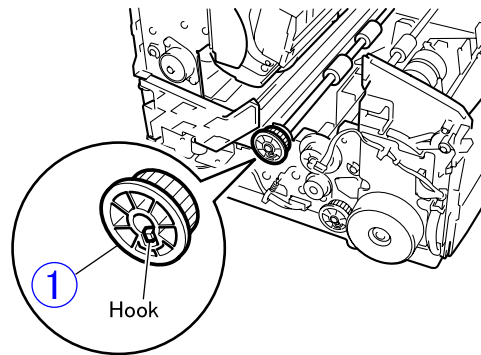

Figure 3-303

- 4) Remove the stopper ① from the left side. Remove the bearings ② from the right and the left and remove the reading roller front ③.

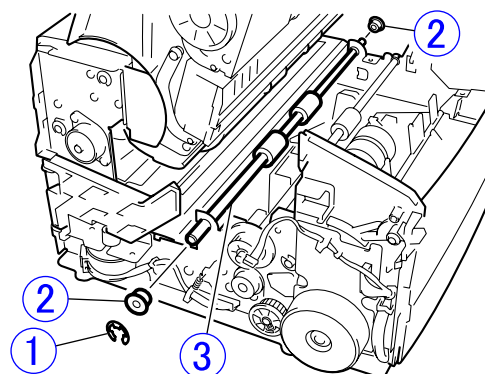

Figure 3-304

5. Reading Roller Rear (Drive)

- 1) Remove the right cover.
(Page 3-5)
- 2) Remove the left cover.
(Page 3-4)
- 3) Remove the rear cover.
(Page 3-7)
- 4) Remove the shading motor unit.
(Page 3-17)
- 5) Remove the belt right.
(Page 3-19)
- 6) Unhook the hook of the gear ① on the right side and remove the gear. The internal pin is also removed at this time. Remove the stopper ② from the left side. Remove the bearings ③ from the right and the left and remove the reading roller rear ④.

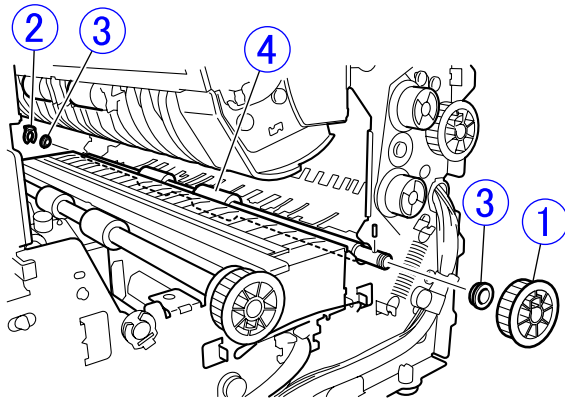

Figure 3-305

6. Registration Roller (Follower)

- 1) Remove the roller unit.
(Page 3-6)
- 2) Remove the eject tray.
(Page 3-29)
- 3) Remove the entrance guide plate upper.
(Page 3-8)
- 4) Remove the follower roller unit front.
(Page 3-13)

Note: The registration roller (follower) can be disassembled without removing the follower roller unit front, but it is necessary to remove it when assembling the registration roller (follower).

- 6) Remove 2 screws ① (black).

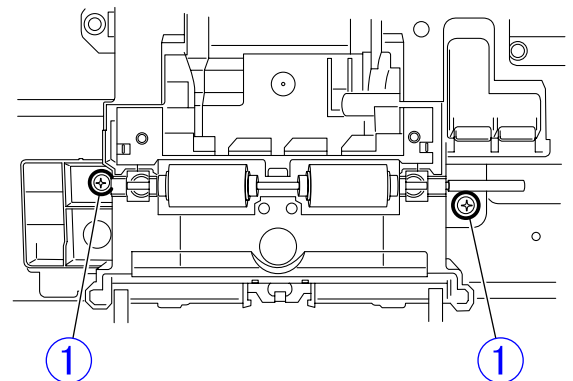

Figure 3-306

- 7) Unhook 2 hooks ①. While unhooking 2 pairs of the fitting parts ② and removing the feed clutch rotation stopper, remove the roller unit holder ③.

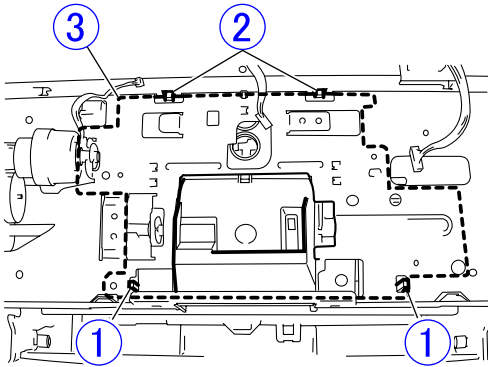

Figure 3-307

- 8) Unhook the hooks ① (2x2 parts) and remove 2 coil springs ②.

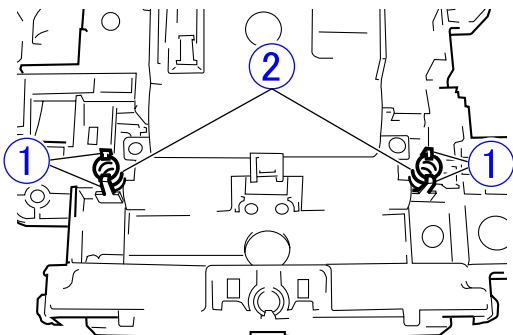

Figure 3-308

- 9) Remove the roller shaft ① and remove 2 registration rollers (follower) ②.

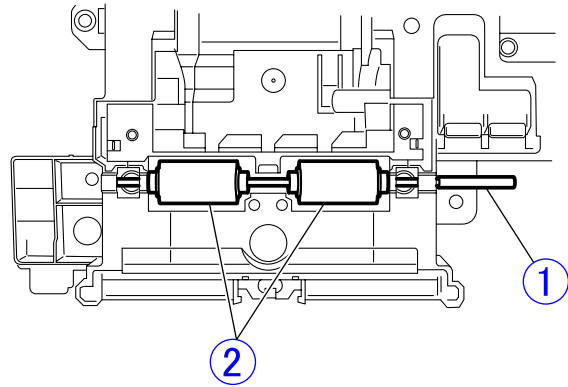

Figure 3-309

◆ **Notes on assembling**

Position the coil springs so that their ends touch the surfaces of “D” cutout sections of the roller shaft and hook them securely. When assembling the roller unit holder, first hook the fitting parts ① and insert the feed clutch rotation stopper ②.

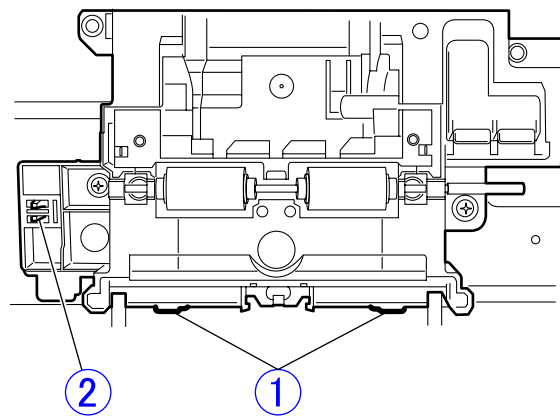

Figure 3-310

7. Follower Roller Unit Front

- 1) Remove the roller unit.
- 2) Remove the eject tray.
(Page 3-6)
- 3) Remove the entrance guide plate upper.
(Page 3-8)
- 4) Open and remove 4 hooks ① and remove the follower roller unit front ②.

Note: Be sure not to break the hooks.

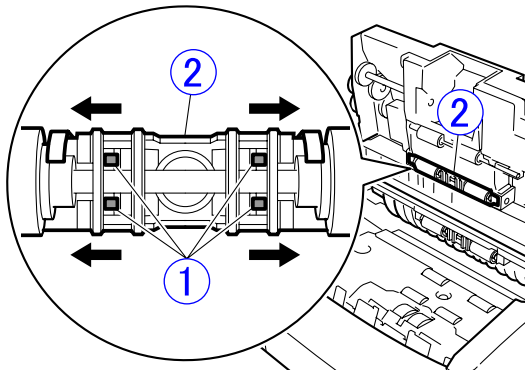

Figure 3-311

◆ Notes on assembling

Pay attention to the right and left directions. The document guides ① must be positioned upward (on the pickup section side).

The follower roller unit front and the follower roller unit rear are the same components.

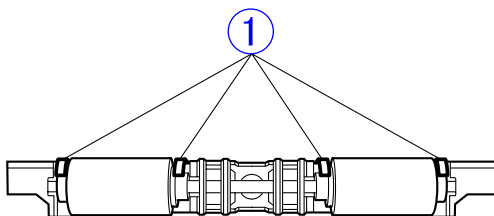

Figure 3-312

8. Follower Roller Unit Rear

- 1) Open and remove 4 hooks ① and remove the follower roller unit rear ②.

Note: Be sure not to break the hooks.

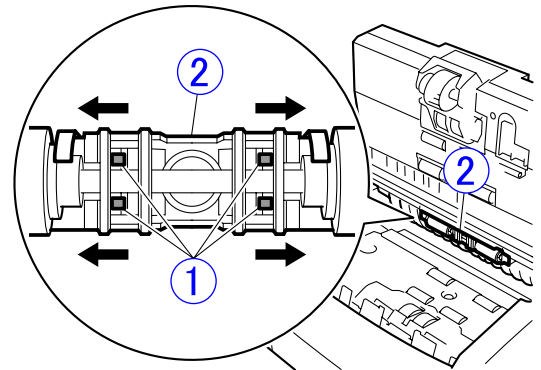

Figure 3-313

◆ Notes on assembling

Pay attention to the right and left directions. The document guides must be positioned upward (on the pickup section side). The follower roller unit front and the follower roller unit rear are the same components.

9. U-Turn Feed Roller (Drive)

- 1) Remove the right cover.
([Page 3-5](#))
- 2) Remove the left cover.
([Page 3-4](#))
- 3) Remove the rear cover.
([Page 3-7](#))
- 4) Remove the belt right.
([Page 3-19](#))
- 5) Unhook the hook of the gear ① and remove the gear. The internal pin is also removed at this time. Remove the stopper ② on the other side and the bearings ③ on both sides and remove the U-turn feed roller (drive) ④.

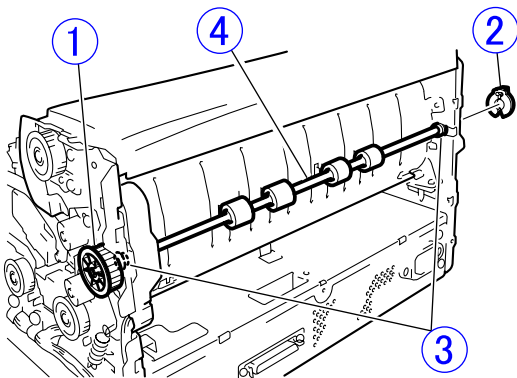

Figure 3-314

10. U-Turn Eject Roller (Drive)

- 1) Remove the right cover.
([Page 3-5](#))
- 2) Remove the left cover.
([Page 3-4](#))
- 3) Remove the eject tray.
([Page 3-6](#))
- 4) Remove the upper cover.
([Page 3-7](#))
- 5) Remove the belt right.
([Page 3-19](#))
- 6) Unhook the hook of the gear ① and remove the gear. The internal pin is also removed at this time. Remove the stopper ② on the other side and the bearings ③ on both sides and remove the U-turn eject roller (drive) ④.

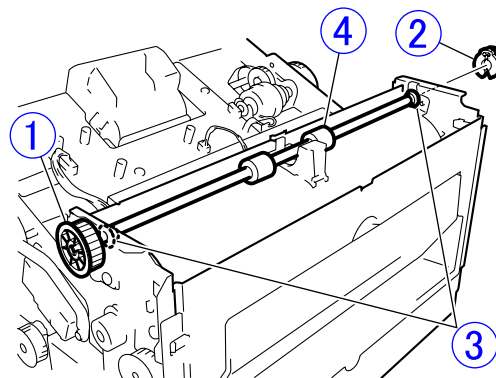

Figure 3-315

11. U-Turn Feed Roller (Follower)

- 1) Remove the right cover.
(Page 3-5)
- 2) Remove the left cover.
(Page 3-4)
- 3) Remove the eject tray.
(Page 3-6)
- 4) Remove the upper cover.
(Page 3-7)
- 5) Remove the follower roller unit rear.
(Page 3-13)
- 6) Remove the belt right.
(Page 3-19)
- 7) Disconnect the connector of the cable ①, remove the cable holder and remove the cable from the upper unit.

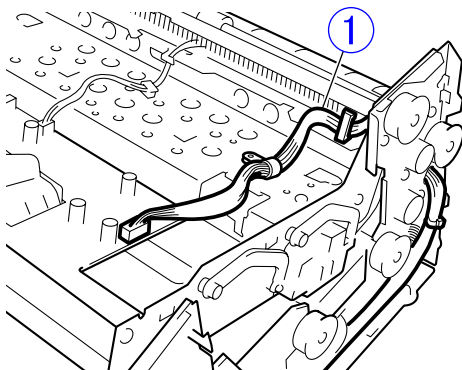

Figure 3-316

- 8) Remove the screws ① from the right and the left (2x2 places). While holding the upper unit, remove the hinges ② on both sides to remove the upper unit.

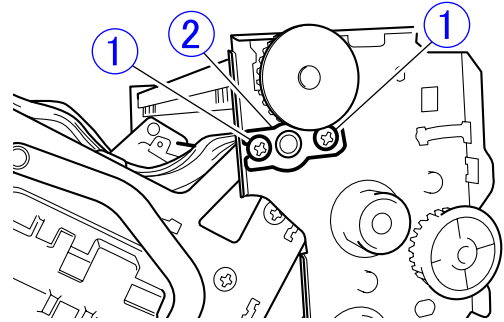

Figure 3-317

- 9) Remove the screw ① (black) on the rear side.

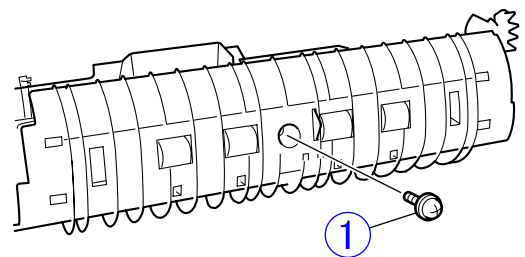

Figure 3-318

- 10) Unhook 2 hooks ① on the upper side by pressing them downward. Then unhook 2 hooks ② on the lower side by pressing them upward and remove the U-turn guide internal ③.

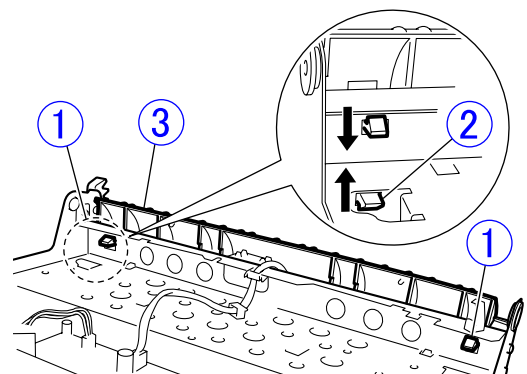

Figure 3-319

11) The U-turn guide internal has 4 U-turn feed rollers (follower) ① attached.

Note: The entire component of “U-turn guide internal” is specified as a service part.

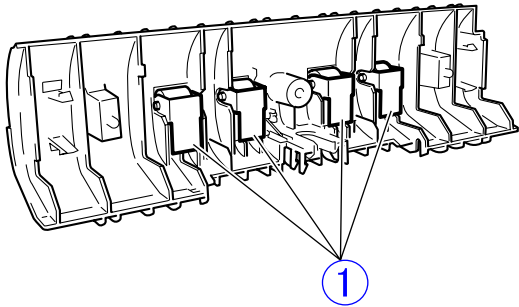

Figure 3-320

12. U-Turn Eject Roller (Follower)

- 1) Remove the eject tray.
(Page 3-6)
- 2) While lightly holding the roller shaft ①, insert a tool under it and slowly lift it.

Note: When removed, the roller shaft comes with 2 U-turn eject rollers (follower) ② around it.

Do not lose 2 coil springs that are built in the eject tray.

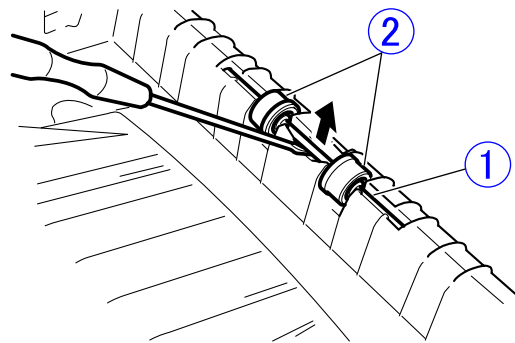

Figure 3-321

◆ Notes on assembling

Place the rollers so that their fringes ① inward.

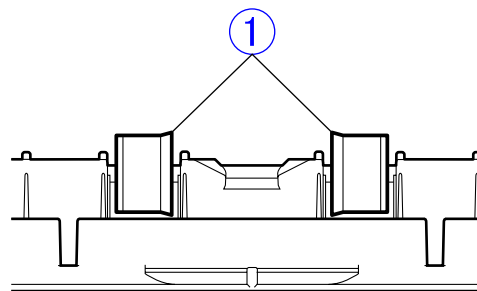

Figure 3-322

IV. DRIVE SYSTEM (MOTOR, ETC.)

1. Main Motor

- 1) Remove the left cover.
(Page 3-4)
- 2) Disconnect the connector ① and remove 3 screws ② to remove the main motor ③.

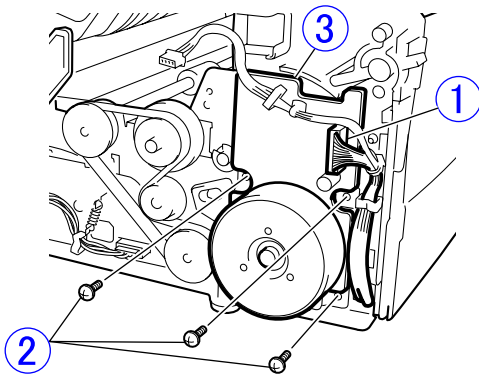

Figure 3-401

2. Shading Motor

- 1) Remove the left cover.
(Page 3-4)
- 2) Disconnect the connector ① and remove 3 screws ② to remove the shading motor unit ③.

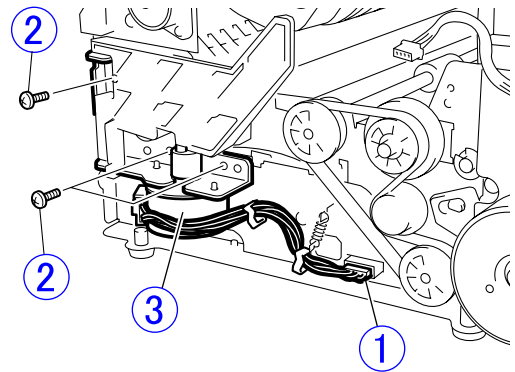

Figure 3-402

- 3) Remove 2 screws ① to remove the shading motor ②.

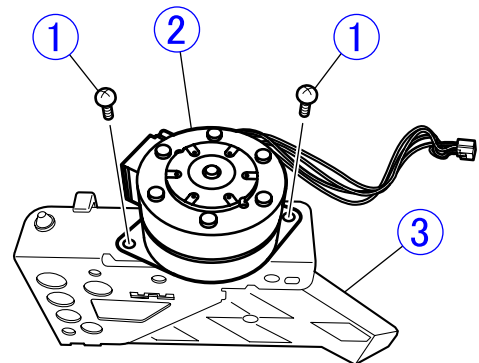

Figure 3-403

◆ Notes on assembling

When assembling the shading motor, mount the pressure plate ① so that it is positioned between the mounting plate ② and the motor shaft ③.

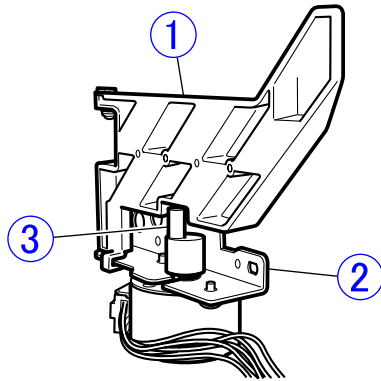

Figure 3-404

3. Feed Clutch

- 1) Remove the eject tray.
[\(Page 3-6\)](#)
- 2) Remove the sub PCB.
[\(Page 3-29\)](#)
- 3) Remove 2 hooks on gear ① and remove the gear. Remove the stopper ② on the other side and the bearings ③ on both sides to remove the feed clutch ④.

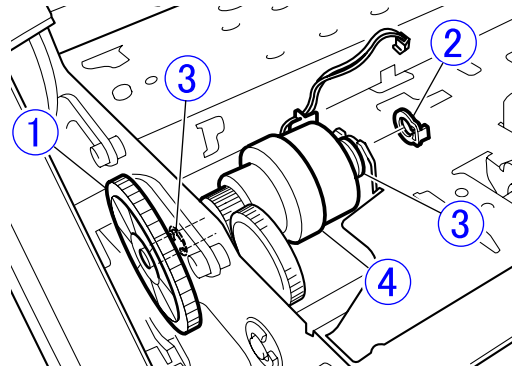

Figure 3-405

◆ Notes on assembling

Face the feed clutch rotation stopper downward when hooking the fitting parts. Hang the feed clutch cable on the cable hook.

4. Belt Left

- 1) Remove the left cover.
(Page 3-4)
- 2) Loosen the screw ① that retains the belt tension plate, then remove the belt left ②.

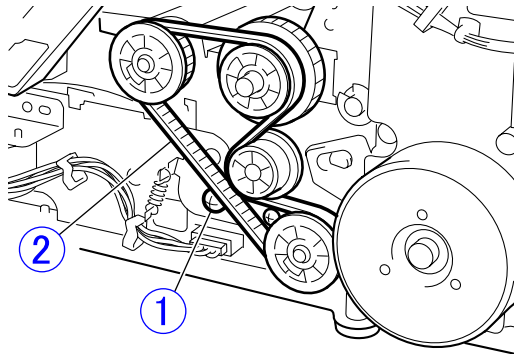

Figure 3-406

◆ Notes on assembling

Referring to the above figure, correctly engage the belt with the gear. Tighten the screw after engaging the belt.

5. Belt Right

- 1) Remove the right cover.
(Page 3-5)
- 2) Loosen the screw ① that retains the belt tension plate, then remove the belt right ②.

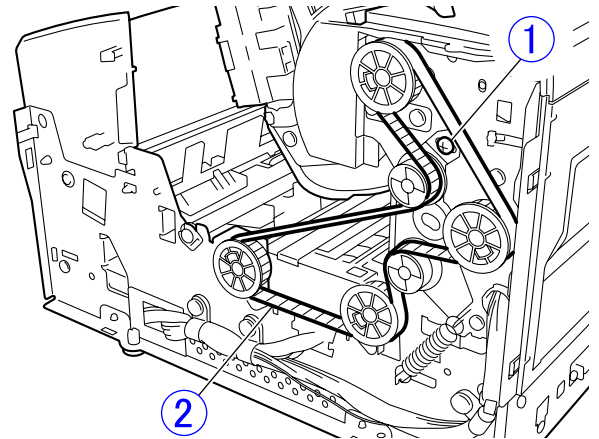

Figure 3-407

◆ Notes on assembling

Referring to the above figure, correctly engage the belt with the gear. Tighten the screw after engaging the belt.

6. Roller Unit Drive Shaft

- 1) Remove the roller unit.
- 2) Remove the eject tray.
[\(Page 3-6\)](#)
- 3) Remove the entrance guide plate upper.
[\(Page 3-8\)](#)
- 4) Remove the stopper ① and remove the bearing ②. Slide the roller unit drive shaft ③, remove the gear ④, then remove the drive shaft.

Note: On the other side, a pair of stopper and bearing is also mounted.

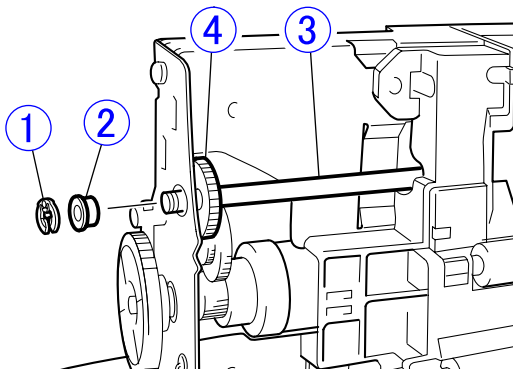

Figure 3-408

7. Roller Unit Retaining Shaft

- 1) Referring to procedures 1 to 7 for “Registration Roller (Follower),” remove the roller unit holder.
[\(Page 3-11\)](#)
- 2) Unhook the hook ① and slide the roller unit retaining shaft ② to remove it.

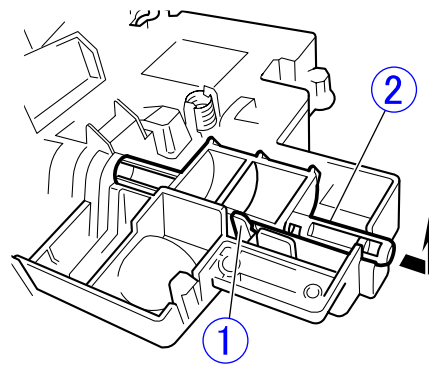

Figure 3-409

8. Retard Roller Drive Shaft

- 1) Remove the retard roller.
- 2) Remove the entrance guide cover.
([Page 3-8](#))
- 3) Remove the stoppers ① and slide the connection shaft ②. Unhook 2 hooks ③ by bending them inward, rotate 2 stopper bearings ④ and remove the retard roller drive shaft ⑤.

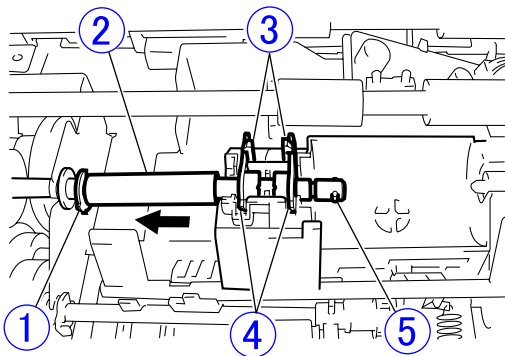

Figure 3-410

◆ Notes on assembling

The shapes of the holes in the connection shaft are different. Position the bigger hole on the motor side and the smaller hole on the retard roller drive shaft side when assembling.

9. Retard Roller Retaining Shaft

- 1) Remove the right cover.
([Page 3-5](#))
- 2) Remove the left cover.
([Page 3-4](#))
- 3) Remove the front cover.
([Page 3-6](#))
- 4) Remove the reading roller front (drive).
([Page 3-10](#))
- 5) Remove the retard roller drive shaft.
([Page 3-21](#))
- 6) Unhook the coil spring ①. Slide the stopper ② and align 2 pairs of the fitting parts ③. Then remove the stopper while turning it to the back.

Note: If the stopper does not slide, slide it while unhooking the hook ④.

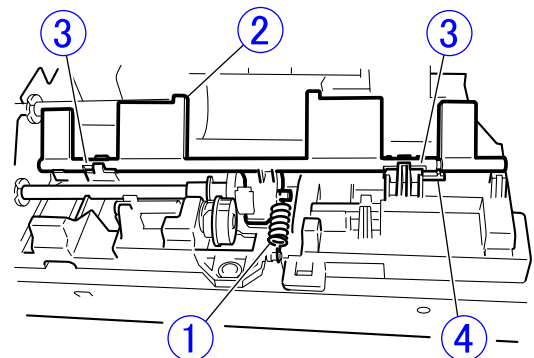

Figure 3-411

- 7) Remove the stopper ① and slide the bearing ②. Unhook the gear ③ and gear with the spring ④ and remove them. Remove the bearing ⑤ and remove the stopper drive shaft ⑥.

Note:The hook from the gear ③ is located on the end surface of the gear. The hook for the gear ④ is located at the end of the shaft.

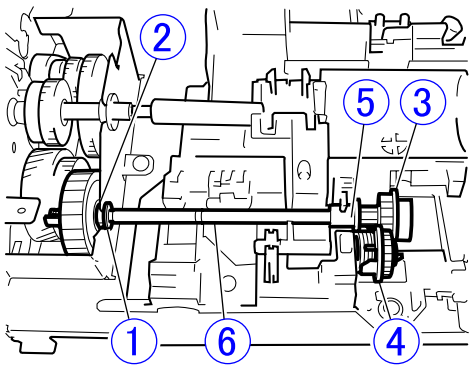

Figure 3-412

- 8) While holding the retard roller holder ①, unhook 2 hooks ②, rotate the holder to align 2 pairs of the fitting parts ③, then remove the holder.

Note:As a coil spring is mounted under the holder, the holder jumps up when unhooked.

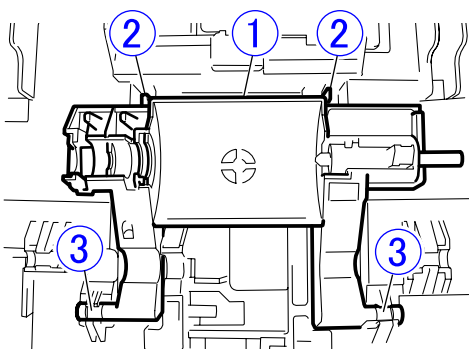

Figure 3-413

- 9) Remove the retard roller retaining shaft ② while unhooking the hook ① on the back side of the holder.

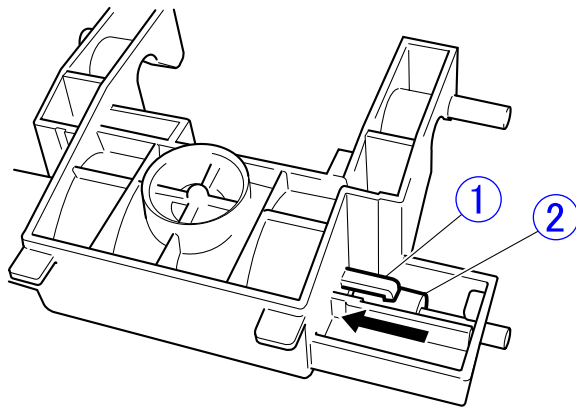

Figure 3-414

◆ **Notes on assembling**

Rotate the gear with spring when assembling it so that the spring tension is applied to the gear.

After completion of reassembling, manually rotate the motor to make sure that the stopper should correctly operate. When the motor is rotated in the reverse direction (clockwise), the stopper opens and closes and when the motor is rotated in the normal direction (counterclockwise), the stopper lies down and is held.

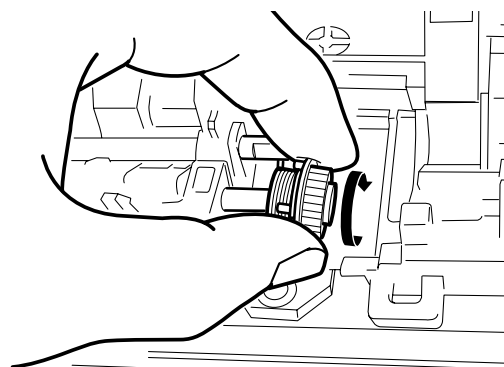

Figure 3-415

V. READING SYSTEM

1. Reading Unit (Upper)

- 1) Remove the right cover.
(Page 3-5)
- 2) Remove the left cover.
(Page 3-4)
- 3) Remove the eject tray.
(Page 3-6)
- 4) Remove the roller unit.
- 5) Remove the entrance guide plate upper.
(Page 3-8)
- 6) Unhook 4 hooks ① by opening them outward and at the same time remove the follower roller unit front ②.
In the same way, while unhooking the hooks, remove the follower roller unit rear ③.

Note: Be sure not to break the hooks.

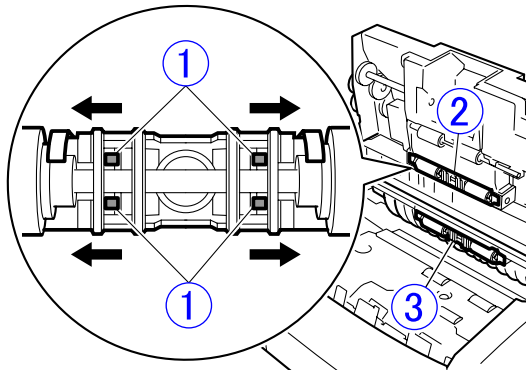

Figure 3-501

- 7) Disconnect the connector ① and remove 2 screws ②.

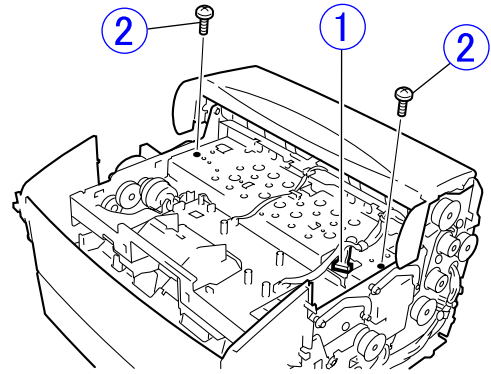

Figure 3-502

- 8) While holding the reading unit ①, unhook the fitting parts ② (2x2 places) on both sides of the link arm to remove the reading unit.

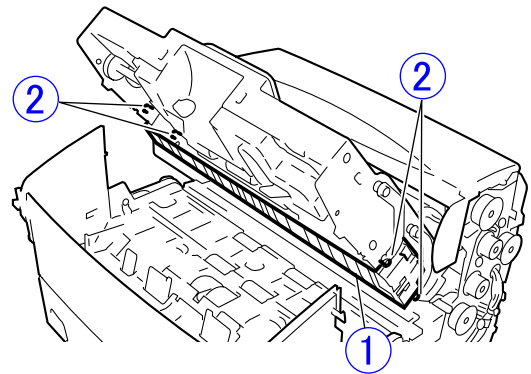

Figure 3-503

- 9) Lift the reading unit a little by retaining it from the lower side, unhook 2 pairs of the fitting parts ①, then draws the upper side of the reading unit ② to the front and remove the upper side only from the main body. Then lay the upper side down to the front and remove the lower side being careful not to press the internal cable (FFC).

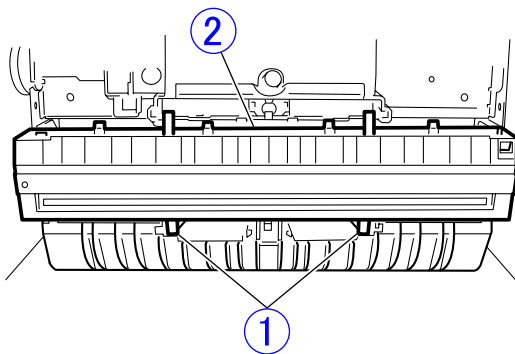

Figure 3-504

◆ **Notes on assembling**

Do not press or fold the cable (FFC).
The reading unit (upper) and the reading unit (lower) are different parts.

2. Reading Unit (Lower)

- 1) Remove the right cover.
[\(Page 3-5\)](#)
- 2) Remove the left cover.
[\(Page 3-4\)](#)
- 3) Remove the entrance guide cover.
[\(Page 3-8\)](#)
- 4) Remove the shading motor unit.
[\(Page 3-17\)](#)
- 5) Remove the reading roller front (drive).
[\(Page 3-10\)](#)

Note:When removing the reading unit, first remove this roller so as not to press the cable (FFC).

- 6) Bend the linear springs ① on both sides and remove them from the hooks ②.

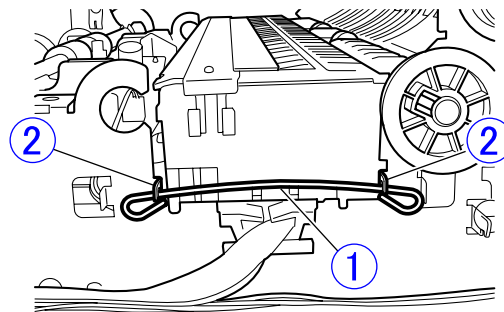

Figure 3-505

- 7) Lift the reading unit ① a little and remove the cable ② from the cable holder ③.

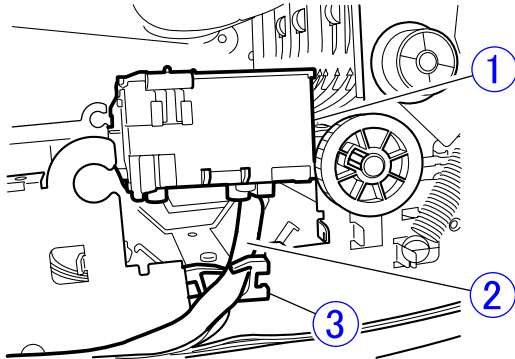

Figure 3-506

- 8) Further take the reading unit ① out of the machine, disconnect the connector ②, then completely remove the reading unit, being careful not to hit any part against another.

Note:When removing the reading unit, be careful not to damage the reading glass on the reading unit and the cable (FFC).

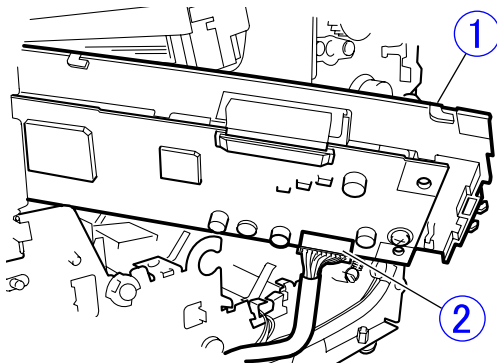

Figure 3-507

3. Reading Glass (Upper)

- 1) Clean the reading unit and the area around it not to allow paper powder and other dust to enter the reading unit.
- 2) While pressing the fitting parts ①, slide and remove the reading glass ②.

Note:Do not drop the reading glass.

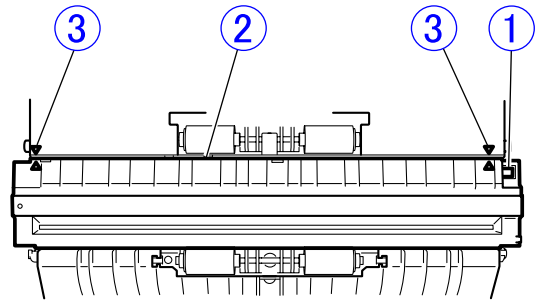

Figure 3-508

◆ Notes on assembling

The reading glass (upper) and the reading glass (lower) are different parts and have position marks ③ to prevent incorrect assembly. Align these marks when assembling.

Do not allow paper powder and other dust to enter the reading unit.

Clean both sides of the glass.

4. Reading Glass (Lower)

- 1) Clean the reading unit and the area around it not to allow paper powder and other dust to enter the reading unit.
- 2) While pressing the fitting parts ①, slide and remove the reading glass ②.

Note: If removal is difficult, remove the right and left covers.

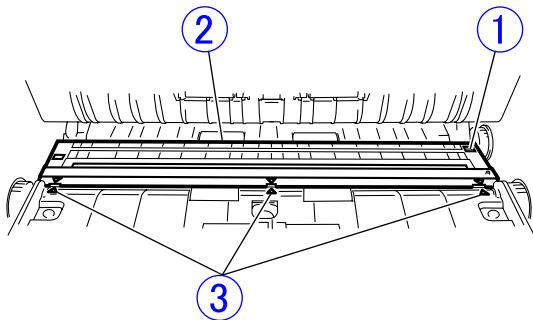

Figure 3-509

◆ Notes on assembling

The reading glass (upper) and the reading glass (lower) are different parts and have position marks ③ to prevent incorrect assembly. Align these marks when assembling.

Do not allow paper powder and other dust to enter the reading unit.

Clean both sides of the glass.

VI. ELECTRICAL SYSTEM (PCB, ETC.)

1. Bottom Plate Unit

- 1) Keeping the pickup tray closed, turn over this machine.

Note: Hold the pickup tray and the upper unit when turning over this machine. Otherwise the pickup tray and the upper unit may open under their own weight. Therefore, be sure to hold them when turning over this machine.

- 2) Remove 6 screws ①. Lift the bottom plate unit ② a little, remove 4 position setters ③, slide the bottom plate unit so as to get it away from the SCSI connector ④ and at the same time, take the power switch button out of the hole on the other side.

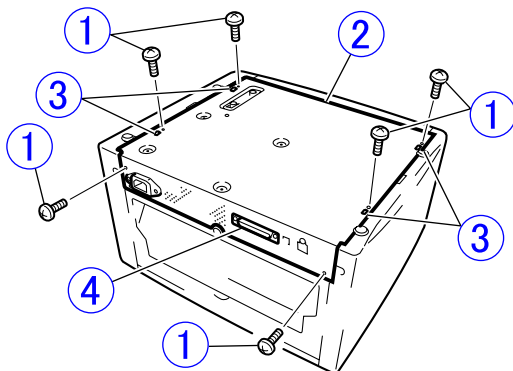

Figure 3-601

- 3) Open the bottom plate unit ① by half, disconnect the connector ② (with a lock), then remove the bottom plate unit.

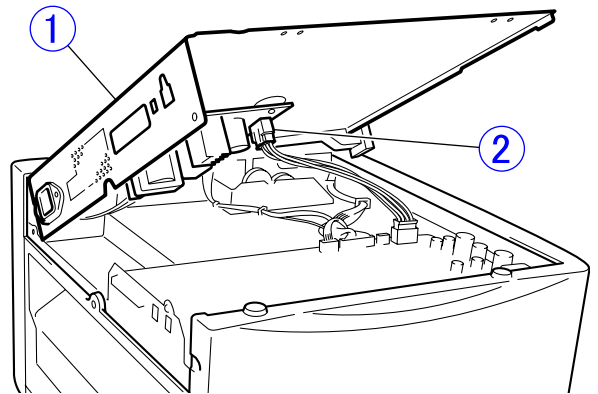

Figure 3-602

2. Control PCB

- 1) Remove the bottom plate unit.
(Page 3-27)
- 2) Disconnect all connectors ①. Remove 2 screws ② (M2.5×4) for the SCSI connector, the screw ③ for the USB connector and 8 other screws ④. Then while lifting the SCSI connector from the opposite side (capacitors, etc.) and taking it out of the hole, remove the control PCB ⑤.

Note: The connector for the DC power supply has a lock.

When removing the control PCB, take care not to hit the elements such as a capacitor against the cover.

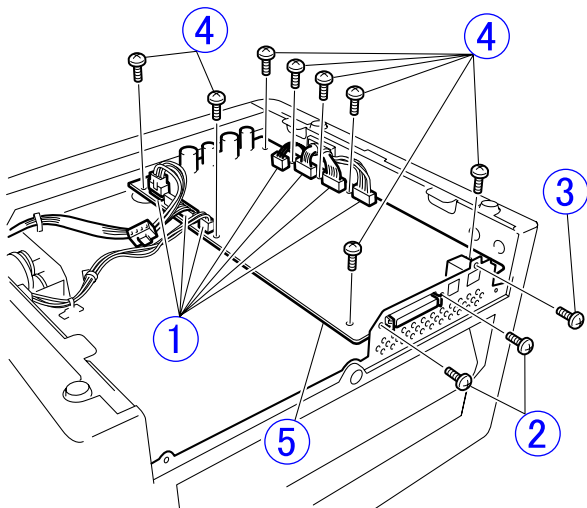

Figure 3-603

◆ Notes on assembling

The size of 2 screws ② for the SCSI connector is M2.5, different from those of other screws (M3).

3. Power Supply PCB

- 1) Remove the bottom plate unit.
(Page 3-27)
- 2) Disconnect the connector ① (with a lock) and remove the screw ② (with a washer) and 2 screws ③ (countersink head), then remove the inlet ④.

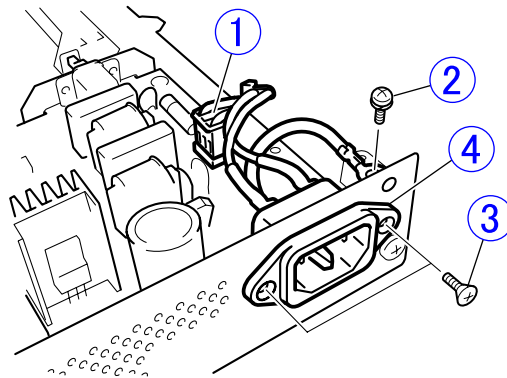

Figure 3-604

- 3) Remove 5 screws ① and remove the power supply PCB ②.

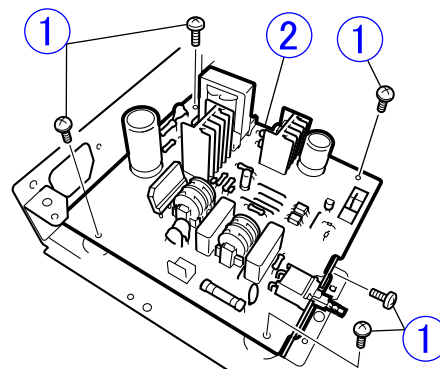

Figure 3-605

◆ Notes on assembling

Be sure to put the screw for the power switch.

4. Sub PCB

- 1) Remove the eject tray.
([Page 3-6](#))
- 2) Disconnect 3 connectors ① and remove 2 screws ②. Then remove the sub PCB ③ by unhooking 2 pairs of the fitting parts ④.

Note: The PCB has sensors on the other side.
Do not hit them against anything.

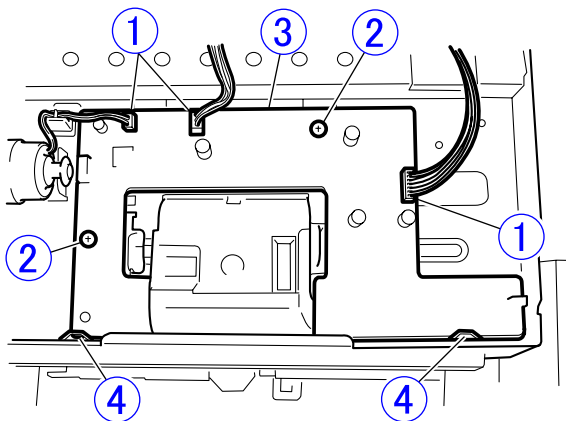

Figure 3-606

5. Ultrasonic PCB

- 1) Remove the entrance guide cover.
([Page 3-8](#))
- 2) Disconnect the connector ①. While unhooking 2 hooks ②, remove the ultrasonic PCB ③.

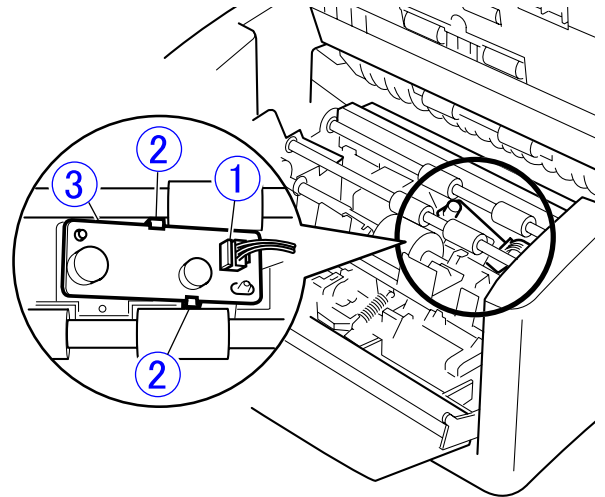

Figure 3-607

◆ Notes on assembling

Prior to tightening the screws, set the positioning bosses in 2 positioning holes in the PCB. Incorrect positioning or spacing may cause the sensors to fail to operate correctly.

Hang the feed clutch cable on the cable hook.

6. Operation PCB

- 1) Remove the left cover.
[\(Page 3-4\)](#)
- 2) While unhooking the hook ①, pull the operation PCB ②.

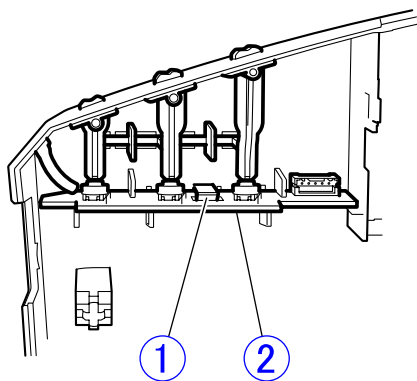

Figure 3-608

CHAPTER 4

INSTALLATION & MAINTENANCE

| | | | |
|----------------------------|------|------------------------|------|
| I. INSTALLATION | 4-1 | III. MAINTENANCE | 4-13 |
| II. PARTS REPLACEMENT..... | 4-11 | | |

I. INSTALLATION

This machine is installed by the user. The user should be advised to install the scanner by reading the “Easy Start Guide” thoroughly.

This machine includes 2 printed manuals; the “Easy Start Guide” and the “Reference Guide.” In addition, the setup disc contains the “User Manual.”

This section presents an outline of the procedures and important matters.

1. Selection of Location

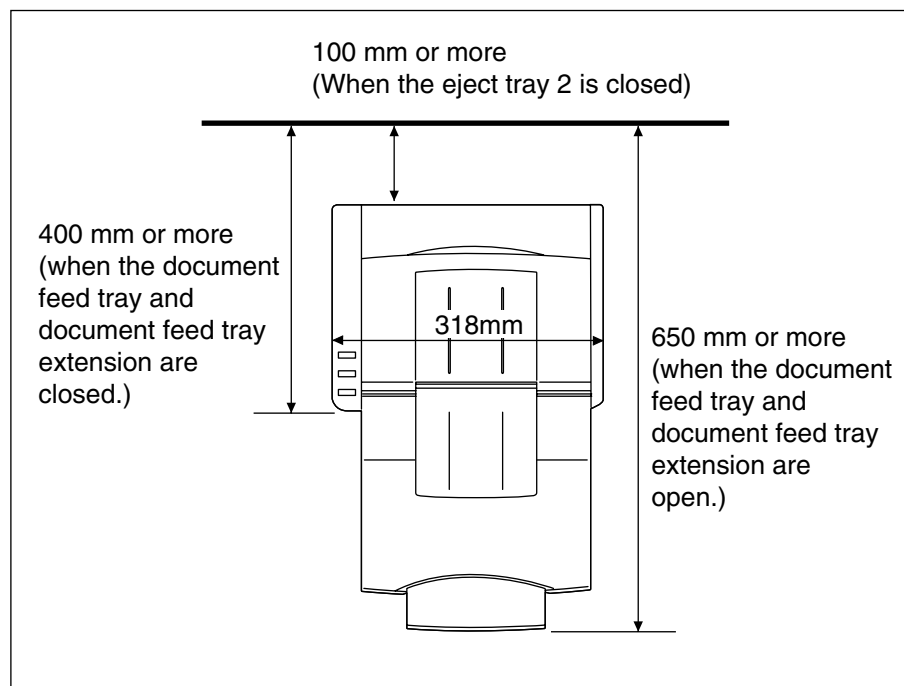

Figure 4-101

- Maintain sufficient spaces around this machine for operation and maintenance, and to allow ventilation.
- When using the straight path, there must be a sufficient space for ejecting the document behind this machine.

2. Checking Accessories

Open the outer packaging box and take out the main body and the accessories.

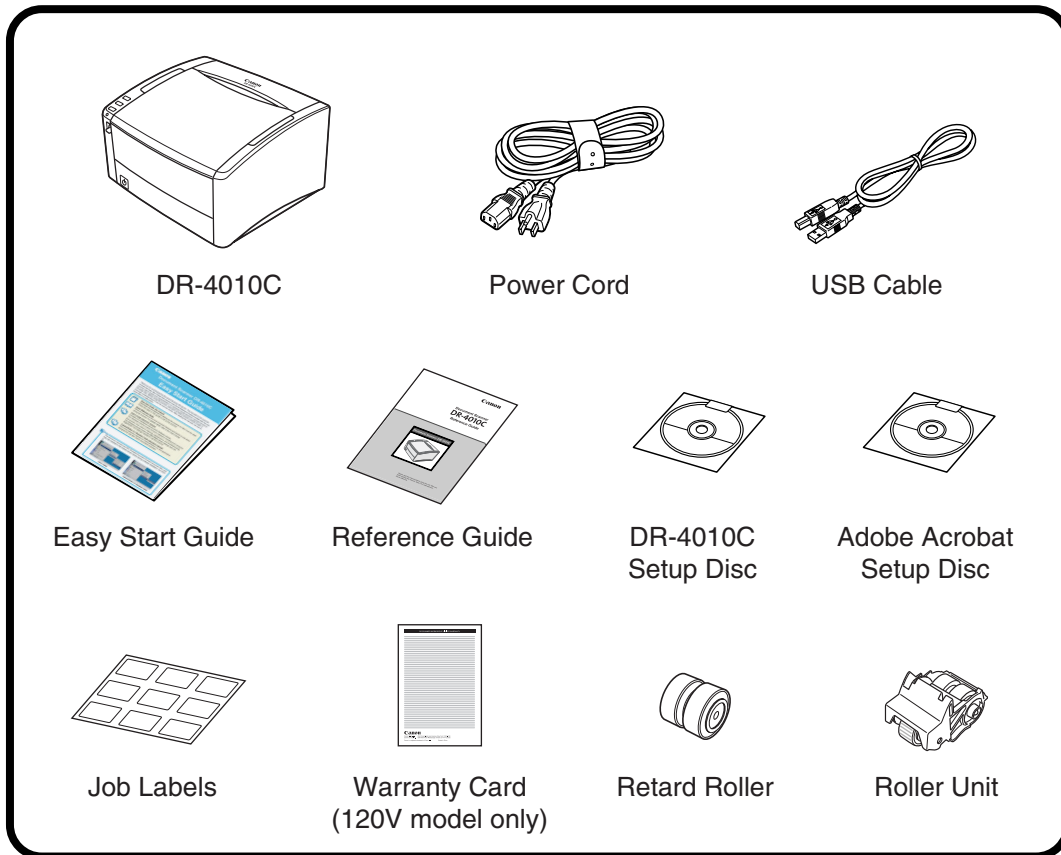

Figure 4-102

- Retain the outer packaging box and packing materials because they are required to store and transport this machine.
- Firmly hold the main body with both hands.

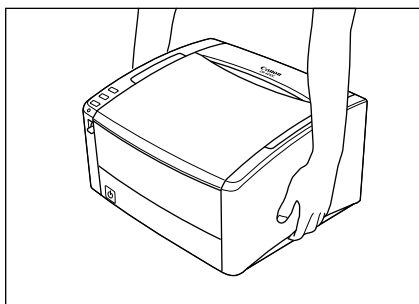

Figure 4-103

3. Protection Material Removal

- 1) Peel off the protection tape from the main body.

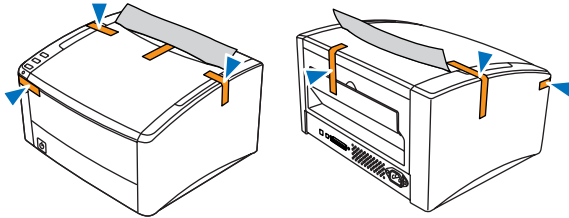

Figure 4-104

- 2) Open the document feed tray slowly.

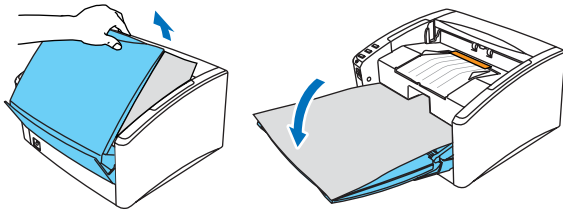

Figure 4-105

- 3) Open the upper unit ① slowly and remove 2 protection sheets ②.

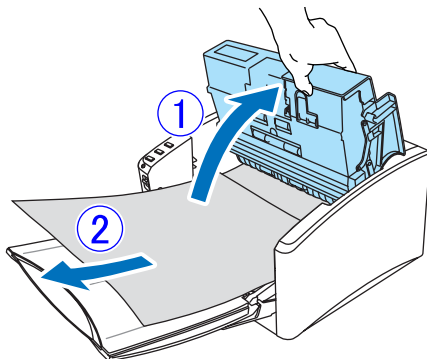

Figure 4-106

4. Attaching the Roller Unit

- 1) Flip the lock lever down (①), then slide it to the right (②).

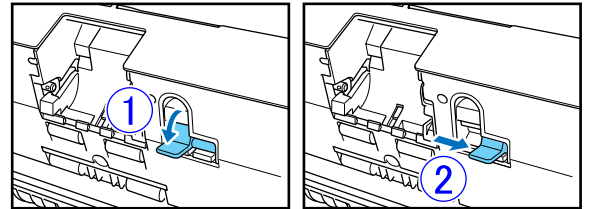

Figure 4-107

- 2) Place the roller unit so that its notch aligns with the shaft pin on the main body.

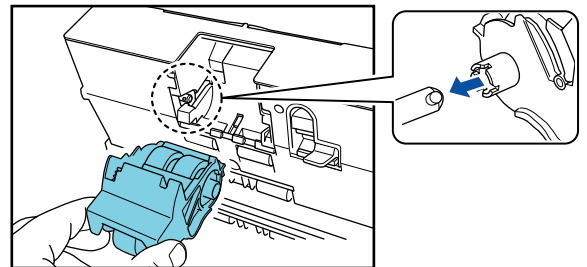

Figure 4-108

- 3) Slide the lock lever to the left, then raise the roller unit.

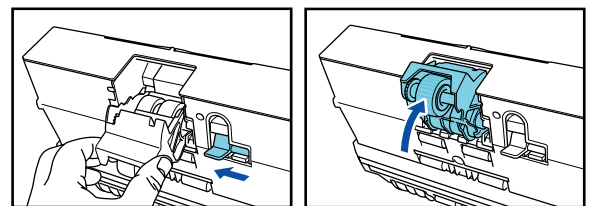

Figure 4-109

4) Flip the lock lever up to lock the roller unit.

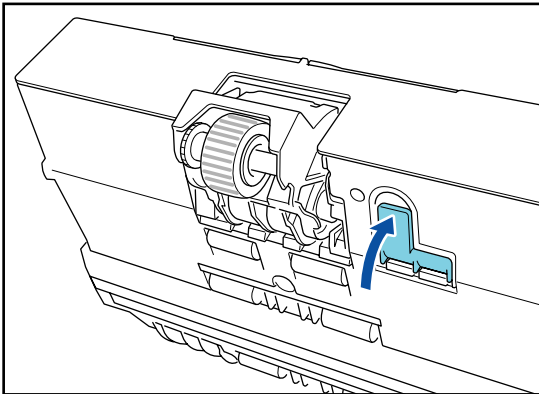

Figure 4-110

Note: Once the roller unit is attached, do not hold the pickup roller section when opening/closing the upper unit. The caution label is affixed on the front of the upper unit.

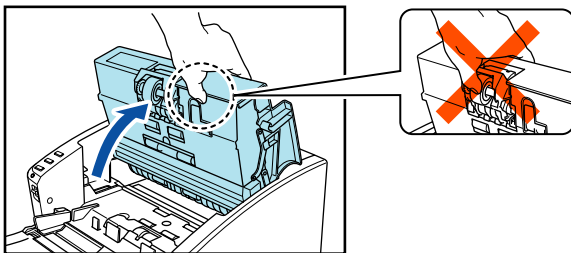

Figure 4-111

5. Attaching the Retard Roller

1) Insert your fingers in the grooves on both sides of the roller cover and remove it.

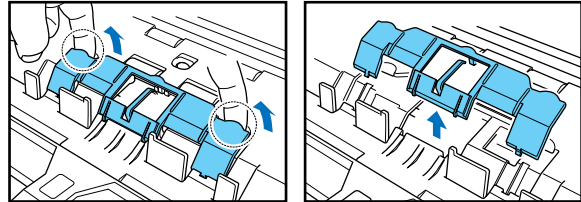

Figure 4-112

2) Flip up the lock lever (①), then slide it to the right (②).

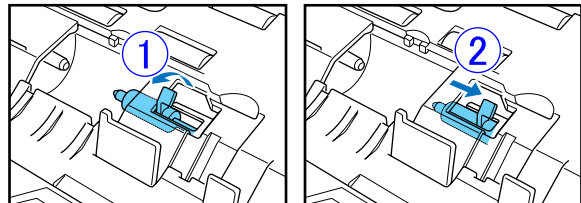

Figure 4-113

3) Place the retard roller so that its notch aligns with the shaft on the main body.

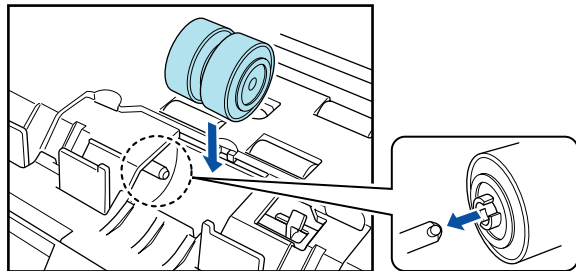

Figure 4-114

- 4) Insert the lock lever shaft in the retard roller (①), then turn the lock lever to the back to lock the retard roller (②).

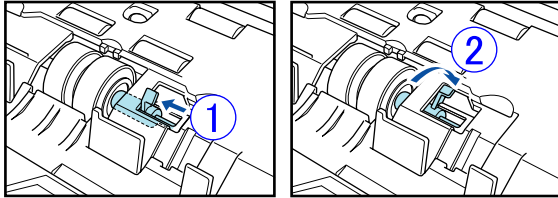

Figure 4-115

- 5) Attach the roller cover. Press the center of the roller cover until you hear a click. This verifies that the roller cover is locked.

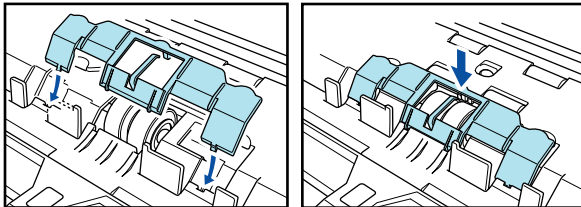

Figure 4-116

Note: Once the roller unit and retard roller are attached, gently close the upper unit. Make sure the upper unit is closed securely by pushing on both edges with both hands until you hear a click.

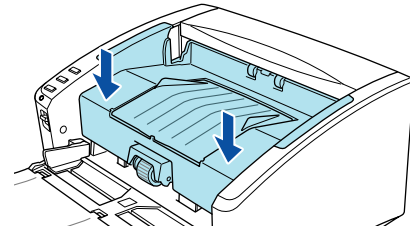
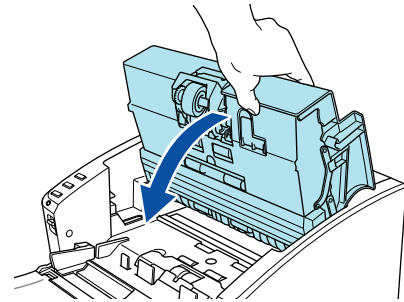

Figure 4-117

6. Installing the Software

Precautions

- ◆ Install the software before connecting the scanner to the computer.
- ◆ Be sure to log on to the OS (Windows) with administrator privileges.
- ◆ Close all other applications before installing the software.
- ◆ Check the requirements of the computer system.

Unless the recommended conditions are satisfied, such specifications as the scanning speed may not be satisfied. Refer to the "User Manual" for the details.

- * The OS must be one of those listed below.

Windows 2000 Professional SP4 or later

Windows XP Home Edition SP2 or later

Windows XP Professional SP2 or later

Windows XP Professional x64 Edition

- * CPU: Pentium4 3.2 GHz or higher
- * Memory: 1 GB or more
- * HDD: Empty capacity of 1 GB or more
- * Interface:

USB port (Hi-speed USB2.0) supplied with computer as standard or recommended SCSI card supplied by Adaptec

- 1) Turn the computer power ON.

Note: If the scanner is connected and the computer power is turned ON before the software is installed, the following wizard screen appears. Click the [Cancel] button to close the wizard. Install the software before connecting the scanner.

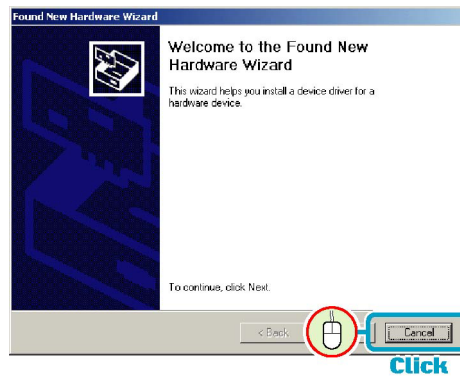

Wizard Screen (Windows2000)

Figure 4-118

- 2) Insert the DR-4010C Setup Disc into the CD drive. The setup menu automatically starts up.

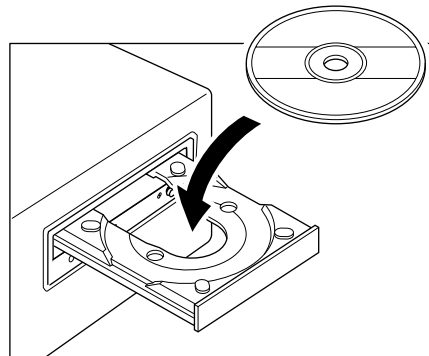

Figure 4-119

- 3) Click [Typical Installation] after the setup menu screen is displayed.
All the software is installed. Refer to the "User Manual" for the other options.

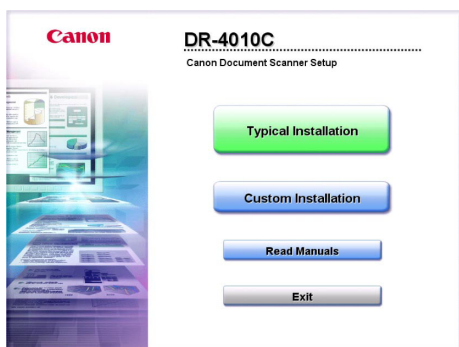

Figure 4-120

- ◆ The mid procedures are abbreviated. Following the screen messages, proceed on installation of the items. Refer to the "Easy Start Guide" or the "User Manual" for the details.
- ◆ Click [Exit] to complete.

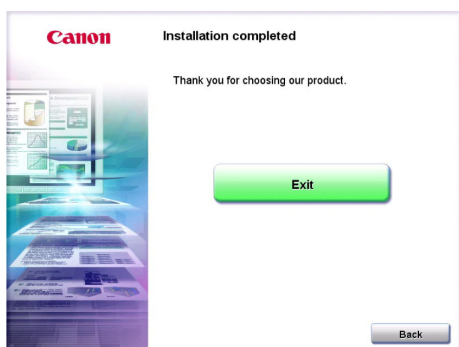

Figure 4-121

7. Connecting to the Computer

Precautions

- ◆ Ensure that this machine power is switched OFF before connecting.
- ◆ Select either USB connection or SCSI connection.
- ◆ Do not connect a USB cable and an SCSI cable at the same time.
- ◆ Be sure to use the supplied power code as an accessory.
- ◆ SCSI connection
Switch the computer OFF before connecting.

This scanner does not include a SCSI cable. Provide a cable with matching connector types. This machine uses a pin type SCSI connector with 50 half-pitch pins.

Turn ON the scanner power first, and then turn ON the computer.

The SCSI ID is set to "2" at the factory. This may be changed if necessary.

| SCSI ID | SW2 | SW1 |
|---------|-----|-----|
| 2 | OFF | OFF |
| 3 | OFF | ON |
| 4 | ON | OFF |
| 5 | ON | ON |



Figure 4-122

- 1) Ensure that this machine power is switched OFF.
For SCSI connection, ensure that the computer power is also switched OFF.

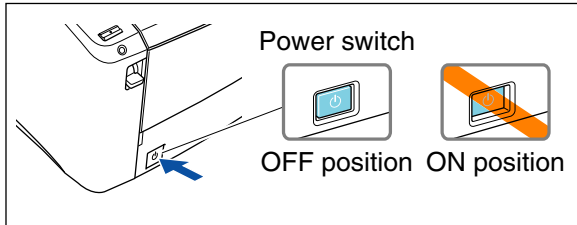

Figure 4-123

- 2) Connect the supplied power code to the power connector on the rear side of the main body. ①
- 3) Insert the power plug in a receptacle. ②

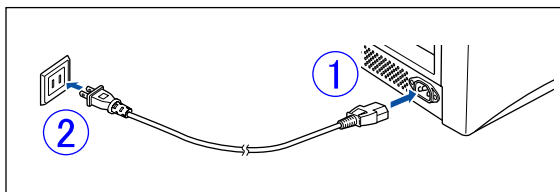

Figure 4-124

- 4) Connect this machine and the computer using the supplied USB cable or a separately prepared SCSI cable.

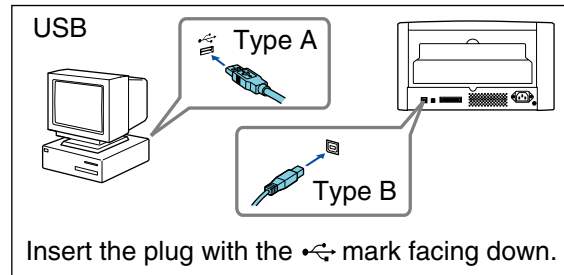

Figure 4-125

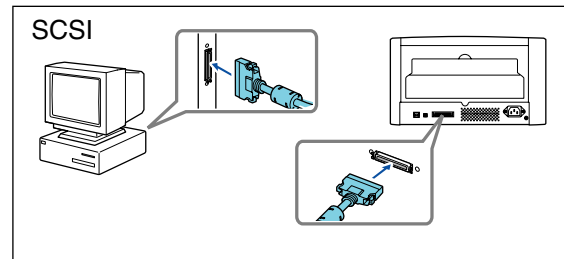

Figure 4-126

8. Power ON (scanner recognition)

Precautions

- ◆ Be sure to log on to the OS (Windows) with administrator privileges. Recognition of the scanner requires the authority of the administrator.
- ◆ For the SCSI connection, switch the scanner power ON first, then the computer power.

- 1) Press the power switch to switch this machine power ON.
The power indicator is lit up green.

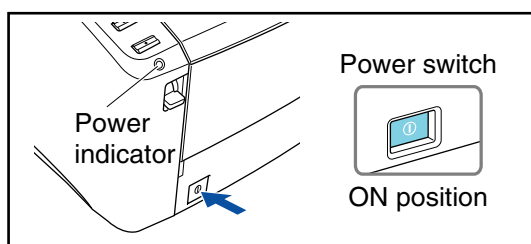

Figure 4-127

- 2) Switch the computer power ON.
(For SCSI connection)
- 3) Windows recognizes DR-4010C as a new hardware and automatically installs the device information.



Windows 2000



Windows XP

Figure 4-128

9. Scanning

After completing the steps described above, load the documents on the scanner and check the operation.

To operate the scanner, refer to the “Easy Start Guide” or the “User Manual.”

The “Easy Start Guide” instructs how to scan the documents with the job functions. The procedures are as follows.

- 1) Open the document feed tray.
- 2) Thoroughly fan the documents and align their edges.

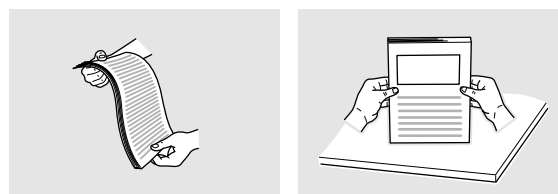

Figure 4-129

- 3) Load the documents on the document feed tray with the printed side facing up and adjust the document guides to the width of the documents.

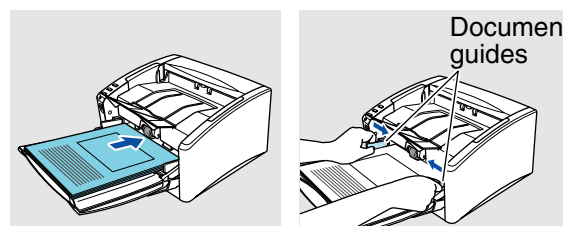

Figure 4-130

- 4) Make sure that the feed selection lever is set to the bottom position (separation pickup).

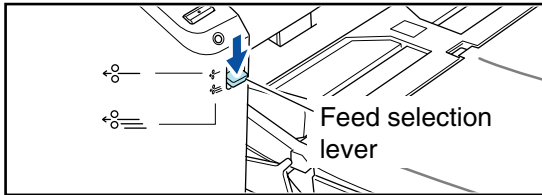

Figure 4-131

- 5) Press job button 3.
The "Monitor for DR-4010C" window appears on the lower right of the display and scanning starts.

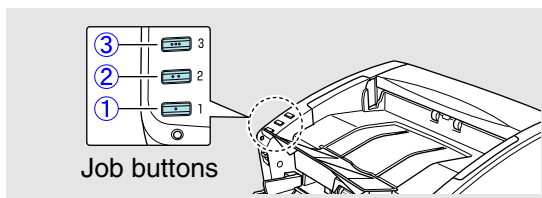

Figure 4-132

- 6) Scanning is completed when "Sending complete." appears on the DR-4010C monitor.
Click [Close] to close the "Monitor for DR-4010C" window.

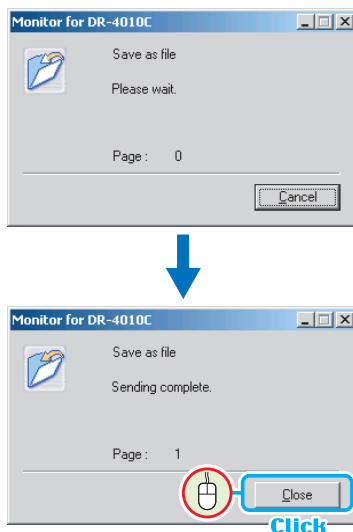

Figure 4-133

Precautions

- ◆ The following functions are assigned to each job button as a default settings.
Job button 1: Start
Job button 2: Stop
Job button 3: Save as file
- ◆ The files of the scanned images are saved in "My Pictures" folder in "My Documents" as PDF files with a 17-digit file name that indicates the data and time when the document is scanned.
- ◆ The scan settings and the save destination folders can be changed by using the "Job Registration Tool" located in the Programs menu.

II. PARTS REPLACEMENT

1. Periodically Replaced Parts

This machine does not have any periodically replaced parts.

2. Consumable Parts

1) Replaced by users

| No. | Parts name | Parts number | Expected life | Remarks |
|-----|---|--------------|----------------|---|
| 1 | Roller unit (Pickup/ Feed roller) | MG1-3938-000 | 250,000 sheets | Because of the worn rollers, it is necessary to replace when the pickup failures or the document jams are occurred after the roller cleaning. |
| 2 | Retard roller | MG1-3939-000 | | |

Note: The items above are assigned as service parts and an exchange roller kit is assigned as commercially available products for a set.

Table 4-201

1) Replaced by service technicians

| No. | Parts name | Parts number | Expected life | Remarks |
|-----|------------------------------|--------------|------------------|--------------------------------|
| 1 | Registration roller (drive) | MA2-7738-000 | 3,500,000 sheets | |
| 2 | Reading roller front (drive) | MA2-7739-000 | 3,500,000 sheets | |
| 3 | Reading roller rear (drive) | MA2-7740-000 | 3,500,000 sheets | |
| 4 | Follower roller | MA2-7758-000 | 3,500,000 sheets | Registration roller (follower) |
| 5 | Follower roller unit | MG1-3926-000 | 3,500,000 sheets | Reading roller (follower) |
| 6 | Main motor | MH7-1150-000 | 3,500,000 sheets | |
| 7 | Magnet clutch | MH7-5057-000 | 3,500,000 sheets | Pickup |

Note: The expected life of 3,500,000 sheets on the above is equivalent to the product life.

Table 4-202

3. Major Parts List

The list below shows the major service parts. Refer to the "Parts Catalog" for the details.

| No. | Parts name | Parts number | Q'ty | Remarks |
|-----|------------------------------|--------------|------|------------------------------|
| 1 | Control PCB | MG1-3943-000 | 1 | |
| 2 | Sub PCB | MG1-3945-000 | 1 | |
| 3 | Reading unit (lower) | MG1-8270-000 | 1 | Including the reading glass. |
| 4 | Reading unit (upper) | MG1-8271-000 | 1 | |
| 5 | Power supply PCB (100V) | MH3-2067-000 | 1 | 100V, 120V model |
| | Power supply PCB (200V) | MH3-2068-000 | 1 | 200V model |
| 6 | Reading glass (lower) | MF1-4430-000 | 1 | |
| 7 | Reading glass (upper) | MF1-4432-000 | 1 | |
| 8 | Main motor | MH7-1150-000 | 1 | Blushless motor |
| 9 | Shading motor | MF1-4437-000 | 1 | Stepping motor |
| 10 | Magnet clutch | MH7-5057-000 | 1 | |
| 11 | Roller unit | MG1-3938-000 | 1 | |
| 12 | Retard roller | MG1-3939-000 | 1 | |
| 13 | Registration roller (drive) | MA2-7738-000 | 1 | |
| 14 | Reading roller front (drive) | MA2-7739-000 | 1 | |
| 15 | Reading roller rear (drive) | MA2-7740-000 | 1 | |
| 16 | Follower roller | MA2-7758-000 | 2 | |
| 17 | Follower roller unit | MG1-3926-000 | 2 | |

Table 4-203

III. MAINTENANCE

1. User Maintenance

Refer to the User Manual for the details.

1) List

[▲: Cleaning, ●: Replace]

| No. | Location/Parts | Intervals | | Details |
|-----|--------------------------|--------------|----------------|---|
| | | As necessary | 250,000 sheets | |
| 1 | Roller unit | ▲ | ● | Remove the roller unit and the retard roller from the main body. Wipe them with a cloth dipped into water and wrung tightly, then wipe dry. They should be replaced after an expected life of 250,000 sheets. |
| 2 | Retard roller | ▲ | ● | |
| 3 | Rollers (except No. 1-2) | ▲ | | Wipe the rollers with a cloth dipped into water and wrung tightly, then wipe dry. |
| 4 | Reading glasses | ▲ | | Wipe with a clean and dry cloth. |
| 5 | Feed path | ▲ | | Using a blower, etc., remove dust and paper powder from the pickup opening and the feed path inside of the main body. |
| 6 | Main body | ▲ | | Wipe the main body surfaces with a cloth dipped into water and wrung tightly, then wipe dry. |

Table 4-301

2) Locations to be cleaned

Where to clean is as follows.

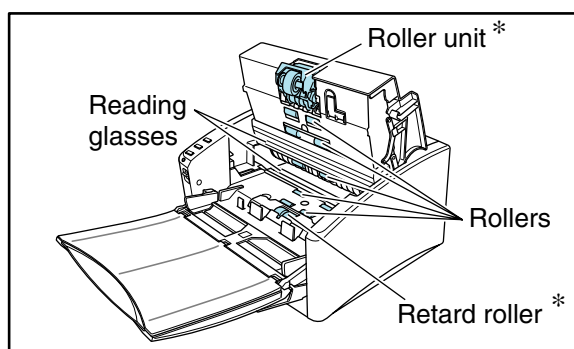

Figure 4-301

Note: Refer to the "User Manual" or the "Chapter 4 I. INSTALLATION" in this manual for removing/attaching the roller unit and the retard roller.

3) Roller replacement display

When the number of sheets fed exceeds the expected life of 250,000, a "roller replacement" message is displayed on the display when the computer recognizes this machine next time.

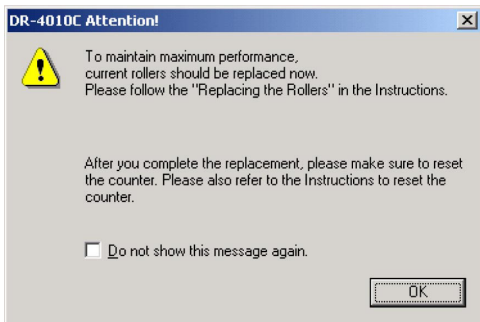

Figure 4-302

When the rollers are replaced, the counter must be reset.

To reset the counter, display the "Properties" screen for this machine, and click the [Reset] button on the "Maintenance" tab by following procedures of the using OS.

Clicking the [Reset] button resets "Current Rollers" counter to "0."

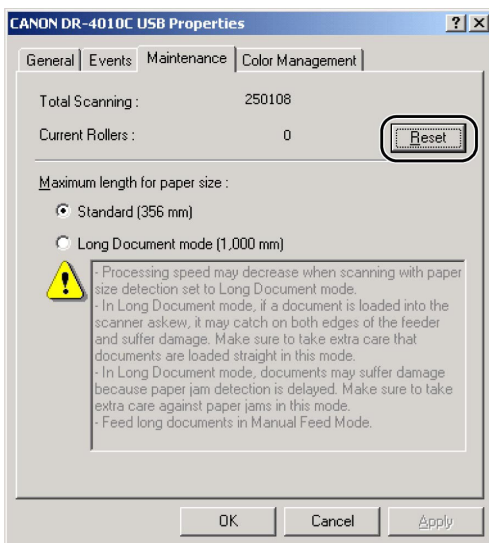

Figure 4-303

2. Service Maintenance

For this machine, no periodical maintenance item by the service technicians is specified.

However, when visiting a user, check whether the reading glasses and the rollers are dirty. If they are very dirty, instruct the user to follow the "user maintenance" procedures. Recommend the user to replace consumable part(s) if necessary.

CHAPTER 5

TROUBLESHOOTING

| | | | |
|-----------------------------|------|-------------------------------------|------|
| I. ERROR DISPLAY | 5-1 | IV. OPERATION TROUBLESHOOTING | 5-18 |
| II. SERVICE MODE | 5-3 | V. IMAGE TROUBLESHOOTING..... | 5-23 |
| III. LIST OF FAILURES | 5-17 | VI. AFTER REPLACING PARTS | 5-28 |

I. ERROR DISPLAY

1. Power Indicator

This machine does not have an error display section, but some errors are indicated by the power indicator on the operation panel of the main body.

If this machine operates normally, the power indicator lights. It lights even in the sleep mode. The power indicator flashes if this machine can not scan the document in case that the upper unit opens or the document jam occurs, etc.

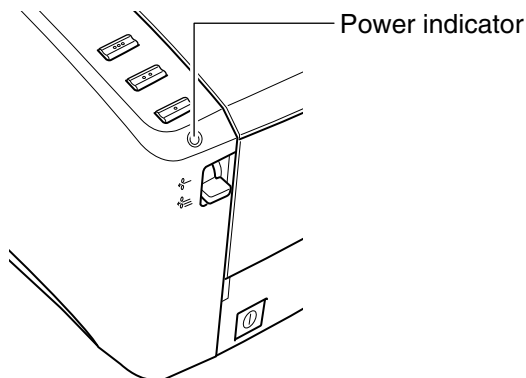

Figure 5-101

2. Error Messages

The display connected to the computer shows error messages. The details of the messages may differ depending on the software in use.

The user is advisable to refer to the error messages and take measures for such events as user's own mistakes in operation and document jams. If the user cannot solve the problem, however, the service technician should do.

*CapturePerfect 3.0

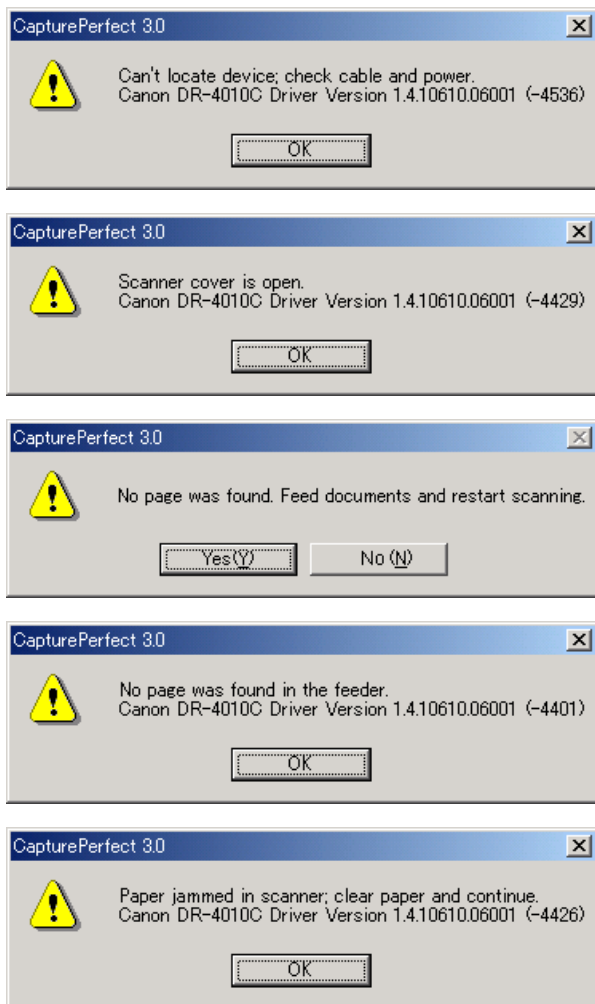

Figure 5-102

The followings are the major error messages appearing when "CapturePerfect 3.0" and "Job" are used. Note, however, that some of these error messages displayed by "CapturePerfect 3.0" are not shown when "Job" is used.

*Job

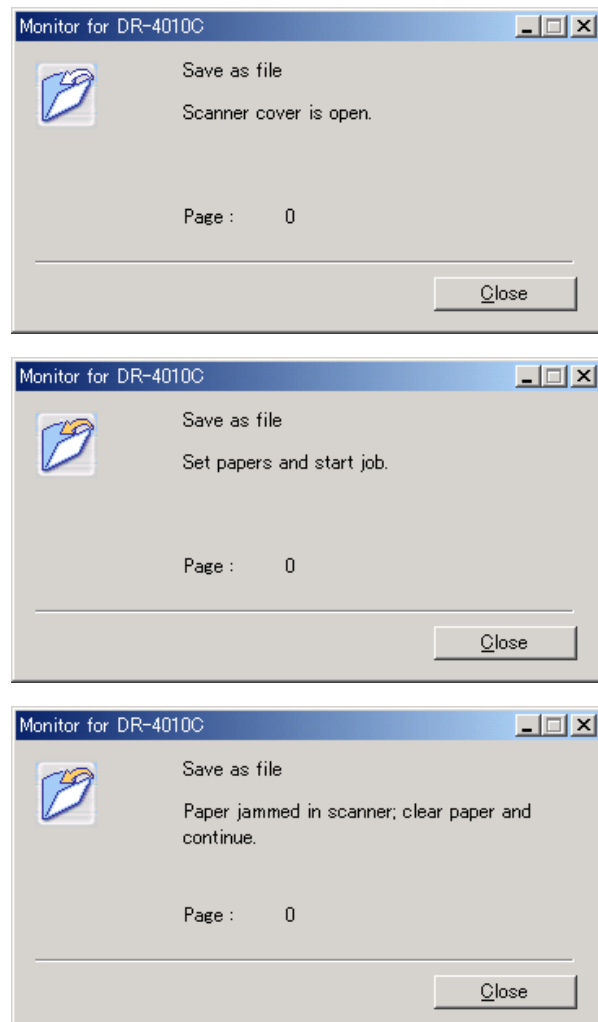

Figure 5-103

II. SERVICE MODE

1. Outline

The service mode of this machine can be executed by installing on the computer for servicing the service mode software (service tool) located in the setup disc bundled with this machine.

This software is based on the software for DR-5010C and can be used with this machine. The software offers screens suitable to each of these products.

The system requirements for the computer to be used are the same as those described in the user manual. The lower the CPU performance or memory capacity, the longer the processing time, but the service mode can still be used.

Figure 5-201 shows the service screen.

The service screen displays the buttons for selecting the various modes. Each service mode is started from this screen.

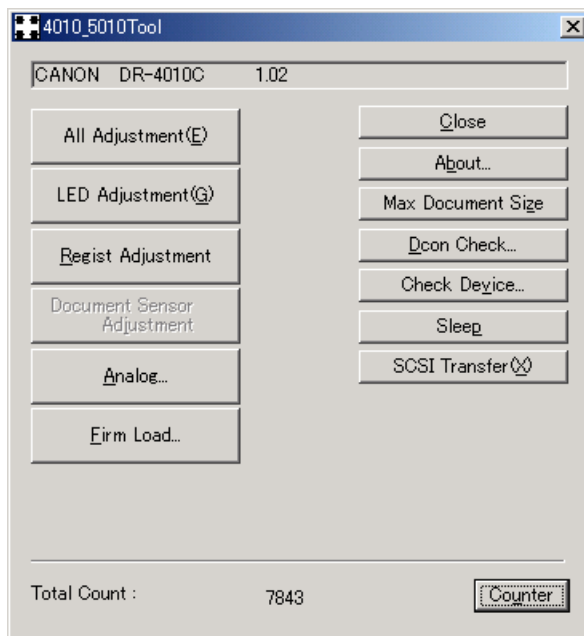

Figure 5-201

Table 5-201 shows the list of the service modes.

| No. | Button name | Functions | Usage |
|-----|--------------------|--|---|
| 1 | All Adjustment | Perform all adjustments related to image reading. (CIS adjustment and registration adjustment) | Adjustment after replacement of the control PCB and the reading unit. |
| 2 | LED Adjustment | Perform the CIS adjustments. | Measures against image failures. |
| 3 | Regist Adjustment | Perform the registration adjustments. | Measures against leading edge/trailing edge failures. |
| 4 | Analog | Display the analog value of each sensor. | Checking operation of the ultrasonic sensor. |
| 5 | Firm Load | Change the firmware. | Updating the firmware version. |
| 6 | About | Display this service tool version. | Checking the detailed version of this service tool. |
| 7 | Max. Document Size | Set the long document mode. | Using the long document mode. (Also available from the user screen.) |
| 8 | Dcon Check | Check the operation of the hardware such as job buttons, sensors, motors, CIS unit LED, etc. | Checking the operation of the hardware in case of feeding faults and image faults. |
| 9 | Check Device | Display the version of the firmware such as the main body and the internal devices. | Checking the version of the firmware such as the main body and the ultrasonic sensor. (The main body firmware can also be checked from the user screen.) |
| 10 | Sleep | Set the sleep mode. | Switching the sleep mode off. |
| 11 | SCSI Transfer | Set the SCSI transfer speed. | Changing the SCSI transfer speed. (Typically, there is no need to change it.) |
| 12 | Counter | Display and change the total scanning count and the number of document jams. | Checking the total scanning count and the number of document jams. Adjustment after replacement of the control PCB. |

Table 5-201

2. Installation Procedure

The service mode software installation procedure is described below. Do not install the service mode software on the user's computer.

- 1) Power ON the computer for servicing and start up the OS (Windows).
- 2) Set the DR-4010C setup disc that is bundled with this machine.
- 3) The normal installation screen appears but ignore it. Right click on the [Start] button on the computer and select [Explorer].
- 4) Copy the "\Driver\Tools" folder in the setup disc to a desired drive of the computer for servicing.

Note:For how to install the general software, refer to the "User Manual."

However, for the specifications, such as the reading speed, refer to the computer system requirements described in the "User Manual."

Note:To execute the service mode with the user's computer, start up "4010_5010Tool.exe" on the setup disc bundled with this machine. Do not copy this program to the user's computer. Do not let the user know the folder name and password to be used.

3. Starting Up and Exiting Service Mode

The procedure for starting up the service mode is described below.

- 1) Connect the computer for servicing with this machine using a SCSI interface cable or a USB interface cable.
- 2) After powering ON this machine, power ON the computer.
- 3) Open the installed "Tools" folder and start up the "4010_5010Tool.exe" file. (See Figure 5-202.)
- 4) The password screen is displayed, so after inputting the 6 characters "market," select [OK]. (See Figure 5-203.)
- 5) The service screen is displayed.

To exit the service mode, select [Close] on the service screen.

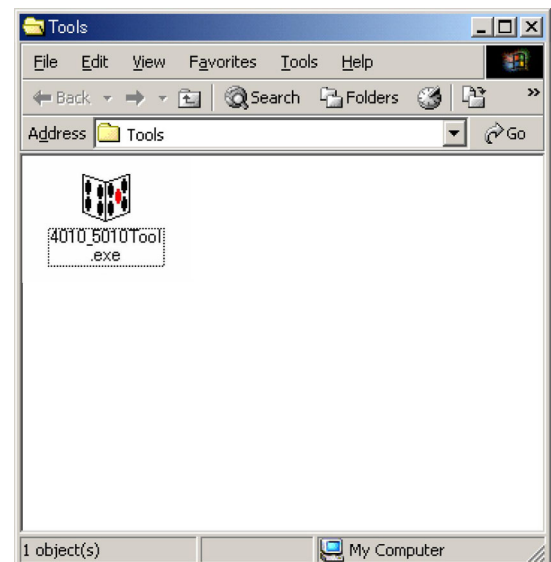

Figure 5-202



Figure 5-203

4. All Adjustment

This mode is used to adjust all image reading adjustments at the same time. Be sure to execute this mode after the control PCB or the reading unit has been replaced.

This mode consists of 2 individual adjustment items: "LED Adjustment," "Regist Adjustment."

- Operation Procedure

- 1) Clean the feed path, the rollers and the reading glasses.
- 2) Set 2 pieces of regular white copy paper (A4 or LTR). Set the document guide position to the paper. The separation pickup is set.
- 3) Select [All Adjustment] on the service screen.

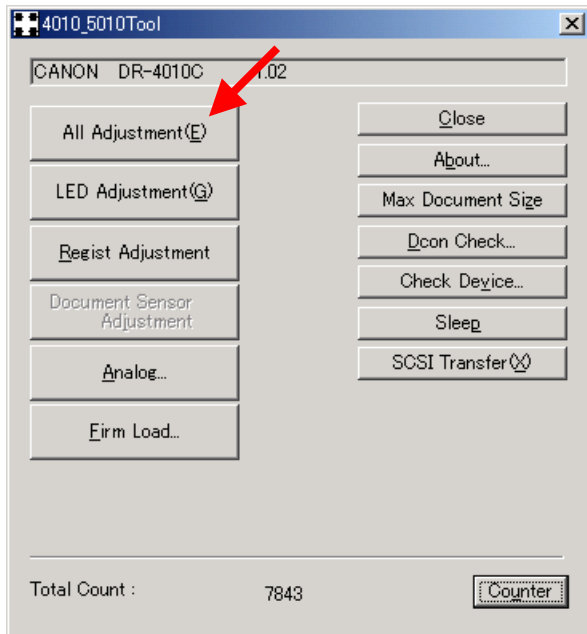

Figure 5-204

- 4) The adjustment starts automatically. The progress screen appears on the display. "LED Adjustment" and "Regist Adjustment" are performed in this order. The display examples are shown below.

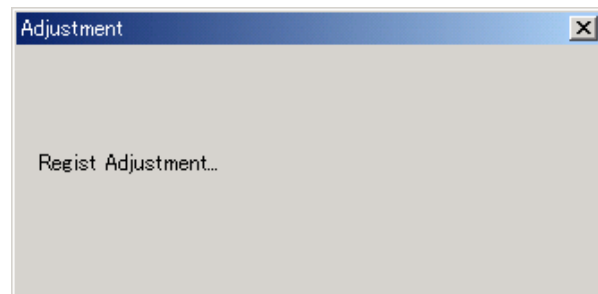
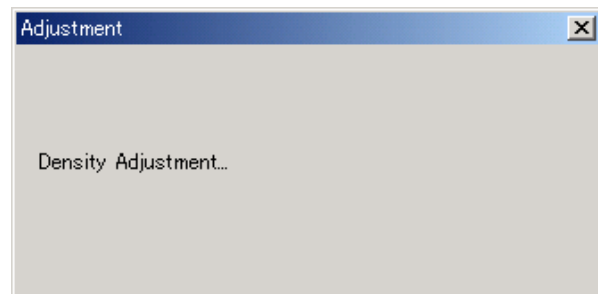
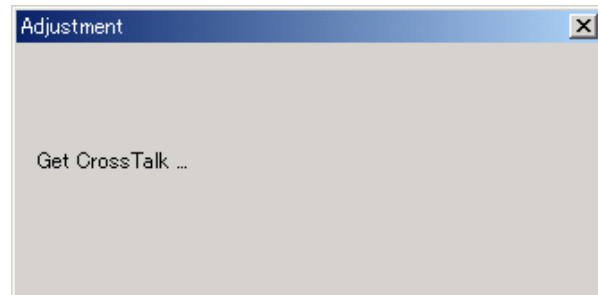
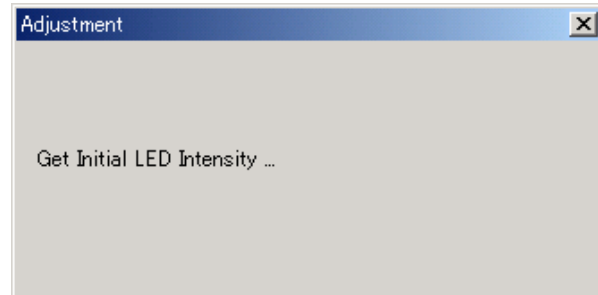

Figure 5-205

- 5) When the adjustment is finished, the progress screen disappears and the service screen appears.

It takes approx. 1 minute to finish.

- Errors

If an anomaly occurs in the adjustment value while executing this mode, an error screen is displayed, and adjustment is interrupted. If an error screen is displayed, select [OK] in the screen to stop adjustment. Then after checking the operating procedure, perform adjustment again. If adjustment is interrupted, the adjustment value remains the value prior to adjustment.

Sample error screens are shown below.



Figure 5-206

If the computer gets uncontrollable during use of the service mode including this mode, reset both the scanner and the computer.

5. Individual Adjustments

This section describes the following individual adjustment items. If all the 2 adjustments are performed, use [All Adjustment].

- [LED Adjustment]
- [Regist Adjustment]

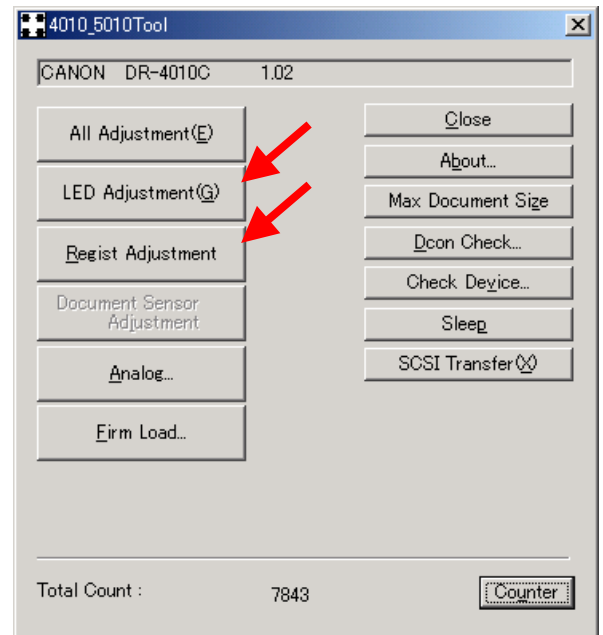

Figure 5-207

a. LED Adjustment

In this mode, 3-color LED intensity adjustment, 3-line sensor data output correction of the CIS unit, and back/front density adjustments are performed. Execute this mode when the quality of the read image is faulty.

- Operation Procedure

- 1) Clean the feed path, rollers, and the reading glasses.
- 2) Set a piece of regular white copy paper (A4 or LTR). Set the document guide position to the paper.
- 3) Select [LED Adjustment] on the service screen.
- 4) The adjustment starts automatically. The progress screen appears on the display.
- 5) When the adjustment is finished, the progress screen disappears and the service screen appears.

b. Regist Adjustment

The reading position is adjusted in this mode. Execute this mode if the leading edge and trailing edge of a read image is faulty.

- Operation Procedure

- 1) Set a piece of regular white copy paper (A4 or LTR). Set the document guide position to the paper.
- 2) Select [Regist Adjustment] on the service screen.
- 3) The adjustment starts automatically. The progress screen appears on the display.
- 4) When the adjustment is finished, the progress screen disappears and the service screen appears.

6. Analog

This mode is used to check analog data for sensors. This section describes the ultrasonic sensor. The operation check of normal sensors is performed in the “Dcon Check.”

a. Ultrasonic sensor

When [Analog] is selected on the service screen, [USS screen] is displayed.

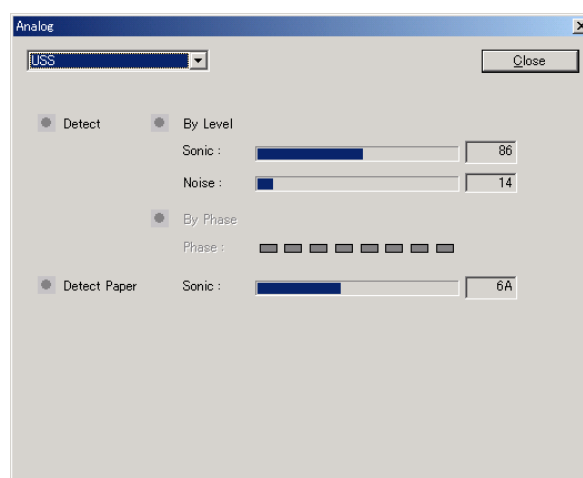

Figure 5-208

When a sheet of paper is set in the ultrasonic sensor section, the “document judgment indicator” is lit red. When more than 2 sheets of paper are set on this section, the “double feed judgment indicator” and the “amplitude judgment indicator” are lit red. The screen displayed when a double feed is detected is shown below.

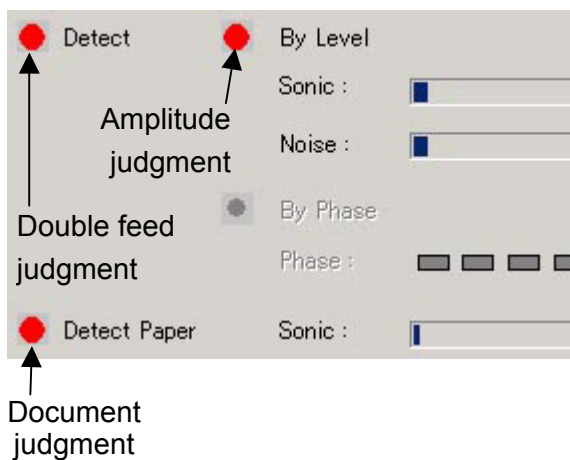

Figure 5-209

b. Sensor

When [Sensor] is selected on the [USS screen] pulldown box, [Sensor] is displayed.

The sensor analog data is displayed. But it is not used in the market.

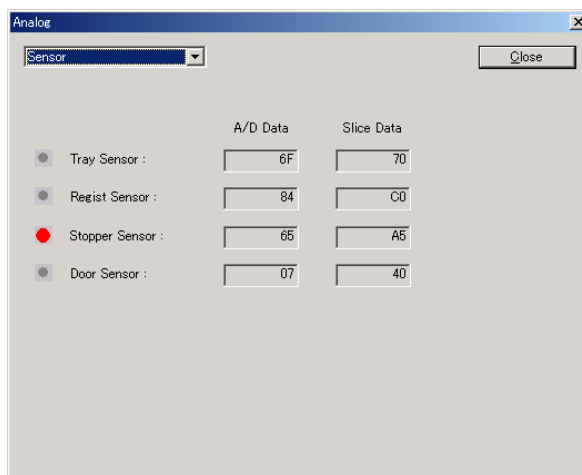

Figure 5-210

7. Firm Load

This mode is used to change the firmware of this machine. For details, refer to the service information issued during firmware changes. Be careful not to execute this mode by mistake.

- Operation procedure outline
- 1) Select [Firm Load] on the service screen.
- 2) The screen for selecting the file of the firmware is displayed.
- 3) Select and open the file.
- 4) The firmware is loaded to this machine.

8. About

This mode is used to check the detailed version of the software for this service mode.

When [About] is selected on the service screen, the version screen is displayed.

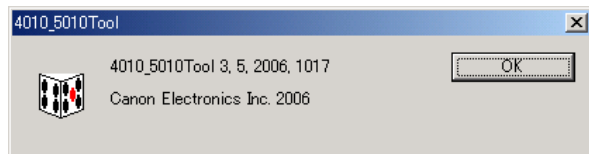

Figure 5-211

9. Max Document Size

This mode is used to set the long document mode. It is set to the standard mode at the factory setting.

The long document mode is settable on the user screen that is the same as the counter reset screen. Refer to the “User Manual” for the details.

When the long document mode is set, the document length is 1000 mm at the maximum, but there are restrictions shown below:

- Document size: “Auto-detection” only
- Document thickness: 0.2 mm or less
- Image size: 128 MB or less
- Feed: Feed a sheet of paper. Performance of paper pickup/eject is not guaranteed.

When [Max Document Size] is selected on the service screen, the setting screen is displayed. To set the long document mode, change the setting to [1000.0(mm)] and press the [OK] button.

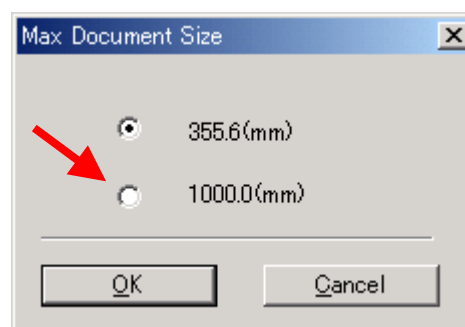

Figure 5-212

10.Dcon Check

This mode is used when checking the operation of the hardware controlled with the control PCB.

- Operation screen

When [Dcon Check] is selected on the service screen, the operation screen is displayed.

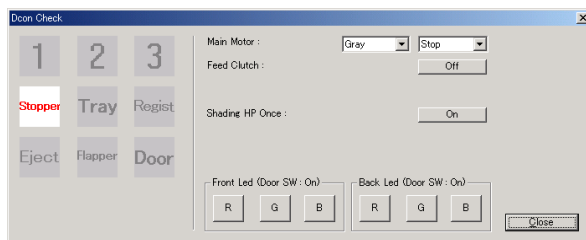

Figure 5-213

- a. Job button

When the job button is pressed, the corresponding mark lights.

The figure below shows that “Job Button 1” is pressed.



Figure 5-214

- b. Sensors

When sensors enter the detection state, the corresponding mark lights.

The figure below shows that the “Stopper sensor” is in the detection state.



Figure 5-215

The contents of marks are shown below.

| Mark | Sensor name | Lighting state |
|---------|-----------------------|---|
| Stopper | Stopper sensor | The stopper is raised. |
| Tray | Document board sensor | A document is set. |
| Regist | Registration sensor | The registration sensor detects a document. |
| Eject | Eject sensor | The eject sensor detects a document. |
| Flapper | Flapper sensor | The flapper is in straight path mode. |
| Door | Open detect switch | The upper unit is open. |

c. Motor, clutch

This section describes the operation check of motor and clutch.

- Main Motor (main motor)
- Feed Clutch (feed clutch)
- Shading HP Once (shading motor)

When a reading mode and a resolution are selected from the pulldown boxes corresponding to "Main Motor", the main motor turns at the speed that meets the condition. Selecting [Stop] causes the motor stop.



Figure 5-216

Selecting the [Off] button for "Feed Clutch" causes it to change to [On] and the function to be performed. When the [On] button is pressed, the previous state is resumed.

Selecting the "On" button for "Shading HP Once" causes the shading motor to start and the upper and lower CIS units to move for 1 cycle.



Figure 5-217

However, each motor does not operate when the upper unit is open.

d. CIS unit LED

When the corresponding LED button is selected, the LED lights.

However, when the upper unit is opened to check lighting, the correct lighting operation is not performed.

Therefore, be sure to close the upper unit and check the lighting operation through the opening on the rear side.

- Operation Procedure
- 1) Open eject tray 2 of main body and position this machine so that the rear side is visible.
 - 2) Selecting a button causes the corresponding LED to be lit on. Select the same button again to reset the LED.

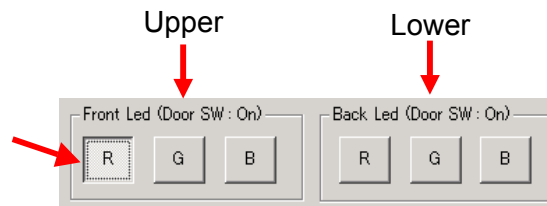

Figure 5-218

- 3) Check operations of the LEDs through the opening in the feed path.

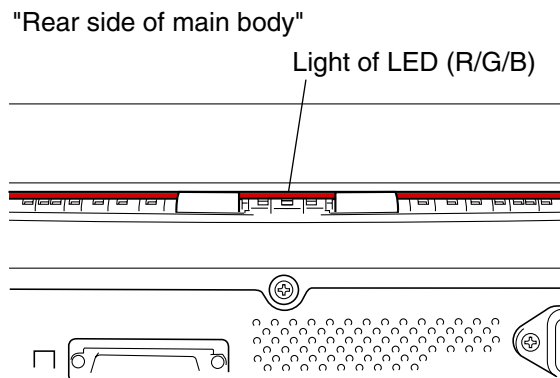

Figure 5-219

11. Check Device

This mode is used to check the versions of the main body firmware and the internal devices of this machine.

When [Check Device] is selected on the service screen, the version screen is displayed.

“MAIN” indicates the firmware of the control PCB and “DFD SUB” indicates the version number of the firmware of the ultrasonic sensor PCB.

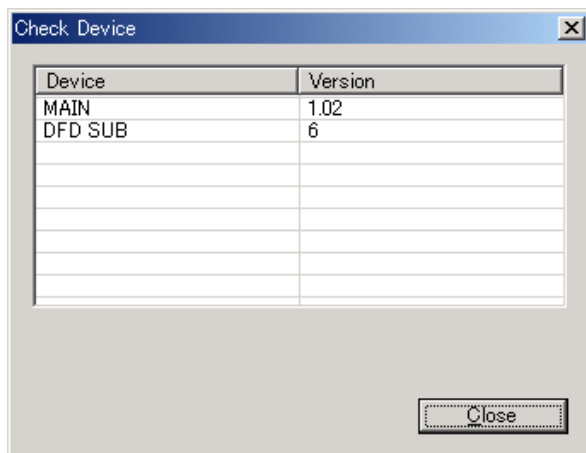

Figure 5-220

12. Sleep

This mode is used to set so that the sleep mode is not effective. However, the sleep mode OFF is not the standard specification, so it is used for special users only. Do not use it for general users.

When [Sleep] is selected on the service screen, the setting screen is displayed. To set the sleep mode OFF, change the setting to [Sleep Mode Off] and press the [OK] button.

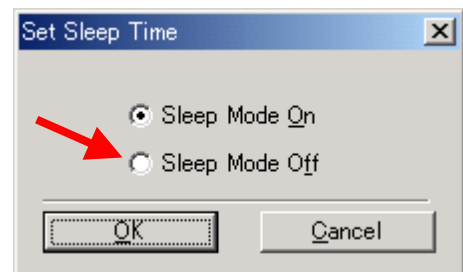

Figure 5-221

13. SCSI Transfer

This mode is used to change the maximum value of the synchronizing transfer speed of the SCSI interface.

However, there is normally no problem with the factory setting (20 MB/sec), so change the setting only if the machine does not function properly.

When [SCSI Transfer] is selected on the service screen, the setting screen is displayed. Change the setting as required and press the [OK] button.

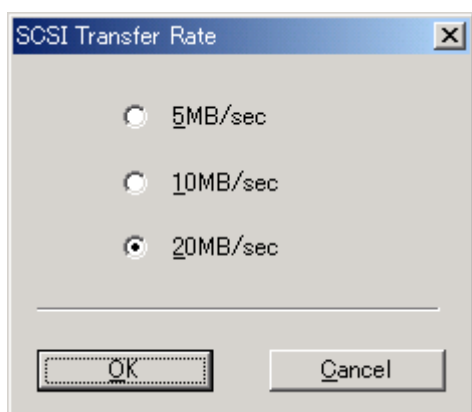

Figure 5-222

14. Counter

This mode is used to display/change the total scanning count and display/change the number of document jams.

When [Counter] is selected on the service screen, the counter screen is displayed.

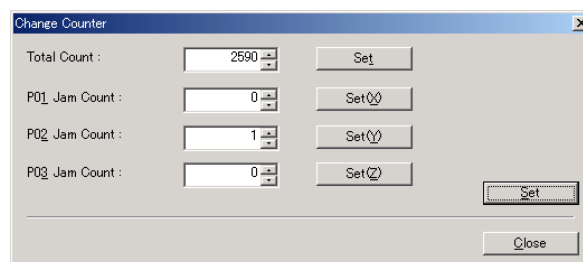

Figure 5-223

The contents of display are as follows:

- Total Count
Indicates the total scanning count.
- P01_Jam Count
Indicates the number of early reach jams.
- P02_Jam Count
Indicates the number of residual jams.
- P03_Jam Count
Indicates the number of fast feed jams.

When the [Set] button on the right or the [Set] on the lower right of the screen is selected after the value is changed, the changed value is determined.

To close the screen, press the [Close] button.

These values might be changed if the control PCB is replaced. Therefore, inputting the values again is required after the replacement. If the values before the replacement are not clear, it is better to input the recommended values.

The “Roller Replacement” counter is also changed when the controller PCB is replaced or the “Total Count” is changed. When the user switches the machine power ON for the next time, the “Replacing the Roller” message may appear or the “Current Rollers” counter may indicate an abnormal count. After exiting from the service mode, therefore, be sure to check the count of “Current Rollers” and reset it if necessary.



Figure 5-224

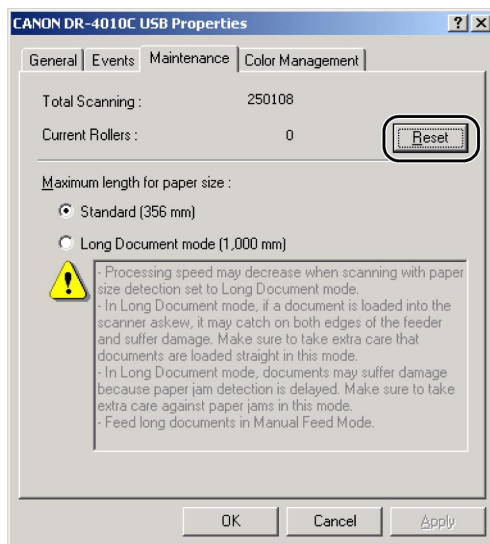

Figure 5-225

15. Mechanical Feed Mode

This machine also supports a mechanical feed mode to check the feed condition without using a computer. This mode is not the service mode to use the service tool. Use this mode if necessary. However, this mode should not be available to the users.

The mechanical feed mode can be activated by pressing the buttons on the operation panel as follows.

- 1) Turn ON the power switch with Job Buttons 1 and 2 pressed with a finger.
- 2) Press off Job Buttons 1 and 2 after the power indicator lights.
- 3) When it is in the mechanical feed mode, the power indicator keeps blinking.

If Job Button 1 is pressed while in the mechanical feed mode, with documents in the document board, the machine will feed the documents at high speed.

Pressing Job Button 3 once causes the mode to change to the low speed (equivalent to 400/600 dpi) and pressing it again returns the mode to the high speed. Images are not scanned at this time.

To end the mechanical feed mode, turn the power OFF.

16. “About” Screen

The version of the main body firmware and other information are available from a screen that the user can use.

Select the [About] button in the basic tag screen of the driver causes the “About” screen to appear.

The screen shows the versions of the driver and the main body firmware and the total scanning count.

Information on these items is available from the user.

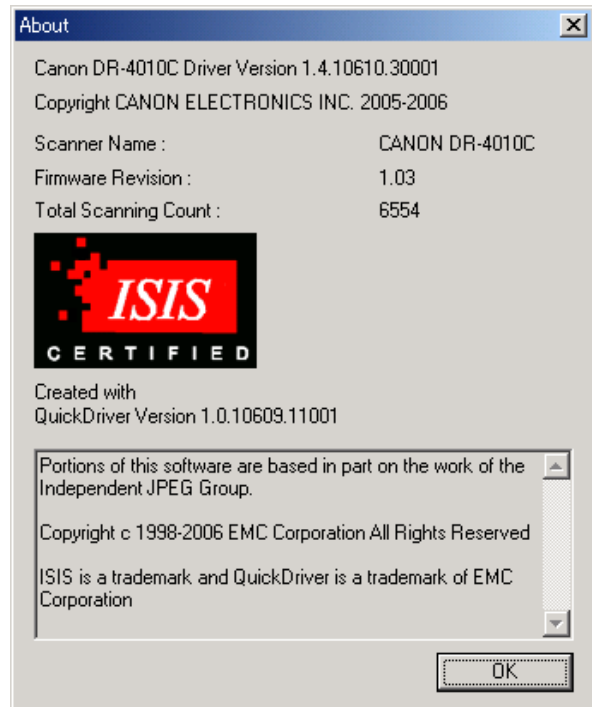
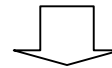
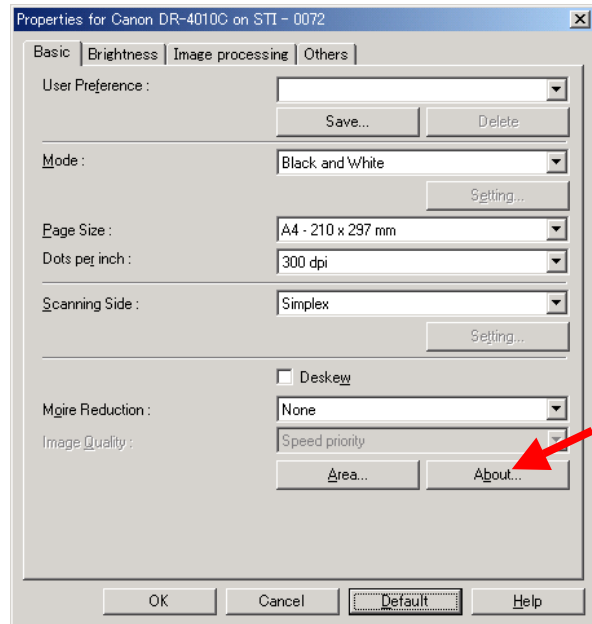

Figure 5-226

III. LIST OF FAILURES

The lists below give the major failures conditions and their causes. Refer to the next section for details of the causes and the measures to be taken.

1. Operation Failures

Note: Major causes of each failure are marked "X."

| No. | Failure | Cause | System/ Software | Hard- ware | Conne- tion | Dirt | Docu- ment | Setting |
|-----|----------------------------|-------|---------------------|---------------|----------------|------|---------------|---------|
| 1 | No power | | | X | X | | | |
| 2 | Not recognized by computer | | X | | X | | | |
| 3 | Scanning does not start | | X | X | X | | | X |
| 4 | Jam, double feed, skew | | | X | | X | X | |
| 5 | Slow scanning speed | | X | | | | | X |

Table 5-301

2. Images Failures

Note: Major causes of each failure are marked "X."

| No. | Failure | Cause | System/ Software | Hard- ware | Conne- tion | Dirt | Docu- ment | Setting |
|-----|---|-------|---------------------|---------------|----------------|------|---------------|---------|
| 1 | Completely black, completely white, all streaks | | | X | | X | | X |
| 2 | Too dark, too light | | | | | X | | X |
| 3 | Black borders around image | | | | | | X | X |
| 4 | Image skews | | | | | | X | X |
| 5 | Moire on image | | | | | | X | X |
| 6 | Streaks and spots on image | | | X | | X | | |
| 7 | Outer areas of image disappear | | | | | | X | X |

Table 5-302

IV. OPERATION TROUBLESHOOTING

When an operation failure occurs, first check for an “Error Messages” on the display connected to the computer. In addition, check the operation of the various sensors, motors using the “Service Modes.”

1. No Power

This machine power indicator does not light.

| Cause/faulty location | Step | Check item | Result | Action |
|---------------------------------|------|---|--------|--|
| Connection of power cord | 1 | Is the power cord connected? | NO | Connect it properly. |
| AC power supply voltage | 2 | Is the specified voltage being supplied at the outlet? | NO | Explain to the user that the trouble is not with this machine. |
| Power switch | 3 | Is the power switch turned ON? | NO | Turn the power switch ON. |
| Power cord | 4 | Is the problem solved when the power cord is replaced? | YES | End. |
| Operation PCB | 5 | Are the cables connected to the operation PCB? | NO | Connect it properly. |
| Bottom plate unit (connection) | 6 | Are the power related cables connected? | NO | Connect it properly. |
| Power supply PCB Control PCB | 7 | Is the problem solved when the power supply PCB or the control PCB is replaced? | YES | End. |

Table 5-401

2. Not Recognized by Computer

| Cause/faulty location | Step | Check item | Result | Action |
|--|------|---|--------|---|
| Power supply | 1 | Is the power supplied to this machine? | NO | Perform the actions in section 1: "No power." |
| Connection of SCSI/USB interface cable | 2 | Is the SCSI/USB interface cable properly connected? | NO | Connect it properly. |
| Power-on sequence | 3 | Was the power to this machine turned ON before the computer was turned ON in the case of the SCSI connection? | NO | Follow the proper power-on sequence. |
| SCSI ID settings | 4 | Is the SCSI ID set properly? | NO | Set them properly. |
| Computer, I/F card | 5 | Are the computer and I/F card set properly? | NO | Use them properly. |

Table 5-402

3. Scanning Does Not Start

Note: If a sensor failure occurs an error message such as “Paper jam” or “Double feed” may be shown. This will prevent the scanning operation from starting.

| Cause/faulty location | Step | Check item | Result | Action |
|--------------------------|------|---|--------|--|
| System | 1 | Is the problem solved when the scanner power is reset and the computer is restarted? | YES | End. |
| Software | 2 | Is the problem solved when the scanner driver and the application are reinstalled? | YES | End. |
| Connector connection | 3 | Are the connectors for the faulty motor or sensor connected properly? | NO | Connect them properly. |
| Transmission system load | 4 | Is the transmission system driven by the motor normal? Are such parts as gears and belts normal? | NO | Remove the abnormal load. Replace needed parts. |
| Sensor | 5 | Is the operation normal when checking the sensor detection display in the service mode? | NO | Check the attachment of the sensor and light guide. Check the cable connections for the sensor. |
| Motor, clutch | 6 | Is the operation normal when checking the operation in the service mode? | NO | Check the cable connections. Replace the motor, clutch. |
| Control PCB | 7 | Is the problem solved when the control PCB is replaced? | YES | End. |

Table 5-403

4. Jam, Double Feed, Skew

Note: If a sensor failure occurs an error message such as “Paper jam” or “Double feed” may be shown.

| Cause/faulty location | Step | Check item | Result | Action |
|---|------|---|--------|--|
| Document | 1 | Is the document within the specifications (thickness, dimensions, fold, curl, etc.)? | NO | Ask the user to use documents within the specifications. |
| Roller | 2 | Are the roller unit and the retard roller properly mounted? | NO | Mount them properly. |
| | 3 | Are they dirty or deformed? | NO | Clean or replace them. |
| Parts in feed path | 4 | Are all parts that the documents contact properly mounted (not loose or tilted)? | NO | Mount them properly. |
| | 5 | Is the surface in contact with the document smooth (not scratched, no burrs)? | NO | Replace faulty parts. |
| Drive transmission system | 6 | Is any abnormal noise emitted when feeding documents? Are any gears broken or is the belt loose? | YES | Replace faulty parts. Tighten the belt properly. |
| Sensors (document board, registration, eject) | 7 | Are the sensors and the light guide properly mounted? | NO | Mount them properly. |
| | 8 | Are the cables for each sensor properly connected? | NO | Connect them properly. |
| Ultrasonic sensor | 9 | Is the ultrasonic sensor properly mounted? | NO | Mount them properly. |
| | 10 | Is the problem solved when the ultrasonic sensor is replaced? | YES | End. |

Table 5-404

5. Slow Scanning Speed

The basic scanning speed of this machine is 42 sheets per minute. (A4/200 dpi)

Selecting higher resolutions, color setting and/or special functions further makes the scanning speed slower.

Should the scanning speed be too slow after taking all of these considerations, the possible causes are as listed below.

| Cause/Faulty location | Step | Check item | Result | Action |
|--|------|--|--------|---|
| Insufficient memory capacity in computer | 1 | Is memory capacity sufficient? | NO | Add the memory capacity. |
| | 2 | Is any other application started up? | YES | Close other applications. |
| | 3 | Is any resident application started up such as a virus protection application? | YES | Close resident applications. |
| | 4 | Is the hard disk short of empty capacity? | YES | Increase empty capacity of the hard disk. |
| Hi-Speed USB2.0 is not supported | 5 | Is the USB port supported? | NO | Use a supported computer. |
| | 6 | Is the USB cable supported? | NO | Use a supported USB cable. |
| SCSI-III is not supported | 5 | Is the SCSI card supported? | NO | Use a supported SCSI card. |
| | 6 | Is the SCSI cable supported? | NO | Use a supported SCSI cable. |

Table 5-405

V. IMAGE TROUBLESHOOTING

◆ Image Samples

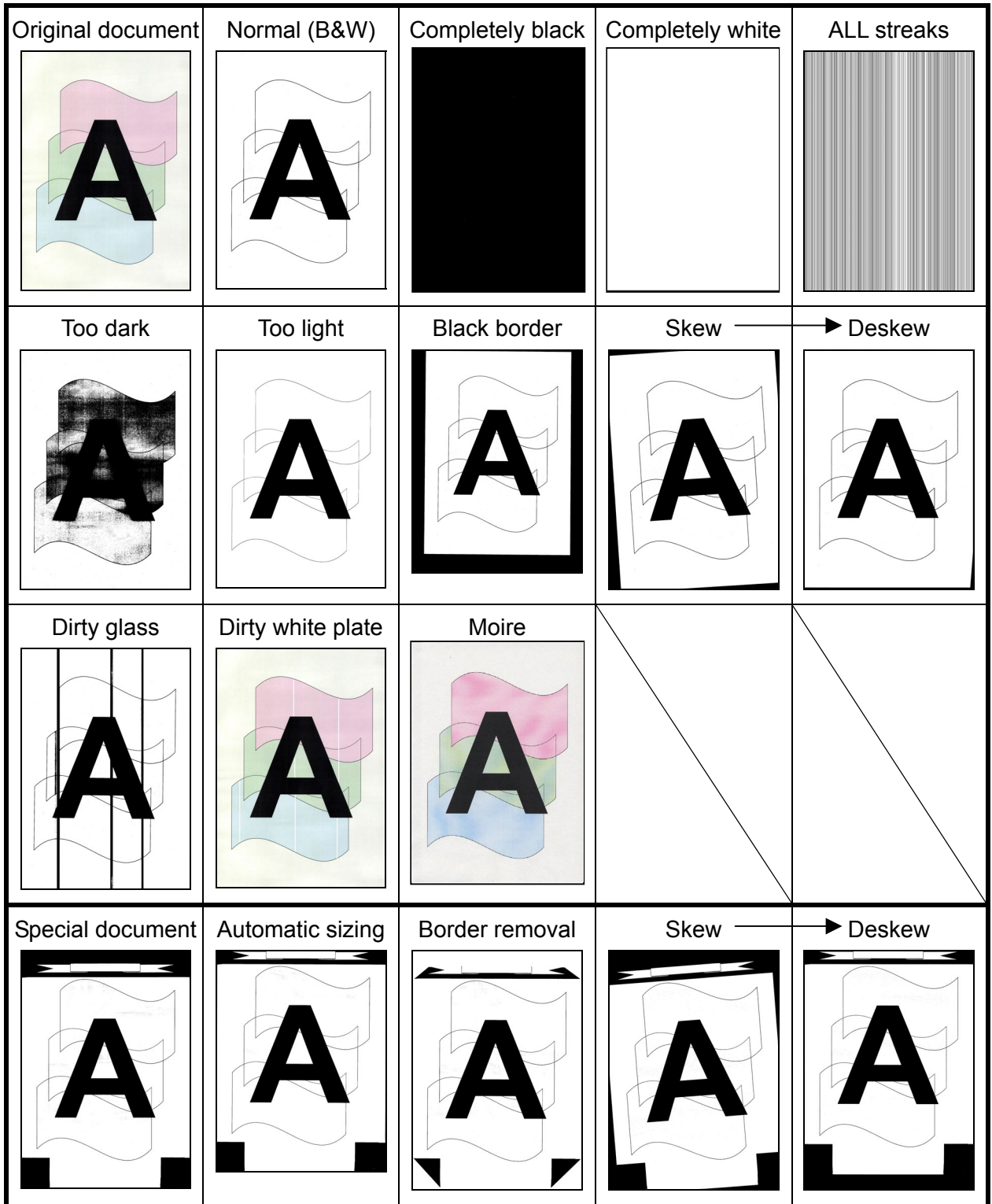

Figure 5-501

Note: There are times when, depending on the type of image and settings, document reproducibility becomes poor. In such case, the image may be improved by changing the settings.

1. Completely Black, Completely White, All Streaks

Completely Black, Completely White, or All Streaks are output.

| Cause/faulty location | Step | Check item | Result | Action |
|-----------------------|------|--|--------|--|
| "Brightness" setting | 1 | Is the "Brightness" setting appropriate? | NO | Change the setting. Also change "Contrast" if necessary. |
| Reading glass | 2 | Are the reading glasses clean? | NO | Clean the reading glasses. If necessary, clean the roller too. |
| System | 3 | Is the problem solved when the scanner power is reset and the computer is restarted? | YES | End. |
| LED adjustment | 4 | Is the problem solved when performing "LED Adjustment" in the service mode? | YES | End. |
| Reading unit | 5 | Are the reading related cables connected properly? | NO | Check all connections. |
| | 6 | Is the problem solved when the reading unit is replaced? | YES | End. |
| Control PCB | 7 | Is the problem solved when the control PCB is replaced? | YES | End. |

Table 5-502

2. Too Dark, Too Light

Image does not look appropriate due to improper brightness.

| Cause/faulty location | Step | Check item | Result | Action |
|--------------------------|------|--|--------|---|
| "Brightness" setting | 1 | Is the "Brightness" properly set? The brightness should be set to "128" in normal case but may be required to change according to the type of document. | NO | Change the setting. Adjust the "Contrast" in addition if necessary. |
| Dark background document | 2 | Are the special modes such as "Advanced Text Enhancement" selected? | NO | Select. Dark background is removed and the scanned image looks better. |

Table 5-503

3. Black Borders Around Image

Black borders appear around the images.

Note, however, that borders having a thickness of about 1 mm are within the specifications, so they are not a failure.

| Cause/faulty location | Step | Check item | Result | Action |
|---|------|--|--------|---|
| "Page Size" setting | 1 | Is the "Page Size" properly set? | NO | Change the setting. |
| Document setting | 2 | Is the document set at the correct position? | NO | Set at the correct position. |
| Setting of "Auto-detection" for page size or "Border Removal" | 3 | Is "Auto-detection" or "Border Removal" set? | NO | Set. Black border can be removed by image processing. |

Table 5-504

4. Image Skews

If the document skews when fed, the scanned image also skews.

| Cause/faulty location | Step | Check item | Result | Action |
|-----------------------|------|-------------------------------|--------|--|
| Document setting | 1 | Is the document properly set? | NO | Properly set the document. |
| "Deskew" setting | 2 | Is the "Deskew" set? | NO | Set. Slant can be corrected by image processing. |
| Document feeding | 3 | Is the document fed straight? | NO | Carry out check items listed in "IV. OPERATION TROUBLESHOOTING 4. Jam, Double Feed, Skew." |

Table 5-505

5. Moire on Image

Moire is likely to appear when a photograph is color scanned with a low resolution from a magazine or a catalog.

| Cause/faulty location | Step | Check item | Result | Action |
|---------------------------|------|-------------------------------|--------|--------------------------|
| "Moire Reduction" setting | 1 | Is the "Moire Reduction" set? | NO | Set. |
| | | | YES | Heighten the resolution. |

Table 5-506

6. Streaks and Spots on Image

If the reading glass surface is dirty, streaks appear on the scanned images in the feed direction. If the feed roller has spots, they may be copied on the scanned images.

On the other hand, white streaks appearing on the scanned images are, in most cases, caused by the problem with the standard white sheet. The standard white sheet of this machine must not be touched.

| Cause/faulty location | Step | Check item | Result | Action |
|--------------------------------|------|--------------------------------|--------|---|
| Reading glasses | 1 | Are the reading glasses clean? | NO | Clean the reading glasses. Replace the reading glasses if scratches are found. |
| Roller unit and separation pad | 2 | Are the surfaces clean? | NO | Clean or replace the roller unit and/or the separation pad. |
| Feed unit | 3 | Is the feed path clean? | NO | Clean the feed path. |
| CIS unit | 4 | Is the CIS unit inside clean? | NO | Clean or replace the reading unit. |

Table 5-507

7. Outer Areas of Image Disappear

When scanning a document with characters, photographs, illustrations, etc. reaching the edges of it, selecting the "Auto-detection," the "Deskew" or the "Border Removal" may cause the outer areas to disappear from the scanned image.

| Cause/faulty location | Step | Check item | Result | Action |
|-----------------------|------|--|--------|---|
| Document | 1 | Does any of the document edges have black-colored object(s)? | YES | Set off such functions as the "Auto-detection." |
| | 2 | Does any of the document edges have object(s) that is brighter than black? | YES | Scan the document using the "24-bit Color". This may result in a correctly scanned image. |

Table 5-508

VI. AFTER REPLACING PARTS

Some of the parts used in this machine require adjustments and settings after being replaced or disassembled/reassembled.

Check document feed and images after the replacement or disassembly/reassembly of the parts.

1. Control PCB

- 1) When the SCSI is used, the SCSI ID must be set.
- 2) Perform "All Adjustment," "Counter" in the service mode.
- 3) Perform the following service mode settings as required.
 - "Max Document Size"
 - "Sleep"
 - "SCSI Transfer"

2. Reading Unit

Perform "All Adjustment" in the service mode.

3. Registration Related Parts

Perform "Regist Adjustment" in the service mode if the leading edge and trailing edge of a read image is faulty after replacing or reassembling parts related to registration such as a registration sensor, sensor lever.

APPENDIX

| | |
|--------------------------|-----|
| I. GENERAL DIAGRAM | A-1 |
|--------------------------|-----|

I. GENERAL DIAGRAM

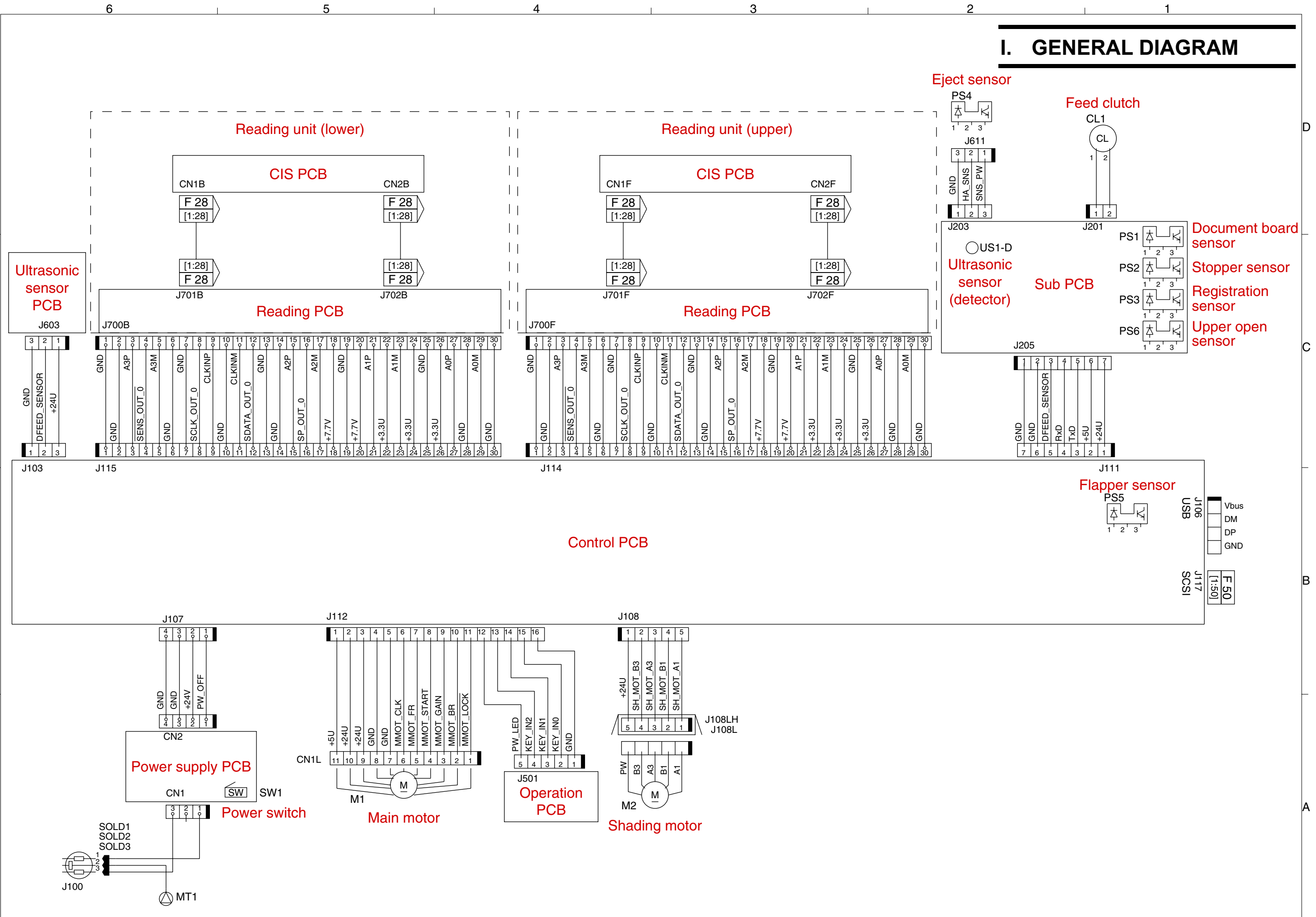

Prepared by

**Quality Assurance Center
Canon Electronics Inc.**

**3-17-7 Shibaura, Minato-ku
Tokyo 108-0023, Japan**

FIRST EDITION: NOV. 2006 (63999)

Canon