

PARTS CATALOG

MF8050Cn/MF8030Cn Series

Canon

Jul 20 2009

PREFACE

This Parts Catalog contains listings of parts used

Diagrams are provided with the listings to aid the service technician in identifying clearly, the item to be ordered.

Whenever ordering parts, consult this Parts Catalog for all of the information pertaining to each item. Be sure to include, in the Parts Request, the full item description, the item part number, and the quantity.

COPYRIGHT (C) 1999 CANON INC.

Use of this manual should be strictly supervised to avoid disclosure of confidential information.

Contents

NUMERICAL INDEX

MF8050Cn/MF8030Cn Series(Numerical Index)..... 1-1

MF8050Cn/MF8030Cn Series(Parts Catalog)

A	ASSEMBLY LOCATION DIAGRAM	2-1
001	ACCESSORIES	2-2
100	EXTERNAL COVERS, PANELS, ETC.	2-4
101	INTERNAL COMPONENTS 1	2-6
102	INTERNAL COMPONENTS 2	2-8
103	INTERNAL COMPONENTS 3	2-10
104	INTERNAL COMPONENTS 4	2-13
105	INTERNAL COMPONENTS 5	2-15
160	READER/ADF ASSEMBLY	2-17
162	PAPER FEEDER ASSEMBLY	2-20
300	CASSETTE ASSEMBLY	2-22
400	READER ASSEMBLY	2-23
810	FIXING ASS'Y	2-25
900	MAIN CONTROLLER PCB ASS'Y	2-27
ZZA	MECHANICAL STANDARD PARTS (HOW TO USE)	2-28
ZZB	MECHANICAL STANDARD PARTS (SCREWS)	2-29
ZZC	MECHANICAL STANDARD PARTS (BOLTS)	2-36
ZZD	MECHANICAL STANDARD PARTS (NUTS)	2-37
ZZE	MECHANICAL STANDARD PARTS (RETAINING RINGS)	2-38

NUMERICAL INDEX

MF8050Cn/MF8030Cn Series(Numerical Index)

PARTS NUMBER	FIGURE & KEY NO.	PARTS NUMBER	FIGURE & KEY NO.	PARTS NUMBER	FIGURE & KEY NO
FC5-5256-000	100 - 1	FC9-7565-000	160 - 18	FM4-1502-000	100 - 13
FC7-6052-000	162 - 1	FC9-7566-000	160 - 18	FM4-1503-000	100 - 13
FC7-6189-000	160 - 1	FC9-7567-000	160 - 18	FM4-1504-000	100 - 13
FC7-6297-000	162 - 2	FC9-7568-000	160 - 18	FM4-1505-000	100 - 13
FC7-6299-000	162 - 3	FC9-7571-000	400 - 3	FM4-1879-000	162 -
FC7-6300-000	162 - 4	FC9-7573-000	400 - 3	FM4-1880-000	162 - 13
FC7-6320-000	160 - 2	FC9-7574-000	400 - 3	FM4-1881-000	162 - 14
FC7-6321-000	160 - 3	FH2-7080-000	102 - 11	FM4-1882-000	162 - 31
FC7-6322-000	160 - 4	FH2-7082-000	102 - 11	FM4-1883-000	160 - 22
FC7-9827-000	104 - 1	FH2-7170-000	102 - 11	FM4-1885-000	162 - 11
FC7-9828-000	104 - 2	FK2-4390-000	102 - 11	FM4-3653-000	400 - 7
FC7-9868-000	101 - 1	FK2-5274-000	001 - 13	FM4-3676-000	105 - 3
FC7-9869-000	101 - 2	FK2-5275-000	001 - 1	FM4-3678-000	102 - 3
FC9-1486-000	160 - 13	FK2-5281-000	001 - 3	FM4-3679-000	102 - 3
FC9-1503-000	160 - 5	FK2-8321-000	900 - 1C	FM4-3683-000	105 - 9
FC9-1512-000	162 - 5	FK2-8643-000	001 - 17	FM4-3684-000	102 - 3
FC9-1523-000	162 - 6	FK2-8767-000	105 - 7	FM4-3690-000	105 - 6
FC9-1526-000	162 - 7	FK2-9581-000	400 - 4	FM4-3695-000	102 - 4
FC9-1532-000	160 - 6	FK2-9582-000	105 - 2	FM4-3696-000	102 - 4
FC9-1533-000	160 - 7	FK2-9583-000	102 - 11	FM4-3970-000	102 - 2
FC9-1534-000	160 - 8	FK2-9861-000	400 - 5	FM4-3971-000	102 - 2
FC9-1535-000	160 - 9	FK2-9877-000	001 - 18	FM4-3972-000	102 - 2
FC9-1536-000	160 - 10	FK2-9879-000	001 - 10	FM4-3973-000	102 - 2
FC9-1539-000	160 - 11	FK2-9880-000	001 - 10	FM4-3976-000	900 -
FC9-1650-000	400 - 1	FK2-9881-000	001 - 10	FM4-3977-000	900 -
FC9-2101-000	400 - 2	FK2-9882-000	001 - 10	FM4-3985-000	105 - 5
FC9-4440-000	100 - 2	FK2-9883-000	001 - 10	FM4-3989-000	105 - 4
FC9-4441-000	100 - 3	FK2-9884-000	001 - 10	FM4-4262-000	100 - 14
FC9-4442-000	100 - 4	FK2-9885-000	001 - 10	FM4-4263-000	300 -
FC9-4443-000	100 - 5	FL2-6637-000	160 - 19	FM4-4266-000	100 - 15
FC9-4446-000	100 - 6	FL3-1431-000	162 - 9	FM4-4300-000	400 -
FC9-4449-000	100 - 7	FL3-1437-000	162 - 10	FM4-4301-000	400 - 8
FC9-4451-000	100 - 8	FL3-2326-000	102 - 17	FM4-4307-000	400 - 9
FC9-4452-000	100 - 9	FL3-2453-000	160 - 20	FM4-4308-000	400 - 6
FC9-4454-000	100 - 10	FL3-2458-000	162 - 12	FU5-6992-000	162 - 15
FC9-4455-000	104 - 3	FL3-3539-000	160 - 21	FU6-2998-000	162 - 16
FC9-4456-000	104 - 4	FM3-3434-000	810 - 1	FU6-2999-000	162 - 17
FC9-4502-000	160 - 12	FM3-3435-000	810 -	FU7-0667-000	162 - 18
FC9-4507-000	105 - 1	FM3-3441-000	101 - 3	FU7-0668-000	162 - 19
FC9-4510-000	001 - 12	FM3-3453-000	101 - 4	FU7-0669-000	162 - 20
FC9-4584-000	100 - 11	FM3-3454-000	103 - 27	FU7-0671-000	162 - 21
FC9-5109-000	160 - 13	FM3-3455-000	104 - 5	FU7-0672-000	160 - 25
FC9-5110-000	160 - 13	FM3-5378-000	102 - 1	FU7-0676-000	162 - 22
FC9-5115-000	160 - 13	FM3-9538-000	160 - 23	FU7-0678-000	162 - 23
FC9-5654-000	162 - 8	FM4-1493-000	100 - 12	FU7-2016-000	162 - 24
FC9-5655-000	160 - 14	FM4-1495-000	100 - 13	FU7-2018-000	160 - 26
FC9-5656-000	160 - 15	FM4-1496-000	100 - 13	FU7-8088-000	100 - 16
FC9-5657-000	160 - 16	FM4-1497-000	100 - 13	FU7-8089-000	100 - 17
FC9-7561-000	160 - 17	FM4-1498-000	100 - 13	FU7-8090-000	100 - 18
FC9-7562-000	160 - 17	FM4-1499-000	100 - 13	FU7-8091-000	100 - 20
FC9-7563-000	160 - 17	FM4-1500-000	100 - 13	FU7-8093-000	001 - 14
FC9-7564-000	160 - 17	FM4-1501-000	100 - 13	FU7-8094-000	001 - 9

NUMERICAL INDEX

MF8050Cn/MF8030Cn Series(Numerical Index)

PARTS NUMBER	FIGURE & KEY NO.	PARTS NUMBER	FIGURE & KEY NO.	PARTS NUMBER	FIGURE & KEY NO.
FU7-8405-000	160 - 27	RC2-2007-000	101 - 14	RU6-2042-000	101 - 7
FU7-8406-000	160 - 27	RC2-2014-000	103 - 30	VS1-7177-002	810 - 3
FU7-8407-000	160 - 27	RC2-2111-000	103 - 3	VS1-7177-003	400 - 10
FU7-8408-000	160 - 27	RC2-2112-000	103 - 4	VS1-7177-004	400 - 11
FU7-8410-000	160 - 27	RC2-2142-000	103 - 5	VS1-7207-004	162 - 29
FU7-8411-000	001 - 11	RC2-2143-000	103 - 6	WG8-5696-000	102 - 15
FU7-8413-000	001 - 11	RC2-2144-000	103 - 7	WG8-5696-000	162 - 30
FU8-0895-000	160 - 28	RC2-2146-000	810 - 2	WG8-5696-000	400 - 12
FU8-2007-000	160 - 29	RC2-2871-000	104 - 11	WG8-5696-000	810 - 5
FU8-2008-000	162 - 25	RC2-2872-000	104 - 12	XA9-0476-000	160 - 32
FU8-2010-000	162 - 26	RC2-2877-000	104 - 13	XA9-0476-000	400 - 13
HB1-4978-000	001 - 15	RC2-2878-000	104 - 14	XA9-0831-000	160 - 24
HC1-0586-000	160 - 30	RC2-2879-000	103 - 8	XA9-1420-000	810 - 4
HC1-0586-000	162 - 27	RC2-2880-000	103 - 9	XA9-1449-000	103 - 28
HC1-2034-000	001 - 16	RC2-2881-000	103 - 10	XA9-1449-000	105 - 13
HK1-0175-000	001 - 4	RC2-2887-000	102 - 9	XA9-1561-000	104 - 19
HU1-1022-000	160 - 31	RC2-2889-000	105 - 12	XA9-1671-000	100 - 19
HU1-1022-000	162 - 28	RC2-2899-000	103 - 11	XA9-1671-000	102 - 18
NPN	001 -	RC2-2902-000	103 - 12	XA9-1671-000	103 - 29
NPN	100 -	RC2-2904-000	103 - 13	XA9-1671-000	104 - 20
NPN	101 -	RC2-2906-000	103 - 14	XA9-1671-000	105 - 14
NPN	102 -	RC2-2907-000	103 - 15	XD9-0104-000	102 - 16
NPN	103 -	RC2-3071-000	102 - 10		
NPN	104 -	RC2-3100-000	103 - 16		
NPN	105 -	RC2-3108-000	104 - 15		
NPN	160 -	RC2-3109-000	104 - 16		
QK1-6441-000	001 - 5	RK2-1872-000	104 - 17		
QK1-6443-000	001 - 7	RK2-1955-000	105 - 8		
QK1-6446-000	001 - 6	RL1-1617-000	102 - 12		
QK1-6449-000	001 - 8	RL1-1844-000	103 - 17		
QK1-6455-000	001 - 2	RL1-1845-000	103 - 18		
RC2-0062-000	100 - 1	RL1-1846-000	103 - 19		
RC2-1784-000	104 - 6	RL1-1849-000	101 - 17		
RC2-1819-000	102 - 5	RL1-1850-000	101 - 15		
RC2-1820-000	102 - 6	RM1-4425-000	103 - 31		
RC2-1821-000	102 - 7	RM1-4426-000	103 - 32		
RC2-1822-000	103 - 1	RM1-4428-000	104 - 18		
RC2-1823-000	105 - 10	RM1-4430-000	810 -		
RC2-1824-000	103 - 2	RM1-4431-000	810 -		
RC2-1830-000	105 - 11	RM1-4432-000	810 - 1		
RC2-1871-000	104 - 7	RM1-4433-000	810 - 1		
RC2-1872-000	104 - 8	RM1-4436-050	103 - 20		
RC2-1878-000	101 - 8	RM1-4443-000	102 - 13		
RC2-1879-000	101 - 9	RM1-4445-000	103 - 25		
RC2-1882-000	101 - 10	RM1-4448-000	103 - 21		
RC2-1883-000	101 - 11	RM1-4459-000	101 - 16		
RC2-1911-000	104 - 9	RM1-4478-000	102 - 14		
RC2-1914-000	104 - 10	RM1-4482-000	103 - 22		
RC2-1922-000	102 - 8	RM1-4483-000	103 - 23		
RC2-1993-000	101 - 12	RM1-4689-000	103 - 24		
RC2-1997-000	101 - 13	RU6-2016-000	101 - 6		
RC2-2006-000	101 - 5	RU6-2017-000	103 - 26		

MF8050Cn/MF8030Cn Catalog)

Series(Parts

Satera MF8050Cn

JP F15-7811-000 EYR

Satera MF8030Cn

JP F15-7812-000 EZP

Color imageCLASS MF8050Cn

US F15-7831-000 EXP

CA F15-7831-000 EYT

imageCLASS MF8050Cn

ASIA F15-7841-000 EYV

CN F15-7851-000 EYX

KR F15-7861-000 EYY

AU F15-7881-000 EYW

imageCLASS MF8030Cn

ASIA F15-7842-000 EZJ

CN F15-7852-000 EZB

KR F15-7862-000 EZG

i-SENSYS MF8050Cn

EUR1 F15-7891-000 EYA

EUR2 F15-7891-000 EYC

EUR3 F15-7891-000 EYD

i-SENSYS MF8030Cn

EUR1 F15-7892-000 EYZ

EUR2 F15-7892-000 EZA

Contents

A	ASSEMBLY LOCATION DIAGRAM	2-1
001	ACCESSORIES	2-2
100	EXTERNAL COVERS, PANELS, ETC.	2-4
101	INTERNAL COMPONENTS 1	2-6
102	INTERNAL COMPONENTS 2	2-8
103	INTERNAL COMPONENTS 3	2-10
104	INTERNAL COMPONENTS 4	2-13
105	INTERNAL COMPONENTS 5	2-15
160	READER/ADF ASSEMBLY	2-17
162	PAPER FEEDER ASSEMBLY	2-20
300	CASSETTE ASSEMBLY	2-22
400	READER ASSEMBLY	2-23
810	FIXING ASS'Y	2-25
900	MAIN CONTOROLLER PCB ASS'Y	2-27
ZZA	MECHANICAL STANDARDS PARTS (HOW TO USE)	2-28
ZZB	MECHANICAL STANDARD PARTS (SCREWS).....	2-29
ZZC	MECHANICAL STANDARD PARTS (BOLTS).....	2-36
ZZD	MECHANICAL STANDARD PARTS (NUTS).....	2-37
ZZE	MECHANICAL STANDARD PARTS (RETAINING RINGS)	2-38

FIGURE A ASSEMBLY LOCATION DIAGRAM

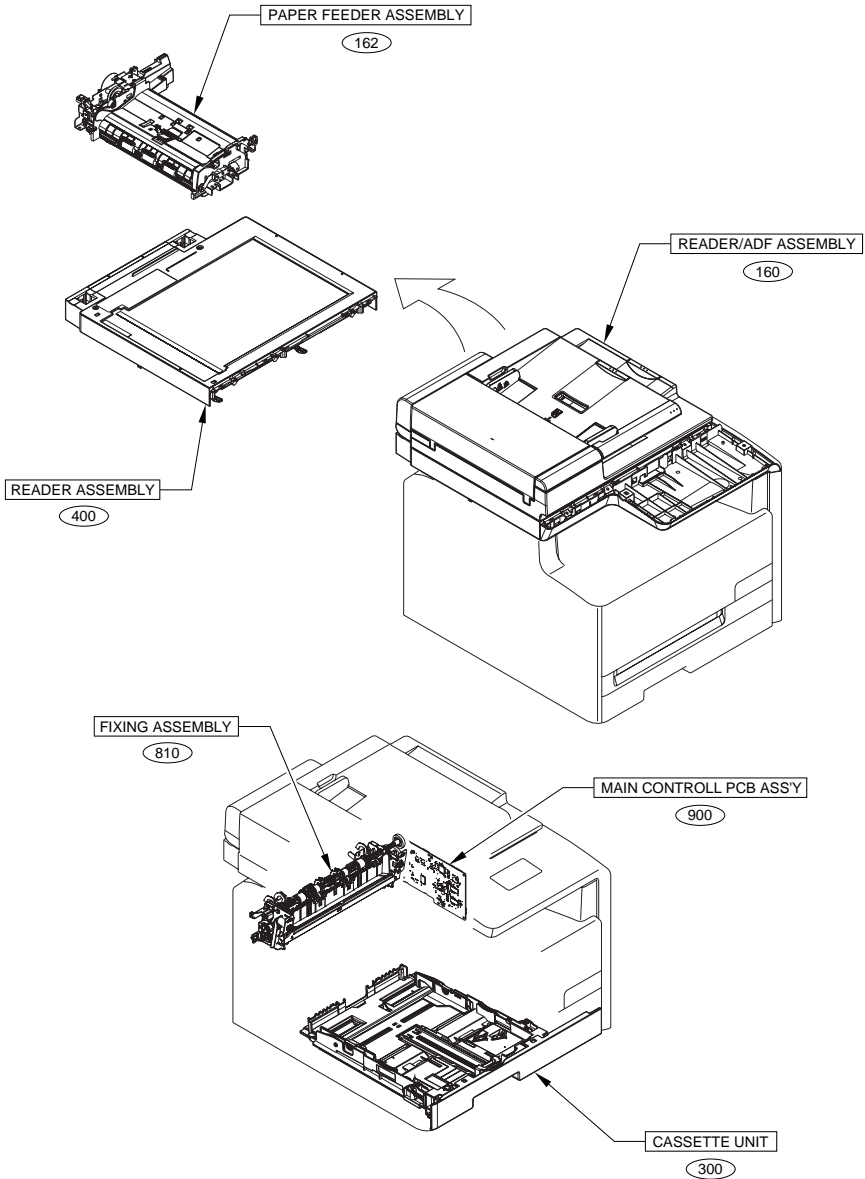
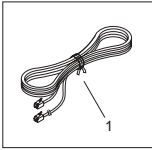
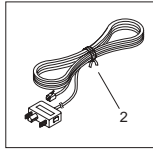

FIGURE 001 ACCESSORIES



JP,CN,ASIA,US,CA,EUR



AU

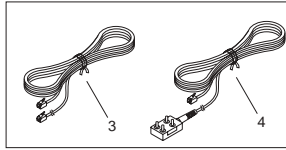

KR

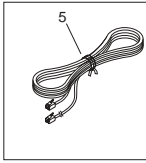

EUR

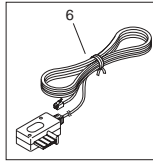

FR

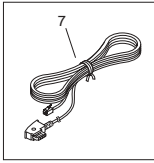

DE

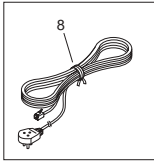

IT

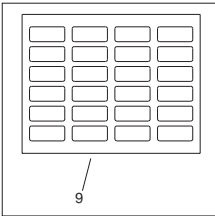

MF8050



10

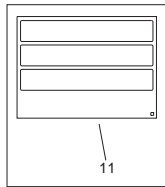

US,CA,ASIA

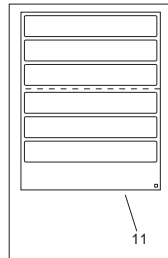

EUR

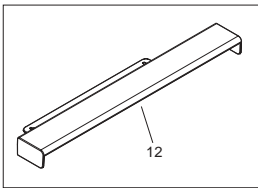

US,CA

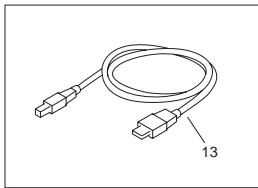

EXCEPT EUR,US,CA

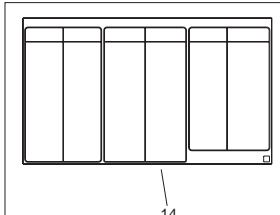

US,CA

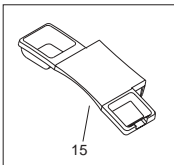

15



16 16

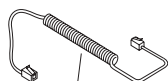

17

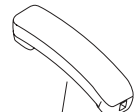

18

MF8050 CN

FIGURE & KEY NO.	PARTS NUMBER	R A N K	Q'TY	DESCRIPTION	SERIAL NUMBER/ REMARKS	S V C
Fig.001	NPN		RF	ACCESSORIES		
1	FK2-5275-000		1	CORD, MODULAR	MF8050 JP,US,CA,ASIA,CN,EUR	
2	QK1-6455-000		1	CORD, MODULAR	MF8050 AU	
3	FK2-5281-000		1	CORD, MODULAR	MF8050 KR	
4	HK1-0175-000		1	CORD, MODULAR	MF8050 KR	
5	QK1-6441-000		1	CORD, MODULAR	MF8050 EUR	
6	QK1-6446-000		1	CORD, MODULAR	MF8050 FR	
7	QK1-6443-000		1	CORD, MODULAR	MF8050 DE	
8	QK1-6449-000		1	CORD, MODULAR	MF8050 IT	
9	FU7-8094-000		1	LABEL, DESTINATION	MF8050	
10	FK2-9879-000		1	CD-ROM, USER SOFTWARE	US,CA	
10	FK2-9882-000		1	CD-ROM, USER SOFTWARE	EUR	
10	FK2-9883-000		1	CD-ROM, USER SOFTWARE	EUR	
10	FK2-9881-000		1	CD-ROM, USER SOFTWARE	JP	
10	FK2-9880-000		1	CD-ROM, USER SOFTWARE	US,CA	
10	FK2-9884-000		1	CD-ROM, USER SOFTWARE	ASIA,AU	
10	FK2-9885-000		1	CD-ROM, USER SOFTWARE	CN,KR	
11	FU7-8413-000		1	LABEL, COPY PROHIBITION	EUR	
11	FU7-8411-000		1	LABEL, COPY PROHIBITION	US,CA,ASIA	
12	FC9-4510-000		1	COVER, DUST	US,CA	
13	FK2-5274-000		1	CABLE, USB	EXCEPT US,CA,EUR	
14	FU7-8093-000		1	LABEL, CONTROL PANEL	US,CA	
15	HB1-4978-000		1	HOLDER, HANDSET CRADLE	MF8050 CN	
16	HC1-2034-000		2	RIVET	MF8050 CN	
17	FK2-8643-000		1	CORD, CURL	MF8050 CN	
18	FK2-9877-000		1	HANDSET	MF8050 CN	

FIGURE 100 EXTERNAL COVERS, PANELS, ETC.

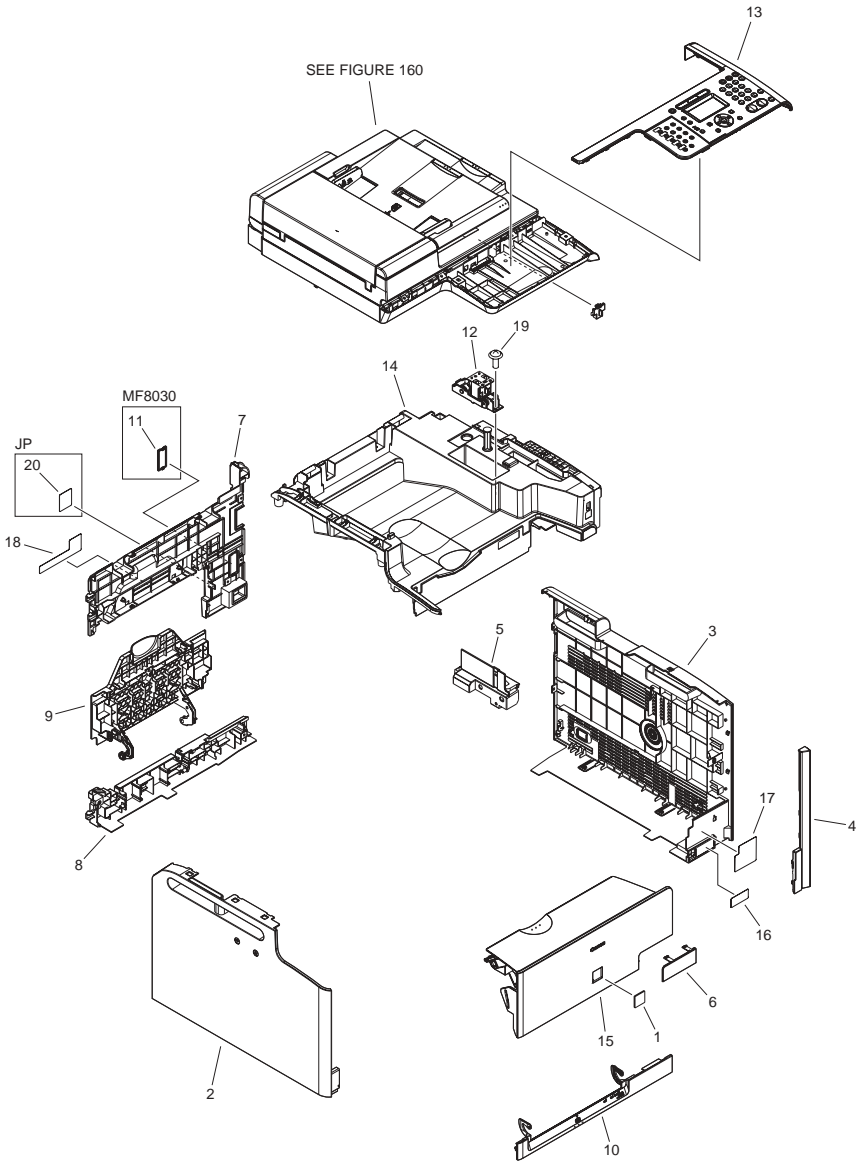

FIGURE & KEY NO.	PARTS NUMBER	R A N K	Q'TY	DESCRIPTION	SERIAL NUMBER/ REMARKS	S V C
Fig.100	NPN		1	EXTERNAL COVERS, PANELS, ETC.		
1	FC5-5256-000		1	EMBLEM	JP	
1	RC2-0062-000		1	EMBLEM	EXCEPT JP	
2	FC9-4440-000		1	COVER,LEFT		
3	FC9-4441-000		1	COVER, RIGHT		
4	FC9-4442-000		1	GUIDE, SIDE, RIGHT		
5	FC9-4443-000		1	GUIDE, HANDLE		
6	FC9-4446-000		1	COVER, RIGHT FRONT		
7	FC9-4449-000		1	COVER, UPPER REAR		
8	FC9-4451-000		1	COVER, LOWER REAR		
9	FC9-4452-000		1	GUIDE, REAR		
10	FC9-4454-000		1	COVER, PAPER PICK-UP SLOT		
11	FC9-4584-000		1	COVER, MODULAR	MF8030	
12	FM4-1493-000		1	HINGE ASSMBLY		
13	FM4-1496-000		1	CONTROL PANEL ASSEMBLY	MF8050 JP	
13	FM4-1505-000		1	CONTROL PANEL ASSEMBLY	MF8030 JP	
13	FM4-1495-000		1	CONTROL PANEL ASSEMBLY	MF8050 US,CA	
13	FM4-1499-000		1	CONTROL PANEL ASSEMBLY	MF8050 ASIA,AU	
13	FM4-1502-000		1	CONTROL PANEL ASSEMBLY	MF8030 ASIA	
13	FM4-1500-000		1	CONTROL PANEL ASSEMBLY	MF8050 CN	
13	FM4-1503-000		1	CONTROL PANEL ASSEMBLY	MF8030 CN	
13	FM4-1501-000		1	CONTROL PANEL ASSEMBLY	MF8050 KR	
13	FM4-1504-000		1	CONTROL PANEL ASSEMBLY	MF8030 KR	
13	FM4-1498-000		1	CONTROL PANEL ASSEMBLY	MF8050 EUR	
13	FM4-1497-000		1	CONTROL PANEL ASSEMBLY	MF8030 EUR	
14	FM4-4262-000		1	COVER, TOP		
15	FM4-4266-000		1	COVER UNIT, FRONT		
16	FU7-8088-000		1	LABEL, FEED JAM CLEARING		
17	FU7-8089-000		1	LABEL, FEED JAM CLEARING		
18	FU7-8090-000		1	LABEL, HIGH TMP. CAUTION		
19	XA9-1671-000		AR	SCREW, D, M3X8		
20	FU7-8091-000		1	LABEL,GROUNDING CAUTION	JP	

FIGURE 101
INTERNAL COMPONENTS 1

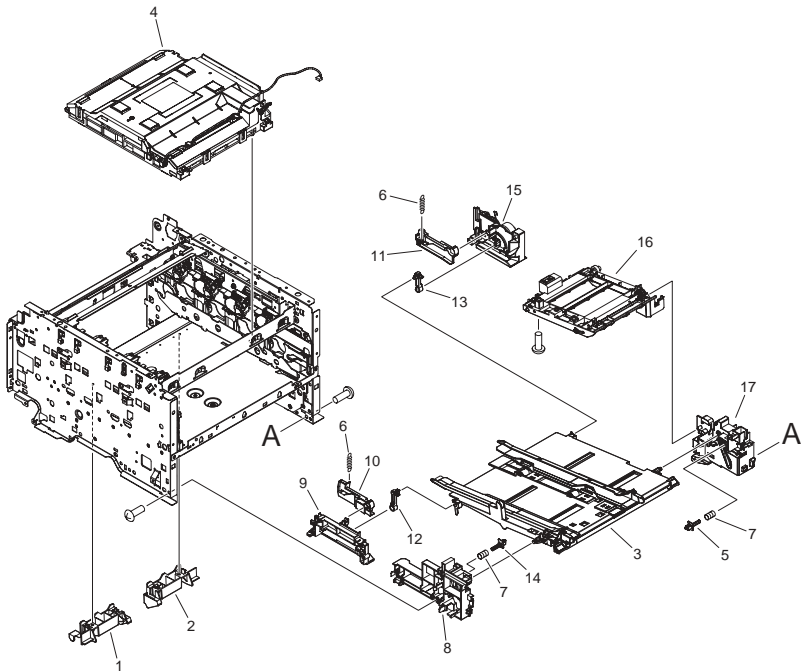

FIGURE & KEY NO.	PARTS NUMBER	R A N K	Q'TY	DESCRIPTION	SERIAL NUMBER/ REMARKS	S V C
Fig.101	NPN		RF	INTERNAL COMPONENTS 1		
1	FC7-9868-000		1	COVER, SPRING, LEFT		
2	FC7-9869-000		1	COVER, SPRING, RIGHT		
3	FM3-3441-000		1	PAPER FEED ASSEMBLY		
4	FM3-3453-000		1	LASER SCANNER ASS'Y		
5	RC2-2006-000		1	HOLDER, MF TRAY, RIGHT		
6	RU6-2016-000		2	SPRING, TENSION		
7	RU6-2042-000		2	SPRING, COMPRESSION		
8	RC2-1878-000		1	RAIL, CASSETTE, LEFT FRONT		
9	RC2-1879-000		1	RAIL, CASSETTE, LEFT REAR		
10	RC2-1882-000		1	ARM, PRESSURE, LEFT		
11	RC2-1883-000		1	ARM, PRESSURE, RIGHT		
12	RC2-1993-000		1	ARM, MF TRAY, LEFT		
13	RC2-1997-000		1	ARM, MF TRAY, RIGHT		
14	RC2-2007-000		1	HOLDER, MF TRAY, LEFT		
15	RL1-1850-000		1	RAIL, CASSETTE, RIGHT REAR		
16	RM1-4459-000		1	PRIORITY SLOT DRIVE ASS'Y		
17	RL1-1849-000		1	RAIL, CASSETTE, RIGHT FRONT		

FIGURE 102 INTERNAL COMPONENTS 2

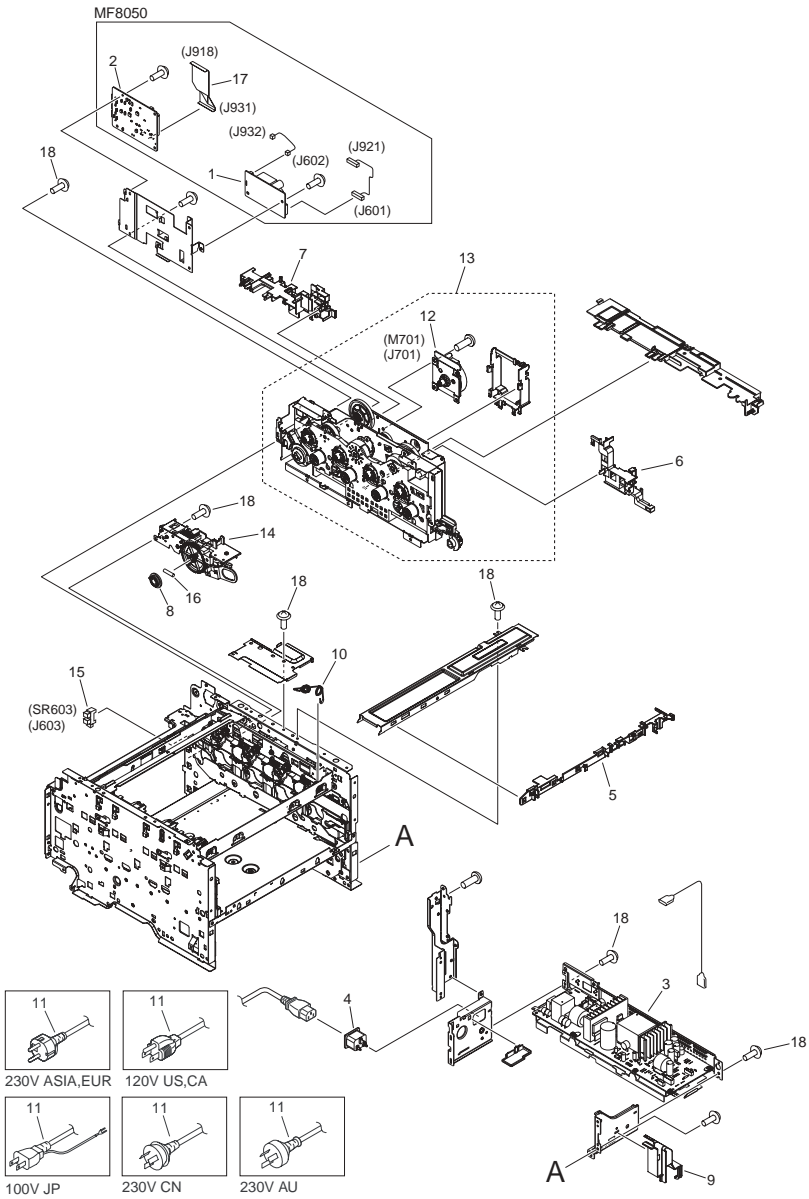

FIGURE & KEY NO.	PARTS NUMBER	R A N K	Q'TY	DESCRIPTION	SERIAL NUMBER/ REMARKS	S V C
Fig.102	NPN		RF	INTERNAL COMPONENTS 2		
1	FM3-5378-000		1	PSEUDO CI PCB ASSEMBLY	MF8050 JP	
2	FM4-3970-000		1	NCU BOARD PCB ASSEMBLY	MF8050 100V	
2	FM4-3971-000		1	NCU BOARD PCB ASSEMBLY	MF8050 120V	
2	FM4-3972-000		1	NCU BOARD PCB ASSEMBLY	MF8050 230V	
2	FM4-3973-000		1	NCU BOARD PCB ASSEMBLY	MF8050 AU	
3	FM4-3678-000		1	POWER SUPPLY ASS'Y	100V	
3	FM4-3684-000		1	POWER SUPPLY ASS'Y	120V	
3	FM4-3679-000		1	POWER SUPPLY ASS'Y	230V	
4	FM4-3695-000		1	CORD, POWER SUPPLY	100V	
4	FM4-3696-000		1	CORD, POWER SUPPLY	230V	
5	RC2-1819-000		1	GUIDE, CABLE, A		
6	RC2-1820-000		1	GUIDE, CABLE, B		
7	RC2-1821-000		1	GUIDE, CABLE		
8	RC2-1922-000		1	BUSHING		
9	RC2-2887-000		1	GUIDE, CABLE, RIGHT		
10	RC2-3071-000		1	SPRING, TORSION		
11	FK2-4390-000		1	CORD, POWER	100V JP	
11	FK2-9583-000		1	CORD, POWER	120V US,CA	
11	FH2-7080-000		1	CORD, POWER	230V ASIA,KR,EUR	
11	FH2-7170-000		1	CORD, POWER	230V CN	
11	FH2-7082-000		1	CORD, POWER	230V AU	
12	RL1-1617-000		1	MOTOR, DC	M701	
13	RM1-4443-000		1	MAIN DRIVE ASS'Y		
14	RM1-4478-000		1	SUB DRIVE ASS'Y		
15	WG8-5696-000		1	PHOTO INTERRUPTER, TLP1243	SR603	
16	XD9-0104-000		1	PIN, DOWEL		
17	FL3-2326-000		1	CABLE, FLAT	MF8050	
18	XA9-1671-000		AR	SCREW, D, M3X8		

FIGURE 103 INTERNAL COMPONENTS 3

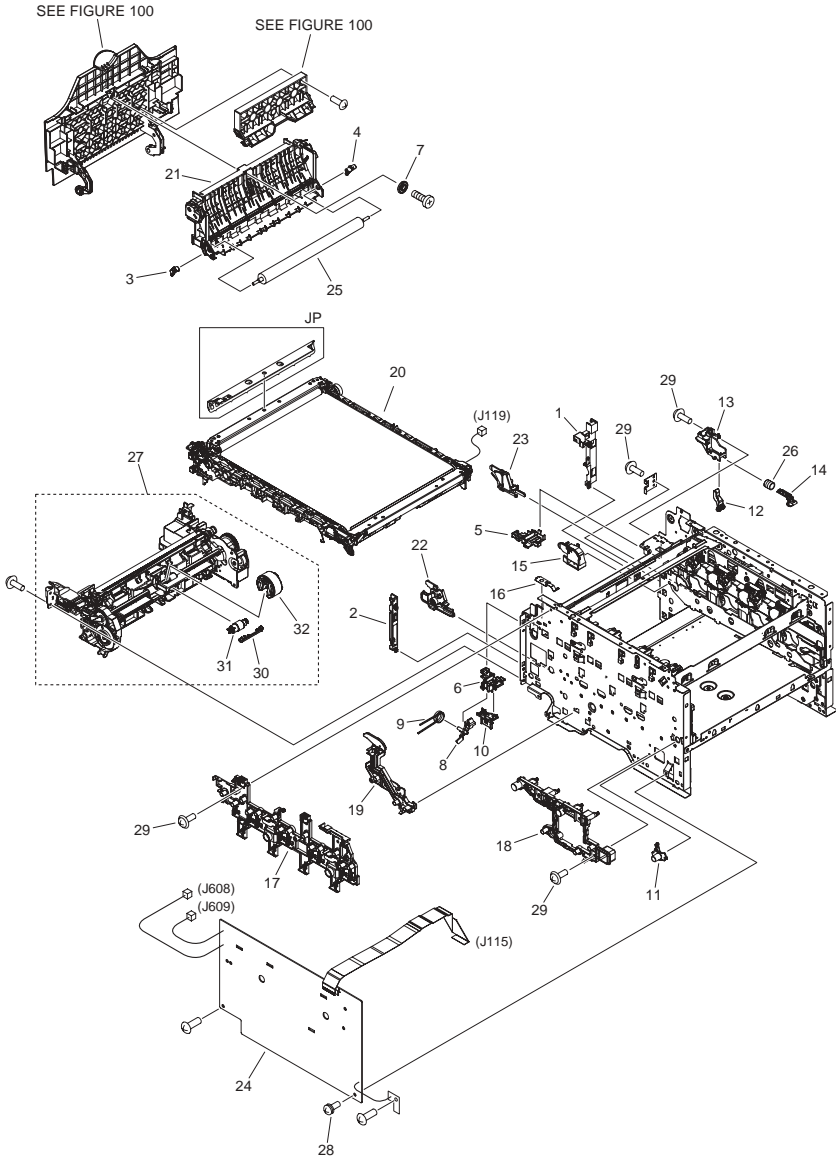

FIGURE & KEY NO.	PARTS NUMBER	R A N K	Q'TY	DESCRIPTION	SERIAL NUMBER/ REMARKS	S V C
Fig.103	NPN		RF	INTERNAL COMPONENTS 3		
1	RC2-1822-000		1	GUIDE, CABLE, D		
2	RC2-1824-000		1	GUIDE, CABLE, F		
3	RC2-2111-000		1	BUSHING		
4	RC2-2112-000		1	BUSHING		
5	RC2-2142-000		1	BLOCK, LOCK, RIGHT		
6	RC2-2143-000		1	BLOCK, LOCK, LEFT		
7	RC2-2144-000		1	CAP, GUIDE		
8	RC2-2879-000		1	FLAG, DOOR SENSOR, REAR		
9	RC2-2880-000		1	SPRING, COMPRESSION		
10	RC2-2881-000		1	COVER, DOOR SENSOR		
11	RC2-2899-000		1	SUPPORT, HIGH VOLTAGE PCB		
12	RC2-2902-000		1	LEVER, CARTRIDGE TRAY PUSH		
13	RC2-2904-000		1	HOLDER, CARTRIDGE TRAY PUSH		
14	RC2-2906-000		1	LEVER, CARTRIDGE TRAY PUSH		
15	RC2-2907-000		1	GUIDE, I.T.B., R		
16	RC2-3100-000		1	SPRING, GROUNDING		
17	RL1-1844-000		1	HOLDER, CONTACT SPRING		
18	RL1-1845-000		1	HOLDER, CONTACT SPRING		
19	RL1-1846-000		1	HOLDER, CONTACT SPRING		
20	RM1-4436-050		1	INTERMEDIATE TRANS. BELT ASS'Y		
21	RM1-4448-000		1	PAPER FEED GUIDE ASS'Y		
22	RM1-4482-000		1	I.T.B. LOCK LEVER ASS'Y, LEFT		
23	RM1-4483-000		1	I.T.B. LOCK LEVER ASS'Y, RIGHT		
24	RM1-4689-000		1	H.V. POWER SUPPLY PCB ASS'Y		
25	RM1-4445-000		1	ROLLER, TRANSFER		
26	RU6-2017-000		1	SPRING, COMPRESSION		
27	FM3-3454-000		1	PAPER PICK-UP DRIVE ASS'Y		
28	XA9-1449-000		1	SCREW, RS, M3X8		
29	XA9-1671-000		AR	SCREW, D, M3X8		
30	RC2-2014-000		1	COVER, HOLDER		
31	RM1-4425-000		1	SEPARATION ROLLER ASS'Y		

FIGURE & KEY NO.	PARTS NUMBER	R A N K	Q'TY	DESCRIPTION	SERIAL NUMBER/ REMARKS	S V C
32	RM1-4426-000		1	PICK-UP ROLLER ASS'Y		

FIGURE 104 INTERNAL COMPONENTS 4

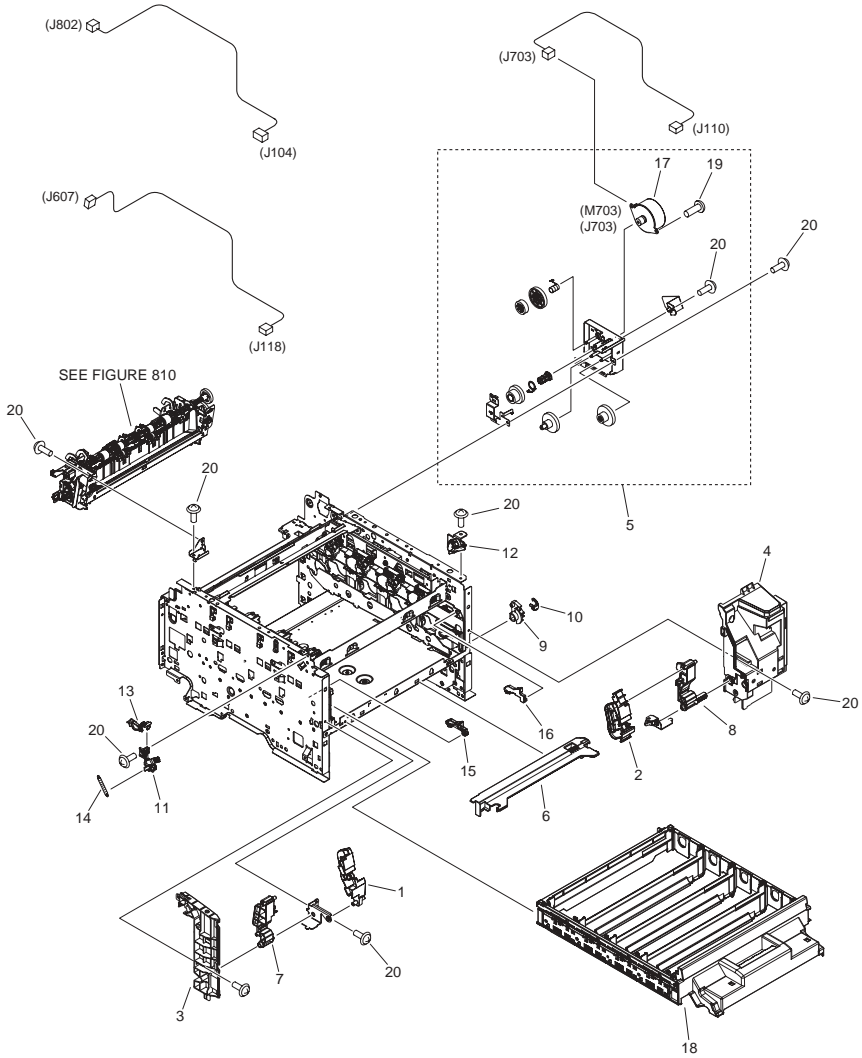

FIGURE & KEY NO.	PARTS NUMBER	R A N K	Q'TY	DESCRIPTION	SERIAL NUMBER/ REMARKS	S V C
Fig.104	NPN		RF	INTERNAL COMPONENTS 4		
1	FC7-9827-000		1	CAM, FRONT DOOR, LEFT		
2	FC7-9828-000		1	CAM, FRONT DOOR, RIGHT		
3	FC9-4455-000		1	COVER, DOOR SIDE, LEFT		
4	FC9-4456-000		1	COVER, DOOR SIDE, RIGHT		
5	FM3-3455-000		1	FIXING DRIVE ASS'Y		
6	RC2-1784-000		1	COVER, CARTRIDGE TRAY, LOWER		
7	RC2-1871-000		1	LEVER, RAIL, LEFT		
8	RC2-1872-000		1	LEVER, RAIL, RIGHT		
9	RC2-1911-000		1	LEVER, ESTRANGEMENT		
10	RC2-1914-000		1	STOPPER, LEVER		
11	RC2-2871-000		1	CLAW, FRONT DOOR, LEFT		
12	RC2-2872-000		1	CLAW, FRONT DOOR, RIGHT		
13	RC2-2877-000		1	FLAG, DOOR SENSOR, FRONT		
14	RC2-2878-000		1	SPRING, TENSION		
15	RC2-3108-000		1	CLAMP, CARTRIDGE TRAY, LEFT		
16	RC2-3109-000		1	CLAMP, CARTRIDGE TRAY, RIGHT		
17	RK2-1872-000		1	MOTOR, STEPPING, DC	M703	
18	RM1-4428-000		1	CARTRIDGE TRAY ASS'Y		
19	XA9-1561-000		2	SCREW, RS, M3X6		
20	XA9-1671-000		AR	SCREW, D, M3X8		

FIGURE 105 INTERNAL COMPONENTS 5

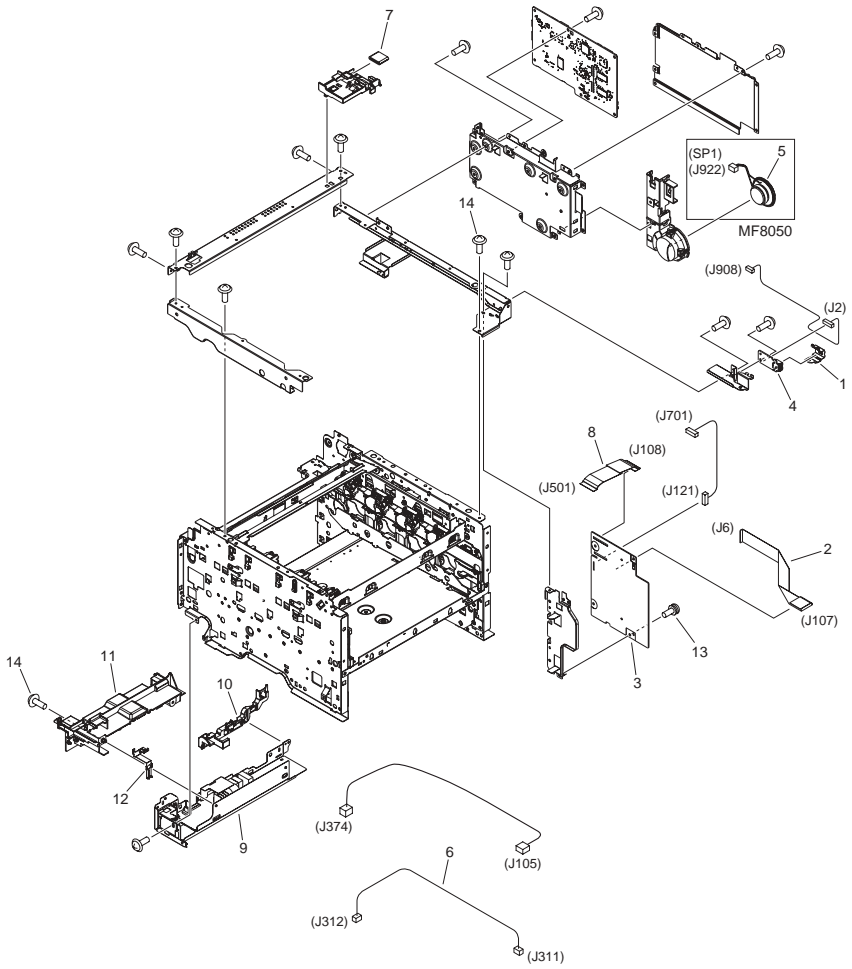

FIGURE & KEY NO.	PARTS NUMBER	R A N K	Q'TY	DESCRIPTION	SERIAL NUMBER/ REMARKS	S V C
Fig.105	NPN		RF	INTERNAL COMPONENTS 5		
1	FC9-4507-000		1	PLATE, USB GROUNDING		
2	FK2-9582-000		1	CABLE, FLAT		
3	FM4-3676-000		1	DC CONTROLLER PCB ASS'Y		
4	FM4-3989-000		1	USB PCB ASSEMBLY		
5	FM4-3985-000		1	SPEAKER ASSEMBLY	MF8050 SP1	
6	FM4-3690-000		1	CABLE, FIXING OUTER		
7	FK2-8767-000		1	CORE, FERRITE		
8	RK2-1955-000		1	CABLE, FLAT		
9	FM4-3683-000		1	FIXING POWER SUPPLY ASSEMBLY		
10	RC2-1823-000		1	GUIDE, CABLE, E		
11	RC2-1830-000		1	COVER, FIXING POWER SUPPLY		
12	RC2-2889-000		1	PLATE, STATIC CHARGE		
13	XA9-1449-000		4	SCREW, RS, M3X8		
14	XA9-1671-000		AR	SCREW, D, M3X8		

FIGURE 160 READER/ADF ASSEMBLY

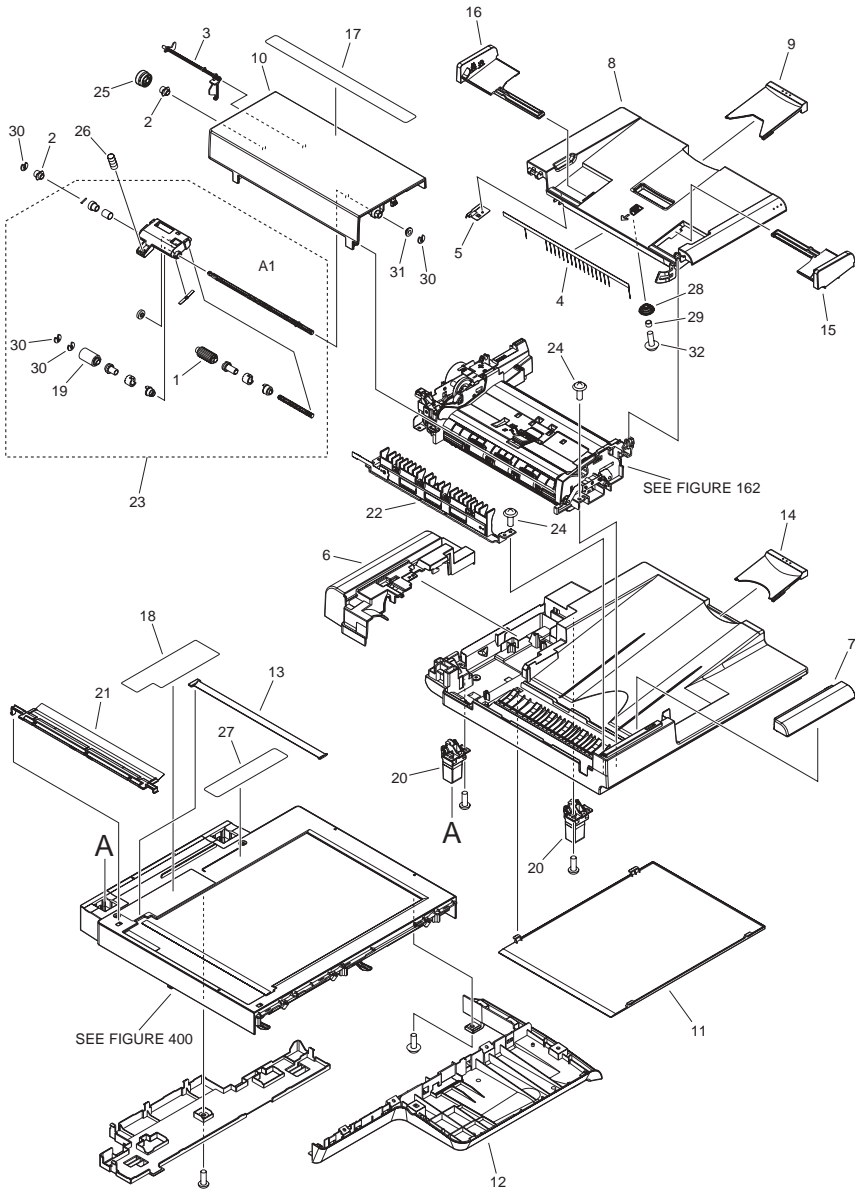

FIGURE & KEY NO.	PARTS NUMBER	R A N K	Q'TY	DESCRIPTION	SERIAL NUMBER/ REMARKS	S V C
Fig.160	NPN		RF	READER/ADF ASSEMBLY		
1	FC7-6189-000		1	ROLLER, PICK-UP		
2	FC7-6320-000		2	BUSHING		
3	FC7-6321-000		1	FLAG, DOCUMENT SCANNER		
4	FC7-6322-000		1	ELIMINATOR, STATIC CHARGE		
5	FC9-1503-000		1	PLATE, GROUNDING		
6	FC9-1532-000		1	COVER, REAR		
7	FC9-1533-000		1	COVER, FRONT UPPER		
8	FC9-1534-000		1	TRAY, DOCUMENT		
9	FC9-1535-000		1	TRAY, SUB DOCUMENT		
10	FC9-1536-000		1	PANEL, OPEN/CLOSE		
11	FC9-1539-000		1	SHEET, WHITE		
12	FC9-4502-000		1	COVER, BASE		
13	FC9-5115-000		1	PLATE, PAPER SIZE	AB	
13	FC9-5109-000		1	PLATE, PAPER SIZE	A	
13	FC9-5110-000		1	PLATE, PAPER SIZE	INCH/AB	
13	FC9-1486-000		1	PLATE, PAPER SIZE	INCH/A	
14	FC9-5655-000		1	TRAY, SUB		
15	FC9-5656-000		1	GUIDE, DOCUMENT, FRONT		
16	FC9-5657-000		1	GUIDE, DOCUMENT, REAR		
17	FC9-7561-000		1	LABEL, SIZE INDEX	AB	
17	FC9-7563-000		1	LABEL, SIZE INDEX	A	
17	FC9-7564-000		1	LABEL, SIZE INDEX	INCH/AB	
17	FC9-7562-000		1	LABEL, SIZE INDEX	INCH/A	
18	FC9-7565-000		1	LABEL, GLASS CLEANING	JP	
18	FC9-7566-000		1	LABEL, GLASS CLEANING	US,CA	
18	FC9-7568-000		1	LABEL, GLASS CLEANING	ASIA,CN,KR,AU	
18	FC9-7567-000		1	LABEL, GLASS CLEANING	EUR	
19	FL2-6637-000		1	ROLLER, SEPARATION		
20	FL3-2453-000		2	HINGE, ADF		
21	FL3-3539-000		1	HOLDER, DOCUMENT,RELEASE SHEET		
22	FM4-1883-000		1	PAPER FEED GUIDE ASSEMBLY		

FIGURE & KEY NO.	PARTS NUMBER	RANK	Q'TY	DESCRIPTION	SERIAL NUMBER/REMARKS	SVC
23	FM3-9538-000		1	SEPARATION ROLLER ASSEMBLY		
24	XA9-0831-000		7	SCREW,M3X10		
25	FU7-0672-000		1	GEAR, 24T		
26	FU7-2018-000		1	SPRING, COMPRESSION		
27	FU7-8405-000		1	LABEL, COPY PROHIBITION	JP	
27	FU7-8406-000		1	LABEL, COPY PROHIBITION	US,CA,ASIA,AU	
27	FU7-8408-000		1	LABEL, COPY PROHIBITION	CN	
27	FU7-8410-000		1	LABEL, COPY PROHIBITION	KR	
27	FU7-8407-000		1	LABEL, COPY PROHIBITION	EUR	
28	FU8-0895-000		1	GEAR, 18T		
29	FU8-2007-000		1	SPRING, COMPRESSION		
30	HC1-0586-000		4	RETAINING RING		
31	HU1-1022-000		1	BUSHING		
32	XA9-0476-000		AR	SCREW,TP M3X8		

FIGURE 162 PAPER FEEDER ASSEMBLY

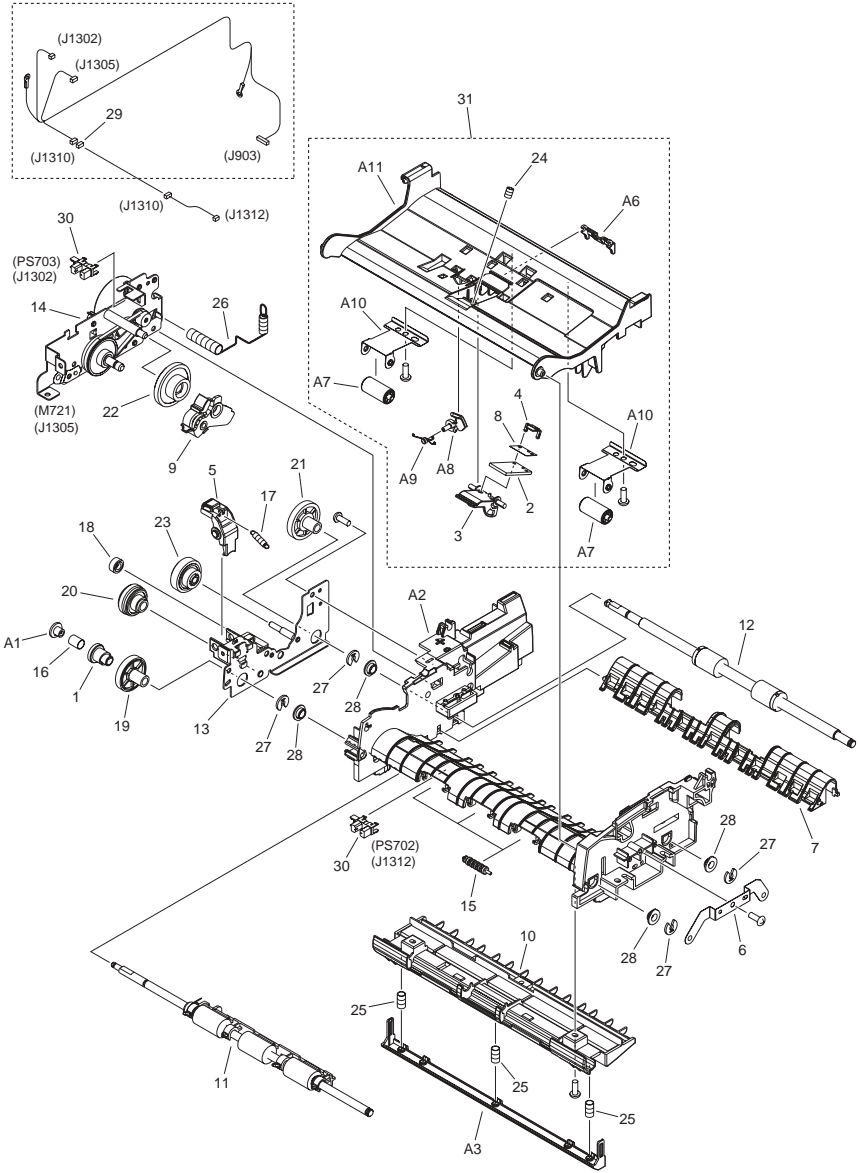

FIGURE & KEY NO.	PARTS NUMBER	R A N K	Q'TY	DESCRIPTION	SERIAL NUMBER/ REMARKS	S V C
Fig.162	FM4-1879-000		1	PAPER FEEDER ASSEMBLY		
1	FC7-6052-000		1	RATCHET, PAPER FEED ROLLER		
2	FC7-6297-000		1	PAD, SEPARATION		
3	FC7-6299-000		1	HOLDER, SEPARATION PAD		
4	FC7-6300-000		1	CLAMP, SEPARATION PAD		
5	FC9-1512-000		1	LEVER, RELEASE		
6	FC9-1523-000		1	PLATE, ROLLER GROUNDING		
7	FC9-1526-000		1	GUIDE, PAPER DELIVERY		
8	FC9-5654-000		1	SHEET, SEPARATION PAD		
9	FL3-1431-000		1	ARM, SEPARATION SWING		
10	FL3-1437-000		1	GUIDE, LOWER ASSEMBLY		
11	FM4-1885-000		1	PAPER FEED ROLLER ASSEMBLY		
12	FL3-2458-000		1	PAPER DELIVERY ROLLER ASS'Y		
13	FM4-1880-000		1	DRIVE PLATE ASSEMBLY		
14	FM4-1881-000		1	MOTOR DRIVE ASSEMBLY	M721	
15	FU5-6992-000		3	ROLLER, AUXILIARY		
16	FU6-2998-000		1	SPRING, COMPRESSION		
17	FU6-2999-000		1	SPRING, TENSION		
18	FU7-0667-000		1	GEAR, 20T		
19	FU7-0668-000		1	GEAR, 54T		
20	FU7-0669-000		1	GEAR, 46T/23T		
21	FU7-0671-000		1	GEAR, 36T		
22	FU7-0676-000		1	GEAR, 21T/42T		
23	FU7-0678-000		1	GEAR, 51T/17T		
24	FU7-2016-000		1	SPRING, COMPRESSION		
25	FU8-2008-000		3	SPRING, COMPRESSION		
26	FU8-2010-000		1	SPRING, COMPRESSION		
27	HC1-0586-000		4	RETAINING RING		
28	HU1-1022-000		4	BUSHING		
29	VS1-7207-004		1	CONNECTOR, SNAP TIGHT, BK		
30	WG8-5696-000		2	PHOTO INTERRUPTER, TLP1243	PS702,PS703	
31	FM4-1882-000		1	GUIDE ASSEMBLY, UPPER		

FIGURE 300 CASSETTE ASSEMBLY

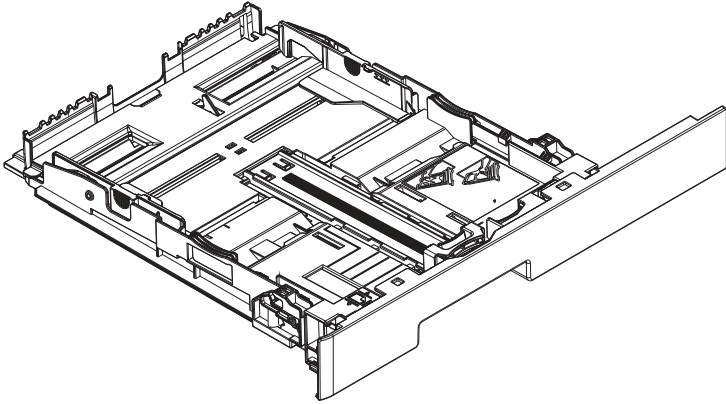

FIGURE & KEY NO.	PARTS NUMBER	RANK	QTY	DESCRIPTION	SERIAL NUMBER/REMARKS	SVC
Fig.300	FM4-4263-000		1	CASSETTE		

FIGURE 400 READER ASSEMBLY

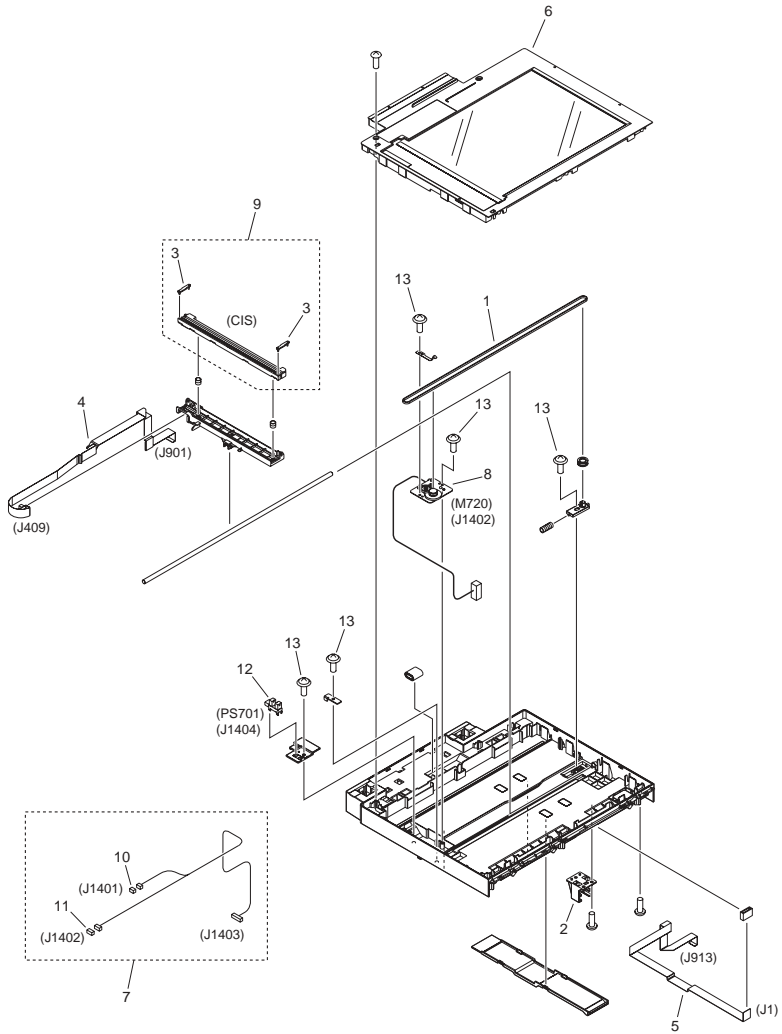

FIGURE & KEY NO.	PARTS NUMBER	RANK	Q'TY	DESCRIPTION	SERIAL NUMBER/REMARKS	SVC
Fig.400	FM4-4300-000		1	READER, ASSEMBLY		
1	FC9-1650-000		1	BELT, TIMING		
2	FC9-2101-000		1	MOUNT, SUPPORTER		
3	FC9-7573-000		2	SPACER, CIS	rankA	
3	FC9-7571-000		2	SPACER, CIS	rankB	
3	FC9-7574-000		2	SPACER, CIS	rankC	
4	FK2-9581-000		1	CABLE, FLAT		
5	FK2-9861-000		1	CABLE, FLAT		
6	FM4-4308-000		1	READER COVER UNIT		
7	FM4-3653-000		1	CABLE, READER		
8	FM4-4301-000		1	DC MOTOR ASSEMBLY	M720	
9	FM4-4307-000		1	CONTACT IMAGE SENSOR ASSY	CIS	
10	VS1-7177-003		1	CONNECTOR, SNAP TIGHT, BK		
11	VS1-7177-004		1	CONNECTOR, SNAP TIGHT, BK		
12	WG8-5696-000		1	PHOTO INTERRUPTER, TLP1243	PS701	
13	XA9-0476-000		11	SCREW,TP M3X8		

FIGURE 810
FIXING ASS'Y

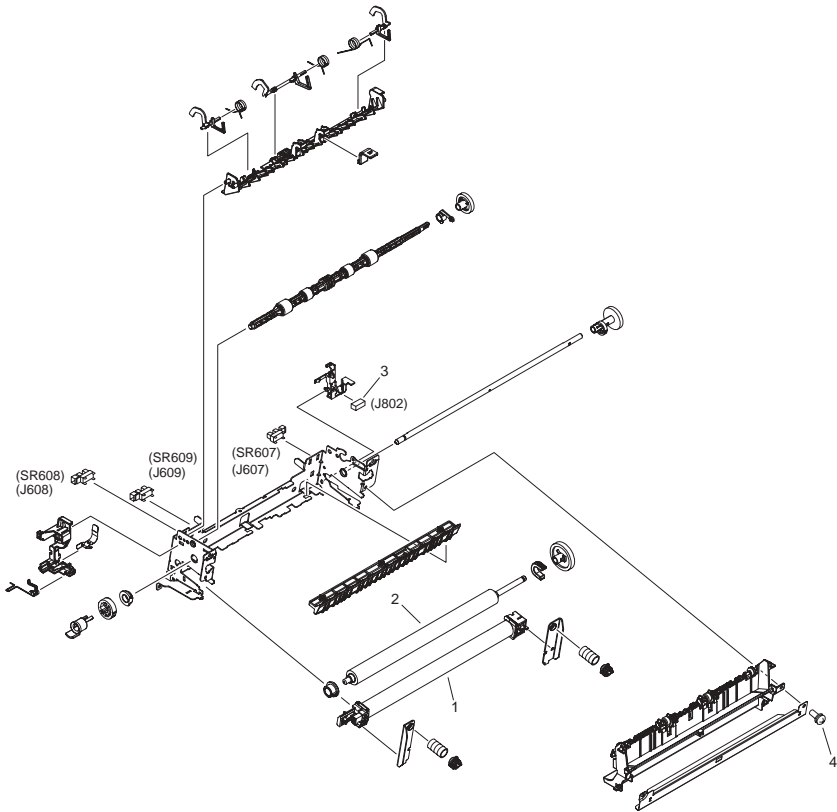

FIGURE & KEY NO.	PARTS NUMBER	RANK	Q'TY	DESCRIPTION	SERIAL NUMBER/REMARKS	SVC
Fig.810	FM3-3435-000		1	FIXING ASS'Y	100V	
Fig.810	RM1-4430-000		1	FIXING ASS'Y	120V	
Fig.810	RM1-4431-000		1	FIXING ASS'Y	230V	
1	FM3-3434-000		1	FIXING FILM ASSEMBLY	JP	
1	RM1-4432-000		1	FIXING FILM ASSEMBLY	US,CA	
1	RM1-4433-000		1	FIXING FILM ASSEMBLY	EXCEPT JP,US,CA	
2	RC2-2146-000		1	ROLLER, PRESSURE		
3	VS1-7177-002		1	CONNECTOR, SNAP TIGHT, BK		
4	XA9-1420-000		1	SCREW, W/WASHER, M3X8		
5	WG8-5696-000		3	PHOTO INTERRUPTER, TLP1243	SR607,SR608,SR609	

FIGURE 900 MAIN CONTORROLLER PCB ASS'Y

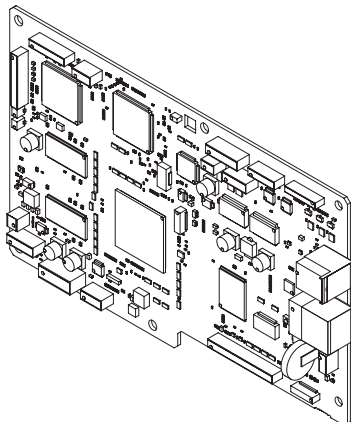

FIGURE & KEY NO.	PARTS NUMBER	RANK	QTY	DESCRIPTION	SERIAL NUMBER/REMARKS	SVC
Fig.900	FM4-3977-000		1	MAIN CONTROLLER PCB ASSEMBLY	MF8050	
Fig.900	FM4-3976-000		1	MAIN CONTROLLER PCB ASSEMBLY	MF8030	
IC	FK2-8321-000		1	IC, MB87S1801		

FIGURE ZZA

MECHANICAL STANDARD PARTS (HOW TO USE)

Mechanical standard parts

機械標準部品

About a mechanical standard parts

A Mechanical standard parts is a mechanical part which not parts peculiar to a product. They are parts which are common to a Canon product and are used, such as a screw and a washer. The Fig No. and parts number of the mechanical standard parts are not listed in the product parts catalog. Refer to the parts catalog of mechanical standard parts when checking the parts number for screw or washer etc. and identify them by part shape or size.

機械標準部品とは

機械標準部品とは、製品特有の部品ではなく、ねじやワッシャなどキヤノン製品共通で使用されている機械部品（メカ部品）のことです。
製品のパーツカタログには、機械標準部品のFig No.や部品番号は記載しておりません。
ねじや、ワッシャ等の部品番号を調べるときは、機械標準部品のパーツカタログを参照し、部品の形状や大きさから判断し、使用している部品を調べてください。

Material and surface treatment of a mechanical standard parts

Material and surface treatment of mechanical standard parts are assigned commonly for each part. Refer to the Table 1 for the parts which material and surface treatment are assigned as numbers.

機械標準部品の材料および表面処理

機械標準部品の材料および表面処理については、各種部品共通で決められています。
材料および表面処理が番号で決められている部品については、表1を参照してください。

Table 1 Material and Surface treatment
表1 材料および表面処理

No. 番号	Material 材料	Surface treatment 表面処理	Color 色
1	Stainless steel ステンレス	Stainless steel black coloring (BC4) ステンレス黒着色(BC4)	Black 黒
2		not to be given なし	White 白
3	Brass 黄銅	Regular nickel plating (NL) 普通ニッケルメッキ(NL)	White 白
4		Black nickel plating (BN) 黒色ニッケルメッキ(BN)	Black 黒
5	Steel 鋼	White zinc trivalent chromate treating (ZC3) 白色亜鉛3価クロメート(ZC3)	White 白
6		Regular nickel chromium plating (NC) 普通ニッケルクロムメッキ(NC)	White 白
7		Regular nickel plating (NL) 普通ニッケルメッキ(NL)	White 白
8		Iron and steel phosphating (P1) 鉄鋼磷酸塩処理(P1)	Black 黒
9		Black zinc trivalent chromate treating (BZ3) 黒色亜鉛3価クロメート(BZ3)	Black 黒

FIGURE ZZB MECHANICAL STANDARD PARTS (SCREWS)

1. Screws ねじ

How to read Parts Numbers
部品番号の見方

Screws
ねじ

XB1-2400-609

Type No.
類別番号

Normal designation (d)
ねじの呼び(d)

Length (L)
ねじの長さ(L)

Material and Surface treatment
材料および表面処理

XB1-2 expresses Binding head machine screw.
XB1-2は、バインドねじを表す

40 expresses M4.0.
40は、M4.0を表す

0-60 expresses a length of 6.0mm.
0-60は、6.0mmの長さを表す

9 expresses Steel (Black zinc trivalent chromate
treating) from Table 1.

9は、表1より鋼(黒色亜鉛3価クロメート)を表す

1-1. Cross Recessed Head Screws for Precision Equipments

精密機器用十字穴付き小ねじ

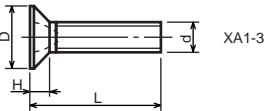
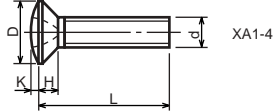
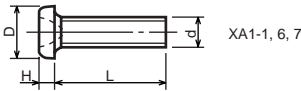

Type No. 類別番号	Type 類別
XA1-1	Pan head Class 1 なべ1種
XA1-3	Countersunk head Class 1 さら1種
XA1-4	Oval countersunk head Class 1 丸さら1種
XA1-6	Pan head Class 3 なべ3種
XA1-7	Pan head Class 2 なべ2種

		Head size (mm) 頭部寸法 (mm)					
		M1.4	M1.6	M1.7	M2	M2.5	M2.6
D	XA1-1	2	2.4	2.5	3	3.8	4
H	XA1-1	0.5	0.55	0.5	0.6	0.9	0.8
D	XA1-3	2	2.4	2.5	3	3.8	4
H	XA1-3	0.48	0.55	0.58	0.73	0.85	0.93
D	XA1-4	2	2.4	2.5	3	3.8	4
H + K	XA1-4	0.68	0.8	0.88	1	1.25	1.3
D	XA1-6	2.5	2.8	3	3.5	4.3	4.5
H	XA1-6	0.8	0.85	0.9	1	1.3	1.2
D	XA1-7	2.5	2.8	3	3.5	4.3	4.5
H	XA1-7	0.5	0.55	0.5	0.6	0.9	0.8

1-2. Precision Tapping Screws
精密用タッピンねじ

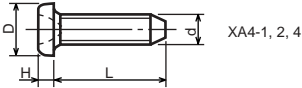

XA4-1, 2, 4

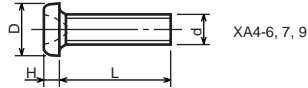

XA4-6, 7, 9

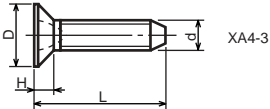

XA4-3

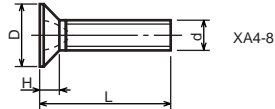

XA4-8

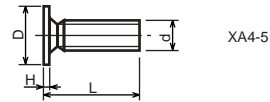

XA4-5

Type No. 類別番号	Type 類別	Head size (mm) 頭部寸法 (mm)						
		M1.4	M1.6	M1.7	M2	M2.5	M2.6	
XA4-1	With tapered end pan head Class 1 絞りなべ1種	D XA4-1	2	2.4	2.5	3	3.8	4
		H XA4-1	0.5	0.55	0.5	0.6	0.9	0.8
XA4-2	With tapered end pan head Class 3 絞りなべ3種	D XA4-2	2.5	2.8	3	3.5	4.3	4.5
		H XA4-2	0.8	0.85	0.9	1	1.3	1.2
XA4-3	With tapered end countersunk head 絞り-さら	D XA4-3	2	2.4	2.5	3	3.8	4
		H XA4-3	0.48	0.55	0.58	0.73	0.85	0.93
XA4-4	With tapered end pan head Class 2 絞りなべ2種	D XA4-4	2.5	2.8	3	3.5	4.3	4.5
		H XA4-4	0.5	0.55	0.5	0.6	0.9	0.8
XA4-5	With parallel end ultra thin head ストレート-超薄頭	D XA4-5	2.5	2.8	3	-	-	-
		H XA4-5	0.2	0.2	0.2	-	-	-
XA4-6	With parallel end pan head Class 1 ストレートなべ1種	D XA4-6	2	2.4	2.5	3	3.8	4
		H XA4-6	0.5	0.55	0.5	0.6	0.9	0.8
XA4-7	With parallel end pan head Class 3 ストレートなべ3種	D XA4-7	2.5	2.8	3	3.5	4.3	4.5
		H XA4-7	0.8	0.85	0.9	1	1.3	1.2
XA4-8	With parallel end countersunk head ストレート-さら	D XA4-8	2	2.4	2.5	3	3.8	4
		H XA4-8	0.48	0.55	0.58	0.73	0.85	0.93
XA4-9	With parallel end pan head Class 2 ストレートなべ2種	D XA4-9	2.5	2.8	3	3.5	4.3	4.5
		H XA4-9	0.5	0.55	0.5	0.6	0.9	0.8

1-3. Cross Recessed Head Screws
 一般用十字穴付き小ねじ

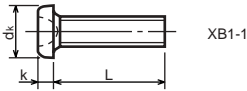

XB1-1

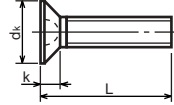

XB1-3

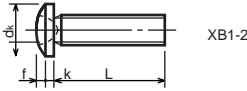

XB1-2

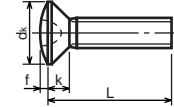

XB1-4

Type No. 類別番号	Type 類別
XB1-1	Pan head なべ
XB1-2	Binding head バインド
XB1-3	Countersunk head ざら
XB1-4	Oval countersunk head 丸ざら

		Head size (mm) 頭部寸法 (mm)					
		M2	M2.5	M2.6	M3	M4	M5
dk	XB1-1	3.5	4.5	4.5	5.5	7	9
k	XB1-1	1.3	1.7	1.7	2	2.6	3.3
dk	XB1-2	4.3	5.3	5.5	6.3	8.3	10.3
k+f	XB1-2	1.2	1.5	1.6	1.9	2.5	3.1
dk	XB1-3	4	5	-	6	8	10
k	XB1-3	1.2	1.45	-	1.75	2.3	2.8
dk	XB1-4	4	5	-	6	8	10
k+f	XB1-4	1.6	2	-	2.45	3.2	4
Screw part length ねじ部長さ b		8	12	12	12	16	20

1-4. Cross Recessed Head Screws with Captive Washer
座金組み込み十字穴付き小ねじ

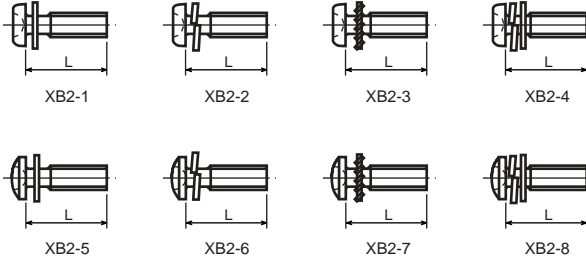

Type No. 類別番号	Type 類別
XB2-1	Pan head + Plain washer (circular bright) なべねじ+平座金
XB2-2	Pan head + Spring washer なべねじ+ばね座金
XB2-3	Pan head + Toothed lock washer なべねじ+歯付座金
XB2-4	Pan head + Spring washer and plain washer (circular bright) なべねじ+(ばね+平)座金
XB2-5	Binding head + Plain washer (circular bright) バインドねじ+平座金
XB2-6	Binding head + Spring washer バインドねじ+ばね座金
XB2-7	Binding head + Toothed lock washer バインドねじ+歯付座金
XB2-8	Binding head + Spring washer and plain washer (circular bright) バインドねじ+(ばね+平)座金

1-5. Hexagon Head Tapping Screws for Metallic Materials
 金属用六角タッピンねじ

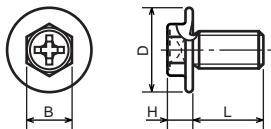

Type No. 類別番号	Type 類別	Head size (mm) 頭部寸法 (mm)	
		M3	M4
XB3-6	For metallic materials 金属用タッピン	D	8 10
		B	5.5 5.5
XB3-7	For metallic materials with clawed 金属用タッピン-つめ付き	H XB3-6	3.1 3.1
		H XB3-7	3.2 3.2

1-6. Special Tapping Screws
 特殊タッピンねじ

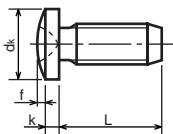

Type No. 類別番号	Type 類別	Head size (mm) 頭部寸法 (mm)	
		M3	M4
XB4-5	Binding head バインド	d _k	6.3 8.3
		k	1.3 1.7
		k+f	1.9 2.5

1-7. General Head Tapping Screws
一般用タッピンねじ

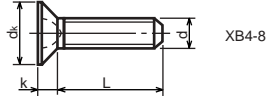
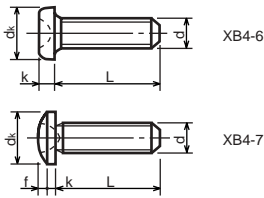

Type No. 類別番号	Type 類別	Head size (mm) 頭部寸法 (mm)						
		M2	M2.5	M2.6	M3	M4	M5	
XB4-6	Pan head なべ	d _k	3.5	4.5	4.5	5.5	7	9
		k	1.3	1.7	1.7	2	2.6	3.3
XB4-7	Binding head バインド	d _k	4.3	5.3	5.5	6.3	8.3	10.3
		k+f	1.2	1.5	1.6	1.9	2.5	3.1
XB4-8	Countersunk head さら	d _k	4	5	5.2	6	8	10
		k	1.2	1.45	1.5	1.75	2.3	2.8

1-8. Tapping Screws for Metallic Materials
金属用タッピンねじ

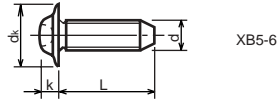
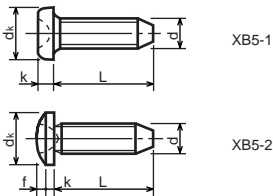

Type No. 類別番号	Type 類別	Head size (mm) 頭部寸法 (mm)					
		M2.5	M2.6	M3	M4	M5	
XB5-1	Pan head なべ	d _k	4.5	4.5	5.5	7	9
		k	1.7	1.7	2	2.6	3.3
XB5-2	Binding head バインド	d _k	5.5	5.5	6.3	8.3	10.3
		k+f	1.6	1.6	1.9	2.5	3.1
XB5-6	Flanged pan head つば付きなべ	d _k	6.5	6.5	8	10	12
		k	2.1	2.1	1.75	3.2	4

1-9. Hexagon Socket Set Screws
六角穴付止めねじ

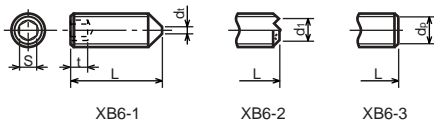

Type No. 類別番号	Type 類別	Head size (mm) 頭部寸法 (mm)							
		M1.6 M1.7	M2	M2.5 M2.6	M3	M5	M5	M6	
XB6-1	Cone point とがり先	S	0.7	0.9	1.3	1.5	2	2.5	3
		t	1.5	1.7	2	2	2.5	3	3.5
		$d_{t \max}$ XB6-1	0.4	0.5	0.65	0.75	1	1.25	1.5
		$d_{l \max}$ XB6-2	-	1.2	1.5	1.7	2.2	2.8	3.3
		$d_{l \min}$ XB6-2	-	1	1.2	1.4	1.9	2.4	2.9
		$d_{p \max}$ XB6-3	0.8	1	1.5	2	2.5	3.5	4
		$d_{p \min}$ XB6-3	0.55	0.75	1.25	1.75	2.25	3.2	3.7

1-10. Flanged Pan Head Machine Screws
つば付きなべ小ねじ

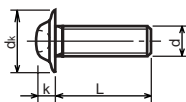

Type No. 類別番号	Type 類別	Head size (mm) 頭部寸法 (mm)					
		M2	M2.5 M2.6	M3	M5	M5	
XB6-7	Flanged pan head つば付きなべ	d_k	5	6.5	8	10	12
		k	1.7	2.1	2.5	3.2	4

FIGURE ZZC MECHANICAL STANDARD PARTS (BOLTS)

2. Bolts (Socket head cap screw) ボルト

How to read Parts Numbers
部品番号の見方

Bolt (Socket head cap screw)
ボルト

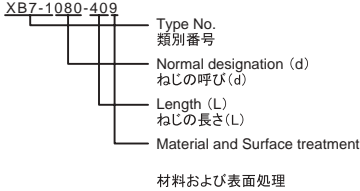

XB7-1 expresses Hexagon socket head cap screws.
XB7-1は、六角穴付きボルトを表す

080 expresses M8.0.
080は、M8.0を表す

40 expresses a length of 40mm.
40は、40mmの長さを表す

9 expresses Steel (Black zinc trivalent chromate treating) from Table 1.
9は、表1より鋼 (黒色亜鉛3価クロメート)を表す

2-1. Hexagon socket head cap screws 六角穴付きボルト

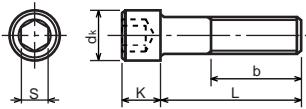

Type No. 類別番号	Type 類別
XB7-1	Hexagon socket head cap screws 六角穴付きボルト

	Head size (mm) 頭部寸法 (mm)						
	M3	M4	M5	M6	M8	M10	M12
S	2.5	3	4	5	6	8	10
d _k	5.5	7	8.5	10	13	16	18
K	3	4	5	6	8	10	12
Screw part length ねじ部長さ b _{max}	18	20	22	24	28	32	36

FIGURE ZZD MECHANICAL STANDARD PARTS (NUTS)

3. Nuts ナット

How to read Parts Numbers
部品番号の見方

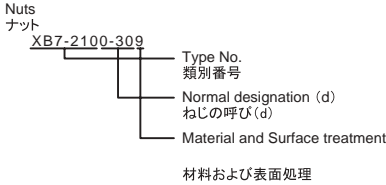

XB7-210 expresses Hexagon nut class 1.
XB7-210は、六角ナット1種を表す

0-30 expresses M3.0.
0-30は、M3.0を表す

9 expresses Steel (Black zinc trivalent chromate treating) from Table 1.
9は、表1より鋼(黒色亜鉛3価クロメート)を表す

3-1. Hexagon Nuts and Hexagon Thin Nuts 六角ナット

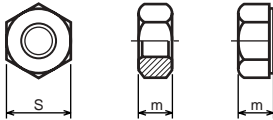

Type No. 類別番号	Type 類別
XB7-210	Hexagon nut Class 1 六角ナット-1種
XB7-220	Hexagon nut Class 3 六角ナット-3種
XB7-230	Hexagon nut Style 1 double chamfered 六角ナット-スタイル1-両面とり
XB7-231	Hexagon nut Style 1 washer faced 六角ナット-スタイル1-座付き
XB7-240	Hexagon nut Style 2 double chamfered 六角ナット-スタイル2-両面とり
XB7-241	Hexagon nut Style 2 washer faced 六角ナット-スタイル2-座付き
XB7-250	Hexagon nut 六角ナット
XB7-260	Hexagon thin nut double chamfered 六角低ナット-両面とり
XB7-270	Hexagon thin nut not chamfered 六角低ナット-面とり無し

	Head size (mm) 頭部寸法 (mm)						
	M2	M2.5	M3	M4	M5	M6	M8
S	4	5	5.5	7	8	10	13
m XB7-210	1.6	2	2.4	3.2	4	5	6.5
m XB7-220	1.2	1.6	1.8	2.4	3.2	3.6	5
m XB7-230, 231	1.6	2	2.4	3.2	4.7	5.2	6.8
m XB7-240, 241	-	-	-	-	5.1	5.7	7.5
m XB7-250	-	-	-	-	5.6	6.1	7.9
m XB7-260	1.2	1.6	1.8	2.2	2.7	3.2	4
m XB7-270	1.2	1.6	1.8	2.2	2.7	3.2	4

FIGURE ZZE MECHANICAL STANDARD PARTS (RETAINING RINGS)

5. Retaining Rings 止め輪

How to read Parts Numbers
部品番号の見方

Retaining Rings 止め輪

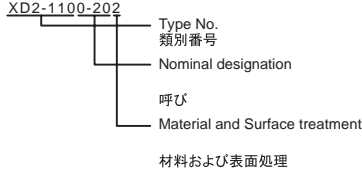

XD2-110 expresses retaining ring-E type (Type1).
XD2-110は、E形止め輪(1種)を表す

0-20 expresses a 020 of nominal designation.
(See Table 5)

0-20は、呼び020を表す(表5参照)

2 expresses Stainless steel (Surface treatment is not to be given) from Table 1.

2は、表1よりステンレス(表面処理なし)を表す

5-1. Retaining Rings - E type E形止め輪

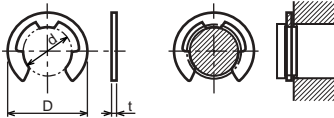

Type No. 類別番号	Type 類別
XD2-110	Retaining ring - E type (Type 1) E形止め輪(1種)
XD2-120	Retaining ring - E type (Type 2) E形止め輪(2種)

Table 5 表5

Type 種類	Nominal designation 呼び	d (mm)	D (mm)	t (mm)
Type 1 1種	007	0.65	2	0.2
	010	0.95	2.8	0.2
	013	1.25	3.3	0.3
	017	1.65	4.2	0.4
	020	1.95	4.6	0.5
	024	2.35	6	0.6
	028	2.74	6.5	0.6
	032	3.14	7.2	0.6
	037	3.64	8	0.7
	040	3.93	10	0.7
	042	4.13	10	0.7
	050	4.93	11	0.7
	058	5.73	12	0.7
	060	5.93	12.7	0.9
	064	6.32	13.5	0.9
	074	7.31	15	0.9
080	7.91	16.5	1	
Type 2 2種	008	0.8	2	0.2
	012	1.2	3	0.3
	015	1.5	4	0.4
	020	2	5	0.4
	025	2.5	6	0.4
	030	3	7	0.6
	040	4	9	0.6
	050	5	11	0.6
	060	6	12	0.8
	070	7	14	0.8
	080	8	16	0.8
	090	9	18	0.8
	100	10	20	1

5-2. Grip Rings
グリップ止め輪

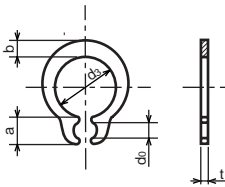

Type No. 類別番号	Type 類別
XD2-210	Grip ring グリップ止め輪

Table 5 表5

Nominal designation 呼び	d_3 (mm)	t (mm)	b (mm)	a (mm)	d_0 (mm)
020	1.9	0.5	1	1.8	0.8
025	2.35	0.5	1.2	1.9	0.9
030	2.85	0.6	1.4	1.9	0.9
035	3.3	0.6	1.6	2	0.9
040	3.8	0.8	1.8	2.8	1.2
045	4.25	0.8	2	2.9	1.3
050	4.75	0.8	2.2	2.9	1.3
060	5.7	1	2.4	3.1	1.4
070	6.7	1	2.7	3.3	1.4
080	7.7	1	3	3.5	1.4
090	8.65	1.2	3.3	4.7	1.5
100	9.65	1.2	3.5	4.7	2

5-3. Toothed Retaining Rings
歯付き形止め輪

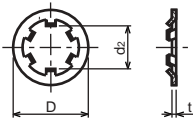

Type No. 類別番号	Type 類別
XD2-230	Toothed retaining ring 歯付き形止め輪

Table 5 表5

Nominal designation 呼び	d_z (mm)	D (mm)	t (mm)	No of teeth 歯数
015	1.4	5.2	0.25	3
020	1.9	6	0.25	3
024	2.3	6.4	0.25	3
030	2.8	8	0.25	4
040	3.8	9	0.25	4
050	4.8	10	0.25	5
060	5.8	11	0.25	5
080	7.8	13	0.25	5
100	9.8	15.4	0.25	6

5-4. Retaining Rings - C Type

C形止め輪

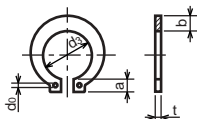

Type No. 類別番号	Type 類別
XD2-310	Retaining ring - C type for shaft C形止め輪 軸用

Table 5 表5

Nominal designation 呼び	d ₃ (mm)	t (mm)	b (mm)	a (mm)	d ₀ (mm)
010	9.3	1	1.6	3	1.2
012	11.1	1	1.8	3.2	1.5
014	12.9	1	2	3.4	1.7
015	13.8	1	2.1	3.5	1.7
016	14.7	1	2.2	3.6	1.7
017	15.7	1	2.2	3.7	1.7
018	16.5	1.2	2.6	3.8	1.7
020	18.5	1.2	2.7	3.9	2
022	20.5	1.2	2.7	4.1	2
025	23.2	1.2	3.1	4.3	2
028	25.9	1.5	3.1	4.6	2
030	27.9	1.5	3.5	4.8	2
032	29.6	1.5	3.5	5	2.5
035	32.2	1.5	4	5.4	2.5

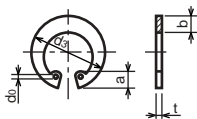

Type No. 類別番号	Type 類別
XD2-320	Retaining ring - C type for hole C形止め輪 穴用

Table 5 表5

Nominal designation 呼び	d ₃ (mm)	t (mm)	b (mm)	a (mm)	d ₀ (mm)
010	10.7	1	1.8	3.1	1.2
011	11.8	1	1.8	3.2	1.2
012	13	1	1.8	3.3	1.5
014	15.1	1	2	3.6	1.7
016	17.3	1	2	3.7	1.7
018	19.5	1	2.5	4	1.7
019	20.5	1	2.5	4	2
020	21.5	1	2.5	4	2
022	23.5	1	2.5	4.1	2
025	26.9	1.2	3	4.4	2
028	30.1	1.2	3	4.6	2
030	32.1	1.2	3	4.7	2
032	34.4	1.2	3.5	5.2	2.5
035	37.8	1.5	3.5	5.2	2.5
037	39.8	1.5	3.5	5.2	2.5
040	43.5	1.8	4	5.7	2.5
042	45.5	1.8	4	5.8	2.5
045	48.5	1.8	4.5	5.9	2.5
047	50.5	1.8	4.5	6.1	2.5
050	54.2	2	4.5	6.5	2.5
052	56.2	2	5.1	6.5	2.5
055	59.2	2	5.1	6.5	2.5
060	64.2	2	5.1	6.8	2.5
062	66.2	2	5.5	6.9	2.5
068	72.5	2.5	6	7.4	2.5
072	76.5	2.5	6.6	7.4	2.5
075	79.5	2.5	6.6	7.8	2.5
080	85.5	2.5	7	8	2.5
085	90.5	3	7	8	3
090	95.5	3	7.6	8.3	3
095	100.5	3	8	8.5	3

Prepared by
OIP Service Management Center
CANON INC.

Canon