

MF720 Series

PARTS CATALOG

Canon

MAY. 2015

Figure SNL Product Code No./Serial No.

	Product Code No.	Model Name	Remarks	Serial No.
1	F16-7991-000	i-SENSYS MF729Cx	ADF + WIRELESS + FAX + NFC	TWW
2	F16-7896-000	i-SENSYS MF728Cdw	ADF + WIRELESS + FAX	TWL
3	F16-7892-000	i-SENSYS MF724Cdw	ADF + WIRELESS	TWS

	中オーダー	製品名	備考	シリアル No.
1	F16-7991-000	i-SENSYS MF729Cx	A D F + ワイヤレス + F A X + N F C	TWW
2	F16-7896-000	i-SENSYS MF728Cdw	A D F + ワイヤレス + F A X	TWL
3	F16-7892-000	i-SENSYS MF724Cdw	A D F + ワイヤレス	TWS

FIG/KEY	PART NUMBER	RANK	QTY	DESCRIPTION	REMARKS
SNL	NPN		RF	Product Code No./Serial No.	
1	F16-7991-000		1	i-SENSYS MF729Cx	TWW ADF + WIRELESS + FAX + NFC
2	F16-7896-000		1	i-SENSYS MF728Cdw	TWL ADF + WIRELESS + FAX
3	F16-7892-000		1	i-SENSYS MF724Cdw	TWS ADF + WIRELESS

Figure A1 ASSEMBLY LOCATION DIAGRAM

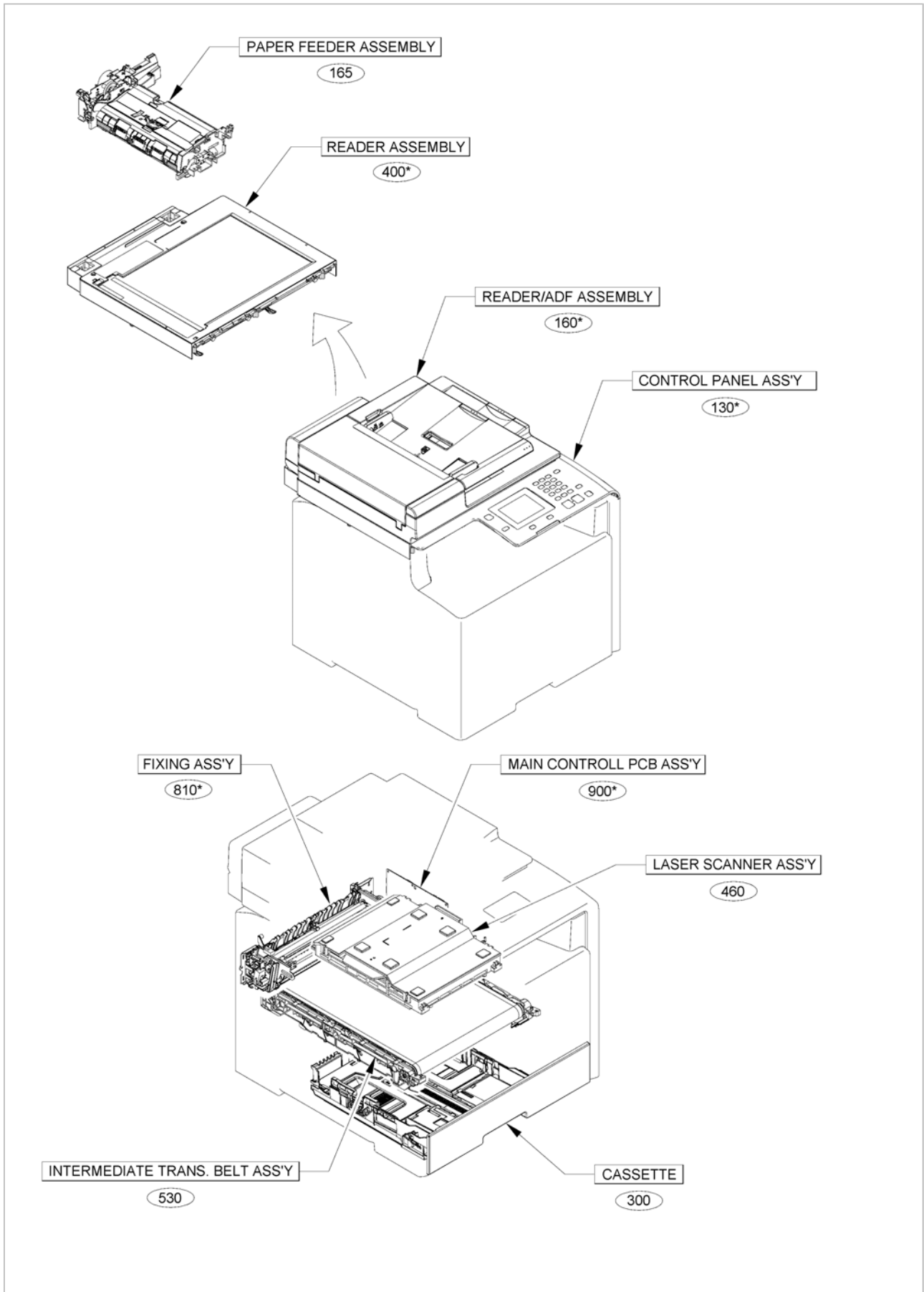

FIG/KEY	PART NUMBER	RANK	QTY	DESCRIPTION	REMARKS
---------	-------------	------	-----	-------------	---------

Figure A2 OPTION PARTS CATALOG LIST

This is the table of the machine's options whose parts catalog is issued.
本機のオプションで、パーツカタログが発行されている機種の一覧である。

No.	Model Name(English)	Model Name(Japanese)
1	Cassette Feeding Module-V1	1 段カセットユニット・V 1
2	HANDSET KIT 3 Long cord	(日本仕向けなし)
3	TELEPHONE 6 KIT Long cord	(日本仕向けなし)
4	Copy Control Interface Kit-C1	(日本仕向けなし)
5	Copy Card Reader-F1	(日本仕向けなし)
6	Copy Card Reader Attachment-J1	(日本仕向けなし)
7	MiCARD Attachment Kit-B1	(日本仕向けなし)

FIG/KEY	PART NUMBER	RANK	QTY	DESCRIPTION	REMARKS
---------	-------------	------	-----	-------------	---------

Figure 001D ACCESSORIES (EXCEPT FAX model)

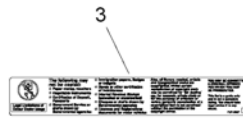
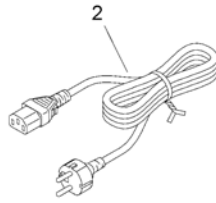
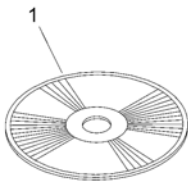

FIG/KEY	PART NUMBER	RANK	QTY	DESCRIPTION	REMARKS
001D	NPN		1	ACCESSORIES	EXCEPT FAX model
1	FK4-3434-000		1	DVD-ROM, USER SOFTWARE	
2	FH2-7080-000		1	CORD, POWER, 230V	
3	FU7-8407-000		1	LABEL, COPY PROHIBITION	
4	FU7-8413-000		1	LABEL, COPY PROHIBITION	

Figure 001E ACCESSORIES (FAX model)

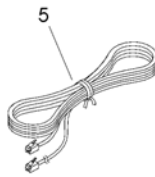
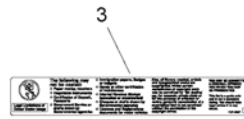
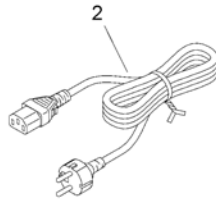
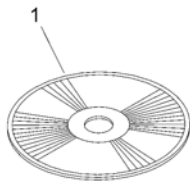

FIG/KEY	PART NUMBER	RANK	QTY	DESCRIPTION	REMARKS
001E	NPN		1	ACCESSORIES	FAX model
1	FK4-3434-000		1	DVD-ROM, USER SOFTWARE	
2	FH2-7080-000		1	CORD, POWER, 230V	
3	FU7-8407-000		1	LABEL, COPY PROHIBITION	
4	FU7-8413-000		1	LABEL, COPY PROHIBITION	
5	FK2-5275-000		1	CORD, MODULAR	
6	FK2-3531-000		4	CLAMP, CABLE	

Figure 100D EXTERNAL COVERS, PANELS, ETC. (EXCEPT FAX model)

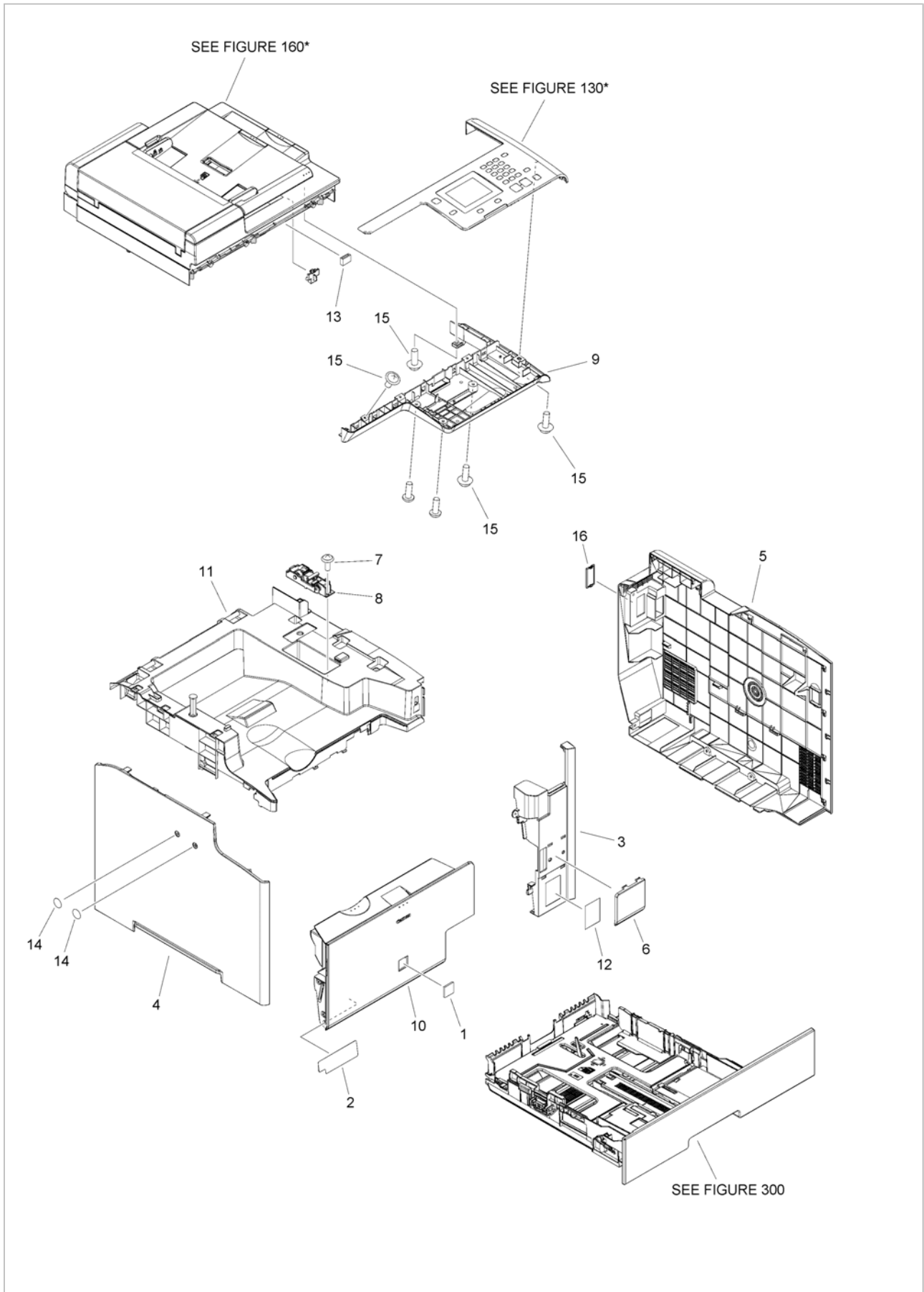

FIG/KEY	PART NUMBER	RANK	QTY	DESCRIPTION	REMARKS
100D	NPN		1	EXTERNAL COVERS, PANELS, ETC.	EXCEPT FAX model
1	RC2-0062-000		1	EMBLEM	
2	FC8-8742-000		1	LABEL, PAPER SIZE	
3	FC9-4541-000		1	COVER, RIGHT FRONT	
4	FC9-4545-000		1	COVER, LEFT	
5	FE3-9944-000		1	COVER, RIGHT	
6	FC9-4579-000		1	COVER, SUB, FRONT	
7	XA9-1671-000		8	SCREW, D, M3X8	
8	FM3-9816-000		1	HINGE ASSEMBLY	
9	FE4-0076-000		1	COVER, BASE	
10	FM4-4285-000		1	FRONT DOOR ASS'Y	
11	FM4-4287-000		1	COVER, TOP	
12	FU7-8109-000		1	LABEL, JAM	
13	FK2-5242-000		1	CORE	
14	HB1-5537-000		4	SHEET, BLANKING	
15	XA9-0476-000		13	SCREW, TP M3X8	
16	FC9-4584-000		1	COVER, MODULAR	

Figure 100E EXTERNAL COVERS, PANELS, ETC. (FAX model)

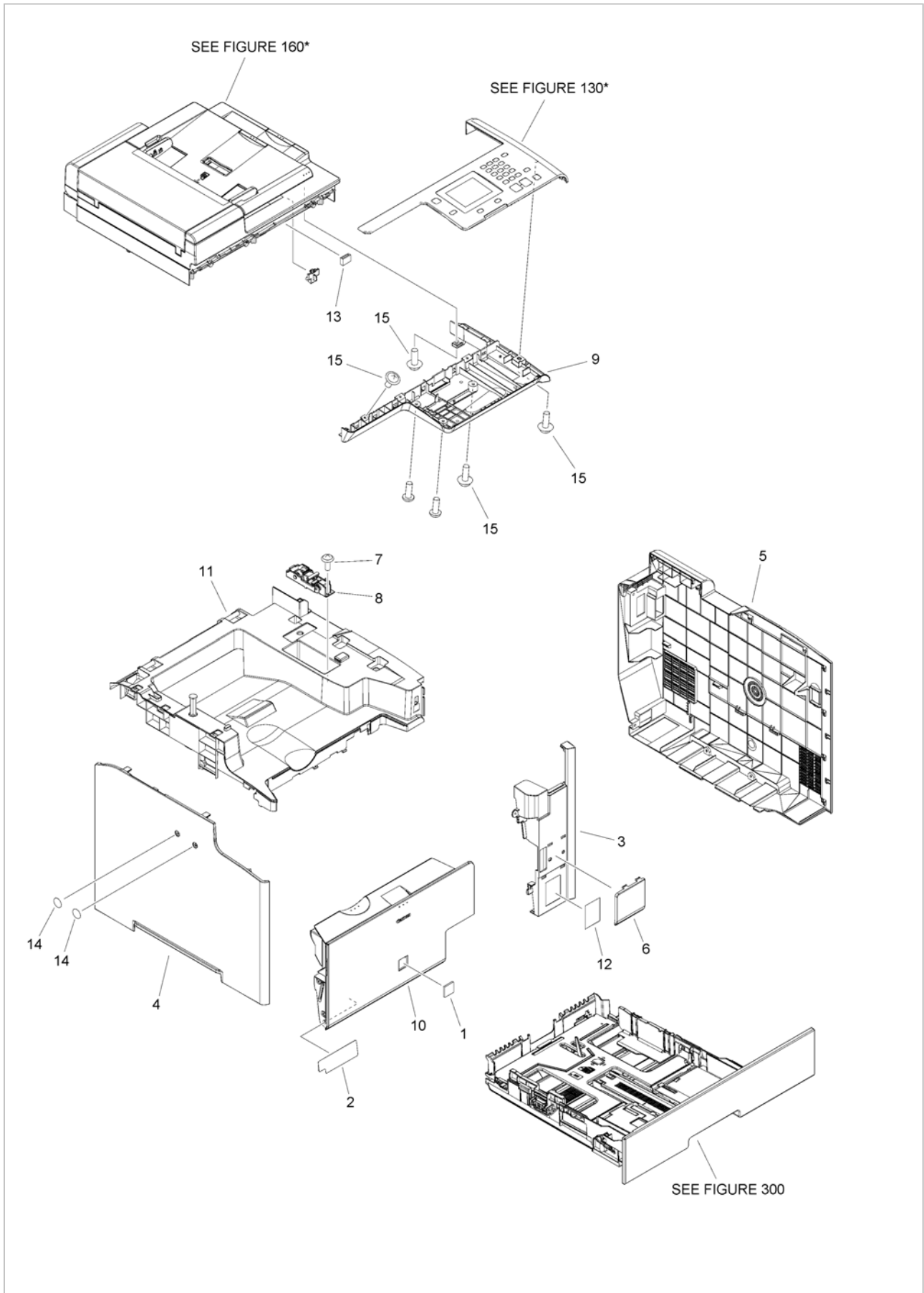

FIG/KEY	PART NUMBER	RANK	QTY	DESCRIPTION	REMARKS
100E	NPN		1	EXTERNAL COVERS, PANELS, ETC.	FAX model
1	RC2-0062-000		1	EMBLEM	
2	FC8-8742-000		1	LABEL, PAPER SIZE	
3	FC9-4541-000		1	COVER, RIGHT FRONT	
4	FC9-4545-000		1	COVER, LEFT	
5	FE3-9944-000		1	COVER, RIGHT	
6	FC9-4579-000		1	COVER, SUB, FRONT	
7	XA9-1671-000		8	SCREW, D, M3X8	
8	FM3-9816-000		1	HINGE ASSEMBLY	
9	FE4-0076-000		1	COVER, BASE	
10	FM4-4285-000		1	FRONT DOOR ASS'Y	
11	FM4-4287-000		1	COVER, TOP	
12	FU7-8109-000		1	LABEL, JAM	
13	FK2-5242-000		1	CORE	
14	HB1-5537-000		4	SHEET, BLANKING	
15	XA9-0476-000		13	SCREW, TP M3X8	

Figure 101 INTERNAL COMPONENTS 1

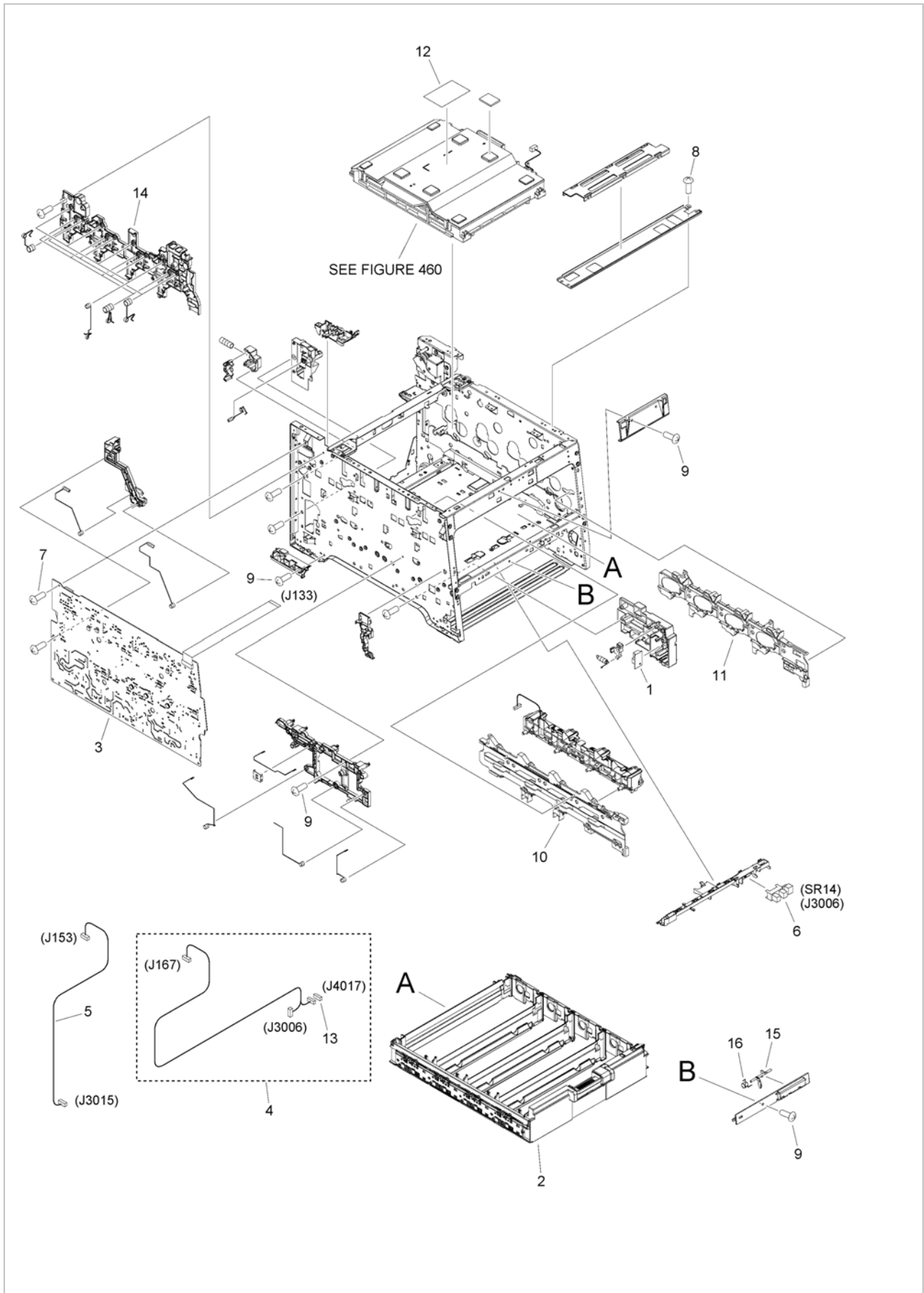

FIG/KEY	PART NUMBER	RANK	QTY	DESCRIPTION	REMARKS
101	NPN		1	INTERNAL COMPONENTS 1	
1	RK2-3267-000		1	TEMPERATURE SENSOR UNIT	
2	RM1-4836-000		1	CARTRIDGE TRAY ASS'Y	
3	RM1-5294-050		1	H. V. POWER SUPPLY PCB ASS'Y	
4	RM1-5398-000		1	SENSOR CABLE ASS'Y	
5	RM1-5399-000		1	ENV. SENSOR CABLE ASS'Y	
6	WG8-5696-000		1	PHOTO INTERRUPTER, TLP1243	SR14
7	XA9-1420-000		4	SCREW, W/WASHER, M3X8	
8	XA9-1835-000		4	SCREW, D, M3X6	
9	XA9-1671-000		7	SCREW, D, M3X8	
10	RC2-3800-000		1	RAIL, LEFT	
11	RC2-3801-000		1	RAIL, RIGHT	
12	RU5-8126-000		1	LABEL, WARNING LASER	
13	VS1-7207-003		1	CONNECTOR, SNAP TIGHT, BK	
14	RC2-3122-000		1	HOLDER, H.V. CONTACT SPRING	
15	RC2-3393-000		1	FLAG, SENSOR	
16	RU6-2176-000		1	SPRING, TORSION	

Figure 102 INTERNAL COMPONENTS 2

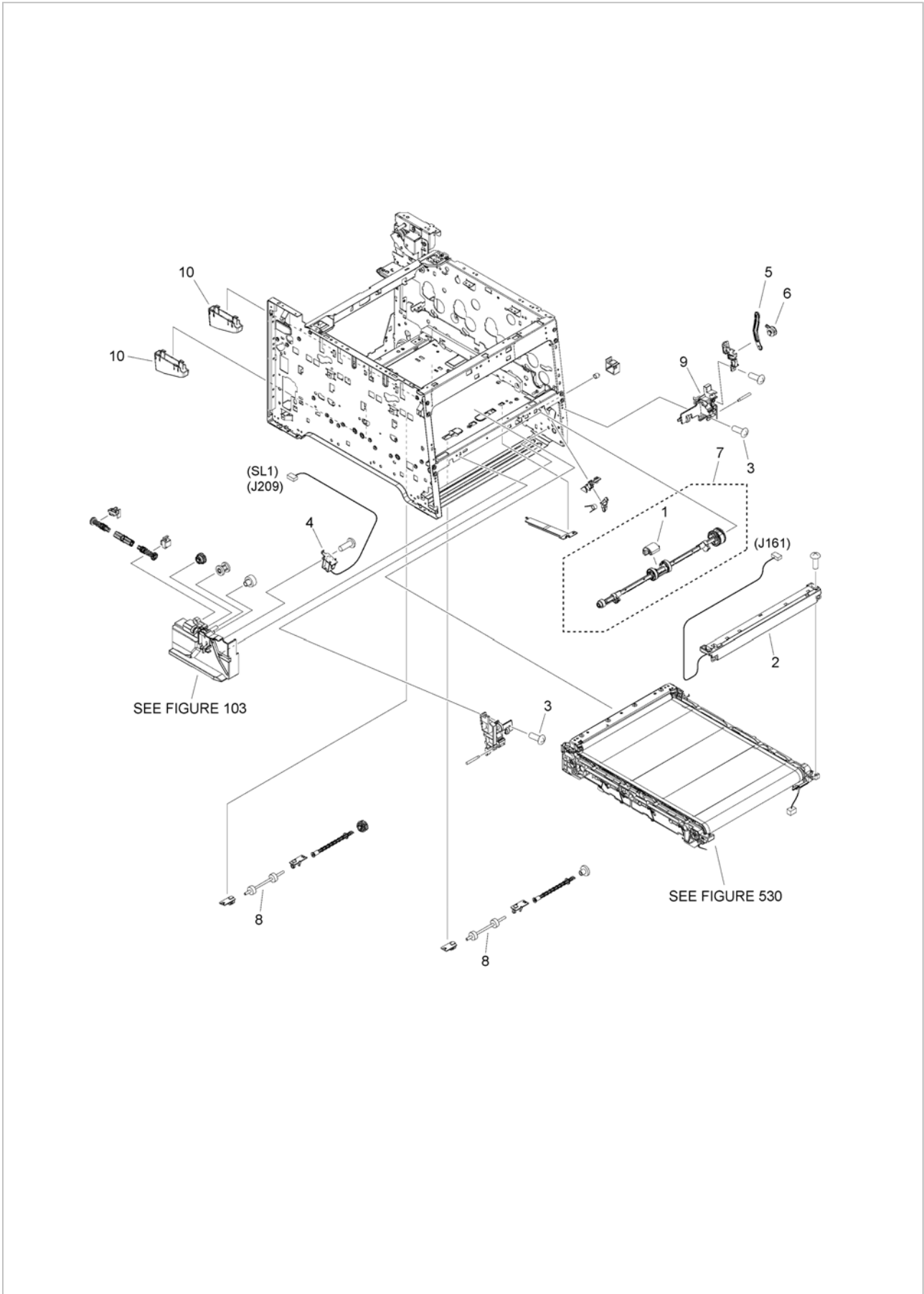

FIG/KEY	PART NUMBER	RANK	QTY	DESCRIPTION	REMARKS
102	NPN		1	INTERNAL COMPONENTS 2	
1	RL1-1802-000		1	ROLLER, PAPER PICK-UP	
2	RM1-4850-000		1	COLOR MISREGIST. SENSOR ASS'Y	
3	XA9-1671-000		2	SCREW, D, M3X8	
4	RM1-5420-000		1	MP SOLENOID ASS'Y	SL1
5	RC2-3395-000		1	HINGE, MULTI-PURPOSE COVER	
6	RC2-3396-000		1	BUSHING	
7	RM1-4881-000		1	MP PAPER PICK-UP ROLLER ASS'Y	
8	RC2-3389-000		2	ROLLER, SHAFT	
9	RC2-3406-000		1	FLANGE, DOOR, RIGHT	

Figure 103 INTERNAL COMPONENTS 3

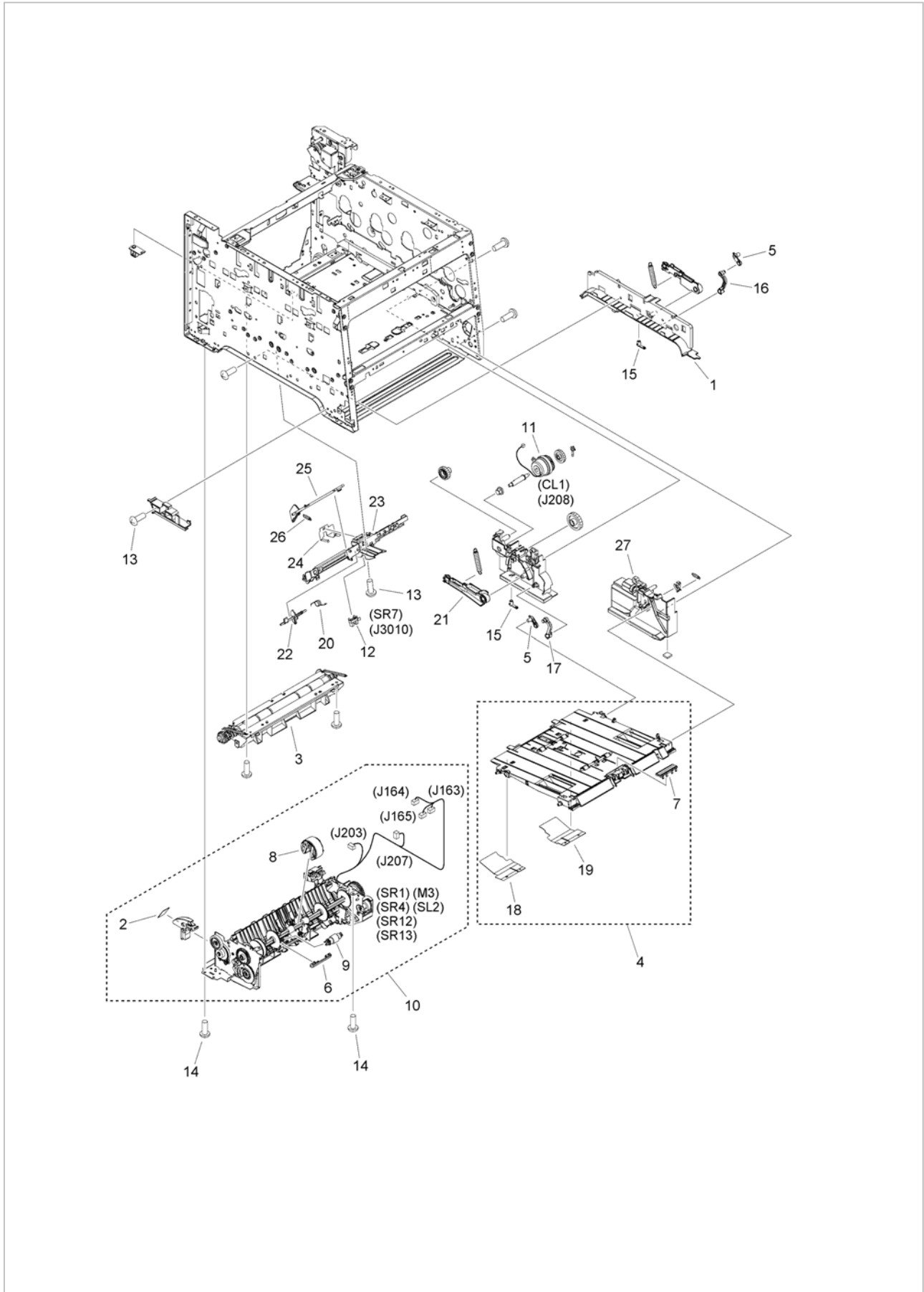

FIG/KEY	PART NUMBER	RANK	QTY	DESCRIPTION	REMARKS
103	NPN		1	INTERNAL COMPONENTS 3	
1	FC8-8715-000		1	HANDLE, LEFT	
2	FC8-8748-000		1	LABEL, MOTOR CAUTION	
3	FM4-8513-000		1	REGISTRATION ASS'Y	
4	FM4-8514-000		1	MP PAPER PICK-UP ASS'Y	
5	RC2-3388-000		2	ARM, TRAY	
6	RC2-2014-000		1	COVER, HOLDER	
7	RL1-1785-000		1	PAD, SEPARATION	
8	RM1-8047-030		1	PICK-UP ROLLER ASS'Y	
9	RM1-4840-000		1	SEPARATION ROLLER ASS'Y	
10	FM0-3571-000		1	PAPER PICK-UP ASS'Y	SR1, SR4, SR12, SR13, M3, SL2
11	RM1-5428-000		1	MP CLUTCH ASS'Y	CL1
12	WG8-5696-000		1	PHOTO INTERRUPTER, TLP1243	SR7
13	XA9-1671-000		4	SCREW, D, M3X8	
14	XA9-1835-000		6	SCREW, D, M3X6	
15	RC2-3555-000		2	STOPPER, ARM	
16	RC2-3386-000		1	ARM, TRAY, LEFT	
17	RC2-3387-000		1	ARM, TRAY, RIGHT	
18	FC0-3943-000		1	SHEET, GUIDE, LEFT	
19	FC0-3944-000		1	SHEET, GUIDE, RIGHT	
20	RU6-2174-000		1	SPRING, TORSION	
21	RC2-3509-000		1	ARM, PRESSURE, RIGHT	
22	RC2-3390-000		1	FLAG, SENSOR	
23	RC2-3401-000		1	HOLDER, SENSOR	
24	RC2-3423-000		1	PLATE, GROUNDING	
25	RC2-3556-000		1	ARM, SENSOR	
26	RU6-2205-000		1	SPRING, TORSION	
27	RC2-3505-000		1	RAIL, CASSETTE, RIGHT FRONT	

Figure 104C INTERNAL COMPONENTS 4 (230V)

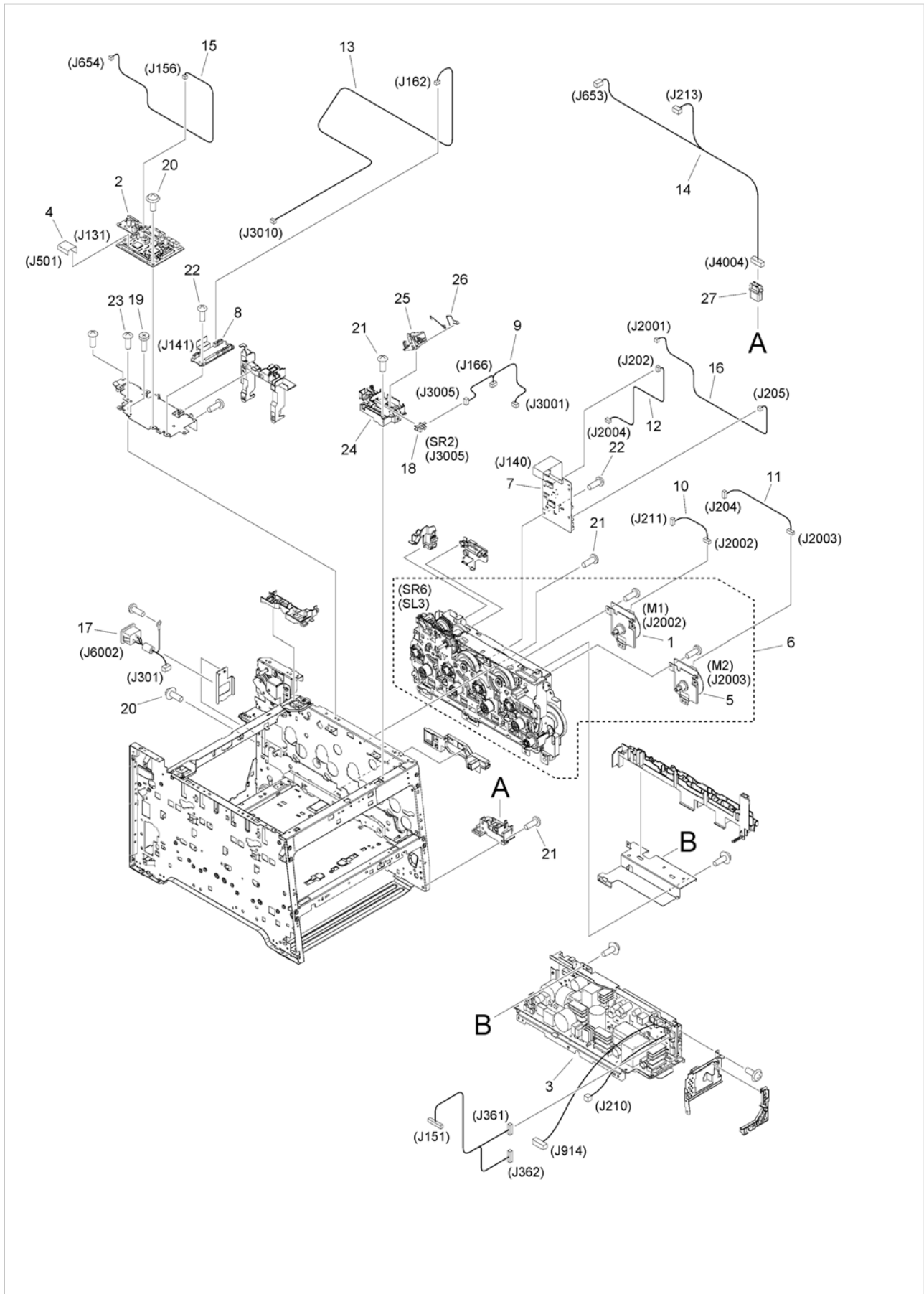

FIG/KEY	PART NUMBER	RANK	QTY	DESCRIPTION	REMARKS
104C	NPN		1	INTERNAL COMPONENTS 4	230V
1	RL1-3053-000		1	MOTOR, DC	M1
2	FMO-4754-000		1	DC CONTROLLER PCB ASS'Y	
3	FMO-4753-000		1	POWER SUPPLY ASS'Y	
4	RK2-2302-000		1	CABLE, FLAT	
5	RL1-1800-000		1	MOTOR, DC	M2
6	RM1-8042-010		1	MAIN DRIVE ASS'Y	
7	FM1-P897-000		1	DRIVER PCB ASS'Y	
8	RM1-5293-000		1	RELAY PCB ASS'Y	
9	RM1-5385-000		1	SENSOR CABLE ASS'Y	
10	RM1-5393-000		1	DRAM MOTOR CABLE ASS'Y	
11	RM1-5394-000		1	DEVELOPING MOTOR CABLE ASS'Y	
12	RM1-5395-000		1	FEED MOTOR CABLE ASS'Y	
13	RM1-5400-000		1	SENSOR CABLE ASS'Y	
14	RM1-5434-000		1	OPTION CABLE ASS'Y	
15	RM1-5435-000		1	RLD CABLE ASS'Y	
16	RM1-5438-000		1	FIXING MOTOR CABLE ASS'Y	
17	FM4-3800-000		1	CORD, POWER SUPPLY	
18	WG8-5696-000		1	PHOTO INTERRUPTER, TLP1243	SR2
19	XA9-0679-000		1	SCREW, MACH. , FLAT HEAD, M3X4	
20	XA9-1418-000		5	SCREW, TP, M3X6	
21	XA9-1671-000		7	SCREW, D, M3X8	
22	XA9-1420-000		2	SCREW, W/WASHER, M3X8	
23	XA9-1835-000		2	SCREW, D, M3X6	
24	RC2-3220-000		1	HOLDER, CARTRIDGE DOOR SENSOR	
25	RC2-3221-000		1	ARM, DOOR SENSOR	
26	RC2-3222-000		1	SPRING, TORSION	
27	VS1-7258-007		1	CONNECTOR, DRAWER	

Figure 105 INTERNAL COMPONENTS 5

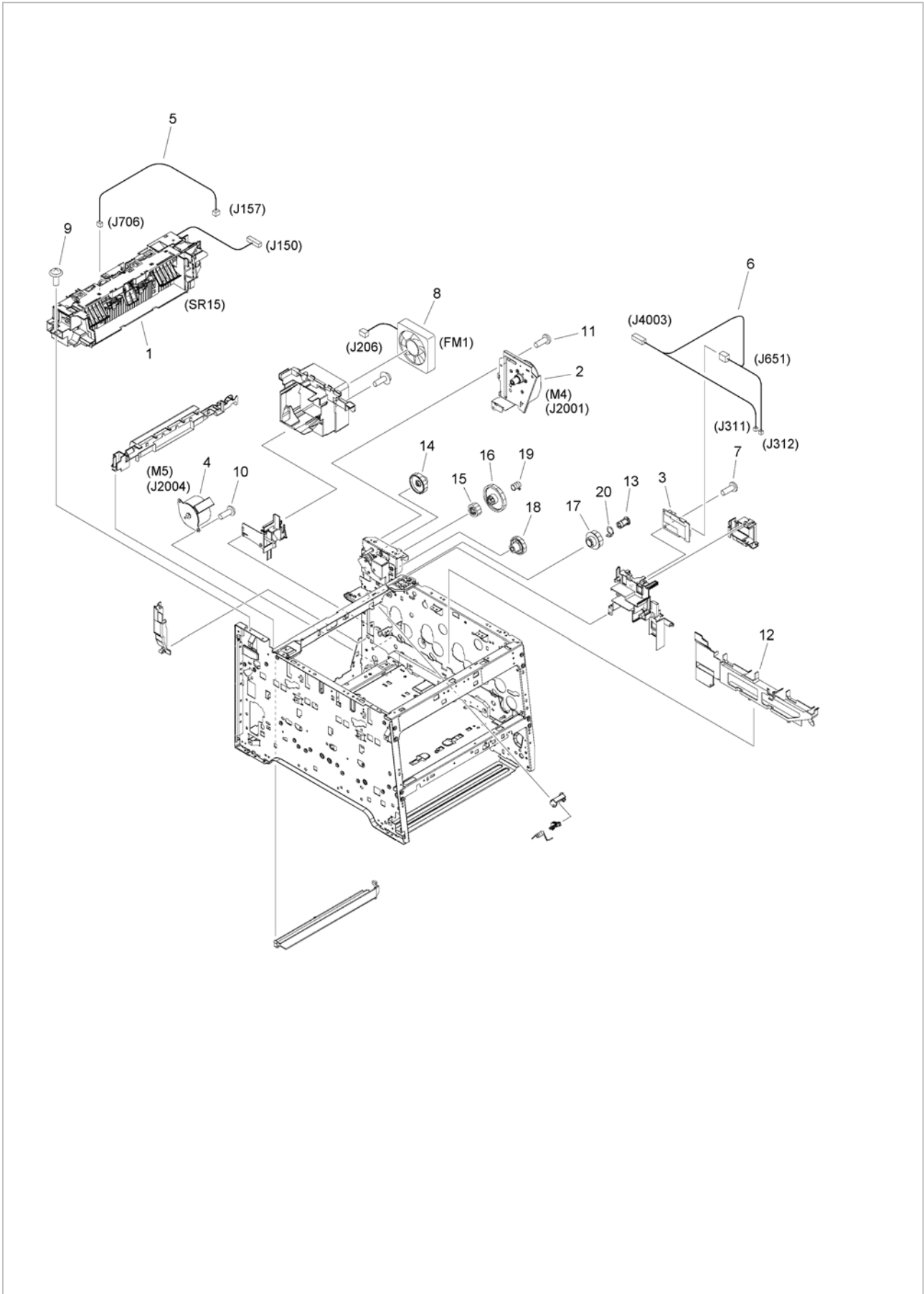

FIG/KEY	PART NUMBER	RANK	QTY	DESCRIPTION	REMARKS
105	NPN		1	INTERNAL COMPONENTS 5	
1	FM4-4286-010		1	PAPER DELIVERY ASS'Y	SR15
2	RM1-4896-000		1	FIXING MOTOR UNIT	M4
3	RM1-7355-000		1	POWER SUPPLY SUB PCB ASS'Y	
4	RM1-5419-000		1	FEED MOTOR ASS'Y	M5
5	RM1-5433-000		1	THERMISTOR CABLE ASS'Y	
6	FM4-3803-000		1	CABLE, FIXING	
7	XA9-1420-000		2	SCREW, W/WASHER, M3X8	
8	RK2-2276-000		1	FAN	FM1
9	XA9-1418-000		2	SCREW, TP, M3X6	
10	XA9-1835-000		2	SCREW, D, M3X6	
11	XA9-1671-000		3	SCREW, D, M3X8	
12	RC2-3136-000		1	DUCT, 5	
13	RC2-3194-000		1	HOLDER, GEAR	
14	RU6-0270-000		1	GEAR, 67T/16T	
15	RU6-0302-000		1	GEAR, 21T	
16	RU6-0303-000		1	GEAR, 57T	
17	RU6-0307-000		1	GEAR, 33T/21T	
18	RU6-0308-000		1	GEAR, 39T/15T	
19	RU6-2178-000		1	SPRING, COMPRESSION	
20	RU6-2179-000		1	SPRING	

Figure 106 INTERNAL COMPONENTS 6

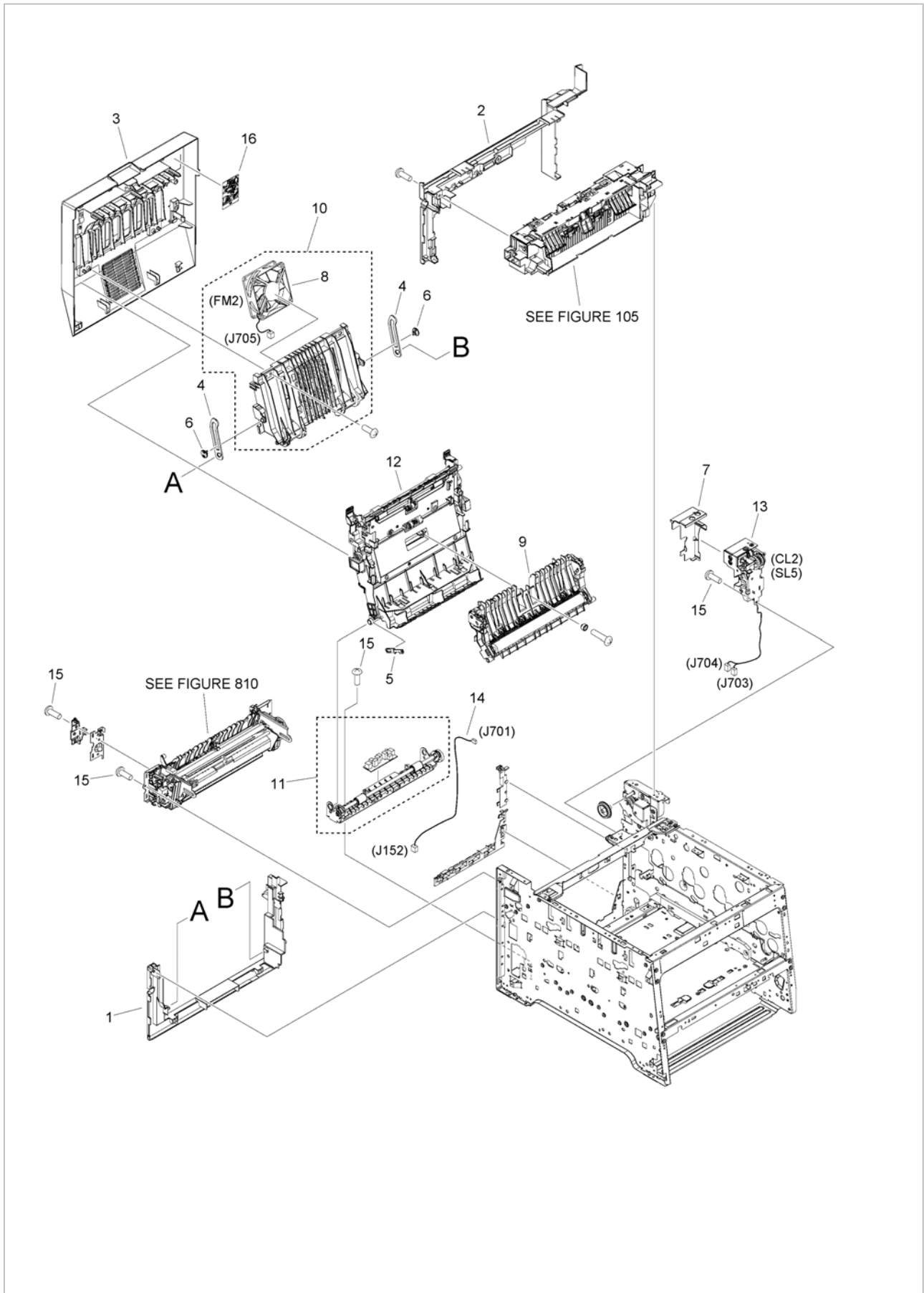

FIG/KEY	PART NUMBER	RANK	QTY	DESCRIPTION	REMARKS
106	NPN		1	INTERNAL COMPONENTS 6	
1	FC9-4546-000		1	COVER, REAR LOWER	
2	FC9-4547-000		1	COVER, REAR UPPER	
3	FM4-4284-000		1	REAR DOOR ASS'Y	
4	RC2-3750-000		2	LINK, DOOR	
5	RC2-3752-000		1	LINK, GUIDE	
6	RC2-3774-000		2	CAP, LINK	
7	FC8-8730-000		1	COVER, REVERSE	
8	RK2-2276-000		1	FAN	FM2
9	RM1-4838-000		1	PAPER FEED GUIDE ASS'Y	
10	RM1-4876-000		1	REAR DOOR RIB ASS'Y	
11	RM1-4877-000		1	PAPER RE-PICK UP GUIDE ASS'Y	
12	RM1-4879-000		1	DUPLEXING FEED GUIDE ASS'Y	
13	RM1-4880-000		1	REVERSE DRIVE ASS'Y	CL2, SL5
14	RM1-5397-000		1	DUPLEX CABLE ASS'Y	
15	XA9-1671-000		6	SCREW, D, M3X8	
16	FU7-8108-000		1	LABEL, DUPLEX JAM	

Figure 107E INTERNAL COMPONENTS 7 (EXCEPT FAX model)

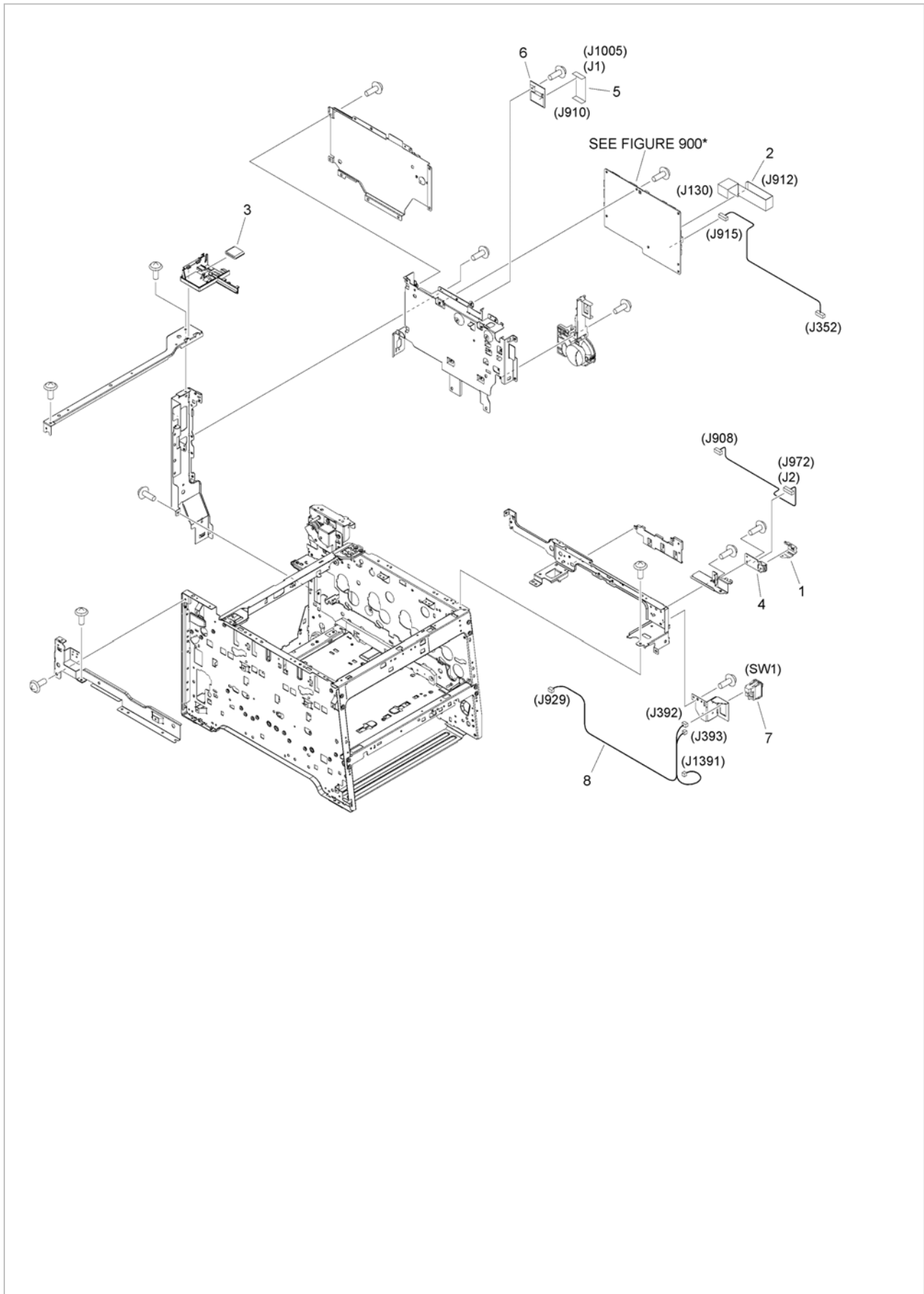

FIG/KEY	PART NUMBER	RANK	QTY	DESCRIPTION	REMARKS
107E	NPN		1	INTERNAL COMPONENTS 7	EXCEPT FAX model
1	FC9-4507-000		1	PLATE, USB GROUNDING	
2	FK3-1894-000		1	CABLE, FLAT	
3	FK2-8767-000		1	CORE, FERRITE	
4	FMO-4655-000		1	USB PCB ASSEMBLY	
5	FK4-2613-000		1	CABLE, FLAT	
6	FK4-1248-020		1	MODULE, WLAN 88W8782	
7	FK3-3266-000		1	SWITCH, POWER SUPPLY	SW1
8	FMO-3915-000		1	CABLE, MAIN SWITCH	

Figure 107F INTERNAL COMPONENTS 7 (FAX model MF728Cdw)

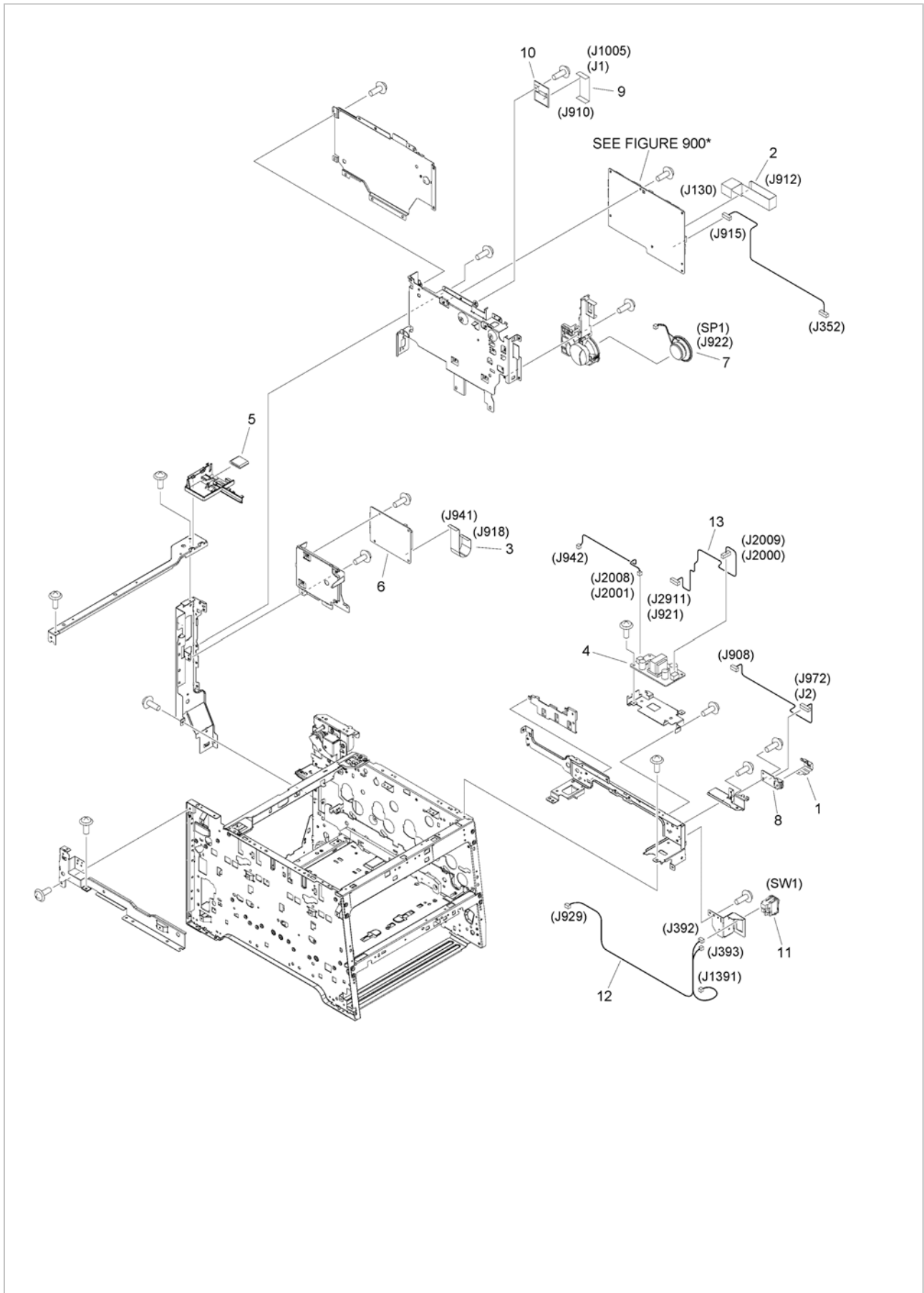

FIG/KEY	PART NUMBER	RANK	QTY	DESCRIPTION	REMARKS
107F	NPN		1	INTERNAL COMPONENTS 7	FAX model MF728Cdw
1	FC9-4507-000		1	PLATE, USB GROUNDING	
2	FK3-1894-000		1	CABLE, FLAT	
3	FK3-3940-000		1	CABLE, FLAT	
4	FM4-8968-010		1	OFFHOOK PCB ASSEMBLY	
5	FK2-8767-000		1	CORE, FERRITE	
6	FM1-N815-000		1	FAX-NCU PCB ASSEMBLY	
7	FK2-9878-000		1	SPEAKER ASSEMBLY	SP1
8	FMO-4655-000		1	USB PCB ASSEMBLY	
9	FK4-2613-000		1	CABLE, FLAT	
10	FK4-1248-020		1	MODULE, WLAN 88W8782	
11	FK3-3266-000		1	SWITCH, POWER SUPPLY	SW1
12	FMO-3915-000		1	CABLE, MAIN SWITCH	
13	FMO-4682-000		1	CABLE, OFFHOOK	

Figure 107G INTERNAL COMPONENTS 7 (FAX model MF729Cx)

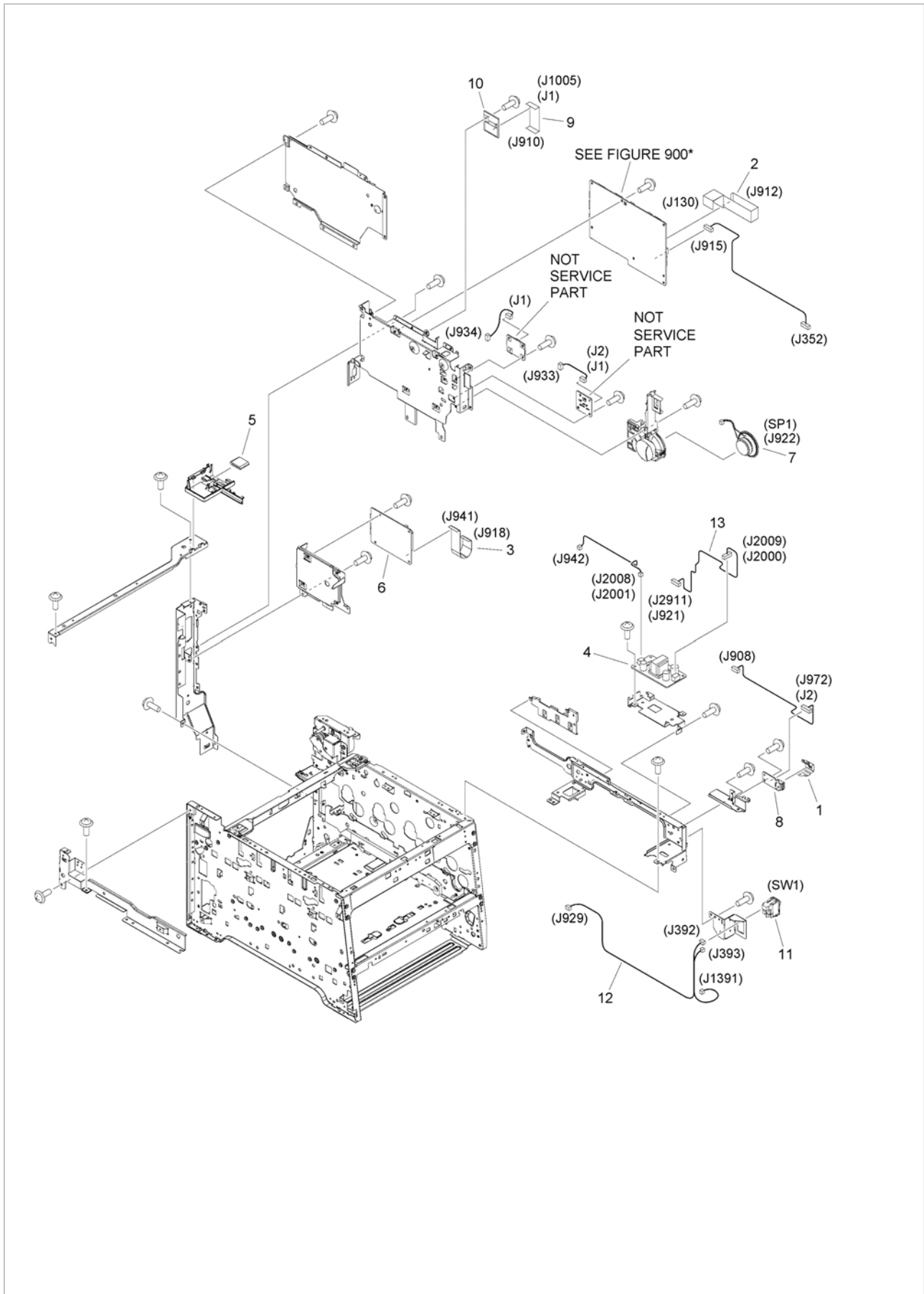

FIG/KEY	PART NUMBER	RANK	QTY	DESCRIPTION	REMARKS
107G	NPN		1	INTERNAL COMPONENTS 7	FAX model MF729Cx
1	FC9-4507-000		1	PLATE, USB GROUNDING	
2	FK3-1894-000		1	CABLE, FLAT	
3	FK3-3940-000		1	CABLE, FLAT	
4	FM4-8968-010		1	OFFHOOK PCB ASSEMBLY	
5	FK2-8767-000		1	CORE, FERRITE	
6	FM1-N815-000		1	FAX-NCU PCB ASSEMBLY	
7	FK2-9878-000		1	SPEAKER ASSEMBLY	SP1
8	FMO-4655-000		1	USB PCB ASSEMBLY	
9	FK4-2613-000		1	CABLE, FLAT	
10	FK4-1248-020		1	MODULE, WLAN 88W8782	
11	FK3-3266-000		1	SWITCH, POWER SUPPLY	SW1
12	FMO-3915-000		1	CABLE, MAIN SWITCH	
13	FMO-4682-000		1	CABLE, OFFHOOK	

Figure 130E CONTROL PANEL ASS'Y (i-SENSYS MF724Cdw)

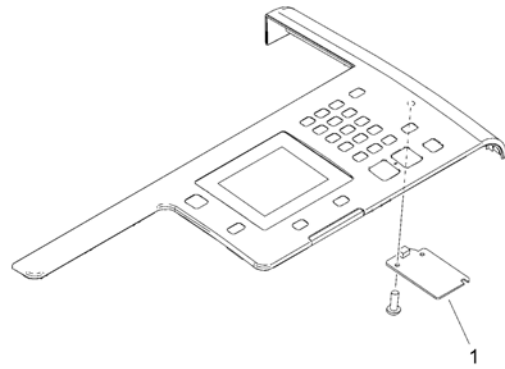

FIG/KEY	PART NUMBER	RANK	QTY	DESCRIPTION	REMARKS
130E	FM1-H435-000		1	CONTROL PANEL ASS' Y	i-SENSYS MF724Cdw

Figure 130G CONTROL PANEL ASS'Y (i-SENSYS MF729Cx)

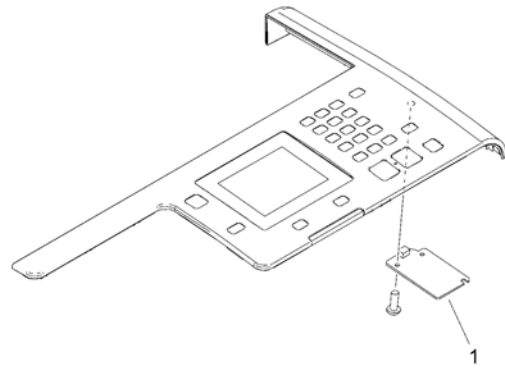

FIG/KEY	PART NUMBER	RANK	QTY	DESCRIPTION	REMARKS
130G	FM1-H440-000		1	CONTROL PANEL ASS' Y	i-SENSYS MF729Cx
1	FM1-N812-000		1	NFC PCB ASSEMBLY	NFC MODEL

Figure 130G CONTROL PANEL ASS'Y (i-SENSYS MF729Cx)

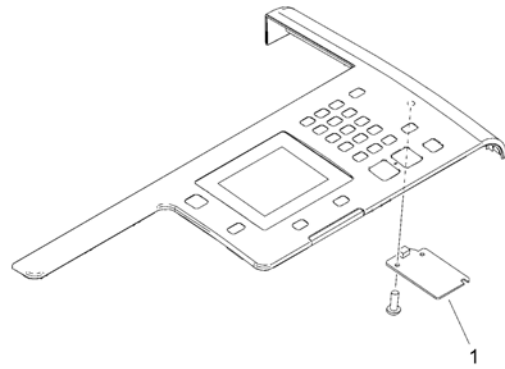

FIG/KEY	PART NUMBER	RANK	QTY	DESCRIPTION	REMARKS
130G	FM1-H440-000		1	CONTROL PANEL ASS'Y	i-SENSYS MF729Cx
1	FM1-N812-000		1	NFC PCB ASSEMBLY	NFC MODEL

Figure 160C READER/ADF ASSEMBLY

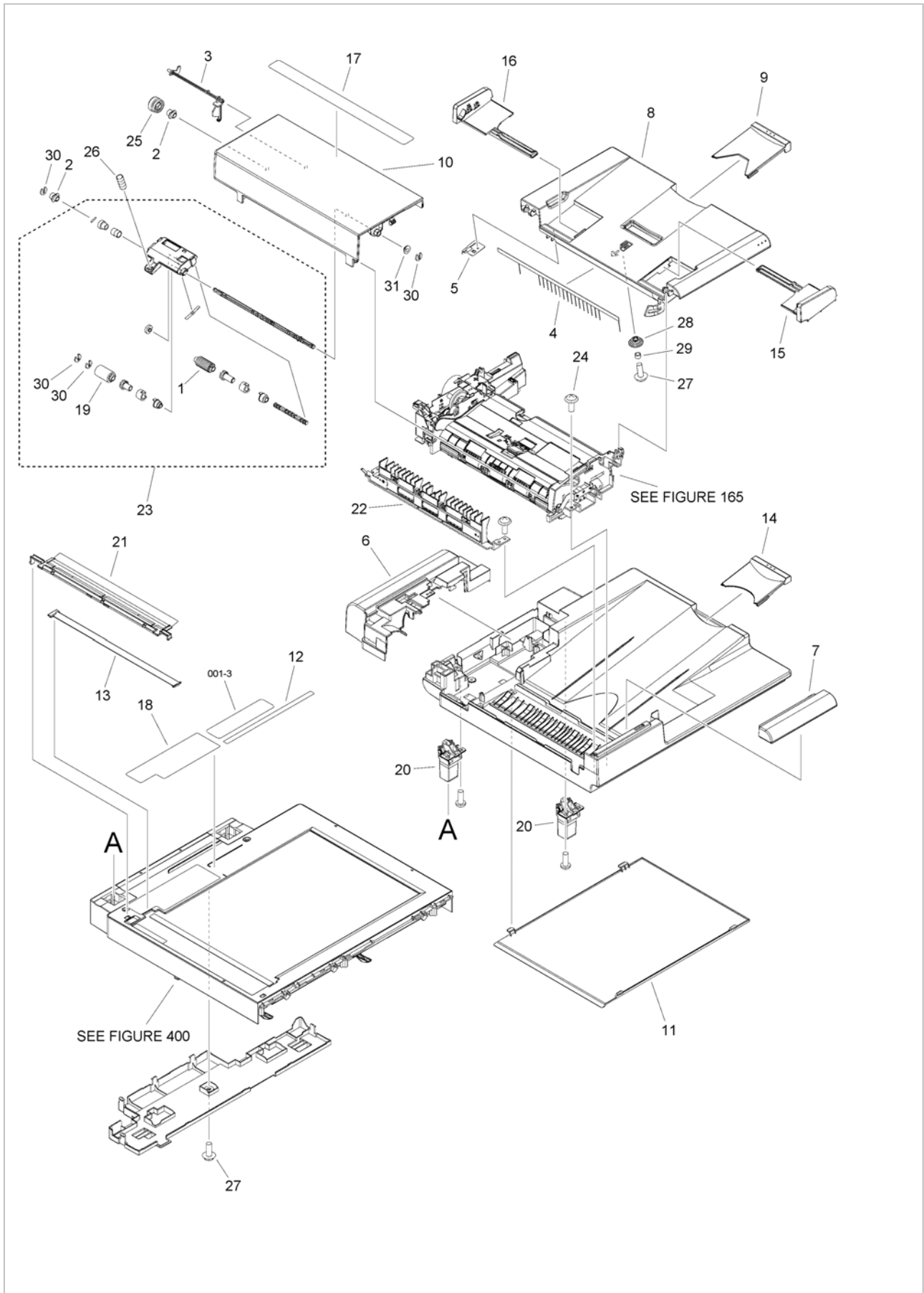

FIG/KEY	PART NUMBER	RANK	QTY	DESCRIPTION	REMARKS
160C	NPN		1	READER/ADF ASSEMBLY	
1	FC7-6189-000		1	ROLLER, PICK-UP	
2	FC7-6320-000		2	BUSHING	
3	FC7-6321-000		1	FLAG, DOCUMENT SCANNER	
4	FC7-6322-000		1	ELIMINATOR, STATIC CHARGE	
5	FC9-1503-000		1	PLATE, GROUNDING	
6	FL3-9296-000		1	COVER, REAR	
7	FL3-9295-000		1	COVER, FRONT UPPER	
8	FC9-1534-000		1	TRAY, DOCUMENT	
9	FC9-1535-000		1	TRAY, SUB DOCUMENT	
10	FL0-1992-000		1	PANEL, OPEN/CLOSE	
11	FC0-4435-000		1	SHEET, WHITE	
12	FE2-2444-000		1	LABEL, SIZE INDEX	
13	FE2-3485-000		1	PLATE, PAPER SIZE	
14	FC9-5655-000		1	TRAY, SUB	
15	FC9-5656-000		1	GUIDE, DOCUMENT, FRONT	
16	FC9-5657-000		1	GUIDE, DOCUMENT, REAR	
17	FC9-7563-000		1	LABEL, SIZE INDEX	
18	FC9-7567-000		1	LABEL, GLASS CLEANING	
19	FL2-6637-000		1	ROLLER, SEPARATION	
20	FL3-2453-000		2	HINGE, ADF	
21	FL3-3539-000		1	HOLDER, DOCUMENT, RELEASE SHEET	
22	FMO-4855-000		1	PAPER FEED GUIDE ASSEMBLY	
23	FM3-9538-000		1	SEPARATION ROLLER ASSEMBLY	
24	XA9-0831-000		5	SCREW, M3X10	
25	FU7-0672-000		1	GEAR, 24T	
26	FU7-2018-000		1	SPRING, COMPRESSION	
27	XA9-0476-000		2	SCREW, TP M3X8	
28	FU8-0895-000		1	GEAR, 18T	
29	FU8-2007-000		1	SPRING, COMPRESSION	
30	HC1-0586-000		4	RETAINING RING	
31	HU1-1022-000		1	BUSHING	

Figure 165 PAPER FEEDER ASSEMBLY

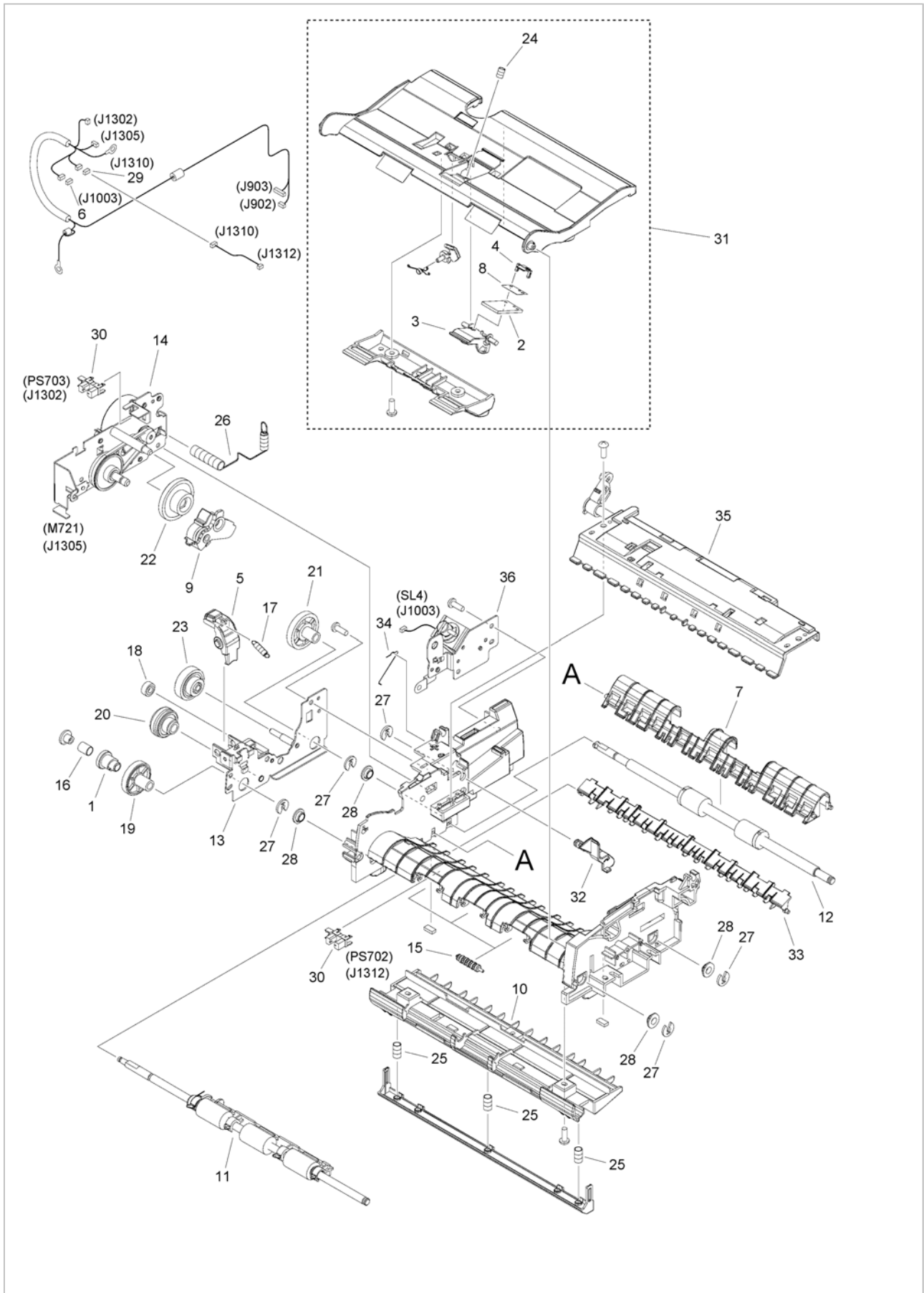

FIG/KEY	PART NUMBER	RANK	QTY	DESCRIPTION	REMARKS
165	FMO-4857-000		1	PAPER FEEDER ASSEMBLY	
1	FC7-6052-010		1	RATCHET, PAPER FEED ROLLER	
2	FC7-6297-000		1	PAD, SEPARATION	
3	FC7-6299-000		1	HOLDER, SEPARATION PAD	
4	FC7-6300-000		1	CLAMP, SEPARATION PAD	
5	FC9-1512-000		1	LEVER, RELEASE	
6	VS1-7177-002		1	CONNECTOR, SNAP TIGHT, BK	
7	FC9-1526-000		1	GUIDE, PAPER DELIVERY	
8	FC9-5654-000		1	SHEET, SEPARATION PAD	
9	FL3-1431-000		1	ARM, SEPARATION SWING	
10	FL3-1437-000		1	GUIDE LOWER ASSEMBLY	
11	FM4-1885-000		1	PAPER FEED ROLLER ASSEMBLY	
12	FL3-2458-000		1	PAPER DELIVERY ROLLER ASS' Y	
13	FM3-9542-000		1	DRIVE PLATE ASSEMBLY	
14	FMO-4859-000		1	MOTOR DRIVE ASS' Y	M721
15	FU5-6992-000		3	ROLLER, AUXILIARY	
16	FU6-2998-000		1	SPRING, COMPRESSION	
17	FU6-2999-000		1	SPRING, TENSION	
18	FU7-0667-000		1	GEAR, 20T	
19	FU7-0668-000		1	GEAR, 54T	
20	FU7-0669-000		1	GEAR, 46T/23T	
21	FU7-0671-000		1	GEAR, 36T	
22	FU7-0676-000		1	GEAR, 21T/42T	
23	FU7-0678-000		1	GEAR, 51T/17T	
24	FU7-2016-000		1	SPRING, COMPRESSION	
25	FU8-2008-000		3	SPRING, COMPRESSION	
26	FU7-2021-000		1	SPRING, COMPRESSION	
27	HC1-0586-000		5	RETAINING RING	
28	HU1-1022-000		4	BUSHING	
29	VS1-7207-004		1	CONNECTOR, SNAP TIGHT, BK	
30	WG8-5696-000		2	PHOTO INTERRUPTER, TLP1243	PS702, PS703
31	FM4-1873-000		1	GUIDE ASSEMBLY, UPPER	
32	FC7-6182-000		1	LEVER, ROLLER RELEASE	
33	FC7-6278-000		1	FLAPPER, PAPER DELIVERY	
34	FC7-6281-000		1	SPRING, ARM	
35	FM3-9541-000		1	PAPER DELIVERY ASSEMBLY	
36	FM3-9543-000		1	SOLENOID ASSEMBLY	SL4

Figure 300 CASSETTE

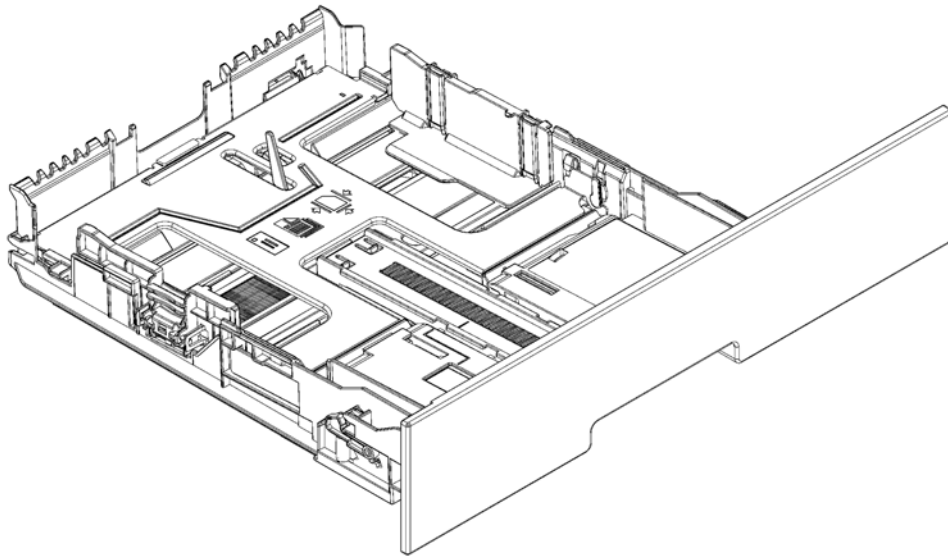

FIG/KEY	PART NUMBER	RANK	QTY	DESCRIPTION	REMARKS
300	FM4-4279-000		1	CASSETTE	

Figure 400 READER ASSEMBLY

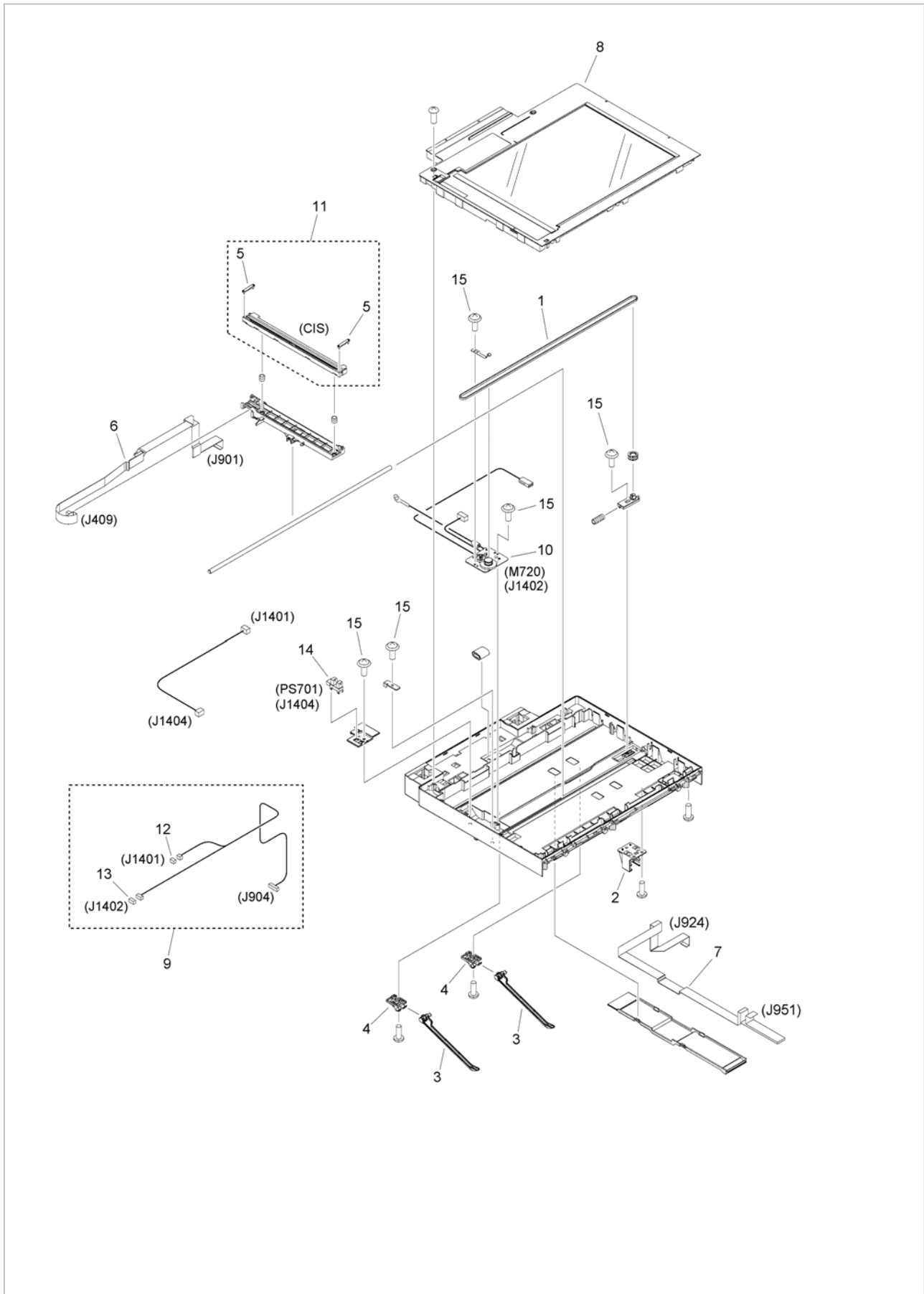

FIG/KEY	PART NUMBER	RANK	QTY	DESCRIPTION	REMARKS
400	FM1-J270-000		1	READER ASSEMBLY	
1	FC9-1650-000		1	BELT, TIMING	
2	FC9-2101-000		1	MOUNT, SUPPORTER	
3	FC9-4589-000		2	LEVER, FACE-DOWN	
4	FC9-4590-000		2	HOLDER, FACE-DOWN LEVER	
5	FC9-7571-000		2	SPACER, CIS	
5	FC9-7573-000		2	SPACER, CIS	
5	FC9-7574-000		2	SPACER, CIS	
6	FK3-1884-000		1	CABLE, FLAT	
7	FK4-2614-000		1	CABLE, FLAT	
8	FMO-3591-000		1	READER COVER UNIT	
9	FM4-3653-000		1	CABLE, READER	
10	FM4-4301-000		1	DC MOTOR ASSEMBLY	M720
11	FM4-9076-000		1	CONTACT IMAGE SENSOR ASS'Y	CIS
12	VS1-7177-003		1	CONNECTOR, SNAP TIGHT, BK	
13	VS1-7177-004		1	CONNECTOR, SNAP TIGHT, BK	
14	WG8-5696-000		1	PHOTO INTERRUPTER, TLP1243	PS701
15	XA9-0476-000		10	SCREW, TP M3X8	

Figure 460 LASER SCANNER ASS'Y

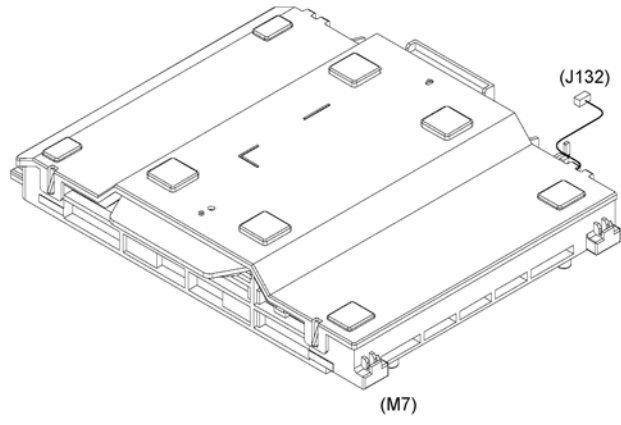

FIG/KEY	PART NUMBER	RANK	QTY	DESCRIPTION	REMARKS
460	FM4-3359-000		1	LASER SCANNER ASS' Y	M7

Figure 530 INTERMEDIATE TRANS. BELT ASS'Y

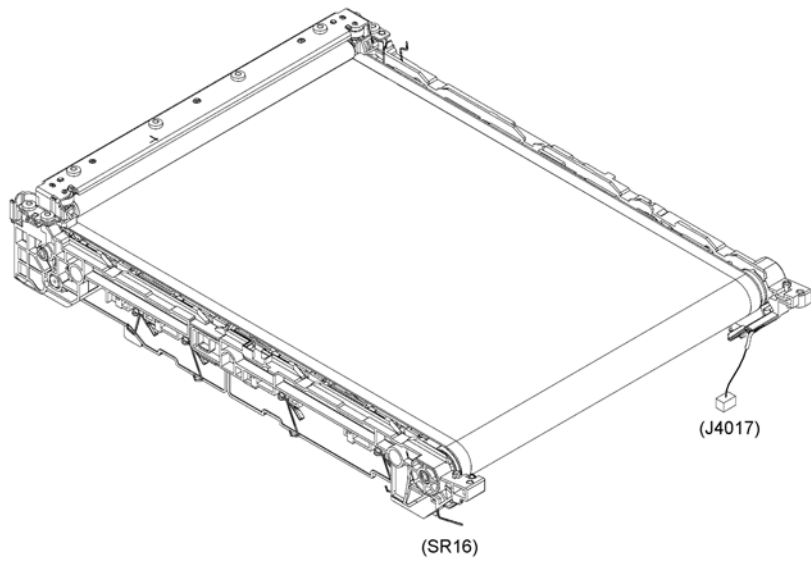

FIG/KEY	PART NUMBER	RANK	QTY	DESCRIPTION	REMARKS
530	RM1-4852-000		1	INTERMEDIATE TRANS. BELT ASS'Y	SR16

Figure 810C FIXING ASS'Y

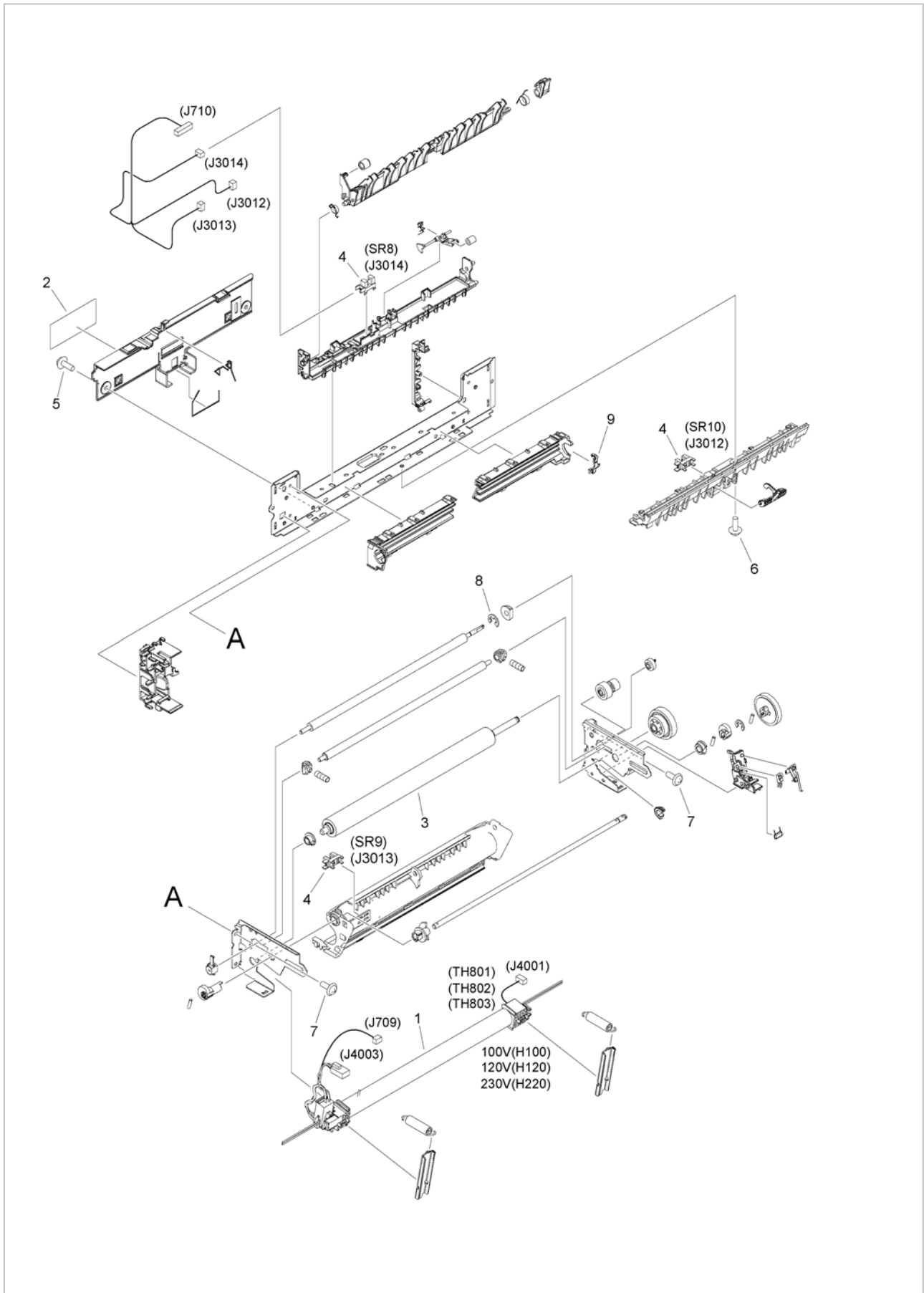

FIG/KEY	PART NUMBER	RANK	QTY	DESCRIPTION	REMARKS
810C	FM1-D608-000		1	FIXING ASS'Y	
1	FM4-3063-000		1	FIXING FILM ASSEMBLY	H220, TH801, TH802, T H803
2	FU7-8111-000		1	LABEL, CAUTION	
3	RC2-3367-000		1	ROLLER, PRESSURE	
4	WG8-5696-000		3	PHOTO INTERRUPTER, TLP1243	SR8, SR9, SR10
5	XA9-1418-000		2	SCREW, TP, M3X6	
6	XA9-1420-000		1	SCREW, W/WASHER, M3X8	
7	XA9-1835-000		4	SCREW, D, M3X6	
8	XD9-0235-000		1	RING, E	
9	FE3-8643-000		1	GUIDE, PRESSURE, RIGHT UPPER	

Figure 900C MAIN CONTROLLER PCB ASSEMBLY (MF729Cdw, MF729Cx)

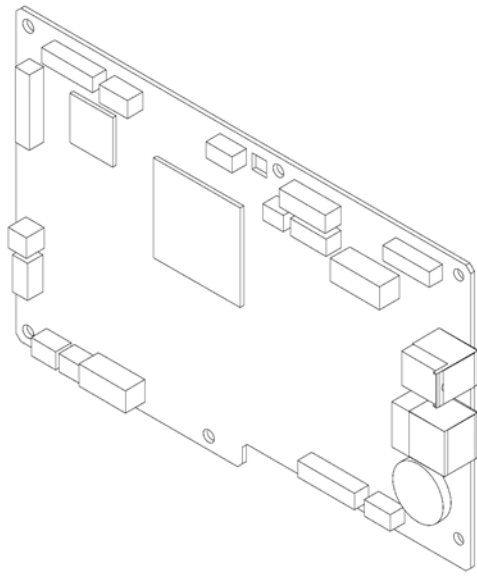

FIG/KEY	PART NUMBER	RANK	QTY	DESCRIPTION	REMARKS
900C	FM1-N833-000		1	MAIN CONTROLLER PCB ASSEMBLY	MF729Cdw, MF729Cx
IC	FK2-7852-000		1	IC, T6TH5EFG-0002 (0), STANDARD	IC18
IC	FK3-1800-000		1	IC, ASIC, MB8AA4241EPBH-GE1	IC14

Figure 900D MAIN CONTROLLER PCB ASSEMBLY (MF724Cdw)

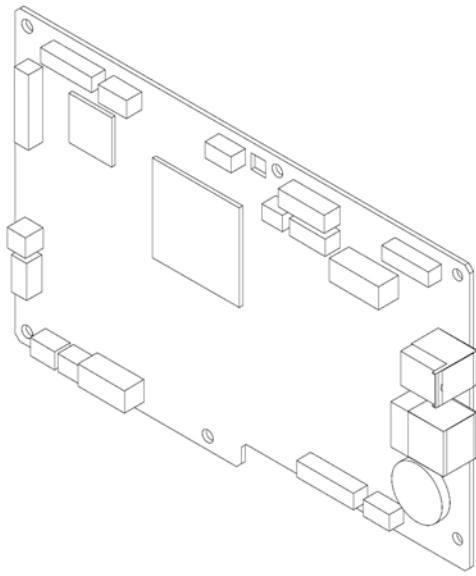

FIG/KEY	PART NUMBER	RANK	QTY	DESCRIPTION	REMARKS
900D	FM1-N821-000		1	MAIN CONTROLLER PCB ASSEMBLY	MF724Cdw
IC	FK2-7852-000		1	IC, T6TH5EFG-0002 (0), STANDARD	IC18
IC	FK3-1800-000		1	IC, ASIC, MB8AA4241EPBH-GE1	IC14

Figure 900E MAIN CONTROLLER PCB ASSEMBLY (MF728Cdw)

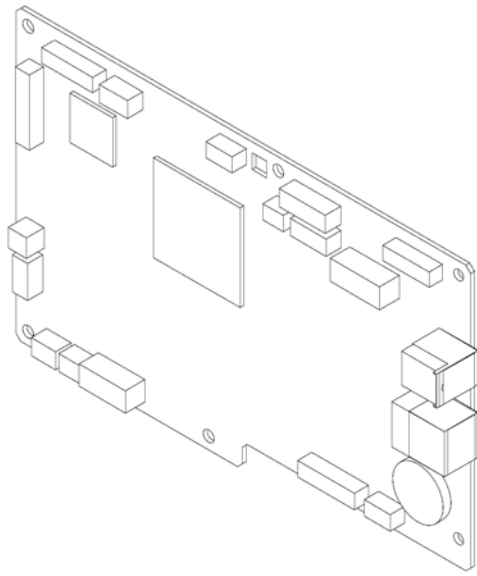

FIG/KEY	PART NUMBER	RANK	QTY	DESCRIPTION	REMARKS
900E	FM1-N825-000		1	MAIN CONTROLLER PCB ASSEMBLY	MF728Cdw
IC	FK2-7852-000		1	IC, T6TH5EFG-0002 (0), STANDARD	IC18
IC	FK3-1800-000		1	IC, ASIC, MB8AA4241EPBH-GE1	IC14

Figure ZZA MECHANICAL STANDARD PARTS (HOW TO USE)

Mechanical standard parts

機械標準部品

About a mechanical standard parts

A Mechanical standard parts is a mechanical part which not parts peculiar to a product.
They are parts which are common to a Canon product and are used, such as a screw and a washer.
The Fig No. and parts number of the mechanical standard parts are not listed in the product parts catalog.
Refer to the parts catalog of mechanical standard parts when checking the parts number for screw or washer etc. and identify them by part shape or size.

機械標準部品とは

機械標準部品とは、製品特有の部品ではなく、ねじやワッシャなどキヤノン製品共通で使用されている機械部品（メカ部品）のことです。
製品のパーツカタログには、機械標準部品のFig No.や部品番号は記載しておりません。
ねじや、ワッシャ等の部品番号を調べるときは、機械標準部品のパーツカタログを参照し、部品の形状や大きさから判断し、使用している部品を調べてください。

Material and surface treatment of a mechanical standard parts

Material and surface treatment of mechanical standard parts are assigned commonly for each part.
Refer to the Table 1 for the parts which material and surface treatment are assigned as numbers.

機械標準部品の材料および表面処理

機械標準部品の材料および表面処理については、各種部品共通で決められています。
材料および表面処理が番号で決められている部品については、表1を参照してください。

Table 1 Material and Surface treatment

表1 材料および表面処理

No. 番号	Material 材料	Surface treatment 表面処理	Color 色
1	Stainless steel ステンレス	Stainless steel black coloring (BC4) ステンレス黒着色(BC4)	Black 黒
2		not to be given なし	White 白
3	Brass 黄銅	Regular nickel plating (NL) 普通ニッケルメッキ(NL)	White 白
4		Black nickel plating (BN) 黒色ニッケルメッキ(BN)	Black 黒
5	Steel 鋼	White zinc trivalent chromate treating (ZC3) 白色亜鉛3価クロメート(ZC3)	White 白
6		Regular nickel chromium plating (NC) 普通ニッケルクロムメッキ(NC)	White 白
7		Regular nickel plating (NL) 普通ニッケルメッキ(NL)	White 白
8		Iron and steel phosphating (P1) 鉄鋼燐酸塩処理(P1)	Black 黒
9		Black zinc trivalent chromate treating (BZ3) 黒色亜鉛3価クロメート(BZ3)	Black 黒

FIG/KEY	PART NUMBER	RANK	QTY	DESCRIPTION	REMARKS
---------	-------------	------	-----	-------------	---------

Figure ZZB (1 / 7) MECHANICAL STANDARD PARTS (SCREWS)

1. Screws ねじ

How to read Parts Numbers
部品番号の見方

Screws
ねじ

XB1-2400-609

Type No.
類別番号

Normal designation (d)
ねじの呼び (d)

Length (L)
ねじの長さ (L)

Material and Surface treatment
材料および表面処理

XB1-2 expresses Binding head machine screw.
XB1-2は、バインドねじを表す

40 expresses M4.0.
40は、M4.0を表す

0-60 expresses a length of 6.0mm.
0-60は、6.0mmの長さを表す

9 expresses Steel (Black zinc trivalent chromate
treating) from Table 1.

9は、表1より鋼（黒色亜鉛3価クロメート）を表す

1-1. Cross Recessed Head Screws for Precision Equipments 精密機器用十字穴付き小ねじ

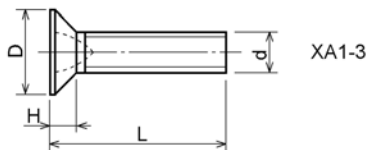
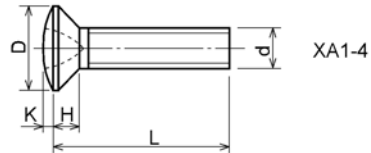
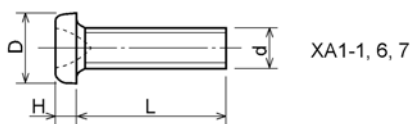

Type No. 類別番号	Type 類別	Head size (mm) 頭部寸法 (mm)						
		M1.4	M1.6	M1.7	M2	M2.5	M2.6	
XA1-1	Pan head Class 1 なべ1種	D	2	2.4	2.5	3	3.8	4
		H	0.5	0.55	0.5	0.6	0.9	0.8
XA1-3	Countersunk head Class 1 さら1種	D	2	2.4	2.5	3	3.8	4
		H	0.48	0.55	0.58	0.73	0.85	0.93
XA1-4	Oval countersunk head Class 1 丸さら1種	D	2	2.4	2.5	3	3.8	4
		H + K	0.68	0.8	0.88	1	1.25	1.3
XA1-6	Pan head Class 3 なべ3種	D	2.5	2.8	3	3.5	4.3	4.5
		H	0.8	0.85	0.9	1	1.3	1.2
XA1-7	Pan head Class 2 なべ2種	D	2.5	2.8	3	3.5	4.3	4.5
		H	0.5	0.55	0.5	0.6	0.9	0.8

Figure ZZB (2 / 7) MECHANICAL STANDARD PARTS (SCREWS)

1-2. Precision Tapping Screws
精密用タッピンねじ

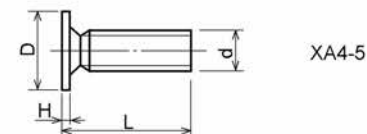
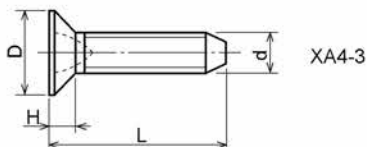
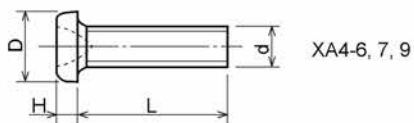
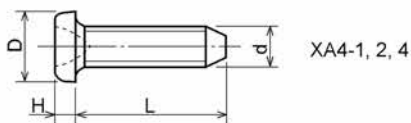

Type No. 類別番号	Type 類別
XA4-1	With tapered end pan head Class 1 絞り-なべ1種
XA4-2	With tapered end pan head Class 3 絞り-なべ3種
XA4-3	With tapered end countersunk head 絞り-さら
XA4-4	With tapered end pan head Class 2 絞り-なべ2種
XA4-5	With parallel end ultra thin head ストレート-超薄頭
XA4-6	With parallel end pan head Class 1 ストレート-なべ1種
XA4-7	With parallel end pan head Class 3 ストレート-なべ3種
XA4-8	With parallel end countersunk head ストレート-さら
XA4-9	With parallel end pan head Class 2 ストレート-なべ2種

	Head size (mm) 頭部寸法 (mm)					
	M1.4	M1.6	M1.7	M2	M2.5	M2.6
D XA4-1	2	2.4	2.5	3	3.8	4
H XA4-1	0.5	0.55	0.5	0.6	0.9	0.8
D XA4-2	2.5	2.8	3	3.5	4.3	4.5
H XA4-2	0.8	0.85	0.9	1	1.3	1.2
D XA4-3	2	2.4	2.5	3	3.8	4
H XA4-3	0.48	0.55	0.58	0.73	0.85	0.93
D XA4-4	2.5	2.8	3	3.5	4.3	4.5
H XA4-4	0.5	0.55	0.5	0.6	0.9	0.8
D XA4-5	2.5	2.8	3	-	-	-
H XA4-5	0.2	0.2	0.2	-	-	-
D XA4-6	2	2.4	2.5	3	3.8	4
H XA4-6	0.5	0.55	0.5	0.6	0.9	0.8
D XA4-7	2.5	2.8	3	3.5	4.3	4.5
H XA4-7	0.8	0.85	0.9	1	1.3	1.2
D XA4-8	2	2.4	2.5	3	3.8	4
H XA4-8	0.48	0.55	0.58	0.73	0.85	0.93
D XA4-9	2.5	2.8	3	3.5	4.3	4.5
H XA4-9	0.5	0.55	0.5	0.6	0.9	0.8

Figure ZZB (3 / 7) MECHANICAL STANDARD PARTS (SCREWS)

1-3. Cross Recessed Head Screws
 一般用十字穴付き小ねじ

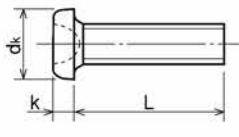

XB1-1

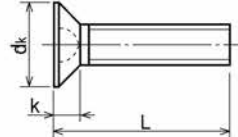

XB1-3

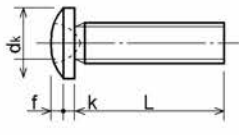

XB1-2

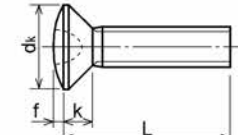

XB1-4

Type No. 類別番号	Type 類別
XB1-1	Pan head なべ
XB1-2	Binding head バインド
XB1-3	Countersunk head さら
XB1-4	Oval countersunk head 丸さら

		Head size (mm) 頭部寸法 (mm)					
		M2	M2.5	M2.6	M3	M4	M5
dk	XB1-1	3.5	4.5	4.5	5.5	7	9
k	XB1-1	1.3	1.7	1.7	2	2.6	3.3
dk	XB1-2	4.3	5.3	5.5	6.3	8.3	10.3
k+f	XB1-2	1.2	1.5	1.6	1.9	2.5	3.1
dk	XB1-3	4	5	-	6	8	10
k	XB1-3	1.2	1.45	-	1.75	2.3	2.8
dk	XB1-4	4	5	-	6	8	10
k+f	XB1-4	1.6	2	-	2.45	3.2	4
Screw part length ねじ部長さ b		8	12	12	12	16	20

Figure ZZB (4 / 7) MECHANICAL STANDARD PARTS (SCREWS)

1-4. Cross Recessed Head Screws with Captive Washer 座金組み込み十字穴付き小ねじ

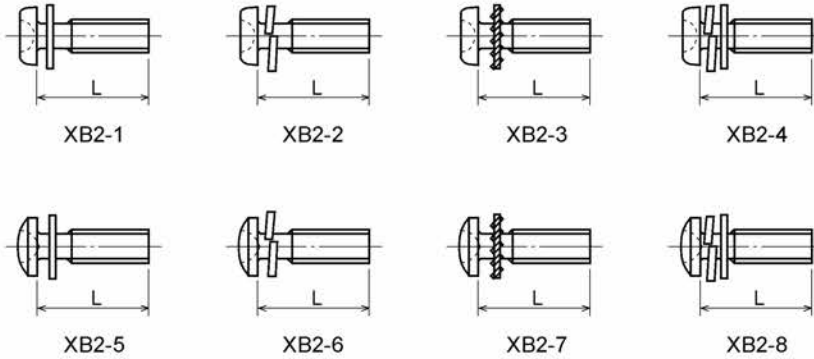

Type No. 類別番号	Type 類別
XB2-1	Pan head + Plain washer (circular bright) なべねじ+平座金
XB2-2	Pan head + Spring washer なべねじ+ばね座金
XB2-3	Pan head + Toothed lock washer なべねじ+歯付座金
XB2-4	Pan head + Spring washer and plain washer (circular bright) なべねじ+(ばね+平)座金
XB2-5	Binding head + Plain washer (circular bright) バインドねじ+平座金
XB2-6	Binding head + Spring washer バインドねじ+ばね座金
XB2-7	Binding head + Toothed lock washer バインドねじ+歯付座金
XB2-8	Binding head + Spring washer and plain washer (circular bright) バインドねじ+(ばね+平)座金

Figure ZZB (5 / 7) MECHANICAL STANDARD PARTS (SCREWS)

1-5. Hexagon Head Tapping Screws for Matallic Materials 金属用六角タッピンねじ

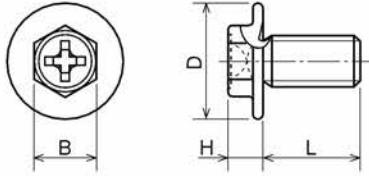

Type No. 類別番号	Type 類別
XB3-6	For metallic materials 金属用タッピン
XB3-7	For metallic materials with clawed 金属用タッピン-つめ付き

	Head size (mm) 頭部寸法 (mm)	
	M3	M4
D	8	10
B	5.5	5.5
H XB3-6	3.1	3.1
H XB3-7	3.2	3.2

1-6. Special Tapping Screws 特殊タッピンねじ

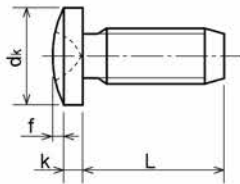

Type No. 類別番号	Type 類別
XB4-5	Binding head バインド

	Head size (mm) 頭部寸法 (mm)	
	M3	M4
dk	6.3	8.3
k	1.3	1.7
k+f	1.9	2.5

Figure ZZB (6 / 7) MECHANICAL STANDARD PARTS (SCREWS)

1-7. General Head Tapping Screws 一般用タッピンねじ

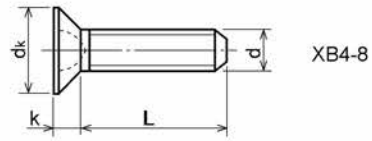
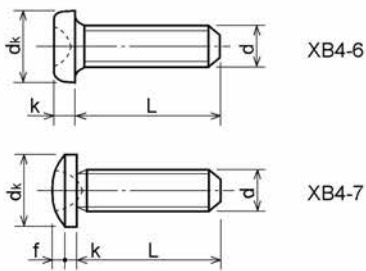

Type No. 類別番号	Type 類別
XB4-6	Pan head なべ
XB4-7	Binding head バインド
XB4-8	Countersunk head さら

		Head size (mm) 頭部寸法 (mm)					
		M2	M2.5	M2.6	M3	M4	M5
dk	XB4-6	3.5	4.5	4.5	5.5	7	9
k	XB4-6	1.3	1.7	1.7	2	2.6	3.3
dk	XB4-7	4.3	5.3	5.5	6.3	8.3	10.3
k+f	XB4-7	1.2	1.5	1.6	1.9	2.5	3.1
dk	XB4-8	4	5	5.2	6	8	10
k	XB4-8	1.2	1.45	1.5	1.75	2.3	2.8

1-8. Tapping Screws for Metallic Materials 金属用タッピンねじ

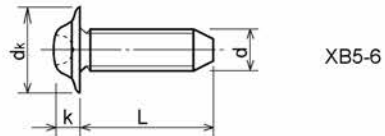
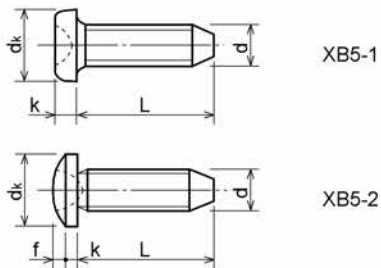

Type No. 類別番号	Type 類別
XB5-1	Pan head なべ
XB5-2	Binding head バインド
XB5-6	Flanged pan head つば付きなべ

		Head size (mm) 頭部寸法 (mm)				
		M2.5	M2.6	M3	M4	M5
dk	XB5-1	4.5	4.5	5.5	7	9
k	XB5-1	1.7	1.7	2	2.6	3.3
dk	XB5-2	5.5	5.5	6.3	8.3	10.3
k+f	XB5-2	1.6	1.6	1.9	2.5	3.1
dk	XB5-6	6.5	6.5	8	10	12
k	XB5-6	2.1	2.1	1.75	3.2	4

Figure ZZB (7 / 7) MECHANICAL STANDARD PARTS (SCREWS)

1-9. Hexagon Socket Set Screws 六角穴付き止めねじ

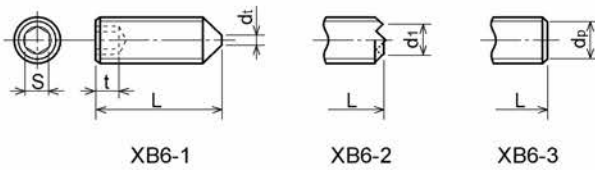

Type No. 類別番号	Type 類別	Head size (mm) 頭部寸法 (mm)						
		M1.6 M1.7	M2	M2.5 M2.6	M3	M5	M5	M6
	S	0.7	0.9	1.3	1.5	2	2.5	3
	t	1.5	1.7	2	2	2.5	3	3.5
	d _{t max} XB6-1	0.4	0.5	0.65	0.75	1	1.25	1.5
	d _{1 max} XB6-2	-	1.2	1.5	1.7	2.2	2.8	3.3
	d _{1 min} XB6-2	-	1	1.2	1.4	1.9	2.4	2.9
	d _{p max} XB6-3	0.8	1	1.5	2	2.5	3.5	4
	d _{p min} XB6-3	0.55	0.75	1.25	1.75	2.25	3.2	3.7

1-10. Flanged Pan Head Machine Screws つば付きなべ小ねじ

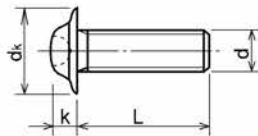

Type No. 類別番号	Type 類別	Head size (mm) 頭部寸法 (mm)				
		M2	M2.5 M2.6	M3	M5	M5
	d _k	5	6.5	8	10	12
	k	1.7	2.1	2.5	3.2	4

FIG/KEY	PART NUMBER	RANK	QTY	DESCRIPTION	REMARKS
---------	-------------	------	-----	-------------	---------

Figure ZZC MECHANICAL STANDARD PARTS (BOLTS)

2. Bolts (Socket head cap screw) ボルト

How to read Parts Numbers
部品番号の見方

Bolt (Socket head cap screw)
ボルト

XB7-1080-409

Type No.
類別番号

Normal designation (d)
ねじの呼び (d)

Length (L)
ねじの長さ (L)

Material and Surface treatment
材料および表面処理

XB7-1 expresses Hexagon socket head cap screws.
XB7-1は、六角穴付きボルトを表す

080 expresses M8.0.
080は、M8.0を表す

40 expresses a length of 40mm.
40は、40mmの長さを表す

9 expresses Steel (Black zinc trivalent chromate treating) from Table 1.

9は、表1より鋼（黒色亜鉛3価クロメート）を表す

2-1. Hexagon socket head cap screws 六角穴付きボルト

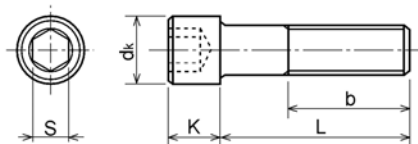

Type No. 類別番号	Type 類別
XB7-1	Hexagon socket head cap screws 六角穴付きボルト

	Head size (mm) 頭部寸法 (mm)						
	M3	M4	M5	M6	M8	M10	M12
S	2.5	3	4	5	6	8	10
dk	5.5	7	8.5	10	13	16	18
K	3	4	5	6	8	10	12
Screw part length ねじ部長さ b_{max}	18	20	22	24	28	32	36

FIG/KEY	PART NUMBER	RANK	QTY	DESCRIPTION	REMARKS
---------	-------------	------	-----	-------------	---------

Figure ZZD MECHANICAL STANDARD PARTS (NUTS)

3. Nuts ナット

How to read Parts Numbers
部品番号の見方

Nuts
ナット

XB7-2100-309

Type No.
類別番号
Normal designation (d)
ねじの呼び (d)
Material and Surface treatment

材料および表面処理

XB7-210 expresses Hexagon nut class 1.
XB7-210は、六角ナット1種を表す

0-30 expresses M3.0.
0-30は、M3.0を表す

9 expresses Steel (Black zinc trivalent chromate
treating) from Table 1.

9は、表1より鋼（黒色亜鉛3価クロメート）を表す

3-1. Hexagon Nuts and Hexagon Thin Nuts 六角ナット

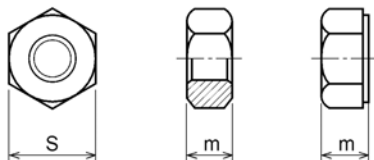

Type No. 類別番号	Type 類別
XB7-210	Hexagon nut Class 1 六角ナット-1種
XB7-220	Hexagon nut Class 3 六角ナット-3種
XB7-230	Hexagon nut Style 1 double chamfered 六角ナット-スタイル1-両面とり
XB7-231	Hexagon nut Style 1 washer faced 六角ナット-スタイル1-座付き
XB7-240	Hexagon nut Style 2 double chamfered 六角ナット-スタイル2-両面とり
XB7-241	Hexagon nut Style 2 washer faced 六角ナット-スタイル2-座付き
XB7-250	Hexagon nut 六角ナット
XB7-260	Hexagon thin nut double chamfered 六角低ナット-両面とり
XB7-270	Hexagon thin nut not chamfered 六角低ナット-面とり無し

	Head size (mm) 頭部寸法 (mm)						
	M2	M2.5	M3	M4	M5	M6	M8
S	4	5	5.5	7	8	10	13
m XB7-210	1.6	2	2.4	3.2	4	5	6.5
m XB7-220	1.2	1.6	1.8	2.4	3.2	3.6	5
m XB7-230, 231	1.6	2	2.4	3.2	4.7	5.2	6.8
m XB7-240, 241	-	-	-	-	5.1	5.7	7.5
m XB7-250	-	-	-	-	5.6	6.1	7.9
m XB7-260	1.2	1.6	1.8	2.2	2.7	3.2	4
m XB7-270	1.2	1.6	1.8	2.2	2.7	3.2	4

FIG/KEY	PART NUMBER	RANK	QTY	DESCRIPTION	REMARKS
---------	-------------	------	-----	-------------	---------

Figure ZZE (1 / 3) MECHANICAL STANDARD PARTS (RETAINING RINGS)

5. Retaining Rings 止め輪

How to read Parts Numbers
部品番号の見方

Retaining Rings
止め輪

XD2-1100-202

Type No.
類別番号
Nominal designation
呼び
Material and Surface treatment
材料および表面処理

XD2-110 expresses retaining ring-E type (Type1).
XD2-110は、E形止め輪（1種）を表す

0-20 expresses a 020 of nominal designation.
(See Table 5)

0-20は、呼び020を表す（表5参照）

2 expresses Stainless steel (Surface treatment is not to be given) from Table 1.

2は、表1よりステンレス（表面処理なし）を表す

5-1. Retaining Rings - E type E形止め輪

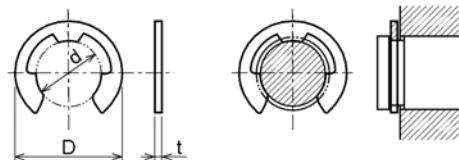

Type No. 類別番号	Type 類別
XD2-110	Retaining ring - E type (Type 1) E形止め輪（1種）
XD2-120	Retaining ring - E type (Type 2) E形止め輪（2種）

Table 5 表5

Type 種類	Nominal designation 呼び	d (mm)	D (mm)	t (mm)
Type 1 1種	007	0.65	2	0.2
	010	0.95	2.8	0.2
	013	1.25	3.3	0.3
	017	1.65	4.2	0.4
	020	1.95	4.6	0.5
	024	2.35	6	0.6
	028	2.74	6.5	0.6
	032	3.14	7.2	0.6
	037	3.64	8	0.7
	040	3.93	10	0.7
	042	4.13	10	0.7
	050	4.93	11	0.7
	058	5.73	12	0.7
	060	5.93	12.7	0.9
Type 2 2種	064	6.32	13.5	0.9
	074	7.31	15	0.9
	080	7.91	16.5	1
	008	0.8	2	0.2
	012	1.2	3	0.3
	015	1.5	4	0.4
	020	2	5	0.4
	025	2.5	6	0.4
	030	3	7	0.6
	040	4	9	0.6
	050	5	11	0.6
	060	6	12	0.8
	070	7	14	0.8
	080	8	16	0.8
090	9	18	0.8	
100	10	20	1	

Figure ZZE (2 / 3) MECHANICAL STANDARD PARTS (RETAINING RINGS)

5-2. Grip Rings
グリップ止め輪

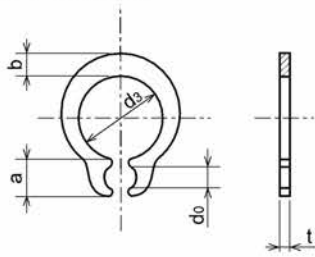

Table 5 表5

Nominal designation 呼び	d_3 (mm)	t (mm)	b (mm)	a (mm)	d_o (mm)
020	1.9	0.5	1	1.8	0.8
025	2.35	0.5	1.2	1.9	0.9
030	2.85	0.6	1.4	1.9	0.9
035	3.3	0.6	1.6	2	0.9
040	3.8	0.8	1.8	2.8	1.2
045	4.25	0.8	2	2.9	1.3
050	4.75	0.8	2.2	2.9	1.3
060	5.7	1	2.4	3.1	1.4
070	6.7	1	2.7	3.3	1.4
080	7.7	1	3	3.5	1.4
090	8.65	1.2	3.3	4.7	1.5
100	9.65	1.2	3.5	4.7	2

Type No. 類別番号	Type 類別
XD2-210	Grip ring グリップ止め輪

5-3. Toothed Retaining Rings
歯付き形止め輪

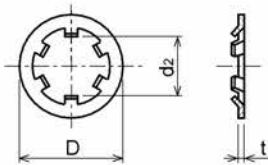

Table 5 表5

Nominal designation 呼び	d_2 (mm)	D (mm)	t (mm)	No of teeth 歯数
015	1.4	5.2	0.25	3
020	1.9	6	0.25	3
024	2.3	6.4	0.25	3
030	2.8	8	0.25	4
040	3.8	9	0.25	4
050	4.8	10	0.25	5
060	5.8	11	0.25	5
080	7.8	13	0.25	5
100	9.8	15.4	0.25	6

Type No. 類別番号	Type 類別
XD2-230	Toothed retaining ring 歯付き形止め輪

Figure ZZE (3 / 3) MECHANICAL STANDARD PARTS (RETAINING RINGS)

5-4. Retaining Rings - C Type C形止め輪

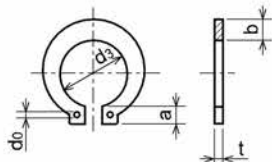

Type No. 類別番号	Type 類別
XD2-310	Retaining ring - C type for shaft C形止め輪 軸用

Table 5 表5

Nominal designation 呼び	d ₃ (mm)	t (mm)	b (mm)	a (mm)	d ₀ (mm)
010	9.3	1	1.6	3	1.2
012	11.1	1	1.8	3.2	1.5
014	12.9	1	2	3.4	1.7
015	13.8	1	2.1	3.5	1.7
016	14.7	1	2.2	3.6	1.7
017	15.7	1	2.2	3.7	1.7
018	16.5	1.2	2.6	3.8	1.7
020	18.5	1.2	2.7	3.9	2
022	20.5	1.2	2.7	4.1	2
025	23.2	1.2	3.1	4.3	2
028	25.9	1.5	3.1	4.6	2
030	27.9	1.5	3.5	4.8	2
032	29.6	1.5	3.5	5	2.5
035	32.2	1.5	4	5.4	2.5

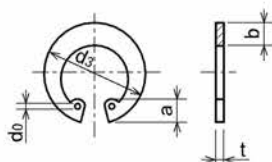

Type No. 類別番号	Type 類別
XD2-320	Retaining ring - C type for hole C形止め輪 穴用

Table 5 表5

Nominal designation 呼び	d ₃ (mm)	t (mm)	b (mm)	a (mm)	d ₀ (mm)
010	10.7	1	1.8	3.1	1.2
011	11.8	1	1.8	3.2	1.2
012	13	1	1.8	3.3	1.5
014	15.1	1	2	3.6	1.7
016	17.3	1	2	3.7	1.7
018	19.5	1	2.5	4	1.7
019	20.5	1	2.5	4	2
020	21.5	1	2.5	4	2
022	23.5	1	2.5	4.1	2
025	26.9	1.2	3	4.4	2
028	30.1	1.2	3	4.6	2
030	32.1	1.2	3	4.7	2
032	34.4	1.2	3.5	5.2	2.5
035	37.8	1.5	3.5	5.2	2.5
037	39.8	1.5	3.5	5.2	2.5
040	43.5	1.8	4	5.7	2.5
042	45.5	1.8	4	5.8	2.5
045	48.5	1.8	4.5	5.9	2.5
047	50.5	1.8	4.5	6.1	2.5
050	54.2	2	4.5	6.5	2.5
052	56.2	2	5.1	6.5	2.5
055	59.2	2	5.1	6.5	2.5
060	64.2	2	5.1	6.8	2.5
062	66.2	2	5.5	6.9	2.5
068	72.5	2.5	6	7.4	2.5
072	76.5	2.5	6.6	7.4	2.5
075	79.5	2.5	6.6	7.8	2.5
080	85.5	2.5	7	8	2.5
085	90.5	3	7	8	3
090	95.5	3	7.6	8.3	3
095	100.5	3	8	8.5	3

FIG/KEY	PART NUMBER	RANK	QTY	DESCRIPTION	REMARKS
---------	-------------	------	-----	-------------	---------