

imageRUNNER LBP3470

PARTS CATALOG



Canon

**September 14, 2010
Rev. 0**

PREFACE

This Parts Catalog contains listings of parts used

Diagrams are provided with the listings to aid the service technician in identifying clearly, the item to be ordered.

Whenever ordering parts, consult this Parts Catalog for all of the information pertaining to each item. Be sure to include, in the Parts Request, the full item description, the item part number, and the quantity.

COPYRIGHT (C) 1999 CANON INC.

Use of this manual should be strictly supervised to avoid disclosure of confidential information.

Contents

NUMERICAL INDEX

imageRUNNER LBP3470(Numerical Index) 1-1

imageRUNNER LBP3470(Parts Catalog)

A1	ASSEMBLY LOCATION DIAGRAM	2-1
A2	OPTION PARTS CATALOG LIST	2-2
001	ACCESSORIES	2-3
100	EXTERNAL COVERS, PANELS, ETC.	2-4
101	INTERNAL COMPONENTS 1	2-6
102	INTERNAL COMPONENTS 2	2-8
103	INTERNAL COMPONENTS 3	2-10
104	INTERNAL COMPONENTS 4	2-12
105	INTERNAL COMPONENTS 5	2-14
900	MAIN CONTROLLER PCB ASSY	2-16
ZZA	MECHANICAL STANDARD PARTS (HOW TO USE)	2-17
ZZB	MECHANICAL STANDARD PARTS (SCREWS)	2-18
ZZC	MECHANICAL STANDARD PARTS (BOLTS)	2-25
ZZD	MECHANICAL STANDARD PARTS (NUTS)	2-26
ZZE	MECHANICAL STANDARD PARTS (RETAINING RINGS)	2-27

NUMERICAL INDEX

imageRUNNER LBP3470(Numerical Index)

PARTS NUMBER	FIGURE & KEY NO.	PARTS NUMBER	FIGURE & KEY NO.	PARTS NUMBER	FIGURE & KEY NO
FC7-0509-000	100 - 1	RM1-6350-000	102 - 3		
FC7-0810-000	100 - 2	RM1-6375-000	102 - 4		
FC7-3206-000	105 - 1	RM1-6378-000	102 - 5		
FC8-0103-000	100 - 4	RM1-6397-000	104 - 9		
FC8-0109-000	100 - 12	RM1-6401-000	101 - 2		
FC8-9828-000	100 - 5	RM1-6402-000	103 - 5		
FC8-9837-000	100 - 6	RM1-6405-000	101 - 1		
FC8-9846-000	100 - 7	RM1-6414-000	102 - 6		
FC8-9858-000	100 - 3	RM1-6419-000	103 - 6		
FC8-9870-000	100 - 8	RM1-6421-000	101 - 3		
FC8-9871-000	100 - 9	RM1-6423-000	105 - 9		
FC8-9872-000	100 - 10	RM1-6424-000	103 - 2		
FC8-9878-000	104 - 12	RM1-6441-000	105 - 4		
FC8-9895-000	100 - 13	RM1-6445-000	101 - 4		
FC8-9896-000	100 - 11	RM1-6450-000	103 - 3		
FH4-6302-000	900 - IC	RU5-2895-000	100 - 24		
FK2-9583-000	001 - 2	WA7-3525-000	900 - 1		
FK3-0676-000	001 - 1	WC4-5171-000	104 - 10		
FL3-2802-000	900 - IC	XA9-1420-000	103 - 7		
FM2-8329-000	100 - 14	XA9-1420-000	105 - 8		
FM2-8342-000	100 - 15	XA9-1503-000	100 - 26		
FM3-8834-000	100 - 16	XA9-1503-000	101 - 5		
FM3-8837-000	100 - 17	XA9-1503-000	105 - 5		
FM3-8838-000	100 - 18	XA9-1671-000	100 - 25		
FM3-8839-000	104 - 1	XA9-1671-000	101 - 6		
FM3-8841-000	100 - 19	XA9-1671-000	102 - 7		
FM3-8855-000	103 - 1	XA9-1671-000	103 - 8		
FM3-8857-000	100 - 20	XA9-1671-000	104 - 11		
FM4-2367-000	900 -	XA9-1671-000	105 - 6		
FM4-2465-000	105 - 7				
FM4-2469-000	100 - 21				
FM4-3336-000	104 - 2				
FM4-3879-000	104 - 3				
NPN	001 -				
NPN	100 -				
NPN	101 -				
NPN	102 -				
NPN	103 -				
NPN	104 -				
NPN	105 -				
RC2-6273-000	100 - 22				
RC2-8291-000	100 - 23				
RC2-8349-000	101 - 7				
RK2-2719-000	103 - 4				
RK2-2727-000	104 - 4				
RK2-2729-000	104 - 5				
RK2-2731-000	104 - 6				
RK2-2733-000	105 - 2				
RL1-2115-000	102 - 1				
RL1-2120-000	104 - 7				
RM1-1301-000	102 - 2				
RM1-4275-000	104 - 8				

imageRUNNER Catalog)

LBP3470(Parts

image RUNNER LBP3470

120V US

F15-6732-000 MGHA

Contents

A1	ASSEMBLY LOCATION DIAGRAM	2-1
A2	OPTION PARTS CATALOG LIST	2-2
001	ACCESSORIES	2-3
100	EXTERNAL COVERS, PANELS, ETC.	2-4
101	INTERNAL COMPONENTS 1	2-6
102	INTERNAL COMPONENTS 2	2-8
103	INTERNAL COMPONENTS 3	2-10
104	INTERNAL COMPONENTS 4	2-12
105	INTERNAL COMPONENTS 5	2-14
900	MAIN CONTROLLER PCB ASS'Y	2-16
ZZA	MECHANICAL STANDARD PARTS (HOW TO USE)	2-17
ZZB	MECHANICAL STANDARD PARTS (SCREWS).....	2-18
ZZC	MECHANICAL STANDARD PARTS (BOLTS).....	2-25
ZZD	MECHANICAL STANDARD PARTS (NUTS).....	2-26
ZZE	MECHANICAL STANDARD PARTS (RETAINING RINGS)	2-27

FIGURE A1 ASSEMBLY LOCATION DIAGRAM

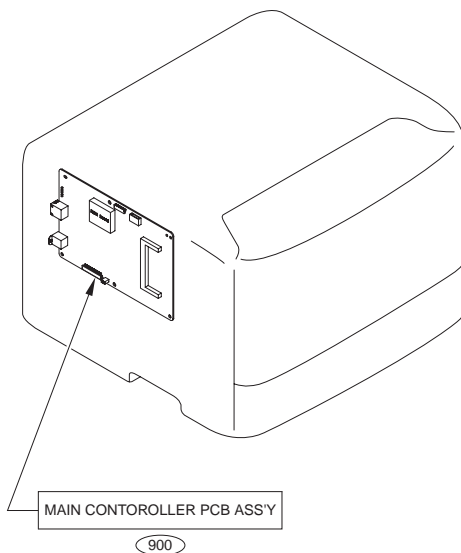

FIGURE A2 OPTION PARTS CATALOG LIST

This is the table of the machine's options whose parts catalog is issued.
本機のオプションで、パーツカタログが発行されている機種の一覧である。

No.	Model Name(English)	Model Name(Japanese)
1	Paper Feeder Unit PF-44	ペーパーフィーダーユニット PF-44
2	PS ROM A-44	PS拡張ROM A-44

FIGURE 001 ACCESSORIES

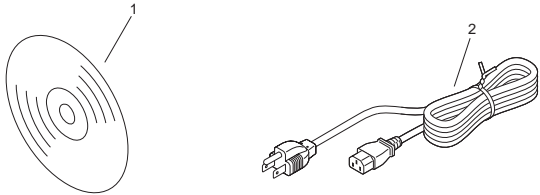

FIGURE & KEY NO.	PARTS NUMBER	RANK	QTY	DESCRIPTION	SERIAL NUMBER/REMARKS	SVC
Fig.001	NPN		RF	ACCESSORIES		
1	FK3-0676-000		1	CD- ROM, USER SOFTWARE		
2	FK2-9583-000		1	CORD, POWER		

FIGURE 100 EXTERNAL COVERS, PANELS, ETC.

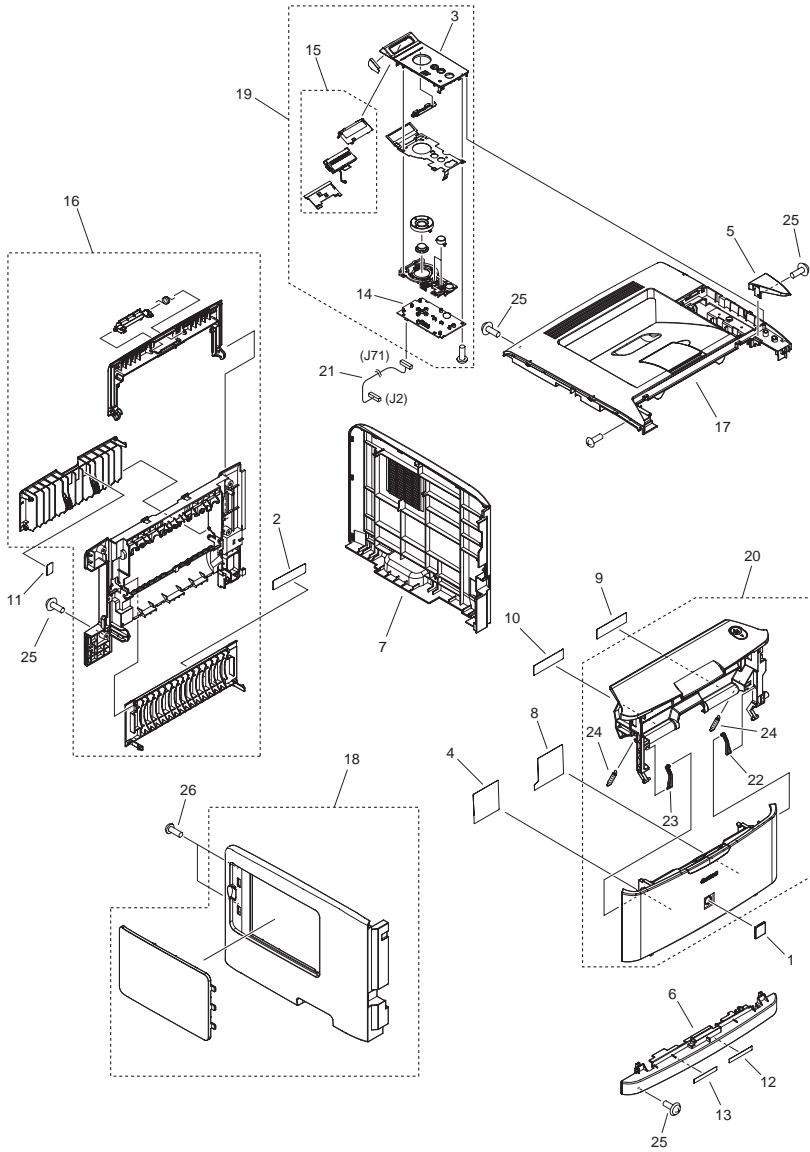

FIGURE & KEY NO.	PARTS NUMBER	R A N K	Q'TY	DESCRIPTION	SERIAL NUMBER/ REMARKS	S V C
Fig.100	NPN		RF	EXTERNAL COVERS, PANELS, ETC.		
1	FC7-0509-000		1	EMBLEM		
2	FC7-0810-000		1	LABEL, DUPLEXING SIZE CONTROL		
3	FC8-9858-000		1	PANEL, OPERATE		
4	FC8-0103-000		1	LABEL, PRINT INSTRUCTION		
5	FC8-9828-000		1	COVER, RIGHT, UPPER		
6	FC8-9837-000		1	COVER, FRONT		
7	FC8-9846-000		1	COVER, RIGHT		
8	FC8-9870-000		1	LABEL, MP, SIZE		
9	FC8-9871-000		1	LABEL, JAM, HANDLE, C		
10	FC8-9872-000		1	LABEL, FUSER, PRESS, RELEASE		
11	FC8-9896-000		1	LABEL, H.V. CAUTION		
12	FC8-0109-000		1	LABEL, DUPLEX, OPE, C		
13	FC8-9895-000		1	LABEL, RELEASE, LEVERE, C		
14	FM2-8329-000		1	DISPLAY PCB ASS'Y		
15	FM2-8342-000		1	LCD COVER ASS'Y		
16	FM3-8834-000		1	REAR COVER ASS'Y		
17	FM3-8837-000		1	TOP COVER ASS'Y		
18	FM3-8838-000		1	LEFT COVER ASS'Y		
19	FM3-8841-000		1	OPERATION PANNEL ASS'Y		
20	FM3-8857-000		1	CARTRIDGE DOOR ASS'Y		
21	FM4-2469-000		1	CABEL, PANEL		
22	RC2-6273-000		1	HINGE, MULTI-PURPOSE, RIGHT		
23	RC2-8291-000		1	HINGE, MULTI-PURPOSE, LEFT		
24	RU5-2895-000		2	SPRING, TENSION		
25	XA9-1671-000		AR	SCREW, D, M3X8		
26	XA9-1503-000		2	SCREW, TAP, M3X6		

FIGURE & KEY NO.	PARTS NUMBER	RANK	Q'TY	DESCRIPTION	SERIAL NUMBER/REMARKS	SVC
Fig.101	NPN		RF	INTERNAL COMPONENTS 1		
1	RM1-6405-000		1	FIXING ASS'Y		
2	RM1-6401-000		1	PAPER RETAINING DELIVERY ASS'Y		
3	RM1-6421-000		1	MAIN DRIVE ASS'Y		
4	RM1-6445-000		1	REVERSE SENSOR ASS'Y	PS917	
5	XA9-1503-000		3	SCREW, TAP, M3X6		
6	XA9-1671-000		AR	SCREW, D, M3X8		
7	RC2-8349-000		1	PIN LARGE GEAR		

FIGURE 102 INTERNAL COMPONENTS 2

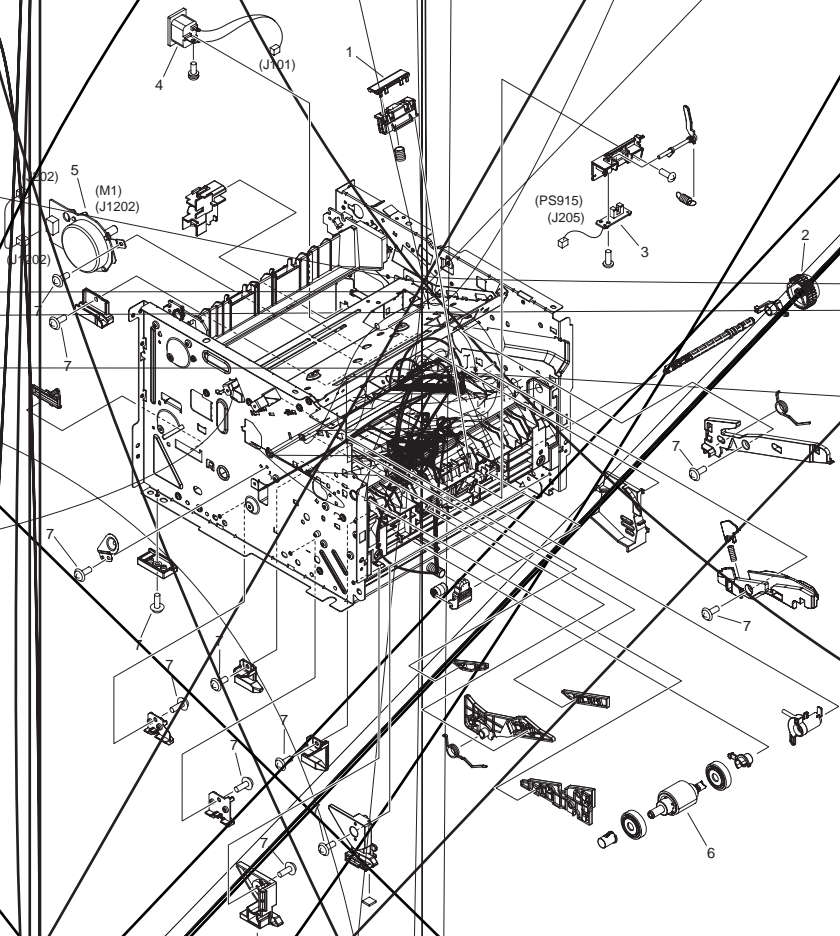

FIGURE & KEY NO.	PARTS NUMBER	RANK	Q'TY	DESCRIPTION	SERIAL NUMBER/REMARKS	SVC
Fig.102	NPN		RF	INTERNAL COMPONENTS 2		
1	RL1-2115-000		1	PAD, MULTI-PURPOSE SEPARATION		
2	RM1-1301-000		1	PAPER PICK-UP GEAR ASS'Y		
3	RM1-6350-000		1	MULTI-PURPOSE SENSOR PCB ASS'Y	PS915	
4	RM1-6375-000		1	INLET CABLE ASS'Y		
5	RM1-6378-000		1	MAIN MOTOR ASS'Y	M1	
6	RM1-6414-000		1	PAPER PICK-UP ROLLER ASS'Y		
7	XA9-1671-000		AR	SCREW, D, M3X8		

FIGURE 103
INTERNAL COMPONENTS 3

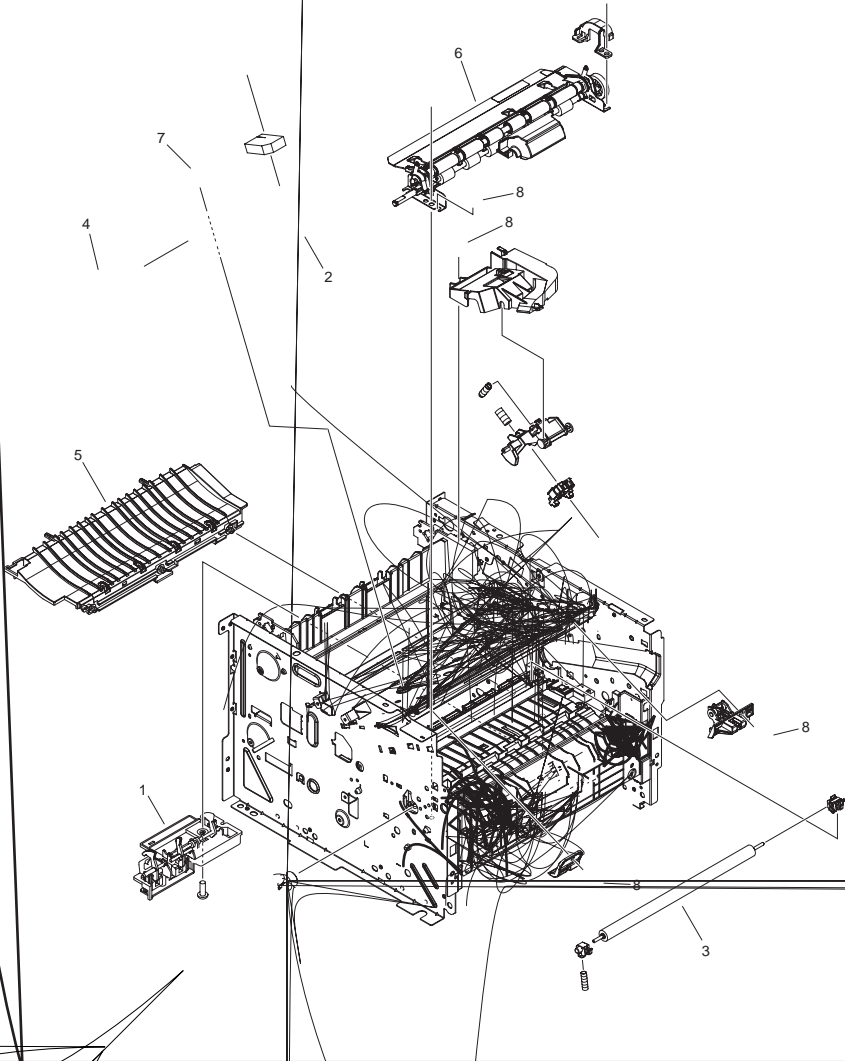

FIGURE & KEY NO.	PARTS NUMBER	RANK	Q'TY	DESCRIPTION	SERIAL NUMBER/REMARKS	SVC
Fig.103	NPN		RF	INTERNAL COMPONENTS 3		
1	FM3-8855-000		1	TOP SENSOR ASS'Y	PS912,PS922	
2	RM1-6424-000		1	SCANNER ASS'Y		
3	RM1-6450-000		1	TRANSFER ROLLER ASS'Y		
4	RK2-2719-000		1	CABLE, LASER FLEXIBLE FLAT		
5	RM1-6402-000		1	PAPER FEED GUIDE ASS'Y		
6	RM1-6419-000		1	REGISTRATION ASS'Y		
7	XA9-1420-000		4	SCREW, WWASHER, M3X8		
8	XA9-1671-000		5	SCREW, D, M3X8		

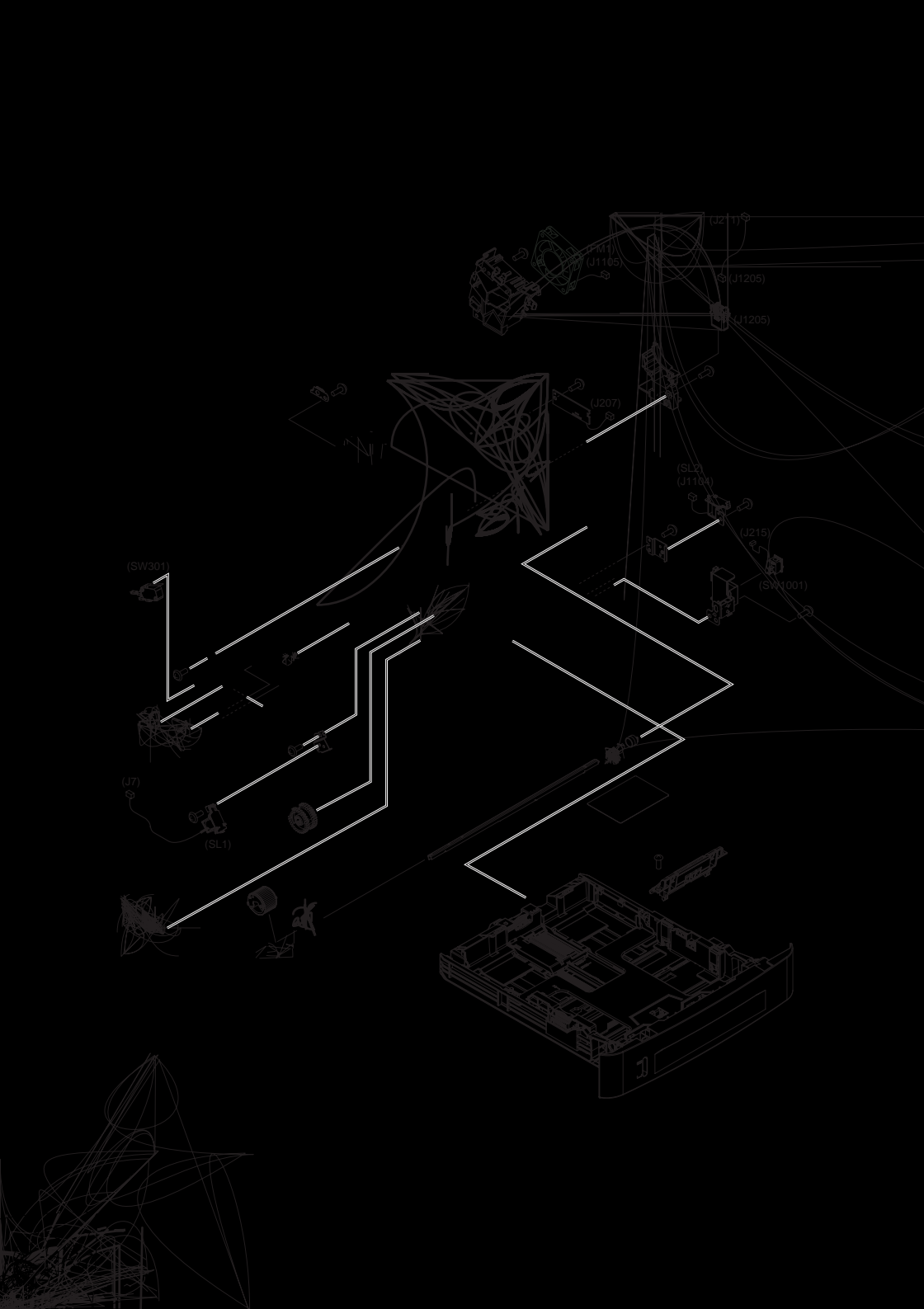

FIGURE & KEY NO.	PARTS NUMBER	R A N K	Q'TY	DESCRIPTION	SERIAL NUMBER/REMARKS	S V C
Fig.104	NPN		RF	INTERNAL COMPONENTS 4		
1	FM3-8839-000		1	CASSETTE ASS'Y		
2	FM4-3336-000		1	POWER SUPPLY SWITCH ASS'Y	SW1001	
3	FM4-3879-000		1	DUPLEX DRIVER PCB ASS'Y		
4	RK2-2727-000		1	FAN	FM1	
5	RK2-2729-000		1	SOLENOID	SL2	
6	RK2-2731-000		1	SOLENOID	SL1	
7	RL1-2120-000		1	ROLLER, MULTI-PURPOSE PICK-UP		
8	RM1-4275-000		1	PAPER PICK-UP GEAR ASS'Y		
9	RM1-6397-000		1	SEPARATION PAD HOLDER ASS'Y		
10	WC4-5171-000		1	MICROSWITCH	SW301	
11	XA9-1671-000		AR	SCREW, D, M3X8		
12	FC8-9878-000		1	LABEL, OPE, CHANGE, PAPER		

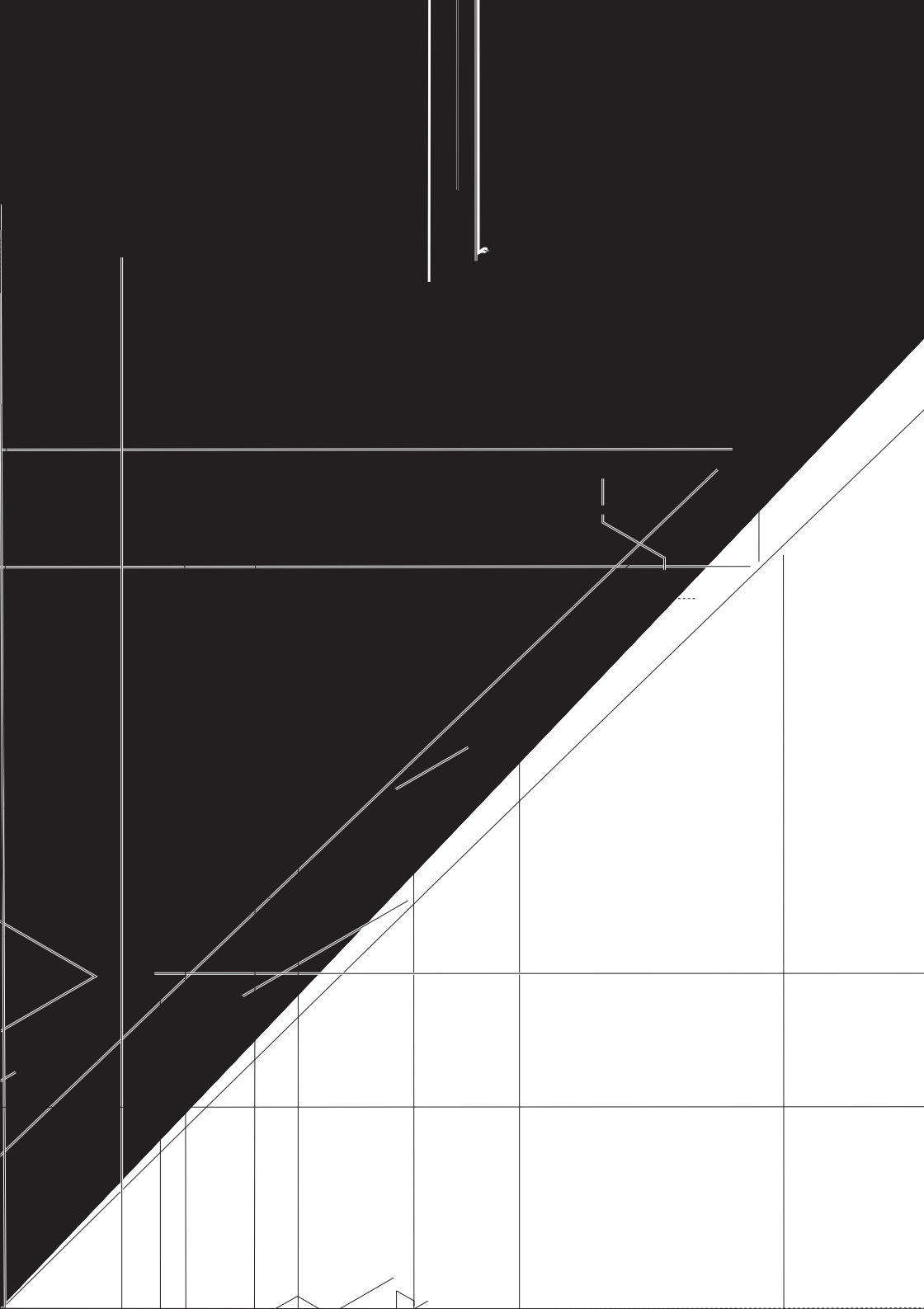

FIGURE & KEY NO.	PARTS NUMBER	RANK	Q'TY	DESCRIPTION	SERIAL NUMBER/REMARKS	SVC
Fig.105	NPN		RF	INTERNAL COMPONENTS 5		
1	FC7-3206-000		1	PLATE, GROUNDING		
2	RK2-2733-000		1	SOLENOID	SL3	
3	RM1-6423-000		1	REVERSE DRIVE ASS'Y		
4	RM1-6441-000		1	DUPLEXING PAPER FEED ASS'Y		
5	XA9-1503-000		AR	SCREW, TAP, M3X6		
6	XA9-1671-000		6	SCREW, D, M3X8		
7	FM4-2465-000		1	ENGINE CONTROLLER ASS'Y		
8	XA9-1420-000		4	SCREW, W/WASHER, M3X8		

FIGURE 900 MAIN CONTROLLER PCB ASS'Y

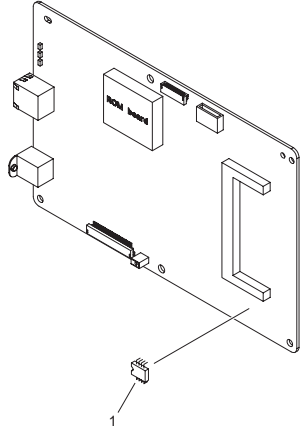

FIGURE & KEY NO.	PARTS NUMBER	RANK	QTY	DESCRIPTION	SERIAL NUMBER/REMARKS	SVC
Fig.900	FM4-2367-000		1	MAIN CONTROLLER PCB ASS'Y		
1	WA7-3525-000		1	IC, 24LC128-I/PG, EEP-ROM,	IC9	
IC	FH4-6302-000		1	IC, S1L50552F32L000, ASIC	IC1009	
IC	FL3-2802-000		1	IC, M29W128GL70N6, FLASH-ROM	IC16	

FIGURE ZZA

MECHANICAL STANDARD PARTS (HOW TO USE)

Mechanical standard parts

機械標準部品

About a mechanical standard parts

A Mechanical standard parts is a mechanical part which not parts peculiar to a product. They are parts which are common to a Canon product and are used, such as a screw and a washer. The Fig No. and parts number of the mechanical standard parts are not listed in the product parts catalog. Refer to the parts catalog of mechanical standard parts when checking the parts number for screw or washer etc. and identify them by part shape or size.

機械標準部品とは

機械標準部品とは、製品特有の部品ではなく、ねじやワッシャなどキヤノン製品共通で使用されている機械部品（メカ部品）のことです。
製品のパーツカタログには、機械標準部品のFig No.や部品番号は記載していません。
ねじや、ワッシャ等の部品番号を調べるときは、機械標準部品のパーツカタログを参照し、部品の形状や大きさから判断し、使用している部品を調べてください。

Material and surface treatment of a mechanical standard parts

Material and surface treatment of mechanical standard parts are assigned commonly for each part. Refer to the Table 1 for the parts which material and surface treatment are assigned as numbers.

機械標準部品の材料および表面処理

機械標準部品の材料および表面処理については、各種部品共通で決められています。
材料および表面処理が番号で決められている部品については、表1を参照してください。

Table 1 Material and Surface treatment
表1 材料および表面処理

No. 番号	Material 材料	Surface treatment 表面処理	Color 色
1	Stainless steel ステンレス	Stainless steel black coloring (BC4) ステンレス黒着色(BC4)	Black 黒
2		not to be given なし	White 白
3	Brass 黄銅	Regular nickel plating (NL) 普通ニッケルメッキ(NL)	White 白
4		Black nickel plating (BN) 黒色ニッケルメッキ(BN)	Black 黒
5	Steel 鋼	White zinc trivalent chromate treating (ZC3) 白色亜鉛3価クロメート(ZC3)	White 白
6		Regular nickel chromium plating (NC) 普通ニッケルクロムメッキ(NC)	White 白
7		Regular nickel plating (NL) 普通ニッケルメッキ(NL)	White 白
8		Iron and steel phosphating (P1) 鉄鋼磷酸塩処理(P1)	Black 黒
9		Black zinc trivalent chromate treating (BZ3) 黒色亜鉛3価クロメート(BZ3)	Black 黒

FIGURE ZZB MECHANICAL STANDARD PARTS (SCREWS)

1. Screws ねじ

How to read Parts Numbers
部品番号の見方

Screws
ねじ

XB1-2400-609

Type No.
類別番号
Normal designation (d)
ねじの呼び(d)
Length (L)
ねじの長さ(L)
Material and Surface treatment
材料および表面処理

XB1-2 expresses Binding head machine screw.
XB1-2は、バインドねじを表す
40 expresses M4.0.
40は、M4.0を表す
0-60 expresses a length of 6.0mm.
0-60は、6.0mmの長さを表す
9 expresses Steel (Black zinc trivalent chromate treating) from Table 1.
9は、表1より鋼(黒色亜鉛3価クロメート)を表す

1-1. Cross Recessed Head Screws for Precision Equipments 精密機器用十字穴付き小ねじ

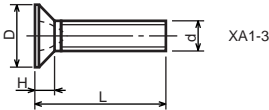
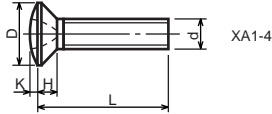
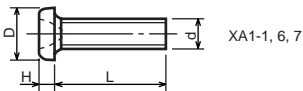

Type No. 類別番号	Type 類別	Head size (mm) 頭部寸法 (mm)							
		M1.4	M1.6	M1.7	M2	M2.5	M2.6		
XA1-1	Pan head Class 1 なべ1種	D	XA1-1	2	2.4	2.5	3	3.8	4
		H	XA1-1	0.5	0.55	0.5	0.6	0.9	0.8
XA1-3	Countersunk head Class 1 さら1種	D	XA1-3	2	2.4	2.5	3	3.8	4
		H	XA1-3	0.48	0.55	0.58	0.73	0.85	0.93
XA1-4	Oval countersunk head Class 1 丸さら1種	D	XA1-4	2	2.4	2.5	3	3.8	4
		H + K	XA1-4	0.68	0.8	0.88	1	1.25	1.3
XA1-6	Pan head Class 3 なべ3種	D	XA1-6	2.5	2.8	3	3.5	4.3	4.5
		H	XA1-6	0.8	0.85	0.9	1	1.3	1.2
XA1-7	Pan head Class 2 なべ2種	D	XA1-7	2.5	2.8	3	3.5	4.3	4.5
		H	XA1-7	0.5	0.55	0.5	0.6	0.9	0.8

1-2. Precision Tapping Screws
精密用タッピンねじ

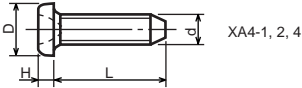

XA4-1, 2, 4

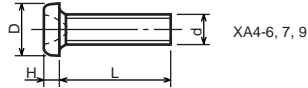

XA4-6, 7, 9

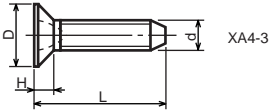

XA4-3

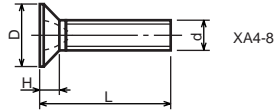

XA4-8

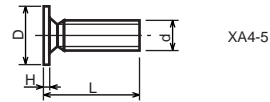

XA4-5

Type No. 類別番号	Type 類別	Head size (mm) 頭部寸法 (mm)						
		M1.4	M1.6	M1.7	M2	M2.5	M2.6	
XA4-1	With tapered end pan head Class 1 絞りなべ1種	D XA4-1	2	2.4	2.5	3	3.8	4
		H XA4-1	0.5	0.55	0.5	0.6	0.9	0.8
XA4-2	With tapered end pan head Class 3 絞りなべ3種	D XA4-2	2.5	2.8	3	3.5	4.3	4.5
		H XA4-2	0.8	0.85	0.9	1	1.3	1.2
XA4-3	With tapered end countersunk head 絞り-さら	D XA4-3	2	2.4	2.5	3	3.8	4
		H XA4-3	0.48	0.55	0.58	0.73	0.85	0.93
XA4-4	With tapered end pan head Class 2 絞りなべ2種	D XA4-4	2.5	2.8	3	3.5	4.3	4.5
		H XA4-4	0.5	0.55	0.5	0.6	0.9	0.8
XA4-5	With parallel end ultra thin head ストレート-超薄頭	D XA4-5	2.5	2.8	3	-	-	-
		H XA4-5	0.2	0.2	0.2	-	-	-
XA4-6	With parallel end pan head Class 1 ストレートなべ1種	D XA4-6	2	2.4	2.5	3	3.8	4
		H XA4-6	0.5	0.55	0.5	0.6	0.9	0.8
XA4-7	With parallel end pan head Class 3 ストレートなべ3種	D XA4-7	2.5	2.8	3	3.5	4.3	4.5
		H XA4-7	0.8	0.85	0.9	1	1.3	1.2
XA4-8	With parallel end countersunk head ストレート-さら	D XA4-8	2	2.4	2.5	3	3.8	4
		H XA4-8	0.48	0.55	0.58	0.73	0.85	0.93
XA4-9	With parallel end pan head Class 2 ストレートなべ2種	D XA4-9	2.5	2.8	3	3.5	4.3	4.5
		H XA4-9	0.5	0.55	0.5	0.6	0.9	0.8

1-3. Cross Recessed Head Screws
 一般用十字穴付き小ねじ

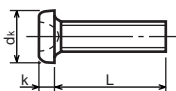

XB1-1

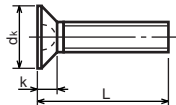

XB1-3

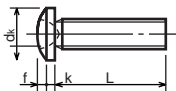

XB1-2

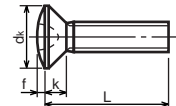

XB1-4

Type No. 類別番号	Type 類別
XB1-1	Pan head なべ
XB1-2	Binding head バインド
XB1-3	Countersunk head ざら
XB1-4	Oval countersunk head 丸ざら

		Head size (mm) 頭部寸法 (mm)					
		M2	M2.5	M2.6	M3	M4	M5
dk	XB1-1	3.5	4.5	4.5	5.5	7	9
k	XB1-1	1.3	1.7	1.7	2	2.6	3.3
dk	XB1-2	4.3	5.3	5.5	6.3	8.3	10.3
k+f	XB1-2	1.2	1.5	1.6	1.9	2.5	3.1
dk	XB1-3	4	5	-	6	8	10
k	XB1-3	1.2	1.45	-	1.75	2.3	2.8
dk	XB1-4	4	5	-	6	8	10
k+f	XB1-4	1.6	2	-	2.45	3.2	4
Screw part length ねじ部長さ b		8	12	12	12	16	20

1-4. Cross Recessed Head Screws with Captive Washer
 座金組込み十字穴付き小ねじ

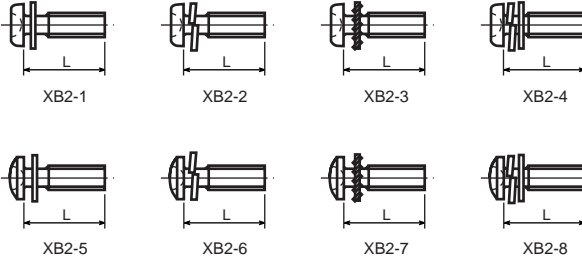

Type No. 類別番号	Type 類別
XB2-1	Pan head + Plain washer (circular bright) なべねじ+平座金
XB2-2	Pan head + Spring washer なべねじ+ばね座金
XB2-3	Pan head + Toothed lock washer なべねじ+歯付座金
XB2-4	Pan head + Spring washer and plain washer (circular bright) なべねじ+(ばね+平)座金
XB2-5	Binding head + Plain washer (circular bright) バインドねじ+平座金
XB2-6	Binding head + Spring washer バインドねじ+ばね座金
XB2-7	Binding head + Toothed lock washer バインドねじ+歯付座金
XB2-8	Binding head + Spring washer and plain washer (circular bright) バインドねじ+(ばね+平)座金

		Head size (mm) 頭部寸法 (mm)		
		M3	M4	
XB3-6	For metallic materials 金属用タッ	D	8	10
		B	5.5	5.5
		H XB3-6	3.1	3.1
		H XB3-7	3.2	3.2

Head size (mm) 頭部寸法 (mm)		
	M3	M4
d _k	6.3	8.3
k	1.3	1.7
k+f	1.9	2.5

1-7. General Head Tapping Screws
一般用タッピンねじ

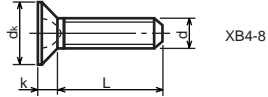
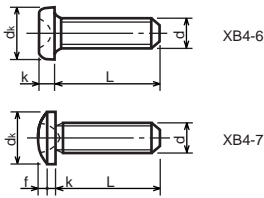

Type No. 類別番号	Type 類別	Head size (mm) 頭部寸法 (mm)						
		M2	M2.5	M2.6	M3	M4	M5	
XB4-6	Pan head なべ	d_k XB4-6	3.5	4.5	4.5	5.5	7	9
		k XB4-6	1.3	1.7	1.7	2	2.6	3.3
XB4-7	Binding head バインド	d_k XB4-7	4.3	5.3	5.5	6.3	8.3	10.3
		$k+f$ XB4-7	1.2	1.5	1.6	1.9	2.5	3.1
XB4-8	Countersunk head さら	d_k XB4-8	4	5	5.2	6	8	10
		k XB4-8	1.2	1.45	1.5	1.75	2.3	2.8

1-8. Tapping Screws for Metallic Materials
金属用タッピンねじ

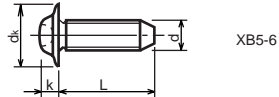
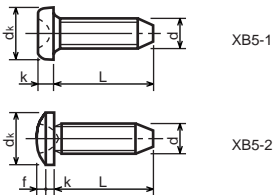

Type No. 類別番号	Type 類別	Head size (mm) 頭部寸法 (mm)					
		M2.5	M2.6	M3	M4	M5	
XB5-1	Pan head なべ	d_k XB5-1	4.5	4.5	5.5	7	9
		k XB5-1	1.7	1.7	2	2.6	3.3
XB5-2	Binding head バインド	d_k XB5-2	5.5	5.5	6.3	8.3	10.3
		$k+f$ XB5-2	1.6	1.6	1.9	2.5	3.1
XB5-6	Flanged pan head つば付きなべ	d_k XB5-6	6.5	6.5	8	10	12
		k XB5-6	2.1	2.1	1.75	3.2	4

1-9. Hexagon Socket Set Screws
六角穴付止めねじ

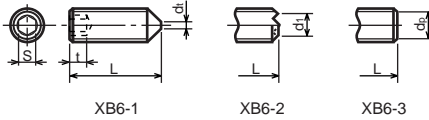

Type No. 類別番号	Type 類別	Head size (mm) 頭部寸法 (mm)							
		M1.6 M1.7	M2	M2.5 M2.6	M3	M5	M5	M6	
XB6-1	Cone point とがり先	S	0.7	0.9	1.3	1.5	2	2.5	3
		t	1.5	1.7	2	2	2.5	3	3.5
		$d_{t \max}$ XB6-1	0.4	0.5	0.65	0.75	1	1.25	1.5
		$d_{l \max}$ XB6-2	-	1.2	1.5	1.7	2.2	2.8	3.3
		$d_{l \min}$ XB6-2	-	1	1.2	1.4	1.9	2.4	2.9
		$d_{p \max}$ XB6-3	0.8	1	1.5	2	2.5	3.5	4
		$d_{p \min}$ XB6-3	0.55	0.75	1.25	1.75	2.25	3.2	3.7

1-10. Flanged Pan Head Machine Screws
つば付きなべ小ねじ

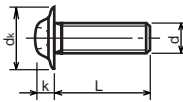

Type No. 類別番号	Type 類別	Head size (mm) 頭部寸法 (mm)					
		M2	M2.5 M2.6	M3	M5	M5	
XB6-7	Flanged pan head つば付きなべ	d_k	5	6.5	8	10	12
		k	1.7	2.1	2.5	3.2	4

FIGURE ZZC MECHANICAL STANDARD PARTS (BOLTS)

2. Bolts (Socket head cap screw) ボルト

How to read Parts Numbers
部品番号の見方

Bolt (Socket head cap screw)
ボルト

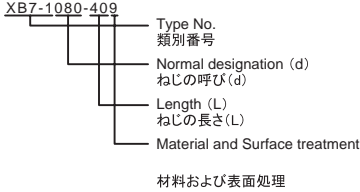

XB7-1 expresses Hexagon socket head cap screws.
XB7-1は、六角穴付きボルトを表す

080 expresses M8.0.
080は、M8.0を表す

40 expresses a length of 40mm.
40は、40mmの長さを表す

9 expresses Steel (Black zinc trivalent chromate
treating) from Table 1.

9は、表1より鋼(黒色亜鉛3価クロメート)を表す

2-1. Hexagon socket head cap screws 六角穴付きボルト

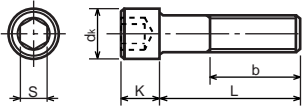

Type No. 類別番号	Type 類別
XB7-1	Hexagon socket head cap screws 六角穴付きボルト

	Head size (mm) 頭部寸法 (mm)						
	M3	M4	M5	M6	M8	M10	M12
S	2.5	3	4	5	6	8	10
d_k	5.5	7	8.5	10	13	16	18
K	3	4	5	6	8	10	12
Screw part length b_{max} ねじ部長さ b_{max}	18	20	22	24	28	32	36

FIGURE ZZD MECHANICAL STANDARD PARTS (NUTS)

3. Nuts ナット

How to read Parts Numbers
部品番号の見方

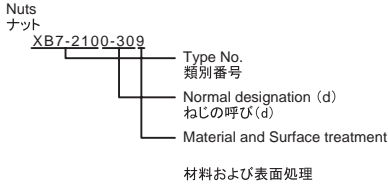

XB7-210 expresses Hexagon nut class 1.
XB7-210は、六角ナット1種を表す

0-30 expresses M3.0.
0-30は、M3.0を表す

9 expresses Steel (Black zinc trivalent chromate
treating) from Table 1.

9は、表1より鋼(黒色亜鉛3価クロメート)を表す

3-1. Hexagon Nuts and Hexagon Thin Nuts 六角ナット

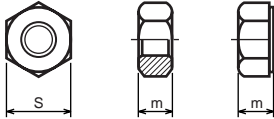

Type No. 類別番号	Type 類別
XB7-210	Hexagon nut Class 1 六角ナット-1種
XB7-220	Hexagon nut Class 3 六角ナット-3種
XB7-230	Hexagon nut Style 1 double chamfered 六角ナット-スタイル1-両面とり
XB7-231	Hexagon nut Style 1 washer faced 六角ナット-スタイル1-座付き
XB7-240	Hexagon nut Style 2 double chamfered 六角ナット-スタイル2-両面とり
XB7-241	Hexagon nut Style 2 washer faced 六角ナット-スタイル2-座付き
XB7-250	Hexagon nut 六角ナット
XB7-260	Hexagon thin nut double chamfered 六角低ナット-両面とり
XB7-270	Hexagon thin nut not chamfered 六角低ナット-面とり無し

	Head size (mm) 頭部寸法 (mm)						
	M2	M2.5	M3	M4	M5	M6	M8
S	4	5	5.5	7	8	10	13
m XB7-210	1.6	2	2.4	3.2	4	5	6.5
m XB7-220	1.2	1.6	1.8	2.4	3.2	3.6	5
m XB7-230, 231	1.6	2	2.4	3.2	4.7	5.2	6.8
m XB7-240, 241	-	-	-	-	5.1	5.7	7.5
m XB7-250	-	-	-	-	5.6	6.1	7.9
m XB7-260	1.2	1.6	1.8	2.2	2.7	3.2	4
m XB7-270	1.2	1.6	1.8	2.2	2.7	3.2	4

FIGURE ZZE MECHANICAL STANDARD PARTS (RETAINING RINGS)

5. Retaining Rings

止め輪

How to read Parts Numbers
部品番号の見方

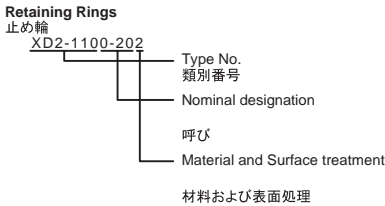

XD2-110 expresses retaining ring-E type (Type1).
XD2-110は、E形止め輪(1種)を表す

0-20 expresses a 020 of nominal designation.
(See Table 5)

0-20は、呼び020を表す(表5参照)

2 expresses Stainless steel (Surface treatment is not to be given) from Table 1.
2は、表1よりステンレス(表面処理なし)を表す

5-1. Retaining Rings - E type

E形止め輪

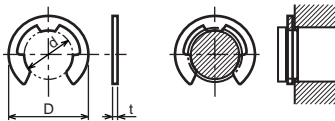

Type No. 類別番号	Type 類別
XD2-110	Retaining ring - E type (Type 1) E形止め輪(1種)
XD2-120	Retaining ring - E type (Type 2) E形止め輪(2種)

Table 5 表5

Type 種類	Nominal designation 呼び	d (mm)	D (mm)	t (mm)
Type 1 1種	007	0.65	2	0.2
	010	0.95	2.8	0.2
	013	1.25	3.3	0.3
	017	1.65	4.2	0.4
	020	1.95	4.6	0.5
	024	2.35	6	0.6
	028	2.74	6.5	0.6
	032	3.14	7.2	0.6
	037	3.64	8	0.7
	040	3.93	10	0.7
	042	4.13	10	0.7
	050	4.93	11	0.7
	058	5.73	12	0.7
	060	5.93	12.7	0.9
	064	6.32	13.5	0.9
	074	7.31	15	0.9
080	7.91	16.5	1	
Type 2 2種	008	0.8	2	0.2
	012	1.2	3	0.3
	015	1.5	4	0.4
	020	2	5	0.4
	025	2.5	6	0.4
	030	3	7	0.6
	040	4	9	0.6
	050	5	11	0.6
	060	6	12	0.8
	070	7	14	0.8
	080	8	16	0.8
	090	9	18	0.8
	100	10	20	1

5-2. Grip Rings
グリップ止め輪

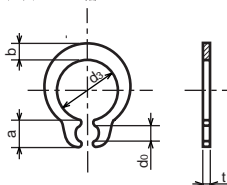

Type No. 類別番号	Type 類別
XD2-210	Grip ring グリップ止め輪

Table 5 表5

Nominal designation 呼び	d ₃ (mm)	t (mm)	b (mm)	a (mm)	d ₀ (mm)
020	1.9	0.5	1	1.8	0.8
025	2.35	0.5	1.2	1.9	0.9
030	2.85	0.6	1.4	1.9	0.9
035	3.3	0.6	1.6	2	0.9
040	3.8	0.8	1.8	2.8	1.2
045	4.25	0.8	2	2.9	1.3
050	4.75	0.8	2.2	2.9	1.3
060	5.7	1	2.4	3.1	1.4
070	6.7	1	2.7	3.3	1.4
080	7.7	1	3	3.5	1.4
090	8.65	1.2	3.3	4.7	1.5
100	9.65	1.2	3.5	4.7	2

5-3. Toothed Retaining Rings
歯付き形止め輪

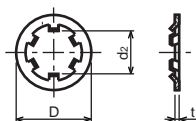

Type No. 類別番号	Type 類別
XD2-230	Toothed retaining ring 歯付き形止め輪

Table 5 表5

Nominal designation 呼び	d _z (mm)	D (mm)	t (mm)	No of teeth 歯数
015	1.4	5.2	0.25	3
020	1.9	6	0.25	3
024	2.3	6.4	0.25	3
030	2.8	8	0.25	4
040	3.8	9	0.25	4
050	4.8	10	0.25	5
060	5.8	11	0.25	5
080	7.8	13	0.25	5
100	9.8	15.4	0.25	6

5-4. Retaining Rings - C Type

C形止め輪

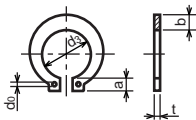

Type No. 類別番号	Type 類別
XD2-310	Retaining ring - C type for shaft C形止め輪 軸用

Table 5 表5

Nominal designation 呼び	d ₃ (mm)	t (mm)	b (mm)	a (mm)	d ₀ (mm)
010	9.3	1	1.6	3	1.2
012	11.1	1	1.8	3.2	1.5
014	12.9	1	2	3.4	1.7
015	13.8	1	2.1	3.5	1.7
016	14.7	1	2.2	3.6	1.7
017	15.7	1	2.2	3.7	1.7
018	16.5	1.2	2.6	3.8	1.7
020	18.5	1.2	2.7	3.9	2
022	20.5	1.2	2.7	4.1	2
025	23.2	1.2	3.1	4.3	2
028	25.9	1.5	3.1	4.6	2
030	27.9	1.5	3.5	4.8	2
032	29.6	1.5	3.5	5	2.5
035	32.2	1.5	4	5.4	2.5

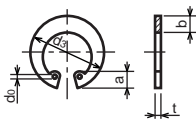

Type No. 類別番号	Type 類別
XD2-320	Retaining ring - C type for hole C形止め輪 穴用

Table 5 表5

Nominal designation 呼び	d ₃ (mm)	t (mm)	b (mm)	a (mm)	d ₀ (mm)
010	10.7	1	1.8	3.1	1.2
011	11.8	1	1.8	3.2	1.2
012	13	1	1.8	3.3	1.5
014	15.1	1	2	3.6	1.7
016	17.3	1	2	3.7	1.7
018	19.5	1	2.5	4	1.7
019	20.5	1	2.5	4	2
020	21.5	1	2.5	4	2
022	23.5	1	2.5	4.1	2
025	26.9	1.2	3	4.4	2
028	30.1	1.2	3	4.6	2
030	32.1	1.2	3	4.7	2
032	34.4	1.2	3.5	5.2	2.5
035	37.8	1.5	3.5	5.2	2.5
037	39.8	1.5	3.5	5.2	2.5
040	43.5	1.8	4	5.7	2.5
042	45.5	1.8	4	5.8	2.5
045	48.5	1.8	4.5	5.9	2.5
047	50.5	1.8	4.5	6.1	2.5
050	54.2	2	4.5	6.5	2.5
052	56.2	2	5.1	6.5	2.5
055	59.2	2	5.1	6.5	2.5
060	64.2	2	5.1	6.8	2.5
062	66.2	2	5.5	6.9	2.5
068	72.5	2.5	6	7.4	2.5
072	76.5	2.5	6.6	7.4	2.5
075	79.5	2.5	6.6	7.8	2.5
080	85.5	2.5	7	8	2.5
085	90.5	3	7	8	3
090	95.5	3	7.6	8.3	3
095	100.5	3	8	8.5	3

Prepared by
OIP Service Management Center
CANON INC.

Canon