

imageCLASS LBP162dw

PARTS CATALOG



Canon

November 14, 2017
Rev. 0

Index

SNL	PRODUCT CODE NO. /SERIAL NO.
001A	ACCESSORIES (LBP162dw 120V US, CA, LTN)
001B	ACCESSORIES (LBP162dw 230V LTN, SG, HK, KR)
100A	EXTERNAL COVERS, PANELS, ETC. (LBP162dw)
101A	INTERNAL COMPONENTS 1 (120V WIRELESS LAN model)
101B	INTERNAL COMPONENTS 1 (230V WIRELESS LAN model)
102A	INTERNAL COMPONENTS 2 (120V)
102B	INTERNAL COMPONENTS 2 (230V)
103	INTERNAL COMPONENTS 3
ZZA	MECHANICAL STANDARD PARTS (HOW TO USE)
ZZB	MECHANICAL STANDARD PARTS (SCREWS)
ZZC	MECHANICAL STANDARD PARTS (BOLTS)
ZZD	MECHANICAL STANDARD PARTS (NUTS)
ZZE	MECHANICAL STANDARD PARTS (RETAINING RINGS)

Figure SNL PRODUCT CODE NO. /SERIAL NO.

	Product Code No.	Model Name	Remarks	Serial No.
1	F17-3131-000	imageCLASS LBP162dw	120V US, CA, LTN WIRELESS LAN model	NMHA
2	F17-3141-000	imageCLASS LBP162dw	230V LTN WIRELESS LAN model	NMEA

	中オーダー	製品名	備考	シリアル No.
1	F17-3131-000	imageCLASS LBP162dw	120V US, CA, LTN ワイヤレスLANモデル	NMHA
2	F17-3141-000	imageCLASS LBP162dw	230V LTN ワイヤレスLANモデル	NMEA

FIGURE & KEY NO.	PART NUMBER	RANK	QTY	DESCRIPTION	SERIAL NUMBER /REMARKS
SNL	NPN		RF	Product Code No./Serial No.	
1	F17-3131-000		1	imageCLASS LBP162dw	NMHA 120V US, CA, LTN WIRELESS LAN model
2	F17-3141-000		1	imageCLASS LBP162dw	NMEA 230V LTN WIRELESS LAN model

Figure 001A ACCESSORIES (LBP162dw 120V US, CA, LTN)

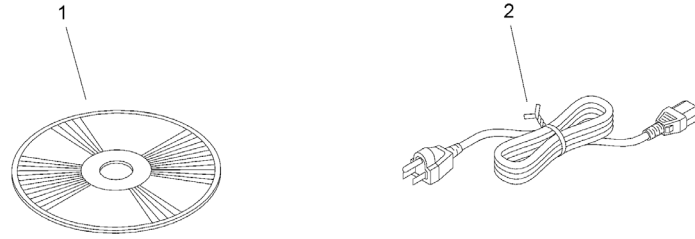

FIGURE & KEY NO.	PART NUMBER	RANK	QTY	DESCRIPTION	SERIAL NUMBER /REMARKS
001A	NPN		RF	ACCESSORIES	LBP162dw 120V US, CA, LTN
1	FM2-G807-000		1	CD-ROM, USER SOFTWARE	
2	FK4-3387-000		1	CORD, POWER	

Figure 001B ACCESSORIES (LBP162dw 230V LTN, SG, HK, KR)

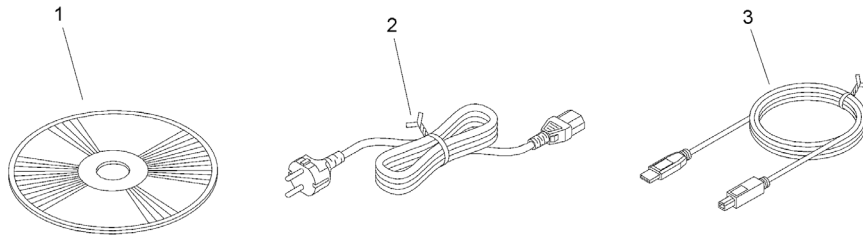

FIGURE & KEY NO.	PART NUMBER	RANK	QTY	DESCRIPTION	SERIAL NUMBER /REMARKS
001B	NPN		RF	ACCESSORIES	LBP162dw 230V LTN, SG, HK, KR
1	FM2-G810-000		1	DVD-ROM, USER SOFTWARE	
2	FK4-3388-000		1	CORD, POWER	
3	FK3-1187-000		1	CORD, USB	

Figure 100A EXTERNAL COVERS, PANELS, ETC. (LBP162dw)

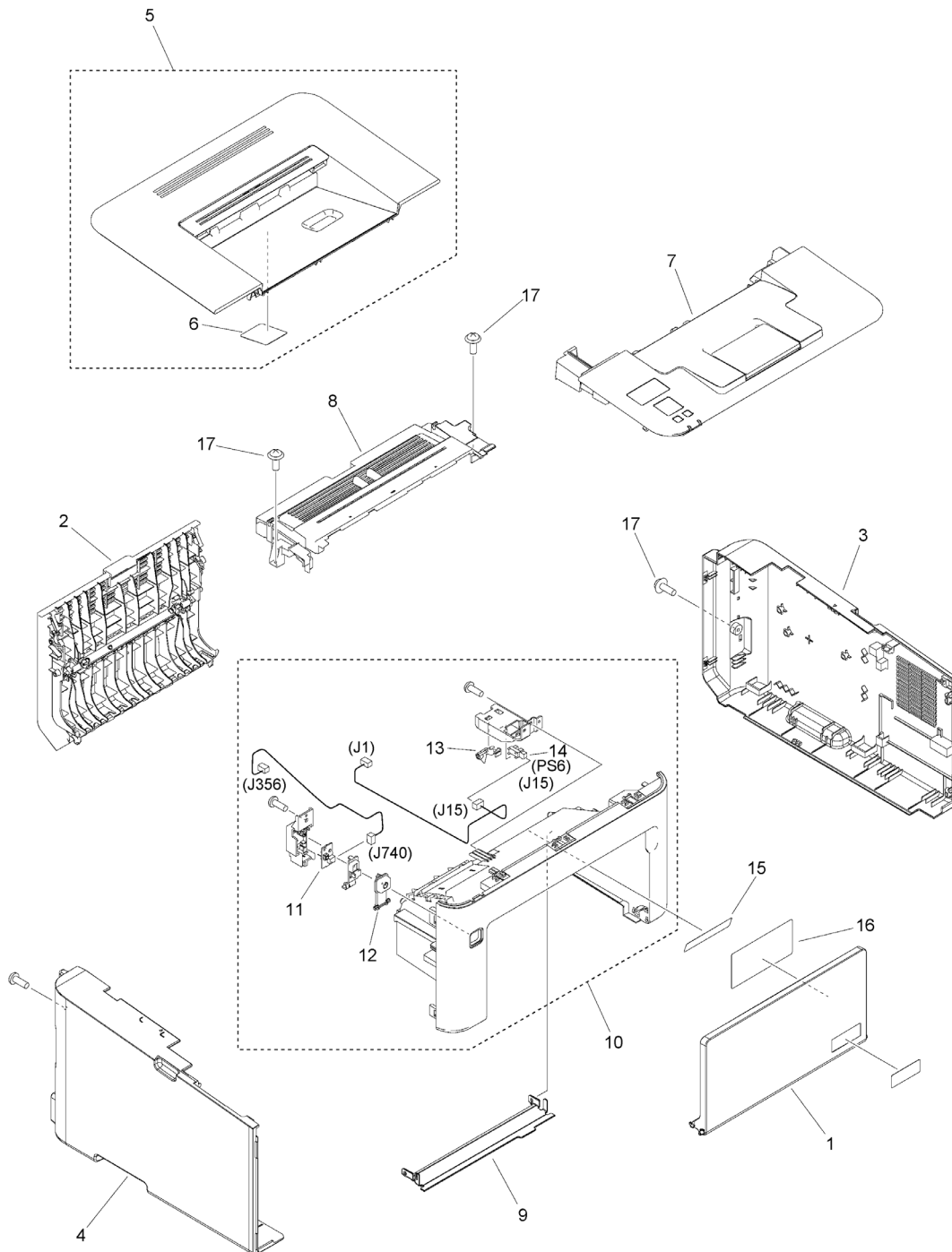

FIGURE & KEY NO.	PART NUMBER	RANK	QTY	DESCRIPTION	SERIAL NUMBER /REMARKS
100A	NPN		RF	EXTERNAL COVERS, PANELS, ETC.	LBP162dw
1	FE8-8628-000		1	COVER, MULTI-PURPOSE	
2	FM1-T707-000		1	DUPLEXING DOOR ASS'Y	
3	FE8-8621-000		1	COVER, RIGHT	
4	FL1-5015-000		1	COVER, LEFT	
5	FM1-T710-000		1	CARTRIDGE DOOR ASS'Y	
6	FE8-8773-000		1	LABEL, HIGH TMP. CAUTION	
7	FM1-T709-000		1	TOP FRONT COVER ASS'Y	
8	FE8-8623-000		1	COVER, TOP, REAR	
9	RC4-7985-000		1	GUIDE, FEED, FRONT	
10	FM1-T708-000		1	FRONT COVER ASS'Y	
11	RM2-8273-000		1	POWER SWITCH PCB ASS'Y	
12	FM1-T713-000		1	BUTTON, SWITCH	
13	FE8-8631-000		1	FLAG, PAPER SENSOR	
14	WG8-5935-000		1	IC, PHOTO INTERRUPTER	PS6
15	FE8-9374-000		1	LABEL, SIZE	
16	FE8-9375-000		1	LABEL, CAUTION	
17	XA9-1503-000		3	SCREW, TAP, M3X6	

Figure 101A INTERNAL COMPONENTS 1 (120V WIRELESS LAN model)

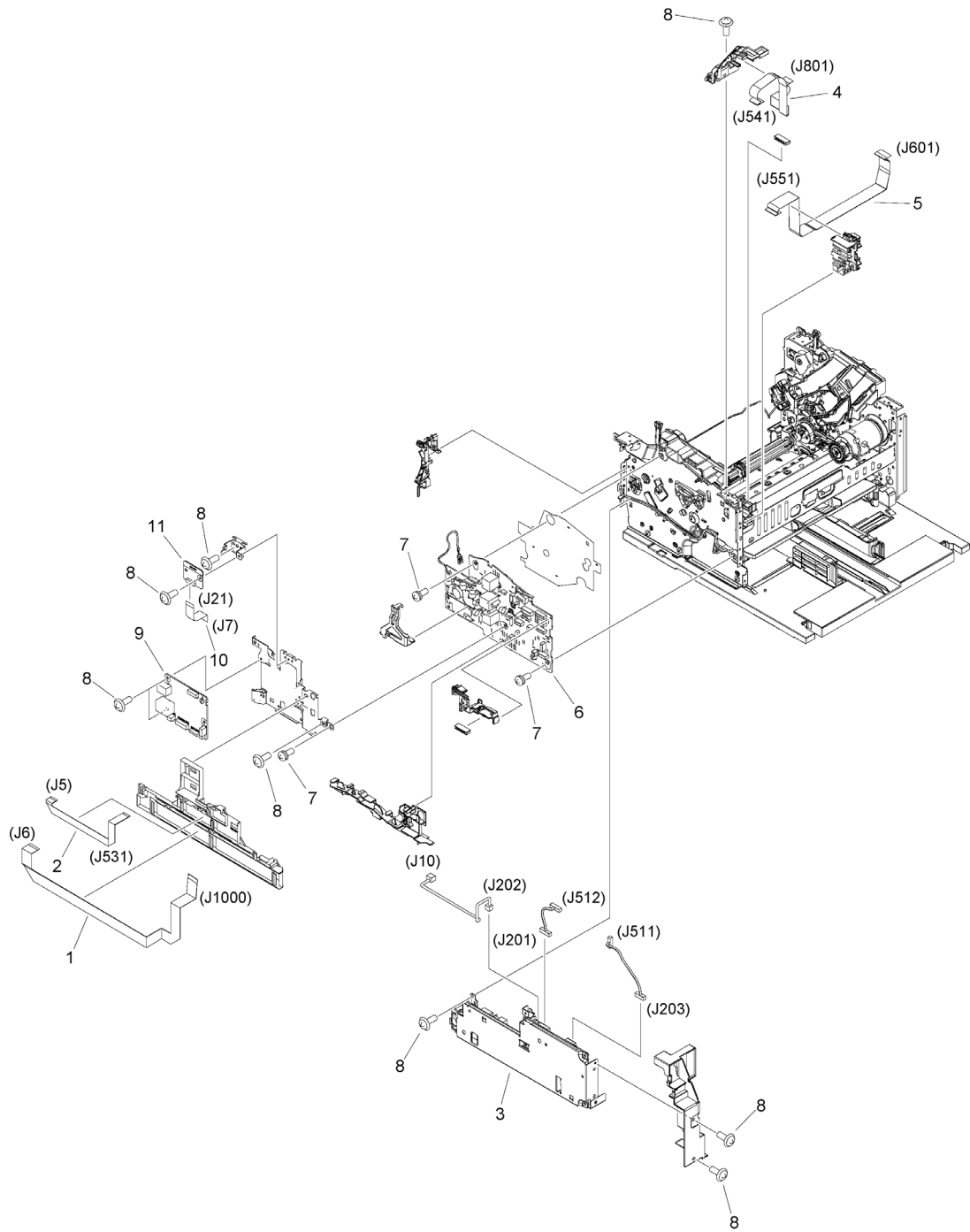

FIGURE & KEY NO.	PART NUMBER	RANK	QTY	DESCRIPTION	SERIAL NUMBER /REMARKS
101A	NPN		RF	INTERNAL COMPONENTS 1	120V WIRELESS LAN model
1	FK4-5166-000		1	CABLE, FLEXIBLE FLAT	
2	FK4-5208-000		1	CABLE, FLEXIBLE FLAT	
3	RM2-0837-000		1	L.V. POWER SUPPLY PCB ASS'Y	
4	RM2-8381-000		1	CABLE, FLEXIBLE FLAT	
5	RM2-9191-000		1	CABLE, FLEXIBLE FLAT	
6	FM2-B929-000		1	ENGINE CONTROL PCB ASS'Y	
7	XA9-1420-000		4	SCREW, W/WASHER, M3X8	
8	XA9-1503-000		15	SCREW, TAP, M3X6	
9	FM2-D855-000		1	MAIN CONTROLLER PCB ASS'Y	
10	FK4-4645-000		1	CABLE, FLEXIBLE FLAT	
11	FK4-4651-000		1	MODULE, WLAN	

Figure 101B INTERNAL COMPONENTS 1 (230V WIRELESS LAN model)

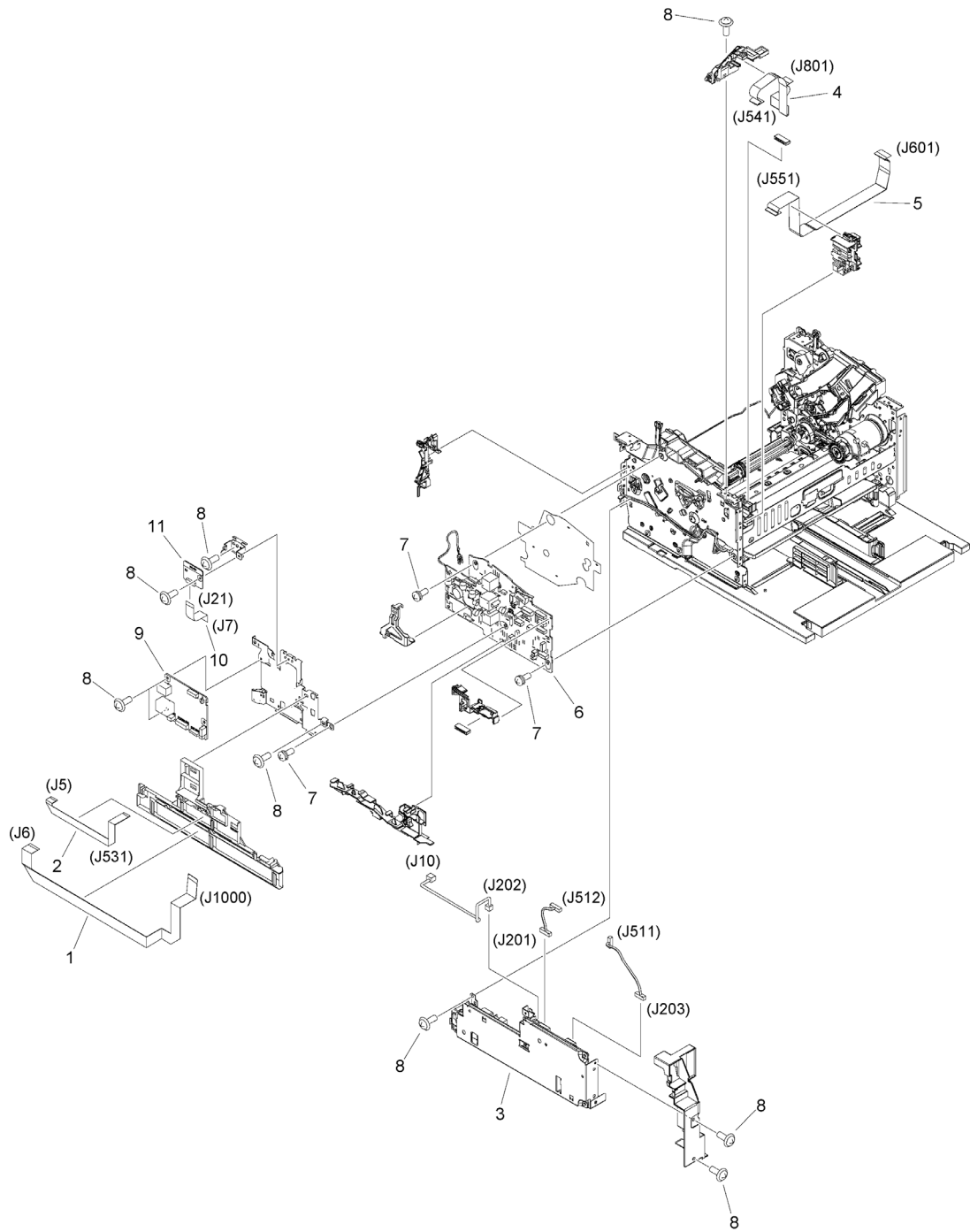

FIGURE & KEY NO.	PART NUMBER	RANK	QTY	DESCRIPTION	SERIAL NUMBER /REMARKS
101B	NPN		RF	INTERNAL COMPONENTS 1	230V WIRELESS LAN model
1	FK4-5166-000		1	CABLE, FLEXIBLE FLAT	
2	FK4-5208-000		1	CABLE, FLEXIBLE FLAT	
3	RM2-0839-000		1	L.V. POWER SUPPLY PCB ASS'Y	
4	RM2-8381-000		1	CABLE, FLEXIBLE FLAT	
5	RM2-9191-000		1	CABLE, FLEXIBLE FLAT	
6	FM2-B929-000		1	ENGINE CONTROL PCB ASS'Y	
7	XA9-1420-000		4	SCREW, W/WASHER, M3X8	
8	XA9-1503-000		15	SCREW, TAP, M3X6	
9	FM2-D855-000		1	MAIN CONTROLLER PCB ASS'Y	
10	FK4-4645-000		1	CABLE, FLEXIBLE FLAT	
11	FK4-4651-000		1	MODULE, WLAN	

Figure 102A INTERNAL COMPONENTS 2 (120V)

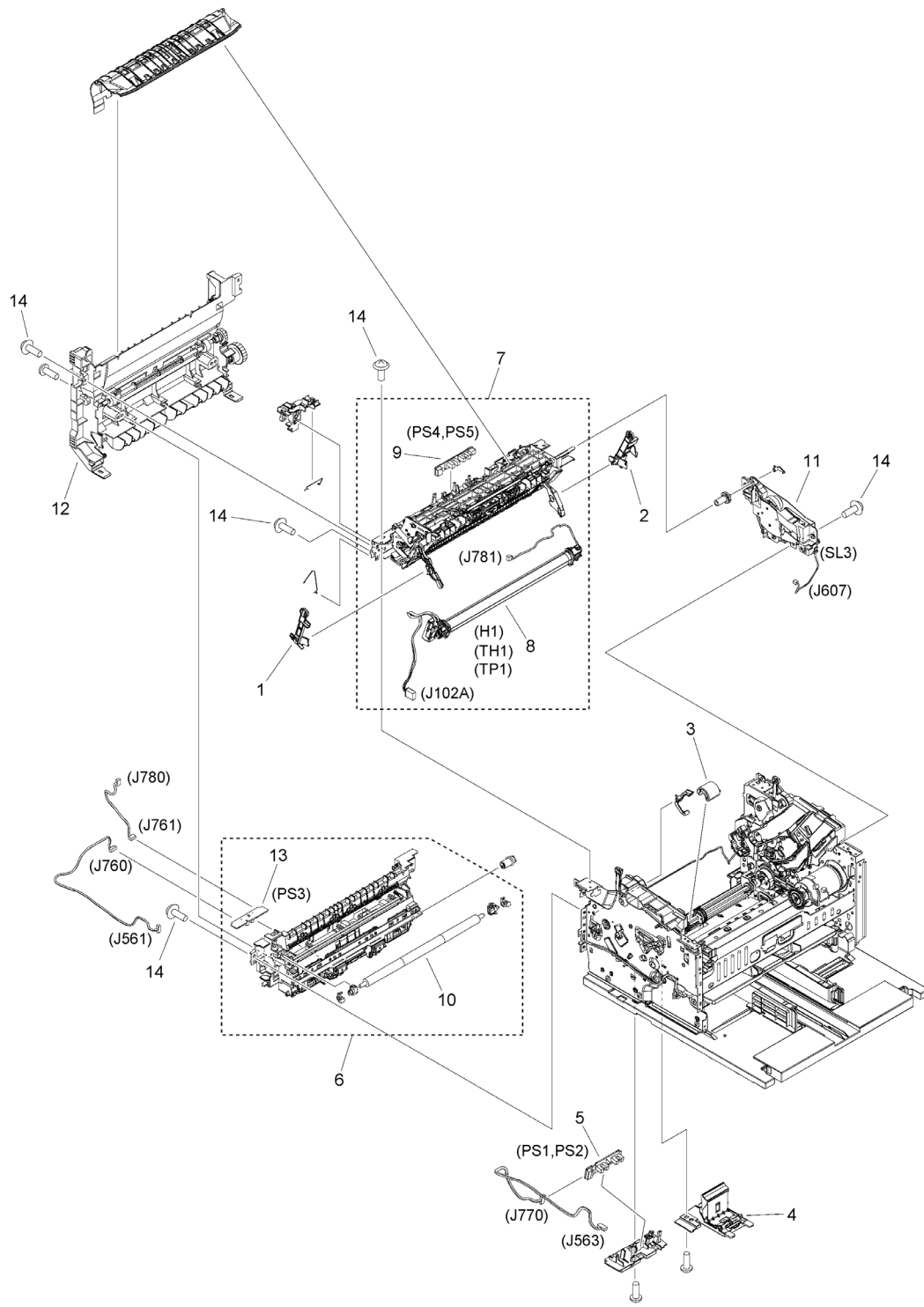

FIGURE & KEY NO.	PART NUMBER	RANK	QTY	DESCRIPTION	SERIAL NUMBER /REMARKS
102A	NPN		RF	INTERNAL COMPONENTS 2	120V
1	RC4-7980-000		1	LINK, PRESSURE RELEASE, LEFT	
2	RC4-7981-000		1	LINK, PRESSURE RELEASE, RIGHT	
3	RL1-2593-000		1	ROLLER, PAPER PICK-UP	
4	RM2-0812-000		1	SEPARATION PAD HOLDER ASS'Y	
5	FM2-B920-000		1	ENVIRONMENT SENSOR PCB ASS'Y	PS1, PS2
6	FM1-U357-000		1	TRANSFER ASS'Y	
7	RM2-0835-000		1	FIXING ASS'Y	
8	RM2-0814-000		1	FIXING FILM ASS'Y	H1, TH1, TP1
9	RM2-8279-000		1	DELIVERY SENSOR PCB ASS'Y	PS4, PS5
10	RM2-1660-000		1	TRANSFER ROLLER ASS'Y	
11	RM2-0807-000		1	SWITCH BACK ASS'Y	SL3
12	RM2-2086-000		1	DUPLEXING PAPER FEED ASS'Y	
13	FM2-B921-000		1	PAPER PICK-UP SENSOR PCB ASS'Y	PS3
14	XA9-1503-000		15	SCREW, TAP, M3X6	

Figure 102B INTERNAL COMPONENTS 2 (230V)

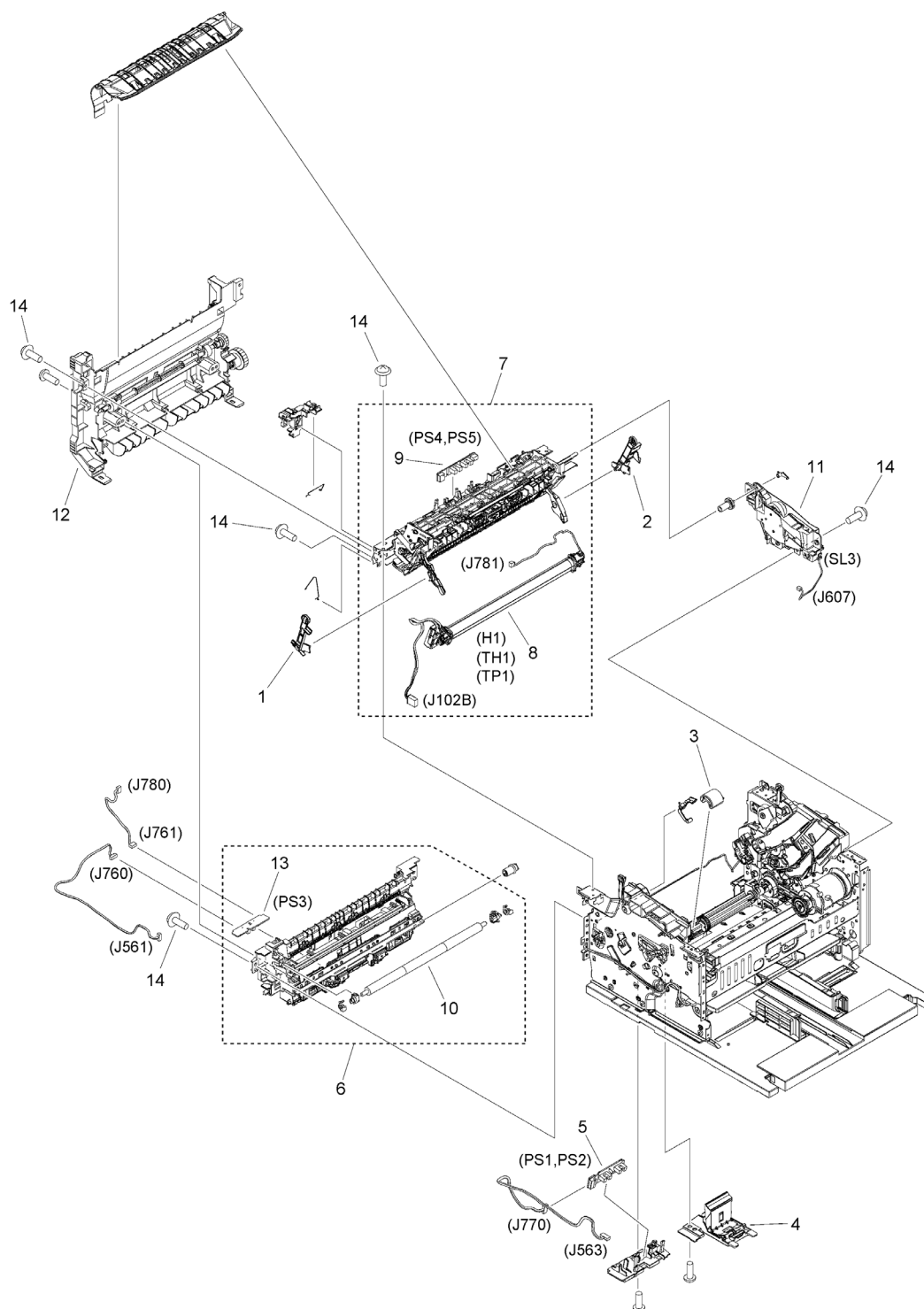

FIGURE & KEY NO.	PART NUMBER	RANK	QTY	DESCRIPTION	SERIAL NUMBER /REMARKS
102B	NPN		RF	INTERNAL COMPONENTS 2	230V
1	RC4-7980-000		1	LINK, PRESSURE RELEASE, LEFT	
2	RC4-7981-000		1	LINK, PRESSURE RELEASE, RIGHT	
3	RL1-2593-000		1	ROLLER, PAPER PICK-UP	
4	RM2-0812-000		1	SEPARATION PAD HOLDER ASS'Y	
5	FM2-B920-000		1	ENVIRONMENT SENSOR PCB ASS'Y	PS1, PS2
6	FM1-U357-000		1	TRANSFER ASS'Y	
7	RM2-0836-000		1	FIXING ASS'Y	
8	RM2-0815-000		1	FIXING FILM ASS'Y	H1, TH1, TP1
9	RM2-8279-000		1	DELIVERY SENSOR PCB ASS'Y	PS4, PS5
10	RM2-1660-000		1	TRANSFER ROLLER ASS'Y	
11	RM2-0807-000		1	SWITCH BACK ASS'Y	SL3
12	RM2-2086-000		1	DUPLEXING PAPER FEED ASS'Y	
13	FM2-B921-000		1	PAPER PICK-UP SENSOR PCB ASS'Y	PS3
14	XA9-1503-000		15	SCREW, TAP, M3X6	

Figure 103 INTERNAL COMPONENTS 3

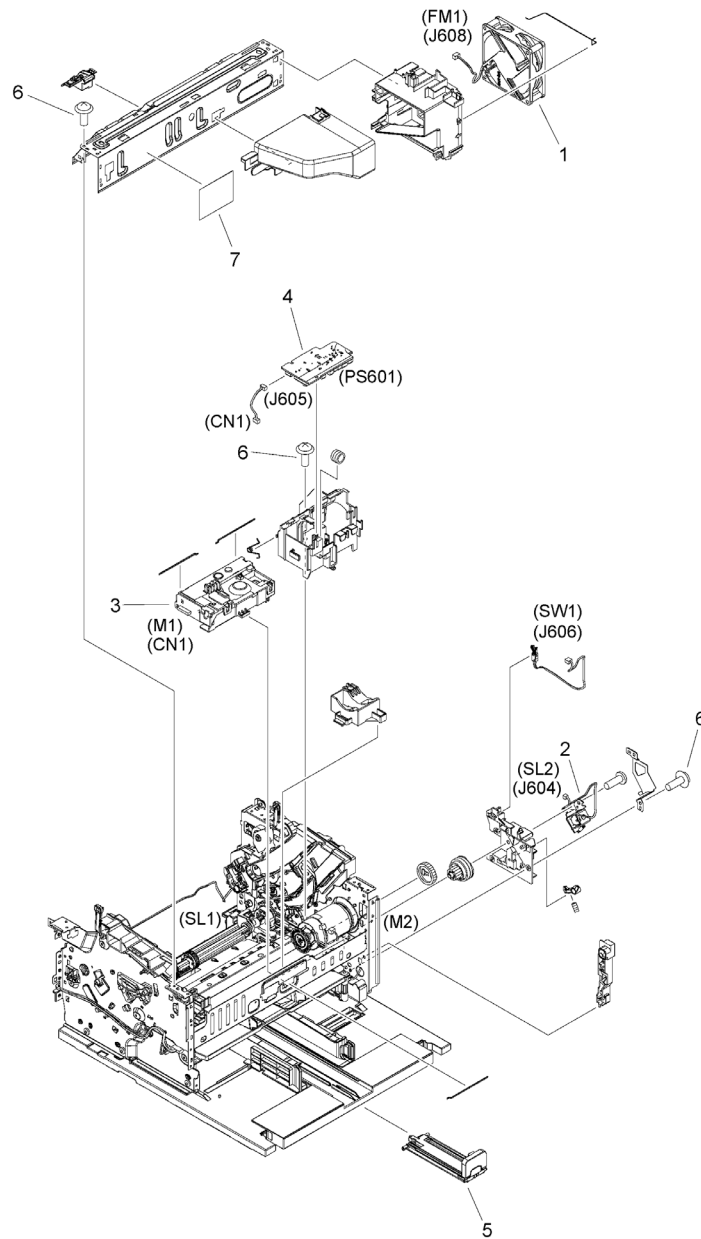

FIGURE & KEY NO.	PART NUMBER	RANK	QTY	DESCRIPTION	SERIAL NUMBER /REMARKS
103	NPN		RF	INTERNAL COMPONENTS 3	
1	RK2-1378-000		1	FAN	FM1
2	RK2-7601-000		1	SOLENOID	SL2
3	RM2-6911-000		1	LASER SCANNER ASS'Y	M1
4	RM2-8351-000		1	MOTOR PCB ASS'Y	PS601
5	RL2-5016-000		1	GUIDE, END	
6	XA9-1503-000		15	SCREW, TAP, M3X6	
7	RU5-8841-000		1	LABEL, ATTENTION	

Figure ZZA MECHANICAL STANDARD PARTS (HOW TO USE)

Mechanical standard parts 機械標準部品

About a mechanical standard parts

A Mechanical standard parts is a mechanical part which not parts peculiar to a product.
They are parts which are common to a Canon product and are used, such as a screw and a washer.
The Fig No. and parts number of the mechanical standard parts are not listed in the product parts catalog.
Refer to the parts catalog of mechanical standard parts when checking the parts number for screw or washer etc. and identify them by part shape or size.

機械標準部品とは

機械標準部品とは、製品特有の部品ではなく、ねじやワッシャなどキヤノン製品共通で使用されている機械部品（メカ部品）のことです。
製品のパーツカタログには、機械標準部品のFig No.や部品番号は記載していません。
ねじや、ワッシャ等の部品番号を調べる時は、機械標準部品のパーツカタログを参照し、部品の形状や大きさから判断し、使用している部品を調べてください。

Material and surface treatment of a mechanical standard parts

Material and surface treatment of mechanical standard parts are assigned commonly for each part.
Refer to the Table 1 for the parts which material and surface treatment are assigned as numbers.

機械標準部品の材料および表面処理

機械標準部品の材料および表面処理については、各種部品共通で決められています。
材料および表面処理が番号で決められている部品については、表1を参照してください。

Table 1 Material and Surface treatment
表1 材料および表面処理

No. 番号	Material 材料	Surface treatment 表面処理	Color 色
1	Stainless steel ステンレス	Stainless steel black coloring (BC4) ステンレス黒着色(BC4)	Black 黒
2		not to be given なし	White 白
3	Brass 黄銅	Regular nickel plating (NL) 普通ニッケルメッキ(NL)	White 白
4		Black nickel plating (BN) 黒色ニッケルメッキ(BN)	Black 黒
5	Steel 鋼	White zinc trivalent chromate treating (ZC3) 白色亜鉛3価クロメート(ZC3)	White 白
6		Regular nickel chromium plating (NC) 普通ニッケルクロムメッキ(NC)	White 白
7		Regular nickel plating (NL) 普通ニッケルメッキ(NL)	White 白
8		Iron and steel phosphating (P1) 鉄鋼燐酸塩処理(P1)	Black 黒
9		Black zinc trivalent chromate treating (BZ3) 黒色亜鉛3価クロメート(BZ3)	Black 黒

Figure ZZB (1/7)MECHANICAL STANDARD PARTS (SCREWS)

1. Screws
ねじ

How to read Parts Numbers
部品番号の見方

Screws
ねじ

XB1-2400-609

Type No.
類別番号
Normal designation (d)
ねじの呼び (d)
Length (L)
ねじの長さ (L)
Material and Surface treatment
材料および表面処理

XB1-2 expresses Binding head machine screw.
XB1-2は、バインドねじを表す
40 expresses M4.0.
40は、M4.0を表す
0-60 expresses a length of 6.0mm.
0-60は、6.0mmの長さを表す
9 expresses Steel (Black zinc trivalent chromate
treating) from Table 1.
9は、表1より鋼 (黒色亜鉛3価クロメート) を表す

1-1. Cross Recessed Head Screws for Precision Equipments
精密機器用十字穴付き小ねじ

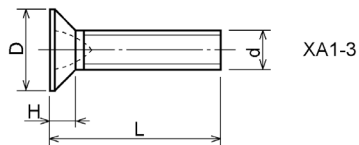
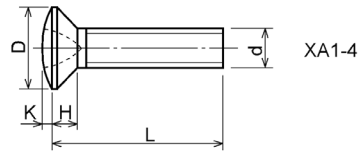
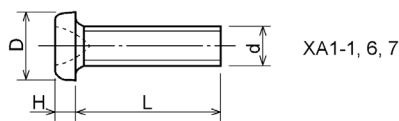

Type No. 類別番号	Type 類別	Head size (mm) 頭部寸法 (mm)						
		M1.4	M1.6	M1.7	M2	M2.5	M2.6	
XA1-1	Pan head Class 1 なべ1種	D	2	2.4	2.5	3	3.8	4
		H	0.5	0.55	0.5	0.6	0.9	0.8
XA1-3	Countersunk head Class 1 さら1種	D	2	2.4	2.5	3	3.8	4
		H	0.48	0.55	0.58	0.73	0.85	0.93
XA1-4	Oval countersunk head Class 1 丸さら1種	D	2	2.4	2.5	3	3.8	4
		H + K	0.68	0.8	0.88	1	1.25	1.3
XA1-6	Pan head Class 3 なべ3種	D	2.5	2.8	3	3.5	4.3	4.5
		H	0.8	0.85	0.9	1	1.3	1.2
XA1-7	Pan head Class 2 なべ2種	D	2.5	2.8	3	3.5	4.3	4.5
		H	0.5	0.55	0.5	0.6	0.9	0.8

Figure ZZB (2/7) MECHANICAL STANDARD PARTS (SCREWS)

1-2. Precision Tapping Screws
精密用タッピンねじ

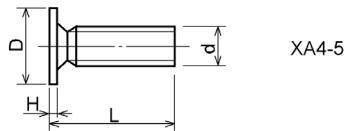
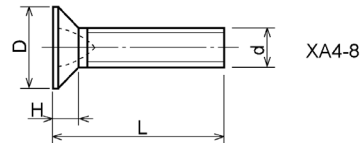
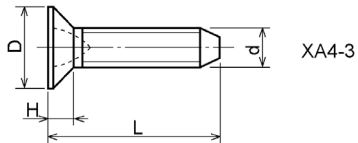
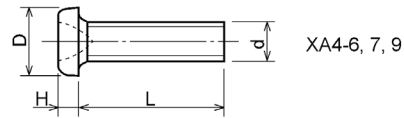
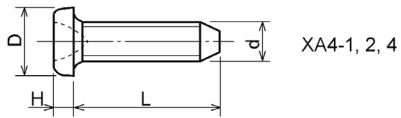

Type No. 類別番号	Type 類別	Head size (mm) 頭部寸法 (mm)						
		M1.4	M1.6	M1.7	M2	M2.5	M2.6	
XA4-1	With tapered end pan head Class 1 絞り-なべ1種	D XA4-1	2	2.4	2.5	3	3.8	4
		H XA4-1	0.5	0.55	0.5	0.6	0.9	0.8
XA4-2	With tapered end pan head Class 3 絞り-なべ3種	D XA4-2	2.5	2.8	3	3.5	4.3	4.5
		H XA4-2	0.8	0.85	0.9	1	1.3	1.2
XA4-3	With tapered end countersunk head 絞り-さら	D XA4-3	2	2.4	2.5	3	3.8	4
		H XA4-3	0.48	0.55	0.58	0.73	0.85	0.93
XA4-4	With tapered end pan head Class 2 絞り-なべ2種	D XA4-4	2.5	2.8	3	3.5	4.3	4.5
		H XA4-4	0.5	0.55	0.5	0.6	0.9	0.8
XA4-5	With parallel end ultra thin head ストレート-超薄頭	D XA4-5	2.5	2.8	3	-	-	-
		H XA4-5	0.2	0.2	0.2	-	-	-
XA4-6	With parallel end pan head Class 1 ストレート-なべ1種	D XA4-6	2	2.4	2.5	3	3.8	4
		H XA4-6	0.5	0.55	0.5	0.6	0.9	0.8
XA4-7	With parallel end pan head Class 3 ストレート-なべ3種	D XA4-7	2.5	2.8	3	3.5	4.3	4.5
		H XA4-7	0.8	0.85	0.9	1	1.3	1.2
XA4-8	With parallel end countersunk head ストレート-さら	D XA4-8	2	2.4	2.5	3	3.8	4
		H XA4-8	0.48	0.55	0.58	0.73	0.85	0.93
XA4-9	With parallel end pan head Class 2 ストレート-なべ2種	D XA4-9	2.5	2.8	3	3.5	4.3	4.5
		H XA4-9	0.5	0.55	0.5	0.6	0.9	0.8

Figure ZZB (3/7)MECHANICAL STANDARD PARTS (SCREWS)

1-3. Cross Recessed Head Screws
一般用十字穴付き小ねじ

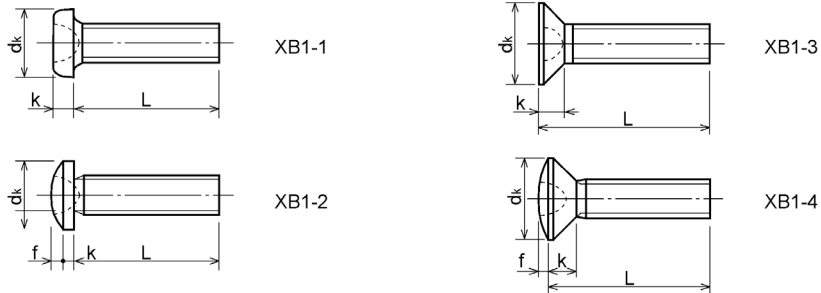

Type No. 類別番号	Type 類別
XB1-1	Pan head なべ
XB1-2	Binding head バインド
XB1-3	Countersunk head さら
XB1-4	Oval countersunk head 丸さら

		Head size (mm) 頭部寸法 (mm)					
		M2	M2.5	M2.6	M3	M4	M5
d_k	XB1-1	3.5	4.5	4.5	5.5	7	9
k	XB1-1	1.3	1.7	1.7	2	2.6	3.3
d_k	XB1-2	4.3	5.3	5.5	6.3	8.3	10.3
$k+f$	XB1-2	1.2	1.5	1.6	1.9	2.5	3.1
d_k	XB1-3	4	5	-	6	8	10
k	XB1-3	1.2	1.45	-	1.75	2.3	2.8
d_k	XB1-4	4	5	-	6	8	10
$k+f$	XB1-4	1.6	2	-	2.45	3.2	4
Screw part length ねじ部長さ b		8	12	12	12	16	20

Figure ZZB (4/7) MECHANICAL STANDARD PARTS (SCREWS)

1-4. Cross Recessed Head Screws with Captive Washer
座金組込み十字穴付き小ねじ

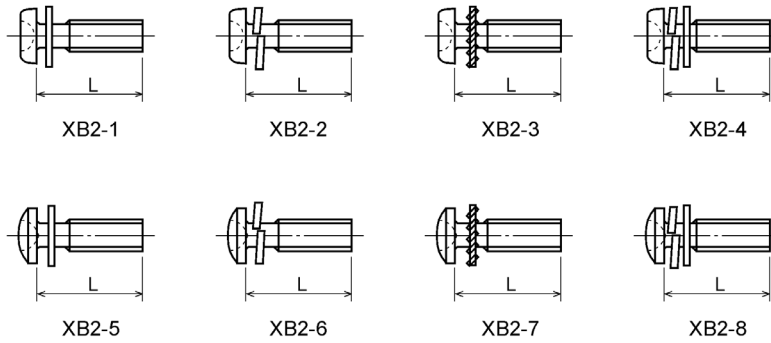

Type No. 類別番号	Type 類別
XB2-1	Pan head + Plain washer (circular bright) なべねじ+平座金
XB2-2	Pan head + Spring washer なべねじ+ばね座金
XB2-3	Pan head + Toothed lock washer なべねじ+歯付座金
XB2-4	Pan head + Spring washer and plain washer (circular bright) なべねじ+(ばね+平)座金
XB2-5	Binding head + Plain washer (circular bright) バインドねじ+平座金
XB2-6	Binding head + Spring washer バインドねじ+ばね座金
XB2-7	Binding head + Toothed lock washer バインドねじ+歯付座金
XB2-8	Binding head + Spring washer and plain washer (circular bright) バインドねじ+(ばね+平)座金

Figure ZZB (5/7) MECHANICAL STANDARD PARTS (SCREWS)

1-5. Hexagon Head Tapping Screws for Matallic Materials
 金属用六角タッピンねじ

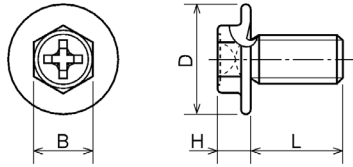

Type No. 類別番号	Type 類別	Head size (mm) 頭部寸法 (mm)		
		M3	M4	
XB3-6	For metallic materials 金属用タッピン	D	8	10
		B	5.5	5.5
XB3-7	For metallic materials with clawed 金属用タッピン-つめ付き	H XB3-6	3.1	3.1
		H XB3-7	3.2	3.2

1-6. Special Tapping Screws
 特殊タッピンねじ

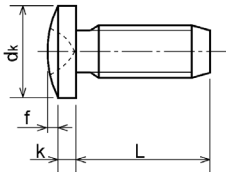

Type No. 類別番号	Type 類別	Head size (mm) 頭部寸法 (mm)		
		M3	M4	
XB4-5	Binding head バインド	dk	6.3	8.3
		k	1.3	1.7
		k+f	1.9	2.5

Figure ZZB (6/7) MECHANICAL STANDARD PARTS (SCREWS)

1-7. General Head Tapping Screws
一般用タッピンねじ

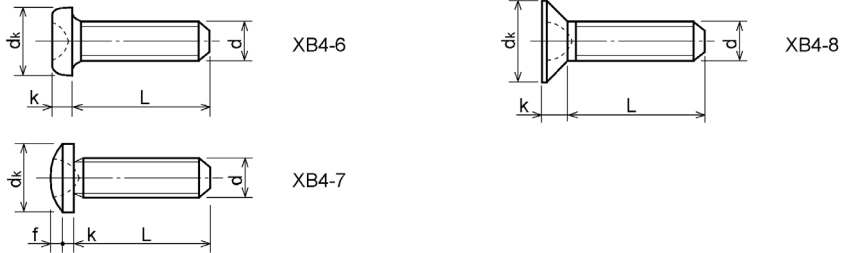

Type No. 類別番号	Type 類別	Head size (mm) 頭部寸法 (mm)						
		M2	M2.5	M2.6	M3	M4	M5	
XB4-6	Pan head なべ	dk	3.5	4.5	4.5	5.5	7	9
		k	1.3	1.7	1.7	2	2.6	3.3
XB4-7	Binding head バインド	dk	4.3	5.3	5.5	6.3	8.3	10.3
		k+f	1.2	1.5	1.6	1.9	2.5	3.1
XB4-8	Countersunk head さら	dk	4	5	5.2	6	8	10
		k	1.2	1.45	1.5	1.75	2.3	2.8

1-8. Tapping Screws for Metallic Materials
金属用タッピンねじ

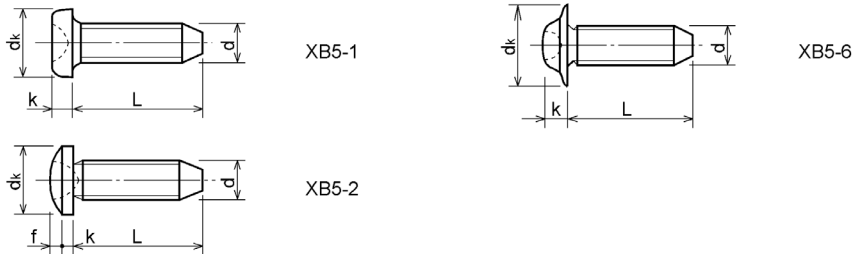

Type No. 類別番号	Type 類別	Head size (mm) 頭部寸法 (mm)					
		M2.5	M2.6	M3	M4	M5	
XB5-1	Pan head なべ	dk	4.5	4.5	5.5	7	9
		k	1.7	1.7	2	2.6	3.3
XB5-2	Binding head バインド	dk	5.5	5.5	6.3	8.3	10.3
		k+f	1.6	1.6	1.9	2.5	3.1
XB5-6	Flanged pan head つば付きなべ	dk	6.5	6.5	8	10	12
		k	2.1	2.1	1.75	3.2	4

Figure ZZB (7/7) MECHANICAL STANDARD PARTS (SCREWS)

1-9. Hexagon Socket Set Screws
六角穴付き止めねじ

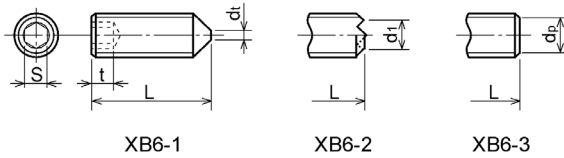

Type No. 類別番号	Type 類別	Head size (mm) 頭部寸法 (mm)						
		M1.6 M1.7	M2	M2.5 M2.6	M3	M5	M5	M6
	S	0.7	0.9	1.3	1.5	2	2.5	3
	t	1.5	1.7	2	2	2.5	3	3.5
	dt max XB6-1	0.4	0.5	0.65	0.75	1	1.25	1.5
	d1 max XB6-2	-	1.2	1.5	1.7	2.2	2.8	3.3
	d1 min XB6-2	-	1	1.2	1.4	1.9	2.4	2.9
	dp max XB6-3	0.8	1	1.5	2	2.5	3.5	4
	dp min XB6-3	0.55	0.75	1.25	1.75	2.25	3.2	3.7

1-10. Flanged Pan Head Machine Screws
つば付きなべ小ねじ

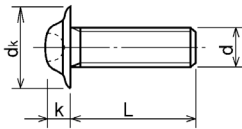

Type No. 類別番号	Type 類別	Head size (mm) 頭部寸法 (mm)				
		M2	M2.5 M2.6	M3	M5	M5
	dk	5	6.5	8	10	12
	k	1.7	2.1	2.5	3.2	4

Figure ZZC MECHANICAL STANDARD PARTS (BOLTS)

2. Bolts (Socket head cap screw)
ボルト

How to read Parts Numbers
部品番号の見方

Bolt (Socket head cap screw)
ボルト

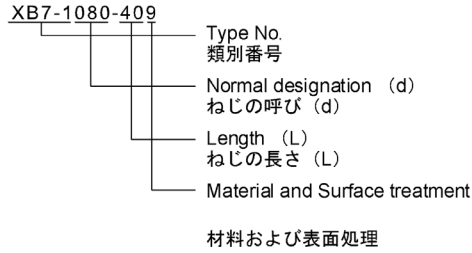

XB7-1 expresses Hexagon socket head cap screws.
XB7-1は、六角穴付きボルトを表す

080 expresses M8.0.
080は、M8.0を表す

40 expresses a length of 40mm.
40は、40mmの長さを表す

9 expresses Steel (Black zinc trivalent chromate treating) from Table 1.
9は、表1より鋼（黒色亜鉛3価クロメート）を表す

2-1. Hexagon socket head cap screws
六角穴付きボルト

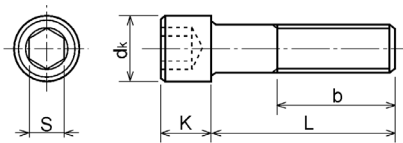

Type No. 類別番号	Type 類別	Head size (mm) 頭部寸法 (mm)						
		M3	M4	M5	M6	M8	M10	M12
S		2.5	3	4	5	6	8	10
dk		5.5	7	8.5	10	13	16	18
K		3	4	5	6	8	10	12
Screw part length ねじ部長さ b_{max}		18	20	22	24	28	32	36

Figure ZZD MECHANICAL STANDARD PARTS (NUTS)

3. Nuts
ナット

How to read Parts Numbers
部品番号の見方

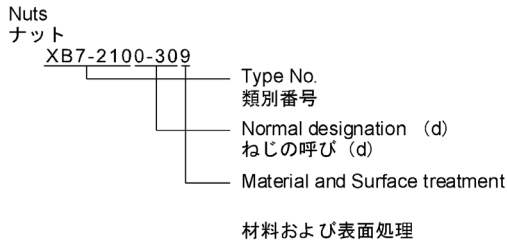

XB7-210 expresses Hexagon nut class 1.
XB7-210は、六角ナット1種を表す
0-30 expresses M3.0.
0-30は、M3.0を表す
9 expresses Steel (Black zinc trivalent chromate treating) from Table 1.
9は、表1より鋼（黒色亜鉛3価クロメート）を表す

3-1. Hexagon Nuts and Hexagon Thin Nuts
六角ナット

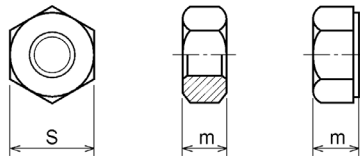

Type No. 類別番号	Type 類別
XB7-210	Hexagon nut Class 1 六角ナット-1種
XB7-220	Hexagon nut Class 3 六角ナット-3種
XB7-230	Hexagon nut Style 1 double chamfered 六角ナット-スタイル1-両面とり
XB7-231	Hexagon nut Style 1 washer faced 六角ナット-スタイル1-座付き
XB7-240	Hexagon nut Style 2 double chamfered 六角ナット-スタイル2-両面とり
XB7-241	Hexagon nut Style 2 washer faced 六角ナット-スタイル2-座付き
XB7-250	Hexagon nut 六角ナット
XB7-260	Hexagon thin nut double chamfered 六角低ナット-両面とり
XB7-270	Hexagon thin nut not chamfered 六角低ナット-面とり無し

	Head size (mm) 頭部寸法 (mm)						
	M2	M2.5	M3	M4	M5	M6	M8
S	4	5	5.5	7	8	10	13
m XB7-210	1.6	2	2.4	3.2	4	5	6.5
m XB7-220	1.2	1.6	1.8	2.4	3.2	3.6	5
m XB7-230, 231	1.6	2	2.4	3.2	4.7	5.2	6.8
m XB7-240, 241	-	-	-	-	5.1	5.7	7.5
m XB7-250	-	-	-	-	5.6	6.1	7.9
m XB7-260	1.2	1.6	1.8	2.2	2.7	3.2	4
m XB7-270	1.2	1.6	1.8	2.2	2.7	3.2	4

Figure ZZE (1/3)MECHANICAL STANDARD PARTS (RETAINING RINGS)

5. Retaining Rings
止め輪

How to read Parts Numbers
部品番号の見方

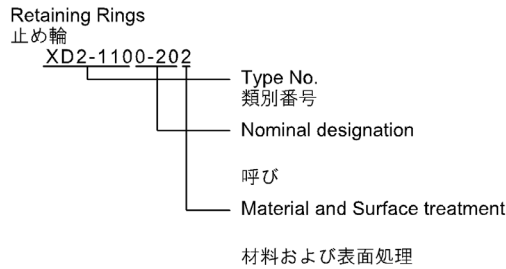

XD2-110 expresses retaining ring-E type (Type1).
XD2-110は、E形止め輪（1種）を表す

0-20 expresses a 020 of nominal designation.
(See Table 5)
0-20は、呼び020を表す（表5参照）

2 expresses Stainless steel (Surface treatment is not to be given) from Table 1.
2は、表1よりステンレス（表面処理なし）を表す

5-1. Retaining Rings - E type
E形止め輪

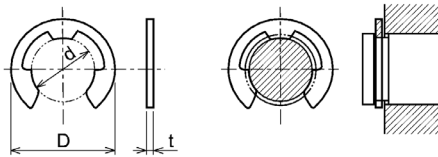

Type No. 類別番号	Type 類別
XD2-110	Retaining ring - E type (Type 1) E形止め輪（1種）
XD2-120	Retaining ring - E type (Type 2) E形止め輪（2種）

Table 5 表5

Type 種類	Nominal designation 呼び	d (mm)	D (mm)	t (mm)
Type 1 1種	007	0.65	2	0.2
	010	0.95	2.8	0.2
	013	1.25	3.3	0.3
	017	1.65	4.2	0.4
	020	1.95	4.6	0.5
	024	2.35	6	0.6
	028	2.74	6.5	0.6
	032	3.14	7.2	0.6
	037	3.64	8	0.7
	040	3.93	10	0.7
	042	4.13	10	0.7
	050	4.93	11	0.7
	058	5.73	12	0.7
	060	5.93	12.7	0.9
064	6.32	13.5	0.9	
074	7.31	15	0.9	
080	7.91	16.5	1	
Type 2 2種	008	0.8	2	0.2
	012	1.2	3	0.3
	015	1.5	4	0.4
	020	2	5	0.4
	025	2.5	6	0.4
	030	3	7	0.6
	040	4	9	0.6
	050	5	11	0.6
	060	6	12	0.8
	070	7	14	0.8
	080	8	16	0.8
	090	9	18	0.8
	100	10	20	1

Figure ZZE (2/3)MECHANICAL STANDARD PARTS (RETAINING RINGS)

5-2. Grip Rings
グリップ止め輪

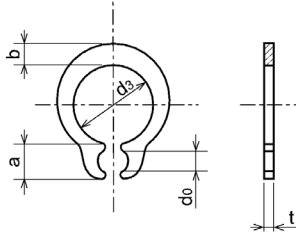

Table 5 表5

Nominal designation 呼び	d_3 (mm)	t (mm)	b (mm)	a (mm)	d_0 (mm)
020	1.9	0.5	1	1.8	0.8
025	2.35	0.5	1.2	1.9	0.9
030	2.85	0.6	1.4	1.9	0.9
035	3.3	0.6	1.6	2	0.9
040	3.8	0.8	1.8	2.8	1.2
045	4.25	0.8	2	2.9	1.3
050	4.75	0.8	2.2	2.9	1.3
060	5.7	1	2.4	3.1	1.4
070	6.7	1	2.7	3.3	1.4
080	7.7	1	3	3.5	1.4
090	8.65	1.2	3.3	4.7	1.5
100	9.65	1.2	3.5	4.7	2

Type No. 類別番号	Type 類別
XD2-210	Grip ring グリップ止め輪

5-3. Toothed Retaining Rings
歯付き形止め輪

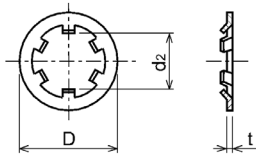

Table 5 表5

Nominal designation 呼び	d_2 (mm)	D (mm)	t (mm)	No of teeth 歯数
015	1.4	5.2	0.25	3
020	1.9	6	0.25	3
024	2.3	6.4	0.25	3
030	2.8	8	0.25	4
040	3.8	9	0.25	4
050	4.8	10	0.25	5
060	5.8	11	0.25	5
080	7.8	13	0.25	5
100	9.8	15.4	0.25	6

Type No. 類別番号	Type 類別
XD2-230	Toothed retaining ring 歯付き形止め輪

Figure ZZE (3/3)MECHANICAL STANDARD PARTS (RETAINING RINGS)

5-4. Retaining Rings - C Type
C形止め輪

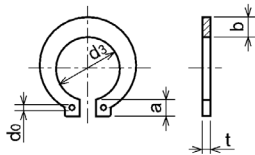

Type No. 類別番号	Type 類別
XD2-310	Retaining ring - C type for shaft C形止め輪 軸用

Table 5 表5

Nominal designation 呼び	ds (mm)	t (mm)	b (mm)	a (mm)	do (mm)
010	9.3	1	1.6	3	1.2
012	11.1	1	1.8	3.2	1.5
014	12.9	1	2	3.4	1.7
015	13.8	1	2.1	3.5	1.7
016	14.7	1	2.2	3.6	1.7
017	15.7	1	2.2	3.7	1.7
018	16.5	1.2	2.6	3.8	1.7
020	18.5	1.2	2.7	3.9	2
022	20.5	1.2	2.7	4.1	2
025	23.2	1.2	3.1	4.3	2
028	25.9	1.5	3.1	4.6	2
030	27.9	1.5	3.5	4.8	2
032	29.6	1.5	3.5	5	2.5
035	32.2	1.5	4	5.4	2.5

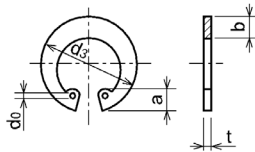

Type No. 類別番号	Type 類別
XD2-320	Retaining ring - C type for hole C形止め輪 穴用

Table 5 表5

Nominal designation 呼び	ds (mm)	t (mm)	b (mm)	a (mm)	do (mm)
010	10.7	1	1.8	3.1	1.2
011	11.8	1	1.8	3.2	1.2
012	13	1	1.8	3.3	1.5
014	15.1	1	2	3.6	1.7
016	17.3	1	2	3.7	1.7
018	19.5	1	2.5	4	1.7
019	20.5	1	2.5	4	2
020	21.5	1	2.5	4	2
022	23.5	1	2.5	4.1	2
025	26.9	1.2	3	4.4	2
028	30.1	1.2	3	4.6	2
030	32.1	1.2	3	4.7	2
032	34.4	1.2	3.5	5.2	2.5
035	37.8	1.5	3.5	5.2	2.5
037	39.8	1.5	3.5	5.2	2.5
040	43.5	1.8	4	5.7	2.5
042	45.5	1.8	4	5.8	2.5
045	48.5	1.8	4.5	5.9	2.5
047	50.5	1.8	4.5	6.1	2.5
050	54.2	2	4.5	6.5	2.5
052	56.2	2	5.1	6.5	2.5
055	59.2	2	5.1	6.5	2.5
060	64.2	2	5.1	6.8	2.5
062	66.2	2	5.5	6.9	2.5
068	72.5	2.5	6	7.4	2.5
072	76.5	2.5	6.6	7.4	2.5
075	79.5	2.5	6.6	7.8	2.5
080	85.5	2.5	7	8	2.5
085	90.5	3	7	8	3
090	95.5	3	7.6	8.3	3
095	100.5	3	8	8.5	3