

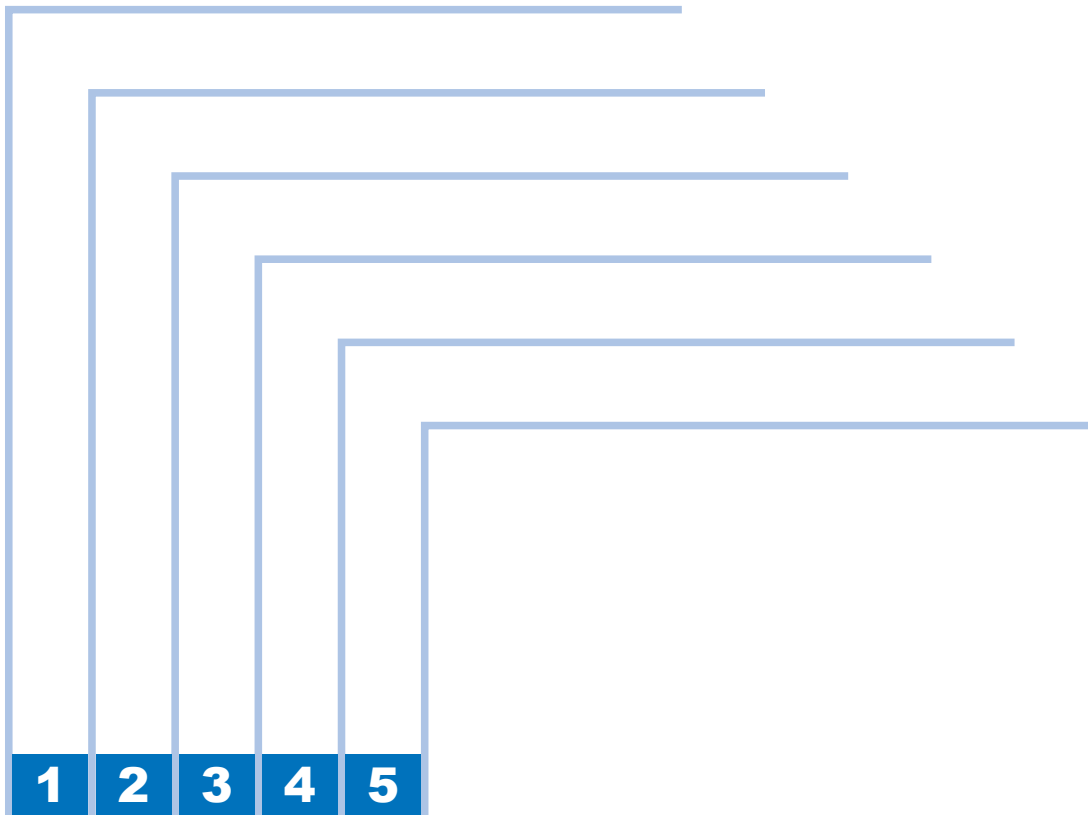

LBP7210Cdn/7600C/7660Cdn/7680Cx Series

Service Manual Rev.4

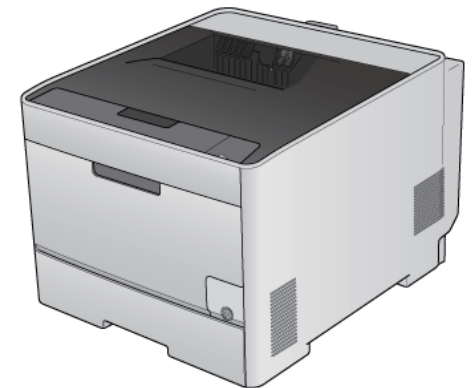

Application

This manual has been issued by Canon Inc. for qualified persons to learn technical theory, installation, maintenance, and repair of products. This manual covers all localities where the products are sold. For this reason, there may be information in this manual that does not apply to your locality.

Corrections

This manual may contain technical inaccuracies or typographical errors due to improvements or changes in products. When changes occur in applicable products or in the contents of this manual, Canon will release technical information as the need arises. In the event of major changes in the contents of this manual over a long or short period, Canon will issue a new edition of this manual.

The following paragraph does not apply to any countries where such provisions are inconsistent with local law.

Trademarks

The product names and company names used in this manual are the registered trademarks of the individual companies.

Copyright

This manual is copyrighted with all rights reserved. Under the copyright laws, this manual may not be copied, reproduced or translated into another language, in whole or in part, without the written consent of Canon Inc.

(C) CANON INC. 2012

Caution

Use of this manual should be strictly supervised to avoid disclosure of confidential information.



Explanation of Symbols

The following symbols are used throughout this Service Manual.

Symbols	Explanation	Symbols	Explanation
	Used to show permission.		Remove the screw.
	Used to show prohibition.		Tighten the screw.
	Check.		Remove the claw.
	Check visually.		Insert the claw.
	Check the noise.		Use the bundled part.
	Disconnect the connector.		Push the part.
	Connect the connector.		Plug the power cable.
	Remove the cable/wire from the cable guide or wire saddle.		Turn on the power.
	Set the cable/wire to the cable guide or wire saddle.		

The following rules apply throughout this Service Manual:

1. Each chapter contains sections explaining the purpose of specific functions and the relationship between electrical and mechanical systems with reference to the timing of operation.

In the diagrams,  represents the path of mechanical drive; where a signal name accompanies the symbol, the arrow  indicates the direction of the electric signal.

The expression "turn on the power" means flipping on the power switch, closing the front door, and closing the delivery unit door, which results in supplying the machine with power.

2. In the digital circuits, '1' is used to indicate that the voltage level of a given signal is "High", while '0' is used to indicate "Low". (The voltage value, however, differs from circuit to circuit.) In addition, the asterisk (*) as in "DRMD*" indicates that the DRMD signal goes on when '0'.

In practically all cases, the internal mechanisms of a microprocessor cannot be checked in the field. Therefore, the operations of the microprocessors used in the machines are not discussed: they are explained in terms of from sensors to the input of the DC controller PCB and from the output of the DC controller PCB to the loads.

The descriptions in this Service Manual are subject to change without notice for product improvement or other purposes, and major changes will be communicated in the form of Service Information bulletins.

All service persons are expected to have a good understanding of the contents of this Service Manual and all relevant Service Information bulletins and be able to identify and isolate faults in the machine.

Blank Page

Contents

1 Product Description

Characteristics	1-2
Product Specifications	1-3
Host Machine Specifications	1-3
Detailed Specification	1-4
Printing Speed	1-4
Parts Name	1-6
External View	1-6
Cross Section View	1-8
Operation	1-8
Control panel(LBP7210Cdn)	1-8
Control panel(LBP7600C/7660Cdn)	1-9
Functions of the LEDs	1-9
Control Panel Key	1-9
LBP7680Cx	1-10
Functions of the LEDs	1-10
Control Panel Key	1-11
Safety Precautions	1-12
Safety of the Laser Light	1-12
Safety of Toner	1-12
Toner in General	1-12
Contact with Toner	1-12
Remedy against toner spill	1-12
Store of Copy/Print Output	1-12
Handling the Laser Unit	1-12
Points to note at disassembly/installation procedure	1-13

2 Technical Reference

Basic Configuration	2-2
Outline	2-2
Basic Sequence of Operation	2-2

Laser Exposure System	2-4
Outline	2-4
Fault Detection	2-4
Image Formation System	2-5
Construction	2-5
Outline	2-5
Image-formation Process	2-5
Latent image formation block	2-6
Developing block	2-6
Transfer block	2-6
Fixing block	2-7
ITB cleaning block	2-8
Photosensitive drum cleaning block	2-8
Driving and Controlling the High-Voltage System	2-9
Outline	2-9
Image Stabilization Control(LBP7600C/7660C/7680Cx)	2-9
Overview of the Image Stabilization Control Mechanism	2-9
Image density correction control (D-max control)	2-9
Image gradation correction control (D-half control)	2-10
Color displacement correction control	2-11
Image Stabilization Control(LBP7210Cdn)	2-12
Overview of the Image Stabilization Control Mechanism	2-12
Image density correction control (D-max control)	2-12
Image gradation correction control (D-half control)	2-12
Color displacement correction control	2-12
Startup Settings	2-12
Other behaviors	2-13
Drum Cartridge	2-13
Developing roller engagement/disengagement control	2-13
Transfer Unit	2-14
Pad transfer	2-14
Fixing System	2-15
Overview	2-15
Overview	2-15
Various Control Mechanisms	2-15
Controlling the Speed of Fixing Assembly	2-15
Fixing temperature control	2-16
Protective Functions	2-17

Protective function-----	2-17	About System Management -----	2-40
Fixing assembly failure detection-----	2-17	Preparation for Using SMS-----	2-40
Pickup/Feed/Delivery System-----	2-19	Preparation of PC for Accessing SMS -----	2-40
Construction-----	2-19	Device Settings-----	2-41
Overview-----	2-19	How to Check the Serial Number-----	2-46
Detecting Jam -----	2-20	Login to SMS-----	2-47
Jam Detection Outline-----	2-20	Procedure to Log in -----	2-47
Delay Jams-----	2-20	Installing an MEAP Application-----	2-50
Stationary Jams-----	2-20	Outline-----	2-50
Other Jams-----	2-20	Procedure to install applications-----	2-50
Cassette Pickup Unit-----	2-21	Resource Information-----	2-52
Separation Roller Method -----	2-21	About MEAP Application Management Page-----	2-52
Controller System-----	2-22	MEAP Specifications-----	2-53
Construction-----	2-22	What is MEAP Specifications (MEAP Spec Version)? -----	2-53
Outline-----	2-22	MEAP Application Management-----	2-55
Motor control-----	2-22	Outline-----	2-55
Safety-----	2-22	Starting, Stopping, or Uninstalling the MEAP Application -----	2-55
Main Controller(LBP7600C/7660Cdn/7680Cx)-----	2-23	Managing the License File -----	2-57
Outline-----	2-23	Other License File Management Functions-----	2-61
Overview of the Block -----	2-24	Enhanced System Application Management-----	2-64
Main Controller(LBP7210Cdn) -----	2-25	Outline-----	2-64
Outline-----	2-25	About Login Service-----	2-64
Power Supply -----	2-27	Default Authentication overview-----	2-64
Low-voltage power supply-----	2-27	Other Log in service-----	2-64
Other function-----	2-28	Procedure Changing Login Services -----	2-64
Counter -----	2-28	Procedure Installing Login Services -----	2-65
SSL -----	2-29	Procedure Uninstalling Login Services-----	2-66
A making procedure-----	2-29	System Application Management-----	2-66
Setting the SSL Encryption Communication Function-----	2-34	Procedure to manage System Application -----	2-66
MEAP(Not supported by LBP7210Cdn)-----	2-38	System Information-----	2-67
Introduction -----	2-38	Outline-----	2-67
References by purpose -----	2-38	Checking the System Information -----	2-67
About MEAP -----	2-38	Display of System Information Details-----	2-67
Overview-----	2-38	Printing the System Information of a MEAP Application -----	2-68
About SMS -----	2-39	Content of MEAP system information -----	2-68
Overview-----	2-39	MEAP Application Information-----	2-69
About the MEAP Application Management Screen -----	2-39	Outline-----	2-69
About the MEAP Application Installation Screen -----	2-39	Procedure to Check MEAP Application Information -----	2-69

	0-3
Check License-----	2-70
Outline-----	2-70
Procedure to Check the License File-----	2-70
Changing SMS Login Password-----	2-70
Outline-----	2-70
Procedure to Change the SMS Login Password-----	2-70
MEAP Application Setting Information Management and Log Management-----	2-71
Outline-----	2-71
Advantages Obtained When Using the Services-----	2-71
MEAP Application Setting Information Management-----	2-72
MEAP Application Log Management-----	2-72
Maintenance-----	2-73
When Replacing the PCB-----	2-73
Actions to be taken when E616 is displayed-----	2-74
MEAP Safe Mode-----	2-75
Using USB Devices-----	2-76
Reference material-----	2-77
Glossary-----	2-77
Embedded RDS(Not supported by LBP7210Cdn)-----	2-80
Product Overview-----	2-80
Overview-----	2-80
Features and benefits-----	2-80
Service cautions-----	2-80
E-RDS Setup-----	2-81
Confirmation and preparation in advance-----	2-81
E-RDS setting items (service mode)-----	2-81
Steps to E-RDS settings-----	2-82
Initializing E-RDS settings-----	2-84
FAQ-----	2-85
Troubleshooting-----	2-86
Error code and strings-----	2-88
LBP7600C/7660Cdn/7680Cx-----	3-3
External Cover / Interior	
LBP7210Cdn-----	3-4
Main Unit	
LBP7600C/7660Cdn/7680Cx/7210Cdn-----	3-5
Motor / Fan	
LBP7600C/7660Cdn/7680Cx/7210Cdn-----	3-7
Clutch / Solenoid / Switch	
/ Thermistor / Heater	
LBP7600C/7660Cdn/7680Cx/7210Cdn-----	3-8
Sensor	
LBP7600C/7660Cdn/7680Cx/7210Cdn-----	3-9
PCB	
LBP7600C/7660Cdn/7680Cx/7210Cdn-----	3-10
List of Connectors	
-----	3-11
External Cover/Internal System-----	3-12
Layout Drawing-----	3-12
Removing the Rear Cover	
LBP7600C/7660Cdn/7680Cx-----	3-15
Procedure-----	3-15
Removing the Rear Cover	
LBP7210Cdn-----	3-15
Procedure-----	3-15
Removing the Rear Cover Rib Unit	
LBP7600C/7660Cdn/7680Cx/7210Cdn-----	3-16
Preparation-----	3-16
Procedure-----	3-16
Removing the Rear Upper Cover (Left)	
LBP7600C/7660Cdn/7680Cx/7210Cdn-----	3-17
Procedure-----	3-17
Removing the Rear Lower Cover	
LBP7600C/7660Cdn/7680Cx-----	3-17
Preparation-----	3-17
Procedure-----	3-17
Removing the Rear Lower Cover	

3 Disassembly/Assembly

Outline-----	3-2
List of Parts-----	3-3
External Cover / Interior	

	0-4
LBP7210Cdn-----	3-19
Preparation-----	3-19
Procedure-----	3-19
Removing the Right Cover	
LBP7600C/7660Cdn/7680Cx-----	3-20
Procedure-----	3-20
Removing the Right Cover	
LBP7210Cdn-----	3-21
Procedure-----	3-21
Removing the Left Cover	
LBP7600C/7660Cdn/7680Cx/7210Cdn-----	3-22
Preparation-----	3-22
Procedure-----	3-22
Removing the Upper Front Cover (Right)/USB Cover	
LBP7600C/7660Cdn/7680Cx-----	3-23
Procedure-----	3-23
Removing the Upper Front Cover (Right)	
LBP7210Cdn-----	3-24
Procedure-----	3-24
Removing the Upper Cover	
LBP7600C/7660Cdn/7680Cx-----	3-24
Preparation-----	3-24
Procedure-----	3-24
Removing the Upper Cover	
LBP7210Cdn-----	3-25
Preparation-----	3-25
Procedure-----	3-25
Removing the Front Cover	
LBP7600C/7660Cdn/7680Cx/7210Cdn-----	3-26
Preparation-----	3-26
Procedure-----	3-27
Controller System-----	3-29
Layout Drawing-----	3-29
Removing the Main Controller PCB	
LBP7600C/7660Cdn-----	3-31
When Replacing the Main Controller PCB(LBP7600C/7660Cdn)-----	3-31
Preparation-----	3-33
Procedure-----	3-33
Removing the Main Controller PCB	
LBP7600C/7660Cdn/7680Cx-----	3-34
When Replacing the Main Controller PCB(LBP7680Cx)-----	3-34
Preparation-----	3-36
Procedure-----	3-36
Removing the Main Controller PCB	
LBP7210Cdn-----	3-37
Preparation-----	3-37
Procedure-----	3-37
Removing the Right Frame Cover	
LBP7600C/7660Cdn/7680Cx-----	3-38
Preparation-----	3-38
Procedure-----	3-38
Removing the Right Frame Cover	
LBP7210Cdn-----	3-40
Preparation-----	3-40
Procedure-----	3-40
Removing the Right Upper Frame	
LBP7600C/7660Cdn-----	3-42
Preparation-----	3-42
Procedure-----	3-42
Removing the Right Upper Frame Unit	
LBP7680Cx-----	3-43
Preparation-----	3-43
Procedure-----	3-43
Removing the Right Upper Frame	
LBP7210Cdn-----	3-44
Preparation-----	3-44
Procedure-----	3-44
Removing the Main Controller Support Plate	
LBP7600C/7660Cdn/7680Cx-----	3-45
Preparation-----	3-45
Procedure-----	3-45
Removing the Main Controller Support Plate	
LBP7210Cdn-----	3-46
Preparation-----	3-46

Procedure	3-46
Removing the Main Drive Unit	
LBP7600C/7660Cdn/7680Cx	3-47
Preparation	3-47
Procedure	3-47
Removing the Main Drive Unit	
LBP7210Cdn	3-50
Preparation	3-50
Procedure	3-51
Removing the Duplex Reverse Drive Unit	
LBP7600C/7660Cdn/7680Cx	3-54
Preparation	3-54
Procedure	3-54
Removing the Duplex Reverse Drive Unit	
LBP7210Cdn	3-55
Preparation	3-55
Procedure	3-55
Removing the Operation Panel Unit	
LBP7600C/7660Cdn/7680Cx	3-56
Preparation	3-56
Procedure	3-56
Removing the Operation Panel Unit	
LBP7210Cdn	3-57
Preparation	3-57
Procedure	3-57
Removing the SD Slot PCB	
LBP7680Cx	3-58
Preparation	3-58
Procedure	3-58
Removing the DC Controller PCB	
LBP7600C/7660Cdn/7680Cx	3-59
Preparation	3-59
Procedure	3-60
Removing the DC Controller PCB	
LBP7210Cdn	3-60
Preparation	3-60
Procedure	3-61

Removing the Relay PCB	
LBP7600C/7660Cdn/7680Cx	3-61
Preparation	3-61
Procedure	3-61
Removing the Relay PCB	
LBP7210Cdn	3-62
Preparation	3-62
Procedure	3-62
Removing the Sub Power Supply PCB	
LBP7600C/7660Cdn/7680Cx/7210Cdn	3-63
Preparation	3-63
Procedure	3-63
Removing the Driver PCB	
LBP7600C/7660Cdn/7680Cx	3-64
Preparation	3-64
Procedure	3-64
Removing the Driver PCB	
LBP7210Cdn	3-65
Preparation	3-65
Procedure	3-65
Removing the Power Supply Unit	
LBP7600C/7660Cdn/7680Cx	3-65
Preparation	3-65
Procedure	3-66
Installation Method	3-70
Removing the Power Supply Unit	
LBP7210Cdn	3-73
Preparation	3-73
Procedure	3-74
Installation Method	3-77
Removing the High Voltage Power Supply PCB	
LBP7600C/7660Cdn/7680Cx	3-81
Preparation	3-81
Procedure	3-81
Removing the High Voltage Power Supply PCB	
LBP7210Cdn	3-82
Preparation	3-82

Procedure-----	3-83	Removing the Developing Motor	
Removing the Fixing/Power Supply Cooling Fan		LBP7210Cdn-----	3-102
LBP7600C/7660Cdn/7680Cx-----	3-84	Preparation-----	3-102
Preparation-----	3-84	Procedure-----	3-102
Procedure-----	3-84	Removing the ITB Unit	
Removing the Fixing/Power Supply Cooling Fan		LBP7600C/7660Cdn/7680Cx-----	3-104
LBP7210Cdn-----	3-85	Procedure-----	3-104
Preparation-----	3-85	Removing the ITB Unit	
Procedure-----	3-85	LBP7210Cdn-----	3-107
Removing the Duplex Feed Fan		Procedure-----	3-107
LBP7600C/7660Cdn/7680Cx/7210Cdn-----	3-87	Removing the Patch Sensor Unit	
Preparation-----	3-87	LBP7600C/7660Cdn/7680Cx/7210Cdn-----	3-110
Procedure-----	3-87	Preparation-----	3-110
Laser Exposure System-----	3-89	Procedure-----	3-110
Layout Drawing-----	3-89	Fixing System-----	3-111
Removing the Laser Scanner Unit		Layout Drawing-----	3-111
LBP7600C/7660Cdn/7680Cx-----	3-89	Removing the Fixing Assembly	
Preparation-----	3-89	LBP7600C/7660Cdn/7680Cx-----	3-112
Procedure-----	3-89	Preparation-----	3-112
Removing the Laser Scanner Unit		Procedure-----	3-112
LBP7210Cdn-----	3-93	Removing the Fixing Assembly	
Preparation-----	3-93	LBP7210Cdn-----	3-113
Procedure-----	3-93	Preparation-----	3-113
Image Formation System-----	3-97	Procedure-----	3-114
Layout Drawing-----	3-97	Removing the Fixing Film Unit	
Removing the Drum Motor		LBP7600C/7660Cdn/7680Cx-----	3-115
LBP7600C/7660Cdn/7680Cx-----	3-98	Preparation-----	3-115
Preparation-----	3-98	Procedure-----	3-116
Procedure-----	3-98	Removing the Fixing Film Unit	
Removing the Drum Motor		LBP7210Cdn-----	3-120
LBP7210Cdn-----	3-99	Preparation-----	3-120
Preparation-----	3-99	Procedure-----	3-120
Procedure-----	3-99	Removing the Fixing Pressure Roller	
Removing the Developing Motor		LBP7600C/7660Cdn/7680Cx/7210Cdn-----	3-124
LBP7600C/7660Cdn/7680Cx-----	3-101	Preparation-----	3-124
Preparation-----	3-101	Procedure-----	3-125
Procedure-----	3-101	Removing the Fixing Motor	

LBP7600C/7660Cdn/7680Cx/7210Cdn	3-125
Preparation	3-125
Procedure	3-125
Pickup/Feed/Delivery System	3-128
Layout Drawing	3-128
Removing the Pickup Motor	
LBP7600C/7660Cdn/7680Cx	3-130
Preparation	3-130
Procedure	3-130
Removing the Pickup Motor	
LBP7210Cdn	3-131
Preparation	3-131
Procedure	3-131
Removing the Pickup Unit	
LBP7600C/7660Cdn/7680Cx	3-133
Preparation	3-133
Procedure	3-133
Installation Method	3-135
Removing the Pickup Unit	
LBP7210Cdn	3-137
Preparation	3-137
Procedure	3-137
Installation Method	3-139
Removing the Manual Feed Tray Pickup Unit	
LBP7600C/7660Cdn/7680Cx/7210Cdn	3-142
Procedure	3-142
Removing the Delivery Unit	
LBP7600C/7660Cdn/7680Cx	3-143
Preparation	3-143
Procedure	3-143
Removing the Delivery Unit	
LBP7210Cdn	3-145
Preparation	3-145
Procedure	3-145
Removing the Cassette Pickup Roller	
LBP7600C/7660Cdn/7680Cx	3-147
Procedure	3-147

Removing the Cassette Pickup Roller	
LBP7210Cdn	3-147
Procedure	3-147
Removing the Cassette Separation Roller	
LBP7600C/7660Cdn/7680Cx/7210Cdn	3-148
Procedure	3-148
Removing the Manual Feed Tray Pickup Roller	
LBP7600C/7660Cdn/7680Cx	3-149
Procedure	3-149
Removing the Manual Feed Tray Pickup Roller	
LBP7210Cdn	3-149
Procedure	3-149
Removing the Manual Feed Tray Separation Pad	
LBP7600C/7660Cdn/7680Cx	3-150
Procedure	3-150
Removing the Manual Feed Tray Separation Pad	
LBP7210Cdn	3-150
Procedure	3-150
Removing the Duplex Feed Unit	
LBP7600C/7660Cdn/7680Cx	3-151
Preparation	3-151
Procedure	3-151
Removing the Duplex Feed Unit	
LBP7210Cdn	3-152
Preparation	3-152
Procedure	3-152
Removing the Secondary Transfer Feed Unit	
LBP7600C/7660Cdn/7680Cx/7210Cdn	3-153
Procedure	3-153
Removing the Re-pickup Guide Unit	
LBP7600C/7660Cdn/7680Cx/7210Cdn	3-154
Preparation	3-154
Procedure	3-154

4 Maintenance and Inspection

Periodically Replaced Parts	4-2
Periodically Replaced Parts	4-2

Consumables -----	4-2
Life Expectancy of Consumable Parts-----	4-2
Periodical Service-----	4-2
Periodical Service-----	4-2
Cleaning -----	4-2
Cleaning-----	4-2

5 Troubleshooting

Corrective Actions-----	5-2
Image Failure -----	5-2
Partially Blank/Streaked-----	5-2
Image Failure(LBP7210Cdn) -----	5-2
Partially Blank/Streaked-----	5-2
Stretching/Shrinking-----	5-2
Printing / Scanning(LBP7210Cdn)-----	5-4
No Output-----	5-4
Standard/Adjustment-----	5-6
Test Print-----	5-6
Engine Test Print-----	5-6
Adjustment of Laser Exposure System-----	5-7
After Replacing the laser scanner unit -----	5-7
After Replacing the laser scanner unit(LBP7210Cdn) -----	5-8
Adjustment of Electrical Parts -----	5-9
When Replacing the Engine Controller PCB -----	5-9
When Replacing the DC Controller PCB(LBP7210Cdn) -----	5-9
When Replacing the Main Controller PCB(LBP7600C/7660Cdn)-----	5-9
When Replacing the Main Controller PCB(LBP7680Cx) -----	5-11
When Replacing the Main Controller PCB(LBP7210Cdn) -----	5-13
Electrical Parts Layout/Function Assignment -----	5-14
Clutch/Solenoid-----	5-14
Motor/Fan -----	5-14
Sensor -----	5-15
PCBs -----	5-15
Connector Location-----	5-17
Connector List -----	5-17
Service Tools -----	5-19
Standard Tools-----	5-19

Special Tools(Not supported by LBP7210Cdn) -----	5-19
Solvents and Oils -----	5-19
Error Code -----	5-20
Error Code Details -----	5-20
Jam Code-----	5-26
Version Upgrade -----	5-27
Overview -----	5-27
Overview of Version Upgrade -----	5-27
Checking the Version -----	5-27
Version Upgrade Using UST -----	5-28
Preparation-----	5-28
Downloading the Firmware-----	5-29
Upgrading the Firmware(LBP7210Cdn)-----	5-31
Main Controller Firmware -----	5-31
DC Controller Firmware -----	5-31
Updater(Not supported by LBP7210Cdn) -----	5-32
Overview -----	5-32
Limitations and Cautions-----	5-35
Preparation-----	5-36
System Management Operations-----	5-42
Maintenance -----	5-45
FAQ -----	5-46
Error Messages -----	5-49
Error Codes -----	5-55
Service Mode -----	5-60
Entering Service Mode -----	5-60
Service Mode List -----	5-60
ADJUST GR.-----	5-60
OPTION GR.-----	5-61
FUNCTION GR.-----	5-61
LOG GR. -----	5-62
PANEL LOCK GR.-----	5-63
F/W UPDATE GR.-----	5-63
NETWORK GR.-----	5-63
SP .ADMIN.MODE -----	5-64
Service Mode List (LBP7210Cdn)-----	5-64
Service Chart Print 1-----	5-65

Service Chart Print 2-----	5-68
Print Status Print-----	5-71
Status Print B-----	5-72
Debug log(Not supported by LBP7210Cdn)-----	5-74
Sublog-----	5-74
Function Overview-----	5-74
How the log is written-----	5-74
Collecting Sublog-----	5-75
Flow of collecting Sublog-----	5-75
Installing the Sublog Board-----	5-75
Generating the log-----	5-75
Collecting log-----	5-76
Backup/Restoration by Expansion ROM for servicing and Sublog Board(Not supported by LBP7210Cdn)-----	5-77
Function Overview-----	5-77
What to Prepare-----	5-77
Prerequisites-----	5-77
Target Data for Backup-----	5-77
Backup and Restoration (Export and Import)-----	5-78
Flow of Export and Import-----	5-78
Installing the Expansion ROM for servicing and Sublog Board-----	5-78
Backup Procedure (Export)-----	5-79
Restoration Procedure (Import)-----	5-79
Others-----	5-80
Deletion (Erase)-----	5-80
List of Error Messages-----	5-81

Appendix

General Timing Chart-----	6-2
General Circuit Diagram-----	6-3
General Circuit Diagram-----	6-3
Signal Input/Output List-----	6-5
Backup Data-----	6-7



Product Description

- Characteristics
- Product Specifications
- Detailed Specification
- Parts Name
- Operation
- Safety Precautions

Characteristics

● Small and low-cost printer

The printer uses a flat in-line cartridge method for the first time in the small printer. This lowers the height and reduces the printer size. The printer uses the transfer pad and the separation roller to reduce the parts expenses.

● Intermediate transfer method

The intermediate transfer method transfers toner images to the Intermediate Transfer Belt (ITB) and transfers the images in four colors onto the print media at once. It realizes a stabilized color-print on various media without being affected by the primary transfer operation.

● Improved usability

The printer improves usability by using the pullout cartridge and the front side accessibility to the media. This small-sized printer is user-friendly on the space of the desktop.

● Automatic shutdown(LBP7210Cdn only)

With LBP7210Cdn, when the time specified as the automatic shutdown time has passed after entering sleep mode, the power is automatically turned OFF.

Product Specifications

Host Machine Specifications

Item	Function / Method
Body installation method	Desktop page printer
Photosensitive medium	OPC drum
Charging method	Roller charging
Exposure method	Laser scanning
Developing method	Contact development
Transfer method	Intermediate transfer (ITB)
Separation method	Curvature
Pickup method	Cassette: simple retard method Manual feed tray : pad separation method
Drum cleaning method	Rubber blade
Transfer cleaning method	Cleaning brush + roller method (drum electrostatic collection)
Fixing method	On-demand fixing
Delivery method	Face-down
Contrast adjustment function	Auto
Toner level function	Available
Warm-up time	30 seconds or less -May vary depending on the usage conditions, such as the availability of the optional accessories and installation environment. -Approximately 220 seconds when the printer is turned on after a toner cartridge is replaced.
Image margin(Leading edge)	5.0+1.5/-1.5mm
Image margin(Trailing edge)	5.0+1.5/-1.5mm
Image margin(left/right)	5.0+1.0/-1.0mm
Number of gradations	16 gradations
Print resolution	600 dpi×600 dpi
First print time	Black and white printing: 16 seconds or less(LBP7210Cdn) Color printing: 16 seconds or less(LBP7210Cdn) Black and white printing: 17 seconds or less Color printing: 17 seconds or less -May vary depending on the output environment.
Print speed(A4)	Black and white printing: 20 ppm Color printing: 20 ppm -The print speed may drop depending on the settings for the paper size, paper type, number of pages printed, and fixing mode setting. -If the printer is used continuously for an extended period of time, the internal temperature of the printer may increase, activating a safety mechanism and pausing printing temporarily.

Item	Function / Method
Cassette paper size	Standard sizes: A4, B5, A5, Legal, Letter, Executive, Statement, Foolscap, Index Card, Envelope DL, Envelope COM10, Envelope ISO-C5, Envelope ISO-B5 , and Envelope Monarch Custom paper sizes: Width 100.0 to 215.9 mm , Length 148.0 to 355.6 mm If you are using the UFR II printer driver , you can load custom size paper that is 148.0 to 215.9 mm wide and 148.0 to 215.9 mm long also in landscape orientation.
Multifeeder paper size	Standard sizes: A4, B5, A5, Legal, Letter, Executive, Statement, Foolscap, 16K, Envelope C5, Envelope B5, Envelope Monarch, and Index Card Custom paper sizes: 76.2 to 215.9 mm wide and 127.0 to 355.6 mm long
Cassette paper type	Plain paper (60 to 90g/m2),Heavy paper (86 to 263g/m2),Label,Coated paper(120 to 220g/m2),Envelope
Multifeeder tray paper type	Plain paper (60 to 90g/m2),Heavy paper (86 to 263g/m2),Transparency,Label,Coated paper(120 to 220g/m2),Envelope
Cassette capacity	Approx. 250 sheets (80 g/m2)
Multifeeder tray capacity	Approx. 50 sheets (80 g/m2)
Delivery tray stack	Approx. 125 sheets (80 g/m2)
Memory	Standard: 768MB, option: none 16MB(only buffer memory):LBP7210Cdn
Hard disk	Standard: none, option: none
Interface	LBP7680Cx USB interface: For computer (1) For USB devices (1 front and 1 back) Network interface: Shared 10BASE-T/100BASE-TX/1000BASE-T (RJ-45) Full duplex/Half duplex LBP7600C/7660Cdn USB interface: For computer (1) For USB devices (1) Network interface: Shared 10BASE-T/100BASE-TX/1000BASE-T (RJ-45) Full duplex/Half duplex LBP7210Cdn USB interface: For computer (1) For USB devices (1) Network interface: Shared 10BASE-T/100BASE-TX
Auto gradation correction	available(A4, B5, Legal, Letter, Executive, and Foolscap)

Item	Function / Method
Operating environment (Temperature range)	10 to 30 degree C
Operating environment (Humidity range)	Operating environment Temperature range: 10 to 30 degree C (50 to 86 degree F) Humidity range: 20 to 80 % RH (no condensation)
Noise	LwAd (declared A-weighted sound power level (1 B = 10 dB)) During standby: 4.3 B or less During operation: 6.7 B or less LpAm (declared A-weighted sound pressure level (bystander position)) During standby: 24 dB During operation: 52 dB (Declared noise emission in accordance with ISO 9296)
Power supply rating	220 to 240 V (±10%), 50/60 Hz (±2 Hz)
Power consumption(Maximum)	Maximum: 950 W or less Maximum: 947.5 W or less(LBP7210Cdn)
Power consumption	Average during operation: Approx. 405 W Average during standby: Approx. 23 W Average during Panel Off Mode (Sleep Mode 1): Approx. 23 W Average during Printer Sleep Mode (Sleep Mode 2): Approx. 7.5 W Average during Deep Sleep Mode (Sleep Mode 3): Approx. 1 W* When the main power switch is turned OFF: 0.1 W or less * It is the default setting. For details on [Sleep Mode], see "Setting the Printer to the Energy Saving Mode." (LBP7210Cdn) Average during operation: Approx. 405 W Average during standby: Approx. 20 W Average during Deep Sleep Mode (Sleep Mode 3): Approx. 3.2 W* When the main power switch is turned OFF: 0.1 W or less * It is the default setting. For details on [Sleep Mode], see "Setting the Printer to the Energy Saving Mode."
Dimensions	409 (W) x 490 (W) x 331(H) mm 414 (W) x 499 (W) x 328(H) mm:LBP7210Cdn
Weight	Printer unit (excluding toner cartridges):Approx. 22.0 kg Option Cassette:4.0Kg (LBP7210Cdn) Printer unit (excluding toner cartridges):Approx. 22.3 kg Option Cassette:4.0Kg

T-1-1

Detailed Specification

Printing Speed

Unit: sheets / min

Name in the driver (grammage)	speed	Paper Size	Single-sided			Double-sided		
			Manual feed tray	Cassette	Option cassette	Manual feed tray	Cassette	Option cassette
Plain paper (75 to 90g/m2) plain paper L (60 to 74g/m2) heavy paper 1 (86 to 119g/2) heavy paper2 (120 to 128g/2)	1/1	A4	16.0	20.0	20.0	9.1	10.0	10.0
		LTR	16.0	21.0	21.0	9.2	10.3	10.3
		LGL	14.1	17.1	17.1	8.4	9.2	9.2
Heavy paper 3 (129 to 176g/2)	1/2	A4	11.9	11.9	11.9	4.4	4.4	4.4
		LTR	12.2	12.2	12.2	4.5	4.5	4.5
		LGL	10.8	10.8	10.8	4.1	4.1	4.1
Coat paper1 (100 to 110g/m2) Coat paper2 (120 to 130g/m2) Coat paper3 (155 to 165g/m2) Coat paper4 (210 to 220g/m2)	1/3	A4	7.6	9.7	9.7	2.3	2.6	2.6
		LTR	7.6	9.7	9.7	2.3	2.6	2.6
		LGL	6.7	8.3	8.3	2.1	2.4	2.4
Envelope	1/3	Com 10	5.4	7.6	7.6	-	-	-
Labels	1/3	A4	7.6	9.7	9.7	-	-	-
Transparency	1/3	A4	5.0	-	-	-	-	-

LBP7210Cdn

Unit: sheets / min

Name in the driver (grammage)	speed	Paper Size	Single-sided			Double-sided		
			Manual feed tray	Cassette	Option cassette	Manual feed tray	Cassette	Option cassette
Plain paper (75 to 90g/m ²) plain paper L (60 to 74g/m ²) heavy paper 1 (86 to 119g/2)	1/1	A4	16.0	20.0	20.0	9.1	10.0	10.0
		LTR	16.0	21.0	21.0	9.2	10.3	10.3
		LGL	14.1	17.1	17.1	8.5	9.2	9.2
heavy paper2 (120 to 128g/2)	1/1	A4	11.9	11.9	11.9			
		LTR	12.2	12.2	12.2			
		LGL	9.9	10.8	10.8			
Heavy paper 3 (129 to 176g/2)	1/2	A4	7.4	9.7	9.7	4.5	5.1	5.1
		LTR	7.4	9.9	9.9	4.6	5.2	5.2
		LGL	6.5	8.3	8.3	4.2	4.7	4.7
Coat paper1 (100 to 110g/m ²) Coat paper2 (120 to 130g/ m ²) Coat paper3 (155 to 165g/ m ²) Coat paper4 (210 to 220g/ m ²)	1/3	A4	6.5	6.5	6.5	3.2	3.5	3.5
		LTR	6.9	6.9	6.9	3.2	3.6	3.6
		LGL	5.6	5.6	5.6	3.0	3.2	3.2
Envelope	1/2	Com 10 Monarch	5.4	7.6	7.6	-	-	-
	1/3	C5,B5	3.7	5.6	5.6	-	-	-
Labels	1/2	A4	7.6	9.7	9.7	-	-	-
Transparency	1/3	A4	5.0	-	-	-	-	-

Parts Name

External View

● Front View of the Printer(LBP7210Cdn)

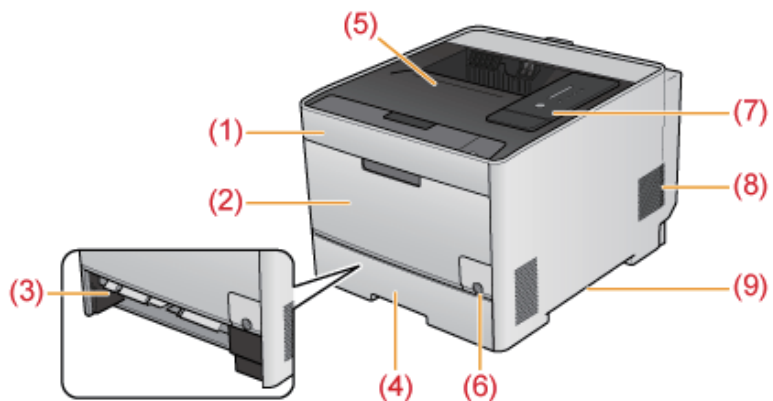

F-1-1

[1]	Front Cover	[6]	Power Switch
[2]	Multi-purpose Tray	[7]	Control Panel
[3]	Manual Feed Transport Guide	[8]	Ventilation Slots
[4]	Paper Drawer	[9]	Lift Handles
[5]	Output Tray		

● Back View of the Printer(LBP7210Cdn)

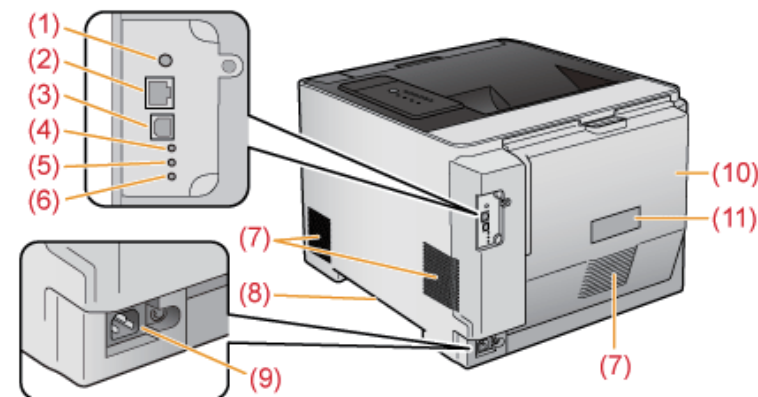

F-1-2

[1]	Reset Button	[7]	Ventilation Slots
[2]	LAN Connector	[8]	Lift Handles
[3]	USB Connector	[9]	Power Socket
[4]	100 Indicator (Green)	[10]	Rear Cover
[5]	LNK Indicator (Green)	[11]	Rating Label
[6]	ERR Indicator (Orange)		

● Front View of the Printer

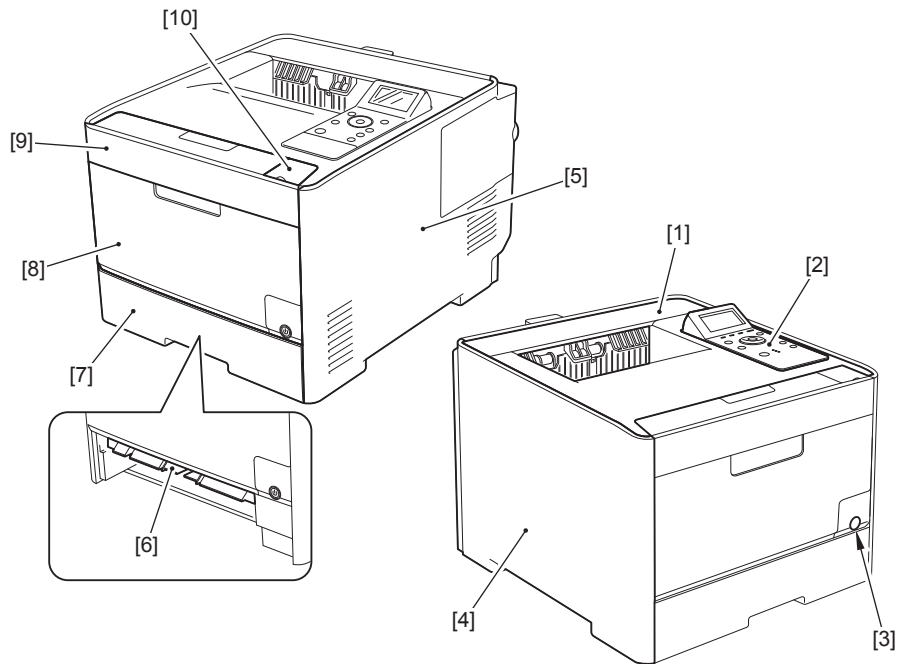

F-1-3

- | | |
|------------------------------------|---|
| [1] Upper Cover | [8] Manual Feed Tray |
| [2] Operation Panel | [9] Front Cover |
| [3] Power Switch | [10] Upper Front Cover (Right)
(LBP7600C/7660Cdn Only) |
| [4] Left Cover | [2] USB Cover
(LBP7680CxOnly) |
| [5] Right Cover | |
| [6] Manual Feed Tray Feeding Guide | |
| [7] Pickup Cassette | |

● Back View of the Printer

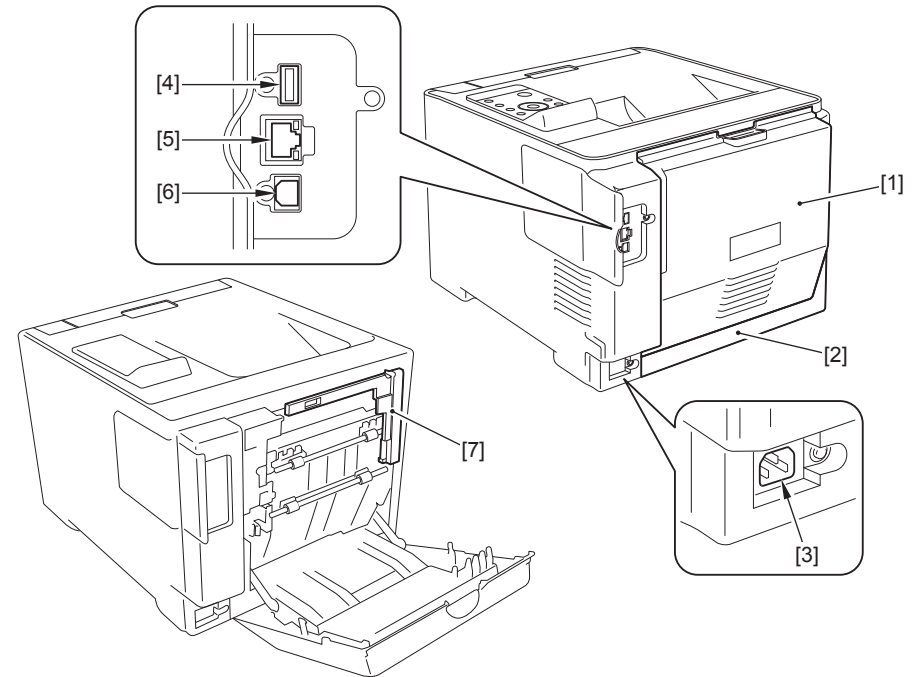

F-1-4

- | |
|-----------------------------|
| [1] Rear Cover |
| [2] Rear Lower Cover |
| [3] Power Socket |
| [4] USB Port |
| [5] LAN Port |
| [6] USB Port |
| [7] Rear Upper Cover (Left) |

T-1-2

Cross Section View

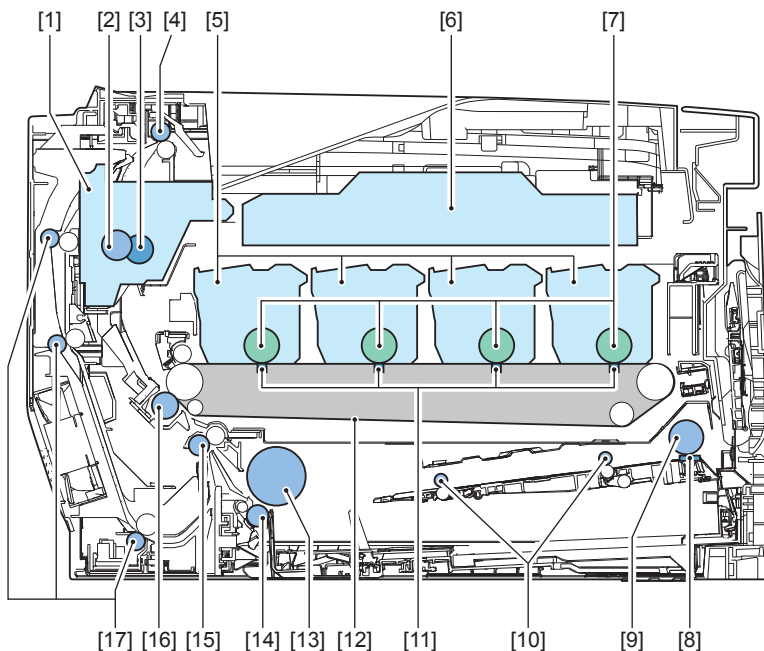

F-1-5

- | | |
|-------------------------------|--|
| [1] Fixing unit | [10] Multi tray feed roller |
| [2] Pressure roller | [11] Primary transfer pad |
| [3] Fixing film unit | [12] ITB Unit |
| [4] Delivery roller | [13] Cassette pickup roller |
| [5] Cartridge | [14] Cassette separation roller |
| [6] Laser scanner unit | [15] Registration roller |
| [7] Photosensitive drum | [16] Secondary transfer roller |
| [8] Multi tray separation pad | [17] Duplex feed roller (Duplex model) |
| [9] Multi tray pickup roller | |

T-1-3

Operation

Control panel(LBP7210Cdn)

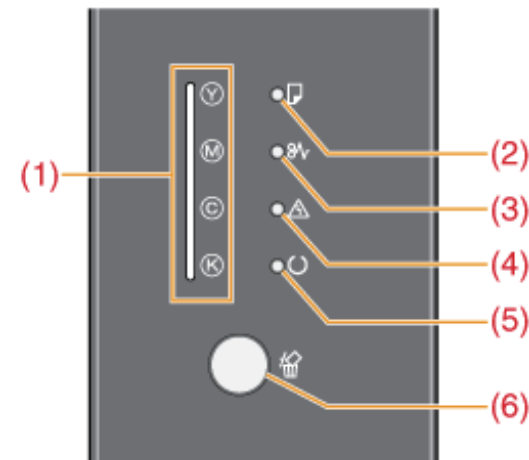

F-1-6

	Name	Status	Discription
[1]	Toner Indicator	On	A toner cartridge needs to be replaced.
		Blinking	The printer cannot print because a toner cartridge needs to be replaced. One or more toner cartridges are not installed in the correct positions.
[2]	Load Paper Indicator	Blinking	Printing cannot be performed because no paper is loaded. Paper of the correct size is not loaded.
[3]	Paper Jam Indicator	Blinking	A paper jam has occurred and printing cannot be performed.
[4]	Alarm Indicator	On	A service call has occurred and printing cannot be performed.
		Blinking	An error has occurred and printing cannot be performed.
[5]	Ready Indicator	On	The printer is ready to print.
		Blinking	The printer is busy printing, preparing to print, shutting down or cleaning.
[6]	Cancel Job Indicator	On	The (Cancel Job) key has been pressed.
		Blinking	A job is being canceled.

Control panel(LBP7600C/7660Cdn)

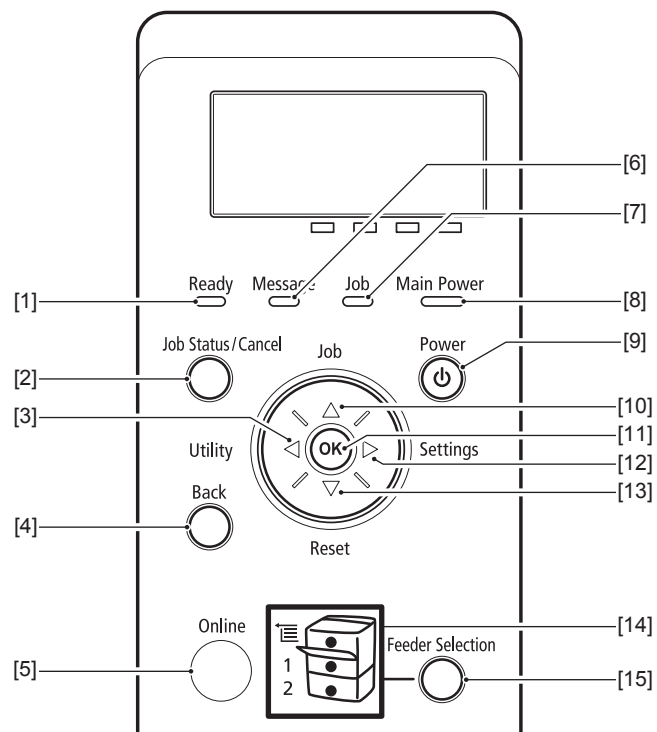

F-1-7

Name	Status	Description
[7] Job Indicator	On	The printer is receiving data. Data remains in the printer memory.
	Blinking	The printer is processing data.
[8] Main Power Indicator	On	The power of the printer is ON.
[14] Paper Source Indicator	On	A paper source is selected.
	Blinking	Printing cannot be performed because no paper is loaded.
		The paper drawer is not installed.

Control Panel Key

Name	Function		
[2] Status/Cancel Key	When the printer is online	When the printer is offline	When the menu is displayed
	If pressed when the Job indicator is on or blinking (When data is being processed or received), display the job list. Select a job from the list to cancel the job.		Does not function.
[3] Utility Key	Display the [Utility Menu]. Prints information about the printer settings including the current settings.	Does not function	Goes back up the previous hierarchy.
[4] Back Key	Does not function		Goes back up the previous hierarchy.
[5] Online Key	Switches between online and offline . The printer is online when the indicator under the key is on and is offline when the indicator is off.		
[9] Power Key	If [Sleep Mode] is set to a setting other than [Off], the printer enters Sleep Mode.		
[10] Job Key	Displays the [Job] menu. You can print various log list.	Does not function	Select the next upper item in the same hierarchy. When the setting value is numeric, increase the value. If you keep holding down the key, the speed of the value increasing is increased depending on the item.

Functions of the LEDs

Name	Status	Description
[1] Ready Indicator	On	The printer is ready to print.
	Blinking	The printer is preparing to print.
[5] Online Indicator	On	Online (The printer can receive print data from the computer) If the printer enters Sleep Mode, the Online indicator is off even when the printer is online.
[6] Message Indicator	On	A problem has occurred and printing cannot be performed. (If the printer's Sleep Mode when it is offline, the Message indicator comes on even when no problem is occurring)

Name	Function	
[11] Settings Key	Displays the [Setup] menu. Configure the printing environment including the layout adjustment and scaling print output.	Gose down the hierarchy
[12] OK Key	Does not function	Executes the selected item. Otherwise, goes down the hierarchy.
[13] Reset Key	Display the [Reset] menu. Performs the printer reset operation, the print data output, and the shutdown operation.	Select the next lower item in the same hierarchy. When the setting value is numeric, reduces the value. If you keep holding down the key, the speed of the value decreasing is increased depending on the item.
[15] Feeder Selection Key	Displays the [Select Feeder] menu. Specify which paper source is used to print between the paper drawer and multi-purpose tray and the paper size.	Does not function

LBP7680Cx

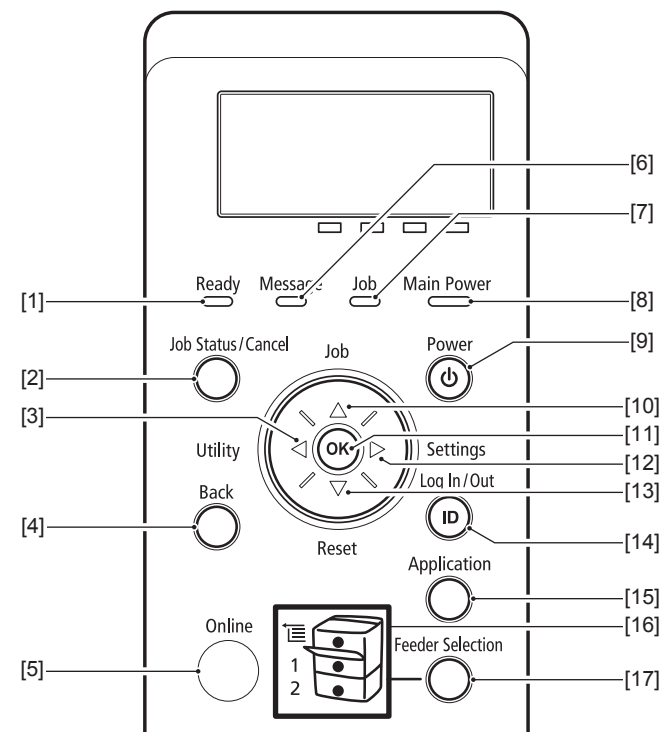

F-1-8

■ Functions of the LEDs

Name	Status	Discription
[1] Ready Indicator	On	The printer is ready to print.
	Blinking	The printer is preparing to print.
[5] Online Indicator	On	Online (The printer can receive print data from the computer) If the printer enters Sleep Mode, the Online indicator is off even when the printer is online.
[6] Message Indicator	On	Aproblem has occurred and printing cannot be performed. (If the printers Sleep Mode when it is offline, the Message indicator comes on even when no problem is occurring)
	Blinking	The printer is processing data.
[7] Job Indicator	On	The printer is receiving data. Data remains in the printer memory.
	Blinking	The printer is processing data.
[8] Main Power Indicator	On	The power of the printer is ON.

Name	Status	Discription
[16] Paper Source Indicator	On	A paper source is selected.
	Blinking	Printing cannot be performed because no paper is loaded.
		The paper drawer is not installed.

Control Panel Key

Name	Function		
[2] Status/Cancel Key	When the printer is online	When the printer is offline	When the menu is displayed
	If pressed when the Job indicator is on or blinking (When data is being processed or received), diaplay the job list. Select a job from the list to cancel the job.		Does not function.
[3] Utility Key	Diaplay the [Utility Menu] menu. Prints information about the printer settings including the current settings.	Does not function	Goes back up the previous hierarchy.
[4] Back Key	Does not function		Goes back up the previous hierarchy.
[5] Online Key	Switches between online and offline . The printer is online when the indicator under the key is on and is offline when the indicator is off.		
[9] Power Key	If [Sleep Mode] is set to a setting other than [Off], the printer enters Sleep Mode.		
[10] Job Key	Diaplays the [Job] menu. You can print various log list.	Does not function	Select the next upper item in the same hierarchy. When the setting value is numeric, increase the value. If you keep holding down the key, the speed of the value increasing is increased depending on the item.
[11] Settings Key	Diaplays the [Setup] menu. Configure the printing environment including the layout adjustment and scaling print output.		Gose down the hierarchy

Name	Function	
[12] OK Key	Does not function	Executes the selected item. Otherwise, goes down the hierarchy.
[13] Reset Key	Display the [Reset] menu. Performs the printer reset operation, the print data output, and the shutdown operation.	Select the next lower item in the same hierarchy. When the setting value is numeric, reduces the value. If you keep holding down the key, the speed of the value decreasing is increased depending on the item.
[14] Log In/Out Key	The log in screen for using MEAP functions is displayed. Enter the Dept. ID/PIN and log in to the printer.	
[15] Application Key	It will transition to the Menu Screen. Whenever the key is pressed, the Printing Screen switches to → MEAP Application 1 → MEAP Application 2...Meap Application 8 → USB Direct Print → Printing Screen → Menu Screen	
[17] Feeder Selection Key	Displays the [Select Feeder] menu. Specify which paper source is used to print between the paper drawer and multi-purpose tray and the paper size.	Does not function

Safety Precautions

Safety of the Laser Light

Laser beam radiation may pose a danger to the human body. A laser scanner mounted on the machine is sealed with the protection housing and external cover to prevent the laser beam from leaking to the outside. The laser beam never leaks out of the scanner as far as users operate the machine normally

The following warnings are given to comply with Safety Principles (EN60950).

Laserstrahlen können für den menschlichen Körper gefährlich sein. Aus diesem Grund ist das optische Lasersystem mit einem Schutzgehäuse und einer Außenabdeckung dicht verschlossen und hat eine Struktur, die keine Laserstrahlen nach außen dringen lässt.

Unter der Voraussetzung, dass der Benutzer dieses Gerät normal bedient, ist ein Austritt von Laserstrahlen daher ausgeschlossen.

Safety of Toner

Toner in General

Toner is a non-toxic material made up of plastic, iron, and small amounts of dye.

Caution :

Do not throw toner into fire. Doing so can lead to explosion.

Contact with Toner

- Toner on the skin or clothes must be removed using dry tissue and then washed with water.
- The use of warm water must be avoided, doing so will cause the toner to turn gel-like and to permanently fuse with the fibers of the clothes.
- Contact with vinyl must also be avoided, as toner can readily react.

Contact with Toner

Remedy against toner spill

- When you spilled toner, be sure to sweep toner dust while paying attention not to inhale it, or wipe off it with wet cloth, etc.
- When using a vacuum cleaner, be sure to use one specially designed to suction toner dust.

Never use a general vacuum cleaner because dust explosion may occur when toner dust is suctioned.

Store of Copy/Print Output

- Be sure to use transparency cases for storing copy/print output.
- Do not use transparency cases made from polyvinyl chloride materials. If the copied surface contacts to the case, toner on the surface of the output dissolves and the output may adhere to the case. .

Handling the Laser Unit

When servicing the area around the laser assembly, be sure to turn off the main power.

If you must service while the power is turned on, be sure to keep the followings:

- Do not use a screwdriver or tools that have a high level of reflectance in the laser path.
- Remove watches and rings before starting the work. (They can reflect the laser beam, possibly hitting the eye.)

The machine's covers that can reflect laser light are identified by means of a warning label (Figure). If you must detach a cover showing the label, be sure to take extra caution during the work.

The following warnings are given to comply with Safety Principles (EN60950).

Handhabung des Laserteils

Bei Servicearbeiten am oder in der Nähe des Laserteils zuerst das Hauptgerät abschalten.

Bei Servicearbeiten, die unbedingt bei eingeschaltetem Gerät durchgeführt werden müssen, auf jeden Fall die folgenden Vorsichtsmaßnahmen beachten.

- Keine stark reflektierenden Schraubenzieher oder ähnliche Werkzeuge direkt in den Lichtpfad des Laserstrahls bringen.
- Vor Beginn der Arbeit Uhren, Ringe und ähnliche Gegenstände abnehmen. (Reflektierte Laserstrahlen könnten sonst in die Augen geraten.)

Abdeckungen, die möglicherweise Laserstrahlen reflektieren, haben in der auf dem Bild gezeigten Position einen Aufkleber. Bei Servicearbeiten auf der Innenseite von Abdeckungen mit Aufkleber ist besondere Vorsicht erforderlich.

F-1-9

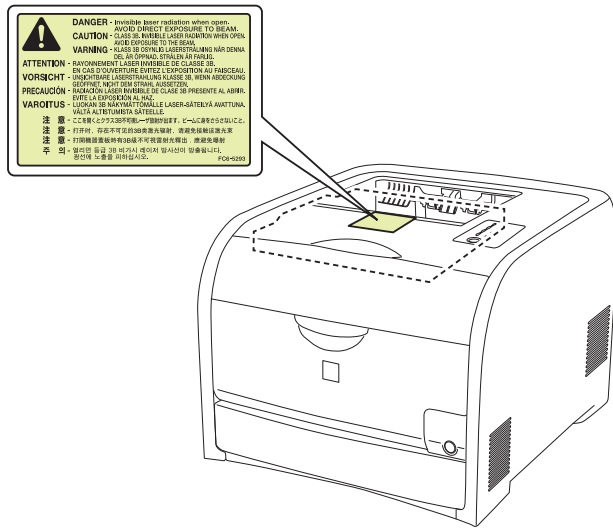

F-1-10

Points to note at disassembly/installation procedure

At disassembly/installation procedure, make sure to follow the instruction below to proceed.

1. Be sure to unplug the power cord before disassembly/installation.
2. At installation, follow the procedure in the reverse order of disassembly unless otherwise instructed.
3. Be careful of the screw type (length, diameter) and corresponding part.
4. To check the electrical conductivity, washer equipped screw is used to attach the grounding wire and the varistor etc. When attaching them, be sure to use this screw.
5. In principle, do not operate the machine without any part.
6. Be sure not to unscrew the screw with painting at disassembly.

2

Technical Reference

- Basic Configuration
- Laser Exposure System
- Image Formation System
- Fixing System
- Pickup/Feed/Delivery System
- Controller System
- SSL
- MEAP
- Embedded RDS

Basic Configuration

Outline

The machine may be broadly divided into the following 6 functional blocks: engine control system, laser exposure system, image formation system, pickup/transport/delivery system, fixing system, and externals/auxiliary control system.

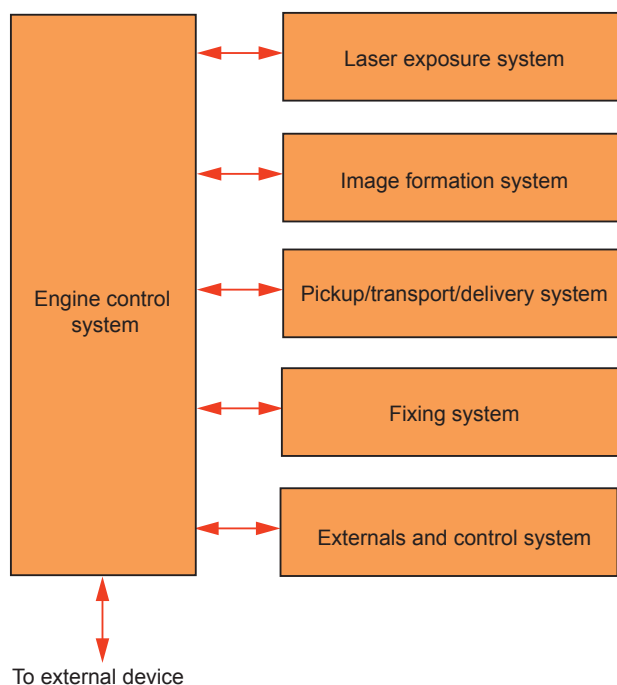

F-2-1

Basic Sequence of Operation

The operational sequence of the printer is controlled by the DC controller in the engine control system.

Table describes periods, durations and operations for each period of a print operation from the printer is turned on until the motors stop rotating.

Period	Duration	Operation
WAIT	From the time the power switch is turned on, the door is closed or the Sleep mode is released until the printer gets ready for a print operation	Brings the printer to printable condition The printer performs the following during this period: <ul style="list-style-type: none"> • Detects the pressure roller pressurized status • Detects the presence of each cartridge and unit • Determines the home position of the development unit • Cleans the ITB • Completes any required calibration, such as color
STBY (standby)	From the end of WAIT or LSTR period until either the print command is received from the main controller or the power switch is turned off	Maintains the printer in printable condition The printer performs the following during this period: <ul style="list-style-type: none"> • Enters Sleep mode when the main controller sends a sleep command • Completes any required calibration, such as color misregistration control and image stabilization control, when the main controller sends a command
INTR (Initial rotation period)	From the time the print command is received from the main controller during STBY period until the temperature of the fixing assembly reaches the targeted temperature	Starts up each high-voltage bias, laser scanner unit and fixing assembly for preparing a print operation
PRINT	From the end of INTR period until the last media completes the fixing operation	Forms the image on the photosensitive drum based on the video signals from the main controller, transfers and fuses the toner image to the print media The printer performs color misregistration control and image stabilization control at a specified print interval after the printer is turned on

Period	Duration	Operation
LSTR (Last rotation period)	From the end of PRINT period until the motors stop rotating	Moves the last printed sheet out of the printer and stops the laser scanner unit operation and high-voltage biases. The printer enters INTR period as soon as the LSTR period is completed if another print command is received from the main controller.

T-2-1

Laser Exposure System

Outline

The laser scanner system forms the latent image on the photosensitive drum according to the VIDEO signals sent from the main controller.

The main components of the laser scanner unit are the laser driver and the scanner motor unit and are controlled by the signals sent from the DC controller.

The following figure shows the diagrammatic sketch of the laser scanner ass'y.

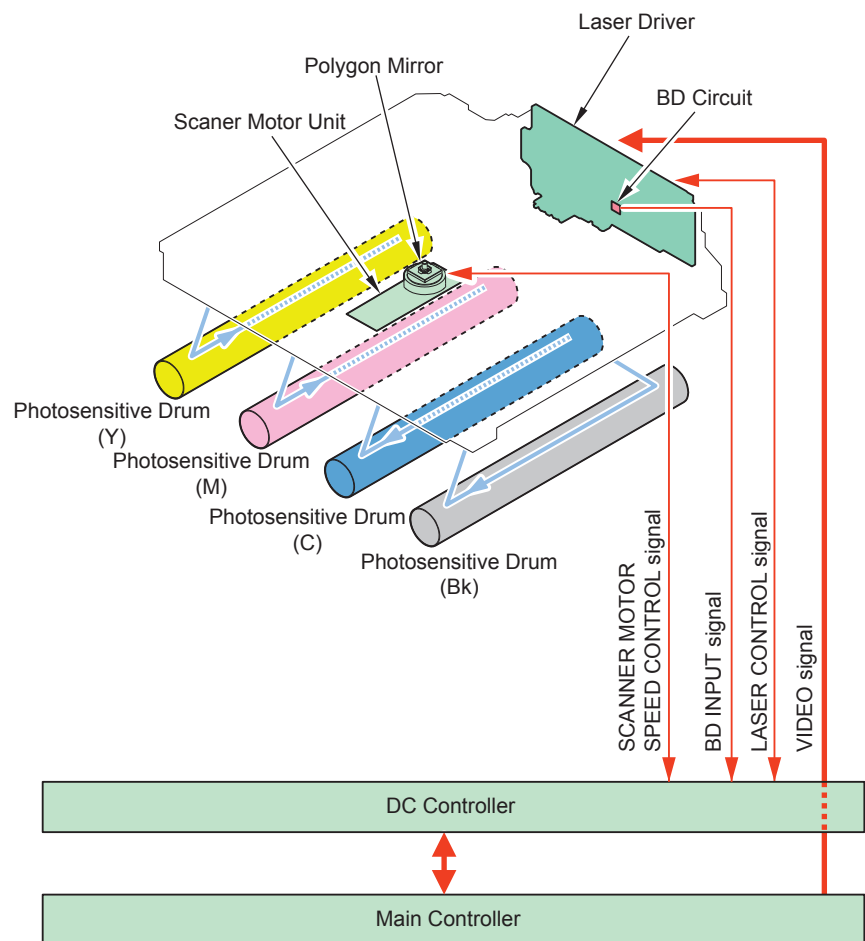

F-2-2

Controlling the Laser Scanner Motor

Fault Detection

- Scanner motor failure
 - The scanner motor does not reach a specified rotation within a specified period after starting-up the laser scanner motor.
 - The rotation of the scanner motor is out of specified range for a specified period during scanner motor drive.
- BD failure
 - The BD interval is detected at out of a specified value during a print operation.

Image Formation System

Construction

Outline

The image-formation system is the central hub of the printer. It forms the toner image on the media.

The following are the main components of the image-formation system:

- Four cartridges
- ITB
- Laser scanner unit
- Fixing assembly

The DC controller controls the laser scanner unit and high-voltage power supply to form the toner image on the photosensitive drums according to the VIDEO signals. The image is transferred to the print media through the ITB and fixed.

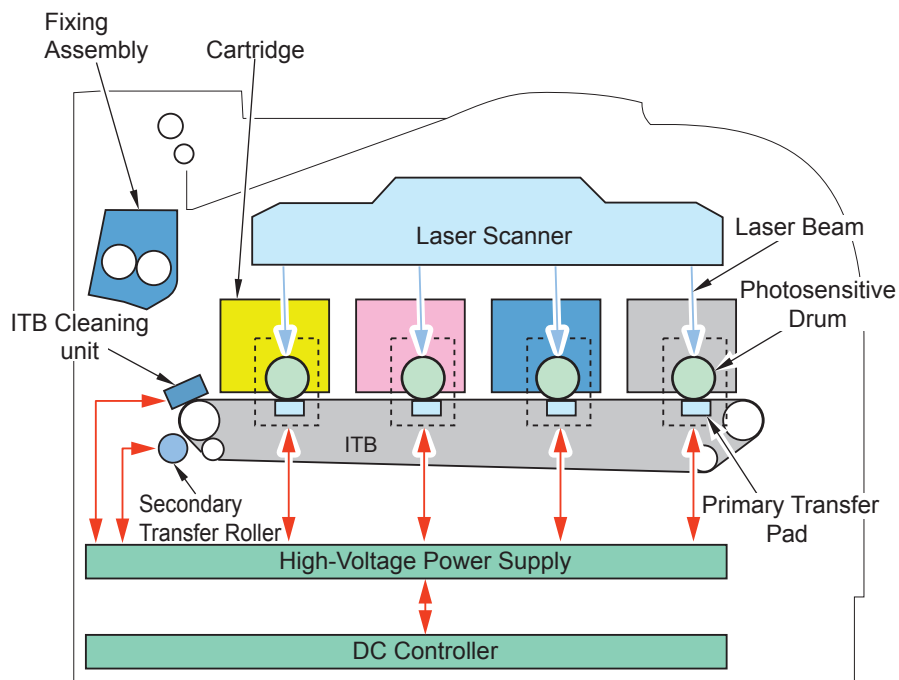

F-2-3

Image-formation Process

The image-formation process consists of the following nine steps divided among six functional blocks:

- Step 1: Primary charging
- Step 2: Laser-beam exposure
- Step 3: Development
- Step 4: Primary transfer
- Step 5: Secondary transfer
- Step 6: Separation
- Step 7: Fixing
- Step 8: ITB cleaning
- Step 9: Drum cleaning

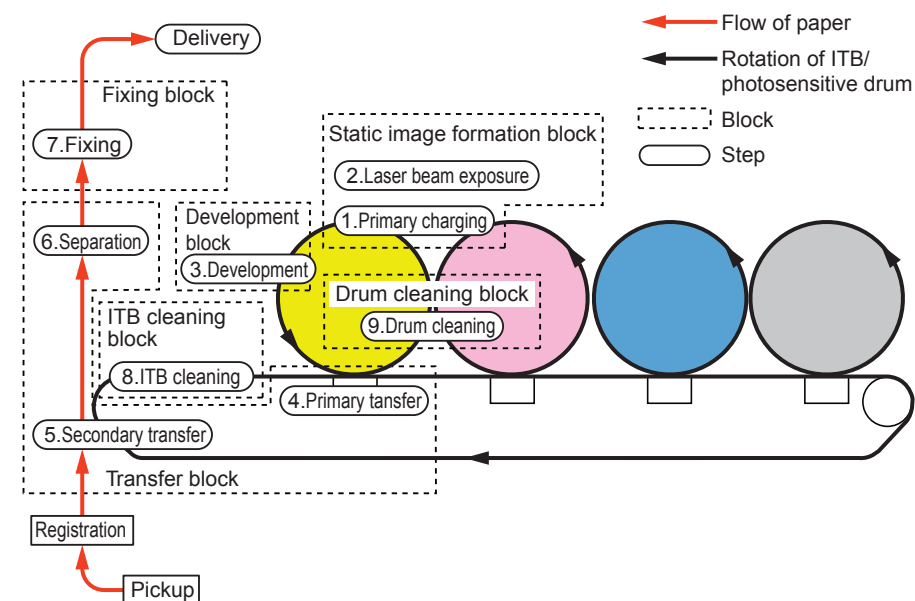

F-2-4

Latent image formation block

During the two steps that comprise this block, an invisible latent image is formed on the photosensitive drum.

Step 1: Primary charging

To prepare for latent image formation, the surface of the photosensitive drum is charged with a uniform negative potential. The primary charging roller charges the photosensitive drum directly. The primary charging bias is applied to the primary charging roller to keep a negative potential on the drum surface.

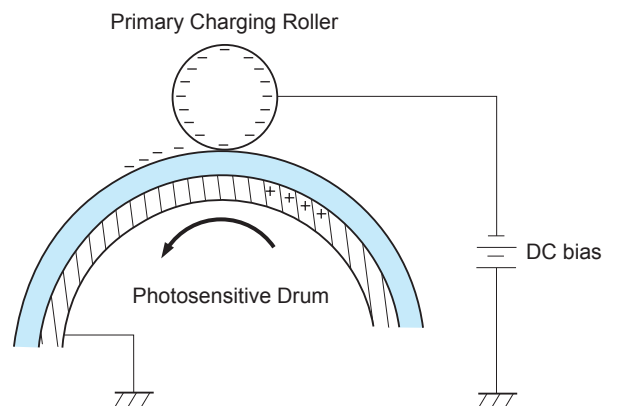

F-2-5

Step 2: Laser-beam exposure

The laser beam scans the photosensitive drum to neutralize the negative charge on portions of the drum surface. An electrostatic latent image forms where the negative charge was neutralized.

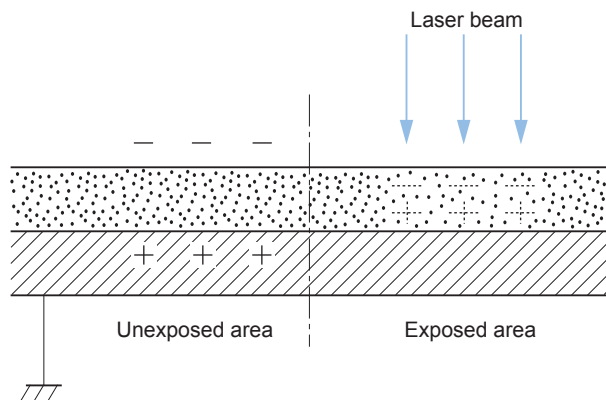

F-2-6

Developing block

Toner adheres to the electrostatic latent image on the photosensitive drum, which becomes visible.

Step 3: Developing

Toner acquires a negative charge from the friction that occurs when the developing roller rotates against the developer blade. The developing bias is applied to the developing roller to make difference in the electric potential of the drum. When the negatively charged toner comes in contact with the photosensitive drum, it adheres to the latent image because the drum surface has a higher potential.

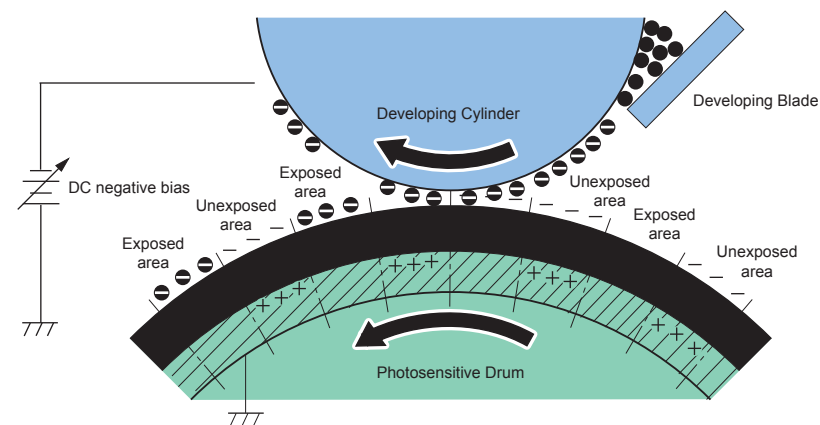

F-2-7

Transfer block

During the three steps that comprise this block, a toner image on the photosensitive drum transfers to the print media through the ITB.

Step 4: Primary transfer

The toner image on the photosensitive drum is transferred to the ITB. The DC positive bias is applied to the primary transfer pad. The negatively charged toner transfers to the ITB from the drum surface.

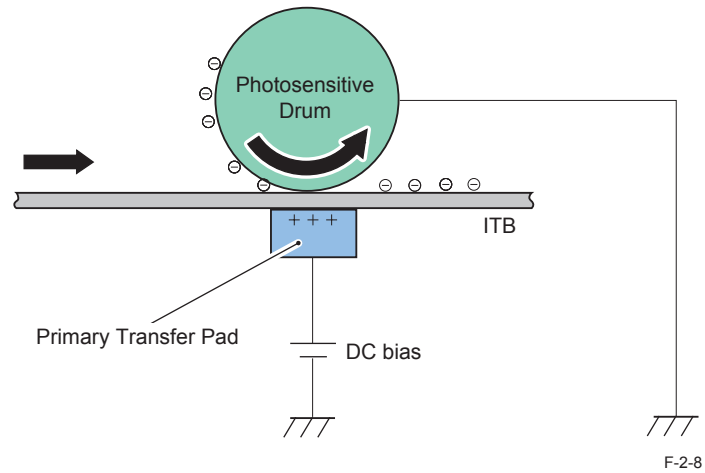

Step 5: Secondary transfer

The toner image on the ITB is transferred to the print media. The DC positive bias is applied to the secondary transfer roller. As the media passes between the secondary transfer roller and the ITB, the toner image is transferred to the media.

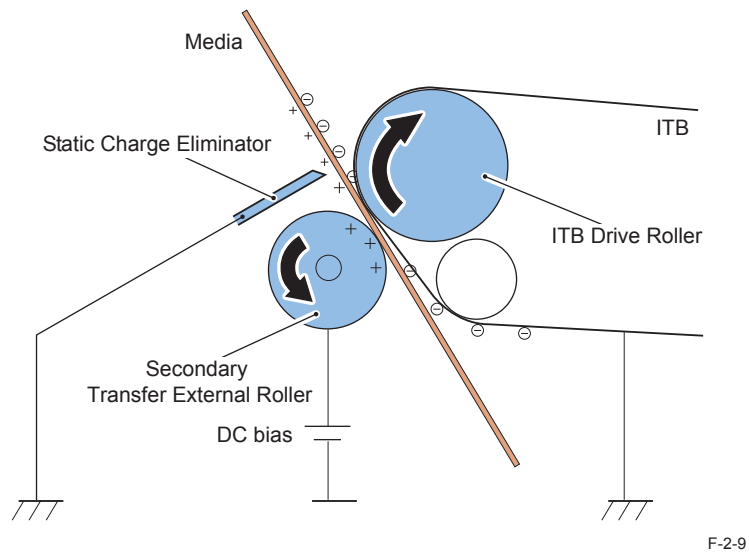

Step 6: Separation

The elasticity of the print media and the curvature of the ITB drive roller cause the media to separate from the ITB.

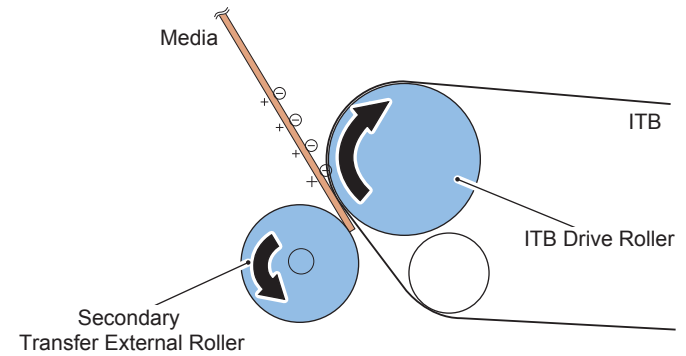

Fixing block

The toner image is fixed onto the print media.

Step 7: Fixing

The printer uses an on-demand fixing method to fix the toner image onto the media. The toner image is permanently affixed to the print media by the heat and pressure.

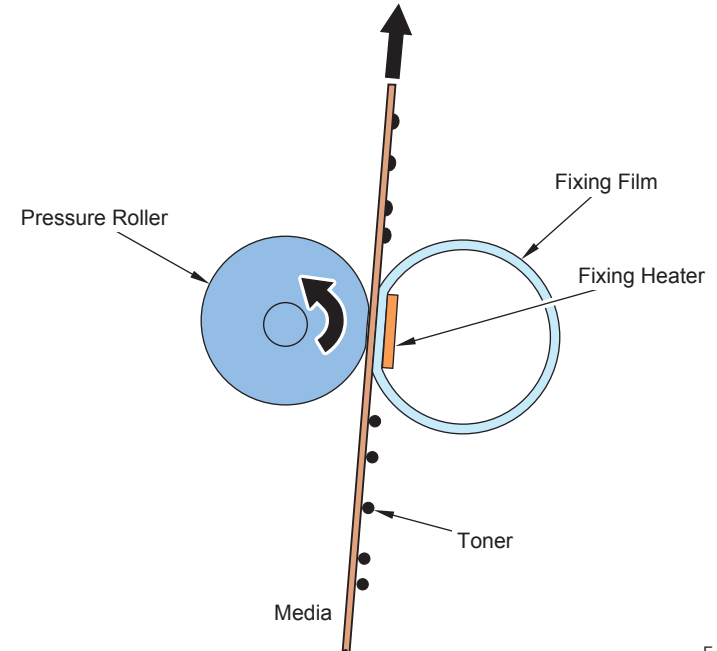

ITB cleaning block

The residual (waste) toner is cleared from the ITB surface.

Step 8: ITB cleaning

The ITB cleaning roller and the cleaning brush are applied with DC positive bias to charge the residual toner positive.

As the primary transfer pad is also applied with DC positive bias, the positively charged residual toner is reverse transferred to the photosensitive drum from the ITB surface.

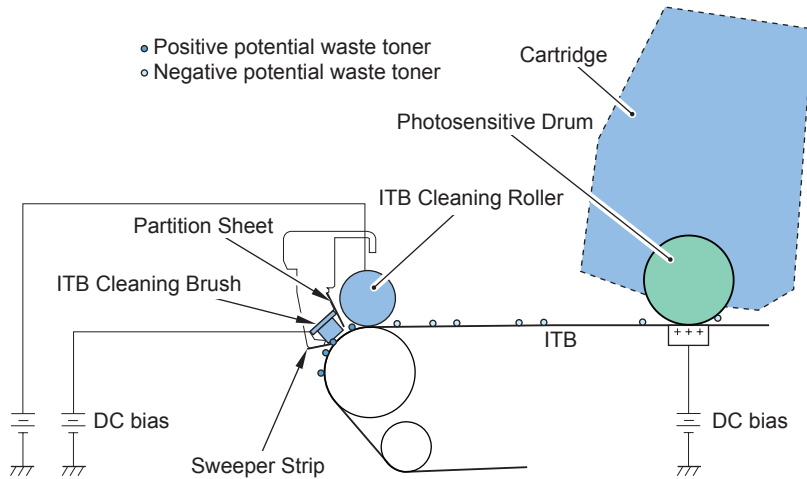

F-2-12

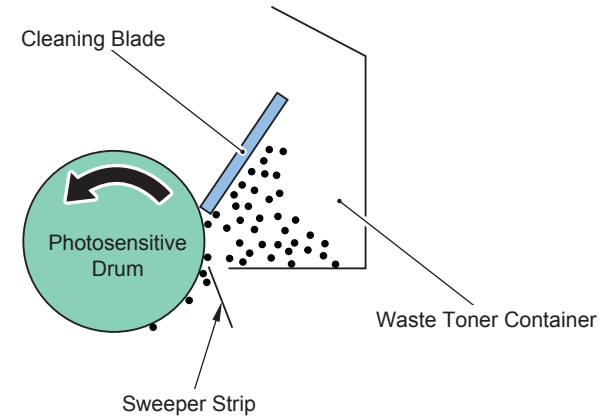

F-2-13

Photosensitive drum cleaning block

The waste toner is cleared from the photosensitive drum surface.

Step 9: Drum cleaning

The cleaning blade scrapes the waste toner off the surface of the photosensitive drum. The waste toner is deposited in the waste toner container.

Driving and Controlling the High-Voltage System

Outline

The high-voltage power supply generates the high-voltage biases that are applied to the primary charging roller, developing roller, primary transfer pad, secondary transfer roller and ITB cleaning unit. The DC controller controls the high-voltage power supply to generate high-voltage biases.

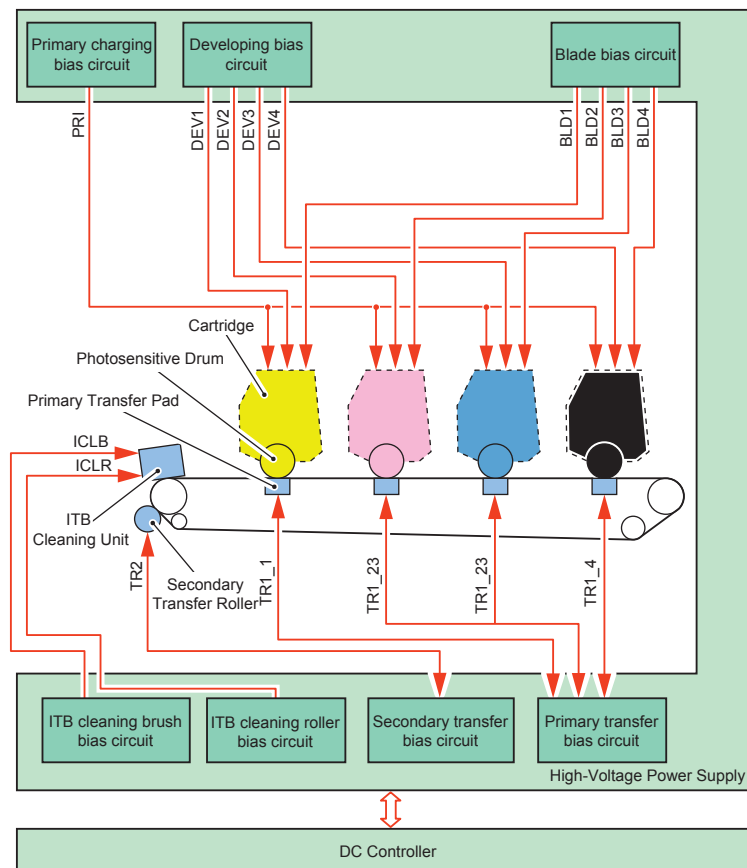

F-2-14

Image Stabilization Control(LBP7600C/7660C/7680Cx)

Overview of the Image Stabilization Control Mechanism

The machine uses its image stabilization control mechanism to prevent lowering of image quality (e.g., in the form of a faulty image) otherwise caused by changes in the environment or deterioration of the photosensitive drum or toner.

The machine's image stabilization control mechanism may be any of 3 types: Image density corrective control (D-max control), Image halftone corrective control (D-half control), Color Misregistration Corrective Control.

Image density correction control (D-max control)

This control is to stabilize the image density of the printer engine.

If the prescribed condition is met, DC controller PCB performs D-max control in the following procedure.

1. Measure the each density detection pattern made on the ITB.
2. According to the measured density of each pattern, controls the primary charge bias and developing bias to get the appropriate density.

The following is the conditions that trigger the image density correction control.

The conditions and timing for executing D-max control are shown below.

Conditions for execution	Execution timing
At power-on	Not executed by default (*1)
When recovering from deep sleep after 8 hours or more have passed	Not executed by default (*1)
When the door is closed after replacing the Toner Cartridge	Immediately (right after replacement)
After every 500 pages of printing since the execution of the last density control (However, the count of the number of printed pages is reset when the power is turned OFF or the machine enters deep sleep, and the count starts again when density control has been executed after that.)	When shifting to idle state (*2)

Conditions for execution	Execution timing
When 5 hours have passed since the execution of the last density control (However, the count of the elapsed time is reset when the power is turned OFF or the machine enters deep sleep, and the count starts again when density control has been executed after that.)	When shifting to idle state (*2, *3)
When the environment (temperature and humidity) has changed by a specified value or more	When shifting to idle state (*2)
When requested by the user	After completion of the jobs in wait (*4)

*1: This item is used to control the execution timing by executing the following setting: Setup > User Maintenance > First Calibration > Density Control. There are 3 types of execution timing.

Off: Not executed (default)

After Jobs: Executed when shifting to idle state (immediately after the machine has completed all the jobs to be executed)

Immediately: Executed during initialization of the engine

*2: Executed immediately after the machine has completed all the jobs to be executed after the execution conditions have been achieved. (In some cases, density control is executed after a job received after achievement of the execution conditions has been completed.)

*3: When the machine is in panel off mode, density control is executed when the execution conditions have been achieved. Density control is not executed during deep sleep. However, if the execution conditions are satisfied when recovering from deep sleep mode, density control is executed when shifting to idle state.

*4: When the execution conditions have been achieved, density control is executed immediately after the machine has completed all the jobs to be executed (before executing jobs received after the execution conditions have been achieved).

■ Image gradation correction control (D-half control)

This is a control that main controller PCB executes the gradation correction based on result of the halftone density measurement that is executed by DC controller PCB.

After D-max control, DC controller PCB and main controller PCB execute the D-half control in the following procedure.

The conditions and timing for executing D-half control are shown below.

Conditions for execution	Execution timing
At power-on	Not executed by default (*1)

Conditions for execution	Execution timing
When recovering from deep sleep after 8 hours or more have passed	Not executed by default (*1)
When the door is closed after replacing the Toner Cartridge	Immediately (right after replacement)
After every 500 pages of printing since the execution of the last density control (However, the count of the number of printed pages is reset when the power is turned OFF or the machine enters deep sleep, and the count starts again when density control has been executed after that.)	When shifting to idle state (*2)
When 5 hours have passed since the execution of the last density control (However, the count of the elapsed time is reset when the power is turned OFF or the machine enters deep sleep, and the count starts again when density control has been executed after that.)	When shifting to idle state (*2, *3)
When the environment (temperature and humidity) has changed by a specified value or more	When shifting to idle state (*2)
When requested by the user	After completion of the jobs in wait (*4)

*1: This item is used to control the execution timing by executing the following setting: Setup > User Maintenance > First Calibration > Density Control. There are 3 types of execution timing.

Off: Not executed (default)

After Jobs: Executed when shifting to idle state (immediately after the machine has completed all the jobs to be executed)

Immediately: Executed during initialization of the engine

*2: Executed immediately after the machine has completed all the jobs to be executed after the execution conditions have been achieved. (In some cases, density control is executed after a job received after achievement of the execution conditions has been completed.)

*3: When the machine is in panel off mode, density control is executed when the execution conditions have been achieved. Density control is not executed during deep sleep. However, if the execution conditions are satisfied when recovering from deep sleep mode, density control is executed when shifting to idle state.

*4: When the execution conditions have been achieved, density control is executed immediately after the machine has completed all the jobs to be executed (before executing jobs received after the execution conditions have been achieved).

Color displacement correction control

This control is to correct the color displacement that appears due to the variation of laser scanner unit or toner cartridge.

The following objects are controlled by this color displacement correction.

- Write start position in main scanning direction
- Magnification in main scanning direction
- Write start position in sub scanning direction

When one of the following conditions is met, DC controller PCB controls the color displacement/density sensor and displacement sensor.

The conditions and timing for executing color displacement correction control are shown below.

Conditions for execution	Execution timing
At power-on	When shifting to idle state (*5, *2)
When recovering from deep sleep after 8 hours or more have passed	When shifting to idle state (*5, *2)
When the door is closed after replacing the Toner Cartridge	Immediately (right after replacement)
After every 150 pages of printing since the execution of the last color displacement correction (However, the count of the number of printed pages is reset when the power is turned OFF or the machine enters deep sleep, and the count starts again when color displacement correction has been executed after that.)	When shifting to idle state (*2)
When 1 hour has passed since the execution of the first printing after power ON or the execution of the first color displacement correction, whichever is earlier, or when 4 hours have passed since the execution of the last color displacement correction. (However, the count of the elapsed time is reset when the power is turned OFF or the machine enters deep sleep, and the count starts again when color displacement correction has been executed after that.)	When shifting to idle state (*2, *3)
When the environment (temperature and humidity) has changed by a specified value or more	When shifting to idle state (*2)
When requested by the user	After completion of the jobs in wait (*4)

*2: Executed immediately after the machine has completed all the jobs to be executed after the execution conditions have been achieved. (In some cases, density control is executed after a job received after achievement of the execution conditions has been completed.)

*3: When the machine is in panel off mode, density control is executed when the execution conditions have been achieved. Density control is not executed during deep sleep. However, if the execution conditions are satisfied when recovering from deep sleep mode, density control is executed when shifting to idle state.

*4: When the execution conditions have been achieved, density control is executed immediately after the machine has completed all the jobs to be executed (before executing jobs received after the execution conditions have been achieved).

*5: This item is used to control the execution timing by executing the following setting: Setup > User Maintenance > First Calibration > Color Mismatch Corr. There are 2 types of execution timing.

After Jobs: Executed when shifting to idle state (immediately after the machine has completed all the jobs to be executed)

(Default)

Immediately: Executed during initialization of the engine

The following is the sequences of this control.

- 1) DC controller calculates the degree of each color displacement by the color displacement detection pattern made on ITB and sends the color displacement information to main controller.
- 2) Main controller controls the each color video signal according the color displacement data and adjusts the write start position in main scanning direction, the magnification in main scanning direction and the write start position in sub scanning direction.

At printer engine side, DC controller PCB also controls the scanner motor speed to correct the color displacement in sub scanning direction.

Note:

This indicates the image size in the main scanning direction.

Since this machine is equipped with the independent photosensitive drum for each color, the photosensitive drum position differs due to the toner cartridge variation and that leads to the laser wave length difference. Thus, image range differs depending on a color in main scanning direction so that the color displacement occurs at the edge of the image.

Image Stabilization Control(LBP7210Cdn)

Overview of the Image Stabilization Control Mechanism

The machine uses its image stabilization control mechanism to prevent lowering of image quality (e.g., in the form of a faulty image) otherwise caused by changes in the environment or deterioration of the photosensitive drum or toner.

The machine's image stabilization control mechanism may be any of 3 types: Image density corrective control (D-max control), Image halftone corrective control (D-half control), Color Misregistration Corrective Control.

Image density correction control (D-max control)

This control is to stabilize the image density of the printer engine.

If the prescribed condition is met, DC controller PCB controls the primary charge bias and developing bias to get the appropriate density.

The following is the conditions that trigger the image density correction control

- When the power is ON

At power ON, Out-of-Register Colors Correction is suspended until the initial print process is completed and the machine is ready or until 15 min passes after the power ON. The time setting can be changed from Option > Device Settings > Startup Settings in printer status window.

Image gradation correction control (D-half control)

This is a control that main controller PCB executes the gradation correction based on result of the halftone density measurement that is executed by DC controller PCB.

After D-max control, DC controller PCB and main controller PCB execute the D-half control in the following procedure.

1. DC controller PCB measures the each color density detection pattern on ITB that is made by the appropriate primary charge bias that is determined at D-max control and developing bias, and sends the density data to main controller PCB.
2. Main controller PCB executes the gradation correction to realize the ideal halftone image based on the data.

Color displacement correction control

This control is to correct the color displacement that appears due to the variation of laser scanner unit or toner cartridge.

The following objects are controlled by this color displacement correction.

- Write start position in main scanning direction
- Magnification in main scanning direction
- Write start position in sub scanning direction

When one of the following conditions is met, DC controller PCB controls the color displacement/density sensor and displacement sensor.

- At power ON

At power ON, Out-of-Register Colors Correction is suspended until the initial print process is completed and the machine is ready or until 15 min passes after the power ON. The time setting can be changed from Option > Device Settings > Startup Settings in printer status window.

Startup Settings

You can configure the printer operation for immediately after the printer is turned on.

1 Select whether or not to perform calibration or correction of "Out-of-Register Colors".

[Execute Later]	Only correction of a phenomenon of "Out-of-Register Colors" is performed on completion of the first printing after the printer is turned on.
[Execute Immediately (Level 1)]	Only correction of a phenomenon of "Out-of-Register Colors" is performed immediately after the printer is turned on.
[Execute Immediately (Level 2)]	Calibration and correction of "Out-of-Register Colors" are performed immediately after the printer is turned on.

2 Click [OK]

IMPORTANT

- When [Execute Later] is selected

If correction of a phenomenon of "Out-of-Register Colors" is performed for some reason before the printer is turned ON and performs first printing, another correction of a phenomenon of "Out-of-Register Colors" is not performed after completion of the first printing even if [Execute Later] is selected.

- When [Execute Immediately (Level 1)] or [Execute Immediately (Level 2)] is selected

Calibration and correction of "Out-of-Register Colors" may not be performed immediately after the printer is turned on depending on the inside state of the printer.

- When less than eight hours has elapsed from the time the printer was turned Off until the time the printer was turned On again.

Calibration or correction of a phenomenon of "Out-of-Register Colors" may not be performed immediately after the printer is turned On or after completion of the first printing.

- When eight or more hours has elapsed from the time the printer entered the sleep mode until the time the sleep mode was canceled

Calibration or correction of a phenomenon of "Out-of-Register Colors" will be performed according to the setting of [Quality Correction] when the sleep mode is canceled.

- * Depending on your environment, calibration or correction of a phenomenon of "Out-of-Register Colors" may be performed even if less than eight hours has elapsed.

Other behaviors

Image density correction control / Image gradation correction control

- During toner cartridge replacement
- After a specified sheet number printing (200 sheets)
- If there is major environment change
- after the printing is completed, or 300 minutes after Image density correction control (D-max control)
- If there is calibration execution instruction from user.

MEMO

- When the calibration is executed, sheet counter reading and elapsed time timer are cleared.
- Calibration is not executed in sleep mode.

Color displacement correction

- When closing the door after toner cartridge replacement
- After a specified sheet number printing (150 sheets)
- 60 minutes after the power is turned ON
- 240 minutes after the printing is completed, or 240 minutes after color displacement adjustment control execution
- If there is major environment change

MEMO

- When the calibration is executed, sheet counter reading and elapsed time timer are cleared.
- Calibration is not executed in sleep mode.

The following is the sequences of this control.

- 1) DC controller calculates the degree of each color displacement by the color displacement detection pattern made on ITB and sends the color displacement information to main controller.
- 2) Main controller controls the each color video signal according the color displacement data

and adjusts the write start position in main scanning direction, the magnification in main scanning direction and the write start position in sub scanning direction.

At printer engine side, DC controller PCB also controls the scanner motor speed to correct the color displacement in sub scanning direction.

Scanning magnification

This indicates the image size in the main scanning direction.

Since this machine is equipped with the independent photosensitive drum for each color, the photosensitive drum position differs due to the toner cartridge variation and that leads to the laser wave length difference. Thus, image range differs depending on a color in main scanning direction so that the color displacement occurs at the edge of the image.

Drum Cartridge

Developing roller engagement/disengagement control

The developing cylinder engagement/disengagement control engages the required developing cylinder with the photosensitive drum according to the print mode, full-color mode or monochrome mode.

The necessary developing cylinder is engaged with the photosensitive drum only when required, preventing a deterioration of the drums and making maximum use of the life. The engagement/disengagement of the developing cylinder is controlled by the DC controller rotating the main motor and changing the direction of the developing disengagement cam. The DC controller controls the developing cylinder state, whether engaged or disengaged, by counting the main motor rotation after it detects the signal from the developing homeposition sensor.

All four colors' developing cylinders disengage from the photosensitive drums when the printer is turned on and when a print operation is completed. All four colors' developing cylinders engage with the photosensitive drums when the full-color mode is designated. Only black's developing cylinder engages with the photosensitive drum when the monochrome mode is designated.

The DC controller determines an abnormality of the developing cylinder engagement/disengagement function and notifies the main controller when it does not sense the signal from the developing homeposition sensor for a specified period during the developing cylinder engagement/disengagement operation.

Transfer Unit

Pad transfer

The printer has a pad transfer method for the primary transfer operation.

The pad transfer method stabilizes an image compared to the conventional separation roller method. The features for the pad transfer method are as follows:

The wider nip width between the transfer pad and the photosensitive drum improves the transfer performance.

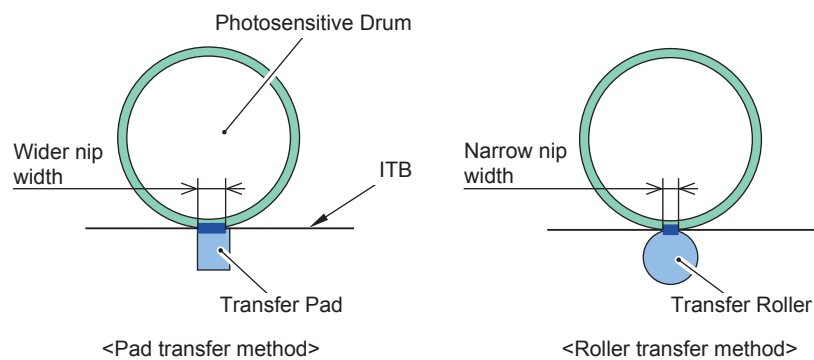

F-2-15

Fixing System

Overview

Overview

The fixing power supply controls the temperature in the fixing assembly. The printer uses an on-demand fixing method.

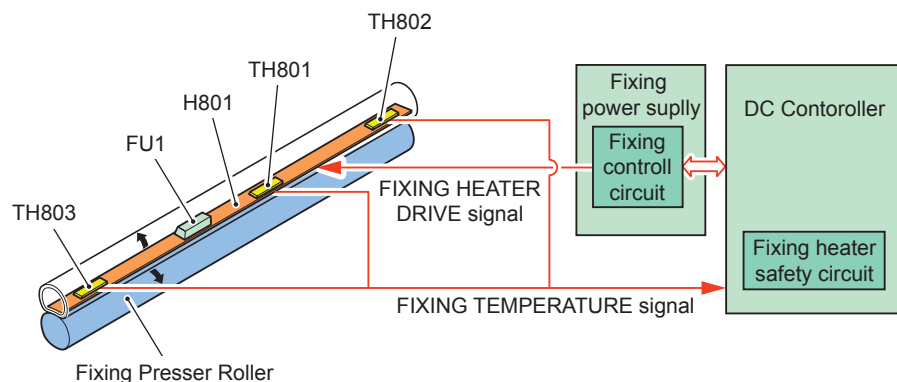

F-2-16

- Heater (H801): Heats the fixing film
- Main Thermistor (T801): for detecting the temperature of the Fixing Film(Contact Thermistor)
- Sub Thermistor (T802): for detecting the temperature of the Fixing Film(Contact Thermistor)
- Sub Thermistor (T803): for detecting the temperature of the Fixing Film(Contact Thermistor)
- Thermal fuse (FU1): Prevents the fixing heater temperature from rising abnormally high

The thermal fuse is located at the center of the fixing heater.

If the temperature of the fixing heater rises abnormally high, the thermal fuse blows to interrupt power supply to the fixing heater.

These temperature controls in the fixing assembly are performed by the fixing control circuit and the fixing heater safety circuit according to the commands from the DC controller.

Various Control Mechanisms

Controlling the Speed of Fixing Assembly

The speed control of small size paper (throughput down control)

This is a control to prevent the abnormal temperature rising of the fixing heater end side when printing continuously using less than A4 size width paper.

If the paper width is less 210 mm (A4 size) is printed continuously, it adjusts the number of the sheets printed, spread the pickup interval and slow the throughput.

Setting on the driver	Paper type	Paper	Print speed (ppm)
Normal paper	Normal paper (70 to 90g/m2)	LTR	21.0 < 10.2 < 6.7 < 5.0 < 3.3
		LGL	17.1 < 9.2 < 6.3 < 4.7 < 3.2
Normal paper L	Thin paper (60 to 74g/m2)	LTR	21.0 < 10.2 < 6.7 < 5.0 < 3.3
		LGL	17.1 < 9.2 < 6.3 < 4.7 < 3.2
Heavy paper 1	Thick paper (86 to 119g/m2)	LTR	21.0 < 10.2 < 6.7 < 5.0 < 3.3
		LGL	17.1 < 9.2 < 6.3 < 4.7 < 3.2
Heavy paper 2	Thick paper (120 to 128g/m2)	LTR	21.0 < 10.2 < 6.7 < 5.0 < 3.3
		LGL	17.1 < 9.2 < 6.3 < 4.7 < 3.2
Heavy paper	Thick paper (129 to 176g/m2)	LTR	9.9 < 6.7 < 4.9 < 3.9 < 2.7
		LGL	8.3 < 5.8 < 4.4 < 3.6 < 2.6
Coat paper 1	Coat paper (100 to 110g/m2)	LTR	6.9 < 5.1 < 4.0 < 3.3 < 2.5
		LGL	5.6 < 4.3 < 3.5 < 3.0 < 2.3
Coat paper 2	Coat paper (120 to 130g/m2)	LTR	6.9 < 5.1 < 4.0 < 3.3 < 2.5
		LGL	5.6 < 4.3 < 3.5 < 3.0 < 2.3
Coat paper 3	Coat paper (155 to 165g/m2)	LTR	6.9 < 5.1 < 4.0 < 3.3 < 2.5
		LGL	5.6 < 4.3 < 3.5 < 3.0 < 2.3

LBP7210Cdn

Setting on the driver	Paper type	Paper	Print speed (ppm)
Normal paper	Normal paper (70 to 90g/m2)	LTR	21.0 < 10.2 < 6.7 < 5.0 < 3.3
		LGL	17.1 < 9.2 < 6.3 < 4.7 < 3.2
Normal paper L Normal paper L2	Thin paper (60 to 74g/m2) Thin paper (60g/m2)	LTR	21.0 < 10.2 < 6.7 < 5.0 < 3.3
		LGL	17.1 < 9.2 < 6.3 < 4.7 < 3.2
Heavy paper 1	Thick paper (86 to 119g/m2)	LTR	21.0 < 10.2 < 6.7 < 5.0 < 3.3
		LGL	17.1 < 9.2 < 6.3 < 4.7 < 3.2
Heavy paper 2	Thick paper (120 to 128g/m2)	LTR	21.0 < 10.2 < 6.7 < 5.0 < 3.3
		LGL	17.1 < 9.2 < 6.3 < 4.7 < 3.2
Heavy paper	Thick paper (129 to 176g/m2)	LTR	9.9 < 6.7 < 4.9 < 3.9 < 2.7
		LGL	8.3 < 5.8 < 4.4 < 3.6 < 2.6
Coat paper 1	Coat paper (100 to 110g/m2)	LTR	6.9 < 5.1 < 4.0 < 3.3 < 2.5
		LGL	5.6 < 4.3 < 3.5 < 3.0 < 2.3
Coat paper 2	Coat paper (120 to 130g/m2)	LTR	6.9 < 5.1 < 4.0 < 3.3 < 2.5
		LGL	5.6 < 4.3 < 3.5 < 3.0 < 2.3

Setting on the driver	Paper type	Paper	Print speed (ppm)
Coat paper 3	Coat paper (155 to 165g/m2)	LTR	6.9 < 5.1 < 4.0 < 3.3 < 2.5
		LGL	5.6 < 4.3 < 3.5 < 3.0 < 2.3
Coat paper 4	Coat paper (210 to 220g/m2)	LTR	6.9 < 5.1 < 4.0 < 3.3 < 2.5
		LGL	5.6 < 4.3 < 3.5 < 3.0 < 2.3

Fixing temperature control

The fixing control circuit brings the fixing heater temperature at the targeted temperature.

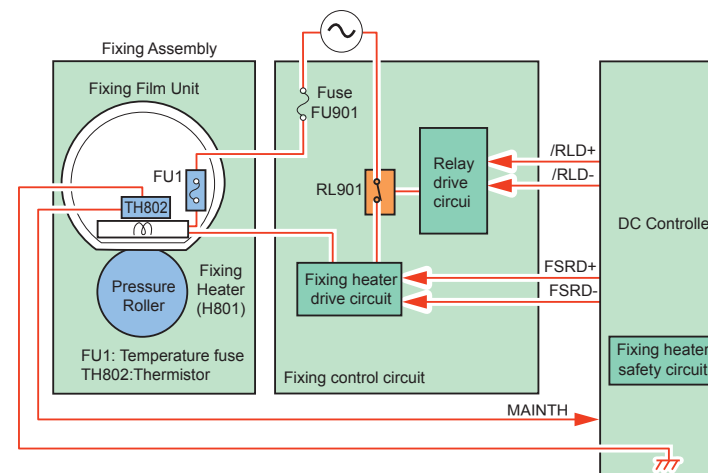

F-2-17

The DC controller monitors the FIXING HEATER TEMPERATURE (MAINTH) signal and sends the FIXING HEATER DRIVE (FSRD+, FSRD-) signals according to the detected temperature. The fixing heater drive circuit controls the fixing heater depending on the signals so that the heater remains at the targeted temperature.

1) Warm up temperature control

This control is to warm up the fixing heater until the fixing temperature reaches the required fixing temperature.

Warm up temperature differs depending on the elapsed time from the previous print, paper type or environment.

2) Print temperature control

This control is to keep the fixing sleeve temperature at a targeted temperature during printing. Target temperature of fixing sleeve differs, depending on the paper type.

3) Paper interval temperature control

This control is to bring the fixing heater temperature lower than the fixing temperature at paper interval to prevent the pressure roller from overheating during continuous printing in low speed mode at paper interval.

Temperature during paper interval is changed corresponding to the distance and paper type.

Protective Functions

Protective function

The protective function detects an abnormal temperature rise of the fixing assembly and interrupts power supply to the fixing heater.

The following three protective components prevent an abnormal temperature rise of the fixing heater:

- DC controller
- Fixing heater safety circuit
- Thermal fuse

1) DC controller

The DC controller monitors the detected temperature of the thermistor located at the center of the fixing heater. The DC controller sets the FIXING HEATER DRIVE (FSRD+, FSRD-) signals to inactive and releases the relay to interrupt power supply to the fixing heater under the following condition:

- Thermistor: 230 deg C or higher

2) Fixing heater safety circuit

The fixing heater safety circuit monitors the detected temperature of the thermistor located at the center of the fixing heater. The fixing heater safety circuit releases the relay to interrupt power supply to the fixing heater under the following condition:

- Thermistor: 240 deg C or higher

3) Thermal fuse

When the temperature of the fixing heater rises abnormally high and the detected temperature of the thermal fuse is the following condition, the fuse blows to interrupt power supply to the fixing heater:

- Thermal fuse: 226 deg C or higher

Fixing assembly failure detection

The DC controller determines a fixing assembly failure, sets the FIXING HEATER DRIVE (FSRD+, FSRD-) signals to inactive, releases the relay to interrupt power supply to the fixing heater and notifies the main controller of a fixing assembly failure when it encounters the following conditions:

1) Start-up failure

- If the detected temperature of the thermistor does not reach 40 deg C within a specified period from the heater energization during the wait period.

- If the detected temperature of the thermistor does not reach 70 deg C within a specified period after it once reaches 40 deg C after the heater energization during the wait period.
- If the detected temperature of the thermistor does not reach the targeted temperature within a specified period under the heater temperature control during the initial rotation period.

2) Abnormal low temperature

- If the detected temperature of the thermistor is kept 100 deg C or lower for a specified period under the heater temperature control during the print period.

3) Abnormal high temperature

- If the detected temperature of the thermistor is kept 230 deg C or higher for a specified period.

4) Fixing heater drive circuit failure

- If the specified count of the ZERO CROSSING signal is not detected within a specified period after the printer is turned on.
- If the ZERO CROSSING signal is not detected for a specified period during the print period after the signal is once detected after the printer is turned on.

Pickup/Feed/Delivery System

Construction

Overview

In the pickup/feeding system, each type of feeding roller is configured in the part where printing paper feeding and pickup are conducted.

The main configuration for pickup/feeding system is as the following.

<Pickup slot>

- Cassette
- Manual feed pickup slot

<Delivery slot>

- Face down tray

<Feeding system motor>

- Drum motor (M1)
- Registration motor (M3)
- Fixing motor (M4)
- Pickup motor (M5)

<Pickup system solenoid>

- Manual feed tray pickup solenoid (SL1)
- Cassette pickup solenoid (SL2)
- Duplex reversal solenoid (SL5)

<Feeding system clutch>

- Manual feeding tray feeding clutch (CL1)
- Duplex delivery clutch (CL2)

<Feeding system sensor>

- Registration sensor (SR4)
- Manual feed tray pre-registration sensor (SR7)
- Fixing delivery sensor (SR8)
- Fixing loop sensor (SR10)
- Pre-registration sensor (SR12)
- Cassette paper sensor (SR13)
- Manual feed paper sensor (SR14)
- Delivery full sensor (SR15)

The following are the outline figure for each motor, solenoid, and sensor.

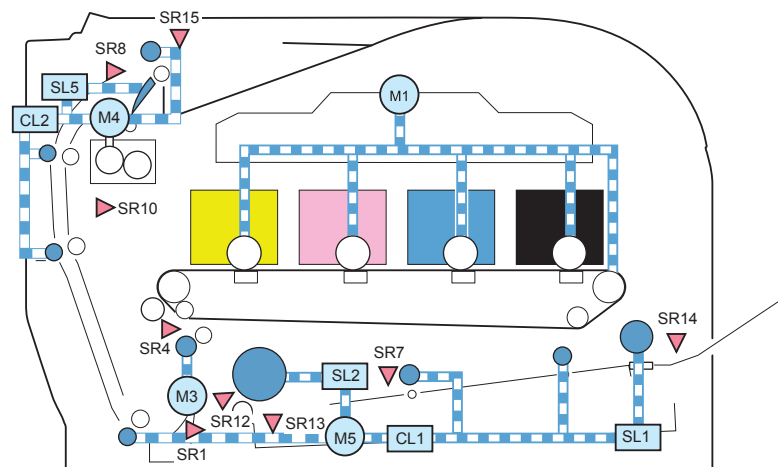

Name		Signal name	Driver
Drum motor	M1	Drum motor driver signal	DC Controller
Registration motor	M3	Registration motor driver signal	DC Controller
Fixing motor	M4	Fixing motor driver signal	DC Controller
Pickup motor	M5	Pickup motor driver signal	DC Controller
Manual feed trayPickup solenoid	SL1	Manual feed trayPickup solenoid control signal	DC Controller
Cassette pickup solenoid	SL2	Cassette pickup solenoid driver signal	DC Controller
Duplex reversal solenoid	SL5	Duplex reversal solenoid driver signal	DC Controller
Paper feederPre-registration sensor	SR1	Paper feeder pre-registration detection signal	DC Controller
Registration sensor	SR4	Registration detection signal	DC Controller
Manual feed trayPre-registration sensor	SR7	Manual feed tray Pre-registration detection signal	DC Controller
Fixing delivery sensor	SR8	Fixing delivery detection signal	DC Controller
Fixing loop sensor	SR10	Fixing loop detection signal	DC Controller
Pre-registration sensor	SR12	Pre-registration detection signal	DC Controller
Cassette paper sensor	SR13	Cassette paper detection signal	DC Controller
Manual feedPaper sensor	SR14	Manual feed paper detection signal	DC Controller
Delivery full sensor	SR15	Delivery full detection signal	DC Controller
Manual feed trayFeeding clutch	CL1	Manual feed trayFeeding clutch control signal	DC Controller
Duplex feeding clutch	CL2	Duplex feeding clutch control signal	DC Controller

T-2-2

Detecting Jam

Jam Detection Outline

Outline

The following is the detection sensors for paper, to detect whether there is paper or not, and whether the paper is properly fed.

- Registration detection sensor
- Multi manual feed tray pre registration detection sensor
- Fixing delivery detection sensor
- Loop detection sensor
- Pre-registration detection sensor
- Cassette paper detection sensor
- Multi manual feed tray paper detection sensor
- Delivery full detection sensor
- Paper feeder pre-registration detection sensor

The following is the jam that detected by the host machine.

1. Pickup delay jam
2. Pickup stationary jam
3. Fixing delivery delay jam
4. Delivery stationary jam
5. Fixing wrapping-over jam
6. Inside stationary jam.
7. Duplex re-pickup jam.
8. Door open jam.

Delay Jams

● Pickup delay jam 1

If the registration sensor (SR4) cannot detect the paper leading edge after the image format starts until the re-pickup is started.

● Pickup delay jam 2

The manual feed tray pre-registration sensor (SR7) cannot detect the paper leading edge within a specified time after manual feed tray pickup starts.

● Fixing delivery delay jam

The fixing delivery sensor (SR8) cannot detect the paper leading edge within a specified time after the re-pickup starts.

The delivery full sensor (SR15) cannot detect the paper leading edge within a specified time after the registration sensor (SR4) detects the paper trailing edge.

Stationary Jams

● Pickup stationary jam

If the registration sensor (SR4) cannot detect the paper trailing edge after the re-pickup is started.

● Fixing delivery stationary jam

If within a specified time after the registration sensor (SR4) detects the paper trailing edge, the fixing delivery sensor (SR8) cannot detect the paper trailing edge.

Other Jams

● Fixing wrapping-up jam

If the fixing delivery sensor (SR8) cannot detect the paper, after it detects paper leading edge until the fixing delivery stationary starts the detection.

● Inside stationary jam 1

If during power ON/door close, paper feeder pre-registration sensor (SR1)/registration sensor (SR4)/manual feed tray registration sensor (SR7)/fixing delivery sensor (SR8)/fixing loop sensor (SR10)/pre-registration sensor (SR12)/cassette paper sensor (SR13) detect paper.

● Inside stationary jam 2

If before/after printing, paper feeder pre-registration sensor (SR1)/registration sensor (SR4)/manual feed tray registration sensor (SR7)/fixing delivery sensor (SR8)/fixing loop sensor (SR10)/pre-registration sensor (SR12) detect paper.

● Duplex re-pickup jam

If the registration sensor (SR4) cannot detect the paper leading edge in a specified time after reversal starts.

● Door open jam

During printing, if each sensor detects paper when the door-open is detected.

Cassette Pickup Unit

■ Separation Roller Method

The printer has a separation roller method to prevent multiple sheets of media from entering to the printer.

The paper separation roller follows the rotational direction of the pick-up roller because it does not have its own driving force.

- Normal-feed

The separation roller is driven by the pickup roller through a sheet of print media. That is, the separation roller rotates in the media feed direction.

- Multiple-feed

The low friction force between the sheets weakens the rotational force from the pickup roller. The separation roller is limited its rotational force and it does not rotate with such weak driving force from the pickup roller. As the separation roller does not rotate, the multiple sheets are not fed to the printer.

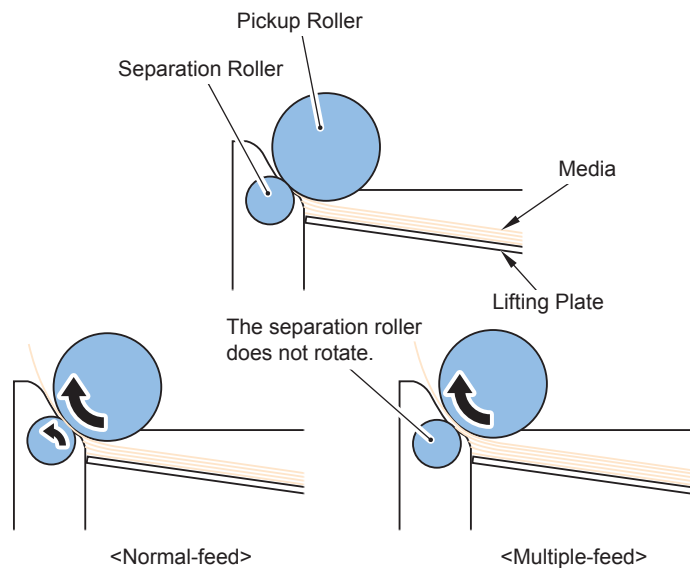

F-2-18

Controller System

Construction

Outline

The DC controller controls the operational sequence of the printer.

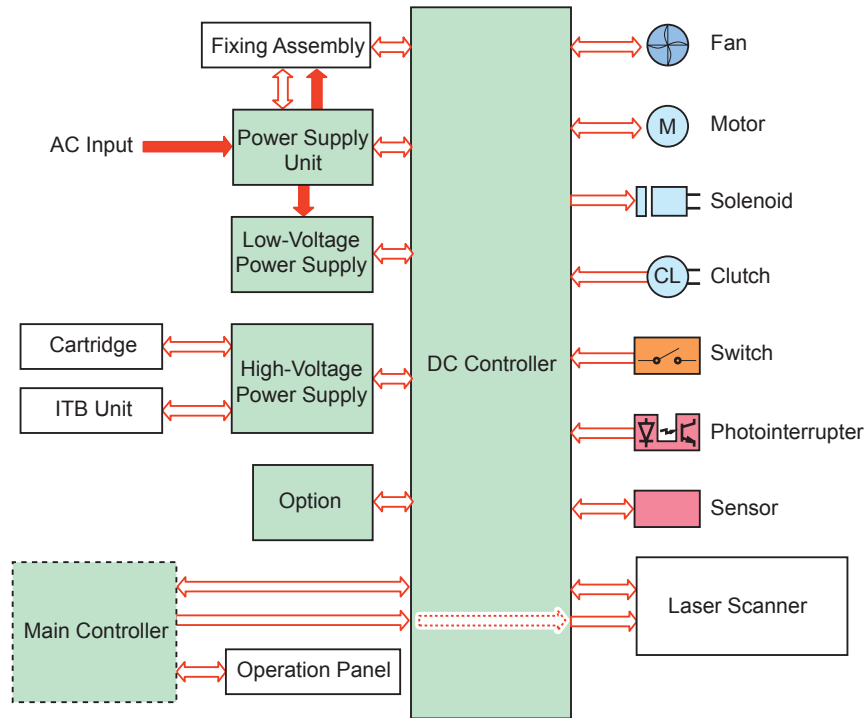

F-2-19

Symbol for component		Name
Motor	M1	Drum motor
	M2	Developing motor
	M3	Registration motor
	M4	Fixing motor
	M5	Pickup motor
	M7	Scanner motor
FAN	FM1	Fixing/Fixing power supply cooling fan
	FM2	Duplex cooling fan

Symbol for component		Name
Solenoid	SL1	Bypass tray pickup solenoid
	SL2	Cassette pickup solenoid
	SL3	Developing separation solenoid
	SL5	Duplex reversal solenoid
	SL6	Paper feeder pickup solenoid
	Sensor	SR1
SR2		Front door open/close sensor
SR3		Paper feeder paper detection sensor
SR4		Registration detection sensor
SR6		Developing HP sensor
SR7		Bypass tray pre registration detection sensor
SR8		Fixing delivery sensor
SR9		Fixing pressure release sensor
SR10		Fixing loop sensor
SR12		Pre-registration detection sensor
SR13		Cassette paper detection sensor
Clutch	SR14	Bypass paper detection sensor
	SR15	Delivery full sensor
	SR16	ITB pressure release sensor
	CL1	Bypass tray feeding clutch
	CL2	Duplex feeding clutch

T-2-3

Motor control

The printer has five motors. The motors are used for the media feeding and image formation.

Name		Driving parts	Failure detection
Drum motor	M1	Photosensitive drum, ITB	Available
Developing motor	M2	Developing Cylinder, developing disengagement assembly	Available
Registration motor	M3	Registration roller	NA
Fixing motor	M4	Pressure roller, delivery roller, duplex feeding roller	Available
Pickup motor	M5	Pickup roller, multi manual feed feeding roller, multi manual feed pickup roller	NA

T-2-4

Safety

The printer detects the door open and close status by monitoring the door open detection sensors.

The DC controller stops driving the motors and solenoids if the sensor detects a door open.

Main Controller(LBP7600C/7660Cdn/7680Cx)

Outline

The main controller receives print information from external devices (e.g., host computer) by way of interface cables. The information contains a CAPT command used to communicate printer status and printer-specific characteristics and dot data, which is the result of conversion of print data by the host computer.

The data is sent to the DC controller circuit for control of laser diode activation.

If properly connected with a bi-directional interface, an external device may be used to check the printer status.

When printing is executed in a Microsoft Windows or Macintosh environment, CAPT (Canon Advanced Printing Technology) serves to reduce processing speed and enhance the ease of operation to provide a user-friendly printing environment. To that end, CPU is designed for the following:

The following figure shows the block diagram of the DC controller.

- The print data from the application is turned into dot data and sent to the printer without conversion into the printer's page description language (PDL).
- The printing environment may be checked and set on the host computer display by responding to dialog boxes.
- The printer status is indicated on the host computer screen: print end time, print paper movement, error status.

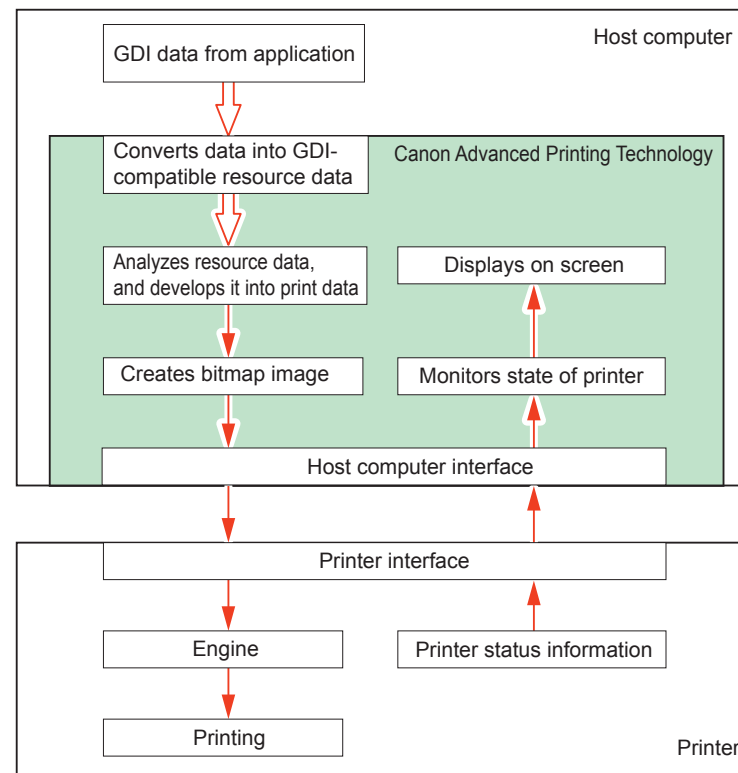

F-2-20

Note

GDI (graphics device interface)
It is a graphical interface used in a Windows environment for printing and screen display (also for the application being in use).

Overview of the Block

LBP7600C/7660Cdn

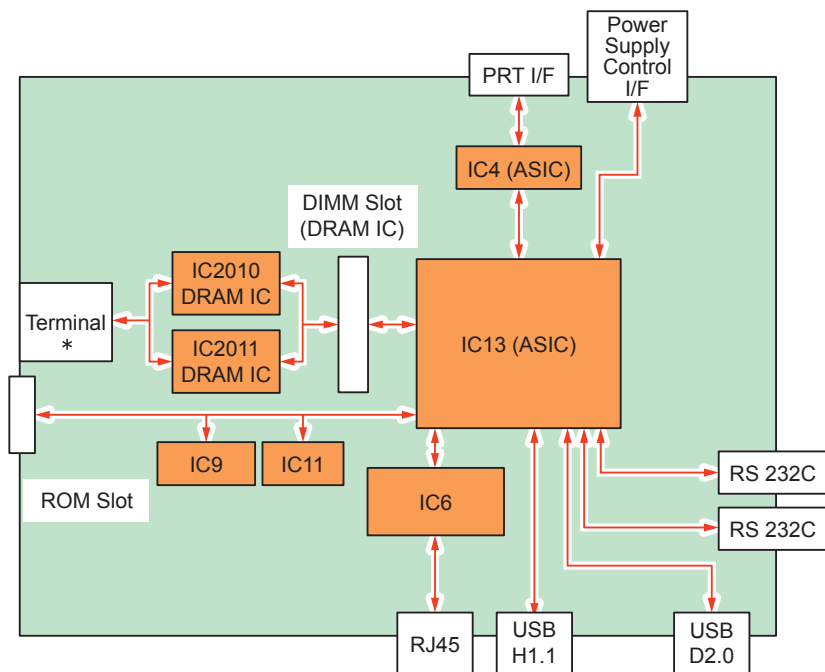

F-2-21

LBP7680Cx

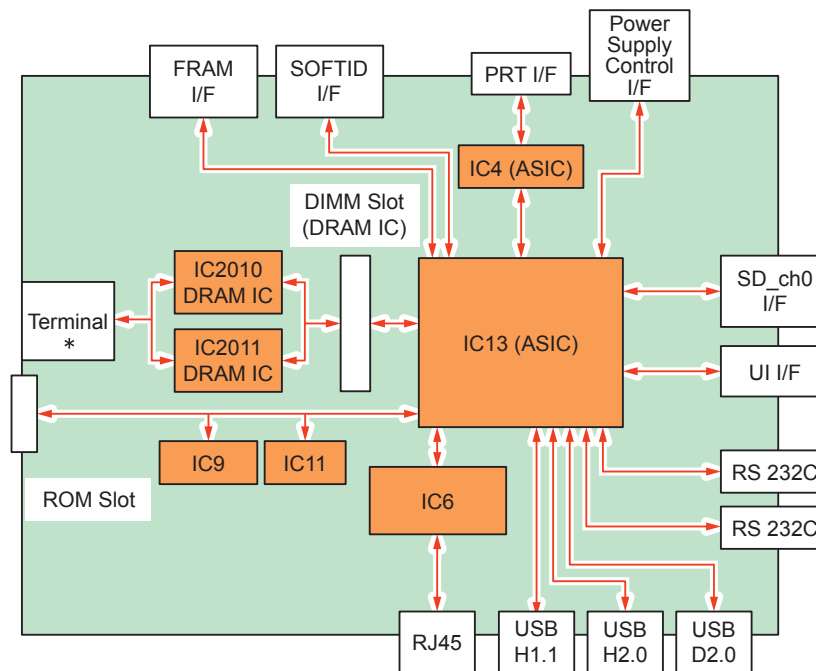

F-2-22

No.	Name	Description
IC4	ASIC	IC for processing image data and sending video output to the Printer Engine
IC6	ETHERNET CONTROLLER IC	IC for controlling communication of Ethernet
IC9	FLASH MEMORY IC	Nonvolatile memory for storing programs for executing various functions
IC11	FLASH MEMORY IC	Nonvolatile memory for storing the startup program of IC13
IC13	ASIC	IC including a processor core and having functions such as real-time image processing, PDL rendering, memory control, various IO control, and external IF control
IC2010	DRAM IC	IC13 main memory and image data storage memory
IC2011	DRAM IC	Image data storage memory

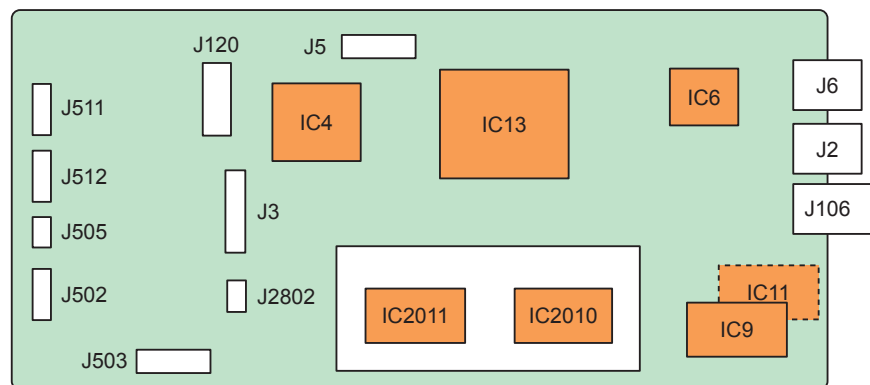

F-2-23

Main Controller(LBP7210Cdn)

Outline

The main controller receives print information from external devices (e.g., host computer) by way of interface cables. The information contains a CAPT command used to communicate printer status and printer-specific characteristics and dot data, which is the result of conversion of print data by the host computer.

The data is sent to the DC controller circuit for control of laser diode activation.

If properly connected with a bi-directional interface, an external device may be used to check the printer status.

When printing is executed in a Microsoft Windows or Macintosh environment, CAPT (Canon Advanced Printing Technology) serves to reduce processing speed and enhance the ease of operation to provide a user-friendly printing environment. To that end, CPU is designed for the following:

- The print data from the application is turned into dot data and sent to the printer without conversion into the printer's page description language (PDL).
- The printing environment may be checked and set on the host computer display by responding to dialog boxes.
- The printer status is indicated on the host computer screen: print end time, print paper movement, error status.

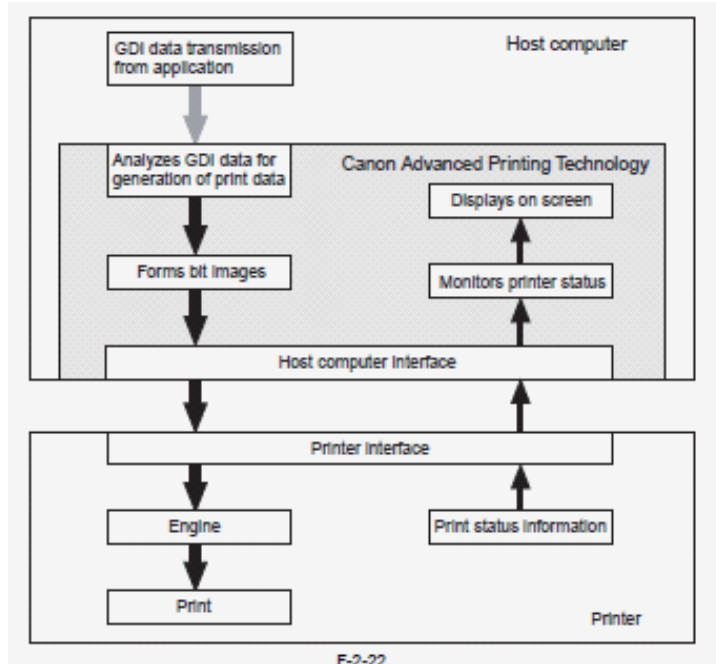

F-2-24

GDI (graphics device interface)

It is a graphical interface used in a Windows environment for printing and screen display (also for the application being in use).

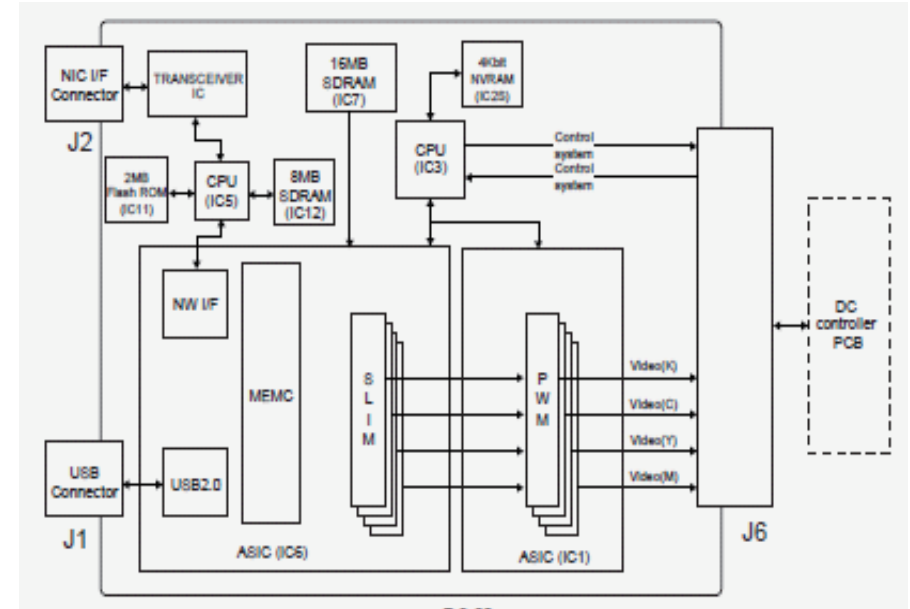

F-2-25

No.	Name	Description
IC1	ASIC	handle the image data
IC3	CPU	Controls the board.
IC5	CPU	Control the network
IC6	ASIC	Serves as an IC for USB device controller, memory controller, main controller, and NIC interface controller.
IC7	SDRAM	Retains image data.
IC11	Flash ROM	Network system order firmware storage
IC12	SDRAM	Retains image data.
IC2S	NVRAM	Serves to retain image data.

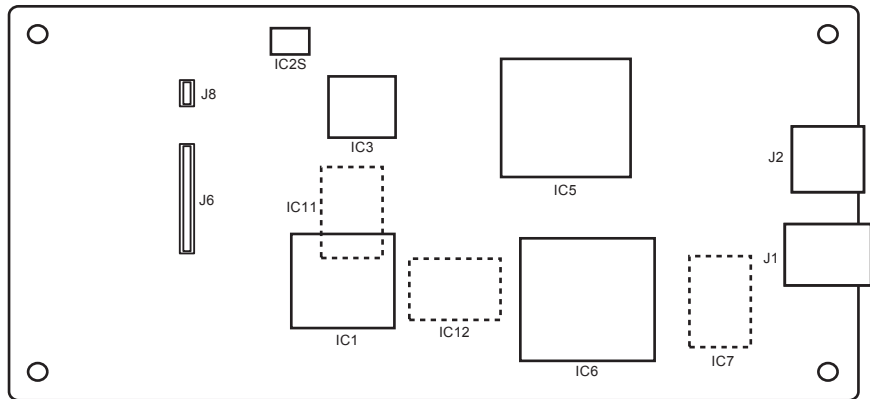

F-2-26

Power Supply

Low-voltage power supply

The low-voltage power supply and the fixing power supply convert AC power from the power receptacle into DC power to cover the DC loads.

- Low-voltage power supply:

Generates DC power required in the printer

- Fixing power supply:

Supplies AC power to the low-voltage power supply

Controls the fixing heater temperature in the fixing assembly

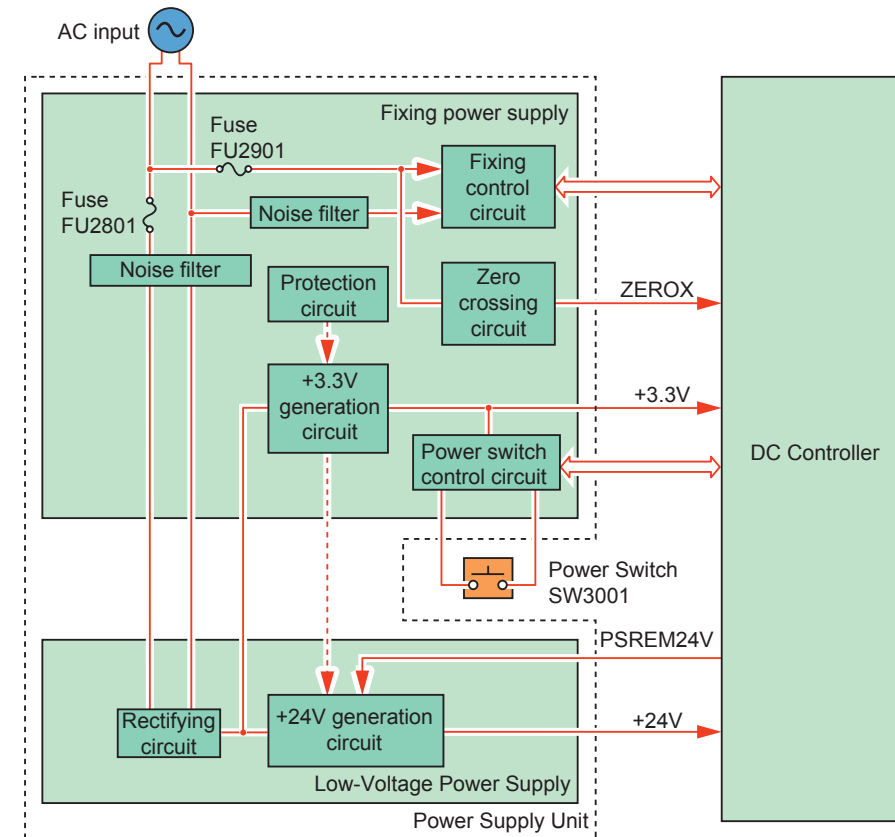

F-2-27

For low pressure power, insert the AC power in the inlet, switch the power ON, and it will start. The AC power generates +3.3V in the fixing power, +24V in the low pressure power, and supplies to the host machine.

Other function

Protective function

The low-voltage power supply has a protective function against overcurrent and overvoltage to prevent failures in the power supply circuit. If there flows an overcurrent or overvoltage, the low-voltage system automatically cuts off the output voltage.

If the DC voltage is not being supplied from the low-voltage power supply, turn off the power switch and unplug the AC power cord. Do not turn the power switch on again until the root cause is found.

In addition, two fuses in the fixing power supply protect against overcurrent. If overcurrent flows into the AC line, the fuses blow and cut off the AC power.

Power-save mode

The power-save mode reduces power consumption of the printer.

When the low-voltage power supply receives the POWER SAVE (REM24V) signal from the DC controller, it stops the power supply from the +24V generation circuit.

Auto Shutdown(LBP7210Cdn)

You can configure the printer to shut down when the specified time is elapsed after entering the sleep mode.

IMPORTANT

Power consumption when the power is off (when the power switch is not pressed)

Even if the power of the printer is turned off, power is consumed only slightly while the power plug is inserted into the AC power outlet. To cut the power consumption completely, unplug the power plug from the AC power outlet.

Counter

This machine has the software counter which counts the number of prints/copies according to the job type. The counter value is displayed as follows: Press "Setting" key on the Control Panel, and select Set Up > COUNTER-Check on UI screen.

Default counters for each country (model) are listed below.

Counter No.	Definition	USA	OCEANIA	EUR	ASIA
101	Total 1	<input type="radio"/> (MODEL 1)	<input type="radio"/>	-	<input type="radio"/>
102	Total 2	<input type="radio"/> (MODEL 2)	-	-	
108	Total (Black 1)	<input type="radio"/> (MODEL 1)	<input type="radio"/>	-	<input type="radio"/>
109	Total (Black 2)	<input type="radio"/> (MODEL 2)	-	-	-
113	Total (Black/Small)	-	-	<input type="radio"/>	-
114	Total 1 (2-sided)	-	-	-	<input type="radio"/>
123	Total (Full Color + Single Color/ Small)	-	-	<input type="radio"/>	-
322	Print (Full Color + Single Color/ Small)	<input type="radio"/> *1	<input type="radio"/>	-	-

*1: On color machines, this is displayed regardless of settings for "MODEL 1" and "MODEL 2".

SSL

In this machine, there is not SSL which was made by default. It is necessary to make it from Remote UI when you use it.

Note:

SSL encrypted communication function

This is a function that enables exchange of encrypted data between this printer and a computer when performing IPP printing in which data is printed via a network or when using the Remote UI in which you manage the printer with the Web browser.

Using the SSL encrypted communication function achieves safer printing environments by preventing theft and falsification of data.

Caution:

When you are managing SSL, it disappears by board exchange. Therefore it is necessary to make it again.

A making procedure

There are two ways below.

Newly Creating a Key and Its Certificate

1. Start the Remote UI, and then log in as Administrator.

2. Select [Settings/Registration] > [Management Settings] > [Security] > [Key and Certificate Settings].

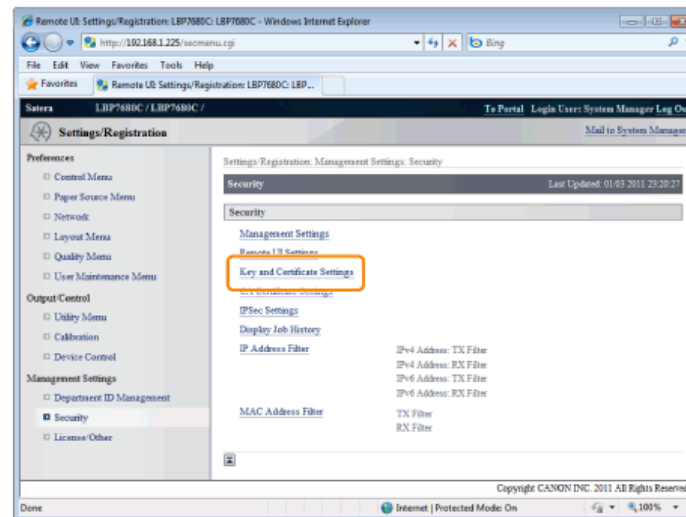

F-2-28

3. Click [Generate Key].

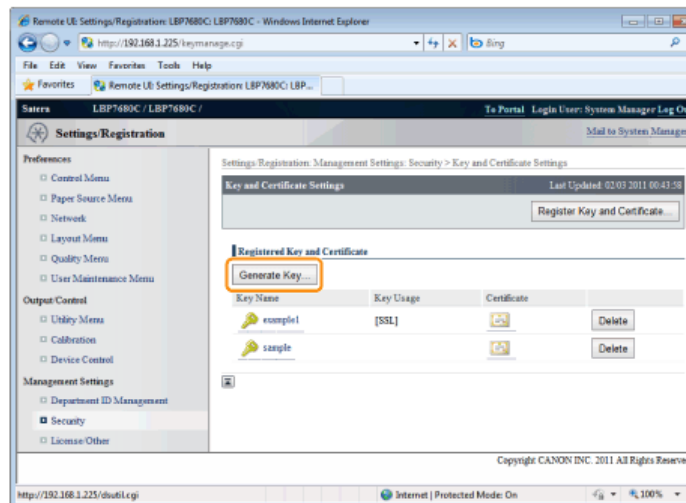

F-2-29

4. Enter the name of the key to be newly created. Up to 24 alphanumeric characters can be entered.

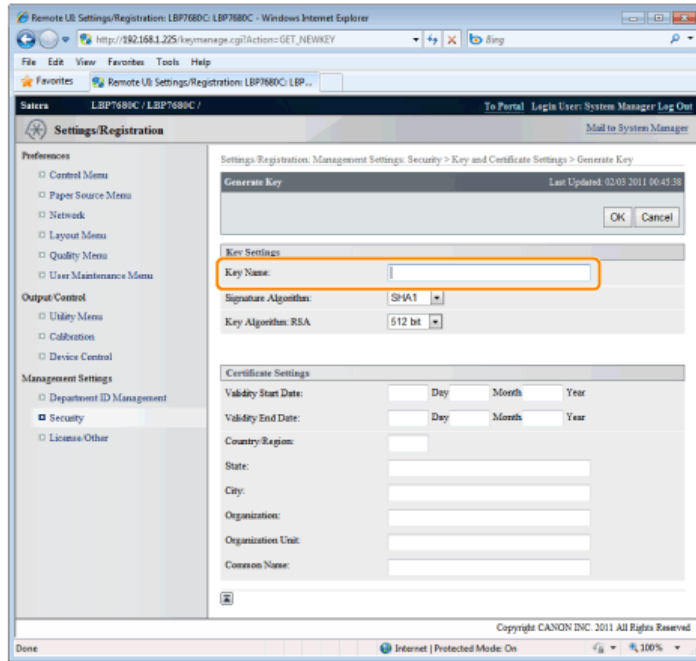

F-2-30

5. Select [Signature Algorithm]. Select from [512 bit], [1024 bit], [2048 bit], or [4096 bit].

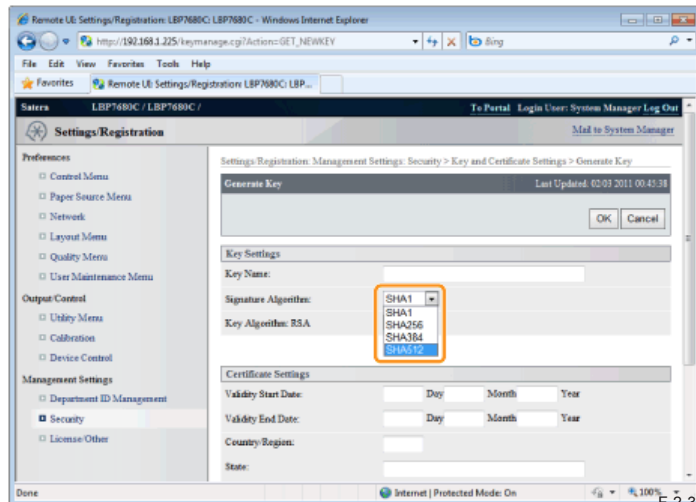

F-2-31

6. Select [Key Algorithm]. Select from [SHA1], [SHA256], [SHA384], or [SHA512]. For [SHA384] and [SHA512], you can create a key only when other than [512 bit] is selected for [RSA].

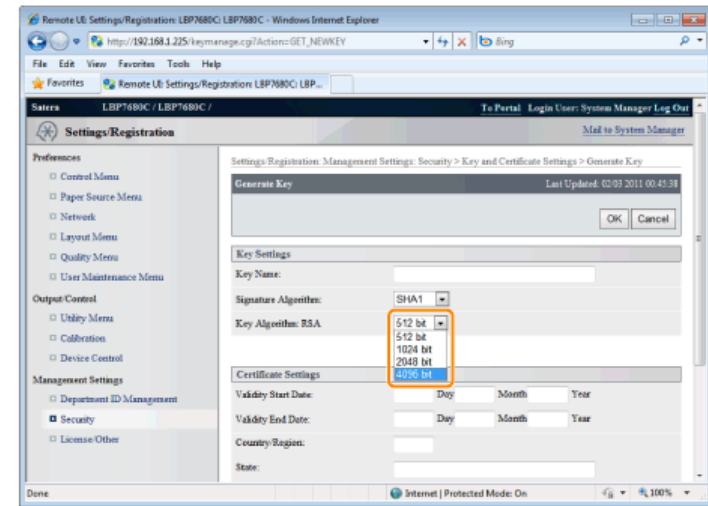

F-2-32

Note:

- Key Generation Algorithm
The generation algorithm when the printer generates a key is RSA.
- About the key length
Although using the longer key makes it more difficult to decode data, the processing speed on encryption and decryption is slower.

7. Specify the effective date and expiration date and the country/region name for the self-sign server certificate. Then click [OK]. → The key and certificate creation starts.

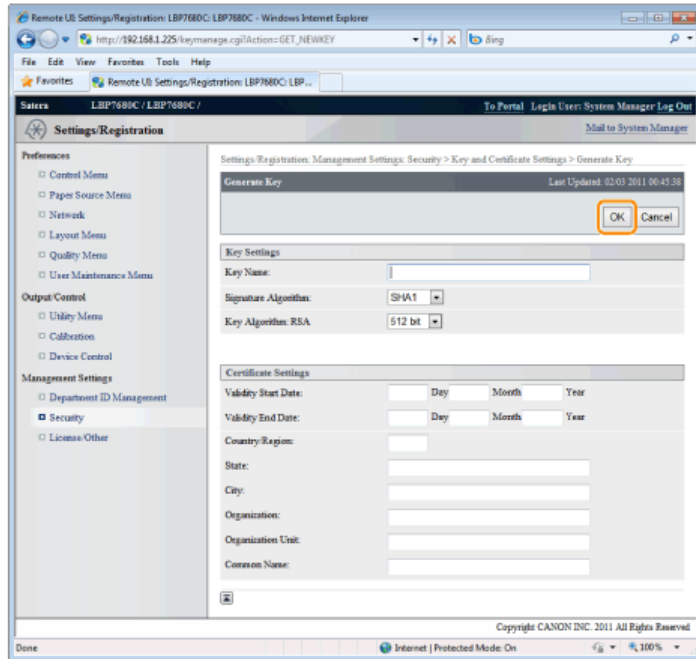

F-2-33

● Installing a Key/Certificate File on the Printer

If there are an extra Key and Certificate file, you can also install/register it from a PC.

1. Click [Register Key and Certificate].

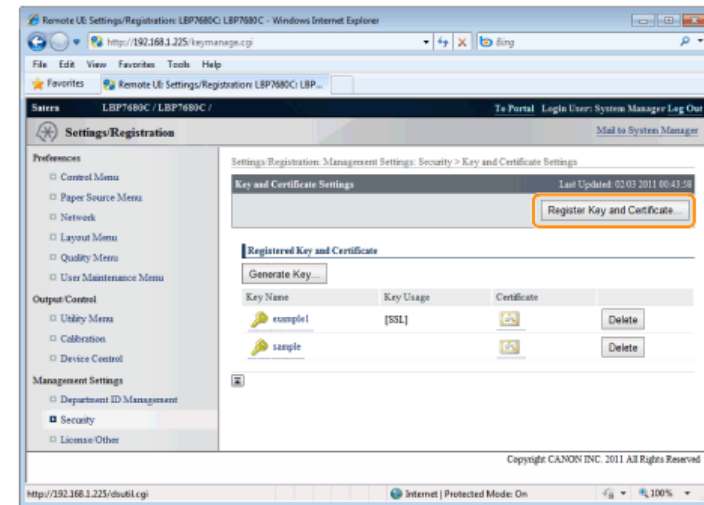

F-2-34

2. Click [Install].

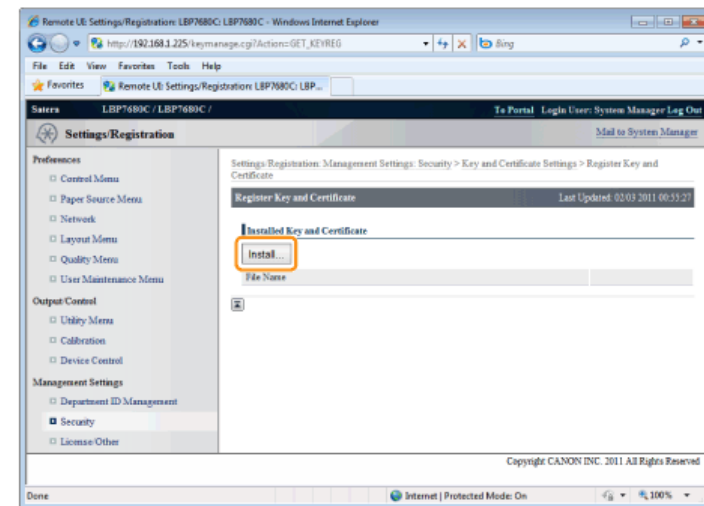

F-2-35

3. Specify the directory of a key/certificate file.

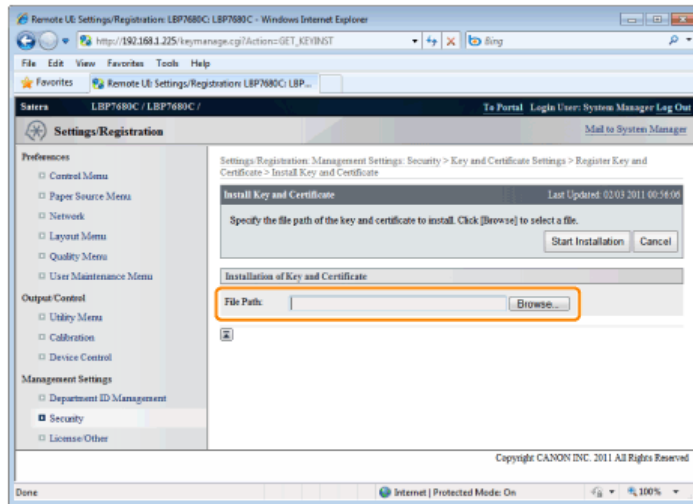

F-2-36

4. Click [Start installation].→ The installation of the key/certificate file starts

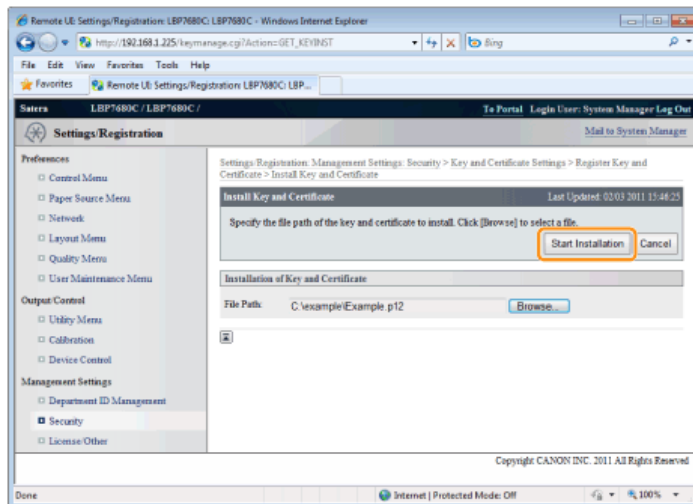

F-2-37

5. Click [Register Key and Certificate].

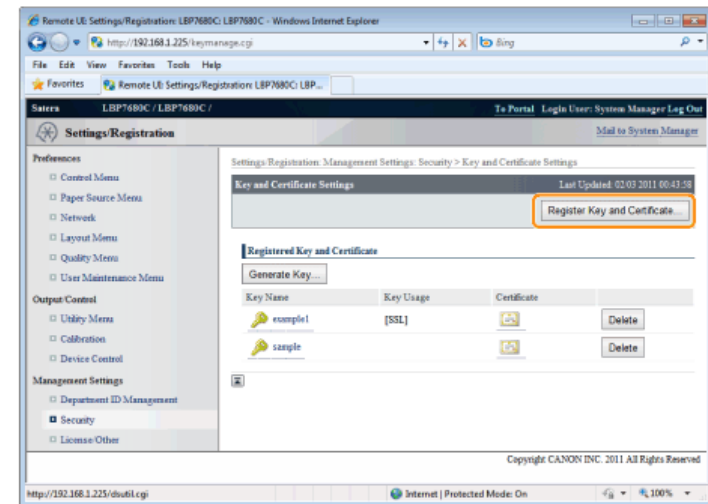

F-2-38

6. Click [Register].

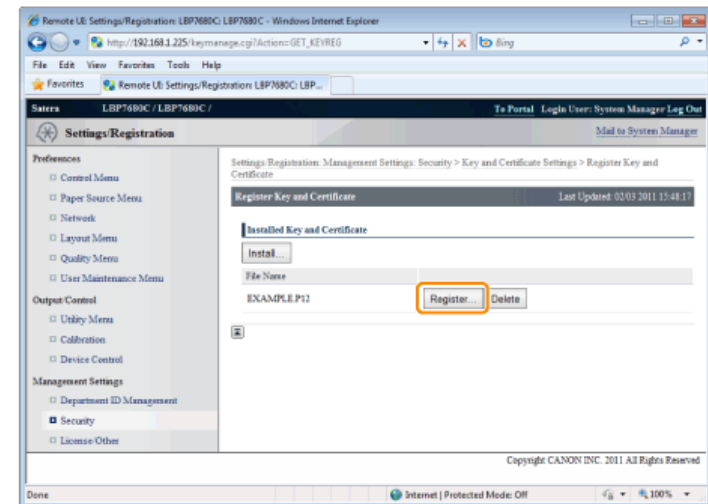

F-2-39

7. Enter the name of the key to be registered.

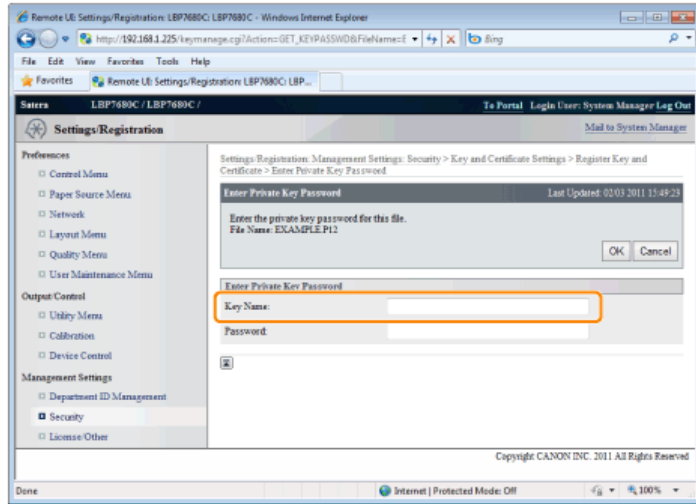

F-2-40

9. Click [OK]. → The key and certificate registration starts.

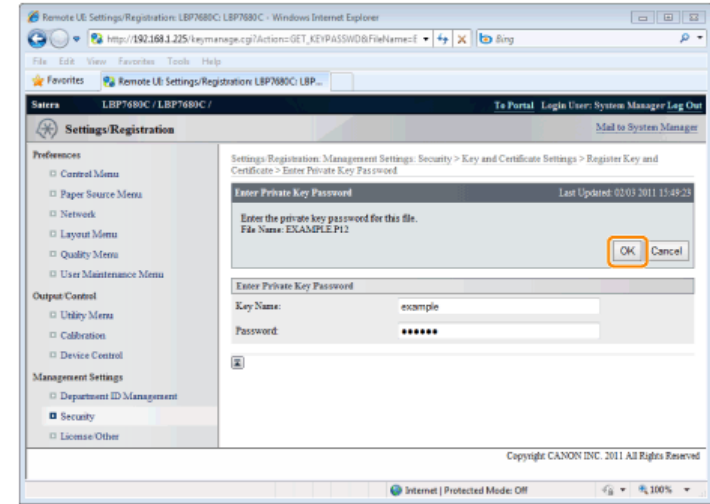

F-2-42

8. Enter the password specified for the private key.

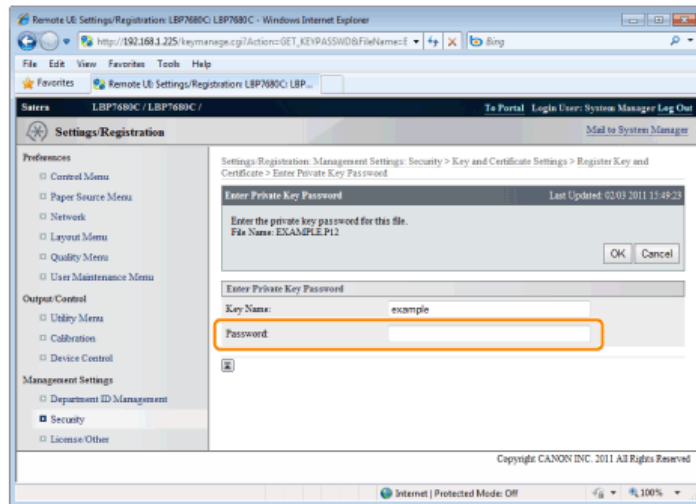

F-2-41

Setting the SSL Encryption Communication Function

Select the Key and Certificate which was made or registered by the method mentioned.

Selecting Keys and Certificates

1. Start the Remote UI, and then log in as Administrator.
2. Click [Settings/Registration].

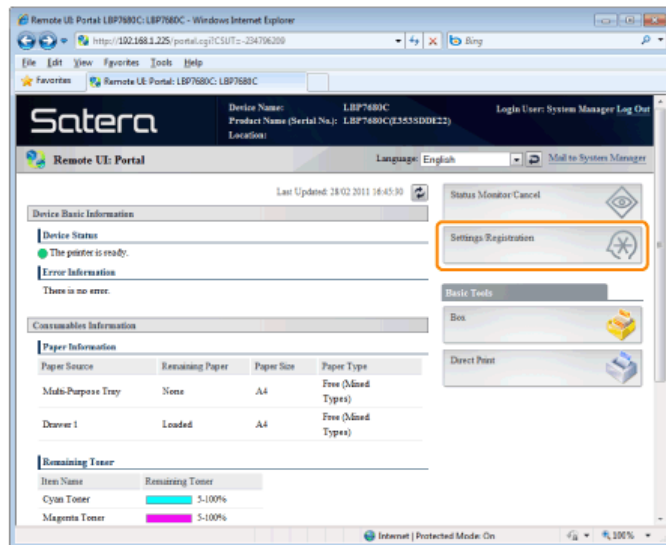

F-2-43

3. Select [Network] from the [Preferences] menu.

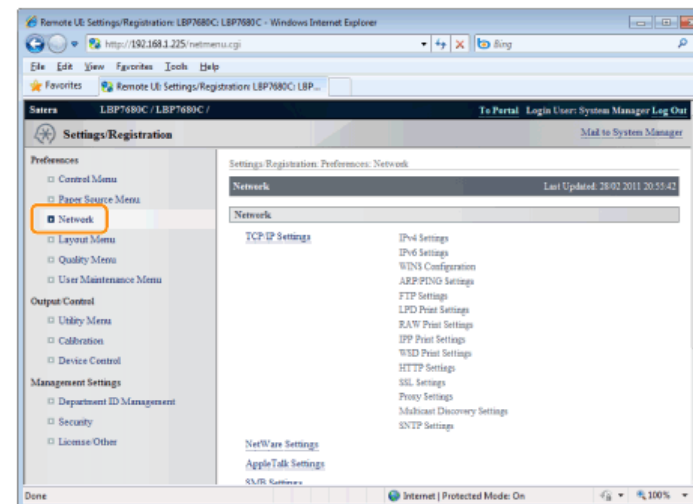

F-2-44

4. Click [TCP/IP Settings].

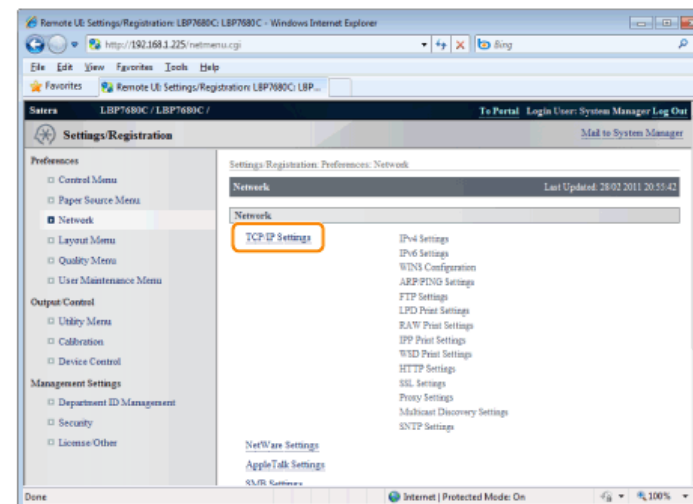

F-2-45

5. Click [Key and Certificate] under [SSL Settings].

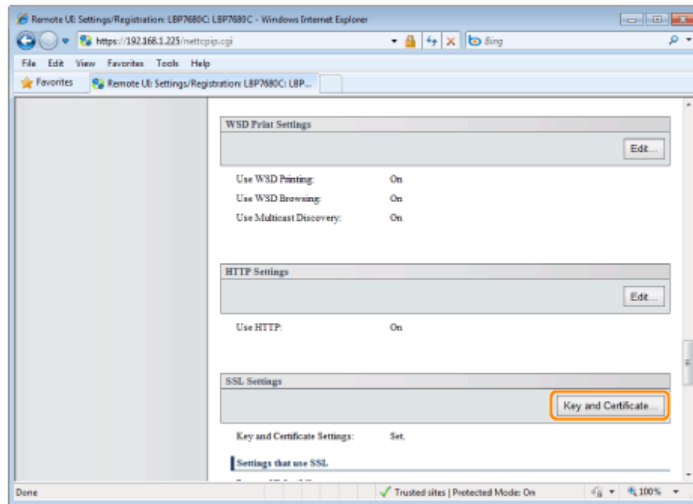

F-2-46

6. Select the key to use, and then click [Default Key Settings].

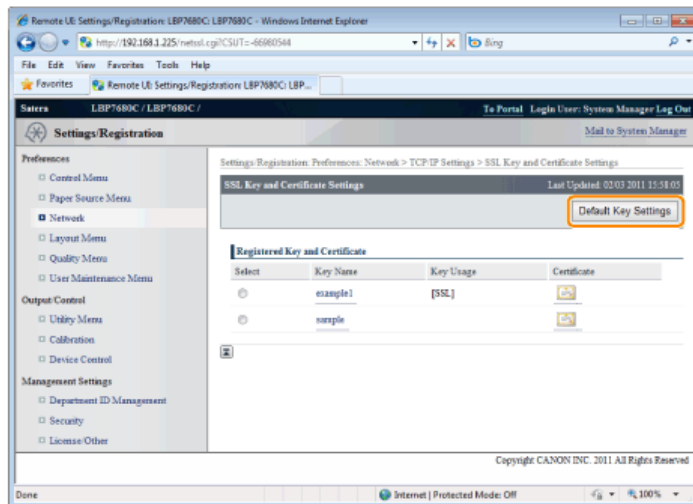

F-2-47

7. Click [OK].

● Changing the Remote UI Settings

Specify whether the SSL encrypted communication function should be used for the Remote UI.

1. Start the Remote UI, and then log in as Administrator.
2. Click [Settings/Registration].

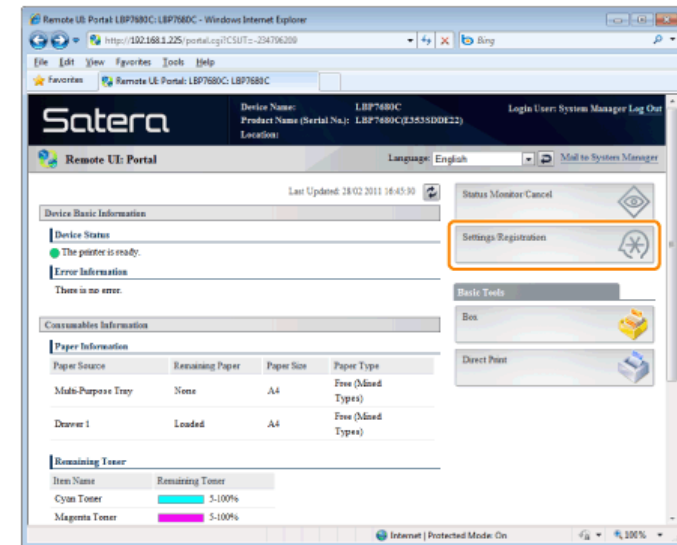

F-2-48

3. Select [Security] from the [Management Settings] menu.

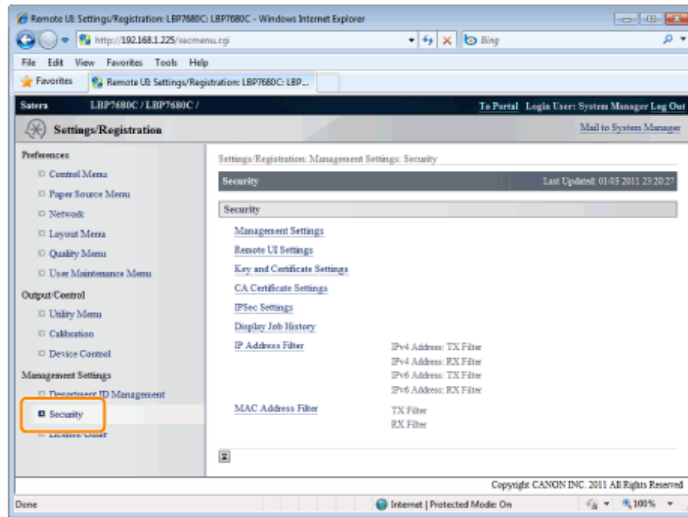

F-2-49

4. Click [Remote UI Settings].

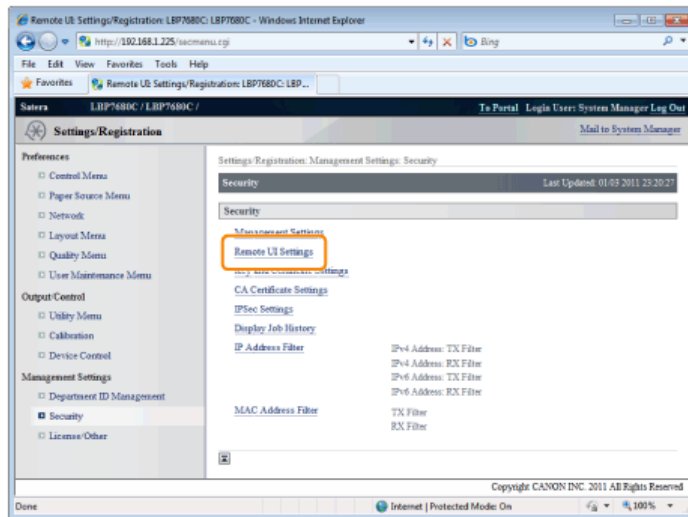

F-2-50

5. Click [Edit].

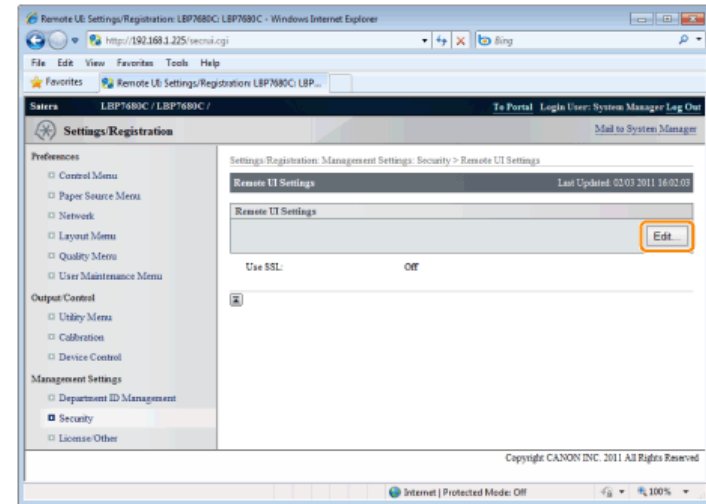

F-2-51

6. Change the Remote UI settings.

(1) Select the [Use SSL] check box.

If you clear the check box, the remote UI cannot use SSL encrypted communication.

(2) Click [OK].

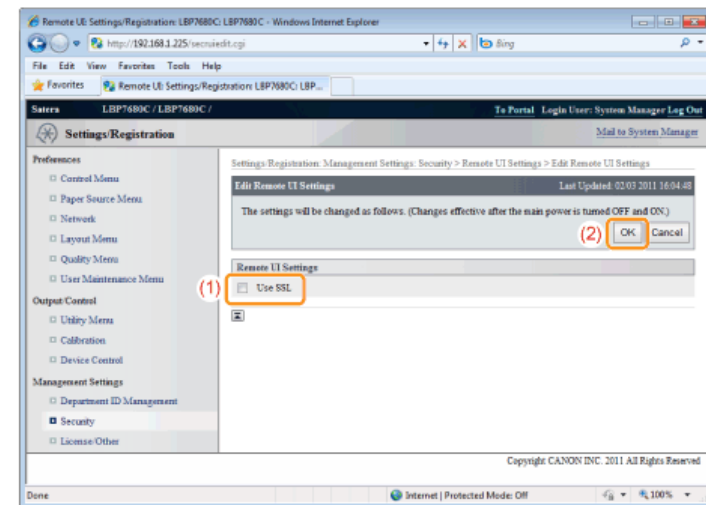

F-2-52

Caution:

You cannot select the [Use SSL] check box if a key and certificate are not created and registered in advance and a key used by SSL is not selected.

7. Perform a hard reset or restart the printer.→ After performing a hard reset or restarting the printer, the settings are effective.

Note:

You can perform a hard reset using the following procedure.

1. Click [Settings/Registration].
2. Select [Device Control] from the [Output/Control] menu.
3. Select [Hard Reset], then click [Execute].

MEAP(Not supported by LBP7210Cdn)

Introduction

References by purpose

This chapter describes information for maintenance related to MEAP.

The following table lists references (item names and pages) by purpose.

Purpose	Reference
To install a MEAP application.	Installing an MEAP Application
To start or stop a MEAP application.	Procedure to start and stop a MEAP application
To uninstall a MEAP application.	Procedure to uninstall the MEAP application
To change the method to log in to SMS.	Procedure to manage System Application
To change the password for logging in to SMS.	Changing SMS Login Password
To change the method to log in to the device.	Procedure Changing Login Services
To install a login service for the device.	Procedure Installing Login Services
To check the device's resource information.	Resource Information
To check the device's platform information.	System Information
To check the device's system application information.	MEAP Application Information
To check the contents of the license file.	Check License
To delete the MEAP application's setting information.	MEAP Application Setting Information Management
To download the MEAP application's log information.	MEAP Application Log Management
To check information for using SMS	Preparation for Using SMS
To check the version of MEAP Specifications supported by the device.	MEAP Specifications

T-2-5

About MEAP

Overview

MEAP (Multifunctional Embedded Application Platform) is an application platform (execution platform) that allows the user to execute an application written in the Java language on a Java virtual machine installed on the device.

In this chapter, a device with MEAP is called a device supporting MEAP, and an application which runs on MEAP is called a MEAP application.

MEAP applications are installed on a MEAP device to provide various functions to the device.

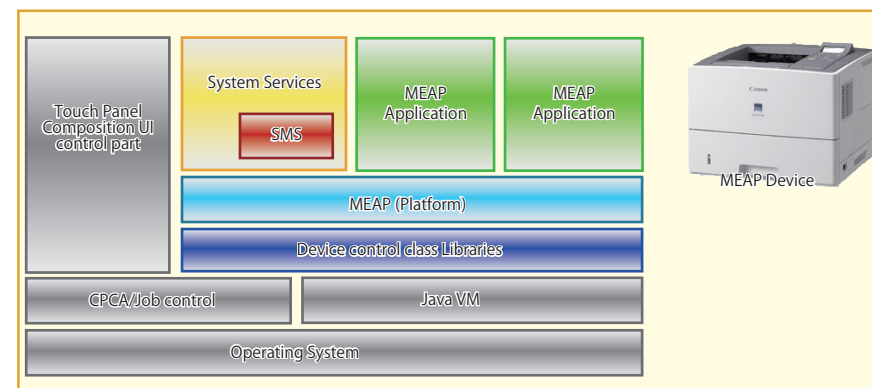

F-2-53

About SMS

Overview

MEAP has SMS (Service Management Service) as a service for managing login services and MEAP applications.

SMS is a servlet-type service which is used via a PC's browser.



F-2-54

Example of the SMS screen

Satara LBP7680C / LBP7680C / To Remote UI Log Out from SMS

Service Management Service

Device Serial Number: MKBA000023

MEAP Application Management

MEAP Application Management Updated On: 11/03 2011 22:54:29

Application Name	Installed on	Status	License
SampleApp_A	4.4.0 11/03 2011	Installed	Installed
SampleApp_B	4.4.0 11/03 2011	Installed	Installed
SampleApp_C	4.4.0 11/03 2011	Installed	Installed

Resource Information

Resource Name	Amount Used	Remaining	Percent Used
Storage	12505 KB	20263 KB	38%
Memory	1050 KB	19430 KB	5%
Threads	5	123	4%
Sockets	0	128	0%
File Descriptors	4	124	3%

meap Version 3.1.0.16 Copyright CANON INC. 2011 All Rights Reserved

F-2-55

About the MEAP Application Management Screen

This screen is used to perform basic management of MEAP applications. Its main functions are listed below.

- Start and stop a MEAP application.
- Uninstall a MEAP application.
- Disable or delete a license file.
- Check the MEAP application information.
- Check the resource information.

Example of the MEAP application management screen

Satara LBP7680C / LBP7680C / To Remote UI Log Out from SMS

Service Management Service

MEAP Application Management

MEAP Application Management Updated On: 11/03 2011 22:54:29

Application Name	Installed on	Status	License
SampleApp_A	4.4.0 11/03 2011	Installed	Installed
SampleApp_B	4.4.0 11/03 2011	Installed	Installed
SampleApp_C	4.4.0 11/03 2011	Installed	Installed

Resource Information

Resource Name	Amount Used	Remaining	Percent Used
Storage	12505 KB	20263 KB	38%
Memory	1050 KB	19430 KB	5%
Threads	5	123	4%
Sockets	0	128	0%
File Descriptors	4	124	3%

meap Version 3.1.0.16 Copyright CANON INC. 2011 All Rights Reserved

F-2-56

For details of this function, see "MEAP Application Management" in this chapter.

About the MEAP Application Installation Screen

It is used to install a MEAP application and license. Its main functions are listed below.

- Install a MEAP application and license file.

Example of the MEAP application installation screen

Satara LBP7680C / LBP7680C / To Remote UI Log Out from SMS

Service Management Service

Device Serial Number: MKBA000023

Install MEAP Application/License

Install MEAP Application/License

Application File Path: Browse

License File Path: Browse

meap Version 3.1.0.16 Copyright CANON INC. 2011 All Rights Reserved

For details of this function, see "Install MEAP Application" in this chapter.

F-2-57

About System Management

It is used to perform MEAP management other than management of MEAP applications and installation of MEAP applications. Its main functions are listed below.

- Enhanced System Application Management
- System Application Management
- System Information
- MEAP Application Information
- Check License
- Change Password (Change SMS login password)
- MEAP Application Setting Information Management
- MEAP Application Log Management

Example of the system management screen

The screenshot shows the 'Service Management Service' interface. The left sidebar contains a 'System Management' menu with the following items: Panel Display Order Settings, Enhanced System Application Management, System Application Management, System Information, MEAP Application Information, Check License, Change Password, MEAP Application Setting Information Management, and MEAP Application Log Management. The main content area displays 'MEAP Application Management' with a table of installed applications:

Application Name	Installed on	Status	License
SampleApp_A	4.4.0 11/03 2011	Installed	Installed
SampleApp_B	4.4.0 11/03 2011	Installed	Installed
SampleApp_C	4.4.0 11/03 2011	Installed	Installed

Below the table is a 'Resource Information' section with a table:

Resource Name	Amount Used	Remaining	Percent Used
Storage	12505 KB	20263 KB	38%
Memory	1050 KB	19430 KB	5%
Threads	5	123	4%
Sockets	0	128	0%
File Descriptors	4	124	3%

The interface also includes a 'meap' logo and version information: Version 3.1.0.16 Copyright CANON INC. 2011 All Rights Reserved.

F-2-58

Preparation for Using SMS

To use SMS, you need to set up network settings for the PC, browser, and devices that are used to access SMS.

Preparation of PC for Accessing SMS

Checking of operation environment

The PC and browser used to access SMS require the following system environment.

Operating System	Supported browser
Windows XP Professional	Microsoft Internet Explorer 6 SP1 or later
Windows Vista SP2	Windows Internet Explorer 8
Windows 7	Windows Internet Explorer 8
Mac OS X 10.3	Safari 1.3.2
Mac OS X 10.4	Safari 2.0.4
Mac OS X 10.5	Safari 3.1.2
Mac OS X 10.6	Safari 4.0.3

T-2-6

CAUTION:

For the following operations in the combined environment of Windows XP and Internet Explorer 6, Java 2 Runtime Environment Standard Edition 1.5 or later is required.

- User registration / edit in SSO-H local device
- Use of remote login in SSO-H.

PC and browser settings

The PC and browser used to access SMS must meet the following conditions.

- Session cookie is enabled.
- Java Script is enabled.

■ Device Settings

● Network configuration (Activate Network Settings)

To support a MEAP-enabled iR device via network (SMS, etc.), set up the network setting on the touch panel of the iR device (this setting is [ON] by default).

1) Press [Setup] button, select [Network] > [Control Menu] > [HTTP] and select [On].

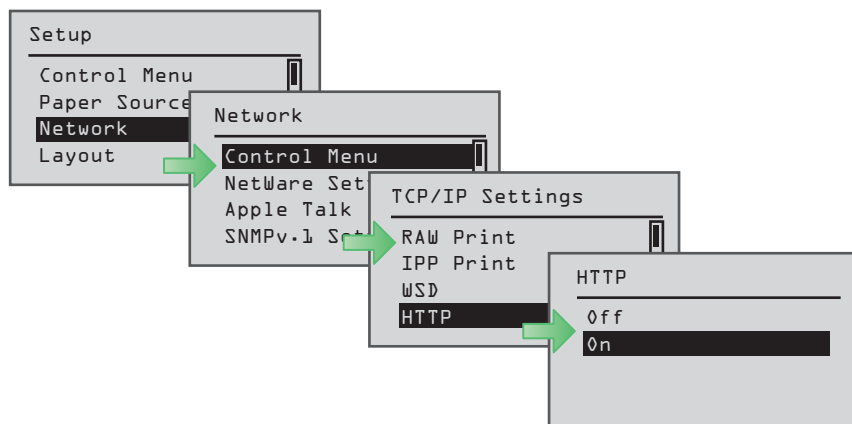

F-2-59

2) Select [On], and then press [OK] on the Control Panel.

3) Restart the machine.

CAUTION:

- The setting [Use HTTP] is not actually enabled/disabled until you have restarted the device.
- You cannot make a connection through a proxy server. If a proxy server is in use, enter the IP address of the MEAP device in the Exceptions field for the browser. Open Internet Options dialog of Internet Explorer and select Connections tab, LAN Settings button, Use a proxy server option, and Advanced button of Proxy server group. Proxy Settings dialog will open. The Exceptions field is in the dialog. As network settings vary among environments, consult the network administrator.
- If Cookie and JavaScript are not enabled in the Web browser, you will not be able to use SMS.

● Key Pair and Server Certificate when Using Encrypted SSL Communication

To use SMS via SSL connection, it is required to specify a key pair and server certificate as the key to be used.

When specifying the key pair and server certificate necessary for encrypted SSL communication, perform the following procedure in remote UI.

Note:

- Although Server Certificate is registered as standard on MFP, it is not registered in the machine (SFP). Therefore, this procedure is necessary.
- For detailed procedures of the Default Key setting, refer to [e-Manual > Security].
- As for SMS, by setting a Default Key, encrypted SSL communication is always executed regardless of the following setting: [Settings/Registration] > [Management Settings] (Settings/Registration) > [MEAP Settings] > [SSL Settings]: ON/OFF.

Generating a key pair

1) From a PC on the same network as the device, use a web browser to access the remote UI's portal page. Then, select [Settings/Registration] from the menu on the right side of the screen.

URL to access: <http://<device's IP address>:8000/>

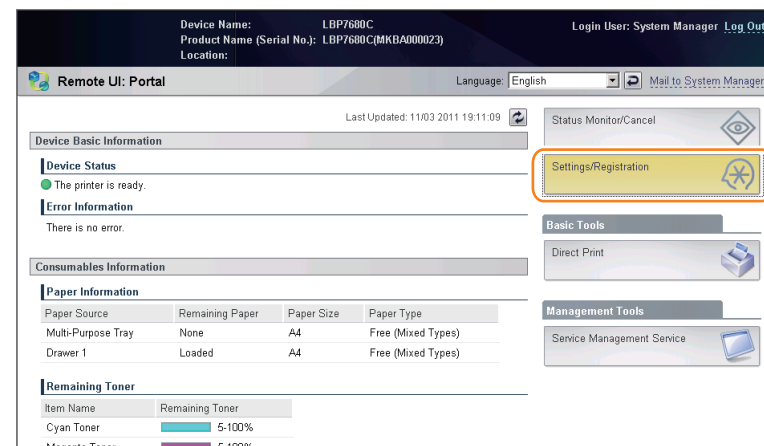

F-2-60

2) Click [Management Settings] > [Security] > [Key and Certificate Settings].

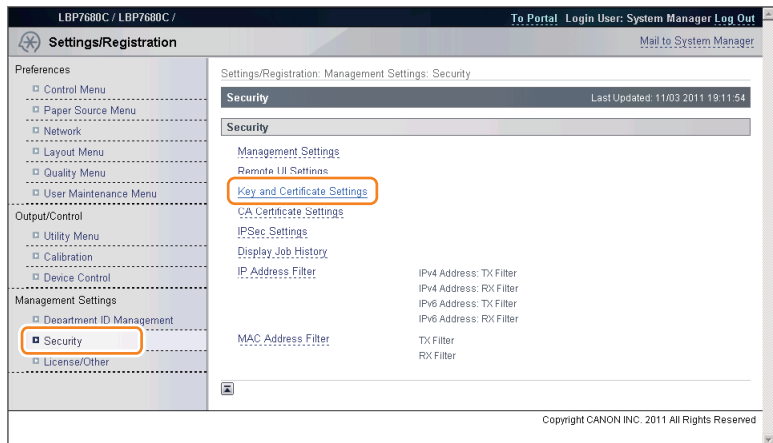

F-2-61

3) Click [Generate Key...] button.

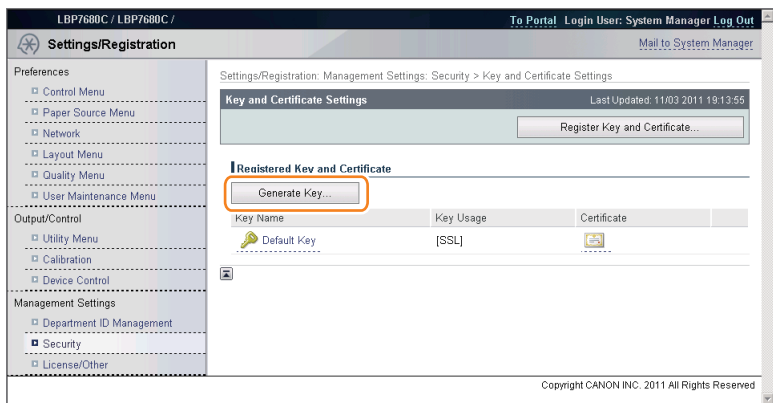

F-2-62

4) Enter the necessary information, and then click the [OK] button.

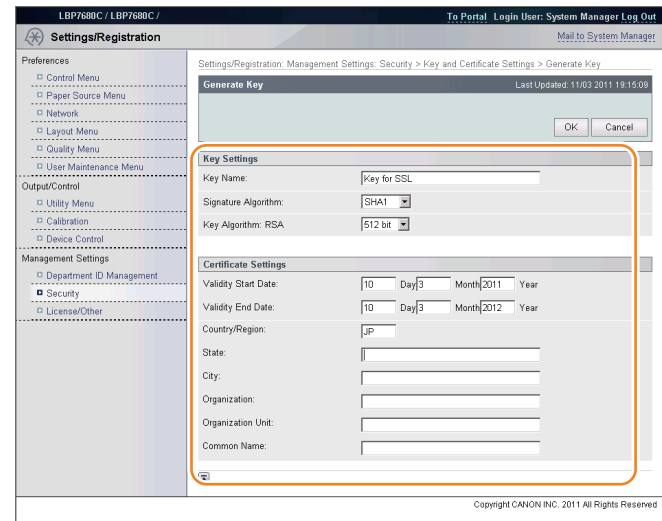

F-2-63

Input example

Item name	Type	Content	Entry
Key Settings			
Key Name	Compulsory	An arbitrary character string	Default Key
Signature Algorithm	Compulsory	Selected from:SHA1/SHA256/SHA384/SHA512	RSA
Key Algorithm	Compulsory	Selected from:512/1024/2048/4096	512
Certificate Settings			
Validity Start Date	Compulsory	Date	15/5/2011
Validity End Date	Compulsory	Date	15/5/2036
Country/Region	Compulsory	Country or region name	US
State	Arbitrary	State name	-
City	Arbitrary	City name	-
Organization	Arbitrary	Organization name	-
Organization Unit	Arbitrary	Organization unit	-
Common Name	Arbitrary	Common Name*	-

T-2-7

Note:

When the IP address of the device has been entered in the [Common Name] entry field, if you install a server certificate to the browser (see "Installing a server certificate (reference information)"), the message "Certificate Error" that usually appears when access is made from Internet Explorer 7 or later will not be displayed.

5) Check to see that the generated key appears in [Registered Key and Certificate].

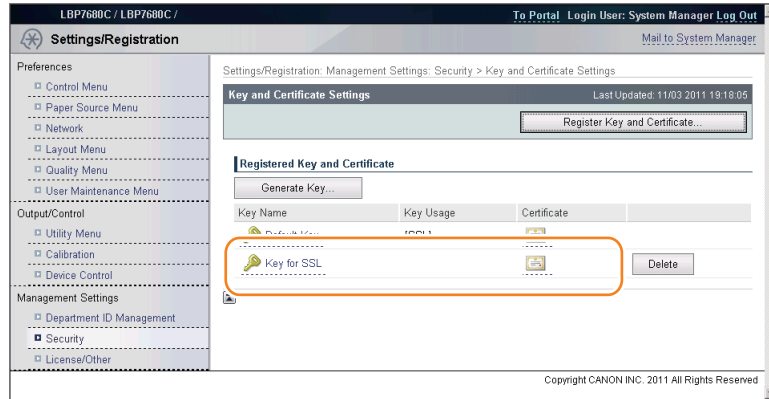

F-2-64

3) Select the generated key, and then click the [Default Key Settings] button.

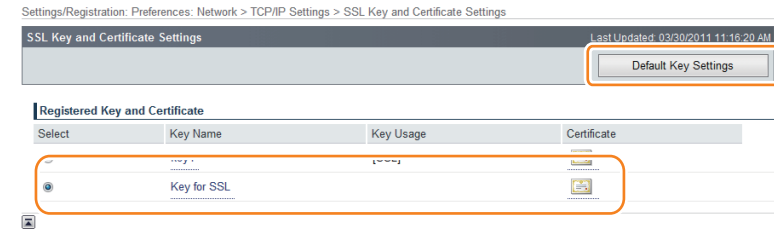

F-2-67

4) Check that [SSL] is displayed in the [Key Usage] entry field.

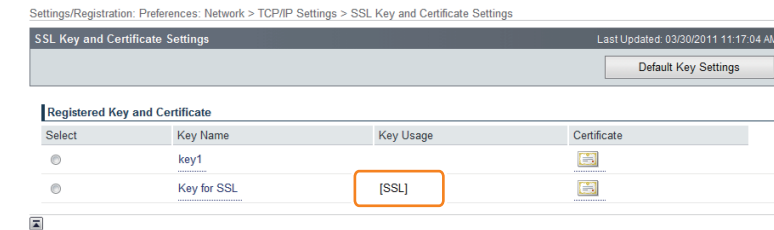

F-2-68

5) Log out from the remote UI, and then restart the device.

Default Key Settings

1) Click [Preferences] > [Network] > [TCP/IP Settings].

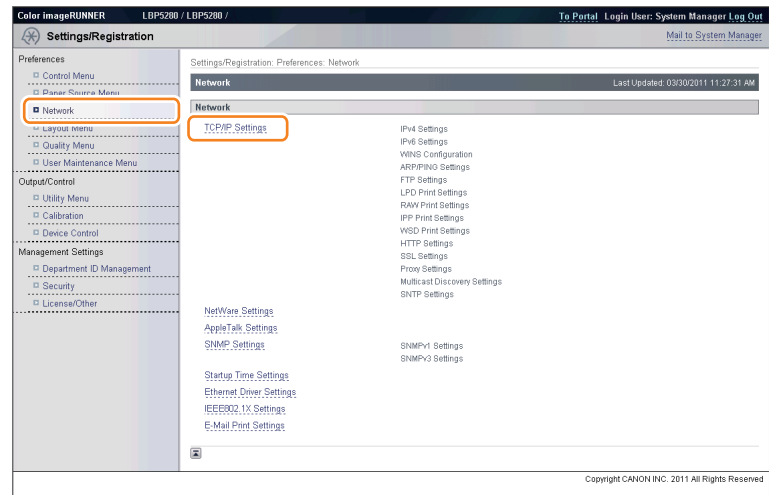

F-2-65

2) Click [Key and Certificate...] button.

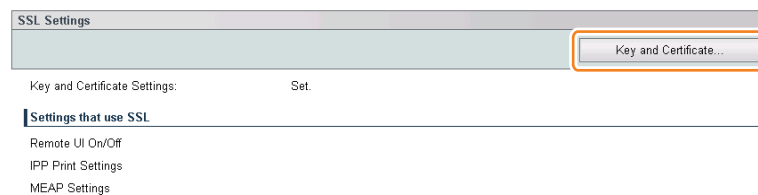

F-2-66

Installing a server certificate (reference information)

On Internet Explorer 7 (IE) or later, if [Default Key] installed as standard on the device is used, "Certificate Error" appears during access due to "Internet Explorer Enhanced Security Configuration".

Error display example



F-2-69

To disable display of "Certificate Error", use the following procedure (for IE8) to set the key generated in "Key Pair and Server Certificate when Using Encrypted SSL Communication" (i.e. the key with the IP address of the device specified as the shared name) as an SSL key.

1) Access SMS from the browser, and then click "Certificate Error" in the URL entry field.

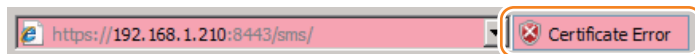

F-2-70

2) Click [View certificates].

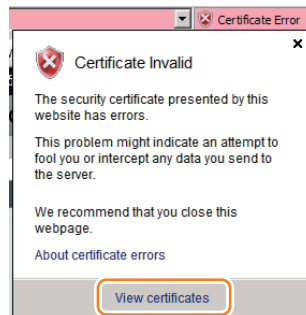

F-2-71

3) Click the [Install Certificate...] button on the [General] tab.

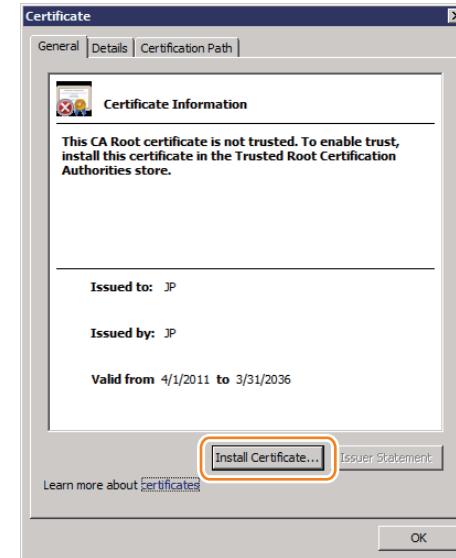

F-2-72

4) [Certificate Import Wizard] will appear. Click the [Next] button.



F-2-73

5) In [Certificate Store], select the [Place all certificates in the following store] option, and then click the [Browse] button.

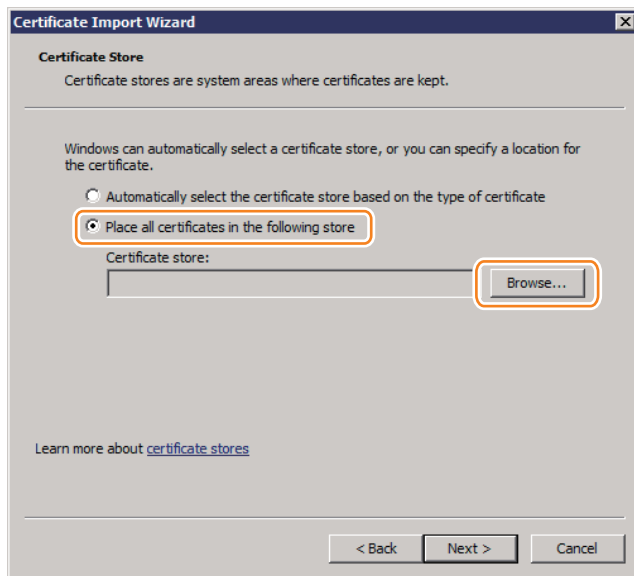

F-2-74

6) In [Select Certificate Store], select [Trusted Root Certification Authorities], and then click the [OK] button.

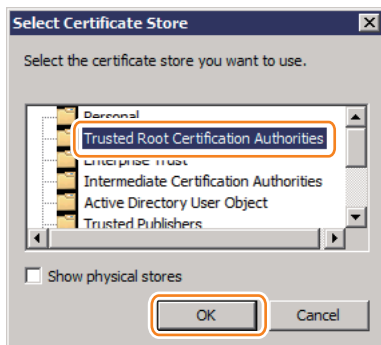

F-2-75

7) You will return to the [Certificate Store] dialog. Check that "Trusted Root Certification Authorities" appears in [Certificate], and then click the [Next] button.

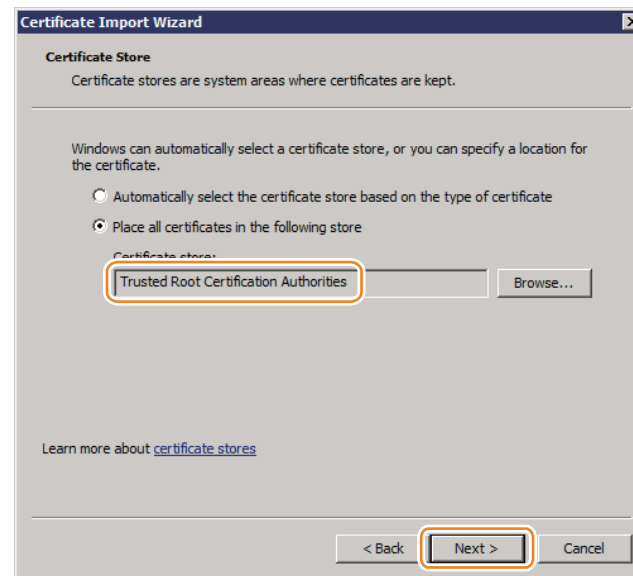

F-2-76

8) [Completing the Certificate Import Wizard] will appear. Click the [Finish] button.

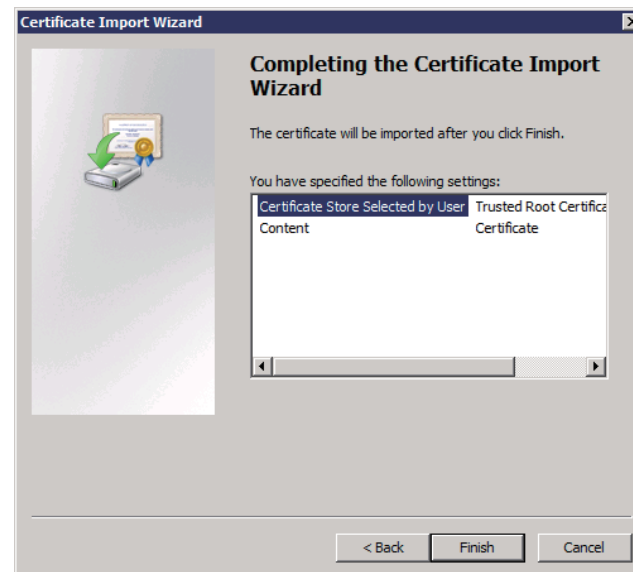

F-2-77

9) A message will appear to indicate that import has been completed successfully. Click the [OK] button.

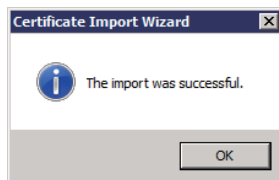

F-2-78

● Network Port Settings

The default port of the HTTP server used for MEAP and MEAP applications to provide the servlet function is 8000, and the HTTPS server's default port is 8443. In the case that these ports have already been used by the customer who is to introduce this application, the MEAP application cannot use the HTTP (or HTTPS) server(s).

By changing the following ports to use, however, the MEAP application can be used as well as the existing system.

The procedure for setting the HTTP/HTTPS server port is shown below.

1) Start service mode. From the [Setup] menu, select [SERVICE MODE] > [FUNCTION GR.] > [MEAP].

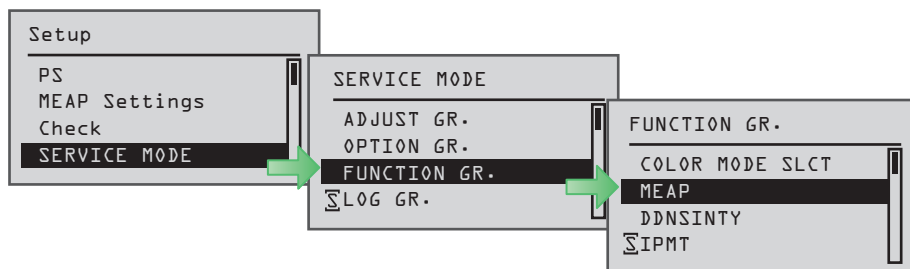

F-2-79

2) To set up the HTTP server port, select [MEAP-PN]. To set up the HTTPS server port, select [MEAP-SSL]. When the port number setting screen appears, specify a port number. Use the Up and Down keys to specify the setting.

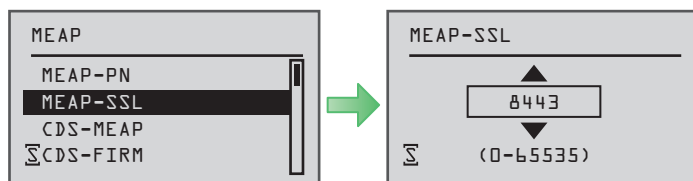

F-2-80

Note:

A port number can be any integer from 0 to 65535. To avoid port numbers that are frequently used, do not use any integer from 0 to 1023.

Server	Setting value	Default value / Value after RAM clear
HTTP Server	1024 to 65535	8000
HTTPS Server	1024 to 65535	8443

T-2-8

Note:

If PS Print Server Unit is connected, do not specify port 8080. If port 8080 is specified, the RUI of the device where the MEAP authentication application is running cannot be displayed. (Port 8080 is reserved to allow the PS Print Server Unit to redirect to the iR device.)

3) Restart the device if the port number is set.

■ How to Check the Serial Number

When performing MEAP device support, the serial number of the device is necessary in some cases.

Examples of where the serial number is necessary

- When initializing SMS login password (obtaining a switch license)
- When obtaining a MEAP application license from LMS
- When obtaining a transfer license of MEAP application
- When obtaining a special license for reinstalling MEAP application

If a problem occurs in the MEAP device and you want to contact the support department of the sales company, you need to provide the serial number. Perform the following procedure to get the serial number.

● Checking from the PC browser

The serial number of the device is displayed on the SMS login screen, SMS screen, and remote UI portal screen.

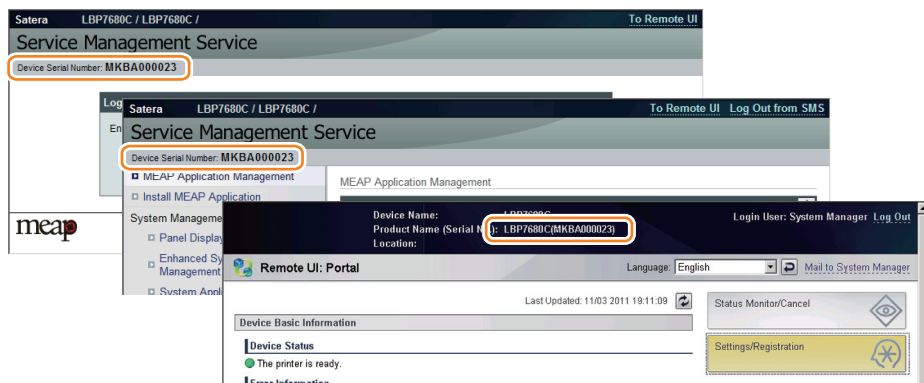

F-2-81

● Checking from the device's Control Panel

From [Utility Menu], select [Serial Number].

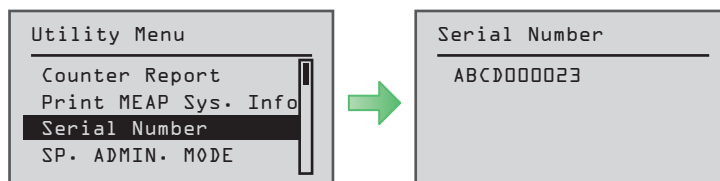

F-2-82

Note:
While MFPs of iR and iR-ADV series have 8-digit serial numbers, this machine (SFP) has a 10-digit serial number.

● Login to SMS

■ Procedure to Log in

Use the following procedure to log in to SMS.

1) From a browser of a PC on the same network as the device, enter the following URL to access SMS.

URL: `https://<MEAP Device IP address>:8443/sms/`

Ex.) `https://172.16.188.240:8443/sms/`

Note:

To encrypt the password information input when logging in, SSL of the login screen was made effective. However, even if you access SMS using a URL that has not been encrypted with SSL (non-SSL), you will be redirected to a SSL encrypted URL (SSL enabled).

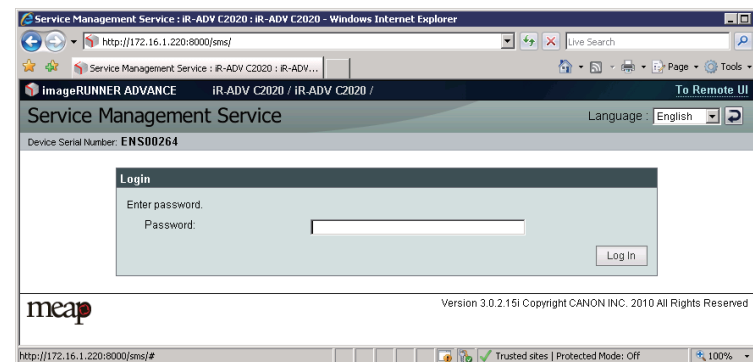

F-2-83

2) Enter the SMS login password in the password entry field, and then click the [Log In] button.

Note:

- The default password is "MeapSmsLogin." (The password is case-sensitive.)
- When you want to change the display original language, change in the box in the right of the screen. This setting is not affect by the setting of the language of the device.

Note:

SMS Access can be gained also from Remote UI.

Access Remote UI and click on SMS shortcut shown on the lower right of the screen to gain access to SMS.

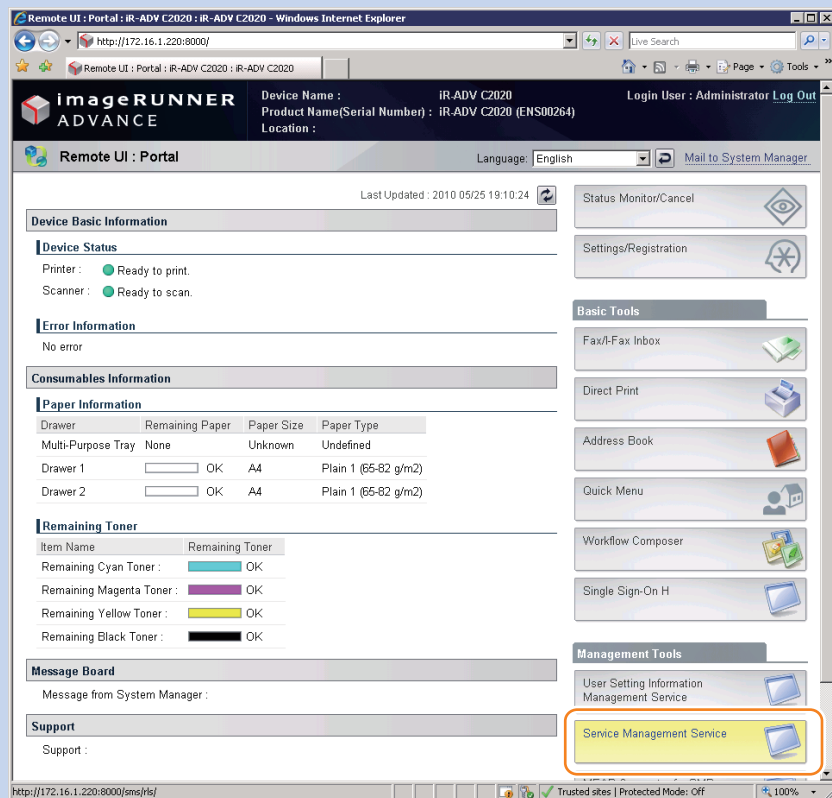

F-2-84

● When SMS Cannot Be Accessed

If you forgot the password (SMS login password initialization)

After changing the default SMS login password, if you forgot the new password and cannot log in to SMS, you can use a switch license for password initialization to change the password back to the default value "MeapSmsLogin".

Note that there is no special password for service.

1) Obtain a switch license file for password initialization.

Contact the person in charge of support at the sales company, give the device's serial number, and have a switch license file for password initialization issued.

2) Load the switch license file.

With nothing entered, click the [Log in] button to display the area for specifying a switch license file for password initialization.

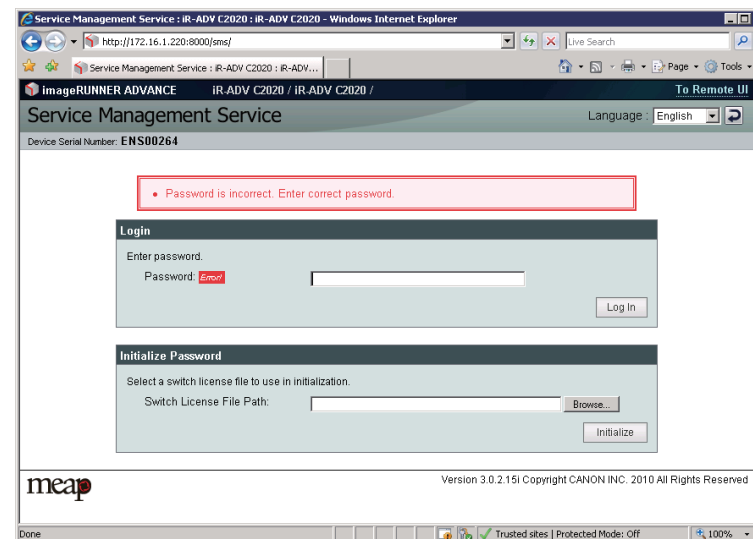

F-2-85

3) Specify the switch license file.

Click the [Browse] button and specify the switch license file.

4) Initialize the login password.

Click the [Initialize] button to display an initialization confirmation page, and click the [OK] button.

Note:

- The default password is "MeapSmsLogin." (The password is case-sensitive.)
- If you click the [Cancel] button on the initialization confirmation page, password initialization is not performed and the login page appears.

● If login is not possible due to exclusive control

Because SMS uses exclusive control, if there is another user already logged in to the SMS of the same device, then you cannot log in.

Exclusive control message example

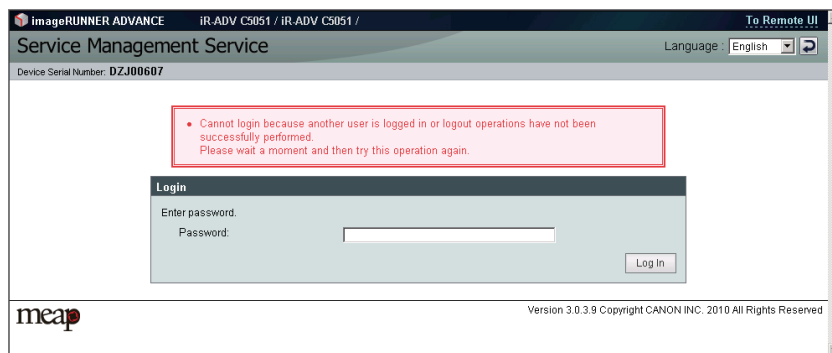

F-2-86

If you cannot log in due to exclusive control, you need to ask the other user to log out before you can try again.

Note:

If you close the browser without logging out, the session remains active. In this case, you cannot log in again.
If this problem occurs, you can wait for 5 minutes so that the session is disconnected.
Or, you can restart the device to force the session to disconnect.

● If [Key and Certificate Settings] is not set

If [Key and Certificate Settings] is not set correctly, you cannot access the URL for SMS (<https://<device's IP address>:8443/sms/>). In this case, you can use the following procedure to solve the problem.

1. Go to <http://<device's IP address>:8000/sms/>, and check to see that "HTTP 500 Internal Server Error" appears.
2. If the message is displayed, see the procedure described in "Key Pair and Server Certificate when Using Encrypted SSL Communication" in this manual to deal with the problem.

Note:

As for SMS, by setting the key to be used, encrypted SSL communication is always executed regardless of the following setting: (Settings/Registration) > [Management Settings] > [License/Other] > [MEAP Settings] > [Use SSL] > ON/OFF.

● How to deal with a message "Certificate Error" appearing during access

If "Certificate Error" appears when you access SMS from a browser, refer to the procedure described in "Installing a server certificate (reference information)" in this manual to deal with the problem.

Installing an MEAP Application

Outline

From the MEAP application installation screen, you can install the MEAP application as well as the license file.

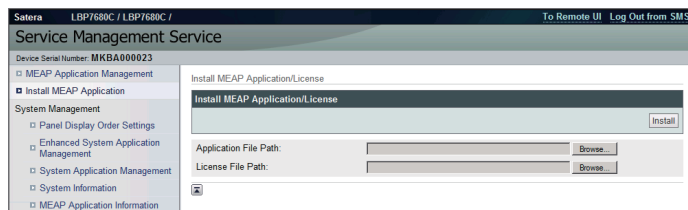

F-2-87

Before installing the MEAP application, be sure to check the following items.

Device compatibility with the MEAP application

To find out whether the device is compatible with the MEAP application, check the devices supported by the MEAP application. Depending on the application, the device's firmware may require version upgrade.

Resources availability (remaining amount)

The necessary resources (free storage space and free memory available) must be secured for an MEAP application to run; otherwise, you cannot install the MEAP application.

To check the resource information, see "Device's resources," on p. 2-53. in this manual.

Procedure to install applications

- 1) Long on to SMS.
- 2) Click [Install MEAP Application] on the menu.

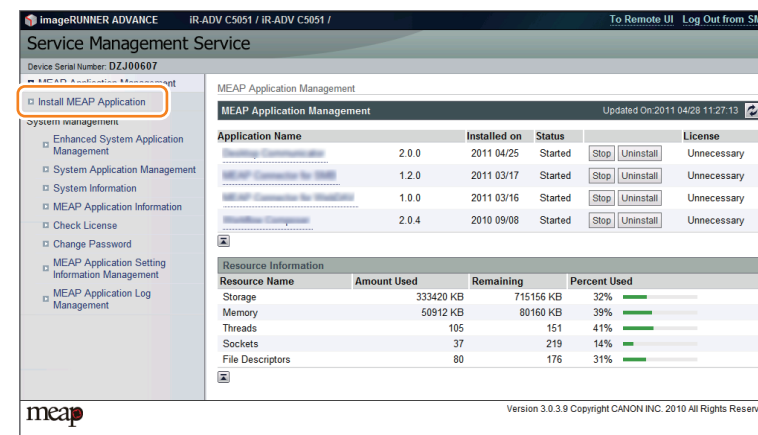

F-2-88

- 3) Check [Install MEAP Application/License] page appears.
- 4) Click [Browse..] button, and select the application file and the license file of the application; then, click [Install] button.

Note:

Application File: identified by the extension "jar".

License File: identified by the extension "lic".

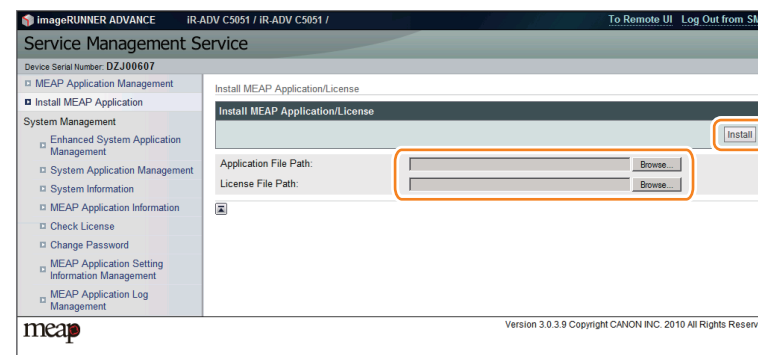

F-2-89

CAUTION:

- You cannot install only the license.
- You will not be able to install the application without using the appropriate license. Be sure to select its license file.
- If you are adding a license to an existing application, see "Procedure adding a license file".
- If you are updating an existing application, stop the application; then, install the new application or its license file. You will not be able to update an application while it is running.

5) Check the contents of the Confirm page; then, click [OK] button.

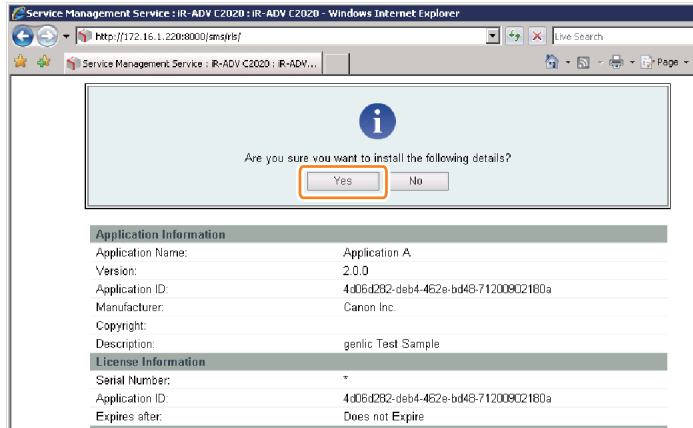

F-2-90

6) Some applications show a screen to indicate the terms of agreement. Read the terms, and click [OK].

7) Check the message "Installing...Please wait." appears, beginning the installation.

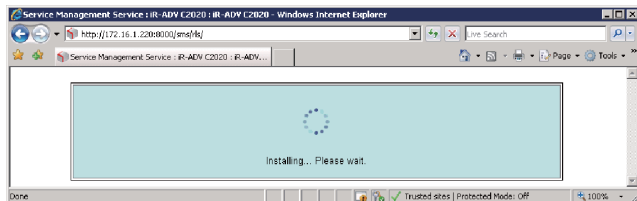

F-2-91

8) Upon installation completed, click [To MEAP Application Management] button shown on the screen to view MEAP Application Management page.

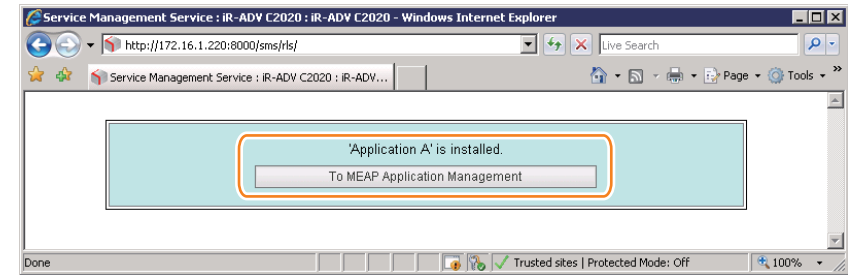

F-2-92

Note:

To use the application that you have just installed, you must make sure that the application status is Started.

Note:

The license file is provided in text file format, enabling to view in a text editor. The application ID and device serial number shown in the file allow users to confirm which device to install with the license file.

Note that any changes added to the license file may disable installation. Cares should be taken when confirming the contents of the license file.

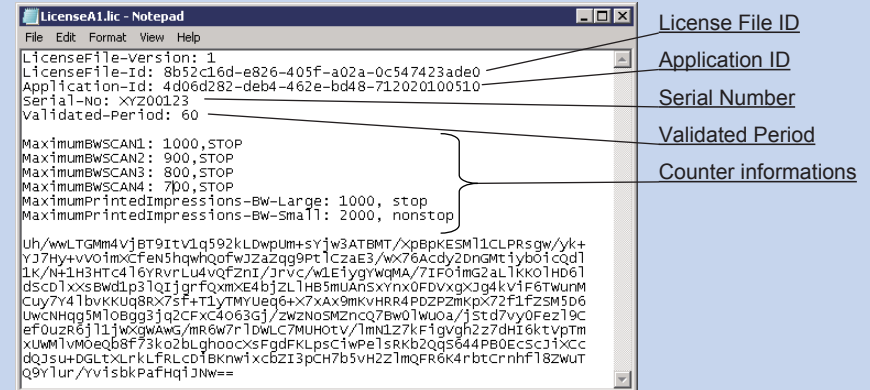
Sample file

F-2-93

Note:

There are two ways to install an MEAP application. You can install using SMS, or install using the [Register/Update Software] screen of the remote UI.

Screen example

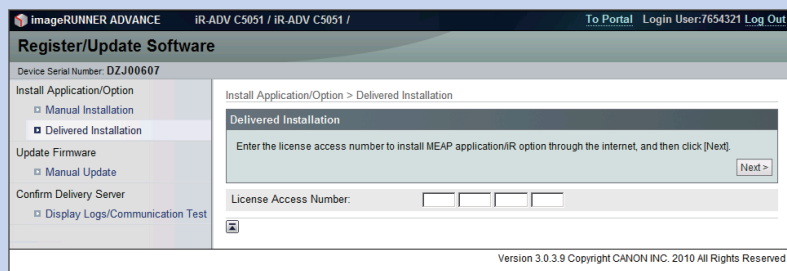

F-2-94

[Register/Update Software] provides two types of installations. One is [Manual Installation] where you specify a jar file and a license file and then install. The other is [Delivered Installation] where you enter a license access number. For details of the procedures, please refer to the e-Manual.

Resource Information

About MEAP Application Management Page

Application Management page shows [resource information] for information of the whole device resources including Amount Used, Remaining, and Percent Used.

This function enables users to judge the remaining resources before installing the additional application. Such resource information is shown based on the manifest header stated at the top of each application, which declares the resources required in the application. Therefore, the information does not necessarily show the resources actually in use.

The following resource information is shown:

- Storage
- Memory
- Thread
- Socket
- File Descriptor

You will not be able to install an application if the size of the remaining disk space falls short of the size declared by the application. Moreover, the specifications have been designed so that an application will not be able to start up if there is a shortage of memory for any of the foregoing items (i.e., memory, thread, socket, file descriptor).

Follow the steps below to check the remaining memory:

- 1) Log in to SMS.
- 2) Click [MEAP Application Management].
- 3) Check [Resource Information] for information of the whole device resources.

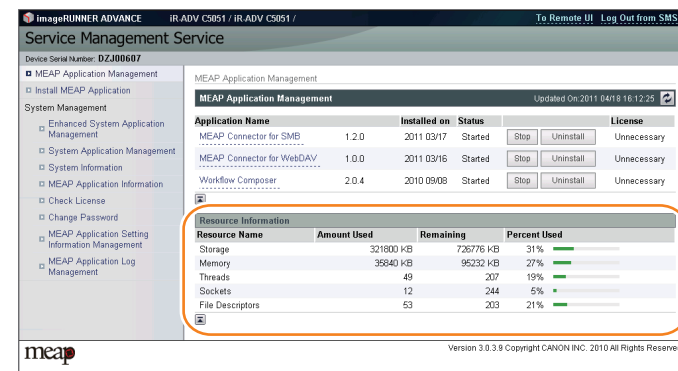

F-2-95

● Device's resources

When 1 MEAP application operates, the resource volume allocated to each device is as follows (loaded resource list). Since the following value is an estimate, when installing the MEAP applications, it needs to check the available resource of SMS.

Since the indication of SMS resource volume fluctuates by the login service (authentication function) and configuration (future model), which the user selected, it may show a bigger value than the following values.

List of Available Resources

Product Name	Storage	Memory	Thread	Socket	File Description
imageRUNNER LBP5280	32MB	20MB	256	128	128
imageCLASS LBP7680	32MB	20MB	256	128	128

T-2-9

Note:

- As for memory, check the available resource when starting up the application. For other resources other than memory, check them when installing.
- Some applications call for a specific set of conditions for installation. For details, see the User's Guide that comes with the individual applications.
- Maximum installable application is up to 20 even if the remaining resource is adequate. (However, the Send function consumes 1, it must be 19 in practice.) Authentication application is not included in this number.
- The MEAP application, which can be started simultaneously, is up to 19. (Authentication application is not included in this number.)

CAUTION:

To install an application, the user needs to use the following URL when accessing the license control system to obtain a license file. In doing so, he/she needs to register the license access number of the application and the serial number of the device.

<http://www.canon.com/lms/license/>

● MEAP Specifications

■ What is MEAP Specifications (MEAP Spec Version)?

MEAP Specifications is one of the information required to judge whether MEAP applications can be operated or not. With MEAP Specifications, you can prevent an application that uses a specific function of device from being installed onto the device that does not have the function.

● About Name

MEAP Specification is shown as 'MEAP Specifications' in the screen to check the version on the side of device that supports MEAP (counter confirmation button) and MEAP platform (SMS). On the other hand, in the manifest file of MEAP application, it is shown as 'MeapSpecVersion' (described in the same way in the SDK document) (Note) 'MEAP Specifications' hereafter in this document.

● Mechanism

MEAP platform judges whether MEAP applications can be operated on it using on the 2 information below:

- Device Specification ID
- MEAP Specifications

Device Specification ID shows information such as the original functions of MFP (including print, scan, and copy), and one that differs by model such as maximum copy number, thus each model has a different ID. (It is easy to determine the IDs for this reason.) MEAP application declares 1 or more Device Specification ID required for its execution. Declaration of multiple Device Specification IDs means that the application is operable in all the models declared. Upon installation of MEAP application in (using) SMS or MEAP Enterprise Service Manager, matching of Device Specification ID is executed on the side of MEAP platform machine. The machine which doesn't support the ID declared by the application rejects installation of such an application.

Meanwhile, MEAP Specifications shows other information than defined by Device Specification ID above, including network and security. Thus each model does not always have the same version.

MEAP application declares 1 or more MEAP Specifications required for its execution. Declaration of multiple Device Specification IDs means that the application is operable in all the environments declared. Upon installation of MEAP application in SMS or MEAP Enterprise Service Manager, matching of MEAP Specifications is executed on the side of MEAP platform machine. The machine which doesn't support the version declared by the application rejects installation of such an application.

MEAP Specifications for each model

Product Name	Initial MEAP SpecVer
imageRUNNER LBP5280	15, 19, 25, 26, 27, 29, 34, 39, 45, 47, 50, 51, 52, 54, 55, 57, 58, 60, 61, 62, 63
imageCLASS LBP7680	15, 19, 25, 26, 27, 29, 34, 39, 45, 47, 50, 51, 52, 54, 55, 57, 58, 60, 61, 62, 63

T-2-10

MEAP Specifications List

Ver	Description
1	MEAP basic function
2	MEAP Spec Version 1 function and SSL/TSL + Proxy
5	MEAP Spec Version 1 function and CPCA V2 + ERS (Error Recovery Service) + New SSL/TSL
6	Reserved
7	MEAP Spec Version 5 function and Compact PDF + OCR PDF (Text Searchable) + USB Host (Buffering of Interrupt Transfer)
9	Reserved
10	MEAP Spec Version 5 function and USB-Host (Exception + Clear Feature + Set Feature+ Hot Plug) + WINS address acquisition using MIB Agent + Timer Service + SSL client authentication
11	MEAP Spec Version 5 function and AMS
13	MEAP Spec Version 5 function and J2ME1.1 Support + Encrypted PDF + Trace and smooth PDF + CTK2.0
14	Device signature PDF
15	IMI + ERS (API addition for IMI) , IPv6, Extended encryption function (AES/RC4)
17	Acquiring images of JBIG format
18	Parsing XML documents (XML parser)
19	Enhancement of IMI function (IMI Version1.2 series)
21	Reserved
25	API to access the HID/Mass Storage class devices.
26	MEAP driver preference function
27	Symbols that can be used with MibAgent added. (symbols for IPv6 address acquisition)
29	IMI API added (IMI version 1.2.1 enabled)
30	Extended address book function. (e-mail/group/i-FAX/file)
31	Integrated ERS function
32	Extended Imaging function (function to generate PDF/OOXML (PowerPoint) with visible signature)
33	Extended function for imageRUNNER / iR ADVANCE series (API for address book/ CTK/ TopMenu)
34	Extended IMI Box function (v1.3.0)
35	Extended SIS function (function to check the network cable status, function to check PS print server unit status)
36	Reserved
37	CLS (Contextual Login Service) Supporting API Added
38	imageRUNNER / iR ADVANCE Series administrative privileges supported
39	MEAP Specifications added according to Jcrypto API Specification Change
40	ImagingAPI (Creation API of Visible Signature PDF) added

Ver	Description
41	Reserved
42	Reserved
44	imageRUNNER / iR ADVANCE Series Remote Address Book Supported, RemoteFAX Supported.
45	Addition of API that allows acquisition of the HID installation status
46	Multilingualization of the USB keyboard of the System Driver
47	Addition of API which executes a print order from the MEAP application of the IMI encryption PDF document
48	ID expressing the scan function for iR-ADV C2030/C2025/C2020 series
49	Reserved
50	SecurityOptionalPackage
51	IMI function expansion of iR-ADV C5051 series (Ver.50.xx or later) or later
52	(iR-ADV C5051 series (Ver.50.xx or later)) Addition of registered API to enable SSL communication setting (On/Off) for each URL
53	Disclosure of registration/deletion function to/from Quick Menu
54	Function to notify an event to the application at recovery from the sleep mode.
55	System account release function
56	MEAP User Preference Service
57	MEAP Application Configuration Service
58	MEAP Application Log Service
59	Reserved
60	SFP basic functions
61	LAVS
62	LSIS
63	LDT
64	IMI customization
65	Extension of MEAP User Preference Service (application sharing preference).
66	Reserved
68	Addition of Office Open XML's Word creation API
69	Extension of the encrypted PDF function (AES 128 bit/256 bit)

T-2-11

MEAP Application Management

Outline

You can use the MEAP application management screen to perform basic management tasks of the MEAP application (start, stop, uninstall), or check the device's resource information.

Starting, Stopping, or Uninstalling the MEAP Application

Procedure to start and stop a MEAP application

- 1) Log in to the SMS. (Refer to 'Login to SMS' in this manual.)
- 2) Click [Application List]. (If the Application List is already being displayed, this operation is not necessary.)
- 3) Click [Start] or [Stop] button shown for the MEAP application to be started or stopped.

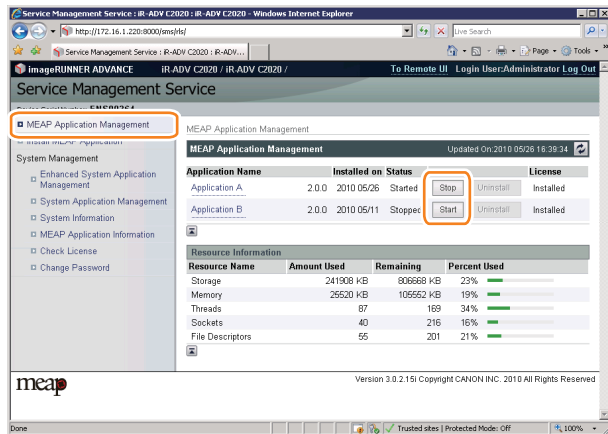

F-2-96

- 4) Check to see that the status of the MEAP application in question is either [Started] or [Stopped].

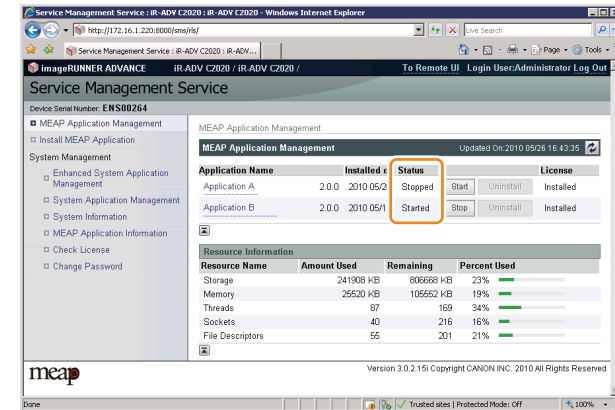

F-2-97

If the MEAP application cannot be started

If the conditions to start the MEAP application are not satisfied, the MEAP application cannot be started.

If the MEAP application cannot be started, check the following items.

Is a valid license installed?

If the license has expired, you cannot start the application. If the license has already expired, obtain a new license and then update the license. (See "Managing the License File" in this manual.)

Are the necessary resources available?

If the resources such as memory capacity or number of threads are not sufficient, the application also cannot be started.

Delete any unnecessary data to secure sufficient resources.

If the application still cannot be started after checking the foregoing conditions, contact the support department of the sales company.

Procedure to uninstall the MEAP application

Before uninstalling the MEAP application, check that the following conditions are met.

- The MEAP application has stopped.
- The license has been disabled or deleted. (The status is "Not Installed".)

Application Name	Installed on	Status	Start	Uninstall	License
Application A	2.0.0 2010 05/26	Stopped	Start	Uninstall	Not Installed
Application B	2.0.0 2010 05/11	Started	Stop	Uninstall	Installed

F-2-98

For information on the procedure to stop the MEAP application, see the previous section "Procedure to start and stop a MEAP application".

For information on the procedure to delete the license file, see the following section "Managing the License File".

Note:

When a user tries to uninstall an application before deleting the license, the following message is shown.

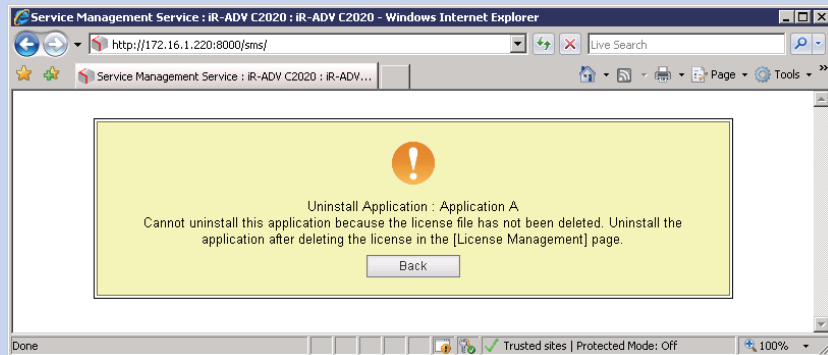

F-2-99

If the license file of the selected application cannot be deleted, the [Uninstall] button is grayed out and therefore the application cannot be uninstalled.

CAUTION:

If the application you are uninstalling is associated with another application, a message will appear to indicate that the package exported by the application will no longer be available. Uninstalling such an application may also disable its associated applications.

1) Log in to SMS to click [MEAP Application Management] on the menu.

2) Check that the status of the application you want to uninstall is [Stop] and the license has been disabled. (The status is "Not Installed".)

Application Name	Installed on	Status	Start	Uninstall	License
Application A	2.0.0 2010 05/26	Stopped	Start	Uninstall	Not Installed
Application B	2.0.0 2010 05/11	Started	Stop	Uninstall	Installed

F-2-100

3) Click [Uninstall] button for the application to be uninstalled.

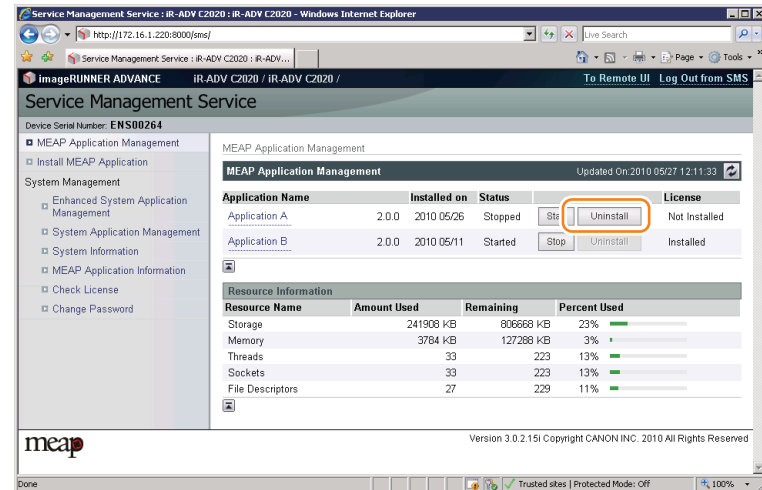

F-2-101

4) Check the application name to be uninstalled shown on the screen to click [Yes] button. Upon [Yes] button clicked, uninstallation process is started.

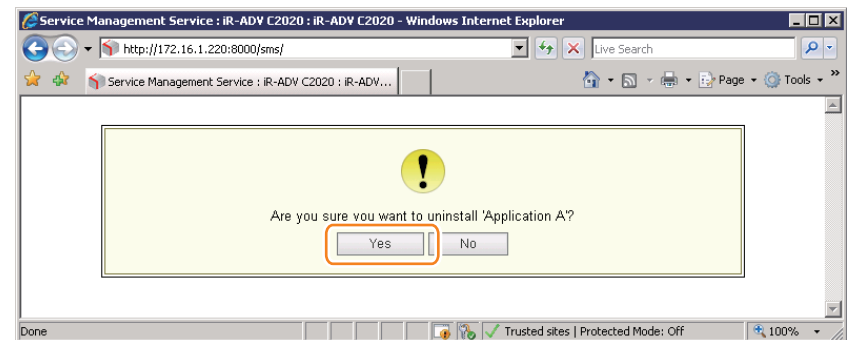

F-2-102

Managing the License File

Outline

The license file management functions allow you to perform the following operations related to the license file necessary for the MEAP application to run.

- Update the license which has already expired.
- Disable or delete the license file in order to uninstall the MEAP application.

These license management functions can be performed from the [MEAP Application Management] screen.

The main license management functions are as follows:

Adding a license

When the license has expired, you can add a license file.

Disabling a License File

Before uninstalling the MEAP application, the license needs to be deleted. In that case, you must first disable the license file because a license file which has not been disabled cannot be downloaded or deleted.

Downloading / Removing an Invalidated License File

Before uninstalling the MEAP application, you need to delete its license file which has already been disabled.

By downloading the license file to your PC before it is deleted, you can use it when installing the application again to the same device.

WARNING:

After deleting the license file which has been disabled, you can no longer download the license file.

Procedure adding a license file

- 1) Log on to SMS.
- 2) On MEAP Application Management, click the name of the application to which you want to add a license file.

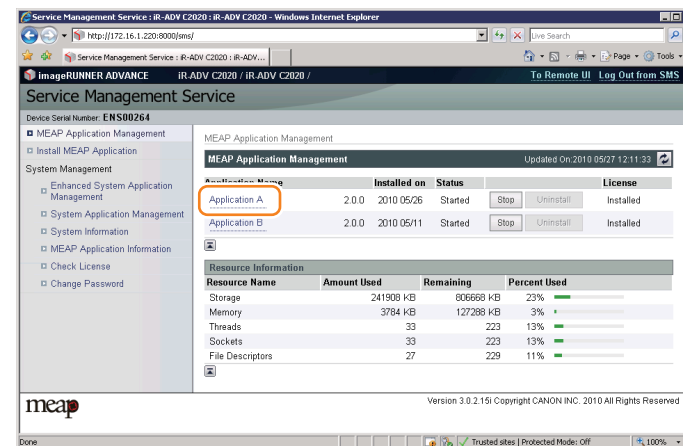

F-2-103

- 3) In [Application / License Information] page shown on the screen, click [License Management] button.

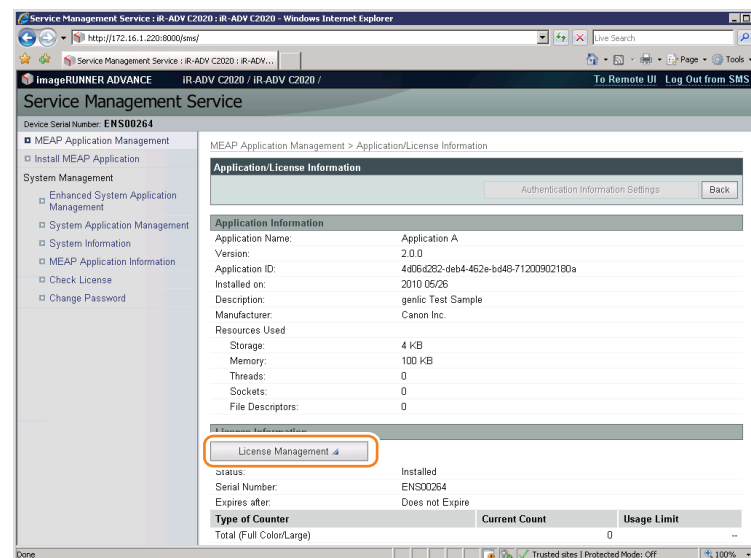

F-2-104

4) Click [Browse] button, and select the license file you want to install.

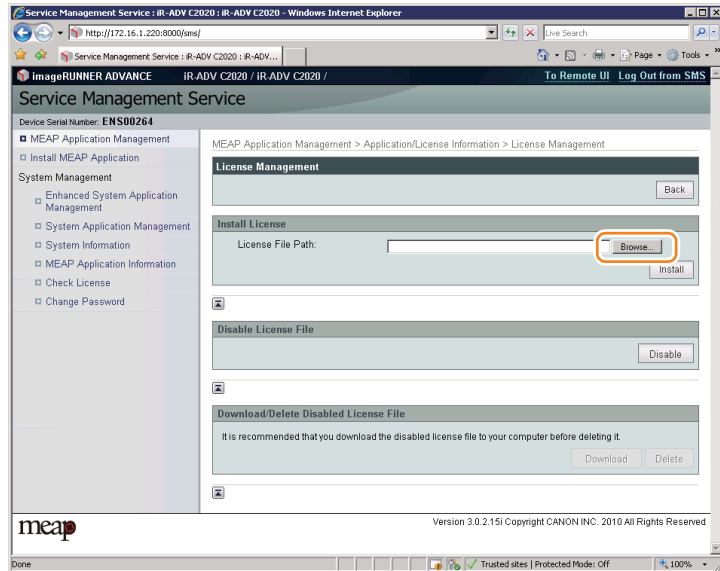

F-2-105

5) Click [Install] button.

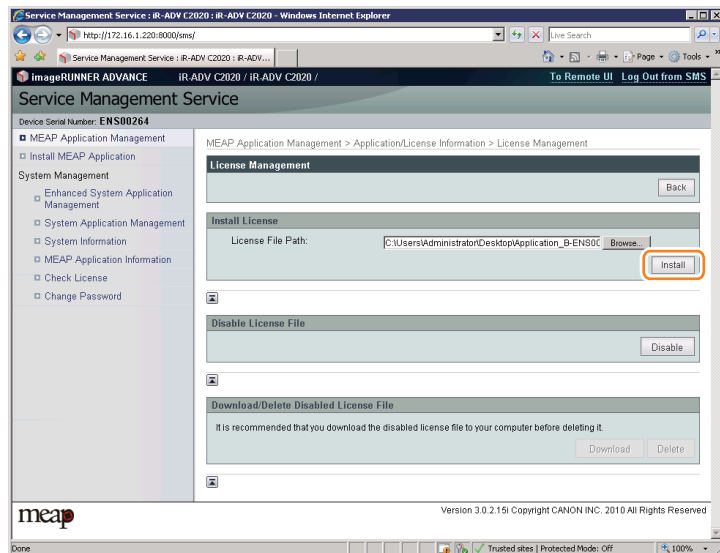

F-2-106

6) Check the content of the confirmation page, and click [OK] button.

● Procedure disabling a license file (suspending a license)

CAUTION:

- Since the license file cannot be disabled when the application is still running, the application needs to be stopped before disabling the license file.
- Once suspended, the status of the license will be 'Not Installed', and its application will no longer be available for use.
- You can later restore a suspended license file as long as you are doing so on the same iR, the device with the same device serial number.
- If the machine needs to be replaced due to a device failure, use the transfer license during the replacement. (See "License for forwarding")

1) Stop the application you want to uninstall on MEAP Application Management page.

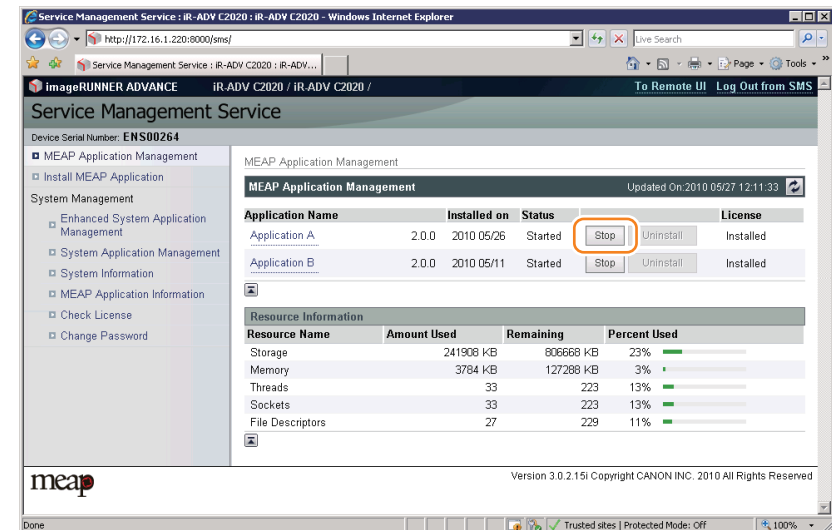

F-2-107

2) Click the name of the application that you want to disable.

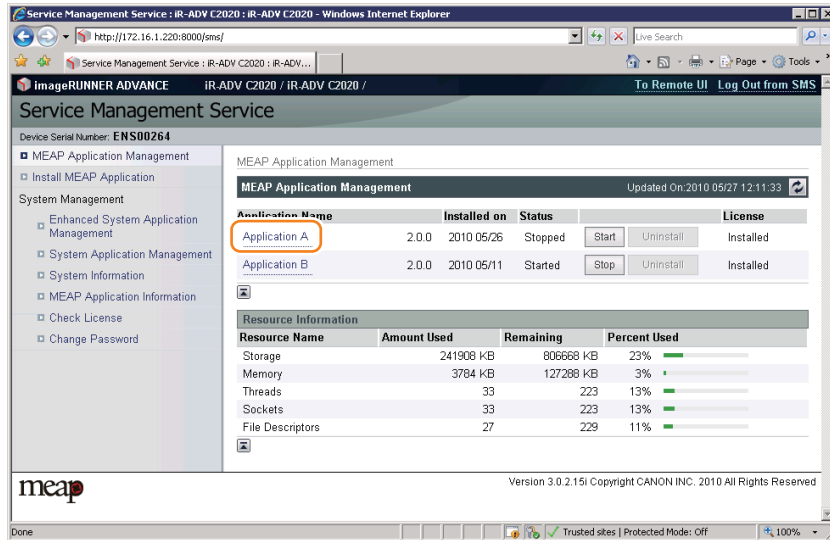

F-2-108

3) On Application/ License Information page, click [License Management] button.

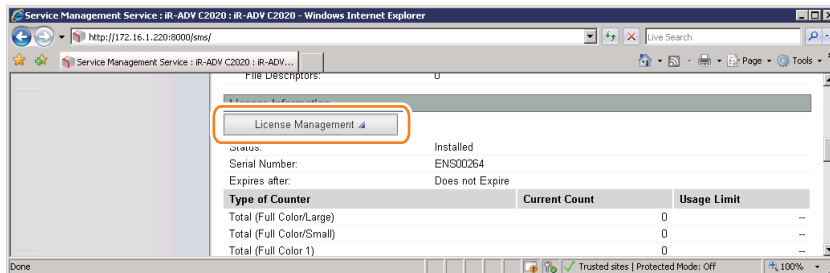

F-2-109

4) License Management page appears. Click [Disable] button.

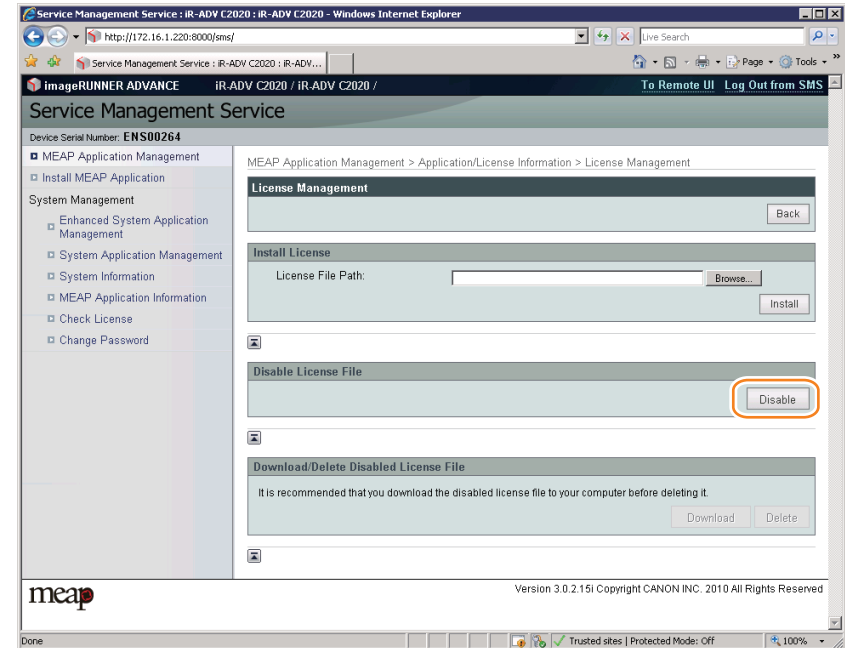

F-2-110

5) Click [Yes].

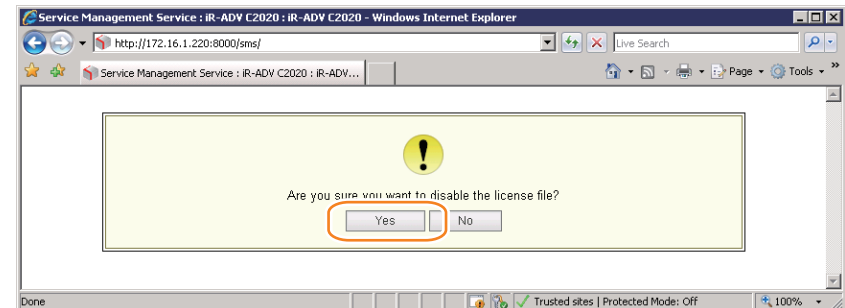

F-2-111

Procedure downloading / removing an invalidated license file

Note:

The downloaded license file can be used for reinstallation only in the same iR device (with the same device serial number).

- 1) Login to SMS.
- 2) Application List page appears. On MEAP Application Management page, click the name of the application you want.

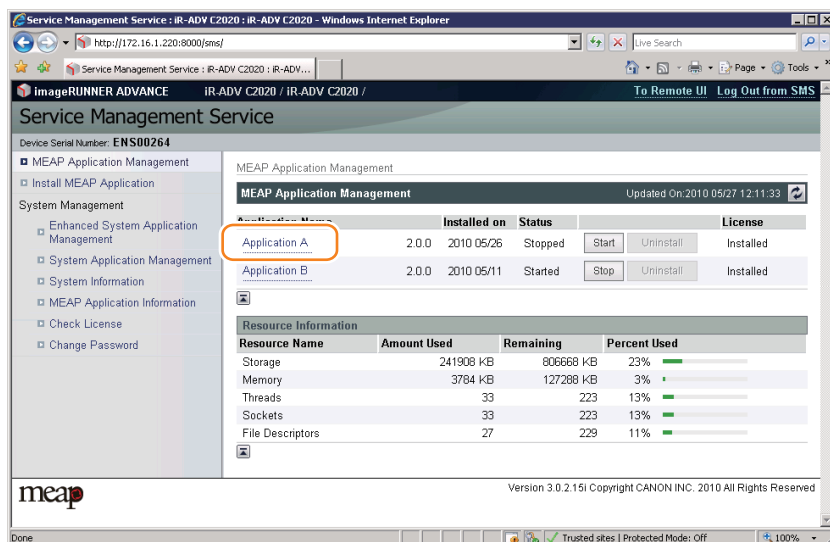

F-2-112

- 3) Check Application/ License Information page appears.
- 4) On Application / License Information page, click [License Management] button.

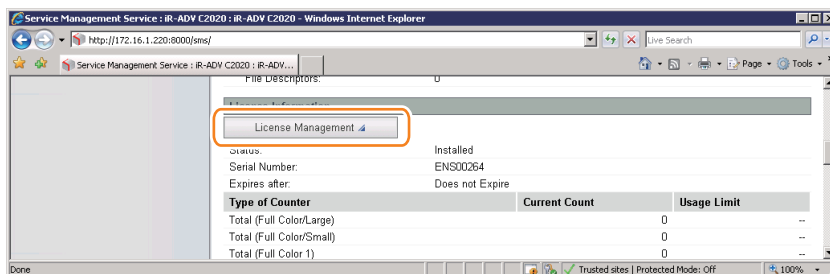

F-2-113

- 5) License Management page appears. To download, click [Download] button.

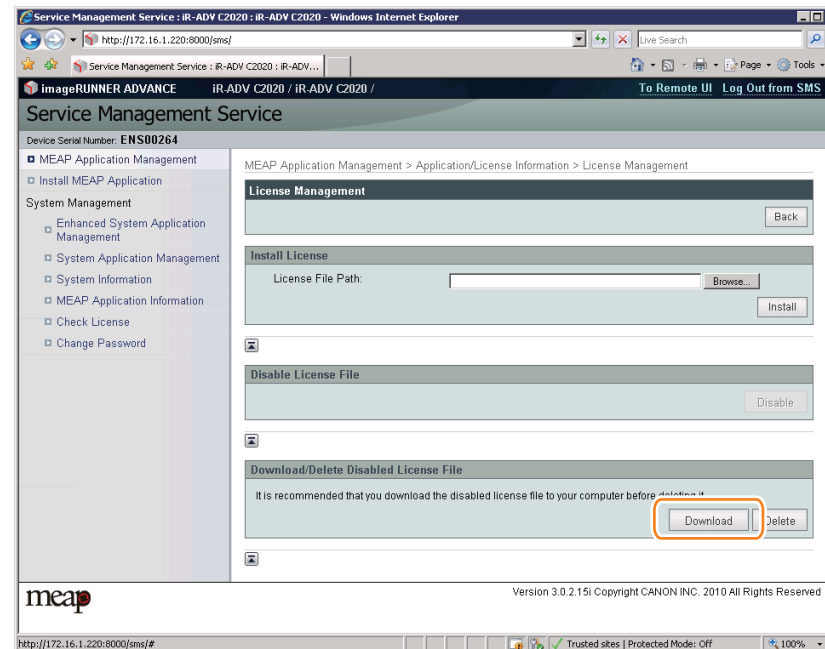

F-2-114

- 6) When you have selected [Download] button, specify where you want to store the file by following the instructions on the screen.

7) To delete, click [Delete] button.

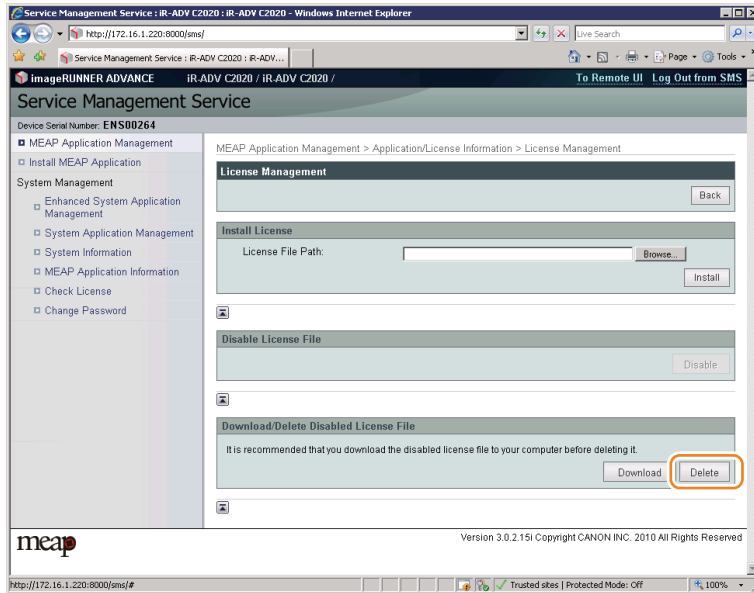

F-2-115

8) When the dialog to confirm deletion is shown, click [Yes] button.

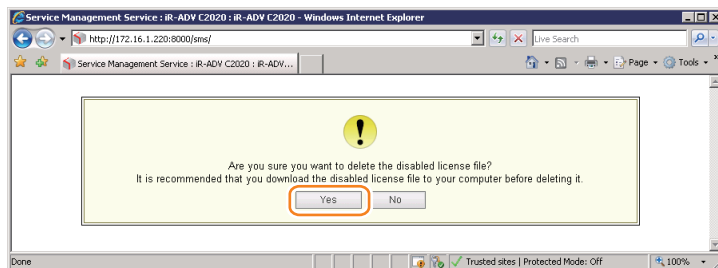

F-2-116

WARNING:

Without the license file, an application cannot be reinstalled even to the MEAP device that the application had been installed last time. Download and save the license file before deleting the application.

Other License File Management Functions

Reusable license

When reinstalling, Disable License file should be downloaded (see "Disabling a License File ." and see "Downloading / Removing an Invalidated License File." in this manual) or a license for reinstallation should be obtained from LMS, before reinstallation.

This specification aims to prevent misuse of applications.

To increase convenience of users, only application with unlimited validity date and application counter (e.g. Portal Service, SDL, SSO) has been made to be able to install as many times as needed by the same license file. This kind of license is called 'Reusable license'.

After replacing the Main PCB, the MEAP applications need to be reinstalled.

In that case, the installation requires use of reusable licenses.

As for other MEAP applications without reusable licenses, use special license files for reinstallation, in the same as way as handling a storage drive failure.

For information on how to obtain a special license for reinstallation, refer to "Special license for reinstallation" in this chapter.

License for forwarding

If the machine needs to be replaced due to a device failure, you can transfer the license information used in the MEAP application to the new machine and continue its usage. Service engineers are responsible for license transfer as this task requires the SMS hidden page (not open to users).

The procedure is shown below.

- 1) Log in to SMS, stop the application to be forwarded (see Chapter 0, "Starting and Stopping a MEAP Application." in this manual).

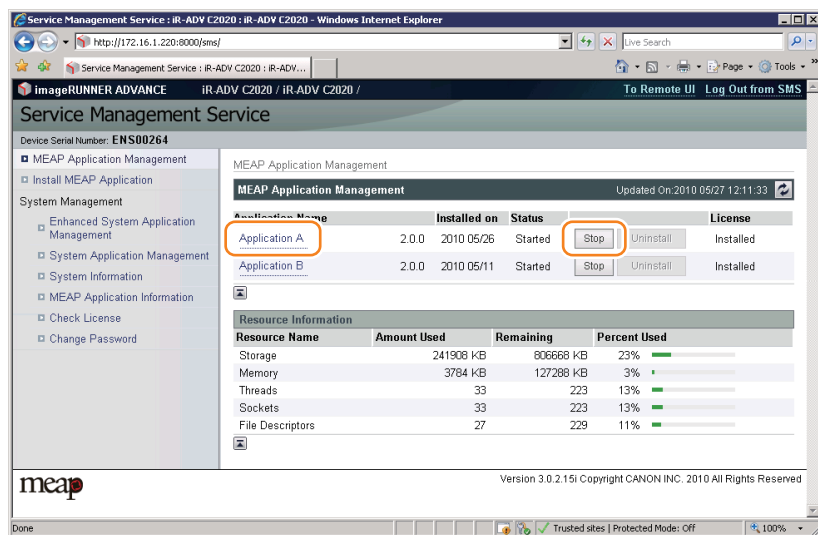

F-2-117

- 2) Move to the download page of license forwarded for the device as sender ([https:// IP address of device: 8443/sms/ForwardLicense](https://IP address of device: 8443/sms/ForwardLicense)).



F-2-118

- 3) Specify the application to be forwarded.

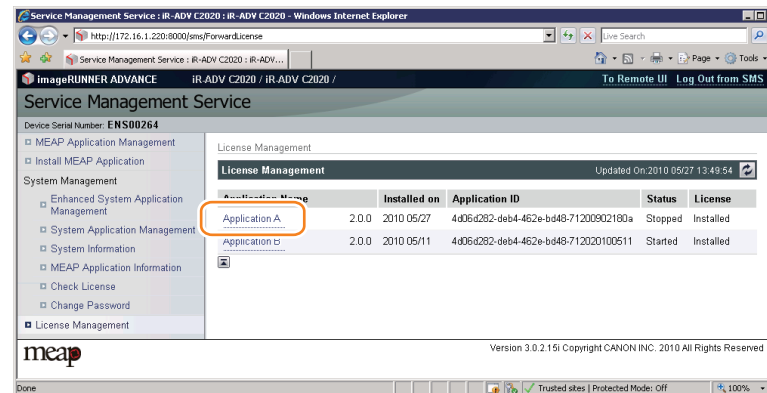

F-2-119

- 4) Click [Create] at Create Transfer License File.

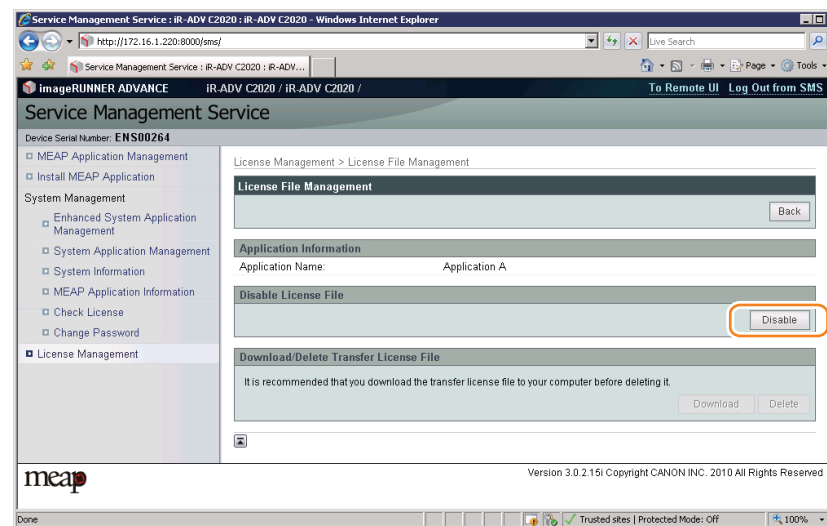

F-2-120

5) The window to confirm whether to create a transfer licence will be displayed. Click [Yes].

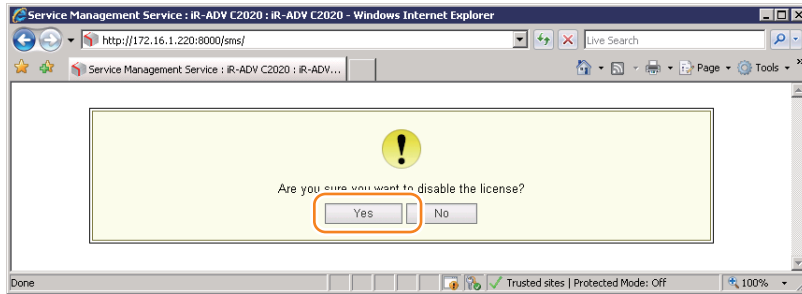

F-2-121

6) When [Download] button on the [Download / Delete Transfer License File] becomes effective, click [Download] button.

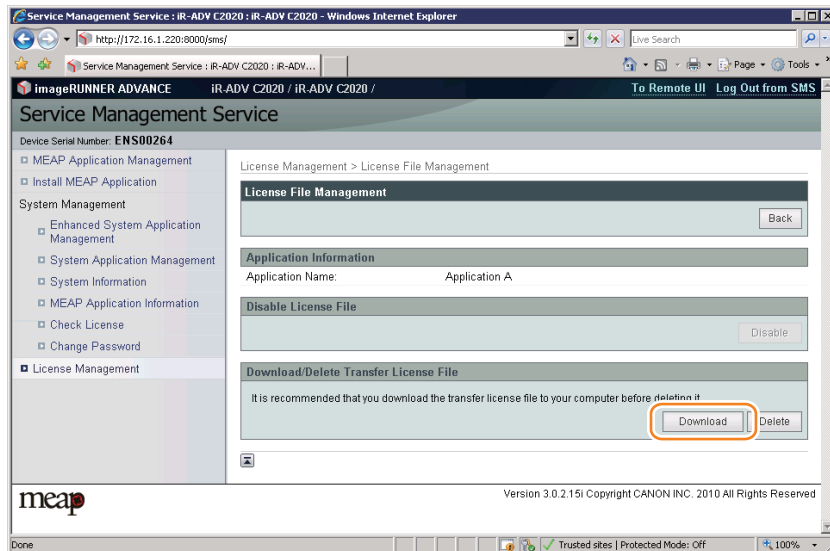

F-2-122

7) The dialogue [File Download] is displayed. Click [Save].

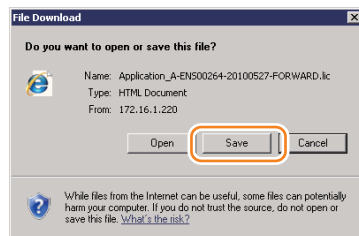

F-2-123

8) Specify the download destination, click [Save].

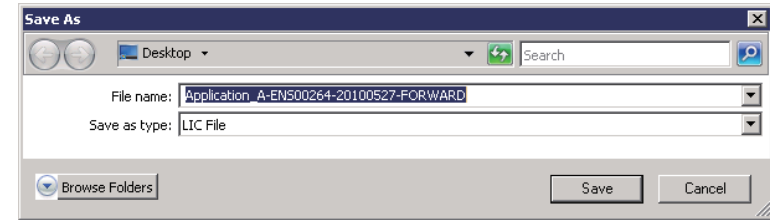

F-2-124

9) After downloading the license file for forwarding, click [Delete] to display the confirmation screen and click [Yes] to delete the file (in consideration of breakage of license for forwarding, deleting disabled license can be executed after all steps have been completed).

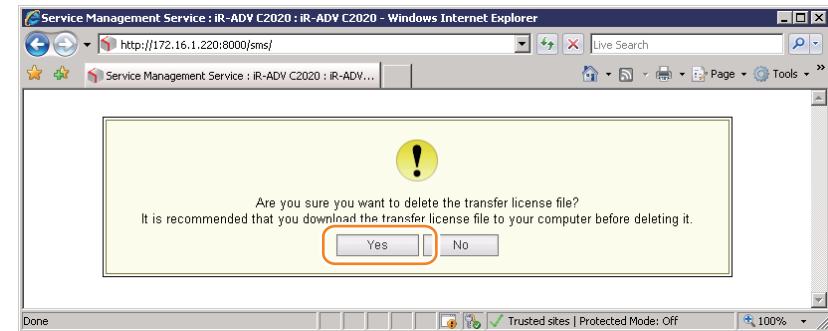

F-2-125

10) Log out of SMS.

11) Since this downloaded transfer license is the file only to prove the license invalidation, it cannot be used for installation to the other device as it is. Send the transfer license to the service support contact of your nearest sales company to request issuance of the new license for installation in the new device.

Note:

When requesting issuance of license for forwarding, inform the sales company of the name of product name and serial No. of the device as sender, and of the name of product name and serial No. of the forwarding destination.

12) Install application using the license for forwarding issued by the sales company.

Enhanced System Application Management

Outline

[Enhanced System Application Management] mainly manages the login services for logging in to devices.

- Installing and uninstalling Enhanced System Application Management (login services, etc.)
- Switching login services (switching the method to log in to devices)
- Checking installation status of other System Applications

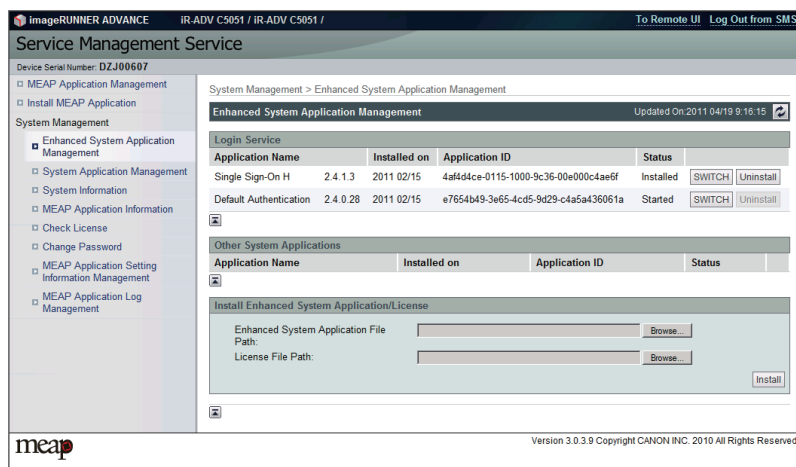

F-2-126

About Login Service

The login service is started up to authenticate the user when MEAP-enabled iR device is booted up. Login service changes and install/ uninstall are carried out from the 'System Management' page.

The pre-installed login application is Default Authentication, and the default setting is [Start].

Default Authentication overview

Default Authentication is a pre-installed login application that runs by default. It provides authentication functions to allow minimum operation of the Controller System, even when no other login application is running.

Other Log in service

There are login services besides the foregoing Default Authentication, such as card authentication. For details, refer to the manuals for those login services.

Procedure Changing Login Services

If 2 or more login services are installed, you can use the following procedure to switch among them.

- 1) Access SMS. From the [System Management] menu, select [Enhanced System Application Management].

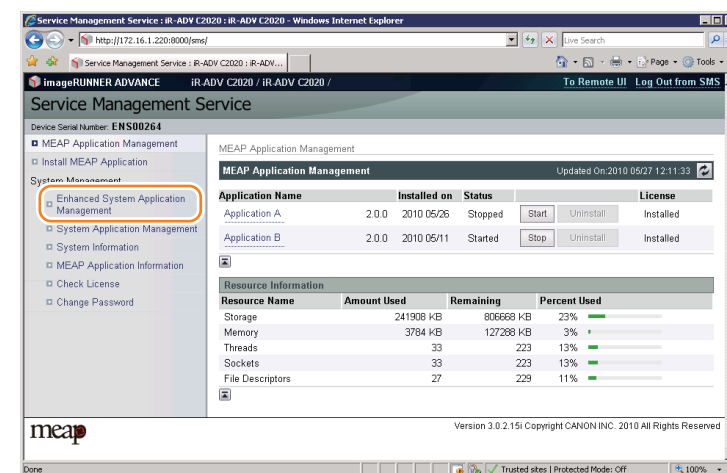

F-2-127

2) Click the [SWITCH] button of the login service you want to switch to.

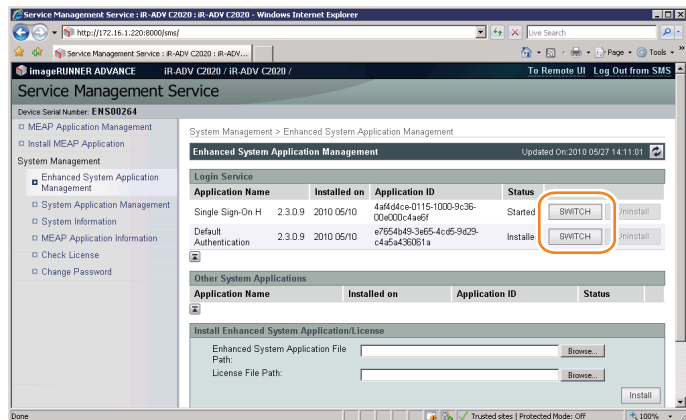

F-2-128

3) Check that the status of the selected login service application has changed to [Start after Restart]. Then, log out of SMS and restart the device.

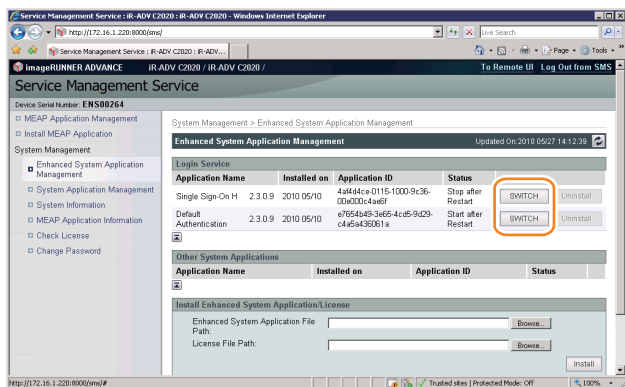

F-2-129

Procedure Installing Login Services

Use the following procedure to install the login services.

- 1) Access SMS, and then click [System Management] > [Enhanced System Application Management].
- 2) Click the [Browse] button, and specify the Enhanced System Application file/License file.

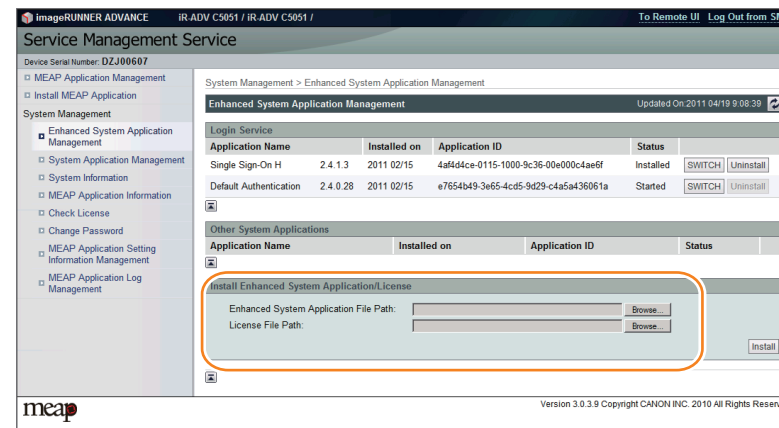

F-2-130

3) Click [Install] button.

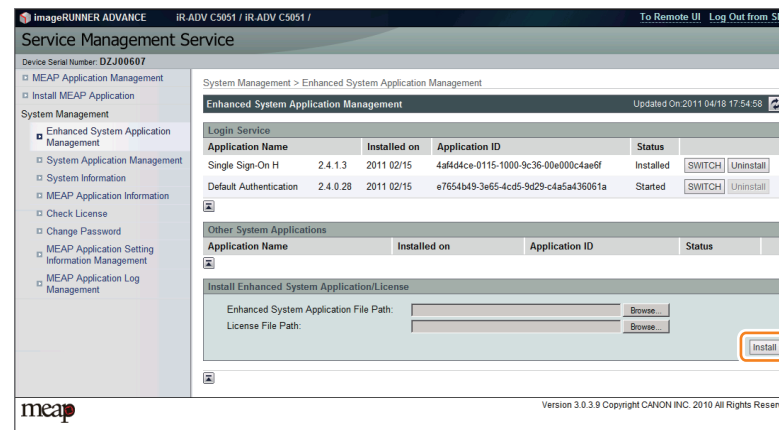

F-2-131

Procedure Uninstalling Login Services

Use the following procedure to uninstall the login services.

Also, note that the services need to be stopped ("Installed" status) in order to uninstall the login services.

- 1) Access SMS, and then select [System Management] > [Enhanced System Application Management].

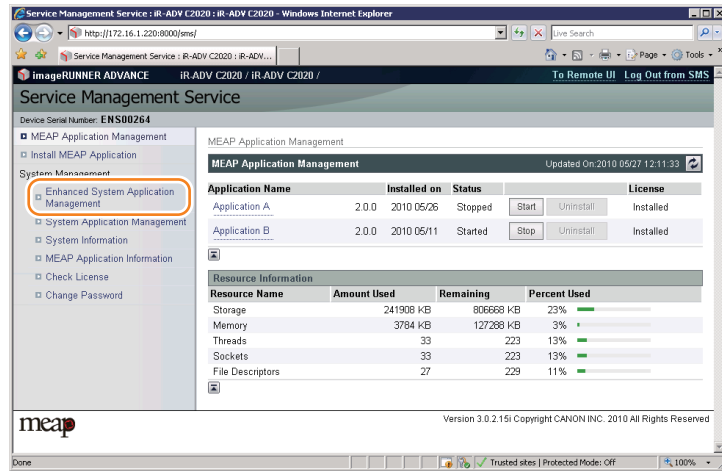

F-2-132

- 2) Click the [Uninstall] button of the login service you want to uninstall.

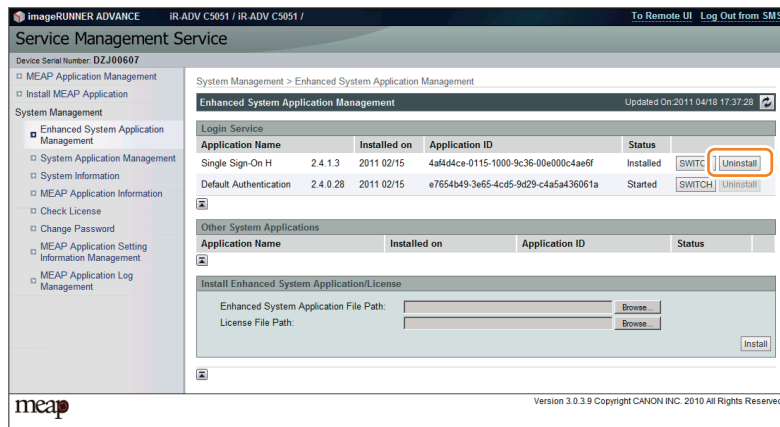

F-2-133

System Application Management

This function manages the login services for logging in to SMS.

Procedure to manage System Application

Use the following procedure to manage the System Application.

- 1) Access SMS, and then click [System Management] > [System Application Management].
- 2) Click [Start] or [Stop] button in the status column of the system application that wants to start or stops.

System Management > System Application Management

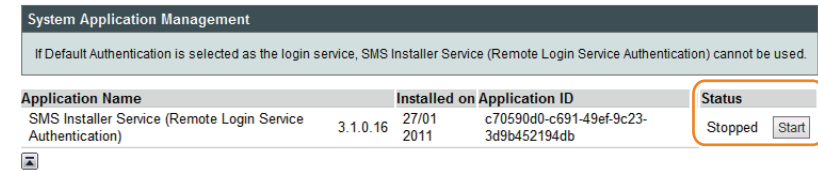

F-2-134

- 3) Log out of SMS. (When you log in next time, a set content becomes effective.)

System Information

Outline

You can check the device's platform information and the MEAP application's system information.

Checking the System Information

System information that can be checked from the screen:

- Platform information
 - MEAP Specifications version (MEAP Spec Ver)
 - MEAP Contents version
 - Java Virtual Machine version
- System application information
 - The name of the installed system application
 - The installation date of the installed system application
 - Application ID of the installed system application
 - The status of the installed system application

The checking procedure is shown below.

- 1) Log in to SMS.
- 2) On System Management menu, click [System Info] button.

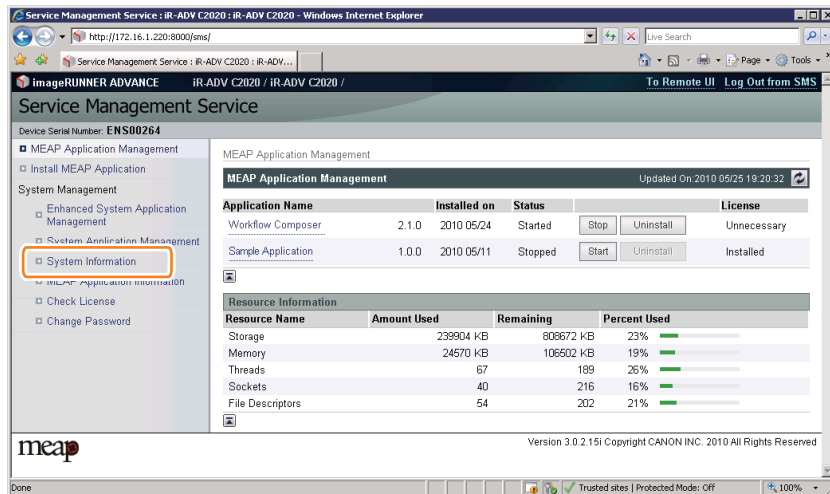

F-2-135

Display of System Information Details

The system information details can be displayed to check more than one pieces of information all at the same time: platform information, system application information, information on the installed MEAP applications, etc.

- 1) Log in to SMS.
- 2) On System Management menu, click [System Info].
- 3) Click [Details] button.

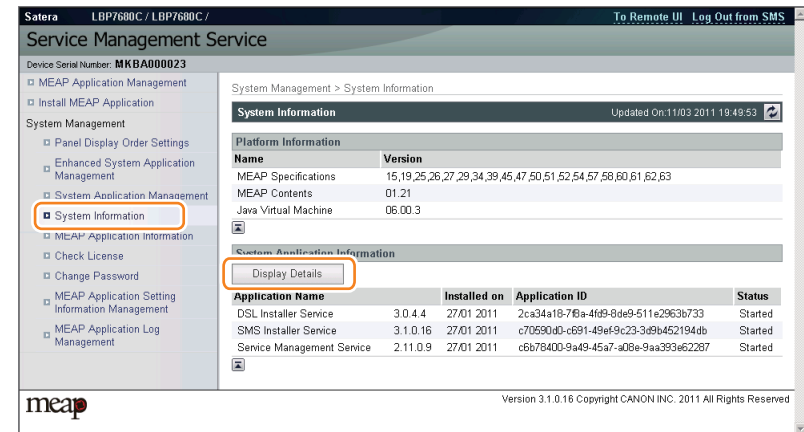

F-2-136

- 4) The system information of each application (including System Application) is shown in a separate window. Copy and paste all the information in a file to attach to AR reports as text information. This function is useful to check status information of each application.



F-2-137

Printing the System Information of a MEAP Application

MEAP system information can be printed out with iR device for confirmation.

Note:

The system information of the MEAP application that you checked in the previous section is exactly the same as the system information of the MEAP application that is output.

Follow the steps below when confirming information:

- 1) From [Utility Menu], select [Print MEAP Sys. Info].
- 2) When the execution confirmation screen appears, select [Yes] and then press the [OK] button on the Control Panel.

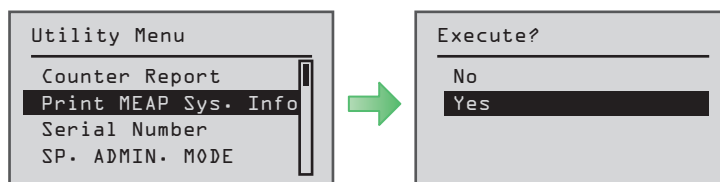

F-2-138

Content of MEAP system information

Application System Information

```
Application Name: C-Cabinet Gateway for MEAP
Application ID/System Application Name: 03a46668-63e4-4636-9cbb-492b6cef05d5
Application Version: 1.0.0
Status: Resolved
Installed on: Tue Oct 21 14:00:11 GMT+09:00 2003
Vendor : Canon Inc.
License Status : Installed
Maximum Memory Usage : 1024
Registered Service :
```

Item	Content
Status	It indicates the status of the application in question; specifically, Installed: the application has been installed. Active: the application is being in use. Resolved: the application is at rest.
Installed On	It indicates the date on which the application was installed.
Vendor	It is the name of the vendor that developed the application, and is the name (bundle-vendor) declared in a statement within the application program.
License Status	It indicates the status of the license; specifically, None: no license is needed. Not Installed: no license has been installed. Installed: the appropriate license has been installed. Invalid: the license has been invalidated. Overlimt: the license has been used beyond its permitted limit.
License Expires After	It indicates the date after which the license expires. If the status of the license is 'none', this item will not be printed.
License Upper Limit	It indicates the limit imposed on individual counter readings. If the status of the license is 'none', this item will not be printed.
Counter Value	It is the current counter reading of a specific counter. If the status of the license is 'none', this item will not be printed.
Maximum Memory Usage	It indicates the maximum amount of memory that the application uses. It is the amount (maximum memory usage) declared in a statement within the application program, and is expressed in kilobytes.
Registered Service	It is a list of services that have been registered by the application with the MEAP framework. Some services may not have printable data.

T-2-12

Item	Content
Application Name	It is the name (bundle-name) declared in a statement within the application program. It may not necessarily be identical to the name of the program.
Application ID/System Application Name	Application ID (application-id) items which are declared on the declaration statement in the application program are printed.
Application Version	It is the version of the application (bundle-version) declared in a statement within the application program.

MEAP Application Information

Outline

You can use this function to check the MEAP application installed on the device.

The following information can be checked on the MEAP application information screen.

- Application Name
- Application ID
- Installed on
- Status
- License Status
- Counter Information

Procedure to Check MEAP Application Information

- 1) Log in to SMS.
- 2) On System Management menu, click [MEAP System ApplicationsSystem Info] button.

Service Management Service

Device Serial Number: MKBA000023

MEAP Application Management

MEAP Application Management Updated On: 11/03 2011 22:54:29

Application Name	Version	Installed on	Status	License
SampleApp_A	4.4.0	11/03 2011	Installed	Installed
SampleApp_B	4.4.0	11/03 2011	Installed	Installed
SampleApp_C	4.4.0	11/03 2011	Installed	Installed

Resource Information

Resource Name	Amount Used	Remaining	Percent Used
Storage	12505 KB	20263 KB	38%
Memory	1050 KB	19430 KB	5%
Threads	5	123	4%
Sockets	0	128	0%
File Descriptors	4	124	3%

meap Version 3.1.0.16 Copyright CANON INC. 2011 All Rights Reserved

F-2-139

- 3) The MEAP application information screen appears.

Service Management Service

Device Serial Number: MKBA000023

System Management > MEAP Application Information

MEAP Application Information Updated On: 17/03 2011 18:34:50

Application View: Installed [Switch]

'SampleApp_A' Information

Application Name: SampleApp_A
 Application ID: 4d06d282-deb4-462e-bd48-71167c17710a
 Installed on: 11/03 2011
 Status: Installed
 License Status: Installed
 Expires after: 54 days

Type of Counter	Current Count	Usage Limit
Total (Full Color/Large)	0	--
Total (Full Color/Small)	0	--
Total (Full Color 1)	0	--
Total (Single Color/Large)	0	--
Total (Single Color/Small)	0	--
Total (Single Color)	0	--
Total (Black and White/Large)	0	1000

F-2-140

Check License

Outline

You can use this function to check the contents of the license file.

Procedure to Check the License File

- 1) Log in to SMS.
- 2) On System Management menu, click [Check License] button.

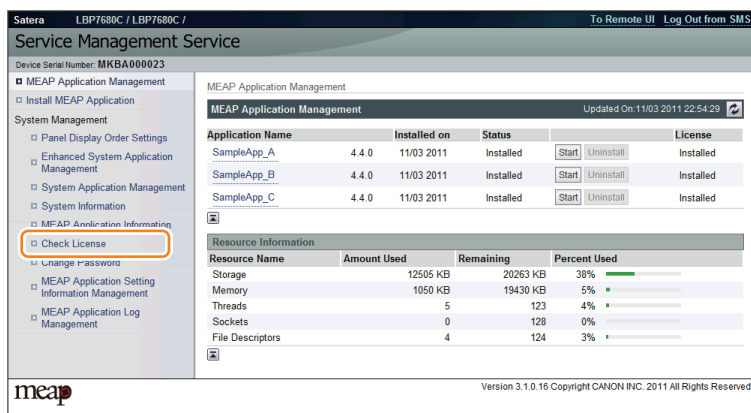

F-2-141

- 3) Click the [Browse..] button, specify a license file, and click the [Check] button.

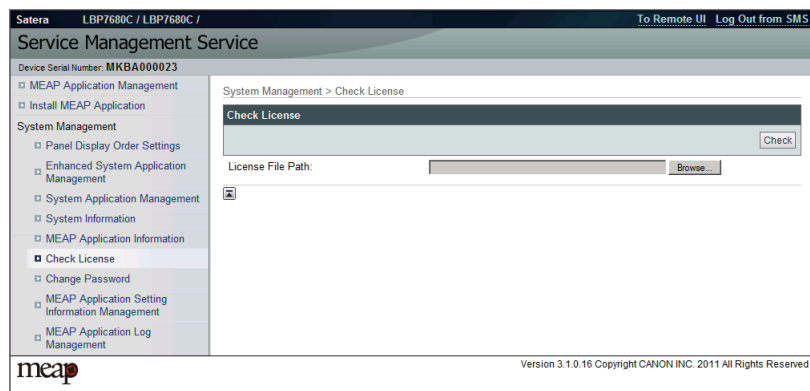

F-2-142

Changing SMS Login Password

Outline

You can change the password for logging in to SMS.

If you forgot the login password and you want to change the password back to the default value (MeapSmsLogin), see "When SMS Cannot Be Accessed" in this manual.

Procedure to Change the SMS Login Password

- 1) Log in to SMS.
- 2) On System Management menu, click [Change Password] button.

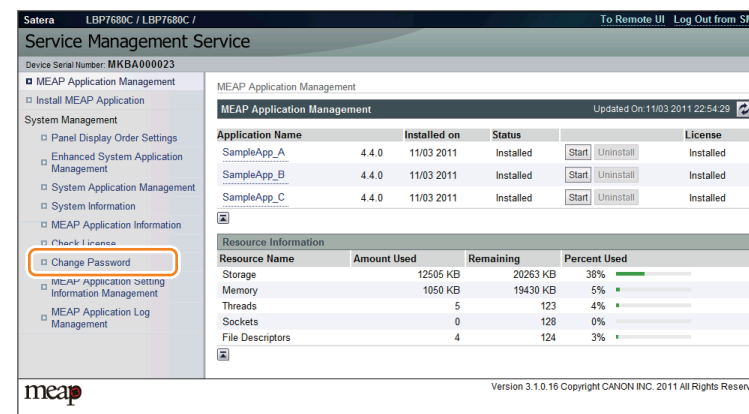

F-2-143

- 3) Enter both the current password and a new password, and then click the [Change] button.

System Management > Change Password

The screenshot shows the 'Change Password' dialog box. It has three input fields: 'Old Password:', 'New Password:', and 'Confirm:'. There are 'Change' and 'Reset' buttons at the top right.

F-2-144

Note:

The [Reset] button on the [Change Password] screen is used to clear the value entered in the text field. It is not a button for changing the SMS login password back to the default value.

MEAP Application Setting Information Management and Log Management

Outline

The MEAP Application Setting Information Management page and the MEAP Application Log Management page provide menu related to "MEAP Application Configuration Service" for managing MEAP application setting information and "MEAP Application Log Service" for managing log information respectively.

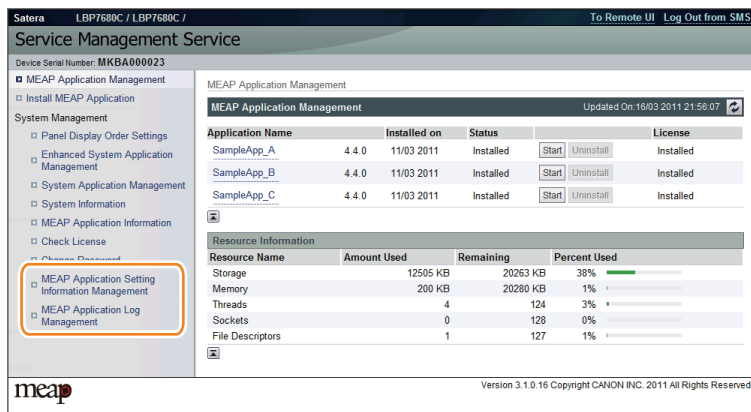

F-2-145

MEAP Application Configuration Service

This service manages the MEAP application setting information. It has functions such as saving setting information to the MEAP area. Ver 57 of MEAP Specifications supports this service.

MEAP Application Log Service

This service is used to collect MEAP application logs (debug logs and authentication logs). Ver.58 of MEAP Specifications supports this service.

Advantages Obtained When Using the Services

By using MEAP Application Configuration Service and MEAP Application Log Service, as long as the MEAP application supports these services, you can perform data management tasks all together.

In case of devices and MEAP application that do not support the service

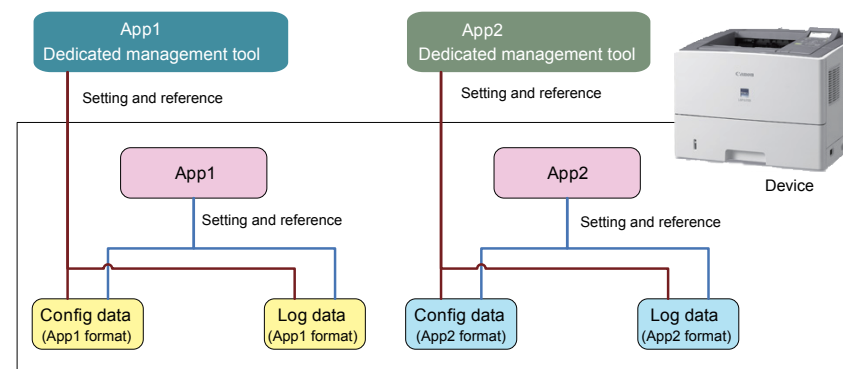

F-2-146

As for devices and MEAP application that do not support the service, the setting information and log data are managed separately by application.

In case of devices and MEAP application that support the service

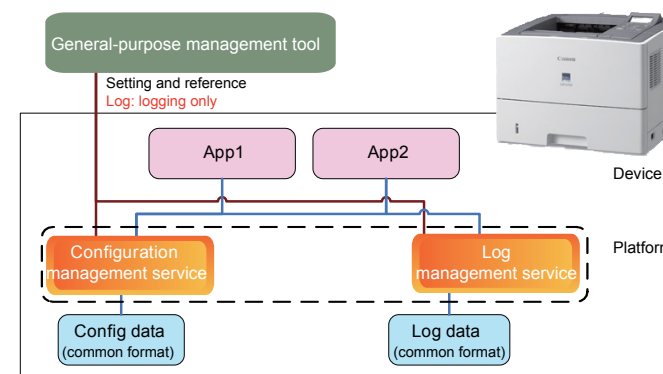

F-2-147

As for devices and MEAP application that support the service, information can be managed all together.

MEAP Application Setting Information Management

The setting data (stored on the device) of the MEAP application which supports the Configuration Service can be deleted. The procedure is shown below.

- 1) Log in to SMS.
- 2) On System Management menu, click [MEAP Application Setting Information Management] button.

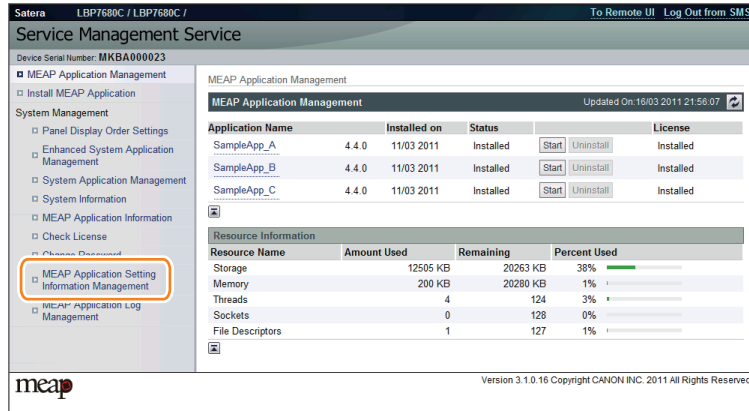

F-2-148

- 3) Select an application you want to delete, and then click the [Delete] button.

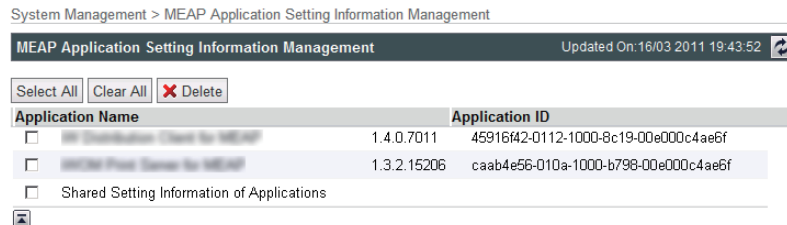

F-2-149

Note:

If the installed MEAP application contains setting data which is not dedicated to the application but can be shared, the application name [Shared Setting Information of Applications] will be displayed.

MEAP Application Log Management

The log data (stored on the device) of the MEAP application which supports the Log Service can be downloaded or deleted. The procedure is shown below.

- 1) Log in to SMS.
- 2) On System Management menu, click [MEAP Application Log Management] button.

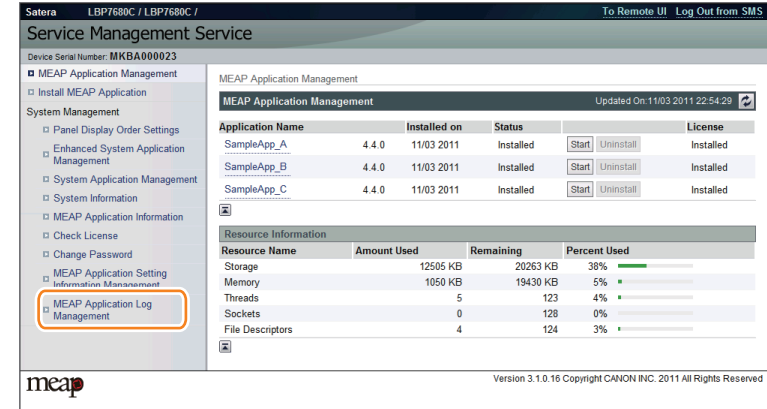

F-2-150

- 3) Click [Download Application Logs] or [Delete Application Logs].

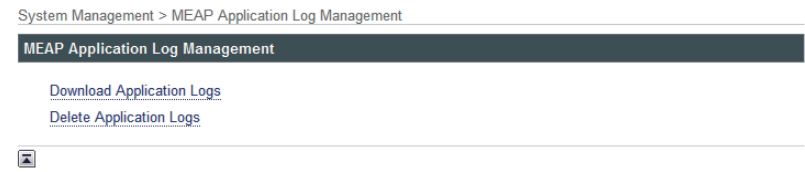

F-2-151

- 4) To download the log

The file save dialog for the log file will appear. Specify a destination and save the file.

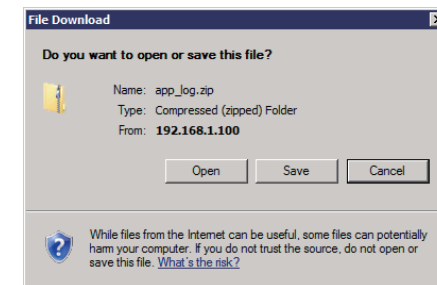

F-2-152

5) To delete the log

The confirmation screen will appear to prompt you to delete the log. Click the [Yes] button to delete the log.

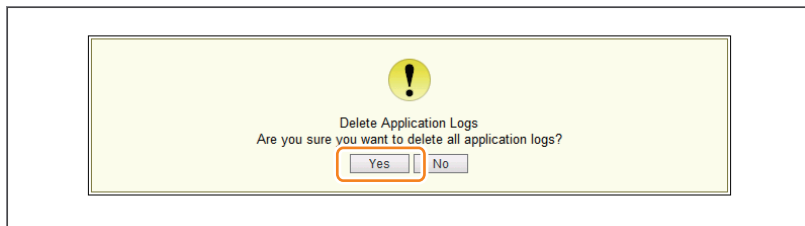

F-2-153

Maintenance

When Replacing the PCB

Outline

If the machine fails to operate normally due to a storage drive (Flash PCB) failure or a system (other than MEAP application) trouble, the storage drive needs to be replaced.

However, since the storage drive in this machine is directly mounted on to the PCB, replacement of the part alone is not possible; it is necessary to replace the PCB.

Since the storage drive of the machine cannot be backed up or restored, the MEAP application and the license file need to be reinstalled when replacing the PCB.

When the storage drive and the system are operating normally but the PCB is replaced due to other reasons, the MEAP application and license file need to be reinstalled.

The MEAP counter information cannot be lost because it is backed up like other conventional counters.

Note:

When the device has E code 616 displayed, this indicates that the trouble was caused by damage to the Flash PCB. If this error occurs, the PCB needs to be replaced.

Special license for reinstallation

When replacing the PCB, a special license file is required to reinstall the application with the expiration date of the current counter value migrated as it is. This special license file is handled as a service tool and cannot be obtained by end users.

In order to obtain a special license file, the service technician needs to contact the person in charge of support at the sales company.

The service technician needs to give the device serial number and the names of the MEAP applications that had been installed.

Since the support department of the sales company manages all the issued application license files by device serial number, it is basically possible for them to successively issue license files once the device serial number is confirmed.

Note:

The application that is installed with a reusable license can be reinstalled by using the same license.

● Procedure for reinstalling MEAP applications after replacing the PCB

The following shows the procedure when replacing the PCB.

1)Preparation before replacement

- If the installed MEAP application has a backup or data export function, use the function to back up or export the data.
- Copy a set of license files for reinstalling the MEAP application (special licenses and reusable licenses) to a laptop for service operation.

2)Replacing the drive

Prepare the necessary service parts, and replace the drive.

3)Reinstalling the MEAP application

When the device has started normally, obtain the jar files of the MEAP applications from the user, and install them using the license files for reinstallation.

Installation method is the same as normal installation.

4)Importing user information

As necessary, make login service selections and import user information.

Note:

When you replace the PCB without uninstalling MEAP applications, make sure to reinstall the previously installed applications. Unless reinstalling them, MEAP counter will not be released and the message "The number of applications that can be installed has exceeded the limit. Try to install this application after uninstalling other applications." is displayed so that the installation of new applications may not be accepted. If you want to install new applications in this case, once reinstall the applications in-stalled before formatting and uninstall unnecessary applications.

Note:

If a PCB which had been used in a device with a different serial number is installed in another device, the MEAP area in the storage drive will be completely initialized.

■ Actions to be taken when E616 is displayed.

● Overview

When E602 is displayed and then the device is restarted as a remedy, E616 may be displayed in some cases.

This is a symptom that occurs when the power is cut off without shutdown (such as disconnecting the plug of the device). The error code is displayed when the file system of the MEAP storage area is in an abnormal status.

When the device is started, it checks the file system. If the device detects an error, it displays the error code E602, disables the MEAP function, and then starts.

When the device is restarted according to the remedy for E602, the file system is recovered automatically in the system. If the recovery procedure succeeds, the device starts normally with the MEAP function enabled.

However, if the file system could not be recovered by auto recovery, E616 is displayed.

Since the system is automatically formatted when E616 is displayed, the installed MEAP applications will disappear and the device's MEAP function itself will also be disabled.

For this reason, it is necessary to enable the MEAP function and then reinstall the MEAP applications.

● Work procedure

Perform the following procedure when E616 is displayed.

- 1)Start the device in service mode.
- 2)Select [Setup] > [SERVICE MODE] > [FUNCTION GR.] > [MEAP FUNCTION] > On to enable the MEAP function.
- 3)Restart the device to start the MEAP function.
- 4)Access SMS, and then use a reusable license or special license for reinstallation to install the MEAP application.

Note:

As for MEAP applications that were installed using reusable licenses, the reusable licenses can be used to reinstall the applications. For other MEAP applications without reusable licenses, use special license files to reinstall them, in the same as way as handling a storage drive failure. For information on how to obtain a special license for reinstallation, see "Special license for reinstallation" in this chapter. Then contact the support department of the sales company to have the license issued before starting the work.

- 5)Start the MEAP application.

MEAP Safe Mode

Outline

Use safe mode if you need to start up the system without worrying about extra applications. It will start up only those system software files (including SMS) that normally start up as default files while preventing MEAP applications and the like from starting up.

When you have made changes and restart the device, the control panel will indicate 'MPSF' in its lower right corner. The MEAP applications that may have been active before you shut down the equipment will not start up on their own. Make use of safe mode when restoring the system software as when MEAP applications or services cause a fault as the result of a conflict or wrong sequence of registration/use. You can access to SMS in this condition so that you can take necessary measures, for example, you can stop application that may cause the trouble.

If default authentication has been selected, the mode of authentication remains valid; otherwise, the message "The login service must be set again with SMS" appears. Change the login service as necessary.

Starting in Safe Mode

To start the device in the MEAP SAFE mode, turn ON the power with the [Application] key and the [ID] key pressed.

How to cancel MEAP SAFE mode

If you want to cancel MEAP SAFE mode, just restart the device as usual. It will start in normal mode.

Note:

If accessed to SMS in MEAP SAFE mode, the device started mode is shown on the title bar of the browser.

When normally started:

Service Management Service : <Device Name>: <Product Name>

When starting in MEAP SAFE mode:

Service Management Service : <Device Name>:<Product Name>: Safe Mode

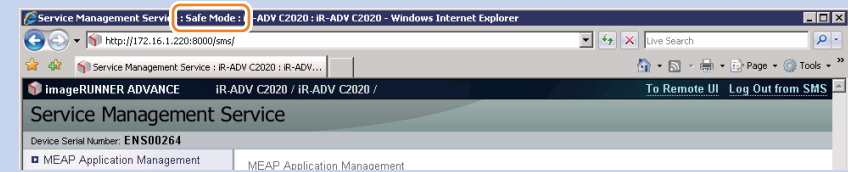

F-2-154

WARNING :

If the device has been started in the MEAP SAFE mode, all MEAP applications stop and the status becomes "Installed".

This status remains unchanged even if the MEAP SAFE mode is cancelled and the device is started again in normal mode. It is therefore necessary to access SMS after normal startup, and start the MEAP application.

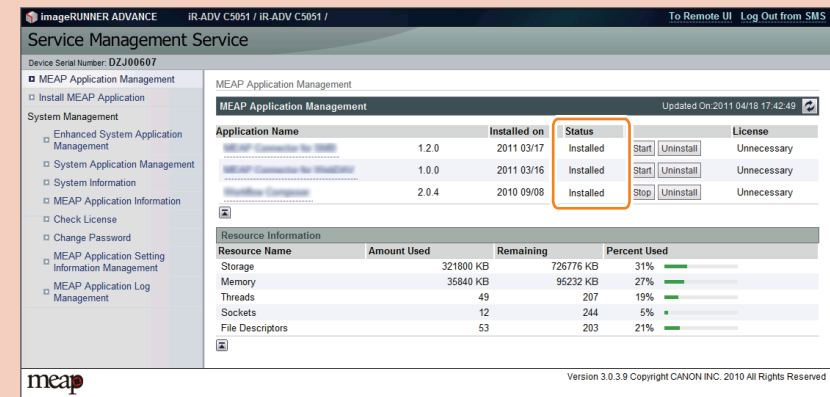

F-2-155

Using USB Devices

USB Driver

Two types of USB drivers

While the USB driver that can be used in iR series is only the USB driver designed exclusively for MEAP application (hereinafter referred to as “MEAP driver”), not only MEAP driver but also USB system driver (hereinafter referred to as “system driver”) can be used in iR-ADV series.

System driver and MEAP driver cannot be used together. When either of them is used, the other driver cannot be used.

In this model, the USB system driver supports only Mass Storage; HID is not supported. In other words, storage devices such as USB Flash memory can be used via system driver, but interface devices such as USB keyboard cannot be used via system driver.

USB driver setting

System driver is active by default in iR-ADV series.

The driver can be changed in setup menu.

Usually, It is not necessary to change the setting because it is specified in the MEAP application side.

Only in the case of a special MEAP application, it is necessary to change the USB driver setting.

For details, refer to specifications of MEAP application side.

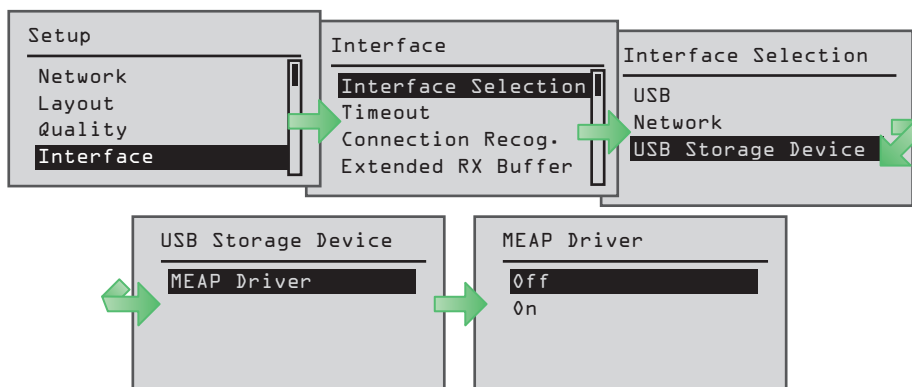

F-2-156

USB Storage Device Settings: [MEAP Driver]	Application that supports mass storage device	MEAP application that supports system driver
ON * MEAP driver (compatibility mode)	Can use USB mass storage device. Can work only on the applications that support the MEAP application driver.	Cannot use USB mass storage device.
OFF (*default) * Native driver	Cannot use USB mass storage device. (Device cannot be detected.)	Can use USB mass storage device.

T-2-13

Note:
When any settings changes are made, the device must be restarted.

● Setting the USB driver for each USB device (MEAP driver preference registration)

If it is set to use the system driver, the conventional applications that support the MEAP application driver cannot use the USB input device.

Therefore, for the USB drivers used by USB devices/MEAP applications, there is setting function (MEAP driver preference registration) to give priority to the MEAP driver.

If you register the ID of the USB device by using this function, the USB device can use the MEAP driver despite the Additional Function settings.

Using this function requires the conditions below:

- Supported MEAP Spec Ver: 26
- Describe the idVendor(VID) and idProduct(PID) of USB device in the manifest or activate/deactivate the VID and PID by calling API from MEAP applications.

The driver setting that is used in a manifest file is reflected in the following timing.

When registering from a manifest file.

- The registration will be enabled when an application is activated and device is restarted.
- The registration will be disabled when an application is stopped and device is restarted.

Availability for MEAP application of the USB device A (either HID keyboard or Mass Storage) plugged to iR device

Registration status of USB device A	USB Setting [Use MEAP driver for USB input device]	Native application	MEAP application		
			System driver supported application	System driver not supported/ conventional application	Application with VID/PID declared in Manifest for x
Not registered	OFF	YES	YES	NO	
	ON	NO	NO	YES	
Registered	OFF	NO	NO	YES	YES
	ON	NO	NO	YES	YES

YES: USB device available

NO: USB device not available

T-2-14

● Reference material

■ Glossary

Terms & Acronyms	Definitions and Explanations
Application	A program unit to provide users with solutions.
Application ID	An identifier assigned to each application. A unique ID is assigned to each MEAP application.
Applet (Applet Type Application)	A MEAP application type created in Java. This type of applications show buttons on the touch panel display.
Code Sign	Information to check if an application is genuine. An application marketed in the normal procedure has a code sign assigned by LMS. MEAP platform rejects applications without Canon code signs for being installed or executed on the device.
CPCA (Common Peripheral Controlling Architecture)	Common Peripheral Controlling Architecture. CPCA defines an object model of peripheral devices. A client can control a device by creating or modifying objects in the device.
CPCA Java CL (Class Library)	CPCA Java Class Library. A Java class library, which is used to control a device.
Default Authentication -Department ID Management	Default Authentication is a pre-installed login application that runs by default. It provides authentication functions to allow minimum operation of the Controller System, even when no other login application is running.
Device Specification ID	ID allocated to each device type. This represents CPCA API specification and the version number to use MFP generic functions or obtain information including maximum allowable copies.
Esplet (Esplet Type Application)	A MEAP application type created in Java. This type of applications do not show user interfaces either on Local UI or Web. Esplet is a coined word created by Canon, consisting of [Espresso] or Italian coffee and [let] derived from Applet/Service.
File Description	An identifier for the OS to identify the destination file requested by a program. A program descriptor includes an identifier and information such as a file name and size, which helps OS to judge the file to be edited.
HID class	HID stands for Human Interface Device, representing man-machine interfaces of PC components and peripheral devices. HID class means USB class classified as HID.
iR Native application	The functionalities that existing imageRUNNER has such as Copy, Universal Send and Mailbox.
ISV (Independent Software Vendor)	Independent Software Vendor. Software manufacturer who develops and/or sells applications and tools but does not entire computer systems. Refers application developer in this document.
J2ME (Java2 Platform Micro Edition)	Java 2 Platform Micro Edition. One of Java Platforms licensed by Sun Microsystems, Inc. It is applied for MEAP. Other devices such as cellular phones and PDA.

Terms & Acronyms	Definitions and Explanations
J2RE (Java 2 Runtime Environment)	A set of basic programs to run applications developed in the programming language of Java2. This set includes Java virtual machine providing runtime environment for Java applications among others. Java applets do not require J2RE since these are executed on Web browsers using Java runtime environment provided on browsers. However, standalone Java applications require Java runtime environment such as J2RE for execution. Runtime environments can be downloaded for free of charge from the Web site of Sun Microsystems, the Java developer.
Java	A programming language developed by Sun Microsystems, in the U. S. A. Low dependent on models and OSes and runs on various platforms. Taking advantage of this feature, many applications that runs on web servers uses Java. The MEAP platform uses J2ME - a type of Java.
JavaScript	A script language developed by Netscape Communications, in the U.S. A., runs on web browsers such as Netscape Navigator and Internet Explorer. Allows web designers to create interactive pages with HTML files such as animated buttons and display of timetables.
Java VM (Java Virtual Machine)	JAVA Virtual Machine. The Java byte code interpreter. The Virtual Machine acts as an interpreter for processing the byte code using the native instruction set.
License Access Number	A number issued for accessing license file. The Licensing server requires entries of application ID, expiration date/times information, and the number of access numbers, to issue license access numbers
License File	A software manufacture of a MEAP application provides the users with the license files. Specifies the terms of agreement that a user concludes with the manufacturer. Required for installing a MEAP application.
LMS (License Management System)	The license is required for installing a MEAP application in a MEAP-enabled iR device. LMS is the server issuing [License Files] as well as license access numbers.
Login Service	Manages user information of MEAP device. Authenticates users with user names and passwords. Three login services are available for MEAP device - Default Authentication, which provides department ID control, SDL (Simple Device Login) and SSO (Single Sign-On).
Mass Storage class	Mass Storage means a storage device with large capacity, generally secondary storage devices. Mass Storage class means USB class classified in the secondary storage device group.
MEAP (Multifunction Embedded Application Platform)	Multifunctional Embedded Application Platform. Provides an environment for executing application programs on a peripheral device. Uses the Java platform (J2ME - Java 2 platform Micro Edition) to run Java application for MEAP.
MEAP Contents	Required to install an MEAP application to a MEAP device.

Terms & Acronyms	Definitions and Explanations
MEAP Specifications (MEAP Spec Version)	MEAP Spec Version, the term used for the SDK. The version number that shows the APIs of the MEAP platform other than CPCA, such as network and security. The version number is not assigned for each device model. MEAP Application Runs on MEAP platform. Consists of application files (*.jar) and the license file (*.lic).
MEAP-enabled iR device	imageRUNNER (iR) devices with built-in MEAP platform.
MFP (Multi Function Peripheral)	Multi Function Peripheral. Peripheral device that supports more than one function, such as digital copier, printer, scanner, and fax.
OSGi (Open Service Gateway Initiative)	Open Service Gateway Initiative. See " http://www.osgi.org/ ".
Portal Service	The web portal to gain access to a MEAP-enabled device. This service has been integrated in Remote UI top page in iR ADVANCE series.
Protocol	A set of rules applied to data transmission procedures over network. Major communication protocols include: <ul style="list-style-type: none"> • FTP: File Transfer Protocol. This is a communication protocol or protocol-implemented commands to provide file transfer between a host and clients over TCP/IP network. • DHCP: An upward compatible protocol of BOOTP. This communication protocol allocates a dynamic IP address to each client machine upon communication startup on TCP/IP network and collects the allocated IP address when communication is completed. The server allocates one of multiple IP addresses and notifies the setup information to a client. • BOOTP: A communication protocol to automatically load setup information including IP address and a domain name from the server to a client on TCP/IP network. • RARP: A communication protocol to request IP address information via the network adaptor address (MAC address) of a client. • IPP: A communication protocol to execute remote printing between the print server and clients via Internet. • TCP/IP: A standard communication protocol required to access to Internet and other large-scale network.
Proxy Server	Provides functions to store data fetched from remote servers. When a user request to display a web page that has been displayed and stored in the proxy, the proxy server reads the stored data but does not access the remote server where the original page is present, for efficient access services. When a proxy server receives a URL from a PC, it searches the file in the cache and sends it to the PC if the requested file is found. If the requested file is not stored in the cache, it accesses the remote server of the URL to acquire the file and, at the same time, stores the acquired file in the cache so that the proxy server can quickly send the file at the next request.
Redistribution module	A built-in module of an application created with SDK. Applications without this module cannot work on MEAP platform.

Terms & Acronyms	Definitions and Explanations
SDK (Software Development Kit)	The kit containing information and tools required for software development.
Service	A functional unit or an application program working on MEAP platform. [Applications] are generally termed [Services] in Java world.
Servlet (Servlet Type Application)	A MEAP application type created in Java. This type of applications is designed to show user interface on the Web browser.
SMS (Service Management Service)	The web-base service to provide user interfaces for application life cycle management.
Socket	A virtual interface of an application for network communication. A user only needs to specify a socket as a unit of an address and a port from an application. This establishes the network connection for data transmission, eliminating complication related to detailed communication procedures.
SSO-H (Single Sign-On H)	Login service providing features of both local device authentication and domain authentication. The former is the method that iR device independently authorizes users; whereas the latter is that iR device links to the domain controller on the network in the Active Directory environment to authorize users.
Thread	A unit for program execution. A multi-task system allowing multiple programs to run concurrently assigns a memory space and other resources independently to each program, providing users with a feel as if only a program is running. At least one thread is generated upon a program generated.
URL (Uniform Resource Locator)	The method to denote Web page locations on Internet and the like. For instance, a URL on the Web is denoted as [http://www.w3.org/default.html]. [http] at the beginning means that an address following this is in a web page on the Internet.
USB	Abbreviation of Universal Serial Bus. This is the interface standard to link between information devices.
USB system driver	The general-purpose driver that control the behavior of the device, there are HID class driver, Mass Storage class driver and so on.

T-2-15

Embedded RDS(Not supported by LBP7210Cdn)

Product Overview

Overview

Embedded RDS (hereafter, referred to as E-RDS, which stands for EMBEDDED-RDS) is a network module embedded with a customer's device and enables e-Maintenance/ imageWARE Remote (Remote Diagnosis System), which can collect and transmit status changes, counter values, error logs, and consumable information such as the toner low/ out of the device to a remote maintenance server called UGW (Universal Gateway Server) via Internet.

The following device information/ status can be monitored.

- Service mode counter (Billing counts)
- Global click counter
- Parts counter
- Mode counter
- Firmware info
- Service call error log
- Jam log
- Alarm log
- Status changes (Toner low/ out, etc.)

Since high confidentiality is required for the information shown above, it performs communication between a device and the UGW using HTTPS/ SOAP protocol.

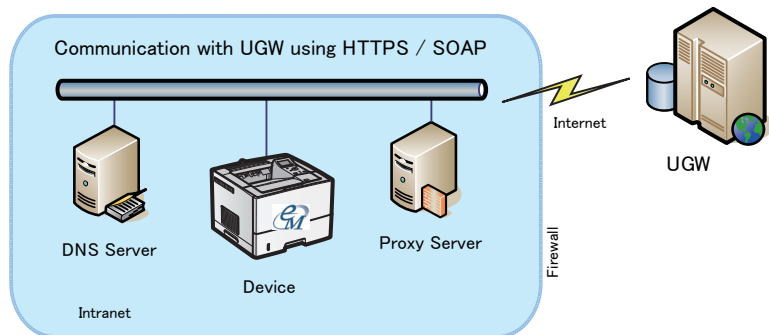

The e-Maintenance/ imageWARE Remote system using E-RDS

F-2-157

Features and benefits

E-RDS embedded with a network module in advance can realize a front-end processing of e-Maintenance/ imageWARE Remote system without attaching any extra hardware equipment.

Service cautions

1) After performing the following service actions, it is necessary to perform initializing E-RDS settings (CLEAR), E-RDS settings (E-RDS SWITCH : ON) and communication test (COM-TEST).

Failure to do so will result that the counter transmitting value to the UGW may become unusual.

- System upgrade
- System installation
- RAM clear of MNCON

Also, after replacing the main controller board, all settings must be reprogrammed.

2) The following settings in service mode must not be change unless there are specific instructions to do so. Changing these values will cause error in communication with UGW.

- Set port number of UGW
[SERVICE MODE] > [NETWORK GR.] > [E-RDS] > [RGW-PORT]
Default : 443
- URL setting of UGW
[SERVICE MODE] > [NETWORK GR.] > [E-RDS] > [RGW-ADDRESS]
Default : https://a01.ugwdevice.net/ugw/agentif010

E-RDS Setup

Confirmation and preparation in advance

To monitor a device with e-Maintenance/ imageWARE Remote, the following settings are required.

(1) Advance confirmation

Confirm with the UGW administrator that the device to be monitored with e-Maintenance/ imageWARE Remote is registered in the UGW.

(2) Advance preparations

Interview the user's system administrator in advance to find out the following information about the network.

Information item 1

IP address settings

- Automatic setting : DHCP, RARP, BOOTP (ON/ OFF selection)
- Manual setting : IP address, subnet mask and gateway address to be set

Information item 2

Is there a DNS server in use?

If there is a DNS server in use, find out the following.

- Primary DNS server address
- Secondary DNS server address

Information item 3

Is there a proxy server?

If there is a proxy server in use, find out the following.

- Proxy server address
- Port No. for proxy server

Information item 4

Is proxy server authentication required?

If proxy server authentication is required, find out the following.

- User name and password required for proxy authentication

(3) Network settings

Based on the results of the information obtained in (2) Advance preparations, make the device network related settings.

See Users' Guide for detailed procedures.

CAUTION:

Ensure to reboot the device when any change is added to the network setting.

E-RDS setting items (service mode)

Item	Description
E-RDS SWITCH (NETWORK GR. > E-RDS)	Set use/ no use of Embedded-RDS function 0: Function not used / 1: Function used e-Maintenance/ imageWARE Remote system to send device information, counter data, error statuses to the UGW. Default : 0 (Function not used)
RGW-ADDRESS (NETWORK GR. > E-RDS)	URL setting of UGW Max 128 characters Default : https://a01.ugwdevice.net/ugw/agentif01
RGW-PORT (NETWORK GR. > E-RDS)	Set port number of UGW Validation : 1 to 65535 Default : 443
COM-TEST (NETWORK GR. > E-RDS)	Execution of a communication test with UGW / Display of the result Perform Communication test with UGW and set "Done." or "Could not execute." as the result.
COM-LOG (NETWORK GR. > E-RDS)	Display of detailed information about a communication error with UGW Error information of a connection failure with UGW is displayed. Error occurrence date and time, error code, and detailed error information are displayed. Max 5 latest loggings retained Max 128 characters for Error information.
CLEAR (NETWORK GR. > E-RDS)	Initialization of E-RDS SRAM data SRAM data of E-RDS is initialized and returned to the factory setting value at shipment.
CLEAR (NETWORK GR. > CA-KEY)	Initialization of CA certificate When the power is turned OFF/ ON after execution, the CA certificate in the factory setting is automatically installed.

T-2-16

Steps to E-RDS settings

1. Start [Service Mode].

1) Press [OK] and [▶] buttons at a time on the control panel.

2) Select [SERVICE MODE] and press [OK] or [▶] button.

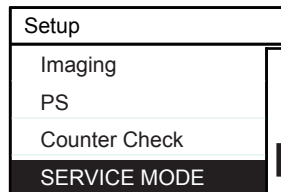

F-2-158

3) Press [OK] or [▶] button.

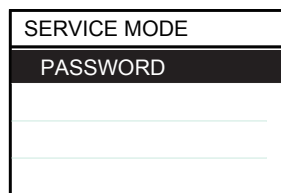

F-2-159

4) Enter [*], [2], [8] and [*] and press [OK] button.

NOTE:

When entering your password, press [▲] or [▼] button to increment or decrement the value, and press [◀] or [▶] button to move forward/backward by digit.

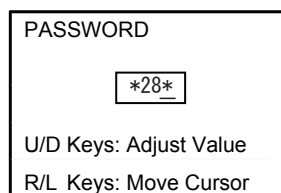

F-2-160

2. Select [NETWORK GR.] and press [OK] or [▶] button to go to the network setting menu.

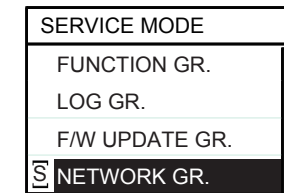

F-2-161

3. Select [E-RDS] and press [OK] or [▶] button to go to E-RDS setting menu.

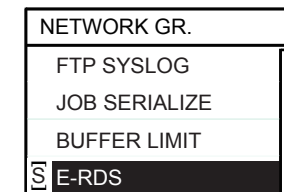

F-2-162

4. Select [CLEAR] and press [OK] or [▶] button to display Confirm Initialization screen. Select [Yes] and press [OK] button.

NOTE:

This operation initializes the E-RDS settings to factory setting values. For the setting values to be initialized, see the section of "Initializing E-RDS settings".

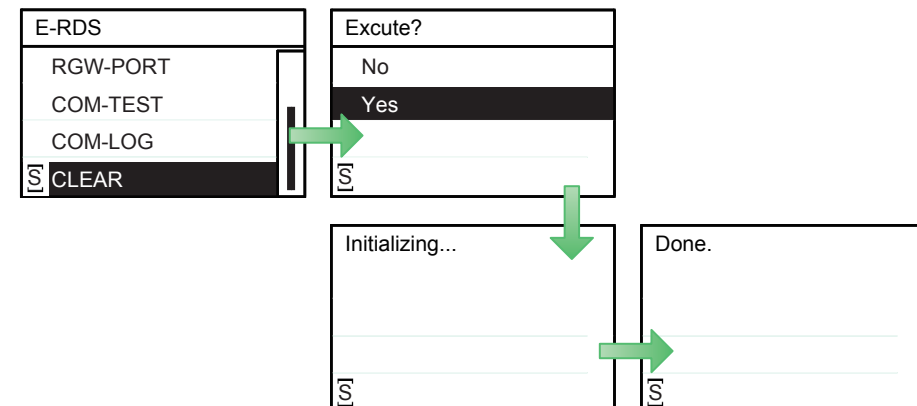

F-2-163

5. Perform installation or deletion of the CA certificate if necessary, and reboot the device.
- Installation of the CA certificate: Perform installation from SST.
 - Deletion of the CA certificate: When the following operation is performed, the CA certificate in the factory setting is automatically installed.
 - 1) Select [NETWORK GR.] > [CA-KEY] > [CLEAR] and press [OK] or [▶] button to display Confirm Clear screen. Select [Yes] and press [OK] button.

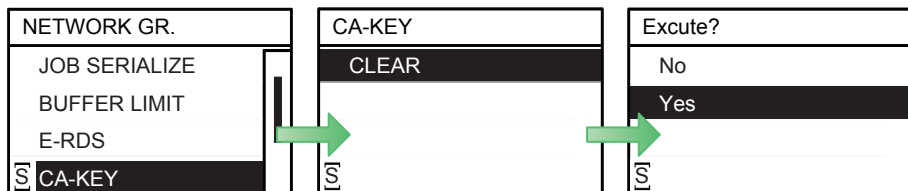

F-2-164

- 2) Reboot the device.

6. Activate [SERVICE MODE]. (See 1. for the procedure.)

7. Select [NETWORK GR.] > [E-RDS] > [E-RDS SWITCH] and press [OK] or [▶] button.

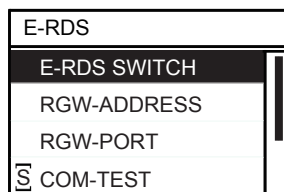

F-2-165

8. Select [On] and press [OK] button.

NOTE:
This operation enables the communication function with UGW.

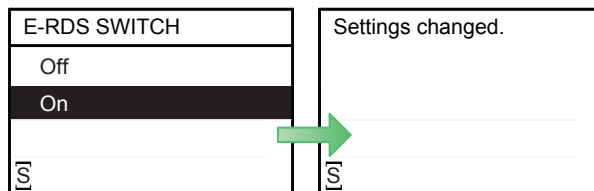

F-2-166

9. Press [Back] or [◀] button to go back to E-RDS Setup menu.

CAUTION:

The following settings i.e. RGW-PORT and RGW-ADDRESS in Service mode must not be change unless there are specific instructions to do so.

Changing these values will cause error in communication with UGW.

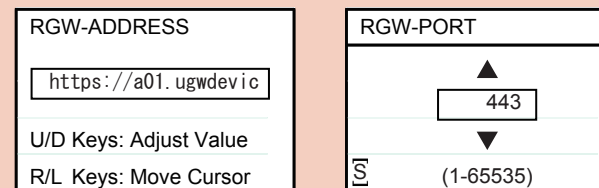

10. Select [COM-TEST] and press [OK] or [▶] button to display Confirm Communication Test screen. Select [Yes] and press [OK] button.

NOTE:

This initiates the communication test between the device and the UGW.

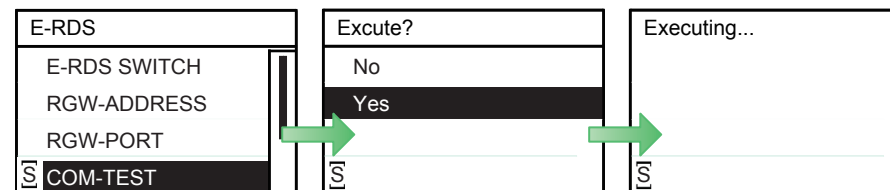

F-2-167

If the communication is successful, "Done." is displayed. If "Could not execute." (failed) appears, refer to the "Troubleshooting" and repeat until "Done." is displayed.

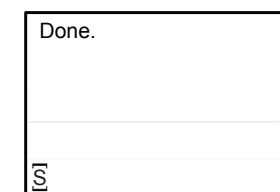

F-2-168

NOTE:

The communication results with UGW can be distinguished by referring to the communication log. By performing the communication test with UGW, E-RDS acquires schedule information and starts monitoring and meter reads operation.

■ Initializing E-RDS settings

It is possible to return E-RDS Settings to factory-shipments value.

● Setting values and data to be initialized

The following E-RDS settings, internal data, and Alarm filtering information are initialized.

- E-RDS > E-RDS SWITCH
- E-RDS > RGW-ADDRESS
- E-RDS > RGW-PORT
- E-RDS > COM-LOG

CAUTION:

In case of replacing the CA certificate file, even if initialization of E-RDS is executed, the status is not returned to the factory default.

When installing the certificate file other than the factory default CA certificate file, it is required to delete the certificate file after E-RDS initialization and install the factory default CA certificate file.

For detailed procedures, see "Steps to E-RDS settings - step 5."

● Initialization procedure

1. Start [Service Mode].

For the procedures, see "Steps to E-RDS settings - step 1."

2. Select [NETWORK GR.] and press [OK] or [▶] button to go to the network setting menu.

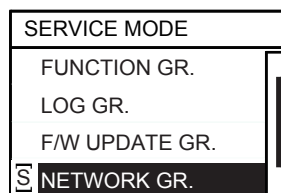

F-2-169

3. Select [E-RDS] and press [OK] or [▶] button to go to E-RDS setting menu.

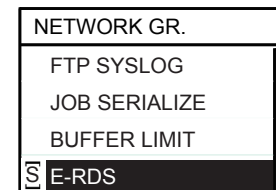

F-2-170

4. Select [CLEAR] and press [OK] or [▶] button to display Confirm Initialization screen. Select [Yes] and press [OK] button.

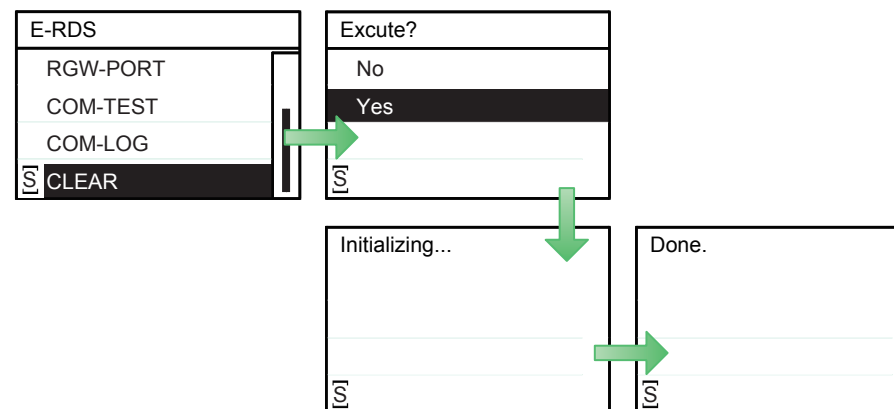

F-2-171

FAQ

No.1

Q: In what case does a communication test with UGW fail?

A: The following cases can be considered in the becoming "Could not execute." case.

1. Name resolution was failed due to an incorrect host name or DNS server has been halted.
2. Network cable is blocked off.
3. Proxy server settings is not correct.

No.2

Q: I want to know the interval of data transmitting from E-RDS to the UGW, and what data size is sent to the UGW?

A: The schedule of data transmitting, the start time are determined by settings in the UGW side. The timing is once per 16 hours by default, and counter data volume could be maximum 250 bytes.

No.3

Q: Does error-retry carry out at the time of a communication error with the UGW?

A: Retry of SOAP communication is performed as follows.

- In the case of an error in SOAP communication (i.e. a trouble at UGW side) at transmission of the alarm code list and the service mode counter (postAlert) due to change of device status, the data failed in transmission equivalent to 3 retries is to be stored in the RAMDISC. In the case of another transmission error (the 4th error), the oldest data of the stored data is deleted and the newly-generated retry data is stored in the RAMDISC.
- In the case of SOAP transmission errors as described below, the unsent (and remaining) data is sent again depending on the storage status of CPCA data:
 - At transmission of a jam log and service mode counter (postJamLog) when the jam log was obtained from the device.
 - At transmission of a service call log and service mode counter (postServiceCallLog) when the service log was obtained from the device.
 - At transmission of an alarm log and service mode counter (postAlarmLog) when the alarm log was obtained from the device.

NOTE:

- The retry data will be sent at interval of 5*n minutes. (n: retries, 5, 10, 15 minutes...up to 30 minutes)
- HDD is not installed in this device; even after the power is turned OFF/ON, postAlert, postJamLog, postServiceCallLog, postAlarmLog will not be resent.

No.4

Q: How many log-data can be stored?

A: Up to 5 log data can be saved. The data size of error information is maximum 128 characters.

No.5

Q: Although Microsoft ISA as a proxy server is introduced, the authentication check is failed. Can E-RDS adopt with Microsoft ISA?

A: E-RDS must comply with "Basic" while "Integrated" authentication is used for Microsoft ISA (as default); therefore, authentication with E-RDS is available if you change the setting to "Basic" authentication on the server.

No.6

Q: Can I turn the device power off during the e-Maintenance/ imageWARE Remote system operation?

A: While operating the e-Maintenance/ imageWARE Remote system, the power of the device must be ON. If power OFF is needed, do not leave the device power OFF for long time. It will become "Device is busy, try later" errors if the power supply of network equipment such as HUB is made prolonged OFF.

No.7

Q: Although a Service call error may not be notified to UGW, the reason is what?

A: If a service technician in charge turns off the power supply of a device immediately after error occurred once, It may be unable to notify to UGW because data processing does not take a time from the controller of the device to NIC though, the data will be saved on the RAM.

If the power supply is blocked off while starting up, the data will be inevitably deleted.

No.8

Q: How does E-RDS operate while the device is placed in the sleep mode?

A: While being in Real Deep Sleep, and if data to be sent is in E-RDS, the system wakes up asleep, then starts to send the data to the UGW. The system also waits for completion of data transmission and let the device to shift to asleep status again.

However, transition time to the Real Deep Sleep depends on the device, and the transition to sleep won't be done if the next data transmission will be done within 1 minute.

No.9

Q: Is E-RDS compatible with Section counter (Department counter)?

A: No, E-RDS does not support Section counter.

Troubleshooting

No.1

Symptom: A communication test (COM-TEST) has failed.

Cause: Initial settings or network conditions is incomplete.

Remedy 1: Check and take actions mentioned below.

1) Check network connections

Is the status indicator LED for the HUB port to which the main unit is connected ON?

YES: Proceed to Step 2).

NO: Check that the network cable is properly connected.

2) Confirmation from another PC connected to same network.

Request the user to ping the main unit from a PC connected to same network.

Does the main unit respond?

YES: Proceed to Step 3).

NO: Confirm the details of the main unit's IP address and subnet mask settings.

3) Confirm DNS connection

(a) Take a note of both primary and secondary DNS server addresses.

See Users' Guide for detailed procedures.

(b) Use ping command to confirm the primary DNS server IP address against the note taken in Step (a).

See Users' Guide for detailed procedures.

Is the IP address properly configured?

YES: Proceed to Remedy 2.

NO: Confirm the secondary DNS server IP address against the note taken in Step (a).

Is the IP address properly configured?

YES: Proceed to Remedy 2.

NO: There is a possibility that the DNS server address is wrong. Reconfirm the address with the user's system administrator.

Remedy 2: Troubleshooting using communication log (COM-LOG)

1) Start [Service Mode].

For the procedures, see "Steps to E-RDS settings - step 1."

2) Select [NETWORK GR.] > [E-RDS] > [COM-LOG] and press [OK] or [▶] button to display List Communication Log screen.



F-2-172

NOTE:

- Only the initial part of error information is displayed in the communication log list screen.
- "None." is shown when nothing is logged.

3) Select the log of your interest and press [OK] or [▶] button to show the date and time of the error occurrence.

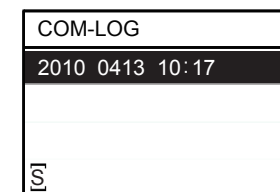

F-2-173

4) Press [OK] or [▶] button to show the detailed error information.

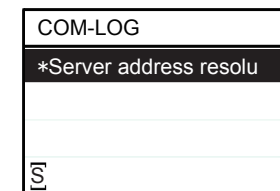

F-2-174

NOTE:

- The detailed error information will be displayed in multiple screens as shown below. Use [◀] or [▶] button to move around the screens.

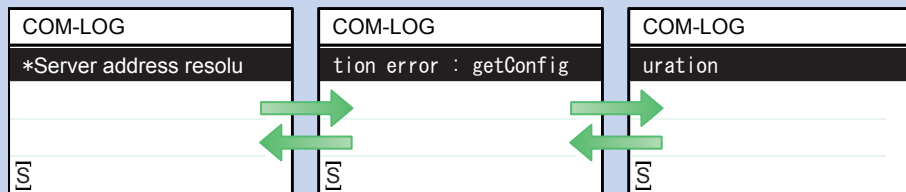

- The data size of error details information is Max 128 characters.
- Press [Back] button to return to Date and Time of Error Occurrence screen.

5) When a message is displayed, take an appropriate action referring to "Error code and strings".

No.2

Symptom: A communication test has failed even if network setting is set properly.

Causes: The network environment is inappropriate, or RGW-ADDRESS or RGW-PORT settings for E-RDS have been changed.

Remedy: The following points should be checked.

- Check network conditions such as proxy server settings and so on.
- Check the E-RDS setting values.
 - Check the communication log from COM-LOG.
 - Check whether RGW-ADDRESS or RGW-PORT settings has changed. If RGW-ADDRESS or RGW-PORT settings has changed, restore initial values. For initial values, see "E-RDS setting items (service mode)".

No.3

Symptom: Registration information of an E-RDS is once deleted from the UGW server, and is re-registered after that. If a communication test is not performed, then device information on the UGW becomes invalid.

Causes: When registration of the E-RDS is deleted from the UGW, the status will be changed to that the communication test has not completed because related information has lost from a database.

So, device information will also become invalid if that condition will be left for seven days without performing the communication test.

Remedy: Perform a communication test before becoming the invalidity state.

No.4

Symptom: There was a log, indicating "Device is not ready, try later" in error details of COM-LOG list.

Cause: A certain problem occurred in networking.

Remedy: Check and take actions mentioned below.

- Check networking conditions and connections.
- Turn on the power supply of a device and perform a communication test about 60 seconds later.

No.5

Symptom: "Unknown error" is displayed though a communication test has done successfully.

Cause: It could be a problem at the server side or the network load is temporarily faulty.

Remedy: Try again after a period of time. If the same error persists, check the UGW status with a network and UGW administrator.

Error code and strings

The following error information is output in the communication error log details display screen.
(Here, "a server" means UGW.)

- The error information are displayed in the following form.
[*] [Error strings] [Method name] [Error details provided by UGW]

NOTE:

"**" is added to the top of the error text in the case of an error in communication test (method name: getConfiguration or communicationTest) only.

No.	Code	Error strings	Cause	Remedy
1	0000 0000	SUSPEND: mode changed.	Unmatched Operation Mode	Clear E-RDS
2	0500 0003	SUSPEND: Communication test is not performed.	Rebooting the device while the communication test had not been performed although E-RDS is enabled.	Perform a communication test (COM-TEST).
3	0xxx 0003	E-RDS switch is settled OFF	A communication test has been attempted with the E-RDS switch being OFF.	Set E-RDS switch (E-RDS SWITCH) to ON, and then perform a communication test (COM-TEST).
4	0xxx 0003	Server schedule is not exist	Blank schedule data have been received from UGW.	Check the device settings status with the UGW administrator.
5	0xxx 0003	Communication test is not performed	Communication test has not completed.	Perform and complete a communication test (COM-TEST).
6	8000 0002 8000 0003 8000 0101 8000 0201 8000 0305 8000 0306 8000 0401 8000 0403 8000 0414 8000 0415	Event Registration is Failed	Processing (event processing) within the device has failed.	Turn the device OFF/ ON. If the error persists, replace the device system software. (Upgrade)

No.	Code	Error strings	Cause	Remedy
7	8000 0101	Server response error (NULL)	Communication with UGW has been successful, but an error of some sort has prevented UGW from responding. When (Null) is displayed at the end of the message, this indicates that there has been an error in the HTTPS communication method.	Try again after a period of time. If the error persists, check the UGW status with the UGW administrator.
8	8300 0306	SRAM version unmatch!	Improper value is written in at the head of the Main Controller PCB 2 SRAM domain of E-RDS.	Turn the device OFF/ ON.
9	8xxx 0004	Operation is not supported	Method which E-RDS is not supporting attempted.	Contact help desk
10	8xxx 0201 8xxx 0202 8xxx 0203 8xxx 0204 8xxx 0206	Server schedule is invalid	During the communication test, there has been some kind of error in the schedule values passed from UGW.	When the error occurs, report the details to the support section. And then, after the UGW side has responded, try the communication test again.
11	8xxx 0207 8xxx 0208	Internal Schedule is broken	The schedule data in the inside of E-RDS is not right.	Perform a communication test (COM-TEST).
12	8xxx 0221	Server specified list is too big	Alert filtering error: The number of elements of the list specified by the server is over restriction value.	Specify the number of elements of alert filtering correctly. (Alarm filtering is not supported)
13	8xxx 0222	Server specified list is wrong	Alert filtering error: Unjust value is included in the element of the list specified by the server.	Specify the element of alert filtering with the right value. (Alarm filtering is not supported)
14	8xxx 0304	Device is busy, try later	The semaphore consumption error at the time of a communication test.	Try again a communication test after a period of time.
15	8xxx 2000	Unknown error	Some other kind of communication error has occurred.	Try again after a period of time. If the error persists, check the UGW status with the UGW administrator.
16	8xxx 2001	URL Scheme error (not https)	The header of the URL of the registered UGW is not in https format.	Check that the value of URL of UGW (RGW-ADDRESS) is https://a01.ugwdevice.net/ugw/agentif010.
17	8xxx 2002	URL server specified is illegal	A URL different to that specified by the UGW has been set.	Check that the value of URL of UGW (RGW-ADDRESS) is https://a01.ugwdevice.net/ugw/agentif010.

No.	Code	Error strings	Cause	Remedy
18	8xxx 2003	Network is not ready, try later	Communication attempted without confirming network connection, just after booting up a device in which the network preparations are not ready.	Check the network connection, as per the initial procedures described in the troubleshooting. Perform a communication test (COM-TEST) about 60 seconds later, after turn on the device.
19	8xxx 2004	Server response error ([Hexadecimal]) [Error detailed in the UGW] *1)	Communication with UGW has been successful, but an error of some sort has prevented UGW from responding.	Try again after a period of time. Check detailed error code (Hexadecimal) and [Error details in UGW] from UGW displayed after the message.
20	8xxx 200A	Server connection error	<ul style="list-style-type: none"> TCP/IP communication fault The IP address of device is not set. 	Check the network connection, as per the initial procedures described in the troubleshooting.
21	8xxx 200B	Server address resolution error	Server address name resolution has failed.	Check that the value of URL of UGW (RGW-ADDRESS) is https://a01.ugwdevice.net/ugw/agentif010.
22	8xxx 2014	Proxy connection error	Could not connect to proxy server due to improper address.	Check proxy server address and re-enter as needed.
23	8xxx 2015	Proxy address resolution error	Could not connect to proxy server due to name resolution error of proxy address.	Check that the proxy server name is correct. If the proxy server name is correct, check the DNS connection, as per the initial procedures described in the troubleshooting.
24	8xxx 201E	Proxy authentication error	Proxy authentication is failed.	Check the user name and password required in order to login to the proxy, and re-enter as needed.
25	8xxx 2028	Server certificate error	<ul style="list-style-type: none"> No route certificate installed in device. Certificate other than that initially registered in the user's operating environment is being used, but has not been registered with the device. 	Install the latest device system software. (Upgrade)
26	8xxx 2029	Server certificate verify error	The server certificate verification error occurred.	Check that the value of URL of UGW (RGW-ADDRESS) is https://a01.ugwdevice.net/ugw/agentif010.

No.	Code	Error strings	Cause	Remedy
27	8xxx 2046	Server certificate expired	<ul style="list-style-type: none"> The route certificate registered with the device has expired. Certificate other than that initially registered in the user's operating environment is being used, but has not been registered with the device. The device time and date is outside of the certificated period. 	Check that the device time and date are correctly set. If the device time and date are correct, upgrade to the latest system software.
28	8xxx 2047	Server response time out	Due to network congestion, etc., the response from UGW does not come within the specified time. (HTTPS level time out)	If this error occurs when the communication test is being run or Service Browser is being set, try again after a period of time.
29	8xxx 2048	Service not found	There is a mistake in the UGW URL, and UGW cannot be accessed. (Path is wrong)	Check that the value of URL of UGW (RGW-ADDRESS) is https://a01.ugwdevice.net/ugw/agentif010.
30	8xxx 2052	URL error	The data which is not URL is inputted into URL field.	Check that the value of URL of UGW (RGW-ADDRESS) is https://a01.ugwdevice.net/ugw/agentif010.
31	8xxx 2063	SOAP Fault	SOAP communication error has occurred.	Check that the value of port number of UGW (RGW-PORT) is 443.
32	xxxx xxxx	Device internal error	An internal error, such as memory unavailable, etc., has occurred during a device internal error phase.	Turn the device OFF/ ON. Or replace the device system software. (Upgrade)
33	xxxx xxxx	SUSPEND: Initialize Failure!	Internal error occurred at the initiating E-RDS.	Turn the device OFF/ ON.

T-2-17

*1) [Hexadecimal]: indicates an error code returned from UGW.
[Error details in UGW]: indicates error details returned from UGW.

3

Disassembly/Assembly

- List of Parts
- External Cover/Internal System
- Controller System
- Laser Exposure System
- Image Formation System
- Fixing System
- Pickup/Feed/Delivery System

Outline

This chapter describes disassembling/assembling procedure of this equipment. The service technician is to identify the cause of the failures according to "Chapter 5 Troubleshooting" and to replace the faulty parts by following the disassembling procedure. In addition, replace the consumable parts by following the same disassembling procedure.

Note the following precautions when working.

1. When turning OFF the power, turn OFF the Power Switch after checking the completion of "initialization"
2. CAUTION: Be sure to disconnect the power plug before disassembling/assembling for safety.
3. When disassembling/assembling or transporting the machine, be sure to remove the cartridge beforehand as needed. However, when the cartridge is removed from the machine, be sure to put the Photosensitive Drum in a protective bag even in a short period of time to prevent the adverse effect of light.
4. When assembling, perform the disassembling procedure in reverse order unless otherwise specified.
5. When assembling, be sure to tighten the screws to their appropriate locations according to the screw types (length, diameter).
6. Do not run the machine with any parts removed as a general rule.
7. When handling the PCB, be sure to touch the metal part of the printer to ground yourself to prevent damaging the PCB by static electricity.
8. When replacing the part with the rating name plate, be sure to affix it to the new part.

List of Parts

External Cover / Interior LBP7600C/7660Cdn/7680Cx

Front Side

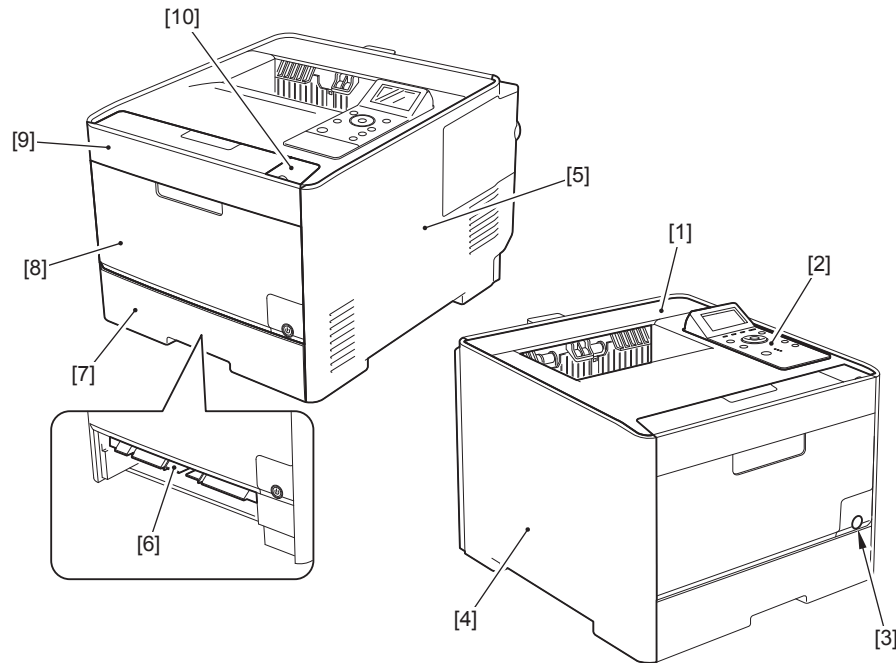

E-3-1

Key No.	Name	Reference	Adjustment during parts replacement	Remarks
[1]	Upper Cover		-	-
[2]	Operation Panel		-	-
[3]	Power Switch		-	-
[4]	Left Cover		-	-
[5]	Right Cover		-	-
[6]	Manual Feed Tray Feeding Guide		-	-
[7]	Pickup Cassette		-	-
[8]	Manual Feed Tray		-	-

Key No.	Name	Reference	Adjustment during parts replacement	Remarks
[9]	Front Cover		-	-
[10]	Upper Front Cover (Right)		-	LBP7600C/ 7660Cdn Only
[10]	USB Cover		-	LBP7680Cx Only

T-3-1

Rear Side

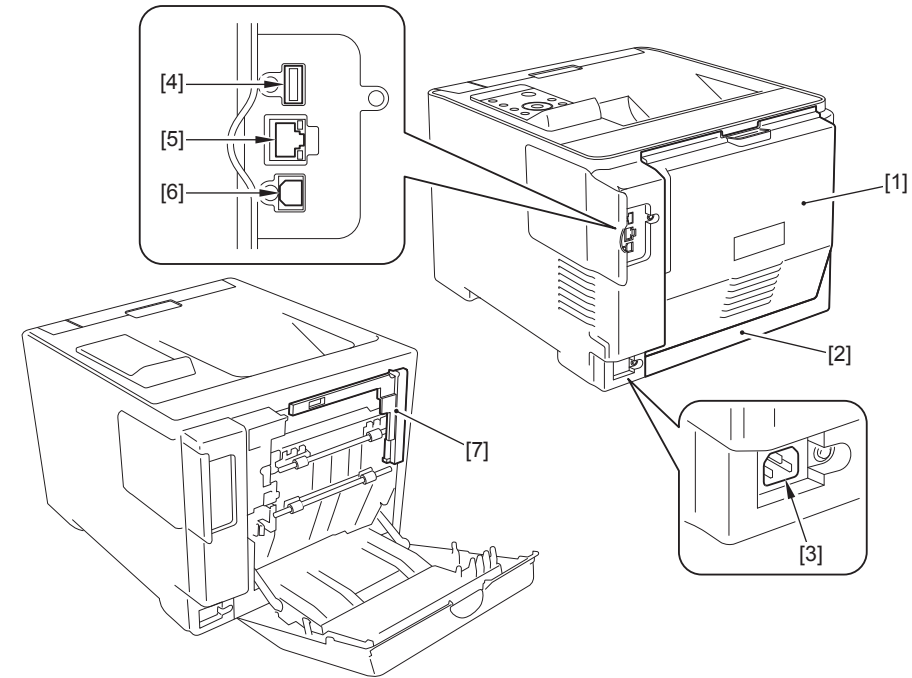

Key No.	Name	Reference	Adjustment during parts replacement	Remarks
[1]	Rear Cover		-	-
[2]	Rear Lower Cover		-	-
[3]	Power Socket		-	-
[4]	USB Port (for USB devices)		-	-
[5]	LAN Port		-	-
[6]	USB Port (for connecting to computer)		-	-
[7]	Rear Upper Cover (Left)		-	-

T-3-2

External Cover / Interior LBP7210Cdn

Front Side

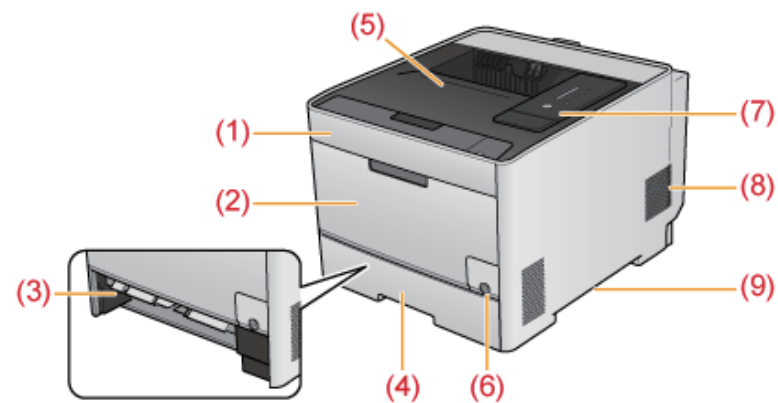

F-3-3

Key No.	Name	Reference	Adjustment during parts replacement	Remarks
[1]	Front Cover		-	-
[2]	Multi-purpose Tray		-	-
[3]	Manual Feed Transport Guide		-	-
[4]	Paper Drawer		-	-
[5]	Output Tray		-	-
[6]	Power Switch		-	-
[7]	Control Panel		-	-
[8]	Ventilation Slots		-	-
[9]	Lift Handles		-	-

Main Unit LBP7600C/7660Cdn/7680Cx/7210Cdn

Rear Side

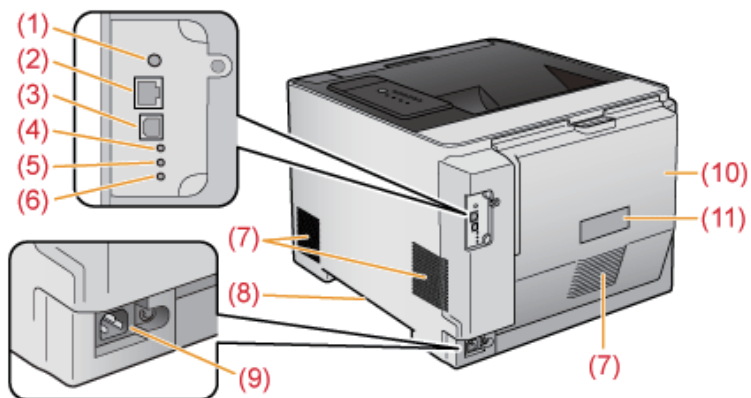

F-3-4

Key No.	Name	Reference	Adjustment during parts replacement	Remarks
[1]	Reset Button		-	-
[2]	LAN Connector		-	-
[3]	USB Connector		-	-
[4]	100 Indicator (Green)		-	-
[5]	LNK Indicator (Green)		-	-
[6]	ERR Indicator (Orange)		-	-
[7]	Ventilation Slots		-	-
[8]	Lift Handles		-	-
[9]	Power Socket		-	-
[10]	Rear Cover		-	-
[11]	Rating Label		-	-

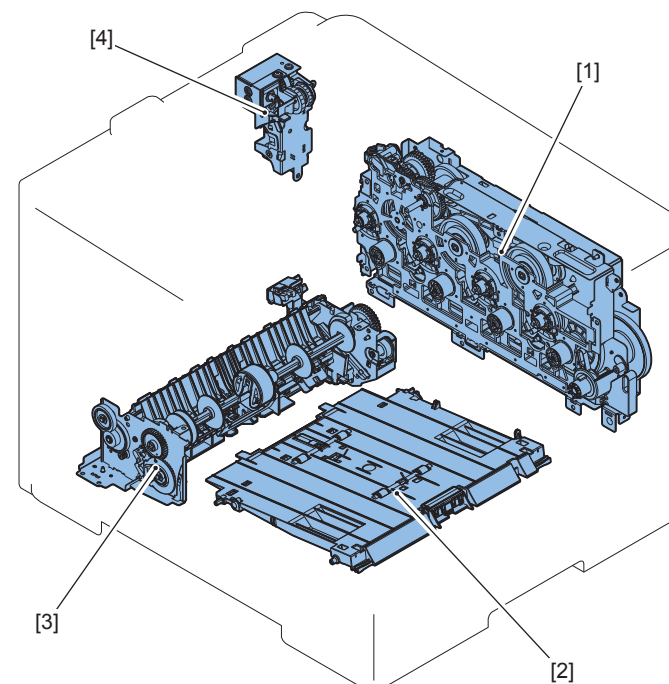

Key No.	Name	Reference	Adjustment during parts replacement	Remarks
[1]	Main Drive Unit		-	LBP7600C/7660Cdn /7680Cx LBP7210Cdn
[2]	Manual Feed Tray Pickup Unit		-	-
[3]	Pickup Unit		-	LBP7600C/7660Cdn /7680Cx LBP7210Cdn
[4]	Duplex Reverse Drive Unit		-	LBP7600C/7660Cdn /7680Cx LBP7210Cdn

T-3-3

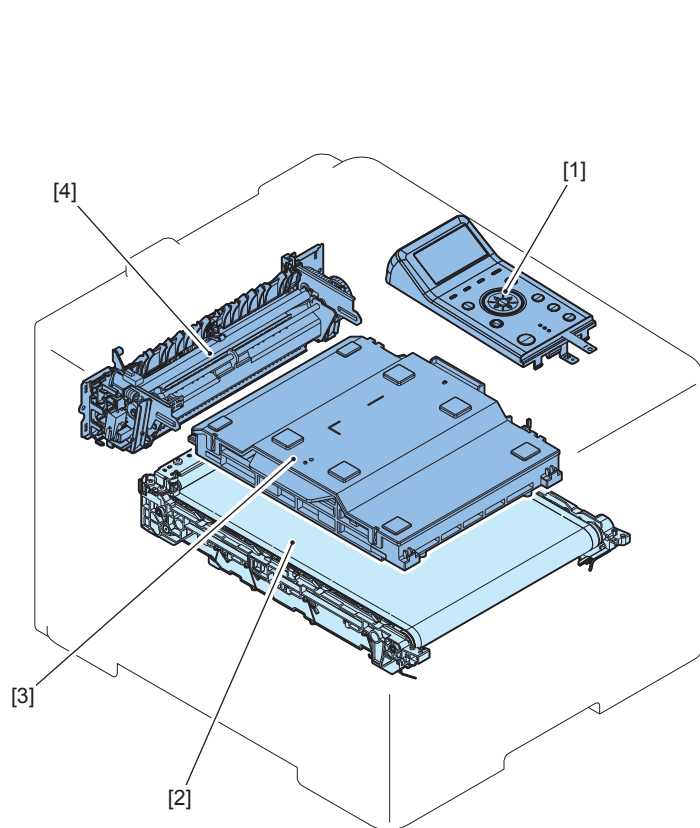

Key No.	Name	Reference	Adjustment during parts replacement	Remarks
[1]	Operation Panel Unit		-	LBP7600C/7660Cdn /7680Cx LBP7210Cdn
[2]	ITB Unit		-	LBP7600C/7660Cdn /7680Cx LBP7210Cdn
[3]	Laser Scanner Unit		-	LBP7600C/7660Cdn /7680Cx LBP7210Cdn
[4]	Fixing Assembly		-	LBP7600C/7660Cdn /7680Cx LBP7210Cdn

T-3-4

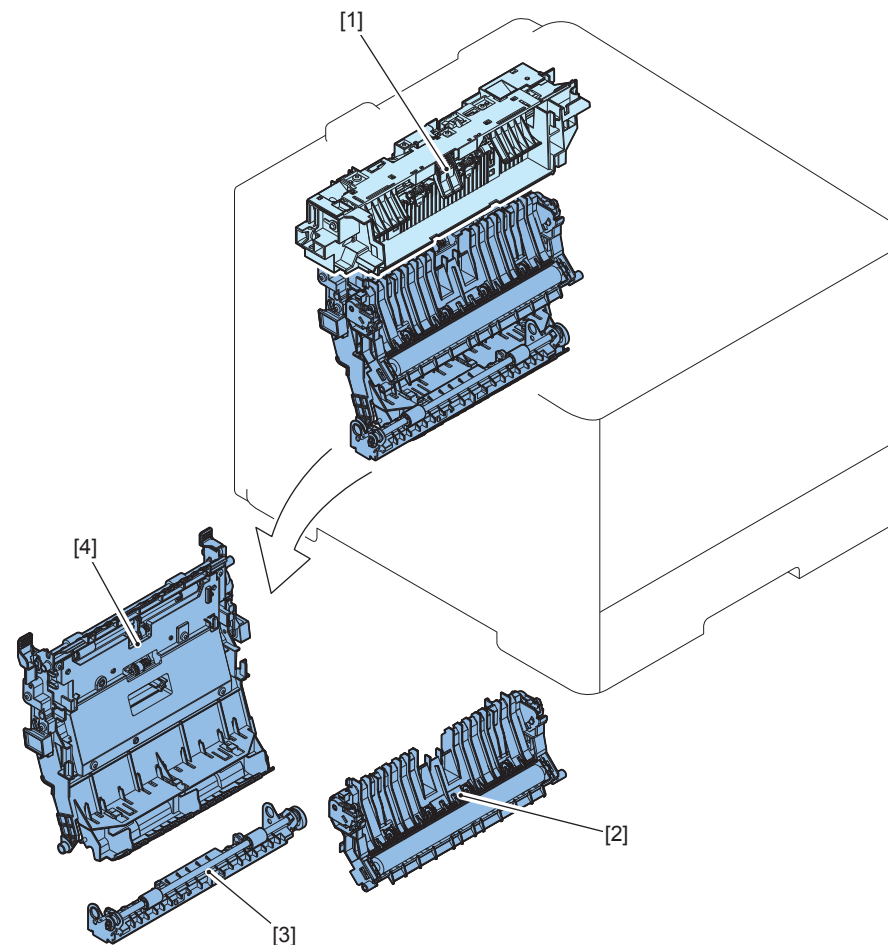

Key No.	Name	Reference	Adjustment during parts replacement	Remarks
[1]	Delivery Unit		-	LBP7600C/7660Cdn /7680Cx LBP7210Cdn
[2]	Secondary Transfer Feeding Unit		-	-
[3]	Re-Pickup Guide Unit		-	-
[4]	Duplexing Feeding Unit		-	LBP7600C/7660Cdn /7680Cx LBP7210Cdn

T-3-5

Motor / Fan LBP7600C/7660Cdn/7680Cx/7210Cdn

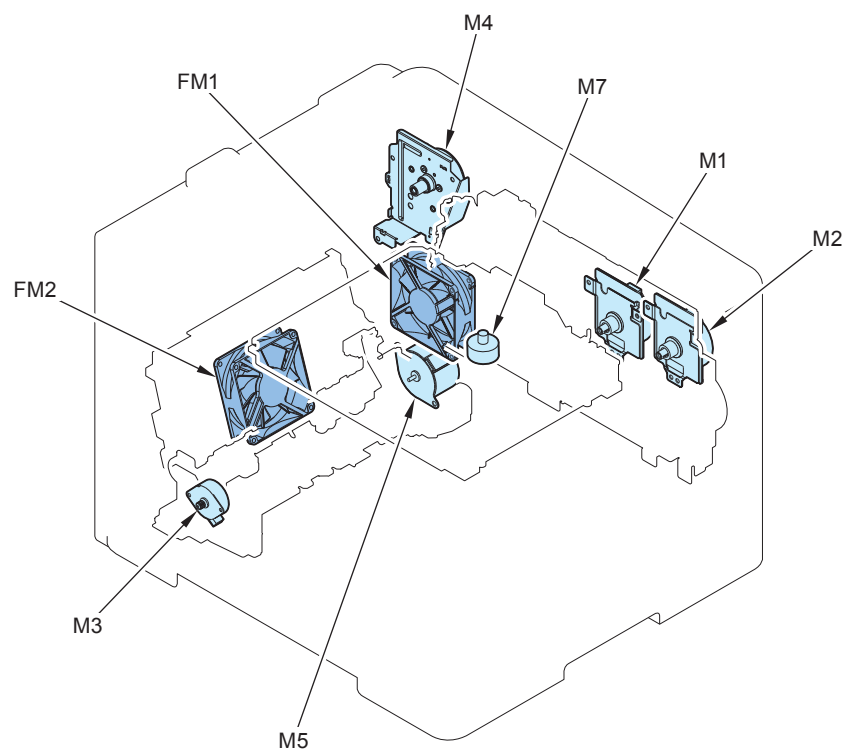

F-3-8

No.	Name	Main Unit	Reference	Adjustment during parts replacement	Remarks
M4	Fixing Motor	Main Unit		-	-
M7	Laser Scanner Motor	Laser Scanner Unit		-	-
M1	Drum Motor	Main Drive Unit		-	LBP7600C/7660Cdn /7680Cx LBP7210Cdn
M2	Developing Motor	Main Drive Unit		-	LBP7600C/7660Cdn /7680Cx LBP7210Cdn
M5	Pickup Motor	Main Unit		-	LBP7600C/7660Cdn /7680Cx LBP7210Cdn
M3	Registration Motor	Pickup Unit		-	-
FM2	Duplexing Feeding Fan	Duplexing Feeding Unit		-	-
FM1	Fixing/Power Supply Cooling Fan	Main Unit		-	LBP7600C/7660Cdn /7680Cx LBP7210Cdn

T-3-6

Clutch / Solenoid / Switch / Thermistor / Heater LBP7600C/7660Cdn/7680Cx/7210Cdn

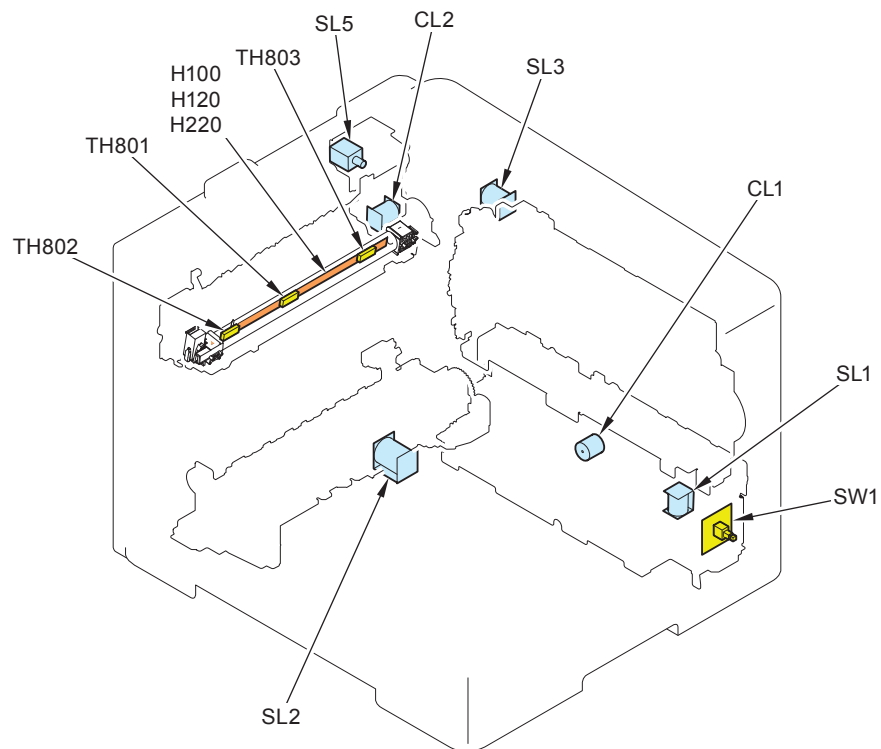

F-3-9

No.	Name	Main Unit	Reference	Adjustment during parts replacement	Remarks
SL5	Duplex Reverse Solenoid	Duplex Reverse Drive Unit	-	-	-
CL2	Duplex Feeding Clutch	Duplex Reverse Drive Unit	-	-	-
SL3	Developing Separation Solenoid	Main Drive Unit	-	-	-
CL1	Manual Feed Tray Feeding Clutch	Main Unit	-	-	-
SL1	Manual Feed Tray Pickup Solenoid	Main Unit	-	-	-
SW1	Power Switch	Main Unit	-	-	-
SL2	Cassette Pickup Solenoid	Pickup Unit	-	-	-
TH802	Sub Thermistor 1	Fixing Assembly	-	-	-
TH801	Main Thermistor	Fixing Assembly	-	-	-
H100	Fixing Heater(100V)	Fixing Assembly	-	-	-
H120	Fixing Heater(120V)	Fixing Assembly	-	-	-
H220	Fixing Heater(230V)	Fixing Assembly	-	-	-
TH803	Sub Thermistor 2	Fixing Assembly	-	-	-

T-3-7

Sensor LBP7600C/7660Cdn/7680Cx/7210Cdn

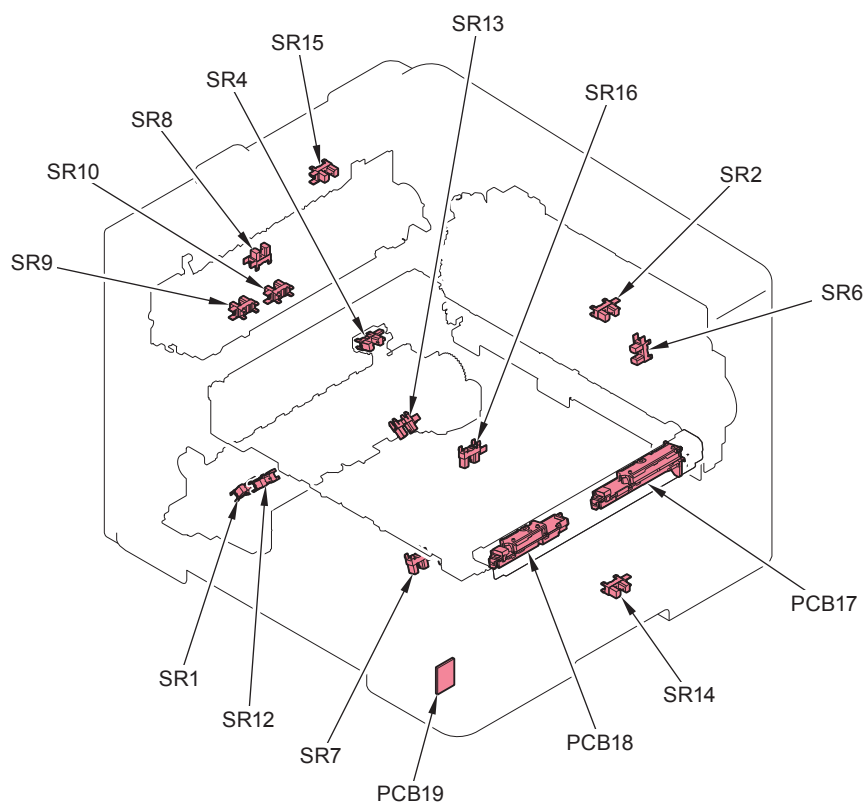

F-3-10

No.	Name	Main Unit	Reference	Adjustment during parts replacement	Remarks
SR13	Cassette Paper Detection Sensor	Pickup Unit	-	-	-
SR16	ITB Pressure Release Sensor	ITB Unit	-	-	-
SR2	Front Door Open/Close Sensor	Main Unit	-	-	-
SR6	Developing HP Sensor	Main Unit	-	-	-
PCB17	Registration Patch Sensor	Main Unit	-	-	-
SR14	Manual Feed Tray Paper Detection Sensor	Main Unit	-	-	-
PCB18	Patch Sensor	Main Unit	-	-	-
PCB19	Environment Sensor	Main Unit	-	-	-
SR7	Manual Feed Tray Pre-registration Detection Sensor	Main Unit	-	-	-
SR12	Pre-registration Detection Sensor	Pickup Unit	-	-	-
SR1	Paper Feeder Pre-registration Detection Sensor	Pickup Unit	-	-	-
SR9	Fixing Pressure Release Sensor	Fixing Assembly	-	-	-
SR10	Fixing Loop Sensor	Fixing Assembly	-	-	-
SR8	Fixing Delivery Sensor	Fixing Assembly	-	-	-
SR4	Registration Detection Sensor	Pickup Unit	-	-	-
SR15	Delivery Full Sensor	Delivery Unit	-	-	-

T-3-8

PCB LBP7600C/7660Cdn/7680Cx/7210Cdn

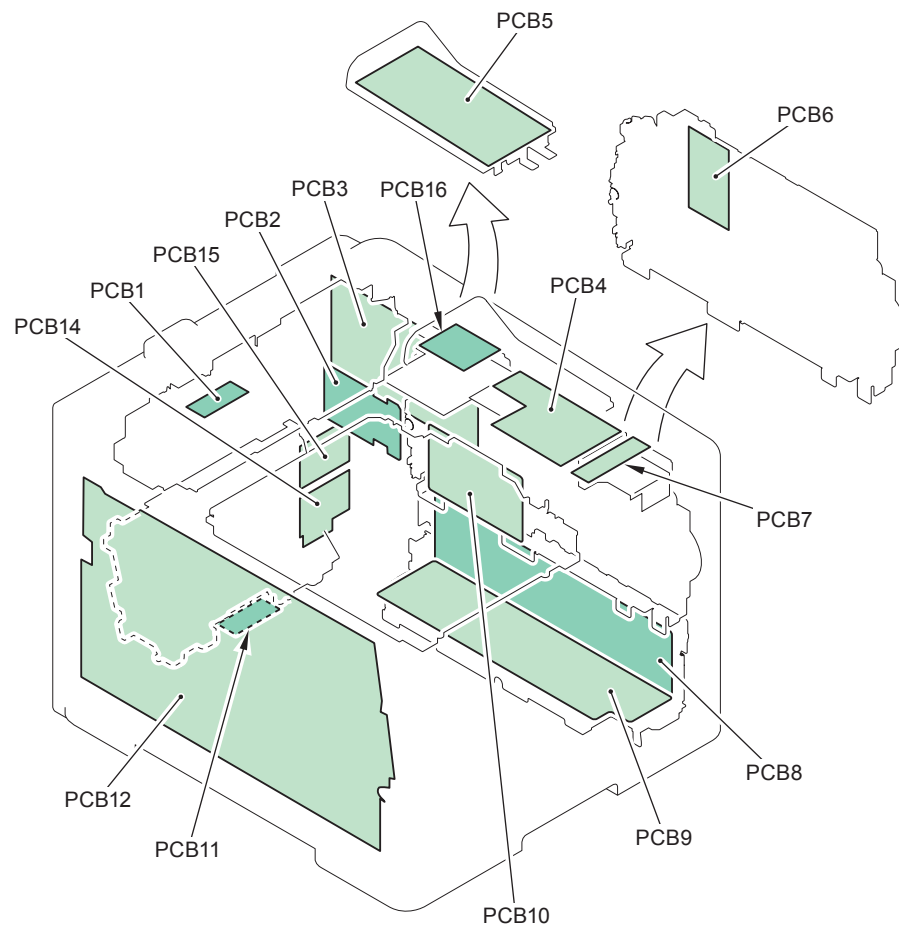

F-3-11

No.	Name	Main Unit	Reference	Adjustment during parts replacement	Remarks
PCB14	AC PCB	Main Unit	-	-	-
PCB1	Fixing Relay PCB	Fixing Assembly	-	-	-
PCB15	All-night Power Supply PCB	Main Unit	-	-	-
PCB2	Sub Power Supply PCB	Main Unit	-	-	-
PCB3	Main Controller PCB	Main Unit	-	-	LBP7600C /7660Cdn
			-	-	LBP7680Cx
			-	-	LBP7210Cdn
PCB16	SD Slot PCB	Main Unit	-	-	LBP7680Cx Only
PCB4	DC Controller PCB	Main Unit	-	-	LBP7600C/7660Cdn /7680Cx
			-	-	LBP7210Cdn
PCB5	Operation Panel PCB	Operation Panel Unit	-	-	LBP7600C/7660Cdn /7680Cx LBP7210Cdn
PCB6	Driver PCB	Main Unit	-	-	LBP7600C/7660Cdn /7680Cx
			-	-	LBP7210Cdn
PCB7	Relay PCB	Main Unit	-	-	LBP7600C/7660Cdn /7680Cx
			-	-	LBP7210Cdn
PCB8	Fixing Power Supply PCB	Main Unit	-	-	
PCB9	Low-voltage Power Supply PCB	Main Unit	-	-	
PCB10	Laser Scanner PCB	Laser Scanner Unit	-	-	
PCB11	Duplex Relay PCB	Main Unit	-	-	
PCB12	High-voltage Power Supply PCB	Main Unit	-	-	LBP7600C/7660Cdn /7680Cx
			-	-	LBP7210Cdn

T-3-9

List of Connectors

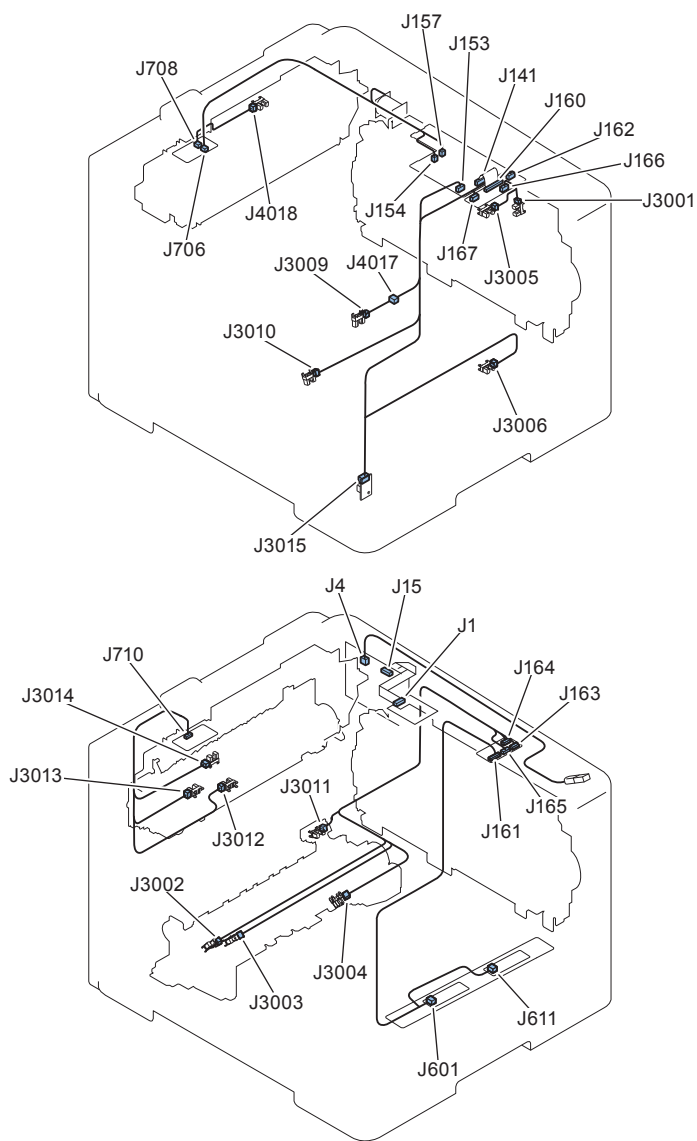

F-3-12

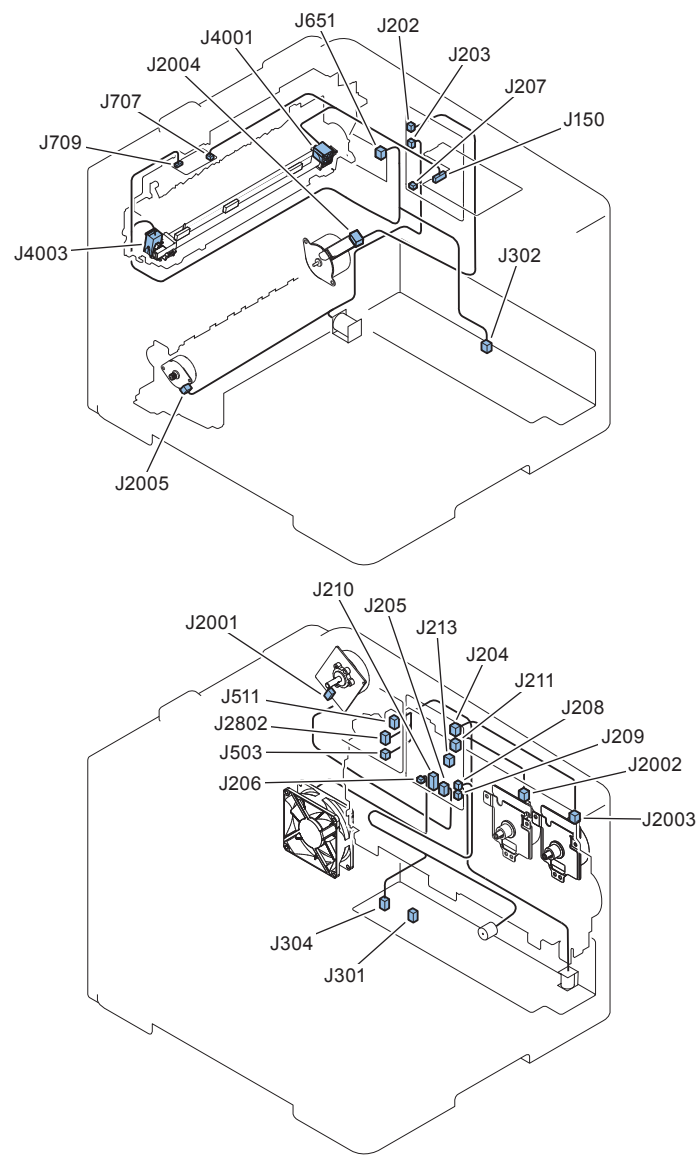

F-3-13

External Cover/Internal System

Layout Drawing

LBP7600C/7660Cdn/7680Cx

Front Side

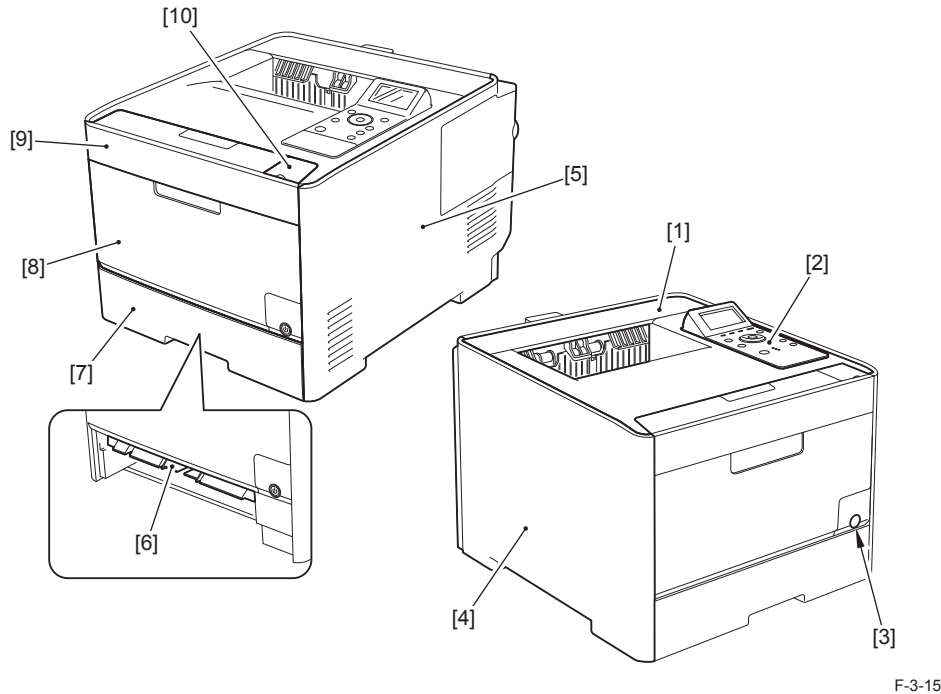

F-3-15

Key No.	Name	Reference	Adjustment during parts replacement	Remarks
[1]	Upper Cover	(Refer to page 3-24)	-	-
[2]	Operation Panel	(Refer to page 3-56)	-	-
[3]	Power Switch		-	-
[4]	Left Cover	(Refer to page 3-22)	-	-
[5]	Right Cover	(Refer to page 3-20)	-	-
[6]	Manual Feed Tray Feeding Guide		-	-
[7]	Pickup Cassette		-	-
[8]	Manual Feed Tray		-	-
[9]	Front Cover	(Refer to page 3-26)	-	-
[10]	Upper Front Cover (Right)	(Refer to page 3-23)	-	LBP7600C /7660Cdn Only
[10]	USB Cover		-	LBP7680Cx Only

T-3-10

Rear Side

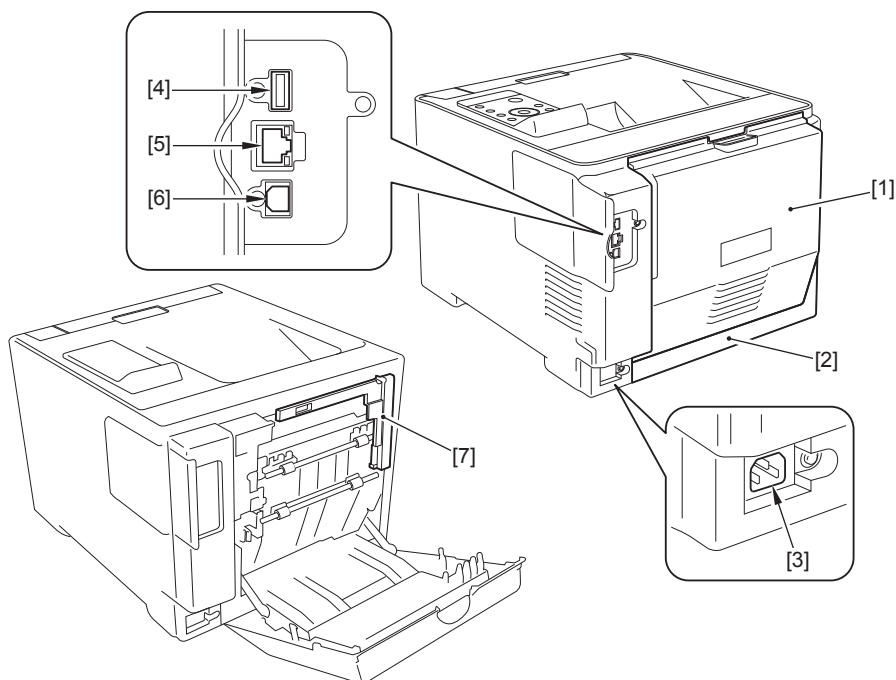

F-3-16

Key No.	Name	Reference	Adjustment during parts replacement	Remarks
[1]	Rear Cover	(Refer to page 3-15)	-	-
[2]	Rear Lower Cover	(Refer to page 3-17)	-	-
[3]	Power Socket		-	-
[4]	USB Port (for USB devices)		-	-
[5]	LAN Port		-	-
[6]	USB Port (for connecting to computer)		-	-
[7]	Rear Upper Cover (Left)	(Refer to page 3-17)	-	-

T-3-11

LBP7210Cdn
Front Side

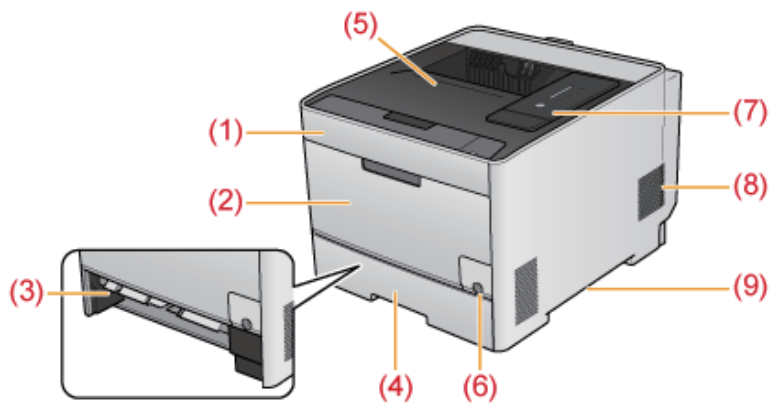

F-3-17

Key No.	Name	Reference	Adjustment during parts replacement	Remarks
[1]	Front Cover	(Refer to page 3-26)	-	-
[2]	Multi-purpose Tray		-	-
[3]	Manual Feed Transport Guide		-	-
[4]	Paper Drawer		-	-
[5]	Output Tray		-	-
[6]	Power Switch		-	-
[7]	Control Panel	(Refer to page 3-56)	-	-
[8]	Ventilation Slots		-	-
[9]	Lift Handles		-	-

Rear Side

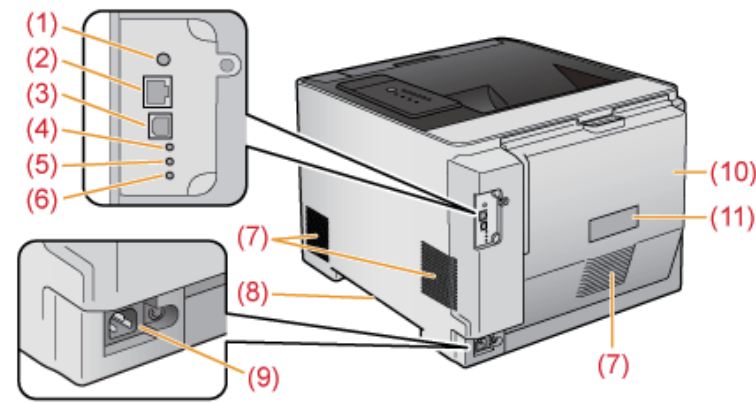

F-3-18

Key No.	Name	Reference	Adjustment during parts replacement	Remarks
[1]	Reset Button		-	-
[2]	LAN Connector		-	-
[3]	USB Connector		-	-
[4]	100 Indicator (Green)		-	-
[5]	LNK Indicator (Green)		-	-
[6]	ERR Indicator (Orange)		-	-
[7]	Ventilation Slots		-	-
[8]	Lift Handles		-	-
[9]	Power Socket		-	-
[10]	Rear Cover	(Refer to page 3-17)	-	-
[11]	Rating Label		-	-

Removing the Rear Cover LBP7600C/7660Cdn/7680Cx

Procedure

- 1) Open the Rear Cover.
- 2) Close the Duplex Feed Unit [1].

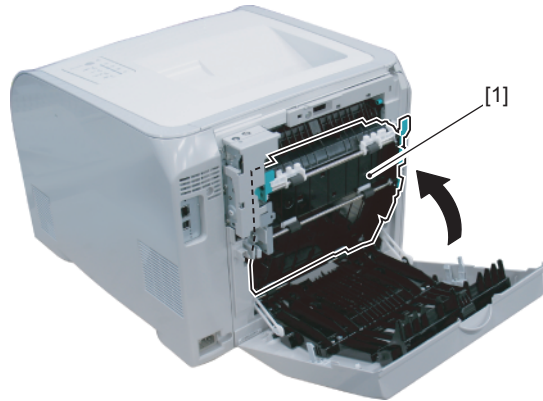

F-3-19

- 3) Remove the Rear Cover [1].
 - 2 Screws [2]
 - 4 Hooks [3]

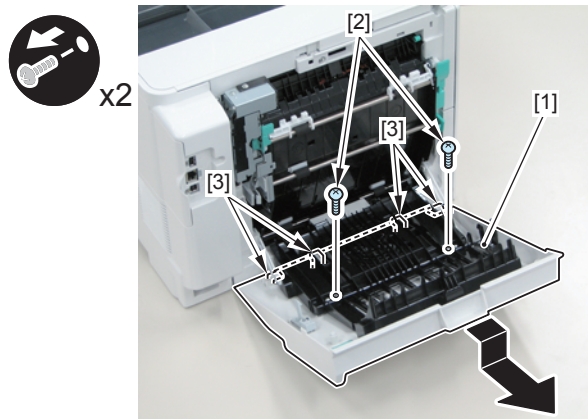

F-3-20

Removing the Rear Cover LBP7210Cdn

Procedure

- 1) Open the Rear Cover.
- 2) Close the Duplex Feed Unit [1].

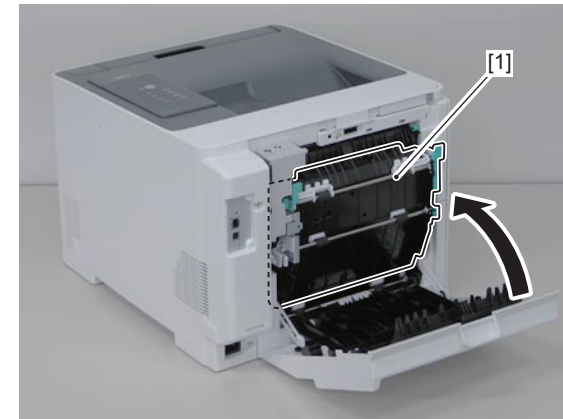

F-3-21

- 3) Remove the Rear Cover [1].
 - 2 Screws [2]
 - 4 Hooks [3]

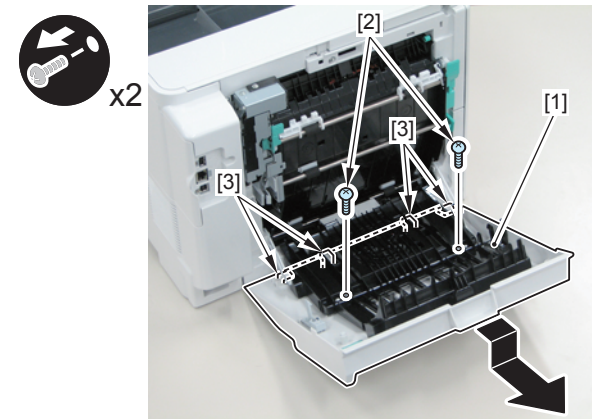

F-3-22

Removing the Rear Cover Rib Unit LBP7600C/7660Cdn/7680Cx/7210Cdn

Preparation

- 1) Remove the Right Cover.(Refer to page 3-16)
- 2) Remove the Rear Upper Cover (Left).(Refer to page 3-17)
- 3) Remove the Rear Cover.(Refer to page 3-15)
- 4) Remove the Rear Lower Cover.(Refer to page 3-17)

Procedure

- 1) Remove the Rear Cover Rib Unit [1].
 - 2 Arm Shafts [2]
 - 1 Harness Guide [A]
 - 1 connector [3]

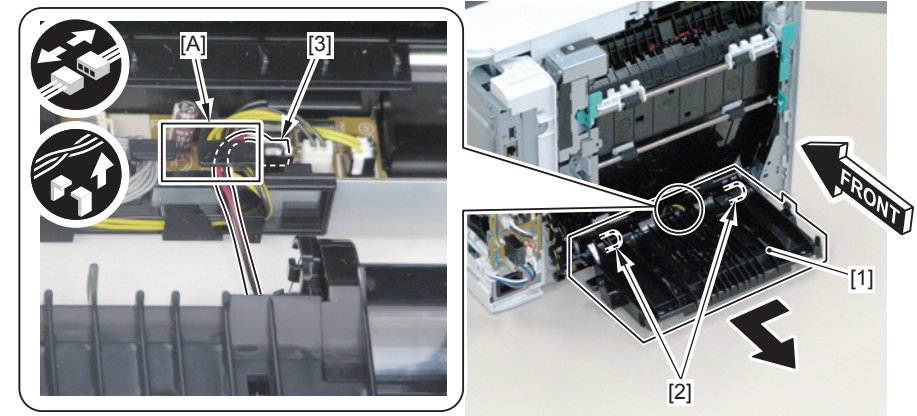

CAUTION:

Be sure to hook the spring [1] on the frame [B] when installing.

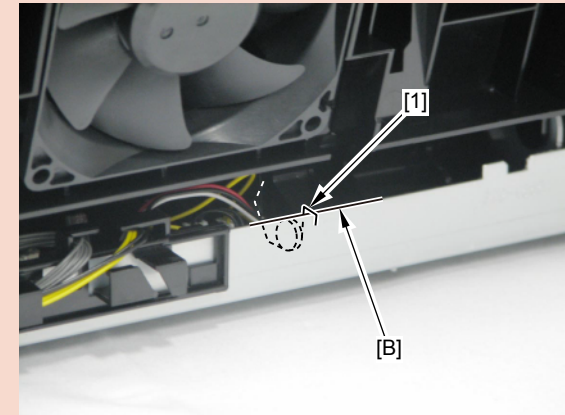

F-3-24

F-3-23

Removing the Rear Upper Cover (Left) LBP7600C/7660Cdn/7680Cx/7210Cdn

Procedure

- 1) Open the Rear Cover.
- 2) Remove the Rear Upper Cover (Left) [1].
 - 2 Screws [2]
 - 1 Claw [3]
 - 1 Boss [4]
 - 1 Protrusion [5]

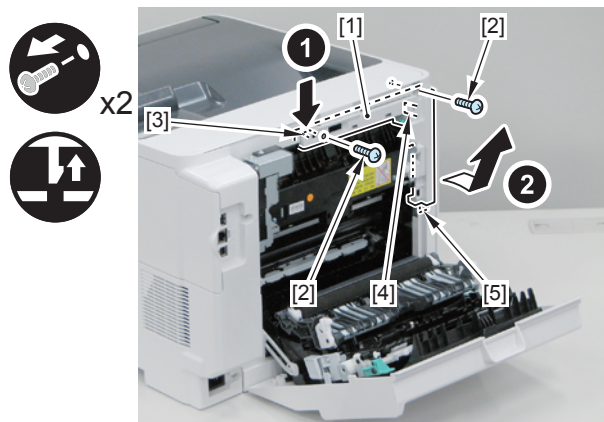

F-3-25

Removing the Rear Lower Cover LBP7600C/7660Cdn/7680Cx

Preparation

- 1) Remove the Right Cover.(Refer to page 3-20)
- 2) Remove the Rear Upper Cover (Left).(Refer to page 3-17)
- 3) Remove the Rear Cover.(Refer to page 3-15)

Procedure

- 1) Remove the 2 stoppers [1], and remove the 2 Link Arms [2].

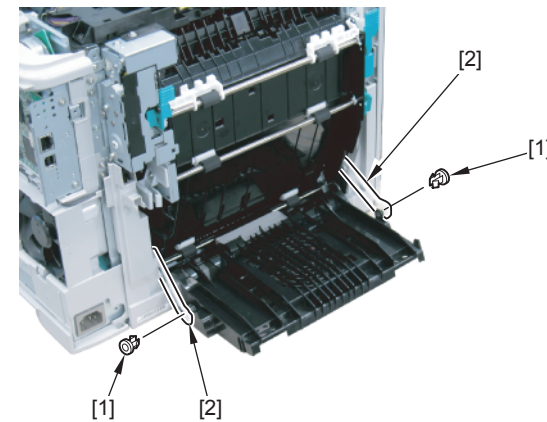

F-3-26

2) Open the Duplex Feed Unit [1].

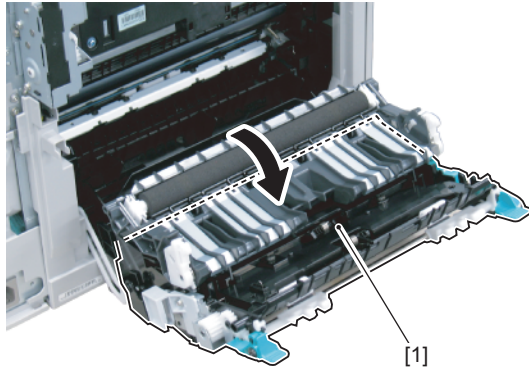

F-3-27

3) Remove the 2 claws [1] and the 2 bosses [2] of the Rear Lower Cover.

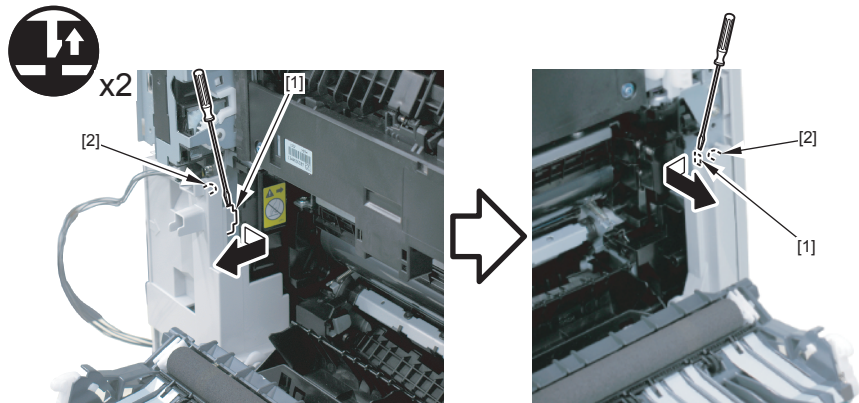

F-3-28

4) Close the Duplex Feed Unit [1] and the Rear Cover Rib Unit [2], and remove the Rear Lower Cover [3].

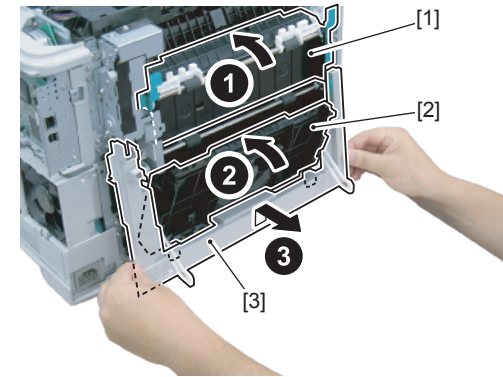

F-3-29

5) Remove the 2 Link Arms [1] from the Rear Lower Cover.

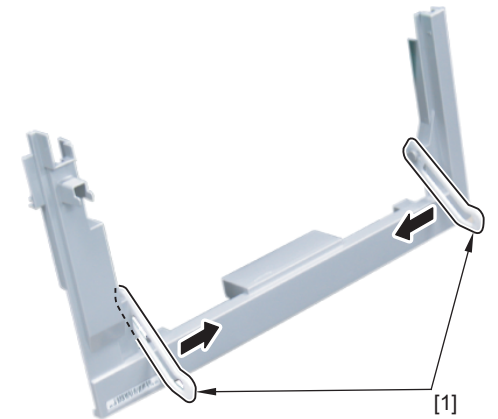

F-3-30

Removing the Rear Lower Cover LBP7210Cdn

Preparation

- 1) Remove the Right Cover.(Refer to page 3-20)
- 2) Remove the Rear Upper Cover (Left).(Refer to page 3-17)
- 3) Remove the Rear Cover.(Refer to page 3-15)

Procedure

- 1) Remove the 2 stoppers [1], and remove the 2 Link Arms [2].

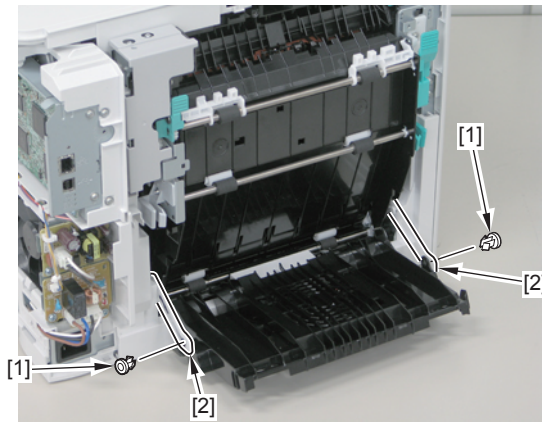

F-3-31

- 2) Open the Duplex Feed Unit [1].

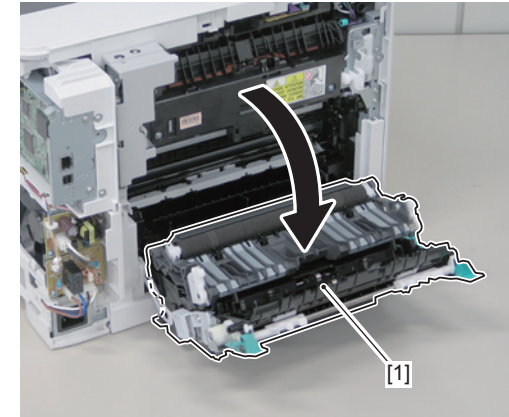

F-3-32

- 3) Remove the 2 claws [1] and the 2 bosses [2] of the Rear Lower Cover.

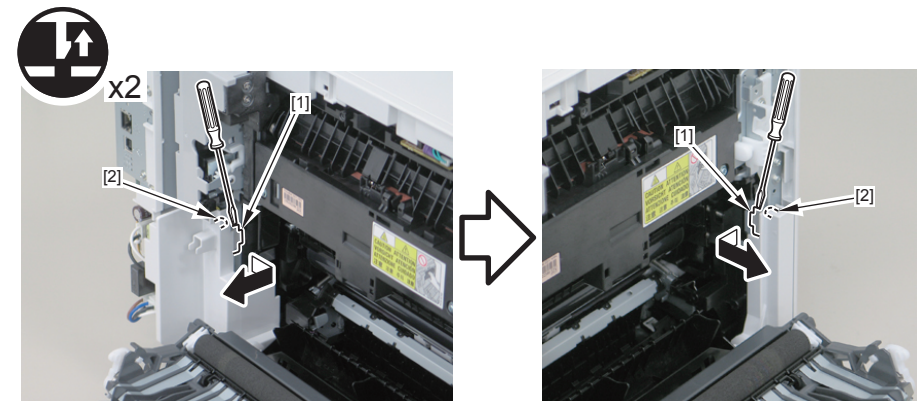

F-3-33

- 4) Close the Duplex Feed Unit [1] and the Rear Cover Rib Unit [2], and remove the Rear Lower Cover [3].

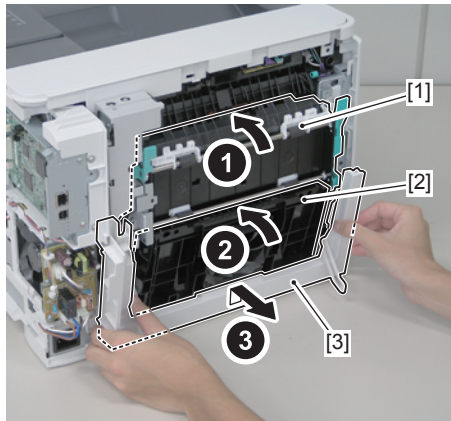

F-3-34

- 5) Remove the 2 Link Arms [1] from the Rear Lower Cover.

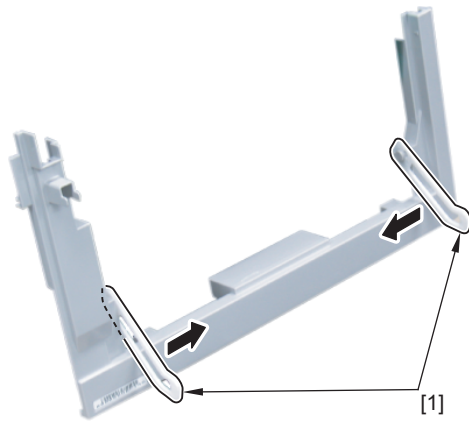

F-3-35

Removing the Right Cover LBP7600C/7660Cdn/7680Cx

Procedure

NOTE:

The following shows the 6 claws [1] and the 3 hooks [2] of the Right Cover.

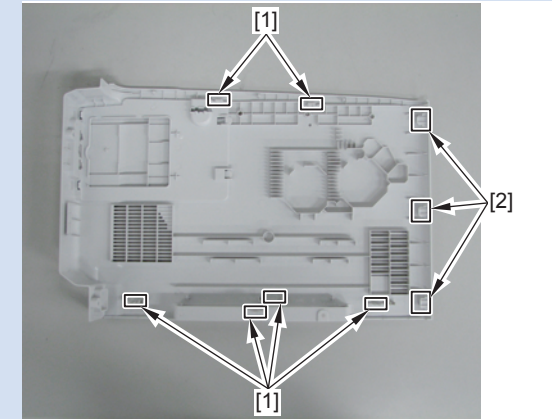

F-3-36

- 1) Open the Front Cover [1], and remove the screw(binding) [2] and 2 screws(TP) [3].

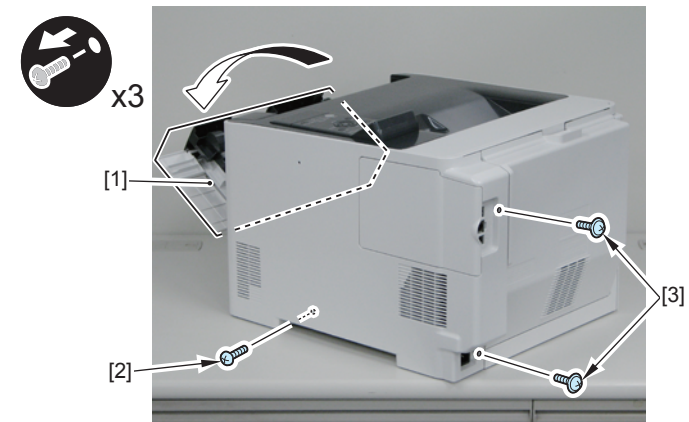

F-3-37

- 2) Remove the 2 claws [1] at the upper side and the 4 claws [2] at the lower side.
- 3) Remove the 3 hooks [3], and remove the Right Cover [4].

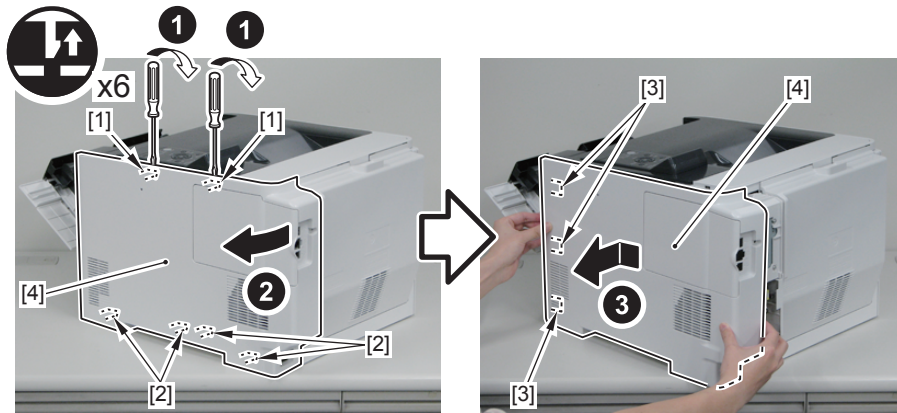

F-3-38

Removing the Right Cover LBP7210Cdn

Procedure

NOTE:

The following shows the 6 claws [1] and the 3 hooks [2] of the Right Cover.

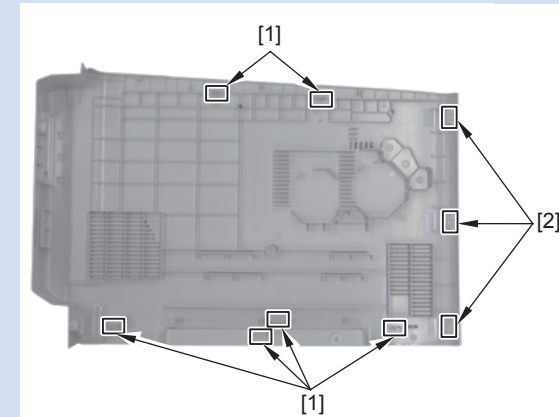

F-3-39

- 1) Open the Front Cover [1], and remove the screw(binding) [2] and 2 screws(TP) [3].

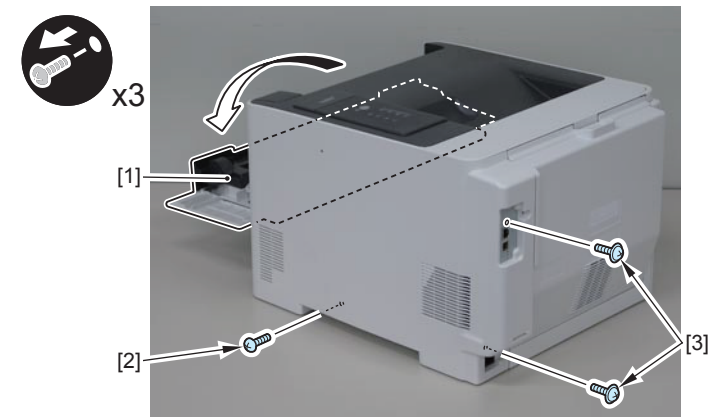

F-3-40

- 2) Remove the 2 claws [1] at the upper side and the 4 claws [2] at the lower side.
- 3) Remove the 3 hooks [3], and remove the Right Cover [4].

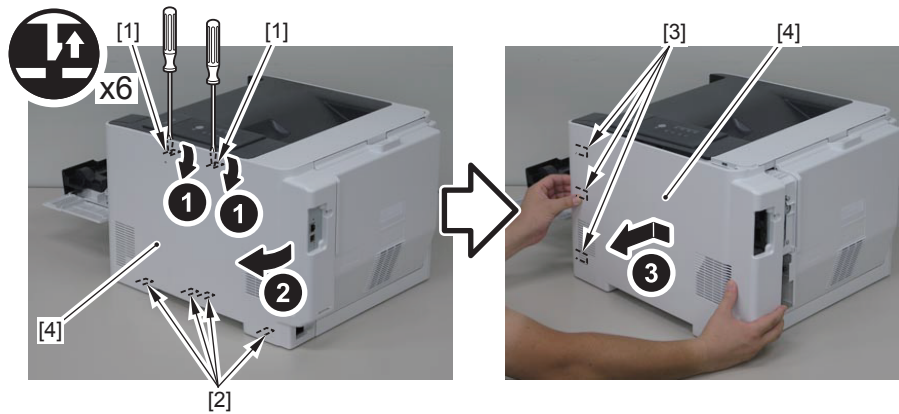

F-3-41

Procedure

NOTE:

The following shows the 8 hooks [1] and the protrusion [2] of the Left Cover.

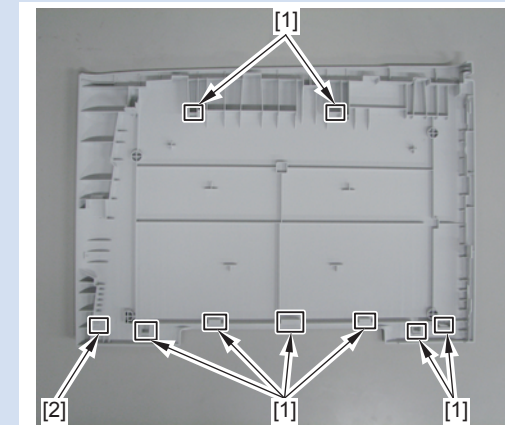

F-3-42

- 1) Remove the claw [2] and the boss [3] of the Rear Lower Cover [1], and remove the Left Cover [4].

- 1 Screw [5]
- 8 Hooks [6]

Removing the Left Cover LBP7600C/7660Cdn/7680Cx/7210Cdn

Preparation

- 1) Remove the Right Cover.(Refer to page 3-20)
- 2) Remove the Operation Panel Unit.(Refer to page 3-56)
- 3) Remove the Rear Upper Cover (Left).(Refer to page 3-17)
- 4) Remove the Upper Front Cover (Right) / USB Cover.(Refer to page 3-23)
- 5) Remove the Upper Cover.(Refer to page 3-24)

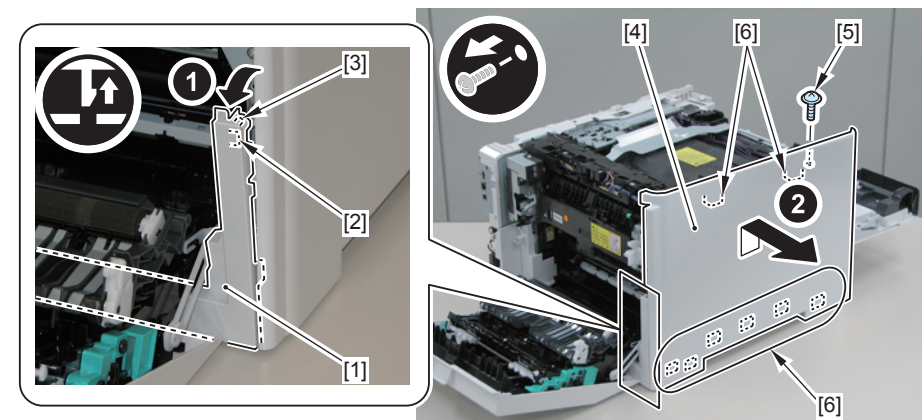

F-3-43

NOTE:

Be sure to follow the following steps when installing.

- 1) While opening the Rear Lower Cover [1], fit the protrusion [2] and the 6 hooks [2] on the lower side of the Left Cover in the cut-off [A] and the hole [B] of the host machine.
- 2) Install the Left Cover [5] by fitting the 2 hooks [4] at the upper side of the Left Cover in the hole [C] of the host machine.

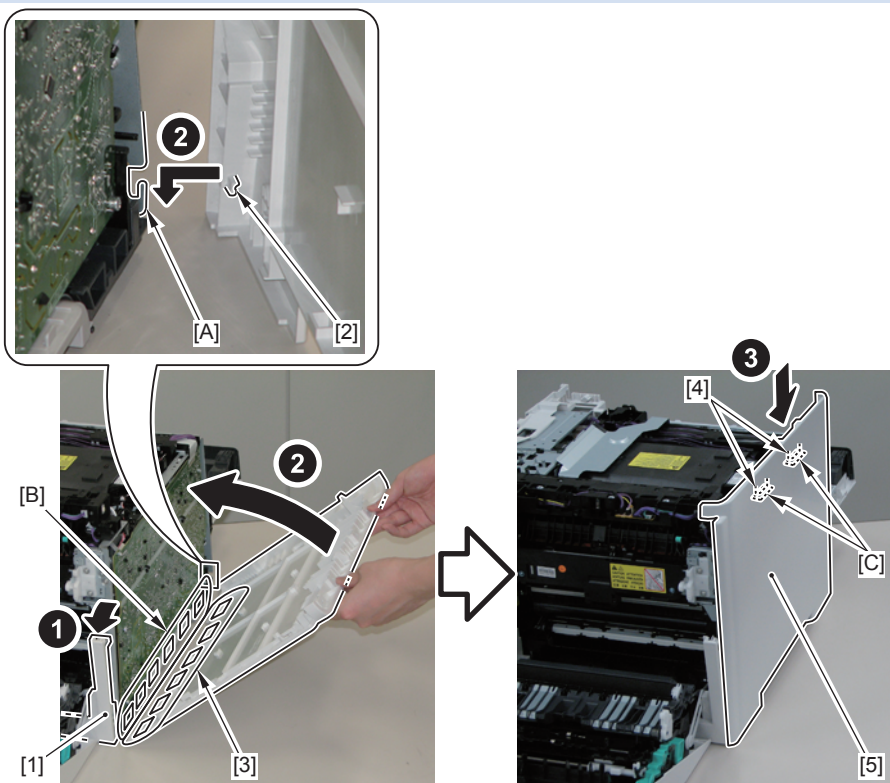

F-3-44

Removing the Upper Front Cover (Right)/USB Cover LBP7600C/7660Cdn/7680Cx

Procedure

- 1) Open the Front Cover.
- 2) Remove the Upper Front Cover (Right)/USB Cover [1].
 - 1 Screw [2]
 - 1 Hook [3]

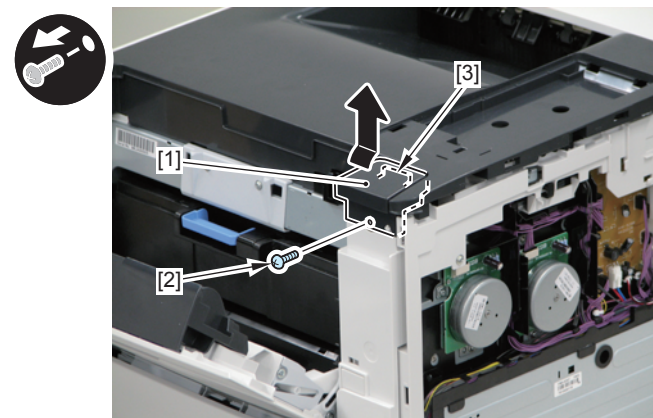

F-3-45

Removing the Upper Front Cover (Right) LBP7210Cdn

Procedure

- 1) Open the Front Cover.
- 2) Remove the Upper Front Cover (Right) [1].
 - 1 Screw [2]
 - 1 Hook [3]

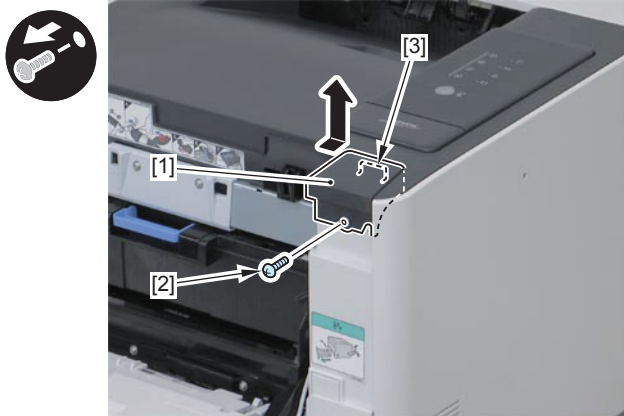

F-3-46

Removing the Upper Cover LBP7600C/7660Cdn/7680Cx

Preparation

- 1) Remove the Right Cover.(Refer to page 3-20)
- 2) Remove the Operation Panel Unit.(Refer to page 3-56)
- 3) Remove the Rear Upper Cover (Left).(Refer to page 3-17)
- 4) Remove the Upper Front Cover (Right) / USB Cover.(Refer to page 3-23)

Procedure

NOTE:

The following shows the 5 claws [1], the 4 bosses [2] and the 3 hooks [3] of the Upper Cover.

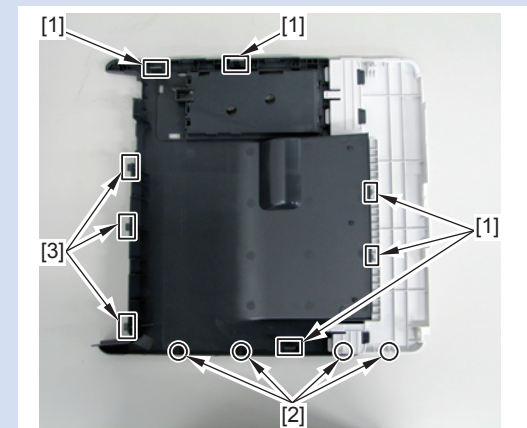

F-3-47

- 1) Remove the screw [1], the boss [2] and the 5 claws [3].

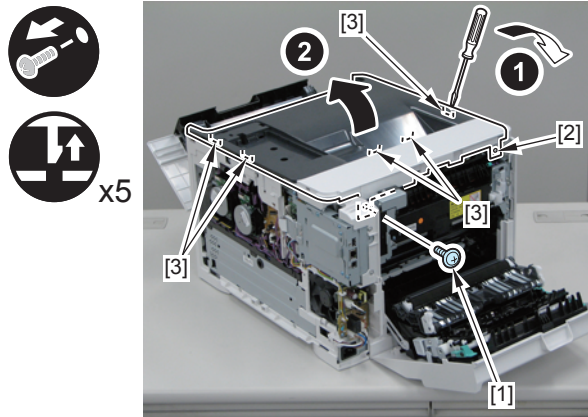

F-3-48

- 2) Remove the Upper Cover [1].

- 3 Hooks [2]

CAUTION:

Be sure to prevent the Upper Cover [1] from hitting against the Delivery Flapper [3] when disassembling/assembling.

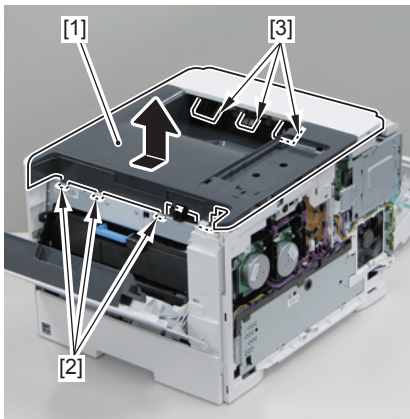

F-3-49

Removing the Upper Cover LBP7210Cdn

Preparation

- 1) Remove the Right Cover. (Refer to page 3-20)
- 2) Remove the Operation Panel Unit. (Refer to page 3-56)
- 3) Remove the Rear Upper Cover (Left). (Refer to page 3-17)
- 4) Remove the Upper Front Cover (Right). (Refer to page 3-23)

Procedure

NOTE:

The following shows the 5 claws [1], the 4 bosses [2] and the 3 hooks [3] of the Upper Cover.

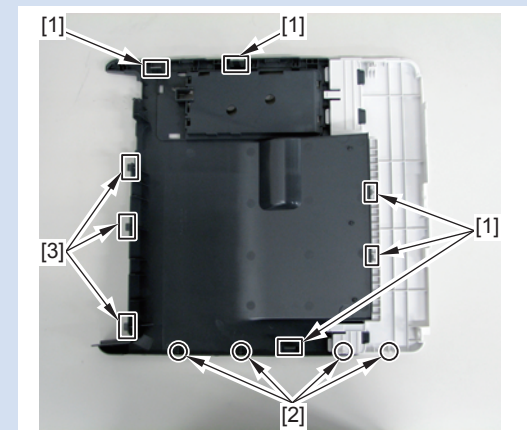

F-3-50

- 1) Remove the screw [1], the boss [2] and the 5 claws [3].

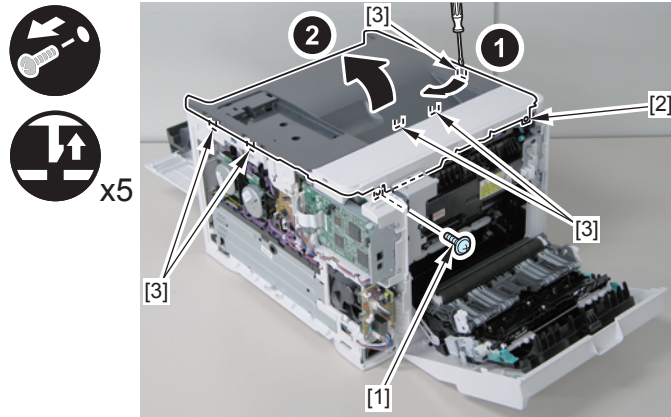

F-3-51

- 2) Remove the Upper Cover [1].

- 3 Hooks [2]

CAUTION:

Be sure to prevent the Upper Cover [1] from hitting against the Delivery Flapper [3] when disassembling/assembling.

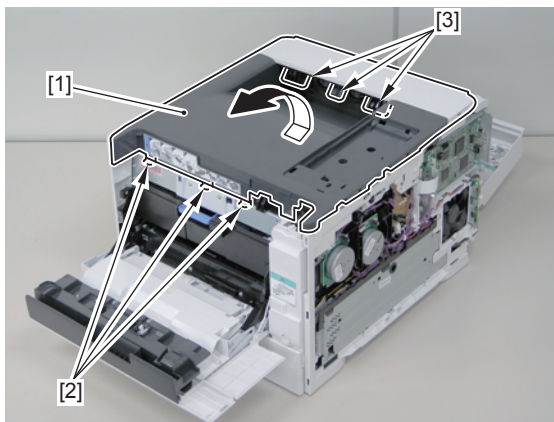

F-3-52

Removing the Front Cover LBP7600C/7660Cdn/7680Cx/7210Cdn

Preparation

- 1) Remove the Toner Cartridges (Y/M/C/Bk).
- 2) Remove the Right Cover.(Refer to page 3-20)
- 3) Remove the Operation Panel Unit.(Refer to page 3-56)
- 4) Remove the Rear Upper Cover (Left).(Refer to page 3-17)
- 5) Remove the Upper Front Cover (Right) / USB Cover.(Refer to page 3-23)
- 6) Remove the Upper Cover.(Refer to page 3-24)
- 7) Remove the Right Frame Cover.(Refer to page 3-38)

Procedure

- 1) Pull out the Cartridge Tray.
- 2) While raising the stopper [1], remove the Cartridge Tray [2].
 - 1 Protrusion [3]

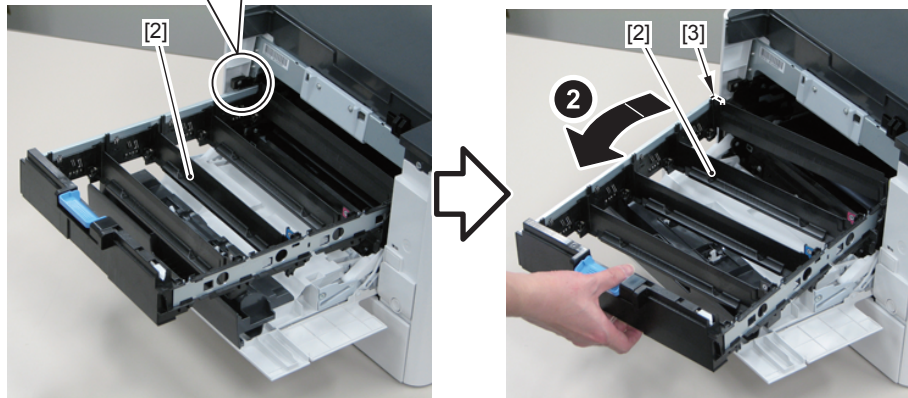
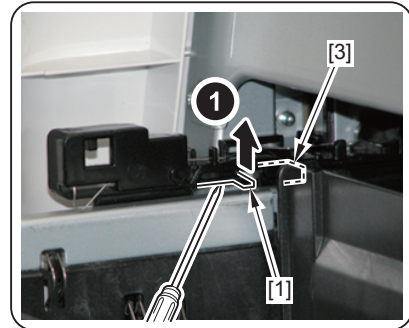

F-3-53

- 3) Remove the Shaft Support Retainer [1].
 - 1 Screw(TP)[2]
 - 1 Screw(binding)[3]

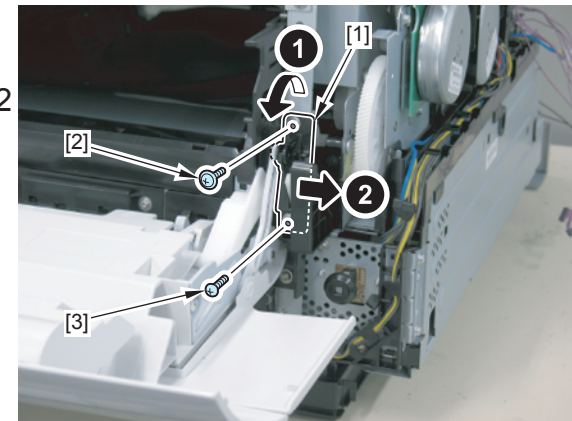

F-3-54

- 4) Remove the 2 pins [1] using a screwdriver.

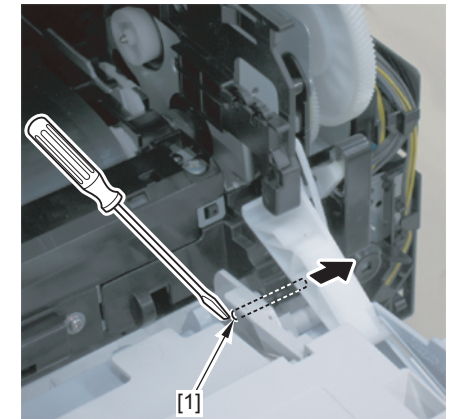
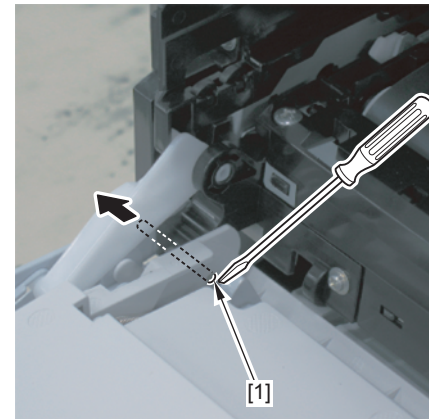

F-3-55

5) Remove the 2 links [1] and the Front Cover [2].

- 2 Shafts [3]
- 2 Protrusions [4]

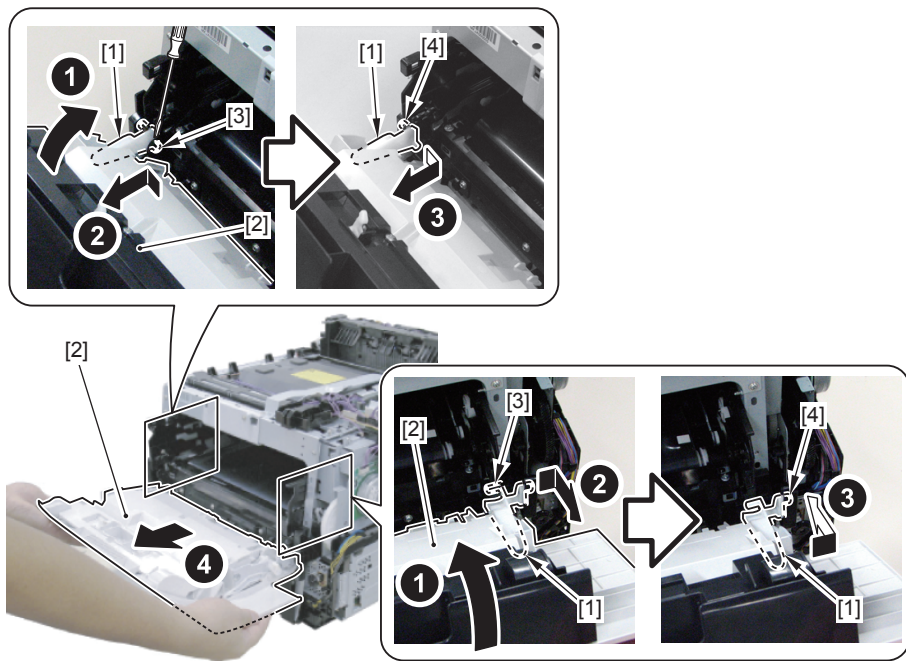

F-3-56

Controller System

Layout Drawing

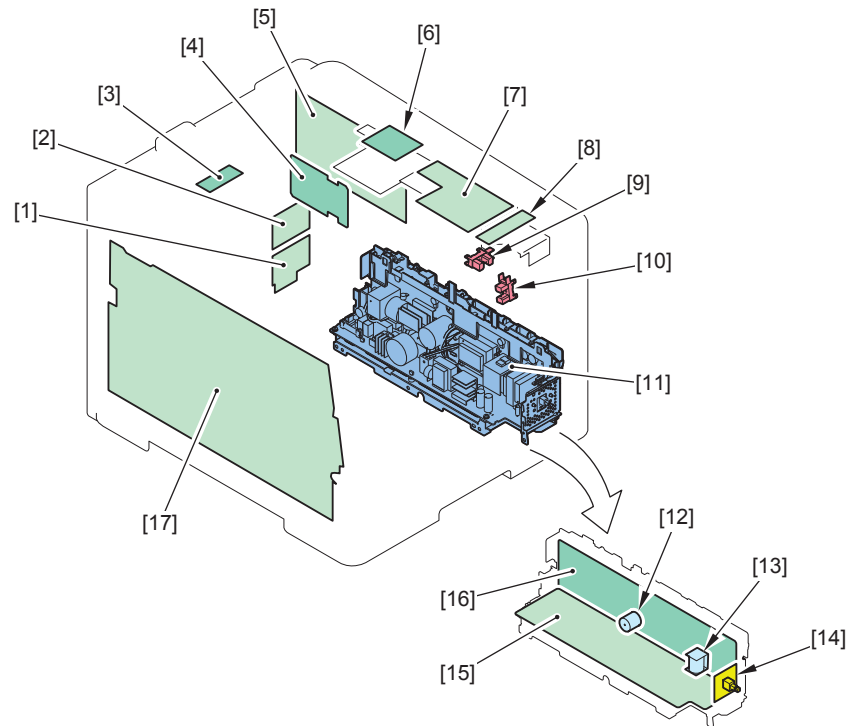

F-3-57

Key No.	Name	Main Unit	Reference	Adjustment during parts replacement	Remarks
[1]	AC PCB	Main Unit		-	PCB14
[2]	All-night Power Supply PCB	Main Unit		-	PCB15
[3]	Fixing Relay PCB	Main Unit		-	PCB1
[4]	Sub Power Supply PCB	Main Unit		-	PCB2
[5]	Main Controller PCB	Main Unit	(Refer to page 3-31)	-	PCB3, LBP7600C /7660Cdn
[5]	Main Controller PCB	Main Unit		-	PCB3, LBP7210Cdn
[6]	SD Slot PCB	Main Unit		-	PCB16, LBP7680 Cx Only
[7]	DC Controller PCB	Main Unit	(Refer to page 3-59)	-	PCB4
[8]	Relay PCB	Main Unit	(Refer to page 3-61)	-	PCB7
[9]	Front Door Open/Close Sensor	Main Unit		-	SR2
[10]	Developing HP Sensor	Main Unit		-	SR6
[11]	Power Supply Unit	Main Unit	(Refer to page 3-65)	-	-
[12]	Manual Feed Tray Feeding Clutch	Main Unit		-	CL1
[13]	Manual Feed Tray Pickup Solenoid	Main Unit		-	SL1
[14]	Power Switch	Main Unit		-	SW1
[15]	Low-voltage Power Supply PCB	Main Unit		-	PCB9
[16]	Fixing Power Supply PCB	Main Unit		-	PCB8
[17]	High-voltage Power Supply PCB	Main Unit	(Refer to page 3-81)	-	PCB12

T-3-12

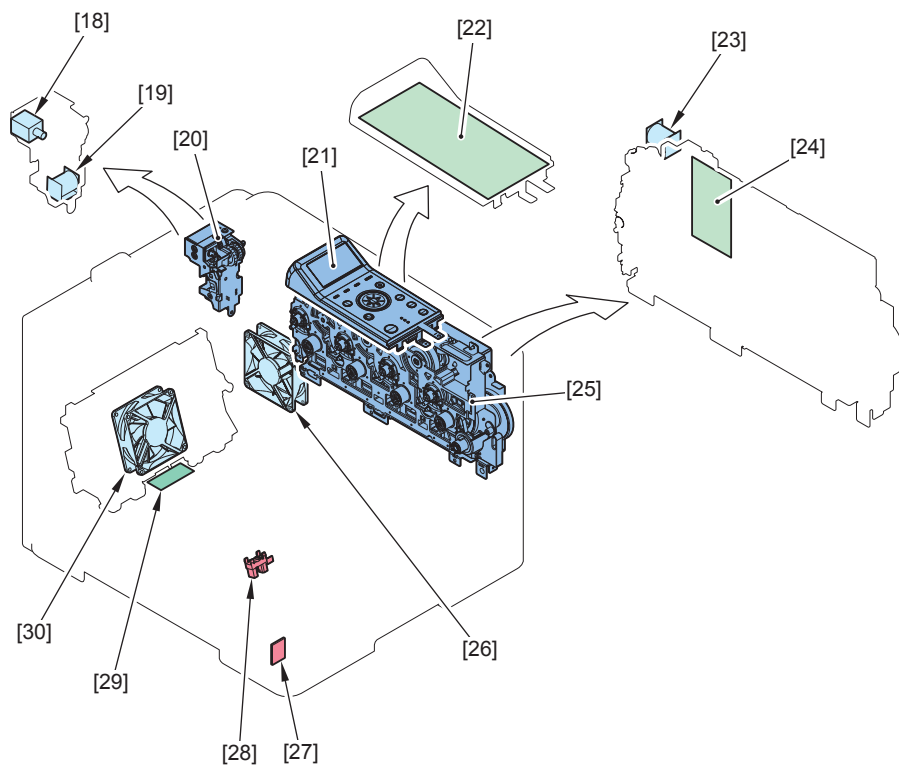

F-3-58

Key No.	Name	Main Unit	Reference	Adjustment during parts replacement	Remarks
[18]	Duplex Reverse Solenoid	Duplex Reverse Drive Unit	-	-	SL5
[19]	Duplex Feeding Clutch	Duplex Reverse Drive Unit	-	-	CL2
[20]	Duplex Reverse Drive Unit	Main Unit	(Refer to page 3-54)	-	
[21]	Operation Panel Unit	Main Unit	(Refer to page 3-56)	-	
[22]	Operation Panel PCB	Operation Panel Unit	-	-	PCB5
[23]	Developing Separation Solenoid	Main Drive Unit	-	-	SL3
[24]	Driver PCB	Main Unit	(Refer to page 3-64)	-	PCB6
[25]	Main Drive Unit	Main Unit	(Refer to page 3-47)	-	
[26]	Fixing/Power Supply Cooling Fan	Main Unit	(Refer to page 3-84)	-	FM1
[27]	Environment Sensor	Main Unit	-	-	PCB19
[28]	Manual Feed Tray Pre-registration Detection Sensor	Main Unit	-	-	SR7
[29]	Duplex Relay PCB	Main Unit	-	-	PCB11
[30]	Duplex Feeding Fan	Duplexing Feeding Unit	(Refer to page 3-87)	-	FM2

T-3-13

Removing the Main Controller PCB LBP7600C/7660Cdn

When Replacing the Main Controller PCB(LBP7600C/7660Cdn)

Because setting values and management data of this machine are stored in the flash memory of the Main Controller PCB, they need to be backed up before replacing the Main Controller PCB.

However, when the Main Controller PCB cannot operate normally because of flash memory failure or system error, the above data cannot be backed up.

Also, when restoring the backup data to the Main Controller PCB, it may be necessary to re-enter the device serial number after restoration depending on the backup method used.

Setting values of this machine: User mode setting values, service mode setting values

Management data of this machine: Page counter, device serial number

1 Backup and restoration of data using Expansion ROM for servicing and Sublog Board (or Sublog Board attached with the Expansion ROM hereafter)

Since setting values and management data can all be backed up by this method, all data can be restored by restoring the backup data after replacing the PCB.

2 Backup and restoration of data using USB memory

Since only setting values can be backed up by this method, the device serial number (management data) needs to be re-entered manually after replacing the PCB and then restoring the backup data.

3 When data cannot be backed up before replacement due to Main Controller PCB error

The device serial number needs to be re-entered manually after replacing the PCB.

1 Backup and restoration of data using Sublog Board attached with Expansion ROM

For details, refer to the Service Manual > Chapter 5 Troubleshooting > Backup/Restoration by Expansion ROM for servicing and Sublog Board

1-1 Backing up data before replacing the PCB

Perform the following operation to back up data of the Main Controller PCB to the Sublog Board attached with the Expansion ROM.

- Turn OFF the power.
- Install the Expansion ROM for servicing to the Sublog Board.
- Install the Sublog Board attached with the Expansion ROM to the Main Controller PCB.
- Turn ON the power.
- When turning ON the power, "NVRAM export" is displayed on the Control Panel.
- Press the down arrow key.

- All data stored on the Main Controller PCB is backed up to the Sublog Board attached with the Expansion ROM.

1-2 Replacing the PCB

- Turn OFF the power.
- Remove the Sublog Board attached with the Expansion ROM from the Main Controller PCB.
- Replace the Main Controller PCB with a new one (service part).
- Install the Sublog Board attached with the Expansion ROM to the Main Controller PCB.

1-3 Restoring data after replacing the PCB

Perform the following operation to restore data backed up in the Sublog Board attached with the Expansion ROM to the Main Controller PCB.

- Turn ON the power.
- When the menu is displayed on the Control Panel upon turning ON the power, select "NVRAM import".
- Press the down arrow key.
- Data backed up in the Sublog Board attached with the Expansion ROM is restored to the Main Controller PCB.
- Turn OFF the power, and remove the Sublog Board attached with the Expansion ROM.

1-4 Checking the device serial number

Perform the following operation to check whether the device serial number is correctly restored.

Execute Utility>Common Status Print to output the status print.

Check that the serial number indicated in the device field is the same as that written on the rating name plate of the host machine.

2 Backup and restoration of data using USB memory

2-1 Backing up data before replacing the PCB

Perform the following operation to back up data of the Main Controller PCB to the USB memory.

- Connect the USB memory to the host machine.
- Select Setup Menu>SERVICE MODE>FUNCTION GR.>USB-H>On.
- Back up data of the Main Controller PCB to the USB memory.
Select Setup Menu>SERVICE MODE>FUNCTION GR.>ECONF>EXPORT>ALL>Yes.
- Select Setup Menu>SERVICE MODE>FUNCTION GR.>USB-H>Off.
- Disconnect the USB memory from the host machine.

2-2 Replacing the PCB

- Turn OFF the power.
- Replace the Main Controller PCB with a new one (service part).

2-3 Performing operation after power-on and entering/checking device serial number

- Turn ON the power.
- "Initializing NVRAM" is displayed on the Control Panel for a few seconds.
- "Panel Language" is displayed.
- Here, select your own language or English.
- When the date setting screen appears, set the date and then press the OK key.
- When the time setting screen appears, set the time and then press the OK key.
- After the message "Setting Completed" appears, the message "Ready to print" appears, indicating the machine can be used normally.
- Select Setup Menu>SERVICE MODE >FUNCTION GR.>SN MAIN, and then enter the device serial number written on the rating name plate of the equipment. Pay attention not to make any mistakes when entering the device serial number of the equipment because #####000000 is already entered in SN MAIN after replacing the PCB.
- The display language of the Control Panel changes to your own language.
- Execute Utility>Common Status Print to output the status print.
- Check that the serial number indicated in the device field is the same as that written on the rating name plate of the host machine.

2-4 Restoring data after replacing the PCB

Perform the following operation to restore data backed up in the USB memory to the Main Controller PCB.

- Connect the USB memory to the host machine.
- Select Setup Menu>SERVICE MODE>FUNCTION GR.>USB-H>On.
- Restore data backed up in the USB memory to the Main Controller PCB.
Select Setup Menu>SERVICE MODE>FUNCTION GR.>ECONF>IMPORT>Yes.
- Select Setup Menu>SERVICE MODE>FUNCTION GR.>USB-H>Off.
- Disconnect the USB memory from the host machine.

NOTE

When you execute Setup Menu>SERVIVE MODE>FUNCTION GR.>ECONF>EXPORT>ALL>Yes upon backup of data by the USB memory, information kept by NVRAM on the DC Controller PCB is also backed up. Therefore, if "ALL" is selected, the operation to back up the information kept by NVRAM of the DC Controller PCB is not necessary.

● 3 When data cannot be backed up before replacement due to Main Controller PCB error

When the Main Controller PCB cannot operate normally, then backup of various data is not possible.

In this case, perform the following procedure to replace the PCB.

3-1 Replacing the PCB

- Turn OFF the power.
- Replace the Main Controller PCB with a new one (service part).

3-2 Performing operation after power-on and entering/checking device serial number

- Turn ON the power.
- "Initializing NVRAM" is displayed on the Control Panel for a few seconds.
- "Panel Language" is displayed.
- Here, select your own language or English.
- When the date setting screen appears, set the date and then press the OK key.
- When the time setting screen appears, set the time and then press the OK key.
- After the message "Setting Completed" appears, the message "Ready to print" appears, indicating the machine can be used normally.
- Select Setup Menu>SERVICE MODE >FUNCTION GR.>SN MAIN, and then enter the device serial number written on the rating name plate of the equipment. Pay attention not to make any mistakes when entering the device serial number of the equipment because #####000000 is already entered in SN MAIN after replacing the PCB.
- The display language of the Control Panel changes to your own language.
- Execute Utility>Common Status Print to output the status print.
- Check that the serial number indicated in the device field is the same as that written on the rating name plate of the host machine.

3-3 Backing up data kept by the NVRAM of the DC Controller PCB to the Main Controller PCB

- Initialize the DC Controller NVRAM backup area kept in the Main Controller PCB.
Select Setup Menu>SERVICE MODE>FUNCTION GR.>CLEAR DCON.
- Turn OFF and then ON the power.
- By turning OFF and then ON the power, data kept by the DC Controller PCB NVRAM is backed up to the DC Controller NVRAM backup area in the Main Controller PCB.

Preparation

1) Remove the Right Cover.(Refer to page 3-20)

Procedure

CAUTION:

When replacing this part, execute the actions to be taken when replacing the Main Controller PCB.

1) Remove the Flat Cable Guide Cover Plate [1].

- 1 Screw [2]

2) Remove the Main Controller Shield Plate [3] and the Flat Cable Guide [4].

- 5 Screws [5]
- 1 Hook [6]

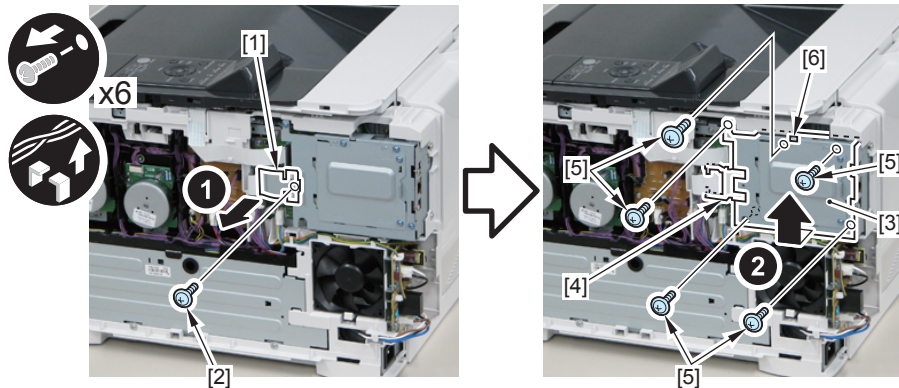

F-3-59

3) Disconnect the 2 Flat Cables [1] and the 6 connectors [2] from the Main Controller PCB.

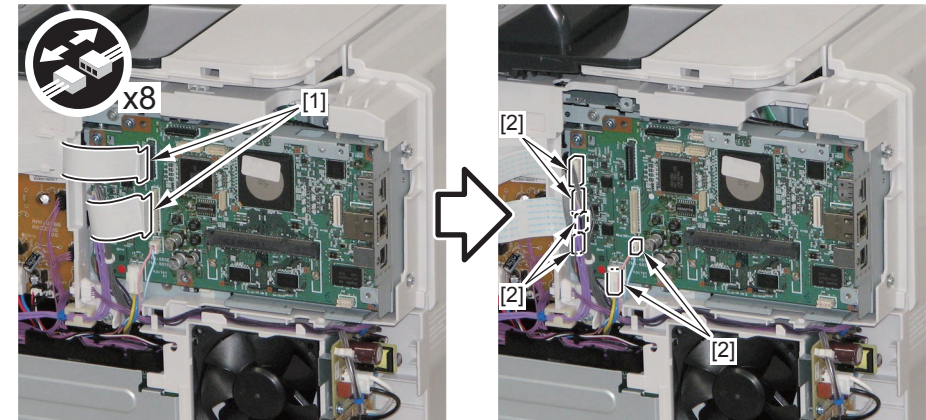

F-3-60

4) Remove the Main Controller PCB [1].

- 2 Screws (binding) [2]
- 5 Screws (TP) [3]
- 1 Hook [4]

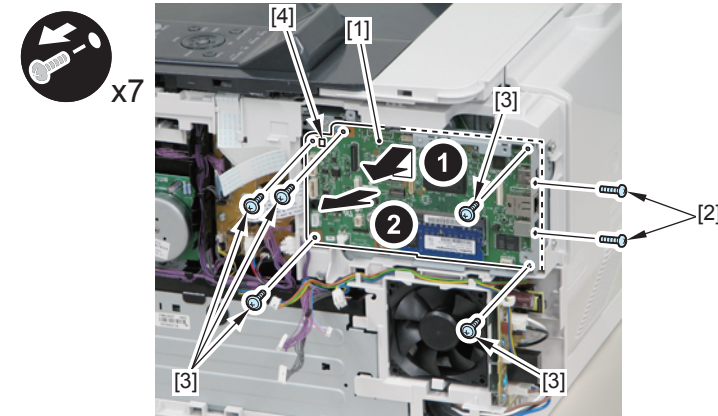

F-3-61

Removing the Main Controller PCB LBP7680Cx

When Replacing the Main Controller PCB(LBP7680Cx)

Because setting values, management data of this machine and the MEAP application, etc. are stored in the flash memory of the Main Controller PCB, they need to be backed up before replacing the Main Controller PCB. However, when the Main Controller PCB cannot operate normally because of flash memory failure or system error, the above data cannot be backed up.

Also, restoration of the backup data and reinstallation of the MEAP application is necessary after replacing the Main Controller PCB.

Setting values of this machine: User mode setting values, service mode setting values

Management data of this machine: Page counter, device serial number

1 Backup and restoration of data using Expansion ROM for servicing and Sublog Board (or Sublog Board attached with the Expansion ROM hereafter)

While setting values and management data can be backed by this method, the MEAP application cannot be backed up by the method. Therefore, reinstallation of the MEAP application is necessary after replacing the PCB and then restoring the backup data.

2 Backup and restoration of data using USB memory

Only setting values can be backed up by this method. Therefore, reinstallation of the MEAP application is necessary after replacing the PCB and then restoring the backup data.

3 When data cannot be backed up before replacement due to Main Controller PCB error

Reinstallation of the MEAP application is necessary after replacing the PCB.

1 Backup and restoration of data using Sublog Board attached with Expansion ROM and copy of data using laptop PC for servicing

1-1 Actions before replacing the PCB

1-1-1 Preparation required for reinstalling the MEAP application

For details on preparation required for reinstalling the MEAP application, refer to the Service Manual > Chapter 2 Technical Description > MEAP > Maintenance > Procedure for reinstalling MEAP applications after replacing the PCB.

1-1-2 Backing up to Sublog Board attached with the Expansion ROM

For details on backup to Sublog Board attached with the Expansion ROM, refer to the Service Manual > Chapter 5 Troubleshooting > Backup/Restoration by Expansion ROM for servicing and Sublog Board

- Turn OFF the power.
- Install the Expansion ROM for servicing to the Sublog Board.
- Install the Sublog Board attached with the Expansion ROM to the Main Controller PCB.
- Turn ON the power.
- When turning ON the power, "NVRAM export" is displayed on the Control Panel.
- Press the down arrow key.
- The data of the Main Controller PCB is backed up to the Sublog Board attached with the Expansion ROM.

1-2 Replacing the PCB

- Turn OFF the power.
- Replace the Main Controller PCB with a new one (service part).
- Install the Sublog Board attached with the Expansion ROM to the Main Controller PCB.

1-3 Restoring data after replacing the PCB

Perform the following operation to restore data backed up in the Sublog Board attached with the Expansion ROM to the Main Controller PCB.

- Turn ON the power.
- When the menu is displayed on the Control Panel upon turning ON the power, select "NVRAM import".
- Press the down arrow key.
- Data backed up in the Sublog Board attached with the Expansion ROM is restored to the Main Controller PCB.
- Turn OFF the power, and remove the Sublog Board attached with the Expansion ROM.

1-4 Reinstalling the MEAP application and importing user information

For details on preparation required for reinstalling the MEAP application and importing user information, refer to the Service Manual > Chapter 2 Technical Description > MEAP > Maintenance > Procedure for reinstalling MEAP applications after replacing the PCB.

2 Backup and restoration of data using USB memory and copy of data using laptop PC for servicing

2-1 Actions before replacing the PCB

2-1-1 Preparation required for reinstalling the MEAP application

For details on preparation required for reinstalling the MEAP application, refer to the Service Manual > Chapter 2 Technical Description > MEAP > Maintenance > Procedure for reinstalling MEAP applications after replacing the PCB.

2-1-2 Backup to USB memory

- Connect the USB memory to the host machine.
- Select Setup Menu>SERVICE MODE>FUNCTION GR.>USB-H>On.
- Back up data of the Main Controller PCB to the USB memory.

Select Setup Menu>SERVICE MODE>FUNCTION GR.>ECONF>EXPORT>ALL>Yes.

- Select Setup Menu>SERVICE MODE>FUNCTION GR.>USB-H>Off.
- Disconnect the USB memory from the host machine.

2-2 Replacing the PCB and turning ON the power

- Turn OFF the power.
- Replace the Main Controller PCB with a new one (service part).
- Turn ON the power.
- The equipment is started and can be used normally.

2-3 Restoring data after replacing the PCB

Perform the following operation to restore data backed up in the USB memory to the Main Controller PCB.

- Connect the USB memory to the host machine.
- Select Setup Menu>SERVICE MODE>FUNCTION GR.>USB-H>On.
- Restore data backed up in the USB memory to the Main Controller PCB.
Select Setup Menu>SERVICE MODE>FUNCTION GR.>ECONF>IMPORT>Yes.
- Select Setup Menu>SERVICE MODE>FUNCTION GR.>USB-H>Off.
- Disconnect the USB memory from the host machine.

NOTE

When you execute Setup Menu>SERVIVE MODE>FUNCTIONGR.>ECONF>EXPORT>ALL>Yes upon backup of data by the USB memory, information kept by NVRAM on the DC Controller PCB is also backed up. Therefore, if "ALL" is selected, the operation to back up the information kept by NVRAM of the DC Controller PCB is not necessary.

2-4 Reinstalling the MEAP application and importing user information

For details on preparation required for reinstalling the MEAP application and importing user information, refer to the Service Manual > Chapter 2 Technical Description > MEAP > Maintenance > Procedure for reinstalling MEAP applications after replacing the PCB.

● 3 When data backup from the Main Controller PCB is not possible

When the Main Controller PCB cannot operate normally, then backup of various data is not possible.

In this case, perform the following procedure to replace the PCB.

3-1 Replacing the PCB and turning ON the power

- Turn OFF the power.
- Replace the Main Controller PCB with a new one (service part).
- Turn ON the power.
- The equipment is started and can be used normally.

3-2 Backing up data kept by the NVRAM of the DC Controller PCB to the Main Controller PCB

- Perform the following operation to initialize the DC Controller NVRAM backup area of the Main Controller PCB.

Select Setup Menu>SERVICE MODE>FUNCTION GR.>CLEAR DCON.

- Turn OFF and then ON the power.
- By turning OFF and then ON the power, information kept by the DC Controller PCB NVRAM is backed up to the DC Controller NVRAM backup area in the Main Controller PCB.

3-3 Reinstalling the MEAP application

For details on reinstalling the MEAP application, refer to the Service Manual > Chapter 2 Technical Description > MEAP > Maintenance > Procedure for reinstalling MEAP applications after replacing the PCB.

Preparation

1) Remove the Right Cover.(Refer to page 3-20)

Procedure

CAUTION:

When replacing this part, execute the actions to be taken when replacing the Main Controller PCB.

- 1) Remove the Flat Cable Guide Cover Plate [1].
 - 1 Screw [2]
- 2) Remove the Main Controller Shield Plate [3] and the Flat Cable Guide [4].
 - 5 Screws [5]
 - 1 Hook [6]

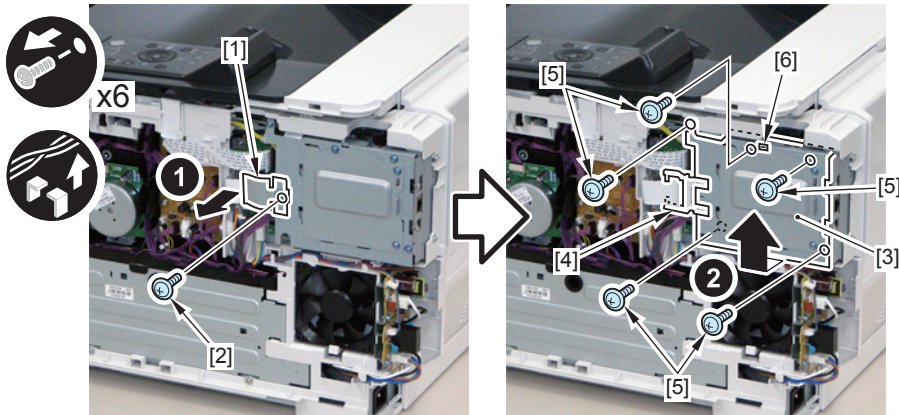

F-3-62

- 3) Disconnect the 3 Flat Cables [1] and 9 connectors [2] from the Main Controller PCB, and free the harness from the Wire Saddle [3].

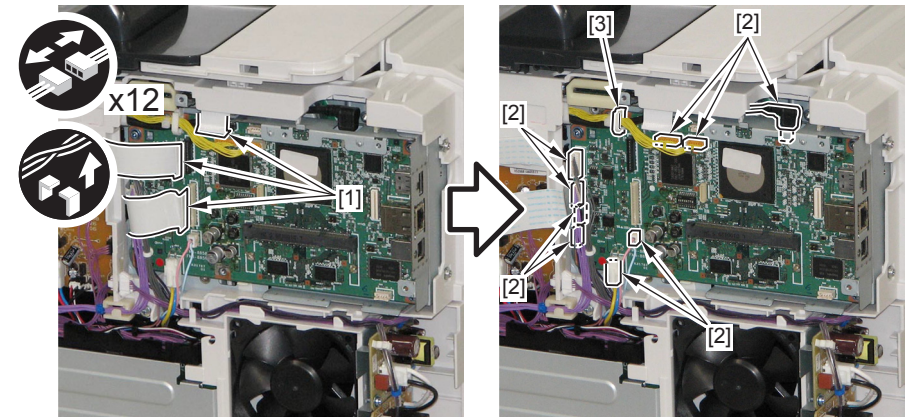

F-3-63

CAUTION:

Be sure to place the Harness Band [2] of the harness [1] on the left side of the Wire Saddle [3] at installation.

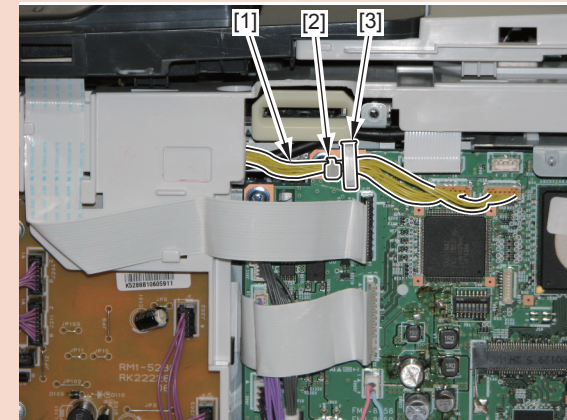

F-3-64

4) Remove the Main Controller PCB [1].

- 2 Screws (binding) [2]
- 5 Screws (TP) [3]
- 1 Hook [4]

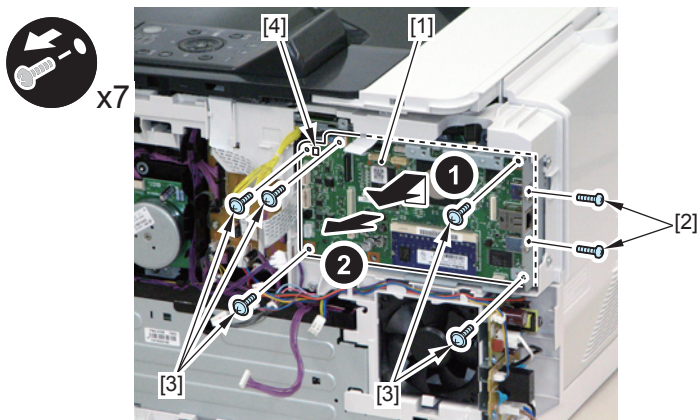

F-3-65

Removing the Main Controller PCB LBP7210Cdn

Preparation

- 1) Remove the Right Cover.(Refer to page 3-20)

The settings and management data of host machine is saved in the NVRAM (IC2S) of the main controller PCB. When replacing the main controller PCB, be sure to move the NVRAM from the old PCB and to the new PCB.

After moving the NVRAM, execute color displacement correction and calibration.

- 1) Turn on the power supply of the host machine.
- 2) Start the Status window.
- 3) Execute Option Menu > Utility > Out-of-Register Colors Correction in the status window.
- 4) Execute Option Menu > Utility > Calibration in the status window.

Caution

The information in the NVRAM on the DC controller PCB is saved in the NVRAM (IC2S) as backup data. When replacing the NVRAM, perform the same operation as replacing the main controller PCB and execute the following item; Option Menu > Service Mode > Printer Information settings > DCON data back up.

- 5) Put the MAC address label that is included with the main controller PCB (service part) onto the MAC address label on the back of the host machine.

Procedure

- 1) Disconnect the 2 Flat Cables [1] and the 6 connectors [2] from the Main Controller PCB.

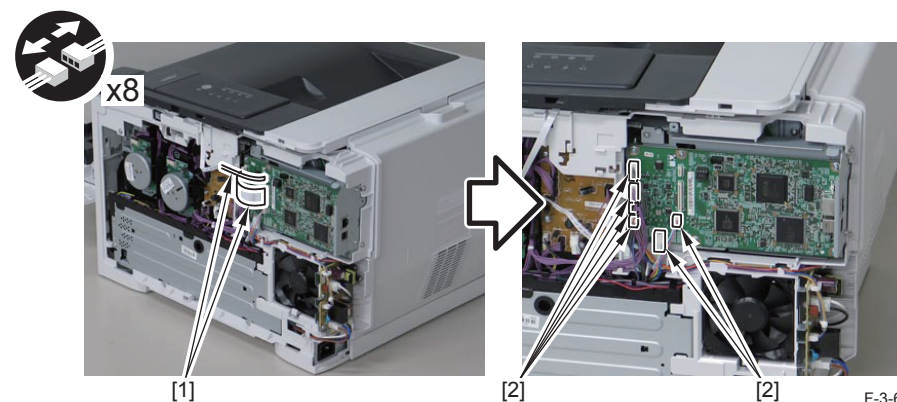

F-3-66

2) Remove the Main Controller PCB [1].

- 6 Screws (TP) [2]

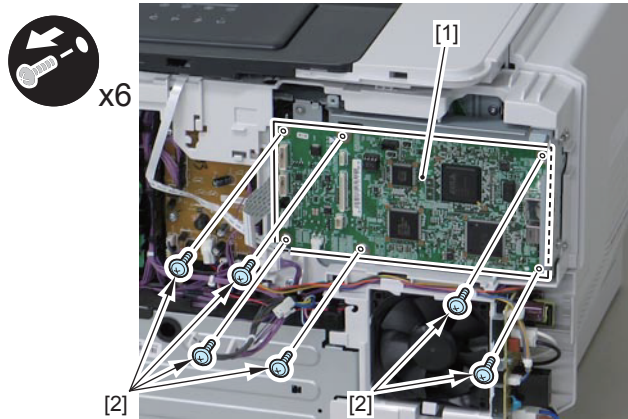

F-3-67

Removing the Right Frame Cover LBP7600C/7660Cdn/7680Cx

Preparation

- 1) Remove the Right Cover.(Refer to page 3-20)
- 2) Remove the Operation Panel Unit.(Refer to page 3-56)
- 3) Remove the Rear Upper Cover (Left).(Refer to page 3-17)
- 4) Remove the Upper Front Cover (Right) / USB Cover.(Refer to page 3-23)
- 5) Remove the Upper Cover.(Refer to page 3-24)

Procedure

- 1) Remove the Flat Cable Guide Cover Plate [1].
 - 1 Screw [2]
- 2) Remove the Flat Cable Guide [3].
 - 2 Bosses [4]

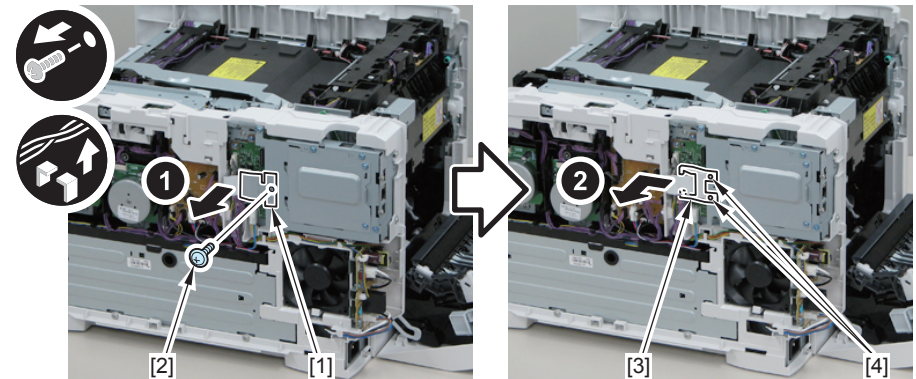

F-3-68

- 3) Disconnect the Flat Cable [1] and the 2 connectors [2] on the Relay Connector.
- 4) Disconnect the 8 connectors [3], and free the harness from the guides [A], [B], [C], and [D].

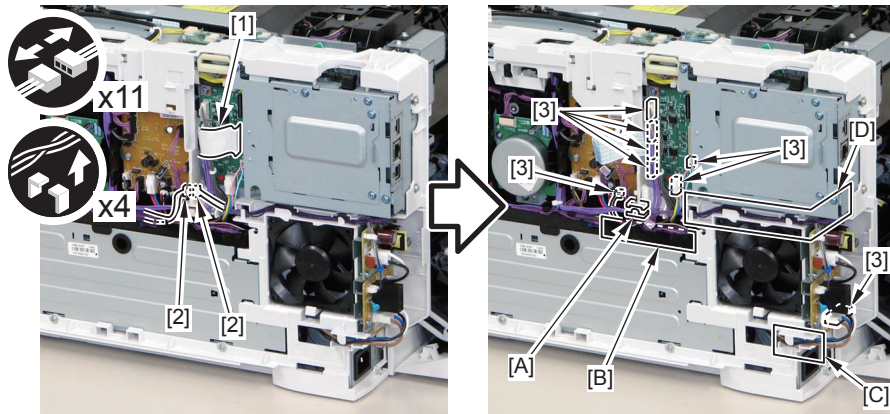

F-3-69

CAUTION: Points to Note at Installation

- Be sure to hook the harness [1] on the guide [A].
- Be sure to place the Harness Band [3] of the harness [2] on the left side of the guide [4].

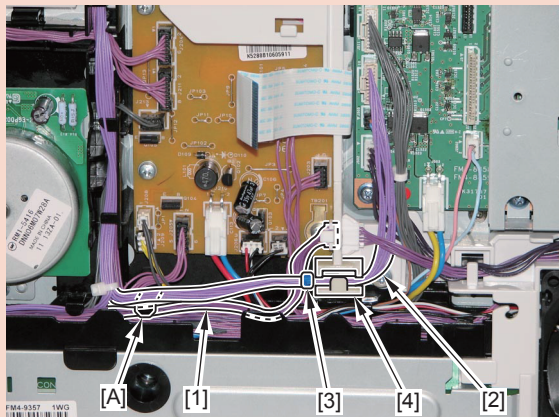

F-3-70

- 5) Remove the cassette.
- 6) Remove the screws from the Right Frame Cover [1].
 - 8 Screws (D tightening; 8mm) [2]
 - 1 Screw (TP; 3mm) [3]
 - 1 Screw (Tapping) [4]

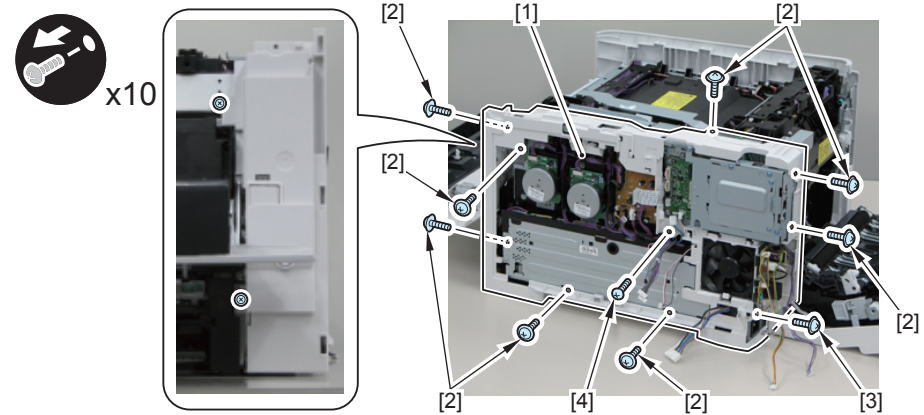

F-3-71

- 7) Put the connector [1] through the hole [A], and remove the Right Frame Cover [2].
 - 2 Claws [3]
 - 1 Rib [4]

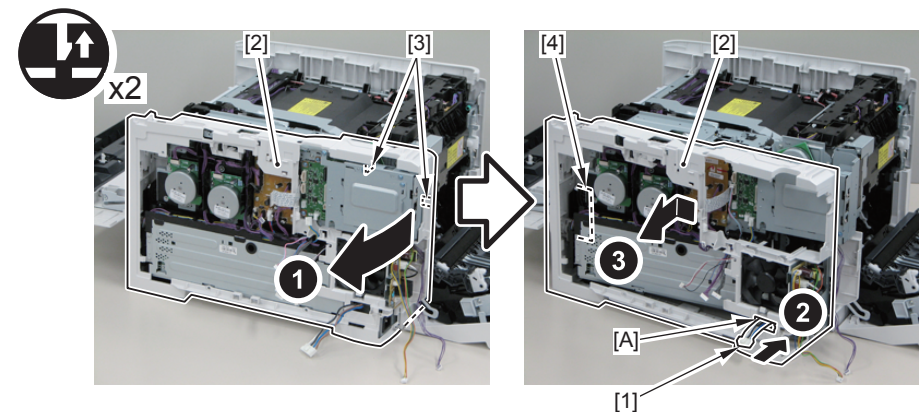

F-3-72

CAUTION:

Be sure to put the harness [1] of the fan through the guide [A] when installing.

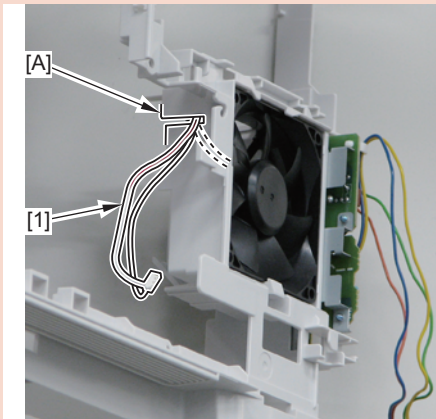

F-3-73

Removing the Right Frame Cover LBP7210Cdn

Preparation

- 1) Remove the Right Cover.(Refer to page 3-20)
- 2) Remove the Operation Panel Unit.(Refer to page 3-56)
- 3) Remove the Rear Upper Cover (Left).(Refer to page 3-17)
- 4) Remove the Upper Front Cover (Right).(Refer to page 3-23)
- 5) Remove the Upper Cover.(Refer to page 3-24)

Procedure

- 1) Disconnect the Flat Cable [1] and the 2 connectors [2] on the Relay Connector.
- 2) Disconnect the 8 connectors [3], and free the harness from the guides [A], [B], [C], and [D].

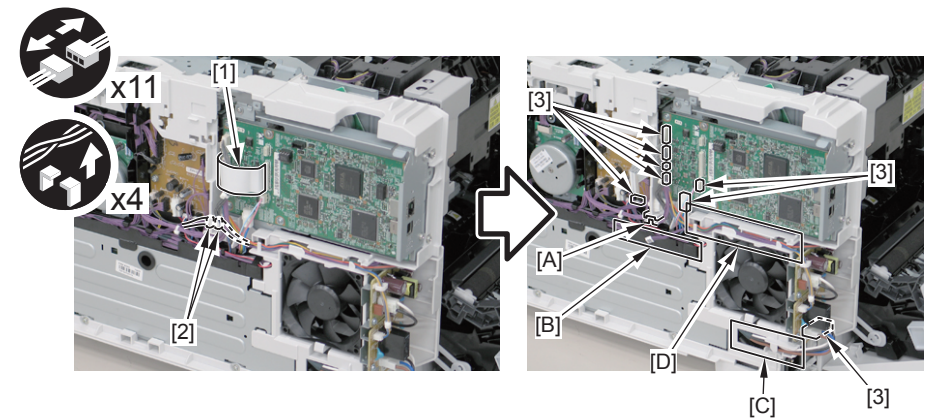

F-3-74

CAUTION: Points to Note at Installation

- Be sure to hook the harness [1] on the guide [A].
- Be sure to hook the harness [2] on the guide [3].

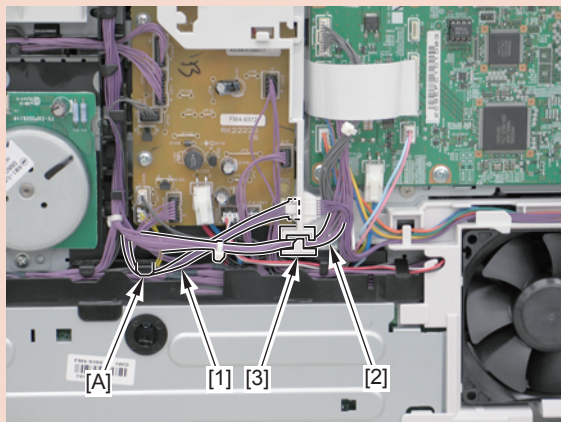

F-3-75

- 3) Remove the cassette.
- 4) Remove the screws from the Right Frame Cover [1].
 - 9 Screws (D tightening; 8mm) [2]
 - 1 Screw (Tapping) [3]

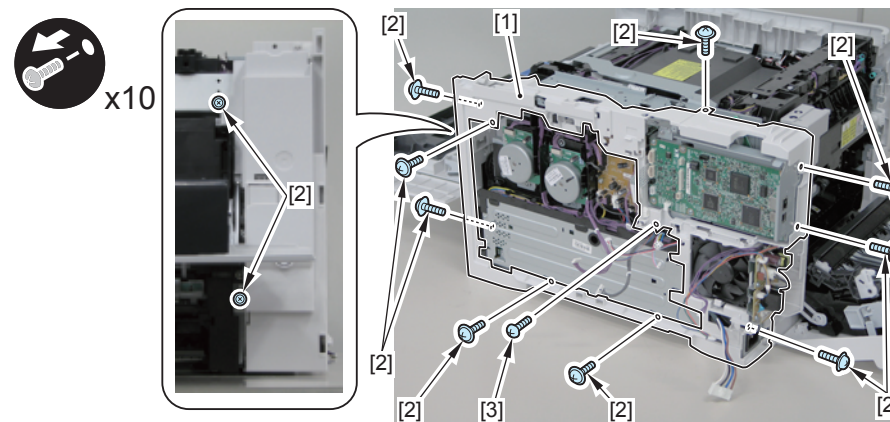

F-3-76

- 5) Put the connector [1] through the hole [A], and remove the Right Frame Cover [2].
 - 1 Claw [3]

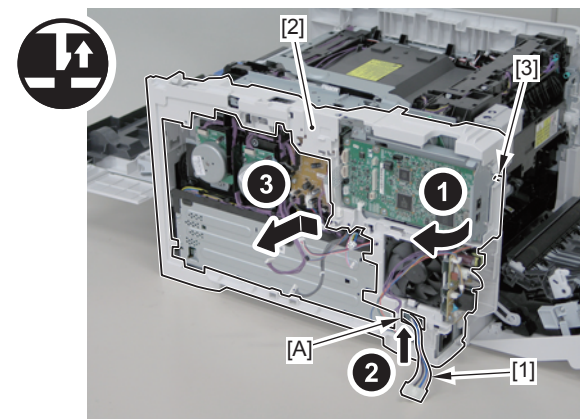

F-3-77

CAUTION:

Be sure to put the harness [1] of the fan through the guide [A] when installing.

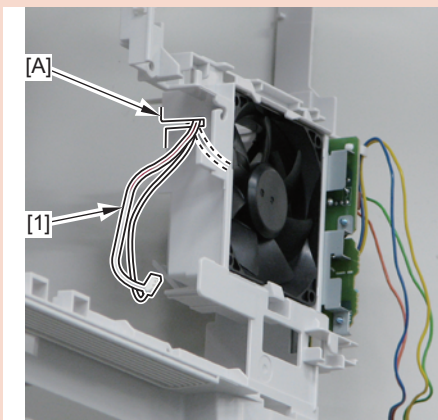

F-3-78

Removing the Right Upper Frame LBP7600C/7660Cdn

Preparation

- 1) Remove the Right Cover.(Refer to page 3-20)
- 2) Remove the Operation Panel Unit.(Refer to page 3-56)
- 3) Remove the Rear Upper Cover (Left).(Refer to page 3-17)
- 4) Remove the Upper Front Cover (Right).(Refer to page 3-23)
- 5) Remove the Upper Cover.(Refer to page 3-24)
- 6) Remove the Right Frame Cover.(Refer to page 3-38)

Procedure

- 1) Remove the Right Upper Frame [1].
 - 5 Screws [2]
 - 2 Screws (Blue) [3]
 - 1 Hook [4]

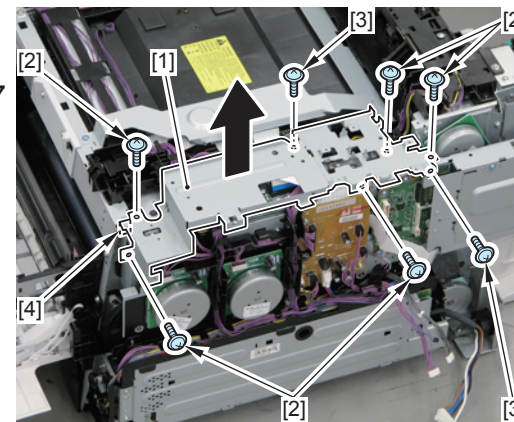

F-3-79

Removing the Right Upper Frame Unit LBP7680Cx

Preparation

- 1) Remove the Right Cover.(Refer to page 3-20)
- 2) Remove the Operation Panel Unit.(Refer to page 3-56)
- 3) Remove the Rear Upper Cover (Left).(Refer to page 3-17)
- 4) Remove the Upper Front Cover (Right).(Refer to page 3-23)
- 5) Remove the Upper Cover.(Refer to page 3-24)
- 6) Remove the Right Frame Cover.(Refer to page 3-38)

Procedure

- 1) Remove the Main Controller Shield Plate [1].
 - 5 Screws [2]
 - 1 Hook [3]

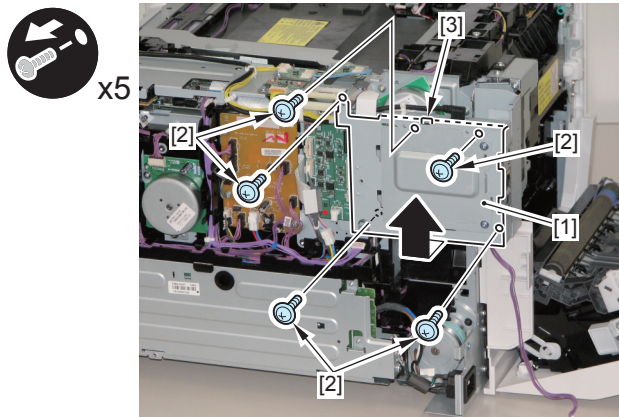

F-3-80

- 2) Remove the following parts.

- 1 Flat Cable [1]
- 3 Connectors [2]
- 3 Wire Saddles [3]

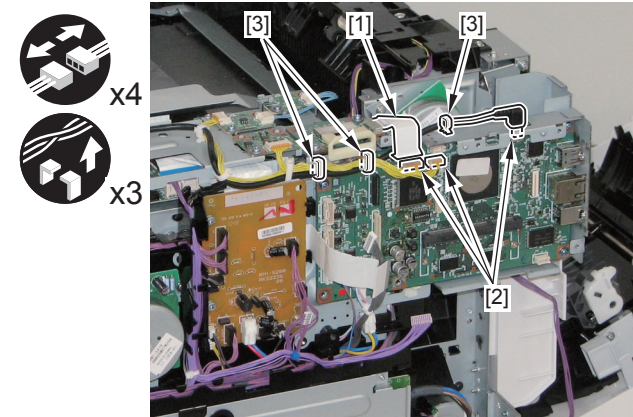

F-3-81

CAUTION: Points to Note at Installation

- Be sure to place the Harness Band [2] of the harness [1] on the left side of the guide [3].
- Be sure to place the Harness Band [4] of the harness [1] on the left side of the guide [5].

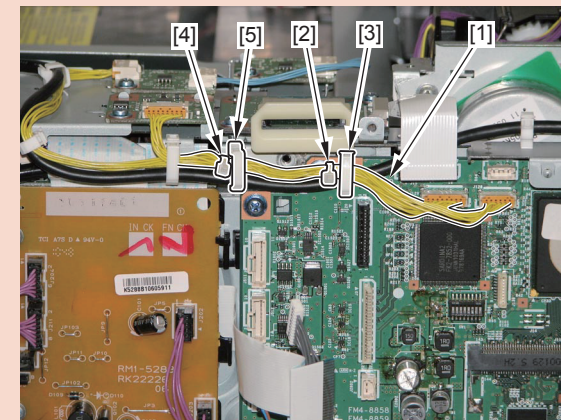

F-3-82

3) Remove the Right Upper Frame Unit [1].

- 5 Screws [2]
- 1 Screw (Blue) [3]
- 1 Hook [4]



x6

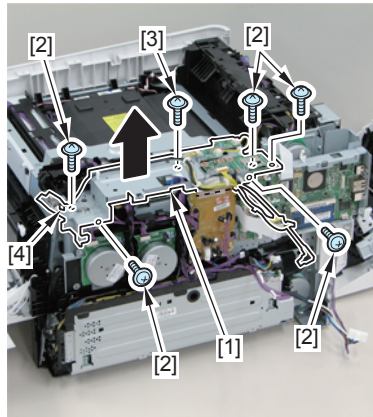

F-3-83

NOTE:

When removing the Right Upper Frame Unit at disassembly of other units, the SD Guide needs not be removed.

4) Remove the SD Guide [2] from the Right Upper Frame Unit [1].

- 1 Boss [3]

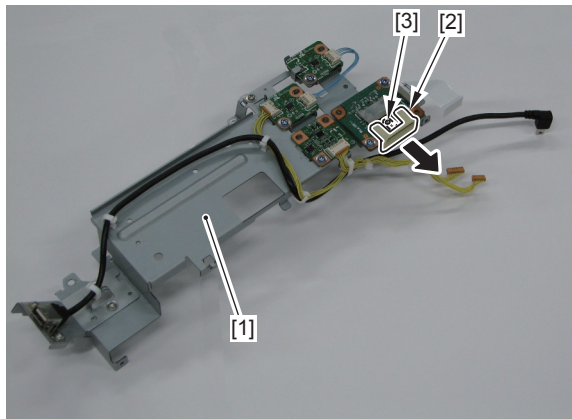

F-3-84

Removing the Right Upper Frame LBP7210Cdn

Preparation

- 1) Remove the Right Cover.(Refer to page 3-20)
- 2) Remove the Operation Panel Unit.(Refer to page 3-56)
- 3) Remove the Rear Upper Cover (Left).(Refer to page 3-17)
- 4) Remove the Upper Front Cover (Right).(Refer to page 3-23)
- 5) Remove the Upper Cover.(Refer to page 3-24)
- 6) Remove the Right Frame Cover.(Refer to page 3-38)

Procedure

- 1) Remove the Right Upper Frame [1].
 - 4 Screws [2]



x4

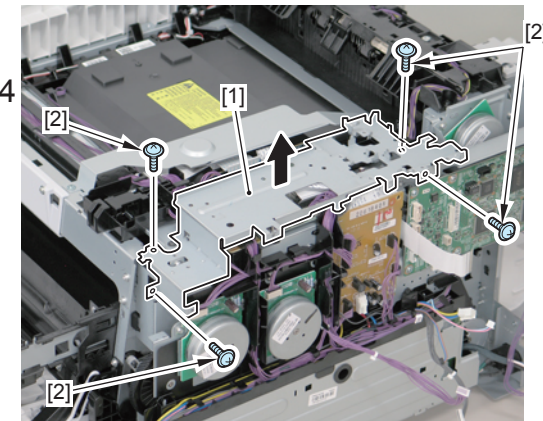

F-3-85

Removing the Main Controller Support Plate LBP7600C/7660Cdn/7680Cx

Preparation

- 1) Remove the Right Cover.(Refer to page 3-20)
- 2) Remove the Operation Panel Unit.(Refer to page 3-56)
- 3) Remove the Rear Upper Cover (Left).(Refer to page 3-17)
- 4) Remove the Upper Front Cover (Right).(Refer to page 3-23)
- 5) Remove the Upper Cover.(Refer to page 3-24)
- 6) Remove the Right Frame Cover.(Refer to page 3-38)
- 7) Remove the Right Upper Frame Unit.(Refer to page 3-43)

Procedure

- 1) Remove the Main Controller PCB [1].
 - 2 Screws (binding) [2]
 - 5 Screws (TP) [3]
 - 1 Hook [4]

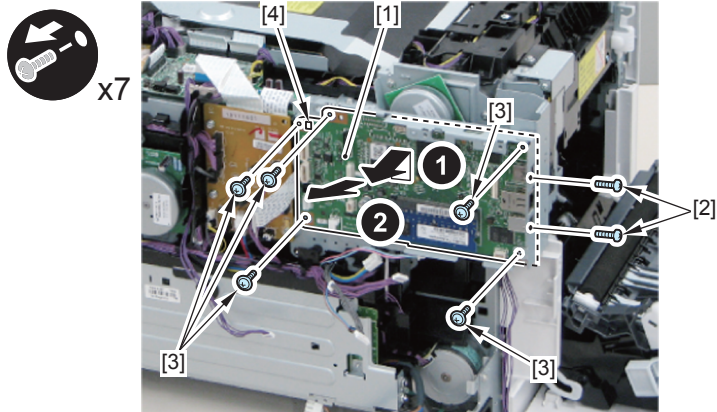

F-3-86

- 2) Remove the Main Controller Support Plate [1].
 - 6 Screws (Special Flat-head) [2]
 - 1 Screw [3]

CAUTION:

Since the Special Flat-head screws [2] adjust the interval between the Main Controller Support Plate [1] and parts in the vicinity, be sure to install the Special Flat-head Screws [2] in the location they were in before removal.

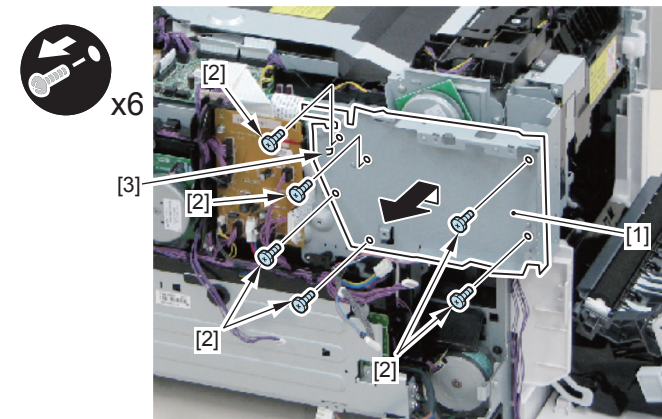

F-3-87

Removing the Main Controller Support Plate LBP7210Cdn

Preparation

- 1) Remove the Right Cover.(Refer to page 3-20)
- 2) Remove the Operation Panel Unit.(Refer to page 3-56)
- 3) Remove the Rear Upper Cover (Left).(Refer to page 3-17)
- 4) Remove the Upper Front Cover (Right).(Refer to page 3-23)
- 5) Remove the Upper Cover.(Refer to page 3-24)
- 6) Remove the Right Frame Cover.(Refer to page 3-38)
- 7) Remove the Right Upper Frame Unit.(Refer to page 3-43)

Procedure

- 1) Remove the Main Controller PCB [1].
 - 6 Screws (TP) [2]
 - 1 Hook [3]



x6

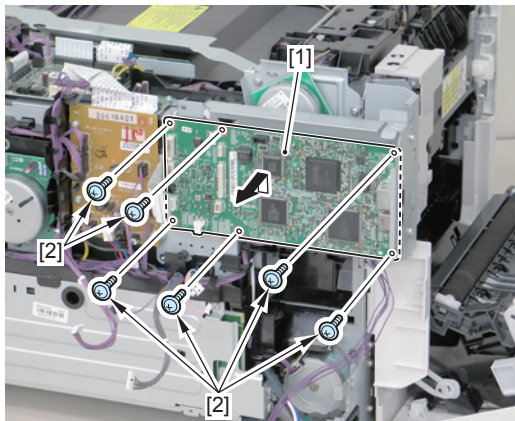

F-3-88

- 2) Remove the Main Controller Support Plate [1].

- 5 Screws (Special Flat-head) [2]
- 1 Screw [3]

CAUTION:

Since the Special Flat-head screws [2] adjust the interval between the Main Controller Support Plate [1] and parts in the vicinity, be sure to install the Special Flat-head Screws [2] in the location they were in before removal.



x5

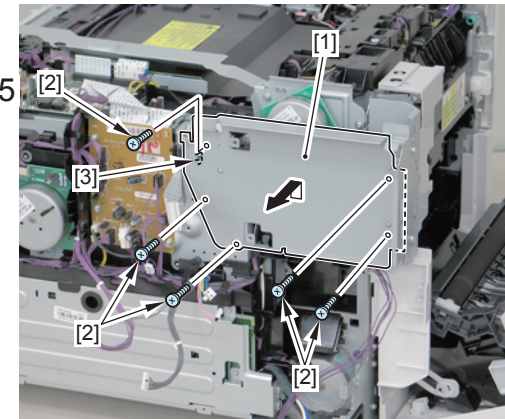

F-3-89

Removing the Main Drive Unit LBP7600C/7660Cdn/7680Cx

Preparation

- 1) Remove the Right Cover.(Refer to page 3-20)
- 2) Remove the Operation Panel Unit.(Refer to page 3-56)
- 3) Remove the Rear Upper Cover (Left).(Refer to page 3-17)
- 4) Remove the Upper Front Cover (Right).(Refer to page 3-23)
- 5) Remove the Upper Cover.(Refer to page 3-24)
- 6) Remove the Right Frame Cover.(Refer to page 3-38)
- 7) Remove the Right Upper Frame Unit.(Refer to page 3-43)
- 8) Remove the Main Controller Support Plate.(Refer to page 3-45)
- 9) Remove the Drum Motor.(Refer to page 3-98)
- 10) Remove the Developing Motor.(Refer to page 3-101)
- 11) Remove the DC Controller PCB.(Refer to page 3-59)
- 12) Remove the Driver PCB.(Refer to page 3-64)
- 13) Remove the Relay PCB.(Refer to page 3-61)
- 14) Remove the Fixing Motor.(Refer to page 3-125)
- 15) Remove the Power Supply Unit.(Refer to page 3-65)

Procedure

- 1) Remove the plate [1].
 - 1 Special Flat-head Screw [2]
 - 2 Black Screws [3]
 - 3 Screws [4]
 - 2 Bosses [5]
 - 1 Protrusion [6]

CAUTION:

Since the Special Flat-head Screw [2] adjusts the interval between the plate [1] and parts in the vicinity, be sure to install the Special Flat-head Screw [2] in the location it was in before removal.

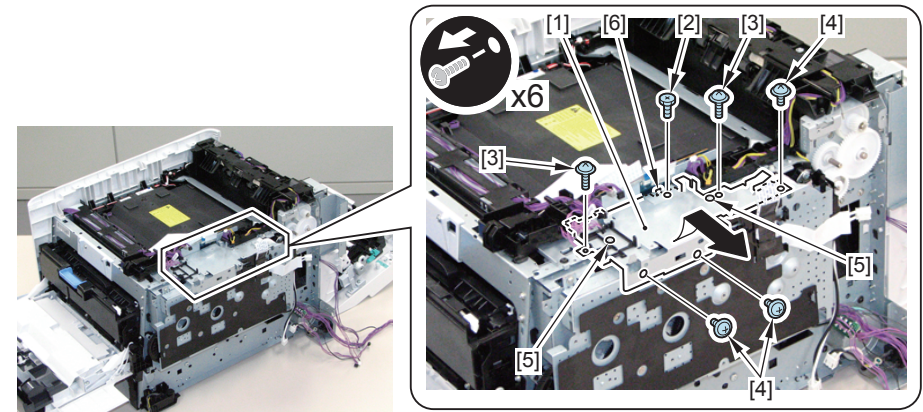

F-3-90

2) Remove the Harness Guide [1] and the Flat Cable [2].

- 3 Claws [3]

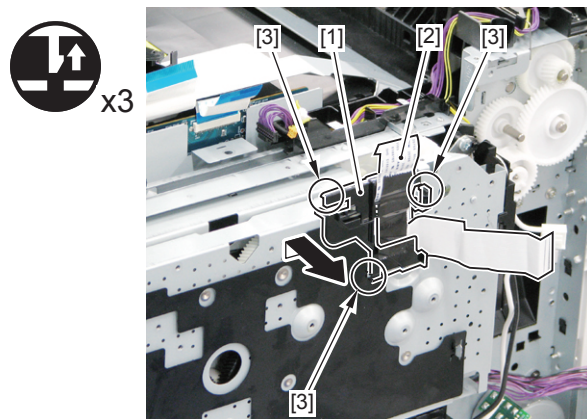

F-3-91

4) Remove the harness [1] and guide [2].

- 1 Claw [3]

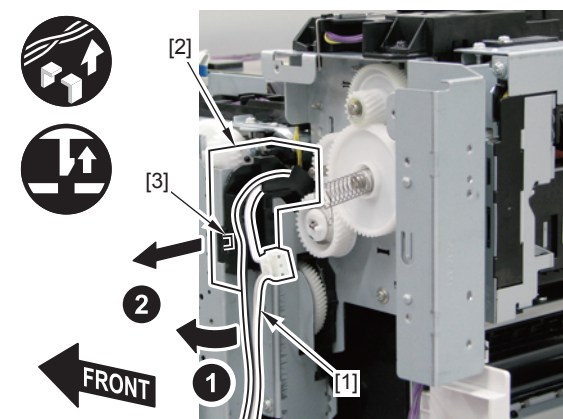

F-3-93

3) Remove the sheet [1].

- 3 Hooks [2]

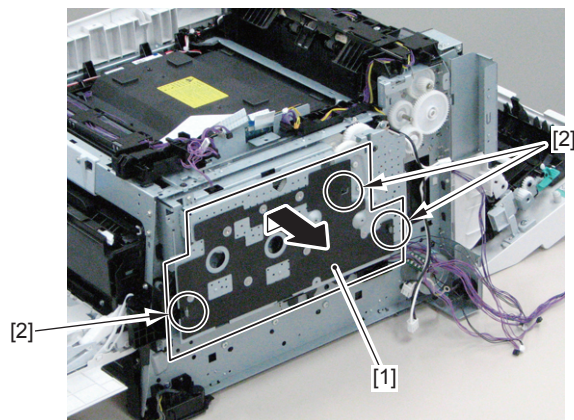

F-3-92

CAUTION:

When removing the Main Drive Unit, the Contact Spring [1] may come off so be sure not to lose it. When it comes off, attach it on the protrusion [A] on the plate at the right side of the host machine.

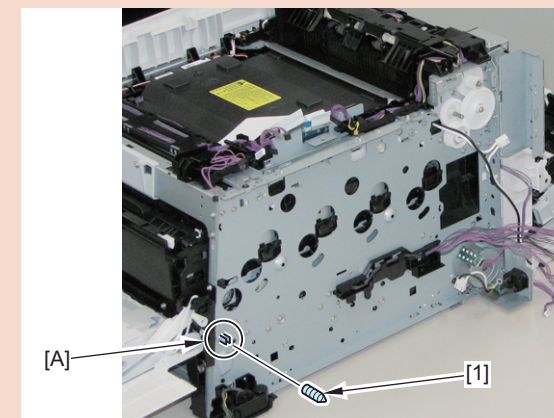

F-3-94

- 5) Free the harness [1] from the Harness Guide [A].
 - 6) Remove the Main Drive Unit [2].
- 1 Connector [3]
 - 6 Screws [4]
 - 1 Protrusion [5]

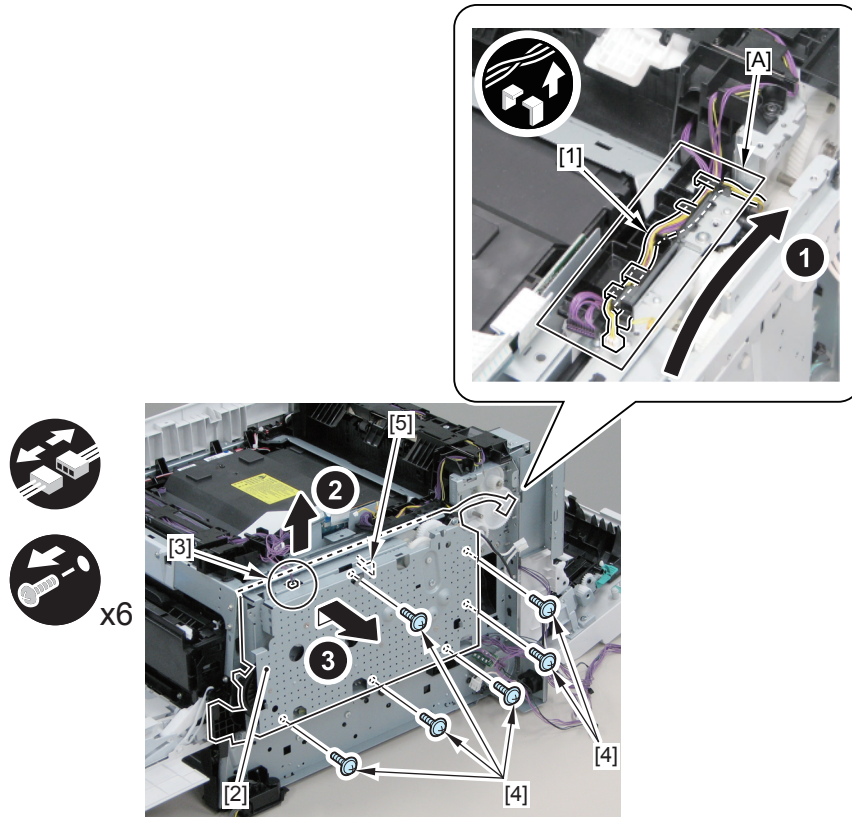

F-3-95

CAUTION: Installing the Main Drive Unit

1. Before installing it, make sure that following 1) to 4) statuses are met.

[Main Drive Unit side]

- 1) 4 Arm Shafts [1] are on the right side.
- 2) 1 Front Door Arm [2] is pulled out.
(If they are not in above positions, the protrusion of cartridge's joint remains protruded and Cartridge Tray cannot be stored.)

- 3) 1 Link [3] is on the right side.

[Host machine side]

- 4) The Front Cover must be open.

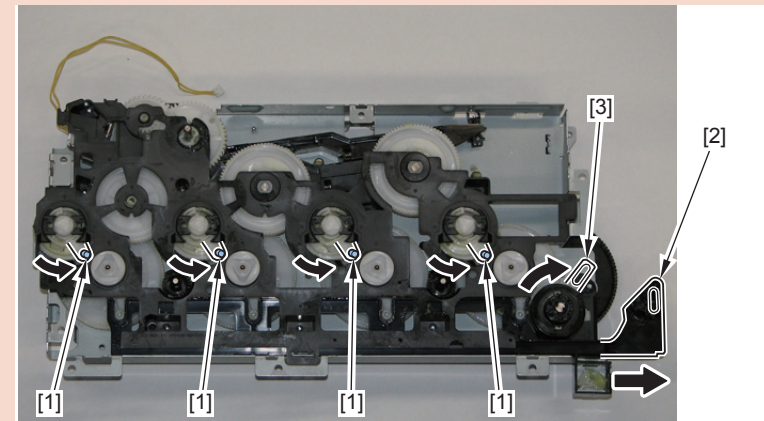

F-3-96

2. Be sure to keep the following in mind when installing.

- Fit the gear shaft [1] of the Main Drive Unit in the hole [2] of the host machine.
- Fit the hole [3] on the link with the shaft [4] on the host machine.
- Fit the hole [5] on the Front Door Arm with the shaft [6] on the host machine.

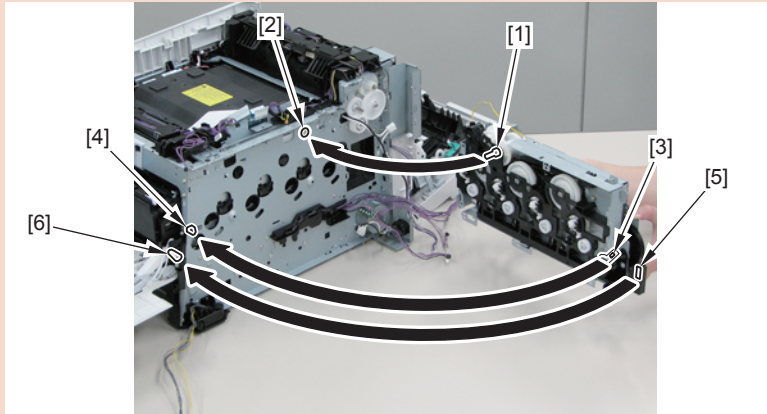

F-3-97

Removing the Main Drive Unit LBP7210Cdn

Preparation

- 1) Remove the Right Cover.(Refer to page 3-20)
- 2) Remove the Operation Panel Unit.(Refer to page 3-56)
- 3) Remove the Rear Upper Cover (Left).(Refer to page 3-17)
- 4) Remove the Upper Front Cover (Right).(Refer to page 3-23)
- 5) Remove the Upper Cover.(Refer to page 3-24)
- 6) Remove the Right Frame Cover.(Refer to page 3-38)
- 7) Remove the Right Upper Frame Unit.(Refer to page 3-43)
- 8) Remove the Main Controller Support Plate.(Refer to page 3-45)
- 9) Remove the Drum Motor.(Refer to page 3-98)
- 10) Remove the Developing Motor.(Refer to page 3-101)
- 11) Remove the DC Controller PCB.(Refer to page 3-59)
- 12) Remove the Driver PCB.(Refer to page 3-64)
- 13) Remove the Relay PCB.(Refer to page 3-61)
- 14) Remove the Fixing Motor.(Refer to page 3-125)
- 15) Remove the Power Supply Unit.(Refer to page 3-65)

Procedure

- 1) Remove the plate [1].
 - 1 Special Flat-head Screw [2]
 - 2 Black Screws [3]
 - 3 Screws [4]
 - 2 Bosses [5]
 - 1 Protrusion [6]

CAUTION:

Since the Special Flat-head Screw [2] adjusts the interval between the plate [1] and parts in the vicinity, be sure to install the Special Flat-head Screw [2] in the location it was in before removal.

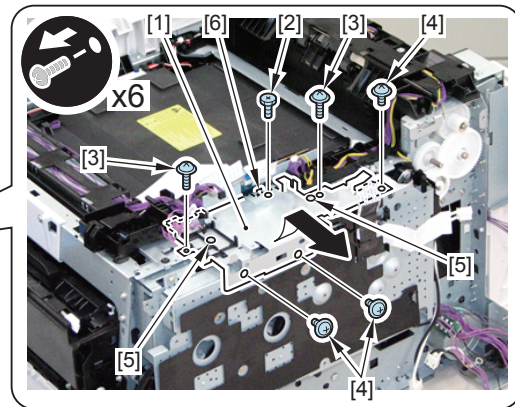
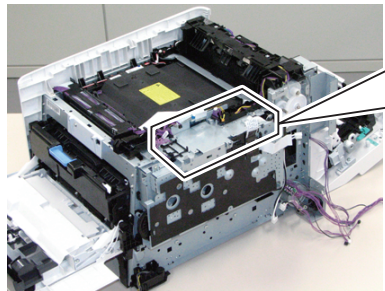

F-3-98

- 2) Remove the Harness Guide [1] and the Flat Cable [2].
 - 3 Claws [3]

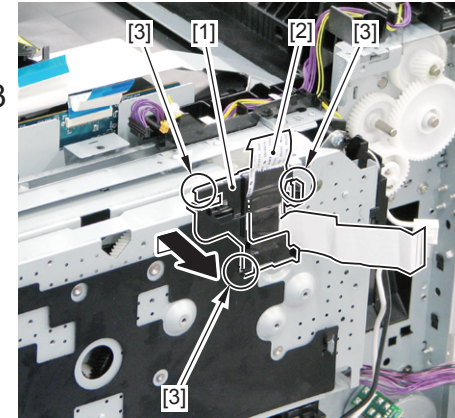

F-3-99

- 3) Remove the sheet [1].
 - 3 Hooks [2]

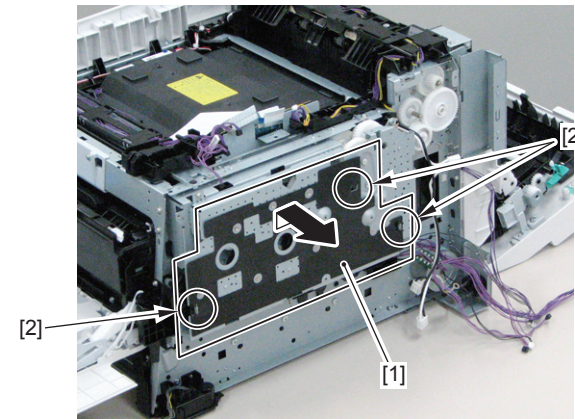

F-3-100

4) Remove the harness [1] and guide [2].

- 1 Claw [3]

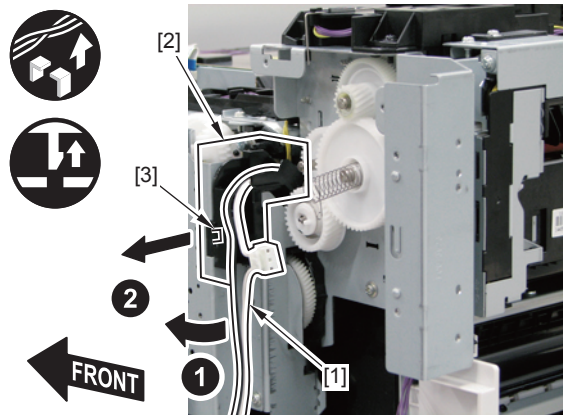

F-3-101

CAUTION:

When removing the Main Drive Unit, the Contact Spring [1] may come off so be sure not to lose it. When it comes off, attach it on the protrusion [A] on the plate at the right side of the host machine.

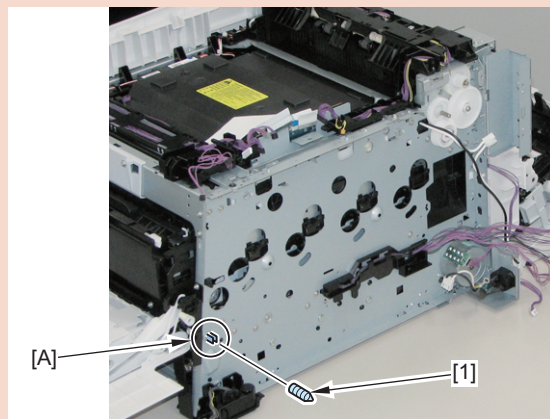

F-3-102

5) Free the harness [1] from the Harness Guide [A].

6) Remove the Main Drive Unit [2].

- 1 Connector [3]
- 7 Screws [4]
- 1 Protrusion [5]

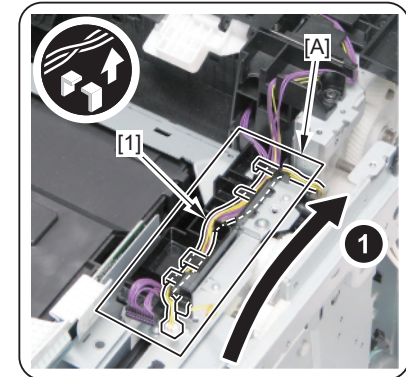

x7

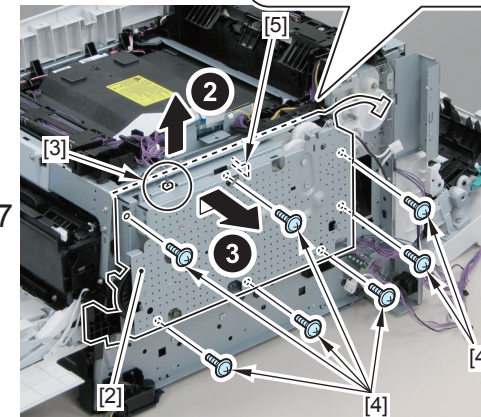

F-3-103

CAUTION: Installing the Main Drive Unit

1. Before installing it, make sure that following 1) to 4) statuses are met.

[Main Drive Unit side]

1) 4 Arm Shafts [1] are on the right side.

2) 1 Front Door Arm [2] is pulled out.

(If they are not in above positions, the protrusion of cartridge's joint remains protruded and Cartridge Tray cannot be stored.)

3) 1 Link [3] is on the right side.

[Host machine side]

4) The Front Cover must be open.

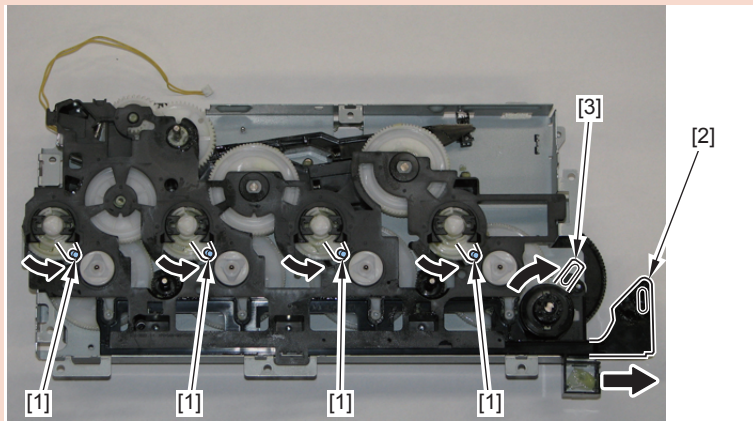

F-3-104

2. Be sure to keep the following in mind when installing.

- Fit the gear shaft [1] of the Main Drive Unit in the hole [2] of the host machine.
- Fit the hole [3] on the link with the shaft [4] on the host machine.
- Fit the hole [5] on the Front Door Arm with the shaft [6] on the host machine.

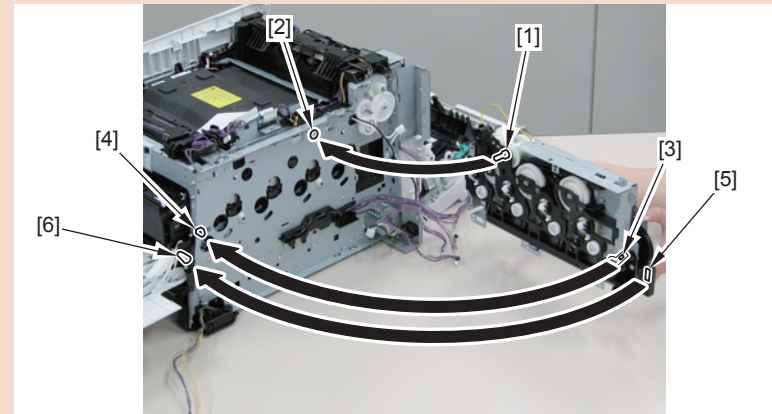

F-3-105

Removing the Duplex Reverse Drive Unit LBP7600C/7660Cdn/7680Cx

Preparation

- 1) Remove the Right Cover.(Refer to page 3-20)
- 2) Remove the Rear Upper Cover (Left).(Refer to page 3-17)
- 3) Remove the Rear Cover.(Refer to page 3-15)
- 4) Remove the Rear Lower Cover.(Refer to page 3-17)
- 5) Remove the Rear Cover Rib Unit.(Refer to page 3-16)

Procedure

- 1) Free the harness [1] from the Harness Guide [A].
 - 2 Connectors [2]

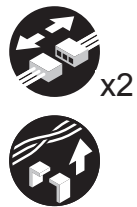

x2

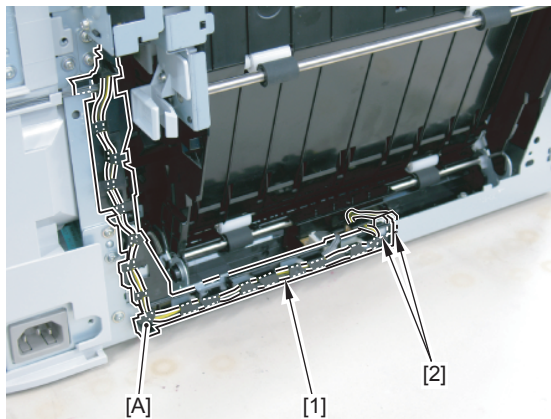

F-3-106

CAUTION:

Be sure to insert the 2 harnesses [1] at the bottom of the Guide [A] when installing.

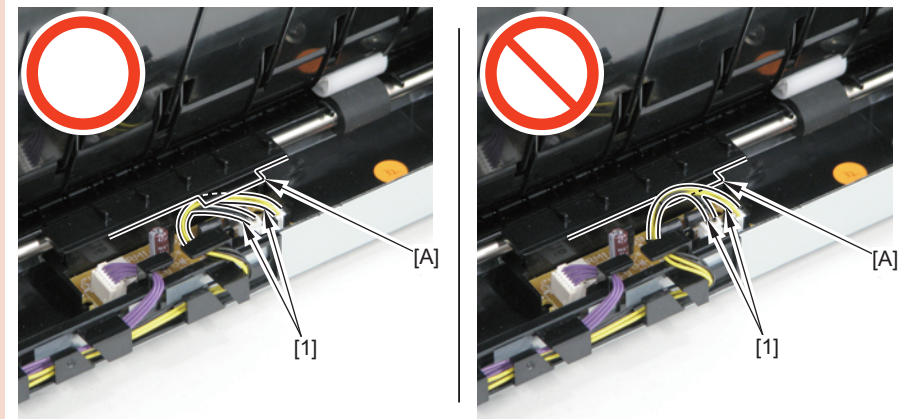

F-3-107

- 2) Open the Duplex Feed Unit [1], and remove the Duplex Reverse Drive Unit [2].
 - 3 Screws [3]



x3

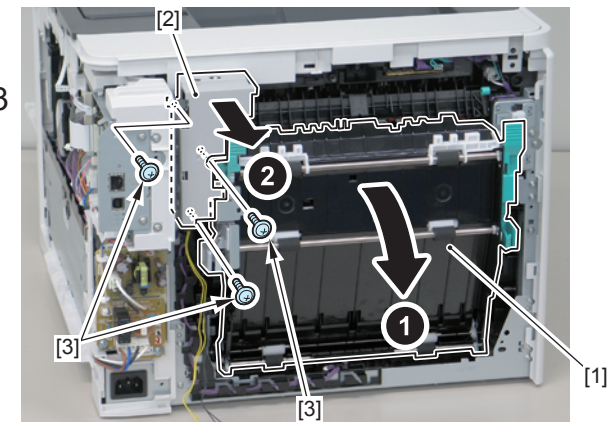

F-3-108

Removing the Duplex Reverse Drive Unit LBP7210Cdn

Preparation

- 1) Remove the Right Cover.(Refer to page 3-20)
- 2) Remove the Rear Upper Cover (Left).(Refer to page 3-17)
- 3) Remove the Rear Cover.(Refer to page 3-15)
- 4) Remove the Rear Lower Cover.(Refer to page 3-17)
- 5) Remove the Rear Cover Rib Unit.(Refer to page 3-16)

Procedure

- 1) Free the harness [1] from the Harness Guide [A].
 - 2 Connectors [2]

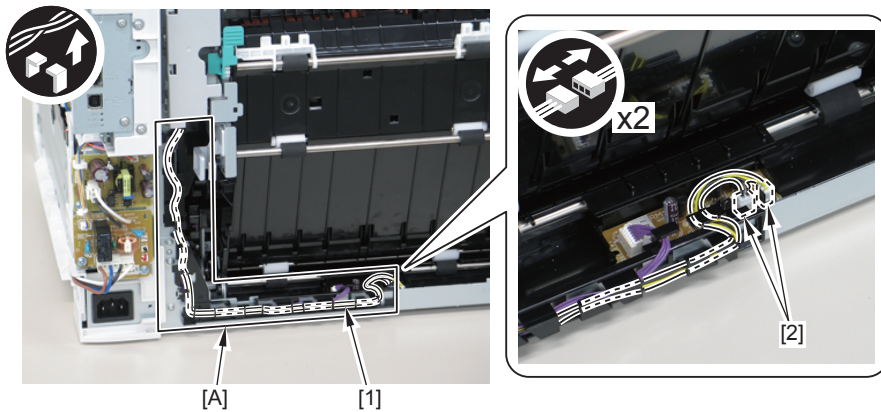

F-3-109

CAUTION:

Be sure to insert the 2 harnesses [1] at the bottom of the Guide [A] when installing.

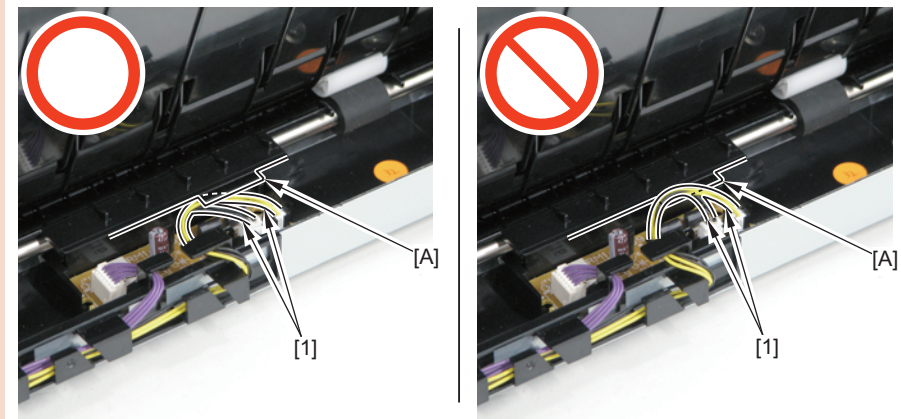

F-3-110

- 2) Open the Duplex Feed Unit [1], and remove the Duplex Reverse Drive Unit [2].
 - 3 Screws [3]

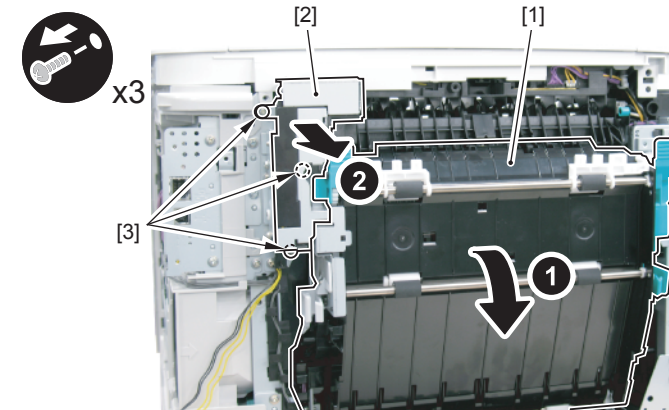

F-3-111

Removing the Operation Panel Unit LBP7600C/7660Cdn/7680Cx

Preparation

1) Remove the Right Cover.(Refer to page 3-20)

Procedure

1) Remove the Control Panel Sub Cover [1].

- 2 Claws [2]
- 1 Hook [3]

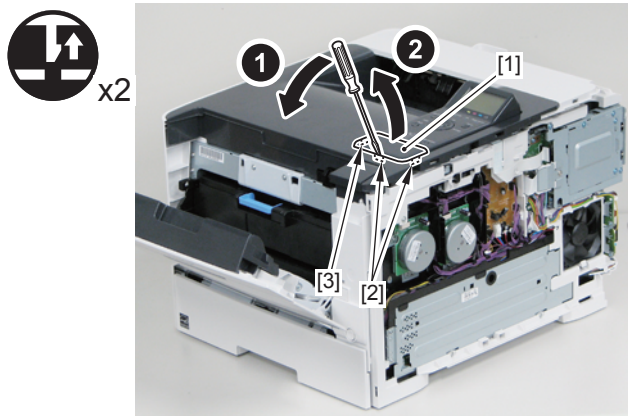

F-3-112

2) Disconnect the Flat Cable [1] from the Harness Guide [A].

- 1 Connector [2]

3) Put the Flat Cable [1] through the hole [B] of the Upper Cover, and remove the Control Panel Unit [3].

- 1 Screw [4]
- 2 Claws [5]
- 2 Hooks [6]

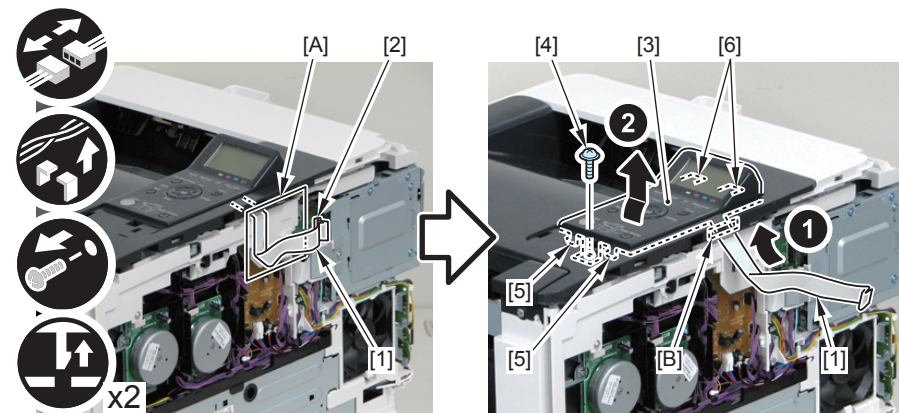

F-3-113

CAUTION:

Be sure to put the Flat Cable [1] first through the hole [B] when installing.

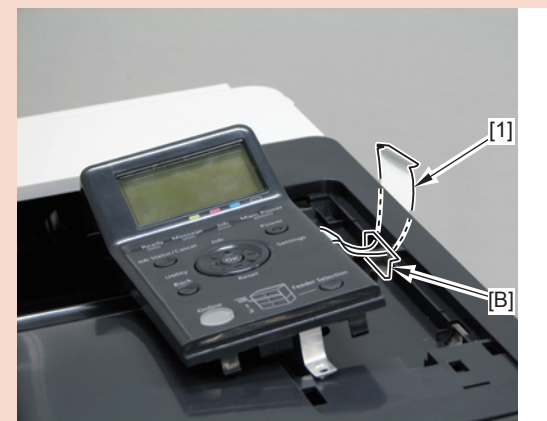

F-3-114

Removing the Operation Panel Unit LBP7210Cdn

Preparation

1) Remove the Right Cover.(Refer to page 3-20)

Procedure

1) Remove the Control Panel Sub Cover [1].

- 2 Claws [2]
- 1 Hook [3]



x2

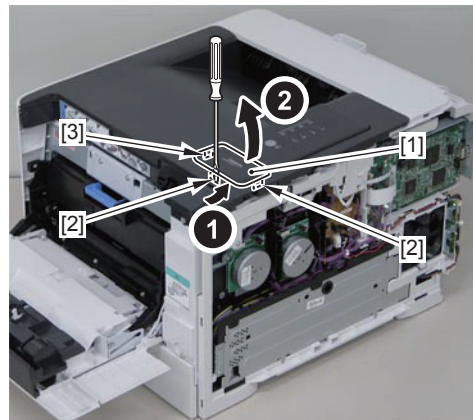

F-3-115

2) Disconnect the Flat Cable [1] from the Harness Guide [A].

- 1 Connector [2]

3) Put the Flat Cable [1] through the hole [B] of the Upper Cover, and remove the Control Panel Unit [3].

- 2 Claws [4]
- 2 Hooks [5]



x2

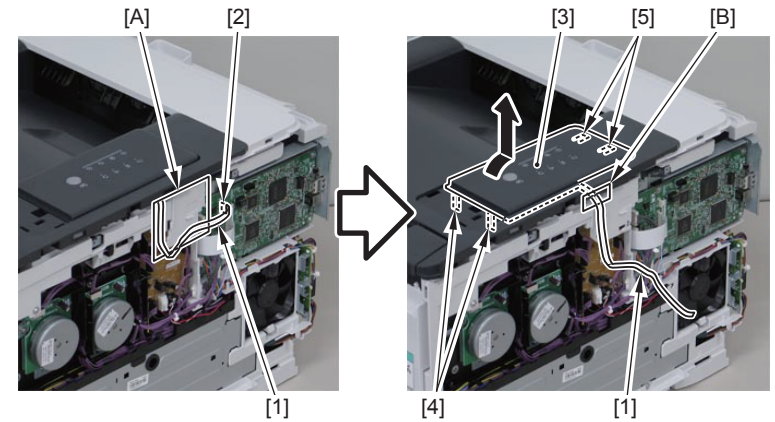

CAUTION:

Be sure to put the Flat Cable [1] first through the hole [B] when installing.

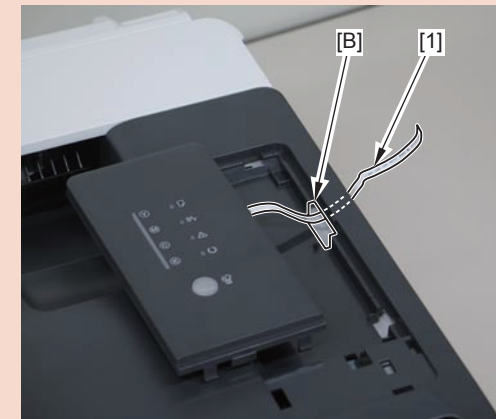

F-3-117

Removing the SD Slot PCB LBP7680Cx

Preparation

- 1) Remove the Right Cover.(Refer to page 3-20)
- 2) Remove the Operation Panel Unit.(Refer to page 3-56)
- 3) Remove the Rear Upper Cover (Left).(Refer to page 3-17)
- 4) Remove the Upper Front Cover (Right) / USB Cover.(Refer to page 3-23)
- 5) Remove the Upper Cover.(Refer to page 3-24)

Procedure

- 1) Remove the Flat Cable Guide Cover Plate [1].
 - 1 Screw [2]
- 2) Remove the Main Controller Shield Plate [3] and the Flat Cable Guide [4].
 - 5 Screws [5]
 - 1 Hook [6]

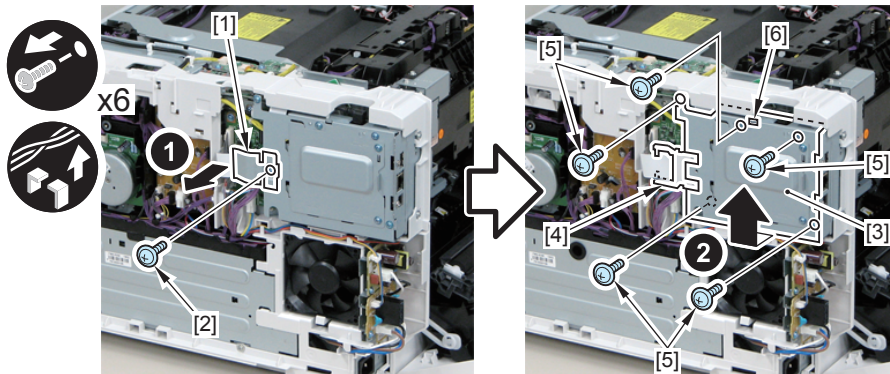

F-3-118

- 3) Remove the SD Guide [1].

- 1 Boss [2]

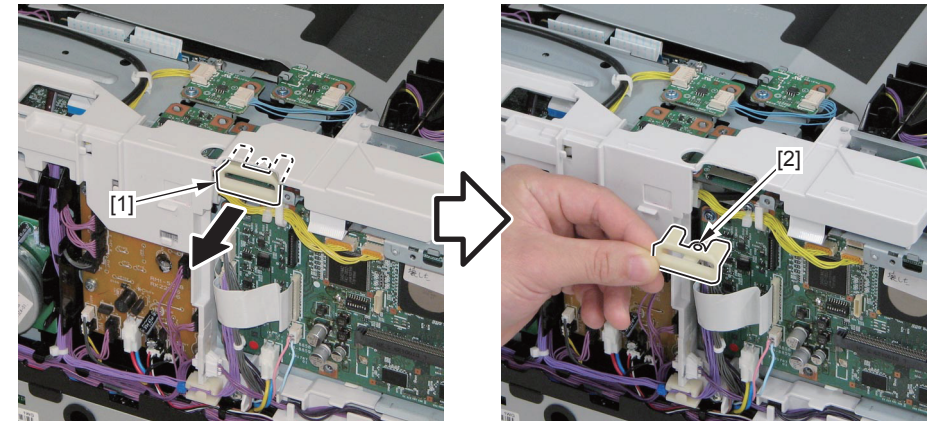

F-3-119

- 4) Remove the SD Slot PCB [1].

- 1 Connector [2]
- 2 Screws [3]
- 1 Protrusion [4]

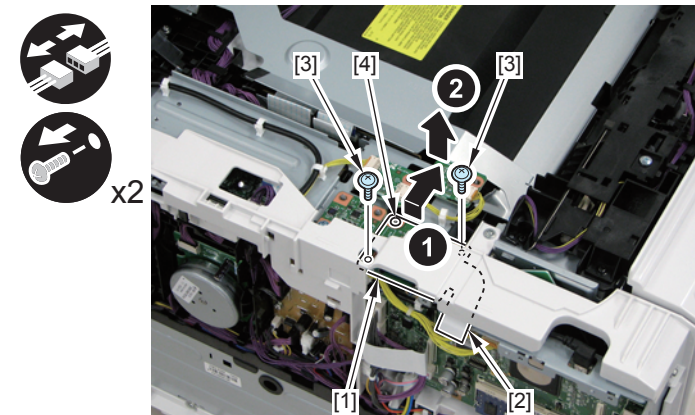

F-3-120

- 5) Pass the Flat Cable [1] through the clearance [A] of the Right Frame Cover, and disconnect the connector [2] of the Flat Cable from the SD Slot PCB [3].

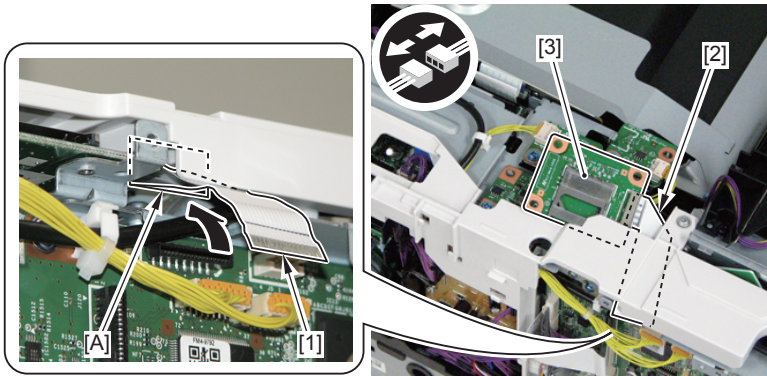

F-3-121

Removing the DC Controller PCB LBP7600C/7660Cdn/7680Cx

Preparation

- 1) Remove the Right Cover.(Refer to page 3-20)
- 2) Remove the Operation Panel Unit.(Refer to page 3-56)
- 3) Remove the Rear Upper Cover (Left).(Refer to page 3-17)
- 4) Remove the Upper Front Cover (Right) / USB Cover.(Refer to page 3-23)
- 5) Remove the Upper Cover.(Refer to page 3-24)
- 6) Remove the Right Frame Cover.(Refer to page 3-38)
- 7) Remove the Right Upper Frame Unit.(Refer to page 3-43)

NVRAM information on the DC Controller PCB is stored in the NVRAM on the Main Controller PCB as a backup.

The data that has been backed up can be restored to the NVRAM on the DC Controller PCB in the service mode.

- 1) Execute the following: service mode > FUNCTION GR.>RESTORE DCON.
- 2) Turn OFF and then ON the power of the host machine.

Procedure

CAUTION:

When replacing this part, execute the actions to be taken when replacing the DC Controller PCB.

1) Remove the DC Controller PCB [1].

- 5 Flat Cables [2]
- 8 Connectors [3]
- 4 Screws [4]

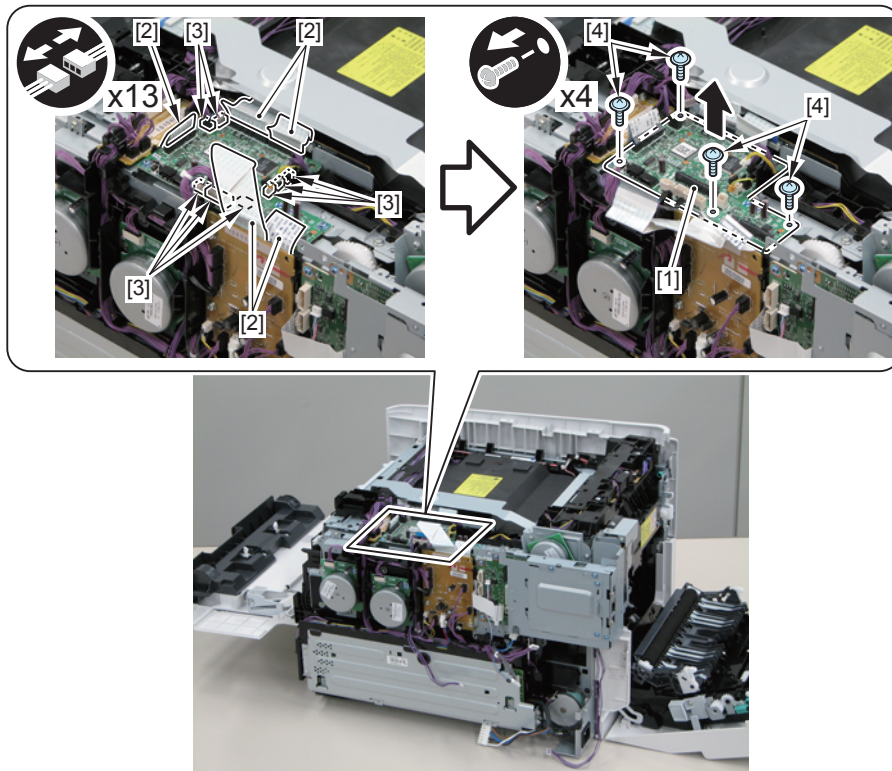

F-3-122

Removing the DC Controller PCB LBP7210Cdn

Preparation

- 1) Remove the Right Cover.(Refer to page 3-20)
- 2) Remove the Operation Panel Unit.(Refer to page 3-56)
- 3) Remove the Rear Upper Cover (Left).(Refer to page 3-17)
- 4) Remove the Upper Front Cover (Right) / USB Cover.(Refer to page 3-23)
- 5) Remove the Upper Cover.(Refer to page 3-24)
- 6) Remove the Right Frame Cover.(Refer to page 3-38)
- 7) Remove the Right Upper Frame Unit.(Refer to page 3-43)

The information in the NVRAM on the DC controller PCB is saved as backup data in the NVRAM on the main controller PCB.

Executing Printer Setting Restoration in service mode recovers the backup data in the NVRAM on the DC controller PCB.

When replacing the DC controller PCB, execute recovery of backup data, color displacement correction, and calibration in service mode.

- 1) Execute Option Menu > Service Mode > Printer Information settings > Printer Setting Restoration.

Caution

After executing the printer recovery setting, wait completion of the processing for approx. 15 sec.

- 2) Turn off/on the power supply of the host machine.
- 3) Start the Status window.
- 4) Execute Option Menu > Utility > Out-of-Register Colors Correction.
- 5) Execute Option Menu > Utility > Calibration.

Procedure

CAUTION:

When replacing this part, execute the actions to be taken when replacing the DC Controller PCB.

1) Remove the DC Controller PCB [1].

- 5 Flat Cables [2]
- 8 Connectors [3]
- 5 Screws [4]

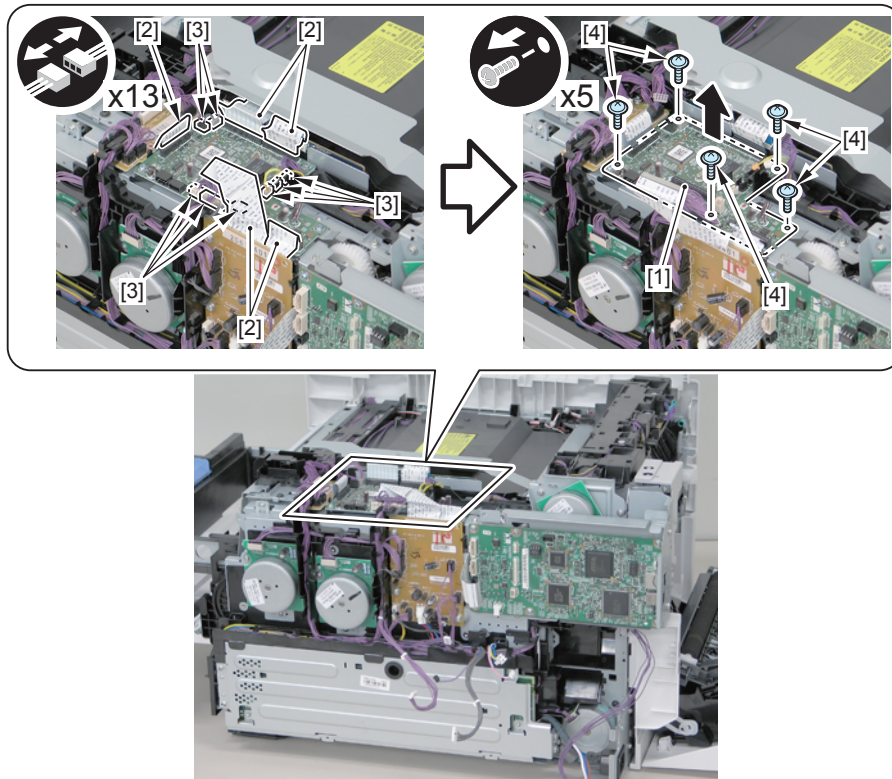

F-3-123

Removing the Relay PCB LBP7600C/7660Cdn/7680Cx

Preparation

- 1) Remove the Right Cover.(Refer to page 3-20)
- 2) Remove the Operation Panel Unit.(Refer to page 3-56)
- 3) Remove the Rear Upper Cover (Left).(Refer to page 3-17)
- 4) Remove the Upper Front Cover (Right) / USB Cover.(Refer to page 3-23)
- 5) Remove the Upper Cover.(Refer to page 3-24)
- 6) Remove the Right Frame Cover.(Refer to page 3-38)
- 7) Remove the Right Upper Frame Unit.(Refer to page 3-43)

Procedure

- 1) Remove the Flat Cable [1], 7 connectors [2] and the harness from the guide [A].

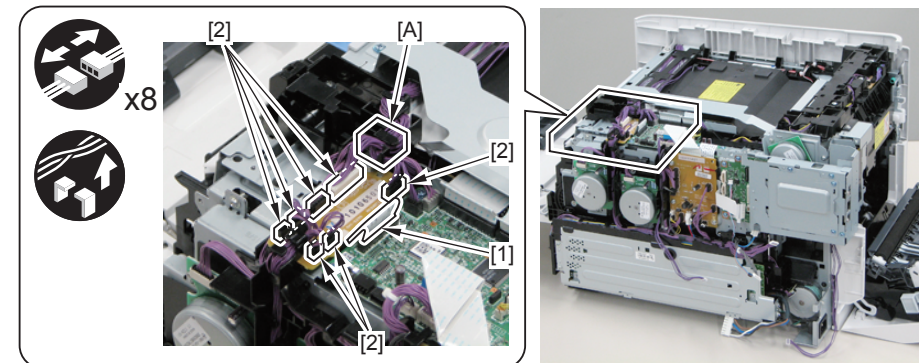

F-3-124

2) Move the Harness Guide [1].

- 1 Screw [2]
- 2 Hooks [3]

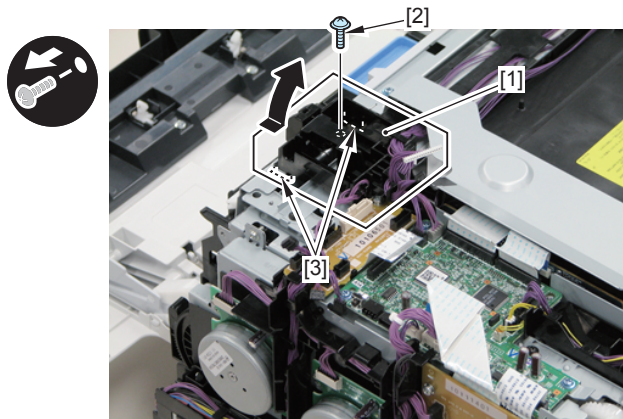

F-3-125

3) Remove the Relay PCB [1].

- 1 Screw [2]

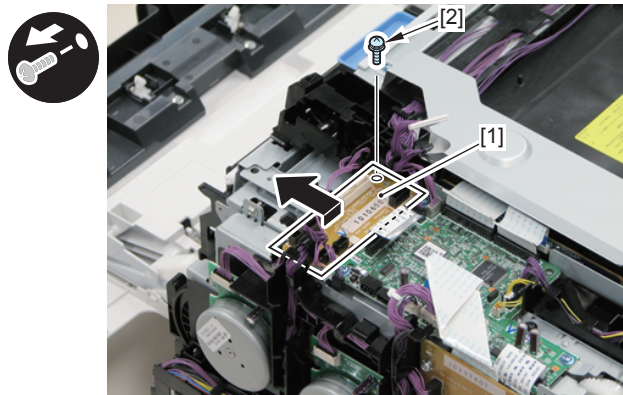

F-3-126

Removing the Relay PCB LBP7210Cdn

Preparation

- 1) Remove the Right Cover. (Refer to page 3-20)
- 2) Remove the Operation Panel Unit. (Refer to page 3-56)
- 3) Remove the Rear Upper Cover (Left). (Refer to page 3-17)
- 4) Remove the Upper Front Cover (Right) / USB Cover. (Refer to page 3-23)
- 5) Remove the Upper Cover. (Refer to page 3-24)
- 6) Remove the Right Frame Cover. (Refer to page 3-38)
- 7) Remove the Right Upper Frame Unit. (Refer to page 3-43)

Procedure

- 1) Remove the Flat Cable [1], 7 connectors [2] and the harness from the guide [A].

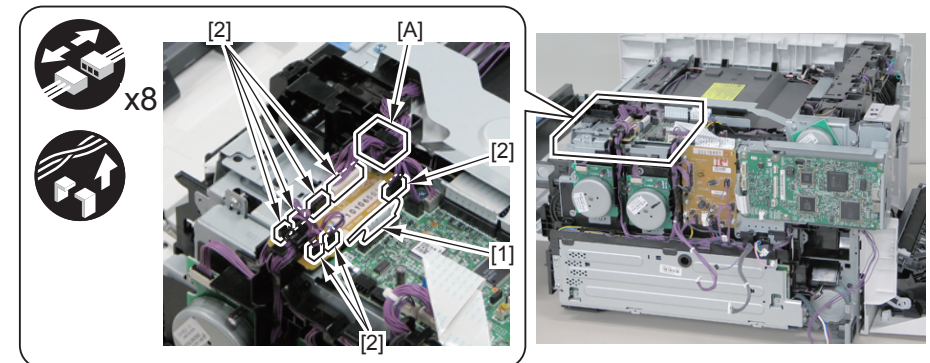

F-3-127

2) Move the Harness Guide [1].

- 1 Screw [2]
- 2 Hooks [3]

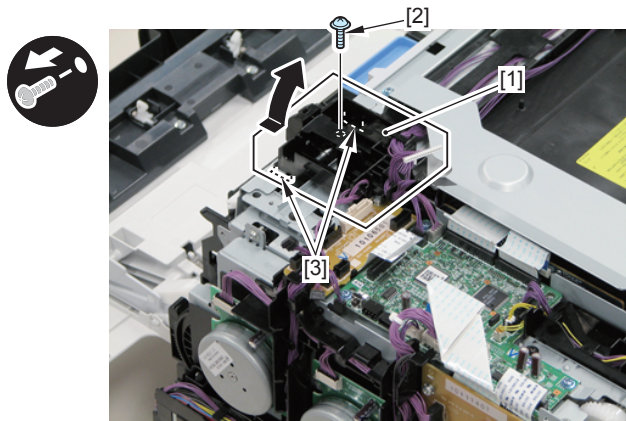

F-3-128

3) Remove the Relay PCB [1].

- 1 Screw [2]
- 1 Protrusion [3]

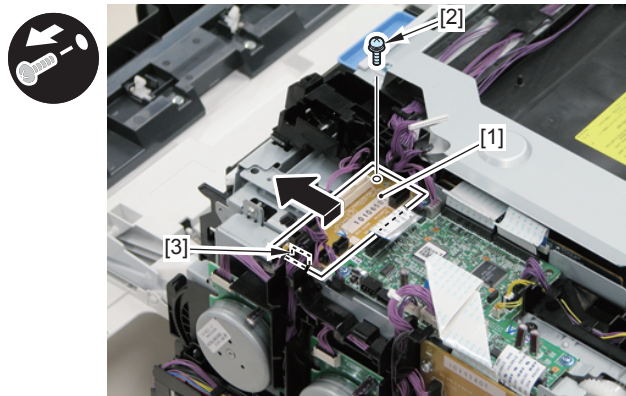

F-3-129

Removing the Sub Power Supply PCB LBP7600C/7660Cdn/7680Cx/7210Cdn

Preparation

- 1) Remove the Right Cover.(Refer to page 3-20)
- 2) Remove the Operation Panel Unit.(Refer to page 3-56)
- 3) Remove the Rear Upper Cover (Left).(Refer to page 3-17)
- 4) Remove the Upper Front Cover (Right) / USB Cover.(Refer to page 3-23)
- 5) Remove the Upper Cover.(Refer to page 3-24)
- 6) Remove the Right Frame Cover.(Refer to page 3-38)
- 7) Remove the Right Upper Frame Unit.(Refer to page 3-43)
- 8) Remove the Main Controller Support Plate.(Refer to page 3-45)

Procedure

- 1) Disconnect the 3 connectors [1], and free the harness [2] from the Harness Guide [A].

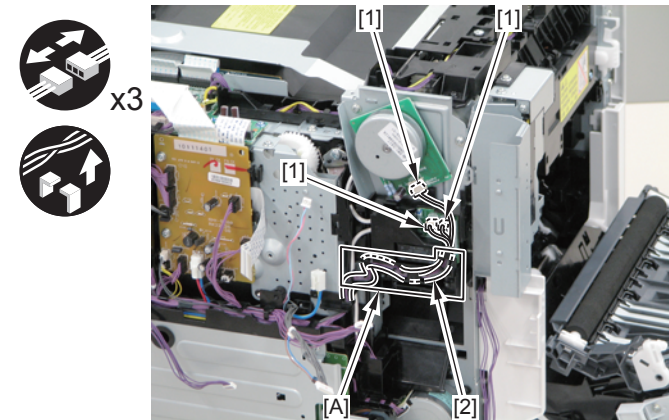

F-3-130

2) Remove the Harness Guide [1].

- 2 Claws [2]
- 1 Hooks [3]

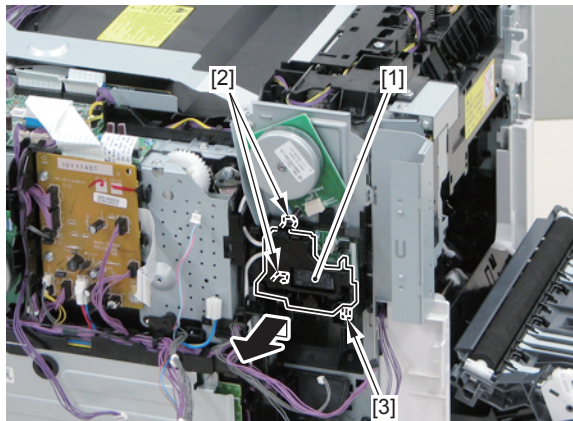

F-3-131

3) Remove the Sub Power Supply PCB [1].

- 1 Connector [2]
- 1 Screw [3]

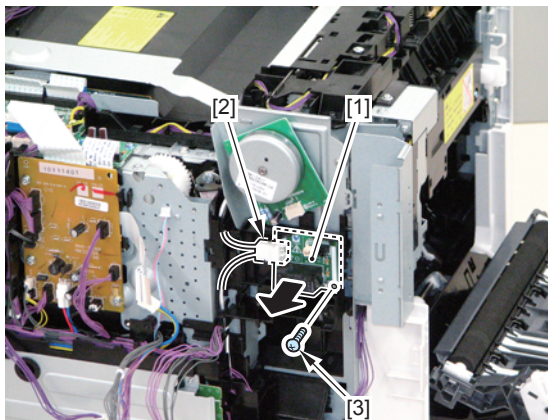

F-3-132

Removing the Driver PCB LBP7600C/7660Cdn/7680Cx

Preparation

- 1) Remove the Right Cover.(Refer to page 3-20)
- 2) Remove the Operation Panel Unit.(Refer to page 3-56)
- 3) Remove the Rear Upper Cover (Left).(Refer to page 3-17)
- 4) Remove the Upper Front Cover (Right) / USB Cover.(Refer to page 3-23)
- 5) Remove the Upper Cover.(Refer to page 3-24)
- 6) Remove the Right Frame Cover.(Refer to page 3-38)
- 7) Remove the Right Upper Frame Unit.(Refer to page 3-43)

Procedure

1) Remove the Driver PCB [1].

- 2 Flat Cables [2]
- 10 Connectors [3]
- 3 Screws [4]
- 1 Claw [5]
- 1 Protrusion [6]

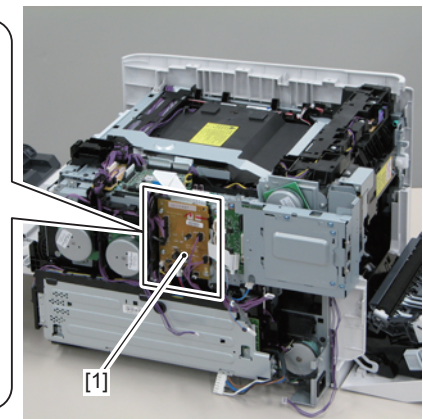
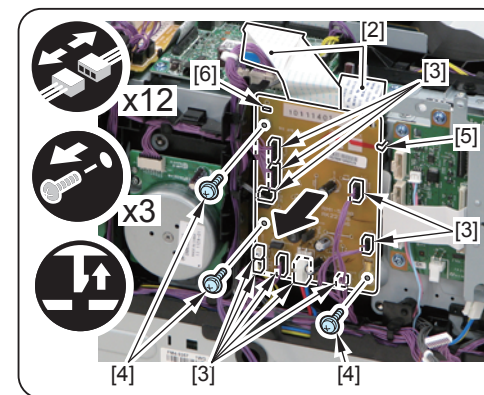

F-3-133

Removing the Driver PCB LBP7210Cdn

Preparation

- 1) Remove the Right Cover.(Refer to page 3-20)
- 2) Remove the Operation Panel Unit.(Refer to page 3-56)
- 3) Remove the Rear Upper Cover (Left).(Refer to page 3-17)
- 4) Remove the Upper Front Cover (Right) / USB Cover.(Refer to page 3-23)
- 5) Remove the Upper Cover.(Refer to page 3-24)
- 6) Remove the Right Frame Cover.(Refer to page 3-38)
- 7) Remove the Right Upper Frame Unit.(Refer to page 3-43)

Procedure

- 1) Remove the Driver PCB [1].
 - 1 Flat Cable [2]
 - 10 Connectors [3]
 - 3 Screws [4]
 - 1 Claw [5]
 - 1 Protrusion [6]

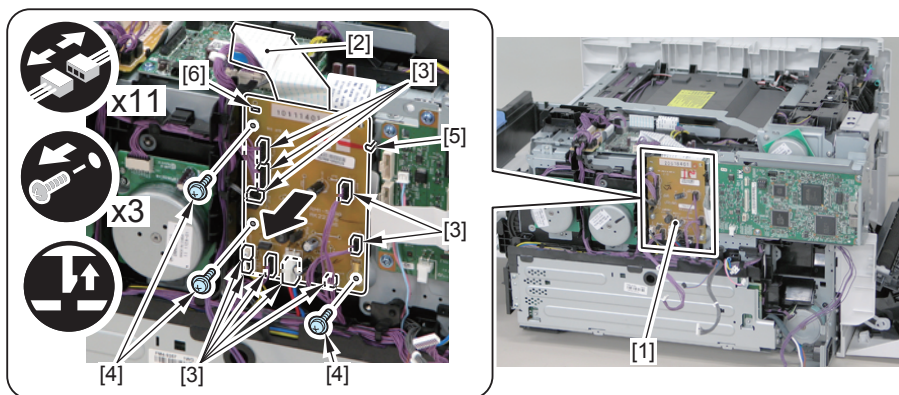

F-3-134

Removing the Power Supply Unit LBP7600C/7660Cdn/7680Cx

Preparation

- 1) Remove the Right Cover.(Refer to page 3-20)
- 2) Remove the Operation Panel Unit.(Refer to page 3-56)
- 3) Remove the Rear Upper Cover (Left).(Refer to page 3-17)
- 4) Remove the Upper Front Cover (Right) / USB Cover.(Refer to page 3-23)
- 5) Remove the Upper Cover.(Refer to page 3-24)
- 6) Remove the Right Frame Cover.(Refer to page 3-38)
- 7) Remove the Right Upper Frame Unit.(Refer to page 3-43)
- 8) Remove the Main Controller Support Plate.(Refer to page 3-45)

Procedure

1) Disconnect the 8 connectors [1], and free the harness [2] from the Harness Guide [A].

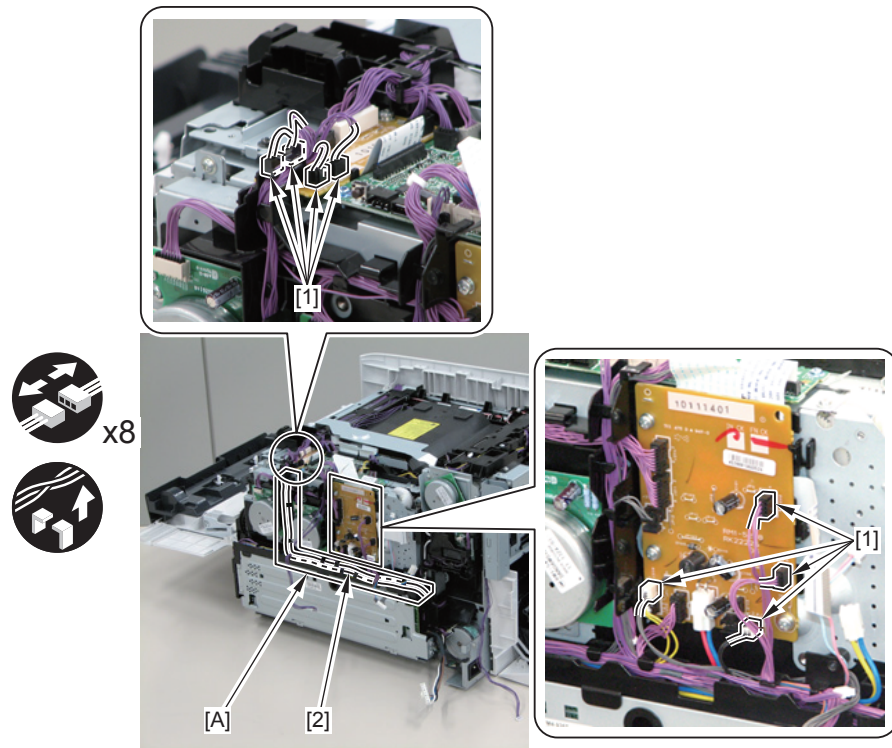

F-3-135

2) Free the harness [1] and [2] from the Harness Guide [A] and [B].

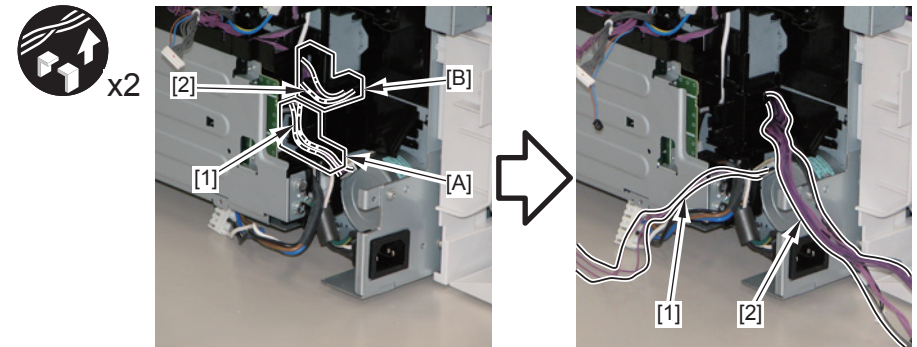

F-3-136

3) Remove the Harness Guide [1].

- Harness Guide [A]
- 2 Bosses [2]
- 2 Hooks [3]

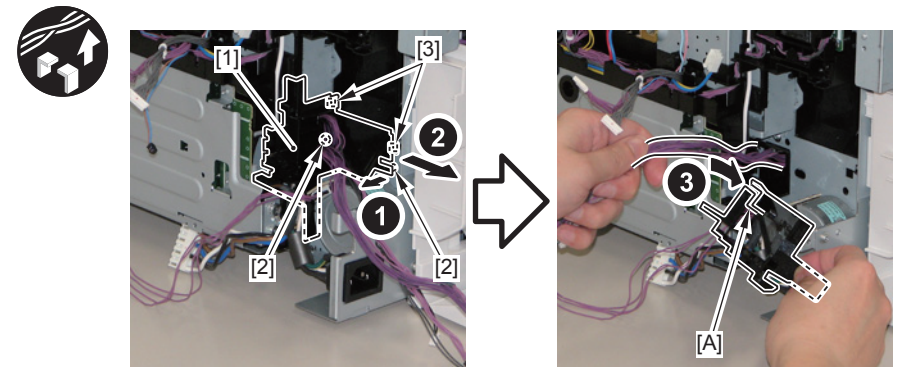

F-3-137

4) Disconnect the Main Power Connector [1] and remove the Toothed Washer Screw [2].

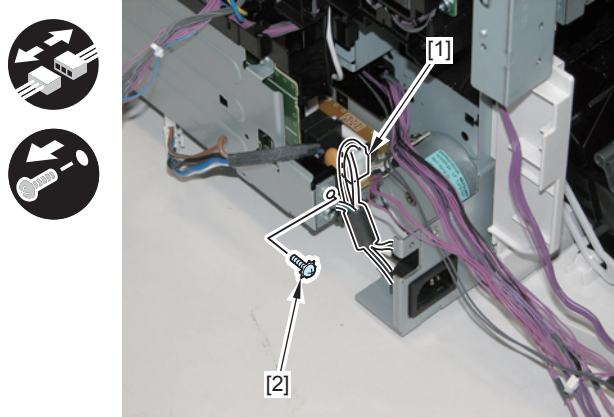

F-3-138

5) Disconnect the Flat Cable [1].

6) Disconnect the 4 connectors [2], and free the harnesses [3] and [4] from the guides [A] and [B].

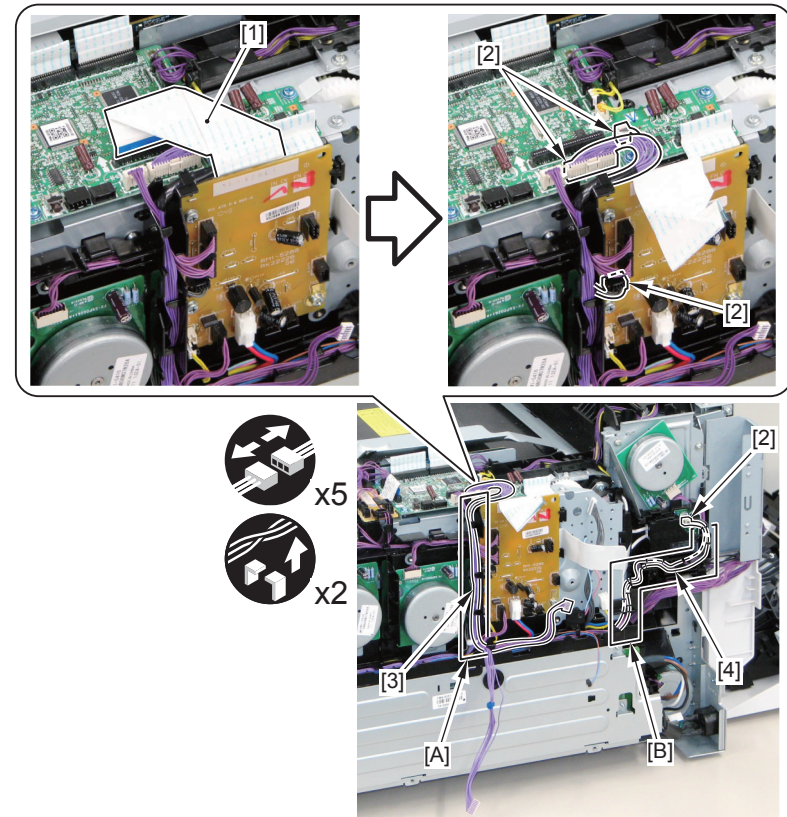

F-3-139

CAUTION:

Be sure to place the Harness Band [2] of the harness [1] between the 2 claws [3] of the Harness Guide at installation.

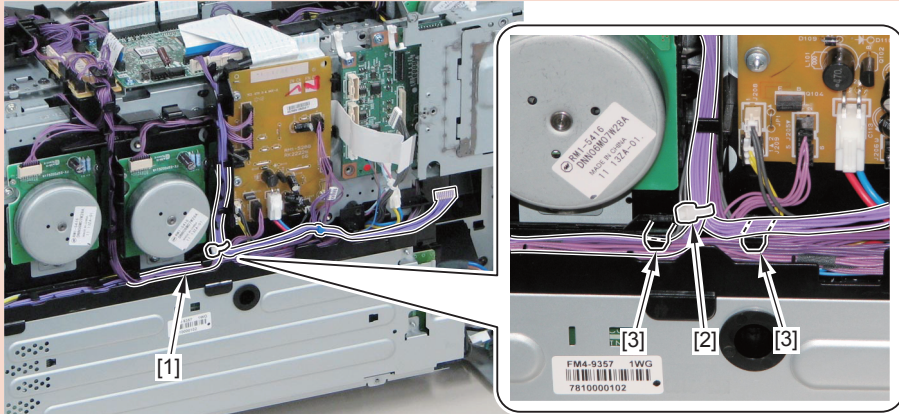

7) Disconnect the 3 connectors [1], and free the harness [2] from the guide [C].

8) Free the harness [3] from the guides [C] and [D].

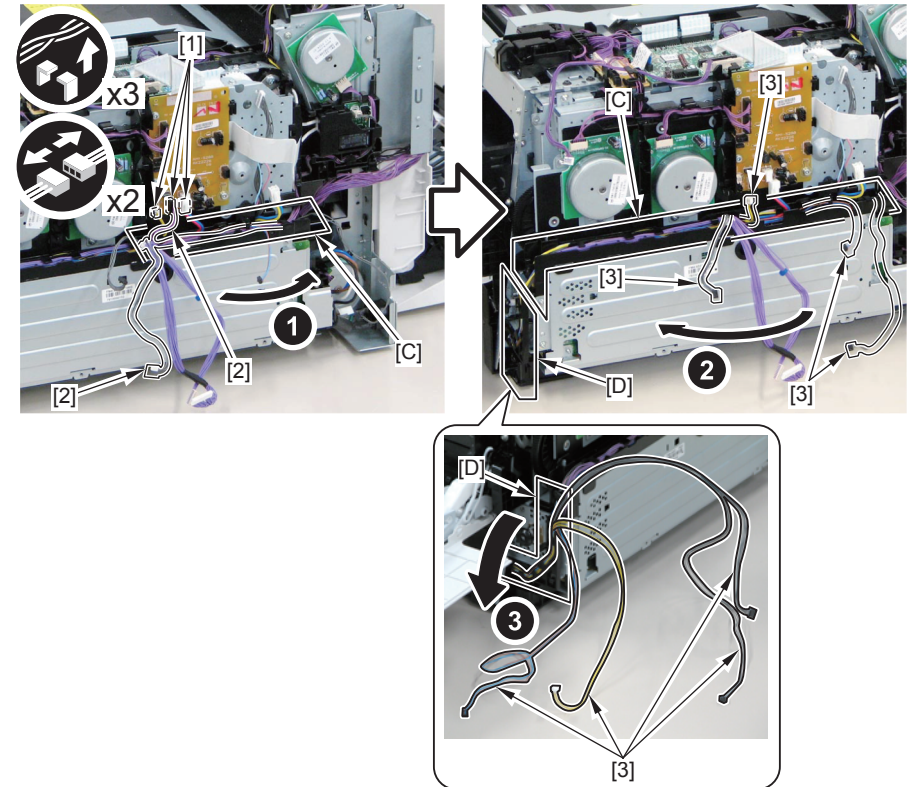

F-3-141

9) Remove the Harness Guide [1].

- 2 Claws [2]

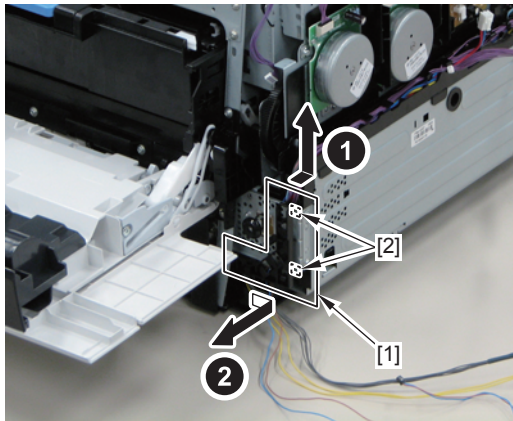

F-3-142

11) Remove the Switch Cap [2] and the connector [3] from the Power Supply Unit [1].

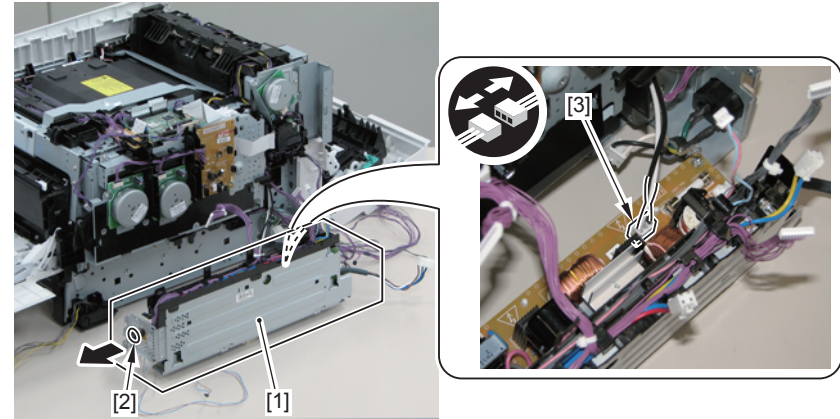

F-3-144

10) Remove the Power Supply Unit [1].

- 5 Screws [2]
- 1 Cap [3]
- 2 Hooks [4]

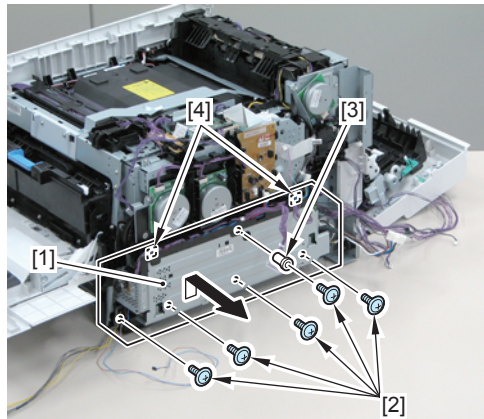

F-3-143

Installation Method

NOTE:

The figure below shows where the harness of the Power Supply Unit should be connected.

- [1] Main Controller PCB
- [2] DC Controller PCB
- [3] Driver PCB
- [4] AC PCB

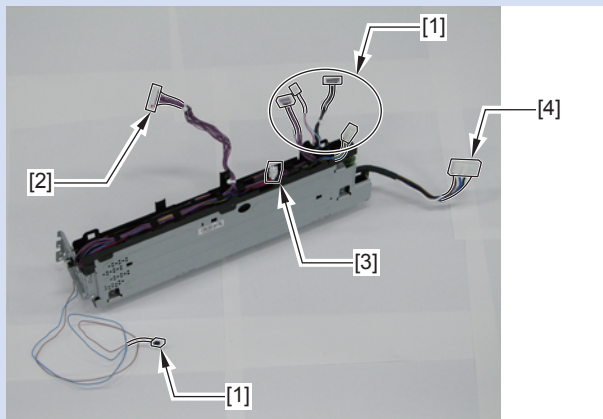

F-3-145

- 1) Install the Switch Cap [2] and the connector [3] to the Power Supply Unit [1].

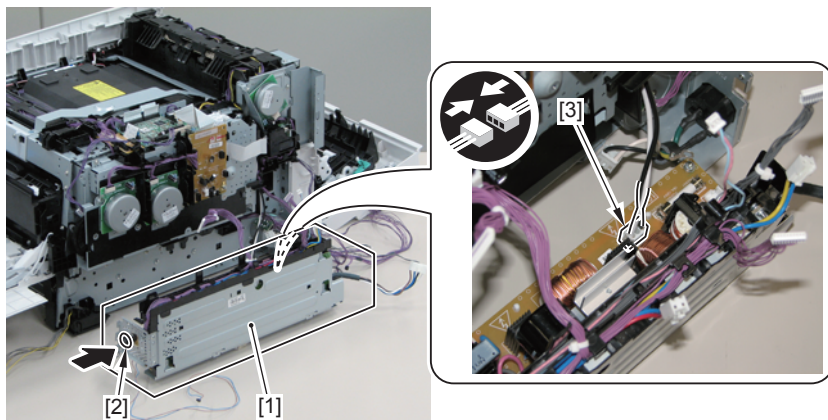

F-3-146

- 2) Install the Power Supply Unit [1] to the host machine.

- 2 Hooks [2]
- 1 Cap [3]
- 5 Screws [4]

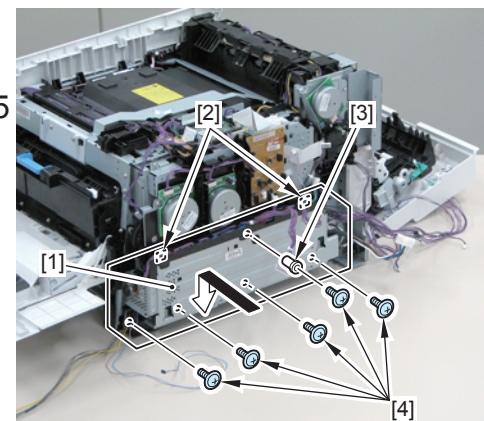

F-3-147

- 3) Install the Harness Guide [1].

- 2 Claws [2]

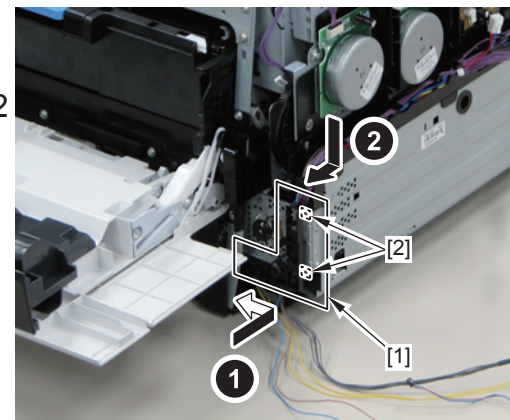

F-3-148

- 4) Install the harness [1] to the guides [D] and [C].
 5) Hook the harness [2] on the guide [C], and connect the 3 connectors [3].

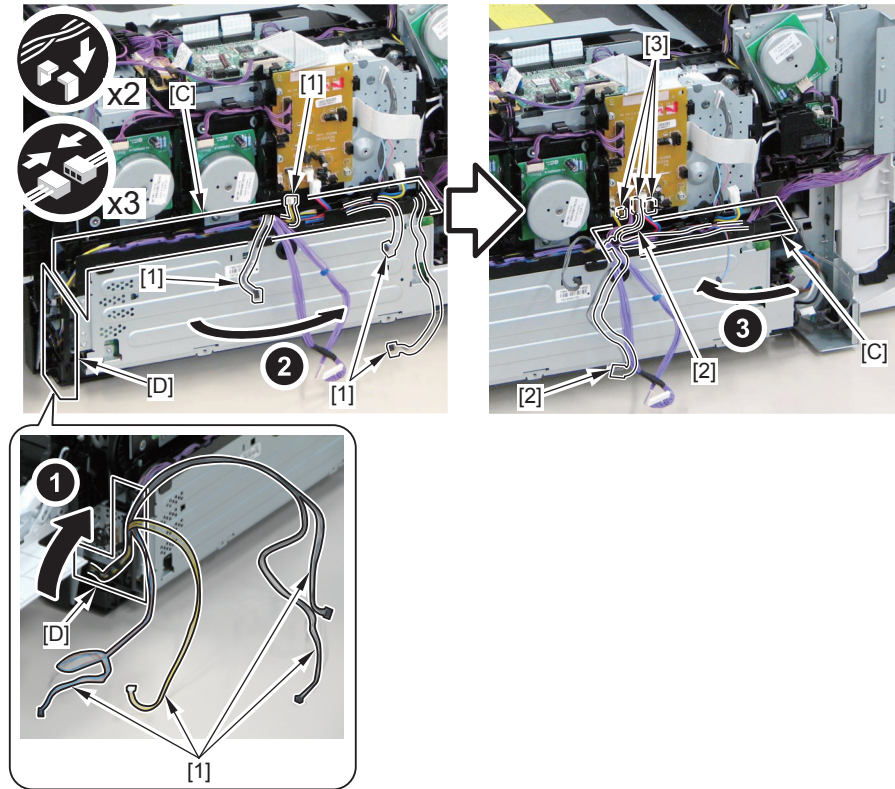

F-3-149

- 6) Hook the harnesses [1] and [2] on the guides [A] and [B], and connect the 4 connectors [3].
 7) Install the Flat Cable [4].

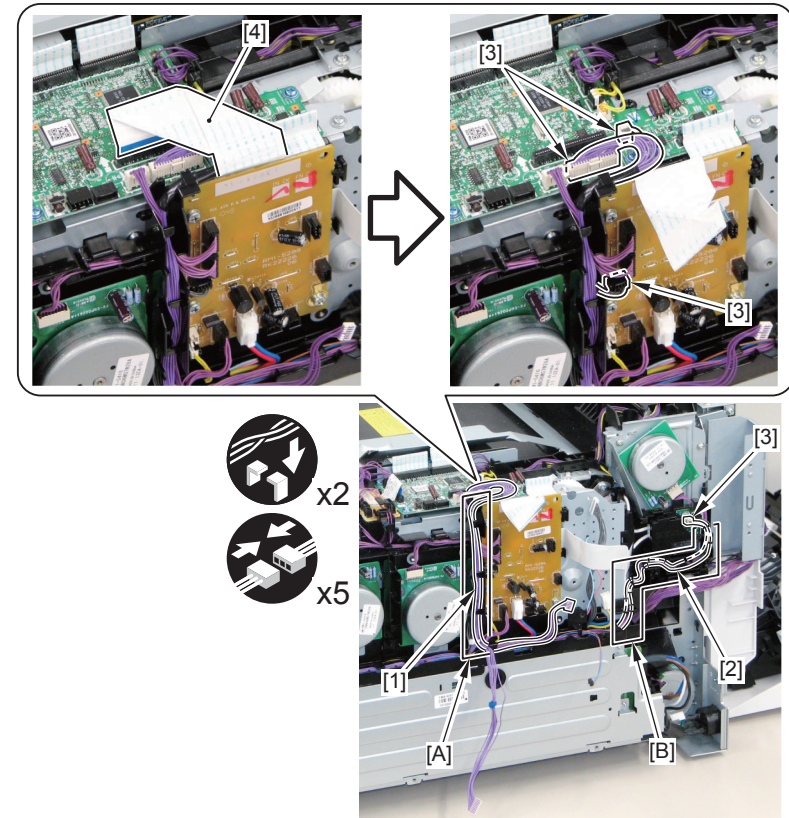

F-3-150

CAUTION:

Be sure to place the Harness Band [2] of the harness [1] between the 2 claws [3] of the Harness Guide at installation.

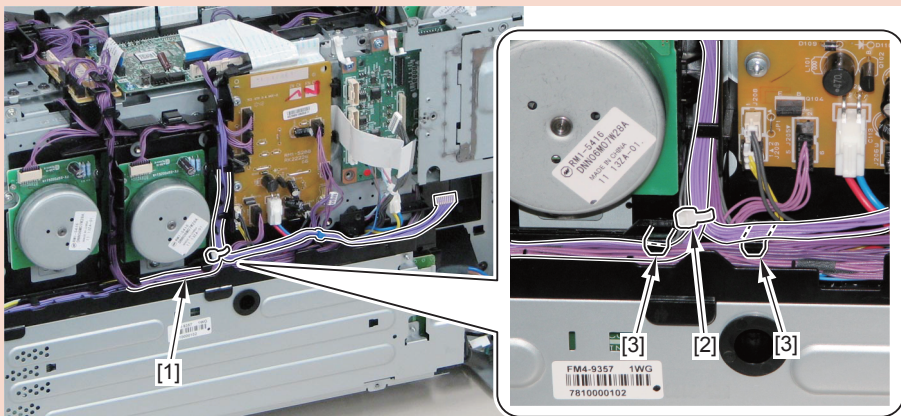

F-3-151

8) Connect the Main Power Connector [1] and install the Toothed Washer Screw [2].

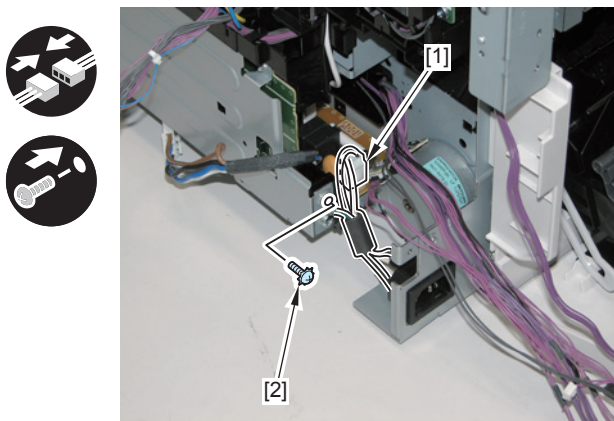

F-3-152

9) Install the Harness Guide [1].

- Harness Guide [A]
- 2 Bosses [2]
- 2 Hooks [3]

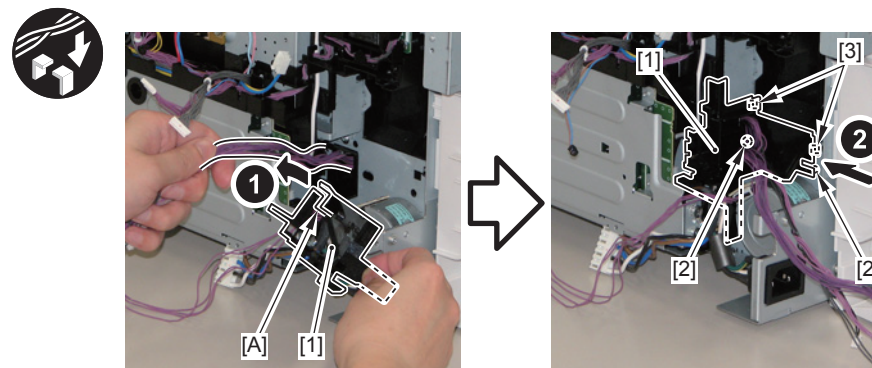

F-3-153

10) Install the harness [1] and [2] to the Harness Guide [A] and [B].

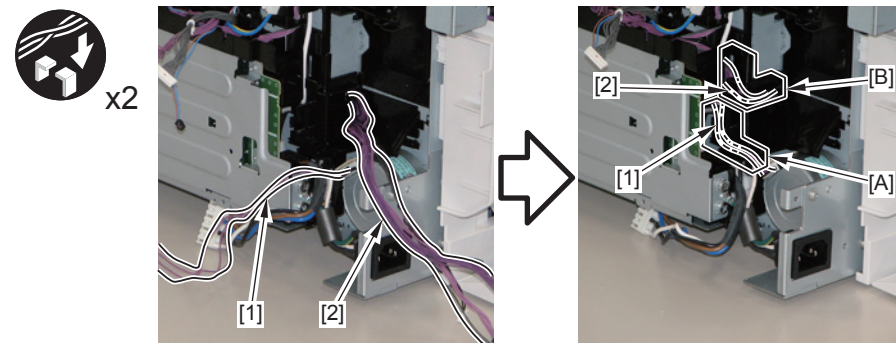

F-3-154

11) Install the harness [1] to the Harness Guide [A], and connect the 8 connectors [2] of the PCB.

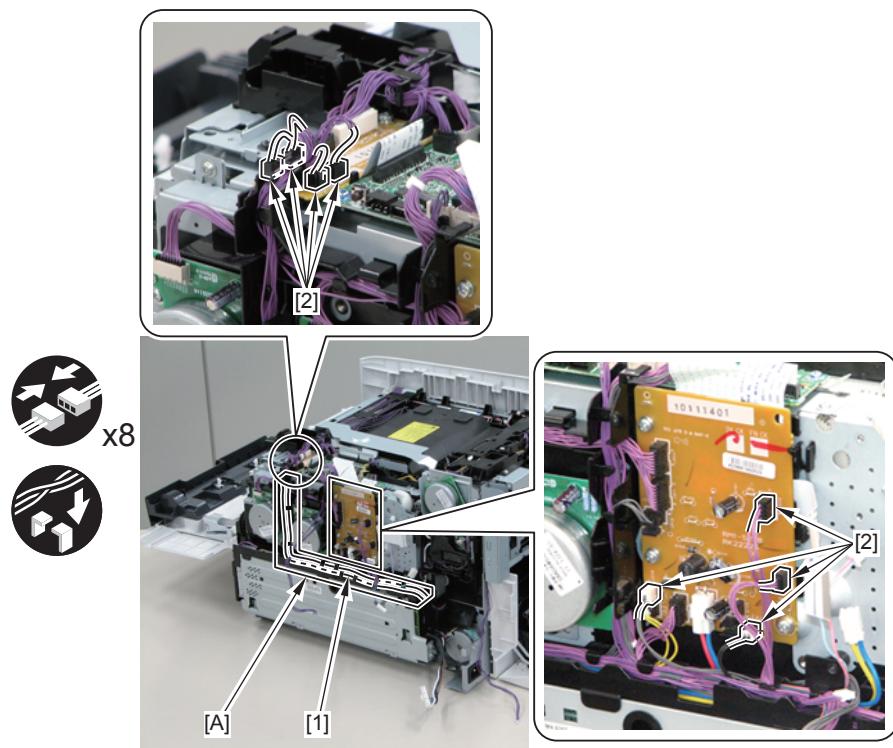

Removing the Power Supply Unit LBP7210Cdn

Preparation

- 1) Remove the Right Cover.(Refer to page 3-20)
- 2) Remove the Operation Panel Unit.(Refer to page 3-56)
- 3) Remove the Rear Upper Cover (Left).(Refer to page 3-17)
- 4) Remove the Upper Front Cover (Right) / USB Cover.(Refer to page 3-23)
- 5) Remove the Upper Cover.(Refer to page 3-24)
- 6) Remove the Right Frame Cover.(Refer to page 3-38)
- 7) Remove the Right Upper Frame Unit.(Refer to page 3-43)
- 8) Remove the Main Controller Support Plate.(Refer to page 3-45)

Procedure

1) Disconnect the 8 connectors [1], and free the harness [2] from the Harness Guide [A].

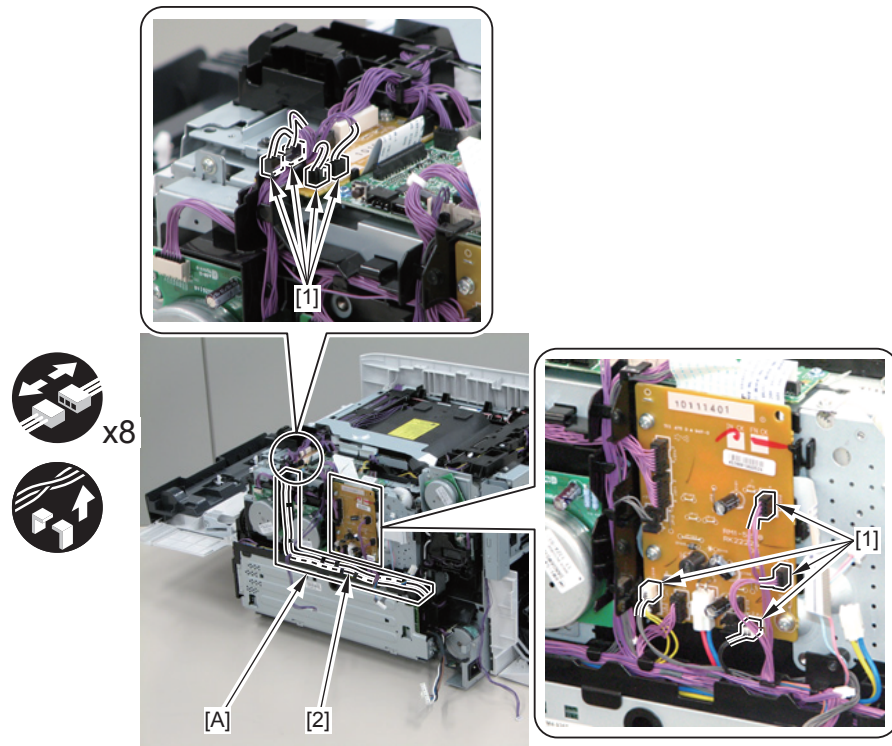

F-3-155

2) Free the harness [1] and [2] from the Harness Guide [A] and [B].

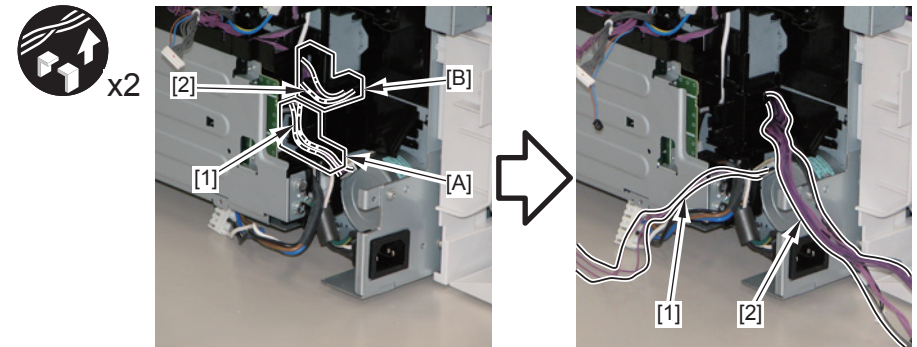

F-3-156

3) Remove the Harness Guide [1].

- Harness Guide [A]
- 2 Bosses [2]
- 2 Hooks [3]

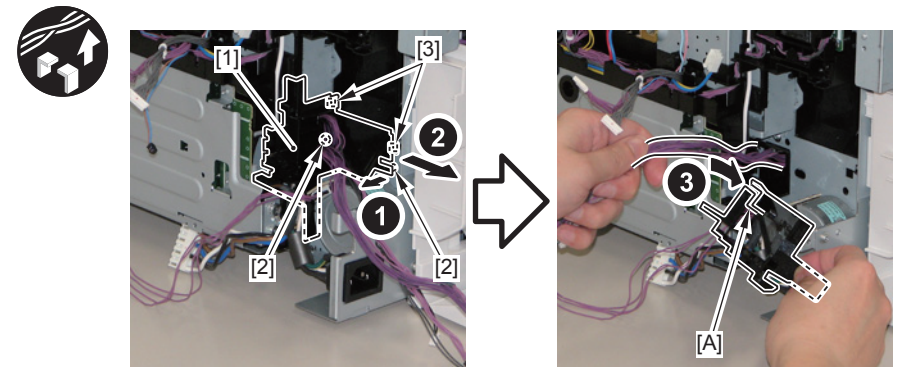

F-3-157

4) Disconnect the Main Power Connector [1] and remove the Toothed Washer Screw [2].

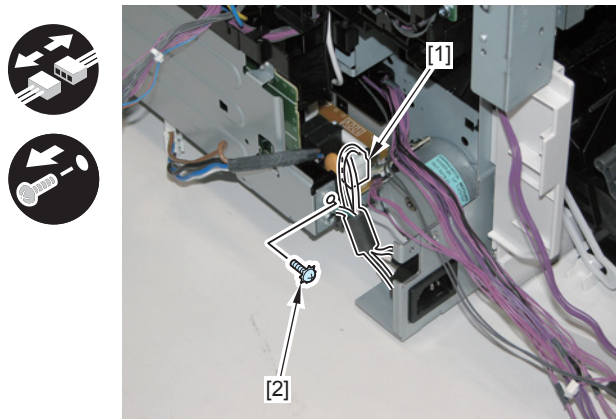

F-3-158

5) Disconnect the Flat Cable [1].

6) Disconnect the 4 connectors [2], and free the harnesses [3] and [4] from the guides [A] and [B].

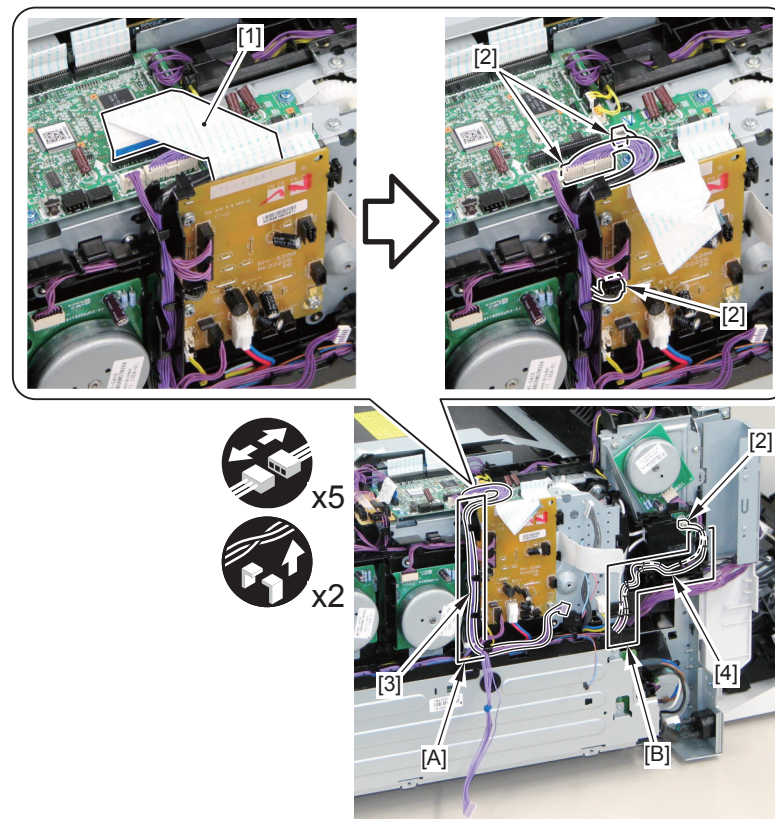

F-3-159

7) Disconnect the 3 connectors [1], and free the harness [2] from the guide [C].

8) Free the harness [3] from the guides [C] and [D].

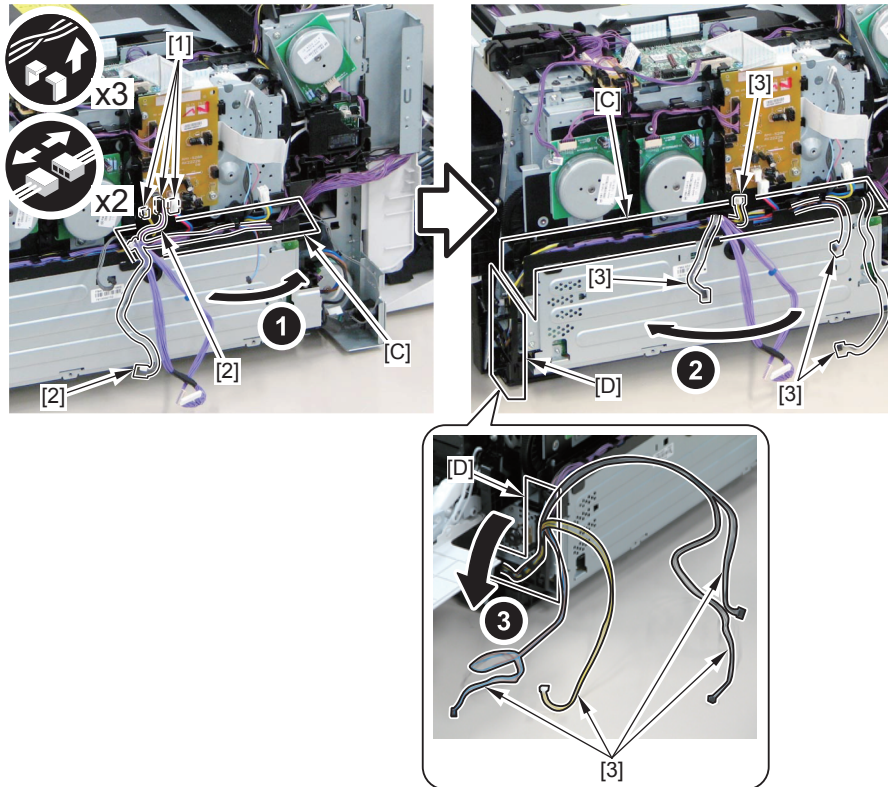

F-3-160

9) Remove the Harness Guide [1].

- 2 Claws [2]

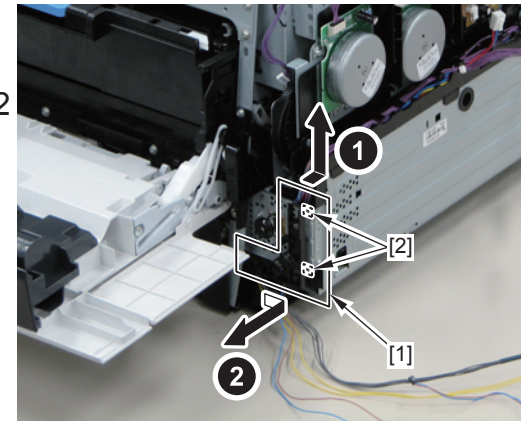

F-3-161

10) Remove the Power Supply Unit [1].

- 6 Screws [2]
- 1 Cap [3]
- 2 Hooks [4]

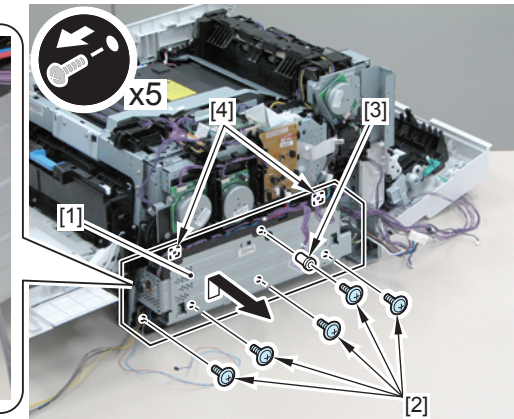
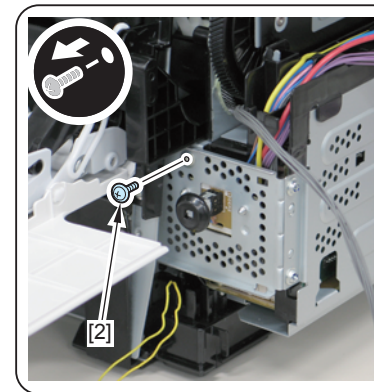

F-3-162

11) Remove the Switch Cap [2] and the connector [3] from the Power Supply Unit [1].

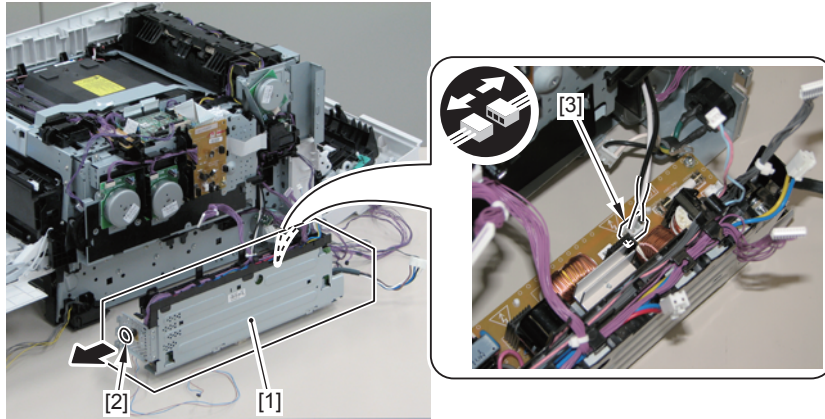

F-3-163

Installation Method

NOTE:

The figure below shows where the harness of the Power Supply Unit should be connected.

- [1] Main Controller PCB
- [2] DC Controller PCB
- [3] Driver PCB
- [4] AC PCB

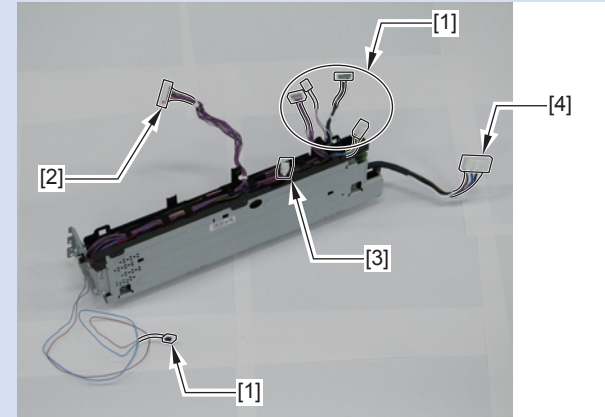

F-3-164

1) Install the Switch Cap [2] and the connector [3] to the Power Supply Unit [1].

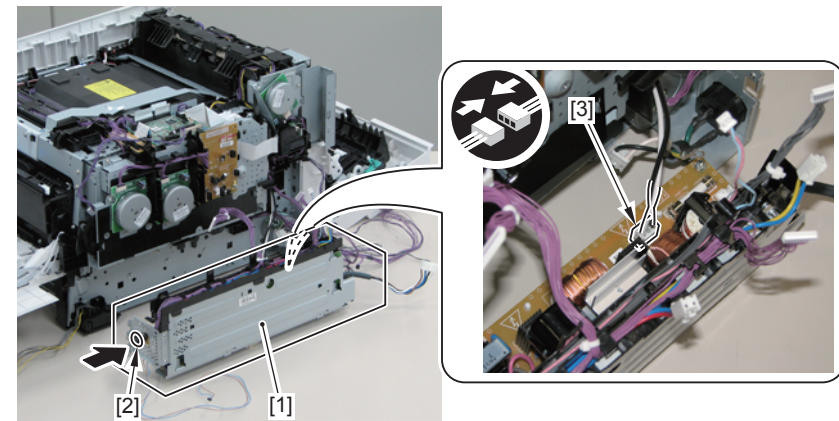

F-3-165

2) Install the Power Supply Unit [1] to the host machine.

- 2 Hooks [2]
- 1 Cap [3]
- 5 Screws [4]

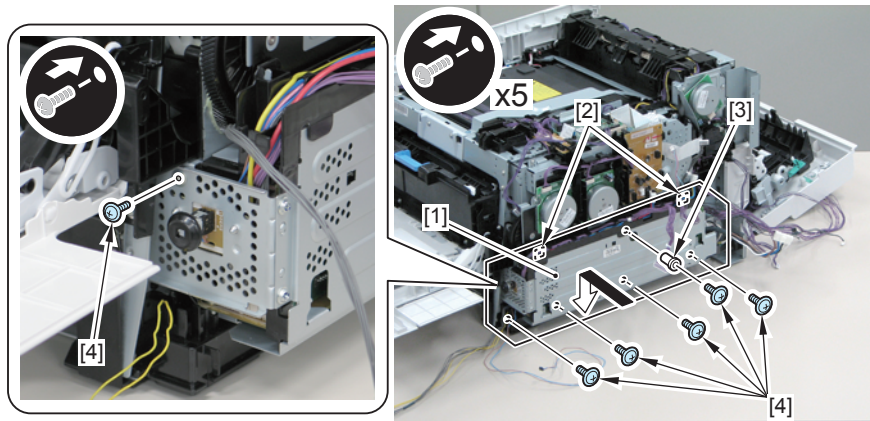

F-3-166

3) Install the Harness Guide [1].

- 2 Claws [2]

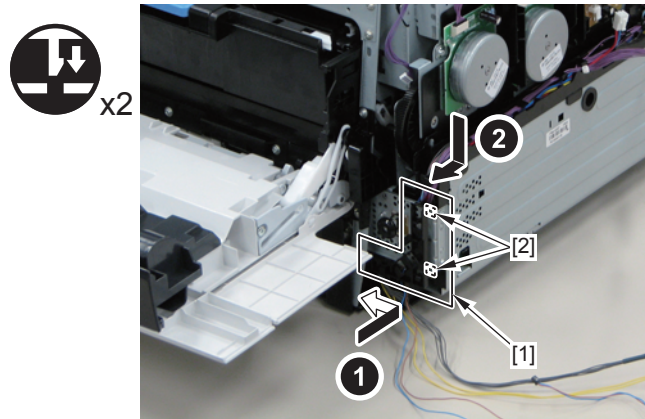

F-3-167

4) Install the harness [1] to the guides [D] and [C].

5) Hook the harness [2] on the guide [C], and connect the 3 connectors [3].

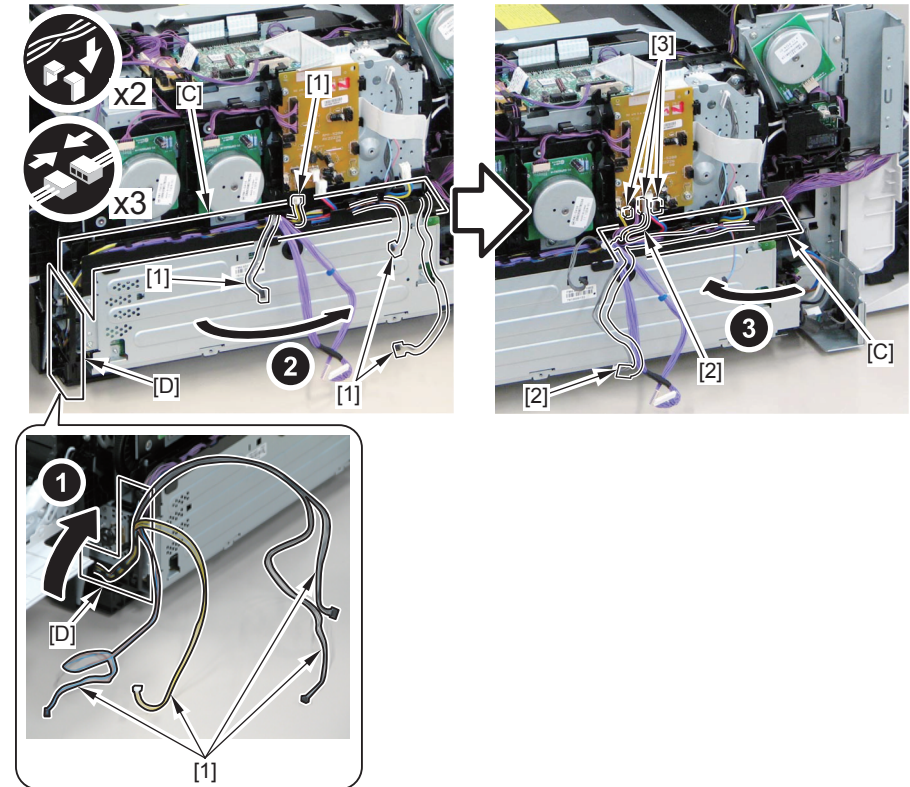

F-3-168

6) Hook the harnesses [1] and [2] on the guides [A] and [B], and connect the 4 connectors [3].

7) Install the Flat Cable [4].

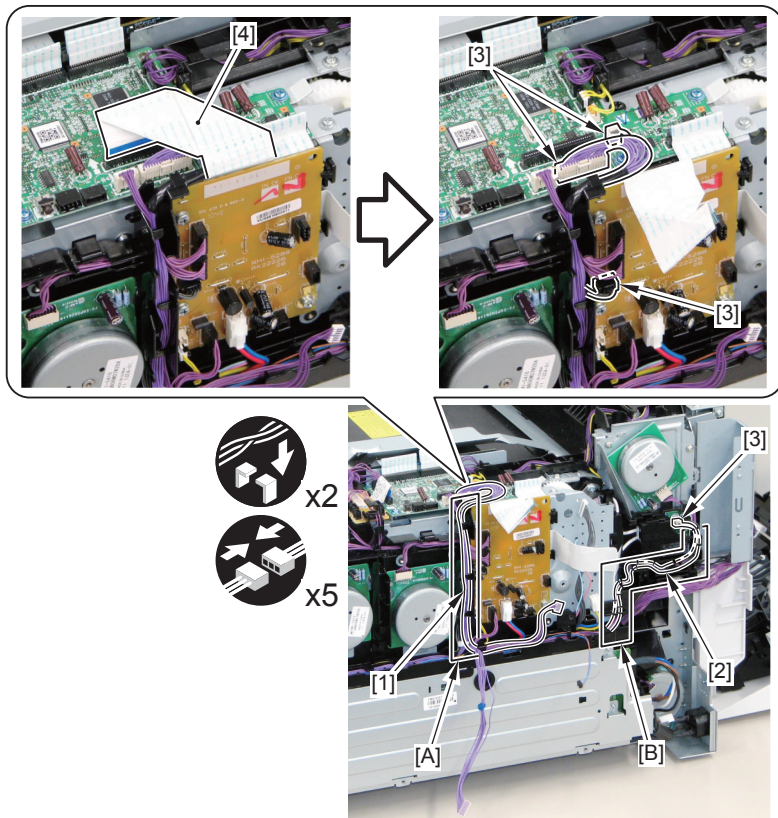

F-3-169

8) Connect the Main Power Connector [1] and install the Toothed Washer Screw [2].

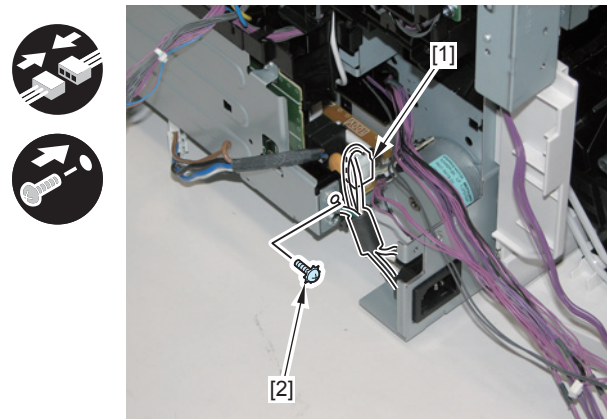

F-3-170

9) Install the Harness Guide [1].

- Harness Guide [A]
- 2 Bosses [2]
- 2 Hooks [3]

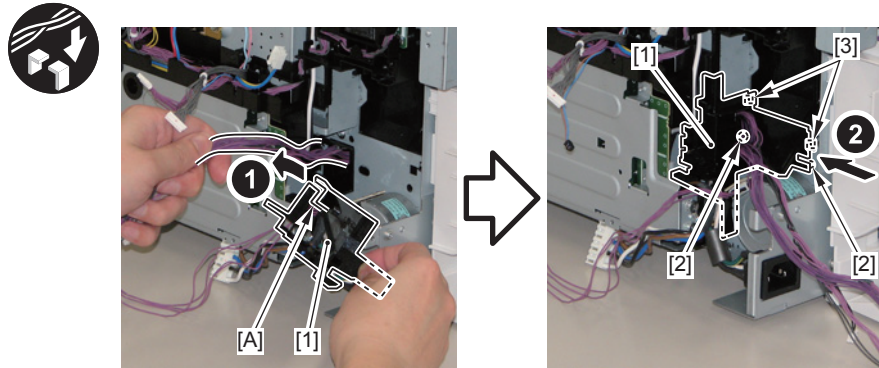

F-3-171

10) Install the harness [1] and [2] to the Harness Guide [A] and [B].

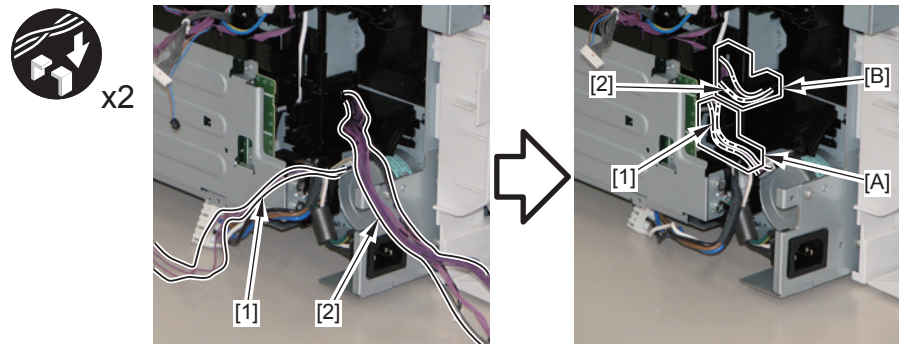

F-3-172

11) Install the harness [1] to the Harness Guide [A], and connect the 8 connectors [2] of the PCB.

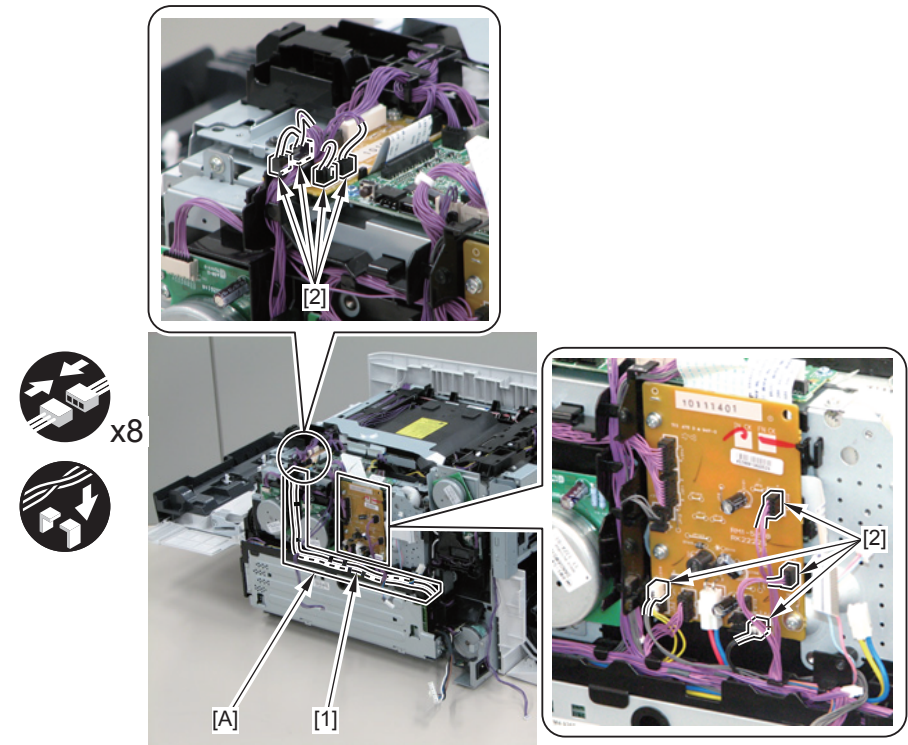

Removing the High Voltage Power Supply PCB LBP7600C/7660Cdn/7680Cx

Preparation

- 1) Remove the Right Cover.(Refer to page 3-20)
- 2) Remove the Operation Panel Unit.(Refer to page 3-56)
- 3) Remove the Rear Upper Cover (Left).(Refer to page 3-17)
- 4) Remove the Upper Front Cover (Right) / USB Cover.(Refer to page 3-23)
- 5) Remove the Upper Cover.(Refer to page 3-24)
- 6) Remove the Left Cover.(Refer to page 3-22)

Procedure

- 1) Open the Front Cover.
- 2) Remove the Harness Cover Plate [1].
 - 2 Screws [2]

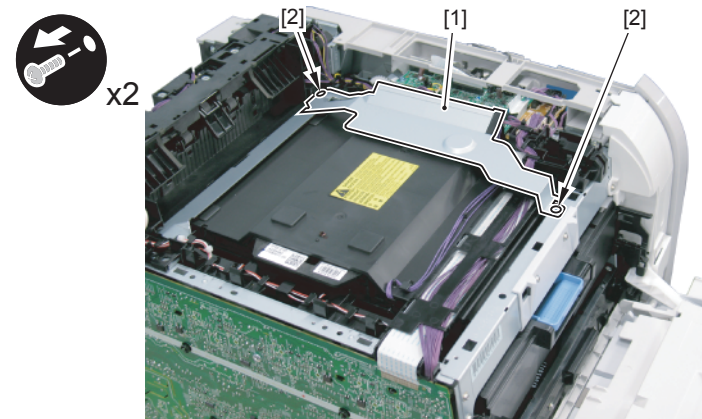

F-3-173

- 3) Remove the Guide Plate [1].
 - 6 Claws [2]

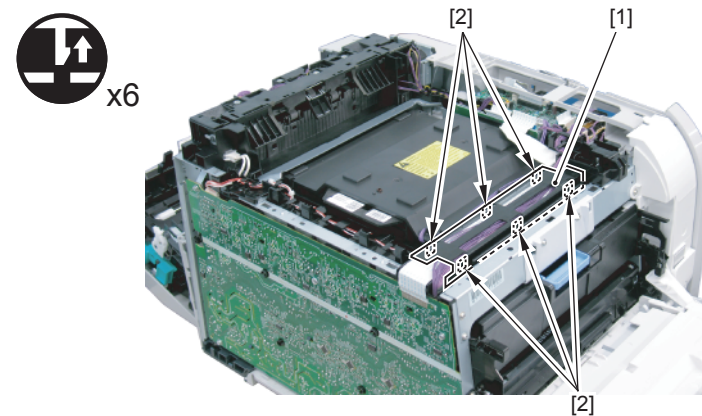

F-3-174

4) Disconnect the Flat Cable [1].

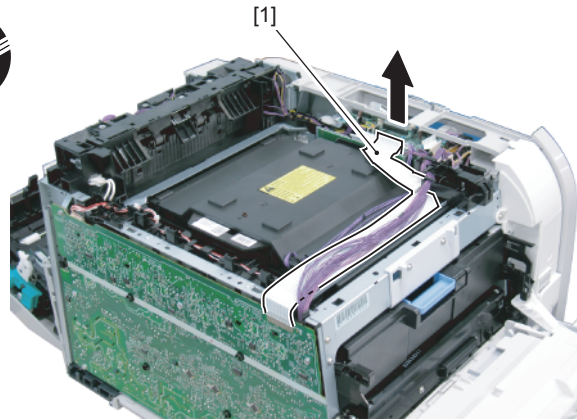

F-3-175

5) Remove the High Voltage Power Supply PCB [1].

- 4 Screws (with washers) [2]
- 2 Screws [3]
- 10 Claws [4]
- 1 Connector [5]

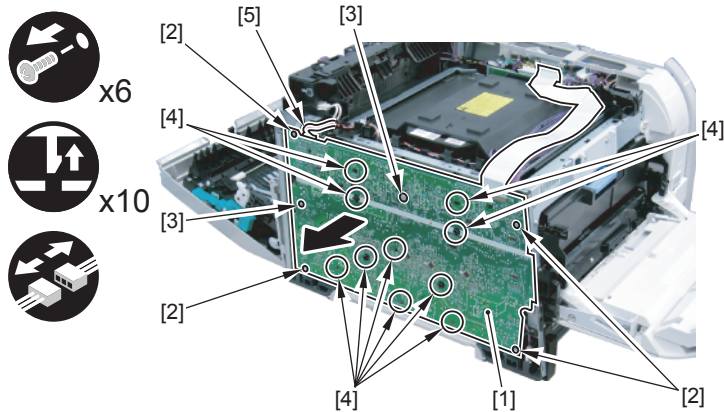

F-3-176

Removing the High Voltage Power Supply PCB LBP7210Cdn

Preparation

- 1) Remove the Right Cover.(Refer to page 3-20)
- 2) Remove the Operation Panel Unit.(Refer to page 3-56)
- 3) Remove the Rear Upper Cover (Left).(Refer to page 3-17)
- 4) Remove the Upper Front Cover .(Refer to page 3-23)
- 5) Remove the Upper Cover.(Refer to page 3-24)
- 6) Remove the Left Cover.(Refer to page 3-22)

Procedure

- 1) Open the Front Cover.
- 2) Remove the Harness Cover Plate [1].
 - 2 Screws [2]

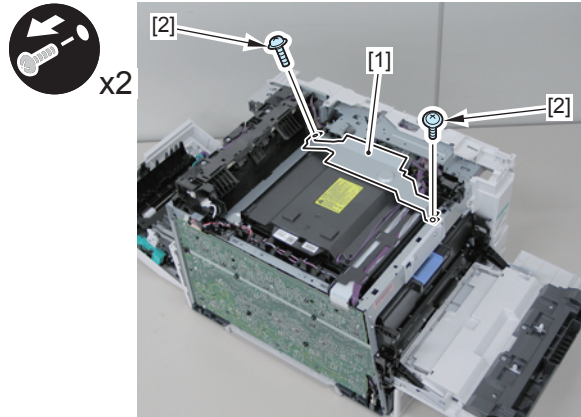

F-3-177

- 3) Remove the Guide Plate [1].
 - 6 Claws [2]

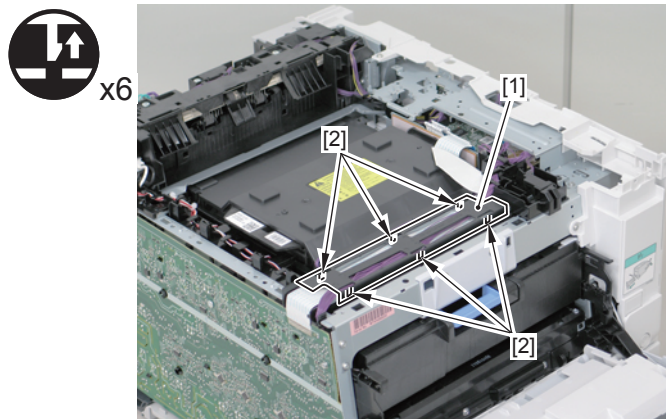

F-3-178

- 4) Disconnect the Flat Cable [1].

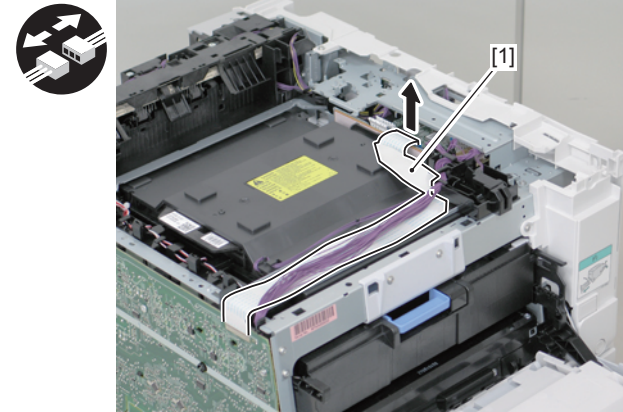

F-3-179

- 5) Remove the High Voltage Power Supply PCB [1].
 - 4 Screws (with washers) [2]
 - 2 Screws [3]
 - 10 Claws [4]
 - 1 Connector [5]

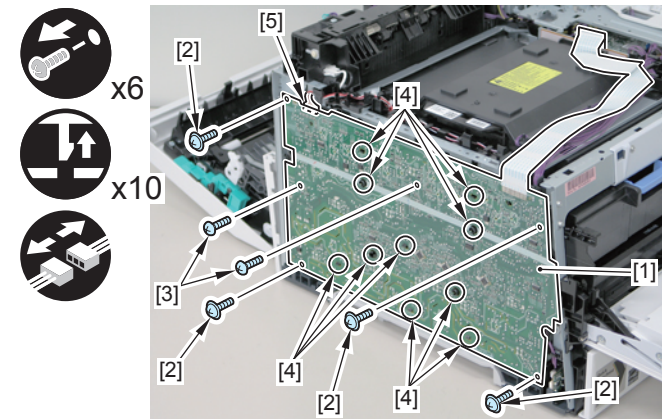

F-3-180

Removing the Fixing/Power Supply Cooling Fan LBP7600C/7660Cdn/7680Cx

Preparation

1) Remove the Right Cover.(Refer to page 3-20)

Procedure

1) Free the harness [1] from the guide [A].

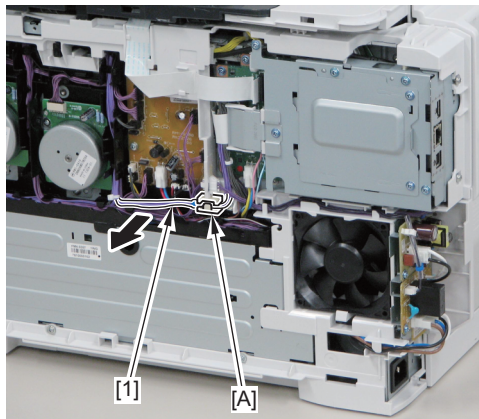

F-3-181

CAUTION:

Be sure to place the Harness Band [2] of the harness [1] on the left side of the guide [3] at installation.

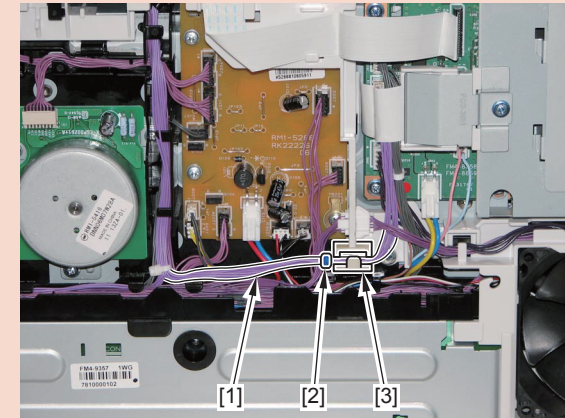

F-3-182

2) Pass the harness [1] through the groove [A] of the Right Frame Cover, and remove the Fixing/Power Supply Cooling Fan [2].

- 1 Connector [3]
- Harness Guide [B]
- 3 Claws [4]

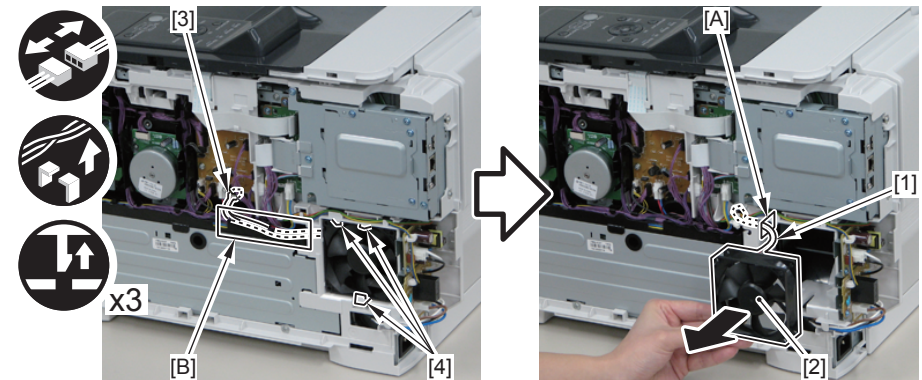

F-3-183

CAUTION:

Be sure to check the following when installing.

- Connect the Fan Cable [1] to the guide [C] of the fan.
- The label [2] of the fan should face the host machine.

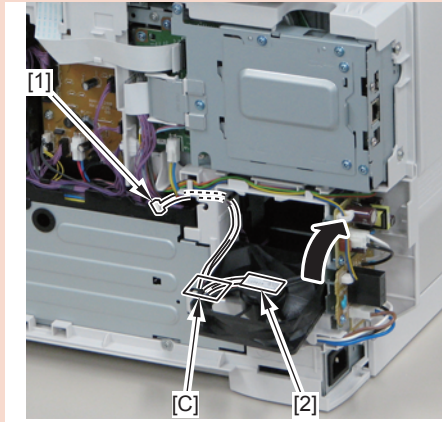

F-3-184

Removing the Fixing/Power Supply Cooling Fan LBP7210Cdn

Preparation

- 1) Remove the Right Cover.(Refer to page 3-20)

Procedure

- 1) Free the harness [1] from the guide [A].

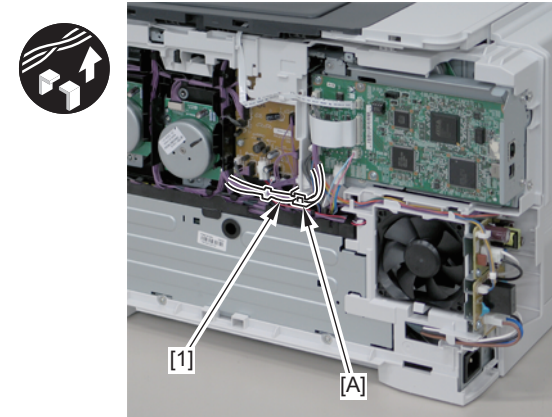

F-3-185

CAUTION:

Be sure to hook the harness [1] on the guide [2] at installation.

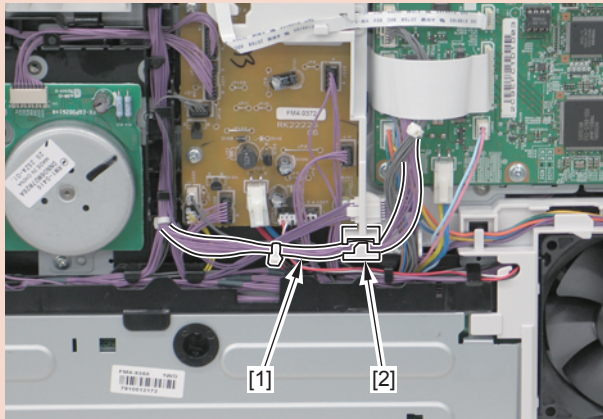

F-3-186

CAUTION:

Be sure to check the following when installing.

- Connect the Fan Cable [1] to the guide [C] of the fan.
- The label [2] of the fan should face the host machine.

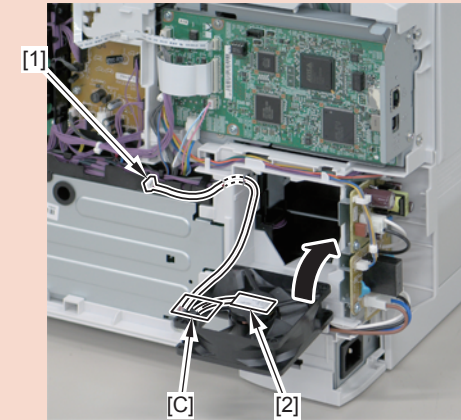

F-3-188

2) Pass the harness [1] through the groove [A] of the Right Frame Cover, and remove the Fixing/Power Supply Cooling Fan [2].

- 1 Connector [3]
- Harness Guide [B]
- 3 Claws [4]

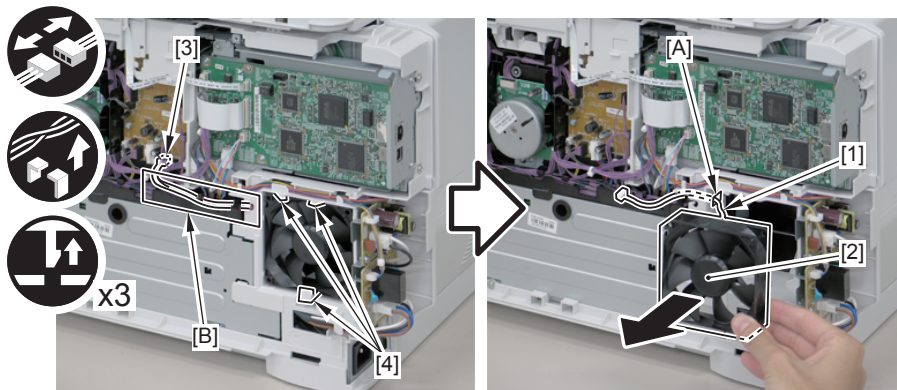

F-3-187

Removing the Duplex Feed Fan LBP7600C/7660Cdn/7680Cx/7210Cdn

Preparation

- 1) Remove the Right Cover.(Refer to page 3-20)
- 2) Remove the Rear Upper Cover (Left).(Refer to page 3-17)
- 3) Remove the Rear Cover.(Refer to page 3-15)
- 4) Remove the Rear Lower Cover.(Refer to page 3-17)
- 5) Remove the Rear Cover Rib Unit.(Refer to page 3-16)

Procedure

- 1) Remove the spring [1].
 - Harness Guide [A]

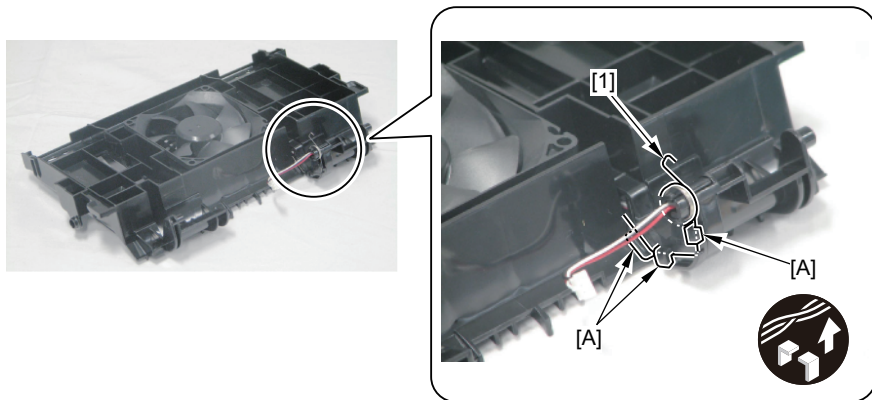

F-3-189

- 2) Free the harness [2] from the spring [1].

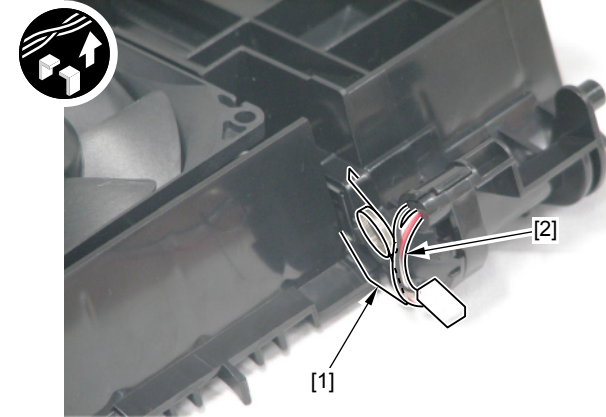

F-3-190

- 3) Remove the Guide Cover [1], and free the harness [2] from the Harness Guide [A].

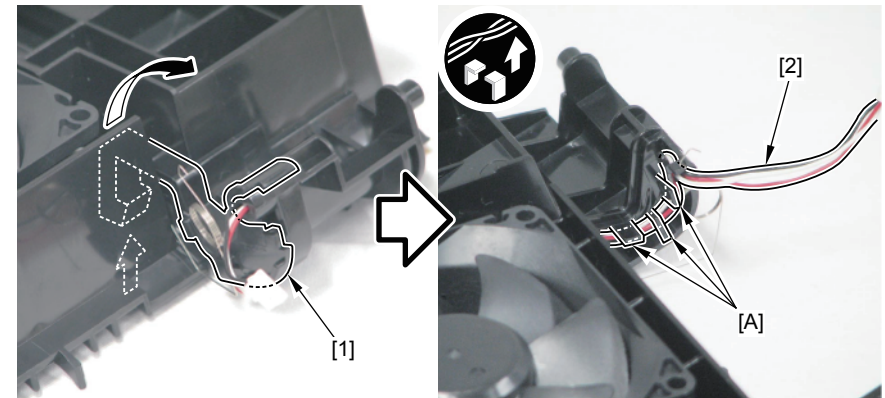

F-3-191

4) Remove the Duplex Feed Fan [1].

- 2 Claws [2]

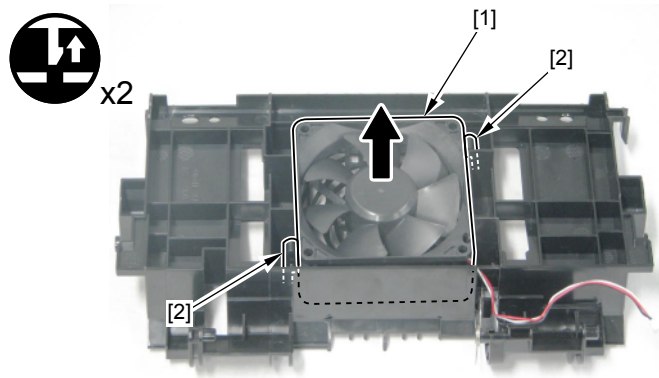

F-3-192

CAUTION:

Be sure to check the following when installing.

- Connect the Fan Cable [1] to the guide [A] of the fan.
- The label [2] of the fan should face the Duplex Feed Unit.

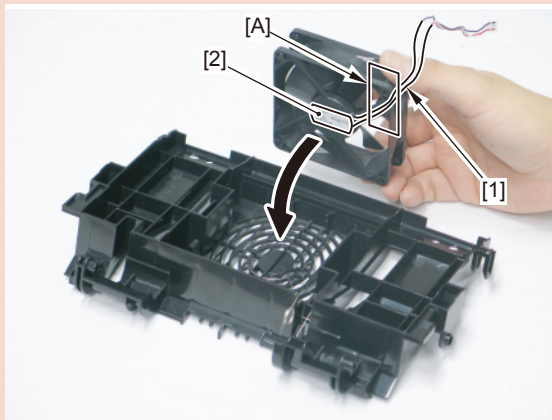

F-3-193

Laser Exposure System

Layout Drawing

LBP7600C/7660Cdn/7680Cx/7210Cdn

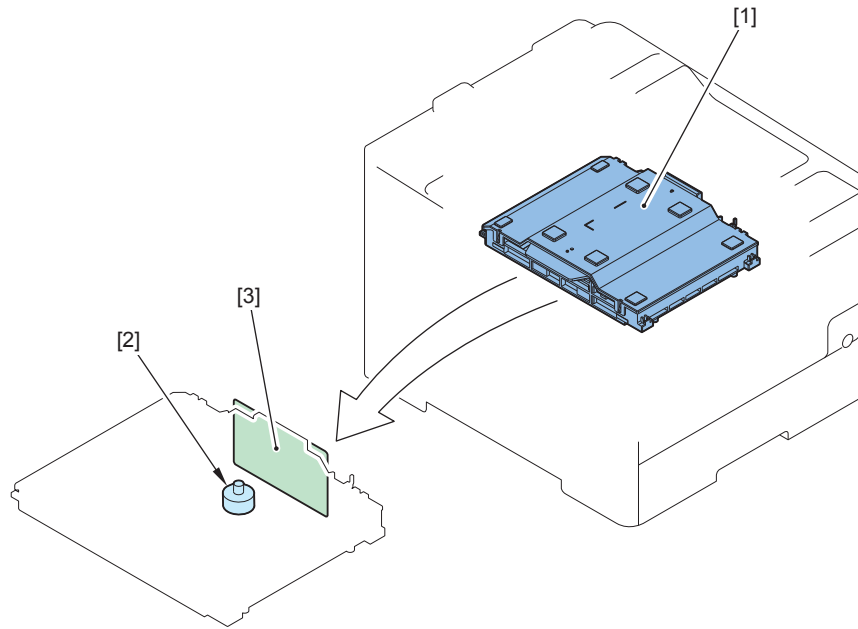

F-3-194

Key No.	Name	Main Unit	Reference	Adjustment during parts replacement	Remarks
[1]	Laser Scanner Unit	Main Unit	(Refer to page 3-89)	-	LBP7600C/7660Cdn /7680Cx LBP7210Cdn
[2]	Laser Scanner Motor	Laser Scanner Unit		-	M7
[3]	Laser Scanner PCB	Laser Scanner Unit		-	PCB10

T-3-14

Removing the Laser Scanner Unit LBP7600C/7660Cdn/7680Cx

Preparation

- 1) Remove the Right Cover.(Refer to page 3-20)
- 2) Remove the Operation Panel Unit.(Refer to page 3-56)
- 3) Remove the Rear Upper Cover (Left).(Refer to page 3-17)
- 4) Remove the Upper Front Cover (Right) / USB Cover.(Refer to page 3-23)
- 5) Remove the Upper Cover.(Refer to page 3-24)
- 6) Remove the Right Frame Cover.(Refer to page 3-38)
- 7) Remove the Right Upper Frame Unit.(Refer to page 3-43)
- 8) Remove the Left Cover.(Refer to page 3-22)
- 9) Remove the Rear Cover.(Refer to page 3-15)
- 10) Remove the Rear Lower Cover.(Refer to page 3-17)
- 11) Remove the Rear Cover Rib Unit.(Refer to page 3-16)
- 12) Remove the Duplex Reverse Drive Unit.(Refer to page 3-54)
- 13) Remove the Delivery Unit.(Refer to page 3-143)

Procedure

CAUTION:

When replacing this part, execute the actions to be taken when replacing the Laser Scanner Unit.

CAUTION:

Be sure not to disassemble the Laser Scanner Unit because it requires adjustment.

1) Remove the Harness Cover Plate [1].

- 2 Screws [2]

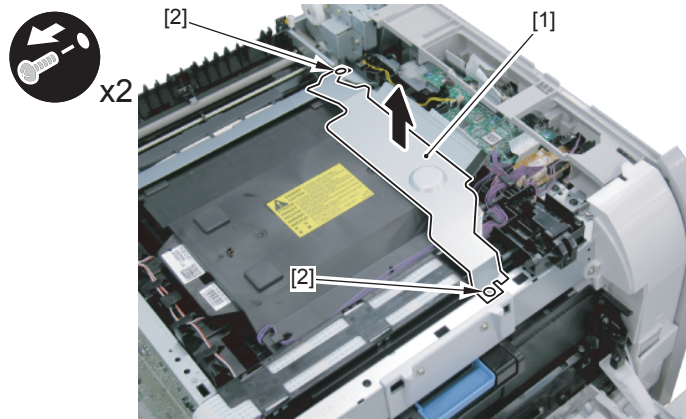

F-3-195

2) Remove the Guide Plate [1].

- 6 Claws [2]

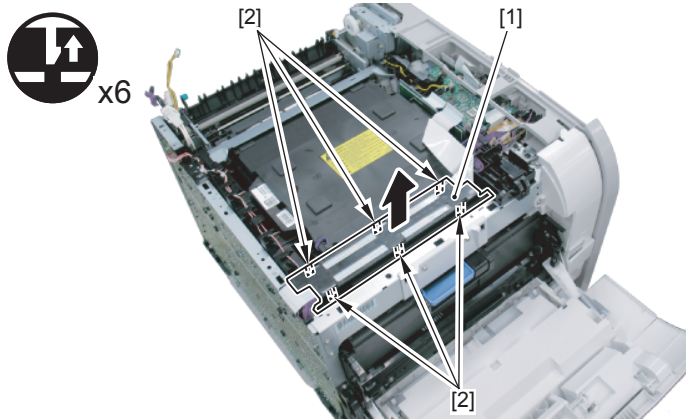

F-3-196

3) Disconnect the Flat Cable [1].

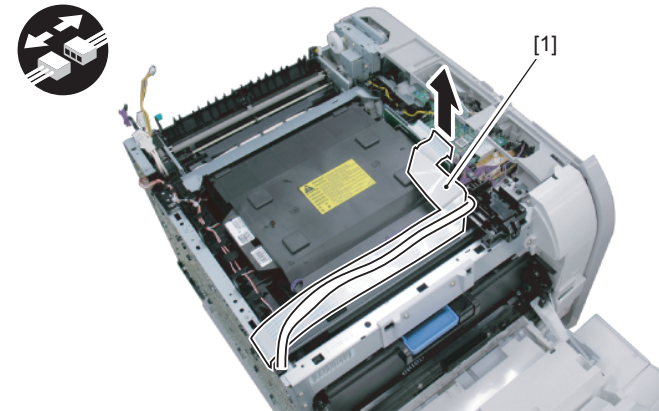

F-3-197

4) Free the harness [1] from the guide [A].

- 3 Connectors [2]

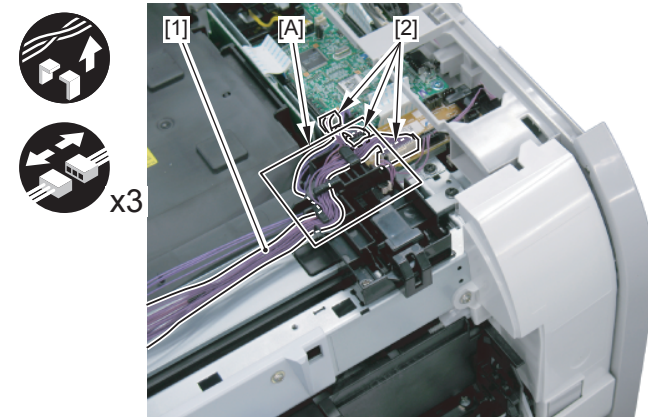

F-3-198

5) Remove the Harness Guide [1].

- 1 Screw [2]
- 1 Spring [3]
- 2 Hooks [4]

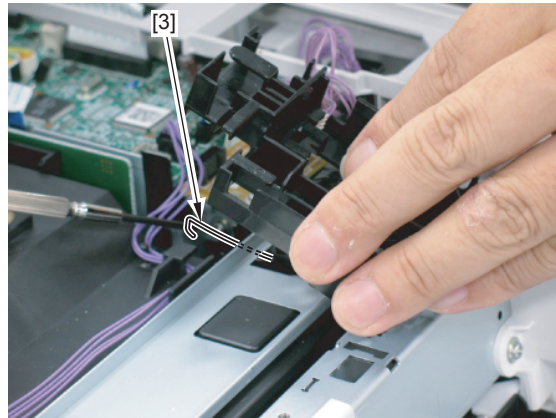
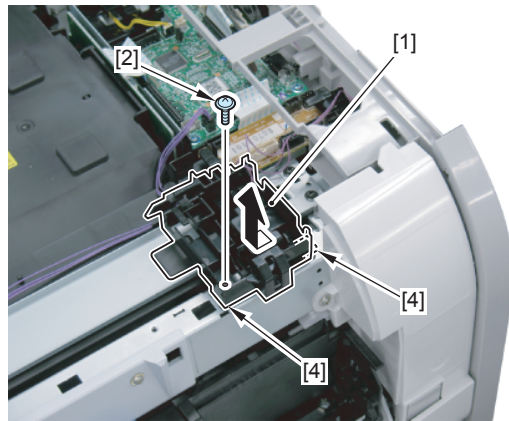

F-3-199

F-3-200

CAUTION:

Be sure to put the flag [1] of the Harness Guide through the hole [A] of the plate, and hook the spring [2] on the flag [3] of the Laser Scanner Unit when installing.

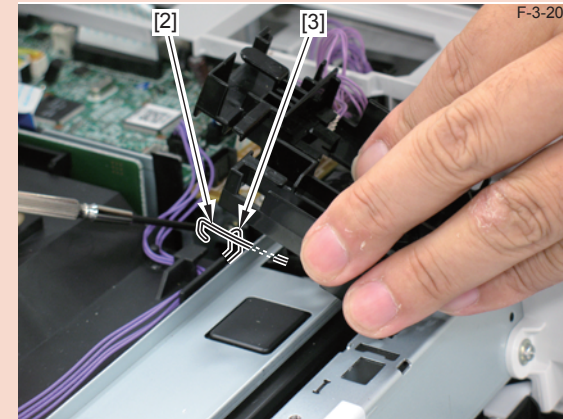
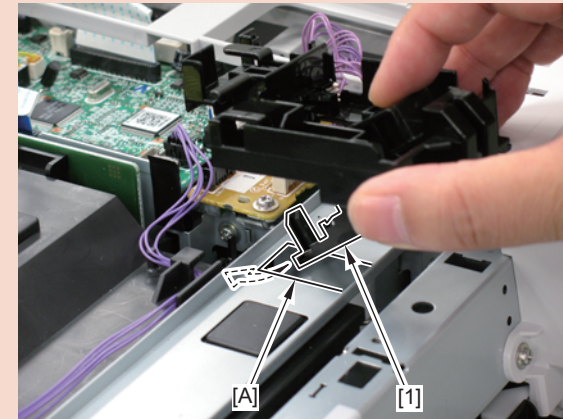

F-3-201

F-3-202

6) Remove the plate [1].

- 4 Screws [2]

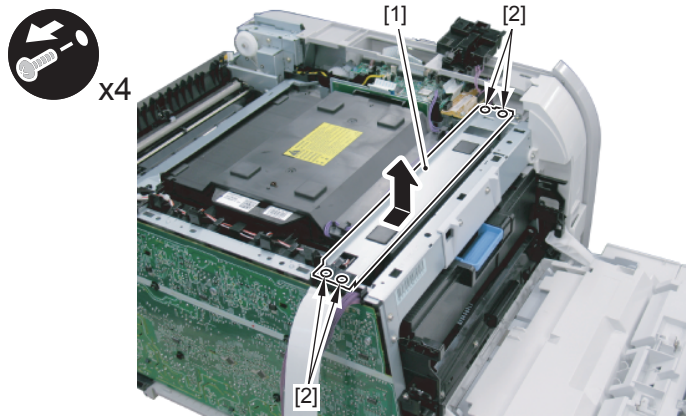

F-3-203

7) Disconnect the Flat Cable [1] and the connector [2].

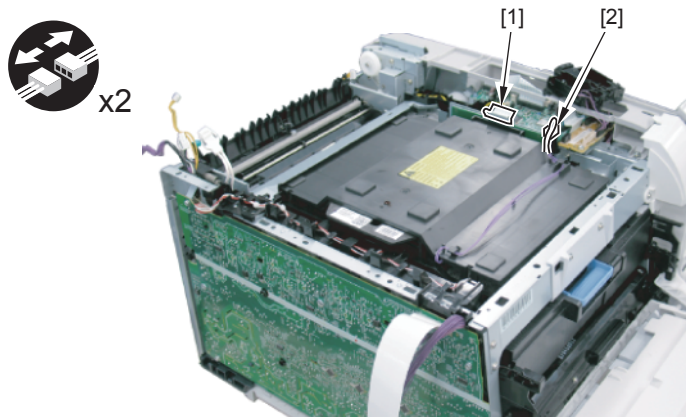

F-3-204

8) Remove the 3 springs [1].

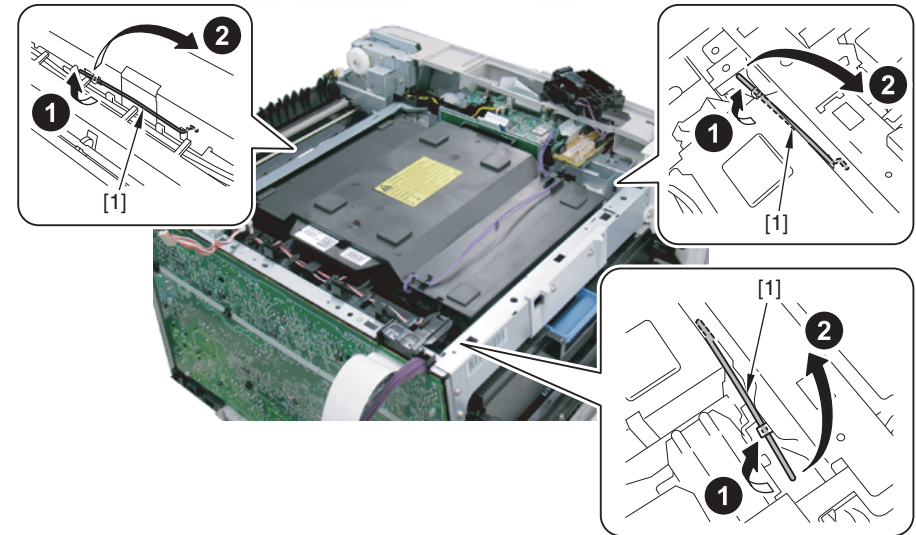

F-3-205

9) Remove the Laser Scanner Unit [1].

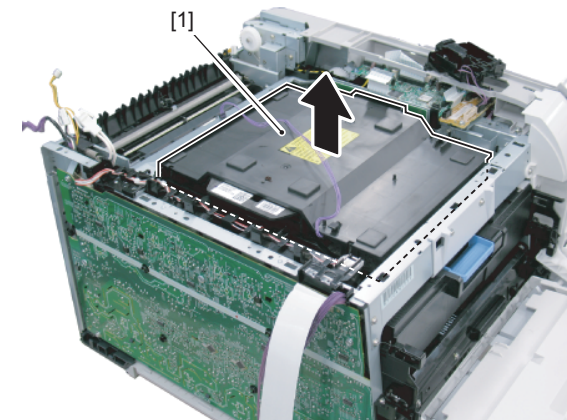

F-3-206

Removing the Laser Scanner Unit LBP7210Cdn

Preparation

- 1) Remove the Right Cover.(Refer to page 3-20)
- 2) Remove the Operation Panel Unit.(Refer to page 3-56)
- 3) Remove the Rear Upper Cover (Left).(Refer to page 3-17)
- 4) Remove the Upper Front Cover (Right) / USB Cover.(Refer to page 3-23)
- 5) Remove the Upper Cover.(Refer to page 3-24)
- 6) Remove the Right Frame Cover.(Refer to page 3-38)
- 7) Remove the Right Upper Frame Unit.(Refer to page 3-43)
- 8) Remove the Left Cover.(Refer to page 3-22)
- 9) Remove the Rear Cover.(Refer to page 3-15)
- 10) Remove the Rear Lower Cover.(Refer to page 3-17)
- 11) Remove the Rear Cover Rib Unit.(Refer to page 3-16)
- 12) Remove the Duplex Reverse Drive Unit.(Refer to page 3-54)
- 13) Remove the Delivery Unit.(Refer to page 3-143)

Procedure

CAUTION:

When replacing this part, execute the actions to be taken when replacing the Laser Scanner Unit.

CAUTION:

Be sure not to disassemble the Laser Scanner Unit because it requires adjustment.

- 1) Remove the Harness Cover Plate [1].
 - 2 Screws [2]

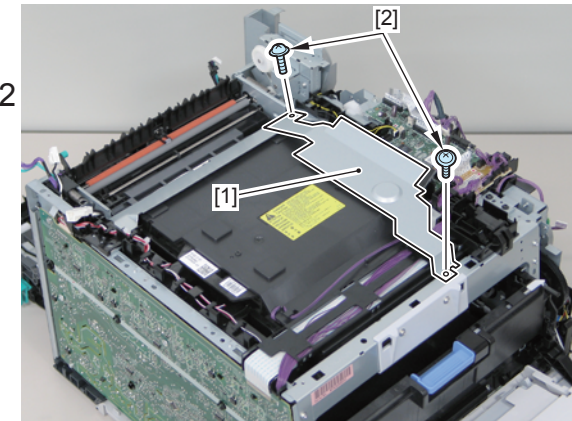

F-3-207

- 2) Remove the Guide Plate [1].
 - 6 Claws [2]

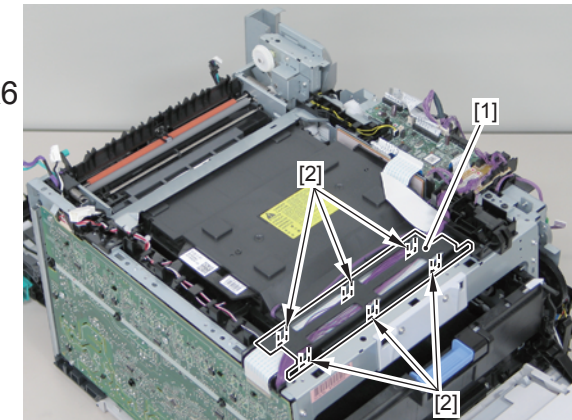

F-3-208

3) Disconnect the Flat Cable [1].

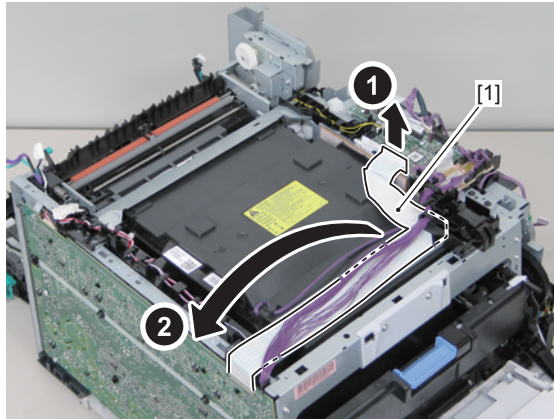

F-3-209

4) Free the harness [1] from the guide [A].

- 3 Connectors [2]



x3

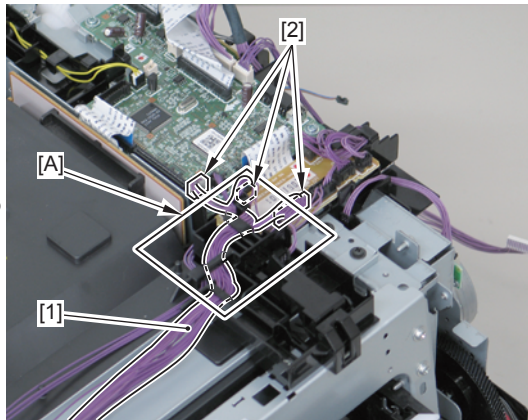

F-3-210

5) Remove the Harness Guide [1].

- 1 Screw [2]
- 1 Spring [3]
- 2 Hooks [4]

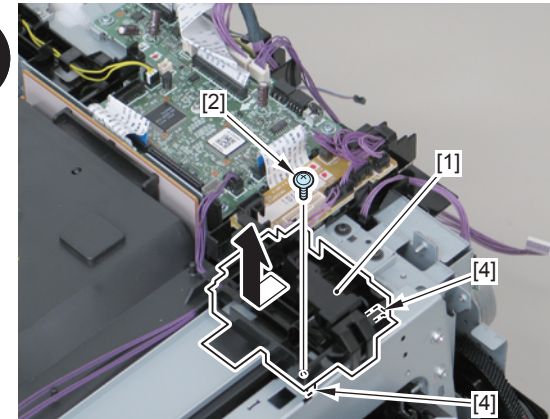

F-3-211

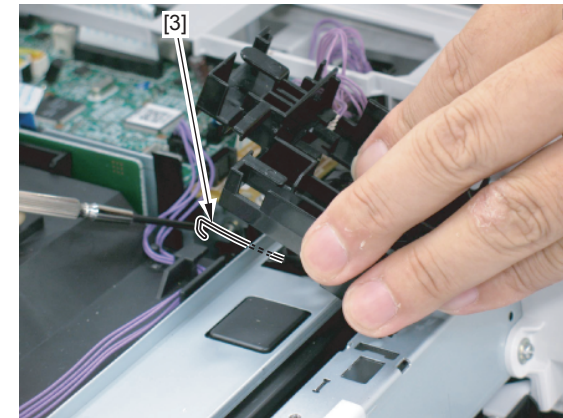

F-3-212

CAUTION:

Be sure to put the flag [1] of the Harness Guide through the hole [A] of the plate, and hook the spring [2] on the flag [3] of the Laser Scanner Unit when installing.

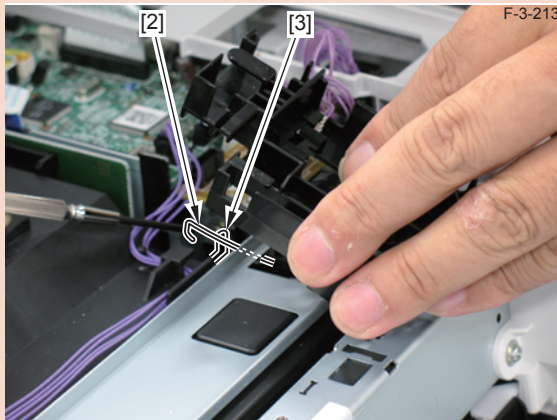
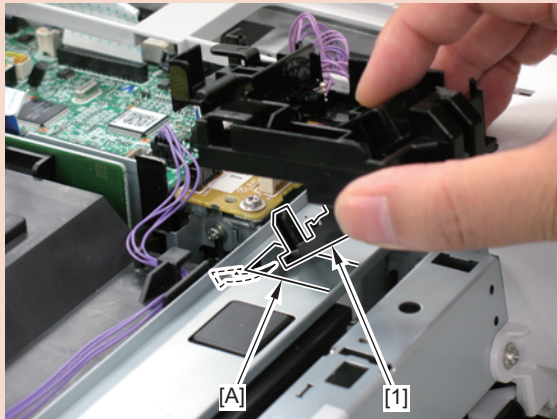

F-3-213

F-3-214

6) Remove the plate [1].

- 4 Screws [2]

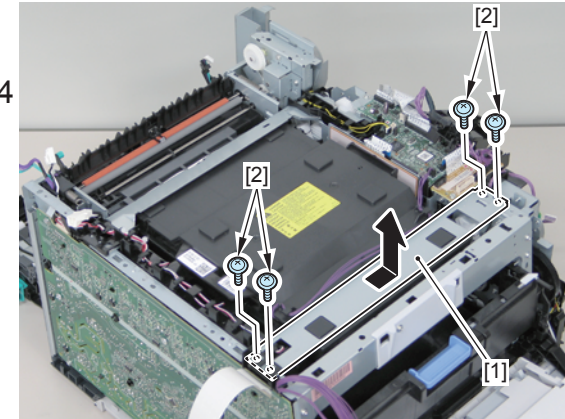

F-3-215

7) Disconnect the Flat Cable [1] and the connector [2].

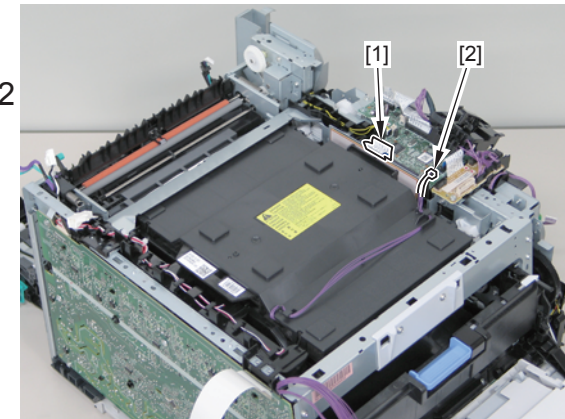

F-3-216

8) Remove the 3 springs [1].

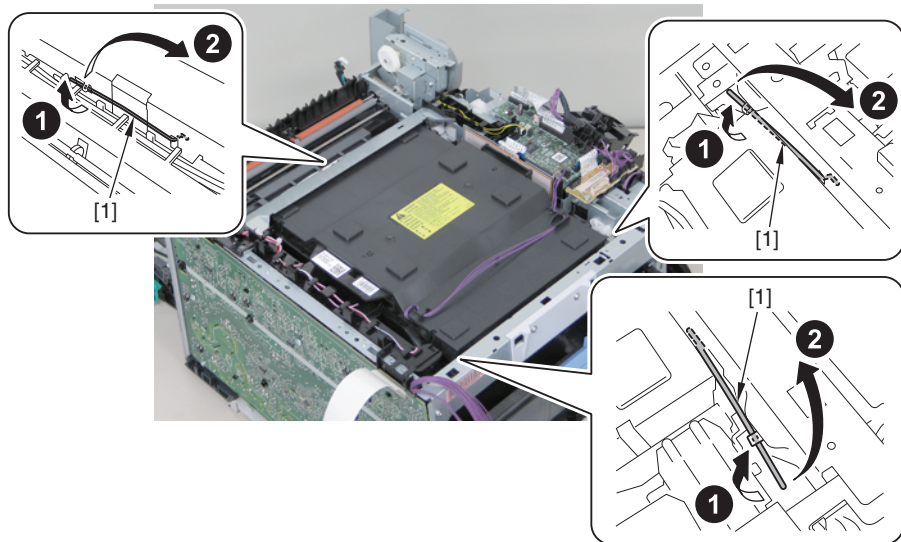

F-3-217

9) Remove the Laser Scanner Unit [1].

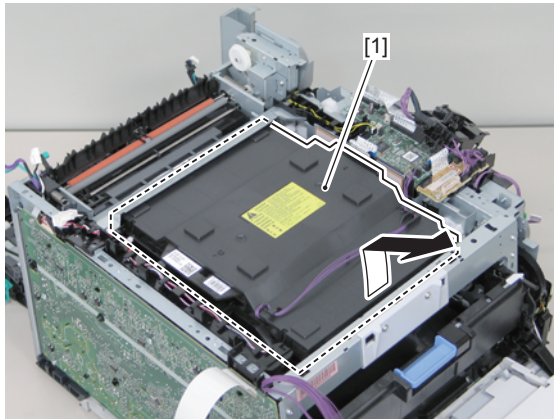

F-3-218

Image Formation System

Layout Drawing

LBP7600C/7660Cdn/7680Cx/7210Cdn

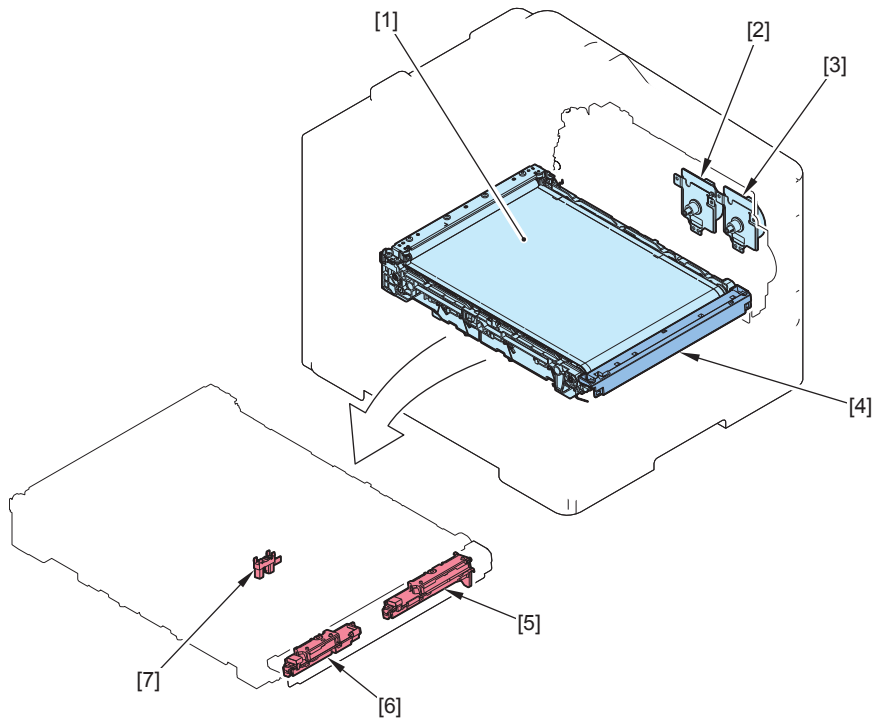

F-3-219

Key No.	Name	Main Unit	Reference	Adjustment during parts replacement	Remarks
[1]	ITB Unit	Main Unit	(Refer to page 3-104)	-	LBP7600C/7660Cdn /7680Cx LBP7210Cdn
[2]	Drum Motor	Main Drive Unit	(Refer to page 3-98)	-	M1, LBP7600C/7660Cdn /7680Cx M1, LBP7210Cdn
[3]	Developing Motor	Main Drive Unit	(Refer to page 3-101)	-	M2, LBP7600C/7660Cdn /7680Cx M2, LBP7210Cdn
[4]	Patch Sensor Unit	Main Unit	(Refer to page 3-110)	-	-
[5]	Registration Patch Sensor	Main Unit	-	-	PCB17
[6]	Patch Sensor	Main Unit	-	-	PCB18
[7]	ITB Pressure Release Sensor	ITB Unit	-	-	SR16

T-3-15

Removing the Drum Motor LBP7600C/7660Cdn/7680Cx

Preparation

- 1) Remove the Right Cover.(Refer to page 3-20)
- 2) Remove the Operation Panel Unit.(Refer to page 3-56)
- 3) Remove the Rear Upper Cover (Left).(Refer to page 3-17)
- 4) Remove the Upper Front Cover (Right) / USB Cover.(Refer to page 3-23)
- 5) Remove the Upper Cover.(Refer to page 3-24)
- 6) Remove the Right Frame Cover.(Refer to page 3-38)
- 7) Remove the Right Upper Frame Unit.(Refer to page 3-43)

Procedure

- 1) Disconnect the Flat Cable [1] and the 10 connectors [2], and free the harness [3] from the Harness Guide [A].

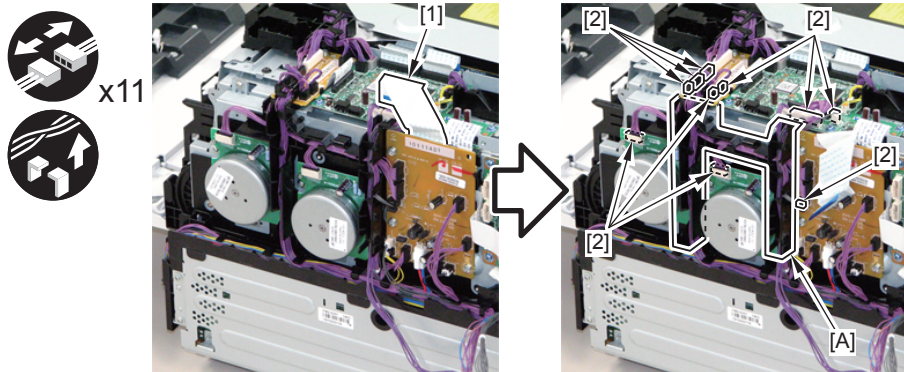

F-3-220

CAUTION:

Be sure to place the Harness Band [2] of the harness [1] between the 2 claws [3] of the Harness Guide at installation.

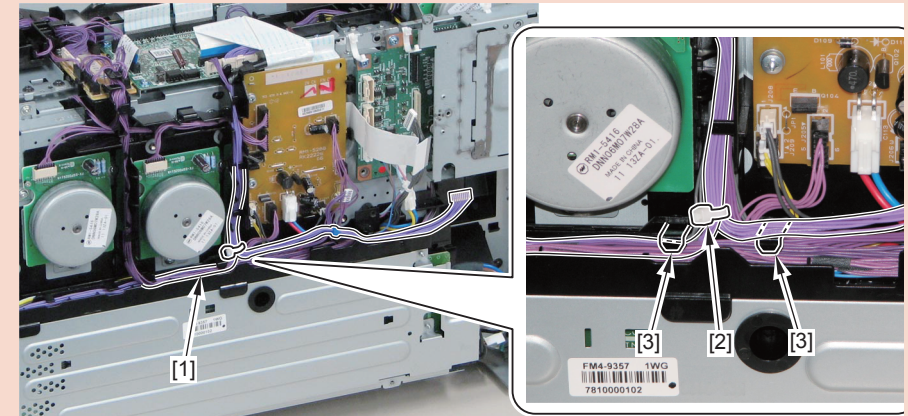

F-3-221

- 2) Remove the Harness Guide [1].

- 1 Claw [2]
- 2 Bosses [3]
- 2 Hooks [4]

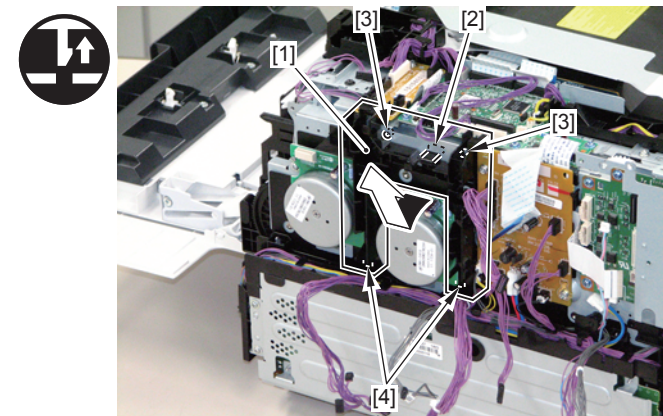

F-3-222

3) Remove the Drum Motor [1].

- 3 Screws [2]

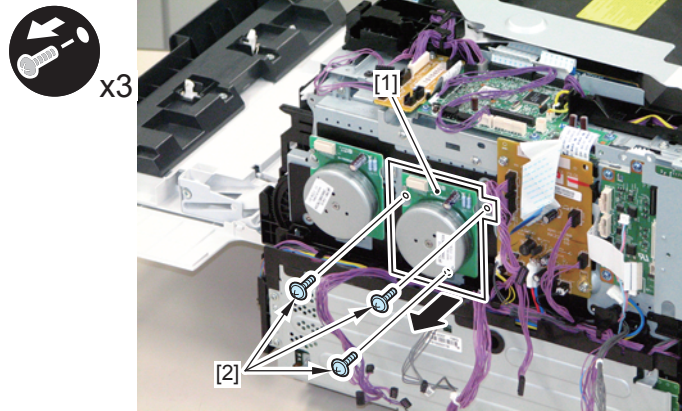

F-3-223

CAUTION:

Be sure to identify the Drum Motor and the Developing Motor by the difference in gears.

- Gear [1] of the Drum Motor: White, with a groove [A] on its side
- Gear [2] of the Developing Motor: Black, with no groove

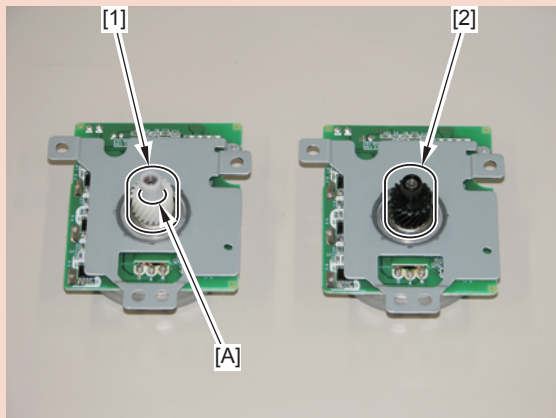

F-3-224

Removing the Drum Motor LBP7210Cdn

Preparation

- 1) Remove the Right Cover.(Refer to page 3-20)
- 2) Remove the Operation Panel Unit.(Refer to page 3-56)
- 3) Remove the Rear Upper Cover (Left).(Refer to page 3-17)
- 4) Remove the Upper Front Cover (Right) / USB Cover.(Refer to page 3-23)
- 5) Remove the Upper Cover.(Refer to page 3-24)
- 6) Remove the Right Frame Cover.(Refer to page 3-38)
- 7) Remove the Right Upper Frame Unit.(Refer to page 3-43)

Procedure

- 1) Disconnect the Flat Cable [1] and the 10 connectors [2], and free the harness [3] from the Harness Guide [A].

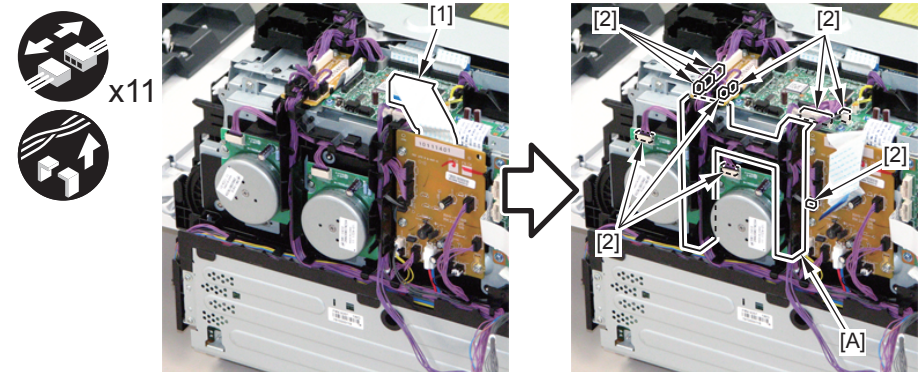

F-3-225

2) Remove the Harness Guide [1].

- 1 Claw [2]
- 2 Bosses [3]
- 2 Hooks [4]

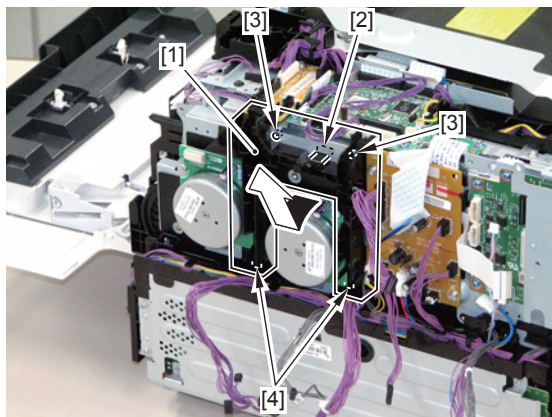

F-3-226

3) Remove the Drum Motor [1].

- 3 Screws [2]



x3

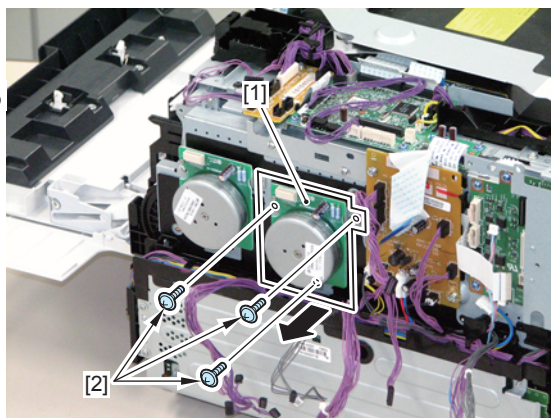

F-3-227

CAUTION:

Be sure to identify the Drum Motor and the Developing Motor by the difference in gears.

- Gear [1] of the Drum Motor: White, with a groove [A] on its side
- Gear [2] of the Developing Motor: Black, with no groove

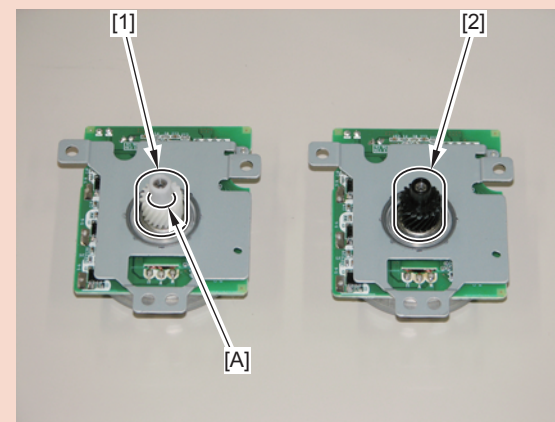

F-3-228

Removing the Developing Motor LBP7600C/7660Cdn/7680Cx

Preparation

- 1) Remove the Right Cover.(Refer to page 3-20)
- 2) Remove the Operation Panel Unit.(Refer to page 3-56)
- 3) Remove the Rear Upper Cover (Left).(Refer to page 3-17)
- 4) Remove the Upper Front Cover (Right) / USB Cover.(Refer to page 3-23)
- 5) Remove the Upper Cover.(Refer to page 3-24)
- 6) Remove the Right Frame Cover.(Refer to page 3-38)
- 7) Remove the Right Upper Frame Unit.(Refer to page 3-43)

Procedure

- 1) Disconnect the Flat Cable [1] and the 10 connectors [2], and free the harness [3] from the Harness Guide [A].

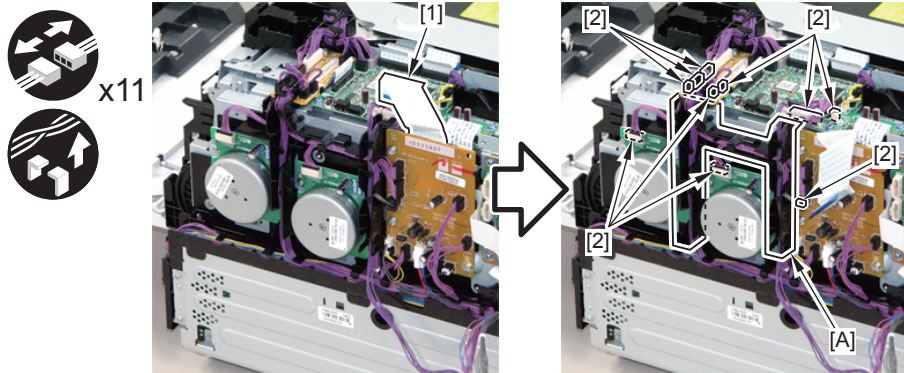

F-3-229

CAUTION:

Be sure to place the Harness Band [2] of the harness [1] between the 2 claws [3] of the Harness Guide at installation.

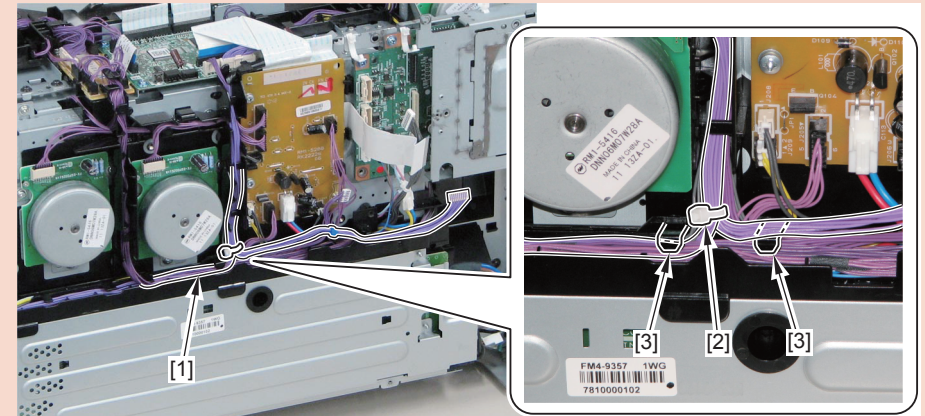

F-3-230

- 2) Remove the Harness Guide [1].

- 1 Claw [2]
- 2 Bosses [3]
- 2 Hooks [4]

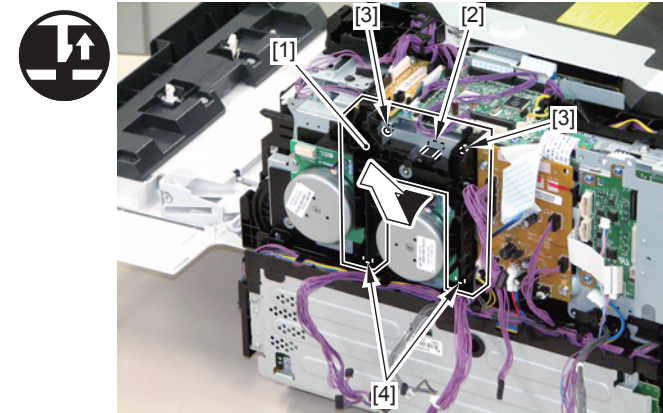

F-3-231

3) Remove the Developing Motor [1].

- 3 Screws [2]

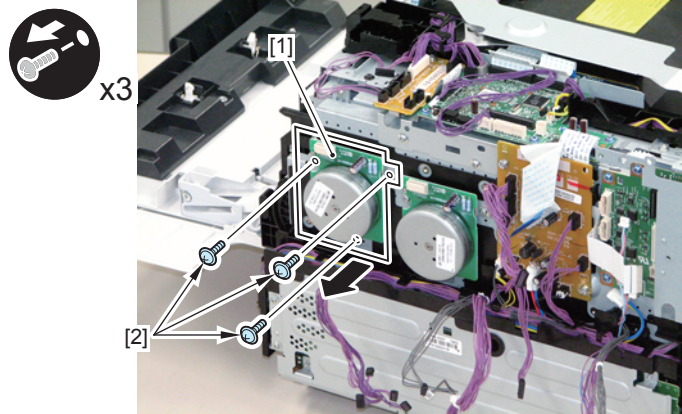

F-3-232

CAUTION:

Be sure to identify the Drum Motor and the Developing Motor by the difference in gears.

- Gear [1] of the Drum Motor: White, with a groove [A] on its side
- Gear [2] of the Developing Motor: Black, with no groove

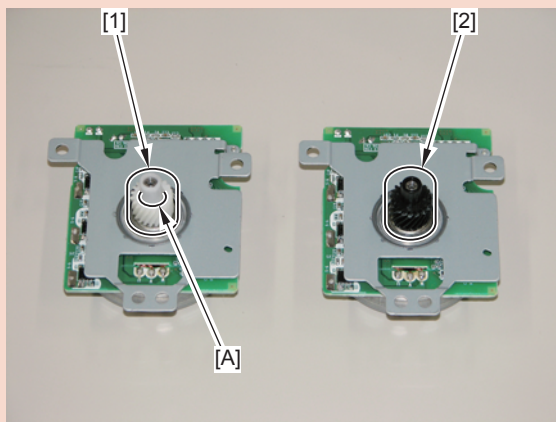

F-3-233

Removing the Developing Motor LBP7210Cdn

Preparation

- 1) Remove the Right Cover.(Refer to page 3-20)
- 2) Remove the Operation Panel Unit.(Refer to page 3-56)
- 3) Remove the Rear Upper Cover (Left).(Refer to page 3-17)
- 4) Remove the Upper Front Cover (Right) / USB Cover.(Refer to page 3-23)
- 5) Remove the Upper Cover.(Refer to page 3-24)
- 6) Remove the Right Frame Cover.(Refer to page 3-38)
- 7) Remove the Right Upper Frame Unit.(Refer to page 3-43)

Procedure

- 1) Disconnect the Flat Cable [1] and the 10 connectors [2], and free the harness [3] from the Harness Guide [A].

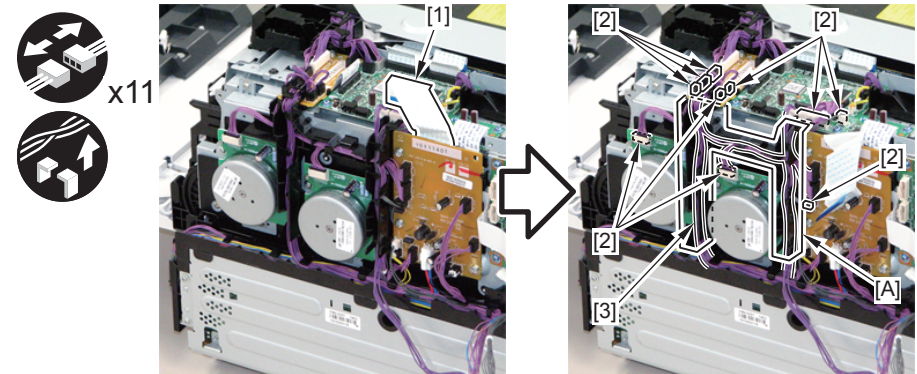

F-3-234

2) Remove the Harness Guide [1].

- 1 Claw [2]
- 2 Bosses [3]
- 2 Hooks [4]

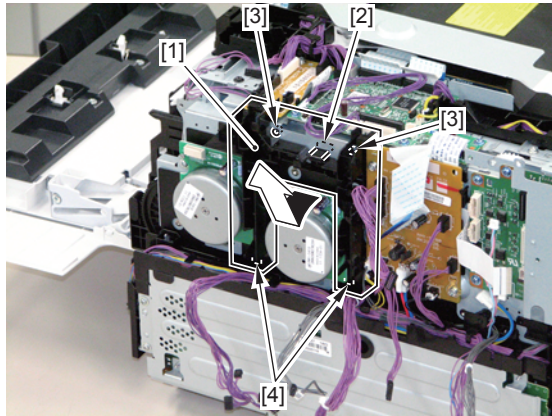

F-3-235

3) Remove the Developing Motor [1].

- 3 Screws [2]



x3

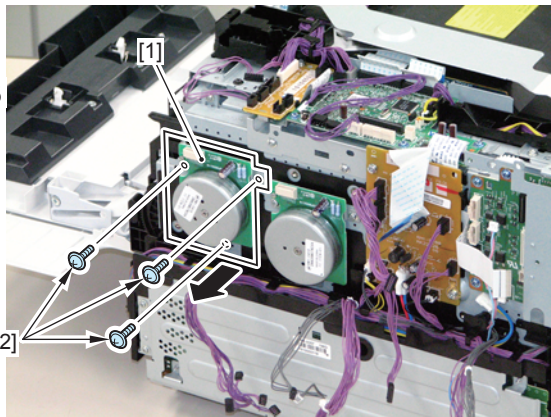

F-3-236

CAUTION:

Be sure to identify the Drum Motor and the Developing Motor by the difference in gears.

- Gear [1] of the Drum Motor: White, with a groove [A] on its side
- Gear [2] of the Developing Motor: Black, with no groove

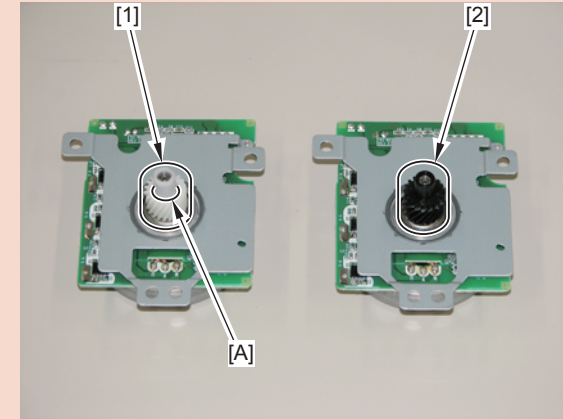

F-3-237

Removing the ITB Unit LBP7600C/7660Cdn/7680Cx

Procedure

CAUTION:

Be sure not to touch the surface of the ITB and the Secondary Transfer Roller when disassembling/assembling.

- 1) Open the Rear Cover and Front Cover.
- 2) Remove the Toner Cartridges (Y/M/C/Bk).
- 3) While raising the stopper [1], pull out the Cartridge Tray [2].
 - 1 Protrusion [3]

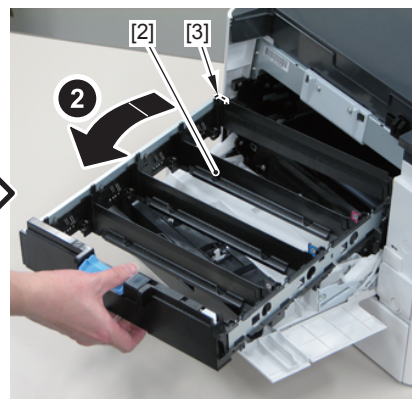
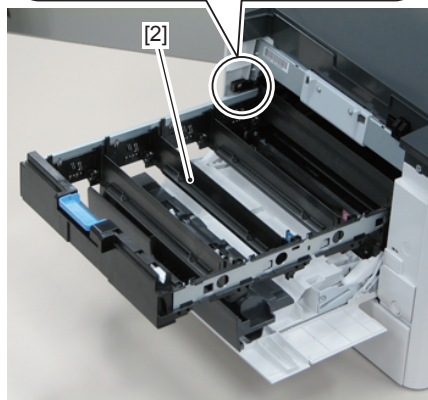
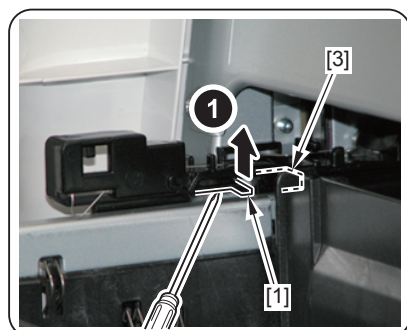

F-3-238

- 4) Move the Patch Sensor Unit [1].
 - 2 Screws [2]
 - 2 Bosses [3]
 - 2 Protrusions [4]

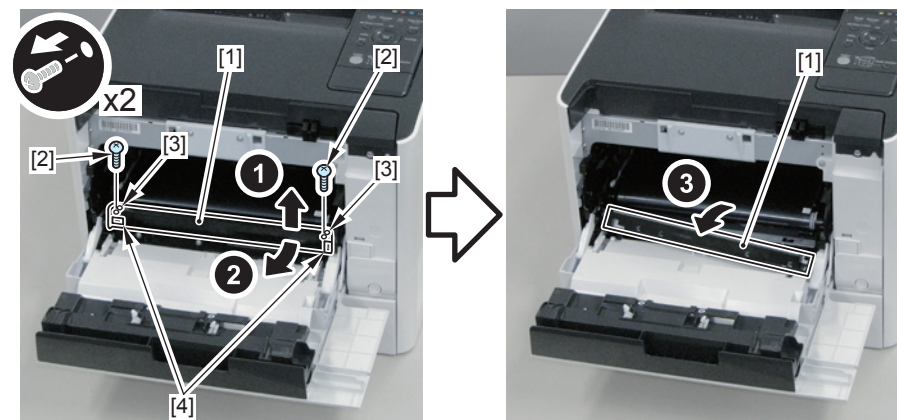

F-3-239

- 5) Disconnect the connector [1].

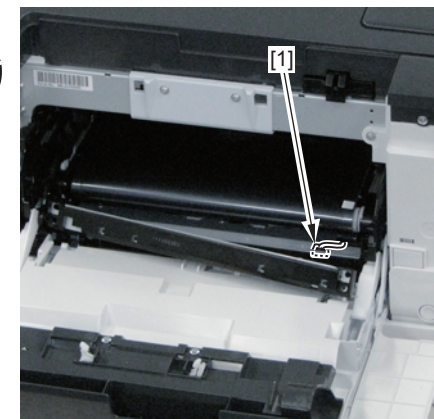

F-3-240

6) Lift the 2 parts [A] at the front side of the ITB Unit to release the 2 protrusions [1].

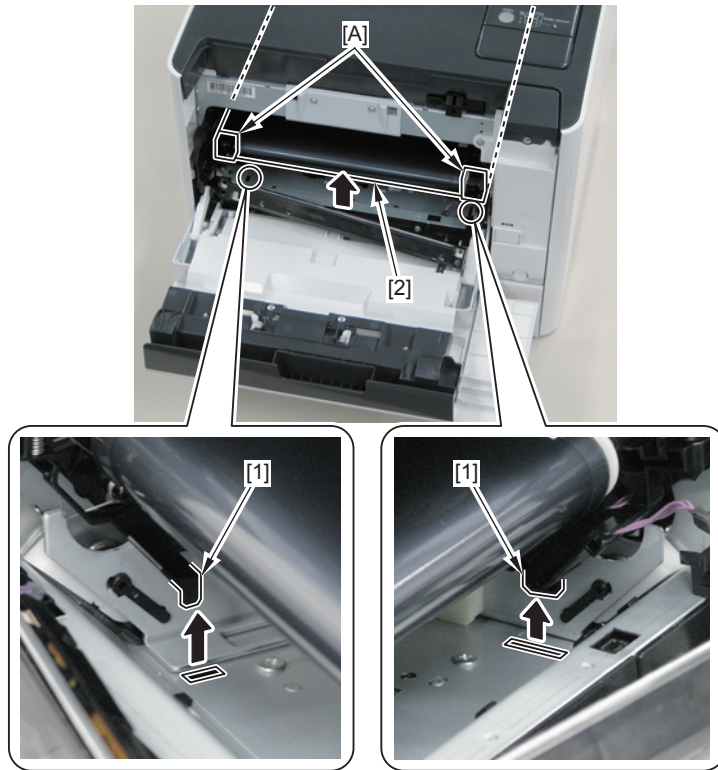

F-3-241

7) Place the 2 parts [B] at the rear side of ITB Unit on the rail [C].

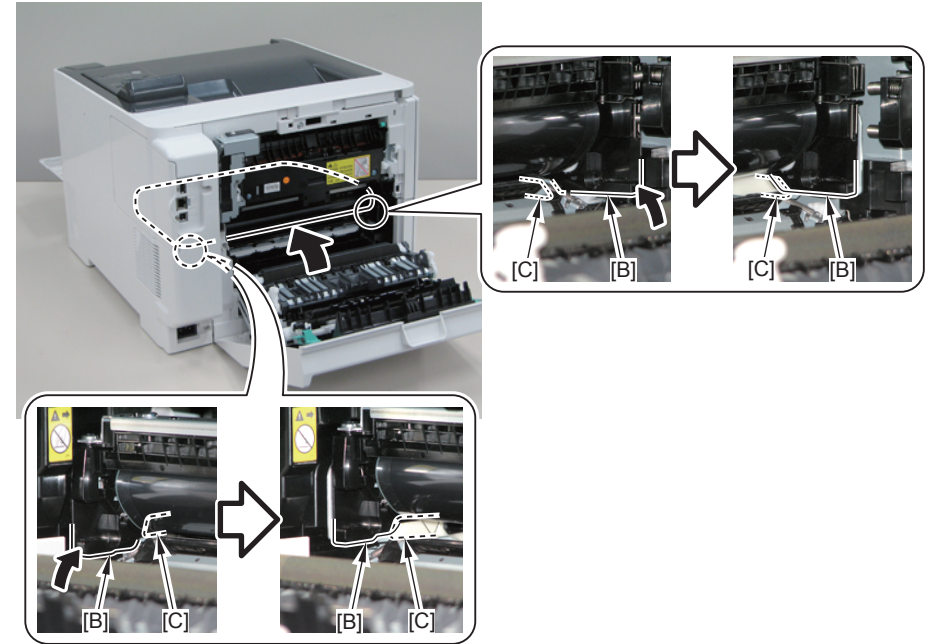

CAUTION:

Be sure that the ITB [1] does not come into contact with the Patch Sensor Unit [2] when installing/removing

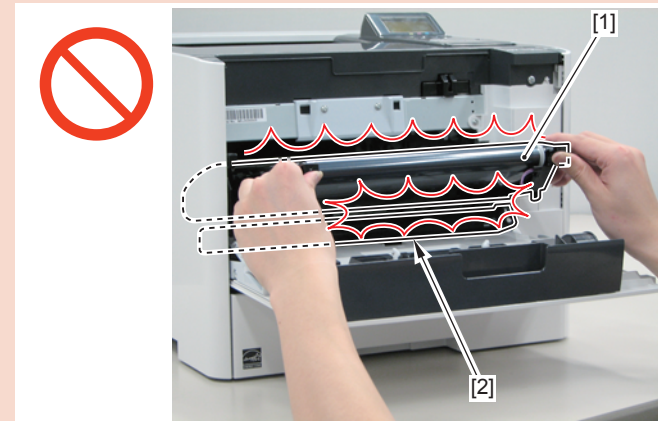

F-3-243

- 8) Hold the 2 parts [A] at the front side of the ITB Unit to tilt the ITB Unit [1].
- 9) Slide the 2 parts [B] at the rear side of the ITB Unit along the rail [2], and remove it by pulling it out.

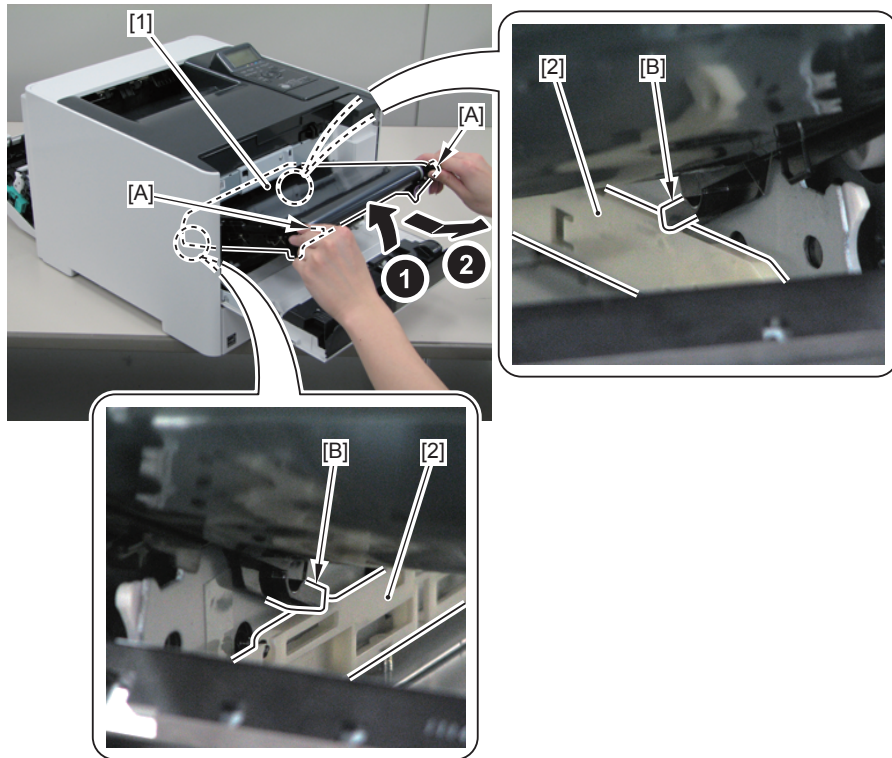

F-3-244

CAUTION:

Be sure to install the harness [1] to the guide [A] of the ITB Unit when installing.

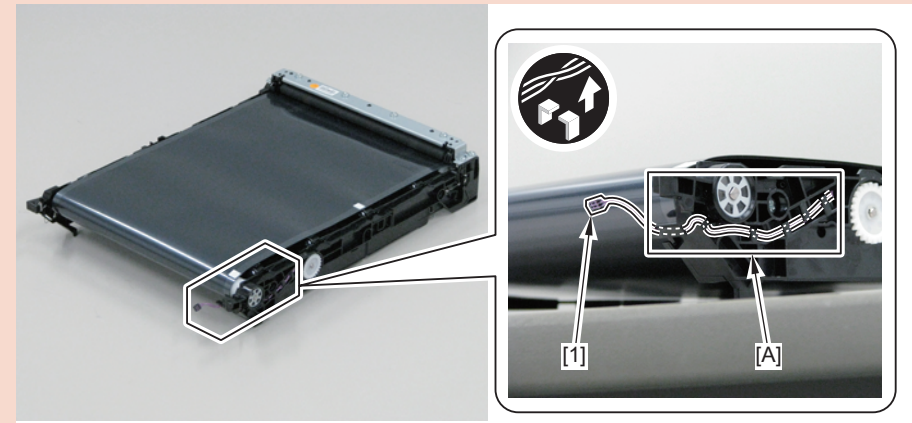

F-3-245

Removing the ITB Unit LBP7210Cdn

Procedure

CAUTION:

Be sure not to touch the surface of the ITB and the Secondary Transfer Roller when disassembling/assembling.

- 1) Open the Rear Cover and Front Cover.
- 2) Remove the Toner Cartridges (Y/M/C/Bk).
- 3) While raising the stopper [1], pull out the Cartridge Tray [2].
 - 1 Protrusion [3]

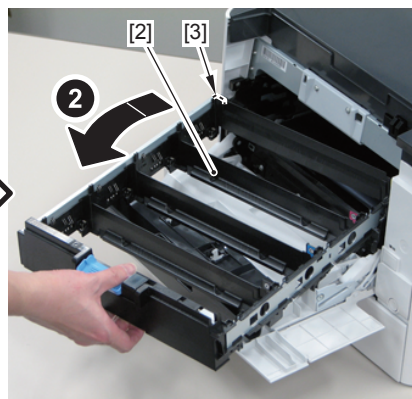
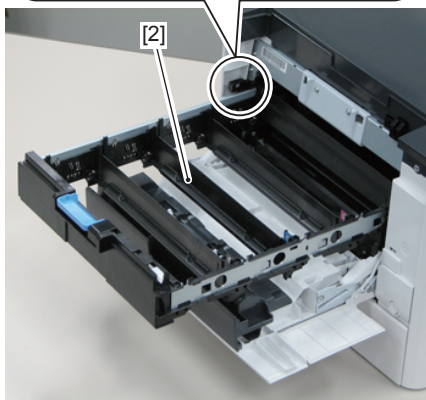
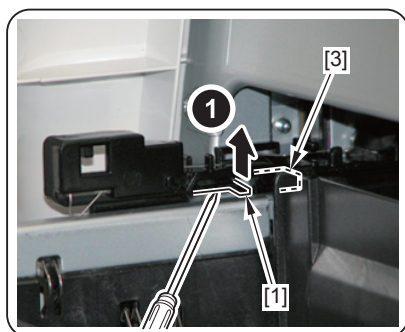

F-3-246

- 4) Move the Patch Sensor Unit [1].
 - 2 Screws [2]
 - 2 Bosses [3]
 - 2 Protrusions [4]

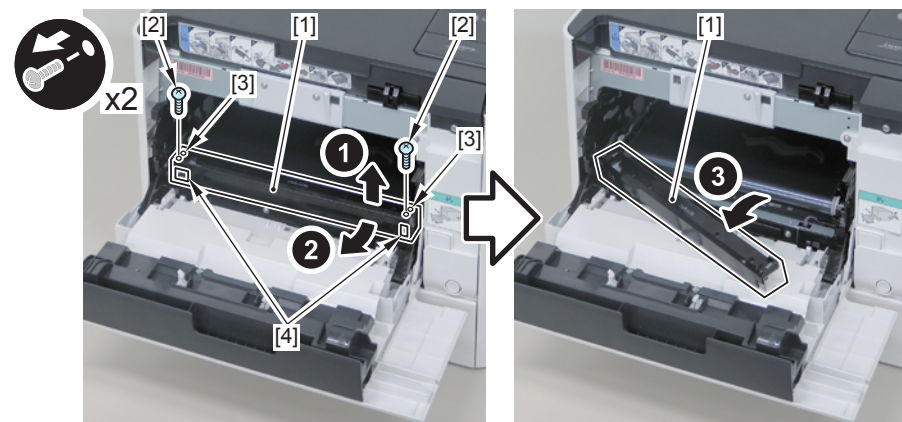

F-3-247

- 5) Disconnect the connector [1].

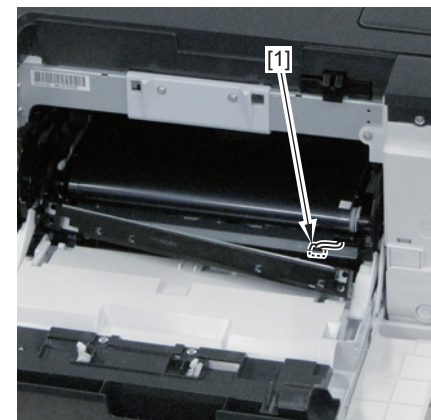

F-3-248

6) Lift the 2 parts [A] at the front side of the ITB Unit to release the 2 protrusions [1].

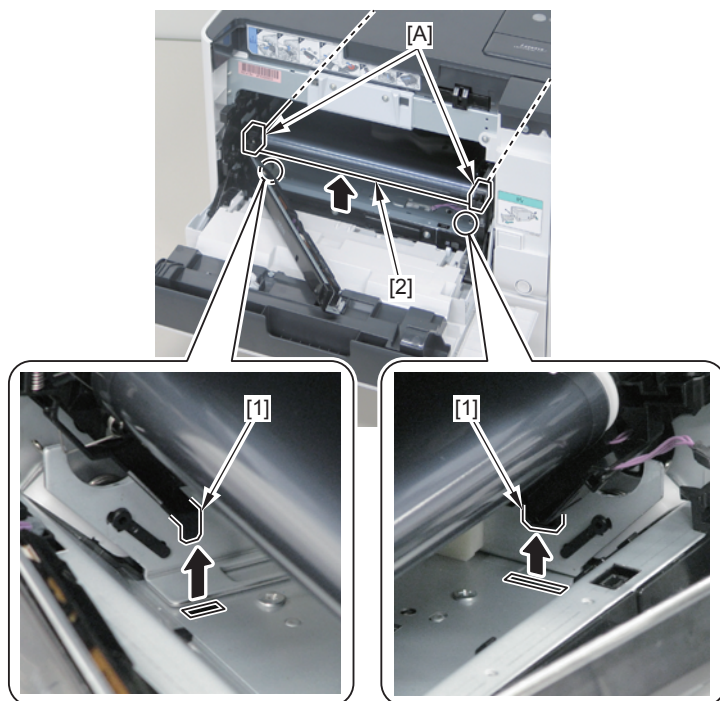

F-3-249

7) Place the 2 parts [B] at the rear side of ITB Unit on the rail [C].

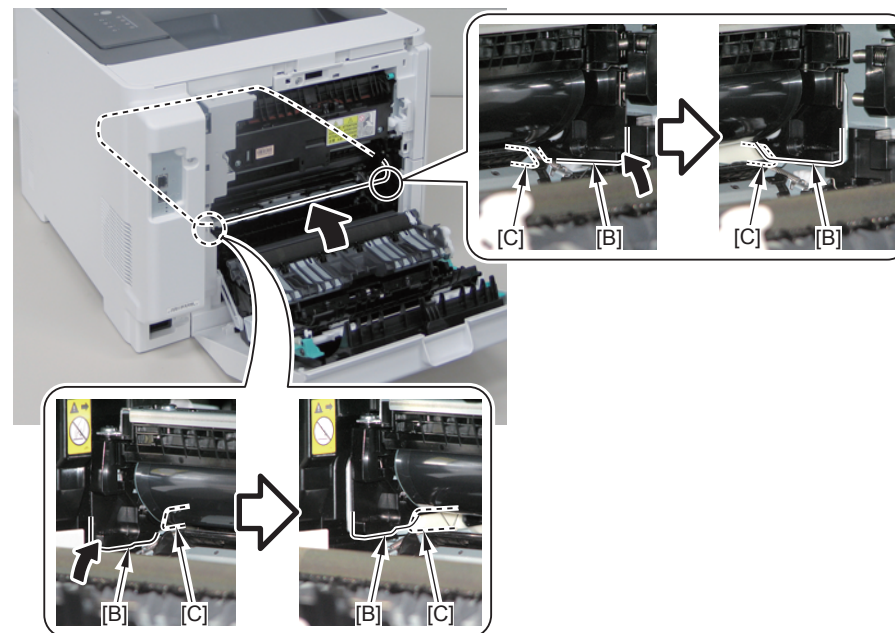

CAUTION:

F-3-250

Be sure that the ITB [1] does not come into contact with the Patch Sensor Unit [2] when installing/removing

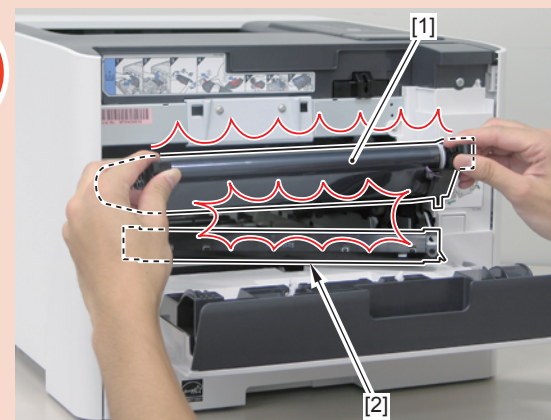

F-3-251

- 8) Hold the 2 parts [A] at the front side of the ITB Unit to tilt the ITB Unit [1].
- 9) Slide the 2 parts [B] at the rear side of the ITB Unit along the rail [2], and remove it by pulling it out.

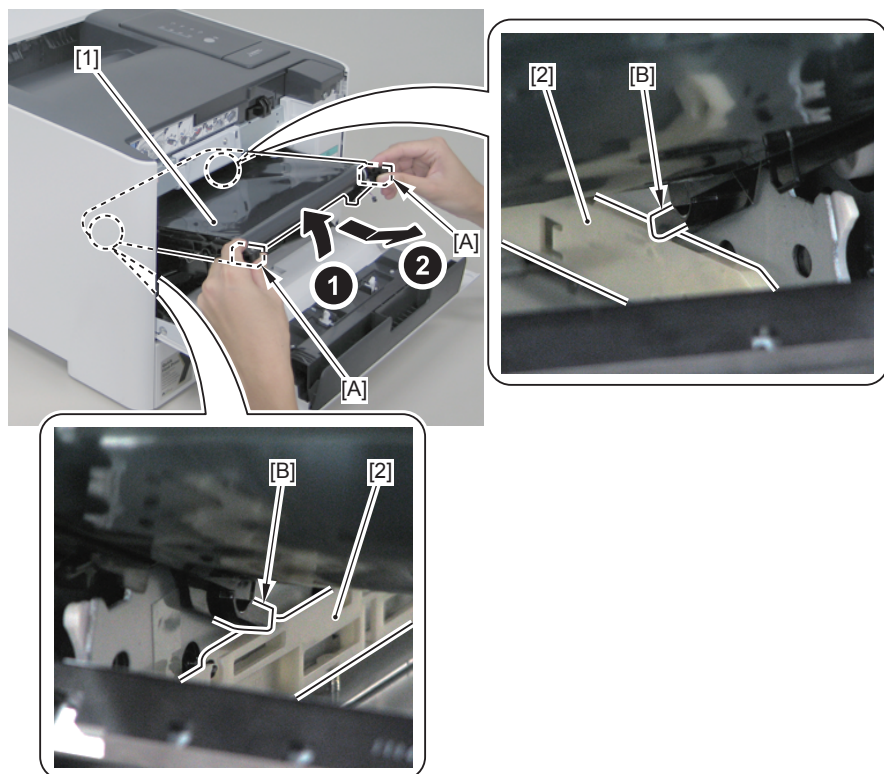

F-3-252

CAUTION:

Be sure to install the harness [1] to the guide [A] of the ITB Unit when installing.

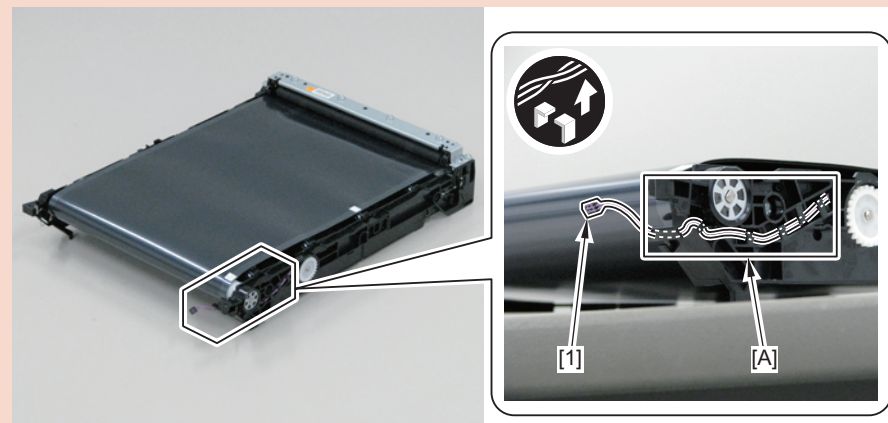

F-3-253

Removing the Patch Sensor Unit LBP7600C/7660Cdn/7680Cx/7210Cdn

Preparation

- 1) Remove the ITB Unit.(Refer to page 3-104)
- 2) Remove the Right Cover.(Refer to page 3-20)
- 3) Remove the Operation Panel Unit.(Refer to page 3-56)
- 4) Remove the Rear Upper Cover (Left).(Refer to page 3-17)
- 5) Remove the Upper Front Cover (Right) / USB Cover.(Refer to page 3-23)
- 6) Remove the Upper Cover.(Refer to page 3-24)
- 7) Remove the Left Cover.(Refer to page 3-22)
- 8) Remove the High-voltage Power Supply PCB.(Refer to page 3-81)
- 9) Remove the Right Frame Cover.(Refer to page 3-38)
- 10) Remove the Right Upper Frame Unit.(Refer to page 3-43)

Procedure

- 1) Free the harness [1] from the Harness Guide [A] and [B].
 - 1 Connector [2]

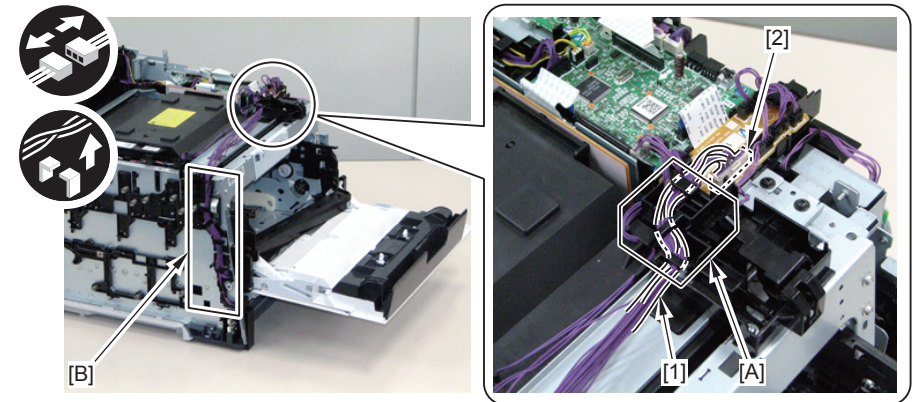

F-3-254

- 2) Put the connector [1] facing up through the hole [C] of the guide, and remove the Patch Sensor Unit [2].

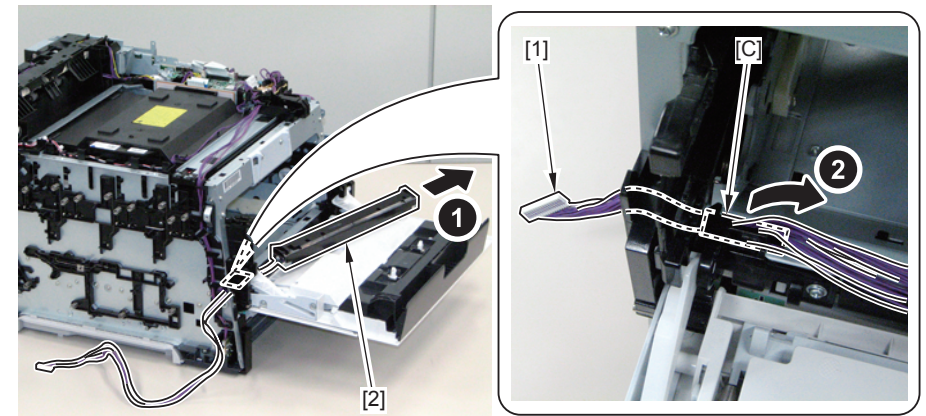

F-3-255

Fixing System

Layout Drawing

LBP7600C/7660Cdn/7680Cx/7210Cdn

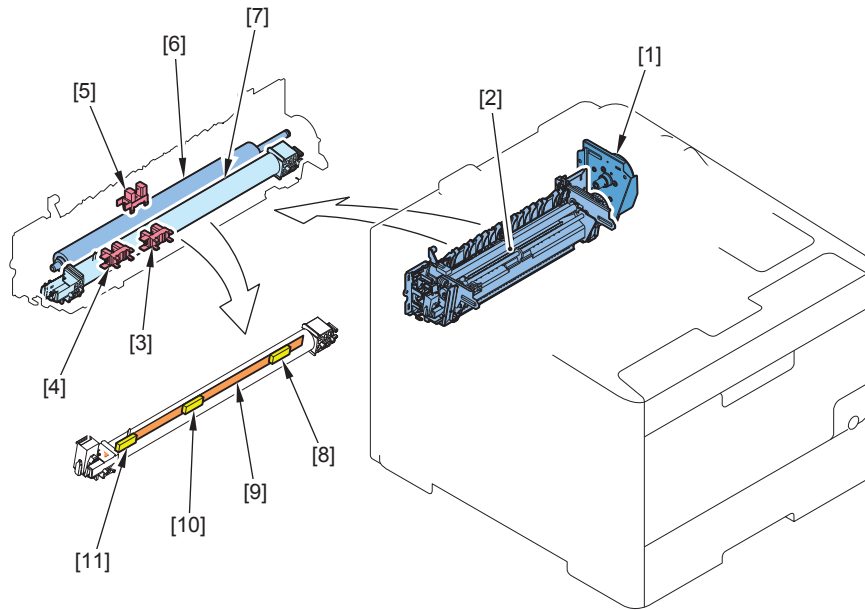

F-3-256

Key No.	Name	Main Unit	Reference	Adjustment during parts replacement	Remarks
[1]	Fixing Motor	Main Unit	(Refer to page 3-125)	-	M4
[2]	Fixing Assembly	Main Unit	(Refer to page 3-112)	-	LBP7600C/7660Cdn /7680Cx LBP7210Cdn
[3]	Fixing Loop Sensor	Fixing Assembly	-	-	SR10
[4]	Fixing Pressure Release Sensor	Fixing Assembly	-	-	SR9
[5]	Fixing Delivery Sensor	Fixing Assembly	-	-	SR8
[6]	Fixing Pressure Roller	Fixing Assembly	(Refer to page 3-124)	-	-
[7]	Fixing Film Unit	Fixing Assembly	(Refer to page 3-115)	-	LBP7600C/7660Cdn /7680Cx LBP7210Cdn
[8]	Sub Thermistor 2	Fixing Assembly	-	-	TH803
[9]	Fixing Heater	Fixing Assembly	-	-	H100 (100V) /H120 (120V) /H220 (220V)
[10]	Main Thermistor	Fixing Assembly	-	-	TH801
[11]	Sub Thermistor 1	Fixing Assembly	-	-	TH802

T-3-16

Removing the Fixing Assembly LBP7600C/7660Cdn/7680Cx

Preparation

- 1) Remove the Right Cover.(Refer to page 3-20)
- 2) Remove the Rear Upper Cover (Left).(Refer to page 3-17)
- 3) Remove the Rear Cover.(Refer to page 3-15)
- 4) Remove the Rear Lower Cover.(Refer to page 3-17)
- 5) Remove the Rear Cover Rib Unit.(Refer to page 3-16)
- 6) Remove the Duplex Reverse Drive Unit.(Refer to page 3-54)

Procedure

- 1) Release the claw [1], move the Harness Guide [2] and disconnect the connector [3].

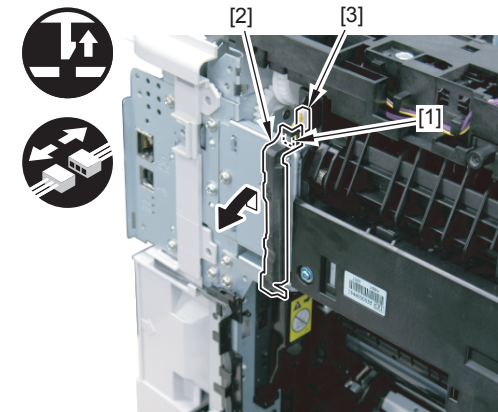

F-3-257

- 2) Free the harness [1] from the Harness Guide [A].

- 1 Wire Saddle [2]
- 2 Connectors [3]
- 1 Connector [4]

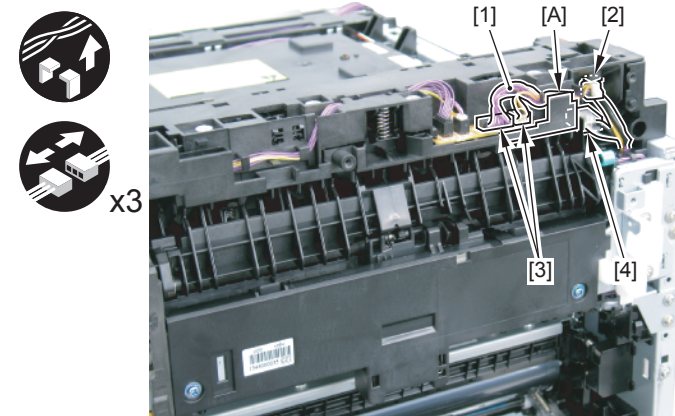

F-3-258

CAUTION:

At installation, be sure to locate the harness as shown in the figure below.

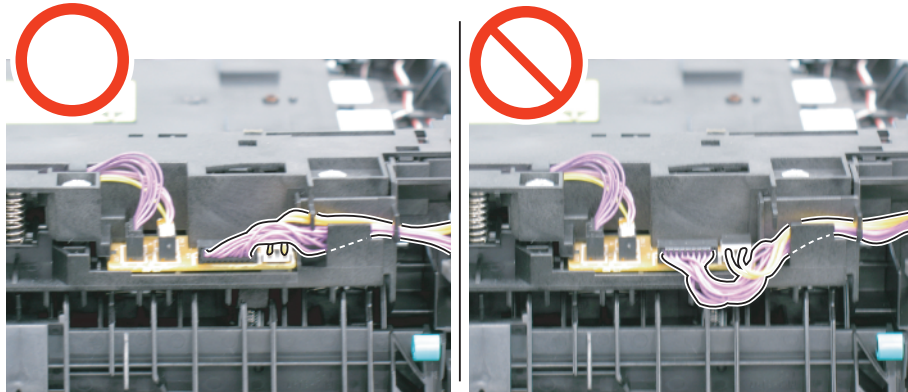

F-3-259

Removing the Fixing Assembly LBP7210Cdn

Preparation

- 1) Remove the Right Cover.(Refer to page 3-20)
- 2) Remove the Rear Upper Cover (Left).(Refer to page 3-17)
- 3) Remove the Rear Cover.(Refer to page 3-15)
- 4) Remove the Rear Lower Cover.(Refer to page 3-17)
- 5) Remove the Rear Cover Rib Unit.(Refer to page 3-16)
- 6) Remove the Duplex Reverse Drive Unit.(Refer to page 3-54)

3) Remove the Fixing Assembly [1].

- 2 Screws [2]

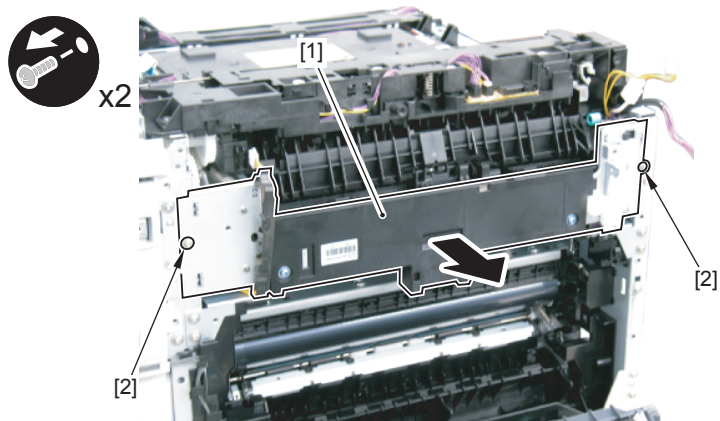

F-3-260

Procedure

1) Release the claw [1], move the Harness Guide [2] and disconnect the connector [3].

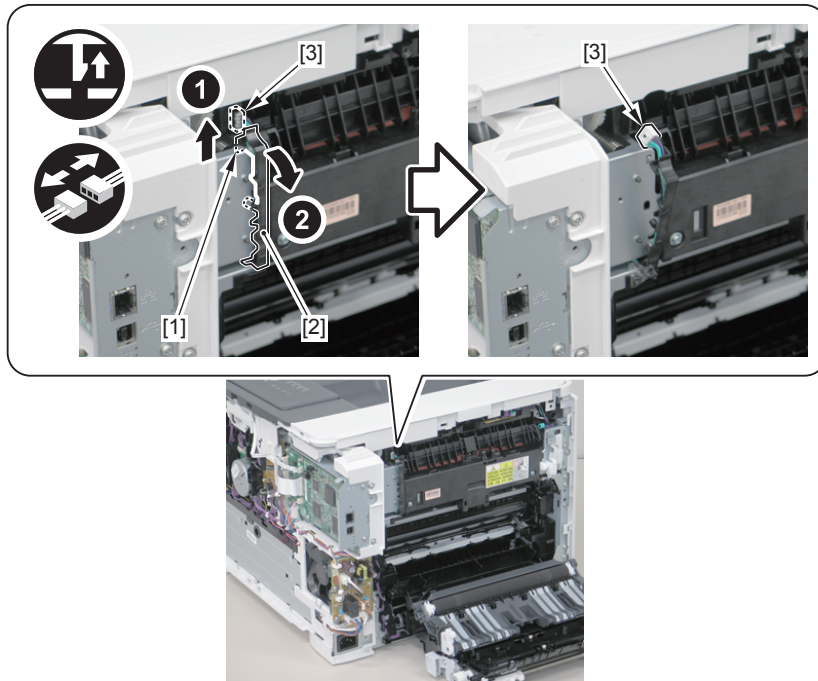

F-3-261

2) Free the harness [1] from the Harness Guide [A].

- 1 Wire Saddle [2]
- 3 Connectors [3]

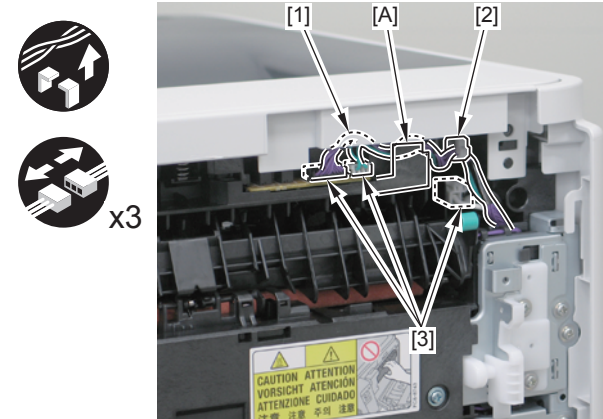

F-3-262

CAUTION:

At installation, be sure to locate the harness as shown in the figure below.

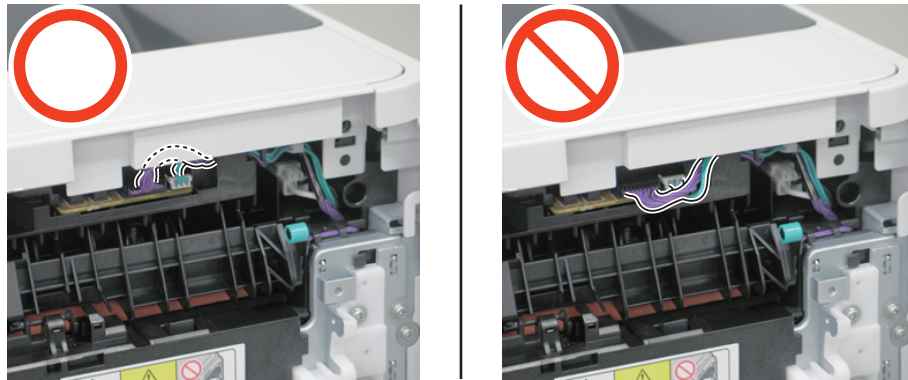

F-3-263

Removing the Fixing Film Unit LBP7600C/7660Cdn/7680Cx

Preparation

- 1) Remove the Right Cover.(Refer to page 3-20)
- 2) Remove the Rear Upper Cover (Left).(Refer to page 3-17)
- 3) Remove the Rear Cover.(Refer to page 3-15)
- 4) Remove the Rear Lower Cover.(Refer to page 3-17)
- 5) Remove the Rear Cover Rib Unit.(Refer to page 3-16)
- 6) Remove the Duplex Reverse Drive Unit.(Refer to page 3-54)
- 7) Remove the Fixing Assembly.(Refer to page 3-112)

3) Remove the Fixing Assembly [1].

- 2 Screws [2]



x2

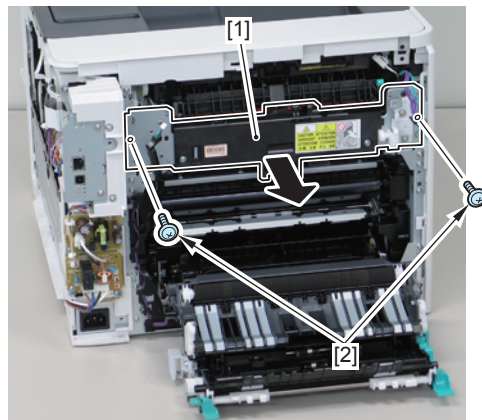

F-3-264

Procedure

- 1) Remove the 2 Pressure Springs [1] on the right and left and the 2 Pressure Plates [2].
 - 4 Hooks [3]
 - 4 Bosses [4]
 - 2 Protrusions [5]

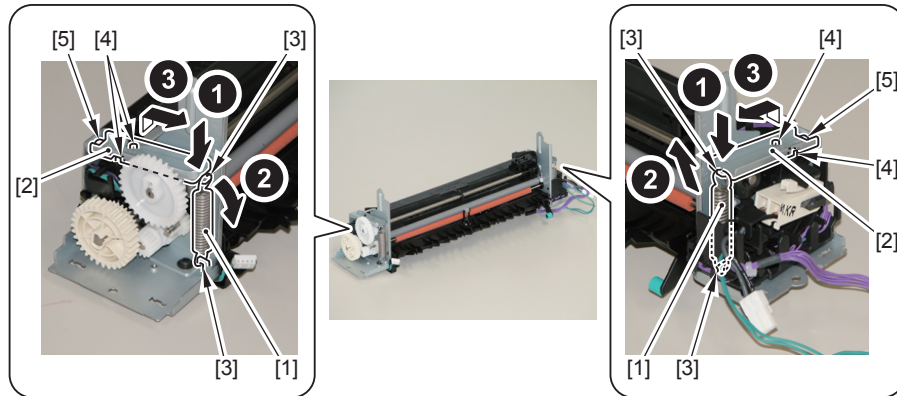

F-3-265

- 2) Remove the gear [1], Parallel Pin [2], E-Ring [3], cam [4], and bushing [5].
 - 1 Claws [6]

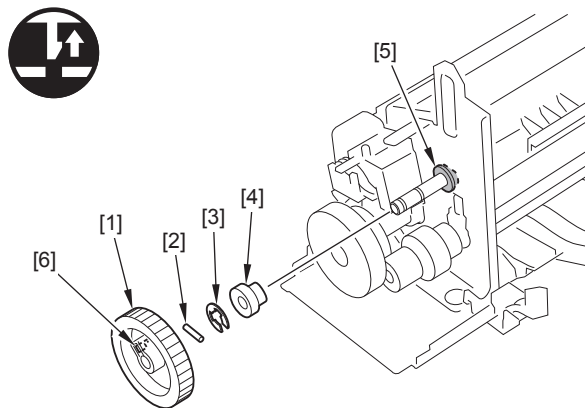

F-3-266

CAUTION:

At installation, be sure to match the direction of the cam [4] with that of the cam [6] on the other side of the Fixing Assembly.

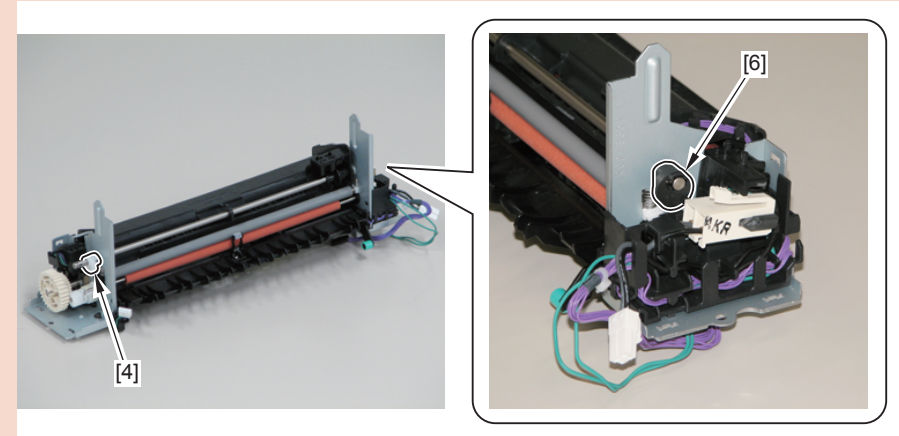

F-3-267

- 3) After sliding the shaft [1] to remove the Parallel Pins [2] and the cam [3], remove the shaft [1] and the Sensor Flag [4].

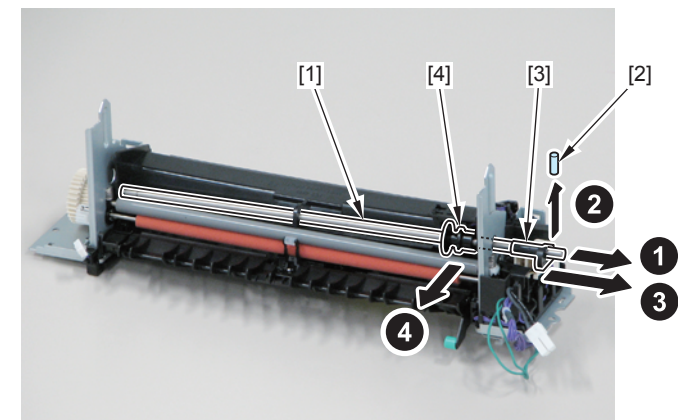

F-3-268

CAUTION:

At installation, be sure to align the protrusion of the cam [1] with the groove of the Sensor Flag [2].

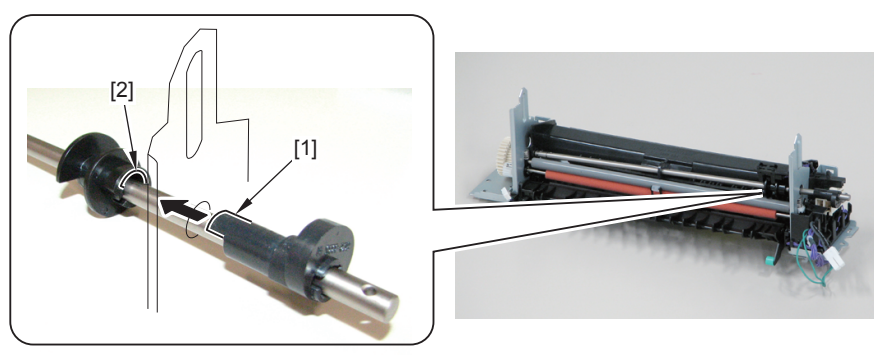

F-3-269

CAUTION:

Be sure to prevent the guide [1] from hitting against the Fixing Film Unit [2] when installing/removing.

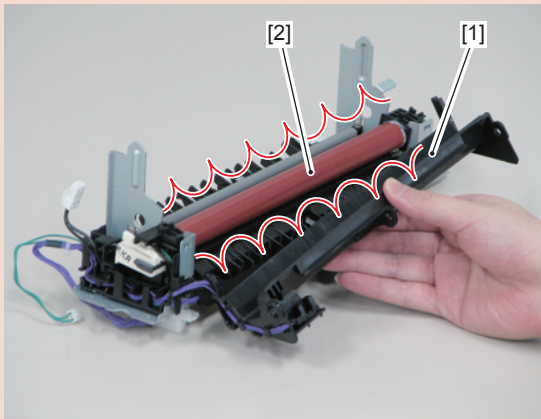

F-3-270

4) While securing the harness [1] to the guide [A], remove the harness [1] and the guide [2].

- Harness Guide [B]

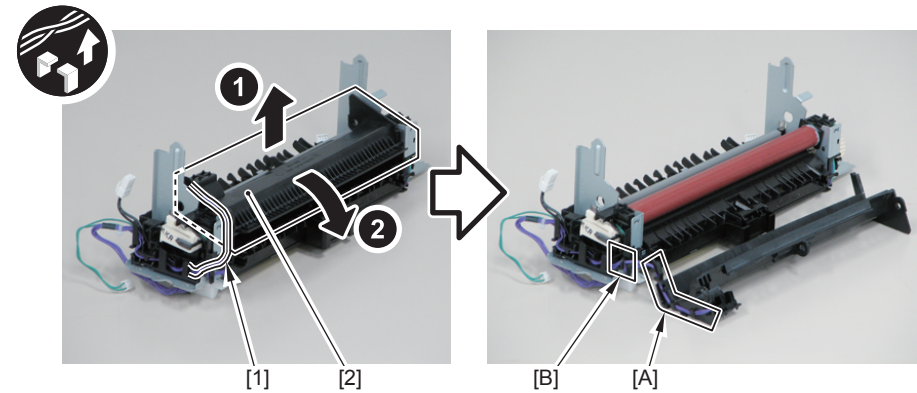

F-3-271

5) Free the harness (black) [1] from the Harness Guide [A], [B], [C] and [D].

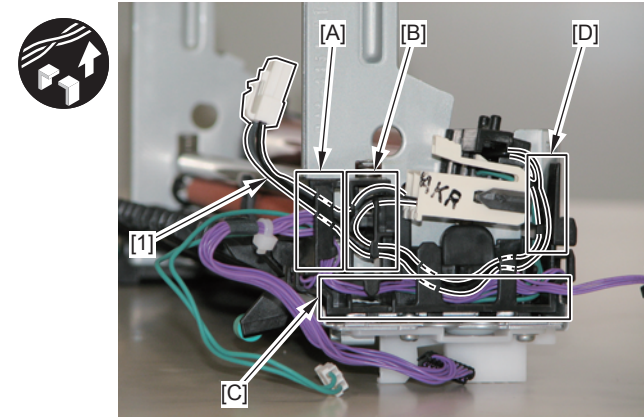

F-3-272

6) Free the harness (purple) [1] from the Harness Guide [A] and [C].

7) Free the harness (green) [2] from the Harness Guide [A], [C] and [D].

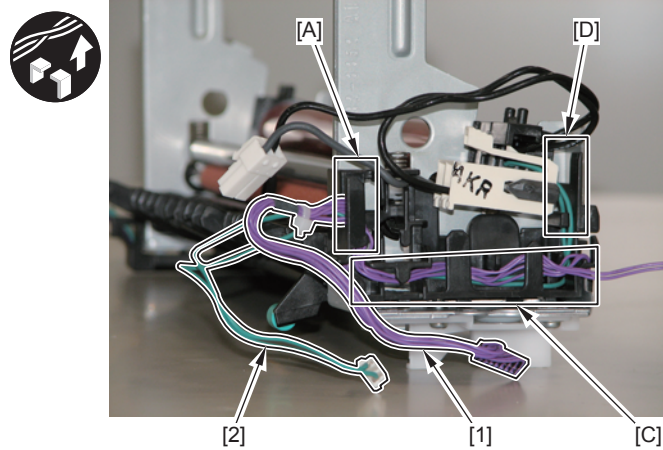

F-3-273

8) Remove the harness [1] and the guide [2].

- 1 Claws [3]
- 2 Bosses [4]

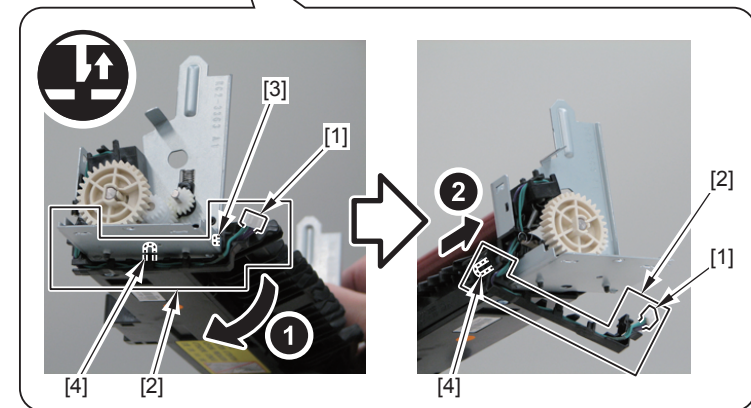
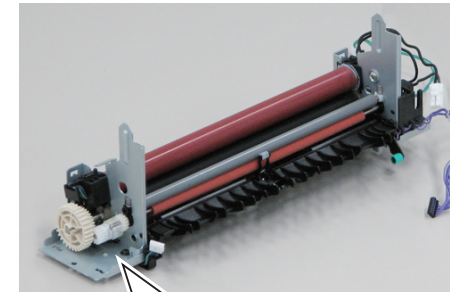

F-3-274

CAUTION:

When installing/removing the Fixing Film Unit, be sure not to touch the Fixing Film [1].

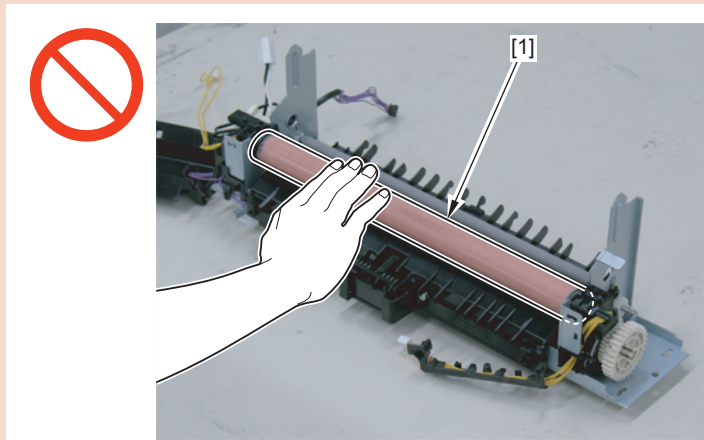

F-3-275

9) Remove the spring [1] and the Fixing Film Unit [2].

- 2 Hooks [3]
- Harness Guide [A]

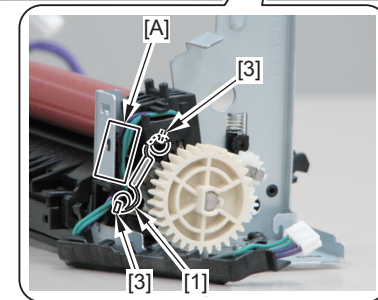
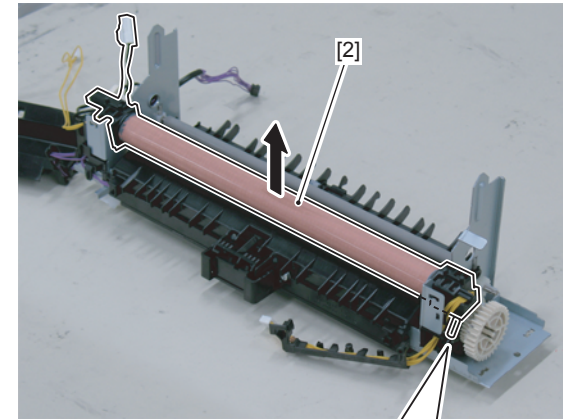

F-3-276

Removing the Fixing Film Unit LBP7210Cdn

Preparation

- 1) Remove the Right Cover.(Refer to page 3-20)
- 2) Remove the Rear Upper Cover (Left).(Refer to page 3-17)
- 3) Remove the Rear Cover.(Refer to page 3-15)
- 4) Remove the Rear Lower Cover.(Refer to page 3-17)
- 5) Remove the Rear Cover Rib Unit.(Refer to page 3-16)
- 6) Remove the Duplex Reverse Drive Unit.(Refer to page 3-54)
- 7) Remove the Fixing Assembly.(Refer to page 3-112)

Procedure

- 1) While Pushing the [A] Part, Remove the 2 Pressure Plates [1].
 - 2 Pressure Springs [2]
 - 4 Hooks [3]
 - 4 Bosses [4]
 - 2 Protrusions [5]

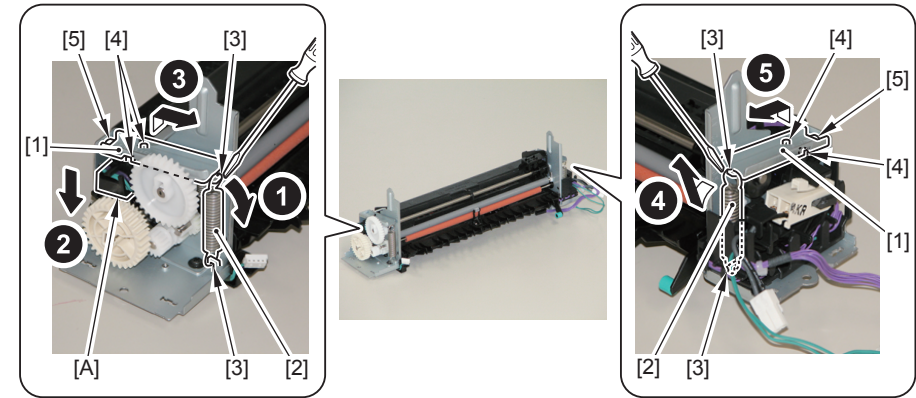

F-3-277

- 2) Remove the gear [1], 2 Parallel Pins [2], E-Ring [3], cam [4], and bushing [5].
 - 1 Claws [6]

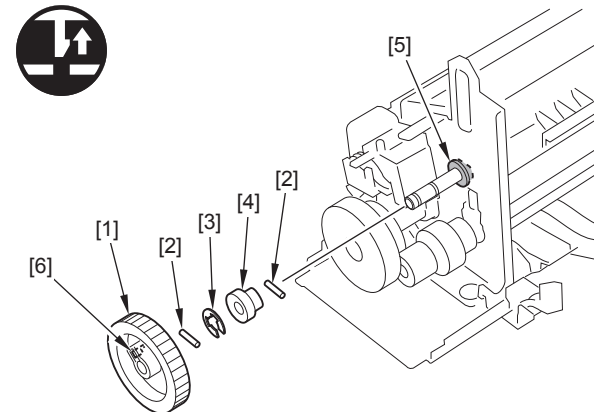

F-3-278

CAUTION:

At installation, be sure to match the direction of the cam [4] with that of the cam [6] on the other side of the Fixing Assembly.

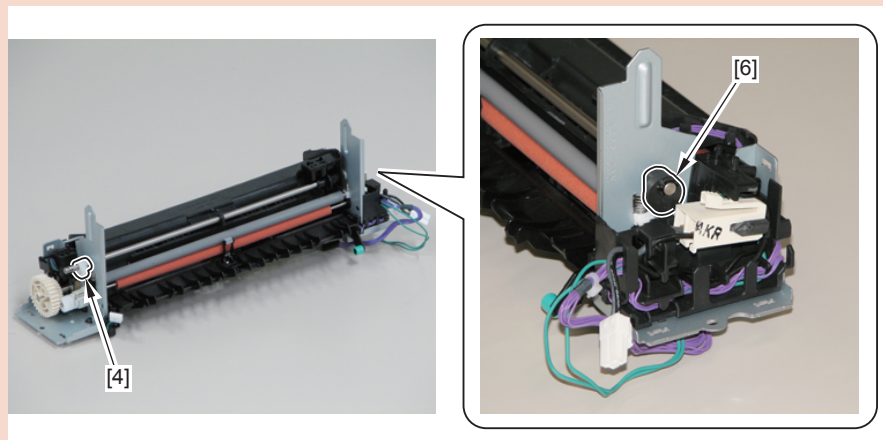

F-3-279

CAUTION:

At installation, be sure to align the protrusion of the cam [1] with the groove of the Sensor Flag [2].

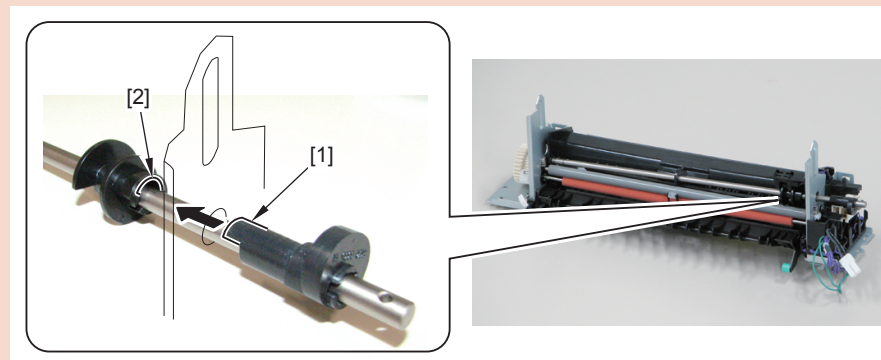

F-3-281

3) After sliding the shaft [1] to remove the Parallel Pins [2] and the cam [3], remove the shaft [1] and the Sensor Flag [4].

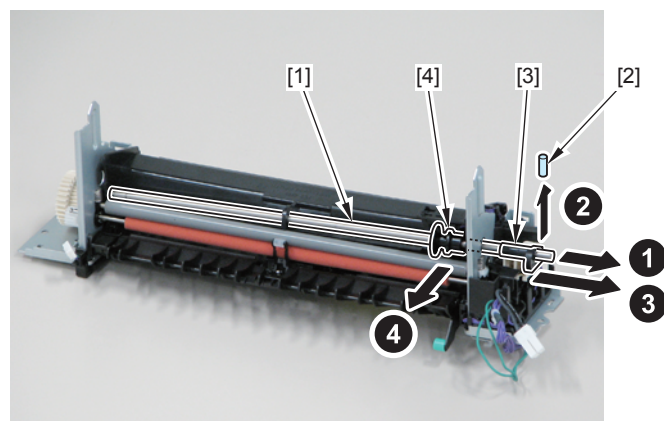

F-3-280

CAUTION:

Be sure to prevent the guide [1] from hitting against the Fixing Film Unit [2] when installing/removing.

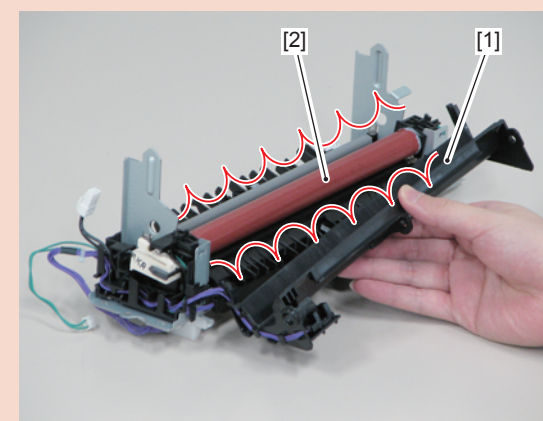

F-3-282

4) While securing the harness [1] to the guide [A], remove the harness [1] and the guide [2].

- Harness Guide [B]

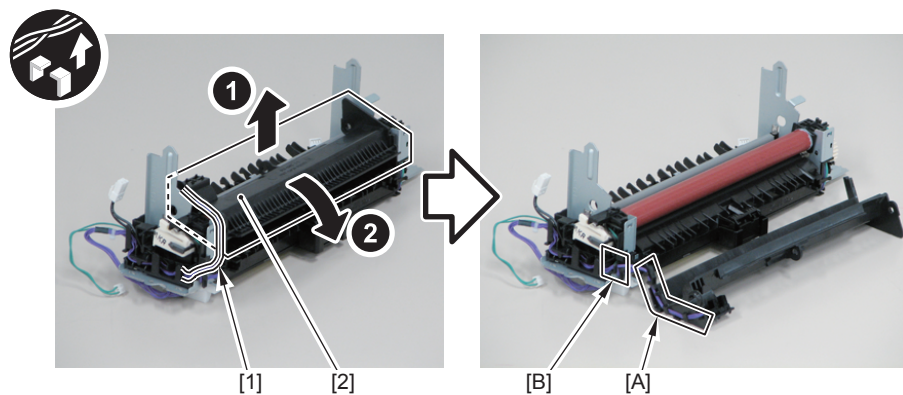

F-3-283

5) Free the harness (black) [1] from the Harness Guide [A], [B], [C] and [D].

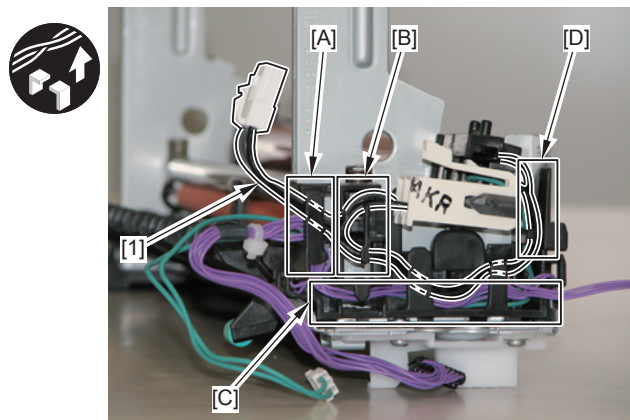

F-3-284

6) Free the harness (purple) [1] from the Harness Guide [A] and [C].

7) Free the harness (green) [2] from the Harness Guide [A], [C] and [D].

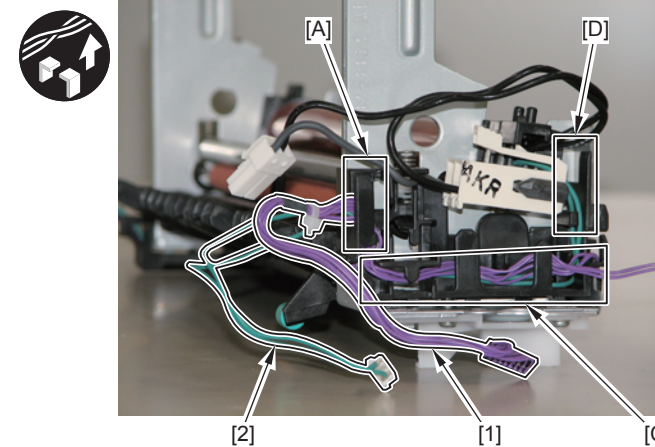

F-3-285

8) Remove the harness [1] and the guide [2].

- 1 Claws [3]
- 2 Bosses [4]

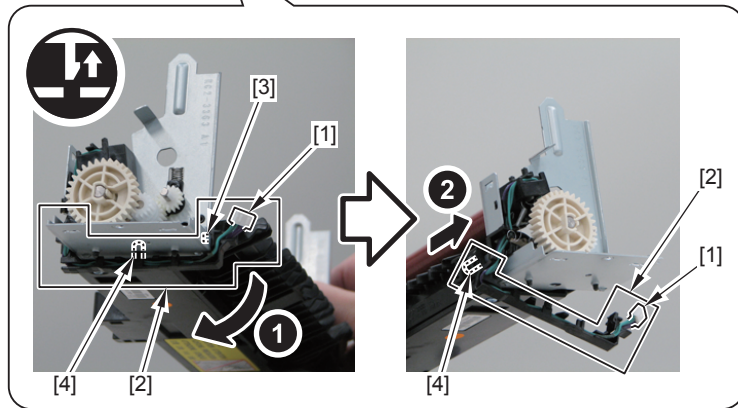
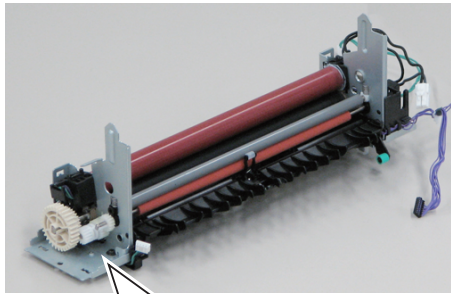

F-3-286

CAUTION:

When installing/removing the Fixing Film Unit, be sure not to touch the Fixing Film [1].

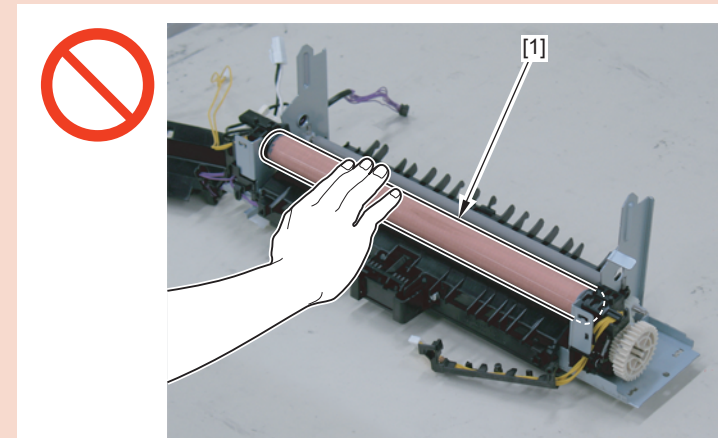

F-3-287

9) Remove the spring [1] and the Fixing Film Unit [2].

- 2 Hooks [3]
- Harness Guide [A]

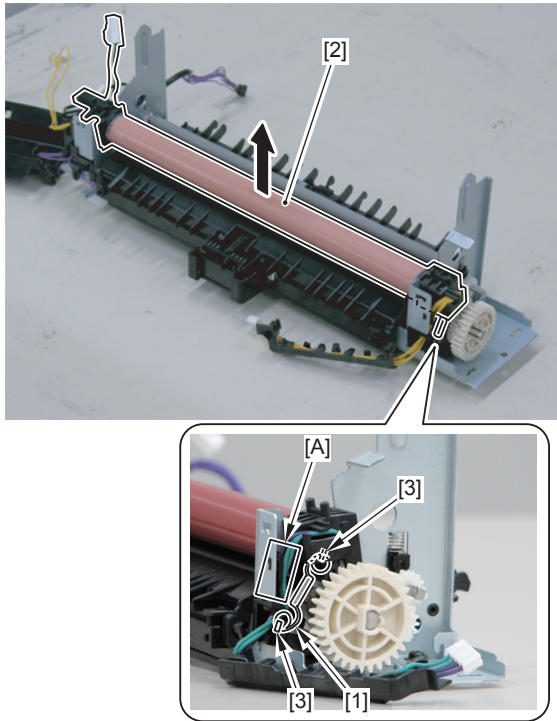

F-3-288

Removing the Fixing Pressure Roller LBP7600C/7660Cdn/7680Cx/7210Cdn

Preparation

- 1) Remove the Right Cover.(Refer to page 3-20)
- 2) Remove the Rear Upper Cover (Left).(Refer to page 3-17)
- 3) Remove the Rear Cover.(Refer to page 3-15)
- 4) Remove the Rear Lower Cover.(Refer to page 3-17)
- 5) Remove the Rear Cover Rib Unit.(Refer to page 3-16)
- 6) Remove the Duplex Reverse Drive Unit.(Refer to page 3-54)
- 7) Remove the Fixing Assembly.(Refer to page 3-112)
- 8) Remove the Fixing Film Unit.(Refer to page 3-115)

Procedure

CAUTION:

Be sure not to touch the surface of the Fixing Pressure Roller.

1) Remove the Fixing Pressure Roller [1].

- 2 Bushings [2]
- 1 Gear [3]

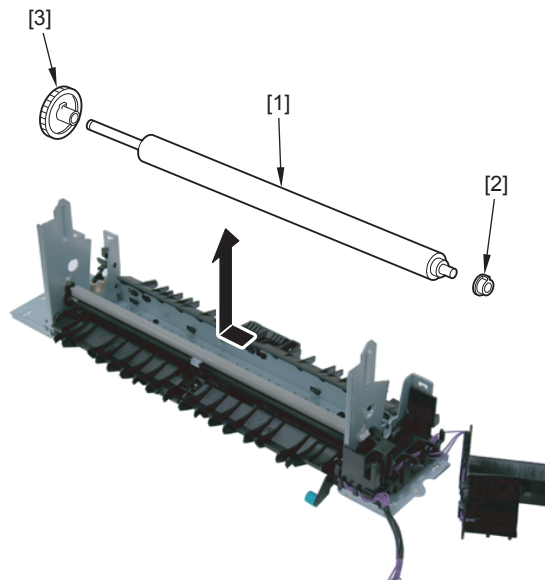

F-3-289

Removing the Fixing Motor LBP7600C/7660Cdn/7680Cx/7210Cdn

Preparation

- 1) Remove the Right Cover..(Refer to page 3-20)
- 2) Remove the Operation Panel Unit.(Refer to page 3-56)
- 3) Remove the Rear Upper Cover (Left).(Refer to page 3-17)
- 4) Remove the Upper Front Cover (Right) / USB Cover.(Refer to page 3-23)
- 5) Remove the Upper Cover.(Refer to page 3-24)
- 6) Remove the Right Frame Cover.(Refer to page 3-38)
- 7) Remove the Right Upper Frame Unit.(Refer to page 3-43)
- 8) Remove the Main Controller Support Plate.(Refer to page 3-45)

Procedure

- 1) Disconnect the 3 connectors [1], and free the harness [2] from the Harness Guide [A].

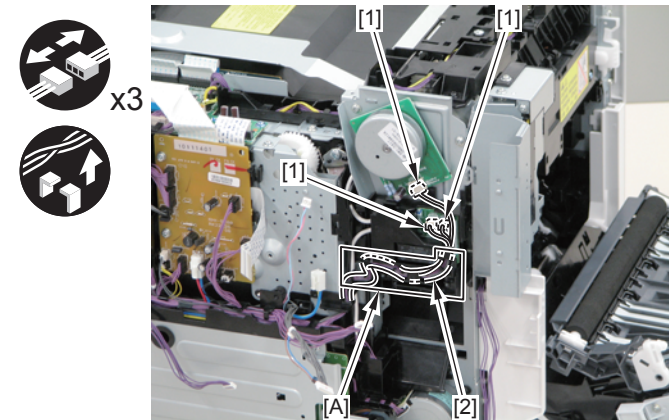

F-3-290

2) Remove the Harness Guide [1].

- 2 Claws [2]
- 1 Hook [3]

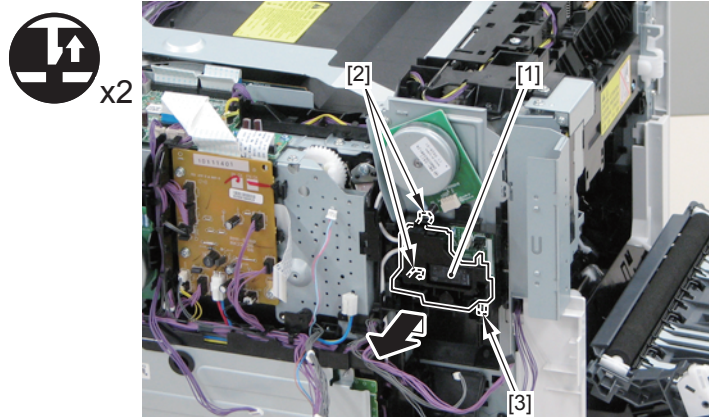

F-3-291

3) Free the harness from the Harness Guide [A], and remove the Sub Power Supply PCB Unit [1].

- 1 Connector [2]
- 2 Claws [3]
- 2 Bosses [4]

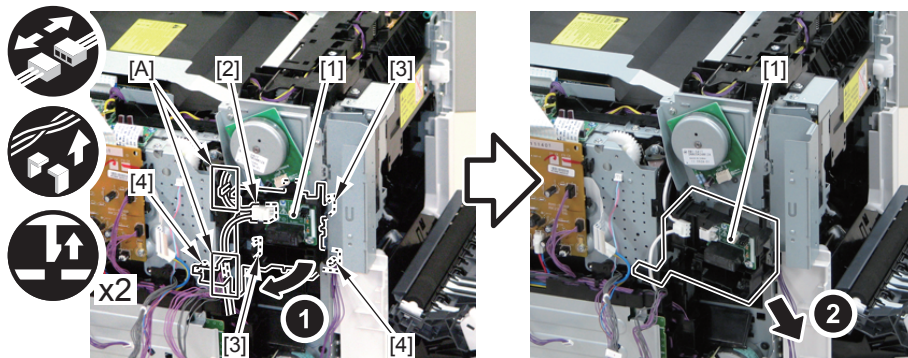

F-3-292

4) Remove the Fixing Motor [1].

- 3 Screws [2]

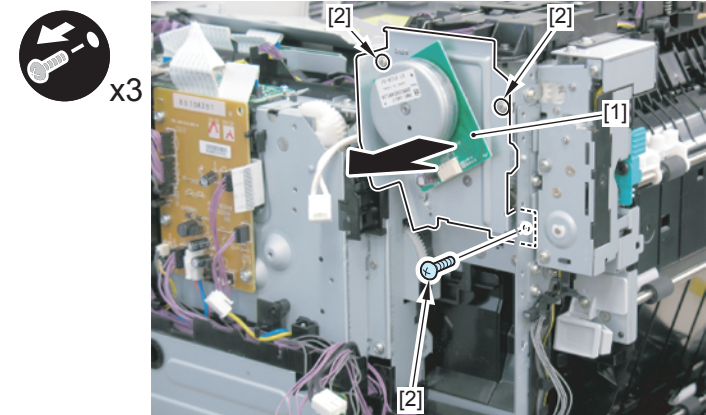

F-3-293

CAUTION:

Be sure not to lose the spring [1] on the back side when installing/removing.

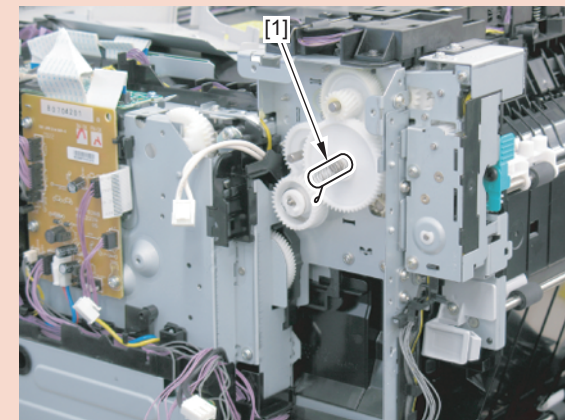

F-3-294

CAUTION:

Be sure to align the leading edge [1] of the spring and the protrusion [2] of the gear with the holes [A] and [B] of the plate when installing.

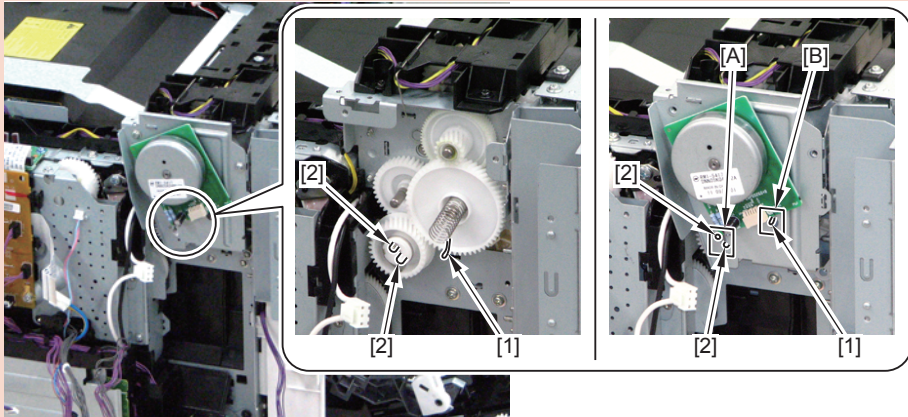

F-3-295

Pickup/Feed/Delivery System

Layout Drawing

LBP7600C/7660Cdn/7680Cx/7210Cdn(1/2)

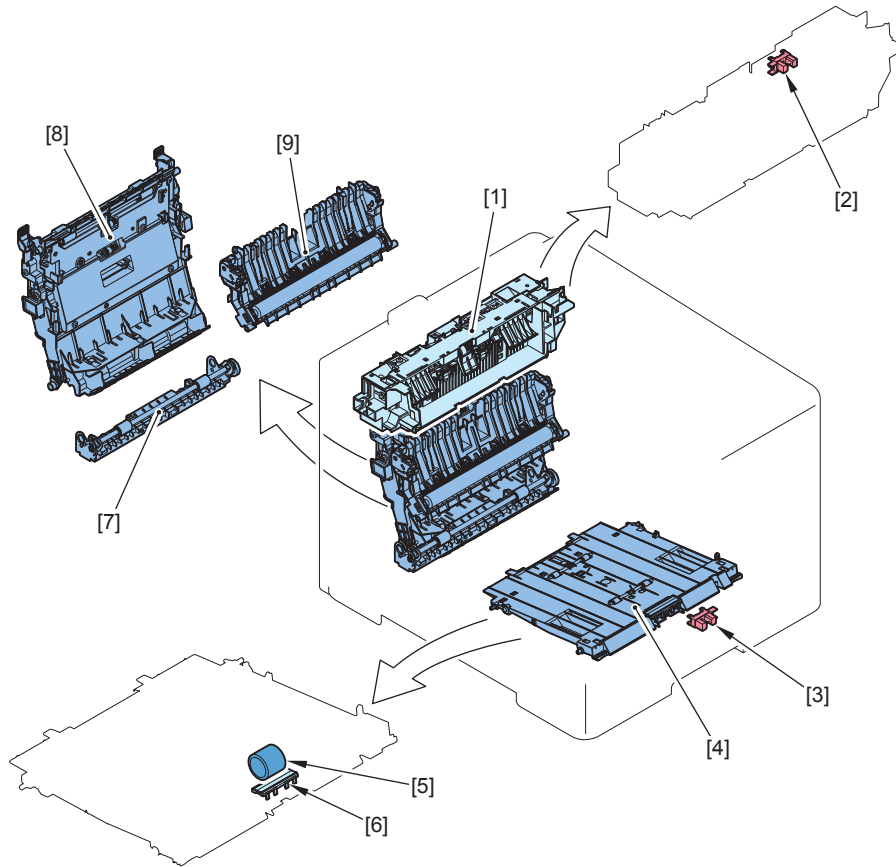

F-3-296

Key No.	Name	Main Unit	Reference	Adjustment during parts replacement	Remarks
[1]	Delivery Unit	Main Unit	(Refer to page 3-143)	-	LBP7600C/7660Cdn /7680Cx LBP7210Cdn
[2]	Delivery Full Sensor	Delivery Unit		-	SR15
[3]	Manual Feed Tray Paper Detection Sensor	Main Unit		-	SR14
[4]	Manual Feed Tray Pickup Unit	Main Unit	(Refer to page 3-142)	-	-
[5]	Manual Feed Tray Pickup Roller	Manual Feed Tray Pickup Unit	(Refer to page 3-149)	-	LBP7600C/7660Cdn /7680Cx LBP7210Cdn
[6]	Manual Feed Tray Separation Pad	Manual Feed Tray Pickup Unit	(Refer to page 3-150)	-	LBP7600C/7660Cdn /7680Cx LBP7210Cdn
[7]	Re-Pickup Guide Unit	Main Unit	(Refer to page 3-154)	-	-
[8]	Duplexing Feeding Unit	Main Unit	(Refer to page 3-151)	-	LBP7600C/7660Cdn /7680Cx LBP7210Cdn
[9]	Secondary Transfer Feeding Unit	Main Unit	(Refer to page 3-153)	-	-

T-3-17

LBP7600C/7660Cdn/7680Cx/7210Cdn(2/2)

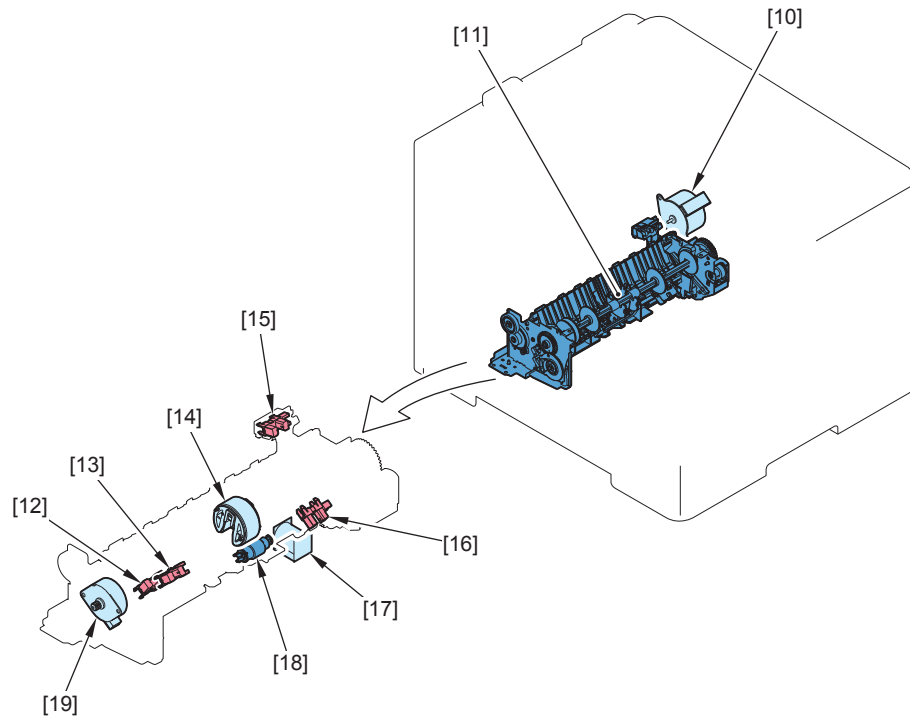

F-3-297

Key No.	Name	Main Unit	Reference	Adjustment during parts replacement	Remarks
[10]	Pickup Motor	Main Unit	(Refer to page 3-130)	-	M5, LBP7600C/7660Cdn /7680Cx M5, LBP7210Cdn
[11]	Pickup Unit	Main Unit	(Refer to page 3-133)	-	LBP7600C/7660Cdn /7680Cx LBP7210Cdn
[12]	Paper Feeder Pre-registration Detection Sensor	Pickup Unit		-	SR1
[13]	Pre-registration Detection Sensor	Pickup Unit		-	SR12
[14]	Cassette Pickup Roller	Pickup Unit	(Refer to page 3-147)	-	LBP7600C/7660Cdn /7680Cx LBP7210Cdn
[15]	Registration Detection Sensor	Pickup Unit		-	SR4
[16]	Cassette Paper Detection Sensor	Pickup Unit		-	SR13
[17]	Cassette Pickup Solenoid	Pickup Unit		-	SL2
[18]	Cassette Separation Roller	Pickup Unit	(Refer to page 3-148)	-	-
[19]	Registration Motor	Pickup Unit		-	M3

T-3-18

Removing the Pickup Motor LBP7600C/7660Cdn/7680Cx

Preparation

- 1) Remove the Right Cover.(Refer to page 3-20)
- 2) Remove the Operation Panel Unit.(Refer to page 3-56)
- 3) Remove the Rear Upper Cover (Left).(Refer to page 3-17)
- 4) Remove the Upper Front Cover (Right) / USB Cover.(Refer to page 3-23)
- 5) Remove the Upper Cover.(Refer to page 3-24)
- 6) Remove the Right Frame Cover.(Refer to page 3-38)
- 7) Remove the Right Upper FrameUnit.(Refer to page 3-43)

Procedure

- 1) Disconnect the 8 connectors [1], and free the harness [2] from the Harness Guide [A].

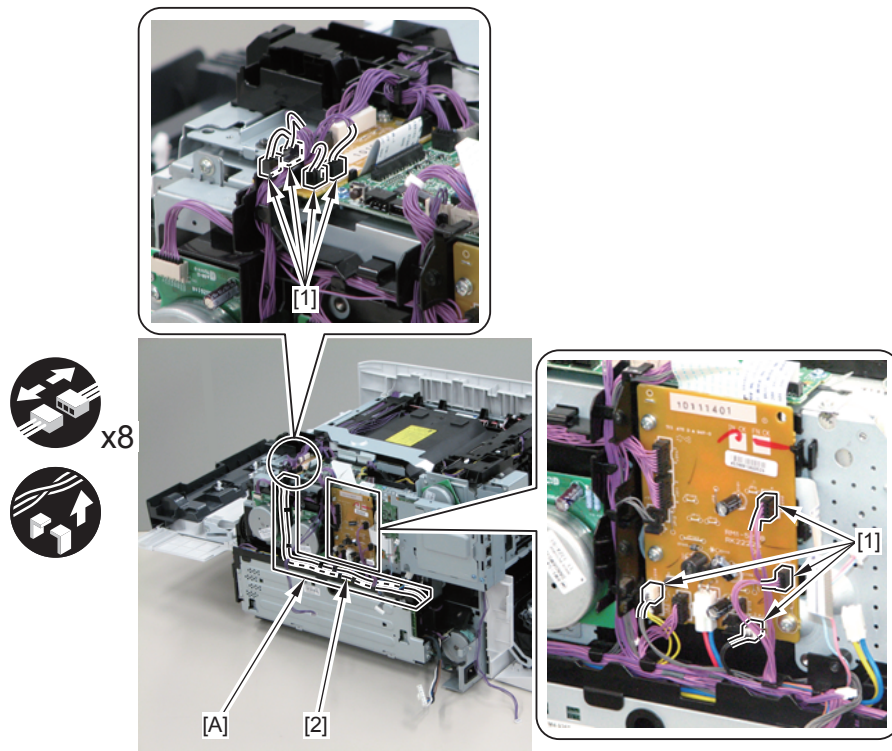

F-3-298

- 2) Free the harness [1] and [2] from the Harness Guide [A] and [B].

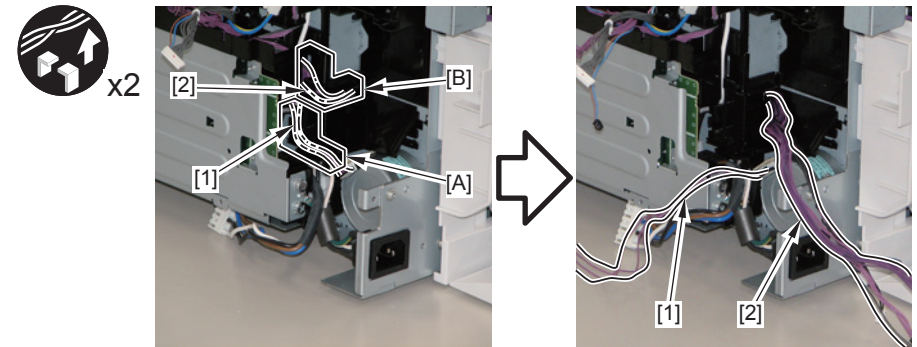

F-3-299

- 3) Remove the Harness Guide [1].

- Harness Guide [A]
- 2 Boss [2]
- 2 Hooks [3]

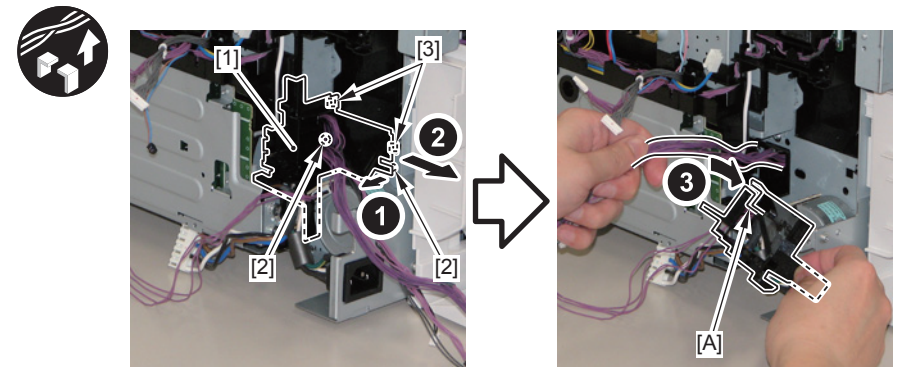

F-3-300

4) Remove the Pickup Motor [1].

- 2 Screws [2]
- 1 Connector [3]

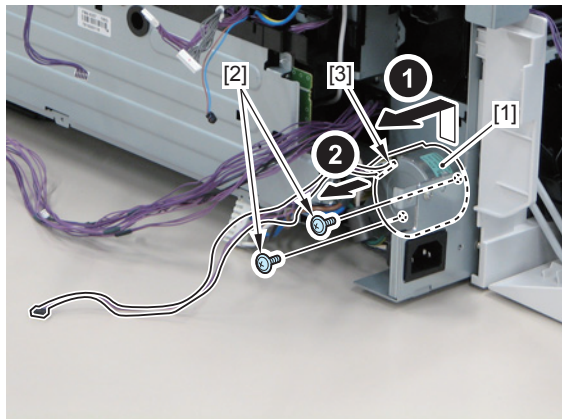

F-3-301

Removing the Pickup Motor LBP7210Cdn

Preparation

- 1) Remove the Right Cover.(Refer to page 3-20)
- 2) Remove the Operation Panel Unit.(Refer to page 3-56)
- 3) Remove the Rear Upper Cover (Left)..(Refer to page 3-17)
- 4) Remove the Upper Front Cover (Right)(Refer to page 3-23)
- 5) Remove the Upper Cover..(Refer to page 3-24)
- 6) Remove the Right Frame Cover.(Refer to page 3-38)
- 7) Remove the Right Upper Frame unit.(Refer to page 3-43)

Procedure

- 1) Disconnect the 8 connectors [1], and free the harness [2] from the Harness Guide [A].

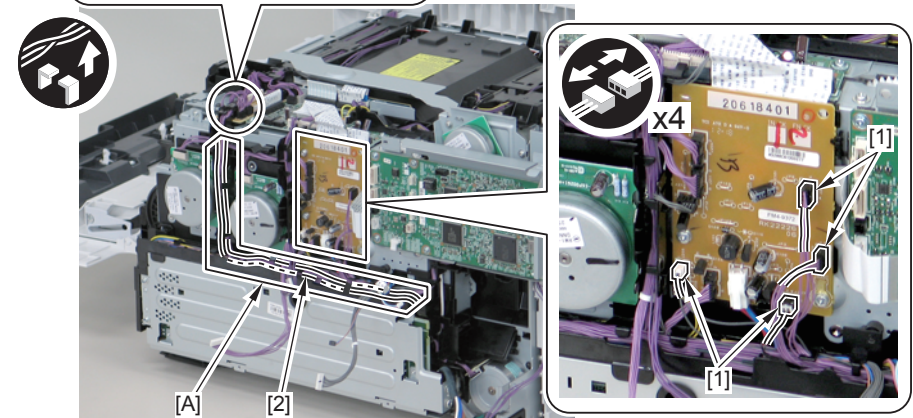
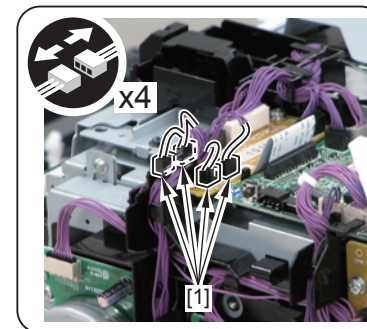

F-3-302

2) Free the harness [1] and [2] from the Harness Guide [A] and [B].

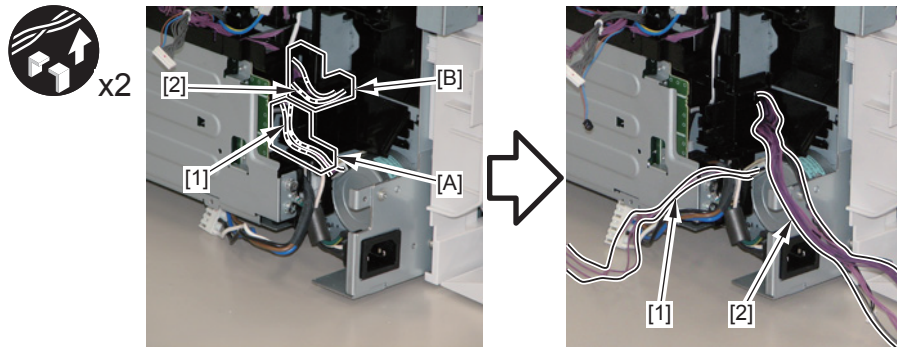

F-3-303

3) Remove the Harness Guide [1].

- Harness Guide [A]
- 2 Boss [2]
- 2 Hooks [3]

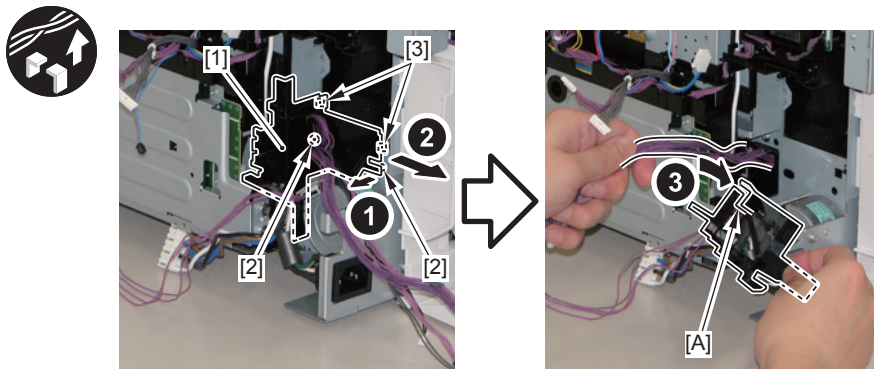

F-3-304

4) Remove the Pickup Motor [1].

- 2 Screws [2]
- 1 Connector [3]

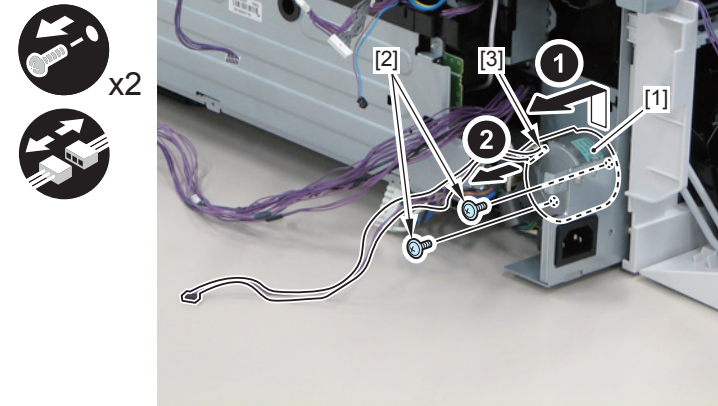

F-3-305

Removing the Pickup Unit LBP7600C/7660Cdn/7680Cx

Preparation

- 1) Remove the Toner Cartridges (Y/M/C/Bk).
- 2) Remove the Right Cover.(Refer to page 3-20)
- 3) Remove the Operation Panel Unit.(Refer to page 3-56)
- 4) Remove the Rear Upper Cover (Left).(Refer to page 3-17)
- 5) Remove the Upper Front Cover (Right) / USB Cover.(Refer to page 3-23)
- 6) Remove the Upper Cover.(Refer to page 3-24)
- 7) Remove the Right Frame Cover.(Refer to page 3-38)
- 8) Remove the Right Upper Frame Unit.(Refer to page 3-43)

Procedure

CAUTION:

Be sure not to touch the Secondary Transfer Roller [1] and the ITB [2].

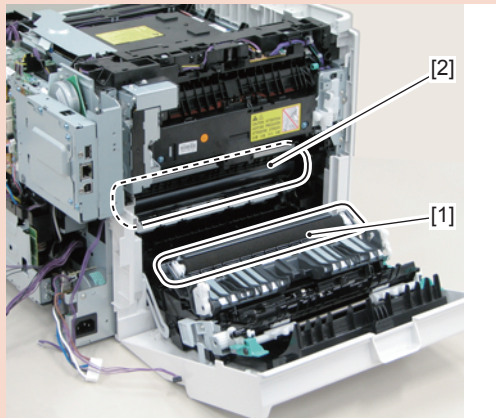

F-3-306

- 1) Disconnect the 8 connectors [1], and free the harness [2] from the Harness Guide [A].

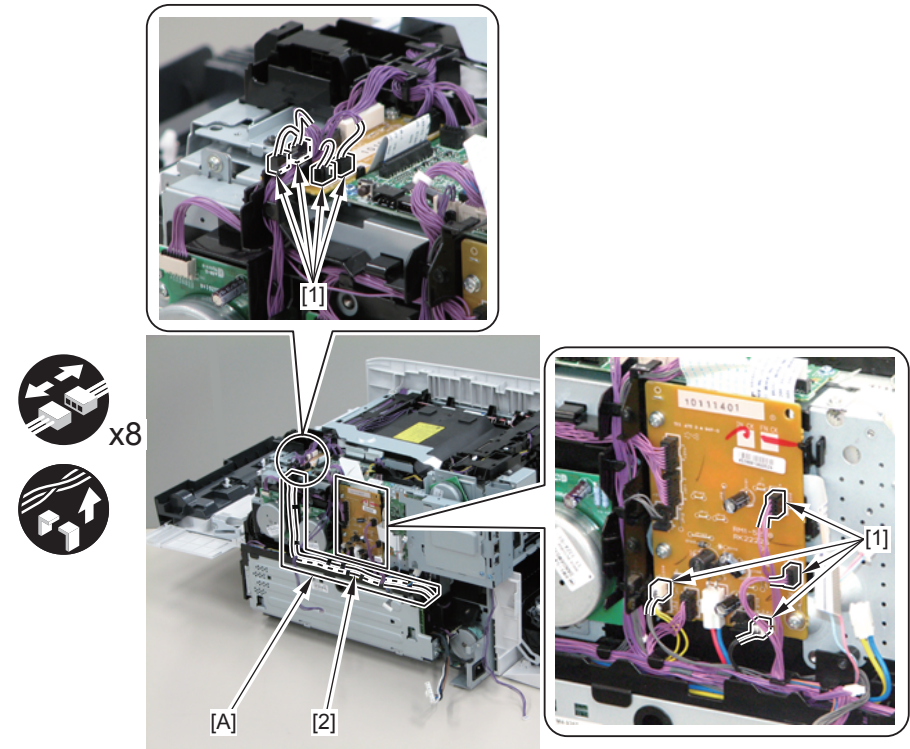

F-3-307

- 2) Free the harness [1] and [2] from the Harness Guide [A] and [B].

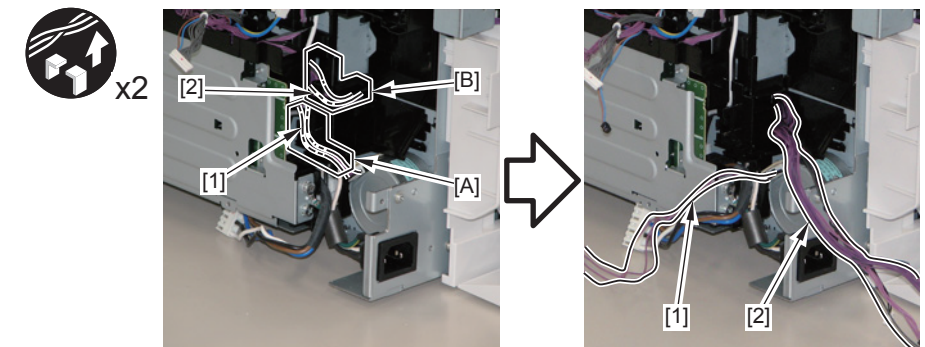

F-3-308

3) Remove the Harness Guide [1].

- Harness Guide [A]
- 2 Boss [2]
- 2 Hooks [3]

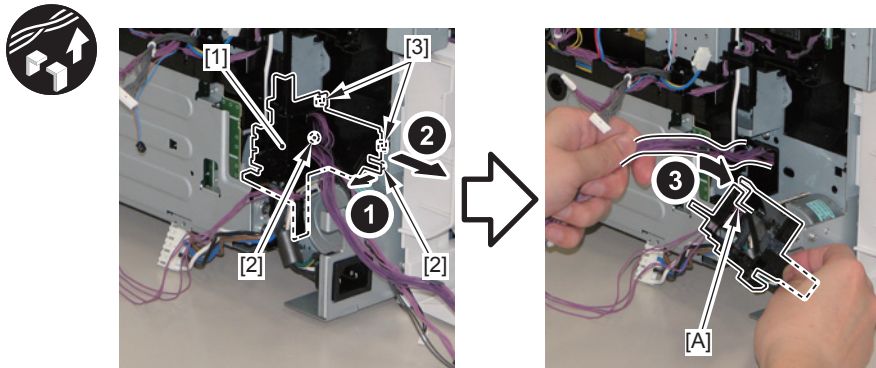

F-3-309

4) Remove the Feed Guide [1].

- 2 Claws [2]
- 3 Hooks [3]
- Rib [A]
- 1 Arm [4]

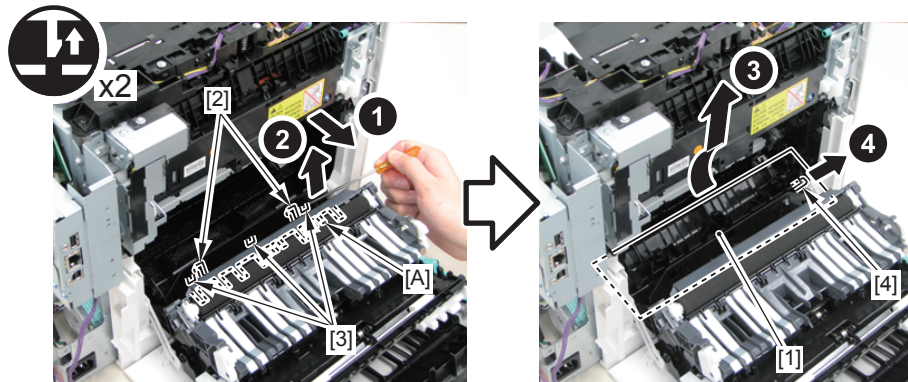

F-3-310

5) Close the Front Cover and the Rear Cover, and place the host machine by placing the Left Cover [1] down.

6) Remove the 2 stoppers [2].

- 2 Bosses [3]

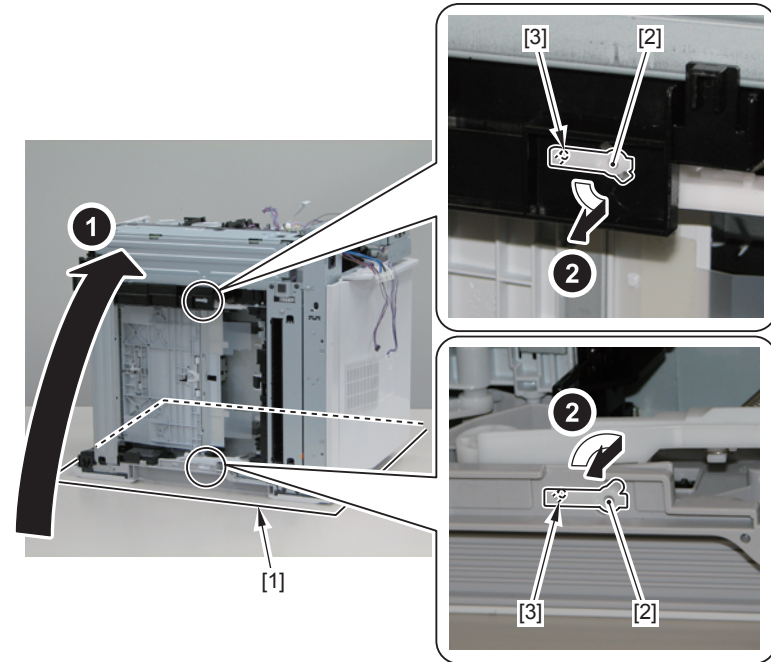

F-3-311

7) Remove the 2 arms [1] and the 2 springs [2].

- 2 Shafts [3]
- 5 Hooks [4]

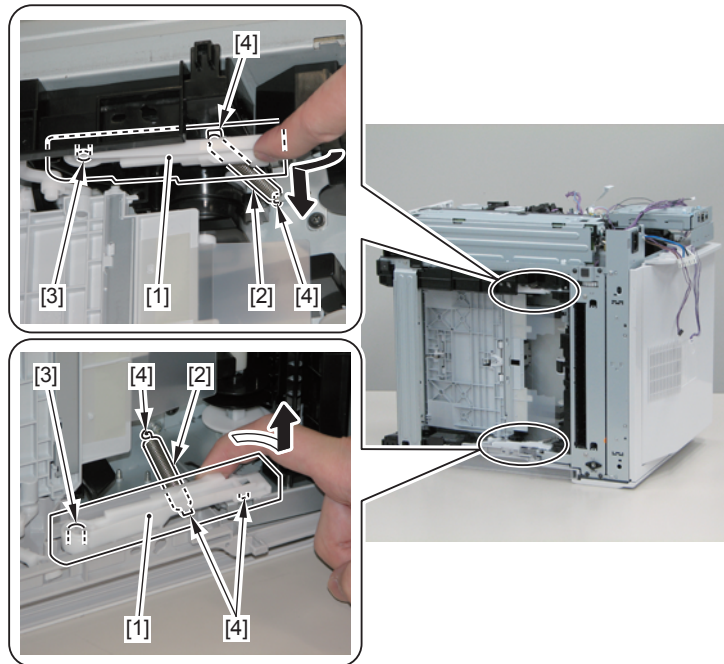

F-3-312

8) Put the harness [1] through the hole [A] of the Side Plate, and remove the Pickup Unit [2].

- 6 Screws [3]

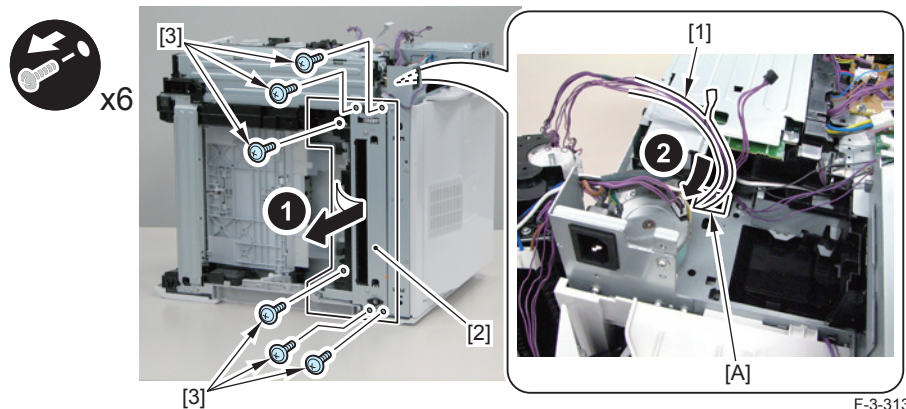

F-3-313

Installation Method

CAUTION:

Be sure not to touch the Pickup Roller [1] and the Secondary Transfer Roller [2].

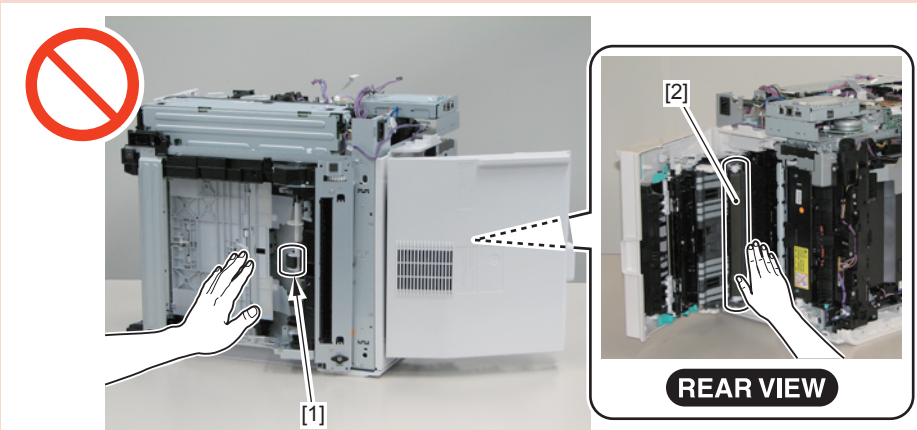

F-3-314

1) Open the Rear Cover [1], Put the harness [2] through the hole [A] of the Side Plate, and Install the Pickup Unit [3] to the host machine.

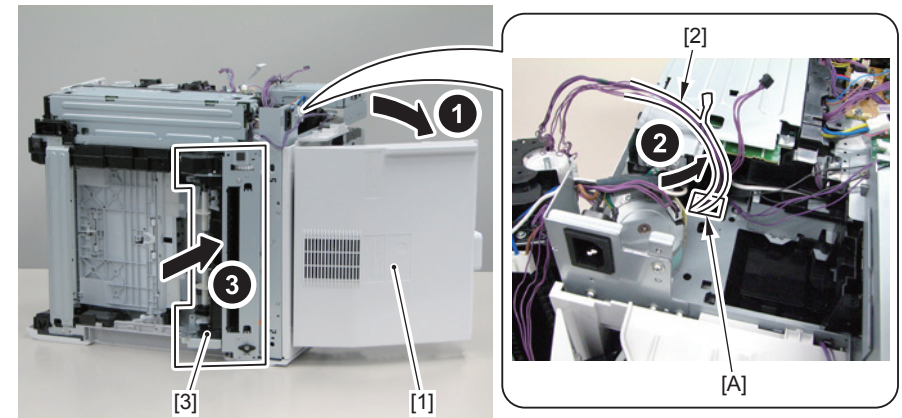

F-3-315

- 2) Place the edge [A] of the guide of the Pickup Unit over the spring [1] of the host machine.
 3) Place the Sensor Flag Cover [B] of the Pickup Unit over the plate [C] of the Roller Unit of the host machine.

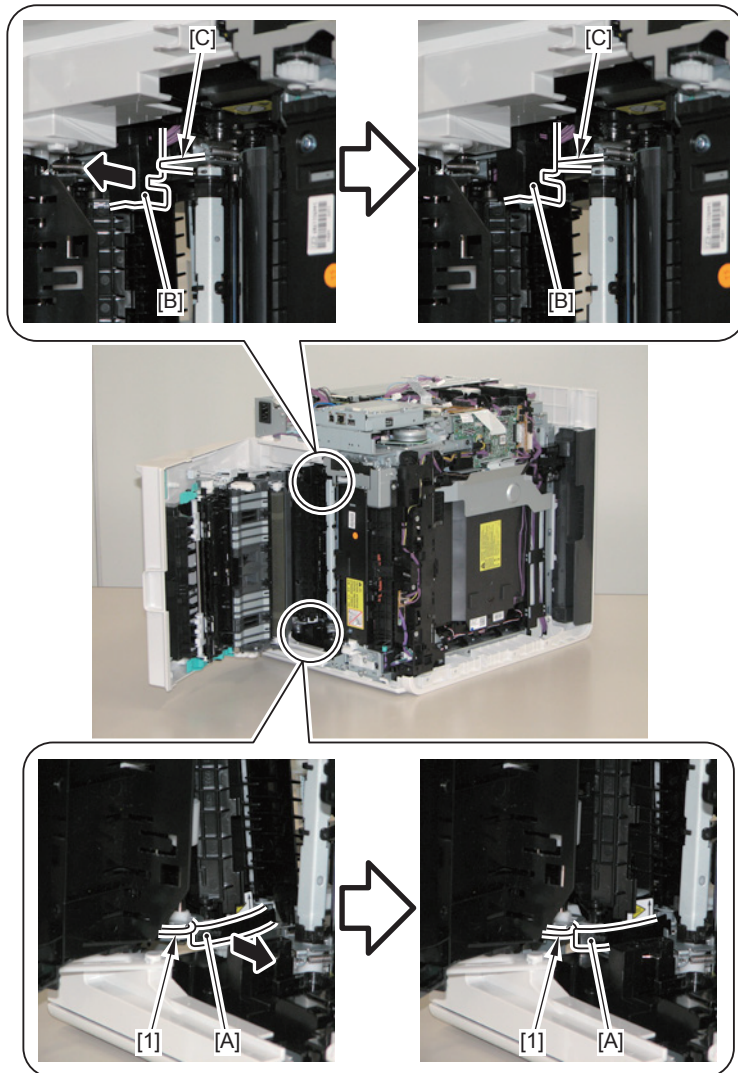

F-3-316

- 4) Place the edge [D] of the Feed Guide of the Pickup Unit over the edge [E] of the Roller Unit of the host machine.

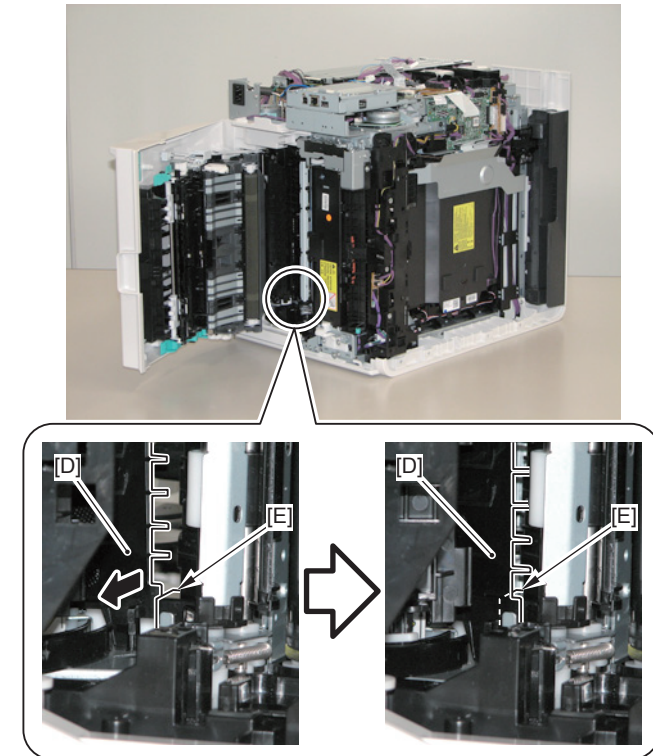

F-3-317

- 5) Align the 4 protrusions [1], and secure the Pickup Unit with the 6 screws [2].

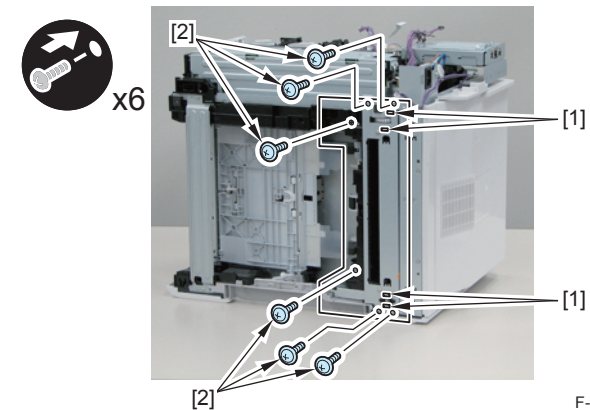

F-3-318

Removing the Pickup Unit LBP7210Cdn

Preparation

- 1) Remove the Toner Cartridges (Y/M/C/Bk).
- 2) Remove the Right Cover.(Refer to page 3-20)
- 3) Remove the Operation Panel Unit.(Refer to page 3-56)
- 4) Remove the Rear Upper Cover (Left).(Refer to page 3-17)
- 5) Remove the Upper Front Cover (Right).(Refer to page 3-23)
- 6) Remove the Upper Cover.(Refer to page 3-24)
- 7) Remove the Right Frame Cover..(Refer to page 3-38)
- 8) Remove the Right Upper Frame.(Refer to page 3-43)

Procedure

CAUTION:

Be sure not to touch the Secondary Transfer Roller [1] and the ITB [2].

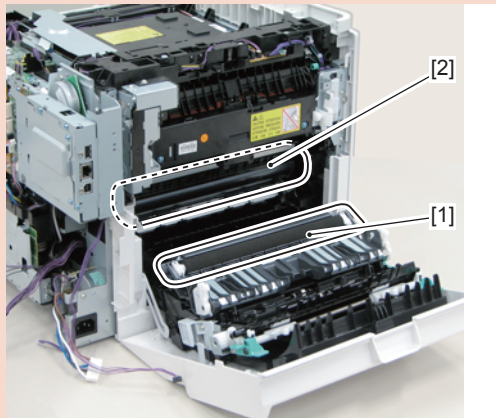

F-3-319

- 1) Disconnect the 8 connectors [1], and free the harness [2] from the Harness Guide [A].

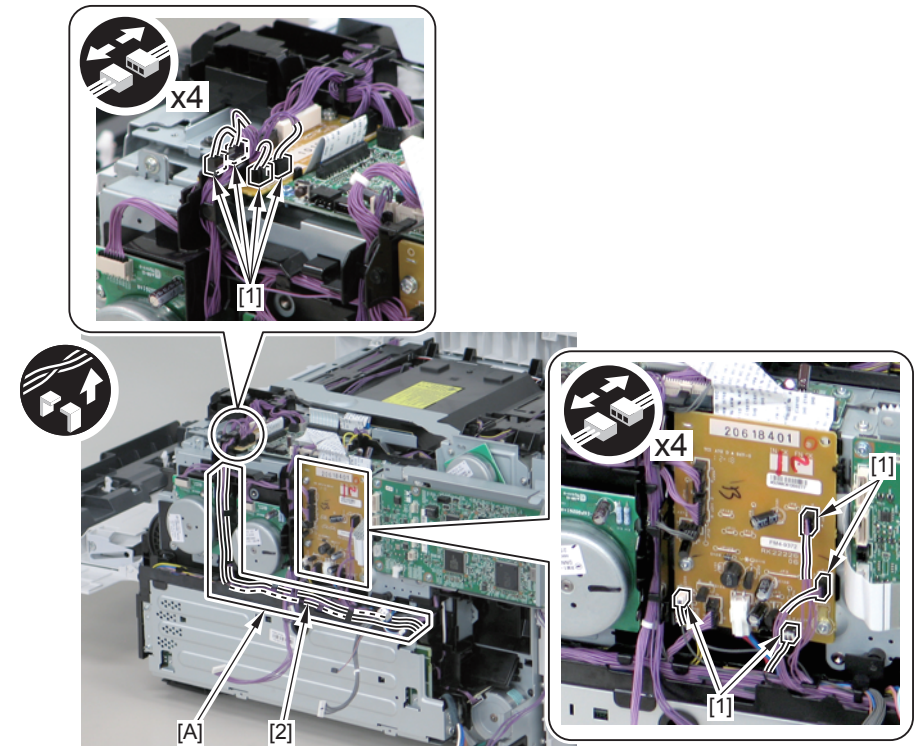

F-3-320

- 2) Free the harness [1] and [2] from the Harness Guide [A] and [B].

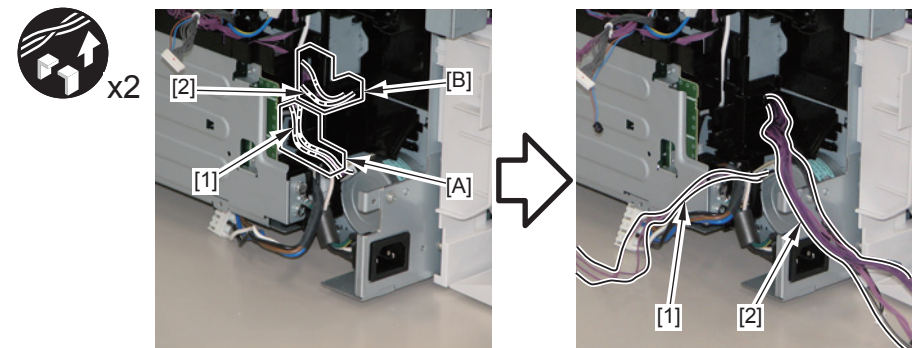

F-3-321

3) Remove the Harness Guide [1].

- Harness Guide [1]
- 2 Boss [2]
- 2 Hooks [3]

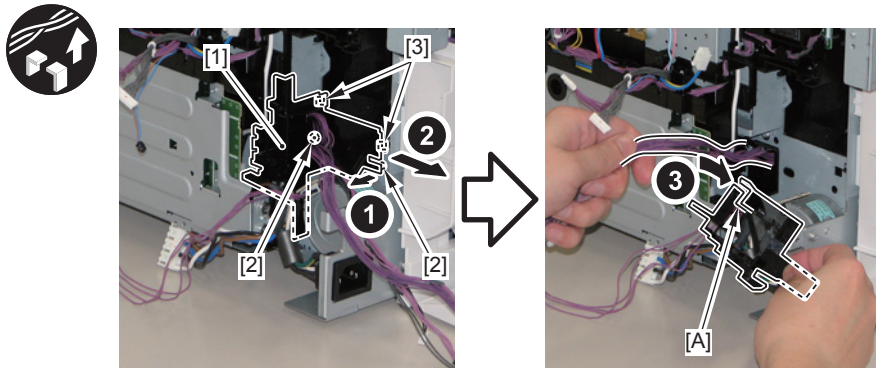

F-3-322

4) Remove the Feed Guide [1].

- 2 Claws [2]
- 3 Hooks [3]
- Rib [A]
- 1 Arm [4]

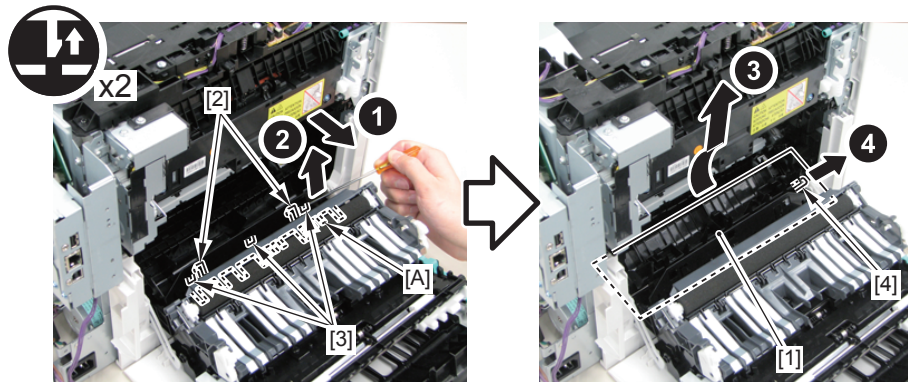

F-3-323

5) Close the Front Cover and the Rear Cover, and place the host machine by placing the Left Cover [1] down.

6) Remove the 2 stoppers [2].

- 2 Bosses [3]

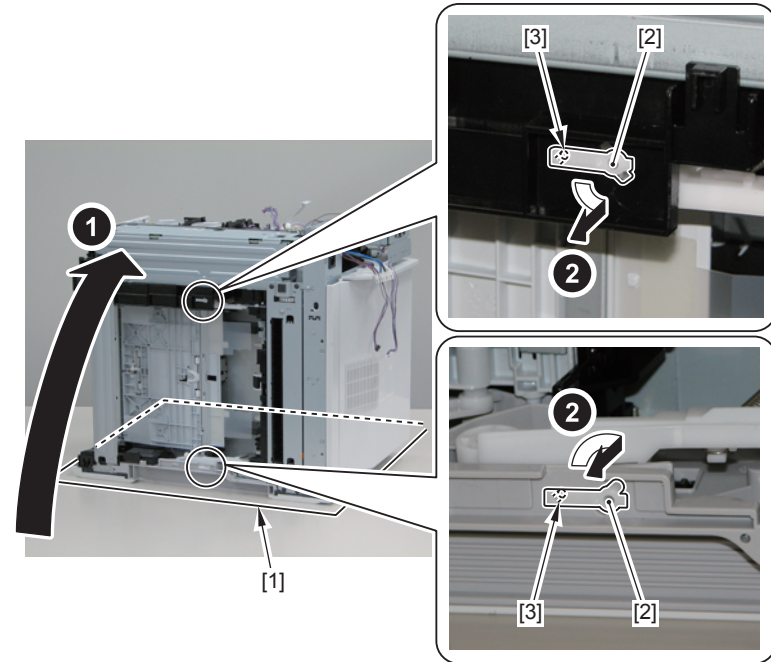

F-3-324

7) Remove the 2 arms [1] and the 2 springs [2].

- 2 Shafts [3]
- 5 Hooks [4]

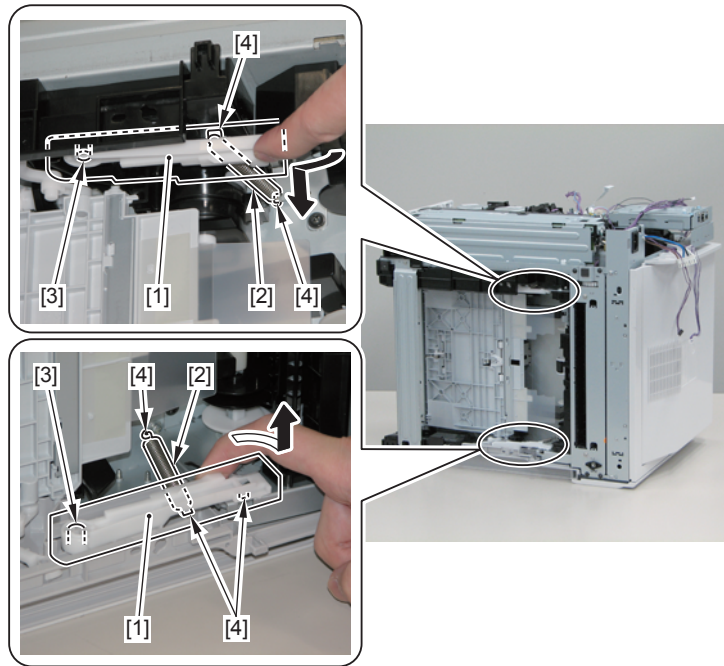

F-3-325

8) Put the harness [1] through the hole [A] of the Side Plate, and remove the Pickup Unit [2].

- 6 Screws [3]

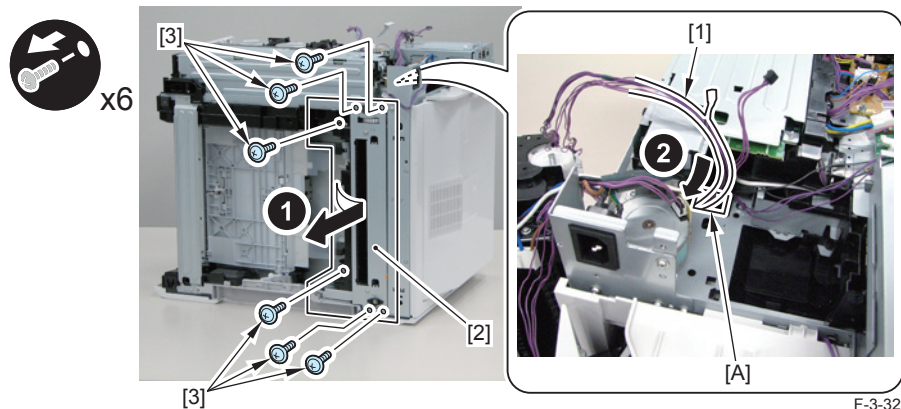

F-3-326

Installation Method

CAUTION:

Be sure not to touch the Pickup Roller [1] and the Secondary Transfer Roller [2].

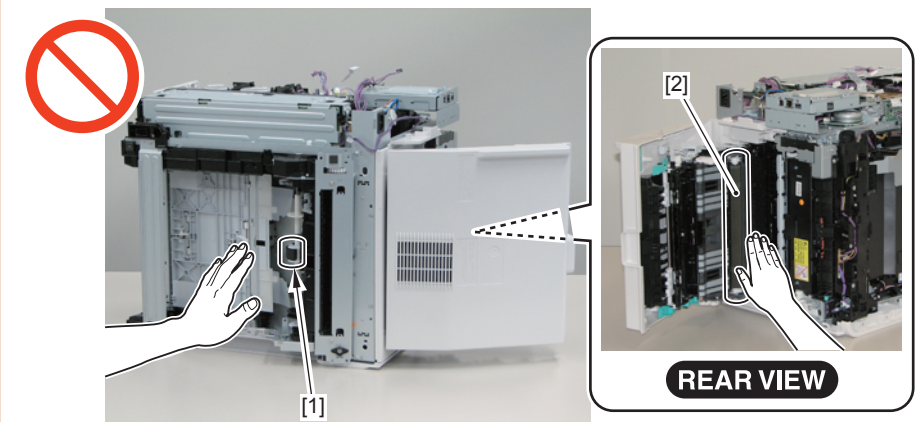

F-3-327

1) Remove the 2 Guides [1]

- 4 Claws [2]
- 4 Hooks [3]

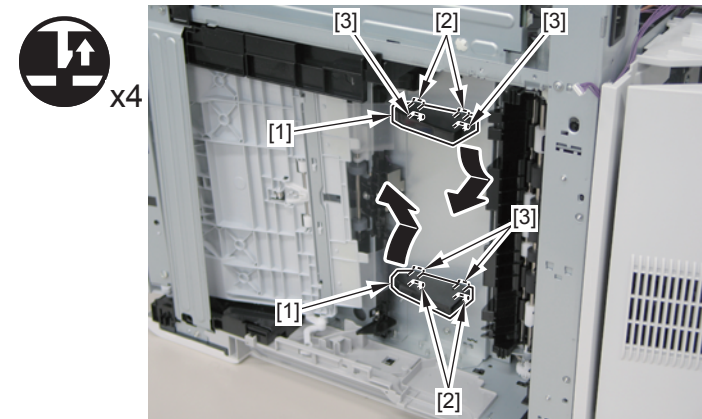

F-3-328

- 2) Open the Rear Cover [1], Put the harness [2] through the hole [A] of the Side Plate, and Install the Pickup Unit [3] to the host machine.

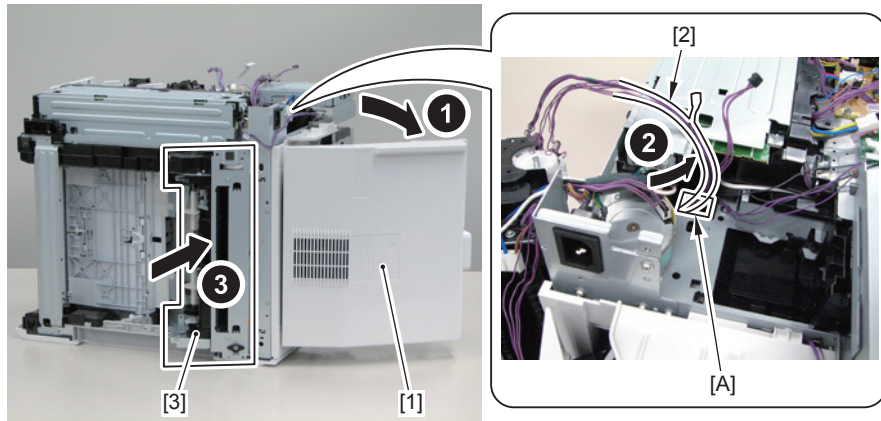

F-3-329

- 3) Place the edge [A] of the guide of the Pickup Unit over the spring [1] of the host machine.
4) Place the Sensor Flag Cover [B] of the Pickup Unit over the plate [C] of the Roller Unit of the host machine.

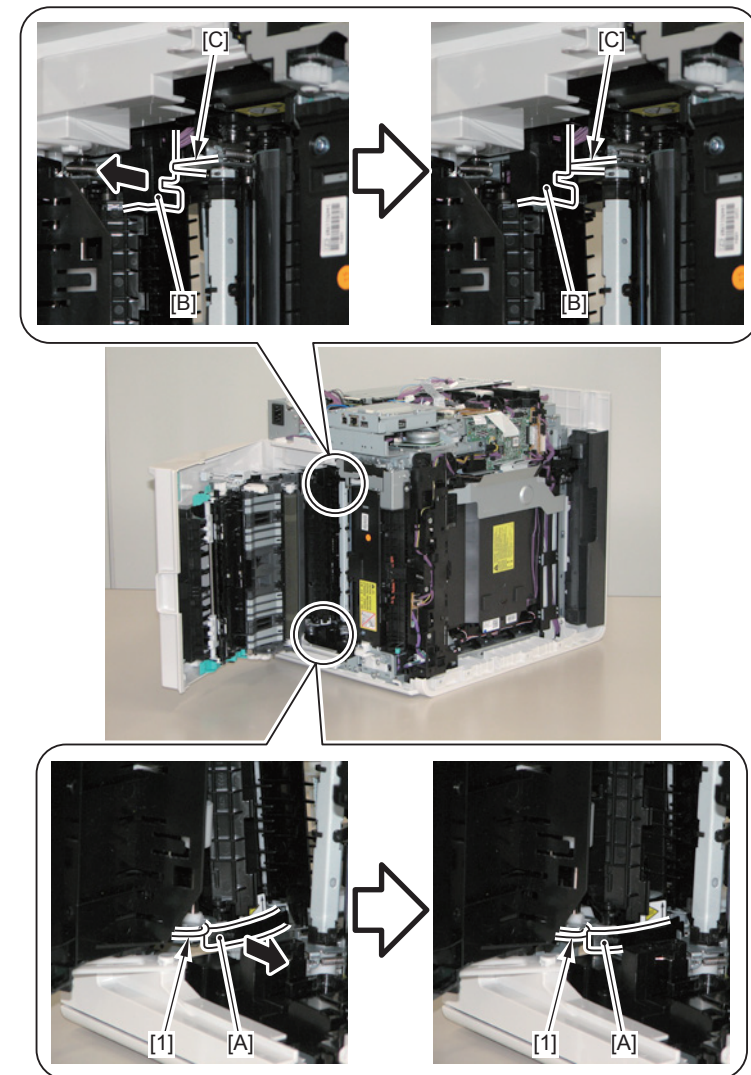

F-3-330

5) Place the edge [D] of the Feed Guide of the Pickup Unit over the edge [E] of the Roller Unit of the host machine.

7) Install the 2 Guides removed in step 1.

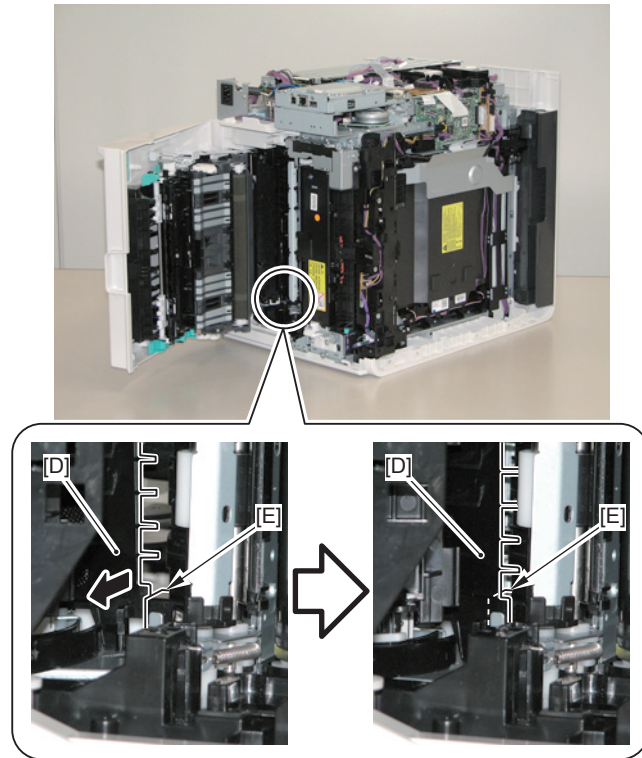

F-3-331

6) Align the 4 protrusions [1], and secure the Pickup Unit with the 6 screws [2].

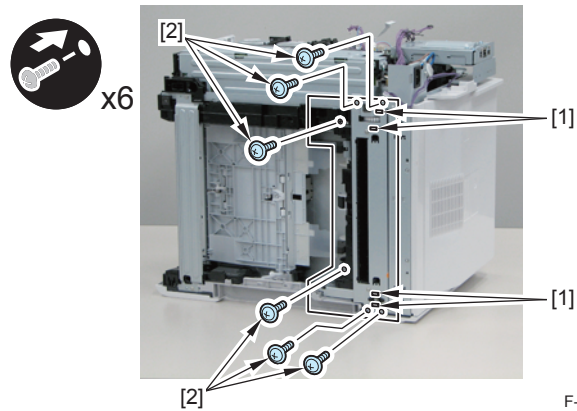

F-3-332

Removing the Manual Feed Tray Pickup Unit LBP7600C/7660Cdn/7680Cx/7210Cdn

Procedure

- 1) Remove the Toner Cartridges (Y/M/C/Bk).
- 2) Remove the Cassette.
- 3) Place the host machine by placing the Rear Cover down.

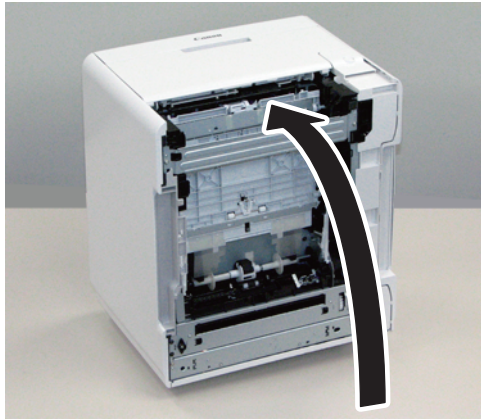

F-3-333

- 4) Move the Manual Feed Tray Pickup Unit [1], and remove the 2 Links [2] on the right and left from the Shaft Support [3].

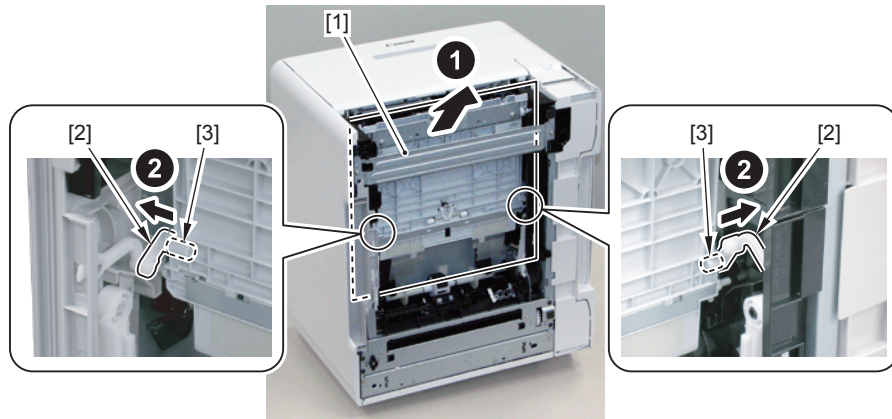

F-3-334

- 5) While pressing the stopper [1], remove the Manual Feed Tray Pickup Unit [2].

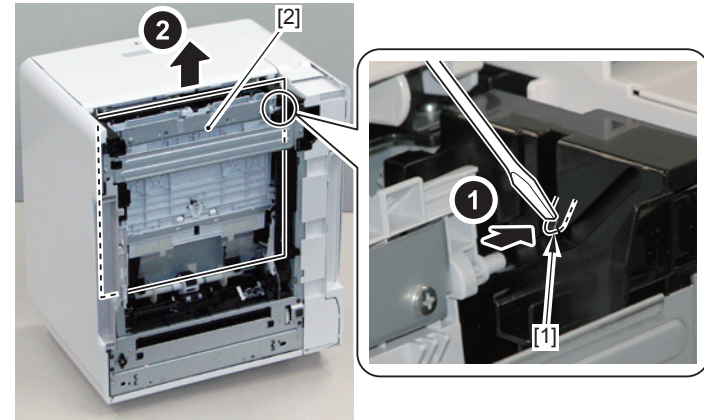

F-3-335

Removing the Delivery Unit LBP7600C/7660Cdn/7680Cx

Preparation

- 1) Remove the Right Cover.(Refer to page 3-20)
- 2) Remove the Operation Panel Unit.(Refer to page 3-56)
- 3) Remove the Rear Upper Cover (Left).(Refer to page 3-17)
- 4) Remove the Upper Front Cover (Right).(Refer to page 3-23)
- 5) Remove the Upper Cover.(Refer to page 3-24)
- 6) Remove the Right Frame Cover..(Refer to page 3-38)
- 8) Remove the Right Upper Frame unit.(Refer to page 3-43)
- 9) Remove the Left Cover.(Refer to page 3-22)
- 10) Remove the Rear Cover.(Refer to page 3-20)
- 11) Remove the Rear Lower Cover.(Refer to page 3-17)
- 12) Remove the Rear Cover Rib Unit.(Refer to page 3-16)
- 13) Remove the Duplex Reverse Drive Unit.(Refer to page 3-54)

Procedure

- 1) Release the claw [1], move the Harness Guide [2] and disconnect the connector [3].

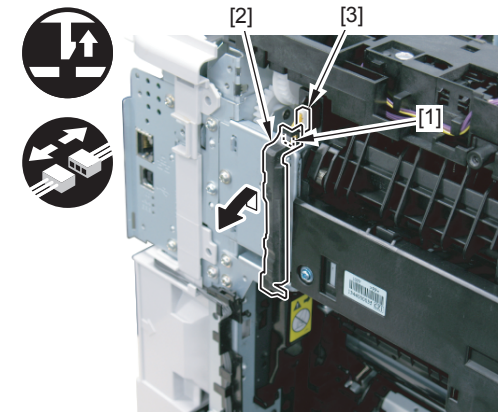

F-3-336

- 2) Free the harness [1] from the Harness Guide [A].

- 1 Wire Saddle [2]
- 3 Connectors [3]

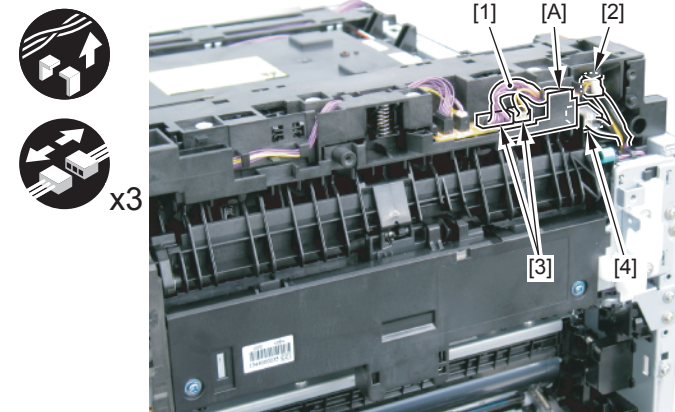

F-3-337

CAUTION:

At installation, be sure to locate the harness as shown in the figure below.

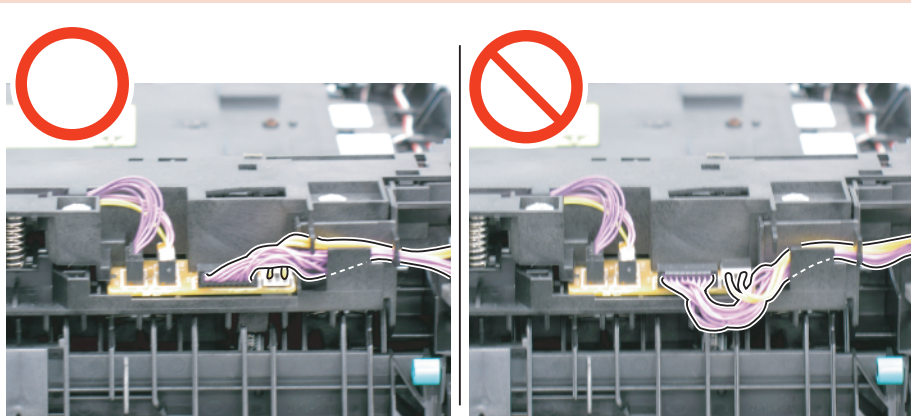

F-3-338

3) Release the 2 claws [1], and disconnect the connector [2].

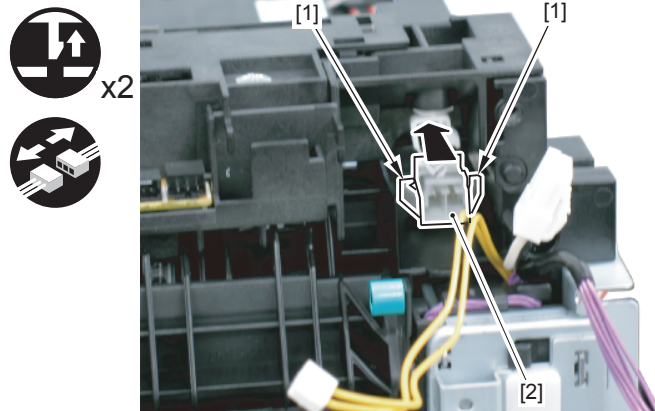

F-3-339

4) Free the harness [1] from the Harness Guide [A].

- 2 Connectors [2]

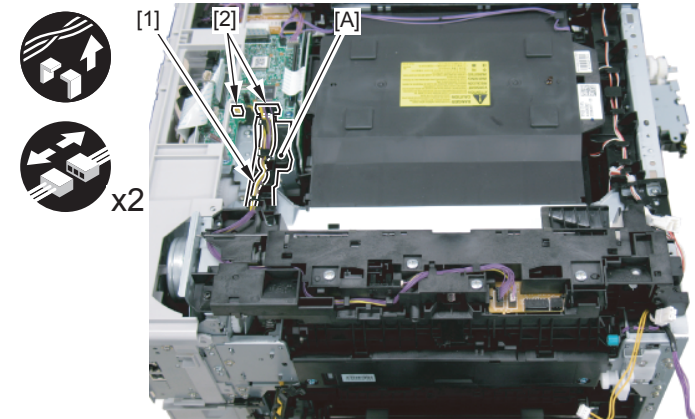

F-3-340

5) Remove the Delivery Unit [1].

- 3 Screws [2]

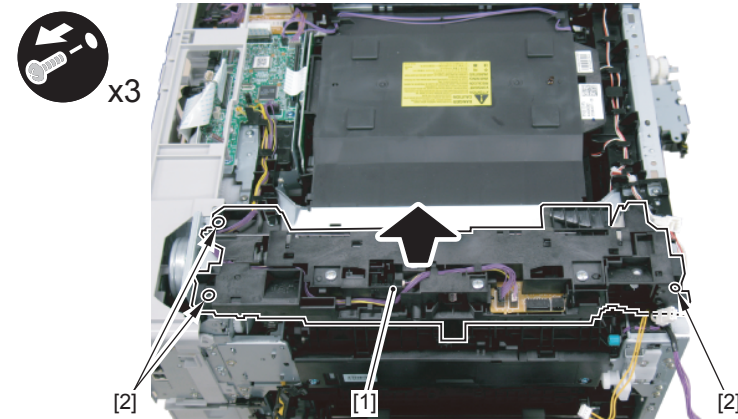

F-3-341

Removing the Delivery Unit LBP7210Cdn

Preparation

- 1) Remove the Right Cover.(Refer to page 3-20)
- 2) Remove the Operation Panel Unit.(Refer to page 3-56)
- 3) Remove the Rear Upper Cover (Left).(Refer to page 3-17)
- 4) Remove the Upper Front Cover (Right).(Refer to page 3-23)
- 5) Remove the Upper Cover.(Refer to page 3-24)
- 6) Remove the Right Frame Cover..(Refer to page 3-38)
- 7) Remove the Right Upper Frame unit.(Refer to page 3-43)
- 8) Remove the Left Cover.(Refer to page 3-22)
- 9) Remove the Rear Cover.(Refer to page 3-20)
- 10) Remove the Rear Lower Cover.(Refer to page 3-17)
- 11) Remove the Rear Cover Rib Unit.(Refer to page 3-16)
- 12) Remove the Duplex Reverse Drive Unit.(Refer to page 3-54)

Procedure

- 1) Release the claw [1], move the Harness Guide [2] and disconnect the connector [3].

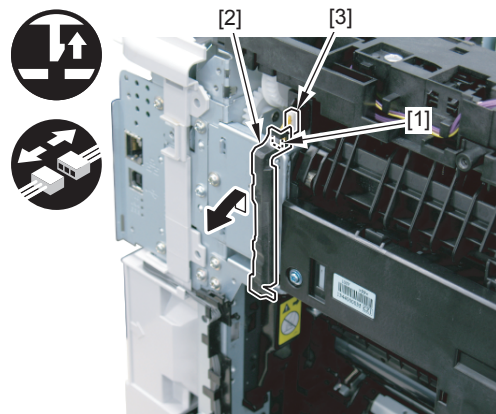

F-3-342

- 2) Free the harness [1] from the Harness Guide [A].

- 1 Wire Saddle [2]
- 3 Connectors [3]

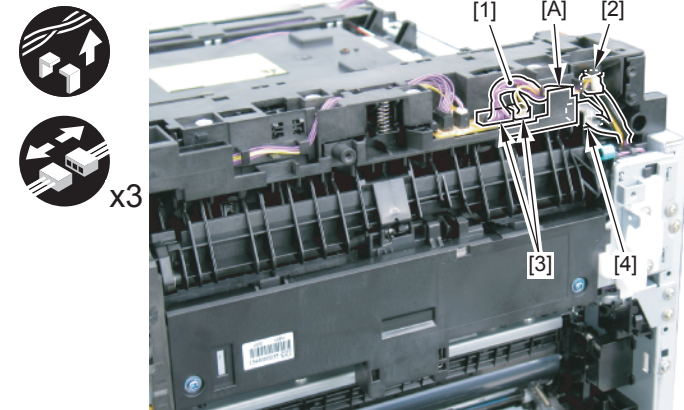

F-3-343

CAUTION:

At installation, be sure to locate the harness as shown in the figure below.

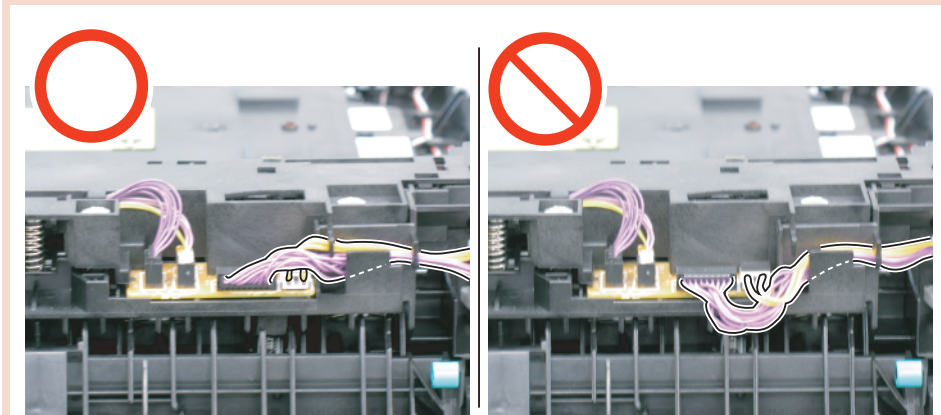

F-3-344

3) Release the 2 claws [1], and disconnect the connector [2].

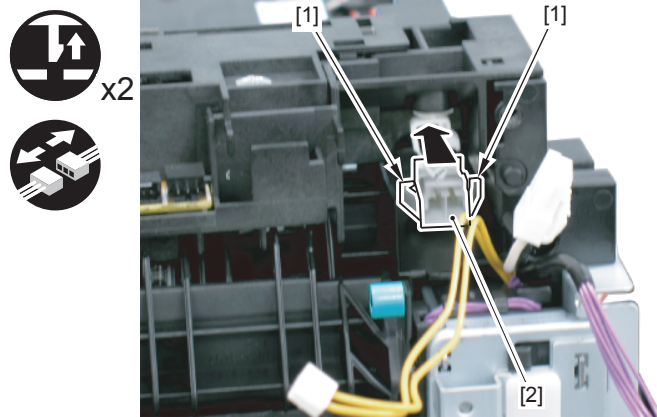

F-3-345

4) Free the harness [1] from the Harness Guide [A].

• 2 Connectors [2]

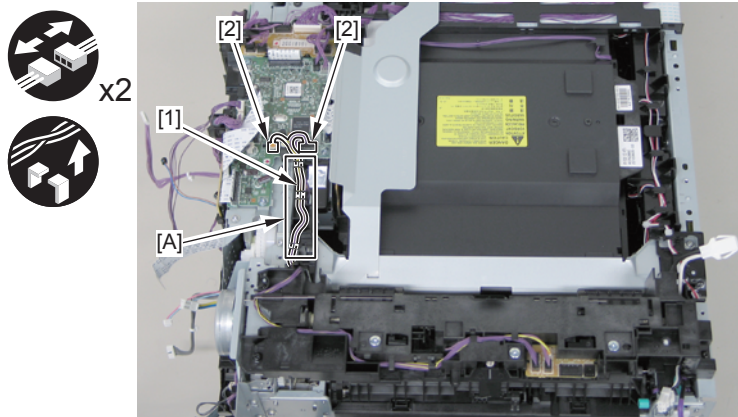

F-3-346

5) Remove the Delivery Unit [1].

• 3 Screws [2]

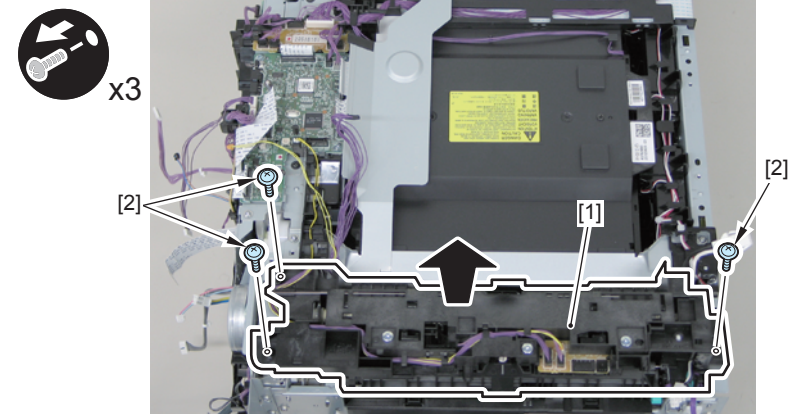

F-3-347

Removing the Cassette Pickup Roller LBP7600C/7660Cdn/7680Cx

Procedure

CAUTION:

Be sure not to touch the surface of the Pickup Roller.

- 1) Turn ON the power, and open the service mode screen menu.
- 2) Enter the password and move to the service mode menu.
- 3) In the service mode menu, execute [FUNCTION GR.] > [FEED ROLLER CHG.].
- 4) The Pickup Roller rotates to the replacement position.
- 5) Remove the Toner Cartridges (Y/M/C/Bk).
- 6) Remove the cassette.
- 7) Place the host machine by placing the Rear Cover down.
- 8) Remove the 2 Protrusions [1] and Pickup Roller [2].
 - 2 Claws [3]
 - 2 Hooks [4]

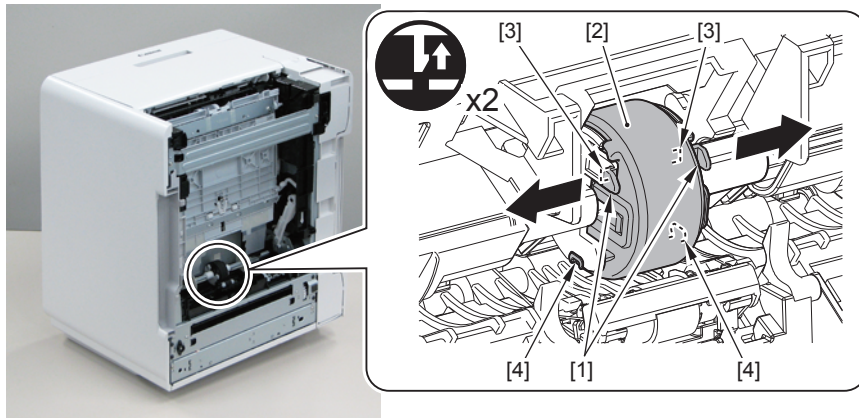

F-3-348

- 9) After replacing the Pickup Roller, turn ON the power, and return the Pickup Roller to its original position from the replacement position.

Removing the Cassette Pickup Roller LBP7210Cdn

Procedure

CAUTION:

Be sure not to touch the surface of the Pickup Roller.

- 1) Connect a PC to the host machine, and start service mode on the Printer Status Window.
- 2) In service mode, select "Replace Service Parts" - "Pick-up Roller Position shift"
- 3) The Pickup Roller rotates to the replacement position.
- 4) Remove the Toner Cartridges (Y/M/C/Bk).
- 5) Remove the cassette.
- 6) Place the host machine by placing the Rear Cover down.
- 7) Remove the 2 Protrusions [1] and Pickup Roller [2].
 - 2 Claws [3]
 - 2 Hooks [4]

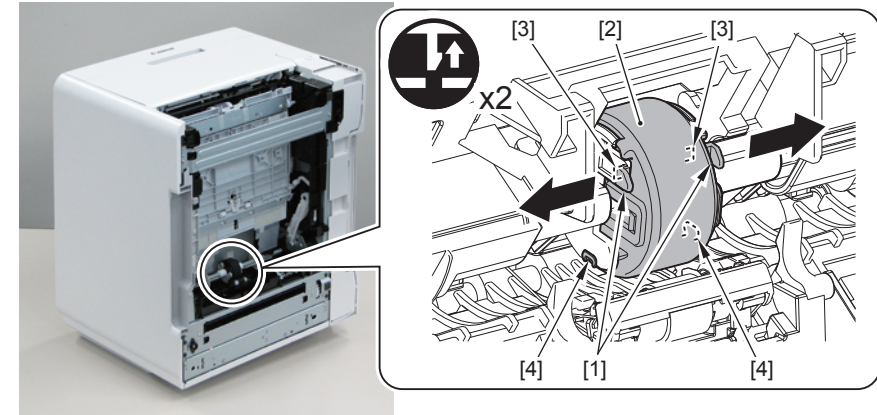

F-3-349

- 8) After replacing the Pickup Roller, turn ON the power, and return the Pickup Roller to its original position from the replacement position.

Removing the Cassette Separation Roller LBP7600C/7660Cdn/7680Cx/7210Cdn

Procedure

CAUTION:

Be sure not to touch the surface of the Separation Roller and the Pickup Roller.

- 1) Remove the Toner Cartridges (Y/M/C/Bk).
- 2) Remove the cassette.
- 3) Place the host machine by placing the Rear Cover down.
- 4) Remove the Separation Roller Cover [1].
 - 2 claws [2]

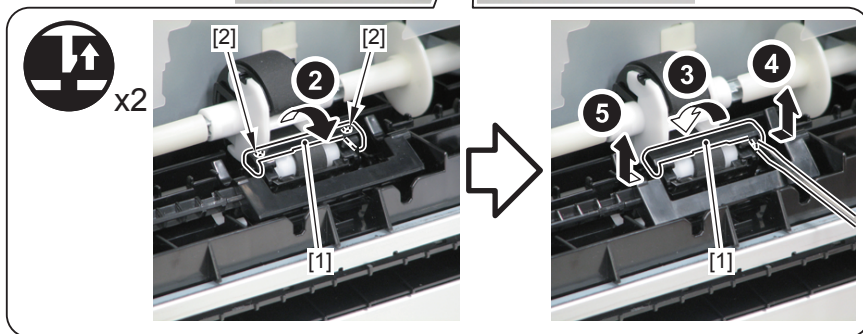
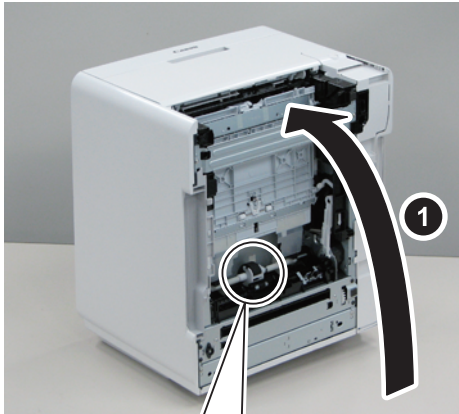

F-3-350

- 5) Open the holder [1] and remove the Separation Roller [2].

- 2 Claws [3]
- 1 Protrusions [4]

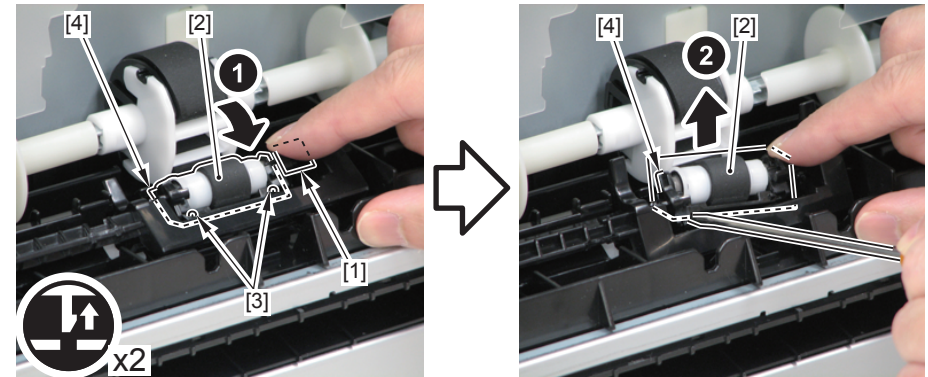

F-3-351

Removing the Manual Feed Tray Pickup Roller LBP7600C/7660Cdn/7680Cx

Procedure

CAUTION:

Be sure not to touch the surface of the Manual Feed Tray Pickup Roller.

- 1) Turn ON the power, and open the service mode screen menu.
- 2) Enter the password and move to the service mode menu.
- 3) In the service mode menu, execute [FUNCTION GR.] > [FEED ROLLER CHG.].
- 4) The Pickup Roller rotates to the replacement position.
- 5) Remove the Toner Cartridges (Y/M/C/Bk).
- 6) Remove the cassette.
- 7) Place the host machine by placing the Rear Cover down.
- 8) Remove the Manual Feed Tray Pickup Roller [1].
 - 2 Protrusions [2]
 - 2 Claws [3]
 - 2 Hooks [4]

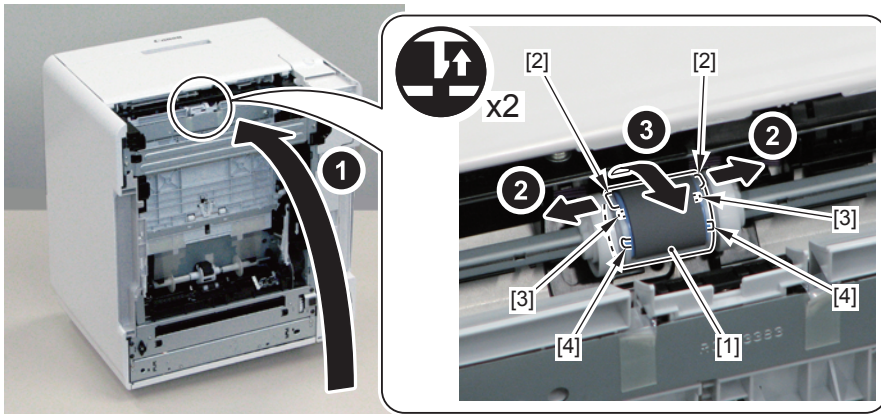

- 9) After replacing, turn ON the power, and return the Pickup Roller to its original position from the replacement position.

Removing the Manual Feed Tray Pickup Roller LBP7210Cdn

Procedure

CAUTION:

Be sure not to touch the surface of the Manual Feed Tray Pickup Roller.

- 1) Remove the Toner Cartridges (Y/M/C/Bk).
- 2) Remove the cassette.
- 3) Place the host machine by placing the Rear Cover down.
- 4) Turn the Manual Feed Tray Pickup Roller till it stop toward.
- 5) Remove the Manual Feed Tray Pickup Roller [1].
 - 2 Protrusions [2]
 - 2 Claws [3]
 - 2 Hooks [4]

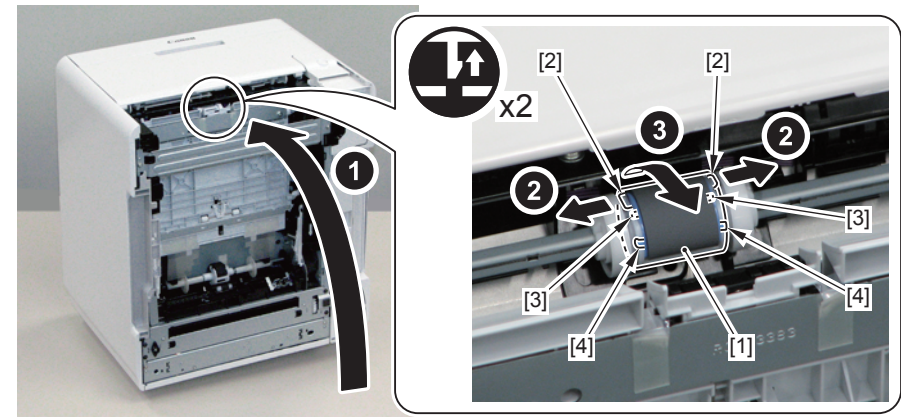

Removing the Manual Feed Tray Separation Pad LBP7600C/7660Cdn/7680Cx

Procedure

CAUTION:

Be sure not to touch the surface of the Manual Feed Tray Separation Pad.

- 1) Remove the cassette.
 - 2) Lower the Tray.
 - 3) Insert a screwdriver in the clearance [A] between the Manual Feed Tray Separation Pad [1] and the Pad Holder, and remove the Manual Feed Tray Separation Pad [1].
- 2 Protrusions [2]

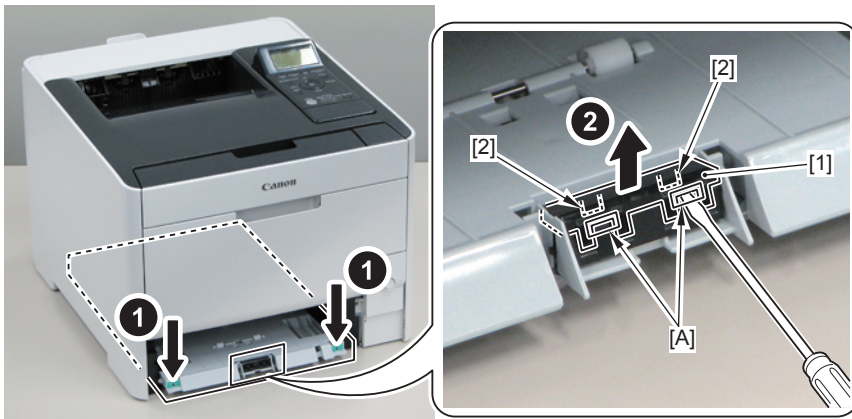

Removing the Manual Feed Tray Separation Pad LBP7210Cdn

Procedure

CAUTION:

Be sure not to touch the surface of the Manual Feed Tray Separation Pad.

- 1) Remove the cassette.
 - 2) Lower the Tray.
 - 3) Insert a screwdriver in the clearance [A] between the Manual Feed Tray Separation Pad [1] and the Pad Holder, and remove the Manual Feed Tray Separation Pad [1].
- 2 Protrusions [2]

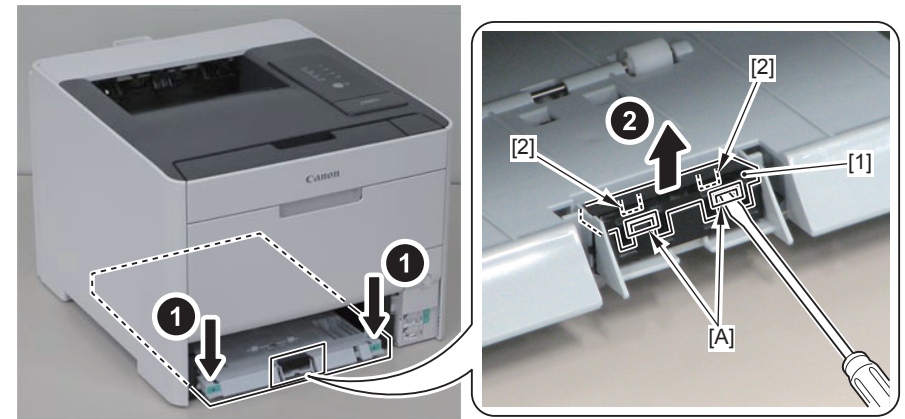

F-3-352

Removing the Duplex Feed Unit LBP7600C/7660Cdn/7680Cx

Preparation

- 1) Remove the Right Cover.(Refer to page 3-20)
- 2) Remove the Rear Upper Cover (Left).(Refer to page 3-17)
- 3) Remove the Secondary Transfer Feeding Unit.(Refer to page 3-153)
- 4) Remove the Rear Cover.(Refer to page 3-15)
- 5) Remove the Rear Lower Cover.(Refer to page 3-17)

Procedure

- 1) Remove the Duplex Feed Unit [1] by opening it.
 - 2 Shaft Supports [2]

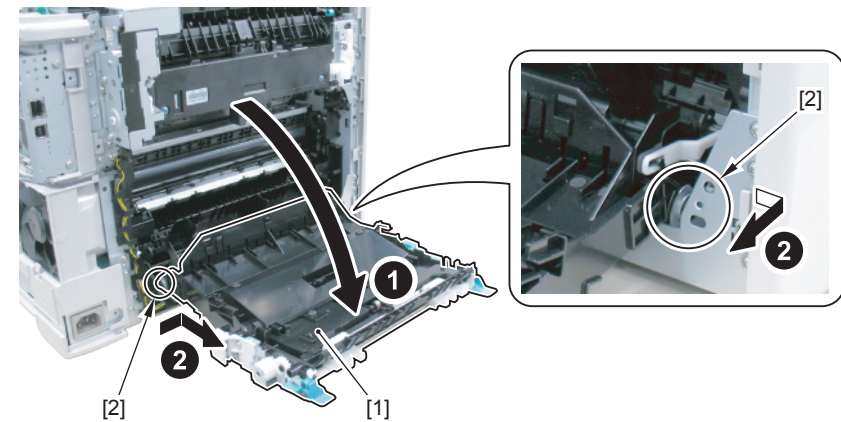

F-3-353

- 2) Remove the Link [2] from the Duplex Feed Unit [1].
 - 1 Protrusion [3]

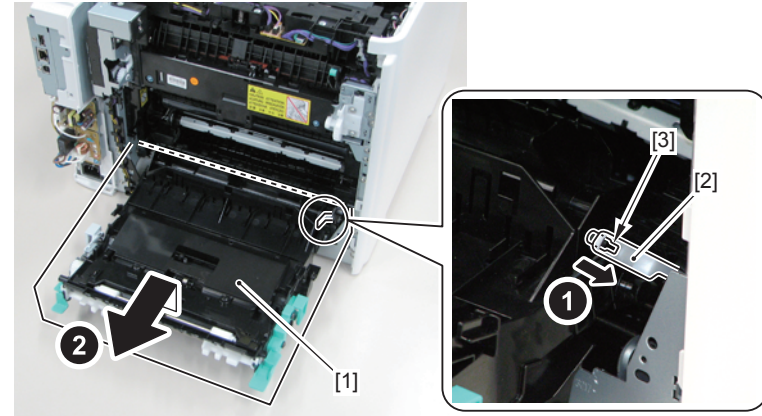

F-3-354

Removing the Duplex Feed Unit LBP7210Cdn

Preparation

- 1) Remove the Right Cover.(Refer to page 3-20)
- 2) Remove the Rear Upper Cover (Left).(Refer to page 3-17)
- 3) Remove the Secondary Transfer Feeding Unit.(Refer to page 3-153)
- 4) Remove the Rear Cover.(Refer to page 3-15)
- 5) Remove the Rear Lower Cover.(Refer to page 3-17)

Procedure

- 1) Remove the Duplex Feed Unit [1] by opening it.
 - 2 Shaft Supports [2]

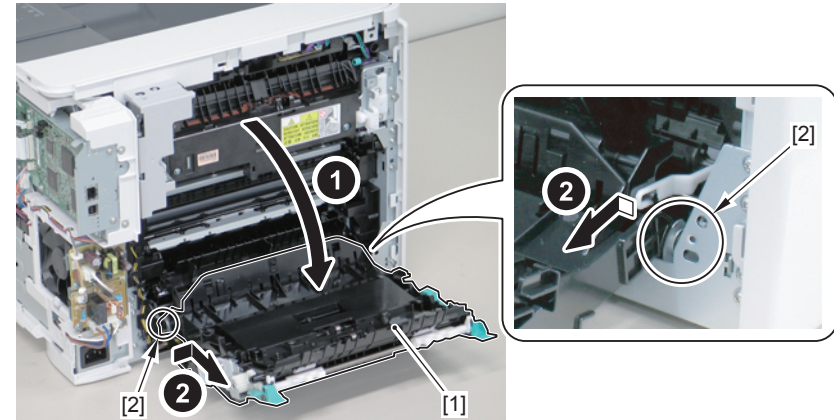

F-3-355

- 2) Remove the Link [2] from the Duplex Feed Unit [1].
 - 1 Protrusion [3]

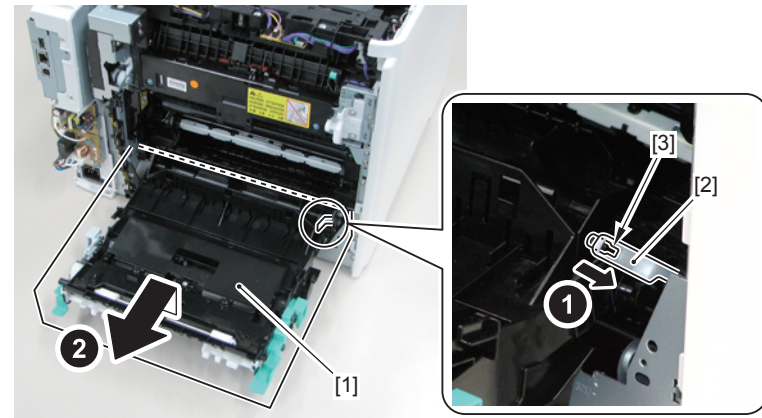

F-3-356

Removing the Secondary Transfer Feed Unit LBP7600C/7660Cdn/7680Cx/7210Cdn

Procedure

CAUTION:

Be sure not to touch the surface of the Secondary Transfer Roller.

1) Open the Rear Cover, and remove the Secondary Transfer Feed Unit [1].

- 1 Screw [2]
- 2 Hooks [3]

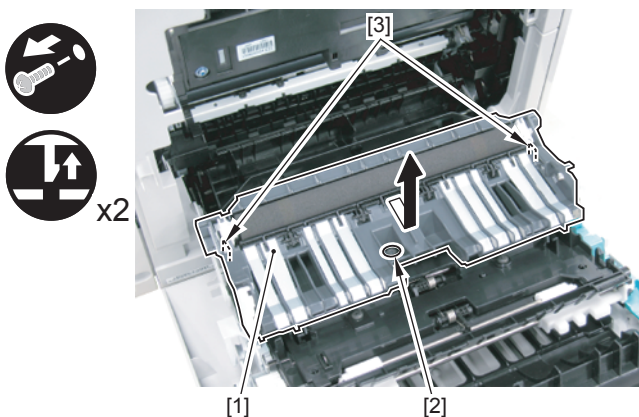

F-3-357

CAUTION:

When removing the screws, be sure not to lose the Guide Cap [1] since it comes off.

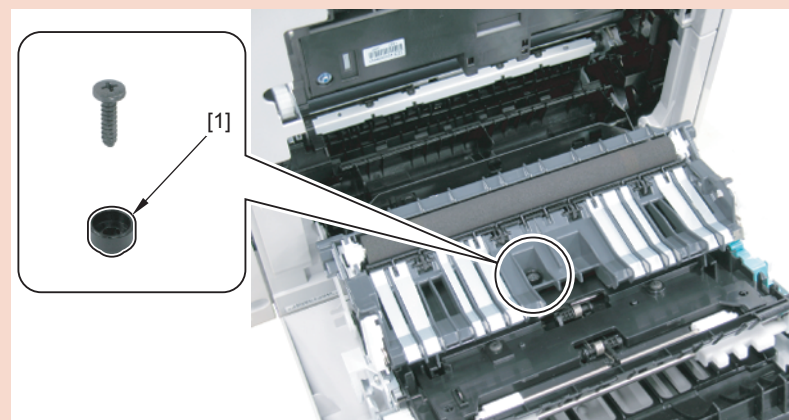

F-3-358

Removing the Re-pickup Guide Unit LBP7600C/7660Cdn/7680Cx/7210Cdn

Preparation

- 1) Remove the Right Cover.(Refer to page 3-20)
- 2) Remove the Rear Upper Cover (Left).(Refer to page 3-17)
- 3) Remove the Secondary Transfer Feeding Unit.(Refer to page 3-153)
- 4) Remove the Rear Cover.(Refer to page 3-15)
- 5) Remove the Rear Lower Cover.(Refer to page 3-17)
- 6) Remove the Rear Cover Rib Unit.(Refer to page 3-16)
- 7) Remove the Duplexing Feeding Unit.(Refer to page 3-151)

Procedure

- 1) Remove the Re-pickup Guide Unit [1].
 - 3 Connectors [2]
 - 4 Screws [3]
 - 2 Protrusions [4]

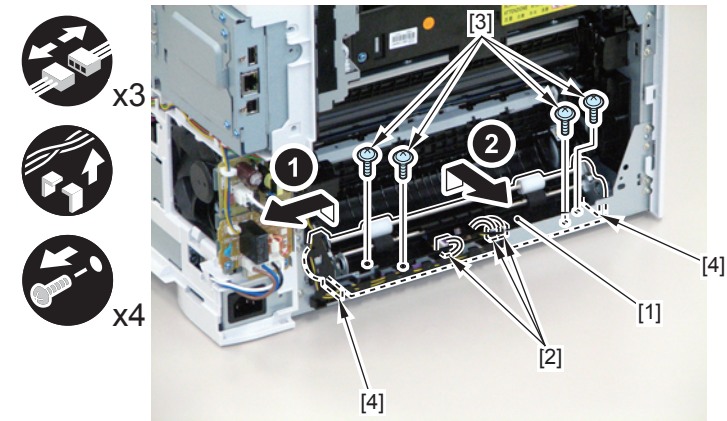

CAUTION:

F-3-359

Be sure to insert the 2 harnesses [1] at the bottom of the Guide [A] when installing.

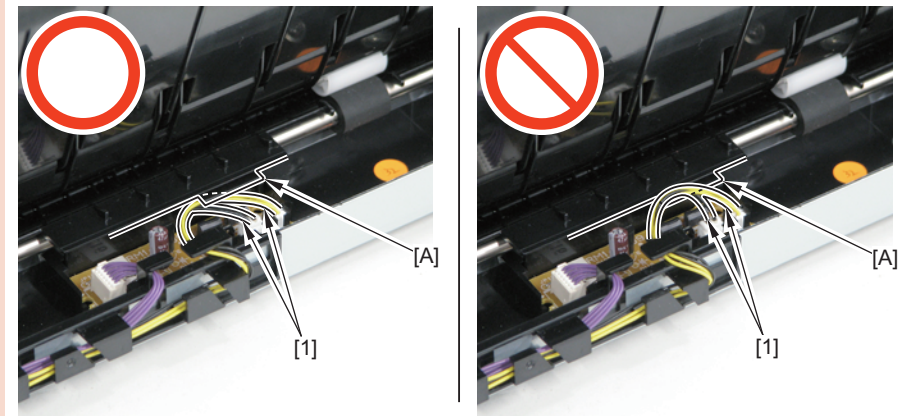

F-3-360

4

Maintenance and Inspection

- Periodically Replaced Parts
- Consumables
- Periodical Service
- Cleaning

Periodically Replaced Parts

Periodically Replaced Parts

The machine does not have parts that require periodical replacement.

Consumables

Life Expectancy of Consumable Parts

No consumable parts are required in this printer.

Periodical Service

Periodical Service

The printer has no parts that require periodic servicing.

Cleaning

Cleaning

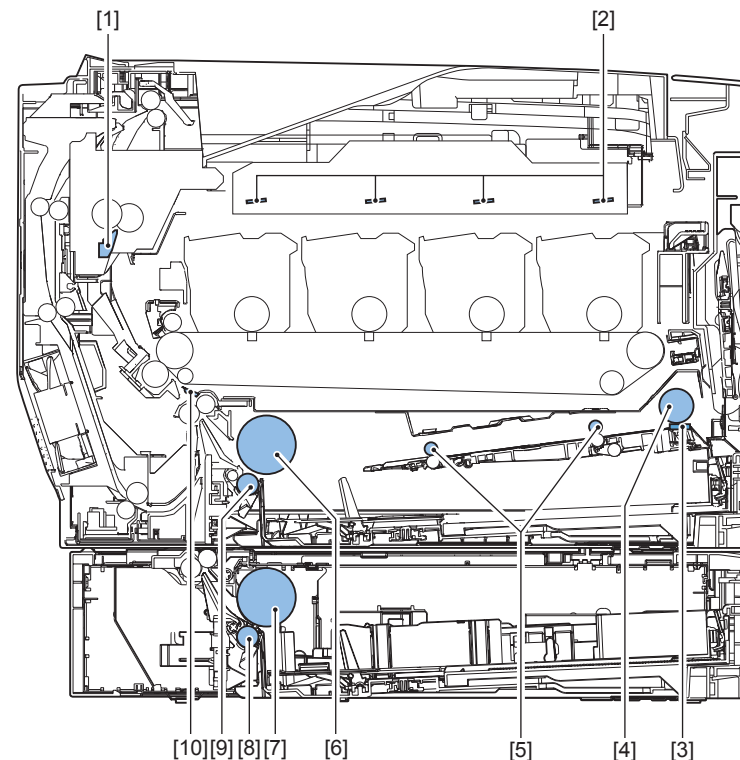

F-4-1

Components		Cleaning procedure
[1]	Pre-fixing guide	Wipe with a lint-free cloth. If dirt cannot be removed, dampen the lint-free cloth with alcohol.
[2]	Laser beam window glass	
[3]	Multi tray separation pad	Wipe with a lint-free cloth. If dirt cannot be removed, dampen the lint-free cloth with alcohol.
[4]	Multi tray pickup roller	
[5]	Multi tray feed roller	
[6]	Cassette pickup roller	
[7]*	PF pickup roller	
[8]*	PF separation roller	
[9]	Cassette separation roller	
[10]	Upper registration guide	

* paper feeder

5

Troubleshooting

- Corrective Actions
- Standard/Adjustment
- Electrical Parts Layout/Function Assignment
- Connector Location
- Service Tools
- Error Code
- Version Upgrade
- Service Mode
- Debug log
- Backup/Restoration by Expansion ROM for servicing and Sublog Board

Corrective Actions

Image Failure

Partially Blank/Streaked

Image Faults Occurring at Specific Intervals

Description

The fault occurs in main scanning direction.

Field Remedy

Refer to the following table to identify a specific roller or component. Then, clean or replace the roller or component

Distance between defects (mm)	Component
About 44	Registration roller
About 58	Secondary transfer external roller
About 75	Photosensitive drum
About 22	Developing cylinder
About 58	Fixing film
About 63	Pressure roller
About 78	ITB(drive roller,Secondary transfer inside roller)

Image Failure(LBP7210Cdn)

Partially Blank/Streaked

Image Faults Occurring at Specific Intervals

Description

The fault occurs in main scanning direction.

Field Remedy

Refer to the following table to identify a specific roller or component. Then, clean or replace the roller or component:

Distance between defects (mm)	Component
About 44	Registration roller
About 58	Secondary transfer external roller
About 75	Photosensitive drum
About 22	Developing cylinder
About 58	Fixing film
About 63	Pressure roller
About 78	ITB(drive roller,Secondary transfer inside roller)

Stretching/Shrinking

- The 1st print is reduced in size when continuously performing WebPrint from Windows7 with Internet Explorer 8 or 9.

Description

By following the steps below, when continuously performing WebPrint from Windows7 with Internet Explorer 8 or 9, the 1st print was reduced in size. The phenomenon occurs depending on pages generated by Java Script or conditions of HTML data settings.

- 1) Open any Web page. If the security warning popup is displayed, click the bar to select "Allow Blocked Content...".

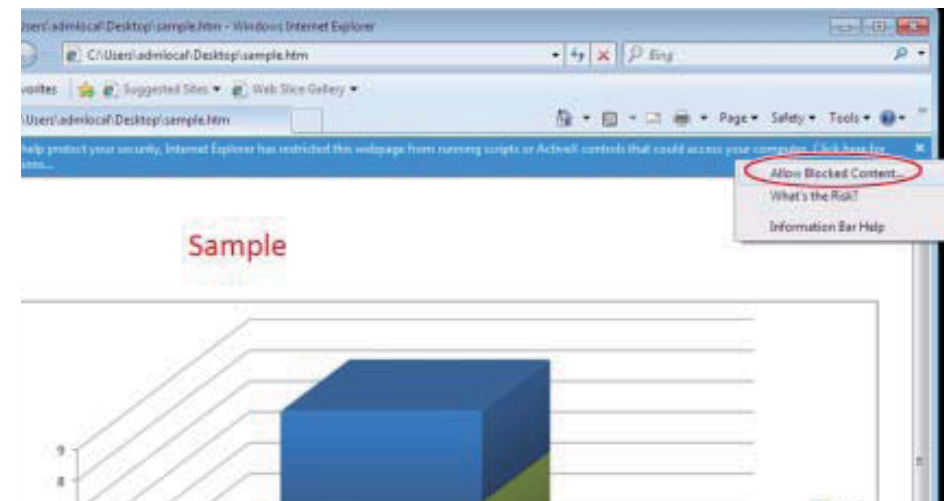

F-5-1

2) If the security warning dialog box opens, click "Yes" to close.

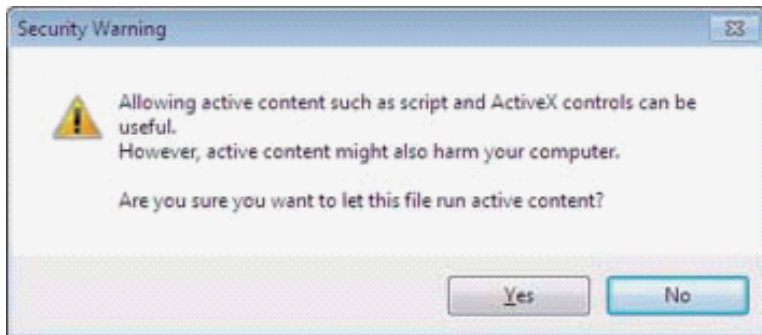

F-5-2

3) Leave the default: "Portrait" as it is for Page Setup for Internet Explorer.

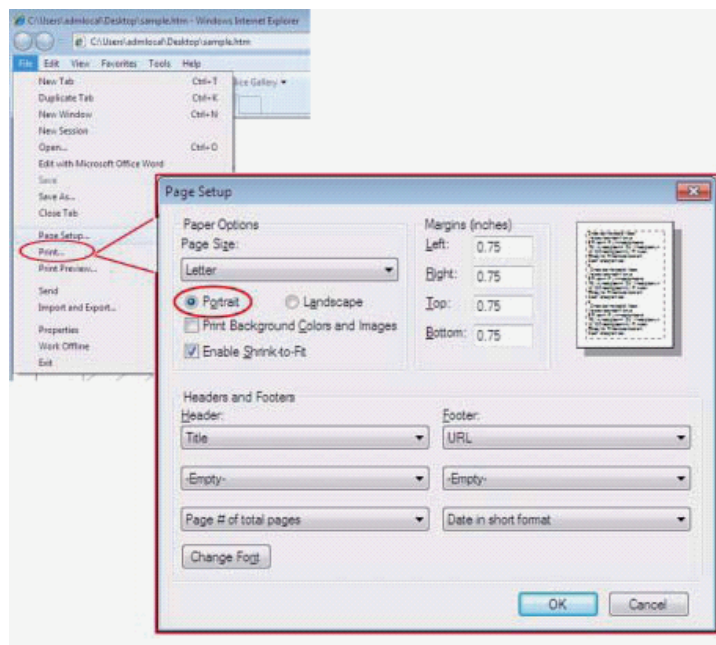

F-5-3

4) File > Print > Printing Preferences > Page Setup > Orientation, and set "Landscape".

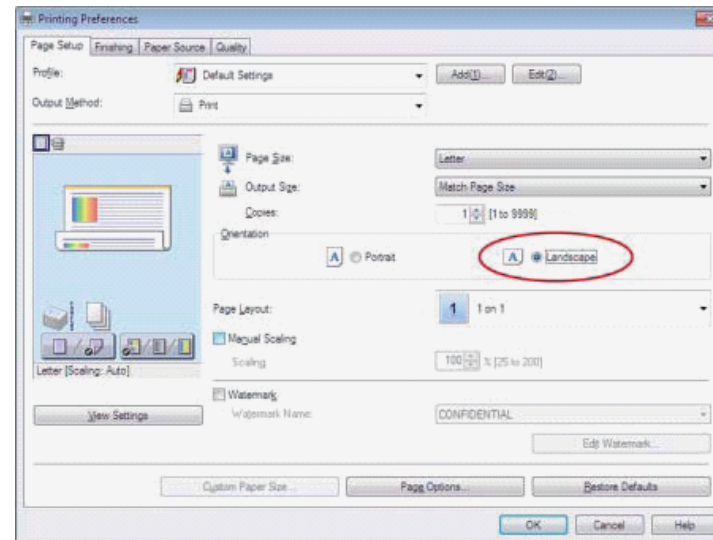

F-5-4

5) Click the OK button to close the page setup screen for the printer driver, and press "Print" button to print.

6) When continuously press "Print" button again to print, the first print is reduced in size[A] while the second print is not [B].

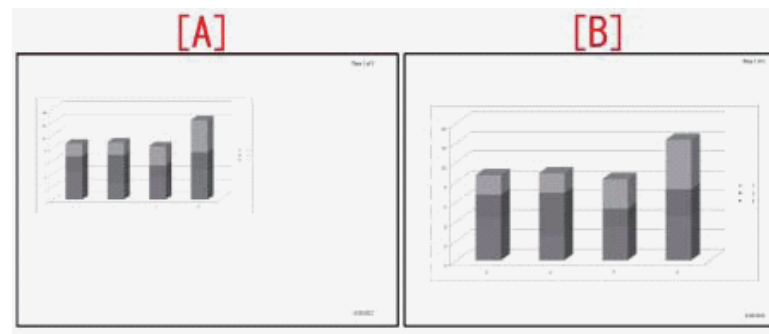

F-5-5

Cause

This is a problem in the OS/application. As a result of analyzing EMF data (OS command to draw) which was forwarded by Internet Explorer to the printer driver, the data was already reduced in size. We assume that at the 1st printing, because the orientation of default paper for Internet Explorer is "Portrait", even though "Landscape" was set in the printer driver, the orientation for Internet Explorer remained unchanged. Therefore, the image was reduced in size as the image processing was performed with the portrait size. At the 2nd printing, the orientation of paper for Internet Explorer was changed to "Landscape", the print result seems to have been correct. In addition, this issue seems to be something to do with HTML data. If 700 or over is put for Width for Table, the first print from Internet Explorer is always reduced in size.

```

333 <div class="..." >
334 <table summary="*" border="0" cellpadding="0"
335 <table cellpadding="0" class="..." width="940*"
336 <colgroup>
337 <col width="50*"
338 <col width="650*"
339 <col width="*"
340 </colgroup>
341 <tr>
342 <td colspan="3"
343 class="..." bold-font="..." </td>
344 </tr>
345 <td>
346 <table summary="*"
347 <table cellpadding="0" class="..."
348 <colgroup>
349 <col
350 <col width="80*"
351 <col width="80*"
352 <col width="80*"

```

F-5-6

Printing / Scanning(LBP7210Cdn)

No Output

Method for identifying whether the cause of printing problem is on the printer driver side or on the printer side

Description

Upon printing, if the printer stops during spooling and is not able to execute printing or if such problem occurs, there is a method for identifying whether the cause is on the printer driver side or on the printer side.

Field Remedy

1) Ask the PC administrator to do the following:

1-1) Put a checkmark in Printer properties > Advanced Tab > "Keep printed documents"

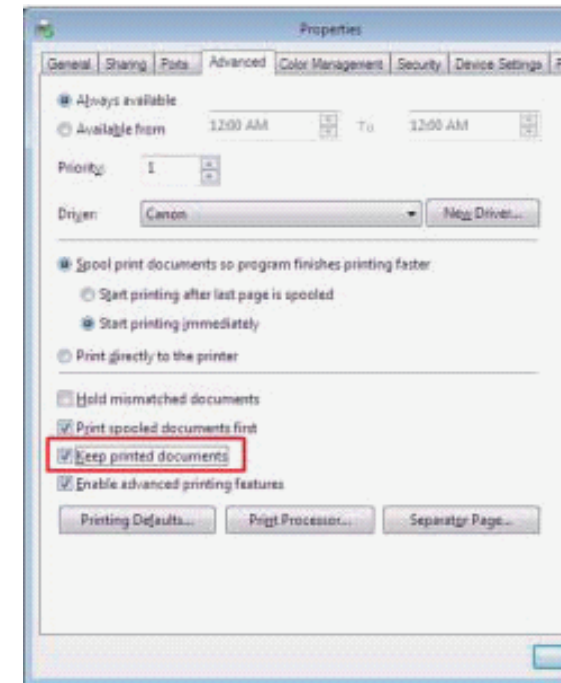

F-5-7

1-2) Execute printing and reproduce the problem.

1-3) Copy the spool files with the extensions .spl and .shd in the folder:

C:\Windows\System32\spool\PRINTERS

2) Provide the support department of the sales company with the spool files

together with the following:

- OS
- Application
- Version and environment (local/network) of the printer driver
- Version of the printer and its option information, and the status at the time of occurrence of the problem (for example, though printing is not performed, "Execution/Memory" Lamp keeps blinking).

[Caution] After the work is done, remove the checkmark that was put in "Keep printed documents" in 1) to be back to the original state.

[Reference] The spool files created at 1-3) are the files that have been processed on the printer driver side. If this data has no problem, the data generation processing on the printer driver side is normal. Therefore, it is determined that the cause is on the printer side or the spooler (OS) side.

Standard/Adjustment

Test Print

Engine Test Print

Test Print is an object used to check whether this equipment works properly or not.

Execute engine test print, as the following steps.

1. Turn ON the power, and when this equipment has turned to 'standby', press test print switch

[1]

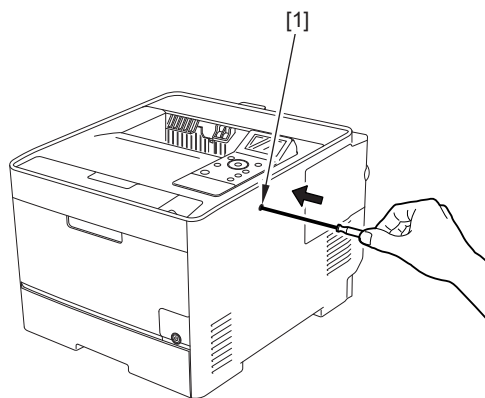

F-5-8

(LBP7210Cdn)

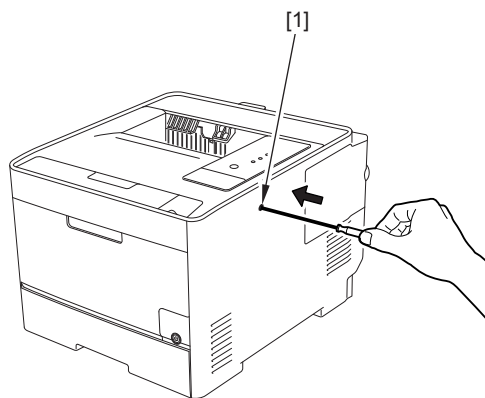

F-5-9

2. Engine test print will be executed, and one page of the horizontal line pattern as the below figure will be printed.

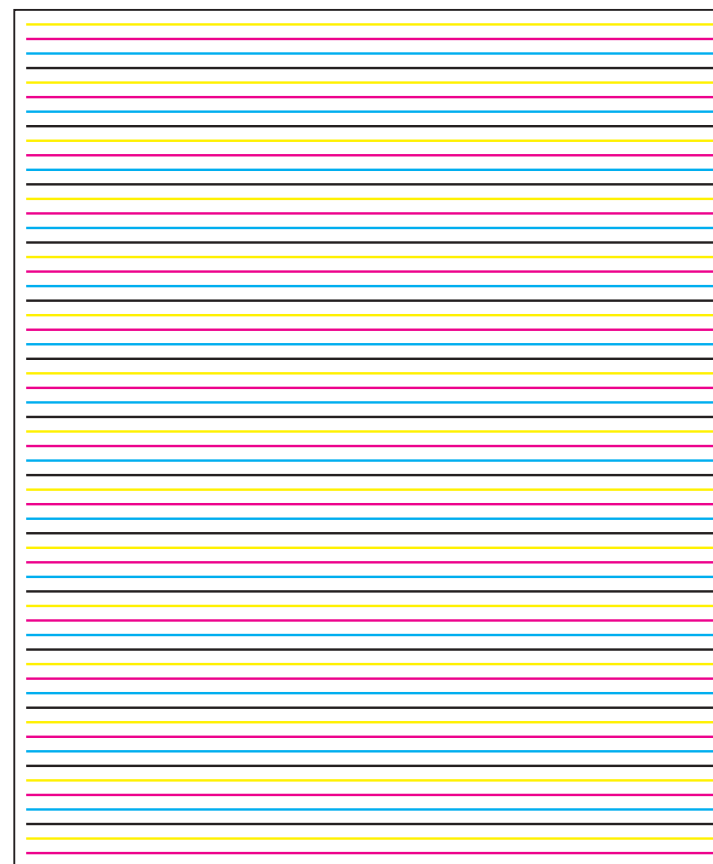

F-5-10

Adjustment of Laser Exposure System

After Replacing the laser scanner unit

When replacing the laser unit, enter the value described on the label included in the scanner unit into the following service mode.

After entry, put the label [2] inside the right cover [1].

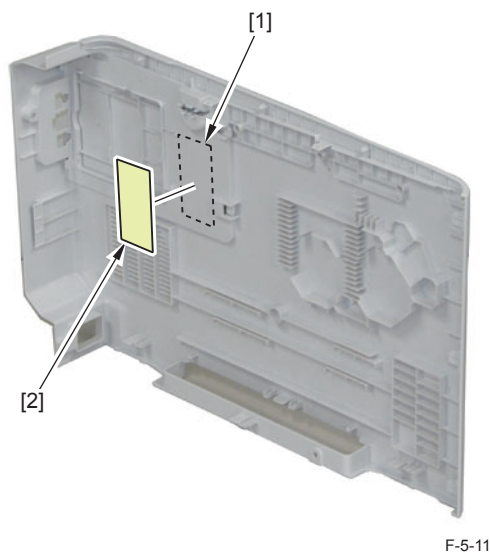

Service Mode > ADJUST GR. > SUB-S-Y0 to SUB-S-K2
MAI-S-Y0 to MAI-S-K2

After registration in service mode, perform the following measure.

1) Service Mode > FUNCTION GR. > CLEAR DCON

To initialize the backup area of the DC Controller PCB NVRAM in the Main Controller PCB.

2) Turn OFF and then ON the power.

By turning OFF and then ON the power, data of the DC Controller PCB NVRAM is backed up to the Main Controller PCB automatically.

Scanner Unit Replace Settings
✕

Scanner Informations:Sub Scanning Line

	00	01	02
Y(00)	<input style="width: 40px; height: 20px;" type="text"/>	<input style="width: 40px; height: 20px;" type="text"/>	<input style="width: 40px; height: 20px;" type="text"/>
M(01)	<input style="width: 40px; height: 20px;" type="text"/>	<input style="width: 40px; height: 20px;" type="text"/>	<input style="width: 40px; height: 20px;" type="text"/>
C(02)	<input style="width: 40px; height: 20px;" type="text"/>	<input style="width: 40px; height: 20px;" type="text"/>	<input style="width: 40px; height: 20px;" type="text"/>
K(03)	<input style="width: 40px; height: 20px;" type="text"/>	<input style="width: 40px; height: 20px;" type="text"/>	<input style="width: 40px; height: 20px;" type="text"/>

Scanner Informations:Main Scanning Line

	00	01	02
Y(00)	<input style="width: 40px; height: 20px;" type="text"/>	<input style="width: 40px; height: 20px;" type="text"/>	<input style="width: 40px; height: 20px;" type="text"/>
M(01)	<input style="width: 40px; height: 20px;" type="text"/>	<input style="width: 40px; height: 20px;" type="text"/>	<input style="width: 40px; height: 20px;" type="text"/>
C(02)	<input style="width: 40px; height: 20px;" type="text"/>	<input style="width: 40px; height: 20px;" type="text"/>	<input style="width: 40px; height: 20px;" type="text"/>
K(03)	<input style="width: 40px; height: 20px;" type="text"/>	<input style="width: 40px; height: 20px;" type="text"/>	<input style="width: 40px; height: 20px;" type="text"/>

F-5-12

5

Troubleshooting > Standard/Adjustment > Adjustment of Laser Exposure System > After Replacing the laser scanner unit

5-7

After Replacing the laser scanner unit(LBP7210Cdn)

When replacing the laser unit, enter the value described on the label included in the scanner unit into the following service mode.

After entry, put the label [2] inside the right cover [1].

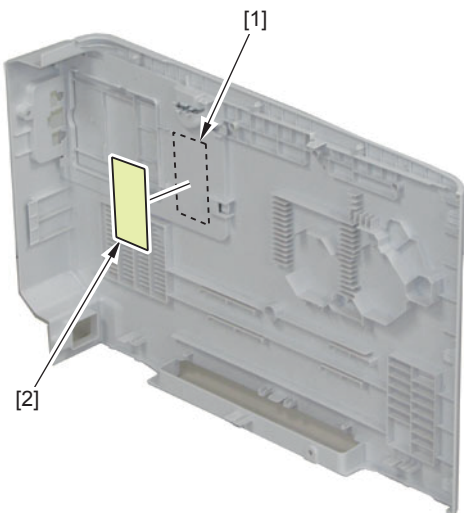

F-5-13

How to transit to the service mode

1. After the power ON, display the printer driver screen.
2. Change the display from the driver screen to status window.
3. Enter the password “*28*” with keyboards.
4. Select: Option menu > Service mode > Service parts replacement > Scanner unit replace settings from the status window.

Scanner Unit Replace Settings X

Scanner Informations:Sub Scanning Line

	00	01	02
Y(00)	<input style="width: 40px; height: 20px;" type="text"/>	<input style="width: 40px; height: 20px;" type="text"/>	<input style="width: 40px; height: 20px;" type="text"/>
M(01)	<input style="width: 40px; height: 20px;" type="text"/>	<input style="width: 40px; height: 20px;" type="text"/>	<input style="width: 40px; height: 20px;" type="text"/>
C(02)	<input style="width: 40px; height: 20px;" type="text"/>	<input style="width: 40px; height: 20px;" type="text"/>	<input style="width: 40px; height: 20px;" type="text"/>
K(03)	<input style="width: 40px; height: 20px;" type="text"/>	<input style="width: 40px; height: 20px;" type="text"/>	<input style="width: 40px; height: 20px;" type="text"/>

Scanner Informations:Main Scanning Line

	00	01	02
Y(00)	<input style="width: 40px; height: 20px;" type="text"/>	<input style="width: 40px; height: 20px;" type="text"/>	<input style="width: 40px; height: 20px;" type="text"/>
M(01)	<input style="width: 40px; height: 20px;" type="text"/>	<input style="width: 40px; height: 20px;" type="text"/>	<input style="width: 40px; height: 20px;" type="text"/>
C(02)	<input style="width: 40px; height: 20px;" type="text"/>	<input style="width: 40px; height: 20px;" type="text"/>	<input style="width: 40px; height: 20px;" type="text"/>
K(03)	<input style="width: 40px; height: 20px;" type="text"/>	<input style="width: 40px; height: 20px;" type="text"/>	<input style="width: 40px; height: 20px;" type="text"/>

F-5-14

Adjustment of Electrical Parts

When Replacing the Engine Controller PCB

NVRAM information on the DC Controller PCB is stored in the NVRAM on the Main Controller PCB as a backup.

The data that has been backed up can be restored to the NVRAM on the DC Controller PCB in the service mode.

- 1) Execute the following: service mode > FUNCTION GR.>RESTORE DCON.
- 2) Turn OFF and then ON the power of the host machine.

When Replacing the DC Controller PCB(LBP7210Cdn)

The information in the NVRAM on the DC controller PCB is saved as backup data in the NVRAM on the main controller PCB.

Executing Printer Setting Restoration in service mode recovers the backup data in the NVRAM on the DC controller PCB.

When replacing the DC controller PCB, execute recovery of backup data, color displacement correction, and calibration in service mode.

- 1) Execute Option Menu > Service Mode > Printer Information settings > Printer Setting Restoration.

Caution

After executing the printer recovery setting, wait completion of the processing for approx. 15 sec.

- 2) Turn off/on the power supply of the host machine.
- 3) Start the Status window.
- 4) Execute Option Menu > Utility > Out-of-Register Colors Correction.
- 5) Execute Option Menu > Utility > Calibration.

When Replacing the Main Controller PCB(LBP7600C/7660Cdn)

Because setting values and management data of this machine are stored in the flash memory of the Main Controller PCB, they need to be backed up before replacing the Main Controller PCB.

However, when the Main Controller PCB cannot operate normally because of flash memory failure or system error, the above data cannot be backed up.

Also, when restoring the backup data to the Main Controller PCB, it may be necessary to re-enter the device serial number after restoration depending on the backup method used.

Setting values of this machine: User mode setting values, service mode setting values

Management data of this machine: Page counter, device serial number

1 Backup and restoration of data using Expansion ROM for servicing and Sublog Board (or Sublog Board attached with the Expansion ROM hereafter)

Since setting values and management data can all be backed up by this method, all data can be restored by restoring the backup data after replacing the PCB.

2 Backup and restoration of data using USB memory

Since only setting values can be backed up by this method, the device serial number (management data) needs to be re-entered manually after replacing the PCB and then restoring the backup data.

3 When data cannot be backed up before replacement due to Main Controller PCB error The device serial number needs to be re-entered manually after replacing the PCB.

1 Backup and restoration of data using Sublog Board attached with Expansion ROM

For details, refer to the Service Manual > Chapter 5 Troubleshooting > Backup/Restoration by Expansion ROM for servicing and Sublog Board

1-1 Backing up data before replacing the PCB

Perform the following operation to back up data of the Main Controller PCB to the Sublog Board attached with the Expansion ROM.

- Turn OFF the power.
- Install the Expansion ROM for servicing to the Sublog Board.
- Install the Sublog Board attached with the Expansion ROM to the Main Controller PCB.
- Turn ON the power.
- When turning ON the power, "NVRAM export" is displayed on the Control Panel.
- Press the down arrow key.
- All data stored on the Main Controller PCB is backed up to the Sublog Board attached with the Expansion ROM.

1-2 Replacing the PCB

- Turn OFF the power.
- Remove the Sublog Board attached with the Expansion ROM from the Main Controller PCB.
- Replace the Main Controller PCB with a new one (service part).
- Install the Sublog Board attached with the Expansion ROM to the Main Controller PCB.

1-3 Restoring data after replacing the PCB

Perform the following operation to restore data backed up in the Sublog Board attached with the Expansion ROM to the Main Controller PCB.

- Turn ON the power.
- When the menu is displayed on the Control Panel upon turning ON the power, select "NVRAM import".

- Press the down arrow key.
- Data backed up in the Sublog Board attached with the Expansion ROM is restored to the Main Controller PCB.
- Turn OFF the power, and remove the Sublog Board attached with the Expansion ROM.

1-4 Checking the device serial number

Perform the following operation to check whether the device serial number is correctly restored.

Execute Utility>Common Status Print to output the status print.

Check that the serial number indicated in the device field is the same as that written on the rating name plate of the host machine.

2 Backup and restoration of data using USB memory

2-1 Backing up data before replacing the PCB

Perform the following operation to back up data of the Main Controller PCB to the USB memory.

- Connect the USB memory to the host machine.
- Select Setup Menu>SERVICE MODE>FUNCTION GR.>USB-H>On.
- Back up data of the Main Controller PCB to the USB memory.
Select Setup Menu>SERVICE MODE>FUNCTION GR.>ECONF>EXPORT>ALL>Yes.
- Select Setup Menu>SERVICE MODE>FUNCTION GR.>USB-H>Off.
- Disconnect the USB memory from the host machine.

2-2 Replacing the PCB

- Turn OFF the power.
- Replace the Main Controller PCB with a new one (service part).

2-3 Performing operation after power-on and entering/checking device serial number

- Turn ON the power.
- "Initializing NVRAM" is displayed on the Control Panel for a few seconds.
- "Panel Language" is displayed.
- Here, select your own language or English.
- When the date setting screen appears, set the date and then press the OK key.
- When the time setting screen appears, set the time and then press the OK key.
- After the message "Setting Completed" appears, the message "Ready to print" appears, indicating the machine can be used normally.
- Select Setup Menu>SERVICE MODE >FUNCTION GR.>SN MAIN, and then enter the device serial number written on the rating name plate of the equipment. Pay attention not to make any mistakes when entering the device serial number of the equipment because #####000000 is already entered in SN MAIN after replacing the PCB.
- The display language of the Control Panel changes to your own language.

- Execute Utility>Common Status Print to output the status print.
- Check that the serial number indicated in the device field is the same as that written on the rating name plate of the host machine.

2-4 Restoring data after replacing the PCB

Perform the following operation to restore data backed up in the USB memory to the Main Controller PCB.

- Connect the USB memory to the host machine.
- Select Setup Menu>SERVICE MODE>FUNCTION GR.>USB-H>On.
- Restore data backed up in the USB memory to the Main Controller PCB.
Select Setup Menu>SERVICE MODE>FUNCTION GR.>ECONF>IMPORT>Yes.
- Select Setup Menu>SERVICE MODE>FUNCTION GR.>USB-H>Off.
- Disconnect the USB memory from the host machine.

NOTE

When you execute Setup Menu>SERVICE MODE>FUNCTION GR.>ECONF>EXPORT>ALL>Yes upon backup of data by the USB memory, information kept by NVRAM on the DC Controller PCB is also backed up. Therefore, if "ALL" is selected, the operation to back up the information kept by NVRAM of the DC Controller PCB is not necessary.

3 When data cannot be backed up before replacement due to Main Controller PCB error

When the Main Controller PCB cannot operate normally, then backup of various data is not possible.

In this case, perform the following procedure to replace the PCB.

3-1 Replacing the PCB

- Turn OFF the power.
- Replace the Main Controller PCB with a new one (service part).

3-2 Performing operation after power-on and entering/checking device serial number

- Turn ON the power.
- "Initializing NVRAM" is displayed on the Control Panel for a few seconds.
- "Panel Language" is displayed.
- Here, select your own language or English.
- When the date setting screen appears, set the date and then press the OK key.
- When the time setting screen appears, set the time and then press the OK key.
- After the message "Setting Completed" appears, the message "Ready to print" appears, indicating the machine can be used normally.
- Select Setup Menu>SERVICE MODE >FUNCTION GR.>SN MAIN, and then enter the device serial number written on the rating name plate of the equipment. Pay attention not to make any mistakes when entering the device serial number of the equipment because

####000000 is already entered in SN MAIN after replacing the PCB.

- The display language of the Control Panel changes to your own language.
- Execute Utility>Common Status Print to output the status print.
- Check that the serial number indicated in the device field is the same as that written on the rating name plate of the host machine.

3-3 Backing up data kept by the NVRAM of the DC Controller PCB to the Main Controller PCB

- Initialize the DC Controller NVRAM backup area kept in the Main Controller PCB.

Select Setup Menu>SERVICE MODE>FUNCTION GR.>CLEAR DCON.

- Turn OFF and then ON the power.
- By turning OFF and then ON the power, data kept by the DC Controller PCB NVRAM is backed up to the DC Controller NVRAM backup area in the Main Controller PCB.

■ When Replacing the Main Controller PCB(LBP7680Cx)

Because setting values, management data of this machine and the MEAP application, etc. are stored in the flash memory of the Main Controller PCB, they need to be backed up before replacing the Main Controller PCB. However, when the Main Controller PCB cannot operate normally because of flash memory failure or system error, the above data cannot be backed up.

Also, restoration of the backup data and reinstallation of the MEAP application is necessary after replacing the Main Controller PCB.

Setting values of this machine: User mode setting values, service mode setting values

Management data of this machine: Page counter, device serial number

1 Backup and restoration of data using Expansion ROM for servicing and Sublog Board (or Sublog Board attached with the Expansion ROM hereafter)

While setting values and management data can be backed by this method, the MEAP application cannot be backed up by the method. Therefore, reinstallation of the MEAP application is necessary after replacing the PCB and then restoring the backup data.

2 Backup and restoration of data using USB memory

Only setting values can be backed up by this method. Therefore, reinstallation of the MEAP application is necessary after replacing the PCB and then restoring the backup data.

3 When data cannot be backed up before replacement due to Main Controller PCB error
Reinstallation of the MEAP application is necessary after replacing the PCB.

● 1 Backup and restoration of data using Sublog Board attached with Expansion ROM and copy of data using laptop PC for servicing

1-1 Actions before replacing the PCB

1-1-1 Preparation required for reinstalling the MEAP application

For details on preparation required for reinstalling the MEAP application, refer to the Service Manual > Chapter 2 Technical Description > MEAP > Maintenance > Procedure for reinstalling MEAP applications after replacing the PCB.

1-1-2 Backing up to Sublog Board attached with the Expansion ROM

For details on backup to Sublog Board attached with the Expansion ROM, refer to the Service Manual > Chapter 5 Troubleshooting > Backup/Restoration by Expansion ROM for servicing and Sublog Board

- Turn OFF the power.
- Install the Expansion ROM for servicing to the Sublog Board.
- Install the Sublog Board attached with the Expansion ROM to the Main Controller PCB.
- Turn ON the power.

- When turning ON the power, "NVRAM export" is displayed on the Control Panel.
- Press the down arrow key.
- The data of the Main Controller PCB is backed up to the Sublog Board attached with the Expansion ROM.

1-2 Replacing the PCB

- Turn OFF the power.
- Replace the Main Controller PCB with a new one (service part).
- Install the Sublog Board attached with the Expansion ROM to the Main Controller PCB.

1-3 Restoring data after replacing the PCB

Perform the following operation to restore data backed up in the Sublog Board attached with the Expansion ROM to the Main Controller PCB.

- Turn ON the power.
- When the menu is displayed on the Control Panel upon turning ON the power, select "NVRAM import".
- Press the down arrow key.
- Data backed up in the Sublog Board attached with the Expansion ROM is restored to the Main Controller PCB.
- Turn OFF the power, and remove the Sublog Board attached with the Expansion ROM.

1-4 Reinstalling the MEAP application and importing user information

For details on preparation required for reinstalling the MEAP application and importing user information, refer to the Service Manual > Chapter 2 Technical Description > MEAP > Maintenance > Procedure for reinstalling MEAP applications after replacing the PCB.

● 2 Backup and restoration of data using USB memory and copy of data using laptop PC for servicing

2-1 Actions before replacing the PCB

2-1-1 Preparation required for reinstalling the MEAP application

For details on preparation required for reinstalling the MEAP application, refer to the Service Manual > Chapter 2 Technical Description > MEAP > Maintenance > Procedure for reinstalling MEAP applications after replacing the PCB.

2-1-2 Backup to USB memory

- Connect the USB memory to the host machine.
- Select Setup Menu>SERVICE MODE>FUNCTION GR.>USB-H>On.
- Back up data of the Main Controller PCB to the USB memory.
Select Setup Menu>SERVICE MODE>FUNCTION GR.>ECONF>EXPORT>ALL>Yes.
- Select Setup Menu>SERVICE MODE>FUNCTION GR.>USB-H>Off.
- Disconnect the USB memory from the host machine.

2-2 Replacing the PCB and turning ON the power

- Turn OFF the power.
- Replace the Main Controller PCB with a new one (service part).
- Turn ON the power.
- The equipment is started and can be used normally.

2-3 Restoring data after replacing the PCB

Perform the following operation to restore data backed up in the USB memory to the Main Controller PCB.

- Connect the USB memory to the host machine.
- Select Setup Menu>SERVICE MODE>FUNCTION GR.>USB-H>On.
- Restore data backed up in the USB memory to the Main Controller PCB.
Select Setup Menu>SERVICE MODE>FUNCTION GR.>ECONF>IMPORT>Yes.
- Select Setup Menu>SERVICE MODE>FUNCTION GR.>USB-H>Off.
- Disconnect the USB memory from the host machine.

NOTE

When you execute Setup Menu>SERVICE MODE>FUNCTIONGR.>ECONF>EXPORT>ALL>Yes upon backup of data by the USB memory, information kept by NVRAM on the DC Controller PCB is also backed up. Therefore, if "ALL" is selected, the operation to back up the information kept by NVRAM of the DC Controller PCB is not necessary.

2-4 Reinstalling the MEAP application and importing user information

For details on preparation required for reinstalling the MEAP application and importing user information, refer to the Service Manual > Chapter 2 Technical Description > MEAP > Maintenance > Procedure for reinstalling MEAP applications after replacing the PCB.

● 3 When data backup from the Main Controller PCB is not possible

When the Main Controller PCB cannot operate normally, then backup of various data is not possible.

In this case, perform the following procedure to replace the PCB.

3-1 Replacing the PCB and turning ON the power

- Turn OFF the power.
- Replace the Main Controller PCB with a new one (service part).
- Turn ON the power.
- The equipment is started and can be used normally.

3-2 Backing up data kept by the NVRAM of the DC Controller PCB to the Main Controller PCB

- Perform the following operation to initialize the DC Controller NVRAM backup area of the Main Controller PCB.
Select Setup Menu>SERVICE MODE>FUNCTION GR.>CLEAR DCON.
- Turn OFF and then ON the power.

- By turning OFF and then ON the power, information kept by the DC Controller PCB NVRAM is backed up to the DC Controller NVRAM backup area in the Main Controller PCB.

3-3 Reinstalling the MEAP application

For details on reinstalling the MEAP application, refer to the Service Manual > Chapter 2 Technical Description > MEAP > Maintenance > Procedure for reinstalling MEAP applications after replacing the PCB.

■ When Replacing the Main Controller PCB(LBP7210Cdn)

The settings and management data of host machine is saved in the NVRAM (IC2S) of the main controller PCB. When replacing the main controller PCB, be sure to move the NVRAM from the old PCB and to the new PCB.

After moving the NVRAM, execute color displacement correction and calibration.

- 1) Turn on the power supply of the host machine.
- 2) Start the Status window.
- 3) Execute Option Menu > Utility > Out-of-Register Colors Correction in the status window.
- 4) Execute Option Menu > Utility > Calibration in the status window.

Caution

The information in the NVRAM on the DC controller PCB is saved in the NVRAM (IC2S) as backup data. When replacing the NVRAM, perform the same operation as replacing the main controller PCB and execute the following item; Option Menu > Service Mode > Printer Information settings > DCON data back up.

- 5) Put the MAC address label that is included with the main controller PCB (service part) onto the MAC address label on the back of the host machine.

Electrical Parts Layout/Function Assignment

Motor/Fan

Clutch/Solenoid

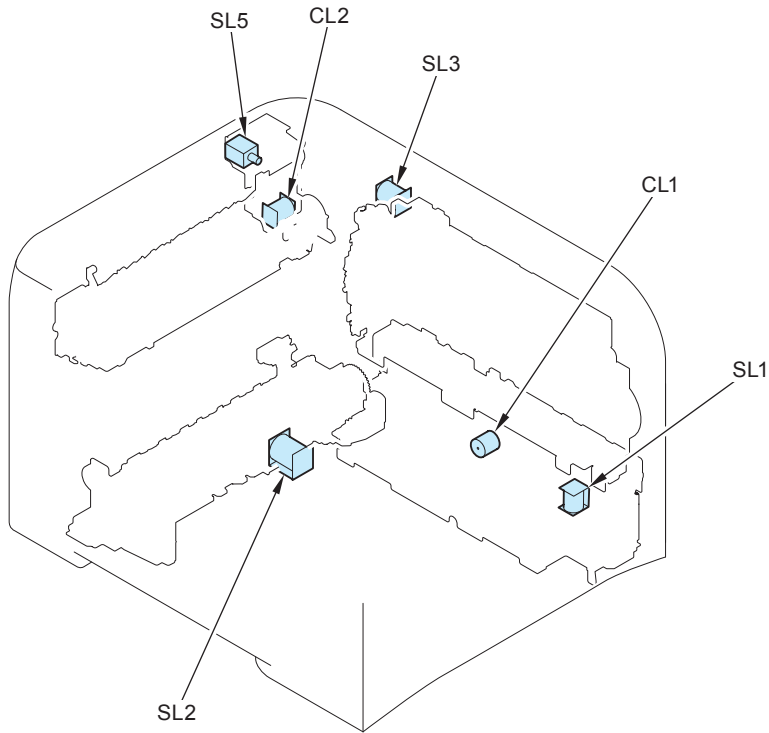

F-5-15

Notation	Name
CL1	Manual feed tray feeding clutch
CL2	Duplex feeding clutch
SL1	Manual feed tray pickup solenoid
SL2	Cassette pickup solenoid
SL3	Developing separation solenoid
SL5	Duplex reversal solenoid

T-5-1

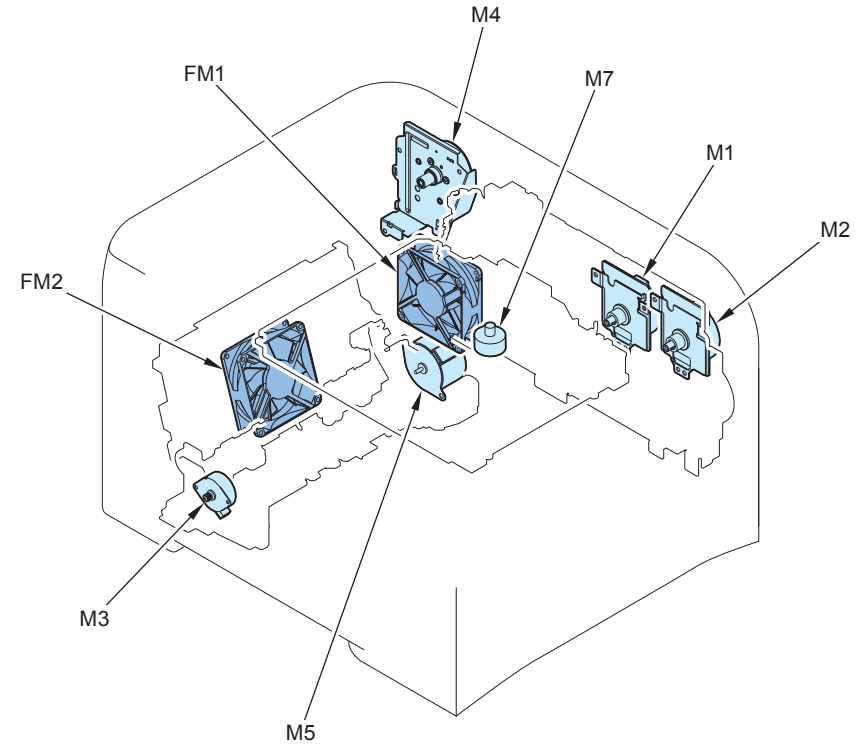

F-5-16

Notation	Name
M1	Drum motor
M2	Developing motor
M3	Registration motor
M4	Fixing motor
M5	Pickup motor
M7	Scanner motor
FM1	Fixing/Fixing power supply cooling fan
FM2	Duplex cooling fan

T-5-2

Sensor

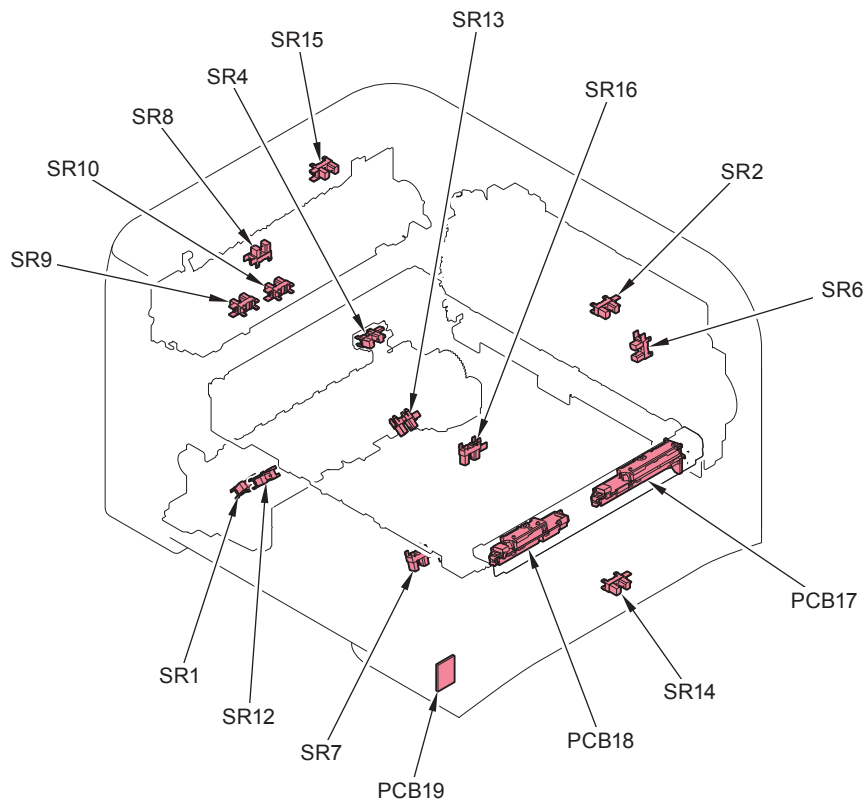

Notation	Name
SR16	ITB pressure release sensor
SR17	Registration patch sensor
SR18	Patch density sensor
PCB19	Environment sensor

PCBs

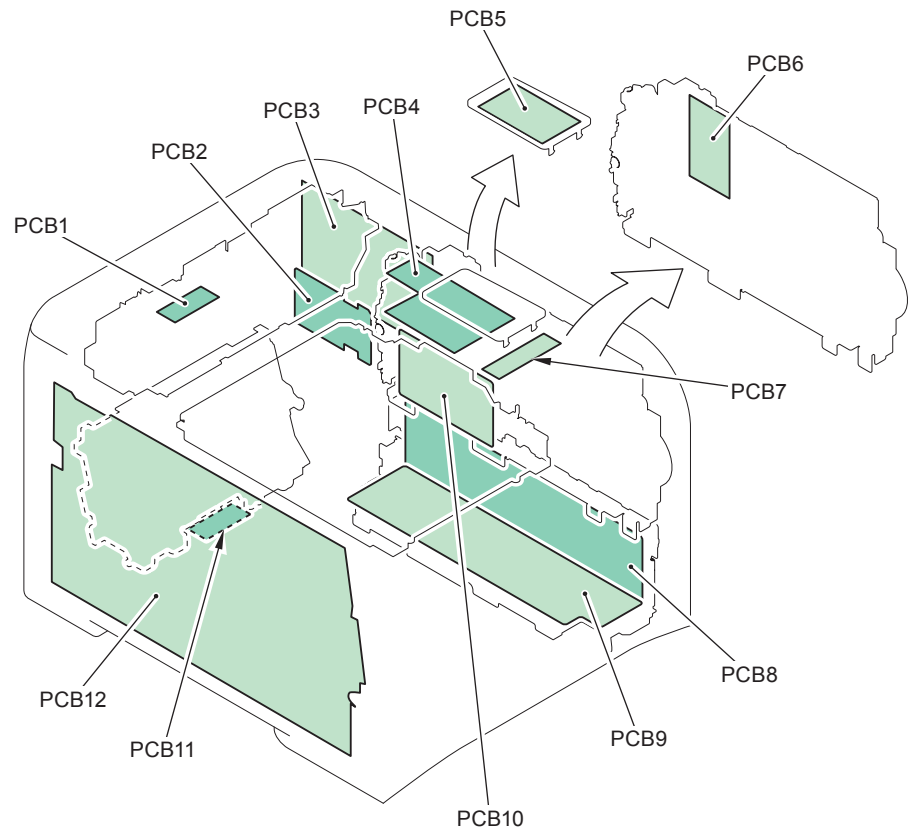

Notation	Name
SR1	Paper feeder pre-registration detection sensor
SR2	Front door open/close sensor
SR4	Developing HP sensor
SR6	Bypass tray pre registration detection sensor
SR7	Registration detection sensor
SR8	Fixing delivery sensor
SR9	Fixing pressure release sensor
SR10	Fixing loop sensor
SR12	Pre-registration detection sensor
SR13	Cassette paper detection sensor
SR14	Bypass paper detection sensor
SR15	Delivery full sensor

F-5-17

Notation	Name
PCB1	Fixing Relay PCB
PCB2	Sub Power Supply PCB
PCB3	Main Controller PCB
PCB4	DC Controller PCB
PCB5	Operation Panel PCB

F-5-18

Notation	Name
PCB6	Driver PCB
PCB7	Relay PCB
PCB8	Fixing power supply PCB
PCB9	Low-voltage Power Supply PCB
PCB10	Laser Scanning PCB
PCB11	Duplex Relay PCB
PCB12	High-voltage power supply PCB

Connector Location

Connector List

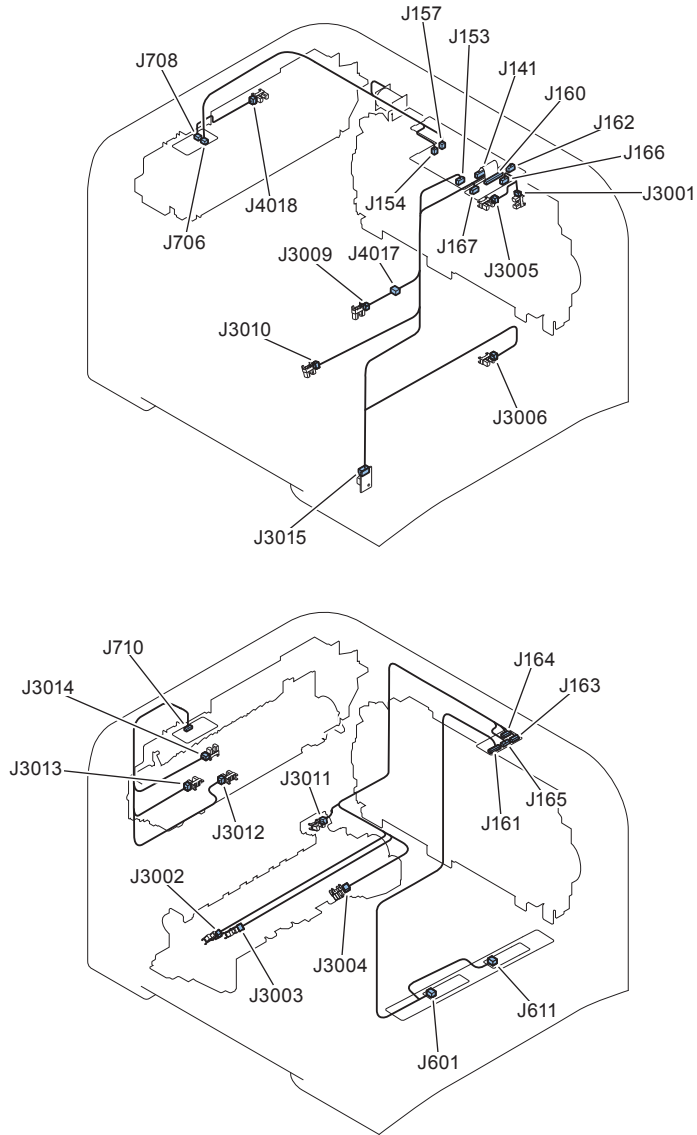

F-5-19

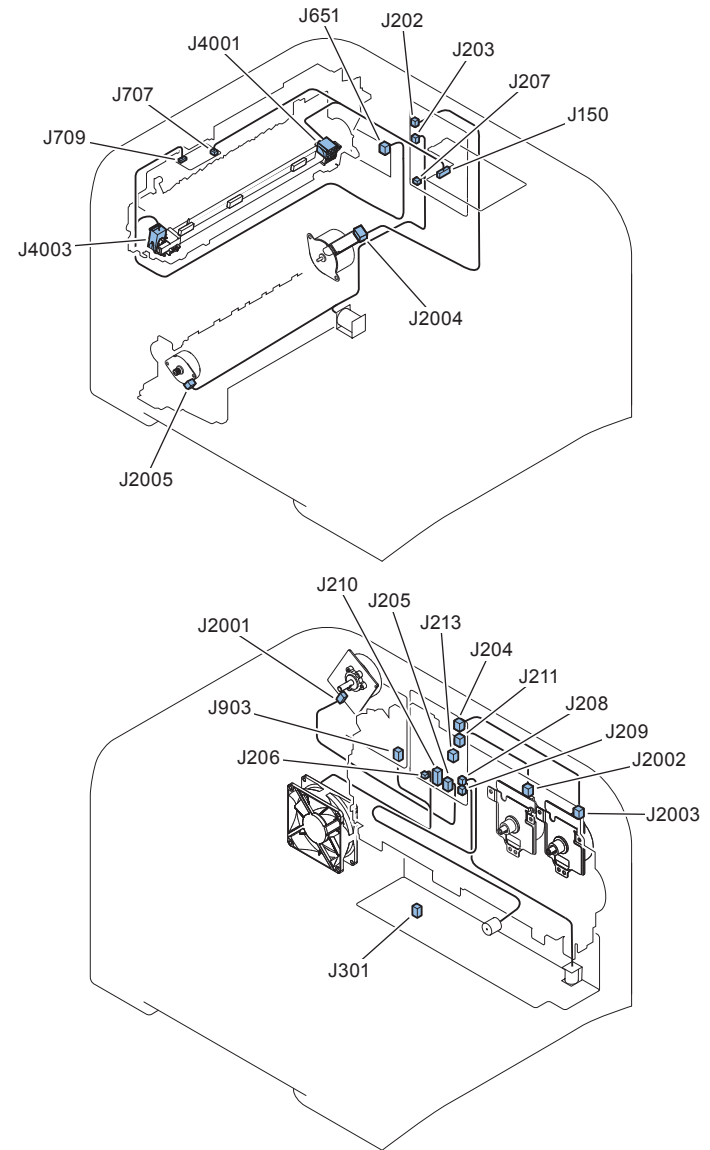

F-5-20

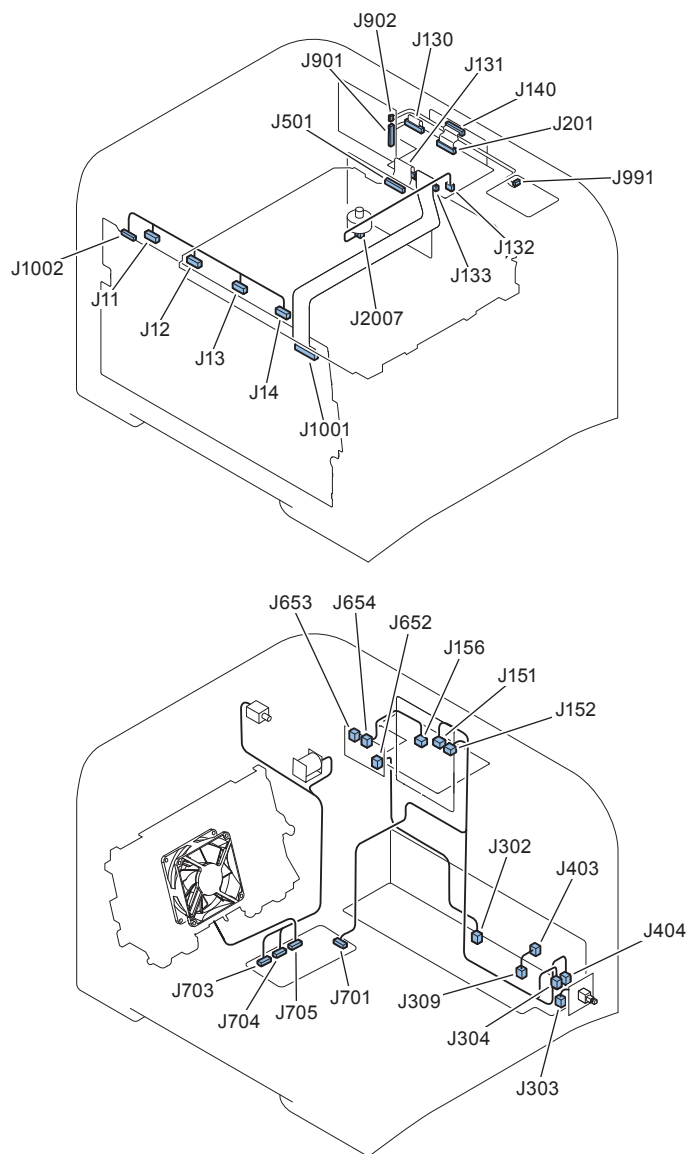

F-5-21

Service Tools

Standard Tools

No.	Tool name	Tool No.	Purpose/Remarks
1	Tool bag	TKN-0001	
2	Jumper wire	TKN-0069	With a clip
3	Clearance gauge	CK-0057	0.02 to 0.3mm
4	Compression spring scale	CK-0058	For checking the spring pressure of the cassette: 0 to 600g
5	Phillips screwdriver	CK-0101	M4, M5 length: 363mm
6	Phillips screwdriver	CK-0104	M3, M4 length: 155mm
7	Phillips screwdriver	CK-0105	M4, M5 length: 191mm
8	Phillips screwdriver	CK-0106	M4, M5 length: 85mm
9	Flat blade screwdriver	CK-0111	
10	Precision flat-blade screwdriver set	CK-0114	6-piece set
11	Allen wrench set	CK-0151	5-piece set
12	File, fine	CK-0161	
13	Allen (hex) screwdriver	CK-0170	M4 length: 107mm
14	Diagonal cutting pliers	CK-0201	
15	Needle-nose pliers	CK-0202	
16	Pliers	CK-0203	
17	Retaining ring pliers	CK-0205	Applied to the axis ring
18	Crimper	CK-0218	
19	Tweezers	CK-0302	
20	Ruler	CK-0303	Employed to measure 150 mm
21	Mallet, plastic head	CK-0314	
22	Brush	CK-0315	
23	Penlight	CK-0327	
24	Plastic bottle	CK-0328	100cc
25	Lint-free paper	CK-0336	500SH/PKG
26	Oiler	CK-0349	30 cc
27	Plastic jar	CK-0351	30 cc
28	Digital multi-meter	FY9-2032	

T-5-3

Special Tools(Not supported by LBP7210Cdn)

No	Tool name	Tool No.	Purpose/Remarks
1	Expansion ROM for servicing	FM0-2725	• Backup/Restoration by Expansion ROM for servicing and Sublog Board
2	Sublog Board	FM0-1774	• Backup/Restoration by Expansion ROM for servicing and Sublog Board • Collecting Debug Log

Solvents and Oils

No.	Type	Purpose	Remark
1	Alcohol	Cleaning: • Plastic • Rubber • Oil stain • Toner stain	• Keep away from flame
2	Lubricant	Apply to gear	- MOLYKOTE® EM-50L (Dow Corning Corporation) - Tool No. HY9-0007

MEMO

To clean the external covers, use a cloth moistened with water (well wrung).

Error Code

 Error Code Details

Code	Detection description	Remedy
E000	Failure in fixing assembly start-up.	
0000	If increasing temperature is not detected by main thermistor after current distribution to the heater is started. Cause Open circuit in the main thermistor, disconnection in the fixing heater, failure in DC controller PCB	- Check the connectors of fixing assembly, DC controller PCB, and fixing power supply assembly.(J150,J151,J651) - Replace the fixing film unit - Replace the fixing power unit - Replace the DC controller PCB
E001	Abnormal high temperature in fixing assembly	
0000	If abnormal high temperature is detected by main thermistor. Cause Failure in sub thermistor, failure in DC controller PCB.	- Check the connectors of fixing assembly and DC controller PCB(J150,J151,J651) - Replace the fixing film unit - Replace the fixing power unit - Replace the DC controller PCB
0001	If abnormal high temperature is detected by sub thermistor (caused by sub thermistor). Cause Failure in sub thermistor, failure in DC controller PCB	- Check the connectors of fixing assembly and DC controller PCB(J150,J151,J651,J709) - Replace the fixing film unit - Replace the fixing power unit - Replace the DC controller PCB
E003	Abnormal low temperature in fixing assembly	
0000	If decreasing temperature is detected after the main thermistor reaches a specified temperature. Cause Failure in fixing power unit, open circuit in the main thermistor, failure in DC controller PCB.	- Check the connectors of fixing assembly and DC controller PCB(J150,J151,J651) - Replace the fixing film unit - Replace the fixing power unit - Replace the DC controller PCB

Code	Detection description	Remedy
0001	If decreasing temperature is detected after the sub thermistor reaches a specified temperature. (cause by sub thermistor) Cause Failure in fixing power unit, open circuit in the sub thermistor, failure in DC controller PCB.	- Check the connectors of fixing assembly and DC controller PCB(J150,J151,J651,J709) - Replace the fixing film unit - Replace the fixing power unit - Replace the DC controller PCB
E004	Error in fixing current drive circuit	
0000	Zero cross signal is not detected within specified time. Cause Failure in fixing control circuit assembly	- Check the connectors of fixing assembly and DC controller PCB(J150,J302,J651,J652) - Replace the fixing power unit
E012	Error in ITB motor activation.	
0000	The cycle of ITB motor speed detection signal does not move in the specified cycle after ITB motor drive is started. Cause Failure in ITB motor, failure in DC controller PCB	- Check the connectors of ITB motor and DC controller PCB(J211,J201,J140) - Replace the ITB motor - Replace the DC controller PCB
0001	If the ITB motor speed detection signal comes off the specified cycle after it turned once to the specified cycle. Cause Failure in ITB motor, failure in DC controller PCB.	
E014	Error in fixing motor drive.	

Code	Detection description	Remedy
0000	The cycle of fixing motor speed detection signal does not move in the specified cycle after fixing motor drive is started. Cause Failure in fixing motor, failure in DC controller PCB	- Check the connectors of ITB motor and DC controller PCB(J205,J201,J140) - Replace the ITB motor - Replace the DC controller PCB
0001	If the fixing motor speed detection signal comes off the specified cycle after it turned once to the specified cycle. Cause Failure in fixing motor, failure in DC controller PCB.	
E015	Error in the developing disengagement movement	
0000	For engagement/disengagement movement of the developing roller, the change on the signal condition of the the developing home position sensor cannot be detected within specified time after main motor rotates. Cause Failure in developing home position sensor, failure in main motor, failure in DC controller PCB.	- Check the connectors of the developing home position sensor, main(J166,J211,J201,J140) motor, and DC controller PCB. - Replace the developing home position sensor - Replace the main motor - Replace the DC controller PCB
E020	Error in density sensor	

Code	Detection description	Remedy
0000	Insufficient light receiving during image density detection. Cause Soiling in density detection sensor, failure in density detection sensor, failure in DC controller PCB, failure in toner cartridge.	- Check the connectors of the DC controller PCB.(J161,J160,J141) - Replace the density detection sensor - Replace the ITB unit - Replace the DC controller PCB - Replace the toner cartridge
E021	Error in developing motor	
0003	Motor (Bk) rotation error	- Replace the DC controller PCB - Check the Cartridge (Bk) Drive Assembly. - Check the ITB Drive Assembly. - Replace the toner cartridge(Bk)
0007	Error in startup of the Motor (Bk)	- Replace the DC controller PCB - Check the Cartridge (Bk) Drive Assembly. - Check the ITB Drive Assembly. - Replace the toner cartridge(Bk)
E021	Error in developing motor(LBP7210Cdn only)	
1003	Developing motor does not rotate. Cause Failure in developing motor, failure in DC controller PCB.	- Check the connectors of developing motor, DC controller PCB - Replace the developing motor - Replace the DC controller PCB
2003	The cycle of developing motor speed detection signal does not move in the specified cycle after developing motor drive is started. Cause Failure in developing motor, failure in DC controller PCB	- Check the connectors of developing motor, DC controller PCB - Replace the developing motor - Replace the DC controller PCB
E052	Error in duplex unit detection(LBP7210Cdn only)	
0000	Can not detect duplex unit. Cause Error in the connection of duplex unit.	- Check the connectors of duplex unit and DC controller PCB - Replace the DC controller PCB
E066	Error in the environment sensor	

Code	Detection description	Remedy
	0000 Error in the environment sensor Cause Failure in environment sensor, failure in DC controller PCB	- Check the connectors of the environment sensor and DC(J153) controller PCB - Replace the environment sensor - Replace the DC controller PCB
E06F	EEPRPM access error(Not supported by LBP7210Cdn)	
	0068 EEPRPM access error	- Replace the DC controller PCB
E070	ITB Pressure Release Sensor error	
	0000 Error in ITB Pressure Release sensor Cause Failure in ITB Pressure Release sensor, failure in DC controller PCB	- Check the connectors of the ITB unit and DC controller PCB(J161,J160,J141) - Replace the ITB - Replace the DC controller PCB
E078	Error in primary transfer disengagement.	
	0001 Primary transfer disengagement mechanism did not work properly. Cause Disengagement mechanism error, ITB Tension Sensor error, Pickup Motor error, DC Controller PCB error	- Check the disengagement mechanism. - Check the connectors of the ITB Tension Sensor, Pickup Motor and the DC Controller PCB (J167, J202, J160, J201, J140). - Replace the ITB Tension Sensor. - Replace the Pickup Motor. - Replace the DC Controller PCB.
E100	Error in scanner motor, laser unit, and BD.	

Code	Detection description	Remedy
	0000 Breakdown in yellow scanner assembly. Cause Failure in laser scanner unit, failure in DC controller PCB.	- Check the connectors of the laser scanner unit and DC controller PCB(J131,J132) - Replace the laser scanner unit - Replace the DC controller PCB
	0001 Breakdown in magenta scanner assembly. Cause Failure in laser scanner unit, failure in DC controller PCB.	
	0002 Breakdown in cyan scanner assembly. Cause Failure in laser scanner unit, failure in DC controller PCB	
	0003 Breakdown in black scanner assembly. Cause Failure in laser scanner unit, failure in DC controller PCB.	
E110	Pseudo BD correction error	
	0002 Pseudo BD correction processing delay	- Replace the laser scanner unit - Replace the DC controller PCB
E194	Error in CPR sensor	
	0000 If CPR sensor is judged error. Cause Soiling in density detection sensor, failure in density detection sensor, failure in DC controller PCB, failure in toner cartridge.	- Check the connector of DC controller PCB - Replace the ITB unit - Replace the DC controller PCB - Replace the toner cartridge
E196	Error in DCON ROM	

Code	Detection description	Remedy
	0000 Failure in ROM update of DC controller PCB	- Replace the DC controller PCB
	0002 Can not access to DC controller NVRAM Cause Failure in DC controller PCB	- Replace the DC controller PCB
	0003 DC Controller not compatible with Main Controller is detected.	- Update the firmware compatible with the Main Controller in the DC Controller.
E197	Engine communication error(LBP7210Cdn only)	
	0001 Error between DC controller PCB and main controller PCB. Cause Failure in connection between PCB, failure in DC controller PCB, failure in controller PCB.	- Check the connection of the connector of the DC controller PCB and controller PCB - Replace the DC controller PCB - Replace the controller PCB
E198	Breakdown in DC controller memory	
	0000 Breakdown in DC controller memory Cause Failure in DC controller PCB	- Replace the DC controller PCB
E245	System Error (Only LBP7680Cx is supported.)	
	1xxx	Contact the sales companies.
	2xxx	Contact the sales companies.
E246	System Error (Only LBP7680Cx is supported.)	
	xxxx	Contact the sales companies.
E247	System Error (Only LBP7680Cx is supported.)	
	xxxx	Contact the sales companies.
E350	System Error (Only LBP7680Cx is supported.)	
	xxxx	Contact the sales companies.
E355	System Error (Only LBP7680Cx is supported.)	
	xxxx	Contact the sales companies.
E602	Error in Main Controller memory : (E602-1102 to 1613 Only LBP7680Cx is supported.)	

Code	Detection description	Remedy
	0002 Loading of Bootable ends in failure. Cause (Bootable is not stored or damaged.)	- Reinstall the firmware. - Replace the Main Controller PCB.
	0003 Flash memory access error Cause An error occurred to the device or the hardware when the flash memory was being accessed during execution of bootrom.	- Turn OFF and then ON the power. - Replace the Main Controller PCB.
	0006 Loading of SubBootable ends in failure. Cause (SubBootable is not stored or damaged.)	- Reinstall the firmware. - Replace the Main Controller PCB.
	0008 Alternative block of flash memory is almost depleted.	Perform the following procedure to replace the the Main Controller PCB and export/import user information. 1. Export user information from the flash memory of the old Main Controller PCB (before replacement). 2. Replace the Main Controller PCB. Import user information to the flash memory of the new Main Controller PCB (after replacement).

Code	Detection description	Remedy
1102	Error detection of file system (LBP7680Cx only)	Execute the following procedures. 1. Turn OFF and then ON the power. 2. Download the /APL_CDS firmware again by Updater. If E616-0001 occurs at restart after turning OFF and then ON the power, execute the following procedures. 1. Initialize MEAP area, and install MEAP application again. (Refer to the remedy for E616-0001.) 2. Download the /APL_CDS firmware again by Updater.
1112	Device access error (LBP7680Cx only)	Execute the following procedures. If E616-0001 occurs after turning OFF and then ON the power (procedure 1), install MEAP application again by following the remedy for E616-0001 first. Then, execute the procedure 2. 1. Turn OFF and then ON the power. 2. Download the /APL_CDS firmware again by Updater.
1113	Device access error (LBP7680Cx only)	Execute the following procedures. If E616-0001 occurs after turning OFF and then ON the power (procedure 1), install MEAP application again by following the remedy for E616-0001 first. Then, execute the procedure 2. 1. Turn OFF and then ON the power. 2. Download the /APL_CDS firmware again by Updater.
1302	File system initialization error (LBP7680Cx only)	Execute the following procedures. 1. Turn OFF and then ON the power. 2. Download the /APL_CDS firmware again by Updater.
1312	Device access error (LBP7680Cx only)	Execute the following procedures. 1. Turn OFF and then ON the power. 2. Download the /APL_CDS firmware again by Updater.

Code	Detection description	Remedy
1313	Device access error (LBP7680Cx only)	Execute the following procedures. 1. Turn OFF and then ON the power. 2. Download the /APL_CDS firmware again by Updater.
1602	File system initialization error (LBP7680Cx only)	Execute the following procedures. 1. Turn OFF and then ON the power. 2. Download the /APL_CDS firmware again by Updater.
1612	Device access error (LBP7680Cx only)	Execute the following procedures. 1. Turn OFF and then ON the power. 2. Download the /APL_CDS firmware again by Updater.
1613	Device access error (LBP7680Cx only)	Execute the following procedures. 1. Turn OFF and then ON the power. 2. Download the /APL_CDS firmware again by Updater.
E604	Insufficient memory capacity(Not supported by LBP7210Cdn)	
0000	Insufficient memory capacity	- Remove and then install the additional memory. - Replace the additional memory with a correct one. - Turn OFF and then ON the power. - Replace the Controller PCB.
0001	Failed to allocate the memory required to start PDL.	
E616	Error in MEAP application (LBP7680Cx only)	
0001	MEAP application was deleted by auto recovery at restart after E602-11XX.	Initialize MEAP area in the flash memory with the following procedures, and install MEAP application again. 1. Initialize the MEAP area. Service Mode > FUNCTION GR. > MEAP > MEAP FUNCTION > ON 2. Install MEAP application again.
E730	Printer service call(Not supported by LBP7210Cdn)	
100A	Printer service call	- Turn OFF and then ON the power. - Replace the Main Controller PCB.
C000	An error, such as failure in memory retrieval at initialization, occurred.	- Turn OFF and then ON the power. - Replace the Main Controller PCB.
C001	An error occurred when accessing the flash memory.	- Turn OFF and then ON the power. - Replace the Main Controller PCB.

Code	Detection description	Remedy
	D000 An error, such as failure in memory retrieval at initialization, occurred.	- Turn OFF and then ON the power. - Replace the Main Controller PCB.
	D001 Printer communication error (communication error at initial communication and negotiation packet error)	- Turn OFF and then ON the power. - Replace the Main Controller PCB.
E733	Printer communication error(Not supported by LBP7210Cdn)	
	0000 Printer communication error (communication error at initial communication and negotiation packet error)	- Turn OFF and then ON the power. - Replace the Main Controller PCB.
	0001 Printer communication error (communication error after establishment of communication and parity error)	
	0004 Printer communication error (undefined command error)	
	0006 Printer communication error (unknown communication error)	
E740	Invalid MAC address detection(Not supported by LBP7210Cdn)	
	0002 Invalid MAC address detection	- Check the content at Mac address. - Write the Mac address. - Replace the Main Controller PCB.
	0004 LAN Controller Chip access error	- Reinstall the firmware
E744	Model code mismatch(0800 to 0900:LBP7680Cx only)	
	0800 Model code mismatch	- Turn OFF and then ON the power. - Replace the Main Controller PCB.
	0900 Model code mismatch	- Turn OFF and then ON the power. - Replace the Main Controller PCB.
	1000 Mismatch of the model of firmware sent when downloading	- Turn OFF and then ON the power. - Replace the Main Controller PCB.
	1100 Detection of falsification of the Controller Board	- Turn OFF and then ON the power. - Replace the Main Controller PCB.
E747	EEPROM error(LBP7210Cdn only)	

Code	Detection description	Remedy
	EEPROM error Cause Failure in main controller PCB	- Replace the main controller PCB
E748	Error in Main Controller (Not supported by LBP7210Cdn)	
	2012 Failed to rewrite due to no more alternative block of Flash ROM (NAND) available.	- Replace the Main Controller PCB.
	4000 G-Chip loopback ended in timeout.	- Turn OFF and then ON the power. - Replace the Main Controller PCB.
	4020 Unknown device was detected on PCI.	- Turn OFF and then ON the power. - Replace the Main Controller PCB.
E760	CPU Processing Error(Not supported by LBP7210Cdn)	
	0000 Exception of CPU processing occurred.	- Turn OFF and then ON the power.
E805	Error in duplex cooling fan	
	0001 Fixing/Power Supply Cooling Fan failure	- Replace the Fixing/Power Supply Cooling Fan
	0003 Detection of error in Fixing/Power Supply Cooling FAN Rotation ended in failure due to an error that occurred in Fixing/Power Supply Cooling Fan.	- Check the connectors of duplex cooling fan and DC controller PCB(J206) - Replace the Fixing/Power Supply Cooling Fan
	0005 Duplex cooling fan can not rotate the specified number of rotations. Cause Failure in duplex cooling fan, failure in DC controller PCB	- Check the connectors of duplex cooling fan and DC controller PCB(J705,J701,J152) - Replace the duplex cooling fan - Replace DC controller PCB
E806	Error in power supply cooling fan(LBP7210Cdn only)	
	Power cooling fan can not rotate the specified number of rotations. Cause Failure in power supply cooling fan, failure in DC controller PCB	- Check the connectors of power supply cooling fan and DC controller PCB - Replace the power cooling fan
E808	Error in low voltage power supply	

Code	Detection description	Remedy
0001	Low-voltage power supply failure Cause Failure in low voltage power supply PCB Failure in DC controller PCB	- Replace the low voltage power supply PCB - Replace the DC controller PCB
E840	Error in pressure release system	
0000	Control home position (in pressured condition) cannot function after the home position control is started. Cause Failure in fixing drive assembly, failure in fixing pressure release cam	- Replace the fixing drive assembly - Replace the fixing pressure release cam - Check gears related to fixing pressure release. - Replace the Fixing Pressure Release Sensor (SR9) - Check the connection of the connector.

Jam Code

(Not supported by LBP7210Cdn)

Jam code		Cause of jam	Location of jammed paper
Upper digit	Lower digit		
84		Pickup delay jam 1	
85		Pickup delay jam 2	
88		Pickup stationary jam 1	
8C		Fixing delivery delay jam 1	
9C		Fixing delivery stationary jam 2	
94		Internal stationary jam 1	
98		Door open jam 1	
9C		Paper wrapping jam 1	
A4		Duplex Re-pickup Assembly jam 1	
	00		Unknown area
	01		Area from Pickup Slot 1 to registration position
	02		Area from Pickup Slot 2 to registration position
	03		Area from Pickup Slot 3 to registration position
	07		Area from registration position to cartridge
	08		Area from cartridge to Fixing Roller
	09		Area from Fixing Roller to Delivery Assembly
	0C		Adjacent area of Duplex Reverse Assembly

Version Upgrade

Overview

Overview of Version Upgrade

1. Download via the user support tool (hereinafter referred to as "UST")

The system software is downloaded from a PC connected with the machine by a USB cable.

2. Only LBP7680C (LBP5280 in the US), download via Contents Delivery System (hereinafter referred to as "CDS")

Download the system software directly to the machine from CDS via Internet.

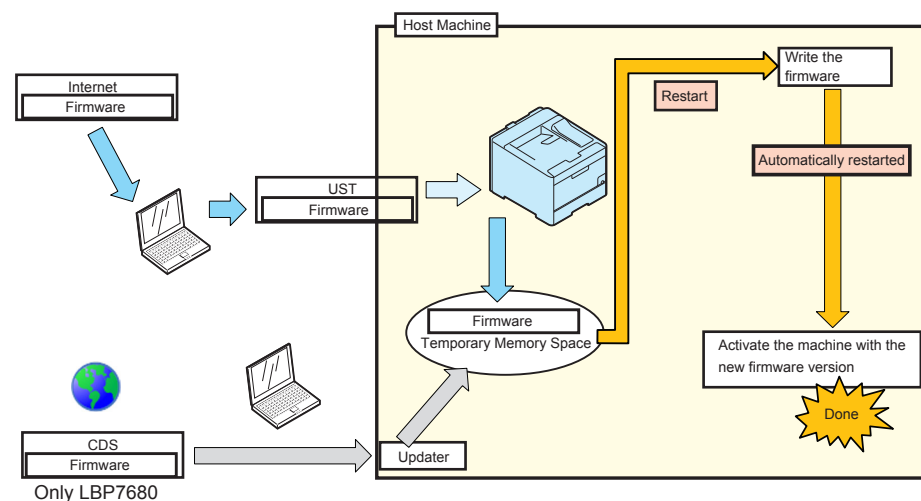

F-5-22

Checking the Version

In order to check the model name and the version, it is necessary to output a status print.

1) Utility Menu > Configuration Page

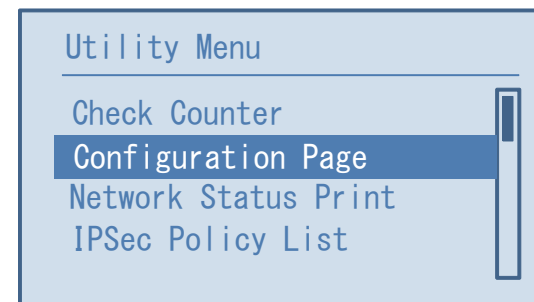

F-5-23

2) Check the printed status. You can upgrade the machine when the downloaded UST is later than the machine's version.



R1.12 means the version of BOOTABLE in the main controller.
B27.44 means the version of BOOTROM in the main controller.

Version Upgrade Using UST

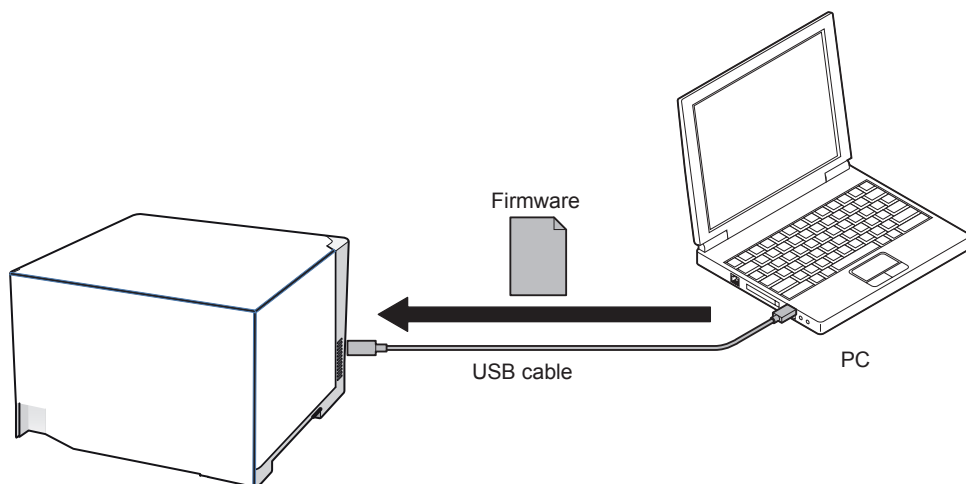

F-5-24

Firmware Configuration

Firmware	Function	Storage area
BOOTROM	Startup of the main controller	Main controller PCB
BOOTABLE	Overall control	Main controller PCB
DCON	Control of the printer Assembly	DC controller PCB

T-5-4

A number of firmware may be less than the above depending on the UST version.

Preparation

Necessary System Environment

- OS (Any of the following)
 - Microsoft Windows 2000 Server/Professional Edition
 - Microsoft Windows XP Professional/Home Edition*
 - Microsoft Windows Server 2003 Edition*
 - Microsoft Windows Server 2008 Edition*
 - Microsoft Windows Vista*
 - Microsoft Windows 7*
 - Mac OS X 10.4.x
 - Mac OS X 10.5 and later
- * : 32-bit /64-bit processor version available
- PC
 - The OS listed above operates.
 - Memory (RAM): 128MB or greater
 - Hard disk: 100MB or greater
 - Display: Resolution 640 x 480 pixel or greater, 256-color or greater
 - Equipped with USB port
- UST file* of this machine
 - * : Download the file from website. (It differs depending on the sales company.)
- USB cable (USB1.1/2.0)

Before Downloading the System Software

- 1) Start up the PC.
- 2) Connect the host machine and the PC with a USB cable.
- 3) Turn on the host machine, and place it in the standby status.

■ Downloading the Firmware

1) Select Setup > User Maintenance > Update Firmware

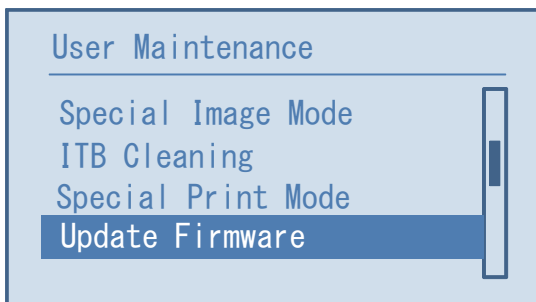

F-5-25

2) Select [USB].

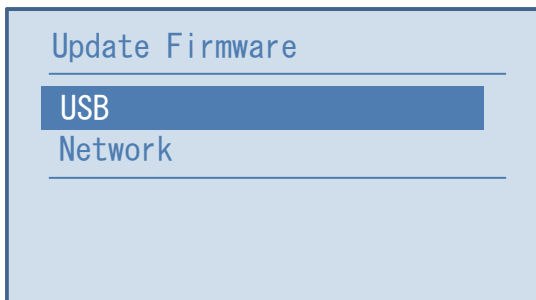

F-5-26

3) Select [Yes].

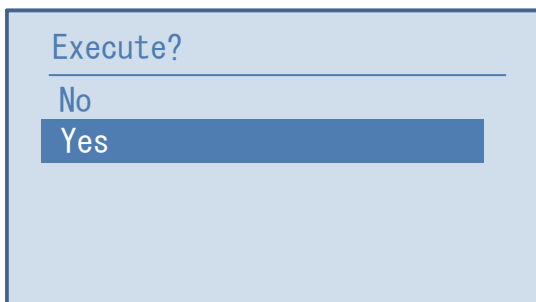

F-5-27

4) A reset starts and [UPDATEMODE READY] is displayed.

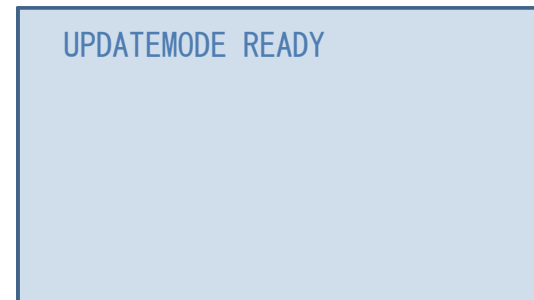

F-5-28

5) Carrying out the file of UST in the connected PC side.

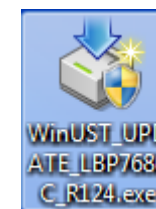

F-5-29

6) Write down the firmware version to upgrade, and click the "Next" button.

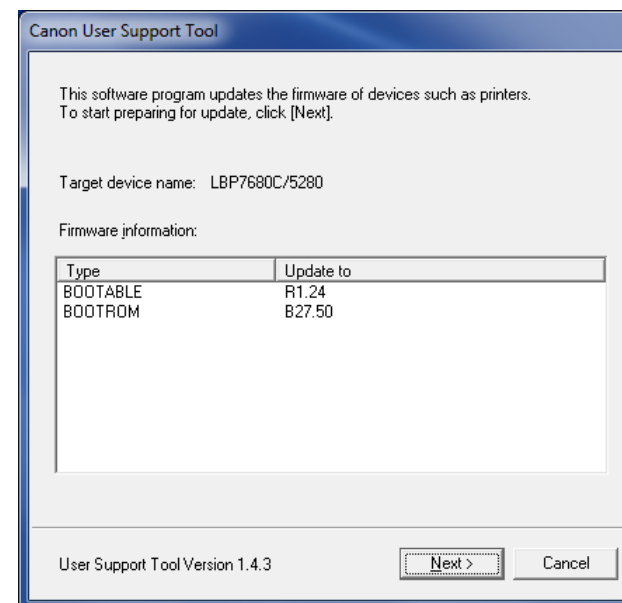

F-5-30

7) Click the "Next" button.

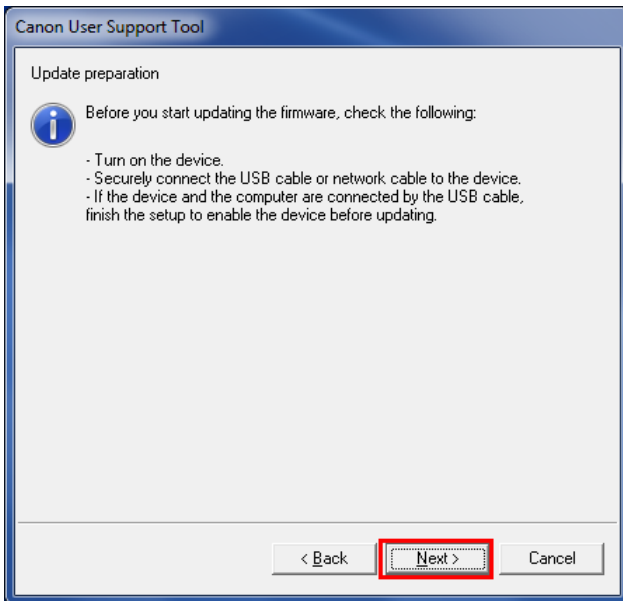

F-5-31

9) Click the "Start" button.

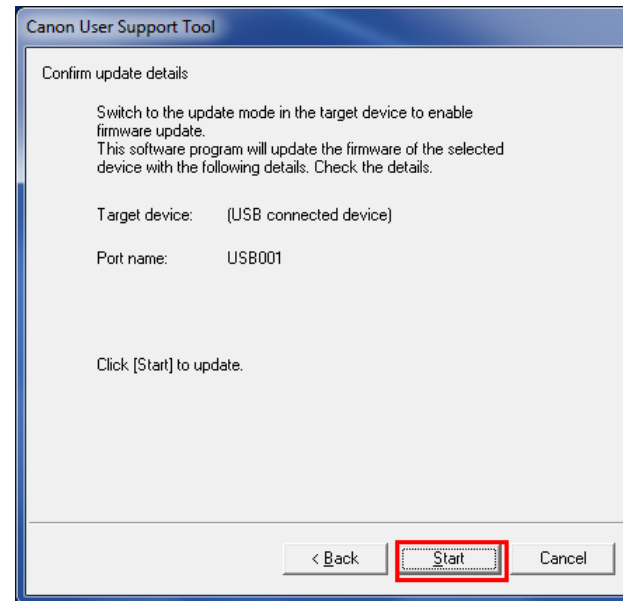

F-5-33

8) Select the USB connection device, and click the "Next" button.

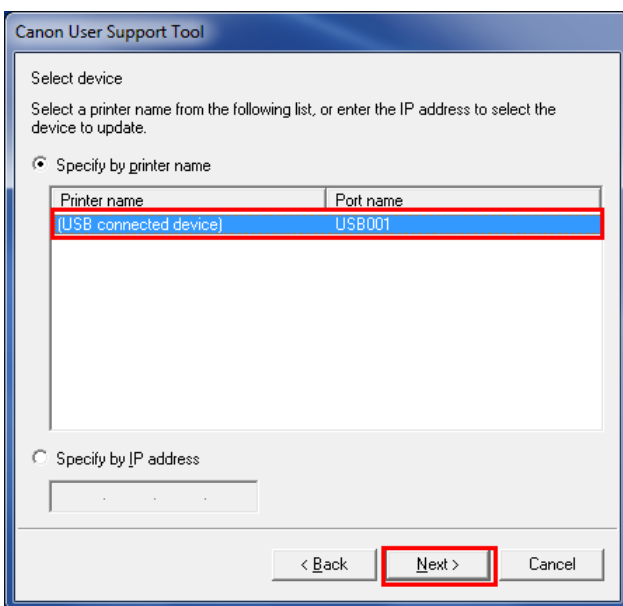

F-5-32

10) When the warning screen is displayed, click the "Yes" button.

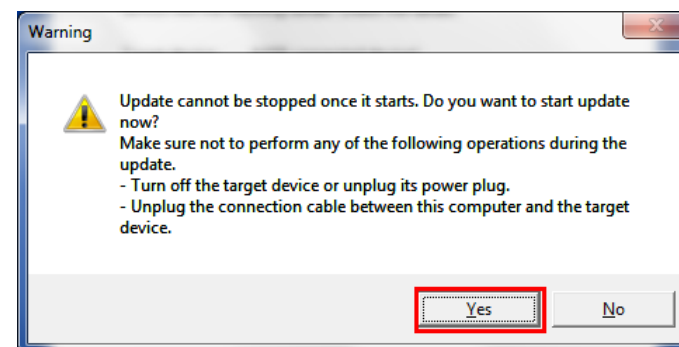

F-5-34

Then start downloading.

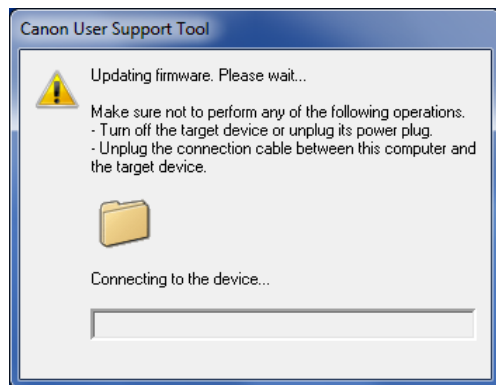

F-5-35

Note:
"DOWNLOADING XX%" and "UPDATING XX%" are displayed in the display of the host machine during downloading. (XX shows the progress degree.)

11) When downloading is completed, click the "OK" button.

The host machine automatically restarts up

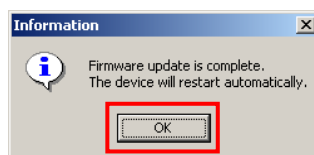

F-5-36

12) Perform Configuration Page print via the user mode, and make sure that the firmware version matches the information written down in Procedure 2).

Utility Menu > Configuration Page

Upgrading the Firmware(LBP7210Cdn)

Main Controller Firmware

Since the firmware on the Main Controller PCB is stored in the ROM on the board, the data cannot be updated. Therefore, upgrade of the firmware is done by replacing the PCB as with the CAPT machine.

DC Controller Firmware

DC Controller PCB is equipped with the flash-type ROM, so it can be upgraded by the user using UST.

Service technician can also upgrade the machine using UST. Upgrade using SST is not supported. For details,

The upgrade method using UST is shown below.

1. Install the printer driver.
2. Copy the UST to PC HDD for service technicians.
3. Connect the machine and PC using the USB Cable. * 1
4. Set the machine to the download mode of user mode.
5. Start the UST and upgrade the firmware.
6. Output a status print from the utilities menu of the host machine to see the firmware version.

*1 If you have already set to print from the driver via network, you can use the network. As for the machine which has not been set the IP address, we recommend connecting via USB Cable.

Updater(Not supported by LBP7210Cdn)

Overview

Outline

Updater provides functions that enable network communication with Content Delivery System V1.0 (hereinafter CDS) to install firmware, MEAP applications and system options.

Firmware Installation

Updater function enables users to distribute firmware through CDS via Internet. Particularly on e-Maintenance/UGW (called NETEYE in Japan)-enabled devices, firmware can be updated remotely, which effectively slashes costs incurred in field services.

MEAP Application/System Option Installation

By linking devices to CDS and License Management System (providing the function to manage licenses; hereinafter LMS), applications can be installed in devices via Updater, regardless of those not embedded (MEAP application) or embedded (system options) in devices.

Installing Firmware

With link to Updater, service technicians provide firmware install services in the following 3 methods.

Distribution Method	Download Commanded by:	Update Timing	Downloadable Firmware Versions		
			Previous Ver	Current Ver	Newer Ver
a. UGW-linked Download / Update (Full-remote update)	UGW	Auto	No	Yes	Yes*1
b. UGW-linked Download (Remote Distribution / Update)	UGW	Manual	Yes	Yes	Yes
c. Update via SST	SST	-	Yes	Yes	Yes

*1:You can select the version allowed Remote Update.

T-5-5

a. UGW-linked Download and Update (Full-Remote Update)

If the device is linked to UGW and the distribution schedule and update setting are registered on UGW in advance, full remote firmware update is available. Upon downloaded from CDS, the firmware is updated on the device.

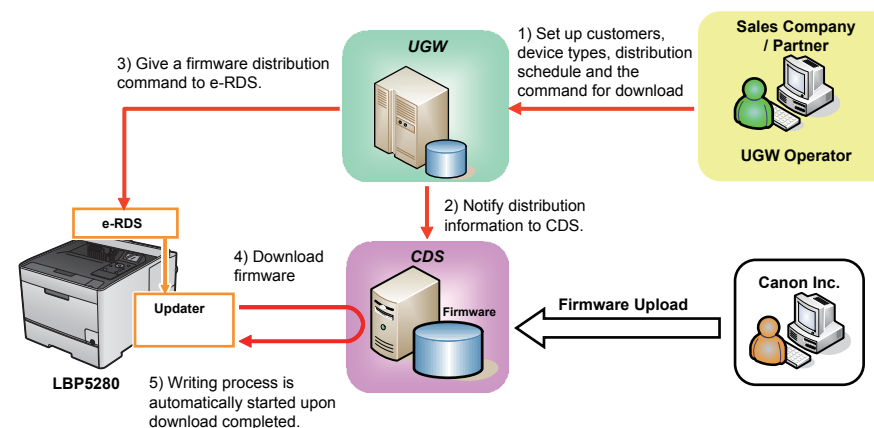

F-5-37

b. UGW-linked Download (Remote Distribution / Update)

If the device is linked to UGW and the distribution schedule is registered on UGW in advance, firmware can be distributed to the device before a service technician actually visits the customer site. This allows the service technician to update the firmware manually immediately after completing device inspection.

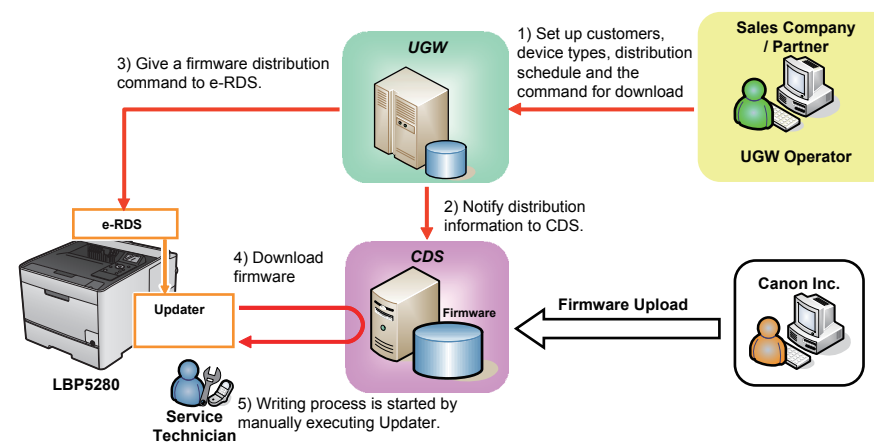

F-5-38

System Configuration

The figure below schematically shows the system configuration.

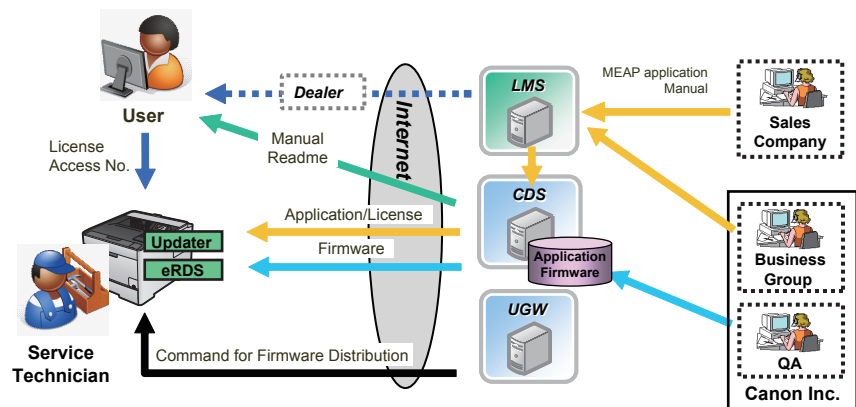

F-5-39

List of Functions

The matrix below shows the list of functions provided by Updater.

Category	Function	Remote UI	UGW-linked
Firmware	Checking firmware compatibility	-	-
	Checking special firmware	-	-
	Checking latest firmware version	Yes	-
	Registering/deleting firmware distribution schedule	Yes	-
	Confirming and downloading firmware	Yes	Yes
	Updating downloaded firmware	Yes	-
	Cancelling downloaded firmware	Yes	-
	Acquiring firmware distribution information registered from UGW	-	Yes
	Notifying firmware version information	-	Yes
	Periodical update	-	-
MEAP application/system option	Inquiring license for MEAP application option	Yes	-
	Installing MEAP application / system option	Yes	-
System Management	Settings	-	-
	Testing communications	Yes	-
	Displaying update logs	Yes	-
Internal system error notification	Displaying system logs	Yes	-
	Notifying internal system error occurrence to distribution server	Yes	Yes

T-5-6

Distribution Flow

Firmware Installation Flow

Service technicians provide firmware install services in the following 4 methods.

- a: UGW-linked download and update
- b: UGW-linked download
- c: Update via SST

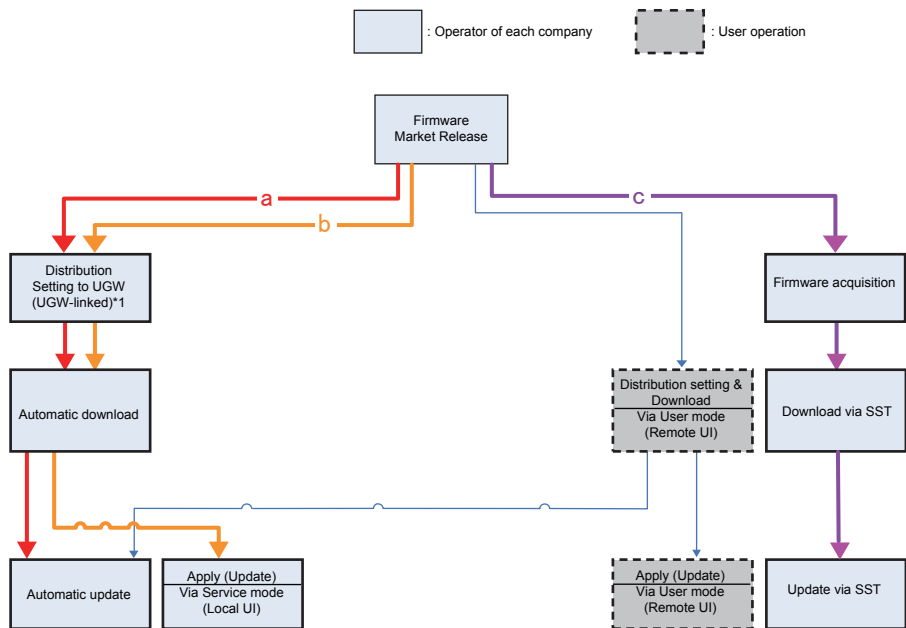

F-5-40

*1: Schedules for UGW-linked distribution are maintained on CDS.

MEAP Application/System Option Installation Flow

MEAP application/system option installation method using service mode is not provided. Be sure to use the user mode to install.

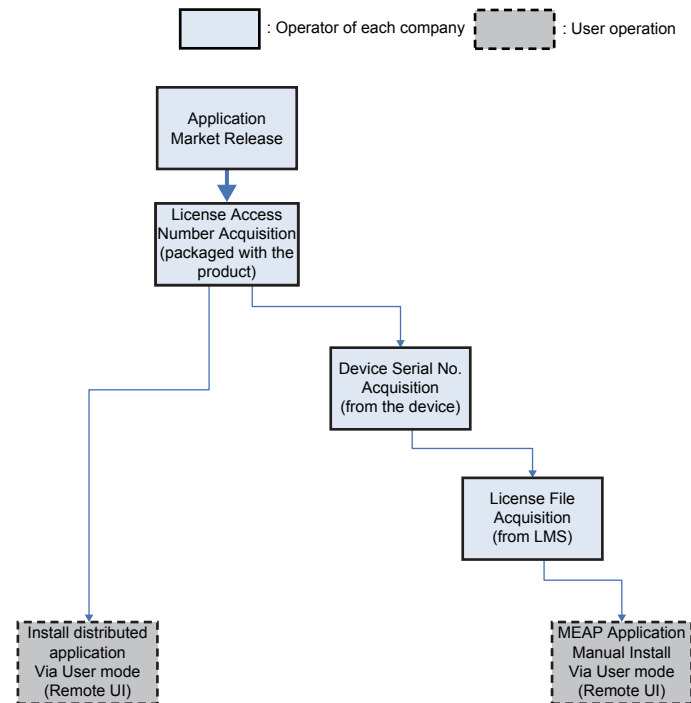

F-5-41

■ Limitations and Cautions

● Limitations

Changing Date/Time on Device

When a user changes the date/time setting on the device (including change of the setting according to daylight saving time), the firmware distribution may not be performed as scheduled.

But there is not the problem if it is time adjustment of several minutes with NTP servers.

Change of Setting from Service mode

Any settings from Service mode will be enabled after restarting the device.

● Cautions

Concurrent use of Updater functions

Multiple users cannot use Updater functions on a device concurrently by using it together with Remote UI.

Coexistence of Remote UI and other tools

Users logged in SMS (Service Management Service) are unable to use Update functions from Remote UI.

Using Updater function from Remote UI

Upon the following operations done, Updater functions are suspended from Remote UI for certain duration.

- When a user exits Web browser without clicking [Portal] or [Log Out] button in the setting of Remote Login Service via SMS
- When a user exits Web browser without clicking [Portal] button in the setting of not to use Remote Login Service via SMS.
- When a user exits Web browser without clicking [Log out from SMS] or [To Remote UI] button.

Wait for EOJ (end of job) Function

Firmware update will be triggered only after the following jobs are completed.

This is the Updater-specific specification.

Job/Function type	Receiving	Printing	Queued print jobs
PRINT	Wait for EOJ (end of job)	Wait for EOJ	Wait for EOJ
I-FAX Receipt	Cancel processing to trigger update *	Wait for EOJ	Wait for EOJ
Report Print	-	Wait for EOJ	Wait for EOJ

T-5-7

*The data are guaranteed even if cut off in the middle of a job. It becomes the recovery object after the device reboot and carry out send / reception again.

Even during transfer, Pull SCAN job processing is cancelled soon after scanning is completed.

Firmware update is cancelled if the jobs are not completed within 10 minutes. If this occurs, the error code, 8x001106, will be returned (different numbers will be shown for x depending on the execution modes).

Firmware update is executed if the jobs stated above are not in the queue.

Follow the shutdown sequence to reboot the device after the firmware is updated.

■ Preparation

● Overview of Preparation

The following should be prepared before using Updater.

- For updating of firmware

Installation Method	Setting Sales Company's HQ	Network Settings	Enabling UGW Link	Enabling [Update Firmware] Button of User Mode	Enabling [Manual Update] Button of User Mode (Remote UI)
UGW-linked Download and Update	Yes	Yes	Yes	-	-
UGW-linked Download	Yes	Yes	Yes	-	-

T-5-8

● Setting Sales Company's HQ

When using devices input in the markets listed below, the default setting of Sales Company's HQ should be changed before obtaining firmware distributed from CDS. Unless the setting is changed properly, the desired firmware may not be able to be selected.

Market	Default Setting of Sales Company's HQ	Setting of Sales Company's HQ after Change
Canada	US	CA
Latin America	US	LA

T-5-9

Go to the following screen to change the setting of Sales Company's HQ.

Service Technician	Setting of Device Service Mode	SERVICE MODE > FUNCTION GR. > MEAP:2 > CDS-CTL
--------------------	--------------------------------	--

NOTE:

The list below shows the setting of Sales Company's HQ for CDS-CTS by market. Check and adhere to the appropriate setting for your market.

<List of Sales Company's HQ and the settings for CDS-CTL>

Japan = JP

China = CN

USA = US

Hong Kong = HK

Singapore = SG

Australia = AU

Europe = NL

Canada = CA

Korea = KR

Latin America= LA

Network Settings

Connecting to External Network

The method of connecting to external network is similar to a normal network connection method. Refer to user manual of the device for details.

NOTE:

- Before using UGW link or User mode, see the sections below to prepare as required. "Enabling UGW Link"

NOTE:

"External Network" here means the network connecting the device to CDS via Internet.

Confirming URL Setting of Distribution Server

This section describes how to confirm the URL setting of the distribution server. One of the MEAP system service, [Register/Update Software(Management Settings)] is available.

1. You can log in it from a browser on a PC connected in a network.

Type the address [https://machine's IP address:8443/svm/].

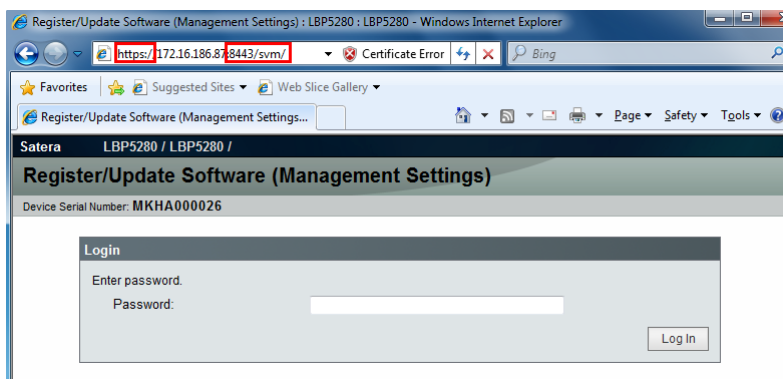

F-5-42

2. Type the password [*28*] then log in it.

Caution:

In the case of the following, you cannot log in even if you input a right password.

- The other user is using "Register/Update Software (Management Settings)" .
- The other user is using "Register/Update Software" in normal Remote UI.
- Because you have closed a browser without logging out definitely, you are still logging in it. Waiting for time-out.

3. After login, select [System Settings] > [Edit].

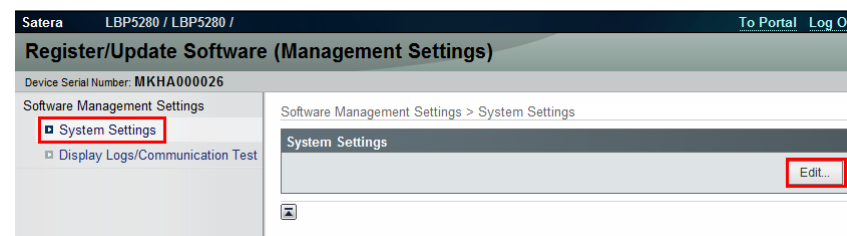

F-5-43

4. Confirm that "https://device.c-cdsknn.net/cds_soap/updaterif" is typed in [Delivery Server URL].

If the URL is not entered or wrong URL is entered, enter the right URL in [Delivery Server URL].

When you set output level of the log, input numerical value (0-4). Setting the bigger numerical value, you can get more detailed output log.



F-5-44

Caution:

The setting change of the output level influences a performance.

Refer to System Management Operations> Various Setting> Setting Log Level in detail.

5. When you have changed the settings, press [Configure] button. The confirmation dialog is displayed. If there is no problem, select [Yes]. In this, the URL of the delivery server and setting editing of the log output level are the end.

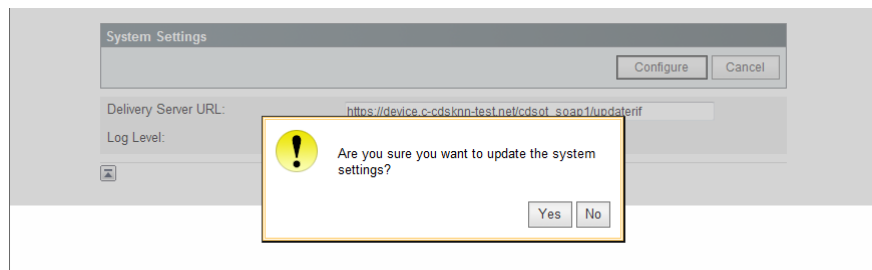

F-5-45

Communication Test

This section describes how to check if the communication is normally done to the distribution server and/or the file server.

Note:

CDS Server and RDS Server are different. So carry out the communication test with both Embedded RDS and CDS.

1. Enter [Register / Updater Software (Management Settings)].
2. Select [Display Logs / Communication Test] > [Communication Test].

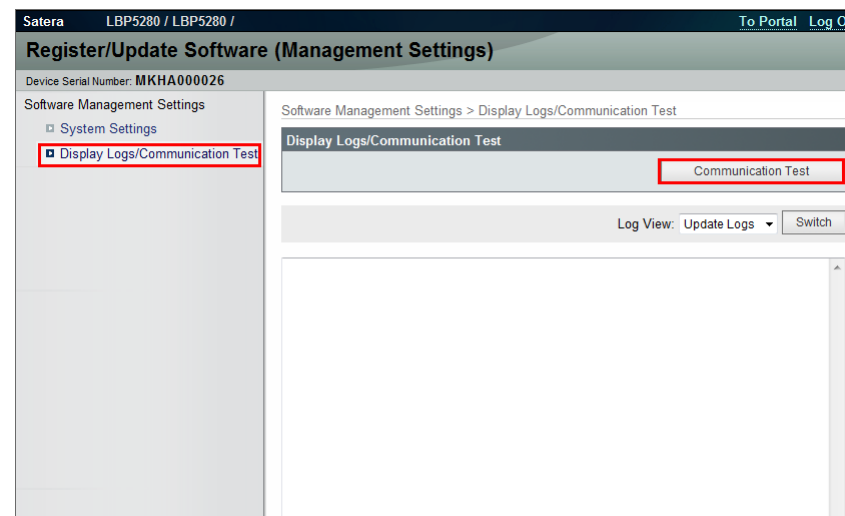

F-5-46

3. The Communication Test is carried out.

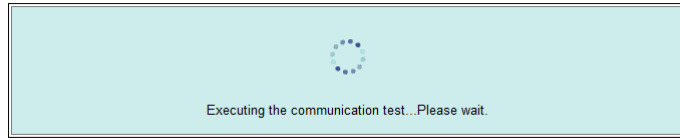

F-5-47

Obtain the download file information for communication test from the distribution server (to execute the communication test to the distribution server).

Using the download file information for communication test, the contents for test are downloaded from the file server (for the communication test to the file server).

4. Upon the communication test completed, the communication test result screen is shown.

Press [OK] button to exit this operation.

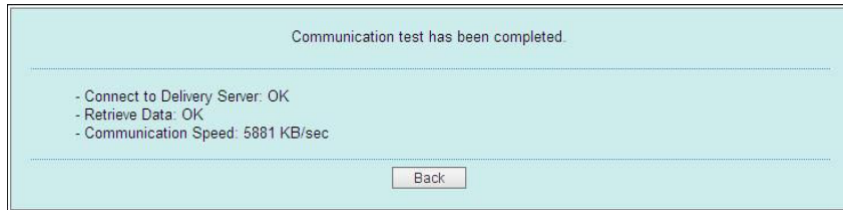

F-5-48

● Enabling UGW Link

When installing the firmware in the method of “UGW-linked Download and Update” or “UGW-linked Download”, the following should be set before actually using UGW link.

Service Technician	Setting of Device Service Mode	SERVICE MODE >FUNCTION GR. >MEAP >CDS-UGW (On -> Off)
	Setting of UGW WebPortal	In [Customer Management] screen, set [Do not distribute firmware] to [Distribute firmware].
Sales Company's HQ	Setting of Authorities on UGW WebPortal	See "Analysis>Firmware Distribution Information" to grant the appropriate authorities to each account.

NOTE:

- See “imageWARE Remote Operator's Manual / e-Maintenance Business Operation Manual” for how to operate UGW WebPortal.
- [Distribute Firmware] should be set on [Customer Management] screen for staff in charge of setting for [Enter customer information] or [Command for firmware distribution] in order to allow them to select the desired device on [Firmware Distribution Information] screen.
- If [Distribute Firmware] is not shown on [Customer Management] screen of UGW WebPortal, appropriate authorities may not be set to each account in Firmware Distribution Information. Contact the Sales Company HQ concerned for confirmation.

● Enabling [Install Application/Options] Button of User Mode (Remote UI)

To allow users to install applications using Updater, the setting of application installation should be set to ON for users in advance.

Service Technician	Setting of Device Service Mode	SERVICE MODE >FUNCTION GR. >MEAP >CDS-MEAP (On -> Off)
--------------------	--------------------------------	---

- Remote UI screen of Updater when the setting is not enabled (CDS-MEAP(Off)):

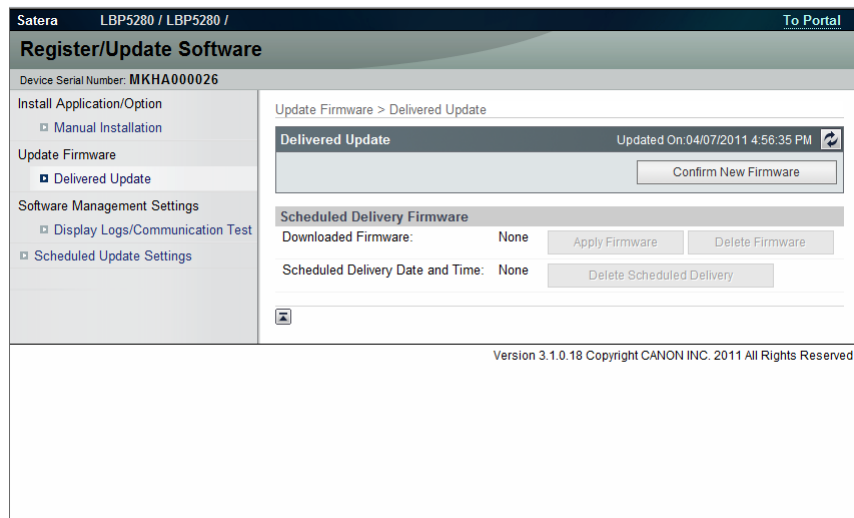

F-5-49

- Remote UI screen of Updater when the setting is enabled (CDS-MEAP(On)):

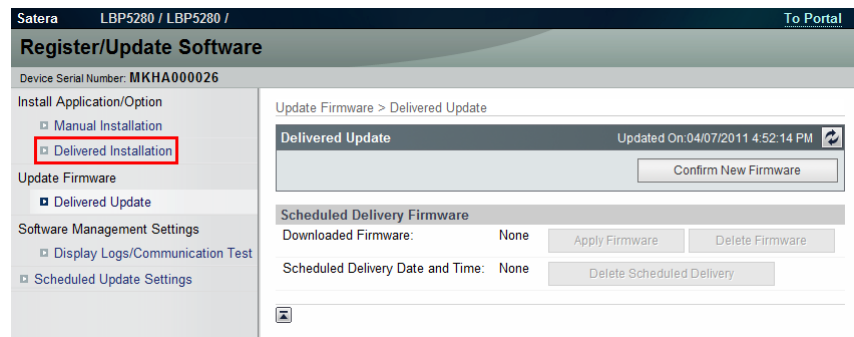

F-5-50

● Enabling [Manual Update] Button of User Mode (Remote UI)

To allow users to install firmware from Updater using the file on Local PCs, the setting of firmware installation should be set to ON for users in advance.

Service Technician	Setting of Device Service Mode	SERVICE MODE >FUNCTION GR. >MEAP >CDS-FIRM (On -> Off)
--------------------	--------------------------------	---

- Remote UI screen of Updater when the setting is not enabled (CDS-FIRM (Off)):

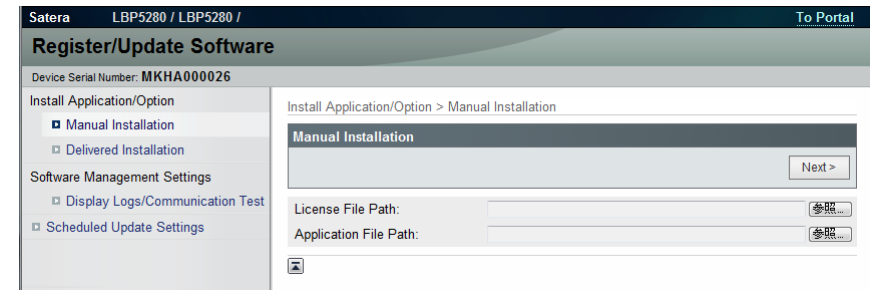

F-5-51

- Remote UI screen of Updater when the setting is enabled (CDS-FIRM (On)):

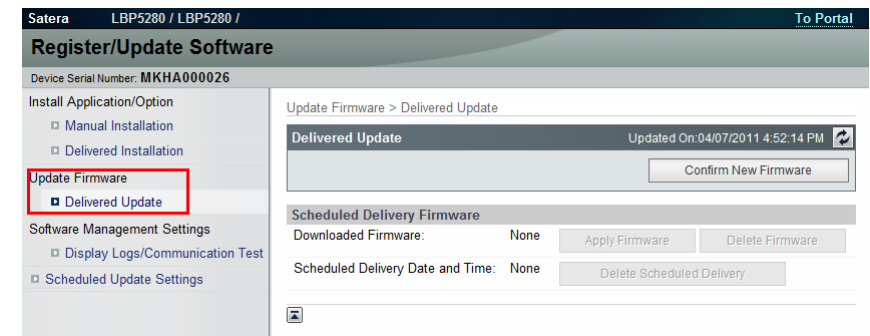

F-5-52

Caution:
CDS-FIRM
CDS-FIRM is default On in LBP7680C (EU model).
It is default Off in LBP5280 (US model).

● Enabling [Scheduled Update] Button of User Mode

Service Technician	Setting of Device Service Mode	SERVICE MODE >FUNCTION GR. >MEAP >CDS-LVUP (On -> Off)
--------------------	--------------------------------	--

- Remote UI screen of Updater when the setting is not enabled (CDS-LVUP (Off)):

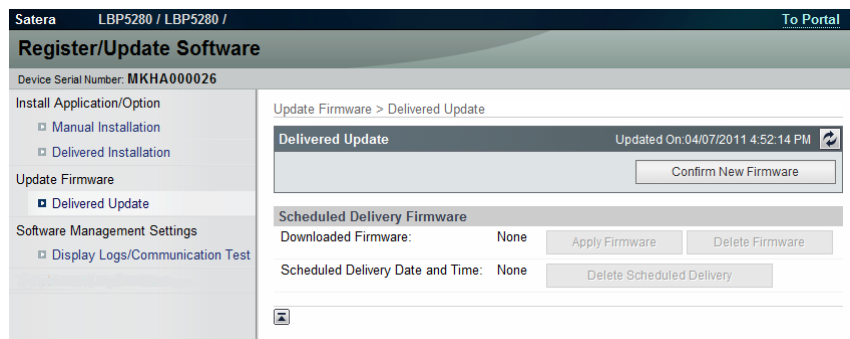

F-5-53

- Remote UI screen of Updater when the setting is enabled (CDS-LVUP (On)):

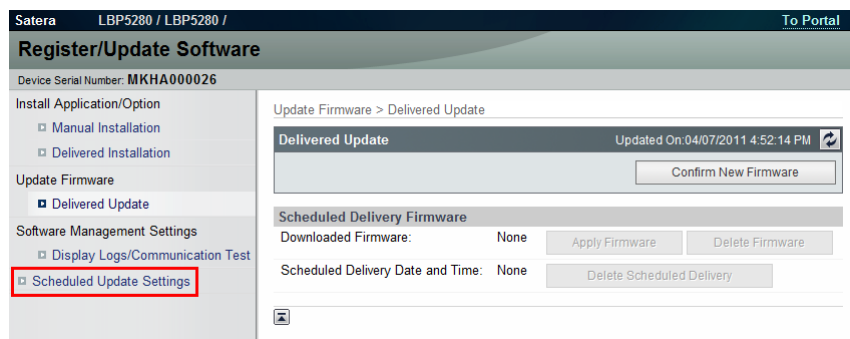

F-5-54

Caution:

CDS-LVUP

CDS-LVUP is default On in LBP7680C (EU model).

It is default Off in LBP5280 (US model).

System Management Operations

Various Setting

Setting Log Level

This section describes how to set system log levels.

1. Activate [Register/Updater Software (Management Settings)] from browser.
 - 1). Enter [https://machine's IP address:8443/svm/] to the URL of browser.
 - 2). Type the password [*28*] then log in it.
 - 3). After login, select [System Settings] > [Edit].

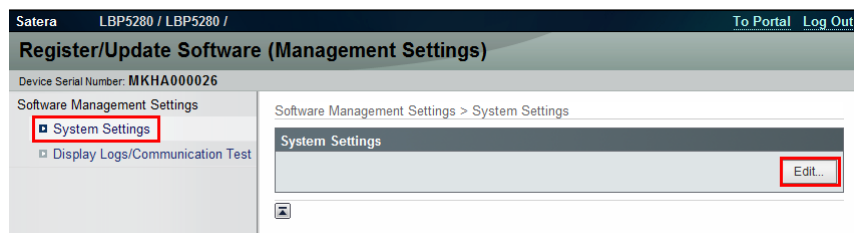

F-5-55

2. Select a log level from [Log Level] dropdown list.



F-5-56

- [Log Level]:
Select one of 5 levels ranging from [0] to [4]. (The default [3].)
See the table below for logs output in each level.

Log Level	Log Output				
	Trace	Information	Important Message	Ordinary Error	System Error
0	-	-	-	-	Yes
1	-	-	-	Yes	Yes
2	-	-	Yes	Yes	Yes
3	-	Yes	Yes	Yes	Yes
4	Yes	Yes	Yes	Yes	Yes

T-5-10

NOTE:

This list shows the contents of the Log Output.

Log Output	Description
Trace	Detailed logs for debug
Information	Logs related to operations done on the system
Important Message	Update logs output by firmware type Installation logs by MEAP application Logs related to enabled functions by system option
Ordinary Error	Logs for ordinary errors
System Error	Logs for internal system errors

3. Press [Configure] button to set the selected log level. Now the log level is successfully set.

Caution:

When you set it to log level 4, a performance falls, and the log acquisition takes time remarkably .

● Displaying Logs

Update Logs

This section describes how to confirm System Option/MEAP Application Installation Logs and Firmware Update Logs.

1. Select [Settings/Registration] > [License/Other] > [Register/Update Software] > [Display Logs/Communication Test] from management mode of Remote UI.

Note:

You can also access from [Register/Updater Software (Management Settings)] > [Display Logs/Communication Test]

2. Press [Update Logs] button.

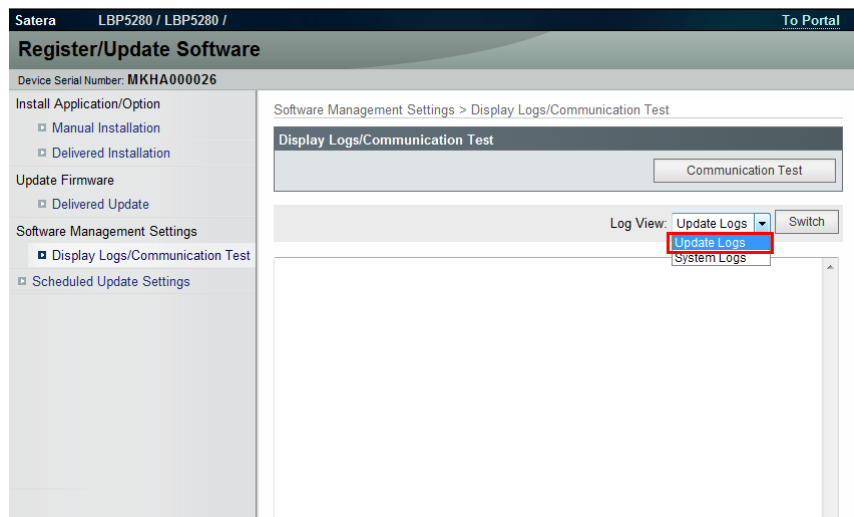

F-5-57

3. Press [Switch] button.

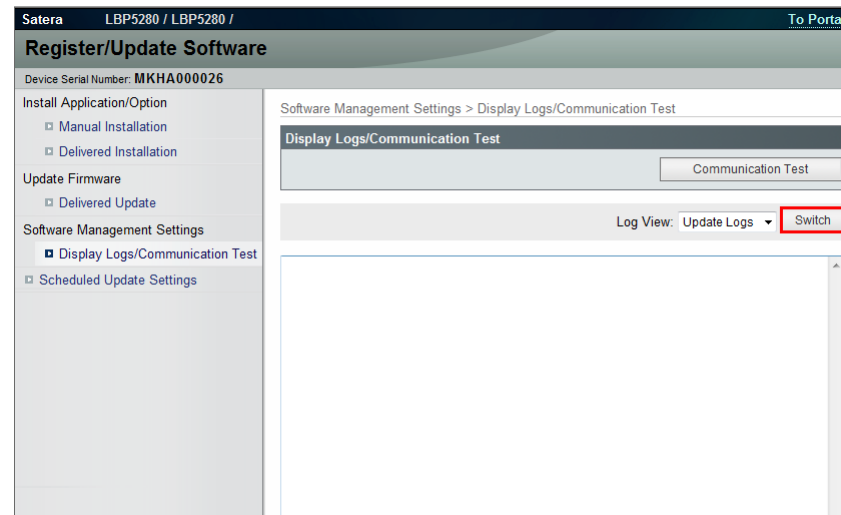

F-5-58

4. System Option/MEAP Application Installation Logs and Firmware Update Logs are shown.

System Logs

This section describes how to confirm System Logs.

1. Select [Settings/Registration] > [License/Other] > [Register/Update Software] > [Display Logs/Communication Test] from management mode of Remote UI.

Note:

You can also access from [Register/Updater Software (Management Settings)] > [Display Logs/Communication Test]

2. Press [System Logs] button.

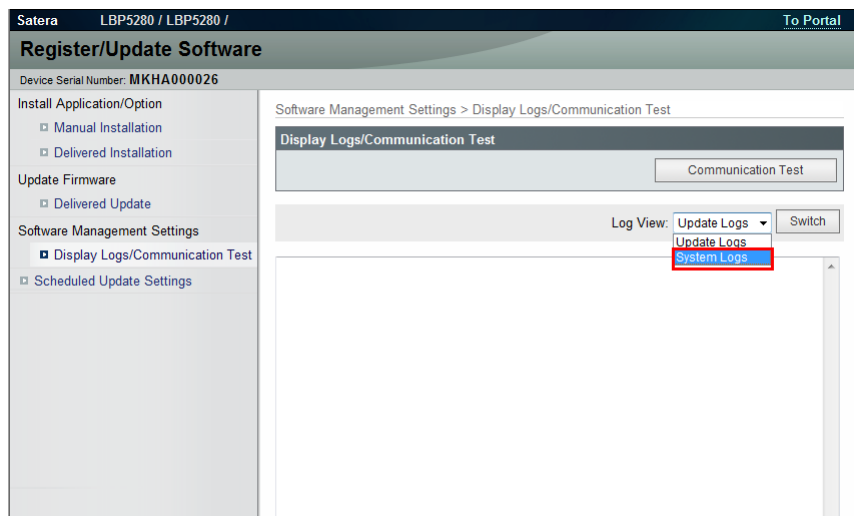

F-5-59

3. Press [Switch] button.

4. Updater internal logs are displayed.

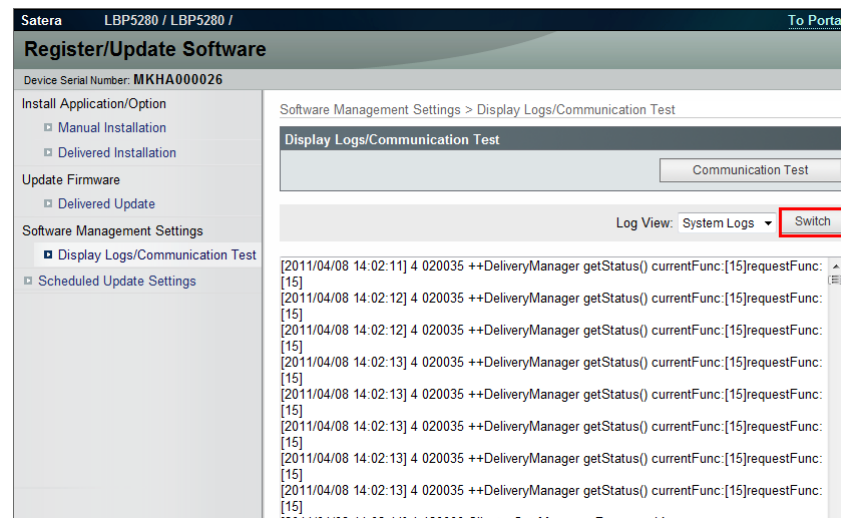

F-5-60

Note:

When you acquire the logs, do copy and paste of it.

■ Maintenance

● Upgrading Updater

The firmware installed in the device should be also upgraded when upgrading Updater. The setting information and logs (update logs/system logs) are inherited in the upgraded version.

● How to Replace Controller Boards

- Main Controller Board PCB (including SRAM)

The network and service mode setting should be set again after initialization. See "Preparation" in "Version Upgrade" of this manual for details.

● How to Replace Devices

All settings should be set again because no data are inherited. See "Preparation" in "Version Upgrade" of this manual for details.

FAQ

FAQ on Installing Firmware

No.1

Q: Is it also possible to downgrade firmware with using CDS?

A: Firmware can be downgraded in some methods shown in the table below.

If download and update are performed consecutively, firmware can't be downgraded.

Distribution Method	Downgrade Possibility
UGW-linked Download and Update	No
UGW-linked Download	Yes

T-5-11

No.2

Q: How can we confirm that the firmware is properly updated after "UGW-linked download and update" done?

A: You can confirm this in E-mail or the Device List on UGW-linked screen.

E-mail to notify firmware update will be sent from CDS server to the addresses set as destinations at the time of distribution setting to notify update completion.

On UGW-linked screen, search the device of your interest on [Select Device] screen to find the distribution status per device as shown in the search result.

No.3

Q: In the course of "UGW-linked download", what will happen if the user downloads the firmware before the service technician update the firmware downloaded with "UGW-linked download" before?

A: The previously downloaded firmware in the method of "UGW-linked download" will be overridden by the subsequently downloaded one.

This is because only one downloaded firmware can be held on the device.

The firmware downloaded in the method of "Service mode-linked download" and "UGW-linked download" can be checked/deleted from User mode, but cannot be updated, so it cannot be updated by the user unnoticed by the service technician.

No.4

Q: How is an individual response edition of firmware distributed?

A: Any individual response edition of firmware can be installed in all the methods provided by service technicians. Before installing the individual response edition, ensure to obtain the ID and password separately.

No.5

Q: If the device is down during firmware update, can the device be started using the older firmware version?

A: No, it is impossible to start the device using older versions. If this occurs, the service technician in charge should reinstall the firmware via SST. See "Troubleshooting on Firmware Installation" in chapter 6 of this manual for details.

No.6

Q: If the device is down during firmware download, is it possible to download the firmware again?

A: Firmware cannot be downloaded again automatically. Instead, the error is notified in E-mail. The user should register the firmware distribution schedule again accordingly.

No.7

Q: Can we cancel the operation during firmware download?

A: Yes. [Cancel] button is shown.

No.8

Q: E-mail is sent to users to notify update completion. Can service technicians also receive such a notification?

A: Yes. The notification E-mail is also set for the service technician in charge if the user enters his/her E-mail address at the time of firmware distribution setting.

Multiple E-mail addresses can be entered in the field. Delimit each E-mail address with “,” (comma) or “;” (semicolon) when you enter multiple E-mail addresses in the field.

No.9

Q: How long does the firmware update take?

A: Approx. 10 min. However, this does not include the download time. Download time relies on the network environment.

● FAQ on Installing MEAP Application/System Option

No.1

Q: What happens if a MEAP application is installed in the system with insufficient storage free space?

A: An error message is shown. Upon starting installation, the MEAP application checks the required space against free space to judge installation availability.

No.2

Q: Can we cancel the operation during installation of MEAP application?

A: Yes. [Cancel] button is shown.

No.3

Q: Is the device automatically restarted after the system option is enabled?

A: The device is not automatically restarted. Users should restart the device manually.

● FAQ on General Matters of Updater

No.1

Q: What preparation is needed in each installation method?

A: See the table below for preparation required in each installation method.

- For updating firmware

Installation Method	Setting Sales Company's HQ	Network Settings	Enabling UGW Link	Enabling [Update Firmware] Button of User Mode	Enabling [Manual Update] Button of User Mode (Remote UI)
UGW-linked Download and Update	Yes	Yes	Yes	-	-
UGW-linked Download	Yes	Yes	Yes	-	-

T-5-12

- For install Application

Installation Method	Network Settings	Enabling [Install Application/ Options] Button of User Mode (Remote UI)
LMS-linked Installation	Yes	-
LMS-linked installation via Remote UI	Yes	Yes

T-5-13

No.2

Q: How can operations using Updater be masked on the users' side?

A: Be sure to perform the following from the service mode.

- Masking Firmware Installation

Setting Device Service Mode	SERVICE MODE >FUNCTION GR. >MEAP >CDS-FIRM (On -> Off)
-----------------------------	---

- Masking Application Installation

Setting Device Service Mode	SERVICE MODE >FUNCTION GR.>MEAP >CDS-MEAP (On -> Off)
-----------------------------	--

No.3

Q: Can the communication be cancelled during the communication test?

A: No. During the communication test, there is no "Cancel" button.

Error Messages

Error messages displayed in Remote UI are shown below. As to error codes, see the next list.

No.	Messages	Timing of display	Cause	Remedy
1	An error occurred with the delivery server. Contact your sales representative. Error Code: [xxx]	In communicating with the delivery server.	System error occurred in server.	Obtain the log etc. (Refer to "System Management Operations" under "Version Upgrade" of "Updater" in Chapter 6 "Troubleshooting" of this manual.) and contact Support Div. of the sales company.
2	Delivery server is stopped. Wait a while and then try to perform the operation again. Check the following URL for details. <Stopped Delivery Server URL>	In communicating with the delivery server.	Delivery server stopped.	Check the delivery server stop information. After the delivery server starts, perform the operation from this application. When the delivery server stop information is not available, contact the sales company's Support Department.
3	Failed to connect to delivery server. Check the delivery server and network.	In communicating with the delivery server.	Communication error due to incorrect settings of CDS URL. Excluding delivery server stop, communication error to the delivery server occurred.	Set correct CDS URL in the Updater settings. Check if the network environment is correct to solve the cause of the error occurrence. If the network environment of the device is correct, obtain the log etc. (Refer to "System Management Operations" under "Version Upgrade" of "Updater" in Chapter 6 "Troubleshooting" of this manual.) and contact Support Div. of the sales company.
4	Download was stopped because an error occurred with the file server. Check the network.	At the time of file download	Communication error to the delivery server occurred.	Check if the network environment is correct to solve the cause of the error occurrence. If the network environment of the device is correct, obtain the log etc. (Refer to "System Management Operations" under "Version Upgrade" of "Updater" in Chapter 6 "Troubleshooting" of this manual.) and contact Support Div. of the sales company.
5	Downloaded files are invalid. Check the network.	At the time of file download	The received file is broken.	After checking the network environment of the device, re-execute the job. If it recurs, obtain the log etc. (Refer to "System Management Operations" under "Version Upgrade" of "Updater" in Chapter 6 "Troubleshooting" of this manual.) and contact Support Div. of the sales company.
6	Failed to retrieve information of special firmware. Check the retrieval ID and password.	Acquisition of applicable firmware information	No information exists about firmware for special firmware retrieval ID or Password is invalid.	Enter the correct firmware ID or Password applicable to the firmware information. If it recurs, obtain the log etc. (Refer to "System Management Operations" under "Version Upgrade" of "Updater" in Chapter 6 "Troubleshooting" of this manual.) and contact Support Div. of the sales company.
7	Scheduled delivery information of firmware does not exist. Check it because it may already have been deleted.	Acquisition of applicable firmware information	Delivery information with specified delivery ID does not exist.	Register the delivery schedule again. If this occurs at the time of canceling file download, deleting downloaded firmware or deleting scheduled delivery, no remedy is required.
8	Failed to apply firmware.	Firmware application error	Error due to the application (NLM)	Obtain the log etc. (Refer to "System Management Operations" under "Version Upgrade" of "Updater" in Chapter 6 "Troubleshooting" of this manual.) and contact Support Div. of the sales company.

No.	Messages	Timing of display	Cause	Remedy
9	Delivery Server : Connect Failed File Server : Retrieve Failed Error Code: [xxxx]	Communication test, etc. (communication test result dialogue)	In the communication test, failed to connect to the delivery server.	Check the network environment of the device, and re-execute the job. If it recurs, obtain the log etc. (Refer to "System Management Operations" under "Version Upgrade" of "Updater" in Chapter 6 "Troubleshooting" of this manual.) and contact Support Div. of the sales company.
			In SOAP communication, failed to success after 1 min retry.	Set proxy and restart the communication test. If it recurs, obtain the log etc. (Refer to "System Management Operations" under "Version Upgrade" of "Updater" in Chapter 6 "Troubleshooting" of this manual.) and contact Support Div. of the sales company.
			ID and Password required for proxy to connect to the internet are not configured in device.	Set the user environment to make the access to the following domain available. https://device.cdsknn.net/ http://cdsknn.net.edgesuite.net/ If it recurs, obtain the log etc. (Refer to "System Management Operations" under "Version Upgrade" of "Updater" in Chapter 6 "Troubleshooting" of this manual.) and contact Support Div. of the sales company.
			The access to the network is limited.	Contact Field Support Group in the sale company. After confirmation that the delivery server has been restored, restart the communication test. If it recurs, obtain the log etc. (Refer to "System Management Operations" under "Version Upgrade" of "Updater" in Chapter 6 "Troubleshooting" of this manual.) and contact Support Div. of the sales company again.
10	Delivery Server : Connect OK File Server : Retrieve Failed Error Code: [XXXX]	Delivery Server : Connect OK File Server : Retrieve Failed Error Code: [XXXX]	Due to no return of data for the communication test, time-out (in HTTP communication, no response for 1min) occurred. After that, retried but failed to connect to server.	Check the network environment of the device and re-execute the job. If it recurs, obtain the log etc. (Refer to "System Management Operations" under "Version Upgrade" of "Updater" in Chapter 6 "Troubleshooting" of this manual.) and contact Support Div. of the sales company.
			The network cable was disconnected during data download in the communication test.	Reconnect the network cable and then restart the communication test. If it recurs, obtain the log etc. (Refer to "System Management Operations" under "Version Upgrade" of "Updater" in Chapter 6 "Troubleshooting" of this manual.) and contact Support Div. of the sales company.
			The file server stopped during data download in the communication test.	Contact the sales company's Support Department. After confirmation that the delivery server has been restored, restart the communication test. If it recurs, obtain the log etc. (Refer to "System Management Operations" under "Version Upgrade" of "Updater" in Chapter 6 "Troubleshooting" of this manual.) and contact Support Div. of the sales company again.
			Hash value in the communication test file is incorrect.	Check the network environment and re-execute the job. If it recurs, obtain the log etc. (Refer to "System Management Operations" under "Version Upgrade" of "Updater" in Chapter 6 "Troubleshooting" of this manual.) and contact Support Div. of the sales company.

No.	Messages	Timing of display	Cause	Remedy
11	An error occurred. Error Code: [xxx]	communication test, etc. (main screen)	The max value (space/file) was exceeded and new log was not accepted. Normally an old log file is deleted before the max value (space/file) is exceeded, but error may occur due to other element (e.g. I/O error).	Check if the log file exceeded the max value. <Update log> Max space: 128KB/file Max file number: 4 <System log> Max space: 512KB/file Max file number: 4 If it recurs, obtain the log etc. (Refer to "System Management Operations" under "Version Upgrade" of "Updater" in Chapter 6 "Troubleshooting" of this manual.) and contact Support Div. of the sales company.
			Notice of version information (main screen)	Failed to acquire version information of device due to no CDS registration of firmware version of device.
		At the time of notifying version information, failed to connect to the delivery server.	Check if the network environment is correct to solve the cause of the error occurrence. If the network environment of the device is correct, obtain the log etc. (Refer to "System Management Operations" under "Version Upgrade" of "Updater" in Chapter 6 "Troubleshooting" of this manual.) and contact Support Div. of the sales company.	
		No return of notifying version information	Re-connect the network cable and re-execute the job. If it recurs, obtain the log etc. (Refer to "System Management Operations" under "Version Upgrade" of "Updater" in Chapter 6 "Troubleshooting" of this manual.) and contact Support Div. of the sales company.	
		Network cable was disconnected during notice of version information.	Re-execute the job. If it recurs, obtain the log etc. (Refer to "System Management Operations" under "Version Upgrade" of "Updater" in Chapter 6 "Troubleshooting" of this manual.) and contact Support Div. of the sales company.	
		Failed to send notice of version information since the main power was turned OFF and then ON during the sending.	Check the network environment of the device and re-execute the job. If it recurs, obtain the log etc. (Refer to "System Management Operations" under "Version Upgrade" of "Updater" in Chapter 6 "Troubleshooting" of this manual.) and contact Support Div. of the sales company.	
		Server stopped at the time of sending notice of version information.	Obtain the log etc. (Refer to "System Management Operations" under "Version Upgrade" of "Updater" in Chapter 6 "Troubleshooting" of this manual.) and contact Support Div. of the sales company.	

No.	Messages	Timing of display	Cause	Remedy
11	An error occurred. Error Code: [xxx]	UGW linkage (main screen)	UGW linkage was turned ON when eRDS was OFF.	For a device using eRDS, turn ON the eRDS. For a device not using eRDS, turn OFF the UGW linkage. If it recurs, obtain the log etc. (Refer to "System Management Operations" under "Version Upgrade" of "Updater" in Chapter 6 "Troubleshooting" of this manual.) and contact Support Div. of the sales company.
			An internal error occurred at the time of acquiring delivery information.	Re-execute the job. If it recurs, obtain the log etc. (Refer to "System Management Operations" under "Version Upgrade" of "Updater" in Chapter 6 "Troubleshooting" of this manual.) and contact Support Div. of the sales company.
		On-site (error dialogue)	An internal error occurred at the time of acquiring applicable firmware information.	Re-execute the job. If it recurs, obtain the log etc. (Refer to "System Management Operations" under "Version Upgrade" of "Updater" in Chapter 6 "Troubleshooting" of this manual.) and contact Support Div. of the sales company.
			An internal error occurred at the time of sending approval information.	Re-execute the job. If it recurs, obtain the log etc. (Refer to "System Management Operations" under "Version Upgrade" of "Updater" in Chapter 6 "Troubleshooting" of this manual.) and contact Support Div. of the sales company.
			An internal error occurred at the time of delivery order	Re-execute the job. If it recurs, obtain the log etc. (Refer to "System Management Operations" under "Version Upgrade" of "Updater" in Chapter 6 "Troubleshooting" of this manual.) and contact Support Div. of the sales company.
		Immediate download (error dialogue)	An internal error occurred at the time of requesting firmware delivery information.	Re-execute the job. If it recurs, obtain the log etc. (Refer to "System Management Operations" under "Version Upgrade" of "Updater" in Chapter 6 "Troubleshooting" of this manual.) and contact Support Div. of the sales company.
			During the download, all space in the storage disk was occupied. (DiskFull)	After adding vacant space of the storage disk, re-execute the job. If it recurs, obtain the log etc. (Refer to "System Management Operations" under "Version Upgrade" of "Updater" in Chapter 6 "Troubleshooting" of this manual.) and contact Support Div. of the sales company.
			At the end of receipt, an internal error occurred.	Re-execute the job. If it recurs, obtain the log etc. (Refer to "System Management Operations" under "Version Upgrade" of "Updater" in Chapter 6 "Troubleshooting" of this manual.) and contact Support Div. of the sales company.
		Manual update (error dialogue)	At the update start, an internal error occurred.	Re-execute the job. If it recurs, obtain the log etc. (Refer to "System Management Operations" under "Version Upgrade" of "Updater" in Chapter 6 "Troubleshooting" of this manual.) and contact Support Div. of the sales company
		Automatic update (error dialogue)	At the update start, an internal error occurred.	Re-execute the job. If it recurs, obtain the log etc. (Refer to "System Management Operations" under "Version Upgrade" of "Updater" in Chapter 6 "Troubleshooting" of this manual.) and contact Support Div. of the sales company.
		Deletion of downloaded firmware	At the time of notifying cancellation, an internal error occurred.	Re-execute the job. If it recurs, obtain the log etc. (Refer to "System Management Operations" under "Version Upgrade" of "Updater" in Chapter 6 "Troubleshooting" of this manual.) and contact Support Div. of the sales company.

No.	Messages	Timing of display	Cause	Remedy
12	An error occurred. Check the Update Firmware screen.	UGW linkage (main screen)	eRDS sent an order but Updater failed to connect to server.	Conduct a communication test to analyze the cause of the error. After solving the cause, resend the order from the eRDS. If it recurs, obtain the log etc. (Refer to "System Management Operations" under "Version Upgrade" of "Updater" in Chapter 6 "Troubleshooting" of this manual.) and contact Support Div. of the sales company.
			Delivery server stopped.	Contact the sales company's Support Department. After confirming restoration of the delivery server, re-execute the job. If it recurs, obtain the log etc. (Refer to "System Management Operations" under "Version Upgrade" of "Updater" in Chapter 6 "Troubleshooting" of this manual.) and contact Support Div. of the sales company.
			Scheduled date and time acquired from the delivery server was before current time (15 or more min had passed.)	Do the delivery setting from UGW again. If it recurs, obtain the log etc. (Refer to "System Management Operations" under "Version Upgrade" of "Updater" in Chapter 6 "Troubleshooting" of this manual.) and contact Support Div. of the sales company.
			Scheduled data and time acquired from the delivery server did not exist.	Do the delivery setting from UGW again. If it recurs, obtain the log etc. (Refer to "System Management Operations" under "Version Upgrade" of "Updater" in Chapter 6 "Troubleshooting" of this manual.) and contact Support Div. of the sales company.
		Immediate download (main screen)	At the time of immediate download, turned OFF and then ON the power of device main body.	Re-execute the job. If it recurs, obtain the log etc. (Refer to "System Management Operations" under "Version Upgrade" of "Updater" in Chapter 6 "Troubleshooting" of this manual.) and contact Support Div. of the sales company.
		Manual update (main screen) Automatic update (main screen)	Updated version was different from the ordered version.	Re-execute the job. If it recurs, obtain the log etc. (Refer to "System Management Operations" under "Version Upgrade" of "Updater" in Chapter 6 "Troubleshooting" of this manual.) and contact Support Div. of the sales company.
			After the update, failed to connect to the delivery server.	Check the network environment and re-execute the job. If it recurs, obtain the log etc. (Refer to "System Management Operations" under "Version Upgrade" of "Updater" in Chapter 6 "Troubleshooting" of this manual.) and contact Support Div. of the sales company.
			After the update, delivery server stopped.	Contact the sales company's Support Department. After confirming restoration of the delivery server, re-execute the job. If it recurs, obtain the log etc. (Refer to "System Management Operations" under "Version Upgrade" of "Updater" in Chapter 6 "Troubleshooting" of this manual.) and contact Support Div. of the sales company.
			After the update, the network cable was disconnected.	Re-connect the network cable and re-execute the job. If it recurs, obtain the log etc. (Refer to "System Management Operations" under "Version Upgrade" of "Updater" in Chapter 6 "Troubleshooting" of this manual.) and contact Support Div. of the sales company.
			After the update, server returned an error.	Obtain the log etc. (Refer to "System Management Operations" under "Version Upgrade" of "Updater" in Chapter 6 "Troubleshooting" of this manual.) and contact Support Div. of the sales company.
			After the update, an internal error occurred.	If it recurs, obtain the log etc. (Refer to "System Management Operations" under "Version Upgrade" of "Updater" in Chapter 6 "Troubleshooting" of this manual.) and contact Support Div. of the sales company.

No.	Messages	Timing of display	Cause	Remedy
13	Delivery Error Error Code: [xxx]	UGW linkage (Update Firmware screen)	eRDS sent an order but Updater failed to connect to the server.	Conduct a communication test to analyze the cause of the error. After solving the cause, resend the order from the eRDS. If it recurs, obtain the log etc. (Refer to "System Management Operations" under "Version Upgrade" of "Updater" in Chapter 6 "Troubleshooting" of this manual.) and contact Support Div. of the sales company.
			The delivery server stopped.	Contact the sales company's Support Department. After confirming restoration of the delivery server, re-execute the job. If it recurs, obtain the log etc. (Refer to "System Management Operations" under "Version Upgrade" of "Updater" in Chapter 6 "Troubleshooting" of this manual.) and contact Support Div. of the sales company.
			The scheduled data and time acquired from delivery server does not exist.	Do the delivery setting from UGW again. If it recurs, obtain the log etc. (Refer to "System Management Operations" under "Version Upgrade" of "Updater" in Chapter 6 "Troubleshooting" of this manual.) and contact Support Div. of the sales company.
14	Delivery Error Delivery Time Delivery Firmware Label Delivery Firmware version Error Code: [xxx]	UGW linkage (Update Firmware screen) Immediate download (Update Firmware screen)	The scheduled date and time acquired from delivery server was before current time (15 or more min had passed).	Do the delivery setting from UGW again. If it recurs, obtain the log etc. (Refer to "System Management Operations" under "Version Upgrade" of "Updater" in Chapter 6 "Troubleshooting" of this manual.) and contact Support Div. of the sales company.
			At the time of immediate download, turned OFF and then ON the power of device main body.	Re-execute the job. If it recurs, obtain the log etc. (Refer to "System Management Operations" under "Version Upgrade" of "Updater" in Chapter 6 "Troubleshooting" of this manual.) and contact Support Div. of the sales company.
15	Applicable firmware is not registered.	On-site (error dialogue)	At the user site, no latest firmware exists.	This means the current firmware is the latest, so this error has no impact. But when the latest firmware to be retrieved must exist e.g. released new firmware information has been notified, contact Field Support Group in the sales company.
			No applicable firmware exists on CDS, so the service person can't select any applicable firmware.	Contact the sales company's Support Department.
16	Restart failed. Turn the main power OFF and ON.	Manual update (error dialogue)	An error occurred at the time of the device restart.	After turning OFF and then ON the main power of the device, re-execute the job. If it recurs, obtain the log etc. (Refer to "System Management Operations" under "Version Upgrade" of "Updater" in Chapter 6 "Troubleshooting" of this manual.) and contact Support Div. of the sales company.
		Automatic update (error dialogue)	An error occurred at the time of the device restart.	After turning OFF and then ON the main power of the device, re-execute the job. If it recurs, obtain the log etc. (Refer to "System Management Operations" under "Version Upgrade" of "Updater" in Chapter 6 "Troubleshooting" of this manual.) and contact Support Div. of the sales company.
17	Specify [E-Mail Address] with up to 64 characters.	At the time of periodical update setting	The specified E-mail address exceeded 64 characters.	Specify E-mail address within 64 characters.
18	The following characters cannot be used for the [E-Mail Address]: .;"()[]<>\	At the time of periodical update setting	The E-mail address was including the characters which could not be used.	Do not specify E-mail address with characters which cannot be used.
19	Specify [Comments] with up to 128 characters.	At the time of periodical update setting	Comments exceeded 128 characters.	Specify comments within 128 characters.
20	The [Delivery Server URL] is incorrect.	In setting with the deliver server URL.	The specified deliver server URL is wrong.	Enter the right URL(https://device.c-cdsknn.net/cds_soap/updaterif)

T-5-14

Error Codes

Error Codes displayed on Remote UI and how to read them.

How to read an error code

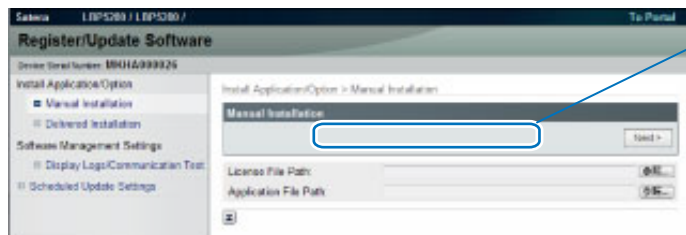

84014206

Code	Value	Contents
The first digit Error field	8	Error
The second digit Operator	0 1 2 3 4 5	Not defined. CDS server Updater UGW Service person IT administrator (User)
The 3rd - 4th digits Method category	xx	Method
The 5th digit Category code	0 1 2 3 4 5 6 7	Category code
The 6 - 8th digits Description code	000-	See Error code list

F-5-61

Error Code

The error code list is shown below. Remedy are error codes of "-", and for all the error codes out of the list, contact Field Support Group in the sales company.

Error Code (hex number)					Description	Remedy	Cause of error							
The first digit Error field	The second digit Operator	The 3rd - 4th digits Method category	The 5th digit Category code	The 6 - 8th digits Description code			CDS delivery server	UP DATER	CDS file server	Network				
8	Error													
	0													
	1													
		x	x		Relating method code									
				0	Not categorized									
				0	0	1				No value is set in a mandatory data entry item	-	-	-	-
				0	0	2				In a string type of a data entry item, digit number and/or character type is/are set against the regulations	-	-	-	-

Error Code (hex number)					Description	Remedy	Cause of error					
The first digit Error field	The second digit Operator	The 3rd - 4th digits Method category	The 5th digit Category code	The 6 - 8th digits Description code			CDS delivery server	UP DATER	CDS file server	Network		
				0 0 3	In an data entry item, the value is set against the regulations (E.g. the set value is other than "Operator: 4. Service person, 5. User")		-	✓	-	-		
				0 0 4	No applicable delivery information exists		✓	-	-	-		
				0 0 5	The setting of the system is imperfect		✓	-	-	-		
			1	Operation								
				0 0 1	Inconsistency between the current firmware component in the data entry item and delivery information (E.g. the conditions for automatic update are not met. The settings of a mandatory additional set are invalid)		✓	✓	-	-		
				0 0 2	In a notice of delivery-allowed information, an install-set was release to the market, but the market release was stopped during the delivery		✓	-	-	-		
				0 0 3	No mail template file exists		✓	-	-	-		
				0 0 4	The device serial number in the data entry item differs from that in delivery information		✓	-	-	-		
				0 0 5	User is selected as Operator in the data entry items and the retrieval type is other than the latest		✓	-	-	-		
				0 0 6	The retrieval type in the data entry item is special and registration ID and individual Password are not set (* Operator did not enter registration ID and individual Password)		✓	-	-	-		
				0 0 7	The retrieval type in the data entry item is special and Operator is not Service person		✓	-	-	-		
				0 0 8	As to the device serial number in the data entry items, there is no applicable device code product		✓	-	-	-		
				0 0 9	The retrieval type in the data entry items is special and there are no basic-set applicable to the registration ID and Password (* When wrong registration ID or Password was entered by an operator)		✓	-	-	-		
				0 0 A	The delivery status is Applying		✓	-	-	-		
				0 0 B	No approval information exists about EULA or the export criteria when the delivery is determined		✓	-	-	-		
				0 0 C	The delivery status is Distributing/Distributed/Applying/Finished/Failed		✓	-	-	-		
				0 0 D	The delivery status is Distributing/Distributed/Applying/Finished/Failed		✓	-	-	-		
				0 0 E	The delivery status is New/Waiting to Distribute/Distributed/Applying/Finished/Failed		✓	-	-	-		
				0 0 F	The delivery code is other than Distributing. (Firmware delivery)		✓	-	-	-		
				0 1 0	The delivery status is New/Waiting to Distribute/Distributing/Applying/Finished/Failed		✓	-	-	-		
				0 1 1	The delivery status is Distributing/Distributed/Applying/Finished/Failed		✓	-	-	-		
				0 1 2	Device is "Not applicable to CDS" (Firmware delivery)		✓	-	-	-		

Error Code (hex number)					Description	Remedy	Cause of error			
The first digit Error field	The second digit Operator	The 3rd - 4th digits Method category	The 5th digit Category code	The 6 - 8th digits Description code			CDS delivery server	UP DATER	CDS file server	Network
				0 1 3	The delivery time which specified is in CDS delivery stop time		✓	-	-	-
				0 1 4	The firmware reservation status of confirmation time-out		✓	-	-	-
				0 1 5	The firmware delivery time-out		✓	-	-	-
				0 1 6	The version upgrade of firmware is time-out		✓	-	-	-
			2	I/O						
				0 0 1	The specified license access number does not exist in LMS		✓	-	-	-
				0 0 2	The specified license access number has been deauthorized		✓	-	-	-
				0 0 3	The package product of the entered license access number doesn't include MEAP application/System Option		✓	-	-	-
				0 0 4	The sales company for the MEAP application isn't identical with the sale company for the package product		✓	-	-	-
				0 0 5	The number of licenses to be issued will exceed the limit number allowed to register		✓	-	-	-
				0 0 6	As for System Option for the same function, the license keys were issued more than the defined number of times for the same device serial number		✓	-	-	-
				0 0 7	No device product exists applicable to the optional product		✓	-	-	-
				0 0 8	No product exists applicable to the device serial number		✓	-	-	-
				0 0 9	The product of the entered license access number cannot be used with this device because the settings of the sales company are incorrect		✓	-	-	-
				0 0 A	No product linked to the license access number is registered in CDS for delivery		✓	-	-	-
				0 0 B	Although the product linked to the license access number is registered in CDS for delivery, the delivery is stopped now		✓	-	-	-
				0 0 C	No existence of optional product applicable to the device serial number.		✓	-	-	-
				0 0 D	The license access number has been registered for another device		✓	-	-	-
				0 0 E	For the device product applicable to the device serial number, no available software (MEAP application, System Option) exists		✓	-	-	-
				0 1 0	LMS system error		✓	-	-	-
			2~5							
		x	x		Relating method code					
				0	Not cartelized					
				0 0 0	Not defined	Normally not indicated				
				1 0 0	Unknown error	Normally not indicated				
			1		Operation					
				0 0 1	Processing exclusively	Start the operation again after terminating other Updater operations being executed simultaneously	-	✓	-	-
				1 0 1	Failed to process preparation for use		-	✓	-	-
				1 0 2	Failed to process use end		-	✓	-	-
				1 0 3	Time out during restart of readiness preparation		-	✓	-	-

Error Code (hex number)					Description	Remedy	Cause of error					
The first digit Error field	The second digit Operator	The 3rd - 4th digits Method category	The 5th digit Category code	The 6 - 8th digits Description code			CDS delivery server	UP DATER	CDS file server	Network		
				1 0 4	Session time-out excluding after application inquiry (after issuing delivery ID)	Start the operation again from the beginning		✓	-	-		
				1 0 5	CDS URL is not set	Set CDS URL	-	✓	-	-		
				1 0 6	There is another job	Start the operation again after terminating the job of the device	-	✓	-	-		
				2 0 1	Appointment of the periodical update for the periodical update non-support model		✓	-	-	-		
			2	I/O								
				1 x x	An internal error about file operation	-	-	✓	-	-		
				2 x x	An internal error about XML file operation	-	-	✓	-	-		
				3 0 1	Failed to output the license file	-	-	✓	-	-		
			3	Device								
				1 x x	An internal error in CPCA	-	-	✓	-	-		
				2 x x	An internal error in IMI	-	-	✓	-	-		
				3 x x	An internal error in SMS	-	-	✓	-	-		
				4 x x	An internal error in NLM	-	-	✓	-	-		
				6 0 1	A permit acquisition error in APL CDS partition		-	✓	-	-		
			4	SOAP communication								
				1 0 1	The processing thread stopped	-	-	✓	-	-		
				1 0 2	Processing SOAP communication now	-	-	✓	-	-		
				1 0 3	The function type is not matched	-	-	✓	-	-		
				1 0 4	An invalid SOAP response error	-	✓	-	-	-		
				2 0 1	An internal error about application information	-	-	✓	-	-		
				2 0 2	config.xml is NOT FOUND	-	-	✓	-	-		
				2 0 3	type.xml is NOT FOUND	-	-	✓	-	-		
				2 0 4	An error in binding type.xml	-	-	✓	-	-		
				2 0 5	An error in creating a service tab	-	-	✓	-	-		
				2 0 6	A runtime error in performing the web method	-	-	✓	-	✓		
				2 0 7	An unknown host error in performing the web method	<ul style="list-style-type: none"> Check the network environment of the device and start the operation again Check if the URL settings of the CDS server are correct, and start the operation again after resetting 	✓	✓	-	✓		
				3 0 1	The delivery server is stopped	-	✓	-	-	-		
				3 0 2	An error occurrence in the delivery server	-	✓	✓	-	-		
			5	HTTP communication								
				1 0 1	Specified Hash Algorithm is unknown	-	-	✓	-	-		
				2 0 1	Invalid HTTP request	-	-	✓	✓	✓		
				2 0 2	Failed to connect to the server	Check the network environment of the device and start the operation again	-	✓	✓	✓		
				2 0 3	Failed to find the server	Check the network environment of the device and start the operation again	-	✓	✓	✓		
				2 0 4	An input/output error occurred during the connecting process to the server	-	-	✓	✓	✓		
				2 0 5	Failed to read a HTTP response	-	-	✓	✓	✓		
				2 0 6	Error in a HTTP response	-	-	✓	✓	✓		
				3 0 1	Failed to retrieve the data stream	-	-	✓	-	✓		
				3 0 2	Failed to create the file object for receipt	-	-	✓	-	✓		
				3 0 3	Failed to create the data stream of the file for receipt	-	-	✓	-	✓		

Error Code (hex number)					Description	Remedy	Cause of error					
The first digit Error field	The second digit Operator	The 3rd - 4th digits Method category	The 5th digit Category code	The 6 - 8th digits Description code			CDS delivery server	UP DATER	CDS file server	Network		
				3 0 4	Failed to receive the data	Check the network environment of the device and start the operation again	-	✓	✓	✓		
				3 0 5	An error about reserving the file data for receipt	-	-	✓	-	-		
				3 0 6	Failed to close the data stream	-	-	✓	-	-		
				3 0 7	Failed to close the file data for receipt	-	-	✓	-	-		
				3 0 8	Invalid hash code of the download file	Check the network environment of the device and start the operation again	✓	✓	✓	✓		
				3 0 9	The proxy authorization method is not applicable	Check the proxy authentication method used, and start the operation again after changing the settings to use the corresponding proxy authentication	-	✓	-	✓		
			6	Socket communication								
				1 0 1	Failed to connect the eRDS	-	-	✓	-	✓		
				1 0 2	No response from eRDS	-	-	✓	-	✓		
				1 0 3	No notice of start from the eRDS	-	-	✓	-	✓		
				1 0 4	Error of socket reading	-	-	✓	-	✓		
				1 0 5	Socket communication time-out	-	-	✓	-	✓		
			7	Other internal codes								
				0 0 2	One of installation, start or authorization failed (When installation or authorization failed, it is regarded as an error) *	-	-	✓	-	-		
				0 3 x	An internal error in processing the installation	-	-	✓	-	-		
				1 x x	An error by using invalid API	-	-	✓	-	-		
				2 x x	An internal error in SMS	-	-	✓	-	-		
				3 0 1	No existence of delivery ID	-	-	✓	-	-		
				3 0 2	Invalid delivery ID	-	-	✓	-	-		
				3 0 3	The updated firmware information is not identical with the firmware information after activation of the Updater	-	-	✓	-	-		
				3 0 4	The process of firmware download is incomplete	-	-	✓	-	-		
				3 0 5	The update process is incomplete	-	-	✓	-	-		
				3 0 6	The installment process is incomplete	-	-	✓	-	-		
				4 0 1	Failed to retrieve delivery information	-	-	✓	-	-		
				5 0 1	Failed to execute the delivery process	-	-	✓	-	-		
				5 0 2	The scheduled delivery was not executed within the defined period of time	Scheduled deliveries not executed within the defined period of time are abandoned, so register a scheduled delivery again. When setting the date and time of the scheduled delivery, be sure to designate a time when the device is ON	-	✓	-	-		

T-5-15

* Not displayed on a device UI

Service Mode

Entering Service Mode

Contact the sales company for the method to enter service mode.

Service Mode List

ADJUST GR.

Items	Description	Setting Range
CALIBRATION	To set whether to enable/disable calibration.	ON*/OFF
DEV DIAS Y	To set the value of developing bias (for yellow).	-5 to 0* to 5
DEV DIAS M	To set the value of developing bias (for magenta).	-5 to 0* to 5
DEV DIAS C	To set the value of developing bias (for cyan).	-5 to 0* to 5
DEV DIAS K	To set the value of developing bias (for black)	-5 to 0* to 5
T1 ATVC BIAS Y	To set the value of T1 ATVC bias (for yellow).	-5 to 0* to 5
T1 ATVC BIAS M	To set the value of T1 ATVC bias (for magenta).	-5 to 0* to 5
T1 ATVC BIAS C	To set the value of T1 ATVC bias (for cyan).	-5 to 0* to 5
T1 ATVC BIAS K	To set the value of T1 ATVC bias (for black).	-5 to 0* to 5
T1 ATVC BIAS F	To set the value of T2 ATVC bias for front side.	-5 to 0* to 5
T1 ATVC BIAS B	To set the value of T2 ATVC bias for back side.	-5 to 0* to 5
ICL BIAS	To set the correction value of the ICL Unit voltage control.	-5 to 0* to 5
FUSE TEMP	To set the correction value of temperature control of the Fixing Assembly.	-2 to 0* to 2
REG INFO CLEAR*1	To clear the information of registration correction value and density correction value.	Yes/No*
SUB-S-Y0	To set the information of emitting position 1 (Yellow) in the vertical scanning position to DCON NVRAM.	-1023 to 1023
SUB-S-M0	To set the information of emitting position 1 (Magenta) in the vertical scanning position to DCON NVRAM.	-1023 to 1023
SUB-S-C0	To set the information of emitting position 1 (cyan) in the vertical scanning position to DCON NVRAM.	-1023 to 1023
SUB-S-K0	To set the information of emitting position 1 (Black) in the vertical scanning position to DCON NVRAM.	-1023 to 1023
SUB-S-Y1	To set the information of emitting position 2 (Yellow) in the vertical scanning position to DCON NVRAM.	-1023 to 1023
SUB-S-M1	To set the information of emitting position 2 (Magenta) in the vertical scanning position to DCON NVRAM.	-1023 to 1023
SUB-S-C1	To set the information of emitting position 2 (cyan) in the vertical scanning position to DCON NVRAM.	-1023 to 1023

Items	Description	Setting Range
SUB-S-K1	To set the information of emitting position 2 (Black) in the vertical scanning position to DCON NVRAM.	-1023 to 1023
SUB-S-Y2	To set the information of emitting position 3 (Yellow) in the vertical scanning position to DCON NVRAM.	-1023 to 1023
SUB-S-M2	To set the information of emitting position 3 (Magenta) in the vertical scanning position to DCON NVRAM.	-1023 to 1023
SUB-S-C2	To set the information of emitting position 3 (cyan) in the vertical scanning position to DCON NVRAM.	-1023 to 1023
SUB-S-K2	To set the information of emitting position 3 (Black) in the vertical scanning position to DCON NVRAM.	-1023 to 1023
MAI-S-Y0	To set the information of scanning time 1 (Yellow) in the horizontal scanning position to DCON NVRAM.	-511 to 511
MAI-S-M0	To set the information of scanning time 1 (Magenta) in the horizontal scanning position to DCON NVRAM.	-511 to 511
MAI-S-C0	To set the information of scanning time 1 (cyan) in the horizontal scanning position to DCON NVRAM.	-511 to 511
MAI-S-K0	To set the information of scanning time 1 (Black) in the horizontal scanning position to DCON NVRAM.	-511 to 511
MAI-S-Y1	To set the information of scanning time 2 (Yellow) in the horizontal scanning position to DCON NVRAM.	-511 to 511
MAI-S-M1	To set the information of scanning time 2 (Magenta) in the horizontal scanning position to DCON NVRAM.	-511 to 511
MAI-S-C1	To set the information of scanning time 2 (cyan) in the horizontal scanning position to DCON NVRAM.	-511 to 511
MAI-S-K1	To set the information of scanning time 2 (Black) in the horizontal scanning position to DCON NVRAM.	-511 to 511
MAI-S-Y2	To set the information of scanning time 3 (Yellow) in the horizontal scanning position to DCON NVRAM.	-127 to 127
MAI-S-M2	To set the information of scanning time 3 (Magenta) in the horizontal scanning position to DCON NVRAM.	-127 to 127
MAI-S-C2	To set the information of scanning time 3 (cyan) in the horizontal scanning position to DCON NVRAM.	-127 to 127
MAI-S-K2	To set the information of scanning time 3 (Black) in the horizontal scanning position to DCON NVRAM.	-127 to 127

*1: Execute this menu when color displacement is not alleviated even if performing color displacement correction.

OPTION GR.

Items	Description	Setting Range
LONG SLEEP TIME	To set the time until it is judged as long sleep. It is judged as long sleep when the time elapsed from the completion of the last job until the recovery from sleep mode is larger than the setting value, while it is judged as short sleep when it is smaller than the setting value. Long sleep is not set when the setting value is 0. When it is judged as long sleep: Since there is no engine adjustment processing at recovery from sleep mode, the machine is recovered without allowing wait time to occur. When it is judged as short sleep: Since there is no engine adjustment processing at recovery from sleep mode, the machine is recovered without allowing wait time to occur.	0*, 2, 4, 6, 8, 12, 16, 18, 24, 48
B4-L-CNT	To set whether to handle B4 size as large or small.	ON/OFF*
SCT-ALL-CLR	To set whether clearing of all counts can be executed from the "Dept ID control setting" screen of RUI.	ON*/OFF
SCT-IDV-CLR	To set whether clearing of counts can be executed from the "Dept editing" screen of RUI.	ON*/OFF
PS-MODE	To set compatibility with EFI at PS 2-sided delivery or default value changing function of StrokeAdjustment.	0* to 65535
COUNTER-SW	To switch of the counter.	MODEL1* MODEL2
LIMIT AUTO CALIBRATE	To control whether to execute or restrain calibration when calibration of color displacement correction and density correction is requested by the engine.	ON/OFF*
TONEROUT CONT. PRINT	To set to enable/disable printing when the toner reaches the end of life. The following is controlled: Whether to continue color printing when YMC toner reaches the end of life, and whether to continue all the printing when Bk toner reaches the end of life.	ON*/OFF

FUNCTION GR.

Items	Description		Setting Range
ECONF	EXPORT	GENERAL Whether to set items whose device settings do not depend on the PCB, but can be performed commonly within the same device as the target	Yes/No*
		DEPEND Whether to set items whose device settings change depending on the PCB as the target	Yes/No*
		SECURITY Whether to set items related to security as the target	Yes/No*
		ALL Whether to set all items exported in GENERAL/DEPEND/SECURITY as the target	Yes/No*
	IMPORT	To import device setting data in the following priority order USB memory > SD card > RAM	Yes/No*
USB-H*	To set to enable/disable the USB host function. By turning ON the host function, USB memory can be used.		ON/OFF*
SUBLOG TO USB	Output Sublog to the USB memory.		Yes/No*
RESTOR DCON	To restore backup information of the DC Controller PCB NVRAM stored in the Main Controller PCB NVRAM to the DC Controller PCB NVRAM.		Yes/No*
CLEAR DCON	To initialize the backup area of the DC Controller PCB NVRAM in the Main Controller PCB.		Yes/No*
COLOR MODE SLCT	Function to avoid the symptom in which data with multiple pages, one of which is specified to be printed in B&W, cannot be printed in color. B&W/color printing is automatically judged by the device		ON/OFF*

Items	Description	Setting Range
MEAP (LBP7680Cx only)	MEAP-PN	To specify the port number of MEAP HTTP. 0 to 8000* to 65535
	MEAP-SSL	To specify the port number of MEAP HTTPS. 0 to 8443* to 65535
	CDS-MEAP	To set whether to permit the user administrator to install MEAP application ON/OFF*
	CDS-FIRM	To set whether to permit the user administrator to update firmware ON/OFF*
	CDS-UGW	To set whether to permit firmware update from UGW ON/OFF*
	CDS-LVUP	To set whether to permit service technician or user administrator to use the periodical update function. ON/OFF*
	CDS-CTL	To switch the country to obtain firmware in CDS.
	MEAP-FUNCTION	MEAP recovery ON/OFF*
DDNSINTY	To change DDNS periodical update interval. When 0 is set, periodical update is not performed 0 to 24* to 48	
IPMTU	To change MTU size of network packet. 1 to 10*	
SN MAIN (LBP7600C/7660Cdn only)	Enter the device serial number written on the rating name plate of the equipment. If you enter an incorrect device serial number, the specification (the paper size and unit at default, etc.) may be changed; therefore be careful not to make any mistakes when entering it.	
PDL Z Logic	FURUYA mode: Composition algorithm of Z (attribute information) suitable for general sentences, and is a default setting of the iR-ADV C series FLAG mode: Composition algorithm adopted by the iR C series VALUE mode, ROP mode: These modes are available based on the logic that the internal processing is possible, but they are basically not used. MODE FURUYA* MODE FLAG MODE VALUE MODE ROP	
FEED ROLLER CHG	To move the Pickup Roller to the replacement position. Yes/No*	

Items	Description	Setting Range
SHIPLOCK	To shift the engine to a shippable state by performing the following operations. (1) Transfer pressure release (2) Fixing pressure release (3) DCON NVRAM Yes/No*	

*1: Be sure to pull out the USB memory after unmounting it by turning USB-H to OFF because USB memory is in the mount state when USB-H is ON.

Pulling out the USB memory while it is being accessed causes an error.

■ LOG GR.

Items	Description	Setting Range
SYSTEM LOG	To set whether to use the system log function. ON*/OFF	
SUBLOG FTP GET	To obtain SUBLOG Yes/No	
Logging Utility	To set whether to use the logging utility function in the utility menu. ON*/OFF	
DEBUGLOG-SW	To set whether to perform sublog auto output when error code/exception/service call occurs. ON*/OFF	

■ PANEL LOCK GR.

Items	Description	Setting Range
PANEL LOCK	To perform access restriction for each key on the Control Panel.	

■ F/W UPDATE GR.

Items	Description	Setting Range	
USB	To use USB to update firmware	Yes/No*	
NETWORK	To use network to update firmware	Yes/No*	
USB STORAGE	ALL	To update various firmware required for the device to those stored in the USB storage. Update is executed even if any of the firmware is lacking in the USB storage	Yes/No*
	CONT	To update the controller firmware of the device to the one stored in the USB storage	Yes/No*
	BOOT	To update the startup firmware of the device to the one stored in the USB storage	Yes/No*
	DCON	To update the engine firmware of the device to the one stored in the USB storage.	Yes/No*
CDS	Firmware auto/manual update function by MEAP application (updater)	Yes/No*	

■ NETWORK GR.

Items	Description	Setting Range	
DNSTRANS	To determine priority order of the protocol (IPv4/IPv6) to be used for DNS query.	IPv4/IPv6*	
FTP SYSLOG	To set whether to use the function to obtain various system log files by FTP.	ON/OFF*	
JOB SERIALIZE	To set whether to use the connection serialize function.	ON/OFF*	
BUFFER LIMIT	To clear the buffer acquisition limit of PSS.	ON/OFF*	
E-RDS	E-RDS SWITCH	To set whether to use the Embedded-RDS	ON/OFF*
	RGW-ADDRESS	To check and set the server URL.	----
	RGW-PORT	To set the port number of the server.	1 to 443* to 65535
	COM-TEST	To execute the communication test.	Yes/No*
	COM-LOG	To display the detail of the communication test result.	----

Items	Description	Setting Range	
	CLEAR	To clear the schedule information and alarm alert filtering information besides the eRDS setting value in service mode by executing this item.	Yes/No*
CA-KEY	CLEAR	To change CA certificate to the default CA certificate by executing this item and turning ON and then OFF the power.	Yes/No*
MIB CHARGECOUNT (LBP7680Cx only)		To set Charge Counter MIB.	ALL ACCESS* DISP ACCESS NON ACCESS
TCP DELAYED ACK		To set ACK delay function of TCP.	ON*/OFF
WOLtrans		To set recovery from sleep mode. 1: Wakeup in the new protocol (WSD) is enabled, and there is no wakeup function in the old utility using the CPCA Echo (broadcast) packet. 2: Wakeup in the new protocol (WSD) is enabled, and there is no wakeup function in the old utility using the SNMP search broadcast packet. 3: Wakeup in the old Canon utility is enabled, and there is no wakeup function in the new protocol (WSD).	1* to 3
SLEEP ADVERTISE	SWITCH	To set whether to use the sleep notification.	ON*/OFF
	PORT	To set the port number as the destination of sleep notification.	1 to 11427* to 65535
	TTL	To set the number of routers which can exceed the number of sleep notification messages	0 to 3* to 254
	INTERVAL	To set the notification interval (seconds) of sleep notification.	60 to 600* to 65535
PROXYRES		To set the proxy response function by Yukon	ON*/OFF

Items	Description		Setting Range
IPSEC SETTING (LBP7680Cx only)	IKERETRY	To set the IKE retry times.	0 to 1* to 3
	IKEINTVL	To set the IKE retry interval.	1 to 5* to 30
	SPDALDEL	The default is "0"; when "1" is set, all registered policies are deleted at next startup to initialize policies. After completion of initialization, the value which has been set to "1" is automatically reset to "0".	0* to 1
	IPSDEBLE	To set when obtaining IPsec log.	0* to 10
PFW SETTING	ILOG KEEP	Log retention time Possible setting range is 1 to 48 hours, and when the value in service mode is "0", it is 1 minute. Restart is required to reflect the setting.	0 to 1* to 48
	ILOG MODE	Filter switching operation	0* to 1
	IPTBROAD	Multicast address application switching value	0* to 10
EAPOL_WT	Time to wait for a response (or the next request) to EAPOL packet sent by the device		10 to 30* to 120

■ SP .ADMIN.MODE

Items	Description	Setting Range
MAINTENANCE C.	Not used.	----

● Service Mode List (LBP7210Cdn)

Group	Description		Setting Range
Service Chart Print	Output from the service chart print 1 (CMYK17 gradation patch data)		A4,
	Output from the service chart print 2 (CMYK256 gradation patch data)		A4,
Counter detail	Display the entire printing sheets of the toner cartridge of each toner		
Service setting	Primary transfer bias	Set the offset value of the primary transfer bias. Decrease the setting value if the reversal icon memory (reverse ghost) occurs.	-5 to +5 (0*)
	Secondary transfer bias	Set the offset value of the secondary transfer bias - Increase the setting value (effective for toner splash/polka dot image) - Decrease the setting value (effective for white spots/coarse image in half tone)	Front : -5 to +5 (0*) Back : -5 to +5 (0*)
	Developing bias	Set the offset value of the developing bias - Increase the setting value (effective for foggy image) - Decrease the setting value (effective for thin density)	-5 to +5 (0*)
	ICL bias	Set the offset value of the ITB cleaning bias. If the setting value is increased, it will improve the poor cleaning.	-5 to +5 (0*)
	Fixing temperature	Set the fixing temperature - To improve the fixing, set the offset value of the fixing temperature adjustment.	-2 to +2 (0*)
	Printer status print	Output of the printer status print	
Status print B	Status print B		
Log save setting	Output of the log file. For trouble analysis. This is not used in normal service.		

Group	Description		Setting Range
Printer information settings	Printer setting restore	Backup data of NVRAM of the DC controller saved in the NVRAM of the main controller, will be re-written in the NVRAM of the DC controller. After replacing the DC controller PCB, execute this mode, the backup data in the NVRAM of the main controller will be copied to NVRAM of the DC controller.	
	Backup of DCON data information	The information on the NVRAM DC controller PCB will be backed up to the NVRAM of the main controller. After replacing the NVRAM of the main controller PCB, execute this mode, perform the backup for the data of the NVRAM of the DC controller.	
	Inilization of CPR information of EEPROM	Clear the value of horizontal scanning direction registration value of the inner RAM during DC controller PCB replacement.	
Service parts replacement	Scanner unit replacement setting	When replacing the laser scanner, input the value written in the label on the service parts package. Record the inputted value in the NVRAM of the DC controller PCB.	
	Movement to replacement home position of the pickup roller	During pickup roller replacement, move the pickup roller to the possible position for replacement.	

Service Chart Print 1

Use Service Chart Print 1 to check image density and color tint.

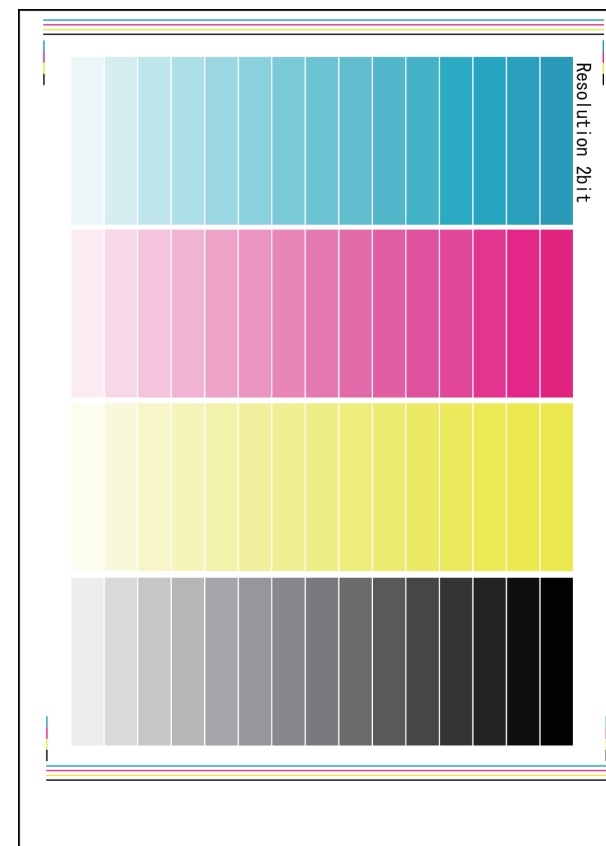

F-5-62

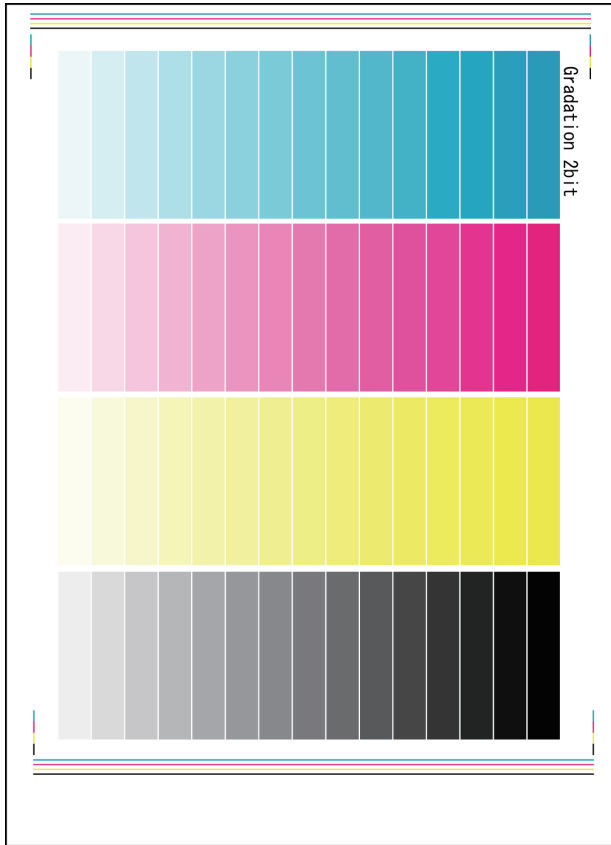

F-5-63

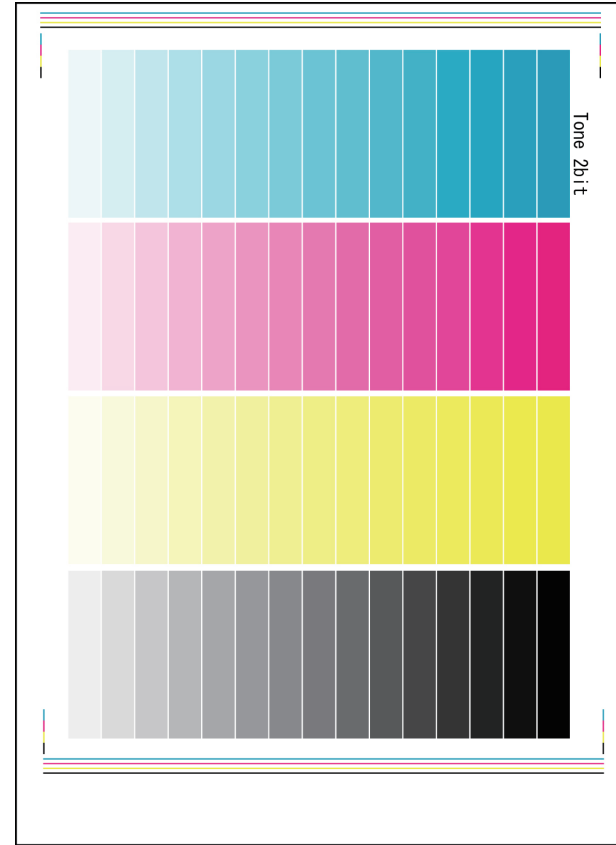

F-5-64

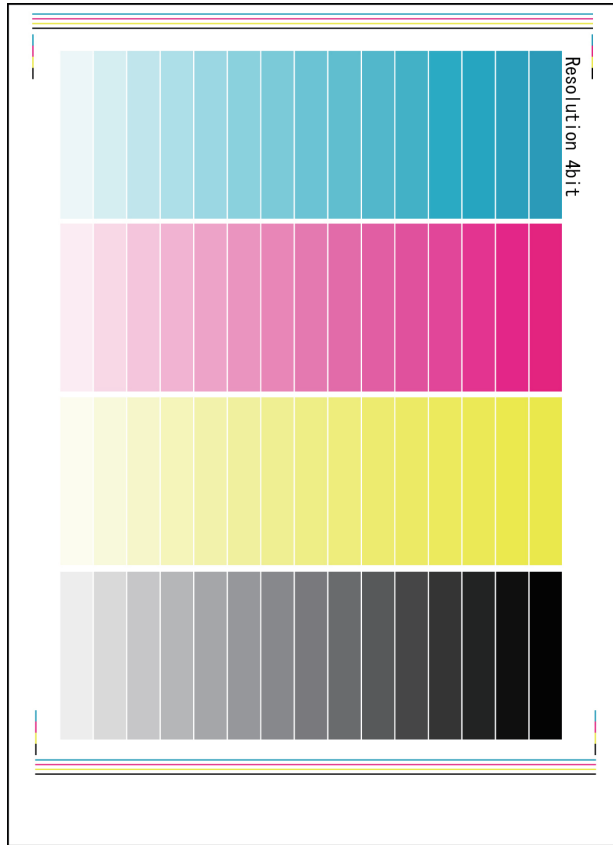

F-5-65

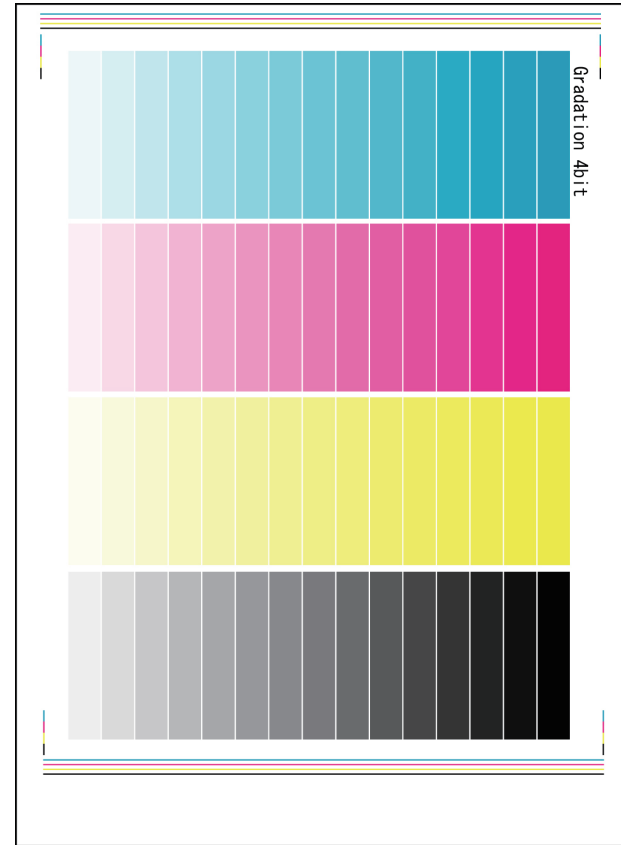

F-5-66

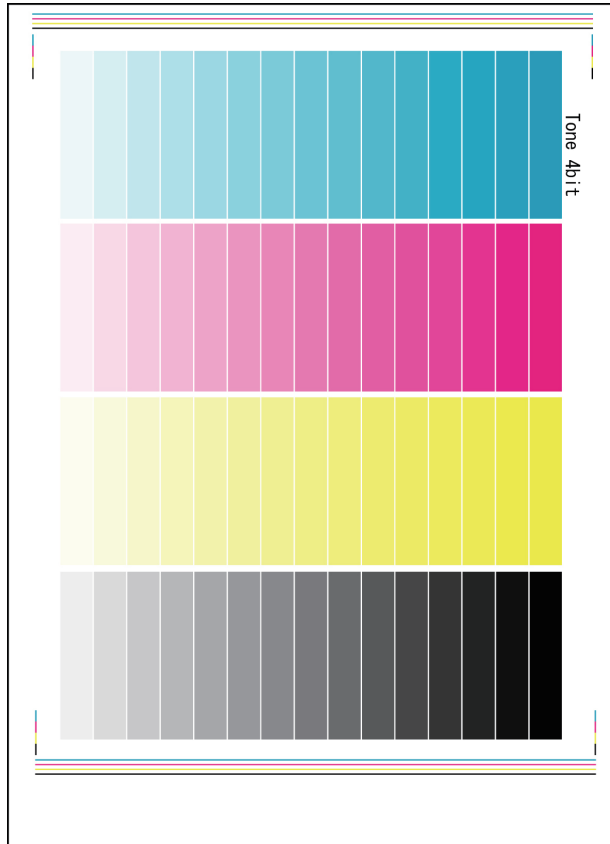

F-5-67

■ Service Chart Print 2

Use Service Chart Print 2 to check image density and color tint.

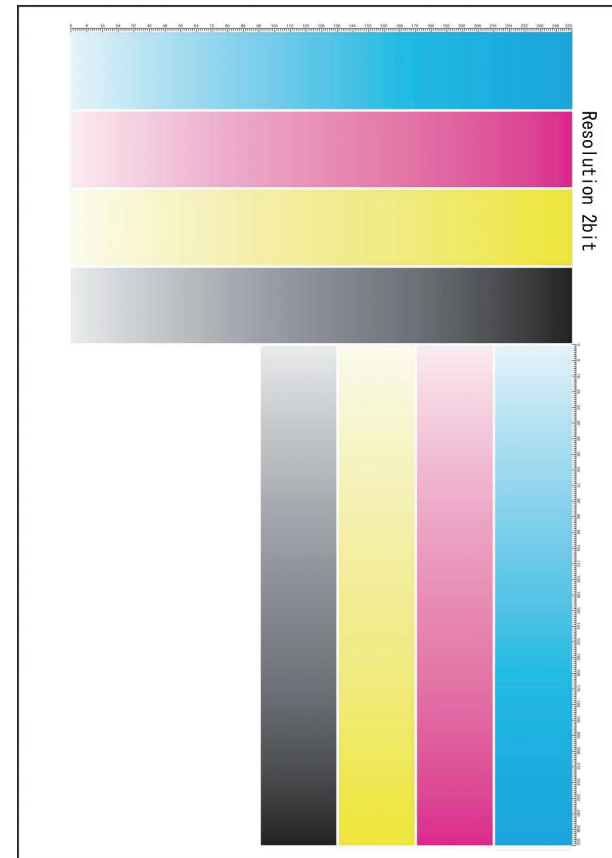

F-5-68

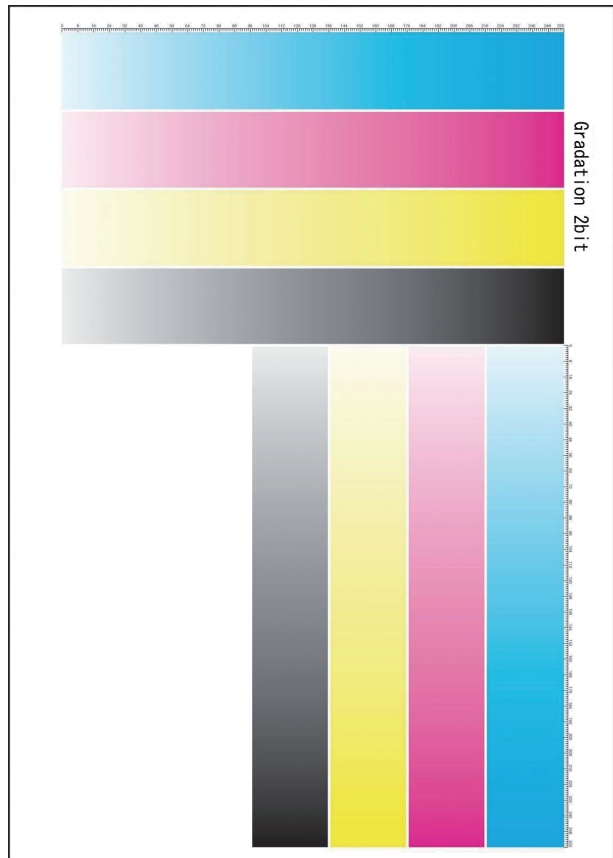

F-5-69

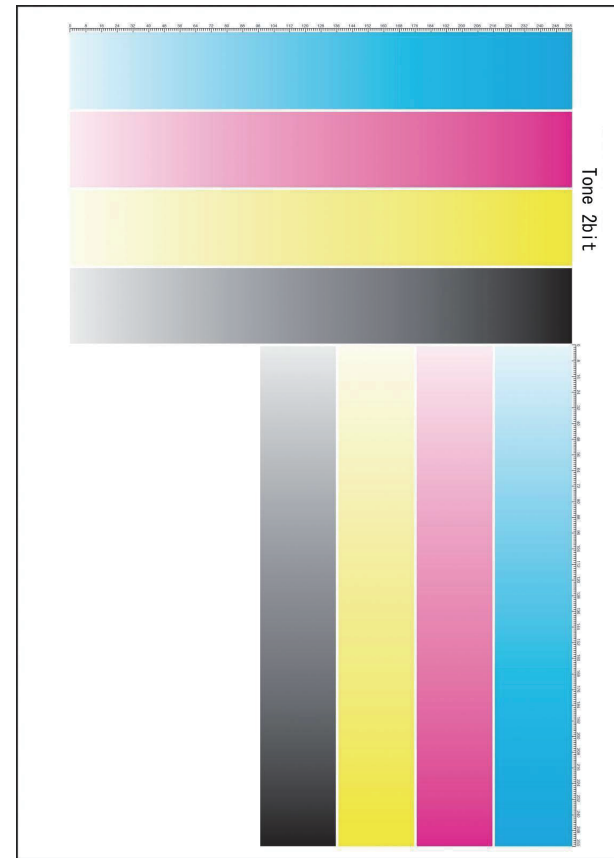

F-5-70

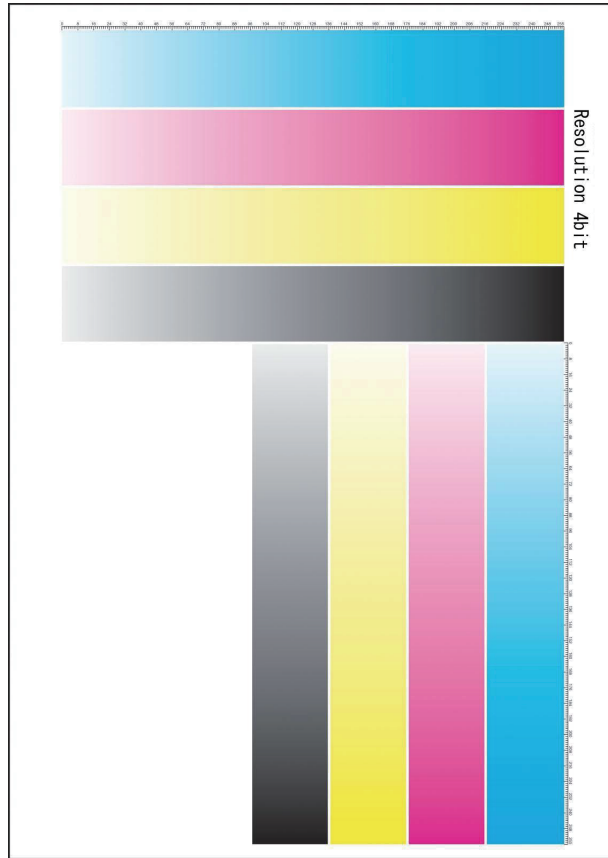

F-5-71

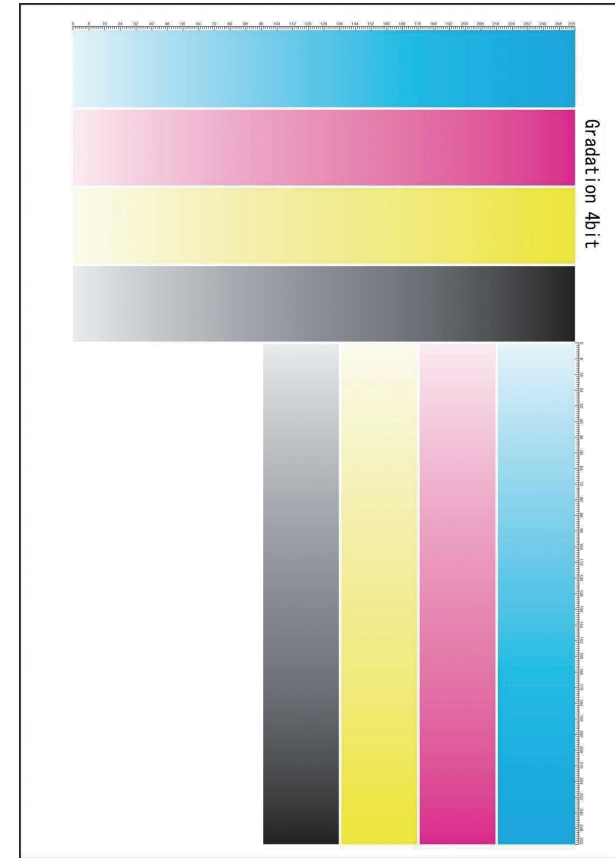

F-5-72

■ Print Status Print

Configuration Page shows a list of device setting items.
The sample page is attached below.

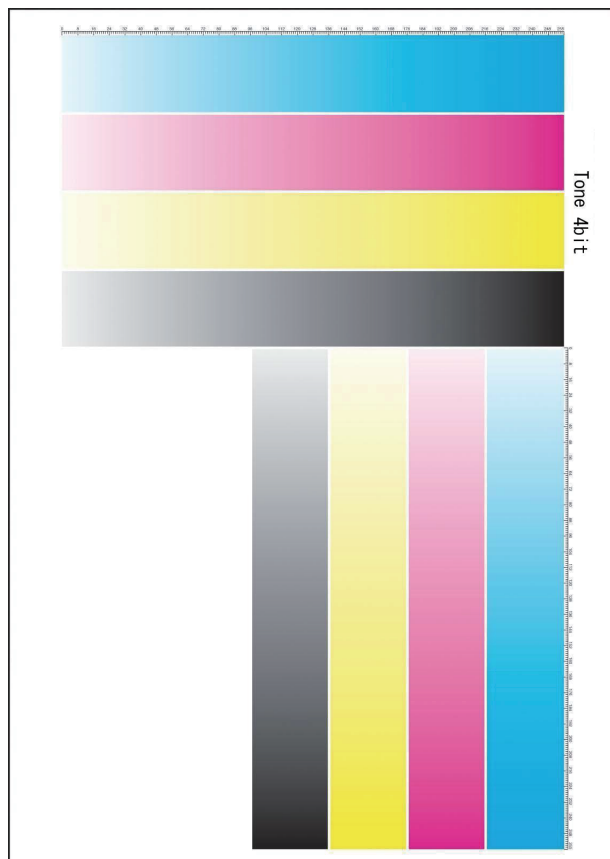

F-5-73

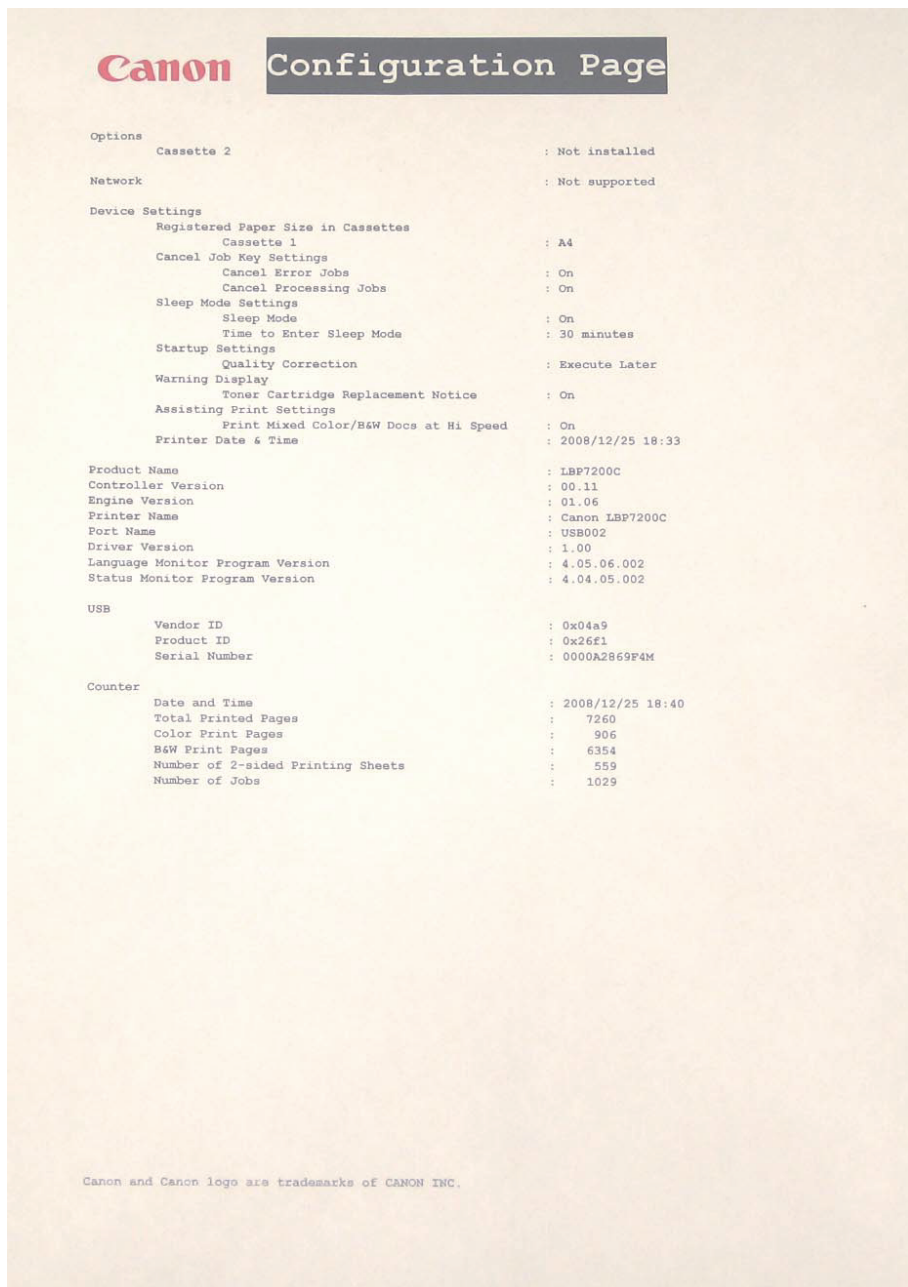

F-5-74

■ Status Print B

In Configuration Page (status window > "Utility" menu), calibration log and scanner bending information are added.

LOG NO 0001: Calibration log

00: Cyan

01: Magenta

02: Yellow

03: Black

LOG NO 0002: Scanner bending information

Line: Toner color (00: Yellow, 01: Magenta, 02: Cyan, 03: black)

Column: 3 points location information (00: Left, 01: Center, 02: Right)

Block 1: Bending information in sub scanning direction

Block 2: Bending information in main scanning direction

Block 3: Bending information of ITB unit

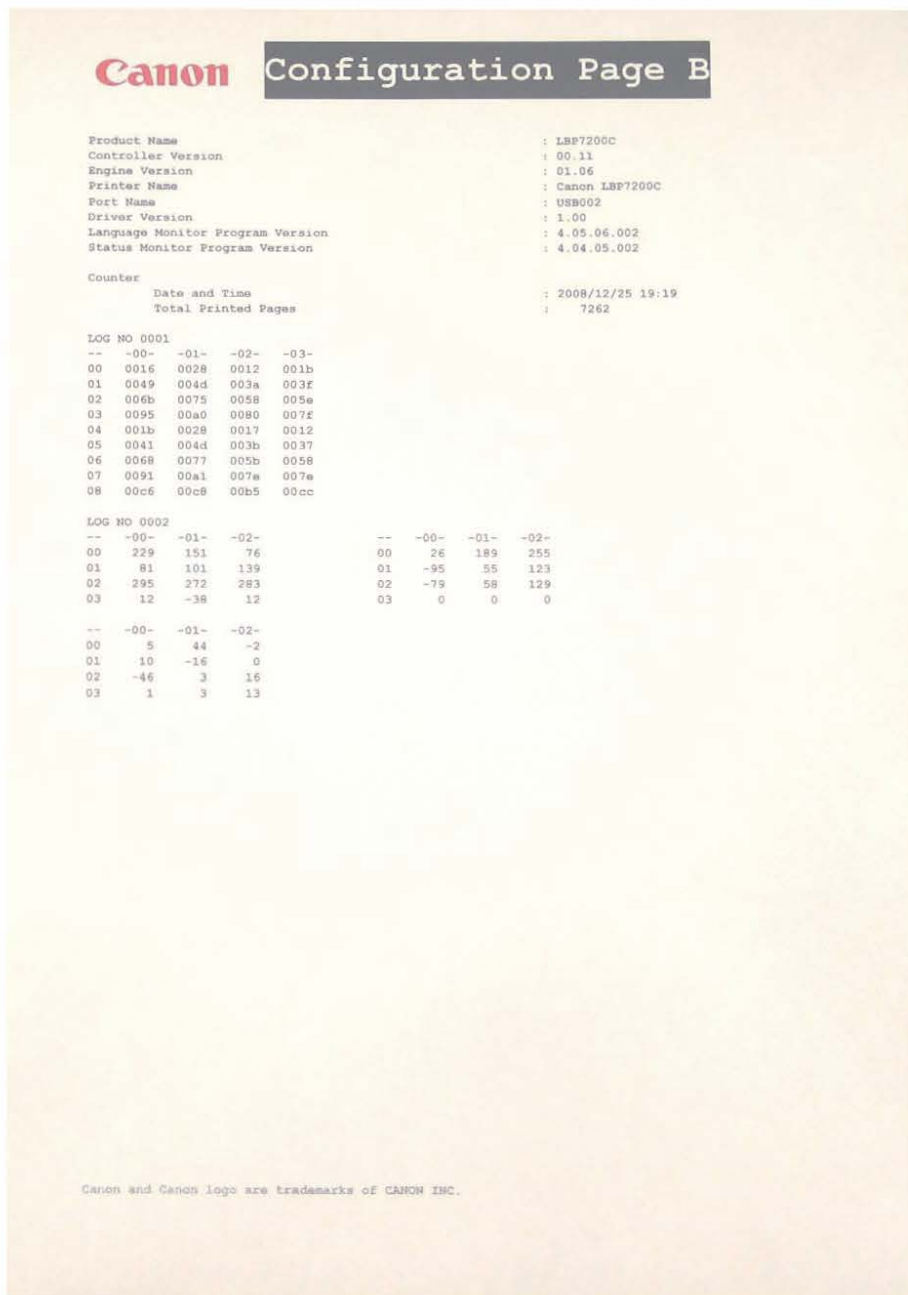

F-5-75

Debug log(Not supported by LBP7210Cdn)

Sublog

Function Overview

Sublog is the record of behavior inside the Main Controller PCB.

In the case of a field failure that is hard to be reproduced, this measure is intended to improve efficiency in failure analysis and reduce the time for failure support by collecting debug log at the user site (which was created immediately after the failure) and sending it to the R&D.

When the Canon staff who is in charge of quality follow-up determines the need for an analysis of firmware debug log by the R&D department, we ask the field to collect log for an investigation to determine the cause.

Sublog

It is available only when the Sublog Board is installed on the Main Controller PCB.

When the Sublog Board is not installed, log is not saved anywhere.

It is stored in the Sublog Board and its content is stored even when the power is turned OFF to be displayable when the power is turned ON again.

The Sublog Board has a limited capacity and when the log exceeding this storage number is attempted to be stored, the log is deleted in the order of length of time stored.

Effective Instances of Collecting Debug Log

- The error occurs only at the customer site and cannot be reproduced by the sales company or the Canon staff who is in charge of quality follow-up.
- When the error frequency is low.
- When the error is suspected of links with firmware rather than a mechanical/electrical failure.
- Collection of Sublog is not necessary when the reproduction procedure is identified and the error can be reproduced by the sales company HQ or the Canon staff who is in charge of quality follow-up.

How the log is written

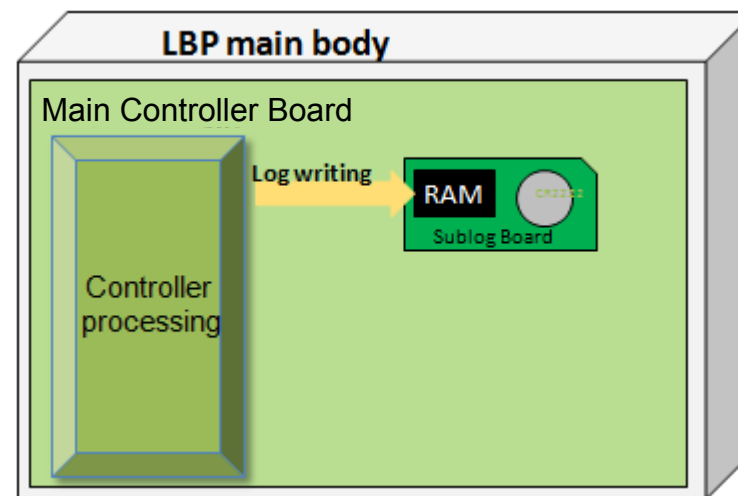

F-5-76

- In case of using the Sublog Board:
 - Write the log directly to RAM on the Sublog Board.
 - The on-board battery prevents data from being erased when the power is turned OFF.

Collecting Sublog

Flow of collecting Sublog

Installing the Sublog Board	Install the board to the host machine.
Generating the log	When the Sublog Board is installed, it records the log all time.
Collecting log	When setting LOG TO USBMEM in service mode, log is transferred to the USB memory device connected to the machine.

T-5-16

Installing the Sublog Board

Note:

The battery on Sublog board is located at BATS1 CR2032.
Push SW1 on the board and confirm that LED1 turns on.
If LED1 does not turn on, You need change battery.

CAUTION:

There is danger of explosion if the battery is replaced with an incorrect type.
Replace it only with the same type of battery.
Dispose of used batteries according to the manufacturer's instructions.

- 1) Remove the cover on the right side of the host machine.

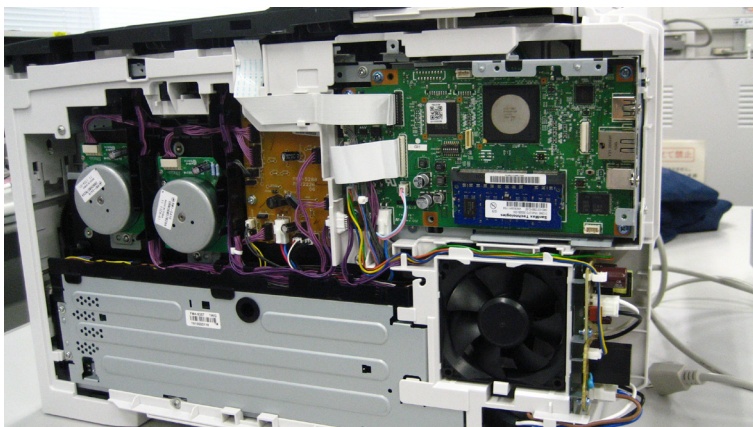

- 2) Install the Sublog Expansion Board into the slot over the controller.

F-5-77

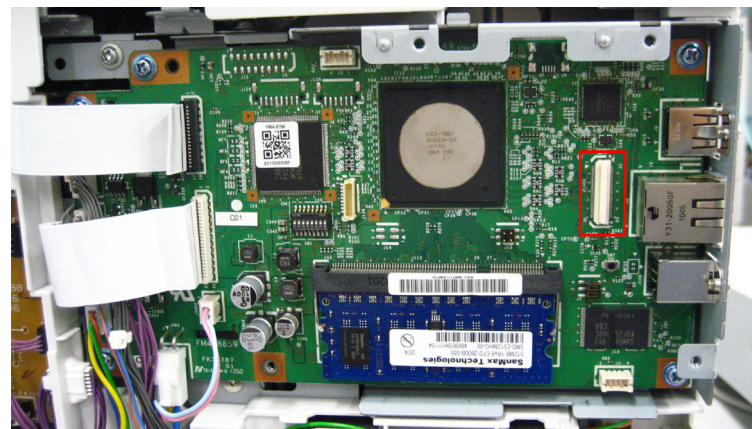

F-5-78

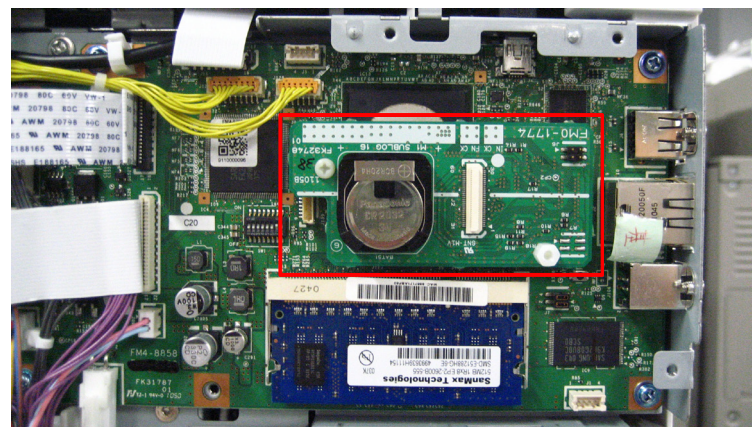

F-5-79

Generating the log

Generation of the log starts as soon as the Sublog Board is installed.

For example, when collecting the log of error, take the following steps immediately after the error occurred.

If the log is not swiftly collected, it is possible for the log written on the schedule to overwrite the target behavior log.

Collecting log

When setting LOG TO USBMEM in service mode, log is transferred to the USB memory device connected to the machine.

Log is transferred to the USB memory device connected to the machine in the following procedure.

- 1) Turn ON the power while pressing down the "<-", "OK" and "Online" simultaneously.

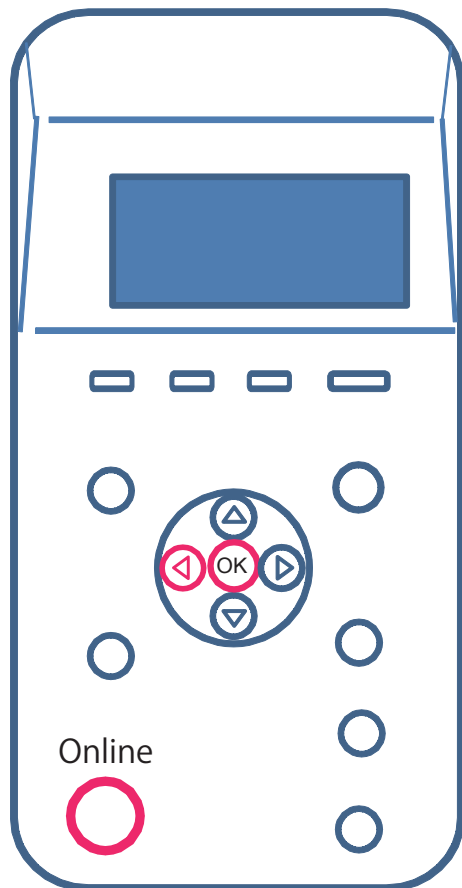

F-5-80

- 2) Scroll to the right and left to display "LOG TO USBMEM". Press the "↓" button to write to the USB memory device.

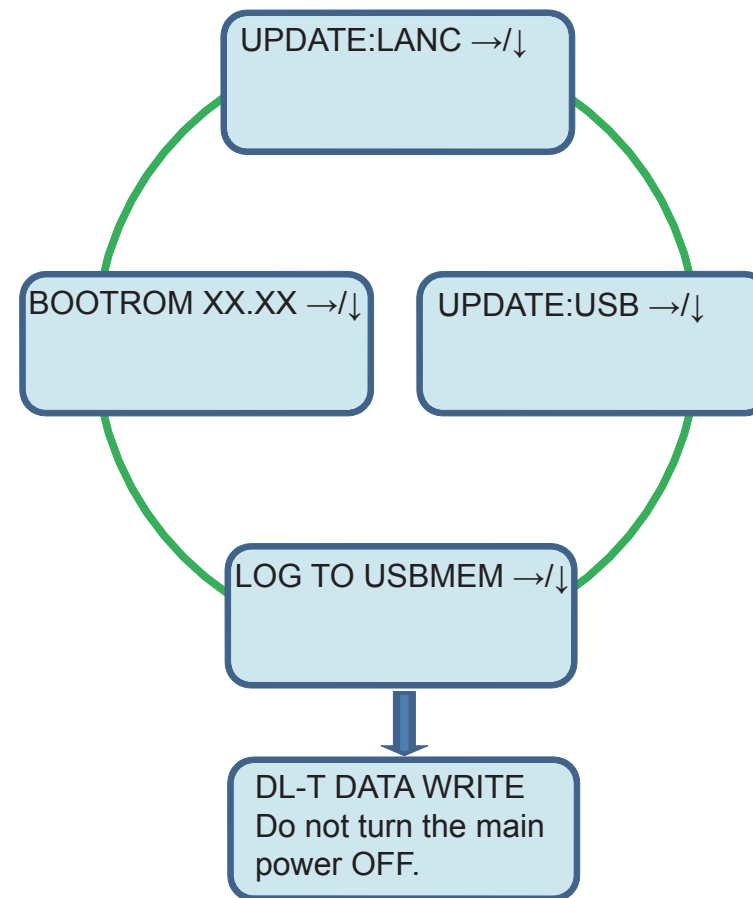

F-5-81

- 3) When the machine is restarted and "Printing is possible" is displayed after writing is complete, remove the USB memory device.
- 4) A sublog file named SUBLOG.BIN is output under /LOG_TMP of the USB memory device. Collect SUBLOG.BIN and send it to the department in charge of quality at the sales company.

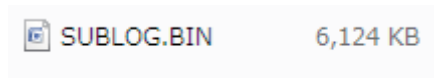

F-5-82

Backup/Restoration by Expansion ROM for servicing and Sublog Board(Not supported by LBP7210Cdn)

Function Overview

Data can be migrated to an unused Main Controller PCB by using the Expansion ROM for servicing + Sublog Board when the Main Controller PCB becomes faulty.

What to Prepare

- Sublog Board
- Expansion ROM for servicing
- Unused Main Controller PCB

CAUTION:

Install the Sublog Board to which data was backed up (exported) and Expansion ROM PCB to an unused Main Controller PCB which has not been installed to the machine.

Data cannot be migrated to a Main Controller PCB which has ever been used, even if only once.

Prerequisites

NOTE:

The battery on Sublog Board is located at BATS1 CR2032.
Push SW1 on the board and confirm that LED1 turns on.
If LED1 does not turn on, You need change battery.

CAUTION:

There is danger of explosion if the battery is replaced with an incorrect type.

Replace it only with the same type of battery.

Dispose of used batteries according to the manufacturer's instructions.

Target Data for Backup

LBP7660C
User mode setting values
Service mode setting values
Page counter
Device serial number

T-5-17

LBP7680C
User mode setting values
Service mode setting values

T-5-18

Backup and Restoration (Export and Import)

Flow of Export and Import

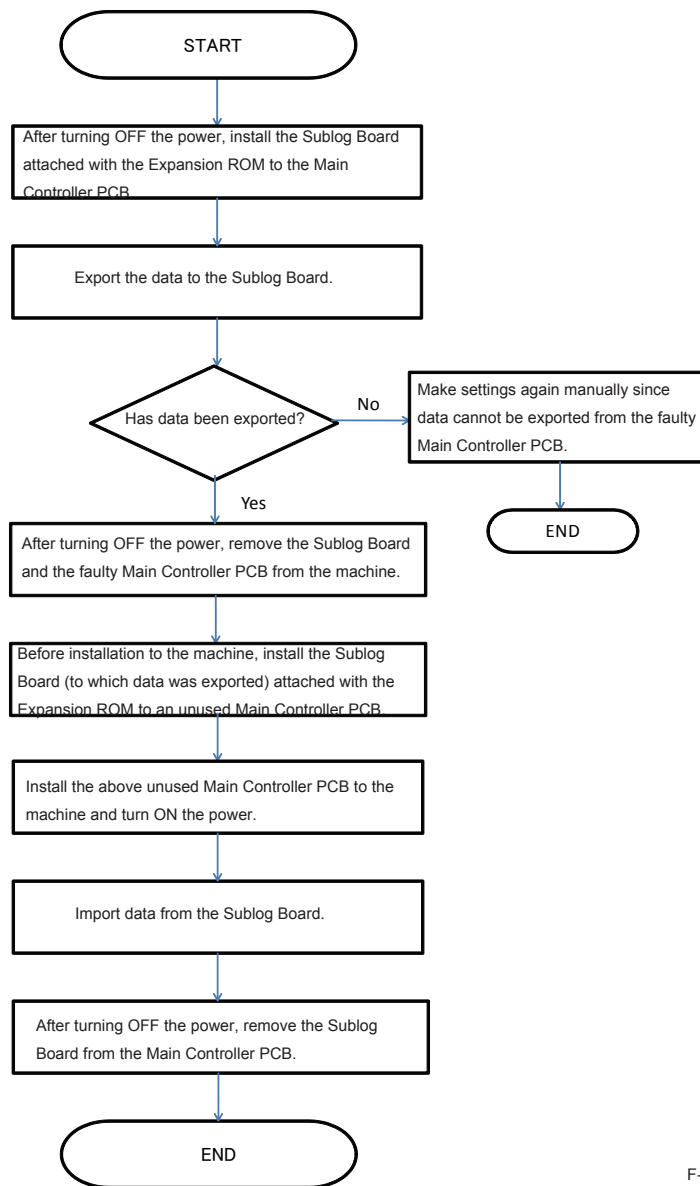

F-5-83

Installing the Expansion ROM for servicing and Sublog Board

1) Install the Expansion ROM for servicing to the Sublog Board.

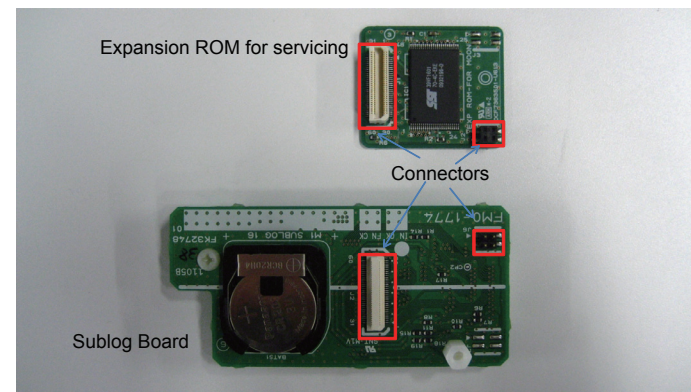

F-5-84

2) Install the above Sublog Board to the machine.

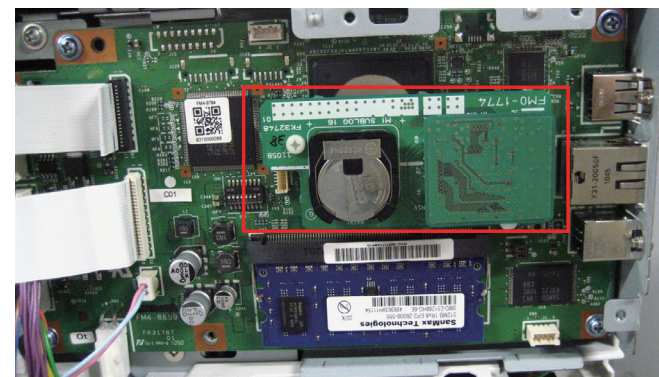

F-5-85

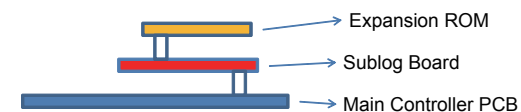

F-5-86

Backup Procedure (Export)

1) The menu is displayed when turning ON the power while the Sublog Board attached with the Expansion ROM for servicing is installed.



F-5-87

2) Use the right and left arrow keys to select [NVRAM export].

3) Press the OK key. This operation causes the information stored in the machine to be exported to the Sublog Board.

4) The following message is displayed when backup is completed successfully.



F-5-88

5) Turn OFF the power, and remove the faulty Main Controller PCB and the Sublog Board to which data was exported.

CAUTION:

Install the Sublog Board to which data was backed up (exported) and Expansion ROM PCB to an unused Main Controller PCB which has not been installed to the machine.

Data cannot be migrated to a Main Controller PCB which has ever been used, even if only once.

Restoration Procedure (Import)

1) Install the unused Main Controller PCB which has been installed with the Sublog Board (to which data was exported) attached with the Expansion ROM to the machine.

2) Turn ON the power and select [NVRAM import] in the menu, and then press the OK key. The information stored in the Sublog Board is written back to the machine.

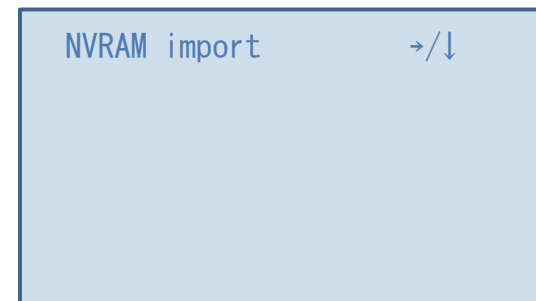

F-5-89

CAUTION:

When not replacing with an unused Main Controller PCB, the following message is displayed and the operation is stopped. In this case, turn OFF the power and replace with an unused Main Controller PCB.

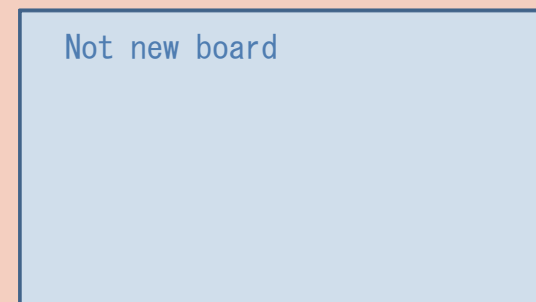

3) The data in the Sublog Board is deleted and the following message is displayed in the case of successful completion.

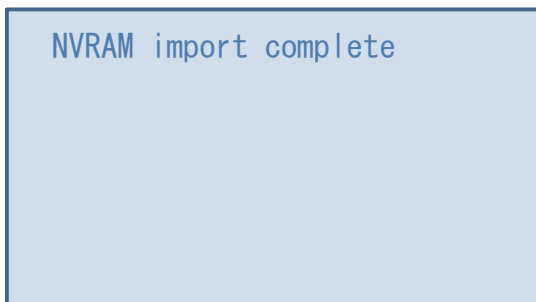

F-5-90

4) Turn OFF the power and remove the Sublog Board.

Others

Deletion (Erase)

When the data is not imported although it was exported, it needs to be deleted to prevent leakage of information.

1) Install the Sublog Board (containing data to be deleted) attached with the Expansion ROM to the Main Controller PCB.

2) Turn ON the power and select [NVRAM erase], and then delete the information stored in the Sublog Board.

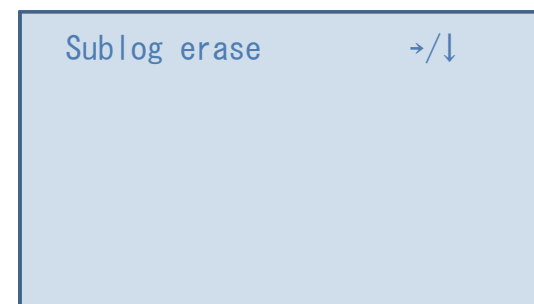

F-5-91

3) The following message is displayed in the case of successful completion.

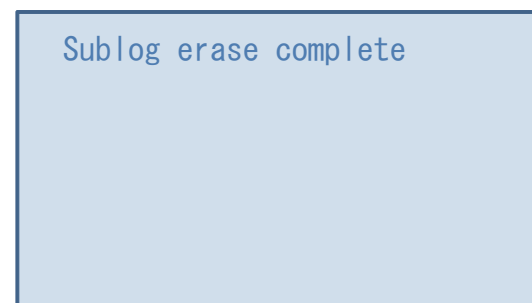

F-5-92

4) Turn OFF the power and remove the Sublog Board.

List of Error Messages

The following messages are displayed when certain failures occur during operation.

List of Messages	Detail
Sublog board not found	Sublog Board is not installed.
NVRAM read error	Export cannot be executed because the faulty Main Controller PCB is too damaged to retrieve information.
Sublog R/W error	When the same data cannot be read 3 consecutive times due to Sublog Board error, the error message is displayed and the operation is stopped.
NVRAM write error	When information cannot be written to an unused Main Controller PCB for some reasons, the error message is displayed and the operation is stopped.
Sublog data not found	When the export data is not stored in the Sublog Board (including checksum check error), import process or erase process cannot be executed.
Not new board	Import cannot be executed since the Main Controller PCB is not unused or the one to which no serial number has been written.
Different product	Data is attempted to be imported to a model different from the one from which data was exported.

T-5-19

Appendix

- General Timing Chart
- General Circuit Diagram
- Signal Input/Output List
- Backup Data

General Timing Chart

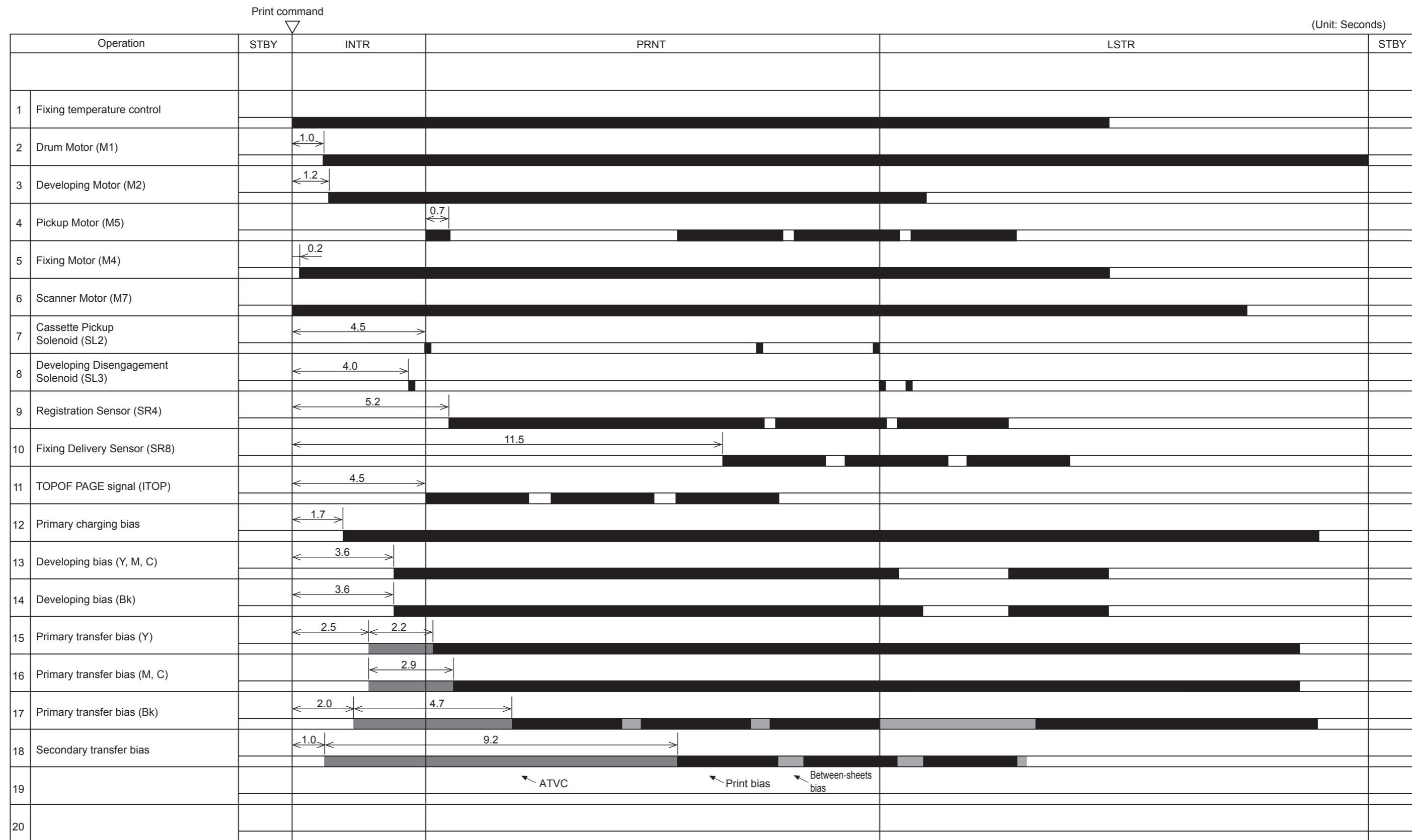

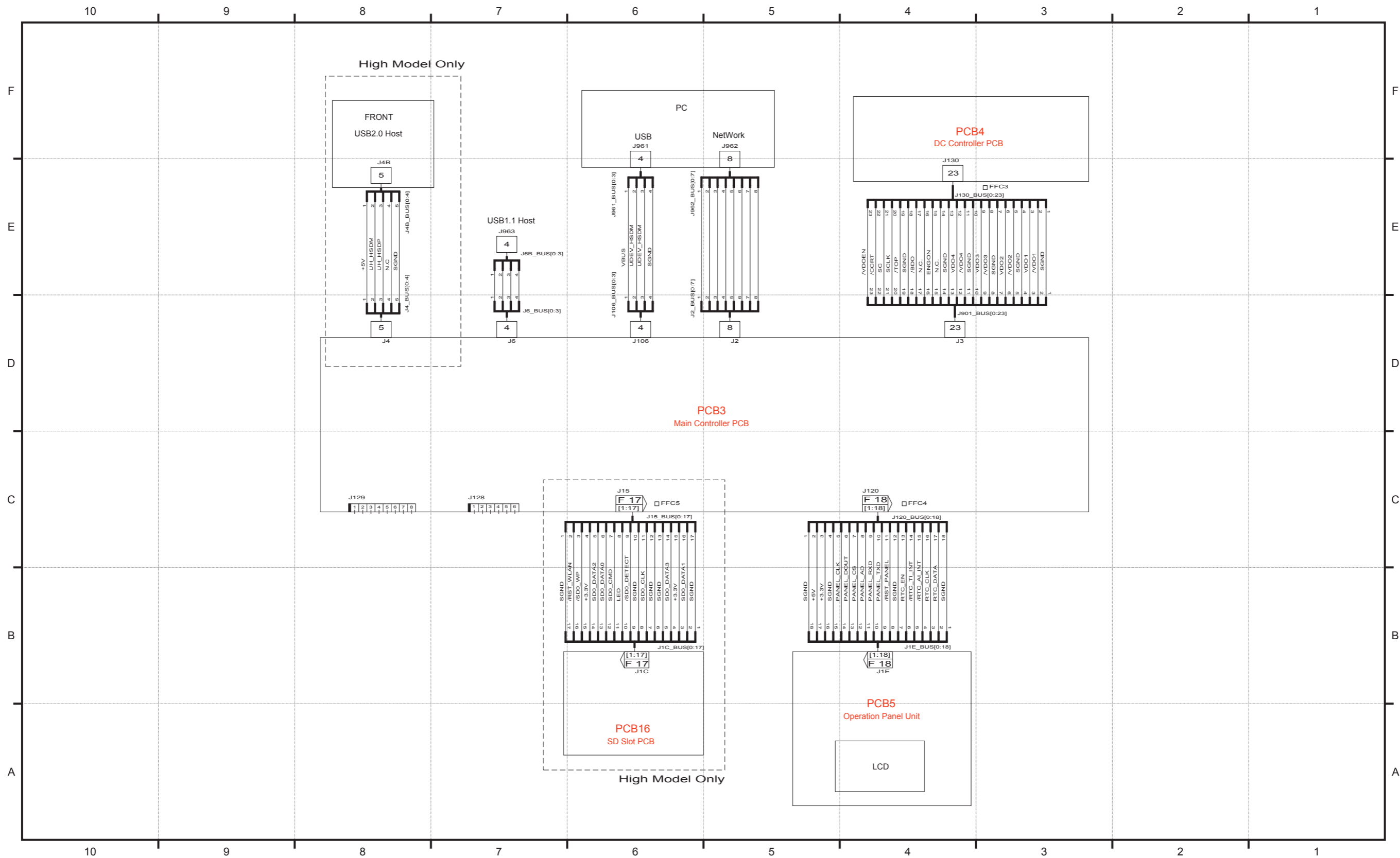

P.2

F-6-3

Signal Input/Output List

Connector	Pin	Abbreviation	I/O	Signal name
J103	1	SLPWUP	I	SLEEP WAKE UP signal
	2	/CCRT	O	CONDITION CHANGE REPORT signal
	3	SC	I/O	STATUS COMMAND signal
	4	SCLK	I	SERIAL CLOCK signal
	5	/TOP	O	TOP signal
	6	SGND		
	7	/BDO	O	DB OUTPUT signal
	8	SGND		
	9	VDI	I	VIDEO signal
	10	/VDI	I	VIDEO signal
	11	SGND		
J104	1	SGND		
	2	/VDO	O	VIDEO signal
	3	VDO	O	VIDEO signal
	4	SGND		
	5	LDCNT1	O	LASER CONTROL signal
	6	LDCNT0	O	LASER CONTROL signal
	7	SGND		
	8	LDPWM	O	LASER LIGHT INTENSITY ADJUSTMENT signal
	9	SGND		
	10	+3.3T		
	11	/BDI	I	BD INPUT signal
J106	1	+3.3T		
	2	SGND		
	3	LOOPSNS	I	LOOP signal
J107	1	POUTSNS	I	DELIVERY signal
	2	PWSNS	I	MEDIA WIDTH signal
	3	+3.3T		
	4	SGND		
	5	MAINTH	I	FIXING TEMPERATURE signal
	6	SGND		

Connector	Pin	Abbreviation	I/O	Signal name
J108	1	SGND		
	2	RLD+	O	RELAY signal
	3	RLD-	O	RELAY signal
	4	FSRD+	O	FIXING HEATER CONTROL signal
	5	FSRD-	O	FIXING HEATER CONTROL signal
	6	FREQSNS	I	FREQUENCY DETECTION signal
	7	LVT100V	I	POWER SUPPLY VOLTAGE signal
	8	/REM3V_V	O	SLEEP signal
	9	PWSV	O	SLEEP signal
	10	+3.3R		
	11	+3.3R		
	12	SGND		
	13	SGND		
	14	FEEDSLD	O	PICKUP SOLENOID signal
	15	+3.3T		
	16	SGND		
	17	PISNS	I	TOP signal
J109	1	+3.3T		
	2	SGND		
	3	ROTHPSNS	I	DEVELOPING ROTARY HOME-POSITION signal
	4	+24B		
	5	+24B		
	6	PGND		
	7	PGND		
	8	MAINMFR	O	MAIN MOTOR REVERSE signal
	9	/MAINMACC	O	MAIN MOTOR ACCELERATION signal
	10	/MAINMDEC	O	MAIN MOTOR DECELERATION signal
	11	/MAINMFG	I	MAIN MOTOR CONTROL signal
	12	+24V		
	13	PWSW	I	POWER SUPPLY signal
	14	+24V		
	15	/SCNACC	O	SCANNER MOTOR ACCELERATION signal
	16	/SCNDEC	O	SCANNER MOTOR DECELERATION signal
	17	PGND		
	18	VIN	I/O	E-LABEL COMMUNICATION signal
	19	CVSS	I/O	E-LABEL COMMUNICATION signal
J110	1	FSRMAN	O	FIXING MOTOR CONTROL signal
	2	FSRMA	O	FIXING MOTOR CONTROL signal
	3	FSRMBN	O	FIXING MOTOR CONTROL signal
	4	FSRMB	O	FIXING MOTOR CONTROL signal
	5	ROTMAN	O	DEVELOPING ROTARY MOTOR CONTROL signal
	6	ROTMA	O	DEVELOPING ROTARY MOTOR CONTROL signal
	7	ROTMBN	O	DEVELOPING ROTARY MOTOR CONTROL signal
	8	ROTM	O	DEVELOPING ROTARY MOTOR CONTROL signal

Connector	Pin	Abbreviation	I/O	Signal name
J112	1	+24V		
	2	TR2ICLSLD	O	T2 ROLLER ITB CLEANER SOLENOID signal
	3	FEEDMA	O	PICKUP MOTOR CONTROL signal
	4	FEEDMAN	O	PICKUP MOTOR CONTROL signal
	5	FEEDMB	O	PICKUP MOTOR CONTROL signal
	6	FEEDMBN	O	PICKUP MOTOR CONTROL signal
J119	1	N.C.		
	2	FSRPRESNS	I	FIXING PRESSURE RELEASE signal
	3	+3.3T		
	4	SGND		
	5	VIN	I/O	E-LABEL COMMUNICATION signal
	6	DVSS	I/O	E-LABEL COMMUNICATION signal
	7	N.C.		
J128	1	DOORSNS_R	I	REAR DOOR OPEN DETECTION signal
	2	SGND		
J130	1	ITBTOPPWM	O	ITB_TOP SENSOR LED CONTROL signal
	2	DNSP	I	DENSITY signal
	3	DNSGAIN1	O	DENSITY SENSOR SENSITIVITY signal
	4	DNSGAIN0	O	DENSITY SENSOR SENSITIVITY signal
	5	DNSPWM	O	DENSITY SENSOR LED CONTROL signal
	6	ITBTOPSNS	I	ITB_TOP signal
	7	DNSS	I	DENSITY signal
	8	+24V		
	9	SGND		
J140	1	+24R		
	2	PGND		

T-6-1

Backup Data

Data to Be Stored	Data Location	Replacement		Delete								User Backup			Service Backup								
		When Replacing Main PCB	DC Controller PCB	User function				Service function				Can Data Be Backed up?	Method	Location to Be Stored	Can Data Be Backed up?	Method 1	Location to Be Stored	Method 2	Location to Be Stored				
				Initializing the [Setup] Menu(Settings)	Initializing the Network Settings(Settings)	IPSec Policy settings delete*1	SD Card Data All Erase Function	(Fixing unit/ITB unit) Initializing the Service counter	FLASH MEMORY initialization Initializing the [Setup] Menu	DC Controller PCB FLASH MEMORY Clear	E-RDS > CLEAR									CA-KEY			
Control Panel set value (Except in network and IPSec Policy Settings*1)	Main Controller PCB	Clear		Clear						Clear				Yes	Setup > User Maintenance > IMPORT/EXPORT > EXPORT	USB memory	Yes	FUNCTION GR. > ECONF > EXPORT ALL(GENERAL/DEPEND/SECURITY)	USB memory	Sublog Expansion Board	Sublog Board		
Control Panel set value(Network)		Clear			Clear																		
Control Panel set value(IPSec Policy Settings) *1		Clear					Clear								No			No					
SSL Keys		Clear													No			No					
CA Certificates		Clear													Clear *5			No					
MEAP(Application/Settings/Data)		Clear													No			No					
e-RDS		Clear													Yes *4	Setup > User Maintenance > IMPORT/EXPORT > EXPORT	USB memory	Yes	FUNCTION GR. > ECONF > EXPORT ALL(GENERAL/DEPEND/SECURITY)	USB memory	Sublog Expansion Board	Sublog Board	
Service DATA(Main Controller PCB)		Clear													Clear *3								
DC Controller PCB FLASH MEMORY Backup(Main Controller PCB)		Clear													No			Yes *9	*6				
Service DATA(DC Controller PCB)		DC Controller PCB		Clear											No			Yes	*6	Main Controller PCB			
Serial Number	Main Controller PCB	Clear												No			Yes *7				Sublog Expansion Board	Sublog Board	
Number of the printed pages		Clear												No			Yes *8, 9						
Main Controller service counter *2																							
Stored Job	SD Card													No			No						

T-6-2

*1. To delete IPSec Policy settings, select the following in service mode: Network.gr >IPSEC SETTING > SPDALDEL.
 *2. It belongs to counter gr. in service mode. Since counter gr. items are not available with this model, it is not applicable.
 *3. It is initialized by selecting the following in service mode: Network gr. > E-RDS > CLEAR.
 *4. Service mode setting values are stored in FLASH MEMORY. When importing/exporting user settings, the service mode items are included.
 *5. It is initialized by selecting the following in service mode: Network gr. > CA-KEY.
 *6. If setting information of the DC Controller PCB does not exist on the Main Controller PCB, automatic backup is performed.
 If DC Controller PCB setting value already exists when installing the Main Controller PCB, automatic backup is not performed.
 In service mode, clear DC Controller PCB FLASH MEMORY. Automatic backup is performed at next startup. FUNCTION GR. > CLEAR DCON (initialization of the backup area of the DC Controller PCB FLASH MEMORY)
 When replacing the DC Controller PCB, restore backup information by selecting the following: FUNCTION GR. > RESTOR DCON.
 *7. With the non-counter charge model, device serial number can be input by selecting the following in service mode: FUNCTION GR. > SN-MAIN.
 With the counter charge model, it is carried over automatically after replacing the PCB.
 *8. With the non-counter charge model, input is not possible. With the counter charge model, it is carried over automatically after replacing the PCB.
 *9. Required Sublog Expansion Board.
 *LBP7210Cdn supports log storage and Dcon NVRAM backup as backup data.