

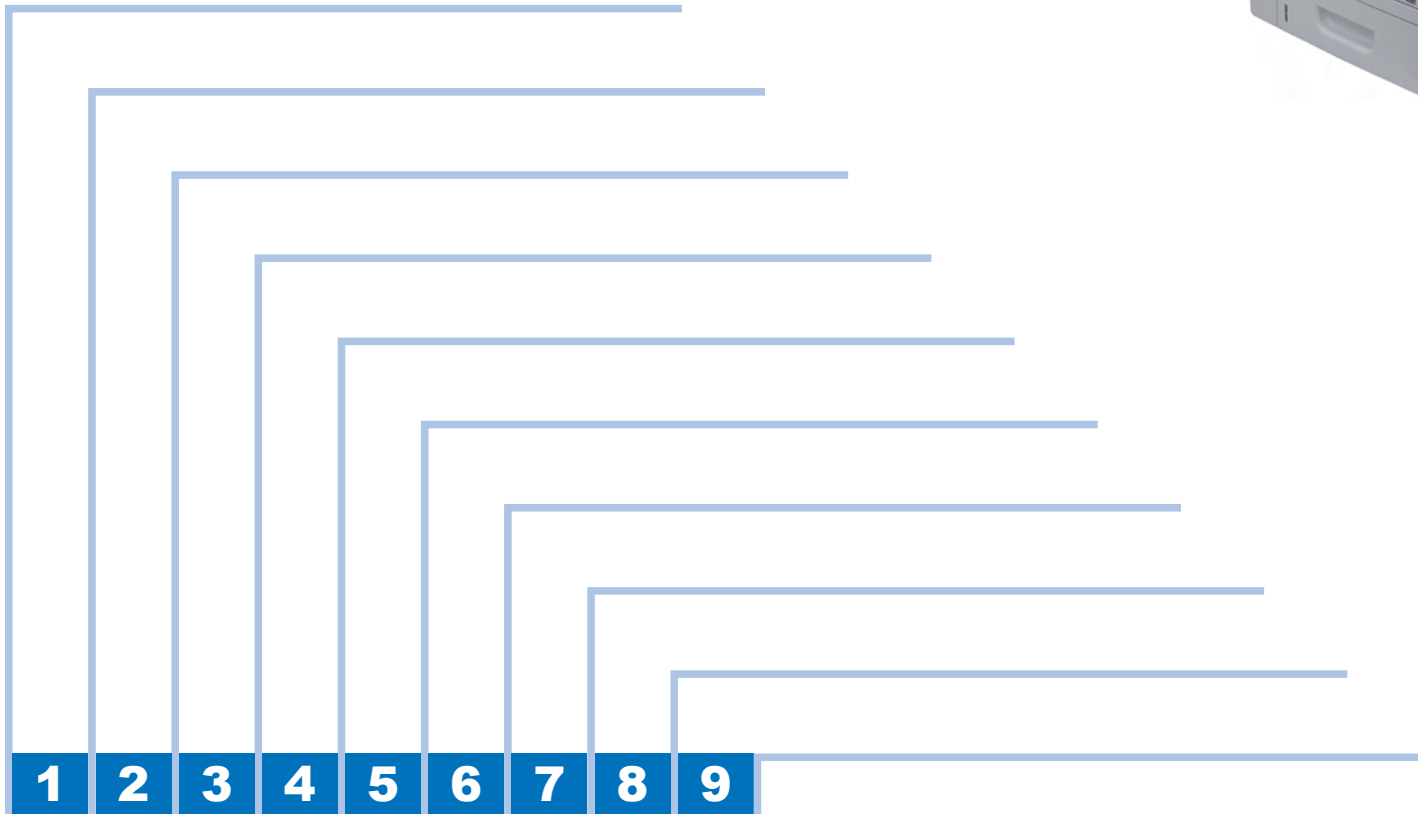

MF5900/D1300 Series Service Manual



F-0-1



Application

This manual has been issued by Canon Inc. for qualified persons to learn technical theory, installation, maintenance, and repair of products. This manual covers all localities where the products are sold. For this reason, there may be information in this manual that does not apply to your locality.

Corrections

This manual may contain technical inaccuracies or typographical errors due to improvements or changes in products. When changes occur in applicable products or in the contents of this manual, Canon will release technical information as the need arises. In the event of major changes in the contents of this manual over a long or short period, Canon will issue a new edition of this manual.

The following paragraph does not apply to any countries where such provisions are inconsistent with local law.

of this manual.

The following paragraph does not apply to any countries where such provisions are inconsistent with local law.

Trademarks

The product names and company names used in this manual are the registered trademarks of the individual companies.

Copyright

This manual is copyrighted with all rights reserved. Under the copyright laws, this manual may not be copied, reproduced or translated into another language, in whole or in part, without the written consent of Canon Inc.

(C) CANON INC. 2011

Caution

Use of this manual should be strictly supervised to avoid disclosure of confidential information.

Explanation of Symbols



The following symbols are used throughout this Service Manual.

Symbols	Explanation		Symbols	Explanation
	Used to show permission.			Remove the screw.
	Used to show prohibition.			Tighten the screw.
	Check.			Remove the claw.
	Check visually.			Insert the claw.
	Check the noise.			Use the bundled part.
	Disconnect the connector.			Push the part.
	Connect the connector.			Plug the power cable.
	Remove the cable/wire from the cable guide or wire saddle.			Turn on the power.
	Set the cable/wire to the cable guide or wire saddle.			

T-0-1

The following rules apply throughout this Service Manual:

1. Each chapter contains sections explaining the purpose of specific functions and the relationship between electrical and mechanical systems with reference to the timing of operation.

In the diagrams,  represents the path of mechanical drive; where a signal name accompanies the symbol, the arrow  indicates the direction of the electric signal.

The expression "turn on the power" means flipping on the power switch, closing the front door, and closing the delivery unit door, which results in supplying the machine with power.

2. In the digital circuits, '1' is used to indicate that the voltage level of a given signal is "High", while '0' is used to indicate "Low". (The voltage value, however, differs from circuit to circuit.) In addition, the asterisk (*) as in "DRMD*" indicates that the DRMD signal goes on when '0'.

In practically all cases, the internal mechanisms of a microprocessor cannot be checked in the field. Therefore, the operations of the microprocessors used in the machines are not discussed: they are explained in terms of from sensors to the input of the DC controller PCB and from the output of the DC controller PCB to the loads.

The descriptions in this Service Manual are subject to change without notice for product improvement or other purposes, and major changes will be communicated in the form of Service Information bulletins.

All service persons are expected to have a good understanding of the contents of this Service Manual and all relevant Service Information bulletins and be able to identify and isolate faults in the machine.

Contents

Safety Precautions

CDRH Provisions	0-2
Laser Safety	0-2
About Laser Beams	0-2
Handling Laser Scanner Unit	0-2
Toner Safety	0-3
About Toner	0-3
Handling Adhered Toner	0-3
Notes When Handling A Battery	0-3
Notes On Assembly/Disassembly	0-3

Product Overview

Product Lineups	1-2
Main Unit	1-2
Options	1-3
Product Features	1-4
Features	1-4
Specifications	1-4
Main Unit Specifications	1-4
ADF Specifications	1-5
FAX Specifications	1-6
Print Speed	1-6
Paper types	1-7
Paper size	1-7
Name of Parts	1-8
External View	1-8
MF5900 Series	1-8
D1300 Series	1-9
Cross Sectional View	1-10
MF5900 Series	1-10
D1300 Series	1-11

Operation Panel	1-12
Main Operation Panel	1-12
FAX Operation Panel	1-13

Technical Overview

Basic Configuration	2-2
Configuration Function	2-2
Basic Sequence	2-2
Basic Operational Sequence	2-2
Print Sequence	2-3
Print Mode	2-4
Document Exposure/feeder System	2-5
Document Exposure System	2-5
Specifications / Control / Function List	
Major Components	2-5
Document Feeder System	2-6
Pickup/Feed/Delivery Operation	2-6
Original Detection	2-7
Jam Detection	2-8
Service Tasks	2-8
Action for Parts Replacement	2-8
Maintenance	2-8
Service Notes	2-8
Engine Control System	2-9
Outline	2-9
Controls	2-9
Outline	2-9
Motor / Fan Control	2-10
Failure Detection	2-11
Low-voltage Power Supply	2-11
Outline	2-11
Protective Function	2-12
Safety	2-12
Low-voltage Power Supply Unit Failure Detection	2-12
Power-Saving Mode	2-12
Service Tasks	2-13
Action for Parts Replacement	2-13

Maintenance	2-13
Service Notes	2-13
Laser Scanner System	2-14
Outline	2-14
Optical Unit Failure Detection	2-14
Service Tasks	2-14
Action for Parts Replacement	2-14
Maintenance	2-14
Service Notes	2-14
Image-formation System	2-15
Outline	2-15
Image-formation Process	2-15
Outline	2-15
Latent Image Formation Block	2-16
Developing Block	2-16
Transfer Block	2-17
Fixing Block	2-17
Drum Cleaning Block	2-17
High-voltage Power Supply	2-18
Outline	2-18
Service Tasks	2-18
Action for Parts Replacement	2-18
Maintenance	2-18
Notes on Field Service	2-18
Fixing Assembly System	2-19
Outline	2-19
Fixing Control Circuit	2-20
Throughput Reduction Control	2-20
Fixing Temperature Control	2-21
Protective Function	2-21
Failure Detection	2-22
Service Tasks	2-22
At Parts Replacement	2-22
Maintenance	2-22
Notes On Service Works	2-22
Media Feed System	2-24
Outline	2-24

Drive Configuration	2-24
Jam Detection	2-25
Outline	2-25
Pickup Delay Jam	2-26
Pickup Stationary Jam	2-26
Delivery Delay Jam	2-26
Delivery Stationary Jam	2-26
Fixing Paper Wrap Jam	2-26
Reverse Delay Jam	2-26
Reverse Stationary Jam	2-26
Internal Residual Jam	2-26
Door Open Jam	2-26
Service Tasks	2-26
At Parts Replacement	2-26
Maintenance	2-26
Notes On Service Works	2-26

Periodical Services

Periodically Replaced Parts	3-2
Consumable Parts	3-2
Periodical Service	3-2
Cleaning	3-2

Disassembly/Assembly

List of Parts	4-2
External View	4-2
MF5900 Series	4-2
D1300 Series	4-3
Main Unit	4-4
Main Parts	4-5
Sensor / Switch	4-5
Motor / Fan	4-6
Other	4-6
PCB	4-7
Connector Layout Drawing	4-8
External Cover (D1300 Series)	4-12
Removing the Left Cover Unit	4-12

Procedure	4-12	Procedure	4-29
Removing the Left Rear Cover	4-14	Removing the ADF Pickup Roller	4-30
Preparations	4-14	Preparations	4-30
Procedure	4-14	Procedure	4-30
Removing the Right Cover Unit	4-15	Removing the ADF Separation Roller	4-31
Procedure	4-15	Preparations	4-31
Removing the Front Cover	4-17	Procedure	4-31
Preparations	4-17	Removing the ADF Separation Pad	4-33
Procedure	4-17	Procedure	4-33
Removing the Rear Cover Unit	4-18	Removing the ADF Pickup Feed Unit	4-34
Preparations	4-18	Procedure	4-34
Procedure	4-18	Removing the ADF Pickup Motor Unit	4-37
Removing the Upper Cover Unit	4-19	Preparations	4-37
Preparations	4-19	Procedure	4-37
Procedure	4-19	Removing the ADF Delivery Solenoid Unit	4-38
External Cover (MF5900 Series)	4-20	Preparations	4-38
Removing the Left Cover Unit	4-20	Procedure	4-38
Procedure	4-20	Removing the Reader Unit Upper Cover	4-38
Removing the Left Rear Cover	4-21	Preparations	4-38
Preparations	4-21	Procedure	4-38
Procedure	4-21	Removing the CIS Unit	4-40
Removing the Right Cover	4-22	Preparations	4-40
Procedure	4-22	Procedure	4-40
Removing the Front Cover	4-24	Controller System	4-42
Preparations	4-24	Removing the Controller Cover	4-42
Procedure	4-24	Preparations	4-42
Removing the Rear Cover Unit	4-24	Procedure	4-42
Preparations	4-24	Removing the Main Controller Board	4-42
Procedure	4-24	Preparations	4-42
Removing the Upper Cover	4-26	Procedure	4-42
Preparations	4-26	Removing the NCU PCB (FAX Model Only)	4-44
Procedure	4-26	Preparations	4-44
Document Exposure, Feed System	4-27	Procedure	4-44
Removing the ADF Unit + Reader Unit	4-27	Removing the OFF Hook PCB (FAX Model Only)	4-44
Preparations	4-27	Preparations	4-44
Procedure	4-27	Procedure	4-44
Removing the ADF Roller Unit	4-29	Removing the Controller Box.	4-45
		Preparations	4-45

Procedure	4-45
Removing the Engine Controller Unit	4-46
Preparations	4-46
Procedure	4-46
Removing the Control Panel	4-49
Removing the Main Motor	4-51
Preparations	4-51
Procedure	4-51
Removing the Main Fan	4-52
Preparations	4-52
Procedure	4-52
Removing the Main Drive Unit	4-53
Preparations	4-53
Procedure	4-53
Removing the Duplex Drive Unit	4-55
Preparations	4-55
Procedure	4-55
Removing the Duplex Reverse Solenoid	4-56
Preparations	4-56
Procedure	4-56
Removing the Cassette Pickup Solenoid	4-57
Preparations	4-57
Procedure	4-57
Laser Exposure System	4-58
Removing the Laser Scanner Unit	4-58
Preparations	4-58
Procedure	4-58
Image Forming System	4-59
Removing the Transfer Roller	4-59
Removing the Registration Unit	4-60
Preparations	4-60
Procedure	4-60
Fixing System	4-61
Removing the Fixing Assembly	4-61
Preparations	4-61
Procedure	4-61
Pickup Feed System	4-63

Removing the Duplex Feed Unit	4-63
Preparations	4-63
Procedure	4-63
Removing the Cassette Pickup Roller	4-65
Removing the Cassette Separation Pad	4-66
Removing the MP Pickup Roller	4-66
Removing the MP Separation Pad	4-67

Adjustment

Overview	5-2
Actions after Replacement Parts	5-2
Document Exposure / Feed System	5-2
After Replacing the Scanner Unit (CIS)	5-2
After Replacing the ADF Unit	5-2
After Replacing the Reader Unit	5-3
After Replacing the Reader Upper Cover	5-3
Controller System	5-4
After Replacing the Main Controller PCB	5-4

Trouble Shooting

Test Print	6-2
Test Pages	6-2
Engine-test Page	6-2
Controller Test Print	6-2
Trouble Shooting Items	6-3
Special Mode	6-3
Trailing edge image soiling	6-4
Repetitive Image Defects Ruler	6-4
Nip-width Specifications	6-5
Version Up	6-6
Overview of Upgrading	6-6
Firmware Configuration	6-6
Preparation	6-7
Necessary System Environment	6-7
Before Downloading the System Software	6-7
Downloading the System Software	6-8
Procedure of Downloading	6-8

Error Codes

Overview	7-2
Outline	7-2
Error Code	7-3
Jam Code	7-5

Service Mode

Overview	8-2
Service Mode Menu	8-2
Backing up Service Mode	8-2
Screen flow of Service Mode	8-3
Service mode structure	8-3
Screen flow of Service mode	8-3
COPIER	8-4
DISPLAY	8-4
VERSION	8-4
ERR	8-4
JAM	8-4
CCD	8-5
I/O	8-5
R-CON	8-5
ADJUST	8-6
ADJ-XY	8-6
CCD	8-7
PASCAL	8-11
FEED-ADJ	8-12
FUNCTION	8-13
CCD	8-13
CLEAR	8-14
MISC-R	8-14
MISC-P	8-14
SYSTEM	8-15
SPLMAN	8-16
INSTALL	8-16
OPTION	8-17
BODY	8-17
USER	8-18

ACC	8-18
SERIAL	8-18
COUNTER	8-19
TOTAL	8-19
PICK-UP	8-20
FEEDER	8-20
JAM	8-20
DRBL-2	8-21
FEEDER	8-22
ADJUST	8-22
FUNCTION	8-23
FAX	8-24
List of SSSW	8-24
List of MENU	8-25
List of NUM	8-25
Setting of NCU Parameters	8-26
TONE/PULSE	8-26
DIAL TONE	8-27
2nd DIAL TONE	8-27
BUSY TONE 0	8-28
BUSY TONE 1	8-28
REORDER TONE	8-29
AUTO RX	8-29
CNG DETECT	8-29
RKEY	8-29
PBX DIAL TONE 1	8-30
PBX BUSY TONE	8-30
TESTMODE	8-31
PRINT	8-31
FAX	8-32
MODEM	8-32
FACULTY	8-33

Appendix

Service Tools	II
Special Tools	II
Solvents and Oils	II

General Timing Chart -----III
General Circuit Diagram----- IV
 General Circuit Diagram (1/2) -----IV
 General Circuit Diagram (2/2) -----V

Safety Precautions

- CDRH Provisions
- Laser Safety
- Toner Safety
- Notes When Handling A Battery
- Notes On Assembly/ Disassembly



F-0-2

MF5900 Series



F-0-3

D1300 Series

CDRH Provisions

Food and Drug CDRH (Center for Devices and Radiological Health) under FDA (Food and Drug Administration) enforced provisions of the section for laser and laser products on August 2, 1976. These provisions are applicable to all laser products manufactured or assembled after August 1, 1976 and allow only products certified their compliance with the provisions to market in the US. Each product shall have affixed the applicable label as shown below to follow the labeling requirements prescribed in CDRH provisions.

Note that the wording included in labels is different depending on laser product classifications.

CAUTION:

Note that the wording included in labels is different depending on laser product classifications.

Laser Safety

About Laser Beams

Laser radiation may be hazardous to human. The laser scanner unit mounted in this device is sealed in the protective housing and the external cover to prevent laser beams from leaking to the environment. As long as the device is operated under normal conditions, users are safely arded from laser leaks.

Handling Laser Scanner Unit

Before providing service works for the laser scanner unit and its peripherals, ensure to turn off the power of the device.

Any cover with potential dangers of laser beam reflection has affixed the caution label at the position shown in the figure below.

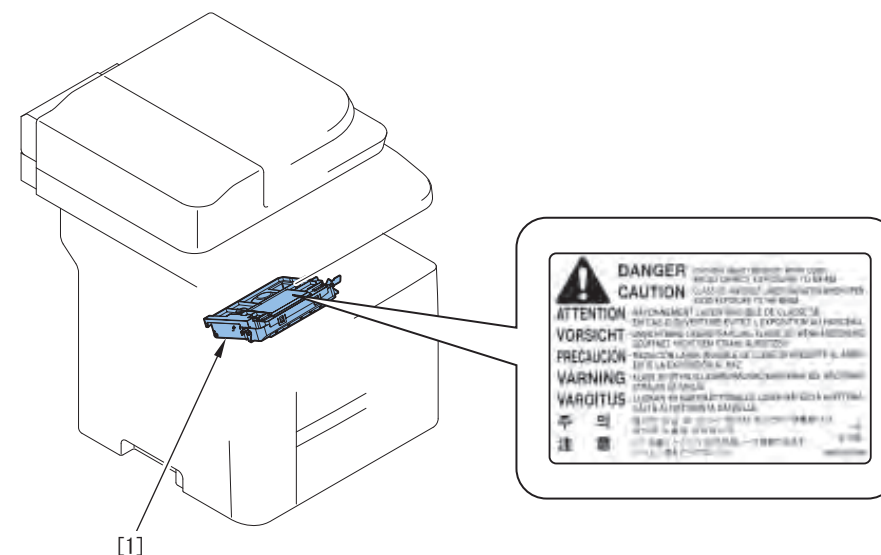

F-0-4

Toner Safety

About Toner

Toner is a nontoxic matter composed of plastic, iron and a trace of pigments.

Never throw toner in flames to avoid explosion.

⚠ CAUTION:

Never throw toner in flames to avoid explosion.

Handling Adhered Toner

- Use dry tissue paper to wipe off toner adhered to skin or clothes and wash in water.
- Never use warm water for cleaning up toner to prevent toner particles from being gelated to soak into fibers permanently.
- Toner particles are reactive with vinyl polymers. Avoid contacting these materials.

Notes When Handling A Battery

⚠ CAUTION:

Risk Of Explosion If Battery Is Replaced By An Incorrect Type.

Dispose Of Used Batteries According To The Instructions.

The following warnings are given to comply with Safety Principles (EN60950).

⚠ CAUTION:

Wenn mit dem falschen Typ ausgewechselt, besteht Explosionsgefahr.

Gebrauchte Batterien gemäß der Anleitung beseitigen.

Notes On Assembly/Disassembly

Follow the items below to assemble/disassemble the device.

1. Disconnect the power plug to avoid any potential dangers during assembling/disassembling works.
2. If not specially instructed, reverse the order of disassembly to reinstall.
3. Ensure to use the right screw type (length, diameter, etc.) at the right position when assembling.
4. To keep electric conduction, binding screws with washers are used to attach the grounding wire and the varistor. Ensure to use the right screw type when assembling.
5. Unless it is specially needed, do not operate the device with some parts removed.
6. Never remove the paint-locked screws when disassembling.

CAUTION

DOUBLE POLE/NEUTRAL FUSING

F-0-5



Product Overview

- Product Lineups
- Product Features
- Specifications
- Name of Parts

Product Lineups

Main Unit

Function	Canon imageCLASS			Canon i-SENSYS	
	MF5930dn	MF5950dw	MF5960dn	MF5940dw	MF5980dn
Appearance					
Copy	○	○	○	○	○
Print	○	○	○	○	○
Fax	○	○	○	○	○
SEND	○	○	○	○	○
Direct Print	○	○	○	○	○
Scan to USB	○	○	○	○	○
Secure Print	○	○	○	○	○
Remote UI	○	○	○	○	○
DADF	○	○	○	○	○
Automatic 2-sided Print	○	○	○	○	○
Wireless LAN	-	○	-	-	○
PS	-	-	○	-	○
PCL	-	-	○	○	○

T-1-1

Function	Canon imageCLASS Series			
	D1320	D1350	D1370	D1380
Appearance				
Copy	○	○	○	○
Print	○	○	○	○
Fax	-	○	○	○
SEND	-	-	○	○
Direct Print	○	○	○	○
Scan to USB	○	○	○	○
Secure Print	-	-	○	○
Remote UI	○	○	○	○
DADF	○	○	○	○
Automatic 2-sided Print	○	○	○	○
Wireless LAN	-	-	-	○
PS	-	-	○	-
PCL	-	-	○	○

T-1-2

Options

MF5900 Series

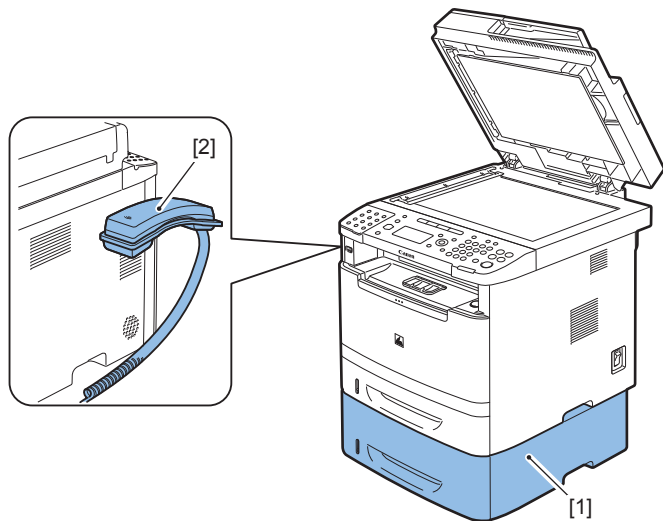

F-1-1

No.	Name	Description	Remarks
[1]	Paper FeederUnit PF-44	Approx. 500 Sheets (Plain paper 80g/ m2)	-
[2]	TELEPHONE 6 KIT Long cord Cool White		

T-1-3

D1300 Series

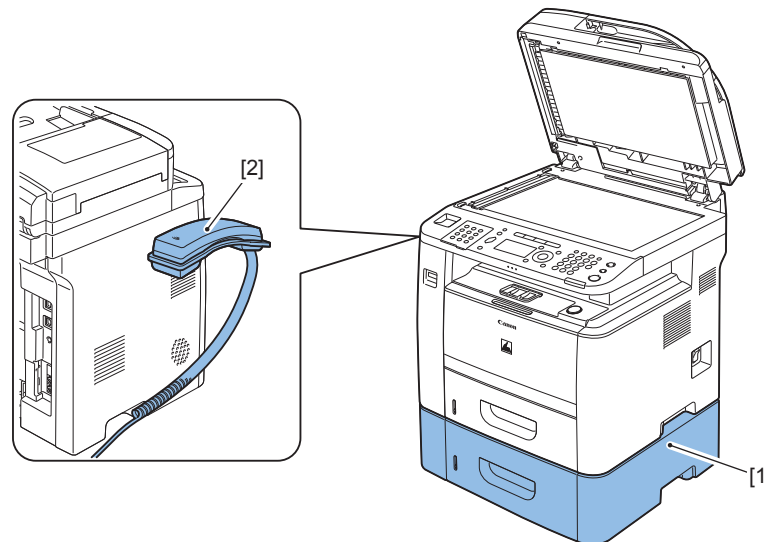

No.	Name	Description	Remarks
[1]	Canon Cassette Feeding Unit-U1	Approx. 500 Sheets (Plain paper 80g/ m2)	-
[2]	TELEPHONE 6 KIT Long cord Cool White		for China / Taiwan only

T-1-4

Product Features

Features

Compact MFP

The product compactified with lower height.



High-speed MFP

This compact A4 color MFP can prints at high speeds of up to 30 pages per minute (A4/LTR).

Power-saving MFP

This product employed SURF fixing method with a ceramic heater and 3W sleep mode to achieve electric power saving.

Specifications

Main Unit Specifications

Item	Specification/function	
	D1300 Series	MF5900 Series
Body	Desktop (DADF standard type)	
Light Source Type	LED	
Photosensitive Medium	OPC drum	
Image Reading Method	Contact Sensor Reading Method	
Reproduction Method	Indirect electrostatic copying method	
Exposure Method	Semiconductor laser	
Charging Method	Roller contact charging method	
Development Method	Dry system - element jumping development method	
Transfer Method	Roller transfer method	
Separation Method	Electrostatic separation (neutralizing needle) and curvature separation	
Cassette Pickup Method	Pad separation method	
MP Pickup Method	Pad separation method	
Drum Cleaning Method	Rubber blade	
Fixing Method	On-demand	
Toner Level Sensor	2 Levels (OK, Low) Unable to detect absence of toner.	
Toner Type	Magnetic negative toner	
Toner Supply Type	By drum style toner cartridge	
Toner Save Mode	Yes	
Original Type	Sheets, books, solids (up to 2 kg)	
Maximum Original Size	Fixed: 216mm x 356mm ADF: 216mm x 356mm	
Reproduction Ratio	Zoom: 0.50 to 2.00 (specified by the percent)	
Warm-up Time	11.0 seconds or less	
Reading Resolution	<TEXT/PHOTO>: 300 dpi x 600 dpi <TEXT>, <PHOTO>, <TEXT/PHOTO+>: 600 dpi x 600 dpi	
Printing Resolution	600 x 600 dpi	
First Print Time	6 seconds or less (A4/LTR)	
First Copy Time	Book: 8 seconds or less (A4/LTR) ADF; 12 seconds or less (A4/LTR)	
Print Speed	Approximately 35/33 sheets / minute (A4/LTR)	

Item	Specification/function	
	D1300 Series	MF5900 Series
Cassette Paper Size	LTR, LGL, A4, B5, A5, Executive, Oficio, Brazil-Oficio, Mexico-Oficio, FLSP, A-FLS, Government-LTR, Government-LGL	
Multifeeder Paper Size	76 × 127 to 216 × 356 mm	
Cassette Paper Type	Plain Paper (60 to 89g / m2), Plain Paper (60 to 89 g/m2) recycled paper (60 to 89 g/m2), Color (64 g/m2), Heavy Paper 1 (90 to 128 g/m2),	
MP Tray Paper Type	Plain Paper (60 to 89g / m2), Plain Paper (60 to 89 g/m2), recycled paper (60 to 89 g/m2), Color (64 g/m2), Heavy Paper 1 (90 to 128 g/m2), Heavy Paper 2 (129 to 163 g/m2), Transparency, Labels, Envelopes	
Cassette Capacity	500 sheets (80g / m2)	
MP Tray Capacity	50 sheets (80g / m2)	
Delivery Tray Stack	75 sheets (60 - 80g / m2)	
Continuous Reproduction	1 to 99 sheets	
Duplex Method	Auto Duplexing	
Interface	Standard:USB2.0, option:No	
Hard Disk	Standard:No, option:No	
Memory	128MB: D1320, D1350 256MB: D1370, D1380	256MB
Energy Save Mode	Yes. (Manual ON / OFF, automatically OFF after a set period of time, automatically ON when receiving facsimile / print data)	
Operating Environment (Temperature Range)	10 to 30 degrees C	
Operating Environment (Humidity Range)	20 to 80 %	
Operating Environment (Atmospheric Pressure)	0.16 to 1.01 hPa (0. 6 to 1 bar)	
Power Supply Rating	120V-127V (60Hz) 220-240V, 50/60Hz	
Power Consumption (Maximum)	Maximum consumption: Less than 1090 W	
Power Consumption	During operation: approximately 550W or less (reference value) At standby: approximately 18W (reference value)In sleep mode: approximately 3W (reference value)	
Dimensions	464 mm (H) × 472 mm (D) × 450 mm (W)	
Weight	Approximately 20.6 kg (including the toner cartridge)	Approximately 19.4 kg (including the toner cartridge)
PDL	BDL-Image, PCL5 / PCLXL	

T-1-5

ADF Specifications

Item	Specification/function
Original position	center reference
Original processing mode	1-sided to 1-sided copy, 2-sided to 2-sided copy, 1-sided to 2-sided copy, 2-sided to 1-sided copy
Original reading	stream reading method
Stack	A4/LTR: 50 sheets, LGL: 30 sheets
Original reading speed	A4/LTR: 300 x 300 dpi Color: 9.3 sheets / minute BW: 28 sheets / minute
Mixed original sizes	Yes
Original AE detection	No
Original size recognition	No
Stamp	No
Operating environment	pursuant to the host machine

T-1-6

FAX Specifications

Item	Specification/function
Suitable Line	Public Switched Telephone Network (PSTN) Up to 28.8Kbps in modem speed is currently available in PSTN. Note that available modem speed is telephone-line dependent. Telephone line connection: 1
Communication Protocol	Super G3
Modulation Method	Image modulation : V.34/V.8/V.17/V.29/V.27ter Transmission procedure : V.21
Transmission Speed	33,600 bps
Coding	Compression method: JBIG, MMR, MR, MH
Error Correction	ECM
Minimum Receivable Input Level	V.17, V.27ter, V.29: -6 to -43 dBm V.34: -10 to -43 dBm
Modem IC	CONEXANT DFX336
Scanning Line Density	Normal : 8 dots/mm x 3.85 lines/mm Fine : 8 dots/mm x 7.7 lines/mm Super fine : 8 dots/mm x 15.4 lines/mm Ultra fine : 16 dots/mm x 15.4 lines/mm
Half Tone	256 tones
Reproduction Resolution	600 x 600 dpi
Receivable Reduction Setting	Automatic reduction: 75-100% (1% increment)
FAX/TEL Switching	Available
Answering Machine Transfer Setting	Available
Remote Reception	Available
Auto-dialing	Available
Delayed Transmission	Available
Broadcast Transmission	Maximum number of destinations: 210 One-touch dial: 19 + coded dial: 181 + new destinations: 10 Priority order of destinations to be sent New destination => one-touch destination => coded destination (sent in this order)
Dual Access	Up to 70 schedules
Image Data Backup	Available

T-1-7

Print Speed.

(Unit: page/minute)

Paper type	Cassette		MP Tray		OP Cassette	
	1-sided	2-sided	1-sided	2-sided	1-sided	2-sided
A4	33	16.8	33	16.8	33	16.8
LTR	35	17	35	17	35	17
LGL	28.7	13.8	28.7	13.8	28.7	13.8
B5	13>12>8>6	-	16>12>8>6	-	10>10>8>6	-
A5	15>12>8>6	-	17>12>8>6	-	11>11>8>6	-
Strip of paper (90 to 297 mm)	-	-	2>1	-	-	-
Postcard	-	-	17>12>8>6	-	-	-
Envelope	-	-	12>8>6	-	-	-

T-1-8

Paper types

(○: available -: not available)

Paper types		Printer driver setting	Cassette	Multi-purpose Tray
Plain	60 to 89 g/m2 (From 16 to 24 lb)	Plain Paper	○	○
	60 to 89 g/m2 (From 16 to 24 lb)	Plain Paper L	○	○
Color	60 to 89 g/m2 (From 16 to 24 lb)	Color	○	○
Recycled*	60 to 89 g/m2 (From 16 to 24 lb)	Recycled	○	○
Thick	90 to 128 g/m2 (From 24 to 33 lb)	Heavy Paper 1	○	-
	129 to 163 g/m2 (From 33 to 43 lb)	Heavy Paper 2	-	○
Transparency		Transparency *1	-	○
Label		Label	-	○
Envelope		Envelope	-	○

T-1-9

*1: Use only LTR or A4 transparencies made especially for this machine.

Paper size

(○: available -: not available)

Paper size	Cassette	Multi-purpose Tray
A4 (210.0 mm × 297.0 mm)	○	○
B5 (182.0 mm × 257.0 mm)	○	○
A5 (148.0 mm × 210.0 mm)	○	○
Legal (LGL) (215.9 mm × 355.6 mm)	○	○
Letter (LTR) (215.9 mm × 279.4 mm)	○	○
Executive (EXEC) (184.0 mm × 266.7 mm)	○	○
Officio (215.9 mm × 317.5 mm)	○	○
Brazil Officio (215.9 mm × 355.6 mm)	○	○
Mexico Officio (215.9 mm × 341 mm)	○	○
Government Letter (203.2 mm × 266.7 mm)	○	○
Government Legal (203.2 mm × 330.2 mm)	○	○
FOOLSCAP (215.9 mm × 330.2 mm)	○	○
A-FLS (205.7 mm × 337.82mm)	○	○
3"×5" to Legal (76 × 127 to 216 mm× 356 mm)	-	○

T-1-10

Name of Parts

External View

MF5900 Series

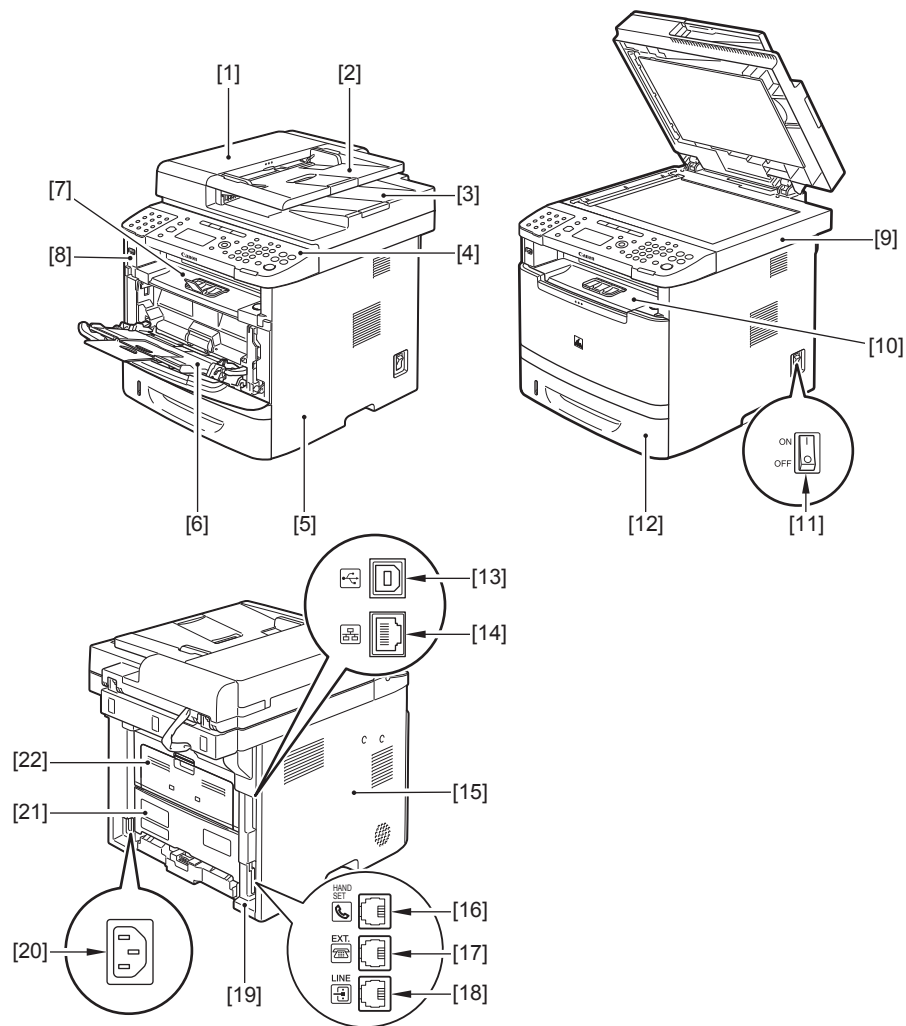

Key	Name	Key	Name
[1]	DADF (Duplex Automatic Document Feeder)	[13]	USB Port 2
[2]	Document Feeder Tray	[14]	Ethernet Port
[3]	Document Delivery Tray	[15]	Left Cover Unit
[4]	Control Panel	[16]	Handset Terminal
[5]	Right Cover	[17]	External Telephone Terminal
[6]	MP Pickup Tray	[18]	Telephone Line Terminal
[7]	Upper Cover	[19]	Left Rear Cover
[8]	USB Port	[20]	Power Socket
[9]	Reader Unit	[21]	Rear Lower Cover
[10]	Front Cover	[22]	Rear Upper Cover
[11]	Main Power Switch		
[12]	Paper Cassette		

T-1-11

F-1-5

D1300 Series

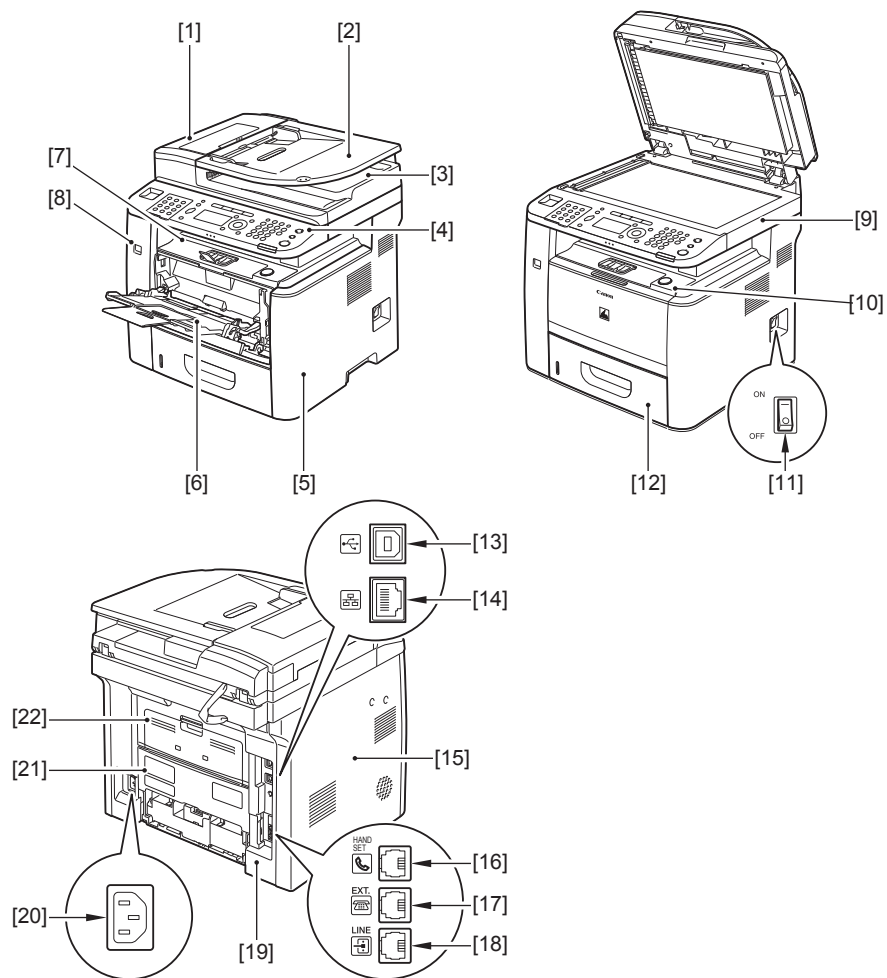

Key	Name	Key	Name
[1]	DADF (Duplex Automatic Document Feeder)	[13]	USB Port 2
[2]	Document Feeder Tray	[14]	Ethernet Port
[3]	Document Delivery Tray	[15]	Left Cover Unit
[4]	Control Panel	[16]	Handset Terminal
[5]	Right Cover	[17]	External Telephone Terminal
[6]	MP Pickup Tray	[18]	Telephone Line Terminal
[7]	Upper Cover	[19]	Left Rear Cover
[8]	USB Port	[20]	Power Socket
[9]	Reader Unit	[21]	Rear Lower Cover
[10]	Front Cover	[22]	Rear Upper Cover
[11]	Main Power Switch		
[12]	Paper Cassette		

T-1-12

F-1-6

Cross Sectional View

MF5900 Series

ADF/Reader Unit

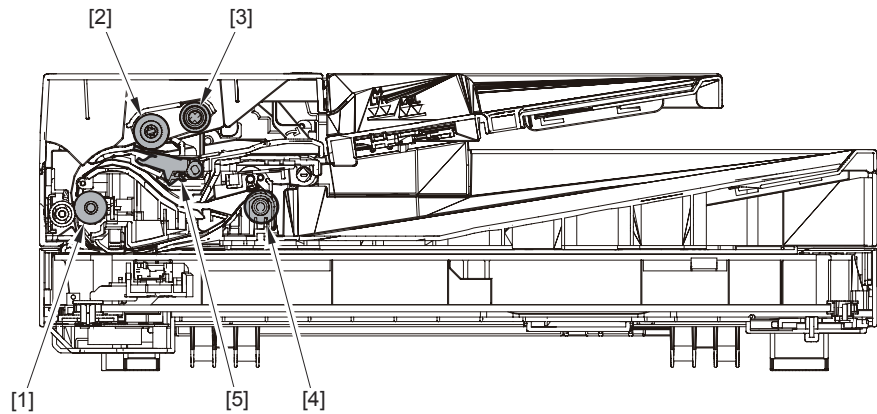

F-1-7

Key	Name	Reference
[1]	ADF Paper Feed Roller	
[2]	ADF Separation Roller	
[3]	ADF Pickup Roller	
[4]	ADF Delivery roller	
[5]	ADF Separation Pad	

T-1-13

Printer

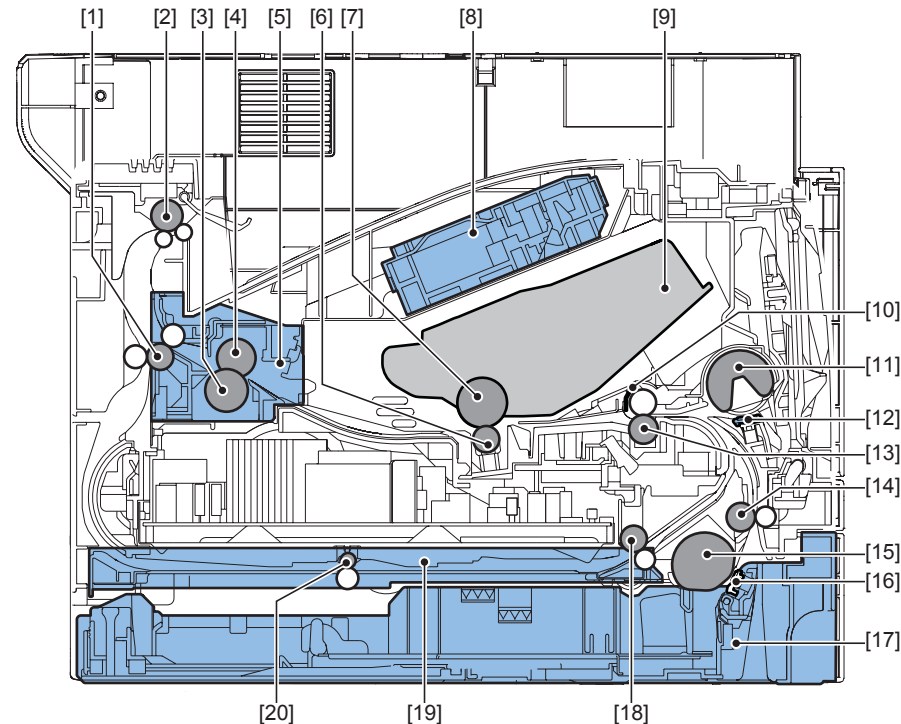

F-1-8

Key	Name	Key	Name
[1]	Fixing delivery roller	[11]	MP tray pickup roller
[2]	Face-down delivery roller	[12]	MP tray separation pad
[3]	Pressure roller	[13]	Registration roller
[4]	Fixing film unit	[14]	Feed roller
[5]	Fixing unit	[15]	Cassette pickup roller
[6]	Transfer roller	[16]	Cassette separation pad
[7]	Photosensitive drum	[17]	Cassette
[8]	Laser scanner unit	[18]	Duplex re-pickup roller
[9]	Cartridge	[19]	Duplex feed unit
[10]	Registration shutteroller	[20]	Duplex feed roller

T-1-14

D1300 Series

ADF / Reader Unit

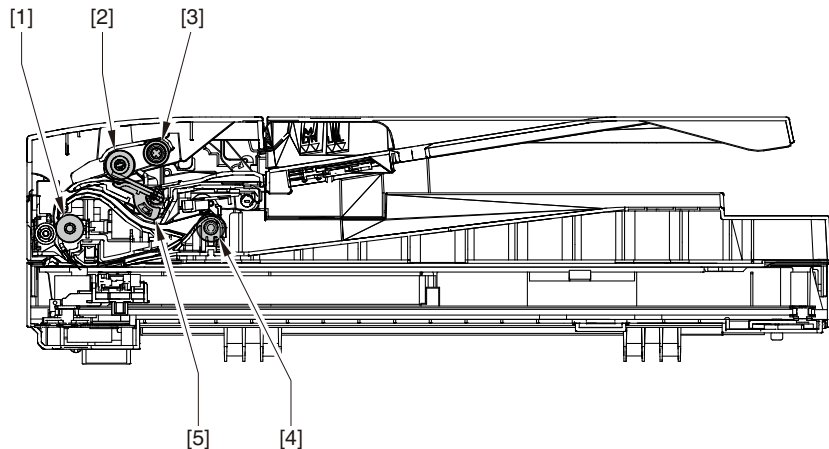

F-1-9

Key	Name	Reference
[1]	ADF Paper Feed Roller	
[2]	ADF Separation Roller	
[3]	ADF Pickup Roller	
[4]	ADF Delivery roller	
[5]	ADF Separation Pad	

T-1-15

Printer

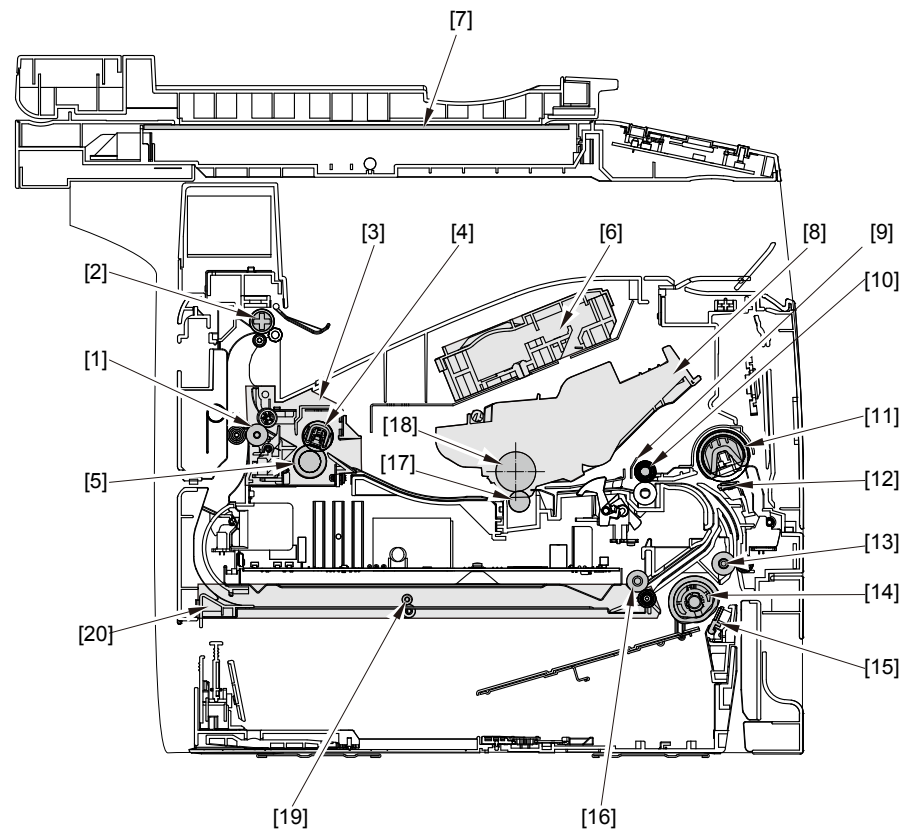

F-1-10

Key	Name	Key	Name
[1]	Fixing delivery roller	[11]	MP tray pickup roller
[2]	Face-down delivery roller	[12]	MP tray separation pad
[3]	Fixing unit	[13]	Feed roller
[4]	Fixing film unit	[14]	Cassette pickup roller
[5]	Pressure roller	[15]	Cassette separation pad
[6]	Laser scanner unit	[16]	Duplex re-pickup roller
[7]	Copyboard glass (scanning glass)	[17]	Transfer roller
[8]	Cartridge	[18]	Photosensitive drum
[9]	Registration shutter	[19]	Duplex feed roller
[10]	Registration roller	[20]	Duplex feed unit

T-1-16

Operation Panel

Main Operation Panel

MF5900 Series

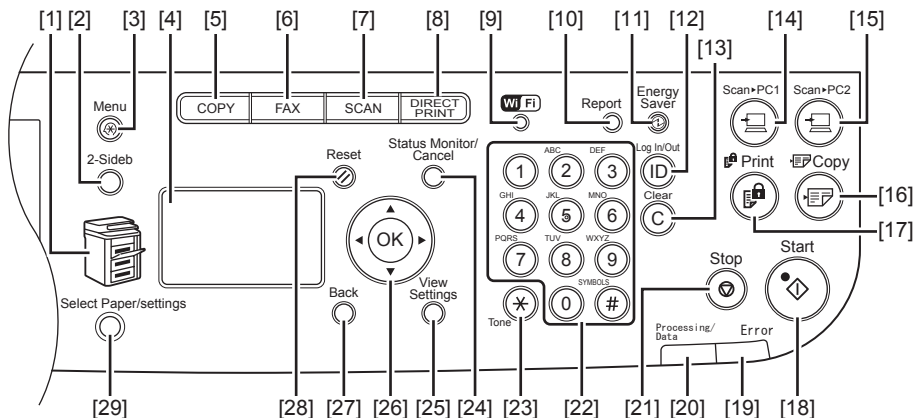

F-1-11

Key	Name	Key	Name
[1]	Paper Select indicator	[16]	[Paper Save Copy] key
[2]	[2-Sided] key	[17]	[Secure print] key
[3]	[Menu] key	[18]	[Start] key
[4]	Display	[19]	Error indicator
[5]	[COPY] key	[20]	Processing/Data indicator
[6]	[FAX] key	[21]	[Stop] key
[7]	[SCAN] key	[22]	[Numeric] key
[8]	[DIRECT PRINT] key	[23]	[Tone] key
[9]	Wi-Fi LED *	[24]	[Status Monitor/Cancel] key
[10]	[Report] key	[25]	[View Settings] key
[11]	[Energy Saver] keys	[26]	[▲][▼][<][>] key
[12]	[Log In/Out] key (ID key)	[27]	[Back] key
[13]	[Clear] key	[28]	[Reset] key
[14]	[Scan to PC1] key	[29]	[Select Paper/Settings] key
[15]	[Scan to PC2] key		

* MF5950/MF5980 only

T-1-17

D1300 Series

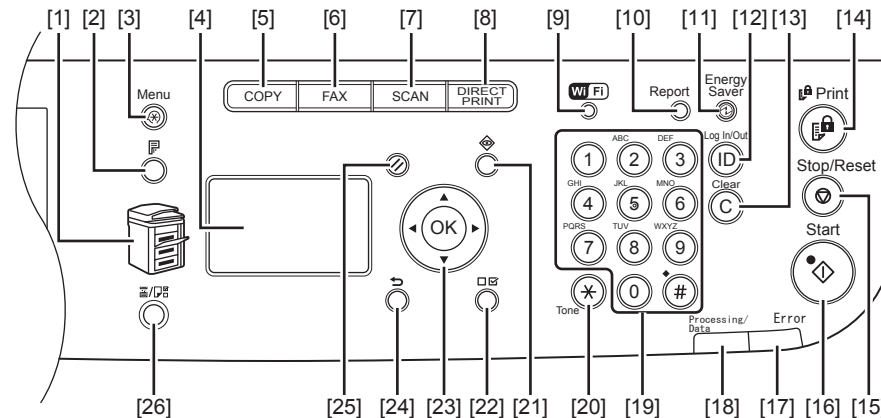

F-1-12

Key	Name	Key	Name
[1]	Paper Select indicator	[16]	[Stop/Reset] key
[2]	[2-Sided] key	[17]	[Start] key
[3]	[Menu] key	[18]	Error indicator
[4]	Display	[19]	Processing/Data indicator
[5]	[COPY] key	[20]	[Numeric] key
[6]	[FAX] key *1	[21]	[Tone] key
[7]	[SCAN] key	[22]	[Status Monitor/Cancel] key
[8]	[DIRECT PRINT] key	[23]	[View Settings] key
[9]	Wi-Fi LED *2	[24]	[▲][▼][<][>] key
[10]	[Counter] key	[25]	[Back] key
[11]	[Report] key	[26]	[Reset] key
[12]	[Energy Saver] keys	[27]	[Select Paper/Settings] key
[13]	[Log In/Out] key (ID key)		
[14]	[Clear] key *3		
[15]	[Secure print] key		

*1 D1350/D1370/D1380 only

*2 D1380 only

*3 D1370/D1380 only

T-1-18

FAX Operation Panel

MF5900 Series

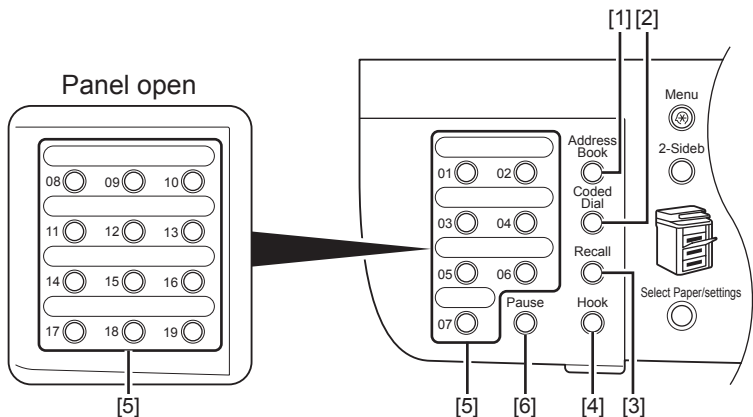

F-1-13

Key	Name	Key	Name
[1]	[Address Book] key	[4]	[Hook] key
[2]	[Coded Dial] key	[5]	[One touch] key
[3]	[Recall] key	[6]	[Pause] key

T-1-19

D1300 Series

* D1380 only

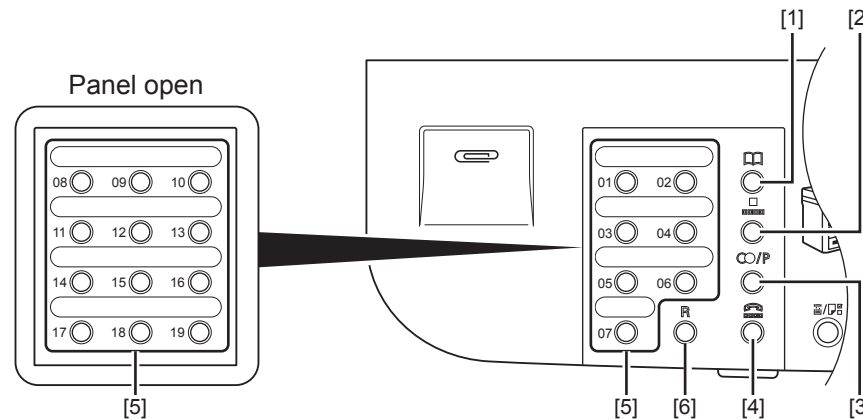

F-1-14

Key	Name	Key	Name
[1]	[Address Book] key	[4]	[Hook] key
[2]	[Coded Dial] key	[5]	[One touch] key
[3]	[Redial] key	[6]	[Pause] key

T-1-20

2

Technical Overview

- Basic Configuration
- Document Exposure/
feeder System
- Engine Control System
- Laser Scanner System
- Image-formation System
- Fixing Assembly System
- Media Feed System

Basic Configuration

Configuration Function

This device is roughly composed of the 6 functional blocks as shown in the figure below

• Document Exposure/Delivery System	• Image Formation System
• Controller System	• Fixing System
• Laser Exposure System	• Pickup / Feed System

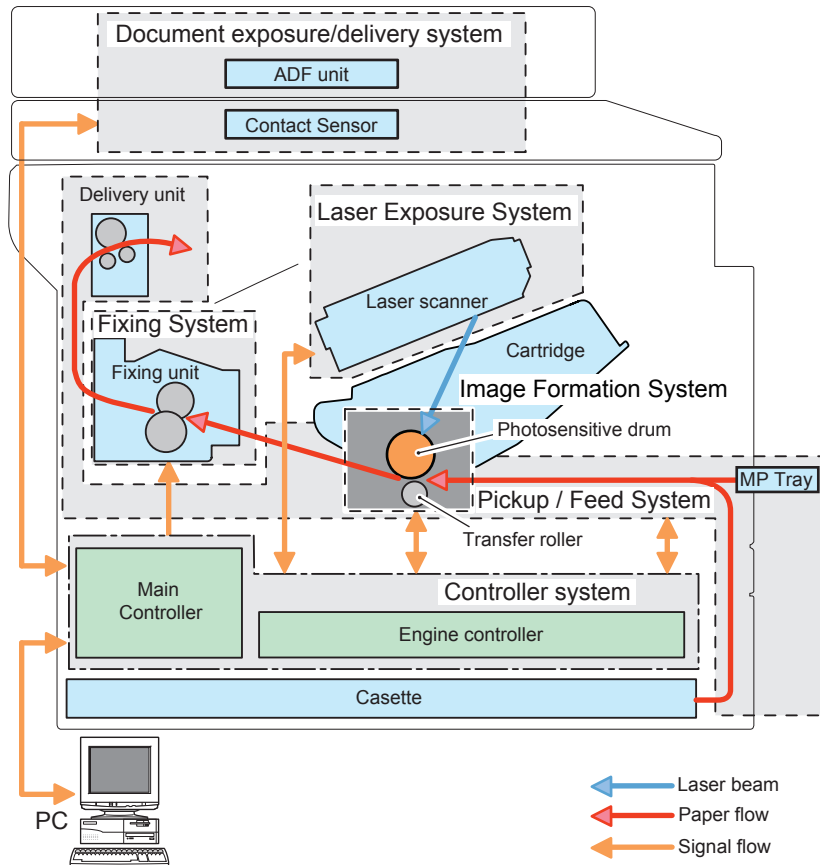

F-2-1

Basic Sequence

Basic Operational Sequence

The CPU on the DC Controller PCB controls the operational sequence. The table below shows the operation and the purposes in each status from start-up of the device and to last rotation after print job completion.

Status	Operation
WAIT (Wait)	Interval from power-ON or reactivation from sleep mode upon shutting the door(s) to entering the print-ready status Activate the printer to be ready for printing. During WAIT time, the following operations are done: pressure is applied to the pressure roller of the Fixing Unit; check cartridges and units being in place; move the developing unit to the home position; and, clean the ITB. When needed, color displacement is corrected and the image is stabilized.
STBY (STBY)	Interval from the wait time or the last rotation to issuance of a print command from the main controller or power-OFF. Maintain the print-ready status. The printer enters the sleep mode upon receiving a "sleep" command from the main controller during the stand-by status. The printer executes color displacement correction or image stabilization upon receiving corresponding commands from the main controller.
INTR (IINTR)	Interval from issuance of a print command from the main controller during the stand-by status to warming up the Fixing Unit to the target temperature. To make the printer ready for print jobs, activate high-voltage bias PCBs, the Laser Scanner Unit and the Fixing Unit.
PRINT (Print)	Interval from the initial rotation to completion of last page fixation. Based on the video signals input from the main controller, form the static latent image on the photosensitive drum to transfer and fix the toner image on paper. When a certain pages are printed after power-ON, the device undergoes color displacement correction and/or image stabilization.
LSTR (Last rotation)	Interval from print job completion to Motor deactivation. The last page of the print job is completely delivered. In this status, the Laser Scanner Unit and high-voltage bias PCBs are inactive. The printer starts the initial rotation upon receiving a print command from the main controller during this status.

T-2-1

Print Sequence

Timing chart two consecutive prints on LTR paper





Print Mode

Print modes	Feeding speed	Media type	Print speed	Remarks
Normal speed mode	1/1 speed	Speed for plain paper A4/LTR width (60 to 89g) Transparencies	33/35 ppm	
1/2 speed mode	1/2 speed	Plain paper A4/LTR width (60 to 89g) Plain paper less than A4 width (60 to 89g) Heavy paper (90 to 163g) Bond paper (60 to 163g) Label paper Postcard, Tab paper Envelope		

T-2-2

*1: Normal mode is recommended for Neenah Bond 60g/m2

Document Exposure/feeder System

Document Exposure System

Specifications / Control / Function List

item	function / method
Document Exposure	LED
Document Scan	Book mode: scan by the shift of the contact Book mode: scan by the shift of the contact sensor (CS) ADF: document stream reading by fixed contact sensor (CS)
Scanning Resolution	600 dpi (horizontal scanner) X 600 dpi (vertical scanner)
Number Of Gradations	256 gradations
Magnification	50% to 200% horizontal: image processing by SCNT PCB vertical: change of carriage shift speed, image processing by SCNT PCB
Lens	rod lens array
CMOS Sensor	number of lines: 1 line number of pixels: 5184 pixels as total pixels (5107 pixels as effective pixels) maximum document scanning width: 216 mm
CS Drive Control	drive control by Reader Motor (M701)
CS HP Detection	Yes
Document Size Detection	None
Dirt Sensor Detection	Yes

T-2-3

Major Components

Followings are the major components for Document Exposure System.

- The Contact Sensor to scan document
 - The Reader Motor (M701), the Drive Pulley, the Drive Belt, to shift the Contact Sensor
- In image scanning control, the Contact Sensor is shifted by rotating the Reader Motor based on the drive signal from the DCNT PCB and scan the original on the Copyboard Glass. When ADF is in use, image is scanned by feeding the originals by ADF instead of shifting the Contact Sensor.

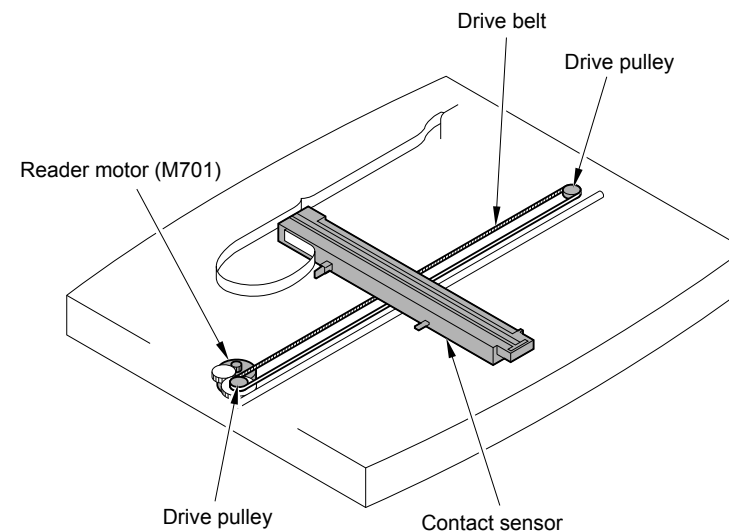

F-2-2

Document Feeder System

Pickup/Feed/Delivery Operation

The Auto Document Feeder (ADF) mounted onto this host machine is dedicated to stream-reading.

1 Motor (DADF Motor: M702) is engaged in pickup/feeding/delivery.

At the start of copy/fax/scan, the DADF Motor (M702) is driven by the drive command from the ADF/Reader driver PCB to pickup/feed the originals set face up on the original tray one by one in order from the top. The original is scanned by the Contact Sensor when moving through the Copyboard Glass, and then delivered face down to the original delivery assembly.

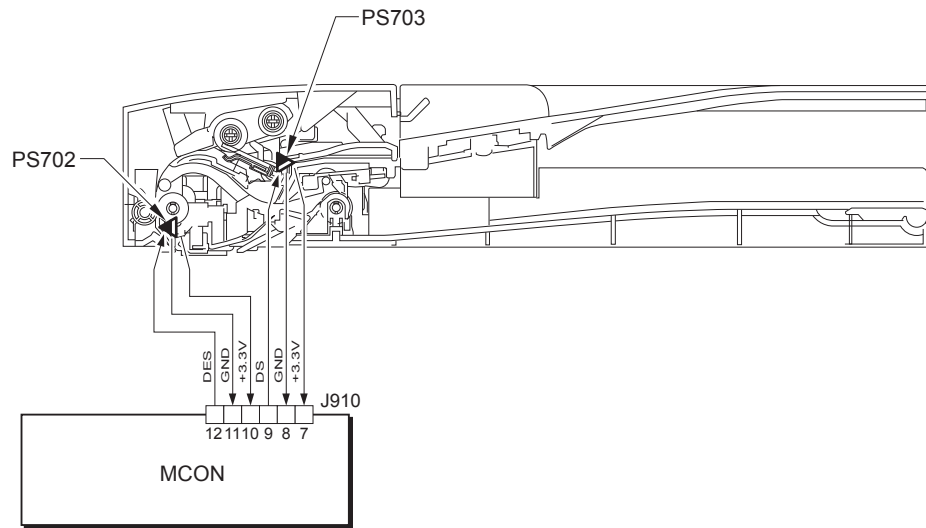

F-2-3

Operation at Duplex Reading
 - Pickup to Reading of the 1st side

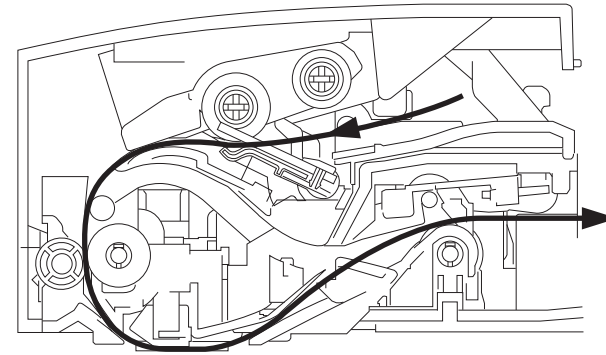

F-2-4

- Reverse to Reading of the 2nd side

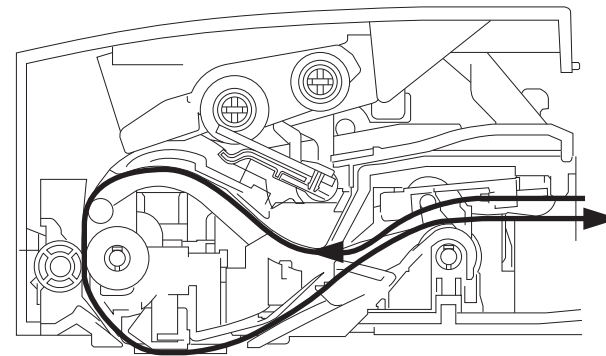

F-2-5

- Delivery

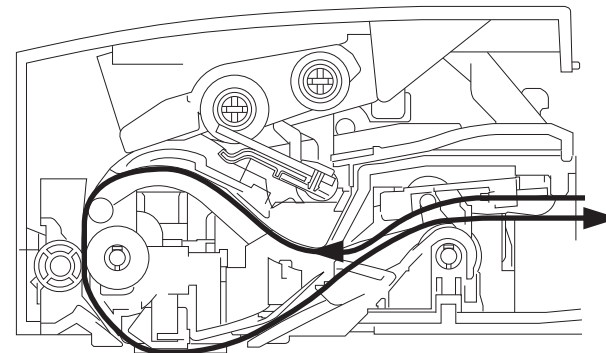

F-2-6

Original Detection

There are two types of Original Detection in this Equipment.

1. Original Presence / Absence Detection

Detected by DS (Document Sensor: PS703)

Setting the original onto the original tray pushes up the actuator, activating (light shielded =>light transmitted) the DS (PS703), and resulting in detection of the presence of original.

2. Detection of the End of the Original

Detected by the DES (Document End Sensor: PS702)

The leading edge of the original that is fed pushes up the actuator, activating the DES (PS702) (light shielded =>light transmitted) and resulting in detection of the reach of the leading edge of original. Furthermore, when the trailing edge of the original passes the actuator position, the actuator returns to the original position, inactivating the DES (PS702) (light transmitted => light shielded). The trailing edge of the original is detected by this mechanism. The original length that can be scanned with this equipment is less than 400 mm. Passing of the original longer than this results in jam stop. The original length is calculated by the time it takes from detection of the leading edge of the original to detection of the trailing edge of the original..

NOTE:

There is no function to detect the original size (original width, length) in this equipment.

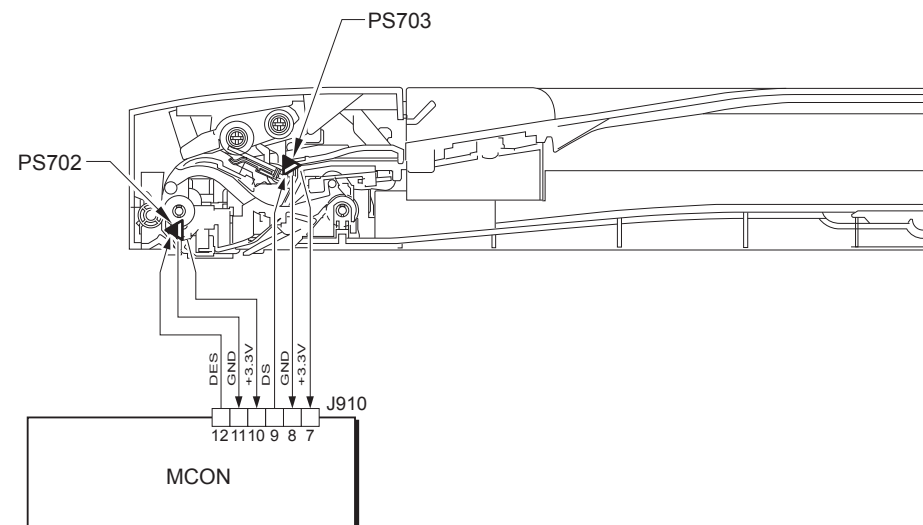

F-2-7

Jam Detection

The following cases are judged as jam.

1. In case of delay in reaching DS/DES or stationary during scanning of original
 2. In case DS/DES is detected as ON at power-on (residual paper jam)
 3. In case of detecting original of which length is 400 mm or longer
- Operation after Detection of Jam
The host machine stops scanning operation and displays "CHECK DOCUMENT" on the control panel. No jam code is displayed.
In case of the model equipped with fax function (with built-in speaker), the warning beep occurs at the detection of jam.
 - How to release Jam.
Remove the jammed paper and open / close the ADF upper cover

Service Tasks

Action for Parts Replacement

Outline of the measures is described in this section. For the detailed procedure, refer to the "SCANNING SYSTEM ADJUSTMENT (Refer to page 0-1)".

Reader Unit

- 1) Enter the setting value of the Standard White Plate.
- 2) Execute the color/B&W AGC adjustment.
- 3) Execute the reading position adjustment.
- 4) Execute the white level adjustment.
- 5) Enter the value on the label packed with the part in the service mode item.
- 6) Execute the image reading adjustment at ADF reading.

Reader Upper Cover Unit (Copyboard Glass)

- 1) Enter the value on the label affixed on the glass in the service mode item.
- 2) Execute the reading position adjustment.
- 3) Execute the white level adjustment.

Contact Sensor Unit

- 1) Execute the color/B&W AGC adjustment.
- 2) Execute the auto detection of the reading position at DF stream reading.
- 3) Execute the white level adjustment.
- 4) Execute the image reading position adjustment.
- 5) Execute the image reading adjustment at ADF reading.

Maintenance

No periodically replaced parts, durable parts or periodical service is set for this product.

Service Notes

None

Engine Control System

Outline

The Engine Control System controls all the other systems according to commands from the Main Controller.

The Engine Control System contains the following components:

- DC Controller
- Low-voltage Power Supply
- High-voltage Power Supply

Block diagram of the Engine Control System is shown below.

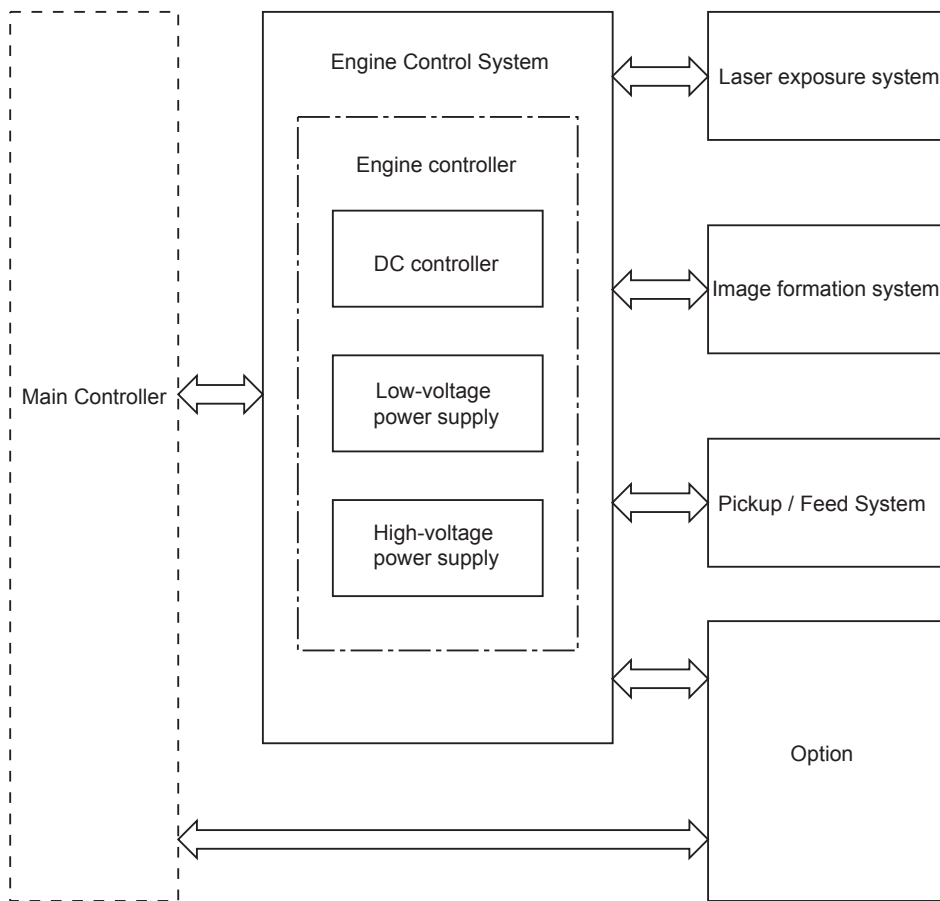

F-2-8

Controls

Outline

The DC Controller controls the operational sequence of the printer.

Block diagram of the DC Controller and table of the electrical components are shown below.

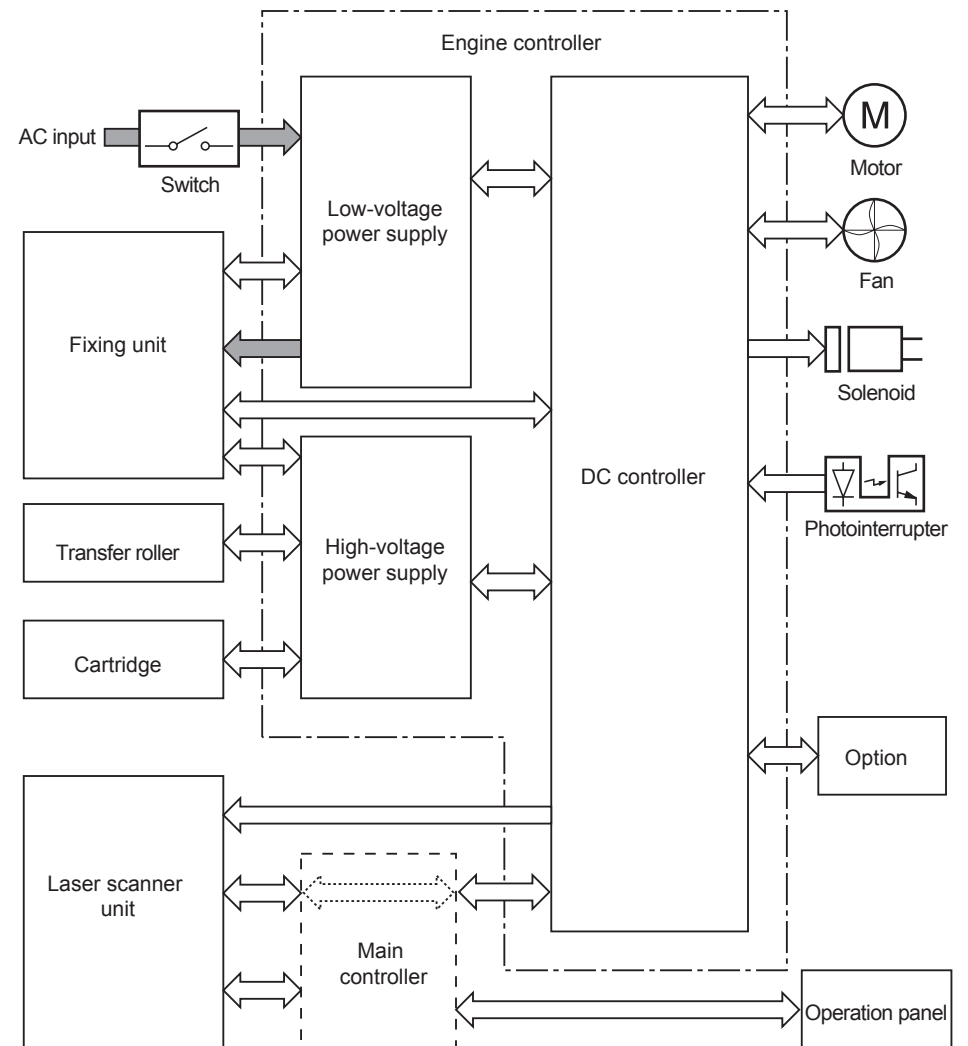

F-2-9

Symbol for component	Component	Remarks
Fan	FM3	Controller Fan
	FM201	Main Fan
	FM203	Controller Fan
Motor	M201	Main Motor
Solenoid	SL201	Cassette Pickup Solenoid
	SL202	Duplex Reverse Solenoid
	SL203	MP Tray Pickup Solenoid
Switch	SW1	Power Switch
	SW2	Door Switch
Photointerrupter	PS201	Duplex Reverse Sensor
	PS202	MP Tray Media Presence Sensor
	PS203	Cassette Media Presence Sensor
	PS204	TOP Sensor
	PS205	Media Width Sensor
	PS206	FD Tray Media Full Sensor
	PS915	Fixing Delivery Sensor

T-2-4

Motor / Fan Control

The printer has one Motor for media feed and image formation. Arrangement of Motor and the specifications are shown below.

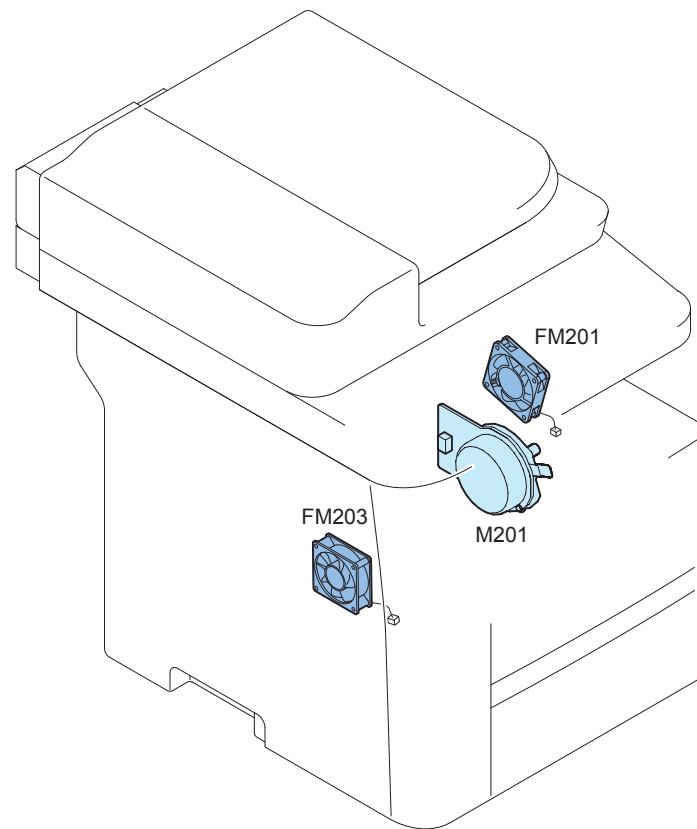

F-2-10

Description		Driving part	Failure detection
M201	Main Motor	Roller in the printer and rollers in the paper feeder	Yes
FM201	Main Fan		
FM203	Controller Fan		

T-2-5

Failure Detection

Failure Point	Cause of Failure
Main Motor	In the case that the speed of Motor does not reach the specified speed after the specified time has passed since the startup of the Main Motor.
Main Fan	In the case that the Fan has been locked continuously for the specified period of time since the startup of the Main Fan Motor.

T-2-6

Low-voltage Power Supply

Outline

The Low-voltage power supply converts AC Power from the power receptacle into DC Power to cover the DC loads.

Block diagram of the Low Voltage Power Supply is shown below.

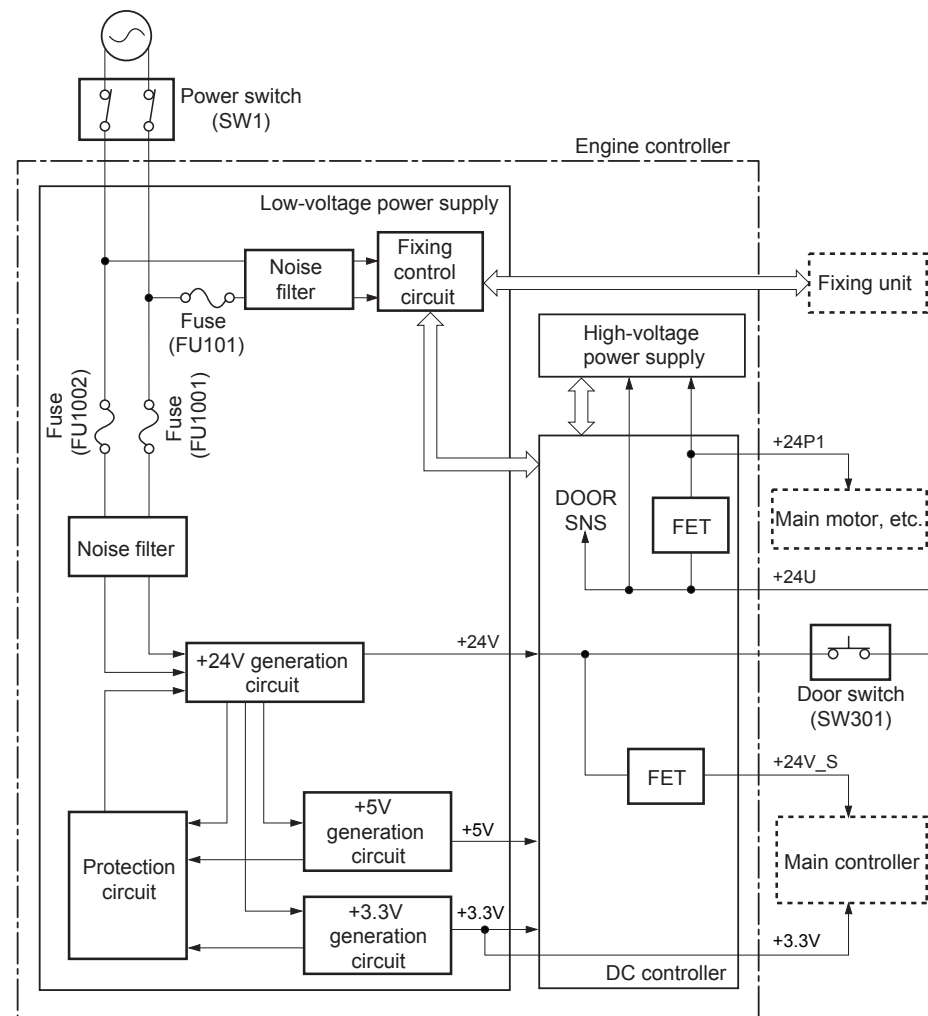

F-2-11

Protective Function

The Low-voltage Power Supply has a protective function against overcurrent and overvoltage to prevent failures in the power supply circuit. If there flows an overcurrent or an overvoltage, the system automatically cuts off the output voltage.

If the DC Power is not being supplied from the Low-voltage Power Supply, the protective function may be running. In such case, turn off the power switch and unplug the power cord. Do not plug in the power cord or turn the power switch on again until the root cause is found. In addition, two fuses in the Low-voltage Power Supply protect against overcurrent. If overcurrent flows into the AC line, the fuse blows and cuts off the power distribution.

Safety

For user and service technician's safety, the printer has a function to interrupt 24V power supply.

The door switch is turned off and 24V power supply to the Fixing Unit and the High-voltage Power Supply Unit stops under the following condition:

- If the cartridge door is opened (SW2 is turned off)

Low-voltage Power Supply Unit Failure Detection

The DC Controller determines a Low-voltage power supply unit failure and stops +24V output. Once 24V output is stopped, 3.3V of the engine CPU stops, so notification is not made. Likely, 3.3V of the controller stops, so the machine seems power-off.

- +24V is higher than a specified voltage
- +3.3V is higher than a specified voltage
- +5V is higher than a specified voltage

Power-Saving Mode

This is the function to save power consumed by the printer.

The table below lists various power-saving modes.

Power-Saving Mode	Status
Stand-by	at power-OFF on the reader
Power-saving (3W)	at power-off on the reader, the engine and the display (LCD) The main controller enters the power-saving mode.

T-2-7

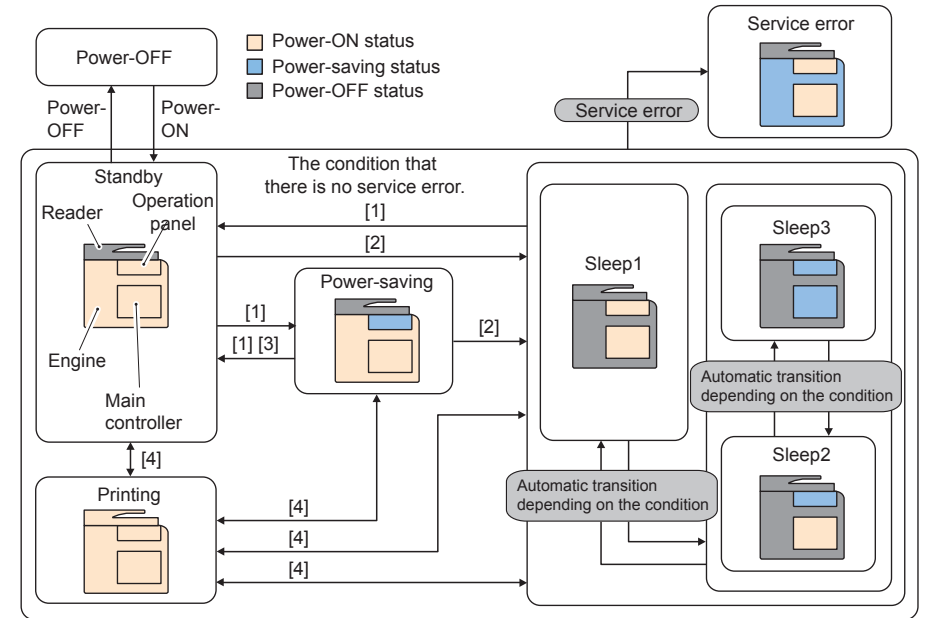

F-2-12

[1]	Press [Power-saving] key. (Power-saving release)	[3]	Detects hook.
[2]	Enters auto-sleep status.	[4]	Start / complete jobs.

Service Tasks

■ Action for Parts Replacement

Outline of the measures is described in this section. For the detailed procedure, refer to the "Chapter 5."

● After Replacing Main Controller PCB

- Before replacing PCBs

Back up user data (settings / registered data, etc.) and Service mode data for setting / registration after replacing PCBs. Take notes of data unable to back up.

- After replacing PCBs

- 1) Enter all items written on the service label.
- 2) Setting of destination / paper size groups
- 3) Execute COPIER > FUNCTION > CLEAR > ALL.
- 4) Enter the serial number.
- 5) Import the back up data before replacement.

■ Maintenance

No periodically replaced parts, durable parts or periodical service is set for this product.

■ Service Notes

None

Laser Scanner System

Outline

The Laser Scanner System forms a latent image on the photosensitive drum according to the VIDEO signals sent from the Main Controller.

The main components of the Laser Scanner are the Laser Unit and the Scanner Motor Unit, which are controlled by the signals sent from the DC Controller.

Diagram of the Laser Scanner Unit is shown below.

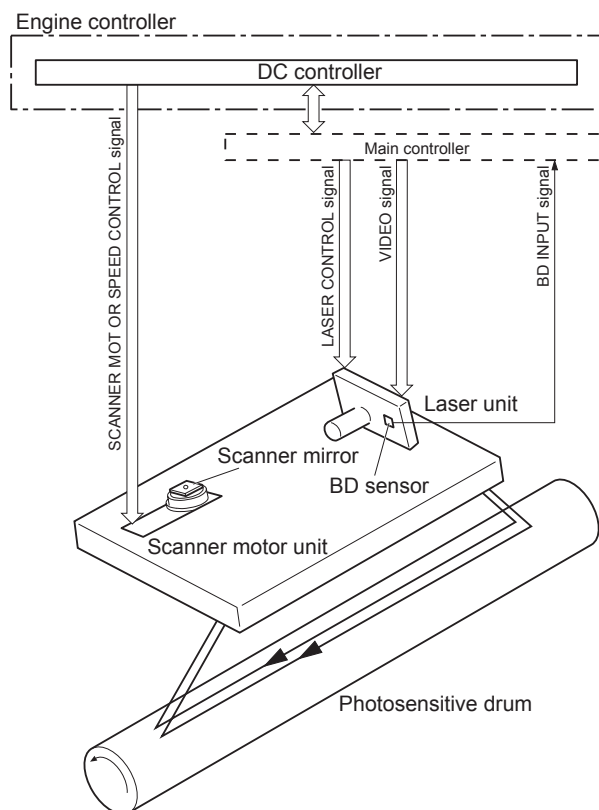

F-2-13

Optical Unit Failure Detection

The Optical Unit failure detection manages the Laser Scanner failure detection functions. The DC Controller determines an Optical Unit failure and notifies the Main Controller if the Laser Scanner encounters the following conditions:

- After the drive of Scanner Motor, BD within a specified period is not detected.
- If the Scanner Motor does not reach a specified rotation within a specified period of start-up.
- If an out of specified BD interval is detected during a print operation.

Service Tasks

Action for Parts Replacement

No work is required at parts replacement of this product.

Maintenance

No periodically replaced parts, durable parts or periodical service is set for this product.

Service Notes

Point to Note When Replacing the Laser Scanner Unit

Do not disassemble the Laser Scanner Unit in the field because it has been adjusted in the factory.

Otherwise, it may cause image fault such as color displacement. (You need to replace the Laser Scanner Unit in that case.)

Image-formation System

Outline

The Image-Formation System forms a toner image on print media.

The following are the main components of the Image-Formation system:

- Cartridge
- Transfer Roller
- Fixing Unit
- Laser Scanner

The DC Controller controls the Laser Scanner and High-voltage power supply to form the toner image on the photosensitive drum. The image is transferred to the print media and fixed.

Diagram of the image formation system is shown below.

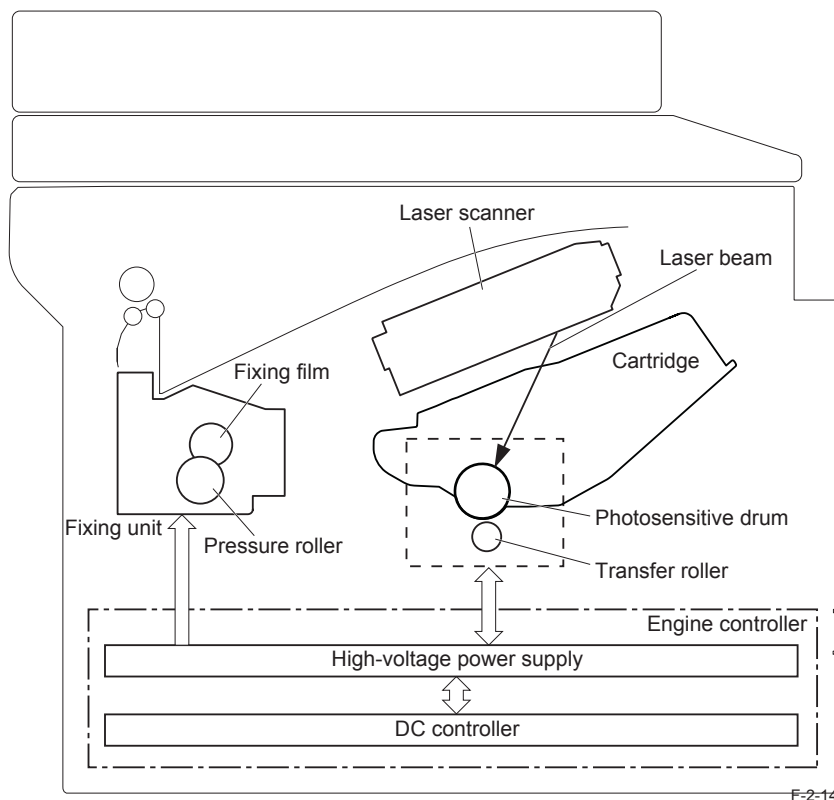

F-2-14

Image-formation Process

Outline

The Image-Formation process consists of the following seven steps divided among five functional blocks:

Latent Image Formation Block

- Step 1: Primary charging
- Step 2: Laser-beam exposure

Developing Block

- Step 3: Developing

Transfer Block

- Step 4: Transfer
- Step 5: Separation

Fixing Block

- Step 6: Fixing

Drum Cleaning Block

- Step 7: Drum cleaning

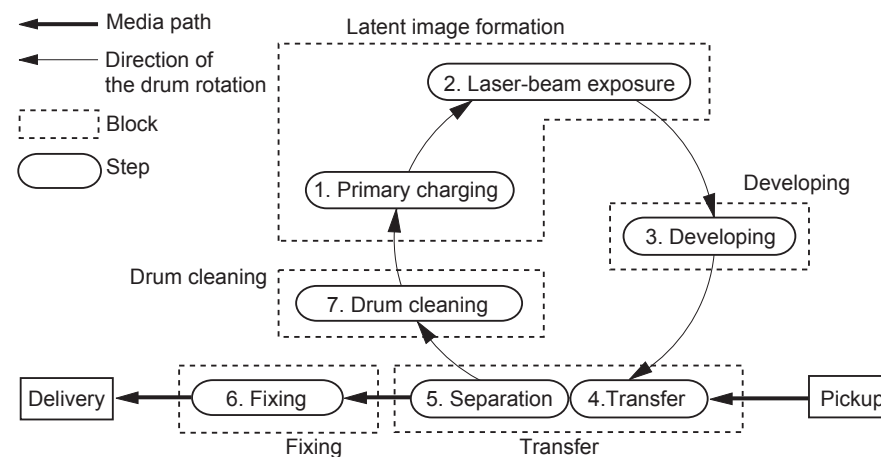

F-2-15

Latent Image Formation Block

During the two steps that comprise this block, an invisible latent image is formed on the photosensitive drum.

Step 1: Primary Charging

To prepare for latent image formation, the surface of the photosensitive drum is charged with a uniform negative potential. The primary charging bias is applied to the primary charging roller and the roller charges the drum directly.

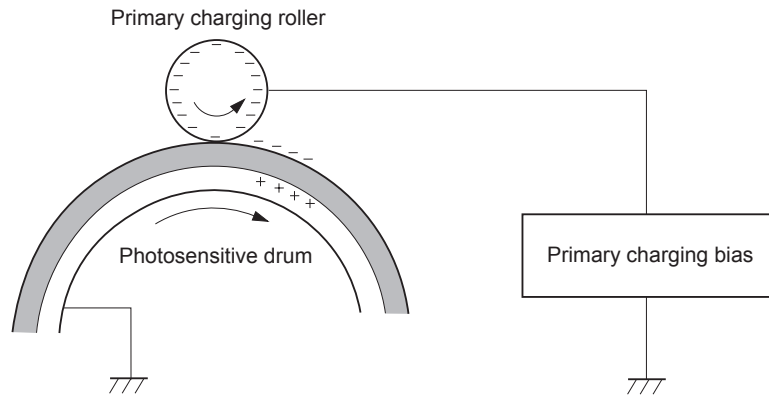

F-2-16

Step 2: Laser-beam Exposure

The laser beam scans the photosensitive drum to neutralize the negative charge on portions of the drum surface. An electrostatic latent image forms where the negative charge was neutralized.

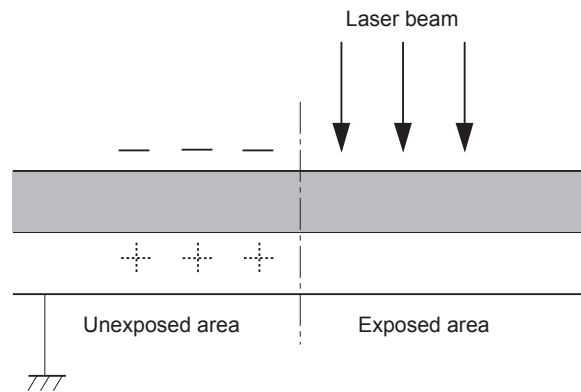

F-2-17

Developing Block

Toner adheres to the electrostatic latent image on the photosensitive drum, which becomes visible.

Step 3: Developing

Toner acquires a negative charge from the friction that occurs when the developing roller rotates against the developing blade. The negatively charged toner is attracted to the latent image on the photosensitive drum surface because the drum surface has a higher potential. The developing bias is applied to the developing roller.

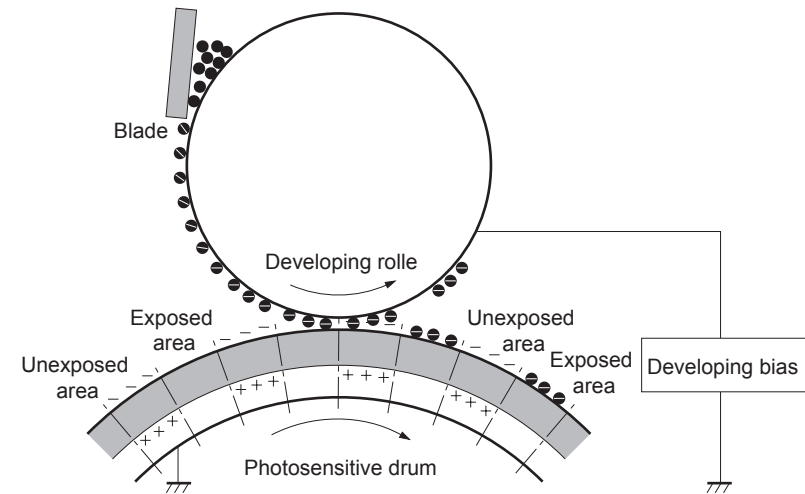

F-2-18

Transfer Block

During the two steps that comprise this block, a toner image on the photosensitive drum is transferred to the print media.

Step 4: Transfer

The transfer bias is applied to the transfer roller to charge the print media positive. The positively charged media attracts the negatively charged toner from the photosensitive drum surface.

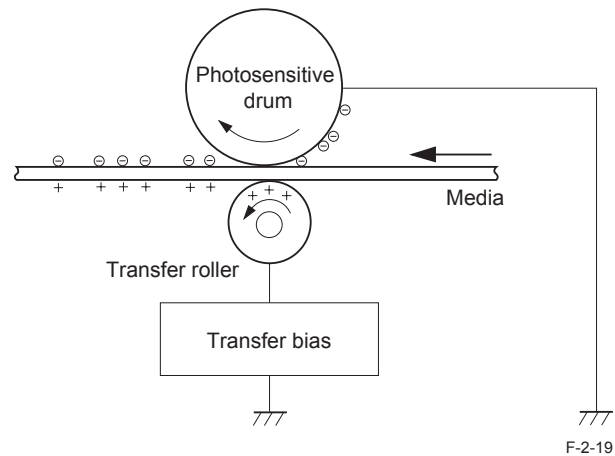

Step 5: Separation

The elasticity of the print media and the curvature of the photosensitive drum cause the media to separate from the drum surface. The static charge eliminator reduces back side static discharge of the media for stable media feed and image quality.

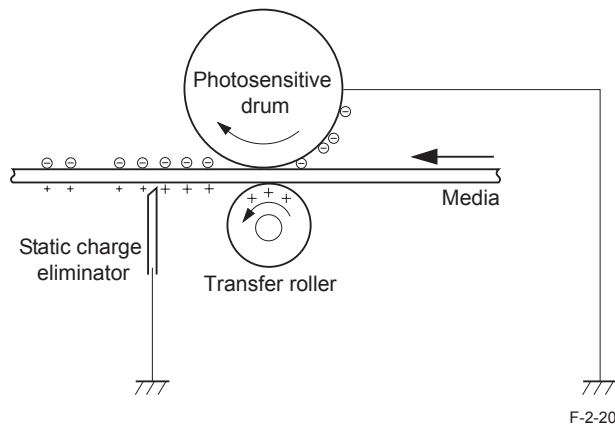

Fixing Block

The toner image is fixed onto the print media.

Step 6: Fixing

The printer uses an on-demand Fixing method. The toner image is permanently affixed to the print media by heat and pressure. The Fixing bias is applied to the Fixing Film to improve image quality.

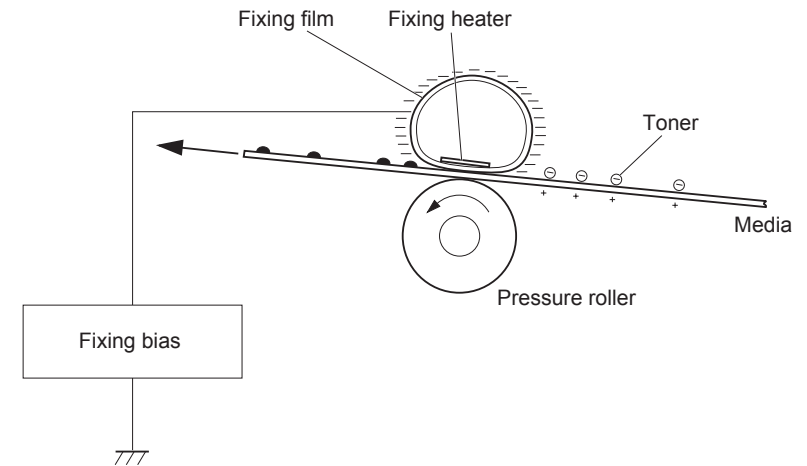

Drum Cleaning Block

The residual toner is cleared from the photosensitive drum surface.

Step 7: Drum Cleaning

The cleaning blade scrapes the residual toner off the surface of the photosensitive drum. The residual toner is deposited in the toner collection box.

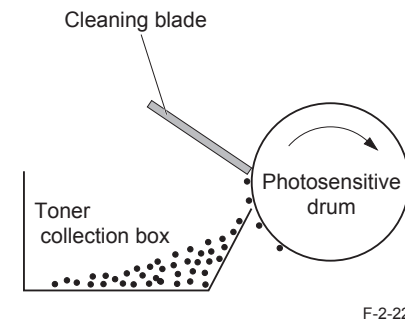

High-voltage Power Supply

Outline

The High-voltage Power Supply applies biases to the following components:

- Primary Charging Roller
- Developing Roller
- Transfer Roller
- Fixing Flm

The DC Controller controls the High-voltage Power Supply to generate biases.

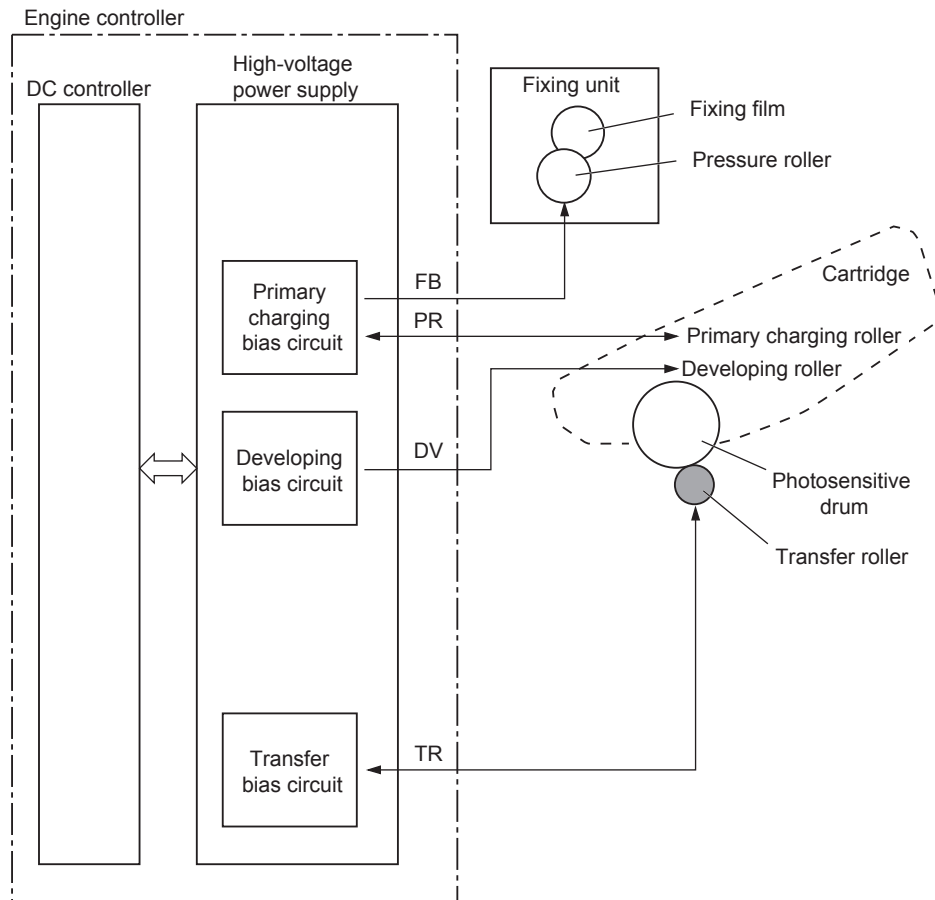

Service Tasks

Action for Parts Replacement

No work is required at parts replacement of this product.

Maintenance

No periodically replaced parts, durable parts or periodical service work is set for this product.

Notes on Field Service

None

Fixing Assembly System

Outline

The Fixing/Delivery Unit fixes the toner onto a print paper and delivers it to the Delivery Tray. The operation of the Fixing/Delivery Unit is explained in the following.

- 1) The print paper fed from the Pickup/Feed Unit is fused the toner by the Fixing Film and the pressure roller.
- 2) The print paper delivered from the Fixing Assembly is delivered to the face-down Delivery Tray or the face-up Delivery slot. When the engine controller detects that the heater temperature reaches 50 deg C after the last rotation is completed, it drives the main Motor for 50 msec. and dislocates the nip part. This prevents the toner adhering to the pressure roller.

The Fixing Assembly of this printer utilizes the on-demand Fixing method. It is structured as shown below.

- Heater:

This Fixing Assembly incorporates one heater.

Fixing Heater (H201/2010): To heat the Fixing Film (ceramic heater)

- Thermistor:

This Fixing Assembly incorporates one thermistor.

Thermistor (TH1/11): Sit almost at the center of the Fixing Film. (contact type)

To control the temperature of the Fixing Film

- Thermal switch:

Thermoswitch (TP201/2010): Sit almost at the center of the Fixing Film (contact type)

If the temperature of the heater rises abnormally high, the contact gets broken and cuts off the AC Voltage Supply to the Fixing Heater to interrupt the power supply to the heater.

The temperature control of the Fixing Assembly incorporated as above is operated by the Fixing temperature control circuit according to the command from the CPU (IC201) on the DC Controller.

The followings describe the each circuit and function of the temperature control of the Fixing Assembly.

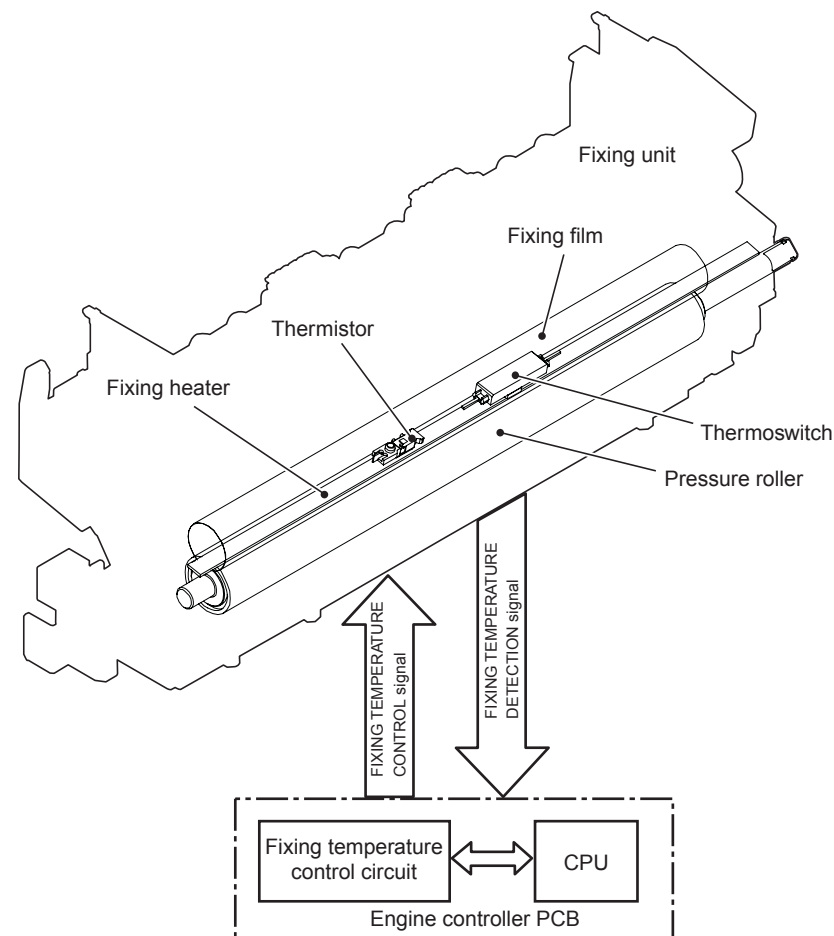

F-2-23

Fixing Control Circuit

The Fixing control circuit controls the temperature in the Fixing Assembly. The printer uses an on-demand Fixing method.

The figure below shows the configuration of the Fixing control circuit.

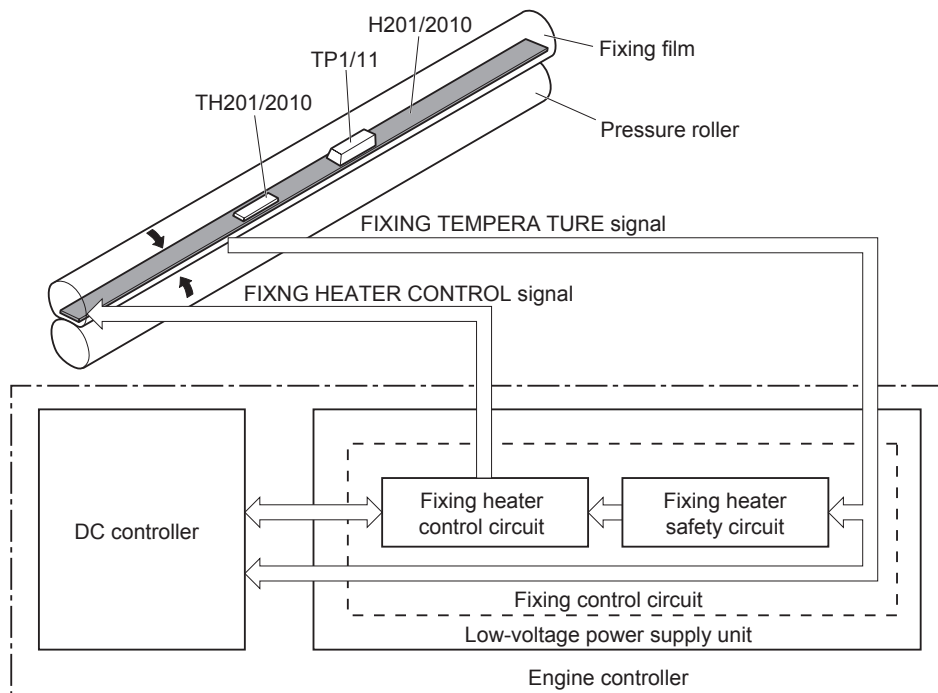

F-2-24

- Fixing Heater (H201/2010): Heats the Fixing Film
- Thermistor (TH1/11): Detects Fixing temperature (Contact type)
- Thermoswitch (TP201/2010): Prevents an abnormal temperature rise of the Fixing Heater (Contact type)

These temperature controls in the Fixing Assembly are performed by the Fixing Heater control circuit and the Fixing Heater safety circuit according to the commands from the DC Controller.

Throughput Reduction Control

During continuous printing, the throughput is changed to reduce heat buildup on parts not in contact with paper, to improve Fixing characteristics and reduce curling.

The throughput reduction is implemented according to the following conditions.

Small Size Paper Speed Control

Fixing Mode	Throughput			
ENVELOPE	1 - 2 imprints 17 ppm	3 - 4 imprints 12 ppm	5 imprints 8 ppm	6 imprints or more 6 ppm
ENVELOPE2	1 - 3 imprints 17 ppm	4 - 7 imprints 12 ppm	8 - 22 imprints 8 ppm	23 imprints or more 6 ppm
ENVELOPE3	1 - 3 imprints 12 ppm	4 - 5 imprints 8 ppm	6 imprints or more 6 ppm	
Postcard	1 - 3 imprints 12 ppm	4 - 5 imprints 8 ppm	6 imprints or more 6 ppm	
Long Narrow				
Normal/Light/OHT	1 - 280 imprints 2 ppm	281 imprints or more 1 ppm		
Label/Heavy1/Heavy2 Envelope/ Envelope2/ Envelope3	1 imprints or more 3 ppm			

T-2-8

16K Paper Speed Control

Fixing Mode	Throughput				
Normal/Light/OHT (Normal mode)	1 - 27 imprints 16 ppm	28 - 39 imprints 14 ppm	40 - 79 imprints 12 ppm	80 - 199 imprints 10 ppm	200 imprints or more 8 ppm
Normal/Light/OHT	1 imprints or more 6 ppm				
Envelope2/ Quiet	1 - 89 imprints 17 ppm	90 imprints or more 14 ppm			
Label/ Envelope/ Envelope3 Heavy1/ Heavy2/ Postcard	1 - 34 imprints 17 ppm	35 imprints or more 8 ppm			

T-2-9

Fixing Temperature Control

The Fixing temperature control maintains the temperature of the Fixing Heater at its targeted temperature.

Block diagram of this control is shown below.

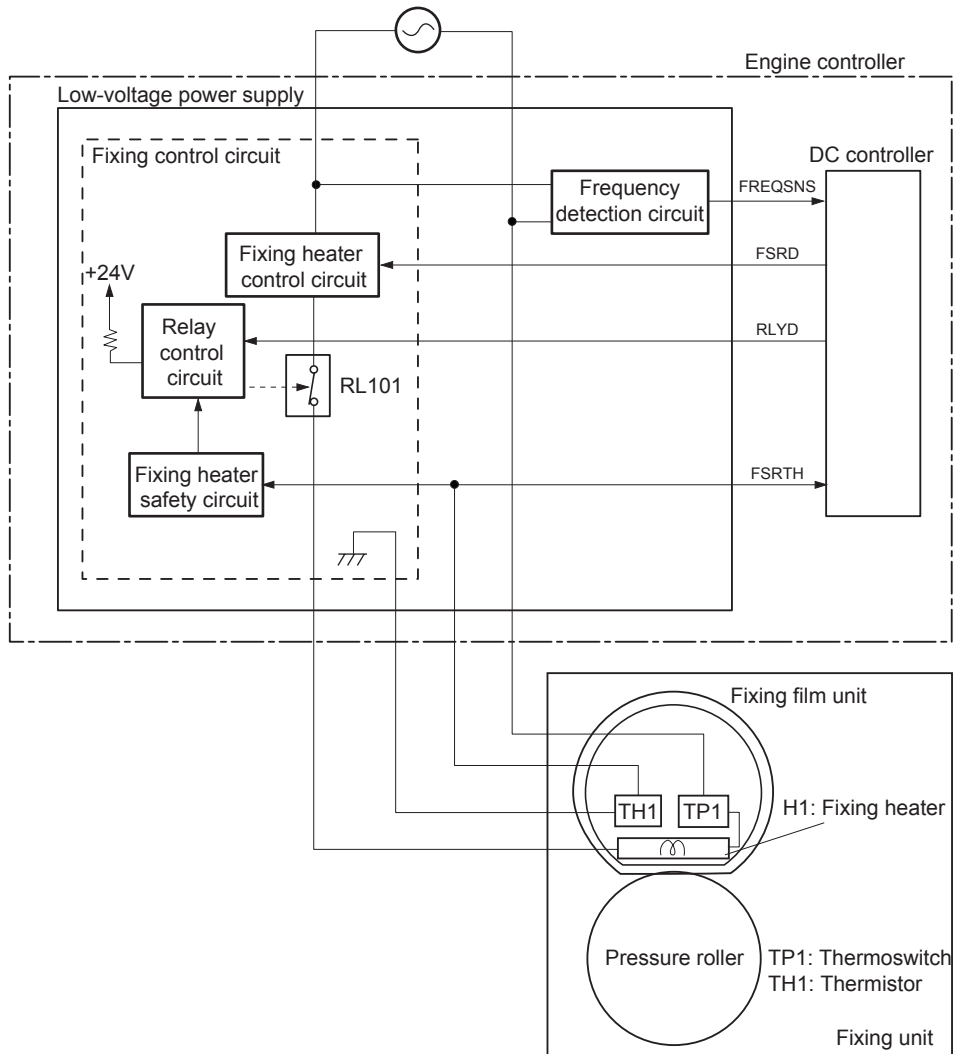

F-2-25

The DC Controller monitors the FIXING TEMPERATURE (FSRTH) signal and sends the FIXING HEATER CONTROL (FSRD) signal according to the detected temperature. The Fixing Heater control circuit controls the Fixing Heater depending on the signal so that the heater remains at the targeted temperature.

Protective Function

The protective function detects an abnormal temperature rise in the Fixing Assembly and interrupts power supply to the Fixing Heater.

The following three protective components prevent an abnormal temperature rise of the Fixing Heater:

- DC Controller
- Fixing Heater safety circuit
- Thermoswitch

1) DC Controller

The DC Controller monitors the detected temperature of the thermistor. The DC Controller makes the FIXING HEATER CONTROL signal inactive and releases the relay to interrupt power supply to the Fixing Heater under the following condition:

2) Fixing Heater safety circuit

The Fixing Heater safety circuit monitors the detected temperature of the thermistor. The Fixing Heater safety circuit releases the relay control circuit to interrupt power supply to the Fixing Heater under the following condition:

3) Thermoswitch

The contact of the thermoswitch is broken to interrupt power supply to the Fixing Heater under the following condition:

■ Failure Detection

The DC Controller determines a Fixing Assembly failure, makes the FIXING HEATER CONTROL signal inactive, releases the relay to interrupt power supply to the Fixing Heater and notifies the formatter of a failure state when it encounters the following conditions:

- 1) Start-up failure
 - If the detected temperature of the thermistor is kept a specified degrees or higher for a specified period of heater start-up during the wait period.
 - If the detected temperature of the thermistor is kept a specified degrees or lower for a specified period under the heater temperature control during the print period.
 - If the detected temperature of the thermistor does not reach its targeted temperature within a specified period under the heater temperature control during the initial rotation period.
- 2) Abnormal low temperature
 - If the detected temperature of the thermistor is kept a specified degrees or lower for a specified period under the heater temperature control.
- 3) Abnormal high temperature
 - If the detected temperature of the main thermistor is kept a specified degrees or higher for a specified period.
- 4) Drive circuit failure
 - If a specified frequency of the FREQUENCY signal is not detected within a specified period after the printer is turned on.

● Service Tasks

■ At Parts Replacement

No work is required for this product at parts replacement.

■ Maintenance

No periodically replaced parts, durable parts or periodical service is set for this product.

■ Notes On Service Works

- When removing the Fixing Assembly, perform the operation after the Fixing Assembly is surely cooled. The Fixing Assembly just after printing may cause burn injury.
- Do not disassemble the Fixing Assembly at a field. It may cause a malfunction.

Media Feed System

Outline

The Media Feed System picks up, feeds and delivers the print media. It consists of several types of rollers.

The Duplex Feed Unit in the Duplex model reverses and Refeeds the print media to print on both sides of media.

The media path is shown below.

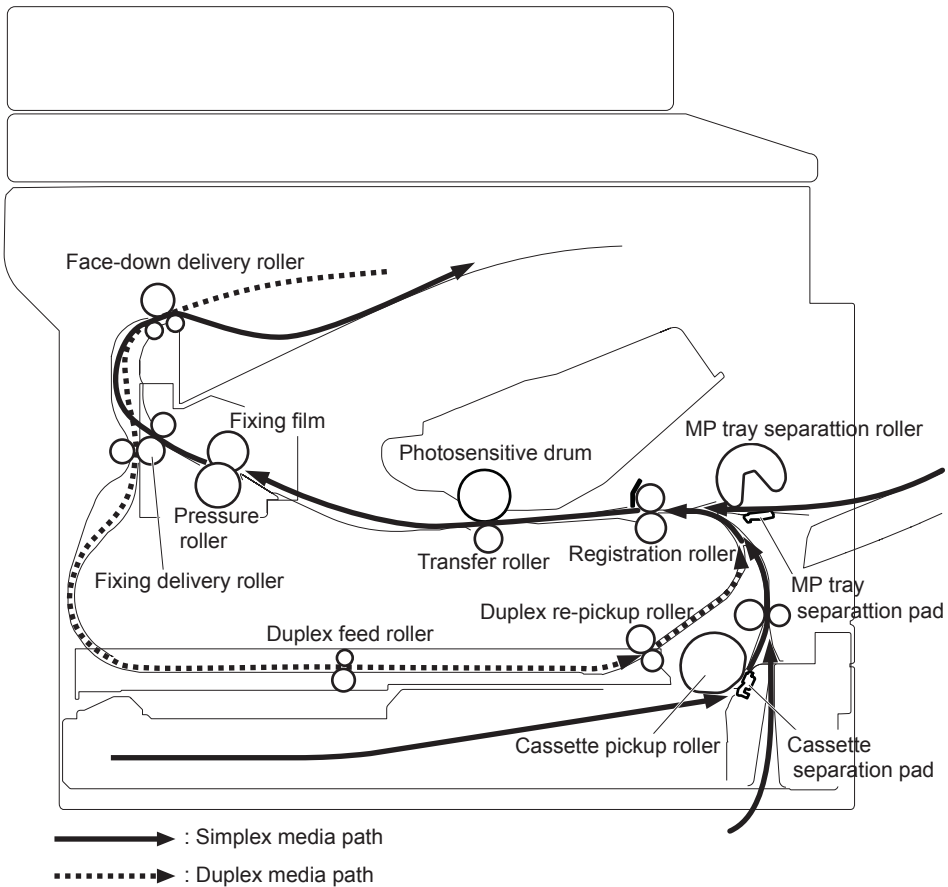

F-2-26

Drive Configuration

Diagram and table of the electrical components are shown below.

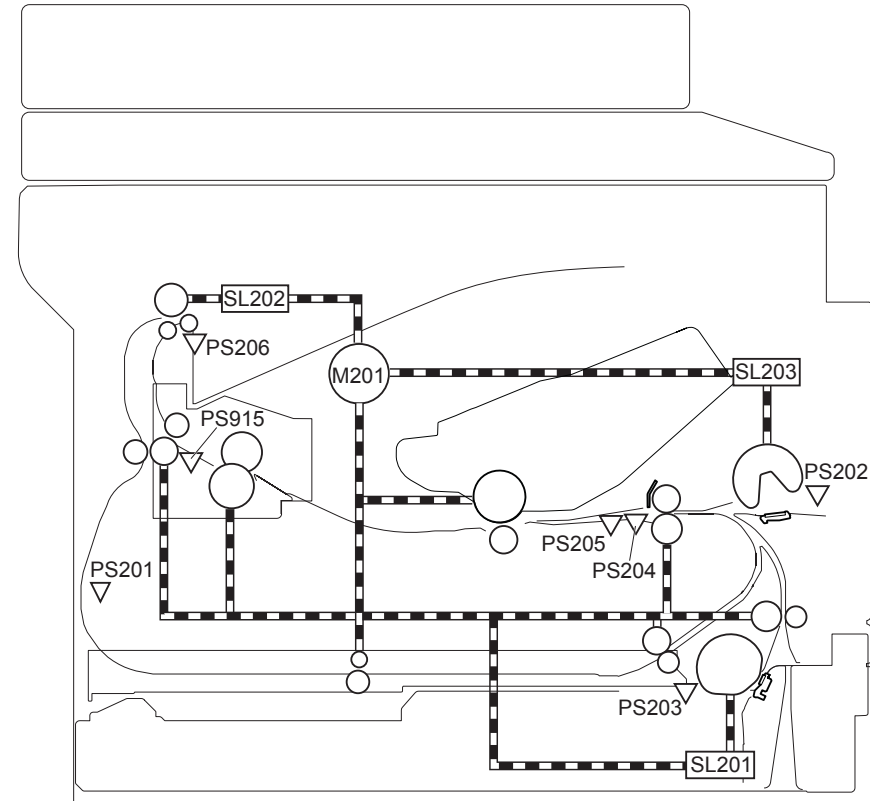

F-2-27

Electrical component	Symbol	Signal
Main Motor	M201	Main Motor Control Signal
Cassette Pickup Solenoid	SL203	Cassette Pickup Solenoid Control Signal
MP Tray Pickup Solenoid	SL201	MP Tray Pickup Solenoid Control Signal
Duplex Reverse Solenoid	SL202	Duplex Reverse Solenoid Control Signal
TOP Sensor	PS204	TOP Signal
Cassette Media Presence Sensor	PS203	Cassette Media Presence Signal
MP Tray Presence Sensor	PS202	MP Tray Media Presence Signal
Fixing Delivery Sensor	PS915	Fixing Delivery Signal (100V)
	PS9150	Fixing Delivery Signal (230V)
Duplex Reverse Sensor	PS201	Duplex Reverse Signal
FD Tray Media Full Sensor	PS206	FD Tray Media Full Signal
Media Width Sensor	PS205	Media Width Signal

T-2-10

Jam Detection

Outline

The printer uses the following sensors to detect the presence of media and to check whether media is being fed correctly or has jammed:

- TOP Sensor (PS204)
- Fixing Delivery Sensor (PS915)
- Duplex Reverse Sensor (PS201)
- Media Width Sensor (PS205)

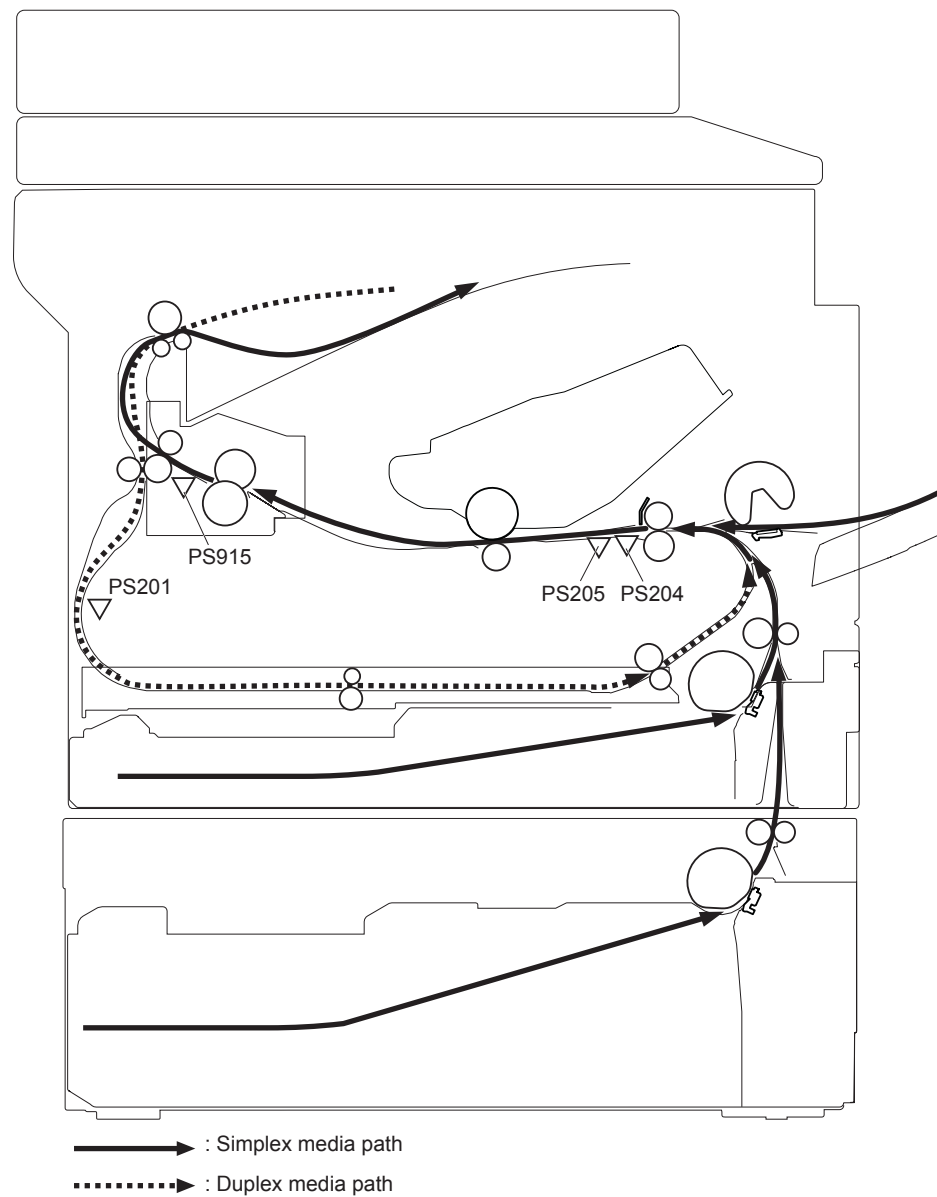

F-2-28

■ Pickup Delay Jam

When the TOP Sensor (PS204) cannot detect the leading edge of paper within the specified time after starting pickup from a cassette, pickup retry is executed twice. After that, the sensor still cannot detect the leading edge of paper within the specified time, it is judged as a pickup jam.

■ Pickup Stationary Jam

When the TOP Sensor (PS204) cannot detect the trailing edge of paper after the specified time has passed since it detected the leading edge of paper, it is judged as a pickup stationary jam.

■ Delivery Delay Jam

When the Fixing Delivery Sensor (100V:PS915, 230V:PS9150) cannot detect the leading edge of paper after the specified time has passed since the TOP Sensor (PS204) detected the leading edge of paper, it is judged as a delivery delay jam.

■ Delivery Stationary Jam

After judging that it is not a Fixing paper wrap, execute the detection of delivery stationary jam.

When the Fixing Delivery Sensor (100V:PS915, 230V:PS9150) does not detect no paper within the specified time since the TOP Sensor (PS204) detected the trailing edge of paper, it is judged as a delivery stationary jam.

■ Fixing Paper Wrap Jam

After judging that it is not a delivery delay jam, execute the detection of Fixing paper wrap jam.

It is judged as a Fixing paper wrap jam when all of the following conditions are met: after the specified time had passed since the Fixing Delivery Sensor (100V:PS915, 230V:PS9150) detected the leading edge of paper, after the specified time had passed since the TOP Sensor (PS204) detected the leading edge of paper, and the Fixing Delivery Sensor (100V:PS915, 230V:PS9150) detects no paper.

■ Reverse Delay Jam

After judging that it is not a delivery stationary jam, execute the detection of reverse stationary jam.

When the Duplex Reverse Sensor (PS201) does not detect paper after the specified time has passed since the Fixing Delivery Sensor (100V:PS915, 230V:PS9150) detected the trailing edge of paper, it is judged as a reverse delay jam.

■ Reverse Stationary Jam

When the Duplex Reverse Sensor (PS201) cannot detect the trailing edge of paper after the specified time has passed since the sensor detected the leading edge of paper, it is judged as a reverse stationary jam.

■ Internal Residual Jam

When a paper is detected by the TOP Sensor (PS204), Fixing Delivery Sensor (100V:PS915, 230V:PS9150), Paper Width Sensor (PS205), or Duplex Reverse Sensor (PS201) at the time of starting initial rotation, it is judged as an internal residual jam.

■ Door Open Jam

When a door-open is detected while feeding papers, it is judged as a door open jam.

● Service Tasks

■ At Parts Replacement

No work is accompanied with parts replacement.

■ Maintenance

No periodically replaced parts, durable parts or periodical service is set for this product.

■ Notes On Service Works

No periodically



Periodical Services

- Periodically Replaced Parts
- Consumable Parts
- Periodical Service
- Cleaning

Periodically Replaced Parts

No periodically replaced parts is set for this product.

Consumable Parts

Parts name	Product No.	Q'ty	Interval	Remarks
ADF Separation Pad	FC7-6297	1	50,000 sheets	
ADF Separation Roller	FL2-6637	1	50,000 sheets	

T-3-1

Periodical Service

No periodically replaced parts is set for this product.

Cleaning

Component	Cleaning method
Scanning Area	Clean with Oil Glass Cleaner (FY9-6020) and lint-free paper. Wipe With a Lint-free Cloth.
Copy board glass	
Cassette Pickup Roller	
Transfer Guide Unit	
Media Feed Belt And Media Feed Guide Unit	
Fixing Inlet Guide	

T-3-2

4

Disassembly/Assembly

- List of Parts
- External Cover (D1300 Series)
- External Cover (MF5900 Series)
- Document Exposure, Feed System
- Controller System
- Laser Exposure System
- Image Forming System
- Fixing System
- Pickup Feed System

List of Parts

External View

MF5900 Series

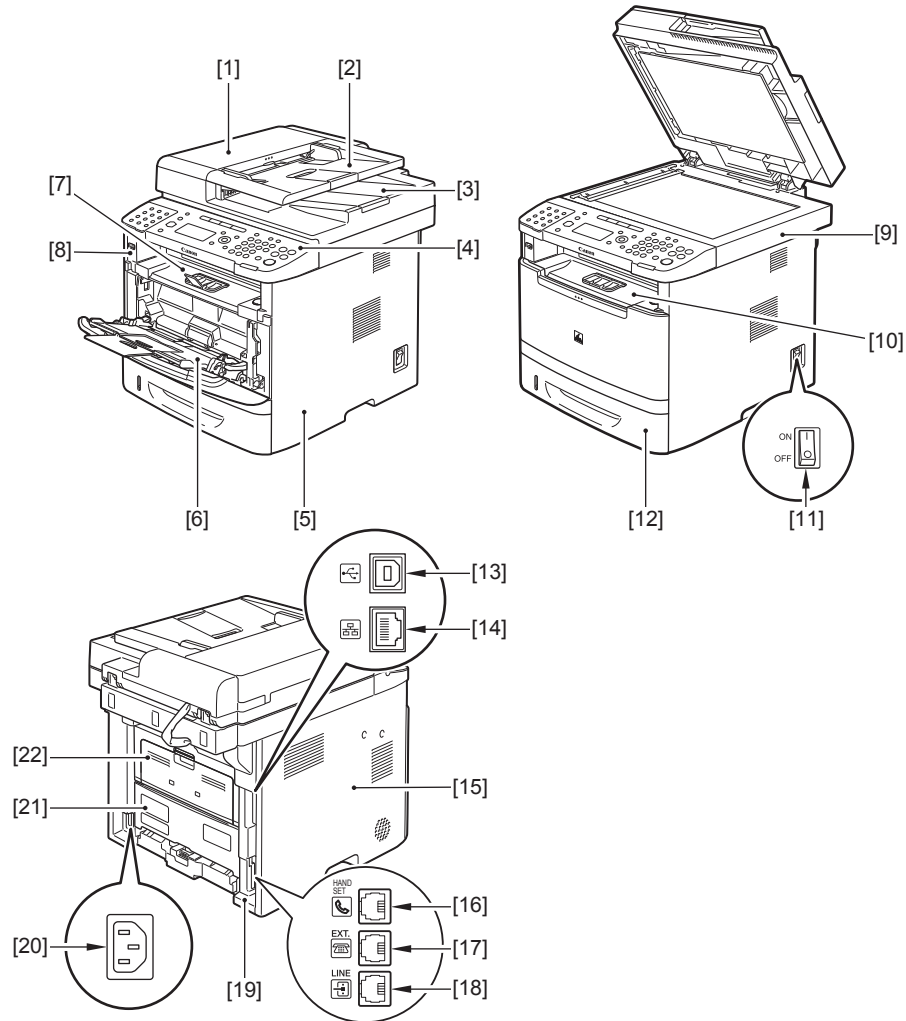

Key	Name	Key	Name
[1]	DADF (Duplex Automatic Document Feeder)	[13]	USB Port 2
[2]	Document Feeder Tray	[14]	Ethernet Port
[3]	Document Delivery Tray	[15]	Left Cover Unit
[4]	Control Panel	[16]	Handset Terminal
[5]	Right Cover	[17]	External Telephone Terminal
[6]	MP Pickup Tray	[18]	Telephone Line Terminal
[7]	Upper Cover	[19]	Left Rear Cover
[8]	USB Port	[20]	Power Socket
[9]	Reader Unit	[21]	Rear Lower Cover
[10]	Front Cover	[22]	Rear Upper Cover
[11]	Main Power Switch		
[12]	Paper Cassette		

T-4-1

F-4-1

D1300 Series

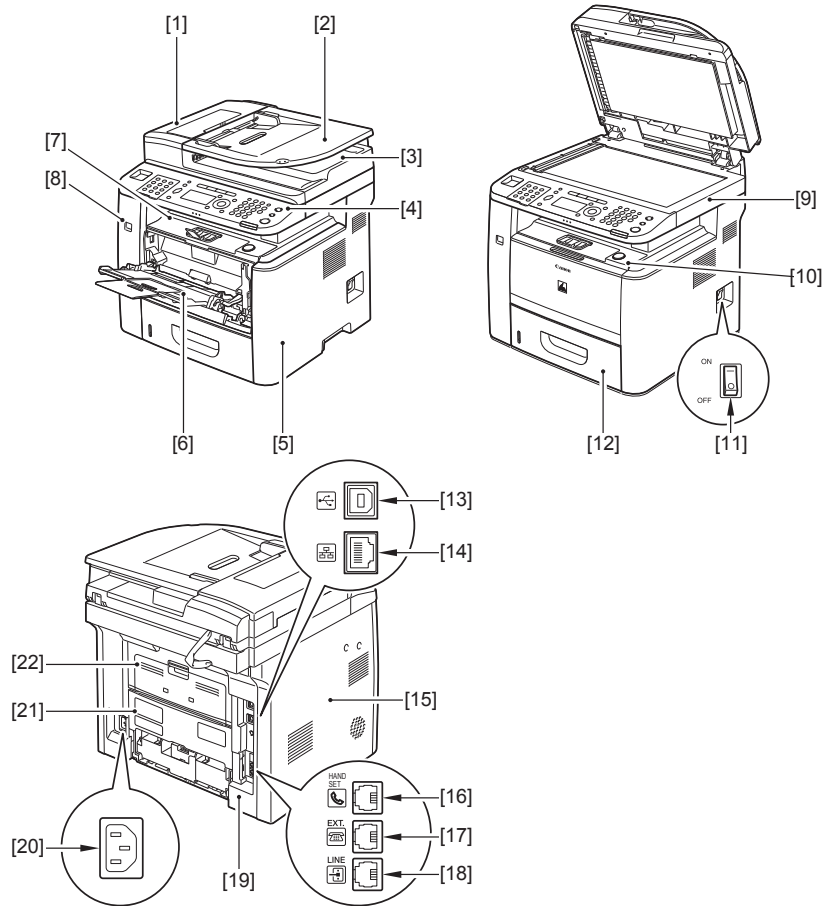

Key	Name	Key	Name
[1]	DADF (Duplex Automatic Document Feeder)	[13]	USB Port 2
[2]	Document Feeder Tray	[14]	Ethernet Port
[3]	Document Delivery Tray	[15]	Left Cover Unit
[4]	Control Panel	[16]	Handset Terminal
[5]	Right Cover Unit	[17]	External Telephone Terminal
[6]	MP Pickup Tray	[18]	Telephone Line Terminal
[7]	Upper Cover	[19]	Left Rear Cover
[8]	USB Port	[20]	Power Socket
[9]	Reader Unit	[21]	Rear Lower Cover
[10]	Front Cover	[22]	Rear Upper Cover
[11]	Main Power Switch		
[12]	Paper Cassette		

T-4-2

F-4-2

Main Unit

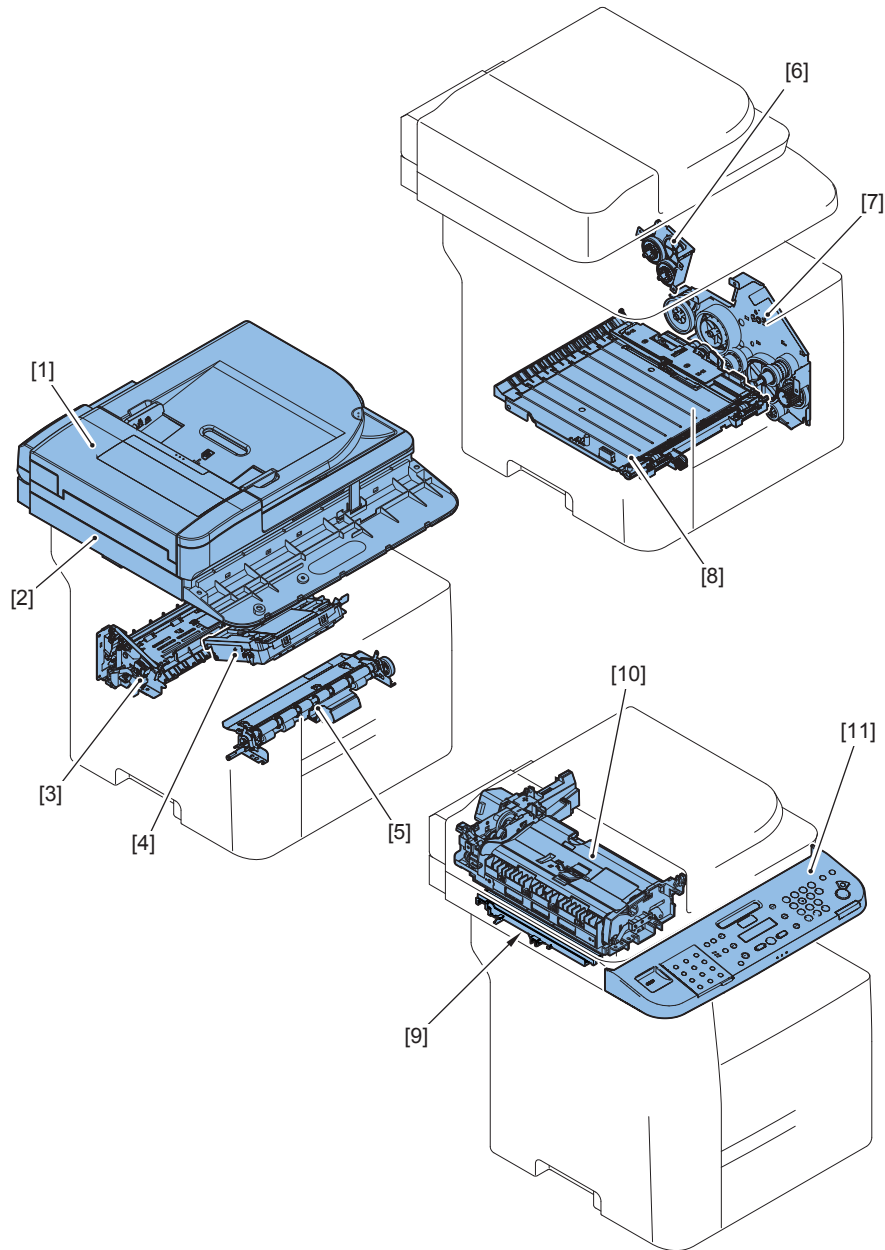

F-4-3

Key	Name	Remarks
[1]	DADF (Duplex Automatic Document Feeder)	-
[2]	Reader Unit	-
[3]	Fixing Unit	(120V) (230V)
[4]	Laser Scanner Unit	-
[5]	Registration Unit	-
[6]	Duplex Drive Unit	
[7]	Main Drive Unit	
[8]	Duplex Feed Unit	
[9]	Contact Sensor	
[10]	ADF Pickup Feed Unit	
[11]	Control Panel	

T-4-3

Main Parts

Sensor / Switch

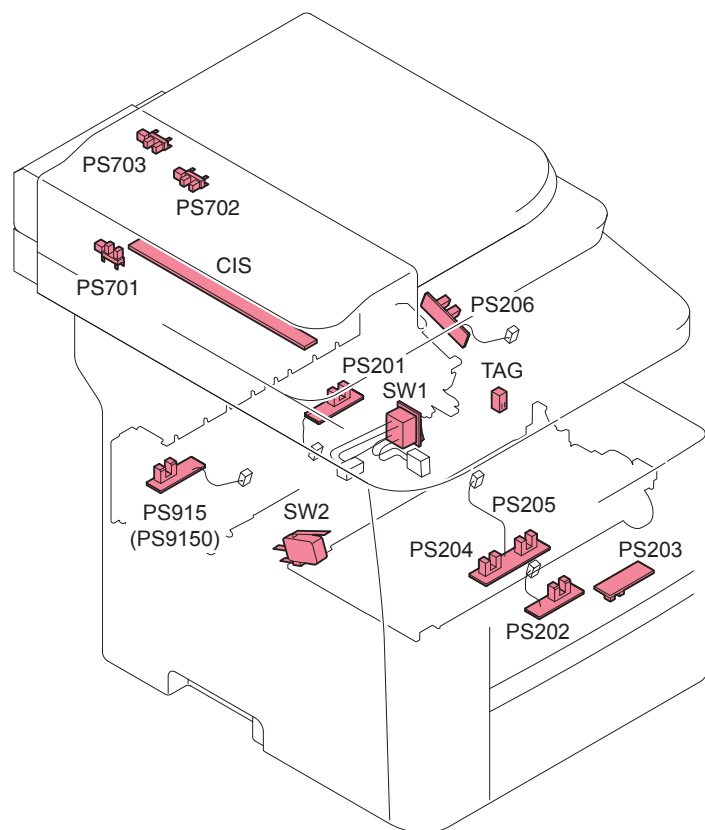

F-4-4

Symbol	Name	Remarks
CIS	CIS Unit	-
PS201	Duplex Reverse Sensor	-
PS202	MP Tray Media Presence Sensor	-
PS203	Cassette Media Presence Sensor	-
PS204	Top Sensor	-
PS205	Media Width Sensor	-
PS206	FD Tray Media Full Sensor	-
PS701	Scanner Home Position Sensor	-
PS702	Document End Sensor	-
PS703	Document Sensor	-
PS915	Fixing Delivery Sensor	(100/120V)
PS9150		(230V)
SW1	Main Switch	-
SW2	Door Switch	-
TAG	Cartridge Sensor	-

T-4-4

Motor / Fan

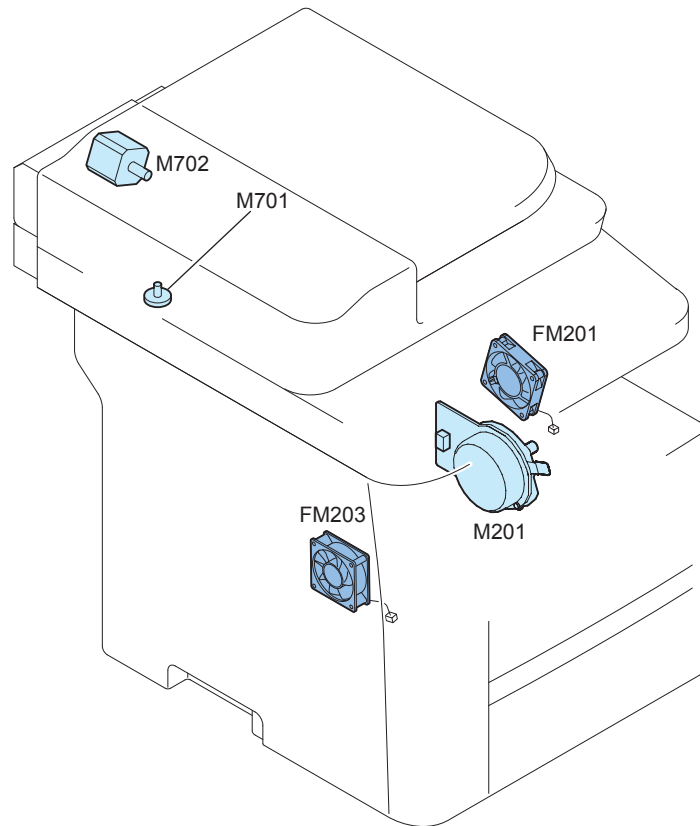

F-4-5

Symbol	Name	Remarks
FM201	Main Fan	-
FM203	Controller Fan	-
M201	Main Motor	-
M701	Scanner Motor	-
M702	ADF Motor	-

T-4-5

Other

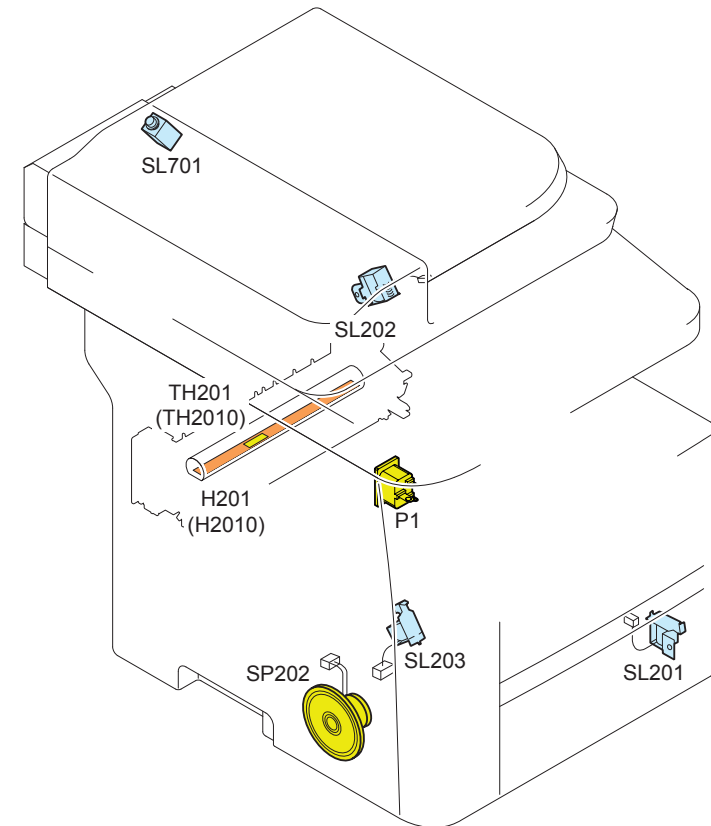

F-4-6

Symbol	Name	Remarks
H201	Heater	-
H2010		-
P1	Power Cord Outlet	-
SL201	Cassette Pickup Sorenoide	-
SL202	Duplex Reverse Sorenoide	-
SL203	MP Tray Pickup Sorenoide	-
SL701	ADF Delivery Sorenoide	-
SP202	Speaker	-
TH201	Thermistor	-
TH2010		-

T-4-6

PCB

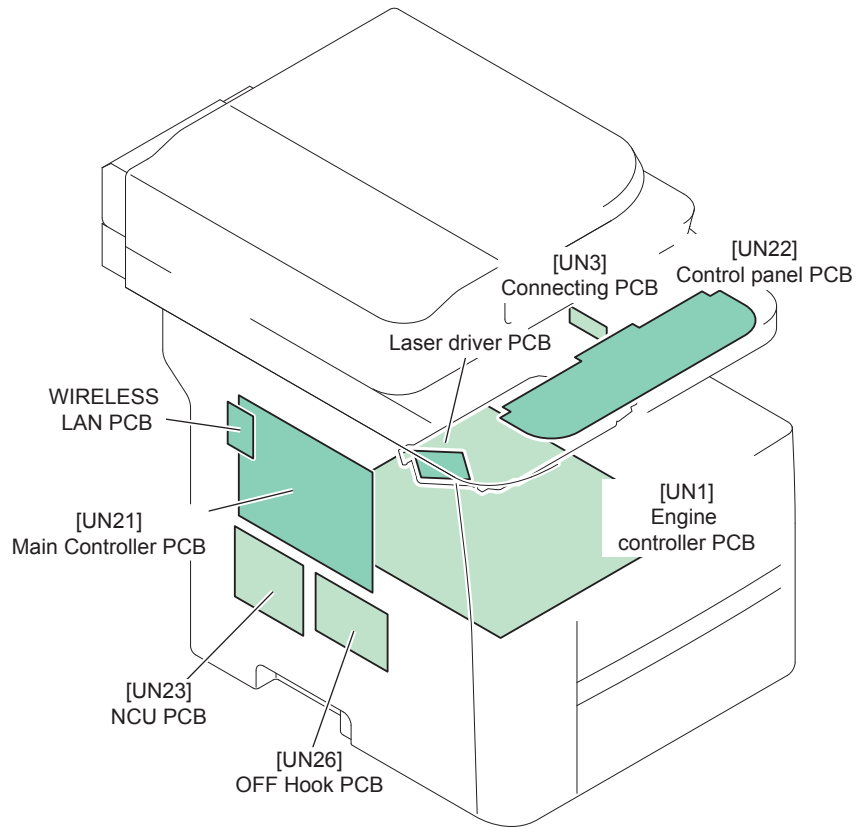

Symbol	Name	Remarks
UN1	Engine Controller PCB	
UN3	Connecting PCB	
UN21	Main Controller PCB	
UN22	Control Panel PCB	
UN23	NCU PCB	Fax ,model only
UN25	OFF Hook PCB	Fax ,model only
-	Laser driver PCB	

T-4-7

Connector Layout Drawing

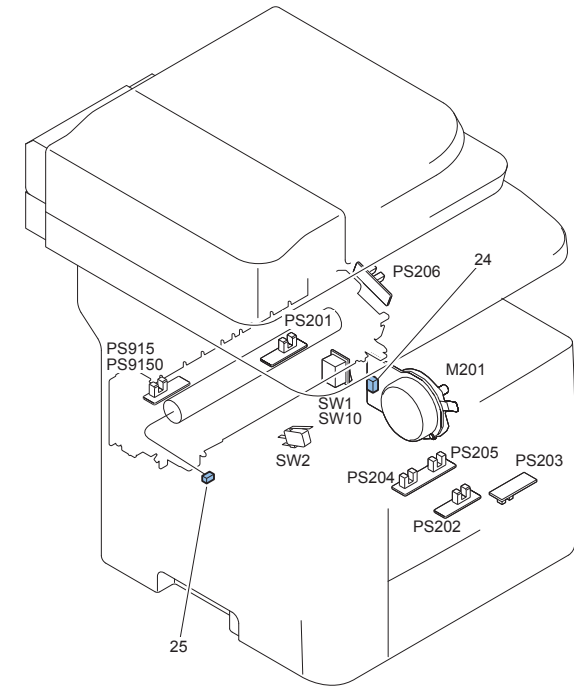
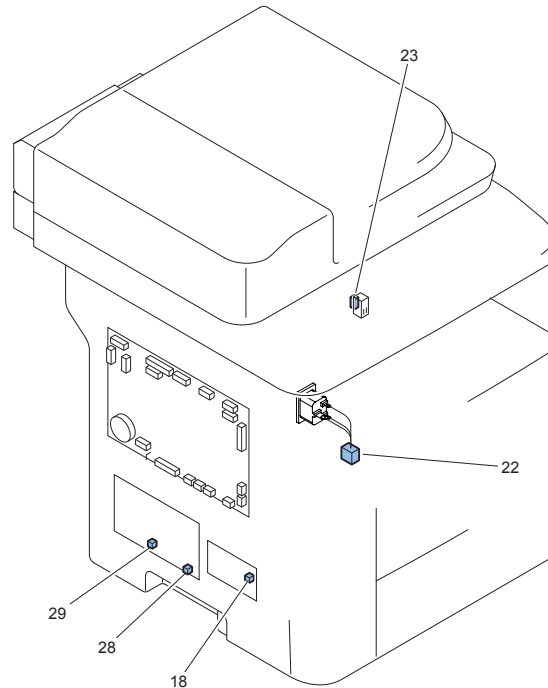
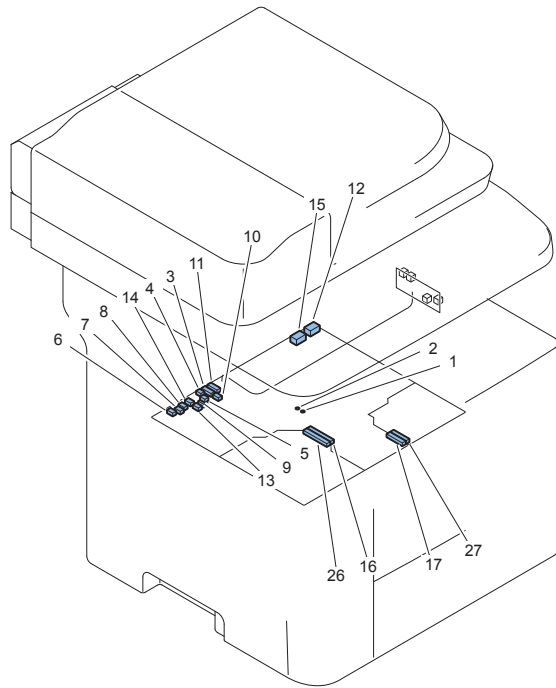

F-4-7

KeyNo.	Symbol	J No.	Parts Name	Intermediate Connector	KeyNo.	J No.	Symbol	Parts Name)	REMARKS
1	UN1	J251	Engine controller PCB	-	-	-	SW2	Door switch	
2	UN1	J252	Engine controller PCB	-	-	-	SW2	Door switch	
3	UN1	J211	Engine controller PCB	-	22	J1205	-	Option Drawer Connector	
4	UN1	J214	Engine controller PCB	-	23	J2100	TAG	Cartridge sensor	
5	UN1	J208	Engine controller PCB	-	-	-	PS201	Duplex Reverse Sensor	
6	UN1	J205	Engine controller PCB	-	-	-	PS202	MP Tray Presence Sensor	
7	UN1	J204	Engine controller PCB	-	-	-	PS203	Cassette Media Presence Sensor	
8	UN1	J203	Engine controller PCB	-	-	-	PS204	Top Sensor	
8	UN1	J203	Engine controller PCB	-	-	-	PS205	Media Full Sensor	
9	UN1	J213	Engine controller PCB	-	-	-	PS206	FD Tray Media Full Sensor	
10	UN1	J202	Engine controller PCB	-	24	J1202	M201	Main motor	
11	UN1	J207	Engine controller PCB	-	-	-	UN3	Connecting PCB	
12	UN1	J212	Engine controller PCB	-	25	J407	H201	Heater (100V/120V)	100V/120V
13	UN1	J210	Engine controller PCB	-	-	-	TH201	Thermistor (100V/120V)	100V/120V
14	UN1	J206	Engine controller PCB	-	-	-	PS915	Fixing delivery sensor (100V/120V)	100V/120V
12	UN1	J2120	Engine controller PCB	-	26	J5	H2010	Heater (230V)	230V
13	UN1	J2200	Engine controller PCB	-	-	-	TH2010	Thermistor (230V)	230V

KeyNo.	Symbol	J No.	Parts Name	Intermediate Connector			KeyNo.	J No.	Symbol	Parts Name)	REMARKS
14	UN1	J2060	Engine controller PCB	-			-	PS9150	Fixing delivery sensor (230V)	230V	
15	UN1	J215	Engine controller PCB	-				SW1	Main Switch	120V/230V	
15	UN1	J209	-	-			-	SW10	-	100V	
	SW1	-	Main switch	-			-	P1	Power Cord Outlet	120V/230V	
16	UN1	J271	Engine controller PCB	-			J257	-	HV DV PCB		
17	UN1	J270	Engine controller PCB	-		27	J256	-	HV TR PCB		
18	-	J952	-	-		28	J932	-	-	100V	
18	-	J2001	OFF Hook PCB	-		28	J9320	-	NCU PCB	120V/230V	
19	UN5	J11	-	-			-	P10	-	100V	
20	UN5	J12	-	-			-	SW10	-	100V	
21	UN5	J13	-	-		29	J936	-	-		

T-4-8

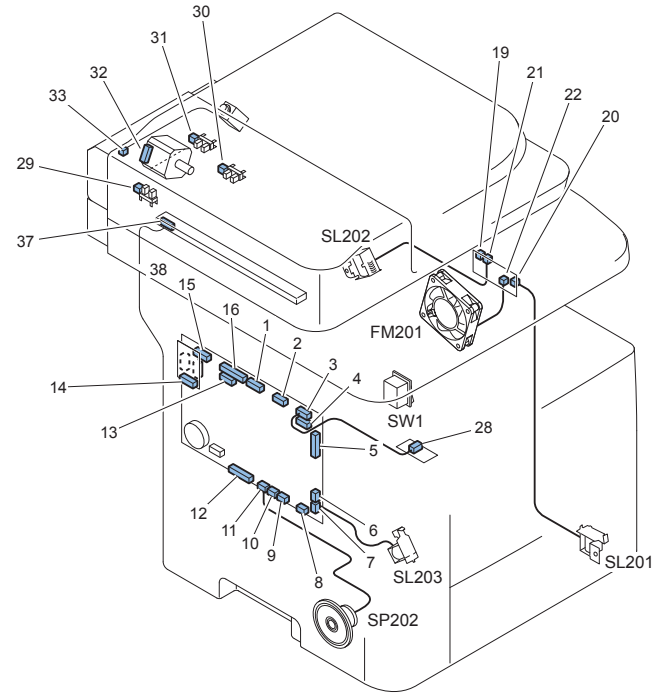
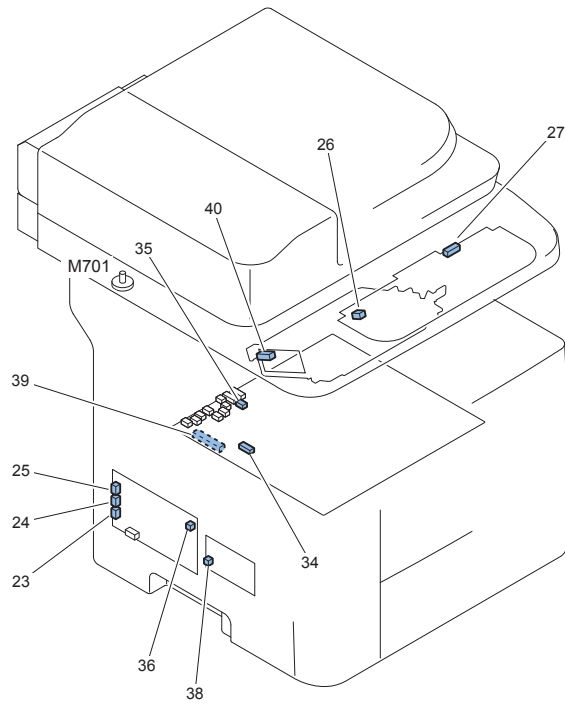

F-4-8

KeyNo.	Symbol	J No.	Parts Name	Intermediate Connector	KeyNo.	J No.	Symbol	Parts Name	REMARKS
1	UN21	J904	Main Controller PCB	-	29	J801	-	Laser Driver PCB	
2	UN21	J902	Main Controller PCB	-	30	J401	-	Operation LCD PCB	
3	UN21	J907	Main Controller PCB	-	31	J2	-	USB Reray PCB	D1300 Series
3	UN21	J9070	Main Controller PCB	-	31	J20	-	USB Reray PCB	MF5900 Series
4	UN21	J909	Main Controller PCB	J1502		-	M701	Scanner Motor	MF5900 Series
4	UN21	J909	Main Controller PCB	-	32	J1401	PS701	Scanner home position sensor	MF5900 Series
4	UN21	J9090	Main Controller PCB	J9502		-	M701	Scanner Motor	D1300 Series
4	UN21	J9090	Main Controller PCB	-	32	J1401	PS701	Scanner home position sensor	D1300 Series
5	UN21	J910	Main Controller PCB	J1755					
5	UN21	J910	Main Controller PCB	-	34	J1302	PS703	Document sensor	
5	UN21	J910	Main Controller PCB	-	35	J1300	M702	ADF motor	
5	UN21	J910	Main Controller PCB	-	36	J1304	SL701	ADF delivery solenoid	
6	UN21	J915	Main Controller PCB	J1501		-	FM203	Controller fan	
7	UN21	J918	Main Controller PCB	-		-	SL203	MP tray pickup solenoid	
8	UN21	J921	Main Controller PCB	-	37	J255	UN1	Engine controller PCB	
9	UN21	J922	-	-	38	J951	-	-	100V
9	UN21	J9220	Main Controller PCB	-	38	J2000	-	OFF Hook PCB	120V/230V
10	UN21	J920	Main Controller PCB	-		-	-	-	
11	UN21	J923	Main Controller PCB	-		-	SP202	Speaker	

KeyNo.	Symbol	J No.	Parts Name	Intermediate Connector			KeyNo.	J No.	Symbol	Parts Name	REMARKS
12	UN21	J925	Main Controller PCB	-			39	J931	-	NCU PCB	
13	UN21	J901	Main Controller PCB	-			40	J409	-	CIS	
15	UN21	J905	Main Controller PCB	-			14	J1	-	Wireless LAN PCB	
16	UN21	J903	Main Controller PCB	-			42	J201	UN1	Engine controller PCB	
22	UN3	J1103	Connecting PCB	-			43	J802	M202	Scanner motor	
23	UN3	J1104	Connecting PCB	-				-	SL201	Cassette pickup solenoid	
24	UN3	J1101	Connecting PCB	-				-	SL202	Duplex reverse solenoid	
25	UN3	J1105	Connecting PCB	J904				-	FM201	Main fan	
26	-	J933	NCU PCB	-				-	-	-	
27	-	J934	NCU PCB	-				-	-	-	
28	-	J935	NCU PCB	-				-	-	-	

T-4-9

External Cover (D1300 Series)

Removing the Left Cover Unit

Procedure

- 1) Remove the cassette [1].
- 2) Press the Open button [2], and open the Front Cover [3].

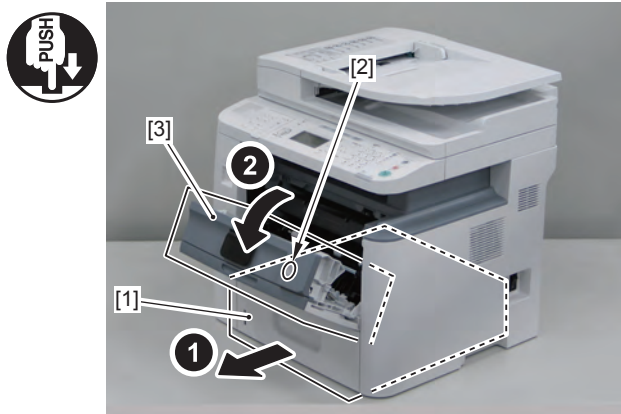

F-4-9

- 3) Open the ADF Unit + Reader Unit [1].

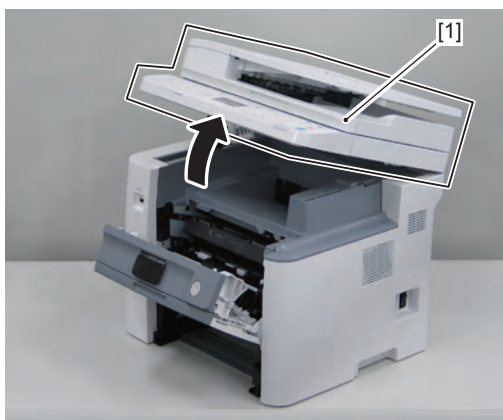

F-4-10

- 4) Place the host machine [1] while shifting the left side of it approx. 10cm from the working table to release the claw at the lower side of the Left Cover Unit.

CAUTION:

Be careful not to drop the host machine when shifting it.

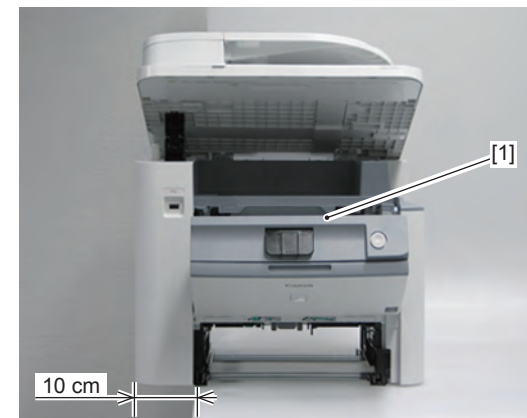

F-4-11

- 5) Release the claw [1].



F-4-12

7) While opening the Left Cover Unit [1] in the direction of the arrow, release the 2 Claws [2] at lower side.

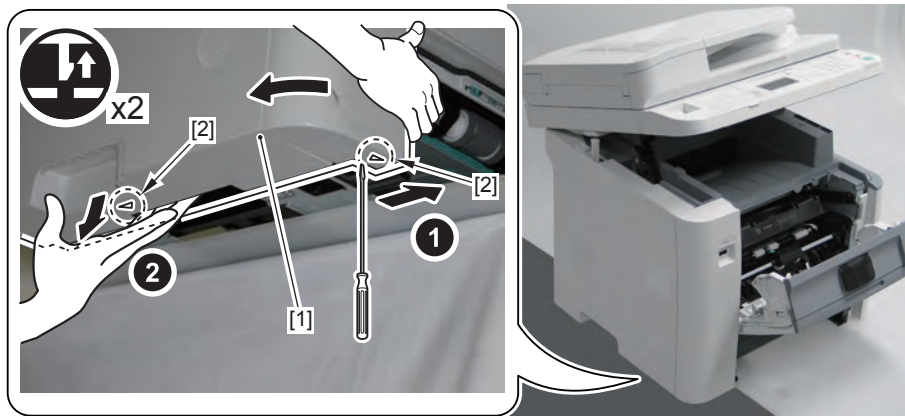

F-4-13

6) Release the claw [2] while pulling the Left Cover Unit [1] in the direction of the arrow.



F-4-14

8) Remove the Left Cover Unit [1] in the direction of the arrow.

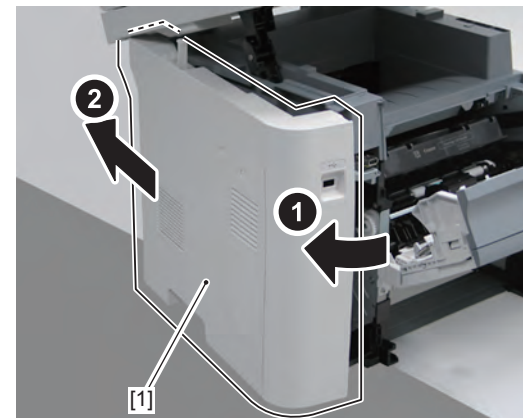

F-4-15

Removing the Left Rear Cover

Preparations

1) Removing the Left Cover Unit.

Procedure

1) Release the claw [1], and remove the Arm Cover [2].

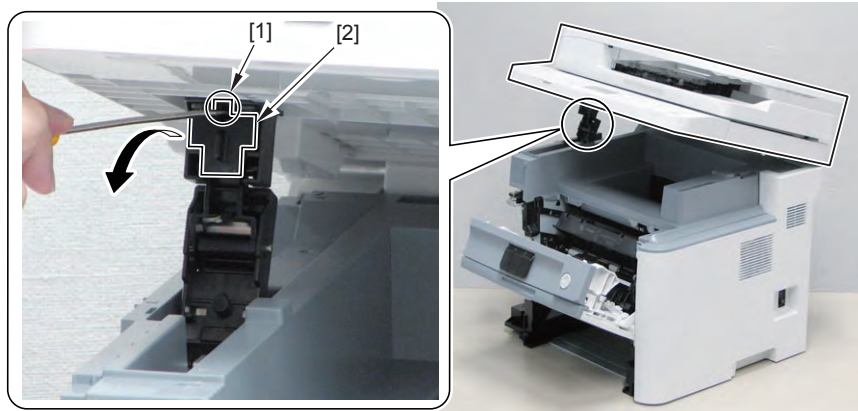

F-4-16

2) Release the Connection of Arm [1] and turn it toward the rear.

CAUTION:

When opening/closing the ADF+Reader Unit after releasing the arm, be sure perform the work while supporting the ADF+Reader Unit. Be careful not to get your hand caught.

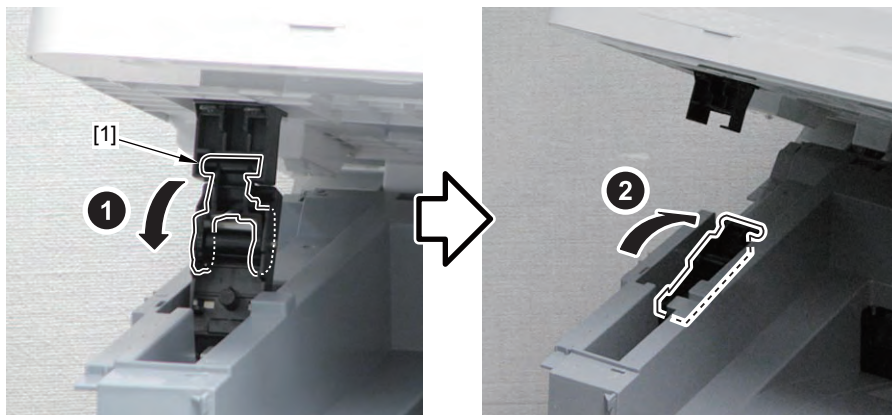

F-4-17

3) Open the ADF Unit + Reader Unit [1], and release the 2 Claws [2].

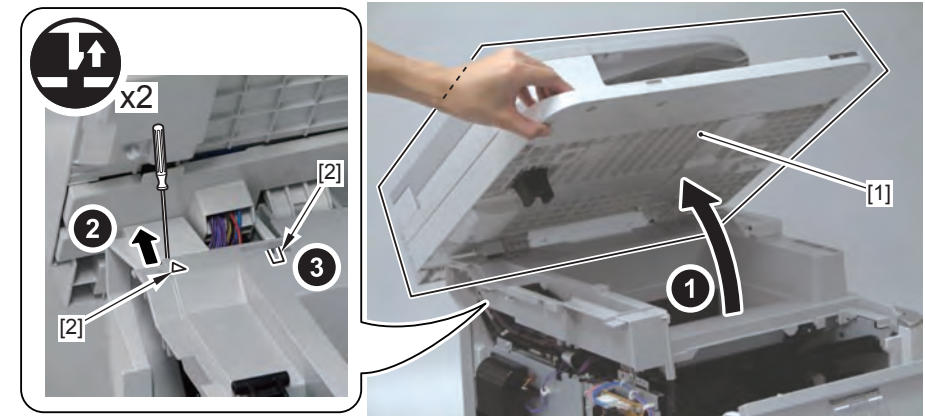

F-4-18

4) While lifting left side of the host machine [1], remove the Left Rear Cover [2].

- 1 Screw [3]
- 2 Hooks [4]

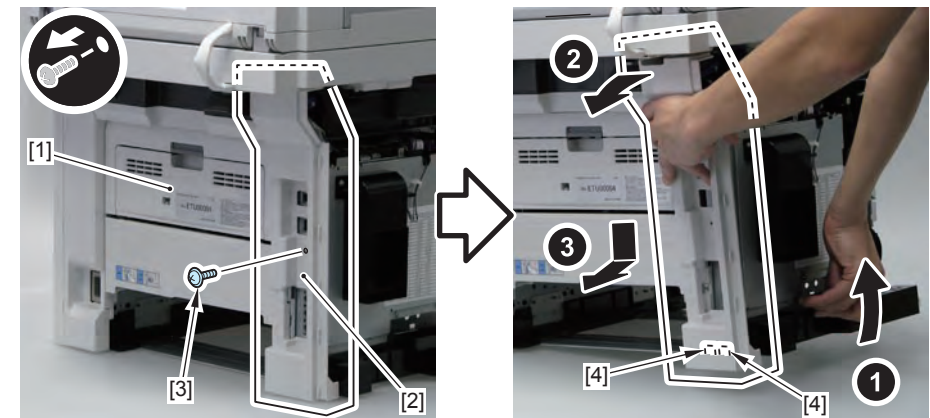

F-4-19

Removing the Right Cover Unit

Procedure

- 1) Remove the cassette [1].
- 2) Press the Open button [2], and open the Front Cover [3].

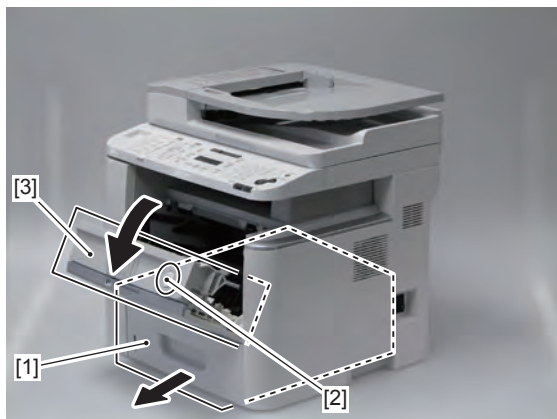

F-4-20

- 3) Open the ADF Unit + Reader Unit [1].

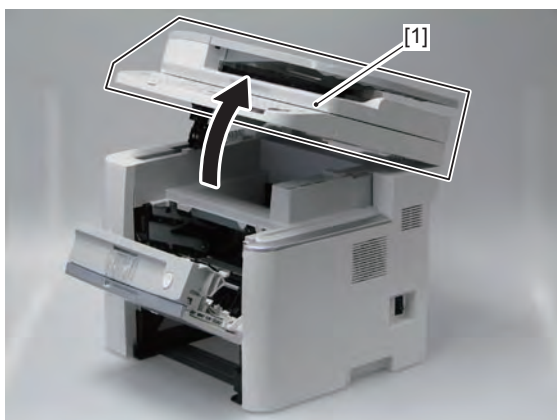

F-4-21

- 4) Release the claw [1], and remove the Arm Cover [2].

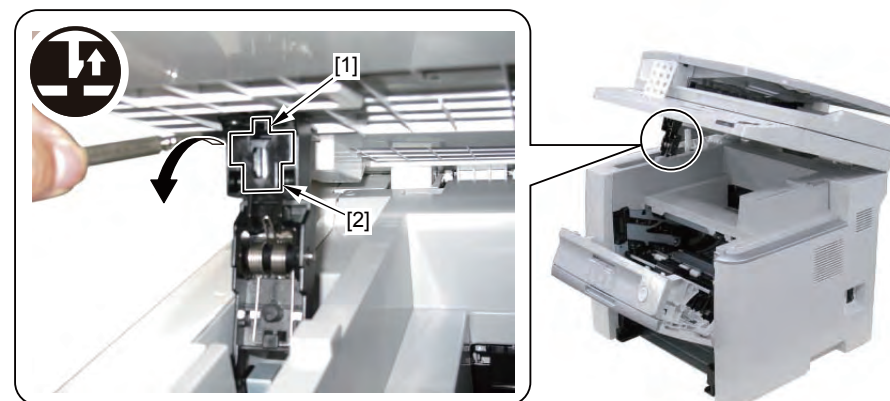

F-4-22

- 5) Release the Connection of Arm [1] and turn it toward the rear.

CAUTION:

When opening/closing the ADF+Reader Unit after releasing the arm, be sure perform the work while supporting the ADF+Reader Unit. Be careful not to get your hand caught.

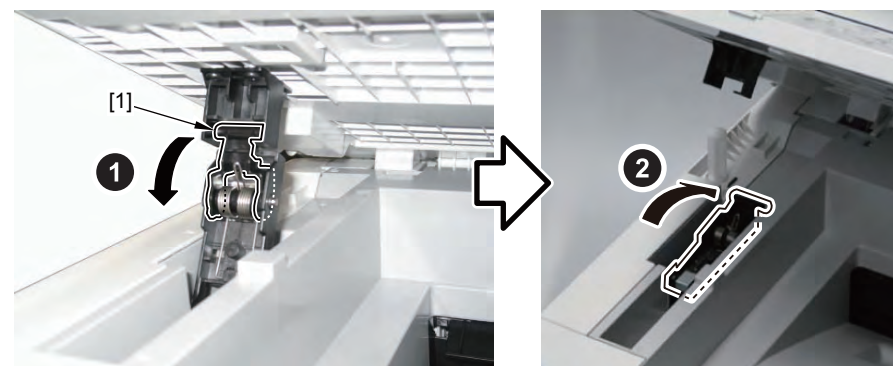

F-4-23

6) Place the host machine [1] while shifting the left side of it approx. 10cm from the working table to release the claw at the lower side of the Right Cover Unit.

CAUTION:

Be careful not to drop the host machine when shifting it.

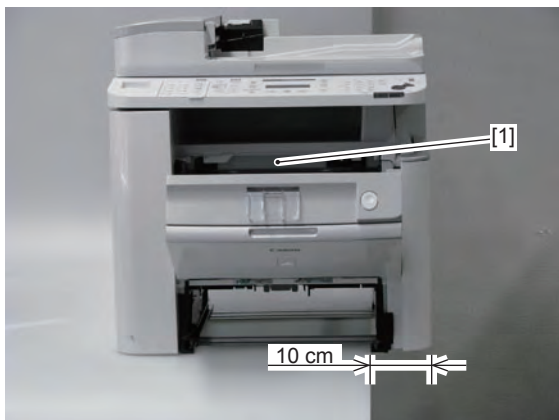

F-4-24

7) Open the ADF Unit + Reader Unit [1], and release the 2 Claws [3] while pulling the Right Cover Unit [2] in the direction of the arrow.

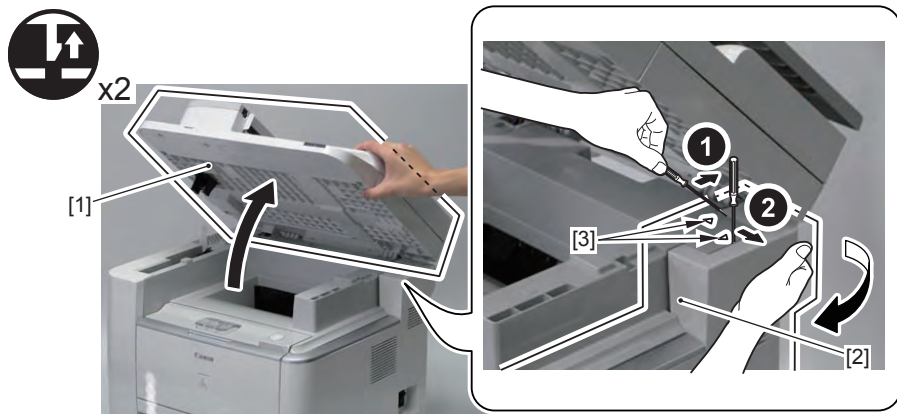

F-4-25

8) Close the ADF Unit + Reader Unit, and release the 2 Claws [2] at lower side while pulling the Right Cover Unit [1] in the direction of the arrow.

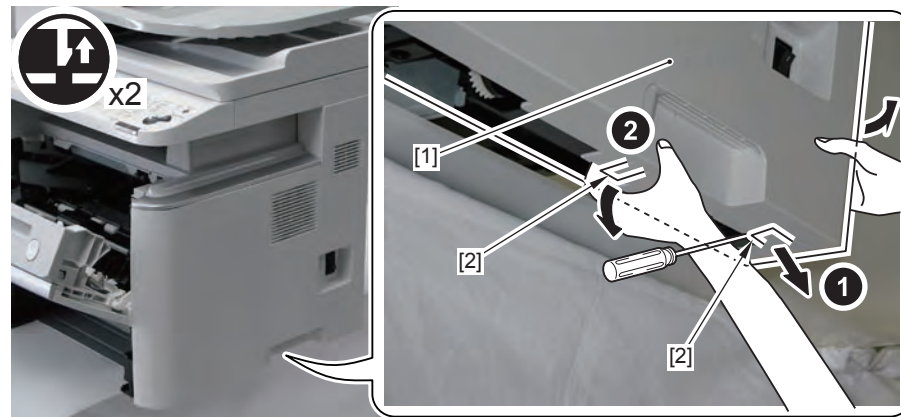

F-4-26

9) Open the ADF Unit + Reader Unit [1], and release the claw [3] while pulling the Right Cover Unit [2] in the direction of the arrow.

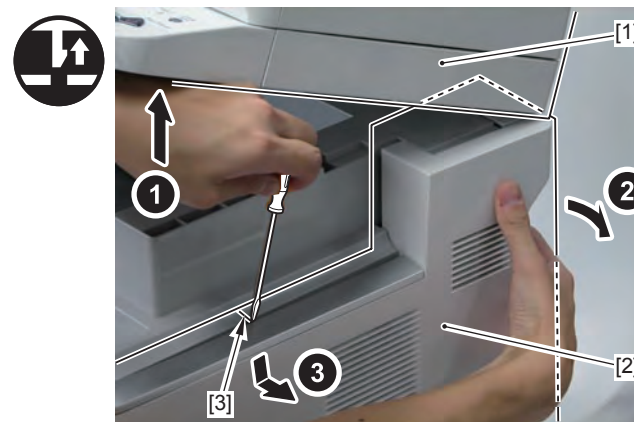

F-4-27

10) Remove the Right Cover Unit [1].

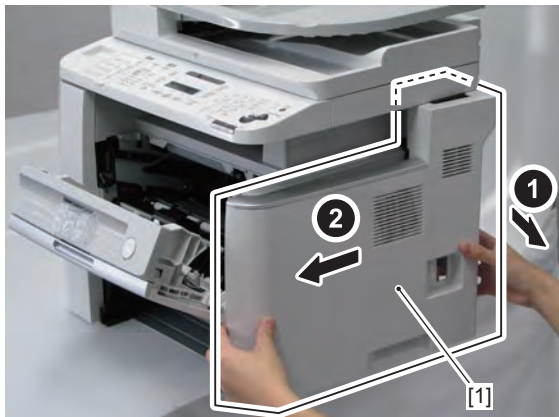

F-4-28

Removing the Front Cover

Preparations

- 1) Removing the Left Cover Unit.
- 2) Removing the Right Cover Unit.

Procedure

- 1) Remove the Link [1].

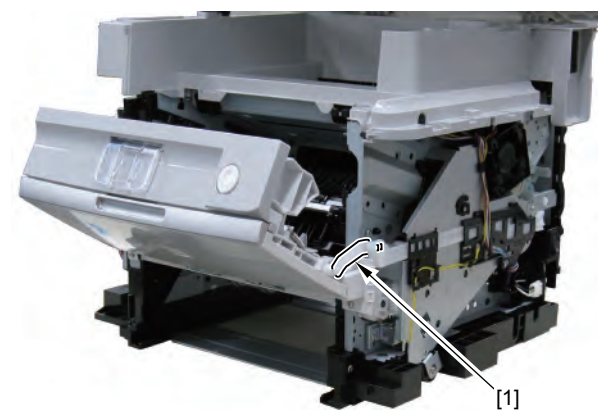

F-4-29

- 2) Remove the Front Cover [1].

- 2 Screws [2]

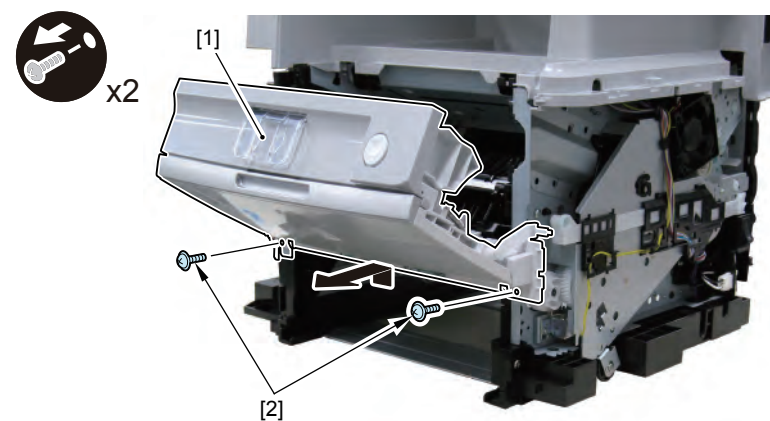

F-4-30

Removing the Rear Cover Unit

Preparations

- 1) Removing the Left Cover Unit.
- 2) Removing the Left Rear Cover.
- 3) Removing the Right Cover Unit.

Procedure

- 1) Push the Grip [1] Downward and Open the Duplex Feed Unit [2].

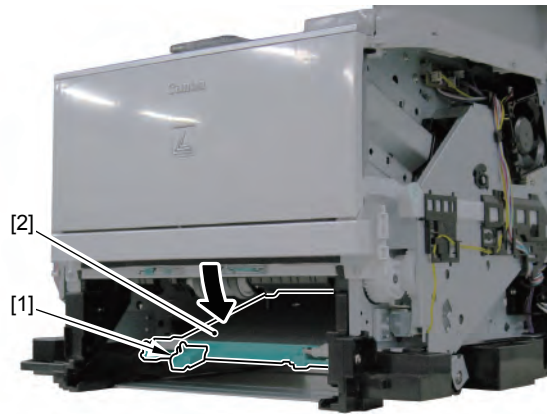

F-4-31

- 2) Remove the Rear Cover Unit [1].

- 5 Screws [2]
- 3 Claws [3]

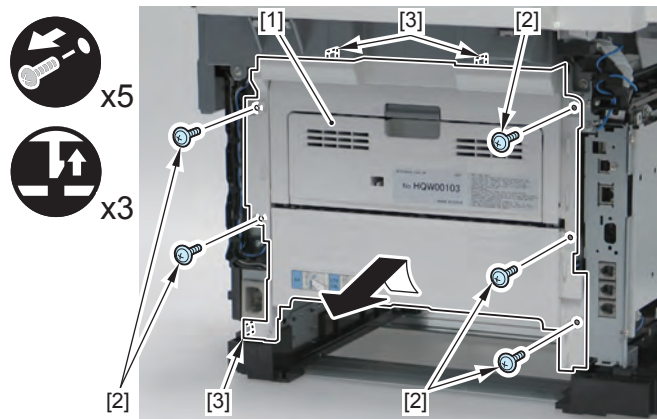

F-4-32

- 3) Remove the Duplex Feed Unit [2] from the Rear Cover Unit [1].

- 2 Bosses [3]

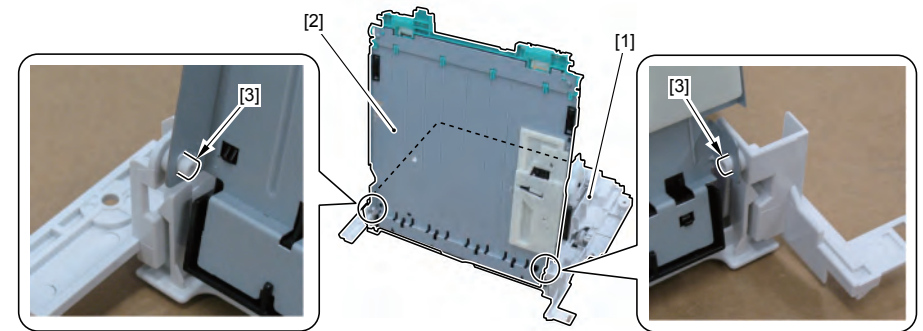

F-4-33

Procedure at installation:

- 1) Fit the 2 Upper Claw [2] of the Rear Cover Unit [1] With the Upper Cover Unit.
- 2) Open the Rear Upper Cover [3] and While Pushing the Duplex Reverse Sensor Flag [4] Downward, Install the Rear Cover Unit.

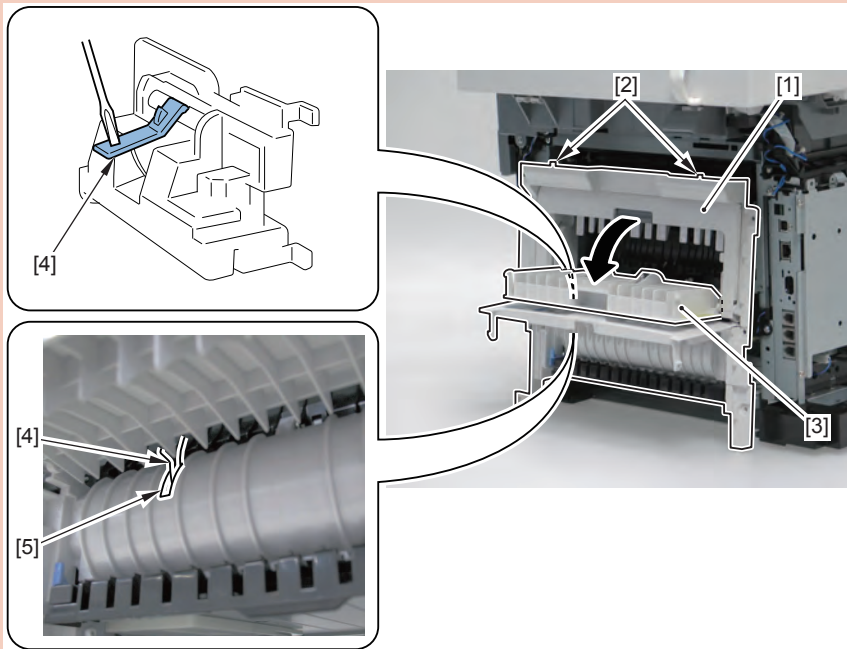

F-4-34

- 3) Check That the Sensor Flag [4] Through the Hole [5] of the Back of the Duplex Unit Cover.

Removing the Upper Cover Unit

Preparations

- 1) Removing the Right Cover Unit.
- 2) Removing the Left Cover Unit.
- 3) Removing the Controller Cover.
- 4) Removing the Left Rear Cover.
- 5) Removing the ADF Unit + the Reader Unit.

Procedure

- 1) Remove the Upper Cover Unit [1].
 - 3 Screws [2]
 - 1 Screw [3] (Loosen)
 - 2 Claws [4]

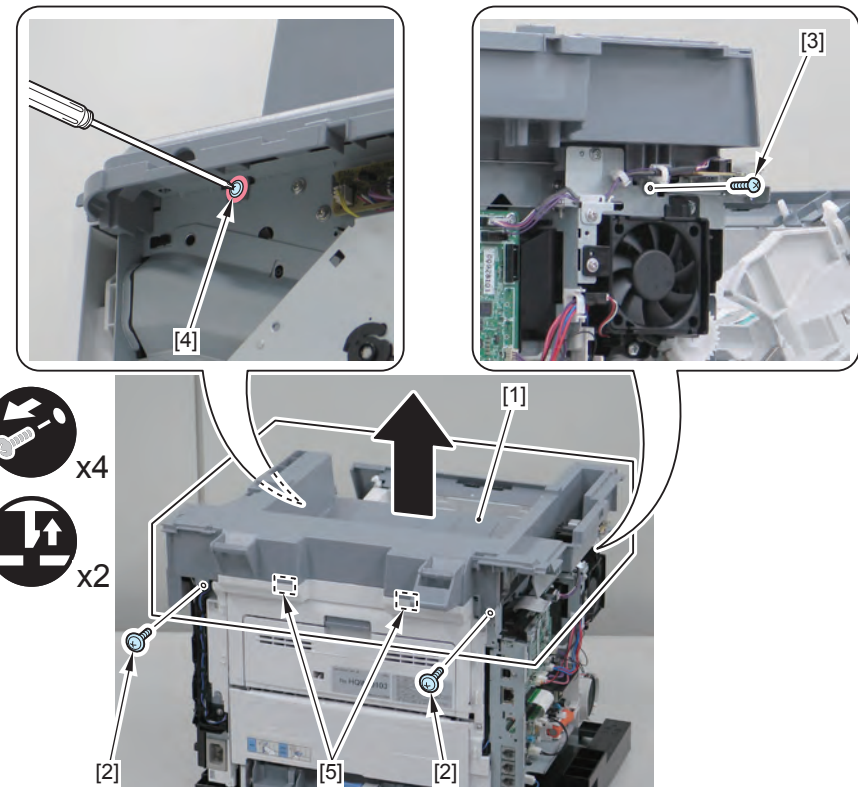

F-4-35

External Cover (MF5900 Series)

Removing the Left Cover Unit

Procedure

- 1) Remove the cassette [1].
- 2) Press the Open button [2], and open the Front Cover [3].

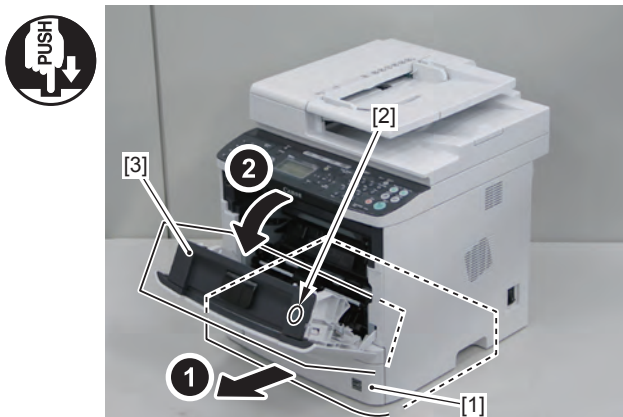

F-4-36

- 3) Open the ADF Unit + Reader Unit [1].

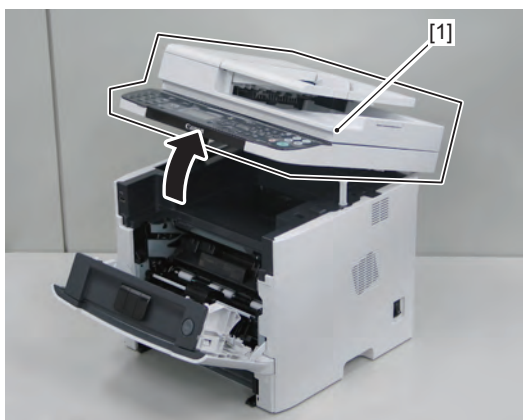

F-4-37

- 3) Place the host machine [1] while shifting the left side of it approx. 10cm from the working table to release the claw at the lower side of the Left Cover Unit.

CAUTION:

Be careful not to drop the host machine when shifting it.

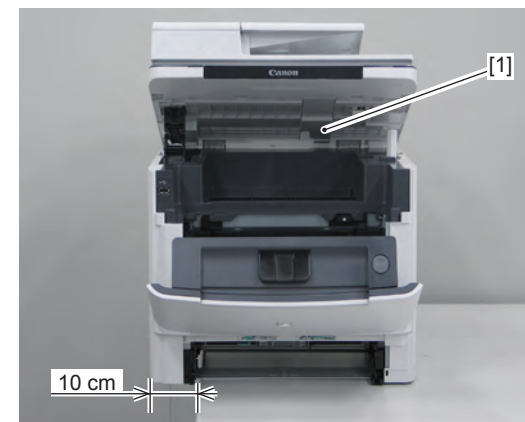

F-4-38

4) Release the 6 Claws [2] of the Left Cover Unit [1].

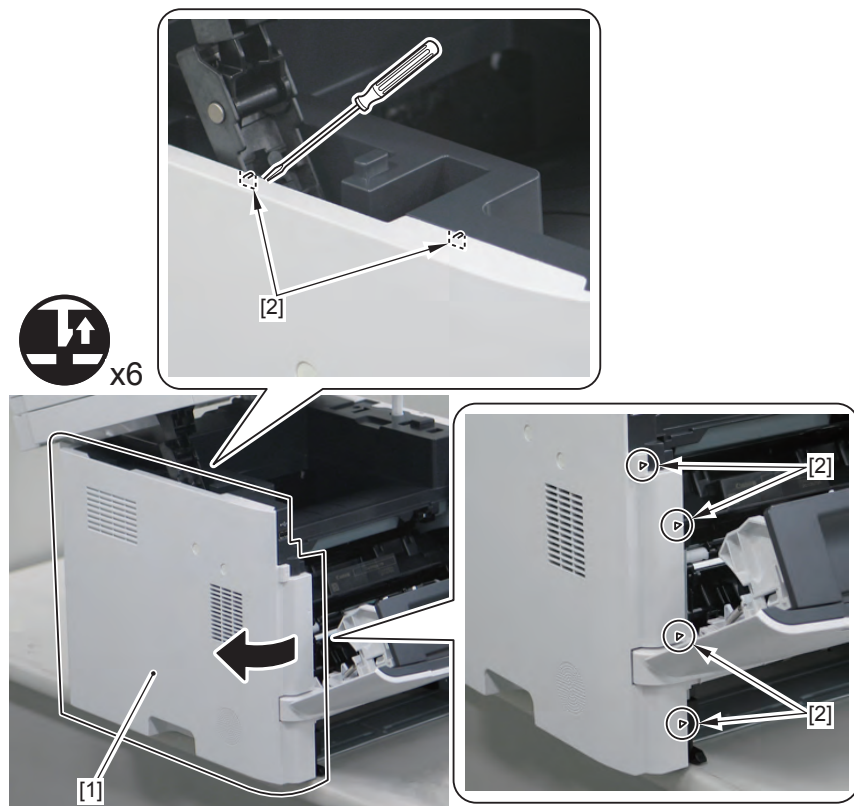

5) Remove the Left Cover Unit [1] in the direction of the arrow.

F-4-39

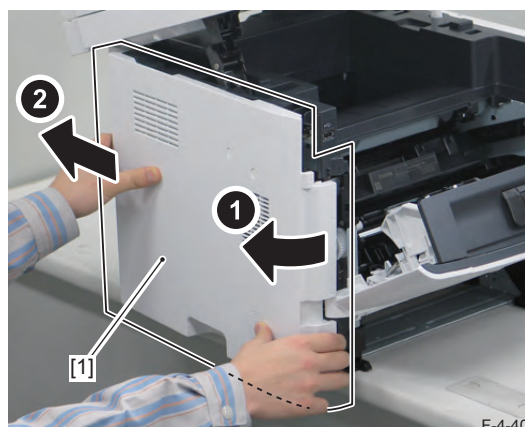

F-4-40

Removing the Left Rear Cover

Preparations

1) Removing the Left Cover Unit.

Procedure

1) Open the ADF Unit + Reader Unit [1], and release the 2 Claws [2].

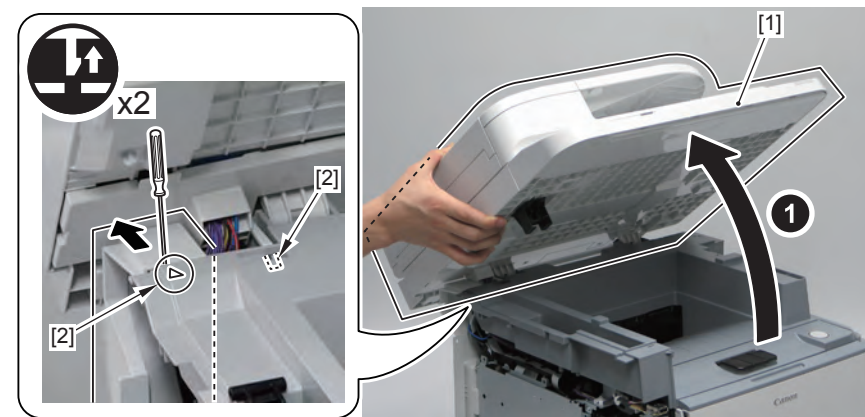

F-4-41

2) While lifting left side of the host machine [1], remove the Left Rear Cover [2].

- 1 Screw [3]
- 2 Claws [4]

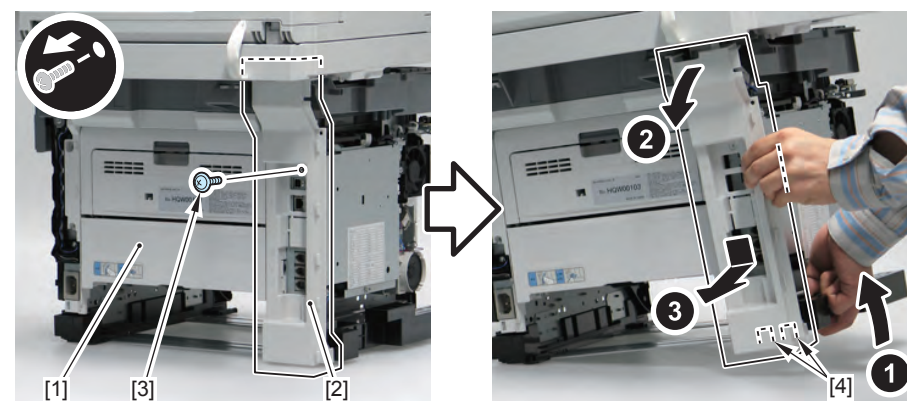

F-4-42

Removing the Right Cover

Procedure

- 1) Remove the cassette [1].
- 2) Press the Open button [2], and open the Front Cover [3].

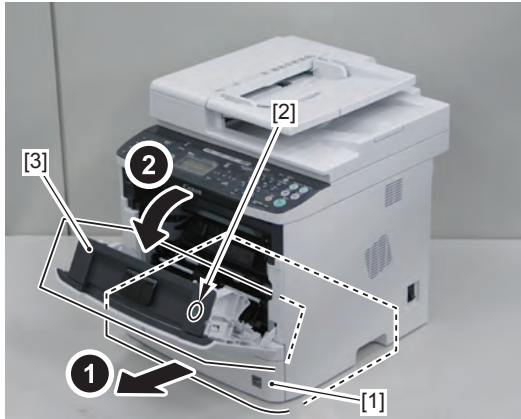

F-4-43

- 3) Open the ADF Unit + Reader Unit [1].

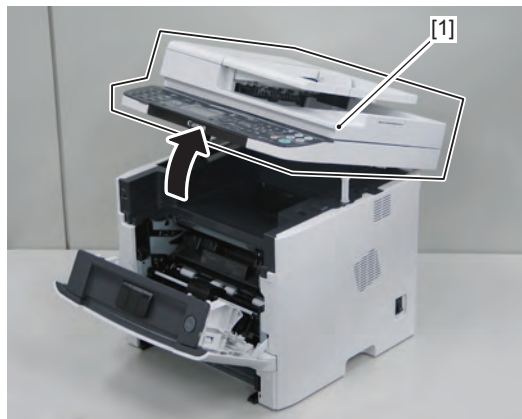

F-4-44

- 4) Place the host machine [1] while shifting the left side of it approx. 10cm from the working table to release the claw at the lower side of the Right Cover Unit.

CAUTION:

Be careful not to drop the host machine when shifting it.

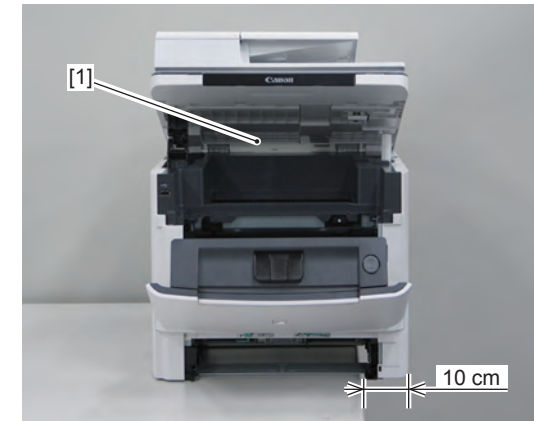

F-4-45

5) Open the ADF Unit + Reader Unit [1], and release the 2 Claws [3] while pulling the Right Cover Unit [2] in the direction of the arrow.

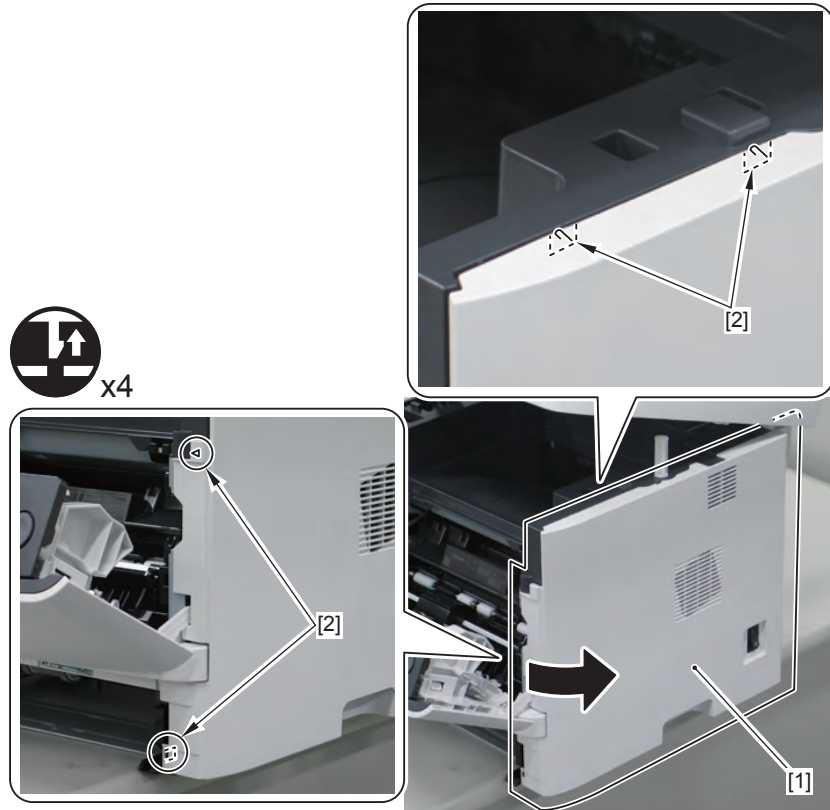

F-4-46

6) Remove the Right Cover Unit [1].

- 3 Claws [2]

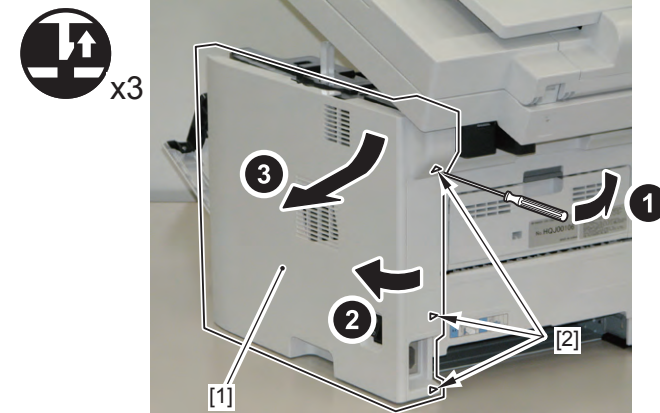

F-4-47

Removing the Front Cover

Preparations

- 1) Removing the Left Cover Unit.
- 2) Removing the Right Cover Unit.

Procedure

- 1) Remove the Link Arm [1].

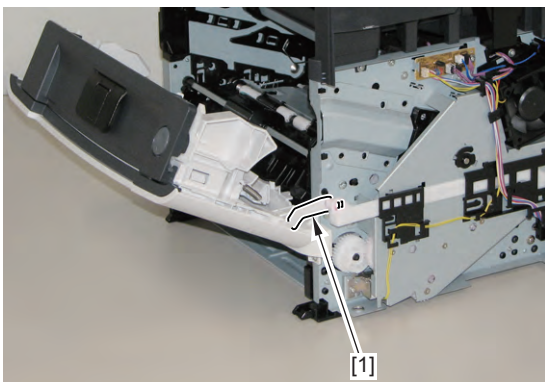

F-4-48

- 2) Remove the Front Cover [1].

- 2 Screws [2]

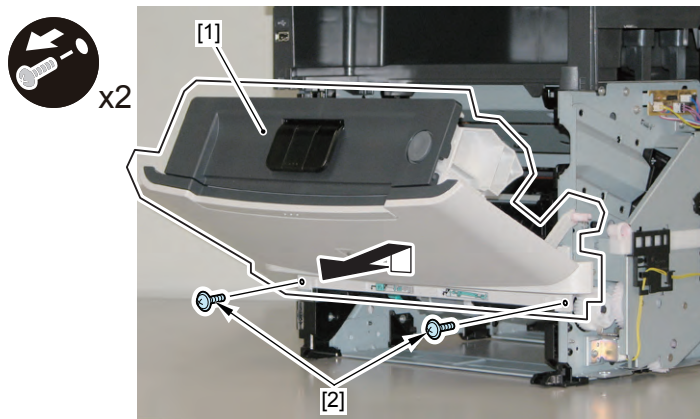

F-4-49

Removing the Rear Cover Unit

Preparations

- 1) Removing the Left Cover Unit.
- 2) Removing the Left Rear Cover.
- 3) Removing the Right Cover Unit.

Procedure

- 1) Push the Grip [1] Downward and Open the Duplex Feed Unit [2].

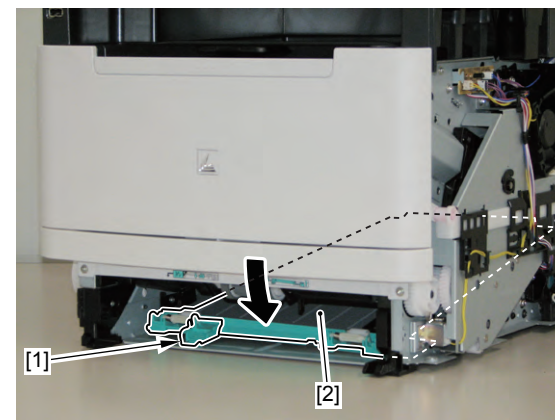

F-4-50

2) Remove the Rear Cover Unit [1].

- 5 Screws [2]
- 3 Claws [3]

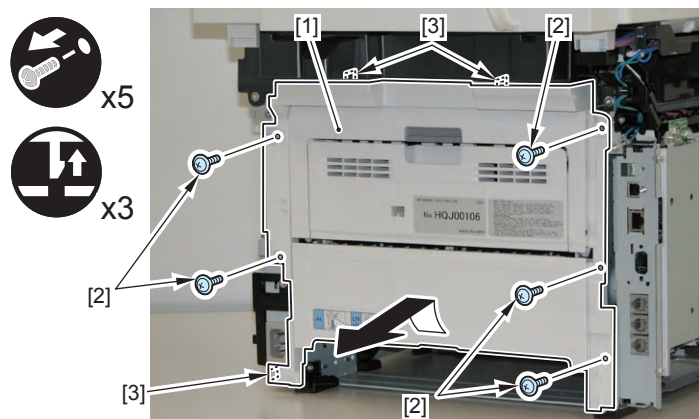

F-4-51

3) Remove the Duplex Feed Unit [2] from the Rear Cover Unit [1].

- 2 Bosses [3]

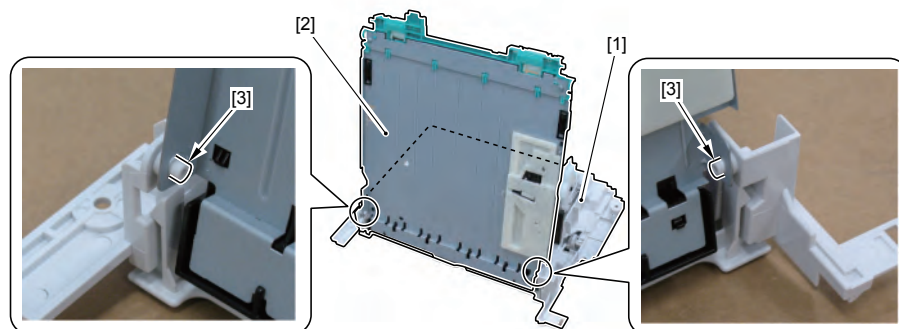

F-4-52

CAUTION: Points to Note at Installation

- 1) Fit the 2 Upper Claw [2] of the Rear Cover Unit [1] With the Upper Cover.
- 2) Open the Rear Sub Tray [3] and While Pushing the Duplex Reverse Sensor Flag [4] Downward, Install the Rear Cover Unit.

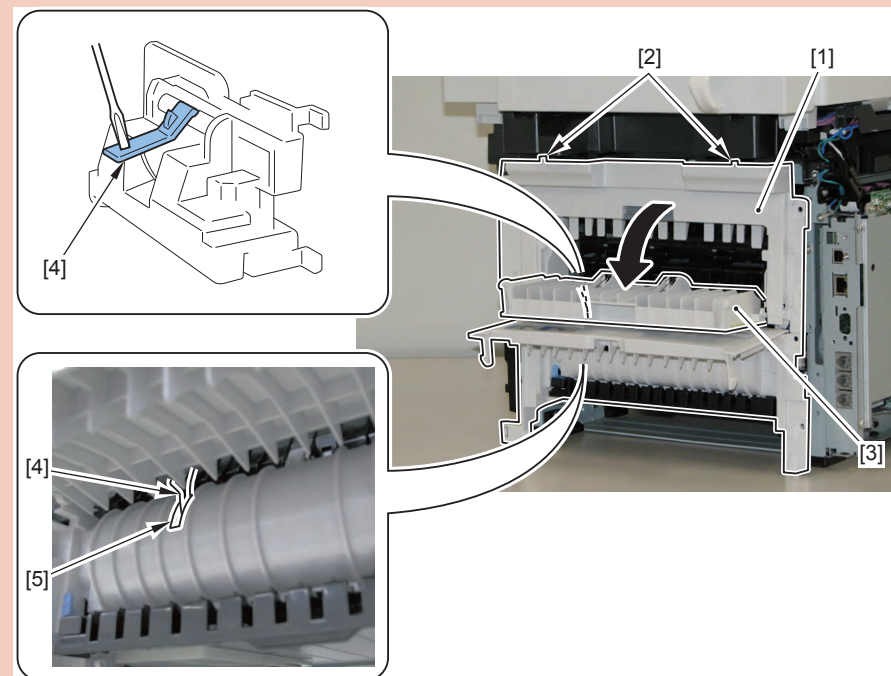

F-4-53

- 3) Check That the Sensor Flag [4] Through the Hole [5] of the Back of the Duplex Unit Cover.

Removing the Upper Cover

Preparations

- 1) Removing the Right Cover Unit.
- 2) Removing the Left Cover Unit.
- 3) Removing the Left Rear Cover.
- 4) Removing the ADF Unit + the Reader Unit.

Procedure

- 1) Remove the Upper Cover [1].
 - 3 Screws [2]
 - 1 Screw [3] (Loosen)
 - 2 Claws [4]

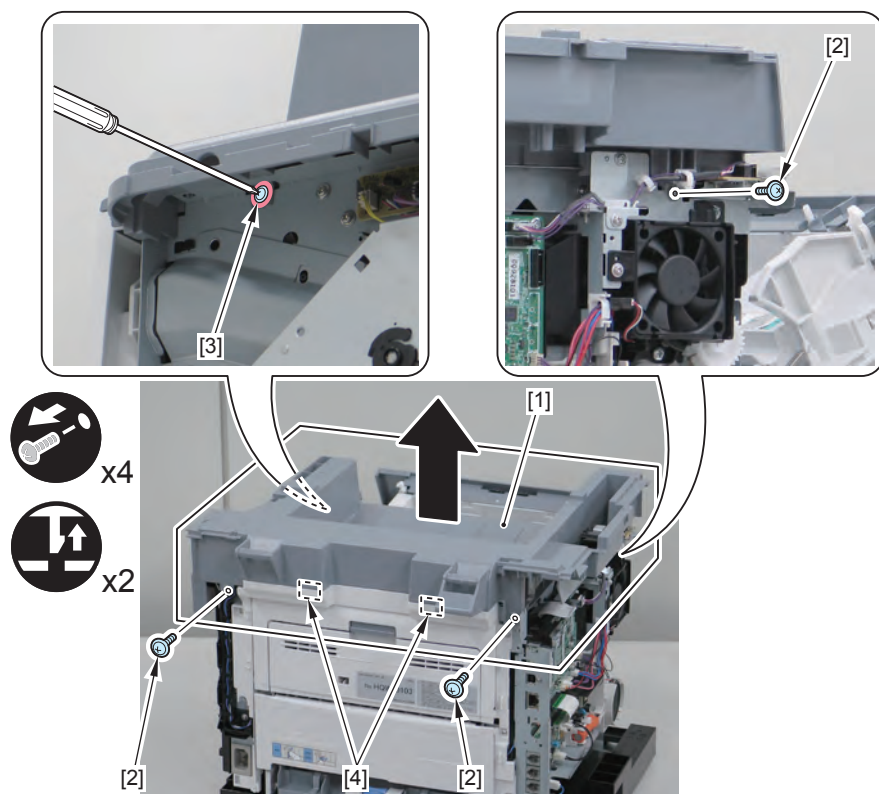

F-4-54

Document Exposure, Feed System

Removing the ADF Unit + Reader Unit

Preparations

- 1) Removing the Left Cover Unit.
- 2) Removing the Controller Cover.
- 3) Removing the Left Rear Cover.

Procedure

- 1) Remove the Flat Cables and Connectors [2].

- 4 Flat cable [1].
- 3 Connectors [2].

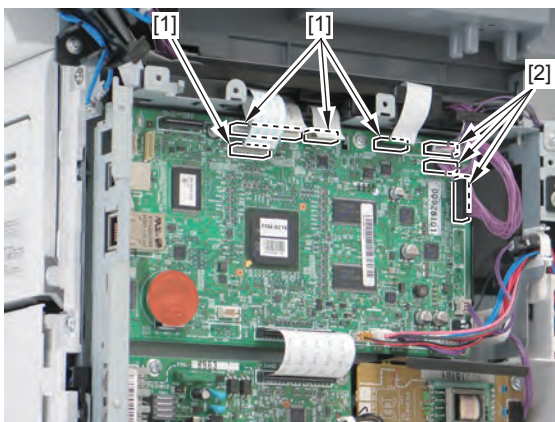

F-4-55

- 2) Remove the Connector [1] from the [A].

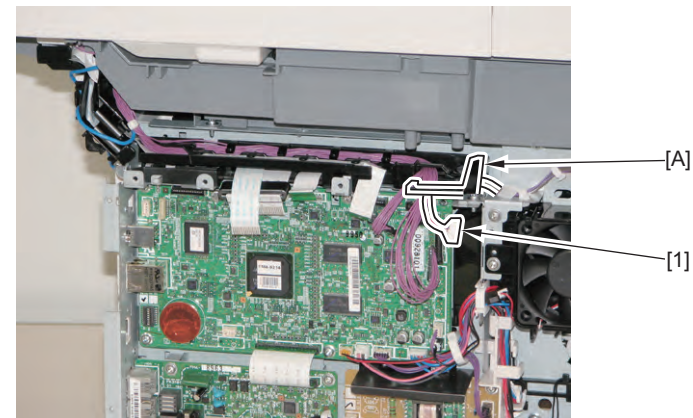

F-4-56

- 3) Remove the Harness Guide [1].

- 3 Claws [2]

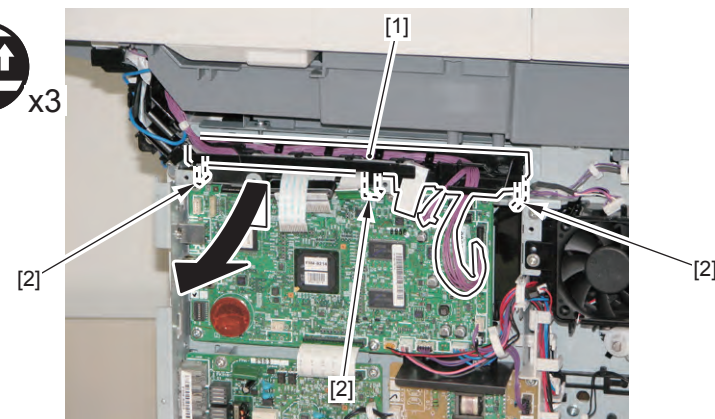

F-4-57

4) Remove the Flat Cable [1] from the [A].

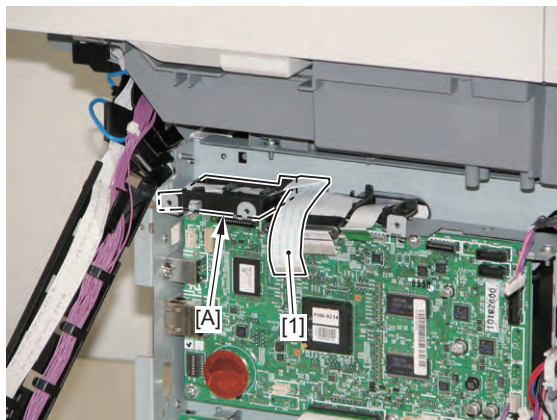

F-4-58

6) Remove the ADF Unit + the Reader Unit [1] In the Direction of the Arrow.

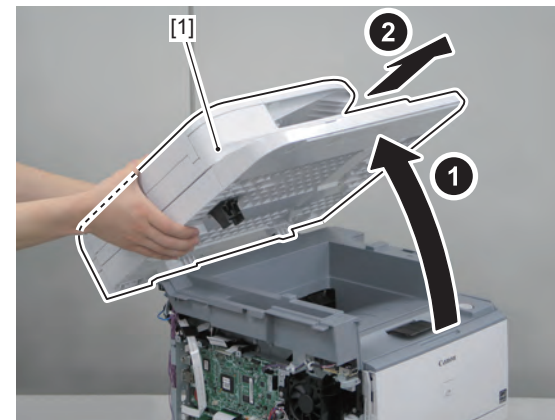

F-4-60

5) Remove the ADF Harness Guide [1].

- 2 Screws [2]
- 1 Hook [3]



x2

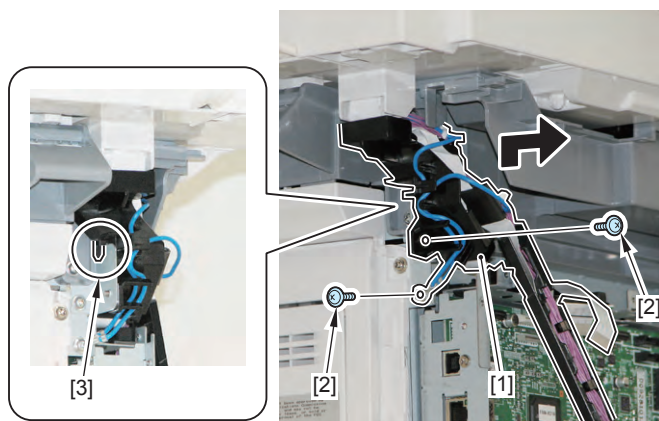

F-4-59

Removing the ADF Roller Unit

Procedure

1) Open the ADF Upper Cover [1].

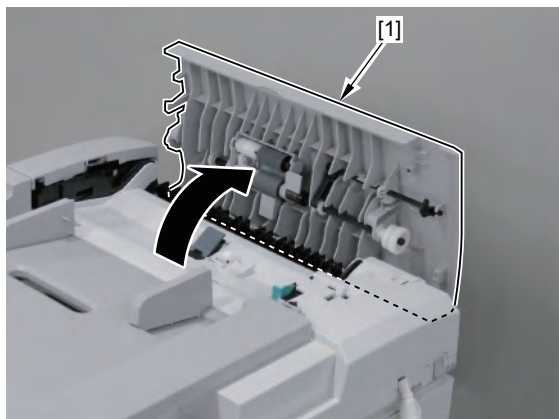

F-4-61

2) Remove the Gear [1] and the Bushing [2].

- 1 Claw [3]

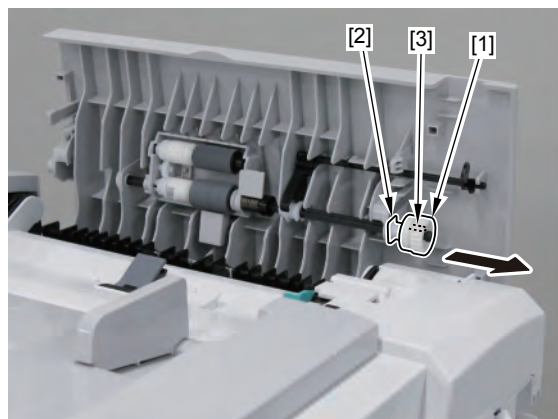

F-4-62

3) Remove the Resin E-ring [1] and Displace the Bushing [2].

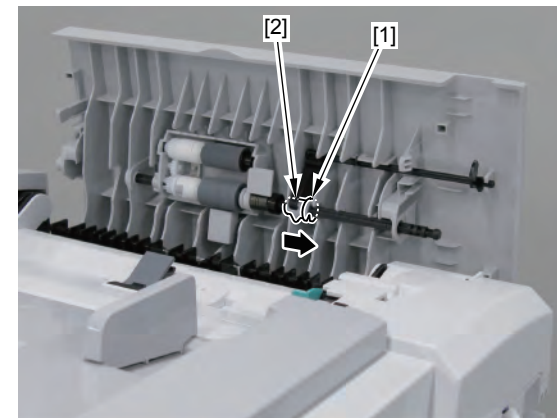

F-4-63

4) Remove the Resin E-ring [1] and the Bushing [2].

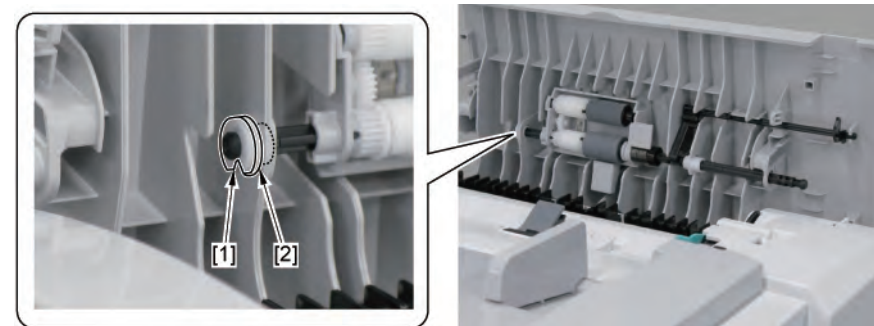

F-4-64

5) Remove the ADF Roller Unit [1].

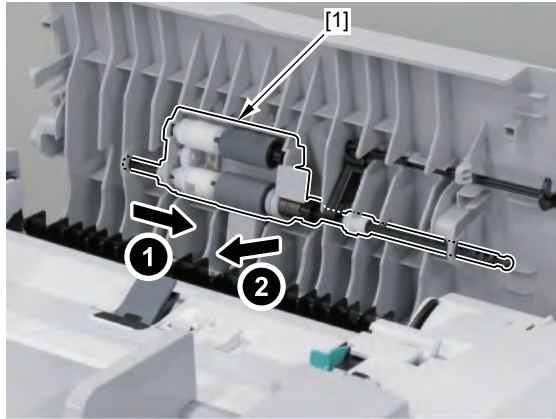

F-4-65

CAUTION :

When Removing It, be Careful Not to Lose the Spring [1] Attached to the ADF Roller Unit.

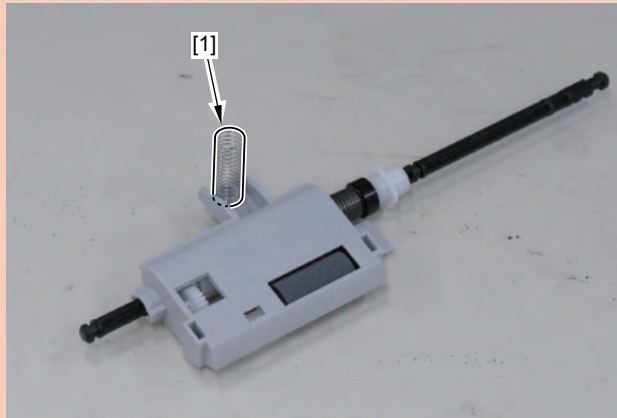

F-4-66

Removing the ADF Pickup Roller

Preparations

1) Removing the ADF Roller Unit.

Procedure

CAUTION:

Do Not Touch the Surface of the ADF Pickup Roller When Removing or Mounting it.

1) Insert the Precision Flat-screwdriver and Remove the Pickup Roller [1] Together With the Shaft.

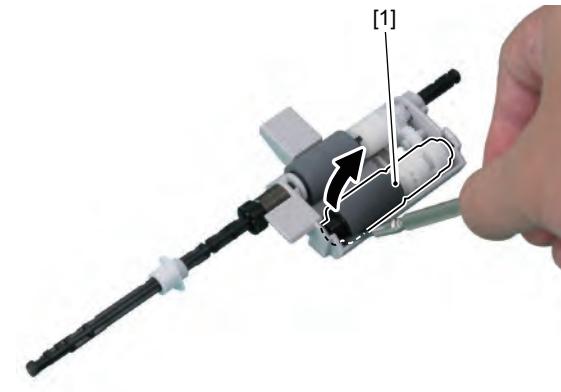

F-4-67

2) Remove the Pickup Roller [1].

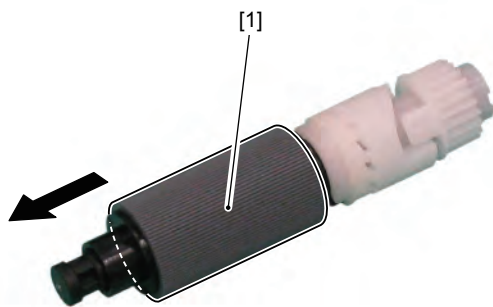

F-4-68

Removing the ADF Separation Roller

Preparations

1) Removing the ADF Roller Unit.

Procedure

CAUTION:

Do Not Touch the Surface of the ADF Separation Roller When Removing or Mounting it.

1) Remove the Bushing [1].



F-4-69

2) Remove the 2 Resin E-rings [1].

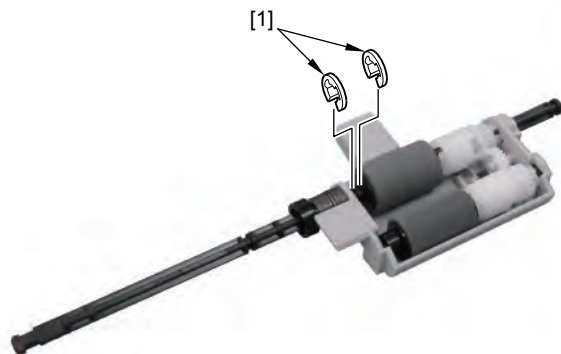

F-4-70

3) Displace the Roller Shaft [1] and Remove the Parallel Pin [2] and the Bushing [3].

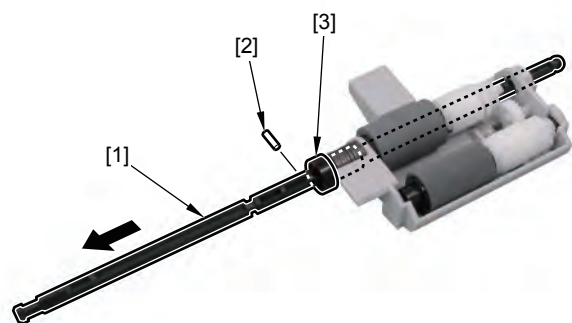

F-4-71

CAUTION :

Since the Parallel Pin is very tiny, be Careful not to Lose it.

4) Turn the Shaft [1] In the Direction of the Arrow, Fit the Protrusion [2] With the Hole of the Roller Holder and Pull It Out.

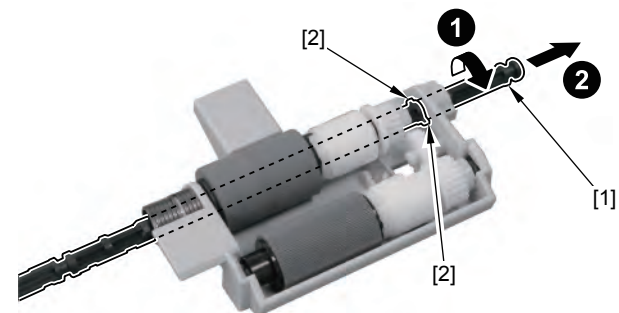

F-4-72

5) Remove the ADF Separation Roller [1].

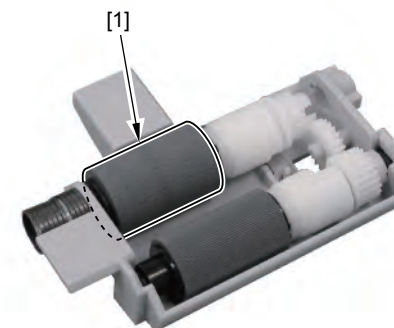

F-4-73

Removing the ADF Separation Pad

Procedure

CAUTION:

Do Not Touch the Surface of the ADF Separation Pad When Removing or Mounting it.

1) Open the ADF Upper Cover [1].

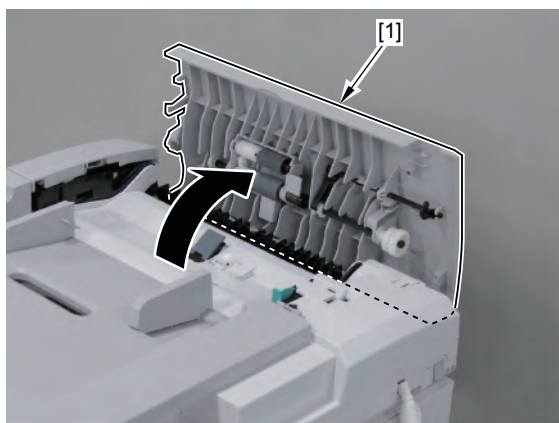

F-4-74

2) Remove the Feed Guide [1].

- 2 Bosses [2]

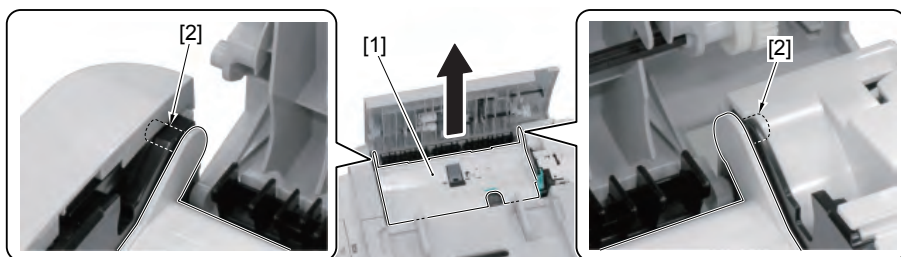

F-4-75

3) Remove the Retaining Plate [1] On the Back of the Feed Guide.

- 2 Screws [2]
- 2 Tabs [3] of the Separation Pad Holder

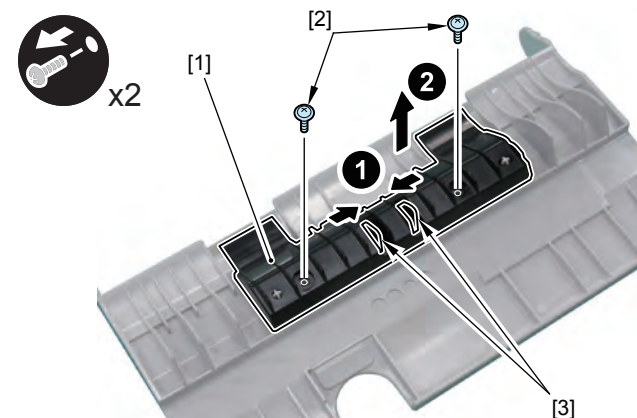

F-4-76

4) Remove the Separation Pad Holder [1].

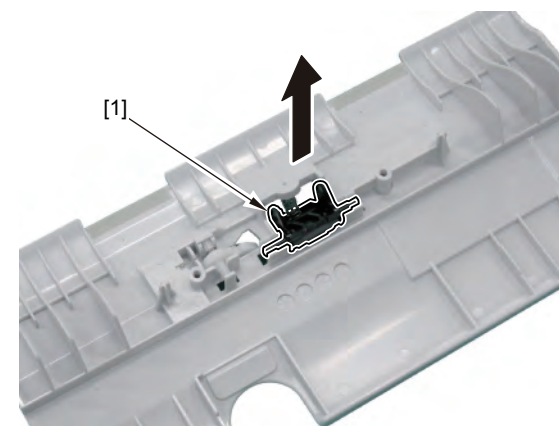

F-4-77

CAUTION :

Be careful not to lose the Spring [1] on the Separation Pad Holder.

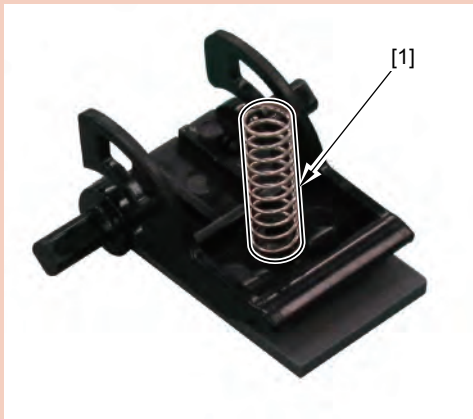

F-4-78

5) Remove the ADF Separation Pad [1].

- Pad Retainer [2]
- Sheet [3]

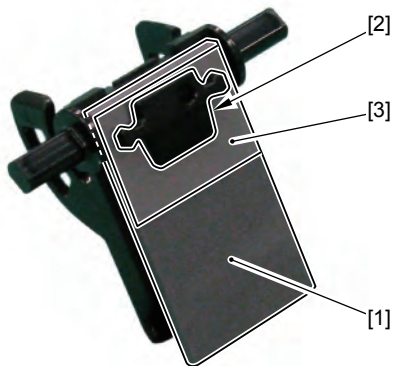

F-4-79

● Removing the ADF Pickup Feed Unit

■ Procedure

1) Open the ADF Upper Cover [1].

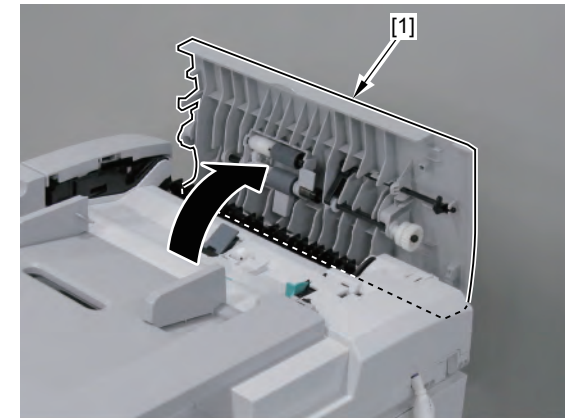

F-4-80

2) Remove the ADF Front Cover [1].

- 4 Claws [2]

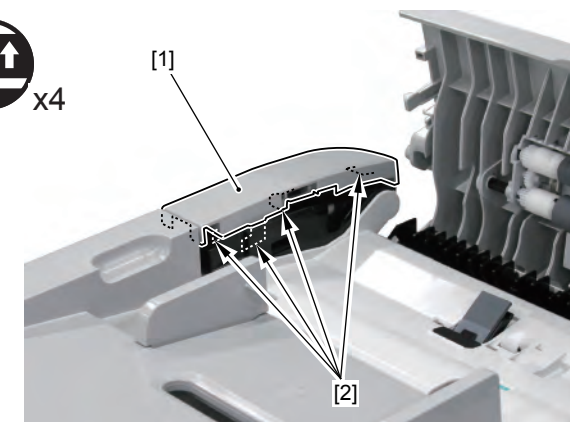

F-4-81

- 3) Slightly Lift the ADF Tray [1] and After Removing the Claw [2], Lift It By 90 Degree and Remove It Upward.

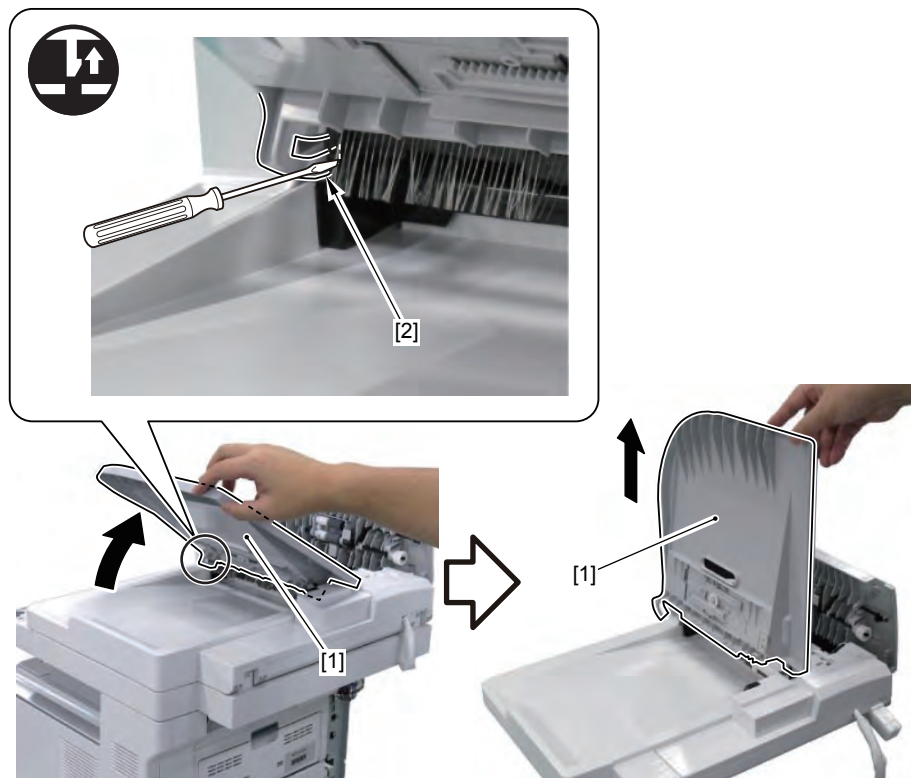

F-4-82

- 4) Remove the ADF Rear Cover [1].

- 1 Boss [2]
- 4 Claws [3]

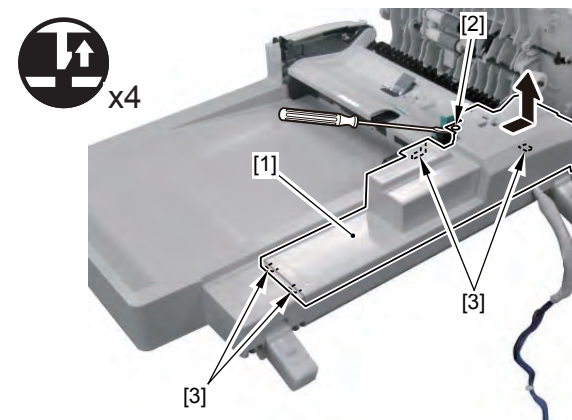

F-4-83

- 5) Remove the Grounding Wire [1].

- 1 Screw [2]

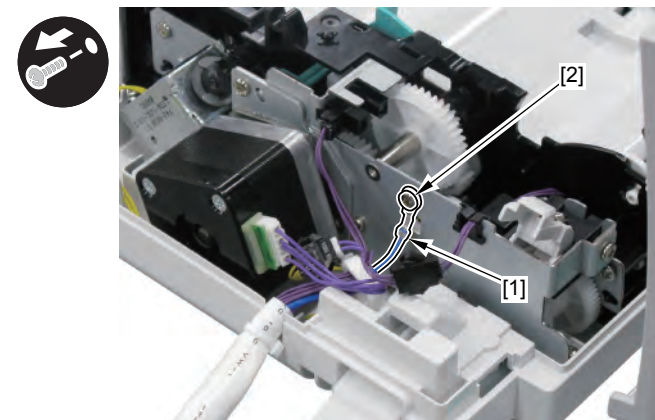

F-4-84

6) Remove the Harness [1].

- 4 Connectors [2]
- 2 Wire Saddles [3]

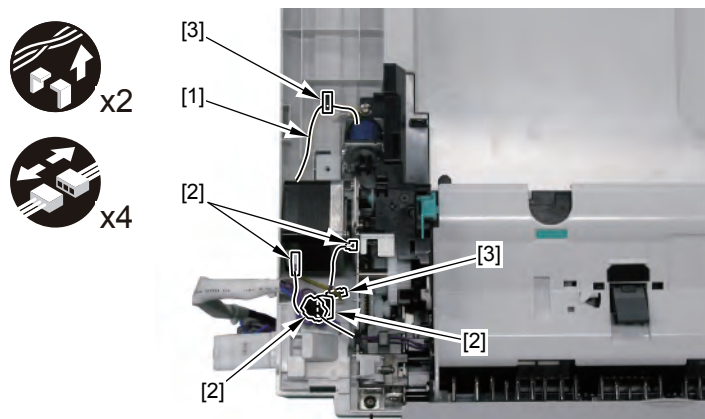

F-4-85

8) Remove the ADF Upper Cover Unit [1].

- 2 Bosses [2]

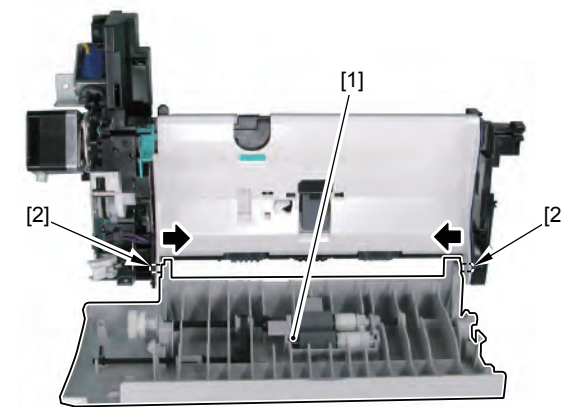

F-4-87

7) Remove the ADF Pickup Feed Unit [1].

- 5 Screws [2]

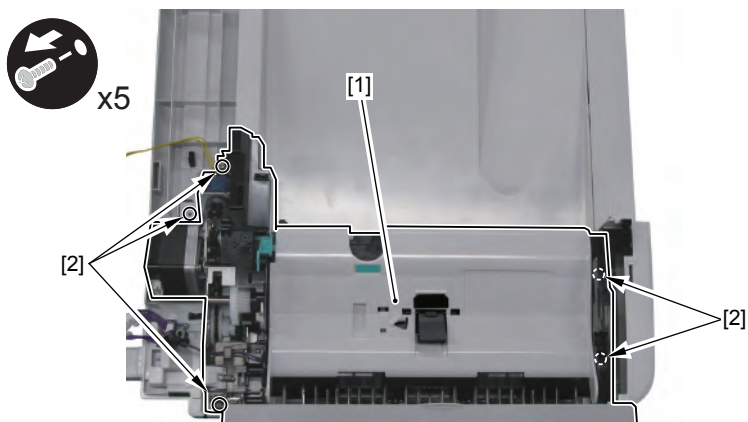

F-4-86

Removing the ADF Pickup Motor Unit

Preparations

1) Removing the ADF Pickup Feed Unit.

Procedure

1) Remove the Harness [1] from the Edge Saddle [2].

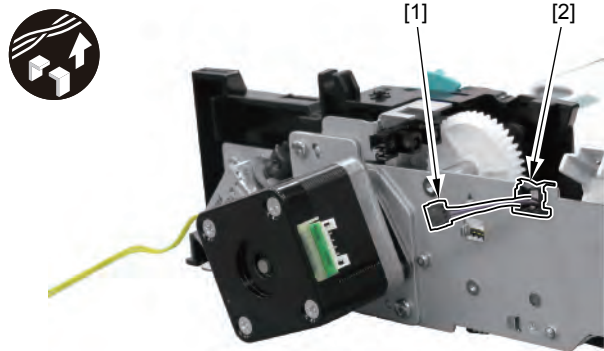

F-4-88

2) Remove the ADF Motor Unit [1].

- 2 Screws [2]

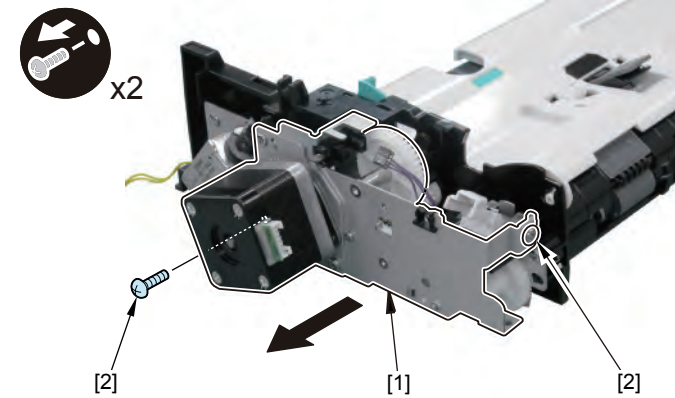

F-4-89

CAUTION :

Since the Gear [1] of the ADF Motor Unit and the Gear [2] on the Frame Side of the Pickup Feed Unit are not Fixed, be Careful not to Drop or Lose Them.

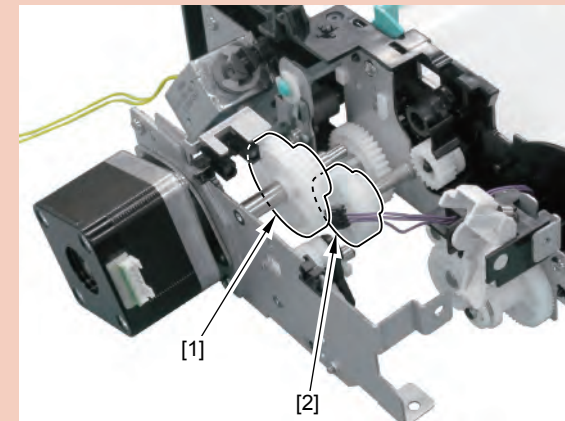

F-4-90

Removing the ADF Delivery Solenoid Unit

Preparations

- 1) Removing the ADF Pickup Feed Unit.

Procedure

- 1) Remove the Resin E-ring [1].

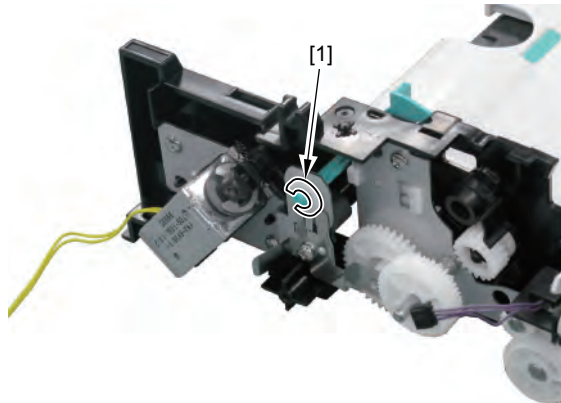

F-4-91

- 2) Remove the Solenoid Unit [1].

- 2 Screws [2]

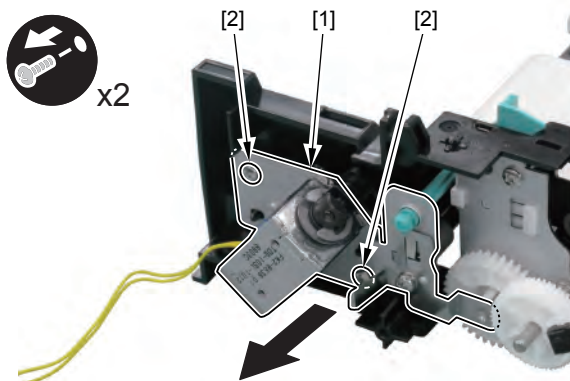

F-4-92

Removing the Reader Unit Upper Cover

Preparations

- 1) Removing the Left Cover Unit.
- 2) Removing the Controller Cover.
- 3) Removing the Left Rear Cover.
- 4) Removing the ADF Unit + Reader Unit.
- 5) Separate the ADF Unit + Reader Unit.

Procedure

- 1) Remove the 2 Screws [1] On the Bottom of the Reader Unit.

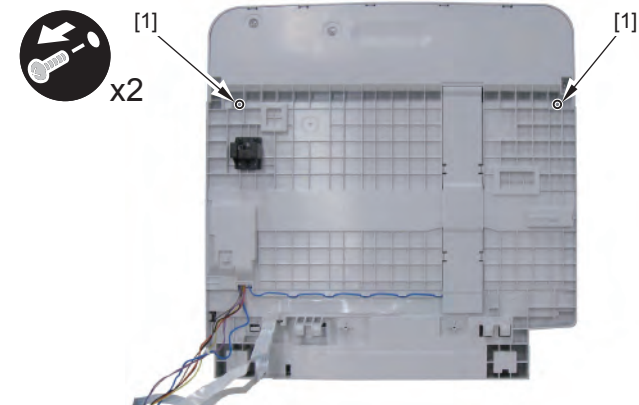

F-4-93

2) Remove the Standard White Plate [1].

- 2 Claws [2]

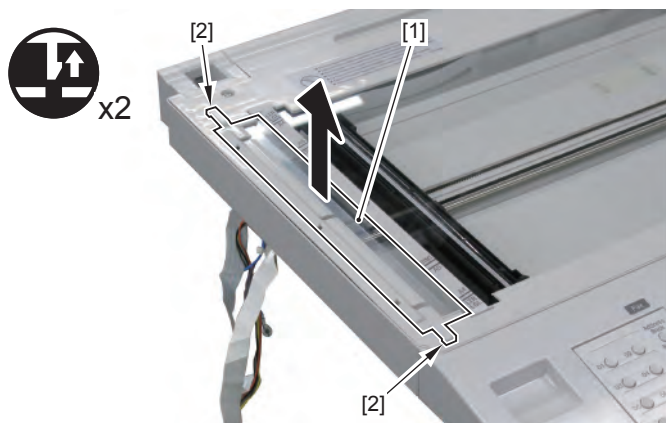

F-4-94

3) Remove the Reader Unit Upper Cover [1].

- 2 Screws [2]
- 7 Claws [3]

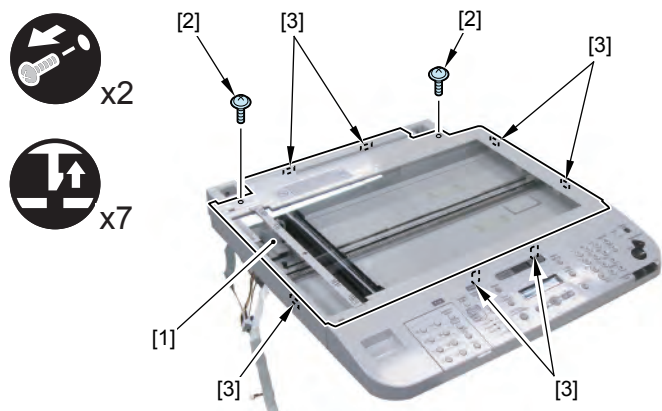

F-4-95

Procedure After Replacing the Reader Upper Cover Unit:

1) Enter the values of the label affixed at the upper left of the glass in the following service mode item, and write the values in the service label.

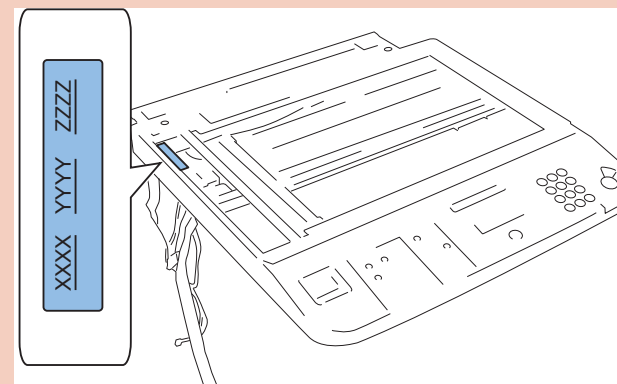

- COPIER > ADJUST > CCD > W-PLT-X (standard White Plate X signal data)
- COPIER > ADJUST > CCD > W-PLT-Y (standard White Plate Y signal data)
- COPIER > ADJUST > CCD > W-PLT-Z (standard White Plate Z signal data)

2) Place a blank paper on the Copyboard Glass, and execute white level adjustment in the following service mode.

COPIER > FUNCTION > CCD > DF-WLVL1 (white level adjustment [copyboard scan])
 COPIER > FUNCTION > CCD > DF-WLVL3 (white level adjustment B&W [copyboard scan])

Next, place the same blank paper on the DF and execute the following service mode.

- COPIER > FUNCTION > CCD > DF-WLVL2 (white level adjustment [DF scan])
- COPIER > FUNCTION > CCD > DF-WLVL4 (white level adjustment B&W [DF scan])

If it results in NG, execute it again after turning OFF and then ON the power.

Removing the CIS Unit

Preparations

- 1) Removing the Left Cover Unit.
- 2) Removing the Controller Cover.
- 3) Removing the Left Rear Cover.
- 4) Removing the ADF Unit + Reader Unit.
- 5) Separate the ADF Unit + Reader Unit.
- 6) Removing the Reader Unit Upper Cover .

Procedure

- 1) Remove the Belt Pulley [1].
 - 1 Claw [2]

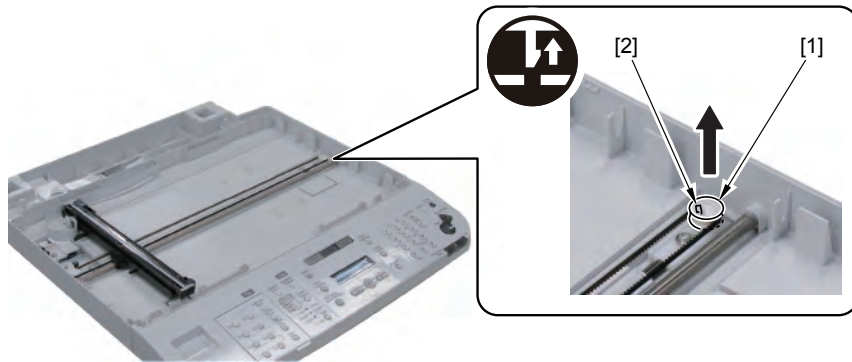

F-4-97

- 2) Remove the CIS Mount [1] Upward and Remove the Flat Cable [2].

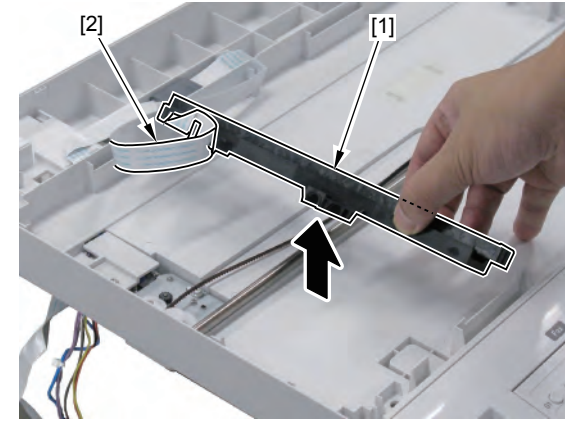

F-4-98

CAUTION:

When CIS Unit Mount is tilt, CIS spacers[1] are removed. Do not lost the CIS spacers.

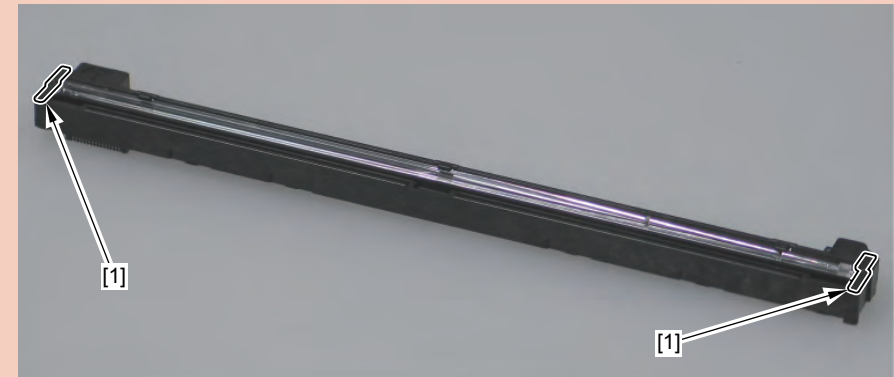

F-4-99

3) Lift the CIS [1] and Remove It In the Direction of the Arrow.

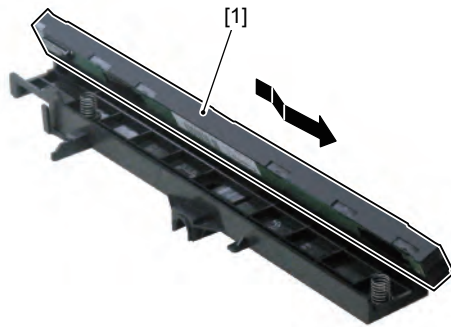

F-4-100

CAUTION:

When installing the CIS Unit, be sure to check that the projection [1] is fitted to the dent [2] to install.

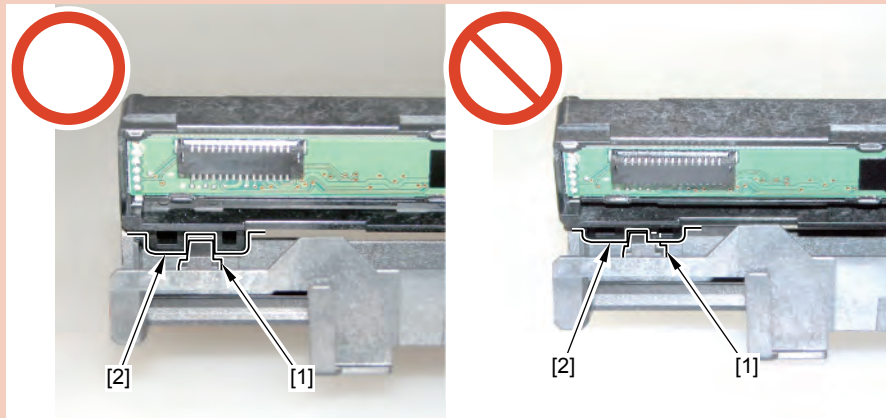

F-4-101

After replacing CIS units:

- 1) Check that there is no problem with the setting values written on the service label.
 - 2) Close the ADF, and execute the following service mode. If it results in NG, execute it again after turning OFF and then ON the power.
 - COPIER > FUNCTION > CCD > CL-AGC (CIS light intensity adjustment (color))
 - COPIER > FUNCTION > CCD > BW-AGC (CIS light intensity adjustment (B&W))
 - 3) After executing the following service mode (a), check the value automatically set with the following service mode (b), and write it in the service label.
 - (a) COPIER > FUNCTION > INSTALL > STRD-POS (executing automatic detection of the reading position at DF stream reading)
 - (b) COPIER > ADJUST > ADJ-XY > STRD-POS (adjusting the reading position at DF stream reading)
 - 4) Place a blank paper on the Copyboard Glass, and execute white level adjustment in the following service mode.
 - COPIER > FUNCTION > CCD > DF-WLVL1 (white level adjustment [copyboard scan])
 - COPIER > FUNCTION > CCD > DF-WLVL3 (white level adjustment B&W [copyboard scan])
- Next, place the same blank paper on the DF and execute the following service mode.
- COPIER > FUNCTION > CCD > DF-WLVL2 (white level adjustment [DF scan])
 - COPIER > FUNCTION > CCD > DF-WLVL4 (white level adjustment B&W [DF scan])
- If it results in NG, execute it again after turning OFF and then ON the power.

Controller System

Removing the Controller Cover

Preparations

1) Removing the Left Cover Unit.

Procedure

1) Remove the Controller Cover [1].

- 6 Screws [2]
- 2 Hooks [3]

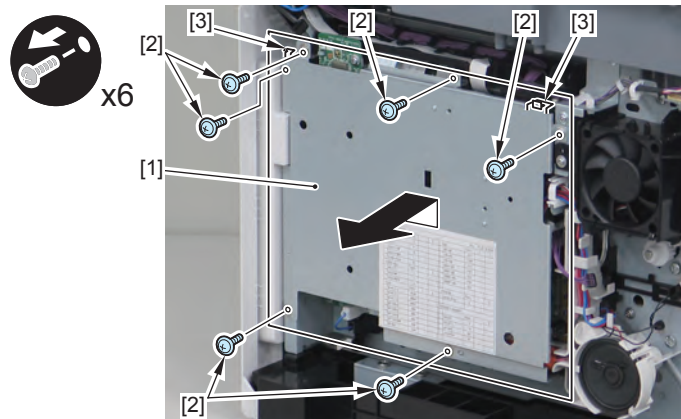

F-4-102

Removing the Main Controller Board

Actions before Replacement

- Write down the data of [Menu] > [Sys.Manager ID/PIN] > [Device Information Settings] > [Location]
- Export user data using remote UI.
- Insert the USB memory into the host machine, and execute COPIER > FUNCTION > SYSTEM > EXPORT to write the setting values of the service mode (excluding those related to the Reader/DADF) to the USB memory.
- Write down the serial number of the host machine and each factory adjustment value written on the service label. (Enter them after replacement.)

Preparations

- 1) Removing the Left Cover Unit.
- 2) Removing the Controller Cover.
- 3) Removing the Wireless LAN PCB. (MF5950dw/5980dn, D1380 Only)

Procedure

- 1) Remove the Flat Cables [1] and the Connectors [3].
- 1 Wire Saddle [2]

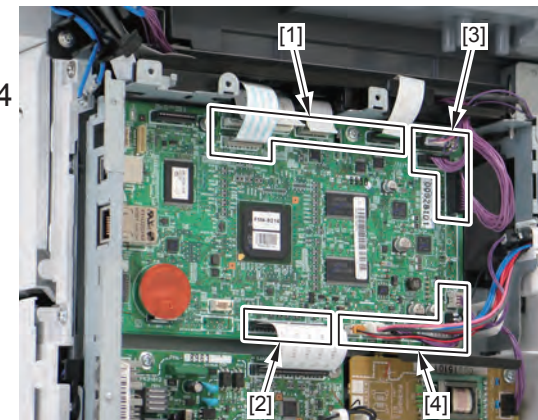

F-4-103

2) Remove the Main Controller Board [1].

- 7 Screws [2]

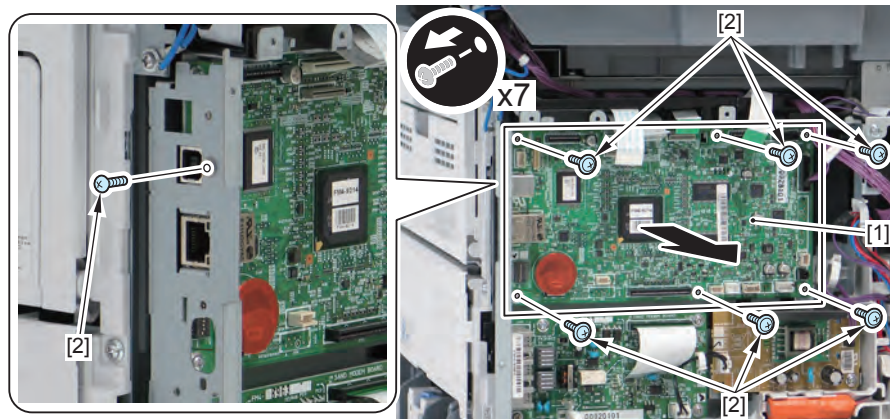

F-4-104

Actions after Replacement

- 1) Error code "E248-0001" lights up when turning ON the power.
- 2) Execute COPIER > FUNCTION > CLEAR > R-CON.
- 3) Enter all items written on the service label.
- 4) Set the location group and paper size group.
 - COPIER > OPTION > BODY > LOCALE (setting the location group)
[Setting value]
1: Japan, 2: North America, 3: Korea, 4: China, 5: Taiwan, 6: Europe, 7: Asia, 8: Oceania
 - COPIER > OPTION > BODY > SIZE-LC (setting the paper size group)
[Setting value]
1: AB configuration, 2: Inch configuration, 3: A configuration, 4: AB/Inch configuration
- 5) Clearing the Settings/Registration data
Execute COPIER > FUNCTION > CLEAR > ALL.
When executing this item, the following data is cleared according to the values of LOCALE and SIZE-LC set in step 4.
 - Settings/Registration data (the initial value according to the location is set.)
 - Service mode data (the initial value according to the location is set.)
 - Job ID
 - Each log data
 - Date data

Note that the following data is not cleared.

- Service counter
- Adjustment value of Reader/DADF

6) Execute COPIER > FUNCTION > VIFFNC > STOR-DCN (the setting value of DC Controller is backed up.)

7) Turn OFF and then ON the power.

8) Operate according to the instruction on the screen since the initial installation mode is activated. (Setting the date/time, executing the auto gradation adjustment)

9) Enter the serial number (8-digit alphanumeric) in Settings/Registration > System Settings > Device Information > Location.

10) After selecting COPIER > OPTION > SERIAL > SN-MAIN, press OK key to write the serial number entered in step 4 in the Main Controller PCB. After writing, the serial number entered in "Location" in step 9 is deleted.

11) Turn OFF and then ON the main power.

12) Execute COPIER > FUNCTION > MISC-P > SPEC to output the spec report to check the serial number (Body.No.).

13) Enter the data backed up earlier in Settings/Registration > System Settings > Device Information > Location.

14) Import the service mode data backed up before replacement.

Insert the USB memory storage device to the slot of the machine, and execute COPIER > FUNCTION > SYSTEM > IMPORT.

15) Import user data using remote UI.

Removing the NCU PCB (FAX Model Only)

Preparations

- 1) Removing the Left Cover Unit.
- 2) Removing the Controller Cover.

Procedure

- 1) Remove the Flat Cable [1].

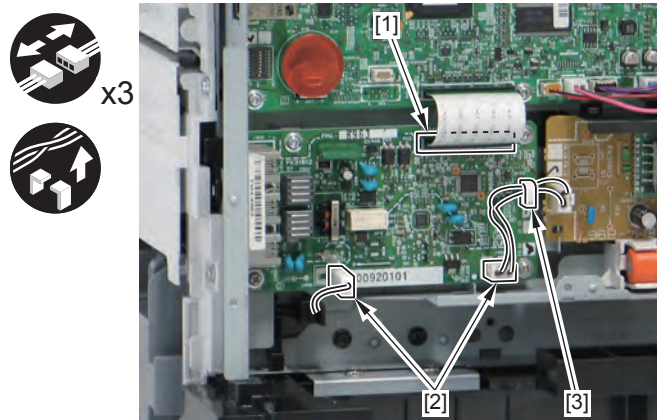

F-4-105

- 2) Remove the NCU PCB [1].

- 3 Screws [2]

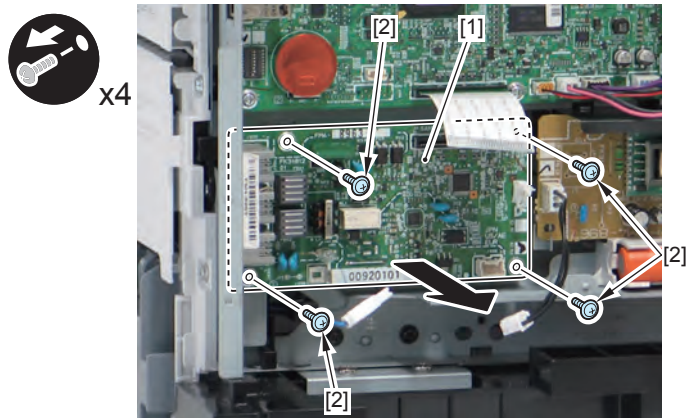

F-4-106

Removing the OFF Hook PCB (FAX Model Only)

Preparations

- 1) Removing the Left Cover Unit.
- 2) Removing the Controller Cover.

Procedure

- 1) Remove the OFF Hook PCB [1].

- 1 Wire Saddle [2]
- 1 Connector [3]
- 2 Screws [4]

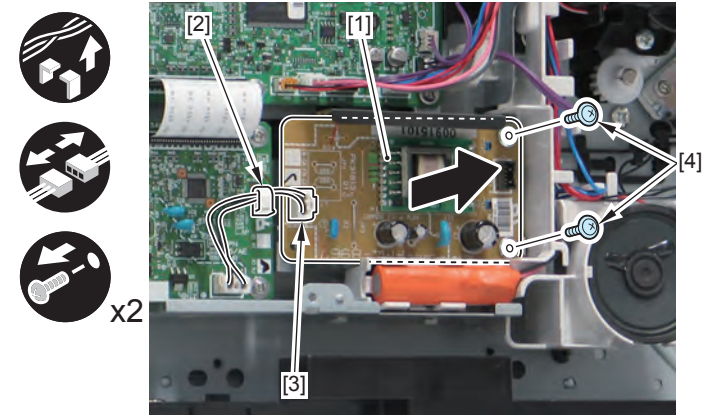

F-4-107

Removing the Controller Box.

Preparations

- 1) Removing the Right Cover Unit.
- 2) Removing the Left Cover Unit.
- 3) Removing the Left Rear Cover.
- 4) Removing the Controller Cover.
- 5) Removing the NCU PCB.(FAX Model Only)
- 6) Removing the Main Controller PCB.

Procedure

- 1) Remove the 2 Harnesses [1] from the Harness Guide [2].
 - 1 Edge Saddle [3]

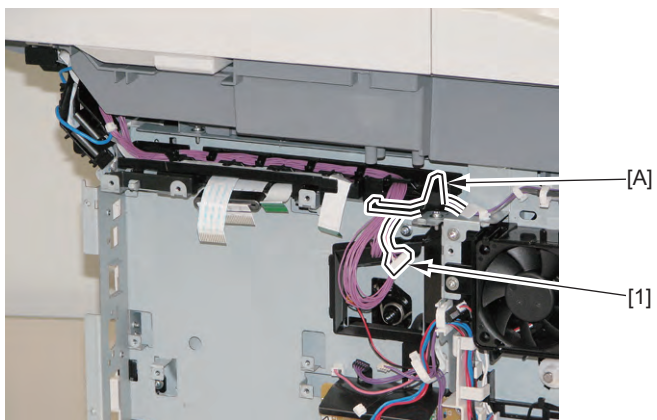

F-4-108

- 2) Remove the Harness Guide [1].
 - 3 Claws [2]

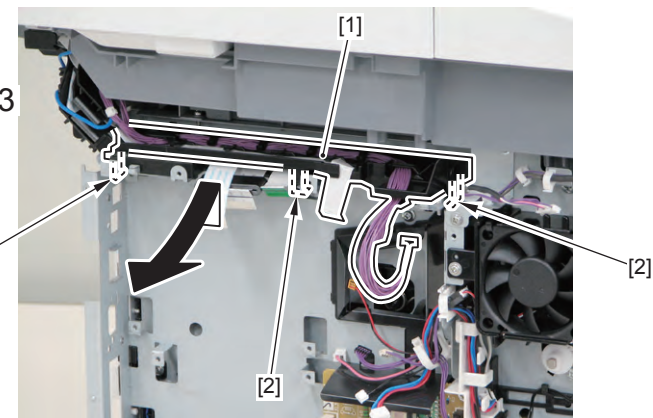

F-4-109

- 3) Remove the Flat Cable [1] from the Harness Guide [2].

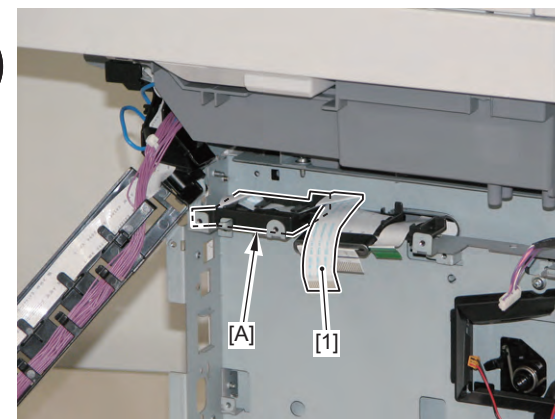

F-4-110

4) Remove the Harness [1] from the Harness Guide [2] and the Edge Saddle [3].

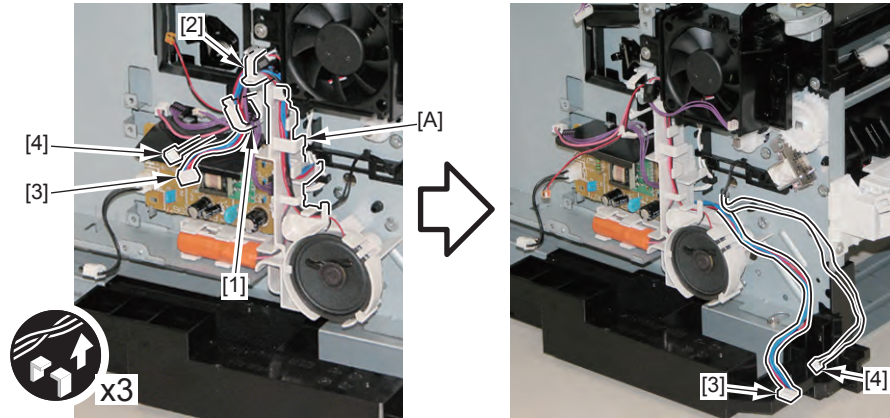

F-4-111

5) Remove the Controller Box [1].

- 6 Screws [2]

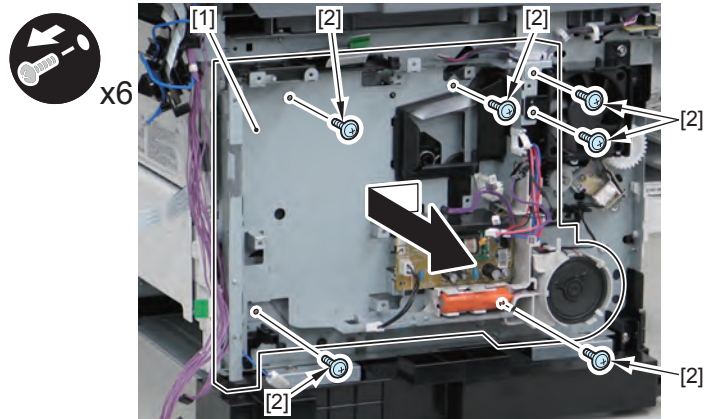

F-4-112

Removing the Engine Controller Unit

Preparations

- 1) Removing the Right Cover Unit.
- 2) Removing the Left Cover Unit.
- 3) Removing the Left Rear Cover.
- 4) Removing the Controller Cover.
- 5) Removing the NCU PCB. (FAX model only)
- 7) Removing the Main Controller PCB.
- 8) Removing the Controller Box.
- 9) Removing the Rear Cover Unit.

Procedure

- 1) Remove the Duplex Reverse Sensor Unit [1].
 - 1 Connector [2]
 - 1 Wire Saddle [3]
 - 1 Guide [4]
 - 1 Screw [5]

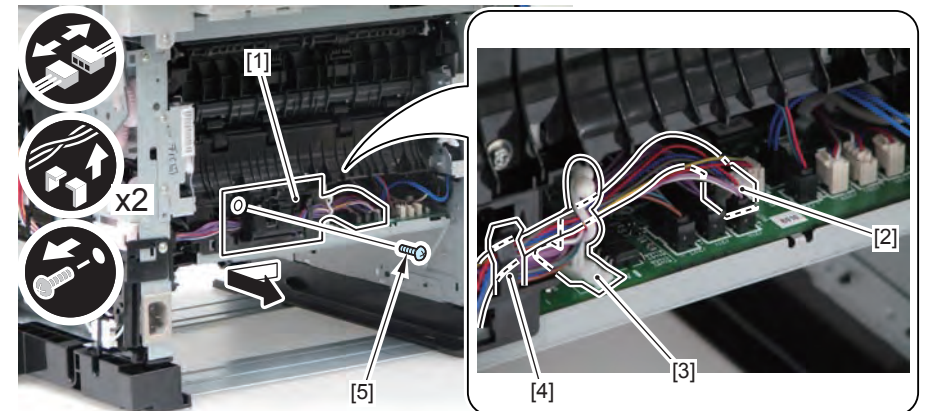

F-4-113

2) Remove the Harness [1] from the Harness Guide [4].

- 5 Connectors [2]
- 1 Wire Saddle [3]

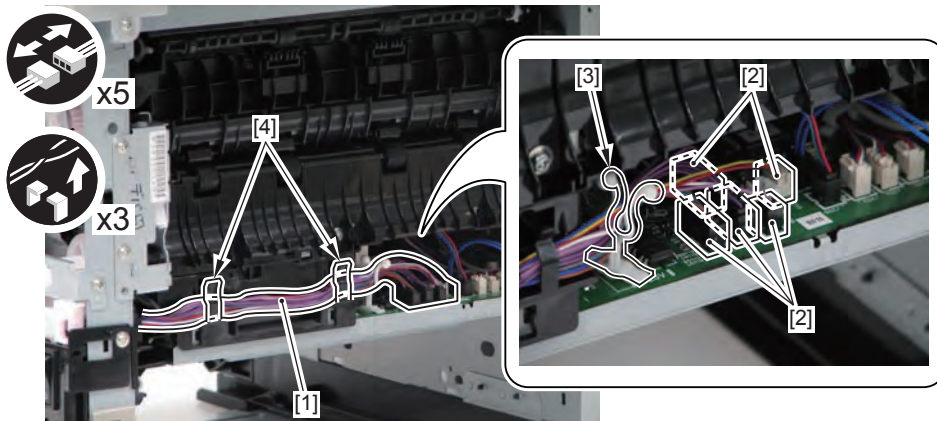

F-4-114

3) Remove the Feed Guide [1].

- 1 Screw [2]

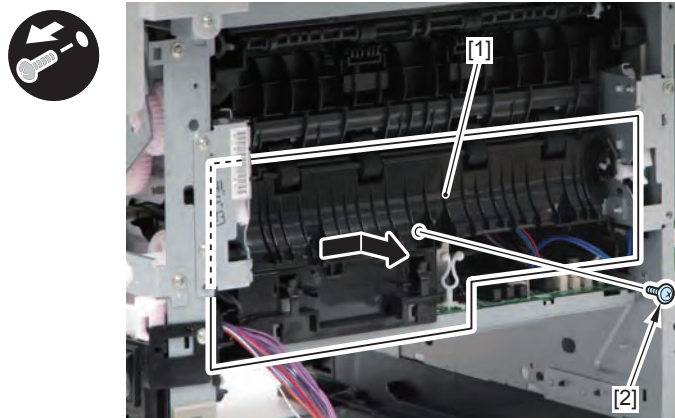

F-4-115

4) Remove the 7 Connectors [1] and the Terminal [2].

- 1 Wire Saddle [3]

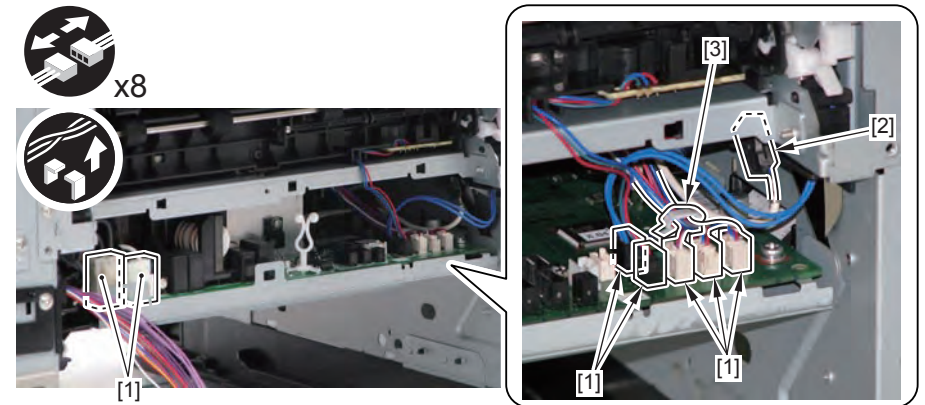

F-4-116

5) Remove the Harness [1] and the Flat Cable [2] from the Harness Guide [3].

- 2 Terminals [4]
- 1 Wire Saddle [5]

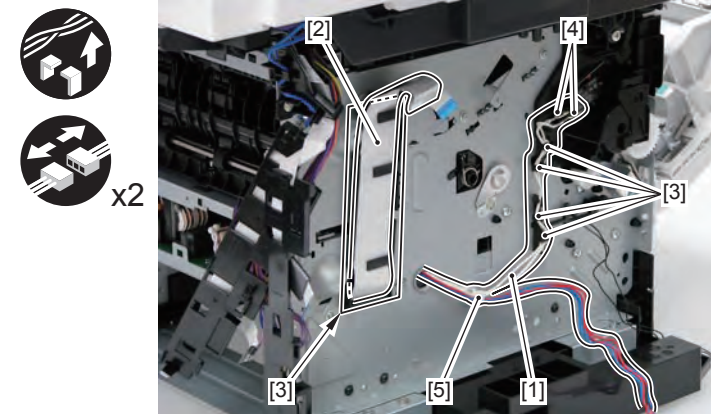

F-4-117

6) Remove the 3 Mounting Screws [1] Of the Engine Controller Unit.

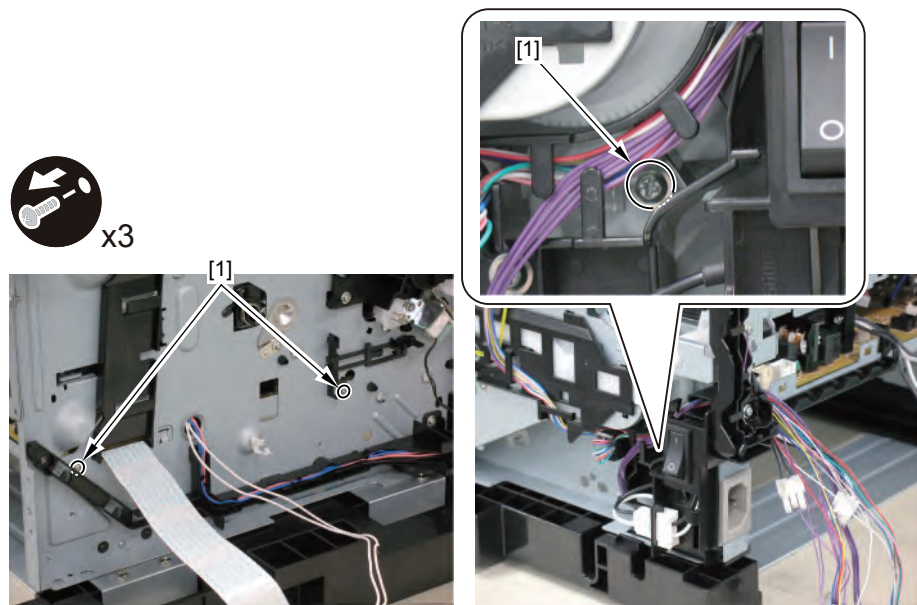

F-4-118

7) Push the 2 Claws [1] and Displace the Engine Controller Unit [2] In the Direction Of the Arrow.

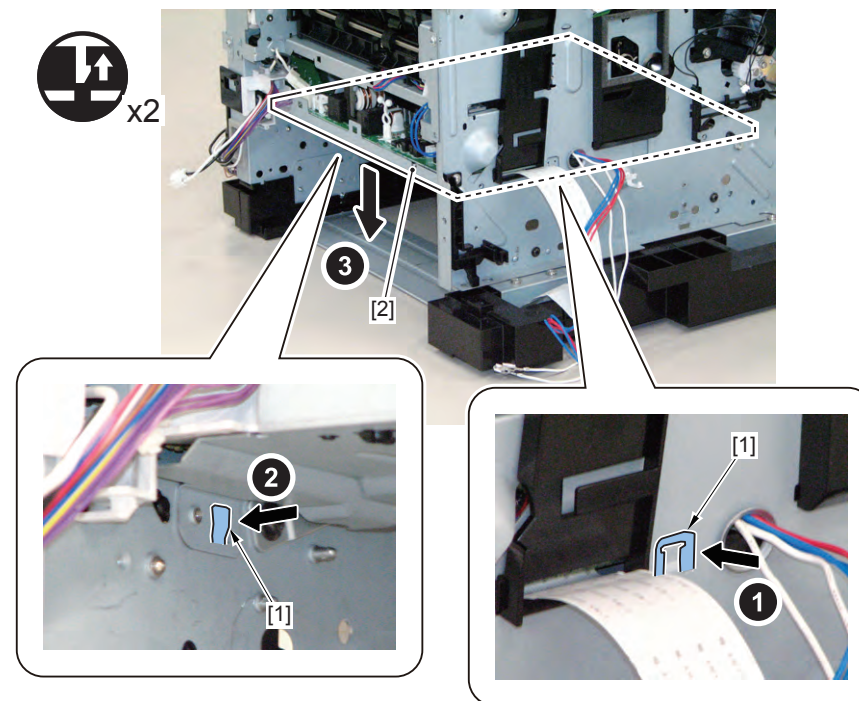

F-4-119

8) While Pulling Out the Flat Cable [1] and the Harness [2] from the Hole Of the Host Machine, Remove the Engine Controller Unit [3].

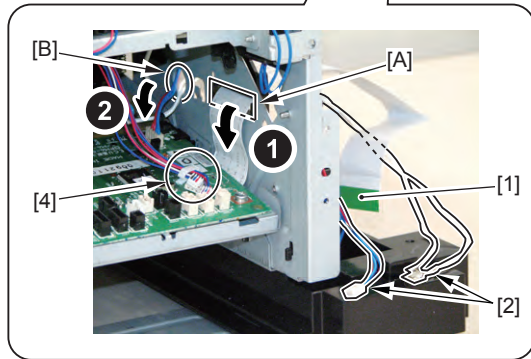
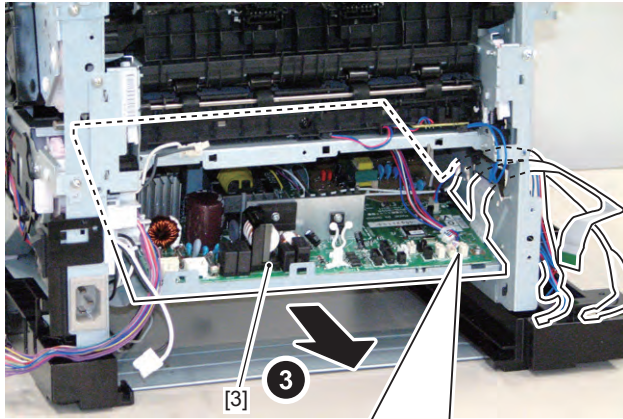

F-4-120

Removing the Control Panel

1) Open the ADF Unit + Reader Unit [1].

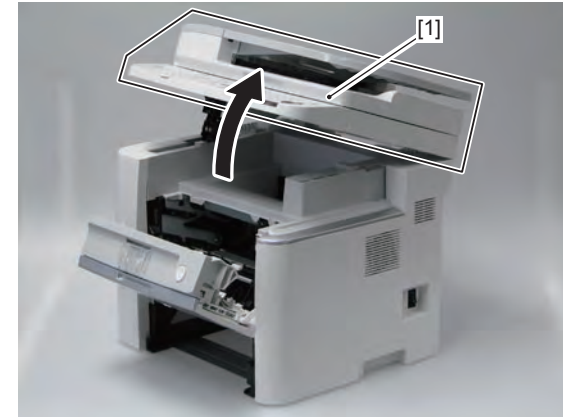

F-4-121

2) Release the claw [1], and remove the Arm Cover [2].

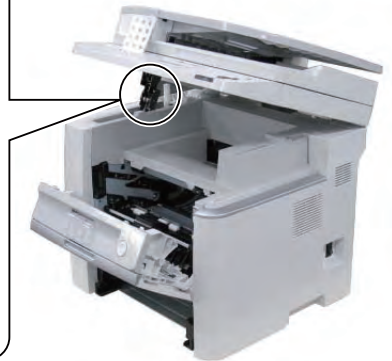
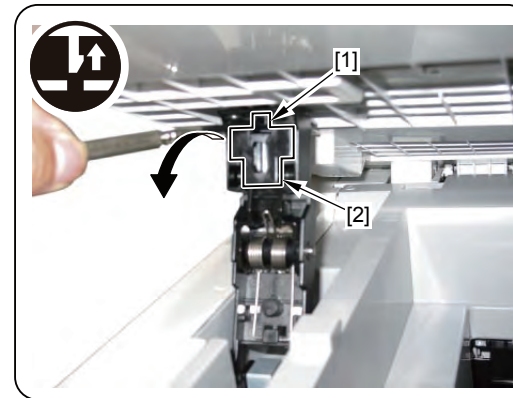

F-4-122

3) Release the Connection of Arm [1] and turn it toward the rear.

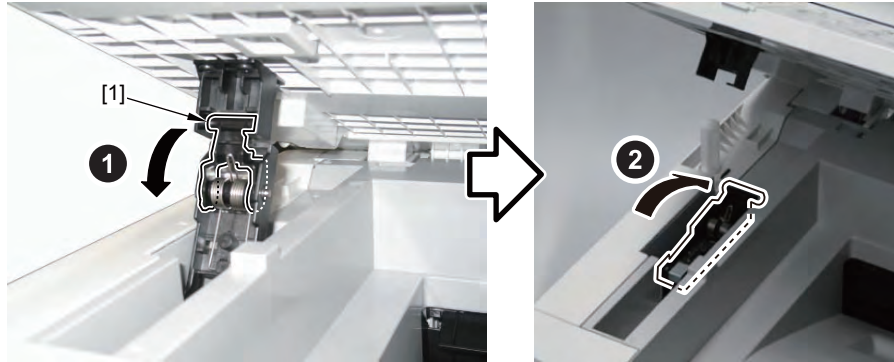

F-4-123

4) Remove the 2 Blanking Sheets [1] and 4 Screws [2] On the Bottom Of the Reader Unit.

CAUTION:

Since the Blanking Sheet [1] Needs to be Purchased Separately, be Careful Not to Lose it After Removing It.

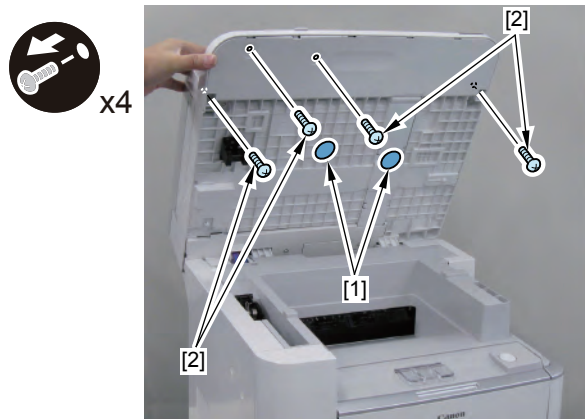

F-4-124

5) Remove the Control Panel [1].

- 9 Claws [2]
- 1 Flat Cable [3]
- 1 Terminal [4]

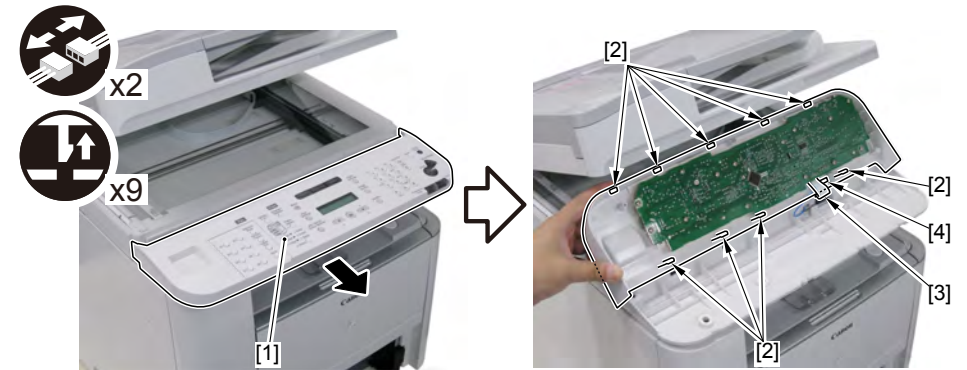

F-4-125

Removing the Main Motor

Preparations

- 1) Removing the Right Cover Unit.
- 2) Removing the Left Cover Unit.
- 3) Removing the Controller Cover.
- 4) Removing the Left Rear Cover.
- 5) Removing the NCU PCB.
- 6) Removing the Main Controller PCB.
- 7) Removing the Controller Box.
- 8) Removing the Fixing Assembly.
- 9) Removing the Engine Controller Unit.

Procedure

- 1) Remove the Main Switch Mount [1].

- 1 Screw [2]
- 2 Claws [3]

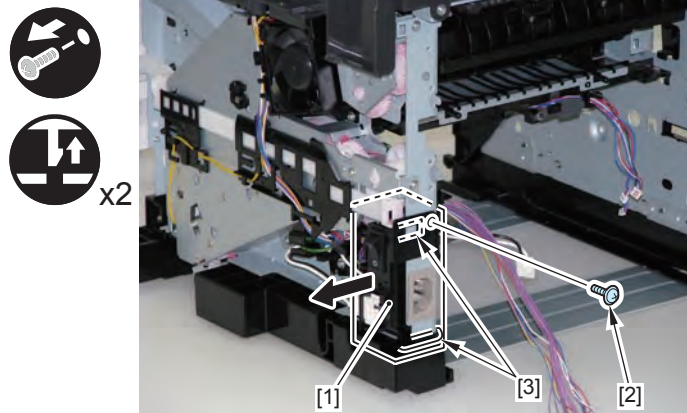

F-4-126

- 2) Shift the Harness Guide [1] to the left.

- 1 Screw [2]
- 2 Bosses [3]

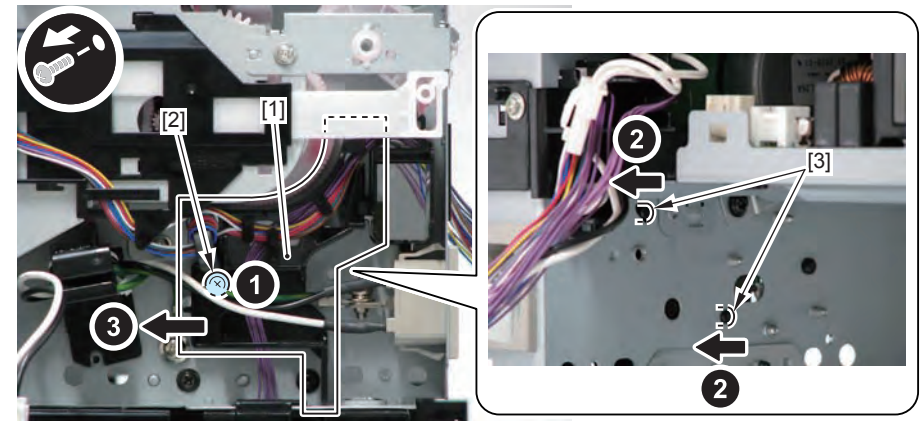

F-4-127

CAUTION:

When installing the Harness Guide [1], be sure to place it at rear side of the hook [3] of the Harness Guide [2].

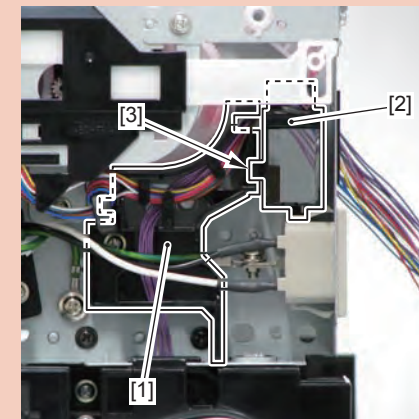

F-4-128

3) Displace the Harness Guide [1].

- 2 Claws [2]

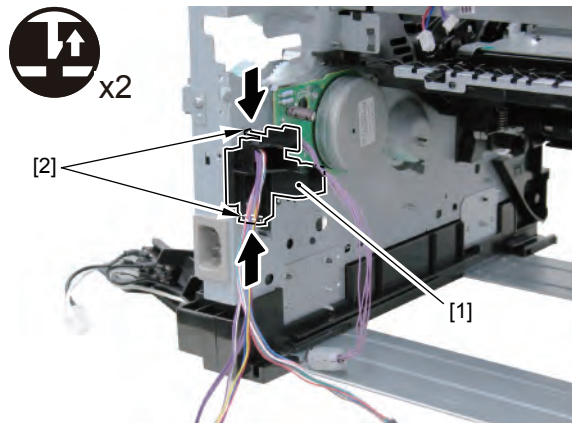

F-4-129

4) Remove the Main Motor [1] Together With the Harness Guide [2].

- 3 Screws [3]

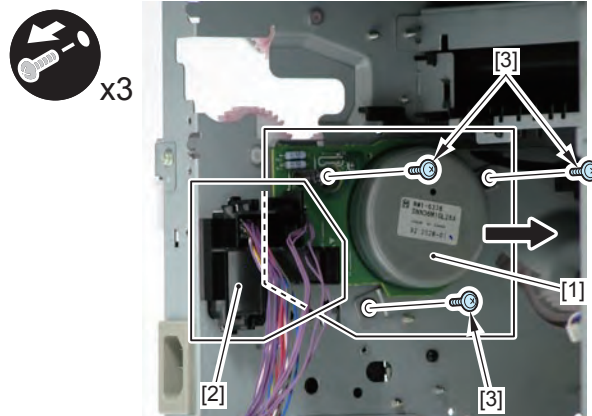

F-4-130

Removing the Main Fan

Preparations

1) Removing the Right Cover Unit.

Procedure

1) Remove the Main Fan [1].

- 1 Connector [2]
- 2 Claws [3]

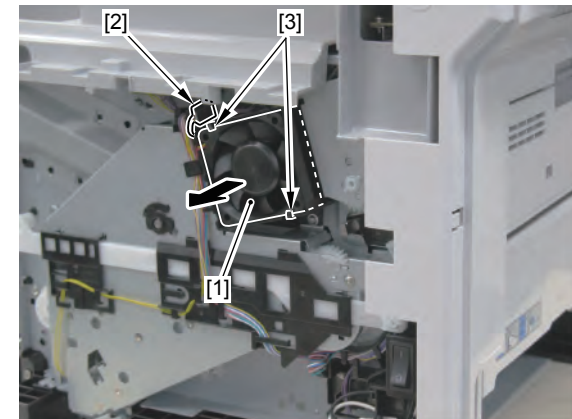

F-4-131

Removing the Main Drive Unit

Preparations

- 1) Removing the Right Cover Unit.
- 2) Removing the Left Cover Unit.
- 3) Removing the Controller Cover.
- 4) Removing the Left Rear Cover.
- 5) Removing the ADF + Reader Unit.
- 6) Removing the Upper Cover.
- 7) Removing the Rear Cover Unit.

Procedure

- 1) Remove the Duplex Reverse Sensor Unit [1].

- 1 Connector [2]
- 1 Wire Saddles [3]
- 1 Harness Guide [4]
- 1 Screw [5]

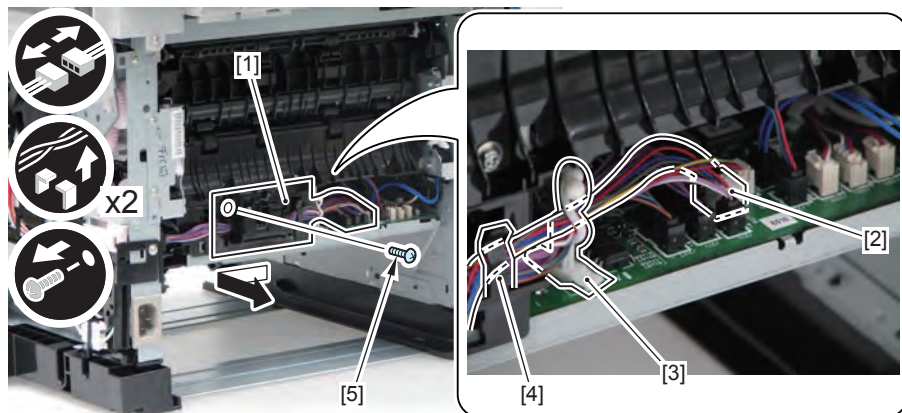

F-4-132

- 2) Remove the Harness [1] from the 2 Harness Guide [4].

- 3 Connectors [2]
- 1 Cable Clip [3]

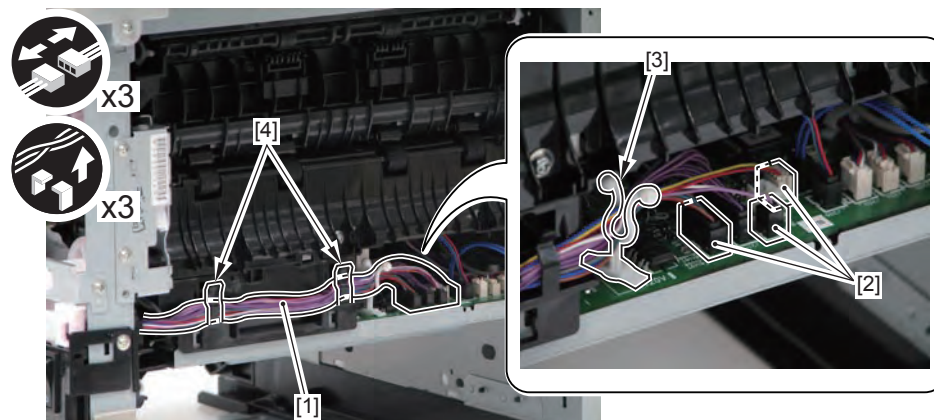

F-4-133

- 3) Remove the Harness [1] from the Harness Guide [2].

- 4 Connectors [3]

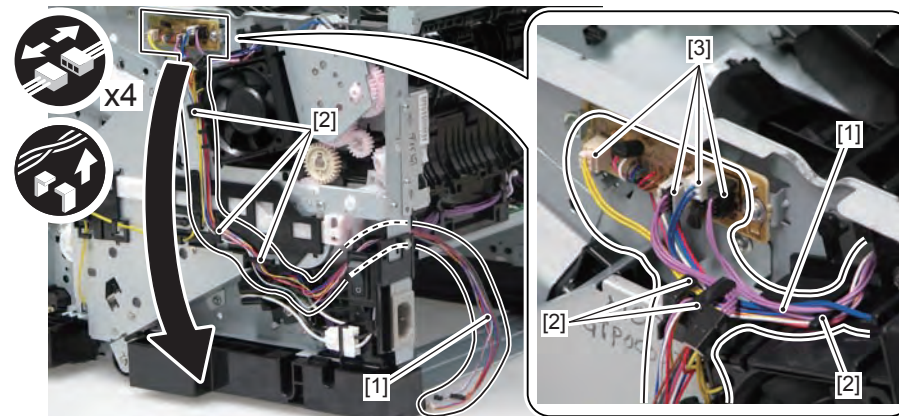

F-4-134

4) Remove the Main Fan Holder [1].

- 2 Screws [2]

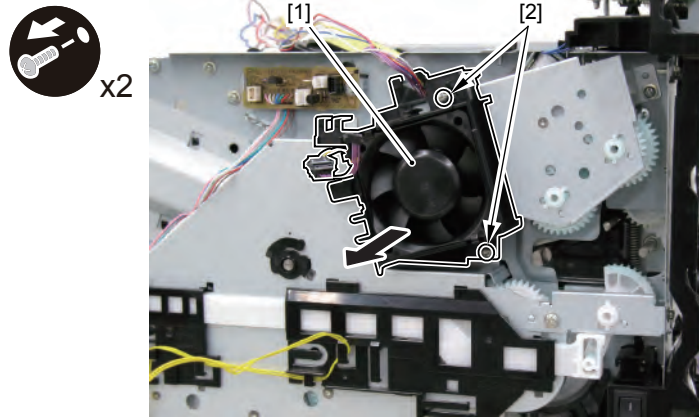

F-4-135

5) Remove the Link [1] and Remove the Harness [2] from the Harness Guide [3].

- 2 Bosses [2]

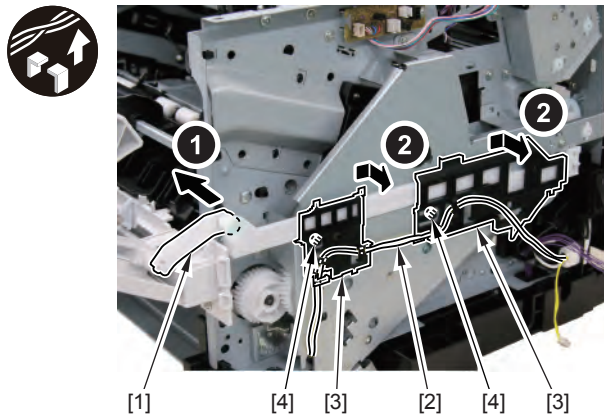

F-4-136

6) Remove the 2 Harness Guides [1].

- 2 Bosses [2]

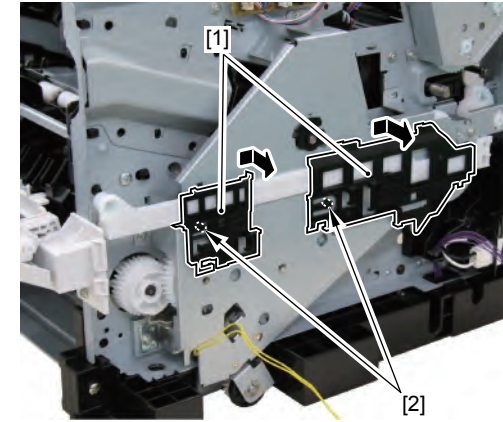

F-4-137

7) Remove the Plate [1], the Fixing Gear [2] and the Link Arm [3].

- 2 Screws [4]

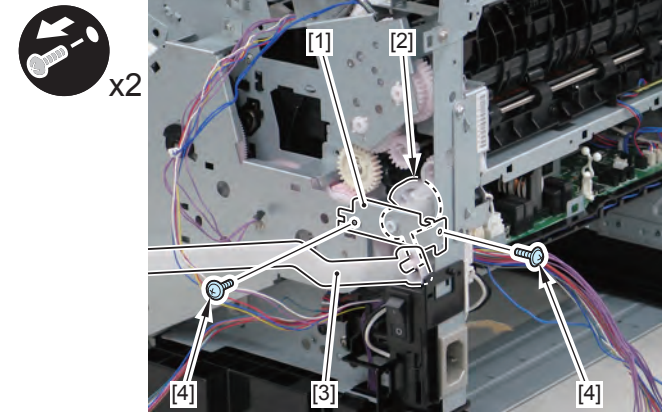

F-4-138

CAUTION:

Points to Note When Removing the Main Drive Unit.

Since the Gear of the Main Drive Unit is not Fixed, be Careful Not to Drop it When Removing it..

8) Remove the Main Drive Unit [1].

- 4 Screws [2]

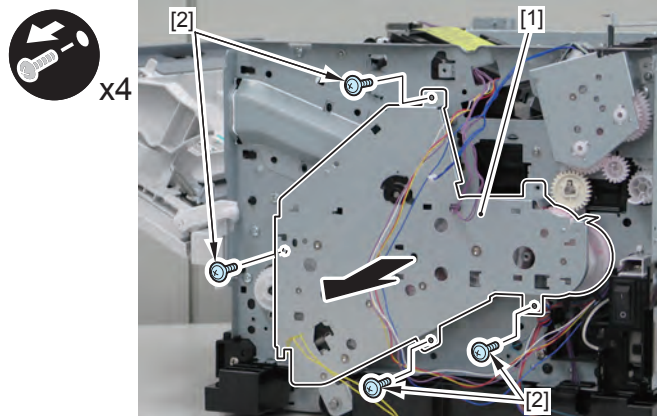

F-4-139

Removing the Duplex Drive Unit

Preparations

- 1) Removing the Right Cover Unit.
- 2) Removing the Left Cover Unit.
- 3) Removing the Controller Cover.
- 4) Removing the Left Rear Cover.
- 5) Removing the ADF Unit + Reader Unit.
- 6) Removing the Upper Cover Unit.
- 7) Removing the Rear Cover Unit.

Procedure

- 1) Remove the Harnesses from the [A], [B], [C], [D].

- 4 Connector [1]

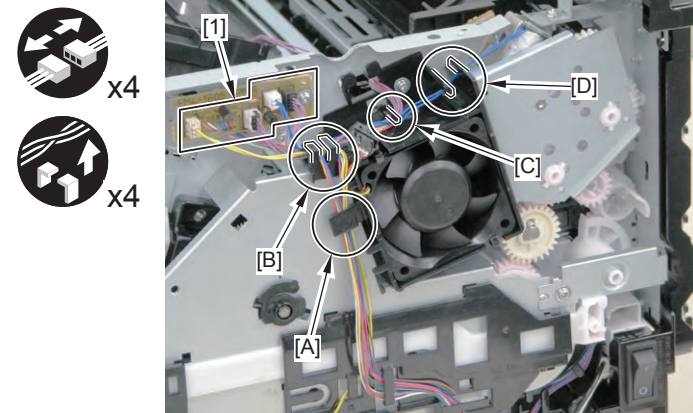

F-4-140

2) Remove the Harness from the [E], and Remove the Main Fan [1].

- 2 Screws [2]

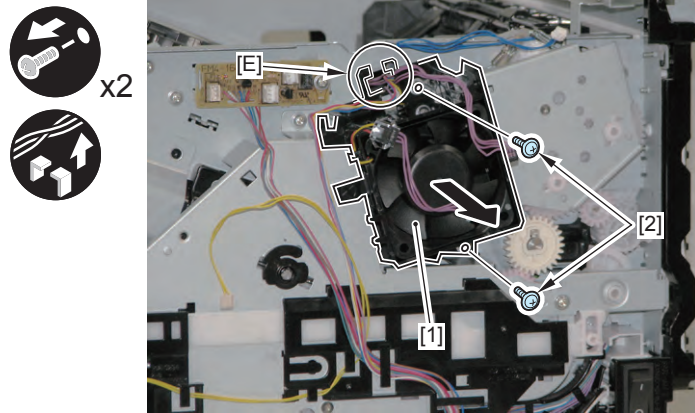

F-4-141

3) Remove the Duplex Drive Unit [1].

- 3 Screws [2]

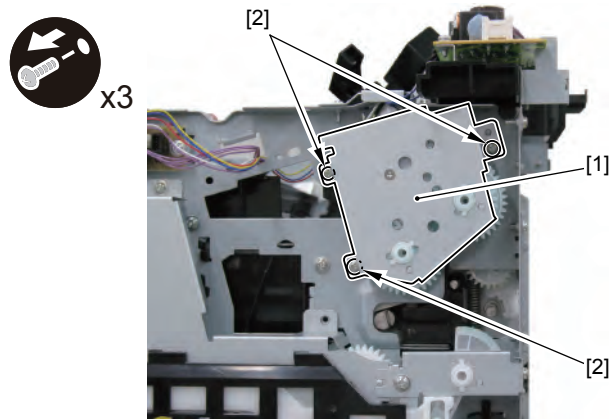

F-4-142

CAUTION :

Since the Gear of the Duplex Drive Unit is Not Fixed, be Careful Not to Drop or Lose it When Removing it.

Removing the Duplex Reverse Solenoid

Preparations

- 1) Removing the Right Cover Unit.
- 2) Removing the Right Rear Cover.
- 3) Removing the Left Cover Unit.
- 4) Removing the Controller Cover.
- 5) Removing the Left Rear Cover.
- 7) Removing the Upper Cover Unit.
- 8) Removing the Duplex Drive Unit.

Procedure

- 1) Remove the Duplex Reverse Solenoid [1].

- 1 Screw [2]

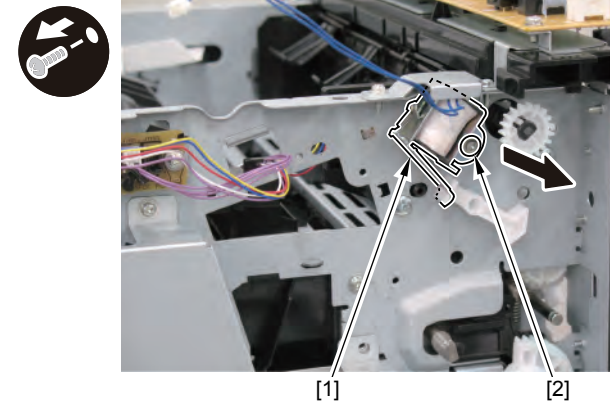

F-4-143

Removing the Cassette Pickup Solenoid

Preparations

1) Removing the Right Cover Unit.

Procedure

1) Free the harness [1] from the Harness Guides [2], and remove the Cassette Pickup Solenoid [3].

- 1 Connector [4]
- 1 Screw [5]

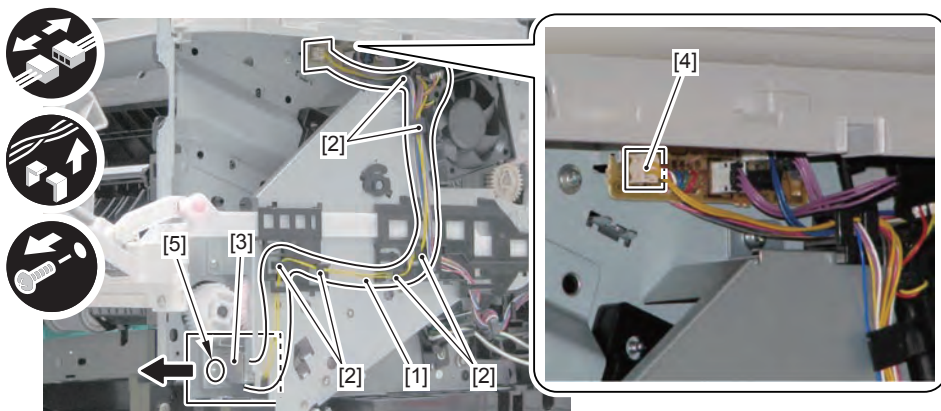

F-4-144

Laser Exposure System

Removing the Laser Scanner Unit

Preparations

- 1) Removing the Right Cover.
- 2) Removing the Left Cover.
- 3) Removing the Controller Cover.
- 4) Removing the Left Rear Cover.
- 5) Removing the ADF + the Reader Unit.

Procedure

- 1) Remove the Laser Scanner Unit [1].
 - 1 Flat Cable [2]
 - 1 Sponge Cover [3]
 - 1 Connector [4]
 - 4 Screw [5]

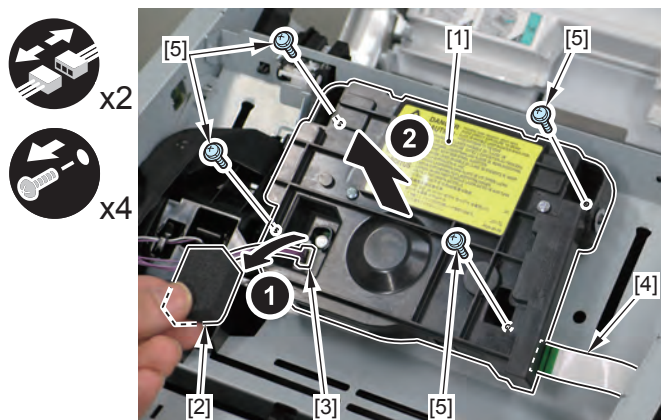

F-4-145

CAUTION:

Do Not Disassemble the Laser Scanner Unit at a Field.
It May Cause a Malfunction.

Image Forming System

Removing the Transfer Roller

- 1) Open the Front Cover.
- 2) Pinch the Holder [1] and Remove It In the Direction Of the Arrow.

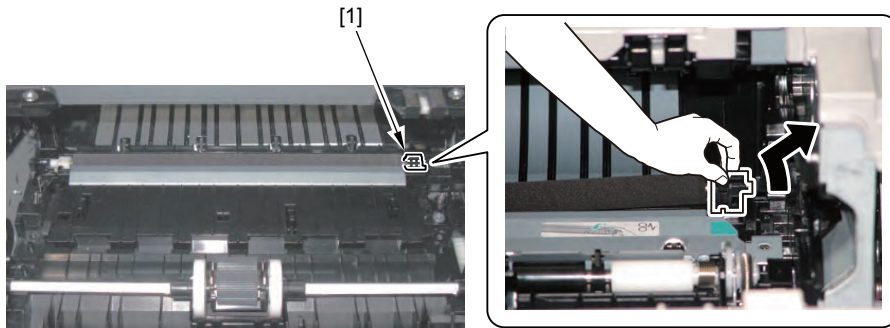

F-4-146

- 3) Remove the Transfer Roller [1] In the Direction Of the Arrow.

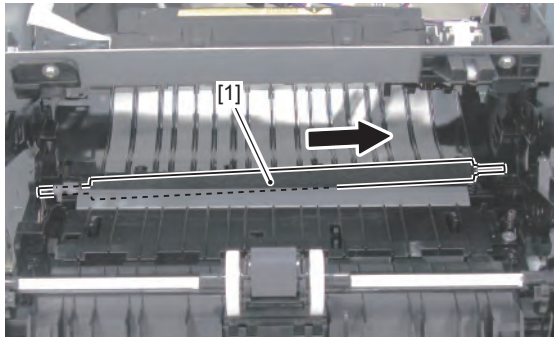

F-4-147

CAUTION :

At Installation, Make Sure to Hold the Shaft [1] of the Transfer Roller and be Careful Not to Touch the Sponge Part [2] of the Roller.

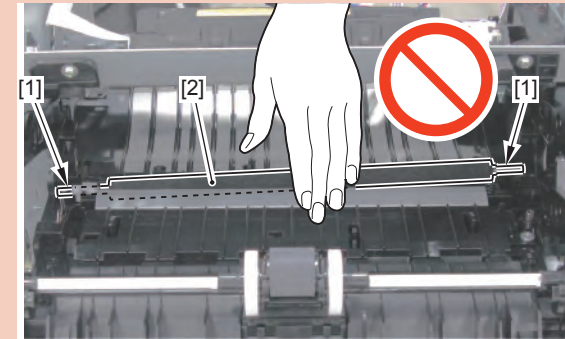

F-4-148

Removing the Registration Unit

Preparations

- 1) Removing the Right Cover.
- 2) Removing the Left Cover.
- 3) Removing the Controller Cover.
- 4) Removing the Left Rear Cover.
- 5) Removing the ADF + Reader Unit.
- 6) Removing the Upper Cover Unit.

Procedure

- 1) Remove the Gear [1].
 - 1 Claw [2]

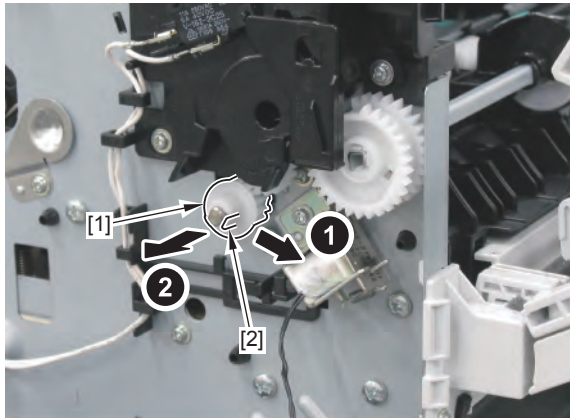

F-4-149

- 2) Remove the Guide [1].
 - 2 Claws [2]

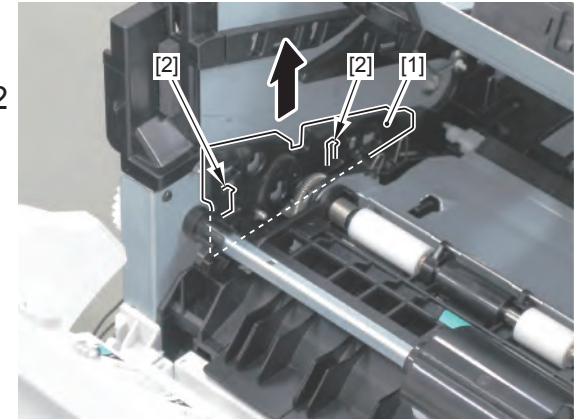

F-4-150

- 3) Remove the Registration Unit [1].
 - 5 Screws [2]
 - 1 Gear Cover [3]

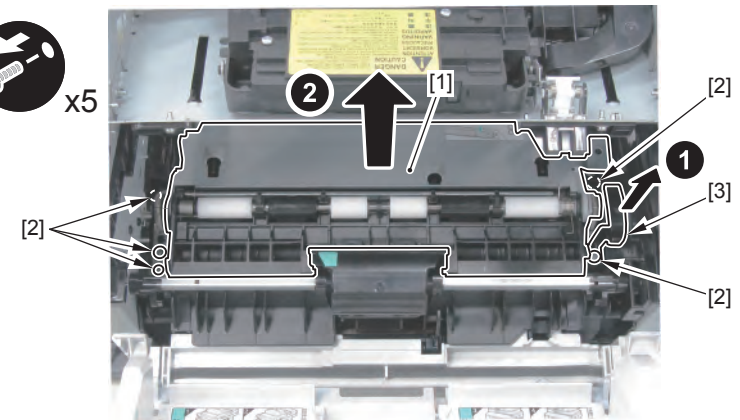

F-4-151

Fixing System

Removing the Fixing Assembly

Preparations

- 1) Removing the Left Cover Unit.
- 2) Removing the Left Rear Cover.
- 3) Removing the Right Cover Unit.
- 4) Removing the Rear Cover Unit.

Procedure

CAUTION:

When Removing the Fixing Assembly, Perform the Operation After the Fixing Assembly is Surely Cooled.

The Fixing Assembly Just After Printing May Cause Burn Injury.

- 1) Close the Front Cover and Move the Gear In the Position Where It Can Be Removed.
- 2) Remove the 3 Gears [1].

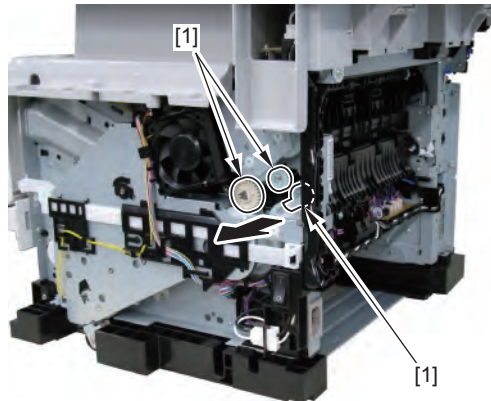

F-4-152

CAUTION:

Points to Note at Installation

- Fit the Protrusion [2] of the Gear [1] With the Cut-off of the Gear [3] and Install it.
- Fit the Cut-off [4] of the Gear [1] With the Teeth of the Fan Gear [5] and Install it.

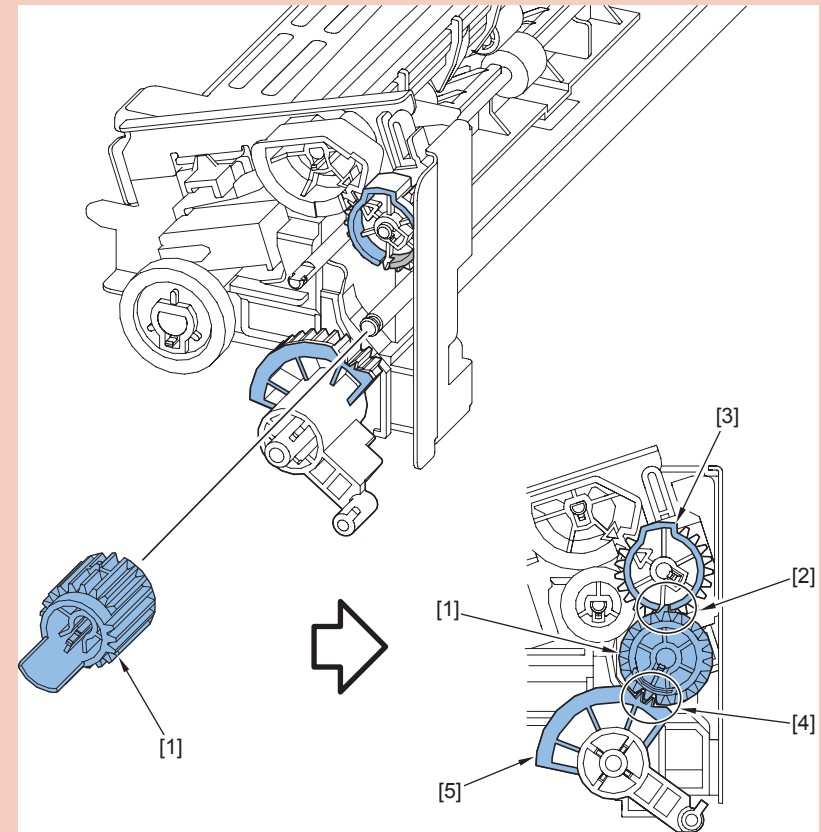

F-4-153

3) Remove the Duplex Feed Sensor Unit [1].

- 1 Connector [2]
- 1 Wire saddle [3]
- 1 Guide [4]
- 1 Screw [5]

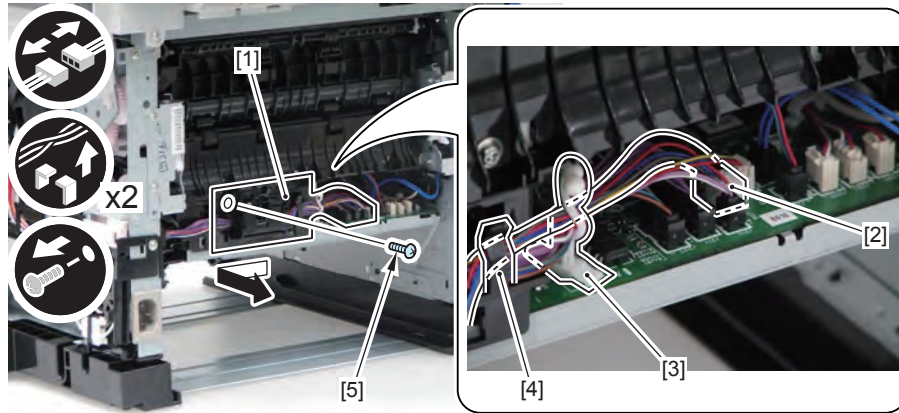

F-4-154

4) Remove the Harness [1] from the Wire saddle [3].

- 5 Connectors [2]
- 3 Guide [4]

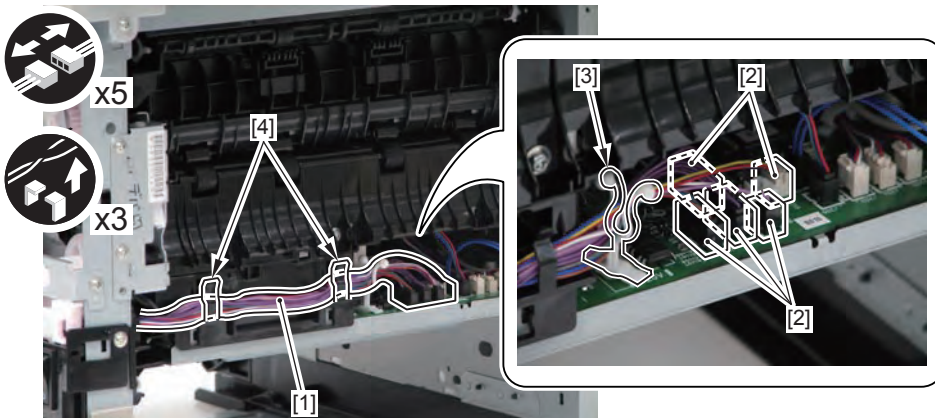

F-4-155

5) Remove the Feed Guide [1].

- 1 Screw [2]

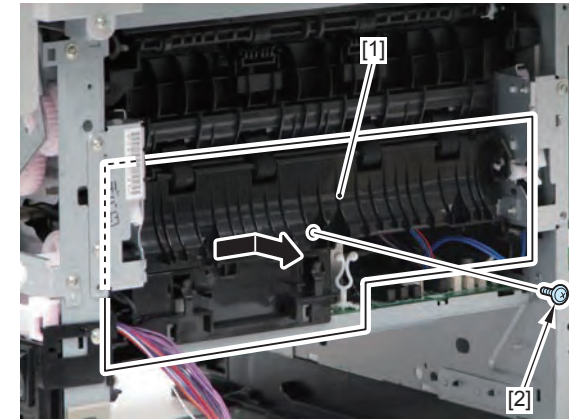

F-4-156

6) Remove the Fixing Assembly [1].

- 3 Connectors [2]
- 1 Terminal [3]
- 3 Screws [4]

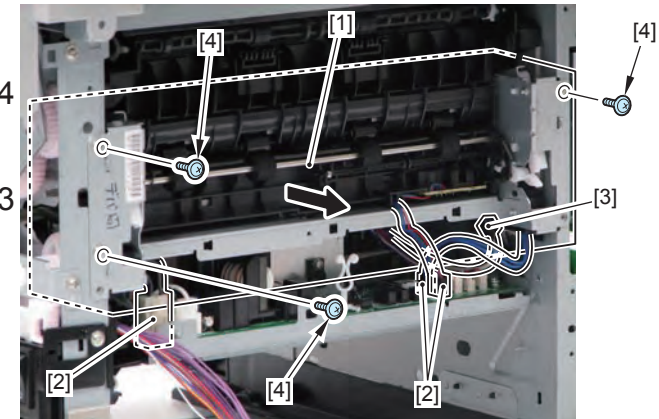

F-4-157

CAUTION:

Do Not Disassemble the Fixing Assembly at a Field.
It May Cause a Malfunction.

Pickup Feed System

Removing the Duplex Feed Unit

Preparations

- 1) Removing the Left Cover Unit.
- 2) Removing the Left Rear Cover.
- 3) Removing the Right Cover Unit.

Procedure

CAUTION:

Do Not Touch the Surface of the Cassette Feed Roller When Removing or Mounting it.

- 1) Push the Grip [1] Downward and Open the Rear Cover Unit [2].

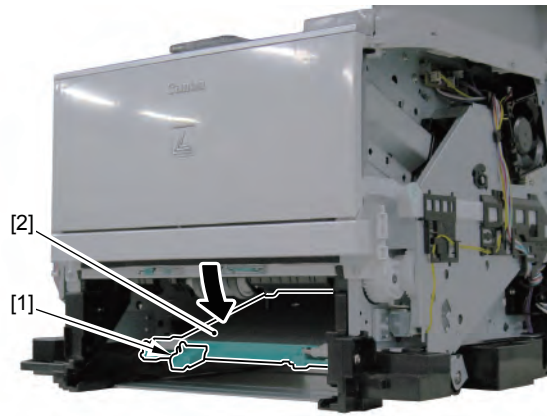

F-4-158

CAUTION:

During Reassembly, 2 Raise Lever [1] of Duplex Transport Unit and Attach Duplex Transport Unit [3] to Main Unit by Using 2 Magnet [2] on Each Side.

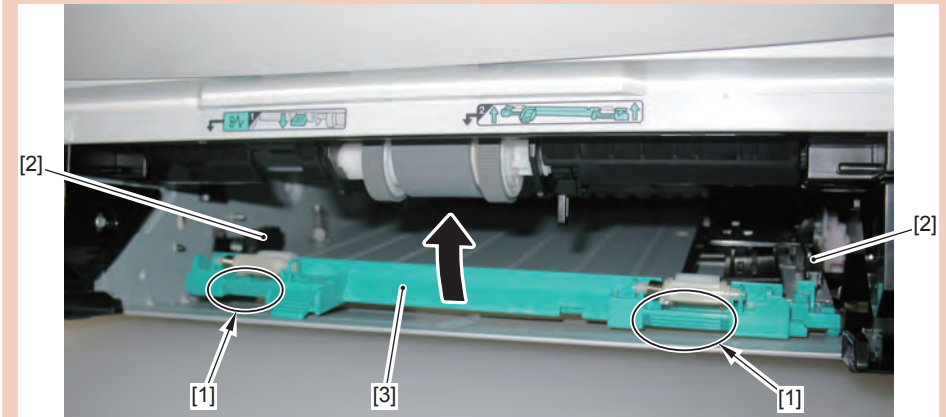

F-4-159

- 2) Remove the Duplex Feed Unit Cover [1].

- 5 Screws [2]
- 3 Claws [3]

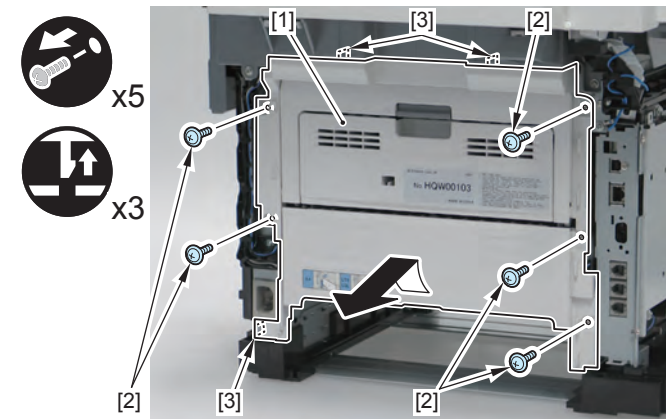

F-4-160

3) Remove the Rear Cover Unit [1] from the Duplex Feed Unit [2].

- 2 Bosses [3]

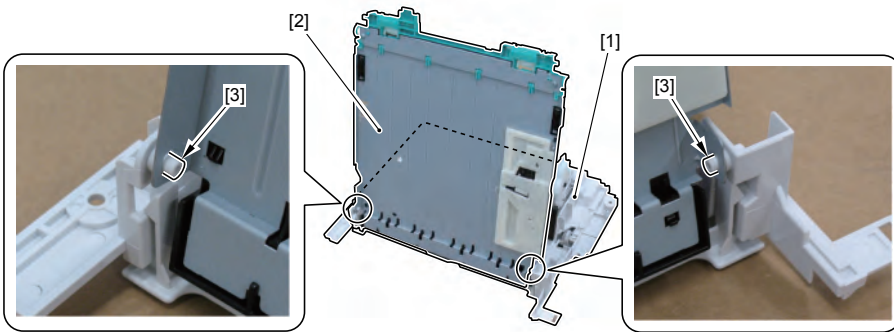

F-4-161

CAUTION :

Procedure at installation

- 1) Fit the 2 Upper Claw [2] of the Rear Cover Unit [1] With the Upper Cover Unit.
- 2) Open the Sub Output Tray [3] and While Pushing the Duplex Reverse Sensor Flag [4] Downward, Install the Rear Cover Unit.
- 3) Check That the Sensor Flag [4] Protrudes Through the Hole [5] of the Guide Unit On the Back of the Duplex Unit Cover.

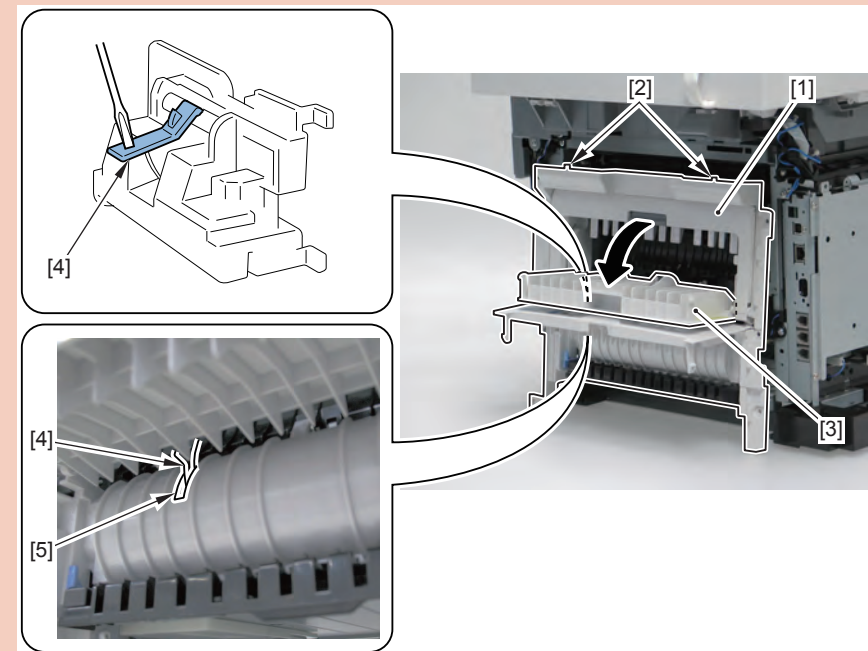

F-4-162

Removing the Cassette Pickup Roller

CAUTION:

Do Not Touch the Surface of the Cassette Pickup Roller When Removing or Mounting it. Cassette

- 1) Remove the Cassette.
- 2) Release the Stopper [1] and Displace the Shaft Support [2].

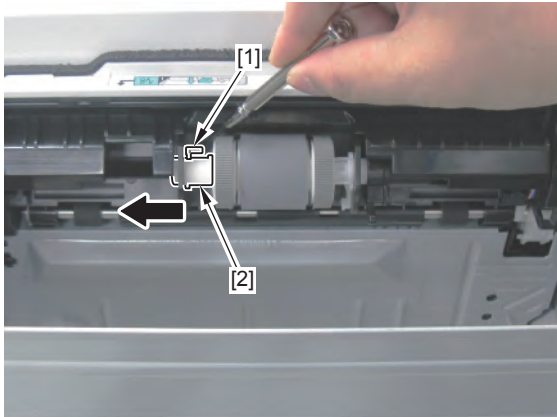

F-4-163

- 3) Remove the Cassette Pickup Roller Unit [1].

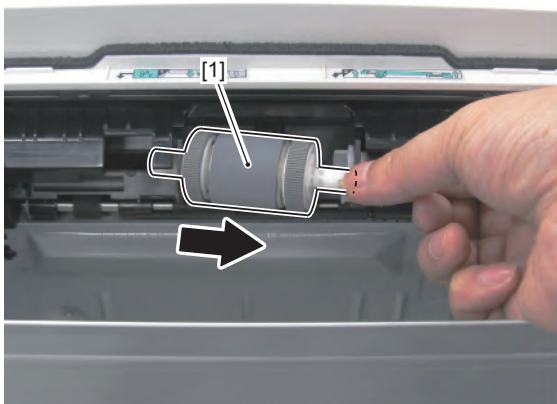

F-4-164

- 4) Remove the 2 Rubber Roller [1] On Both Edges from the Shaft and Remove the Pickup Roller [2].

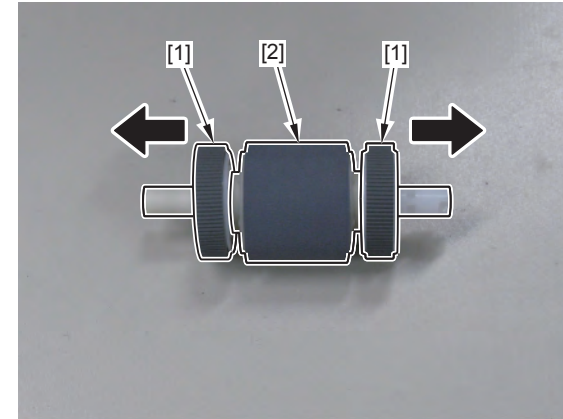

F-4-165

Removing the Cassette Separation Pad

CAUTION:

Do Not Touch the Surface of the Cassette Separator Pad When Removing or Mounting it.

- 1) Remove the Cassette.
- 2) Remove the Separation Pad [1].
 - 2 Screws [2]

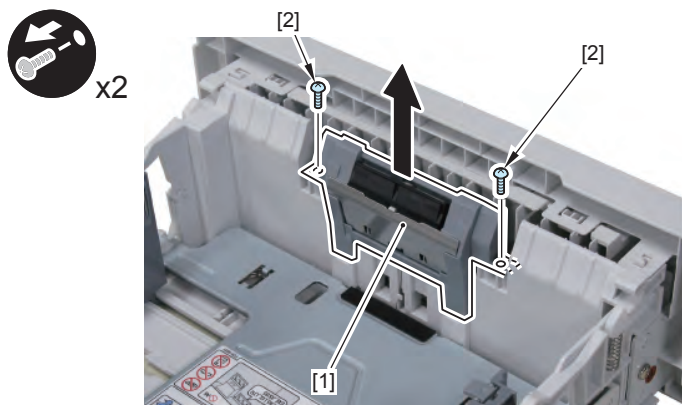

F-4-166

Removing the MP Pickup Roller

CAUTION:

Do Not Touch the Surface of the MP Pickup Roller When Removing or Mounting it.

- 1) Open the Front Cover [1].



F-4-167

- 2) Open the Pickup Roller Cover [1], Move the Roller Holder [2] In the Direction Of the Arrow and Remove the MP Pickup Roller [3].

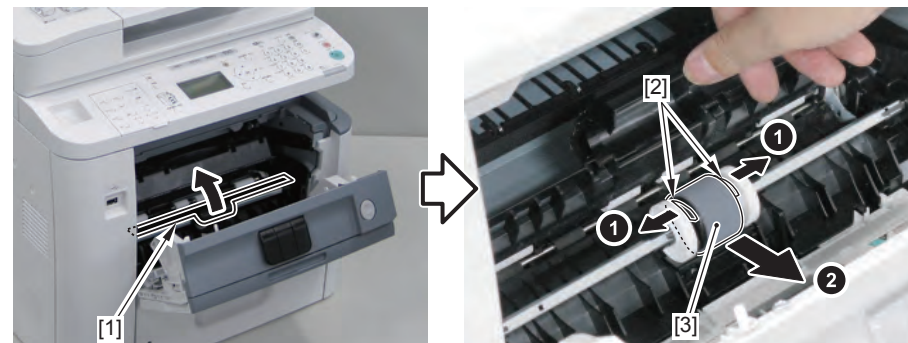

F-4-168

Removing the MP Separation Pad

CAUTION:

Do Not Touch the Surface of the MP Separation Pad When Removing or Mounting it.

1) Open the MP Tray Pickup Cover [1].



F-4-169

2) Lower the MP Guide [1], Insert the Precision Flat-screwdriver Into the Clearance [2] Of the Separation Pad and Displace It In the Direction Of the Arrow.

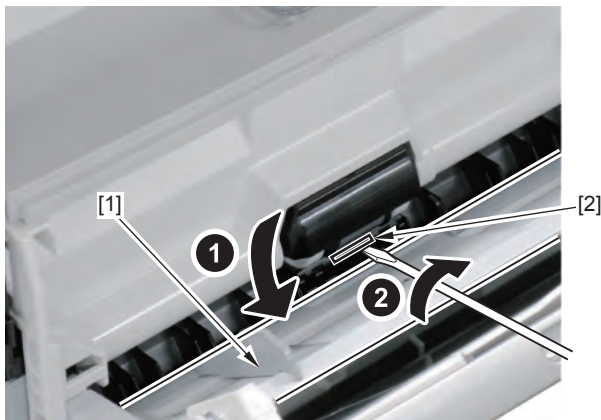

F-4-170

3) Open the Front Cover [1] and Remove the MP Separation Pad [2].

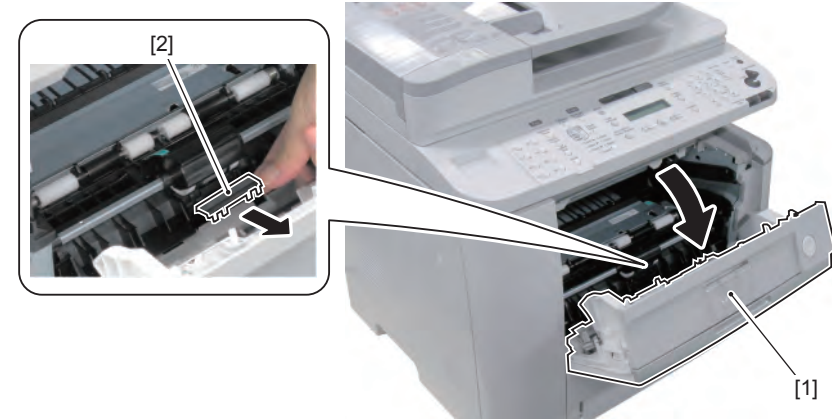

F-4-171

5

Adjustment

- Overview
- Document Exposure /
Feed System
- Controller System

Overview

In this chapter, measures of adjustment when replacing parts in servicing operation are mentioned. Parts to be replaced are categorized into 2 blocks based on their related technology as shown below.

Category	Parts replacement	Reference
Document Exposure / Feed System	CIS Unit	
	ADF Unit	
	Reader Unit	
	Reader Upper Cover Unit	
Controller System	Main Controller PCB	

T-5-1

Actions after Replacement Parts

Document Exposure / Feed System

After Replacing the Scanner Unit (CIS)

- 1) Check that there is no problem with the setting values written on the service label.
- 2) Close the ADF, and execute the following service mode. If it results in NG, execute it again after turning OFF and then ON the power.
 - COPIER > FUNCTION > CCD > CL-AGC (CIS light intensity adjustment (color))
 - COPIER > FUNCTION > CCD > BW-AGC (CIS light intensity adjustment (B&W))
- 3) After executing the following service mode (a), check the value automatically set with the following service mode (b), and write it in the service label.
 - (a) COPIER > FUNCTION > INSTALL > STRD-POS (executing automatic detection of the reading position at DF stream reading)
 - (b) COPIER > ADJUST > ADJ-XY > STRD-POS (adjusting the reading position at DF stream reading)
- 4) Place a blank paper on the Copyboard Glass, and execute white level adjustment in the following service mode.
 - COPIER > FUNCTION > CCD > DF-WLVL1 (white level adjustment [copyboard scan])
 - COPIER > FUNCTION > CCD > DF-WLVL3 (white level adjustment B&W [copyboard scan])
 Next, place the same blank paper on the DF and execute the following service mode.
 - COPIER > FUNCTION > CCD > DF-WLVL2 (white level adjustment [DF scan])
 - COPIER > FUNCTION > CCD > DF-WLVL4 (white level adjustment B&W [DF scan])
 If it results in NG, execute it again after turning OFF and then ON the power.

After Replacing the ADF Unit

- 1) Place a blank paper on the Copyboard Glass, and execute white level adjustment in the following service mode.

White level adjustment

 - COPIER > FUNCTION > CCD > DF-WLVL1 (white level adjustment [copyboard scan])
 - COPIER > FUNCTION > CCD > DF-WLVL3 (white level adjustment B&W [copyboard scan])
 Next, place the same blank paper on the DF and execute the following service mode.
 - COPIER > FUNCTION > CCD > DF-WLVL2 (white level adjustment [DF scan])
 - COPIER > FUNCTION > CCD > DF-WLVL4 (white level adjustment B&W [DF scan])
 If it results in NG, execute it again after turning OFF and then ON the power.

After Replacing the Reader Unit

- 1) Enter the values of the label affixed at the upper left of the glass in the following service mode item, and write the values in the service label.

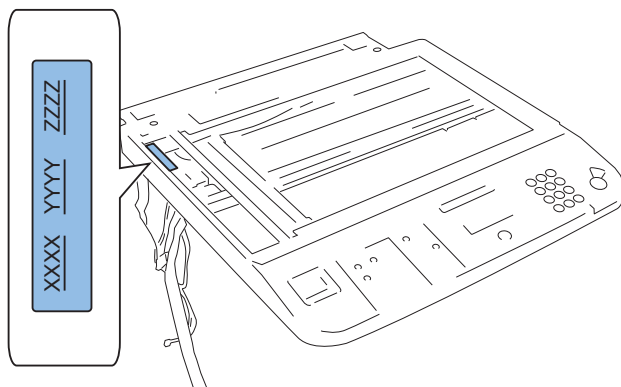

F-5-1

- COPIER > ADJUST > CCD > W-PLT-X (standard White Plate X signal data)
 - COPIER > ADJUST > CCD > W-PLT-Y (standard White Plate Y signal data)
 - COPIER > ADJUST > CCD > W-PLT-Z (standard White Plate Z signal data)
- 2) Check that there is no problem with the setting values written on the service label.
- 3) Close the ADF, and execute the following service mode. If it results in NG, execute it again after turning OFF and then ON the power.
- COPIER > FUNCTION > CCD > CL-AGC (CIS light intensity adjustment (color))
 - COPIER > FUNCTION > CCD > BW-AGC (CIS light intensity adjustment (B&W))
- 4) After executing the following service mode (a), check the value automatically set with the following service mode (b), and write it in the service label.
- (a) COPIER > FUNCTION > INSTALL > STRD-POS (executing automatic detection of the reading position at DF stream reading)
- (b) COPIER > ADJUST > ADJ-XY > STRD-POS (adjusting the reading position at DF stream reading)
- 5) Place a blank paper on the Copyboard Glass, and execute white level adjustment in the following service mode.
- COPIER > FUNCTION > CCD > DF-WLVL1 (white level adjustment [copyboard scan])
 - COPIER > FUNCTION > CCD > DF-WLVL3 (white level adjustment B&W [copyboard scan])
- Next, place the same blank paper on the DF and execute the following service mode.
- COPIER > FUNCTION > CCD > DF-WLVL2 (white level adjustment [DF scan])
 - COPIER > FUNCTION > CCD > DF-WLVL4 (white level adjustment B&W [DF scan])
- If it results in NG, execute it again after turning OFF and then ON the power.

After Replacing the Reader Upper Cover

- 1) Enter the values of the label affixed at the upper left of the glass in the following service mode item, and write the values in the service label.

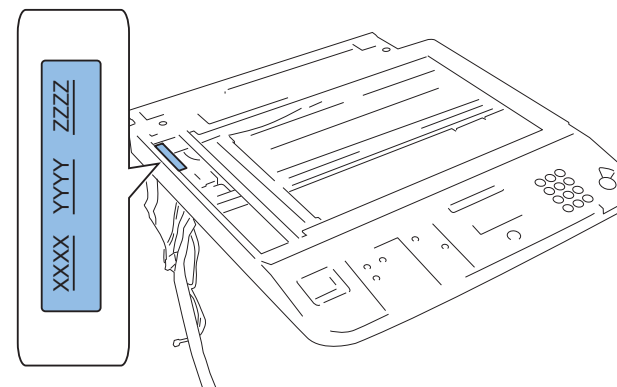

F-5-2

- COPIER > ADJUST > CCD > W-PLT-X (standard White Plate X signal data)
 - COPIER > ADJUST > CCD > W-PLT-Y (standard White Plate Y signal data)
 - COPIER > ADJUST > CCD > W-PLT-Z (standard White Plate Z signal data)
- 2) Place a blank paper on the Copyboard Glass, and execute white level adjustment in the following service mode.
- COPIER > FUNCTION > CCD > DF-WLVL1 (white level adjustment [copyboard scan])
 - COPIER > FUNCTION > CCD > DF-WLVL3 (white level adjustment B&W [copyboard scan])
- Next, place the same blank paper on the DF and execute the following service mode.
- COPIER > FUNCTION > CCD > DF-WLVL2 (white level adjustment [DF scan])
 - COPIER > FUNCTION > CCD > DF-WLVL4 (white level adjustment B&W [DF scan])
- If it results in NG, execute it again after turning OFF and then ON the power.

Controller System

After Replacing the Main Controller PCB

Actions before Replacement

Perform backup of user data (such as Settings/Registration data) and service mode data to set/register them again after replacing the PCB. Write down the data which cannot be backed up.

- 1) Export user data using remote UI.
- 2) Insert the USB memory into the host machine, and execute COPIER > FUNCTION > SYSTEM > EXPORT to write the setting values of the service mode (excluding those related to the Reader/DADF) to the USB memory.
- 3) Write down the serial number of the host machine and each factory adjustment value written on the service label. (Enter them after replacement.)

Actions after Replacement

- 1) Error code "E248-0001" lights up when turning ON the power.
- 2) Execute COPIER > FUNCTION > CLEAR > R-CON.
- 3) Enter all items written on the service label.
- 4) Set the location group and paper size group.
 - COPIER > OPTION > BODY > LOCALE (setting the location group)
[Setting value]
1: Japan, 2: North America, 3: Korea, 4: China, 5: Taiwan, 6: Europe, 7: Asia, 8: Oceania
 - COPIER > OPTION > BODY > SIZE-LC (setting the paper size group)
[Setting value]
1: AB configuration, 2: Inch configuration, 3: A configuration, 4: AB/Inch configuration
- 5) Clearing the Settings/Registration data
Execute COPIER > FUNCTION > CLEAR > ALL.
When executing this item, the following data is cleared according to the values of LOCALE and SIZE-LC set in step 4.
 - Settings/Registration data (the initial value according to the location is set.)
 - Service mode data (the initial value according to the location is set.)
 - Job ID
 - Each log data
 - Date data

Note that the following data is not cleared.

- Service counter
- Adjustment value of Reader/DADF

- 6) Execute COPIER > FUNCTION > VIFFNC > STOR-DCN (the setting value of DC Controller is backed up.)
- 7) Turn OFF and then ON the power.
- 8) Operate according to the instruction on the screen since the initial installation mode is activated. (Setting the date/time, executing the auto gradation adjustment)
- 9) Enter the serial number (8-digit alphanumeric) in Settings/Registration > System Settings > Device Information > Location.
- 10) After selecting COPIER > OPTION > SERIAL > SN-MAIN, press OK key to write the serial number entered in step 4 in the Main Controller PCB. After writing, the serial number entered in "Location" in step 9 is deleted.
- 11) Turn OFF and then ON the main power.
- 12) Execute COPIER > FUNCTION > MISC-P > SPEC to output the spec report to check the serial number (Body.No.).
- 13) Enter the data backed up earlier in Settings/Registration > System Settings > Device Information > Location.
- 14) Import the service mode data backed up before replacement.
Insert the USB memory storage device to the slot of the machine, and execute COPIER > FUNCTION > SYSTEM > IMPORT.
- 15) Import user data using remote UI.

6

Trouble Shooting

- Test Print
- Trouble Shooting Items
- Version Up

Test Print

Test Pages

Printing test pages helps determine if the printer is functioning.

CAUTION:

There are two types of test pages: engine-test page and formatter-test page. Print a test page to make sure the printer engine and the formatter are functioning.

Engine-test Page

There are two types of engine-test pages simplex print and duplex print.

a. Simplex print

Open and close the cartridge door three times continuously within 2 seconds during the standby period. The engine-test page should have a test print pattern on one side of media as shown below.

b. Duplex print

Open and close the cartridge door five times continuously within 2 seconds during the standby period. The engine-test page should have a test print pattern on both sides of media as shown below.

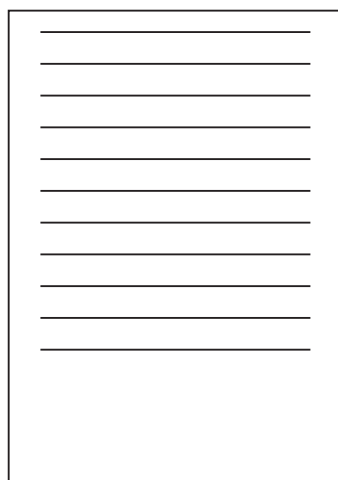

F-6-1

Controller Test Print

This product provides the following 8 test chart types to determine causes of faulty images.

The data for test charts are created in the main controller. If no problem is found on the output test charts, the cause may lie in the PDL input or the reader.

TYPE No. can be selected in TESTMODE > PRINT > PG-TYPE.

TYPE No.	pattern	image check item
0	Grid chart	Right angle accuracy Straight line accuracy
1	Halftone	Transfer failure, Black line, White line, Margin
2	Solid black	Transfer failure, White line, Margin
3	Solid white	Fogging
4	17 gradations	Gradation, Black line, White line
5	Thin horizontal line	Black line, White line, Parallelism
6	PASCAL correction chart	-
7	Chart 128	-

T-6-1

Trouble Shooting Items

Special Mode

This product has settings called Special Mode to solve print quality troubles. This function can be executed in the following user mode.

- Menu> Adjust / Maintenance > Special mode

Special mode	Options	Details
Special Mode U	OFF ON	Due to the paper type (for example, heavy paper) or usage conditions (for example, dry conditions), toner smudges and spatters appear on the output. When this occurs, set this setting to <On>. <ul style="list-style-type: none"> • The print quality may become lower when this setting is enabled, depending on the paper type used (for example, thin paper) or usage conditions (humid conditions).
Special Mode V	OFF Mode 1 Mode 2	If damp paper is used to print, the ejected paper may curl up (the printed side may curl up). In this case, change this setting. the improvement effect is increased in the following order. <Off> -> <Mode 1> -> <Mode 2> (low) (high) <ul style="list-style-type: none"> • Paper curls and creases can be minimized by changing the paper type and usage conditions, without needing to change the setting. • The more effective the setting becomes, the slower the print speed.
Special Mode X (only for media printing and printing from PS/PCL printer driver) (D1370 only)	OFF Mode 1 Mode 2 Mode 3	Depending on the paper type or the printing environment, liner ink stains may appear on the printed document. If it happens, change the setting of this item. The improvement effect is increased in the following order. <Off> -> <Mode 1> -> <Mode 2> -> <Mode 3> (Effect: Weak) (Effect: Strong) <ul style="list-style-type: none"> • If you change the paper type or the printing environment, liner stains may not appear on the printed paper without any setting. • The stronger you make the improvement effect, the lower the print density is. It may cause to blur the outlines or enhance the roughness. • If you cannot solve the problem even setting this item, try to set the <Special Mode D> to <On>.

Special mode	Options	Details
Special Mode Z (only for copying)	OFF Mode 1 Mode 2 Mode 3	Due to the paper type or usage conditions, vertical streaks appear on the output. When this occurs, change this setting. <Off> -> <Mode 1> -> <Mode 2> -> <Mode 3> (low) (high) <ul style="list-style-type: none"> • Streaks can be minimized by changing the paper type or usage conditions, without needing to change the setting. • The more effective the setting, the lower the density becomes. Additionally, the outline of text and images may be reproduced less clearly, and images may appear slightly jagged. • If you cannot solve the problem even setting this item, try to set the <Special Mode D> to <On>.
Special Mode B	OFF Mode 1 Mode 2 Mode 3	Vertical streaks appear on the output after the toner cartridge was replaced recently, or the machine has not printed anything for an extended period of time. When this occurs, change this setting. The effect becomes greater as the number goes up. <Off> -> <Mode 1> -> <Mode 2> -> <Mode 3> (low) (high) <ul style="list-style-type: none"> • If you change the paper type or the printing environment, liner stains may not appear on the printed paper without any setting. • If you turn <On> this item, the printing speed will be reduced.
Special Mode C (only for printing received fax and report printing)	OFF ON	Due to the paper type or usage conditions, vertical streaks appear on the output. When this occurs, set one of the following settings to <On>. Noise can also be minimized. <ul style="list-style-type: none"> • Streaks can be minimized by changing the paper type or usage conditions, without needing to change the setting.
Special Mode D	OFF ON	<ul style="list-style-type: none"> • If you turn <On> this item, the printing speed will be reduced.
Special Mode G	OFF ON	Depending on the paper type (rough-textured paper, especially 16K size), the output capacity may deteriorate. When this occurs, change the setting to <On>. <ul style="list-style-type: none"> • When <On> is set, the printing speed may decrease during continuous printing. • The paper transfer is carried out in the maximum speed, therefore the operation noise will be louder. • If you set <On> to any of <Special Mode V>, <Special Mode C>, or <Special Mode D>, this option setting will be invalid.

T-6-2

■ Trailing edge image soiling

[Cause]

The image is extended when the paper feed speed is increased due to the temperature rising in the machine.

This causes the trailing edge margin to become narrow, resulting in the occurrence of image soiling (transfer toner scattering).

NOTE :

Because paper slightly shrinks due to its passing through the Fixing Assembly once when printing the 1st side, this symptom is likely to occur on the 2nd side.

[Field Remedy]

Remedy (1): Set the Special Mode U to ON.

Effect: Image soiling is controlled by changing the settings of transfer high voltage current.

Remedy (2): Change the paper type mode from "Plain" to "Plain L".

Effect: Fixing control temperature is reduced => Temperature rising in the machine is controlled => Reduction of trailing edge margin is controlled.

When the effect is not enough with remedy (1), perform the remedies (1) + (2).

■ Repetitive Image Defects Ruler

Component	Distance between defects (mm)
Registration roller	About 43
Primary charging roller	About 38
Photosensitive drum	About 75
Developing roller	About 42
Transfer roller	About 39
Fixing film unit	About 57
Pressure roller	About 63

T-6-3

Nip-width Specifications

The nip-width of the fixing unit is not adjustable in this printer, however the improper nip-width may cause the poor fixing.

Nip width of the Fixing Assembly can be checked by the following procedure.

- 1) Select TESTMODE > PRINT > PG-TYPE, and set the value to "2". (Solid black is printed.)
 - 2) Select TESTMODE > PRINT > START, and press the OK key.
 - 3) Turn the printed side of the solid black printed paper down, and place it in the cassette of the machine.
 - 4) Select TESTMODE > PRINT > PG-TYPE, and set the value to "3". (Blank image is printed.)
 - 5) Select TESTMODE > PRINT > START, and press the OK key.
 - 6) Open the Front Door immediately before the paper is delivered (when the paper is fed through the Fixing Assembly), and take out the printed paper after leaving it for 10 seconds or longer.
- Center (a): 6.1mm to 8.1 mm
 - Edge (b) , (c): 6.1mm to 8.1 mm

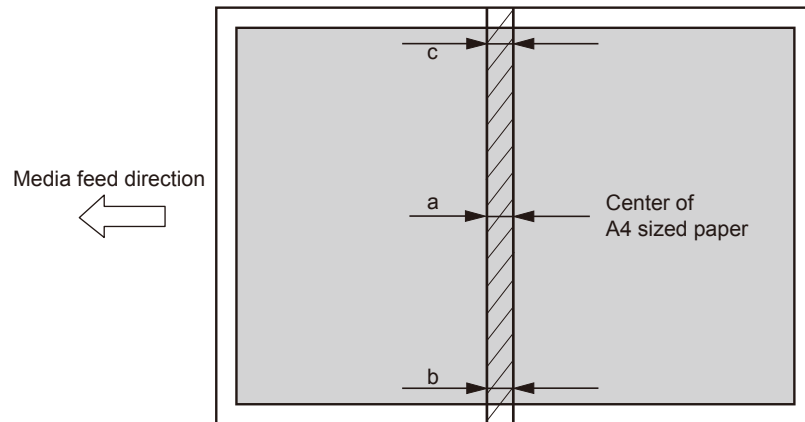

F-6-2

Version Up

Overview of Upgrading

There are two kinds of following version up methods in this machine

- Change it for the PCB of a new version
- Upgrading is performed by downloading firmware from a personal computer (hereinafter called PC) to this machine using a user support tool (hereinafter called UST).

PCB	Upgrading method
Main controller PCB	• PCB replacing
Engin controller PCB	• UST

T-6-4

Firmware Configuration

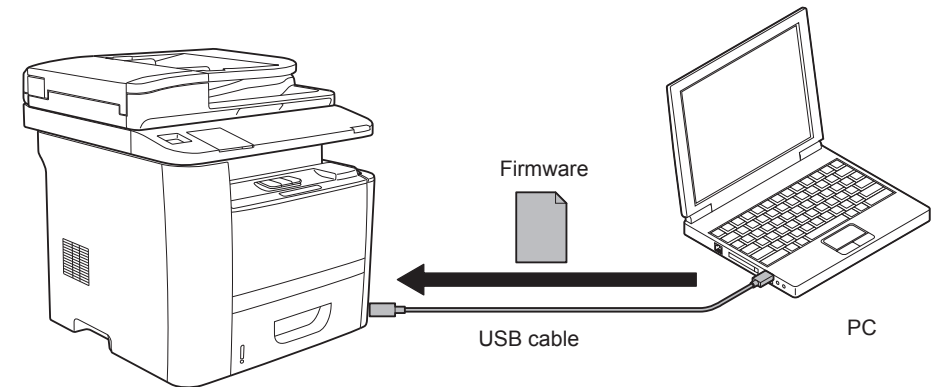

Firmware	Function	Storage area ^{F-6-3}
BOOTABLE	Overall control	Main controller PCB
LANGUAGE	Manage languages used in panel / Remote UI and font data.	Main controller PCB
DCON (ECONT)	Control the printer unit.	Engine controller PCB

T-6-5

A number of firmware may be less than the above depending on the UST version.

Caution:

When you install it every model in this machine so that firmware is different, you must not make a mistake

	MF6700/D1300	MF5900/MF6700/D1300
BOOTABLE/LANGUAGE	typeA	typeB
DCON	Model is common	

T-6-6

Preparation

■ Necessary System Environment

- OS (Any of the following)
 - Microsoft Windows 2000 Server/Professional
 - Microsoft Windows XP Professional/Home Edition
 - Microsoft Windows Server 2003
 - Microsoft Windows Vista
 - Microsoft Windows 7
 - Microsoft Windows Server 2008
 - Mac OS X 10.3 or later

- PC
 - Compatible to the selected OS
 - Memory (RAM): 32MB or greater
 - Hard disk: 100MB or greater
 - Display: Resolution 640 x 480 pixel or greater, 256-color or greater
 - With USB port

- UST file* of this machine
 - * : Download the file from a system CD or website. (It differs depending on the sales company.)

- USB cable (USB1.1/2.0)

■ Before Downloading the System Software

- 1) Start up the PC.
- 2) Connect the host machine and the PC with a USB cable.
- 3) Turn on the host machine, and place it in the standby status.
- 4) Place the machine in the off-line status by pressing the Off-line key, and select Firmware Upgrading in the user mode.
MENU > SYSTEM SETTINGS > UPDATE FIRMWARE > YES
- 5) When pressing the OK key, the host machine automatically restarts up, and "WAITING" > "CONNECTED TO PC" is displayed in the display.

NOTE :

Once the machine enters the upgrading mode, normal operation cannot be performed until upgrading is completed. To discontinue upgrading, turn the power OFF/ON.

Downloading the System Software

Procedure of Downloading

1) Open UST (XXXX.exe).

XXXX: Firmware version



XXXXXXXX
XXXX.exe

F-6-4

2) Write down the firmware version to upgrade, and click the "Next" button.

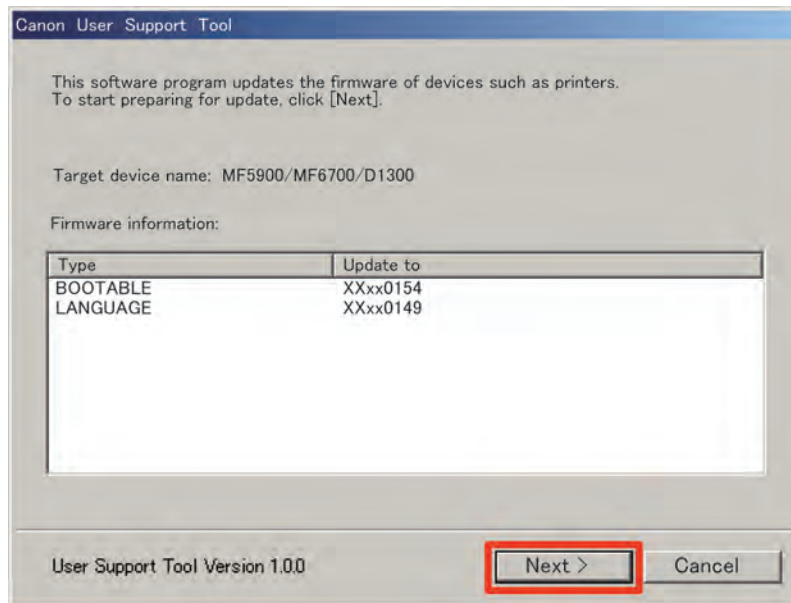

F-6-5

3) Click the "Next" button.

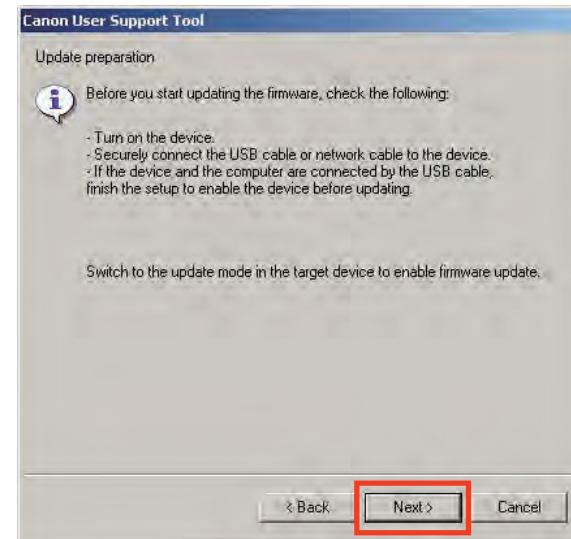

F-6-6

4) Select the USB connection device, and click the "Next" button.

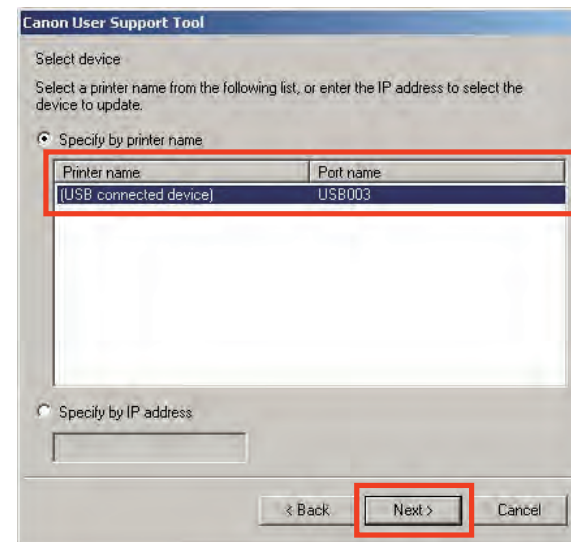

F-6-7

5) Click the "Start" button.

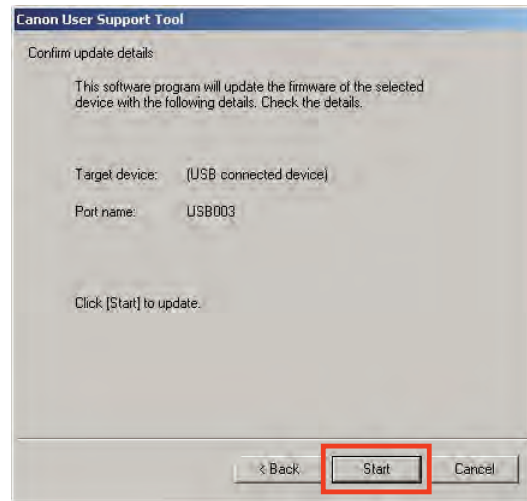

F-6-8

6) When the warning screen is displayed, click the "Yes" button.

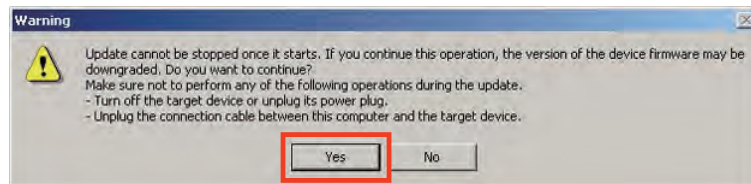

F-6-9



F-6-10

7) When downloading is completed, click the "OK" button.

The host machine automatically restarts up.

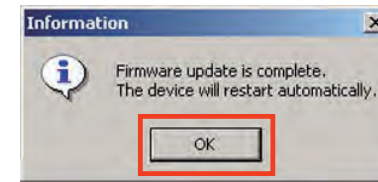

F-6-11

8) Perform common status print via the user mode, and make sure that the firmware version matches the information written down in Procedure 2).

"COPIER > FUNCTION > MISC-P > SPEC

"



Error Codes

- Overview
- Error Code
- Jam Code

Overview

Outline

This section describes codes shown in case any problem is occurred.

Since this product does not collect logs for alarms, no alarm code is shown.

Code type	Explanation
Alarm code	-
Error code	This code is displayed when an error occurs on the machine.
Jam code	This code is displayed when a jam occurs inside the machine.

T-7-1

Error Code

E Code	Detail Code	Item	Description
E000	0000	Title	Error in temperature rising of Fixing Assembly
		Detection description	Temperature of the Fixing Assembly did not reach a certain temperature within the specified period of time.
		Remedy	1. Check the connector between the Fixing Assembly and the DC Controller PCB. 2. Replace the Fixing Assembly. 3. Replace the Engine Controller PCB.
E001	0000	Title	Abnormal high temperature of Fixing Assembly
		Detection description	It was detected that the temperature of the Fixing Assembly was abnormally high.
		Remedy	1. Check the connector between the Fixing Assembly and the DC Controller PCB. 2. Replace the Fixing Assembly. 3. Replace the Engine Controller PCB.
E003	0000	Title	Abnormal low temperature of Fixing Assembly
		Detection description	It was detected that the temperature of the Fixing Assembly was abnormally low.
		Remedy	1. Check the connector between the Fixing Assembly and the DC Controller PCB. 2. Replace the Fixing Assembly. 3. Replace the DC Controller PCB.
E004	0000	Title	Error in fixing power supply drive circuit
		Detection description	Failed to detect the zero cross signal for the specified period of time or more.
		Remedy	1. Check the connection of connector between the Fixing Assembly and the Engine Controller PCB. 2. Replace the Fixing Assembly. 3. Replace the Engine Controller PCB.
E014	0000	Title	Error in startup of the Main Motor
		Detection description	Revolution of the Main Motor did not reach the specified value.
		Remedy	1. Check the connection of connector between the Main Motor and the Engine Controller PCB. 2. Replace the Main Motor. 3. Replace the Engine Controller PCB.
E100	0000	Title	Laser Scanner Assembly error
		Detection description	At the Laser Scanner Unit, BD cycle was not within the specified range.
		Remedy	1. Check the connection of connector between the Main Controller PCB and the Laser Scanner Unit. 2. Check the connection of connector between the Relay PCB and the Laser Scanner Unit. 3. Replace the Laser Scanner Unit.

E Code	Detail Code	Item	Description
E196	1000	Title	Main Controller PCB reading/writing error
		Detection description	Error in reading/writing of main program in the Main Controller PCB
		Remedy	1. Install the set of the controller firmware. 2. Replace the Main Controller PCB.
E196	2000	Title	Main Controller PCB reading/writing error
		Detection description	Error in reading/writing of setting values storage area in the Main Controller PCB
		Remedy	1. Install the set of the controller firmware. 2. Replace the Main Controller PCB.
E202	0001	Title	CIS Unit HP error (outward)
		Detection description	CIS Unit did not move to HP even it moved backward. Reader HP Sensor error, Reader Motor error, CIS Unit error
		Remedy	1. Replace the Reader HP Sensor. 2. Replace the Reader Motor. 3. Replace the CIS Unit. 4. Replace the Reader Unit.
E202	0002	Title	CIS Unit HP error (homeward)
		Detection description	CIS Unit did not move to HP even it moved forward. Reader HP Sensor error, Reader Motor error, CIS Unit error
		Remedy	1. Replace the Reader HP Sensor. 2. Replace the Reader Motor. 3. Replace the CIS Unit. 4. Replace the Reader Unit.
E248	0001	Title	Error in access to backup data for Reader (reading error at power-on)
		Detection description	The Reader-related adjustment values could not be read.
		Remedy	1. Clear the backup RAM of RCON. Execute COPIER>FUNCTION>CLEAR>RCON. 2. Enter all the values written on the service label in service mode again. 3. Turn OFF and then ON the main power.
E351	0000	Title	System error
		Detection description	System error.
		Remedy	1. Install the set of the controller firmware. 2. Replace the Main Controller PCB.
E733	0000	Title	Printer communication error
		Detection description	Communication error between the Engine Controller PCB and the Main Controller PCB occurred.
		Remedy	1. Check the connection of connector between the Engine Controller PCB and the Main Controller PCB. 2. Install the set of the controller firmware. 3. Replace the Main Controller PCB. 4. Replace the Engine Controller PCB.

E Code	Detail Code	Item	Description
E736	0000	Title	Communication error with CCU/modem
		Detection description	Communication error with CCU/modem. NCU PCB type error.
		Remedy	1. Install the set of the controller firmware. 2. Replace the NCU PCB. 3. Replace the Main Controller PCB.
E744	0001	Title	Language file version error
		Detection description	Language file version was not matched with the main program.
		Remedy	Install the set of the controller firmware.
E744	0002	Title	Language file size error
		Detection description	The size of the language file exceeded the upper limit.
		Remedy	Install the set of the controller firmware.
E744	1001	Title	Firmware version error
		Detection description	Version of the main program and the version of the start-up program was not matched.
		Remedy	Install the set of the controller firmware.
E744	4000	Title	Engine ID error
		Detection description	Invalid engine connection was detected.
		Remedy	1. Turn OFF and then ON the main power. 2. Check the Engine Controller PCB. 3. Install the Engine Controller PCB. 4. Install the set of the controller firmware. 5. Check the model code. (When the model code and the engine code are mismatched, E744-4000 occurs.)
E744	5000	Title	Error in the Control Panel PCB
		Detection description	Error in the Control Panel PCB (microcomputer).
		Remedy	1. Check the Control Panel PCB, and install the firmware (PANEL). 2. Install the set of the controller firmware. 3. Replace the Main Controller PCB.
E744	6000	Title	Communication error with the Wireless LAN PCB
		Detection description	Unable to communicate with the Wireless LAN.
		Remedy	1. Turn OFF and then ON the main power. 2. Check the connection of the Wireless LAN. 3. Install the set of the controller firmware. 4. Replace the Main Controller PCB.
E744	7000	Title	Main Controller PCB error
		Detection description	An error in the microcomputer which retains fax job information of the Main Controller PCB.
		Remedy	1. Install the firmware of BKUP. 2. Install the set of the controller firmware. 3. Replace the Main Controller PCB.

E Code	Detail Code	Item	Description
E746	0000	Title	Main Controller PCB error
		Detection description	Main Controller communication error occurred (other than scan).
		Remedy	1. Install the set of the controller firmware. 2. Replace the Main Controller PCB.
E766	xxxx*1	Title	Firmware error
		Detection description	An error due to the controller software occurred so that print could not be proceeded.
		Remedy	Due to firmware error, the possibility of solving the error by replacing the Main Controller PCB is low. Check the installed engine again.
E766	8000	Title	Digital registration error
		Detection description	Information at digital registration could not be obtained.
		Remedy	1. Install the Engine Controller firmware. 2. Install the set of the controller firmware. 3. Replace the Engine Controller PCB.
E766	9000	Title	Scanner power state error
		Detection description	An error was detected in power state of the Laser Scanner Unit.
		Remedy	?
E804	0004	Title	Controller Fan error
		Detection description	Since the startup of the Controller Fan, the Fan was locked for a specified consecutive period of time.
		Remedy	1. Check power supply to the Controller Fan. 2. Replace the Controller Fan.
E805	0000	Title	Main Fan error
		Detection description	The Main Fan was locked for a specified consecutive period of time.
		Remedy	1. Check the connection of the Main Fan. 2. Replace the Main Fan.
E808	0000	Title	Failure detection of Low Voltage Power Supply PCB
		Detection description	Printer detected failure of the Low Voltage Power Supply PCB.
		Remedy	Replace the Engine Controller PCB.

T-7-2

Jam Code

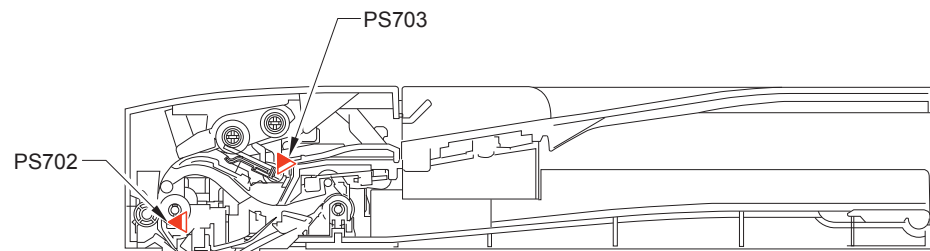

F-7-1

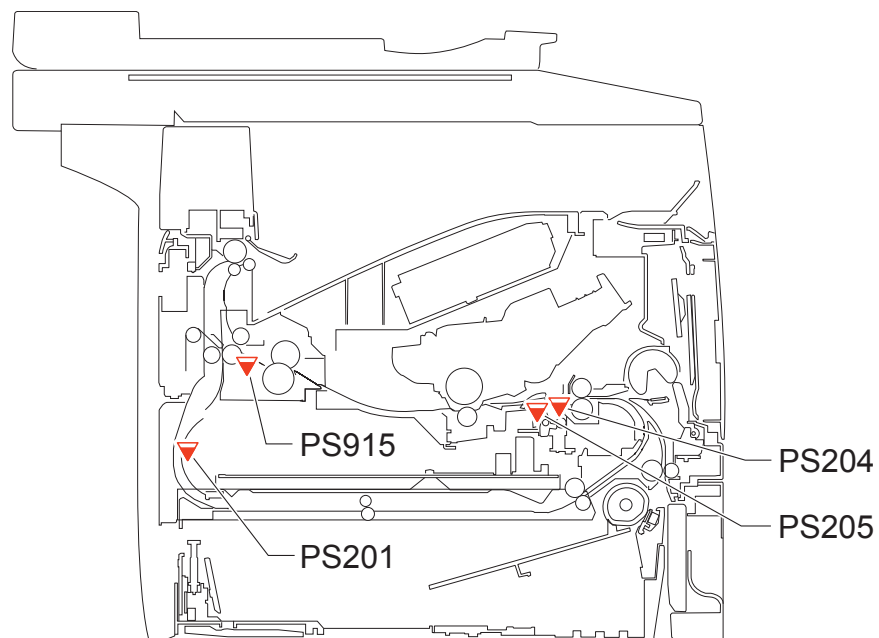

F-7-2

ACC ID	Jam Code	Type	Sensor Name/Detection Contents	Sensor ID
00	0001	Delay	Document End Sensor Delay	-
00	0002	Stationary	Document End Sensor	PS702
00	0004	Delay	Document Sensor Delay	-
00	0005	Stationary	Document Sensor	PS703
00	0040	Size error	Size error	-
00	0060	Size error	Size error	-
00	0071	Sequence	Sequence Error	-
00	0094	Power ON	Document Sensor/Document End Sensor	PS702/703
00	0104	Delay	Top Sensor Delay	-
00	010C		Fixing Delivery Sensor Delay	PS204/205
00	014C		Media Full Sensor Delay	PS204
00	0184		Duplex Feed Sensor Delay	-
00	0208	Stationary	Top Sensor	PS204
00	0210		Fixing Delivery Sensor	PS915
00	021C	Wrap	-	-
00	0248	Stationary	Top Sensor/Media full sensor/Fixing Delivery Sensor	PS204/205/915
00	0250		Top Sensor/Media full sensor/Fixing Delivery Sensor	PS204/205/915
00	025C	Wrap	Top Sensor/Media Full Sensor	PS204/205
00	0260	Delay	Duplex Feed Sensor Delay	-
00	0261	Stationary	Duplex Feed Sensor	P201
00	02A0	Delay	Duplex Feed Sensor Delay	-
00	02A1	Stationary	Duplex Feed Sensor	P201
00	02E0	Delay	Duplex Feed Sensor Delay	-
00	02E1	Stationalr	Duplex Feed Sensor	P201
00	1014	Power ON	Top Sensor/Media Full Sensor	PS204/205
00	1054		Top Sensor/Media full sensor/Fixing Delivery Sensor	PS204/205/915
00	1094		Top Sensor/Media full sensor/Fixing Delivery Sensor	PS204/205/915
00	10D4		Duplex Feed Sensor	PS201
00	1118	Door Open	Duaring a Pickup	-
00	1158		Top Sensor/Media full sensor/Fixing Delivery Sensor	PS204/205/915
00	1198		Top Sensor/Media full sensor/Fixing Delivery Sensor	PS204/205/915
00	11D8		Duplex Feed Sensor	PS201

T-7-3



Service Mode

- Overview
- COPIER
- FEEDER
- FAX
- TESTMODE

Overview

Service Mode Menu

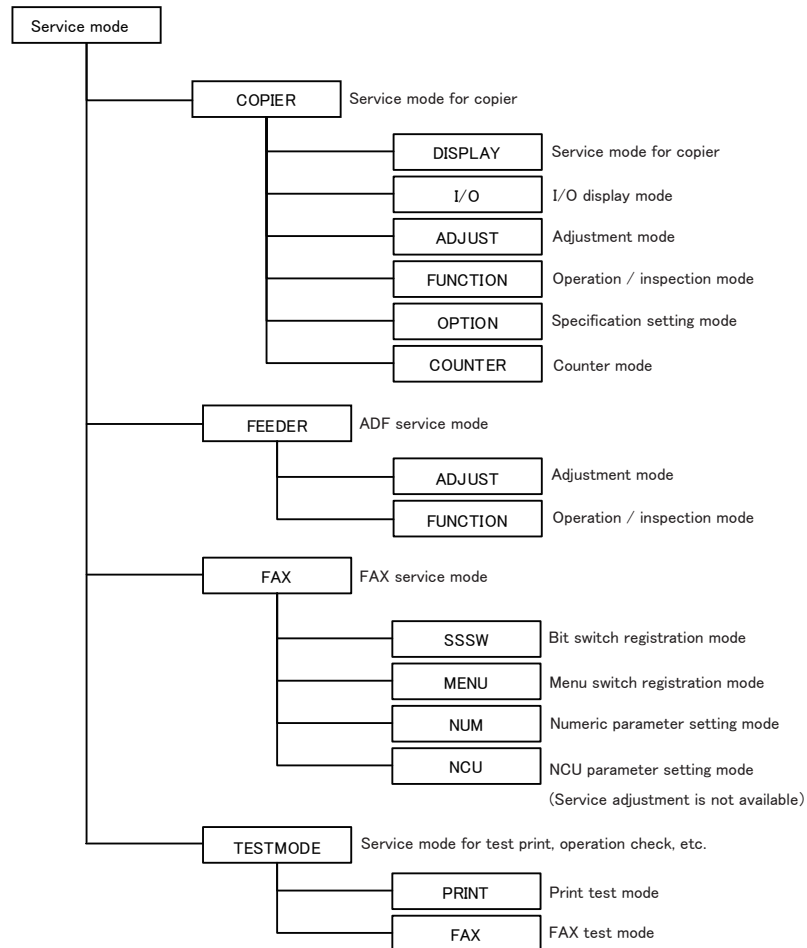

F-8-1

Backing up Service Mode

Each device is tuned at the time of shipment and the tuned values are written on the service label.

However, when replacing the main controller PCBs / DC controller PCBs or clearing RAM, tuned ADJUST and OPTION values are reset to defaults. Each service technician should adjust these values in field and ensure to write values after changes in the service label. If the corresponding item is not found on the service label, enter the value in the blank space.

Screen flow of Service Mode

Service mode structure

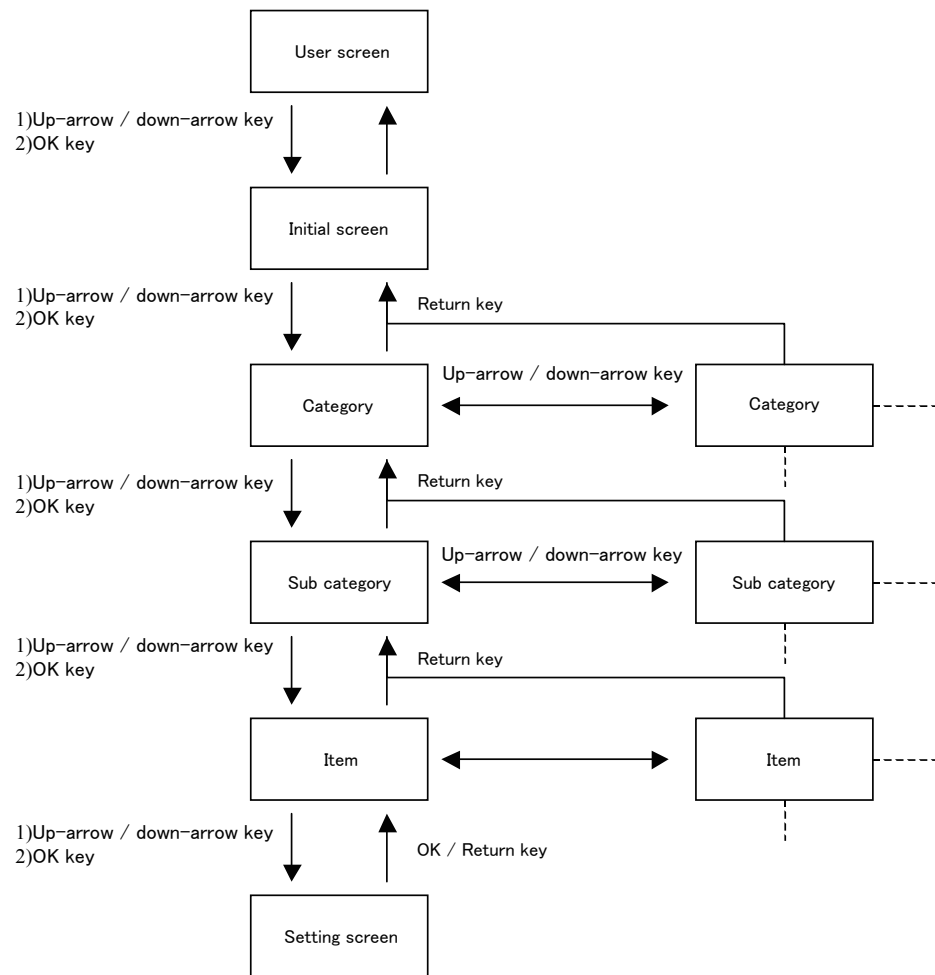

F-8-2

Screen flow of Service mode

- Initial / Category / Sub category screen
 - Select the item : Up-arrow / down-arrow key
 - Go to Sub category screen : OK key
 - Go to Initial screen : Return key

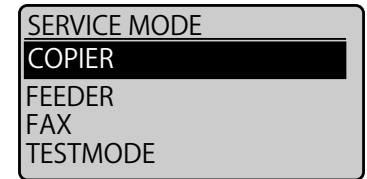

F-8-3

- Item selection screen
 - Select the item : Up-arrow / down-arrow key
 - Go to Setting screen : OK key
 - Go to Sub category screen : Return key

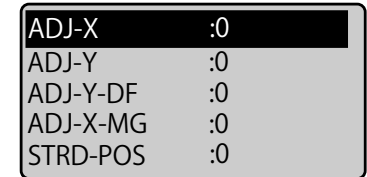

F-8-4

- Input value screen
 - Enter the setting value : numeric keypad
 - Increment the setting value one by one : Up-arrow key
 - Decrease the setting value one by one : Down-arrow key
 - Nullify the setting value : Clear key
 - Change the setting : OK key
 - Maintain the setting : Return key

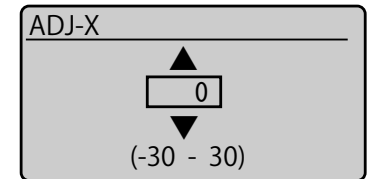

F-8-5

- How to input the switch setting value

[Enter the decimal value converted from binary 8 bit value.]

See the table below to obtain the total decimal value by summing respective digits with 1.

Bit	Bit0	Bit1	Bit2	Bit3	Bit4	Bit5	Bit6	Bit7
Decimal value for "1"	128	64	32	16	8	4	2	1

T-8-1

(Ex.)

When converting "00100010", enter "34" as the sum of 32 (Bit 2) + 2 (Bit 6).

COPIER

DISPLAY

VERSION

COPIER > DISPLAY > VERSION	
MAIN	Display of MAIN (main program) version
Details	To display the firmware version of Main Controller PCB.
Use case	When upgrading the firmware
Adj/set/operate method	N/A (Display only)
Display/adj/set range	00.00 to 99.99
Default value	0
BOOT	Boot ROM version
Details	To display the version of Boot ROM (BOOT program).
Use case	When upgrading the firmware
Adj/set/operate method	N/A (Display only)
Display/adj/set range	00.01 to 99.99
Default value	0
LANG	Language pack version
Details	To display the version of language pack.
Use case	When upgrading the firmware
Adj/set/operate method	N/A (Display only)
Display/adj/set range	00.00 to 99.99
Default value	0
DEMODATA	Demo print data version
Details	To display the version of demo print data. Since this machine does not have demo print function, "FF.FF" is displayed.
Use case	When upgrading the firmware
Adj/set/operate method	N/A (Display only)
Display/adj/set range	00.00 to 99.99
Default value	0
ECONT	ECONT version
Details	To display the version of Engine Controller PCB.
Use case	When upgrading the firmware
Adj/set/operate method	N/A (Display only)
Display/adj/set range	00.00 to 99.99
Default value	0

COPIER > DISPLAY > VERSION	
PANEL	PANEL version
Details	To display the version of PANEL.
Use case	When upgrading the firmware
Adj/set/operate method	N/A (Display only)
Display/adj/set range	00.00 to 99.99
Default value	0
Related service mode	COPIER> FUNCTION> SYSTEM> PANEL-UP
BKUP	BKUP version
Details	To display the version of BKUP.
Use case	When upgrading the firmware
Adj/set/operate method	N/A (Display only)
Display/adj/set range	00.00 to 99.99
Default value	0
Related service mode	COPIER> FUNCTION> SYSTEM> BKUP-UP

T-8-2

ERR

Error code display screen

Up to 10 E codes and detailed codes for system errors can be shown.

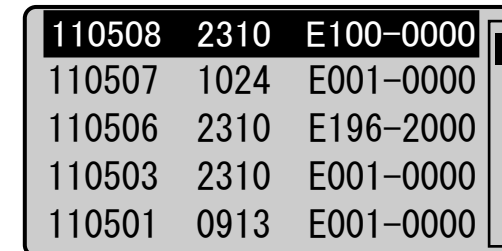

110508	2310	E100-0000
110507	1024	E001-0000
110506	2310	E196-2000
110503	2310	E001-0000
110501	0913	E001-0000

F-8-6

JAM

Jam code display screen

Up to 10 Jam codes and detailed codes for system errors can be shown.

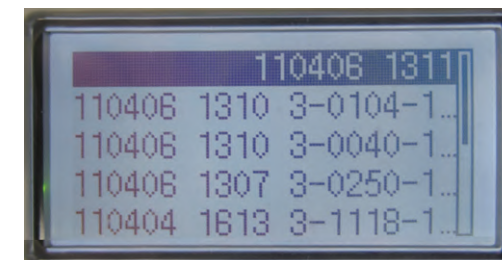

110406	1311	
110406	1310	3-0104-1..
110406	1310	3-0040-1..
110406	1307	3-0250-1..
110404	1613	3-1118-1..

F-8-7



COPIER > DISPLAY > CCD	
TARGET-B Shading target value (B)	
Details	To display the shading target value of Blue. Continuous display of 128 (minimum) or 384 (maximum) is considered a failure of the CIS Unit.
Use case	At scanned image failure
Adj/set/operate method	N/A (Display only)
Display/adj/set range	128 to 384
Default value	269
Related service mode	COPIER> ADJUST> CCD> DFTAR-B
TARGET-G Shading target value (G)	
Details	To display the shading target value of Green. Continuous display of 128 (minimum) or 384 (maximum) is considered a failure of the CIS Unit.
Use case	At scanned image failure
Adj/set/operate method	N/A (Display only)
Display/adj/set range	128 to 384
Default value	270
Related service mode	COPIER> ADJUST> CCD> DFTAR-G
TARGET-R Shading target value (R)	
Details	To display the shading target value of Red. Continuous display of 128 (minimum) or 384 (maximum) is considered a failure of the CIS Unit.
Use case	At scanned image failure
Adj/set/operate method	N/A (Display only)
Display/adj/set range	128 to 384
Default value	263
Related service mode	COPIER> ADJUST> CCD> DFTAR-R
TARGETBW Shading target value (B&W)	
Details	To display the shading target value at B&W jobs. Continuous display of 128 (minimum) or 384 (maximum) is considered a failure of the Main Controller PCB.
Use case	At scanned image failure
Adj/set/operate method	N/A (Display only)
Display/adj/set range	128 to 384
Default value	276
Related service mode	COPIER> ADJUST> CCD> DFTAR-BW

T-8-3



COPIER>IO>R-CON			
Address	BIT	Description	Remarks
P001	0	Display sensor status (Document end sensor)	1:Paper
	1	Display sensor status (Document sensor)	1:Paper
	2	Display sensor status (CIS home position sensor)	0: HP
	3 - 7	No sensor allocated; 0 is always shown	-
P002	-	No sensor allocated; 0 is always shown	-

T-8-4



ADJ-XY

COPIER > ADJUST > ADJ-XY	
ADJ-X	Adj of img pstn in book mode: vert scan
Details	To adjust the image reading start position (image leading edge position) in the vertical scanning direction at copyboard reading. When replacing the Main Controller PCB/clearing the RAM data, enter the value of service label. When the non-image width is larger than the standard value, set the smaller value. When out of original area is copied, set the larger value. As the value is incremented by 1, the image position moves to the trailing edge side by 0.1 mm.
Use case	<ul style="list-style-type: none"> When replacing the Reader Unit When replacing the CIS Unit When replacing the Main Controller PCB
Adj/set/operate method	Enter the setting value (switch negative/positive by +/- key) and press OK key.
Caution	After the setting value is changed, write the changed value in the service label.
Display/adj/set range	-30 to 30
Unit	0.1 mm
Default value	0
ADJ-Y	Adj of img pstn in book mode: horz scan
Details	To adjust the image reading start position in the horizontal scanning direction at copyboard reading. When replacing the Engine Controller PCB/clearing the RAM data, enter the value of service label. When the non-image width is larger than the standard value, set the smaller value. When out of original area is copied, set the larger value. As the value is incremented by 1, the image position moves to the rear side by 0.1 mm.
Use case	<ul style="list-style-type: none"> When replacing the Reader Unit When replacing the CIS Unit When replacing the Main Controller PCB
Adj/set/operate method	Enter the setting value (switch negative/positive by +/- key) and press OK key.
Caution	After the setting value is changed, write the changed value in the service label.
Display/adj/set range	-10 to 10
Unit	0.1 mm
Default value	0

COPIER > ADJUST > ADJ-XY	
ADJ-Y-DF	Adj img pstn in ADF mode:horz scan
Details	To adjust the image reading start position in the horizontal scanning direction at ADF reading. When replacing the Main Controller PCB/clearing the RAM data, enter the value of service label. As the value is incremented by 1, the image position moves to the trailing edge side by 0.1 mm.
Use case	<ul style="list-style-type: none"> When replacing the Reader Unit When replacing the CIS Unit When replacing the Main Controller PCB
Adj/set/operate method	Enter the setting value (switch negative/positive by +/- key) and press OK key.
Caution	After the setting value is changed, write the changed value in the service label.
Display/adj/set range	-10 to 10
Unit	0.1 mm
Default value	0
ADJ-X-MG	Fine adjustment of image magnification ratio (vertical scanning direction)
Details	To make a fine adjustment of image magnification ratio in the vertical scanning direction by changing the reading cycle of CIS. When replacing the Main Controller PCB/clearing the RAM data, enter the value of service label. As the value is incremented by 1, the image magnification changes by 0.01%. +: Reduce -: Enlarge
Use case	<ul style="list-style-type: none"> When replacing the Reader Unit When replacing the CIS Unit When replacing the Main Controller PCB
Adj/set/operate method	Enter the setting value (switch negative/positive by +/- key) and press OK key.
Caution	After the setting value is changed, write the changed value in the service label.
Display/adj/set range	-200 to 200
Unit	0.01 %
Default value	0

COPIER > ADJUST > ADJ-XY	
STRD-POS	Adjustment of reading position at ADF stream reading
Details	To adjust the reading position at ADF stream reading. When replacing the Main Controller PCB/clearing the RAM data, enter the value of service label.
Use case	When replacing the Main Controller PCB/clearing RAM data
Adj/set/operate method	Enter the setting value (switch negative/positive by +/- key) and press OK key.
Caution	After the setting value is changed, write the changed value in the service label.
Display/adj/set range	-20 to 20
Unit	0.1 mm
Default value	0
Related service mode	COPIER> FUNCTION> INSTALL> STRD-POS

T-8-5

■ CCD

COPIER > ADJUST > CCD	
W-PLT-X	White level data(X) entry of white plate
Details	To enter the white level data (X) for the Standard White Plate. When replacing the ADF/Reader Unit, enter the value of service label. When replacing the Reader Upper Cover Unit, enter the value of barcode label which is affixed on the glass. When replacing the Main Controller PCB, enter the value of service label.
Use case	<ul style="list-style-type: none"> • When replacing the ADF/Reader Unit • When replacing the Reader Upper Cover Unit • When replacing the Main Controller PCB
Adj/set/operate method	Enter the setting value, and then press OK key.
Caution	After the setting value is changed, write the changed value in the service label.
Display/adj/set range	7000 to 9999
Default value	8273
Related service mode	COPIER.> ADJUST> CCD> W-PLT-Y, W-PLT-Z
W-PLT-Y	White level data(Y) entry of white plate
Details	To enter the white level data (Y) for the Standard White Plate. When replacing the ADF/Reader Unit, enter the value of service label. When replacing the Reader Upper Cover Unit, enter the value of barcode label which is affixed on the glass. When replacing the Main Controller PCB, enter the value of service label.
Use case	<ul style="list-style-type: none"> • When replacing the ADF/Reader Unit • When replacing the Reader Upper Cover Unit • When replacing the Main Controller PCB
Adj/set/operate method	Enter the setting value, and then press OK key.
Caution	After the setting value is changed, write the changed value in the service label.
Display/adj/set range	7000 to 9999
Default value	8737
Related service mode	COPIER.> ADJUST> CCD> W-PLT-X, W-PLT-Z

COPIER > ADJUST > CCD	
W-PLT-Z	White level data(Z) entry of white plate
Details	To enter the white level data (Z) for the Standard White Plate. When replacing the ADF/Reader Unit, enter the value of service label. When replacing the Reader Upper Cover Unit, enter the value of barcode label which is affixed on the glass. When replacing the Main Controller PCB, enter the value of service label.
Use case	<ul style="list-style-type: none"> When replacing the ADF/Reader Unit When replacing the Reader Upper Cover Unit When replacing the Main Controller PCB
Adj/set/operate method	Enter the setting value, and then press OK key.
Caution	After the setting value is changed, write the changed value in the service label.
Display/adj/set range	7000 to 9999
Default value	9427
Related service mode	COPIER.> ADJUST> CCD> W-PLT-X, W-PLT-Y
DFTAR-R	Adjustment of shading target value (R) at ADF reading
Details	To adjust the shading target value of Red at ADF reading. When replacing the Main Controller PCB, enter the value of service label. After executing COPIER> FUNCTION> CCD> DF-WLVL1, DF-WLVL2, write the value which is automatically set in the service label.
Use case	<ul style="list-style-type: none"> When replacing the ADF/Reader Unit When replacing the CIS Unit When replacing the Reader Upper Cover Unit When replacing the Main Controller PCB
Adj/set/operate method	Enter the setting value, and then press OK key.
Display/adj/set range	128 to 384
Default value	299
Related service mode	COPIER> DISPLAY> CCD> TARGET-R COPIER> FUNCTION> CCD> DF-WLVL1, DF-WLVL2
DFTAR-G	Adjustment of shading target value (G) at ADF reading
Details	To adjust the shading target value of Green at ADF reading. When replacing the Main Controller PCB, enter the value of service label. After executing COPIER> FUNCTION> CCD> DF-WLVL1, DF-WLVL2, write the value which is automatically set in the service label.
Use case	<ul style="list-style-type: none"> When replacing the ADF/Reader Unit When replacing the CIS Unit When replacing the Reader Upper Cover Unit When replacing the Main Controller PCB
Adj/set/operate method	Enter the setting value, and then press OK key.
Display/adj/set range	128 to 384
Default value	309
Related service mode	COPIER> DISPLAY> CCD> TARGET-G COPIER> FUNCTION> CCD> DF-WLVL1, DF-WLVL2

COPIER > ADJUST > CCD	
DFTAR-B	Adjustment of shading target value (B) at ADF reading
Details	To adjust the shading target value of Blue at ADF reading. When replacing the Main Controller PCB, enter the value of service label. After executing COPIER> FUNCTION> CCD> DF-WLVL1, DF-WLVL2, write the value which is automatically set in the service label.
Use case	<ul style="list-style-type: none"> When replacing the ADF/Reader Unit When replacing the CIS Unit When replacing the Reader Upper Cover Unit When replacing the Main Controller PCB
Adj/set/operate method	Enter the setting value, and then press OK key.
Display/adj/set range	128 to 384
Default value	307
Related service mode	COPIER> DISPLAY> CCD> TARGET-B COPIER> FUNCTION> CCD> DF-WLVL1, DF-WLVL2
DFTAR-BW	Adjustment of shading target value (B&W) at ADF reading
Details	When replacing the Main Controller PCB, enter the value of service label. After executing COPIER> FUNCTION> CCD> DF-WLVL3, DF-WLVL4, write the value which is automatically set in the service label.
Use case	<ul style="list-style-type: none"> When replacing the ADF/Reader Unit When replacing the CIS Unit When replacing the Reader Upper Cover Unit When replacing the Main Controller PCB
Adj/set/operate method	Enter the setting value, and then press OK key.
Display/adj/set range	128 to 384
Default value	315
Related service mode	COPIER> DISPLAY> CCD> TARGETBW COPIER> FUNCTION> CCD> DF-WLVL3, DF-WLVL4
50-RG	Color displacement (R and G lines) correction value in the vertical scanning direction (50 %)
Details	To correct the color displacement (R and G lines) in the vertical scanning direction at 50% copyboard reading. When replacing the Main Controller PCB, enter the value of service label.
Use case	When replacing the Main Controller PCB
Adj/set/operate method	Enter the setting value (switch negative/positive by -/+ key) and press OK key.
Caution	After the setting value is changed, write the changed value in the service label.
Display/adj/set range	-512 to 512
Unit	0.001 line
Default value	-333
Supplement/memo	50% reading: 300 dpi in horizontal scanning direction x 600 dpi in vertical scanning direction reading mode.

COPIER > ADJUST > CCD	
50-GB	Color displacement (G and B lines) correction value in the vertical scanning direction (50 %)
Details	To correct the color displacement (G and B lines) in the vertical scanning direction at 50% copyboard reading. When replacing the Main Controller PCB, enter the value of service label.
Use case	When replacing the Main Controller PCB
Adj/set/operate method	Enter the setting value (switch negative/positive by +/- key) and press OK key.
Caution	After the setting value is changed, write the changed value in the service label.
Display/adj/set range	-512 to 512
Unit	0.001 line
Default value	333
Supplement/memo	50 % reading: 300 dpi in horizontal scanning direction x 600 dpi in vertical scanning direction reading mode.
100-RG	Color displacement (R and G lines) correction value in the vertical scanning direction (100 %)
Details	To correct the color displacement (R and G lines) in the vertical scanning direction at 100% copyboard reading. When replacing the Main Controller PCB, enter the value of service label.
Use case	When replacing the Main Controller PCB
Adj/set/operate method	Enter the setting value (switch negative/positive by +/- key) and press OK key.
Caution	After the setting value is changed, write the changed value in the service label.
Display/adj/set range	-512 to 512
Unit	0.001 line
Default value	-333
Supplement/memo	100 % reading: 600 dpi in horizontal scanning direction x 600 dpi in vertical scanning direction reading mode.

COPIER > ADJUST > CCD	
100-GB	Color displacement (G and B lines) correction value in the vertical scanning direction (100 %)
Details	To correct the color displacement (G and B lines) in the vertical scanning direction at 100% copyboard reading. When replacing the Main Controller PCB, enter the value of service label.
Use case	When replacing the Main Controller PCB
Adj/set/operate method	Enter the setting value (switch negative/positive by +/- key) and press OK key.
Caution	After the setting value is changed, write the changed value in the service label.
Display/adj/set range	-512 to 512
Unit	0.001 line
Default value	333
Supplement/memo	100 % reading: 600 dpi in horizontal scanning direction x 600 dpi in vertical scanning direction reading mode.
50DF-RG	Color displacement (R and G lines) correction value in the vertical scanning direction at ADF reading (50 %)
Details	To correct the color displacement (R and G lines) in the vertical scanning direction at 50 % ADF reading. When replacing the Main Controller PCB, enter the value of service label.
Use case	When replacing the Main Controller PCB
Adj/set/operate method	Enter the setting value (switch negative/positive by +/- key) and press OK key.
Caution	After the setting value is changed, write the changed value in the service label.
Display/adj/set range	-512 to 512
Unit	0.001 line
Default value	-333
Supplement/memo	50 % reading: 300 dpi in horizontal scanning direction x 600 dpi in vertical scanning direction reading mode.

COPIER > ADJUST > CCD	
50DF-GB	Color displacement (G and B lines) correction value in the vertical scanning direction at ADF reading (50 %)
Details	To correct the color displacement (G and B lines) in the vertical scanning direction at 50% ADF reading. When replacing the Main Controller PCB, enter the value of service label.
Use case	When replacing the Main Controller PCB
Adj/set/operate method	Enter the setting value (switch negative/positive by +/- key) and press OK key.
Caution	After the setting value is changed, write the changed value in the service label.
Display/adj/set range	-512 to 512
Unit	0.001 line
Default value	333
Supplement/memo	50 % reading: 300 dpi in horizontal scanning direction x 600 dpi in vertical scanning direction reading mode.
100DF-RG	Color displacement (R and G lines) correction value in the vertical scanning direction at ADF reading (100 %)
Details	To correct the color displacement (R and G lines) in the vertical scanning direction at 100% ADF reading. When replacing the Main Controller PCB, enter the value of service label.
Use case	When replacing the Main Controller PCB
Adj/set/operate method	Enter the setting value (switch negative/positive by +/- key) and press OK key.
Caution	After the setting value is changed, write the changed value in the service label.
Display/adj/set range	-512 to 512
Unit	0.001 line
Default value	-333
Supplement/memo	100 % reading: 600 dpi in horizontal scanning direction x 600 dpi in vertical scanning direction reading mode.

COPIER > ADJUST > CCD	
100DF-GB	Color displacement (G and B lines) correction value in the vertical scanning direction at ADF reading (100 %)
Details	To correct the color displacement (G and B lines) in the vertical scanning direction at 100% ADF reading. When replacing the Main Controller PCB, enter the value of service label.
Use case	When replacing the Main Controller PCB
Adj/set/operate method	Enter the setting value (switch negative/positive by +/- key) and press OK key.
Caution	After the setting value is changed, write the changed value in the service label.
Display/adj/set range	-512 to 512
Unit	0.001 line
Default value	333
Supplement/memo	100 % reading: 600 dpi in horizontal scanning direction x 600 dpi in vertical scanning direction reading mode.
OFST-BW0	Adjustment of CIS (Rear) at B&W reading
Details	To adjust the offset of the CIS (Rear) when reading B&W original.
Use case	When replacing the CIS Unit
Adj/set/operate method	Enter the setting value, and then press OK key.
Display/adj/set range	0 to 255
Default value	138
Related service mode	COPIER>FUNCTION>CCD>BW-AGC
OFST-BW1	Adjustment of CIS (Center) at B&W reading
Details	To adjust the offset of the CIS (Center) when reading B&W original.
Use case	When replacing the CIS Unit
Adj/set/operate method	Enter the setting value, and then press OK key.
Display/adj/set range	0 to 255
Default value	138
Related service mode	COPIER>FUNCTION>CCD>BW-AGC
OFST-BW2	Adjustment of CIS (Front) at B&W reading
Details	To adjust the offset of the CIS (Front) when reading B&W original.
Use case	When replacing the CIS Unit
Adj/set/operate method	Enter the setting value, and then press OK key.
Display/adj/set range	0 to 255
Default value	138
Related service mode	COPIER>FUNCTION>CCD>BW-AGC
OFST-CL0	Adjustment of CIS (Rear) at color reading
Details	To adjust the offset of the CIS (Rear) when reading color original.
Use case	When replacing the CIS Unit
Adj/set/operate method	Enter the setting value, and then press OK key.
Display/adj/set range	0 to 255
Default value	138
Related service mode	COPIER>FUNCTION>CCD>CL-AGC

COPIER > ADJUST > CCD	
OFST-CL1	Adjustment of CIS (Center) at color reading
Details	To adjust the offset of the CIS (Center) when reading color original.
Use case	When replacing the CIS Unit
Adj/set/operate method	Enter the setting value, and then press OK key.
Display/adj/set range	0 to 255
Default value	138
Related service mode	COPIER>FUNCTION>CCD>CL-AGC
OFST-CL2	Adjustment of CIS (Front) at color reading
Details	To adjust the offset of the CIS (Front) when reading color original.
Use case	When replacing the CIS Unit
Adj/set/operate method	Enter the setting value, and then press OK key.
Display/adj/set range	0 to 255
Default value	138
Related service mode	COPIER>FUNCTION>CCD>CL-AGC
GAIN-BW0	Adjustment of gain at B&W reading
Details	To adjust the gain when reading B&W original.
Use case	When replacing the CIS Unit
Adj/set/operate method	Enter the setting value, and then press OK key.
Display/adj/set range	0 to 255
Default value	54
Related service mode	COPIER>FUNCTION>CCD>BW-AGC
GAIN-CL0	Adjustment of gain at color reading
Details	To adjust the gain when reading color original.
Use case	When replacing the CIS Unit
Adj/set/operate method	Enter the setting value, and then press OK key.
Display/adj/set range	0 to 255
Default value	84
Related service mode	COPIER>FUNCTION>CCD>CL-AGC
LED-BW-R	Adjustment of LED light-up time (R) at B&W reading
Details	To adjust the red color LED light-up time when reading B&W original.
Adj/set/operate method	Enter the setting value, and then press OK key.
Display/adj/set range	0 to 2168
Default value	1000
Related service mode	COPIER>FUNCTION>CCD>CL-AGC
LED-BW-G	Adjustment of LED light-up time (G) at B&W reading
Details	To adjust the green color LED light-up time when reading B&W original.
Adj/set/operate method	Enter the setting value, and then press OK key.
Display/adj/set range	0 to 2168
Default value	1000
Related service mode	COPIER>FUNCTION>CCD>BW-AGC

COPIER > ADJUST > CCD	
LED-BW-B	Adjustment of LED light-up time (B) at B&W reading
Details	To adjust the blue color LED light-up time when reading B&W original.
Adj/set/operate method	Enter the setting value, and then press OK key.
Display/adj/set range	0 to 2168
Default value	1000
Related service mode	COPIER>FUNCTION>CCD>BW-AGC
LED-CL-R	Adjustment of LED light-up time (R) at color reading
Details	To adjust the red color LED light-up time when reading color original.
Adj/set/operate method	Enter the setting value, and then press OK key.
Display/adj/set range	0 to 2168
Default value	1100
Related service mode	COPIER>FUNCTION>CCD>BW-AGC
LED-CL-G	Adjustment of LED light-up time (G) at color reading
Details	To adjust the green color LED light-up time when reading color original.
Adj/set/operate method	Enter the setting value, and then press OK key.
Display/adj/set range	0 to 2168
Default value	1100
Related service mode	COPIER>FUNCTION>CCD>BW-AGC
LED-CL-B	Adjustment of LED light-up time (B) at color reading
Details	To adjust the blue color LED light-up time when reading color original.
Adj/set/operate method	Enter the setting value, and then press OK key.
Display/adj/set range	0 to 2168
Default value	1100
Related service mode	COPIER>FUNCTION>CCD>BW-AGC

T-8-6

PASCAL

COPIER > ADJUST > PASCAL	
OFST-P-K	Bk density adj at test print reading
Details	To adjust the offset of Bk color test print reading signal at Auto Adjust Gradation (Full Adjust). When replacing the Main Controller PCB, enter the value of service label. As the greater value is set, the image after adjustment gets darker.
Use case	<ul style="list-style-type: none"> When replacing the ADF/Reader Unit When replacing the Main Controller PCB
Adj/set/operate method	Enter the setting value (switch negative/positive by +/- key) and press OK key.
Caution	After the setting value is changed, write the changed value in the service label.
Display/adj/set range	-32 to 32
Default value	0

T-8-7

FEED-ADJ

COPIER > ADJUST > FEED-ADJ	
ADJ-C1	Cassette1 write start pstn in horz scan
Details	To adjust the image write start position in the horizontal scanning direction when picking up paper from the Cassette 1 (standard Pickup Cassette). As the value is incremented by 1, the margin on the left edge of paper is increased by 0.25 mm. +: Left margin becomes larger (An image moves to the right.) -: Left margin becomes smaller (An image moves to the left.) When replacing the Main Controller PCB, enter the value of service label.
Use case	When replacing the Main Controller PCB
Adj/set/operate method	1) Enter the setting value (switch negative/positive by +/- key) and press OK key. 2) Turn OFF/ON the main power switch.
Display/adj/set range	-9 to 9 (-2.22 to +2.22 mm)
Unit	Approx. 0.25 mm
Default value	-2
ADJ-C2	Cassette2 write start pstn in horz scan
Details	To adjust the image write start position in the horizontal scanning direction when picking up paper from the Cassette 2 (option Pickup Cassette). As the value is incremented by 1, the margin on the left edge of paper is increased by 0.25 mm. +: Left margin becomes larger (An image moves to the right.) -: Left margin becomes smaller (An image moves to the left.) When replacing the Main Controller PCB, enter the value of service label.
Use case	When replacing the Main Controller PCB
Adj/set/operate method	1) Enter the setting value (switch negative/positive by +/- key) and press OK key. 2) Turn OFF/ON the main power switch.
Display/adj/set range	-9 to 9 (-2.22 to +2.22 mm)
Unit	Approx. 0.25 mm
Default value	-4

COPIER > ADJUST > FEED-ADJ	
ADJ-MF	Write start position in the horizontal scanning direction at pickup from the Multi-purpose Tray
Details	To adjust the image write start position in the horizontal scanning direction when picking up paper from the Multi-purpose Tray. As the value is incremented by 1, the margin on the left edge of paper is increased by 0.25 mm. +: Left margin becomes larger. (An image moves to the right.) -: Left margin becomes smaller. (An image moves to the left.) When replacing the Main Controller PCB, enter the value of service label.
Use case	When replacing the Main Controller PCB
Adj/set/operate method	1) Enter the setting value (switch negative/positive by +/- key) and press OK key. 2) Turn OFF/ON the main power switch.
Display/adj/set range	-9 to 9 (-2.22 to +2.22 mm)
Unit	Approx. 0.25 mm
Default value	-2
ADJ-REFE	Write start position in the horizontal scanning direction at 2-sided pickup
Details	To adjust the image write start position in the horizontal scanning direction at 2-sided pickup. As the value is incremented by 1, the margin on the left edge of paper is increased by 0.25 mm. +: Left margin becomes larger. (An image moves to the right.) -: Left margin becomes smaller. (An image moves to the left.) When replacing the Main Controller PCB, enter the value of service label.
Use case	When replacing the Main Controller PCB
Adj/set/operate method	1) Enter the setting value (switch negative/positive by +/- key) and press OK key. 2) Turn OFF/ON the main power switch.
Display/adj/set range	-9 to 9 (-2.22 to +2.22 mm)
Unit	Approx. 0.25 mm
Default value	0

T-8-8



COPIER > FUNCTION > CCD	
DF-WLVL1	White level adj in book mode: color
Details	To adjust the white level for copyboard scanning automatically by setting the paper which is usually used by the user on the Copyboard Glass.
Use case	<ul style="list-style-type: none"> When replacing the Copyboard Glass When replacing the CIS Unit When replacing the Main Controller PCB/clearing RAM data
Adj/set/operate method	1) Set paper on the Copyboard Glass. 2) Select the item, and then press OK key.
Caution	Be sure to execute DF-WLVL2 in a row.
Related service mode	COPIER> ADJUST> CCD> DFTAR-R, DFTAR-G, DFTAR-B COPIER> FUNCTION> CCD> DF-WLVL2
DF-WLVL2	White level adj in ADF mode: color
Details	To adjust the white level for ADF scanning automatically by setting the paper which is usually used by the user on the ADF.
Use case	<ul style="list-style-type: none"> When replacing the Copyboard Glass When replacing the CIS Unit When replacing the Main Controller PCB/clearing RAM data
Adj/set/operate method	1) Set paper on the ADF. 2) Select the item, and then press OK key.
Caution	Be sure to execute this item after DF-WLVL1.
Related service mode	COPIER> ADJUST> CCD> DFTAR-R, DFTAR-G, DFTAR-B COPIER> FUNCTION> CCD> DF-WLVL1
DF-WLVL3	White level adj in book mode (B&W)
Details	To adjust the white level for copyboard scanning automatically by setting the paper which is usually used by the user on the Copyboard Glass.
Use case	<ul style="list-style-type: none"> When replacing the Copyboard Glass When replacing the CIS Unit When replacing the Main Controller PCB/clearing RAM data
Adj/set/operate method	1) Set paper on the Copyboard Glass. 2) Select the item, and then press OK key.
Caution	Be sure to execute DF-WLVL4 in a row.
Related service mode	COPIER> ADJUST> CCD> DFTAR-BW COPIER> FUNCTION> CCD> DF-WLVL4

COPIER > FUNCTION > CCD	
DF-WLVL4	White level adj in ADF mode (B&W)
Details	To adjust the white level for ADF scanning automatically by setting the paper which is usually used by the user on the DADF.
Use case	<ul style="list-style-type: none"> When replacing the Copyboard Glass When replacing the CIS Unit When replacing the Main Controller PCB/clearing RAM data
Adj/set/operate method	1) Set paper on the ADF. 2) Select the item, and then press OK key.
Caution	Be sure to execute this item after DF-WLVL3.
Related service mode	COPIER> ADJUST> CCD> DFTAR-BW COPIER> FUNCTION> CCD> DF-WLVL3
CL-AGC	CIS light intensity adj in ADF (color)
Details	To adjust the black/white level of the CIS for ADF scanning automatically by setting the paper which is usually used by the user on the ADF. (For color scanning)
Use case	<ul style="list-style-type: none"> When replacing the Copyboard Glass When replacing the CIS Unit When replacing the Main Controller PCB/clearing RAM data
Adj/set/operate method	1) Set paper on the ADF. 2) Select the item, and then press OK key.
Related service mode	COPIER> FUNCTION> CCD> BW-AGC
BW-AGC	CIS light intensity adj in ADF (B&W)
Details	To adjust the black/white level of the CIS for ADF scanning automatically by setting the paper which is usually used by the user on the ADF. (For B&W scanning)
Use case	<ul style="list-style-type: none"> When replacing the Copyboard Glass When replacing the CIS Unit When replacing the Main Controller PCB/clearing RAM data
Adj/set/operate method	1) Set paper on the ADF. 2) Select the item, and then press OK key.
Related service mode	COPIER> FUNCTION> CCD> CL-AGC

T-8-9

CLEAR

COPIER > FUNCTION > CLEAR	
R-CON	Initialization of Reader/ADF
Details	To initialize the factory adjustment values of the Reader/ADF.
Use case	When clearing RAM data of the Main Controller PCB
Adj/set/operate method	Select the item, and then press OK key.
SRVC-DAT	Clearing service mode setting value
Details	To clear the service mode setting values. The user mode setting values are not cleared. The factory adjustment values of the Reader/ADF are not initialized.
Adj/set/operate method	1) Select the item, and then press OK key. 2) Turn OFF/ON the main power switch.
COUNTER	Clearing service counter
Details	To clear the counter by maintenance/part/mode. The numerator printed on a system dump list becomes 0.
Adj/set/operate method	1) Select the item, and then press OK key. 2) Turn OFF/ON the main power switch.
HIST	Clear of logs
Details	To clear the communication management/print/jam/error log.
Use case	When clearing logs
Adj/set/operate method	1) Select the item, and then press OK key. 2) Turn OFF/ON the main power switch.
ALL	Clearing setting information
Details	<ul style="list-style-type: none"> User mode setting values Service mode setting values (excluding the service counter) ID and password of the system administrator Communication management/print/jam/error log E719 error (counter meter-installed models only) The following items are not cleared/initialized. <ul style="list-style-type: none"> Service counter Factory adjustment values of the Reader/ADF
Use case	At installation
Adj/set/operate method	1) Select the item, and then press OK key. 2) Turn OFF/ON the main power switch.
Related service mode	COPIER> OPTION> BODY> LOCALE, SIZE-LC

T-8-10

MISC-R

COPIER > FUNCTION > MISC-R	
SCANLAMP	Light-up check of CIS Unit LED
Details	To light up CIS Unit LED for 3 seconds. Light up in the following order: R->G->B->R->G-B.
Use case	When replacing the CIS Unit LED
Adj/set/operate method	Select the item, and then press OK key.
Required time	3 seconds
SCAN-ON	Execution of copyboard reading
Details	To execute reading of the original on the Copyboard Glass.
Adj/set/operate method	1) Set paper on the Copyboard Glass. 2) Select the item, and then press OK key.

T-8-11

MISC-P

COPIER > FUNCTION > MISC-P	
SRVC-DAT	Output of system data list/system dump list
Details	To execute report output of the system data list and the system dump list. System data list: The service software switches and parameters used in FAX function System dump list: The number of sends/receives, the number of pages sent/received, the number of sheets printed/read, the number of errors, etc.
Adj/set/operate method	Select the item, and then press OK key.
SYS-DAT	Output of system data list
Details	To execute report output of the system data list. The service software switches and parameters used in FAX function are output.
Adj/set/operate method	Select the item, and then press OK key.
SYS-DMP	Output of system dump list
Details	To execute report output of the system dump list. The number of sends/receives, the number of pages sent/received, the number of sheets printed/read, the number of errors, etc. are output.
Adj/set/operate method	Select the item, and then press OK key.
CNTR	Output of counter report
Details	To output the counter report. The usage of functions (reading, recording, communication and copy) is output.
Adj/set/operate method	Select the item, and then press OK key.

COPIER > FUNCTION > MISC-P	
ERR-LOG	Output of error log report
Details	To output the error log report.
Adj/set/operate method	Select the item, and then press OK key.
SPEC	Output of spec report
Details	To output the spec report. The current device specifications such as the location, model information, and ROM version are output.
Adj/set/operate method	Select the item, and then press OK key.

T-8-12

SYSTEM

COPIER > FUNCTION > SYSTEM	
DOWNLOAD	Download from USB memory (except PANEL)
Details	To perform downloading when a specified file exists in the USB memory (except PANEL). Reboot occurs twice before completion of download.
Use case	At upgrade
Adj/set/operate method	1) Install the USB memory. 2) Select the item, and then press OK key.
Caution	Do not turn OFF the power before reboot occurs twice.
Related service mode	COPIER> FUNCTION> SYSTEM> PANEL-UP
PANEL-UP	Download from USB memory (PANEL)
Details	To perform downloading when PANEL exists in the root directory of the USB memory.
Use case	At upgrade
Adj/set/operate method	1) Install the USB memory. 2) Select the item, and then press OK key. 3) Turn OFF/ON the main power switch.
Caution	Do not turn OFF/ON the power before "Executing..." disappears.
Related service mode	COPIER> FUNCTION> SYSTEM> DOWNLOAD, BKUP-UP
BKUP-UP	Download from USB memory (BKUP)
Details	To perform downloading when BKUP exists in the root directory of the USB memory.
Use case	At upgrade
Adj/set/operate method	1) Install the USB memory. 2) Select the item, and then press OK key. 3) Turn OFF/ON the main power switch.
Caution	Do not turn OFF/ON the power before "Executing..." disappears.
Related service mode	COPIER> FUNCTION> SYSTEM> PANEL-UP

COPIER > FUNCTION > SYSTEM	
LOGWRITE	Writing sublog to USB memory
Details	To write sublog that includes the following information to the USB memory. <ul style="list-style-type: none"> • Job list (job names, user names, and destinations) • Communications log (destinations and user names) • Job log (user names and job names)
Use case	When analyzing the cause of a problem
Adj/set/operate method	1) Install the USB memory. 2) Select the item, and then press OK key. 3) Turn OFF/ON the main power switch.
Caution	Do not turn OFF/ON the power before "Executing..." disappears.
IMPORT	Reading of service mode setting value from USB memory
Details	To write the service mode setting values (excluding those related to Reader/ADF) to the USB memory.
Use case	When replacing the Main Controller PCB as a measure against failures
Adj/set/operate method	1) Install the USB memory. 2) Select the item, and then press OK key. 3) Turn OFF/ON the main power switch.
Caution	Do not turn OFF/ON the power before "Executing..." disappears.
EXPORT	Writing service mode setting value to USB memory
Details	To write the service mode setting values (excluding those related to Reader/ADF) to the USB memory.
Use case	When replacing the Main Controller PCB as a measure against failures
Adj/set/operate method	1) Install the USB memory. 2) Select the item, and then press OK key.
Caution	"Executing..." disappears when writing is completed.

T-8-13

SPLMAN

COPIER > FUNCTION > SPLMAN	
SPL14159	Fixing of USB device ID
Details	To fix the USB device ID to "000000000000". Driver for each machine is installed to a PC. However, by fixing the serial number, the PC considers that any connected machine to be the same machine; thus, there will be no need to install the drivers many times.
Adj/set/operate method	1) Enter the value, and then press OK key. 2) Turn OFF/ON the main power switch.
Display/adj/set range	0 to 1 0: OFF, 1: ON
Default value	0
SPL65677	Increase of paper leading edge margin
Details	To increase the margin on the leading edge of paper. As the value is incremented by 1, the margin is increased by 0.1 mm. If the setting is incompatible with SPL68676 (decrease of margin), the setting is disabled (the margin will be standard).
Adj/set/operate method	1) Enter the setting value, and then press OK key. 2) Turn OFF/ON the main power switch.
Display/adj/set range	0 to 20
Unit	0.1 mm
Default value	0
Related service mode	COPIER> FUNCTION> SPLMAN> SPL68676
SPL68676	Decrease of paper leading edge margin
Details	To decrease the margin on the leading edge of paper. As the value is incremented by 1, the margin is decreased by 0.1 mm. If the setting is incompatible with SPL65677(increase of margin), the setting is disabled (the margin will be standard).
Adj/set/operate method	1) Enter the setting value, and then press OK key. 2) Turn OFF/ON the main power switch.
Display/adj/set range	0 to 20
Unit	0.1 mm
Default value	0
Related service mode	COPIER> FUNCTION> SPLMAN> SPL65677
SPL68677	Increase of paper right and left margins
Details	To increase the margins on the right and left edges of paper. As the value is incremented by 1, the margin is increased by 0.1 mm. If the setting is incompatible with SPL25607 (decrease of margins), the setting is disabled (the margins will be standard).
Adj/set/operate method	1) Enter the setting value, and then press OK key. 2) Turn OFF/ON the main power switch.
Display/adj/set range	0 to 20
Unit	0.1 mm
Default value	0
Related service mode	COPIER> FUNCTION> SPLMAN> SPL25607

COPIER > FUNCTION > SPLMAN	
SPL25607	Decrease of paper right and left margins
Details	To decrease the margins on the right and left edges of paper. As the value is incremented by 1, the margin is decreased by 0.1 mm. If the setting is incompatible with SPL68677 (increase of margins), the setting is disabled (the margins will be standard).
Adj/set/operate method	1) Enter the setting value, and then press OK key. 2) Turn OFF/ON the main power switch.
Display/adj/set range	0 to 20
Unit	0.1 mm
Default value	0
Related service mode	COPIER> FUNCTION> SPLMAN> SPL68677
SPL93822	Setting of department ID count all clear
Details	To set whether to disable clearing of all department ID counts.
Adj/set/operate method	Enter the setting value, and then press OK key.
Caution	Be sure to perform this mode after consulting with the system administrator at user's site.
Display/adj/set range	0 to 1 0: Enabled, 1: Disabled
Default value	0
Related service mode	COPIER> FUNCTION> SPLMAN> SPL78788
SPL78788	Setting of department ID count clear
Details	To set whether to disable clearing of department ID count.
Adj/set/operate method	Enter the setting value, and then press OK key.
Caution	Be sure to perform this mode after consulting with the system administrator at user's site.
Display/adj/set range	0 to 1 0: Enabled, 1: Disabled
Default value	0
Related service mode	COPIER> FUNCTION> SPLMAN> SPL93822

T-8-14

INSTALL

COPIER > FUNCTION > INSTALL	
STRD-POS	Scan position auto adj in ADF mode
Details	To adjust the ADF scanning position automatically.
Use case	At ADF installation/uninstallation
Adj/set/operate method	1) Set a paper for stream reading position adjustment, and then close the ADF. 2) Select the item, and then press OK key. The operation automatically stops after the adjustment. 3) Write the value displayed by COPIER>ADJUST>ADJ-XY>STRD-POS in the service label.
Caution	Write the adjusted value in the service label.
Related service mode	COPIER> ADJUST> ADJ-XY> STRD-POS

T-8-15





COPIER > OPTION > BODY	
LOCALE	Setting of location
Details	To set the location. At installation in areas other than Japan, perform the following procedure to match the setting information with that of the location.
Use case	<ul style="list-style-type: none"> At installation When changing the location information
Adj/set/operate method	1) Enter the setting value under LOCALE, and then press OK key. 2) Set the paper size configuration under SIZE-LC. 3) Execute COPIER> FUNCTION> CLEAR> ALL. 4) Turn OFF/ON the main power switch.
Caution	Since COPIER> FUNCTION> CLEAR> ALL is executed when changing the location, the setting information of user mode, service mode, etc. is initialized. The setting information of this item is not initialized.
Display/adj/set range	1 to 8 1: Japan, 2: North America, 3: Korea, 4: China, 5: Taiwan, 6: Europe, 7: Asia, 8: Oceania
Default value	1
Related service mode	COPIER> FUNCTION> CLEAR> ALL COPIER> OPTION> BODY> SIZE-LC
SIZE-LC	Setting of paper size configuration
Details	To set the paper size configuration. At installation in areas other than Japan, perform the following procedure to match the setting information with that of the location.
Use case	<ul style="list-style-type: none"> At installation Upon user's request
Adj/set/operate method	1) Set the location under LOCALE. 2) Enter the setting value under SIZE-LC, and then press OK key. 3) Execute COPIER> FUNCTION> CLEAR> ALL. 4) Turn OFF/ON the main power switch.
Caution	Since COPIER> FUNCTION> CLEAR> ALL is executed when changing the location, the setting information of user mode, service mode, etc. is initialized. The setting information of this item is not initialized.
Display/adj/set range	1 to 4 1: AB configuration, 2: Inch configuration, 3: A configuration, 4: AB/Inch configuration
Related service mode	COPIER> FUNCTION> CLEAR> ALL COPIER> OPTION> BODY> LOCALE

COPIER > OPTION > BODY	
NS-CMD5	Setting of CRAM-MD5 authentication method at SMTP authentication
Details	To restrict use of CRAM-MD5 authentication method at the time of SMTP authentication. When 1 is set, CRAM-MD5 authentication method is not used.
Use case	Upon user's request
Adj/set/operate method	1) Enter the setting value, and then press OK key. 2) Turn OFF/ON the main power switch.
Display/adj/set range	0 to 1 0: Used (SMTP server-dependent), 1: Not used
Default value	0
Supplement/memo	SMTP authentication: Protocol in which user authentication function is added to SMTP, which is the protocol to be used for e-mail transmission. At the time of e-mail transmission, this protocol executes authentication of the user account and the password between the SMTP server and the user to approve e-mail transmission only when it's authenticated.
NS-PLN	Setting of plaintext authentication at SMTP authentication
Details	To restrict use of PLAIN/LOGIN authentication, which is plaintext authentication, at the time of SMTP authentication under the environment where the communication packet is not encrypted. When 1 is set, plaintext authentication is not used.
Use case	Upon user's request
Adj/set/operate method	1) Enter the setting value, and then press OK key. 2) Turn OFF/ON the main power switch.
Display/adj/set range	0 to 1 0: Used (SMTP server-dependent), 1: Not used
Default value	0
Supplement/memo	SMTP authentication: Protocol in which user authentication function is added to SMTP, which is the protocol to be used for e-mail transmission. At the time of e-mail transmission, this protocol executes authentication of the user account and the password between the SMTP server and the user to approve e-mail transmission only when it's authenticated.

COPIER > OPTION > BODY	
NS-LGN	Setting of LOGIN authentication at SMTP authentication
Details	To restrict use of LOGIN authentication at the time of SMTP authentication. When 1 is set, LOGIN authentication is not used.
Use case	Upon user's request
Adj/set/operate method	1) Enter the setting value, and then press OK key. 2) Turn OFF/ON the main power switch.
Display/adj/set range	0 to 1 0: Used (SMTP server-dependent), 1: Not used
Default value	0
Supplement/memo	SMTP authentication: Protocol in which user authentication function is added to SMTP, which is the protocol to be used for e-mail transmission. At the time of e-mail transmission, this protocol executes authentication of the user account and the password between the SMTP server and the user to approve e-mail transmission only when it's authenticated.
SLPMODE	Setting of shift to sleep mode
Details	To restrict shift to sleep mode 1/sleep mode 3. When 1 is set, the machine does not shift to sleep mode.
Use case	When sleep failure occurs
Adj/set/operate method	1) Enter the setting value, and then press OK key. 2) Turn OFF/ON the main power switch.
Display/adj/set range	0 to 1 0: Shift is available., 1: Shift is not available.
Default value	0

T-8-16

USER

COPIER > OPTION > ACC	
PS-MODE	Compatible mode setting at PS usage
Details	To set for compatibility with existing machine regarding image process or print specification with PS print. Depending on a setting value, it means that multiple settings are combined. (Example: 44 = 4 + 8 + 32)
Use case	At replacement
Adj/set/operate method	1) Enter the setting value, and then press OK key. 2) Turn OFF/ON the main power switch.
Display/adj/set range	0 to 63 1: not use 2: not use 4: PS duplex feed 8: Change default value of Stroke Adjust 16: Change default value of Extra long paper 32: Change horizontal line printing precision of small text
Default value	0

T-8-17

ACC

COPIER > OPTION > ACC	
WLANMODE	Setting of IEEE802.11n
Details	To set whether to enable IEEE802.11n which is the wireless LAN standard.
Use case	Upon user's request
Adj/set/operate method	1) Enter the setting value, and then press OK key. 2) Turn OFF/ON the main power switch.
Display/adj/set range	0 to 1 0: Disabled, 1: Enabled
Default value	0 (Europe, Middle East, Africa), 1 (Others)
Caution	In Russia and Ukraine, do not change the setting value because T-8-18 setting it to 1 conflicts with the regulation.

SERIAL

COPIER > OPTION > SERIAL	
SN-MAIN	Entry of serial number
Details	To write the serial number of this machine in the Main Controller PCB. When this item is executed, the 8-digit alphanumeric entered in System Settings > Device Information > Location in user mode is written in the Main Controller PCB. When replacing the Main Controller PCB, be sure to write the serial number in the new PBC to prepare for trouble since the serial number of the device is not succeeded.
Use case	When replacing the Main Controller PCB
Adj/set/operate method	1) Write down the current data in System Settings > Device Information > Location in user mode. 2) Replace the Main Controller PCB after turning OFF the main power switch. 3) Enter the serial number (8-digit alphanumeric) in "Location" of step 1. 4) Select SN-MAIN, and then press OK key to write in the Main Controller PCB. After writing, the serial number entered in step 3 is deleted. 5) Turn OFF/ON the main power switch. 6) Output the spec report from COPIER> FUNCTION> MISC-P> SPEC to check the serial number (Body No.). 7) Enter the data backed up in step 1 in "Location".
Caution	Since the above "Location" is only temporarily used to store data, back up the data before input and enter it again after writing is completed.
Related service mode	COPIER> FUNCTION> MISC-P> DHALF
Related user mode	System Settings > Device Information> Location

T-8-19



COPIER > COUNTER > TOTAL	
SERVICE1	Service-purposed total counter 1
Details	To count up when the paper is delivered outside the machine. The counter is advanced regardless of the original size. The counter is not advanced by delivery in service mode.
Display/adj/set range	0 to 99999999
Unit	Number of sheets
Default value	0
SERVICE2	Service-purposed total counter 2
Details	To count up when the paper is delivered outside the machine. The counter is advanced regardless of the original size. The counter is not advanced by delivery in service mode.
Display/adj/set range	0 to 99999999
Unit	Number of sheets
Default value	0
TTL	Total counter
Details	To display the total of counters of copy, PDL print, FAX, report print and media print. (Total of COPY, PDL-PRT, FAX-PRT, RPT-PRT and MD-PRT in service mode described below)
Display/adj/set range	0 to 99999999
Unit	Number of sheets
Default value	0
Related service mode	COPIER> COUNTER> TOTAL> COPY, PDL-PRT, FAX-PRT, RPT-PRT, MD-PRT
COPY	Total copy counter
Details	To count up when the copy is delivered outside the machine. The counter is advanced regardless of the original size. The counter is not advanced by delivery in service mode.
Display/adj/set range	0 to 99999999
Unit	Number of sheets
Default value	0
Related service mode	COPIER> COUNTER> TOTAL> TTL
PDL-PRT	PDL print counter
Details	To count up when the PDL print is delivered outside the machine/2-sided printout is stacked. The counter is advanced regardless of the original size. The counter is not advanced by blank paper or delivery in service mode.
Display/adj/set range	0 to 99999999
Unit	Number of sheets
Default value	0
Related service mode	COPIER> COUNTER> TOTAL> TTL

COPIER > COUNTER > TOTAL	
FAX-PRT	FAX reception print counter
Details	To count up when the FAX reception print is delivered outside the machine/2-sided printout is stacked. The counter is advanced regardless of the original size. The counter is not advanced by blank paper or delivery in service mode.
Display/adj/set range	0 to 99999999
Unit	Number of sheets
Default value	0
Related service mode	COPIER> COUNTER> TOTAL> TTL
RPT-PRT	Report print counter
Details	To count up when the report print is delivered outside the machine/2-sided printout is stacked. The counter is advanced regardless of the original size. The counter is not advanced by blank paper or delivery in service mode.
Display/adj/set range	0 to 99999999
Unit	Number of sheets
Related service mode	COPIER> COUNTER> TOTAL> TTL
MD-PRT	Media print counter
Details	To count up when the media print is delivered outside the machine. The counter is advanced regardless of the original size. The counter is not advanced by blank paper or delivery in service mode.
Display/adj/set range	0 to 99999999
Unit	Number of sheets
Default value	0
Related service mode	COPIER> COUNTER> TOTAL> TTL
2-SIDE	2-sided copy/print counter
Details	To count up the number of 2-sided copies/prints when the copy/printout is delivered outside the machine/2-sided copy/printout is stacked. The counter is advanced regardless of the original size. The counter is not advanced by blank paper or delivery in service mode.
Display/adj/set range	0 to 99999999
Unit	Number of times
Default value	0
SCAN	Scan counter
Details	To count up the number of scan operations when the scanning operation is complete. The counter is advanced regardless of the original size. The counter is not advanced by delivery in service mode.
Display/adj/set range	0 to 99999999
Unit	Number of times
Default value	0

PICK-UP

COPIER > COUNTER > PICK-UP	
C1	Cassette 1 pickup total counter
Details	To count up the number of sheets picked up from the Cassette 1 (standard Pickup Cassette). The counter is advanced regardless of the original size. The counter is advanced by printout in service mode.
Display/adj/set range	0 to 99999999
Unit	Number of sheets
Default value	0
C2	Cassette 2 pickup total counter
Details	To count up the number of sheets picked up from the Cassette 2 (option Pickup Cassette). The counter is advanced regardless of the original size. The counter is advanced by printout in service mode.
Display/adj/set range	0 to 99999999
Unit	Number of sheets
Default value	0
MF	Multi-purpose Tray pickup total counter
Details	To count up the number of sheets picked up from the Multi-purpose Tray Pickup Unit. The counter is advanced regardless of the original size. The counter is advanced by printout in service mode.
Display/adj/set range	0 to 99999999
Unit	Number of sheets
Default value	0
2-SIDE	2-sided pickup total counter
Details	To count up the number of sheets picked up in duplex mode. The counter is advanced regardless of the original size. The counter is advanced by printout in service mode.
Display/adj/set range	0 to 99999999
Unit	Number of sheets
Default value	0

T-8-21

FEEDER

COPIER > COUNTER > FEEDER	
FEED	ADF original pickup total counter
Details	To count up the number of originals picked up from the ADF. The counter is advanced regardless of the original size.
Use case	When checking the total counter of original pickup by ADF
Display/adj/set range	0 to 99999999
Unit	Number of sheets
Default value	0

T-8-22

JAM

COPIER > COUNTER > JAM	
TOTAL	Printer total jam counter
Details	To count up the number of total jam occurrences.
Use case	When checking the total jam counter of printer
Display/adj/set range	0 to 99999999
Unit	Number of times
Default value	0
FEEDER	ADF total jam counter
Details	When checking the total jam counter of ADF
Display/adj/set range	0 to 99999999
Unit	Number of times
Default value	0
2-SIDE	Duplex Unit jam counter
Details	To count up the number of jam occurrences in the Duplex Unit.
Use case	When checking the jam counter of Duplex Unit
Display/adj/set range	0 to 99999999
Unit	Number of times
Default value	0
MF	Multi-purpose Pickup Tray jam counter
Details	To count up the number of jam occurrences in the Multi-purpose Tray Pickup Unit. The counter is advanced by paper size mismatch or misprint.
Use case	When checking the jam counter of Multi-purpose Pickup Tray
Display/adj/set range	0 to 99999999
Unit	Number of times
Default value	0
C1	Cassette 1 pickup jam counter
Details	To count up the number of jam occurrences in the Cassette 1 (standard Pickup Cassette). The counter is advanced by paper size mismatch or misprint.
Display/adj/set range	0 to 99999999
Unit	Number of times
Default value	0
C2	Cassette 2 pickup jam counter
Details	To count up the number of jam occurrences in the Cassette 2 (option Pickup Cassette). The counter is advanced by paper size mismatch or misprint.
Display/adj/set range	0 to 99999999
Unit	Number of times
Default value	0

T-8-23

■ DRBL-2

COPIER > COUNTER > DRBL-2	
DF-SP-PD	Separation Pad parts counter: ADF
Details	To count up the number of sheets to be fed regardless of 1-sided/2-sided mode. Accumulated counter value
Use case	When checking the consumption level of parts/replacing the parts
Adj/set/operate method	To clear the counter value: Select the item, and then enter 0.
Caution	Clear the counter value after replacement.
Display/adj/set range	0 to 99999999
Unit	Number of sheets
Default value	0
DF-SP-RL	ADF Pickup Roller parts counter
Details	To count up the number of sheets to be fed regardless of 1-sided/2-sided mode. Accumulated counter value
Use case	When checking the consumption level of parts/replacing the parts
Adj/set/operate method	To clear the counter value: Select the item, and then enter 0.
Caution	Clear the counter value after replacement.
Display/adj/set range	0 to 99999999
Unit	Number of sheets
Default value	0

T-8-24

FEEDER

 ADJUST

FEEDER > ADJUST	
DOCST	Fine adjustment of VSYNC timing at ADF reading [front side]
Details	To make a fine adjustment of VSYNC timing when reading the front side of original with ADF. Execute when the output image after ADF installation is displaced. When replacing the Main Controller PCB, enter the value of service label. As the value is incremented by 1, the margin at the leading edge of the image is decreased by 0.1mm. (The image moves in the direction of the leading edge of the sheet.)
Use case	<ul style="list-style-type: none"> When installing ADF When replacing the Main Controller PCB
Adj/set/operate method	Enter the setting value (switch negative/positive by +/- key) and press OK key.
Display/adj/set range	-30 to 30
Unit	0.1 mm
Default value	0
LA-SPD	Fine adjustment of magnification ratio in vertical scanning direction at ADF stream reading [front side]
Details	To make a fine adjustment of the image magnification ratio in vertical scanning direction when stream reading the front side of original with ADF. As the value is incremented by 1, the image is reduced by 0.01% in vertical scanning direction. (The feeding speed increases, and the image is reduced.)
Use case	<ul style="list-style-type: none"> When installing ADF When replacing the Main Controller PCB
Adj/set/operate method	Enter the value, and then press OK key.
Display/adj/set range	-200 to 200
Unit	0.01%
Default value	0

FEEDER > ADJUST	
DOCST2	Fine adjustment of VSYNC timing at ADF reading [back side]
Details	To make a fine adjustment of VSYNC timing when reading the back side of original with ADF. Execute when the output image after ADF installation is displaced. When replacing the Main Controller PCB, enter the value of service label. As the value is incremented by 1, the margin at the leading edge of the image is decreased by 0.1mm. (The image moves in the direction of the leading edge of the sheet.)
Use case	<ul style="list-style-type: none"> When installing ADF When replacing the Main Controller PCB
Adj/set/operate method	Enter the setting value (switch negative/positive by +/- key) and press OK key.
Display/adj/set range	-30 to 30
Unit	0.1 mm
Default value	0
DOCST-R	Fine adjustment of trailing edge at ADF reading
Details	To make a fine adjustment of trailing edge when reading original with ADF. Execute when the output image after ADF installation is displaced. When replacing the Main Controller PCB, enter the value of service label. As the value is incremented by 1, the margin at the trailing edge of the image is decreased by 0.1mm. (The image moves in the direction of the trailing edge of the sheet.)
Use case	<ul style="list-style-type: none"> When installing ADF When replacing the Main Controller PCB
Adj/set/operate method	Enter the setting value (switch negative/positive by +/- key) and press OK key.
Display/adj/set range	-30 to 30
Unit	0.1 mm
Default value	0
LA-SPD2	Fine adjustment of magnification ratio in vertical scanning direction at ADF stream reading [back side]
Details	To make a fine adjustment of the image magnification ratio in vertical scanning direction when stream reading the back side of original with ADF. As the value is incremented by 1, the image is reduced by 0.01% in vertical scanning direction. (The feeding speed increases, and the image is reduced.)
Use case	When replacing the Main Controller PCB
Adj/set/operate method	Enter the value, and then press OK key.
Display/adj/set range	-200 to 200
Unit	0.01%
Default value	0

T-8-25

FUNCTION

FEEDER > FUNCTION	
MTR-ON	Operation check of ADF Motor
Details	To start operation check of ADF Motor (M702).
Use case	At operation check
Adj/set/operate method	1) Select the item, and then press OK key. The unit operates for approximately 5 seconds and automatically stops. 2) Press OK key. The operation check is completed.
Caution	Be sure to press the OK key again after execution. The operation automatically stops after approximately 5 seconds, but is not completed unless the OK key is pressed (STOP is not displayed).
Required time	Approx. 5 seconds
FEED-ON	Operation check of ADF individual feed
Details	To start operation check of the ADF individual feed in the mode specified by FEED-CHK.
Use case	At operation check
Adj/set/operate method	Select the item, and then press OK key.
Related service mode	FEEDER> FUNCTION> FEED-CHK
FEED-CHK	Setting of ADF individual feed mode
Details	To set the ADF feed mode. Feed operation is activated in the specified feed mode by executing FEED-ON.
Use case	At operation check
Adj/set/operate method	Enter the value, and then press OK key.
Display/adj/set range	0 to 1 0: 1-sided, 1: 2-sided
Default value	0
Related service mode	FEEDER> FUNCTION> FEED-ON

T-8-26

FAX

 List of SSSW

FAX > SSSW		
SSSW No.	Bit No.	Function
SW 01		(Errors, Copy functions)
	Bit 0	Output error codes for service technicians
	Bit 1-7	Not in use
SW 02		(Setting for network connection criteria)
	Bit 0	-
	Bit 1	-
	Bit 2	-
	Bit 3	-
	Bit 4	V34 CCR TN OFF
	Bit 5	-
	Bit 6	-
SW 03		(Echo measures)
	Bit 0	Check EQM of TCF
	Bit 1	Apply echo protect tone to V.29
	Bit 2	-
	Bit 3	-
	Bit 4	-
	Bit 5	-
	Bit 6	-
SW 04		(Measures against communication troubles)
	Bit 0	-
	Bit 1	Check CI signal frequency
	Bit 2	V21 end flag
	Bit 3	Prohibit T.30 node F kept by both parties
	Bit 4	T.30 node F echo timer
	Bit 5	Check CI signal frequency when setting PBX
	Bit 6	Do not send CNG for manual outgoing transmission
SW 05		(Standard functions, DIS signal setting)
	Bit 0	-
	Bit 1	-
	Bit 2	mm/inch conversion (text and picture / picture mode)
	Bit 3	Prohibit DIS from transmitting bit33 and the followings.
	Bit 4	Declare cut sheets
	Bit 5	-
	Bit 6	-
Bit 7	-	

FAX > SSSW		
SSSW No.	Bit No.	Function
SW 06		(Setting of reading criteria)
	Bit 0	-
	Bit 1	-
	Bit 2	-
	Bit 3	-
	Bit 4	Reading Widthe 0:A4 1:LTR
	Bit 5	-
	Bit 6	-
Bit 7	-	
SW 07 - SW 11		Not in use
SW 12		(Page timer setting)
	Bit 0	1 page timeout (outgoing transmission)
	Bit 1	1 page timeout (outgoing transmission)
	Bit 2	1 page timeout (HT transmission)
	Bit 3	1 page timeout (HT transmission)
	Bit 4	1 page timeout (incoming transmission)
	Bit 5	1 page timeout (incoming transmission)
	Bit 6	-
Bit 7	1 page timeout	
SW 13		-
	Bit 0	-
	Bit 1	-
	Bit 2	Convert mm/inch when transmitting received image
	Bit 3	-
	Bit 4	-
	Bit 5	-
	Bit 6	-
Bit 7	-	
SW 14		-
	Bit 0	-
	Bit 1	-
	Bit 2	Convert inch to mm in both main/vertical scanning directions or only in vertical scanning direction
	Bit 3	-
	Bit 4	Declare resolution for inch series
	Bit 5	-
	Bit 6	-
Bit 7	-	
SW 15 - SW 17		Not in use

FAX > SSSW		
SSSW No.	Bit No.	Function
SW 18		-
	Bit 0	Detect carrier disconnection between DCS and TCF
	Bit 1	Waiting time for carrier disconnection between DCS and TCF
	Bit 2	Prohibit communication control for IP network
	Bit 3	-
	Bit 4	-
	Bit 5	-
	Bit 6	-
SW 19 - SW 21	Not in use	
SW 22		-
	Bit 0	-
	Bit 1	-
	Bit 2	-
	Bit 3	Prohibit manual polling actions
	Bit 4	-
	Bit 5	-
	Bit 6	-
SW 23 - SW 24	Not in use	
SW 25		(Setting for report display function)
	Bit 0	Prioritize the received abbreviated name to the dialed abbreviated name
	Bit 1-7	Not in use
SW 26 - SW 27	Not in use	
SW 28		-
	Bit 0	Prohibit calling party for V8 procedure
	Bit 1	Prohibit called party from V8 procedure
	Bit 2	Prohibit calling party from V8 late-start
	Bit 3	Prohibit called party from V8 late-start
	Bit 4	Prohibit V.34 called party from starting fallback
	Bit 5	Prohibit V.34 calling party from starting fallback
	Bit 6	-
Bit 7	-	
SW 29	Not in use	
SW 30		-
	Bit 0	-
	Bit 1	-
	Bit 2	-
	Bit 3	-
	Bit 4	-
	Bit 5	New duak tibe detection
	Bit 6	-
Bit 7	-	
SW 31 - SW 35	Not in use	

T-8-27

List of MENU

Menu switch registration mode		
No.	Parameter	Selection
01 - 04	Not in use	
05	ON/OFF of NL equalizer	0: OFF, 1: ON
06	Telephone line monitor	0 - 3 0: DIAL, 1: SERVICEMAN1, 2: SERVICEMAN2, 3: OFF
07	Transmission level (ATT)	0 - 15
08	Upper limit of V.34 modulation speed	0 - 5 0: 3429 BAUD, 1: 3200 BAUD, 2: 3000 BAUD, 3: 2800 BAUD, 4: 2743 BAUD, 5: 2400 BAUD
09	Upper limit of V.34 data speed	0-13 0: 33.6 kbps, 1: 31.2 kbps, 2: 28.8 kbps, 3: 26.4 kbps, 4: 24.0 kbps, 5: 21.6 kbps, 6: 19.2 kbps, 7: 16.8 kbps, 8: 14.4 kbps, 9: 12.0 kbps, 10: 9.6 kbps, 11: 7.2 kbps, 12: 4.8 kbps, 13: 2.4 kbps
10	OFF Hook signal frequency	0-2 0: 50 Hz, 1: 25 Hz, 2: 17 Hz
11 - 20	Not in use	

T-8-28

List of NUM

Numeric parameter setting mode		
No.	Parameter	Allowable setting range
01	Not in use	
02	RTN transmission criteria X	1 to 99 %
03	RTN transmission criteria n	2 to 99 times
04	RTN transmission criteria m	1 to 99 lines
05	NCC pause (before ID code)	1 to 60 sec
06	NCC pause (after ID code)	1 to 60 sec
07	Spare	
08	STORED_DIAL_MODE wait timer	0 to 65 sec
09	Not in use	
10	T.30 T0 timer	55 sec principally
11	T.30 T1 timer (for incoming transmission)	0 to 9999 (France: 3500, Others: 3000)
12	Maximum incoming lines	0 to 65535 (line) 0: without limitation
13	T.30 EOL timer	500 to 3000 (set to 55 sec by default)
14	Not in use	
15	Threshold between hokking nad on-hook	0 to 999

Numeric parameter setting mode		
No.	Parameter	Allowable setting range
16	Lead time to the first response when switching between FAX and TEL	0 to 9
17	Duration to activate pseudo-RBT cadence	0 to 999
18	Duration to deactivate pseudo-RBT cadence (short)	0 to 999
19	Duration to deactivate pseudo-RBT cadence (long)	0 to 999
20	Duration to activate pseudo-ring cadence	0 to 999
21	Duration to deactivate OFF Hook cadence (short)	0 to 999
22	Duration to deactivate OFF Hook cadence (long)	0 to 999
23	CNG detection level when switching between FAX and TEL	0 to 7
24	Pseudo-RBT outgoing level when switching between FAX and TEL	10 to 20 (100 V) 0 to 20 (120, 230 V)
25	CNG monitor duration while the answering device is activated	0 to 999
26	No signal detection level while the answering device is activated	0 to 7
27 - 48	Not in use	
49	NSX MODEL ID	0 to 4095
50	Not in use	
51	Threshold to detect hook	10 to 9999
52	Not in use	
53	Set DTMF calling counts when receiving FAX remotely	10 to 9999 (default 25)
54	Set Busy Tone outgoing duration when using handset	
55 - 80	Not in use	

T-8-29

Setting of NCU Parameters

TONE/PULSE

Operation Method

1) Setting of Tone Parameters

While "#NCU" is displayed, press "OK" key -> Select "#TONE" and press "OK" key so that it becomes tone parameter setting mode.

2) Setting of Pulse Parameters

While "#NCU" is displayed, press "OK" key -> Select "#PULSE" and press "OK" key so that it becomes pulse parameter setting mode.

Item		Function	Setting range
TONE	01;	Tone signal sending time (PSTN)	10 to 9999 (msec)
	02;	Minimum pause time (PSTN)	10 to 9999 (msec)
PULSE	PULSE FORM	Pulse digit format	0 -> DP (N)
			1 -> DP (N+1)
			2 -> DP (10-N)
	PULSE NUM	01;	-
02;		-	-
03;		Pulse dial make ratio	10 to 90 (%)
04;		Minimum pause time	10 to 9999 (msec)

T-8-30

DIAL TONE

Bit Switch

Bit No.	Function	1	0
Bit 0	-	-	-
Bit 1	-	-	-
Bit 2	Signal frequency	Changed	Not changed
Bit 3	-	-	-
Bit 4	Judgment of intermittent signal	start from valid ON signal	start from either valid ON signal or OFF signal
Bit 5	-	-	-
Bit 6	Signal form	Continuous	Intermittent
Bit 7	Signal detection	Detected	Not detected

T-8-31

Numeric value parameter

Parameter No.	Function	Setting range
01;	T0 timer	0 to 9999 (x 10 msec)
02;	T1 timer	0 to 9999 (x 10 msec)
03;	T2 timer	0 to 9999 (x 10 msec)
04;	T3 timer	0 to 9999 (x 10 msec)
05;	T4 timer	0 to 9999 (x 10 msec)
06;	Signal detection table	0 to 16
07;	Signal detection level	0 to 7
08;	Number of signal frequency	0 to 9999

T-8-32

2nd DIAL TONE

Bit Switch

Bit No.	Function	1	0
Bit 0	-	-	-
Bit 1	-	-	-
Bit 2	Signal frequency	Changed	Not changed
Bit 3	-	-	-
Bit 4	Judgment of intermittent signal	start from valid ON signal	start from either valid ON signal or OFF signal
Bit 5	-	-	-
Bit 6	Signal form	Continuous	Intermittent
Bit 7	Signal detection	Detected	Not detected

T-8-33

Numeric value parameter

Parameter No.	Function	Setting range
01;	T0 timer	0 to 9999 (x 10 msec)
02;	T1 timer	0 to 9999 (x 10 msec)
03;	T2 timer	0 to 9999 (x 10 msec)
04;	T3 timer	0 to 9999 (x 10 msec)
05;	T4 timer	0 to 9999 (x 10 msec)
06;	Signal detection table	0 to 16
07;	Signal detection level	0 to 7
08;	Number of signal frequency	0 to 9999

T-8-34

BUSY TONE 0

Bit Switch

Bit No.	Function	1	0
Bit 0	-	-	-
Bit 1	-	-	-
Bit 2	-	-	-
Bit 3	-	-	-
Bit 4	-	-	-
Bit 5	-	-	-
Bit 6	-	-	-
Bit 7	Signal detection	Detected	Not detected

T-8-35

Numeric value parameter

Parameter No.	Function	Setting range
01;	-	-
02;	T1 timer	0 to 9999 (x 10 msec)
03;	T2 timer	0 to 9999 (x 10 msec)
04;	T3 timer	0 to 9999 (x 10 msec)
05;	T4 timer	0 to 9999 (x 10 msec)
06;	-	-
07;	-	-
08;	Number of signal frequency	0 to 9999

T-8-36

BUSY TONE 1

Bit Switch

Bit No.	Function	1	0
Bit 0	-	-	-
Bit 1	-	-	-
Bit 2	Signal frequency	Changed	Not changed
Bit 3	RBT signal detection	Detected	Not detected
Bit 4	Judgment of intermittent signal	start from valid ON signal	start from either valid ON signal or OFF signal
Bit 5	RBT signal check cycle	1cycle	1/2 cycle
Bit 6	Signal form	Continuous	Intermittent
Bit 7	Signal detection	Detected	Not detected

T-8-37

Numeric value parameter

Parameter No.	Function	Setting range
01;	-	-
02;	T1 timer	0 to 9999 (x 10 msec)
03;	T2 timer	0 to 9999 (x 10 msec)
04;	T3 timer	0 to 9999 (x 10 msec)
05;	T4 timer	0 to 9999 (x 10 msec)
06;	Signal detection table	0 to 16
07;	Signal detection level	0 to 7
08;	Number of signal frequency	0 to 9999

T-8-38

REORDER TONE

Bit Switch

Bit No.	Function	1	0
Bit 0	-	-	-
Bit 1	-	-	-
Bit 2	Signal frequency	Changed	Not changed
Bit 3	-	-	-
Bit 4	Judgment of intermittent signal	start from valid ON signal	start from either valid ON signal or OFF signal
Bit 5	-	-	-
Bit 6	Signal form	Continuous	Intermittent
Bit 7	Signal detection	Detected	Not detected

T-8-39

Numeric value parameter

Parameter No.	Function	Setting range
01;	-	-
02;	T1 timer	0 to 9999 (x 10 msec)
03;	T2 timer	0 to 9999 (x 10 msec)
04;	T3 timer	0 to 9999 (x 10 msec)
05;	T4 timer	0 to 9999 (x 10 msec)
06;	Signal detection table	0 to 16
07;	Signal detection level	0 to 7
08;	Number of signal frequency	0 to 9999

T-8-40

AUTO RX

Numeric value parameter

Parameter No.	Function	Setting range
01;	CI ON time	0 to 9999 (x 10 msec)
02;	CI LONG ON time	0 to 9999 (x 10 msec)
03;	CI OFF time	0 to 9999 (x 10 msec)
04;	CI LONG OFF time	0 to 9999 (x 10 msec)
05;	CI MAX OFF time	0 to 9999 (x 10 msec)
06;	CI WAIT time	0 to 9999 (x 10 msec)
07;	CI frequency	0 to 9999 (cycle)
08;	CI frequency lower limit	0 to 9999 (Hz)
09;	CI frequency upper limit	0 to 9999 (Hz)

T-8-41

CNG DETECT

Numeric value parameter

Parameter No.	Description	Setting range
01;	At F/T switching	CNG mIN ON time 0 to 9999 (x 10 msec)
02;		CNG mAX ON time 0 to 9999 (x 10 msec)
06;		Hit ratio 0 to 9999 (%)
07;	At direct connecting to answering phone	CNG mIN ON time 0 to 9999 (x 10 msec)
08;		CNG mAX ON time 0 to 9999 (x 10 msec)
09;		Tolerable time of instantaneous interruption 0 to 9999 (x 10 msec)
11;		Number of detection 0 to 9999 (times)
12;		Hit ratio 0 to 9999 (%)

T-8-42

RKEY

Numeric value parameter

Parameter No.	Function	Setting range
01;	Connection time of flash	0 to 9999 (x 10 msec)
02;	Connection time of grounding wire	0 to 9999 (x 10 msec)

T-8-43

■ PBX DIAL TONE 1

● Bit Switch

Bit No.	Function	1	0
Bit 0	-	-	-
Bit 1	-	-	-
Bit 2	Signal frequency	Changed	Not changed
Bit 3	-	-	-
Bit 4	Judgment of intermittent signal	start from valid ON signal	start from either valid ON signal or OFF signal
Bit 5	-	-	-
Bit 6	Signal form	Continuous	Intermittent
Bit 7	Signal detection	Detected	Not detected

T-8-44

● Numeric value parameter

Parameter No.	Function	Setting range
01;	T0 timer	0 to 9999 (x 10 msec)
02;	T1 timer	0 to 9999 (x 10 msec)
03;	T2 timer	0 to 9999 (x 10 msec)
04;	T3 timer	0 to 9999 (x 10 msec)
05;	T4 timer	0 to 9999 (x 10 msec)
06;	Signal detection table	0 to 16
07;	Signal detection level	0 to 9
08;	Number of signal frequency	0 to 9999

T-8-45

■ PBX BUSY TONE

● Bit Switch

Bit No.	Function	1	0
Bit 0	-	-	-
Bit 1	-	-	-
Bit 2	-	-	-
Bit 3	-	-	-
Bit 4	-	-	-
Bit 5	-	-	-
Bit 6	-	-	-
Bit 7	Signal detection	Detected	Not detected

T-8-46

● Numeric value parameter

Parameter No.	Function	Setting range
01;	-	-
02;	T1 timer	0 to 9999 (x 10 msec)
03;	T2 timer	0 to 9999 (x 10 msec)
04;	T3 timer	0 to 9999 (x 10 msec)
05;	T4 timer	0 to 9999 (x 10 msec)
06;	-	-
07;	-	-
08;	Number of signal frequency	0 to 9999

T-8-47

TESTMODE

 PRINT

TESTMODE > PRINT	
PG-TYPE	Setting of PG number
Details	To set the PG number of the test print.
Use case	At trouble analysis
Adj/set/operate method	Enter the setting value, and then press OK key.
Display/adj/set range	0 to 7 0: Grid Bk, 1: Halftone, 2: Solid black, 3: Solid white, 4: 17 gradations, 5: Thin horizontal line, 6: PASCAL correction chart, 7: Chart 128
Default value	0
COUNT	Setting of PG output quantity
Details	To set the number of sheets for PG output.
Use case	At trouble analysis
Adj/set/operate method	Enter the setting value, and then press OK key.
Display/adj/set range	1 to 99
Unit	1 sheet
Default value	1
PHASE	Setting of PG 2-sided mode
Details	To set 1-sided/2-sided print for PG output. Even if 2-sided print is set for a machine that only supports 1-sided print, the setting is disabled.
Use case	At trouble analysis
Adj/set/operate method	Enter the setting value, and then press OK key.
Display/adj/set range	0 to 1 0: 1-sided, 1: 2-sided
Default value	0
MODE	Setting of test print image formation method
Details	To set the image formation method for the test print. If PG-TYPE is 0/1, this setting is disabled because a specific image formation method is applied.
Use case	At trouble analysis
Adj/set/operate method	Enter the setting value, and then press OK key.
Display/adj/set range	0 to 4 0: TBIC, 1: Resolution dithering, 2: Gradation dithering, 3: Color tone dithering, 4: High-resolution dithering
Default value	0

TESTMODE > PRINT	
THRU	Setting of image correction table at test print
Details	It is possible to check the density characteristics due to the density correction process when normal gamma LUT is used, and the density characteristics of the engine when the linear gamma LUT is used.
Use case	At trouble analysis
Adj/set/operate method	Enter the setting value, and then press OK key.
Display/adj/set range	0 to 1 0: Normal gamma LUT, 1: Through (linear) gamma LUT
Default value	0
Supplement/memo	Gamma LUT: Density gradation characteristic table
DENS	Adjustment of test print engine F value
Details	To adjust the engine F value for the test print. As the value is larger, the image gets darker.
Use case	At trouble analysis
Adj/set/operate method	Enter the setting value (switch negative/positive by +/- key) and press OK key.
Display/adj/set range	-4 to 4
Default value	0
Supplement/memo	F value: The value used as an index for indicating lens brightness
MABK	Setting of toner thinning process at test print
Details	To execute the thinning process to alleviate the toner scattering at test print. The thinning amount of toner increases in accordance with Mode 1 to Mode 3.
Use case	When outputting a test print
Adj/set/operate method	Enter the setting value, and then press OK key.
Display/adj/set range	0 to 3 0: OFF, 1: Mode1, 2: Mode2, 3: Mode3
Default value	0
FEED	Setting of paper source at test print
Details	To set the paper sources at the time of test print output. If this mode is set when there is no Cassette 2 (option Pickup Cassette), output is from Cassette 1 (standard Pickup Cassette). If color paper is loaded in the specified paper source, there is no output because the setting is disabled.
Use case	When outputting a test print
Adj/set/operate method	Enter the setting value, and then press OK key.
Display/adj/set range	0 to 2 0: Multi-purpose Tray, 1: Cassette 1, 2: Cassette 2
Default value	1
START	Output of test print
Details	To output a test print with the PG pattern set in PG-TYPE, MODE, etc.
Use case	At trouble analysis
Adj/set/operate method	Press OK key.



TESTMODE > FAX > MODEM	
RELAY-1	NCU relay test 1
Details	To test ON/OFF of relay and port switch of NCU. This mode is disabled for an NCU with no relay and port switch.
Use case	When analyzing the cause of a problem
Adj/set/operate method	Enter the setting value, and then press OK key.
Caution	Be sure to set the value back to 0 after the test.
Display/adj/set range	0 to 6 0: All OFF, 1: CML ON/OFF, 2: P ON/OFF, 3: S ON/OFF, 4: H ON/OFF, 5: HD ON/OFF, 6: R ON/OFF
Default value	0
Related service mode	TESTMODE> FAX> MODEM> RELAY-2
RELAY-2	NCU relay test 2
Details	To test ON/OFF of relay and port switch of NCU. This mode is disabled for an NCU with no relay and port switch.
Use case	When analyzing the cause of a problem
Adj/set/operate method	Enter the setting value, and then press OK key.
Caution	Be sure to set the value back to 0 after the test.
Display/adj/set range	0 to 7 0: All OFF, 1: CIST2 ON/OFF, 2: C1 ON/OFF, 3: NORG ON/OFF, 4: DCSEL ON/OFF, 5: DCLIM ON/OFF, 6: IPSEL1 ON/OFF, 7: IPSEL2 ON/OFF
Default value	0
Related service mode	TESTMODE> FAX> MODEM> RELAY-1
FREQ	Frequency test
Details	To test whether the specified frequency is oscillated. By closing or opening the DC circuit in accordance with the setting value, the specified frequency is oscillated by the tone transmission function of the modem. Check this with the speaker.
Use case	When analyzing the cause of a problem
Adj/set/operate method	Enter the setting value, and then press OK key.
Caution	Be sure to set the value back to 0 after the test.
Display/adj/set range	0 to 7 0: OFF, 1: 462 Hz, 2: 1100 Hz, 3: 1300 Hz, 4: 1500 Hz, 5: 1650 Hz, 6: 1850 Hz, 7: 2100 Hz
Default value	0

TESTMODE > FAX > MODEM	
G3TX	G3 signal transmission test
Details	To test whether the specified G3 signal is transmitted. By closing or opening the DC circuit in accordance with the setting value, the specific G3 signal pattern is transmitted at the specified transmission speed by the G3 signal transmission function of the modem. Check this with the speaker.
Adj/set/operate method	Enter the setting value, and then press OK key.
Caution	Be sure to set the value back to 0 after the test.
Display/adj/set range	0 to 9 0: OFF, 1: 300 bps, 2: 2400 bps, 3: 4800 bps, 4: 7200 bps, 5: 9600 bps, 6: TC7200 bps, 7: TC9600 bps, 8: 12000 bps, 9: 14400 bps
Default value	0
DTMFTX	DTMF transmission test
Details	To test whether the specified DTMF signal is transmitted. By closing or opening the DC circuit in accordance with the setting value, the specified DTMF signal is transmitted by the DTMF transmission function of the modem. Check this with the speaker.
Adj/set/operate method	Enter the setting value, and then press OK key.
Caution	Be sure to set the value back to 0 after the test.
Display/adj/set range	0 to 12 0: OFF, 1: 1, 2: 2, 3: 3, 4: 4, 5: 5, 6: 6, 7: 7, 8: 8, 9: 9, 10: 0, 11: *, 12: #
Default value	0
Supplement/memo	DTMF (Dual Tone Multi Frequency): Signal method combining two specific frequencies like a push-tone phone.

TESTMODE > FAX > MODEM	
V34G3TX	V.34 G3 signal transmission test
Details	To test whether the specified V.34 G3 signal is transmitted. By closing or opening the DC circuit in accordance with the setting value, the specific G3 signal pattern is transmitted at the specified transmission speed and modulation speed by the G3 signal transmission function (V.34) of the modem. Check this with the speaker. A setting value other than 0 is indicated as a 3-digit integer (1st digit: modulation speed, last 2 digits: transmission speed). A value other than the specified numerical value is invalid.
Adj/set/operate method	Enter the setting value, and then press OK key.
Caution	Be sure to set the value back to 0 after the test.
Display/adj/set range	0 to 614 0: OFF <ul style="list-style-type: none"> First digit (Modulation speed/baud rate) 1: 2400 baud, 2: 2743 baud, 3: 2800 baud, 4: 3000 baud, 5: 3200 baud, 6: 3429 baud Last 2 digits (Transmission speed) 01: 2400 bps, 02: 4800 bps, 03: 7200 bps, 04: 9600 bps, 05: 12000 bps, 06: 14400 bps, 07: 16800 bps, 08: 19200 bps, 09: 21600 bps, 10: 24000 bps, 11: 26400 bps, 12: 28800 bps, 13: 31200 bps, 14: 33600 bps
Default value	0

T-8-49

TESTMODE > PRINT	
DETECT2	Calling tone detection test 1
Details	To check calling tone signal and FED. Set the CML relay to ON and detect the calling tone. The detection results are displayed on the console (UART).
Adj/set/operate method	Enter the setting value, and then press OK key.
Caution	Be sure to set the value back to 0 after the test.
Display/adj/set range	0 to 1 0: OFF, 1: ON
Default value	0
Supplement/memo	CML (Connect Modem to Line) relay: Relay installed at the NCU (Network Control Unit) Board to switch between the telephone and fax.
DETECT3	Calling tone detection test 2
Details	To check calling tone signal and FED. Set the CML relay to OFF and detect the calling tone. The detection results are displayed on the console (UART).
Adj/set/operate method	Enter the setting value, and then press OK key.
Caution	Be sure to set the value back to 0 after the test.
Display/adj/set range	0 to 1 0: OFF, 1: ON
Default value	0
Supplement/memo	CML (Connect Modem to Line) relay: Relay installed at the NCU (Network Control Unit) Board to switch between the telephone and fax.

T-8-50

FACULTY

TESTMODE > PRINT	
G34800TX	G3 4800 bps signal transmission test
Details	To test whether the G3 signal is transmitted at 4800 bps. By closing or opening the DC circuit, the specific G3 signal pattern is transmitted at 4800 bps by the G3 signal transmission function. Check this with the speaker.
Adj/set/operate method	Enter the setting value, and then press OK key.
Caution	Be sure to set the value back to 0 after the test.
Display/adj/set range	0 to 1 0: OFF, 1: ON
Default value	0
DETECT1	Ring detection
Details	To check the ON/OFF state of CI, FC, and hook from the line. The detection results are displayed on the console (UART).
Adj/set/operate method	Enter the setting value, and then press OK key.
Caution	Be sure to set the value back to 0 after the test.
Display/adj/set range	0 to 1 0: OFF, 1: ON
Default value	0
Supplement/memo	CI (Calling Identification): Ring signal UART (Universal Asynchronous Receiver Transmitter): Console

Appendex

- Special Tools
- Solvents and Oils
- General Timing Chart
- General Circuit Diagram

Service Tools

Special Tools

In addition to the standard tools set, the following special tools are required when servicing the machine:

Name of Tool	Parts.No	Use
Digital Multimeter	FY9-2002	Used as a probe extension when making electrical checks.

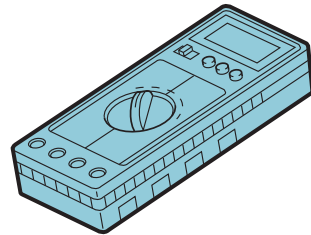

F-9-1

T-9-1

Solvents and Oils

The table below lists the standard tools required in service works for this product.

No.	Name of Tool	Use	Remarks
1	Alcohol	Cleaning: Plastic Rubber Metal part Oil stain Toner stain	<ul style="list-style-type: none"> Keep away from flame Purchase locally
2	Lubricant	Apply to gear	<ul style="list-style-type: none"> HY9-0007 (MOLYCOTE EM-50L)
3	Lubricant	Apply to ADF scanning area	<ul style="list-style-type: none"> FY9-6020(Oil glass cleaner)

T-9-2

General Timing Chart

Timing chart two consecutive prints on LTR paper

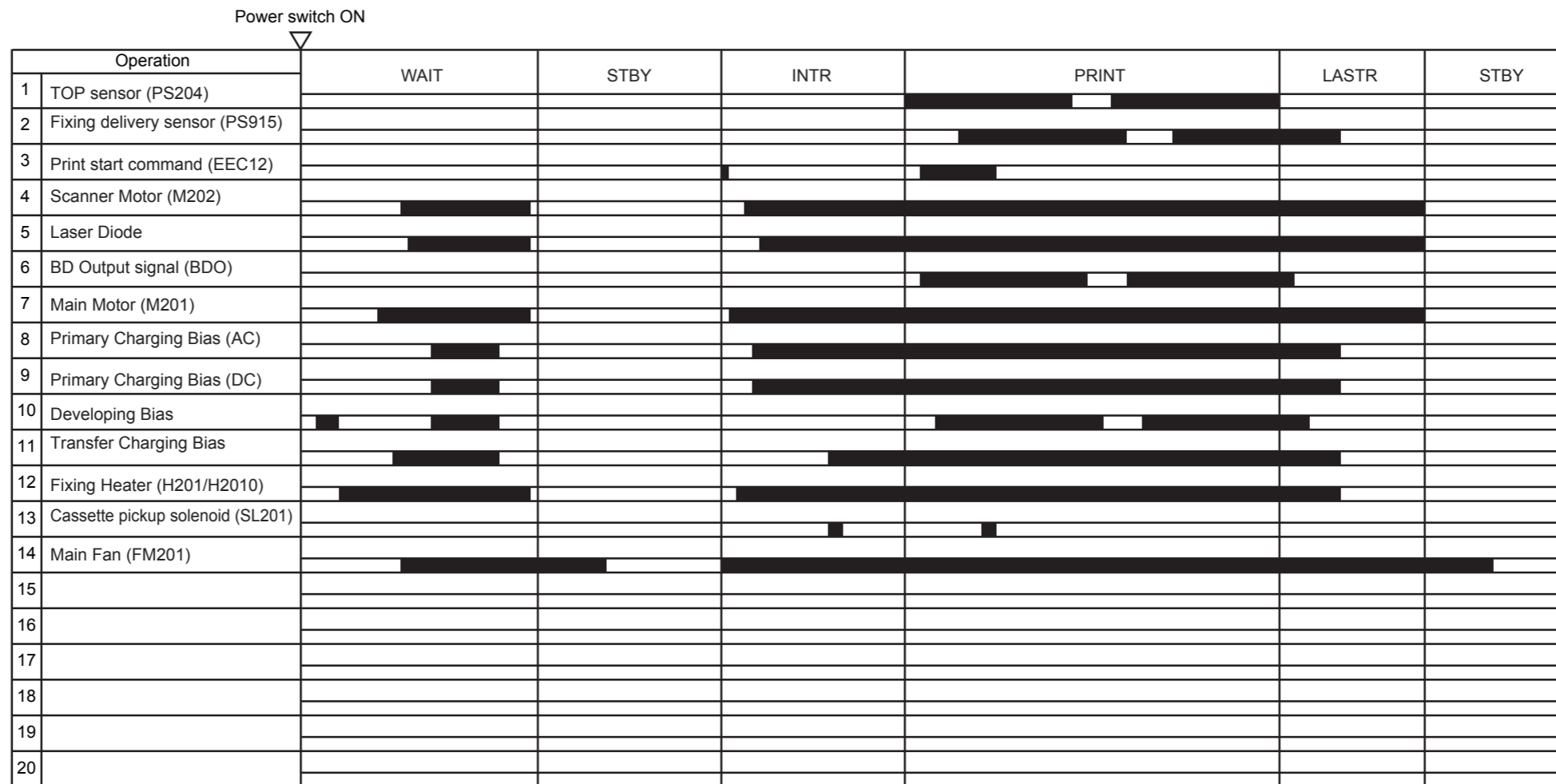

F-9-2

General Circuit Diagram

General Circuit Diagram (1/2)

